

BOSTON PUBLIC LIBRARY



3 9999 06503 257 3

NEW YORK  
PROTECTOR  
COATED

Accessions

397.206

★ Shelf No.

042.281

~~7972.1~~

v. 23, pt. 2  
1886.

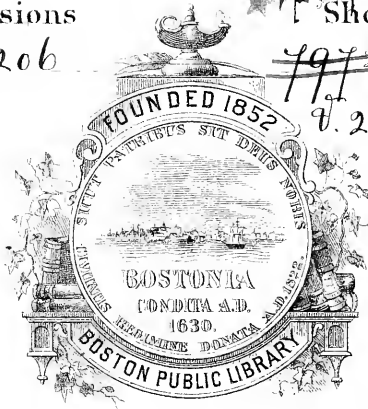

Received. Apr. 23, 1887.

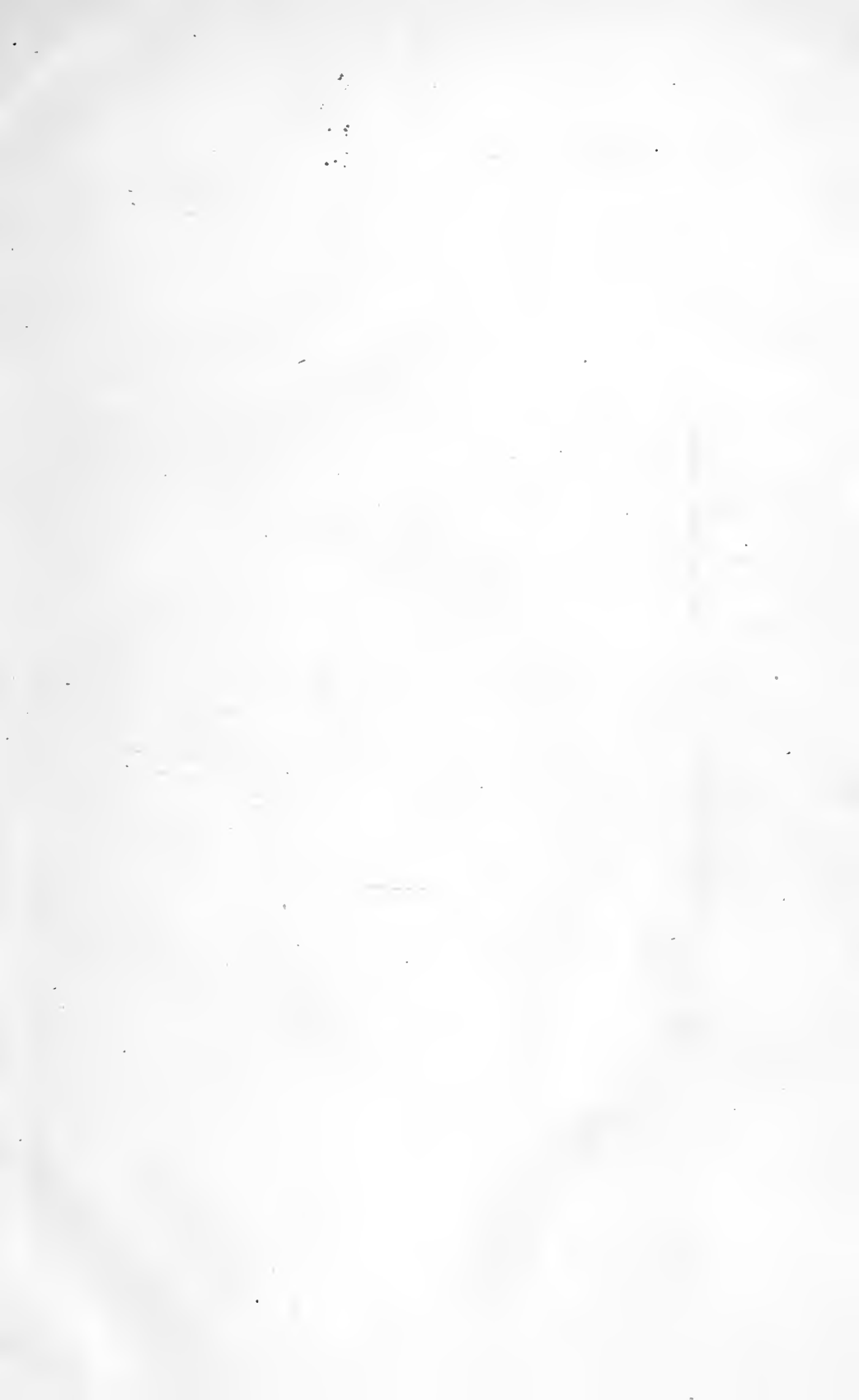







Digitized by the Internet Archive  
in 2011 with funding from  
Boston Public Library

Number 277.

30 Cents.

THE  
PHILADELPHIA  
**Photographer.**

AN ILLUSTRATED SEMI-MONTHLY JOURNAL,  
DEVOTED TO PHOTOGRAPHY.

SUMMARY OF CONTENTS.

PAGE	PAGE
The St. Louis Convention, . . . . . 385	What an Old Teacher says of Wilson's Photographics, . . . . . 403
An Answer to Mr. W. J. Stillman's Opinion of Photo. Art. By CHARLOTTE ADAMS, 386	Our Picture, . . . . . 404
Photography as an Art Educator, . . . . . 389	Yesterday and To-day, or Justice to all. By MRS. E. N. LOCKWOOD, . . . . . 404
Printing Positives on Gelatino-chloride Paper. By M. CHARBO, . . . . . 390	Brains and Judgment most needed in Photography. By C. F. MOELK, . . . 405
Photography in Newfoundland, . . . . . 391	On the Business Management of a Photo- graphic Establishment. By C. M, CARLISLE, . . . . . 406
Is Photography an Art? By F. H. WILSON, 392	The Progress of Photography in Germany and Austria. By DR. J. M. EDER, . . 408
Gelatine, a Substitute for Albumen in Silver Printing. By W. M. ASHMAN, . . . 395	Practical Points from the Studios, . . . 413
Very Slow Gelatino-bromide for Landscape Work. By W. K. BURTON, . . . . . 397	Editor's Table, . . . . . 415
The World's Photography Focussed, . . . 399	
The New Studio of Mr. P. H. ROSE, at Providence, R. I., . . . . . 401	

OUR PICTURE.—A Study from the "Merry Wives of Windsor." Negatives by REICHMANN & Co.,  
New York, on "Eagle" Dry Plates. Prints by Roberts & Fellows, Philadelphia, Pa.

EDWARD L. WILSON,

853 Broadway, New York.

SUBSCRIPTIONS RECEIVED BY ALL NEWS AND STOCKDEALERS

Five Dollars per Annum, in Advance.

## A D V E R T I S E M E N T S .

AIR BRUSH.

ALLEN BROTHERS. The Suter Lens.

ANTHONY & CO., E. & H. T. The New N. P. A.

Pensé Extra Brilliant Dresden Albumen Paper.

BARHYDT, J. A. Solar Crayon Portraits.

BIGELOW'S ARTISTIC PHOTOGRAPHY.

BUCHANAN, SMEDLEY & BROMLEY. Photo.

Stockdealers.

CARBUTT, J. Gelatine Dry Plates and Improved Dry Plate Lantern.

CARPENTER, H. F. Analytical and Manufacturing Chemist.

CODMAN, C. H. & CO. Photo. Stockdealers.

COLLINS, SON & CO., A. M. Photograph Cards.

CRAMER, G. Lightning Plates.

DR. VOGEL'S AZALINE.

DEALERS' DIRECTORY.

dealers.

EASTMAN DRY-PLATE AND FILM CO.

ENTREKIN, W. G. Patent Eureka Burnisher.

Duplex Rotary Burnisher. Duplicating Print-Cutter.

FRENCH & CO., BENJ. Voigtlander & Son and Darlot Lenses. The Wonderful Euryscope.

GENNERT, G. Eagle Dry Plates.

HANCE'S SPECIALTIES.

HERRMANN, CHAS. A. W. Hypo. Soda.

HODGE & HUSTON. The Solar Printers.

HYATT, H. A. New Brand of Dry Plates.

MAGEE & CO., JAS. F. Photographic Chemicals.

MOORE, ALBERT. Solar Enlarger.

MOSS ENGRAVING CO.

MURPHY, GEORGE. Photo. Stockdealer.

PHOTOGRAPHIC TIMES.

SCOVILL MANUFACTURING CO. New Dresden Albumen Three Crown Paper. Gibon's Cut-Outs. Photo. Apparatus.

STANLEY DRY PLATE.

STEINHEIL LENS.

ST. LOUIS DRY PLATE COMPANY.

SWEET, WALLACH & CO. Photo. Supplies.

SOMERVILLE, J. C. Photo. Supplies.

THE DU BOIS FILE.

WALMSLEY & CO. Beck's Rectilinear Lens.

WILSON, HOOD & CO. Ross and Steinheil Lenses, Photo. Frames, Goods, Stereoscopes, and Views.

WILSON'S PHOTOGRAPHICS.

WILSON'S PHOTOGRAPHIC PUBLICATIONS.

WILSON'S LANTERN JOURNEYS.

## A D V E R T I S I N G R A T E S .

THE PHILADELPHIA PHOTOGRAPHER is acknowledged to be the best advertising medium in the trade.

Its circulation is among the first class, at home and in nearly every foreign country.

Its rates, all advantages considered, are the most favorable, and it will bring you fine returns.

	One Issue.	Six Issues.	Twelve Issues.	Twenty-four Issues.
1 Page.....	\$20.00	\$110.00	\$200.00	\$350.00
1-2 " .....	12.00	66.00	120.00	200.00
1-4 " .....	7.00	38.50	70.00	120.00
1-8 " .....	4.00	22.00	40.00	70.00

Special contracts made with bona-fide dealers and manufacturers. Address

**EDWARD L. WILSON,**

853 BROADWAY, NEW YORK.

## N O T I C E T O S U B S C R I B E R S .

In remitting by mail, a post-office order, or draft, payable to the order of EDWARD L. WILSON, is preferable to bank-notes. Postage stamps of the denomination of two and five cents each will be taken. Clearly give your Post-Office, County, and State.

Foreign subscriptions must be accompanied by the postage in addition.

**FIRE!** Our books having been all destroyed by fire at and with our establishment, all who owe us will confer a great favor by remitting at once.

**CROSSCUP & WEST ENGRAVING CO.**

907 Filbert St., Philadelphia.



# EXTRA.

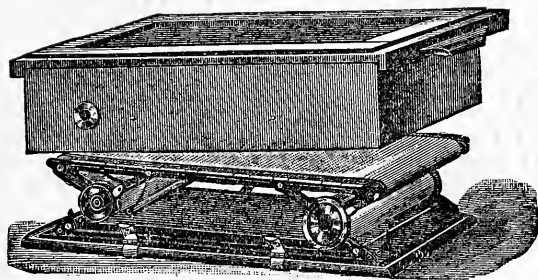

“NOTHING SUCCEEDS LIKE SUCCESS.”

---

The attention of the photographic public is directed to the special information regarding the productions of

The Eastman Dry-Plate and Film Co.

contained in the following pages:

The fact that their new specialties have already become *standard goods* in both hemispheres, is the best of evidence as to their merit.

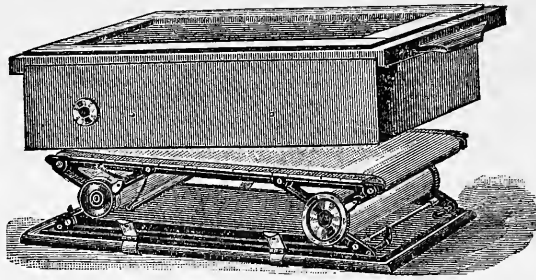

## The Eastman-Walker Roll-Holder

Is the only perfect device for exposing sensitive paper in the continuous roll. The numerous instances where we have sold a second Roll Holder to a party who has had one in use, affords gratifying evidence that they are liked by those who use them most. Among those who have purchased a second Roll Holder are the following:

RUFUS K. DRYER, of Cunningham, Son & Co., Rochester, N.Y.,  $4\frac{1}{2} \times 7\frac{1}{2}$  and  $8 \times 10$ .

JAMES IRVING, Troy, N. Y.,  $8 \times 10$  and  $11 \times 14$ .

C. C. MERRIMAN, Rochester, N. Y., 3 holders,  $4 \times 5$ ,  $4\frac{1}{2} \times 7\frac{1}{2}$  and  $6\frac{1}{2} \times 8\frac{1}{2}$ .

H. G. LATIMER, Wilmington, N. C.,  $5 \times 8$ ,  $6\frac{1}{2} \times 8\frac{1}{2}$ .

CHAS. BIERSTADT, Niagara Falls, N. Y.,  $5 \times 8$  and  $8 \times 10$ .

GEO. UNGLINK, German Insurance Co., Rochester, N. Y.,  $5 \times 8$  and  $6\frac{1}{2} \times 8\frac{1}{2}$ .

WM. H. JACKSON, Denver, Col., 3 holders,  $5 \times 8$ ,  $6\frac{1}{2} \times 11$  and  $18 \times 22$ .

J. S. WATSON, Rochester, N. Y.,  $4 \times 5$  and  $6\frac{1}{2} \times 8\frac{1}{2}$ .

### Read what Mr. Latimer says about his second Holder:

GENTLEMEN: Your favor of the 14th inst., containing bill, and also Roll Holder and extra back, received. I am very much pleased. I have tested the Roll Holder, and it works to perfection. Will be in your city in August, and will call. Enclosed please find check for \$31.80 to your order.

Yours, etc., H. G. LATIMER.

To those who hesitate to buy a Roll Holder, we would say try a couple of our carriers and some cut sheets of Negative Paper or American Film in your ordinary double holder. A fair trial will convince any unbiased operator of the advantages of paper over glass, especially for view work.

## Negative Paper *vs.* American Film.

To those who object to printing through the paper, we offer the perfected American Film which strips off the paper. The operations are simple and certain, and the resulting negative is as transparent as glass.

---

### Mr. Henderson's Experience:

MONTREAL, CANADA, June 9, 1886.

GEO. EASTMAN, ESQ., Rochester, N. Y.

DEAR SIR: I have just finished 22 negatives taken on the last 36 exposure rolls you sent me; and I wish two more of the same number. The paper is very different, indeed, from last year's, although your representative, Mr. Cooper, on looking over last summer's negatives, which gave me so much trouble, agreed with me, or rather pointed out to me, that all were much over exposed. This was probably the chief cause of trouble, and the next, the vile castor oil. You could not tell these new negatives from glass ones, and I had no failures. I was on a ten days trip in the woods.

I had a long talk with Mr. Cooper, who gave me a great deal of information, and many hints. Both you and he say, that the markings I wrote about, were caused by a slot,\* but I cannot make it out. I can see no reason for its doing so. There are none, however, on the last roll with the new roller. I think that here, two of my friends will soon get Roll Holders, and one at home who has passed here lately. Please, if any paper is better than another by chance, send me the best, 36-inch roll.

These 22 negatives were taken in sun, shade, wind, and rain, drop shutter, same with hand, and hand exposure, and developed up beautifully with your concentrated developer, and also with oxalate, but I think the first is best. The potash developer is very good also, although your Mr. Cooper does not approve of it. The advantage of yours is, that the solutions are more concentrated.

Yours truly,

ALEX. HENDERSON.

\* The slotted guide roll in the old model holders marks the paper, and we furnish a new roll not slotted to replace it, on application, free of charge.—EASTMAN DRY PLATE & FILM CO.

## Eastman's Special Plates.

These Plates retain the fine chemical quality which has always been characteristic of them. Crispness in the lights is what is most often lacking in other gelatine dry plates. Eastman Special Plates never give that flat, foggy appearance in the high lights so often found in other plates.

## Eastman's Bromide Transparency Plates.

These Plates are coated with the same emulsion as our Permanent Bromide Paper. Everybody knows that means a good tone and perfect purity in the lights. Since the introduction of these Plates, other makers have been compelled to reduce their prices. Our Plates command a higher price on their merits.

We use the finest selected thin glass for small sizes, and the best English glass for larger sizes.

### PRICES OF

### EASTMAN'S BROMIDE TRANSPARENCY PLATES

ON BEST ENGLISH GLASS.

NO REDUCTION.

Size.	Per Doz.	Size.	Per Doz.
* $3\frac{1}{4} \times 4$ , . . . . .	\$0 70	5 x 7, . . . . .	\$1 55
$3\frac{1}{4} \times 4\frac{1}{4}$ , . . . . .	60	5 x $7\frac{1}{2}$ , . . . . .	1 65
4 x 5, . . . . .	90	5 x 8, . . . . .	1 75
$4\frac{1}{4} \times 5\frac{1}{2}$ , . . . . .	1 00	$6\frac{1}{2} \times 8\frac{1}{2}$ , . . . . .	2 30
$4\frac{1}{4} \times 6\frac{1}{2}$ , . . . . .	1 20	8 x 10, . . . . .	3 40
$4\frac{3}{4} \times 6\frac{1}{2}$ , . . . . .	1 35	10 x 12, . . . . .	5 00

\* Thin Crystal Glass.

### SPECIAL OFFER.

We will send to any address in the United States, a sample dozen of any size not larger than 4 x 5, postage paid, on receipt of price.

THE EASTMAN DRY-PLATE AND FILM CO.

ROCHESTER, N. Y.

## EMINENT TESTIMONY

AS TO THE

PERMANENCY OF THE

## Wonderful Permanent Bromide Paper.

---

MASSACHUSETTS INSTITUTE OF TECHNOLOGY, Boston, April 9, 1886.

EASTMAN DRY PLATE & FILM CO., Rochester, N. Y.

GENTLEMEN: In regard to the permanency of prints on your Permanent Bromide Paper, its introduction has been so recent that, of course, only theoretical consideration can be advanced with regard to it. I do not see how the paper, if pure, could act chemically on the precipitated silver; and, if not, the paper prints should be as permanent as gelatine negatives. These latter, general experience shows, have no tendency to fade, and some recent experiments of my own in which a glass dry plate was carefully measured shortly after development, and again at the end of a year, showed that precisely the same amount of light was transmitted in one case as in the other. Therefore until some satisfactory evidence is adduced to the contrary, I shall hold that there would be *no trouble whatever in regard to the permanency of the Bromide Paper.*

Yours truly,

W. H. PICKERING,  
*Professor of Physics.*

---

## ITS SUPERIORITY ACKNOWLEDGED ALL OVER THE WORLD.

“The Eastman Bromide Paper is the best. I find it easy to work. *I have never found a bad sheet.* The time of exposure varies from one to three minutes with daylight, regulated by the density of the negative and the size of the lens used.”—  
A. R. DRESSER, Secretary of the Camera Club, in *British Journal of Photography*, London, May 14, 1886.

## The Wonderful Permanent Bromide Paper.

### CRAYON AND PASTEL WORK.

OFFICE OF THE CRAMER DRY-PLATE WORKS,  
St. Louis, April 16, 1886.

EASTMAN DRY-PLATE AND FILM Co., Rochester, N.Y.

GENTLEMEN: The Bromide Paper "C," which you have sent me gives vigorous and clear prints, and my artist finds it to have an excellent surface for crayon and pastel work, so that I believe it to be well adapted for the purpose intended. Yours truly,

G. CRAMER.

See our Circular on Enlarging—to be had  
from any Dealer.

1206 CHESTNUT STREET,  
PHILADELPHIA, March 26, 1886.

EASTMAN DRY-PLATE AND FILM Co., Rochester, N.Y.

GENTLEMEN: We have had so many applications for bromide enlargements that we think seriously of fitting up for this kind of work. So far it has stopped other work while it is under way, but we will soon have more room, and may fix up a room especially for this work. Any suggestions as to the building of the apparatus, kind of lenses, etc., will be gratefully received. We are making a great many bromide prints (contacts), and deal through Walmsley & Co. The prints seem to give more satisfaction every day, and we find the paper more easily managed than ever. Awaiting a response, we are,

Truly yours, Wm. H. RAU & Co.

### THEY ALL WANT MORE.

WILMINGTON, DEL., March 30 1886.

EASTMAN DRY-PLATE AND FILM Co., Rochester, N.Y.

GENTLEMEN: The bromide paper is all a person could ask for. I have made some very fine prints. I think I will need some soon to make some enlargements on. I remain, respectfully yours,

L. H. FAIVRE, Photographer.

### NO FINISHING REQUIRED.

HENDERSON, N. C., April 27, 1886.

EASTMAN DRY-PLATE AND FILM Co., Rochester, N.Y.

GENTLEMEN: The sample lot of paper sent me proved a success beyond my brightest expectations. I had not mounted my first attempt on the 14 x 17 paper before it was sold for a good price. There was scarcely any room for the crayon and stump to work, so perfect was the enlargement. I had retouched an 8 x 10 head as fine as possible, and when the enlargement was made it was perfect.

Respectfully, GEO. M. NEWELL.

### PERFECTION A THIRD TIME.

AKRON, OHIO, April 2, 1886.

EASTMAN DRY-PLATE AND FILM Co., Rochester, N.Y.

GENTLEMEN: Your bromide paper is a great success. I think it simply perfection. I made some splendid prints on those sample sheets that I ordered of you. I will shortly send an order for larger sizes.

Yours truly,

C. E. GROESSEL, 132 S. Howard St.

### FOR WATER COLORS.

GREENE, IOWA, March 27, 1886.

EASTMAN DRY-PLATE AND FILM Co., Rochester, N.Y.

DEAR SIR: My sample prints came to hand, also the bromide paper ordered for Mr. Harvey through Hiram J. Thompson, Chicago. Mr. Harvey and myself got most gratifying results with the paper, and it takes more kindly to water colors than any other paper I have ever seen.

I shall find a wide use for it in both portraiture and landscapes, as well as preparing studies for the art classes in the school. I used for enlarging, my stereopticon apparatus, using the ether-oxygen light.

Respectfully yours, JAMES R. TAGGART.

### "GOOD BYE, SOLARS."

OFFICE OF RUR'S STUDIO,

341 FOURTH AVE., BET. MARKET AND JEFFERSON STS.  
LOUISVILLE, Ky., April 3, 1886.

EASTMAN DRY-PLATE AND FILM Co., Rochester, N.Y.

GENTS: I am dead in love with your Permanent Bromide Paper. I was induced a few weeks ago by my friend Gatchel to give it a trial. I hesitated at first, as I had an idea it was no good, but acted on my friend's suggestion and went to work. The very first print I made was a grand success; it came up in the developer like magic, and I remarked at once, "three cheers for Eastman & Co.!" I am now making prints almost daily on bromide paper, and they not only please me, but my customers are delighted with them. Oil and crayon work beautifully on "C" paper. I have made some fifteen or twenty life-size solars in the last few weeks, and have not lost a single print or an inch of paper. I do all my printing at night with a magic lantern.

Good-bye, old solar camera, I bid you farewell forever! I will lay you down to rest beside your old companion, the old silver bath, and I will promise to let you rest in peace so long as I can procure Eastman's Permanent Bromide Paper.

Yours, etc., A. B. RUE.

Permanent Bromide Paper for Sale by all Dealers.

THE WONDERFUL  
Permanent Bromide Paper.

LABEL REGISTERED, 1885.

PERMANENT

BROMIDE ENLARGEMENTS.

Having equipped an enlarging department for testing our Permanent Bromide Paper, we are prepared to make Enlargements from photographer's negatives promptly and of the best quality. When good original negatives are furnished, these enlargements require little or no finishing, and are far superior to those made by any other process whatever.

Permanent Bromide Enlargements can be finished in India ink, crayon, water colors, or oils.

Pack negatives carefully and specify whether to be vignettted or solid. Plain enlargements signifies unfinished.

Specify whether stretcher or card mount is desired.

PRICES OF PERMANENT BROMIDE ENLARGEMENTS ON CRAYON PAPER.

	Unmounted.	Mounted.
10 x 12, each, . . .	\$1 00	\$1 50
11 x 14 " . . .	1 25	1 75
14 x 17 " . . .	1 50	2 00
16 x 20 " . . .	1 75	2 25
18 x 22 " . . .	2 25	2 75
20 x 24 " . . .	2 50	3 00
22 x 27 " . . .	2 75	3 50
25 x 30 " . . .	3 00	3 75
24 x 36 " . . .	4 00	4 75
30 x 40 " . . .	6 00	7 25

We recommend every photographer to make his own enlargements. If any one has doubts as to the capabilities of the process, let him send us a *good negative* for a trial, and we guarantee his doubts will be dispelled.

Terms cash with order.

Specimens furnished from our own negatives at above prices.

OUR ENLARGING DEPARTMENT.

STUDIO OF S. L. STEIN,  
MILWAUKEE, Wis., April 26, 1886.

EASTMAN DRY-PLATE AND FILM Co., Rochester, N. Y.

GENTS: Enlargements from the fourteen negatives came to hand; am more than pleased with results. I anticipated good prints; but assure you they surpassed all my expectations. Enclosed please find my check for amount of bill, \$51.25. Acknowledge receipt, and oblige, Yours respectfully,  
S. L. STEIN.

337 WEST MADISON STREET, CHICAGO, April 26, 1886.  
MR. G. EASTMAN.

The prints you have made for me are the finest I have ever seen, and have given perfect satisfaction.  
Respectfully,  
J. W. GERRIG.

DETROIT, April 27, 1886.

EASTMAN DRY-PLATE AND FILM Co., Rochester, N. Y.

GENTLEMEN: Since your demonstrator was here about six weeks ago, I have used a good many of your bromide enlargements and find them to give more detail, and, from a good negative, to require less working up than ordinary solars. Respectfully yours,  
F. N. TOMLINSON.

J. HENRY DOERR'S PHOTO. ART GALLERY,  
COR. TWELFTH AND MARKET STREETS,  
LOUISVILLE, Ky, April 26, 1886.

EASTMAN DRY-PLATE AND FILM Co., Rochester, N. Y.

GENTLEMEN: The two 25 x 30 permanent bromide enlargements you sent me are fine, they are as soft and clear in the shadows as the cabinet I made from the same negative. I received an order for three from one gentleman as soon as he saw the prints.

Yours truly,  
J. HENRY DOERR.

217 WEST THIRD STREET,  
ST. PAUL, MINN., May 10, 1886.

MR. EASTMAN, Rochester, N. Y.

DEAR SIR: Enlargements received, and are fine—much better than I expected.

Yours truly,  
S. M. TAYLOR.

609 NICOLLET AVENUE,  
MINNEAPOLIS, MINN., May 21, 1886.

EASTMAN DRY-PLATE AND FILM Co., Rochester, N. Y.

DEAR SIR: The enlargements you sent came all O K. and give splendid satisfaction. I will send negatives in a day or so for some more. Please send me price list and what you will charge for one unmounted, 22 x 34. I shall order an outfit soon and try the work myself. Hoping you will do as well by the next lot, I remain,  
Most respectfully,  
J. A. BRUSH.

## Eastman's Permanent Bromide Paper is made in Three Varieties.

"A"—SMOOTH SURFACE, THIN, for proofs, positive printing, copying drawings, etc., by contact.

"B"—SMOOTH SURFACE, HEAVY, for positive printing, enlarging, and working in ink, oil, and water colors.

"C"—ROUGH SURFACE, HEAVY, for positive printing, enlarging, and working in crayon, ink, water colors, and oil.

### NOTICE.

In addition to our *Standard* Quality of Permanent Bromide Paper, we keep in stock and supply on special order a quicker kind called *Medium*. We can furnish it on "A," "B," or "C," paper. *Medium* Paper is especially adapted for enlarging from hard negatives, as it works softer and with more detail. It is also suited for enlarging by lamplight, as it is twice as quick as *Standard*. For all ordinary work we recommend the *Standard* paper on account of its great brilliancy and easy working qualities. *All orders* for Permanent Bromide Paper will be filled with *Standard Quality*, except where *medium* is specified.

### PRICES OF EASTMAN'S PERMANENT BROMIDE PAPER.

#### "A," "B," OR "C." CUT SHEETS.

3¼ x 4¼, per dozen, . . . . .	\$0 25	11 x 14, per dozen, . . . . .	\$3 00
4 x 5, " . . . . .	40	12 x 15, " . . . . .	3 35
4¼ x 5½, " . . . . .	50	14 x 17, " . . . . .	4 50
4¼ x 6½, " . . . . .	55	16 x 20, " . . . . .	6 00
4¾ x 6½, " . . . . .	60	17 x 20, " . . . . .	6 40
5 x 7, " . . . . .	65	18 x 22, " . . . . .	7 50
5 x 7½, " . . . . .	70	20 x 24, " . . . . .	9 00
5 x 8, " . . . . .	75	22 x 27, " . . . . .	11 25
6½ x 8½, " . . . . .	1 10	24 x 30, " . . . . .	13 50
8 x 10, " . . . . .	1 50	25 x 30, " . . . . .	14 00
10 x 12, " . . . . .	2 25	24 x 36, " . . . . .	16 00
10 x 14, " . . . . .	2 65	30 x 40, " . . . . .	22 50

Other sizes in proportion. If ordered in packages of less than one dozen, an extra charge of 25 cents will be made for packing.

#### IN ROLLS OR ON PATENT SPOOLS FOR ENLARGING EASELS.

10 inches wide, per yard, . . . . .	\$0 56	20 inches wide, per yard, . . . . .	\$1 12
11 " " . . . . .	62	22 " " . . . . .	1 34
12 " " . . . . .	68	24 " " . . . . .	1 35
14 " " . . . . .	79	25 " " . . . . .	1 40
16 " " . . . . .	90	30 " " . . . . .	1 68
18 " " . . . . .	1 00	31 " " . . . . .	1 75

Not less than ten yards on a spool.

MANUFACTURED ONLY BY

THE EASTMAN DRY-PLATE AND FILM Co.  
ROCHESTER, N. Y., U. S. A.

BRANCH OFFICE: 13 SOHO SQUARE, LONDON.

Send for Illustrated Circular "ENLARGING WITH PERMANENT BROMIDE PAPER," showing how to improvise an Enlarging Apparatus with apparatus in ordinary use.

FOR SALE BY ALL DEALERS THROUGHOUT THE WORLD.



SOLE AGENTS FOR THE AMERICAN CONTINENT.

DETROIT, MICH.

# ALLEN BROTHERS,

In the above letters, where blanks occur, the Lenses referred to are the best known on both Continents. Mr. E. Suter was awarded a silver medal for invention and construction of Lenses at the recent International Exhibition at London, England. The late Prince Frederick Carl used a Suter Lens. Her Britannic Majesty's Government has purchased a set of Suter Lenses for the use of the South Kensington Museum. Count Schouvaloff, Russian Ambassador at Paris, uses a Suter Lens. Andrew Pringle, Esq., the Eminent Scotch Photographer, uses Suter Lenses. A. L. Henderson, the English professional photographer, gets fine effects with a Suter Lens. A European maker of high reputation has made unsuccessful overtures to Mr. Suter to make all their photographic lenses. We commend these facts to the people who assert that because the Suter Lens is sold at a low price, it must be an inferior instrument.

Dear Sir: Your price current has reached me and I thank you for it. My friend and Photographic Colleague, Prof. W. Donkin, Honorary Secretary of the Photographic Society of England, has said to me that in the opinion of Captain W. De. W. Abney, your photographic lenses are perfect, giving negatives extremely fine. I send you my cheque, praying you to send me at the earliest possible moment your Aplanatic Lens, No. 8 B. I intend taking with this Lens some large views on the high Alps. Hoping to receive soon a perfect instrument. Please accept the assurance of my highest consideration.

BIELLA S. GROSOLAMO, ITALIA, 30th April, 1886.

This is from a prominent Italian amateur:

Mr. E. Suter, Bale: I wait with impatience the two lenses you have promised to make me. Observe the beautiful season, and I am anxious to make some instantaneous views. The lens No. 5 A. which you have sold me is *excellent* and above all, very rapid. I rely on your kindness, and pray you to accept my best regards.

FRANCK, France, April 28, 1886.

Mr Dear Mr. Suter: At last I have received your price list (the second one), as the first letter has been lost on the way. To-day I send you from Kalitowitz, Silesia, a photograph of myself taken at Warsaw, by Brandel. The picture was taken with an aplanatic, made by —, with fourth stop, in two seconds (amission). I would have bought one of these instruments if Mr. H. Warmerke, who owns an emission factory in London had not dissuaded me. This gentleman spoke about your instruments which were unknown to me and Mr. Brandel, as follows: "The instruments of — are quicker and stronger than the — instruments, but far better than either of these are the instruments of Suter, which by accident I have seen in London." You can imagine that both of us took note of same can do as good work as the enclosed picture shows. I only wish to use the Aplanat for photographing horses, on plates not smaller than 40 x 50 centimeters. Mr. Brandel will undoubtedly also become your customer as soon as he has sufficient proof of the excellency of your instruments. The gentleman is an amateur. Please tell me by return mail what you would advise me to do. May be that an Aplanat No. 6 would be better. In —'s Lenses I put no confidence, neither does my friend, because neither of us was able to take a good picture with same. I remain your obedient servant.

F. S. I would like to get one of your Objectives sent to Vienna on trial. I will be there during January.

SOSNOWITZ, 29th October.

The following is from an Austrian officer:

Mr. Suter, Bale: Mr. Warmerke, of London, England, tells me that you manufacture an Objective marked "Series A," which greatly excels in the instantaneous process, especially in photographing in the public streets, with movable objects. He bases his good opinion of your Objectives upon the experience of the renowned London photographer, Wilson, who has used your instruments with the best success. We intend to take Street Photographs (size 13 x 18 centimeters), in this city, but must have the picture clear and strong up to the very edge of the plate. We use neutral (largest) stop.

WARSAW, Poland, March 12, 1886

Extract from a letter from the noted Polish firm of Karol & Pusch, Warsaw:

From eminent sources. From personal information gained in England and Continental Europe, we make the unqualified assertion that the Suter Lenses are now the Best in the World. We submit a few testimonials

# THE SUTER LENS IN EUROPE.

---

# WILSON'S LANTERN JOURNEYS

---

**VOL. III. NOW READY.**

---

All Mr. Edward L. Wilson's personal descriptions of personally made views in one volume.

---

**\$2.00.—TO ANY ADDRESS—\$2.00.**

---

IT CONTAINS DESCRIPTIONS OF THE FOLLOWING SLIDES:

The Sinal Peninsula and Petra, 204; From Hebron to Bethel, 50; Round about Jerusalem, 50; Picturesque Palestine, 50; From Damascus to the Sea, 50; A Thousand Miles in Nile Land, 50; Nile Tombs and Temples, 50; How They Live in Egypt, 50; Egypt and the Egyptians, 50; Egypt, Old and New, 50; New Pictures of Old Places, 150.

**EDWARD L. WILSON**, Author and Publisher, 853 Broadway, N. Y.

For Sale by **ROBERTS & FELLOWS**, 1125 Chestnut St., Philadelphia.

---

# DR. VOGEL'S AZALINE.

FOR SALE BY

**W. KURTZ**, 6 East 23d Street, New York.

---

**ALBERT MOORE** THE **SOLAR ENLARGER**,  
 THE LONGEST, LARGEST, AND BEST.  
 828 Wood Street, Philadelphia.

---

**JAMES F. MAGEE & CO.**

*522 Race St., Philadelphia,*

**Manufacturers of Pure Photographic Chemicals,**

**Specialties: NITRATE OF SILVER and CHLORIDE OF GOLD.**

✻**REFINERS OF GOLD AND SILVER WASTE.**✻

✻Waste sent through Stockdealers will receive prompt attention.

# BENJ. FRENCH & Co.

No. 319 WASHINGTON STREET, BOSTON,

Sole Agents in the United States for the Celebrated Lenses  
Manufactured by

## VOIGTLÄNDER & SON.

ALSO, THEIR FAMOUS

# EURYSCOPE,

Which is unrivalled for groups, full-length figures, and other demands in the gallery, and every species of out-door work, including instantaneous photography.

☞ **THE EURYSCOPE** is made *exclusively* by Voigtländer & Son, and their name is engraved on the tube.

---

FOR **DARLOT LENSES** FOR  
PORTRAITS. VIEWS.

---

IMPORTERS, ALSO, OF THE CELEBRATED

TRAPP & MÜNCH

## ALBUMEN PAPER,

AND DEALERS IN ALL KINDS OF

*Photographic Materials and Magic Lantern Slides.*

---

SEND FOR OUR NEW ILLUSTRATED PRICE LIST OF LENSES.

**H. F. CARPENTER,**  
29 & 31 Page St., Providence, R. I.  
**ANALYTICAL AND MANUFACTURING CHEMIST.**  
Refiner of PHOTOGRAPHIC WASTES.

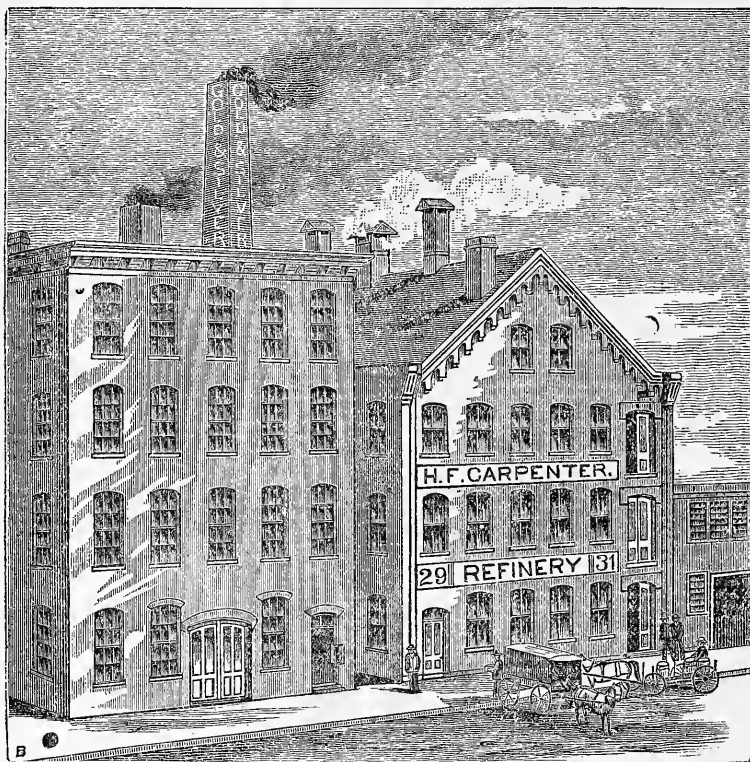

**Assayer and Sweep Smelter.**

**Nitrate of Silver and Chloride of Gold.**

Chemically pure gold prepared especially for Photographers' use at \$1.10 per dwt.

Information given on application in regard to methods of saving waste.

# ONE MONTH MORE.

A



IG OFFER.

## \$8.00 WORTH OF BOOKS FOR \$4.00.

"How doth the little busy bee  
Improve each shining hour,  
And gather honey all the day,  
From every opening flower!"

When Isaac Watts wrote that immortal verse, which for generations has served to shame many a laggard into photography or some other honest effort for a living, he only used the bee as a figure to represent the amateur and adept photographer, and to "gather honey" meant to read carefully from the "opening flower," which is plain English for photographic books.

And now, as the season of sunshine approaches, is the proper time to follow the injunctions of the wide-awake and observant bard.

To enable the enterprising "busy" ones to do this, we have combined with the Scovill Manufacturing Co., to offer, for sixty days only, certain of our publications at one-half price, *i. e.*, four dollars will purchase eight dollars worth of books, postage paid to any American address. Dr. Vogel's *Progress of Photography*; Tissandier's *Hand-Book of Photography*; Robinson's *Pictorial Effect in Photography*; *Gihon's Guide*. A few words as to these.

Dr. Vogel's *Progress* is the best instructor on dry-plate manipulation there is; no library is complete without it. It treats of all classes of work, including the æsthetic department and finishing and printing the negative. It is profusely illustrated; handsomely printed; bound in cloth-gilt, and is exhaustive on the subjects of light, chemistry, optics, apparatus, processes, technique, and amateur photography. It is published at \$3.00.

Mr. H. P. Robinson's *Pictorial Effect in Photography* teaches wrinkles and dodges that you would never dream of in your photography. It is as full of bright, brilliant ideas—told so pleasantly—as a film is of molecules. It is the best art authority you can study. It is amply illustrated, is bound in paper (cloth 50 cents extra), and is published at \$1.00.

*Gihon's Guide*, though called the *Colorist's Guide*, is by no means confined to instruction in coloring. Its chapters on linear perspective should be memorized by every one who can focus. Every page instructs. It is bound in cloth, finely illustrated, and published at \$1.50.

Tissandier's *History and Hand-Book of Photography*, is one of the most attractive

books on photography that has ever appeared in any country.

Part first gives a history of photography, from the discovery of the camera obscura by the Italian philosopher, Porta, including all the interesting details of Daguerre's and Niepce's experiments, their partnership, the death of the latter, the final perfection and publication to the world of the daguerrotype process, the discovery of photography on paper by Talbot, and down to the taking of negatives.

Part second treats of the operations and processes of photography, describing and illustrating the studio and apparatus, the manipulations of the negative process; all the operations of the printing department; theory and practice, including the modifications required by various kinds of photography, such as landscapes, portraits, skies, and instantaneous photography, retouching, enlargements, dry processes, etc.

Part third enumerates the applications of photography, such as heliography, the Woodbury process, photosculpture, photographic enamels, photomicrography, microscopic dispatches during the siege of Paris, astronomical photography, photographic registering instruments, the stereoscope, photography and art, and the future of photography.

The appendix describes panoramic photography, the heliotype process, the photoint process, the most approved formulæ of the wet collodion process, a simple method of repairing dry plates, and English weights and measures.

The book is beautifully illustrated throughout with fifteen full-page engravings and sixty wood-cuts. It comprises three hundred and twenty-six pages, and is printed on heavy tinted paper. It is bound in cloth, and published at \$2.50.

These four books, whose aggregate publication price is \$8.00, we offer for \$4.00 until our joint stock is exhausted. Any two of them to one address, one-third discount from publication price. No discount on a single publication.

The "busy bee" must fly quickly if he would "improve each shining hour. Every book is guaranteed, fresh, clean, and new and from our best stock.

Societies and others forming libraries will do well to secure sets before they are all gone, for after all, the stock of sheets in the bindery is limited.

**EDWARD L. WILSON, 853 Broadway (Domestic Building), New York.**

The Following is of Interest to every Photographer.



---

THE NEW N. P. A.  
P E N S É.

We desire to call attention to our **NEW PENSÉ N. P. A.** Extra Brilliant Dresden Albumen Paper.

The manufacturers at Rives have recently made many marked improvements in their celebrated paper, and all the sheets of this brand are **manufactured specially for it**, and are readily distinguished from all other papers by the **water-mark N. P. A.**

It is doubly albumenized by the **most experienced house** in Germany, with **new and improved** formulas, and we are confident that on trial it will be found **superior** to any other in market.

Its excellence has induced some unscrupulous persons to **place the STAMP on the Paper of other makers**, in order to work it off, trusting that photographers will not look through to see if the **water-mark** is there. To prevent this we have registered  This Trade Mark  in Washington, which will subject to heavy damages all those who stamp this brand on paper which does not bear the **water-mark N. P. A.** This Paper can be had also in

EXTRA-BRILLIANT  
N.P.A.  
DRESDEN.

PINK, PEARL or WHITE.

**FOR SALE BY ALL DEALERS IN PHOTO. GOODS IN U. S. AND CANADA.**

---

**E. & H. T. ANTHONY & CO.,**  
591 Broadway, NEW YORK.

N. B.—When any paper is offered to you at a low price, **Measure it.**

Also note whether it runs **Uniform**, for some albumenizers mix the first and second qualities, not discarding that which has defects, and thus get their paper cheaper.

# THE STANLEY DRY PLATE

Has passed through the ordeal of its first summer, and its manufacturers have almost entirely escaped the usual trials of fogging, frilling, and other perplexities. In fact, the quantity sold in July exceeds that of any former month.

Its *unusual combination of sensitiveness and brilliancy* have made it a general favorite, and the territory into which it penetrates grows constantly larger.

## AMONG ITS RECENT ACHIEVEMENTS ARE

*Instantaneous Views of the Decoration Day Parade* (3d size stop), taken without sunlight, used as a Bulletin Illustration.

*Views of Horses and Carriages entering Central Park*, trotting rapidly across the field of view, sharp and clear cut. These will appear in the Bulletin.

*Views of Steamboats* going twenty miles an hour directly across the field, taken at 5.30 P. M. Sharp and clear as if standing still.

*The Life-size Portrait of J. F. Ryder*, by McMichael, shown at the Buffalo Convention, was made on an 18 x 22 Stanley Plate in five seconds, with a Dallmeyer Rapid Rectilinear Lens.

*Instantaneous Views*, by Mr. Henry J. Newton, President of Photographic Section of the American Institute, about which he writes:

"I found that sunshine was not absolutely necessary for instantaneous negatives on these plates, and I think a majority of the negatives I send you were made when there was not sufficient sunlight to cast a visible shadow. I think it is due that I should say that the plates worked satisfactorily in every respect, exhibiting extreme sensitiveness, responding readily to the developer, and going steadily on to the finish.

P. S. I used the Prosch Shutter at its full speed."

(Signed),

H. J. NEWTON.

And now to crown the whole, Mr. Parkinson writes as follows:

E. & H. T. ANTHONY & Co.:

PARKINSON PHOTO. PARLORS, 29 W. 26TH ST.,  
NEW YORK, August 12, 1885.

"GENTLEMEN: I take pleasure in assuring you that I made a group portrait in my gallery of an old lady of eighty years, with child of four years, a month or two since, on a Stanley 18 x 22 plate, in one second, with Dallmeyer Rapid Rectilinear Lens. A little more time would have done no harm; but the picture in question has elicited as many words of praise from visitors to my studio as any other in same length of time."

Yours truly,

W. B. PARKINSON.

The Stanley Dry Plates can be had from any dealer, or direct from

**E. & H. T. ANTHONY & CO.,**  
591 BROADWAY, NEW YORK.

Another thing that has gone rapidly to the front is the

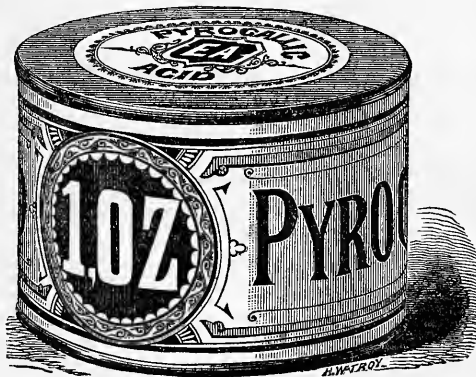

When Dry Plates were first introduced it was not yet on the market, and the old stereotyped developing formulas do not mention it; but in the developing formulas of the more recent popular plates, as the STANLEY and the ST. LOUIS, the E. A. Pyro is recommended as most desirable, and in the EASTMAN DRY PLATE CO. formulas the same preference is given ever since they knew of its merits.

It is always used by the veteran "Roche," and constitutes one of the main elements in the popular Cooper's Developer.

Every photographer should try the E. A. Pyro. Every dealer has it, or ought to have it, or it can be had direct from

**E. & H. T. ANTHONY & CO., 591 Broadway, N. Y.**

## A GLOW of PHOTOGRAPHIC PUBLICATIONS

The amateur and his old friend, the daily worker, are well taken care of in the literature line, and we ask their attention to the following list, which includes about everything there is need for. There is, in fact, a treatise on every branch of photography.

**Wilson's Photographics.** The newest and most complete photographic lesson-book. Covers every department. 352 pages. Finely illustrated. Only \$4. By Edward L. Wilson.

**The Philadelphia Photographer.** A monthly magazine, illustrated by photographs of superior merit. \$5 a year; \$2.50 for six months.—Stands ahead of all its kindred. Twenty-two years of success is a sufficient guarantee of its value and use to the practical, working, growing photographer. Do not go without its valuable help.

**The Ferrotyper's Guide.** Price, 75 cents.—Cheap and complete. For the ferrotyper this is the only standard work. Seventh thousand.

**Pictorial Effect in Photography.** By H. P. Robinson. Cloth, \$1.50; paper cover, \$1.—For the art photographer.

**Wilson's Lantern Journeys.** By Edward L. Wilson. In three volumes. Price, \$2 per volume.—For the lantern exhibitor. Gives incidents and facts in entertaining style of about 2,000 places and things, including Mr. Wilson's last travels.

**Bigelow's Artistic Photography.** Price reduced to \$4—For the lover of art. Beats his "Album of Lighting and Posing." Suberb! With twelve photographs and instructions.

**The Photographic Colorists' Guide.** By John L. Gihon. Cloth, \$1.50.—The newest and best work on painting photographs.

**Photographic Mosaics, 1886.** A year-book. Cloth bound, \$1; paper cover 50 cents. Better than any of its predecessors.—Back volumes, same price.

**The Photographic Amateur.** By J. Traill Taylor. A guide to the young photographer, either professional or amateur. Price, 50 cents.

**The Art and Practice of Silver-Printing.** By H. P. Robinson and Capt. Abney, R.E., F.R.S. Price, 50 cents. Illuminated cover. Cloth bound, 75 cents.

**How to Make Pictures.** (Second edition of 5,000 copies.) The ABC of Dry-plate photography. By Henry Clay Price. Price, illuminated cover, 50 cents; cloth, 75 cents.

**Photography with Emulsion.** By Capt. W. De W Abney, R.E., F.R.S. Price, \$1 per copy.

**The Modern Practice of Retouching.** Price, 25 cents per copy.

The Spanish edition of **How to Make Pictures.** Ligeras Lecciones sobre Fotografia Dedicados a Los Aficionados. Price, \$1 per copy.

**The Progress of Photography.** By Dr. H. W. Vogel. A splendid helper to all workers. Price, \$3.

**Hardwich's Chemistry.** A manual of photographic chemistry, theoretical and practical. Ninth Edition. Edited by J. Traill Taylor. Price, \$2; cloth, \$2.50

**Twelve Elementary Lessons on Silver Printing.** Presented in very concise and attractive shape. Price, 25 cents.

**About Photography and Photographers.** A series of interesting essays for the studio and study, to which is added European Rambles with a camera. By H. Baden Pritchard, F. C. S. Price, \$1.

**The Chemical Effect of the Spectrum.** By Dr. J. M. Eder. Price, \$1.

**Picture Making by Photography.** By H. P. Robinson, author of Pictorial Effect in Photography. Written in popular form and finely illustrated. Illuminated Cover. Price, 75 cents; cloth, \$1.

**First Lessons in Amateur Photography.** By Prof. Randall Spaulding. A series of popular lectures, giving instructions in dry-plate photography, optics, etc. Price, 25 cents.

**The Studio and what to do in it.** By H. P. Robinson, author of Pictorial Effect in Photography, Picture Making by Photography, etc. Illuminated Cover. Price 75 cents.

**Picture Making.** By H. P. Robinson. Cloth, \$1. Paper, 50 cents.

All orders for above will be filled, free by post, on receipt of price at the office of this magazine.

**EDWARD L. WILSON, Photo. Publisher, 853 Broadway, New York.**



---

## TO THE TRADE.

---

I will receive from time to time the Cabinet Stock of a prominent card factory, from which the perfect goods have been selected.

This will consist of all grades and tints, and range in price from \$2.50 to \$5.00 per thousand. For various purposes this line will be found useful.

---

### GEORGE MURPHY,

250 Mercer Street.

NEW YORK.

---

## THE AIR BRUSH.

---

This New Art Tool applies color by a jet of air. It is invaluable to any photographer who produces his own large work. Portraits may be made over solar or contact prints, on plain or Albumen Paper, in India Ink, or Water Colors, etc.

*Lights built up on Flat Negatives, Cloud Effects in Backgrounds for View Work, etc., all can be accomplished by this Tool,*

with the greatest rapidity, and with a perfection bounded only by the capacity of the artist. Full particulars FREE. Address

**AIR BRUSH MFG. CO., 50 Nassau St., Rockford, Ill.**

---

## ARTISTIC PHOTOGRAPHY.

By LYMAN G. BIGELOW.

---

The best work there is to teach how to light and pose the human figure. Instructions and formulæ and **Twelve Photo. Cabinet Illustrations** of varied sexes and ages.

---

**\$4.00. POST-PAID. \$4.00.**

---

**EDWARD L. WILSON, Publisher, 853 Broadway, N. Y.**

A. M. Collins, Son & Co.

*MANUFACTURE ALL KINDS OF*

**CARDS AND CARDBOARDS**

FOR

**P** PHOTOGRAPHERS **S**

AND

**MATS, MOUNTS, AND ENVELOPES**

FOR

**FERROTYPES.**

---

OFFICE AND WAREHOUSE,

**No. 527 ARCH STREET,**

PHILADELPHIA.

---

Price Lists may be had by intending purchasers on application to us, or to all Photographic Merchants, through whom your favors are respectfully solicited.

JOHN G. HOOD.

ESTABLISHED 1865.

WM. D. H. WILSON.

# WILSON, HOOD & CO.

825 Arch St., Philadelphia,

SOLE AGENTS IN THE UNITED STATES FOR THE



Centennial, 1876.



Centennial, 1876.

## Ross' Portrait and View Lenses.

Portrait Lenses, from 1-4 to 8 x 10.  
Cabinet Lenses, Nos. 2 and 3.  
Card Lenses, Nos. 1, 2, and 3.  
Triplets, Nos. 1, 2, 3, 4, 5, 6, and 7.  
Symmetricals. Rapid Symmetricals.

Instantaneous Doublets, all sizes.  
Medium Angle Doublets, all sizes.  
Large Angle Doublets, all sizes.  
Stereographic Lenses, all sizes.  
New Universal Lens.

Numerous testimonials pronounce them to be the *best* as well as the *cheapest* Foreign Lenses ever offered to the American Photographer. We will mail price list on application, and promptly fill all orders. Always in stock,

## CAMERA BOXES,

Made by AMERICAN OPTICAL CO., ANTHONY, BLAIR, and ROCHESTER OPTICAL CO.

WE KEEP IN STOCK FULL ASSORTMENT OF

## AMATEUR PHOTO. OUTFITS

DRY PLATES OF ALL MAKES.

N. P. A., EAGLE, and S. & M. PAPER, PER REAM, \$34.00.

Any article needed we can supply, as

WE MANUFACTURE, IMPORT, AND DEAL IN ALL KINDS OF

*Photo. Goods, Frames, Stereoscopes and Views,*

At prices as low as are consistent with the quality of goods furnished. We are indebted to our customers for the patronage during the past *Twenty Years*, and our efforts shall be to merit a continuance of it.

Illustrated Price Lists supplied free. Correspondence solicited.

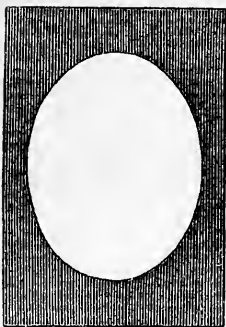

# GIHON'S CUT-OUTS

An Entirely New Variety for  
PRINTING MEDALLION PICTURES.

Are the very best that are made, and are now without a rival in the market. They are clean cut, most desirable shapes and sizes, and made of non-actinic paper, manufactured specially for the purpose. Each package contains 30 Cut-Outs, or Masks, with corresponding Insides, assorted for five differently sized ovals and one arch-top.

*Price, \$1.00 per Package. Sent by mail on receipt of price.*

Parties wishing special sizes, or large lots of a few sizes, may have them cut to order promptly, by addressing the manufacturer. No lot costing less than \$1.00 made at a time.

*No printer should attempt to make Medallion Pictures without them.*

## THEY HAVE NO EQUAL FOR QUALITY.

Beware of spurious imitations made of common paper, full of holes, badly cut, and odd shapes and sizes. Ask your Stock-dealer for GIHON'S CUT-OUTS, and see that they are in his envelope, with instruction circular included. The recent packages are composed of an entirely new variety and of a new paper. TRY THEM.

Promenade Size now Ready. Sold Separately at 50 cents per Dozen.

# GIHON'S OPAQUE

Is designed for Completely obscuring the Imperfect Backgrounds of Copies, Retouching Negatives, Faulty Skies in Landscapes, Coating the Inside of Lenses or Camera Boxes, Backing Solar Negatives, Covering Vignetting Boards, And for Answering all the Requirements of the Intelligent Photographer in the Production of Artistic Results in Printing.

Wherever you want to keep out Light, use Opaque.

IT IS APPLIED WITH A BRUSH, DRIES QUICKLY AND STICKS.

**CUT-OUTS (thirty), \$1.00. OPAQUE, 50 Cents.**

FOR SALE BY ALL DEALERS.

ROBERTS & FELLOWS, Makers, Philadelphia.

Address all orders to

SCOVILL MANUFACTURING CO., New York.

**NOTICE.**

REMOVAL TO

**111 North Broadway,**

**ST. LOUIS.**

**PHOTO. SUPPLIES,**

COMPLETE STOCK.

NEW GOODS. NEW STORE.  
IMPROVED FACILITIES.

Call and See Sample Room.

**J. C. SOMERVILLE.**

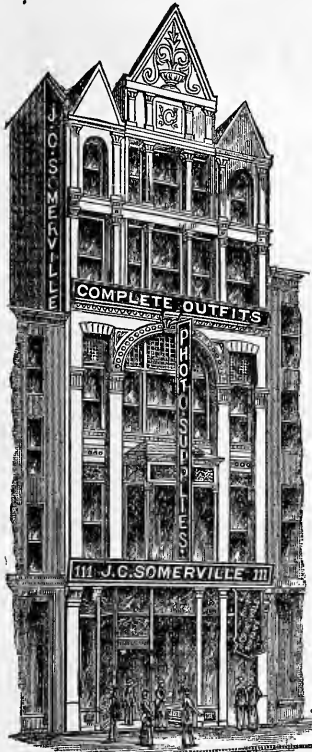

**SHARP FOCUS**

INSTANTLY OBTAINED WITH

**Collins' Focusing Attachment, Patented**

SWEET, WALLACH & CO., SOLE AGENTS FOR THE UNITED STATES.

FOR SALE BY ALL DEALERS.

NO FOCUSING CLOTH REQUIRED.

NO GROUND GLASS REQUIRED.



THE NEW WAY.

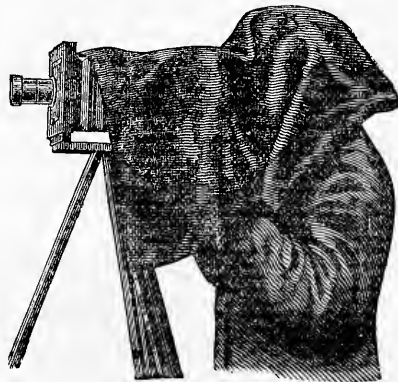

THE OLD WAY.

P  
R  
I  
C  
E

\$3.50

Send for Circulars.

**Sweet, Wallach & Co.,**

PHOTOGRAPHERS' SUPPLIES,

229 & 231 STATE STREET,

CHICAGO.

**ENTREKIN'S**  
IMPROVED  
**DUPLEX ROTARY BURNISHER.**  
PATENTED.

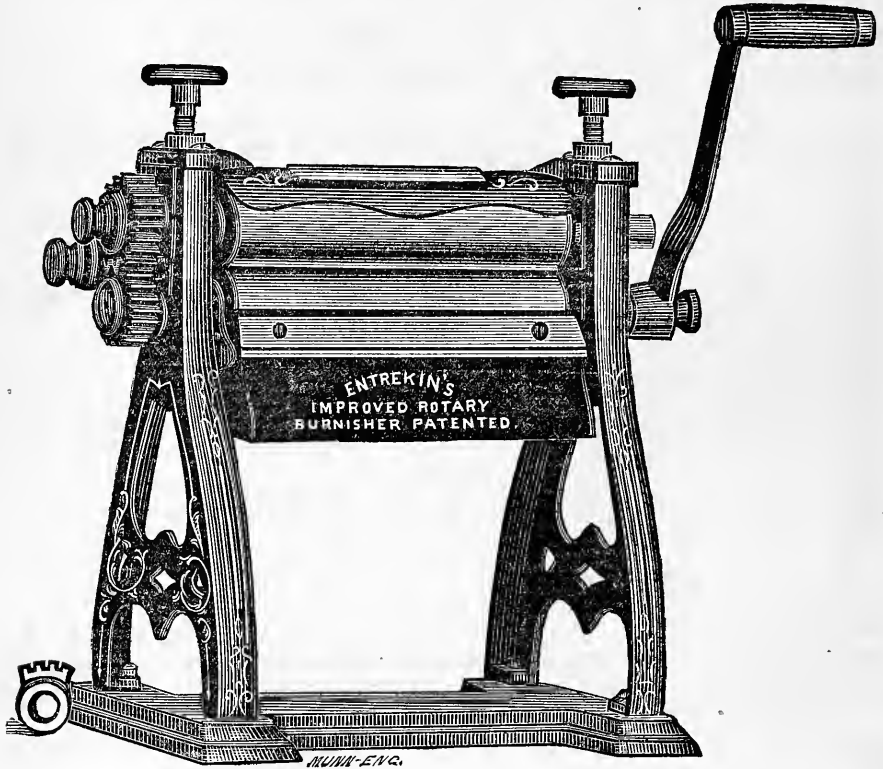

10 in., \$25.00. 15 in., \$35.00. 20 in., \$45.00. 25 in., \$60.00.

**This Machine is an improvement on our old Duplex Rotary Burnisher, invented by us in 1874.**

It is so constructed that by changing the Large Gear or Cog-wheel, from the stud to the end of the draw-file or upper roll, you reverse and change the speed of the lower or polishing roll, thus getting the same result as in the old Duplex Rotary; but to secure the best polishing surface, use the machine with the large cog-wheel on the Stud, by so doing you secure three times the polishing surface. All the machines will be sent out with gearing so arranged as to give this result. It is optional with the Photographer how he may use the machine. The Fire-Pan is so arranged that it is impossible for it to come in contact with the surface of the polished roll, and it can be turned away to cleanse the roll.

**EVERY MACHINE WARRANTED PERFECT.**

FOR SALE BY

**W. G. ENTREKIN, Inventor and Sole Manufacturer,**

4384 Main St., Manayunk, Philadelphia, Pa.

AND BY ALL PHOTOGRAPHIC STOCKDEALERS.



# WILSON'S LANTERN JOURNEYS

DESCRIBES  
SLIDES  
ALL OVER  
THE WORLD.



DESCRIBES  
SLIDES  
ALL OVER  
THE WORLD

3 VOLUMES.

3 VOLUMES.

VOLUME I. 306 PAGES,

*Contains NINE Journeys:*

- A—France and Switzerland.
- B—Belgium, Germany, Austria, Saxony, and Bavaria.
- C—Italy—Lakes, Cities, and the Italian Art Galleries.
- D—Holland, Denmark, Norway, Sweden, Russia, and Spain.
- E—Egypt, Palestine, Syria, Turkey, Greece, and India.
- F—England, Scotland, and United States of America.
- G—Centennial Exhibition, Philada.
- H—Centennial Exhibition, Philada.
- I—The Paris Exposition, 1878.

**IN ALL, OVER 900 SUBJECTS.**

VOLUME II. 331 PAGES,

*Contains TWELVE Journeys:*

- J—Germany and Russia.
- K—Belgium and Austria.
- L—France—Cities and Provinces.
- M—Spain and Portugal.
- N—Switzerland—The Four Alpine Routes.
- O—Italy, Ischia, and Sicily.
- P—Turkey, Greece, and Egypt.
- Q—Palestine and India.
- R—Scotland—Cities and Ruins.
- S—Ireland.
- T—England—Cities, Museums, and Ruins.
- U—United States of America.

**IN ALL, 1073 SUBJECTS.**

VOLUME III. 322 PAGES, CONTAINS ELEVEN JOURNEYS:

- Sinai Peninsula and Petra.
- From Hebron to Bethel.
- Round about Jerusalem.
- Picturesque Palestine,
- From Damascus to the Sea.
- A Thousand Miles in Nile Land.

- Nile Tombs and Temples.
- How They Live in Egypt.
- Egypt and the Egyptians.
- Egypt, Old and New.
- New Pictures of Old Places.

**IN ALL, 700 SUBJECTS.**

PRICE \$2, POST-PAID.

Gives descriptions of all the slides made by Mr. Edward L. Wilson of his personally taken views of The Sinai Peninsula; The Desert of the Exodus; The Route of the Israelites to the Promised Land; and

## THE TAKING OF PETRA

FOR SALE BY ALL DEALERS.

EDWARD L. WILSON, Photo. Publisher, 853 Broadway, New York.



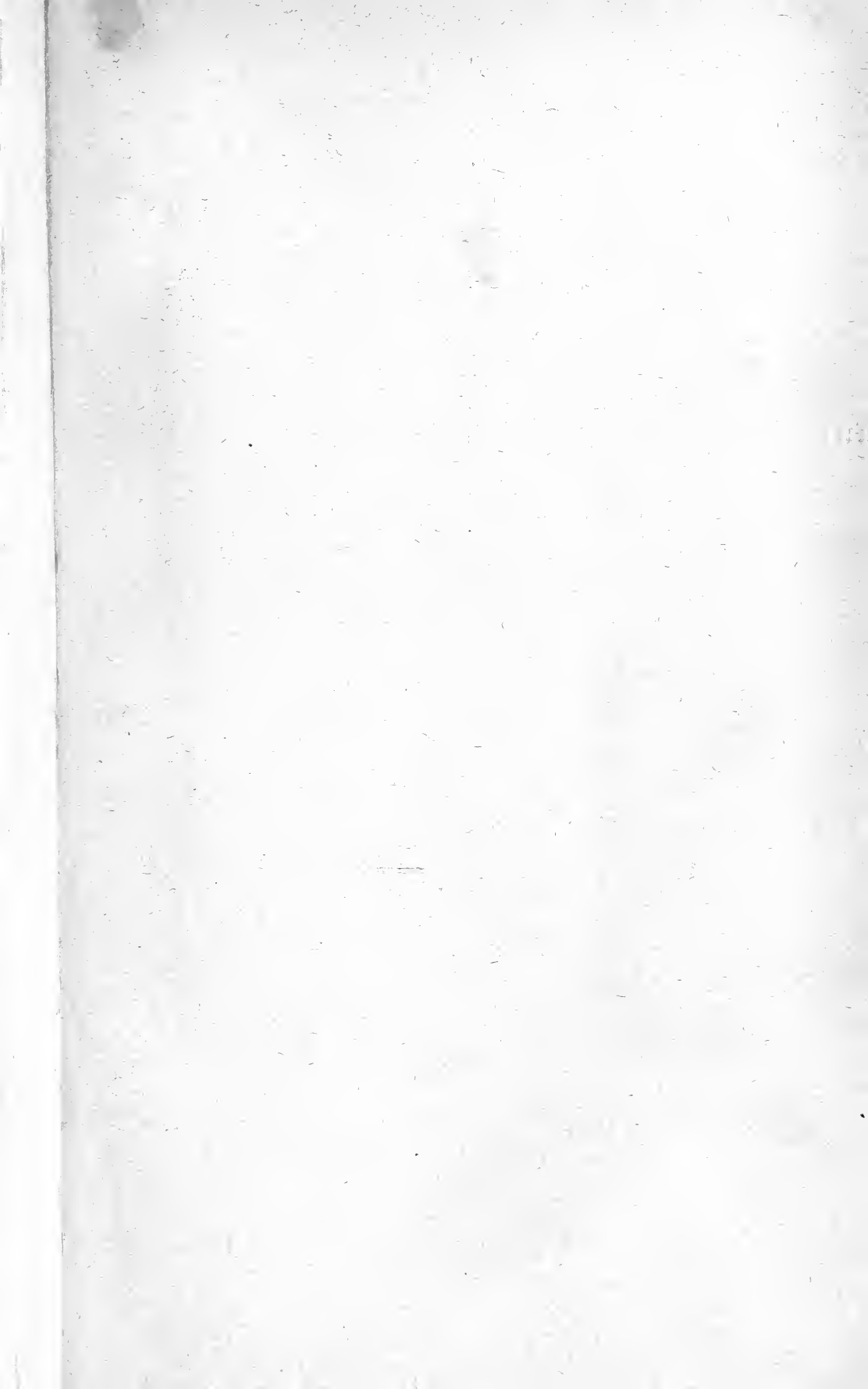



STUDY FROM

THE WIT



70.4  
397.206  
Apr. 23, 1887

\* 7972.1  
v. 23, p. 2  
1886

THE

# Philadelphia Photographer.

EDITED BY EDWARD L. WILSON.

Vol. XXIII.

JULY 3, 1886.

No. 277.

## THE ST. LOUIS CONVENTION.

BEFORE this reaches our readers, the 1886 Convention of the Photographers' Association of America will be a thing of the past. Our regular day of issue has come to hand too soon for us to include any great portion of the proceedings in our current number, for the reason that the stenographer was not able to supply us with a copy of his report sufficiently early. But through the courtesy of Mr. H. McMichael, the always obliging Secretary, we were favored with advance copies of some of the papers read in competition for the \$100 prize, and thus early present them to our readers, further on. It is rather a singular coincidence that some of the papers should so evenly and harmoniously accord with the æsthetic spirit of two of our regular contributions.

And how well these papers were supported by the photographers at St. Louis, anyone who saw the grand display will at once agree. There never was an exhibition in our country wherein so many photographs were shown which were entitled to be considered works of art as were shown at St.

Louis. Most wonderful progress has been made by some of our American photographers since last year. The Committee who awarded the prizes found their task a difficult one, although there was such a generous quantity of medals placed at their disposal.

We deemed it our duty to decline the appointment offered us as one of the jurors, in order that we might fulfil the wider duty of giving our readers a fair *résumé* of the worthiest of the whole. This will appear in our next issue, together with the report of the proceedings, carefully revised.

We were personally present at the Convention, and write these lines during its session. We have found much interesting matter worthy of comment, which shall have our best attention as early as possible. Enthusiasm and desire for growth characterized the whole grand proceedings so decidedly that the few drawbacks which occurred are scarcely worthy of reference. Of all this, however, more anon. Much gratitude is due to those who earnestly and unselfishly labored for such an end. And those who came and saw are, we trust, wiser and better photographic artists than they were.

## AN ANSWER TO MR. W. J. STILLMAN'S OPINION OF PHOTO. ART.

BY CHARLOTTE ADAMS.

MR. W. J. STILLMAN, a gentleman who has made a certain amount of reputation as an art-critic of the old-fashioned, conservative school, has undertaken to show the photographic public that photography is not art. He expounded his views in a series of three articles which appeared in the *Photographic Times and American Photographer* of March 19 and 26, and April 2, 1886.

Amateurs, professional photographers, and persons who are simply interested in art in a general way and who love fair play for its own sake, have doubtless read these articles with a touch of indignation. Mr. Stillman denies *in toto* the right of photography to be classed as an art. The reasons he adduces are sufficiently weak and illogical, and the whole tone of his argument suggests the art-theories and views of thirty or forty years ago. It would be easy to take up Mr. Stillman's remarks, point by point, and oppose them in detail; but this would be very largely a waste of time. I prefer to argue from premises of modern art-feeling, as Mr. Stillman has done from conservative, merely emphasising and illustrating my views by reference to what he has said.

These articles bear internal evidence that their author belongs to the English school of art-criticism, rather than the French or American, and, moreover, it is art-criticism of a very *arriéré* character. We Americans are forming a distinct school of photography as well as of art in the limited sense; and the principles of one are the principles of the other. There is no reason why our photography or our art should be hampered by the ideas that prevailed in England in the fifties. We, as a nation, draw our artistic inspiration from many sources, but that which comes from England is of the least value to us and the least in sympathy with our aims and aspirations.

Mr. Stillman's views on photography and his denial of its right to be classed as an art are based on English theories of pseudo-idealism. The English art-critic shrinks from realism unless it be sugar-coated with idealism.

Our American art, on the other hand, is grounded, root and branch, in realism and this love for hard, positive facts, so natural to the American temperament, is the rainbow of hope in our artistic system. Now photography, whether regarded as an art or as a mechanical process, owes its existence, in the higher sense, to the place accorded to realism in modern life; in other words, the insistence upon positive truths. It is essentially a modern thing. Why then attempt to apply to the practice of photography art-principles which were virtually out of date before its invention?

There will always be two factions in the artistic camp. The idealists and the realists are always at war. But, in this country, the realists now have the best of it, and the majority wins. Creative art, in its highest conventional sense, that is, in the sense of working through pure imagination and fancy, does not belong among us. Reproductive art, in the sense of depicting human life and nature as they exist, is the foundation of the modern American art-idea. Photography is simply a form of reproductive art. Realism and reproduction are one—with the difference of the informing spirit of intellect and feeling, which in some subtle, indefinable way raises the artistic above the mechanical. This difference holds good in literature no less than in art. Flaubert's "Madame Bovary" is a magnificent piece of realism, while the *New York Herald* contains every day examples of excellent reproductive writing.

Photography is, however, no less realistic than reproductive, and the barriers between modern art and modern photography are every year being broken down. A photographer may be an artist or an artist may be merely a photographer, in the ordinary trade meaning of the word. A man of genius does not trouble himself about methods or vehicles of expression and he will accomplish as much with one set of tools as another. He will do more with the camera than a man of mediocre ability will accomplish with all the color-tubes, palettes, and brushes in the world. Therefore let photography take its place among us as one more recognized and legitimate form of artistic expression, equal in value to any of

the other known and accepted technical vehicles.

The possibilities of development open to the art of photography are practically limitless, and particularly is this the case in America. Let us put aside the thousand and one so-called mechanical processes in which it plays the part of an applied art. It is not too much to say, that, in a few years, the annual exhibition of original photographic *pictures* will rank in importance with our other New York exhibitions. It is but a few years since the idea of holding an exhibition of black-and-white work originated in the brains of a few ambitious young illustrators who formed the Salmandi Club. The value of these exhibitions in dignifying the illustrator's calling has been incalculable. It is not long since the American art-public talked of illustrators in slightly contemptuous or at best deprecatory terms. The artistic importance of water-color art is now universally acknowledged. The most interesting of our New York winter exhibitions is that of the American Water-Color Society. Yet where was water-color art in this country twenty years ago? Then, the public and the amateur spoke of a man who was chiefly known for his aquarelles as "only a watercolorist." To-day, we have "only a photographer," according to Mr. Stillman and the fossilized portion of the American art-public. It is important to dwell upon this point in Mr. Stillman's oracular utterances. The tone of contempt towards photographers which runs through the articles and is especially strong in the first of the series, merits a word of rebuke.

The photographer's modest claim to recognition as being in some sort a worker in the art-field, is regarded by Mr. Stillman as "nonsense." This writer is so much a Philistine and is so strongly animated by the spirit of social flunkeyism, which is a factor of English art, as to attribute the photographer's natural desire for acceptance as an artist to a yearning for "higher social rank." May the shade of James Yellowplush protect Mr. Stillman in all his social peregrinations.

One would like to ask Mr. Stillman if the position of artists in England and America

be so secure as to make them objects of envy to the photographer whose breast is inflamed with horrid social ambitions? There is not space here to quote Mr. Stillman's remarks on the social aspirations of photographers. Suffice it to say that he adopts towards these poor would-be artists the tone of proud disdain which characterizes a New York dowager weeding out a list of charity patronesses.

The development of the art-idea has, it is true, brought about in recent years, an improvement in the position of artists as artists. Why should not the development of photography do the same for photographers? It is also true that artists in England are now often treated as social pets, and as "no gentleman's library is complete" without books on art, so no gentleman's dinner-table is fully set without the society of some representative of the fine arts. There is, however, nothing very substantial in this kind of social position, in any country, and it is hardly enough to make the honest American photographer turn green and yellow with jealousy. It is not very long since English artists sat below the salt.

It is generally supposed that the social status of artists, in France at least, is unquestioned. But I find that M. Chesneau, a French art-critic of considerable authority, in his work, called "The Education of the Artist," deprecates the low place accorded to artists as such in the social scale and the constantly strengthening prejudice felt by the prosperous middle-class against the art-calling.

In America, the last fifteen years have given us a recognized art-system, a distinct school of art and a large art-following—master and disciple, professional and amateur. But things have not always been thus. Even so late as twenty years ago, the position of an artist, in American commercial communities, was a doubtful and disagreeable one. The struggles of art for recognition in this country have been very painful.

I remember when a band of determined young painters, scarcely more than students, started out to redeem fresco-painting, in the form of mural decoration, from the disrepute into which it had fallen in this country. That was less than fifteen years ago, and yet

the mural decorator was then ranked in the public mind with the kalsominer and the paper-hanger. Now mural decoration is regarded as a distinct branch of art, and some of the most brilliant names in American art are identified with it.

If American art has undergone a process of social and intellectual evolution, why may not American photography hope for similar development? In any case, American art and American photography are both established on too solid a basis to require any assistance in the matter of self-assertion from imported snobbery.

Mr. Stillman complacently remarks that "people who make and use language have never used the word artist in indicating a photographer, nor have they ever recognized photography as one of the arts of design." Pray, who are these "people?" And since when have dictionary makers known anything about art? All the philologists of England, with Max Müller at their head, would have less influence on the art of their country than Watts or Millais. And if the great authorities mentioned by Mr. Stillman, who are presumably English, do not recognize photography as one of the arts of design, then it becomes America to step forward in championship of the young and bewilderingly brilliant artistic waif, take her by the hand and accord her an honored place in the magnificent art-system of the New World.

It is not from young artists that the refusal to grant photography a place among the arts comes, in this country. They appreciate too highly, both its actual value and its vigorous possibilities. Photography plays an important part in our exhibitions of easel art, although the public is not often let into the secret, and the artist-painter frequently receives the credit which is due to the artist-photographer.

Modern art is under great obligations to photography. There was a time when the artist who employed the camera in painting pictures was regarded as a person who made use of illegitimate processes. That time has now gone by. How far the use of the camera may go is a matter that depends on individual bias and conscience. A mere mechanical worker in paint will let his

tools, whether camera or brush, do all they can for him, while an artist will always hold the thing expressed higher than the method or vehicle of expression. A great deal of what appears to be the best work shown at our National Academy of Design is primarily camera work. That is, the camera has been used to make studies or photographic sketches—to seize poses or expressions that are too fleeting to be grasped by the brush and to convey general impressions of parts or the whole of the composition. Here the legitimate use of the camera, as an accessory of easel painting, stops. By all means let us have good camera pictures. Let us work from nature with the camera as freely as with the brush, but do not let us attempt to make one do the work of the other. Let us not make a photographic foundation on canvas and then color it with oil-paint. Honest camera work is a good thing, and the time will come when it will be recognized as art. Honest brush work is also a good thing, but the union of the two with intent to deceive, only brings the feeblest side of each process to the surface. Artistic insincerity always carries its penalty with it, and this kind of mongrel work, although it is often effective at first sight, is rarely satisfying after a few glances have been bestowed upon it.

I do not agree with Mr. Stillman when he says, "in photography we must neglect what is due to color." I think that the color-possibilities of photography are as great as those of any other black and white medium. The intermediate tones between the union of all colors and the absence of all colors are numerous and can be handled with the utmost suggestiveness by skilled and appreciative workers.

Appropos of the use of photography as an accessory of easel art, I shall quote here three sentences which I find in a charming little book by Alfred Stevens, the great Belgian impressionist painter. The book was published a few months ago at Paris. It is called "Impressions sur la Peinture". Alfred Stevens is one of the most "modern" of painters in the sense in which artists use the word, and what he says of photography is worth considering. This collection of impressions contains the literary expression

of the man's artistic creed, which, be it observed, is diametrically opposed to that of Mr. Stillman.

He says, "The invention of photography has caused in art a revolution as great as that which the invention of railways brought about in industry." What greater tribute of recognition could an artist pay to this noble handmaiden of his own creative genius?

This painter, whose technique alone places him in the front rank of European artists, certainly has the right to demand, as he does, that "no picture should allow the spectator to suspect that the artist has called in the aid of photography." In these two sentences is defined the entire range of photography in its relations with "art" in its narrow current sense.

The limitations of photography are defined by M. Stevens in the following sentence: "Photography proves to us that art is far superior to this admirable invention; even if it had color, it would still be inferior to painting." To the dictum of so great a master as Mr. Stevens we bow gracefully, reserving to ourselves the right of private judgment, and remembering that photography is yet in its infancy. In claiming for it recognition as an art, the champions of photography have not demanded that it should usurp the place of so-called "art." But the matter of its inferiority to painting depends largely upon the quality of the painting. A poor oil picture is vastly inferior to a fine photograph, and not all the artists in the world could bring us to hold a different opinion. We have at least a right, assuming the most modest position possible, to demand for photography equality of recognition with other kinds of black and white work, which are by common consent now classed under the generic head of "art."

---

### PHOTOGRAPHY AS AN ART EDUCATOR.

#### A VETERAN'S ESTIMATE OF PHOTOGRAPHY.

ABOUT the year 1844 I saw the first photograph ever taken in Philadelphia. It was, however, called a "daguerrotype," from

M. Daguerre, the inventor, or at least the introducer, a Frenchman. I was at that time a teacher of drawing and painting. I had classes in many of the highest and best private schools in Philadelphia, besides classes in public schools and at my own home, both night and day. I was thus brought in direct contact with all classes of pupils, from those who were apprentices to trades, and who studied to apply their knowledge to their future profession—architecture, mechanics, ornamentation, etc., up to those who never expected to be called upon to work for a living, and who consequently learned only to acquire one more elegant accomplishment. The first class studied as they did at the trade or profession they were preparing for, the last, some because it was the fashion, some because their parents desired it, and some took hold *con amore*. The amount of ignorance of "the principles of the beautiful" in some marked the low average state of artistic feeling, while the real genius in others created a hope that so valuable an aid to all education would some day in the future spread and leaven the whole.

How long it would have required to bring the world up to its present point of appreciation without any particular spur or incentive will never be known, but I believe ages might have elapsed first. Suddenly Daguerre appeared upon the scene, and although the first pictures cost fifteen dollars each, they created a furore never known before. Every one at once became a critic. The picture and the subject were examined minutely together, every little discrepancy was noted and treated artistically, scientifically, and wonderfully; every striking point of resemblance was dwelt upon as the last wonder of the world, as it really was at that time. Every man, woman and child at once became a critic, an embryo artist, an observer of nature, and one man became so excitable, so observant of the little things which go to make up a whole, that he told me he noticed every shadow across the sidewalk, and involuntarily "stepped over it," as if possessed height as well as breadth. Here was a silent educator, but so powerful that no organization could withstand its influence.

Daguerre had jogged the world into a new path; the eyesight of the people was sharpened; their intellects were brought to a focus and were thrown upon nature, the fountain-head of all knowledge; the reflection back upon their minds gave a new understanding, a command of thought, of ideas, a positive knowledge of size, shape, light and shade, distance, foreshortening, perspective, unity, congruity, and placed every observer upon a pinnacle from which to survey the world, hitherto absolutely unattainable. Every one became an embryo artist, and as this new faculty did not interfere with the power of speech, but seemed to give it new and advanced ideas to work with, the powers of description, so lacking in many, began to feel the influence of the hour, and good drawings, good descriptions grew so fast that now, at this day, there are many persons who are first-rate writers on subjects not often even considered by those previous to Daguerre.

The ignorance of pupils was most lamentable. I had a pupil, a boy of twelve or thirteen, who did not, would not, or could not put his mind to his work at all. I was on point of writing to his father to advise taking the boy away for a few years, till his mind should naturally turn toward art studies, when lo! I received a most kind and complimentary note from the father thanking me for the care and attention I was bestowing upon his son, as shown by the boy's *wonderful progress*. Well, I redoubled my efforts, and the boy's work grew worse and worse.

What is the status of art information now, 1886, in this country? What is the average ability of the masses to express ideas? How far forward in the scale of civilization has the habit of constant criticism placed the people of our country beyond its status fifty-two years ago? A man who can see no faults can see no beauties. His ideas, his faculties, his ability to think, his power of expression even seems to lie dormant; he is a stick, a log, built to be an active, living member of society; he is a mere clod, he has innately all the machinery of mind necessary to constitute him a "man of mark," but he has no incentive, no stirring influence, to rouse his faculties; he

is a mere lucifer match, of no earthly use till some one rubs his back.

Education is a cultivation of the faculties with which we are amply supplied. Curiosity is the most powerful incentive of the human mind, and the boy who is constantly asking questions proves his possession of a mind which demands education and will have it, and the parent who is able, by the tendency of his replies, to lead the boy to the truth, will never feel that there is any danger of a wicked tendency.

Let every child learn observation; drawing, by directing the mind to minutæ, best develops that faculty. Pictured illustrations are now so common that criticism of art is universal, and as a picture tells more in a few square inches than whole pages of letterpress can, let us encourage pictures, the power to produce them, and the ability to discuss them fairly and artistically. I give Daguerre the whole credit of inaugurating this great boon to mankind.—S. RUFUS MASON, in the *Germanatown Telegraph*.

(Translated for the Philadelphia Photographer.)

## PRINTING POSITIVES ON GELATINO-CHLORIDE PAPER.

BY M. CHARBO.

THIS skilful amateur recently gave, before the Belgian Photographic Association, a complete demonstration in printing and enlargements on chloride of silver emulsion paper by means of the lime-light. M. Charbo explained first, in a few words, the great advantages he derived from the use of these papers. The rapidity in printing is considerable; in fifteen minutes, and at eight inches from a gas jet, it is possible to obtain twelve uniform prints. Bad negatives can give passable prints. Developing, toning, and fixing are easy and require but little time. The prints are more permanent than those made with albumen; it is true, however, that experience does not go back far enough to enable us to assert positively the unalterability of emulsion paper, but there is every reason to suppose that this is the case. M. Charbo now gave his mode of operating. A sensitized sheet is placed behind a negative in the pressure frame.



After an exposure of a few seconds to the lime-light, it is placed in a dish, and on the film is poured a mixture in equal parts of the following solutions, A. B.:

## A.

Neutral Oxalate of Potash	6 drachms.
Bromide of Ammonium	15 grains.
Distilled Water	3 fl. oz. 3 drs.

## B.

Sulphate of Iron	92 grains.
Distilled Water	3 fl. oz. 3 drs.

M. Charbo recommends adding to this last solution a crystal of citric acid. It is prudent, in practice, to put not more than three or four prints together in developing, as towards the end the development is very rapid, and care must be taken not to exceed a certain limit. As oxalate of iron may be kept exposed to the air fifteen or twenty minutes the bath may be used several times. The time to stop the development is judged by the transparency; the image is washed in water four times renewed, then an alum solution at  $7\frac{1}{2}$  per cent. is poured over the print and allowed to remain from ten to fifteen minutes. Wash again in four waters for about five minutes. Professor Charbo prefers the toning and fixing bath in one solution. He passes the paper in a bath of hyposulphite of soda at 15 per cent., to which he adds 4 per cent. of a solution of chloride of gold at 1 per cent. The tone shown by the transparency will be preserved in drying. If the image is blue it is because the exposure has been too long and that it has been not sufficiently developed. Want of exposure and too long development are indicated by a greenish-black tone. As soon as the image appears in the development, the red light is replaced by a white light, that is to say, by a candle. Several enlargements (four diameters) were then made by M. Charbo in about three minutes with a lime-light. The paper is fixed upon a plate covered with a special paste made as follows:

Water	2 fl. oz. $4\frac{1}{2}$ drs.
Gelatine	6 drachms.
Glycerine	1 oz. 7 drs.
Sugar	2 pieces.

The adherence is perfect and the paper may be removed without difficulty.—*Bulletin de l'Association belge Photographique.*

## PHOTOGRAPHY IN NEWFOUNDLAND.

I PROMISED you I would give you some details of my method of working. I am afraid there is nothing to detail. I have used Marion's Britannia Plates for the last five or six years, the ordinary and extra-rapid series. Lately I have used the rapid altogether for gallery work. They make beautifully soft pictures, or at least such pictures could be made with them. As I mentioned in a former letter, I have to make my faces considerably stronger than I should if my own inclination was consulted. My patrons want what they call *clear faces*, and of course I have to make them; this is likely to cause more or less *hardness*, and very often I have praises bestowed upon work that I regard as "cast-iron" productions.

Before I made up the parcels I sent you, the mail came in, bringing the last number of the *P. P.*, containing that beautiful picture of Ryder's, *The Bride*. It almost put me out of *conceit* of sending any of my work. I have made none for the special purpose of sending you; it is my average work. I wish it was better. I *have* to make white faces to suit this community; it is the acme of their ambition to get *nice clear pictures*. Such a beautiful face as that of Ryder's would be a good many shades too dark for any of our brides, but if my own taste was consulted I would not want to make anything lighter than that.

I have never had to resort to intensification, and have adhered religiously to the manufacturer's formula, and have found it equal to all emergencies.

I have used oxalate developer, but it does not work well with those plates. With the pyro developer, as given in the printed formula, I can get almost any effect I want, whether the exposure is long or short, or instantaneous, and only by a slight modification of the quantities of No. 1 and No. 2 solutions, and, in plates that were a little overexposed, by flooding the plate with the bromide solution I have got all the density needed. I have not used any brand of American plates except Carbutt's, and those were excellent, but the English plates were so much cheaper, and the quality so good,

that I have kept to them right along. Our printing and toning is the same as that published in *Hearn's Practical Printer*, the one he gave the preference to, viz., the sal soda toning, and we have no reason or wish to change for any other.

My view trade is on the increase, but it is a source of regret to me that I cannot get out more. I do not make any wet plate negatives, in fact all my baths have been discarded for the last two years.

As soon as my plates are varnished, I paste cut-out masks onto my negatives. This not only makes a nice finish to the prints, but also serves to keep the negatives separated when stored away, prevents rubbing together, and prevents scratches, etc., while in use. To get the names of the places printed in, I work in this way: I make out a list of all the titles or names of the places, and send to the printer, and have quite a lot printed upon that paper, known in the carbon process as mineral; it is more transparent and tougher than tissue; when first I had this done I found the ink in some parts was not opaque enough to produce the letters sufficiently white in the resulting print. To overcome this defect, upon receiving the sheets from the printer, and while the ink was quite fresh and hardly dry, I just dusted them over with bronze powder rubbed on with a camel's-hair brush. When properly dry the title was neatly cut out and gummed, printed side down to the negative. If this is properly done, the result is all that could be desired, the letters come out sharp and distinct, and if the paper is kept clean, the difference of opacity outside the actual letters is scarcely perceptible, and if fixed carefully upon the negative, is there for all time. I generally go over the back of the little slip with a soft brush dipped in negative varnish with just enough heat to prevent chilling; this not only makes the paper more transparent, but allows it to be wiped off and cleaned like another part of the negative, as well as preventing it from getting soiled and dirty. This seems a small matter to say so much about, but if any one wishes to have the name of his view upon the print he will be amply repaid for the small amount of trouble and labors bestowed upon it.

I make all my enlargements upon the Argentic bromide paper, and do them at night with a special apparatus for the purpose, made by Marion & Co. The instrument has a large condenser, and I can work from a size larger than cabinet plate. I use an Argand burner with kerosene oil, and make a life size bust with from three to eight minutes exposure, depending upon density of negative. Use oxalate developer and have no failures. I am so used to the new process now that I can make just the right tone from the developer. I have used gold toning, but don't think it necessary. One hour or two crayon work upon one of those large heads make a very nicely finished picture, And here I may tell you of a dodge I have not seen in print, although many of your readers may have used the same. When my large print is mounted and thoroughly dry, with a ball of cotton-wool and some finely powdered pumice stone, I grind over the whole surface of the picture, then with a stump, and the necessary crayons or crayon powder, I can do all that is required to produce a pleasing portrait or improve an inferior one. The same may be applied to landscapes. Just try a picture with a hard white sky, and see what beautiful cloud effects can be worked in. The greater the skill of the worker, of course the better the result. I have some hanging around my gallery, enlarged up to 18 x 26, with all the skies worked in, in that way.

Fraternally yours, etc.,

S. H. PARSONS.

ST. JOHN'S, NEWFOUNDLAND.

[Competing Prize Paper, read at the St. Louis Convention.]

## IS PHOTOGRAPHY ART?

BY F. H. WILSON.

WHEN, fifty years ago, the new baby, Photography, was born, Science and Art stood together over her cradle, doubting what they might expect from her, wondering what place she would take among their other children. Science soon learned that she had come with her hands full of gifts, and her bounty to astronomy, microscopy, chemistry, made her name blessed among these her elder sisters. Art, always more conservative, hung back. The gifts at first were fewer, and she seemed an ominous rival

to the others. She threatened to leave them nothing to do. But slowly jealous Art, who first frowned and called the rest of her brood around her away from the parvenue, has let her come near, has taken her hand, and is looking her over with questioning eyes. Soon, without a doubt, she will have her on her lap with the rest.

Why has she been kept out so long? Almost from the beginning she claimed a place in the house beautiful of art. In spite of rebuffs she knocked at its doors, though the portrait painter and the critic flung stones at her from the house-top, and the law itself stood at the threshold denying her entrance. Those early efforts were not uninflected with a fear that if she did get in she would run the establishment; but the law long since owned her right, and instead of the crashing boulders of artistic dislike and critical indignation the volleys that drop at her feet now are mere mossy pebbles flung by similarly mossy critics or artist-bigots. Still, the world at large hears them rattle, and does not yet give her the place and estimation she has won.

For she is a true daughter of art. The name of artist, implying technical skill above the common craftsman's, a dexterity of hand guided by high intelligence, a glorious marriage of manual and mental excellency, has always been a proud and honorable one. It is none too high and honorable for those who faithfully follow her. Art meant, originally, handwork. Painting, now so haughty, was once considered simply a superior kind of artisanry, as some would have our art now. The artist in colors and the artist in gold or glass were quite on a footing. Michael Angelo asked only the title of "master-workman." As fine art with pleasure alone, not use, its object, developed, the idea became higher; yet still, skilled handwork is art. Photography is surely this. Indeed, if the question were to be waged on definition it would be easily won. Ruskin himself opens a gate wide enough to let in photography with all her tools when he says art is the "expression of man's delight in the work of his creator." Hamerton says art is "selection;" that is exactly the main idea of good photography.

But suppose painter and photographer out together in search of a picture; with equal artistic perception they choose a scene, a bit of landscape. Figures and accessories are posed and arranged; and they will find the photographer's the severer examination to pass, as his work must be done before the execution of the picture. When both are finished, although the painting may be very like the photograph, save in its colors, yet it may claim a place of dis-

inction in the gallery while the aspirations of its companion may not soar above the parlor table. Where did their ways separate? Where did this difference begin? "With the first stroke of the brush," answers the unbeliever, "when the painter began to modify crude nature by his art." There is the key to the whole question. "Nature does not compose, and the photographer could only take her as she is." But what of the careful choice of the view-point, the posing of the figures? Why did he lop off that branch and put that dark stone in the foreground?

There art began—with the first touch of a man to shape things towards his ideal, be that ideal merely an agreeable composition or the loftiest conception of genius. The higher it is the more is it art. Art is head-and-hand-work, and a creation deserves the name of art according to the quantity and quality of this expended on it. Simply sit down squarely before a thing and imitate it as an ox would do if an ox could draw, with no thought or intention save imitation, and the result will cry from every line, "I am not art, but machine work," though its technique be perfection. Toil over arrangement and meditate on point of view and light, and though the result be the rudest, it will bear the impress of thought and of art. I tell you art begins when either man, with thought forming a standard of beauty in his mind, commences to shape the raw material toward it. In pure landscape, where modification is limited, it begins when the artist takes one standpoint in preference to another. In figure composition, where modification is infinite, it begins with the first touch to bring the model into pose. When he bends a twig or turns a fold of drapery, the spirit of art has come and is stirring in him. What matters his process?

Some such ignorance reminds one of the early dread of the locomotive. It was incomprehensible, uncanny; it went too fast. So it is with photography—that goes too fast for the critical "one-horse shay" to keep up with it, and so out of the dust in its wake comes the shout of the caviller, "You are not art!" Surely it is time this artistic bigotry was ended. In one of last winter's exhibitions hung a painting of a French peasant girl. It was a most careful study of this awkward and far from handsome daughter of the soil, standing in a garden in her faded blue working clothes. Her expression was one very familiar to some photographers. One would almost have guessed how much she was paid an hour for standing for her picture. It told no story, it had no attractive-

ness, yet every critic noticed it, for its painting was supremely clever—the perfection of process. But it fell cold and flat on the warmest feeling for beauty and sentiment. In a much less conspicuous position is a little photograph of a group of five girls. When I say its title is "A Merry Tale," you will need no further description. Its composition is as nearly perfect as may be, its lines and contrasts of black and white and play of light and shade are a marvel and delight, and no one ever saw it without pleasure—which it is the first duty of art to give. Which is the work of art? Art feeling, like blood, will tell and show in the results. Those pictures show that a mechanic is a mechanic and an artist an artist, whatever he may work with.

And there are many of them among the men who paint with the sun. Their ranks are full of men of strong artistic feeling whose hunger for art has found satisfaction here. Many a one has found his profession a delight, and in his spare time, too often scanty, forgotten task-work and commonplace when feeding his soul on beauty and nature. Among such men abide warm enthusiasm, real appreciation of art, and an understanding of its works above the vulgar admiration—the sympathy of fellow-workers with those who produce them. It needs an artist to appreciate an artist; and that is why photographers' work in popular estimation sometimes falls so low. It is so easy. Art is said to be long; the drop-shutter is very fleet. Photography is a condensed art, but every item of it is the sum of long experience. There were three generations of research even in the plate that could catch the image in that shutter's snap; but think of the science and skill that prepared plate and instruments, the chemical miracle of development, the avoidance of the ills and accidents that hover around the negative in locust swarms; and then the crises of printing, toning, and fixing. Sir Joshua Reynolds said that in some arts men may work with half-knowledge, "but the artist must have all." I think the photographer answers the description.

Yet by division of this labor it has been made all too easy. How could its productions keep up to a high excellence with this fatal facility dragging them down? Art is not easy, but plate-spoiling is. The impression a plate may bear in different hands has as varied possibilities as those of a blank sheet of paper: one may hold a poem or a butcher's bill, the other a photographic song of nature or a record of equal slaughter. How would etching, sculpture—painting, itself—have kept its walls up and its standards high against such a barbaric horde

as have raged through the streets of photography's citadel? No wonder the broadcast results made the world think that nothing good could come out of such an artistic Nazareth. True, as some front parlors bear witness, some stragglers of the same tribe found their way into the camp of art, and hang up the spoils of plaque and canvas. But these people do not so seek publicity, nor cover the country with their "libels on unoffending landscapes," and signs of "artistic photographer; cabinets, \$1.50 per dozen."

Photography, again, has a glorious mission in popularizing art, and has hurt itself in so doing, till it is thought of only as a method of reproduction, never as itself creative. And man values a thing as it is hard to get. If the photograph hung up in the galleries, and was quoted at fifty dollars in the catalogue, its quiet virtues would soon blaze forth very pronouncedly indeed, and we should bear what miraculous art it was. And I firmly believe that some day the work of some men will enjoy this very distinction. When the first daguerrotypes were being made, and sold for the price of a good etching or a water-color sketch, they were thought the last work of art, and their process the most marvellous discovery of modern times. How familiarity has bred contempt! When more accessible, they fell in popular esteem. When the moon was within grasp, the children ceased to cry for it.

Yet I think some day they may find themselves coveting it again, and the moon riding higher than ever. Photography has only just begun to grow. The fruits of her tree we eat to-day are only a few windfalls compared with what we may expect in her autumn. Look how she has grown in the last twenty years, and think where she will be at the end of the century. And her growth in art will not lag behind her progress elsewhere. Art has been ungrateful to her; has made her, indeed, as Dr. Vogel calls her, a Cinderella, sitting among the ashes while her proud sisters flaunted abroad in robes borrowed from her. More than sisterly help have they had from her; she has been their school-mistress, and her lessons have had deep effect, and show plainly in the works of the younger painters of the day. The age of ideal, impossible compositions is past; the modern taste is for the actual. It is naturalistic, realistic, asks things as they are. The heroic novel is dead; it is some time since Macbeth was played in red velvet hat and tie-wig. They do not paint noble ladies as Olympian goddesses, nor shepherdesses in skirt and panier now. "Give

us realities," they say to-day; there is interest enough in them. Paint the man as he is—full of nature, character, and life, sincere, and therefore original. What a pity that stern and splendid old realist, Oliver Cromwell, did not live to have his photograph taken—"wart and all!" The note of photography rings thoroughly in accord here. They would have clean naturalness, faithful realism, clear detail; these she gives. There is greater fondness for landscape than ever before; this is, above all, the province and most favorable field of photography. The life of the time, studies and stories of the people; she can render these. Late-born, she is in sympathy with the age. She is in the very forefront of the march of modern feeling.

The future holds great things for her. She has battles to win, wars against foes within and without—against the fever of facility, against cheapness and carelessness and ignorance, that have brought down on her artistic dislike and popular light esteem. But beyond a doubt she will surmount these troubles as she grows, and gain the place she deserves; and it will be by the aid and effort of the men who gallantly and rightly seek to exalt their calling, to make it pure and of good report, and to hold as high and as honorable as any the name of Artist-Photographer.

New York, June 17, 1886.

[Competing Prize Paper, read at the St. Louis Convention.]

## GELATINE, A SUBSTITUTE FOR ALBUMEN IN SILVER PRINTING.

BY W. M. ASHMAN.

THROUGH the courtesy of Mr. W. Irving Adams, of the Seovill Manufacturing Company, who has kindly undertaken to bring this communication of mine under your notice, I am enabled to lay before the great Convention of 1886 something in the nature of a paper to be read thereat. It will, I trust, be understood from the term used to qualify my contribution, that anything approaching an elaborated scientific memoir is not the sort of thing which is about to follow, since you will doubtless obtain more than a sufficiency to occupy the valuable time of the Convention from abler pens than mine located nearer home.

My desire is rather to make a few practical remarks upon a subject which, though not highly scientific, is one concerning the interests of every photographer, so that upon returning to your ordinary everyday work, and thinking about those things which you have seen and heard at this gathering, you may be induced to give a

share of your attention to the subject I am bringing before you.

Gelatine has displaced collodion in negative work everywhere now, and the change which has been wrought is not altogether an unsatisfactory one, while many claim for it great advantages; but gelatine has not undermined albumen in the positive printing process.

Attempts have been made commercially to bring about this change by the aid of developers, and some success has attended those efforts; but silver rapidly reduced to the metallic state by development does not form an image which pleases everybody, and, what is of equal importance, successful printing by development for business purposes is an accomplishment unknown to the majority of workers.

It is no assumption to state that a reliable commercially prepared gelatine paper has yet to be placed upon the market which shall prove an effective rival to albumen from every point of view. It can be done, however, and as the market is wide open and waiting, we may anticipate its realization before long.

In support of the opinion just expressed, it may be well to remark that Robert Offord and myself have, within the last three years, made numerous experiments in this direction, from which we have deduced many important points in regard to the conditions applicable to success, and these have been embodied in a series of articles recently published in the *Photographic News*.

Although a careful study of these, our joint writings, is to be commended, it is not necessary that those who have not had the opportunity to follow us should read up, before starting a few simple experiments for themselves, and with a view to assist those desirous of making a positive printing paper, a few plain directions are here given which will smooth the way for those unaccustomed to breaking fresh ground, and help others in the pursuit of further research.

Primarily, then, a good quality of paper must be used, one free of chemical impurities, if first-rate results are to ensue. Plain sized Rives and Saxe papers answer well enough, but are expensive for general adoption. The Eastman Company, Rochester, N. Y., are sending out a capital material as a basis for their new positive films, which I am inclined to think would be just the thing for our purpose if it could be obtained uncoated. Having procured a suitable paper, the next consideration is the kind of gelatine coating which it is intended to spread thereon, and the method of achieving it. There are two very distinct ways of bringing the intended results

about. The first of these being the making of a silver chloride emulsion in gelatine, and mixing with the emulsion so made a suitable proportion of silver citrate, silver oxalate, silver tartrate, or one of the other organic silver salts, also emulsified in gelatine.

This mixture, after a little washing, is then ready for spreading on paper in any of the following ways: Drawing over a trough containing the liquefied emulsion from a roll as in coating carbon tissue. Pouring a measured quantity of liquid emulsion on damp paper formed into a dish by turning up the corners, as bromide paper was formerly coated.

Floating in the manner adopted for albumenizing and sensitizing. Brushing on, afterwards equalizing the coating by passing through steam or over a water oven. When dry, the coated paper is ready for use, and will darken in daylight slowly or quickly, as determined by the composition of the emulsion.

The second method is that of coating paper with hard, colorless gelatine containing a soluble chloride and citrate, or other organic salt, together with an organifying substance like caseine, starch, etc., for the purpose of increasing printing vigor. Such prepared paper, when dry, may be stored similarly to unsensitized albumen paper, and only needs to be floated upon silver nitrate solution to render it sensitive to light, the sensitizing process being the same as with albumen.

Paper prepared by either of these processes can be made to print with speed and vigor, toned with gold, fixed in soda, bear washing without blistering, tearing, or cracking; can be mounted, rolled, and under special conditions burnished; and when dried in contact with glass plates that have been polished with talc, the stripped surface presents the highest degree of gloss.

Regarding permanency over albumen, little can be said at present beyond remarking that gelatine hardened with chrome alum offers considerable resistance to atmospheric influences.

I have before me such a print which has been exposed to the influence of a south light for seventeen months, and it is unaffected. A covered portion has, however, undergone change, due to contact with impure paper, so that the only evidence that can be brought forward is favorable to the use of gelatine as a substitute for albumen.

Well knowing the value of your time, and the necessity of my remarks being brief, all speculations concerning commercial advantages that may be derived will be left aside for future de-

velopment, and in lieu of such, substitute formula which will prove a good starting point whereon to make such variations as may strike any one of you.

No. 1 is an emulsion which is fairly rapid and is made up as follows:

A.—Citric acid . . . . 20 parts.  
Water . . . . . 80 "

Liquid ammonia sufficient to leave solution distinctly acid.

B.—Gelatine (white, hard) . . . . 45 parts.  
Water . . . . . 500 "

Mix A and B.

C.—Gelatine . . . . . 45 parts.  
Water . . . . . 460 "  
Ammonium chloride . . . . 6½ "

D.—Silver nitrate . . . . . 40 parts.  
Water . . . . . 240 "

Dissolve. Divide into two parts. Mix one with C, and the other with A and B.

Mix all together, or in such proportions as may be resolved upon, taking care that the temperature shall not at any time reach a higher point than is necessary to insure perfect solution—90° Fabr. should be the limit. Set for some hours to get a firm jelly, then squeeze it through mosquito net into cold water. Give the shreddy emulsion three changes of water, which should be effected within fifteen minutes, or printing vigor will suffer. The shreds may then be rinsed in alcohol, remelted, filtered through swan's-down or sheep-skin, and is ready for coating.

The work may be carried on in gaslight or subdued daylight, according to sensitiveness; either borax or acetate toning may be used. Splendid opals or transparencies can be made with this emulsion, when thin coatings are laid upon these surfaces.

No. 2 formula will also serve for experimental work. Good transfer paper is immersed or floated on a salting solution similar to the following:

Ammonium chloride . . . . . 1 part.  
Ammonium sodium, or other citrate 1 "  
Water . . . . . 100 parts.

Citric acid sufficient to render distinctly red a leaf of blue litmus paper.

The time of immersion need not exceed one minute, and three minutes is amply long enough for floating. The surface of the paper should then be drawn over a glass rod to remove excess, which latter, if permitted to dry in spontane-

ously, might be productive of patches or lines. These papers are then suspended to dry, after which they should be sensitized by floating upon an acid solution of silver nitrate made acid with citric acid. The time of floating need not exceed that of salting, viz., three minutes; and when any difficulty is experienced in making the paper lie flat upon the solution—from curling in very dry weather—the same may be readily overcome by placing the paper in a damp room for a short time, so that some moisture may be absorbed before sensitizing takes place. When dry it is ready for printing, but the speed of that operation is quickened considerably by fuming. Mockhoven's enamel double transfer paper treated in the manner mentioned, toned with borax and gold, fixed and washed, and stripped from a glass surface, produces the most brilliant silver print obtainable by any known means.

All transfer papers the writer has met with which have been fumed after sensitizing, have a tendency to blister in washing, unless hardened by means of alum. This agent may be conveniently added to either of the above baths, or the prints may be soaked after toning in a solution of common alum—in fact, the use of alum at some stage is an absolute necessity when burnishing has to follow. It is not intended that transfer paper in its present form should take the place of albumen, and the details given are rather to illustrate its capability of yielding silver prints than to recommend it; and those who will take the trouble to test the truth of these assertions, may probably be led to coat paper for themselves in a manner indicated in the earlier part of this communication, viz., to employ colorless gelatine mixed with starch or other substance, plus the soluble chloride and organic salts. Paper prepared in this manner could be stored for any reasonable time without deterioration, and sensitizing could take place when required, a convenience not altogether compensated for by the extra speed attainable in the emulsion given in the No. 1 formula. I dare not occupy more of your time in detailing further of the many methods of preparing sensitive gelatine surfaces, for enough has been said already to illustrate the probabilities of gelatine assuming the important position claimed for it in the title of what I fear is a very incomplete communication to place before this, the largest assembly of practical men the photographic fraternity has ever been able to bring together.

Before closing, if this further remark is not considered out of order, I should like to mention that the method of washing the fixing salt out

of gelatine negatives, by the aid of a portable wire support, which I had the honor to submit to your notice at Buffalo, continues to give complete satisfaction to all who have tried it here. I have washed large numbers of negatives that way since the event referred to; and in no instance has any of them shown signs of imperfect removal of hypo.

[Competing Prize Paper, read at the St. Louis Convention.]

## VERY SLOW GELATINO-BROMIDE FOR LANDSCAPE WORK.

BY W. K. BURTON.

It has always been a matter of surprise to me that no maker of dry plates has thought of issuing a brand of really slow plates. I mean by slow plates, such as have a speed little, if at all, greater than that of collodion.

In landscape work pure and simple, leaving out of the question on the one hand figure subjects, on the other, instantaneous work, what does it matter to us whether our exposure be two seconds or twenty, or even sixty? It matters not at all, and there are great, I may say enormous advantages in the very slow plates. There is, in the first place, a quality to be got which cannot be had with rapid plates. Certainly quite as good quality of negative as could ever be got with collodion. I don't mean here to infer that we cannot get all round as good prints from rapid dry plates as we can from wet plates, but I am quite certain that we cannot get negatives which will give the prints as rapidly and as easily. Now, with a very slow plate we can get negatives which will give the very highest class prints, and which may be printed from in as short a time as from a wet plate.

Then the ease in manipulating slow plates is so great an advantage. Not because of the ease and comfort itself, but because this ease and comfort lead to a higher average quality and to a smaller percentage of failures. I need scarcely point out that, other things being equal, our success in development, etc., will increase with the amount of light that we may safely work in. I do not now talk of ease in the preparation of the plates; that I shall consider afterwards. But besides the greater percentage of successful negatives due to increase of light allowable, we have an increased probability of success, from the fact that with a slow plate there is very much more—even proportionally—latitude of exposure than with a rapid plate.

A very great point of superiority in a very slow plate over a rapid one, is that in the case of the former, the film (if the emulsion has been properly made) is ruby red, and that, as a consequence, such a thing as halation is out of the question. This is a matter of the greatest importance. Few appreciate how much the general character of our landscape work is degraded by the existence of halation, but let anyone take three or four landscape plates, back one-half of each with bitumen solution and expose them on various landscape subjects, including trees, he will be convinced that the amount of degradation is very great.

It is true that many makers of plates send out goods of two different degrees of sensitiveness; but at any rate, in the case of those over here, the slower of these two is always, in my opinion, of such a speed as not to give the advantages of a very rapid plate, whilst it fails to give the quality of a very slow plate.

Possibly it is otherwise in America, or, if it is not, possibly some enterprising platemaker may take the hint I offer, and make a plate of the nature that I describe. Meantime, I feel sure that any amateur who will take the trouble to make such plates as I describe for himself, will find his labors very well repaid. I am by no means fond of advising amateurs to take up the work of platemaking; I know too well what the troubles involved in making rapid plates are, and, of course, it is always a rapid plate that the amateur aspires to manufacture.

I am not fond of starting amateurs to make rapid plates, but I should have no hesitation in starting them to make very slow plates, if I thought they would confine themselves to that work. The thing is comparatively so very simple. In the first place, barring extreme carelessness, failure is scarcely possible. There is no need to fear the various fogs—chemical, green, red, etc.—which are liable to make their appearance when we are striving after rapidity, and there is not the frequent disappointment in finding that, after all, our emulsion is not so sensitive as it should be.

Lastly, the drying of the plates is not, by a very long way, the serious process that it is with very rapid emulsion. A very rapid emulsion is always comparatively transparent, and it is necessary to put a large quantity of it onto the plates to get a film dense enough, and it is quite a problem, especially in varying weather, to dry the films. If it is dried too quickly, one kind of evil makes its appearance, and if it takes too long in drying, we have another, and perhaps worse form of evil, but when

we are using very slow emulsions the affair is quite different. A slow emulsion is opaque, even when spread in a comparatively thin film, so that far less of it than of a rapid emulsion needs to be spread on the plate. Then the slow emulsion is much less delicate, and therefore less likely to be damaged by too great heat and remaining too long in a damp state. It is not generally understood that as a film increases in sensitiveness to light, it also increases in sensitiveness to all sorts of actions having a deleterious tendency. The coating of plates with a slow emulsion is comparatively a very easy process. If the dark-room be tolerably large and be well ventilated, a dozen large plates, or several dozen small ones, may be dried by simply leaving them in racks over night; that is if the weather be warm and dry, if not, a little heat must be applied by hot water-pipes, or a gas stove arranged not to let any light or any products of combustion escape into the dark-room. Of course, I am supposing that the amateur does not care to go in for a regular drying-box or cupboard; if he does, the problem is considerably simplified.

I will give a formula, although I claim no particular merit for it except that I have tried so to adjust the details that the process may be as simple as possible, and that the chance of failure may be reduced to the minimum:

A.—Nitrate of silver . . .	200	grains.
Distilled water . . .	3	ounces.
B.—Bromide of potassium .	160	grains.
Iodide of potassium . . .	10	"
Soft gelatine* . . .	40	"
Muriatic acid . . .	2½	minims.
Water . . .	3	ounces.
C.—Hard gelatine . . .	150	grains.
D.—Hard gelatine . . .	150	"

The gelatine of B is allowed to soften. At the same time water may be poured over the lots of gelatine C and D (kept separate one from the other) to let them swell.

A and B are now heated to 120° F., and A is poured into B slowly, with vigorous stirring. The emulsion thus formed is allowed to stand for ten minutes with occasional stirring. Meantime as much of the water is squeezed out of the gelatine C as is possible, by wrapping it in a towel or similar piece of cloth and wringing the cloth round.

After ten minutes the emulsion (having been allowed to remain without stirring for at least two minutes to allow any granular bromide

\* In England we use Nelson's No. 1 Gelatine.



which may have been formed, to subside) is poured over C, heat being if necessary applied to melt the gelatine. When the gelatine and the emulsion are thoroughly incorporated, the jar containing them is set on one side to allow the whole to set into a stiff jelly. In cold weather there is no difficulty in getting the emulsion to set, but if the weather be warm it should be allowed to stand in a vessel containing water with a lump or two of ice in it. Once thoroughly set the emulsion is washed in any of the well-known ways, being either squeezed through canvas, or otherwise cut into small fragments. When it has been washed thoroughly and drained till no more water will run from it, D (having had as much water as possible wrung out of it) is added. The whole is melted up and one-half ounce of pure alcohol is added, when it is ready to be used for coating plates.

The reason for adding the hard gelatine in two lots may not be evident at first, but there is a very good reason. If the whole of the gelatine were added before washing, the result would be that a great deal of unnecessary water would be taken up during the washing process, and could not be got rid of otherwise than by precipitation with alcohol.

It would not, it is true, be necessary to get rid of this water if the plates were to be coated in very cold weather, or if they were to pass under an ice tunnel, as is sometimes the practice; but if an emulsion takes up all the water it will when being washed in very small pieces, and no further gelatine be added, the films will take a long time to set except in the cold weather, and there is nothing that damages the quality of a film more than to remain in a liquid state long on the surface of the glass plate.

The emulsion made up as I have described, will tend to set very quickly. It will probably not be more than about ten ounces in quantity, and will set far too quickly in cold weather, but this is a difficulty that is very readily gotten over. When I say that it will set too quickly, I mean that it will begin to set before it has had time to spread evenly on the glass. If this be the case it is only necessary to add a few more ounces of water. Barring such rapid setting that the emulsion cannot be spread evenly, the quicker the setting the better.

I do not know what kind of gelatine you have at your command in America, but with the best kinds of emulsion gelatine (German or Swiss) that we can get here, an emulsion made up as I have just described, and not diluted with water, would set in a few minutes in a

temperature of about 80° F., and I think it is useless to attempt to make emulsions, or at least to coat plates, when the temperature is higher than this.

The quantity of emulsion that I have described should serve to coat a dozen 8 x 10 plates. A skilled coater could make it cover a dozen 10 x 12 plates without any part being too thin.

Those who will take the trouble to make for themselves a few plates according to the instructions I have just given, will, I am sure, not think that their time has been thrown away.

They will find themselves possessed of plates very slow, it is true, as plates go in these days, but having all the qualities which are considered the most desirable for landscape work. Easy to manipulate, allowing of very great latitude of exposure, capable of giving any density required, with a perfect gradation of density and absolutely clear shadows, showing no halation, and lastly, capable, should an error of judgment have been made during development, of being intensified with silver almost as readily as a wet plate.

### THE WORLD'S PHOTOGRAPHY FOCUSSED.

DR. LIESEGANG, editor of the Dusseldorf *Photographic Archiv*, compliments Mr. W. B. Tyler, of San Francisco, on his theatre pictures. In commenting upon the devoted pair recently married before the camera in Newark, Dr. Liesegang (who speaks English, and is a good friend to America) writes: "It will soon come to pass in the happy Republic that group pictures will be taken at funerals to commemorate the sad occasion."

A PENNSYLVANIA veteran, who must be prospering, has the grace to write about our magazine as follows:

"Having basked in its sunshine for twenty years, I am afraid darkness would reign supreme were it to cease paying us its semi-monthly visits."

THE progress made by the brothers Henry, in what may be termed photographic astronomical research, has caused an immense stimulus in this direction in France. We learn that the French astronomers have resolved on constructing three photographic telescopes of great power, one of which is to be sent to Algiers.—*Photographic News*.

A SMALL stockdealer in England has been fined over eleven dollars for selling an ounce of cyanide of potassium—an "illegal sale of poison."

**PHOTOGRAPHING THINGS INVISIBLE.**—That photography reveals colors in the spectrum which are hidden from the naked eye, is acknowledged—ultra violet and ultra red, for instance. It is accordingly clear that it could unveil objects to us under certain conditions whose presence is not discovered at all by the eye. An important proof of the possibility of such a thing is presented to us in the picture of the Pleiades, taken by the Henry Bros. at the Paris conservatory, with their telescope constructed particularly for astro-photography, which contains an opening of 32 cm. As is known, an exposure of from one to two hours is made in this instrument, the clock-work of which is of such great precision as to obtain pictures of stars of the fifteenth or sixteenth magnitude, while stars of the sixth magnitude are invisible to the unaided eye. There were two pictures taken; one November 6, the other December 8. Both times they not only presented the known stars of this well-studded constellation by ocular observation, but also a formerly unknown nebula of distinct form and great intensity, which could in no wise be discerned by optical observation through the same instrument. It remains now with the spectroscope and camera conjointly to decide what kind of light this is.

**PHOTOGRAPHIC SERVICES.**—A well-known London physician has erected in his waiting-room an excellent photographic apparatus, and keeps on hand a store of dry plates, etc. All plates, which are taken of his visitors during their time of waiting, are developed by an assistant, and ready to be shown at the next visit of the patient. Barbers and hair-dressers have adopted the same plan with their customers in America.

DR. EDER has completed his work on *Instantaneous Photography, and its Relation to Art and Science*. It contains much valuable knowledge and interesting matter, instructive alike to photographers proper and to amateurs. Its best recommendation lies

in the fact that the first edition, which appeared in 1884, sold so rapidly as to call for this present one. We notice with pleasure the number of illustrated plates (eighteen) in the book, for in no other way can this subject be made plain to the reader, and one good picture is worth many pages of reading matter. A few headings of chapters will show how exhaustively and thoroughly the subject is treated:

- I. History of Instantaneous Photography.
- II. The Camera and Objective.
- III. Determining the Duration of Time for Instantaneous Exposures.
- IV. Instantaneous Shutters.
- V. Examination of Apparatus for Instantaneous Photos, and Determination of the Speed of Shutters.

MR. E. E. PULLMAN writes to the *Amateur Photographer* this receipt for making translucent the Eastman films:

Take a piece of half-inch planed pine board about one-quarter of an inch wider all round than the film. Fasten the film tightly to it with drawing tacks at each corner, film side down. Heat the oil and immerse the board, negative down, avoiding air-bubbles. The board can be left in the oil for almost any time, as, even if there is not enough to float it, the heads of the drawing tacks keep it off bottom. When withdrawn the negative must be allowed to cool and drain before untacking, when it will be perfectly flat.

MR. W. H. STACKPOOLE WESTROPP, writes to the *Amateur Photographer* his mode of carrying paper films in ordinary double plate-holders, thus;

For each holder there are two pieces of ferrotype, cut the same size as holder's plate and one piece of cardboard fitting between them. The film paper is cut about three-quarters of an inch larger than these, placed film side down on a clean surface, one of the pieces of ferrotype laid on it, and the paper's edges folded evenly round it. It then, of course, is held by the ferrotype, and there is sufficient spring in the folded-back margins to press the faces of the films against the rebates of the holder. Flatness and perfect register with the ground-glass are thus secured.

**THE NEW STUDIO OF MR. P. H. ROSE, AT PROVIDENCE, R. I.**

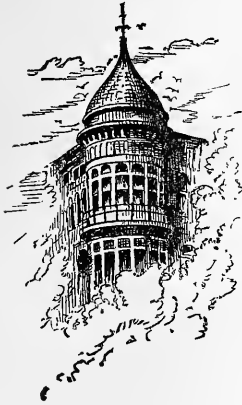

THE opening of a new photographic studio, as a rule, does not give cause for any particular remark, because there is a monotony about such transactions, so frequent in these days of photographic growth, and so we cease to wonder when

they occur. But when a temple of art, such as we are about to describe, is thrown open to the public in all its æsthetic completeness, it marks an *era* in photography—it is an evidence of photographic advance.

In the new Conrad Building at Providence, R. I., on June 23d, the public was received at his new studio by Mr. P. H. Rose, formerly of Galveston, Texas. Our personal visit to the establishment was made a few days later.

Long before we reached the entrance to the Conrad building we could see the gilt, pointed, oriental dome which surmounts its tower, and it served to guide us to the Mecca of our pilgrimage. On either side of the entrance are glass show-cases containing specimens. Passing these, the elevator is taken and, saved from climbing the tiresome stairs, in an instant we stood at the door of the Rose Studio.

Here, too, on either side, hang specimens of master art-work whose lights and shades are in true harmony with the dark door and its delicately tinted drapery.

We enter. At once our æsthetic sense is on the alert. As when visiting some rich foreign museum, a sort of tremor of fear takes possession of us lest some tasteful bit escape our notice in our impatient haste to take in the whole, so here, as we enter the softly carpeted hallway, we tax our eyes and mind exactly, that we may see and enjoy the entire feast that is spread before us.

The pretty lines of the mosque furniture of red wood, polished and decorated with brass, are a passing attraction. From a cone-shaped skylight the hallway is lighted, and shares the generous supply with the toilet apartment on the left, by means of windows near the ceiling. Now the reception-room is reached.

If one comes to this for the purpose of procuring a portrait for posterity, with a sort of martyr-like feeling—like a lamb led to the slaughter—all that feeling will make its departure the moment Mr. Rose's reception-room is entered.

Here, all that excellent taste and artistic judgment could suggest in the line of furniture and draperies has been supplied, in order to secure a home-like appearance and to create a subduing, home-like influence upon the visitor.

The floor is carpeted with velvety moquette of tender shades. The walls are lined with choice Lincrusta-Walton, gilt, broken by broad lines of redwood. The ceiling is broken up into corners and squares, in tasteful contrast, all variously decorated in colors and gilt, the centre-piece being, very properly, the sun with broad rays gleaming in every direction. The light is admitted tenderly by lines near the ceiling, glazed with stained glass, and again subdued by delicate hangings of various tints.

The furniture is most choice, the chief collections of New York and Boston having been carefully examined before a decision was made. A black-oak set, part upholstered with real Japanese leather, embossed and colored richly, and part with gold-bullion Italian tapestry, is superb. A French chair, gilt and upholstered with blue velvet, is admirable—as pretty as a piece of jewelry. Ceramics and bronzes and cloisonnes stand upon the tables. Upon one table is a field-glass for the use of visitors.

A good idea is this last, for, looking from the windows to the hills surrounding Providence, the beholder is constantly reminded of the lovely glimpses had when standing upon Giotto's Tower in Florence. But we are getting too far away.

From the reception-room the waiting-

room is reached, broad hangings of rich tapestry being spread apart to admit us.

Here the same rich taste has been displayed in the choice of all the surroundings.

Upon a table, near the window, every day fresh flowers are placed. On the opposite side are the entrances to the two toilet rooms. The approaches to these are hidden by genuine Italian draperies hanging from ceiling to floor, and between them is a broad mirror of almost the same height, framed in redwood.

All that the most fanciful daughter of fashion could wish for to perfect her toilet has been supplied by Mr. Rose, together with everything pleasant and beautiful to mould the feelings into agreeable composure before the studio is reached and the vital processes of photography begin.

The perfect harmony of all the surroundings is sure to have this much desired effect upon the patron.

And so it should be, for now we enter the skylight.

It would be expected that one who has so lavishly and generously provided the means of bringing out the best elements of their character into the faces of his patrons, would accoutre his magnificent and roomy studio with the best possible instruments and accessories obtainable to secure those elements of character in his pictures.

And, truly, there is no room for disappointment in this direction either. The master artist—the expert workman is shown in this department as well, in this studio wide and deep. In no country have we seen such elaborate preparation made for the production of the best results. And this assertion is made, after a careful visit, with expert eyes, to Mr. Rose's work-rooms, where all the stages of the preparation of artistic photographs is carried on.

For our practical readers we shall return to these last and supply them with a drawing of Mr. Rose's splendid studio. We have long been familiar with his results and have long watched his progress as an artist. Last year we embellished our magazine with one of his cabinets and then expressed our admiration of his work.

The great charm of Mr. Rose's produc-

tions is their technique, and evidence which they display of the master-workman—the true artist. He never resorts to artificiality. He holds that the highest art should always hold a soul of truth within its body of beauty. The body may be never so beautifully rendered, if the soul of truth is obscured. If the likeness is gone, the beauty is also departed. And likeness does not consist alone in the counterfeit presentment of the body. As much as possible, the carriage of the body and of the head must be as nature controls it, but quick, like a flash, at sight almost, the artist must not only discern the temper of the man but he must deftly bring the very scintillations of the soul beaming out upon the face. He must make them create the delicate elevations and depressions, curves and lines, which make up the modulations of the flesh, and while they catch the light and receive the shadows under the lighting he has arranged, they must be seized upon his sensitive palette. And is his work done then? No. He must repair to the darkness lest the very element which helped him should destroy all. Then there, with wondrous patience while with agile hand he pours the potent lotions upon his plate, he watches and applies, and retards, and accelerates and moulds and forms, as the painter with his brush, as the potter with his clay, and with brains alert, until lo! the man, in the likeness of his own image. His eye for the beautiful guided by his love for the beautiful has enabled him to bring out the beauties of the soul of the man upon his face, and thus he is a promoter of refinement of the highest type. The man who sends out a bad picture into the world is a doer of evil. If he is a poet and a true artist he will never permit that.

He must be as a magician who, from sources unobserved and not understood by others, brings out the soul and spirit upon the face.

One has written as to the poet, "If he leave the body untenanted, it is well, for it is a body of beauty; if he beckon in an angel of light, it is noble, and he has done well for his kind; if the devil of darkness have taken possession at his word, he has earned for his name a place on the scroll of

the enemies of our race." It is precisely so with the artist—if he be a *true* artist.

And, as we have said, what a magician he must be, since during the day he must originate some means of developing visibly what soul he intuitively feels must have existence within the beauty of the bodies presented before his camera.

"Originate? Can there be anything original in photography?" it has been said over and over again. Do not the workmen of his guild all have the same tools of light and shade to build up the image upon the sensitive plate? Verily, but originality does not consist in swinging them at random until their trickery astonishes you by the maudlin results. Nature must be rendered truthfully and yet surprisingly. The elements of character held dear by relatives and friends must be secured not only, but with a degree of refined intensity that will make them appear more lovely in the picture than they are seen even in nature. No two persons see alike exactly. It is a rare thing for both eyes of one person to see exactly alike. Remembering this the quick artist seizes upon the elements of character which he sees and adroitly brings them to the surface. He cannot tell how any more than the orator can tell you how he holds his audience. He can—he does, and therefore he is an inventor—an artist. No more passes before his eyes than before others, but he *perceives* more, because his mind is more susceptible. How many thousands and tens of thousands could say that they had *seen* the lovely effects of light and shade, which Master Rembrandt painted with such effect, after he had placed them in rich masses of harmony upon his canvas, but none *revealed* their charms before him. Why do we fall back overcome with emotion when we enter the stanzas of Raphael in the Vatican? It is because he saw so much more in a human face than we can, and could translate it into paint upon canvas with feeling which we do not have. But, like a puzzle, we can partly understand it when it is put before us even in such a bewildering way.

The objects then are given to all of us to see. But the power of perceiving the soul—man—of bringing it out upon his face, is reserved for the mind of the true artist.

Thus, the reason why one excels another.

Mr. Rose's productions prove him to be possessed in an unusual degree of this wondrous sense. He is not content with mere technique—with "seizing the shadow ere the substance perish"—he wants more. He wants the man within to reveal the *soul* expression without.

Surely he has done all in his power—and done it understandingly—artistically—to secure *likenesses* as well as good photographs.

And his ability to do all this, proves that he is a true artist. If not, he never could have reached his present position in art-photography.

---

### WHAT AN OLD TEACHER SAYS OF WILSON'S PHOTOGRAPHICS.

We have nearly one thousand letters testifying to the usefulness of *Photographics*, but none more valued than the last one, viz.:

NORTHWESTERN BUSINESS COLLEGE AND NORMAL  
SCHOOL, SIOUX CITY, IOWA, May 25, 1886.

EDWARD L. WILSON, New York City.

DEAR SIR: The books have arrived safely. Inclosed I hand you New York Exchange for \$12.32, amount of bill. I am more than delighted with *Photographics*. Have been a teacher over 30 years, and have never examined a text book on any subject so exhaustive and practical. Theory and practice are so clearly presented that amateur and professional can have a mine of valuable information. Indeed, every one who is interested in art cannot fail to read it with pleasure and profit. Besides presenting the best results of years of practical experience of the author, the notes embrace similar experiences of over 200 eminent artists and photographers. If I had time I would write you a ringing recommendation of the book.

Yours very truly,

C. C. COCHRAN,  
Principal.

---

THE Eastman Dry Plate and Film Co., were awarded a gold medal of merit at St. Louis. Further convention matters in our next.

### OUR PICTURE.

To Elizabethan comedy we go this month. The journal's embellishment breathes Shakespearean life in the "Merry Wives of Windsor," with fair Mistress Ford, fat Jack and his goblet of sack, and their fellows. They stepped on the stage to be caught by Messrs. Reichmann & Co., in a recent presentation of the play in this city. Real pictures are they, showing in their posing the good results of the combined skill of the stage artist and the photographer. Their technical qualities are excellent—notably the soft, clear light, transparent shadows, and most able preservation of detail, without hardness, in some rather difficult masses of blacks and whites.

In this midsummer time there will be leisure, now the Convention is over, for our readers to read up the play and find out the meaning of all the scenes, if the comedy is not already familiar. Five are used.

There are two points about these pictures which are worthy of special mention. They are the first examples we have been privileged to present, made from negatives on the "Eagle" plates. Although these plates have been in the market but a few months, they have already won enviable fame all over the country. The reasons are obvious when we examine such work as was exhibited at the St. Louis Convention, and such as is now before us. For portraiture they are specially desirable. They secure to the appreciative photographer a sort of a liquid softness of tone and delicate blending of lights and shades which make the prints from them so charming. They are sure to win patronage wherever they are found.

Next, attention should be directed to the tasteful cards upon which the pictures are mounted. The design was engraved specially for them by Messrs. A. M. Collins, Son & Co., Philadelphia, and is as attractive as a piece of jewelry. A pleasing contrast with the gold, is the tint of the card-face. We suggest that it is much more tasteful than the maroon color so largely in use, and that a change would be agreeable to the public. Moreover, the trouble had in burnishing maroon cards (due to the dissolving of the color-material by heat and the lubricator) is

avoided in the use of this newer color, since the pigment used in its production is not affected thus. Various shades of the same color are supplied, as well as several new colors with varied shades of each. The prints were made on N. P. A. paper, supplied by Messrs. E. & H. T. Anthony & Co., New York.

[Competing Prize Paper, read at the St. Louis Convention.]

### YESTERDAY AND TO-DAY, OR JUSTICE TO ALL.

BY MRS. E. N. LOCKWOOD.

THE past five years have marked the most radical changes in the manipulation and formula for making negatives of any like period since photographs were first invented.

The processes, from being so full of complication that our laboratory was not unlike a well-filled drug house, have steadily been lessening the numbers of the bottles and chemicals, and doing away with the unwholesome and poisonous fumes, until our "dark-room" may be kept as fresh, clean, and neat as many parlors, and the death-dealing, offensive odors are put to flight.

The labor of former years was constant and full of little perplexities, that none but "one who has been there" can fully appreciate.

Sixteen hours were about a day's work, because of the needed preparations of glass, compounding of various chemicals, cleaning up plate-holders and the like, which must needs be done, out of regular business hours.

And sometimes with what "fear and trembling" would we make our first exposure in the morning, and perhaps only a beclouded or obscure shadow of our customer would we obtain, or one well variegated with spots and streaks, and then how we would have to search for the cause and try to overcome it as soon as possible, fully putting into practice the old song, "If at first you don't succeed, try, try again."

Oh, the old, old days, how they fit before our eyes, as we turn back to the records of the past.

We do not long for them to return again—no, no; let the past remain under our feet, or, for a background to the present. Those experiences have lifted us up a little higher and broadened our lives in some measure—at least, they have been stepping-stones to something better.

To-day we can work with clean hands and clothes, and be always ready for our customers from sunrise to sunset, in sunshine or in clouds, if we only have a well-filled shelf of Cramer lightning plates, or some other reliable brand.

We used to think making eighteen negatives a very hard day's work, and we recall the terrible bad feeling of head and throat after being shut up almost constantly for several hours in the dark-room with the fumes of the necessary poisons. No wonder photographers looked pale, worn and hollow-eyed, nor that they grew cross and irritable.

Now, we can make three times as many negatives, with one-third the weariness and anxiety.

Thanks to the dry-plate inventors. Long may they live to enjoy much good and happiness, for the blessings they have brought to others.

Yet, with this greater ease in making negatives comes to us the annoyance of low prices, and a great variety of them.

The wide-spreading knowledge of what the real cost is of making a negative and print (aside from the thousand and one expenses necessitated in fitting up and running a gallery) is being figured on by thousands of amateurs, and hence they say we charge too much.

And again we have "old-time" photographers putting cabinet photographs away down, because some one else does, or because they expect to make more money at it, by the increase of patronage; and all of these seem to call for some change to be made which shall regulate prices, and be just and right for all.

We are certain that in union there is greater strength, and as one thought in this matter would suggest that this body of photographers unite, if possible, upon some price for cabinet photographs, which shall be considered as having a fair profit, for the expense and time of making one sitting full length. (I think \$3.00 for one dozen is as low as they can be made, and this only under certain conditions, charging always more for larger heads, and also for each additional sitting.) I am well aware many have attempted this, alone and single handed, but found it hard work to adhere to it when others in the same place would advertise at less price, and as many sittings as desired free of charge.

Yet it seems to me it is but just and right to make at least one style of photographs as low as we can afford to, which will give the poorer class and those who are easily satisfied an opportunity to obtain what they often much desire, but cannot afford, at our present price of \$5.00 and \$6.00 per dozen. And, again, those who are very desirous for several sittings, and to experiment on toilets, are the ones to pay for the extra work and expense.

Will not this be giving an opportunity for each class to pay for what they have and at the

same time protect ourselves from being imposed upon by the fancies of some of our notional customers, as well as receiving some recompense for extra material and time wasted, and also be a fortification against the "Cheap Johns" and amateurs?

If this honorable body so decide, I will most gladly be one to join with them in anything which they believe will be just and equitable for all, and will do my best toward educating the public into a later and better method of conducting photographing, even though it should place my prices down to \$3.00, instead of \$5.00 and \$6.00 for cabinets.

Will it not be feasible to appoint a committee during this convention to draft a scale of prices for the different styles of cabinet photographs, and also the price to be charged for each extra sitting, and submit it to the Association, that they may act upon it during this annual gathering?

We hope it may be thought well to do this, and that it may lead us all into a way of doing business which shall be just and right for everyone, and satisfactory to patrons and photographers.

[Competing Price Paper, read at the St. Louis Convention.]

## BRAINS AND JUDGMENT MOST NEEDED IN PHOTOGRAPHY.

BY C. F. MOELK.

I WILL endeavor to show in this paper the many obstacles that many photographers have to contend with daily owing to the lack of judgment and the use of brains.

I will now give the first lesson.

I was employed in a first-class photographic establishment in the city of St. Louis, and taking into consideration the excellent work being done and fine negatives produced, I began to investigate how it was done. The proprietor of the establishment was the operator. As I stated above, the negatives were excellent; some of the finest productions I have seen in the West; and it proved that this work was being done with what I thought ordinary instruments—Holmes, Booth & Hayden lenses (old style). The proprietor had occasion to absent himself from his place of business, and the assistant operator was called to the front to handle the subject and take the place of the operator-in-chief, to manage the light and pose the subject—a bride (with an elegant trousseau, valued at \$500). After the sitting was completed, I had an opportunity to touch on the result; it was anything but good. It made me shudder with disgust. It had the

appearance of a five-dollar dress, in place of five hundred dollars, as stated before. Another appointment was made for a resitting. Now, my friends, everything was used except a different set of brains and judgment. An elegant negative was the result; made with same Holmes, Booth & Hayden lens. Were you to see the work you would judge it to be made with a Suter, Dallmeyer, or some high-priced lens. But, my friends, it is not this. Where would you be on the deep waters in a craft and no knowledge how to handle the sails? Lost! So with the photographer with like appliances. He must have knowledge to meet with success.

I will not confine my article to different matters in everyday work in the studio. The negative made, next comes the paper and printing. Reading the photographic journals, I see so many complain about the printing and paper.

First, if you have a formula and it gives you good results, stick to it and do as the formula says. Nitrate of silver is the principal article used; its relations to others must be the same. Ascertain strength, neutral or acid, as to the season, summer or winter, dry or wet atmosphere. Again, I want to call your attention to the fact that, when you make a paper bath you must not expect it to last forever; add a little silver every day. Recruit it up as it gets out of order (the same as you yourself get out of order). Our old albumen friend, John R. Clemens, of Philadelphia, gave a most excellent remedy for a disordered paper bath some years ago; a great many seem to have lost sight of it. I will give it. Remember, you cannot spoil albumen out of the bath.

Formula: Make a solution; take alcohol four ounces and a piece of gum camphor. Place it in alcohol until all is taken up—a saturated solution. Pour in a little at a time until the albumen curdles and comes to the surface, then filter.

These are points worth remembering.

The next is the toning bath. Chloride of gold is the principal agent; it should at all times be neutral; not charged with soda, but neutral and harmonized with the other solutions.

Hyposulphite of soda, or fixing, is the next. Make the solution as near the same temperature as the other solutions used before, and you will not be troubled with blisters and other trouble. Your prints will fix even and clear. As to the other work, such as mounting and burnishing, it must be done in like manner with good judgment and taste.

In conclusion, I will say that our art-signs of photography are coming out grander and

grander—the photographing of the heavens, sound, and other photographic scientific wonders—almost daily. You have the same chance as your neighbor. The same light shines for you, the same instruments, the same lenses, appliances made by the same firm, sold by the same dealer. But it takes brains, judgment, and patience. If there is any member or photographer that wishes any information on these subjects, I will be pleased to hear from him, or them, at any time.

EDINA, Mo., June 1, 1886.

[Competing Prize Paper, read at the St. Louis Convention]

### ON THE BUSINESS MANAGEMENT OF A PHOTOGRAPHIC ESTABLISHMENT.

BY C. M. CARLISLE.

JOSH BILLINGS once advertised a lecture on "Milk." I attended that lecture. Upon a table on the platform was a pitcher of milk and a glass. When Mr. Billings came upon the platform he poured from the pitcher and drank a glass of milk, remarking that "the best thing he ever saw on milk was the cream," and made no further allusion to milk during his discourse.

This Association has asked for papers upon photography. Like Josh Billings, the best thing I ever saw on photography was money.

I conclude that all professional photographers will agree that money is their chief aim in pursuance of the photograph business.

However much we may love the art for its art, we none of us wish, nor can we afford, to ignore the money value of our labor while pursuing the shadowy art of photography.

Much, yes, very much, has already been written upon optics, lighting, posing, developing, printing, toning, and retouching. It would be very difficult to adduce anything new or interesting upon any of these subjects; and while I admit the subjects named offer a broad field for the use of technical terms and a display of learning, I conclude that the average photographer has long since tired of elaborately written papers offering no advancement of a nature to fill the purse.



The question which presents itself to me at this present time would be something in this form: "Is the status of the photographic business as managed or conducted satisfactory?" If not, is there a remedy? It would seem that a solution of this question would be of more value to the profession to-day than the most learned or elaborate paper upon the art or chemical science of photography. And a way to obtain more dollars with the means at hand is what we all need more than a greater number or variety of developers; for, as the *New York Sun* said editorially, some months ago, that a large proportion of the very much prevailing insanity of the present age could be traced to new developers, having reference, I presume, to the "missing link" in developers, supposed to have been discovered in a mortar-bed in Chicago not long since. The question of prices, too, has been more or less discussed and written upon in this and other countries. Even legislation has been asked for. The Photographers' Association of America has many times been appealed to for some means of relief from the curse of cut prices. The opinion of the men of greatest experience and good judgment has been that no legislation by our society can possibly determine what value a man shall set upon his labor and skill.

Even if it were possible for the Association to fix a scale of prices, membership is not compulsory, and any member would have the right to withdraw and make a price to suit himself.

The cabinet size seems to regulate the price in all photographic establishments in this country; therefore we will consider only that size in this paper.

It is a well-known fact that some subjects or patrons require very much more of their photographer than do others, and under the present system of conducting the business there is no way to obtain compensation for the extraordinary trouble and labor we are frequently called upon to perform, in order to gratify the more exacting people who desire to try more than one costume or mode of hair-dressing.

Is not the fault largely due to our want of proper business rules or tact in managing our affairs in the studio?

Business men engaged in other callings seems to have adopted rules and established customs which afford perfect control of time and labor, and at the same time give no offence to patrons.

The plumber manages to get paid for his time, even to that spent in passing to and from his shop to your place of business when he is called upon to repair your water-pipes, and you not only pay for what solder he has used, but for what he has wasted.

The dentist so manages as to be paid for every moment spent in your interest, and you pay for every particle of gold or other stock used or wasted. We certainly ought to be able to devise means by which we can control our patronage.

We have seen that the plumber and the dentist succeed in doing so.

Are we not as good business men as either?

My remedy for the evils complained of is a scale of prices.

Each photographer charges for cabinets, say, from \$3 to \$8 per dozen, mounting each class differently. To illustrate: The grade at \$3 per dozen, cheap mounts, one sitting and proof. Second grade, better mounts, two negatives and proofs, at \$5. Third grade, \$6, with better mounts, three negatives and proofs. Fourth grade, \$8, the best mounts procurable, elegantly printed, and negatives made until you are satisfied yourself, and render proofs with different lighting and posing that will will not fail to earn the appreciation of your patron.

I firmly believe that there is not a man in the photograph business to-day, however cheap he may cut his prices, but that under such a scale of prices can find a certain percentage of his trade who will order the higher grades when the plan is properly presented; therefore, scaled prices will help the cheap man.

Now let us see what it will do for the man of higher prices.

In every establishment, however select, there will come people who cannot afford to pay \$8 per dozen for cabinets, any more than all families can afford to live in brown-stone mansions, and he who has no scale of prices must see a certain percentage of peo-

ple go out from his place to obtain cheaper work.

I claim that no man compromises himself or lowers his dignity in trying to meet the demands of the people, and photographers can properly cater to the masses as well as dealers in other merchandise.

Even the best hotels in the country have of late fallen into that line of practice, and prices are scaled according to rooms.

What merchant would think of opening a boot and shoe store with only \$3 boots or shoes? Who could succeed in the carpet trade with only one price for carpets?

By the method of scaling prices, every photographer would find his level in his community, and if incapable of showing samples of good work, would probably receive a majority of orders from people who only patronized cheap goods in other lines.

It costs nothing to try the plan of scaled prices, and I assure you of satisfactory results if the plan is managed in a thorough business way.

The people are becoming demoralized upon this question of prices.

Establishments which have for years been rated first-class, and whose proprietors have charged high prices, made a break to \$3 per dozen, and the people naturally think strange of such a course; whereas, if they would maintain a good price for a portion of their work under the graded system, it would show at once why a low price could be made for a class who wished it, and at the same time people who wanted special care taken of their work, by paying the old rate, could receive the same attention as in former years.

There is no doubt but that money can be made on cabinets at \$3 per dozen, provided they are ground out upon the ready-made clothing principle, but every one does not wish that class of photograph, and here comes in the scaled price system, both to the advantage of the photographer and his patrons.

I do not claim that a larger volume of business will be done by this method, but a more satisfactory and equitable business is sure to result.

There is an old proverb which says:

"Yield not to misfortunes, but surmount them."

Do not complain of your neighbors' low prices but scale your own to meet the exigencies of the day.

PROVIDENCE, R. I., June, 1886.

## THE PROGRESS OF PHOTOGRAPHY IN GERMANY AND AUSTRIA.

BY DR. J. M. EDER,  
of Vienna.

PHOTOGRAPHY has made remarkable progress lately in its optical, physical, and chemical branches, as well as technically.

In the construction of photographic objectives, efforts have particularly been made at the present time to obtain exact pictures with considerable depth of delineation. As the most strongly diaphanous portrait-objective, the one made by Petzval in 1840 (double objective) still ranks first. The great light sensitiveness of the bromide of silver gelatine plates does not any longer require the greatest possible bright light in the foreground, as the sharpness is obtained by additional diaphragms and somewhat aplanatic constructions, which possess great depth.

Instantaneous pictures and groups require a sharp delineation of objects at various distances. For this kind of work, the Steinheil group antiplanat and Voigtländer's Euryscope are particularly suited. The former consists of two pair of lenses of great but opposite defects, which correct one another. The construction is not symmetrical. The antiplanat finds particular favor for outdoor instantaneous views. The largest size gives pictures of 17 x 22 cm. without a diaphragm. The likewise excellent Euryscope of Voigtländer, of Brunswick, is a symmetrical lens combination. It is particularly good for large groups and instantaneous pictures. The euryscopes were made to a lens diameter of 13 cm., giving a picture the size of a sheet of albumen paper. Lately Voigtländer has constructed some very strongly diaphanous euryscope portrait lenses.

Dr. Steinheil has made an improvement in his aplanats by changing the kind of glass (lighter flint glass), thus making them more strongly diaphanous. The front lens is also movable in his new instruments. If the lenses are brought nearer together, the objective is suitable for groups standing in a half circle; when removed, the instrument can be used for taking views of houses or other objects on the same conditions.

In regard to photographic equipments for sci-

entific travellers, Dr. Vogel recommends a size of 13 x 18 cm., or 13 x 21 cm. for a Steinheil wide-angle aplanat of 7 mm. opening and 12 cm. focal length; also an ordinary Steinheil aplanat of 25 mm. opening and 19 cm. focal length. Stolze advises, besides these objectives, others of much longer focal length, to obtain inscriptions, etc., of sufficiently large size.

In the line of instantaneous shutters for very short exposures, many constructions have been shown; amongst them many bad or useless ones—causing a vibration of the apparatus, giving pictures not sharp, or not being reliable for some reason or other. The writer is of the opinion that the well-known drop shutter made according to designs of Engineer Wight, in Berlin, with metal frame, wooden slide, and pneumatic release, is the most preferable; also the shutter of Thury and Amey, of Geneva. The shutter of Talbot, of Berlin, which is inserted between the two lenses in place of the diaphragm, deserves also recommendation. A metal plate moves quickly up and down by the mechanism of the shutter.

In Austria, Germany, and France, the oxalate of iron developer (one part saturated iron solution mixed with four parts saturated oxalate of potassium solution) as introduced by the writer in 1879, is generally used; whereas in England and America the pyrogallic developer finds more favor. They prefer to work there with pyrogallic acid and soda or potash. Ammonia is now seldom used, on account of its bad odor, losing strength by evaporation, and producing green fog on many plates.

The addition of sulphite of soda to the pyro developer, causing a grayish-black coloring of the plates in place of yellow, is now generally applied.

A very good developer for instantaneous views is the potassium developer mentioned by Stolze, of Berlin, in 1879. The formula used by the writer, and published in 1885, is the following:

## A.

Neutral sulphite of soda	25 grammes.
Pyrogallic acid	. . . 10 "
Sulphuric acid	. . . 3 to 8 drops.
Water	. . . . 100 cc.

## B.

Pure carb. of potassium	90 grammes.
Neutral sulphite of soda	25 "
Water	. . . . 200 cc.

Before using, mix 100 cc. water with 3 cc. of A and 3 cc. of B. The pictures develop softer by an increased addition of water. As a strainer for too long exposures, a little citrate of potassium,

or the more energetic bromide of potassium, is added.

The soda developer, which was first practically introduced in America (by Cooper, Newton, and others) has also given ample proof of its good action.

## A.

Sulphite of soda	. . . 100 grammes.
Pyrogallic acid	. . . 14 "
Sulphuric acid	. . . 5 to 10 drops.
Water	. . . . 500 cc.

## B.

Soda crystals	. . . 50 grammes.
Water	. . . . 500 cc.

Mix, before using, 20 parts of A, 20 parts of B, and 20 parts of water.

The developed plates are well washed with water, placed in a strong alum solution for a few minutes, washed again, and then fixed in a solution of hyposulphite of soda (1 to 5).

Worth notice also is the communication of Stolze, according to which the bromide of silver gelatine can be mixed with pyrogallic acid and sulphite of soda. When dried and exposed, these plates will develop in a simple soda solution. The possibility is therefore determined that the manufacturer of the emulsion can add at once the necessary quantity of pyrogallic acid; this being a great convenience and a saving of much time for travelling photographers. Meydenbauer asserts that the sensitiveness of the plates is increased by this addition. About the durability of such emulsions no observations have been made yet, except one of six weeks.

Dr. Eder introduced with success in April, 1885, the sulphite of ammonia in the pyro developer; and on May 5, 1885, he communicated to the Vienna Photographic Society his discovery of the property of hydrazine (particularly the phenylhydrazine as sent to him by Dr. Walter, of Basle) acting in alkaline solutions as a developer for transparent pictures upon bromide and chloride of silver.

To prevent the loosening of the gelatine film in the fixing bath, which happens very easily during the warm weather of summer time, and to harden the film, 1 part of hypo solution (1 to 4) is mixed with  $\frac{1}{2}$  to 2 parts of saturated aqueous alum solution. The mixture will pretty soon become muddy by separation of sulphur and sulphurous acid, but for all that it acts satisfactory.

The negatives easily become milky, which is no hindrance in their printing qualities, but it does not look very well, and is the reason for using the mixed hypo and alum baths only in exceptional cases. The first negatives are washed, dried, var-

nished, and, according to requirement, strengthened or reduced.

Of the various intensifying methods, the mercury intensifier has maintained its place. Besides the well-known methods with chloride of mercury, there is a process, introduced from England in 1884 which meets with much favor. The fixed and washed negative is placed into a solution of

Chloride of mercury . . . . .	2 parts.
Bromide of potassium . . . . .	2 "
Water . . . . .	100 "

until it has obtained the necessary strength. The color of the negative is then white, but is blackened by washing with water and flowing on a solution of

Neutral sulphite of soda . . . . .	1 part.
Water . . . . .	6 to 8 parts.

The silver negative is transformed into bromide of silver and chloride of mercury by the mercury solution; sulphite of soda reduces the chloride to metallic mercury, and thus darkens the negative.

The advantage of this process is that there is no necessity for careful washing between the treatment with chloride of mercury and sulphite of soda. Further, the intensified plate is very constant, and does not change during printing, which latter evil sometimes happens to some of the mercury methods.

For the reduction of too dense parts of gelatine negatives, a simple mechanical process serves, proposed by Lenhard, of Vienna, in 1885, and which can be recommended. The dense parts are rubbed with a linen rag steeped in alcohol. It will be seen that the rag will soon become black, the picture clears up, and the softness of delineation will not suffer in the least.

In applied photography the advantage of shorter exposure has been observed, particularly since the introduction of the gelatine dry plates, and numerous excellent instantaneous artists may be mentioned.

Lugardon and Boissonas, of Geneva; Uhlenhuth, of Coburg; David and Scolik, of Vienna, with pictures of animals, street scenes, etc., are the most prominent. Strictly scientifically executed instantaneous views were made by Anschütz, of Lissa, who photographed men and animals in motion, birds flying, etc., and who is unsurpassed in this branch. That Kayser succeeded, in 1884, in obtaining a lightning photograph on a large scale, is known. Numerous experiments with the photography of the electric spark by Welten, Melckeecke-Plüker, Stein, etc., may be added to this.

Photogrammetry, which was invented by Meydenbauer, serves, as is known, as a very good means of obtaining a simple estimation of masonry by means of photographing measuring apparatus.

The method has been known since 1867, but on account of the great exactness required of the instruments, and extremely careful execution, had not been applied with success. The German Reichstag allowed 10,000 marks for the progress of photogrammetry. By the continual exertions of Meydenbauer, Dr. Stolze, and others, an important step in the development of measuring photography seems to have been taken, and deserves every consideration.

In Vienna, Lenhard made some arrangements for balloon photography (with an antiplanat) and the aeronaut Silberer accomplished the exposures of the plates. Very fine pictures of the Danube and the Prater were obtained.

Applied photography has particularly advanced by the introduction of orthochromatic or isochromatic photography—that is, the photography of colored objects in their proper tone relations. Dr. H. W. Vogel discovered in 1873 the property of many coloring matters to increase the color-sensitiveness of the bromide of silver for those rays of the spectrum which they absorb. The practical application of this combination of silver compounds mixed with coloring matter, for taking colored objects photographically with the collodion process, was practically introduced, particularly by Ducos du Hauron (1875 and 1878), who worked with eosine; further by H. W. Vogel (1884), who used the same coloring matter, but made many improvements; and finally by Ives (1884), who colored bromide of silver plates with chlorophyl. E. Albert, of Munich, also worked with the same isochromatic collodion process. All these methods are based upon the strong coloring of bromide collodion by eosine, when strongly yellow—sensitive eosine-silver will form in the silver bath besides colored bromide of silver. Particulars about this process are to be found in the writer's work, *Collodion Emulsions* (published by Knapp, of Halle, 1885; also see No. 8 of the *Complete Handbook of Photography*) as well as in Vogel's book, *The Photography of Colored Objects in their Proper Tone Values*, 1885.

Of greater practical importance has become the photography with dry orthochromatic bromide of silver gelatine plates.

Attout and Clayton, in France, were the first to introduce into the market gelatine dry plates colored with eosine for the production of colored objects, under the name of isochromatic plates.

H. W. Vogel's azalin plates followed, in 1884, and Eder's orthochromatic plates (August, 1884). The latter name, proposed by the writer, is now generally used for all those plates which show an increased sensitiveness for green, yellow, and red, and therefore reproduce the colors in their proper tone relations.

About the production of eosine plates, reports were made by Schumann, Vogel, and the writer. For the practical photographer the purchase of orthochromatic plates from the manufacturer may be recommended, the manufacturers possessing the secret of the correct application of the coloring matter and its quantity for the emulsion, a successful result not being possible without the exact execution in inactive light. The most simple is the bathing of ordinary dry plates in the color solution. One part of coloring matter is dissolved in 30,000 to 50,000 parts of water, and the plate is placed in that solution for two to three minutes.

As a coloring matter making sensitive for green and orange, a mixture of equal parts of cyanin and eosine is most suitable. Cyanin alone makes strongly red-sensitive, but not sufficiently green-sensitive. Eosine alone is good for green and yellow-green, less for orange.

Schumann recommends a bromide of silver gelatine emulsion (without iodide of silver) of moderate sensitiveness, produced by boiling (but not according to the ammonia process). The plates are at first put into a preliminary bath of 0.25 to 2 cc. of caustic ammonia in 100 cc. water, wherein the film will soften. After two minutes they are taken out and bathed in a cyanin solution, 1 to 2 parts ammonia, 5 to 10 parts alcohol, 2 to 5 parts alcoholic cyanin solution (1 to 500), and 100 parts of water, for two to four minutes, after which they are dried.

Schumann obtained with the cyanin plates not only very handsome spectrum photographs up to red, but also orthochromatic photographs of oil paintings.

Mallmann and Scolik (*Photogr. Correspondenz*, 1866, page 40) are closely attached to Schumann's proceedings, and also use an ammonia preliminary bath, but apply an erythrosin bath (25 cc. erythrosin solution, 1 to 1000; 4 cc. ammonia; 175 cc. water) in place of the cyanin.

The orthochromatic plates should be placed into the developing tray in a very subdued dark ruby light. In front of the photographic object a light yellow glass is placed to weaken the blue in the picture. Orange colored collodion, coated on white glass-plate in the desired strength, can be recommended. Aurantia (H. W. Vogel) 0.3 grammes, or methyl-orange mixed with dimethyl-

orange (Eder), is dissolved in 25 cc. of warm alcohol, and the solution is added to 75 cc. of 2 per cent, plain collodion. This will give films which act or have the same effect as dark yellow glass. Such a film is obtained with 0.22 gramme aurantia in 100 cc. of the mixture. This collodion is flowed upon fine plate-glass, which is placed before the objective. The exposure can be three to four times longer than without any yellow glass. The development is the same as ordinarily applied, only the tray should be carefully covered in the beginning, and the development should be in dark ruby light.

Schumann, and shortly afterward Vogel, made known, in November, 1885, that pictures could be produced in their true color value upon orthochromatic plates by lamp-light, in consequence of its yellow coloration, without a yellow glass in front of the objective. Mallmann and Scolik, of Vienna, produced in February, 1886, successful portraits upon erythrosin plates by a kerosene light. Notwithstanding the comparatively small illumination of only 250 to 300 candles, the exposure lasted but from three to five seconds.

These gentlemen use as coloring matter erythrosin (from iodo-tetra fluorescein), whose advantages over ordinary eosine were made known first by the writer in 1884.

*Photographic printing process upon chloride of silver collodion paper.*—Pictures upon chloride of silver collodion are much finer and more brilliant than upon albumen paper. Obernetter, of Munich, introduced, in 1868, printing (copying) paper into the market which was coated with chloride of silver collodion. The process went gradually out of use, because the production of the paper in large quantities offered difficulties. It is true the pictures did not bleach, but the collodion film would peel off the paper if great caution was not exercised, or by improper treatment. Liesegang, of Dusseldorf, has now made some efforts to introduce the process again. He brings chloride collodion and silver collodion in separate bottles into the market, which give chloride of silver collodion when mixed. As is known, chloride of magnesia, or chloride of strontia, and citric acid are dissolved in collodion on the one side, nitrate of silver on the other and are then mixed. The pictures are printed on the paper coated with this solution without the aid of a developer, and then toned and fixed. These paper pictures with chloride of silver collodion are called "aristotypes."

The process with chloride of silver gelatine paper, discovered by Eder and Pizzighetti in 1880 met with much favor, and has been manufactured since on a large scale in Vienna (Dr. Just, 1885).

Just uses for its manipulation in large quantities a so called automatic exposer invented by Schlotterhoss, which furnishes from 400 to 600 proofs in an hour by electric or daylight. The pictures are developed with a weak solution of oxalate of iron, citrate of iron, or hydrokinone.

*Photo-zincotypy and other photographic printing methods for the printing-press.*—In place of wood-cuts, photo-zincotypes are very often used. The reproduction of line drawings is executed easily and securely by the well-known methods of the photographic zinc-etching, which offers no difficulties so long as half-tones are not to be reproduced. For the production of photo-zincotypes, the transfer process with chrome-gelatine or chrome-albumen paper takes place after the well known method.

Some large houses use the asphaltum method, which gives greater sharpness of the fine lines. In the production of the asphaltum solutions great improvements have been lately made. Hustink dissolves the asphaltum in rectified oil of turpentine to a thick liquid, requiring several days. With stirring, three to four times the volume of ether is added; a dough-like precipitate separates, which, after twenty-four hours, is washed with ether and then dried. The dry asphaltum is dissolved in pure benzole, free from any water, and mixed with 1.5 per cent. of Venice turpentine to make the coating more flexible.

The zinc plates are coated with a thin asphaltum coating, and exposed in the sun under a drawing from ten to sixty minutes. Oil of turpentine serves as the developer. As soon as the picture is developed, benzole is poured over the same without hesitation, and after draining it is washed with water. The dried zinc plate is etched as usual.

The production of photo zincotypes in half-tones, which can be printed in the printing-press, is of the greatest importance for book illustrations. A short description might be appropriate, the many views about the manner of their production not being very clear. The idea of producing photographic reliefs by dividing the picture into lines and dots is an old one. It is the intention to have the dots compose surfaces in the deep shadows, while in the half tones the black dots are separated by white lines. The picture surface consists, so to speak, of a grain, which represents by its more or less close arrangement the half-tones, without any actual half-tones existing. Meisenbach, of Munich; Angerer and Goschl, of Vienna; and the Military Geographic Institution, deserve particular mention in this direction.

The Heliogravure, or the production of *copper printing plates* by way of photography, is done

by etching or the galvano-plastic process. Both processes are based upon the works of Poitevin and Woodbury, of more than twenty years ago.

The helio-engraving by etching was brought to a high degree of completion by Klic, of Vienna, in 1883. The process was sold to some persons and was kept strictly secret, so that it has only become known recently. In Volkmer's "Technik of the Reproduction of Military Maps" (1885), we find communications referring to it which have been obtained by practical observations in the Austrian Military Institution. The process is as follows: A copper plate is dusted over with asphaltum powder to produce a grain when afterwards etched. After this a glue (gelatine) picture is put on the copper plate by transfer (like the carbon process). This tender glue relief is etched into the copper with chloride of iron solution of 1.3 sp. gr. After this the gelatine film is hardened by the action of the chloride of iron, and is finally gradually penetrated and etches by the small excess of water in it. The picture obtained in the beginning is monotonous. By rolling in with heavy ink the finest tones are covered, the deeper ones remain open, and can be etched afterwards. Such plates print very delicate, and are durable when steeled, being capable of furnishing over one thousand copies, as seen by the writer.

In the Imperial Military Geographic Institution of Vienna, the heliographic copper plates (for maps, etc.) are produced by way of the galvano-plastic method, by converting a gelatine relief into copper. The galvanic current is produced with a dynamo machine of Captain Von Huble. The plates to be treated are inserted one behind the other, giving more uniform copper deposits than when placed side by side.

Colored lichtdrucks are at present mostly made with the aid of retouchers and draughtsmen. The process executed by J. Löwy, of Vienna, approaches nearest to that of a genuine photographic picture. From the original or negative, stopped out by retouching, leaving open only those parts which are intended to print, yellow for instance, a photolithographic plate is taken. In a similar manner a plate is made for blue, etc. The colored picture so obtained (chromolithography) lacks softness. This is obtained by final reprinting of the chromolithograph with a lichtdruck plate in half-tone, which prints over the picture all those colors which give the picture its finish, the picture thereby gaining in fine half-tones.

Troitzsch, of Berlin, prints the picture upon the stone by way of lichtdruck, and this serves as a base for the colorist. Hösch, of Berlin, pro-

duces color plates with the aid of photography and painting. He prints the several colored pictures, not from stone, but from lichtdruck plates.

These plates, of course, will wear off pretty soon, and give less uniformity than the stone; but a smaller number of color plates are sufficient, while in chromolithography seldom less than 20 are used.

*Photozincotypes in colors.*—Angerer and Goschl, of Vienna, produce by a new process colored prints, so-called "photo-chromotypes," which are made in the printing-press. The principle which is applied here is similar to the colored lichtdruck. At first photo-lithographs are made from the picture to be multiplied, which serve to some extent as copies for the draughtsman. The latter works up only the parts which are to be yellow; upon a second sheet those only which are intended for blue, and so on. Negatives are produced which show only a picture of the blue parts, others for yellow, red, etc. From these negatives zinc printing-plates are etched in half-tone, and the rest of the manipulation is the same as the fitting of the several color stones in chromolithography.

Many newspapers, for instance the *Neue Illustrirte Zeitung*, are furnished with these color prints.

---

### PRACTICAL POINTS FROM THE STUDIOS.

**ZIRCON LIGHT.**—This light is again brought to notice. Disks of zirconia, according to the process of Lyndemann, are now made by using this oxide in an extremely fine powder, such as results from the action of heat on chloride of zirconium; a paste is made of this powder by pressing it in a steel mortar, having a diameter of five-eighths of an inch; the disk thus obtained is heated to a high degree, and then attached to a thin sheet of platinum. Placed in the flame that results from the combustion of illuminating gas, either by oxygen or by air (supplied by a blowpipe), such a disk yields an intense light with a continuous spectrum. This zirconia disk may be used in this manner, it is said, hundreds of times without losing its properties.—DR. PHIPSON.

**PHOSPHORUS AS A PHOTOGRAPHIC AGENT.**—At the South London Photographic Society, Mr. Charles Quirson read an interesting paper on "The Use of Phosphorus in

Photography." The author insists first on the sensitiveness of phosphorus to solar light. He makes a solution of this metalloid in carbon disulphide, and applies it to stone. The thin film of phosphorus that remains after the liquid is volatilized is easily printed from under a negative, and the image obtained may be modified by the application of silver salts, etc. But the process, besides the danger in the use of phosphorus, is hardly practical. The author makes use of a lithographic stone; if the solution were poured on paper, the whole would take fire as soon as the carbon disulphide has evaporated.

**NEGATIVE OR POSITIVE PRINTS, ACCORDING TO THE LIGHT.**—At the London Photographic Association, a letter was read from Mr. John Henderson, of Perth, Scotland, which was accompanied by a print representing a silver vase. To avoid reflection during the reproduction of this vase, the author was careful to arrange the light and shade in a suitable manner; but, to his great surprise, the print obtained was a negative, instead of being a positive. On this occasion Mr. L. Henderson, of London, remarked that he had experienced a great deal of difficulty recently in reproducing a mirror to prevent the production of the image of the lens on the negative; and in this case, he found that it was easy to obtain either a negative or a positive, according to the way the object was shaded.

**PHOTOGRAPHY AS A DETECTIVE.**—A daily sheet has attacked in a discourteous manner the young persons employed at the local post-offices in London. A series of anonymous letters appeared, in which it was asserted that these young ladies spend their time in chatting, instead of attending to their business. It has been known for a long time that anonymous letters which appear in a daily sheet are very often written by the editor of the paper. In the above case, photography has furnished the proof of this. The portrait of a suitor for the hand of one of these ladies, made, unknown by him, on a rapid plate, proved conclusively that it was he who caused a certain employé to talk, and it was only after she had begged him politely, but ur-

gently, to move on, that these anonymous charges appeared. The portrait was recognized as being that of the editor of the daily sheet!—DR. PHIPSON.

**NEW GALVANOPLASTIC BATH OF SILVER WITHOUT CYANIDE.**—The iodide may be substituted for the cyanide of potassium, according to the process of Luyri, to silver by means of the pile. This new bath may be kept for a long time without decomposition, and is not acted upon by the solar rays. It consists of a solution of iodide of potassium, and is made by dissolving 100 grains of nitrate of silver in 34 fluidounces of water, and adding 16 ounces Troy of iodide of potassium. The copper articles are prepared as for the cyanide bath; the positive pole is formed by a plate of silver. The electric current should be very weak.—*Moniteur*.

**TO REMOVE THE FOG OF OXALATE OF LIME FROM THE SURFACE OF PLATES.**—For the baths and washings, use ordinary water; then, after fixing, plunge the plate in a bath of—

Ordinary water . . .	100 parts.
Ferrous Sulphate . . .	20 "
Alum . . . . .	8 "
Tartaric Acid . . . . .	2 "

The fog rapidly disappears, and ordinary water is used in the washing. This process will be especially useful for prints intended for projections.—M. SIMON, in *Moniteur*.

**INDIA RUBBER VARNISH**—The scraps of vulcanized rubber, which is a mixture of rubber and sulphur, and which dealers in hard rubber goods can deliver in abundance, can furnish, by doing as follows, an excellent varnish, which dries promptly. Its color can be varied from a golden yellow to the deepest brown. It sticks very well to metals, and can be employed on electric apparatus. These clippings are put into a deep earthen pot, covered with a tight lid. The pot is set upon hot coals. At the end of five minutes take the pot from the fire and see if the material is melted. While the pot is on the fire, take care not to lift the lid up, because the vapors which would be thrown off take fire easily. After the

rubber is all melted, so that it can be poured out, and there are no more whole pieces, which can be discovered by fumbling through the mass with a large file: pour it into a flat tin basin. This basin should be rubbed with grease beforehand, and after the mass is cooled it is readily detached. Then break it into pieces, put it into a large bottle, pour on some benzol and rectified spirits of turpentine, and shake the mixture up several times. The solution being complete, pour out the liquor to get rid of the impurities and hardened rubber, which remains at the bottom, and a very limpid, beautiful, and excellent varnish is obtained.—*La Nature*.

**SENSITIZED ALBUMENIZED GREEN PAPER.**—MM. Eugene Cheron and Gattraux exhibited, before the French Photographic Society, some prints printed on green albumenized paper. These papers in certain cases may be useful in obtaining agreeable effects, especially in taking trees and fields, for night effects, where, however, the blue color seems better adapted.

**TO REMOVE OLD PAINT.**—Old paints and varnish may be removed from wood and iron by applying a mixture of one part of American pearlsh to three parts of quick stone-lime. Slake the lime with water and add the pearlsh, making the mixture of the consistency of paint. With an old brush lay the mixture over the whole of the surface to be cleaned, and after fourteen or sixteen hours the paint can easily be scraped off.

**"SNAP SHORT."**—A diamond is best for cutting glass. The substance sold by fire-works dealers under the name of punk has been found to afford a satisfactory means of cutting, or rather, cracking glass. A stick of punk is lighted, and the incandescent part, which takes the shape of a cone, is held very close to, or in actual contact with the glass, and drawn in the direction it is desired to lead the crack. Heating the glass and touching with a drop of water generally start several slight cracks, and the one pointing in the most convenient direction may be led where desired with the lighted punk.



## Editor's Table.

THE Photographic Society of Philadelphia has selected two very pleasing prints for its presentation pictures. The first, "Near Seal Harbor, Mount Desert Island, Maine," is by Mr. R. S. REDFIELD. It is a beautiful picture, taken with a judgment as to light and point of view that makes it remarkable. A mass of dark trees on a jutting point give fine distance and breadth, with the misty mountains rearing their heads across the white water. The sky and quality of light we have not often seen excelled. The whole forms a delightful composition. Mr. F. G. CAUFFMAN's picture is entitled "Crossing the Brook." It shows a pleasant nook in the woods, with the stream winding down among the rocks, where a mass of logs and branches forms a bridge. A rustic maid has been caught by the camera as she is picking her way over. It is a very clever picture of a pretty spot.

THE Talcott method of mounting is made plainer by the following excerpts from a letter sent us by the inventor:

As specimens of our improvement in mounts for pictures, photographs, etc., have been placed for inspection, which must naturally be subject to more or less criticism, it may be well for us to give some description of the method and its merits.

Upon superficial examination, some may say that it is merely a picture placed back of plate glass, but this is, as you know, far from the case, as herein to a great extent exists the cause of the fine effect produced by this mount: the picture, being firmly pressed upon the transparent plate, is made to adhere fast thereto by a transparent enamel of fine glass, made by us expressly for this purpose, and is of singular purity.

The pressure process is accomplished by a unique device of our own invention, which effectually expels all superfluous cement, and disposes of all corrugations and unevenness common in photographs otherwise mounted.

The compound used gives much gloss, and in connection with the transparent plate produces a soft and brilliant appearance, bringing out the strength of the picture to a fulness of a surprising degree.

In this manner the picture becomes so closely identified with the plate as in appearance and effect being one and the same.

From the considerable length of time we have experimented with this process and noted the

results, we feel confident in making the assertion that any photographic print may be preserved an indefinite period, if subjected to our process before chemical change begins.

The plate is of the finest quality that can be procured, shaped and finished to each individual print, which print is securely enclosed and hermetically sealed in a neat and durable manner.

The mount is provided with a strong suspension and support, the whole presenting a finish and richness to correspond with any surroundings, however elegant. E. K. TALCOTT.

216 NORTHAMPTON ST., BOSTON.

We have some fine specimens in our office.

THE CENTURY DICTIONARY.—For the past five years THE CENTURY Co. has been engaged in preparing a dictionary of the English language, of which Professor WILLIAM D. WHITNEY, of Yale College, is editor-in-chief—the purpose being to make a more comprehensive work than has yet appeared in popular form, to include, in addition to a very full collection of individual words in all departments of the language, all technical phrases, not self-explaining, in law, the mechanical arts, the sciences, etc. Indeed, it is designed to make this dictionary so complete in its definitions of all branches of science and art that even the specialist will need nothing further. The number of "new" words in many of these departments is said to be surprisingly great. The dictionary will have also a remarkably complete system of cross-references, and will embody in itself a dictionary of synonyms which will add greatly to its value.

A prominent feature of the new work will be its encyclopedic character. Its definitions will be fuller and more complete than is customary in works of this kind; it will go further into the various uses and meanings of words, and in many cases will give full explanations and descriptions of matters historical, scientific, legal, mechanical, etc.

The publishers are taking great pains with the illustrations, of which there will be about 5000. They are employing the same class of artists and engravers that contribute to their magazines, and they mean to make the result something hitherto unknown in the world of dictionaries. Each picture as it is drawn, and again after it is engraved, is submitted to the specialist to whose department it belongs, that its scientific accuracy may be guaranteed.

The inception of this scheme was a desire to

improve and Americanize the "Imperial Dictionary" of Great Britain, brought out in this country by the THE CENTURY Co. five years ago. As the work of altering it advanced, it became apparent that a better plan was to begin *de novo*, and so the far greater work of making a new dictionary of the English language was begun. Two or three years must still elapse before it will appear, and in the mean time opportunity is offered by the publishers to those interested in helping on so useful a work to contribute material and suggestions to it. Much valuable matter has been received in this way from many scholars and practical men all over the world.

It is estimated that upwards of a quarter of a million of dollars will be spent upon the Century Dictionary before it is ready for publication.

Photography will doubtless cover a large page in it.

EAGLE.—The spread eagle which Mr. G. GENNERT has chosen as his favorite trade-mark has become, if not a household word among photographers, certainly a studio word. Moreover, the various articles of use in our art which come to us under the protection of the great American songster are among the choicest favorites of the photographer. A splendid example of the productions from "Eagle" plates is our embellishment this month. It is appropriate, therefore, that we allude now to the wonderful growth of the trade in the "Eagle" Albumen Papers, which have been perfected and so zealously pushed by the energetic American agent, Mr. GENNERT. Our readers are so well acquainted with the "Pensée," and "Pearl" brands that we need hardly draw attention to them. Yet we would not close without calling attention to one of their most advantageous features, namely, the very small stamp upon the sheets. Owing to this a great deal of waste is prevented, and the photographer is enabled to "save," as Mr. GENNERT states in his well-put advertisement elsewhere.

If anyone who visited the St. Louis Exposition is skeptical as to the advantages of the "Eagle" papers he must become proselyted by the charming prints shown upon them from Germany and from our own American printing-rooms.

SOUVENIRS.—One of the most novel sights of the Convention was had at the close of the days when the visitors made their departure loaded down with the souvenirs given them. Besides copies of all the magazines, we have in our own collection, among other things, the following:

A miniature *facsimile* of the cover of the *St. Louis Photographer*, with two of Mr. CLARKE'S tender verses on the back dedicated "To Our Friends;" a tasteful little brochure printed on white shagreen paper, bound in crimson, and tied with an old gold silken cord, from the publishers of the *Photographic Times*; a four page leaflet from Mr. G. CRAMER, giving a lot of information, with a map of St. Louis and a cut of his gallery; a larger leaflet from Mr. J. C. SOMERVILLE, devoted to the programme of the Convention, and a map with a cut of his new store; last, the Association badge, which was of old gold silk, with the Association monogram printed in black, attachable by means of a golden safety-pin. All these now lie among the archives in our office, and their duplicates decorate a thousand other collections. Copies of our last issue made up our contribution to the pile.

WE have received from Mr. WILFRED A. FRENCH, of Boston, a fine series of prints taken at the launch of the new yacht "Mayflower," which is expected to be the coming boat. These pictures of the clean white vessel on her entrée into the watery world are exceedingly interesting. "Before the Launch" shows the model craft on her stocks, the curious throng awaiting the supreme moment. "The Launch" shows the "Mayflower" as she is entering her natural element, gracefully parting the waters, which curl up on each side in clear white spray, and seem to exult round her bows. The two other views were taken after the launch, and show the coming winner of this summer's contests to better advantage, enabling one to better admire her beautiful lines. The lens used was a No. 2 euryscope, *smallest stop but one*; Hoover shutter set at unnecessarily high speed. The day was cloudy, yet the plates were fully timed and crisp, showing faultless depth of focus and perfect definition. All are instantaneous, and were made under uniform conditions as to size of stop, rate of speed, etc.

Mr. GEORGE F. MUGNIER, of New Orleans, La., who now has the privilege of photographing the Exposition there, sends us a very handsome series of photographs taken from the pictures in the art gallery. As reproductions of paintings they are excellent, being clear and clean, and preserving well the qualities of the originals. It is a pity, however, that the isochromatic process was not used on one or two of them. One very successful view shows the fountain with its white jets of water, and the foliage around the basin is full of good detail.

# Specialties.

## ADVERTISING RATES FOR SPECIALTIES.

25 cents for each line, seven words to a line—in advance. *Operators desiring situations, no charge.* Matter must be received a week before issue to *secure* insertion. Advertisers will please not ask us for recommendations. ~~As~~ We cannot undertake to mail answers to parties who advertise. Please always add your address to the advertisement. **Postage-stamps taken.**

**MAKE OUT YOUR OWN BILL**, and remit cash with your advertisements, or they will not be inserted.



### NOTICE.

By an arrangement with the owners of the copyright of Kate Greenaway's designs, for the United States, the undersigned is entitled to the exclusive use of the same for adaptation to children's photographic backgrounds.

LAFAYETTE W. SEAVEY,  
Studio, 216 E. 9th St.,  
New York.

**RETOUCHING BUREAU.**—Under the direction of Mr. H. Harshman. None but skilled help employed. Quality of work guaranteed. Prices moderate. Send your negatives in wooden box with cover screwed on, and prepay charges. Address GAYTON A. DOUGLASS & Co.,

Merchants in Photo. Supplies,  
185 & 187 Wabash Avenue,  
Chicago, Ill.

DEAR SIR: Please send us three copies of *Long's Art of Making Crayons on Solar Enlargements*, and oblige

BUCHANAN, SMEDLEY & BROMLEY,  
25 N. Seventh Street, Phila.

AMONG all the photographic lenses of various makes and styles which have been introduced during the past ten years, the euryscopes, of which Voigtlander & Son are the sole manufacturers, loom up conspicuously. The success of these lenses has been unparalleled, and the demand is as lively as ever. They can be found in nearly every gallery in the land, and the amount of satisfaction and profit they produce is difficult to calculate. Most convincing proof of their superiority over other lenses is the exquisite work done with them, and the fact that it is simply impossible to get along without them.

Send for our bargain list.

WILSON, HOOD & Co.,  
285 Arch St., Phila.

### BARGAIN LIST.

- |                                                                                                                                                     |         |
|-----------------------------------------------------------------------------------------------------------------------------------------------------|---------|
| 1 5 x 8 Scovill Manufacturing Company's Camera, with Eastman Roll-holder, with tripod, focusing-cloth and light carrying case. <i>All new</i> ..... | \$35 00 |
| 1 5 x 7 Scovill Manufacturing Company's Revolving-back Camera, three extra holders, with kits; 1 tripod.....                                        | 30 00   |
| 1 18-inch Entreklin Burnisher (old style)...                                                                                                        | 10 00   |
| 1 14-inch Entreklin Burnisher, (nearly new).....                                                                                                    | 15 00   |
| 1 Centennial Head-rest, perfect.....                                                                                                                | 8 00    |
| 1 Spencer Head-rest (old style).....                                                                                                                | 1 50    |
| 2 Bergner Cutters, stereoscopic arch top, each.....                                                                                                 | 15 00   |
| 1 Bergner Cutter, stereoscopic square top..                                                                                                         | 10 00   |
| Printing-frames, 10 x 12 (nearly new).....                                                                                                          | 60      |
| “ “ 6½ x 8½ “ “                                                                                                                                     | 35      |
| “ “ 5 x 8 “ “                                                                                                                                       | 30      |
| Negative boxes 5 x 8, 8 x 10, 10 x 12, and 14 x 18 from 25 cents to \$1.10.                                                                         |         |

ROBERTS & FELLOWS,  
1125 Chestnut St., Phila.

## CANOE & CAMERA



BY THOMAS SEDGWICK STEELE.

A PHOTOGRAPHIC TOUR

OF

TWO HUNDRED MILES

THROUGH THE

MAINE FORESTS.

(Illustrated.)

Price . . . . . \$1.50.

ESTES & LAURIAT, Publishers, Boston.

FOR SALE BY

THE PHILADELPHIA PHOTOGRAPHER.

Having contracted for a special make of glass, the SEED DRY-PLATE CO. can now guarantee a *flat, even, and straight plate*. A full stock of this well-known brand kept at the *New York Depot by the Agent*. GEORGE MURPHY,

250 Mercer St., N. Y.

**A REAL NECESSITY.**

We presume there is hardly a lady to be found in our broad land who if she does not already possess a sewing machine, expects some day to become the owner of one.

But after the mind has been fully made up to purchase one of these indispensable articles, the question arises as to what kind of machine to buy.

It should be so simply constructed that the most inexperienced can successfully operate it. The other points mainly to be considered, and which are the most desirable, are durability, rapidity, capacity for work, ease of operation, regularity of motion, uniformity of tension, and silence while in operation.

The "Light-Running New Home" fills the above requirements, and is said to combine the good points of all sewing machines, with the addition of many new improvements and labor-saving devices.

The price is no higher than that of other machines, and every lady who is the happy possessor of one may rest assured she has indeed a treasure.

**THE LIGHT RUNNING**

**NEW HOME**

**SEWING MACHINE**

**HAS NO EQUAL.**

**PERFECT SATISFACTION**

**New Home Sewing Machine Co.**  
—ORANGE, MASS.—

30 Union Square, N. Y. Chicago, Ill. St. Louis, Mo.  
Atlanta, Ga. Dallas, Tex. San Francisco, Cal.

**FOR SALE BY**

THE AGENTS, at the above named places.

FOR SALE.—Evans' branch gallery in Courtland, N. Y. Best in the country. Address  
E. D. EVANS,  
Ithaca, N. Y.

**AT ST. LOUIS**

Everybody saw, admired, and ordered  
**THE MAGEE VIGNETTER.**

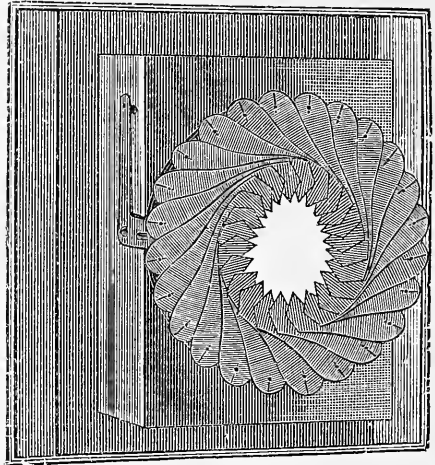

It is for the new  
**BLACK VIGNETTE.**

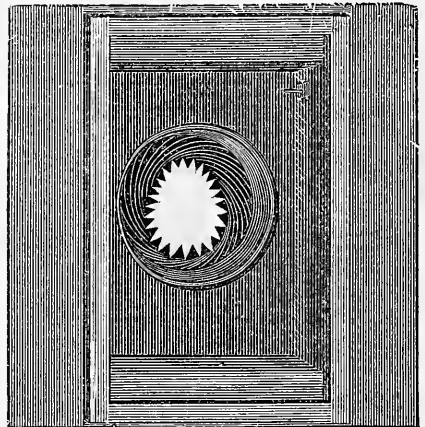

Look at its work. Also try the celebrated  
**P. A. OF A. PAPER.**

Albuminized for

H. A. HYATT, Eighth & Locust Sts., St. Louis.

WANTED.—A first-class operator who can re-touch. Send specimens of work and photo. of self. Address

**GEORGE N. COBB,**  
Binghamton, N. Y.

ANTHONY'S Adjustable Developing Fork, especially for warm weather, is one of the greatest boons recently introduced. By its use the fingers are kept absolutely free from the developer. Ask your dealer to show you one.

EVERY photographer in want of excellent lenses, for any purpose, will best serve his interest by consulting the new illustrated price-list of Messrs. BENJAMIN FRENCH & Co. before purchasing.

OUR dark-room and laboratory are under the charge of Dr. John Nicol, photographic chemist, late of Edinburgh. None but purest chemicals used in our preparations. All the standard dry-plate developers kept in stock. Your patronage desired.

GARTON A. DOUGLAS & Co.,  
 Merchants in Photo. Supplies,  
 185 & 187 Wabash Avenue,  
 Chicago, Ill.

825 REVISED LIST. 825

We call attention (circular free) to our revised price-lists of *albumen papers*, *Magee's nitrate of silver*, *dry plates*, and *pyrogallie acid*. Consult it before you buy. WILSON, HOOD & Co.,  
 825 Arch St., Phila.

SPECIAL CARD.

Talcott's Improved Mounting for photographs softens the lines, gives much strength and great brilliancy to the picture, and is the only process by which a photograph may become indelible.

Patented March 23, 1886.

For preserving from all soiling engravings, etchings, crayons, diplomas, certificates, etc., this mounting has no equal, the picture or parchment being hermetically sealed.

Pictures thus mounted can be displayed or packed in less than one-half the space required by pictures with other framings, as by this process all other framing becomes wholly unnecessary, yet it is so constructed that if desired it can be placed in any ordinary picture frame intact, free from all interference.

E. K. TALCOTT,  
 216 Nothampton St.,  
 Boston, Mass.

TO PHOTOGRAPHERS.

I have now added a new floor to my stock-house, which will be specially devoted to accessories, camera-stands, camera-boxes, chairs, etc. A call solicited. New lists on application.

GEORGE MURPHY,  
 250 Mercer St., N. Y.

THE DUPLEX NOVELETTE CAMERA

Is a marvel of Camera architecture. In an instant a "vertical" camera may be turned into a "horizontal," and in another the change made from the 5 x 8 to the 8 x 10 size, and vice

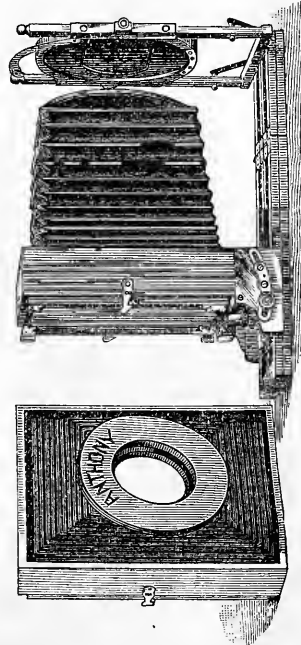

versa. It is supplied in two carrying cases, so that you may leave one part at home if you desire. The same platform and one front serves for both sizes. It is as complete an equipment as ever was invented. One holder, each size, goes with the "Duplex" at \$35. Messrs. E. & H. T. Anthony & Co. are the makers.

EAGLE STOCKHOUSE.

NOW IN STOCK

TRAPP & MUNCH'S CELEBRATED  
 Extra Brilliant Albumen Paper,

ALSO

The Chicken Brand—Extra Brilliant.

TRY THEM.

FOR SALE BY

GEORGE MURPHY,

250 MERCER STREET, NEW YORK.

Reed's Common-sense Negative Washing-box.  
 New. Send for circular.

WILSON, HOOD & Co.,  
 825 Arch St., Phila.

The Anthony Universal Finder is a cute, complete little camera in itself. Instead of being

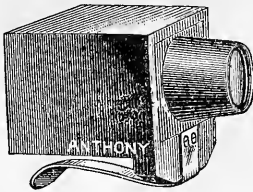

fastened to the camera it is supplied independently (Fig. 1), and may be applied to any camera by the means shown in Fig. 2. Its ap-

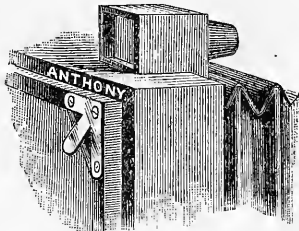

plication to your camera tells you at once what the camera will "take." And only \$1.50 to occupy one.

The American Artists' Association is re-established for solar printing in silver, solar printing in platinum, finishing in ink, water-colors, crayon, pastel, and oil.

WILSON, HOOD & Co.,  
Trade Agents, Phila.

**WILSON, HOOD & CO.,**  
825 Arch St.,  
PHILADELPHIA.

We have now in stock  
THE NEW EAGLE DRY PLATE.

ALSO

THE INGLIS TRIUMPH PLATE.

A new brand of

GERMAN PYRO ACID.

(35 cents per ounce.)

POCKET GLASS CUTTER.

(15 cents each.)

NEW STYLE CORNER CHAIR.

(\$10.00 each.)

PAPER MACHÉ STUMP.

(\$6.00 each.)

SUNSHINE MAILING ENVELOPE.

FOR SALE.—Strictly first-class gallery; best location on Broadway. Address

E. L. WILSON,  
553 Broadway, New York.

Another preserver of neatness is Anthony's Artist's Cuffs. The engraving makes the article



and its use plain. No more spoiled shirts or soiled wrists.

M. WERNER,

PORTRAIT ARTIST,

No. 102 N. TENTH STREET, PHILADELPHIA.

Photographs finished in crayon, India-ink, water-colors, and pastel, in all sizes, in the very best styles, and at moderate prices.

Solar Prints and Enlargements Furnished.

**DOWN SHE GOES!**

NEW PRICE-LIST

OF THE

ROCKWOOD SOLAR PRINTING CO.

17 UNION SQUARE NEW YORK.

Size.	Unmounted.	Mounted.
11 x 14.....	\$1 00	\$1 25
13 x 16.....	1 00	1 25
14 x 17.....	1 00	1 25
16 x 20.....	1 00	1 25
18 x 22.....	1 20	1 50
20 x 24.....	1 35	1 50
22 x 27.....	1 40	1 90
25 x 30.....	1 40	1 90
27 x 32.....	2 25	3 00
29 x 36.....	3 00	4 00
30 x 40.....	4 00	5 00

No charge for negatives. All orders must be accompanied by the cash. Make all P. O. orders payable to ROCKWOOD SOLAR PRINTING CO., 17 Union Square, New York.

**SITUATIONS WANTED.**

No charge for advertisements under this head; limited to four lines. Inserted once only, unless by request.

By a thoroughly first-class operator and retoucher. Would take management of gallery. Not less than \$18 per week. Address Photographer, 1733 Tenth Street, Washington, D. C.

By an experienced capable man, useful in all branches of the art; best of references. Address Pyro, P. O. Box 279, Portsmouth, Va.

By an experienced man, as retoucher, printer, or toner; can assist in operating. Address P. O. Box 518, Rochester, N. Y.

By a workman of thirteen years' experience. Can do neat and clean work in all branches of the art. Address S. W. Wesley, 108 Goodrich Street, Akron, O.



[TRADE MARK]

TRY THE NEW

**3 KINGS** EXTRA BRILLIANT  
ALBUMEN PAPER.*Vio-Pensee*, a most delicate violet tint, and  
*Pearl-Email*, a beautiful shade of pearl.

SUPERIOR PRINTING QUALITIES

Price per Ream, \$34.00.

Sample dozen post-paid to any address on receipt of \$1.00.

**BUCHANAN, SMEDLEY & BROMLEY,**

Importers,

25 N. 7th St., Phila.

THE PLATINOTYPE (Patented).

Send ten cents for instructions and sample,  
portrait or landscape.

WILLIS &amp; CLEMENTS,

1112 HUNTER ST., PHILADELPHIA,  
BUCHANAN, SMEDLEY & BROMLEY,  
General Agents for the sale of materials.**HODGE & HUSTON,**  
**THE SOLAR PRINTERS,**  
622 ARCH STREET, PHILADELPHIA.*Permanent Prints by the Platinum Process. Electric Light.*

Those

**FINDERS**beat the world. You ought to see them. If you are making *instantaneous* views you can save ten times their *value* in annoyance and *failures* the first dozen plates you expose. Easily adjusted, always in focus, light, cheap and durable. Size of ground glass 1 x 1 3-10 inches. *Price, \$1.50*, post-paid to any address in the United States.**BUCHANAN, SMEDLEY & BROMLEY,**  
**PHILADELPHIA.**The best artists and solar printers in the United States and Europe use PLATINOTYPE PAPER for large and small pictures. This paper is manufactured for Willis & Clements' Platinotype Process, and is the *purest and most desirable* grade of paper made in the world for ink, crayon, or pastel. Samples free.BUCHANAN, SMEDLEY & BROMLEY,  
Importers, 25 N. Seventh St., Phila.



OFFICE OF

# G. GENNERT.

## 54 East Tenth Street.

---

### SAVE!

The great manufacturers of plain paper for albumenizers have their factory at Rives, France, where from distant mountain streams the purest water is brought.

But the great *albumenizers of this plain paper are at Dresden*, where the eggs of the *genuine and only Saxon hen abound* as plentifully as does water in Southern France. Years ago the *Importer of the Eagle Paper* received a great many complaints from his customers, and photographers all over came to the conclusion that *a water mark in the plain paper was a nuisance* that caused a great loss of prints, as the *the part of the sheet with the water mark was useless and waste*.

Desiring to gratify the demand of the photographers, save them from waste of paper, and prevent a *general strike, and the boycotting* of albumen paper on account of the water mark, the *Importer of the Eagle paper made a special trip to Europe*, for the purpose of inducing the great manufacturers of plain paper to *leave out all water marks*, but he only succeeded in having it reduced to the smallest size. He left out his own water mark, and has not had any in his paper since. Other parties thinking perhaps they knew more about prints and albumen paper than photographers do, *picked up the water mark he had dropped*, and try continually to impress upon photographers the fact, that water marks, instead of being a nuisance, are a blessing. *But it does not prevent photographers seeing how they could SAVE*, so they wisely preferred the cheapest.

In the *increased demand for our Eagle Paper*, we found our triumph, and we are not afraid of counterfeiting, for no one can imitate the good qualities possessed by the Eagle paper.

The *manufacturers of the Eagle Paper* announce that in order to retain the lead in albumen paper, they have to *keep moving*, and have just built a new factory, with all the improvements ingenuity and long experience can suggest. They were the first who brought out the *PENSEC EXTRA BRILLIANT*, and now they offer, through the undersigned, their new *Rose Extra Brilliant*, which ought to be tried to be appreciated in its fine qualities.

---

ASK YOUR DEALER FOR IT.

---

G. GENNERT, Importer,

54 East Tenth Street, N. Y.



ASK FOR THE  
BLUE LABEL.

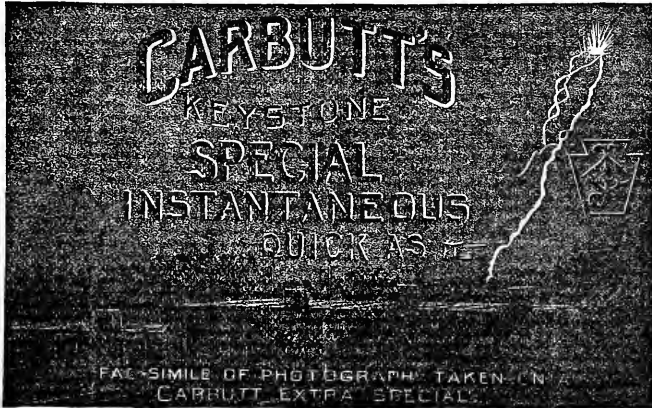

TRY THEM  
and you will continue to  
USE THEM.

Pronounced the "Ne Plus Ultra" of Dry Plates.

UNSOLICITED TESTIMONIALS.

MR. JOHN CARBUTT, Wayne Junction, Philadelphia.

WORCESTER, MASS., December 25, 1885.

DEAR SIR: I have been using some of your new plates, emulsion 1024, sensitometer 24. I think they are, without exception, the finest and best plates I ever used. They are not only very fine and delicate in their structure, but, when properly manipulated, result in a blooming negative, possessing all the desirable qualities that any artist could wish for. I could most appropriately christen them the "Ne Plus Ultra Dry Plate."

Yours truly, E. R. B. CLAFLIN.

MESSRS. HARRIS & KITTLE.

DETROIT, MICH., January 16, 1886.

GENTLEMEN: I am very much pleased with the Carbutt Plate; in fact, I call them the best plate *by far* that I tried so far. I find them especially useful for my theatrical subjects, as the quick emulsions are *absolutely instantaneous*.

Yours truly, A. B. TAYLOR.

*For Sale by all Dealers in Photo. Materials.*

JOHN CARBUTT, Keystone Dry Plate Works, Wayne Junction, Philada., Pa.

THE UNRIVALLED

# STEINHEIL LENSES.

In Six Different Series and Forty Numbers, for  
Every Description of Work.

These Lenses not only maintain their old-established reputation, but continue to lead in the field of progress.

Special attention is called to

**Series No. II.**, Patent Antiplanatic, the newest conception in lenses. For Instantaneous Portraits, Large Heads, Full Figure Groups, Architecture, and Landscape. A marvel of illumination, depth, and rapidity. No Photographer or Amateur should purchase a lens before testing a Steinheil, Series No. II.

**Series No. III.**, the famous Aplanatic tube, the illumination of which has been increased, and which is recommended for large Portraits, full-size Figures, Groups, Architecture, and Landscape.

**Series No. VI.**, Wide Angle Aplanat, which has no rival for copying Maps, Charts, Paintings and Engravings. It is the Photo-lithographer's favorite.

Send for Illustrated Catalogue and Price-List to your dealer or to

H. G. RAMSPERGER & CO., Sole Agents,  
180 Pearl Street, New York.

## BECK'S AUTOGRAPH RECTILINEAR LENSES.

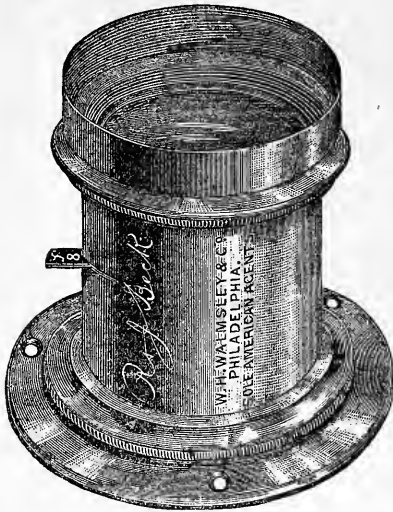

THESE extraordinary lenses attracted universal attention at the late Buffalo Convention; the specimens of work in Portraiture, Groups, Landscapes, Instantaneous Views, etc., executed by them being of unequalled excellence. A life-sized head, made with the 8 x 10 lens of 13 inches focus, was considered by the experts present, as being far ahead of any similar performance ever seen. A full description of these and our other specialties will be found in our full catalogue. *Mailed Free.*

### W. H. WALMSLEY & CO.,

Photographic Stockdealers.

1016 Chestnut St., Phila., Pa.

“THE MOUND CITY”

## Photographic Stock House



Offers the Most Complete line of

Photographic Apparatus, Chemicals,  
Picture Frames, Mountings, Mats,  
Albums, Etc., in the market,  
at bottom prices.

Professional and Amateur Outfits a Specialty.

AGENT FOR

KUHNS LIGHTNING DRY-PLATE INTENSIFIER,

AND

KUHNS SENSITIZED PAPER STRETCHER AND DRYER.

Address

**H. A. HYATT,**

8th & Locust Sts.,

ST. LOUIS, MO.

Send for Illustrated Catalogues of Photographic Goods and Picture Frames.



**H. P. ROBINSON,**

OF TUNBRIDGE WELLS, ENGLAND,

Contributes *ANOTHER PAPER* to the

# PHOTOGRAPHIC TIMES

FOR JULY.

There will also be interesting articles from

**VICTOR SCHUMANN**, of Leipsic,

AND

**CHARLES SCOLIK**, of Vienna.

THE POPULAR SERIES OF ARTICLES

ON

## TOURIST PHOTOGRAPHY

By **ANDREW PRINGLE**,

Commenced in June will be continued in the July Weeklies,  
besides articles from

**G. WATMOUGH WEBSTER, F.C.S.,**

**C. D. CHENEY, D.D.S.,**

**DR. GEO. L. SINCLAIR,**

**MR. ERNEST EDWARDS,**

and many others. All this will be given with the **Editorials, Society News, Letters to the Editors, Notes and Queries, and Commercial Intelligence.**

### A PARTIAL RECAPITULATION FOR JUNE.

TOURIST PHOTOGRAPHY (a Series).....	By ANDREW PRINGLE.
HALATION.....	By W. K. BURTON.
ORTHOCHROMATIC PHOTOGRAPHY.....	By E. BIERSTADT.
ON VIGNETTS AND VIGNETTING.....	By G. WATMOUGH WEBSTER, F.C.S.
SIMPLEX PICTURES.....	By C. D. CHENEY, D.D.S.
ART IN RELATION TO PHOTOGRAPHY.....	By W. C. WAY.
SYSTEMATIC EXPOSURE.....	By A. S. PLATTS.
A GOOD METHOD FOR DEVELOPING.....	By W. A. FOSTER.
PHOTO-MICROGRAPHY.....	By ROMYV HITCHCOCK, F.R.M.S.
THE REMOVAL OF SILVER STAINS FROM GELATINE NEGATIVES.....	By DANIEL ROBERTSON.
PHENER'S COLD EMULSION.....	.....
CONVENTION MATTERS.....	By D. R. CLARK.
THE CORRECT PLACE FOR A SHUTTER.....	By M. H. R.
PHOTOGRAPHY IN CHICAGO.....	.....
OUR EDITORIAL TABLE.....	.....
NOTES AND QUERIES.....	By the EDITORS.
GENERAL NOTES.....	.....

There may be some who are not fully aware of the growth of our journal, so to such and others an offer is made of a month's trial (four weeklies) for 30 cts.

**W. IRVING ADAMS, Agt. SCOVILL MFG. CO., Publishers.**

**SUBSCRIBE NOW AND SECURE THE BACK NOS. BEFORE THEY ARE ALL SOLD.**

## DEALERS' DIRECTORY.

*The following houses are to be recommended as the best for photographers in their localities.*

<p>S. T. BLESSING, New Orleans, La. And Galveston, Texas.</p>	<p>THE BEST BOOK IS</p>	<p>SMITH &amp; PATTISON, NEW LOCATION, 145 &amp; 147 Wabash Avenue, Chicago.</p>
<p>H. A. HYATT, Mound City Photo. Stock House, 8th and Locust Sts. St. Louis, Mo.</p>	<p>WILSON'S PHOTOGRAPHICS, \$4.00.</p>	<p>GAYTON A. DOUGLASS &amp; CO. 185 &amp; 187 Wabash Ave. CHICAGO.</p>
<p>SCOVILL MANF'G CO. 323 Broome St. New York.</p>	<p>D. TUCKER &amp; CO. Buffalo, N. Y.</p>	<p>ALLEN BROS. Detroit, Michigan.</p>
<p>C. H. CODMAN &amp; CO. Boston, Mass.</p>	<p>WILSON, HOOD &amp; CO. 825 Arch Street, Philadelphia, Pa.</p>	<p>B. FRENCH &amp; CO. Boston, Mass.</p>
<p>BUCHANAN, SMEDLEY &amp; BROMLEY, 25 N. Seventh St. Philadelphia.</p>	<p>A. B. PAINE &amp; CO. Fort Scott, Kansas.</p>	<p>MULLETT BROS. Kansas City, Mo.</p>
<p>OSCAR FOSS, San Francisco, Cal.</p>	<p>E. &amp; H. T. ANTHONY &amp; CO. 591 Broadway, New York.</p>	<p>SHEEN &amp; SIMPKINSON, Cincinnati, Ohio.</p>

# THE DUBOIS FILING CASES.

For Preserving Photographic Negatives, Prints, &c., Letters, Bills, and Miscellaneous Papers.

PATENTED SEPTEMBER 2, 1884.

**Economical! No Binding! Either a Temporary or a Permanent File.**

Made in  
five sizes and cabinet  
form.

**AGENTS WANTED.**

Write for Descriptive  
Circular.

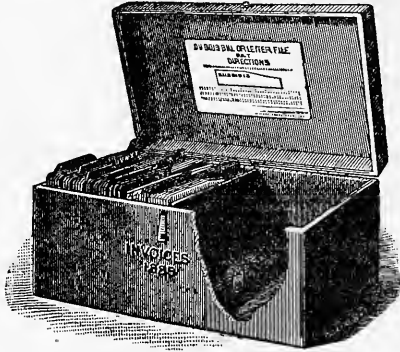

NEW YORK,  
April 27, 1886.  
Mr. FRANK G. DuBOIS,  
No. 512 W. 30th St., N.Y.  
DEAR SIR: Your File supplies a need that I have felt for some time past. It is the best thing of the kind that I have ever seen, and I shall be much pleased to recommend it to all my friends for preserving bills, notes, receipts, recipes, unmounted prints, photographs, and all kinds of miscellaneous papers to which easy reference may be wanted at any time. Respectfully,  
MISS SOPHIE L. MAURER.

Sent by Express, on receipt of \$3.00, or with lock and key, \$4.00.

PATENTEE AND SOLE MANUFACTURER,

FRANK G. DuBOIS, 512 W. 30th St., New York.

TO THE TRADE ONLY.

## HYPOSULPHITE OF SODA

FOR PHOTOGRAPHERS.

**CHAS. A. W. HERRMANN,**

16 Cedar St.

New York.

TO THE TRADE ONLY.

THE LARGEST PHOTO ENGRAVING ESTABLISHMENT IN THE WORLD

SIXTEEN YEARS PRACTICAL EXPERIENCE

**MOSS ENGRAVING CO.**

535 PEARL ST. COR. ELM. NEW YORK.

MOSS' NEW PROCESS Superior to Any Other Method.

ILLUSTRATIONS OF EVERY DESCRIPTION FOR BOOKS, MAGAZINES, NEWSPAPERS, CATALOGUES, CIRCULARS, &c. IN THE HIGHEST STYLE OF THE ART.

SEND GREEN STAMP FOR 24 PAGE CIRCULAR - SEND PHOTOGRAPH, DRAWING OR PRINT FOR ESTIMATE.

**C. H. CODMAN & CO.**

**Photographic Stockdealers**

Sole Agents for the NEW ORTHO-PANACTINIC LENS, Moor's Photographic Enamel, the Perfect Mounting Solution for mounting Photographs on the thinnest mount without wrinkling.

New England Agents for American Optical Co.'s Apparatus. The best in the world. Send for Price List.

34 Bromfield Street.

BOSTON, MASS.

# THE PHILADELPHIA PHOTOGRAPHER.

TWENTY-THIRD YEAR, 1886.

*Devoted to the Advancement of Photography and the Dissemination of Art Principles.*

SEMI-MONTHLY: issued the First and Third Saturday of each month.

\$5.00 a year, \$2.50 for six months, \$1.25 for three months—in advance. 30 cts. per copy.

## CONTENTS OF THE FIRST QUARTER.

**JANUARY 2.**—A Happy New Year. Dry Plates—Continued, by THOMAS PRAY, JR. Washing Dry Plates, by C. W. HUNT. Practical Points from the Studios. Bibliography. Good Things from Mosaics, 1886. An Amateur in Australia, by CHAS. D. IRWIN. The Humor of It. A Model Studio "Away Down in Maine," by W. C. TUTTLE. Translations from Unus. A Plea for Overtiming, by EUGENE ALBERT. Photographic Facts and Fancies. Society Gossip. The Open Corner. The Department of Art. Queries, Conundrums, and Conclusions. Our Picture. Correspondence. German Correspondence. The World's Photography Focussed. Studio Studies. Editor's Table.

EMBELLISHMENT.—"Child Portrait," by J. LANDY, Cincinnati, Ohio.

**JANUARY 16.**—A Word or Two for '86. On "Type" Pictures, by KARL KLAUSER. Development with Carbonate of Soda, by M. E. AUDRE. Practical Points from the Studios. Cheap Prices, by T. H. BLAIR. Pertaining to the P. A. of A. Photographic Facts and Fancies. To the Photographers of America. The Open Corner. Photography at the Louvre Gallery. Our Picture. Composition, by XANTHUS SMITH. Society Gossip. The Humor of It. Art and Photography, by G. H. CROUGHTON. A New Picture. Views from My Office Window. The Exhibition of the Photographic Society of Philadelphia. The World's Photography Focussed. Editor's Table.

EMBELLISHMENT.—"Mother Shipton," by FALK, N. Y.

**FEBRUARY 6.**—Enlarged Reproductions, by G. HANMER CROUGHTON. German Correspondence. The Photography of the Future. A Marvellous Accomplishment, by W. B. TYLER. Practical Points from the Studio. Use Good Cardboard Only. Photo. Electric Illustrated Newspapers. The Open Corner. "Words, Words, Words." Molteni's Enlarging and Projecting Lantern. Society Gossip. Exhibition of the Photographic Society of Philadelphia. Our Picture. Pertaining to the P. A. of A. The World's Photography Focussed. Editor's Table.

EMBELLISHMENT.—"Good Morning," by D. T. BURRELL, Brockton, Mass.

**FEBRUARY 20.**—Composition—Part II., by XANTHUS SMITH. Development in Two Solutions, by D. BACHRACH, JR. Photographically Illustrated Books. Where Art Begins, by HUME NISBIT. Correspondence. Queries, Conundrums, and Conclusions. The Humor of It. Views from my Office Window. Photo. Facts and Fancies. The Open Corner. Our Picture. Pertaining to the P. A. of A. Society Gossip. The World's Photography Focussed. Editor's Table.

EMBELLISHMENT.—A Study from Themasses, by H. L. ROBERTS, Philadelphia.

**MARCH 6.**—Recent Photographs of Stars, by PROF. C. PIAZZI SMYTH. The Department of Art. Cardboard Support for Emulsion Films. The Open Corner. Photography for the Newspapers, by STEPHEN H. HORGAN. Another Amateur's Experience in Toning, by P. H. MASON, M.D. Practical Points from the Studios. Our Picture. More "Words." Society Gossip. Pertaining to the P. A. of A. The Secret Order of Scientific Photographers. Photo. Facts and Fancies. Queries, Conundrums, and Conclusions. The World's Photography Focussed. The Improved American Permanent Bromide Paper for Positive Prints and Enlargements, by F. C. BEACH. Editor's Table.

EMBELLISHMENT.—"The South," by H. L. ROBERTS & Co., Philadelphia.

**MARCH 20.**—"Please Do Not Fold." The Open Corner. Words of Wisdom. Practical Points from the Studios. On Printing and Toning. M. Balagny's Flexible Gelatino-Bromide Plates. Light and Shade. The Humor of It. The Illumination of the Transparency in Enlarging, by CHAPMAN JONES. Prints with Gallate or Tannate of Iron. Queries, Conundrums, and Conclusions. Light and Shadow, by XANTHUS SMITH. Society Gossip. First Annual Exhibition of the Camera Club of Hartford. Pertaining to the P. A. of A. The Society of Amateur Photographers of New York. A Visit to the Eagle Dry Plate Company's Works. Our Picture. Correspondence. Obituary. The World's Photography Focussed. Editor's Table.

EMBELLISHMENT.—"The Toilers of the Sea," by H. S. WYER, Yonkers, N. Y. A splendid Marine Study, in green.

The above six numbers to one address for \$1.25, prepaid.

The Philadelphia Photographer and Weekly Photographic Times to one address, \$6.50.

The Philadelphia Photographer and Anthony's Bulletin to one address, \$7.00.

EDWARD L. WILSON, 853 Broadway, New York.

OFFICE OF

# G. CRAMER DRY PLATE WORKS,

Shenandoah and Buena Vista Sts., St. Louis.

---

The demand for the Cramer Plates having outgrown our capacity, we have been compelled to enlarge, and are now erecting large additions to our works which will more than double our present capacity.

Thanking the fraternity for their kind support, we ask their indulgence for a short time longer, and we hope soon to be able to supply our friends regularly and promptly.      Fraternally,



DRY-PLATE WORKS, ST. LOUIS, MO.

---

**THE**

## ST. LOUIS DRY PLATE COMPANY

Beg to announce that under their New Management they have recently made Important Improvements and Increased their Facilities, so that they are now making better and more uniform plates than heretofore.

---

ALL ORDERS WILL RECEIVE PROMPT ATTENTION.

---

## ST. LOUIS DRY PLATE CO.

No. 827 Chouteau Avenue,

ST. LOUIS, MO.



Number 278.

30 Cents.

THE  
 PHILADELPHIA  
**Photographer.**

AN ILLUSTRATED SEMI-MONTHLY JOURNAL,  
 DEVOTED TO PHOTOGRAPHY.

SUMMARY OF CONTENTS.

PAGE	PAGE
Figures in Landscape. By XANTHUS SMITH, 417	Convention Items, . . . . . 437
Report on the Progress of Photography in America. By ARTHUR H. ELLIOTT, P.H.D., F.C.S., . . . . . 420	The Humor of It, . . . . . 437
Report on the Progress of Photography in Great Britain. By J. TRAILL TAYLOR, 424	Improvements in Photographic Printing and Enlarging. By DAVID COOPER, . 438
A Tribute to Photography. By CHARLES T. STUART, . . . . . 426	A Simple Device for Accurately Timing an Exposure. By WINFIELD A. FRENCH, . 446
Pertaining to the P. A. of A., . . . . . 429	Our Picture, . . . . . 446
	Queries, Conundrums, and Conclusions, . . 446
	Editor's Table, . . . . . 448

OUR PICTURE.—“On the Pennyback.” From an original painting by XANTHUS SMITH, Philadelphia.  
 Mosstype by the Moss Engraving Co., New York.

EDWARD L. WILSON,  
 853 Broadway, New York.

SUBSCRIPTIONS RECEIVED BY ALL NEWS AND STOCKDEALERS

Five Dollars per Annum, in Advance.

## ADVERTISEMENTS.

ANTHONY & CO., E. & H. T. The New N. P. A.  
 Pensé Extra Brilliant Dresden Albumen Paper.  
 CARBUTT, J. Gelatine Dry Plates and Improved  
 Dry Plate Lantern.  
 CODMAN, C. H. & CO. Photo. Stockdealers.  
 COLLINS, SON & CO., A. M. Photograph  
 Cards.  
 COOPER, CHAS. & CO. Photo. Stockdealers.  
 CRAMER, G. Lightning Plates.  
 DOUGLASS, GAYTON A. & CO. Photo. Stock-  
 dealers.  
 EASTMAN DRY-PLATE AND FILM CO.  
 ENTREKIN, W. G. Patent Eureka Burnisher.  
 Duplex Rotary Burnisher. Duplicating Print-  
 Cutter.  
 FRENCH & CO., BENJ. Voigtlander & Son and  
 Darlot Lenses. The Wonderful Euryscope.  
 GENNERT, G. Eagle Dry Plates.  
 HERRMANN, CHAS. A. W. Hypo. Soda.

McINTOSH GALVANIC AND FARADIC BAT-  
 TERY CO.  
 MOSS ENGRAVING CO.  
 MURPHY, GEORGE. Photo. Stockdealer.  
 PASSAVANT'S DRY PLATES.  
 PHOTOGRAPHERS' ART VINE.  
 PHOTO-GRAVURE CO.  
 PHOTOGRAPHIC TIMES.  
 ROBERTS & FELLOWS. Photo. Stockdealers.  
 SCOVILL MANUFACTURING CO. New Dres-  
 den Albumen Three Crown Paper. Gihon's  
 Cut-Outs. Photo. Apparatus.  
 ST. LOUIS DRY PLATE COMPANY.  
 SWEET, WALLACH & CO. Photo. Supplies.  
 THE DU BOIS FILE.  
 WAYMOUTH'S VIGNETTE PAPER.  
 WILSON, G. W. & CO. Magic Lantern Slides.  
 WILSON'S PHOTOGRAPHICS.  
 WILSON'S PHOTOGRAPHIC PUBLICATIONS.

---

## ADVERTISING RATES.

THE PHILADELPHIA PHOTOGRAPHER is acknowledged to be the best advertising medium in the trade.

Its circulation is among the first class, at home and in nearly every foreign country.

Its rates, all advantages considered, are the most favorable, and it will bring you fine returns.

	One Issue.	Six Issues.	Twelve Issues.	Twenty-four Issues.
1 Page.....	\$20.00	\$110.00	\$200.00	\$350.00
1-2 " .....	12.00	66.00	120.00	200.00
1-4 " .....	7.00	38.50	70.00	120.00
1-8 " .....	4.00	22.00	40.00	70.00

Special contracts made with bona-fide dealers and manufacturers. Address

**EDWARD L. WILSON,**

853 BROADWAY, NEW YORK.

---

## NOTICE TO SUBSCRIBERS.

In remitting by mail, a post-office order, or draft, payable to the order of EDWARD L. WILSON, is preferable to bank-notes. Postage stamps of the denomination of two and five cents each will be taken. Clearly give your Post-Office, County, and State.

Foreign subscriptions must be accompanied by the postage in addition.

**FIRE!** Our books having been all destroyed by fire at and with our establishment, all who owe us will confer a great favor by remitting at once.

**CROSSCUP & WEST ENGRAVING CO.**

907 Filbert St., Philadelphia.

---

A. M. Collins, Son & Co.

*MANUFACTURE ALL KINDS OF*

**CARDS AND CARDBOARDS**

FOR

**P** PHOTOGRAPHERS **S**

AND

**MATS, MOUNTS, AND ENVELOPES**

FOR

**F E R R O T Y P E S .**

---

OFFICE AND WAREHOUSE,

**No. 527 ARCH STREET,**

**PHILADELPHIA.**

---

Price Lists may be had by intending purchasers on application to us, or to all Photographic Merchants, through whom your favors are respectfully solicited.

# ENTREKIN'S PATENT EUREKA BURNISHER.

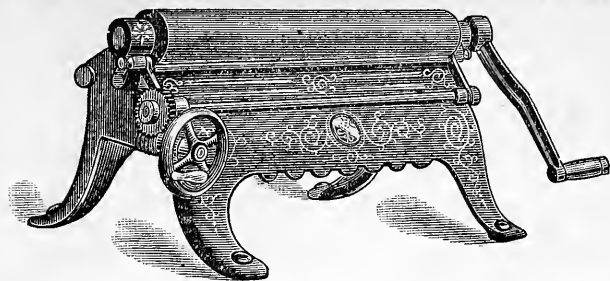

The above cut represents our 25 inch Eureka.

The unprecedented popularity of this Burnisher is wonderful. Over seventeen thousand (17,000) sold in less than five years. Agencies in London, Berlin, and Vienna, and sold by all stockdealers in the United States. The machines are built in first-class style, and warranted to do the work claimed.

Full directions accompany each machine.

## PRICES:

6 inch Roll, . . . . .	\$15 00	20 inch Roll, . . . . .	\$60 00
10 " " . . . . .	25 00	25 " " . . . . .	70 00
14 " " . . . . .	35 00		

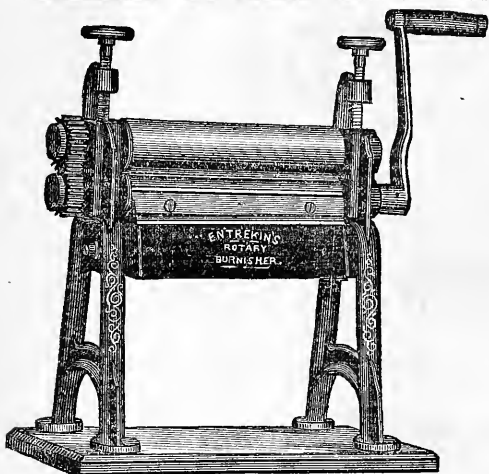

# ENTREKIN'S Duplex Rotary Burnisher.

PATENTED JUNE 1, 1875.

## PRICES:

10 inch, . . . . .	\$15 00
15 " . . . . .	25 00
20 " . . . . .	35 00
25 " . . . . .	45 00

# ENTREKIN'S DUPLICATING PRINT CUTTER.

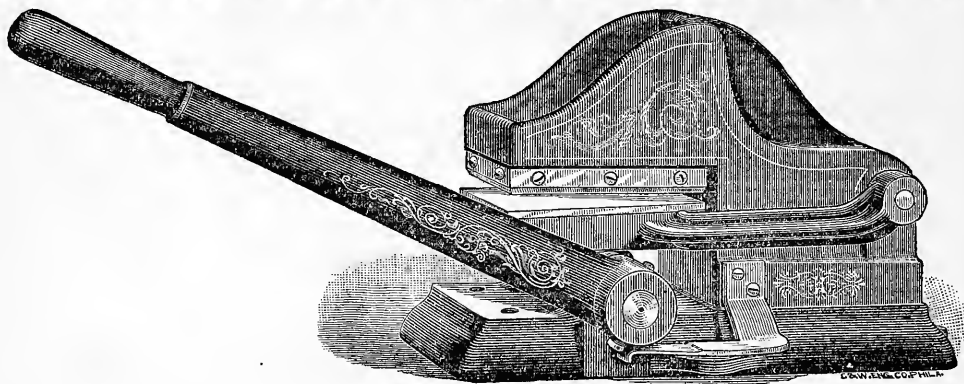

Cabinet and Stereo. Sizes, \$25.00

Small Panel Size, \$35.00.

Size 6½ x 8½, \$40.00.

MANUFACTURED AND FOR SALE BY

W. G. ENTREKIN, 4384 Main St., Manayunk, Phila., Pa.

# ENTREKIN'S

IMPROVED

## DUPLEX ROTARY BURNISHER.

PATENTED.

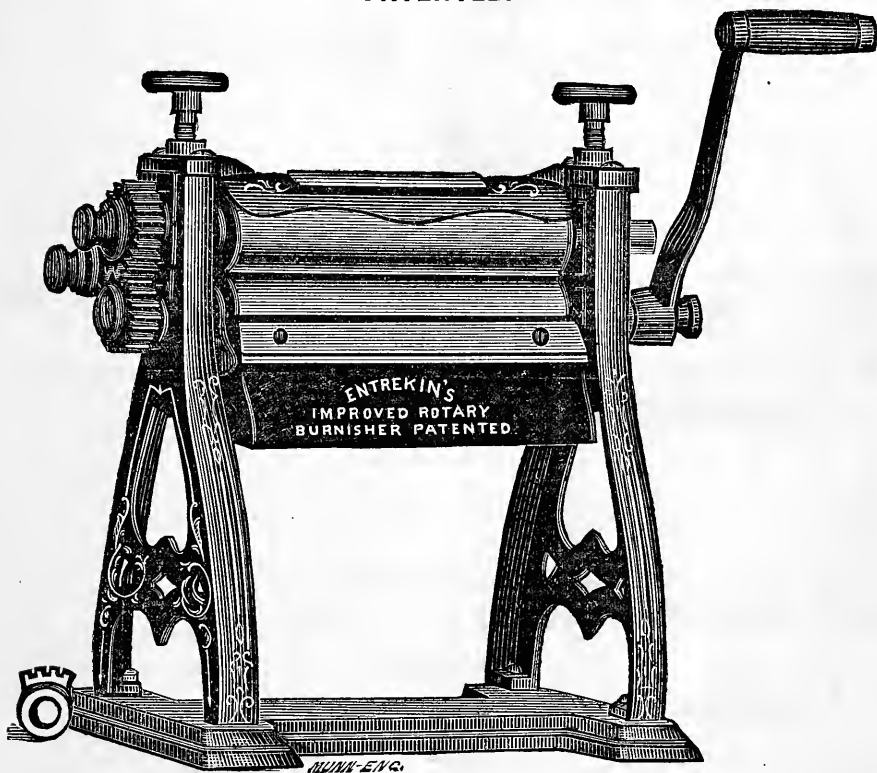

10 in., \$25.00. 15 in., \$35.00. 20 in., \$45.00. 25 in., \$60.00.

This Machine is an improvement on our old Duplex Rotary Burnisher, invented by us in 1874.

It is so constructed that by changing the Large Gear or Cog-wheel, from the stud to the end of the draw-file or upper roll, you reverse and change the speed of the lower or polishing roll, thus getting the same result as in the old Duplex Rotary; but to secure the best polishing surface, use the machine with the large cog-wheel on the Stud, by so doing you secure three times the polishing surface. All the machines will be sent out with gearing so arranged as to give this result. It is optional with the Photographer how he may use the machine. The Fire-Pan is so arranged that it is impossible for it to come in contact with the surface of the polished roll, and it can be turned away to cleanse the roll.

**EVERY MACHINE WARRANTED PERFECT.**

FOR SALE BY

**W. G. ENTREKIN, Inventor and Sole Manufacturer,**

4384 Main St., Manayunk, Philadelphia, Pa.

AND BY ALL PHOTOGRAPHIC STOCKDEALERS.

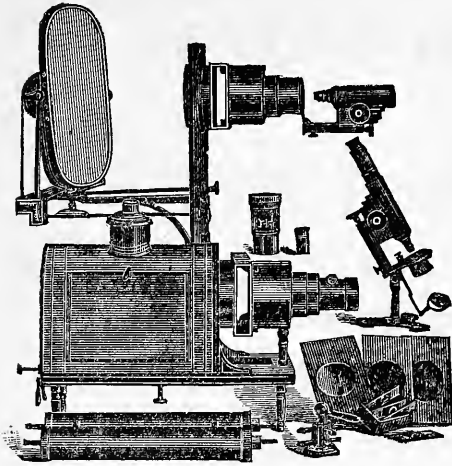

# OPTICAL AND ELECTRICAL INSTRUMENTS.

We desire to call the attention of  
TEACHERS, SCIENTISTS, LECTURERS, and  
those interested, to our

**Stereopticons, Microscopes, Dr. McIntosh's Solar Microscope and  
Stereopticon Combination Apparatus for  
the Oxy-hydrogen and Ether-oxygen Line Light, Photographic  
Transparencies, Microscopical Preparations, etc.**

Our Instruments and Apparatus are new in design and have many improvements  
that overcome difficulties heretofore considered unavoidable. We also manufacture

**Static Electric Machines, Batteries, Magnets, and a Full Line of  
Electrical Apparatus for Practical and Experimental  
Purposes.**



We received the highest  
award at the New Orleans  
World's Exposition, on  
both Optical and Elec-  
trical Apparatus, in com-  
petition with the best of  
home and foreign manu-  
facturers.



Illustrated Catalogue of Optical and Electrical Apparatus sent free on application  
by mentioning this journal.

**McIntosh Galvanic and Faradic Battery Co.**

Nos. 300 & 302 Dearborn Street,

CHICAGO, ILL., U. S. A.

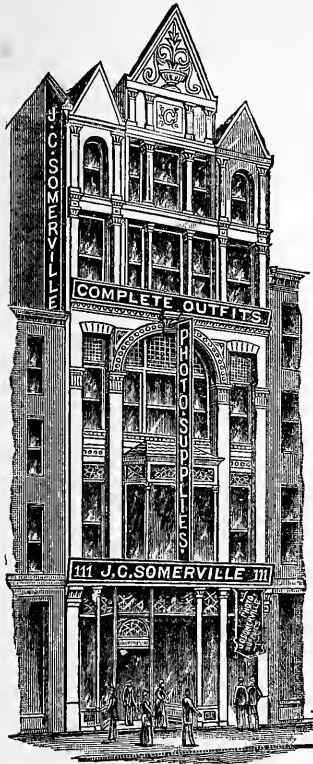

## NOTICE.

REMOVAL TO

111 North Broadway,  
ST. LOUIS.

---

PHOTO. SUPPLIES,  
COMPLETE STOCK.

---

NEW GOODS.            NEW STORE.  
IMPROVED FACILITIES.

Call and See Sample Room.

J. C. SOMERVILLE.

---

## OUR SPECIALTIES.

---

BROMIDE AMMONIUM, Chem. Pure.

BROMIDE POTASS., Chem. Pure.

NITRATE SILVER, Chem. Pure.

FOR DRY PLATES.

CROSS-SWORD DRESDEN ALBUMEN PAPER,

Single and Extra Brilliant. The Best in the Market.

ALSO A GENERAL LINE OF

PHOTOGRAPHIC CHEMICALS.

A circular, "How to Save Waste," sent on application.

CHAS. COOPER & CO.

194 Worth St., New York.

# BUY THE BEST!

No other will give you half so much satisfaction.

FOR DRY PLATES  
ANTHONY'S Patent Perfect PLATE HOLDERS  
ARE SUPERIOR TO ALL.

SEND FOR OUR CATALOGUE, AND GET THE BEST Of Everything.

DALLMEYER LENSES,  
SUCCESS CAMERAS,  
THE FAIRY CAMERAS,  
THE NOVEL CAMERAS,  
SCHMID'S DETECTIVE CAMERA

APPARATUS OF ALL KINDS.  
Chairs,  
Neg. Boxes,  
Camera Stands  
Printing Frames,  
Etc., Etc.

DALLMEYER

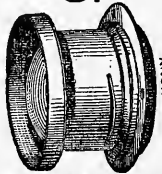

FOR WET

OR DRY

WIDE-ANGLE RECTILINEAR

E. A.

SINGLE COMBINATION, RAPID,  
WIDE ANGLE, PLATYSCOPE,  
PORTRAIT AND VIEW LENSES.

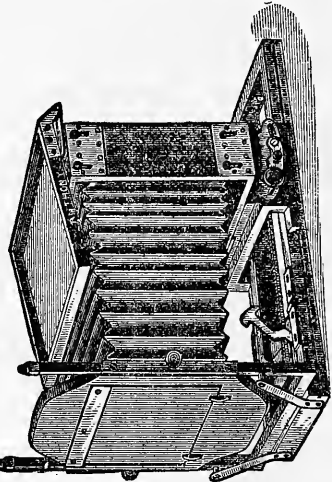

THE FAIRY CAMERA.

*The Lightest and Best for Out-door Work.*

FOR EITHER DRY OR WET PLATES  
NOTHING EQUALS

THE BENSTER PLATE HOLDER.

DALLMEYER

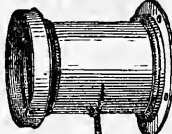

NOTHING

COMPARES

RAPID RECTILINEAR

O. I. C.

PORTRAIT, COPYING, CLIMAX  
PORTRAIT, GEM, AND  
COMPACT VIEW CAMERAS.

**E. & H. T. ANTHONY & CO., BROADWAY, NEW YORK.**

--591--



# WILSON'S PHOTOGRAPHIC PUBLICATIONS.

→\*A TREATISE ON EVERY BRANCH OF PHOTOGRAPHY.\*←

## THE PHILADELPHIA PHOTOGRAPHER

A Semi-monthly Magazine, illustrated by photographs of superior merit. \$5.00 a year; \$2.50 for six months.

Stands ahead of all its kindred. Twenty-one years of success is a sufficient guarantee of its value and use to the practical, working, growing photographer. Do not go without its valuable help. See Prospectus.

### WILSON'S LANTERN JOURNEYS.

By EDWARD L. WILSON. In Three Vols.  
Price, \$2.00 per vol.

For the lantern exhibitor. Gives incidents and facts in entertaining style of about 2000 places and things, including 200 of the Centennial Exhibition.

### WILSON'S PHOTOGRAPHICS

THE NEWEST AND MOST COMPLETE

PHOTOGRAPHIC LESSON-BOOK.

COVERS EVERY DEPARTMENT.

352 Pages. *Finely Illustrated.* Only \$4.00.

By EDWARD L. WILSON.

### THE FERROTYPYER'S GUIDE.

Price, 75 cents.

Cheap and complete. For the Ferrotyper, this is the only standard work. Seventh thousand.

### THE PROGRESS OF PHOTOGRAPHY

A NEW BOOK.

By Dr. H. VOGEL. Price, \$3.00.

A splendid work.

### STUDIES IN ARTISTIC PRINTING.

By C. W. HEARN. Price, \$3.50.

Embellished with six fine cabinet and promenade portrait studies.

### PICTORIAL EFFECT IN PHOTOGRAPHY.

By H. P. ROBINSON. For the Art Photographer. Cloth, \$1.50. Paper cover, \$1.00.

THE

### PHOTOGRAPHIC COLORISTS' GUIDE.

By JOHN L. GIBON. Cloth bound, \$1.50.

The newest and best work on painting photographs.

### PHOTOGRAPHIC MOSAICS, 1886.

Cloth bound, \$1.00; paper cover, 50 cents.  
Back volumess. same price.

Better than any of its predecessors.

COPIES MAILED POST-PAID ON RECEIPT OF PRICE.

## EDWARD L. WILSON,

Photo. Publisher.

853 Broadway, New York

# ONE MONTH MORE.

A



IG OFFER.

## \$8.00 WORTH OF BOOKS FOR \$4.00.

"How doth the little busy bee  
Improve each shining hour,  
And gather honey all the day,  
From every opening flower!"

When Isaac Watts wrote that immortal verse, which for generations has served to shame many a laggard into photography or some other honest effort for a living, he only used the bee as a figure to represent the amateur and adept photographer, and to "gather honey" meant to read carefully from the "opening flower," which is plain English for photographic books.

And now, as the season of sunshine approaches, is the proper time to follow the injunctions of the wide-awake and observant bard.

To enable the enterprising "busy" ones to do this, we have combined with the Scovill Manufacturing Co., to offer, for sixty days only, certain of our publications at one-half price, *i. e.*, four dollars will purchase eight dollars worth of books, postage paid to any American address. Dr. Vogel's *Progress of Photography*; Tissandier's *Hand-Book of Photography*; Robinson's *Pictorial Effect in Photography*; *Gihon's Guide*. A few words as to these.

Dr. Vogel's *Progress* is the best instructor on dry-plate manipulation there is; no library is complete without it. It treats of all classes of work, including the æsthetic department and finishing and printing the negative. It is profusely illustrated; handsomely printed; bound in cloth-gilt, and is exhaustive on the subjects of light, chemistry, optics, apparatus, processes, technique, and amateur photography. It is published at \$3.00.

Mr. H. P. Robinson's *Pictorial Effect in Photography* teaches wrinkles and dodges that you would never dream of in your photography. It is as full of bright, brilliant ideas—told so pleasantly—as a film is of molecules. It is the best art authority you can study. It is amply illustrated, is bound in paper (cloth 50 cents extra), and is published at \$1.00.

*Gihon's Guide*, though called the *Colorist's Guide*, is by no means confined to instruction in coloring. Its chapters on linear perspective should be memorized by every one who can focus. Every page instructs. It is bound in cloth, finely illustrated, and published at \$1.50.

Tissandier's *History and Hand-Book of Photography*, is one of the most attractive

books on photography that has ever appeared in any country.

Part first gives a history of photography, from the discovery of the camera obscura by the Italian philosopher, Porta, including all the interesting details of Daguerre's and Niepce's experiments, their partnership, the death of the latter, the final perfection and publication to the world of the daguerrotype process, the discovery of photography on paper by Talbot, and down to the taking of negatives.

Part second treats of the operations and processes of photography, describing and illustrating the studio and apparatus, the manipulations of the negative process; all the operations of the printing department; theory and practice, including the modifications required by various kinds of photography, such as landscapes, portraits, skies, and instantaneous photography, retouching, enlargements, dry processes, etc.

Part third enumerates the applications of photography, such as heliography, the Woodbury process, photo-sculpture, photographic enamels, photomicrography, microscopic dispatches during the siege of Paris, astronomical photography, photographic registering instruments, the stereoscope, photography and art, and the future of photography.

The appendix describes panoramic photography, the heliotype process, the phototint process, the most approved formulæ of the wet collodion process, a simple method of repairing dry plates, and English weights and measures.

The book is beautifully illustrated throughout with fifteen full-page engravings and sixty wood-cuts. It comprises three hundred and twenty-six pages, and is printed on heavy tinted paper. It is bound in cloth, and published at \$2.50.

These four books, whose aggregate publication price is \$8.00, we offer for \$4.00 until our joint stock is exhausted. Any two of them to one address, one-third discount from publication price. No discount on a single publication.

The "busy bee" must fly quickly if he would "improve each shining hour. Every book is guaranteed, fresh, clean, and new and from our best stock.

Societies and others forming libraries will do well to secure sets before they are all gone, for after all, the stock of sheets in the bindery is limited.

**EDWARD L. WILSON, 853 Broadway (Domestic Building), New York.**

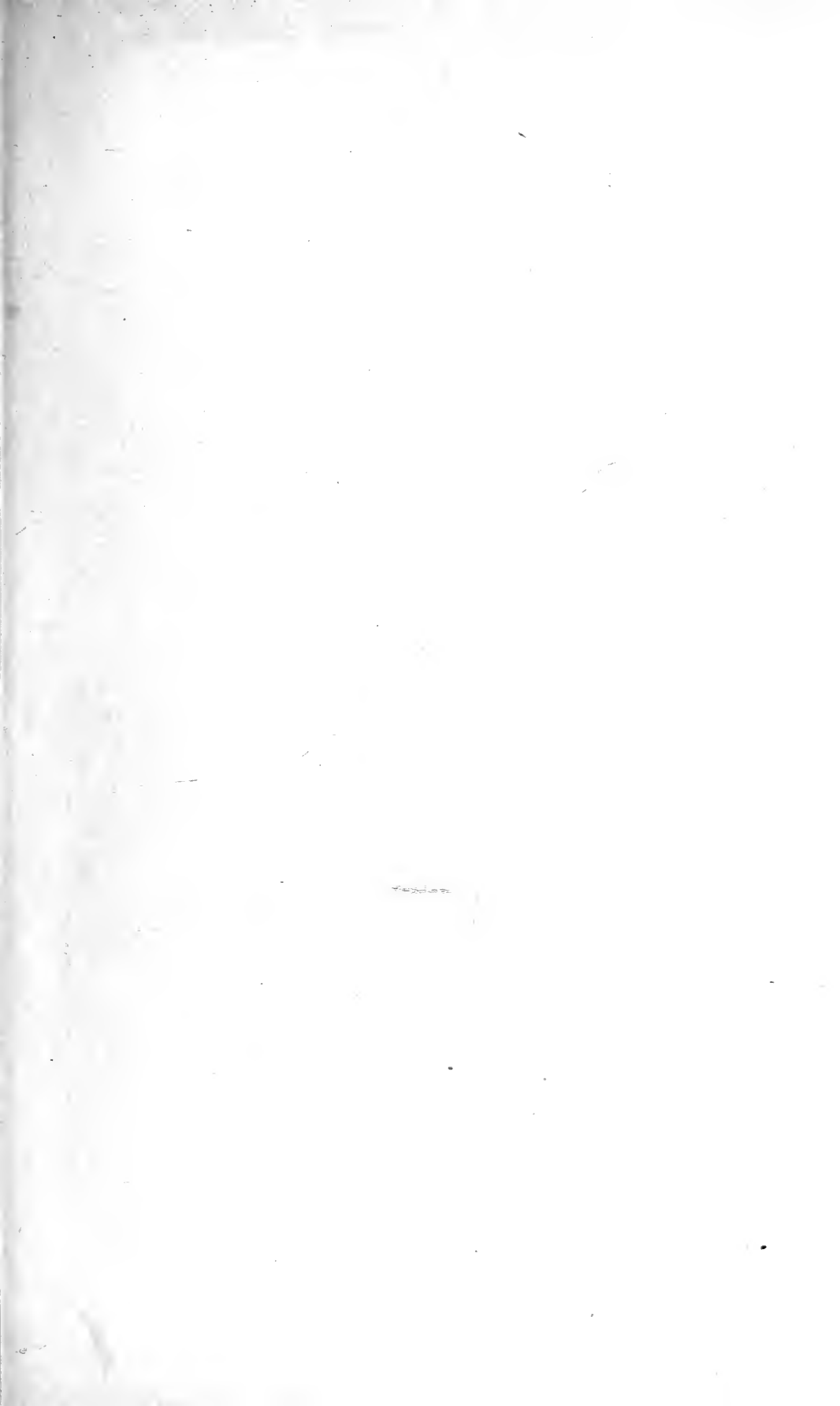



ON THE PENNYPACK.

From an Oil Drawing in black and white, by Xanthus Smith, Philadelphia, Pa.

THE  
**Philadelphia Photographer.**

EDITED BY EDWARD L. WILSON.

Vol. XXIII.

JULY 17, 1886.

No. 278.

**FIGURES IN LANDSCAPES.**

BY XANTHUS SMITH.

THERE is nothing which adds so much to the completeness of rural landscape scenes, as figures or cattle. By making points of interest they break up the monotony of foregrounds. If judiciously placed they give fulness and completeness to the composition, and as points of light and dark they are of great importance often in giving the proper value to the tones throughout the rest of the picture.

It is only of late years that artists even are growing to appreciate fully, in this country, the beauty of picturesque figures in many subjects. Partly from the character of our grand wild scenery which has formed the field of study for our landscape painters, and does not require the addition of human life, being, indeed, often better without it, and partly from a want of training of landscape painters in the figure branch of the art, those interesting rural home bits which are so much enhanced by suitable figures and domestic animals, have been to a great extent neglected, and I think with loss to the art of the country, because works of this class, while they illustrate so much that is interesting and dear to us, and full of poetic sentiment of home, are capable of showing the highest degree of talent and skill in all the best art qualities. As fully typical of this kind of art, the works of Birket Foster stand preëmi-

nent. His quaint and graceful trees are full of character, sometimes grouping over picturesque cottages, sometimes lining and casting their shadows across rural lanes, and often enclosing pools where tired horses from the plough are led to water, or where resting cattle stand. Or again, he spreads their outstretched limbs over stiles where gather groups of healthy country children, or maidens, gleaners, or bearers of milk and eggs to the market, and hedges bordering ripe and waving fields of grain, with men and women busy with sickle garnering their golden harvest. How full of that good, sunny, happy, honest kind of art which should be nearest to the heart of all lovers of true nature are these inimitable works of Foster's, and how infinitely more wholesome would be this kind of eminently English art, or a large proportion of it, than so much that we get from Paris, either by French artists or our own indefatigable students who must needs study there. Think of their cold, harsh, green, and slaty, smeary daubs of landscapes, with sickly leathery skinned peasants, clad in blue and black and ash-colored garments. What is there of the sunny and cheerful phase which constitutes rural country life in the works of Millet, now so much extolled? Think of the dirty, sombre monotones of his landscapes, and the awkward, heavy, impasted look of his sickly drudges of figures. No brilliant glowing effects of sunlight, such as charm us in nature and

give the artist such chances for picturesqueness and relief. No tender flow of healthful flesh and blood; no garments of bright and tasteful hue. What a pity that the

if they may. Let them search for a certain grace and harmony of design even in picturesqueness, and those agreeable contrasts which give life to a work and make it



busy pens of ignorant or thoughtless critics should make such art fashionable and set so many following in its track. Let the workers with the camera steer clear of it

stand out upon its own merits from the mass of mediocre.

Much more is attainable in landscape photography in the way of small rural

scenes than in grand extended landscape. And one reason, in addition to such bits that compose well being infinitely more numerous than scenes more extended, is that the principal objects are all near, and consequently admit of the finished rendering of those exquisite details which constitute one of the principal beauties of photographs. But such rural bits are almost invariably greatly enhanced in their interest and beauty by suitable groups of figures. And here exists one of the greatest difficulties that the earnest worker after agreeable pictures, got with the camera, has to contend with, for while, as I say, there is nothing which so enhances the completeness of such pictures, there is, on the other hand, nothing which so completely mars, I may even say destroys a picture as figures which are ill adapted to it, or badly placed, or unsuitably clad, or awkwardly posed. Even the getting them of a proper size in a photograph is a very difficult matter always. If retired to such distance that they become buried in insignificance, of course they are useless, and the nearer we approach them, not only from their increased size, but from the inevitable distortion caused by the lens, the greater become our difficulties.

When groups of figures attain so much importance as to balance equally the attention with the landscape, the effect is not apt to be good, one or the other must be subordinated, and in the character of work of which I am now writing, the figure groups, while they play an important part in the picture, should at the same time be entirely subordinate to their surroundings. It is a difficult matter to manage a single figure, especially a man; standing he is like a post, and sitting he is an unpleasant conglomeration of angles. The drapery in the skirts of women and girls, and their more varied hues of attire, are a great assistance. Two figures are better than one, and three still better. Occasionally a group of a half a dozen will come in, but rarely. The more you have the greater become your difficulties in posing them. A grown, or nearly grown person and one or two children make a picturesque combination, and they should be clad in such garments that those on the upper portion of the figure be in light and

the lower in dark mass, or *vice versa*. This will enable the getting of the light portion of the figure relieved from a dark shadow back of it, or the dark from a light backing, which adds greatly to the relief and picturesqueness. A person clad in gray, or black, or white from head to foot is absolutely useless to introduce into a picture, for in coming against a varied background one half or the other is sure to be absorbed in its backing, and you have only half of your figure, or if in entire relief against an opposite ground, from head to foot, you have a cut-out patch which is dry and hard.

A very difficult matter is the posing. Even with figures in repose there should be a certain kind of action, I mean a reversing of the direction of the upper and lower portions, and of the limbs. This may be carried to a much greater extent in figures in landscapes without an appearance of affectation than it can in figure subjects.

Instead, now, of being confined to figures in attitudes of repose, as we were heretofore, resting by the wayside, fishing, or standing conversing, for instance, we are enabled by the introduction of the highly sensitive plates and rapid drop-shutters, to secure groups in action, which will often be a particular advantage, for one great objection to purposely posed figures is their look of self-consciousness and consequent constraint. It is so difficult to get their attention off of the camera and upon what they should be doing; at best they are only too apt to have a conventional and purposely posed look. But those fortunate individuals who have the time to be about, and the means to shoot away at every chance they may see which looks at all favorable to a good result, stand a fair chance of getting many a happy combination of figure and landscape.

There are two modes which may be practised in endeavoring to get good figure groups in photographic landscape subjects. The one being to doctor them in from separate negatives, which must always be a lame way, and the other to provide yourself with suitable people and pose them in the scene. Suppose, for instance, a few amateur friends are going for a day's outing with their cameras in some region which

abounds in picturesque subjects; let them make it worth their while at the outset to have, if possible, a good sized chunk of a boy and a horse or two, one light and the other dark, with work harness on, and a half-grown girl or two. Or if their course should be along a large stream where boats may go, hire one or two of the oldest and most picturesque boats to be had, and if you cannot secure suitable persons to go in them let some of your own party get themselves up in as picturesque a way as they can, and do duty as posers for the rest. And if their genteel appearance should betray them through their garb, there will be this compensating circumstance, that they will place themselves much more understandingly and suitably than nine out of ten of the people who would be encountered in the neighborhood. I know from personal experience the difficulties of inducing the people whom one generally meets with, to stop what they are about, and become interested in what we wish them to do. One always has the feeling that if they ask anyone suitable who may be at hand, that they will be entailing a great deal of trouble on themselves in making what they want understood, and after all, probably, the loss of the plate will be the result. But we must, whenever there seems to be the least possible hope of success, make the effort.

A universal effort on the part of amateurs in the direction of securing good figure groups in their subjects, would not only be certain to result in a great advance in the art, but would gradually bring about a change in the inhabitants of rural districts, so that in times to come the more fortunate followers of our pursuit would be met half way by those whom they encountered in the fields. It would then be here more as it is in many parts of Europe. An artist would not be looked at with a suspicion that he is a lunatic escaped from an asylum, when seen with sketching apparatus and camera endeavoring to secure a beautiful landscape scene or picturesque figure group.

THE remainder of the proceedings of the St. Louis Convention will appear in our next issue.

## REPORT ON THE PROGRESS OF PHOTOGRAPHY IN AMERICA.\*

BY ARTHUR H. ELLIOTT, PH.D., F.C.S.

SINCE our last meeting in the City of Buffalo, in July last, the development of the photographic art in America has showed steady and healthful progress. While no remarkable discoveries have startled us, there has been a steady improvement in the art, and considerable activity in the line of inventions that help to further its onward march. Looking over the records of the past twelve months, we note eight improvements in cameras, the same number in shutters or exposers; three camera stands and attachments, two printing frames, two plate holders, three washing apparatus, one chair, two boxes for shipping dry plates, one revolving background and foreground, one burnisher, one sensitive bromide paper, one case for sensitive paper, one roller for the same, one focussing attachment to camera, one photographic printing apparatus, one stamp-photo process, and two photo-mechanical processes for printing.

It is not necessary to go into details with a description of all these improvements, but the more important of them deserve a passing notice.

In the matter of cameras, we have the method of Flammang for making the folding bed rigid by means of sliding plate and small bolts working in the side pieces of the bed, which appears to be simple and effective.

A camera to facilitate the production of double negatives, giving the sitter and background by separate exposures, invented by W. W. Grant, appears an ingenious apparatus to produce artistic combinations in portraits.

The Ripley camera is an invention by which one camera can be applied to both very long and very short focus work at will. It is practically an extension-bed camera with a detachable after-section.

Another long-bellows camera is that lately devised by E. B. Barker, of New

\* Read at the St. Louis Convention of the Photographers' Association of America, June, 1886.



York. This camera has a separate extension bed, and is very compact when closed, at the same time giving a long extension of bellows.

Mr. G. B. Brainard's camera is a modification of the well-known detective camera, originally invented and patented by Schmid, and consists of a number of devices to assist in focussing and exposing the plates, together with facilities for changing plates and concealing the operating parts of the whole apparatus.

W. H. Lewis and E. B. Barker have made several neat and ingenious improvements in camera fittings. One of these is a detachable extension bed, which allows the base of the well-known copying camera to be folded into a small space. This is accomplished by means of tongue and groove joints, together with the well-known clamp hooks. Another improvement is the use of a pressure-cam attachment for securing the sliding back of the camera on the bed, instead of the usual screw arrangements. This latter device is simple, quick, and very effective. The third, and perhaps the most ingenious, improvement made by these gentlemen, is their method of fastening the camera to the tripod or stand without the usual screw. This latter device consists in having a keyhole slot in the camera bed, which locks over a small bolt on the tripod or stand, which latter bolt, by a short cam movement, firmly secures the camera in place. By this invention the annoyance of losing the tripod screw is entirely overcome, as none of the parts of this new attachment are loose.

W. H. Lewis has also invented an improved swing back to the camera, which is simple, and answers its purpose quite well.

Another improvement in the cameras is the satchel detective camera, invented by Mr. Richard A. Anthony, of New York. The chief use of this class of instruments is for taking pictures without making any special demonstration and without previously focusing upon the object to be caught. This new device of which we speak, carries out these ideas very perfectly. In outward appearance, and to the ordinary observer, the camera looks exactly like an alligator hand-satchel that is carried by a shoulder-strap at

the side of the pedestrian. This form of the detective camera allows the operator to carry with him twelve plates in the interior of the apparatus, and so carefully packed away that no light can strike them. It is also furnished with an ingenious attachment by which the speed of the shutter can be regulated to suit the speed of objects moving with greater or less velocity; while by simply releasing a catch, time exposures can be made at the will of the operator.

Numerous efforts have from time to time been made to place a number of dry plates in a camera and expose them in sequence without opening the camera. A recent improvement in this class of instruments comes from Mr. Nash, of Harrisburg, Pennsylvania. His invention consists in arranging the plates upon a kind of band with plate holders attached to it, somewhat upon the style of the boxes used for viewing a large number of stereoscopic pictures. In this way his camera serves also as a changing box; while by means of screens parts of a plate can be covered, and from two to four pictures can be taken on one plate at will. The camera ready for operation contains one dozen plates, the ground glass, the device for taking parts of plates, a time and instantaneous shutter, and all arranged to operate from the outside without opening the box.

In the matter of improvements in shutters, it is almost impossible to give an idea of the many devices that have been brought out for exposing the sensitive plate. All are modifications of the well-known sliding plates either working horizontally or vertically, or else they are rapidly moving disks passing one another. Quite a variety of positions relative to the lens have been assigned to shutters—some work behind the lens, some in front; while others take the same position as a diaphragm. One or two of these shutters are worth noting. That of S. S. Benster is very ingenious, and consists of a number of overlapping thin disks of metal that rapidly open and close from the center, upon the principle of the iris of the human eye. It is under perfect control, either a small or large opening being obtainable at the will of the operator, as well as time exposures. The shutter of W. C.

Hadden is also a light, ingenious, and thoroughly convenient device. It is practically two disks, swinging pendulum-like, that rapidly pass one another, and are controlled by a spring which can be set to various speeds. A simple mechanism allows of the shutter being used for time exposures.

The camera stands have been improved in the direction of lightness and portability for landscape photography. The printing frames have been made lighter, and with more secure fastenings to prevent opening when moving them during the printing operations.

Improvements in the boxes for shipping dry plates have had for their object the prevention of contact between the sensitive surface and the paper packing. Although much trouble was experienced in the damage of plates from the action of the packing paper, we have not heard much about it lately, probably owing to the more careful selection of the paper used for separators in the packing boxes.

The invention of the double-coated negative paper, by Mr. T. C. Roche, appears to be an extremely important advance. This paper having the emulsion on both sides, entirely does away with the oiling of the paper negative as usually practised. We understand that the machinery for making this material is now being constructed. It will be very interesting to watch the progress of this unique invention.

A marked advance has been made during the past year in the production of gelatino-bromide paper for printing. It had been known for some years that such paper could be prepared upon a large scale. It was patented by T. C. Roche and used quite extensively, especially in illustrating photographic journals, both here and in Europe, and also for many book illustrations. But it never became very popular until the Eastman Company took up its preparation and used American machinery to coat the paper with emulsion. Since they have undertaken the manufacture of gelatino-bromide paper for positives, its use has extended, and many beautiful results are now attainable by means of it.

During the past year renewed efforts have been made for the preparation of ferrotype

dry plates, and with some success. The specimens of work done with these plates which we have seen were very good.

An ingenious and novel invention in the way of developing trays comes from Mr. Atkinson. The idea of the device is to use the plate to be developed as the bottom of the tray, the sides being formed of two frames that are clamped together with the glass between, and rubber strips to make a tight joint. The advantage claimed for this tray is that the negative can readily be viewed by transmitted light, and as a reservoir serves to hold the developer in one end when the tray is held vertical, there is much less staining of the hands than by the old method. It can also be used for developing paper negatives, in which case a plain glass plate forms the bottom of the tray, which, together with the paper, is clamped between the sides. In this manner the curling of the paper negatives is prevented.

An ingenious device to get rid of the ground glass and focussing cloth consists in having a small sight hole in the front of the camera alongside of the lens, the image being seen on an opaque white surface placed where the ground glass is usually situated.

The stamp-photo invention appears to be very popular in many sections of the country, being much used in connection with advertising.

In the direction of photo-mechanical printing, we have two ingenious processes for printing from relief plates made indirectly from gelatine surfaces sensitized with bichromate of potash. One of these, by Mr. Sherman, of Milwaukee, consists in the production of a stipple effect by spraying upon paper, or other suitable material, a mixture of a pigment and gelatine sensitized with bichromate of potassium; then exposing under a negative and afterward washing away the unexposed and soluble parts. This leaves a picture consisting of a number of dots, more or less thick according to the amount of light that has reached them, and the prints from the surface are said to have the appearance of mezzotint engravings.

The other photo-mechanical process that we have noted is called the Moss-type, and is the invention of Mr. Moss, of the Moss Engraving Company, of New York. We

do not know how the surface is produced, but it appears to consist of a number of cross lines that are more or less in relief according to the lights and shadows of the picture. The pictures produced by this method are very good indeed. Wash drawings, stump work in crayon, fine line work, are all very accurately reproduced.

Photo-mechanical printing is coming more and more into use for book illustrations. Our large magazines are using it extensively, and great improvements are being made in the older methods of procedure.

In photographic literature (which should be supported by every intelligent photographer) there has been one new candidate for favor, and a steady improvement in the older journals. *The Photographic Beacon* started since our last meeting, and is a most serviceable addition to photographic literature. *The American Journal of Photography*, hitherto partly a trade circular, has now joined the ranks of legitimate journalism.

Among photographic societies, we note the consolidation of the Chicago societies with decidedly beneficial results, the proceedings of the new society being of a progressive nature. Several photographic society exhibitions have taken place during the past year, and great interest has been taken in them by the general public, which certainly tends to a better appreciation of the art by the people at large.

In purely scientific photography, America is beginning to follow the lines already laid out by German investigators. The late Dr. Henry Draper, a distinguished son of a famous father, was well known as an earnest investigator in spectrum analysis, for which purpose he called to his aid the art of photography. At his death it became a problem among scientific men as to who should carry on his extremely delicate and exhaustive researches, and his widow finally decided to supply a fund to continue his work as a memorial to her distinguished husband. It was ultimately arranged that this fund should be placed at the disposal of Prof. E. C. Pickering, of Harvard Observatory, under whose auspices the work is now being carried on. Prof. Pickering is well known as an earnest worker in photographic

research applied to astronomy, and this memorial fund could not have been placed in better hands.

Another line of scientific photography is also being carried out under the auspices of the University of Pennsylvania—that is, those wonderful experiments in instantaneous photography, by Mr. Muybridge, for determining the character of the movements of men and animals. Perhaps the most curious result of this work is the discovery that in flying, a bird not only moves its wings up and down, but each feather appears to move on its axis, being vertical in the upward movement and horizontal when passing downward.

But experimental photography never attained more beautiful results than in the researches upon orthochromatic plates; and the United States can claim to-day one of the most successful workers in this line of investigation—we mean Mr. Fred. E. Ives, of Philadelphia. As is well known, silver bromide is insensitive to green, yellow, and red; but by treatment with certain dyes and other organic compounds, it becomes sensitive to these colors. Mr. Ives was the first to publish a process by which all colors could be photographed correctly, and used for the purpose collodio-bromide emulsion plates treated with chlorophyl, the green coloring matter of plants. The plates were exposed through a yellow screen to moderate the action of the blue rays. Lately Mr. Ives uses eosine in addition to chlorophyl in his process, and obtains better results. The pictures obtained by this method of procedure are remarkably beautiful, being rich in fine gradations of light and shade.

This rapid review of one year's work in photography does meagre justice to the subject; but it will serve to remind you of one thing, and that is, America is well abreast of other nations in her achievements in photography. Of the artistic side of the subject we need say nothing; the exhibition of pictures by this Association speaks more eloquently for the artists of our country than any words of ours. Every one must admit that photographic art work is making most rapid strides to higher levels, and this is most probably due to the perfection and great uniformity of modern dry plates, and

the skill of those who use them. It is not now haphazard work to make dry plates, but a matter of certainty with our best manufacturers, and the accuracy with which their work is done is truly wonderful.

One thing remains to complete this report, and that is to recall those who have left us during the last year and are now in the silence of the grave.

Since we last met, death has also been busy in our ranks, and it will be well to recall the names of some of the more prominent figures that have yielded to his sharp scythe.

August Semmendinger, the well-known camera manufacturer, died at Fort Lee, N. J., on August 6, 1885, at the age of 65. He was a native of Wurtemberg, Germany, and always an active man, whether in business or social life. He was the inventor of a number of improvements in the camera, for which he held patents. Mr. Semmendinger's sons still carry on the business founded by their father.

Douglas Hovey, the President of the American Albumen Paper Company, died February 8, 1886, at the age of 58. He was about twenty years in the business of manufacturing albumen paper, and passed away after a sickness extending over seven or eight years. He has left a name that is always mentioned with respect by those who had business dealings with him.

John A. Scholten, the well-known St. Louis photographer, died on March 7, 1886, from an acute attack of pneumonia, at the age of 57. Mr. Scholten was a native of Prussia, where he lived until he was about 14 years old, when he came to this country with his parents. In 1857 he took up photography as a profession and followed it to the day of his death, honored by all who knew him, and with a fame that extended to the photographic circles of Europe. His loss was keenly felt by his immediate associates, and cast a gloom over the photographic fraternity of the United States. He was one of those men that help photography for its own sake, and was very active in promoting the progress of the art.

Joseph W. Bates, late President of the Photographic Society of Philadelphia, died a few weeks ago. He was a member of the Philadelphia Society for twenty-three years,

and for seven years its honored President. All who knew him testify to his genial character, his energetic work, and sincere love of the photographic art.

Dr. John C. Draper, the son of the illustrious John W. Draper, well known to early photographers in America, died December 20, 1885, from pneumonia, at the age of 51. He inherited much of his father's love for photography, and was deeply interested in the application of photography to microscopical investigations.

Dr. John F. Weightman, of the well-known firm of Powers & Weightman, the large chemical manufacturers of Philadelphia, died on May 6, 1886. His name was well known to all who use fine chemicals in the United States.

These were our fellow-laborers in life's journey; these have added their quota to the advantages we enjoy in the art we love so well; and, while we remember with sorrow that they are no longer with us, let our lives be as useful as theirs, that they who come after us may honor our memories.

---

## REPORT ON THE PROGRESS OF PHOTOGRAPHY IN GREAT BRITAIN.

BY J. TRAILL TAYLOR.

WERE a period of five years, instead of one year, to intervene between the presentation of reports of progress in photography, then would a more definite advance be recorded, for photography improves by steps that are slow and perceptible in only a limited degree.

A noteworthy feature in British societies and photographic circles is the prominent part played by the optical or magic lantern. There are few photographers now who do not possess a lantern by which to project their pictures in the interest of themselves and friends. This has led to a high degree of refinement being imparted into the production of transparencies, each member of which aims at a high standard. The frequent lantern exhibitions at the London clubs and societies, at which from one to three hundred slides are often projected in succession on the screen, serve as a photographic exhibition, and by enabling each exhibitor to compare his own

---

\* Read at the St. Louis Convention of the Photographers' Association of America, June, 1886.

work with that of others, act as an incentive for each to eliminate the faults or errors of his own slides and aim at rivaling his fellows by producing a higher degree of perfection on the next occasion. The influence of this has been greatly ramified and extended. The lantern itself has been improved in regard to increased efficiency in its illumination and optical construction. I have seen, only a few days ago, what at present seems to me to be a lamp destined yet to be widely known. It is an electric incandescent burner, operated by a primary battery, possessing great powers of endurance and occupying little bulk, being a little larger in this respect than the well-known volume, the U. S. Dispensatory. The light was most brilliant and steady. The battery differs from any of those now in use, and from the fact that the whole apparatus is being got up by Mr. J. W. Swan, at once an eminent electrician, chemist, and photographer, no doubt need be entertained as to its practicability. Its commercial introduction will bring about the golden age of lantern projection, especially on the domestic scale.

The perfecting of the lantern is also causing a small revolution in tourist methods of photography, for with bromized paper for subsequent development, the temptation arises for taking negatives on quarter plates, or at most 4 x 5 plates, from which, in any darkened room, prints from whole plates upwards are produced by a very brief exposure, and which rival the finest engraving in tone and general effect. I have seen many of these produced, and am convinced that an important future in this direction is before us. But for this purpose an electric lamp is not necessary, for an oil lamp with circular wick will answer equally well by extending the time of exposure. Another outcome of this lantern mania is the improvement of lantern lenses, especially the object glasses. These are now being constructed of short focus with an aperture of two inches, the connection being so perfect as to define the margin of a picture as sharply as the centre without any stop or diaphragm.

The public taste is being educated here to appreciate the rich engraving-like black tones of developed bromized paper tints obtained by ferrous oxalate development and without gold toning. The more general introduction of this system of printing will prove a boon to photographers in the reduction of the time and cost involved in producing such prints.

Photography has achieved a triumph in the world of microscopy within the past four weeks. It had always been contended by skilful micro-

scopists that by no process of photography whatever could a very minute object be enlarged so as to rival its appearance in a first-class microscope by a competent observer. But at the last meeting of the Royal Microscopic Society, when one object, the foot of that minute entity, the parasite of the common bee, was thrown upon a screen from the lantern slides of three and a quarter inches, the most conservative members of that scientific body, to employ sporting parlance, at once threw up the sponge and admitted the photographic triumph. A slide prepared by the Woodbury process was the all conquering agent in this case.

This suggests the mention of the death, by accident or misadventure, of Mr. Walter H. Woodbury, an event which occurred since the last Convention of the Photographers' Association of America. He was an original experimentalist, a man of vast resources in practical science, and a careful, plodding worker-out of ideas. But with faculty of research, the art of carrying out his ideas to such a commercial issue as would adequately remunerate him for his inventions, were not equally blended, and so his financial ability was far from being on a par with his deserts. By an underestimated dose of sedative his career was suddenly cut short in the midst of his usefulness, and when a bright future was beginning to dawn. All honor to Woodbury! I knew him well since 1864, and bear testimony to his many excellent qualities.

The principle of centrifugal action as applied to the separation of one body from another of different weight, and as still narrowed down in its application to the gelatine-bromide of silver emulsion, is at present receiving much attention. If a vessel containing emulsion is put in a state of rapid rotation, the particles of bromide of silver fly toward, and adhere to, the walls of the vessel, allowing the gelatine and the water to be poured out as a transparent fluid. I could keep you listening for an hour were I to recount all the uses of this system in emulsion work, but will confine myself to one only. If through an endeavor to obtain the greatest possible sensitiveness, the gelatine has been decomposed to such an extent as to produce fogginess, all that is necessary is to pour the emulsion into the machine, rotate it rapidly from one to four minutes, pour off the now clear solution of gelatine, and mix the separated bromide with a solution of fresh gelatine, and an emulsion is obtained possessing all the good and none of the bad qualities of the former. The separation of substances in this way was first practically applied by an American for the purpose of separating

butter and cheese from milk by this nearly "instantaneous" process. Herr Plener saw its value for separating emulsion and applied it, and now Mr. A. L. Henderson has further improved it, and applied it to the requirements of every day use by the introduction of a machine which is worked by hand. Old and worthless emulsions may now be utilized instead of being relegated to the tank of residues. I know full well the value of your time at the conventions, and hence abstain from saying anything on this important subject.

There is a tendency now in London to favor the use of ready-sensitized silvered paper, which yields good tones without the use of gold. While I would be cautious in recommending a departure from trusted methods from the point of view of permanence, yet it must be admitted that I have in my possession many prints which were made more than thirty years ago, and in which no gold, platina, or other toning agent was employed, and most of these are still of the rich purple color they originally were. Where fading has taken place it is directly traceable to the influence of an improper paste, by which they were attached to the mounts, which latter also contained hyposulphite of soda, employed as an anti-chlor by the paper makers, and which was not perfectly removed. In this connection I may observe, that salting the paper with chloride of barium and sensitizing with ammonio-nitrate of silver, will yield rich tones without a gold bath, and prints thus prepared will, if mounted with freshly made starch on the excellent mounting boards now so easily procurable in the States, give effective pictures possessing a reasonable degree of permanence, if I may judge by some that I have prepared and subjected to the action of deleterious gases.

Why are gelatine plates so much more sensitive than collodion? This is a question which is receiving some attention here. But at present it would be premature to give even a summary of the theories that are being advanced.

The subject of the influence of the amateur upon professional photography is one possessing too great an importance to the latter to be lightly passed over. As several in this country who call themselves amateurs and as such belong to clubs and societies alleged to be purely amateur, yet derive pecuniary advantage in a greater or less degree from the sale or manufacture of photographic requisites, the question has arisen, as a side issue, what constitutes a photographic amateur? There are few amateurs who would decline to make money, when they can do so, from their productions, either directly or through

the medium of a professional printer or dealer, and when one does so the question becomes narrowed down to whether he is then an amateur and not a professional. If such a one produces work of a high class, as many do, it acts as a stimulant to the professional to surpass him in the quality of his work, and thus does good; but if this amateur work is given to the public at a low price—just to defray the cost of chemicals, you know—then it is seriously detrimental to professional interests. I know many instances in this country where this is the case, and I am greatly mistaken if you in America can not also cite similar instances. It is much to be regretted because it leads directly to the cutting down of professional prices, so greatly to be deplored, and against which every true professional ought to lend his aid strenuously in opposition. It is sad, indeed, to anticipate the probability of able men having to retire from the profession in consequence of there not being a respectable living left to them by remaining in it. It is easy to lower prices in hope of competing with others, but terribly difficult to raise them again. The public will reason thus: that when prices for art work are greatly reduced, it is either an indication of work of an inferior class being now produced, or that they have been overcharged in previous times. England and America are both suffering in common in this direction.

[*Competing Price Paper, read at the St. Louis Convention.*]

## A TRIBUTE TO PHOTOGRAPHY.

BY CHARLES T. STUART.

It is exceedingly pleasant to note that our art has not deteriorated since the last annual convention at Buffalo, which I still hold in memory as one of the pleasant events of the Photographers' Association of America. The exhibition of another year's work here shows conclusively that photography is in good hands, and only needs the constant application of an earnest spirit to continue its rise upward and onward, excelsior-like, to entwine it in the hearts of the people. Composed as it is of elements that are practically inexhaustible in resource, and abounding in devices and contrivances, it simply remains for us properly to rise to and grasp the situation and it becomes clear that success must be inevitable. Let it always be our aim to keep pace with the marvellous growth of our

art, the pride of our lives that seems to grow by its own law of attraction and necessity, and by faithfulness, integrity, and unwearied industry place it upon that basis which shall deservedly merit for it universal respect and patronage. One of our mottoes should be "strive hard to please," both our customer and ourselves, for certainly there is a more heartfelt glow of inner satisfaction in pleasing the patron than always appears upon the surface, in fact, a gratifying sense of pride, without which, in my estimation, our daily toil would become decidedly prosaic. The past improvements and present condition of Photography give high promise for its future. Do your duty, stand by the photographic ship, fame and reward are the powerful incentives which will ultimately reach you. Attend to the trifles, for inasmuch as trifles make the sum of human things, they are also necessary to our success. How many assembled in this hall owe to photography a debt of gratitude? 'Tis true that those who follow our profession have their sorrows as well as joys, the latter, however, more than neutralizing the former. It will generally be observed that the successful worker, to a certain extent at least, is quite invincible, possesses an acknowledged capacity of discernment, and an unswerving loyalty of heart to his chosen profession. In the limited sphere of your studios at home, cultivate the graces of gentleness, yet firmness, of patience and generosity to employés as well as patrons. You will find them the "loadstone magnetic" that will contribute to the fulness of your success. Many cases of ill-success in our business can almost invariably be traced to lack of will-power, idleness, extravagance, and dissipation. The stages of photographic careers I have divided into three. The first is decidedly romantic, and he thinks he knows it all; the second may, I think, be rightly termed "humiliation," as we have now become convinced that we know so little (this is the hopeful stage), the most of us I think belong to this; and the third we will name "philosophic," and the man who lives to get there after having passed through an experience varied with the aforesaid romance and humiliation will be transformed into so much knowledge and goodness as to make it equal to saying

good-bye as to trust him near the "air-car" which will then be making regular trips. We read in the great book of books where King David was forbidden the erection of a temple for the worship of God because he had shed blood, and with noble unselfishness he, before his death, laid up the materials by which his son Solomon might have the glory of erecting it. The application of the moral to this is plain.

Let us then imitate the glorious example of the ancient king, and bequeath to those who follow us, at least here in America, where art is building her "rosy bowers," the materials of constancy, professional pride and love of knowledge that they may build the future temple of photography, seeing the probable completion of which already excites impatient expectation from the scientific world. The photographic finger with graceful curve, points upward, and with cultivated, intellectual development, must lead to increased popular growth and power. Tried by the generous range of possibilities, it surpasses all other professions. The photographic fire still burns, its effects can be plainly seen, its heat felt, and the brilliant effulgence of its tremendous rays of light safely guides the course of its devotees.

We should surround ourselves with influences refining and elevating, these then will form the basis for education of the public and ourselves which must result in stimulating and expanding an increased interest for our art.

Be ever vigilant, and thus keep off the corroding rust of inactivity. Vigilance yields a rich reward.

We all know that there exist in our nature latent capabilities unexercised, perhaps unsuspected, which are as susceptible of development as light and shadow in the sensitive films we daily work.

This convention of 1886, so well and largely attended, places one more milestone on the good road to the creditable history of our beautiful and fascinating art. That it has now permanently won its place in every home is undisputed, and we note this feature, that where formerly it was considered an unnecessary luxury it has now become a recognized necessity in the humblest circle.

How much it has done for human affec-

tions may never be known, and we must ever owe to it the debt of gratitude. Were we obliged to drop from the list one of the art sciences, which one, tell me, would be missed so much as photography? I think more pictures were produced the past year than ever before, and this brings up the thought that while the production has become so prolific, and prices depressed, it would be a good idea for us as members of this association to put our shoulders to the wheel of "quality," and thus not only maintain our reputation as progressive, but also stay the prices downward. Resolve not to remain in the "slough of despond," but at it early and late, until by constant endeavor, like the valiant knight of old, we pave the way to fame. One peculiarity of photography is that while it hardly notices insipidity of feeling it richly recognizes enthusiasm.

These annual meetings, where are gathered together the friends, admirers, and workers of photography, are exceedingly pleasant, and I hope, that attended as they are so strongly with the social spirit, will always be perpetuated. Let not envy, mammon, hatred, or any uncharitableness whatever stand in the way of our rising art which is yet destined to make the world glad.

I am a firm believer that we are gradually but surely erecting a colossal monument of future fame to photography, and this too in a quiet but effectual manner, as, without the aid of tumultuous thousands, are tossed to the top where they immediately cling and fit, fragmentary morsels of improved practical formula, until finally after many changes kaleidoscopic, and often swifter than the weaver's shuttle, there are destined to be presented to an ever anxious world processes well nigh complete.

We have now reached that point in the grand triumphal march of our wonderful art where there is no turn back, not even a pause.

Photography, an art unrivalled, that more than all others is characteristically capable of creating and crowning the reputation of its competent and faithful follower, and youthful as it is, is one of the most complete, evenly balanced, ingenious, and interesting of the art sciences; having the effect continually to spur on the sympathetic and am-

bitious spirit that permits itself to roam in its inviting field of subtlety and artistic execution; therefore, pardon me if I affectionately lean toward it like one imbued as with a loyal impulse to an art to which I have consecrated my life.

Photography is very friendly as well as just, for while its truthful and fascinating delineations are equally at home with love or lightning, it gracefully enfolds within its capacious arms history and religion, and also if this were not enough, kindly lends a helpful hand to manufactures, banking, and all commerce.

To the younger members of our profession, I would say be watchful and observant, inquisitive and careful, in the infant blossom of your career until that line is safely passed where your minds have become enthroned and fixed to such an extent as to make it impossible to divert you from the life, soul, and secret of photographic success.

Simplicity and harmony should be the two great points for your guidance in the introduction of accessories or innovations upon known principles. Then it follows that the results must be well-balanced and reflect the character of your individual workmanship.

Good taste and a quick and accurate sense of observation is essential to success, and may I not remark that on the "equipoise" of the photographer's temper depends to a considerable degree that success.

Before us is stretched not only the history of photography in the past and the improved work of to-day, but to the imaginative eye, the wondrous photographic panorama of the future.

The sweetest lives are those to duty wed,

Whose deeds both great and small

Are close knit strands of an unbroken thread,

Where love ennobles all.

The world may sound no trumpets, ring no bells,

The photographic book the truthful, shining  
record tells.

Who the happy photographer? He

While scanning his professional life,

Can truly say, with conscience free,

"I was faithful to photography."

---

SEVERAL other papers read at St. Louis are reserved for our next.



## PERTAINING TO THE



ST. LOUIS, Mo. June 22, 1886.

## PROCEEDINGS OF THE FIRST DAY.

THE seventh annual session of the P. A. of A. was held in the Exposition building. The Association was called to order by the President, Mr. Potter, who announced the first business on the programme to be an address of welcome, by Mr. G. Cramer, who spoke as follows:

*Mr. President, Ladies and Gentlemen:* The grand day, which we have been anxiously awaiting and preparing for since our last meeting at Buffalo, has now come—the opening day of the Seventh Annual Convention of the Photographers' Association of America, for which our city of St. Louis has been chosen. It affords me great pleasure to see such a large attendance from all parts of the United States and Canada, members who have left their homes and dear ones, and have travelled many miles, all for one purpose—to participate in our annual gathering, and to advance the progress and interests of Photography. It affords me great pleasure to see again the many faces of those who attend regularly, and also to see many new ones. The intimate intercourse and friendship between the photographers of the whole country is not the least of the glorious achievements of our Association, and I hope that many new bonds of friendship will be tied during this meeting. The advancement of our art, the present high standard of photography, is due, to a great extent, to our annual exhibitions. They have become a school of art for all members of our profession; and, supported by an able press—by the several photographic journals, which are enlightening and teaching the craft—our country ranks

foremost in the progress which we notice all along the line. We also note that those who have made it their business to attend our meetings, and who consider it an honor to belong to this grand Association, have made rapid progress in our art, because they are always ready to learn, while those who think themselves too good, and too far above their fellow-craftsmen, gradually lose ground, and are compelled to take a back seat. Our grand exhibition which adorns the walls of this building, and which excels any previous one ever held, and to which even Europe has sent its finest work, is the greatest testimonial to our Association; and it is a great satisfaction to all of us to see that our Association has assumed such magnificent proportions, to feel assured that there is life in it, that it will prosper and grow on the fertile soil of this grand country.

I hope the St. Louis Convention will mark a mile-stone of progress in our Association. It is now my pleasant duty to welcome you most heartily in the name of the photographers of St. Louis, and to tender you the hospitality of the city in which I have had the pleasure of living half my life-time. I hope you will carry away with you pleasant memories of it. During the days of your stay with us most of your time will be occupied in seeing and hearing, learning and teaching; but I hope the present meeting will combine the pleasant with the useful, and that you will enjoy temporary relief from the cares of your business.

The members of our local society of photographers all join in giving you a cordial greeting. It affords me great pleasure to tender you, in their name, a hearty welcome to our city and our galleries.

May you be happy with us, and may peace and harmony prevail during our Convention.

To this, the President, Mr. Potter, of Indianapolis, replied:

Mr. Cramer: I feel that no words of mine can possibly add to the splendid reputation of St. Louis for large-hearted hospitality. It is well known that the generous impulses of your citizens are not mere superficial eddies, but that they are as broad and

deep as the mighty river which flows by your borders. Consequently, we feel assured that your welcome wells up from the heart. On the other hand, while the members of our Association will gratefully accept the courtesies shown them, they will in no wise abuse the privileges extended to them. Therefore, it is an exceeding great pleasure to me, on behalf of the officers and members of this Association, to accept your hearty welcome, and return our sincere thanks to you and all whom you represent.

On motion of Mr. J. A. W. Pittman, of Springfield, Ill., the reading of the minutes of the last session were dispensed with.

The report on the "Progress of Photography in America" was then read by Dr. A. H. Elliott. (See page 420.)

The report of the "Progress of Photography in England," by J. Traill Taylor, was then read. (See page 424.)

The report on the "Progress of Photography in Germany," by Dr. J. M. Eder, was next read. (Page 408 of our last issue.)

Mr. Landy: I move that a vote of thanks be tendered for these excellent papers.

Agreed to.

The President: The next business is the appointment of a Committee on Location, and the nomination of officers. I appoint on that committee C. W. Motes, Atlanta, Ga.; L. M. Felt, Chicago, Ill.; Edward Cope, Philadelphia, Pa.; and D. A. Clifford, St. Johnsbury, Vt. Under the head of miscellaneous business, I would announce the Committee on Awards. The committee on awarding the Association medals for the best competitive exhibits is as follows: Mr. F. W. Guerin, St. Louis, Mo.; Mr. James Mullen, Kentucky; Mr. J. D. Cadwallader, Ohio.

It is ordered by the Executive Committee that all displays of photographs, of whatever description, shall remain in place in the art department until Saturday morning.

The local Secretary will see to the enforcement of this order.

The President: The next business in order is the Treasurer's report. I suppose you have all read this report made by the Treasurer, as it has been published. At the meeting of the Executive Committee in January, Mr. Cramer, Mr. Clark, and my-

self audited the Treasurer's report and found it correct to a cent; but if you want to read it, it can be read now; it will only take a few moments to read it.

The Secretary then read the report.

Quite a debate followed.

The President said there was no doubt that the accounts of the Secretary were right, but they did not balance when before the Executive Committee, and, therefore, they could not be signed.

This brought up the Recording Secretary, who promptly explained that the reason he had not balanced the accounts was because the Executive Committee had no power under the constitution to audit them.

A burst of applause testified to the popularity of Mr. McMichael, who proceeded to move that an auditing committee be appointed to go through the accounts.

Mr. Cramer moved as an amendment, that the Executive Committee do the auditing.

Mr. McMichael thought an auditing committee ought to be appointed, and, on a vote being taken, he was supported by an overwhelming majority.

After some discussion the following gentlemen were appointed to audit the report of the Secretary, at his special request: Messrs. E. Long, D. R. Clark, D. A. Clifford.

The paper by W. M. Ashman was then read, and on motion was accepted with thanks. (See page 395 of our last issue.)

The President then read his annual address, which was as follows:

*Ladies and Gentlemen of the Convention:* By the gracious dealings of a kind Providence, we are permitted to assemble in this, our seventh annual Convention, to renew the devising of means and the discussion of plans by which we may attain unto a larger life, a broader culture, and a more enlightened and generous enthusiasm; for, as I take it, what we do here cannot be confined altogether to the technical or professional, but it takes in the moral and social, as well as the business, the intellectual, and the æsthetical conditions of our environment. And we must have progress in all these directions would we continue to live as an Association. Even now some one is drifting into poetry and shall we not add a muse?

The time is ripe now, or will be by Thursday,

for a Convention song, and I hope our poets and musicians will put their heads together, and give us a Convention rallying song. A tree that is seven years old ought to put forth some flowers.

Then again, our chance at legislation and general discussion is a schoolmaster to us in parliamentary proceedings. In this connection I will say that considerable advice has been given me to give the young men a chance, to consider them in the appointment of committees, etc. With regard to this it may be said the young man must first demonstrate what kind of stuff he is made of—must give us a knowledge of the kind of talents he possesses. It is easy to change, and as it has a considerable show of reason, is likely to be believed, that a presiding officer appoints weak or unknown men on committees, that he may more readily influence or control them; or that he fears that the lustre of an eminent committee may dim his own. Therefore, I hope the ambitious young man will seize his opportunity to step to the front and give us a sample of his metal. It is creditable for him so to do, and I promise all due consideration shall be shown him. When one has given evidence of his fitness, there is no difficulty about the bestowal of the honor due to his talents. In the meantime, "all things come to the one who waits." Plant and water, and patiently wait for the increase which will surely come.

While the photograph business for the past year has been moderately prosperous, yet the outlook for the immediate future is not altogether reassuring. Need I tell you the prices are down, and are still tending downward? Ought we not face the danger of our situation, and see if we cannot provide a remedy? For, if a new levee is not built, or a new channel dug, or the rubbish taken out of the old one, the floods of folly will sweep us as a profession out of existence, or the sand and drift will so beslime us as to make us a reproach and a by-word to society.

The evil at the root of this matter is "man's inhumanity to man." Too many assume the rights of a patentee on their town and aim for a monopoly of its photograph business, their motto being to keep out and drive out all opposition, at whatever cost. They laugh to scorn the moral principle that they are their brother's keepers, and that the duty rests upon them to help bear his burden. But, gentlemen, the law of these moral obligations is just as unchangeable and eternal as the law of gravitation or the laws of health; and, if violated, the penalty will just as certainly be followed. Hence our deplorable condition to-day. We are our brother's

keepers. It is our duty to bear our burdens and help bear our brother's burdens. Let us illustrate: It is my duty to keep prices up to that point which will give a fair return for the capital and time, labor and skill employed, and enable me to retain a proper social position. Should my peer and competitor do likewise, each will bear his own burden and also help the other to bear his, for we are bound to stand or fall together.

You and your peers may be of a higher station, and if you help keep together in your station, you not only help each other, but you help me to keep in mine; and my peers and I, in turn, help those in the station below us to hold their own. By the decrees of the Almighty, we are under those moral duties and obligations; but we have violated them, and are but suffering the legitimate consequences.

Feeling that proper recognition of, and conformity to these principles, furnish the only solution to our present difficulties, I shall try and bring the argument a little nearer home to each of us. Go into any city, and you will find a certain number of galleries where the productions are so near the same, as to quality, that only an expert could say whose are the best, and the public is not an infallible expert. In all such cases, you will also find that each man's trade hinges mainly on his personality, which, by the way, is a very tangible thing. The ways and the manner of conducting business attract a certain class to one and the different ways and methods of the other attract a different class of customers. Now, should these two get fighting for each other's trade, they would only succeed in killing the goose that lays the golden egg.

You will find also the different stations or grades already mentioned, in cities where they have not yet attempted to cut each other's throats. In our city all the figures from two to eight dollars per dozen for cabinets are represented. Should some of us lower our prices the equilibrium would be disturbed and destruction would set in.

I would be a coward were I to contend with a weaker brother, and rob his children of their bread and raiment. The blame for the bad condition of affairs lies not with the man of limited means and little skill, but it does lie at the door of the man with superior talents, large means, and great opportunities. And it is becoming more and more the fashion to use these superior advantages for utterly selfish ends, and in the mad race for gain we hate the brother who stands in the way. But in the light of the Fatherhood of God and the brotherhood of man,

there is no absolute ownership of talents or property, but we hold them in trust, and an account is kept of the trust, and if we abuse it our misdeeds, like chickens, come home to roost. We must either heed the obligation or pay the penalty.

The following recommendations are respectfully submitted to your careful consideration:

1. That a rule be adopted that all new legislation shall be assigned, without discussion as to the merits, to appropriate committees.

2. That a committee on Constitution and By-Laws be appointed, to which will be referred all papers on that subject, now in the hands of the Secretary.

3. The appointment of a Committee on Incorporation. This step is necessary to give us legal status, to enable us to sue and be sued, to enforce the collection of dues and other obligations, and to hold our officers to a strict accountability. It would also be another factor contributing to the permanency of the Association.

4. That the by-laws be so amended that once a member always a member, with certain limitations. As matters now stand we have really only a floating membership, which goes up and down, owing to the presence or absence of exciting causes—a very uncertain thing on which to base calculations or make estimates. An effort should be made at least to discover a better plan.

I feel that all present have the interest and welfare of the Association at heart, and that there is a general desire that our proceedings shall be harmonious and highly instructive; and I hope that we shall not be disappointed, but that the outcome shall exceed our most ardent expectations.

The Convention then adjourned until next day.

#### SECOND DAY.—JUNE 23D.

The President called the Association to order at 9.40 A. M. The President said: I will make a few announcements. The Art Department will be opened to the public on Friday, from 10 A. M. to 10 P. M. This will be advertised in the columns of the daily papers, and the reporters will please help us to make the public understand all about it.

The excursion is to be on Thursday afternoon, as the programme stated. I think that the good people of St. Louis are going to surprise us. They have not given the officers any notion as to what is going to take place. There is to be music, and if

they keep us from dancing they will have something to do, I suppose.

I will now call on the Committee on Nomination and Location. Is that Committee ready to report?

Mr. Bellsmith: Your Committee to whom was referred the duty of the nomination of officers for the ensuing year, would respectfully nominate the following:

*President.*—H. McMichael, of Buffalo.

*Secretary.*—F. W. Guerin, of St. Louis.

*Treasurer.*—G. M. Carlisle, of Providence.

*Executive Committee.*—James Landy and W. H. Potter.

*Location for Next Convention.*—Chicago, Ill.

In regard to the Vice-Presidents, we would say that we had no recent roll of members, and that we would like a little further time on that; or let the Convention nominate, as the members of the Committee are not sufficiently acquainted with the members to do it in all the States, to make a good selection. Therefore, if you desire that the Committee should make the nomination, we ask for time on that. Respectfully submitted,

(Signed) C. W. MOTES,  
EDWARD COPE,  
D. L. CLIFFORD,  
L. M. FELT.

A motion that the report be accepted and approved was carried.

A short discussion on printing followed here, but nothing new was evolved. Of course, "blisters" came in for a share of condemnation.

The President then said: Miscellaneous business is now in order. If there is none, we will take up new business. There is a convention to be held in August, in Braunschweig, Germany. We have promised our German friends across the ocean that, in return for past favors and what they would do for us at this Convention, we would send them a representative exhibit from this Convention; therefore, I would suggest that a committee of judges be instructed to select from the exhibits winning prizes and other good exhibits not competing, enough pictures to constitute such a representative exhibit.

I say that to you without giving any de-

tails of this matter. I thought it hardly necessary to take up the time of the Convention, however; I thought I could attend to it just as well now as at any other time. The suggestion is, that these judges select three or four from each exhibit winning a medal, and ship them from St. Louis abroad; and also select from the exhibits not competing enough pictures to make a representative exhibit of the pictures at this Convention. Now, then, a committee should be appointed to take charge of this matter—a committee of judges—merely selecting them; and a committee can be appointed to take charge of them afterward in New York, to send them abroad and attend to paying the duties. They can be taken and packed without framing, by packing them in tin-foil, which can be done at a very moderate price. They should be sent to this German convention, which meets in August; and after they are through with them in Germany, they can go to England or other parts of Europe—to any country which requests them. Let them go the grand rounds, and then send them back to Germany, where they want them as a permanent exhibit. They could go back there and remain there. It would not be necessary to have them returned to this country. If we inaugurate something of this kind whenever they hold conventions there, they would feel under obligations to return the compliment, and in the course of time we should get up a transference of pictures that would be a great benefit to all. We all realize the importance of the German exhibit; especially was it the case last year; and I can say right in this Convention, that many have been thoroughly convinced by the German exhibit last year of the beauty of some of the styles of lighting and posing, and so on; and we have been wonderfully benefited by it. I am in hopes, at least, that they will receive some benefit from what we send them. I hope that we can make some return for what they have done for us.

If there is no further action to be taken on this subject, and if there is no objection to it, I will instruct the judges to make the selection. I think, under the circumstances, that there is no exhibitor who will object.

Agreed to.

The Secretary then read a paper by W. K. Burton, of England; subject: "Very Slow Gelatino-bromide for Landscape Work" (see page 397, of our last issue).

On motion of Mr. Ryder, a vote of thanks was tendered to Mr. W. K. Burton for his very able paper.

The President: You know that in all tragedies there is a comedy, and while I hope none will arise, still we have serious discussions, and probably very dry discussions, but sometimes they become tame. We should try, therefore, to lend a little variety to them.

At this point, Mr. W. H. Clark, of St. Louis, stepped forward, bearing a splendid silk banner, and made the following address:

*Mr. President, Ladies and Gentlemen of the Photographers' Association of America:* It is my privilege to-day to appear before you as the representative of an old friend of yours, and in my humble way perform a pleasant duty, which I would rather had fallen into more competent hands.

Mr. President, in the days of chivalry the aspirant for glory on the field of carnage was presented with a shield and a banner, without a motto, and was required to earn one with his sword. To-day I have the honor to present you, sir, as the representative of an influential, large, and rapidly increasing brotherhood, with a banner, upon whose silken folds is already inscribed by the fingers of the great orb of day something nobler than any motto ever earned by man by the slaughter of his fellows.

The glory of the knights of old was won at the cost of the life of the vanquished, and the tears of the mothers, wives, and loved ones of those who fell beneath their swords. This banner represents something higher and holier than blood and wailing.

It represents an art-science which is, without doubt, the greatest boon ever offered to man. One which, instead of the sorrow and anguish inflicted by the sword, gives to the weeping wife and mother the portrait of the loved and absent, and recalls in all their manly beauty the features of him who is far away in person, but ever present in thought.

This banner bears on its face a record of the Association over which you have the honor to preside. It is unique and original in conception. Upon its folds appear not only the names of the past and present officers of the Associa-

tion, but their features as delineated by the unerring fingers of Old Sol himself, the first and grandest painter this earth has ever beheld; and while it waves over you, may it ever be the emblem of peace and good will amongst those whose art-science it represents.

This banner is the gift of the publisher and proprietor of the *St. Louis Photographer*. The sudden death of the late lamented John H. Fitzgibbon, and the consequent suspension of his journal, *The Practical Photographer*, left a great blank in American photographic literature. To fill this blank as far as possible, the *St. Louis Photographer* was started by his widow. How well she has succeeded is shown by the support she has received from the membership of the P. A. of A., and other members of the fraternity—by the constantly increasing circulation of the journal, notwithstanding the keen competition of weekly and semi-monthly photographic publications; by the number and reputation of its contributors; and by its standing amongst the photographic literature of this country and Europe.

As a small token of the gratitude felt by the proprietor of the *St. Louis Photographer*, for the appreciation of her efforts shown by friends within the ranks of the P. A. of A., this banner is presented. Its manufacture has been a labor of love, welling up from the innermost depths of a heart overflowing with gratitude for the many favors received from the Association you so ably represent.

The beautiful embroidery with which it is adorned was wrought by the deft fingers of a lady with whose features the readers of the journal are familiar, through the illustration in the issue for May last.

Mr. President, to you, as representative of the P. A. of A., and on behalf of Mrs. Fitzgibbon-Clark and the *St. Louis Photographer*, I present this banner. When your term of office expires, and your successor assumes the position you now occupy, turn it over to him. He can appoint some one to take charge of it for the Association, or do so himself, until his successor is duly elected. Should the P. A. of A. cease to be, or the banner be no longer desired, it is then to revert to the donor. Accept it, sir, and with it the best wishes for the welfare and success of the Association you represent, by one whose heart is overflowing with good will toward the whole photographic fraternity, and especially to the Photographers' Association of America.

The banner was a lovely work of art, and was made of rosy silk, richly embroidered,

corded with red and yellow and bullion, and mounted upon a tall oak standard. The needlework was done by Mrs. John F. Gregory, of Kansas City, whose lovely picture embellished the last issue of the *St. Louis Photographer*, and who was personally present—the niece of Mr. and Mrs. Clark.

The inscription, in gold bullion, was:  
To the Photographers' Association of America,  
with the

Compliments of the ST. LOUIS PHOTOGRAPHER.

Upon the white silk photographs were carefully printed the names of the workers in photography, which follow:

Alex. Hesler.	Jas. Landy.
A. J. W. Copelin.	John Carbutt.
J. H. Reid.	J. E. Beebe.
A. E. Dumble.	G. Cramer.
J. F. Ryder.	W. A. Armstrong.
J. D. Cadwallader.	R. Benecke.
Henry Rocher.	D. R. Clark.
H. McMichael.	W. H. Potter.
G. A. Douglass.	J. A. Scholten.
G. M. Carlisle.	Edw. L. Wilson.
W. H. Sherman.	W. H. H. Clark.
Joshua Smith.	Mrs. W. H. H. Clark.
J. H. Kent.	

Upon each side of the banner was printed the Presentation Poem, written by Mr. W. H. H. Clark.

Mediæval times in verse are sung  
When men to battle gaily rode,  
Each to the breeze his banner flung,  
His colors on his standard broad.  
And where its pennons waving flushed,  
The gathering hosts allegiance gave,  
And 'neath its wavings onward rushed,  
Its cause to conquer and to save.  
We bring a banner wrought in love,  
And spread its folds for your delight;  
Its colors your allegiance prove,  
To officers who lead aright.  
The gold is trust, red charity,  
The blue is purity and peace,  
The broidery, in its rarity,  
Is wrought, the beauty to increase.

Of this fair gift we bring to thee,  
And hoping that its silken fold  
Will wrap our hearts in harmony,  
And lead to good untold.  
We give the gift to each one here,  
And hold each as our friend in art,  
Believing that one standard dear,  
Will bind us ever friends at heart.

In many councils wisdom reigns,  
 And so we gather here to-day,  
 That from the multitude, the gains  
 In knowledge may each one repay.  
 And each shall bring his gift of thought,  
 The treasures of the whole to swell;  
 And truth thus garnered and thus sought,  
 In progress on our art shall tell.

Our wondrous art, whose power can reach  
 Beyond remotest realms of air,  
 The mysteries of the stars can teach,  
 And all their hidden secrets bare.  
 Revealing by a mystic beam  
 To man, God's glorious work on high,  
 And holding in its lofty scheme  
 The universe of earth and sky.

We know not yet where it may lead,  
 Nor what its leading may reveal;  
 A vaster science we may read,  
 Which now the distant worlds conceal.  
 For if by lightning's subtle force  
 We speak across a world of space,  
 May not light from some planet's course,  
 Bring us its message, face to face?

It marks an epoch of our age,  
 A 'nitial in new worlds of thought,  
 When light became of art the page,  
 And by its hands such work was wrought.  
 The chisel, brush, and pen, to shame  
 By its deep skill have all been brought;  
 Creative genius by its flame,  
 In higher truths is daily taught.

To ideal heights our art to raise,  
 And votaries to its altar bring,  
 We give the incense of our lays,  
 Best gifts of our poesy sing.  
 And he who deems his calling low,  
 And uses it for gain alone,  
 Unworthy is his knee to bow,  
 Or at its altar to be known.

Then bannered host, lead on, lead on!  
 Be in the van of forward march;  
 Your science now is in its dawn,  
 'Twill be the keystone of art's arch.

After Mr. Clark had finished, and the applause was ended, the President said: I have the honor, in behalf of the officers of this Association, with the deepest feeling of emotion, to accept this banner.

Woman—lovely woman—we bow to thee. Your presence pervades our Association, and we welcome you, as our better halves. How we go to battle; how many loving hands have worked on what we have taken

with us. How many men have given up their lives for the love they bore to woman. The best flag of the country is carried by brave men in defence of lovely women. They give up their lives in their defence. How our hearts throb and how brave we become on such an occasion. Those who have gone from home to battle for their country, and those who have had fathers, brothers, and children, die for the flag. What will we not do for the flag? And now we have a banner—the banner of our Association. Around that we can rally, and we should rally; and that banner will unite us and keep us together, and make a purpose in our heart that this Association shall live as long as photography lives. (Applause.)

There is the banner, and here are we, living men; but how soon the time will come that we will drop out and be laid to rest. There is the banner which, from this time forward, will be the banner of this Association; and when we are gone, there will be a representative. There will be something to unite the members of this Association, keep the men together, to enable them to keep step together, to go forward in the future in the same direction that we are going ourselves.

I know that we all feel that Mrs. Fitzgibbon-Clark has passed through the greatest affliction of life, and with affection we look on her as a lady of our Association. She is a representative lady, and we are glad to know that there are so many ladies taking an interest in the Association; and we cannot look on that flag now nor in the future without remembering the kind assistance and generous impulses given us by these ladies being present, and by their encouragement. I think that, in the future, there will probably be a greater influence exerted over this Convention by the ladies. While I accept this kindly offering, I hope it will be the flag that will exist forever, and so also the Association. (Applause.)

Mr. Bellsmith: The Committee on Investigation, appointed at Buffalo, made their report, which was accepted and adopted.

Mr. Ranger: I would inquire if there is a permanent Committee on the By-laws and the Constitution?

The President: No.

The question being on a motion that the President appoint a committee of three on the Constitution and By-laws, it was agreed to.

Mr. Hulburt: Ladies and Gentlemen: you are invited by the St. Louis photographers to attend an excursion to-morrow afternoon, at half-past one o'clock. The expenses will be entirely borne by the St. Louis photographers. The boat leaves the foot of Vine Street at 1.30 p. m.—the steamer "Charles P. Chouteau," one block south of the bridge. Convention badges will admit members of the Convention to the boat. No others will be admitted except the employés of the St. Louis galleries. It will be necessary to bring your badges. Be there promptly at half-past one.

On motion of Mr. Pugh, the invitation was accepted with thanks.

Mr. Hulburt: I forgot to mention one thing. Arrangements have been made, so that views can be taken from the boat. The boat will go up the river, above the bridge, and stop for a few minutes, so that both sides can be taken. Various places down the river can be taken. The party will land at Montesano Springs, and will be back about half-past ten o'clock.

The President read communications from the librarians of the Mercantile and the Public Library, of St. Louis, inviting the visitors to the courtesies of their institutions, which were accepted with thanks.

Mr. Cross, of Iowa: Mr. President, Ladies and Gentlemen, Members of the Association: The properties of this hall have proved themselves poor to my hearing, but I will do my best and not delay you but a few moments. There is one point that I think has been overlooked in the management of the dry plate. I think too much dependence has been placed on changing development to suit errors of exposure. In my opinion, correct results are only obtained by correct manipulations from beginning to end. Faults may be remedied by changes in the manipulation; the general result, as a whole, may be slightly remedied by changes of the developer. Correct exposure should be borne in mind, and that is about all I have to say.

The report of the committee on the death of the late Henry T. Anthony was now read as follows:

*Mr. President and Members of the Photographers' Association of America:*

Just before the adjournment of the last meeting, held at Buffalo, N. Y., last year, your President appointed Mr. J. Traill Taylor and the undersigned a committee to draw up resolutions with regard to the death of the late Henry T. Anthony. Mr. Taylor being abroad, I submit for your approbation the following:

*Whereas*, In my report on the progress of photography, last year, I mentioned the great and irreparable loss photography had sustained in the death of Mr. Henry T. Anthony, a gentleman who was much beloved by all who knew him. Perhaps all the members of the Photographers' Association of America are not aware of the great services rendered by that estimable gentleman to our art-science. In the early days of the introduction of photography in the United States, no one did more to spread the knowledge of the art and assist those engaged in its mysteries than Mr. Anthony. I know that he rendered most substantial aid to many an artist, not only with words and advice, but with pecuniary assistance when they stood in need of it, and it was always done in the most kindly and unostentatious manner; in fact, it will never be known what amounts this benevolent and kind-hearted man bestowed on those whom he knew to be in want of assistance; he aided them with a free hand, and not with a pittance—giving large sums of money, often sufficient to start in business. I have the assurance from parties who were the recipients of his generosity, that he never asked for a return of the same; therefore, the following resolutions are the least we can pass.

*Resolved*, That in the death, last year, of Mr. Henry T. Anthony, the whole photographic fraternity sustains a loss of one of its most valued supports.

*Resolved*, That this Association have a memorial tablet presented to the firm, to be placed by them in an appropriate place, with a suitable inscription marking the



esteem in which his memory is held by the Photographers' Association of America.

C. GENTILE,  
Committee.

On motion, the report was accepted, and committee discharged.

The President: I will appoint the following Committee on Constitution and By-laws: Mr. J. F. Ryder, Mr. James Landy, and Mr. H. F. Bellsmith.

On account of the inability to hear the further reading of papers, they were dispensed with.

The president declined to hold any office in future, and then the Convention adjourned till Thursday June 24th, 9 A. M.

### CONVENTION ITEMS.

WE have concluded to modify our old plan of giving the Convention proceedings all in one issue, by giving part now and the balance in our next.

Thus we will be enabled to include in each number items of interest which come to us from all over the world, and thus please a number of our subscribers who "do not take much stock in conventions," and who have heretofore cried out against us for giving "too much convention."

One thing our readers all will escape this year, namely, reports of long discussions upon "blisters," "developers," and other hackneyed subjects which have been gone over again and again. They sound well and are well in a convention, but neither the deft pencil of the stenographer nor the dying agonies of the poor editor who has to condense them can ever make them read well.

Our critique on the pictures and our notes on the trade exhibits will also be reserved for our next.

THE election resulted as follows:

*President.*—Mr. G. Cramer, of St. Louis.

*Secretary.*—Mr. H. S. Bellsmith, of Rochester.

*Treasurer.*—Mr. G. M. Carlisle, of Providence.

*Executive Committee.*—Mr. J. Landy, of Cincinnati; Mr. W. V. Ranger, of Syracuse.

*Location for 1887.*—Chicago.

The President-elect, Mr. G. Cramer, is popular with everybody, not only on account of his generosity, but because of many amiable personal qualities which have won him universal friendship. Everyone will strive to help him make next year's Convention "the best of all."

WE are sure that the kind friends in St. Louis to whom we are indebted for many courtesies and kindnesses, and those in Chicago whom we saw in passing, will bear with us until we can more fully express our thanks in our next number. Our anxiety to give as much Convention news as possible has crowded us for space.

PRESIDENT-ELECT Mr. G. Cramer, and Ex-president W. H. Potter, were each given a gold-headed cane at St. Louis.

THE complete report of the Jury of Awards did not reach us promptly, and rather than publish it in a garbled form we will retain all until another issue.

### THE HUMOR OF IT.

NOTES OF THE ST. LOUIS CONVENTION.

(Overheard in a Sleeping Car.)

"Oh, where are you going, my pretty maid?"

"I go to St. Louis, sir," she said,

"A town far away in Missouri."

"May I go with you, my pretty maid?"

"Oh, that would'nt do, dear sir," she said—

"Are you on the prize-medal jury?"

"And suppose I am, then what, pretty maid?"

"You could help me get a gold medal," she said,

"For my patent duplexing triplexter."

"If I do, may I marry you, my pretty maid?"

"No one has asked you to, sir," she said,

And she vanished as though he had vexed her.

And why did she hurry so? this pretty maid.

"'Tis a race for a medal, sir," she said,

"And I must get there while they're plenty."

SCENE IN AN ALCOVE.—Compressed Pyro:

"What do you think of my \$1.99 cabinets?"

Swing-back: "Do you sell them?"

Compressed Pyro: "I got them up for this show."

After I take them home, if the journals should notice them, my friends may want to get up a club." Swing-back Hypo: "What! for pictures at that price?" "Certainly. What did you suppose?" Swing-back Hypo: "Why, *for you*, of course."

ART ILLUSTRATED.—"Angular composition"—a fisherman and his line.

"Triangular composition"—three fishermen and their lines.

"Die-agonyal composition"—a sheriff reading the Lynch law.

"Linear perspective"—a horse thief hanging to a tree.

"Circular composition"—a conventional prize medal.

"Facial expression"—a disappointed competitor.

"Point of sight"—the emptied beer kegs after the excursion.

"Aerial perspective"—Doughty's views from a balloon.

"Light and shade"—love under an umbrella.

[Competing Prize Paper, read at the St. Louis Convention.]

## IMPROVEMENTS IN PHOTOGRAPHIC PRINTING AND ENLARGING.

BY DAVID COOPER.

WE all know what progress has been made in negative making, or if we don't we'd or'ter in these days of gratuitous information. Thanks to the public-spirited manufacturers of dry plates, the enterprising and very ably edited journals devoted to our art, and last but not least, to the multitudinous and oft much-abused (behind his back) demonstrator, popularly known in photographic vernacular as "the dry-plate fiend," there is a torrent of information, more or less valuable, being continually poured into the ear of the anxious inquirer on this subject, and that is what I mean when I say, as I just now remarked, "if you ain't you'd or'ter."

But while all this attention has been devoted to negative making, a most important subject has been almost totally neglected. I refer to the matter of positive printing. Who can say that photographic positives, so far as they relate to gallery work, have

in any way advanced in fifteen years? The same silver print on albumen paper, with its accompanying inconvenience, its limited range of application, its necessarily imperfect condition unburnished, its liability to injury at some one of the many stages of its production, its provoking insensitiveness unless under the most favorable conditions of light, and last, but by no means least, the concededly unartistic result of the completed picture, which is dependent on the high gloss of the burnisher for a so-called finish. The public has noticed this, and as their acquaintance with photography is mostly cultivated through the medium of prints, they are naturally led orally as well as mentally, to inquire where are the very much boasted improvements in photography?

Certainly there is nothing novel in the work they receive. A few little conceits in the matter of background, accessories or style of mount sum up all the claim to novelty that can possibly be made by the most pretentious in business.

The fact is just this, that the people are hungering and thirsting after some tangible proof that there is something new about the specimens of photography brought into their homes, and the question you should ask yourselves is this, are we doing justice to our patrons when we fail to place before them for their approval those evidences of progress which appeal to their tastes and enable them to judge of what they do or do not like? What right has any individual to assume that his judgment is infallible as to what his customers want? Give them the opportunity of expressing their own opinion on the subject, and if it costs you more to give them what they really want, they will not, as a rule, be unwilling to help you bear any reasonable expense.

It is not to be expected that the fraternity will, with eagerness, adopt each new thing that comes along, before first satisfying themselves of the justice of its claims. This is reasonable and to be expected. No really valuable thing is ever hurt by the most careful investigation, which is rather to be courted than otherwise. It is with the object of courting this investigation of the merits

of the permanent bromide paper process, that such a variety of results has been presented at this Convention by the manufacturers.

Many are the uses to which this printing method may be adapted, as exemplified by the variety on exhibition. We find contact printing for custom work side by side with book illustration or mechanical drawings. Each possesses the characteristics particularly valued in work of these classes. In the one, softness of half tone and brilliancy both of light and shadow, in the others, intense blacks with pure and sparkling whites. But the most important of all, and that to which I shall endeavor to call your special attention, is the subject of enlargement. It is no exaggeration to state that never before in the history of photography has anything like the class of work which is accomplished by this process in enlargement been placed before the public. The results are as near perfection as the comparative infancy of the method will admit. Its superiority over all other methods is admitted on sight of the results, while this conviction is intensified when its simplicity, rapidity, and certainty of operation are understood. Nothing can exceed the softness and beauty of an enlarged print, say life-sized, from a well retouched and otherwise perfect cabinet negative. It is a fact that prints far superior in softness and detail are to be obtained by enlargement by this process, than can be got by contact printing from the same negative on albumen paper. As this may be difficult to believe without proof, I will present you a few samples, and then by means of this apparatus, give an idea of the methods of procedure.

It may, however, be best to give first an idea of the most simple and complete apparatus found suitable for the purpose, and prepared for use with the paper, so as to secure success to experimenters at the outset. The simplest, which may be purchased of any dealer, is represented here partly by the apparatus on this platform.

The easel, as you see, consists of a firmly supported pair of uprights, which are slotted a distance of about six inches. This admits of the focussing-screen being moved up and

down so as to locate your picture correctly in the centre of your sheet. On the face of the board you see a black frame which is

FIG. 1.

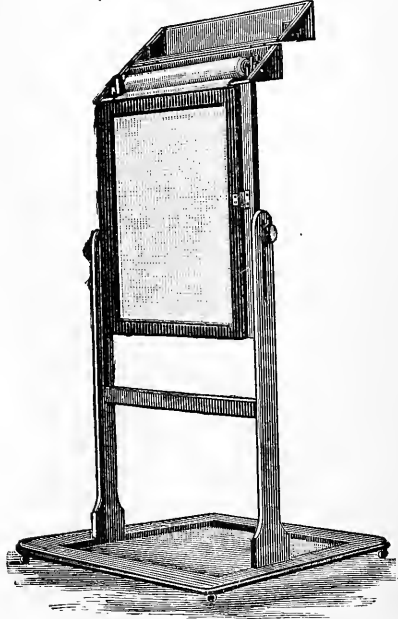

The Easel.

hinged on one side and caught by a spring catch on the other; its object I will describe in its order. Seated on brackets which are screwed to the back of the focussing-board is a long narrow box that is designed to hold the sensitive paper, which comes wound on a paper tube that slides on an axle journaled on the box. At the back is a brake of simple construction which prevents the paper unwinding faster than is desired. This box is perfectly light-tight, and the dark-room may be opened after use without at all affecting the paper if kept in the box closed. As all the spools fit on the same axle, any width may be used in the same box, provided the kits which come with each apparatus for adjusting the various sizes be used discreetly, any sized enlargement to as low as 11 x 14 can be centred accurately. This brings me back to the frame which, as I noticed, passes around the face of the board. Its object is the securing of the flatness of the paper when

stretched across the face of the board after it is pulled from the box. This frame is rabbetted on the inside to admit of the attachment of a smaller frame or kit which again accommodates one still smaller, and so on; the whole being held together by buttons on each side. With this apparatus and its parts with their uses accurately described, it will be seen that although it is quite possible to do very satisfactory work by an improvised apparatus, the saving of time and convenience of using such an implement must weigh greatly in the favor of its possession by the practised worker. As a very necessary adjunct to this portion of the apparatus, we will examine the enlarging camera, which is a part of the outfit.

front very useful in correctly centering the picture. The manner of focussing is as follows: Place your negative in position, and the easel as nearly as possible at right-angles to the lens (this is easily accomplished, as each apparatus is furnished with ways, which should be screwed to the floor to secure certainty of position). Uncap the lens, and the picture will appear on the screen; the size may be increased or decreased by having the easel nearer or further from the lens, as may be desired—further in the first case, and *vice versa*. The sharpening of the image is accomplished with the rack and pinion on the camera. All being sharp, cap the lens and open the spool-box, unclasp the square frame and throw it back, pull

FIG. 2.

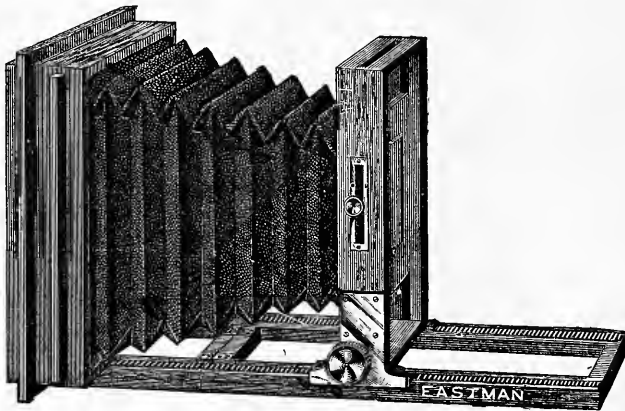

The Camera.

While possessing all the appearance of an ordinary cone-view camera, it will be found on closer inspection to be very different at the end on which the plate-holder usually sits. This is provided with a ground glass, which is a fixture and is intended as an equalizer of the light that passes through to the negative, which is adjusted by means of a carrier and kits that will accommodate every sized negative from a  $3\frac{1}{2} \times 4\frac{1}{2}$  to  $8 \times 10$ . This apparatus in the simple form is intended to be used with daylight, and is fixed in an aperture in the window of a room darkened for the purpose. A suitable lens should be mounted on the front, which is provided with a rack and pinion movement for focussing, and rising and falling

down enough paper for use, and swing back the frame to its original position, and the paper will be held firmly. Now close the box and uncap the lens. Time according to your judgment of the circumstances. Experience only will determine this. I will now proceed to demonstrate the working of the apparatus on the stage, and give a few hints on the way of obtaining results from a negative superior to the quality of its printing character on albumen paper.

Before commencing the operation, I will pass around for your inspection some samples of work by this method. You will observe that they represent two pictures, which we will number 1 and 2, from the same negative. No. 1 being fully timed in

the face, but lacking in the drapery; No. 2 fully exposed with soft detail all over. The first represents the result from that class of negative unaided, the second shows the effect of auxiliary printing, and demonstrates not only what may be accomplished in the way of improving the result from a

aperture no greater than will admit such portions of the bust and drapery as it is desired to aid by additional printing. Again uncap the lens, using the cardboard as in the first case, only being careful to cover up those parts which judgment assures us are already sufficiently timed, and proceed with

FIG. 3.

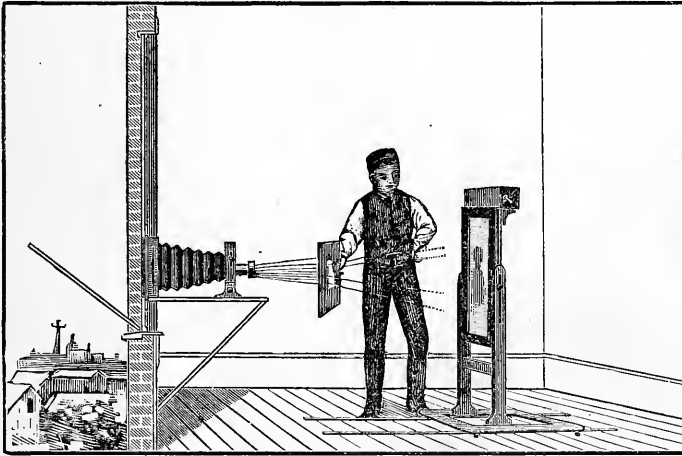

Operation of Vignetting.

poor negative, but the possibility of enhancing the valuable qualities of a really good one. I will now throw on the screen, or focussing board of the easel, an image of the negative from which these prints were made, reduced to convenient size, and then exemplify both ways of operating.

Having obtained a focus, I cap the lens and open the light-tight box on the upper part of the easel, and taking hold of the loose end of the sensitive paper therein contained, draw down sufficient to accommodate the dimensions of the picture desired. Closing the box, and holding in the right hand this piece of strawboard of sufficient size to completely cover the margins of the picture, admitting the image through an aperture in the centre of suitable form for vignetting purposes, cautiously uncap the lens, gently moving the vignetting board back and forth to insure softness of blend. We give ten seconds over the whole image. This we know is sufficient time for the face and thinner portions of the negative. Now recap the lens, and take another piece of cardboard as large as the first, but with an

another exposure of ten seconds. Thus you see we secure just twice as much time on the denser parts as on the thinner, with the result that the image will appear like the print No. 2 exhibited, while No. 1 shows what the effect would have been, if we had been contented with ten seconds over all. Extra time over the whole image would not answer the same purpose, as then the shadows would be overdone. This local aid may be applied to any class of negative presenting marked contrasts, with the most satisfactory results.

Development is accomplished in an exceedingly simple and cleanly manner. The well-known oxalate of iron developer, in a slightly modified form, is being found the most suitable for all purposes so far. The formula and directions for using Eastman's permanent bromide paper read as follows:

## No 1.

Oxalate of Potash	. . .	1 pound.
Hot Water	. . .	3 pints.

Acidify with sulphuric or citric acid.  
Test with litmus paper.

## No. 2.

Protosulphate of Iron	. 1 pound.
Hot Water	. . . 1 quart.
Sulphuric Acid (or Citric Acid, $\frac{1}{2}$ ounce)	. . . $\frac{1}{2}$ drachm.

## No. 3.

Bromide of Potassium	. 1 ounce.
Water	. . . . 1 quart.

These solutions keep separately, but must be mixed only for immediate use.

*To Develop.*—Take in a suitable tray—No. 1, 6 ounces; No. 2, 1 ounce; No. 3,  $\frac{1}{2}$  drachm.

Mix in the order given; use cold. After exposure, soak the paper in water until limp; then immerse in the developer.

The image should appear slowly, and should develop up strong, clear, and brilliant. When the shadows are sufficiently black, pour off the developer and flood the print with the

*Clearing Solution.*

Acetic Acid	. . . 1 drachm.
Water	. . . . 1 quart.

Do not wash the print after pouring off the developer and before applying the clearing solution.

Use a sufficient quantity to flow over the print—say 2 ounces for an 8 x 10. Allow it to act for one minute, and then pour it off and apply a fresh portion; repeat the operation a third time, then rinse in pure water and immerse for ten minutes in the

*Fixing Bath.*

Hyposulphite of Soda	. 3 ounces.
Water	. . . . 1 pint.

After fixing, wash thoroughly for two hours and hang up to dry. Use fresh developer for each batch of prints. With a glass-bottomed tray, seven ounces of developer are sufficient for a 25 x 30 print.

*Object of Clearing Solution.*—The object of the clearing solution is to prevent the precipitation of the iron from the developer in the fibre of the paper. This can only be done by keeping the paper acid while washing out the developer.

Citric acid may be used instead of acetic in the clearing solution, in which case use  $\frac{1}{2}$  ounce to the quart of water. Citric acid is less liable to cause blisters.

Blisters sometimes appear in bromide paper, and may be avoided by using a little common salt in the first washing water after fixing. The hypo must not be stronger than 3 ounces to the pint of water.

*No Toning Required.*—With Eastman's permanent bromide paper the final tones are obtained entirely by development, and range from a soft gray to a rich velvety black, depending somewhat upon the density of the negative and the quality of the light used in printing.

*Clean Dishes. Clean Hands.*—The faintest trace of hyposulphite of soda or of pyrogallic acid is fatal to good results with bromide paper, and the operator cannot be too careful to avoid any contamination. The tray used for developing with oxalate should never be used for anything else.

Mention has been made in these directions regarding the use of a dilute solution of acetic acid and water immediately after development, and before washing with water at all. This is a most important point and cannot be too strongly impressed upon the mind. A brief hint as to the reason for using the acidulated water is given in the foregoing directions, but it is so important that it deserves further consideration. Pure whites cannot possibly be *obtained and retained* where this precaution is neglected. As noticed in the directions, it has been proved that thorough removal of the oxalate of iron can only be accomplished while the print and water are kept acid. It seems that the degree of acidity needs only to be very slight as the formula shows. This has been commented on, and several who doubt the efficacy of the homœopathic dose prescribed have increased the proportion, but have not found any additional advantage. While in cold weather a moderate increase of the acid may not have any serious influence, it may in hot weather develop a tendency to blistering and should be avoided. In any case it is not so much the amount of acid as the repeated application of the very fine dilute solution recommended, which will fulfil the demands.

After fixing, another important measure is the use of a first washing water containing common salt—say half a pound to two gallons of water. This will most effectually



fectly; which is so well depicted here that it hardly needs explanation. It consists of a camera and lens placed before an aperture in a darkened room which will accommodate the negative. To prevent any extraneous light entering the room, the lens is hooded with some suitable flexible material

FIG. 5.

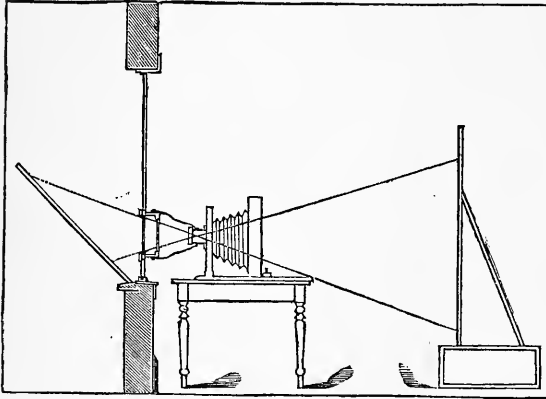

An Improvised Enlarging Apparatus.

which will allow of a focussing movement of the box, the large end of the hood is fastened around the aperture containing the negative, so as to make the room secure from the entrance of daylight.

FIG. 6.

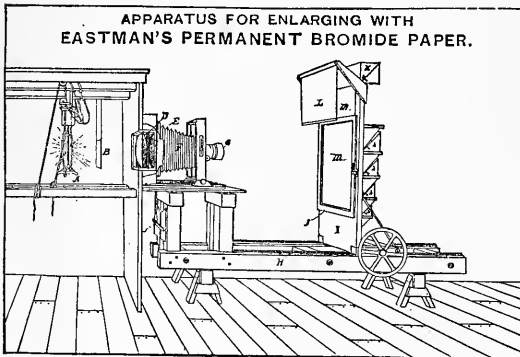

The easel is a simple affair and may be a flat door or drawing-board or table-top, tipped up endwise and secured in position, on this the focussing is done, after which the sensitive paper is pinned up, and the exposure is made.

A number of persons desirous of embarking in this business on a large scale, having come many miles to see the apparatus at the factory, the Eastman Dry Plate and Film Company have permitted me to prepare a diagram of their own outfit, having no secrets connected with enlarging that are not free to the world; this, with the object of saving time and expense to would-be extensive enlargers. It may be said right here, that no better work chemically is to be obtained with an elaborate apparatus, nothing being gained save convenience in a large business.

By means of the magic lantern I will project the diagram spoken of onto the screen; its purpose is plain, and being precisely similar in principle to the apparatus already described, I will merely call attention to the fact that it is provided with a pair of twelve-inch condensers, which are always a necessity where artificial light is used. In this case the electric light supplies the illumination, which it is necessary to soften by means of a piece of ground glass between the condensers.

Immediately in front of the light hangs a frame *B* which is designed to carry stained glass of exceedingly light tints—yellow, to increase contrast in a weak negative, and a very light blue to decrease it in the case of strong and yellow plates. This is quite a dodge, and may be used as a most efficient aid in these cases, and is recommended to work equally well with any method of illumination.

The satisfaction with which this paper has been received and generally endorsed in England

and on the Continent, is an important indication of the appreciation of men who know what has been attempted before in this line, and can remember the failures and shortcomings of all previous and contemporary applicants for favor.



Now let us glance at the practical importance of this subject to the photographers of to-day. When I say of the "photographers of to-day," it is with good reason. The long period of comparative quiet in photographic discovery that succeeded the introduction of the wet plate, dropped multitudes of photographers into the mire of self-satisfaction, born of a consciousness that they knew all there was to be known about photography as it existed in their generation, and they felt quite certain that nothing was going to be produced that would disturb them in their day. So when the dry plate came around modestly asking for recognition, it was met in numerous instances with the upturned nose of scorn, by the men who hugged the belief that photographic knowledge and experience had its Alpha and Omega in their establishments. It was with supercilious chuckles that they watched the struggles of the young men on the other side of the street in their determination to overcome the difficulties of a new process which would be a power that would enable them to get the lead of their older and more self-confident competitors. Did they succeed? Aye, they did, and to-day from every part of the country is to be heard the wail of the once leading artist, that "The business is ruined." The fact is that he failed to adopt the new process in time to make it a feature of his establishment at increased prices, until his neighbor at reduced rates showed better work than he was making, captured first the babies and then the rest of the family. That should be a lesson, and, therefore, I urge it upon the photographers of to-day, to investigate this matter thoroughly for themselves; don't persuade yourselves that it is best for you to wait until Smith, or Jones, or Robinson makes a success of it before you will try, because either one or the other of them will get your trade while you are waiting, and the observing public will quickly remark, when you advertise that you are prepared to supply the demand, "Aha, I see those young chaps across the way have forced old man Gallic to follow their lead." Quite a drop to fall from the proud position of the "leading photographer" to what the public

quickly recognizes you as, "the following photographer."

Apart from this consideration, is there any money in it? Five minutes thought, after seeing the work that can be produced, will settle that question in the affirmative. The possibility of being able to assure your customer of an absolute counterpart of a cabinet, with which he or she expresses perfect satisfaction, unaltered in facial line or expression by idealization of any artist, and at a cost vastly below that ever asked before for anything approaching it in quality, is a guarantee of itself that there is money in it. Besides this, consider the possibilities of pushing business by advertising this specialty. If you look at the advertising columns of the journals, you will see that the dealers recognize in it a specialty that will demand attention, and make it a prominent feature of their notices, and with good reason, for this is one of the lights which it would be unwise to place under a bushel.

The matter of quick proofs from wet negatives on "A" paper is one of immense importance, and no photographer can afford to lose sight of it. The ease with which this can be accomplished, and the result of such a method of dealing with your sitters is too evident to be enlarged upon. It is rather early perhaps to urge the adoption of the permanent bromide paper for general work, as the public needs to be educated, perhaps gradually, to a change. For while the most cultivated and art loving class are unanimous in favor of the engraving black tone, those less informed on these subjects no doubt entertain other preferences. These will gradually die out, as intelligent taste sets the example and leads in another direction.

Before closing it is important to state, as showing the certainty and uniformity both of the paper and the method of manipulation, that the large exhibit of prints presented at this Convention was begun and completed in three days.

This needs explanation. So great was the pressure of business on regular orders, that it was almost decided to abandon the contemplated exhibition, as it seemed a hopeless task to do anything creditable in such

limited time. Bolder counsel prevailed. and with great energy the work was pushed. "Fortune favors the brave." The results speak for themselves.

---

### A SIMPLE DEVICE FOR ACCURATELY TIMING AN EXPOSURE.

BY WILFRED A. FRENCH.

It frequently happens that amateurs, and particularly beginners, lose many valuable plates by not correctly determining the amount of exposure, the method of counting "seconds" differing very greatly. Many conscientious workers are under the impression that anything less than ten seconds can be calculated by means of an ordinary watch, and thus, for instance, two seconds are measured off, when in reality three, or even one, were given. When, because of failure, the exposure is advised to be doubled (four seconds), this unreliable method of counting would yield anywhere from two to six seconds, and with results generally disastrous. Then the lens, plates, etc., come in for their share of condemnation. It requires but little practice to be able to measure off a minute without varying more than a second, and in that case both stop-watch and the device I am going to recommend may be dispensed with entirely, though a novice is liable to become disconcerted by any sudden excitement. I therefore suggest the use of a time-ball, which consists of a half-inch bullet firmly attached to a cord twelve inches long in which a knot is made just  $9\frac{3}{4}$  inches from the centre of the bullet. Swing the ball, not violently, holding the cord *at the knot*, and the intervals will be exact half-seconds, though for seconds every other beat only should be counted. This principle is based on the fact that the length of a pendulum, beating seconds, measures 39.37 inches, which is a metre, the French standard of linear measure. If one wishes, however, to be quite certain in determining the amount of exposure, one should not commit the common mistake of sacrificing one count, which is done by calling the removal of the cap "one," and, for twelve seconds, replacing it at "twelve." That is but eleven seconds, twelve seconds being from one to thirteen.

The time-ball, as above described, is by no means a novelty, though not in general use, and, as it is so handy, useful, and inexpensive a device, I cheerfully recommend it to my amateur friends, believing that they will find it a great aid.

---

### OUR PICTURE

MR. Xanthus Smith's timely article on "Figures in Landscape Photography" will prove helpful to the many who are anticipating pleasure with their cameras during the coming weeks in making outdoor pictures. One splendid example is given by Mr. Smith in his paper, and a second one, illustrating his remarks, is supplied by "Our Picture."

It is a lovely little study, chosen from one of the pretty bits of Pennsylvania scenery, and is a reproduction by Mosstype from one of Mr. Smith's own paintings—painted for this very purpose in black and white. We are indebted to both Mr. Smith and the Moss Engraving Company for their care in producing such an excellent result. It was not an easy task, either for the talented artist to illustrate in an understandable way the information he desired to impart, or for the Moss Engraving Company to secure such a lovely result from a rather difficult subject, and then to print it with so much effect.

---

### QUERIES, CONUNDRUMS, AND CONCLUSIONS.

"Young Printer" should remember not to use such strong silvering solution for paper in summer as in winter. Mr. G. Gennert offers the following excellent suggestions for the treatment of his "Improved Extra Brilliant Dresden Paper:"

Keep albuminized paper in a dry, cool place.

Paper to be sensitized requires a certain amount of moisture, as if very dry, it does not take the silver readily, dries in tears and causes dark spots on the prints.

It is therefore necessary to place the paper to be sensitized between sheets of filter or blotting paper in a cool and moist place the night before use (a moist cellar is the most

convenient place), when it will absorb sufficient moisture to be fit for floating without trouble.

High surface papers are apt to blister, especially during warm weather, however this can be easily and effectively prevented by the following simple process:

To every three gallons of water used for the first washing after fixing take about a handful of common cooking salt, and there will never even be a trace of blisters. This weak solution does not affect the tone of the prints in the slightest degree.

"SAMUEL OF POSING."—To cleanse glass or porcelain vessels from organic dirt, use a mixture of sulphuric acid and bichromate of potash.

A PAINT for blackboards which has been much used in schools and elsewhere, and is found very satisfactory, is composed of four ounces of common glue, three ounces flour of emery, and sufficient lampblack to give the preparation an inky color. The glue is first dissolved in one and a half pints of water, the lampblack and emery are then put in, and the mixture stirred until all lumps have disappeared. The board should be given two or three coats, the paint being applied with a woolen rag smoothly rolled. The very same thing will serve you for the "cone" of your camera, for inside "fronts," and for all sorts of "black" appliances in your work.

G. W. COOPER.—Your patrons will surely appreciate your care to make your waiting-room pleasant. Here is a hint for a "Water Museum."

A water museum consists of glass vessels containing fish, mollusks, larvæ, and such other creatures as will live in the small quantity of water these vessels hold. The great advantage that the water museum has over an aquarium is that while the latter is bulky and has many dark corners in which you can see only with difficulty, if at all, the jars of the museum can be easily carried about and held to the light, so that you can readily see all in it.

PHOTO TOURIST.—You should look out for poison in your enthusiasm to take pretty

vines and such. We once ran away and left our camera among a lot of poison vines not discovered until we focussed. "Poison oak," or "ivy poison," is alleviated by the application, three or four times a day, with a sponge or soft linen, of

Sulphate of Copper . . . 1 ounce.  
Water enough to dissolve.

It is soothing, and cures.

R. S., St. LOUIS, Mo.—To make a good tracing cloth, varnish the cloth with Canada balsam dissolved in turpentine, to which may be added a few drops of castor oil, but do not add too much or it will not dry. Try a little piece first with a small quantity of varnish. The kind of cloth to use is fine linen. Do not let the varnish be too thick.

L. P.—To silver mirrors, a sheet of metallic tin is laid upon a flat surface and thoroughly rubbed with mercury to make an amalgam. Then the glass to be coated is slid on at one side until it touches the amalgam at all points. It must be held in that position firmly, so long as may be necessary to deposit a fine uniform coating. Care must be observed that no air-bubbles remain under the glass, the amalgam must be well made, and above all, the glass must be perfectly clean, free from any grease.

GEORGE HART, WATERTOWN.—A drawing or writing on white paper with chloride of platinum is invisible, but if such a drawing is held over a plate containing mercury, the lines traced come out in dark tints, giving a very pleasing effect in consequence of the soft tone produced.

A. J. TRIPPE.—Clear shellac varnish is made as follows: First make an alcoholic solution of shellac in the usual way, then add a little benzole, and shake the mixture well. In the course of from twenty-four to forty-eight hours the fluid will have separated into two distinct layers; an upper alcoholic stratum, perfectly clear, and of a dark red color, while under it is a turbid mixture containing the impurities. The clear solution may be decanted or drawn off with a pipette.

**IVORYIZING A PLASTER CAST.**--Yellow beeswax dissolved in turpentine in sufficient quantity to form a mixture of the consistency of thin oil or dammar varnish, is one of the best compounds for ivoryizing a plaster cast. It may be applied with a brush, but immersion insures a more equal color. Casts treated in this way have a soft

tone and exquisite smoothness of surface, without any objectionable glossiness, and will in a short time become a color scarcely distinguishable from real ivory. If a less yellow tinge is desired, paraffine may be substituted for the yellow beeswax.

COPYRIGHT.—See our last "Queries."

## Editor's Table.

A REWRITTEN and enlarged edition of "The Art of Making Portraits in Crayon on Solar Enlargements," has just been published by Mr. E. LONG, of Quincy, Ill. The new issue of this well-known work ought to be welcomed by photographers. Beginning with the fitting of the studio and the ordering of the solar print, it describes and explains every stage of the finishing of the portrait. It is written with thorough technical knowledge, and its instruction is minute and clear. It should be most useful, indeed, to those it is specially written for—the "artists struggling alone beyond the reach of competent teachers" to learn crayon portraiture.

THE medal winners are respectfully requested to send the pictures selected by the judges from their exhibit to any one of the following committee, who are appointed to pack and send the same to the German Convention to be held in August next: Mr. G. Gennert, 54 E. Tenth Street, N. Y.; Dr. Elliott, 591 Broadway, N. Y.; Mr. W. U. Fuller, 423 Broome Street, N. Y. Mr. Gennert sails for Europe on July 22d, and any panels reaching him by the 21st he will carry with him.

WE have received from Mr. W. I. L. ADAMS, Editor of the *Photographic Times*, a sample of his work with the camera. It is a scene in the woods near his home in Montclair, N. J. Oaks and chestnuts shade a little stream, which makes a pretty curve across the foreground, while further back it disappears among the thickly growing tree-trunks. The picture is clear, sharp, and yet full of atmosphere, and is altogether a very beautiful bit, proving that Mr. ADAMS is at home behind the camera as well as before the desk, and that his utterances from the latter may command consideration as coming from thoroughly practical knowledge.

MR. L. WALKUP, Secretary of the Air-Brush Manufacturing Company, says the air-brush did well at St. Louis. The Rockford, Ill., *Gazette*, and the St. Louis *Post-Dispatch*, as well as other papers, gave it a good notice, and at the Convention it was highly commended by artists. The *Post-Dispatch* said: "One of the most attractive and interesting exhibits at the photographers' display at the Exposition, is that of the Air-Brush Manufacturing Company, of Rockford, Ill. Exquisite results are obtained with the air-brush."

FROM the McINTOSH GALVANIC AND FARADIC BATTERY Co., of Chicago, we have received the splendid catalogue of their Optical Department. Its one hundred and twenty pages tell of everything that can be needed for lantern projection, for microscopy, and for amateur photography. The famous specialties of this great stockhouse of the West are described, including the McIntosh Solar Microscope and Stereopticon Combination and the McIntosh Sciopicon and Microscope. These, and many other instruments, the first of the three parts of the catalogue describes with many useful explanations and instructions. The second part is in effect a valuable condensed treatise on light for projection, describing among other things the patented McIntosh-Ives Saturator. The third part is an immense list of lantern slides of every class, on every possible subject—geographical, educational, scientific, and the whole of Mr. EDWARD L. WILSON'S catalogue of Oriental views. A superb series of microscopic objects are also found catalogued. On the back page of the cover of this book are cuts of the gold medals awarded for excellence in both optical and electrical apparatus at the World's Exposition at New Orleans, which were taken by the McINTOSH COMPANY over many other competitors, both home and foreign.

# Specialties.

## ADVERTISING RATES FOR SPECIALTIES.

25 cents for each line, seven words to a line—in advance. *Operators desiring situations, no charge.* Matter must be received a week before issue to *secure* insertion. Advertisers will please not ask us for recommendations. ~~We~~ We cannot undertake to mail answers to parties who advertise. Please always add your address to the advertisement. **Postage-stamps taken.**

**MAKE OUT YOUR OWN BILL,** and remit cash with your advertisements, or they will not be inserted.

### CUT RATES ON ACCESSORIES.

Send for catalogue.

L. W. SEAVEY,  
216 E. Ninth Street, New York.

**RETOUCHING BUREAU.**—Under the direction of Mr. H. Harshman. None but skilled help employed. Quality of work guaranteed. Prices moderate. Send your negatives in wooden box with cover screwed on, and prepay charges.

Address **GAYTON A. DOUGLASS & Co.,**  
Merchants in Photo. Supplies,  
185 & 187 Wabash Avenue,  
Chicago, Ill.

### BARGAIN LIST.

- 1 5 x 8 Scovill Manufacturing Company's Camera, with Eastman Roll-holder, with tripod, focusing-cloth and light carrying case. *All new*.....\$35 00
- 1 5 x 7 Scovill Manufacturing Company's Revolving-back Camera, three extra holders, with kits; 1 tripod..... 30 00
- 1 18-inch Entrekin Burnisher (old style)... 10 00
- 1 14-inch Entrekin Burnisher, (nearly new)..... 15 00
- 1 Centennial Head-rest, perfect..... 8 00
- 1 Spencer Head-rest (old style)..... 1 50
- 2 Bergner Cutters, stereoscopic arch top, each..... 15 00
- 1 Bergner Cutter, stereoscopic square top.. 10 00
- Printing-frames, 10 x 12 (nearly new)..... 60
- “ “ 6½ x 8½ “ “ 35
- “ “ 5 x 8 “ “ 30
- Negative boxes 5 x 8, 8 x 10, 10 x 12, and 14 x 18 from 25 cents to \$1.10.

**ESTES & FELLOWS,**  
1125 Chestnut St., Phila.

### TO PHOTOGRAPHERS.

I have now added a new floor to my stock-house, which will be specially devoted to *accessories, camera-stands, camera-boxes, chairs, etc.* A call solicited. New lists on application.

**GEORGE MURPHY,**  
250 Mercer St., N. Y.

## DOWN SHE GOES!

NEW PRICE-LIST

OF THE

**ROCKWOOD SOLAR PRINTING CO.**

17 UNION SQUARE NEW YORK.

Size.	Unmounted.	Mounted.
11 x 14.....	\$1 00	\$1 25
13 x 16.....	1 00	1 25
14 x 17.....	1 00	1 25
16 x 20.....	1 00	1 25
18 x 22.....	1 20	1 50
20 x 24.....	1 35	1 50
22 x 27.....	1 40	1 90
25 x 30.....	1 40	1 90
27 x 32.....	2 25	3 00
29 x 36.....	3 00	4 00
30 x 40.....	4 00	5 00

No charge for negatives. All orders must be accompanied by the cash. Make all P. O. orders payable to **ROCKWOOD SOLAR PRINTING CO.,** 17 Union Square, New York.

### PADDLE AND PORTAGE,

BY

**THOMAS SEDGWICK STEELE,**

AUTHOR OF

“CANOE AND CAMERA,” ETC.

### A PHOTOGRAPHIC TOUR

Of over 500 miles through the Maine wilderness. 60 illustrations from negatives by the author.

Price, in cloth and gold . . . . \$1.50

**ESTES & LAURIAT,** Publishers, Boston.

OR

**EDWARD L. WILSON,** 853 BROADWAY, New York.

**FOR SALE.**—Cheap for cash. A photographic and tintype outfit. Has only been used two years. For particulars, address

Lock Box 403,  
Mankato, Minn.

**WILSON, HOOD & CO.,**  
**825 Arch St.,**  
**PHILADELPHIA.**

We have now in stock  
**THE NEW EAGLE DRY PLATE.**

ALSO

**THE INGLIS TRIUMPH PLATE.**

A new brand of

**GERMAN PYRO ACID.**

(35 cents per ounce.)

**POCKET GLASS CUTTER.**

(15 cents each.)

**NEW STYLE CORNER CHAIR.**

(\$10.00 each.)

**PAPIER MACHÉ STUMP.**

(\$6.00 each.)

**SUNSHINE MAILING ENVELOPE.**

FOR SALE.—Strictly first-class gallery; best location on Broadway. Address

E. L. WILSON,  
 853 Broadway, New York.

FOR SALE.—One of the finest photographic studios in New England; established twenty-nine years, and has always done a good business. Location the best; good entrance and in a first-class block, and up only one flight. Reception and skylight-room nicely frescoed and furnished and heated by steam. Size of skylight 24 feet square, and side light 6 x 24 feet, with plenty of room to work all around it. About 32,000 negatives, all in good order. Prices good, \$6.00 for cabinets and \$3.00 for cards. Population about 38,000. Plenty of good running water. Sold for no fault; I have stood and worked by the camera for over thirty years, and am now ready to retire. There is no old plunder; everything first-class; instruments the best. My present operator would remain if wanted. For particulars, price, etc., address

M. C. LOVELL,  
 P. O. Box 1146.  
 Springfield, Mass.

**THE USUAL RESULT.**

It is not to be denied that a good sewing machine is one of the most important appurtenances of the modern household.

We thought we had a good machine until one day the agent of the *New Home* presented himself at our door and proceeded to deliver an oration upon its characteristic merits.

"But," we answered, "our machine suits us well and we do not care for another."

The agent, however, begged the privilege of leaving one of his machines with us "for the ladies to try."

The request was not unreasonable, so we granted it, but more to oblige the agent than anything else, for we really did not want the machine, and had not the remotest idea of buying it.

The machine once in the house, it was natural that the ladies should look it over; they did so, and as a consequence fell in love with it. They say that without the slightest wish to decry or disparage any other machine, this, all things considered, is, in their opinion, the most desirable one to be had.

**THE LIGHT RUNNING**

**NEW HOME**

**SEWING MACHINE**

**HAS NO EQUAL.**

**PERFECT SATISFACTION**

**New Home Sewing Machine Co.**

**—ORANGE, MASS.—**

30 Union Square, N. Y. Chicago, Ill. St. Louis, Mo.  
 Atlanta, Ga. Dallas, Tex. San Francisco, Cal.

**FOR SALE BY**

This unrivalled machine is manufactured by the **NEW HOME SEWING MACHINE CO.**, and sold at the above-named places.

**WANTED.**—A young man of some experience, who would like to learn more about operating and retouching. Good business end in view.  
 Address **McFARLIN & SPECK,**  
 Moravia, N. Y.

Having contracted for a special make of glass, the SEED DRY-PLATE CO. can now guarantee a flat, even, and straight plate. A full stock of this well-known brand kept at the *New York Depot by the Agent.* GEORGE MURPHY, 250 Mercer St., N. Y.

**BROMIDE ENLARGEMENTS.**

We are now prepared to furnish fine permanent bromide enlargements from photographers' negatives, as follows :

	Unmounted.	Mounted.
10 x 12.....	\$1 00 each.	\$1 50 each.
11 x 14.....	1 25 "	1 75 "
14 x 17.....	1 50 "	2 00 "
16 x 20.....	1 75 "	2 25 "
18 x 22.....	2 25 "	2 75 "
20 x 24.....	2 50 "	3 00 "
22 x 27.....	2 75 "	3 50 "
25 x 30.....	3 00 "	3 75 "
24 x 36.....	4 00 "	4 75 "
30 x 40.....	6 00 "	7 25 "
30 x 48.....	8 50 "	10 00 "

Terms cash with order.  
Specimens furnished from our own negatives at above prices.

If fine negatives are sent, finely retouched, no working up will be necessary.

We will retouch negatives or finish prints in crayon, pastel, India-ink, or water-colors at very reasonable prices, putting on any amount of work you may wish from \$1.00 upwards.

Please specify size of print, whether vignettted or solid, if vignettted how far down to show, whether mounted or unmounted on card or stretcher, whether to retouch negative or not; if you wish us to work up print give full instructions, if not, state what you want the print for, etc.

If to be made from a picture the print will cost 50 cents more, and will require finishing.

Patent stamp photos. 75 cents per hundred.

Respectfully,  
HULBERT BROS. (Genelli),  
923 Olive Street, St. Louis, Mo.

Another preserver of neatness is Anthony's Artist's Cuffs. The engraving makes the article



and its use plain. No more spoiled shirts or soiled wrists.

**THE DUPLEX NOVELETTE CAMERA**

Is a marvel of Camera architecture. In an instant a "vertical" camera may be turned into a "horizontal," and in another the change made from the 5 x 8 to the 8 x 10 size, and vice versa. It is supplied in two carrying cases, so that you may leave one part at home if you desire. The same platform and one front serves for both sizes. It is as complete an equipment as ever was invented. One holder, each size, goes with the "Duplex" at \$35. Messrs. E. & H. T. Anthony & Co. are the makers.

**EAGLE STOCKHOUSE.**

NOW IN STOCK

TRAPP & MUNCH'S CELEBRATED

Extra Brilliant Albumen Paper,

ALSO

The Chicken Brand—Extra Brilliant.

TRY THEM.

FOR SALE BY

GEORGE MURPHY,

250 MERCER STREET, NEW YORK.

Reed's Common-sense Negative Washing-box. New. Send for circular.

WILSON, HOOD & Co.,  
[825 Arch St., Phila.

Among all the photographic lenses of various makes and styles which have been introduced during the past ten years, the euryscopes, of which Voigtlander & Son are the sole manufacturers, loom up conspicuously. The success of these lenses has been unparalleled, and the demand is as lively as ever. They can be found in nearly every gallery in the land, and the amount of satisfaction and profit they produce is difficult to calculate. Most convincing proof of their superiority over other lenses is the exquisite work done with them, and the fact that it is simply impossible to get along without them.

DEAR SIR: Please send us three copies of *Long's Art of Making Crayons on Solar Enlargements*, and oblige

BUCHANAN, SMEDLEY & BROMLEY,  
25 N. Seventh Street, Phila.

FOR SALE.—Big bargain, pair of gas-bags and low pressure dissolver. All O. K.

WANTED.—A matched pair of 1/2 and 1/4 size lenses. Address H., Box 128, Indiana, Pa.

Send for our bargain list.

WILSON, HOOD & Co.,  
825 Arch St., Phila.

FOR SALE.—Photograph gallery. Price \$700. Require only about one-third cash, time given for balance; a fine chance to get a good business—ill health my only reason for selling. Don't write unless you mean business. Address

NAGLE,

162 W. First St.,

Oswego, N. Y.

SPECIAL CARD.

Talcott's Improved Mounting for photographs softens the lines, gives much strength and great brilliancy to the picture, and is the only process by which a photograph may become indelible.

Patented March 23, 1886.

For preserving from all soiling engravings, etchings, crayons, diplomas, certificates, etc., this mounting has no equal, the picture or parchment being hermetically sealed.

Pictures thus mounted can be displayed or packed in less than one-half the space required by pictures with other framings, as by this process all other framing becomes wholly unnecessary, yet it is so constructed that if desired it can be placed in any ordinary picture frame intact, free from all interference.

E. K. TALCOTT,

216 Nothampton St.,

Boston, Mass.

FOR SALE.—For \$3000, one of the best galleries in Cincinnati. Six doors from Van Loo's gallery. Rare chance. Address

THEO. C. MARCEAU,

148 W. Fourth St., Cincinnati, O.

The American Artists' Association is reestablished for solar printing in silver, solar printing in platinum, finishing in ink, water-colors, crayon, pastel, and oil.

WILSON, HOOD & Co.,

Trade Agents, Phila.

OUR dark-room and laboratory are under the charge of Dr. John Nicol, photographic chemist, late of Edinburgh. None but purest chemicals used in our preparations. All the standard dry-plate developers kept in stock. Your patronage desired.

GAYTON A. DOUGLASS & Co.,

Merchants in Photo. Supplies,

185 & 187 Wabash Avenue,

Chicago, Ill.

EVERY photographer in want of excellent lenses, for any purpose, will best serve his interest by consulting the new illustrated price-list of Messrs. BENJAMIN FRENCH & Co. before purchasing.

### SITUATIONS WANTED.

No charge for advertisements under this head; limited to four lines. Inserted once only, unless by request.

By an energetic and experienced operator, either on salary or percentage. Well up in all branches of photography. For references and samples, address Photographer, 118 D Street, N. W., Washington, D. C.

In first-class gallery, as dark-room man, or as printer and assistant retoucher. Has been connected for the last eight years with first-class galleries only. Address Photographer, Lock Box 946, Mobile, Ala.

Permanently, by a German of many years' experience, as printer and toner. His wife is a No. 1 retoucher and an artist in crayon and pastel. Recommended by Mr. Kurtz, of New York. Address A. De Lernos, 400 E. Broad Street, Richmond, Va.

In the gallery of an educated photographer, by a first-class retoucher as general assistant. Salary \$15 per week. Address Jacob Lutberg, 320 W. Thirtieth Street, N. Y.

As first-class general assistant. Steady employment more an object than wages. Address E. R. Sherman, Port Jervis, Orange Co., N. Y.

To retouch negatives. Address C. L. Philipps, Box 389, W. Newton, Mass.

## PHOTOGRAPHERS' ART VINE.

Beautiful and durable Ivy Vine for scenic effects; manufactured especially for photographers. All natural vines and leaves imitated. Send for circular. Special rates to dealers in photographers' supplies.

S. G. SHERWOOD,

232 Vermont St., Buffalo, N. Y.

## G. W. WILSON & CO.

(By special appointment Photographers to Her Majesty the Queen),

MANUFACTURERS OF MAGIC LANTERN SLIDES,  
St. Swithin Street, Aberdeen.

Catalogue of 12,000 subjects in England and Scotland, and Price Lists, post free on application.



**SHARP FOCUS**

INSTANTLY OBTAINED WITH

**Collins' Focusing Attachment, Patented**

SWEET, WALLACH & CO.. SOLE AGENTS FOR THE UNITED STATES.

FOR SALE BY ALL DEALERS.

NO FOCUSING CLOTH REQUIRED.

NO GROUND GLASS REQUIRED.



THE NEW WAY.

P  
R  
I  
C  
E

\$3.50

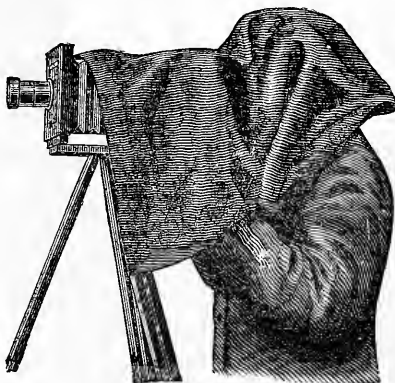

THE OLD WAY.

Send for Circulars.

**Sweet, Wallach & Co.,**

PHOTOGRAPHERS' SUPPLIES,

229 & 231 STATE STREET,

CHICAGO.

---

**GAYTON A. DOUGLASS & CO.**

MERCHANTS IN

**SUPPLIES FOR PHOTOGRAPHY,**

**185 & 187 Wabash Ave.,**

**CHICAGO.**

# THE DUBOIS FILING CASES.

*For Preserving Photographic Negatives, Prints, &c., Letters, Bills, and Miscellaneous Papers.*

PATENTED SEPTEMBER 2, 1884.

**Economical! No Binding! Either a Temporary or a Permanent File.**

Made in  
five sizes and cabinet  
form.

**AGENTS WANTED.**

Write for Descriptive  
Circular.

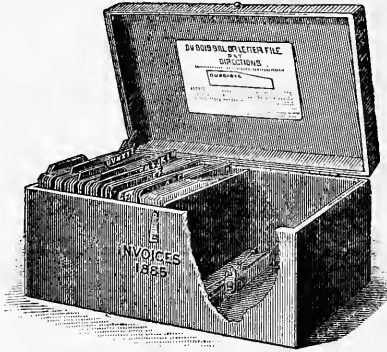

New York,  
April 27, 1886.  
Mr. FRANK G. DuBois,  
No. 512 W. 30th St., N. Y.  
DEAR SIR: Your File supplies a need that I have felt for some time past. It is the best thing of the kind that I have ever seen, and I shall be much pleased to recommend it to all my friends for preserving bills, notes, receipts, recipes, unmounted prints, photographs, and all kinds of miscellaneous papers to which easy reference may be wanted at any time. Respectfully,  
MISS SOPHIE L. MAURER.

Sent by Express, on receipt of \$3.00, or with lock and key, \$4.00.

PATENTEE AND SOLE MANUFACTURER,

FRANK G. DuBOIS, 512 W. 30th St., New York.

TO THE TRADE ONLY.

## HYPOSULPHITE OF SODA

FOR PHOTOGRAPHERS.

### CHAS. A. W. HERRMANN,

16 Cedar St.

New York.

TO THE TRADE ONLY.

SIXTEEN YEARS PRACTICAL EXPERIENCE

**MOSS ENGRAVING CO.**

1535 PEARL ST. COR. ELM. NEW YORK

MOSS' NEW PROCESS Superior to any other method.

THE LARGEST Photo Engraving ESTABLISHMENT IN THE WORLD

ILLUSTRATIONS of Every Description For Books, Magazines, Newspapers, Catalogues, CIRCULARS, &c. in the Highest Style of the Art.

SEND GREEN STAMP FOR 24-PAGE CIRCULAR → SEND PHOTOGRAPH, DRAWING OR PRINT FOR ESTIMATE.

**C. H. CODMAN & CO.**

**Photographic Stockdealers**

Sole Agents for the NEW ORTHO-PANACTINIC LENS, Moor's Photographic Enamel, the Perfect Mounting Solution for mounting Photographs on the thinnest mount without wrinkling.

New England Agents for American Optical Co.'s Apparatus. The best in the world. Send for Price List.

34 Bromfield Street.

BOSTON, MASS.

# The Photo-Gravure Company,

853 Broadway, New York.

PHOTO- { GRAVURE  
LITHOGRAPH  
CAUSTIC  
GELATINE } PRINTING

## PROCESSES OF THE PHOTO-GRAVURE COMPANY.

**PHOTO-GRAVURE.**—By this process the highest artistic effects are produced. Metal plates are engraved (in intaglio) by photography and printed in copper-plate presses. The effects produced by photography may be altered by the hand of the artist, values may be increased or diminished, and almost any omission or addition made. The work may be carried on till the desired effect is produced and the edition is always uniform. The plates can be supplied when desired, or the Photo-Gravure Co. will do the printing. The results obtained by the Photo-Gravure Co. equal the best results obtained abroad, and reference to this effect is permitted to leading Publishers and Artists who have used these plates. All classes of subjects, whether in half-tone or line, can be produced by this process.

**PHOTO-GELATINE PRINTING.**—The results produced by this process are similar to what is known as Albotype, Artotype, Heliotype, Autoglyph, Phototype, Lichtdruck, etc. The particular method used is that patented by Mr. T. C. Roche, and is believed to give the best results at the least cost. The Photo-Gravure Co. has in this department the best staff of printers in the country and a most extended experience of the treatment of gelatine for the purposes of printing. All classes of subjects are suitable for reproduction by this process, and it is especially suitable for portraits, views, architecture, art catalogues, scientific and natural objects, book illustration, town, county, and family histories, theatrical and general advertising, reproductions of engravings, machinery, animals, and still life, copies of deeds, instantaneous effects, scientific records, mill labels, etc.

**PHOTO-CAUSTIC PRINTING.**—This term is applied to a modification of the results produced by Meisenbach, Ives, and others. By this modification the photographic effect is produced from stone. No attempt is made to produce engraved plates, but the printing is done by the Photo-Gravure Co., and by this means greatly better results are obtained than where plates are made and placed in the hands of the ordinary printer. The results are not as good as those obtained from Gelatine or by Photo-Gravure, but they are sufficiently good for a number of purposes where the quality of the higher grades of work is not necessary. It is applicable to all the purposes of the other processes, but is lower both in cost and quality.

**PHOTO-LITHOGRAPHY.**—The results of this well-established process are well known. It is the oldest of the photo-mechanical processes, but is only adapted to the reproduction of original drawings or engravings which are made in a black or other non-actinic color on a white or light ground. We have in our employ on this work the most skillful staff in the country, who for many years have made it a specialty. Photo-Lithography is unrivalled for the reproduction of maps, plans, tracings, surveys, patents, and other drawings, engineers' and architects' designs, *fac-simile* letters and circulars, exhibits in law cases, miniature catalogues, copies of line engravings, reduction or enlargement of line work, etc.

A Book of Specimens of our various processes will be forwarded on receipt of One Dollar, and all inquiries will be promptly answered. Special arrangements made with photographers.

THE PHOTO-GRAVURE CO.,  
853 Broadway, New York.

*The Eagle Paper Keeps its Place as Leader.*

Try the New Colors of the Leading

**DRESDEN ALBUMEN PAPER.**

**IMPROVED**

**EXTRA-BRILLIANT PENSEC,**

10 KILOS.



10 KILOS.

**EXTRA-BRILLIANT NEW ROSE.**

**It Possesses the Highest Durability of Color.**

It Never Blisters. It Keeps Well after Silvering.

It Tones Easily. It Gives the Most Vigorous  
and Brilliant Prints. It is the Best

Selected Paper.

It is Always Uniform and Reliable, and has the Least  
Objectionable Water-Mark. The Majority  
of Artists will Have It.

**SAMPLES FREE ON APPLICATION.**

For Sale by all Stockdealers in the United States  
and Canada.

**G. GENNERT,**

Importer,

**No. 54 EAST TENTH STREET,**

**NEW YORK.**

720 (5 gross) of these trimmers were sold to one party in July.

**ROBINSON'S NEW MODEL PHOTOGRAPH TRIMMERS!**

This drawing is of the full natural size and shape of the New Model Revolving Trimmer. The Straight Cut is of same size, varying but little in shape.

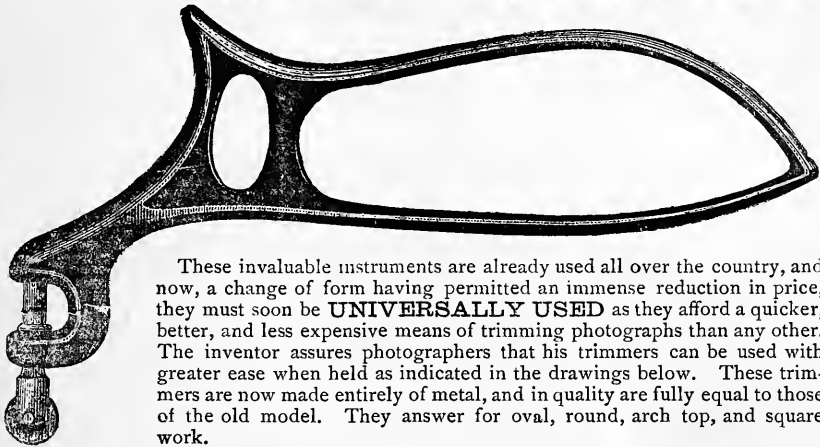

These invaluable instruments are already used all over the country, and now, a change of form having permitted an immense reduction in price, they must soon be **UNIVERSALLY USED** as they afford a quicker, better, and less expensive means of trimming photographs than any other. The inventor assures photographers that his trimmers can be used with greater ease when held as indicated in the drawings below. These trimmers are now made entirely of metal, and in quality are fully equal to those of the old model. They answer for oval, round, arch top, and square work.



Plan of holding the *Straight Cut* Trimmer when in use. **PRICE, 50 CENTS.**

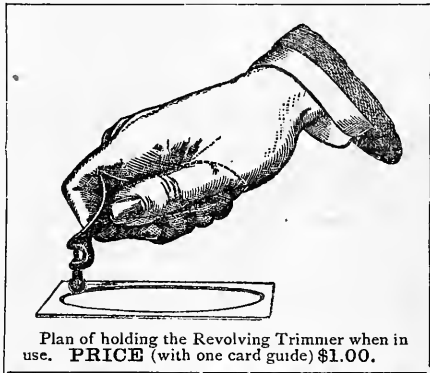

Plan of holding the *Revolving* Trimmer when in use. **PRICE (with one card guide) \$1.00.**

**ROBINSON'S GUIDES.**

MADE OF SHEET-IRON.

We have the following Regular Sizes always on hand at 10 cents per inch the longest way of the aperture.

**OVALS.**

2 x 2 <sup>7</sup> / <sub>8</sub>	3 <sup>3</sup> / <sub>8</sub> x 4 <sup>3</sup> / <sub>8</sub>	5 x 7	6 <sup>1</sup> / <sub>2</sub> x 8 <sup>1</sup> / <sub>2</sub>
2 <sup>1</sup> / <sub>2</sub> x 3 <sup>1</sup> / <sub>8</sub>	3 <sup>3</sup> / <sub>8</sub> x 4 <sup>3</sup> / <sub>8</sub>	5 <sup>1</sup> / <sub>2</sub> x 7 <sup>1</sup> / <sub>4</sub>	6 <sup>1</sup> / <sub>2</sub> x 8 <sup>1</sup> / <sub>2</sub>
2 <sup>1</sup> / <sub>2</sub> x 3	3 <sup>3</sup> / <sub>8</sub> x 4	5 x 7 <sup>3</sup> / <sub>8</sub>	7 x 9
2 <sup>1</sup> / <sub>2</sub> x 3	3 <sup>3</sup> / <sub>8</sub> x 5	5 x 7 <sup>3</sup> / <sub>8</sub>	7 <sup>1</sup> / <sub>2</sub> x 9 <sup>1</sup> / <sub>2</sub>
2 <sup>1</sup> / <sub>2</sub> x 3	4 x 5	5 <sup>3</sup> / <sub>8</sub> x 7 <sup>3</sup> / <sub>8</sub>	7 <sup>1</sup> / <sub>2</sub> x 9 <sup>1</sup> / <sub>2</sub>
2 x 4 <sup>1</sup> / <sub>2</sub>	4 <sup>3</sup> / <sub>8</sub> x 6	6 x 8	7 <sup>1</sup> / <sub>2</sub> x 9 <sup>1</sup> / <sub>2</sub>

**SQUARE OR ROUND CORNERED.**

2 <sup>1</sup> / <sub>5</sub> x 3 <sup>3</sup> / <sub>4</sub>	2 <sup>5</sup> / <sub>8</sub> x 3 <sup>3</sup> / <sub>4</sub>	2 <sup>3</sup> / <sub>4</sub> x 4 <sup>1</sup> / <sub>2</sub>	4 x 5 <sup>5</sup> / <sub>8</sub>
2 <sup>1</sup> / <sub>2</sub> x 3 <sup>3</sup> / <sub>4</sub>	2 <sup>5</sup> / <sub>8</sub> x 3 <sup>7</sup> / <sub>8</sub>	2 <sup>3</sup> / <sub>4</sub> x 4 <sup>5</sup> / <sub>8</sub>	4 <sup>1</sup> / <sub>8</sub> x 5 <sup>5</sup> / <sub>8</sub>
2 <sup>1</sup> / <sub>2</sub> x 3 <sup>3</sup> / <sub>4</sub>	2 <sup>3</sup> / <sub>4</sub> x 4 <sup>1</sup> / <sub>2</sub>	3 <sup>3</sup> / <sub>8</sub> x 5 <sup>1</sup> / <sub>4</sub>	3 <sup>7</sup> / <sub>8</sub> x 6
2 <sup>5</sup> / <sub>8</sub> x 3 <sup>1</sup> / <sub>8</sub>			4 x 6 <sup>1</sup> / <sub>8</sub>

**FOR STEREOGRAPHS.**

Arch Tops.	Round Cornered.	Round.
3 <sup>1</sup> / <sub>5</sub> x 3 <sup>3</sup> / <sub>4</sub> , 3 x 3	3 <sup>1</sup> / <sub>5</sub> x 3 <sup>3</sup> / <sub>4</sub> , 3 x 3	3 x 3

The above sizes suit the Collins Card Mounts, and photographers knowing that they can be always had at the low price of ten cents per inch, would do well to *make their sizes accord*, as orders can also be filled more quickly. Ten days are required to make special sizes.

Special Sizes made to order, at 15 cents per inch, the longest way of the aperture.

**ROBINSON'S PHOTOGRAPH TRIMMERS** are substitutes for the Knife for Trimming Photographs, and do the work much more expeditiously and elegantly. They Save Time, Save Prints, and Save Money.

They do not cut, but pinch off the waste paper, and leave the print with a neatly bevelled edge which facilitates adherence to the mount. Try one, and you will discard the knife and punch at once. For ovals and rounded corners they are worth their weight in gold.

For sale by all Dealers.

**ROBERTS & FELLOWS,**

Successors to E. L. WILSON,

1125 Chestnut St., Philadelphia, Pa.

**H. P. ROBINSON,**

OF TUNBRIDGE WELLS, ENGLAND,

Contributes *ANOTHER PAPER* to the

# PHOTOGRAPHIC TIMES

FOR JULY.

There will also be interesting articles from

**VICTOR SCHUMANN,** of Leipsic,

AND

**CHARLES SCOLIK,** of Vienna.

THE POPULAR SERIES OF ARTICLES

ON

## TOURIST PHOTOGRAPHY

By **ANDREW PRINGLE,**

Commenced in June will be continued in the July Weeklies,  
besides articles from

**G. WATMOUGH WEBSTER, F.C.S.,**

**C. D. CHENEY, D.D.S.,**

**DR. GEO. L. SINCLAIR,**

**MR. ERNEST EDWARDS,**

and many others. All this will be given with the **Editorials, Society News, Letters to the Editors, Notes and Queries, and Commercial Intelligence.**

### A PARTIAL RECAPITULATION FOR JUNE.

TOURIST PHOTOGRAPHY (a Series).....	By ANDREW PRINGLE.
HALATION.....	By W. K. BURTON.
ORTHOCHROMATIC PHOTOGRAPHY.....	By E. BRERSTADT.
ON VIGNETTS AND VIGNETTING.....	By G. WATMOUGH WEBSTER, F.C.S.
SIMPLEX PICTURES.....	By C. D. CHENEY, D.D.S.
ART IN RELATION TO PHOTOGRAPHY.....	By W. C. WAY.
SYSTEMATIC EXPOSURE.....	By A. S. PLATTS.
A GOOD METHOD FOR DEVELOPING.....	By W. A. FOSTER.
PHOTO-MICROGRAPHY.....	By ROMYN HITCHCOCK, F.R.M.S.
THE REMOVAL OF SILVER STAINS FROM GELATINE NEGATIVES.....	By DANIEL ROBERTSON.
PHENER'S COLD EMULSION.....	.....
CONVENTION MATTERS.....	By D. R. CLARK.
THE CORRECT PLACE FOR A SHUTTER.....	By M. H. R.
PHOTOGRAPHY IN CHICAGO.....	.....
OUR EDITORIAL TABLE.....	.....
NOTES AND QUERIES.....	By the Editors.
GENERAL NOTES.....	” ”

There may be some who are not fully aware of the growth of our journal, so to such and others an offer is made of a month's trial (four weeklies) for 30 cts.

W. IRVING ADAMS, Agt. **SCOVILL MFG. CO.,** Publishers.

SUBSCRIBE NOW AND SECURE THE BACK NOS. BEFORE THEY ARE ALL SOLD.

# PERMANENT BROMIDE ENLARGEMENTS.

Having equipped an Enlarging Department for testing our Permanent Bromide Paper, we are prepared to make enlargements from Photographers' Negatives, promptly and of the best quality. When *good original* negatives are furnished, these enlargements require little or no finishing, and are far superior to those made by any other process whatever.

Permanent Bromide Enlargements can be finished in India ink, crayon, water colors, or oils.

Pack negatives carefully, and specify whether to be *vignetted* or *solid*. *Plain* enlargement signifies unfinished.

Specify whether stretcher or card mount is desired.

## PRICES OF PERMANENT BROMIDE ENLARGEMENTS.

### ON CRAYON PAPER.

	Unmounted.	Mounted.
10 x 12, each.....	\$1 00	\$1 50
11 x 14, " .....	1 25	1 75
14 x 17, " .....	1 50	2 00
16 x 20, " .....	1 75	2 25
18 x 22, " .....	2 25	2 75
20 x 24, " .....	2 50	3 00
22 x 27, " .....	2 75	3 50
25 x 30, " .....	3 00	3 75
24 x 36, " .....	4 00	4 75
30 x 40, " .....	6 00	7 25

## PRICES OF PERMANENT BROMIDE ENLARGEMENTS.

### MATT SURFACE ON OPAL GLASS.

10 x 12, each.....	\$3 00
11 x 14, " .....	3 50
14 x 17, " .....	4 00
16 x 20, " .....	5 00

Terms: Cash with order. Specimens furnished from our own negatives at the above prices.

**The EASTMAN DRY PLATE AND FILM CO.**  
ROCHESTER, N. Y.

ASK FOR THE  
BLUE LABEL.

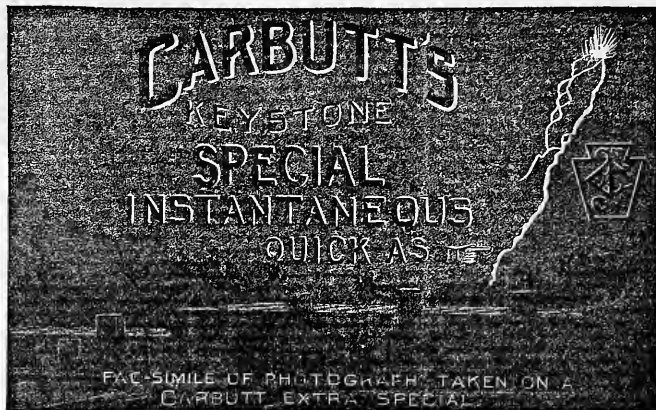

TRY THEM  
and you will continue to  
USE THEM.

Pronounced the "Ne Plus Ultra" of Dry Plates.

UNSOLICITED TESTIMONIALS.

MR. JOHN CARBUTT, Wayne Junction, Philadelphia.

WORCESTER, MASS., December 25, 1885.

DEAR SIR: I have been using some of your new plates, emulsion 1024, sensitometer 24. I think they are, without exception, the finest and best plates I ever used. They are not only very fine and delicate in their structure, but, when properly manipulated, result in a blooming negative, possessing all the desirable qualities that any artist could wish for. I could most appropriately christen them the "Ne Plus Ultra Dry Plate."

Yours truly, E. R. B. CLAFLIN.

DETROIT, MICH., January 16, 1886.

MESSESS. HARRIS & KITTLE.

GENTLEMEN: I am very much pleased with the Carbutt Plate; in fact, I call them the best plate *by far* that I tried so far. I find them especially useful for my theatrical subjects, as the quick emulsions are *absolutely instantaneous*.

Yours truly, A. B. TAYLOR.

*For Sale by all Dealers in Photo. Materials.*

JOHN CARBUTT, Keystone Dry Plate Works, Wayne Junction, Philada., Pa.

HOME FROM THE ST. LOUIS CONVENTION.

## THE GEMS.

The New Goods ordered, and will be in ready stock shortly, viz.:

*Hermagis Lenses.*

*Felt Grounds.*

*Curtains. Late Designs.*

*Knapp & Caldwell's New Accessories.*

*Ashe's New Garden Seat.*

*Ashe's New Telescopic Balustrade.*

*Acme Burnishers.*

*Eastman's Bromide Paper.*

*Young's Patent Double-barrelled Shutter.*

*The New 5 x 8 Novelette View Box, with 8 x 10 Attachment.*

*Barnett's Holders.*

*Nash's Detective Camera.*

*Bird's Patent Vignetter.*

*Perfection Drop Shutter.*

*Perfection Shutter for 4 1/4 Gem Lenses.*

*Moreno's Universal Developer.*

*Collins' New Cabinet Mounts.*

THE CELEBRATED SEED PLATES.

*Two Gold Medals awarded to Exhibitors whose pictures were made on these Plates.*

DETAILED LISTS OF THE ABOVE WILL BE ISSUED SHORTLY.

GEORGE MURPHY,

Photo. Goods.

250 Mercer St., New York.



FORTY-FIFTH HUNDRED BEING SOLD.

FORTY-FIFTH HUNDRED BEING SOLD.

# A PARTIAL PHOTOGRAPHIC ENCYCLOPEDIA.

By EDWARD L. WILSON, Editor "Phila. Photographer," "Photo. Mosaics," etc.

## A STANDARD BOOK FOR ALL WORKERS IN PHOTOGRAPHY.

### CONTENTS.

LESSON A. TREATMENT OF THE SUBJECT—B. THE NEEDFUL APPARATUS—C. THE OBJECTIVE OR LENS—D. THE DARK-ROOM—E. PREPARATION OF THE GLASS—F. CHEMICALS AND SOLUTIONS—G. THE MANIPULATIONS—H. MANIPULATORY MISERIES—I. RETOUCHING THE NEGATIVE—J. THE GLASS STUDIO—K. ACCESSORIES AND LIGHT—L. MANAGING THE MODEL—M. PRINTING ON ALBUMEN PAPER—N. PRINTING ON PLAIN PAPER—O. GENERAL REMARKS ON PRINTING—P. PRINTING ON VARIOUS SURFACES—Q. PRINTING PERPLEXITIES—R. ART IN PRINTING—S. MOUNTING AND FINISHING—T. PHOTOGRAPHY OUTSIDE—U. BROMO-GELATINE EMULSION WORK—V. VOGEL'S COLLODION EMULSION—W. ENLARGEMENTS AND LANTERN SLIDES—X. PHOTOTYPES, PLATINOTYPES, AND COLLODION TRANSFERS—Y. WASTES AND THEIR WORTH—Z. METRICAL MEASURING—&. CONCLUDING CONFAB—INDEX (SIX PAGES).

It is believed that this is the most valuable work ever offered to the working photographer. Its sale was never equalled. It contains 352 pages; 7 x 8½ inch cover, and is 1½ inches thick. More than 100 illustrations. It gives full details of all practical

### PROCESSES, OLD AND NEW, PUBLIC AND SECRET.

Among the latter are the "Phototype," sometimes called the "Artotype" process, with examples; many of the "Lightning" processes; the "Platinotype" process; the "Collodion Transfer" or "Mega-type" process, and many others.

58 pages are devoted to Posing and Lighting; 37 pages give instructions in Emulsion "Dry" Work; 29 pages show how to Build and Use Skylights; 108 pages furnish instructions for Manipulating Negatives; 37 pages are applied to Printing Formula and Dodges; 175 pages give Notes from Authors all over the world. It is printed on fine white paper, made especially for it, and sold at the low price of

**\$4.00 POST-PAID \$4.00.**

For the beginner, for the amateur, for the photographic worker, it is believed to be most complete. No live photographer should fail to get it soon, before his neighbor is ahead. For sale by all dealers.

**EDWARD L. WILSON, Publisher, 853 Broadway, New York.**

# BENJ. FRENCH & Co.

No. 319 WASHINGTON STREET, BOSTON,

Sole Agents in the United States for the Celebrated Lenses  
Manufactured by

## VOIGTLÄNDER & SON.

ALSO, THEIR FAMOUS

# EURYSCOPE,

Which is unrivalled for groups, full-length figures, and other demands in the gallery, and every species of out-door work, including instantaneous photography.

☞ **THE EURYSCOPE** is made *exclusively* by Voigtländer & Son, and their name is engraved on the tube.

FOR **DARLOT LENSES** FOR  
PORTRAITS. VIEWS.

IMPORTERS, ALSO, OF THE CELEBRATED

TRAPP & MÜNCH

## ALBUMEN PAPER,

AND DEALERS IN ALL KINDS OF

*Photographic Materials and Magic Lantern Slides.*

SEND FOR OUR NEW ILLUSTRATED PRICE LIST OF LENSES.

SUBSCRIBE FOR

**ANTHONY'S**  
**Photographic**  
**BULLETIN**



EDITED BY  
 CHAS. F. CHANDLER, Ph. D. LL.D.  
 Prof. of Applied Chemistry in the School of Mines  
 Columbia College, New York City.

**E. & H. T. Anthony & Co.**  
 591 BROADWAY  
 New York.

THE BULLETIN FOR 1886.

That the BULLETIN has proved a success during the past year, our long list of unsolicited testimonials bears ample witness. And we have found it utterly impossible to publish all the good things that have been said of us, owing to the wealth of material always at hand to fill our pages. What is yet more encouraging to us is the large increase in our subscription lists, on which the number of names is now almost double what it was one year ago, and is increasing with every issue of the journal.

We recall with pride the names of some of the contributors to our pages: Prof. C. F. Chandler, Ph. D., Prof. Ogden N. Rood, Dr. A. H. Elliott, Ph. D., Prof. J. M. Eder, Ph. D., Henry J. Newton, E. L. Wilson, Ph. D., L. H. Laudy, Ph. D., Victor Schumann, Prof. Chas. F. Himes, Thos. Bolas, F. C. S., M. Carey Lea, Dr. R. W. Wilcox, F. C. Beach, Dr. John H. Janeway, Prof. Spencer Newberry, A. A. Campbell Swinton, Fred. E. Ives, T. C. Roche, E. K. Hough, G. H. Loomis, J. B. Gardner, W. E. Partridge, P. C. Duchochois, J. F. Ryder, David Cooper, Abraham Bogardus, and a host of others. In addition to the contributions from the above gentlemen, we have given our readers clear and accurate reports of the photographic societies, in many cases from the stenographic notes of our own reporters. Our correspondence column has been a source of pleasure to our editors, and has become an important and unrivaled feature of our publication.

This is what we have done and shall continue to do, with this advantage, that the fund of material upon which we can draw in the future is still larger than that utilized in the past. Among other improvements we intend to illustrate every number of the BULLETIN with a specimen of the best work in both professional and amateur photography. Thus the subscribers will obtain in one year, two dozen gems of the photographic art. Various improvements in the literary part of the journal will also be made. In fact, nothing will be left undone to keep it in the front rank of American Photographic journals.

The improvements we contemplate will involve a large expenditure of money, and as we cannot be expected to furnish so much valuable material at a loss, we shall be compelled to charge three dollars for the illustrated edition of the BULLETIN, and two dollars without the illustrations. Just think of it! Twenty-four illustrations and seven hundred and sixty-eight pages of valuable photographic information for three dollars. There is not another photographic journal in America that does so much for so little. Either the illustrations alone or the literary material alone are worth the price of the subscription, and we give them both, so the subscriber gets twice the worth of his money.

We have laid out a large amount of work for the coming year, and we intend to carry it through. But to do this with energy and pleasure, we must have the encouragement of our readers and subscribers. Help us, and we will help you as much as, if not more, than in the past. Our policy will always be, *With charity for all and malice towards none*

THE PUBLISHERS.



OFFICE OF

# EAGLE DRY PLATE CO.

54 East Tenth Street.

GENTLEMEN :

We beg to inform you that a Company has been organized under the name of

Eagle Dry Plate Company of New York.

We are pleased further to state that henceforth there will no longer be a scarcity of good, reliable Dry Plates. Our factory is in operation and has such capacity as will enable us to fill at short notice the largest orders that may be sent us.

The parties who, up to the 15th of October, 1885, made the St. Louis Dry Plate, and who improved its quality to such a degree that it had no superior in the market and was preferred by the leading photographers of the United States, are connected with us and will manufacture the Eagle Dry Plate, for which we solicit your kind orders, assuring you that they are

**QUICK, CLEAR, RELIABLE.**

and will give perfect satisfaction.

Yours respectfully,

**EAGLE DRY PLATE CO.**

# THE PHILADELPHIA PHOTOGRAPHER.

TWENTY-THIRD YEAR, 1886.

*Devoted to the Advancement of Photography and the Dissemination of Art Principles.*

SEMI-MONTHLY: issued the First and Third Saturday of each month.

\$5.00 a year, \$2.50 for six months, \$1.25 for three months—in advance. 30 cts. per copy.

## CONTENTS OF THE FIRST QUARTER.

**JANUARY 2.**—A Happy New Year. Dry Plates—Continued, by THOMAS PRAY, JR. Washing Dry Plates, by C. W. HUNT. Practical Points from the Studios. Bibliography. Good Things from Mosaics, 1886. An Amateur in Australia, by CHAS. D. IRWIN. The Humor of It. A Model Studio "Away Down in Maine," by W. C. TUTTLE. Translations from Unus. A Plea for Overtiming, by EUGENE ALBERT. Photographic Facts and Fancies. Society Gossip. The Open Corner. The Department of Art. Queries, Conundrums, and Conclusions. Our Picture. Correspondence. German Correspondence. The World's Photography Focussed. Studio Studies. Editor's Table.

EMBELLISHMENT.—"Child Portrait," by J. LANDY, Cincinnati, Ohio.

**JANUARY 16.**—A Word or Two for '86. On "Type" Pictures, by KARL KLAUSER. Development with Carbonate of Soda, by M. E. AUDRE. Practical Points from the Studios. Cheap Prices, by T. H. BLAIR. Pertaining to the P. A. of A. Photographic Facts and Fancies. To the Photographers of America. The Open Corner. Photography at the Louvre Gallery. Our Picture. Composition, by XANTHUS SMITH. Society Gossip. The Humor of It. Art and Photography, by G. H. CROUGHTON. A New Picture. Views from My Office Window. The Exhibition of the Photographic Society of Philadelphia. The World's Photography Focussed. Editor's Table.

EMBELLISHMENT.—"Mother Shipton," by FALK, N. Y.

**FEBRUARY 6.**—Enlarged Reproductions, by G. HANMER CROUGHTON. German Correspondence. The Photography of the Future. A Marvellous Accomplishment, by W. B. TYLER. Practical Points from the Studio. Use Good Cardboard Only. Photo. Electric Illustrated Newspapers. The Open Corner. "Words, Words, Words." Molteni's Enlarging and Projecting Lantern. Society Gossip. Exhibition of the Photographic Society of Philadelphia. Our Picture. Pertaining to the P. A. of A. The World's Photography Focussed. Editor's Table.

EMBELLISHMENT.—"Good Morning," by D. T. BURRELL, Brockton, Mass.

**FEBRUARY 20.**—Composition—Part II., by XANTHUS SMITH. Development in Two Solutions, by D. BACHRACH, JR. Photographically Illustrated Books. Where Art Begins, by HUME NISBIT. Correspondence. Queries, Conundrums, and Conclusions. The Humor of It. Views from my Office Window. Photo. Facts and Fancies. The Open Corner. Our Picture. Pertaining to the P. A. of A. Society Gossip. The World's Photography Focussed. Editor's Table.

EMBELLISHMENT.—A Study from Themasses, by H. L. ROBERTS, Philadelphia.

**MARCH 6.**—Recent Photographs of Stars, by PROF. C. PIAZZI SMYTH. The Department of Art. Cardboard Support for Emulsion Films. The Open Corner. Photography for the Newspapers, by STEPHEN H. HORGAN. Another Amateur's Experience in Toning, by P. H. MASON, M.D. Practical Points from the Studios. Our Picture. More "Words." Society Gossip. Pertaining to the P. A. of A. The Secret Order of Scientific Photographers. Photo. Facts and Fancies. Queries, Conundrums, and Conclusions. The World's Photography Focussed. The Improved American Permanent Bromide Paper for Positive Prints and Enlargements, by F. C. BEACH. Editor's Table.

EMBELLISHMENT.—"The South," by H. L. ROBERTS & Co., Philadelphia.

**MARCH 20.**—"Please Do Not Fold." The Open Corner. Words of Wisdom. Practical Points from the Studios. On Printing and Toning. M. Balagny's Flexible Gelatino-Bromide Plates. Light and Shade. The Humor of It. The Illumination of the Transparency in Enlarging, by CHAPMAN JONES. Prints with Gallate or Tannate of Iron. Queries, Conundrums, and Conclusions. Light and Shadow, by XANTHUS SMITH. Society Gossip. First Annual Exhibition of the Camera Club of Hartford. Pertaining to the P. A. of A. The Society of Amateur Photographers of New York. A Visit to the Eagle Dry Plate Company's Works. Our Picture. Correspondence. Obituary. The World's Photography Focussed. Editor's Table.

EMBELLISHMENT.—"The Toilers of the Sea," by H. S. WYER, Yonkers, N. Y. A splendid Marine Study, in green.

The above six numbers to one address for \$1.25, prepaid.

The Philadelphia Photographer and Weekly Photographic Times to one address, \$6.50.

The Philadelphia Photographer and Anthony's Bulletin to one address, \$7.00.

EDWARD L. WILSON, 853 Broadway, New York.

OFFICE OF

# G. CRAMER DRY PLATE WORKS,

Shenandoah and Buena Vista Sts., St. Louis.

---

The demand for the Cramer Plates having outgrown our capacity, we have been compelled to enlarge, and are now erecting large additions to our works which will more than double our present capacity.

Thanking the fraternity for their kind support, we ask their indulgence for a short time longer, and we hope soon to be able to supply our friends regularly and promptly.                      Fraternaly,



DRY-PLATE WORKS, ST. LOUIS, MO.

---

**THE**

## ST. LOUIS DRY PLATE COMPANY

Beg to announce that under their New Management they have recently made Important Improvements and Increased their Facilities, so that they are now making better and more uniform plates than heretofore.

---

ALL ORDERS WILL RECEIVE PROMPT ATTENTION.

---

### ST. LOUIS DRY PLATE CO.

No. 827 Chouteau Avenue,

ST. LOUIS, MO.

Number 279.

30 Cents.

THE  
 PHILADELPHIA  
**Photographer.**

AN ILLUSTRATED SEMI-MONTHLY JOURNAL,  
 DEVOTED TO PHOTOGRAPHY.

SUMMARY OF CONTENTS.

	PAGE		PAGE
The St. Louis Convention, . . . . .	449	Mr. George Barker's Views of Niagara	
Pertaining to the P. A. of A., . . . . .	458	Falls and Florida, . . . . .	475
The Decline of Prices, and the Remedy.		The Canada Convention, . . . . .	476
By A. St. CLAIR, . . . . .	467	A Chautauqua Photographic Day, . . . . .	477
Art Censorship. By L. H. SCHUMAN, . . . . .	470	Our Picture, . . . . .	478
Money Making. By W. J. GUILD, . . . . .	472	Editor's Table, . . . . .	479
Convention Notes, . . . . .	473		

OUR PICTURE.—"The Valentine." By H. P. ROBINSON, Tunbridge Wells, England. Prints by  
 Roberts & Fellows, Philadelphia, on N. P. A. Paper.

EDWARD L. WILSON,  
*853 Broadway, New York.*

SUBSCRIPTIONS RECEIVED BY ALL NEWS AND STOCKDEALERS

Five Dollars per Annum, in Advance.

## ADVERTISEMENTS.

AIR BRUSH.  
 ALLEN BROTHERS. The Suter Lens.  
 ANTHONY & CO., E. & H. T. The New N. P. A.  
     Pensé Extra Brilliant Dresden Albumen Paper.  
 BARHYDT, J. A. Solar Crayon Portraits.  
 BIGELOW'S ARTISTIC PHOTOGRAPHY.  
 BUCHANAN, SMEDLEY & BROMLEY. Photo.  
     Stockdealers.  
 CARBUTT, J. Gelatine Dry Plates and Improved  
     Dry Plate Lantern.  
 CARPENTER, H. F. Analytical and Manufact-  
     uring Chemist.  
 CODMAN, C. H. & CO. Photo. Stockdealers.  
 COLLINS, SON & CO., A. M. Photograph Cards.  
 CRAMER, G. Lightning Plates.  
 DR. VOGEL'S AZALINE.  
 DEALERS' DIRECTORY.  
 EASTMAN DRY-PLATE AND FILM CO.  
 ENTREKIN, W. G. Patent Eureka Burnisher.  
     Duplex Rotary Burnisher. Duplicating Print-  
     Cutter.  
 FRENCH & CO, BENJ. Voigtlander & Son and  
     Darlot Lenses. The Wonderful Euryscope.  
 GENNERT, G. Eagle Dry Plates.  
 HANCE'S SPECIALTIES.

HERRMANN, CHAS. A. W. Hypo. Soda.  
 HODGE & HUSTON. The Solar Printers.  
 HYATT, H. A. New Brand of Dry Plates.  
 MAGEE & CO., JAS. F. Photographic Chemicals.  
 McINTOSH GALVANIC AND FARADIC BATTERY CO.  
 MOORE, ALBERT. Solar Enlarger.  
 MOSS ENGRAVING CO.  
 MURPHY, GEORGE. Photo. Stockdealer.  
 PAINE, A. B. & CO. Hypo. Eliminator.  
 PHOTOGRAPHIC TIMES.  
 SCOVILL MANUFACTURING CO. New Dres-  
     den Albumen Three Crown Paper. Gihon's  
     Cut-Outs. Photo. Apparatus.  
 STANLEY DRY PLATE.  
 STEINHEIL LENS.  
 ST. LOUIS DRY PLATE COMPANY.  
 SWEET, WALLACH & CO. Photo. Supplies.  
 SOMERVILLE, J. C. Photo. Supplies.  
 THE DU BOIS FILING CASES.  
 WALMSLEY & CO. Beck's Rectilinear Lens.  
 WILSON, HOOD & CO. Ross and Steinheil  
     Lenses, Photo. Frames, Goods, Stereoscopes,  
     and Views.  
 WILSON'S PHOTOGRAPHICS.

## ADVERTISING RATES.

THE PHILADELPHIA PHOTOGRAPHER is acknowledged to be the best advertising medium in the trade.

Its circulation is among the first class, at home and in nearly every foreign country.

Its rates, all advantages considered, are the most favorable, and it will bring you fine returns.

	One Issue.	Six Issues.	Twelve Issues.	Twenty-four Issues.
1 Page.....	\$20.00	\$110.00	\$200.00	\$350.00
1-2 " .....	12.00	66.00	120.00	200.00
1-4 " .....	7.00	38.50	70.00	120.00
1-8 " .....	4.00	22.00	40.00	70.00

Special contracts made with bona-fide dealers and manufacturers. Address

**EDWARD L. WILSON,**  
853 BROADWAY, NEW YORK.

## NOTICE TO SUBSCRIBERS.

In remitting by mail, a post-office order, or draft, payable to the order of EDWARD L. WILSON, is preferable to bank-notes. Postage stamps of the denomination of two and five cents each will be taken. Clearly give your Post-Office, County, and State.

Foreign subscriptions must be accompanied by the postage in addition.

**FIRE!** Our books having been all destroyed by fire at and with our establishment, all who owe us will confer a great favor by remitting at once.

**CROSSCUP & WEST ENGRAVING CO.**  
907 Filbert St., Philadelphia.



SOLE AGENTS FOR THE AMERICAN CONTINENT.

DETROIT, MICH.

# ALLEN BROTHERS,

In the above letters, where blanks occur, the Lenses referred to are the best known on both Continents. Mr. B. Suter was awarded a silver medal for invention and construction of Lenses at the recent International Inventions Exhibition at London, England. Her Britannic Majesty's Government has purchased a set of Suter Lenses for the use of the South Kensington Museum. Count Schouvaloff, Russian Ambassador at Paris, uses a Suter Lens. Andrew Pringle, Esq., the English professional photographer, gets fine effects with a Suter Lens. A. L. Henderson, the English professional photographer, has made unsuccessful overtures to Mr. Suter to make all their photographic lenses. We commend these facts to the people who assert that because the Suter Lens is sold at a low price, it must be an inferior instrument.

Dear Sir: Your price current has reached me and I thank you for it. My friend and Photographic Colleague, Prof. W. Donkin, Honorary Secretary of the Photographic Society of England, has said to me that in the opinion of Captain W. De W. Abney, your photographic lenses are perfect, giving negatives extremely fine. I send you my cheque, paying you to send me at the earliest possible moment your Aplanatic Lens, No. 8 B. I intend taking with this Lens some large views on the high Alps. Hoping to receive soon a perfect instrument. Please accept the assurance of my highest consideration.

This from a prominent Italian amateur :

Mr. E. Suter, Bâle: I await with impatience the two lenses you have promised to make me. Observe the beautiful season, and I am anxious to make some instantaneous views. The lens No. 5 A, which you have sold me is *excellent* and above all, very rapid. I rely on your kindness, and pray you to accept my best regards.

A. ASTRUB.

My Dear Mr. Suter: At last I have received your price list (the second one), as the first letter has been lost on the way. I send you from Kailowitz, Silesia, a photograph of myself taken at Warsaw, by Brandel. The picture was taken with an Aplanat, made by—, with fourth stop, in two seconds, (emission). I would have bought one of these instruments if Mr. H. Warnerke, who owns an emission factory in London had not dissuaded me. This gentleman spoke about your instruments, which were unknown to me and Mr. Brandel, as follows: "The instruments of — are quicker and stronger than the — instruments, but far better than either of these are the instruments of Suter, which by accident I have seen in London." You can imagine that both of us took note of this and asked for your address immediately. I would therefore like to have an Aplanat B. No. 8, provided the same can do as good work as the enclosed picture shows. I only wish to use the Aplanat for photographing horses, on plates not smaller than 40 x 50 centimeters. Mr. Brandel will undoubtedly also become your customer as soon as he has sufficient proof of the excellence of your instruments. The gentleman is an amateur. Please tell me by return mail what you would advise me to do. May be that an Aplanat No. 5 would be better. In —'s Lenses I put no confidence, neither does my friend, because neither of us was able to take a good picture with same. I remain, your obedient servant,

The following is from an Austrian officer :

Mr. Suter, Bâle: Mr. Warnerke, of London, England, tells me that you manufacture an Objective marked "Series A," which greatly excels in the instantaneous process, especially in photographing in the public streets, with movable objects. He bases his good opinion of your Objectives upon the experience of the renowned London photographer, Wilson, who has used your instruments with the best success. We intend to take Street Photographs (size 13 x 18 centimeters), in this city, but must have the picture clear and strong up to the very edge of the plate. We use neutral (largest) stop.

Extract from a letter from the noted Polish firm of Karoli & Pusch, Warsaw :

From personal information gained in England and Continental Europe, we make the unqualified assertion that the Suter Lenses are now the Best in the World. We submit a few testimonials from eminent sources.

# THE SUTER LENS IN EUROPE.

# THE WONDERFUL PERMANENT BROMIDE PAPER.

---

LABEL REGISTERED 1885.

---

A Grand Medal of Merit Awarded at the St. Louis  
Convention.

BUFFALO, N. Y., July, 2, 1886.

THE EASTMAN DRY-PLATE AND FILM CO.

GENTLEMEN: I take great pleasure in informing you that the Committee have awarded you a **Special Medal of Merit** for your elegant display of portraits printed on Permanent Bromide Paper. Congratulating you, I remain,  
Very truly yours, H. McMICHAEL, *Secretary P. A. of A.*

---

When it is explained that of our exhibit at St. Louis, over fifty of the prints, ranging from 20 x 24 to 30 x 40, were made in *two days*, the capacity of our enlarging department for turning out first-class work will be understood.

---

## THERE IS MONEY

in Permanent Bromide Enlargements for the  
Progressive Photographer.

---

Send for Our Illustrated Circular HOW TO IMPROVISE AN ENLARGING APPARATUS.

---

**THE EASTMAN DRY-PLATE AND FILM CO.**

ROCHESTER, N. Y.

# UNSOLICITED TESTIMONIALS.

COR. BROAD AND MARKET STS., NEWARK, N. J., July 3, 1886.

EASTMAN DRY-PLATE AND FILM Co., Rochester, N.Y.

GENTS: The enlargements came duly to hand. We are very much pleased, and they give satisfaction to the customers who ordered them. We must say that this class of work *must take*, and we think it is one of the most beautiful results that we have as yet seen. Will you kindly return the paper negative of men on top of Tally-Ho coach, and oblige, as we have some silver prints to take from it. The glass negatives came all O. K.

Yours truly, THOMAS & Co

P. S. If we had thought, we could have sent you some elegant paper negatives and prints, which we think would have done credit to the process, for exhibition at St. Louis, but we suppose it is too late now.

EASTMAN DRY-PLATE AND FILM Co., Rochester, N. Y.

25 NEW STREET, TRENTON, N. J., June 28, 1886.

GENTS: Please send me circular and sample print of your Permanent Bromide Paper. I have been using your Eastman-Walker Roll-Holder, and it gives me complete satisfaction. Yours respectfully,

CHAS. J. RODGERS.

EASTMAN DRY-PLATE AND FILM Co., Rochester, N. Y.

NIAGARA FALLS, N. Y., May 17, 1886.

GENTLEMEN: I have been making a few paper negatives last week, with perfect success. Have not printed them yet, but will to-day.

Yours truly, CHAS. BIERSTADT.

EASTMAN DRY-PLATE AND FILM Co., Rochester, N. Y.

208 FULTON STREET, BROOKLYN, N. Y., July 2, 1886.

GENTS: Enclosed you will find my check for the Roll-Holder. It is attached to my 8 x 10 compact camera, and the two work so well together that one is led to think that each was intended for the other. As a trial for paper negatives and Roll-Holder (the first I have made), while in a pleasure party, I made nine exposures, and secured nine good negatives, which I consider very satisfactory; and with an experience of thirty years, I feel confident that in a very short time, your invention for making negatives on paper, either on rolls or sheets, will supersede all other sensitive mediums. Congratulating you on the perfection of your negative paper, also the roll-holder, I am,

Very respectfully, G. F. E. PEARSALL.

EASTMAN DRY-PLATE AND FILM Co., Rochester, N. Y.

42 JOHN STREET, NEW YORK, June 18, 1886.

GENTLEMEN: We were much pleased with the results obtained on the last lot of negative paper sent us. The grain seems to be entirely absent, and the rendering of the negative translucent by means of the preparation "Translucine." It seems both effective and easy.

Very truly, E. W. SMITH & Co.

EASTMAN DRY-PLATE AND FILM Co., Rochester, N. Y.

CAZENOVIA, N. Y., June 18, 1886.

GENTLEMEN: Please make two more enlargements from same negatives, same size and style as the first, and return negatives as soon as done. Mail enlargements unmounted. We are very much pleased with the work. It finishes perfectly in crayon.

Yours truly, MARSHALL BROS. & Co.

EASTMAN DRY-PLATE AND FILM Co., Rochester, N. Y.

MONTICELLO, IND., June 12, 1886.

GENTLEMEN: We have been very successful with the bromide paper, and think it is just the thing for enlargements.

Very truly yours, LIGHTY BROS.

EASTMAN DRY-PLATE AND FILM Co., Rochester, N. Y.

230 ST. LOUIS ST., SPRINGFIELD, MO., May 28, 1886.

GENTLEMEN: The two prints, or enlargements, came safely, and I am delighted with them. Think I will want the material to use in my gallery. Hope to see you at the Convention. Very respectfully,

G. W. SITTLER.

EASTMAN DRY-PLATE AND FILM Co., Rochester, N. Y.

DELAVAN, ILL., June 25, 1886

GENTLEMEN: The 24 x 36 Permanent Bromide print and smaller prints at hand. Thanks. The G. A. R. Post seem very well pleased. It is much better than I thought the negative would make. I find I am, by comparison, getting along all right with my prints. Just as soon as I can save the wherewithal, I shall have one of your enlarging outfits. I shall probably send you some more negatives in a few days.

Yours truly, E. D. SHAW.

# BENJ. FRENCH & Co.

No. 319 WASHINGTON STREET, BOSTON,

Sole Agents in the United States for the Celebrated Lenses  
Manufactured by

## VOIGTLÄNDER & SON.

ALSO, THEIR FAMOUS

# EURYSCOPE,

Which is unrivalled for groups, full-length figures, and other demands in the gallery, and every species of out-door work, including instantaneous photography.

 **THE EURYSCOPE** is made *exclusively* by Voigtländer & Son, and their name is engraved on the tube.

FOR **DARLOT LENSES** FOR  
PORTRAITS. VIEWS.

IMPORTERS, ALSO, OF THE CELEBRATED

TRAPP & MÜNCH

## ALBUMEN PAPER,

AND DEALERS IN ALL KINDS OF

*Photographic Materials and Magic Lantern Slides.*

SEND FOR OUR NEW ILLUSTRATED PRICE LIST OF LENSES.

# H. F. CARPENTER,

29 & 31 Page St., Providence, R. I.

## ANALYTICAL AND MANUFACTURING CHEMIST.

Refiner of PHOTOGRAPHIC WASTES.

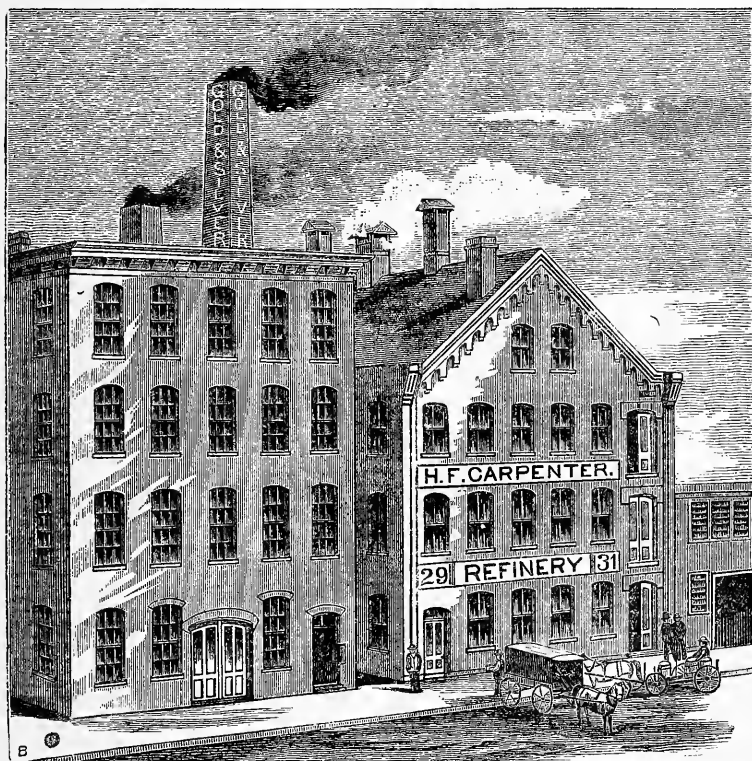

## Assayer and Sweep Smelter.

### Nitrate of Silver and Chloride of Gold.

Chemically pure gold prepared especially for Photographers' use at \$1.10 per dwt.

Information given on application in regard to methods of saving waste.

The Following is of Interest to every Photographer.



---

THE NEW N. P. A.  
PENSE.

We desire to call attention to our **NEW PENSÉ N. P. A.** Extra Brilliant Dresden Albumen Paper.

The manufacturers at Rives have recently made many marked improvements in their celebrated paper, and all the sheets of this brand are **manufactured specially for it**, and are readily distinguished from all other papers by the **water-mark N. P. A.**

It is doubly albumenized by the **most experienced house** in Germany, with **new and improved** formulas, and we are confident that on trial it will be found **superior** to any other in market.

Its excellence has induced some unscrupulous persons to **place the STAMP on the Paper of other makers**, in order to work it off, trusting that photographers will not look through to see if the **water-mark** is there. To prevent this we have registered  This Trade Mark  in Washington, which will subject to heavy damages all those who stamp this brand on paper which does not bear the **water-mark N. P. A.** This Paper can be had also in **EXTRA-BRILLIANT N.P.A. DRESDEN. PINK, PEARL or WHITE.**

**FOR SALE BY ALL DEALERS IN PHOTO. GOODS IN U. S. AND CANADA.**

---

**E. & H. T. ANTHONY & CO.,**  
591 Broadway, **NEW YORK.**

N. B.—When any paper is offered to you at a low price, **Measure it.**

Also note whether it runs **Uniform**, for some albumenizers mix the first and second qualities, not discarding that which has defects, and thus get their paper cheaper.

# THE STANLEY DRY PLATE

Has passed through the ordeal of its first summer, and its manufacturers have almost entirely escaped the usual trials of fogging, frilling, and other perplexities. In fact, the quantity sold in July exceeds that of any former month.

Its *unusual combination of sensitiveness and brilliancy* have made it a general favorite, and the territory into which it penetrates grows constantly larger.

## AMONG ITS RECENT ACHIEVEMENTS ARE

**Instantaneous Views of the Decoration Day Parade** (3d size stop), taken without sunlight, used as a Bulletin Illustration.

**Views of Horses and Carriages entering Central Park**, trotting rapidly across the field of view, sharp and clear cut. These will appear in the Bulletin.

**Views of Steamboats** going twenty miles an hour directly across the field, taken at 5.30 P. M. Sharp and clear as if standing still.

**The Life-size Portrait of J. F. Ryder**, by McMichael, shown at the Buffalo Convention, was made on an 18 x 22 Stanley Plate in five seconds, with a Dallmeyer Rapid Rectilinear Lens.

**Instantaneous Views**, by Mr. Henry J. Newton, President of Photographic Section of the American Institute, about which he writes:

"I found that sunshine was not absolutely necessary for instantaneous negatives on these plates, and I think a majority of the negatives I send you were made when there was not sufficient sunlight to cast a visible shadow. I think it is due that I should say that the plates worked satisfactorily in every respect, exhibiting extreme sensitiveness, responding readily to the developer, and going steadily on to the finish.

P. S. I used the Prosch Shutter at its full speed."

(Signed),

H. J. NEWTON.

And now to crown the whole, Mr. Parkinson writes as follows:

PARKINSON PHOTO. PARLORS, 29 W. 26TH ST.,

NEW YORK, August 12, 1885.

E. & H. T. ANTHONY & Co.:

"GENTLEMEN: I take pleasure in assuring you that I made a group portrait in my gallery of an old lady of eighty years, with child of four years, a month or two since, on a Stanley 18 x 22 plate, in one second, with Dallmeyer Rapid Rectilinear Lens. A little more time would have done no harm; but the picture in question has elicited as many words of praise from visitors to my studio as any other in same length of time."

Yours truly,

W. B. PARKINSON.

The Stanley Dry Plates can be had from any dealer, or direct from

**E. & H. T. ANTHONY & CO.,**  
591 BROADWAY, NEW YORK.

Another thing that has gone rapidly to the front is the

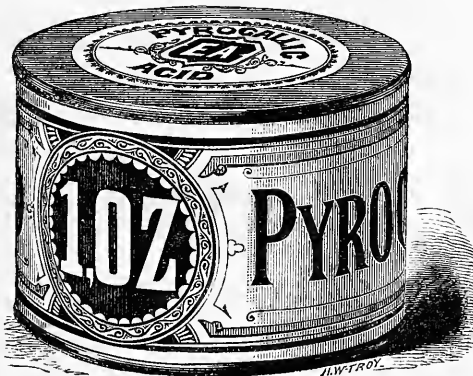

When Dry Plates were first introduced it *was not yet on the market*, and the old stereotyped developing formulas do not mention it; but in the developing formulas of the more recent *popular plates*, as the STANLEY and the ST. LOUIS, the E. A. Pyro is recommended as most desirable, and in the EASTMAN DRY PLATE Co. formulas the same preference is given ever since they *knew of its merits*.

It is always used by the veteran "Roche," and constitutes one of the main elements in the popular Cooper's Developer.

Every photographer should try the E. A. Pyro. Every dealer has it, or ought to have it, or it can be had direct from

**E. & H. T. ANTHONY & CO., 591 Broadway, N. Y.**

---

**A. B. PAINE & CO.'S  
HYPO. ELIMINATOR.**

SOMETHING LONG PRAYED FOR.

No more yellow prints. No more yellow plates. Prints mounted and plates dried one-half hour after fixing. The greatest time-saver ever invented.  
One ounce enough for one day's work.

Price, per Pint, 50 cents; Quart, 90 cents; Two Quarts, \$1.50.

A. B. PAINE & CO., Sole Manufacturers,  
*Photo. Stockdealers.* *FORT SCOTT, KAS.*

Ask your Dealer for it, or send direct to Manufacturers.

---

**DR. VOGEL'S AZALINE.**

FOR SALE BY

W. KURTZ, 6 East 23d Street, New York.

---

**ALBERT MOORE THE SOLAR ENLARGER,**  
THE LONGEST, LARGEST, AND BEST.  
828 Wood Street, Philadelphia.

---

**JAMES F. MAGEE & CO.**

*522 Race St., Philadelphia,*

**Manufacturers of Pure Photographic Chemicals,**

Specialties: NITRATE OF SILVER and CHLORIDE OF GOLD.

❖REFINERS OF GOLD AND SILVER WASTE.❖

❖Waste sent through Stockdealers will receive prompt attention.

---

**G. W. WILSON & CO.**

(By special appointment Photographers to Her Majesty the Queen),

**MANUFACTURERS OF MAGIC LANTERN SLIDES,**  
St. Swithin Street, Aberdeen.

Catalogue of 12,000 subjects in England and Scotland, and Price Lists, post free on application,



---

HOME FROM THE ST. LOUIS CONVENTION.

## THE GEMS.

The New Goods ordered, and will be in ready stock shortly, viz.:

*Hermagis Lenses.*  
*Felt Grounds.*  
*Curtains.* Late Designs.  
*Knapp & Caldwell's New Accessories.*  
*Ashe's New Garden Seat.*  
*Ashe's New Telescopic Balustrade.*  
*Acme Burnishers.*  
*Eastman's Bromide Paper.*  
*Young's Patent Double-barrelled Shutter.*

*The New 5 x 8 Novelette View Box, with 8 x 10 Attachment.*  
*Barnett's Holders.*  
*Nash's Detective Camera.*  
*Bird's Patent Vignetter.*  
*Perfection Drop Shutter.*  
*Perfection Shutter for 4¼ Gem Lenses.*  
*Moreno's Universal Developer.*  
*Collins' New Cabinet Mounts.*

---

## THE CELEBRATED SEED PLATES.

*Two Gold Medals awarded to Exhibitors whose pictures were made on these Plates.*

DETAILED LISTS OF THE ABOVE WILL BE ISSUED SHORTLY.

## GEORGE MURPHY,

Photo. Goods. 250 Mercer St., New York.

---

## THE AIR BRUSH.

This New Art Tool applies color by a jet of air. It is invaluable to any photographer who produces his own large work. Portraits may be made over solar or contact prints, on plain or Albumen Paper, in India Ink, or Water Colors, etc.

*Lights built up on Flat Negatives, Cloud Effects in Backgrounds for View Work, etc., all can be accomplished by this Tool,*

with the greatest rapidity, and with a perfection bounded only by the capacity of the artist. Full particulars FREE. Address

AIR BRUSH MFG. CO., 50 Nassau St., Rockford, Ill.

---

## ARTISTIC PHOTOGRAPHY.

By LYMAN G. BIGELOW.

The best work there is to teach how to light and pose the human figure. Instructions and formulæ and Twelve Photo. Cabinet Illustrations of varied sexes and ages.

\$4.00. POST-PAID. \$4.00.

EDWARD L. WILSON, Publisher, 853 Broadway, N. Y.

A. M. Collins, Son & Co.

*MANUFACTURE ALL KINDS OF*

**CARDS AND CARDBOARDS**

FOR

**P** PHOTOGRAPHERS **S**

AND

**MATS, MOUNTS, AND ENVELOPES**

FOR

**FERROTYPES.**

---

OFFICE AND WAREHOUSE,

**No. 527 ARCH STREET,**

**PHILADELPHIA.**

---

Price Lists may be had by intending purchasers on application to us, or to all Photographic Merchants, through whom your favors are respectfully solicited.

JOHN G. HOOD.

ESTABLISHED 1865.

WM. D. H. WILSON.

# WILSON, HOOD & CO.

## 825 Arch St., Philadelphia,

SOLE AGENTS IN THE UNITED STATES FOR THE



Centennial, 1876.

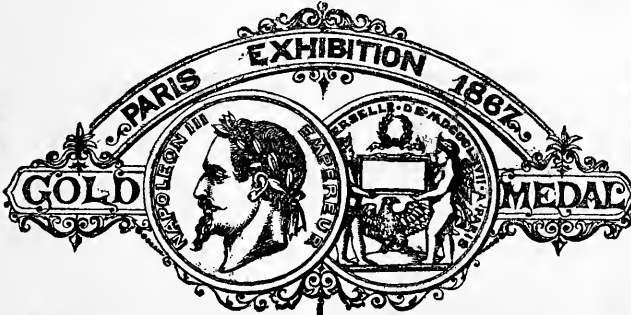

Centennial, 1876.

## Ross' Portrait and View Lenses.

Portrait Lenses, from 1-4 to 8 x 10.  
Cabinet Lenses, Nos. 2 and 3.  
Card Lenses, Nos. 1, 2, and 3.  
Triplets, Nos. 1, 2, 3, 4, 5, 6, and 7.  
Symmetricals. Rapid Symmetricals.

Instantaneous Doublets, all sizes.  
Medium Angle Doublets, all sizes.  
Large Angle Doublets, all sizes.  
Stereographic Lenses, all sizes.  
New Universal Lens.

Numerous testimonials pronounce them to be the *best* as well as the *cheapest* Foreign Lenses ever offered to the American Photographer. We will mail price list on application, and promptly fill all orders. Always in stock,

## CAMERA BOXES,

Made by AMERICAN OPTICAL CO., ANTHONY, BLAIR, and ROCHESTER OPTICAL CO.

WE KEEP IN STOCK FULL ASSORTMENT OF

## AMATEUR PHOTO. OUTFITS

DRY PLATES OF ALL MAKES.

N. P. A., EAGLE, and S. & M. PAPER, PER REAM, \$34.00.

Any article needed we can supply, as

WE MANUFACTURE, IMPORT, AND DEAL IN ALL KINDS OF

### *Photo. Goods, Frames, Stereoscopes and Views,*

At prices as low as are consistent with the quality of goods furnished. We are indebted to our customers for the patronage during the past *Twenty Years*, and our efforts shall be to merit a continuance of it.

Illustrated Price Lists supplied free. Correspondence solicited.

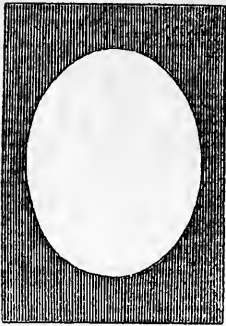

# GIHON'S CUT-OUTS

An Entirely New Variety for  
PRINTING MEDALLION PICTURES.

Are the very best that are made, and are now without a rival in the market. They are clean cut, most desirable shapes and sizes, and made of non-actinic paper, manufactured specially for the purpose. Each package contains 30 Cut-Outs, or Masks, with corresponding Insides, assorted for five differently sized ovals and one arch-top.

*Price, \$1.00 per Package. Sent by mail on receipt of price.*

Parties wishing special sizes, or large lots of a few sizes, may have them cut to order promptly by addressing the manufacturer. No lot costing less than \$1.00 made at a time.

*No printer should attempt to make Medallion Pictures without them.*

## THEY HAVE NO EQUAL FOR QUALITY.

Beware of spurious imitations made of common paper, full of holes, badly cut, and odd shapes and sizes. Ask your Stock-dealer for GIHON'S CUT-OUTS, and see that they are in his envelope, with instruction circular included. The recent packages are composed of an entirely new variety and of a new paper. **TRY THEM.**

Promenade Size now Ready. Sold Separately at 50 cents per Dozen.

# GIHON'S OPAQUE

Is designed for Completely obscuring the Imperfect Backgrounds of Copies, Retouching Negatives, Faulty Skies in Landscapes, Coating the Inside of Lenses or Camera Boxes, Backing Solar Negatives, Covering Vignetting Boards, And for Answering all the Requirements of the Intelligent Photographer in the Production of Artistic Results in Printing.

Wherever you want to keep out Light, use Opaque.

**IT IS APPLIED WITH A BRUSH, DRIES QUICKLY AND STICKS.**

**CUT-OUTS (thirty), \$1.00. OPAQUE, 50 Cents.**

**FOR SALE BY ALL DEALERS**

**ROBERTS & FELLOWS, Makers, Philadelphia.**

Address all orders to

**SCOVILL MANUFACTURING CO., New York.**

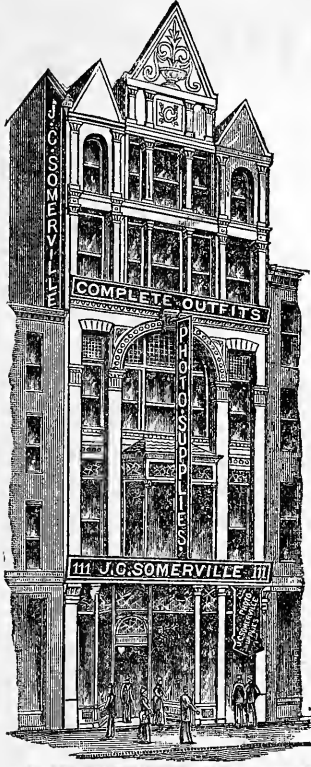

# NOTICE.

REMOVAL TO

111 North Broadway,  
ST. LOUIS.

---

PHOTO. SUPPLIES,  
COMPLETE STOCK.

---

NEW GOODS. NEW STORE.  
IMPROVED FACILITIES.

Call and See Sample Room.

J. C. SOMERVILLE.

---

## SHARP FOCUS INSTANTLY OBTAINED WITH

# Collins' Focusing Attachment, Patented

SWEET, WALLACH & CO.. SOLE AGENTS FOR THE UNITED STATES.

FOR SALE BY ALL DEALERS.

NO FOCUSING CLOTH REQUIRED.

NO GROUND GLASS REQUIRED.



THE NEW WAY.

P  
R  
I  
C  
E

\$3.50



THE OLD WAY.

Send for Circulars.

Sweet, Wallach & Co.,  
PHOTOGRAPHERS' SUPPLIES,

229 & 231 STATE STREET,

CHICAGO.

# ENTREKIN'S

## IMPROVED

# DUPLEX ROTARY BURNISHER.

PATENTED.

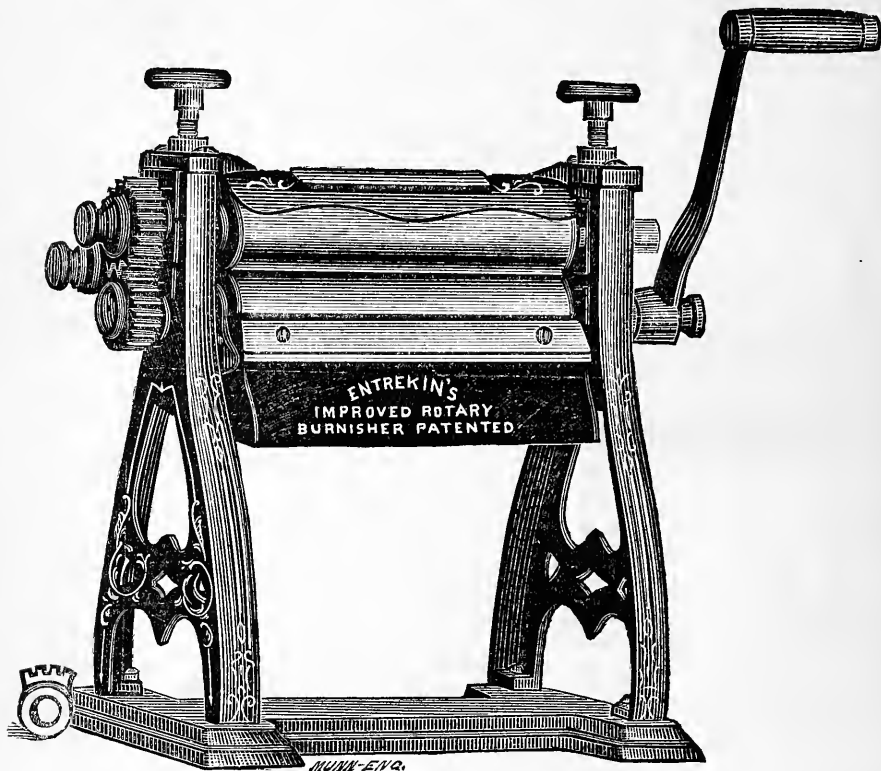

10 in., \$25.00. 15 in., \$35.00. 20 in., \$45.00. 25 in., \$60.00.

This Machine is an improvement on our old Duplex Rotary Burnisher, invented by us in 1874.

It is so constructed that by changing the Large Gear or Cog-wheel, from the stud to the end of the draw-file or upper roll, you reverse and change the speed of the lower or polishing roll, thus getting the same result as in the old Duplex Rotary; but to secure the best polishing surface, use the machine with the large cog-wheel on the Stud, by so doing you secure three times the polishing surface. All the machines will be sent out with gearing so arranged as to give this result. It is optional with the Photographer how he may use the machine. The Fire-Pan is so arranged that it is impossible for it to come in contact with the surface of the polished roll, and it can be turned away to cleanse the roll.

**EVERY MACHINE WARRANTED PERFECT.**

FOR SALE BY

**W. G. ENTREKIN, Inventor and Sole Manufacturer,**

4384 Main St., Manayunk, Philadelphia, Pa.

AND BY ALL PHOTOGRAPHIC STOCKDEALERS.

# ENTREKIN'S PATENT EUREKA BURNISHER.

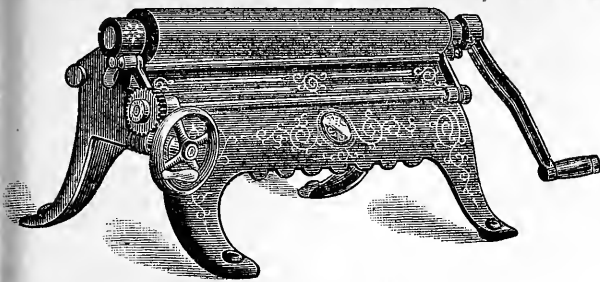

The above cut represents our 25 inch Eureka.

The unprecedented popularity of this Burnisher is wonderful. Over seventeen thousand (17,000) sold in less than five years. Agencies in London, Berlin, and Vienna, and sold by all stockdealers in the United States. The machines are built in first-class style, and warranted to do the work claimed.

Full directions accompany each machine.

## PRICES:

6 inch Roll, . . . . .	\$15 00	20 inch Roll, . . . . .	\$60 00
10 " " . . . . .	25 00	25 " " . . . . .	70 00
14 " " . . . . .	35 00		



# ENTREKIN'S Duplex Rotary Burnisher.

PATENTED JUNE 1, 1875.

## PRICES:

10 inch, . . . . .	\$15 00
15 " . . . . .	25 00
20 " . . . . .	35 00
25 " . . . . .	45 00

# ENTREKIN'S DUPLICATING PRINT CUTTER.

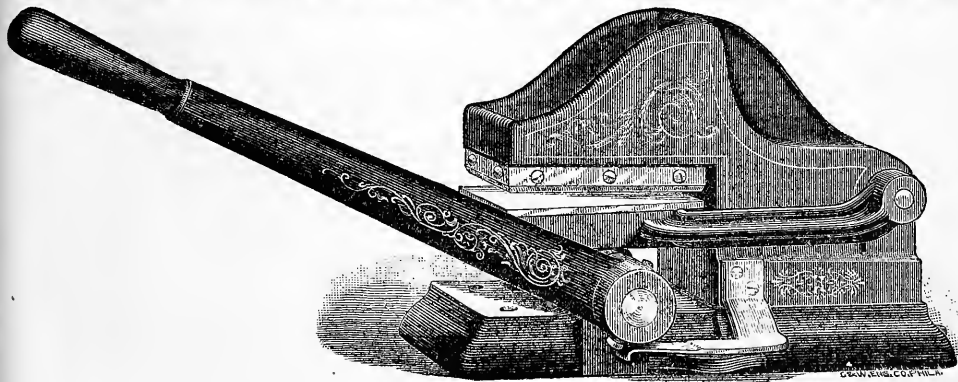

Cabinet and Stereo. Sizes, \$25.00

Small Panel Size, \$35.00.

Size 6½ x 8½, \$40.00.

MANUFACTURED AND FOR SALE BY

W. G. ENTREKIN, 4384 Main St., Manayunk, Phila., Pa.

# 500 UNSOLICITED TESTIMONIALS AND MORE.

PLEASE READ THE LAST ONE.

*Northwestern Business College,  
St. Louis City, Mo. June 4, 1896.*

*Dear Sir:- I am highly pleased with Photographics. In an experience of over 30 years teaching, I have used and examined many text books, but have found none more ably written, or more exhaustive of the subject treated, in so small a compass. Containing, as it does, a clear exposition of the methods tried and proved by the long experience of the Author, together with notes from over 200 eminent practitioners, it cannot fail to prove a valuable aid, not only to the Amateur, but to the professional as well. Theory and Practice follow each other so closely, that the student can learn and do at once.*

*E. L. Cochran*

If your old copy is worn out, get THE CHAUTAUGUA EDITION. If you have never owned Photographics, get THE CHAUTAUGUA EDITION.

A New Edition, with a twenty-four page appendix, giving all new processes practically useful, is now ready—  
THE CHAUTAUGUA EDITION.

\$4.00

## WILSON'S

\$4.00

NEW  
EDITION.

NEW  
EDITION.

JUST  
READY.

# PHOTOGRAPHICS

JUST  
READY.

*Edward L. Wilson.*

\$4.00

\$4.00

## THE BEST PHOTOGRAPHIC LESSON-BOOK.

By EDWARD L. WILSON,

Editor of "The Philadelphia Photographer," "Photographic Mosaics," etc.

The author believes it to be the best effort he has ever made, and begs to call attention to a few of its peculiar advantages as  
A STANDARD WORK FOR ALL WORKERS IN PHOTOGRAPHY.

- A. Treatment of the Subject.
- B. The useful apparatus.
- C. The Objective or Lens.
- D. The Dark Room.
- E. Preparation of the Glass.
- F. Chemicals and Solutions.
- G. The Manipulations.
- H. Manipulatory Miseries.
- I. Retouching the Negative.
- J. The Glass Studio.
- K. Accessories and Light.

- L. Managing the Model.
- M. Printing on Albumen Paper.
- N. Printing on Plain Paper.
- O. General Remarks on Printing
- P. Printing on Various Surfaces.
- Q. Printing Perplexities.
- R. Art in Printing.
- S. Mounting and Finishing.
- T. Photography Outside.

- U. Bromo-Gelatin Emulsion Work.
- V. Vogel's Collodion Emulsion.
- W. Enlargements and Lantern Slides.
- X. Phototypes, Platinotypes, and Collodion Transfers.
- Y. Wastes and their Worth.
- Z. Metrical Measuring.
- & Concluding Confab. Index (six pages).

The index added is very full and will enable the reader to quickly find almost any subject needed on every practical department of the art Sent post-paid for \$4.00 by

EDWARD L. WILSON, 853 Broadway, New York.







The Valentine

W. S. BOSTON

THE

# Philadelphia Photographer.

EDITED BY EDWARD L. WILSON.

Vol. XXIII.

AUGUST 7, 1886.

No. 279.

## THE ST. LOUIS COLLECTION.

A SIMPLE catalogue of the photographs exhibited at the late exhibition of St. Louis, with a few running comments, such as it has been our habit to give heretofore, would not, this time, do justice to the subject.

We have concluded, therefore, to combine our remarks in the form of a review of such individual pictures and entire exhibits as impressed us most, either by their newness of style—as showing the growth of the artist who made them, or his individuality; by the errors in production; by their conception; by their novelty; by the excellence of their technique; by the freaks of their producers, and by the lessons which we gathered from them.

We trust that the exhibitors whose names or work are not mentioned at all will not permit themselves to censure us, when we assure them that only the want of space prevents us from giving ten times as long a review as we do, and favorably noting nearly all; for, as we said a month ago, there never was an exhibition held which gave such abundant testimony of growth and progress in our art, and where so many photographs were shown which are entitled to be considered works of art, as were shown at St. Louis.

Our regret is, that not one-twentieth of the good people photographic of the land could enjoy the privilege of studying them. The more reason, therefore, that we shape

our comments with the double purpose and hope of making what we say useful to those who could not see the pictures as well as to those who did.

The collection was an immense one, and was hung in three sections of the great exposition building art department, in a series of three rooms, which formed a great L. In the majority of cases the lighting was admirable, and the hanging was judicious. Excellent taste was shown by many in framing and arranging their exhibits.

No one familiar with former exhibitions could stroll along among the alcoves of this one without being convinced that a spirit of earnest effort to excel, was shown in his work by almost every exhibitor. Whether the offer of prizes caused all this, or not, we cannot tell. We are inclined to think, however, that our craftsmen, finding out the new possibilities of their art by means of dry plate rapidity, and the use with them of large cameras and lenses, have learned to love it and understand it better than they ever did before, and have become absolutely enthusiastic.

No one's work indicated this more plainly than did that of Mr. F. W. Guerin, of St. Louis. Heretofore, many of his productions were worthy only as to technique. Artistically he produced some strange incongruities. Many will remember such things as his cupids, child in a wash-bowl, young ladies as goddesses, and (mayhap) demons—

all well enough, so far as the photography went, but ruined by incongruous etching upon the negatives, of additions and accessories, and so on. None of that this year for Mr. Guerin. We were fairly startled when first we looked upon his splendid exhibit, at the manifest improvements in the grade of his work æsthetically. All the splendid technique is preserved, and added thereto is a conscientious, careful following of art principles.

The man's eyes have been opened and he is a new man. His work shows it. A gold medal would have been awarded him but for the courtesy which induced the St. Louis photographers not to compete. His pictures were too numerous to name a tithe of them, varying in size from cabinet to 20 x 24. We considered his "Contemplation" as the gem of all. Indeed, we think it had but a single rival in the whole exposition. It was a lady, dressed in white, standing with a garden scene back-ground, her head to her hand inclined, carrying out the conception admirably. The light was also masterly, graded softly and carefully from the dark on one side to the light on the other. The whole effect was harmonious and lovely. We are glad to say that Mr. Guerin has supplied us positives from the original 17 x 21 negative, from which we have made negatives and are printing "Our Picture" from them for an early issue of our magazine.

Of an entirely different style is "Waiting at the Gate," a buxom miss in white apparel standing expectantly at a rustic gate. The picture is breezy and full of life and sunshine, and calls to memory the admirable Berlin work of Loescher & Petsch.

Several other pictures of the suggestive, illustrative sort, full of sentiment, and showing care and thought, might be noticed, but our enthusiasm is running away with our space. Mr. Guerin's work was made on Cramer plates.

If Mr. J. F. Ryder does not astonish us each year with new revelations, disappointment is sure to follow. And yet, with this burden of responsibility upon him, our veteran leader continues to preserve his equanimity.

This year, he not only maintained his character as a progressive artist, but he ex-

hibited several novelties. Two of his life-size heads were labelled "Bottom Facts." They were from direct negatives without a bit of retouching or doctoring of any kind upon the negatives. In light, shade, detail, likeness, and technique they were unexcelled, and caused their worked-up neighbors to look pasty and artificial and unnatural. They attracted great attention, and will have many imitators. One of these pictures is now on exhibition in the window of W. H. Walmsley & Co., Philadelphia, having been made with a Beck lens. The other was made with a Euryscope, from B. French & Co., Boston. Let us have more "bottom facts."

A decided novelty was Mr. Ryder's collection of quaint groups from "The Pantomime Rehearsal," which many of our readers have seen played by the Rosina Vokes Co. The characters were in dress suits, posed with the light from the rear; background white; not in the usual style of composition, but with an utter disregard of the usual rules. The effects are comic indeed, and remind one of the book-plates of a century or more ago. "The Death of the Good Robber" and "The Distinguished Amateurs" are particularly fine. Mr. Ryder's pictures of ladies in white silk; of children; of large heads, and of landscapes, excelled any ever displayed by him previously, and that is a great deal to say.

No gems were so richly set as his, for his choice and variety of frames, in style and richness, were unequalled.

Mr. G. Cramer, St. Louis, departed from the genre style very largely this year, and confined himself almost wholly to a collection of three-quarter and bust pictures from 18 x 22 negatives. His "Lady and Guitar," and "Lady on the Piazza," leaning, were up to his best former works. A heroic bust of "Buffalo Bill," excellent in quality, overhung the rest of Mr. Cramer's most attractive display.

Our task becomes more difficult now, as we become involved in the study of the adjoining exhibits. We must return to our purpose of classifying them, and refer to a few examples under each head.

Among those who show the most gratifying evidences of

*Growth,*

we noticed Messrs. Montfort & Hill, Burlington, Iowa. These gentlemen have made rapid improvement. Some of their studies are ambitious and excellent in every quality. Among the best are "A Negro Blowing Bubbles," "Marguerite at her Spinning-wheel," "The Old Cook," and "Girl with Dove." Mr. Montfort assured us that he found it "good exercise to produce such pictures, even though they did not produce a dollar." He has the right spirit. These gentlemen were both present. Their large heads and cabinets were equally creditable.

Mr. S. L. Stein, Milwaukee, also displayed some ambitious compositions. "The Grave-digger" scene from Hamlet, and "Three Little Girls from School" (Mikado), are among his best. His 11 x 14 portraits of actors and citizens are alike fine and show the artist has profited by the holding of the exhibition in his city.

Mr. Fowler, Chicago, has made progress, we judge, because some of his works so far excelled others. There was such a wide difference that one could scarcely credit the fact that one man made all. In some the light was broad and well massed, soft and lovely, while in others there was the wildest choice of accessories and want of thought in lighting. Mr. Fowler's gem was a lady with a veil, a tuberose in her hand. His exhibit was worthy of a better light than it had.

The work of Messrs. Reichmann & Co., New York, has recently been introduced to our readers.

At St. Louis a fine display of 14 x 17 studies from "The Merry Wives of Windsor" were shown, excellent in every respect as works of art, and excellent technically—resultant from the use of "Eagle" plates.

Mr. J. C. Rasmussen, Davenport, Iowa, has been an exhibitor for several years, and is among the most ambitious and successful of the younger generation. His display of cabinets was very creditable, and some of his compositions were admirable. His "Lady Reading," and "Child with Cat," were carefully done—admirable. Judicious lighting and use of the retouching pencil make his work very charming.

From Mr. H. McMichael, Buffalo, N. Y., we all looked for a display of his best efforts, and no one was disappointed.

A sweet simplicity of lighting, so to speak, characterized this whole, immense display. The artist's method was shown in every picture, and his collection was full of gems. A quartette of these caused us to return to them several times. They hung together, and were full heads of 1. A lady in a cap; 2. A lady in a hat; 3. An old man; 4. An old Quakeress in lace cap. All these showed the influence of Fritz Eilender's admirable heads shown at Buffalo last year, and given reduced, in our issue for October. A portrait of Mrs. McMichael in a plaited straw or chip hat was an admirable example of work and not an easy effort to handle. The light seems to have been cajoled to just where it could give the best effect.

Among Mr. McMichael's "theatricals," Lillian Russell as "Billie Taylor," and the Mikado scenes were the finest. An old lady with an "apex" nose, and another "old lady, knitting," were truly studies of the "old school," splendidly done by masterly modern photography. A little girl "in the dumps" is an admirable example of lighting—of splendid relief. Every detail is perfectly realized. In the picture of a lady standing against a wall, the light seems to have been let in from a supply-pipe as it hurried along above, and allowed it to fall just in the right place for the best effect.

Many of these studies are to go to the German exhibition, and will be appreciated there, we are very certain.

Among the collections teaching

*Good Lessons,*

the exhibit of Mr. James Landy, Cincinnati, was notable. It was the best he has made at our annual exhibitions we think. The master's hand was best shown in Mr. Landy's character pictures of Edwin Booth as "Othello." Of course, our artist was assisted by a kindred spirit, but the actor, while helping the pose, could not secure such skilful lighting—such exquisite technique photographic. Mr. Landy's pictures of old men, and of children, were each one a study—aye, every inch a study.

Mr. Max Platz, Chicago, exhibited some

daring and unusual poses which, when studied, all revealed careful thought and splendid feeling—the sentiment usually genuine and winning. His "Cleopatra" is superb, the leopard skin giving it just what it wanted to complete the conception. "The Queen on the Throne," and the "Serenader with Guitar," are admirable also. We lament that our artist did not help us in understanding his own ideals by placing titles on his pictures. This thoughtlessness was apparent generally throughout the exhibition. We all like to guess, and yet we like to know we are right. The lady on the throne may be Hamlet's mother witnessing the play, or she may be Marie Antoinette. Be not afraid to let us know which, that we may judge how faithfully you have carried out your own conception.

Mr. Platz's large heads are always carefully treated and seem to bring out the best elements of character upon the face.

Mr. C. T. Stuart, Hartford, Conn., also rendered some useful lessons by his fine display, especially of ladies in white dresses. His "Base-ball Club," of ten men, was splendidly composed, and was secured in three seconds. His interiors, 8 x 10, were unequalled by any in the exhibition. The novelty of his display was his capital pictures of animals. The posing of animals has been considered an impossible thing, but Mr. Stuart has attempted it, and succeeded in it, as his "Setter" and other dogs and cats do show. In some instances, too, he has secured expressions which only his genius and patience could secure.

Messrs. Decker & Wilber, Cleveland, O., displayed nineteen 16 x 20 portraits, which were more uniform in excellence than any group shown. They were of young ladies in "Kermes" character costumes; of lovely children, showing splendid feeling in arrangement and pose; a sweet group of two little ones, the arrangement of whose tiny hands alone spelled "artist;" and a line of ordinary subjects, all of which were carefully lighted and given such majesty of pose as brought out the best characteristics of the model—of life brought out to the surface. A life-size head of General H. Q. Sargeant attracted much admiration.

The exhibit of Mr. J. A. H. Parsons, of

Wheeling, W. Va., was frequently surrounded by knots of enthusiastic students, who gathered many good lessons therefrom. In variety of size, subject, and treatment, it was one of the best collections.

Some of the best models of

#### *Conception*

were found among the works of our lamented friend, John A. Scholten. The large portraits of ladies were treated with that careful consideration which characterized the work of the dead artist. His ideas of art were exalted, and he rendered it apparent in his productions. His theatrical groups were carefully conceived and carried to the highest degree of art possible in all respects. Photography lost a master when John A. Scholten was called away.

Mr. Geo. B. Wood's very fine variety of pictures stood alone. We reviewed them at length when they were exhibited in Philadelphia last winter. Mr. Wood is more careful to secure the picturesque—to bring out the spirit and often the humor to the front—than he is to give attention to technique. A hundred useful lessons could be learned from his admirable studies. Each one was titled, which made the studying all the more enjoyable and useful. We wish more of our readers could study them.

Very great

#### *Progress*

was shown by many of the neighboring exhibits. Messrs. Stuber Bros., Louisville, Ky., showed particular care in their choice of accessories and backgrounds. The "Little Child on a Bridge" is a charming bit.

Mr. A. H. Plecker, Lynchburg, Va., made a fine display. Among his gems we noticed a fine portrait of John G. Hood, Esq., of Wilson, Hood & Co., Philadelphia; three nuns in a group; some portraits of Creole girls; some bridal pictures, full length; and a collection of large heads. Mr. Plecker's interiors are also fine.

Mr. Walker, of Philadelphia, surprised us pleasantly by his "Do You Think that Looks Like Me?" "Company Programmes," and "Lady in Balcony." The conceptions in all were carefully carried out, though

here and there is a little too much effort after fancy posing. The technique is admirable.

Mr. Ingersoll, St. Paul, Minn., displayed an interesting collection of interiors, equestrians, Indians, carnival scenes, and of the ice palace, all carefully managed.

The gem of the exhibit of Mr. Temple, Clinton, Iowa, was an old lady in spectacles—full of character.

Mr. Boyd, Des Moines, Iowa, made new reputation on his "Ophelia," "Bootblacks," and "Old Man"

Mr. S. J. Dixon, Toronto, Canada, had, among other novelties, a composition group of the Toronto police force. The original is 9 feet long by 6 feet 3 inches high, and contains 160 carefully captured men of force.

Mr. Dixon's portrait of "A Mother and Child," and of "The Old Poet—92 years," were both very fine. The most attention was attracted by pictures of his horse "Hero." In one group the intelligent animal stands with one forefoot upon a chair, and the other, still higher up on Mr. Dixon's knee, whose foot is also on the chair. The picture of "Hero," with ears alert, is very spirited.

It was a pleasant experience when reviewing these exhibits, to see the individuality of the artist so often evinced in the work. Now

#### *Individuality,*

as we have often remarked, is sure to show, if the operator is a man who studies closely. Scarcely two men handle a subject just the same. It is a pleasure to note the difference. On another page we have occasion, this month, to review some of the works of Mr. George Barker, of Niagara Falls. All the pictures named in that review and an "eighth of a mile" more were shown at St. Louis. The exhibit was an astonishing one. Only an artist living at Niagara can make such a collection. He must be there to catch the "shadow" when the "substance" is clothed in the proper accessories of spray, and cloud, and light, and atmosphere. Mr. Barker's methods of doing this are all his own, wherein he shows his individuality.

Other examples of strong individuality were displayed in the works of Messrs.

Hurd, Providence, R. I., "Old Fiddler," "Old Man Asleep," "Old Men in Slouch Hats," etc., all full of poetic feeling.

In the infinite variety of theatrical posings by Falk, of New York, "Helen Davvray" at her desk, Lillian Russell in "Pepita," and the portraits of Bartholdi the sculptor, and of Anton Seidl, are eminently fine. Mr. Falk's handling of light, drapery, and persons all show good judgment and bring forth ease and naturalness very charmingly.

Mr. J. Henry Doerr, Louisville, Ky., also stamps his work with a character all his own. His variety shown was great and in every way creditable.

From another end of our country came the work of W. G. C. Kimball, Concord, N. H., whose portraits of "Old New Englanders" are full of character, brought out by the careful understanding of the artist. An exquisite bit of technique is Mr. Kimball's view of five oarsmen pulling for the homeward stretch. A portrait of B. W. Kilburn, Esq., the White Mountain photographer, was one of a number of Mr. Kimball's admirable portraits.

Mr. W. H. Jackson, Denver, Colorado, stamps his work with an individuality which makes it easily recognizable no matter where it is found. He treated us to several new series of views this year—some from Texas and some from the line of the B. & O. Railroad. His "Upper Twin Lake" and view of Ouray with the San Juan Mountains, are superb and altogether lovely.

In the line of

#### *New Styles*

there were several things worthy of notice. Mr. G. M. Elton, Palmyra, N. Y., introducer of the "Eltonian Panel" picture, again took the lead with a new vignette picture. The prints were trimmed circular. Around the outer edge of the vignette a gray border was printed. The pictures were about twelve inches in diameter, and framed, hung "diamond"; *i. e.*, by one corner. The order was thus: The portrait; the vignette white margin; the rim or border of gray; a black mat, or spandril; a red velvet inside; the frame.

The style is tasteful to a degree, and

ought to take and help raise prices. Certainly Mr. Elton is a leader in styles. His portraits of bouncing babies and laughing ladies also display the work of a master.

Messrs. Moreno & Lopez, N. Y., were distinguished by their fine display of life-size heads, made with Scovill's Leukoscope lens. The "Young Lady with Curly Bangs," was scarcely equalled in technique by anything in the exhibition.

Mr. G. W. Sittler, Springfield, Ill., besides a splendid collection of children, dogs, and cats, drew most attention by his portraits printed on silk and other fabrics. They were admirably done—rich, soft, and well toned.

Mr. C. W. Motes, Atlanta, Ga., excelled all of his former displays. His "black vignettes" and his new "photo-statuary" subjects were greatly admired. Some of the latter were fully up to his "Daughter of Danaus." His brides, children, and lady with the rose, charmed us exceedingly. Mr. Motes keeps pace with the rapid growth of our art and is an enthusiast in it.

Mr. A. E. Rinehart, Denver, Col., made a grand showing, with which was his "Galatea," "Trappers," "Child Groups," "Street Musicians," "Lady Macbeth," "Child and Dog," were among the best we noticed, and all show the good photographer.

Under the head of

*Novelties,*

there was much that was attractive. Mr. E. Long, Quincy, Ill., made a fine display of solar enlargements on canvas, ready for the work of the artist. His "blue prints" were also excellent—clear, sharp, and free from fuzziness. Mr. Long's plain paper prints are also all the artist could ask for—ready for the easel.

Mr. E. S. Conrad, Reed City, Mich., made a fine display of views in the lumber woods of Michigan.

Mr. G. E. Curtis, Niagara Falls, N. Y., is well known by his admirable large photographs of Niagara Falls, and yet there is always a novel interest about his new works which renders them well worthy of study.

Mr. T. Benecke, St. Louis, son of our

worthy Local Secretary, Robert Benecke, Esq., made a fine exhibit of his artotypes of fine quality. His negatives are "perfection" for mechanical printing.

Mr. A. McDonald, South Bend, Ind., mounted his lovely panel pictures on wooden planks quite an inch thick, gilt and beveled. The result was very attractive, the work excellent.

Messrs. Davis & Rayburn, Little Rock, Ark., exhibited the only collection of portraits made by electric light. They were carefully done and very creditable.

The Photogravure Co., 853 Broadway, New York, had five frames of exquisite productions from their steam and hand-presses, in various colors and tints, of all sorts of subjects. Our readers are quite familiar with their work.

They exhibited some theatre groups from "Adonis," made by electric light, which were remarkably fine.

The Moss Engraving Co., New York, made their usual display of process cuts, including the new Mosstype, all unrivalled by their kind.

Mr. R. H. L. Talcott attracted a great deal of attention by his examples of work mounted upon plate-glass by his new method. This is sure to become a leading picture.

Mr. T. R. Burnham, Boston, as usual, did the biggest thing. His colossal dry plate picture is from a direct negative 39 x 60 inches, which was made with a No. 8 Eury-scope lens in twenty seconds.

Mr. F. B. Bailey, Palestine, Texas, was kind enough to exhibit some daguerrotypes made in 1852. His grave of Sam Houston was the gem of his personal work.

The Eastman Dry Plate and Film Co.'s display of enlargements on bromide paper, was, of course, the most surprising novelty of the exhibition. Mr. Cooper, in our last issue, told their story and gave us the method of their production. These pictures are going to work a revolution in photography. They will not take the place of anything else. They will make their own place and create a new trade. They will add a new value to old negatives, and will make up losses sustained by low prices. Every artist should select a good negative



and hang up a bromide print from it, of every size, steps from cabinet to 30 x 36. Push *now* for holiday orders. We hope to show you a small example soon. In the Eastman exhibit was a frame by Mr. W. H. Walmsley, Philadelphia. The enlargements from his small negatives were better than the contact prints. All were soft and lovely, pure and white and clear.

The Acme Water-Color display (Chicago) attracted a good deal of attention, great improvements having been made in quality and effect. The examples shown were carefully done—on paper and on glass.

Messrs. Hulbert Bros., St. Louis, made a great showing of stamp portraits in connection with their regular portrait work.

Mr. C. G. Geleng, Detroit, Mich, had a large exhibit of his enameled pictures, colored and uncolored.

Messrs. Kuhn Bros., St. Louis, also made a fine display of stamp portraits and of solar enlargements. Their view of the St. Louis Bridge is very fine and about 20 x 30 inches.

Among the pictures which attracted us by their

#### *Technique,*

were those of Messrs. Arthur & Philbrick, Detroit, by Suter lenses; Gehrig, of Chicago; Theo. P. Schurr, Lockport, N. Y.; McLeod, Atchison, Kansas; Geo. W. Wise, Janesville, Wis.; L. F. Hammer, Jr., St. Louis; Mrs. R. Maynard, Victoria, B. C.; Stuber Bros., Louisville, Ky.; Gilbert & Bacon, Philadelphia; S. P. Truesdell and H. Pietz, Springfield, Ill.; John A. Todd, Sacramento, Cal.; B. L. H. Dabbs, Pittsburg, Pa.; A. K. P. Trask, Philadelphia; Heimberger & Son, New Albany, Ind.; R. Goebel, St. Charles, Mo.; D. R. Clark, Indianapolis; Heubinger Bros., Davenport, Iowa.

Mr. Clark's 26 x 42 of a bride, was very well done, and his life-size of Rev. Dr. Schindler very characteristic. The same may be said of the portrait of an "old lady."

President Wm. H. Potter showed some of his former work alongside of that recently made—a good way to show progress. What attracted us most in his exhibit was the head of "An Old Man," "Girl with Fan,"

"Boy Violinist," "Girl with Candle," "Two Little Choiristers," and two horses lovingly posed one with his neck over that of the other. If there is individuality in these pictures it seems to show out in the way of good temper and amiability, for such are the characteristics of the worthy Ex-P.

We have so far spoken mainly in praise of what we saw at St. Louis. We could, however, put on our other spectacles and go right over the ground again and show up some of the

#### *Errors and Freaks*

for which some of the exhibitors are responsible. If our readers could all see the pictures projected upon the screen while we gave vent to our feelings, it might do some good. As the effort would fall to the ground otherwise, we will only give one or two illustrations of what we mean.

In the exhibit of a gentleman whose work we have commended very highly above, is a large picture of a poor little boy jammed in among a lot of Seavey's incongruous and ungeological rocks of an unknown period, who was expected (judging from his forced expression) to look like a little Christian under the hardest circumstances.

In another exhibit, we found crowded in one picture, ostensibly of a pure and harmless lady, the following variety: fans; Japanese fans; plaques; vases; a jewel case; rugs; statuary; draperies in variety; a floral back-ground; rocks, and a lot of bric-a-brac. We do not know what the conception was, but it was not carried out so much as the incongruous trinkets were carried in.

Another example by another party, whose average work is capital: The subject we will call "Adieu!" A lady, standing with her back to us, upon a bluff at the sea-shore. She is carefully posed with hand aloft, a handkerchief in her hand in the act of waving it to her lover departing in the vessel beyond. At her right side is one of those weather-worn old trees of the coast, whose branches hang protectingly over the young lady. A capital picture technically—well conceived artistically—oh! if it had only been left alone. But the artist had been reading some of our art papers, or Mr. Robinson's *Pictorial Effect*, and the word "bal-

ance" came to his head. It *unbalanced* him, for he went kicking about among his accessories, and with maniacal impulse rolled in one of those old-fashioned stuccoed, sanded, straight-lined, hard-cornered pedestals of somebody's, and squeezed it up against the left side of the heart-broken miss. Now, what in the d—irection of art could have induced him to act so thoughtlessly? It was the want of a *thorough* knowledge of art. But, Heaven bless the men who try. If they imitate Sarony's twirling dresses, bless 'em. If they etch after Mr. Guerin's last year's incongruities, bless 'em. If they jam in accessories like a log-boom, and cross their lights, if they try to excel, bless 'em. It will all do them good and they will do better next year. We have been trying, in our humble way, for nearly a quarter of a century to teach them how, and we had to learn as we went on. We are not going to howl because they do not grow faster. Bless 'em, they will grow, they do grow, and the exhibition at Chicago, next year, will give more evidence of it than ever.

#### *The Foreign Exhibits.*

In lieu of extended comments upon the foreign exhibits, we shall soon follow our plan of last year, and present our readers with some mosaics selected from them. The medal offers brought more exhibitors than we had last year, though many were induced by the efforts of Messrs. E. & H. T. Anthony & Co., and by Mr. G. Gennert, who, in behalf of the Eagle Plate Co., sent "Eagle" plates over to his friends in Germany, on which to make the pictures for their exhibits.

Some splendid results followed this effort.

The following is the list of foreign exhibitors:

#### *Germany.*

Theodore Creifeld, Cologne. Karl Wunder, Hanover. Benque & Kindermann, Hamburg. Mayer, Dresden. H. Hoeffert, Dresden. Alma Vonder Trappen, Stuttgart. Schmidt & Wagner, Kiel. Schultz & Suck, Karlsruhe. Von Bosch, Frankfort on the Main. Rudolf Hamsa, Vienna, Austria. Teich & Haenstaengel, Dresden. August Kampf, Aachen. Fritz Eilender,

Cologne. Franz R. Muller, Munich. Wurthle & Spinnhirm, Salzburg. B. Johannes, Partenkirchen. Th. Prumm, Berlin. Loescher & Petsch, Berliu. Karl Kesselhuth, Hildesheim. Mertens, Crefeld. D. Wetter, Hamburg.

#### *England.*

Geo. West & Sons, South Sea.

W. W. Winter, Derby.

H. P. Robinson, Tunbridge Wells.

(Mr. Robinson's "Dawn and Sunset" was the only composition exhibited by him, owing to his late indisposition.)

We trust what we have said will be beneficial to our readers.

#### *The Manufacturers' and Dealers' Exhibit.*

This exhibit did not strike us as being as attractive as the one of last year. It was admirably arranged and much attended.

In our issue for June 19th, page 371, we gave a plan of the Exhibition Hall, upon which, also, are the names of nearly all the exhibitors.

In addition to these, the McIntosh Galvanic and Faradic Battery Co., 302 & 304 Dearborn St., Chicago, made a very fine exhibit of magic lanterns, microscopes, and electrical apparatus. Their goods are beautiful and excellent.

Mr. E. A. Gilbert, Jamestown, N. Y., had specimens on his papers for enlargements.

Among the novelties we noted the following:

At the St. Louis Dry-plate Company's headquarters were pyramids of plate boxes, from the smallest to the largest size of this excellent brand of plates, negatives, and prints.

Then an interesting exhibit of Lafayette W. Seavey, of this city, showed his peculiarly artistic backgrounds. There was always to be seen in front of this exhibit groups, larger or smaller, of interested photographers.

Messrs. Allen Brothers, of Detroit, showed some excellent work made with Suter lenses at their exhibit, and also showed in cases some of the lenses themselves.

The exhibit of A. M. Collins, Son & Co., the card-stock manufacturers, of Philadel-

phia, was one of the most attractive and tasty ones in the entire hall.

In the centre of their space, which was marked off by a neat little rail fence of ash, stood an improved show-case, in the general form of an octagonal pyramid.

It was about thirteen feet high, and covered at its base an octagon of about five feet diameter. This octagonal base contains about four hundred bins for cabinet-size samples, and four drawers, 20 x 20, for price lists, etc. The revolving top, on which hung fifty drawers, 24 x 30, with double fronts, making one hundred spaces, contained five hundred square feet of show space, in which were shown the entire line of cards manufactured by this Company—some eight thousand in all. The case was built of selected ash, carved in an appropriate manner, and surmounted with a silver figure of Mercury.

Each visitor at this exhibit was presented with two neat little boxes containing sample mounts that were greatly admired by all.

The pyramids of plate boxes marked "Cramer" were the next things that attracted attention. By them we were reminded of the superior work we had admired in the halls above, which had been made on these famous plates.

H. Lieber & Co., Indianapolis, Ind., occupied the next space, and made a creditable exhibit of stock. They presented each of their visitors with a pamphlet entitled "Silver Printing on Albumen Paper," by W. H. Potter.

The M. A. Seed Dry-plate Co. occupied space in the exhibition hall, and showed admirable work made on their plates.

The Eastman Dry-plate and Film Co. made their great display in the galleries on the floor above, and of which we have made mention in another place.

In their place down stairs they showed a large interior of a church, which had been made on their paper film.

J. C. Somerville, of St. Louis, showed a fine line of cameras, stands, etc., made by the New Haven factory, and by the noted American Optical Co. of this city. From this exhibit, specimen copies of the photo-

graphic magazines were also distributed to inquiring photographers.

H. A. Hyatt, also of St. Louis, displayed equally as large an assortment of American Optical Co.'s apparatus and cameras from the New Haven factory. He also showed some excellent patented chairs. The magazines were asked for and obtained here as well.

W. G. Entrekin exhibited a large assortment of his well-known burnishers, and made a fine display.

W. H. Walmsley & Co., Philadelphia, showed pictures made by the Beck "Autograph" lens. Mr. Walmsley spoke very highly of the "Ripley" plate, sample packages of which were given away from his exhibit by Mr. George H. Ripley, the manufacturer.

George Murphy, of New York, made a highly creditable exhibit. The bottles of "Moreno's Universal Developer," which he had brought with him, were quickly sold. He showed us a new adjustable balustrade, that is certainly a valuable accessory to any portraitist.

Messrs. Blair & Prince showed a fine line of their cameras, and sold the "Hub" developer.

At the exhibit of Sweet, Wallach & Co., of Chicago, we saw the Collins' focusing attachment, which is advertised in another part of this journal, and admired the fine display of artificial flowers and plants. They also exhibited Gundlach lenses.

Smith & Pattison, of the same city, made equally as fine a display of chairs, accessories, and large pictures.

Messrs. E. & H. T. Anthony & Co., of New York, showed a fine line of their apparatus, which was presided over by Col. Geo. B. Ayres, their representative at the Convention.

Buchanan, Smedley & Bromley's exhibit was the headquarters for the platinotype.

B. French & Co. showed Darlot and Voigtlander lenses.

Mr. John Carbutt, at space No. 18, did not fear to exhibit his work in St. Louis, "the hot-bed" of dry plates.

The PHILADELPHIA PHOTOGRAPHER, for June 19th, was handed to every visitor. Some came for more.

## PERTAINING TO THE



ST. LOUIS, Mo. June 23, 1886.

## PROCEEDINGS OF THE THIRD DAY.

The President: The Convention will please come to order. I have got but one announcement to make. I will read this telegram which is dated June 23, 1886.

To W. H. POTTER,

President Photographers' Association,  
Music Hall, St. Louis, Mo.

Edward Anthony sends greeting to the photographers in convention at St. Louis, and wishes them a happy and profitable time.

ALEXANDRIA BAY, N. Y.

The first business in order is the discussion on dry plates and the causes of failure, this being the unfinished business from yesterday. Will somebody start the discussion.

Dr. Nicol: Mr. Chairman, simply with a view of setting the ball rolling, I will take the liberty of saying that one of the most frequent causes of failure of dry plates, judging not only from what I saw in the hall but what I have seen all over the country, seems to be the simplest and most easily avoided of all causes, and that is the removing of the plate from the hyposoda solution too soon. The result is that on exposure to light there is seen a yellow deposit. It would be supposed that old stagers would know better, but I recently saw in a store a little book of instructions where the order was given, or the recommendation to remove the plate as soon as the white creamy appearance has gone. Now all those who have done much dry-plate working know that the plate is not then ready to be removed from the bath. The first change when the plate is placed in

the hypo bath is to convert the bromide of silver into a two-fold double salt of the hyposulphite of silver and soda. The salt is not visible. Nothing is seen, and if the plate is removed immediately after the white bromide disappears, the smaller structure of the gelatine is still charged with the double salt of hyposulphite of silver and soda, and if it is not left a minute or two (I would recommend two minutes), if it is not left sufficiently long for the hyposulphite to be removed, when placed in washing-water the hyposulphite of silver being insoluble is not removed, and the more washing one gives to it—that is to say, no amount of washing with water will remove the insoluble hyposulphite of silver, and when it is brought into the light in one or two minutes the whole plate, or such portions as are not cleared of the hyposulphite of silver turn yellow. This is, as I said, one of the causes of failure, and the only advice to give is never remove the plate from the hyposulphite of soda too soon. I say this, always leave the plate two minutes after the white cream yellow bromide has disappeared.

Mr. D. R. Clark, Indianapolis: Frequently after washing a picture we notice a yellow color which oftentimes must be removed. This can be done by the use of a preparation of ten ounces of a saturated solution of alum to one ounce of oxalate. That solution will usually remove the yellow color and reduce the strength of the negative. My experience is, if you wish to remove the color from the negative after being fixed, you must be sure it is thoroughly fixed or you will spoil the negative.

Mr. Beckwith, Cleveland: Speaking of this matter reminds me that I had a negative in just such a condition, but unfortunately the original of the negative was dead, and an order came for some photographs from that negative. One whole side of the negative was of this yellow color. In order to fill the order I took the negative to our dark-room and made a transparency. Before doing so, I placed a sheet of yellow gelatine in front of the negative and made my exposure through the yellow gelatine and got a positive free of the stains, and of even color. From that I reproduced and

obtained a good negative from which the order was filled. I think it is a point worth remembering in case our brethren of the profession happen to get caught in the same way, that would be a method of getting out of it.

A member: That is a good thing.

The President: Yes, and that reminds me of a story too. Where we cannot get over the difficulty of a stain of that kind it is worth doing. There are great many negatives which you cannot copy. One portion of the negative may print through but will print very slowly. For instance, if there is a stain on one side of the negative you will have to print, vignette—take and put a tissue paper on of sufficient thickness to cover the weak side and let the full force of the light come upon the side that is discolored, on the weak side. You put these thicknesses of tissue paper on so as to balance the chemical result.

The President: The next thing is the reading of the paper by Mr. Fred. H. Wilson, of New York. Subject, "Is Photography Art." This paper was read by the Secretary. (See page 392 of our issue for July 3d.)

Mr. Gentile moved that a vote of thanks be tendered to Mr. Wilson for his paper.

Agreed to.

The President: I will now appoint as the Henry Anthony Memorial Committee, Messrs. E. Decker, of Cleveland, O., E. Courtney, of Canton, O., and Charles Smith, of Peoria, Ill.

The paper by Dr. Eder, subject "The Progress of Photography in Germany and Austria," was read by Dr. Elliott (see page 408 of our last issue).

On motion of Mr. Cooper, a vote of thanks was tendered to Dr. Eder for his excellent and valuable paper.

On motion of Mr. Cooper a further vote of thanks was tendered to Dr. Elliott for the very able manner in which he read the paper.

The President: Next in order is new business. I have the following resolution to read:

*Resolved*, By the Photographers' Association of America that the action of our good friends and brother photographers, J. F.

Ryder and J. H. Kent, while acting in the capacity of members of the Executive Committee of this Association, be heartily endorsed by the Association as being for the best interests and good of the Association.

This resolution was signed by L. C. Overpeck.

On motion the resolution was adopted.

Mr. Joshua Smith: I would make a motion that a committee be appointed by the Chair with power to incorporate this Association under the laws of the State of Illinois.

The resolution was agreed to.

The President: I appoint Messrs. E. L. Brand, G. A. Douglass, and C. Gentile.

The President: Now we will take up the regular business. We will have a paper read by Mrs. Lockwood, of Wisconsin, entitled "Yesterday and To-day, or Justice to All." (See page 404 of our last issue.)

The paper was read by the Secretary, Mr. McMichael, and a resolution of thanks given Mrs. Lockwood for her timely paper.

The President: In 1883, when the Convention met in Indianapolis, Mr. Cooper came into my dark-room to develop some negatives. He had some new-fangled developer he was trying, and after he went away, a gentleman, I am not going to tell you who he was, said he was a crank. (Subsequent events, I think, have proved that the other man was a crank.) He had a soda developer. He was experimenting with it at that time. We will now have Mr. Cooper's paper, and the title of the paper is "Improvements in Photographic Printing and Enlarging."

The paper was then read. (See page 406 of our last issue.)

Mr. Cooper, always so earnest in all he does here, rested a moment and then continued:

The President suggested to me that as you have a great many things to do this morning, and the time is limited, that we postpone the balance of my remarks until tomorrow's session, when it will come up under the head of unfinished business, so I shall not detain you any longer and hope that I have not bored you with what I have already said.

The President: I have a few announce-

ments to make. The excursion does not leave the wharf until two o'clock, and we get our dinner and supper on the boat. We want to get through our business, then we want to go, if we possibly can, and visit the factories of Mr. Cramer, an invitation having been given.

Mr. Cramer: Mr. President, in regard to that, I must say that everybody is welcome who wishes to visit my factory or my gallery. I am only sorry that I cannot be everywhere myself to attend to each and every one of you individually, but I cannot cut myself into six or more parts—that would spoil the whole thing. [Laughter and applause.] If it is your pleasure to visit my factory, as this afternoon is devoted to the excursion and there will be no more time to-day, we can make it to-morrow afternoon, and all those willing to come will find me there and will be welcome.

The paper of Mr. C. T. Stuart, of Hartford, Conn., "A Tribute to Photography," was then read by Mr. Stuart. (See page 421 of our last issue.)

On motion of Dr. Elliot, a vote of thanks was tendered Mr. Stuart for his excellent paper.

The President: According to Section 6, of the By-Laws, which reads: "The election of officers shall be held at the morning session on the day preceding the last day of the annual convention," the election will now be held.

As the Committee on Awards is now ready to report, before we go into the election we will receive the report of that committee. The Secretary then read the report as follows:

Your Committee on Awards beg leave to submit the following report. After a careful consideration of the entire exhibit, they award the six gold medals to the following parties for the best

#### PORTRAIT WORK.

##### *Gold Medals.*

- Decker & Wilber, Cleveland, O.  
 E. J. Falk, New York City.  
 J. W. Gehrig, Chicago, Ill.  
 J. Landy, Cincinnati, O.  
 J. A. H. Parsons, Wheeling, W. Va.  
 J. F. Ryder, Cleveland, O.

##### *Silver Medals.*

- B. L. H. Dabbs, Pittsburg, Pa.  
 S. J. Dixon, Toronto, Canada.  
 G. M. Elton, Palmyra, N. Y.  
 Gilbert & Bacon, Philadelphia, Pa.  
 H. McMichael, Buffalo, N. Y.  
 C. W. Motes, Atlanta, Ga.

#### PHOTOGRAPHIC PRODUCTIONS OTHER THAN PORTRAITS.

##### *Gold Medals.*

- Geo. Barker, Niagara Falls, N. Y.  
 W. H. Jackson & Co., Denver, Col.

##### *Silver Medals.*

- E. H. Lincoln, Dorchester, Mass.  
 Geo. B. Wood, Philadelphia, Pa.

#### FOREIGN PORTRAIT EXHIBITS.

##### *Gold Medal.*

- P. Muller, Munich, Germany.

##### *Silver Medal.*

- Schultz & Suck, Karlsruhe, Germany.

#### FOREIGN EXHIBITS OTHER THAN PORTRAITS.

##### *Gold Medal.*

- Geo. West & Sons, England.

##### *Silver Medal.*

- R. Hamsa, Vienna, Austria.

F. W. GUERIN,

JAS. MULLEN,

J. D. CADWALLADER.

Committee.

The grand exhibit by the leading St. Louis photographers is as conspicuous for merit as ever, and outside photographers cannot appreciate too highly the magnanimity extended by them in their withdrawal from competition for prizes.

The undersigned, members of this Committee, regret it is not in their power to select from their exhibit, among which are to be found displays second to none.

JAS. MULLEN,

J. D. CADWALLADER.

Of Committee on Awards.

One of the silver medals of merit was voted by the Executive Committee to Mr. T. R. Burnham, of Boston, for large picture, 36 x 60, of a lady.

The other to the Eastman Dry Plate and Film Company, for bromide enlargements. The medals having all been disposed of,

the Executive Committee desire to tender to Geleng, of Detroit, Mich., honorable mention for the excellence of his enamelled photographs.

Joshua Smith, of Chicago, Ill.: Mr. President and Gentlemen of the Association: The medals are in this little box and are ready for distribution at once, unless it is the desire of the Association that your Committee shall engrave the names upon the medals of the lucky competitors.

I have here the names of the following gentlemen who have contributed kindly to this fund:

- G. Cramer Dry Plate Works, \$500.
- John Carbutt, \$50.
- Eagle Dry Plate Company, \$50.
- A. M. Collins, Son & Co., \$50.
- G. Gennert, \$25.
- Gayton A. Douglass & Co., \$10.
- Allen Bros., \$10.
- Blair & Prince, \$10.
- The Blair Camera Co., \$10.
- Scovill Manufacturing Co., \$50.
- E. & H. T. Anthony & Co., \$50.
- P. Smith & Co., \$10.
- Eastman Dry Plate and Film Co., \$25.
- Henry D. Marks, \$10.
- Sweet, Wallach & Co., \$20.
- Smith & Pattison, \$10.
- Hiram J. Thompson, \$10.
- N. C. Thayer & Co., \$10.
- H. Lieber & Co., \$20.
- C. H. Codman & Co., \$10.
- M. A. Seed Dry Plate Co., \$25.
- A. B. Paine, Ft. Scott, \$10.
- J. A. Anderson, \$10.
- St. Louis Dry Plate Co., \$50.
- J. C. Somerville, \$25.
- H. A. Hyatt, \$15.
- Benjamin French & Co., \$25.
- P. A. of A., \$200.
- Making a total of \$1300.

EXPENSES.

Paid Giles, Bro. & Co., for Medals,	\$1214	00
Paid Rand, McNally & Co.,	43	60
Paid for Discounts, Postage, etc.,	1	75
	\$1259	35
Balance on hand,	40	65
	\$1300	00

JOSHUA SMITH,  
Committee on Medals.

Mr. Clark, of St. Louis: We would like to have the names of the rest of the Committee.

The President: I can make a statement that Mr. Smith was made a committee of one on subscriptions to procure medals, and he was made entirely responsible in the matter of procuring the medals. There was a committee of three appointed. The committee was Joshua Smith, James Landy, and F. W. Guerin.

Mr. Gentile: I move that the report of the committee be received and the committee discharged with a vote of thanks.

Agreed to.

The President: The next business in order will be the election of officers for next year.

The result of the election was as follows:

*President.*—G. Cramer, St. Louis.

*Secretary.*—H. M. Bellsmith, Rochester.

*Treasurer.*—G. M. Carlisle, Providence.

*Executive Committee.*—James Landy, Cincinnati; W. V. Ranger, Syracuse.

The selection of Vice-Presidents was left to the Executive Committee.

Mr. Cramer then entering the hall, was called for, and said:

Mr. President, news has been brought to me that you have chosen me for your President, which is an utter surprise to me, as much a surprise as the one which was given to me yesterday afternoon by the presentation of this nice gold-headed cane, which has an inscription on it "from your friends." It seems that I have more friends than I expected, and I must tell you that although I appreciate the honor you have bestowed upon me, I have not wanted the office, and have told my friends to please withdraw my name, that my time is taken up by a great many things, and furthermore, I did not want it to appear as if I acted from a desire to get the office for any private interests of my own. I wanted to stand above suspicion, and if there is one man who objects to my election I will not have it.

Mr. Clark: Your election was unanimous.

Mr. Cramer: If it was made unanimous, I think I will have to accept it. (Applause.)

Three cheers and a "tiger" were then given for Mr. Cramer.

Mr. Cramer: I can only say one more

word, and it is this, I don't know why you have chosen me for this high honor. I am not a good speaker, I am not perfectly posted in parliamentary rules, and all that sort of thing.

A Member: You are a real good man.

Mr. Cramer: I have the interest of the Association at heart, and shall do everything in my power to encourage it and to sustain it, and I hope that you will all work with me to keep it alive and keep it agoing. I thank you again for the honor.

The President: The next place of meeting recommended by the Committee is Chicago.

On motion Chicago was decided to be the next place of meeting for the Association.

On motion the Association adjourned to meet Friday, June 25th, at 9 A.M.

#### FOURTH DAY.

The President: The Convention will come to order.

The Committee appointed to report on the award offered by the Acme Burnishing Company of New York, of a twenty-six inch burnisher, for the largest display at the Exhibition, report as follows:

The above is awarded to F. W. Guerin, of St. Louis.

C. GENTILE,  
Committee.

The Committee on the Anthony prizes report as follows: Prize for 18 x 15 portrait, to Irving Saunders, Alfred Centre, N. Y.; prize for 8 x 10 view, to W. Purviance; prize for cabinets to G. M. Elton, Palmyra, N. Y.

C. T. STUART,  
DAVID COOPER,  
A. G. BECKWITH,  
Committee.

I am sorry the ladies are not present, but we cannot wait. I will read the following tribute of respect to the memory of John A. Scholten:

#### IN MEMORIAM.

JOHN A. SCHOLTEN.

"At rest from the wearying strife  
To focus the aims of this mortal life.  
Condensing to actinic ray  
The murky gleams of vanishing light,  
To translucent beams of dazzling white,  
In the dawn of eternity's day."

"Where to mortal ken appears  
No trace save the dew of the tears,  
Is the latent image purified,  
And the face we have missed,  
Mid the heavenly group forever fixed,  
Lives in joy with the crucified."

MARY NOLAN.

On motion of Mr. McMichael a vote of thanks was tendered to Mary Nolan for the tribute.

The President: Reports of Committees are now in order. Mr. Ryder is not present, he is on the Committee of Amendments to the Constitution and By-Laws. I believe unfinished business is the first thing in order. Mr. Cooper's subject was unfinished. We will hear from Mr. Cooper.

Dr. Elliot: Before Mr. Cooper proceeds with the reading of his paper I move that the papers which have been sent in, where the writers of the paper are not present, be read by title, and that the same be published in the journals. I do this so that we may give Mr. Cooper a chance to read something technical and practical, as he has taken the trouble to come here and speak to us on this subject.

The motion was agreed to.

The following papers were then read by title:

"Brains and Judgment Needed in Photography," by C. F. Moelk; "The Successful Photographer," by Millard P. Brown; "The Decline in Prices and the Remedy," by A. St. Clair; "Art Censorship," by L. A. Sherman, of Beloit, Rock County, Wis.; "Money Making," by W. Guild, Rolla, Missouri.

The President: We will now hear the report of the Auditing Committee.

Mr. Long submitted the following:

*To Photographers' Association of America.*

We, the undersigned, have carefully examined the books of Mr. H. McMichael, your worthy Secretary, and find that there is a balance due him of ten dollars and nine cents (\$10.09).

E. LONG,  
D. A. CLIFFORD,  
D. R. CLARK,  
Auditing Committee.



Mr. Benecke: I am informed that quite a number of unmounted photographs have arrived here, sent by a gentleman by the name of J. Pike, 16 New Bridge Street, Newcastle, England, to be placed on exhibition, and for competition. There is also another box containing a large number of photographs on the way coming. From what I can learn the exhibit would cover at least three hundred square feet, and being photographs of the mountainous regions of Switzerland, and taken by the renowned photographer F. Pietsch, I suppose are very fine. They also were sent to be put in for competition and exhibition. I desire to know what I shall do with them.

The President: I am sorry they were not sent on.

Mr. Gentile, Chicago, read Mr. Carlisle's paper entitled "On the Business Arrangement of a Photographic Establishment." (See page 406 of our July 3, issue.)

On motion of Dr. Elliot a vote of thanks was tendered to Mr. Carlisle for his paper. A further vote of thanks was tendered to Mr. Gentile, also a vote of thanks to all the gentlemen who have written papers which have been read by title. Also a resolution of regret to those foreign exhibitors whose exhibits arrived too late, and thanking them for the trouble of sending them.

The President: Mr. Cooper is in order, we will hear from him.

Mr. Cooper now completed his excellent paper, which appeared in our last issue.

Dr. Elliot: I move a vote of thanks be given to Mr. Cooper for his very able and instructive lecture.

Agreed to.

A discussion on the delivery of the medals now followed, and then one on skylight work, when Mr. Ryder said: I will be brief. I can say some things, however, that are to my mind applicable to the later days of working. In the first place we have now quicker plates and it is possible and beneficial to use more powerful instruments and less light under the skylight. That is our purpose and principal need, to see how rapidly we can work and get good results giving time exposures. The rule,

probably, for the average work like cabinets and boudoir negatives in general, is about five seconds, and to be enabled to do that we slow down our instruments and we slow down the light, working the light softer, using with almost everything the hand screen, interposing that between the strongest source of light and the sitter so that we get a more plastic effect, more half tones, and by holding the hand-screen through a portion of the time of the sitting insure that softer effect, and then taking it away for a part of the sitting secure by that means the higher lights and the getting of a more rotund head. That is the policy that we pursue in our house. With reference to how we shall adjust our sitter to the light, that is something that the man who works the sitter and the camera must know for himself. He does that according to his own judgment.

Mr. Cooper: I think Mr. President, that Mr. Ryder's remark with regard to the time of exposure in which the finest results are to be obtained is unquestionably true. Any man who tells me when I come into a gallery that he makes his exposures just so gives me the impression that it would be a great deal better if his sitters would go in and come out just so. In many cases that is the only way to make pictures. Mr. Ryder has remarked upon the possibility of modelling your subject by the use of a hand-screen. It is a perfect marvel to me with the experience that I possess in passing through the country that this method of working should not commend itself with mere force to photographers—I refer to the simple instrument with which he is able almost with the skill of a painter to model the head. But it is hardly ever used. One or two who have been to the other conventions in which the subject has been introduced I find have made themselves a hand-screen. He has gone to work and got something about the size of a handkerchief or the size of a barrel-head and got it fixed there, and after using it for a short time has thrown it away in the corner where the spiders would have access to it and it is never more disturbed. I almost invariably secure that hand-screen and give the spiders notice to quit. I then proceed to show him

as best I know how the manner in which the screen may be used to the best advantage. Generally, I believe, after I leave the hand-screen is used for a short while, but it seems as though it were difficult to implant in the minds of a majority of men the fact that some care is needed to be taken in the production of good work. The first question which a man asks is how can I accomplish the thing. The next question is how easy can I do it. Well, there are a great many easy ways of doing things. But is the easy way always the best? If a thing is worth doing at all it is worth doing well. How many photographers throughout the United States are there who have got leading positions by means of doing things the easiest way they knew how, and the quickest way they knew how? It is an easy thing to get an operator of this kind but what good is he when you have got him? It is not so easy a thing to get a first-class man, and when you have got him he is not the man who does the work in the easiest way. In like manner the best things are not to be obtained in the easiest way. If it were every man would have the best, and they do not by a large majority.

Mr. Poole: Just one word. I have been in studios where different language is used by operators to their sitters. I heard a good friend a couple of weeks ago speaking about the matter of exposing a plate; his words and my words are different words altogether. It was in reference to the way we could bring about a smile. He said, "Now, give us your best smile." The very fact of talking like that would take away the desire to smile. Now understand me, I do not want the smile that people usually put on. It is a piece of sickly sentimentalism on the face and it is something I actually abominate. We do not want anything of the kind. But I will tell you what we do want. It is just this; something that will make the eye brimful of mischief, and when you have got that you can go ahead. When I have got that I have got the expression I want. The favorite expression I use is: "Now, don't smile, but crowd in the mischief as much as ever you can," and when I get that that is just what I want.

Mr. Rollins, Indiana: I will tell you how

I get up a smile. I had a German operator, and when he was ready to make an exposure he said: "Now, you shoost smile a little inside." I thought that was a good thing and I always repeat that. If they will smile a little inside that will bring out the expression.

The President: That is a good idea.

Mr. Ryder: I want to speak on the question that is so important to all, and that is the matter of developing plates. I would liken the development of a plate to an engine with its train of cars. A good engineer will know how heavy his train is, what his grade is, and how much he must pull out his throttle to start it easily or quickly. The person who develops the plate does not always stop to think how much time his plate was exposed, what is exactly the condition of his developer, and so, as a rule, he puts on too much steam. He opens the throttle too wide and by the time he has found that out it is too late to remedy it. The train is off the track, the plate is overdeveloped and it results in waste of glass. The cautionary method is for the man to start slow, and then it is easy to stop before going too far. If you have not gone far enough it is easy to start up again. So, I believe in the interest of the men who have to furnish these plates and who have to pay out a great many dollars, this matter should be regarded, and I would like to impress it upon the men in whose power it is to save their employers this waste of money, heedless waste of plates, that he may as well save. I would say it is always perfectly safe to start slowly, with the developer weak, until you see that you want to go stronger, and then it should be done. But the rule is, or at least the practice is, that the developer of the usual average strength is thrown over a plate and the plate is gone, lost, and a good image thrown away by not treating it properly and not starting it well.

Mr. Brown, Chicago: I wish to speak in reference to the excursion. We had a very pleasant time, and I think it will be remembered when we return home. We shall also recollect the entertainment we have received. I wish this matter to be embodied in the resolutions that are passed.

The President: You are out of order.

The business on hand now is the discussion of skylights.

Mr. Truman: I have a very interesting question to put before the Convention. I was experimenting with iodine to some extent and I found that negatives of different density, overtimed and undertimed, can be brought back to the original printing quality by using iodine in a saturated solution of alcohol, making a strong tincture and combining it with cyanide and reducing the iodine back to a white state and pouring it in the dilute solution over the plate, if overtimed. It will bring out the shadows completely. If it is undertimed you use a little mercury. A saturated solution of mercury, a drop or two in the solution. If you use this it will give you the full printing quality.

Mr. Cooper: Will not the shadows be reduced in proportion to the high-lights in the case of an undertimed picture?

Mr. Truman: No, sir; the mercury does away with it altogether. I have experimented with it to some extent. I have left a negative in the developer very nearly all night. It was nearly dark, and in treating with iodine and then with the cyanide, I cut it down and made a very good practical negative out of it. It was perfectly intense, free from shadow.

The President: Mr. Cramer is ready to announce the names of those to whom the Committee has awarded his prizes. This does not make it official, but it is here given as a matter of courtesy.

Mr. Cramer: With your permission I will read the report.

SEVENTH ANNUAL CONVENTION, P. A. of A.  
ST. LOUIS, June 23, 1886.

G. CRAMER, Esq.

DEAR SIR: We, the undersigned, appointed by you a committee to award the five prizes of \$100 each, offered by you for five best exhibits made on your plates, beg to state that in making these awards we regret our inability to award a prize to St. Louis exhibitors, they being excluded from competing for prizes by their generosity to their guests. We recommend as entitled to your prizes, the following five exhibits:

George Barker, Niagara Falls, N. Y.  
J. W. Gehrig, Chicago, Ill.  
Gilbert & Bacon, Philadelphia, Pa.  
S. J. Dixon, Toronto, Canada.  
H. McMichael, Buffalo, N. Y.

We wish to state further that many of the exhibits competing for your prizes were mixed with pictures made on other makes of plates, and owing to the difficulty of arriving at a correct conclusion, we resolved to consider only those exhibits made entirely on your plates. Respectfully,

J. LANDY,  
RUDOLPH GOEBEL,  
S. V. COURTNEY.

The parties entitled to the awards can see me after the meeting and get their checks for \$100.

The committee appointed for the purpose of drafting resolutions of thanks to the St. Louis photographers, reported as follows:

*Whereas*, The members of the Photographers' Association have been most royally and hospitably entertained by the free and noble-hearted photographers of the city of St. Louis.

*Resolved*, That language is inadequate to express our feelings of gratitude for the grand entertainment provided for us on the boat excursion on the Mississippi River.

*Resolved*, That our thanks are particularly due to the ladies of the various committees for their exquisite taste and grace manifested on this occasion.

E. DECKER,  
S. J. DIXON,  
E. POOLE,  
C. GENTILE,  
Committee.

On motion of Mr. Ryder the resolutions were adopted.

Mr. Cramer: I invite all to visit my dry-plate factory this afternoon. The party will start at 3 o'clock from Twelfth and Pine Streets. Pine Street is the next street south from Olive, on which this building fronts. As I have been asked to prepare for this visit and have made preparation for it, I hope you will avail yourselves of the opportunity. You will all be back by five o'clock, so you need not be afraid of losing your trains. Now, another point, Mr. Presi-

dent. I have been prevented from being present all the time, and I do not know whether any discussion has come up as to what we shall do at our next convention in regard to prize medals. Is it the will of the Association that prizes should be offered again, or is it your sense rather that prizes should be discontinued? I would like to have the sense of the meeting on that point, and hear some discussion with regard to it. I do not think that \$200 will cover the ground. If we give out prizes we certainly need more than \$200, and as there is plenty of money in the treasury, I do not see why some of the money should not be appropriated for that purpose. If it is the will of the Association to have premiums I do not think it is proper for the Association to go around asking for contributions unless they be voluntarily offered. I have had the opportunity of hearing the expressions of a good many who were asked for contributions. They thought the Association was rich enough now to pay for the medals. There is a good deal of money in the treasury, and I do not see any reason, if we are in favor of the plan of awarding medals and prizes, why we should not appropriate as much as \$1000 for that purpose. Then we will be ready for further contributions, but I am opposed to the idea of appointing a committee to ask for subscriptions. I simply want to get the sense of the meeting whether they are in favor of premiums or not. If so, I would recommend that we appropriate that sum at least—it must be more than \$200.

After discussion, the question being on the motion that the Association appropriate \$1000 to the medal fund, it was agreed to.

Mr. Cramer: There is a group to be taken on the front steps as soon as the Convention adjourns.

The President: I have a communication here from Dr. F. Mallman on "Chromatic Photography." It is in German, and Mr. Benecke has promised our German friends that he would translate our communications. It will be translated and sent to the different journals.

On motion of Dr. Elliott, a vote of thanks was tendered to Dr. Mallman for his paper.

Mr. Cramer: I want to say a few words

more. I will not detain you very long. I wish, furthermore, to state that it has been the object of the Executive Committee in combination with everyone, there being so many prizes and medals, to try to get as much practical information as possible, in relation to the exhibits. As to the lenses used, the developer, and all the practical points. Now I do not know whether you have all paid proper attention to the statements made by exhibitors on their entry cards, which are attached to each exhibit. For instance, the exhibit made by Mr. S. G. Bellinger gives all the details in reference to exposure, lens, and development of these pictures, which are stage scenes taken by electric light. Everyone must perceive the difficulty of taking them and admit that the results are beautiful. I think the information given in regard to their development is valuable. He states the plates were well washed in water then in sulphite solution, afterwards adding pyro as required. I think the information may be of great value for short exposures.

Resolutions were adopted thanking Secretary McMichael for his assiduous labors; Secretary Benecke and the citizens of St. Louis for the manner in which they have entertained us during our stay, to include the ladies and the press.

Mr. Ryder: I move a vote of thanks of this Association be tendered to our esteemed and valued worker, Dr. Morgan, who has been with us so many years, for his efficient labors in our behalf, in taking notes of our proceedings. His genial face is always welcome, and he has become quite an adjunct to our Association of Photographers.

Agreed to.

The President: Ladies and Gentlemen: time will not stay; this Convention is dissolving out; what we have said and done here will soon become fixed in the history of the past. We have come now to get a proper idea of the perspective, what can be done on the largest plate. That this Convention will be a benefit to us all, I think will hardly be questioned by any one here. May God bless you and vouchsafe to you a safe return to your homes.

Mr. Cooper: Could not some arrangements be made at the next convention, by

which it will be practicable to give some ideas of posing?

This point was discussed, but no action taken.

After some discussion as to the kind of talent which should serve on such an important body, the following gentlemen were appointed as the Committee to examine the prize essays and make the Association award of \$100:

Mr. James Landy, Cincinnati; Dr. J. R. Nicol, Chicago; Mr. J. Carbutt, Philadelphia.

A letter, sent with a request to read it, from the Most Illustrious Master Photographic Manipulator of the S. O. S. P., and also a communication for the Association, was announced.

The President: What shall be done with the communication?

Mr. Cramer: I move that it be placed on file and be published.

Agreed to.

On motion, the Convention adjourned *sine die*.

ST. LOUIS, Mo., June 28, 1886.

#### IN EXECUTIVE SESSION.

It is moved and seconded that Mr. Joshua Smith be heartily thanked for the executive ability displayed in securing subscriptions, and the artistic taste shown in selecting the design for the Association medals.

*Further*, He has our thanks for the disinterested spirit shown toward the Association in spending money and time for the consummation of our purposes in offering the said medals.

W. H. POTTER,  
President.

H. McMICHAEL,  
Secretary.

ST. LOUIS, Mo., June 28, 1886.

*Resolved*, That the Executive Committee award the two special medals of merit to the following parties, viz.: one to the Eastman Dry Plate and Film Company, of Rochester, N. Y., for enlargements on bromide paper, and one to S. R. Burnham, of Boston, for the largest contact print from a single negative, 60 x 36 inches.

*Resolved*, That honorable mention be

made of C. G. Geleng, of Detroit, Mich., for photographic enamelling.

W. H. POTTER,  
President.

H. McMICHAEL,  
Secretary.

[Competing Prize Paper, read at the St. Louis Convention.]

## THE DECLINE OF PRICES, AND THE REMEDY.

BY A. ST. CLAIR.

*Mr. President, Ladies and Gentlemen:* Of all the questions affecting the photographic fraternity of the present day, the question of prices is at once the most important, the most difficult, and the most generally discussed.

The question is one which antedates photography by many years. There were Cheap Johns in the land long before the advent of Daguerre, Niepee, or Fox Talbot. Those of us who pushed the buffstick in the days of silver-plate work well remember the time when five dollars was the ordinary price of a daguerrotype. It used to be a common saying in those early days that a man had better break stones by the cord for macadamizing the roads, than make daguerrotypes for less than five dollars. Long before the advent of the collodion process, men were to be found who advertised first-class pictures for a quarter dollar, and *bang-up* pictures for fifty cents.

From the advent of the daguerrotype to the present day, the knights of the camera have quarreled over the question under discussion. The ivory miniature painter raised a howl because the more brilliant, more delicate, and vastly more accurate daguerrotypes superseded his hand-painted, scarcely recognizable picture, stigmatizing it as a machine picture, beneath the notice of genuine artists. In those days a few men obtained fabulous prices for their portraits of distinguished persons; but the average artist was obliged to content himself with from one dollar to five, for such work as the few head men sold readily for a double eagle or more; while scores of men were glad to keep the wolf from the door by making portraits of average quality for twenty-five cents. By this it is plain that the charge made against us is a most unjust one.

In looking for a why and a wherefore, for the present excitement on this question, it is well to make a retrograde inspection, and try if we can find the root of the evil.

The extreme simplicity of the daguerrotype

made it an easy matter for men of average ability to make a start in the new business. Men laid aside the plow, the plane, yea, even the mortar and pestle, and, after a month or less with a peripatetic daguerrotypist, came out as full-fledged artists. A few of these having a natural talent for the art-science, and studying to make each successive picture something better than the one preceding it, made the art-science a success financially, and, as their experience added to their knowledge, they took a higher position on the ladder of fame. Men of lesser note had their families to support, and found the selling of diplomas about as profitable in our business as it afterwards became in the medical profession; and as a consequence, scores of men were induced to embark their entire capital in a business of which they had not yet learned the rudiments.

The natural result was just what might have been expected—the supply exceeded the demand; and as the unskilful artist found no demand for his productions, he naturally concluded that the price he was asking was too high for their market value; so he resolved to find that value by reducing his prices, in the hope that when he found what the public considered them worth, the demand would increase; and as the cost of the material bore no proportion to that of the carpenter or blacksmith, the idea that an increase in his orders would compensate for the decrease in his profits, took such a hold of his mind that, although forty years of experience have proved the fallacy of the idea, it has been handed down from father to son, and is boldly promulgated in these our own times.

That a few isolated cases have occurred wherein men who could not command patronage by the *quality* of their work, have succeeded in doing so by reducing their prices, is no argument in favor of cutting rates, because, where one has succeeded, hundreds have failed. Besides, every little town has its photographer, and as no one has ever succeeded by cutting rates, except in large cities, and so few even in the cities that they may be counted on one's fingers, yet every photographer throughout the land has suffered by the suicidal policy of cutting prices.

It is doubtless true that here one and there another has maintained a fair price, while all around him have been forced to yield to the demand for cheap photographs; but you will immediately find that his health is so impaired that a complete rest from business is necessary, for which reason he is willing to sell out. If the real motive for selling out were known, in nine cases out of ten a failure in patronage

would be found going hand in hand with the failing health.

If in this paper I were not determined to avoid anything which may fairly be construed as personal, a hundred cases could be cited, and every position proved by illustration.

While we all agree that a very unfortunate condition of business affairs really exists, I do not expect all to agree with me as to the causes which have produced this decline, both in business and prices; neither do I expect all to agree with me as to the remedy suggested.

I assert, without fear of successful contradiction, that no resolution of this or any other Convention of photographers will *or can* so affect the question as to afford direct relief. The matter is beyond our reach. Nevertheless, there is something we not only can do, but which we must do. We must put the matter in such a form that those with whom the power rests may know our wishes, and be thereby enabled to proceed understandingly.

To begin with, we must unequivocally admit that the remedy is beyond our reach, and appeal to the acquisitiveness of self-interest; the cupidity, if you will, of one class, and the conscience, the sense of rectitude of the other.

We must also pacify ourselves. Not by appointing a special committee to report on the relative merits as photographers of Messrs. A., B. and C., but by appointing a committee of the whole, to report individually to the public at large upon the grade of his own studio. This can be easily and perfectly done, by adopting their grades or standards of prices; each photographer to place his own studio in the grade to which he thinks it belongs. If we were to appoint a committee of three, consisting of Sarony, of New York, Van Loo, of Cincinnati, and Rocher, of Chicago, to report upon the grade to which the studio of any photographer properly belonged, it is certain that even their report would be unsatisfactory. But if we make each man report upon his own status, by giving him his choice of three grades of prices to choose from, there would be no quarrels on that subject, because the public would either endorse the rating by patronizing the studio, or reject it by the opposite course. In either case there would be no appeal, and the photographer would have no one to complain of or to.

As a little assistance is often of more value than a large amount of dictation, I propose to enforce my thesis by practical suggestions. At present the cabinet size being most popular, I propose to use it as the basis of calculation. I suggest that this Convention adopt three grades

of *minimum prices*, as follows: First or lowest grade, from \$3.00 to \$3.50 per dozen; half dozen, \$2.00 to \$2.50. Second or medium grade, from \$4.00 to \$5.00 per dozen; half a dozen, \$2.50 to \$3.00. Third or highest grade, from \$6.00 and upward per dozen; half dozen, \$4.00 or more, as the artist may decide for himself. My idea is that, while a few in the larger cities who cater to the poorer and the artistically uneducated classes will choose the lowest grade, the great majority of the craftsmen—those who are truly the bone and sinew, “the power behind the throne” of the fraternity, will at once range themselves as belonging to the medium grade, and make \$5.00 per dozen their standard price.

What shall we do with those who refuse to be guided by the grading adopted, and insist upon calling themselves first-class photographers, while cutting prices below living rates? I reply, ignore them utterly, socially; report them to every dealer in your neighborhood, and refuse to deal with any man who supplies them with photographic stock. I do not now, and never did, advise any harsh measures toward them; on the contrary, I proposed to go to them in a fraternal way, and try to induce them to consider the matter. Be courteous toward them, until you find them incorrigible; then drop them entirely. Of them I say, as the prophet said of the incorrigible Jewish infidel, “Ephraim is joined to his idols; let him alone.”

What next must we do? Appeal, as a Convention, to all stockdealers throughout the land, to stop the supplies to all Cheap Johns. Will they heed you? Yea, they will heed you. It will be to their self-interest to heed you, and self-interest rules the world. Permit me to illustrate my recommendation. In 1863, after the draft riots in New York, a grocer with whom I dealt made some remarks which gave offence to a number of those who condemned the riots—remarks which encouraged and approved them. About a dozen others and myself quietly withdrew our patronage, and transferred it to a poor struggling young man, whose sentiments were in unison with our own. What was the result? The loss of any one of his patrons would not have affected his business, but the sudden loss of a dozen did. Our example was followed by others, to such an extent that when I visited the city, after being absent from January, 1864, to December, 1865, I found that the once haughty and prosperous merchant had gone to the wall, while his rival had risen from a little wooden shanty to a double brick store; from delivering his goods in a hand-cart, moved by his only

assistant, a boy, to keeping half a dozen clerks always busy, and half as many delivery wagons.

The boycott is a powerful lever. I do not advise its use, but I have shown what it did upward of twenty years ago, before the word was coined. Do I think the effect of my recommendations would be immediate? I do not. Large bodies move slowly. For over thirty years we have heard complaints of certain ruin from declining prices. Slowly but surely “Cheap John” has gathered power, until the present time, and now he has his grasp on our throat, and is doing his utmost to strangle us. Like the bundle on the back of Bunyan’s pilgrim, the “Cheap John” is a load to carry wherever we go, and the more we squirm and struggle, the more firmly he holds us. Those who are familiar with the story will remember that there came a time when the bundle fell from Christian’s shoulders, and he pursued his journey with a lighter heart and a more elastic step. How did he get rid of it? By first acknowledging that he was powerless to remove it himself, and appealing to one who had the power. The appeal was successful, and the burden was removed. So it is with us. As individuals and as a convention we are utterly powerless. *The stockdealers have the power*, and as their interests and ours are identical, they will rid us of this incubus, if properly approached. There is no need for boycotting, as it is generally understood. If this convention were to say that none of its members should deal with a stockhouse which supplied “Cheap Johns,” it would be considered a conspiracy, and would defeat itself by enlisting the sympathies of the entire association of stockdealers; but *if we, as individuals*, resolved to cease dealing with any particular house which renders itself obnoxious by encouraging “Cheap Johns” and bogus amateurs, we have a perfect right to do so. Nay, more, we can openly say to such a one, Jim Bludsoe is a “Cheap John,” but Hartley is a bogus amateur, who sells his photographs at two dollars a dozen. They are injuring the business generally, and mine particularly. You have a perfect right to encourage them if you please, but I cannot support you while you are helping them to hurt me, therefore if you continue to sell to them, I must look up another dealer. Although a dozen men should thus address a dealer in one day, it would not be a conspiracy, neither would it be recognized as a boycott, because it was the work of *individuals*, each speaking and acting for himself; but it would be just as effective. While such sentiments by a single individual would in all probability go unheeded, a dozen such letters received in a week would

cause a very unpleasant sensation along the spinal column of the strongest dealer in the United States.

In conclusion, Mr. President, and ladies and gentlemen, permit me to condense and express the *gist* of the whole matter, so that you may the more easily remember it.

First then, *as a convention* we can do nothing to rid ourselves of the incubus of Cheap Johnsonism, beyond defining what we consider the very lowest rates permissible.

Second, we must first give the dealers credit for the ability to assist us, and acknowledge our dependence on them.

Third, we must tell them (by resolution or otherwise), that we consider their interest in keeping up prices, identical with ours; and ask their assistance in coöperation.

Fourth, we must act at once. Delays are always dangerous. We have everything to gain and nothing to lose, by acting promptly.

Fifth, we must remember that while the dealers know as well as we what we need; if we do not ask them to help us, we cannot expect them to do so.

[*Competing Prize Paper, read at the St. Louis Convention.*]

## ART CENSORSHIP.

BY L. H. SCHUMAN.

EVERY artist worthy of the name has more than a pecuniary interest in his art. He is a devotee. He loves his art for its own sake. He desires to see it conserved and perfected, not so much because that will put money in his purse, as that it will make his calling a more noble one; he is himself exalted when his calling is; whatever degrades his art in some measure degrades him.

The bungler and the charlatan rob him in a double sense. But one of the inestimable incidents of the development of art, is that opportunity is given to the bungler and the "cheap-John."

When real art has created a demand, and while the popular taste is as yet imperfectly educated, bogus art steps forward with inferior imitations to accomplish the result to degrade the standard of taste, to cheapen the products of art, and to tempt the true artist to become careless of the quality of his work.

No noble growth ever appears but presently its parasite appears also. And so it

happens that a growing art, like a growing plant, must contend with the gnawing tooth of the art parasite, whose work is to enfeeble and degrade.

It will be said that in time a true taste will prevail over a false one, and real merit win its reward. But can nothing be done to aid this process? I believe it can be materially hastened, and at the same time much annoyance and trouble prevented, by the establishment of an art censorship as a civil office. We would have such a censor or critic in each town and city, with a State critic and national critic, to whom should be submitted questions respecting the quality and commercial value of art products; the State and national censors being respectively courts of higher appeal.

The functions of this office would be to set an art or commercial value on all pictures or works of art submitted for criticism, to settle questions in dispute between artists and their customers, and, by any fitting and suitable means, to minister to the cultivation of a correct taste, and to foster a popular appreciation of meritorious artistic work.

To this end it would be the duty of the officer holding this position to mark all photographic work brought to him according to its merit, from a minimum to a maximum price, say from \$4 to \$10 per dozen, for cabinets.

The law should provide that the price fixed by the censor could be recovered, and that by an order from him, thus settling all dispute or further litigation. But if the judge stamps pictures with his official stamp as being below the minimum commercial value, they can be returned to the photographer and money refunded. If there be dissatisfaction with the decision of the local judge, appeal can be taken to the judge for the State, and from his decision to the national judge or censor. In all cases the parties submitting pictures for criticism should be required to pay the fees fixed by law, which would constitute the pay of the officers.

From the operations of such a law as is suggested, we may most confidently expect relief and advantage in the following directions:

1st. An easy and pleasant settlement of



all differences, that, under the present order of things, too often turn to the disadvantage of the artist. It sometimes happens that the photographer and his patrons differ as to the quality of a picture, and unfortunately for all concerned, there is no established rule of amicably adjusting their differences. If a difference arises as to quality, it is easily settled by reference to the standards of weight and measure. But there is no standard for a picture or work of art. And while in the nature of the case there can be no absolute standard, still, by designating some competent persons to speak with authority, many of the advantages of an absolute standard may be secured. A lady may order a dozen cards or an expensive ink, oil, or crayon picture. While it is being made she has concluded not to get a picture at all. All she has to do when it is done is to call, and with a haughty toss of the head exclaim, "I don't like it." The work may be superb, her friends call and admire the likeness, pronounce it good; but alas, she knows too well the way out of paying for it, persists in saying she does not like it, the artist is defrauded and helpless. Now this is a case for the censor; let him decide whether or not the picture is what it should be, and what price shall be paid for it.

2d. The censor is needed to stand between the people and the imposition some would practice on them. Incompetent and irresponsible men, gifted with gab and gilded with brass, travel the country soliciting orders for pictures, and palming off inferior work upon those unskilled to detect the fraud that they feel has been practised upon them. There should be some authority competent to pronounce a decision in such cases, that would protect the people and discourage this class of unscrupulous men from working detriment to art, and to the feelings and pockets of those who patronize them.

3d. Such a court of appeal would check unreasonable fault-finding sometimes indulged in by the people. For if a man takes pictures to the art judge, for which he has only paid \$4.00, and finds the judge thinks them worth \$6.00, and orders him to pay the photographer two more dollars, said fault-finder will be more cautious next time.

4th. Such a censorship competently and impartially administered, would render prices more stable, by giving proper rank and superior money value to the best work. And would thus also encourage the ambitious to strive to attain to higher excellence. As it now is, the dead level of prices, based, of course, on the misleading assumption of a common art value in the work, is only varied by ruinous cutting of prices, by which the best artists suffer most and the Goths and Vandals of the business least. If any photographer is inclined to charge more than he should for his work, a few adverse decisions of the critic would induce him to make better pictures, or charge less for them, and if two or three lots a day was returned to him, the official stamp showing they had no commercial value, he would have to shut up shop and step gently down and out. Under this system of art criticism there will be no room for cheap-Johns; in less than five years they will be a thing of the past.

5th. But better than anything else, this new office might be made the nucleus of a school of art to the people. Some one should be selected for the position who has a natural good taste, and is possessed of a genuine and hearty interest in the growth of fine art.

In his office, fitted for the purpose, every artist in the country should be permitted to compete for the privilege of hanging his best work. That privilege should be a coveted and valued honor. To this gallery the people should have access, and from time to time there might be lectures on topics connected with art and photography, illustrations of new discoveries, and various popular treatments of art subjects that would heighten the appreciation of the people for the best results in the art of picture making. Whatever develops and refines the taste of the masses will be beneficial in every way to the real artist, and in every respect will directly tend to "Ring out the false, ring in the true."

To bring about the happy results pointed out in this paper, let us, as a body, request our several legislatures to create the office of art critic or censor, and pass such laws

as would be necessary for the accomplishment of the objects sought.

Now, fellow craftsmen, my scheme and suggestions are before you, what will you do with them? Our glorious calling is falling into disgrace, her beautiful garments are trailing in the dust, unprincipled men are robbing her of her beauty and her worth. Who will come to her rescue? Something grand and noble must be done at this particular crisis; unless something is done we can look forward to no date when prices will be better and our profession command the dignity and respect it deserves.

This plan of censorship can be easily brought about, for it is not class legislation, but for the people as well. It is the greatest good to the greatest number, and that is American every time, bound to command the attention of our law makers. Hoping you will take immediate action in this direction and have a live, wise committee appointed that will take decisive steps, I am pleased to leave it in your hands.

BELOIT, ROCK COUNTY, WIS.

[*Competing Prize Paper, read at the St. Louis Convention.*]

## MONEY MAKING.

BY W. J. GUILD.

THE object of our coming before you to-day, is to discuss the best or most successful way of making money; and more especially as applied to our art. The rules that apply to money making in our art are the same as those that apply to all other trades or business. You are aware that they appeal to the selfishness of man; pure sordid selfishness alone is to be gratified by the accumulation of wealth.

As this is the point upon which the merit of these papers is to be judged, you will bear with me for adhering strictly to the point, without regard to its moral bearing. The dominating idea is to "get all you can and hold fast to all you get."

This has been the ruling passion in all times past. It is implanted in the very nature of man; it is manifest in the child before it is old enough to talk. It is the first faculty cultivated by the mother, by offering a coveted prize to secure its good

behavior. And the grown-up child has to have the coveted "greenback" held up before him before he will work.

A greenback was held up before the Executive Committee by G. Cramer, when the question was asked, "Upon what point shall the merits of these papers be judged?" the point was considered as well taken.

It is fostered and encouraged by the laws of our government. It is largely the motive power of human action. Our copyright and patent laws are made for the purpose of protecting and encouraging invention by securing to the inventor the exclusive right of his invention.

Then why hold up the process-monger or patent-vender to contumely, as has been done by some of our craft, because he, forsooth, was trying to make money by his wits? Our government says it is his right, and protects him in it. His success in money making depends upon his exertion and the merits of his patent. The buyer is supposed to be his own judge as to its merits. It is your "greenbacks" the vender wants. So pity yourself if you are sold, it is an old adage, "Every man to himself and the devil take the hindmost."

Nothing, however, is more common than energy in money making, quite independent of any higher object than its accumulation. "Seest thou a man diligent in business? he shall stand before kings." A man who devotes himself to this pursuit, body and soul, can scarcely fail to become rich. Very little brains will do; spend less than you earn; add dollar to dollar; scrape and save; and the pile of gold will gradually rise.

But for the stimulus and protection which our government has so wisely given to thought (for thought is the father of the thing), what would have been the condition of our art and science to-day? Right where it is with the aborigines to-day.

Then to make money we must think about our business, gather the thoughts of others, bearing upon our particular occupation, and hoard them up as though they were money, make ourselves thoroughly acquainted with our business, and then the well-trained hand, guided by a well-stored mind, puts thought into form. All works of art are but outward forms of thought,

and just in proportion as they possess merit, or meet the wants of man, are they of value.

Newton, when asked by what means he had worked out his wonderful discoveries, modestly replied, "By always thinking unto them."

Disraeli, the elder, held that the secret of all success consisted in being master of your subject, such a result being only attainable through continuous application and study.

Raphael lived but thirty-seven years, and in that short space, carried the art of painting so far beyond what it had before reached, that he appears to stand alone as a model to his successors.

Among those that have received a liberal reward in their lifetime for their works of art, were Rubens, Vandyke, Teniers, Rembrandt. Moroane received \$1100 for one 11 x 14. Miss Georgianna Campbell, of New York, recently completed an exquisite portrait of one of Vanderbilt's children, for which she received \$3500, and has orders for more work amounting to \$30,000. Turner probably received more than any other painter, he amassed a princely fortune. Hundreds of others we might mention, have ascended the steps of fame by their indomitable perseverance.

If we expect to approximate the achievements of these great men we must labor with the same assiduity, yet

Success the mark no mortal wit,  
Or surest hand can always hit.

It is not possible to lay down any definite rule for each individual. It is said that "Man is the architect of his own fortunes. He who cannot profit by the experience of others certainly cannot expect to succeed."

The successful man does not go about telling every man (or woman) about his business, he thinks more and talks less. The fool makes no money, for he thinks little and talks—well, "right smart."

You must never tell the world you want money.  
Want sense and the world will o'er look it,  
Want feeling 'twill find some excuse.  
But if the world knows you want money,  
You are certain to get its abuse.

The wisest advice in existence,  
Is ne'er on its kindness to call;  
The next way to get its assistance,  
Is—show you don't need it at all.

ROLLA, Mo., April, 1886.

## CONVENTION NOTES.

WE think if the combined cameras of all those who attended the St. Louis Convention could be made to focus upon one plate, that the resultant image would shine out as follows: GOOD TIME.

THERE never was a heartier welcome given to any fraternity than that given by the members of the craft in St. Louis to their visiting co-laborers. It was so genuine that it was beautiful—it was so general as to amount almost to rivalry.

THE ladies assisted the knights of the camera and smiled upon every scheme that was projected for the general enjoyment. Forever will St. Louis' hospitality be remembered by those who were fortunate enough to share it.

THE grand climax of all this was, of course, on Thursday afternoon, when occurred the greatest photographic excursion ever known. The "Chas. P. Chouteau" was gaily bedecked with flowers; the music was lovely; the tables were abundantly supplied; the arrangements were all most complete, and the enjoyment and hilarity of the occasion were not marred by a single incident. A river ride and a visit to Montezano Springs, gave opportunity for some good camera work. At 10.30 P. M. the tired excursionists were again landed at St. Louis, loth to part.

WHILE the Convention was not as rich in the discussion of practical subjects as has been the case heretofore, it will be remembered that only one session per diem was held. For some reasons this was wise. Many excellent papers were read, and all the important business interests of the Association were given attention.

THE officers are deserving of commendation for their patient, painstaking work. It is very easy to criticise and to find fault, and those who only receive—give nothing—are too apt to fall into that error. Once try the onerous duties imposed upon the officership, and feel the fear of the sword hanging over your head ready to fall in case you do not universally please, and then you will sympathize more heartily with the officers.

MR. POTTER gave universal satisfaction as presiding officer. His quick sense of justice; his acquaintance with the rules; his amiability and promptness did much to facilitate and complete the large amount of work which needed attention.

MR. McMICHAEL is a born secretary. His executive ability did much for the success of the Exhibition and Convention as well. He was never perturbed and never allowed a wrong advantage to any one. His readiness to oblige was proverbial.

MR. CARLISLE'S patience was much tried at times, but he handled his duties with excellent tact and with systematic precision. His reelection (third term) proved that he was appreciated and understood.

MR. ROBT. BENECKE, the excellent Local Secretary, won the friendship of all who met him by his good temper and willingness to do the very best in his power for every one. His position was a trying one, but it did not discomfit him at all. His greatest labor was after we had all left him behind us, to clear up the *débris*.

MR. JOSHUA SMITH received a deserved acknowledgement for his disinterested attention to the medals—with characteristic promptitude. He really seemed to enjoy the duties of the post, and it must have given him genuine pleasure to see how the fruits of his labors were accepted.

No better man or a more earnest photographer than Gustav Cramer could have been chosen for president. Some of the croakers say there is danger of his using the position for personal advantage, and that the plate-makers will withdraw their support from him. Don't you believe it. Mr. Cramer stands just as high among his competitors as he does among his co-workers with the camera. He is above any double dealing, and his magnificent generosity in giving prizes should stop all croaking. If that is not enough, permit us to quote the following from a letter just received from one of the oldest and most prominent dry-plate makers, as follows: "I am glad Mr. Cramer was elected, he deserves it. I wrote Mr. ——— before the

Convention, that if I was there and Mr. Cramer was nominated I should vote for him." Good!

CHICAGO has had placed upon it the burden of the next Convention, and, of course, Chicago will do her best. After that, we hope less frequent conventions, say, bi-annually, will be found wiser and better. On this subject we invite discussion.

WE likewise second the suggestion of our St. Louis contemporary, that the Local Secretaryship be dispensed with. Rather pay the elected Secretary an extra sum to reside at the place of convention a few weeks beforehand, and then permit him, with the hired help necessary and the Executive Committee, to manage the whole grand affair. Matters will thus run more smoothly and the Association save a good many hundreds of dollars. We should like to see it tried.

THE conventions cost an immense amount of money each year and do not yield back the returns they ought to. Economy should be studied.

THE visits made to the dry plate factories of Messrs. Cramer, St. Louis Dry Plate Company, and the M. A. Seed Dry Plate Company, were much enjoyed. The majority of the visitors had never been to any place so like sheol before and it was a wonder to them. One man was so green about such things that he actually attempted to strike a match in Mr. Cramer's coating-room, to light his cigar! Fortunately, the first snap of the match failed, or, think of the loss that would have occurred. The hooting at which the stranger received must have made him think he was in an Egyptian tomb among the owls. We could scarcely credit such folly had we not been there.

THE jewelry stores of St. Louis were relieved of two handsome gold-headed canes during the week. One was presented to Mr. G. Cramer on behalf of his personal friends, in a neat and hearty address by Gen. H. Q. Sergeant, of Cleveland, and Mr. C. T. Stuart, of Hartford, Conn., was the orator on the occasion of the second presen-

tation, Mr. President Potter being the recipient. Both occasions were very happy and enjoyable.

THE following prizes were given in addition to those mentioned in the report of the proceedings :

The Anthony Prizes.—\$50 cash to Irving Saunders, Alfred Centre, N. Y., for the best 18 x 22 portrait. \$50 cash to W. E. Purviance, N. Y., for the best 8 x 10 views. \$50 cash to G. M. Elton, Palmyra, N. Y., for the best twelve cabinets.

The Harris & Kittle prize was awarded to F. F. Tomlinson, of Detroit.

The Acme Burnisher Prize was awarded to F. W. Guerin, of St. Louis.

The Robert Dempster Prize was awarded to Montfort & Hill, of Burlington, Iowa.

THE Photographic Merchants' Board of Trade met at the Southern Hotel, on the evening of Monday, June 21st. A large attendance and a useful, harmonious meeting.

"BENECKE'S BELL" did not always succeed in persuading the craft away from the exhibits to the Convention sessions. It was easy to see that the fraternity preferred to learn by example rather than by precept.

IN most cases the exhibits were accompanied by placards stating what lenses and what plates were used in producing the pictures. We cannot tell which predominated. Who they all were can easily be learned by reading the list of enterprising firms on the second page of our cover. Our advertisers are always on the alert.

THE St. Louis dailies did full repertorial justice to the occasion, but great injustice to the good photo's of many of the craft, which they hacked into semblances for their columns. One of the best things said was this: "Before every collection of pictures are little groups of visiting artists, discussing certain effects and inquiring the methods of their production. The most minute bit of information relating to the art is seized with avidity and circulated with generosity by the delegates. The feature of the gathering that most impresses a looker-on, is the earnestness of the men. They all recognize

that they are engaged in a pursuit where every little point is of value and where the competition is most active. All are learning. All are restless, inquisitive, penetrating, and enthusiastic. The papers read to them, as a body, would seem to the uninitiated as sufficient to satisfy the most craving after technical knowledge, but in addition, these gentlemen gather in little knots of two and three and swap items of personal experience and information."

### MR. GEO. BARKER'S VIEWS OF NIAGARA FALLS AND FLORIDA.

THOSE of our readers who were at the Convention will remember vividly the views of Niagara and Florida displayed by Mr. George Barker, of Niagara Falls, N. Y. Twenty-three years ago Mr. Barker took his first views of the falls; and in spite of the countless rivals who have come with their cameras in swarms to that Mecca of photographers, he has always since been at the head. His latest honor won was the first gold medal for landscape photography at St. Louis.

By his kindness we have received a splendid series of examples of his work. At some future time we shall give all our readers pleasure by an example in the journal. Meanwhile, a few lessons in art may be read from them.

Every picture is a study. We cannot enough commend the artist's industry, care, and taste, shown in them. Many are instantaneous, the skies printed in. Technically, in printing and finishing, they are nearly perfection.

Perhaps the most impressive is a large 16 x 21 view of the rapids above the falls. In breadth and power it is first among a lot of views eminent in these qualities. It brings a breath of the indescribable feeling of the ocean; across the whole picture spreads this surging, plunging, tossing mass of waters, spray-drops spinning in the foreground and white breakers bounding against the dark trees on the shore on the other side. The fine heavy frowning sky is in thorough harmony, except one over-conspicuous light spot. The whole, with its storm and strength and movement, could dare comparison with-

out a fear with many of the marines that hung in the galleries of last winter's exhibitions.

Two of the finest views of the falls themselves are taken from a point at their foot. This is perhaps the best place to choose as a standing-point. Besides increasing the impression of height, the feeling of the overwhelming plunge and fall of the water comes more strongly as one looks up and sees its breaking, misty drapery coming down.

One view of the "Cave of the Winds" shows the black masses of the huge rocks at the bottom, with a miniature fall winding among them, and far up above is the great fall, its crest white where the sun falls, and its spray shading it half-way down and utterly hiding its base. Twenty times our artist tried before securing this view. The other shows the great half-circle of the Canadian falls across the background, and the American falls nearer; the soft mass of their water beautifully outlined against the white cloud of mist, and melting into it at the bottom, where the sharp edges of the wet, black rocks peep through. There is marvellous play of light, with white water and reflections from their wet sides among the latter. Interest is cleverly given to the foreground by a rude mass of drift-wood and bristling bits of boughs. And so in other views the same judgment in choosing the point of view, the harmonious balance of dark shore and water and mist are seen. There is hardly a note that rings out of tune in the picture, as so often happens in hampered photography. Not a fretting detail on which one can lay a finger and say it disturbs the rest. The skies deserve especial notice. They are all printed in separately, and chosen with such excellent judgment that they often help the picture immensely. Taken by themselves, there is not one that is not a beautiful cloud-study. But the extreme care that is necessary in this sort of work is shown in one or two cases, where the sky, though magnificent itself, breaks into the rest of the composition with some unfortunate high-light, or discordant line, as in one view where three diagonal bright cloud-edges clash with the white line of the falls, and pull a picture

apart which would otherwise be admirable in concentration. These are notes in the sunbeam of Mr. Barker's art. Yet how we must laud his taste, when in two fine snow-scenes he lays aside all his superb skies and gives a chilly, even gray in one, and quiet, faint cloud-bars in the other. The last is made wonderful by the introduction of just one figure, away down in the snow-gorge below the falls, black against the snow with the setting sun at its back, while opposite towers the icy bank, its rocks and broken trees crusted and covered with fantastic ice-forms. It is worthy of Doré.

The Florida views are more in the usual order, yet they too bear a stamp. They have remarkably clear delicacy of tone, and a balance of light and shade that tell of the artist. Especially pleasing are two views of an old mission church, of the familiar type after which the old Holy Fathers, who first set up the cross before the savage, have built their churches from Florida to California.

Last year, at Buffalo, considerable discussion raged among the local papers as to whether photography was or was not art. That question is fast being settled. Mr. Barker added his contribution in the Convention exhibition of this year. It is a picture of a lake by moonlight. A canoe floats on dark water that throws back the moon from a thousand ripples. Over it is one of Mr. Barker's glorious skies. We wish all the critics whose minds are doubtful, or who assert the negative of the question, could have seen this picture. They would find the reply convincing.

---

### THE CANADA CONVENTION.

THE Third Annual Convention of the Photographic Association of Canada will be held in the city of Toronto, August 17th, 18th, and 19th, 1886. Reduced fares on railroads (full fare one way and one-third fare return).

It is expected that this convention will far excel either of the preceding. Some of the most prominent photographers of the United States have promised to send exhibits, viz: J. F. Ryder and Decker & Wilber, of Cleveland, O.; F. W. Guerin

and G. Cramer, of St. Louis, Mo.; G. Barker, of Niagara Falls, N. Y., splendid views of "the Falls;" Gehrig, of Chicago; Brand, of Chicago, etc.

To those photographers who have not attended the Convention of the Photographic Association of Canada, we would say there is a rich treat in store. You will do well to make up your mind at once that you will be there, even if your business is suspended during your absence. Advertise where you have gone, and the object of your absence, and your patrons will place a higher value on your work thereafter.

Be sure to send or bring along some of your photo work to place on exhibition.

Observe! The meeting is not held this year during week of Toronto Fair. The object of this is to insure the attention and attendance of the photographers of Toronto who are too busy at fair time.

Another suggestion is that any little device or "wrinkle" you may have, kindly bring it along, or a model or drawing of it, or even a written description. Just look at what will take place at the convention, and see if you can afford to slight it:

- I. Exhibit of photo work.
- II. Demonstration—lighting and posing (S. J. Dixon has kindly offered the use of his large studio).
- III. Demonstration—bromide paper (Mr. Cooper, of the Eastman Co.).
- IV. A grand lantern exhibition by Prof. J. A. Moodie, of Hamilton (photo views of Egypt and Palestine—Dr. E. L. Wilson, of the PHILADELPHIA PHOTOGRAPHER, has promised us the loan of a number of his most select slides. These photos were made by himself during his Eastern travels).
- V. An excursion across Lake Ontario (given by the Toronto stockdealers, whose names will appear hereafter). An opportunity will be given to any who desire to make views of "the Falls."
- VI. All the et ceteras.

Other things will be arranged looking toward the pleasure and profit (particularly) of those attending.

One of the stockdealers' agents may call on you and offer membership tickets (coupons attached); such agents are authorized to give the official receipts and receive money

for the association. Don't wait for such call, but send along your fee (\$2.00 proprietor, \$1.00 employé), and secure your receipt and coupon (excursion, etc., and certificate for reduced railway fare) to the Secretary-Treasurer, E. Poole, St. Catharines, Ont.

Come prepared to ask all manner of questions on the subject of photography.

A. T. BARRAUD,  
*President.*

E. POOLE,  
*Sec.-Treas.*

*Executive Committee.*—A. T. Barraud, Barrie; S. J. Dixon, Toronto; E. Poole, St. Catharines; J. N. Edy, London; J. H. Farmer, Hamilton; J. F. Bryce, Toronto.

## A CHAUTAUQUA PHOTOGRAPHIC DAY.

As predicted on page 381 of our issue of June 19th, a Chautauqua Photographic Day has been arranged, and we are permitted to give the particulars.

The superintendent of the enterprise is Mr. Charles Wager Hull, of this city, an adept in photography for nearly a third of a century, and for a number of years chief manager of the annual exhibitions of the American Institute. It could not be placed in worthier or better hands.

"Chautauqua Photographic Day" will be August 17th, next. The inauguration of this new advance of photography into public favor will occur at Chautauqua Lake, New York.

Everybody knows where it is, and everybody knows how to go there.

Mr. Hull is not able at this writing to give us a full programme of the exercises, but assures us that they will be intensely photographic and not too dry.

There will be lectures, talks, demonstrations, practice with the camera on land and lake, and an exhibition—perhaps a lantern exhibition in the evening.

Let not our practical readers conclude at once that this is "some amateur arrangement only."

The object of the Chautauqua photographic enterprise is to enlist the interest

of our whole great public in photography—its advancement, its usefulness, its good name, and the welfare of those who practise it, whether for pleasure or for a living.

Chautauqua is now the great acknowledged centre of all sorts of learning in our country. Its efforts are by no means confined to the assembly grounds on the borders of beautiful Lake Chautauqua. Its branches are all over the country—from Northern Michigan to Southern Florida; from Chautauqua Lake to the Pacific.

The preliminary effort to include photography among the arts, sciences, and classics is to be made on the day and at the place announced.

From there, year by year, the interest will diffuse, though the headquarters and the permanent exhibition will remain at Chautauqua Lake.

There is no limit to what may be developed from this first exposure of Chautauqua plates.

Those who could not go so far as St. Louis, to the Convention, will here find a compensation for their disappointment.

By all means be there if you can, and take your cameras along, for there will be much to attract you, especially on the beautiful lake. Next year you will feel behind, if you do not attend this.

If you can, go a day or two earlier than the 17th, and remain a day or two after, and become infused with the Chautauqua movement.

Mr. Geo. W. Cable is announced to read on the 16th.

On the 18th, is "Recognition Day"—the day on which the diplomas are distributed.

Every hour at Chautauqua offers something of interest.

But August 17th will be a day long to be remembered as an important one in the growth of American photography.

Mr. Hull's address is: Office of the American Institute, New York.

---

MR. EDWARD ANTHONY is luxuriating on vegetables "from his own vine and fig tree," at Alexandria Bay (Thousand Islands), and is in robust health.

## OUR PICTURE.

THE admirers of Mr. H. P. Robinson's work have known of him more recently through his out-door compositions, nine of which appeared, reduced, in our issue for January, 1885. The appearance of the twin pictures, entitled "The Valentine," in our current number, will, therefore, be greeted with a hearty welcome, because they exemplify the work of the master in a different direction.

If those who have Mr. Robinson's excellent work, *Pictorial Effect in Photography*, will consult it, they will see how closely the rules laid down there are followed in the production of the works before us. They will also learn exactly how to produce such pleasant pictures themselves.

"The Valentine" twain was finished about a year ago—just previous to Mr. Robinson's severe indisposition, and has not, therefore, like his "Dawn and Sunset," been going the rounds gathering in the medals for its artistic originator. It is quite as worthy of such distinction, however, as any of its predecessors.

The rustic simplicity of each picture is its chief charm—the complete carrying out of the conception in both is admirable. No one can fail to interpret the expression harmonizing with the attitude so well—no one can fail to read the delight of one and the mystification of the other. The lights, the shadows, the accessories, the composition, are all agreeable to the rules of art and to the eye.

The originals are 17 x 21 inches, and of course "our picture" has suffered some in technical excellence by being copied.

But, withal, we believe the pair will prove useful studies for our more ambitious readers, who, during the coming season, will give more attention than ever to this class of work.

The prints were made for us by Messrs. Roberts & Fellows, Philadelphia, on the popular N. P. A. paper, imported for us by Messrs. E. & H. T. Anthony & Co., N. Y.

---

FROM HULBERT BROS., of St. Louis, we have received a new price-list of the "stamp photos," of which Mr. GINDLE is the patentee.



## Editor's Table.

PICTURES RECEIVED.—Mr. JOHN E. DUMONT, Rochester, sends three of his latest works, "The Clarionet Player," "The Joker," and "The Basket Seller." Mr. DUMONT's artistic talent is well known. His pictures are fine compositions, exceedingly full of sympathy and character. From Mr. J. A. W. PITTMAN, of Springfield, Ill., a view of the photo. excursionists on the steamer "Chas. P. Chouteau." From Mr. J. A. SHERIFF, of San Diego, Cal., a smaller photograph of his large panoramic view of that rising town. From Mr. M. H. ALBEE, of Marboro, Mass., prints of two of his backgrounds. From Mr. THOMAS SEDGEWICK STEELE, five fishing and camping scenes in the Maine lakes. The views are unusual and interesting, the camp-fire scenes particularly so. The Maine guide and the birch canoe form some pleasing compositions. From Mr. W. S. PERKINS, of Colfax, Cal., a fine view of San Francisco harbor from Telegraph Hill, and views of Lake Cabassecuté, Me., and Lake Tahoe, Cal. They are clean and good work. From Mr. J. D. WESTERVELT, of Los Angeles, Cal., a series of excellent cabinet portraits. The subjects are well posed and lighted, and carefully retouched. Mr. C. T. FELLOWS, Phila., sends an instantaneous picture of two chickens exchanging views on the heat, with gaping bills together. From E. M. VAN AKEN, of Elmira, N. Y., an artistic series of child pictures. The little model, with bare feet and tangled hair, is posed among plants and flowers, carrying a basket of roses, or with kindly care watering her flower-pots. By pictures are excellent, especially in the effective arrangement of the accessories.

"SPANGLED EDGE" is the name of the newest style of cabinet mounts manufactured by Messrs. A. M. COLLINS, SON & Co., of Philadelphia. They were first shown at the St. Louis Exhibition, and are very pretty. By a sort of tooling of the beveled gilt edge a slight indentation is made at regular intervals without breaking the line, which gives the appearance of golden light, all around the card. It is the most attractive style we have yet seen—a great improvement on the "Serrated."

A GRAND photographic excursion, under the auspices of the Photographic Society of Chicago, takes place on Tuesday, August 3, 1886, over

the Illinois Central Railroad. Train leaves foot of Lake and Randolph Streets at 8.40 A.M., returning by 8 P.M.

A NEW SOCIETY AT JACKSON, MICH.—We have received the following:

JACKSON, MICH., July 18, 1886.

MR. EDITOR: Will you give in your next issue an account of our new society.

We held our first regular meeting on July 13th, at the studio of the President. The regular meetings will be held first Monday evening of each month. The Jackson Photographic Union Association, of Jackson, is the title. The following are the officers:

*President.*—I. V. Cookingham.

*Vice-President.*—S. W. Le Clear.

*Secretary and Treasurer.*—J. W. Paine.

Should you wish it, I will send you the proceedings of each meeting for publication when they are worth it. Respectfully yours,

J. W. PAINE.

AN OLD HOUSE WITH YOUNG BLOOD.—The house of Messrs. C. H. CODMAN & Co. (formerly JOHN SAWYER) was established forty-one years ago. It goes yet, and has more "go" than it ever had. We are led to these remarks by a recent visit to Boston and the recent revelations of the qualities of the wondrous lenses for which this house serves as American agents, and known in the trade as the "New Orthopan-actinic Lens." They are for all kinds of work, combining *width of angle with rapidity and freedom from distortion—perfectly achromatic*; "little giants," covering the largest plate, in proportion to size of lens, of any in the market, giving perfectly straight lines for architectural work and copying, and "able to do almost everything but eat," Mr. ROBY assures us. Each tube consists of two symmetrical achromatic meniscus lenses, between which the central stops are placed. These lenses have an angle of seventy degrees, and, by removing the front lens, the back one will cut a view twice the size of the combination, giving an angle of fully ninety degrees. Thus a tube covering a plate  $6\frac{1}{2} \times 8\frac{1}{2}$  inches of six inch focus, by using only the back lens, becomes one of twelve inch focus, and will cut a view sixteen by eighteen inches, sharp and clear, allowing the camera to be placed very near to the object.

For interiors of rooms, buildings, churches, etc., they will work sharply without small stops, thus giving *great illuminating power*, and enabling one to make an interior in *one-quarter* the time usually required by other lenses used for that purpose.

The "Orthopanaectinic" seems to be a union of the good qualities of the several kinds of view and portrait tubes, without any of their defects, appears to be as nearly perfect as possible, and is far superior to any in the variety of work it will perform.

A FINE OPPORTUNITY.—We have received the following:

OFFICE OF EAGLE DRY-PLATE CO.,  
54 East Tenth St.

NEW YORK, July 15, 1886.

DEAR SIR: We have the honor to inform you that a large collection of photographs from the St. Louis Convention, made by American and German artists on Eagle Dry Plates, and printed on Eagle Albumen Paper, will be on exhibition at the above address on Monday next, and following days for some weeks.

The pleasure of a visit from you is requested.

Respectfully yours, G. GENNERT.

This is a rare opportunity to study the fine array of prints sent from Germany.

CHICAGO NOTES.—*En route* for St. Louis we halted at Chicago and noted the important changes made there within a few months, some of which we mention below:

Mr. G. A. DOUGLASS, in his new and convenient store at No. 185 and 187 Wabash Avenue, had just erected galleries around his main stockroom, his space having already been found too limited for his rapidly growing business. Mr. DOUGLASS always was deservedly popular among the fraternity, for he has personally and gratuitously done a great deal for their advancement and benefit. He is now reaping his just reward; receiving back the "bread" which was "cast upon the waters" a good time ago. He speaks with glowing hope of his future, and is already planning for the success of the next Convention.

Dr. JOHN NICOL, editor of the *Photographic Beacon* occupies offices in the same building. The success of the *Beacon* is already assured. The jolly doctor and his excellent lady were both at St. Louis, and entered into all the affairs of the Convention with genuine fervor. The doctor promises to be a great favorite among the photo. craft. He is a walking photo-lexicon cyclopædia.

Messrs. N. C. THAYER & Co., surely have the finest stockrooms in America. They have but recently occupied them. The main floor is forty-two by one hundred and seventy feet. Splendidly lighted, shelves and floors supplied with a magnificent stock of goods. Every convenience for business is added. The appearance of things is much improved by the painting—oriental red and yellow. The front, of immense sheets of plate glass, is decorated with fine lettering detailing the wares to be found inside. Mr. THAYER seemed very happy in his new quarters, and as an outgrowth of it, see his offer of prizes in specialties.

Messrs. SWEET, WALLACH & Co., 229 & 231 State Street, are an enterprising trio, doing a good business. Many improvements have been made since the new firm began at the old stand. We were shown a new head-rest, a new holder, a new printing-frame rest, and several other useful articles. Novelties of service will always be pushed by this enterprising firm. They have a host of acquaintances, and are doing well.

Mr. HIRAM J. THOMPSON, 94 Wabash Avenue, was absent when we called, but his ever active captains and lieutenants were present and spoke well of business prospects. The "strikes" have had their influence, but it is all over. Chicago must live and prosper, strikes or no strikes.

THE St. Louis stock trade is divided between Messrs. H. A. HYATT and J. C. SOMERVILLE. Both of these gentlemen have removed into new quarters recently, and neither were fully in order when we visited them, the conventioners having come upon them a few days earlier than they anticipated. Mr. HYATT is located in handsomely lighted rooms at the corner of Eighth and Locust Streets. He has a large and varied stock conveniently arranged. He deals considerably in specialties, such as Kuhn's arrangement for drying paper, Magee's Vignetter for black vignettes, etc. Full of enterprise and zeal for his work, it is no wonder that he is a big growing success. Mr. SOMERVILLE is now located in extensive quarters at 111 North Broadway. His fine sample room is a new feature in the stock line. There the buyer may see clearly and to advantage samples of almost everything sold, so that he may save time in examination and quickly give his order. The whole establishment is convenient and admirably planned for the great business which comes to it. The liberality of both of these gentlemen will not soon be forgotten by their charmed visitors.

# Specialties.

## ADVERTISING RATES FOR SPECIALTIES.

25 cents for each line, seven words to a line—in advance. *Operators desiring situations, no charge.* Matter must be received a week before issue to *secure* insertion. Advertisers will please not ask us for recommendations. We cannot undertake to mail answers to parties who advertise. Please always add your address to the advertisement. **Postage-stamps taken.**

**MAKE OUT YOUR OWN BILL,** and remit cash with your advertisements, or they will not be inserted.

RETOUCHING BUREAU.—Under the direction of Mr. H. Harshman. None but skilled help employed. Quality of work guaranteed. Prices moderate. Send your negatives in wooden box with cover screwed on, and prepay charges. Address GAYTON A. DOUGLASS & Co.,

Merchants in Photo. Supplies,  
185 & 187 Wabash Avenue,  
Chicago, Ill.

### BARGAIN LIST.

- 1 5 x 8 Scovill Manufacturing Company's Camera, with Eastman Roll-holder, with tripod, focusing-cloth and light carrying case. *All new*.....\$35 00
- 1 5 x 7 Scovill Manufacturing Company's Revolving-back Camera, three extra holders, with kits; 1 tripod..... 30 00
- 1 18-inch Entrekin Burnisher (old style)... 10 00
- 1 14-inch Entrekin Burnisher, (nearly new)..... 15 00
- 1 Centennial Head-rest, perfect..... 8 00
- 1 Spencer Head-rest (old style)..... 1 50
- 2 Bergner Cutters, stereoscopic arch top, each..... 15 00
- 1 Bergner Cutter, stereoscopic square top.. 10 00
- Printing-frames, 10 x 12 (nearly new)..... 60
- “ “ 6½ x 8½ “ “ 35
- “ “ 5 x 8 “ “ 30
- Negative boxes 5 x 8, 8 x 10, 10 x 12, and 14 x 18 from 25 cents to \$1.10.

ROBERTS & FELLOWS,  
1125 Chestnut St., Phila.

THE leading gallery between Toledo and Cleveland is for sale. Everything is first-class, and it will take a first-class man to keep the business up to the present standard. No cutting of prices. Address G. W. EDMONSON, Norwalk, O.

FOR SALE.—A good-paying gallery. Everything new and of the best. Good reason for selling. Address M. LIVELL, care Box 173, Woonsocket, R. I.

## DOWN SHE GOES!

### NEW PRICE-LIST

OF THE

ROCKWOOD SOLAR PRINTING CO.

17 UNION SQUARE NEW YORK.

Size.	Unmounted.	Mounted.
11 x 14.....	\$1 00	\$1 25
13 x 16.....	1 00	1 25
14 x 17.....	1 00	1 25
16 x 20.....	1 00	1 25
18 x 22.....	1 20	1 50
20 x 24.....	1 35	1 50
22 x 27.....	1 40	1 90
25 x 30.....	1 40	1 90
27 x 32.....	2 25	3 00
29 x 36.....	3 00	4 00
30 x 40.....	4 00	5 00

No charge for negatives. All orders must be accompanied by the cash. Make all P. O. orders payable to ROCKWOOD SOLAR PRINTING Co., 17 Union Square, New York.

## CANOE & CAMERA



BY THOMAS SEDGWICK STEELE.

### A PHOTOGRAPHIC TOUR

OF

TWO HUNDRED MILES

THROUGH THE

MAINE FORESTS.

(Illustrated.)

Price . . . . . \$1.50.

ESTES & LAURIAT, Publishers, Boston.

FOR SALE BY

THE PHILADELPHIA PHOTOGRAPHER.

**A REAL NECESSITY.**

We presume there is hardly a lady to be found in our broad land who if she does not already possess a sewing machine, expects some day to become the owner of one.

But after the mind has been fully made up to purchase one of these indispensable articles, the question arises as to what kind of machine to buy.

It should be so simply constructed that the most inexperienced can successfully operate it. The other points mainly to be considered, and which are the most desirable, are durability, rapidity, capacity for work, ease of operation, regularity of motion, uniformity of tension, and silence while in operation.

The "Light-Running New Home" fills the above requirements, and is said to combine the good points of all sewing machines, with the addition of many new improvements and labor-saving devices.

The price is no higher than that of other machines, and every lady who is the happy possessor of one may rest assured she has indeed a treasure.

**THE LIGHT RUNNING**

SIMPLE **NEW HOME** STRONG



SWIFT **NEW HOME** SURE

**SEWING MACHINE**  
HAS NO EQUAL.

---

**PERFECT SATISFACTION**

**New Home Sewing Machine Co.**  
—ORANGE, MASS.—

30 Union Square, N. Y. Chicago, Ill. St. Louis, Mo.  
Atlanta, Ga. Dallas, Tex. San Francisco, Cal.

**FOR SALE BY**

THE AGENTS, at the above named places.

**AT ST. LOUIS**

Everybody saw, admired, and ordered  
**THE MAGEE VIGNETTER.**

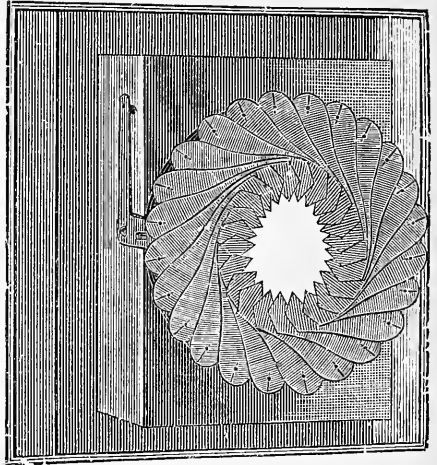

It is for the new  
**BLACK VIGNETTE.**

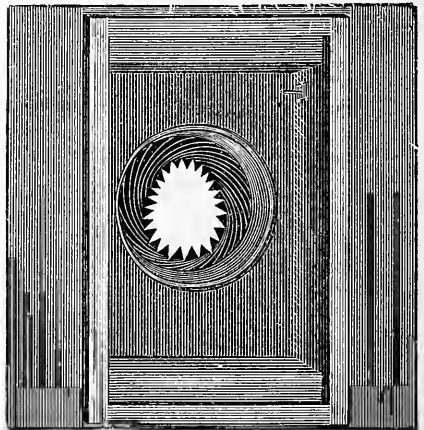

Look at its work. Also try the celebrated

**P. A. OF A. PAPER.**

Albuminized for

**H. A. HYATT, Eighth & Locust Sts., St. Louis.**

WANTED.—An air-brush cheap. Address

**G. W. DAVIS,**

827 Broad St.,

Richmond, Va.

FOR SALE.—At a bargain, the leading gallery in a city of 10,000. A good chance for a good workman. Address

**W. H. ALLEN,**

Chippewa Falls, Wis.

ANTHONY'S Adjustable Developing Fork, especially for warm weather, is one of the greatest boons recently introduced. By its use the fingers are kept absolutely free from the developer. Ask your dealer to show you one.

EVERY photographer in want of excellent lenses, for any purpose, will best serve his interest by consulting the new illustrated price-list of Messrs. BENJAMIN FRENCH & Co. before purchasing.

OUR dark-room and laboratory are under the charge of Dr. John Nicol, photographic chemist, late of Edinburgh. None but purest chemicals used in our preparations. All the standard dry-plate developers kept in stock. Your patronage desired.

GAYTON A. DOUGLASS & Co.,  
Merchants in Photo. Supplies,  
185 & 187 Wabash Avenue,  
Chicago, Ill.

825 REVISED LIST. 825

We call attention (circular free) to our revised price-lists of *albumen papers*, *Magee's nitrate of silver*, *dry plates*, and *pyrogallie acid*. Consult it before you buy.

WILSON, HOOD & Co.,  
825 Arch St., Phila.

#### SPECIAL CARD.

Talcott's Improved Mounting for photographs softens the lines, gives much strength and great brilliancy to the picture, and is the only process by which a photograph may become indelible. Patented March 23, 1886.

For preserving from all soiling engravings, etchings, crayons, diplomas, certificates, etc., this mounting has no equal, the picture or parchment being hermetically sealed.

Pictures thus mounted can be displayed or packed in less than one-half the space required by pictures with other framings, as by this process all other framing becomes wholly unnecessary, yet it is so constructed that if desired it can be placed in any ordinary picture frame intact, free from all interference.

E. K. TALCOTT,  
216 Nothampton St.,  
Boston, Mass.

FOR SALE.—A gallery in New Mexico. A good chance for an honest man out of health, wishing to regain it, and at the same time make money. Not much capital required. For information inquire of

I. S. TIFFANY,  
Secoro, New Mexico.  
or E. A. BASS,  
Photographer, Brockton, Mass.

Having contracted for a special make of glass, the SEED DRY-PLATE CO. can now guarantee a *flat, even, and straight plate*. A full stock of this well-known brand kept at the *New York Depot by the Agent*.

GEORGE MURPHY,  
250 Mercer St., N. Y.

#### EAGLE STOCKHOUSE.

NOW IN STOCK

TRAPP & MUNCH'S CELEBRATED  
Extra Brilliant Albumen Paper,

ALSO

The Chicken Brand—Extra Brilliant.

TRY THEM.

FOR SALE BY

GEORGE MURPHY,  
250 MERCER STREET, NEW YORK.

Reed's Common-sense Negative Washing-box.  
New. Send for circular.

WILSON, HOOD & Co.,  
825 Arch St., Phila.

AMONG all the photographic lenses of various makes and styles which have been introduced during the past ten years, the euryscopes, of which Voigtlander & Son are the sole manufacturers, loom up conspicuously. The success of these lenses has been unparalleled, and the demand is as lively as ever. They can be found in nearly every gallery in the land, and the amount of satisfaction and profit they produce is difficult to calculate. Most convincing proof of their superiority over other lenses is the exquisite work done with them, and the fact that it is simply impossible to get along without them.

\$1.00 New York.

SECOND CHOICE.

#### DOUBLE ALBUMEN PAPER.

Extremely cheap. Samples sent.

W. HENERMANN,  
49 CEDAR STREET, NEW YORK.

FOR SALE.—Cheap for cash. A photographic and tintype outfit. Has only been used two years. For particulars address

LOCK BOX 403,  
Mankato, Minn.

WANTED.—To rent or buy for cash, a well-furnished gallery in city of fifteen thousand or over. Address

J. V. S.,  
care of GEORGE MURPHY,  
250 Mercer Street, N. Y.

The American Artists' Association is re-established for *solar printing in silver, solar printing in platinum, finishing in ink, water-colors, crayon, pastel, and oil.*

WILSON, HOOD & Co.,  
Trade Agents, Phila.

**WILSON, HOOD & CO.,**  
**825 Arch St.,**  
**PHILADELPHIA.**

We have now in stock  
**THE NEW EAGLE DRY PLATE.**

ALSO  
**THE INGLIS TRIUMPH PLATE.**

A new brand of  
**GERMAN PYRO ACID.**

(35 cents per ounce.)

**POCKET GLASS CUTTER.**

(15 cents each.)

**NEW STYLE CORNER CHAIR.**

(\$10.00 each.)

**PAPIER MACHÉ STUMP.**

(\$6.00 each.)

**SUNSHINE MAILING ENVELOPE.**

FOR SALE.—Splendid amateur photographic outfit; all the latest improvements for paper negative or glass, 8 x 10. Detective camera will be taken as part payment, balance in cash.

Address J. C.,  
535 North Tenth Street,  
Philadelphia.

**BECK'S AUTOGRAPH RECTILINEAR LENSES.**

Without exception the finest lenses ever made, possessing qualities entirely their own.

In order more widely to advertise and introduce this wonderful lens, we offer the largest size No. 9, as a

**\$200 PREMIUM**

to any photographer outside of Chicago who sends us the largest *cash order* prior to January, 1887. This offer extends also to the customer who buys and pays for the largest amount of goods during the same period. So that it is possible that the same person may secure *both* premiums, which would amount to

**FOUR HUNDRED DOLLARS.**

To make our offer still more attractive, the successful competitor will be allowed to select any other lens or goods of same value.

N. C. THAYER & CO.,  
257 & 259 STATE STREET, CHICAGO.

FOR SALE.—One of the finest photographic studios in New England; established twenty-nine years, and has always done a good business. Location the best; good entrance and in a first-class block, and up only one flight. Reception and skylight-room nicely frescoed and furnished and heated by steam. Size of skylight 14 feet square, and side light 6 x 14 feet, with plenty of room to work all around it. About 32,000 negatives, all in good order. Prices good, \$6.00 for cabinets and \$3.00 for cards. Population about 38,000. Plenty of good running water. Sold for no fault; I have stood and worked by the camera for over thirty years, and am now ready to retire. There is no old plunder; everything first-class; instruments the best. My present operator would remain if wanted. For particulars, price, etc., address

M. C. LOVELL,  
P. O. Box 1146.  
Springfield, Mass.

**SITUATIONS WANTED.**

*No charge for advertisements under this head; limited to four lines. Inserted once only, unless by request.*

As printer, toner, or assistant operator; can also retouch. Reference and sample of work. Address G. C. Haugh, Canton, O.

As operator, by a man competent in all departments. Fifteen years' experience in leading city galleries. Address, stating gallery, etc., M. A. Alland, Manchester by the Sea, Essex County, Mass.

As printer and toner. Has had four years' experience. References given. Address William Sinclair, Orange, N. J.

As operator and printer, by a thoroughly competent and honest man. Address H. B. Eckenroth, Box 1092, Wooster, Ohio.

By a lady, as retoucher in a small gallery. Address C. L. Barton, 223 Swan Street, Buffalo, New York.

In a good gallery, by a good operator, copyist, solarist, and general workman. Has had nineteen years' experience. Address Operator, 201 South Main Street, Rockford, Winnebago County, Ill.

By a good German operator, retoucher, and printer. Has been in the business for himself. Address Ernest Mock, 9 West Orange Street, Rochester, N. Y.

By young man of two years' experience, as assistant printer, retoucher, view operator, or general assistant. Can work paper negatives. Is willing to work for whatever his services are worth to his employer. Samples and references furnished. Address W. M. L., Bloomsburg, Pa.

By a young lady, as retoucher, printer or general assistant. Address Eva Goans, Attica, Indiana.

As retoucher, in first-class gallery, or will run a gallery on shares. Samples sent on application. Address C. E. Cunningham, Strawberry Point, Iowa.



[TRADE MARK]

TRY THE NEW

**3 KINGS** EXTRA BRILLIANT  
ALBUMEN PAPER.*Vio-Pensee*, a most delicate violet tint, and  
*Pearl-Email*, a beautiful shade of pearl.

SUPERIOR PRINTING QUALITIES.

Price per Ream, \$34.00.

Sample dozen post-paid to any address on receipt of \$1.00.

**BUCHANAN, SMEDLEY & BROMLEY,**  
Importers, 25 N. 7th St., Phila.

THE PLATINOTYPE (Patented).

Send ten cents for instructions and sample,  
portrait or landscape.WILLIS & CLEMENTS,  
1112 HUNTER ST., PHILADELPHIA,  
BUCHANAN, SMEDLEY & BROMLEY,  
General Agents for the sale of materials.**HODGE & HUSTON,**  
**THE SOLAR PRINTERS,**  
622 ARCH STREET, PHILADELPHIA.*Permanent Prints by the Platinum Process. Electric Light.*

Those

**FINDERS**beat the world. You ought to see them. If you are making *instantaneous* views you can save ten times their *value* in annoyance and *failures* the first dozen plates you expose. Easily adjusted, always in focus, light, cheap and durable. Size of ground glass 1 x 1 3-10 inches. *Price, \$1.50*, post-paid to any address in the United States.**BUCHANAN, SMEDLEY & BROMLEY,**  
**PHILADELPHIA.**THE best artists and solar printers in the United States and Europe use PLATINOTYPE PAPER for large and small pictures. This paper is manufactured for Willis & Clements' Platinotype Process, and is the *purest* and *most desirable* grade of paper made in the world for ink, crayon, or pastel. Samples free.BUCHANAN, SMEDLEY & BROMLEY,  
Importers, 25 N. Seventh St., Phila.

# THE DUBOIS FILING CASES.

*For Preserving Photographic Negatives, Prints, &c., Letters, Bills, and Miscellaneous Papers.*

PATENTED SEPTEMBER 2, 1884.

**Economical! No Binding! Either a Temporary or a Permanent File.**

Made in  
five sizes and cabinet  
form.

**AGENTS WANTED.**

Write for Descriptive  
Circular.

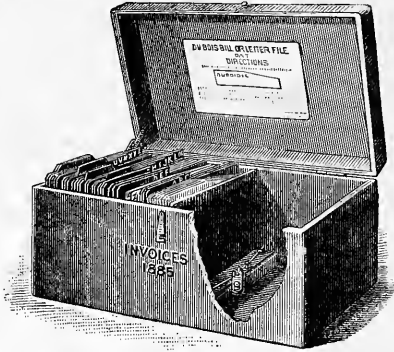

NEW YORK,  
April 27, 1886  
Mr. FRANK G. DuBOIS,  
No. 512 W. 30th St., N. Y.

DEAR SIR: Your File supplies a need that I have felt for some time past. It is the best thing of the kind that I have ever seen, and I shall be much pleased to recommend it to all my friends for preserving bills, notes, receipts, recipes, unmounted prints, photographs, and all kinds of miscellaneous papers to which easy reference may be wanted at any time. Respectfully,  
MISS SOPHIE L. MAURER.

Sent by Express, on receipt of \$3.00, or with lock and key, \$4.00.

PATENTEE AND SOLE MANUFACTURER,

FRANK G. DuBOIS, 512 W. 30th St., New York.

TO THE TRADE ONLY.

## HYPOSULPHITE OF SODA

FOR PHOTOGRAPHERS.

CHAS. A. W. HERRMANN,

16 Cedar St.

New York.

TO THE TRADE ONLY.

SIXTEEN YEARS PRACTICAL EXPERIENCE

**THE LARGEST PHOTO-ENGRAVING ESTABLISHMENT IN THE WORLD**

**MOSS ENGRAVING CO.**

35 PEARL ST. COR. ELM. NEW YORK

Moss' New Process Superior to Any Other Method.

ILLUSTRATIONS OF EVERY DESCRIPTION FOR BOOKS, MAGAZINES, NEWSPAPERS, CATALOGUES, CIRCULARS, &c. IN THE HIGHEST STYLE OF THE ART.

SEND GREEN STAMP FOR 24 PAGE CIRCULAR - SEND PHOTOGRAPH, DRAWING OR PRINT FOR ESTIMATE.

**C. H. CODMAN & CO.**

**Photographic Stockdealers**

Sole Agents for the NEW ORTHO-PANACTINIC LENS, Moor's Photographic Enamel, the Perfect Mounting Solution for mounting Photographs on the thinnest mount without wrinkling.

New England Agents for American Optical Co.'s Apparatus. The best in the world. Send for Price List.

34 Bromfield Street.

BOSTON, MASS.



ASK FOR THE  
BLUE LABEL.

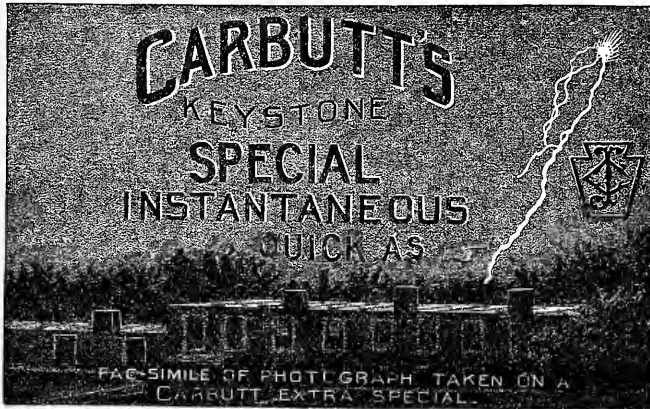

TRY THEM  
and you will continue to  
USE THEM.

Pronounced the "No Plus Ultra" of Dry Plates.

UNSOLICITED TESTIMONIALS.

MR. JOHN CARBUTT, Wayne Junction, Philadelphia.

WORCESTER, MASS., December 25, 1885.

DEAR SIR: I have been using some of your new plates, emulsion 1024, sensitometer 24 I think they are, without exception, the finest and best plates I ever used. They are not only very fine and delicate in their structure, but, when properly manipulated, result in a blooming negative, possessing all the desirable qualities that any artist could wish for. I could most appropriately christen them the "No Plus Ultra Dry Plate."

Yours truly, E. R. B. CLAFLIN.

MESRS. HARRIS & KITTLE.

DETROIT, MICH., January 16, 1886.

GENTLEMEN: I am very much pleased with the Carbutt Plate; in fact, I call them the best plate *by far* that I tried so far. I find them especially useful for my theatrical subjects, as the quick emulsions are *absolutely instantaneous*.

Yours truly, A. B. TAYLOR.

*For Sale by all Dealers in Photo. Materials.*

JOHN CARBUTT, Keystone Dry Plate Works, Wayne Junction, Philada., Pa.

THE UNRIVALLED

STEINHEIL LENSES.

In Six Different Series and Forty Numbers, for  
Every Description of Work.

These Lenses not only maintain their old-established reputation, but continue to lead in the field of progress.

Special attention is called to

**Series No. II.**, Patent Aplanatic, the newest conception in lenses. For Instantaneous Portraits, Large Heads, Full Figure Groups, Architecture, and Landscape. A marvel of illumination, depth, and rapidity. No Photographer or Amateur should purchase a lens before testing a Steinheil, Series No. II.

**Series No. III.**, the famous Aplanatic tube, the illumination of which has been increased, and which is recommended for large Portraits, full-size Figures, Groups, Architecture, and Landscape.

**Series No. VI.**, Wide Angle Aplanat, which has no rival for copying Maps, Charts, Paintings and Engravings. It is the Photo-lithographer's favorite.

Send for Illustrated Catalogue and Price-List to your dealer or to

H. G. RAMSPERGER & CO., Sole Agents,  
180 Pearl Street, New York.

# BECK'S AUTOGRAPH RECTILINEAR LENSES.



THESE extraordinary lenses attracted universal attention at the late Buffalo Convention; the specimens of work in Portraiture, Groups, Landscapes, Instantaneous Views, etc., executed by them being of unequalled excellence. A life-sized head, made with the 8 x 10 lens of 13 inches focus, was considered by the experts present, as being far ahead of any similar performance ever seen. A full description of these and our other specialties will be found in our full catalogue. *Mailed Free.*

## W. H. WALMSLEY & CO.,

*Photographic Stockdealers.*

1016 Chestnut St., Phila., Pa.

### "THE MOUND CITY"

# Photographic Stock House



Offers the Most Complete line of  
Photographic Apparatus, Chemicals,  
Picture Frames, Mouldings, Mats,  
Albums, Etc., in the market,  
at bottom prices.

Professional and Amateur Outfits a Specialty.

AGENT FOR

KUHN'S LIGHTNING DRY-PLATE INTENSIFIER,

AND

KUHN'S SENSITIZED PAPER STRETCHER AND DRYER.

Address

**H. A. HYATT,**

8th & Locust Sts.,

ST. LOUIS, MO.

Send for Illustrated Catalogues of Photographic Goods and Picture Frames.

## DEALERS' DIRECTORY.

*The following houses are to be recommended as the best for photographers in their localities.*

<p>S. T. BLESSING, New Orleans, La. And Galveston, Texas.</p>	<p>THE BEST BOOK IS</p>	<p>SMITH &amp; PATTISON, NEW LOCATION, 145 &amp; 147 Wabash Avenue, Chicago.</p>
<p>H. A. HYATT, Mound City Photo. Stook House, 8th and Locust Sts. St. Louis, Mo.</p>	<p>WILSON'S PHOTOGRAPHICS, \$4.00.</p>	<p>GAYTON A. DOUGLASS &amp; CO. 185 &amp; 187 Wabash Ave. CHICAGO.</p>
<p>SCOVILL MAN'G CO. 323 Broome St. New York.</p>	<p>D. TUCKER &amp; CO. Buffalo, N. Y.</p>	<p>ALLEN BROS. Detroit, Michigan.</p>
<p>C. H. CODMAN &amp; CO. Boston, Mass.</p>	<p>WILSON, HOOD &amp; CO. 825 Arch Street, Philadelphia, Pa.</p>	<p>B. FRENCH &amp; CO. Boston, Mass.</p>
<p>BUCHANAN, SMEDLEY &amp; BROMLEY, 25 N. Seventh St. Philadelphia.</p>	<p>A. B. PAINE &amp; CO. Fort Scott, Kansas.</p>	<p>MULLETT BROS. Kansas City, Mo.</p>
<p>OSCAR FOSS, San Francisco, Cal.</p>	<p>E. &amp; H. T. ANTHONY &amp; CO. 591 Broadway, New York.</p>	<p>SHEEN &amp; SIMPKINSON, Cincinnati, Ohio.</p>

"Tasteful, well edited and crammed full of technical information is THE PHOTOGRAPHIC TIMES."—*The Journalist.*

# The Photographic Times

Is a WEEKLY JOURNAL devoted to the  
THEORY, PRACTICE, AND ADVANCEMENT OF PHOTOGRAPHY.

ITS DEPARTMENTS ARE:

**EDITORIAL.**

**CONTRIBUTED AND MISCELLANEOUS**, articles by the best photographic writers of both hemispheres.  
**COMMUNICATIONS FROM SOCIETIES**, including Papers, Lectures, etc.

**MEETINGS OF SOCIETIES**. Stating date and place of meeting of all Photographic Societies, both professional and amateur, and giving full proceedings of all meetings

**CORRESPONDENCE**. Scientific and practical discussion by practical photographers of important and interesting questions, and letters from all quarters of the globe by intelligent and observing correspondents.

**OUR EDITORIAL TABLE**. Reviews of books, exchanges, etc.

**PICTURES RECEIVED**. Impartial criticism and notice of all photographs sent in

**NOTES AND QUERIES**. Answers by the Editors to correspondents in search of knowledge.

**COMMERCIAL INTELLIGENCE**. Description of new photographic appliances, studio changes, and a record of photographic patents.

## A PARTIAL LIST OF WRITERS TO THE PHOTOGRAPHIC TIMES.

CAPT. W. DE W. ABNEY.....	England	W. H. WALMSLEY.....	Philadelphia
W. M. ASHMAN.....	"	FREDERICK A. JACKSON.....	New Haven
W. K. BURTON.....	"	PROF. RANDALL SPAULDING.....	Montclair, N. J.
W. E. DEBENHAM.....	"	PROF. WM. HARKNESS, U.S.N.....	Washington, D.C.
H. P. ROBINSON.....	"	DR. JOHN H. JANEWAY, U.S.A.....	Governor's Island
G. WATMOUGH WEBSTER.....	"	C. D. CHENEY, D.D.S.....	Hoboken, N.J.
ARNOLD SPILLER.....	"	PROF. KARL KLAUSER.....	Farmington
W. JEROME HARRISON.....	"	GEO. H. JOHNSON.....	Bridgeport
ANDREW PRINGLE.....	Scotland	MISS ADELAIDE SKEEL.....	Newbergh
CHARLES SCOLIK.....	Vienna	CHARLES WAGER HULL.....	New York
KARL SCHWIER.....	Germany	REV. G. M. SEARLE.....	"
VICTOR SCHUMANN.....	"	C. W. CANFIELD.....	"
W. J. STILLMAN.....	Athens	P. C. DUCHOCHOIS.....	"
PROF. H. D. GARRISON.....	Chicago	HENRY M. PARKHURST.....	"
PROF. S. W. BURNHAM.....	"	REV. C. E. WOODMAN, Ph.D.....	"
HENRY L. TOLMAN.....	"	H. EDWARDS-FICKEN.....	"
GAYTON A. DOUGLASS.....	"	S. H. HORGAN.....	"
A. HESLER.....	"	WM. KURTZ.....	"
GUSTAV CRAMER.....	St. Louis	J. M. MORA.....	"
J. F. EDGEWORTH.....	"	PROF. L. C. LAUDY.....	"
W. H. SHERMAN.....	Milwaukee	A. BOGARDUS.....	"
GEORGE EASTMAN.....	Rochester	CHAS. D. FREDERICKS.....	"
DAVID COOPER.....	"	A. MORENO.....	"
PROF. H. W. LORD.....	Columbus	C. W. DEAN.....	"
H. McMICHAEL.....	Buffalo	DR. O. G. MASON.....	"
JOHN CARBUTT.....	Philadelphia	ERNEST EDWARDS.....	"

The Photographic Times { Monthly edition issued on the } Issued Every Friday  
last Friday in the month.

### —SUBSCRIPTIONS.—

One copy Weekly issue, postage included, to all points in U. S. or Canada.....	\$ 3 00
One copy Monthly issue, postage included, to all points in U. S. or Canada.....	2 00
Weekly issue to foreign addresses, postage included.....	4 00
Monthly issue to foreign addresses, postage included.....	3 00

Single copy, Weekly, 10 cents

A month's trial (four weeks), of the Weekly for 30 cents.

A specimen number free.

Single copy, Monthly, 25 cents.

Remit by Express, Money Order, Draft,  
P.O. Order or Registered Letter.

Subscriptions to THE PHOTOGRAPHIC TIMES received by all dealers in photographic materials in this Country,  
Canada, West Indies, Great Britain, Australia, New Zealand, and by the publishers.

## SCOVILL MFG. CO.

W. IRVING ADAMS, Agent.

No. 423 Broome Street, New York.

The Weekly Photographic Times and Philadelphia Photographer to one address, \$6.50.

Subscribe now and Secure the back numbers before they are all sold.

U  
S  
E



U  
S  
E

*Is liable to break his Ground Glass, and to have no ready means of supplying a new one. This article, forced upon plain glass will make a capital substitute.*

ANY PHOTOGRAPHER

HANCES  
GROUND GLASS  
Substitute.

Manufactured only by

ALFRED L. HANCE,  
PHILADELPHIA.

AS A RETOUCHING VARNISH;  
*For making Ground Glass wherever needed; for Doors; for Skylight; for Camera Boxes, it has no equal. Good Ground Glass is hard to get; this Substitute never fails.*



BATH.

Nitrate of Silver Cryst. 35 grs.  
Water 1 Oz.  
Iodide of Silver, Near Saturation,  
Iodine acid with Nitric Acid. C.P.

ELBERT  
ANDERSON'S  
NORTHERN  
COLLODION.



DEVELOPER.

Protosulphate of Iron 1 Oz.  
Acetic Acid "Vogel" 1 Oz.  
Water 24 Oz.  
Alcohol. Quantum Suf.



Scovill Manufacturing Company, Trade Agents.  
FOR SALE BY ALL DEALERS.

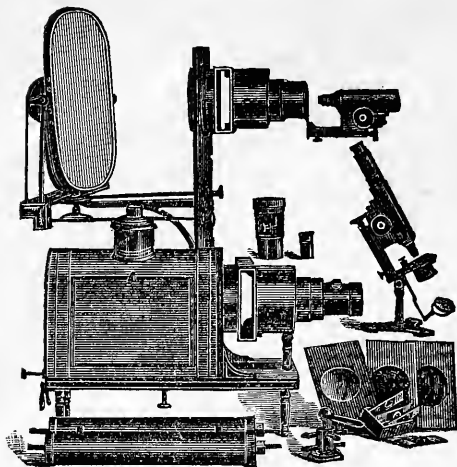

# OPTICAL AND ELECTRICAL INSTRUMENTS.

We desire to call the attention of  
TEACHERS, SCIENTISTS, LECTURERS, and  
those interested, to our

**Stereopticons, Microscopes, Dr. McIntosh's Solar Microscope and  
Stereopticon Combination Apparatus for  
the Oxy-hydrogen and Ether-oxygen Lime Light, Photographic  
Transparencies, Microscopical Preparations, etc.**

Our Instruments and Apparatus are new in design and have many improvements  
that overcome difficulties heretofore considered unavoidable. We also manufacture

**Static Electric Machines, Batteries, Magnets, and a Full Line of  
Electrical Apparatus for Practical and Experimental  
Purposes.**



We received the highest  
award at the New Orleans  
World's Exposition, on  
both Optical and Elec-  
trical Apparatus, in com-  
petition with the best of  
home and foreign manu-  
facturers.



Illustrated Catalogue of Optical and Electrical Apparatus sent free on application  
by mentioning this journal.

**McIntosh Galvanic and Faradic Battery Co.**

Nos. 300 & 302 Dearborn Street,

CHICAGO, ILL., U. S. A.

# THE PHILADELPHIA PHOTOGRAPHER.

TWENTY-THIRD YEAR, 1886.

*ded to the Advancement of Photography and the Dissemination of Art Principles.*

SEMI-MONTHLY: issued the First and Third Saturday of each month.

\$5.00 a year, \$2.50 for six months, \$1.25 for three months—in advance. 30 cts. per copy.

## CONTENTS OF THE FIRST QUARTER.

**JANUARY 2.**—A Happy New Year. Dry Plates—Continued, by THOMAS PRAY, JR. Washing Dry Plates, by C. W. HUNT. Practical Points from the Studios. Bibliography. Good Things from Mosaics, 1886. An Amateur in Australia, by CHAS. D. IRWIN. The Humor of It. A Model Studio "Away Down in Maine," by W. C. TUTTLE. Translations from Unus. A Plea for Overtiming, by EUGENE ALBERT. Photographic Facts and Fancies. Society Gossip. The Open Corner. The Department of Art. Queries, Conundrums, and Conclusions. Our Picture. Correspondence. German Correspondence. The World's Photography Focussed. Studio Studies. Editor's Table.

EMBELLISHMENT.—"Child Portrait," by J. LANDY, Cincinnati, Ohio.

**JANUARY 16.**—A Word or Two for '86. On "Type" Pictures, by KARL KLAUSER. Development with Carbonate of Soda, by M. E. AUDRE. Practical Points from the Studios. Cheap Prices, by T. H. BLAIR. Pertaining to the P. A. of A. Photographic Facts and Fancies. To the Photographers of America. The Open Corner. Photography at the Louvre Gallery. Our Picture. Composition, by XANTHUS SMITH. Society Gossip. The Humor of It. Art and Photography, by G. H. CROUGHTON. A New Picture. Views from My Office Window. The Exhibition of the Photographic Society of Philadelphia. The World's Photography Focussed. Editor's Table.

EMBELLISHMENT.—"Mother Shipton," by FALK, N. Y.

**FEBRUARY 6.**—Enlarged Reproductions, by G. HANMER CROUGHTON. German Correspondence. The Photography of the Future. A Marvellous Accomplishment, by W. B. TYLER. Practical Points from the Studio. Use Good Cardboard Only. Photo. Electric Illustrated Newspapers. The Open Corner. "Words, Words, Words." Molteni's Enlarging and Projecting Lantern. Society Gossip. Exhibition of the Photographic Society of Philadelphia. Our Picture. Pertaining to the P. A. of A. The World's Photography Focussed. Editor's Table.

EMBELLISHMENT.—"Good Morning," by D. T. BURRELL, Brockton, Mass.

**FEBRUARY 20.**—Composition—Part II., by XANTHUS SMITH. Development in Two Solutions, by D. BACHRACH, JR. Photographically Illustrated Books. Where Art Begins, by HUME NISBIT. Correspondence. Queries, Conundrums, and Conclusions. The Humor of It. Views from my Office Window. Photo. Facts and Fancies. The Open Corner. Our Picture. Pertaining to the P. A. of A. Society Gossip. The World's Photography Focussed. Editor's Table.

EMBELLISHMENT.—A Study from Themasses, by H. L. ROBERTS, Philadelphia.

**MARCH 6.**—Recent Photographs of Stars, by PROF. C. PIAZZI SMYTH. The Department of Art. Cardboard Support for Emulsion Films. The Open Corner. Photography for the Newspapers, by STEPHEN H. HORGAN. Another Amateur's Experience in Toning, by P. H. MASON, M.D. Practical Points from the Studios. Our Picture. More "Words." Society Gossip. Pertaining to the P. A. of A. The Secret Order of Scientific Photographers. Photo. Facts and Fancies. Queries, Conundrums, and Conclusions. The World's Photography Focussed. The Improved American Permanent Bromide Paper for Positive Prints and Enlargements, by F. C. BEACH. Editor's Table.

EMBELLISHMENT.—"The South," by H. L. ROBERTS & Co., Philadelphia.

**MARCH 20.**—"Please Do Not Fold." The Open Corner. Words of Wisdom. Practical Points from the Studios. On Printing and Toning. M. Balagny's Flexible Gelatino-Bromide Plates. Light and Shade. The Humor of It. The Illumination of the Transparency in Enlarging, by CHAPMAN JONES. Prints with Gallate or Tannate of Iron. Queries, Conundrums, and Conclusions. Light and Shadow, by XANTHUS SMITH. Society Gossip. First Annual Exhibition of the Camera Club of Hartford. Pertaining to the P. A. of A. The Society of Amateur Photographers of New York. A Visit to the Eagle Dry Plate Company's Works. Our Picture. Correspondence. Obituary. The World's Photography Focussed. Editor's Table.

EMBELLISHMENT.—"The Toilers of the Sea," by H. S. WYER, Yonkers, N. Y. A splendid Marine Study, in green.

The above six numbers to one address for \$1.25, prepaid.

The Philadelphia Photographer and Weekly Photographic Times to one address, \$6.50.

The Philadelphia Photographer and Anthony's Bulletin to one address, \$7.00.

EDWARD L. WILSON, 853 Broadway, New York.

OFFICE OF

# G. CRAMER DRY PLATE WORKS,

Shenandoah and Buena Vista Sts., St. Louis.

---

The demand for the Cramer Plates having outgrown our capacity, we have been compelled to enlarge, and are now erecting large additions to our works which will more than double our present capacity.

Thanking the fraternity for their kind support, we ask their indulgence for a short time longer, and we hope soon to be able to supply our friends regularly and promptly. Fraternaly,



DRY-PLATE WORKS, ST. LOUIS, MO.

---

**THE**

## ST. LOUIS DRY PLATE COMPANY

Beg to announce that under their New Management they have recently made Important Improvements and Increased their Facilities, so that they are now making better and more uniform plates than heretofore.

---

ALL ORDERS WILL RECEIVE PROMPT ATTENTION.

---

**ST. LOUIS DRY PLATE CO.**

No. 827 Chouteau Avenue,

ST. LOUIS, MO.



Number 280.

30 Cents.

THE  
PHILADELPHIA  
**Photographer.**

AN ILLUSTRATED SEMI-MONTHLY JOURNAL,  
DEVOTED TO PHOTOGRAPHY.

## SUMMARY OF CONTENTS.

PAGE	PAGE		
The Uses of Rainy Days. By CHARLES F. FELLOWS, . . . . .	481	Bleaching Overprinted Photos. for Photo-Engraving, . . . . .	497
Process for Developing Negatives with very Short Exposures. By M. BALAGNY, . . . . .	482	Mr. T. R. Burnham's Large Negative, . . . . .	497
Rambling Remarks. By RANALD DOUGLASS, . . . . .	484	Society Gossip, . . . . .	499
Views from My Office Window, . . . . .	484	Queries, Conundrums, and Conclusions, . . . . .	501
Useful Hints, . . . . .	486	Our Picture, . . . . .	502
Photo. Facts and Fancies, . . . . .	487	Paper Coated with Gelatine Emulsion for Direct Printing, . . . . .	502
Alaska Correspondence, . . . . .	488	Instantaneous Portraiture, . . . . .	504
Practical Points from The Studios, . . . . .	488	Answer to a Question Concerning the Toning of Albumen Paper, . . . . .	505
The Humor of It, . . . . .	490	The World's Photography Focussed, . . . . .	506
Chatterings of This and That, . . . . .	491	Editor's Table, . . . . .	507
A Camera Without a Lens. By M. MEHEUX . . . . .	492		
Open Corner, . . . . .	496		

OUR PICTURE.—"After Play." Negative by Messrs, ABELL & SON, Portland, Oregon.  
Prints by Photogravure Co., 853 Broadway, New York.

EDWARD L. WILSON,  
*853 Broadway, New York.*

SUBSCRIPTIONS RECEIVED BY ALL NEWS AND STOCKDEALERS

Five Dollars per Annum, in Advance.

## ADVERTISEMENTS.

ANTHONY & CO., E. & H. T. The New N. P. A.  
Pensé Extra Brilliant Dresden Albumen  
Paper.

CARBUTT, J. Gelatine Dry Plates and Improved  
Dry Plate Lantern.

CODMAN, C. H. & CO. Photo. Stockdealers.

COLLINS, SON & CO., A. M. Photograph Cards.

COOPER, CHAS. & CO. Photo. Stockdealers.

CRAMER, G. Lightning Plates.

DOUGLASS, GAYTON A. & CO. Photo. Stock-  
dealers.

EASTMAN DRY-PLATE AND FILM CO.

ENTREKIN, W. G. Patent Eureka Burnisher.  
Duplex Rotary Burnisher. Duplicating Print-  
Cutter.

FRENCH & CO., BENJ. Voigtlander & Son and  
Darlot Lenses. The Wonderful Euryscope.

GENNERT, G. Eagle Dry Plates.

HERRMANN, CHAS. A. W. Hypo. Soda.

INGLIS, JAMES. Dry Plates.

McINTOSH GALVANIC AND FARADIC BAT-  
TERY CO.

MOSS ENGRAVING CO.

MURPHY, GEORGE. Photo. Stockdealer.

PASSAVANT'S DRY PLATES.

PHOTOGRAPHERS' ART VINE.

PHOTO-GRAYURE CO.

PHOTOGRAPHIC TIMES.

ROBERTS & FELLOWS. Photo. Stockdealers.

SCOVILL MANUFACTURING CO. New Dres-  
den Albumen Three Crown Paper. Gihon's  
Cut-Outs. Photo. Apparatus.

ST. LOUIS DRY PLATE COMPANY.

SMITH & PATTISON. Photo. Requisites.

THE DU BOIS FILING CASES.

THAYER, N. C. & CO. Photo. Stockdealers.

WAYMOUTH'S VIGNETTE PAPER.

WILSON, G. W. & CO. Magic Lantern Slides.

WILSON'S PHOTOGRAPHICS.

WILSON'S LANTERN JOURNEYS.

---

## ADVERTISING RATES.

THE PHILADELPHIA PHOTOGRAPHER is acknowledged to be the best advertising medium  
in the trade.

Its circulation is among the first class, at home and in nearly every foreign country.

Its rates, all advantages considered, are the most favorable, and it will bring you fine  
returns.

	One Issue.	Six Issues.	Twelve Issues.	Twenty-four Issues.
1 Page.....	\$20.00	\$110.00	\$200.00	\$350.00
1-2 " .....	12.00	66.00	120.00	200.00
1-4 " .....	7.00	38.50	70.00	120.00
1-8 " .....	4.00	22.00	40.00	70.00

\* Special contracts made with bona-fide dealers and manufacturers. Address

**EDWARD L. WILSON,**  
853 BROADWAY, NEW YORK.

---

## NOTICE TO SUBSCRIBERS.

In remitting by mail, a post-office order, or draft, payable to the order of EDWARD L.  
WILSON, is preferable to bank-notes. Postage stamps of the denomination of two and five  
cents each will be taken. Clearly give your Post-Office, County, and State.

Foreign subscriptions must be accompanied by the postage in addition.

**FIRE!** Our books having been all destroyed by fire at and with our establishment, all  
who owe us will confer a great favor by remitting at once.

**CROSSCUP & WEST ENGRAVING CO.**  
907 Filbert St., Philadelphia.

---

A. M. Collins, Son & Co.

*MANUFACTURE ALL KINDS OF*

**CARDS AND CARDBOARDS**

FOR

**P** PHOTOGRAPHERS **S**

AND

**MATS, MOUNTS, AND ENVELOPES**

FOR

**F E R R O T Y P E S .**

---

OFFICE AND WAREHOUSE,

**No. 527 ARCH STREET,**

**PHILADELPHIA.**

---

Price Lists may be had by intending purchasers on application to us, or to all Photographic Merchants, through whom your favors are respectfully solicited.

# ENTREKIN'S PATENT EUREKA BURNISHER.

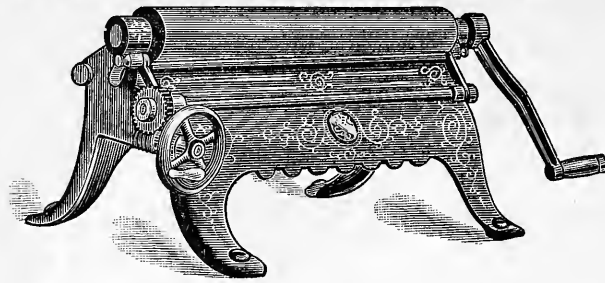

The above cut represents our 25 inch Eureka.

The unprecedented popularity of this Burnisher is wonderful. Over seventeen thousand (17,000) sold in less than five years. Agencies in London, Berlin, and Vienna, and sold by all stockdealers in the United States. The machines are built in first-class style, and warranted to do the work claimed.

Full directions accompany each machine.

## PRICES:

6 inch Roll, . . . . .	\$15 00	20 inch Roll, . . . . .	\$60 00
10 " " . . . . .	25 00	25 " " . . . . .	70 00
14 " " . . . . .	35 00		

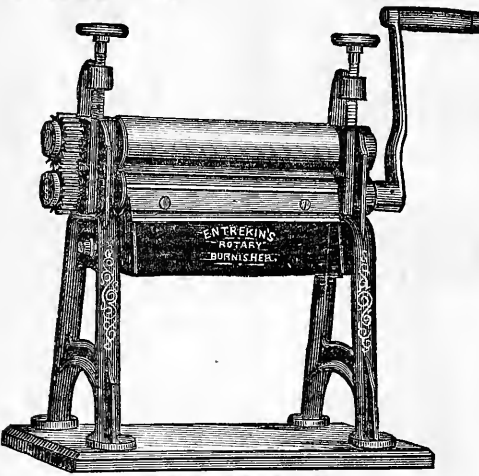

# ENTREKIN'S Duplex Rotary Burnisher.

PATENTED JUNE 1, 1875.

## PRICES:

10 inch, . . . . .	\$15 00
15 " . . . . .	25 00
20 " . . . . .	35 00
25 " . . . . .	45 00

# ENTREKIN'S DUPLICATING PRINT CUTTER.

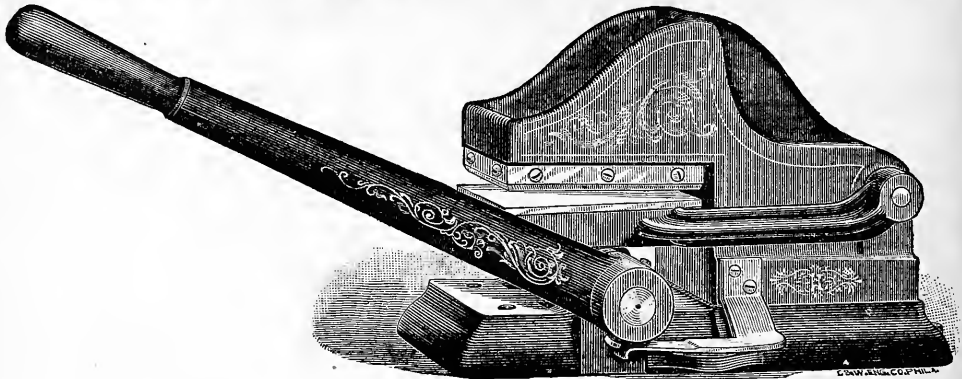

Cabinet and Stereo. Sizes, \$25.00      Small Panel Size, \$35.00.  
 Size 6½ x 8½, \$40.00.

MANUFACTURED AND FOR SALE BY

W. G. ENTREKIN, 4384 Main St., Manayunk, Phila., Pa.

# ENTREKIN'S

## IMPROVED

# DUPLEX ROTARY BURNISHER.

PATENTED.

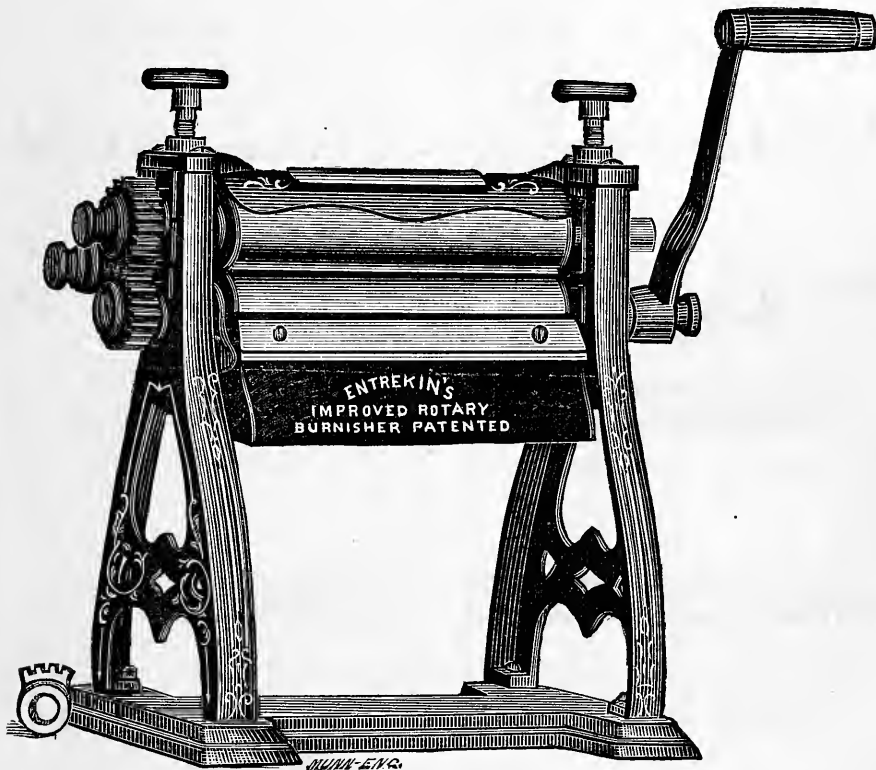

10 in., \$25.00. 15 in., \$35.00. 20 in., \$45.00. 25 in., \$60.00.

This Machine is an improvement on our old Duplex Rotary Burnisher, invented by us in 1874.

It is so constructed that by changing the Large Gear or Cog-wheel, from the stud to the end of the draw-file or upper roll, you reverse and change the speed of the lower or polishing roll, thus getting the same result as in the old Duplex Rotary; but to secure the best polishing surface, use the machine with the large cog-wheel on the Stud, by so doing you secure three times the polishing surface. All the machines will be sent out with gearing so arranged as to give this result. It is optional with the Photographer how he may use the machine. The Fire-Pan is so arranged that it is impossible for it to come in contact with the surface of the polished roll, and it can be turned away to cleanse the roll.

**EVERY MACHINE WARRANTED PERFECT.**

FOR SALE BY

**W. G. ENTREKIN, Inventor and Sole Manufacturer,**

4384 Main St., Manayunk, Philadelphia, Pa.

AND BY ALL PHOTOGRAPHIC STOCKDEALERS.

# BENJ. FRENCH & Co.

No. 319 WASHINGTON STREET, BOSTON,

Sole Agents in the United States for the Celebrated Lenses  
Manufactured by

## VOIGTLÄNDER & SON.

ALSO, THEIR FAMOUS

# EURYSCOPE,

Which is unrivalled for groups, full-length figures, and other demands in the gallery, and every species of out-door work, including instantaneous photography.

☞ THE EURYSCOPE is made *exclusively* by Voigtländer & Son, and their name is engraved on the tube.

FOR **DARLOT LENSES** FOR  
PORTRAITS. VIEWS.

IMPORTERS, ALSO, OF THE CELEBRATED

TRAPP & MÜNCH

## ALBUMEN PAPER,

AND DEALERS IN ALL KINDS OF

*Photographic Materials and Magic Lantern Slides.*

SEND FOR OUR NEW ILLUSTRATED PRICE LIST OF LENSES.

---

# OUR SPECIALTIES.

---

**BROMIDE AMMONIUM, Chem. Pure.**

**BROMIDE POTASS., Chem. Pure.**

**NITRATE SILVER, Chem. Pure.**

**FOR DRY PLATES.**

**CROSS-SWORD DRESDEN ALBUMEN PAPER,**

**Single and Extra Brilliant. The Best in the Market.**

ALSO A GENERAL LINE OF

**PHOTOGRAPHIC CHEMICALS.**

A circular, "How to Save Waste," sent on application.

**CHAS. COOPER & CO.**

**194 Worth St., New York.**

---

## **A CARD.**

---

75 STONE ST., ROCHESTER, N. Y., July 26, 1886.

GENTLEMEN: About three months ago the business of Inglis & Co., of this city was formed into the Inglis Dry Plate Co.

In the articles of agreement, a clause was inserted giving the I. D. P. Co. the exclusive use of the name of "Inglis," and also that James Inglis would not connect himself with any dry plate business using the name of "Inglis."

Matters have taken such a form since then, he has been compelled to leave the I. D. P. Co. And being thus debarred from the use of his own name, adopts this means of making known to his numerous customers where they may still obtain his plate. **And the Only Place.**

A new firm taking the name of the **ROCHESTER DRY PLATE CO.** have engaged his services, and under his supervision a new factory has been fitted with the most modern improvements required for the production of **clean and spotless plates**, with all the other extra qualities that his plate has become so renowned for. The fraternity may therefore depend upon the very finest plate ever yet produced, from the **ROCHESTER DRY PLATE CO.**

**JAMES INGLIS,**

Late Manufacturer of the Inglis Dry Plate, and President  
of the Inglis Dry Plate Co.

**MAGIC CAMERA STANDS. THE BEST MADE.**

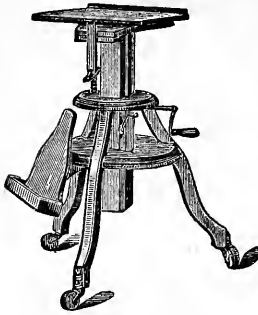

No. 1, 8 x 10, \$12 00

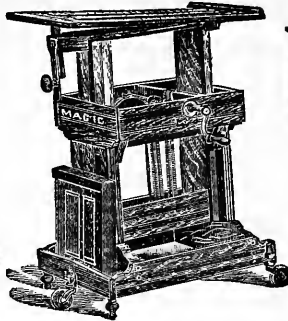

No. 2, 8 x 10 to 11 x 15, \$15 00

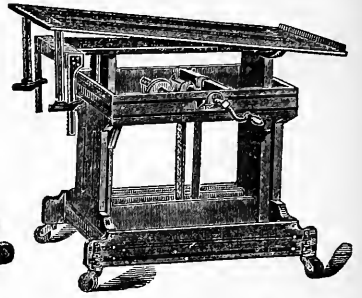

No. 3, 14 x 17..... \$20 00  
No. 4, 18 x 22 and 20 x 24.... 25 00

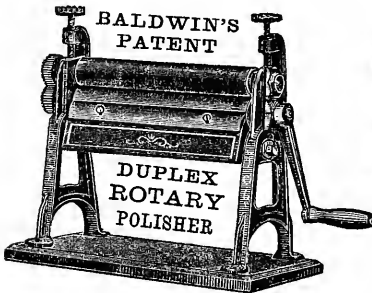

**THE BEST IN THE WORLD.**  
Prices, \$18, \$25, \$35, and \$45.



**CENTENNIAL CHAIRS.**  
Very Popular and Cheap.



**BALDWIN'S BABY HOLDER.**  
Has no Equal.

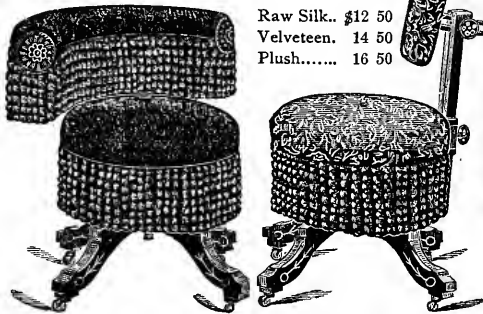

**THE PATENT QUEEN POSERS.**  
The most useful Chair ever invented. Prices include Circular Arm and Back Rest.

Raw Silk.. \$12 50  
Velveteen. 14 50  
Plush..... 16 50

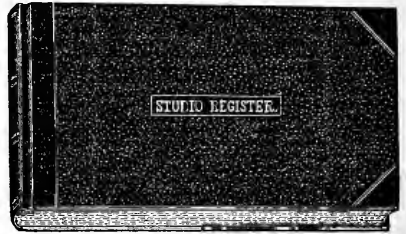

No Studio Complete without it.  
Send for Sample Page.

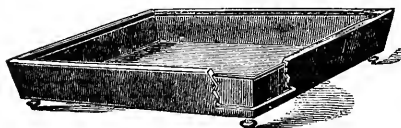

**THE COMMON SENSE TRAY.**  
Is the Best and Cheapest Large Tray Made.

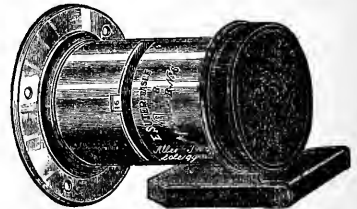

**THE WONDERFUL SUTER LENS.**  
Has no Superior in Quality, and no Equal in Price.

The above represents a few of our leading specialties, all of which (except Suter Lenses), we manufacture and control. *All these items are the best in the class they represent. Take no other.* Send for complete descriptive circular of any or all these items, or any article needed.

**SMITH & PATTISON,**

Wholesale Photo. Supplies  
of every description.

145 & 147 Wabash Ave., Chicago.



# The Photo-Gravure Company,

853 Boadway, New York.

PHOTO-  $\left\{ \begin{array}{l} \text{GRAVURE} \\ \text{LITHOGRAPH} \\ \text{CAUSTIC} \\ \text{GELATINE} \end{array} \right\}$  PRINTING

## PROCESSES OF THE PHOTO-GRAVURE COMPANY.

**PHOTO-GRAVURE.**—By this process the highest artistic effects are produced. Metal plates are engraved (in intaglio) by photography and printed in copper-plate presses. The effects produced by photography may be altered by the hand of the artist, values may be increased or diminished, and almost any omission or addition made. The work may be carried on till the desired effect is produced and the edition is always uniform. The plates can be supplied when desired, or the Photo-Gravure Co. will do the printing. The results obtained by the Photo-Gravure Co. equal the best results obtained abroad, and reference to this effect is permitted to leading Publishers and Artists who have used these plates. All classes of subjects, whether in half-tone or line, can be produced by this process.

**PHOTO-GELATINE PRINTING.**—The results produced by this process are similar to what is known as Albertype, Artotype, Helio type, Autoglyph, Phototype, Lichtdruck, etc. The particular method used is that patented by Mr. T. C. Roche, and is believed to give the best results at the least cost. The Photo-Gravure Co. has in this department the best staff of printers in the country and a most extended experience of the treatment of gelatine for the purposes of printing. All classes of subjects are suitable for reproduction by this process, and it is especially suitable for portraits, views, architecture, art catalogues, scientific and natural objects, book illustration, town, county, and family histories, theatrical and general advertising, reproductions of engravings, machinery, animals, and still life, copies of deeds, instantaneous effects, scientific records, mill labels, etc.

**PHOTO-CAUSTIC PRINTING.**—This term is applied to a modification of the results produced by Meisenbach, Ives, and others. By this modification the photographic effect is produced from stone. No attempt is made to produce engraved plates, but the printing is done by the Photo-Gravure Co., and by this means greatly better results are obtained than where plates are made and placed in the hands of the ordinary printer. The results are not as good as those obtained from Gelatine or by Photo-Gravure, but they are sufficiently good for a number of purposes where the quality of the higher grades of work is not necessary. It is applicable to all the purposes of the other processes, but is lower both in cost and quality.

**PHOTO-LITHOGRAPHY.**—The results of this well-established process are well known. It is the oldest of the photo-mechanical processes, but is only adapted to the reproduction of original drawings or engravings which are made in a black or other non-actinic color on a white or light ground. We have in our employ on this work the most skilful staff in the country, who for many years have made it a specialty. Photo-Lithography is unrivalled for the reproduction of maps, plans, tracings, surveys, patents, and other drawings, engineers' and architects' designs, *fac-simile* letters and circulars, exhibits in law cases, miniature catalogues, copies of line engravings, reduction or enlargement of line work, etc.

A Book of Specimens of our various processes will be forwarded on receipt of One Dollar, and all inquiries will be promptly answered. Special arrangements made with photographers.

THE PHOTO-GRAVURE CO.,

853 Broadway, New York.

# BUY THE BEST!

No other will give you half so much satisfaction.

FOR DRY PLATES  
ANTHONY'S Patent Perfect PLATE HOLDERS  
ARE SUPERIOR TO ALL.

DALLMEYER

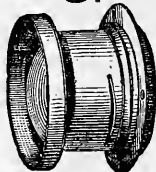

FOR WET

OR DRY

WIDE-ANGLE RECTILINEAR

E. A.

SINGLE COMBINATION, RAPID,  
WIDE ANGLE, PLATYSCOPE,  
PORTRAIT AND VIEW LENSES.

DALLMEYER LENSES,  
SUCCESS CAMERAS,  
THE FAIRY CAMERAS,  
THE NOVEL CAMERAS,  
SCHMID'S DETECTIVE CAMERA

SEND  
FOR OUR  
CATALOGUE,  
AND GET  
THE BEST  
Of Everything.

APPARATUS OF ALL KINDS.  
Chairs,  
Neg. Boxes,  
Camera Stands  
Printing Frames,  
Etc., Etc.

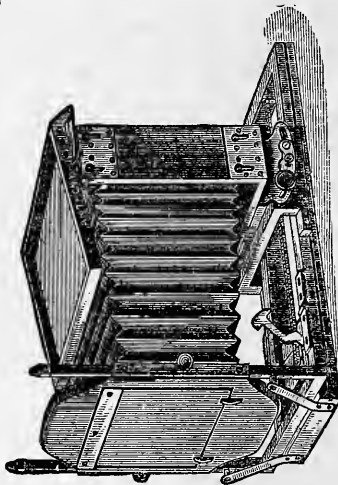

THE FAIRY CAMERA.  
*The Lightest and Best for Out-door Work.*

FOR EITHER DRY OR WET PLATES  
NOTHING EQUALS

THE BENSTER PLATE HOLDER.

DALLMEYER

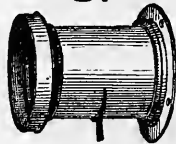

NOTHING

COMPARES

RAPID RECTILINEAR

O. I. C.

PORTRAIT, COPYING, CLIMAX  
PORTRAIT, GEM, AND  
COMPACT VIEW CAMERAS.

**E. & H. T. ANTHONY & CO.** --591-- **NEW YORK.**  
BROADWAY,

THE UNIVERSITY OF CHICAGO



ABELL & SON.

AFTER PLAY.

PORTLAND, OREGON.

PHOTO-GRAYURE CO. N. Y.

THE

# Philadelphia Photographer.

EDITED BY EDWARD L. WILSON.

Vol. XXIII.

AUGUST 21, 1886.

No. 280.

## THE USES OF RAINY DAYS.

BY CHARLES T. FELLOWS.

WE have just passed through a week of rainy weather, and we have had our hands full of work, notwithstanding.

Photographers generally of all people are apt to complain of the weather, and if business should be anyway brisk the invectives heaped upon an inopportune rainy day are truly startling. And yet how useless it all is. How many old proverbs there are applicable to a rainy day! "'Tis an ill wind that blows nobody good."—"What is bad for one is good for another." But the complaints still continue, and I must confess I am not altogether guiltless, but I am endeavoring to cultivate patience as a virtue. I try and bring my mind to the same way of thinking as the poet, who says:

"'Taint no sorter use for to worry and complain—

'Tis just as cheap and easy to rejoice

When the Lord in his Providence sends rain;  
Why! rain 's my choice."

The question may arise, What can be done in a gallery on a "rainy day?" I would answer: All those things, great and small, which are apt to be neglected during the pressure of a busy season. Our experience of the past week may be of interest. We accomplished many things which, with fair weather and a business as brisk as ours has been, would have remained undone for a

long time, perhaps. One of the things we did on the first day was to number and title a lot of newly-acquired negatives for lantern slide subjects. This consumed one whole day. The second day was devoted to looking over our negatives that had been in use and replacing them on the shelves, also in straightening out our dark room, washing bottles, etc. The third day was spent in going over a lot of old negatives and glass that we found stowed away under our cistern—old gelatine plates, stuck together by the dozen as tightly as the "Amalgamated Association," and the perfume exhaled from them was not exactly like "attar of roses" either. Why these things were ever stored so carefully we cannot conjecture; some of them were wrapped in paper, when in truth there was absolutely nothing in them but decomposed gelatine. We disposed of them very soon, after which we had the rooms cleaned, and the general air of freshness and cleanliness amply repaid us for our share in the dirty work. So have I always found it in my experience as an employée. I have been driving work as much as it was possible to drive, endeavoring to fill orders promptly, and have frequently complained bitterly of the rainy day that brought our work to a sudden stop. But we always found something to do. Suppose an employée of a certain department of a gallery should find himself with an hour or so of spare time on his hands. He has already

straightened up his own department and has everything in apple-pie order; what shall he do next? I say *read*—read any good work on photography, any photographic journal; he will always find something of value in them. It is impossible to read too much. Let no man feel afraid to have his employer see him thus occupied. That man who would hinder or object to his assistants thus improving their spare time stands in his own light. The intelligent workman is more valuable than the machine-made man; every employer should realize this and take pains to have plenty of such literature about his place, and to encourage his help to read all such works. The benefit would soon be made manifest.

[Translated for the Philadelphia Photographer.]

### PROCESS FOR DEVELOPING NEGATIVES WITH VERY SHORT EXPOSURE.

BY M. BALAGNY.

(Concluded from page 377.)

THE present communication is in continuation of what I have already said. The subject of instantaneous negatives and their development is so much the order of the day at present, that I revert to it without hesitation.

One of the most desirable qualities to be sought for in sensitive plates or the preparations used in making instantaneous negatives, is that these preparations should be capable of undergoing the strongest development. We should not have to fear an accident whilst the developing bath acts, as in that case we are stopped short, and the negative cannot be brought to the necessary point to give finally a good positive print. The two accidents most frequently met with are fogging and blistering. Of fogging I shall have nothing to say, as I have never been able to understand why a manufacturer who has the habit of testing his emulsions should offer for sale preparations liable to fog. This accident can only be prevented by purchasing before making an excursion, for example, a dozen of a certain number, and ascertaining if the plates are good or not. But the above does not apply to

blistering. It may be possible that an emulsion that does not rise in a developer at 15° C. (50° F.), would rise when the temperature is higher. And at a temperature in which water reaches 20° C. (68° F.) it might be impossible to develop the same emulsion without having creases on the edges, a sure sign of the rising of the film. We think that in most cases this comes from the gelatine being rather soft, and especially from its being spread on plates that were not clean enough. On account of the mechanical means used to clean plates in the factories, we believe that it is very difficult to remove some fatty bodies from the surface, which act as isolating substances between the glass and the emulsion. When the manufacturer has tried such an emulsion, spread upon plates cleaned as above, he may have obtained a very good negative, justifying him in placing his plates on sale. He, therefore, acted in good faith, and we have nothing to reproach him with. But it is certain that, later on, when the temperature becomes higher, his emulsion, in presence of water almost tepid and besides being strongly alkaline, will rise.

We have recently made many experiments in this direction, with the view of ascertaining if the flexible plates prepared by M. Lumière were also liable to blister. We were happy to find that this was not the case, and this is easy to understand, as the support used, on account of its mode of fabrication, is extremely clean. It cannot carry on the surface any fatty body; and, as it is sticky in itself, it adheres strongly to the gelatine.

In experimenting, I was led to plunge the flexible plates in developing baths of great energy. It is especially well in photography to know how *to dare*. I sought for an accident, and I found an excellent developer. As it is the carbonates that most frequently produce blisters, I plunged the flexible plates in pure carbonate at twenty-five per cent., or at saturation, before the development. The plates used had been exposed one or two seconds, at the furthest. As soon as I afterwards added pyrogallie acid, even in very small quantity, the image appeared with such rapidity and such intensity, that I understood that I had before

me a process which would give me instantaneousness without the least trouble. I immediately made another experiment, still using the flexible plates, but making use of the stop of Messrs. Londe & Dessoudeix; same success—image showing well, too intense even, as I had used the slow action, but the results were better and better as I reached the one hundredth of a second, which is the mean of the stop mentioned above. So that my experiments might be more conclusive, I made some instantaneous negatives in the streets of Paris. I used the universal objective of M. Français, No. 2, which is both very rapid and very deep. All the negatives which I show you, except those from argenteuil, were made with the shortest time of the Dessoudeix stop, and a diaphragm of 25 millimetres (1 inch). I might have used a smaller diaphragm as the development is made so rapidly, so easily, that one might suppose that the negative had been exposed several seconds. You can see that all is distinct, even in the shadows, and as to the intensity it is even too great in some of the negatives.

I make a solution of carbonate of soda at 25 per cent.; I also make a solution of sulphite of soda at 25 per cent., say 250 grammes (8 ounces Troy) of one or the other of these two salts, for a quart of water. I allow it to settle, and decant for use. To develop, place in a glass from 25 to 30 c.c. (7 fluidrachms to 1 fluidounce) of carbonate of soda, and from 15 to 20 c.c. (4 fluidrachms to 5½ fluidrachms) of sulphite of soda, the two solutions being mixed together. The flexible plate is placed in a moulded glass dish, so as to be able to follow the development by transparency. (I use moulded glass because the developer is so strong that it entirely dissolves the marine glue with which are made the wood-and-glass receptacles for the bath.) The liquid is thrown on the pellicle, which is well wet and allowed to remain in this state for about two minutes.

During this time of waiting, place in the glass, which is now empty, from 10 to 15 c.c. (4 fluidrachms) of pyrogallic acid dissolved in alcohol in the proportion of 10 grammes (3 drachms) to 150 c.c. (5 fluid-

ounces) of alcohol. A large pinch of pyrogallic acid in powder may also be put at the bottom of the glass. Whether the acid is used in powder or in an alcoholic solution, the mode of operating is the same and the result will be identical. All the alkaline liquid which is in the dish is poured on the acid and the most intimate mixture is obtained. The whole is again poured on the flexible plate which has remained adhering to the bottom of the dish. After agitation, and in a very short time, the image appears, but at first with a rather grayish tint; then it is the blacks alone that come up without intermission, until it is deemed that the action is sufficient. During all the time of development the whites are very well preserved; I may say that I did not miss one, and always without bromide. But a little bromide may be added with advantage when the slow stop has been used. In this case add, at the start, to the mixture of carbonate and sulphite, from 5 to 10 drops of a solution of bromide of ammonium in water in the proportion of 10 per cent.

When the development is ended wash well, especially if pyrogallic acid dissolved in alcohol has been used. When the greasy streaks have entirely disappeared give an alum bath—60 grammes (2 fluidounces) for 1000 grammes (34 fluidounces) of water—and after remaining two minutes in this bath fix with hyposulphite. The rest of the operation for drying the flexible plates has been already described. By using the small instrument of M. Vidal, most beautiful results are obtained, which, when projected, show on the screen very perfect and sharp pictures.

Before ending, I must render justice to the exceptional qualities of the universal objective of M. Français, to the rapidity of which I owe a good part of my success. I can say the same of the stop made by Messrs. Londe & Dessoudeix. It may be asserted that light has really room to pass in this instrument, and, although only about a hundredth of a second, its impressions so well and so completely the flexible plate, that development by the process that I have just communicated is the easiest thing to do.

There is no longer any reason to hesitate in making instantaneous pictures. We find

to-day, at the dealers, the instruments and the sensitive preparations suitable for this kind of work. The development given above is of the simplest, is uniform, and with its use there is no necessity for the addition of pyrogallic acid and carbonate of soda, not even the bichloride of mercury, which I would like to see banished from all our laboratories.—*Moniteur*.

---

### RAMBLING REMARKS.

BY RANALD DOUGLASS.

SOME time ago, while making some negatives of an interior of a gymnasium, it happened that some ropes suspended from the rafters above were the most brilliantly illuminated parts. They were in a direction a little oblique to the lenses. The result was, on developing, these ropes repeated themselves in the picture; in other words, there were two ropes in the negative when there was one in the subject. The explanation of this being that the picture was reflected from the glass back to the film, hence the double impression of the strongest illuminated parts. The plates used were Stanley's, which were very excellent ones. I think if thickly coated plates were used the phenomenon could not occur. It is only in rare circumstances that thickly coated plates need be used. The manufacturers are not to be blamed, for I suppose they are willing to coat extra thick to order. As a rule I find that almost all plates are excellent in their chemical effects as far as the emulsions go, but there is generally a lamentable want of uniformity and evenness of coating on almost all of those in market. This defect does not show itself injuriously in portrait work, but for viewing, unevenly coated plates are an abomination. The photographer seems to have the remedy in his own hands, even if he does not want to cook his own emulsion, he can buy it and coat and dry his own plates. It is generally a very difficult matter to flow emulsion over glass, but if a substratum of silicate of potass, 1 part to 200 of water, is made use of, the emulsion will flow over the same as varnish does, and the film will stick as close as a brother. I speak from my own experience.

Spots and pits in the film continue to bother us yet, in spite of all remedies that have been suggested for them. The best way I know of to rid them is by washing gelatine thoroughly before it is used, also in skimming it before dissolving the salts in it. Still they would come and bother me. Perhaps the gelatine itself is at fault. I am bothered mostly when I use Nelson's with Swiss, less when using Swiss alone. Perhaps other brands of gelatine may give freedom from spots. I also meet with them frequently on certain commercial plates, never with the Stanley. The latter seems the cleanest as far as I have tried. There may probably be others just as good. It seems that the maker who will give the cleanest and most evenly coated plates is the one who will be preferred wherever he can be found. Probably the reduction in price of plates of late has discouraged many. It takes less time to coat unevenly than evenly. To make a profit it seems plates have to be coated as fast as possible. That being the case, the fault lies with us consumers as long as we are not willing to pay a fair price for good plates. For it is apparent that at present cut prices for plates, the manufacturers cannot have much of a margin of profit, should they take more time and care to make perfect plates, for they do cost more than indifferent ones. It is not a healthy sign of the times that they should follow the example of us photographers and cut each other.

It is probable now that the low-price mania in everything is taking backward steps, for we see every day workmen all around us striking for more pay. Won't we do likewise and strike for better plates and better pay?

---

### VIEWS FROM MY OFFICE WINDOW.

I HAVE received the following query:

CARSON CITY, NEV., Aug. 2, 1886.

DEAR SIR: Will you please tell me the object of your department of "Views from my Office Window," and oblige

A YOUNG SUBSCRIBER?



My object in recording my "Views" here is to cultivate among my subscribers who need it the faculty of observation—the way to *see pictures* when they come under their noses, and thus make it easier for them to secure pictures with their cameras.

A great crowd collected near the fountain yesterday. It seemed to widen and grow higher, too, like the sand which runs down from your hour-glass. The people ran across the grass and along the paths like the molecules on your negative when developing. One lady, in her haste, caught her parasol in a tree, and was suddenly brought to a halt; another one was detained by her dress catching on a nail in a bench. What was their hurry? Well, a poor girl had fainted from the heat. They gathered around her as close as they could, so no air could reach her, and fairly tore one another to get a sight at her pale, wan face. Kulling! kul-ling! Already the ambulance was come. The crowd gave way as it does in Cairo when the Khedive's sais runs ahead of him and cries out, "Ooah! ooah! look out for your head, for your ear, your nose! ooah!" The poor creature was taken up tenderly, placed in the ambulance carefully, covered over comfortably, and then driven off to the hospital. Heaven bless such a considerate charity! It is better than the densest crowd.

Union Square seems to possess as great attractions for the street vendors as it does for me. Nearly every corner within hearing of its fountain is occupied by some street merchant. None is busier than the little Italian girl who comes every morning before school to help her grandpapa arrange his banana stand. Her dress is short waisted, and its skirts are long. Her broad white collar makes the body seem still shorter, though the delusion is corrected a little by the long shiny plait, which hangs down from her neatly combed top hair. Her motions are as graceful as a bird's, and as quick. She places stones under its wheels to steady the cart; she pyramids the apples, and she mounds the oranges; the date scales are dusted, and the figs are neatly arranged; the rotted bananas are sorted out and carried—a-w-a-y around the corner, and de-

posited wherever there is the best hiding-place for them. Then near and perspective views are made, a few finishing touches given, and the little busy thing seizes her satchel, kisses grandpa, and is soon romping with her companions, who just arrive on their way to school.

If the Spaniard and cloak who attend the peanut stand at the corner of Sixteenth Street had some such little bit of sunshine every morning, they would not look so brigandish as they do. But the old savage knows how to manage that cloak picturesquely. He must belong to the G. A. R. of Cadiz. He usually stands with one edge towards his business; then, with folded arms, his drapery falls about him in true military lines. His eyes are cast savagely in the direction of his stock in trade. The effect is immense; and well he knows it. Nothing less than a nickel will cause his folds to change; and then they are unadjusted as carefully as if there was some tactics about it, or a fear that his poverty or a stiletto might be revealed. Instead of asking Allah to bless his patrons, as the Arab water-carrier does, he seems to be asking Heaven to curse the man who munches peanuts. But he is stately looking, nevertheless, and he never forgets it.

"There's a special providence in the fall of a sparrow," said Prince Hamlet. So there is in the rise of a sparrow, as I can testify. A mated pair began early to be busy at nest-building on the capital of one of the iron columns at the right of my window. There are young ones now. This morning, as I looked out my window, there, at the foot of the column, on the window-sill, all swollen up to twice his usual size, and his head nearly sunken in to a line with his feathers, was Mr. Cocksparrow, shivering like an aspen leaf. "Hello, Jack! Children grown so large, old lady had to crowd you out?" I said. He turned his head up so cute, as though grateful for sympathy, and just melted me by his pitiful look. "Poor boy!" I said, putting out my hand, "come in and get warm." He trembled more violently than ever, and seemed to grow fainter as I stooped to reach him. He almost toppled over as I came within an

inch of him. (P-o-o-r—l-i-t-t-l-e—thing!) As I almost touched him his eyes full upon me, he gave a blink—a bland, patronizing twinkle—and then flew away over into the Square. He only had the dumps, after all.

### USEFUL HINTS.

[MR. EDWIN DURYEA, one of our most distant subscribers, has caught the spirit of helping his fellow-workers, from taking the PHILADELPHIA PHOTOGRAPHER, and sends us the following.]

**A GOOD CEMENT OR GLUE** is made as follows: Take a small bottle, fill about three parts full of gelatine, just cover with sufficient glacial acetic acid, and let remain until dissolved.

**AN ECONOMICAL TONING BATH.**—400 grains of phosphate of soda, not more than 6 grains of chloride of lime (pure), 40 ounces of water. Dissolve, and add two grains of gold. It will be ready for use about one hour after mixing. This will tone six sheets of albumen paper. When mixing up fresh retain one half of the old bath, and add half new, as per formulæ above. The pure color the bath assumes after using, is in no way a detriment; the tone to obtain is a purplish black.

**CLEARING SOLUTION FOR GELATINE NEGATIVES.**—Very often it is desirable to clear away the yellow appearance in negative films after developing or intensifying; the following acts very rapidly: 1 ounce of alum, 1 ounce of sulphate of iron, 1 ounce of citric acid, 24 ounces of water. Place the plate in the solution, let remain until clear, which will usually be in half a minute. This solution may be used over and over again.

**RELATIVE TO EXPRESSION.**—I think there is no part of photography that requires so much thought and care as that which is required to produce harmonious effect in this respect. Success entirely depends upon expression; even a poor photo in other respects will find a market if pleasing in this one. Procure a stand and small frame; have the

frame so arranged as to be able to place in a series of pictures, they need not be photographs. Procure those that you would think most likely to call out varied expressions—admiration, love, thoughtfulness, merriment, pity, defiance, etc. Practice these on non-sitters, and study their expression; with very little practice, you will find yourself, comparatively speaking, master of what before was very difficult. Have the stand so arranged that you may raise or lower the frame, and direct your sitters to look toward the picture you think most desirable. Have your frame covered with a black flap of cloth, and do not show the picture until ready to expose.

**A USEFUL REFLECTOR FOR THE OPERATING ROOM.**—Have a light deal frame made of sufficient length to extend across your room, and about three feet in breadth; cover it with white calico; hinge this on a level with the eaves, or to the ceiling if not too high, say about nine or ten feet from the floor. This will leave six or seven feet, quite sufficient to walk under; the distance from reflector to sitter should not be less than ten or twelve feet. Arrange pulley with a rope, so as to be able to draw it up, if not required. This is best done by pulling it away from the sitter, not toward. You can arrange a dark blind on wires, over the white reflector, so that if you think it advisable to use only part you can do so. I find this reflector extremely handy in taking groups, to light up the sitters that are furthest from the light, and to modify the light when there appears to be too much contrast, also for the purpose of diffusing.

**BEST OF ALL.**—Procure and read the PHILADELPHIA PHOTOGRAPHER, and advise your co-worker to do likewise. Keep every number, and have them bound; it is an unequalled journal on photography, and a thorough combination of knowledge from some of the most able artists in the world.

E. DURYEA.

MOONTA, SOUTH AUSTRALIA.

**ORDINARY PENCIL-MARKS** can be preserved by coating them over with a solution of collodion, to which two per cent. of stearine has been added.

### PHOTO. FACTS AND FANCIES.

#### FINGER STAINS—IMPERVIOUS GLOVES.—

The use of cupric chloride to remove the stains on the hands, which result almost inevitably from photographic manipulations, has just been again recommended as being efficacious and not dangerous. The fingers are steeped in a highly concentrated solution of the cupric chloride, with which they are slightly rubbed; then the hands are plunged into a rather strong bath of hypsulphite of soda, which removes the chloride of silver formed by the contact with the chloride of copper. We have remarked that many ladies in their photographic operations, use ordinary gloves. This is a useless and dangerous operation, since ordinary gloves imbibe chemical liquids, which they maintain constantly in contact with the skin, and this after awhile produces eczema or ulcerations. For this purpose it is always better to use gloves impervious to liquids.

**THE ACTION OF ACTINIUM.**—A few years ago we discovered in the white sulphuret of zinc, used as a pigment, a new metallic substance, *actinium*, the sulphuret of which possesses the curious property of blackening under the action of solar light, unless protected by a sheet of glass. Several chemists have expressed the idea that this phenomenon is due to the *mercury*, of which zinc and its ores often contain appreciable quantities. We have been unable to find mercury in our samples (it is true they were calcined), and, to-day, manufacturers in England and America, where this kind of zinc-white is produced, complain that after having submitted the zinc solution to all processes suitable for the elimination of the mercury, and after having calcined the final product at a high temperature (which would volatilize the mercury and its sulphurets), the pigment still possesses the property of becoming black in solar light. It follows, therefore, as we have said, that it is to the actinium that the phenomenon in question is due.—*Paris Moniteur*.

**REVIEW OF NEW WORKS.**—M. V. Roux, the author of a *Treatise on Zincography*, has just published, through M. M. Gauthier-

Villars, a little work styled a *Manual of Photography and Calcography*, especially intended for artists and others who use the engraving process, etc., to whom it will prove highly useful, being essentially practical.

**PHOTOGRAPHY APPLIED TO MICROSCOPIC ANATOMICAL STUDIES.**—Photography has already rendered to anatomy some valuable services, and it is it that has allowed M. Pasteur to realize the important discoveries which honor his name. But in this connection the application of our art is delicate and requires a special knowledge. Dr. H. Viallanes has formulated in the publication of which we have given above, the title, *The Laws of Photography as Applied to the Study of Microscopic Anatomy*. This book deserves to become classic, as much by the precision of its lessons as by the reliability of the doctrine; everything is clearly expressed, and everything may be found there.

**INSTANTANEOUS PHOTOGRAPHY.**—For a long time M. Londé has given much attention to the study of instantaneousness from the double point of view of theory and practice, and it is the result of these investigations that is given to us here in this interesting publication. M. Londé's book is filled with useful information for the amateur as well as the professional photographer, and treats of light, of the sensitiveness of plates, of stops, of lenses, of development of plates, of the time of exposure, of the angular displacement of objects in motion, etc.

**PORTRAITS** or other photographs may be obtained by candlelight; the portraits in from three to twelve seconds, with an illuminating power of two hundred and fifty candles. If the negatives are made in daylight, by means of a lens covered with a yellow glass, the colors, except the red, will be reproduced with their proper luminosity, that is to say, the yellows strongly impressed. Dr. Malmann has sent some very interesting portraits as specimens of his process.

**ORTHOCHROMATISM OBTAINED WITH ERYTHOSINE.**—In connection with the

papers emanating from Dr. Malmann, who advises the use of an ammoniacal bath of erythosine to obtain orthochromatism, the *Bulletin de L'Association Belge de Photographie* says that plates prepared by this process seem, however, to have a tendency to fog when they are kept. The plate is first plunged into a bath of ammonia and water at one per cent.; then for one and a half minutes in the following bath:

Erythosine (1.1000) . . . . .	25 parts.
Ammonia . . . . .	4 "
Water . . . . .	175 "

Then dried.

### ALASKA CORRESPONDENCE.

I AM in Alaska this summer, the land of the midnight sun, and to say that I am delighted with the grand natural scenery of this part of the United States, would be a poor expression of my enthusiasm. Starting from Portland, Oregon, on the night of May 29th, in the steamer "Idaho," we awoke the next morning at the wharf at Astoria, at the mouth of the Columbia, the grandest river I have ever sailed upon. Multiply the Hudson at the Palisades by four, and the product will be an approach to the Columbia at a point 150 miles from its mouth.

We visited Glacier Bay, and it is the most sublime spectacle imaginable. Approaching Muir glacier, large icebergs were passed, the shadows of which were of an emerald-green color. The anchor was dropped about 2000 yards from the ice-field, and those who wished had a chance to ascend the side of the glacier. The face is several hundred feet high, three miles wide, and judged to extend back twenty or thirty miles. The falling ice made a noise like the discharge of artillery.

Sitka, the capital, on Baranoff Island, is the oldest and most picturesque city. The old Greek church is the most interesting object, and is a study from its green-and-yellow dome to its heavy ornamented hinges on the huge plank doors. The interior is hung with fine paintings in solid gold and silver frames. The lamps, candlesticks, etc., are of a very odd design. Then there is a castle

on a high point, built by a Russian prince, and the block houses for protection against the Indians in former times.

Alaska is not as cold as most people think, and although the nights are cool the days are very pleasant. You can always look on the mountains and see snow, but there is very little on the sea-level. This is a great place for a man to work if he wishes, for it is light from 2 A.M. to 11 P.M. I have made good negatives at 9 o'clock at night.

The Indians are all friendly and take a great interest in photography, if one can judge by their actions. There are several tribes, all speaking different tongues, but they all can talk in the Chinook jargon, as can also most of the whites. I shall return to Boston in the fall, and will call and show you some of my summer's work, which is very interesting to me, and I think, will be to you.

Faithfully yours,

W. H. PARTRIDGE.

JUNEAU, ALASKA, July 3, 1886.

### PRACTICAL POINTS FROM THE STUDIOS.

ENAMELLING PRINTS.—The process for enamelling, communicated by M. Clairier, consists in heating a glass plate, which is rubbed with ordinary yellow wax, then plunged into an alum bath, and then washed in water. This being done, the plate is coated with a solution of gelatine, which is again plunged into an alum bath when the alum is set. The plate is now allowed to dry. In this way a large number of plates may be prepared in advance.

When the prints are to be enamelled, they are plunged into a warm gelatine bath, and after withdrawal, made to adhere to the alumed gelatine film, as in the ordinary enamelling process. The prints are placed on cardboard, if necessary, and allowed to dry. The prints, it appears, leave the temporary support very readily. There does not seem to be anything particularly new in this process.

WASHING GELATINO-BROMIDE OF SILVER NEGATIVES.—Opinions vary greatly in regard to the time necessary to eliminate thoroughly by washing the last traces of

hyposulphite of soda from gelatino-bromide negatives. Some operators think that the sooner a plate is fixed the less washing it requires. M. Joop is of the opinion that with a small flow of water, running slowly and constantly, three hours at least are necessary, whilst with a strong flow of water, fifteen minutes are sufficient.

We believe that by placing the plates in a bath of weak javelle water, say a table-spoonful in a quart of water, it is possible to eliminate the last trace of hyposulphite. Care must be taken not to use too much of the javelle water, as in this case the negative might be injured; many operators only use a teaspoonful in a quart of water. If the plate has been well washed, twenty drops will suffice. There exists a solution of labarraque for washing, containing dry chloride of lime, which acts in the same manner as the solution of javelle water; its effect is almost instantaneous. The solution of javelle water is made as follows:

Dissolve four ounces of dry chloride of lime in a quart of water; close well the bottle and shake from time to time. In another vessel dissolve four ounces of dry common potash in a quart of water; allow these two solutions to rest from six to ten hours, then slowly pour the potash solution into that of the chloride of lime, agitating the vessel evenly. Allow the mixture to repose for a half-hour, then filter through paper; the product obtained is a pure javelle water, which, in a well stoppered bottle, and kept in a cool place, will not deteriorate. In using, before taking the prints from the hyposulphite bath, pour in three quarts of water as many times five and a half fluidrachms of the solution as there are prints in the fixing bath. The prints taken from the hyposulphite bath are carefully drained and gently placed in the javelle water, in which they are allowed to remain three minutes, keeping them constantly in motion; after which the bath is again renewed for three minutes. The prints, well rinsed, are now ready to be mounted.

**GOLD VARNISH FOR WOOD OR METAL.**—Take one ounce of litharge of gold, two ounces gum sandarac, and forty ounces of clarified linseed oil; boil them together in

a glazed earthenware vessel, when the mixture will assume the hue of a transparent yellow. It is to be applied with a soft brush.

**PAPER SIZE.**—A good size to make paper stick consists of eight ounces of dissolved glue to a pail of water.

**PASTE FOR MOUNTING PRINTS.**—M. Blochouse makes known to the Brussels Session of the Belgian Photographic Association, a receipt for a paste for mounting prints, which has invariably given him good results as regards their preservation. It consists, simply, of a starch paste in the water of which he introduces from 5 to 6 per cent. of bicarbonate of soda. This paste should be renewed daily so as to be always fresh.

**REDUCING NEGATIVES THAT ARE TOO INTENSE BY MEANS OF FERRIC CHLORIDE.**—At the Edinburgh Photographic Society, Mr. Brebner read a paper upon the reduction of negatives that are too intense, which he accomplishes by the addition of a little ferric chloride to the hyposulphite bath. Another member of the Society remarked that when but a slight reduction is required, the plate may simply be left in contact with the air for some time whilst it is still wet coming from the hypo bath. Mr. Whaitte said that it is possible to reduce the intensity of a negative by pouring over the plate a little ferric chloride when coming from the fixing bath.

**A SODA AND POTASH DEVELOPER.**—Dr. Stolze gives the following formula for making a very strong developer:

- A.—Water . . . . . 200 c.c.
- Pyrogallic acid . . . . . 15 grammes.
- Sulphite of soda . . . . . 100 “
- B.—Water . . . . . 200 c.c.
- Carbonate of potash . . . . . 50 grammes.
- C.—Water . . . . . 200 c.c.
- Carbonate of potash . . . . . 25 grammes.

1 part of A is mixed with 1 part of B or C, and 6 parts of water are then added.

**THE ACTION OF DYES UPON BROMIDE OF SILVER.**—In recent experiments upon the

effect of dyes upon bromide of silver, Dr. J. M. Eder has shown that a gelatine plate tinted with naphtha blue is sensitive to all the rays of the solar spectrum, from the red to the ultra violet. This tinted bromide of silver has a sensitiveness exceeding that of any known chemical preparation. It remains to be seen how these plates are to be developed, for if we use plates that are sensitive to all the rays of the spectrum, what kind of light can we use?

**TO REMOVE THE FOG OF OXALATE OF LIME.**—After fixing plunge the negative into the following bath:

Water . . . . .	100 parts.
Ferrous sulphate . . . . .	20 "
Alum . . . . .	8 "
Tartaric acid . . . . .	2 "

The negative soon clears itself and washing finishes the operation.

**GELATINO CHLORIDE POSITIVE PAPER.**—Here is the formula of Messrs. Ashman & Offord. After complete desiccation, a paper of good quality is floated on the following bath:

Gelatine, white and hard . . . . .	160 grammes.
Chloride of ammonium . . . . .	30 "
Citrate of soda . . . . .	20 "
Phenol . . . . .	1 "
Violet aniline . . . . .	100 c.c.

The solution is used at a temperature of from 85° to 95° C. (185° to 203° Fahr.), and sensitizing is done in the usual manner.

To ascertain if the hyposulphite is eliminated, pour one drop of a solution of cold water saturated with iodide (1 part in 7000) on the back of the plate. Should there be no more hyposulphite, the water will become blue; should there be any left, the water will become white.

**A PRINTING PROCESS WHICH GIVES BLACK TONES.**—Make a saturated solution of chloride of lime, mix it with carbonate of lime until complete solution, now filter. Take 3 grammes of this solution and 1.50 grammes of gold and put into 600 c.c. of water. This solution should be prepared a day or two before using. This bath is weak

and the prints may remain thirty minutes in it before the full effects will be reached.

## THE HUMOR OF IT.

**HOW HE TOOK IT.**—"Bromley, do you know that Joe Byers has taken the Mansion House?"

"Good gracious, Darringer! Why, he'll never pull through! Who is backing him?"

"Nobody."

"Why, he's nothing but a poor photographer."

"And that is just what enabled him to take it. He took it with his camera."

**MISS ANN ARBOR.**—"I think it's a shame, mamma, that we have to ride around in that old coupé when Emily Vassar's father is always giving her something new in the way of a vehicle. In her last letter she wrote me that her papa had just sent home a new *carte de visite*."

"Oh! yes, my love, I know. That is one of them new-fangled basket phaetons with two wheels you know—just for making calls."

**WAITER.**—"How will you have your steak done, please?"

Absorbed photographer.—"Dry, of course, Newton's formula—potash and soda."

**POLICEMAN** to amateur with vest camera.—"No suspicious movements now—I've one of them 'ere glass eyes mixed in among me own buttons—the whole force will have thim soon."

**HUSBAND:** "I want my horse taken badly. I think I'll do it myself. **WIFE:** "Yes, do it yourself, if you think it wants to be done badly."

Isn't my photograph excellent?" said a young wife to her husband. "Well, my dear," replied he, "I think there is a little repose about the mouth."

**WANTED**—A party who can sit for their portrait without incidentally comparing the operation to one very often performed in a dentist's apartments.

[Translated for the PHILADELPHIA PHOTOGRAPHER.]

## CHATTERINGS OF THIS AND THAT.

### I.

OH, the horrid plates, they show scarcely any modelling, notwithstanding they have been so well exposed, and there is no strength to them, either! Sensitive—yes, very sensitive; but what good does it do them to be so sensitive, if they present no modelling, and are so faint?

Thus does many a photographer exclaim upon the reception of a number of plates, which, according to his express wish, have been made extra-sensitive. But, herein lies the very point of difficulty—it is not an easy task to manufacture a highly sensitive plate which will yet possess the faculty of exhibiting fine modelling and sharply defined lights. If our esteemed colleagues wish to obtain well-modelled plates and well-defined lights, and yet are unwilling to renounce this great degree of sensitiveness, then the manufacturers are obliged to sacrifice the artistic appearance of the drawing, in order to produce this much-coveted degree of sensitiveness. The thought has often occurred to me, why is it, that since the introduction of dry plates, photographers must have such an extraordinary degree of sensitiveness. In the good old days of the wet process, photographers had often to expose for quite a long time, and with the proper treatment of collodion and silver baths obtained satisfactory results; and yet, to-day, plates cannot be made sensitive enough. Why is it? I cannot explain it in any other way than that it must be that one photographer vies with another in the matter of quick exposure.

I have often secretly pitied the poor manufacturer, who, in order to retain his customers, must often strive to obtain an impossible degree of sensitiveness in his plates. Yet how few really well-modelled pictures are produced at the present day as compared with former times. One photographer will say to a brother in art, as he shows him a negative, "See, my dear friend, this picture was taken in one and a half seconds; is it not good?" meaning thereby

the time of exposure, and possibly the plate, also, which certainly left nothing to be desired in the way of shallowness. He might have obtained a much better result, had he used a plate which would have required from four to five seconds' exposure instead of one and a half.

We still confront this unsolved problem—how to combine the highest sensitiveness with the finest drawing. Many photographers, especially those who have never made any emulsion themselves, recognize this difficulty, which, I fear, will neither soon nor easily be overcome.

It should not be forgotten that a less sensitive plate (by this we do not mean a totally unsensitized plate) permits greater freedom in the exposure than one more sensitive. It would seem reasonable to us, that with a highly sensitized plate and a moderate time of exposure, the result could not be otherwise than an acceptable negative; but not so. Almost every highly sensitive plate gives a flat picture, let it be exposed ever so well; *i. e.*, the fine modelling of the head is missing, and this is the more unfortunate, as it is the modelling which gives the head its beautiful and most characteristic appearance. The shading also is not all that could be desired. A plate of medium sensitiveness, however, will show, with good management, better modelling in the lights and greater perfection in the shadows.

So it is that many photographers complain, some justly, others unjustly. One says that there is a poor light in his studio, and that he must use highly sensitive plates, or the people will not bear with him. Supposing this to be the case, did not the people bear with him when he used "wet" plates, and exposed, with a full opening of the objective, from eight to ten seconds—at times even longer? but, he obtained good results. Now, however, he can do nothing without small screens (and, of course, obtains thereby sharper pictures); he procures the most sensitive plates (about sixty times the sensitiveness), he exposes from one to two seconds, and has, in consequence, a flat picture, and then complains of the poor light in his studio. The man who thinks he can obtain by a short ex-

posure a better expression of his model, makes a great mistake; for so long as he is not able to affect the model by his own personality, that the expression may be as natural and life-like as possible, just so long will he be unable to produce that happy expression of countenance which he could desire, though he should use the most sensitive plates made, for these plates have not the power to reproduce fine shades of expression. It would be best to take a less sensitive plate and use a first bath ("vorbad"), then he would have the satisfaction of being able to produce a well-modelled picture, with the expression reflected in its minutest points. Of course, it must be mentioned at this point, that not all plates are adapted to be washed, but such, at least, that are dried at a high temperature may be safely used in this way.

## II.

IN the first place, according to my opinion, there is generally too much expected of the objectives; *i. e.*, they are pushed open too much upon the person sitting for his picture, or, to speak more clearly, the objectives are used for enlarging pictures (or making large pictures), for which they are not made, and which they cannot do. The nearer a portrait double-objective is placed to the model, just so much more faulty is the picture, and the cause of this evidently lies in optical laws. The head and figure are enlarged at a shorter distance, the cause of which is that the objective has only *one* eye to see with, whereas man has two, consequently those parts at both sides of the head brought to view later are not seen so well, and the head by this means presents a flat appearance. In the stereoscope, we look upon a photograph, which consists of two pictures, apparently just the same, and both pictures together present a perfect representation of the object, whereas each picture observed singly would not give the true picture.

The objective should never have a less distance from the object than 2-3 m. (about 7 to 10 feet); if it be moved nearer, then merely the centre appears sharp and the outer parts of the picture are unpleasantly mixed. It makes no difference what objective or how large a one is used, the fault

will show itself just the same, and the larger the objective the more noticeable this error.

Therefore, I use for larger heads only a single lens, and of course the front lens of a 5''' double-objective. This does not show any part of the head on the ground glass as absolutely sharp, but rather gives the appearance of bluntness to the whole head, which is not unpleasant to the eye, since the finished picture is always observed at a certain distance. Moreover, I can in this way make use of a greater distance, and remove the fault mentioned without injuring the size of the picture. Besides, the proportions of the head are more correct, the nose never looks too thick, and the forehead is not proportionately shortened; the pictures themselves, with proper treatment, are quite as plastic as those which are taken with a double objective. By the use of the single lens, the picture loses in brilliancy, of course, and a longer exposure is necessary, on account of the longer focal distance, yet such is the sensitiveness of the plates of the present day that that does not signify so much. I would rather sacrifice something in the matter of short exposure than in plastic—for a head taken under such conditions as I describe, appears softer, finer, and more according to nature.

In this way I obtain large heads, which certainly lack something in sharpness as that quality is generally seen in pictures, but the characteristics and resemblance are well marked, and so I have never heard a word of complaint from the public regarding this lack of sharpness.

Even in large pictures, the sharpness is never missed, if the lack of it is uniform over the whole picture; but the hard lines, which proceed in part from a too-great sharpness and too-strong retouching, are disagreeably noticeable, although the observer cannot tell exactly just wherein the fault of the picture consists.

But now to the picture itself. It is usually exposed too short a time (because the sitter will not bear a longer exposure; formerly he had to bear it); consequently, the shadows appear much darker than in nature. Then, perhaps, the negative is developed a rather longer time than necessary



(in order to bring it out as much as possible), and the result is a strong negative without the delicate and soft shadings seen in nature. The chief thing is to expose them properly, and not develop them too long; a negative too thin can be more easily printed than one too strong. I make all my large-sized negatives very weak, so as to avoid harshness, and have them printed in faint light for the same reason.

Now the negative is given to the retoucher, who takes it in all good-will and endeavors to produce from it as beautiful a picture as possible. We have many retouchers who, whether academically versed or not, can produce, with proper directions, not only good but excellent work. They often possess a complete knowledge of the formation of the head, but in their situation this knowledge is often rendered valueless, since they are compelled by necessity (owing to the ungraciousness of their principal and of the public) to renounce this, and do much of the work in the retouching. I have noticed that the retoucher undertakes first to work on the light parts of the head, instead, as according to my opinion is the proper way, of brightening the deepest shades and then working upon the middle tones until the picture is in perfect harmony, as we say. By using a weak varnish, and covering the back of the negative with graphite, much can be accomplished; and faults arising from unfavorable relations of light, and from unfortunate technique, can be corrected, without causing the characteristics, and consequently the resemblance to the original, the least harm. It is a great pity that so few rough prints of negatives are made before retouching, for in doing these the intelligent retoucher would notice many points to be corrected, and gain by practice much information concerning his work, and thus insure the perfection of those to come after. I seldom allow the front of the negative retouched, only the back; and if I am uncertain about the effect of this or that part of the head, I would rather have two or three rough prints made each time with the preceding alterations, until it appears right to me, and at last it becomes fit to print. I say to myself that any loss of time or money sustained by this mode of procedure, is

richly repaid by seeing each succeeding negative better than the one before, and by making it possible to attain the highest perfection in depicting a head.

I think it a great mistake that retouchers so seldom see the person whose negative they work on, for it is impossible for the retoucher to make a truthfully correct picture, when all he has to guide him is the negative in his hand; he must necessarily draw on his own mind for the image of the person referred to, using the negative as the basis of his operations.

It is the same with the retouching of the positive. It is usual in doing this to point out the picture as delicately as possible—they strain their eyes that they may omit nothing; and then let this picture be observed from a suitable distance, and what does it look like?—a piece of shining tin, without an atom of feeling in the whole thing. It is necessary in retouching the positive to observe the pictures from time to time from a distance, just as a painter does, and thus criticise his work, and keep correcting until it is perfect; it is preferable, however, to do too little than too much; *i. e.*, to remove the troublesome false lights, but nothing whatever of the characteristics.

I follow these methods myself with larger negatives and positives, and I believe that I avoid having in my pictures the faults mentioned.

The printer is now the one who, after the photographer and retoucher have done often more than their duty on the negative, must produce a really useful print. A thinking printer, *i. e.*, a printer who can produce from a somewhat faulty negative a beautiful and tasteful print, is a jewel who cannot be valued too highly, and who is worth more than a so-called good retoucher. Unfortunately he is only too often treated with a certain degree of contempt, and why? because printing is usually looked upon as a secondary matter, and yet how often the goodness or badness of a picture depends upon the printer, who is supposed to be able to remove all faults that exist in the negative, and to make a good copy from a bad negative. "See there," says his principal, "I did not think that negative would produce so good a print;" but he never thinks that in

many cases he is indebted to the superior intelligence of his printer. By a quicker or slower printing, by allowing the paper to float a longer or shorter time in the silver bath, by displaying taste in the toning of the picture, the printer can whet out many a notch, and be the real cause of the picture meeting with approval from its original. Of course he must possess the necessary ability and possess for his art a special love and desire. By masking, and printing longer this or that part of the negative, he can improve this or that part of the picture to a greater or less extent, and produce a harmonious appearance in the print. These may be very small points, but yet of infinite significance in the general appearance of the finished picture. Of course, his employer ought not to say, so many sheets of pictures the printer must do per day, but he must leave it to his conscientious and industrious assistant to produce as many *good* copies as day is possible.

### III.

Who has not had occasion to compare enlarged photographs, especially large heads, with the original, and what careful observer has not been struck with the great disparity often existing between a picture and the thing itself.

Sometimes we approach the reality more nearly, and think we have taken a head about half as large as life, according to nature, and delicately retouched it. Then we discover lines in it which we did not notice in the original at all. Wrinkles in the brow, which were only faintly visible in nature, appeared in the picture like threads drawn across the forehead; tear-stains, likewise, only faintly noticeable in nature, appear in the photograph like profiles of gutters; the corners of the mouth, possessing naturally delicate curves, and necessarily difficult to reproduce even in a painting, are presented in the photograph as two dark streaks hanging one on each side of the mouth; the cheek-bones stand out like lumps; the whole face so prominent and swollen, as if it consisted of inflamed flesh only—the whole framework of bones, forming a support for the skin and muscles, being entirely lost sight of. With the best will

in the world, it would be impossible to distinguish a single characteristic—the pores of the skin, its delicate and fine gradations; but the whole head appears like a tin plate (pardon the expression) photographed. The photograph is sharp, very sharp, indeed; eyes are sharp, with an unnaturalness, keenness, and fixedness; the whites of the eyes shine with whiteness; the mouth, also, is sharp, even hard; and only the tip of the nose exhibits a striking uncertainty of form, the nostrils having an unusual expansion for the width; and there is a disagreeable diminution of size in the contour of the head, which contrasts unpleasantly with the sharpness of the rest of the picture, and which no sophistry about the insufficiency of the optical instrument can account for.

Does the whole accord with nature? No; and once again, no! And that it does not agree with nature, the photographer and his finisher know full well; but the photographer thinks he is obliged to take as sharp a picture as possible with the help of his objective; and the retoucher holds the opinion that a *finely*, not a *well*-finished picture is the highest attainment.

The whole should and must be done differently, if the observer of the picture (layman) is to find the impression of truth in it. By an excessive and wrongly applied retouching, and a faulty technique, the striking resemblance to the original is quite lost; the observer will miss those characteristics which give the countenance its intellectual appearance and permit complete recognition of the person; and even were the picture not quite so sharp, the sharpness would not be missed so much as the characteristics would be. One can instinctively notice the absence of certain distinguishing traits in a face, without being able to tell just what ails the picture. We are apt to look at the case from a photographic standpoint, and think to ourselves that the picture should be purely technical, without regard to the artistic sense which ought to be combined with the technique.

The model is seated in the studio, examined, the gauging distance accurately determined, the plate exposed, developed (this for the most part too long, whereas the exposure is frequently too short), fixed,

and the plate is finished, and has turned out satisfactorily; it is at least clean and spotless. Of course some bluntness and crudeness appear, but the retoucher can make this all right. But let us examine the negative more closely. Brow, eyes, mouth—sharp; nose less so, for this presents an unpleasant bluntness at the tip, appears thicker than in the original—but that can be corrected; freckles and other imperfections of the skin are unfortunately too prominent, yet the photographer can vindicate himself by the pretention that they were actually present to a great degree; hairs, particularly on the contour, might be more distinct; perhaps the model was not placed just right, but then why do we have a retoucher? he can draw in the hair, and make what is already there more distinct; he, too, must surely be able to cause the freckles and other skin irregularities to disappear. So the retoucher begins his labors on the negative, painfully pointing out the unevenness of the skin from the forehead to the chin, as his principal desires, and finally places lights to the back of the negative, at brow, cheek-bones, and nose, modifies the rather too-deep shadows in the eyes, nose, and chin, and the negative is ready to print; but the lines and wrinkles on the brow, under the eyes, the lines of the nose, and corners of the mouth, remain, and look like disagreeable diaphanous streaks and holes.

Since the picture yet shows so many faults, the retoucher must once more try his skill, and finally the picture is ready to be delivered to its owner.

"But, my dear sir," says the person photographed, "I do not look so old. I am, of course, no longer a young man (conceited fool! thinks the photographer to himself), but I have not such lines in my face yet; and my nose is too thick—why that nose is like a potato; and the mouth is quite black, as if I had been eating cherries; in fact, this picture does not look like me at all," etc.

To the photographer it seems incomprehensible that the man is not pleased with his picture, so he says photography can do nothing different, and it must be a true picture.

But the man will not be convinced, and he is right.

Now, the question is, How can the picture be made otherwise, so as to correspond with nature and with the desire of the sitter?

If I express my views in another article upon the remedy for magnified pictures, yet I do not say that they alone are the correct ones, and I am open to conviction if any one shall say: "Most worthy colleague, I know better; I can do better in such a way; and though you may be sincere in the publication of your opinions, yet you are in a labyrinth of error."

### A CAMERA WITHOUT A LENS.\*

BY M. MEHEUX.

THE experiments of which I am about to speak, are an application of the facts observed by Porta, in 1560. I do not think that this practical application has ever been made before, although, sometimes, a reduced double image shows itself accidentally on the negatives without the operator being able to account for this apparent phenomenon. The negative that I here show you is obtained without a lens, but simply with small hole made in this small brass plate. This is an easy method of taking the picture of any desired object, when we only possess sensitive plates, which are easier to procure than apparatus, especially in travelling. It is true that we do not reach the perfection obtained with good lenses, but you see by the print that it is almost as good a result. I had thought that the theoretical point, that is to say, the smallest possible opening, would be perfection; but with a hole less than  $\frac{1}{10}$  of a millimetre, I got less sharpness. Owing to this result I understood the necessity of taking into account the phenomenon of diffraction.

We know that a luminous ray passing over an opaque body does not follow its initial straight line but deviates from it; consequently, in a very small opening almost all the rays touch the edge and are diffractive. We should, therefore, confine ourselves to an opening having from  $\frac{1}{4}$  to

\* Communication addressed to the French Photographic Society.

$\frac{3}{10}$  of a millimetre. What is peculiar is, that the image is always in focus, whatever may be the focal distance; it is only the size of the image that is different, and naturally the luminous intensity is diminished according to the distance between the sensitized plate and the opening which serves as a lens. With an opening of  $\frac{3}{10}$  of a millimetre the image is but little seen on the ground-glass, but having two openings on the same plate, of which one is of  $\frac{2}{3}$  of a millimetre, the last one is used to get the size and the smaller one substituted to obtain the negative. The exposure, it is true, is very much lengthened; but with equal light to the eye, on the ground-glass, between that given by the small opening and that given by an objective with a stop, this last would require an exposure nearly ten times greater, which shows the immense absorption of the actinic rays made by lenses. Naturally, whatever may be the composition of the opaque body, the opening should be of a conical shape, very wide, without sharp edges and striæ, the cylindrical opening giving reflection by its inner surface in the thickness of the perforated plate. By this means it is possible to obtain a negative at all angles, since there is no cylindrical thickness to limit the field of vision. It would be possible, therefore, in an extreme case to take a monument in all its height by placing the opening at any desired place in the camera, maintaining the parallelism as required by geometrical laws.

I believe that by this method it is possible to obtain prints, which, although not irreplaceable, will at least give us some things impossible to obtain otherwise, even with the best appliances. It is easy to get some kind of a camera, as it is also more easy to procure sensitive plates than the apparatus for obtaining a desired end, should it be nothing more than a remembrance.—*Progress Photographique*.

---

### OPEN CORNER.

EXPERIMENTS RELATING TO THE PRELIMINARY HYOSULPHITE OF SODA BATH.—M. Micthe made twenty-seven plates of the same object—a portrait having an exposure of twelve seconds. In developing,

plate No. 1 showed an image after 25 seconds, without preliminary bath. No. 2. Preliminary bath at 1 to 5000, appearance of the image in 4 seconds, and development in 6 minutes 25 seconds. No. 4. Developed with one drop of hypo at 1 to 200, added to 40 grammes of developer; the image appeared in 33 seconds, and was finished in 6 minutes 25 seconds. No. 6. Four drops of the Gædicke accelerator (1 hypo, 6 bromide of potassium, 60 water) to 40 grammes of the developer; the image appeared in 13 seconds, and was finished in 5 minutes 35 seconds. No. 7. 5 drops of acid water appeared in 16 seconds, completion in 8 minutes. From these experiments may be deduced the following rules:

1. Use of the preliminary bath at 1 to 5000 for plates of normal sensitiveness, and at 1 to 8000 to 1 to 10,000 for very sensitive plates.

2. The plates should only be allowed to remain from 30 to 40 seconds in the bath, so as to avoid fogging.

3. It is advantageous to add to the developer from 1 to 3 drops of a solution of hyposulphite at 1 to 200 when the plates are of medium sensitiveness.

4. Avoid, as much as possible, the use of bromide of potassium, which seems to injure the sharpness of the blacks.

5. The plates developed with hypo are more quickly fixed, and diminish in intensity during the fixing.—*Paris Moniteur*.

TRANSPARENT JAPANESE PAPER—It is said that the Japanese have invented a process by means of which they convert marine algæ (varec) into paper. It appears that the product is a little coarse, but it is transparent and can take the place of window-glass. Moreover, this transparent paper is much lighter than glass, and it is believed that it will find its use in photography. It is probable that soon similar experiments will be made with the algæ which abound on the coast of France and England.—*Paris Moniteur*.

OLD-TIME PAINTERS.—The philosopher Plato studied painting; Marcus Aurelius received lessons in philosophy from a painter; when Paulus Aurelius sent to the Athenians

for an able philosopher to educate his children, they selected Metrodorus, the painter, who also was given charge of one of the Scipios.

A QUESTION TO BE SOLVED.—M. Audra asks: What is the best way to obtain a countertype? What should be the time of exposure? How should the development be made to obtain the best results? M. Audra showed to the society a negative made from a negative, the best he could obtain with an exposure of ten minutes to the diffused light of his glass room. He tried a number of durations of exposure varying between one and fifteen minutes, without being able to obtain a better result than the one shown, which leaves much to desire.

WITH most people the want of a well-defined system or method is one of the chief causes of their getting behindhand with their work. A systematic method of working, combined with industry, will complete a vast amount of work in a day and finish it with ease; but, without system and application, the worker may be in a continual rush and yet accomplish little.

(Translated for *The Philadelphia Photographer*.)

### BLEACHING OVERPRINTED PHOTOS FOR PHOTO-ENGRAVING

OBJECTS which are to be reproduced by means of the photo-engraving process, are generally photographed in an enlarged measure, and drawn upon with India ink. Then the photographic picture is removed by means of bleaching, so that only the drawing remains, and is reproduced by photographic means to the size desired.

As is known, one of the chief requisites for its proper chemical reproduction is that it should exhibit deep black lines, and a pure white ground. By the usual method of bleaching photographic prints with chloride of quicksilver, it often happens that in spite of every precaution the whites of the picture appear yellow or brownish-yellow, a circumstance which greatly increases the difficulty of making a proper negative. To

overcome this fault, Mr. W. Bode recommends the following receipt:

Distilled Water . . . . 9 parts.  
Nitrate of Silver . . . . 1 part.

When the silver has dissolved, pour three parts of the whole into a glass, and add ammonia to it until the oxide of silver which has formed dissolves, and the solution becomes once more clear. Then pour this back into the other six parts. If oxide of silver forms again, it can be run off from the bottom of the vessel, or it can be poured out and filtered. Use only good salted paper. Print until all the details are out, yet not too deep, then wash the print with cold water until it is red. When the residue of silver is completely washed out by frequent changes of water, the print must be fixed in a solution of soda, say equal parts of hypo and of double carbonate of soda. Let it stay in this solution ten to twelve minutes, then wash it many times in clear water and then mount it.

Since the picture will only keep for a few days, the drawing should be made as soon as the print is dry. The bleaching material—a solution of thirty grains chloride of quicksilver in one litre of alcohol—should be poured over the picture in the same way as collodion. In a quarter of an hour the drawing can be had on pure white paper, which does not show a vestige of a photographic picture.—*Archiv*.

### MR. T. R. BURNHAM'S LARGE NEGATIVE.

IN the early part of June of the current year, the news was wired from Boston to all parts of the country, that a local photographer had produced the largest dry-plate negative ever attempted, the success being in every respect complete. As a natural consequence, the author of the big picture was quickly sought out, interviewed, and questioned, and experts very soon discovered that it was not a mere sensational report, but an accomplished fact. There was the huge negative, representing a life-size three-quarter-length portrait of a young lady, and measuring 3 x 5 feet—36 x 60 inches! The weight was over eighty pounds, the thickness of the glass about half an inch. The

plate was coated expressly for the occasion by Messrs. Allen & Rowell, of Boston, professional photographers of high standing, and manufacturers of an excellent brand of dry plates, who declare that the task imposed upon them was a most difficult one, as can well be imagined. And the amount of labor required in developing the huge plate was something they had not anticipated, and are not anxious to experience again. The trays had to be specially made, and the quantity of developing solution is said to have been over three pails full. Everything connected with the undertaking had to be done on a large scale. The camera, though not a model of compactness, such as fastidious amateurs dream about, was home-made, and constructed by Mr. Burnham himself, the lens used on it being a No. 8 Euryscope, the largest of that class made. The upright focussing screen consists of two lights of ground glass divided by a bar running across, similar to a window, the height being such as to necessitate the use of a pair of steps in focussing the image. Thus the "largest camera in America," furnished by a well-known manufacturer to a Boston amateur, and which accommodates a 24 x 36 plate, is effectually eclipsed. As to the picture itself, which was exhibited at the St. Louis Convention, and seen to advantage by admiring groups of photographers, nothing short of sincere praise can be bestowed upon it. Made with Voigtlander's Eury-scope No. 8, in twenty seconds, and fully timed, it possesses all the merits of a first-rate photograph, notwithstanding its huge proportions. The definition is adequately clear and surprisingly even all over, showing how skilfully the focus was divided—the most important factor in the production of large pictures, whether heads, figures, or groups, and in which particular many photographers fail in spite of the excellence of the instrument employed. The most gratifying feature of the print, however, is the illumination, which is brilliant, searching, and almost phenomenally uniform, extending, as it does, to the very edges, showing too that the covering capacity of the lens was not taxed in the least, and that even a larger picture could be produced under similar conditions. Then, too, the

lens in its original form was used, and not one of the combinations, as has been intimated by some biased or inexperienced critic. Had this been the case, it is very doubtful if the feat could have been accomplished, as two very serious obstacles would have presented themselves, namely, the doubling of the focus, and the doubling of the time of exposure. The negative was printed in the usual way on one single sheet of Morgan's albumen paper, 36x60. In producing this picture, Mr. Burnham was actuated by a desire merely to illustrate the undiscovered powers of the instrument, at the same time to put to flight the occasional "photographer of experience" who claims that the same sized lens fails to cover a 20x 24 plate satisfactorily! The proof to the contrary in this instance is a most convincing one, and must be of enduring benefit to those gentlemen who are identified with the use or sale of these favorite and powerful lenses. Last, but not least, is the artist himself. It is greatly to his credit that, in spite of the appeals of his friends to desist from so "foolish" an attempt, and the failures and expense staring him in the face, he manfully persevered, quietly making his preparations at considerable cost, and then suddenly announcing to the world his unequivocal success.

Mr. Burnham was justly awarded one of the Association's special silver medals for his remarkable production, which required a rare combination of enterprise, pluck, and skill. The negative is at his studio in Boston, as well as one of the direct prints, advantageously displayed, and may be inspected by any of our readers inclined to be skeptical.

---

PERMANENT LABELS FOR LABORATORY BOTTLES.—Mr. Bothamley, of Leeds, calls attention to a good process to render permanent the labels on glass bottles. If a label is printed with ordinary printer's ink, after it has been attached to the bottle, it is coated with two layers of copal varnish. If the label is written it should be done with India-ink; when attached to the bottle it is coated once or twice with size, and when this is dry with two coats of copal varnish.

## SOCIETY GOSSIP.

At a recent meeting of the Amateur Society of New York, Mr. Newton explained at some length his recent experience with developers, and spoke substantially as follows:

A modification of the potash developer which I have lately adopted, gives me better results than with formula previously used. I have left out the yellow prussiate of potash, and now advise the use of the following formula:

Each solid ounce contains 480 grains.

## No. 1.

Carbonate of soda (crystals) .	3 ounces.
Carbonate of potash . . . . .	3 "
Sulphite of soda (crystals) .	3 "
Water . . . . .	32 "

## No. 2.

Sulphite of soda (crystals) .	3 ounces.
Water . . . . .	32 "

For a properly exposed plate, one ounce of developer is made up as follows:

No. 1 . . . . .	1 drachm.
No. 2 . . . . .	7 drachms.
Dry pyrogallic acid . . . . .	2½ grains.

In case the plate is greatly underexposed, the quantity of No. 1 can be increased a drachm at a time, to as high as six drachms, with safety, until the image is developed. By using dry pyro the intensity will gain as fast as the detail is brought out.

I have been through the experiment again with the use of the pyro in solution, for the last few weeks, but I have come to the same conclusion as formerly, that it is better to use it dry, although you can get good negatives from pyro in solution, if used immediately, but if allowed to stand for any great length of time you cannot get as good results as if you do not use it in solution. If, in my experiments, I compared negatives made from the use of pyro dry and pyro in solution, I found that the pyro when added dry gave uniformly the better results.

This developer can be used repeatedly. If you have a dozen of exposed plates, say 6½ x 8½, make up six ounces of this developer, and you can develop them all with it one after the other, and the last will be as good

as the first. This quality in a developer gives it great advantage in economizing, both in time and material.

I should state that, for some plates, it will be well to add from three to six grains of dry pyro to the ounce, in order to obtain good density, particularly if the exposure has been extremely short.

*Glazing Albumen Prints.*

Mr. Beach: Dr. Janeway has handed me an albumen photograph which has been polished in a different way from the ordinary plan.

Dr. Janeway: I wish to present to the Society a wrinkle given me by a friend, also a member of the Society. You will notice that this print has a very fine gloss, and this is produced simply by taking the print out of the washing trays and squeegeeing it on a marble-top table. When the print is dry, it remains flat. This one is a little crooked there, on account of being in proximity with my heated body. It was printed on ready sensitized paper, eight months old, and the printing, toning, washing, and drying occupied but a few minutes less than one hour. After fixing, it was treated with the alum bath.

Mr. Beach: While on this subject, I would like to say that I read a few days ago that it is possible to get a gloss on gelatine prints with the ordinary ferrotype plate. I have prints here about a year old, and simply moistened them and placed them on a tin-type, and you see the result. [He pulled the prints off from the varnished side of the plates and passed them around.] The reason I have brought this matter up is that some time ago we had quite a discussion in regard to the use of hand-finished vulcanized rubber, which was so hard to obtain, so I saw the suggestion of using the ferrotype plate, and I find that it works very well, and that the pictures strip off as easily as when on rubber.

POTTSVILLE (PA.) PHOTOGRAPHIC SOCIETY.—The second meeting, July 10, of photographers of this place, called by Mr. E. F. C. Davis, at his residence, was attended by R. W. Kear, William Shaefer, Arthur Shaefer, E. Borden, and "Mine Host" E. F. C. Davis, all amateurs, Mr.

Dockweiler and George M. Bretz, professional, and Howard Walbridge, employe.

The business was a general talk on matters pertaining to photography. The Messrs. Shaefer exhibited quite a number of views made in Virginia, Mr. Kear a number of our own mountain views, and Mr. Davis a series of views at Cape May and Atlantic City, Mr. Bretz an album of 18 x 22 views made for the Schuylkill Valley Railroad, showing the progress of their work as it is completed. After considerable discussion on the merits of the pictures and the difference in construction of lenses, etc., the company were entertained by Mr. Davis in a substantial manner, all hands doing justice to the good things set before us.

After lunch, Mr. Davis lit his lantern, using oxyhydrogen light, and exhibited a number of his slides made at Cape May and Atlantic City, Mr. Borden a slide by himself of O'Brien's Circus tents, and Mr. Bretz four slides of various subjects. The latter slides were developed with pyro, and, while they were sharp and of good tone, they showed a slight trace of granulation compared with the slides developed with oxalate developer.

Mr. Kear exhibited a new stereo shutter of his own manufacture, made of ebonite, which was commented on favorably by all.

The meeting adjourned, with thanks to our host for his kind treatment, about 11.45 P. M., to meet on the second Saturday in August, when we hope to organize permanently, and will be glad to furnish a report of proceedings if THE PHILADELPHIA PHOTOGRAPHER will receive it.

Our meetings have certainly been pleasant, and will, no doubt, result in great good to both amateur and professional.

GEO. M. BRETZ.

POTTSVILLE, August 1, 1886.

THE PHOTOGRAPHIC SOCIETY OF PHILADELPHIA.—At a late meeting of the Society a question in the box asked: "What is the exact meaning of flatness of field (applied to lenses)?"

Flatness of field was described as the quality in a lens of sharply defining the extreme edges and centre of a plate when using a large stop and focussing on objects

all in one plane, that plane being at right angles to the axis of the lens; as, for instance, a piece of printed matter or a picture on a flat surface as arranged for copying.

Mr. Wood, referring to a matter under discussion at the last meeting, asked whether it would not answer as well to put a plate in the alum bath after, instead of before fixing; his idea of the object of the alum being to toughen the film and prepare it for long washing. It was answered that this would do as well if the alum was only needed for its clearing action of the plate, but if the film had a tendency to soften or frill, the alum was needed before fixing to counteract this tendency, which generally showed itself in the fixing bath.

Mr. Eckfeldt asked the cause of mottled markings on a plate, having the appearance of snakes. The markings showed themselves on the plate in question after fixing. Another plate of the same lot, developed and fixed in the same solution, being free from them. It was thought they were occasioned by the plate remaining quiet in the bath during fixation, it being generally advisable to rock the dish occasionally so as to allow fresh portions of the bath to have access to the surface of the plate.

Mr. Edge showed a plate which was disfigured in a number of places with markings like short curved hairs, each about one-quarter of an inch long. The markings seemed to be in the gelatine film itself and not on the surface, and a member suggested their connection with the use of chrome alum in the emulsion.

Mr. Frederick E. Ives showed four negatives of the lime-light spectrum made on plain and color-sensitive collodion emulsion plates. He stated that the spectrum was projected by means of an optical lantern and flint-glass prism, with a slit measuring one-fiftieth of an inch, and all plates received the same exposure and development.

The first negative was on a plain emulsion plate, which was practically insensitive to green, yellow, orange, and red.

The second was on a chlorophyl plate, which was remarkably sensitive to all parts of the visible spectrum, and was more sen-



sitive to red, orange, and blue-green than to violet.

The third negative on an eosine plate showed sensitiveness to red and orange, but was more sensitive to yellow-green than to blue or violet.

The fourth plate prepared with both chlorophyl and eosine appeared to show the full action of both sensitizers, and there was no part of the lower half of the visible spectrum to which this plate was not more sensitive than to the violet.

There appeared a slight reduction of violet sensitiveness in the chlorophyl plate, and a corresponding increase of blue sensitiveness. The eosine and the chlorophyl-eosine appeared to be exactly as sensitive to violet as unstained plates.

Replying to questions asked, Mr. Ives stated that wet collodion emulsion plates were a great many times less sensitive than the rapid gelatine dry plates, and even required three to ten times more exposure than ordinary collodion bath plates, but could be made so sensitive to red and yellow that they required less exposure through a color-screen than the most rapid ordinary gelatine dry plates.

He had tried Carbutt's color-sensitive gelatine dry plates, and thought they were very good indeed, but not yet sufficiently sensitive to red to be satisfactory for some subjects.

The collodion-emulsion chlorophyl plates as prepared by Mr. Ives, would always bring out detail in all the colors, even when no color-screen was used; but in daylight it was necessary to use a color-screen to secure correct color-tone. Color-sensitive gelatine dry plates appeared to show no practical advantage over the ordinary plates for use without the color-screen.

A perfect color-screen could be used either between the sensitive plate and lens, inside the lens mount, or in front of the lens; but if the glass of the color-screen was not of perfectly uniform density and thickness, it would be necessary to place it near the sensitive plate. His lenses for outdoor work had color-screens fitted in between the diaphragm and back lens, where they occupied the least possible space.

He believed color-sensitive plates would

be extensively used. He had made some photographs of difficult oil paintings and similar subjects, which could be made good only on plates remarkably sensitive to red, but there were many subjects that would come almost, if not quite, as good on the orange and yellow sensitive gelatine dry plates now in the market.

Some further discussion of the subject followed, in all of which those present evinced great appreciation of the interesting manner in which this valuable improvement had been illustrated by Mr. Ives.

Adjourned.

ROBERT S REDFIELD,  
Secretary.

THE amateur societies of Boston, Philadelphia, and New York are arranging rules for their coming united exhibition. The place is not yet fixed, but will probably be New York.

---

### QUERIES, CONUNDRUMS, AND CONCLUSIONS.

"MAGIC."—There is no "secret" about coloring slides. It is all in skill and knowledge of colors. Persons experienced in draughtsmanship will find painting on glass an interesting occupation. They need not outline their designs, but it is perhaps advisable to trace them on glass with a lithographic pencil. The masses should be kept broad and telling, and color should not be stinted. Sable brushes are the best for painting on glass, and if the painting is continued on a velvet frame, or with mirrors, a stiff bristle brush should be used.

F. E. WOODIN, an expert Michigan caricaturist, has invented and patented a system of producing facial expression by mathematical principles which it is claimed will enable any student in drawing to delineate whatever expression may be desired.

"DEAD-BLACK PAINT."—For painting brass tubes, optical instruments, etc., a dead black, take two grains of lampblack, put it into any smooth, shallow dish, such as a saucer or small butter plate, add a little gold size and thoroughly mix the two together. Just enough gold size should

be used to hold the lampblack together. About three drops of such size as may be had by dipping the point of a lead-pencil about half an inch into the gold size will be found right for the above quantity of lampblack; it should be added a drop at a time, however. After the lampblack and size are thoroughly mixed and worked, add twenty-four drops of turpentine, and again mix and work. It is then ready for use. Apply it thin with a camel's-hair brush, and when it is thoroughly dried, the articles will have as fine a dead black as they had when they came from the optician's hands. (See, also, answer to "Samuel of Posing.")

**"WATERPROOF VARNISH."**—Two kilogrammes of melted bitumen are poured into a receptacle heated by a mild fire. Add, while continually agitating, 500 to 600 grammes of benzine, 200 to 300 grammes of turpentine, and 200 to 300 grammes of lampblack.

EXPERIMENTS conducted by Prof. Koenig, of Berlin, show that within the range of the normal spectrum a healthy eye can perceive about three hundred differences of color, and its color sensitiveness ranges from more than 1 down to 0.2 millionth of a millimetre.

### OUR PICTURE.

THE charming home-study which embellishes our current number, is from a negative sent us by Messrs. Abell & Son, Portland, Oregon. It is entitled "After Play."

The two individuals who make up the graceful and truly artistic composition, have evidently been rehearsing for some mimic scene studied from Buffalo Bill's "Wild West," and are now composed for rest—and the sly camera—"after play." All the care and study possible could not have resulted in arranging a more natural and enjoyable group than this. The technical excellence of the work is capital, too. A proof from the negative was sent us some months ago, and at once we obtained the promise of it as a study for our readers. We think it is well worth study and the place we have given it. Rather than risk losing any of

its good qualities by reproduction, we entrusted the original negative to the care of the Photogravure Co., 853 Broadway, New York to print by means of their excellent process. We think all will agree that they have done well. Our next issue will present a real view of the "Wild West"—not of Chicago necessarily.

### PAPER COATED WITH GELATINE EMULSION FOR DIRECT PRINTING.

WE hope that all readers of the *News* have followed the carefully written series of articles by Ashman and Offord on the subject of various gelatine emulsions for direct positive printing. These articles will form a standard for reference on the subject; and those who have time on their hands could not do better than work out in practice the instructions given by the authors.

To the majority of busy professional photographers this will, however, be an impossibility. Even had they made up their minds to replace albumenized paper by citro-chloride emulsion paper, few of them would have had time or patience to prepare the material, the process being considerably more complicated than that of floating albumenized paper.

This being the case, we observe with pleasure that more than one manufacturer is now issuing, commercially, gelatinocitro-chloride paper, presumably prepared according to Ashman and Offord's instructions.

It is true that about two years ago there was sold in this country more than one brand of paper for direct positive printing, which was coated with gelatine emulsion containing a chloride and some other salt of silver; but these brands, for some reason or other, did not meet with much approval.

Some little time ago J. R. Gotz showed at the Photographic Club some prints on a gelatine emulsion paper, which appeared to us so remarkably satisfactory, that we took the opportunity of ascertaining the name of the manufacturers, of getting some of the paper, and of thoroughly testing it.

The prints were, in our estimation, decidedly superior to prints on albumenized

paper from the same negatives. The shadow detail was better, there was all the depth and transparency of a print on albumenized paper, and there was not the drawback which has shown itself in the earlier brands of emulsion paper that we have tried, that except in the case of a very thin negative, the prints appeared hard. In fact, some of the *negatives* from which the prints we have mentioned had been produced, erred considerably on the side of hardness. Others, on the other hand, were, if anything, thin, so that the paper would appear to allow of a remarkable amount of latitude as regards quality of negative.

The paper is manufactured by a German firm, the price being about fifty per cent. above that of the best ready-sensitized albumenized paper in the English market. As to the keeping qualities of the article, we can say nothing more as yet, from our own experience, than that it has shown no deterioration in a few weeks.

The manipulation we performed in accordance with the instructions sent with the paper, and with the following results.

The printing was performed in the usual manner, the paper being allowed to print as deeply as albumenized paper. The time taken was remarkably short; we should judge not more than one-third or one-fourth that required for albumenized paper. The color assumed in the printing frames was a surpassingly beautiful purple.

The toning bath is made up as follows :

I.

Sulphocyanide of ammonium	1½ ounces.
Hyposulphite of soda . . . . .	15 grains.
Water . . . . .	50 ounces.

II.

Chloride of gold . . . . .	15 grains.
Water . . . . .	15 drachms.

III. (for actual use).

I. . . . .	5 ounces.
II. . . . .	1 drachm.

The prints are placed in water, and are kept in motion there for two or three minutes. This water evidently contains a large quantity of silver salt after this washing, and should be poured into the residue tub.

The prints show no change of color in the

washing-water, but *immediately* that they are placed in the toning bath they turn a sickly yellow—assume, in fact, about as hopeless an appearance as could well be imagined. There is soon, however, a change of color as the toning proceeds. In all our experiments the procedure at this stage has been very peculiar. The toning has gone on in so irregular a manner—the prints becoming full of streaks—that the natural assumption was that the prints would eventually be quite useless. In all cases, however, except that of a solitary print, the streakiness has disappeared as the process proceeded.

The surface of the print becomes toned to a purple at a very early stage; but if the operation be carried no further than this, the print finally is very brown. It appears to us that the color of the print at the end of the process, by reflected light, is very nearly the same as its color by transmitted light at the end of the toning. It is thus very easy to determine how long toning shall proceed, simply by looking through the prints. To judge by surface color is impossible, as a blue is reached a considerable time before toning even to a brown is complete.

We toned to various colors, from a light brown to a deep purple, finding the final results quite under control.

The prints go direct from the toning bath into a fixing bath made up with two ounces of hyposulphite of soda to the pint. The time for fixing is, according to the instructions, only five minutes; but we found no ill result from a considerably longer time.

After fixing, washing proceeds exactly as for albumenized prints, and after that drying. If a very high enamel surface is required, the prints are squeezed on to glass which has been prepared with powdered talc. The surface, if they are allowed to dry spontaneously on blotting-paper, is very good, and there is not nearly so much cockling as in the case of albumenized paper prints. They may, if it be desired, be burnished like prints on albumenized paper, but in this case it is necessary to be very careful that the surface is absolutely dry before they go through the press, otherwise it will infallibly be destroyed.

It is impossible to say anything final as to the permanency of prints such as we have described, except that there are various reasons to suppose that it may be much greater than that of prints on albumenized paper.

So far as our experiments have gone, the expense is the only drawback of the process. The paper is dearer than albumenized paper, and apparently considerably more gold is used in toning. With regard to the last point—that of the extra use of gold—we would say a few words.

It appears to us that the attempt to tone with the least possible amount of gold is a great mistake. Every photographer appears to look for that formula whereby he can change the color of his print with the smallest quantity of gold, and every papermaker seems to consider it a recommendation of his paper that it may be toned with a particularly small quantity of gold. Thus, we heard one maker the other day state, of his ready-sensitized paper, that a sheet of it could be toned with one-quarter grain of chloride of gold. This, if it were true, would be enough to condemn the paper in our eyes at once.

The toning process is, probably, one of substitution, and the substitution of gold for silver appears materially to increase the permanency of the image. Surely, then, it is a thing not requiring demonstration, that the photographer should look not for that process which will give the greatest amount of change of color of image for a given amount of substitution, but which will allow of the greatest possible amount of substitution for a given change of color; or, to state our propositions differently, other things being equal, that process is the best—in the sense of giving the greatest chance of permanency—in which the greatest amount of gold is used during the toning process—*used*, not *wasted*, be it of course understood. There are some toning processes in which much gold is precipitated, not on to the image, but on to the bottom of the dish. Of course such gold does not tend to render the prints permanent.

---

WILSON'S PHOTOGRAPHICS.—Chautauqua edition, enlarged, \$4.

### INSTANTANEOUS PORTRAITURE.

[This article, published in our magazine in 1871, is republished now for comparison with M. Baligny's paper. What wondrous changes have taken place in our art during fifteen years.—Ed.]

IN all that has been said or written of late upon chemical manipulations, how to build skylights, etc., it seems to me that a very important point has been overlooked by our experimental photographers, and that is the necessity of instantaneous sittings in photo-portraiture. What would more facilitate the true artist in photography in carrying out his conception of the picture he is about to make? Now he may make his artistic drawings in posing, and arrangement of accessories, and throw in the artistic lights and shades, to find oftentimes his whole study completely destroyed, either by a movement or the want of a harmonious expression, which may have been all right when the artist took his last look at his subject, but turns out to be quite a different thing in his picture.

With all the advancement in the art, the vexatious custom of making your subject a living mummy for the space of twenty-five seconds or more still remains with us, and my experience goes to show there is nothing more trying or more dreaded by the sitter, not excepting even the much-abused head-rest. I have long wished for the time when instantaneous sittings could be made, or sittings so nearly instantaneous as to be practically so, and I believe that the time will come. When it does, then good-bye to the horrid head-rest, and the unnatural expressions so often seen in the photographs of the present day. But as far as I can learn, there seems to be no one striving in this direction, and, in my opinion, the present time is the most auspicious for agitating the subject. Photography has advanced so wonderfully in all other directions, that it seems only instantaneous exposure is wanted to make the results perfect, and photo-portraiture a pleasure to the sitter, as well as to the artist.

If photographers would only realize the great importance of an apparent instantaneous exposure, and would go at it with a de-

termination to master it, I think it would soon be an accomplished fact.

I was quite disappointed in not hearing any suggestions upon this point at our last Convention, and my object in calling attention to it now is to stir up our experimental photographers, in the hopes of seeing, at least, some advancement in this direction at our next Convention, and to then and there give it the consideration that its importance to successful photo-portraiture demands.

It is by experimenting upon such subjects individually, and comparing the results at our annual conventions, that will tend to make the conventions of more practical importance, and will, undoubtedly, in time accomplish what we are all striving for—the perfection of our art.

A. A. PEARSALL.

BRADY'S GALLERY, NEW YORK.

[Translated for THE PHILADELPHIA PHOTOGRAPHER.]

### ANSWER TO A QUESTION CONCERNING THE TONING OF ALBUMEN PAPER.

HAVING received many letters in reference to this subject, I feel constrained to discuss it once more in this public manner rather than answering individual letters, believing that the subject appeals to a real need and any elucidation of it will benefit many.

A pamphlet sent me by Mr. G. Rotter, manufacturer of albumen paper, in Dresden, and which is entitled "A Guide for the Photographic Positive Process," with practical directions for the information of the photographic fraternity (price, 1 mark) treats the subject in the most exhaustive manner, therefore, I heartily recommend this little book, and hope that photographers and printers will possess themselves of it and devote to it their most studious attention. This work contains all conceivable information concerning the preservation, preparation, toning, fixing, and especially concerning printing itself, and is, therefore, of infinite service to the printer, furnishing him an excellent argument, in black and white, of possibilities, which, up to the present date, either through negligence or incorrectness, he has not been able to attain.

However, for those whose letters inform me that they have not been able to obtain satisfactory results by means of the chalk bath, I give the following receipt, which, even in unpractised hands, has turned out well, and is absolutely reliable, notwithstanding the fact that the chalk toning bath requires very careful treatment.

Prepare the following solutions :

*a.* The solution of chloride of gold as given in my treatise, or for those who do not prepare their own gold but buy the preparation, 6 grains of chloride of gold to 500 grains of water.

*b.* 30 grammes of borax to 500 grammes of water, dissolved warm, and allowed to cool.

*c.* 10 grammes of simple bicarbonate of soda, chemically pure, crystallized, in 250 grammes of water, dissolved cold.

These three solutions must be mixed at least half a day before they can be used.

Half an hour before using them mix :

25	grammes	of	solution	<i>a.</i>
40	"	"	"	<i>b.</i>
5	"	"	"	<i>c.</i>
500	"	"	distilled water.	

The pictures should be toned until they show a beautiful plum-blue color. If after the finishing touches the color is not blue enough, then 10 grammes of solution *c* must be used instead of 5 grammes. By means of a proof sheet of this kind, a finer tone can be obtained than without drawing off a proof-sheet and simply leaving the picture longer in the gold bath. The toning bath should be prepared afresh for coloring every time.

It is a good idea to cut the papers, when they are silvered, into the sizes to be used, and kept in a portfolio, a blotting-paper book between the sheets, the leaves of which have been dipped in a solution of bicarbonate of soda 1 : 50, and then dried. The silvered paper keeps well in this kind of a portfolio, especially in such rooms, where in the hot time of the year, it (the paper) is apt to turn rapidly yellow, and then white, and thus detracts from the beauty of the print ; it is also advisable to place such wet and dried sheets in the printing frame directly behind the silvered paper. The success of this plan is very evident. In the

winter, especially when, owing to the very gloomy weather, it often takes two days to produce a good print, this measure possesses a great advantage. E. KIEWNING.

### THE WORLD'S PHOTOGRAPHY FOCUSSED.

A CONVENTION of British Photographers was held at Derby, Eng., August 12th, 13th, and 14th. Excursions, conversations, and papers, with some small attempts at an exhibition gave the enterprise a good start. Next year something much more may be looked for. Mr. Bringshaw, 21 Albert Row, Walthamstow, England, is the Secretary.

M. LEON VIDAL, of Paris, has received the first prize (a gold medal) at the International Exhibition of Oporto, for his photographic publications.

PELLICULAR PAPER OF M. HERVE.—The author of this presentation proposes to use red paper as the temporary support of sensitive pellicles, as with this color the halo is not to be feared, and the development can be better followed. We think that black paper would be still better, and we have called attention to the fact for some time back.

For some years past Mr. Stebbing has prepared reversible pellicles having red and afterwards black papers for their temporary support. The black is better because it is possible to see when fixing the complete disappearance of the bromide of silver. We much prefer translucent pellicles to any opaque supports which do not allow watching the development, but if opaque supports are to be used we think black are the best.—*Moniteur*.

ARGENTOTYPE PAPER.—M. Audra, in the name of M. Le Docte, of Brussels, presented a paper for printing positives called "argentotype;" this paper is prepared, it appears, with gelatino-bromide of silver. The prints shown are precisely like those obtained by the platinum process.

MOST of the crowned heads and princes of Europe are ardent amateur photographers.

INSTANTANEOUS photographs of the hearts and intestines of various animals have enabled Dr. W. G. Thompson to determine the actions of the organs more clearly and accurately than is possible by any other method. Such photographs may prove of great value in showing changes effected by drugs, as well as in their physiological teachings.

ACCORDING to the Berlin newspapers photography has lately rendered an important service in causing the arrest of the robber and murderer, named Keller, a warrant for whose capture was, at the time, in the hands of the police. It seems that some time before the murder was committed a Mr. Schiffing lost his dog, and it was this very Keller who was hired to catch it for the gentleman. Now it so happened that just as Keller was in the act of seizing the dog, a military officer, who employed his leisure in studying photography, was at a window of an opposite house, practising his art by taking instantaneous pictures of the passers-by. Thus, by chance, Keller's picture appeared twice on the paper, and reaching the hands of the criminal police by a train of circumstances, rendered their efforts to capture the murderer much easier.

Another German newspaper has lately made itself merry over the expressed intention of a photographer to perpetuate the memory of the Berne Highlands by means of his work of art. The editor of the paper remarked that he would not undertake to affirm that the mountains of Berne might not tumble down sometime in the future, but he judged that they were a little more lasting, at all events, than the photographs of a mountain photographer. Possibly the purpose of the artist was not alone that of "perpetuating," but also that of manufacturing pictures whose duration is sufficient to gladden the hearts of thousands by awaking pleasant remembrances.

MR. KIEWNING suggests the use of black cartoons to those who are striving after a brilliancy in their vignettes. He advises that such pictures be drawn first on ordinary writing paper, then cut, trim, and paste this as a lining upon the black cartoon. The result will justify the trouble.

TO FIND the capacity of a cylindrical vessel in gallons, multiply the area of the base in inches by the height in inches, and divide the product by 231. To find the capacity of a four-sided vessel in gallons, find the cubical contents by multiplying the length, breadth, and height in inches, and divide by 231.

POCKET-BOOK FOR PHOTOGRAPHERS.—Piper & Carter, photographic editors, Castle Street, Holborn, London, have published, this year, Burton's *Pocket-Book for Photographers*, which contains many tables of times of exposure, divers formulas, etc., with sufficient blank-space for pencil notes. Price, one franc. A good pocket note-book is a veritable treasure.

TO CLEAN PAPIER MACHE.—Wipe over with a woollen cloth saturated with olive oil; warm water should never be used.

A CEMENT for resisting water at steam heat may be made by mixing commercial glycerine with dry litharge into a tough dough and applying the same to the part to be covered. The composition is said to answer very satisfactorily for uniting the joints of steam pipes.

THE FILMOGRAPH.—At the Manchester Amateur Society, Mr. Flower showed the filmograph, having 100 folds, to be used as a support for sensitized gelatine sheets, and also the pellicles of M. Thiebaut. These last are sensitized pellicles attached to sheets of cardboard; they are exposed, developed, and fixed in the ordinary way, and after drying the pellicle is detached for printing positives. One hundred of these pellicular cards, it is said, only weigh as much as twelve glass plates occupying the same space.

## Editor's Table.

THOUGH *Photographics* was published five years ago, none of its many competitors has taken from it its place as a text-book of photography. It still leads, and now comes out in a new edition, revised and with added matter that brings it thoroughly up to date. Its sales have been unsurpassed by any photographic book of its class, and every reader has a good word for it. The very first copy sold went with Mr. W. H. PARTRIDGE, of Boston, to California, and has had many wanderings since. Now he writes from Alaska, "I have not forgotten that you gave me the first copy of *Photographics* one morning when I was over in Philadelphia, and I have never had a chance to repay you." From Chihuahua, Mexico, its leading photographer, SENOR VICTOR DE MOREDA, writes, "*Photographics* pleases me very much, and is an excellent encyclopedia." So many others write.

The added matter in the new edition comprises descriptions of the most notable new developers; a full account of the new negative films and paper, their working and manipulations; some points on bromide paper, and notes on transparencies, removing hypo from films, and other things. It is the "Chautauqua edition."

FROM Mr. JAMES LANDY, of Cincinnati, we have received a large panel photograph of Thomas W. Keene as "Othello." The artistic witchcraft Mr. LANDY knows so well how to use, makes the picture a fine one. The Moor stands as before the Senators. The pose is superb, and the picture very characteristic, both of actor and artist.

THE standard work by Mr. CHAS. W. HEARN, "Studies in Artistic Printing," has just come out in a new dress, with new prints. Printing is certainly one of the photographic questions of the day; and this work is a complete manual of the operation. It gives careful and thorough instruction as to every manipulation—preparing the paper, floating, toning, fixing, and finishing. The six beautiful examples in the book are every one a lesson. They were from specially made negatives by MESSRS. ARTHUR & PHILBACK, GILBERT & BACON, ROCHER, KENT, BAKER, and BIGELOW, and are models of what prints should be. The book is most valuable. Its price is \$3.50. There ought to be one in every gallery and amateur home.

MR. G. GENNERT, of this city, is in Germany looking after the exhibit of American pictures

there. He bade us adieu some days since, and is now probably safe in Braunschweig. He expects, among other things, to interview the makers of the "EAGLE" paper, and come back with all the latest improvements.

MR. G. F. MUGNIER, of New Orleans, La., sends us a picture of two handsome boys posed as "the princes in the tower." It is remarkably good technically, and in conception excellent. The staircase background shows what a plucky photographer who will *try* can do. It was painted by Mr. MUGNIER himself with a whitewash brush. The whole does him great credit.

THE good old firm that, with the name of A. M. COLLINS at its head, has made infinite quantities of paper, cardboard, and things made thereof, has grown and increased year by year until now—a corporation entitled the "A. M. COLLINS MANUFACTURING Co." has been formed, and succeeds it. We wish the new corporation every success, and have no doubt that the mounts and cardboard it makes for photographers will be even better than heretofore.

The Company sends out specimens of an excellent new mount, No. 78, "Spangled Edge," to take the place of those distributed at St. Louis.

WE have received a letter from Mr. JAMES ENGLIS, announcing that he has left the ENGLIS D. P. Co., which still retains its name, and will hereafter superintend the ROCHESTER D. P. Co., which will make his plates exclusively. The new Company has every facility, and Mr. ENGLIS's reputation is well known. He writes, "I shall make every effort to allow nothing but the most perfect plates possible to go out from my hands."

FROM A. B. PAINE & Co., Fort Scott, Kas., comes a circular of their "Hypo Eliminator." By its use they claim prints may be ready to mount and plates dried half an hour after fixing. The responsibility of the firm warrants this notice. See advertisement.

In our last number we noticed the offer of N. C. THAYER & Co., of Chicago, of premiums to their customers. They have now modified it by extending the time to the next Convention, and increasing the value of the premiums to \$500. They now offer the choice of a No. 8 Suter, No. 9 Beck, or No. 7 Voigtlander Euryscope, to the photographers outside of Chicago, who shall send

the largest single cash order, and who shall buy the largest amount of goods within the given time. The latter will receive also an 18 x 22 box and stand worth \$100. An efficient way to boom business.

FROM MESSRS. CHARLES COOPER & Co., 194 Worth St., New York, comes their new and large price list of chemicals. For thirty years this firm has supplied photographers and others with pure and reliable chemicals. They can be depended on.

WE have received from MESSRS. CASSELL & Co., several issues of a series of handy little volumes published under the name of "Cassell's National Library." They appear weekly, and for a very moderate sum the photographer finds within his reach a mass of literary treasure. The library is edited by Prof. HENRY MORLEY, which insures its scholarly and apt selection. The good work of making many standard works thus accessible we cannot enough commend. So wide is the ground covered, that every variety of taste will find something desirable. There is Isaac Walton, whom every thoughtful and observing out-door photographer ought to read; Sir John Maundeville's wondrous traveller's tales; our own Ben Franklin's "Poor Richard," many of whose shrewd admonitions fit timely in the photographer's practical work; Latimer and Bacon, Byron and Scott, Goldsmith and Macaulay.

We give this space to non-technical books not without purpose. We want to see photography, and the minds and views of photographers, widened. Their art is continually reaching out, and they should keep up with it. It is one of the main ends of this journal to help them do so. If they have never tried it, they can have no idea what a reviving flood in dry channels is the reading of a good book to the specialist, and this seems a rare chance.

HASTE led us to make a mistake in the last issue in our criticism of the exhibits at St. Louis. The enlargements shown by KUHN BROS., of St. Louis, were permanent bromide, not solar prints; and their bridge view's correct dimensions were 31 x 48 inches, somewhat larger than stated. They showed four more of the same size.

This well-known firm have sold their gallery, and now make bromide enlargements and stamp photos. exclusively.

OUR readers will notice that the journal with this month resumes its usual appearance. Con-



vention matter is ended, and the usual departments have space once more.

We shall, however, take up soon a series of articles, reviewing the management and mismanagement of past Conventions, and seeking to determine what measures of reform are possible. The Association is an organization expected to do the most good with the least expenditure of the money which photographers, who are not wealthy as a class, have given. How this may be done, how it has been done, we shall discuss.

We would be glad to have the suggestions of thoughtful friends. We are gathering material, and shall soon begin.

The remarkable instantaneous work of Mr. H. BUTLER, of Vermillion, Dak., is already known. We have received from him the picture of a midnight lightning flash, which is one of the best lightning-pictures we have ever seen; also, a picture of the discharge of one of Dakota's 4th of July cannons, with the wad caught in the air at the moment of discharge. The clouds of smoke are issuing from touch-hole and muzzle also with patriotic vigor.

We learn with regret of the death on August 4th, of that veteran photographer and close friend, Mr. E. Z. WEBSTER, of Norwich, Conn., after two years lingering illness. It was Mr. WEBSTER who first turned our thoughts towards photography. The first picture we ever saw made was taken by him, in the little country village we both inhabited; and we frequently served as his model, when needed to diversify his Daguerrotypes with a rustic figure.

Mr. WEBSTER was born in Plattsburg, N. Y., sixty-four years ago. About 1850 he moved to Louisville, Ky., where he first took up photography as a business with his brother J. B. Webster. He has lived in Norwich since 1866. He was, while in Louisville, one of the first organizers of the Union League, whose members there, among whom was Mr. GEORGE D. PRENTICE, of the *Courier-Journal*, held their secret meetings in his gallery. Among his other acquirements he was a musician of marked ability. He was a frequent contributor to our magazine a few years ago.

His illness, paralysis, had for the last year rendered him utterly helpless. He leaves a widow, two sons, and one daughter.

We have received a notice of the Exhibition for 1886 of the Photographic Society of Great Britain, to be held in the Gallery of the Royal

Society of Painters by Water Colors, London, from October 4th to November 13th.

We learn from the New York *Tribune* of August 7th, that S. TRIER & SON, New York, who embarked in the manufacture of photographic cards a short time ago, are offering to compromise with unsecured creditors at 25 cents on the dollar. Their liabilities are over \$100,000; preferred claims, \$45,000.

FROM Mr. REDMON, of Cynthia, Ky., we have received some cabinet photos., samples of his work. One of them without retouching, a little girl, shows that he has gotten over this difficulty very well. Among the pictures are a few of the unapproachable Kentucky belles, who ought to be pleased with the portraiture with which Mr. REDMON presents them.

MR. R. GOEBEL, of St. Charles, Mo., sends us a portrait of an interesting animal who varies from the most of his kind in that he has no snout.

A LANTERN exhibitor writes to us offering his entire outfit for sale on account of his failing sight, which forces his retirement. Instruments, slides, fixtures, cases, etc., were all bought less than two years ago, and are quite as good as new. "They have been," he writes, "so carefully used and transported that they are not even tarnished. The purchaser would not be getting any second hand stuff, but what appears and is new." We can endorse his statements, and offer this as an uncommon opportunity to any amateur, or anyone about to enter the lecture field. The outfit at list prices would cost nearly \$650. We will be glad to write further particulars to anyone wishing to purchase.

We have a letter from one of our English subscribers, Mr. HAROLD SANDS, in which he says, "I have just returned from a trip in Yorkshire, where I have been using Eastman films. Result—exposures, 36; good negatives, 34. I consider it almost 99½ per. cent. superior to glass.

I like the PHILADELPHIA PHOTOGRAPHER very much; it contains a lot of useful information, and the illustrated frontispiece is not the least valuable recommendation. My only trouble is that several of my friends will borrow the numbers as they come, and I don't get a chance to read and study them."

A newspaper estimates that each copy is read on an average by five persons. We wonder how many readers there are to each number of ours?

MESSRS. SMITH & PATTISON, the great stock-dealers of 145-147 Wabash Ave., Chicago, have introduced many new and appreciated specialties to the trade. They advertise them, as in this present number, in a rather unusual way—giving a sort of object lesson, which is better than lauding their qualities in print. The value of their articles is patent on inspection of the cuts. The "Magic-Camera" stand and their famous posing-chairs tell their excellence to the eye, and in their pictures speak for themselves.

The enterprise and push of this growing Western firm is well noted. We commend them and their goods to our readers.

1886. All the back numbers of this magazine for 1886 can be had. Parties who began their subscription after January, will find the year *complete* is worth securing. It will make the handsomest volume ever known in photographic journalism.

MOAICS 1886. We have a few copies only left. When they are gone the edition will be exhausted. Better secure one if you have it not. Nearly all back volumes are procurable. 50 cents.

MOAICS 1887. As usual we invite *all* to contribute short, practical articles, for MOAICS 1887 is to be the best for 23 years.

THE Toronto Convention and Chautauqua Photo. day are among the things of the past. Great good is already flowing from them. Full particulars in our next.

We are glad to hear of the safe arrival home of Mr. ALFRED CLEMENTS, of the WILLIS & CLEMENTS PLATINOTYPE Co., after a trip in Europe.

FROM Mr. C. I. NEWMAN, of Kingston, N. Y., we have received two photographs made in that town. One is of the old house where the first Senate of New York State met in 1777; the other of the high trestle of the West Shore Railroad. The point of view in the latter is well chosen, making a good picture.

"AMONG THE DAISIES" is a charming 4 x 4 photograph by Mr. JOHN G. HOOD, of WILSON, HOOD & Co., Philadelphia. The scene is in Fairmount Park, with such grand old trees in the background as that resort is famous for. Standing on a hillside covered with daisies, busied picking and arranging the flowers, carefully posed, are five of Mr. Hood's black-eyed children. The picture is charming and the photography excellent.

MR. P. H. ROSE, of Providence, R. I., has shown further evidence of his excellent taste in his choice of cardmounts. On the back is engraved finely a picture of his new studio, entrance tower, etc. Messrs. A. M. COLLINS, SON & Co. are the manufacturers of the cards—a fine piece of workmanship.

"THREE Kittens and their Tails" is a lively group sent us by Mr. BASS, of Brockton, Mass. It is hard to decide wherein and whereat the most expression lies—in the eyes or in the tails.

MR. H. McMICHAEL seems to have received a hearty (and a deserved) welcome by the press on his return from his labors at St. Louis. The newspapers are profuse in their notices of him. We reprint one example only below:

"Mr. H. McMICHAEL, photographer, has returned from St. Louis, where he attended the Annual Convention of the Photographers' Association of America. He was awarded a superb solid silver medal, with a gold representation of a camera in the centre. The medal is about two inches wide, and a quarter of an inch thick. On the front, in black letters, are the words: 'Convention of the Photographers' Association of America, St. Louis, 1886.' On the reverse is the inscription: 'Awarded for Artistic Photography.' The medal is enclosed in a handsome Russia leather case. Mr. McMICHAEL also received a prize of one hundred dollars cash for the same exhibit. The St. Louis *Post-Dispatch*, in speaking of the display, said: "'One of the very finest of all the display is made by Mr. H. McMICHAEL, of Buffalo. There is a great deal of the German tone about the work on McMicheal photos. There are no bold white spots in the pictures and the technique is wonderful. In one head of an old lady with a lace cap every thread in the meshes of the lace shows plainly. The tendency in taking material of that kind is to have it blend in one mass of white. A splendid head of Lillian Russel in sailor costume is in this collection.'"

The Association never had a harder working officer than Mr. McMICHAEL.

MESSRS. HULBERT BROS. (Genelli), 923 Olive Street, St. Louis, favor us with an 11 x 14 group of the Convention attendants, made on Friday. It is decidedly the best we have seen. An added value is given it by the appearance in the centre of Mrs. CLARK's beautiful banner. Copies of the group may be had for seventy-five cents.

QUITE AMUSING.—MR. IRVING SAUNDERS, Alfred Centre, N. Y., one of our old-time subscribers competed for one of the Anthony fifty dollar prizes, and was awarded it for his excellent 17 x 21 photograph of President J. ALLEN, of Alfred University. His check was promptly sent him by Messrs. E. & H. T. ANTHONY & Co., and with the acknowledgement of it came back a request from Mr. SAUNDERS to purchase the negative (surrendered as a part of the contract), since he could never get another picture so good of his venerable subject. Rather an amusing predicament all around, but happiness reigns.

“THE Suter Lens in Europe” is the title of a circular sent us by the Messrs. ALLEN BROS., of Detroit, which tells how those excellent instruments are estimated by leading European artists.

MR. CHARLES DOREY, Lock Haven, Pa., attracted a great deal of attention at St. Louis by his Photo-Burnisher extension. A circular from him will give you all the details.

THE Collins Patent Focussing Attachment is a great success. We have one, and are much pleased with it. It insures a great deal of comfort in focussing, and preserves the temper unruffled from the contrariness of the focussing cloth, and out of doors it saves many a plate from being lost from vibration of the camera. See specials and advertisement.

THE Chicago Tally-ho managers kindly sent us an invitation to our hotel to accompany them, but we were unable to do so. The affair was a pleasurable success, we are informed.

MR. WILLIAM MYLES, of Wheeling, W. Va., called on us recently on his way to Europe, where he expects to make an extended photographic tour. Success go with him.

MR. THOMAS SEDGEWICK STEELE, the well-known sportsman, amateur photographer, and explorer, has written an interesting work for the tourist photographer in his *Paddle and Portage*. In it he describes his canoe tour through the forests of Maine from Moosehead Lake to the Aroostook River. The camera-case held the position of honor on top of the pack he had to carry in his struggle through the woods, over a route traversed only once before by white men. In delightful breezy style he writes of the hardships and the sport, the oddities of the inhabitants, and the quaint remarks and camp-fire tales of the guides. One who has ever shared

such experience in a lesser degree almost sees the bright light of the camp-fire on the pines, and smells the smoke and the fragrant fir-balsam as he reads. The camera's work brought back a record of the scenes passed through, and from this the book is profusely illustrated. A number of the original 5 x 8 photographs accompany our copy of the book. They are technically and artistically excellent. See the book advertisement in specialties.

THE KALAHARI. Forty-six illustrations, diagrams, and map. New York: Scribner & Wellford, \$5.00. There is a special spice of interest for the photographer in that most interesting book *Through the Kalahari Desert*, by Mr. G. A. FARINI. Mr. FARINI's is an ideal book of travel; his style always runs bright and clear, and he has something for everyone. While he fills the wondering mind as a visitor of strange lands should, with accounts of amiable little bugs that emit a delicious perfume “like Rimmel's shop,” and herds of a hundred herb-intoxicated springboks going through a desert circus, many a page of his book holds most valuable geographic, political, and scientific information, but in the way of photographic achievement, it tells of deeds quite unequalled. With the author went Mr. LULU FARINI, skilled artist and photographer and trained gymnast. This gentleman has now, by the way, settled down in quiet pursuit of his beloved art as owner of the late Singhi studio at Bridgeport, Conn. Mr. LULU FARINI is certainly the only man who ever caught through the lens three lions at home in the desert, and then stood behind his camera as one wounded beast charged him, and first photographed and then scared him away. The last demonstrated the power of photography again, as it was done by waving the tripod feet at the beast while the head was under the focusing-cloth. Other animals, too, and the natives, including Mapaar, great King of part of Kalahari, were caught by the ready camera. The book is illustrated from these views, and remarkably good they are. We do not speak from hearsay, for we have had the pleasure of looking over the entire series at Mr. FARINI's home. A better lot of negatives we have never seen. In a future issue we shall, by Mr. FARINI's kindness, present to our readers a specimen of his work, which he has promised to select for us. Among his views are many most interesting pictures of the natives and the Boers, and their respective homes. Some are instantaneous, in which animals in freedom were photographically captured, like the great oxen who pulled the

wagons, which once they had to draw out of three feet of water caused by a sudden rain. Rather out of the common run, too, besides the lions, is a view of an immense blast at the bottom of one of the great Kimberley diamond mines. Mr. FARINI staid down while it was fired and secured some splendid plates amid a shower of rocks. Perhaps on one of them is impressed, on the rise, the big rock that afterward fell on his tripod and smashed its legs. He, however, escaped unhurt.

Perhaps the most arduous piece of exploration described is a trip to the Falls of the Orange River which was made after coming out of the desert. The Falls lie among mountains in a district whose difficulties but few men have ever surmounted. For several days the explorers were imprisoned on a rock in mid-river by a sudden flood. The whole section seemed split up by gorge and canon, with falls everywhere, and the difficulties in the way were enormous. In many cases Mr. FARINI climbed half way down or across the face of a precipice to secure his views. Once there was only a single spot from which it was possible to get a good view, and to reach this he had to be let down by ropes—the artist first, the camera after. The resulting views, however, are magnificent.

The book is thus, in part, another bit of testimony to the invaluable aid photography gives to exploration, and to the scientific traveller. Its accounts of adventurous picture-making are almost like a romance of the art. The ambitious amateur or professional who would have his blood stirred and his emulation aroused, should not fail to read Mr. FARINI's book. The newspapers have treated it most favorably, the *Tribune* having given nearly three columns to its review.

A NEW developer in solutions for orthochromatic dry plates is being made by Messrs. E. & H. T. ANTHONY & Co. Its use makes possible any degree of softness or intensity. Judging from the testimonials it gives great satisfaction.

MR. SALLOW, of Goderich, receives a very flattering notice from his local paper. It states that his studio is the largest and best appointed in the region.

WE have received a price-list of Talcott's Improved Mounting for pictures and photographs, to which we have already called attention.

THE CAMERA, of London, in its issue of July 1st, publishes an excellent and very interesting

print in three colors by a new process—photocrayon. Editorially it says: "The last number of the PHILADELPHIA PHOTOGRAPHER maintains the high standard of excellence for which this journal has been famous for many years. As usual a good silver print forms its frontispiece, and the text is full of matter which should be interesting to all photographers."

THE BLAIR CAMERA Co., of Boston, Mass., send us their new forty-page catalogue of camera, lenses, and other photographic requisites. In the list are the Blair patent extension and improved reversible back cameras, and the lucidograph.

FROM Mr. C. A. SCHINDLER, of West Hoboken, N. J., we have received a price-list of ninety-three pieces of studio furniture, including chairs, vases, and other decorative accessories. Mr. SCHINDLER has for over forty years done a large furniture business. His designs have been copied by others, and it is desirable to write to him direct in order to secure the real article.

FROM Mr. M. P. WERNER, of North Adams, Mass., we have received some excellent "autoglyph" prints of Massachusetts scenery. The prints, made by Mr. W. P. ALLEN, Gardner, Mass., are remarkably good—clear, sharp, and excellent in tone. Much of their good quality is owing to the most excellent negatives taken. They were on the plates made by Mr. F. N. BLAKE, at North Adams, Mass. They could hardly be better, and speak exceedingly well for the Blake plates.

THE PHILADELPHIA PHOTOGRAPHER AT THE ROYAL OBSERVATORY IN SCOTLAND.—*My Dear Mr. Wilson:* Having been from home for some time, I have found on returning not only several numbers of your interesting photographic journal, for which pray receive my thanks and many thanks and congratulations, but also the request from the Secretary of a Glasgow photographic exhibition about to open to send something there immediately; so, amongst other things, I sent off straightway one of the numbers of your magazine, that they might see what a photographic magazine may, can, and should be. It was the number with the children listening to the birds singing, where the nature of good little children listening artlessly and earnestly to sweet singing of innocent birdies, seemed very happily caught. In haste just now, I remain

Yours truly,

C. PIAZZI SMYTH.

15 ROYAL TERRACE, EDINBURGH.  
July 1, 1886.

# Specialties.

## ADVERTISING RATES FOR SPECIALTIES.

25 cents for each line, seven words to a line—in advance. *Operators desiring situations, no charge.* Matter must be received a week before issue to *secure* insertion. Advertisers will please not ask us for recommendations. We cannot undertake to mail answers to parties who advertise. Please always add your address to the advertisement. **Postage-stamps taken.**

**MAKE OUT YOUR OWN BILL,** and remit cash with your advertisements, or they will not be inserted.

### CUT RATES ON ACCESSORIES.

Send for catalogue.

L. W. SEAVEY,

216 E. Ninth Street, New York.

**RETOUCHING BUREAU.**—Under the direction of Mr. H. Harshman. None but skilled help employed. Quality of work guaranteed. Prices moderate. Send your negatives in wooden box with cover screwed on, and prepay charges.

Address GAYTON A. DOUGLASS & Co.,  
Merchants in Photo. Supplies,  
185 & 187 Wabash Avenue,  
Chicago, Ill.

### BARGAIN LIST.

- 1 5 x 8 Scovill Manufacturing Company's Camera, with Eastman Roll-holder, with tripod, focussing-cloth and light carrying case. *All new*.....\$35 00
- 1 5 x 7 Scovill Manufacturing Company's Revolving-back Camera, three extra holders, with kits; 1 tripod..... 30 00
- 1 18-inch Entrekin Burnisher (old style)... 10 00
- 1 14-inch Entrekin Burnisher, (nearly new)..... 15 00
- 1 Centennial Head-rest, perfect..... 8 00
- 1 Spencer Head-rest (old style)..... 1 50
- 2 Bergner Cutters, stereoscopic arch top, each..... 15 00
- 1 Bergner Cutter, stereoscopic square top.. 10 00
- Printing-frames, 10 x 12 (nearly new)..... 60
- “ “ 6½ x 8½ “ “ 35
- “ “ 5 x 8 “ “ 30
- Negative boxes 5 x 8, 8 x 10, 10 x 12, and 14 x 18 from 25 cents to \$1.10.

ROBERTS & FELLOWS,  
1125 Chestnut St., Phila.

### TO PHOTOGRAPHERS.

I have now added a new floor to my stock-house, which will be specially devoted to *accessories, camera-stands, camera-boxes, chairs, etc.* A call solicited. New lists on application.

GEORGE MURPHY,  
250 Mercer St., N. Y.

## DOWN SHE GOES!

### NEW PRICE-LIST

OF THE

ROCKWOOD SOLAR PRINTING CO.

17 UNION SQUARE NEW YORK.

Size.	Unmounted.	Mounted.
11 x 14.....	\$1 00	\$1 25
13 x 16.....	1 00	1 25
14 x 17.....	1 00	1 25
16 x 20.....	1 00	1 25
18 x 22.....	1 20	1 50
20 x 24.....	1 35	1 50
22 x 27.....	1 40	1 90
25 x 30.....	1 40	1 90
27 x 32.....	2 25	3 00
29 x 36.....	3 00	4 00
30 x 40.....	4 00	5 00

No charge for negatives. All orders must be accompanied by the cash. Make all P. O. orders payable to ROCKWOOD SOLAR PRINTING Co.,  
17 Union Square, New York.

## CANOE & CAMERA



A PHOTOGRAPHIC TOUR

OF

TWO HUNDRED MILES

THROUGH THE

MAINE FORESTS.

(Illustrated.)

Price . . . . \$1.50.

ESTES & LAURIAT, Publishers, Boston.

FOR SALE BY

THE PHILADELPHIA PHOTOGRAPHER.

**WILSON, HOOD & CO.,**  
825 Arch St.,  
PHILADELPHIA.

We have now in stock  
THE NEW EAGLE DRY PLATE.

ALSO  
THE INGLIS TRIUMPH PLATE.

A new brand of  
GERMAN PYRO ACID.

(35 cents per ounce.)  
POCKET GLASS CUTTER.

(15 cents each.)  
NEW STYLE CORNER CHAIR.

(\$10.00 each.)  
PAPIER MACHÉ STUMP.

(\$6.00 each.)  
SUNSHINE MAILING ENVELOPE.

Having contracted for a special make of glass, the SEED DRY-PLATE CO. can now guarantee a flat, even, and straight plate. A full stock of this well-known brand kept at the New York Depot by the Agent. **GEORGE MURPHY,**  
250 Mercer St., N. Y.

**BROMIDE ENLARGEMENTS.**

We are now prepared to furnish fine permanent bromide enlargements from photographers' negatives, as follows :

	Umounted.	Mounted.
10 x 12.....	\$1 00 each.	\$1 50 each.
11 x 14.....	1 25 "	1 75 "
14 x 17.....	1 50 "	2 00 "
16 x 20.....	1 75 "	2 25 "
18 x 22.....	2 25 "	2 75 "
20 x 24.....	2 50 "	3 00 "
22 x 27.....	2 75 "	3 50 "
25 x 30.....	3 00 "	3 75 "
24 x 36.....	4 00 "	4 75 "
30 x 40.....	6 00 "	7 25 "
30 x 48.....	8 50 "	10 00 "

Terms cash with order.

Specimens furnished from our own negatives at above prices.

If fine negatives are sent, finely retouched, no working up will be necessary.

We will retouch negatives or finish prints in crayon, pastel, India-ink, or water-colors at very reasonable prices, putting on any amount of work you may wish from \$1.00 upwards.

Please specify size of print, whether vignetted or solid, if vignetted how far down to show, whether mounted or unmounted on card or stretcher, whether to retouch negative or not; if you wish us to work up print give full instructions, if not, state what you want the print for, etc.

If to be made from a picture the print will cost 50 cents more, and will require finishing.

Patent stamp photos. 75 cents per hundred.

Respectfully,  
**HULBERT BROS. (Genelli),**  
923 Olive Street, St. Louis, Mo.

Another preserver of neatness is Anthony's Artist's Cuffs. The engraving makes the article



and its use plain. No more spoiled shirts or soiled wrists.

**THE LIGHT RUNNING**

**NEW HOME**

**SEWING MACHINE**

**HAS NO EQUAL.**

**PERFECT SATISFACTION**

**New Home Sewing Machine Co.**  
—ORANGE, MASS.—  
30 Union Square, N. Y. Chicago, Ill. St. Louis, Mo.  
Atlanta, Ga. Dallas, Tex. San Francisco, Cal.

**FOR SALE BY**

THE AGENTS, at the above named places.

THE DUPLEX NOVELETTE CAMERA

Is a marvel of Camera architecture. In an instant a "vertical" camera may be turned into a "horizontal," and in another the change made from the 5 x 8 to the 8 x 10 size, and *vice versa*. It is supplied in two carrying cases, so that you may leave one part at home if you desire. The same platform and one front serves for both sizes. It is as complete an equipment as ever was invented. One holder, each size, goes with the "Duplex" at \$35. Messrs. E. & H. T. Anthony & Co. are the makers.

EAGLE STOCKHOUSE.

NOW IN STOCK

TRAPP & MUNCH'S CELEBRATED

Extra Brilliant Albumen Paper,

ALSO

The Chicken Brand—Extra Brilliant.

TRY THEM.

FOR SALE BY

GEORGE MURPHY,

250 MERCER STREET, NEW YORK.

Reed's Common-sense Negative Washing-box. New. Send for circular.

WILSON, HOOD & Co.,  
825 Arch St., Phila.

Among all the photographic lenses of various makes and styles which have been introduced during the past ten years, the euryscopes, of which Voigtlander & Son are the sole manufacturers, loom up conspicuously. The success of these lenses has been unparalleled, and the demand is as lively as ever. They can be found in nearly every gallery in the land, and the amount of satisfaction and profit they produce is difficult to calculate. Most convincing proof of their superiority over other lenses is the exquisite work done with them, and the fact that it is simply impossible to get along without them.

DEAR SIR: Please send us three copies of *Long's Art of Making Crayons on Solar Enlargements*, and oblige

BUCHANAN, SMEDLEY & BRONLEY,  
25 N. Seventh Street, Phila.

FOR SALE.—Big bargain, pair of gas-bags and low pressure dissolver. All O. K.

WANTED.—A matched pair of  $\frac{1}{2}$  and  $\frac{1}{4}$  size lenses. Address H., Box 128, Indiana, Pa.

Send for our bargain list.

WILSON, HOOD & Co.,  
825 Arch St., Phila.

SPECIAL CARD.

Talcott's Improved Mounting for photographs softens the lines, gives much strength and great brilliancy to the picture, and is the only process by which a photograph may become indelible.

Patented March 23, 1886.

For preserving from all soiling engravings, etchings, crayons, diplomas, certificates, etc., this mounting has no equal, the picture or parchment being hermetically sealed.

Pictures thus mounted can be displayed or packed in less than one-half the space required by pictures with other framings, as by this process all other framing becomes wholly unnecessary, yet it is so constructed that if desired it can be placed in any ordinary picture frame intact, free from all interference.

E. K. TALCOTT,  
216 Northampton St.,  
Boston, Mass.

OUR dark-room and laboratory are under the charge of Dr. John Nicol, photographic chemist, late of Edinburgh. None but purest chemicals used in our preparations. All the standard dry-plate developers kept in stock. Your patronage desired.

GAYTON A. DOUGLASS & Co.,  
Merchants in Photo. Supplies,  
185 & 187 Wabash Avenue,  
Chicago, Ill.

EVERY photographer in want of excellent lenses, for *any purpose*, will best serve his interest by consulting the new illustrated price-list of Messrs. BENJAMIN FRENCH & Co. before purchasing.

WANTED.—A lady retoucher and spotter. Only an experienced one need apply.

Address A.,  
care of GEO. MURPHY,  
250 Mercer St., N. Y.

TEN "Dallmeyer Lenses" for sale, also six lenses of other makers, six cameras, a quantity of dry plates, trays, frames, etc., and one Entrekin Eureka Burnisher, 25 inch roll. Send for circular.

WM. A. VALENTINE, M.D.,  
50 W. 32d St., N. Y.

\$1.00

SECOND CHOICE.

New York.

DOUBLE ALBUMEN PAPER.

Extremely cheap. Samples sent.

W. HENERMANN,  
49 CEDAR STREET, NEW YORK.

**SITUATIONS WANTED.**

*No charge for advertisements under this head; limited to four lines. Inserted once only, unless by request.*

By a young man, as printer and toner. Will make himself useful. Address H. H. Snow Eau Claire, Wis.

By an artist, in a Florida photograph gallery. Can paint on plain or albumen paper. Address Helen Devenport, 1205 Filbert Street, Phila.

By a young lady as retoucher. Illinois preferred. Samples sent. Address E. F., 128 N. Orange Street, Peoria, Ill.

In the South, by a young man of good habits, as printer, toner, or general assistant. Can furnish 8 x 10 view outfit and do some operating if desired. Address Lincoln, Box 123, Harwichport, Mass.

By a young lady as retoucher and printer. Understands all kinds of work about a gallery. Address 576 Pine Street, Lockport, New York.

By temperate man, as operator and retoucher. Will not work on Sunday. North preferred. Address Emmett Whiting, Carrollton, Mo.

By a young man as first-class dark-room man and assistant operator. Address G. H. Frommann, 1303 Washington Avenue, St. Louis, Mo.

ASK FOR THE  
BLUE LABEL.

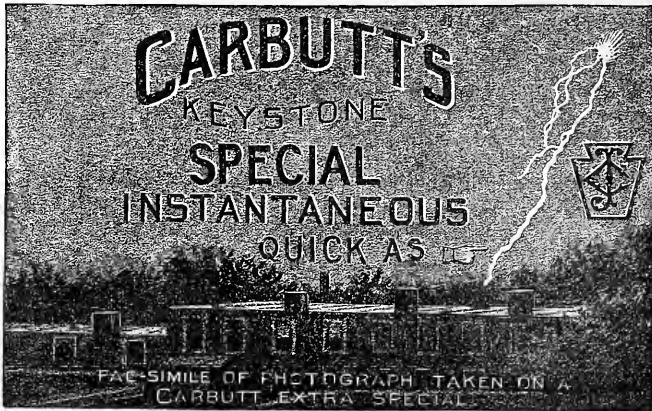

TRY THEM.  
and you will continue to  
USE THEM.

Pronounced the "Ne Plus Ultra" of Dry Plates.

UNSOLICITED TESTIMONIALS.

MR. JOHN CARBUTT, Wayne Junction, Philadelphia.

DEAR SIR: I have been using some of your new plates, emulsion 1024, sensitometer 24. I think they are, without exception, the finest and best plates I ever used. They are not only very fine and delicate in their structure, but, when properly manipulated, result in a blooming negative, possessing all the desirable qualities that any artist could wish for. I could most appropriately christen them the "Ne Plus Ultra Dry Plate."

Yours truly,

E. R. B. CLAFLIN.

DETROIT, MICH., January 16, 1886.

MESSRS. HARRIS & KITTLE.

GENTLEMEN: I am very much pleased with the Carbutt Plate; in fact, I call them the best plate by far that I tried so far. I find them especially useful for my theatrical subjects, as the quick emulsions are absolutely instantaneous.

Yours truly,

A. B. TAYLOR.

For Sale by all Dealers in Photo. Materials.

JOHN CARBUTT, Keystone Dry Plate Works, Wayne Junction, Philada., Pa.

**G. W. WILSON & CO.**

(By special appointment Photographers to Her Majesty the Queen),

MANUFACTURERS OF MAGIC LANTERN SLIDES,  
St. Swithin Street, Aberdeen.

Catalogue of 12,000 subjects in England and Scotland, and Price Lists, post free on application.

**PHOTOGRAPHERS' ART VINE.**

Beautiful and durable Ivy Vine for scenic effects; manufactured especially for photographers. All natural vines and leaves imitated. Send for circular. Special rates to dealers in photographers' supplies.

**S. G. SHERWOOD,**

232 Vermont St., Buffalo, N. Y.



# WILSON'S LANTERN JOURNEYS

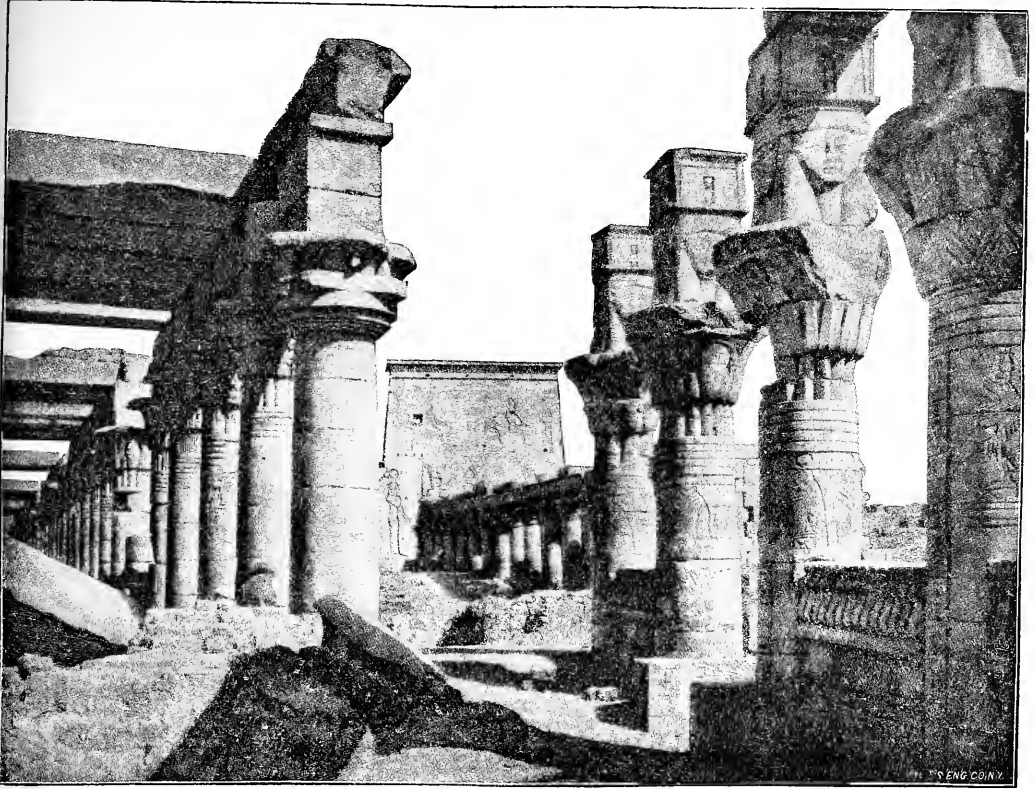

"Splendid summer reading for 'can't-get-aways' and 'can't travels.' It is lovely travel and description combined."—*Herald*.

**3 Volumes.**

**SEE WHAT COUNTRY THEY COVER.**

**3 Volumes.**

**VOLUME I. 306 PAGES, CONTAINS NINE JOURNEYS:**

A—France and Switzerland. B—Belgium, Germany, Austria, Saxony, and Bavaria. C—Italy—Lakes, Cities, and the Italian Art Galleries. D—Holland, Denmark, Norway, Sweden, Russia, and Spain. E—Egypt, Palestine, Syria, Turkey, Greece, and India. F—England, Scotland, and United States of America. G—Centennial Exhibition, Phila. H—Centennial Exhibition, Phila. I—Paris Exposition, 1878.

**IN ALL OVER 900 SUBJECTS.**

**VOLUME II. 331 PAGES, CONTAINS TWELVE JOURNEYS:**

J—Germany and Russia. K—Belgium and Austria. L—France—Cities and Provinces. M—Spain and Portugal. N—Switzerland—The Four Alpine Routes O—Italy, Ischia, and Sicily. P—Turkey, Greece, and Egypt. Q—Palestine and India. R—Scotland—Cities and Ruins. S—Ireland. T—England—Cities, Museums, and Ruins. U—United States of America.

**IN ALL 1073 SUBJECTS.**

**VOLUME III. 323 PAGES, CONTAINS ELEVEN JOURNEYS:**

Sinai Peninsula and Petra. From Hebron to Bethel. Round about Jerusalem. Picturesque Palestine—From Damascus to the Sea. A Thousand Miles in Nile Land. Nile Tombs and Temples. How They Live in Egypt. Egypt and the Egyptians. Egypt, Old and New. New Pictures of Old Places.

**IN ALL 700 SUBJECTS.**

*Gives descriptions of all slides made by Mr. Edward L. Wilson of his personally taken views of The Sinai Peninsula; The Desert of the Exodus; The Route of the Israelites to the Promised Land; and the*

## **TAKING OF PETRA.**

Readers of The Philadelphia Photographer cannot put better books on their reception-room tables than this for waiting patrons.

**PRICE \$2.00 PER VOLUME, POST-PAID.**

For Sale by all Dealers. **EDWARD L. WILSON, Photo. Publisher, 853 Broadway, N. Y.**

# \$400.00

— IN —

**TWO MAGNIFICENT PREMIUMS**

— OFFERED BY —

## N. C. THAYER & CO.

**OFFER No. 1.**—The choice of either No. 8 Suter, No. 9 Beck, or No. 7 Voigtlander Euryscope, will be given to any photographer outside of Chicago who sends us the **LARGEST SINGLE CASH ORDER** between August 1st and the closing day of the next meeting of the Photographers' Association of America.

**OFFER No. 2.**—Same as No. 1 to any photographer outside of Chicago who purchases and pays for the **LARGEST AMOUNT** of goods during the above named period.

To make these offers still more attractive, the successful competitor for one or both premiums will be allowed to select any other Lenses or other goods of equal value.

The award to be made by a committee to be chosen at the Chicago Convention of 1887, who will be authorized to examine our books and name the fortunate customers entitled to the grand prizes.

It is needless to state that our stock of Photographic Merchandise is conceded to be without exception the largest in the country. Orders, whether large or small, will receive the most careful attention.

## **N. C. THAYER & CO.**

257 and 259 State Street, - CHICAGO, ILL.

In addition to offer No. 2, we have concluded to give an 18x22 Box and Stand worth \$100.00 making the value of our Premiums

# \$500.00,

A SUM WORTH STRIVING TO OBTAIN.

*The Eagle Paper Keeps its Place as Leader.*

Try the New Colors of the Leading

**DRESDEN ALBUMEN PAPER.**

**IMPROVED**

**EXTRA-BRILLIANT PENSEC,**

10 KILOS.



10 KILOS.

**EXTRA-BRILLIANT NEW ROSE.**

**It Possesses the Highest Durability of Color.**

It Never Blisters. It Keeps Well after Silvering.  
It Tones Easily. It Gives the Most Vigorous  
and Brilliant Prints. It is the Best  
Selected Paper.

It is Always Uniform and Reliable, and has the Least  
Objectionable Water-Mark. The Majority  
of Artists will Have It.

**SAMPLES FREE ON APPLICATION.**

For Sale by all Stockdealers in the United States  
and Canada.

**G. GENNERT,**

Importer,

**No. 54 EAST TENTH STREET,**

**NEW YORK.**

# THE DUBOIS FILING CASES.

For Preserving Photographic Negatives, Prints, &c., Letters, Bills, and Miscellaneous Papers.

PATENTED SEPTEMBER 2, 1884.

**Economical! No Binding! Either a Temporary or a Permanent File.**

Made in  
five sizes and cabinet  
form.

AGENTS WANTED.

Write for Descriptive  
Circular.

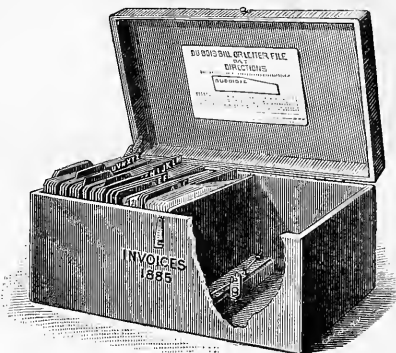

NEW YORK,  
April 27, 1886.  
Mr. FRANK G. DuBois,  
No. 512 W. 30th St., N. Y.  
DEAR SIR: Your File supplies a need that I have felt for some time past. It is the best thing of the kind that I have ever seen, and I shall be much pleased to recommend it to all my friends for preserving bills, notes, receipts, recipes, unmounted prints, photographs, and all kinds of miscellaneous papers to which easy reference may be wanted at any time. Respectfully,  
MISS SOPHIE L. MAURER.

Sent by Express, on receipt of \$3.00, or with lock and key, \$4.00.

PATENTEE AND SOLE MANUFACTURER,

FRANK G. DuBOIS, 512 W. 30th St., New York.

TO THE TRADE ONLY. **HYPOSULPHITE OF SODA** FOR PHOTOGRAPHERS. **CHAS. A. W. HERRMANN,** 16 Cedar St. New York. TO THE TRADE ONLY.

<p>THE LARGEST ESTABLISHMENT IN THE WORLD</p>	<p>SIXTEEN YEARS PRACTICAL EXPERIENCE</p> <p><b>MOSS ENGRAVING CO.</b></p> <p>535 PEARL ST. COR. ELM. NEW YORK</p>	<p>ILLUSTRATIONS OF Every Description For Books, Magazines, Newspapers, Catalogues, CIRCULARS, &amp;c. in the Most Perfect Style of the Art</p>
<p>MOSS' NEW PROCESS Superior to Any Other Method.</p>		
<p>SEND GREEN STAMP FOR 24 PAGE CIRCULAR -- SEND PHOTOGRAPH, DRAWING OR PRINT FOR ESTIMATE.</p>		

**C. H. CODMAN & CO.**  
**Photographic Stockdealers**

Sole Agents for the NEW ORTHO-PANACTINIC LENS, Moor's Photographic Enamel, the Perfect Mounting Solution for mounting Photographs on the thinnest mount without wrinkling.

New England Agents for the American Optical Co.'s Apparatus. The best in the world. Send for Price List.

34 Bromfield Street.

BOSTON, MASS.

720 (5 gross) of these trimmers were sold to one party in July.

# ROBINSON'S NEW MODEL PHOTOGRAPH TRIMMERS!

This drawing is of the full natural size and shape of the New Model Revolving Trimmer. The Straight Cut is of same size, varying but little in shape.

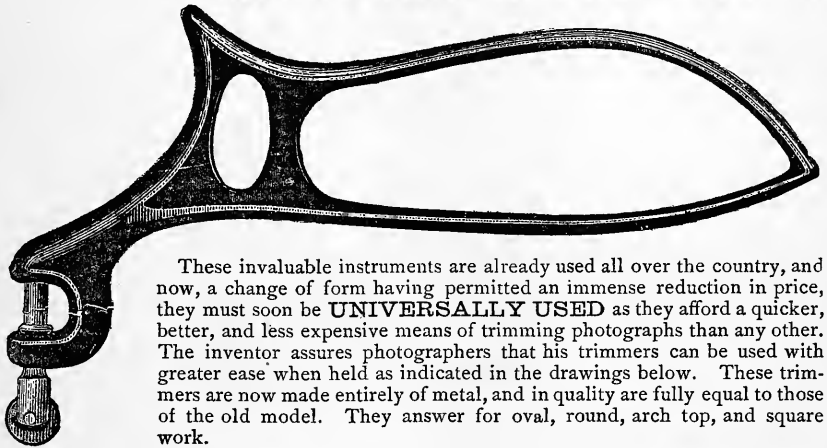

These invaluable instruments are already used all over the country, and now, a change of form having permitted an immense reduction in price, they must soon be **UNIVERSALLY USED** as they afford a quicker, better, and less expensive means of trimming photographs than any other. The inventor assures photographers that his trimmers can be used with greater ease when held as indicated in the drawings below. These trimmers are now made entirely of metal, and in quality are fully equal to those of the old model. They answer for oval, round, arch top, and square work.



Plan of holding the *Straight Cut* Trimmer when in use. PRICE, 50 CENTS.

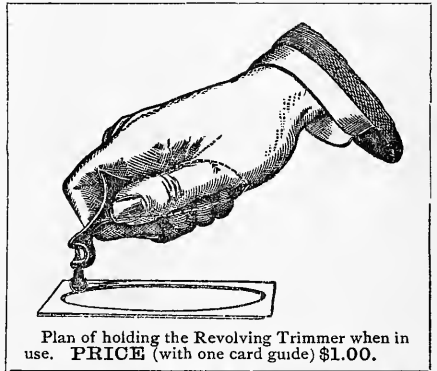

Plan of holding the Revolving Trimmer when in use. PRICE (with one card guide) \$1.00.

## ROBINSON'S GUIDES.

MADE OF SHEET-IRON.

We have the following Regular Sizes always on hand at 10 cents per inch the longest way of the aperture.

OVALS.			SQUARE OR ROUND CORNERED.				
2 x 2 <sup>7</sup> / <sub>8</sub>	3 x 4 <sup>3</sup> / <sub>8</sub>	5 x 7	6 <sup>1</sup> / <sub>2</sub> x 8 <sup>1</sup> / <sub>2</sub>	2 <sup>1</sup> / <sub>8</sub> x 3 <sup>3</sup> / <sub>8</sub>	2 <sup>5</sup> / <sub>8</sub> x 3 <sup>3</sup> / <sub>8</sub>	2 <sup>3</sup> / <sub>4</sub> x 4 <sup>1</sup> / <sub>2</sub>	4 x 5 <sup>5</sup> / <sub>8</sub>
2 <sup>1</sup> / <sub>2</sub> x 3 <sup>1</sup> / <sub>2</sub>	3 <sup>3</sup> / <sub>8</sub> x 4 <sup>3</sup> / <sub>8</sub>	5 <sup>1</sup> / <sub>2</sub> x 7 <sup>1</sup> / <sub>4</sub>	6 <sup>3</sup> / <sub>8</sub> x 8 <sup>3</sup> / <sub>8</sub>	2 <sup>3</sup> / <sub>8</sub> x 3 <sup>3</sup> / <sub>8</sub>	2 <sup>1</sup> / <sub>2</sub> x 3 <sup>5</sup> / <sub>8</sub>	2 <sup>1</sup> / <sub>2</sub> x 4 <sup>3</sup> / <sub>8</sub>	4 <sup>1</sup> / <sub>2</sub> x 5 <sup>3</sup> / <sub>8</sub>
2 <sup>3</sup> / <sub>8</sub> x 3 <sup>1</sup> / <sub>2</sub>	3 <sup>1</sup> / <sub>2</sub> x 4 <sup>1</sup> / <sub>2</sub>	5 <sup>3</sup> / <sub>8</sub> x 7 <sup>3</sup> / <sub>8</sub>	7 x 9	2 <sup>1</sup> / <sub>2</sub> x 3 <sup>1</sup> / <sub>2</sub>	2 <sup>3</sup> / <sub>8</sub> x 4 <sup>1</sup> / <sub>2</sub>	3 <sup>3</sup> / <sub>8</sub> x 5 <sup>1</sup> / <sub>2</sub>	3 <sup>3</sup> / <sub>8</sub> x 6
2 <sup>1</sup> / <sub>2</sub> x 3	3 <sup>5</sup> / <sub>8</sub> x 5	5 <sup>1</sup> / <sub>2</sub> x 7 <sup>3</sup> / <sub>8</sub>	7 <sup>1</sup> / <sub>2</sub> x 9 <sup>1</sup> / <sub>2</sub>	2 <sup>5</sup> / <sub>8</sub> x 3 <sup>1</sup> / <sub>8</sub>			4 x 6 <sup>3</sup> / <sub>8</sub>
2 <sup>3</sup> / <sub>8</sub> x 3 <sup>3</sup> / <sub>8</sub>	4 x 5	5 <sup>3</sup> / <sub>8</sub> x 7 <sup>3</sup> / <sub>8</sub>	7 <sup>3</sup> / <sub>8</sub> x 9 <sup>3</sup> / <sub>8</sub>		<b>FOR STEREOGRAPHS.</b>		
2 <sup>1</sup> / <sub>2</sub> x 4 <sup>1</sup> / <sub>2</sub>	4 <sup>3</sup> / <sub>8</sub> x 6	6 x 8	7 <sup>3</sup> / <sub>8</sub> x 9 <sup>3</sup> / <sub>8</sub>	3 <sup>1</sup> / <sub>8</sub> x 3 <sup>3</sup> / <sub>4</sub>	3 x 3	3 <sup>1</sup> / <sub>8</sub> x 3 <sup>3</sup> / <sub>4</sub>	3 x 3
					Arch Tops.	Round Cornered.	Round.

The above sizes suit the Collins Card Mounts, and photographers knowing that they can be always had at the low price of ten cents per inch, would do well to *make their sizes accord*, as orders can also be filled more quickly. Ten days are required to make special sizes.

Special Sizes made to order, at 15 cents per inch, the longest way of the aperture.

**ROBINSON'S PHOTOGRAPH TRIMMERS** are substitutes for the Knife for Trimming Photographs, and do the work much more expeditiously and elegantly. They Save Time, Save Prints, and Save Money.

They do not cut, but *pinch off* the waste paper, and leave the print with a neatly bevelled edge which facilitates adherence to the mount. Try one, and you will discard the knife and punch at once. For ovals and rounded corners they are worth their weight in gold.

For sale by all Dealers.

**ROBERTS & FELLOWS,**

Successors to E. L. WILSON,

1125 Chestnut St., Philadelphia, Pa.



# PERMANENT BROMIDE ENLARGEMENTS.

Having equipped an Enlarging Department for testing our Permanent Bromide Paper, we are prepared to make enlargements from Photographers' Negatives, promptly and of the best quality. When *good original* negatives are furnished, these enlargements require little or no finishing, and are far superior to those made by any other process whatever.

Permanent Bromide Enlargements can be finished in India ink, crayon, water colors, or oils.

Pack negatives carefully, and specify whether to be *vignetted* or *solid*. *Plain* enlargement signifies unfinished.

Specify whether stretcher or card mount is desired.

## PRICES OF PERMANENT BROMIDE ENLARGEMENTS.

### ON CRAYON PAPER.

	Unmounted.	Mounted.
10 x 12, each.....	\$1 00	\$1 50
11 x 14, " .....	1 25	1 75
14 x 17, " .....	1 50	2 00
16 x 20, " .....	1 75	2 25
18 x 22, " .....	2 25	2 75
20 x 24, " .....	2 50	3 00
22 x 27, " .....	2 75	3 50
25 x 30, " .....	3 00	3 75
24 x 36, " .....	4 00	4 75
30 x 40, " .....	6 00	7 25

## PRICES OF PERMANENT BROMIDE ENLARGEMENTS.

### MATT SURFACE ON OPAL GLASS.

10 x 12, each.....	\$3 00
11 x 14, " .....	3 50
14 x 17, " .....	4 00
16 x 20, " .....	5 00

Terms: Cash with order. Specimens furnished from our own negatives at the above prices.

**The EASTMAN DRY PLATE AND FILM CO.**  
ROCHESTER, N. Y.

# ANTHONY'S SATCHEL DETECTIVE CAMERA.

**I**N outward appearance, and to the ordinary observer, this latest modification of the Detective Camera looks exactly an alligator hand-satchel that is carried by a shoulder-strap at the side of the pedestrian. Upon closer observation, one sees that it consists of an artfully-concealed Detective Camera, in which all the movements to secure a picture are situated upon the under side.



For use the camera is held so that the base of the satchel rests against the body of the operator. By means of a brass pull at the side the shutter is set. A plate in the regular holder is placed in position at the back of the camera and the slide is drawn ready for exposure. The release of a short catch exposes the front of the shutter ready for action, and by raising a small leather-covered lid the little camera obscura called the finder, on the (now) upper side of the camera, shows the position that the object will occupy on the plate. The slightest touch upon a small brass button releases the shutter, and the exposure is made. Replacing the slide in the plate holder, reversing the holder, and setting the shutter again, leaves the apparatus in readiness for another shot, when the plate-holder slide is withdrawn.

By removing a screw that takes the place of the spring lock of an ordinary satchel the camera proper can be removed from its cover and the screw removed serves to attach the camera to a tripod for ordinary use.

This last form of the Detective Camera allows the operator to carry with him twelve plates in the interior of the apparatus, and so carefully packed away that no light can strike them. It is



also furnished with an ingenious attachment by which the speed of the shutter can be regulated to suit the speed of the objects, moving with greater or less velocity; while, by simply releasing a catch, time exposures can be made at the will of the operator. In fact the whole affair is the latest achievement in ingenious and compact light photographic apparatus.

Size 4 x 5 in Imitation Alligator or Grained Leather, with one Patent Double Dry Plate Holder.....	\$80 00
" 4 x 5 in Genuine Alligator, with one Patent Double Dry Plate Holder.....	85 00
" 4 x 5 in Imitation Alligator or Grained Leather with rear compartment containing six Patent Double Dry Plate Holders.....	95 00
" 4 x 5 in Genuine Alligator, with rear compartment containing six Patent Double Dry Plate Holders.....	100 00

LARGER SIZES MADE TO ORDER.

FOR SALE BY ALL DEALERS.

**E. & H. T. ANTHONY & CO., Manufacturers.**



FORTY-FIFTH HUNDRED BEING SOLD.

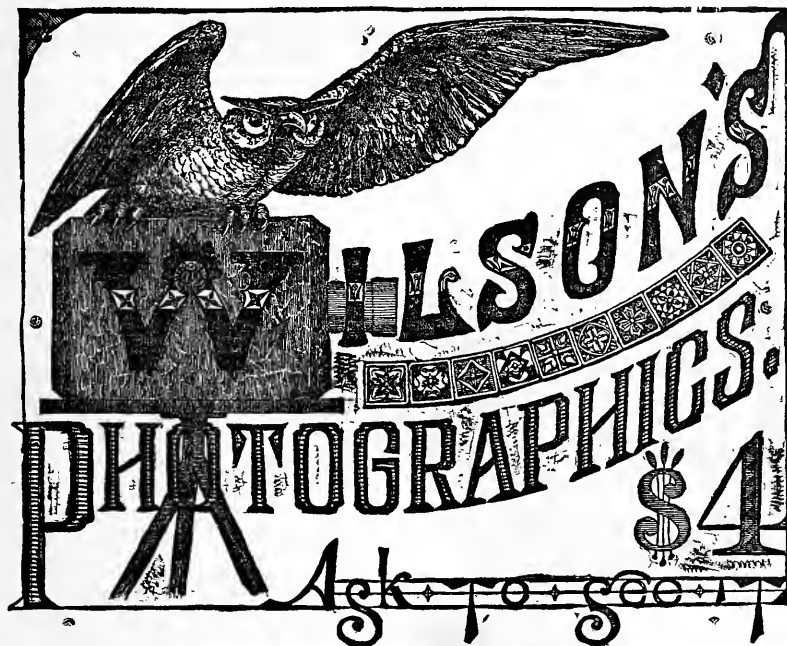

FORTY-FIFTH HUNDRED BEING SOLD.

# A PARTIAL PHOTOGRAPHIC ENCYCLOPEDIA.

By EDWARD L. WILSON, *Editor "Phila. Photographer," "Photo. Mosaics," etc.*

**A STANDARD BOOK FOR ALL WORKERS IN PHOTOGRAPHY.**

## CONTENTS.

LESSON A. TREATMENT OF THE SUBJECT—B. THE NEEDFUL APPARATUS—C. THE OBJECTIVE OR LENS—D. THE DARK-ROOM—E. PREPARATION OF THE GLASS—F. CHEMICALS AND SOLUTIONS—G. THE MANIPULATIONS—H. MANIPULATORY MISERIES—I. RETOUCHING THE NEGATIVE—J. THE GLASS STUDIO—K. ACCESSORIES AND LIGHT—L. MANAGING THE MODEL—M. PRINTING ON ALBUMEN PAPER—N. PRINTING ON PLAIN PAPER—O. GENERAL REMARKS ON PRINTING—P. PRINTING ON VARIOUS SURFACES—Q. PRINTING PERPLEXITIES—R. ART IN PRINTING—S. MOUNTING AND FINISHING—T. PHOTOGRAPHY OUTSIDE—U. BROMO-GELATINE EMULSION WORK—V. VOGEL'S COLLODION EMULSION—W. ENLARGEMENTS AND LANTERN SLIDES—X. PHOTOTYPES, PLATINOTYPES, AND COLLODION TRANSFERS—Y. WASTES AND THEIR WORTH—Z. METRICAL MEASURING—&. CONCLUDING CONFAB—INDEX (SIX PAGES).

It is believed that this is the most valuable work ever offered to the working photographer. Its sale was never equalled. It contains 352 pages; 7 x 8½ inch cover, and is 1½ inches thick. More than 100 illustrations. It gives full details of all practical

## PROCESSES, OLD AND NEW, PUBLIC AND SECRET.

Among the latter are the "Phototype," sometimes called the "Artotype" process, with examples; many of the "Lightning" processes; the "Platinotype" process; the "Collodion Transfer" or "Megatype" process, and many others.

58 pages are devoted to Posing and Lighting; 37 pages give instructions in Emulsion "Dry" Work; 29 pages show how to Build and Use Skylights; 108 pages furnish instructions for Manipulating Negatives; 37 pages are applied to Printing Formula and Dodges; 175 pages give Notes from Authors all over the world. It is printed on fine white paper, made especially for it, and sold at the low price of

**\$4.00 POST-PAID \$4.00.**

For the beginner, for the amateur, for the photographic worker, it is believed to be most complete. No live photographer should fail to get it soon, before his neighbor is ahead. For sale by all dealers.

**EDWARD L. WILSON, Publisher, 853 Broadway, New York.**

**VENI, VIDI, VICI!**

THE WONDER OF THE P. A. of A. CONVENTION  
AT ST. LOUIS.



Only Five Months in Existence, and Carried off the  
Honors from All Comers.

The judges at the St. Louis Convention awarded the exhibitors **Seven Medals**, gold and silver, for work done on the **EAGLE DRY PLATE**, the photographs being, without exception, the gems of the exhibit.

How could it be otherwise with such a plate, when for **Reliability, Rapidity, Delicacy of Detail, and Extreme Brilliancy**, they surpass all other makes of Dry Plates in the market.

Their reception by the photographic profession at large, speaks volumes in their favor, they being now used by the leading lights of the photographic world, both professional and amateur.

Came, saw, and conquered! Truly, such was the case, and in the future our aim will be to lead them to further conquest.

**EAGLE DRY-PLATE CO.**

**G. GENNERT,**

**54 East Tenth Street, New York,**

**GENERAL AGENT.**

HOME FROM THE ST. LOUIS CONVENTION.

## THE GEMS.

The New Goods ordered, and will be in ready stock shortly, viz.:

*Hermagis Lenses.*

*Felt Grounds.*

*Curtains. Late Designs.*

*Knapp & Caldwell's New Accessories.*

*Ashe's New Garden Seat.*

*Ashe's New Telescopic Balustrade.*

*Acme Burnishers.*

*Eastman's Bromide Paper.*

*Young's Patent Double-barrelled Shutter.*

*The New 5 x 8 Novelette View Box, with 8 x 10 Attachment.*

*Barnett's Holders.*

*Nash's Detective Camera.*

*Bird's Patent Vignetter.*

*Perfection Drop Shutter.*

*Perfection Shutter for  $4\frac{1}{4}$  Gem Lenses.*

*Moreno's Universal Developer.*

*Collins' New Cabinet Mounts.*

## THE CELEBRATED SEED PLATES.

*Two Gold Medals awarded to Exhibitors whose pictures were made on these Plates.*

DETAILED LISTS OF THE ABOVE WILL BE ISSUED SHORTLY.

GEORGE MURPHY,

Photo. Goods. 250 Mercer St., New York.

---

# GAYTON A. DOUGLASS & CO.

MERCHANTS IN

# SUPPLIES FOR PHOTOGRAPHY,

185 & 187 Wabash Ave.,

# CHICAGO.

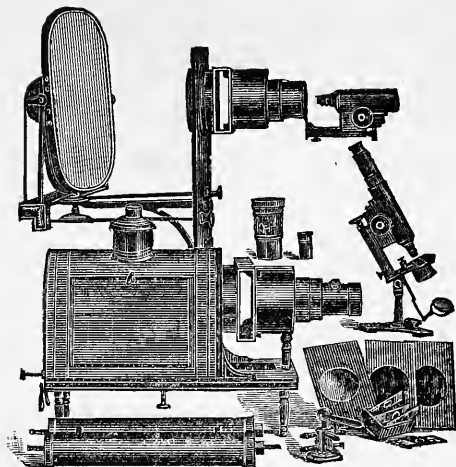

# OPTICAL AND ELECTRICAL INSTRUMENTS.

We desire to call the attention of  
TEACHERS, SCIENTISTS, LECTURERS, and  
those interested, to our

**Stereopticons, Microscopes, Dr. McIntosh's Solar Microscope and  
Stereopticon Combination Apparatus for  
the Oxy-hydrogen and Ether-oxygen Lime Light, Photographic  
Transparencies, Microscopical Preparations, etc.**

Our Instruments and Apparatus are new in design and have many improvements  
that overcome difficulties heretofore considered unavoidable. We also manufacture

**Static Electric Machines, Batteries, Magnets, and a Full Line of  
Electrical Apparatus for Practical and Experimental  
Purposes.**



We received the highest  
award at the New Orleans  
World's Exposition, on  
both Optical and Elec-  
trical Apparatus, in com-  
petition with the best of  
home and foreign manu-  
facturers.



Illustrated Catalogue of Optical and Electrical Apparatus sent free on application  
by mentioning this journal.

**McIntosh Galvanic and Faradic Battery Co.**

Nos. 300 & 302 Dearborn Street,

CHICAGO, ILL., U. S. A.

# THE PHILADELPHIA PHOTOGRAPHER.

TWENTY-THIRD YEAR, 1886.

*Devoted to the Advancement of Photography and the Dissemination of Art Principles.*

SEMI-MONTHLY: issued the First and Third Saturday of each month.

\$5.00 a year, \$2.50 for six months, \$1.25 for three months—in advance. 30 cts. per copy.

## CONTENTS OF THE SECOND QUARTER.

**APRIL 3.**—Art and Photography, by G. HANMER CROUGHTON. Paper Negatives, by W. B. GLINES. Quicker Than the Wind. Developer for Rapid Exposures—Which? A Contribution Toward Precision in Calculation of Exposures. Constitution of Solar Spots, by M. J. JANSSEN. An International Photographic Congress. Photo. Facts and Fancies. Queries, Conundrums, and Conclusions. The World's Photography Focussed. Society Gossip. Pertaining to the P. A. of A. Practical Points from the Studios. What an Old Photographer says for Old and New Workers. Celestial Photography. A Big Offer. Views from My Office Window. Our Picture. Editor's Table.

EMBELLISHMENT.—"The Bride," by J. F. RYDER, Cleveland, Ohio.

**APRIL 17.**—Æsthetics and Photography, by XANTHUS SMITH. Celestial Photography at the Observatory of Paris. Queries, Conundrums, and Conclusions. Defects in Gelatine Dry Plates, by JAS. C. BALMAIN. Weights and Measures, by JOSEPH DORELLA. The Open Corner. A Process for Printing with Fatty Inks. The Humor of It. Photographing the Eclipse of the Sun. Correspondence. Obituary. Society Gossip. Our Picture. Photographing, a Pictorial Art, by P. H. EMERSON, B. A., M. B. Cantab. The World's Photography Focussed. Editor's Table.

EMBELLISHMENT.—"Island of Philæ—South Colonnade," by EDWARD L. WILSON.

**MAY 1.**—Negative Paper and Permanent Bromide Paper. Art and Photography, by G. HANMER CROUGHTON. A Good Notice on Photography from the Globe of the Hub. How We Take with "Artists." Practical Points from the Studios. Photozincographic Process. Home Portraiture. The Open Corner. New Copyright Law in Great Britain. Photo. Facts and Fancies. Queries, Conundrums, and Conclusions. The World's Photography Focussed. Pertaining to the P. A. of A. Society Gossip. Our London Correspondence. Views from My Office Window. Bibliography. Our Picture. The Humor of It. Editor's Table.

EMBELLISHMENT.—"The East," by GEO. HANMER CROUGHTON.

**MAY 15.**—Patience in Art. The Department of Art. Coloring Positive Prints. The Humor of It. Exhibition of the Pacific Coast Amateur Photographic Association. The Open Corner. Views from My Office Window. Queries, Conundrums, and Conclusions. Society Gossip. Kindly Words for a Worthy Colleague, Pertaining to the P. A. of A. Correspondence. A Good Move. A New Method of "Storing" Paper Negatives, Films, and Photographic Prints. Practical Points from the Studio. Managing an Overdeveloped Plate. Sharply. Steinheil Lenses. Our Picture. The World's Photography Focussed. Editor's Table

EMBELLISHMENT.—"Listening to the Birds," by JOHN E. DUMONT, Rochester, N. Y.

**JUNE 5.**—St Louis. About Our Last Call. Light for the Dark-room—Blue Prints, by C. G. BUSCH. Negative Paper and Films, by KEHAMA. How Frenchmen Wash Their Gelatine Plates. Pictures from Newfoundland. How to Print, by CHARLES KRAUSS. On Photographing the Retina of the Living Human Eye, by WM. THOS. JACKMAN, M. R. C. S., ENG., and J. D. WEBSTER. Pertaining to the P. A. of A. Amateurs in New Quarters. Society Gossip. A Convenient and Inexpensive Apparatus for Making Lantern Slides, by C. R. PANCOAST. Gihon on Crayon Portraits. The Photographer and the Anarchist. Our Picture. Queries, Conundrums, and Conclusions. Editor's Table.

EMBELLISHMENT.—"Land of the Morning Calm," by G. CRAMER, of St. Louis.

**JUNE 19.**—My Photographic Hobby. The Department of Art. On the Use of Eastman's Permanent Bromide Paper. Printing Eastman Film Negatives. The S. O. of S. P. Lighting Dark-rooms. Views from My Office Window. That Big Offer. Collodio-chloride Printing by an Improved Method. The Removal of Silver Stains from Gelatine Negatives, by DANIEL ROBERTSON. Practical Points from the Studios. A Question of Conscience. Correspondence. Our Picture. Pertaining to the P. A. of A. Photo-mechanical Printing. A Means of Making Money for Photographers. The Solar Spectrum of 1884. Queries, Conundrums, and Conclusions. Public and Press Recognition of Photography. Development of Instantaneous Negatives with Carbonate of Soda, by M. BALAGNY. Carbon Electrodes without Metal. The Humor of It. Photo-Rival of the Telephone. An Annoying Strike "Off." C. S. F. A.—C. S. P. The World's Photography Focussed. Editor's Table.

EMBELLISHMENT.—"The Studio of Talamea," from "Adonis." By Electric Light, by W. L. MOZART.

The above six numbers to one address for \$1.25, prepaid. The numbers for January, February, and March to one address, post-paid, \$1.25.

The Philadelphia Photographer and Weekly Photographic Times to one address, \$6.50.

The Philadelphia Photographer and Anthony's Bulletin to one address, \$7.00.

EDWARD L. WILSON, 853 Broadway, New York.

OFFICE OF

# G. CRAMER DRY PLATE WORKS,

Shenandoah and Buena Vista Sts., St. Louis.

---

The enlargement of my factory being now completed, I am able to serve my patrons more promptly than heretofore.

Thanking the fraternity for their kind patronage, and soliciting a continuance of the same, I am  
Fraternally yours,



DRY-PLATE WORKS, ST. LOUIS, MO.

---

**THE**

## ST. LOUIS DRY PLATE COMPANY

Beg to announce that under their New Management they have recently made Important Improvements and Increased their Facilities, so that they are now making better and more uniform plates than heretofore.

---

ALL ORDERS WILL RECEIVE PROMPT ATTENTION.

---

**ST. LOUIS DRY PLATE CO.**

No. 827 Chouteau Avenue,

ST. LOUIS, MO.

Number 281.

30 Cents.

THE  
PHILADELPHIA  
**Photographer.**

AN ILLUSTRATED SEMI-MONTHLY JOURNAL,

DEVOTED TO PHOTOGRAPHY.

## SUMMARY OF CONTENTS.

	PAGE		PAGE
Photography from a Balloon, . . . . .	513	Our Picture, . . . . .	525
Art and Photography. By G. HANMER CROUGHTON, . . . . .	515	The Use of the Centrifugal Separator in Preparing Gelatine Emulsion. By JOSEPH PLENNER, . . . . .	526
A New Method of Obtaining Enlarged Negatives, . . . . .	517	Queries, Conundrums, and Conclusions, . . . . .	532
On the Action of Ferric Salts Employed in Conjunction with Sodium or Ferric Hyposulphite in Reducing Overdensity, . . . . .	519	Photographic Day at Chautauqua, . . . . .	535
The Humor of It, . . . . .	521	A Piece of Presumption, . . . . .	536
On Photographing Interiors. By VALEN- TINE BLANCHARD, . . . . .	522	The World's Photography Focussed, . . . . .	537
Practical Points from The Studios, . . . . .	524	Facts and Fancies, . . . . .	540
		The Open Corner, . . . . .	540
		Editor's Table, . . . . .	542

OUR PICTURE.—“The West.” Negatives by H. BUTLER, Vermillion, Dakota. Prints by Messrs. Roberts & Fellows, Phila., on N. P. A. Pensée Paper.

EDWARD L. WILSON,  
*853 Broadway, New York.*

SUBSCRIPTIONS RECEIVED BY ALL NEWS AND STOCKDEALERS

Five Dollars per Annum, in Advance.

## ADVERTISEMENTS.

AIR BRUSH.  
 ALLEN BROTHERS. The Suter Lens.  
 ANTHONY & CO., E. & H. T. The New N. P. A. Pensé Extra Brilliant Dresden Albumen Paper.  
 BARHYDT, J. A. Solar Crayon Portraits.  
 BIGELOW'S ARTISTIC PHOTOGRAPHY.  
 BUCHANAN, SMEDLEY & BROMLEY. Photo. Stockdealers.  
 CARBUTT, J. Gelatine Dry Plates and Improved Dry Plate Lantern.  
 CARPENTER, H. F. Analytical and Manufacturing Chemist.  
 CODMAN, C. H. & CO. Photo. Stockdealers.  
 COLLINS, SON & CO., A. M. Photograph Cards.  
 CRAMER, G. Lightning Plates.  
 DR. VOGEL'S AZALINE.  
 DEALERS' DIRECTORY.  
 EASTMAN DRY-PLATE AND FILM CO.  
 ENTREKIN, W. G. Patent Eureka Burnisher. Duplex Rotary Burnisher. Duplicating Print-Cutter.  
 FRENCH & CO., BENJ. Voigtlander & Son and Darlot Lenses. The Wonderful Euryscope.  
 HANCE'S SPECIALTIES.

HERRMANN, CHAS. A. W. Hypo. Soda.  
 HYATT, H. A. New Brand of Dry Plates.  
 INGLIS, JAMES. Dry Plates.  
 MAGEE & CO., JAS. F. Photographic Chemicals.  
 MCINTOSH GALVANIC AND FARADIC BATTERY CO.  
 MOORE, ALBERT. Solar Enlarger.  
 MOSS ENGRAVING CO.  
 PAINE, A. B. & CO. Hypo. Eliminator. PHOTOGRAPHIC TIMES.  
 SCOVILL MANUFACTURING CO. New Dresden Albumen Three Crown Paper. Gihon's Cut-Outs. Photo. Apparatus.  
 STANLEY DRY PLATE.  
 STEINHEIL LENS.  
 ST. LOUIS DRY PLATE COMPANY.  
 THE DU BOIS FILING CASES.  
 WALMSLEY & CO. Beck's Rectilinear Lens.  
 WILSON, HOOD & CO. Ross and Steinheil Lenses, Photo. Frames, Goods, Stereoscopes. and Views  
 WILSON'S PHOTOGRAPHICS.  
 WILSON, G. W. & CO. Magic Lantern Slides.  
 WILSON'S PHOTOGRAPHIC PUBLICATIONS,  
 WILSON'S LANTERN JOURNEYS.

## ADVERTISING RATES.

THE PHILADELPHIA PHOTOGRAPHER is acknowledged to be the best advertising medium in the trade.

Its circulation is among the first class, at home and in nearly every foreign country.

Its rates, all advantages considered, are the most favorable, and it will bring you fine returns.

	One Issue.	Six Issues.	Twelve Issues.	Twenty-four Issues.
1 Page.....	\$20.00	\$110.00	\$200.00	\$350.00
1-2 " .....	12.00	66.00	120.00	200.00
1-4 " .....	7.00	38.50	70.00	120.00
1-8 " .....	4.00	22.00	40.00	70.00

Special contracts made with bona-fide dealers and manufacturers. Address

**EDWARD L. WILSON,**  
853 BROADWAY, NEW YORK.

## NOTICE TO SUBSCRIBERS.

In remitting by mail, a post-office order, or draft, payable to the order of EDWARD L. WILSON, is preferable to bank-notes. Postage stamps of the denomination of two and five cents each will be taken. Clearly give your Post-Office, County, and State.

Foreign subscriptions must be accompanied by the postage in addition.

**FIRE!** Our books having been all destroyed by fire at and with our establishment, all who owe us will confer a great favor by remitting at once.

**CROSSCUP & WEST ENGRAVING CO.**

907 Filbert St., Philadelphia.



SOLE AGENTS FOR THE AMERICAN CONTINENT,  
DETROIT, MICH.

# ALLEN BROTHERS,

In the above letters, where blanks occur, the Lenses referred to are the best known on both Continents. Mr. E. Suter was awarded a silver medal for invention and construction of Lenses at the recent International Inventions Exhibition at London, England. Her Britannic Majesty's Government has purchased a set of Suter Lenses for the use of the South Kensington Museum. Count Schouvaloff, Russian Ambassador at Paris, uses a Suter Lens. Andrew Pringle, Esq., the eminent Scotch Photographer, uses Suter Lenses. A. L. Henderson, the English professional photographer, gets his effects with a Suter Lens. A European maker of high reputation has made unsuccessful overtures to Mr. Suter to make all their photographic lenses. We comment these facts to the people who assert that because the Suter Lens is sold at a low price, it must be an inferior instrument.

Dear Sir: Your price current has reached me and I thank you for it. My friend and Photographic Colleague, Prof. W. Donkin, Honorary Secretary of the Photographic Society of England, has said to me that in the opinion of Captain W. De W. Abney, your photographic lenses are perfect, giving negatives extremely fine. I send you my cheque, praying you to send me at the earliest possible moment your Aplanatic Lens, No. 8 B. I intend taking with this Lens some large views on the high Alps. Hoping to receive soon a perfect instrument. Please accept the assurance of my highest consideration.

This from a prominent Italian amateur:

Bergnac, France, April 28, 1886.  
Mr. E. Suter, Bâle: I await with impatience the two lenses you have promised to make me. Observe the beautiful seasons, and I am anxious to make some instantaneous views. The lens No. 5 A, which you have sold me is *excellent* and above all, very rapid. I rely on your kindness, and pray you to accept my best regards.

Bergnac, France, April 28, 1886.  
Mr. E. Suter, Bâle: I await with impatience the two lenses you have promised to make me. Observe the beautiful seasons, and I am anxious to make some instantaneous views. The lens No. 5 A, which you have sold me is *excellent* and above all, very rapid. I rely on your kindness, and pray you to accept my best regards.

Sosnowitz, 29th October.  
My Dear Mr. Suter: At last I have received your price list (the second one), as the first letter has been lost on the way. To-day I send you from Kalowitz, Silesia, a photograph of myself taken at Warsaw, by Brandel. The picture was taken with an Aplanat, made by—, with fourth stop, in two seconds (emulsion). I would have bought one of these instruments if Mr. H. Wambeck, who owns an emulsion factory in London, had not dissuaded me. This gentleman spoke about your instruments which were unknown to me and Mr. Brandel, as follows: "The instruments of Suter—are quicker and stronger than the— instruments, but far better than either of these are the instruments of—, are good as the enclosed picture shows. I would therefore like to use the Aplanat for photographing horses, and asked for your address immediately. I would therefore like to have an Aplanat B, No. 8, provided the same can do as good work as the enclosed picture shows. Mr. Brandel will undoubtedly also become your customer as soon as he has sufficient proof of the excellency of your instruments. The gentleman is an amateur. Please tell me by return mail what you would advise me to do. May be that an Aplanat No. 6 would be better. In—'s Lenses I remain your obedient servant.  
P. S. I would like to get one of your Objectives sent to Vienna on trial. I will be there during January.

The following is from an Austrian officer:

Warsaw, Poland, March 12, 1886.  
Mr. Suter, Bâle: Mr. Wambeck, of London, England, tells me that you manufacture an Objective marked "Series A," which greatly excels in the instantaneous process, especially in photographing in the public streets, with movable objects. He has his good opinion of your Objectives upon the experiment of the renowned London photographer, Wilson, who has used your instrument with the best success. We intend to take Street Photographs (size 1 1/2 x 1 1/8 centimetres), in this city, but must have the picture clear and strong up to the very edge of the plate. We use neutral (Arges) stop.

Extract from a letter from the noted Polish firm of Karoli & Pusch, Warsaw:

From personal information gained in England and Continental Europe, we make the unqualified assertion that the Suter Lenses are now the Best in the World. We submit a few testimonials from eminent sources.

# THE SUTER LENS IN EUROPE.

# WILSON'S PHOTOGRAPHIC PUBLICATIONS.

→\*A TREATISE ON EVERY BRANCH OF PHOTOGRAPHY.\*←

## THE PHILADELPHIA PHOTOGRAPHER,

A Semi-monthly Magazine, illustrated by photographs of superior merit. \$5.00 a year; \$2.50 for six months.

Stands ahead of all its kindred. Twenty-one years of success is a sufficient guarantee of its value and use to the practical, working, growing photographer. Do not go without its valuable help. See Prospectus.

### WILSON'S LANTERN JOURNEYS.

By EDWARD L. WILSON. In Three Vols.  
Price, \$2.00 per vol.

For the lantern exhibitor. Gives incidents and facts in entertaining style of about 2000 places and things, including 200 of the Centennial Exhibition.

### WILSON'S PHOTOGRAPHICS

THE NEWEST AND MOST COMPLETE

PHOTOGRAPHIC LESSON-BOOK.

COVERS EVERY DEPARTMENT.

352 Pages. Finely Illustrated. Only \$4.00.

By EDWARD L. WILSON.

### BIGELOW'S ARTISTIC PHOTOGRAPHY.

For lovers of the art. Beats his "Album of Lighting and Posing." Suberb! With twelve photographs and instructions. Price reduced to \$4.00.

### THE FERROTYPERS' GUIDE.

Cheap and complete. For the Ferrotyper, this is the only standard work. Seventh thousand. Price, 75 cts.

### THE PROGRESS OF PHOTOGRAPHY

A NEW BOOK.

By Dr. H. VOGEL. Price, \$3.00.

A splendid work.

### STUDIES IN ARTISTIC PRINTING.

By C. W. HEARN. Price, \$3.50.

Embellished with six fine cabinet and promenade portrait studies.

### PICTORIAL EFFECT IN PHOTOGRAPHY.

By H. P. ROBINSON. For the Art Photographer. Cloth, \$1.50. Paper cover, \$1.00.

THE

### PHOTOGRAPHIC COLORISTS' GUIDE.

By JOHN L. GIBON. Cloth bound, \$1.50.

The newest and best work on painting photographs.

### PHOTOGRAPHIC MOSAICS, 1886.

Cloth bound, \$1.00; paper cover, 50 cents.  
Back volumess. same price.

Better than any of its predecessors.

COPIES MAILED POST-PAID ON RECEIPT OF PRICE.

## EDWARD L. WILSON,

Photo. Publisher.

853 Broadway, New York.

# UNSOLICITED TESTIMONIALS.

COR. BROAD AND MARKET STS., NEWARK, N. J., July 3, 1886.

EASTMAN DRY-PLATE AND FILM CO., Rochester, N. Y.

GENTS: The enlargements came duly to hand. We are very much pleased, and they give satisfaction to the customers who ordered them. We must say that this class of work *must take*, and we think it is one of the most beautiful results that we have as yet seen. Will you kindly return the paper negative of men on top of Tally-Ho coach, and oblige, as we have some silver prints to take from it. The glass negatives came all O. K.

Yours truly, THOMAS & CO

P. S. If we had thought, we could have sent you some elegant paper negatives and prints, which we think would have done credit to the process, for exhibition at St. Louis, but we suppose it is too late now.

25 NEW STREET, TRENTON, N. J., June 28, 1886.

EASTMAN DRY-PLATE AND FILM CO., Rochester, N. Y.

GENTS: Please send me circular and sample print of your Permanent Bromide Paper. I have been using your Eastman-Walker Roll-Holder, and it gives me complete satisfaction. Yours respectfully,

CHAS. J. RODGERS.

NIAGARA FALLS, N. Y., May 17, 1886.

EASTMAN DRY-PLATE AND FILM CO., Rochester, N. Y.

GENTLEMEN: I have been making a few paper negatives last week, with perfect success. Have not printed them yet, but will to-day.

Yours truly, CHAS. BIERSTADT.

208 FULTON STREET, BROOKLYN, N. Y., July 2, 1886.

EASTMAN DRY-PLATE AND FILM CO., Rochester, N. Y.

GENTS: Enclosed you will find my check for the Roll-Holder. It is attached to my 8 x 10 compact camera, and the two work so well together that one is led to think that each was intended for the other. As a trial for paper negatives and Roll-Holder (the first I have made), while in a pleasure party, I made nine exposures, and secured nine good negatives, which I consider very satisfactory; and with an experience of thirty years, I feel confident that in a very short time, your invention for making negatives on paper, either on rolls or sheets, will supersede all other sensitive mediums. Congratulating you on the perfection of your negative paper, also the roll-holder, I am,

Very respectfully, G. F. E. PEARSALL.

42 JOHN STREET, NEW YORK, June 18, 1886.

EASTMAN DRY-PLATE AND FILM CO., Rochester, N. Y.

GENTLEMEN: We were much pleased with the results obtained on the last lot of negative paper sent us. The grain seems to be entirely absent, and the rendering of the negative translucent by means of the preparation "Translucine." It seems both effective and easy.

Very truly, E. W. SMITH & CO.

CAZENOVIA, N. Y., June 18, 1886.

EASTMAN DRY-PLATE AND FILM CO., Rochester, N. Y.

GENTLEMEN: Please make two more enlargements from same negatives, same size and style as the first, and return negatives as soon as done. Mail enlargements unmounted. We are very much pleased with the work. It finishes perfectly in crayon.

Yours truly, MARSHALL BROS. & CO.

MONTICELLO, IND., June 12, 1886.

EASTMAN DRY-PLATE AND FILM CO., Rochester, N. Y.

GENTLEMEN: We have been very successful with the bromide paper, and think it is just the thing for enlargements.

Very truly yours, LIGHTY BROS.

230 ST. LOUIS ST., SPRINGFIELD, MO., May 28, 1886.

EASTMAN DRY-PLATE AND FILM CO., Rochester, N. Y.

GENTLEMEN: The two prints, or enlargements, came safely, and I am delighted with them. Think I will want the material to use in my gallery. Hope to see you at the Convention. Very respectfully,

G. W. SITTLER.

DELAVAN, ILL., June 25, 1886

EASTMAN DRY-PLATE AND FILM CO., Rochester, N. Y.

GENTLEMEN: The 24 x 36 Permanent Bromide print and smaller prints at hand. Thanks. The G. A. R. Post seem very well pleased. It is much better than I thought the negative would make. I find I am, by comparison, getting along all right with my prints. Just as soon as I can save the wherewithal, I shall have one of your enlarging outfits. I shall probably send you some more negatives in a few days.

Yours truly, E. D. SHAW.

# BENJ. FRENCH & Co.

No. 319 WASHINGTON STREET, BOSTON,

Sole Agents in the United States for the Celebrated Lenses  
Manufactured by

## VOIGTLÄNDER & SON.

ALSO, THEIR FAMOUS

# EURYSCOPE,

Which is unrivalled for groups, full-length figures, and other demands in the gallery, and every species of out-door work, including instantaneous photography.

☞ **THE EURYSCOPE** is made *exclusively* by Voigtländer & Son, and their name is engraved on the tube.

FOR **DARLOT LENSES** FOR  
PORTRAITS. VIEWS.

IMPORTERS, ALSO, OF THE CELEBRATED

TRAPP & MÜNCH

## ALBUMEN PAPER,

AND DEALERS IN ALL KINDS OF

*Photographic Materials and Magic Lantern Slides.*

SEND FOR OUR NEW ILLUSTRATED PRICE LIST OF LENSES.

# H. F. CARPENTER,

29 & 31 Page St., Providence, R. I.

## ANALYTICAL AND MANUFACTURING CHEMIST.

Refiner of PHOTOGRAPHIC WASTES.

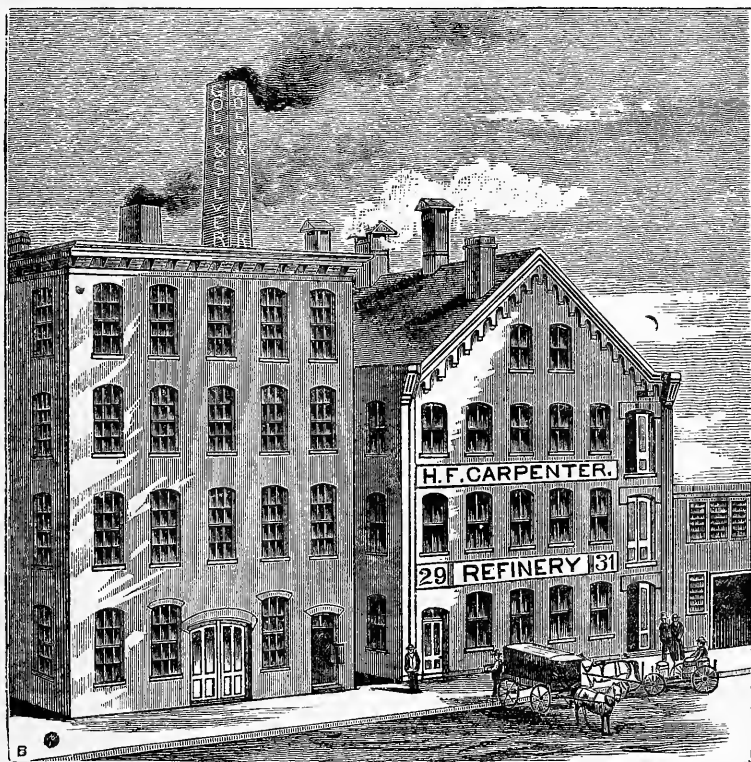

## Assayer and Sweep Smelter.

Nitrate of Silver and Chloride of Gold.

Chemically pure gold prepared especially for Photographers' use at \$1.10 per dwt.

Information given on application in regard to methods of saving waste.

The Following is of Interest to every Photographer.

---

THE NEW N. P. A.  
P E N S E.

We desire to call attention to our **NEW PENSÉ N. P. A.** Extra Brilliant Dresden Albumen Paper.

The manufacturers at Rives have recently made many marked improvements in their celebrated paper, and all the sheets of this brand are **manufactured specially for it**, and are readily distinguished from all other papers by the **water-mark N. P. A.**

It is doubly albumenized by the **most experienced house** in Germany, with **new and improved** formulas, and we are confident that on trial it will be found superior to any other in market.

Its excellence has induced some unscrupulous persons to place the **STAMP** on the Paper of other makers, in order to work it off, trusting that photographers will not look through to see if the **water-mark** is there. To prevent this we have registered ~~as~~ This Trade Mark ~~in~~ in Washington, which will subject to heavy damages all those who stamp this brand on paper which does not bear **EXTRA-BRILLIANT N.P.A.** the **water-mark N. P. A.** This Paper can be had also in **DRESDEN. PINK, PEARL or WHITE.**

**FOR SALE BY ALL DEALERS IN PHOTO. GOODS IN U. S. AND CANADA.**

---

**E. & H. T. ANTHONY & CO.,**  
591 Broadway, **NEW YORK.**

N. B.—When any paper is offered to you at a low price, **Measure it.**

Also note whether it runs **Uniform**, for some albumenizers mix the first and second qualities, not discarding that which has defects, and thus get their paper cheaper.

NEW SIZE, 20½ x 24½, \$45.00 per ream.

# THE STANLEY DRY PLATE

Has passed through the ordeal of its first summer, and its manufacturers have almost entirely escaped the usual trials of fogging, frilling, and other perplexities. In fact, the quantity sold in July exceeds that of any former month.

Its *unusual combination of sensitiveness and brilliancy* have made it a general favorite, and the territory into which it penetrates grows constantly larger.

## AMONG ITS RECENT ACHIEVEMENTS ARE

*Instantaneous Views of the Decoration Day Parade* (3d size stop), taken without sunlight, used as a Bulletin Illustration.

*Views of Horses and Carriages entering Central Park*, trotting rapidly across the field of view, sharp and clear cut. These will appear in the Bulletin.

*Views of Steamboats* going twenty miles an hour directly across the field, taken at 5.30 P. M. Sharp and clear as if standing still.

*The Life-size Portrait of J. F. Ryder*, by McMichael, shown at the Buffalo Convention, was made on an 18 x 22 Stanley Plate in five seconds, with a Dallmeyer Rapid Rectilinear Lens.

*Instantaneous Views*, by Mr Henry J. Newton, President of Photographic Section of the American Institute, about which he writes:

"I found that **sunshine was not absolutely necessary for instantaneous negatives on these plates**, and I think a majority of the negatives I send you were made when there was not sufficient sunlight to cast a visible shadow. I think it is due that I should say that the plates worked satisfactorily in every respect, exhibiting extreme sensitiveness, responding readily to the developer, and going steadily on to the finish.

P. S. I used the Prosch Shutter at its full speed."

(Signed),

H. J. NEWTON.

And now to crown the whole, Mr. Parkinson writes as follows:

E. & H. T. ANTHONY & Co :

PARKINSON PHOTO. PARLORS, 29 W. 26TH ST.,  
NEW YORK, August 12, 1885.

"GENTLEMEN: I take pleasure in assuring you that I made a group portrait in my gallery of an old lady of eighty years, with child of four years, a month or two since, on a Stanley 18 x 22 plate, in one second, with Dallmeyer Rapid Rectilinear Lens. A little more time would have done no harm; but the picture in question has elicited as many words of praise from visitors to my studio as any other in same length of time."

Yours truly,

W. B. PARKINSON.

The Stanley Dry Plates can be had from any dealer, or direct from

**E. & H. T. ANTHONY & CO.,**  
591 BROADWAY, NEW YORK.

Another thing that has gone rapidly to the front is the



When Dry Plates were first introduced it *was not yet on the market*, and the old stereotyped developing formulas do not mention it; but in the developing formulas of the more recent *popular plates*, as the STANLEY and the ST. LOUIS, the E. A. Pyro is recommended as most desirable, and in the EASTMAN DRY PLATE Co. formulas the same preference is given ever since they *knew of its merits*.

It is always used by the veteran "Roche," and constitutes one of the main elements in the popular Cooper's Developer.

Every photographer should try the E. A. Pyro. Every dealer has it, or ought to have it, or it can be had direct from

**E. & H. T. ANTHONY & CO., 591 Broadway, N. Y.**

---

# A. B. PAINE & CO.'S HYPO. ELIMINATOR.

SOMETHING LONG PRAYED FOR.

No more yellow prints. No more yellow plates. Prints mounted and plates dried one-half hour after fixing. The greatest time-saver ever invented.  
One ounce enough for one day's work.

Price, per Pint, 50 cents; Quart, 90 cents; Two Quarts, \$1.50.

A. B. PAINE & CO., Sole Manufacturers,  
*Photo. Stockdealers.* FORT SCOTT, KAS.

Ask your Dealer for it, or send direct to Manufacturers.

---

# DR. VOGEL'S AZALINE.

FOR SALE BY

W. KURTZ, 6 East 23d Street, New York.

---

**ALBERT MOORE** THE SOLAR ENLARGER,  
THE LONGEST, LARGEST, AND BEST.  
828 Wood Street, Philadelphia.

---

**JAMES F. MAGEE & CO.**

*522 Race St., Philadelphia,*

**Manufacturers of Pure Photographic Chemicals,**

**Specialties: NITRATE OF SILVER and CHLORIDE OF GOLD.**

❖REFINERS OF GOLD AND SILVER WASTE.❖

❖Waste sent through Stockdealers will receive prompt attention.

---

**G. W. WILSON & CO.**

(By special appointment Photographers to Her Majesty the Queen),

**MANUFACTURERS OF MAGIC LANTERN SLIDES,**  
St. Swithin Street, Aberdeen.

Catalogue of 12,000 subjects in England and Scotland, and Price Lists, post free on application.



---

## A CARD.

---

75 STONE ST., ROCHESTER, N. Y., July 26, 1886.

GENTLEMEN: About three months ago the business of Inglis & Co., of this city was formed into the Inglis Dry Plate Co.

In the articles of agreement, a clause was inserted giving the I. D. P. Co. the exclusive use of the name of "Inglis," and also that James Inglis would not connect himself with any dry plate business using the name of "Inglis."

Matters have taken such a form since then, he has been compelled to leave the I. D. P. Co. And being thus debarred from the use of his own name, adopts this means of making known to his numerous customers where they may still obtain his plate. **And the Only Place.**

A new firm taking the name of the **ROCHESTER DRY PLATE CO.** have engaged his services, and under his supervision a new factory has been fitted with the most modern improvements required for the production of **clean and spotless** plates, with all the other extra qualities that his plate has become so renowned for. The fraternity may therefore depend upon the very finest plate ever yet produced, from the **ROCHESTER DRY PLATE CO.**

### JAMES INGLIS,

Late Manufacturer of the Inglis Dry Plate, and President  
of the Inglis Dry Plate Co.

---

## THE AIR BRUSH.

---

This New Art Tool applies color by a jet of air. It is invaluable to any photographer who produces his own large work. Portraits may be made over solar or contact prints, on plain or Albumen Paper, in India Ink, or Water Colors, etc.

*Lights built up on Flat Negatives, Cloud Effects in Backgrounds for  
View Work, etc., all can be accomplished by this Tool,*

with the greatest rapidity, and with a perfection bounded only by the capacity of the artist. Full particulars FREE. Address

**AIR BRUSH MFG. CO., 50 Nassau St., Rockford, Ill.**

---

## ARTISTIC PHOTOGRAPHY.

By LYMAN G. BIGELOW.

---

The best work there is to teach how to light and pose the human figure. Instructions and formulæ and **Twelve Photo. Cabinet Illustrations** of varied sexes and ages.

**\$4.00. POST-PAID. \$4.00.**

---

EDWARD L. WILSON, Publisher, 853 Broadway, N. Y.

A. M. Collins, Son & Co.

*MANUFACTURE ALL KINDS OF*

**CARDS AND CARDBOARDS**

FOR

**P**

---

**HOTOGRAPHER**

---

**S**

AND

**MATS, MOUNTS, AND ENVELOPES**

FOR

**FERROTYPES.**

---

OFFICE AND WAREHOUSE,

**No. 527 ARCH STREET,**

**PHILADELPHIA.**

---

Price Lists may be had by intending purchasers on application to us, or to all Photographic Merchants, through whom your favors are respectfully solicited.

JOHN G. HOOD.

ESTABLISHED 1865.

WM. D. H. WILSON.

# WILSON, HOOD & CO.

## 825 Arch St., Philadelphia,

SOLE AGENTS IN THE UNITED STATES FOR THE



Centennial, 1876.



Centennial, 1876.

## Ross' Portrait and View Lenses.

Portrait Lenses, from 1-4 to 8 x 10.  
Cabinet Lenses, Nos. 2 and 3.  
Card Lenses, Nos. 1, 2, and 3.  
Triplets, Nos. 1, 2, 3, 4, 5, 6, and 7.  
Symmetricals. Rapid Symmetricals.

Instantaneous Doublets, all sizes.  
Medium Angle Doublets, all sizes.  
Large Angle Doublets, all sizes.  
Stereographic Lenses, all sizes.  
New Universal Lenses.

Numerous testimonials pronounce them to be the *best* as well as the *cheapest* Foreign Lenses ever offered to the American Photographer. We will mail price list on application, and promptly fill all orders. Always in stock,

## CAMERA BOXES,

Made by AMERICAN OPTICAL CO., ANTHONY, BLAIR, and ROCHESTER OPTICAL CO.

WE KEEP IN STOCK FULL ASSORTMENT OF

## AMATEUR PHOTO. OUTFITS

DRY PLATES OF ALL MAKES.

N. P. A., EAGLE, and S. & M. PAPER, PER REAM, \$34.00.

Any article needed we can supply, as

WE MANUFACTURE, IMPORT, AND DEAL IN ALL KINDS OF

*Photo. Goods, Frames, Stereoscopes and Views,*

At prices as low as are consistent with the quality of goods furnished. We are indebted to our customers for the patronage during the past *Twenty Years*, and our efforts shall be to merit a continuance of it.

Illustrated Price Lists supplied free. Correspondence solicited.

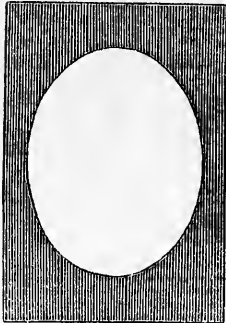

# GIHON'S CUT-OUTS

An Entirely New Variety for  
PRINTING MEDALLION PICTURES.

Are the very best that are made, and are now without a rival in the market. They are clean cut, most desirable shapes and sizes, and made of non-actinic paper, manufactured specially for the purpose. Each package contains 30 Cut-Outs, or Masks, with corresponding Insides, assorted for five differently sized ovals and one arch-top.

*Price, \$1.00 per Package. Sent by mail on receipt of price.*

Parties wishing special sizes, or large lots of a few sizes, may have them cut to order promptly by addressing the manufacturer. No lot costing less than \$1.00 made at a time.

*No printer should attempt to make Medallion Pictures without them.*

## THEY HAVE NO EQUAL FOR QUALITY.

Beware of spurious imitations made of common paper, full of holes, badly cut, and odd shapes and sizes. Ask your Stock-dealer for GIHON'S CUT-OUTS, and see that they are in his envelope, with instruction circular included. The recent packages are composed of an entirely new variety and of a new paper. TRY THEM.

Promenade Size now Ready. Sold Separately at 50 cents per Dozen.

# GIHON'S OPAQUE

Is designed for Completely obscuring the Imperfect Backgrounds of Copies, Retouching Negatives, Faulty Skies in Landscapes, Coating the Inside of Lenses or Camera Boxes, Backing Solar Negatives, Covering Vignetting Boards, And for Answering all the Requirements of the Intelligent Photographer in the Production of Artistic Results in Printing.

Wherever you want to keep out Light, use Opaque.

IT IS APPLIED WITH A BRUSH, DRIES QUICKLY AND STICKS.

**CUT-OUTS (thirty), \$1.00. OPAQUE, 50 Cents.**

FOR SALE BY ALL DEALERS.

ROBERTS & FELLOWS, Makers, Philadelphia.

Address all orders to

SCOVILL MANUFACTURING CO., New York.

“THE MOUND CITY”  
**Photographic Stock House**



Offers the Most Complete line of  
 Photographic Apparatus, Chemicals,  
 Picture Frames, Mouldings, Mats,  
 Albums, Etc., in the market,  
 at bottom prices.

Professional and Amateur Outfits a Specialty.

AGENT FOR

KUH'S LIGHTNING DRY-PLATE INTENSIFIER,

AND

KUH'S SENSITIZED PAPER STRETCHER AND DRYER.

Address

**H. A. HYATT,**

8th & Locust Sts.,

ST. LOUIS, MO.

Send for Illustrated Catalogues of Photographic Goods and Picture Frames.

## BECK'S AUTOGRAPH RECTILINEAR LENSES.

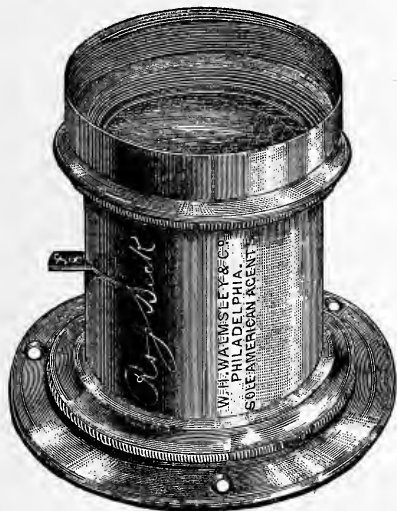

THESE extraordinary lenses attracted universal attention at the late St. Louis Convention; the specimens of work in Portraiture, Groups, Landscapes, Instantaneous Views, etc., executed by them being of unequalled excellence. A life-sized head, made with the 8 x 10 lens of 13 inches focus, was considered by the experts present, as being far ahead of any similar performance ever seen. A full description of these and our other specialties will be found in our full catalogue. *Mailed Free.*

**W. H. WALMSLEY & CO.,**

*Photographic Stockdealers.*

**1016 Chestnut St., Phila., Pa.**

# ENTREKIN'S

## IMPROVED

# DUPLEX ROTARY BURNISHER.

PATENTED.

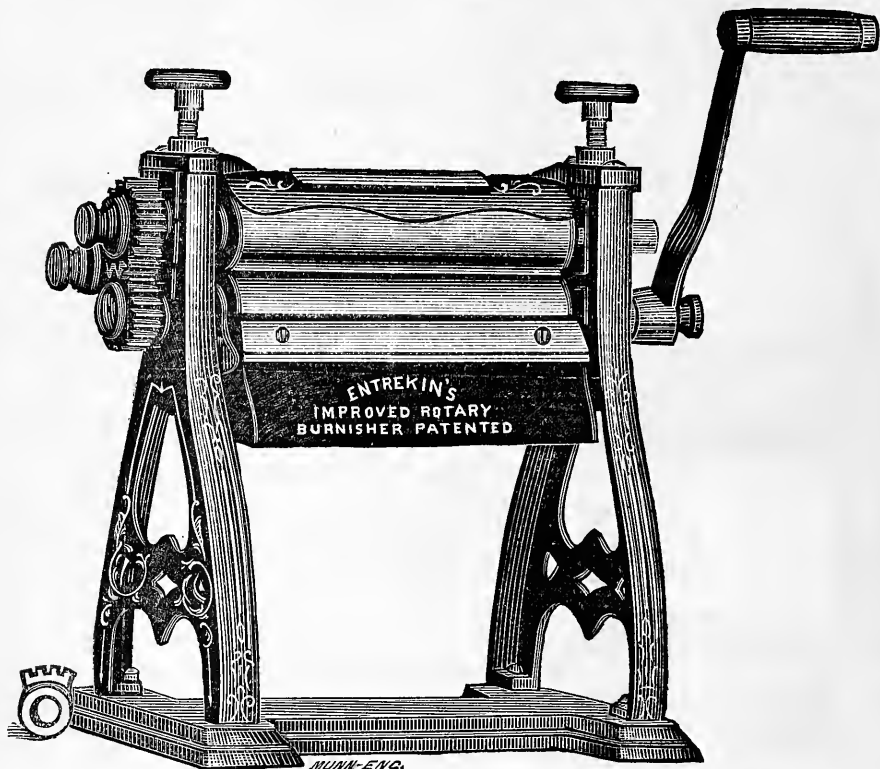

10 in., \$25.00. 15 in., \$35.00. 20 in., \$45.00. 25 in., \$60.00.

This Machine is an improvement on our old Duplex Rotary Burnisher, invented by us in 1874.

It is so constructed that by changing the Large Gear or Cog-wheel, from the stud to the end of the draw-file or upper roll, you reverse and change the speed of the lower or polishing roll, thus getting the same result as in the old Duplex Rotary; but to secure the best polishing surface, use the machine with the large cog-wheel on the Stud, by so doing you secure three times the polishing surface. All the machines will be sent out with gearing so arranged as to give this result. It is optional with the Photographer how he may use the machine. The Fire-Pan is so arranged that it is impossible for it to come in contact with the surface of the polished roll, and it can be turned away to cleanse the roll.

**EVERY MACHINE WARRANTED PERFECT.**

FOR SALE BY

**W. G. ENTREKIN, Inventor and Sole Manufacturer,**

4384 Main St., Manayunk, Philadelphia, Pa.

AND BY ALL PHOTOGRAPHIC STOCKDEALERS.



# 500 UNSOLICITED TESTIMONIALS AND MORE.

PLEASE READ THE LAST ONE.

A New Edition, with a twenty-four page appendix,  
giving all new processes  
practically useful, is now ready—  
**THE CHAUTAUQUA EDITION.**

*Northwestern Business College,  
St. Louis City, Mo. June 14, 1886.  
Edw. L. Wilson, Esq.*  
Dear Sir:— I am highly pleased with *Photographics*. In an experience of over 30 years teaching I have used and examined many text books, but have found none more ably written, or more exhaustive of the subjects treated, in so small a compass. Containing, as it does, a clear exposition of the methods used and proved by the long experience of the Author, together with notes from over 200 eminent practitioners, it cannot fail to prove a valuable aid (not only to the amateur, but to the professional as well. Theory and Practice follow each other so closely, that the student can *know and do* at once.  
*C. Cochran*

If your old copy is worn out, get  
**THE CHAUTAUQUA EDITION.**  
If you have never owned *Photographics*, get  
**THE CHAUTAUQUA EDITION.**

**\$4.00**

## WILSON'S

**\$4.00**

**NEW  
EDITION.**



**NEW  
EDITION.**

**JUST  
READY.**

## PHOTOGRAPHICS

**JUST  
READY.**

*Edward L. Wilson.*

**\$4.00**

**\$4.00**

### THE BEST PHOTOGRAPHIC LESSON-BOOK.

By **EDWARD L. WILSON,**

*Editor of "The Philadelphia Photographer," "Photographic Mosaics," etc.*

The author believes it to be the best effort he has ever made, and begs to call attention to a few of its peculiar advantages as  
**A STANDARD WORK FOR ALL WORKERS IN PHOTOGRAPHY.**

- A. Treatment of the Subject.
- B. The needful apparatus.
- C. The Objective or Lens.
- D. The Dark Room.
- E. Preparation of the Glass.
- F. Chemicals and Solutions.
- G. The Manipulations.
- H. Manipulatory Miseries.
- I. Retouching the Negative.
- J. The Glass Studio.
- K. Accessories and Light.

- L. Managing the Model.
- M. Printing on Albumen Paper.
- N. Printing on Plain Paper.
- O. General Remarks on Printing.
- P. Printing on Various Surfaces.
- Q. Printing Perplexities.
- R. Art in Printing.
- S. Mounting and Finishing.
- T. Photography Outside.

- U. Bromo-Gelatin Emulsion Work.
- V. Vogel's Collodion Emulsion.
- W. Enlargements and Lantern Slides.
- X. Photo types, Platinotypes, and Collodion Transfers.
- Y. Wastes and their Worth.
- Z. Metrical Measuring.
- & Concluding Confab.
- Index (six pages).

The index added is very full and will enable the reader to quickly find almost any subject needed on every practical department of the art Sent post-paid for \$4.00 by

**EDWARD L. WILSON, 853 Broadway, New York.**



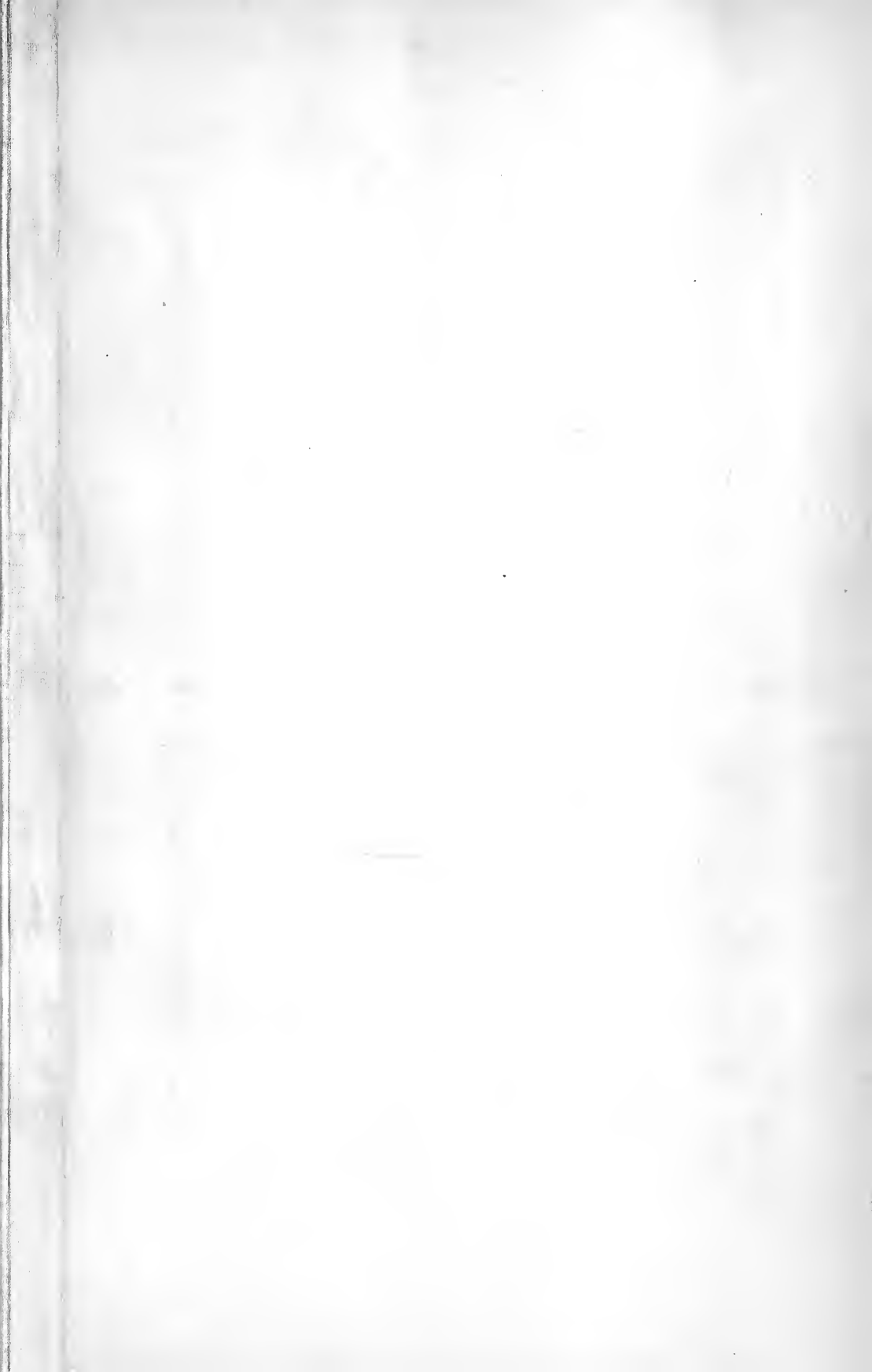



H. BUTLER,

WEST

VERMILION, D. T.

THE

# Philadelphia Photographer.

EDITED BY EDWARD L. WILSON.

Vol. XXIII.

SEPTEMBER 4, 1886.

No. 281.

## PHOTOGRAPHY FROM A BALLOON.

SOME months ago Mr. John G. Doughty, photographer, and Mr. Alfred E. Moore, aeronaut, of Winsted, Conn., called at our office with a series of very excellent and interesting views made from a balloon. We were asked to refrain from any remarks concerning them until a projected paper should appear in one of our leading magazines.

The September *Century* magazine relieves us from our bondage, for it contains a paper by each of the gentlemen upon their balloon experience, illustrated by magnificent engravings from the photographs and from original drawings.

In straightforward, graphic style, both gentlemen tell the stories of their experience which are full of thrilling interest and entertainment. Mr. Moore "would be an aeronaut from youth up," and Mr. Doughty was tempted to step in with him. Their wild chases among and above the clouds resulted in some very curious and very beautiful pictures.

Among others engraved in the *Century* are the following:

No. 2. View of balloon in the air over Winsted, Conn., 3050 feet from the earth. In the car were Messrs. Moore and Doughty, together with several hundred pounds of photographic apparatus, philosophical instruments, and balloon paraphernalia. It

was from *this* point and at *this* time that view No. 3 was taken; thus giving an illustration of a balloon at a given height, and a view of the earth from the balloon at the same height.

No. 3. View of a portion of Winsted, Conn., taken from the balloon 3050 feet from the earth. Mr. Doughty says: "Although we are at this time less than three-quarters of a mile high, and can hear a distant car whistle and the discharge of a gun immediately under us, it is impracticable with the naked eye to distinguish any animal life in the view below unless it be in motion. This view illustrates how the earth looks from a height as shown in view No. 2.

No. 5. View of the earth from an altitude of one mile. Mr. Doughty made this exposure at 2.30 one afternoon late in the autumn and succeeded in getting a beautiful, clean-cut negative. From this height, when there are no clouds to obstruct the vision, the entire state seems to be divided up into irregular plots of ground as shown. The different shades serve to distinguish the various crops.

No. 7. Near view of large cumulus cloud. Mr. Doughty waited until within 100 feet of the cloud before he made the exposure; the next instant they were enveloped within its damp folds. The thermometer will drop from 25 to 35 degrees in as many seconds in these large white

summer-day clouds. They are beautiful to behold, but dark, damp, and disagreeable to encounter.

No. 9. View through a hole in the bottom of the car down one and one-quarter miles. If the reader will place this picture upon the table or floor and look directly down upon it from a distance of at least two feet, he will realize the immense height at which this picture was taken. The roads look like cotton threads, broad streams dwindle to the proportions of mountain trout-brooks, and the beautiful autumnal foliage adds the charm of color to the landscape. From this point of observation Mt. Tom, Mass., the Catskills, N. Y., and Long Island Sound are plainly visible to the naked eye.

No. 11. A view of Windsor, Conn. This was the last view taken before landing, from a height of 2600 feet, and shows objects several miles distant with great clearness. The Connecticut river is seen passing across the center of the view, and winding through the middle distance, the Farmington flowing to its union with the Connecticut. One can observe the many reflections from the smooth water surfaces, even from the further bank of the Connecticut, six miles away. The foreground shows an extent of several miles of woods, in which the landing was made. The effect of a hazy atmosphere in gradually cutting off the view of the earth, is well shown in the view across the river. The mouth of the Scantic river is seen at the left of the centre of the view, across the Connecticut river. The long village of South Windsor is seen at the right of the view in the distance.

Considering all the circumstances, the photo. excellence of these views is phenomenal. The engravings are after the *Century* style, and unapproachable. We were permitted by the Century Co. to inspect them and read the papers before publication, and to make the following extracts from the latter. Mr. Doughty writes on photographing from a balloon as follows:

"The mountains crossed in this delightfully easy manner, we were over the town of Bloomfield; and an exposure was made on what seemed to us a fine type of the better class of New England homestead, which, with its large fields, trim fences, and

ample buildings was directly below us. This view, taken at the height of one mile, is wonderfully distinct, when we consider the distance of the objects from the camera, the conditions necessary to the taking of an instantaneous picture, and our very unsteady support. The stone and rail fences, bounding the fields of all sizes and shapes, are shown with great sharpness. The pasture, meadow, and cultivated land are plainly indicated; also the curiously regular arrangement of the crops. The trim and regular appearance of the orchards is well contrasted with the variety and freedom of growth in the woodland; and the photographic effect of the autumnal colors is indicated by the foliage of a group of white birches near the centre of the view, as contrasted with the dark, unchanged green of the orchards."

Mr. Moore relates some amusing adventures of his first amateur experience when he took a contract to "run a balloon for a show," though he had never before seen one. He writes:

"As nearly as could be judged, I was more than a mile high, and all sounds from the earth had ceased. There was a death-like silence which was simply awful. It seemed to my overstrained nerves to forbode disaster. The ticking of the watch in my pocket sounded like a trip-hammer. I could feel the blood as it shot through the veins of my head and arms. My straw hat and the willow car snapped and cracked, being contracted by the evaporation of the moisture in them and by the fast cooling temperature. I was compelled to breathe a little quicker than usual on account of the rarity of the atmosphere. I became sensible of a loud, monotonous hum in my ears, pitched about on middle C of the piano, which seemed to bore into my head from each side, meeting in the centre with a pop; then for an instant my head would be clear, when the same experience would be repeated. By throwing out small pieces of tissue-paper I saw that the balloon was still rapidly ascending. While debating with myself as to the advisability of pulling the valve-rope (I was afraid to touch it for fear it would break) and discharging some gas, the earth was lost sight of, and the convic-

tion was forced upon me that this must be the clouds! It made me dizzy to think of it. Above, below, and upon all sides was a dense, damp, chilly fog. Upon looking closer, large drops of rain could be seen silently falling down out of sight into what seemed bottomless space.

"I was alone, a mile from the earth, in the midst of a rain-cloud and the silence of the grave. Moreover, I had sole charge of the balloon; if it had not been for this fact I could have taken a little comfort, as I had no confidence in my ability to manage it. A rain-storm upon earth is accompanied by noise; the patter of the rain upon the houses, trees, and walks always attends the storm; while here, although the drops were large, they could not be heard falling upon the balloon or its belongings. Silence reigned supreme. The quiet spoken of by Dr. Kane and other Arctic explorers as existing in the northern regions, was a hubbub beside this place. More tissue-paper was thrown out; seeing that it seemed to ascend, I knew that the apparatus was slowly descending, being brought down by the weight of rain upon it. Soon the earth was in view. How peaceful and quiet it looked! Immediately the whistling of railroad trains could be heard.

"Now mountains could be distinguished from valleys, and the cawing of frightened crows and the shouting of men could be heard. I passed immediately over Tallcott Mountain tower, where there were some two hundred people enjoying the day. I could plainly hear one blowing a horn. As the balloon slowly descended men could be seen running from all sides toward the place of landing. Now the hum of insects could be heard, and the grapnel, with a hundred feet of rope attached, was thrown out; it soon struck the ground, and dragged lazily along through the turf and over the stones without getting a secure hold. I approached a man weighing three hundred pounds, who was sitting upon a stone wall all out of breath from running. Without the formality of an introduction I asked him to 'catch on to that anchor and stop the business.' With a woe-begone look upon his honest face and an ominous shake of the head he replied: 'It's no use, young fellow; I can't work

my bellows.' But as the rope twitched along near him, he fell upon it, and my journey was ended."

The whole of these papers should be read by every photographer, for the adventures of these gentlemen and their publication in the *Century* mark an era in photographic science.

---

## ART AND PHOTOGRAPHY.

### UNDER THE SKYLIGHT—LIGHT AND SHADE.

BY G. H. CROUGHTON.

If I had to build a skylight for portraiture I would build the old-fashioned ridge-roof glass house, at least thirty feet long and not less than twelve feet wide, with glass on one side of both ridge and side twenty feet long, thus leaving five feet at each end unglazed, and this, of course, facing to the north. But the portion of the house in which your business is to be carried on will determine the shape and size of your skylight. It has been my fortune to see a large number of skylights used for photographic purposes in England, Scotland, Ireland and Wales, in Paris and some other Continental towns, but for odd shapes and positions, and every quality that is calculated to drive an artistic photographer to distraction, I have never seen anything that can be compared to the skylights that I have seen in America. But here, as in other parts of the world, it has been the *man*, not the *skylight* that has made the *picture*. I have seen in this country (as I have also seen upon the Continent of Europe) some of the most artistically lighted pictures produced under skylights that upon first sight you would pronounce unfit for the production of artistic light and shade, and I have seen, on the contrary, the most abominable work (artistically) turned out of skylights which were perfect in shape and appointments.

The late Jabez Hughes, Photographer Royal, of Ryde, Isle of Wight, was once showing a brother photographer over his newly erected and perfectly appointed studio. The photographer admired everything he saw, and at last said, "Well, you ought to get artistic pictures here, Mr. Hughes." He turned upon him almost

savagely, saying, "I do not owe the quality of my work to the perfection of this establishment. I could get artistic pictures in a field under a hedge if I had to develop in a ditch." And that expresses the whole idea. Although it is, of course, well to have every facility for the production of good light and shade, it is necessary to *know how* that you may, if placed in an awkward light, be able to modify it and alter it to suit the requirements of artistic lighting.

And now comes in the question, What is artistic lighting? And this is a question most difficult to answer, but as all art is based or founded on nature, let us go through the list of requirements in a portrait, and we shall in that way arrive at an answer to that question.

In the first place a portrait should be easily recognized; it should, therefore, be taken in a light as nearly as possible the same as that in which the sitter is ordinarily seen. This brings me to my first points, viz., that direct top-light should be avoided, for in an ordinary room a person is never seen under a top-light. And yet I think that photographers, as a rule, use far too much direct top-light, the result of which is to cause heavy cast shadows under the eyebrows, under the eyes, the nose, and the chin, making the neck blank in its deepest shadows, while it heightens the light upon the top of the head (a very bad thing when the sitter has thin hair) and the cheek bones, and in fact exaggerates every downward shadow threefold; for there is not only the incidental shadow, but there is a cast shadow besides, and that, with the warm color which is a strongly marked characteristic of all such shadows, gives a threefold depth to the photographic rendering of it.

The same may be said of too direct a side-light; in fact, direct lights of any kind, for any light that is direct enough to cause a cast shadow will cause exaggerations of light and shade in the photograph.

A too direct light may be caused in several ways, placing the sitter too near the light or too small a skylight will give too direct a light. Therefore it is best to have the room in which the skylight is placed large enough to get the sitter so far

away from the source of light that it becomes diffused. The direct light from a small skylight can only be counteracted by a reflector on the shaded side of the face.

A high side-light or a combination of side and top-light falling at an angle of forty-five degrees upon the sitter is the light in which the artist places his sitter when he paints from life, and this is practically the only light in which photographs should be made, the only difference is in the amount of light not in the direction of it. If you could get exposure enough upon the model as arranged by the artist for a life sitting, the result would be all that is wanted to fulfil the requirements of artistic lighting, but as a large amount of light is required the source of light must be enlarged, but care should be taken to keep its direction, viz., the angle of forty-five degrees.

Of course, there are many different methods of using this light, and every face will require study as to the best light for that particular face. The face may be turned from or towards the light as the case may demand, but in all cases care must be taken that the gradations are preserved, that is, that the transition from light to dark should not be abrupt and without intermediate tints from the lights to the shadows.

While on the subject of lighting the face I cannot omit a protest against the method of lighting which of late has become almost universal, although it is decidedly false to nature. I mean that arrangement of light which gives to the face every gradation of tint from white to black. This has been done in the first place to secure what is called brilliancy, but the German exhibits at the Buffalo Convention, which were reproduced for the PHILADELPHIA PHOTOGRAPHER, proved that brilliancy can be secured just as well without sacrificing truth or by this exaggerated method of lighting.

Study this matter out and you will find profit and improvement in it. Place a sitter in any light and study the face; is there any part of the face, any of the high lights which are as light as a white collar? You will find that the highest light upon the fairest face is lower in tone than the white

drapery near it, therefore it is wrong to represent the high lights of a face by white. Now study the shadows. You will find that the deepest shadow is lighter than the middle tints of the eyebrows or dark drapery, therefore it is wrong to represent the deepest shadows of flesh by black as deep as the shadows in the drapery. In fact the scale of tones on flesh, to represent it as it appears to the eye in nature, should be more limited, falling short of white in the high lights and black in the shadows, leaving your white for the high lights of white drapery and your blacks for the deepest shades of black drapery; you thus get brilliancy without sacrificing truths.

It must be remembered that the lighting of the sitter can be assisted (or otherwise) by chemical manipulations in the development. A well-lighted picture full of graduations can be rendered abrupt and harsh by under-exposure and over-development, and a well-modelled face flattened by over-exposure and too quick development. In my practice (and this has been also the experience of many others whose reputations stand far higher than mine) it is best to light strongly or boldly, expose fully and develop with little pyro, keeping the negatives comparatively thin. I am convinced that most of the trouble with the photographer who has only just given up his wet process for gelatino-bromide plates, is under-exposure and too strong a developer. And the dry-plate demonstrators are somewhat to blame for this, for they all boast that their particular brand of plate is quicker than any other, and to prove it will give a shorter exposure and force the development. The true test of a plate (quality) is secondary to its rapidity. The three maxims I would impress upon the tyro are light strongly, expose fully, and develop slowly.

### A NEW METHOD OF OBTAINING ENLARGED NEGATIVES.

A FEW weeks ago I had occasion to obtain from some half-plate negatives copies of them on plates measuring 16 x 13. The problem I put to myself was this— which is the quickest and best way of accomplishing the work? After some con-

sideration I determined to work with the lime-light, for the weather was dull and uncertain at the time I am speaking of, and I thought that I would at once eliminate one common source of error by adopting a mode of illumination which represents a constant quantity. This being settled, I next thought over the different systems of enlarging, and finally decided to try a new plan.

I am so constantly using the lime-light for lecture purposes that a residue bag of oxygen is always at hand ready for any home experiment that I like to try, otherwise I should, perhaps, have decided to carry out my plan with some other illuminant. Fitting a blow-through lime-jet to an experimental lantern with a four-inch condenser, and with a quarter-plate portrait lens as the objective, my optical arrangements were complete. But a four-inch condenser is clearly useless for projecting the image of a negative nearly double its area. My first operation was, therefore, to make some small positives on glass from the negatives. This was easily done by fitting the negatives into my copying apparatus, and using a quarter-plate camera. The size of the resulting positives was just two inches across, smaller, it may be thought, than absolutely necessary. But, by this plan, I employed the best part of the projecting lens, and there was no chance of any falling off in sharpness at the margin of the pictures.

The small positives were made with very great care, the exposure and development being so controlled that the resulting pictures were somewhat denser than would be advisable for an ordinary lantern slide. They exhibited in miniature every detail to be found in the negatives to which they owed their origin, and in more than one case an improvement was effected in the process of reduction, for some of the negatives were yellowed in certain portions, and would, therefore, print unequally. This was obviated by shading during exposure.

The positives, although measuring only two inches across, were taken for convenience on the standard plates for lantern pictures ( $2\frac{1}{4} \times 3\frac{1}{4}$ ), so that a broad margin of clear glass remained all round them. This

was covered with black varnish, after which the glasses were fitted into the usual grooved carriers employed in lantern work.

The next thing was to arrange a proper focussing-screen for the reception of the image. This took the form of a sheet of glass 16 x 13 covered on one side with white paper. Temporary wooden clips, fastened to the wall at a convenient height from the ground, held this papered glass in position, and in such a way that it could be readily removed and a sensitive plate put in its place.

It is with regard to the sensitive plates used that I must now speak. I found that commercial plates of the size required, 16 x 13, were very expensive; if I remember rightly, something like £1 per dozen was the price quoted to me. This was more than I cared to expend on experimental work; besides which, it goes against the grain to buy plates when one has been in the habit for years of making them of unsurpassed quality. I now bethought me that I had put away somewhere a jar of chloride emulsion, which I had made some months before, and had left neglected for want of opportunity to make plates from it. Why should I not make some 16 x 13 plates with this chloride emulsion? thought I. The thing was no sooner thought of than put in practice, and that night the plates were coated and racked to the number of eighteen. I also was careful at the same time to cover a few quarter plates, with which I could make trial exposures.

There is one great advantage in manipulating chloride emulsion and the plates made from it; it is so insensitive (about 100 times less so than the bromide) that the brightest yellow lights can be used without affecting it. I use a brilliant paraffin lamp surrounded by a wire fence, and this is covered with a screen of yellow oiled paper. The light given is so great that a book can easily be read at the further end of the room, and my coating-room is quite a large one.

Two days later I was ready for work, and had the lantern adjusted at the right distance from my focussing-screen on the wall to give an image of the required size. Carefully focussing the first picture, I took

one of the little trial-plates and held it against the focussing-screen for one minute. Upon development it showed under-exposure. One or two more trials resulted in my finding that the correct exposure was ninety-five seconds. I now felt some confidence in dealing with the larger plates, and I exposed three, one after the other.

Now came the development. I mixed, first of all, one pint of developer from my stock solution, and this I put in a jug. The first plate was put in a dish, and the whole jugful swished over it. The image flashed out at once. This is always the case with my chloride plates, so that it did not surprise me. Keeping the developer moving over the plate, I lifted up the glass at intervals so as to watch its progress. In about four minutes it had attained sufficient density. I then emptied the developer back into the jug, for I knew it would serve for several plates in succession. The negative in the dish was now thoroughly washed with about a gallon of water, and transferred to the fixing-bath. The remaining plates were then treated in exactly the same way, and without a single failure.

There was at first some difficulty in thoroughly washing such large plates, but I solved it by making use of the bath-room. The bath was filled with water, and the plates were placed along the sides, film side down. In less than an hour they were thoroughly freed of the fixing salt.

These negatives were all that could be desired. Some of them were purposely reversed for printing by the carbon process, this reversal being brought about by the simple expedient of causing the film side of the little positive to face the light in the lantern. Their perfection of detail may be gauged by the following: In one case the little positive had become rather dusty previous to exposure, and I took it out of the lantern and rubbed its varnished surface with my handkerchief. This caused some tiny scratches upon it which were at the time quite unnoticed, but the scratches were clearly visible on the enlarged negatives. They were certainly not thicker than the finest spider's web, but still there they were.

—J. C. HEPPORTH, Editor of *The Camera*.



## ON THE ACTION OF FERRIC SALTS

EMPLOYED IN CONJUNCTION WITH SODIUM OR FERRIC HYPOSULPHITE IN REDUCING OVER-DENSITY.

At a time when I happened to have an accumulation of over-dense negatives the reduction of which I had put off from day to day, a member of this society discovered that a certain secret preparation—sold to our profession for quite another purpose—when used in conjunction with hyposulphite of soda, made a density-reducer with which he was more than satisfied. I among others saw him successfully demonstrate its capacities, and at once turned my attention to the removal of a cart-load of density from my negatives, and of a good deal of doubt from my mind.

In the following remarks I purpose making a brief enquiry into the nature of the preparation to which I have alluded, sketching the rationale of density-reduction generally, and instituting a comparison of this particular action with others more familiar. We are in the habit of speaking of several kinds of reduction, but I wish this evening to confine my remarks to only two of these, namely, chemical reduction, or the reduction of a persalt to a protosalt, or of a protosalt to the state of metal, and *reduction of density*.

I would restrict the term "reduction of density," and with propriety, I think, to the elimination or removal of a portion of the metal constituting the image; and in order to do this, the image being already a metal, we first require to bring part of it to the state of salt again, and to dissolve away the salt we have just formed.

Modern chemistry teaches us that chemical affinity is exercised by virtue of an opposite electrical state in the bodies which combine. We distinguish in the elements two classes of bodies, metals and non-metals, or electro-positive and electro-negative substances, the extreme in the former class being the alkalies, the extreme in the latter being acids, oxygen, chlorine, bromine, etc. The power of electro-positive bodies is greatest in the simple element, while the electro-negative elements taken as a whole

exhibit their characteristic acid properties most strongly when intercombined. And it is worthy of remark that at least two of these elements, oxygen and sulphur (the halogen also, perhaps), vary in their electric state—within a narrow limit of the entire range—not merely relatively but absolutely.

A salt is a compound of a metal with an acid, and even while speaking of atoms and molecules, or of ultimate particles, compound and homogeneous, we can see that only those metals whose bond-power is plural and variable can form with the same acid more than one kind of salt. Thus it is only under certain circumstances that we can add to the acid character of a salt, although we can reduce all salts to the state of metal. Inversely also we find that there can be no intermediate stage in the reduction of the salt formed on a monad metal.

The reducing agents with which we are most familiar are electricity, light, heat, and the chemical interference of stronger electro-positive bodies than that to which the acid adheres. The reducing agents of the chemist are the metals, nascent hydrogen, ammonium sulphide, hydrogen sulphide, sulphurous acid, and several sub or proto salts.

The reverse of this action is that of oxy-acids, haloid acids, and of oxygen, sulphur, chlorine, etc. Persalts likewise, in so far as they consist of a metal to which is loosely attached what can here be termed an excess of acid, may be looked upon as occasionally fulfilling the function of an acid; for in this case the superfluity of acid, so to speak, is comparatively free to exercise its individual and characteristic influence.

I may here parenthetically remark that while it is among salts that photographers look for their sensitive medium, it is among reducing agents that they look for their aids to rapidity, developers, and accelerators, and to the class of acids for their restrainers.

The first step in the production of a modern negative is the formation of a nicely-balanced insoluble salt, and the suspension thereof in a vehicle capable of supporting it, mechanically only. The next is irregularly to alter the tendency of the sensitive salt to undergo decomposition or reduction. This may be done in a variety of ways. The

film containing the particles of salt may be compressed unequally by physical force; minute metallic substances gently and simply be laid upon the surface; or it may be unequally heated; or it may be exposed over the mouth of a bottle containing ammonia; in all of which cases a visible trace of the direction of the action of the force applied in the dark may be developed. Another method of obtaining the same result is to expose the sensitive salt to light, when again a visible image of the direction and strength of the force employed may be developed. Development being merely the carefully-regulated production of metal from salt, we see that the reduction of density is the production of salt from metal, and removal in place of deposition.

I have here two solutions of ferric salts or persalts of iron. Here is ferric chloride, and here ferric oxalate. Here also is the great unknown.

If we let fall a drop of each upon this porcelain slab, and immerse in each a crystal of hyposulphite of soda, we will see that the colorless crystal in every case becomes tinged with a distinct purple color. Again, if we pour this solution of hypo into this solution of ferric chloride, we recognize the same purple color. The presence of this purple color indicates the formation of ferric hyposulphite. But the purple tinge is no sooner formed than it disappears, the original mixture or solution being decomposed into ferrous chloride, sodium chloride, and sodium tetrathionate.

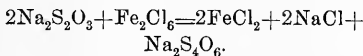

In the same way, from hyposulphite of soda and ferric oxalate we obtain, first ferric hyposulphite, and immediately, ferrous oxalate, sodium oxalate, and soditm tetrathionate.

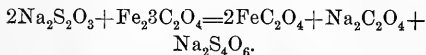

But while the reaction of the third solution with sodium hyposulphite is remarkably similar to that of ferric chloride or oxalate with the same reagent, yet its behavior with other tests is slightly more mysterious. As it is my wish neither to

name the solution in question, nor to suggest its composition further than to explain the rationale of its action, I will confine all enumeration of the experiments to which I subjected it to the following: The addition of ammonia gave an olive-green precipitate, which changed into orange or red-brown with unusual rapidity. Caustic potash behaved in the same way, but more slowly. Yellow prussiate of potash (potassic ferrocyanide  $\text{K}_4\text{Fe}_6\text{Cy}$ ) produced no] apparent discoloration till nitric acid was added, when a prussian-blue precipitate fell. Red prussiate of potash (potassic ferridcyanide  $\text{K}_3\text{FeCy}_6$ ) produced, *not a brown color*, but a prussian-blue precipitate.

In the second place, when to a hot neutral or alkaline solution of the originally *acid* compound I added solution of calcic chloride, I obtained a white precipitate insoluble in acetic, but soluble in nitric and hydrochloric acids. Similar results were obtained by calcic sulphate, baric nitrate, and baric chloride. Sulphuric acid added to the liquid evolved an extremely suggestive odor.

I have stated that a persalt shares the properties of an acid. Formerly it was the custom in order to reduce over-density to saturate the negative in iodine dissolved in potassium iodide, in order to convert the silver into silver iodide, which was then dissolved by hypo or cyanide. The ferric salts I have mentioned, as well as many others, fulfil the same purpose as the iodine, but only what I have termed the superfluous acid converts the metallic silver into the state of salt, while the persalt itself—the chlorinating or oxidizing agent—is reduced to a ferrous salt. In addition to the slow dissolution of silver iodide in hypo, and to the blotchiness which I have found to accrue on the application of the classical remedy, there is another disadvantage which I have yet to mention. I may, here, however, remark that Mr. John Spiller, F.C.S., who seems to have experimented with most of the density-reducers familiar to myself, gives (page 68, *Year-Book of Photography*, 1884) a formula which I have found to answer admirably. He summarizes its action thus: "The chemical action is practically the attack of metallic silver with cupric chloride to form a double argentinc

and cuprous chloride, which is soluble in salt brine." Here, as in density reduction by ferric chloride, which seems at present to be the popular favorite, and by ferric oxalate, to which my attention was but lately attracted, the principle is the same.

There are one or two points, however, customarily insisted upon by advocates of ferric-chloride reduction upon which I would like to have some light thrown. For instance, only a slight rinsing after fixing is recommended, and a slight rinsing after each immersion in hypo. Why not no rinsing at all to save time, or a good thorough but rapid wash to ensure regularity of action? Where I have attempted at the reduction of negatives only slightly over-dense, I have found the most disastrous results follow a slight rinsing, where otherwise I could calculate the amount of work done to a nicety. On the other hand I have seen that with an abnormally opaque negative a great deal of time could be saved at first, by avoiding all washing, and simply popping the negative momentarily into the hypo, for it does not take long to dissolve chloride of silver either by ferric hyposulphite or by sodium hyposulphite and back into the ferric salt. Again, with ferric chloride (or oxalate) where strong and rapid in its action, a comparatively thorough washing, though by no means habitually insisted on, may save the picture a shock which will take all the pluck out of it, and leave it weak for life.

But not only does part of the acid of a persalt act like a free acid, but it bites more regularly—a fact of which advantage is taken in many other etching processes; and, moreover, in cases where the negative is not washed after the dissolution of the metal, the decomposition of the fixing-bath will be greatly minimized by using a persalt for

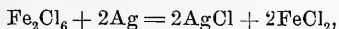

which leaves no acid free to decompose the hyposulphurous acid into water, sulphurous acid, and free sulphur. With an unrestrained acid all the liquid left on the plate is employed in decomposing the hypo, and by weakening it, tending to the formation of the insoluble double hyposulphite of silver and sodium ( $\text{Ag}_2\text{Na}_4\text{S}_2\text{O}_3$ ).

But, as we have seen, ferric salts induce a characteristic decomposition of hypo. Here, however, the reaction is anything but inimical to the dissolution of the silver salt. Even where the ferric and the sodium salts have been mixed beforehand in such proportions as to permit of the supposition that all the hyposulphite of soda has been transformed, as for instance

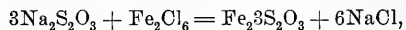

we find that there is a very marked and instantaneous decrease of density, over and above that effected by the ferric chloride alone, which shows that the silver salt originally formed has been dissolved.

Among the side issues to which this inquiry introduced me are two. Can the image be completely removed by strong solutions repeatedly applied? I think not in the case of the persalts I have tried, using hypo as a solvent. A pale image invariably remains ( $\text{Ag}_2\text{S}$ ) which can easily be increased in density, but not removed. Potassium cyanide dissolves it utterly.

In conclusion, might not a further examination and a keener reasoning of this question lead to an elucidation of the part that hypo plays in accelerating the action of the ferrous-oxalate developer.

HUGH BREBNER.

## THE HUMOR OF IT.

MRS. WALDO, to her husband: Dear, do you observe how lovely Clarence is getting on with Miss Bostonborough? He made twenty-seven photographs of her on the beach, yesterday."

Mr. Waldo: "Yes, my darling. There may be a fortune in it, but only see how he's using up the dry plates and de—what do you call it?—de-wollop-her.

A DOUBLE-HEADER.—Guibollard takes a promenade in the Salon, in company with a young painter who has a picture on exhibition, which has been commended by the committee. "Show me," said the former, "your picture that has secured honorable mention." "There it is," said the artist—"portrait of a woman." "Very, very fine as to execution," said Guibollard, "but

how did you come to choose such an ugly model?" "Indeed, sir, this is my mother," replied the artist, coloring quickly. "Your mother!" exclaimed Guibollard, with confusion. "Pardon, monsieur; I am stupid. I ought to have perceived it at a glance. You are as alike as two peas!"

TRIALS OF AN AMATEUR.—Amateur Photographer: "Confound the luck! This picture of my landlady's dining-room with the breakfast-table all set would be perfect if it weren't for that blur on the big platter. It looks as though something there had moved."

Sympathetic Friend: "Those are sausages there on the table, aren't they?"

A. P.: "Yes; why?"

S. F.: "Oh, nothing; only I heard a boy whistle outside just as you exposed the dry plate. Maybe somebody's poor little Fido was trying to wag his tail."

PHOTOGRAPHIC PERILS.—They were sitting together beneath the shade of one of the giants of the forest, gazing with rapture on the beautiful mountain scenery.

"Why, George, are you so cold and distant?" she inquired, placing particular emphasis on the "distant." "Are you so soon growing indifferent?" "No Mary," he answered, "I am not indifferent, but I saw a man leave the hotel with a photographic outfit; and I—well, really, I don't want to put any breach-of-promise temptation in your path."

They finally compromised and put up an umbrella.—*Merchant Traveller.*

## ON PHOTOGRAPHING INTERIORS.

BY VALENTINE BLANCHARD.

MY last paper was mainly devoted to the best method of producing portraits at home, with as much as possible the ordinary effects of light and shade usually produced in the studio. Now, there is an undoubtedly large variety of subjects made possible by the extreme rapidity of modern dry plates, which in the days of wet collodion were almost beyond the range of probability. Among these may be named interiors with figures. Occasionally in the past, it is true,

successful results have been secured under extremely favorable circumstances, and a charming little picture by Mr. H. P. Robinson is at this moment fresh in my memory, though it was produced quite twenty years ago. The subject was a home scene—a fire-side appropriately furnished by a naturally posed figure of a lady with the feet on the fender, enjoying the genial warmth from a briskly burning fire. Though taken by daylight there was sufficient actinic effect in the flame and smoke to give life to the fire-place. The whole scene was most effective.

Now, a home interior without a figure to gladden it is even more lifeless than a landscape without figures, and naturally many people, particularly ladies, desire to have photographs of themselves surrounded by their household gods. And to gratify this desire, one of the first demands on the patience of the amateur photographer will be made by "his sisters, and his cousins, and his aunts." Though modern photography has undoubtedly shortened the way, still the production of successful interiors is by no means easy. A few hints and cautions, however, it is hoped, will lighten the labors of the amateur, and help him over some of his difficulties.

At the outset underexposure is almost sure to be the chief fault. To meet this a golden rule may here be laid down—expose for the shadows and let the lights take care of themselves. To give an idea of the immense gloom of some interiors, an experience of some years ago will be useful. The writer had occasion to make a photograph of the new reredos in Westminster Abbey, and it had to be on a 15 x 12 inch plate, as it was for reproduction in the *Illustrated News*, and had to fill a whole page of that journal. A negative of the south side of the exterior required an exposure of four seconds, and was made immediately before the one in question. The exposure for the one of the interior was commenced immediately after the morning service, and the people were coming in for the afternoon service when it was completed, making an exposure of just three hours, which happened to be exactly right. This illustration will, it is hoped, be useful to those who have occasion to photograph very

gloomy church interiors. The inexperienced are so easily misled by the behavior of an underexposed negative under development. The high lights have such a way of asserting themselves, and start into existence so rapidly on the application of the developer, that the amateur who has had no experience in the photographing of interiors is led to believe that he has hit the exact exposure, when, in fact, double the amount would not have been a second too long, and probably not long enough. As prolonged development is desirable in this class of work, the pyrogallic acid may frequently be weakened one-half with distinct advantage, for it is of the highest importance to bring out every half-tone, down to the deepest shadow, without at the same time building up too much density in the high lights.<sup>1</sup> Underexposure will always produce spottiness, that is to say, the lights will stand apart distinct and separate, and the deeper shadows will be represented by patches of black unrelieved by any details.

Wherever strong high lights, such as windows or very light lace curtains, come in immediate contact with dark shadows, halation will follow. This is a fault well known to the experienced photographer, but it is well, probably, to describe its effects for the benefit of the beginner. Like the halo round the moon, the light is spread beyond its natural boundary, and gradually diminishes and fades away into the shadow in its immediate vicinity, blotting out as it travels any details in its path. Thus, for instance, in a church window all details in the mullions will be lost, and the outer boundary even will be blotted out by a misty halo. To remedy this very serious defect the reflecting power of the wrong side of the negative must be destroyed. To do this some nonactinic color may be smeared over the back of the gelatine plate. A little raw sienna squeezed from a tube of moist water-color will answer admirably when spread with the moistened finger, or by a stiff brush not made too wet. Of course, if a number of plates are required it will be necessary to mix a small quantity of color of the proper consistency, and apply with a brush, dropping the plates

into a grooved plate-box until all are done, and then putting them into the slides.

In making photographs of ordinary domestic interiors, naturally those where most taste has been shown in the selection of the objects and the arrangement of colors will be most successful. The low tone of modern decoration will materially help the photographer, for it is very difficult to produce artistic results in a room with a very light paper on the wall, and the windows hung with staring white curtains.

The most harmonious result will be produced in rooms where the sun is not permitted to enter. It is important, therefore, to select the time when the sun has just left the window, but still has sufficient force to illuminate one side of the room more than the other. If the room should be fortunate enough to have a bow-window, a capital effect may be produced by letting down the Venetian blinds over the main windows and one of the side ones, admitting light from one of the side windows only. A description of two interiors before me and the exact method of their production will, perhaps, better help out my meaning than anything else I could possibly write on the subject.

The room is a modern drawing-room with bow-window, and the walls are covered with an unobtrusive paper. The pattern shows in the photograph, but it is not at all demonstrative. A lady is seated at the piano and is apparently playing. The floor is covered with Indian matting, and a large Eastern rug occupies the centre of the room. Several antique vases and many other objects are tastefully displayed in various parts of the room. Half the bow-window only is shown, and the blinds are down, but are returned, so that a considerable amount of light is admitted. The principal light comes evidently from the side window not shown in the view, and passing behind the figure of the lady, falls on the pictures and objects immediately over the piano, throwing, at the same time, the angle of the bow-window into strong relief. The whole scene is full of detail, and the high lights and deep shadows are not straggling, but joined together. A No. 3 stop of a rapid rectilinear lens was employed, and the exposure

was twenty-five seconds. The scene is full of life, and the figure of the lady natural and unaffected.

In the next picture more of the room is shown, and the opposite side, including the fireplace, comes into view. A lady is reclining on a couch in the bow-window; some knitting has been thrown aside to make room for a picture book, which she is looking at with evident interest. The whole of the bow-window is shown, and the light is admitted from the side window furthest from the figure, and the other Venetian blinds are down, but the glinting light falls on the dark-cream curtains, and dances all over them in irregular bars, the pattern on the curtains, notwithstanding, being well shown. The source of light is nearly hidden by a heavy curtain on the extreme left of the picture, evidently separating two rooms. The light falls on the profile of the lady, and passing across the room, falls on a marble mantel-piece, producing an effect Tadema so loves to paint. The whole scene is well lit and delicate throughout, and the effect very real and natural. The exposure was thirty seconds, with the same stop as that employed in the former picture.

Of course, with many interiors a longer exposure might be necessary, and the difficulty of keeping still, which unfortunately, is too common a fault with many sitters, would add very considerably to the labor of producing successful result, still, by selecting lounging chairs, and giving natural occupation to the sitter, much of the trouble may be considerably lessened.

It is hoped that the above description may serve as a gauge to the inexperienced photographer, and may help him when he is in doubt what to do in a difficult department of photography.—*News*.

### PRACTICAL POINTS FROM THE STUDIOS.

**SODA PAPER AND ITS APPLICATIONS.**—What is soda paper? It consists of sheets of paper of rather large size, that can be cut as desired, and which have been steeped in a solution of pure carbonate of soda at from 10 to 15 per cent., then dried. Silversmiths

have made use for some time of this paper for preserving silverware from the spots or brown tint due to the action of sulphur and its compounds contained in the air. Recently the same soda paper has been used for the preservation of paper positives. The jewellers and dealers in silverware wrap up the metal articles in a thin paper which has been impregnated with carbonate of soda; this last taking up the sulphuretted hydrogen or the sulphurous acid found in the air, the surface of the silver remains white and brilliant. Photographers place a sheet of soda paper between each sheet of sensitized paper, then a flat weight on the whole. Or they make a roll of some sheets of sensitized paper and wrap it in soda paper. It does not suffice to protect the photographic plates and papers from the action of light, but it should also be done from the gaseous emanations found in the atmosphere of cities. Since illuminating gas is more and more used, the quantity of sulphur in the air of our houses increases. If the gas escapes by leaking from the pipes, without being burnt, sulphuretted hydrogen and sulphuret of carbon are found in the air; if the gas is burnt, it is in the form of sulphurous acid that the sulphur is found in the air. This last, in small quantity, is not injurious to health but it can attack photographic preparations. DR. PHIPSON.

CLEAR, watery (muriatic) acid solutions when exposed to the direct rays of the sun for some time, turn, as is well known, yellowish, and gradually send forth a decided smell of chlorine. Since information concerning the cause of this has not been noticed in print, the author has undertaken the following experiments in reference to it: He placed clear, watery acid and clear (pure) dry chloride of hydrogen (?) with air in a glass vessel hermetically sealed, and left it some months to the influence of the sunlight.

Both the watery and gaseous (acids of chloride of hydrogen) were kept under the control of the sunlight with complete exclusion of air, or also with air mixed in the dark. The result of these experiments was, that the gaseous mixture as well as the watery solutions in contact with air suffer a

slow oxidation under the influence of the sunlight.—*Moniteur*.

**GOLD AND PLATINUM TONING BATH FOR BROMIZED PAPERS.**—M. Drener asserts that in using gelatino-bromized papers in making enlargements, it is essential to obtain a good toning bath, otherwise, different sheets of paper give quite different tones. He recommends the use of salt of gold and hyposulphite in the same bath. For eight ounces of a saturated solution of hyposulphite of soda, he uses one grain of chloride of gold, and preferably, if a good brownish tint is required, chloride of gold and chloride of platinum in equal parts.

**WATER IN THE RAW MATERIAL FROM WHICH PAPER IS MADE.**—The organic substances used in the manufacture of paper are like many others sold by weight, and after having been analyzed. But these substances, especially those which come from wood, present at different seasons of the year, and in divers circumstances, very variable quantities of water; this renders any valuation made by analysis very uncertain and difficult. Some large manufacturers have, therefore, agreed among themselves, that in future, the chemist will dry a sample at 212 F., and to the quantity of dry matter thus obtained he will add twelve to represent the normal quantity of water that these substances should contain. The mineral substances are estimated in the same way.

**A PROCESS FOR RETOUCHING.**—At the meeting of the Birmingham Society, M. E. H. Jacques delivered an interesting lecture on retouching.

**SETTING OF PLASTER.**—It is often of importance to the decorator and painter that plaster should set quickly. In order to secure this, the plaster should be mixed with water into which a little sulphate of potash has been dissolved. On the other hand, if it is desired to set slowly it should be mixed with fine slack lime. The time of setting may be regulated by changing the quantities.

**BLACK VARNISH FOR WOOD.**—Take spirits of turpentine one gallon, asphaltum two

and one-fourth pounds, and place in a vessel on a stove. When dissolved, and slightly cool, add copal one pint, boiled linseed oil one pint, and a little lampblack.

To get an absolutely clear solution of shellac has long been a desideratum, not only with microscopists, but with all others who have occasional need of the medium for cements, etc. It may be prepared by first making an alcoholic solution of shellac in the usual way; a little benzole is then added, and the mixture well shaken. In the course of from twenty-four to forty-eight hours the fluid will have separated into two distinct layers, an upper alcoholic stratum, perfectly clear, and of a dark red color, while under it is a turbid mixture, containing the impurities. The clear solution may be decanted or drawn off with a pipette.—*National Druggist*.

**A WATERPROOF VARNISH** for washing tanks, trays, etc., consists of two kilogrammes of melted bitumen poured into a receptacle heated by a mild fire; add, while continually stirring, 500 to 600 grains of benzine, 200 to 300 grains of turpentine and 200 to 300 grains of lampblack.

**TO REMOVE THE GELATINE FROM OLD PLATES.**—Mr. Bothamley says that it is easy to remove the gelatine film from old plates by allowing them to soak for a short time in a bath composed of one part of commercial hydrochloric acid, and water fifty parts. A slight rubbing is sufficient then to clean the plates.

---

## OUR PICTURE.

THE third of our quartette of views from the four quarters of our country we give this month—"The West."

It is a winter scene near Vermillion, Dakota. A few patches of snow still linger in the road, while a freezing storm has made every tree delicately beautiful, and powdered every twig and grass-stalk. The gradation of the picture, from the deep dark of the hay-rick up to the lights of frosty tree and sky, is exquisite. Note what a fine bit of color in the bull in the foreground on one side, what depth and delicacy on the other.

The snow-patches and the children on the road lead well into the distance, although the picture is a little shaky in the centre. A better range of light and shade is however rarely seen. We had but one original negative and were compelled to reproduce. We cannot make ourselves believe that reproductions are ever equal to the original.

The original negative was made by Mr. Henry Butler, of Vermillion, Dakota. Its delicacy is good testimony for the yellow label Cramer plate on which it was made. It bears witness, too, to the capabilities of modern development in its wonderful variety. The soda and pyro. developer was the one used. The prints were made by Messrs. Roberts & Fellows, of Philadelphia, on N. P. A. Pensé paper, imported for us by Messrs. E. & H. T. Anthony & Co., New York.

### THE USE OF THE CENTRIFUGAL SEPARATOR IN PREPARING GELATINE EMULSION.

BY JOSEPH PLENER.

ON receiving an invitation from the Photographic Society of Great Britain to write a paper concerning my centrifugal separator, I felt myself honored, but, at the same time, very much perplexed. The reasons of my embarrassments were manifold. In the first place, my working with the separator had always a practical object, and but few experiments were ever instituted by me with scientific purport. Of course, it happened to me from time to time to fall in with some facts of scientific bearing; but these, being not registered or noted down, were not always remembered. On the other hand, the time which separates me from the meeting at which this paper will be read is so short, that it is impossible to repeat the old experiments in order to furnish the material proofs of my assertions. But should a discussion arise, it will be my duty to do that. As it is, I must depend mostly upon what my memory retained.

To begin with, it seems to me natural to try to define in what the emulsification consists, or, in other words, what is an emulsion? The separator, whose function it is to disintegrate emulsions, ought to give us

a key to the discovery of the character of the relation between the silver haloids and gelatine in an emulsion. It is known that the separation of the silver salts from gelatine can never be complete—that a small quantity of the latter, which we will call, for convenience' sake, constitutional gelatine of sensitive silver compound, remains always combined with the silver salts. Now, my contention is, that re-emulsification consists in dissolving or mixing up of the constitutional gelatine in the bulk of gelatine used for re-emulsification. This opinion is based on the following observations:

1. If I put for a few minutes a piece of coagulated gelatine in some melted emulsion containing dye, and, after taking it out from the emulsion, wash it well in hot water, some dye will remain on the gelatine, in spite of washing. But the most important fact is, that this piece of gelatine will not give up its dye in a solution of gelatine. Now, if I separate the dyed emulsion in which the sheet of coagulated gelatine was dyed, and wash the separated compound till, in the wash-water, no trace of dye is seen, afterwards re-emulsify the compound in some thick solution of gelatine, and again separate the emulsion so obtained—then I notice that the separated gelatine takes dye from the compound. To my mind, it is conclusive that the constitutional gelatine has mixed up or dissolved itself in the bulk of gelatine, and so communicated to it the dye.

2. If I take some emulsion in the highest degree putrid, separate it, wash repeatedly the silver compound, and then re-emulsify the same, I shall have frilling in the plates coated with the above emulsion. To get rid of the frilling, it is necessary to re-emulsify and to separate again and again. It is evident from the above, that the water could not wash away the putrid gelatine; but a solution of sound gelatine did it.

So much for the case of frilling. But should there be any other defect in the emulsion due to some defects in gelatine, the same ought to be done, and the same said as in the latter case. It is not to be expected that all the defects should be entirely got rid of so long as the cause—the gelatine—remains present. It is enough when,



in most cases, with the diminution of gelatine, the defects are so reduced that it becomes possible to overlook or to neglect them.

If it be granted, for argument's sake, that the constitutional gelatine dissolves itself by re-emulsification, then I can take a step farther and ask—What has become of the affinity that existed between the silver salts and the constitutional gelatine? My answer is—This affinity has extended itself to the bulk of gelatine, and has brought about a combination whose character I am unable to define, but whose existence I will endeavor to prove with the aid of the separator.

At the outset, I must remark that when two emulsions are made side by side—one of silver iodide and another of silver bromide—all conditions being equal, then the silver iodide emulsion will be much harder to the touch. It cannot be contended that this difference is due, not to the action of silver haloids on gelatine, but is the result of the influence of all salts present during the ripening, which might have brought about some changes in gelatine, because on separating both emulsions and re-emulsifying the two silver compounds, we find the same difference in the two emulsions as before the separation. Therefore, we conclude that it is the difference in silver haloid that makes the emulsions different. In fact, the silver haloids remain not only suspended in the gelatine, but so combine with it that its physical properties change according to the haloid used.

This difference in the physical properties between the emulsion and the gelatine with which it has been made, can at will be widened by the process of emulsification, or through the different treatments of emulsion. We can, for instance, make with the softest gelatine an emulsion as tough and elastic as leather. For this purpose, we must use the lowest temperature and precipitation method with the greatest concentration of all solutions; a double quantity of ammonium, required for converting the silver nitrate into silver ammonio-nitrate; the digestion for half an hour at 30° to 35° C.; finally, the emulsion must remain in shallow dishes, on ice, for not less than twenty-four hours before washing. This emulsion will

be extremely tough, and, moreover, when well washed from the decomposed gelatine, will give, even with soft gelatine, a very tough emulsion. Through its addition to gelatine, the melting point of the latter will be changed—that is, the emulsion will set at higher temperature than the gelatine. The same emulsion will require less of any precipitating salt to be precipitated than the gelatine. I did not try it, but I think the same is the case with alcohol. I do not mean to say that the silver compounds in general do not possess these properties. When the constitutional gelatine is sound, then each silver compound has the same properties, only in different degree. Of course, when the constitutional gelatine is decomposed—and I must lay stress upon it—then these properties are reversed. The above emulsion has, moreover, before it reaches a very high degree of ripeness, the property of being precipitated by light. There are two bottles; in bottle No. 1 some emulsions was placed immediately after precipitation, and brought to the full daylight. The bottle No. 2 contains emulsion taken after one hour's digestion, in order to see that with the ripening the precipitation diminishes, and as it is common, in different degree, to all ammoniacal emulsions, whenever I prepare such an emulsion, I make use of these properties to observe the going on of ripening, and consider the phenomenon as indicative of the character of the emulsion. This precipitation of the emulsion is more general than would be supposed. In the case of the above tough emulsion, the silver compound on re-emulsification in the full daylight, even without ammonium, sometimes precipitates the gelatine. Further, the pinholes, which are so common even in good plates, are due, I think, to the precipitation of the particles of emulsion during the setting. I will return to the subject later on.

It remains now to bring forward a last observation on the affinities of silver haloids to the gelatine. But I must avow I am loth to do that without being able to show what I have so often seen, and what I have shown to Professor Eder, and to many other gentlemen. The phenomenon is rather strange, and as it served as starting-point

to the opinion I hold, I decided on communicating it to you. It is as follows: The silver compound of a tough emulsion, when mixed in great quantity with a weak solution of gelatine, half per cent. gelatine, after standing for one day in a cool place, will deposit, not as powder does, but in the shape of small nodules, each some millimetres in diameter. It is no more a silver compound, but an emulsion. So here I see nothing which could preclude my saying that the silver haloid has precipitated the gelatine. On closer examination of this precipitated emulsion, I notice that it consists of two different emulsions mixed up—one of white, and another of yellowish nodules. When exposed to light, the white emulsion nodule is soon darkened; while the yellow remains much longer unchanged. This experiment, more than any other, points to the existence of some intimate combination between silver and gelatine; moreover, it throws much light upon the question of homogeneousness of emulsion. We see that an emulsion by cooling is separated, then it was not homogeneous. Here arises the question, whether we have any sign or indication concerning the degree of homogeneousness of the emulsion generally? My answer to this question would be, that if we have unfortunately such defects in the plates as, for instance, depressions, transparent spots, pinholes, etc., they are the consequence of the emulsion not being homogeneous. Moreover, it does not follow, necessarily, that because the plates are without defects, that the emulsion was homogeneous. A great many emulsions which give faultless plates by certain coating manipulations, so to speak, through the same *tours de main*, would show themselves un-homogeneous if otherwise.

The study of emulsion has led me to the following conclusions: A good emulsion ought to be not only homogeneous, or, in other words, the affinity between the silver salts and gelatine ought to be not only equal throughout all the mass of the emulsion, but it ought not to surpass certain limits, because, when it is too small, then the silver compound is getting loose from gelatine, and frillings make their appearance. When it is too great, the plates are less

sensitive, the fixing goes on too slowly, and the capability of reduction is diminished. But what happens when the emulsion is not homogeneous?

First, I will show that the emulsion which gives transparent spots or pinholes is not homogeneous. I separate some of such an emulsion at a comparatively low temperature, and let the separator go with the half of the usual speed. Under these conditions, I shall not be able to separate the silver salts from gelatine; but I separate the emulsion into its component emulsions. I let the separator go until all in vessel is set. Now, I take two samples of emulsion—one from the nearest point to the axis of separator, and the other from the farthest. The former sample gives more sensitiveness and nearly clean plates; the latter less sensitiveness and full of spots. Therefore, the original emulsion must have been un-homogeneous.

Next, I separated the less sensitive emulsion in the usual way, taking precautions that the silver compound be well washed. Professor Dr. Eder had the goodness to analyze the latter, and has found the percentage of gelatine to be 0.93—that is to say, nearly double what he has found on previous occasions when he has analyzed the silver compound of good homogeneous emulsions. Then the percentage was—on one occasion 0.45, and on the other 0.52.

I am of opinion that the percentage of 0.93 as found on the last occasion is much under the real value of silver compound of the white spots emulsion; because it is not easy to separate strictly one component of emulsion from the others—they remain always more or less mixed. Were it otherwise, the above-named samples of component emulsions would have given quite clean plates, different only in sensitiveness and other qualities. For instance, the plates made with the analyzed silver compounds would have presented one defect—that is to say, would have been only insensitive. As it is, the above silver compound must have been a mixture.

From the above, I concluded that the un-homogeneousness of an emulsion stands in relation with the difference of percentage

of constitutional gelatine in different parts of the emulsion.

I must here add that although I have no evidence to adduce, my opinion is that the percentage of constitutional gelatine depends in a certain degree upon the conditions under which the separation is performed. So for instance, high temperature, the presence of ammonia or alcohol would diminish this percentage; in fact, all the substances which accelerate the separation would have the same effects.

It is not enough to prove that an emulsion giving white spots is always unhomogeneous. I must further show how in such an emulsion the white spots and other defects are formed. For this purpose I must make an hypothesis, viz., that by setting of an emulsion some phenomena are produced very much like those which occur on cooling down of an alloy of metals, viz., at first is setting down that alloy which wants the highest temperature for melting it, and so on. Let us suppose that our emulsion consists of two component emulsions—the one tender, another tough, sound, and predominant. When we pour this emulsion on the plate, the latter component-emulsion will begin setting at first, and if the film be broken in a point, we observe that the small semi-detached disk is growing in size more and more till the emulsion is set. A sheet of india-rubber when well stretched and pinholed, would reproduce the same phenomenon. This movement of the tough emulsion is shown by tender emulsion, which remains stretched over the disc.

In this way are formed the semi-transparent spots called depressions. The difference between them and the white spot is that they can be seen before the development. Should the tender component emulsion be predominant, the tough one will have the tendency when melted to agglomerate itself in blotches, and on the developing will appear as white spots on the plates, because, as shown before, it is insensitive.

If the emulsion contains more than two components, they will set one after the other. A first one setting pinholes—perhaps I had better say they are precipitating and not setting, their appearance being suggestive of a torsion taking place, and they are so in-

sensitive that a reduction never occurs in them. If one of them happens to be in a cloud of insensitive emulsion, which is destined to make a white transparent spot, then it serves as a nucleus to the spot. In this case the spot sometimes is not seen under very strong reduction, but the pinhole will always appear. How the clouds of insensitive emulsions combine, and how they behave, would, if written, make a book, whose title would be "The Martyrology of a Platemaker."

Now I come to another set of phenomena. I have already said that when the affinity between the silver salts and the gelatine sinks under certain limits, the silver, of course, must get loose—or, in other words, separate itself from gelatine.

The cause of that sometimes lies in the gelatine, sometimes in the silver compound, and often in both. When the fault is in the gelatine, the silver compound does not get greasy, therefore does not agglomerate, and only through the movements in the emulsion comes to the surface in the form of silvering, which disappears as soon as the gelatine in emulsion is changed. On examining the plates with silvering, one is struck with (so to say) the universality of the phenomenon, there is nothing local, occasionally it conveys the idea of a general cause, and in fact in most cases the gelatine is the cause; when we have pittings then the fault lies with the silver, some particles of the latter getting greasy. How it occurs we shall see by and by.

They are consequently repulsed by gelatine solution, they agglomerate, and when a bubble of air attaches to this agglomerate, we have then an imitation of volcanic eruption, with a crater in the centre, and the lava stretched around it in consequence. In fact the physical theory of the formation of pittings is too well known to be dwelt upon. I will only lay stress on the fact that the substance of the pittings is greasy, because it is possible sometimes to detach from the film a pitting by rubbing. It is clear that the gelatine solution did not moisten the silver compound constituting pittings.

As to the causes of its being greasy, these are manifold—sometimes one cause produces the mischief, sometimes the causes combine.

In the first place, as evidently the silver compound of pittings would not emulsify, the gelatine of the compound would not dissolve, because it has become coagulated.

Nothing is easier than to reproduce the pittings artificially, by acting on silver compound with any coagulator of gelatine, or with the bichromate of potash. In this way the plates will be absolutely full of pittings, but if this emulsion be again separated, and the acetic acid allowed to act on the silver compound, then the spots in most cases disappear totally. Then arises the question, How in an emulsion the constitutional gelatine becomes coagulated? If I let some separated silver compound stand without preservative, or, better, when I digest it, then I get no end of pittings.

My opinion is, that in this case, as in the case of an emulsion, the silver bromide was converted into sub-bromide, and that the iodine had coagulated the constitutional gelatine. Why are the pittings black spots? It is not because of their being unprotected by gelatine from the action of developer. Then if I covered the plate with a sheet of gelatine the pittings came all the same, that is to say, the sub-bromide is reduced in spite of protection, as it always is.

Perhaps the following experiments may serve as an argument in favor of my opinion. I mixed some silver compound with water, and brought it to the full daylight. Stirring the fluid with a glass rod, I saw on the surface some darkened compound which was very like the pittings as they appear on a wet place. Then the silver compound has become greasy through the decomposition, because otherwise it would not float on the surface of water. So much for the coagulation of the constitutional gelatine.

But besides this, I can point to another cause of the surface spots or pittings. It is known that many crystalline bodies when ground to powder would not emulsify in gelatine solution, but their powder has a tendency to float on the surface of gelatine solution, and to produce mat spots. When it can be shown that under certain conditions plenty of the crystals of silver salts are formed in the emulsion, the second cause of the pittings is found. Please to examine the plate marked A. [*Plate shown.*] You

will see a net of crystals upon it. This plate has been prepared in the following way: I wetted it in water, and put it under a bell, together with a disk containing some liquid ammonia. I was exceedingly astonished, and so was Professor Eder, in whose laboratory I carried out this experiment, when after twelve hours I found the plate as you see it now. Indeed, the temperature of the room remained during experiment nearly constant; the plate remained nearly as wet as it was when put under a bell jar, and nevertheless such a considerable work has been done. I was struck with the thought that if some grains could have been displaced in such a way, why pounds should not be? Then, where is the motive power? The only possible explanation, to my mind is the following: The water in the plate absorbed ammonia, which dissolved haloid salts of silver, and next evaporated, leaving behind some crystals; then fresh ammonia came in the emulsion and did the same, and so on; the ammonia always dissolving only granular, but not crystalline silver, the latter being difficult to dissolve. This hypothesis will not, perhaps, seem strong when we remember the rather peculiar property of ammonia, viz., to be absorbed instantaneously by water, and next slowly liberated. I have no time to experiment now; but it is a question of some interest to know what would be the behavior of an exposed plate, of a plate with defects, viz., transparent spots, pittings, etc., or of a pure silver bromide silver iodide plate, etc., if put under the bell?

The above experiment shows what I would, viz., that under certain conditions the crystals of silver salts can be formed in the emulsion. How must I show that crystals can produce pittings? Let us make another experiment.

I make a very concentrated solution of hard gelatine in a mixture of liquor ammonia and water, taken in equal parts; pour this into a dish, and let it set.

Afterwards I pour over the gelatine a film of clean, good emulsion, and let all stand for some hours in a cool place.

There is no difficulty in separating the sheet of emulsion from underlying gelatine. On examination, I find that this emulsion from a fine one has become very coarse,

through crystallization, and when plates have been made with it, they were full of pittings. It remains now to show what circumstances in the known processes of emulsification and ripening can bring about crystallization. In the boiling process the cooling down will produce it, and if the vessel be heated at the bottom only, then during the time of the boiling, heating and evaporation will go on. In the emulsification processes with ammonia the same thing happens as above, and on a much larger scale. Moreover, as the bottle is never full of emulsion, then on the surface of the latter there can be going on the same process of crystallization as under the bell jar in the above-described experiment. The same can be said about each bubble of the froth. That such is the case can be seen from the following observations: When the emulsion is made with a great quantity of gelatine, and the bottle is shaken only at the beginning, then at the end of digestion the emulsion taken from the surface will be more sensitive than that taken at the bottom of the bottle; but the latter emulsion will give denser images than the former. This difference I can only account for by crystallization, because the difference in the pressure would not, according to my experience, be sufficient to produce such an effect.

But the greatest danger of the formation of crystals exists during the setting and the washing of the emulsion. When the emulsion contains some bubbles during these two operations, then the comparatively long duration of the latter gives good opportunity for crystallization to occur. As the alcohol does away with bubbles in the emulsion, it would be a good remedy against the pittings, and, by some processes, really it is. Unfortunately, alcohol has a drawback—it diminishes the affinity between the silver compound and the gelatine; and in this way facilitates the formation of silvering and pittings. The practice of letting the emulsion stand in shallow dishes on ice for a long time produces no end of pittings and spots. The permanent cause of this I think to be crystallization.

It remains now to say a few words concerning the separator, and its relation to

those points of emulsification which I have touched upon in this paper.

1. All defects of emulsion originated in gelatine can be remedied by complete elimination of the latter, with the aid of separator. Moreover, even the insoluble impurities can be got rid of, when they do not increase in size during the digestion, and have a specific gravity smaller than that of the silver compound. These bodies would remain in gelatine.

2. With regard to the unhomogeneous-ness of emulsion—or, in other words, with regard to depressions, transparent spots, and pinholes, as their cause lies in the silver compound, the separator cannot directly cure the evil, but helps indirectly, because it gives to hand the silver compound unprotected by gelatine, which is a considerable advantage when it is desirable to act upon the silver compound.

Concerning the spots and pittings, the nearly certain cure is the addition of a great quantity of hard gelatine; but this is never possible without interfering with the character of emulsion. The aid, therefore, of the separator in this case is valuable; only some precautions are necessary. The separation ought to be carried on (in this case) at the lowest temperature possible; the re-emulsification must follow soon after the separation; the solution of gelatine for re-emulsification must be very thick; and in this state of concentration the emulsion must stand in a cool place for about twelve hours.

I. I cover the interior of the vessel of my separator with gelatine, which I coagulate, and, lastly, cover with collodion. Silver haloids, in contact with metallic silver, are reduced, as proved by the fact that after a short time the interior of the vessel is blackened. Moreover, the pressure of the silver haloids against a hard metal will exceed the limits within which it is of advantage.

It was stated that the riper silver haloids are separated first; consequently, when I found that the silver first separated was less sensitive than the rest, I concluded that it was over-ripe, corresponding to what we find at the bottom of the bottle in which the process of ripening took place. I was soon convinced I was wrong, because this supposed over-ripened silver haloid was a very

fine one, and gave, with gelatine, very tough emulsions. I explain this in the following way: If the speed of the separator, or the temperature of emulsion, be not sufficiently high, then before the silver compound has time to separate itself from gelatine, the separation of emulsion into its component-emulsion begins. The less sensitive part goes farthest from the circumference of the separator, as the most compact. When, after some time, the separation of silver compound commences, the latter emulsion separates first, because the separating centrifugal force increases in proportion to the distance from the circumference of the separator. It is then evident that we shall find the less sensitive compound on the wall of the vessel.

3. I obtained an analysis of only the one component emulsion, which was found in the separator the nearest to the wall, which gave plates completely covered with transparent spots, and concluded (in my paper) that the difference in the percentage of constitutional gelatine produced the difference (or stood in direct proportion to) in the affinities between the silver compound and gelatine. Perhaps many people would find it a rash conclusion, and without solid ground. Now, I say again, I had an emulsion with spots. I separated the spots from the emulsion, but analyzed only the silver compound of the former. I did not analyze the silver compound of the latter, because it is enough to touch it with the hand to see whether it is different from ordinary silver compound. Moreover, the above conclusion harmonizes so perfectly with all I know about emulsion, that I did not hesitate to propound it.

4. When I have said that the pittings, covered with a sheet of gelatine, were all the same reduced under development, I mean the artificially produced pittings, through long standing of silver compound in water. Spottings, and sometimes the ordinary pittings, are not seen after development.

I expressed my opinion that all the accelerators of separation, viz., temperature, alcohol, liquor ammonia, etc., would diminish the percentage of constitutional gelatine. I

said so because I am sure of it, and I wish that this may be verified by experience.

6. I once put some gelatine in the separator, and tried to separate it into its components; but my separator was not powerful enough to accomplish that. Gelatine showed no sign of unhomogeneousness. Nevertheless, when some alcohol is added to a solution of gelatine, and cooling down in ice water begins, then the precipitation is consecutive, viz., with the lowering of temperature new parts of gelatine are precipitating themselves.

7. I said that the pinholes are produced by the particles of precipitated emulsion at the beginning of the setting of the emulsion. But I forgot to say that I can produce at will these pinholes. When I make an ammoniacal emulsion, and add iodide of potassium, after all the silver is mixed with the bromides, then the pinholes always occur. I am curious to know whether my experience tallies with that of others.—*Jour. Photo. Soc.*

### QUERIES, CONUNDRUMS, AND CONCLUSIONS.

“ACCESSORY.”—For making rocks, shields, and other accessories for the studio, you might try a plan for rendering paper as tough as wood or leather, recently introduced. It consists in mixing chloride of zinc with the pulp. It has been found that the greater the degree of concentration of the zinc solution, the greater will be the toughness of the paper. It can be used for making boxes, combs, for roofing, and even for making boots.

“MAGIC.”—No, it is not necessary to photograph every diagram you need for the magic lantern. You can use aniline ink, India ink, or ordinary ink upon glass varnished with Diamond varnish. Muller has given the composition of an ink which can be used with an ordinary pen for etching on glass. It consists of hydrochloric acid, ammonium fluoride, and oxalic acid thickened with barium sulphate. He has also proposed a better substitute, made in this way: Equal parts of the double hydrogen ammonia fluoride and dried precipitated barium sulphate are ground together

in a porcelain mortar. The mixture is then treated in a platinum, lead, or gutta-percha dish with fuming hydrofluoric acid, until the acid ceases to react. Marks made by it will not rub off.

"BACKGROUND."—The best plan is to start with a pure white for your screens and for the backgrounds; use lampblack to get the tint of grayness required. The following is a good stock solution: To 15 pounds of the best whiting, thinned down to proper consistence in cold water, add 6 ounces of clear white glue dissolved in warm water; apply cold. To dissolve the glue, first cover it with cold water, and let it stand and soak until it becomes soft; then pour off the cold water and add hot water; it will then readily dissolve. For very fine work, it is recommended to use zinc white instead of whiting. Half an ounce of ultramarine blue added to the above makes a clearer white. The mixture should be colored to suit before putting in the glue.

"STICKING PAPER."—A mucilage of acacia, which will not spoil, may be made as follows:

Oil of Gaultheria . . .	℥xv.
Calcium Phosphate . . .	Sufficient.
Water . . . . .	℥ viij.
Acacia . . . . .	℥ iv.

Triturate the oil of wintergreen with about one drachm of the phosphate of calcium, and afterward the water, and filter. Then use the filtrate to make a mucilage with the acacia.

"CLEAN BOY."—A good cleaning powder for show windows, which leaves no dirt in the joints, is prepared by moistening calcined magnesia with pure benzine, so that a mass is formed sufficiently moist to let a drop form when pressed. The mixture has to be preserved in glass bottles with ground stoppers, in order to retain the easily volatile benzine. A little of the mixture is placed on a wad of cotton and applied to the glass plate. It may also be used for cleaning mirrors.

"A GOOD BLACK."—We have frequently answered your request for "a good black for cameras, etc., inside." *The Locomotive*

gives the following receipt for painting brass tubes, and such articles as optical instrument makers produce, a "dead black." The writer says he has found all the formulæ and receipts given in the books unsatisfactory because of their vagueness, but that the following can be relied upon to give a first-rate dead black, and it is easily made: Take two grains of lampblack, put it into any smooth, shallow dish, such as a saucer or small butter-plate, add a little gold size, and thoroughly mix the two together. Just enough gold size should be used to hold the lampblack together. About three drops of such size as may be had by dipping the point of a leadpencil about half an inch into the gold size will be found right for the above quantity of lampblack; it should be added a drop at a time, however. After the lampblack and size are thoroughly mixed and worked add twenty-four drops of turpentine, and again mix and work. It is then ready for use. Apply it thin with a camel's-hair brush, and when it is thoroughly dry the articles will have as fine a dead black as they did when they came from the optician's hands.

"BROKEN PAN."—Our experience is that it is cheaper to throw away a broken vessel at once. If you have to temporize, then try the following solder for glass, porcelain, and metals: Copper dust, obtained by precipitation from a solution of the sulphate by means of zinc, is put in a cast-iron or porcelain-lined mortar, and mixed with strong sulphuric acid, specific gravity 1.85. From 20 to 30 or 36 parts of the dust are taken, according to the hardness desired. To the cake formed of acid and copper there is added, under constant stirring 70 parts of mercury. When well mixed, the amalgam is carefully rinsed with warm water to remove all the acid, and then set aside to cool. In ten or twelve hours it is hard enough to scratch tin. If it is to be used now, it is to be heated so hot that when worked over and brayed in a mortar it becomes as soft as wax. In this ductile form it can be spread out on any surface, to which it adheres with great tenacity when it gets cold and hard.

"OLIVIA" wants to know who perfected the telescope, the sliding lens, and all about

it. Our advice would be to join the Chautauqua school of photography, and read up on optics. A page of history here to begin with:

Soon after the death of Galileo, the telescope was further perfected by Huygens, who, in the first place, invented the form of eye-piece which still bears his name, and gives a large flat field with a very sharp definition. Many variations of form, but no improvement in the seeing quality of telescopic eye-pieces, have since been made, so that from this time all improvements in the telescope have been necessarily confined to the object-glass.

Huygens next enlarged the single-lens object-glass to its greatest possible power. His largest telescope had an object-glass five inches in diameter, and a focal length of one hundred and twenty feet; this enormous focal length being absolutely necessary to reduce the blurring effect of the prismatically colored fringes, as well as spherical aberration, to such moderate limits that a magnifying power of upward of two hundred diameters could be employed.

To have watched Huygens at work with this telescope must have been an amusing sight. Its great length precluded the use of a tube, and therefore an assistant was obliged to slide the object-glass up and down a vertical pole one hundred feet high by a cord, while Huygens pointed the eye-piece at the object-glass by sighting along a string connecting the two, meanwhile steadying himself by resting his elbows on a two-legged wooden horse. A more difficult and unsatisfactory contrivance to use can hardly be imagined, yet, with this telescope, in 1655, he discovered the rings of Saturn and one of its satellites.

"AN English Girl" asks if "You Americans think you invented the whole of photography and its applications?" Oh, no; we only started it. Here is an example:

Ingenuity is not confined to Yankeeland alone. Once in a while some Englishman comes forward with an invention which astonishes the world. A certain ironmaster in the north of England has perfected a device which is both brilliant and cruel. In the walls of his office and the rooms of his

house are concealed rolls of Eastman paper attached to clockwork. Once an hour shutters fall, uncover the paper, and instantaneous photographs of the rooms are taken. The result has been most disastrous to certain employes of the ironmaster. The imagination shrinks in horror from a contemplation of the consequences which would ensue should the device become popular in this country. Return from a summer resort would be filled with excitement for many a householder. Accurate photographs of dinner parties given by the servants to their friends, of the best wine in the house hospitably enlivening the coachman's relatives, pictures of strangers with their feet on the parlor tables, etc., would stir to fervor the artistic enthusiasm of the proprietor. Perhaps, after all, "where ignorance is bliss 'tis folly to be wise."

"A GOOD redeveloper for ferrotypes" is viz.: If by overexposure or overdevelopment you have made your picture too light, it may be restored by using the following: Take a one-ounce phial, fill one-quarter full from your cyanide fixing solution, add a few drops tinc. iodine, fill up with water, pour on and off your plate. With a few trials you can get the desired effect.

"SOLAR."—Yes; a case in point: In the *Bulletin de l'Association Belge de Photographie*, a correspondent mentions an experiment that anyone can perform for himself; it is to see the spectrum of a star. Observe a brilliant star in the field of an opera glass. If the glass be gently shaken, if the star scintillates, the spectrum of the star will be seen with great distinctness. This experiment shows the cause of scintillation and the nature of the spectrum. It is easy to deduce from this experiment the difficulty that exists in making stellar maps.

"CORNEA."—If you will look on page 340 you will learn that the retina of the living human eye has been photographed by two English operators. Owing to the non-actinic color of the retina, an exposure of twenty minutes by gaslight was required with an extra sensitive gelatine plate. Although small, the negative shows the bifurcation of the bloodvessels, and also the edge of the blind spot.



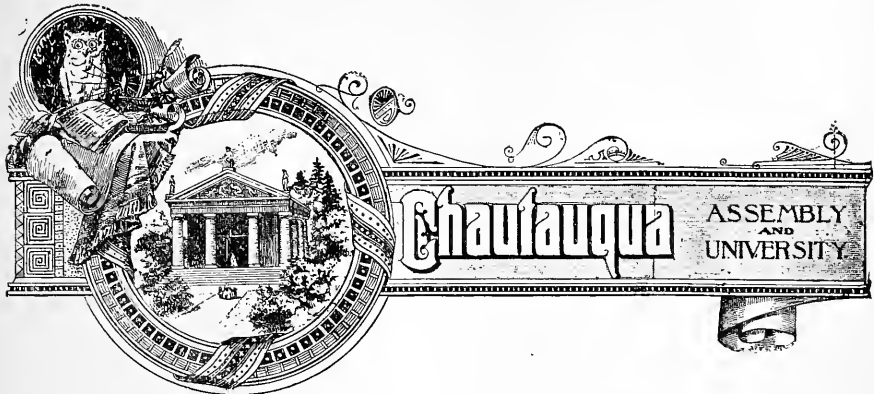

### PHOTOGRAPHIC DAY AT CHAUTAUQUA.

A PUBLIC duty prevented our personal attendance at Chautauqua Lake on Aug. 17, much to our regret.

We understand from the delighted ones who were present, and who have kindly come to give us an account of the exercises, that the whole grand affair was a glorious success.

Chautauqua was well crowded on the 16th, but on the 17th, when the loaded steamers came up the placid lake, the scene was an intensely interesting and encouraging one. The sun shone bright and the wind was hushed, so that a more perfect day for photographic purposes could scarcely be wished for.

The only cloud which fell upon the day was the announcement that Charles Wager Hull, Esq., the Superintendent of the Chautauqua School of Photography, was detained by illness at Alexandria Bay, and could not be present to see the glorious culmination of his earnest work.

Matters went on, however, with a great deal of enthusiasm. Veteran photographers were there, and many would-be experts with the camera, some of whom had been imbibing the careful instruction of Professor Charles Ehrmann for a couple of weeks back.

The morning and the early afternoon were devoted to similar instruction.

The lovely scenery of land and lake all submitted benignly to the requirements of

the camera, often focussed by fairest hands and nimblest fingers for the first time. As the tall asters now tempt the bees from the lower flowers of the garden, so the camera poised upon the graceful tripod seemed to draw the interested attendants from the other attractions always so plenty at Chautauqua.

And this was right, for it was "Photographic Day." That great parent of Education, Chautauqua, was to open its doors to one more interesting child—a most interesting child.

The photographers who were there tell us that a very peculiar good spirit seemed to pervade the day—a strangeness which they could not explain. There is *always* a strangely *good* feeling at Chautauqua. *This* time it was the feeling that comes to the household with every new baby—when "mother and child are doing well." And everybody looked as they do after they have been looking at a baby, and that is why all was so pleasant.

The day ran on like the plunge of a duplex drop-shutter, each hour increasing the enthusiasm.

In the afternoon Chancellor Vincent addressed an audience in the amphitheatre that numbered six thousand, and was listened to with the closest attention and interest. He spoke of the great progress which photography had made in these later years, its usefulness in the sciences and arts, and the ease with which its successful practice could be acquired. He recommended all interested

to join the Chautauqua School of Photography, and to learn the art systematically.

At the same time, in the Temple, an intelligent and equally enthusiastic audience was assembled to listen to the address of Professor Charles Ehrmann, the director of the school, and to the remarks of Professor Spring and others.

Mr. Charles Barnard presided, and, in opening the proceedings, explained the object of the meeting, by referring to the fact that Chautauqua had become the patron of the fine arts, that this was a growing institution, and that any art which held so large a place in the world as photography should have a place in its scheme of instruction. He held that, like music and painting, it should be made a personal accomplishment by persons who might intend to use it only for their own benefit. He stated that children only ten or twelve years of age could learn to use instruments, that the expense would be but a trifle, and that this art could be made of great value to merchants, mechanics, and to other trades and callings.

Professor Spring explained the value of photography as related to his department—clay moulding. A pupil, he said, could photograph his work, send it to him by express or otherwise, and he would be as able to form a judgment of its merits from the picture as if he should see the work itself; and he could in turn, send photographs of correct models to his pupils for their examination and guide.

The photograph, he considered, could be used in a correspondence university to very good advantage.

After these exercises, and while there was still a good light, the entire audience assembled in a chosen spot, and were there photographed in a large group, on a 17 x 20 plate, by Professor Ehrmann, assisted by Mr. John Carbutt.

The day ended with a most enjoyable concert given by the college students.

Thus ended the first Photographic Day at Chautauqua Lake. It was a brilliant success.

Now, what may be expected to grow from it all? What for the professional photographer, we mean, for it is *his* interests that

we, as a journalist, watch with the most jealous care.

When "Photographic Day" at Chautauqua comes along next year it will probably be extended over several periods of twenty-four hours. There will be an exhibition of photographs and apparatus; there will be practical instruction given; there will be lectures; there will be lantern demonstrations, teaching how to see pictures and how to secure them, and something entirely new to the fraternity assembled.

And the great result the professional photographer may expect from all this is a better appreciation by the public; a better understanding by his patrons of his difficulties and of what is really necessary order to procure good work, and, above all, a willingness to pay him a better price for his labor and to *want the best*.

There can never be any harm done to any profession by enlightening the public concerning it. International exhibitions have long since subverted any such idea.

The live, intelligent people of the present dispensation want to see how the thing is done—they even want to do things with their own hands. But this does not mean that they want to take away our bread and butter and sugar.

If the whole fraternity will look intelligently at the situation, grasp it and understand it, and with wide awake zeal keep alongside of the growth of our art, it will soon grow too warm for the low price and bad work structure, and it will go down like the ice palaces at Minneapolis and Montreal.

But Chautauqua will help us build better and stronger and wiser and more permanently. Its machinery is mighty, and its influence is felt all over the land.

---

### A PIECE OF PRESUMPTION.

IN the *Amateur Photographer*, July 30th, is a communication without date or place, signed "Kehāma," headed "St. Louis Convention." It is not an article or communication on the "St. Louis Convention," however, but an uncalled for, presumptuous attack on Dr. A. H. Elliott's portion of the report of the Committee on the Progress of Photography read at St. Louis.

For a reason all his own, President Potter chose to divide the work of his Committee on Progress, so that we had a report of progress "in Germany and Austria," in "Great Britain," and in "America," the latter being the report of our esteemed colleague, Dr. Elliott, editor of *Anthony's Bulletin*.

Because Dr. Elliott confined himself to the business of his appointment, "Kehāma," an English "amateur," well and intensely known in this city, presumes to call him to account with a great swing of Latin "from his little book," and berates President Potter for not appointing "some higher authority on matters photographic." Certainly he has poured on his developer too strong this time, and has produced a very flat image for his pains. He heads his hot-headed attack "*Parturiunt montes, nosutur ridiculus mus.*"

Surely it is *he* who has made the "*ridiculus mus.*"

It would be wise for him to follow his glorious confreré in pretense and pomposity, "His Excellency, Folbach," in Falka, and turning his face away, consult his little manual (Latin or any other tactics) before he gives his friend, the editor of the *Amateur Photographer*, orders again.

Our colleague in London is so sure that "Kehāma" is right that he says editorially: "It is, though it ought not to be, somewhat difficult for the American photographic journals to speak out freely and boldly the truth concerning their Convention. We, on this side of the water, serve no interest but that of the general progress of photographic art and science, and therefore can insert any side of a question, even if it be rough and perhaps disagreeable. Our correspondent's article concerning the American Photographic Convention at St. Louis will be read not only with interest here, but with attention in America. "Kehāma" is a well-known writer, and he is not likely to put his name to statements which will not bear that useful test of "washing."

As to the "no interest but," etc., we cannot see the force of these remarks. All the American photographic magazines have published the stenographic report of the proceedings of the Convention—all the

three reports on "Progress," and full lists of the exhibits both of photographs and of materials.

For ourselves we are free to say that it was *not* "difficult" thus to "speak out freely and boldly."

Perhaps if our *Amateur* confreré will remove his spectacles and wipe from them the dust and fog of Kehāma, he will see a great deal more that is practical in our late Convention. He will also see that the crowded little island on which he lives does not begin to hold *all there is* "on this side of the water."

---

### THE WORLD'S PHOTOGRAPHY FOCUSSED.

THE death of Mr. M. Spirescu, long a member of the German Photographic Union of Galatia, is mentioned with regret. The deceased leaves a wife, who, with her eldest son, will carry on the business of the husband and father.

THE Hamburg Society recently celebrated its anniversary with many of the members present, and two guests, Mr. Meyer and Mr. Seitz. A number of toasts were given, and one of the visitors, Mr. Meyer, entertained the Society during intermission by well-executed piano solos. With the consciousness of having spent a very enjoyable evening, the meeting adjourned about one o'clock A. M.

DR. BORCK, of St. Louis, says that asphaltum varnish is the best disinfectant he knows of. It will destroy all germs at once, and no household insects will approach an article of furniture whose interior has been painted with it.

At the Photographic Society of Berlin, after the usual routine of business was adjusted, an animated discussion on the merits and cost of the backgrounds drawn by Mr. Schwartz, of Königsberg, took place.

In the course of the evening, Mr. Otto Becker submitted a kind of new magnesium lamp which was made by the mechanic, Beisger, and is offered by the firm of Leppin & Marsch, at the cheap rate of fifteen marks, including a roll of magnesium bands. The

apparatus consists of a case, in which this roll is enclosed; by means of a small crooked handle, the band can be made to move slower or quicker, just as you choose, through the central point of a metal reflector. Mr. Becker took with this little apparatus (in preference to insufficiently lighted inner rooms) an excellent bust picture in 45 seconds, as the negative which he showed, proved. After some further discussion on this piece of mechanism, the enterprising Mr. Becker exhibited a number of pictures taken by the instantaneous process. As a matter of course these had been insufficiently exposed, as he himself remarked, but still they served to show what valuable studies could be made in this manner. One picture particularly was very attractive—that of a child playing ball—the ball hangs suspended in the air, while the child is in the act of catching it.

Mr. Himly then submitted for the consideration of the members a report of his latest arrangement of an electric light atelier.—*Wochenblatt*.

In the July *Correspondence* is a long paper entitled "Official Report of the N. O. Commercial and Trades' Board concerning the Formation of a Confederacy of Photographers." It contains an appeal to the government of the Vienna photographers to be allowed to form a confederation of themselves, stating how many associations there are of them and the great improvement made in their art since its invention. The board called a meeting of photographers, and out of 131 invited, about 50 attended. At this meeting it was stated that the photographers of Vienna were originally allotted by governmental decree to the confederacy of book, stone, and copper printers, Sept. 1860, but having never allied themselves with this corporation, they formerly withdrew from it in 1866, having been declared a free trade, by ministerial decree, in 1864.

The board, after listening to all the points in question, promised to consider the matter and further the unanimous wish of all concerned, if possible.

AN exhibition of the Schleswig-Holstein Photographic Society is to take place on the 24th, 25th, and 26th of September in Flens-

burg. Only members of the Society invited. Particulars from Mr. W. Dreesen, Flensburg.

THE summer festival of the society for the advance of photography took place on the 2d of July. Many guests and ladies attended, and owing to the efforts of the committee on entertainment, the whole affair was very enjoyable.

After coffee was served by a blooming young lady in fancy costume, a walk through the woods was proposed, and the celebrated hut of Robinson-Bahnwaters visited, where a band of gypsies entertained the company with song and string instruments, an impromptu dance on the grass being the result. Strawberries and beer, a combination not to be indulged in in the cholera season, served as refreshment, when nightfall called the party back to Grüman, where fireworks and music brought the pleasant evening to a close.—*Berlin Letter*.

In the Ottoman Empire there is an innovation requiring that the photograph of everyone holding a passport be taken at each *pass* (station).

THE notice concerning the murderer, Keller, which we took from Berlin journals and published in the previous number, has been officially contradicted. The court is not in possession of a photograph of him. To be sure, the court did obtain an instantaneous picture, executed by an officer of the Eisenbahn regiment, but it was instantly stated that this was not a picture of Keller.

VERY pretty miniatures may be obtained by applying to *ivorine* (imitation of ivory) photographs transferred by the carbon process. Here is a hint for somebody.

SOME remarkable photographs made by M. Gaston Tissandier have just been presented to the Paris Academy of Sciences. On the 2d of July M. M. Tissandier and Paul Nadar operated in a balloon at altitudes varying from 800 to 1150 metres (874 yards to 1257 yards) in a voyage of about 180 kilometres (112 miles), from Paris to Mans. The prints were obtainable in  $\frac{1}{250}$ th of a second duration, constituting a very great

degree of instantaneousness. The photograph of Versailles and that of a small village in the environs of Mans, are remarkable; they are veritable photographic charts.

THE *Photographic News* recently reproduced from *La Nature* two of Nadar's Mans views. Of course it is unfair to judge photographic results by process prints. If it is, surely Mr. Doughty's admirable views in the *Century* are far ahead of Mr. Nadar's.

DR. HUGH DIAMOND.—The announcement is made of the death, at a very advanced age, of Dr. Hugh Diamond, one of our most learned photographers, friend of David Brewster, John Herschel, Fox Talbot, etc., and who was for some time secretary of the London Photographic Society in its early days, and at a time when there was no other. Dr. Diamond had, at Levickeham, near London, an insane asylum for women; but he always followed, with much interest, the marvellous progress in photographic art, for which, in its infancy, he did so much.

PHOTOGRAPHIC POSING.—I am sometimes moved to wonder whether the photographs which line the shop-windows of Broadway are considered beautiful by their feminine originals. What might be called a contortion craze has invaded the photograph gallery, and women have their pictures taken in poses that would have made their mothers gasp with amazement twenty years ago. This is not only true of actresses, but also of women who are socially eminent. One well-known leader of New York society—not Mrs. Potter, by the way—is on exhibition in numerous copies of a photograph which depicts her in gorgeous evening attire, reclining at half length upon a low chair, with her arms stretched back over her head holding a huge feather fan aloft. She is looking at the fan, and the effort throws her head so far back that the tendons of her throat stand out like whip-cords. Even Miss Ada Rehan, who is usually acknowledged to be a woman of good taste, has had herself photographed in a somewhat similar manner. Only the head and back are shown. The view is from in front and the chin is held so high

in the air that one sees nothing but a long throat very much strained and topping off in a sharp-pointed chin. Above the chin may be seen, in a dim horizontal perspective, the features of Miss Rehan, the nose alone rising distinct from the somewhat blurred hue of the face. The photograph is life-size. The effect is unpleasant.—[*New York Letter to San Francisco Argonaut.*]

A MUNICH ART DEALER has paid \$12,500 for the exclusive right of making and selling photographs of the castles of the late King Ludwig.

ABOUT 200 PHOTOGRAPHIC VIEWS, the property of the Philadelphia Photographic Society, and so marked on the back, were stolen from the Pullman Palace Car building, opposite the City Hall.

DR. OLIVER WENDELL HOLMES used to be an amateur photographer and one of our contributors. When he presented a picture he wrote on the back of it, "Taken by O. W. Holmes & Sun."

LABOR NOTES.—It is announced that the firm of Friedrich Krupp, of Essen, intends to employ instantaneous photography in the solution of highly important ballistic questions. Mr. Ottomar Anschütz, a highly skilled photographer, who has rapidly acquired notoriety by the excellent work which he has recently performed, is taking observations during the experiments at present being carried on at Krupp's range, near Meppen, by order of the German Admiralty. He is to devote his attention chiefly to taking photographs of projectiles in transit, the recoil of gun-carriages, the penetration of armor plates by projectiles having an average velocity of fifteen hundred feet per second. The obstacles to be overcome in obtaining satisfactory photographs are very great, and the most delicate apparatus must be used, in the manipulation of which, however, Mr. Anschütz is said to be very proficient.

A WEALTHY IRONMASTER in the north of England is the subject of an apocryphal-looking narrative in the *Amateur Photographer*, which says that he has adopted an ingenious contrivance, by which he may glean some information as to what goes on

during his not unfrequent absences from home. In several of his rooms, and in his offices, there is a concealed apparatus in the walls, consisting of a roll of Eastman paper and a train of clockwork. Every hour a shutter is silently opened by the machinery and an instantaneous photograph is taken of all that is going on in the room. On the great man's return, he delights to develop these pictures, and it is said that they have furnished some very strange information, indeed. One clerk, who received his dismissal somewhat unexpectedly, and boldly wanted to know the reason why, was horrified when shown a photograph in which he was depicted lolling in an easy chair, with his feet upon the office desk, while the clock on the mantelpiece pointed to an hour at which he ought to have been at his busiest. The servants' party in the best dining-room furnished another thrilling scene.

---

#### FACTS AND FANCIES.

THAT albumen paper has been extensively used for the preservation of butter, we have previously remarked. We find that, in France, this experiment has been used to good advantage. The fresh butter must be rolled up in a double-fold of linen, then kneaded and rolled in the paper. By this means butter can be kept fresh for months.

It is well known that King Ludwig II., of Bavaria, during his last years, was much averse to having his picture taken. The last, and therefore most valuable portrait of the king, was taken (made) by his order, last winter in the castle "Hohenschwangan" by the now deceased court photographer, Joseph Albert. A copy of this portrait has been brought out in different sizes from the art establishment of Mr. Albert; the picture, which is exceptionally true to life (taken to the knee), presents the noble countenance of the unfortunate sovereign in an earnest mood, in civilian's dress (shooting jacket), the hat ornamented with the royal crest. This picture should find an entrance to every household as a memento of the high-minded prince who lost his life in such a tragic manner.

ONE of the most interesting recent discoveries in science is the fact that a ray of

light produces sound. A sunbeam is thrown through a lens on a glass vessel that contains lampblack, colored silk, or worsted, or other substances. A disk having slits or openings cut in it is made to revolve swiftly in this beam of light, so as to cut it up, thus making alternate dashes of light and shadow. On putting the ear to the glass vessel strange sounds are heard so long as the flashing beam is falling on the vessel. Recently a more wonderful discovery has been made. The beam of sunlight is made to pass through a prism so as to produce what is called the solar spectrum or rainbow. The disk is turned and the colored light of the rainbow is made to break through it. Now place the ear to the vessel containing the silk, wool, or other material. As the colored lights of the spectrum fall upon it sounds will be given by different parts of the spectrum, and there will be silence in other parts. For instance, if the vessel contains red worsted, and the green light flashes upon it, loud sounds will be given. Only feeble sounds will be heard when the red and blue parts of the rainbow fall upon the vessel, and other colors make no sound at all. Green silk gives sound best in red light. Every kind of material gives more or less sound in different colors and utters no sound in others.

---

#### THE OPEN CORNER.

SIR ISAAC NEWTON thought that the heat of the sun was at least 2000 times greater than the temperature of red-hot iron. Pouillet calculated that the solar heat which falls on a square centimetre (nearly a sixth part of a square inch) of the terrestrial surface is sufficient to raise 1.7633 grains (nearly a troy pennyweight) of water 1° of Centigrade every minute, and, having adopted this as what he termed a "caloric," or constant unit of solar heat, he, estimating backward, inferred that the heat issuing from a similar measure on the surface of the sun would there serve to melt a layer of ice 11.80 meters (36 feet 1 inch thick) every minute. Pouillet spoke of a temperature somewhere between 2630° and 3170° Fahrenheit as the probable amount of the heat

of the sun. Ericsson assumed the enormously higher quantity of 4,000,000° Fahrenheit. Professor Langley, from observations made with his recently constructed bolometer, or ray measurer—a very sensitive instrument, in which calorific vibrations are converted into electric currents—gives as a probably exact result from 1800° to 2000° Centigrade, and by a very beautiful series of experiments of an altogether independent nature he satisfies himself that the sun's hemisphere radiates 87 times as much heat and 53,000 times as much light as an equal area of incandescent steel in a Bessemer converter in which the air-blast has been sustained for about twenty minutes. This may, perhaps, be fairly looked upon as the most trustworthy approximation to any definite conclusion that has yet been found possible in this very difficult branch of human knowledge.

EVERY one, says Professor Matthieu-Williams, in one of his lectures on the "Chemistry of Cookery," who eats his matutinal egg eats a sermon and a miracle. Inside of that smooth, symmetrical, beautiful shell lurks a question which has been the Troy town for all the philosophers and scientists since Adam. Armed with the engines of war—the microscope, the scales, the offensive weapons of chemistry and reason—they have probed and weighed and experimented; and still the question is unsolved, the citadel unsacked. Professor Bokorny can tell you that albumen is composed of so many molecules of carbon and nitrogen and hydrogen, and can persuade you of the difference between active and passive albumen, and can show by wonderfully delicate experiments what the aldehydes have to do in the separation of gold from his complicated solutions; but he can't tell you why from one egg comes a "little rid hin," and from another a bantam. You leave your little silver spoon an hour in your egg-cup, and it is coated with a compound of sulphur. Why is that sulphur there? Wonderful, that evolution should provide for the bones of the future hen! There is phosphorus also in that little microcosm; and the oxygen of the air, passing through the shell, unites with it, and the

acid dissolves the shell, thus making good strong bones for the chick, and at the same time thinning the prison walls. Chemists know a good deal now about albumen, and if they cannot tell us why life differentiates itself therein and thereby they can tell you how not to spoil your breakfast, and how to produce brilliantly toned photographs.

"No crime so great as daring to excel."  
*Churchill.*

There are a great many photographers who are great criminals.

"Oft it falls out, that while one thinks too much of doing, he leaves to do the effect of this thinking."—*Sidney.*

Or, in other words, "do not put off until to-morrow that which can be done to-day," for "a stitch in time saves nine."

"He who wishes to secure the good of others has already secured his own."—*Confucius.*

That is, be communicative. What little useful dodges and wrinkles you find good in your practice, communicate for the good of the craft. It will grow infectious and you will be well repaid, soon.

"We may outrun,  
By violent swiftness, that which we run at,  
And lose by violent running."

—*Shakespeare.*

Gods! It seems as though friend William *must* have been a photographer. Substitute develop for "run," and see what you get.

"Let a prince be guarded with soldiers, attended by councillors, and shut up in forts; yet if his thoughts disturb him, he is miserable."—*Plutarch.*

Change the "prince" into photographer, and "thoughts" into "dry plates," and see how the royal things of earth lean toward you fellow man-iplulator.

"No man was ever scolded out of his sins."—*Cowper.*

Neither can you keep a plate from frilling by swearing at it.

"In the exhaustless catalogue of heaven's mercies to mankind, the power we have of

finding some germs of comfort in the hardest trials must ever occupy the foremost place."—*Eickens*.

That is the photographer's only consolation.

"A fixed idea ends in madness or heroism."—*Victor Hugo*.

Right you go Victor, but a properly fixed negative prevents madness.

"No matter how much faculty of idle seeing a man has, the step from knowing to doing is rarely taken."—*Emerson*.

That's why dry-plate makers are discussed so warmly by photographers who

won't use the developer which is sent out with their plates.

"Every noble life leaves the fibre of it interwoven for ever in the work of the world."—*Ruskin*.

Let this cheer you and help you to leave your "fibre" in your own "work."

"Genius may be sometimes arrogant, but nothing is so diffident as knowledge."—*Bulwer Lytton*.

It is egotistical though to hold back from the fellow-craft what you know under pretence of being diffident. *Mosaics*, for 1887, offers its arms to us. Let's get in.—*Aunt Dottie*.

## Editor's Table.

A FINE opportunity for investment is offered by F. H. in "Specialties." The studio is well known to us, and the statements of the party having it for sale may be relied on.

"THE Singing Bird," has been laid aside, and now is the season for the "Wag-Tail," a new, brilliantly plumaged bird which sitteth upon the finger of the operant and keepeth the child still while the drop-shutter droppeth. It is the contrivance of Messrs. GAYTON A. DOUGLASS & Co., Chicago, who sellet it at twenty cents.

MESSRS. LOEBER BROS., 121 Nassau Street, New York, are two reliable young men who supply photo. stock and artists' materials, and who print for the trade. They are highly commended by their patrons.

*Mosaics*, 1887, is forming and promises to be a fine volume. Articles for its pages are now overdue, and if you have it in your mind to contribute, please do not delay.

STOP THIEF!"—The following appeared in the *Atlantic City Review*, July 29th:

"Last Monday afternoon James Scott and Samuel Kelly, two young men in the employ of Mr. EDWARD T. MCKEAN, a photographer, whose place of business is on Atlantic Avenue just below Kuehnle's Hotel, disappeared, taking with them over five hundred dollars worth of

the goods of Mr. MCKEAN and about twenty dollars in cash. Mr. MCKEAN called at the *Review* office yesterday afternoon and stated that he had learned that the thieves were in Washington, and that he expected that they would be arrested at once, and that he would recover his property. Mr. MCKEAN is at present a resident of Hammonton, and his father was at one time a lay judge of this county."

A RARE chance at some excellent lenses, etc., is offered by Dr. W. A. VALENTINE, 50 W. Thirty-second Street, New York. A list will be sent to applicants. See "Specialties."

MESSRS. N. B. GRAVES, Cairo, Ill., and H. W. and M. A. PARDOE, Keithsburg, Ill., have recently had "openings" of their new studios. Success be theirs.

MESSRS. GEORGE W. WILSON & Co., Aberdeen, Scotland, as our older patrons know, astonished the world by the excellence of their landscapes when no one scarcely ventured out to make a view. Frequently we used pictures from their negatives for "Our Picture," and held them up as studies to our readers. We know where they have had wondrous influence in shaping the future of now successful landscape photographers.

They continue to hold their place as "head." Dealers in the beautiful should look at their advertisement, and send for their catalogue.



They have contracted with us for their space for two years, the longest single contract we have ever made, though many of our advertisers have held their place with us for over twenty years.

We shall soon show our readers another example of work from negatives by our esteemed namesakes.

PICTURES RECEIVED.—Mr. W. M. FLICKINGER, Bethlehem, Pa., has favored us with a series of eight cabinets illustrating the life of the "Mower." No. 1 is of "Old Time going out for his day's work" with his scythe on his shoulder, and No. 8 represents him seated, weary, after the day's work. Both the model and the photographer have done excellently well, as have also Mr. CARBUTT's quick plates. One of the most interesting is No. 4, which shows the old mower putting an edge on his scythe with a hammer in old German style. The whole series is very natural and has a smack of good old times which is charming. Mr. FRANK Z. FRITZ, Lambertville, N. J., regales us with two cabinets called "The First Melon of the Season." A jolly boy in each is gladly gloating over a generous slice in his hands with a prospective three-quarters lying near by. Both are well taken. We are glad to see efforts in this direction.

*The Canoe and Camera*, by THOMAS SEDGWICK STEELE, Hartford, Conn., is a companion volume to *Paddle and Portage*, or rather *vice versa*, for *Canoe and Camera* was published first. It is even more interesting than its companion to photographers, as it relates the trials, tribulations, and successes of the author with camera and dry plates in the wild woods. Its style is entertaining and amusing, and as a specimen of bookmaking it is unique. A seventh edition is now ready.

THE MOSS ENGRAVING Co., 535 Pearl-Street, New York, have given us a pleasant surprise in their new specimen book of Mosstypes. Portraits, engravings, machinery, landscapes, and Linerusta Waltons are done with equal facility and excellence. We cannot see how anything can be better. The work is superbly printed.

*First Lessons in Amateur Photography*, by Prof. RANDALL SPAULDING, red-cover edition, is the first issue from the Chautauqua Press C. L. S. C. Depot, 423 Broome Street, New York, and is to serve as the primary instruction book of the converts to photography by means of Chautauqua. We have already spoken of the clear, concise treatment of the subject by Prof.

SPAULDING, and are glad again to commend his work.

*Dry-Plate Making for Amateurs*, by Dr. GEO. L. SINCLAIR, is No. 20 of SCOVILL'S Photo. Series. The essays on making and using emulsion plates, which Dr. SINCLAIR contributed to the *Photographic Times*, have been carefully revised, augmented, and arranged into book form by Mr. W. I. LINCOLN ADAMS, editor of the *Times*, and are offered in most acceptable shape. The work seems so easy after reading this capital compilation, that doubtless it will in the future be held accountable by many and thanked by an equal number for persuading them into the fascinations of photography.

THE illustrations in the September number of *The Magazine of Art* would make a beautiful little album by themselves. The number opens with a suggestive paper on "Art in Australia," by R. A. STEVENSON, which is practically an essay on all colonial art, its aims and limitations and successes. Hamo Thornycroft's "The Sower," a statue exhibited at the Royal Academy, 1886, is the leading illustration. "Female Headgear" always is a curious topic, and Mr. RICHARD HEATH treats of it in this number. The lofty elevations erected on women's heads in the time of Marie Antoinette were due to Mlle. Bertin, the milliner, and Léonardi, the hairdresser, though the modern photographer "could a tale unfold," also, if he were permitted to tell tales out of school. Four-foot structures composed of false hair, wire, and ribbons, gave elegance to some of the heads of that day.

"Give Chloe a bushel of horsehair and wool,  
Of paste and pomatum a pound,"

and then the thing was possible.

The landscape studies in this number are particularly attractive. The article on colonial art is full of instruction—every line. One exquisite illustration in the number is that of "A Nunnery at Bruyes," and a noteworthy page is filled with AUSTIN DOBSON'S dainty verses, daintily set in FREDERICK BARNARD'S drawings. Photographers studying art will find this magazine a cheap and valuable paper. MESSRS CASSELL & Co., limited, New York: \$3.50 a year in advance.

DANISH PHOTOGRAPHS.—A charming surprise has come to us from Mr. H. RUSE, one of our Copenhagen subscribers, in the shape of a series of cabinet portraits of great technical excellence. The type pictures of the commonplace folk are particularly interesting. The Danish ladies are also very fascinating, and are fortu-

nate in having so appreciative an artist to render their lovely character so splendidly as Mr. RÛSE does. His posing and lighting are done with understanding, and in every way his results are admirable. He writes: "I am a constant reader of your magazine, and I have your splendid *Photographics*."

A WELCOME ANNOUNCEMENT.—Formerly photographic paper of larger than usual size has cost very much more in proportion.

The reason being there was so little demand that it was only made in small quantities.

Now that pictures 20 x 24 have become very common, the manufacturer of the Rives paper and the albumenizers of the celebrated N. P. A. brand have been induced, by large orders, to make a paper to suit large pictures and cut up economically into smaller sizes, at a price to suit all.

The size is about 20½ x 24½, and will cut 20 cabinets lengthwise of the sheet, and the grain of the paper will run the same way in all the prints.

The economy of this is at once apparent, as 66½ per cent. more cabinet prints can be cut from a sheet of this size than from a sheet of the regular size, while the cost is only 33½ per cent. more.

It will be known as the 13 Kilo N, P. A. Albumen Paper, and will have the water-mark N. P. A. in it as a guarantee of genuineness.

Pensé only is on the market now, and all the dealers have it.

To Messrs. E. & H. T. ANTHONY & Co., 591 Broadway, New York, is due the credit for this welcome bit of enterprise. It was quite an undertaking to move from their rut such European houses as those named, but being repeatedly and persistently informed of the need of a larger size in America, and assured of a constant demand, after many months of waiting the product is here.

The thanks of the trade are due to Messrs. E. & H. T. ANTHONY & Co. for so aptly anticipating and supplying the wants of the trade.

*The Agenda de L'Amateur Photographie, pour 1886 (Note-book of the Amateur Photographer, for 1886, by FRANCOIS VEYNES, editor of the Amateur Photographer, first year, published at Paris by M. J. MICHELET), contains 180 pages with blank pages on the verso for making notes, and is a very concise and carefully compiled volume. Our French readers will find it very useful.*

THE BLAIR CAMERA Co. are about to open a branch establishment in New York. They will keep a fine line of goods here for all demands. Mr. BLAIR has confided to us a very pleasant surprise which he has to announce soon to the craft—a prize cup. Full particulars presently.

MR. WILLIAM McCOMB, Muskegon, Mich., has favored us with some of his "black vignettes," which are very tasteful and pretty. The posing and lighting are particularly creditable, the technique fine.

"THANKS" is all a St. Louis exhibitor writes for our review of his work, but it is in a bold, manly hand, and is understood.

MR. S. T. BLESSING announces that he will open a branch of his New Orleans establishment at Dallas, Texas, September 1st, in order to be more central in that State. The Galveston branch will be closed.

A MAGNIFICENT WORK.—For the last nine months Mr. D. H. ANDERSON, 735 Broadway, New York, has been engaged on a composition picture of the veteran firemen of this city. It is now complete and on exhibition. It is a grand work of art, and is even more picturesque than his "Seventh Regiment." It is equal in size, and contains not only about two hundred of the noted veterans, but a lot of street arabs, etc., in the foreground, which add greatly to the picturesqueness.

The location is City Hall Park, and the background the buildings beyond, with a fine perspective of Chambers Street on the left. The whole thing is artistically conceived and admirably executed. Copies have been made on dry-plate negatives thirty-six inches long.

Mr. ANDERSON deserves the greatest credit for his patience in such works. They entail a vast deal of labor.

THE GERMAN PRIZES.—Just as we close a cablegram from Mr. GENNERT informs us that the prize medals to Americans at the Braunschweig Exhibition have been awarded to Messrs. DECKER & WILBER and J. F. RYDER, Cleveland, Ohio, and for outdoor work to Mr. GEORGE F. BARKER, Niagara Falls, N. Y. We congratulate our esteemed subscribers (all three) on this

THE Annual Field-day Excursion of the Photographic Section of the American Institute passed off successfully at Fort Lee, August 27th. We were present, and will give full particulars in our next.

# Specialties.

## ADVERTISING RATES FOR SPECIALTIES.

25 cents for each line, seven words to a line—in advance. *Operators desiring situations, no charge.* Matter must be received a week before issue to *secure* insertion. Advertisers will please not ask us for recommendations. We cannot undertake to mail answers to parties who advertise. Please always add your address to the advertisement. **Postage-stamps taken.**

**MAKE OUT YOUR OWN BILL**, and remit cash with your advertisements, or they will not be inserted.

RETOUCHING BUREAU.—Under the direction of Mr. H. Harshman. None but skilled help employed. Quality of work guaranteed. Prices moderate. Send your negatives in wooden box with cover screwed on, and prepay charges. Address GAYTON A. DOUGLASS & Co., Merchants in Photo. Supplies, 185 & 187 Wabash Avenue, Chicago, Ill.

### BARGAIN LIST.

- 1 5 x 8 Scovill Manufacturing Company's Camera, with Eastman Roll-holder, with tripod, focussing-cloth and light carrying case. *All new*.....\$35 00
- 1 5 x 7 Scovill Manufacturing Company's Revolving-back Camera, three extra holders, with kits; 1 tripod..... 30 00
- 1 18-inch Entrekin Burnisher (old style)... 10 00
- 1 14-inch Entrekin Burnisher, (nearly new)..... 15 00
- 1 Centennial Head-rest, perfect..... 8 00
- 1 Spencer Head-rest (old style)..... 1 50
- 2 Bergner Cutters, stereoscopic arch top, each..... 15 00
- 1 Bergner Cutter, stereoscopic square top.. 10 00
- Printing-frames, 10 x 12 (nearly new)..... 60
- “ “ 6½ x 8½ “ “ 35
- “ “ 5 x 8 “ “ 30
- Negative boxes 5 x 8, 8 x 10, 10 x 12, and 14 x 18 from 25 cents to \$1.10.

ROBERTS & FELLOWS,  
1125 Chestnut St., Phila.

TEN "Dallmeyer Lenses" for sale, also six lenses of other makers, six cameras, a quantity of dry plates, trays, frames, etc., and one Entrekin Eureka Burnisher, 2½ inch roll. Send for circular. WM. A. VALENTINE, M.D., 50 W. 32d St., N. Y.

A FIRST-CLASS gallery on Broadway for sale. Good business. *For cash only.* For particulars, Address F. H., care SPECKMAN, 744 Broadway, N. Y.

## DOWN SHE GOES!

### NEW PRICE-LIST

OF THE

ROCKWOOD SOLAR PRINTING CO.

17 UNION SQUARE NEW YORK.

Size.	Unmounted.	Mounted.
11 x 14.....	\$1 00	\$1 25
13 x 16.....	1 00	1 25
14 x 17.....	1 00	1 25
16 x 20.....	1 00	1 25
18 x 22.....	1 20	1 50
20 x 24.....	1 35	1 50
22 x 27.....	1 40	1 90
25 x 30.....	1 40	1 90
27 x 32.....	2 25	3 00
29 x 36.....	3 00	4 00
30 x 40.....	4 00	5 00

No charge for negatives. All orders must be accompanied by the cash. Make all P. O. orders payable to ROCKWOOD SOLAR PRINTING CO., 17 Union Square, New York.

PRINTING AND TONING FOR AMATEURS  
A SPECIALTY.

PLATES DEVELOPED.

Try our freshly made photographers' paper. Made fresh daily, and fumed ready for use. 25 cents per sheet, 18 x 22, cut any size, and sent by mail without extra charge.

Our Concentrated Toning Solution is pronounced the *best* by all who have used it. Price, seventy-five cents.

Photographic supplies of all kinds. Largest variety of stock in the city. Send for catalogue.

LOEBER BROS.,  
119 & 121 Nassau St.,  
New York.

A lady assistant; one that can retouch, print, etc. Reference required. Address

C. F. COOK,  
17 S. Main St.,  
Wilkesbarre, Pa.

**WILSON, HOOD & CO.,**  
 825 Arch St.,  
 PHILADELPHIA.

We have now in stock  
 THE NEW EAGLE DRY PLATE.

ALSO

THE INGLIS TRIUMPH PLATE.

A new brand of  
 GERMAN PYRO ACID.

(35 cents per ounce.)

POCKET GLASS CUTTER.

(15 cents each.)

NEW STYLE CORNER CHAIR.

(\$10.00 each.)

PAPIER MACHÉ STUMP.

(\$6.00 each.)

SUNSHINE MAILING ENVELOPE.

**THE LIGHT RUNNING**

**NEW HOME SEWING MACHINE**

**SWIFT SURE**

**SEWING MACHINE HAS NO EQUAL.**

**PERFECT SATISFACTION**

**New Home Sewing Machine Co.**  
 —ORANGE, MASS.—  
 30 Union Square, N. Y. Chicago, Ill. St. Louis, Mo.  
 Atlanta, Ga. Dallas, Tex. San Francisco, Cal.

**FOR SALE BY**

THE AGENTS, at the above named places.

AT ST. LOUIS

Everybody saw, admired, and ordered  
 THE MAGEE VIGNETTER.

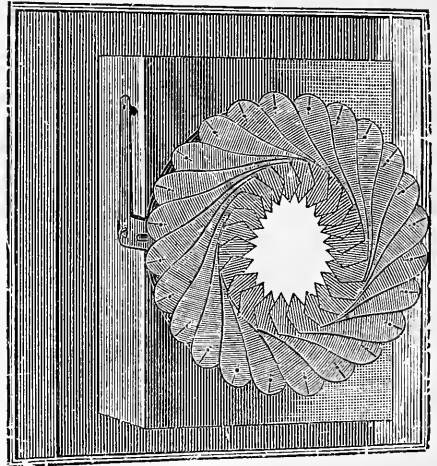

It is for the new  
 BLACK VIGNETTE.

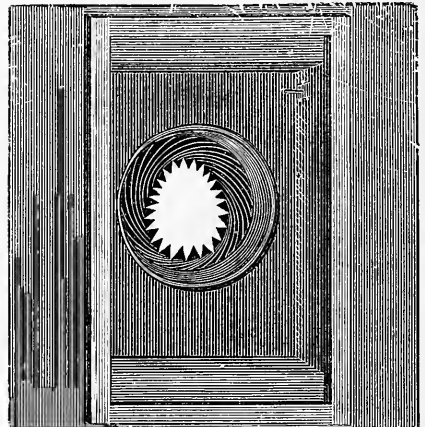

Look at its work. Also try the celebrated  
 P. A. OF A. PAPER.

Albuminized for  
 H. A. HYATT, Eighth & Locust Sts., St. Louis.

FOR SALE.—A first-class gallery in the boom-  
 ing city of Creston, Iowa. Population 10,000.  
 Everything new and first-class; only one other  
 gallery. Will sell cheap if sold before January 1,  
 1887. Want to go to California. Address

J. A. REYNOLDS,  
 Creston, Iowa

ANTHONY'S Adjustable Developing Fork, especially for warm weather, is one of the greatest boons recently introduced. By its use the fingers are kept absolutely free from the developer. Ask your dealer to show you one.

EVERY photographer in want of excellent lenses, for any purpose, will best serve his interest by consulting the new illustrated price-list of Messrs. BENJAMIN FRENCH & Co. before purchasing.

Our dark-room and laboratory are under the charge of Dr. John Nicol, photographic chemist, late of Edinburgh. None but purest chemicals used in our preparations. All the standard dry-plate developers kept in stock. Your patronage desired.

GAYTON A. DOUGLASS & Co.,  
 Merchants in Photo. Supplies,  
 185 & 187 Wabash Avenue,  
 Chicago, Ill.

825 REVISED LIST. 825

We call attention (circular free) to our revised price-lists of *albumen papers*, *Magee's nitrate of silver*, *dry plates*, and *pyrogallie acid*. Consult it before you buy. WILSON, HOOD & Co.,  
 825 Arch St., Phila.

SPECIAL CARD.

Talcott's Improved Mounting for photographs softens the lines, gives much strength and great brilliancy to the picture, and is the only process by which a photograph may become indelible.

Patented March 23, 1886.

For preserving from all soiling engravings, etchings, crayons, diplomas, certificates, etc., this mounting has no equal, the picture or parchment being hermetically sealed.

Pictures thus mounted can be displayed or packed in less than one-half the space required by pictures with other framings, as by this process all other framing becomes wholly unnecessary, yet it is so constructed that if desired it can be placed in any ordinary picture frame intact, free from all interference.

E. K. TALCOTT,  
 216 Northampton St.,  
 Boston, Mass.

FOR SALE.—An old-established photographic business, commanding the best trade of the two Saginaws, and without exception the best paying business in the State. Receipts from January 1, 1886, to August 1, 1886, over \$3000. Rent low. Everything in first-class order, and fitted up in elegant shape. Address

W. T. DOOLE,  
 Lock Box 257,  
 Saginaw City, Mich.

BROMIDE ENLARGEMENTS.

We are now prepared to furnish fine permanent bromide enlargements from photographers' negatives, as follows :

	Unmounted.	Mounted.
10 x 12.....	\$1 00 each.	\$1 50 each.
11 x 14.....	1 25 "	1 75 "
14 x 17.....	1 50 "	2 00 "
16 x 20.....	1 75 "	2 25 "
18 x 22.....	2 25 "	2 75 "
20 x 24.....	2 50 "	3 00 "
22 x 27.....	2 75 "	3 50 "
25 x 30.....	3 00 "	3 75 "
24 x 36.....	4 00 "	4 75 "
30 x 40.....	6 00 "	7 25 "
30 x 48.....	8 50 "	10 00 "

Terms cash with order.

Specimens furnished from our own negatives at above prices.

If fine negatives are sent, finely retouched, no working up will be necessary.

We will retouch negatives or finish prints in crayon, pastel, India-ink, or water-colors at very reasonable prices, putting on any amount of work you may wish from \$1.00 upwards.

Please specify size of print, whether vignetted or solid, if vignetted how far down to show, whether mounted or unmounted on card or stretcher, whether to retouch negative or not; if you wish us to work up print give full instructions, if not, state what you want the print for, etc.

If to be made from a picture the print will cost 50 cents more, and will require finishing.

Patent stamp photos. 75 cents per hundred.

Respectfully,  
 HULBERT BROS. (Genelli),  
 923 Olive Street, St. Louis, Mo.

Among all the photographic lenses of various makes and styles which have been introduced during the past ten years, the euryscopes, of which Voigtlander & Son are the sole manufacturers, loom up conspicuously. The success of these lenses has been unparalleled, and the demand is as lively as ever. They can be found in nearly every gallery in the land, and the amount of satisfaction and profit they produce is difficult to calculate. Most convincing proof of their superiority over other lenses is the exquisite work done with them, and the fact that it is simply impossible to get along without them.

Send for our bargain list.

WILSON, HOOD & Co.,  
 825 Arch St., Phila.

Reed's Common-sense Negative Washing-box.  
New. Send for circular.

WILSON, HOOD & Co.,  
825 Arch St., Phila.

#### THE DUPLEX NOVELETTE CAMERA

Is a marvel of Camera architecture. In an instant a "vertical" camera may be turned into a "horizontal," and in another the change made from the 5 x 8 to the 8 x 10 size, and *vice versa*. It is supplied in two carrying cases, so that you may leave one part at home if you desire. The same platform and one front serves for both sizes. It is as complete an equipment as ever was invented. One holder, each size, goes with the "Duplex" at \$35. Messrs. E. & H. T. Anthony & Co. are the makers.

The American Artists' Association is reëstablished for *solar printing in silver, solar printing in platinum, finishing in ink, water-colors, crayon, pastel, and oil.*

WILSON, HOOD & Co.,  
Trade Agents, Phila.

\$1.00 New York.

SECOND CHOICE.

#### DOUBLE ALBUMEN PAPER.

Extremely cheap. Samples sent.

W. HENERMANN,  
49 CEDAR STREET, NEW YORK.

#### SITUATIONS WANTED.

*No charge for advertisements under this head; limited to four lines. Inserted once only, unless by request.*

To retouch and attend reception-room. Willing to assist generally. Address C. Barton, 223 Swan Street, Buffalo, N. Y.

As general workman, or will run a gallery on shaees. Can furnish reference if desired. Address J. L. Jones, Mansfield, Tioga County, Pa.

As operator, by a man of sixteen years' experience, who has been successful with dry plates, or would form a copartnership with the right man with some capital. Outdoor large work preferred. Can furnish plenty work. Address X., Box 84, Hammonton, N. J.

As retoucher and assistant operator. Address D. A. Lauder, Whitney's Point, N. Y.

By an operator of fifteen years' experience. Address L. F., care Phillips & Bergstresser, Danville, Ill.

By an expert retoucher. Can take charge of printing. West preferred. H. M. L., Box 17, Brunswick, Me.

By a man of fifteen years' experience in first-class house. Can work in branch. Address E. G. Maire, 373 Superior Street, Cleveland, O.

In or near Philadelphia, by a young lady as retoucher or general assistant. Address L. W., Box 915, Woonsocket, R. I.

By a lady of ten years' experience, in a first-class studio. Can retouch, mount, spot, and understands reception-room. Address Photos., P. O., Providence, R. I.

By a first-class photographer, or would rent a gallery or run one on shares. Address Edward E. Elliott, care John W. Morrison, No. 10 Sixth Street, Pittsburgh, Pa.

## OUR SPECIALTIES.

BROMIDE AMMONIUM, Chem. Pure.

BROMIDE POTASS., Chem. Pure.

NITRATE SILVER, Chem. Pure.

### FOR DRY PLATES.

CROSS-SWORD DRESDEN ALBUMEN PAPER,

Single and Extra Brilliant. The Best in the Market.

ALSO A GENERAL LINE OF

### PHOTOGRAPHIC CHEMICALS.

A circular, "How to Save Waste," sent on application.

**CHAS. COOPER & CO.**

194 Worth St., New York.



TRY THE NEW  
**3 KINGS** EXTRA BRILLIANT  
 ALBUMEN PAPER.

*Vio-Pensee*, a most delicate violet tint, and  
*Pearl-Email*, a beautiful shade of pearl.

SUPERIOR PRINTING QUALITIES.

Price per Ream, \$34.00.

Sample dozen post-paid to any address on receipt of \$1.00.

**BUCHANAN, SMEDLEY & BROMLEY,**  
 Importers, 25 N. 7th St., Phila.

THE PLATINOTYPE (Patented).

Send ten cents for instructions and sample,  
 portrait or landscape.

WILLIS & CLEMENTS,  
 1112 HUNTER ST., PHILADELPHIA,  
 BUCHANAN, SMEDLEY & BROMLEY,  
 General Agents for the sale of materials.

**HODGE & HUSTON,**  
**THE SOLAR PRINTERS,**  
 622 ARCH STREET, PHILADELPHIA.

*Permanent Prints by the Platinum Process. Electric Light.*

Those

**FINDERS**

beat the world. You ought to see them. If you are making *instantaneous* views you can save ten times their *value* in annoyance and *failures* the first dozen plates you expose. Easily adjusted, always in focus, light, cheap and durable. Size of ground glass 1 x 1 3-10 inches. *Price, \$1.50*, post-paid to any address in the United States.

**BUCHANAN, SMEDLEY & BROMLEY,**  
**PHILADELPHIA.**

THE best artists and solar printers in the United States and Europe use PLATINOTYPE PAPER for large and small pictures. This paper is manufactured for Willis & Clements' Platinotype Process, and is the *purest* and *most desirable* grade of paper made in the world for ink, crayon, or pastel. Samples free.

BUCHANAN, SMEDLEY & BROMLEY,  
 Importers, 25 N. Seventh St., Phila.

# THE DUBOIS FILING CASES.

*For Preserving Photographic Negatives, Prints, &c., Letters, Bills, and Miscellaneous Papers.*

PATENTED SEPTEMBER 2, 1884.

**Economical! No Binding! Either a Temporary or a Permanent File.**

Made in  
five sizes and cabinet  
form.

**AGENTS WANTED.**

Write for Descriptive  
Circular.

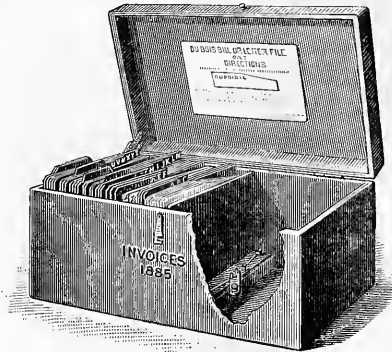

NEW YORK,  
April 27, 1886.  
Mr. FRANK G. DuBois,  
No. 512 W. 30th St., N.Y.  
DEAR SIR: Your File supplies a need that I have felt for some time past. It is the best thing of the kind that I have ever seen, and I shall be much pleased to recommend it to all my friends for preserving bills, notes, receipts, recipes, unmounted prints, photographs, and all kinds of miscellaneous papers to which easy reference may be wanted at any time. Respectfully,  
MISS SOPHIE L. MAURER.

Sent by Express, on receipt of \$3.00, or with lock and key, \$4.00.

PATENTEE AND SOLE MANUFACTURER,

FRANK G. DuBOIS, 512 W. 30th St., New York.

TO THE TRADE ONLY.

## HYPOSULPHITE OF SODA

FOR PHOTOGRAPHERS.

### CHAS. A. W. HERRMANN,

16 Cedar St.

New York.

TO THE TRADE ONLY.

<p>THE LARGEST Photo-Engraving ESTABLISHMENT IN THE WORLD</p>	<p>SIXTEEN YEARS PRACTICAL EXPERIENCE</p>		<p>ILLUSTRATIONS OF EVERY Description for Books, Magazines, Newspapers, Catalogues, CIRCULARS, &amp;c. IN THE FINEST STYLE OF THE ART</p>
	<p><b>MOSS ENGRAVING CO.</b></p> <p>535 PEARL ST. COR. ELM. NEW YORK.</p> <p>Moss' New Process Superior to Any Other Method.</p>		
<p>SEND GREEN STAMP FOR 24-PAGE CIRCULAR -- SEND PHOTOGRAPH, DRAWING OR PRINT FOR ESTIMATE.</p>			

### C. H. CODMAN & CO.

### Photographic Stockdealers

Sole Agents for the NEW ORTHO-PANACTINIC LENS, Moor's Photographic Enamel, the Perfect Mounting Solution for mounting Photographs on the thinnest mount without wrinkling.

New England Agents for American Optical Co.'s Apparatus. The best in the world. Send for Price List.

34 Bromfield Street.

BOSTON, MASS.



# WILSON'S LANTERN JOURNEYS

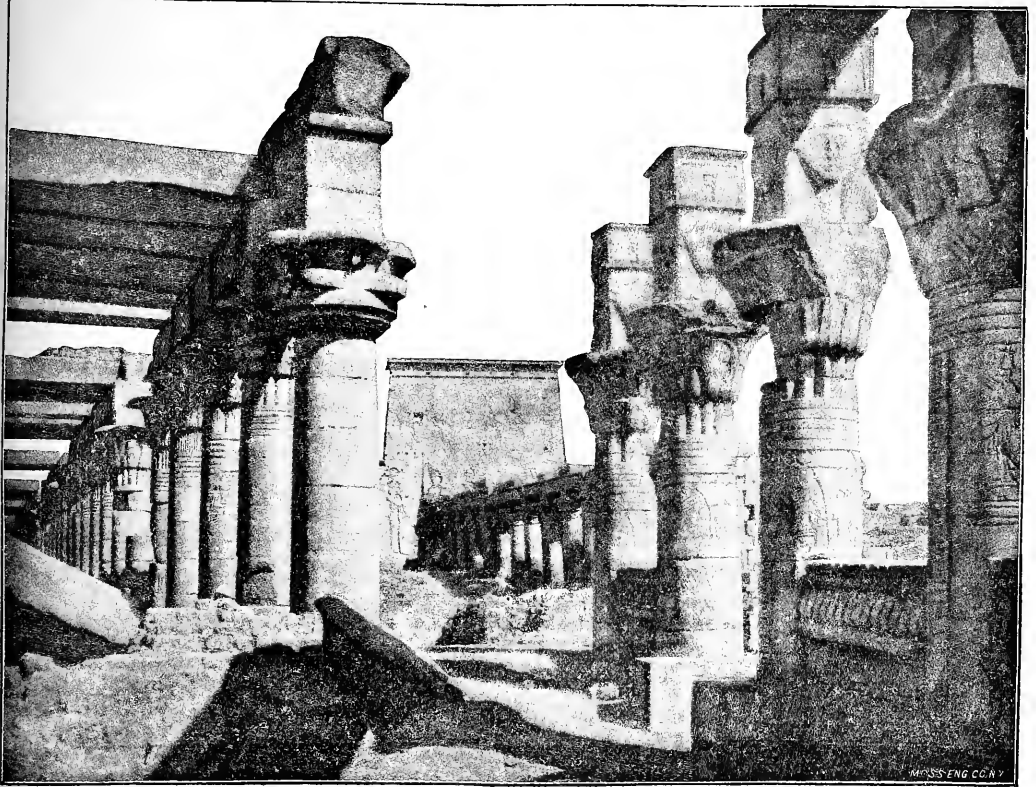

"Splendid summer reading for 'can't-get-aways' and 'can't-travels.' It is lovely travel and description combined."—*Herald.*

**3 Volumes. SEE WHAT COUNTRY THEY COVER. 3 Volumes.**

## VOLUME I. 306 PAGES, CONTAINS NINE JOURNEYS:

A—France and Switzerland. B—Belgium, Germany, Austria, Saxony, and Bavaria. C—Italy—Lakes, Cities, and the Italian Art Galleries. D—Holland, Denmark, Norway, Sweden, Russia, and Spain. E—Egypt, Palestine, Syria, Turkey, Greece, and India. F—England, Scotland, and United States of America. G—Centennial Exhibition, Phila. H—Centennial Exhibition, Phila. I—Paris Exposition, 1878.

**IN ALL OVER 900 SUBJECTS.**

## VOLUME II. 331 PAGES, CONTAINS TWELVE JOURNEYS:

J—Germany and Russia. K—Belgium and Austria. L—France—Cities and Provinces. M—Spain and Portugal. N—Switzerland—The Four Alpine Routes. O—Italy, Ischia, and Sicily. P—Turkey, Greece, and Egypt. Q—Palestine and India. R—Scotland—Cities and Ruins. S—Ireland. T—England—Cities, Museums, and Ruins. U—United States of America.

**IN ALL 1073 SUBJECTS.**

## VOLUME III. 322 PAGES, CONTAINS ELEVEN JOURNEYS:

Sinai Peninsula and Petra. From Hebron to Bethel. Round about Jerusalem. Picturesque Palestine. From Damascus to the Sea. A Thousand Miles in Nile Land. Nile Tombs and Temples. How They Live in Egypt. Egypt and the Egyptians. Egypt, Old and New. New Pictures of Old Places.

**IN ALL 700 SUBJECTS.**

*Gives descriptions of all slides made by Mr. Edward L. Wilson of his personally taken views of The Sinai Peninsula; The Desert of the Exodus; The Route of the Israelites to the Promised Land; and the*

## **TAKING OF PETRA.**

Readers of The Philadelphia Photographer cannot put better books on their reception-room tables than this for waiting patrons.

**PRICE \$2.00 PER VOLUME, POST-PAID.**

For Sale by all Dealers. **EDWARD L. WILSON, Photo. Publisher, 853 Broadway, N. Y.**

ASK FOR THE  
BLUE LABEL.

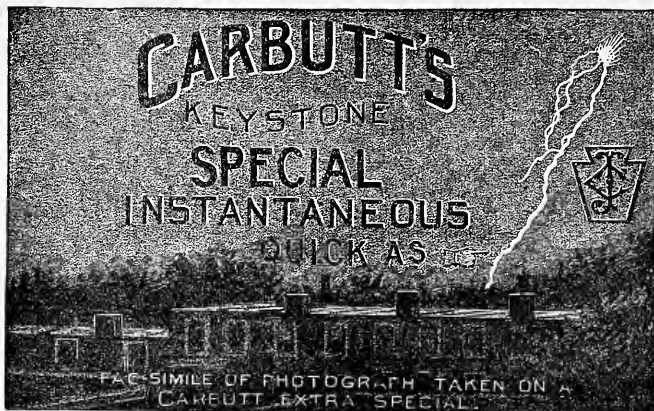

TRY THEM!  
and you will continue to  
USE THEM!

Pronounced the "Ne Plus Ultra" of Dry Plates.

UNSOLICITED TESTIMONIALS.

MR. JOHN CARBUTT, Wayne Junction, Philadelphia.

WORCESTER, MASS., December 25, 1885.

DEAR SIR: I have been using some of your new plates, emulsion 1024, sensitometer 24. I think they are, without exception, the finest and best plates I ever used. They are not only very fine and delicate in their structure, but, when properly manipulated, result in a blooming negative, possessing all the desirable qualities that any artist could wish for. I could most appropriately christen them the "Ne Plus Ultra Dry Plate."

Yours truly,

E. R. B. CLAFLIN.

DETROIT, MICH., January 16, 1886.

MESSERS. HARRIS & KITTLE.

GENTLEMEN: I am very much pleased with the Carbutt Plate; in fact, I call them the best plate by far that I tried so far. I find them especially useful for my theatrical subjects, as the quick emulsions are *absolutely instantaneous*.

Yours truly,

A. B. TAYLOR.

*For Sale by all Dealers in Photo. Materials.*

JOHN CARBUTT, Keystone Dry Plate Works, Wayne Junction, Philada., Pa.

THE UNRIVALLED

# STEINHEIL LENSES.

In Six Different Series and Forty Numbers, for  
Every Description of Work.

These Lenses not only maintain their old-established reputation, but continue to lead in the field of progress.

Special attention is called to

**Series No. II.**, Patent Antiplanatic, the newest conception in lenses. For Instantaneous Portraits, Large Heads, Full Figure Groups, Architecture, and Landscape. A marvel of illumination, depth, and rapidity. No Photographer or Amateur should purchase a lens before testing a Steinheil, Series No. II.

**Series No. III.**, the famous Aplanatic tube, the illumination of which has been increased, and which is recommended for large Portraits, full-size Figures, Groups, Architecture, and Landscape.

**Series No. VI.**, Wide Angle Aplanat, which has no rival for copying Maps, Charts, Paintings and Engravings. It is the Photo-lithographer's favorite.

Send for Illustrated Catalogue and Price-List to your dealer or to

H. G. RAMSPERGER & CO., Sole Agents,  
180 Pearl Street, New York.

## DEALERS' DIRECTORY.

*The following houses are to be recommended as the best for photographers in their localities.*

<p>S. T. BLESSING, New Orleans, La. And Dallas, Texas.</p>	<p>THE BEST BOOK IS</p>	<p>SMITH &amp; PATTISON, NEW LOCATION, 145 &amp; 147 Wabash Avenue, Chicago.</p>
<p>H. A. HYATT, Mound City Photo. Stock House, 8th and Locust Sts. St. Louis, Mo.</p>	<p>WILSON'S PHOTOGRAPHICS, \$4.00.</p>	<p>GAYTON A. DOUGLASS &amp; CO. 185 &amp; 187 Wabash Ave. CHICAGO.</p>
<p>SCOVILL MAN'G CO. 323 Broome St. New York.</p>	<p>D. TUCKER &amp; CO. Buffalo, N. Y.</p>	<p>ALLEN BROS. Detroit, Michigan.</p>
<p>G. H. CODMAN &amp; CO. Boston, Mass.</p>	<p>WILSON, HOOD &amp; CO. 825 Arch Street, Philadelphia, Pa.</p>	<p>B. FRENCH &amp; CO. Boston, Mass.</p>
<p>BUCHANAN, SMEDLEY &amp; BROMLEY, 25 N. Seventh St. Philadelphia.</p>	<p>A. B. PAINE &amp; CO. Fort Scott, Kansas.</p>	<p>MULLETT BROS. Kansas City, Mo.</p>
<p>OSCAR FOSS, San Francisco, Cal.</p>	<p>E. &amp; H. T. ANTHONY &amp; CO. 591 Broadway, New York.</p>	<p>SHEEN &amp; SIMPKINSON, Cincinnati, Ohio.</p>



USE

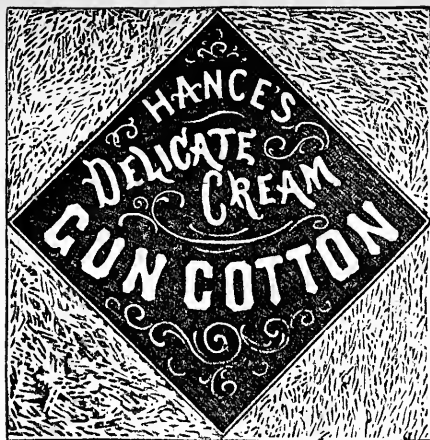

USE

*Is liable to break his Ground Glass, and to have no ready means of supplying a new one. This article flowed upon plain glass will make a capital substitute.*

ANY PHOTOGRAPHER

HANCES  
GROUND GLASS  
Substitute.

Manufactured only by  
ALFRED L. HANCE,  
PHILADELPHIA.

AS A RETOUCHING VARNISH;  
*For making Ground Glass whenever needed; for Doors; for Skylight; for Camera Boxes, it has no equal. Good Ground Glass is hard to get; this Substitute never fails.*

BATH.

Nitrate of Silver Cryst. 35 grs.  
Water 1 Oz.

Iodide of Silver, Near Saturation,  
Slightly acid with Nitric Acid. C.P.

ELBERT  
ANDERSON'S  
NORTON  
COLLOIDION.

Protosulphate of Iron 1 Oz.  
Acetic Acid "V.P.G." 1 Oz.  
Water 24 Oz.  
Alcohol. Quantum Suf.

DEVELOPER.

Scovill Manufacturing Company, Trade Agents.  
FOR SALE BY ALL DEALERS.

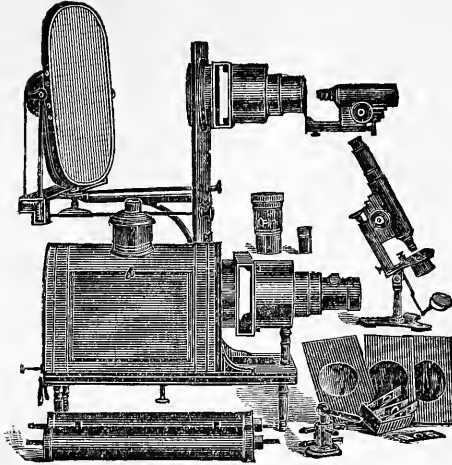

# OPTICAL AND ELECTRICAL INSTRUMENTS.

We desire to call the attention of  
TEACHERS, SCIENTISTS, LECTURERS, and  
those interested, to our

**Stereopticons, Microscopes, Dr. McIntosh's Solar Microscope and  
Stereopticon Combination Apparatus for  
the Oxy-hydrogen and Ether-oxygen Lime Light, Photographic  
Transparencies, Microscopical Preparations, etc.**

Our Instruments and Apparatus are new in design and have many improvements  
that overcome difficulties heretofore considered unavoidable. We also manufacture

**Static Electric Machines, Batteries, Magnets, and a Full Line of  
Electrical Apparatus for Practical and Experimental  
Purposes.**



We received the highest  
award at the New Orleans  
World's Exposition, on  
both Optical and Elec-  
trical Apparatus, in com-  
petition with the best of  
home and foreign manu-  
facturers.



Illustrated Catalogue of Optical and Electrical Apparatus sent free on application  
by mentioning this journal.

**McIntosh Galvanic and Faradic Battery Co.**

Nos. 300 & 302 Dearborn Street,

CHICAGO, ILL., U. S. A.

# THE PHILADELPHIA PHOTOGRAPHER.

TWENTY-THIRD YEAR, 1886.

*Devoted to the Advancement of Photography and the Dissemination of Art Principles.*

SEMI-MONTHLY: issued the First and Third Saturday of each month.

\$5.00 a year, \$2.50 for six months, \$1.25 for three months—in advance. 30 cts. per copy.

## CONTENTS OF THE SECOND QUARTER.

**APRIL 3.**—Art and Photography, by G. HANMER CROUGHTON. Paper Negatives, by W. B. GLINES. Quicker Than the Wind. Developer for Rapid Exposures—Which? A Contribution Toward Precision in Calculation of Exposures. Constitution of Solar Spots, by M. J. JANSSEN. An International Photographic Congress. Photo. Facts and Fancies. Queries, Conundrums, and Conclusions. The World's Photography Focussed. Society Gossip. Pertaining to the P. A. of A. Practical Points from the Studios. What an Old Photographer says for Old and New Workers. Celestial Photography. A Big Offer. Views from My Office Window. Our Picture. Editor's Table.

EMBELLISHMENT.—“The Bride,” by J. F. RYDER, Cleveland, Ohio.

**APRIL 17.**—Æsthetics and Photography, by XANTHUS SMITH. Celestial Photography at the Observatory of Paris. Queries, Conundrums, and Conclusions. Defects in Gelatine Dry Plates, by JAS. C. BALMAIN. Weights and Measures, by JOSEPH DORELLA. The Open Corner. A Process for Printing with Fatty Inks. The Humor of It. Photographing the Eclipse of the Sun. Correspondence. Obituary. Society Gossip. Our Picture. Photographing, a Pictorial Art, by P. H. EMERSON, B. A., M. B. Cantab. The World's Photography Focussed. Editor's Table.

EMBELLISHMENT.—“Island of Philæ—South Colonnade,” by EDWARD L. WILSON.

**MAY 1.**—Negative Paper and Permanent Bromide Paper. Art and Photography, by G. HANMER CROUGHTON. A Good Notice on Photography from the Globe of the Hub. How We Take with “Artists.” Practical Points from the Studios. Photozincographic Process. Home Portraiture. The Open Corner. New Copyright Law in Great Britain. Photo. Facts and Fancies. Queries, Conundrums, and Conclusions. The World's Photography Focussed. Pertaining to the P. A. of A. Society Gossip. Our London Correspondence. Views from My Office Window. Bibliography. Our Picture. The Humor of It. Editor's Table.

EMBELLISHMENT.—“The East,” by GEO. HANMER CROUGHTON.

**MAY 15.**—Patience in Art. The Department of Art, Coloring Positive Prints. The Humor of It. Exhibition of the Pacific Coast Amateur Photographic Association. The Open Corner. Views from My Office Window. Queries, Conundrums, and Conclusions. Society Gossip. Kindly Words for a Worthy Colleague, Pertaining to the P. A. of A. Correspondence. A Good Move. A New Method of “Storing” Paper Negatives, Films, and Photographic Prints. Practical Points from the Studio. Managing an Overdeveloped Plate. Sharply. Steinheil Lenses. Our Picture. The World's Photography Focussed. Editor's Table

EMBELLISHMENT.—“Listening to the Birds,” by JOHN E. DUMONT, Rochester, N. Y.

**JUNE 5.**—St Louis. About Our Last Call. Light for the Dark-room—Blue Prints, by C. G. BUSCH. Negative Paper and Films, by KEHAMA. How Frenchmen Wash Their Gelatine Plates. Pictures from Newfoundland. How to Print, by CHARLES KRAUSS. On Photographing the Retina of the Living Human Eye, by WM. THOS. JACKMAN, M. R. C. S., ENG., and J. D. WEBSTER. Pertaining to the P. A. of A. Amateurs in New Quarters. Society Gossip. A Convenient and Inexpensive Apparatus for Making Lantern Slides, by C. R. PANCOAST. Gihon on Crayon Portraits. The Photographer and the Anarchist. Our Picture. Queries, Conundrums, and Conclusions. Editor's Table.

EMBELLISHMENT.—“Land of the Morning Calm,” by G. CRAMER, of St. Louis.

**JUNE 19.**—My Photographic Hobby. The Department of Art. On the Use of Eastman's Permanent Bromide Paper. Printing Eastman Film Negatives. The S. O. of S. P. Lighting Dark-rooms. Views from My Office Window. That Big Offer. Collodio-chloride Printing by an Improved Method. The Removal of Silver Stains from Gelatine Negatives, by DANIEL ROBERTSON. Practical Points from the Studios. A Question of Conscience. Correspondence. Our Picture. Pertaining to the P. A. of A. Photo-mechanical Printing. A Means of Making Money for Photographers. The Solar Spectrum of 1884. Queries, Conundrums, and Conclusions. Public and Press Recognition of Photography. Development of Instantaneous Negatives with Carbonate of Soda, by M. BALAGNY. Carbon Electrodes without Metal. The Humor of It. Photo-Rival of the Telephone. An Annoying Strike “Off.” C. S. F. A.—C. S. P. The World's Photography Focussed. Editor's Table.

EMBELLISHMENT.—“The Studio of Talamea,” from “Adonis.” By Electric Light, by W. L. MOZART.

The above six numbers to one address for \$1.25, prepaid. The numbers for January, February, and March to one address, post-paid, \$1.25.

The Philadelphia Photographer and Weekly Photographic Times to one address, \$6.50.

The Philadelphia Photographer and Anthony's Bulletin to one address, \$7.00.

EDWARD L. WILSON, 853 Broadway, New York.

OFFICE OF

# G. CRAMER DRY PLATE WORKS,

Shenandoah and Buena Vista Sts., St. Louis.

---

The enlargement of my factory being now completed, I am able to serve my patrons more promptly than heretofore.

Thanking the fraternity for their kind patronage, and soliciting a continuance of the same, I am                      Fraternally yours,

A large, elegant handwritten signature in black ink, reading "G. Cramer." The signature is written in a cursive style with a prominent, sweeping flourish at the end.

DRY-PLATE WORKS, ST. LOUIS, MO.

---

**THE**

## ST. LOUIS DRY PLATE COMPANY

Beg to announce that under their New Management they have recently made Important Improvements and Increased their Facilities, so that they are now making better and more uniform plates than heretofore.

---

ALL ORDERS WILL RECEIVE PROMPT ATTENTION.

---

**ST. LOUIS DRY PLATE CO.**

No. 827 Chouteau Avenue,

ST. LOUIS, MO.



Number 282.

30 Cents.

THE  
 PHILADELPHIA  
**Photographer.**

AN ILLUSTRATED SEMI-MONTHLY JOURNAL,  
 DEVOTED TO PHOTOGRAPHY.

SUMMARY OF CONTENTS.

	PAGE		PAGE
A Pleasant Field Day, . . . . .	545	The Canada Convention, . . . . .	564
Practical Points from the St. Louis Exhibition, . . . . .	551	Queries, Conundrums, and Conclusions, . . . . .	564
On the Use of Aristotypic Paper, . . . . .	555	The Photographic Convention of the United Kingdom, . . . . .	565
Photographs of South Africa, . . . . .	556	On Men's Heads. By WILLIAM ADCOCK, . . . . .	565
On Framing Photographs. By PORTER-CRAYON, . . . . .	557	Success. By H. P. ROBINSON, . . . . .	567
The Spectroscopic Detection of Alkaloids, . . . . .	559	The Treatment of Negatives after Development—a Mystery Unravelling. By W. B. BOLTON, . . . . .	568
Remarks on the Process of Direct Reproduction in Black Lines on a White Ground of Plans, Drawings, Maps, Engravings, etc. By M. DE SAINT-FLORENT, . . . . .	560	Photographing the Late Eclipse, . . . . .	568
Official Report of the Committee Appointed by the Photographic Society of Vienna to Test Voigtlander & Son's New Portrait Euryscope, . . . . .	563	Our Picture, . . . . .	569
		Practical Points from the Studios, . . . . .	569
		Elimination of Hyposulphite of Soda by the Salts of Lead, . . . . .	570
		Photo. Facts and Fancies, . . . . .	570
		The World's Photography Focussed, . . . . .	572
		Editor's Table, . . . . .	574

OUR PICTURE.—"A Ramesian Studio." Negative by EDWARD L. WILSON.  
 Prints by the Photogravure Co., 853 Broadway, New York.

EDWARD L. WILSON,  
 853 Broadway, New York.

SUBSCRIPTIONS RECEIVED BY ALL NEWS AND STOCKDEALERS  
 Five Dollars per Annum, in Advance.

## A D V E R T I S E M E N T S .

ANTHONY & CO., E. & H. T. The New N. P. A.  
 Pensé Extra Brilliant Dresden Albumen  
 Paper.  
 BIGELOW'S ARTISTIC PHOTOGRAPHY.  
 CARBUTT, J. Gelatine Dry Plates and Improved  
 Dry Plate Lantern.  
 CODMAN, C. H. & CO. Photo. Stockdealers.  
 COLLINS, SON & CO., A. M. Photograph Cards.  
 CRAMER, G. Lightning Plates.  
 DOUGLASS, GAYTON A. & CO. Photo. Stock-  
 dealers.  
 EASTMAN DRY-PLATE AND FILM CO.  
 ENTREKIN, W. G. Patent Eureka Burnisher.  
 Duplex Rotary Burnisher. Duplicating Print-  
 Cutter.  
 FRENCH & CO., BENJ. Voigtlander & Son and  
 Darlot Lenses. The Wonderful Euryscope.  
 GENNERT, G. Eagle Dry Plates.  
 HERRMANN, CHAS. A. W. Hypo. Soda.

INGLIS, JAMES. Dry Plates.  
 JANENTZKY & WEBER. Artist Materials.  
 McINTOSH GALVANIC AND FARADIC BATTERY CO.  
 MOSS ENGRAVING CO.  
 PHOTOGRAPHERS' ART VINE.  
 PHOTO-GRAVURE CO.  
 PHOTOGRAPHIC TIMES.  
 PHOTOGRAPHISCHE MITTHEILUNGEN.  
 ROBERTS & FELLOWS. Photo. Stockdealers.  
 SCOVILL MANUFACTURING CO. New Dres-  
 den Albumen Three Crown Paper. Gihon's  
 Cut-Outs. Photo. Apparatus.  
 ST. LOUIS DRY PLATE COMPANY.  
 SMITH & PATTISON. Photo. Requisites.  
 THE DU BOIS FILING CASES.  
 WILSON, G. W. & CO. Magic Lantern Slides.  
 WILSON'S PHOTOGRAPHICS.  
 WILSON'S LANTERN JOURNEYS.

## A D V E R T I S I N G R A T E S .

THE PHILADELPHIA PHOTOGRAPHER is acknowledged to be the best advertising medium in the trade.

Its circulation is among the first class, at home and in nearly every foreign country.

Its rates, all advantages considered, are the most favorable, and it will bring you fine returns.

	One Issue.	Six Issues.	Twelve Issues.	Twenty-four Issues.
1 Page.....	\$20.00	\$110.00	\$200.00	\$350.00
1-2 " .....	12.00	66.00	120.00	200.00
1-4 " .....	7.00	38.50	70.00	120.00
1-8 " .....	4.00	22.00	40.00	70.00

Special contracts made with bona-fide dealers and manufacturers. Address

**EDWARD L. WILSON,**  
 853 BROADWAY, NEW YORK.

## N O T I C E T O S U B S C R I B E R S .

In remitting by mail, a post-office order, or draft, payable to the order of EDWARD L. WILSON, is preferable to bank-notes. Postage stamps of the denomination of two and five cents each will be taken. Clearly give your Post-Office, County, and State.

Foreign subscriptions must be accompanied by the postage in addition.

**FIRE!** Our books having been all destroyed by fire at and with our establishment, all who owe us will confer a great favor by remitting at once.

**CROSSCUP & WEST ENGRAVING CO.**  
 907 Filbert St., Philadelphia.

---

A. M. Collins, Son & Co.

*MANUFACTURE ALL KINDS OF*

**CARDS AND CARDBOARDS**

FOR

**P** PHOTOGRAPHERS **S**

AND

**MATS, MOUNTS, AND ENVELOPES**

FOR

**FERROTYPES.**

---

OFFICE AND WAREHOUSE,

**No. 527 ARCH STREET,**

**PHILADELPHIA.**

---

Price Lists may be had by intending purchasers on application  
to us, or to all Photographic Merchants, through whom  
your favors are respectfully solicited.

# ENTREKIN'S PATENT EUREKA BURNISHER.

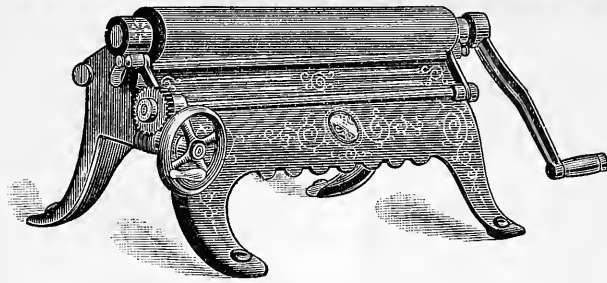

The above cut represents our 25 inch Eureka.

The unprecedented popularity of this Burnisher is wonderful. Over seventeen thousand (17,000) sold in less than five years. Agencies in London, Berlin, and Vienna, and sold by all stockdealers in the United States. The machines are built in first-class style, and warranted to do the work claimed.

Full directions accompany each machine.

## PRICES:

6 inch Roll, . . . . .	\$15 00	20 inch Roll, . . . . .	\$60 00
10 " " . . . . .	25 00	25 " " . . . . .	70 00
14 " " . . . . .	35 00		

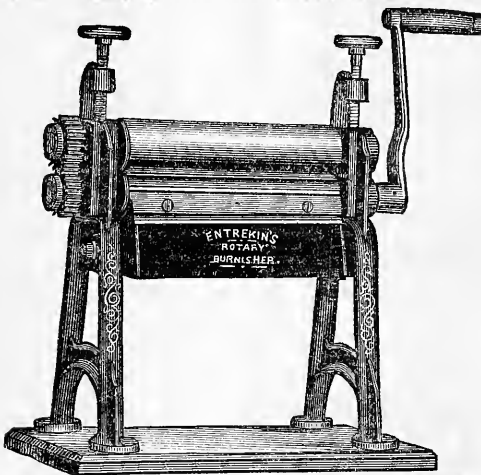

# ENTREKIN'S Duplex Rotary Burnisher.

PATENTED JUNE 1, 1875.

## PRICES:

10 inch, . . . . .	\$15 00
15 " . . . . .	25 00
20 " . . . . .	35 00
25 " . . . . .	45 00

# ENTREKIN'S DUPLICATING PRINT CUTTER.

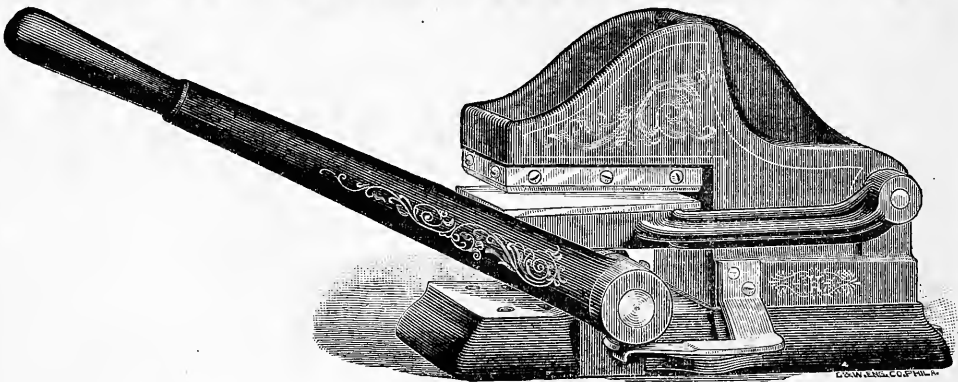

Cabinet and Stereo. Sizes, \$25.00

Small Panel Size, \$35.00.

Size 6½ x 8½, \$40.00.

MANUFACTURED AND FOR SALE BY

W. G. ENTREKIN, 4384 Main St., Manayunk, Phila., Pa.

**ENTREKIN'S**  
 IMPROVED  
**DUPLEX ROTARY BURNISHER.**  
 PATENTED.

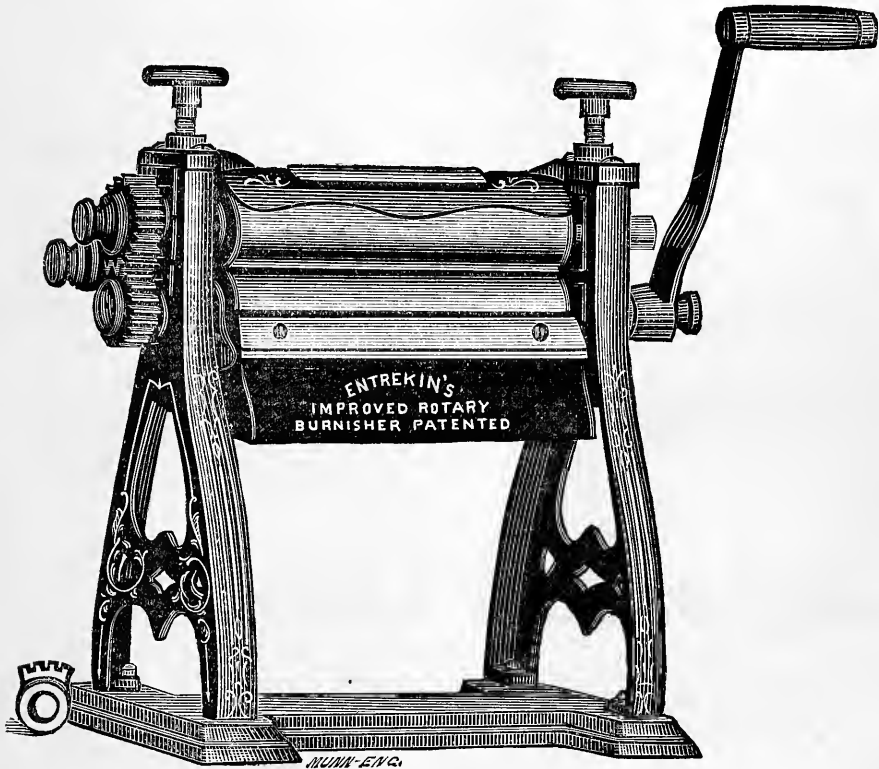

10 in., \$25.00. 15 in., \$35.00. 20 in., \$45.00. 25 in., \$60.00.

This Machine is an improvement on our old Duplex Rotary Burnisher, invented by us in 1874.

It is so constructed that by changing the Large Gear or Cog-wheel, from the stud to the end of the draw-file or upper roll, you reverse and change the speed of the lower or polishing roll, thus getting the same result as in the old Duplex Rotary; but to secure the best polishing surface, use the machine with the large cog-wheel on the Stud, by so doing you secure three times the polishing surface. All the machines will be sent out with gearing so arranged as to give this result. It is optional with the Photographer how he may use the machine. The Fire-Pan is so arranged that it is impossible for it to come in contact with the surface of the polished roll, and it can be turned away to cleanse the roll.

**EVERY MACHINE WARRANTED PERFECT.**

FOR SALE BY

**W. G. ENTREKIN, Inventor and Sole Manufacturer,**

4384 Main St., Manayunk, Philadelphia, Pa.

AND BY ALL PHOTOGRAPHIC STOCKDEALERS.

# BENJ. FRENCH & Co.

No. 319 WASHINGTON STREET, BOSTON,

Sole Agents in the United States for the Celebrated Lenses  
Manufactured by

## VOIGTLÄNDER & SON.

ALSO, THEIR FAMOUS

# EURYSCOPE,

Which is unrivalled for groups, full-length figures, and other demands in the gallery, and every species of out-door work, including instantaneous photography.

☞ **THE EURYSCOPE** is made *exclusively* by Voigtländer & Son, and their name is engraved on the tube.

---

FOR **DARLOT LENSES** FOR  
PORTRAITS. VIEWS.

---

IMPORTERS, ALSO, OF THE CELEBRATED

TRAPP & MÜNCH

## ALBUMEN PAPER,

AND DEALERS IN ALL KINDS OF

*Photographic Materials and Magic Lantern Slides.*

---

SEND FOR OUR NEW ILLUSTRATED PRICE LIST OF LENSES.

# A CARD.

75 STONE ST., ROCHESTER, N. Y., July 26, 1886.

GENTLEMEN: About three months ago the business of Inglis & Co., of this city was formed into the Inglis Dry Plate Co.

In the articles of agreement, a clause was inserted giving the I. D. P. Co. the exclusive use of the name of "Inglis," and also that James Inglis would not connect himself with any dry plate business using the name of "Inglis."

Matters have taken such a form since then, he has been compelled to leave the I. D. P. Co. And being thus debarred from the use of his own name, adopts this means of making known to his numerous customers where they may still obtain his plate. **And the Only Place.**

A new firm taking the name of the **ROCHESTER DRY PLATE CO.** have engaged his services, and under his supervision a new factory has been fitted with the most modern improvements required for the production of **clean and spotless** plates, with all the other extra qualities that his plate has become so renowned for. The fraternity may therefore depend upon the very finest plate ever yet produced, from the **ROCHESTER DRY PLATE CO.**

## JAMES INGLIS,

Late Manufacturer of the Inglis Dry Plate, and President  
of the Inglis Dry Plate Co.

---

## OUR SPECIALTIES.

BROMIDE AMMONIUM, Chem. Pure.

BROMIDE POTASS., Chem. Pure.

NITRATE SILVER, Chem. Pure.

### FOR DRY PLATES.

CROSS-SWORD DRESDEN ALBUMEN PAPER,

Single and Extra Brilliant. The Best in the Market.

ALSO A GENERAL LINE OF

## PHOTOGRAPHIC CHEMICALS.

A circular, "How to Save Waste," sent on application.

## CHAS. COOPER & CO.

194 Worth St., New York.

MAGIC CAMERA STANDS. THE BEST MADE.

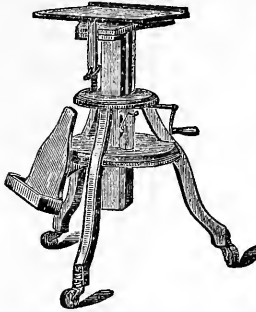

No. 1, 8 x 10, \$12 00



No. 2, 8 x 10 to 11 x 15, \$15 00

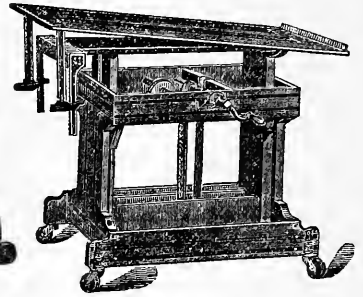

No. 3, 14 x 17..... \$20 00  
No. 4, 18 x 22 and 20 x 24.... 25 00

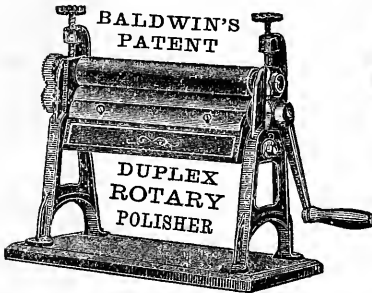

THE BEST IN THE WORLD.  
Prices, \$18, \$25, \$35, and \$45.



CENTENNIAL CHAIRS.  
Very Popular and Cheap.



BALDWIN'S BABY HOLDER.  
Has no Equal.



THE PATENT QUEEN POSERS.  
The most useful Chair ever invented. Prices include  
Circular Arm and Back Rest.

Raw Silk.. \$12 50  
Velveteen. 14 50  
Plush..... 16 50

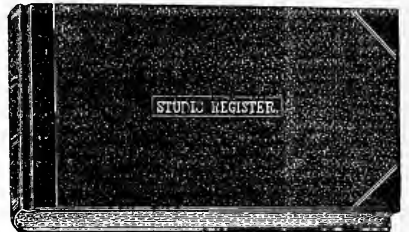
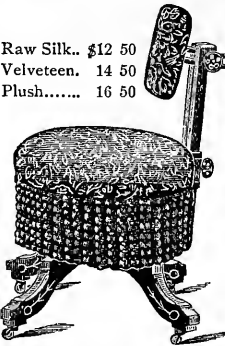

No Studio Complete without it.  
Send for Sample Page.

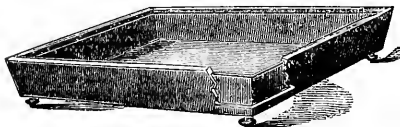

THE COMMON SENSE TRAY.  
Is the Best and Cheapest Large Tray Made.

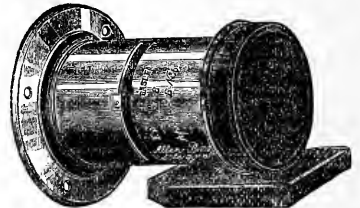

THE WONDERFUL SUTER LENS.  
Has no Superior in Quality, and no Equal  
in Price.

The above represents a few of our leading specialties, all of which (except Suter Lenses), we manufacture and control. All these items are the best in the class they represent. Take no other. Send for complete descriptive circular of any or all these items, or any article needed.

SMITH & PATTISON,

Wholesale Photo. Supplies  
of every description.

145 & 147 Wabash Ave., Chicago.



# The Photo-Gravure Company,

853 Broadway, New York.

PHOTO- { GRAVURE  
LITHOGRAPH  
CAUSTIC  
GELATIN } PRINTING

## PROCESSES OF THE PHOTO-GRAVURE COMPANY.

**PHOTO-GRAVURE.**—By this process the highest artistic effects are produced. Metal plates are engraved (in intaglio) by photography and printed in copper-plate presses. The effects produced by photography may be altered by the hand of the artist, values may be increased or diminished, and almost any omission or addition made. The work may be carried on till the desired effect is produced and the edition is always uniform. The plates can be supplied when desired, or the Photo-Gravure Co. will do the printing. The results obtained by the Photo-Gravure Co. equal the best results obtained abroad, and reference to this effect is permitted to leading Publishers and Artists who have used these plates. All classes of subjects, whether in half-tone or line, can be produced by this process.

**PHOTO-GELATINE PRINTING.**—The results produced by this process are similar to what is known as Albortype, Artotype, Heliotype, Autoglyph, Phototype, Lichtdruck, etc. The particular method used is that patented by Mr. T. C. Roche, and is believed to give the best results at the least cost. The Photo-Gravure Co. has in this department the best staff of printers in the country and a most extended experience of the treatment of gelatine for the purposes of printing. All classes of subjects are suitable for reproduction by this process, and it is especially suitable for portraits, views, architecture, art catalogues, scientific and natural objects, book illustration, town, county, and family histories, theatrical and general advertising, reproductions of engravings, machinery, animals, and still life, copies of deeds, instantaneous effects, scientific records, mill labels, etc.

**PHOTO-CAUSTIC PRINTING.**—This term is applied to a modification of the results produced by Meisenbach, Ives, and others. By this modification the photographic effect is produced from stone. No attempt is made to produce engraved plates, but the printing is done by the Photo-Gravure Co., and by this means greatly better results are obtained than where plates are made and placed in the hands of the ordinary printer. The results are not as good as those obtained from Gelatine or by Photo-Gravure, but they are sufficiently good for a number of purposes where the quality of the higher grades of work is not necessary. It is applicable to all the purposes of the other processes, but is lower both in cost and quality.

**PHOTO-LITHOGRAPHY.**—The results of this well-established process are well known. It is the oldest of the photo-mechanical processes, but is only adapted to the reproduction of original drawings or engravings which are made in a black or other non-actinic color on a white or light ground. We have in our employ on this work the most skilful staff in the country, who for many years have made it a specialty. Photo-Lithography is unrivalled for the reproduction of maps, plans, tracings, surveys, patents, and other drawings, engineers' and architects' designs, *fac-simile* letters and circulars, exhibits in law cases, miniature catalogues, copies of line engravings, reduction or enlargement of line work, etc.

A Book of Specimens of our various processes will be forwarded on receipt of One Dollar, and all inquiries will be promptly answered. Special arrangements made with photographers.

THE PHOTO-GRAVURE CO.,

853 Broadway, New York.

**BUY THE BEST!**

No other will give you half so much satisfaction.

FOR DRY PLATES  
ANTHONY'S Patent Perfect PLATE HOLDERS  
ARE SUPERIOR TO ALL.

DALLMEYER

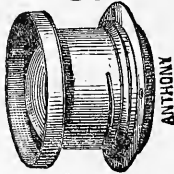

FOR WET

OR DRY

WIDE-ANGLE RECTILINEAR

E. A.

SINGLE COMBINATION, RAPID,  
WIDE ANGLE, PLATYSCOPE,  
PORTRAIT AND VIEW LENSES.

DALLMEYER LENSES,  
SUCCESS CAMERAS,  
THE FAIRY CAMERAS,  
THE NOVEL CAMERAS,  
SCHMID'S DETECTIVE CAMERA

SEND FOR OUR CATALOGUE, AND GET THE BEST Of Everything.

APPARATUS OF ALL KINDS:  
Chairs,  
Neg. Boxes,  
Camera Stands  
Printing Frames,  
Etc., Etc.

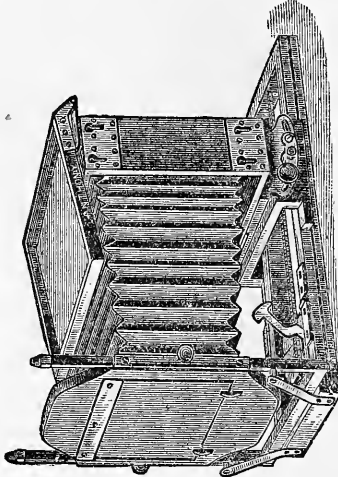

THE FAIRY CAMERA.  
*The Lightest and Best for Out-door Work.*

FOR EITHER DRY OR WET PLATES  
NOTHING EQUALS  
THE BENSTER PLATE HOLDER.

DALLMEYER

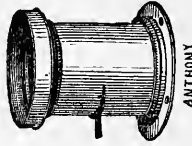

NOTHING

COMPARES

RAPID RECTILINEAR

O. I. C.

PORTRAIT, COPYING, CLIMAX  
PORTRAIT, GEM, AND  
COMPACT VIEW CAMERAS.

**E. & H. T. ANTHONY & CO. BROADWAY, NEW YORK.**

-591-



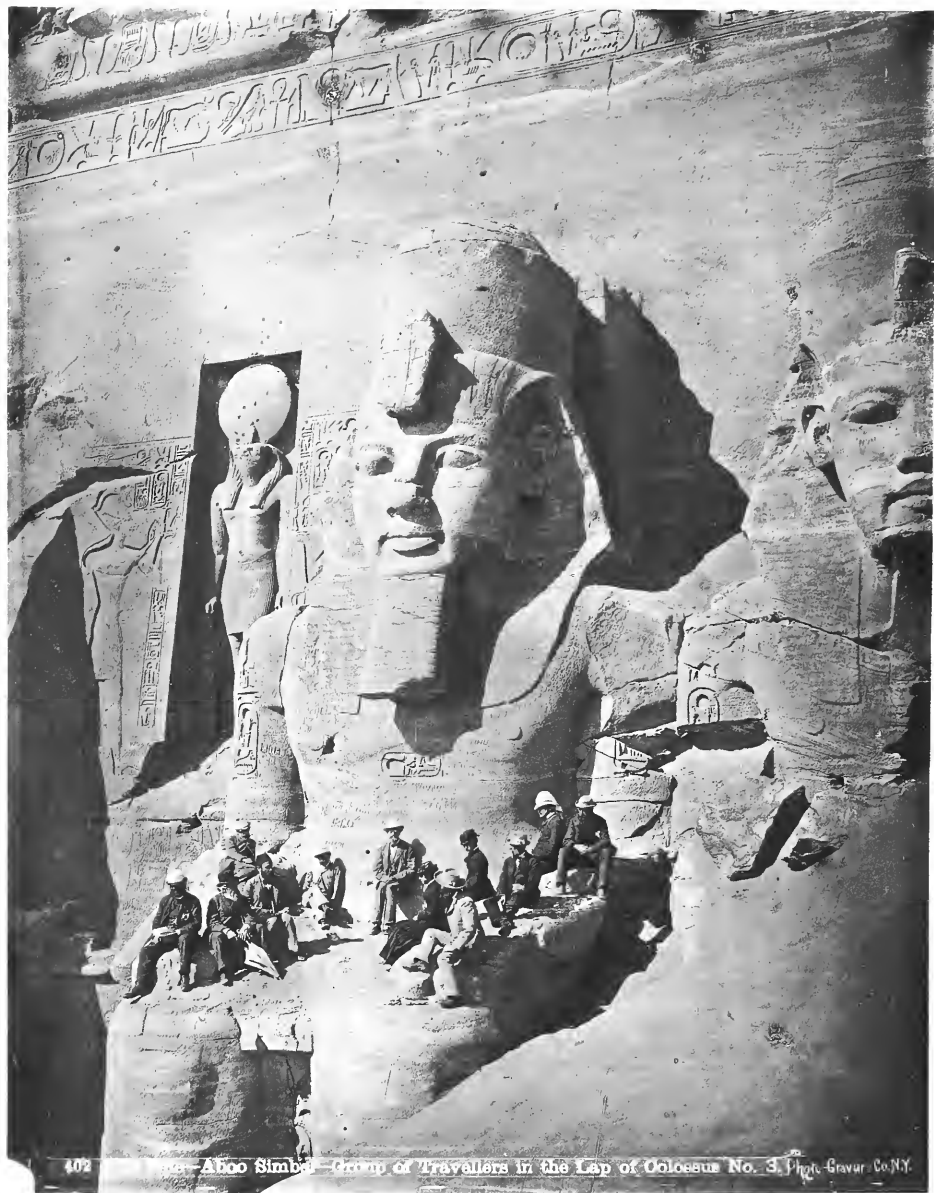

EDWARD L. WILSON.

A RAMESIAN STUDIO.

NEW YORK.

THE

# Philadelphia Photographer.

EDITED BY EDWARD L. WILSON.

Vol. XXIII.

SEPTEMBER 18, 1886.

No. 282.

## A PLEASANT FIELD DAY.

### INTRODUCTORY REMARKS.

A FEW weeks ago we received a circular which partly reads, viz.:

NEW YORK, AUGUST 2, 1886.

DEAR SIR: You are cordially invited to attend the Annual Field Day Excursion of the Photographic Section of the American Institute, at Fort Lee, N. J., August 26, 1886.

The headquarters will be at Schuler's Park Hotel, where the Chairman of the Reception Committee (O. G. Mason) will be in attendance throughout the day.

Dinner will be served in one of the private dining rooms at 5 o'clock P. M.

It is hoped that all will be in time to participate in making up the group to be photographed by a number of our most distinguished amateur and professional experts, at 4 o'clock P.M. Proofs of these efforts will be exhibited at the September meeting of the Section, and the usual awards for excellence conferred by the members.

J. B. GARDNER,  
Chairman of Executive Committee.

It is needless to say that we were "present" on the happy occasion alluded to above and derived a great deal of pleasure and instruction from association with such a number of the veteran and younger members of the time-honored photo-section.

It was an enjoyable occasion from the time the steamer left the dock until she landed us all safely again in New York. A

great deal of photographic development was combined in the groups that were taken on the shady hillside and some of it flowed after dinner, as some of the addresses given below are proof positive. The bill of fare was as follows:

### M E N U .

*Soup.*

Mock Turtle.

*Fish.*

Sea Bass au gratin.

Potatoes.

*Entrée.*

Roast Beef aux Champignons.

Stewed Tomatoes.

Carrots and Peas.

*Roast.*

Spring Chicken.

Salad.

*Dessert.*

Ice Cream.

Coffee.

THURSDAY, AUGUST 26, 1886.

Among those present were Prof. Henry J. Newton, Mr. A. H. Beckers, Prof. P. H. Vanderweyde, Mr. J. B. Gardner, Dr. J. H. Janeway, Dr. Oscar G. Mason, Dr. Arthur H. Elliott, Prof. L. H. Laundry, Mr. Garden and Mr. Estabrooke. Addresses in addition to those below were made by Dr. Janeway, Mr. Estabrooke, Prof.

Laudy, Prof. Vanderweyde, and Mr. Gardner. There was also an address by Dr. Wilcox which he was prevented from reading in person by an urgent call to attend to professional duty at the last moment.

Prof. Newton presided and of course was guilty of some dry remarks. A great many bright things were said. Prof. Vanderweyde said his first photograph was of a chimney, and he remembers how surprised he felt, when on counting the bricks he found the number exactly as in nature, showing the superiority of the photograph over the paintings of chimneys then in vogue. Dr. Janeway said amateur and professional were like man and wife—the one did the work and the other planned and thought it out. Prof. Laudy said all had been very successful in *cleaning plates*. He was a former employé of Mr. Estabrooke, and testified to getting his pay regularly. Mr. Estabrooke tried to explain how that could be but made an ignominious failure of it. Prof. Mason told of crooked-legged Italians in Bellevue Hospital, who came from the land of the Farnese Hercules.

After all the discussions were over and the jocular president had developed all the merriment he could from the table, he adjourned the meeting and there was an instantaneous drop made down the shady roadway to the steamer.

So far as we could gather copies of the addresses made, they follow :

#### THE FUNCTIONS OF A PHOTOGRAPHIC SOCIETY.\*

BY ARTHUR H. ELLIOTT, PH.D., F.C.S.

THE first and most important function of any photographic society is, of course, the encouraging of the advancement of photography. The question then arises what will encourage the advancement of this art? What particular course of procedure on the part of the individual members of the society is best calculated to develop the art and attain the highest results for the good of all the members?

Undoubtedly, the first thing to do is to

\* An address before the Photographic Section of the American Institute, at the Annual Reunion at Fort Lee, N. J., August, 1886.

see that the members are what they claim to be, interested in the advancement of photography. This consideration leads to another question. What particular members of any community are thus interested?

In the smaller towns and cities we can count on many people who would undoubtedly lend their influence if their attention was properly called to the subject. Among these I would mention the men connected with large manufactories, engineers, architects mill-owners, and those interested in railroads and machinery. These men would appreciate the art for its accuracy and beauty of delineation, and contribute their share to the maintenance of a society for its development. Nothing strikes the eye of an engineer or architect so much as a fine photograph of a beautiful machine or a fine building, and if they could be induced to try their hands at making such pictures, they would better appreciate the wonderful skill of the expert photographer in such difficult work.

Another class of individuals that should be interested in advancing our art is the doctors. Nothing is more interesting to a physician than a series of photographs showing the progress of some disease or the management of some skilful piece of surgery. Again, photo-micrography is of inestimable value for studying the etiology of epidemic disease. By the aid of the microscope the physician sees the growth and development of the germs that are devastating the tissues, and photography admirably lends her aid to make permanent records of their evanescent forms. The doctors then should be interested in photography.

Still another class of individuals should be interested. I mean the professors and teachers in our schools and colleges. What better means of instruction could be devised than lectures illustrated by lantern slides? There is scarcely a single department of learning that does not admit of being taught with lantern illustrations. In astronomy, physics, chemistry, botany, and geology, the lantern pictures are invaluable aids to instruction, and are so much better than the old-fashioned diagrams that any one who has used them would never think of returning to the more

ancient forms of illustration. The teachers and professors then are interested in photography.

There is yet another class of the community interested in our art. These are interested, not from any utilitarian ideas, but from their natural keen appreciation of art and art work, and a love of the beautiful generally; I mean the ladies. These are interested in our art because it is beautiful, because it is wonderful, because it is curious; and I don't think sufficient effort has been made to obtain lady members in most of our societies.

In addition to the above lay members of every community who are interested in our work, there are the orthodox professional photographers. Of course these are interested in photography, for by it they live. And I am satisfied that these men are more interested in the progress of any good photographic society than any other class of individuals. Why are they so interested? Because the experimental members of the society can help them; because they can compare their individual work with the work of their fellows and their peers. And those who excel in the art have in the society a stimulus to work in the approbation of fellow-workers with kindred tastes. So that there is no question that the best interests of both amateur and professional photographers are insured, when they are fellow-laborers in the advancement of the same cause.

Another, and by no means an unimportant, class who are interested in the advancement of our art, are the producers of the materials and apparatus wherewith we obtain our results. What photography owes to these men, nobody can fully appreciate unless he has seen the difficulties they have overcome in making dry plates, and the experiments they constantly make to perfect the ingenious devices that tend to our comfort and pleasure. And why are these men interested in photography? Because the advancement of the art means life to them, and money in their pockets.

These are the various classes of the community that are interested in our art. How then shall a society be conducted that each

one will feel at home at its meetings and will contribute to its support?

The engineers and those of allied professions should be encouraged to present material that would interest their fellows as well as the other members. Who amongst us, engineer or not, is not interested in a fine piece of bridge work or an ingenious machine that works with a precision that is almost intelligent? Who amongst us, architect or not, is not moved with admiration on looking at some stately pile where the mind of the man who designed it looks upward and conceives a structure that carries our thoughts beyond our little span of life into the future and the lives of those who come after us?

The development of disease is not always a pleasant subject to look upon; but the photo-micrographs of the physician, together with an intelligent interpretation of their meaning, do much to enlighten us, and help us to combat the dreadful scourges that often sever us from those that are near and dear.

The professors and teachers, if properly appealed to, could furnish abundant material of interest for a photographic society. The experimental work in photography often executed by this class would be of exceeding great value to all the members of the society. The ladies who are members of the society, could teach us many things in fine taste, and matters of an artistic character, that would make them an invaluable aid in the development of our art. Every effort should be made to encourage them to come to our meetings, to help us think out these points that make our art beautiful, that make us more manly, give us finer feelings, and generally civilize us. We are inclined to be too rough toward each other; we often lack charity and want of sympathy for the work of our fellows. With ladies around, these characteristics of crude nature disappear, and we feel better for conquering our rough dispositions.

With members of a society gathered from the various classes of the community as I have mentioned, the professional photographer will perhaps think he has little or nothing to do. The man that has that feeling I think makes a serious mistake. Usually the professional photographer has

little time for experiments. Perhaps he don't want to experiment. But I think there are few who do not long for a little leisure to try some new method of working or some new effects. To such men the photographic society is an invaluable aid, for there are members who do nothing but experiment. From these the professional photographers can obtain many hints and little devices that will prove useful to him in his every-day work. In turn he could help the experimental members in suggesting new lines of work and new phases of the art to be developed, that he has noted during his daily experiences.

Those who supply the materials with which we obtain our results should also be encouraged to let us see everything new in their departments. This should be done systematically and with a distinct understanding that the Society is not a stock exchange. At some specified time during the proceedings of the Society an opportunity should be given for the display of new results upon dry plates and new forms of apparatus, and the time for this exhibition should be specially limited. This would give every one the same opportunity. It might be said that this will be advertising in the time of the Society. Well, perhaps it would; but it will be regulated advertising. And if these men have something new, something of value to us, why should they not advertise it? Above all things, we cannot afford to miss anything new in the manufacture of plates or apparatus that is conducive to the progress of our art. Therefore give the producers of materials every opportunity to show us new devices that help us either in comfort or the attainment of new results.

I have thus rapidly discussed some of the more important functions of the Photographic Society. I will now close with a few thoughts upon the awarding of prizes. During the past two years I have been very much interested in the various photographic exhibitions, and although I note much improvement in the methods of giving prizes, yet I think there is considerable room for more. In the first place, there is in many cases too many classes in some exhibitions, and too few or none in others. In the case

of those exhibitions having a large number of classes, the judges are at their wits' end to know how to decide the awards, especially if these awards are few in number. In the case of those exhibitions where there are few or no classes, the judges are embarrassed in their decisions when comparing the work of men who excel in different phases of photographic art. Now it appears to me that the best classification of pictures is one where size is the first consideration. Some men can handle large plates skilfully, while others have neither the skill nor the opportunity of working with large plates. It is therefore absurd to compare two pictures, one, say 18 x 22, and another 4 x 5, that are classified as views. The smaller picture may be the finer photograph, but the skill involved in the production of the larger one is altogether out of proportion to the smaller. Therefore the first consideration should be size. The next point is the number of pictures exhibited of any given size. Some men have no difficulty in preparing a large number of pictures for exhibition, while others have only the means and opportunities to furnish a few. Therefore the number of pictures should be limited, say one dozen for the larger sizes and two dozen in the case of small pictures.

Then the mounting of the pictures should be regulated. The glitter of a fine frame often dazzles the judge's eye, and no such unphotographic influence should be brought to bear on him. The pictures should be mounted in a simple manner.

As to the question of judging the pictures themselves, this is best left to those who are selected for the purpose. But a far simpler classification of pictures than is generally devised is what is necessary to make the work of the judges reasonably easy, and cause the least dissatisfaction in their decisions. Such classifications as architecture, groups, portraits, landscapes, waterscapes, marine views, machinery, and so forth, would perhaps be all that is necessary, without further subdivisions. A man that can take a good portrait is often unable to take a group; while one who would make a good group would make a miserable portrait; and the same is true in regard to the other classes mentioned. Men with artistic eyes



for landscape views may never obtain good yacht pictures. I do not mean to say these abilities are never combined; but the combination is exceptional, and not the rule; each man has his special abilities, and their development makes him excel. The awarding of prizes for photographic work is a most admirable encouragement to the art, and what I have said is the result of remembering a discussion of the subject at the St. Louis Convention.

And now, having commented upon the various functions of a photographic Society, let me exhort you as members of one of the oldest associations in America, to do your share to encourage those who are willing to advance the art, by giving them your interest in their efforts to develop new phases of photographic work, and opportunities to publish their results to the world at large. Let each one work, so that his results may be admired by his fellow-men, and every step he takes be to a higher level, till it shall be said of his work,

"It tutors nature; artificial strife  
Lives in these touches, livelier than life."

#### SECTION ON PHOTOGRAPHY OF THE AMERICAN INSTITUTE.\*

BY D. R. GARDEN,

Secretary of the Farmers' Club of American Institute.

THE American Institute is now nearing the fifty-seventh anniversary of its incorporation. During these long; varied, and eventful years, its fostering influence has given an impetus to American genius which cannot be accurately calculated.

Scores of inventions have, through its annual exhibitions, been introduced to the great, bustling world; their utility recognized, and the inventors benefited. The awards to science and art have amounted to hundreds of thousands of dollars. The benefits bestowed on the human family would amount to untold millions; for if we were deprived of the ordinary comforts and luxuries which the majority in these days enjoy, what a crude, cheerless world this would be! The unattended fruit tree will grow, but its fruit will be shrivelled

\* An address before the Photographic Section of the American Institute, at its Annual Field Day Excursion, Fort Lee, N. J.

and tasteless; while under the attentive care of scientific experience, its strength must be invigorated, its foliage luxuriant, its fruit plump and luscious.

The long, healthful life of the American Institute is owing to the foresight, care, and attention of those into whose hands its interests have been committed. Many analogous societies have sprung into existence with very many promises; all have silently sunk into obscurity; nor has one had a syllable on the page of history.

Of the sections of the Institute, none is more progressive than the Photographical art. On the 26th day of February, 1859, a preliminary meeting for the organization of a Photographical Society was held in the lecture-room of the American Institute, and on the corresponding day of March, John W. Draper, Peter Cooper, Lewis W. Rutherford, Charles Wager Hull, R. Ogden Doremus, Charles A. Joy, Samuel D. Tillman, Napoleon Sarony, and fifty-three other prominent and well-known citizens, completed the organization of the American Photographical Society. For the first five years Dr. John W. Draper was President. From that time (1864) till April, 1867, Mr. Lewis M. Rutherford was President, when the Society amended its Constitution and By-Laws and became a Section of the American Institute in May, 1867, with the following officers:

*President.*—Lewis M. Rutherford.

*Vice-Presidents.*—John W. Draper, Chas. A. Joy, Abraham Bogardus.

*Cor. Secretary.*—Charles Wager Hull.

*Recording Secretary.*—Oscar G. Mason.

*Treasurer.*—Henry J. Newton.

Of this family circle of officers, but one rests from the activities of life—Dr. John W. Draper, and this convocation is graced with the presence of two gentlemen whose names shadow over and above every active camera—Mr. Henry J. Newton and Mr. O. G. Mason.

On June 10, 1867, the eighty-third meeting of the Association, and first under its new title, was held. Among those who took part in the primal meeting were: Mr. Charles Wager Hull, Mr. D. C. Chapman, Dr. P. H. Vanderweyde, Prof. S. D. Tillman, Prof. Ogden N. Rood, and Mr. Henry J. Newton.

From this initial meeting the Section has

continued peacefully, successfully. It has witnessed great advancement in its art-science in the Old World and the New. It has greeted the springing into active life of photographic societies all over this broad land. Within these expanding circles are numbered many honored in other branches of science; many who practise its intricate details, and are urged on by the pleasure its scientific results develop.

Photography is to art what the luxuriously equipped, trans-continental express train is to the four-horse mail coach of other days; what the telephone and the telegraph are to the old methods of mail conveyance; what the modern improved house is to the homes of our forefathers; what the electric light is to the "lamp of other days." But I need not dwell on those things which "you yourselves do know."

As to the future of the American Institute, inferring from the past, we predict a prolonged career of usefulness. With the history of its earliest and latest years is entwined the name of Mr. John W. Chambers, who now, in his serene and venerable days, can recall the frail infancy of this Institute, whose fame did not extend beyond the New York City of fifty-two years ago.

The possibilities of photography in the future! Who is there bold enough to predict in what new arenas of science or of art it may be used for pleasure, and the profit of future generations?

To many of you gentlemen who have been the pioneers, and have helped along and watched over the progress of your photo-art, it will ever be a verdant pleasure for your thoughts to wander away and dwell with a lingering fondness upon the days which are no more.

ADDRESS BY E. L. WILSON AT FORT LEE.

President Newton: We have with us a gentleman who has done more hard work for photography than any one in America, and I am going to call upon him to give us a few words on what impresses him the most concerning the art. I allude to Mr. Edward L. Wilson, editor of the PHILADELPHIA PHOTOGRAPHER.

Mr. Wilson addressed the assemblage as follows:

*Mr. President and Gentlemen:* I had no expectation of being called upon to-day, or I should have prepared some thoughts worthy of this pleasant anniversary occasion.

Our worthy chairman does not know what tender recollections he arouses when he asks me to dilate upon what impresses me the most concerning our beautiful art.

A short time ago, when in the mountains of New Hampshire, I unwisely placed my camera at the head of a recent land-slide in order to obtain a view I had long coveted. Just as I reached my holder to place it in the camera, horror of horrors, the rocky débris at our feet began to slide, my tripod lost confidence in itself, and we all fell together. I had time to grasp my tripod at the joints, and fell with it in one hand and the plate-holder in the other.

And then we all began to slide and bump down the incline. The commotion we developed was something stupendous. A sectional view of the elevations and depressions we created on the way must have looked like a section of a very hard negative film. My heels were high in air and my arms extended until we had pranced about one hundred and fifty feet. Then, by an extraordinary effort, I succeeded in planting my heels into the bottom of the slide and the excursion was brought to a halt. I saved my camera, ground glass, and plates, and went back and made the view.

I repaired my trousers with a red handkerchief, the only material convenient, which caused a New Hampshire tramp to fire at me for a robin. But I am here and so are the trousers if there is any doubt about my adventure. That slide still impresses me "most." I was much impressed, too, by the address of my old friend Prof. Vanderweyde, who has just taken his seat. He gave me a new thought which fairly thrilled me, when he said that he remembered the time when there were no photographs. Does it not seem strange to us younger votaries of the most wonderful discovery of the world, to look upon a man who can remember when the world had to get along without photographs, who remembers what a sensation was caused by the birth of our art?

What would the world do *now* without photography? If such a thing were inevitable there would be a weeping, a wailing, and a gnashing of teeth which would be terrible to witness.

But there is no fear of this. At no time since our art was born has there been so much thought devoted to it, and so much promise of advancement as there is now. I was much impressed with this fact, when, during the past few days, I read the exchanges which came to me from various parts of the world, previous to arranging the matter for the coming issue of my magazine.

Why, some of the most distinguished scientists of the world, and some of the most thoughtful amateurs are pursuing investigations with the help of photography, with results that are simply marvelous.

In all directions they are working, from the deep soundings of the sea to the mysterious clusterings of the Pleiades. Men plunge into the caves and grottoes of the earth and bring forth pictures of the marvels there. The face of the globe is alive with camera collectors of views. The aeronaut bores a hole for the lens in the bottom of his car, and brings back to the earth vast expanses made from above the clouds. Far beyond the highest altitude reached by the balloonist the eye-piece reaches and brings before us accurate maps of the starry heavens. Is it not incomprehensible? And in behalf of photography itself, some careful investigations are being pursued which will tend to enlarge its influences, its capabilities, and its hold upon the world.

And yet, with all this cheerful outlook, we may not boast too much. For over twenty years it has been my lot to serve as a teacher in our art. Loving art for art's sake, I have loved to teach it. And to enable me to do so I have made pilgrimages to the galleries of the old countries as a student.

But, alas! my heart sometimes goes down, when, reviewing the results of my countrymen at our annual exhibitions, I see how far back they follow what has been taught them.

When I see a fine composition ruined by the introduction of a single incongruous ac-

cessory—a good chance lost by neglect of a proper choice of light; a careless placing of the camera ruining every line of beauty in an architectural study—then my twenty years of toil seem but for naught.

But it is not true. Photography *grows!*—grows mightier—grows mightily every day of the world.

We are almost all of us veterans in its cause now. A younger generation is coming up who will see greater things than we have seen, and our art will continue to live and grow. Forever the cry shall come from a charmed world, "*God bless photography.*"

---

### PRACTICAL POINTS FROM THE ST. LOUIS EXHIBITION.

THOSE who competed for the prizes at the St. Louis Exhibition were requested by the committee to supply information as to the instruments, plates, paper, and formula used by them in the production of their exhibits.

A great deal of good would have resulted from a generous and universal response to this reasonable request.

The object of it was not to mould the jury in their decisions, or to affect them in the least. But it was to inform the good earnest workers, who come to the Exhibitions for what they can learn.

Many a time we saw such making notes from the exhibits for their future guidance.

But the response was *not* general. We do not believe, in these enlightened days, that any expert worker would *withhold* his formulæ lest some one should equal his work. The absence of information was due more to carelessness and haste, than anything else.

It would have been a great gratification to know how *all* the prize-takers and would-be prize-takers proceeded in order to produce the very best work in their power; but, as we have said, many of them did not choose to enlighten us. Perhaps they will accept this hint as an invitation to let us hear from them hereafter.

A list of those who did respond has been kindly sent us by Secretary Benecke, from which we cull what we think will be of service to our readers.

For more careful study, our notes upon the pictures might be consulted again.

NAME.	LENS.	PLATE.	DEVELOPER.	PAPER.	REMARKS.
J. A. Todd, San Francisco	Darlot and Euryscope.	Cramer.	What is termed an alkaline pyro in a weak form, that is plenty of water and conse- quently slow development.	N. P. A., white	
Geo. B. Wood, Philadelphia	Dallmeyer, Ross.	Cramer, Car- butt.	Carbutt devel- oper.	N. P. A., albumenized.	
J. F. Ryder, Cleveland, O.	eck, Voigt- lander, Eury- scope, Walzl.	St. Louis, Seed, Inglis, Eagle, and Stanley.	Pyro, sal soda.	N. P. A.	
Theo. Schurr, Lockport, N. Y.	Euryscope, No. 3.	Inglis Triumph.	No. 1. Water 12 oz., sulph. soda 3 oz., pyro 480 grs. No. 2. Water 12 oz., carbon. potas. 4 oz.	Dresden, N. P. A. extra, brilliant white.	For a properly timed plate I use 2 oz. of No. 2, 1 drachm of No. 1 to 2 oz. of water. This for a 5 x 8 plate. When negative is most developed I add 2 more drachms of No. 1. Undertimed negatives 2 parts of No. 2 to 1 part of No. 1, and 3 oz. of water. Overtimed negatives use 2 or 3 parts of No. 1 to 1 part No. 2, and 2 oz. water. Intense negatives I reduce by putting same for a few minutes in a saturated solution of cyanide of potash
G. W. Sittler, Springfield, Mo.	No. 7, No. 6, No. 3 Dall- meyer.	Cramer.	Soda and pyro.	Lion brand, Pensé.	Sittler's developer. Sulphite of soda 1-6, sal. soda 1-6, Glauber's salts 80 -100 grs., chloride of calcium 25 grs., nitrate of baryta 5 grs, suffi- cient water to make 64 oz. Dissolve with heat, let cool, and filter. Pyro stock. Water 6 oz., pyro 1 oz., C. P., sulph. acid 10 m. by measure or 20 drops. To use take 2 oz. soda stock and 1/2 oz. pyro to 5 or 6 oz. of water. Always keep some old de- veloper, and by adding new to the old you can develop Cramer light- ning as quick as a wet plate, and you can get a soft or strong nega- tive at will by using more or less old or new. We never use ice, and have no frilling, and we have no Cramer lightning. Keep your de- veloper, hypo, and wash-water all about the same temperature.
I. Saunders, Alfred Centre, N. Y.	For cabinet work Saverne mostly used, large work 16-18 Dall- meyer R. R. Suter No. 4.	St. Louis Dry Plate.	Mostly soda, perhaps a few with ammonia.	N. P. A.	Sometimes reduce with sesquichlo- ride of iron 60 grs., citric acid 60 grs., water 8 oz. Saverne lens, im- ported by C. H. Codman & Co., Boston.
A. Pietz, Springfield, Ill.	Euryscope No. 5, Darlot No. 5.	Cramer, Seed, St. Louis, Iowa City.	Soda.	Eagle, N. P. A.	Try the time correctly, and use nor- mal developer, never reduce, never intensify. If a little overtimed, wash plate immediately, and finish de- veloping in weak solution, and clear after fixing with solution of alum, iron, and citric acid.
John Reed, Paterson, N. J.	Harrison globe Zentmayer, Lerebour Pairs Morrison single achi- romatic.	Eagle.	Cooper's soda.	Dresden, extra brilliant Pensé.	
A. E. Reinhardt, Denver, Col.	Dallmeyer No. 3 B. 5 D. and R. B. 2-22.	Stanley, Seed, and Eastman.	Cooper.	N. P. A.	I prefer 1 oz. of pyro to 5 of sulphite and 1 oz. pyro to 48 oz. water, keep all in concentrated stock, and dilute as needed. Very seldom intensify, and less seldom reduce. Use a part of old developer in preference to bromide.
H. P. Robinson, Tunbridge Wells, Eng.	Dallmeyer 7 D.	.....	Edwards' pyro and ammonia.	Rivot, acetate toning.	No intensifier or reducer used; the pyro ammonia is made as follows: No. 1: 32 oz. water, 100 grs. pyro, 50 grs. brom. potass., 20 drops nitric acid. No. 2: 32 oz. water, 2 1/2 water ammon; take 2 parts No. 1, and 1 part of No. 2.
Jos. Menzen, New York.	Euryscope, Voigtlander No. 6, large work aplanet of Steinheil.	Eagle.	Pyro and am- monia for large work, sulphite and soda for small work.	Dresden Eagle paper.	
H. McMichael, Buffalo, N. Y.	Dallmeyer.	Cramer	Soda and pyro.	Eagle.	
Montfort & Hill, Burlington, Ia.	Euryscope.	Cramer	Dry pyro am- monia.	Eagle, Pensé, and Pearl.	The negatives are not intensified or reduced in any way. Dry pyro measured out with a little mustard spoon, a stock solution of bromide of ammon. and one of ammonia; the developer is made fresh each time, and used only once; care taken in giving each case the proper time.

NAME.	LENS.	PLATE.	DEVELOPER.	PAPER.	REMARKS.
C. W. Motes, Atlanta, Ga.	Dallmeyer; all above 8x10 were made with rec. lens, under 8x10 3 A.	St. Louis and Eagle.	Pyro, sal soda, and sulphite of soda, also pyro, carbonate of potash, and sulphite of soda.	N. P. A.	Reducing agent: hypo. soda and red prussiate of potash. Intensifier, bichloride of mercury 2 drachms, bromide of potash 2 drachms, water 12 oz. 2. Cyanide of potash 2 drms., water 6 oz. Add nitrate of silver in solution until the precipitate ceases to dissolve, after thoroughly shak- ing. Whiten the negative with No. 1 according to amount of intensity desired. Wash well, and flow over it No. 2 until blackened.
W. H. Jackson & Co., Denver, Col.	Dallmeyer's No. 4, wide, large rectilin'r for large work the back combi- nation for all but 3 of the pictures; for small work a variety of lenses used, in- cluding Voigt- lander, Ross, Dallmeyer and Darlot.	Cramer's, Car- butt's special and B. East- man's spec- ial; Stanley and East- man's nega- tive paper and American films.	Chiefly carbo- nate of soda. Eastman's negative pa- pers are nearly all developed with the oxal- ate developer.	N. P. A., brilliant for all our work, ex- cepting the 3 large panora- ma views; they are printed on Morgan's pa- pers, especially prepared for us.	The alkaline developer used by us for the last 3 yrs. has been a simple one: No. 1, pyro 1 oz., sulph. of soda, crystals 4 oz., water 48 oz. No. 2, Carbonate of soda 4 oz., water 48 oz., brom. potass. 1; 12 q. s. For reducing red prussiate of potash and hypo 1 oz. of each in 8 oz. of water. For intensifying, plain bichloride of mercury followed by ammonia.
W. G. C. Kim- ball, Concord, N. H.	Voigtlander, Euryscope, and Dallmeyer.	Cramer.	Cooper's.	N. P. A.	
C. D. Kirkland, Cheyenne, Wy.	Voigtlander, 4-4, for small work; Dall- meyer 5 D. for large.	Cramer.	Cooper formu- la, pyro, and soda.	Eagle, Satin.	For large work I use 1 oz. pyro so- lution to 8 oz. soda, giving short exposure, which gives plenty of contrast, and places negatives un- der control in development. If neg- ative is mottled in coming from fixing bath that has alum in it, use hydrochloric acid 1 drachm, water 8 oz. after washing, which will clear it perfectly.
J. Landy, Cincinnati, O.	Dallmeyer.	Cramer.	Cramer.	Eagle, 3 Crown.	
E. H. Lincoln, Dorchester, Mass.	Dallmeyer.	Eastman special, except 1 plate on Inglis.	Soda and pyro.	N. P. A., pink.	In no case were any of the plates in- tensified. The effects were all made by original development. No dodges in printing. The negatives are pre- cisely what the plates show them to be.
W. E. Hook, Manitou Springs, Col.	Dallmeyer and Darlot.	Cramer.	Cramer soda.	S. and M. pink, double gloss.	No reducing or intensifying. When negative does not suit make another one. Develop as Cramer's instruc- tions.
W. Ingersoll, St. Paul, Minn.	Morrison C. C., Darlot W. A. 3, Stereoscope 0, Darlot W. A. 1, Zentmayer 2 focus.	St. Paul, East- man and others.	Pyro and sal soda.	3 Crown Dres- den, Eagle, Pensé, etc.	
J. E. Hale, Seneca Falls, N. Y.	Voigtlander,	Cramer.	Cramer.	N. P. A. Pink.	I do not intensify after development. If a plate is not strong enough I make another one if possible. I regulate development with a little old developer when necessary.
J. H. Hastings, Boston, Mass.	Euryscope No. 6, Voigtlander & Son.	Eagle.	No. 1. Sal soda 4 oz., water 4-6 oz.; No. 2. Sul- phite soda 4oz. pyro 1 oz., brom. ammo- nia 40 grs., water 4-6 oz.; use equal quantities.	N. P. A., brilliant	
C. Heimberger & Son, New Albany, Ind.	Euryscope No. 6, Globe, Stein- heil No. 4 Harrison for cabinets.	Cramer, Seed's, Carbutt's Key- stone, Eagle.	Soda developer	N. P. A.	Have never yet intensified or re- duced a "dry plate negative."
Decker & Wil- ber, Cleveland, O.	Dallmeyer.	Cramer and Seed.	Pyro and soda.	Eagle.	
G. M. Elton, Palmyra, N. Y.	Voigtlander, Euryscope, Dallmeyer R. R.	Cramer.	Soda and pot- ash.	N. P. A.	

NAME.	LENS.	PLATE.	DEVELOPER.	PAPER.	REMARKS.
A. J. Falk, New York.	Hermagis 4-4 size, and Voigtlander, Euryscope No. 6, both quick acting.	All the pic- tures were on Seed plates, ex- cepting 1 panel which was on Cramer's.	Seed's sulphite developer, using, how- ever, instead of the sal soda by him recom- mended, half the quantity of carbonate of potassium.	Cross Swords, Pensé.	In developing we use no restrainer other than old developer. For counteracting the effect of too slight or insufficient exposure we thin the developer much with water. In in- tensifying we use two methods: the iodide of potash and mercury and hypo mixture for negatives where the shadows are proportionately too weak, and the mercury and ammon. or mercury and sulphite of soda where the lights principally want strengthening.
R. Galloway, Bellinger, England and New York.	Dallmeyer Rapid recti- linear.	Cramer.	Pyro and sul- phite.	N. P. A.	The negatives are of Rice & Dixey's Adonis Co. They were taken by aid of electric light put up for the purpose by the Brush Electric Light Co. Time of exposure 8 sec., using No. 3 stop in lens. The plates were well soaked in water, then in sulphite and carbonate solution, afterwards adding pyro as required.
T. A. Coyle, Monticello, Ia.	On 11 x 14 and larger work the No. 3 S. B. Suter lens; on all work smaller than 11x14 inches Voigtlander 14 in. focus, and 4-4 Peerless 8 in. focus.	Cramer.	Cramer's sal- and sulphite of soda-pyro de- veloper and sulphite of so- da, ammonia, and pyro de- veloper (2) dif- ferent devel- opers.	.....	The negatives were developed to the strength from which I printed from just as they came out of developer. No intensifying or reducing. Am- monia, pyro, and sulphite of soda developer, No. 1. Water 8 oz., sul- phite soda 2 oz., sulphuric acid 2 drachms, pyro acid 1 oz. No. 2. Water 12 oz., brom. ammon. 80 grs., liq. ammon. 1 1/4 oz., glycerine 1 oz. To use: to 16 oz. water add No. 1 1/2 oz. and of No. 2 1/2 oz. For thin negatives use more No. 2; for in- tense more No. 1.
J. V. Dabbs, Fort Scott, Kan.	Cabinets and 8x10 taken with the No. 3 Dallmeyer; larger with No. 8 Suter.	Cabinets and 8x10 on St. Louis, larger sizes on Cramer's.	No. 1. Water 4 oz., sulph. acid 3 oz., sulph. soda 1/2 oz., pyro acid 1/4 oz. No. 2. Water 6 oz., stronger ammonia 1 oz., brom. ammon. 60 grs., glyce- rine 1 oz., sul- acid 30 m. No. 1. Pyro 1 oz., water 6 oz. No. 2. Water 64 oz., sulph. soda 16 oz., carb. soda 16 oz.	The Eagle Paper brilliant Pensé.	
B. L. H. Dabbs, Pittsburg, Pa.	Voigtlander, large work, cabinets Suter, Harrison,	Cramer, Stanley, St. Louis.		S. and M. Pensé.	
Geo. Barker, Niagara Falls N. Y.	Dallmeyer, Voigtlander, and Darlot.	Florida exhibit made exclu- sively on Cra- mer plates. Niagara exhib- its on Cramer plate, with 1 or 2 exceptions.	Pyro and sal- soda.	Buffalo Brand, David Tucker & Co., Buffalo.	
T. R. Burn- ham, Boston, Mass.	Voigtlander (portrait), Darlot (views).	5x8 port. on Allen and Ro- well; 24x3 port. on Allen; 20x24 port. on Inglis; 20x24 group on In- glis.	American sub- jects with pyro and ammonia; views, oxalate of potash.	Haven's Extra Brilliant, T. W. Collins.	Pyro and soda develops the plate. Use the chemicals with as good judgment as you have. I did.
D. R. Clark, Indianapolis, Ind	No. 7 B. Voigt- lander, No. 5 A. Dallmeyer, No. 8 Eury- scope.	Cramer and St. Louis.	Soda devel- oper.	Imported 20x 24 inches for large work.	
E. S. Conrad, Reed City, Mich.	Darlot.	Rockford.	Inglis with bromide left out.	S. and M.	

[Translated for the Philadelphia Photographer.]

## ON THE USE OF ARISTOTYPIC PAPER.

THIS communication sent to us by our learned colleague Mr. E. Liesegang, of Dusseldorf, is a complement of the article relating to the same subject, published in the *Moniteur* of the year 1885: (Page 124.) The superb results given by aristotypic paper cause regrets that it is not in more general use.

Aristotypic paper is the name of a new paper for making photographic prints in the pressure frame. The paper is sensitized and preserves its good qualities for several months; it should be kept in a very dry place, and the surface should not be touched with the fingers. The paper having been cut the required size, is placed in the pressure frame quite dry, as is done in the case of albumenized paper. Print until the blackest portions are a little metallized. The paper is much more sensitive than albumenized paper. To wash the prints they are placed in water, one by one, the printed side underneath. The water is changed five or six times, until it is no longer milky. The first water should act in from three to five minutes; it is kept to extract the silver, which is precipitated by chlorhydric acid, or ordinary salt. From a sheet of aristotypic paper of 50 to 60 centimetres (18 sheets, card size), 23 grains of chloride of silver are obtained. The prints, well washed, are toned in a gold bath. One specially adapted to this purpose is compounded as follows:

A.—Water, . . . . .	1500 parts.
Chloride of gold, . . . . .	2 “
B.—Water, . . . . .	1500 “
Sulpho-cyanide of ammonium, . . . . .	40 “
Hyposulphite of soda, . . . . .	1 part.
Carbonate of soda, . . . . .	3 parts.

Before toning, pour a portion of *A* into a portion of *B*. If the operation were made another way, the gold would be precipitated. With the right hand take the prints, one after another, and place them in the toning bath; whilst there, they should be kept in motion, because if they were to stick to one another, the bath could not act uniformly. Very many prints should not be put at one

time in the bath, as each print has to be watched. The prints first become yellow, then acquire a brown tone, and finally, a purplish-brown tone. When this last color has made its appearance, the print is taken with the right hand, allowed to fall in the fixing bath into which it is immersed with the left. Should a trace of hyposulphite come in contact with the unfixed prints, yellow spots will show themselves. Should the bath contain too much chloride of gold, the prints will not become yellow, but immediately blue. In this case it is necessary to dilute the bath with water. The bath may be used several times, but if exhausted, it is better to renew it.

The fixing bath is composed of:

Water, . . . . .	1000 parts,
Hyposulphite of soda, . . . . .	100 “

It should be placed at a certain distance from the toning bath; fingers that have touched the prints in the toning bath should never come in contact with the fixing bath. From 5 to 10 minutes are sufficient to fix the prints; looking by transparency it is easy to determine if the fixing is ended. The fixed prints are washed in often renewed water and their places changed from time to time in order to free them from any trace of hyposulphite. The washing should last at least two hours. When certain that the prints are thoroughly washed, they are taken out and hung on a round bar covered with bibulous paper; they should never be placed between sheets of bibulous paper. The prints are cut and mounted. The following paste is recommended:

Dissolve 20 parts of hard gelatine in 200 parts of water, and pour into the warm solution 10 parts of alcohol, stirring the mixture. The burnisher should only be used when the prints are thoroughly dry. If a very brilliant surface is desired, operate in the following manner: Take a plate sufficiently large to hold half a dozen card pictures, some talc in impalpable powder, cotton, or a sufficient quantity of bibulous paper, and an india-rubber squeegee. The cleaned plate is placed on a table covered with bibulous paper, and the talc rubbed over the surface by means of a cotton tuft. With a fresh cotton tuft, rub over again to remove the talc which has ad-

hered. The prints are taken out from the washing-bath, allowed to drain, and placed side by side on the plate, the printed side down. When the plate is covered with prints, two sheets of bibulous paper are placed over it, and pressed with the hands to take up the humidity. This being done, the papers are removed, and the back of the prints are vigorously rubbed in every direction with the squeegee. The plate may now be turned over and more prints placed on the other side. When well dried, detach the prints from the plate by means of a knife-blade. If a mat surface is desired, use ground glass. A sheet of polished ebonite may take the place of a glass plate, but in this case, the powdered talc is not to be used. It is easy to place in one hour one hundred prints on the plates. The advantages of aristotypic paper over albumenized paper, may be summed up as follows:

The prints give with greater fidelity the details of the negative; even weak negatives give good prints, because aristotypic paper possesses the peculiarity of rendering the lights whiter and the shadows stronger than albumenized paper; printing is quicker and it is easy to obtain either a mat or a brilliant surface. In warm and damp climates, it is recommended to immerse the washed prints in the following bath: Water, 200 parts; pulverized alum, 15 parts; in which they are allowed to remain ten minutes; wash in water four times changed. The alum bath renders the image more resistant.

E. LIESEGANG.

---

### PHOTOGRAPHS OF SOUTH AFRICA.

The photographic achievements of Mr. Farini, now of Bridgeport, Conn., have already been noticed in these columns. Only lately, however, have the results been seen in this office, where a set of the views has, by his kindness, just been received.

They are an interesting collection. Some strike at once as quite unique. Such are those that show the long-necked giraffe at home, towering over the bushes, or the tree-top filled with the nests of the sociable grosbeak. But all, besides bearing a notable stamp of high artistic power, have an out-

of-the-common character. They are fresh, a far-brought and pleasing novelty. Among the different regions traversed, the diamond fields are very notable. It were possible to use them to illustrate how hideous man can make a country. Nature never did much for it, but under the ravaging pick of the diamond-digger it becomes a dreadful, desolate, yet ignoble, rubbish-scattered wreck. Yet the pictures are interesting. Among them is that of the blast, that the artist stayed down in the abandoned mine to secure, the smoke jetting from the side of the bluff, and rocks, stones, and dirt flying wildly out of it.

In the Kalahari series are invaluable photographs of the scenery, the natives, and the fauna and flora of the desert. Scenes on the journey and hunting pieces are there too, whose picturesque quality is often high, as in one where the narrow road stretches away over the hill, over whose top is toiling the great wagon with its team of a dozen oxen, while all around is the curious scrubby desert, with sand and stone and dry grass-tufts.

There are some good pictures, taken around Cape Town. One is magnificent, a bird's eye view of the town and Table Bay from an elevation of 4500 feet up the mountain. And finally, most precious and hard-won of all, are the views of the Hundred Falls of the Orange River. The views of the wild, desolate gorges, and lonely falls, are wonderful. All is rock—and battered, rounded rock, showing the force of the torrents everywhere, in the deep dark courses cut for the river, in the enormous boulders piled about. There is not a tree, only stunted bushes, and the landscape frequently becomes magnificent, and sometimes awful. Mr. Farini's talent seems to shine all the more grandly for difficulties. We have never seen an artist who could so set his figures, purely subordinate, yet telling like a bell-stroke in the picture; silhouetted against a fall, perched on the edge of a precipice, they are always splendidly placed.

The technical work shows that in this direction also Mr. Farini is a master. Everything about the pictures is excellent. This strange country is happy in having an artist so skilled, so thorough, and so discern-



ing, to be the first to bring back to other continents the photographic record of its aspects.

## ON FRAMING PHOTOGRAPHS.

BY PORTECRAYON.

FRAMING a pictorial work has always been considered the most important act in bringing the labors of the artist to a close; and there is a vast amount of significance in the oft-repeated story of the critic, who, venturing upon a remark, which he thought would redound to his personal knowledge of art—"that the picture" he then saw "of course was not finished"—was met with the reply, "Certainly not; for it had to be framed."

Now, as the amount of surface covered, however large or small it may be, appears only to represent a portion of the scene, it follows that some artificial boundary must be provided, to prevent a feeling of the necessity of a continuation of the subject, and also to realize to its fullest extent the value of the representation. Well, then, every person who looks at picture, receives impressions which at the moment are wonderfully dependent upon this boundary or *entourage*; it is a good study, and worth trying the experiment, to reverse this impression, and this can be done by looking at a picture, for a short time, through a square-made cone, where the end, away from the eyes, is made just to cover the height and width, and the picture alone is seen, without its frame, then suddenly withdraw the cone, look at the frame, and notice the impression received. At once the sensation will be either that of disturbance, or that of repose.

If disturbance arises, the cause should be at once apparent, and means can be taken to effect a remedy. Now, one of the most usual disturbing effects results from the edge of part of the frame coming in contact with the picture, in that in galleries, or rooms, where the light is admitted from the top, a vivid bright line, directly under the lower part of the picture, becomes exceedingly disturbing, and a wrong is done to the picture.

Without probably being able to define

the ultimate impressions received, those who designed the Sir Thomas Lawrence frame, some years ago, produced something which had repose in it, when compared with the demonstrative Sir Joshua Reynolds' frame; and this had been carried on still further of late years, the introduction of the "Alhambra" detail, and more decidedly the rejection of those elaborate corners, which, projecting so much, became resting-places for vast quantities of disturbing light.

Then there is the modelling of the frame—as regards certain parts coming forward, or retiring—which rise, or come forward to some considerable extent, almost at right-angles from the wall upon which it is hung, and which then descends by various stages to the level of the picture. The effect produced is to cause the picture to retire, and to be as it were, shut up in solitary confinement. For some very peculiar subjects this may be tolerated; but it is much out of place with the majority of pictures. It will be found that more universal satisfaction is produced by a frame which, starting gradually from the wall, projects but little (of course, this projection is governed by the relative size of each frame), then continues along a level, and then descends to the picture; but this descent must be very gradual, otherwise the disturbing line of light will assert itself. Then upon the surface there might be separating lines, in flat, not half round, enclosing designs full of regular but small detail, the idea to be realized is an enriched boundary to the picture, which has nothing disturbing about it, or which attracts more attention than the picture itself; in fact, the presence of the frame should be unfelt when looking at the picture. It will be gathered from these remarks, that whilst frames are an absolute necessity, they must be subordinate to the picture itself; and that this subordination must not be of a poverty-stricken character, but be rich in elaboration—care only being taken that there should be equality of size in the ornamentation, for, as already stated, it is the inequality, or some parts being so much larger than others, that immediately introduces disturbances and consequent destruction of repose.

The question arises: Can we apply this to photographs? The reply must be, that the

same rules apply, but, that to a certain extent, greater care must be exercised in getting rid of the horizontal line of light on the frame close to the picture. The reason is, that the lights of a painting are much more powerful in luminosity than those of the best photograph, and it therefore follows that frames for photographs should be made from mouldings which give the least possible tendency to disturbing light surfaces.

A word or two upon the material of the frame. It would be of infinite value to photographic pictures if they could all be surrounded with gold. Whether it is from long association with exhibitions of paintings, or whether the consensus of artistic taste has established the matter, certain it is that no other material so readily adapts itself as the "boundary" of colored, or black and white art, as gold; and the same can, therefore, be most decidedly advocated for photographs.

The points already insisted upon, respecting the section of a frame, and the small detail of the ornamentation, so as to avoid great lines, or masses of light, will certainly be found of much greater value when adapted to photography. It is a question whether even other metallic surfaces than gold, might not be found very desirable for some photographic work; but until such time as any other metals can be made adaptable for this purpose, we will retain our strong attachment for gold.

Our opinion is, that it is rather questionable taste to frame photographs with light-colored wood. This method of framing prevails to a great extent at photographic exhibitions, and these are always seen in connection with a large margin of tinted card-board, which may not be quite so objectionable when viewed quite close, but which, when seen at a distance, has the effect of making the photograph look dark. It should be a Median law, that the flat "boundary" of a photograph, at the very least, must be several degrees lower in tone than the middle lights. If this were done, then the photographic print would stand a chance of having even the very least of its merits appreciated.

The use of tinted mounting boards at all, is a matter which requires consideration, and

the exercise of much taste and judgment. They are very difficult to adapt properly to any photograph, and, in many instances, they appear as if they were solely used for the purpose of conferring importance, by increasing the size of the frame. At any rate, when tinted mountings are used, gold mouldings should be used, as they would add considerably to the intrinsic effect of mounted photographs, and also by the juxtaposition at exhibitions, with other gold frames, their own value would be increased.

A few words may here be said upon the principles that determine whether a photographic picture should be mounted on a tinted board or framed close up in a gold frame. When a photograph is full of delicate detail, and there is the absence of deep masses of dark, then probably a suitable colored mount would produce the best effect, especially as it almost follows that a photograph having these characteristics must be toned with a tendency to purple-black. It may then be treated somewhat like an engraving; but when there are broad effects of light and shade, and masses of graduated tints, then the tendency of the toning naturally tends towards warmth. In this case, nothing can sit as a "boundary" so well as the gold frame coming right up to the picture, and these two principles can be carried out whether the picture is large or small.

This treatment is being recognized now more than it used to be; and it is gratifying to notice how this was carried out in some few instances at the Photographic Exhibition at Pall Mall last year.

It may be said, is not gold of a bright, sparkling surface, and does this quite meet the requirements which have been laid down? It must not be overlooked that there is another wonderful property about gold which nothing else can approach to—this is its tendency to give repose whilst at the same time it asserts itself most powerfully and enriches everything with which it comes into contact. Take any two rooms of the same size, and furnished precisely alike; then in one introduce gold into the cornice, above the windows and curtain poles, on the console table, in the looking-glasses, and elsewhere wherever possible,

and then realize the effect produced. There will be no doubt which is the more cheerful.

So with frames to pictures. What would the Royal Academy Exhibition be supposing it were ordered that nothing but black and light-colored wood frames should be admitted. However enthusiastic visitors might be, and however fine the art of the pictures, it would very soon be found that something was wanting to enable a realization of the full pictorial effect. In the same way, if at the Photographic Society's Annual Exhibition every picture hung on the walls could be ordered to be fitted up in gold frames, we venture to say the "show" would be so effective that we should never more see the wooden "boundary" again. These remarks apply equally to the black and gold and brown wood frames, which, however suitable for private rooms, most decidedly exercise a depressing effect, not only upon the visitor, but upon the photograph itself. The black and brown colors do no doubt interfere with the color of the photograph, and the latter loses much of its charm.

Much ingenuity might be exercised by frame-makers in carefully preparing frames for photographs embodying these principles, and more especially should this be done in the arrangement of the gold flat, which comes in direct contact with the picture. It is contended that there should be no bevelled edge or rounding or hollow, which catches the light, and creates, may we say, an irritating effect upon the mind. That there must be an edge is a matter that cannot be avoided; but we want to see this reduced to the least possible. If the photograph be mounted on a thick board it could be fitted to a rebate inside the gold flat, and then when both were fastened together a very small line would be left. Even this could be bettered by planing a small bevel on the picture side, and so the disturbing horizontal line would be reduced to a minimum. The great object is to banish the usual bevel, which is usually cut out of the square of the thickness of the gold flat or tinted board.

To summarize the ideas, the first thing is to get rid of horizontal lines of light in whatever kind of "boundary" used; next, to avoid frames which start forward at right angles with the wall, but to use the more

pleasing form of the frame which starts at a little distance from the wall, and then rises gently to a level, and again sinks gradually to the picture; to avoid black, brown, and light-colored wood frames, but to use gold frames for every picture, and, if mounting boards with colored tints are found desirable, to choose the tint with so much care and taste that it will harmonize with the color of the photograph, and be lower in tone than the middle lights in the picture. Finally have nothing to do with those most unnatural blue mounts, which not only murder the photograph upon them, but also destroy the vitality of surrounding pictures.

The framing of photographs is worthy of a vast amount of attention being given to it. It is utterly impossible to strictly formulate in words what to do or what to avoid, because so much depends upon each photograph, which possesses an unknown quality. Of one thing we may be certain—that no one will be wrong if he surrounds his photograph with that rich material which fine art has so long accepted as the best *entourage* for its productions.—*Photographic Journal*.

### THE SPECTROSCOPIC DETECTION OF ALKALOIDS.

IN a paper on "Photography and the Spectroscope in their Applications to Chemical Analysis," recently read by Prof. Hartley before the Society of Arts, the following references are made to the spectroscopic identification of organic compounds, including especially the alkaloids: "The ultraviolet rays are exceedingly sensitive to the action of carbon compounds—so much so, that the photographic absorption can be employed as a means of identifying organic substances, and as a most delicate test of their purity. The curve obtained by coordinating the extent of dilution with the position of the rays of the spectrum absorbed by the solution of a compound forms a strongly marked and often its most highly characteristic physical property. Organic substances are of three classes: 1. Those which transmit continuous spectra and are highly diactinic. Examples: The alcohols, acids, ethereal and haloid salts, and carbo-

hydrates. 2. Those which transmit continuous spectra, but yet possess strong absorptive power. Examples: Most essential oils and camphor. 3. Those which exhibit absorption bands. This class includes benzene, naphthalene, anthracene, and all their derivatives, nearly all the natural alkaloids, and many substances in which nitrogen and oxygen are united. Cymene, which is a derivative of benzene, has been detected, and even the amount estimated in many essential oils. All these substances contain a nucleus with the same constitution as that of benzene. By the process of diluting with alcohol the presence of bodies of the aromatic series has been detected in essential oils, and even in some cases the amount of these substances has been estimated. The greatest interest attaches to the examination of the alkaloids. Many of these substances are highly poisonous, they give no distinctive chemical reactions by which they may be identified, and the only means of recognizing them are their crystalline form and physiological action. Some of the alkaloids have never been crystallized, and even such as are usually obtained in crystals are not always recognizable; moreover, the form and grouping of crystals is occasionally modified by such reactions or treatment as is necessary in the extraction of an organic base. No absolute reliance can be placed upon the mere appearance of crystals which are microscopic; they must be submitted to recrystallization by sublimation or some other process. The physiological action of certain alkaloids is remarkable enough to prove a means of identifying when the effect on the human subject is under observation; but it is to some extent capable of being modified by the extent of the dose, the administration of other drugs, or the idiosyncrasy of the patient. These are well-known and grave objections to experiments of a physiological character. . . . The absorption spectra offer so ready and valuable a means of ascertaining the purity and of establishing the identity of the alkaloids, that drugs of such potency as aconitine, morphine, quinine, strychnine, etc., should be submitted to spectroscopic examination, so that their exact nature and degree of purity may be

guaranteed before they are prescribed. The differences in character of the various specimens of aconitine are remarkable; the comparatively harmless base is easily distinguished, and of those which are physiologically active, each has its distinctive absorption curve. The cinchona alkaloids show strikingly distinct curves; so in like manner do those of the Papaveraceæ. Two specimens of morphine exhibit the same curve, and so do two of codéine. There is a difference but yet a similarity between the morphine and the codéine, which arises from the constitution of the two bodies being only slightly different, codéine being a methyl-morphine."

(Translated for the Philadelphia Photographer.)

### REMARKS ON THE PROCESS OF DIRECT REPRODUCTION IN BLACK LINES ON A WHITE GROUND OF PLANS, DRAWINGS, MAPS, ENGRAVINGS, ETC.

BY M. DE SAINT-FLORENT.

MR. L. VIDAL, our esteemed colleague, and editor of the *Moniteur*, refers to the accompanying article as follows:

"We call the attention of our readers to M. de Saint Florent's intensely interesting paper reproduced in the present number of the journal. The author, in his investigations, tends towards the creation of superior processes of photographic calcography having in view simplicity of manipulation and especially permanence of prints made with salts of iron. It may be that the processes that he describes will have to be improved upon before they can come into practical industrial use, but there can be no doubt that with these improvements they will supersede all the direct processes for making prints after original designs."

The processes that I now give seem new and have for a starting point chemical reactions which have not yet been utilized for the result in view.

1. *Powder Process*.—All are familiar with the processes used for reproducing either negatives or positives by means of inert powders. These are the processes by which

are obtained the magnificent photographic enamels so much admired for some years back at our exhibitions. I have endeavored to use an analogous method for reproducing maps, plans, engravings, etc. There is nothing in common, however, between the two methods except the starting-point. The paper used is either albumenized paper or gelatinized paper, sensitized in a bath of bichromate of potash. This bath should be at saturation, if albumenized paper is used, and contain 10 per. cent. of bichromate when gelatinized paper is made use of. In the first case sensitizing is done on the reverse and in the second on the obverse of the sheet. If the sheet is of large size the use of the dish may be dispensed with and the paper sensitized by applying the bichromate solution by means of a large flat brush. The paper having been dried, protected from the light, is exposed in a positive frame behind an engraving, a drawing on tracing paper, etc. With an engraving the paper is too thick in general to obtain a direct print, and the obverse of the image should be placed in contact with the obverse of the prepared paper. With a drawing on tracing paper, on the contrary, the Prellat and Collas processes are used, that is to say, the drawing should be made with India ink mixed with a little chrome yellow, the reverse being placed in contact with the albumenized side of the prepared sheet. It is difficult to give exactly the time of exposure and it is necessary in most cases to make use of a special photometer. It is possible, however, to reach a sufficient approximation by adopting the following times of exposure.

1. For a drawing on tracing paper (exposure to the sun) from 3 to 6 minutes.

2. For an engraving (paper of medium thickness exposed to the sun) from 10 to 15 minutes.

3. Architectural drawing on thick paper (exposure to the sun) from 20 to 25 minutes.

Taken from the frame the print is washed in a bath of ordinary water to which a few drops of ammonia have been added, then *drained* and not *dried* between sheets of bibulous paper. The print, which we supposed to have obtained in albumen, is now found in a peculiar state. The bichromate

has *slightly* coagulated the albumen on the whole surface of the paper, and the reduction of the chromic salt, in the insulated portions, has rendered these portions impervious to water, provided, however, that the *varnish* of the albumen has been preserved, which does not happen.

1st. If the time of the exposure has been insufficient;

2d. If ammoniacal albumen is used for the preparation of the paper;

3d. If the sheet is sensitized by the obverse, or finally,

4th. If too great a quantity of ammonia has been added to the washing bath.

In the noninsulated portions the albumen, although it has been slightly coagulated by the bichromate, remains permeable to the water and swells a little in the washing bath. After the print has remained a sufficient time between the sheets of bibulous paper, the whites alone, that is to say, the parts corresponding to the blacks of the image to be reproduced, possess an *adhesive property*, and can retain the black powder or any other inert color applied to them, either by means of a tuft of cotton or a brush. The image is cleared with a new tuft, which is renewed until the background is as free as possible from black. The image is now treated with a 10 per cent. solution of sulphuric acid, which changes the oxide of chrome into a violet sulphate, and coagulates at the same time the albumen of the black lines. The background obtained, after several washings, is almost white. Unfortunately we meet here with the difficulty found in all powder processes. The background is always more or less dissolved notwithstanding the use of all the palliatives indicated for restoring the white backgrounds of carbon prints. The prints obtained, however, are very clear and in the case of documents to be copied hurriedly, the process mentioned above is valuable. The varnish on the insulated portions is removed by plunging the prints from ten to fifteen minutes into a solution of caustic soda and then washing with care. When the time of exposure has been insufficient, a negative instead of a positive print is obtained. It has been possible to obtain direct positives of landscapes by means of the

camera, with exposures varying from thirty to forty-five minutes in the sun. Experiments have been made to increase the sensitiveness of the bichromate of potash. Acetate of manganese, mentioned by Abbé Laborde, has given no good results. We have here some interesting experiments to be tried.

2. *First Process with India Ink.*—The process just described is very rapid and has the advantage of being able to furnish in a short time copies of documents which, under certain circumstances, could not be more easily obtained; but it offers the objection, mentioned above, of giving prints somewhat smoky and less permanent than those obtained by the process now about to be described. This method is based upon the following fact: The negative bichromate print obtained in the manner mentioned above, is composed of portions permeable to water, corresponding to the lines of the image, and of impermeable portions, corresponding to the whites and formed of albumen and oxide of chrome. The albumen has undergone a commencement of coagulation when the sheet has been passed over the bath of bichromate of potash after exposure, the noninsulated portions are composed of albumen which has been rendered slightly insoluble, whilst still remaining permeable to liquids. This albumen may be rendered entirely insoluble by means of the ordinary coagulants of this substance—warm water, alcohol, alkalis, and metallic salts in considerable number, among which is bichloride of mercury. The insulated portions of the print, on the contrary, become entirely impermeable to liquids, and, in general, are not acted upon by the substances having the property of coagulating albumen. This being said, here is the mode of operating:

The print, after insulation, is washed in ordinary water to which a little ammonia has been added. Then placed between sheets of bibulous paper so as to preserve a certain amount of humidity. The insulated portions should be of a brown color and present a certain *brilliancy*.

The noninsulated portions should be, on the contrary, mat and slightly in relief. By means of a brush spread on the sheet, fixed by the angles to a board by the aid of

thumb tacks, an ink, of which the composition is as follows:

Liquid India ink . . .	100 parts.
Sulphuric acid . . .	7 “
Caustic potash . . .	3 “

India ink, in sticks, may also be used as thick as possible. Certain inks are better than others and it is not easy to say why on account of secrecy in their manufacture and the difficulty in analyzing them. A great number of inert colors may be substituted for the India ink. When the print has been inked it is allowed to dry spontaneously in a horizontal position. The sulphuric acid coagulates the albumen of the portions corresponding to the black of the image and converts into soluble violet sulphate of chrome the oxide of chrome which has formed in the insulated portions. The added potash gives intensity to the blacks by permitting a greater quantity of the coloring matter to become fixed. When the print is entirely dry it is placed on a bath of ordinary water and after an immersion of about ten minutes the surface is rubbed with a soft brush, care being taken to cross the direction of the rubbing. The image soon shows itself and if the time of exposure has been suitable, we obtain a rather permanent print which is, in general, an exact reproduction of the original if this last is sufficiently transparent to be taken on the reverse side. In the contrary case, unless the image to be copied has been made transparent, the print is a symmetrical copy of the original. If the blacks are not sufficiently strong, more vigor may be given to them by using a second coat of India ink and continuing the operations as above.

Instead of sulphuric acid, nitric acid and a great number of other acids may be used, either mineral or organic (phenic or picric acids), bichloride of mercury, perchloride of iron, and many other salts, etc. Warm water may also be used after applying the black. Highly concentrated alcohol, even absolute, gives but very poor results. The brilliancy of the print may be made to disappear by means of a 10 per cent. solution of caustic soda. The washings that follow this bath should be made with great care. If instead of albumenized paper a thin film

gelatine paper is used, and the noninsulated gelatine removed by means of warm water, it is also possible to obtain very sharp positives by the use of acidulated inks which fix themselves then upon the uncovered paper. This is an application of the process formerly proposed by the Academy of Sciences for obtaining indelible inks. It is also evident that it is impossible to dissolve the albumen of the albumenized paper by using a bath strong in ammonia, and rubbing the print with a rather hard brush.

The experiments were made with two new portrait Euryscopes, of three and four inch diameter, in comparison with the corresponding ordinary portrait-objectives (back-lens separated); single portraits and groups being selected for the purpose.

The portrait Euryscope consists of two symmetrical combinations, the lenses of which are sealed together.

Diameter, focal length, and illuminating power of the lenses tested is explained in the following table :

Portrait Euryscopes.	Diameter of Lenses.	Equivalent Focal Length.	Ratio of Aperture to Focus.
No. 5 A	68 Mill. = 3 inches.	340 Mill. = 13 inches.	1 to 4½.
No. 7 A	104 Mill. = 4 inches.	500 Mill. = 19½ inches.	1 to 4¾.

3. *Second Process with India Ink.*—It is also possible to obtain a positive from a positive by operating as follows :

On coming from the frame, the print is washed as usual and drained in bibulous paper. It is then covered with *nonacidulated* India ink mixed with bichromate of potash and allowed to dry. The print is then exposed to the light by the *reverse side*. The albumen or the gelatine which has not been rendered insoluble during the first exposure now becomes so. This second exposure produces no effect upon the portions already insulated. Development is now made, as above, with warm or cold water as the case may call for, rubbing with a rather hard brush.—*Paris Moniteur.*

The angle of view of the portrait Eury-scope is over fifty degrees, whilst in the ordinary four-inch portrait objective it does not exceed forty degrees.

The experiments made by the undersigned showed that in general the work of the portrait Euryscopes is equal to that of the best portrait objectives. The illuminating power of the portrait Euryscopes No. 5 A and No. 7 A proved to be, in practical photographic experiments under the sky-light, just as great as that of Voigtlander's portrait objective of normal focus (*i. e.*, 4-inch diameter and 18½-inch focus, or a ratio of 1 to 4½), although the latter possesses a shorter focus than the former. The reason for this is that light passes more readily through *sealed* back-lenses than through *separated* back-lenses. The depth of focus is greater in the portrait Eury-scope than in the regular portrait objectives; the definition of the picture much improved, the field more uniformly illuminated, and the angle of view larger. The portrait Euryscope is rectilinear, and defines lines correctly.

[Translated for the Philadelphia Photographer from the Photographische Correspondenz.]

**OFFICIAL REPORT OF THE COMMITTEE APPOINTED BY THE PHOTOGRAPHIC SOCIETY OF VIENNA TO TEST VOIGTLANDER & SON'S NEW PORTRAIT EURYSCOPE.**

THE undersigned were requested to test the new portrait Euryscope of Mr. Friedrich von Voigtlander, with the view of ascertaining its fitness for photographing portraits and groups, in comparison with the portrait-combination (Petzval system), with separated back-lens, as heretofore used, and have reported as below.

The size of plate for groups as obtained with the portrait Euryscopes was as follows : The 4-inch portrait Euryscope yielded a plate 18½ inches in diameter, whereas the 4-inch regular portrait objective with separated back-lenses produced a plate only of 14½-inch diameter.

The portrait Euryscope is equal to all demands that may be made upon it in the

studio, and for the reason that it yields a greater angle of view and larger size of plate it is particularly adapted to the photographing of groups in short studios.

In conclusion it should be stated that Voigtlander's new portrait Euryscope marks the first great and important improvement in portrait objectives since the introduction, in 1840, of the portrait combination with separated back-lenses, which is in use up to the present day.

*Committee.*—Victor Angerer, Prof. J. M. Eder, J. Lowy, Fritz Luckhardt, Ch. Scolik, Dr. Jos. Szekely, Victor Toth, O. Volkmer, Carl Wrabetz.

All of the gentlemen are well-known experts in our art, and we congratulate Herr Voigtlander and Messrs. B. French & Co., his American agents, on such a grand report.

### THE CANADA CONVENTION.

THE third annual Convention of the Photographer's Association of Canada was also enthusiastic and successful. A fine display of exhibits was made; the meetings were thrice as well attended as last year; the excursion was most enjoyable, and the lantern exhibition put money in the treasury. Addresses were made; discussions held; and demonstrations practical took place.

It was our intention to be present at the lantern exhibition, at least, and lecture, as invited, upon our slides of Egypt shown. Our place was taken very ably by Mr. J. R. Moodie, of Hamilton, a public duty preventing our attendance.

The election of officers for the ensuing year resulted as follows:

*President.*—A. T. Barraud.

*Vice President.*—E. Staunton.

*Secretary and Treasurer.*—E. Poole.

*Ex. Committee.*—Messrs. J. H. Farmer, S. J. Dixon, and J. D. Bayley.

*Auditing Committee.*—J. F. Bryce and S. J. Dixon.

Toronto is to be the next meeting place.

We have received no official report of the Convention from the Secretary.

Doubtless great good will result from the affair. In one respect it was like our own conventions—*prices* were discussed.

We learn a little immodesty was shown by some of the American experts present. Men who frequently face death grow very familiar sometimes.

### QUERIES, CONUNDRUMS, AND CONCLUSIONS.

W. A. LAPHAM, Los Angeles. The mottled appearance of your prints is due to imperfect fixing or else to insufficient silver being taken up by the paper. From your letter we judge the latter may be the cause; if so it is because the surface of your paper is too dry or "horny" when you float it upon the solution, and, therefore, repels the silver. Result is sure, mottled prints. Wilson's *Photographics*, Lesson Q, informs you fully on all "printing perplexities." Paper should be slightly limpid before floating.

"GRADATION."—Over and over again we have explained "the meaning of gradation and contrast" to our readers. We shall do

FIG. 1.



so again some time. It is quite a long story. Meanwhile permit us to refer you to Lesson A, of Wilson's *Photographics*, wherein you



will find 76 pages and many illustrations on these and kindred topics. As a bite two illustrations herewith may serve to whet your appetite for more. Fig. 1 is an example of "gradation"—a growing of the light from shade or of the shade from light of one side of the picture and some of the parts of it, to the other. It is a very excellent study.

Lessons in "contrast" may be had by comparing the dark and light parts of the picture or the light border and the dark background with each other; or again by

give in full elsewhere, were read; daily photo-excursions were made, and there was a good deal of enthusiasm all through.

Doubtless much good will arise from the proper conduct of such Conventions, and we heartily wish a larger and better one will follow next year at Glasgow, the place chosen. In this wish we are sure that all of our wide minded, growing readers will unite.

Then, some day, we may live to see an International Convention. It would require a year to discuss all the vital photographic

**GAYTON A. DOUGLASS & Co.**  
**MERCHANTS IN**  
**PHOTOGRAPHIC SUPPLIES**  
**185 & 187 WABASH AVE. CHICAGO.**

means of the beautiful card of Messrs. Gayton A. Douglass & Co., which is just at hand, and a neat example of "contrast" and light and dark without chiaro-oscuro or gradation as generally understood.

A NUMBER of queries must remain conundrums until our next.

### THE PHOTOGRAPHIC CONVENTION OF THE UNITED KINGDOM.

THE results of this Convention, held at Derby, England, seem to have satisfied its projectors. We cannot get at the attendance. In one of the reports we are told that it was "large," while in the same report we afterwards read the regret of one of the speakers that the attendance was "so small." Be this as it may, the Mayor of Derby presided. Several valuable papers, which we

topics that must come up if photography continues to grow as it is growing now.

### ON MEN'S HEADS.\*

BY WILLIAM ADCOCK.\*

In addressing professional gentlemen who are present, I feel as a layman may be supposed to feel who pushes under the notice of a bishop, saturated with Greek and Hebrew, his interpretation of a difficult passage, or as an ordinary medical student should feel if advising a distinguished local oculist how to treat a case of threatened blindness. In photography I am a mere amateur, important business occupations claim me, especially in summer, as their own; and yet I am presuming to offer advice to those whose daily

\* A communication read at the Derby Convention.

study is the production of portraiture of a high class, which shall meet and satisfy the demands made upon them. On these grounds I ask your forbearance, and indulgent interpretation of my address to-day.

It has happened that an onlooker of a combat has seen where a defensive movement or an onslaught would, at a given moment, have changed the fortunes of a day. Is it possible that an onlooker of the struggle going on on all sides for more and more sitters, may see a chance for some, at least, getting fame and profit by adopting his suggestions? I have an idea about men's heads which may, in your opinion, be worthless; but this is the foundation of it: that I should wish to purchase from some of you the thing I recommend, were I not able to supply myself with it, and I assume many others have the same desire, who are not able to take their own portraits. This paper is on "Men's Heads" only.

By what I say, do not think I am un-mindful of, or underrate, the beautiful work you do. Portraiture is daily better done than formerly. It is artistic, refined, polished, and charming; but is not the almost universality of it apt to pall? Should we not value more much of this delicate and refined work if we saw some contrast to it? For heads suitable I am about to suggest more size, more ruggedness, more abrupt lighting, more vigor, more character; less *finesse*, less prettiness, less of the pencil—more of the lens.

Painting is many-sided: why should not photography have more sides than we see? The beautiful work of the miniature painter is rivalled by the beautiful retouching, or overwork of your artists; but the subjects of the miniature painter are chiefly women and children, not strong, massive-faced men. Again there are artists who work with big hog's-hair tools. Who amongst you, gentlemen, imitate these? Who tries to do in photography what is done by the sweeping brush of Millais, or Frank Holl? You take large heads—that is, you enlarge to them; but here again comes the overwork, which makes them drawings. I suggest five-inch direct heads—strongly, not delicately lighted—with every scar or wrinkle left on them. A negative a retoucher is

never allowed to see; a print nought beyond a mere spotter is ever allowed to handle. Rough, rugged, demonstrative, truth-telling photography!

Tell men who have heads what pictures they would make, and show them what you can do. Have two styles of heads, a masher's and a man's. Let the former be beautiful as Rachel's enamel once was, let no egg-shell beat the skin in smoothness, let no wrinkle or marking be unobliterated; but when you get a man with a character in his head, make a man of him. Make two portraits if you like, but let one be the big, direct, untouched one. If untaken, that is, unbought, show it as a specimen. Let artists see it. Grist will come to the mill. In saying this I ask you to employ your best powers, your artistic taste; study old masters and imitate them; aim at grand effects of light and shadow. *For a change*, underexpose and overdevelop. You will get a Spaguoletto. Who remembers the Duke of Cleveland in the Academy just closed? Was this head smooth and polished and wrinkleless? Indeed no; it was wondrously painted, rough, old, corrugated skin, with all those marks and discolorations which belong to advanced life. Now, am I wrong in saying an ordinary portrait, and an ordinary enlargement from it, of that man's head would be smooth as the cheek of a girl, and in that respect a fiction? I have advised direct heads, and shall probably be met by the inquiry, Why not enlarge? Well, this is reasonable to ask, and all I can reply is, If, as a rule, one copy only would be likely to be wanted, and you can get as fine results, by all means consider the difference of cost between buying a large lens and enlarging. When I asked a well-known maker to supply to me a large lens, the facilities for enlarging effectively were not what exist to-day. I am not unmindful of what may be done on the specially prepared papers offered to us. I have seen fine things as enlargements, but I remember others, in days gone by, where the hair was thatch, and where, without overwork, the thing could not be accepted. This brings me again to the point I would insist upon. Produce them as you like, but give us five-inch heads that look pictures in themselves,

that have never been retouched, and never worked upon.

I will take no more of your time; I do not expect my words to pass unchallenged. From my point of view, and my hope that some here trace the rut I have pointed to, it is scarcely desirable they should.

---

### SUCCESS.\*

BY H. P. ROBINSON.

It has often been said, perhaps ironically, that nothing succeeds like success. But how are we to estimate what success is? We must know what it is before we strive for it. An approximate definition may be that it is doing everything as well as it can be done. This is only partially correct. It would be nearer right to say that is doing every thing *worth doing* correctly that is entirely successful.

Finally, Is success worth achieving? Is success to be its own exceeding great and only reward? or are those who win success to reap only the revilings of those to whom they have hitherto looked for encouragement and support—those who once were, and still ought to be, leaders of photographic opinion. I think it will be admitted by all impartial minds, that those photographers who have competed for and won medals at exhibitions, have allowed singularly little of the trade element to influence them in competing. I take credit to myself (and I freely claim the same for others) that I have steadily kept in mind in everything I have exhibited, that my efforts, however weak, should be to add to the honor and glory of the art, and I admit that I have had a very sufficient reward in the appreciation of my brother photographers. I may also mention that I have been asked by many medal holders—including amateurs who have no commercial interests—both at home and abroad to speak on this subject, and I do not desire now to speak so much for myself as for those very numerous winners of medals who appear to have incurred the displeasure of one whose journal has hitherto been the support of all that was honorable

---

\* Abstract from a paper read at the Convention at Derby.

in our art. Only the other day the editor of the *Photographic News*, in alluding in an editorial note to the Glasgow Exhibition, at which no medals were offered, said, "So we may expect to see nothing of the works of those *enterprising traders* who look upon medals as a means of making the untrained public regard them as 'the salt of the earth.'" As it turned out these "enterprising traders" exhibited very largely.

And this is success, to have the meanest motives imputed to the most successful! There are a large number of medal winners in England and Scotland, and this snub, to call it nothing worse, applies to all. I am afraid that many photographers whose pride and happiness it has been to support the *Photographic News*, are not unlike that often-quoted "Struck Eagle" of Byron's, who—

"Viewed his own feather on the fatal dart,  
And winged the shaft that quivered in his  
heart:  
Keen were his pangs, but keener far to feel,  
He nursed the pinion which impelled the  
steel."

It is a Socialist doctrine that all men ought to be equal in all things, in which case one would no more deserve a medal than another, a comfortable creed oftener held by those who "have not" than those who "have;" but I think we may leave Socialism to the congenial street mud in which it usually wallows, and not introduce it into photography. There can be no doubt that medals have done great good and educed better work than would have been done without them, and thereby materially aided in the advancement of the art. I do not expect to be a competitor much longer, therefore, the awarding of medals in the future has little to do with me personally, but I know that the honorable incentive of competing for medals has brought out of me the best work of which I was capable, and which, otherwise, would not have been done. The endeavor to win medals, or in other words, the struggle to produce the best that their materials would allow, that they may obtain the recognition of their fellows, has been the means of many photographers finding success.

**THE TREATMENT OF NEGATIVES AFTER DEVELOPMENT.  
—A MYSTERY UNRAVELLED.\***

BY W. B. BOLTON.

I WILL not vouch that the preceding is a *verbatim* report of our conversation, but at least it is an accurate summary of the spirit of it, and as such I hope you will accept it.

Now for the moral. If any of you—only one of you—think that an unfixd plate will stand with impunity exposure to daylight try the following experiments: Cut an unexposed quarter-plate into strips, and place one of them in daylight for half a minute or a minute with one-half covered with a card. A certain amount of discoloration takes place, which many people suppose disappears in fixing; but if you fix this exposed strip you will see that this is not the case. Next dip half of another strip into water, and take it into daylight; the wet portion will blacken much more rapidly, and take a deeper color than the dry; and with some plates exposed in sunlight, a depth sufficient for the shadows of a transparency can be attained, and what is more, will not be very greatly reduced in hypo. If the plate be moistened with sulphite of soda, dilute ammonia, or anything having a slight solvent action on silver bromide, a still deeper discoloration will take place.

I do not imagine that very many photographers are in the habit of taking their negatives into the open air before fixing, but I know that many like to examine the image by daylight, "just to judge its density before fixing." It is a rather useless and illogical proceeding truly, for if the density be wrong it cannot be remedied without fixing; and then if intensification be required there is a little unnecessary veil to intensify along with the picture. On the other hand, a plate that has been kept from white light until it has been fixed *and washed* will be in the best possible condition to undergo any subsequent treatment.

I told my friend I should make a "fearful example" of him, and I have tried to do so

\* Abstract from a paper read at the Convention at Derby.

in as gentle a manner as possible. Should there be one more sinner present to take the hint, this paper will not have been written for nothing.

**PHOTOGRAPHING THE LATE  
ECLIPSE.**

THE total eclipse of the sun which occurred recently in the Southern Hemisphere had some points of significance in scientific research not before obtainable, owing chiefly to the improvements in the art of photography and the instruments to be used in photographing the present phenomena. Since the period of the last solar eclipse the film of the photographic plate has been so much improved in its sensitive qualities that what then required thirty seconds exposure is now accomplished by the pulling of a trigger. This makes it possible to dispense with the clock-work before required to move the telescope with the motion of the sun, and also makes possible the mode to be used in photographing the present eclipse, for the instrument, is in fact, a telescope of forty feet in length, which would be very difficult of adjustment upon an equatorial stand, temporarily erected for this occasion, and would be liable to fall at the critical moment. As now used it lies horizontal and stationary with a polished reflector so adjusted as to throw the light and image of the sun down the tube during all the phases of the eclipse, and as the lens of the telescope brings the light to a focus forty feet from it, the image of the sun formed there will be only six inches in diameter. Assuming the defining qualities of the lens to be good, the results obtained will be greatly superior to those of former years, and the details shown in the corona will be on a correspondingly larger scale than when photographed, as formerly, by telescopes of five or seven feet in length.

The scientific object of the expeditions to photograph these solar eclipses is to obtain as many photographs as possible of the varying stages of the phenomena from the "moment of contact" with one limb of the sun till the moon's disk departs from the opposite limb, but especially to place on

record the appearances presented during totality, for it is only while that lasts that the corona can be seen. Because the moment the moon moves away from the central position the light of the thinnest crescent of the sun is sufficiently intense to make that of the corona photographically invisible. It is from the different aspects presented by this corona that scientists hope to deduce some knowledge of the physical nature of the sun; but whatever may be the final conclusions arrived at, the terrible energy of action constantly taking place at the solar surface cannot but be made plain to us by the variety of forms which present themselves about the black disk of the interposed moon. Aside from these tongues and masses of light which are leaping above the sun's surface to heights ten times as great as the diameter of our earth, there is a halo also, but whether it is an illuminated atmosphere or detached particles of solar matter in a state of incandescence it is difficult to determine, though the solution of the problem would be an invaluable addition to the knowledge already gained of the nature of the solar fires.

---

### OUR PICTURE.

OUR picture takes us back again to the centuries of the past, away down into Nubia to the rock-cut temple of Abou-Simbel.

In front of this temple there are four colossal statues of Rameses II., the Pharaoh of Moses, which are sixty-eight feet in height. Three of them have been badly used by the elements, by the vandals, and by the glacier of golden sand which sometimes sweeps around, driven by the northeast wind, and acts like a tremendous brush upon the red sandstone faces. But the southernmost one, protected by its neighbor on the north and a great buttress on the south, has escaped all material injury and retains its pristine glory and beauty of expression.

Our picture is from one of our own 8 x 10 negatives of the profile of that wonderful art production, which, for over 3000 years has smilingly faced the East. When we first clambered up to it we were sure we saw the lips part and the cheeks dimple, so strikingly lifelike did the great face seem. Though

startled, we made the exposure and present it to our readers as an example of dry-plate work made four years ago, nearly half a year after the plate was made in America, and not developed until nearly another half year had gone by.

The Volume III. of Wilson's *Lantern Journeys* tells all about the wondrous temple, as do also our letters written on the spot, and published in our volume for 1883.

The prints were made for us by the Photogravure Co., 853 Broadway, New York, in color as near as possible to the stone from which the great likeness is cut.

---

### PRACTICAL POINTS FROM THE STUDIOS.

H. KRAETZER recommends the following directions for cementing the lenses in the objective settings, he having put them to practical proof. 1. 160 grammes of the finest pulverized resin, 40 grammes of white wax, and eighty grammes of English red (*caput mortuum*) melted together carefully, and to the melted mass add 20 grammes of Venetian turpentine, then stir the prepared cement (away from the fire) with a wooden spoon until cool. The cement is applied warm. 2. A good but not brittle sealing-wax is serviceable. At any time the brittleness may be increased by the addition of a little Venetian turpentine. In cementing the glass in metal shells, the glass as well as the metal setting must be previously heated to the melting point of the sealing-wax. 3. Shellac must be cautiously (to avoid overheating) mixed with an equal amount of very fine powdered pumice and put on warm. 4. In order to fasten metal or glass objects for optical glasses, so that they can be kept in a fixed position during the polishing, a good cement is a mixture of ten parts of pitch (or cobbler's wax) and one part of white wax.

RED WINDOW FOR THE DARK ROOM.—According to M. Cassan a very secure, and quite inexpensive red window for the dark room can be prepared in the following manner. To cover a piece of glass of one and a half metres, dissolve five grammes of carmine in forty centimetres of ammonia

fluid. Also two grammes of picric acid must be dissolved in 450 cubic centimetres of water, to which seven grammes of glycerine have been added. To this yellow solution fifty grammes of gelatine are to be added, and let it soak an hour and then dissolve in a warm water bath. As soon as the gelatine is dissolved, the carmine solution must be carefully added to it and kept warm in the water bath. Now take an ordinary window-pane and spread the mixture over it with a broad, flat brush. As soon as the first layer of colors is dry, then a second one and then a third can be put on, until the desired intensity is reached. In order that this brilliant red light may not affect the operators' eyes, put two pieces of yellow paper in place of curtains in front of the window.

**TO PASTE GELATINE PICTURES UPON LINEN (OR CANVAS).**—Stretch dry white canvas on a frame such as painters use, lay the dried copy picture side downward on the table, and cover the back with thin paste if the paper become soft; the canvas also must be covered or spread over with paste and laid upon the picture. It should be rubbed on well with a soft rag at first, and then gone over with a paper knife. The paste should never be rubbed on the picture side. After the picture is dry it appears smooth and even.

### ELIMINATION OF HYPOSULPHITE OF SODA BY THE SALTS OF LEAD.

The acetate of lead has been used up to the present time in the water with which the prints are washed, for the purpose of eliminating the hyposulphite that might remain; but this important operation requires a great deal of time. A solution of acetate of lead even when carefully filtered, becomes cloudy; for this reason another salt is used—the nitrate—which remains always clear and limpid, however concentrated it may be. When one of these solutions is added to a solution of hyposulphite of soda or *vice versa*, a whitish precipitate is formed, that is to say hyposulphite of lead, whilst the nitrate of soda or the acetate

of soda remains in solution. This precipitate, however, is soluble in an excess of hyposulphite or of salt of lead. From these facts alone we are able to infer what happens when similar exchanges are made, either in the gelatine pellicle or in the porous paper, and what results may be expected. If iodide of starch is added to the mixture it is instantly discolored if there is an excess of hyposulphite, and iodide of sodium is formed; whilst the iodide of lead is formed by an excess of the salt of lead, the hyposulphite changing into sulphurous acid. We see in this way that under the most favorable circumstances we simply change the alkaline salt into a lead salt. We observe the readiness with which these salts are changed into sulphurets by adding a little soluble silver salt to one of the precipitates; it soon becomes brown or black. Experiments show that hyposulphite of lead changes with the light; it becomes discolored and is decomposed. By adding a small quantity of hyposulphite of soda to a solution of lead we perceive a white precipitate which is the hyposulphite of lead.—*Le Progrès Photographique.*

### PHOTO FACTS AND FANCIES.

**ALBUMENIZED PAPER AS A BUTTER PRESERVER**—If albumenized paper must now give way to emulsion paper, the first may still be used in the kitchen, so it is said! According to Mr. W. E. Woodbury (the son of the late distinguished photographer), farmers have found that albumenized paper is excellent for keeping butter fresh: it is wrapped in two thicknesses of cloth, then the whole is carefully covered with a sheet of albumenized paper. Fresh butter may be kept in this manner for whole months, we are told. The reason, doubtless, is that not being porous, plain albumenized paper thoroughly prevents the contact of the air. Now here is another idea: if, instead of sensitizing albumenized paper there was used a little salicylic acid, incorporating this last in the albuminous liquid, or otherwise, we would obtain a paper suitable for preserving butter for a much longer time, and, perhaps, it might be possible to do away altogether with the use of albumen.

**INFLUENCE OF THE RAYS REFLECTED BY THE SIDES OF CAMERAS.**—This interesting question was made the subject of a communication, by M. Rossignol, to the French Photographic Society, August 6, 1886. He suggests placing a partition, having a rectangular opening in the centre, so as to cut off all useless rays. This partition might have a backward and forward motion at the will of the operator.

**A CHANGING BOX TO HOLD TWELVE PLATES.**—M. David presented to the French Photographic Society, August 6th, this box, made of wood; on one of its sides is affixed a rubber bag of the length and width of the sensitized plates, which are placed in supplementary copper frames; on each copper frame there is on the outside a copper button, but not having the same position on all. The length of the plate is divided into twelve spaces. On the first frame, at about two centimetres (three-quarters of an inch) from the edge, a copper button is soldered. On the second, the button is soldered at about four centimeters (one and a half inches) from the edge, and so on until the button of the twelfth frame which is at two centimeters (three quarters of an inch) from the opposite edge. All the frames containing their plates or pellicles, are placed in the holder; through the rubber the different buttons can be felt. The front part of the frame is divided into centimeters, so that each button has its corresponding division. Should the operator desire to expose frame No. 6, he looks for the sixth division on the front of the frame. When he has found it he touches the button with the finger, and in this manner seizes the holder containing the desired plate and places it with the greatest care. In this way the operator can choose any one of the plates and place it in the negative frame.

**SMALL INSTANTANEOUS CAMERA.**—M. Hieckel showed at the meeting of the French Photographic Society, August 6th, a sort of automatic camera, in which the focussing is operated by a forward and backward movement of the objective. A finder placed on top of the camera shows the size of the objects on the plate.

**LITHOGRAPHIC PROCESS OF M. GERMEUIL BONNAUD.**—This process consists in the use of a photograph or of an original drawing upon white ground for its transformation into a lithograph or typograph without the aid of a lithographer. M. Germeuil Bonnaud proceeds as follows: with a brush he gives a slight coating of gelatine to the drawing or photograph for the purpose of protecting it, and as soon as the gelatine has set, with another brush he gives a coating of a solution of a paste composed of dextrine and starch powder in equal parts, the whole dissolved in tepid water. To obtain the grain, he adds an equal quantity of pulverized kaolin; when this coating is dry, he follows very exactly, with a lithographic pencil, or with a brush dipped in lithographic ink, the drawing or the photograph, which he afterwards transfers to the stone. This is a sort of photo-transfer for modelled images. To obtain typographic *clichés* the drawing is pressed on a copper plate having a special grain and suitable for the *gillotage*. This process may be applied to the decoration of china, etc.—*Moniteur*.

**WATER TESTS.**—*Test for Hard or Soft Water.*—Dissolve a small quantity of good soap in alcohol. Let a few drops fall into a glass of water. If it turn milky it is hard; if not, it is soft. *Test for Earthy Matters or Alkali.*—Take litmus paper dipped in vinegar, and if, on immersion, the paper returns to its true shade, the water does not contain earthy matter or alkali. If a few drops of syrup be added to a water containing an earthy matter, it will turn green. *Test for Carbonic Acid.*—Take equal parts of water and clear lime water. If combined or free carbonic acid is present a precipitate is seen, in which, if a few drops of muriatic acid be added, an effervescence commences. *Test for Magnesia.*—Boil the water to a twentieth part of its weight, and then drop a few grains of neutral carbonate of ammonia into a glass of it, and a few drops of phosphate of soda. If magnesia be present, it will fall to the bottom. *Tests for Iron.*—1. Boil a little nut gall and add to the water. If it turns gray or slate black iron is present. 2. Dissolve a little prussiate of potash, and if iron is present it will turn

blue. *Test for Lime.*—Into a glass of the water put two drops of oxalic acid and blow upon it; if it gets milky lime is present. *Test for Acid.*—Take a piece of litmus paper. If it turns red, there must be acid. If it precipitates on adding lime water, it is carbonic acid. If a blue sugar paper is turned red, it is a mineral acid.—*Public Opinion, London.*

### THE WORLD'S PHOTOGRAPHY FOCUSSED.

"THE convict officer at the Scotland Yard Prison can now boast of the photos of 32,000 convicts in his album," says the *News*.

Unless a certain English "amateur" ceases to expose his peculiar methods in our midst, pretty soon, there will be 32,001 photographs at Scotland Yard. "Borrowing" lenses, etc., and pawning them "to get along" is not relished by American photographers.

Inspector Byrnes and his assistants are busied in the preparations of several albums of portraits of criminals, which will soon be offered for sale publicly.

THE price of metal silver continues to depreciate in England.

A PHOTOGRAPHIC exhibition is to be held in Florence, Italy. Our esteemed colleague, Professor Louis Borlinetto, editor of *La Camera Oscura*, is the director. His address is 33 Rue S. Gallo, Florence, Italy.

The exhibition of Florence is under the auspices of the commission appointed to manage the grand festivals connected with the unveiling of the new façade of the wonderful cathedral of *St. Maria del Fiore*, and to celebrate the fifth centenary of Donatello.

When we first visited Florence and looked upon the grand old cathedral of magnificent architectural beauty and marvellous proportions, with only the roughest, raggedest sort of facade, the thought occurred to us that, as with some modern church corporations, so that of ancient Firenze ran out of funds before the church could be finished. This was not so, however. A splendid facade was once erected with the effort to make it harmonize with the splendid "Tower of Giotto"—the campanile of the church close

by. But the populace was not pleased and the facade was torn away.

For some time past the church front has been hidden by scaffolding shut in by plaited screens of rush, and workmen have been busy carrying out the designs of a new architect and erecting a new façade. This is to be unveiled presently, and it is to be a grand gala day for Florence.

The proposed photographic exhibition is to be one of the features of the grand æsthetic feast. Our friend, Mr. Leon Van Loo, of Cincinnati, expects to be present, and will act as our special correspondent. He is now on his way.

No 3 of *The Camera*, edited by our esteemed colleague T. C. Hepworth, Esq., and published by Messrs. Wyman & Sons, 74-76 Great Queen Street, W. E., London, comes to us laden down with good things. Capital suggestions, formulæ, accounts of camera trips, correspondence, reviews, and several admirable papers, from which we republish, combine to make up an exceedingly useful magazine. May it so continue.

The real fact is, our exchanges are more than usually filled with solid, substantial matter at present. A number of thoughtful men are pursuing most interesting researches, striving to find the various "philosophers' stones," which we all wish to have revealed to us.

Most of us sit like the Bedouin of Petra, who look at the huge vase over the pediment of the Kuzneh, with the all-abiding faith that it contains great treasure, and when Allah! is ready for them to have it, he will reveal it to them. A few, however, like some other Bedouins, keep firing away at the treasure, and some day they will lay it at our feet.

In the exchanges alluded to we find valuable papers on the following topics: Balloon Photography; Meteorology for Photographers; A knowledge of Photography desirable for Artists (the tables turned); Tables of Exposure; A New Method of Obtaining Enlarged Negatives; On Photographing Interiors; New Eyes for Science; Astronomical Photography; Photomicrography; Correct Exposures and the Area System of



making Lenses and Stops; Spectroscopic Work; True Color Value; Aristotype Paper; Direct Reproductions with Black Lines; Photo-engraving and Washing Emulsion by the Centrifugal Separator—and last comes the *Chautauqua Herald* full of good words for photography as a whole.

This all shows a marvellous activity going on in photography, and should cheer and strengthen every earnest person interested in its welfare. We have for this reason devoted more than usual of our space to selected articles. They are too useful to be allowed to pass by without the widest diffusion and commendation it is in our power to give them.

JOHN SARTAIN, the artist, goes to London in the spring to take charge of the Fine Art department of the American Exhibition. Mr. Sartain held a similar position in the Centennial Exhibition.

HE WAS AFRAID OF THE CAMERA.—James Lyon, of Elmira, desired a photograph of his fine St. Bernard dog. When the dog saw the camera pointed at him he suspected that something was wrong and bolted out of the door. He was coaxed back and posed again. Again he took alarm, and the door being shut, jumped out of a window, fell on an awning, broke through, fell on two young men, smashed a hat flat, and terribly scared a small colored bootblack. The dog weighs 150 pounds.

THE EGGSHELL BLOWN AWAY.—German photographers have succeeded in photographing a projectile in the course of its flight, and some of these photographs show the head of condensed air which precedes every shot. It is said to be this "head" which prevents even skilful riflemen from hitting an empty eggshell when hung on a long thread. The air blows the shell out of the way of the bullet.

PHOTOGRAPHING CONVICTS AT ALTON.—It was your correspondent's good fortune to visit the prison on a recent date, while the prison artist was engaged in taking the pictures of 152 new arrivals—convicts who had arrived during July and August—and of

witnessing the *modus operandi* of reproducing their "mugs" on paper. Everything was in readiness at 9.30 A.M. The artist handed a list of names to a guard and requested him to bring in a gang of thirty or forty new convicts from the chair shop. The officer soon had the raw recruits in line and marched them across the yard to the gallery, where they were seated on a bench along the wall in the outer room. Captain Luke, the receiving officer, then took the list of names, and entering the operating room—where all was ready, the camera and chair in position—called out the name of the first man on the list, and the guard, picking out that man, hustled him into the room.

"Sit right down here. What's yer name? What's yer register number? See that little red star on the wall? Place yer eyes on that and don't move till I tell yer—hold up that head a little."

While this volley was being fired into the ears of the trembling convict, the captain grabbed the man by the shoulders, squared him back in the chair, yanked his head around in the direction of the star on the wall, chucked him under the chin to elevate his head, and then pulling around a wooden arm attached to the head-rest, and containing a place in which to put some pasteboard figures to represent the prison number of the convict, pushed it up against the man's chest, so that the number would show in the resulting picture. All these manipulations were gone through with in a moment's time, and then came the ominous "click" of the instantaneous shutter on the camera—the exposure was completed. A second later and the captain yells:

"Next!"

And in comes another victim. They follow each other in rapid succession, like sheep coming to a shearing.—*Letter in St. Louis Globe-Democrat.*

THE Geneva Society of Photography held its first international exposition from Sept. 1st, and will close Sept. 30th. Native and foreign photographers were cordially invited to participate in this exposition, which was solely devoted to photography, and the first to take place in Switzerland.

RETOUCHING THE NEGATIVE.—M. P. Spirenz gives as an excellent medium, 1 part of gum damar in 80 parts of rectified turpentine, filtered after solution through absorbent cotton. This solution is applied with a piece of chamois, and may be used equally as well after varnishing.—*British Journal of Photography.*

M. ANT. SCHAEFFNER has just published *Notes Photographiques*, explaining the use of the appliances and products necessary in photography. This publication contains many interesting facts and much useful information.

L'ASTRONOMIE—in the August number—contains a very interesting article, by Messrs. Paul and Prosper Henry, on double stars and stellar masses measured by photography. Astronomers and scientists, who are interested in the study of double stars and of the stellar systems, will learn with much satisfaction that, henceforth, photography will have a practical application in these important investigations. The photographs of Jupiter show very clearly the rotation of the planet, as well as the displacement of its satellites. In regard to the red spot it is more apparent and better defined on the photographs than when seen directly through the telescope. "We see," say Messrs. Paul and Prosper Henry, "that celestial photography more than keeps its promises."—*Moniteur.*

PHOTOGRAPHY FOR BEGINNERS.—The recent volume of M. León Vidal, styled *La Photographie des Débutants*, has been well

received in London; one of our journals speaks of it as an "admirable manual;" what more could be said? We may add, however, in what concerns the English readers of this charming little volume, that, unless we are much deceived, the *débutantes* will receive as much profit from it as the others. In truth, the number of young girls who, on leaving school, enter "into photography," is considerable; and we think that Mr. Vidal's work will save them from the discouragement resulting from the study of incomplete or old manuals.

MODERN PHOTOGRAPHY.—The little volume of *Modern Photography*, by W. R. Burton, of which there exists a French translation, has also met with success. Messrs. Piper & Carter, of London, have just announced the sixth edition.

NEW HYDROQUINONE PLATE.—Mention is made of a new kind of plate invented by Captain Biering, and which seems to be a modification or an improvement of the gelatine plate containing pyrogallic acid. It will be remembered that these last, made with an emulsion of bromide of silver, containing a certain quantity of pyrogallic acid, were developed in an alkaline bath. The new plates of which we speak contain *hydroquinone* instead of pyrogallic acid, and it is said that they are very good. They are developed by means of a solution of *sweetened lime*—that is to say, a solution of quick lime in sugared water, or of syrup of sugar. The image appears in about thirty seconds, but it is very often necessary to dilute the developer to obtain soft negatives.

## Editor's Table.

MESSRS. DEMERS & SON are among the enterprising photographers of Holyoke, Mass. We had a very interesting interview with the senior member of the firm in our office a short time ago. Formerly a resident of Montreal, he had not visited New York for over twenty-four years. It was very interesting to hear him tell of the status of photography here at that time, and to listen to his surprise over the changes made since. Nearly all the old landmarks are

gone, he says. Mr. DEMERS has always maintained a connecting link, however, through the medium of the PHILADELPHIA PHOTOGRAPHER.

MESSRS. JANENTZKY & WEBER, 1125 Chestnut Street, Philadelphia, make an announcement in our advertising pages this month that will interest many of our readers. The large amount of crayon work done and the revival in coloring photographs makes it desirable to be informed

as to where the best materials and requisites may be had. Messrs. JANENTZKY & WEBER stand at the head of their department, and their reputation is second to none. We have known them personally ever since we entered photography to figure out a fortune.

"The Dubois Filing Cases" are coming into general use by photographers for storing the negative films, proofs, papers and other articles which need to be kept alphabetically and systematically. They are exceedingly convenient also for counting-room and office use. We have purchased several of them and have them in active use. They are the greatest comfort and are worth their weight in silver metal.

**THEATRE PHOTOGRAPHY.**—Theatre managers are beginning to desire a rest from the gaudy and tasteless chromos and lithographs so long used by them, and have come to photography for help. One of the first to see the advantages of our art was Mr. HARRY MINER, lessee of the People's Theatre, Mr. J. CHARLES DAVIS, Acting Manager. A short time ago we were present at that theatre when the striking scenes in "Zitka" (the interesting play now having such a run here and to follow in other cities) were photographed by the Photogravure Co. Three cameras were set before the stage, the largest being a 13 x 16 size. The operations lasted several hours, and the results were completely successful. A long line of electric lights was swung in front of the stage, some eighteen feet high, and at the wings there were groups of lights in convenient and appropriate localities. Among the most striking tableaux secured were "The Red Cafe," "The Salon of the Countess Petroskey," "Interior of the Regimental Chapel," "Terrace of the Chateau Petroskey," "The Exiles' Hut in Siberia," and "The Winter Palace at St. Petersburg." Actors, actresses, and photographers all did their very best to obtain successful pictures, and but for a trifling movement here and there of those who had the most trying positions, the success was marvellous. The principal lady, Miss CHARLOTTE BEHRENS, did much to make the tableau picturesque. Her figure and acting remind one of COUNTESS MODJESKA.

*Chapters in a Human Life*, is the title of a twelve-page pamphlet in a handsome cover, issued to his friends by Mr. LULU FARINI, 61 Fairfield Avenue, Bridgeport, Conn. Two portraits, one of "Lulu" in 1865, and the other of Mr. FARINI, in 1886, embellish the work. It

tells of the adventures of the wonderful gymnast, of the experiences of the African traveller and photographer, and of the future plans of the Bridgeport artist. We have alluded to Mr. FARINI's work repeatedly. The author of *Chapters*, Mr. E. K. STIMSON, closes thus:

"The third and latest chapter in Mr. FARINI's life has but just begun.

"He has settled in Bridgeport to remain. No more wandering on the face of the earth or over the drifting surface of the deep. That which he brings to the permanent home of his selection will add to its honorable citizenship, and will still further swell the fund of fine art collections already accumulated by the lovers of iconography among its people.

"The gallery which he opens to the public will come to be a place often revisited, for with each return new beauties of refined-delineation will reveal themselves.

"As one draws aside a curtain  
And beholds the statue in a temple,"

It will be fascinating to be photographed by the same camera that was the dumb witness of so many thrilling events, also to remain for hours reviewing enchanting pictures among surroundings of tasteful elegance.

"The career of 'Lulu' is to me one of intense interest; many portions of it are instructive. His progress is worthy of the most marked approbation. I wish him the fullest measure of success which fortune sometimes showers upon a favored object, and I lay this sketch, for whatever use he may wish to make of it, in friendly tribute at his feet."

We heartily wish our friend the greatest success in his new and beautiful studio. His ambition is to uphold the honor of our art, and to rival the best artists in it.

In a recent issue of the *Photographic Times* Mr. G. A. DOUGLASS, an excellent authority, advocates holding our American Conventions once every three years, after the one appointed for Chicago next year; every year, however, a practical meeting to be held without an exhibition. On the whole we think this is a good scheme, and it has already been suggested by us.

Mr. DOUGLASS speaks of our former conventions as being attended by success. This is true, but only measurably true. There has been a kind of success which the fabled spider had when he jumped up his web and fell partly back after each effort. Advance we have not had commensurate with our success. We have advanced, but then we let go each time and

have to begin again. There is no *continuing action*, and there will not be until we keep up the movement between conventions through a strong organization and an active secretary. We hope to see this happy day for our art yet, but there is a large change in management and methods to be brought about first. Mr. DOUGLASS suggests a correct step.

THOSE contributors who wish their names to appear in *Mosaics*, for 1887, are requested to kindly send in their articles at once if possible. We wish the book to issue promptly, and a little error will save us much trouble and delay.

MR. XANTHUS SMITH, the well-known artist, writes to us as follows:

No. 1020 CHESTNUT STREET,  
PHILADELPHIA, August 30, 1886.

E. L. WILSON, Esq.

DEAR SIR: On my return from Mt. Desert I found awaiting me the number of the PHILADELPHIA PHOTOGRAPHER of August 21st, and so delighted am I with it that I cannot refrain from writing you a line to tell you so. The print of the child and dog is beautiful. Father is of the same opinion as myself with regard to the admirable taste displayed in the get up of your journal. You seem to be working on the excellent principle that anything that is worth doing is worth doing well.

I hope, indeed, that your efforts are meeting with success.

With kind regards, I am

Very respectfully yours,  
XANTHUS SMITH.

THE new "Chautauqua edition," of *Photographics* was an eminent success. It is now adopted as the standard Chautauqua text-book on the subject it treats, and is doubtless helping many eager students along to an efficient knowledge of our art. The edition has gone like snow in midsummer, and more are already being printed. For a technical treatise the sale of *Photographics* has been positively phenomenal.

FROM Mr. N. M. WILCOX, of Burnet, Texas, we have received a pretty pair of pictures. The first represents little Miss Mischief, worn from play, taking a refresher (aqueous) from a pitcher perilously tipped on the table-edge. In the second the law of gravity has taken its course, and she views with remorse the fragments, while we can read in the corner of her eye how she is thinking what account she shall give of the accident.

FROM Messrs. BUCHANAN, SMEDLEY & BROMLEY, of 25 N. Seventh Street, Philadelphia, we have received their "Bargain List" for September, telling of the many chances they offer of bargains in apparatus and accessories. It ought to be very interesting to many photographers. Their excellent "Three Kings" brand of Albumen Paper and the Philadelphia Wide-angle Lenses (90°-95°) are also mentioned.

MESSRS. SWEET, WALLACH & Co., of Chicago, dealers in photographic supplies, have issued a large new one hundred and fifty page catalogue of all needful in the art, with many illustrations. There is a healthy rivalry to get and dispense the best, among the great firms, of which this is a sign. This latest addition to the literature of stockdealing is a fine affair.

A WAIL from the earthquake quarter, and this little sound from one of our own fraternity, is nothing compared to what must come out daily from poor broken-down Charleston. We hope some one can make a place for him soon. This is the letter in full:

CHARLESTON, September 6, 1886.

EDWARD L. WILSON, Esq.

SIR: Will you do me the favor to insert in your paper the following request.

WANTED.—Situation as first-class retoucher and crayon artist (married). Have had many years' experience. Also for Joseph Weiser, retoucher.

I am forced to ask for a place inasmuch as the sudden calamity which has befallen this city renders it impossible for me to make a living. Have been with Mr. Nowell for several years.

Yours truly,

FRANK YANTZON,  
110 Church Street.

THE Argentic Plate, manufactured by the PHOENIX PLATE Co., Worcester, Mass., is now all right and perfect, we are informed, and full particulars will be given in our next issue. *This* time look out for something par excellence.

THE Suter Lens will surely be "on top" when Mr. JOHN G. DOUGHERY makes his next balloon ascent, as he has just purchased a No. 3 A for his exacting and grasping aeronautic view work. The prize pictures exhibited at St. Louis by Mr. B. L. H. DABBS, of Pittsburg, were made with a No. 7 B Suter Lens. New laurels are added to the Suter wreath almost weekly.

## THE DUPLEX NOVELETTE CAMERA

Is a marvel of Camera architecture. In an instant a "vertical" camera may be turned into a "horizontal," and in another the change made from the 5 x 8 to the 8 x 10 size, and *vice versa*. It is supplied in two carrying cases, so that you may leave one part at home if you desire. The same platform and one front serves for both sizes. It is as complete an equipment as ever was invented. One holder, each size, goes with the "Duplex" at \$35. Messrs. E. & H. T. Anthony & Co. are the makers.

AMONG all the photographic lenses of various makes and styles which have been introduced during the past ten years, the euryscopes, of which Voigtlander & Son are the sole manufacturers, loom up conspicuously. The success of these lenses has been unparalleled, and the demand is as lively as ever. They can be found in nearly every gallery in the land, and the amount of satisfaction and profit they produce is difficult to calculate. Most convincing proof of their superiority over other lenses is the exquisite work done with them, and the fact that it is simply impossible to get along without them.

## SPECIAL CARD.

Talcott's Improved Mounting for photographs softens the lines, gives much strength and great brilliancy to the picture, and is the only process by which a photograph may become indelible.

Patented March 23, 1886.

For preserving from all soiling engravings, etchings, crayons, diplomas, certificates, etc., this mounting has no equal, the picture or parchment being hermetically sealed.

Pictures thus mounted can be displayed or packed in less than one-half the space required by pictures with other framings, as by this process all other framing becomes wholly unnecessary, yet it is so constructed that if desired it can be placed in any ordinary picture frame intact, free from all interference.

E. K. TALCOTT,  
216 Northampton St.,  
Boston, Mass.

Our dark-room and laboratory are under the charge of Dr. John Nicol, photographic chemist, late of Edinburgh. None but purest chemicals used in our preparations. All the standard dry-plate developers kept in stock. Your patronage desired.

GAYTON A. DOUGLASS & Co.,  
Merchants in Photo. Supplies,  
185 & 187 Wabash Avenue,  
Chicago, Ill.

FOR SALE.—Atkinson's Railroad Photo Palace Car "Jumbo." It has raised roof and platform at each end, and door. It is 57 feet long and 10 feet wide. Will be sold at bargain. Photo stock, instruments, and accessories taken as part payment. Photo of car sent if desired. For further particulars, address

C. W. ATKINSON, Artist,  
Lock Box 2126,  
Moline, Ill.

825 REVISED LIST. 825

We call attention (circular free) to our revised price-lists of *albumen papers, Magee's nitrate of silver, dry plates, and pyrogallic acid.* Consult it before you buy. WILSON, HOOD & Co.,  
825 Arch St., Phila.

WANTED.—At once, a young man of good habits and gentlemanly address, to do first-class retouching and printing. None but a thorough workman need apply. Send photo and salary wanted to F. C. WESTON,  
Bangor, Me.

## SITUATIONS WANTED.

No charge for advertisements under this head; limited to four lines. Inserted once only, unless by request.

After October 1st by an accomplished workman. Address S. J. Doughan, Newport, R. I.

By a young man, of sixteen months' experience, with chance for improvement. Address H. C. Voorhees, Hackettstown, N. J.

By October 1st or 15th, by a strictly first-class retoucher, is also good printer and operator. City or country. Samples and references. Address Julius Kraus, 23 Second Avenue, N. Y.

Permanently, after October 1st, by an A No. 1 retoucher who is a good operator and printer. Salary moderate. City or country. Samples and first-class New York references. Address George Bassman, 23 Second Avenue, New York.

By a first-class printer and toner. Best of reference and samples of work furnished. West or South preferred. Address J. H. Rice 214 St. Clair Street, Cleveland, Ohio.

By November 1st. Willing to make himself generally useful. Reference from present employer. Address E. S. Courtright, Hackettstown, N. J.

As printer and retoucher or assistant operator, the latter preferred. Five years' experience. Address S. R. Lewis, 73 Dudley St., Utica, N. Y.

A first-class retoucher and crayon artist (married) of many years' experience. Address Frank Yantzon, 110 Church St., Charlesten, S. C.

ASK FOR THE  
BLUE LABEL.

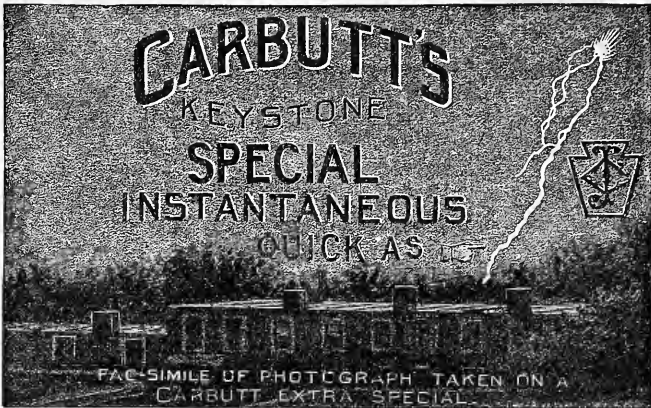

TRY THEM.  
and you will continue to  
USE THEM.

Pronounced the "Ne Plus Ultra" of Dry Plates.

UNSOLICITED TESTIMONIALS.

MR. JOHN CARBUTT, Wayne Junction, Philadelphia.

WORCESTER, MASS., December 25, 1885.

DEAR SIR: I have been using some of your new plates, emulsion 1024, sensitometer 24. I think they are, without exception, the finest and best plates I ever used. They are not only very fine and delicate in their structure, but, when properly manipulated, result in a blooming negative, possessing all the desirable qualities that any artist could wish for. I could most appropriately christen them the "Ne Plus Ultra Dry Plate."

Yours truly, E. R. B. CLAFLIN.

DETROIT, MICH., January 16, 1886.

MESSRS. HARRIS & KITTLE.

GENTLEMEN: I am very much pleased with the Carbutt Plate; in fact, I call them the best plate *by far* that I tried so far. I find them especially useful for my theatrical subjects, as the quick emulsions are *absolutely instantaneous*.

Yours truly, A. B. TAYLOR.

*For Sale by all Dealers in Photo. Materials.*

JOHN CARBUTT, Keystone Dry Plate Works, Wayne Junction, Philada., Pa.

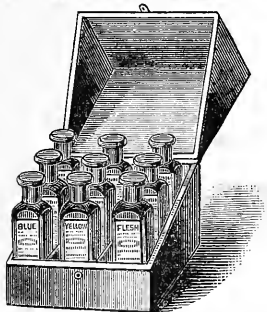

**JANENTZKY & WEBER,**

MANUFACTURERS OF

**ARTISTS' MATERIALS**

J. & W.'s Superfine Artists' Oil Colors in collapsible tubes,

J. & W.'s Artists' Canvas, Fine Brushes for Oil or

Water Colors, Academy Boards, Water Colors

in cakes and pans, Soft Pastels,

Monochromatic Boards, Pastel Canvas, Pastel Plaques,

Liquid Photograph Colors, Blue Print Papers, plain

and sensitized, Solar Printing Papers.

Crayon Drawing Materials,

Everything required for Drawing, Painting, Etching, Modeling, etc.

Wax and Paper Flower Materials.

Send for Catalogue.

No. 1125 Chestnut Street, Philadelphia.

**G. W. WILSON & CO.**

(By special appointment Photographers to Her Majesty the Queen),

**MANUFACTURERS OF MAGIC LANTERN SLIDES,**

St. Swithin Street, Aberdeen.

Catalogue of 12,000 subjects in England and Scotland, and Price Lists, post free on application.

**PHOTOGRAPHERS' ART VINE.**

Beautiful and durable Ivy Vine for scenic effects; manufactured especially for photographers. All natural vines and leaves imitated. Send for circular. Special rates to dealers in photographers' supplies.

**S. G. SHERWOOD,**

232 Vermont St., Buffalo, N. Y.

# WILSON'S LANTERN JOURNEYS.

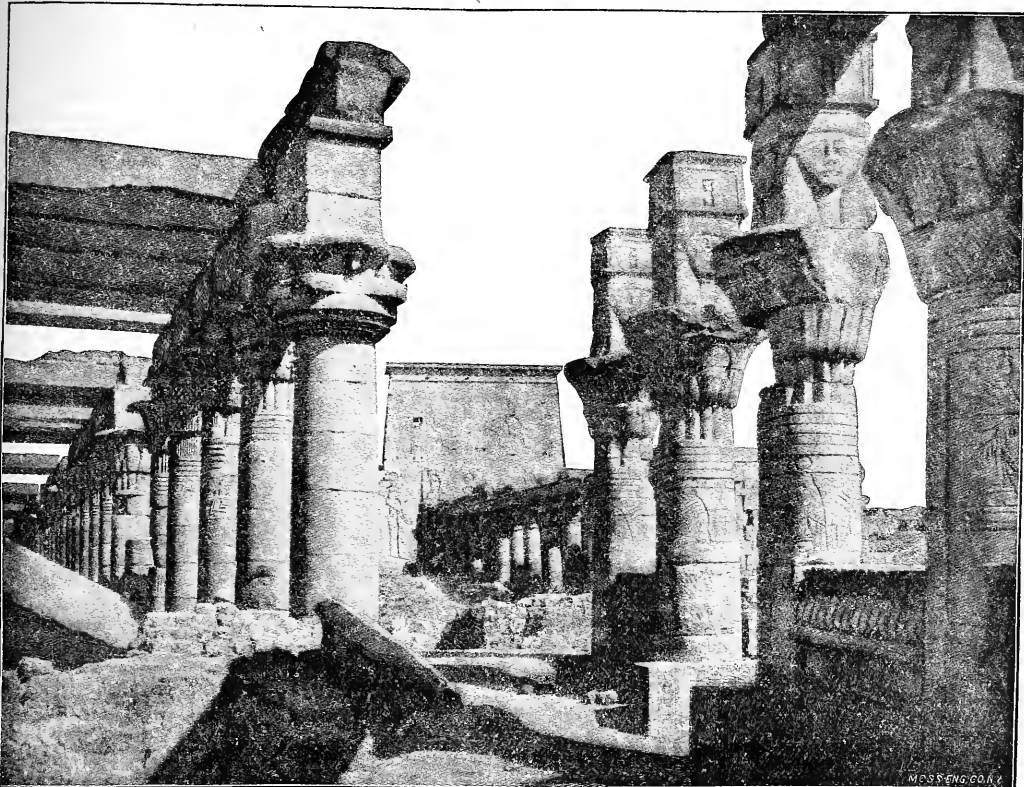

"Splendid summer reading for 'can't-get-aways' and 'can't-travels.' It is lovely travel and description combined."—*Herald*.

**3 Volumes. SEE WHAT COUNTRY THEY COVER. 3 Volumes.**

## VOLUME I. 306 PAGES, CONTAINS NINE JOURNEYS:

A—France and Switzerland. B—Belgium, Germany, Austria, Saxony, and Bavaria. C—Italy—Lakes, Cities, and the Italian Art Galleries. D—Holland, Denmark, Norway, Sweden, Russia, and Spain. E—Egypt, Palestine, Syria, Turkey, Greece, and India. F—England, Scotland, and United States of America. G—Centennial Exhibition, Phila. H—Centennial Exhibition, Phila. I—Paris Exposition, 1878.

**IN ALL OVER 900 SUBJECTS.**

## VOLUME II. 331 PAGES, CONTAINS TWELVE JOURNEYS:

J—Germany and Russia. K—Belgium and Austria. L—France—Cities and Provinces. M—Spain and Portugal. N—Switzerland—The Four Alpine Routes. O—Italy, Ischia, and Sicily. P—Turkey, Greece, and Egypt. Q—Palestine and India. R—Scotland—Cities and Ruins. S—Ireland. T—England—Cities, Museums, and Ruins. U—United States of America.

**IN ALL 1073 SUBJECTS.**

## VOLUME III. 322 PAGES, CONTAINS ELEVEN JOURNEYS:

Sinai Peninsula and Petra. From Hebron to Bethel. Round about Jerusalem. Picturesque Palestine. From Damascus to the Sea. A Thousand Miles in Nile Land. Nile Tombs and Temples. How They Live in Egypt. Egypt and the Egyptians. Egypt, Old and New. New Pictures of Old Places.

**IN ALL 700 SUBJECTS.**

*Gives descriptions of all slides made by Mr. Edward L. Wilson of his personally taken views of The Sinai Peninsula; The Desert of the Exodus; The Route of the Israelites to the Promised Land; and the*

## **TAKING OF PETRA.**

Readers of The Philadelphia Photographer cannot put better books on their reception-room tables than this for waiting patrons.

**PRICE \$2.00 PER VOLUME, POST-PAID.**

For Sale by all Dealers. **EDWARD L. WILSON, Photo. Publisher, 853 Broadway, N. Y.**

The Following is of Interest to every Photographer.



---

THE NEW N. P. A.  
P E N S É.

We desire to call attention to our **NEW PENSÉ N. P. A.** Extra Brilliant Dresden Albumen Paper.

The manufacturers at Rives have recently made many marked improvements in their celebrated paper, and all the sheets of this brand are **manufactured specially for it**, and are readily distinguished from all other papers by the **water-mark N. P. A.**

It is doubly albumenized by the **most experienced house** in Germany, with **new and improved** formulas, and we are confident that on trial it will be found **superior** to any other in market.

Its excellence has induced some unscrupulous persons to place the **STAMP** on the Paper of other makers, in order to work it off, trusting that photographers will not look through to see if the **water-mark** is there. To prevent this we have registered  This Trade Mark  in Washington, which will subject to heavy damages all those who stamp this brand on paper which does not bear **EXTRA-BRILLIANT N.P.A.** the **water-mark N. P. A.** This Paper can be had also in **DRESDEN.** **PINK, PEARL or WHITE.**

**FOR SALE BY ALL DEALERS IN PHOTO. GOODS IN U. S. AND CANADA.**

---

**E. & H. T. ANTHONY & CO.,**  
591 Broadway, NEW YORK.

N. B.—When any paper is offered to you at a low price, **Measure it.**

Also note whether it runs **Uniform**, for some albumenizers mix the first and second qualities, not discarding that which has defects, and thus get their paper cheaper.

NEW SIZE, 20 $\frac{1}{2}$  x 24 $\frac{1}{2}$ , \$45.00 per ream.



720 (5 gross) of these trimmers were sold to one party in July.

# ROBINSON'S NEW MODEL PHOTOGRAPH TRIMMERS!

This drawing is of the full natural size and shape of the New Model Revolving Trimmer. The *Straight Cut* is of same size, varying but little in shape.

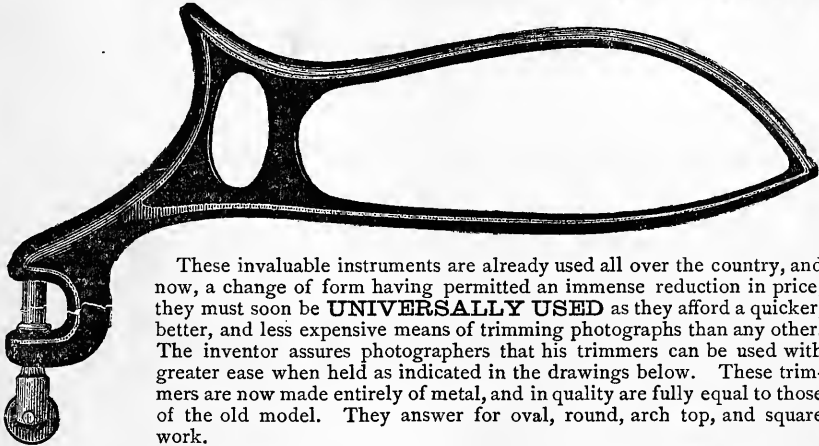

These invaluable instruments are already used all over the country, and now, a change of form having permitted an immense reduction in price, they must soon be **UNIVERSALLY USED** as they afford a quicker, better, and less expensive means of trimming photographs than any other. The inventor assures photographers that his trimmers can be used with greater ease when held as indicated in the drawings below. These trimmers are now made entirely of metal, and in quality are fully equal to those of the old model. They answer for oval, round, arch top, and square work.



Plan of holding the *Straight Cut* Trimmer when in use. PRICE, 50 CENTS.

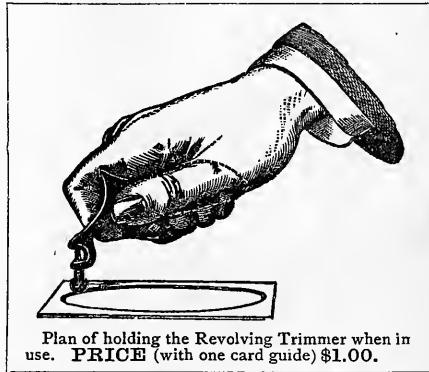

Plan of holding the Revolving Trimmer when in use. PRICE (with one card guide) \$1.00.

## ROBINSON'S GUIDES.

MADE OF SHEET-IRON.

We have the following Regular Sizes always on hand at 10 cents per inch the longest way of the aperture.

OVALS.			SQUARE OR ROUND CORNERED.		
2 x 2 <sup>7</sup> / <sub>8</sub>	3 x 4 <sup>1</sup> / <sub>8</sub>	5 x 7	2 <sup>1</sup> / <sub>16</sub> x 3 <sup>3</sup> / <sub>8</sub>	2 <sup>5</sup> / <sub>16</sub> x 3 <sup>3</sup> / <sub>8</sub>	2 <sup>3</sup> / <sub>4</sub> x 4 <sup>1</sup> / <sub>8</sub>
2 <sup>1</sup> / <sub>8</sub> x 3	3 <sup>3</sup> / <sub>8</sub> x 4 <sup>1</sup> / <sub>8</sub>	5 <sup>1</sup> / <sub>4</sub> x 7 <sup>1</sup> / <sub>4</sub>	2 <sup>1</sup> / <sub>8</sub> x 3 <sup>3</sup> / <sub>8</sub>	2 <sup>5</sup> / <sub>8</sub> x 3 <sup>5</sup> / <sub>8</sub>	2 <sup>7</sup> / <sub>8</sub> x 4 <sup>1</sup> / <sub>8</sub>
2 <sup>1</sup> / <sub>2</sub> x 3 <sup>1</sup> / <sub>8</sub>	3 <sup>1</sup> / <sub>2</sub> x 4 <sup>1</sup> / <sub>8</sub>	5 <sup>3</sup> / <sub>8</sub> x 7 <sup>1</sup> / <sub>8</sub>	2 <sup>1</sup> / <sub>8</sub> x 3 <sup>1</sup> / <sub>8</sub>	2 <sup>3</sup> / <sub>4</sub> x 4 <sup>1</sup> / <sub>8</sub>	3 <sup>7</sup> / <sub>8</sub> x 5 <sup>1</sup> / <sub>4</sub>
2 x 3 <sup>1</sup> / <sub>8</sub>	3 <sup>1</sup> / <sub>8</sub> x 5	5 <sup>3</sup> / <sub>8</sub> x 7 <sup>1</sup> / <sub>8</sub>	2 <sup>5</sup> / <sub>16</sub> x 3 <sup>1</sup> / <sub>8</sub>	FOR STEREOGRAPHS.	
2 x 3 <sup>3</sup> / <sub>8</sub>	4 x 5	5 <sup>3</sup> / <sub>8</sub> x 7 <sup>1</sup> / <sub>8</sub>	Arch Tops. Round. Round.		
2 x 4 <sup>1</sup> / <sub>8</sub>	4 <sup>3</sup> / <sub>8</sub> x 6	6 x 8	3 <sup>1</sup> / <sub>16</sub> x 3 <sup>3</sup> / <sub>4</sub>	3 x 3	3 <sup>1</sup> / <sub>16</sub> x 3 <sup>3</sup> / <sub>4</sub>
					3 x 3

The above sizes suit the Collins Card Mounts, and photographers knowing that they can be always had at the low price of ten cents per inch, would do well to *make their sizes accord*, as orders can also be filled more quickly. Ten days are required to make special sizes.

Special Sizes made to order, at 15 cents per inch, the longest way of the aperture.

**ROBINSON'S PHOTOGRAPH TRIMMERS** are substitutes for the Knife for Trimming Photographs, and do the work much more expeditiously and elegantly. They Save Time, Save Prints, and Save Money.

They do not cut, but pinch off the waste paper, and leave the print with a neatly bevelled edge which facilitates adherence to the mount. Try one, and you will discard the knife and punch at once. For ovals and rounded corners they are worth their weight in gold.

For sale by all Dealers.

**ROBERTS & FELLOWS,**

Successors to E. L. WILSON,

1125 Chestnut St., Philadelphia, Pa.

# The Photographic Times

Is a WEEKLY JOURNAL devoted to the

**THEORY, PRACTICE, AND ADVANCEMENT OF PHOTOGRAPHY.**

ITS DEPARTMENTS ARE:

**EDITORIAL.**

**CONTRIBUTED AND MISCELLANEOUS.** articles by the best photographic writers of both hemispheres.

**COMMUNICATIONS FROM SOCIETIES.** Including Papers, Lectures, etc.

**MEETINGS OF SOCIETIES.** Stating date and place of meeting of all Photographic Societies, both professional and amateur, and giving full proceedings of all meetings.

**CORRESPONDENCE.** Scientific and practical discussion by practical photographers of important and interesting questions, and letters from all quarters of the globe by intelligent and observing correspondents.

**OUR EDITORIAL TABLE.** Reviews of books, exchanges, etc.

**PICTURES RECEIVED.** Impartial criticism and notice of all photographs sent in

**NOTES AND QUERIES.** Answers by the Editors to correspondents in search of knowledge.

**COMMERCIAL INTELLIGENCE.** Description of new photographic appliances, studio changes, and a record of photographic patents.

## A PARTIAL LIST OF WRITERS TO THE PHOTOGRAPHIC TIMES.

CAPT. W. DE W. ABNEY.....	England	W. H. WALMSLEY.....	Philadelphia
W. M. ASHMAN.....	"	FREDERICK A. JACKSON.....	New Haven
W. K. BURTON.....	"	PROF. RANDALL SPAULDING.....	Montclair, N. J.
W. E. DEBENHAM.....	"	PROF. WM. HARKNESS, U. S. N.....	Washington, D. C.
H. P. ROBINSON.....	"	DR. JOHN H. JANEWAY, U. S. A.....	Governor's Island
G. WATMOUGH WEBSTER.....	"	C. D. CHENEY, D. D S.....	Hoboken, N. J.
ARNOLD SPILLER.....	"	PROF. KARL KLAUSER.....	Farmington
W. JEROME HARRISON.....	"	GEO. H. JOHNSON.....	Bridgeport
ANDREW PRINGLE.....	Scotland	MISS ADELAIDE SKEEL.....	Newbergh
CHARLES SCOLIK.....	Vienna	CHARLES WAGER HULL.....	New York
KARL SCHWIER.....	Germany	REV. G. M. SEARLE.....	"
VICTOR SCHUMANN.....	"	C. W. CANFIELD.....	"
W. J. STILLMAN.....	Athens	P. C. DUCHOCHOIS.....	"
PROF. H. D. GARRISON.....	Chicago	HENRY M. PARKHURST.....	"
PROF. S. W. BURNHAM.....	"	REV. C. E. WOODMAN, Ph. D.....	"
HENRY L. TOLMAN.....	"	H. EDWARDS-FICKEN.....	"
GAYTON A. DOUGLASS.....	"	S. H. HORGAN.....	"
A. HESLER.....	"	WM. KURTZ.....	"
GUSTAV CRAMER.....	St. Louis	J. M. MORA.....	"
J. F. EDGEWORTH.....	"	PROF. L. C. LAUDY.....	"
W. H. SHERMAN.....	Milwaukee	A. BOGARDUS.....	"
GEORGE EASTMAN.....	Rochester	CHAS. D. FREDERICKS.....	"
DAVID COOPER.....	"	A. MORENO.....	"
PROF. H. W. LORD.....	Columbus	C. W. DEAN.....	"
H. McMICHAEL.....	Buffalo	DR. O. G. MASON.....	"
JOHN CARBUTT.....	Philadelphia	ERNEST EDWARDS.....	"

The Photographic Times { Monthly edition issued on the } Issued Every Friday  
 { last Friday in the month. }

### —••—SUBSCRIPTIONS.—••—

One copy Weekly issue, postage included, to all points in U. S. or Canada.....	\$ 3 00
One copy Monthly issue, postage included, to all points in U. S. or Canada.....	2 00
Weekly issue to foreign addresses, postage included.....	4 00
Monthly issue to foreign addresses, postage included.....	3 00

Single copy, Weekly, 10 cents  
 A month's trial (four weeks), of the Weekly for 30 cents.  
 A specimen number free.

Single copy, Monthly, 25 cents.  
 Remit by Express, Money Order, Draft,  
 P. O. Order or Registered Letter.

Subscriptions to THE PHOTOGRAPHIC TIMES received by all dealers in photographic materials in this Country, Canada, West Indies, Great Britain, Australia, New Zealand, and by the publishers,

## SCOVILL MFG. CO.

W. IRVING ADAMS, Agent.

No. 423 Broome Street, New York.

The Weekly Photographic Times and Philadelphia Photographer to one address, \$6.50.

Subscribe now and Secure the back numbers before they are all sold.

FORTY-FIFTH HUNDRED BEING SOLD.

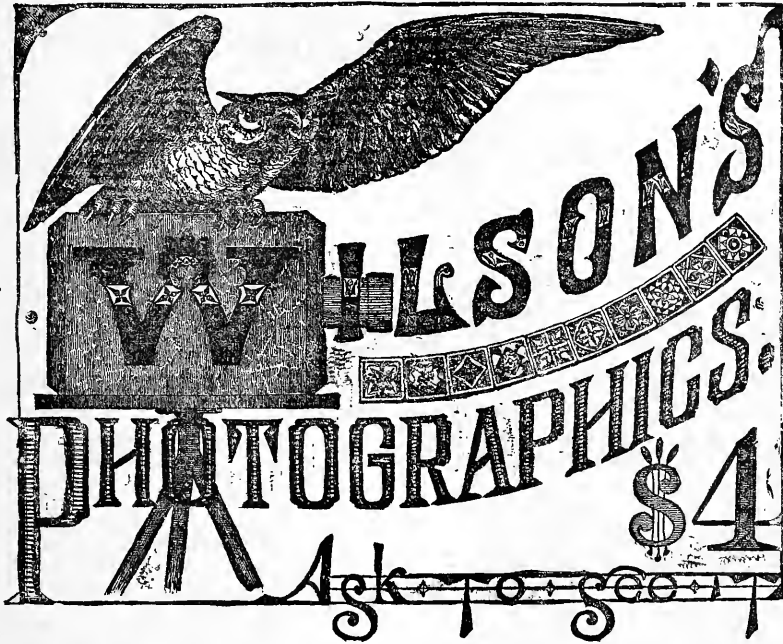

FORTY-FIFTH HUNDRED BEING SOLD.

# A PARTIAL PHOTOGRAPHIC ENCYCLOPEDIA.

By EDWARD L. WILSON, *Editor "Phila. Photographer," "Photo. Mosaics," etc.*

**A STANDARD BOOK FOR ALL WORKERS IN PHOTOGRAPHY.**

## CONTENTS.

LESSON A. TREATMENT OF THE SUBJECT—B. THE NEEDFUL APPARATUS—C. THE OBJECTIVE OR LENS—D. THE DARK-ROOM—E. PREPARATION OF THE GLASS—F. CHEMICALS AND SOLUTIONS—G. THE MANIPULATIONS—H. MANIPULATORY MISERIES—I. RETOUCHING THE NEGATIVE—J. THE GLASS STUDIO—K. ACCESSORIES AND LIGHT—L. MANAGING THE MODEL—M. PRINTING ON ALBUMEN PAPER—N. PRINTING ON PLAIN PAPER—O. GENERAL REMARKS ON PRINTING—P. PRINTING ON VARIOUS SURFACES—Q. PRINTING PERPLEXITIES—R. ART IN PRINTING—S. MOUNTING AND FINISHING—T. PHOTOGRAPHY OUTSIDE—U. BROMO-GELATINE EMULSION WORK—V. VOGEL'S COLLODION EMULSION—W. ENLARGEMENTS AND LANTERN SLIDES—X. PHOTOTYPES, PLATINOTYPES, AND COLLODION TRANSFERS—Y. WASTES AND THEIR WORTH—Z. METRICAL MEASURING—&. CONCLUDING CONFAB—INDEX (SIX PAGES).

It is believed that this is the most valuable work ever offered to the working photographer. Its sale was never equalled. It contains 352 pages; 7 x 8½ inch cover, and is 1½ inches thick. More than 100 illustrations. It gives full details of all practical

## PROCESSES, OLD AND NEW, PUBLIC AND SECRET.

Among the latter are the "Phototype," sometimes called the "Artotype" process, with examples; many of the "Lightning" processes; the "Platinotype" process; the "Collodion Transfer" or "Mega-type" process, and many others.

58 pages are devoted to Posing and Lighting; 37 pages give instructions in Emulsion "Dry" Work; 29 pages show how to Build and Use Skylights; 108 pages furnish instructions for Manipulating Negatives; 37 pages are applied to Printing Formula and Dodges; 175 pages give Notes from Authors all over the world. It is printed on fine white paper, made especially for it, and sold at the low price of

**\$4.00 POST-PAID \$4.00.**

For the beginner, for the amateur, for the photographic worker, it is believed to be most complete. No live photographer should fail to get it soon, before his neighbor is ahead. For sale by all dealers.

**EDWARD L. WILSON, Publisher, 853 Broadway, New York.**

VENI, VIDI, VICI!

THE WONDER OF THE P. A. of A. CONVENTION  
AT ST. LOUIS.

THE  DRY  
EAGLE PLATE

Only Five Months in Existence, and Carried off the  
Honors from All Comers.

The judges at the St. Louis Convention awarded the exhibitors **Seven Medals**, gold and silver, for work done on the **EAGLE DRY PLATE**, the photographs being, without exception, the gems of the exhibit.

How could it be otherwise with such a plate, when for **Reliability, Rapidity, Delicacy of Detail, and Extreme Brilliancy**, they surpass all other makes of Dry Plates in the market.

Their reception by the photographic profession at large, speaks volumes in their favor, they being now used by the leading lights of the photographic world, both professional and amateur.

Came, saw, and conquered! Truly, such was the case, and in the future our aim will be to lead them to further conquest.

EAGLE DRY-PLATE CO.

**G. GENNERT,**  
**54 East Tenth Street, New York,**  
GENERAL AGENT.

## SUBSCRIBE FOR

ANTHONY'S  
Photographic  
BULLETIN

EDITED BY  
PROF. CHAS. F. CHANDLER, Ph. D. LL. D.  
Prof. of Applied Chemistry in the School of Mines  
Columbia College, New York City.

E. & H. T. Anthony & Co.  
591 BROADWAY  
New York.

## THE BULLETIN FOR 1886.

That the BULLETIN has proved a success during the past year, our long list of unsolicited testimonials bears ample witness. And we have found it utterly impossible to publish all the good things that have been said of us, owing to the wealth of material always at hand to fill our pages. What is yet more encouraging to us is the large increase in our subscription lists, on which the number of names is now almost double what it was one year ago, and is increasing with every issue of the journal.

We recall with pride the names of some of the contributors to our pages: Prof. C. F. Chandler, Ph. D., Prof. Ogden N. Rood, Dr. A. H. Elliott, Ph. D., Prof. J. M. Eder, Ph. D., Henry J. Newton, E. L. Wilson, Ph. D., L. H. Laudy, Ph. D., Victor Schumann, Prof. Chas. F. Himes, Thos. Bolas, F. C. S., M. Carey Lea, Dr. R. W. Wilcox, F. C. Beach, Dr. John H. Janeway, Prof. Spencer Newberry, A. A. Campbell Swinton, Fred. E. Ives, T. C. Roche, E. K. Hough, G. H. Loomis, J. B. Gardner, W. E. Partridge, P. C. Duchochois, J. F. Ryder, David Cooper, Abraham Bogardus, and a host of others. In addition to the contributions from the above gentlemen, we have given our readers clear and accurate reports of the photographic societies, in many cases from the stenographic notes of our own reporters. Our correspondence column has been a source of pleasure to our editors, and has become an important and unrivaled feature of our publication.

This is what we have done and shall continue to do, with this advantage, that the fund of material upon which we can draw in the future is still larger than that utilized in the past. Among other improvements we intend to illustrate every number of the BULLETIN with a specimen of the best work in both professional and amateur photography. Thus the subscribers will obtain in one year, two dozen gems of the photographic art. Various improvements in the literary part of the journal will also be made. In fact, nothing will be left undone to keep it in the front rank of American Photographic journals.

The improvements we contemplate will involve a large expenditure of money, and as we cannot be expected to furnish so much valuable material at a loss, we shall be compelled to charge three dollars for the illustrated edition of the BULLETIN, and two dollars without the illustrations. Just think of it! Twenty-four illustrations and seven hundred and sixty-eight pages of valuable photographic information for three dollars. There is not another photographic journal in America that does so much for so little. Either the illustrations alone or the literary material alone are worth the price of the subscription, and we give them both, so the subscriber gets twice the worth of his money.

We have laid out a large amount of work for the coming year, and we intend to carry it through. But to do this with energy and pleasure, we must have the encouragement of our readers and subscribers. Help us, and we will help you as much as, if not more, than in the past. Our policy will always be, *With charity for all and malice towards none*

THE PUBLISHERS.

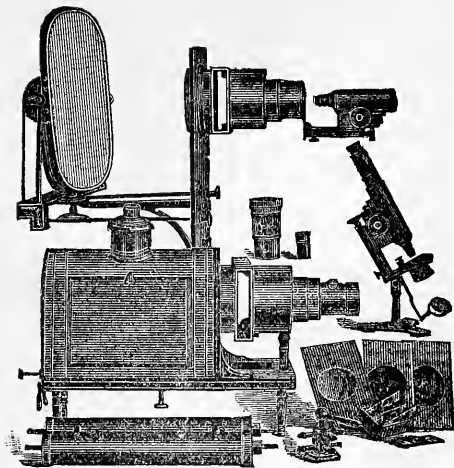

# OPTICAL AND ELECTRICAL INSTRUMENTS.

We desire to call the attention of  
TEACHERS, SCIENTISTS, LECTURERS, and  
those interested, to our

**Stereopticons, Microscopes, Dr. McIntosh's Solar Microscope and  
Stereopticon Combination Apparatus for  
the Oxy-hydrogen and Ether-oxygen Lime Light, Photographic  
Transparencies, Microscopical Preparations, etc.**

Our Instruments and Apparatus are new in design and have many improvements  
that overcome difficulties heretofore considered unavoidable. We also manufacture

**Static Electric Machines, Batteries, Magnets, and a Full Line of  
Electrical Apparatus for Practical and Experimental  
Purposes.**



We received the highest  
award at the New Orleans  
World's Exposition, on  
both Optical and Elec-  
trical Apparatus, in com-  
petition with the best of  
home and foreign manu-  
facturers.



Illustrated Catalogue of Optical and Electrical Apparatus sent free on application  
by mentioning this journal.

**McIntosh Galvanic and Faradic Battery Co.**

Nos. 300 & 302 Dearborn Street,

CHICAGO, ILL., U. S. A.

# THE PHILADELPHIA PHOTOGRAPHER.

TWENTY-THIRD YEAR, 1886.

*Devoted to the Advancement of Photography and the Dissemination of Art Principles.*

SEMI-MONTHLY: issued the First and Third Saturday of each month.

\$5.00 a year, \$2.50 for six months, \$1.25 for three months—in advance. 30 cts. per copy.

## CONTENTS OF THE SECOND QUARTER.

**APRIL 3.**—Art and Photography, by G. HANMER CROUGHTON. Paper Negatives, by W. B. GLINES. Quicker Than the Wind. Developer for Rapid Exposures—Which? A Contribution Toward Precision in Calculation of Exposures. Constitution of Solar Spots, by M. J. JANSSEN. An International Photographic Congress. Photo. Facts and Fancies. Queries, Conundrums, and Conclusions. The World's Photography Focussed. Society Gossip. Pertaining to the P. A. of A. Practical Points from the Studios. What an Old Photographer says for Old and New Workers. Celestial Photography. A Big Offer. Views from my Office Window. Our Picture. Editor's Table.

EMBELLISHMENT.—"The Bride," by J. F. RYDER, Cleveland, Ohio.

**APRIL 17.**—Æsthetics and Photography, by XANTHUS SMITH. Celestial Photography at the Observatory of Paris. Queries, Conundrums, and Conclusions. Defects in Gelatine Dry Plates, by JAS. C. BALMAIN. Weights and Measures, by JOSEPH DORELLA. The Open Corner. A Process for Printing with Fatty Inks. The Humor of It. Photographing the Eclipse of the Sun. Correspondence. Obituary. Society Gossip. Our Picture. Photographing, a Pictorial Art, by P. H. EMERSON, B.A., M.B. Cantab. The World's Photography Focussed. Editor's Table.

EMBELLISHMENT.—"Island of Philæ—South Colonnade," by EDWARD L. WILSON.

**MAY 1.**—Negative Paper and Permanent Bromide Paper. Art and Photography, by G. HANMER CROUGHTON. A Good Notice on Photography from the Globe of the Hub. How We Take with "Artists." Practical Points from the Studios. Photozincographic Process. Home Portraiture. The Open Corner. New Copyright Law in Great Britain. Photo. Facts and Fancies. Queries, Conundrums, and Conclusions. The World's Photography Focussed. Pertaining to the P. A. of A. Society Gossip. Our London Correspondence. Views from My Office Window. Bibliography. Our Picture. The Humor of It. Editor's Table.

EMBELLISHMENT.—"The East," by GEO. HANMER CROUGHTON.

**MAY 15.**—Patience in Art. The Department of Art. Coloring Positive Prints. The Humor of It. Exhibition of the Pacific Coast Amateur Photographic Association. The Open Corner. Views from My Office Window. Queries, Conundrums, and Conclusions. Society Gossip. Kindly Words for a Worthy Colleague, Pertaining to the P. A. of A. Correspondence. A Good Move. A New Method of "Storing" Paper Negatives, Films, and Photographic Prints. Practical Points from the Studio. Managing an Overdeveloped Plate. Sharply. Steinheil Lenses. Our Picture. The World's Photography Focussed. Editor's Table.

EMBELLISHMENT.—"Listening to the Birds," by JOHN E. DUMONT, Rochester, N. Y.

**JUNE 5.**—St Louis. About Our Last Call. Light for the Dark-room—Blue Prints, by C. G. BUSCH. Negative Paper and Films, by KEHAMA. How Frenchmen Wash Their Gelatine Plates. Pictures from Newfoundland. How to Print, by CHARLES KRAUSS. On Photographing the Retina of the Living Human Eye, by WM. THOS. JACKMAN, M.R.C.S., ENG., and J. D. WEBSTER. Pertaining to the P. A. of A. Amateurs in New Quarters. Society Gossip. A Convenient and Inexpensive Apparatus for Making Lantern Slides, by C. R. PANCOAST. Gihon on Crayon Portraits. The Photographer and the Anarchist. Our Picture. Queries, Conundrums, and Conclusions. Editor's Table.

EMBELLISHMENT.—"Land of the Morning Calm," by G. CRAMER, of St. Louis.

**JUNE 19.**—My Photographic Hobby. The Department of Art. On the Use of Eastman's Permanent Bromide Paper. Printing Eastman Film Negatives. The S. O. of S. P. Lighting Dark-rooms. Views from My Office Window. That Big Offer. Collodio-chloride Printing by an Improved Method. The Removal of Silver Stains from Gelatine Negatives, by DANIEL ROBERTSON. Practical Points from the Studios. A Question of Conscience. Correspondence. Our Picture. Pertaining to the P. A. of A. Photo-mechanical Printing. A Means of Making Money for Photographers. The Solar Spectrum of 1884. Queries, Conundrums, and Conclusions. Public and Press Recognition of Photography. Development of Instantaneous Negatives with Carbonate of Soda, by M. BALAGNY. Carbon Electrodes without Metal. The Humor of It. Photo Rival of the Telephone. An Annoying Strike "Off." C. S. F. A.—C. S. P. The World's Photography Focussed. Editor's Table.

EMBELLISHMENT.—"The Studio of Talamea," from "Adonis." By Electric Light, by W. L. MOZART.

The above six numbers to one address for \$1.25, prepaid. The numbers for January, February, and March to one address, post-paid, \$1.25.

The Philadelphia Photographer and Weekly Photographic Times to one address, \$6.50.

The Philadelphia Photographer and Anthony's Bulletin to one address, \$7.00.

EDWARD L. WILSON, 853 Broadway, New York.

OFFICE OF

# G. CRAMER DRY PLATE WORKS,

Shenandoah and Buena Vista Sts., St. Louis.

---

The enlargement of my factory being now completed, I am able to serve my patrons more promptly than heretofore.

Thanking the fraternity for their kind patronage, and soliciting a continuance of the same, I am  
Fraternally yours,



DRY-PLATE WORKS, ST. LOUIS, MO.

---

**THE**

## ST. LOUIS DRY PLATE COMPANY

Beg to announce that under their New Management they have recently made Important Improvements and Increased their Facilities, so that they are now making better and more uniform plates than heretofore.

---

ALL ORDERS WILL RECEIVE PROMPT ATTENTION.

---

**ST. LOUIS DRY PLATE CO.**

No. 827 Chouteau Avenue,

ST. LOUIS, MO.



Number 283.

30 Cents.

THE  
PHILADELPHIA  
**Photographer.**

AN ILLUSTRATED SEMI-MONTHLY JOURNAL,  
DEVOTED TO PHOTOGRAPHY.

## SUMMARY OF CONTENTS.

	PAGE		PAGE
Our Young Men, . . . . .	577	Method of Restoring Discolored Paper	
A Magnificent Work, . . . . .	578	Prepared with Platina Salts. By M.	
The Department of Art, . . . . .	579	H. BARY, . . . . .	594
A Centenarian Chemist, . . . . .	583	Yachting with the Camera. By WILFRED	
Concerning Gelatine Emulsions, Etc. By		A. FRENCH, . . . . .	595
A. L. HENDERSON, . . . . .	584	True Color-value by Photography, . . . . .	596
Daylight Enlargements. By ANDREW		Do Our Conventions Pay—Enough? . . . . .	597
PRINGLE, . . . . .	585	The German Convention, . . . . .	598
Notes on Emulsion Making and Plate Coat-		The Motions of a Galloping Horse Repro-	
ing. By W. K. BURTON, . . . . .	588	duced by Instantaneous Photography, . . . . .	599
Development—Another Word for Oxalate.		The World's Photography Focussed, . . . . .	600
By JOHN CROSBY, . . . . .	591	Queries, Conundrums, and Conclusions, . . . . .	601
Our Picture, . . . . .	592	Practical Points from the Studios, . . . . .	604
Dr. Vogel's Color-sensitive Patent Specifica-		Chatterings of This and That, . . . . .	605
tions, . . . . .	593	Editor's Table, . . . . .	606

OUR PICTURE.—“Meditation.” From negatives by F. W. GUERIN, St. Louis.  
Printed by Messrs. Roberts & Fellows, Philadelphia, on N. P. A. Paper.

EDWARD L. WILSON,  
*853 Broadway, New York.*

SUBSCRIPTIONS RECEIVED BY ALL NEWS AND STOCKDEALERS  
Five Dollars per Annum, in Advance.

## ADVERTISEMENTS.

AIR BRUSH.

ALLEN BROTHERS. The Suter Lens.

ANTHONY & CO., E. & H. T. The New N. P. A. Pensé Extra Brilliant Dresden Albumen Paper.

BUCHANAN, SMEDLEY & BROMLEY. Photo. Stockdealers.

CARBUTT, J. Gelatine Dry Plates and Improved Dry Plate Lantern.

CARPENTER, H. F. Analytical and Manufacturing Chemist.

CODMAN, C. H. & CO. Photo. Stockdealers.

CRAMER, G. Lightning Plates.

COOPER, CHAS. & CO. Photo. Stockdealers.

COLLINS, A. M. MFG. CO., Photograph Cards. DEALERS' DIRECTORY.

EASTMAN DRY-PLATE AND FILM CO.

ENTREKIN, W. G. Patent Eureka Burnisher. Duplex Rotary Burnisher. Duplicating Print-Cutter.

FRENCH & CO., BENJ. Voigtlander & Son and Darlot Lenses. The Wonderful Euryscope.

HANCE'S SPECIALTIES.

HERRMANN, CHAS. A. W. Hypo. Soda.

HYATT, H. A. New Brand of Dry Plates.

HODGE & HUSTON. Solar Printers.

INGLIS, JAMES. Dry Plates.

MAGEE & CO., JAS. F. Photographic Chemicals.

McINTOSH GALVANIC AND FARADIC BATTERY CO.

MOORE, ALBERT. Solar Enlarger.

MOSS ENGRAVING CO.

PHOTOGRAPHIC TIMES.

SCOVILL MANUFACTURING CO. New Dresden Albumen Three Crown Paper. Gibon's Cut-Outs. Photo. Apparatus.

STANLEY DRY PLATE.

STEINHEIL LENS.

ST. LOUIS DRY PLATE COMPANY.

SWEET, WALLACH & CO. Photo. Supplies.

SCHINDLER'S POSING CHAIR.

THE DU BOIS FILING CASES.

WILSON, HOOD & CO. Ross and Steinheil Lenses, Photo. Frames, Goods, Stereoscopes. and Views

WILSON'S PHOTOGRAPHICS.

WILSON, G. W. & CO. Magic Lantern Slides.

WILSON'S LANTERN JOURNEYS.

## ADVERTISING RATES.

THE PHILADELPHIA PHOTOGRAPHER is acknowledged to be the best advertising medium in the trade.

Its circulation is among the first class, at home and in nearly every foreign country.

Its rates, all advantages considered, are the most favorable, and it will bring you fine returns.

	One Issue.	Six Issues.	Twelve Issues.	Twenty-four Issues.
1 Page.....	\$20.00	\$110.00	\$200.00	\$350.00
1-2 " .....	12.00	66.00	120.00	200.00
1-4 " .....	7.00	38.50	70.00	120.00
1-8 " .....	4.00	22.00	40.00	70.00

Special contracts made with bona-fide dealers and manufacturers. Address

**EDWARD L. WILSON,**  
853 BROADWAY, NEW YORK.

## NOTICE TO SUBSCRIBERS.

In remitting by mail, a post-office order, or draft, payable to the order of EDWARD L. WILSON, is preferable to bank-notes. Postage stamps of the denomination of two and five cents each will be taken. Clearly give your Post-Office, County, and State.

Foreign subscriptions must be accompanied by the postage in addition.

**FIRE!** Our books having been all destroyed by fire at and with our establishment, all who owe us will confer a great favor by remitting at once.

**CROSSCUP & WEST ENGRAVING CO.**

907 Filbert St., Philadelphia.

SOLE AGENTS FOR THE AMERICAN CONTINENT.

DETROIT, MICH.

# ALLEN BROTHERS,

In the above letters, where blanks occur, the Lenses referred to are the best known on both Continents. Mr. E. Suter was awarded a silver medal for invention and construction of Lenses at the recent International Exhibition at London, England. The late Prince Frederick Carl used a Suter Lens. Her Britannic Majesty's Government has purchased a set of Suter Lenses for the use of the South Kensington Museum. Count Schouvaloff, Russian Ambassador at Paris, uses a Suter Lens. Count Andrew Pringle, Esq., the Russian Ambassador at Paris, uses a Suter Lens. A European maker of high reputation has made unsuccessful overtures to Mr. Suter to make all their photographic lenses. We comment these facts to the people who assert that because the Suter Lens is sold at a low price, it must be an inferior instrument.

Dear Sir: Your price current has reached me and I thank you for it. My friend and Photographic Collegue, Prof. W. Donkin, Honorary Secretary of the Photographic Society of England, has said to me that in the opinion of Captain W. De W. Abney, your photographic lenses are perfect, giving negatives extremely fine. I send you my return mail with this Lens some large views on the high Alps. Hoping to receive soon a perfect instrument. Please accept the assurance of my highest consideration.

V. Sella, Amateur Photographer.

This is from a prominent Italian amateur:

Mr. E. Suter, Bale: I await with impatience the two lenses you have promised to make me. Observe the beautiful season, and I am anxious to make some instantaneous views. The lens No. 5 A, which you have sold me is *excellent* and above all, very rapid. I rely on your kindness, and pray you to accept my best regards.

A. Astruc.

My Dear Mr. Suter: At last I have received your price list (the second one), as the first letter has been lost on the picture was taken with an Aplanat, made by—, with fourth stop, in two seconds, (emulsion). I would have bought one of these instruments if Mr. H. Warnke, who owns an emulsion factory in London had not dissuaded me. This gentleman spoke about your instruments which were unknown to me and Mr. Brandel, as follows: "The instruments of— are quicker and stronger than the— instruments, but far better than either of these are the instruments of Suter, which by accident I have seen in London." You can imagine that both of us took note of this and asked for your address immediately. I would therefore like to have an Aplanat B. No. 8, provided the same can do as good work as the enclosed picture shows. Mr. Brandel will undoubtedly also become your customer as soon as he has sufficient proof of the excellency of your instruments. The gentleman is an amateur. Please tell me by return mail what you would advise me to do. May be that an Aplanat No. 6 would be better. In—'s Lenses I put no confidence, neither does my friend, because neither of us was able to take a good picture with same. I remain, your obedient servant,

P. S. I would like to get one of your Objectives sent to Vienna on trial. I will be there during January.

Von Bkurst.

The following is from an Austrian officer:

My Dear Mr. Suter, Bale: Mr. Warnke, of London, England, tells me that you manufacture an Objective marked "Series A," which greatly excels in the instantaneous process, especially in photographing in the public streets, with movable object. He bases his good opinion of your Objectives upon the experience of the renowned London photographer, Wilson, who has used your instruments with the best success. We intend to take Street Photographs (size 13 x 18 centimetres), in this city, but must have the picture clear and strong up to the very edge of the plate. We use neutral (largest) stop.

Warsaw, Poland, March 12, 1856.

Extract from a letter from the noted Polish firm of Karoli & Pusch, Warsaw:

From personal information gained in England and Continental Europe, we make the unqualified assertion that the Suter Lenses are now the Best in the World. We submit a few testimonials from eminent sources.

# THE SUTER LENS IN EUROPE.

# WILSON'S PHOTOGRAPHIC PUBLICATIONS.

→\*A TREATISE ON EVERY BRANCH OF PHOTOGRAPHY.\*←

## THE PHILADELPHIA PHOTOGRAPHER,

A Semi-monthly Magazine, illustrated by photographs of superior merit. \$5.00 a year; \$2.50 for six months.

Stands ahead of all its kindred. Twenty-one years of success is a sufficient guarantee of its value and use to the practical, working, growing photographer. Do not go without its valuable help. See Prospectus.

### WILSON'S LANTERN JOURNEYS.

By EDWARD L. WILSON. In Three Vols.  
Price, \$2.00 per vol.

For the lantern exhibitor. Gives incidents and facts in entertaining style of about 2000 places and things, including 200 of the Centennial Exhibition.

### WILSON'S PHOTOGRAPHICS

THE NEWEST AND MOST COMPLETE

PHOTOGRAPHIC LESSON-BOOK.

COVERS EVERY DEPARTMENT.

352 Pages. Finely Illustrated. Only \$4.00.

By EDWARD L. WILSON.

### BIGELOW'S ARTISTIC PHOTOGRAPHY.

For lovers of the art. Beats his "Album of Lighting and Posing." Suberb! With twelve photographs and instructions. Price reduced to \$4.00.

### THE FERROTYPYER'S GUIDE.

Cheap and complete. For the Ferrotypier, this is the only standard work. Seventh thousand. Price, 75 cts.

### THE PROGRESS OF PHOTOGRAPHY

A NEW BOOK.

By Dr. H. VOGEL. Price, \$3.00.

A splendid work.

### STUDIES IN ARTISTIC PRINTING.

By C. W. HEARN. Price, \$3.50.

Embellished with six fine cabinet and promenade portrait studies.

### PICTORIAL EFFECT IN PHOTOGRAPHY.

By H. P. ROBINSON. For the Art Photographer. Cloth, \$1.50. Paper cover, \$1.00.

THE

### PHOTOGRAPHIC COLORISTS' GUIDE.

By JOHN L. GIBON. Cloth bound, \$1.50.

The newest and best work on painting photographs.

### PHOTOGRAPHIC MOSAICS, 1886.

Cloth bound, \$1.00; paper cover, 50 cents.  
Back volumess. same price.

Better than any of its predecessors.

COPIES MAILED POST-PAID ON RECEIPT OF PRICE.

## EDWARD L. WILSON,

Photo. Publisher.

853 Broadway, New York.

# UNSOLICITED TESTIMONIALS.

COR. BROAD AND MARKET STS., NEWARK, N. J., July 3, 1886.

EASTMAN DRY-PLATE AND FILM CO., Rochester, N.Y.

GENTS: The enlargements came duly to hand. We are very much pleased, and they give satisfaction to the customers who ordered them. We must say that this class of work *must take*, and we think it is one of the most beautiful results that we have as yet seen. Will you kindly return the paper negative of men on top of Tally-Ho coach, and oblige, as we have some silver prints to take from it. The glass negatives came all O. K.

Yours truly, THOMAS & Co

P. S. If we had thought, we could have sent you some elegant paper negatives and prints, which we think would have done credit to the process, for exhibition at St. Louis, but we suppose it is too late now.

25 NEW STREET, TRENTON, N. J., June 28, 1886.

EASTMAN DRY-PLATE AND FILM CO., Rochester, N. Y.

GENTS: Please send me circular and sample print of your Permanent Bromide Paper. I have been using your Eastman-Walker Roll-Holder, and it gives me complete satisfaction. Yours respectfully,

CHAS. J. RODGERS.

NIAGARA FALLS, N. Y., May 17, 1886.

EASTMAN DRY-PLATE AND FILM CO., Rochester, N.Y.

GENTLEMEN: I have been making a few paper negatives last week, with perfect success. Have not printed them yet, but will to-day.

Yours truly, CHAS. BIERSTADT.

208 FULTON STREET, BROOKLYN, N. Y., July 2, 1886.

EASTMAN DRY-PLATE AND FILM CO., Rochester, N.Y.

GENTS: Enclosed you will find my check for the Roll-Holder. It is attached to my 8 x 10 compact camera, and the two work so well together that one is led to think that each was intended for the other. As a trial for paper negatives and Roll-Holder (the first I have made), while in a pleasure party, I made nine exposures, and secured nine good negatives, which I consider very satisfactory; and with an experience of thirty years, I feel confident that in a very short time, your invention for making negatives on paper, either on rolls or sheets, will supersede all other sensitive mediums. Congratulating you on the perfection of your negative paper, also the roll-holder, I am,

Very respectfully, G. F. E. PEARSALL.

42 JOHN STREET, NEW YORK, June 18, 1886.

EASTMAN DRY-PLATE AND FILM CO., Rochester, N.Y.

GENTLEMEN: We were much pleased with the results obtained on the last lot of negative paper sent us. The grain seems to be entirely absent, and the rendering of the negative translucent by means of the preparation "Translucine." It seems both effective and easy.

Very truly, E. W. SMITH & Co.

CAZENOVIA, N. Y., June 18, 1886.

EASTMAN DRY-PLATE AND FILM CO., Rochester, N.Y.

GENTLEMEN: Please make two more enlargements from same negatives, same size and style as the first and return negatives as soon as done. Mail enlargements unmounted. We are very much pleased with the work. It finishes perfectly in crayon.

Yours truly, MARSHALL BROS. & Co.

MONTICELLO, IND., June 12, 1886.

EASTMAN DRY-PLATE AND FILM CO., Rochester, N.Y.

GENTLEMEN: We have been very successful with the bromide paper, and think it is just the thing for enlargements.

Very truly yours, LIGHTY BROS.

230 ST. LOUIS ST., SPRINGFIELD, MO., May 28, 1886.

EASTMAN DRY-PLATE AND FILM CO., Rochester, N.Y.

GENTLEMEN: The two prints, or enlargements, came safely, and I am delighted with them. Think I will want the material to use in my gallery. Hope to see you at the Convention. Very respectfully,

G. W. SITTLER.

DELAVAN, ILL., June 25, 1886

EASTMAN DRY-PLATE AND FILM CO. Rochester, N.Y.

GENTLEMEN: The 24 x 36 Permanent Bromide print and smaller prints at hand. Thanks. The G. A. R. Post seem very well pleased. It is much better than I thought the negative would make. I find I am, by comparison getting along all right with my prints. Just as soon as I can save the wherewithal, I shall have one of your enlarging outfits. I shall probably send you some more negatives in a few days.

Yours truly, E. D. SHAW.

# BENJ. FRENCH & Co.

No. 319 WASHINGTON STREET, BOSTON,

Sole Agents in the United States for the Celebrated Lenses  
Manufactured by

## VOIGTLÄNDER & SON.

ALSO, THEIR FAMOUS

# EURYSCOPE,

Which is unrivalled for groups, full-length figures, and other demands in the gallery, and every species of out-door work, including instantaneous photography.

☛ **THE EURYSCOPE** is made *exclusively* by Voigtländer & Son, and their name is engraved on the tube.

FOR **DARLOT LENSES** FOR  
PORTRAITS. VIEWS.

IMPORTERS, ALSO, OF THE CELEBRATED

## TRAPP & MÜNCH

# ALBUMEN PAPER,

AND DEALERS IN ALL KINDS OF

*Photographic Materials and Magic Lantern Slides.*

SEND FOR OUR NEW ILLUSTRATED PRICE LIST OF LENSES.

# H. F. CARPENTER,

29 & 31 Page St., Providence, R. I.

## ANALYTICAL AND MANUFACTURING CHEMIST.

Refiner of PHOTOGRAPHIC WASTES.



## Assayer and Sweep Smelter.

Nitrate of Silver and Chloride of Gold.

Chemically pure gold prepared especially for Photographers' use at \$1.10 per dwt.

Information given on application in regard to methods of saving waste.

## ANTHONY'S PATENT TRIPLEX TRIPOD.



This is the finest finished in the market and is perfectly rigid, combining both the folding and telescopic, besides which it occupies little space, and for transportation can be packed with clothing in a large grip-sack. It is made of cherry throughout, and has the patent springs on under side of top, by which it is impossible for the legs to become unfastened accidentally. When the leg is fully extended, it is held automatically by a spring, saving necessity of using thumb-screw for clamping same.

PRICE, . . . \$4.00

## ANTHONY'S HELIOS DARK-ROOM LANTERN.

This is a new Lantern for the dark-room for those who desire more light than can be had from the ruby lamp. This lantern or lamp will be found to be all that can be desired. The draught is as perfect as can be. It has a glass  $6\frac{1}{2} \times 8\frac{1}{4}$  inches, with a burner capable of great volume of light when desired. It is intended to fill a want long expressed by many for a good dark-room lantern at a reasonable price.

PRICE, \$4.00

For sale by all dealers. Manufactured by

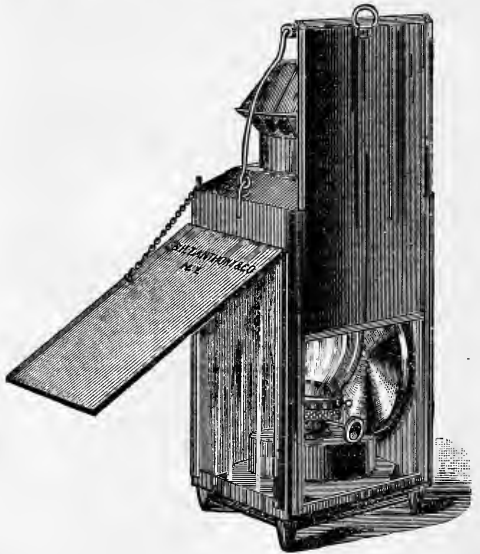

**E. & H. T. ANTHONY & CO.**  
**591 Broadway,** **NEW YORK.**



# THE STANLEY DRY PLATE

Has passed through the ordeal of its first summer, and its manufacturers have almost entirely escaped the usual trials of fogging, frilling, and other perplexities. In fact, the quantity sold in July exceeds that of any former month.

Its *unusual combination of sensitiveness and brilliancy* have made it a general favorite, and the territory into which it penetrates grows constantly larger.

## AMONG ITS RECENT ACHIEVEMENTS ARE

*Instantaneous Views of the Decoration Day Parade* (3d size stop), taken without sunlight, used as a Bulletin Illustration.

*Views of Horses and Carriages entering Central Park*, trotting rapidly across the field of view, sharp and clear cut. These will appear in the Bulletin.

*Views of Steamboats* going twenty miles an hour directly across the field, taken at 5.30 P. M. Sharp and clear as if standing still.

*The Life-size Portrait of J. F. Ryder*, by McMichael, shown at the Buffalo Convention, was made on an 18 x 22 Stanley Plate in five seconds, with a Dallmeyer Rapid Rectilinear Lens.

*Instantaneous Views*, by Mr. Henry J. Newton, President of Photographic Section of the American Institute, about which he writes:

"I found that sunshine was not absolutely necessary for instantaneous negatives on these plates, and I think a majority of the negatives I send you were made when there was not sufficient sunlight to cast a visible shadow. I think it is due that I should say that the plates worked satisfactorily in every respect, exhibiting extreme sensitiveness, responding readily to the developer, and going steadily on to the finish.

P. S. I used the Prosch Shutter at its full speed."

(Signed),

H. J. NEWTON.

And now to crown the whole, Mr. Parkinson writes as follows:

E. & H. T. ANTHONY & Co.:

PARKINSON PHOTO. PARLORS, 29 W. 26TH ST.,  
NEW YORK, August 12, 1885.

"GENTLEMEN: I take pleasure in assuring you that I made a group portrait in my gallery of an old lady of eighty years, with child of four years, a month or two since, on a Stanley 18 x 22 plate, in one second, with Dallmeyer Rapid Rectilinear Lens. A little more time would have done no harm; but the picture in question has elicited as many words of praise from visitors to my studio as any other in same length of time."

Yours truly,

W. B. PARKINSON.

The Stanley Dry Plates can be had from any dealer, or direct from

**E. & H. T. ANTHONY & CO.,**  
591 BROADWAY, NEW YORK.

Another thing that has gone rapidly to the front is the

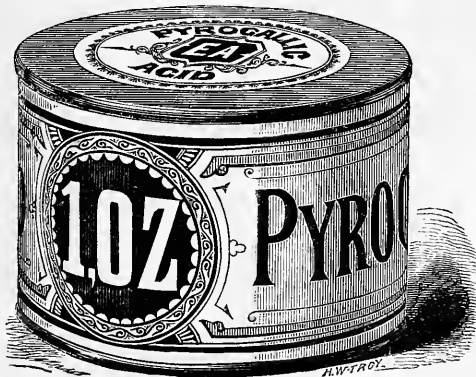

When Dry Plates were first introduced it *was not yet on the market*, and the old stereotyped developing formulas do not mention it; but in the developing formulas of the more recent *popular plates*, as the STANLEY and the ST. LOUIS, the E. A. Pyro is recommended as most desirable, and in the EASTMAN DRY PLATE CO. formulas the same preference is given ever since they *knew of its merits*.

It is always used by the veteran "Roche," and constitutes one of the main elements in the popular Cooper's Developer.

Every photographer should try the E. A. Pyro. Every dealer has it, or ought to have it, or it can be had direct from

**E. & H. T. ANTHONY & CO., 591 Broadway, N. Y.**

1849

**SCHINDLER'S**

1886

**PICTURESQUE AND EASY POSING CHAIRS,****STUDIO FURNITURE, AND ACCESSORIES.**

Of our latest, the No. 72 "Élité" Posing Chair, Mr. Kent says: "It is ever so much better." Mr. D. R. Clark, Indiana, is very much pleased with the "Élité," the plastic interior background decorations, the revolving album, the No. 71 vignetting chairs, velvet cushions, etc. Mr. Noble, Nebraska, finds the "Élité" very pleasing and useful, adopted to a large variety of positions, both sitting and standing. Mr. Falk, New York City says: "It is far superior in design," etc. All others are pleased.

**CAUTION.**—Since several members of the Photographic Merchants Board of Trade made a fraudulent use of a copy of the electros of chairs, designed, patented, and introduced by us, and substituted worthless abortive trash as our make, we sell our *Genuine No. 53, Centennial Chairs* in manilla or velvet, for \$18.00. Packing in crate, \$1.00. No discount.

**DECEIVED PHOTOGRAPHERS.**

MINNEAPOLIS, MINN., July 27, 1886.  
DEAR SIR: We ordered through a dealer such a Centennial Chair as we bought of you for our Altoona, Pa., Gallery some years ago, and supposed we were getting the same, but find it is an imitation, and will not keep it. It has not the iron back; is clumsy and common looking, and has a poor cover; a trimming of bad color. Please send one of your No. 53 chairs, in the *double-thick velveteen*, usual color, at \$20.00, and we will remit at once. Refer to Mr. J. P. C.

To C. A. SCHINDLER, West Hoboken, N. J.

MINNEAPOLIS, MINN., August 16, 1886.

DEAR SIR: Enclosed sight draft on N. Y. for \$21 00. We are greatly pleased with the chair, and more so every day; the counterfeits we would not keep at any price; being badly made, clumsy and awkward, in fact the worst looking chair I ever saw pretending to be good. I would not exchange yours for half dozen of the bogus. For our own use, I must say yours is even better than I expected at that price, and I like it better than the one we have in the East. Send catalogue for further orders.

Yours respectfully, BISHOP BROS.

**ALBERT MOORE THE SOLAR ENLARGER,****THE LONGEST, LARGEST, AND BEST.****828 Wood Street, Philadelphia.****JAMES F. MAGEE & CO.***522 Race St., Philadelphia,***Manufacturers of Pure Photographic Chemicals,****Specialties: NITRATE OF SILVER and CHLORIDE OF GOLD.****\*REFINERS OF GOLD AND SILVER WASTE.\****Waste sent through Stockdealers will receive prompt attention.***G. W. WILSON & CO.***(By special appointment Photographers to Her Majesty the Queen),***MANUFACTURERS OF MAGIC LANTERN SLIDES,  
St. Swithin Street, Aberdeen.**

Catalogue of 12,000 subjects in England and Scotland, and Price Lists, post free on application.

# SWEET, WALLACH & CO.

## Photographers' Supplies,

229 & 231 STATE ST., CHICAGO.

**Best Goods! Lowest Prices! Complete Stock!**  
**ORDERS PROMPTLY FILLED. SATISFACTION GUARANTEED**

**Your Patronage Solicited. Send for Catalogue.**

## A CARD.

75 STONE ST., ROCHESTER, N. Y., July 26, 1886.

GENTLEMEN: About three months ago the business of Inglis & Co., of this city was formed into the Inglis Dry Plate Co.

In the articles of agreement, a clause was inserted giving the I. D. P. Co. the exclusive use of the name of "Inglis," and also that James Inglis would not connect himself with any dry plate business using the name of "Inglis."

Matters have taken such a form since then, he has been compelled to leave the I. D. P. Co. And being thus debarred from the use of his own name, adopts this means of making known to his numerous customers where they may still obtain his plate. **And the Only Place.**

A new firm taking the name of the **ROCHESTER DRY PLATE CO.** have engaged his services, and under his supervision a new factory has been fitted with the most modern improvements required for the production of **clean and spotless** plates, with all the other extra qualities that his plate has become so renowned for. The fraternity may therefore depend upon the very finest plate ever yet produced, from the **ROCHESTER DRY PLATE CO.**

### JAMES INGLIS,

Late Manufacturer of the Inglis Dry Plate, and President  
of the Inglis Dry Plate Co.

## THE AIR BRUSH.

This New Art Tool applies color by a jet of air. It is invaluable to any photographer who produces his own large work. Portraits may be made over solar or contact prints, on plain or Albumen Paper, in India Ink, or Water Colors, etc.

*Lights built up on Flat Negatives, Cloud Effects in Backgrounds for  
View Work, etc., all can be accomplished by this Tool,*

with the greatest rapidity, and with a perfection bounded only by the capacity of the artist.  
Full particulars FREE. Address

**AIR BRUSH MFG. CO., 50 Nassau St., Rockford, Ill.**

ALFRED M. COLLINS,  
*Secretary and Treasurer.*

HENRY H. COLLINS,  
*President.*

EDWARD COPE,  
*Vice-President.*

A. M. Collins Mfg. Co.

*MAKE ALL KINDS OF*

**CARDS AND CARDBOARDS**

FOR

**P** PHOTOGRAPHERS **S**

AND

**MATS, MOUNTS, AND ENVELOPES**

FOR

**FERROTYPES.**

---

OFFICE AND WAREHOUSE,

**No. 527 ARCH STREET,**

**PHILADELPHIA.**

---

Price Lists may be had by intending purchasers on application to us, or to all Photographic Merchants, through whom your favors are respectfully solicited.

JOHN G. HOOD.

ESTABLISHED 1865.

WM. D. H. WILSON.

# WILSON, HOOD & CO.

## 825 Arch St., Philadelphia,

SOLE AGENTS IN THE UNITED STATES FOR THE



Centennial, 1876.



Centennial, 1876.

## Ross' Portrait and View Lenses.

Portrait Lenses, from 1-4 to 8 x 10.  
Cabinet Lenses, Nos. 2 and 3.  
Card Lenses, Nos. 1, 2, and 3.  
Triplets, Nos. 1, 2, 3, 4, 5, 6, and 7.  
Symmetricals. Rapid Symmetricals.

Instantaneous Doublets, all sizes.  
Medium Angle Doublets, all sizes.  
Large Angle Doublets, all sizes.  
Stereographic Lenses, all sizes.  
New Universal Lens.

Numerous testimonials pronounce them to be the *best* as well as the *cheapest* Foreign Lenses ever offered to the American Photographer. We will mail price list on application, and promptly fill all orders. Always in stock,

## CAMERA BOXES,

Made by AMERICAN OPTICAL CO., ANTHONY, BLAIR, and ROCHESTER OPTICAL CO.

WE KEEP IN STOCK FULL ASSORTMENT OF

## AMATEUR PHOTO. OUTFITS

DRY PLATES OF ALL MAKES.

N. P. A., EAGLE, and S. & M. PAPER, PER REAM, \$34.00.

Any article needed we can supply, as

WE MANUFACTURE, IMPORT, AND DEAL IN ALL KINDS OF

*Photo. Goods, Frames, Stereoscopes and Views,*

At prices as low as are consistent with the quality of goods furnished. We are indebted to our customers for the patronage during the past *Twenty Years*, and our efforts shall be to merit a continuance of it.

Illustrated Price Lists supplied free. Correspondence solicited.

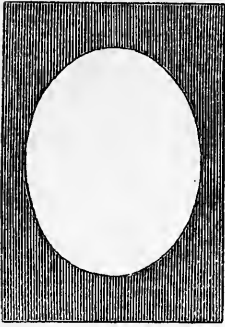

# GIHON'S CUT-OUTS

An Entirely New Variety for  
PRINTING MEDALLION PICTURES.

Are the very best that are made, and are now without a rival in the market. They are clean cut, most desirable shapes and sizes, and made of non-actinic paper, manufactured specially for the purpose. Each package contains 30 Cut-Outs, or Masks, with corresponding Insides, assorted for five differently sized ovals and one arch-top.

*Price, \$1.00 per Package. Sent by mail on receipt of price.*

Parties wishing special sizes, or large lots of a few sizes, may have them cut to order promptly by addressing the manufacturer. No lot costing less than \$1.00 made at a time.

*No printer should attempt to make Medallion Pictures without them.*

## THEY HAVE NO EQUAL FOR QUALITY.

Beware of spurious imitations made of common paper, full of holes, badly cut, and odd shapes and sizes. Ask your Stock-dealer for GIHON'S CUT-OUTS, and see that they are in his envelope, with instruction circular included. The recent packages are composed of an entirely new variety and of a new paper. TRY THEM.

Promenade Size now Ready. Sold Separately at 50 cents per Dozen.

# GIHON'S OPAQUE

Is designed for Completely obscuring the Imperfect Backgrounds of Copies, Retouching Negatives, Faulty Skies in Landscapes, Coating the Inside of Lenses or Camera Boxes, Backing Solar Negatives, Covering Vignetting Boards, And for Answering all the Requirements of the Intelligent Photographer in the Production of Artistic Results in Printing.

Wherever you want to keep out Light, use Opaque.

IT IS APPLIED WITH A BRUSH, DRIES QUICKLY AND STICKS.

**CUT-OUTS (thirty), \$1.00. OPAQUE, 50 Cents.**

FOR SALE BY ALL DEALERS.

ROBERTS & FELLOWS, Makers, Philadelphia.

Address all orders to

SCOVILL MANUFACTURING CO., New York.

“THE MOUND CITY”  
**Photographic Stock House**



Offers the Most Complete line of  
 Photographic Apparatus, Chemicals,  
 Picture Frames, Mouldings, Mats,  
 Albums, Etc., in the market,  
 at bottom prices.

Professional and Amateur Outfits a Specialty.

AGENT FOR

KUHNS LIGHTNING DRY-PLATE INTENSIFIER,

AND

KUHNS SENSITIZED PAPER STRETCHER AND DRYER.

Address

**H. A. HYATT,**

8th & Locust Sts.,

ST. LOUIS, MO.

Send for Illustrated Catalogues of Photographic Goods and Picture Frames.

## BECK'S AUTOGRAPH RECTILINEAR LENSES.

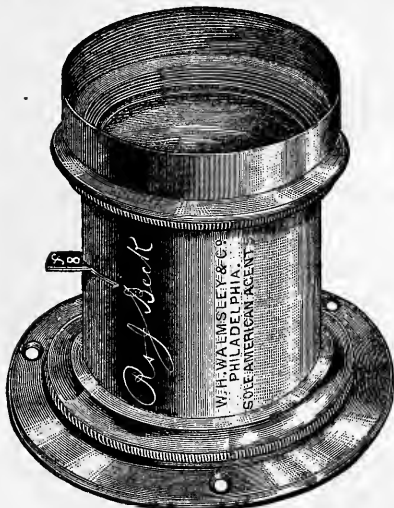

THESE extraordinary lenses attracted universal attention at the late St. Louis Convention; the specimens of work in Portraiture, Groups, Landscapes, Instantaneous Views, etc., executed by them being of unequalled excellence. A life-sized head, made with the 8 x 10 lens of 13 inches focus, was considered by the experts present, as being far ahead of any similar performance ever seen. A full description of these and our other specialties will be found in our full catalogue. *Mailed Free.*

**W. H. WALMSLEY & CO.,**

*Photographic Stockdealers.*

**1016 Chestnut St., Phila., Pa.**

**ENTREKIN'S**  
 IMPROVED  
**DUPLEX ROTARY BURNISHER.**  
 PATENTED.

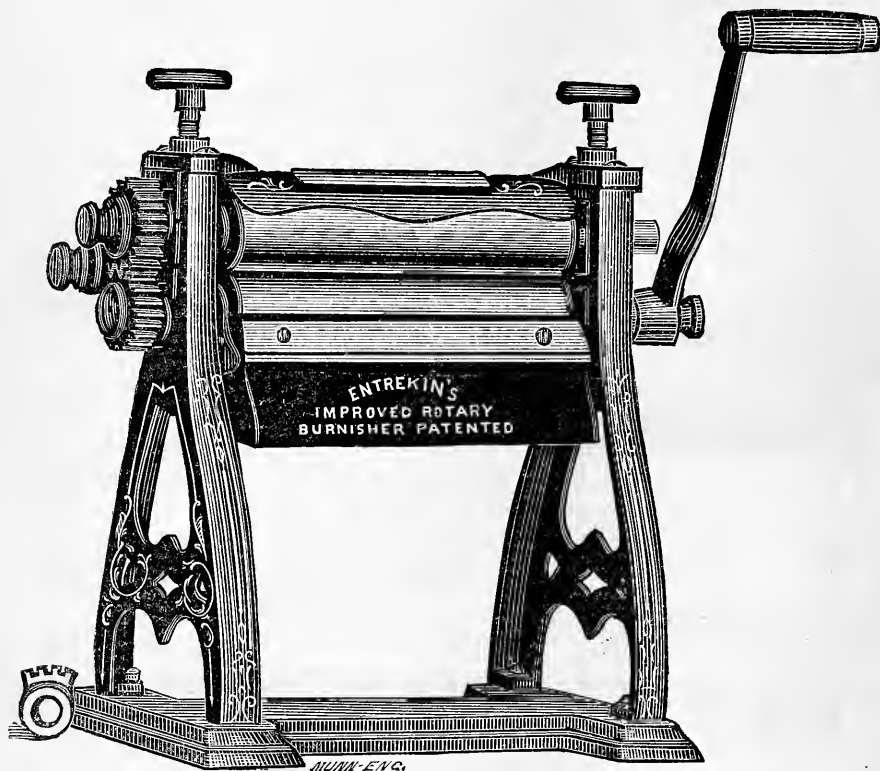

10 in., \$25.00. 15 in., \$35.00. 20 in., \$45.00. 25 in., \$60.00.

This Machine is an improvement on our old Duplex Rotary Burnisher, invented by us in 1874.

It is so constructed that by changing the Large Gear or Cog-wheel, from the stud to the end of the draw-file or upper roll, you reverse and change the speed of the lower or polishing roll, thus getting the same result as in the old Duplex Rotary; but to secure the best polishing surface, use the machine with the large cog-wheel on the Stud, by so doing you secure three times the polishing surface. All the machines will be sent out with gearing so arranged as to give this result. It is optional with the Photographer how he may use the machine. The Fire-Pan is so arranged that it is impossible for it to come in contact with the surface of the polished roll, and it can be turned away to cleanse the roll.

**EVERY MACHINE WARRANTED PERFECT.**

FOR SLE BY

**W. G. ENTREKIN, Inventor and Sole Manufacturer,**  
 4384 Main St., Manayunk, Philadelphia, Pa.  
 AND BY ALL PHOTOGRAPHIC STOCKDEALERS.



# ENTREKIN'S PATENT EUREKA BURNISHER.

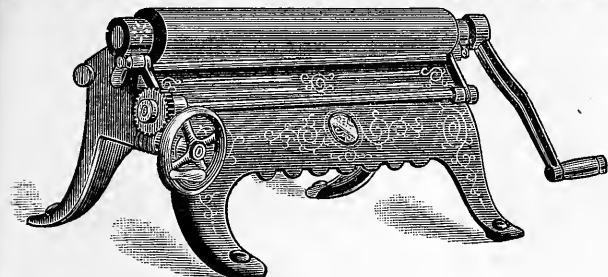

The above cut represents our 25 inch Eureka.

The unprecedented popularity of this Burnisher is wonderful. Over seventeen thousand (17,000) sold in less than five years. Agencies in London, Berlin, and Vienna, and sold by all stockdealers in the United States. The machines are built in first-class style, and warranted to do the work claimed.

Full directions accompany each machine.

## PRICES:

6 inch Roll, . . . . .	\$15 00	20 inch Roll, . . . . .	\$60 00
10 " " . . . . .	25 00	25 " " . . . . .	70 00
14 " " . . . . .	35 00		

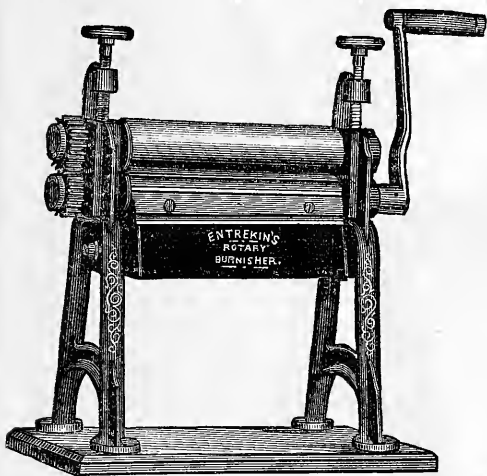

## ENTREKIN'S Duplex Rotary Burnisher.

PATENTED JUNE 1, 1875.

## PRICES:

10 inch, . . . . .	\$15 00
15 " . . . . .	25 00
20 " . . . . .	35 00
25 " . . . . .	45 00

# ENTREKIN'S DUPLICATING PRINT CUTTER.

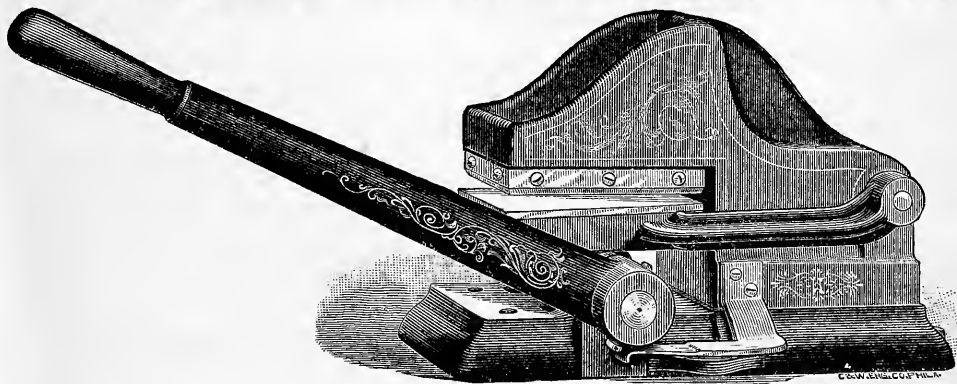

Cabinet and Stereo. Sizes, \$25.00

Small Panel Size, \$35.00.

Size 6½ x 8½, \$40.00.

MANUFACTURED AND FOR SALE BY

W. G. ENTREKIN, 4384 Main St., Manayunk, Phila., Pa.

# 500 UNSOLICITED TESTIMONIALS AND MORE.

PLEASE READ THE LAST ONE.

A New Edition, with a twenty-four page appendix,  
giving all new processes  
practically useful, is now ready—  
**THE CHAUTAUQUA EDITION.**

*Northwestern Business College,  
St. Louis City, Mo. June 11, 1896.*  
Dear Sir:—I am highly pleased with the  
Photographic. In an experience of over 35 years teaching,  
I have used and examined many text books, but have  
found none more ably written, or more exhaustive  
of the subject treated, in so small a compass.  
Containing, as it does, a clear exposition of the  
methods tried and proved by the long experience of  
the Author, together with notes from over 200 eminent  
practitioners, it cannot fail to prove a valuable aid,  
not only to the Amateur, but to the professional  
as well. Theory and Practice follow each other so  
closely, that the student can know and do  
at once.

*E. C. Archman*

If your old copy is worn out, get  
**THE CHAUTAUQUA EDITION.**  
If you have never owned *Photographics*, get  
**THE CHAUTAUQUA EDITION.**

**\$4.00**

## WILSON'S

**\$4.00**

**NEW  
EDITION.**

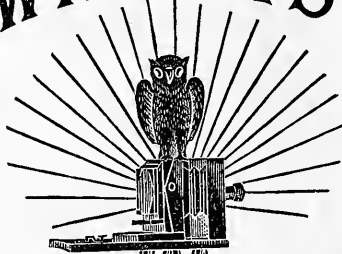

**NEW  
EDITION.**

**JUST  
READY.**

# PHOTOGRAPHICS

**JUST  
READY.**

*Edward L. Wilson.*

**\$4.00**

**\$4.00**

## THE BEST PHOTOGRAPHIC LESSON-BOOK.

By **EDWARD L. WILSON,**

Editor of "The Philadelphia Photographer," "Photographic Mosaics," etc.

The author believes it to be the best effort he has ever made, and begs to call attention to a few of its peculiar advantages as  
**A STANDARD WORK FOR ALL WORKERS IN PHOTOGRAPHY.**

- A. Treatment of the Subject.
- B. The needful apparatus.
- C. The Objective or Lens.
- D. The Dark Room.
- E. Preparation of the Glass.
- F. Chemicals and Solutions.
- G. The Manipulations.
- H. Manipulatory Miseries.
- I. Retouching the Negative.
- J. The Glass Studio.
- K. Accessories and Light.

- L. Managing the Model.
- M. Printing on Albumen Paper.
- N. Printing on Plain Paper.
- O. General Remarks on Printing
- P. Printing on Various Surfaces.
- Q. Printing Perplexities.
- R. Art in Printing.
- S. Mounting and Finishing.
- T. Photography Outside.

- U. Bromo-Gelatine Emulsion Work.
- V. Vogel's Collodion Emulsion.
- W. Enlargements and Lantern Slides.
- X. Phototypes, Platinotypes, and Collodion Transfers.
- Y. Wastes and their Worth.
- Z. Metrical Measuring.
- & Concluding Confab.
- Index (six pages).

The index added is very full and will enable the reader to quickly find almost any subject needed on every practical department of the art Sent post-paid for \$4.00 by

**EDWARD L. WILSON, 853 Broadway, New York.**

THE

# Philadelphia Photographer.

EDITED BY EDWARD L. WILSON.

Vol. XXIII.

OCTOBER 2, 1886.

No. 283.

## OUR YOUNG MEN.

THE opening address of Mr. Potter, President of the Photographers' Association of America, contained the following:

"Then again, our chance at legislation and general discussion is a schoolmaster to us in parliamentary proceedings. In this connection I will say, that considerable advice has been given me to give the young men a chance, to consider them in the appointment of committees, etc. With regard to this it may be said the young man must first demonstrate what kind of stuff he is made of—must give us a knowledge of the kind of talents he possesses. It is easy to charge, and as it has a considerable show of reason is likely to be believed, that a presiding officer appoints weak or unknown men on committees, that he may more readily influence or control them; or that he fears that the lustre of an eminent committee may dim his own. Therefore, I hope the ambitious young man will seize his opportunity to step to the front and give us a sample of his metal. It is creditable for him so to do, and I promise all due consideration shall be shown him. When one has given evidence of his fitness, there is no difficulty about the bestowal of the honor due to his talents. In the meantime, 'all things come to the one who waits.' Plant and water, and patiently wait for the increase which will surely come."

Evidently this part of Mr. Potter's address was written before he saw the conven-

tion and exhibition, or he would not have said "I hope the ambitious young man will seize his opportunity to step to the front and give us a sample of his metal."

The "ambitious young man" was there, in quantity, and well "to the front," and did "give us a sample of his metal," by means of some of the finest exhibits in the exhibition.

Mr. M. L. Cormany, of Augusta, Ga., is a very young man and displayed some of the most creditable work shown. His large heads and his compositions were excelled by but few. On the face of every picture there was evidence of real honest effort to win a medal. And we understand that he was "marked very high" by the jury. Mr. Cormany is an enthusiast—"a photographer all through." Another such is Mr. Montfort, of Davenport, Iowa, to whose exhibit we have already called attention.

On the same side of the great Mississippi and at Davenport, Iowa, is Mr. J. C. Rasmussen, another "ambitious young man," who has exhibited splendid work at several of our conventions. Mr. Max Platz, of Chicago; Mr. S. L. Stein, of Milwaukee; Mr. Ingersoll, of St. Paul; Mr. T. Benecke, of St. Louis; Mr. Heimberger, Jr., of New Albany, Ind.; Messrs. Deane, of Texas; Falk, of New York; Kimball, of Concord, N. H.; Rinehart, of Denver; Schurr, of Lockport, N. Y., and the "dry" Eastman, are all young men; all exhibited

at St. Louis, and nearly all of them were present, *full* of "ambition," but our worthy president did not seem to see the "samples" of their "metal"—their sparkling works of gold and silver.

He therefore laid himself open to the charges which he mentions in his address, and which have been reiterated since the convention. We do not say this in the spirit of fault-finding. We have abundant sympathy for any officer of the Photographers' Association of America, who, without pay, is willing to work and risk fault-finding for the good of the craft. If we elect him, we are bound to accept his free service without complaint. We took the risk of his pleasing us when we elected him. The risk was not his. It would be unfair to expect any such thing from him; and still more unfair to suspect and accuse him of evil intentions, after his work is done, and we have hurrahed over it.

But, if an office is accepted by a party, it becomes his duty to devote more earnest thought to the work than what appears on a sheet of paper. He should *know* the men whom he calls around him to help in committee work, and if they blunder, it ill becomes him to calumniate them.

But our young men (and those whom we have named we know personally) are not to be snubbed by any official oversight. We know them too well to believe that of them.

And we could name a hundred or two such—sons of veterans who have taken our magazine for over twenty years consecutively—who are growing up splendidly, and perpetuating good names in our art. On such the future of photography depends.

Wherever there is such a young man let him continue to "seize his opportunity." Committee work is thankless work—transient, and not worth your "metal." Add to your fame—and your funds first.

### A MAGNIFICENT WORK.

THOSE of our readers who see such magnificent engravings as are sent forth monthly by the *Century* and *Harper's* magazines, have not been far wrong in considering them "perfection." Certainly our American magazine illustrations have no superior.

A publication has been launched in Paris recently, however, which, at the astonishingly low rate of fifty cents (two and a half francs) per number, sends out magnificent actinized engravings from popular modern paintings, as many as sixteen in each number, some of them double-page—12 x 20 inches in size, and every one worthy of a frame.

The publication is called *Le Figaro Salon*, and is published by Messrs. Boussod, Valadon & Co., successors to Goupil & Co., Paris. Letter-press accompanies the pictures, and the whole is magnificently printed. Some of them are in two tints. The 12 x 20 of M. Constant's "Judith," is in a warm brown, most suitable to the natural complexion of the subject, and in harmonious feeling with the original painting. The "Frimaire," of Kaemmerer is a full page, in a delicate blue—a superb effect. "The Arrival," of Mesdag, has a cool, brown foreground, with a faint blue sky, while Turpheme's "Dinner in the Communal School," is in warm tint, gray and black and white.

Thus the wondrous capabilities of the skilful printer are shown. But what of these tremendous photo-engraved plates? They are the marvel of photography, and in size beyond anything we dared hope to see for a long time to come. They are made by the process known as the Typogravure, and which, alas! is a secret. In effect it seems similar to the "On the Pennypack," by the Mosstype process, in our issue for July 17, 1886, but the size of these plates is beyond anything before produced—and their quality—superb.

Messrs. Boussod, Valadon & Co. do not, however, retain the Typogravure process for their own publications. They make a generous offer to produce plates for the trade, and to print them or not, as the parties may prefer.

We make some quotations from their circular, and will be glad to give any further information in our power. Again and again we return charmed to these grand pictures; charmed, too, that our art is able to accomplish so much towards the enjoyment of the most beautiful works of the Salons.

The following is from the circular which

accompanies the five numbers of *Le Figaro Salon* before us :

"Typogravure is a process which gives, by means of a photographic cliché, a reproduction in relief, engraved on copper, of any object. The blocks thus obtained may be printed on any printing press. The price of the cuts is calculated at the rate of 30 centimes a square centimetre. Those that have less than 130 square centimetres of surface, are furnished at 40 francs. When we have to make typographic reproductions in color, each color requires a separate plate; these color plates are sold at the rate of 10 centimes the square centimetre. It takes about eight days to make a cut. Should our customers desire it, we print the cuts which we make for them.

"Should there be colored plates, besides the imprint from the block, an impression is necessary for each color plate.

"The photographic cliché of the object to be reproduced being indispensable for making a plate or a cut, this cliché is charged to the customer when it has not been furnished to us. The essential condition for obtaining a good reproduction is in having a good photographic cliché; and we advise our customers, whenever it is possible, to send us the originals, so that we may make a photographic cliché. In this manner they may be absolutely sure of obtaining perfect plates or cuts. We accept no responsibility for accidents that may happen to the clichés. When the customer desires that the clichés made by us should be returned to him, we send them in the pellicular form. When a cliché has not been made in our establishment an extra charge is made for the outside work."

*Mosaics* for 1877, will surpass all others in the quality of matter; we have, therefore, increased the number of the issue, and are confident that a few months will exhaust them.

## THE DEPARTMENT OF ART.

### IMPRESSION—FEELING.

JUST as a learned musician may spoil all effectiveness by lack of expression in his performances, and an elocutionist or actor fail to move his audiences for want of the ability to "suit the action to the word," so may the artist fail to win applause, no matter how strictly he follows the rules of composition and *chiaro-oscuro*, if there is no show of feeling in his work.

The rightful effect of all kinds of study should be to exercise and excite the imagination. If they do, then there is growth, and in art the effect of study of the works of others is to make us more observant. Browning has said that paintings teach us to notice things in nature that never would have been noticed by us but for the painting. This is most true. Moreover, when we look at paintings we find ourselves comparing the work of the artist with our own knowledge of nature, to see how exactly he has followed

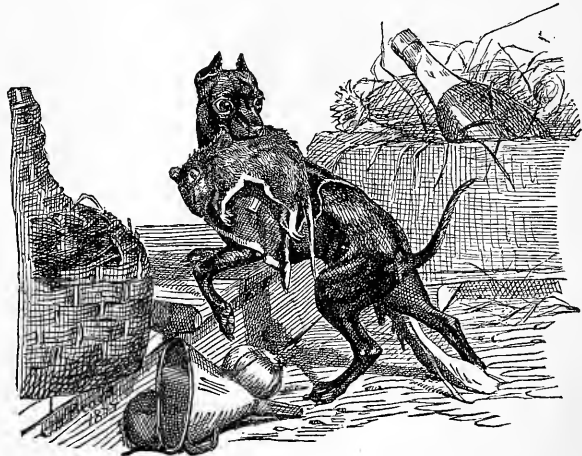

nature. This is good discipline, and, as artists, causes within us a desire not only to follow nature, but to exercise our imagination in bringing out from nature her inmost meaning.

All the impressions made upon us by what we see, exercise what is called in art, our "Feeling." No one who understands art, can be devoid of feeling. He enjoys and appreciates what he sees more heartily than another, and his thoughts are fraught with

tenderness and pathos. He cannot close his mind against either the gladness or the sorrow of his fellow men. And when he looks at paintings he will find that this capacity—this gift of feeling—will enable him to see and enjoy more than those who are not blessed with it.

An example or two. Suppose a subject like Mr. E. M. Ward's "Blood Will Tell." When you see such a picture as that don't you always want to start at the tip of the dog's ear with your hand, and pass it approvingly down his back, and up again to the tip of his victorious tail, and there, with a red ribbon, attach your national colors? Yes (be frank), you do; for nothing is too humble for your loving observation, nothing too strong or terrible for your scrutiny.

You may be sauntering along the quiet lane, and meet a scene such as is so splendidly painted in "The Tramp," by Mr. Eastman

school of painters, calling themselves "Impressionists," held an exhibition in this city. Some of their pictures are very wonderful. One could scarcely believe it possible for a "school" to exist whose methods of securing results could be so widely different from those practised by the ordinary painter. In speaking of them, a critic says:

"It is to them we owe the out-of-door study, the perception not only of colors, but of the most delicate shades of colors, the distinctions of tones, and the attempt to record truly the relation between the atmosphere which lights the picture, and the tone of all the objects contained in it.

"The Impressionist seats himself on the bank of a stream; according to the aspect of the sky, the angle of vision, the hour of the day, the quiet or disturbed state of the atmosphere, the water takes this, that, or the other hue, and he paints without hesitation



Johnson. Even if there were no ladies there to excite your knighthood, and the house was alone, you would want to help the geese hiss at the intruder, if you could do nothing more, to frighten the man of experience in D. B. (and what a bit of true feeling, by the way, for the artist to place those geese just as he did, and just where he did.)

As we have before noticed, last winter a

upon his canvas, water which has this, that, or the other hue. The sky is overcast, the weather is rainy: he paints water that is milky, heavy, opaque. The sky is clear, the sun shines: he paints the water sparkling, silvery, with an azure sheen. The wind is stirring: he paints the reflections broken by the ripples. The sun comes up as in "On the Road to Market," and darts its rays

across the landscape: the Impressionist, quick to seize the effect, dashes upon his canvas yellow and red. Then the public begins to laugh.



“The winter comes like ‘A December Day.’ The Impressionist paints the snow. He perceives that in the sunlight the shadows thrown upon the snow are blue. Without hesitating, he paints blue shadows. Then the public laughs outright!

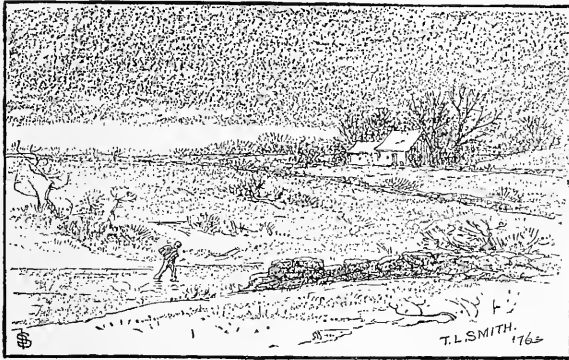

“Certain clay soils in the country take on a lilac tone: the Impressionist paints lilac landscapes. Then the public begins to lose its temper!

“Under a summer sun, in the shade of green leafage, the skin and the clothes take a violet tint: the Impressionist paints violet people in the woods. Then the public loses all self-control! The critics shake their fists, and cry after the artist, ‘Communist!’ and ‘Wretch!’

“In vain the unhappy Impressionist protests his perfect sincerity, declares that he

only paints what he sees, that he has been faithful to nature; the public and the critics condemn him. They do not take the trouble to find out whether what they see painted

corresponds or not to what the painter has really seen in nature. For them there is only one fact, and that suffices: the Impressionist's work does not look like the work of the painters who went before him. It is different from theirs, therefore it is bad.”

But, after all, it is good to imbibe a certain amount of the nature of

the Impressionist. We are all more or less such, no matter how unwilling we are to admit it.

The French “school,” probably, leans more to impressionism than the English—more to the mental attitude of the artist respecting the work he undertakes, than to the consideration of the colors he uses, or his mixing of them. It proceeds on the theory that unless a positive and accurate mental impression is gained—whether the subject be a piece of visible nature or a pure mental conception of the artist—it is impossible that there should be a positive and accurate record of an impression made on the canvas or paper.

This is the secret of the success of French art, and of the success of French teaching. The French, taking them in a bunch, are not strong painters, although they are strong technicians in the sense indicated above, and great manipulators of pigments have been even rarer among them than they have been among the English. Many of their pictures are painted in a masterly fashion; some of them are crude in finish, while others again look like designs for a kitchen carpet, or a new idea for a South Sea Island postage stamp. The Impressionist school has succeeded in

success of French art, and of the success of French teaching. The French, taking them in a bunch, are not strong painters, although they are strong technicians in the sense indicated above, and great manipulators of pigments have been even rarer among them than they have been among the English. Many of their pictures are painted in a masterly fashion; some of them are crude in finish, while others again look like designs for a kitchen carpet, or a new idea for a South Sea Island postage stamp. The Impressionist school has succeeded in

evolving very much more than so much wall covering of a fanciful sort, while a large number of the artists—and well-known names may be found among them—show a decidedly slovenly method in drawing, if not

The purpose of our remarks is to induce that observation of things beautiful, which will enable you to see more quickly, and thus help you in your work under the skylight, or out in the field.



downright ignorance. But good, earnest, sincere work of a highly meritorious sort, can be found in plenty, and these paintings afford an instructive study to the visitor to

When you pose an old gentleman like Mr. L. G. Sellstedt's "Portrait of Rev. Wm. Shelton, D.D.," it is desirable for you, and for his posterity, to bring out as much of his

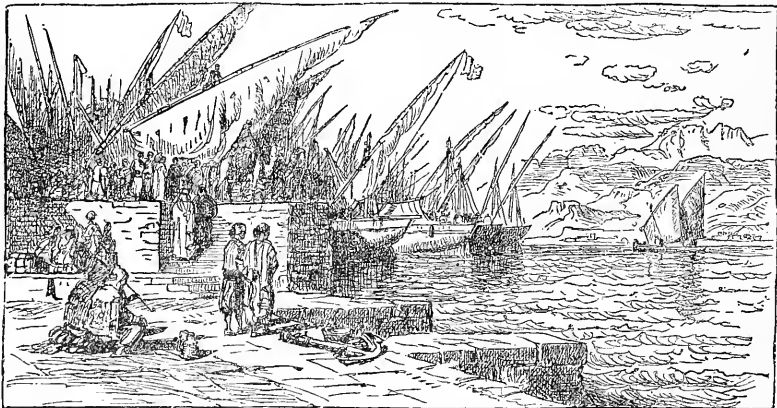

the galleries. But the champions of the schools or branches may fight that out among themselves.

character as you can in your photograph. Your position is ten times as trying as that of a painter, yet just as much is expected of



you. He floats a canal-boat, and you drive a locomotive with the fear of a switch misplaced, or a sudden curve, always over you.

Again, when you treat yourself to a day's outing with the camera, if you come to a fountain scene like Mr. Frost Johnson's "First Come, First Served," you want to be able to render it, as he has done, so that when your patrons look at it, they want to carry the old man's burden for him, and to lift the poor little forgotten dog up to the trough to drink.

Or, if you are ever blessed with a camera trip to the Orient, and a picture like Mr. Samuel Coleman's "Sunny Afternoon in the Port of Algiers," is presented to you, you will not even focus on the charming line of dahabeahs until you have added to the sense—the feeling of repose—rest—by placing in your foreground two or three groups of picturesque Arab sailors. This is feeling—yielding to impression. The very element which causes somebody to pay \$30,000 for a picture of two swarthy Arabs kneeling by their camels in the desert, in answer to the Muezzin call, or \$10,000 for an old drummer and fifer tramping along a dusty road in '76.

Let your art take possession of you, and do not be ashamed to let the fact be seen in your work.

REMARKING upon what appears to be the unusual size of the sun and moon upon rising or setting, Stroobant points out the common error that intervening objects enable an observer to better estimate the real size of the heavenly bodies, in that the same effect is visible at sea, and indicates the fallacy of several other theories. There are, he asserts, two real causes of the phenomenon in question, both purely physiological—one, the greater sensitiveness of the eye to angular magnitude near the horizon; the other, a direct effect of the feebler light in the enlargement of the pupil, which, it would seem, tends to magnify objects, even when artificially produced. Thus it is shown by experiments that the distance between two luminous points within a room suffers the same apparent change as in the constellations when, without altering the distance from the eye, the altitude is gradually increased.

### A CENTENARIAN CHEMIST.

IT is almost a duty for every scientific magazine to place on record the fact that Mons. Michael Eugene Chevreul, the eminent chemist, reached his one hundredth birthday, August 31st. He is a Frenchman, and lives in Paris. He was over half a century old when Daguerre announced his invention, and was intimate with all the savans contemporary with Daguerre. Chevreul and Sir Humphrey Davy were bosom friends. He did not "take much stock" in photography, however, since his employment by the great Gobelin tapestry manufacturers precluded him from experiment in our direction. If any one living could give us photographs in colors, M. Chevreul could, for his specialty is the question of colors, and his principal books on that subject have been translated into several languages, and have had a greater circulation in England than in France. A recent visitor says:

"He was not long before he was on his favorite topic, and I quite lost him in the mazes of his 'cercles' and 'zones chromatiques,' and among the technicalities of 'chromochalcographie.' He has a profound belief in Newton, and was greatly annoyed because M<sup>de</sup>. de Chantilly misrepresented Newton on the matter of colors in her translation. He would insist on sitting up in bed, and giving a demonstration on the propagation of colors. His strong point was that the 'colors are in us, and the cause in the things we look at' (*de hors*). Although he had talked a great deal during the day, there was no stopping him when once he started on the color question, or getting him to change his subject, and when we rose to leave he protested that we were going because his exposition wearied us. He is as earnest and enthusiastic a student yet as if he had another hundred years before him."

Chevreul was born at Angiers on the 21st of August, 1786. His longevity is hereditary, for his mother lived until ninety-two, and his father ninety-three. His studies in chemistry began after he left school at his native town and came to Paris in 1803. Entering the chemical factory of the celebrated Vauquelin, he soon showed great ability, and was appointed director of the

laboratory. In 1810 he was preparator of the chemical course in the Museum, and three years later was professor at the Lyceé Charlemagne. Four years afterwards he became assistant naturalist at the Museum, and director of the dyes at the Gobelins. He rose rapidly, and in 1834 was director of the Museum. It is seventy-six years since he first entered the Museum, seventy since he was connected with the Gobelins, and sixty since he was elected a member of the Institute. His abilities as a scientist were recognized in England before they were in France, and he was made a member of the Royal Society when, as his son says, he was only a "petit professeur" at Paris. Since then he has received many similar honors. Only last month he was made an LL.D. of Glasgow University. He has worked with many eminent chemists, and has produced several valuable and well-known works. His discoveries are numerous and are chiefly in chemical oils, soap, and colors. In 1823 he received a prize of 12,000f. from the Society for the Encouragement of National Industries for one of his books. He was sorely tried during the last war, and for the courage and endurance he then displayed is regarded as one of the greatest patriots. The Jardin des Plantes was the place that suffered most from the bombardment by the Prussians. The Museum was shattered and the zoological collection destroyed. M. Chevreul, in spite of his great age, bravely stuck to his post while the shells were flying about, and tried to gather up and save some of his specimens.

For half his life nearly he refused to sit to the camera. Some inducement to live a century after all.

---

### CONCERNING GELATINE - EMULSIONS, Etc.\*

BY A. L. HENDERSON.

THE smallest departure from the usual recognized lines necessitates such an enormous amount of experimental work that it is an impossibility that any one individual can exhaust the numerous changes in consequence of the said departure. My only regret is that photographers are so reticent

and uncommunicative. If the trade had fewer so-called trade secrets, photography as an art science would make much more rapid strides. For the last few months I have been more and more convinced of the absurdity of—plate makers more particularly—making secrets of what is common property; per example, if a person contemplates purchasing a centrifugal machine they usually bring emulsion (which is faulty in some respects) to be put through the mill. My usual question is, "What do you want done with it? How is it made?" Now it must be apparent that the latter question is not put with the idea of knowing any one's particular formulæ, but I work literally enough in the dark, without any inclination to increase the difficulties. I have published that the length of time required to produce complete separation, depends on the speed of the emulsion, also the amount of gelatine present; for any one to purposely deceive me is deceiving themselves, without throwing dust in my eyes. Yet, in spite of all this, I have only failed twice in completely restoring bad emulsion, and I believe that the faults were that the examples got light-fogged. Through this new departure, *i. e.*, using a centrifugal separator, I have gained more knowledge in six months than the whole previous year's experiments. By the complete removal of the colloid matter and soluble salts, I am enabled to examine the finely divided bromide, and then add other substances that I venture to think will still more revolutionize photography. I particularly allude to the addition of what may be called accelerators (physical or chemical) to emulsion. If an emulsion, being perfectly free from soluble matter, is boiled for a time, it will darken in color; the same emulsion might have been boiled as long in the presence of free bromide and nitrates without darkening. If in the former case I add some nitrate that will dissolve oxide of silver, and add some free bromide, I decolorize the emulsion, but I will not altogether eliminate fog, for this reason: the free silver (*i. e.*, I will call it free silver for argument's sake) has acted on the colloid before the addition of the free bromide which has to play the part of reconversion, but, as I have previously stated, if both the nitrates and free bromide are pres-

\* Read at the Convention at Derby.

ent from the first, no chemical fog will result.

Some few years ago, Professor Stebbing published "that a washed bromide of silver coarsely precipitated, when boiled with the addition of free bromide, a breaking up of the granules took place." I tried this at the time without noticing this effect, but on my adding some gelatine a rapid breaking was the result, and I found that this occurred without the free bromide. It is very evident that the addition of fresh gelatine to a finished emulsion, will frequently accelerate, and sometimes slow it. Accelerate if the gelatine is neutral, and restrain or slow if it is acid. I have discovered that a finished emulsion may be ripened considerably by keeping it liquid, with the addition of a very small quantity of pure nitrate of potassium and bromide of potassium. My reason for suggesting potassium salts is that they are less deliquescent, and no harm will come over the plates prepared without the removal of the salts. The quantity must not be so large as to give any appearance of crystallization when the plates are dry. The larger the quantity the finer is the emulsion in density, speed, and clearness of shadows. I generally add to every ounce of gelatine five grains of potassium nitrate, and two of bromide. Here are two plates, you will see the effect, not only does the speed increase, but, strange to say, the density also; both these plates have had the same exposure under the sensitometer tablet. I calculate the speed has been increased nearly four times. I am not quite sure if my explanation is correct, but it looks as if the very partial crystallization allows more light to penetrate the film, and perhaps absorb certain rays less actinic. I think this idea will open a wide field of research, namely that crystalline matter introduced in emulsion may take the place of the various substances recommended to give orthochromatic or isochromatic effects.

Here is another curious result occasioned by the mixture of a very rapid and a slower emulsion. You will see that the plate is covered with black spots. At first I thought that some impurity had got into the emulsion, but on close examination it will be seen that where there is no exposure the black

spots do not exist, showing that the black spots are silver compounds. The addition of nitrate of potassium and bromide caused a breaking up, and possibly dissolving of the more sensitive particles (these particles are so fine that they have passed through a chamois leather filter). This will explain why that an emulsion is more homogeneous and better for being set and remelted. I called attention to the fact some years ago that setting and remelting several times improved the quality of emulsion, although at the time I was not sure of the reason. I see that Mr. Plener has given it as his opinion that a putrid emulsion that frilled could not be cured by the removal of the decomposed gelatine. I differ from Mr. Plener in this matter. Mr. Plener doubtless made this statement believing that frilling was produced only from decomposed gelatine. The most common cause of frilling is the subsidence of the silver bromide to the glass from slow setting. An emulsion that has become sloppy is usually coarser. I believe that Mr. Plener is, to a certain extent, correct regarding the reemulsifying of the bromide after being passed through the separator. The addition of acids to the bromide of silver will remove all the gelatine, and, in fact, will permit the bromide to be washed in alcohol, and added to vehicles other than gelatine. If the gelatine is not perfectly removed the granules of silver bromide will harden under the alcoholic treatment and be useless for mixing with collodion, but they soften in water again, and are easily miscible in gelatine.

One word more regarding the keeping qualities of emulsion containing nitrates and bromide. The antiseptic properties of nitrate of potassium are well known to picklers of meat. I have some emulsion put away to test the keeping qualities. I am in hope that at the next Convention I may be able to show this emulsion, and tell you something more of its properties.

### DAYLIGHT ENLARGEMENT.\*

BY ANDREW PRINGLE.

UNTIL quite lately I have always been under the impression that solar enlarging in

\* Read at the Convention at Derby.

every shape was a tedious, a complex, a difficult, and an expensive amusement and business. I know better now. When once I set myself to try the process deliberately and carefully, the difficulties which at first presented themselves disappeared, and those which I had in imagination anticipated never put in an appearance. I had taken the unknown for serious, and like a *cowherd* I had seen a lion in the path. My present object is to blow away any unfounded fears that may appal any one present who feels the desire to produce solar enlargements, and to show such diffident persons that there is no real difficulty in the matter if the business is set about with proper appliances and proper intelligence. I am surprised that so few photographers attempt to produce their own enlargements, and that so many send their negatives to firms who make a business of "enlarging and finishing" from photographers' negatives. I have nothing to do with what is called "finishing," which consists, more or less, in painting, stippling, hatching, and generally transmogrifying the enlargements; that is out of my line and to a certain extent contrary to my creed. I mean to stick to the amplification of negatives by means of daylight, and what I shall say refers to printing enlarged positives on paper, or opal, or glass coated with an emulsion of (chiefly) silver bromide and gelatine. The same practice would be equally applicable to albumenized and sensitized silver paper, or platinotype paper, or carbon tissue, if to what I shall suggest were added arrangements for greatly increasing the power of the light used, arrangements such as condensers, heliostats, and so on, with which I have nothing to do and of which I have very scanty knowledge.

The arrangements necessary for solar enlarging are (1) optical, (2) mechanical, (3) chemical. The optics of enlarging consist briefly in using the greater conjugate foci of lenses to do the work done in ordinary negative work with the lesser conjugate foci. This is not a very accurate statement, for in both cases both foci are used, but I fancy I shall be understood. In making my enlargements I use any doublet lens which will "cover," as the phrase is, the plate or

portion of plate to be enlarged. The limit in the other direction is fixed only by the length of my room or of my arrangement for holding and squaring my easel. It is highly important to work at a window looking toward the north; before I annexed my wife's storeroom I used a west window, and all but ruined a film negative by letting the sun shine on it. I am very fond of the sun but I like it in its proper place, which is not shining on my enlarging apparatus. The room which is used for enlarging purposes should be illuminated with a "safe" light, but this light should be of such a kind as to shut off at will, for when much light enters the room it is difficult and even impossible to focus properly, for a tentative focus is much better than a mathematical one, as will soon be found by any one trying to enlarge.

The mechanical arrangements may be said to consist of centering and squaring. To start with, at least the centre of the negative, the axis of the lens, and the centre of the sensitive surface ought to be all in one line, but in later operations facility for shifting all the parts will be found convenient, if not necessary. But squareness or parallelism of all the parts is essential from beginning to end; the negative, lens, and the easel must always be parallel to each other. An ordinary camera used wrong end foremost at once suggests itself as likely to prove useful for at least one part of the arrangement. Take a camera large enough to hold the largest negative or positive to be enlarged, and fix it in a north window with the dark slide to the outside, and open both front and back of the slide, screw a lens into the usual place, and you have the first part of the apparatus necessary. Of course no light must get into the room except through the negative and the lens. The camera need not be dead level, but if it has any cant there will be greater trouble in arranging the apparatus for holding and sliding the easel. The window may be glazed opposite the negative with ground-glass, or tissue paper may be pasted on, but in any case, landscape or clouds must not be visible through the glass behind the negative. For my own part, not caring to leave my 10 x 8 camera fixed in the window of the store-

room, I bought a sort of camera fitted with a set of carriers for various sizes of negatives and arranged so that the carriers bearing the plates can be slipped in sideways and held in position by a spring which also prevents the light getting into the room when changing one negative for another.

The rest of the arrangement I made myself, and it consists, roughly speaking (and rather roughly made, too), of a baseboard, an easel, and arrangements for sliding the easel back and forward. The baseboard is six feet long and sixteen inches broad, and right up the centre, nearly the whole length, is a slit half an inch—it ought to be a whole inch—wide. Along this slit runs a piece of wood about a foot long, and to this at right angles is firmly fixed the easel, which is kept accurately perpendicular by a triangular right-angled piece of wood to which the easel is screwed. As the camera is fixed in the upper half the window, the baseboard has to be supported on tressels, the height being such that everything is centered. This centering I accomplished by putting into the carrier a 10 x 8 plate having a cross drawn at its centre and having the lens at its centre also, and throwing the image of the cross upon the easel which also had a cross at its centre. A careful use of the spirit level, combined with the above precautions, enabled me to fix the baseboard and easel accurately centred once for all; and as the camera was dead level and the baseboard also, and the easel running *easily* but steadily in its slit, nothing remains but to stretch the camera and slide the easel till the proper size and focus are found. I have a bolt on the runner by which I fix it after focussing, and along the baseboard I have marked certain distances, so that by a glance, first at a table of enlargements and then at my baseboard, I can at once very nearly hit off the proper focus. If I always knew exactly how much of my negatives I meant to enlarge I could focus without ocular examination by the use of tables, but I never enlarge the whole of a negative, and until I see the image on the easel I never know how much I want to enlarge. If my sensitive surface is on paper, I pin a white sheet permanently to

the easel and the sensitive paper on top of it. If I am going to enlarge on glass or opal I use runners tacked to the face of the easel and focus on an opal plate, substituting for it the other sensitive plate when about to make the exposure. This takes a long time to describe, and it took me a longer time to make, but it is really all plain sailing if a little trouble be taken to ensure accuracy and steadiness. There should be no "wobbling" of any kind about any part of the arrangements, else the thing will get out of the square, and any movement in the room will produce blurring.

When about to make an enlargement I first find the approximate focus and determine what part of the negative I mean to enlarge, in other words, I throw the image out on the focussing screen or easel. By sliding the frame holding the negative and also the front of the camera, I place the picture as I wish it on the easel, and then proceed to focus accurately by sliding the easel back and forward; I am then ready to consider the question of exposure. I never put any stop into the lens, but I make sure that the lens is of sufficient focus to "cover" well the part of the negative undergoing enlargement. Nothing under these circumstances is gained by stopping the lens, but time is lost. The exposure—always using the same sensitive surface and the same aperture of lens in proportion to focus—varies with the distance of the sensitive surface from the optical centre of the lens, and the exposure varies as the *square* of this distance. I will not trouble you—nor run the risk of fooling myself—with a formula, you can "take it as read." As a rule, when I am in doubt I pin in the middle, or in any ticklish-looking part of my enlarged image, a small bit of my sensitive surface, and try it first.

In the course of exposure a vast amount of dodging is practicable. I have a lot of boards with apertures of different shapes and sizes cut out, and with these I vignette by moving the board back and forward. Any hard bit of a negative—very black on the sensitive enlarging surface—gets extra exposure through small holes cut in the board.

In fact, there is hardly any dodging of

this kind that cannot be easily and effectually carried out.

I do not intend to go into the chemistry of development, there are so many kinds of paper and opal and glass surface on which we may enlarge. But, briefly, I recommended for positives a developer heavily restrained and watery. Ferrous oxalate seems the developer best adapted for this process. But I find a powerful developer of any kind is apt to produce heavy, hard, black and white positives.

I never before realized so fully the importance of *good negatives* as I did when I came to enlarge from different kinds of negatives. A negative may be dense, or it may be thin, in both cases, if the gradations of light and shade be correct, a good, even a perfect enlargement can be made. But if a negative be blocked up with density or wanting all over in "grip," it will not enlarge to satisfaction. So my advice to every one is to make thoroughly good negatives.

### NOTES ON EMULSION MAKING AND PLATE COATING.\*

BY W. K. BURTON.

I PROPOSE to say a few words on my favorite subject, namely, emulsion work. I am not going to give a new formula, or to write anything startlingly—or even, I fear at all—new; but to draw attention to a certain number of matters of detail, the real importance of which is frequently overlooked, even if the bearing of the matter has been taken into consideration at all.

Taking first of all the formula. It may seem strange when I state my belief that the factor of this, which usually receives the least attention—namely, the water—is the one, a variation in the quantity of which has the greatest influence of any on the time taken to gain sensitiveness by the process of boiling or stewing, which is to immediately follow. I presume, of course, that the quantities of the soluble bromide and iodide, and of the nitrate of silver, are not such as to permit an excess of silver nitrate.

If there be no such excess, then I say that the quantity of water used will have more influence on the time or temperature, or

both, required to gain sensitiveness, than will either the excess of bromide or the quantity of the gelatine, provided always that there be enough of the latter to hold the bromide of silver in suspension.

To take an example: a boiling formula is used with 400 grains of silver nitrate, and only 10 ounces of water, to both solutions. This is very nearly as concentrated as the emulsion can be made without a very considerable loss by precipitation of the bromide of silver in a granular form.

By boiling, sensitiveness will be gained in a certain number of minutes.

Now suppose the experiment be repeated with all quantities the same but that of the water, and that doubled. It will be found that much more than double the time is required to gain sensitiveness, being likely four or five times as long—a result which would certainly not arise from doubling or halving the excess of soluble bromide or the amount of the gelatine.

If this applies in the case of an emulsion, neutral or acid, intended to be boiled, it applies still more strongly in the case of an ammonia nitrate emulsion, for, as first pointed out by Eder, it is not according to the quantity of ammonia used, but according to the percentage, that there is a gain in rapidity with a certain time of stewing at a certain temperature. Now, in an ammonia-nitrate emulsion, the quantity of ammonia is regulated by the weight of silver used, entirely independently of the amount of water, so that the *smaller* the quantity of water, the *larger* the percentage of ammonia.

I have adopted, for all formulas, whether boiling or with ammonia, as a mean between the very smallest quantity of water that can be used, and a very large quantity which introduces difficulties of various kinds, a total quantity of 12 ounces to each 400 grains of silver nitrate used.

I do not think it makes much difference whether the water be equally divided between the two solutions, or unequally, or whether the method of Davis of adding the silver nitrate in crystals to the solution of soluble bromide and gelatine be adopted. If, however, either solution is to be more concentrated than the other, I prefer that it be the silver nitrate solution.

\* A paper read before the Derby Convention.

On the vexed question of iodide, I am almost afraid to say a word; there is so great divergence in the experience of different workers. I will therefore protect myself by saying that I refer only to the experience of my own working, and do not attempt to lay down a general rule, when I say that the highest sensitiveness is to be gained with tolerable certainty only when a very considerable percentage of iodide is used. I mean by a considerable percentage, say  $\frac{1}{20}$ th as much iodide of potassium as nitrate of silver.

I now come to what is, I consider, a most important part of the process of plate making, namely, that which lies between the termination of the boiling or stewing process and the coating of the plates. There appears to be a common impression that, at the end of the stewing process, a certain fixed amount of sensitiveness is gained, and that it is of but little consequence, so far as sensitiveness is concerned, what further action takes place.

Now there can be few greater mistakes than this. I think it is no exaggeration to say that even supposing washing to be so performed that all excess of bromide is removed, the emulsion may be so treated that plates representing a sensitiveness of anything between 1 and 10 may be produced; that is to say, the sensitiveness may be degraded by ill-judged manipulation, to one-tenth what it might possibly be. And in this connection it should be born in mind that it is always that emulsion which is capable of giving the rapidest plates that is most liable to be damaged in the matter of sensitiveness.

I will take, first of all, the mere freeing of the emulsions from the soluble salts, etc. A certain trace of these left in the emulsion does not appear to damage sensitiveness, but it appears to be liable—and especially in the case of an ammonia emulsion—to produce a peculiar surface fog during drying. It was W. Cobb who first pointed out to me that lack of sufficient washing was the cause of a surface fog that probably most workers in emulsion are familiar with, and my thanks, at any rate, are due to him. It is not generally known how difficult it is to remove the last trace of ammonia (and presumably of

other soluble constituents of an emulsion), but the difficulty was brought forcibly home to me not long ago.

An emulsion had been precipitated in alcohol, had afterwards been cut into pieces and allowed to soak in water for forty-eight hours, after which it had turned out unsatisfactory. It was all melted up, was allowed to set, and was broken up into pieces to dry, so as to be sent to the refiner. Whilst it was drying some hydrochloric acid happened to be used in the room for cleaning plates, whereupon a very distinct vapor was seen to rise from the drying emulsion, indicating, I have no doubt, the presence of ammonia.

That the method of getting rid of the soluble salts and ammonia must be thorough in the sense of its being capable in ridding the emulsion of the last trace of them, probably every one will admit; but there is another point I wish to draw particular attention to, and that is, that it must not be such a process as will give rise to an undue increase in the bulk of the emulsion. This brings me to a point on which I wish to lay much stress. It is the keeping down of the quantity of water in the finished emulsion. I think few matters are of much greater importance in emulsion work than this.

There are two reasons for keeping down the quantity of water. One is the mere fact that the less water there is in the film the less there will be to dry out, and that, therefore, the dangers of possible fog, etc., during drying, which are always present, but which increase with the sensitiveness of the emulsion, will be reduced. But another is of still greater importance, I think. It has its origin in the fact that the bromide of silver in a liquid emulsion inclines to sink from the surface, and that the more dilute is the emulsion, the more rapid is the sinking.

With bromide of silver in the very finest state of division, such as we have it in a very slow emulsion, this depositing action may not be so rapid that the bromide will perceptibly fall away from the surface of the films in, say, five or ten minutes, even in a fairly dilute emulsion; but just as the size of the particles of silver bromide increase, so does the rapidity of deposition, until, when we get to the size of particle common in the more rapid emulsions, the deposition is so

rapid that at ordinary temperatures it has a perceptible effect before the emulsion can set on the plate. The result on the dried plate, if the bromide has perceptibly settled from the surface of the film, is that the sensitiveness of the emulsion is greatly decreased, whilst the quality also suffers. If the settling have gone on to any considerable extent, the result is actual fog.

These facts have been published over and over again, but I think I am right in saying that there is not even yet a due appreciation, by most, of the amount of deterioration that is liable to be brought about by a slight amount of settlement; nor do they bear thoroughly in mind the fact that the more sensitive the emulsion, the more chance is there of deterioration, and the greater is it likely to be in quantity.

I will state as a general rule that, except where ice is used to hasten setting (and probably even then), it is well to have at least as much as thirty grains of quick-setting gelatine to each ounce of emulsion.

Where great sensitiveness is not required, it may be sufficient simply to add as much gelatine as may be required to the washed emulsion; but I will state that, in my experience, there is always liability to a reduction in sensitiveness from pursuing such a course. Sometimes this is but slight, but often I have found the reduction to be very appreciable, and to be greater in the case of a very sensitive emulsion, than in that of one less sensitive. Probably the nature of the gelatine has a good deal to do with this, but I have been unable to find any rule.

Unfortunately, I am not practically acquainted with the centrifugal method of depositing the bromide of silver from an emulsion, and therefore cannot give an opinion of the efficiency of this method as a means of concentrating the emulsion, but from a purely theoretical point of view it looks the most perfect, if a gelatine which, when added after sensitiveness is gained, does not reduce, this gelatine can be obtained. In this connection, I think it only fair to say that I have had from my friend W. Cobb a sample of gelatine which is remarkable, inasmuch as it does not appear to reduce sensitiveness appreciably, at whatever stage of the process it is added.

Leaving on one side the centrifugal method as one on which I am not competent to express an opinion, I come to others which require no particular appliance.

I shall first take the spontaneous precipitation method, as I am personally in part responsible for its introduction. And in connection with this I would say at once that, although I have got by its means the very best emulsion that I have ever made, and although for a considerable time I worked it with uniform success, there is some factor of uncertainty not yet explained, since the operations may be performed in apparently precisely similar manner, with the result that a very fine emulsion of splendid quality will be produced in one case, a thin, granular, useless emulsion in the other. I know several operators who have worked and do work the process with uniform success, but as I cannot do so myself, I do not recommend it to others.

Another means of ridding the emulsion of excessive water is the well-known one of precipitation with alcohol. This requires no description here, but I may mention a few details in connection with it. In the first place, of course, it is of advantage, for economic reasons, to keep down the quantity of methylated spirit to be used as much as possible. The quantity of this needed seems to depend entirely, or almost so, on the quantity of water present in the emulsion, about two and a half times as much methylated spirit as water being required. There is no need to add any water to the emulsion after stewing, as the bulk of the gelatine may be added dry, the solution being allowed to get cool first, and the gelatine being allowed to soak in the cool solution until it is quite soft before an attempt is made to melt it.

By keeping to the quantities of water that I gave above, and by adding none after stewing, it is quite easy to manage with two pints of methylated spirit to each ounce of silver nitrate used, a quantity which is by no means enormous.

I need scarcely say that methylated spirit is a substance of very uncertain constitution, and that a sample should be well tried before it is adopted for general use.

One point must not be overlooked in con-



nection with this process, and that is, that a very thorough washing is required after precipitation. The stiffened emulsion must be broken up into *very small* pieces, and must be allowed to soak in frequent changes of water for at least twenty-four hours. It will swell considerably during this soaking, but will not take up more than one-half or one-third the amount of water that it would were it washed in the usual manner.

The washing after precipitation is very much facilitated by keeping the quantity of the gelatine very much down, adding, say, only about one-third or one-quarter of the bulk. There is, of course, a smaller mass to wash, and it is in a much more porous state; but then, as already stated, there is a possibility of lowering the sensitiveness by adding the remaining bulk of the gelatine afterwards, which addition is, of course, quite necessary.

The emulsion got by simply melting the swelled gelatine, will probably be too thick for coating at a moderate temperature. It will very likely set on the plates before it has thoroughly spread; but a trial should always be made before diluting it. In any case, great care should be taken not to secure even coating by excessive raising of the temperature of the emulsion just before coating. If it will not flow at a maximum temperature of about 110° Fahr., it should be diluted; the temperature should not be raised.

This matter of keeping the emulsion at such a state of concentration that it will set quickly—only just giving time to let the film spread itself evenly on the glass, with the temperature of the emulsion at from 90° to 110°—is one of the very greatest importance if the highest sensitiveness is required in the plates.

I have little else to say, except that it is necessary to exert the extremest caution in the matter of additions made to the emulsion after it is complete. Thus I have known some samples of methylated spirit that would cause an enormous reduction in sensitiveness when added only to the extent of five per cent. There are others I know which do not; still it is well to be on the safe side, and to add nothing but pure alcohol, and of this not too much. Ten per cent. of pure alcohol is enough at times to produce an appreciable

reduction in sensitiveness. Then, again, caution is necessary in the matter of adding antiseptics. In fact, I believe that in the case of emulsions of extreme sensitiveness—such, for example, as will give a strong 25, after fixing, on Warnerke's sensitometer, and will show figure 10 of sufficient density to serve as the maximum density of a negative—the safest course is to coat the emulsion without any addition whatever; that is, if it be desired to retain the full sensitiveness.

### DEVELOPMENT—ANOTHER WORD FOR OXALATE.\*

BY JOHN CROSBY.

IN one of the photographic annuals for 1885 will be found a short article on development by the oxalate developer. In that article I ventured to state that I was surprised that the oxalate method of development was not much more in use than was the case. Since that time there is every reason to believe that many photographers have adopted oxalate with the most gratifying results. It is often said that on the Continent and America oxalate holds full sway, whilst here in England it does not find that general favor which is accorded to pyro.

Now this could be well understood if pyro had such great advantages as to utterly cast oxalate into the shade; but from a long experience of each, I believe that results equal in every way to those gained by pyro may be had by the use of oxalate—all things, of course, being equal. One great mistake made by those who give oxalate a trial is not making sufficiently large stock solutions of iron and oxalate of potash; then, again, sufficient care is not taken to have the oxalate solution give a decided red tint to litmus paper; this is most important, for it will be found almost impossible to get clear and brilliant negatives if the oxalate is not decidedly acid.

Those who have most strongly advocated the claims of pyro say there is a greater power by its use for the correction of faults in exposure than is the case by the use of

\* Read at the Convention at Derby.

oxalate. For myself, I find quite as great latitude with oxalate as with pyro. And in cases of under exposure I have many times in dull weather got a passable negative of a child by the addition of hypo to the oxalate developer, when I should have failed entirely with pyro. At times I have large numbers of plates to develop for amateurs, of which I do not know anything of the circumstances attending the exposures. Now, by a careful use of bromide in the case of overexposure, or of hypo if underexposed, I have been enabled to get much better results all around than I used to by pyro. I am fully aware that work of the very highest class is daily produced by the use of pyro, work some of which at times almost makes one think that the very topmost rung of the photographic ladder has been attained; nor do I for a moment wish to infer that by the use of oxalate a great advance will result all around. But what I do claim is, that work just as good will result when the worker has gained the same experience in its use as is the case with pyro.

Another very important matter, more especially to those who may suffer in any way from a weak chest or bronchial troubles, is the absence of ammonia fumes, the constant inhalation of which results in great liability to take cold. For this reason I would urge all who have not yet given the oxalate a fair trial to do so, and I certainly think they will be pleased with the results.

My method of working is as follows: Make up large stock solutions of oxalate of potassium and sulphate of iron. Most samples of oxalate will be found very alkaline. This must be corrected by the addition of oxalic acid until there is just a slight acid reaction upon the litmus paper; to every ten ounces of the iron solution add two drops of sulphuric acid. Now, when all sitters have left, develop the day's work. Make up three ounces of developer—three parts of oxalate to one part iron solution; divide this into three parts, to one part of which add half a drachm of a solution of hyposulphite (1 part hypo in 200 parts water); to the second part add one drachm of a solution of bromide of potassium (8 grains bromide potassium to the ounce of

water); the third part leave plain, and commence development with it.

It will soon be seen if the exposure has been right; if so, development may be finished with the plain solution; but if the picture flash out too quickly at once, pour back into the cup, and apply the one containing bromide; on the other hand, if it be found that the plate is underexposed, the one containing hypo must be used. By these means it will be found most easy to correct any small faults of exposure. The power of the hypo in underexposed plates will be found of great service; the negatives come up round, and any amount of vigor may be got by prolonged development.

---

### OUR PICTURE.

"MEDITATION," is the title of this issue's picture. It is worth considerable meditation and study itself; for there is a great deal in it.

The elegance of the conception is equalled by the power with which it is carried out. The splendidly simple scheme of lighting gives the picture a breadth which is exactly what most photographs lack, and which carries those that possess it far into art. We do not think that any picture at St. Louis made a more pronounced and general impression than this. Leaving a gallery, one carries in the mind vivid recollections only of perhaps some three or four pictures he has seen. These will always stay with him, will mark in a way a step higher in his æsthetic education, and will brightly recur to him when he afterwards recalls the collection. This picture must be one that holds such position in the recollections of most of us of St. Louis.

We have already spoken of Mr. Guerin's art in the most flattering terms at our command, noting his great progress. Technical criticism is needless. The original was on a 14 x 17 plate, from which, at our request, Mr. Guerin sent us glass positives. From these the negatives for our illustration were made. The prints are by Roberts & Fellows, of Philadelphia, on the N. P. A. Pensé paper of Messrs. E. & H. T. Anthony & Co., of this city.

### DR. VOGEL'S COLOR-SENSITIVE PATENT SPECIFICATIONS.

7963. HERMANN WILHELM VOGEL, of 124A, Kurfirsten Strasse, in the city of Berlin, Prussia, Germany, chemist, for "An improved process for manufacturing color-sensitive (isochromatic or orthochromatic) photographic emulsions or plates by dyeing the same with dyes highly sensitive to light."—15th June, 1886.

My invention relates to an improved process for manufacturing color-sensitive isochromatic or orthochromatic photographic emulsions or plates by dyeing the same with dyes highly sensitive to light. In the year 1873 I discovered that the sensitiveness of the haloid salts of silver for green, yellow, and red rays of light, which is very feeble, can be augmented by the addition of bodies which absorb such said rays. As such bodies I recognized at first coralline, picrate of methyl, rosaniline, cyanine, fuchsine or aniline red, naphthaline red, aldehyde green, methyl violet, etc. These researches were continued by Waterhouse, Becquerel, Ducos du Hauron, Eder, Schumann, and others, and in this manner a large number of such light-absorbing bodies were discovered, which I denominate optical sensitizers. This discovery is the basis of the isochromatic or orthochromatic process now in use. The first isochromatic—*i. e.*, color sensitive—collodion process was published by me in the May, 1884, number of the *Photographische Mittheilungen*, Berlin.

Continuing my researches and experiments, I observed that some dyes which absorb colored rays are not sensitizers for such rays, and ascertained that only those dyes are optical sensitizers which are not only powerful absorbents of certain rays, but which are themselves readily decomposed by light. The more readily colored bodies fade under the influence of light, the better is the same adapted for rendering silver sensitive to light. When this fact has once been established, it will be an easy matter to determine whether any new dye or color is a good medium for increasing the sensitiveness of the haloid salts of silver, it only being necessary to test its sensitiveness under exposure to light, and if it fades readily, it is a good medium for rendering

such silver salts sensitive. In order to carry out this test, I prefer to prepare paper, gelatine, or collodion with the dye or color in question, and expose the same to the light (preferably sunlight) under a perforated screen or photographic negative. In this manner I ascertained that cyanine is one of the best sensitizers or mediums for increasing the sensitiveness of the salts of silver employed in photography, and I furthermore discovered other valuable colors for achieving the same object.

I discovered further that all the red, violet, and blue chinoline and pyrodine dyes, which cannot be employed by dyers, on account of their fading so rapidly when exposed to light, are first class optical sensitizers for photographic plates.

The application of the aforementioned dyes is extremely easy; for instance (*a*), the dye is either dissolved in alcohol in the proportion of about 1:1000 alone or mixed with other colors, and then mixed with the prepared emulsion, and with or without an addition of liquor of ammonia or carbonate of ammonia; or (*b*), the dye is dissolved in water alone, or mixed with other dyes, with or without adding liquor of ammonia or carbonate of ammonia to the solution. The quantity of dye to be added to the emulsion varies according to the quality of the latter, and must be determined by an experiment. An excellent formula for many emulsions is: 2 to 4 cubic centimeters of a solution of chinoline red in alcohol (1 to 500), 5 drops of a solution of cyanine (1 to 500), 100 cubic centimeters of water, 1 cubic centimeter liquor of ammonia. The emulsion plates are dipped or steeped in this solution for one minute, and then dried. On the other hand, I have ascertained that the chemical stability of certain dyes—such, for instance, as cyanine—can be increased to a great extent by combining the same with certain other dyes, so that colors which produce plates which will keep only a short time can be used to advantage in combination with other dyes, whereby plates of good keeping quality are produced; for instance, cyanine is very much improved by an addition of chinoline red, and for the above-named reason I prefer in many cases to use mixed dyes instead of single dyes. What I claim is:

1. The method of rendering photographic emulsions and plates sensitive to colored rays of light by treating the same with a dye or color which readily fades when exposed to light.

2. The method of rendering the haloid salts of silver more sensitive to colored rays of light, by treating the photographic emulsions or photographic plates containing the same with a solution of chinoline dyes in alcohol.

3. The method of rendering the haloid salts of silver in photographic emulsions and photographic plates sensitive to colored rays, by treating the same with a solution of chinoline in water.

4. The method of rendering the haloid salts of silver in photographic emulsions and photographic plates sensitive to colored rays, with a solution of colors made from chinoline.

5. The method of rendering the haloid salts of silver in photographic emulsions and photographic plates sensitive to colored rays, with a combination of two or more dyes or colors which readily fade when exposed to light.

6. The method of rendering the haloid salts of silver in photographic emulsions and photographic plates sensitive to colored rays, with a solution of one dye, and subsequently with the solution of a second dye for wet or dry plates.

7. The method of rendering the haloid salts of silver in photographic emulsions and photographic plates sensitive to colored rays, with a solution of colors made from pyrodine.

8. The method of rendering the haloid salts of silver in photographic emulsions and photographic plates sensitive to colored rays, by treating the same with a solution of colors made from chinoline.

(Translated for the Philadelphia Photographer.)

### METHOD OF RESTORING DIS-COLORED PAPER PREPARED WITH PLATINA SALTS.

BY. M. H. BARY.

PAPER sensitized with the salts of platinum and iron may be kept without injury

for about a month; after that, if not used, it commences to lose its qualities, fogs, and gives imperfect images. After six or eight months' preparation, it seems to have attained, notwithstanding all possible care, the maximum of its loss; in this state it may be kept for several years without danger of any further change, even without keeping it in a box containing chloride of lime. Notwithstanding this change in the sensitive surface of the paper, it is easy to restore it to its original condition. In making my experiments I used paper bought in 1884, of MM. Poulenc Bros., of Paris; this paper, well prepared, and charged with a strong dose of platinum salt, an indispensable condition, is well suited for any subsequent manipulation; it is even possible to make it undergo several successive impressions without any visible change.

I make use of two processes to restore the paper:

1. Of the normal solution of chlorate of iron.\*

2. Of a solution of from eight to sixteen grains at the most of chloride of potassium, in one quart of distilled water.

By means of a brush mounted on a wooden handle I pass one or the other of these solutions, singly, or well mixed, over the surface of the paper, which at once assumes a lighter tint; dry at once, print, and develop in the ordinary way; the sensitiveness of the paper remains the same. The chlorate of iron leaves on the paper a slight yellowish tint, which may be avoided by adding a solution of chlorate of potassium, or, if it is desired to obtain very pure whites and if the negative is very soft, it is preferable to use the solution of chloride of potassium alone. It is possible, therefore, with one of these processes to use for a long time platinum sensitized paper without being obliged to take more care of it than if it were paper sensitized with nitrate of silver, even less, since, when greatly fogged, either by humidity or light, it is sure to restore to it at once all its remarkable properties.—*Paris Moniteur*.

\* The author has neglected to indicate what he means by a normal solution of chlorate of iron.—Ed.

## YACHTING WITH THE CAMERA.

BY WILFRED A. FRENCH.

You will receive by express a photo. of the "Galatea," made at the first race for the America's cup, and mounted by Mr. Talcott, hence it is accompanied by our combined compliments. The others are all successful, but this makes a most perfect picture, the arrangement being harmonious and, if I may say, artistic. With the camera on my left arm, and the bulb in my right hand, I waited the most favorable moment for a *picture*, and leave it to you, if I did not succeed. My experience was an exciting one. Arriving in New York late the preceding night, I left my camera, together with four loaded plate-holders, and a box of plates, in the office of the hotel. Being obliged to leave early the next morning, I quickly dispatched my breakfast, grabbed the outfit, and started for the L road, which took me to the Battery, where I boarded the steamboat "Sirius," which was to follow the two racers. When opening the case containing my apparatus, I was horrified in discovering evidences of outside interference, and the suspicion flashed across my mind that the clerks at the hotel had examined my plateholders, for they were all disarranged, etc. Of course I could not think of exposing those plates, considering that they might be light-struck; and, for the moment, I was in a dreadful state of uncertainty. I was not provided with a ruby-lantern, and, besides, there was, apparently, no opportunity to change plates on board. I hastily examined several cabins to see if all light could be successfully excluded, but none were available. Finally I found an apartment in the hold; it was rather damp, very odorous, and close, but then it had the virtue of being as dark as pitch. I was not long getting into it with my apparatus, and after having provided against any intrusion, I proceeded to empty my plate-holders, though the plates I was throwing away *might* have seen no gas or daylight, but how was I to know? So, without the aid of a non-actinic light, but simply guided by the sense of touch, I re-filled the plate-holders, marking the plates in the corner with a lead-pencil, and seeing (?) that the slides were

right side out, "exposed" sides in. All this had to be done in great haste, as I momentarily expected to hear the signal for the yachts to start, and yet I had to keep my mind on the subject. The task was soon completed and, feeling greatly relieved, I was soon on the upper deck pointing my camera at the rival yachts.

The "Sirius" kept at a respectful distance from the "Galatea," the "Mayflower" having outsped her rival, so as to give her no trouble, consequently I had no opportunity to get a near view of either yacht. The "Priscilla" crossed our bow, when in the Narrows, and when she came within 75 feet of us I secured a superb view, which covered my  $6\frac{1}{2} \times 8\frac{1}{2}$  plate. At the Sandy Hook Lightship there was a glorious opportunity to get the yachts. The "Sirius," together with a large number of steamers, tugs, and launches, had made direct for the Sandy Hook Lightship, which the yachts were to round. We stationed ourselves about 500 feet from the light-ship, awaiting the pleasure of the two racers, whom we had left astern.

Although about two miles back, the "Mayflower" was not long in reducing the distance between us, and very soon came tearing along at a very high rate of speed. She then came about, and, amidst the most deafening noise, gracefully rounded the light-ship, a sure winner of the first race. But I was not so fortunate, for when ready to make the exposure, a number of yachts and launches had crowded ahead of us, obscuring the view, and I had no inclination to photograph a confused mass of sails and masts, so the "Mayflower" slipped away, and my best opportunity was lost.

The "Galatea" coming up soon after, passed us in splendid style, and, as the field was clear, I was enabled to exercise considerable fastidious care, especially as a tug on the left and a steam-yacht on the right foreground, gave promise of a pretty and effective group. In a few seconds the picture was complete; a slight squeeze of the bulb, and it was mine.

Then all the steam craft got under way, and followed close in the wake of the "Galatea," but soon left her to her fate, preferring to be on hand when the "Mayflower" crossed the finishing line.

The handsome steam-yacht "Atalanta," of Jay Gould, passed alongside of us, and I, being at a considerable height above her, had a splendid opportunity to get a shot at her, which I quickly put in execution. The view before us was one of extreme beauty, with the hundreds of different craft, among which the fleeting "Mayflower" was easily distinguishable. I never before realized such delight in being able to secure without the least trouble any number of charming marine views, which were constantly changing, making the variety unlimited.

While making the exposures I was disturbed by feelings of uncertainty regarding the speed of my shutter, which was a Hoover, and was placed between the lenses. The spring was a new one, and very strong, and desiring to successfully counteract the vibration of the machinery, and the motion made by myself, I set the shutter at the very highest rate of speed, also using a small stop in my Euryscope lens. Several experts near me, noting the extreme rapidity of the shutter,  $\frac{1}{250}$  of a second, advised me to use no stop; claiming, and rightly too, that it was next to impossible to secure an impression; but having great faith in the lens, and relying on a little skill in developing the plates, I politely, but firmly, declined their advice, and had no occasion for regrets, as my results plainly show.

(Translated for the Philadelphia Photographer.)

### TRUE COLOR-VALUE BY PHOTOGRAPHY.

A PAMPHLET describing some experiments performed in the photochemical laboratory at Vienna, by Dr. Mallman and Ch. Scolik, contains a treatise on "Erythrosin-Ammonia Washed Plates;" also a chapter on the "Cyanin-Ammonia Process," and one on the dye called "Azalin."

In discussing the first subject, reference is made to the experiments of Prof. Vogel and to those of Mr. Himly, in the use of the erythrosin process. These gentlemen obtained very different results from those reached by Messrs. Mallman and Scolik, and the latter gentlemen affirm that the directions given by them for the use of erythrosin could not have been carried out by the former.

Dr. Mallman avers that he and his colleague took their pictures by means of petroleum light, and not by gaslight, still less by electric light, which latter, owing to its greater brilliancy, must necessarily have an unfavorable effect upon the sensitiveness of the blue and violet rays of an erythrosin plate. Moreover, since Mr. Himly, as well as Prof. Vogel, permitted themselves considerable latitude in the kind of bath they used, the inventors of the process decline to bear the responsibility of their unsatisfactory results.

A closer study of the experiments made by Mr. Himly reveals the fact that the results obtained by him are directly opposed to those of Prof. Vogel.

Taking one of Mr. Himly's pictures, from which he deduces the astonishing fact that an ordinary Schlessner plate gave more details in 40 seconds than an erythrosin plate with the same emulsion in 70 seconds. In consequence of this avowal, Dr. Mallman feels himself compelled to ask if Mr. Himly is ignorant of the most common facts of photo-chemistry, for it is well known that every nitrate of silver plate (without regard to the coloring matter) is doubly increased in sensitiveness by means of an ammonia bath.

Prof. Vogel's pictures are not satisfactory either, and in both cases the fault lies in the fact that the directions given for the so-called erythrosin process were not *accurately* followed. The following fact is established: "The richer the light in blue rays, the sensitiveness of the strongly yellow sensitive erythrosin plate must decrease in the same proportion as that of the ordinary plate increases, and inversely."

Mr. Schumann writes to Dr. Mallman that he used plates washed according to directions, only adding to the cyanin alcohol, in order to preserve it. He gives the following formula:

	Yellow Sen.	Blue Sen.
Pure nitrate of silver gelatine . . .	5	1.00
The same washed in iodeosin . . .	3.6	1.01
"    "    erythrosin . . .	15.6	1.67
"    "    cyanin . . .	15.6	0.00

Mr. Schumann also states that of all materials which he tried in coloring the emulsion, erythrosin produced the plates most sensitive to yellow. Leaving orange out of

the question, such a plate is orthochromatically more valuable than a plate washed in cyanin, and on account of its total sensitiveness is always preferable.

This process with cyanin was invented by Mr. Schumann, and excited much controversy among photographers. At first there were many difficulties encountered in the use of cyanin; but now, since Mr. Schumann has laid down accurate rules to be used in this process, it is found that excellent results can be obtained. Cyanin plates are most sensitive to orange-red, and in this respect surpass every other color-sensitive plate, not excepting the azaline. To compensate, therefore, for the lack of red-orange sensitiveness in the erythrosin plates, a combination of cyanin and erythrosin has been tried, and with success.

*Azalin.*—Since the year 1884, two German firms have been making gelatine plates sensitized with a dye called by its inventor, Prof. Vogel, azalin. Azalin in alcoholic solution, and in a concentration of about 1:500, is a deep carmine red fluid with active red-brown fluorescence. In the spectrum, the solution shows with sufficient dilution two absorption bands, one very intense and broad in green and blue-green, and one small and faint at the line D; dilute it still more, then the broad band divides itself into two streaks, which are connected by a half-shade, and now the band at D can scarcely be seen. A drop of the solution of azalin dries upon porcelain with nearly a pure violet color, having a metallic lustre. Mixed with muriatic acid the color of azalin solution turns to a yellow-red, and when diluted more it becomes rosy, while the fluorescence changes from red-brown to a lustrous fire-yellow or an orange-yellow. By adding ammonia to alkaline reaction the original color of the solution and fluorescence is regained. A precipitate cannot be formed with muriatic acid.

The reactions to be mentioned are: 1. The disappearing of the violet impressions of the original azalin solution by the addition of acid. 2. The reappearance of the same, as soon as the solution becomes alkaline. 3. The rapid bleaching of the violet by exposure to the light. 4. The spectral retention of the extract of ether. 5. The

retention of the same for reagents. 6. The loss of the sensitizing power of the coloring solution for orange and red, as soon as it is separated from the violet coloring material. And, finally, 7. The beginning of this power by the addition of small quantities of cyanin, assures us almost positively that in this dye, eliminated by ether, we have to do with cyanin.

Another coloring matter, called chinolin, was discovered by E. Jacobson, of Berlin, in 1882. A mixture of chinolin red and cyanin (which will form azalin) should occur in the following proportions: 1:10. The following solution: 1 gr. chinolin red in 500 c. cm. alcohol. To this add 50 c. cm. of a solution of 1 gr. cyanin and 500 c. cm. alcohol.

Mr. Schumann writes concerning his experiments:

1. That M. and S. azalin is quite as sensitive as Vogel's azalin in coloring the emulsion, as in washing. The dried plate is much more sensitive than azalin plates wet with colored emulsion. Everything works clear, and only with too strong a developer does the latter appear a little dim.

2. Both azalins make the layer for blue most sensitive. Later the yellow shows, and at last orange. This all comes out strongly on the part washed.

3. A comparison with the erythrosin plate results in favor of the latter; it is quite as strongly sensitive as the azalin plate. Erythrosin, however, does not work well with the spectrum, and is unfit for the spectrum orange CD.

At the same time, I consider the erythrosin plate in the main as the best orthochromatic plate we at present know of.

If I manufactured plates, I would not have the slightest hesitation in choosing between azalin and erythrosin (cyanin cannot be taken into account at all).

---

### DO OUR CONVENTIONS PAY— ENOUGH?

It has been our opinion for some years that our Conventions, as managed at present, do not yield enough return for the money expended for them—an enormous amount in truth.

To satisfy us on this point, about a month ago we directed a note to about thirty of the attendants of the St. Louis Convention, asking them to state what money it cost them, time thrown in, to be present.

We have received answers from twenty-five, including parties who live from ten to five hundred miles away from St. Louis. A large part of them were exhibitors, but the cost of their exhibits is not included—only railroad fare and living expenses are counted.

Eight of the twenty-five are dealers or agents for manufacturers, who declare they did not count "extras." The parties were

From New Hampshire, . . . . .	2
" Massachusetts, . . . . .	1
" Rhode Island, . . . . .	1
" New York, . . . . .	2
" Western New York, . . . . .	4
" Pennsylvania, . . . . .	2
" Ohio, . . . . .	2
" Michigan, . . . . .	1
" Wisconsin, . . . . .	1
" Iowa, . . . . .	1
" Minnesota, . . . . .	1
" Illinois, . . . . .	2
" Virginia, . . . . .	1
" Missouri, . . . . .	3
" Georgia, . . . . .	1
In all, . . . . .	25

Their expenses aggregated \$2,091.75, which foots up an average of \$80 per man. Now, there were present at the Convention

320 New members, who paid \$5.00 each,	\$1600
235 Old " " \$2.00 " "	470

555 at \$80.00 each = . . . \$44,400

Now, add to this the actual costs of exhibits of photographers and dealers, and the footing cannot be much short of \$60,000 for the St. Louis Convention.

Now, old Sol forbid that we should be accused of saying that so much money expended did no good. Rather would we feel as one of our New Hampshire respondents writes: "Cost \$100—worth \$1000."

But we do not feel that there was *enough* good given for the money, or, in other words, that for such a tremendous sum, a great deal more good should be done for our common cause, aside from those fortunate enough to be present.

We shall endeavor to give our reasons in our next issue. Meanwhile we should be glad to hear from any of our readers on the subject.

### THE GERMAN CONVENTION.

THE Convention of the German Photographers' Society, held August 26th-27th, at Brunswick, was a decided success. It was very notable for the enthusiasm shown by those attending, and especially for the good feeling displayed towards American photographers. The *Braunschweiger Tageblatt* gives a full account of the Convention. It states that President Schwier's report showed a membership of 476, as against 432 for last year, and total receipts of 7784 marks (\$1930), and a balance of 2183 marks. "Mr. Schwier," it says, "was re-elected by a large majority, and the exhibition jury was composed of Messrs. Festge (Gera), Gebhard (Halle), Wettern (Hamburg), Ponger (Cologne), Kückler (Bielefeld), Hertel (Weimar), Brokesch (Leipzig), and Hase (Freiburg). In conclusion, the Convention approved a motion that the *Deutsche Photographen Zeitung* be passed over to the ownership of its former editor, Mr. Schwier. Then took place a criticism of the exhibition, which, according to the judgment of scientific people (thanks to the exertions of the committee here, consisting of Messrs. Beddies, Carbonnier, and Sternitzky), was so very successful, and will be opened to the public to-morrow."

Mr. G. Gennert, agent in New York for the Eagle plates and paper, also writes that the Convention was a great success, and the American show a fair one, and well displayed. "The pictures," he writes, "were in a church, which was most excellently lighted. The American display, all together, was on the side, close by Voigtländer's splendid exhibit. The American pictures attracted much attention, being so different in style and effect from the German."

There was some difficulty about the conditions, only one of the thirteen exhibitors, Mr. McMichael, of Buffalo, having complied with those prescribed and published in the American journals four months ago. It was decided, however, largely at Mr. Gen-



ner's persuasion, to waive these conditions. "Messrs. Eilender, of Cologne, and Müller, of Munich," writes Mr. Gennert, "had each given a prize—the former a clock in a beautifully carved case; the latter, a cup, an ostrich egg mounted handsomely in bronze and gilt; the society adding a silver medal. The judges elected for the American exhibit awarded the first prize to Decker & Wilber, of Cleveland; the second to J. F. Ryder, of Cleveland; and the medal to George Barker, of Niagara Falls."

The prizes are to be packed and shipped with Mr. Gennert's next consignment from Hamburg, and will reach here early next month. We congratulate the happy winners; every exhibitor, indeed, deserved a prize for his energy in spreading the name of American photography abroad. Such effort, too, was appreciated, as may be seen by the quotations above. It is very pleasant to see such kindly relations springing up between the photographers of this and other countries. We hope it is only the beginning of greater things. At the banquet given by the society Mr. Gennert was called upon to respond to the toast of "American Photographers," which was enthusiastically given.

---

### THE MOTIONS OF A GALLOPING HORSE REPRODUCED BY INSTANTANEOUS PHOTOGRAPHY.

IN the August number of *La Nature*, a very interesting article appears with the above title, from which we extract the following instructive passages:

"In the opinion of the writer the number of instantaneous stops giving one-two hundredths of a second, is very limited; he knew of but three. The ordinary drop-shutter can give, as desired, one-sixth or one-twelfth of a second. With the above rapidity portraits of children may be made without the head-rest; with a rubber appliance it may be carried to one-thirtieth of a second; with a stop having double shutters, and a celerity varying from one-twelfth to one-twenty-fifth of a second, street scenes may be obtained, and without sharpness, persons presenting a face view. For a walking horse, one-sixtieth of a second is required; one or two legs will be sharp, and two hoofs blurred.

But to obtain fine negatives it is necessary to reach one-one hundred and twentieth of a second, then we can get the slow trot, and from one-one hundred and fiftieth of a second, horses leaping over obstacles. This representation is one which appears most astonishing to persons who have not made a special study of instantaneousness. It is, however, much easier to obtain than the gallop, and for the following reason: In the leap the legs of the horse are but slightly displaced relatively to the body; the animal moves, it may be said, as a whole, whilst in the gallop the limbs in stretching and bending acquire a celerity calculated at three times that of the rest of the body, and may attain fifty-five yards in a second, and even more. It is, therefore, easy to understand the difficulty in making a negative in these conditions. In a front, or three-quarter view, the perspective diminishes this extreme rapidity; at a great distance, the movement also appears less.

"Some photographers using stops of one-two hundredths to one three hundredths of a second (I speak of positive figures and not those given in the prospectuses), have been able to obtain some prints worthy of interest; but up to the present time galloping in profile has not been represented in a sharp and precise manner, at least to my knowledge. In proof of this, three horses were shown on a full run. It is difficult to believe, on examination of these prints, that such was the pace. They appear rather to be going at a rapid walk. Nothing can be more exact, however; these three horses were running, covering the distance of from six and a half to nine yards in a second. But it is very difficult to see with our own eyes; the most skilful observers allow themselves to be influenced by their surroundings, and by those who have preceded them. It might be supposed that the human eye is powerless to perceive this rapidity; this is what we constantly hear. I have seen, however, recently, a very fine fac-simile reproduction of an Etruscan painting ornamenting a hypogæum, and representing, probably, a horseman who had just carried off the prize in a race. Now, the horse has the same position as that in the above-mentioned print. We must admit that if some of the gallop of the

attitudes are lacking in grace, this one is beautiful and noble, and there is no artistic reason for not reproducing it. Naturally, I was led to examine the Greek vases in the Louvre collection, and I found there a considerable number of galloping horses. Some are represented in the attitude reproduced so often later by Van der Meulen and Carle Vernet; the animal greatly raised, the front limbs slightly bent, and the posterior ones on the ground, and much extended. But I also saw there, with surprise, three exact attitudes of the gallop. How can we explain that in modern times, and for so many years, painters, sculptors, or engravers, did not fall once in accord with nature? Were their eyes less good than those of the ancients? Let us hasten to add that in the last years, some artists in making illustrations, and even in oil paintings, have given us *natural* movements; notably one in which the animal, raised from the ground, has all feet gathered under it. In the *Salon* of this year was exhibited a grand charge of *cuirassiers*, painted in this order of ideas, and with much talent."

### WORLD'S PHOTOGRAPHY FOCUSSED.

THE African chief Diavule-Karamoko, who has been for some time residing in Paris, has forbidden the public exhibition of his photographs. Perhaps he does not like the high lights reflected by his burnished cuticle. Or, it may be, he has not been "seen" by his photographer.

In order to avoid the array of detective cameras fired at him since his "decision," the chief from "Afric's sunny fountains" has been obliged to do his morning prancing under an umbrella.

MRS. PRESIDENT CLEVELAND is showing an amiable disposition by allowing her photographs to be sold to the public. The more so because some of them are horribly bad. In both of the series of portraits we have seen of Mrs. Cleveland, there is evidence of careless haste on the part of the photographer. They look as though effort had been made to secure the greatest number of negatives possible, with variety of light and pose, without much thought as to quality, rather

than to take time to secure a fewer number of really good likenesses. There is a hit-or-miss sort of a look about them, which is all the more pity, since the men who took them knew better.

CHEVREUL, the eminent French chemist, now over one hundred years of age, has permitted himself to be photographed recently. For nearly half a century he objected, because a portrait he had painted in 1839 was "good enough for him."

THE ECLIPSE EXPEDITION is reported "eminently successful."

A LADY bull-fighter in Spain has proved a bonanza to photographers.

NONE of the photographers at Charleston suffered damage to their studios further than loosening of the plaster here and there. But their business is at a stand-still, since they have no articles for sale, and the people are not in the spirit of having their pictures made.

A BALLOON, with a camera attached, escaped from the English War Department at Chatham recently. It has probably gone to Pleiades to help the Henry Bros.

"AS QUICK AS A FLASH," can no longer be used to indicate extreme rapidity; because, according to Prof. Langley, a flash of lightning, if ten miles long, would give light for the twentieth of a second; and since photography can catch a flash in much less time, it must truly be "quicker than lightning."

HUMAN NATURE is much the same all over the world. The English photographers are discussing low prices, and howling at the insurance companies for the high rates exacted from them. Certainly dry plates should put us beyond the "danger line," and bring down the charges for risk.

PROF. PICKERING, of the Boston Institute of Technology, has made a forty-foot instrument and photographed the sun on a large scale. It is said to be a very satisfactory picture, considering the disadvantages under which he labored. The disadvantages referred to were that he could not jam

the back of old Sol's head in an iron vise, and tell him to keep his eyes "on this card and look pleasant."

SEVERAL photographers in England have been fined for working on Sunday. "A nice quiet business" is done by many photographers in this country on that day.

EGYPT, Italy, France, Germany, Austria, England, and Scotland, will all be represented among the contributors to *Photographic Mosaics for 1887*. It will be a superior issue, characterized by short, strong, practical articles.

By order of the German Admiralty, Krupp is employing an expert instantaneous photographer to record the flight of projectiles, record of carriages, penetration of armor plates, etc.

A PHOTOGRAPH, lately taken in Williamsport, Md., shows a young couple and their infant child, surrounded by the latter's two grandfathers and three great-grandfathers.

At the eighth annual examination in Technical Education in the city and guilds of London Institute, eighty-one young gentlemen were examined in photography, and sixty-one of them passed successfully.

COMPOSITE photography has been applied by Dr. Persifer Frazer to the testing of signatures. Though his experiments cannot yet be said to insure absolute certainty in discriminating true from forged writing, it is considered that one great point, at least, has been gained, "in the fact that it removes the judgment . . . from the possible bias of personal expert opinion, and allows the testimony of the photograph to be weighed by judge and jury, like any other testimony.

LIGHTNING PHOTOGRAPHS.—The account of the "photograph" of Miss Lillian Paul, taken by lightning the other day at Plainfield, leads J. W. Brady, of Bartow, Fla., to tell of an incident that occurred in Americus, Ga. A little child was playing under a cherry tree when a thunder-storm came up. At a certain vivid flash of lightning the child fell, and when picked up it was found to have a perfect and beautiful representa-

tion of a limb of a tree "photographed" upon its right hip. Every twig and leaf was delicately yet distinctly traced in red lines. The photograph remained visible for a month at least, and perhaps until now, for all Mr. Brady knows.

At the August meeting of the French Academy of Sciences, M. Chevreul, who has just celebrated his one hundredth birthday, set forth some principles relative to the vision of colors. According to the opinion of this scientist, color is not in light, but in us. Many experiments might prove this, and this new theory can give the explanation of phenomena incomprehensible up to the present time. M. Chevreul intends shortly to speak on this subject, which offers such great interest.

WATER PURIFIED BY ALUM.—Two or three grains of alum is sufficient to clarify and purify a gallon of water. It is well to dissolve the alum in hot water and keep ready for use. Add the solution, and filter through cotton two or three inches in thickness. Some recommend much more alum, and turbid water has been rendered clear by a piece of alum suspended in it by a thread for a short time.

---

### QUERIES, CONUNDRUMS, AND CONCLUSIONS.

"IN A SWEAT."—A thin coat of pure glycerine applied to both sides of glass will prevent any moisture forming thereon, and will remain until it collects dust enough to become obscure. Surveyors can use this to advantage on their instruments in foggy weather. It will also prevent the accumulation of steam and frost on windows during cold weather.

"PHOTO-ENGRAVER."—No doubt "the time is coming when all live photographers will be required to make photo-engravings for the local newspapers." The following will help to answer your queries:

1. The shrinkage of paper used by draughtsmen may be overcome by a system which has been adopted for many years. All drawing paper is ruled with very faint lines to either one-quarter or one-fifth scale, and

the drawings are made to correspond with these lines. Whatever the alteration in size or form of the paper, the variation in any square of one-quarter or one-fifth of an inch is a matter of no importance, and the drawing and scale both being on the same base, a ready and certain means of correction always exists.

Paper ruled in various ways can be procured in this city.

2. A liquid for etching on glass has recently been introduced into commerce, and can be used with an ordinary pen. It consists of hydrofluoric acid, ammonium fluoride, and oxalic acid, and is thickened with barium sulphate. A better ink is obtained as follows: equal parts of the double hydrogen ammonium fluoride, and dried precipitated barium sulphate are ground together in a porcelain mortar. The mixture is then treated, in a platinum, lead, or gutta-percha dish, with fuming hydrochloric acid, until the latter ceases to react.

"IN A STICK."—Certainly you seem to have had a good deal of trouble. To toughen it, filter paper is recommended to be immersed in nitric acid, rel. den. 1.42, and to be washed with water. It is then remarkably toughened, the product being pervious to liquids, and quite different to the parchment paper made by means of sulphuric acid. It can be washed like a piece of linen. So treated, it contracts in size, and the ash is diminished, the weight is slightly reduced, and it contains no nitrogen. The toughened paper can be used with the vacuum pump in ordinary funnels, without extra support, and fits sufficiently close to prevent undue access of air, which is not the case with parchment paper. An admirable way of preparing filters is also suggested: Dip only the apex of the folded paper into nitric acid, and then wash with water; the weak part is thus effectually toughened.

"SELF-FRAMER."—Such lovely frames are now sold in the market at such low prices that it will hardly pay you to bother making your own. However, that is for *your* conclusion. Your conundrum is met thus:

One plan for gilding ornate designs on ivory or glass is to paint over the design with a fine camel's-hair brush moistened with ni-

tro-muriate of gold. Then hold the glass or ivory thus painted over the mouth of a flask in which hydrogen gas is being generated (by the action of dilute sulphuric acid on zinc scraps). The hydrogen will reduce the gold chloride to metallic gold on the painted surface, and the gold film thus deposited will, in a short time, be found to have considerable luster.

"ALBUMEN."—In our issue for June 5th, Mr. Krauss teaches "How to Print," from beginning to end, in plain understandable terms. You would find Mr. Hearn's *Studies in Artistic Printing* of great value to you. In the first place, it gives you six fine examples of modern printing to study. Then it tells you how to equal them. Economy in silver printing is something we never believed in. It has been stated that results can be obtained as good with a 25-grain positive bath, as with any other. Dissolve 1 part of nitrate of silver in 18 of water (1 ounce in 16 fluidounces of water). Add thereto liquid ammonia until the precipitate at first produced re-dissolves. Then add nitric acid until a strip of litmus paper is faintly reddened. Float albumenized paper 4 to 5 minutes on the bath, and proceed otherwise as usual. Prints made in this way have been pronounced "extremely satisfactory." They could not be so to us, for in what does this differ from the old ammonio-nitrate bath? All ammonio-nitrate baths consist of oxide of silver dissolved in nitrate of ammonium, and the only difference consists in the relative proportion of nitrate of ammonium used. We are at one time advised to use as little nitrate of ammonium as possible, as, for example, in the case of Van Monckhoven's bath, made by saturating nitrate of ammonium with oxide of silver; and then the advantage of a large excess is urged, as in the bath just described, which appears to be virtually the same as that in every day use.

In our practice this is a better silver bath for albumen paper:

Water . . . . .	1 ounce.
Nitrate of Silver . . . . .	60 grains.
Liq. Ammonia . . . . .	1 or more drops.
Nitrate of Ammonium . . . . .	a few grains.

First dissolve the silver in the water; in warm weather add but a small portion of

liq. ammonia, until a brown precipitate takes place, then add the nitrate until the solution is clear, then filter it and add alcohol, one ounce to ten ounces of bath, and when bubbles appear add more alcohol. Always keep the strength of the silver up in the bath, or the prints are apt to be measles, spotted, and weak. The foregoing bath can be used for years and never color as the old-fashioned baths do by constant use. In adding silver to the bath the liq. am. and nitrate of ammonium must be added in like proportions. The more liq. ammonia used the colder the chocolate tones in the prints.

"YOUNG PRINTER."—As a rule, float the paper sixty seconds, and draw it over a smooth glass rod. Dry *quickly*, and fume ten minutes. Print about *two* shades dark.

#### ACIDIFYING SOLUTION.

Lukewarm Water	. . .	1 gallon.
Acetic Acid, No. 8	. . .	½ ounce.

Acidify fifteen minutes; keep moving *all* the prints constantly. Pour off this water and save it, also the next rinsing water. Wash in another fresh bath of water five minutes, and they are ready for toning.

#### TONING BATH.

Acetate of Soda	. . .	15 grains.
Chloride of Soda	. . .	10 "
Chloride of Gold	. . .	1 grain.
Filtered Rain-water	. . .	15 ounces.

This bath ought to be a *week old* for stock, and every day, about two hours before toning, make up in the same proportion as above a fresh lot of sixteen ounces, and mix the two together. The prints will tone in about *ten* minutes, which is plenty quick enough. Tone a little purple.

Now stick to this until you succeed, and attempt no wandering away from it until you *do* succeed with it.

"THINKER," of Boston.—Of course, if you are from Boston, you *must* be a thinker. But *some* printers, evidently were not given any thinkers by the Almighty when he made them, and should not start to thinking too early in life. You can try this:

Chloride of gold is prepared by dissolving gold in aqua regia, and evaporating to dryness. Aqua regia is nitric and hydrochloric

acids combined. The salt is always left in an acid condition, *i. e.*, with an excess of acid, for if all the acid be driven off, the neutral salt is too easily reduced to the metal form again. We, therefore, keep the gold acid, and when wanted for toning add to it some carbonate of soda to neutralize the acid. Into the gold solution in the graduate I throw a small piece of litmus paper; this paper loses its blue color when in contact with an acid, turning more or less red, according to the strength of the acid. When soda is added to neutralize the acid, the blue color is restored to the litmus paper. In daylight the solution would look yellow; when the soda has been added, the yellow color gradually goes away in the formation of aurichloride of sodium. This reaction takes place quicker when the solution is exposed to sunlight.

There is a reaction taking place in this solution at the present time; that reaction results in what I have said is the aurichloride of sodium. In that condition it is best adapted to produce proper tones.

"C. S. W."—There is nothing worse than bad "spotting" of prints. It is "a nuisance" we know, but the only way is to accept the situation, and set down to it with proper resignation. Since it must be done, it pays to do it well.

Touch out the spot *before burnishing* a *very little warmer than desired*, using considerable gum or rock-candy with the color. Do not use India-ink alone, but mix with other colors, to make a warmer tone. If touched out with India-ink before burnishing, the spot will show as black as a coal by contrast with the rest of the photograph, because the color of the picture changes to a warmer tint, which *partially* but not entirely disappears after a few weeks, and becomes more like the tone of the picture before it is burnished. In burnishing photographs which are touched out, use a light pressure, and *not too hot* a burnisher. If you still desire to touch out after burnishing, then use more gum in your colors. Powdered mica can also be used by mixing it carefully with the color.

Photographic Mosaics for 1887. Advertisers, please send copy *now*.

## PRACTICAL POINTS FROM THE STUDIOS.

**INSTANTANEOUS POSITIVE PAPER IN 1855.**—Mr. S. R. Majendie, of London, has reproduced as a historical curiosity a process published by Claudet in the Journal of the London Photographic Society, and also in *La Lumière*, of Paris, March 24th, 1855, for obtaining an instantaneous positive paper. The paper is first treated with a diluted solution of bichloride of mercury, and then sensitized, after drying, with a solution of nitrate of silver. This preparation is made by the light of a candle, the flame of which is surrounded by yellow glass. To obtain an impression the exposure is from two to ten seconds in summer, and about one minute in winter. A very weak image is produced, but it may be perfectly developed with the aid of sulphate of iron acidulated with acetic acid. Such are the principal facts contained in this paper, that the English journal reproduced on August 21st, 1855. From 1855 to 1885, what marvels in photography we have been able to chronicle.—*Moniteur*.

**INSTANTANEOUS PHOTOGRAPHY AT 7 P.M.**—Mr. Woodbury tells us that whilst recently in Berlin, at the time of an artistic celebration, he saw Mr. Anschutz (who is known for his success with instantaneous photographs), obtain a street view at 7 P.M., and in rather unfavorable weather. For this purpose he used a portrait lens, the subjects being at about the distance of 200 feet. Several small negatives were thus obtained, and by removing the foreground, it was possible to enlarge them to eight and ten inches, the final result being rather satisfactory.—*Moniteur*.

**PERCHLORIC ACID FOR THE PRESERVATION OF SENSITIZED PAPER.**—At the London Photographic Society, Mr. Debenham called attention to the use of *perchloric acid* for the preservation of sensitized paper. He adds ten drops of commercial perchloric acid for each fluidounce of the sensitizing bath. Toning is done with paper thus prepared quite as well as with ordinary paper, and even better. The paper may be kept for a long time. Mr. Taylor remarked that from his experiments he prefers using tartaric acid

rather than citric acid, which is generally used for preserving positive paper. Captain Abney declares that if the sensitized paper is put in a perfectly dry place, and in a vacuum, it might be kept for an indefinite period of time.

**FERROUS OXALATE DEVELOPER THREE YEARS OLD—PHOTOGRAPHY AT NIGHT.**—At the same meeting, Mr. T. Wood exhibited a sample of the oxalate of iron developer which he had kept for three years, and which still gives very satisfactory results; and Mr. England showed some transparent views obtained from negatives made during the bright summer nights, with exposures of from fifteen minutes to one hour.—*Moniteur*.

**BALANCING BOARD FOR DEVELOPING DISHES.**—Whether it is better to keep the saucer containing the developer in motion, or to let it stand still, is yet an open question. In either case the dish must be moved at first, so as to cover the part (layer) uniformly. We have, heretofore, not been able to observe any difference between negatives kept in motion during the whole time of development, and those allowed to remain quite still in the developer. Yet it is well, when a small quantity of developing material is used, or when the plate is not quite even, to keep the dish in motion. For this purpose is suggested the use of a rocking balancing-board, upon which the dish is to be placed. This is a board, under which are two round ledges. By pushing it against the dish, the board rocks to and fro, and causes the developer to *flow back and forth over the plate*.

**RING FOR THE OBLIQUE ADJUSTMENT OF THE OBJECTIVE.**—Although it has been customary of late to discard the use of the oblique position of the camera entirely, because the greater sensitiveness of the modern photographic plate occasions the use of objectives with longer focal distance, or with stronger blinds, yet under certain circumstances a similar arrangement is quite essential. The shifting of the camera front sideways, as well as upwards and downwards, is sufficient in most cases to occasion the displacement of the sight-disk. Therefore it is evident that the construction of the camera,

especially of that with the conical bellows allows too little room for this.

Several years ago, a proposal was made in the *Archives* (1868), to make the objective board round, hemispherical in form. It is simpler, however, in the objective setting itself to make use of the principle of the oblique spherical ring. It is, therefore, by this means, possible to *give to the objective any position whatever*.

### CHATTERINGS OF THIS AND THAT.

(Continued from page 493.)

I AM under the impression that some of my esteemed colleagues, after reading the foregoing lines, will feel like saying, "Oh, yes; he can write well, but things do not always happen just as he writes." Granting this, that it does not always happen just as I think it will and have reason to expect, yet in most cases I follow the principles as laid down, and in the majority of instances am successful; that an occasional slip occurs may be easily comprehended. The writer of this article is just as much subject to public opinion as every other person, and must suffer from it, and must often do things contrary to his feelings; but a photographer who has formed certain ideas of his profession, can, in many ways, exert an influence upon his public, and finally (very frequently only by evasions) obtain his own ends, if he only begins right and yields at the right time, without losing sight of his aim.

I have often made the remark (formerly very sympathetic, but now appearing rather ludicrous) that when two colleagues from different cities meet, exchange salutations, and then start a conversation about business, I, as an incarnate photographer, as my friends usually call me, find it to be quite the order of things that each artist censures as severely as possible the public in his city; each seems to have the most unintelligent public for his customers; each one has to suffer more than the other from the whims of the public. It is even true, that smaller cities often possess a less intelligent public, more difficult to convince, and to bring its ideas into accord with those of the photographer. But, to be real candid, do we not then yield a little to

the feelings of the public? No, at least in the most exceptional cases; and we ask ourselves, sometimes, whether we would not manifest the same dissatisfaction as expressed by the public. I have many a time worried myself half to death over the retouching to be done (notwithstanding I am still alive and well, and write articles for the *D. Ph. Ztg.*); but, by exercising proper judgment, I have found so many grains of truth in the expectations of the public, that I must confess the man is not really so wrong in his criticisms, and I have profited thereby in subsequent cases; and believe that, without becoming a martyr to my photographic convictions, or causing the latter to be sacrificed, I have derived much good therefrom. If the customer makes objection to his picture, which has sometimes happened in my experience, occasioned by ill-fitting garments, untidy loops, ruffles, etc., which I do not consider in my line; for the most part things which the photographer, were he to see the picture with the public's eye, could easily improve without burdening his photographic knowledge at all. This is just the mistake that we photographers make—looking at the picture too much as a photograph and not soberly enough, because we are accustomed too much to them, seeing so many of them. When we have been away some time from our business—removed entirely from our sphere of action—we look at pictures on our return in quite a different light from before; and everyone will bear me witness in this, that we find the results of our labor, which previously appeared very fine, quite the reverse. How often have I noticed that when I looked over pictures in my book of samples (where every picture that I have taken—of course, only the head—is kept with its name and number) of former years, and have come upon pictures of men whom I knew only slightly at the time the picture was taken, but with whom I afterward formed quite an intimacy, and so had a better opportunity of studying their lineaments and expressions than at the time the picture was taken—how often, I say, have I been compelled to exclaim, Heavens, how is it possible that this picture pleased the people at that time, and was even considered excellent, when such faults

in illumination, arrangement, etc., exist! Just as in this case, a contemplation of the subject is needed, whereas the photographer unfortunately deals too often in an objective contemplation of the object; and yet such pictures as these were often represented in my book of samples in terms of audacious significance. At the present day I would not make such a picture, certainly not consciously; and yet, who will certify that a picture nowadays should have more praise than the former?

I have now come to the end of my tirade upon the joys and sorrows of the honored photographic art, and would end it with satisfaction if I could be assured that some of my assiduous and intelligent colleagues had found in it a seed which would fall on fruitful ground, and thus be an inducement to them to build upon their well-nourished soil (talent, so called), and thus bring to still greater perfection our beautiful "ars photographica," and the position of photographers to still greater honor.

## Editor's Table.

WE have still a few complete sets of back numbers for the year 1886. With their matter and pictures they ought to be valuable to any photographer, professional or amateur. They are full of information on every department of the art—almost a manual in themselves—and all of the newest and latest advances are noted.

FROM MESSRS. SMITH & PATTISON, of Chicago, we have received some pictures burnished on Baldwin's Patent Duplex Rotary Polisher. This polisher certainly does its work well. The lustre it imparts to the print is quite above anything we have yet seen.

MR. T. H. BLAIR, of Boston, Mass., has offered a silver cup, to cost \$250, for competition among the amateur photographers of the country. Each amateur club is to select from its own exhibition pictures to go to a National Exhibition, where a board of judges shall award the cup. The competition shall be repeated from year to year, or at other intervals, as may be decided by vote of the clubs. These rules are suggested:

"1. No one practising photography professionally, either the whole or a portion of his time, shall be allowed to compete.

"2. Each competing picture shall be made by the contributor personally, allowing him to use prepared sensitive plates and paper.

"3. No picture having been previously entered for competition shall compete for this prize."

"No restriction whatever," writes Mr. BLAIR, "shall be placed upon the style or make of lens,

camera, plates, or paper used, neither shall the contributor be allowed to place conspicuously on his exhibit the name of any of the apparatus or materials used in making the competing pictures.

"My object in admitting only non-professionals is that many amateurs have but a few days in the year in which to practise photography, and therefore could not compete with the professional possessing equally good taste who makes the art a daily study."

"Also to discourage the class who style themselves 'amateurs,' yet employ Sundays and holidays in making photographs for prices which the professional could not afford."

MR. BLAIR invites suggestion as to the best method of competition and award.

"ALL this summer business has been more than usually depressed here, and we have felt it very much. From the middle of July last I was forced to work only three days in the week. We hoped it would improve, as it generally does by September, and now—!" So writes an operator from Charleston, S. C. The four galleries of the town escaped with little damage, but their business is absolutely dead. The photograph is an inaccessible luxury in the face of the ruin that must be repaired. MR. YANTZON, who writes, has already been mentioned, and in his letter he speaks more of his friend, MR. WIESER, than himself. Both are excellent operators and retouchers, capable of taking entire charge of a gallery. Let us see if some of the fraternity cannot give a speedy answer to their appeal. MR. YANTZON'S address is 110 Church Street; MR. WIESER'S, 12-St. Philip Street.



THE Chautauqua courses have been enriched by the formation of a school of photography, which promises to be a very efficient and valuable addition. The instruction is carried on by the usual Chautauqua system, under a superintendent, who arranges the course of lessons, consisting of reading and practical work, conducts examinations, and by answering inquiries, etc., generally sees to the progress of the pupil, who in twenty-four (weekly) lessons, it is expected will be competent to take up the art practically. A course of lectures on photography is to be given at Chautauqua during July and August of next year. To join the C. S. P., send 50 cents to Mr. K. F. Kimball, Plainfield, N. J.

A MANLY SELF OF ART DEFENCE.—Mr. W. J. STILLMAN, in the *Photographic Times*, answers Miss CHARLOTTE ADAMS' strictures by an aesthetic flight of his imagination which leads him to assert that Miss ADAMS is a *man*; that some hated rival has attacked him, whom he knows as well as Hamlet knew the jester. But our readers know too well who Miss ADAMS is, and have been benefited too much by her excellent art criticisms to be influenced by Mr. STILLMAN's fancy as to her identity, or his queer and antique inclination to brand photography "no art."

A DESERVED HONOR.—We are glad to know that Mr. THERON GEDDES, whom many of our subscribers will remember as our confidential assistant for many years, has been appointed Auditor of the Denver and Rio Grande Western Railway. Four or five years ago Mr. GEDDES was obliged to go to Denver to recover from a sudden lung trouble, and concluded to remain there. This appointment means that his health has been established, and that his excellent qualities have been found out and appreciated by a large corporation. His many friends among our readers will be glad to know this, we are sure.

FIRE.—We regret to learn that Messrs. Buchanan, Smedley & Bromley, 25 North Seventh Street, Philadelphia, had their entire stock destroyed by fire at midnight on Monday, Sept. 20. Loss about \$15,000. Business going on.

Mr. M. L. CORMANY, Augusta, Ga., made an exhibit of large heads at St. Louis, Mo., which at least caused the jurors to halt and mark him very high on their list. Certainly his work did him the highest credit. He has long been ambitious to excel. We have watched his growth

with a great deal of interest, since he is a young man. If he grows another year as he has during the past we predict that he will be one of the medalled men of our craft. He is an artist in feeling and a true photographer in technique.

WE have received from Dr. J. L. WILLIAMS, of this city, some very excellent whole-size views of Dixville Notch, N. H.—that delectable region so full of pictures for the camera.

OUR readers could not but notice something on looking down the column for "paper" in the "Practical Points from St. Louis," in our last number. It was the remarkably frequent occurrence in it of three little letters, "N. P. A." It may be stated that seventy per cent. of the exhibitors put themselves on record as using wholly or in part this excellent paper. Its qualities are such that it deserves well the general approval that it has gained. There is a sample of it in the front of the present journal, as there has been in every alternate issue of this year and all of last.

FROM PACKARD BROS., of Jamaica Plains, Mass., we have received their new price-list of backgrounds and accessories, with cuts. They certainly offer some excellent things at extremely moderate rates. Some of their backgrounds are of a high artistic order, quite above the ordinary slip. Especially is this so with their Interior No. 85 A and the Tree Slip, No. 77 A. These seem to be painted in thorough understanding and accordance with the rules of art. They are most excellent accessories. We commend them to the attention of our readers.

WE have notice of the marriage of Mr. W. H. PARTRIDGE, of Boston, and Miss EMMA M. ABELL, of Portland, Oregon, at the latter place. We congratulate the happy pair, and hope no fog—green, chemical, or otherwise—will cloud their honeymoon.

MR. HAROLD SANB'S, one of our English subscribers, sends us an article for *Mosaics*, and after making some suggestions for that annual, writes: "As far as the PHILADELPHIA PHOTOGRAPHER is concerned, I don't think it capable of any further improvement. I enjoy reading it as it comes more every month."

FROM Messrs. B. FRENCH & Co., of Boston, we have received a most beautiful instantaneous picture of the plucky English yacht, the "Galatea." It is a wonderfully clear and delicate

print, every line of her cordage plain. With her accompanying fleet she makes a splendid composition. The picture's excellences are brought out by its being on one of Talcott's improved mounts, which promise to become so popular.

WE have received a note from one of our subscribers in Seattle, W. T., saying that after five months' war, the photographers of that place have, by common consent, gone back to decent prices. The man who it is alleged made all trouble suddenly disappeared from a neighboring town, it is said, leaving \$500 debts behind him. The following notice was printed in all the Seattle papers. We heartily commend its spirit, and would call to it the attention of photographers elsewhere, similarly troubled:

NOTICE.

We the undersigned photographers, doing business in the city of Seattle, have decided that the present prices for photographs are below those of other reputable galleries in other cities, and have concluded to act in concert and harmony, and ask a more reasonable recompense for our skill and labor. Therefore, on and after September 4, 1886, the scale of prices will be as follows:

Cartes de visite, per dozen.....	\$3 00
Cartes de visite, per half dozen.....	2 00
Cabinets, per dozen.....	5 00
Cabinets, per half dozen.....	3 00
Panels, per dozen.....	6 00
Panels, per half dozen.....	4 00
Boudoirs, per dozen.....	8 00
Boudoirs, per half dozen.....	6 00

Groups will be charged fifty cents extra for each head.

This agreement we solemnly pledge our honor to sustain, and politely request the public not to ask us to deviate from the same, as our determination is unalterable and just.

M. S. McCLAIRE,  
D. R. JUDKINS,  
GEO. MOORE,  
THEO. E. PEISER.

SEATTLE, September 3, 1886.

AN early "Our Picture" will be one from the German exhibit at St. Louis. It was entitled "Bad News"—a splendid study of a young girl with a letter. Its artist is Mr. C. PIETZNER, of Teplitz, Germany.

AMONG the pictures for the coming months are two mosaics of German gems—one of nine pictures, by Messrs. SCHULZ & SUCK, of Carlsruhe, and one of four by FRANZ WERNER, of Munich.

A charming child study, by Mr. G. M. DEANE, of Galveston, Texas, is also coming, and a real photographic "view from our office window."

IN the November number of the *Century Magazine* will begin, as a serial, the life of ABRAHAM LINCOLN, by his confidential secretaries, MR. JOHN G. NICOLAY and Col. JOHN HAY. It will be the first authentic biography of LINCOLN ever published.

WE have received from Mr. W. N. MANCHESTER, of Factoryville, Pa., some very good pictures of a rock-bound mountain stream. They are good, clean, photographs.

MR. H. McMICHAEL, of Buffalo, was very deservedly awarded the first medal given for photographs at the late Industrial Exhibition at Toronto, Ont. We tender him our hearty congratulations. His excellent work merits this recognition.

MR. H. HEPWORTH, F.C.S., Editor of *The Camera*, London, England, has written an excellent book on *Photography for Amateurs*. It contains nearly 200 pages of clear and careful instruction. Besides treating thoroughly every part of the process of dry-plate photography and silver printing necessary to amateurs, it also has chapters on enlargements, platinum printing, and transparencies. It is well illustrated, and is just such a reliable, intelligent guide for the first uncertain steps of the amateur as he feels the need of. It is published by Messrs. CASSELL & Co. All in all it is the most concise and clear of its now quite numerous family. We shall take occasion to quote from our friend's book presently.

THE MAGIC LANTERN.—The readers of *Anthony's Bulletin* for some months back have been instructed and delighted with a series of articles on "The Magic Lantern and its Applications," by Prof. L. H. LAUDY, Ph.D., of the School of Mines, Columbia College. The series has now been published in book form by Messrs. E. & H. T. ANTHONY & Co. The work is printed on heavy plate paper, royal octavo size, and is handsomely bound in cloth. It has forty-seven illustrations showing lantern construction and models of all the forms of lanterns in use from the first, described in *Smith's Optics*, 1838, to the modern "Triplexicon."

Fig. 46 is of Prof. LAUDY's new apparatus for the oxycalcium light for the production of oxygen during projection. The work should be studied by all lantern men.

# Specialties.

## ADVERTISING RATES FOR SPECIALTIES.

25 cents for each line, seven words to a line—in advance. *Operators desiring situations, no charge.* Matter must be received a week before issue to *secure* insertion. Advertisers will please not ask us for recommendations. ~~5¢~~ We cannot undertake to mail answers to parties who advertise. Please always add your address to the advertisement. **Postage-stamps taken.**

**MAKE OUT YOUR OWN BILL,** and remit cash with your advertisements, or they will not be inserted.

### HOLD!

With but one exception our sales at St. Louis were larger than at any previous convention. Having but just completed the Convention orders, we are now ready for the fall trade, and invite attention to our popular and attractive novelties and specialties.

#### RICH HOME INTERIORS.

QUAINT DESIGNS, ESPECIALLY FOR CHILDREN.  
USEFUL AND REALISTIC ACCESSORIES.

AT

#### PARTICULARLY CLOSE PRICES.

THE LARGEST LINE OF BACKGROUNDS  
IN THE WORLD.

Correspondence solicited. Samples to the profession.

LAFAYETTE W. SEAVEY,  
Studio 216 E. 9th St.,  
New York.

RETOUCHING BUREAU.—Under the direction of Mr. H. Harshman. None but skilled help employed. Quality of work guaranteed. Prices moderate. Send your negatives in wooden box with cover screwed on, and prepay charges. Address GAYTON A. DOUGLASS & Co.,

Merchants in Photo. Supplies,  
185 & 187 Wabash Avenue,  
Chicago, Ill.

A first-class gallery on Broadway for sale. Good business. *For cash only.* For particulars address

F. H.,  
226 E. Fifteenth St.,  
New York.

FOR SALE.—One 3 A Dalmeyer; one 6 x 8 Harrison. Address P. E. THUMLER,  
211 Reed St.,  
Milwaukee, Wis.

RETOUCHER WANTED.—Must be A 1. No other need apply. State salary, and send samples of own work to GEO. N. DEANE,  
Galveston, Texas.

### DOWN SHE GOES!

#### NEW PRICE-LIST

OF THE

ROCKWOOD SOLAR PRINTING CO.

17 UNION SQUARE NEW YORK.

Size.	Unmounted.	Mounted.
11 x 14.....	\$1 00	\$1 25
13 x 16.....	1 00	1 25
14 x 17.....	1 00	1 25
16 x 20.....	1 00	1 25
18 x 22.....	1 20	1 50
20 x 24.....	1 35	1 50
22 x 27.....	1 40	1 90
25 x 30.....	1 40	1 90
27 x 32.....	2 25	3 00
29 x 36.....	3 00	4 00
30 x 40.....	4 00	5 00

No charge for negatives. All orders must be accompanied by the cash. Make all P. O. orders payable to ROCKWOOD SOLAR PRINTING CO.,  
17 Union Square, New York.

PRINTING AND TONING FOR AMATEURS  
A SPECIALTY.

PLATES DEVELOPED.

Try our freshly made photographers' paper. Made fresh daily, and fumed ready for use. 25 cents per sheet, 18 x 22, cut any size, and sent by mail without extra charge.

Our Concentrated Toning Solution is pronounced the *best* by *all* who have used it. Price, seventy-five cents.

Photographic supplies of all kinds. Largest variety of stock in the city. Send for catalogue.

LOEBER BROS.,  
119 & 121 Nassau St.,  
New York.

EVERY photographer in want of excellent lenses, for *any purpose*, will best serve his interest by consulting the new illustrated price-list of Messrs. BENJAMIN FRENCH & Co. before purchasing.

FOR SALE.—Photo business of the late J. W. Laming, Boston Highlands. A rare chance to buy a paying business. Building, apparatus, stock, and fixtures will be sold for \$1500. For particulars address **PACKARD BROS.**, Jamaica Plains, Boston, Mass.

FOR SALE.—An excellent opportunity for a good photographer to purchase the leading gallery in a city of 60,000. Address **GALLERY**, care **Geo. MURPHY**, 250 Mercer St., N. Y.

**“QUADRUPLEX ENAMELER.”**

Is the name of the best burnisher for photographs yet introduced. Lubricator, scratches, ridges, stopping, and kicking all overcome. **SMITH & PATTISON**, Manufacturers, Chicago, Ill.

Send for descriptive circular.

**THE LIGHT RUNNING**

**NEW**

**HOME**

**SEWING MACHINE**

**HAS NO EQUAL.**

**PERFECT SATISFACTION**

**New Home Sewing Machine Co.**

**—ORANGE, MASS.—**

30 Union Square, N. Y. Chicago, Ill. St. Louis, Mo.  
Atlanta, Ga. Dallas, Tex. San Francisco, Cal.

**FOR SALE BY**

THE AGENTS, at the above named places.

**BARGAIN LIST.**

- 1 5 x 8 Scovill Manufacturing Company's Camera, with Eastman Roll-holder, with tripod, focussing-cloth and light carrying case. All new.....\$35 00
- 5 x 7 Scovill Manufacturing Company's Revolving-back Camera, three extra holders, with kits; 1 tripod..... 30 00
- 1 18 inch Entrekin Burnisher (old style)... 10 00
- 1 14-inch Entrekin Burnisher, (nearly new)..... 15 00
- 1 Centennial Head-rest, perfect..... 8 00
- 1 Spencer Head-rest (old style)..... 1 50
- 2 Bergner Cutters, stereoscopic arch top, each..... 15 00
- 1 Bergner Cutter, stereoscopic square top.. 10 00
- Printing-frames, 10 x 12 (nearly new)..... 60
- “ “ 6½ x 8½ “ “ 35
- “ “ 5 x 8 “ “ 30
- Negative boxes 5 x 8, 8 x 10, 10 x 12, and 14 x 18 from 25 cents to \$1.10.

**ROBERTS & FELLOWS**,  
1125 Chestnut St., Phila.

WANTED.—At once, a young man of good habits and gentlemanly address, to do first-class retouching and printing. None but a thorough workmen need apply. Send photo and name salary expected to **F. C. WESTON**, Bangor, Me.

**SEASON OF 1886-87.**

**NEW DESIGNS IN**  
**BACKGROUNDS AND ACCESSORIES.**  
Including Interior Slips in Profile. Winter, Backgrounds, Set Pieces, etc., from the Studio of  
**PACKARD BROTHERS**, Scenic Artist.  
JAMAICA PLAINS, BOSTON, MASS.  
Send for illustrated catalogue.

**“QUEEN” POSER.**

The most popular chair ever introduced for bust and figure posing. It pleases everybody. Hundreds have already been sold.  
**SMITH & PATTISON**,  
Chicago, Ill.

The manufacturers will be pleased to furnish descriptive catalogue free.

825 **REVISED LIST.** 825

We call attention (circular free) to our revised price-lists of albumen papers, Magee's nitrate of silver, dry plates, and pyrogallie acid. Consult it before you buy. **WILSON, HOOD & Co.**,  
825 Arch St., Phila.

FOR SALE.—A convenient and well-equipped gallery. Fine ground floor. Location in one of the leading cities of Central Illinois. Cheap for cash. Must go quick. Address all correspondence to

M. B. J.,  
care of H. LIEBER & Co.,  
Indianapolis, Ind.

Reed's Common-sense Negative Washing-box. New. Send for circular.

WILSON, HOOD & Co.,  
825 Arch St., Phila.

#### SPECIAL CARD.

Talcott's Improved Mounting for photographs softens the lines, gives much strength and great brilliancy to the picture, and is the only process by which a photograph may become indelible.

Patented March 23, 1886.

For preserving from all soiling engravings, etchings, crayons, diplomas, certificates, etc., this mounting has no equal, the picture or parchment being hermetically sealed.

Pictures thus mounted can be displayed or packed in less than one-half the space required by pictures with other framings, as by this process all other framing becomes wholly unnecessary, yet it is so constructed that if desired it can be placed in any ordinary picture frame intact, free from all interference.

E. K. TALCOTT,  
216 Northampton St.,  
Boston, Mass.

OUR dark-room and laboratory are under the charge of Dr. John Nicol, photographic chemist, late of Edinburgh. None but purest chemicals used in our preparations. All the standard dry-plate developers kept in stock. Your patronage desired.

GAYTON A. DOUGLASS & Co.,  
Merchants in Photo. Supplies,  
185 & 187 Wabash Avenue,  
Chicago, Ill.

AMONG all the photographic lenses of various makes and styles which have been introduced during the past ten years, the euryscopes, of which Voigtlander & Son are the sole manufacturers, loom up conspicuously. The success of these lenses has been unparalleled, and the demand is as lively as ever. They can be found in nearly every gallery in the land, and the amount of satisfaction and profit they produce is difficult to calculate. Most convincing proof of their superiority over other lenses is the exquisite work done with them, and the fact that it is simply impossible to get along without them.

#### COMMON-SENSE TRAY.

This is the only paper tray ever made that proved a success. It is a thick chemical-proof pasteboard tray, inside a wooden case, guaranteed and manufactured by

SMITH & PATTISON,  
Chicago, Ill.

Send for descriptive circular.

"Long's Art of Making Crayons on Solar Enlargements." Price 50 cents.

EDWARD L. WILSON,  
853 Broadway, N. Y.

#### THE DUPLEX NOVELETTE CAMERA

Is a marvel of Camera architecture. In an instant a "vertical" camera may be turned into a "horizontal," and in another the change made from the 5 x 8 to the 8 x 10 size, and *vice versa*. It is supplied in two carrying cases, so that you may leave one part at home if you desire. The same platform and one front serves for both sizes. It is as complete an equipment as ever was invented. One holder, each size, goes with the "Duplex" at \$35. Messrs. E. & H. T. Anthony & Co. are the makers.

Another preserver of neatness is Anthony's Artist's Cuffs. The engraving makes the article



and its use plain. No more spoiled shirts or soiled wrists.

DEAR SIR: Please send us three copies of *Long's Art of Making Crayons on Solar Enlargements*, and oblige

BUCHANAN, SMEDLEY & BROMLEY,  
25 N. Seventh Street, Phila.

The American Artists' Association is reëstablished for *solar printing in silver, solar printing in platinum, finishing in ink, water-colors, crayon, pastel, and oil.*

WILSON, HOOD & Co.,  
Trade Agents, Phila.

WANTED.—At once, one good poser and operator, and one good retoucher. No Sunday work nor tin types. Only competent persons need apply. Address

B. FRANK SAYLOR,  
Lancaster, Pa.

A GENTLEMAN ARTIST, of acknowledged ability in ink, crayon, and water colors, with many years' experience in photography, a fine retoucher, well acquainted with dry plate, platino-type, artotype, etc., would like to engage with some first-class establishment where his services can be fully employed. A Southern city preferred. Best of reference. Address

ARTIST, Box 324,  
Conneaut, Ohio.

WANTED.—A reliable printer with good recommendations. One who can do crayon and India-ink preferred. Address

HENRY FREY, Scranton, Pa.

FOR SALE.—Gallery, established sixteen years. Trade will average \$50.00 per week the year round. Sickness of wife, reason for selling. Only persons having the cash need apply.

Address W. G. Coss, Kenton, Ohio.

M. WERNER,

PORTRAIT ARTIST,

No. 102 N. TENTH STREET, PHILADELPHIA.

Photographs finished in crayon, India-ink, water-colors, and pastel, in all sizes, in the very best styles, and at moderate prices.

Solar Prints and Enlargements Furnished.

## SITUATIONS WANTED.

*No charge for advertisements under this head; limited to four lines. Inserted once only, unless by request.*

By young man as printer, or will do any part but retouch. References furnished if desired. Address F. G. A., care E. R. Starbird, Farmington, Me.

By a man of ten years' experience, who is an excellent printer and good at any branch of the business. Has good habits and is capable of taking charge of a gallery. Address G. H. Dale, Moorestown, Vermont.

An operator desires to change. Only first-class galleries considered. Refers to Messrs. George Heyn, Omaha, and Gustav Cramer, St. Louis, present and former employers. Address Justus Zahn, care Heyn, Omaha, Neb.

By young operator, as view operator, to go South. Wet or dry. Best of reference. One year with last company. Address A. R. Klingensmith, Hadley, Saratoga Co., N. Y.

By an experienced water-color artist and ink finisher for portraits and landscapes, in photograph gallery or lithographic establishment in Southern or Western States. Address H. Gilbert, 51 Washington Street, 3d floor, Boston, Mass.

Permanently, as general workman in a good gallery. Will work cheap. No Sunday work. Address W. E. Swartz, Van Wert, Ohio.

By a first-class operator, of fourteen years' experience; wet or dry plates; portrait on landscape work. Address H. Geissinger, 1512 N. Sixth St., Philadelphia.

# OUR SPECIALTIES.

BROMIDE AMMONIUM, Chem. Pure.

BROMIDE POTASS., Chem. Pure.

NITRATE SILVER, Chem. Pure.

FOR DRY PLATES.

CROSS-SWORD DRESDEN ALBUMEN PAPER,

Single and Extra Brilliant. The Best in the Market.

ALSO A GENERAL LINE OF

PHOTOGRAPHIC CHEMICALS.

A circular, "How to Save Waste," sent on application.

**CHAS. COOPER & CO.**

194 Worth St., New York.



TRY THE NEW

**3 KINGS** EXTRA BRILLIANT ALBUMEN PAPER.

*Vio-Pensee*, a most delicate violet tint, and  
*Pearl-Email*, a beautiful shade of pearl.

SUPERIOR PRINTING QUALITIES.

Price per Ream, \$34.00.

Sample dozen post-paid to any address on receipt of \$1.00.

**BUCHANAN, SMEDLEY & BROMLEY,**  
 Importers, 25 N. 7th St., Phila.

THE PLATINOTYPE (Patented).

Send ten cents for instructions and sample,  
 portrait or landscape.

WILLIS &amp; CLEMENTS,

1112 HUNTER ST., PHILADELPHIA,  
 BUCHANAN, SMEDLEY & BROMLEY,  
 General Agents for the sale of materials.

**HODGE & HUSTON,**  
**THE SOLAR PRINTERS,**  
 622 ARCH STREET, PHILADELPHIA.

*Permanent Prints by the Platinum Process. Electric Light.*

Those

**FINDERS**

beat the world. You ought to see them. If you are making *instantaneous* views you can save ten times their *value* in annoyance and *failures* the first dozen plates you expose. Easily adjusted, always in focus, light, cheap and durable. Size of ground glass 1 x 1 3-10 inches. *Price, \$1.50*, post-paid to any address in the United States.

**BUCHANAN, SMEDLEY & BROMLEY,**  
**PHILADELPHIA.**

THE best artists and solar printers in the United States and Europe use PLATINOTYPE PAPER for large and small pictures. This paper is manufactured for Willis & Clements' Platinotype Process, and is the *purest and most desirable* grade of paper made in the world for ink, crayon, or pastel. Samples free.

BUCHANAN, SMEDLEY & BROMLEY,  
 Importers, 25 N. Seventh St., Phila.

# THE DUBOIS FILING CASES.

*For Preserving Photographic Negatives, Prints, &c., Letters, Bills, and Miscellaneous Papers.*

PATENTED SEPTEMBER 2, 1884.

**Economical! No Binding! Either a Temporary or a Permanent File.**

Made in  
five sizes and cabinet  
form.

**AGENTS WANTED.**

Write for Descriptive  
Circular.

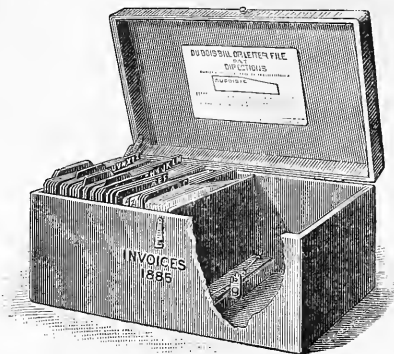

NEW YORK,  
April 27, 1886  
Mr. FRANK G. DuBOIS,  
No. 512 W. 30th St., N.Y.  
DEAR SIR: Your File supplies a need that I have felt for some time past. It is the best thing of the kind that I have ever seen, and I shall be much pleased to recommend it to all my friends for preserving bills, notes, receipts, recipes, unmounted prints, photographs, and all kinds of miscellaneous papers to which easy reference may be wanted at any time. Respectfully,  
MISS SOPHIE L MAURER.

Sent by Express, on receipt of \$3.00, or with lock and key, \$4.00.

PATENTEE AND SOLE MANUFACTURER,

FRANK G. DuBOIS, 512 W. 30th St., New York.

TO THE TRADE ONLY.

## HYPOSULPHITE OF SODA

FOR PHOTOGRAPHERS.

### CHAS. A. W. HERRMANN,

16 Cedar St.

New York.

TO THE TRADE ONLY.

<p>THE LARGEST ESTABLISHMENT IN THE WORLD</p>	<p>SIXTEEN YEARS PRACTICAL EXPERIENCE</p>		<p>ILLUSTRATIONS OF EVERY DESCRIPTION FOR BOOKS, MAGAZINES, NEWSPAPERS, CATALOGUES, CIRCULARS, &amp;c. IN THE MOST ELEGANT STYLE OF THE ART</p>
	<p><b>MOSS ENGRAVING CO.</b></p>		
<p>535 PEARL ST. COR. ELM.</p>		<p>MOSS' NEW PROCESS Superior to Any Other Method.</p>	
<p>SEND GREEN STAMP FOR 24 PAGE CIRCULAR -- SEND PHOTOGRAPH, DRAWING OR PRINT FOR ESTIMATE.</p>			

## C. H. CODMAN & CO.

### Photographic Stockdealers

Sole Agents for the NEW ORTHO-PANACTINIC LENS, Moor's Photographic Enamel, the Perfect Mounting Solution for mounting Photographs on the thinnest mount without wrinkling.

New England Agents for American Optical Co.'s Apparatus. The best in the world. Send for Price List.

34 Bromfield Street.

BOSTON, MASS.



## DEALERS' DIRECTORY.

*The following houses are to be recommended as the best for photographers in their localities.*

S. T. BLESSING, New Orleans, La. And Dallas, Texas.	THE BEST BOOK IS	SMITH & PATTISON, NEW LOCATION, 145 & 147 Wabash Avenue, Chicago.
H. A. HYATT, Mound City Photo. Stook House, 8th and Locust Sts. St. Louis, Mo.	WILSON'S PHOTOGRAPHICS, \$4.00.	GAYTON A. DOUGLASS & CO. 185 & 187 Wabash Ave. CHICAGO.
SCOVILL MANF'G CO. 323 Broome St. New York.	D. TUCKER & CO. Buffalo, N. Y.	ALLEN BROS. Detroit, Michigan.
C. H. CODMAN & CO. Boston, Mass.	WILSON, HOOD & CO. 825 Arch Street, Philadelphia, Pa.	B. FRENCH & CO. Boston, Mass.
BUCHANAN, SMEDLEY & BROMLEY, 25 N. Seventh St. Philadelphia.	A. B. PINE & CO. Fort Scott, Kansas.	MULLETT BROS. Kansas City, Mo.
OSCAR FOSS, San Francisco, Cal.	E. & H. T. ANTHONY & CO. 591 Broadway, New York.	SHEEN & SIMPKINSON, Cincinnati, Ohio.

"Tasteful, well edited, and crammed full of technical information is THE PHOTOGRAPHIC TIMES."—*The Journalist.*

# The Photographic Times

Is a WEEKLY JOURNAL devoted to the  
THEORY, PRACTICE, AND ADVANCEMENT OF PHOTOGRAPHY.

ITS DEPARTMENTS ARE:

**EDITORIAL.**

**CONTRIBUTED AND MISCELLANEOUS**, articles by the best photographic writers of both hemispheres.  
**COMMUNICATIONS FROM SOCIETIES**, including Papers, Lectures, etc.  
**MEETINGS OF SOCIETIES**. Stating date and place of meeting of all Photographic Societies, both professional and amateur, and giving full proceedings of all meetings  
**CORRESPONDENCE**. Scientific and practical discussion by practical photographers of important and interesting questions, and letters from all quarters of the globe by intelligent and observing correspondents.  
**OUR EDITORIAL TABLE**. Reviews of books, exchanges, etc.  
**PICTURES RECEIVED**. Impartial criticism and notice of all photographs sent in  
**NOTES AND QUERIES**. Answers by the Editors to correspondents in search of knowledge.  
**COMMERCIAL INTELLIGENCE**. Description of new photographic appliances, studio changes, and a record of photographic patents.

## A PARTIAL LIST OF WRITERS TO THE PHOTOGRAPHIC TIMES.

CAPT. W. DE W. ABNEY.....	England	W. H. WALMSLEY.....	Philadelphia
W. M. ASHMAN.....	"	FREDERICK A. JACKSON.....	New Haven
W. K. BURTON.....	"	PROF. RANDALL SPAULDING.....	Montclair, N. J.
W. E. DEBENHAM.....	"	PROF. WM. HARKNESS, U. S. N.....	Washington, D. C.
H. P. ROBINSON.....	"	DR. JOHN H. JANEWAY, U. S. A.....	Governor's Island
G. WATMOUGH WEBSTER.....	"	C. D. CHENEY, D. D. S.....	Hoboken, N. J.
ARNOLD SPILLER.....	"	PROF. KARL KLAUSER.....	Farmington
W. JEROME HARRISON.....	"	GEO. H. JOHNSON.....	Bridgeport
ANDREW PRINGLE.....	Scotland	MISS ADELAIDE SKEEL.....	Newbergh
CHARLES SCOLIK.....	Vienna	CHARLES WAGER HULL.....	New York
KARL SCHWIER.....	Germany	REV. G. M. SEARLE.....	"
VICTOR SCHUMANN.....	"	C. W. CANFIELD.....	"
W. J. STILLMAN.....	Athens	P. C. DUCHOCHOIS.....	"
PROF. H. D. GARRISON.....	Chicago	HENRY M. PARKHURST.....	"
PROF. S. W. BURNHAM.....	"	REV. C. E. WOODMAN, PH. D.....	"
HENRY L. TOLMAN.....	"	H. EDWARDS-FICKEN.....	"
GAYTON A. DOUGLASS.....	"	S. H. HORGAN.....	"
A. HESLER.....	"	WM. KURTZ.....	"
GUSTAV CRAMER.....	St. Louis	J. M. MORA.....	"
J. F. EDGEWORTH.....	"	PROF. L. C. LAUDY.....	"
W. H. SHERMAN.....	Milwaukee	A. BOGARDUS.....	"
GEORGE EASTMAN.....	Rochester	CHAS. D. FREDERICKS.....	"
DAVID COOPER.....	"	A. MORENO.....	"
PROF. H. W. LORD.....	Columbus	C. W. DEAN.....	"
H. MCMICHAEL.....	Buffalo	DR. O. G. MASON.....	"
JOHN CARBUTT.....	Philadelphia	ERNEST EDWARDS.....	"

The Photographic Times { Monthly edition issued on the } Issued Every Friday  
 last Friday in the month.

### —SUBSCRIPTIONS.—

One copy Weekly issue, postage included, to all points in U. S. or Canada.....	\$ 3 00
One copy Monthly issue, postage included, to all points in U. S. or Canada.....	2 00
Weekly issue to foreign addresses, postage included.....	4 00
Monthly issue to foreign addresses, postage included.....	3 00

Single copy, Weekly, 10 cents  
 A month's trial (four weeks), of the Weekly for 30 cents.  
 A specimen number free.

Single copy, Monthly, 25 cents.  
 Remit by Express, Money Order, Draft,  
 P. O. Order or Registered Letter.

Subscriptions to THE PHOTOGRAPHIC TIMES received by all dealers in photographic materials in this Country, Canada, West Indies, Great Britain, Australia, New Zealand, and by the publishers,

## SCOVILL MFG. CO.

W. IRVING ADAMS, Agent.

No. 423 Broome Street, New York.

The Weekly Photographic Times and Philadelphia Photographer to one address, \$6.50.

Subscribe now and Secure the back numbers before they are all sold.

USE



USE

*Is liable to break his Ground Glass, and to have no ready means of supplying a new one. This article frowed upon plain glass will make a capital substitute.*

ANY PHOTOGRAPHER

HANCE'S  
GROUND GLASS  
Substitute.

Manufactured only by

ALFRED L. HANCE,  
PHILADELPHIA.

AS A RETOUCHING VARNISH;  
*For making Ground Glass wherever needed; for Doors; for Skylight; for Camera Boxes, it has no equal. Good Ground Glass is hard to get; this Substitute never fails.*

BATH.

Nitrate of Silver Cryst. 35 grs.  
Water. 1 OZ.  
Iodate of Silver. Near Saturation.  
Sulphate of Nitric Acid. C.P.

ELBERT  
ANDERSON'S  
ORTHO  
COLLODION.

Protosulphate of Iron. 1 OZ.  
Acetic Acid "Vogel" 1 OZ.  
Water. 24 OZ.  
Alcohol. Quantum Suf.

DEVELOPER.

Scovill Manufacturing Company, Trade Agents.  
FOR SALE BY ALL DEALERS.

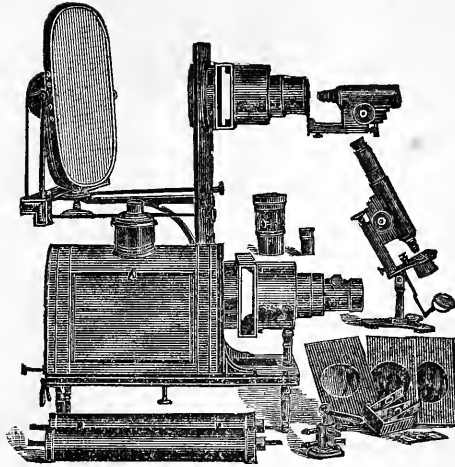

# OPTICAL AND ELECTRICAL INSTRUMENTS.

We desire to call the attention of  
TEACHERS, SCIENTISTS, LECTURERS, and  
those interested, to our

**Stereopticons, Microscopes, Dr. McIntosh's Solar Microscope and  
Stereopticon Combination Apparatus for  
the Oxy-hydrogen and Ether-oxygen Lime Light, Photographic  
Transparencies, Microscopical Preparations, etc.**

Our Instruments and Apparatus are new in design and have many improvements  
that overcome difficulties heretofore considered unavoidable. We also manufacture

**Static Electric Machines, Batteries, Magnets, and a Full Line of  
Electrical Apparatus for Practical and Experimental  
Purposes.**



We received the highest  
award at the New Orleans  
World's Exposition, on  
both Optical and Elec-  
trical Apparatus, in com-  
petition with the best of  
home and foreign manu-  
facturers.



Illustrated Catalogue of Optical and Electrical Apparatus sent free on application  
by mentioning this journal.

**McIntosh Galvanic and Faradic Battery Co.**  
Nos. 300 & 302 Dearborn Street,  
CHICAGO, ILL., U. S. A.

Number 284.

30 Cents.

THE  
PHILADELPHIA  
**Photographer.**

AN ILLUSTRATED SEMI-MONTHLY JOURNAL,  
DEVOTED TO PHOTOGRAPHY.

## SUMMARY OF CONTENTS.

	PAGE		PAGE
Millions Wanted, and Money in It. By A		Stellar Photography, . . . . .	625
RETIRED WATCHMAKER, . . . . .	609	Our Picture, . . . . .	627
Photographing the Living Heart, . . . . .	610	Photo. Facts and Fancies, . . . . .	628
How Shall We Aim? By J. F. RYDER, . . . . .	613	Hepworth's Four Poster. By F. C. HEP-	
Cloud Portraits with Orthochromatic Plates		WORTH, . . . . .	628
Behind Orange-Yellow Glasses, . . . . .	614	Developers for Instantaneous Prints, . . . . .	630
Good Dry Plates Nineteen Years Old, . . . . .	614	A Photographic Feat Extraordinary, . . . . .	630
New Eyes for Science, . . . . .	615	Argentic Dry Plates for Positives, . . . . .	632
The Humor of It, . . . . .	618	On the "Triennial," . . . . .	633
The Flap Shutter. By G. G. MITCHELL, . . . . .	619	Concerning Cardboard, . . . . .	634
Queries, Conundrums, and Conclusions, . . . . .	621	Practical Points from the Studios, . . . . .	634
Printing on Silk, . . . . .	622	On the Use of Hydroquinone in Photog-	
Production of Grained Gelatine Sheets, . . . . .	622	raphy. By M. E. JOLY, . . . . .	635
Salts of Iron Printing Processes. By W. E.		The World's Photography Focussed, . . . . .	635
WOODBURY, . . . . .	622	Gray's Vest Camera, . . . . .	638
Society Gossip, . . . . .	624	Editor's Table, . . . . .	639

OUR PICTURE.—"A Child Study." Negative and Phototype print by F. GUTKUNST, Philadelphia.

EDWARD L. WILSON,

853 Broadway, New York.

SUBSCRIPTIONS RECEIVED BY ALL NEWS AND STOCKDEALERS

Five Dollars per Annum, in Advance.

## ADVERTISEMENT S.

ANTHONY & CO., E. & H. T. The New N. P. A.  
 Pensé Extra Brilliant Dresden Albumen  
 Paper.  
 BIGELOW'S ARTISTIC PHOTOGRAPHY.  
 CARBUTT, J. Gelatine Dry Plates and Improved  
 Dry Plate Lantern.  
 CODMAN, C. H. & CO. Photo. Stockdealers.  
 COLLINS, A. M. MFG. CO., Photograph Cards.  
 CRAMER, G. Lightning Plates.  
 COOPER, CHAS. & CO. Photo. Stockdealers.  
 DOUGLASS, GAYTON A. & CO. Photo. Stock-  
 dealers.  
 DRESCHER, F. & CO.'S. Improved Gelatine for  
 Emulsion.  
 EASTMAN DRY-PLATE AND FILM CO.  
 ENTREKIN, W. G. Patent Eureka Burnisher.  
 Duplex Rotary Burnisher. Duplicating Print-  
 Cutter.  
 FRENCH & CO., BENJ. Voigtlander & Son and  
 Darlot Lenses. The Wonderful Euryscope.  
 GENNERT, G. Eagle Dry Plates.  
 HERRMANN, CHAS. A. W. Hypo. Soda.  
 INGLIS, JAMES. Dry Plates.

JANENTZKY & WEBER. Artist Materials.  
 McINTOSH GALVANIC AND FARADIC BAT-  
 TERY CO.  
 MOSS ENGRAVING CO.  
 PHELPS ENAMELING CO. Non-gelatine Pro-  
 cess of Enameling.  
 PHOTOGRAPHERS' ART VINE.  
 PHOTO-GRAVURE CO.  
 PHOTOGRAPHIC TIMES.  
 ROBERTS & FELLOWS. Photo. Stockdealers.  
 SCHMIERS, WERNER & STEIN, Phototype or  
 Heliotype Steam Presses, Leipzig, Germany.  
 SCOVILL MANUFACTURING CO. New Dres-  
 den Albumen Three Crown Paper. Gihon's  
 Cut-Outs. Photo. Apparatus.  
 SMITH & PATTISON. Photo. Requisites.  
 ST. LOUIS DRY PLATE COMPANY.  
 SWEET, WALLACH & CO. Photo. Supplies.  
 THE ARGENTIC DRY PLATE.  
 THE DU BOIS FILING CASES.  
 WILSON, G. W. & CO. Magic Lantern Slides.  
 WILSON'S BIG OFFER.

---

## ADVERTISING RATES.

THE PHILADELPHIA PHOTOGRAPHER is acknowledged to be the best advertising medium in the trade.

Its circulation is among the first class, at home and in nearly every foreign country.

Its rates, all advantages considered, are the most favorable, and it will bring you fine returns.

	One Issue.	Six Issues.	Twelve Issues.	Twenty-four Issues.
1 Page.....	\$20.00	\$110.00	\$200.00	\$350.00
1-2 " .....	12.00	66.00	120.00	200.00
1-4 " .....	7.00	38.50	70.00	120.00
1-8 " .....	4.00	22.00	40.00	70.00

Special contracts made with bona-fide dealers and manufacturers. Address

**EDWARD L. WILSON,**  
 853 BROADWAY, NEW YORK.

---

## NOTICE TO SUBSCRIBERS.

In remitting by mail, a post-office order, or draft, payable to the order of EDWARD L. WILSON, is preferable to bank-notes. Postage stamps of the denomination of two and five cents each will be taken. Clearly give your Post-Office, County, and State.

Foreign subscriptions must be accompanied by the postage in addition.

---

**FIRE!** Our books having been all destroyed by fire at and with our establishment, all who owe us will confer a great favor by remitting at once.

**CROSSCUP & WEST ENGRAVING CO.**  
 907 Filbert St., Philadelphia.

ALFRED M. COLLINS,  
*Secretary and Treasurer.*

HENRY H. COLLINS,  
*President.*

EDWARD COPE,  
*Vice-President.*

A. M. Collins Mfg. Co.

*MAKE ALL KINDS OF*

**CARDS AND CARDBOARDS**

FOR

**P** PHOTOGRAPHERS **S**

AND

**MATS, MOUNTS, AND ENVELOPES**

FOR

**FERROTYPES.**

---

OFFICE AND WAREHOUSE,

**No. 527 ARCH STREET,**

**PHILADELPHIA.**

---

Price Lists may be had by intending purchasers on application to us, or to all Photographic Merchants, through whom your favors are respectfully solicited.

# ENTREKIN'S PATENT EUREKA BURNISHER.

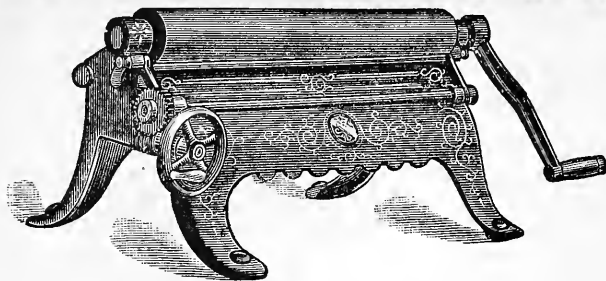

The above cut represents our 25 inch Eureka.

The unprecedented popularity of this Burnisher is wonderful. Over seventeen thousand (17,000) sold in less than five years. Agencies in London, Berlin, and Vienna, and sold by all stockdealers in the United States. The machines are built in first-class style, and warranted to do the work claimed.

Full directions accompany each machine.

## PRICES:

6 inch Roll, . . . . .	\$15 00	20 inch Roll, . . . . .	\$60 00
10 " " . . . . .	25 00	25 " " . . . . .	70 00
14 " " . . . . .	35 00		

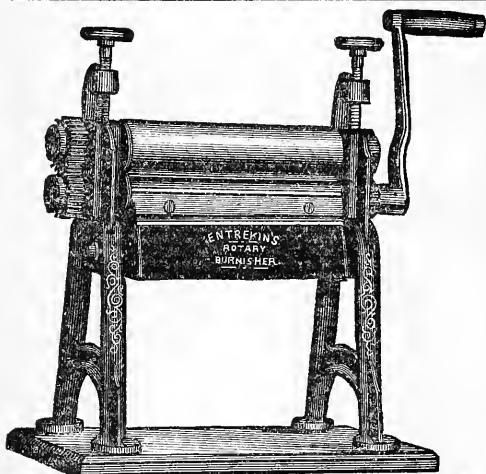

# ENTREKIN'S Duplex Rotary Burnisher.

PATENTED JUNE 1, 1875.

## PRICES:

10 inch, . . . . .	\$15 00
15 " . . . . .	25 00
20 " . . . . .	35 00
25 " . . . . .	45 00

# ENTREKIN'S DUPLICATING PRINT CUTTER.

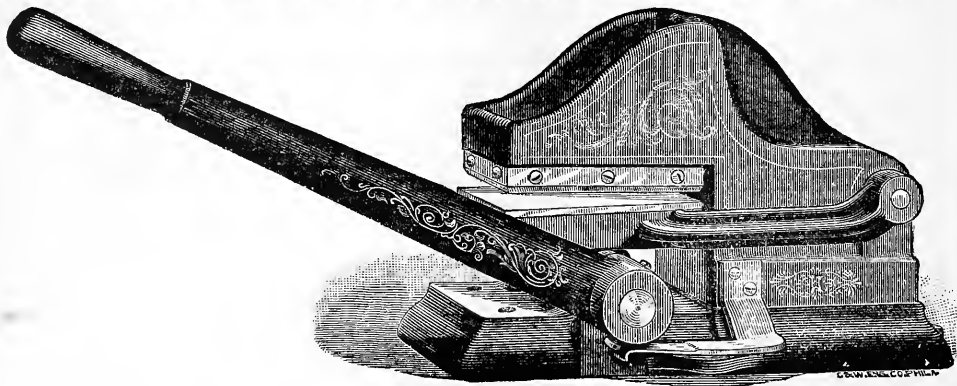

Cabinet and Stereo. Sizes, \$25.00

Small Panel Size, \$35.00.

Size 6½ x 8½, \$40.00.

MANUFACTURED AND FOR SALE BY

W. G. ENTREKIN, 4384 Main St., Manayunk, Phila., Pa



# ENTREKIN'S

## IMPROVED

# DUPLEX ROTARY BURNISHER.

PATENTED.

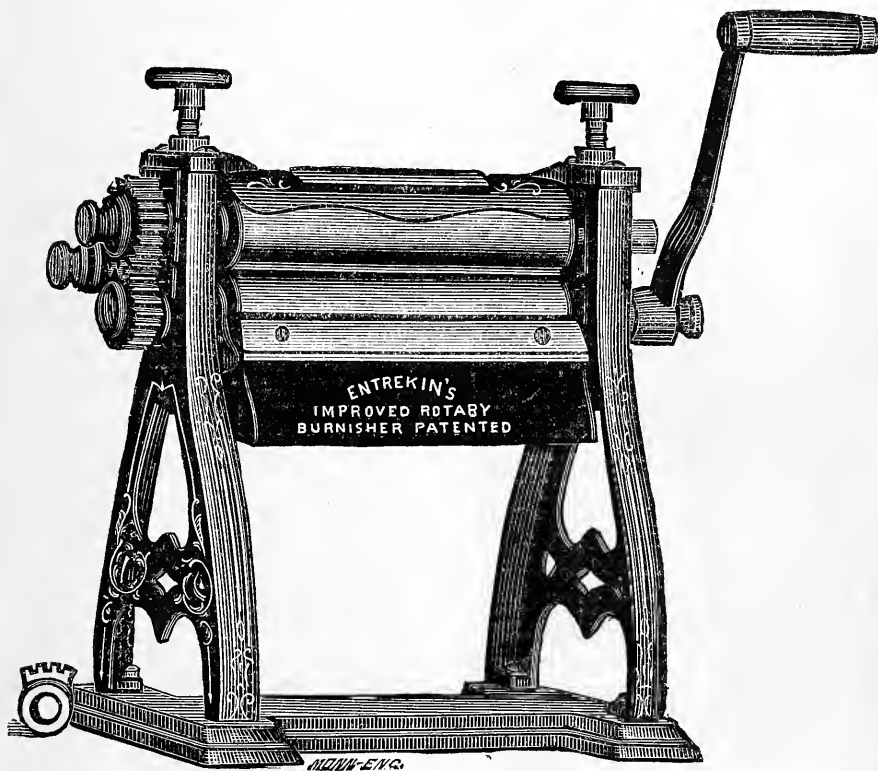

10 in., \$25.00. 15 in., \$35.00. 20 in., \$45.00. 25 in., \$60.00.

This Machine is an improvement on our old Duplex Rotary Burnisher, invented by us in 1874.

It is so constructed that by changing the Large Gear or Cog-wheel, from the stud to the end of the draw-file or upper roll, you reverse and change the speed of the lower or polishing roll, thus getting the same result as in the old Duplex Rotary; but to secure the best polishing surface, use the machine with the large cog-wheel on the Stud, by so doing you secure three times the polishing surface. All the machines will be sent out with gearing so arranged as to give this result. It is optional with the Photographer how he may use the machine. The Fire-Pan is so arranged that it is impossible for it to come in contact with the surface of the polished roll, and it can be turned away to cleanse the roll.

**EVERY MACHINE WARRANTED PERFECT.**

FOR SLE BY

**W. G. ENTREKIN, Inventor and Sole Manufacturer,**

4384 Main St., Manayunk, Philadelphia, Pa.

AND BY ALL PHOTOGRAPHIC STOCKDEALERS.

# BENJ. FRENCH & Co.

No. 319 WASHINGTON STREET, BOSTON,

Sole Agents in the United States for the Celebrated Lenses  
Manufactured by

## VOIGTLÄNDER & SON.

ALSO, THEIR FAMOUS

### EURYSCOPE,

Which is unrivalled for groups, full-length figures, and other demands in the gallery, and every species of out-door work, including instantaneous photography.

☛ **THE EURYSCOPE** is made *exclusively* by Voigtländer & Son, and their name is engraved on the tube.

FOR **DARLOT LENSES** FOR  
PORTRAITS. VIEWS.

IMPORTERS, ALSO, OF THE CELEBRATED

TRAPP & MÜNCH

## ALBUMEN PAPER,

AND DEALERS IN ALL KINDS OF

*Photographic Materials and Magic Lantern Slides.*

SEND FOR OUR NEW ILLUSTRATED PRICE LIST OF LENSES.

# A CARD.

75 STONE ST., ROCHESTER, N. Y., July 26, 1886.

GENTLEMEN: About three months ago the business of Inglis & Co., of this city was formed into the Inglis Dry Plate Co.

In the articles of agreement, a clause was inserted giving the I. D. P. Co. the exclusive use of the name of "Inglis," and also that James Inglis would not connect himself with any dry plate business using the name of "Inglis."

Matters have taken such a form since then, he has been compelled to leave the I. D. P. Co. And being thus debarred from the use of his own name, adopts this means of making known to his numerous customers where they may still obtain his plate. **And the Only Place.**

A new firm taking the name of the **ROCHESTER DRY PLATE CO.** have engaged his services, and under his supervision a new factory has been fitted with the most modern improvements required for the production of **clean and spotless** plates, with all the other extra qualities that his plate has become so renowned for. The fraternity may therefore depend upon the very finest plate ever yet produced, from the **ROCHESTER DRY PLATE CO.**

## JAMES INGLIS,

Late Manufacturer of the Inglis Dry Plate, and President  
of the Inglis Dry Plate Co.

---

## OUR SPECIALTIES.

BROMIDE AMMONIUM, Chem. Pure.

BROMIDE POTASS., Chem. Pure.

NITRATE SILVER, Chem. Pure.

### FOR DRY PLATES.

CROSS-SWORD DRESDEN ALBUMEN PAPER,

Single and Extra Brilliant. The Best in the Market.

ALSO A GENERAL LINE OF

PHOTOGRAPHIC CHEMICALS.

A circular, "How to Save Waste," sent on application.

**CHAS. COOPER & CO.**

194 Worth St., New York.

**THE LATEST!**

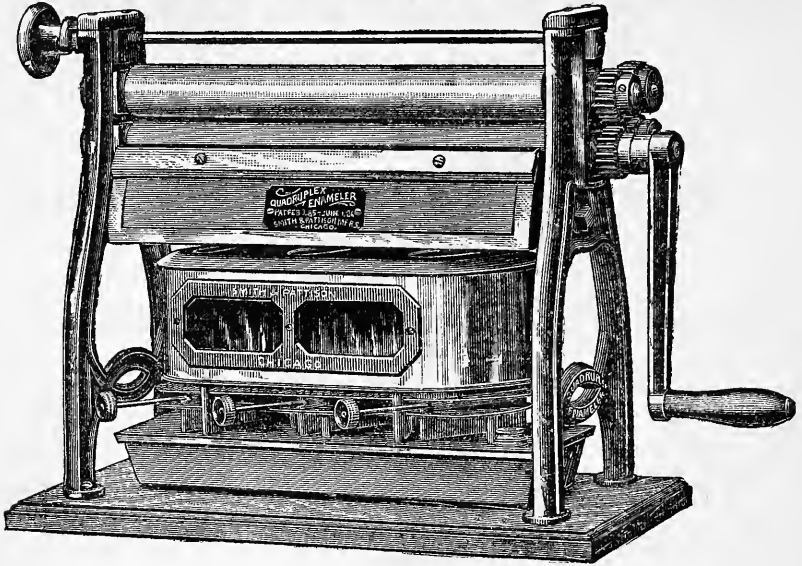

Patented Feb. 3, 1885, and June 1, 1886.

**THE QUADRUPLEX ENAMELER.**

**A GREAT IMPROVEMENT OVER ALL DUPLEX ROTARY MACHINES HERETOFORE MADE.**

**IMPROVEMENT No. 1** consists of a new device for regulating the pressure on the cards by means of one *hand screw* instead of two as heretofore used, making the pressure *uniform* and *positive* the whole length of the roll, while with all "Duplex" machines it takes a great deal of *time* and *care* to maintain a *uniform pressure*.

**IMPROVEMENT No. 2** consists of such an arrangement of *4 cogs* as enables the operator to adjust the distance between the two rollers to accommodate any thickness of card, from the very thinnest to the heaviest made, without visibly *disconnecting or separating the cogs from each other*, causing the rollers to revolve just as smoothly, and the gearing to operate just as perfectly on thick as on thin cards. *This is impossible when but 2 cogs are used.*

**IMPROVEMENT No. 3**, covers the general construction of the machine. It is *new in design*, and more perfect *mechanically* than any of the "Duplex" machines, one of the most noticeable improvements being in the roller bearings.

**IMPROVEMENT No. 4** consists of the *beautiful finish* given these machines. *They are full nickel plated, all over.* They are a *handsome ornament* for any studio.

**IMPROVEMENT No. 5** consists of a new Kerosene Heater of our own design, which will heat them up fully one-third quicker than those heretofore used.

The finish given to photographs with this machine is superior in brilliancy to many "enameled" pictures we have seen, and much more durable than enamel. **NO LUBRICATOR USED. NO SCRATCHES POSSIBLE. NO SPOILING OF PRINTS.**

**IT IS THE BEST. TAKE NO OTHER.**

**PRICES.**

**GAS OR OIL HEATERS INCLUDED.**

10 Incl., . . . . .	\$25 00	20 Inch, . . . . .	\$45 00
15 " . . . . .	35 00	25 " . . . . .	55 00

**MANUFACTURED BY**

**SMITH & PATTISON,**

145 & 147 Wabash Ave., CHICAGO.

# The Photo-Gravure Company,

853 Broadway, New York.

PHOTO-  $\left\{ \begin{array}{l} \text{GRAVURE} \\ \text{LITHOGRAPH} \\ \text{CAUSTIC} \\ \text{GELATINE} \end{array} \right\}$  PRINTING

## PROCESSES OF THE PHOTO-GRAVURE COMPANY.

**PHOTO-GRAVURE.**—By this process the highest artistic effects are produced. Metal plates are engraved (in intaglio) by photography and printed in copper-plate presses. The effects produced by photography may be altered by the hand of the artist, values may be increased or diminished, and almost any omission or addition made. The work may be carried on till the desired effect is produced and the edition is always uniform. The plates can be supplied when desired, or the Photo-Gravure Co. will do the printing. The results obtained by the Photo-Gravure Co. equal the best results obtained abroad, and reference to this effect is permitted to leading Publishers and Artists who have used these plates. All classes of subjects, whether in half-tone or line, can be produced by this process.

**PHOTO-GELATINE PRINTING.**—The results produced by this process are similar to what is known as Albotype, Artotype, Heliotype, Autoglyph, Phototype, Lichtdruck, etc. The particular method used is that patented by Mr. T. C. Roche, and is believed to give the best results at the least cost. The Photo-Gravure Co. has in this department the best staff of printers in the country and a most extended experience of the treatment of gelatine for the purposes of printing. All classes of subjects are suitable for reproduction by this process, and it is especially suitable for portraits, views, architecture, art catalogues, scientific and natural objects, book illustration, town, county, and family histories, theatrical and general advertising, reproductions of engravings, machinery, animals, and still life, copies of deeds, instantaneous effects, scientific records, mill labels, etc.

**PHOTO-CAUSTIC PRINTING.**—This term is applied to a modification of the results produced by Meisenbach, Ives, and others. By this modification the photographic effect is produced from stone. No attempt is made to produce engraved plates, but the printing is done by the Photo-Gravure Co., and by this means greatly better results are obtained than where plates are made and placed in the hands of the ordinary printer. The results are not as good as those obtained from Gelatine or by Photo-Gravure, but they are sufficiently good for a number of purposes where the quality of the higher grades of work is not necessary. It is applicable to all the purposes of the other processes, but is lower both in cost and quality.

**PHOTO-LITHOGRAPHY.**—The results of this well-established process are well known. It is the oldest of the photo-mechanical processes, but is only adapted to the reproduction of original drawings or engravings which are made in a black or other non-actinic color on a white or light ground. We have in our employ on this work the most skilful staff in the country, who for many years have made it a specialty. Photo-Lithography is unrivalled for the reproduction of maps, plans, tracings, surveys, patents, and other drawings, engineers' and architects' designs, *fac-simile* letters and circulars, exhibits in law cases, miniature catalogues, copies of line engravings, reduction or enlargement of line work, etc.

A Book of Specimens of our various processes will be forwarded on receipt of One Dollar, and all inquiries will be promptly answered. Special arrangements made with photographers.

THE PHOTO-GRAVURE CO.,  
853 Broadway, New York.

SEND FOR OUR CATALOGUE, AND GET THE BEST Of Everything.

DALLMEYER LENSES,  
SUCCESS CAMERAS,  
THE FAIRY CAMERAS,  
THE NOVEL CAMERAS,  
SCHMID'S DETECTIVE CAMERA

APPARATUS OF ALL KINDS.  
Chairs,  
Neg. Boxes,  
Camera Stands  
Printing Frames,  
Etc., Etc.

**BUY THE BEST!**

No other will give you half so much satisfaction.

FOR DRY PLATES  
ANTHONY'S Patent Perfect PLATE HOLDERS  
ARE SUPERIOR TO ALL.

DALLMEYER

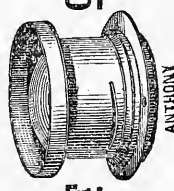

FOR WET

OR DRY

WIDE-ANGLE RECTILINEAR

E. A.

SINGLE COMBINATION, RAPID,  
WIDE ANGLE, PLATYSCOPE,  
PORTRAIT AND VIEW LENSES.

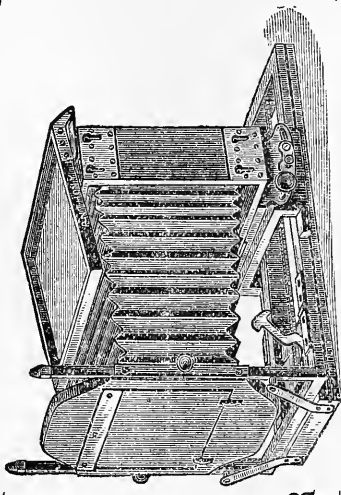

THE FAIRY CAMERA.

*The Lightest and Best for Out-door Work.*

FOR EITHER DRY OR WET PLATES  
NOTHING EQUALS

THE BENSTER PLATE HOLDER.

DALLMEYER

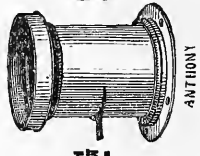

NOTHING

COMPARES

RAPID RECTILINEAR

O. I. C.

PORTRAIT, COPYING, CLIMAX  
PORTRAIT, GEM, AND  
COMPACT VIEW CAMERAS.

**E. & H. T. ANTHONY & CO. BROADWAY, NEW YORK.**

--591--

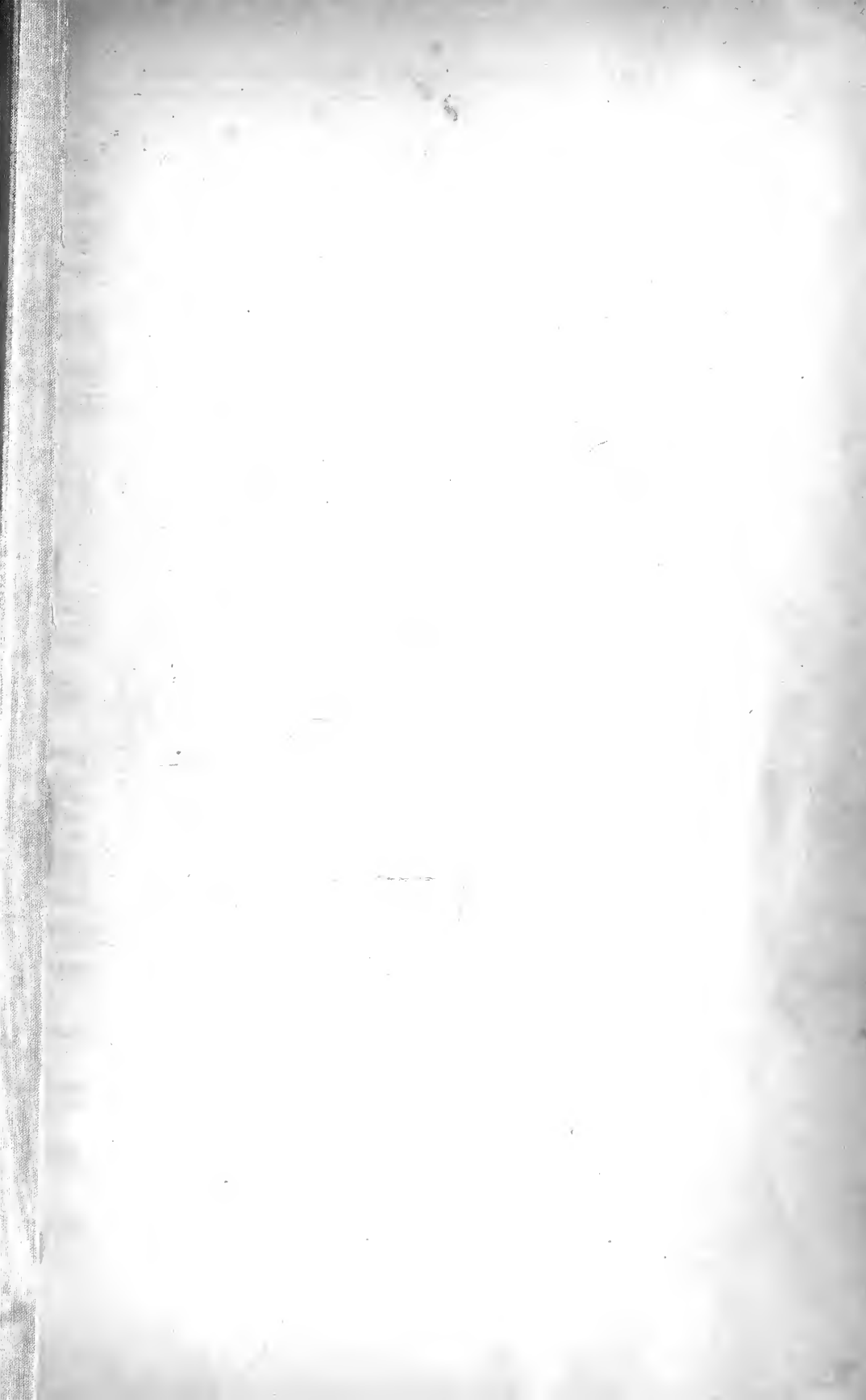





THE

# Philadelphia Photographer.

EDITED BY EDWARD L. WILSON.

Vol. XXIII.

OCTOBER 16, 1886.

No. 284.

## MILLIONS WANTED, AND MONEY IN IT.\*

BY A RETIRED WATCHMAKER.

WHAT! Trade Dollars? Oh! No! What then? Simply Watch Dials. They are made yet in a great many places by hand drawing in vitrifiable colors, and burnt in; others have plates engraved, the design filled up with color, collodion poured on when set, then transferred to the dial. Simple collodion positives toned with gold or platinum, after being transferred, have been burnt in. Several of the old formulæ, by using a positive and dusting on the color, have also been tried, giving good results. But the most of them are slow and uncertain, and require skilled labor. Hundreds of experiments have been made to manufacture watch-dials by some cheap mode of photography. An old and reliable process like photo-lithography, which has been tried for similar work, is now applied to the watch-dial business with satisfactory results. The mode of operation is as follows: The watch-dial design is drawn on a large scale, say eight inches circle. From this make, by the collodion process, a first-class black and white negative, reduced to the regulation size. Next clean the dials and coat them with the following solution: Water, 20 ounces; white of two eggs; bichromate of ammonia, 60 grains; liquid ammonia, 10 drops. Well beat this with broken glass in the bottle; allow to settle, then filter

carefully. After coating the dial, place it on soap-stone, or a flat iron plate to dry, under which you have a gentle heat. When dry, expose to contact with your negative from three to four minutes in sun light. After printing, ink the whole face of the dial with fine thin lithographic ink, using any kind of a soft roller; now place the dial in a dish of cold water for a few seconds, then take some clean cotton and *gently* try to rub the ink off. You will find that where the light has acted the ink will stick, and the other portion will wash out clear. If the proof all washes out it shows you have not exposed long enough, and *vice versa*. You now give the dial a wash with some clean water, and set up to surface-dry for a few minutes. Lastly, you require some of the finest powdered vitrified black, or any color you may choose (any first-class enameler will furnish it). This you apply all over your dial with a soft, camel's hair brush. The color will stick readily to your ink; any excess you can brush off with another clean brush (keep your brushes dry). The dial is now all ready for burning-in, and should be handled carefully; any enameler will do the vitrifying at a very low price. When burnt it requires no flux; you cannot injure it by scraping.

The above formula can be used without any restrictions. There are to-day more watch cases than dials to put on them. Of course, the above process can be used on tile, etc. Try it.

\* In advance, from *Mosaics*, 1887.

### PHOTOGRAPHING THE LIVING HEART.

OUR readers have, from time to time, been informed of the interesting results of Dr. Stein, of Vienna, in photographing the

graphing instantaneously the movements of the heart while in motion.

In the *Medical Record*, published by Wm. Wood & Co., Lafayette Place, New York, Dr. Thompson details his experiments and

FIG. 1.

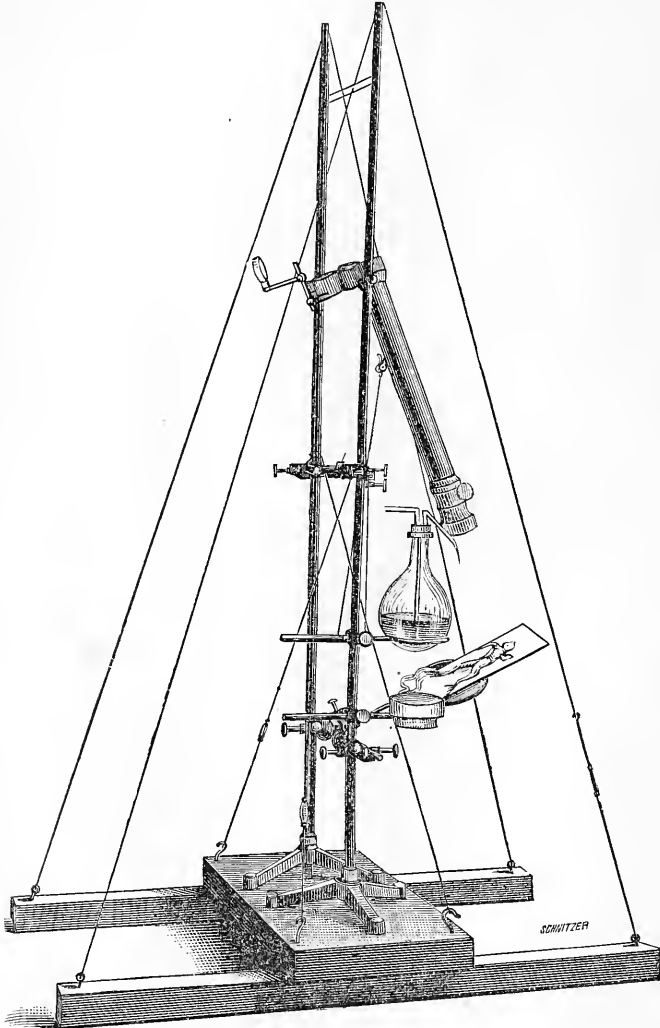

The Camera mounted.

throat, stomach, etc., but his daring attempts with the camera have been eclipsed recently by Dr. William Gilman Thompson of this city, who has succeeded in photo-

successes, and illustrates his papers with engravings from his pictures. Moreover, he supplies a drawing of his most ingenious apparatus for doing his work. Through

the courtesy of the publishers we are able to reproduce these, with some excerpts from Dr. Thompson's contributions.

Dr. Thompson says:

In so far as I am aware, the application of instantaneous photography to the study of the movements of the heart and intestines has not heretofore been undertaken. For some time I have sought a satisfactory method to measure the degree of alteration in size and form of the living heart between systole and diastole, both normally and under the influence of drugs. The methods I have attempted were: 1. To adapt various forms of linear measures, disks, etc., to the contour of the heart. 2. To encase the beating heart in a chamber of some plastic material which soon hardens and is impervious to serum. The chamber communicates with an upright graduated glass tube, and if the portion of the chamber not occupied by the heart be filled with serum, the latter will be driven into the tube at each pulsation with a force proportionate to the strength of the systole. The volume of serum displaced represents the change in size of the heart. The evident difficulty is to make the plastic material fit tightly about the great vessels of the heart without compressing them too much. Moreover, this method only measures changes of the heart in bulk, not in form, and is so difficult as to be wholly unsatisfactory. 3. To throw a magnified image of the pulsating heart upon a screen by a modified magic-lantern ("panopticon"). A scale marked upon the screen serves to measure changes in size, or a ground-glass screen can be used, upon which the heart can be drawn. Any one who has studied the living heart is convinced of the difficulty of making drawings of it while in motion which are at all accurate.

To study the movements of the heart and intestines, I have had constructed a special apparatus which leaves little or nothing to be desired in accuracy and rapidity of movement. The apparatus was devised by Mr. R. D. Gray (the inventor of the ingenious "vest camera" and other photographic improvements) and by myself. I described what was required and suggested various modifications and improvements, but the mechan-

ical details were worked out exclusively by him. To test the rapidity of the camera we photographed a "horse-timer" clock, with a dial marking quarter-seconds, and succeeded in taking five distinct photographs in half a second with *one* lens, which has never before been accomplished excepting by Professor Marey, at the College de France, who has taken successive views of flying birds, falling balls, etc., with one lens at a very rapid rate. His camera was unknown to me until after mine was constructed, so that as a success in photography alone the work is interesting.

The camera consists of a circular brass box, five and a half inches in diameter and one and a quarter inches deep, containing a circular vulcanite shutter with two apertures, behind which is placed a circular dry plate. Both plate and shutter are revolved in opposite directions to each other by a simple arrangement of four cogged wheels moved by a single crank. The box is perforated at one side by a circular opening, one and three-quarter inches in diameter, from the margin of which projects at a right angle a long brass tube (Fig. 1), which carries the lens. In Fig. 2 the lid of the box has been removed, and the bottom of the box, with the wheels, springs, and partially closed shutter, is presented. The lid is double—that is, it is a flat box in itself. It contains nothing but the dry plate, supported at its centre upon a small brass disk, against which disk it firmly pressed by a pivot attached to a spring fastened in the lid. The aperture in one side of this double lid, which corresponds with that seen in the floor of the box, may be closed by a slide, so that the lid containing the plate can be removed like an ordinary plate-holder and carried to a dark room, where it is opened and the plate is changed. When the lid is replaced this slide is removed, and as the shutter is made to revolve, the light falls upon whatever portion of the dry plate happens to be opposite the opening.

By reference to Fig. 2 it will be seen that when the large wheel which projects outside of the box is revolved by a crank it turns the small ratchet-wheel, which bears an eccentric pawl. (The crank has been removed in Fig. 2; it is seen in Fig. 1.)

The central wheel has only six cogs. The pawl is pressed into one of these cogs by a spring. It pushes the central wheel around one-sixth of its circumference, when it returns to be pressed into the next cog. While the pawl returns it necessarily leaves the central wheel at rest, and whatever mo-

The two apertures in the shutter are so placed that at the instant of exposure of the plate it is momentarily at rest, while the plate when moving is covered by the shutters. This arrangement prevents vibration of the plate and blurring of the image. The camera is mounted by two lateral axes with

FIG. 2.

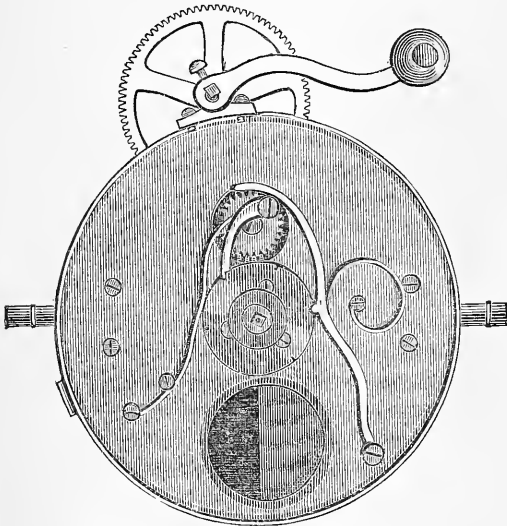

Interior of the Camera.

mentum this wheel carries is checked by a simple stop pressed by a spring upon the opposite side. The central wheel carries a square axle, which projects through a small hole in the centre of the double lid and fits into the brass disk before alluded to, causing the disk to revolve with the axle. The disk is covered by rubber cloth; and as the dry plate is pressed firmly against the rubber surface by the spring in the lid, the plate adheres to the rubber and revolves with the disk. Thus every complete revolution of the central wheel in the floor of the box carries with it the dry plate, stops it, and moves it on again six times. The velocity of revolution of the plate is only limited by the rapidity with which one can turn the crank.

The shutter is revolved in the opposite direction by a wheel whose cogs are seen fitting into those of the little wheel carrying the eccentric pawl.

screw clamps upon two iron stands, such as are in common use in chemical laboratories. A brass rod attached to the tube steadies it, and allows it to be screwed fast at any angle corresponding to the angle at which the heart is placed. It is thus easy to put a manometer tube in the femoral artery of an animal, bend it if alongside of the exposed heart, and simultaneously photograph the cardiac contraction and the degree of rise of the fluid in the manometer. The tube is arranged like the draw-tube of a microscope. It is made long, so as to admit of taking small hearts at life-size. The stand carries a support for the frog or other animal to be experimented upon, and a bottle of physiological salt solution kept warm by a spirit lamp beneath.

The whole apparatus is readily packed in a small space. It has the great advantage that six photographs of a single cardiac pulsation, or of any muscular contraction, may be easily taken in less than one second, or, by simply turning the crank slower, they may be taken at any desired rate to keep pace with the rhythm of the heart. The second-hand of a watch may be placed in the field of view and simultaneously photographed with the heart, so that there can be no question about the series of photographs all belonging to one pulsation.

Dr. Thompson further says: "I have taken a large number of instantaneous photographs of the hearts of different etherized animals beating *in situ*, and they demonstrate the following points:

"1. For students and those who have not inclination or facility to study the living heart for themselves, they give a clearer conception of its phenomena than any other method.

"2. They are more accurate than drawings or casts.

"3. The heart is as nearly in a natural condition, both as to the systole and diastole, as is possible with an open chest-wall. Artificial respiration may be easily maintained, and, with assistants, kymographic and other observations may be simultaneously recorded.



Pigeon's heart in motion. A, full diastole; B, full systole, produced by application of hot salt and water.

"4. A series of photographs may be taken between full systole and full diastole which can be compared and studied at leisure.

"5. The photographic method shows more than simple linear measurements, for it gives an accurate periphery as well as diameters, and by perspective gives a fair idea of changes in bulk as well as in form.

"6. The movements of the heart as a whole, and the forward and upward movement of the apex, which occurs in many animals, is clearly demonstrable.

"7. In addition, the most practical application of the method is the illustration of the changes in the form of the heart produced by drugs. Thus instantaneous photographs of normal systole and diastole are taken, then an injection of digitaline is given and the effect of increased force of the systole is photographed and compared with the normal. The effects of doses of varying strength may be thus compared. The contraction produced by dropping a one per cent. solution of glonoin upon the heart shows exceedingly well in a photograph as contrasted with normal systole. I have also obtained photographs of the transverse section of the ventricles in relaxation, and in the contraction that follows thermic stimuli, even after the heart is cut in two. Any experimental work upon the heart while beating *in situ*

may be accurately photographed, and many details become apparent when studying the photographs at leisure, which are otherwise almost impossible to observe, or quite impossible to record at the time of observation.

"8. The negatives placed in a magic-lantern, show admirably upon a very large scale.

"The series of instantaneous photographs which I have taken of peristaltic movement in the intestines show plainly the effects of progressive degrees of contraction of both longitudinal and circular muscular fibres, and the effects of stimuli, chemical, thermic, mechanical, etc.

"It is difficult to follow accurately with the eye at one time the changes that take place in more than a single loop of intestine, but the camera records the progressive changes occurring in a number of loops, both above and below the one experimented upon.

"The application of instantaneous photography may be further extended to the study of the contractions of the stomach, bladder, and diaphragm, and possibly to the study of the movements of the uterus in pregnant animals, and the lungs in artificial respiration.

"The method is so easy and so accurate that I trust it may prove of permanent value in enlarging our knowledge of the action of drugs upon the cardiac and intestinal viscera, and possibly other organs."

Surely this is one of the most wonderful scientific applications of our art, and entitles Dr. Thompson to the highest praise for his industrious efforts.

---

### HOW SHALL WE AIM?

BY J. F. RYDER,  
Cleveland, O.  
(In *Mosaics*, 1887.)

NEARLY two score years of intimacy with photography, together with the affection it begets by association and the pride it engenders from success (if the follower be true to himself and his calling), should be sufficient to hold one from hesitation; but, Ike Marvel like, a man may sometimes muse through the clouds from his good pipe, or the haze which rises from the road that stretches into the past, over which he has

toted his burden. He may look aloft and alow; he may "cast about" and wipe his specs before pointing his camera.

The *grand aim* shows him the best achievements of photography, wherein enter painstaking care, honest and faithful work, whose careful study proclaims a dash of art such as the maker may contemplate with satisfaction, such as the connoisseur may behold with pleasure, and the patron may cheerfully pay for without haggling.

That is conscientious photography. Ideal photography, perhaps—and, possibly, the fact of it—in the hands of some.

The veteran may look back upon what seems to him in this light the best days of photography.

The future he must regard with suspicion, and he hesitates to point his camera into it.

The "live photographer," the "hustler," and the young man of "marked enterprise," have done much toward killing *good, honest photography*. They have cheapened it in a double sense; they have robbed it of its former status of respectability.

The converting of quiet studios into manufactories, rushing sitters through by the score or hundred, grinding cabinets out by the thousand daily, at prices so shamefully low that quantity of production must represent profit, may be enterprise, but it is fatal to excellence.

Few men pursue photography for pleasure alone. The money-consideration which, until the past very few years, has been fair, becomes now the problem.

Shall the earnest, conscientious photographer throw himself in the midst of the struggling rabble, with a dozen cabinets in one hand and the other outstretched for a dollar? Let each man answer for himself. How shall we aim?

### CLOUD PORTRAITS WITH ORTHOCHROMATIC PLATES BEHIND ORANGE-YELLOW GLASSES.

I HAVE recently made an experiment concerning the effect of yellow and red glasses upon the clearness with which glaringly illuminated clouds detach themselves from the blue sky, and I have observed an extraordinarily favorable influence in this direction.

If the sky be viewed through dark-yellow, or, better still, red glasses, it appears almost black, and the clouds stand out clearly and plastically. A trial picture confirmed the supposition that by bringing these colored glasses before the objective, and by using yellow or red sensitive plates, the clouds can be better photographed than by the ordinary method. If a dark-yellow glass screen is used, then erythrosin or eosin plates can be employed, but when red glasses are used these plates will not do, on account of their inferior sensitiveness to red; therefore, cyanin or azalin plates, or some other kind very sensitive to red, must be used. This is to be explained in this way: by the use of the red glass, the absorption of the blue and the green part of the spectrum extends up to D (in the yellow), and lets the orange and red pass through, so that the plates for this spectral range must be as sensitive as is the case with azalin and cyanin plates.—*Photo. Correspondenz.*

### GOOD DRY PLATES NINETEEN YEARS OLD.

THE following remarkable experience is worthy of record:

JACKSONVILLE, FLA., September 21, 1886.

DEAR SIR: It is only natural that the memory of the "undersigned" should have long since faded from your recollection. These "few lines" may, however, recall the fact that I called upon you at Philadelphia in the fall of 1867, on my way to Florida, with a lot of dry tannin plates, and that I sent you some of the pictures the following season.

In the summer of 1869 I prepared a small lot of plates, but did not use them all; what I had left were put in a "Stock changing box," made by the American Optical Co. This box has been "knocking around" from that time until this summer, when I got my "rig" together; knocked off the thickest of the dust, and made the negatives from which the enclosed prints were made. If there is any case on record where plates of any kind have been kept for so long a time and retained their sensitiveness, I think it would be a fact worth knowing. These plates

were prepared according to the formula published by Charles Wager Hull in the *PHILADELPHIA PHOTOGRAPHER*, in 1865 or 1866. I followed his directions with the utmost precision, and after I had had a little practice, I scarcely ever failed to get a good negative; the only objection being the long exposure required. By the way, I claim to be the *first person* who used *dry plates* in every-day practical photography in the United States. I had already made several hundred negatives before I came to Florida, from which I had sold many thousand pictures. If there is any one ahead of me, bring him out. Although my camera has been idle since 1869, I still have a liking for the pleasures of tramping over the hills and valleys in search of "views," and hope at some future time to get a modern outfit and learn how to use it.

I was always a subscriber to the *PHILADELPHIA PHOTOGRAPHER* while I remained in the business, and you will find my name on your list again soon. Should you happen to meet Mr. Hull please tell him of the prints.

Very truly,

A. F. STYLES.

[The prints Mr. Styles sends us are most interesting, and any doubt of their genuineness is proven by the old-time opaque spots and other proofs peculiar to tannin plates. But the keeping qualities of tannin are surely established now.—ED. P. P.]

### NEW EYES FOR SCIENCE.

A VERY interesting article appears in the current number of the *Cornhill Magazine*, from which we abstract the following:

There is something almost pathetic in the poverty of the picture which the actual eyesight of the astronomer can see, as compared with that over which his mental vision ranges. . . Who would have thought that the art of taking pictures by the aid of light, which Niepce, Daguerre, Talbot, John Herschel, and others, invented almost but yesterday, would have come to the aid of the astronomer, eagerly longing to look farther out into the star depths, and to obtain clearer views of objects already within the range of his telescopes? Yet so it has been.

The stonily staring daguerrotypes, which were regarded rather as curiosities than as portraits half a century ago, contained—unpromising though they seemed—the promise of astronomical discoveries such as even a perfect telescope of the size of Lord Rosse's could not achieve.

Photography has two great advantages over ordinary vision in the work of astronomical survey. Regarding the photographic plate as replacing the retina of the human eye, and receiving, instead of it, the telescopic image of a heavenly body, we may say that this photographic eye can do three things which the human eye cannot do:

1. The photographic eye can see, on occasion, in an instant of time in which the human eye could not even begin to see.

2. The photographic eye can, on occasion, see more and more by steady staring for many minutes—nay, for many hours in succession—where the human eye, if it cannot see in a few seconds, may as well give up looking.

3. The photographic eye can record what it sees in an instant of time, or in several hours of time, as occasion may require, in a perfectly trustworthy manner, unaffected by any theories, hypotheses, or fancies, as to what the object looked at is, or may be, or ought to be.

Observe how these qualities of the photographic eye promise to help the astronomer.

In the first place, when observing the sun, the astronomer is all the time troubled by the movements taking place in our air. There is a constant fluctuation by which, when a powerful telescope is used, the image of an object is so blurred and confused, as far as the finer details are concerned, that we see these as we might see the delicate details of a very fine engraving through the disturbed air above a heated stove. Now, in reality, this blurring arises from the combination of a multitude of different pictures. At any given instant a view is presented which, though it may be slightly distorted in details, is perfectly clear; but immediately another takes its place, also perfectly clear, and only slightly distorted in details—the distortion in one view being different, however, from the distortion in the other, the two combine into a view which is not clear.

In the course of a single second, hundreds of different views are thus seen, and these are combined into a single blurred view. For though, in the case of an object of moderate brightness, the tenth of a second may be about the duration of a visual impression, yet, in observing the sun, even when his light is softened by one or other of the various devices employed for this purpose by astronomers, the successive visual impressions certainly last at least a full second.

The reader must not fall into the mistake of supposing that the image of the sun, seen in the ordinary way through a telescope, is blurred and confused so that the details of spots cannot be quite clearly seen. Under ordinary conditions the features described in the books of astronomy can be well seen, even with large telescopes in which the atmospheric fluctuations are greatly magnified. It is the minute details which escape the observer, unless the conditions are altogether exceptional, and even then there is always some fluctuation, and these details of structure can only be seen as it were by momentary flashes.

To show that this is so, we need only consider the case of Nasmyth's "willow leaves." Nasmyth supposed he had detected a number of bright interlacing objects, shaped like willow leaves, all over the sun's surface. They were willow leaves on a rather large scale, being two or three hundred miles wide and several thousand miles long! Sir John Herschel accepted Nasmyth's description as correct, though all his own observations, as well as his father's, had failed to reveal these marvellous objects. In Herschel's *Outlines of Astronomy* there is an elaborate picture of many hundreds of the interlacing bright willow leaves with dark spots where the reticulations leave uncovered spaces. But, in reality, the solar willow leaves thus shown over the general surface of the sun are only optical illusions. Instead of bright reticulations [with dark spots, the sun's surface shows dark reticulations with bright spots. Yet, long after Nasmyth had announced his supposed discovery, the matter remained in dispute because astronomers were unable to decide what they actually saw—so blurred and confused were the delicate details in question.

The photographic eye of science, had it then been directed to the sun, would have settled the question in very much less than a second; in fact, the very rapidity of its glance at the sun would have made its view of the matter decisive. At the observatory of M. Janssen, at Meudon, pictures of the sun are taken with such rapidity that each part of the solar image rests on the sensitive surface of the plate for less than one two-thousandth part of a second. Here we imagine a reader saying that *this*, at any rate, cannot be possible, because the two-thousandth part of a second is far too short a period to be measured. As a mere matter of fact, Wheatstone and Foucault have measured much less than the two-thousandth—even so little as the five hundred-thousandth part of a second. But in Janssen's photographic work, the passage of the slide through which the sun's light passed occupied perhaps as much as the tenth of a second. Since, however, only about the two-hundredth part of the entire width of the slide was open, each part of the field over which the slide swept received the solar rays only for the time we have named; and the solar image occupied the whole width of the field.

In the pictures obtained by Janssen, although the telescopic power is far less than that which astronomers have applied to the sun, the solar "rice-grains," which had only displaced the solar willow leaves after a long struggle among telescopists, are perfectly distinct. We may be said to see more of the sun, in thus viewing it at second hand, by aid of the photographic eye of science, than Sir William Herschel saw during all the many years of his long observing career. Yet, beside his largest telescope, the instrument used by Janssen at Meudon would be like a child beside a giant.

But though the promise of discovery by means of the swiftly seeing eye of photography may be great, it seems small, compared with what we may hope for from the power which the photographic eye possesses of staring steadfastly at an object until, after hours perhaps of contemplation, details come into view which would not be shown to ordinary human vision using a telescope



ten times stronger than that to which the photographic eye has been applied. Nay, it is not going at all too far to say that in this way the photographic eye will reveal what the human eye, no matter how aided by telescopic power, can never avail to see.

There is nothing to be explained in considering this method of using photography. All that has to be done is to direct a telescope of adequate strength to the celestial region to be surveyed, to let the optical image fall on a duly sensitized dry plate, and to keep the telescope moving with perfect uniformity, so as to correct the effect of the earth's rotational movement, by which otherwise the image would not only be shifted, but would presently be carried clean off the photographic field.

Observe now what promise there is in the new method of research. There seems scarcely any limit to the delicacy and sensitiveness of photographic plates. Already the movements of a galloping horse, of an express train, nay, even of a cannon-ball, have been recorded by photography. Every increase of sensitiveness means, of course, an increase of space-penetrating power for the photographic eye. Then, next, the qualities of telescopes for work of this sort admit of being greatly increased. Our telescopes have nearly all been made hitherto for ordinary vision, and the human eye observes chiefly with rays rather different from those selected by the photographic eye. Hitherto opticians have directed very little attention to the preparation of telescopes for photographic as distinguished from ordinary observing work. But this is far from being all. The steadiness with which telescopes may be poised, and the accuracy with which they may be swayed by clockwork, are daily being increased by ingeniously devised mechanism. Formerly it was thought a difficult task to keep a telescope upon an object for an hour. Now the necessary exactness of direction can be maintained for three or four hours at a stretch. And there seems absolutely no reason for doubting that hereafter the telescope may be directed, night after night, on precisely the same celestial region, and maintained throughout the night on the same region, until at last that region has been gazed on

steadily by the photographic eye for thirty or forty hours in succession.

If, instead of considering what may be, we direct our thoughts to what has been done, we find still more obvious reasons for hoping great things from this method of employing the photographic eye.

We do not dwell on the photographs of the moon and planets obtained even so late as ten or twelve years ago. Compared with the kind of work we are dealing with now, these may be regarded as among the early failures of photography. But already, though success only began to be achieved about a dozen years ago, the triumphs of the new method have been so remarkable as to leave no doubt about the future of celestial photography.

In the sword of the giant Orion there is a streak of misty light, visible even to the naked eye on a clear dark night, which has shown more and more detail as telescopes of greater and greater power have been turned upon it. But already photography has shown more in this object than has been seen through the most powerful telescope in the ordinary way. For one hour and a half the late Dr. Henry Draper kept the giant eye of his telescope turned steadfastly upon this marvellous mass of misty light, whose wisps extend from the middle star of the belt down to the lower star of the sword; and a picture of the nebula was the result which far surpasses in value all the drawings yet made by astronomers. Since Draper's early and lamented death, Mr. Common, following in the same path with a more powerful telescope and more delicately sensitized plates, has obtained an even finer picture with only half an hour's exposure. It is clear that much higher magnifying power may be employed, with exposures of three or four hours to make up for the diminished telescopic light. Nay, in the tropical regions, where Orion shines for nine or ten hours,\* still longer exposures may be given. Yet even in the photographs obtained by Draper and Common,

---

\* Orion shines as long in our skies as in the tropics—namely, about twelve hours; but his daily course is so slanted that he is most of the time very low down.

stars show which the very telescope used for obtaining the photographs would not show to ordinary vision.

Recently this method has been applied with singular success by the Brothers Henry in France. They have photographed field after field of stars in the richest regions of the Milky Way, showing stars so minute that telescopes far higher in power than is the instrument used by MM. Henry for the photographic eye would be required to show them in the usual way. In this case photography has not only done the work of seeing and charting, but also of engraving. From the negative, self-pictured by the stars, have been obtained zincographs by the usual process, which are in reality blocks engraved by the stars themselves, aided only by their fellow-star, our own sun. In the May number of the scientific journal *Knowledge*, for example, there is an engraving showing more than two thousand stars, yet the block from which this engraving has been printed has never been touched by graver made with human hands.

Even this is not all. When surveying the Pleiades the photographic eye discovered nebulous wisps clinging around two of the well-known group of seven stars, and though one of these nebulous objects had been observed several years ago, its existence had been doubted by many, while that of the other had not been even suspected. In effecting this discovery the photographic eye detected a new proof of the theory recently advanced that nebulous patches in the star-depths are not external star-systems, but part of our own galaxy—for how otherwise could we explain the close clinging of these nebulous wisps around stars in the Pleiad group?

Can we wonder if astronomers should already boldly entertain the thought of making a complete survey of the heavens by means of photography? Admiral Mouchez has shown that in the course of ten years fully fifteen millions of stars might be made to record their exact position and true relative brightness in a series of large photographic charts! Nothing done by man since astronomy was a science can be compared with such work as this, which yet

might be well accomplished in a decade of years.

But even all this, wonderful as it is, seems less impressive than what has been done, and what astronomers are even now planning to do, in applying the photographic eye of science to analyzing the structure of remote suns. Already they have made the waves of light from many of the leading stars record their story on the tiny shore of photographic film, after journeying millions of millions of miles through space. But now a complete survey is to be made in this way. A giant eye, so constructed that not only will it gather, but it will sift, the light from multitudes of stars at once, will be directed in succession towards different parts of the heavens. For an hour at each view will this monstrous eye, more wonderful by far than the ichthyosaurian eye with which we began, gaze analyzingly on many hundreds of stars at once, leaving on record at the close of its survey the photographic spectra of all those stars, by which the elements present in them, nay the very condition in which these elements exist will be written down in letters and words which (for the astronomer) there is no mistaking. Truly a wonderful era of astronomical research is now beginning. Probably the next half-century will reveal more about the millions of millions of tenants of interstellar space than all the years which have elapsed since Hipparchus, noticing a new star, was led to form the first of all known star-catalogues.

---

### THE HUMOR OF IT.

APROPOS of the Russian amateur photo who claims to have made photographs of the "inmates of hell," a correspondent suggests that it could be done by letting down an exploring apparatus such as was used at Chancleade for photographing the miners imprisoned by a cave-in.

APROPOS of the volume just published for Police Inspector Byrnes of New York by Cassells, containing photographs of all the principal rogues of the country, another correspondent suggests that a similar album of portraits of the noted treasurers of corpo-

rations, presidents of banks, cashiers of insurance companies and directors of saving funds, be published for the use of sneak thieves, burglars, and bank robbers. He thinks it would have a large sale and promote rogue recognition, save time, etc. A scheme, surely.

## LOVE AND THE CAMERA.

(A PARODY.)

Half the size of her mouth, sliding back of her eyes,

By the curls of her tresses half hidden,  
Two ears, stereoscopic, of daintiest size,  
Are kissed by the breezes unbidden.

Focuss'd sharp, just above each exquisite cheek  
Lie her eyes, of a brilliancy tender.  
Their color I know not, but in them I seek  
Some sign of approaching surrender.

Never fogged is the dimple that hides in her chin,  
Two lips, obscure music behind them;  
When a smile exposes them, Cupids begin  
To break from the bonds that confine them.

Just under her chin is develop'd a throat  
Whose whiteness than marble is whiter;  
Vignetted beneath it two shoulders I note,  
No curves are more graceful or lighter.

Beneath her fair bosom, the light just the best,  
Is the greatest of all of her beauties;  
My holder's the heart that is hid in her breast,  
To shield it's my sweetest of duties.

**BEGINNING WORK.**—Cigarette manufacturer (to young woman applicant). "Have you ever had any experience in making cigarettes?"

Young Woman.—"No, sir."

C. M.—"H'm; what size shoe do you wear?"

Y. W.—"Twos."

C. M.—"We will give you a trial."

Y. W.—"Thank you, sir. What shall I do first, sir?"

C. M.—"Have your photograph taken."

**SOLDIER.**—"Mr. Photographer, you must take another picture for me. My friends say this does not resemble me." Photographer: "So? Let me see it. Well, did you wear gloves?" "Yes." "Did you have a cigar?" "Yes." "Well, that is just like you then."

**A PECULIAR EARTHQUAKE PICTURE.**—  
"Last year an amateur photographer tried to get pictures of several public buildings at Washington. His colors ran, and the result was that his proofs presented a group of buildings falling in every direction. He had some blue prints made of the remarkable production, and the other day one of them was passed around the departments. The print was passed off as taken from an instantaneous photograph of the earthquake at Charleston. It was stated that the first shock awakened the photographer, and he got his traps together, rushed into the street and got an excellent negative of the second shock. All of the officials and clerks believed the story. Some of them went into a scientific dissertation over the blue print. They all endeavored to explain why the buildings on one side bulged out and on the other appeared to be falling inward. At last one of the clerks, laughing at his befuddled companions, called their attention to the fact that the earthquake occurred at night."—*Baltimore Sun*.

**A BIT OF COLOR FRESH FROM VIENNA.**  
—The old professor, teaching his juvenile class the names of colors, holds up his old bandanna handkerchief and asks: "What color is this?" "Red," cry all the boys, with one voice. Then taking up a piece of chalk, "What is the color of this?" "White," shout out the intelligent youths. "Right, my boys," said the dominie; "now what color is that?" pointing to a print from one of his amateur negatives. An ominous silence pervaded the room, when suddenly the bad boy cried out: "Yaller, sir." The bad boy did not sit down comfortably after that for at least two days.

**THE FLAP-SHUTTER.\***

BY G. G. MITCHELL,  
Edinburgh, Scotland.

It is possible that in some odd corner of the world a photographer may still be found making use of the old brass cap, with which, in days gone by, every lens was furnished. A solid air-tight, able-bodied article it was,

\* In advance from *Mosaics*, 1887.

that required some exercise of force to wrench off when an exposure was *about to be made*, and a degree of circumspection in putting it on again. And it may actually be that that photographer likes it. Very well! Let Ephraim alone.

There are caps and caps, and the latest is the shutter. It belongs to an uncommonly large and ever-increasing family, and it exhibits in its numerous members widely different characteristics and degrees of proficiency. We may smile at Ephraim's old brass business, but some shutters are regular ironclads beside it—like the inventor's idea, fearfully and wonderfully put together. Some go by clock-work, and make a rattle that would be of service to a policeman; while some give the camera a sort of peculiar jolt just at the moment of opening. All are patented, and each are guaranteed to be perfect.

I have no intention of recommending any particular shutter; let the reader exercise his own judgment in making his selection, but I would say a word or two in favor of the *description* of apparatus I think the best for nearly all possible requirements both in studio and field work.

There are very many photographers who yet make exposures in the studio with cap in hand. They have always been accustomed to it, and never troubled themselves to try any other way. Let me advise them to get a flap-shutter, working on the pneumatic principle, and I have no doubt they will be so well pleased that they will never do without it again. To expose by hand ties the operator close to the camera in a sort of side posture, and causes him to inconveniently divide his attention between the physical operation of exposure and the physical eccentricities of the subject, which, in the case of a child, may be considerable and perplexing. Whereas, if he possesses a flap-shutter, which he can open and close at once, or sustain open as long or short a time as he pleases, he can give his whole care to the little sitter. He can leave the camera and make pleasant advances to the child, which in itself is a valuable advantage, all the time having the flexible ball in his hand ready to press at the most favorable moment, and so secure the very best results. The whole

operation under these circumstances does not so much present itself as a difficult and troublesome proceeding as when he stands hand on cap ready to "fire," worried with anxiety to get matters right, while at the same time heavily *handicapped* in the matter. My refrain is, get a good flap-shutter, and so have freedom of action, and the means of exposure at the same time—literally, quite "in your own hand."

As to field work, unless an express train be the subject, which, by the way, is seldom worth the trouble of taking, or a galloping horse, extreme rapidity of exposure is not wanted, and is not very often of much use or excellence when made. The quick movement of a flap-shutter is perfectly equal to most occasions, and the same advantages which accompany its use in the studio follow it to the field; while in addition it may easily be adapted so as to act in the manner of a sky shade. Such a shutter should be light and portable, and there seems no good reason why it should not be made very little larger than the hood of the lens.

Like most shutters, the pneumatic flap has its weak point, but I do not see why it should not be easy of remedy by the makers. The way in which the bellows is generally made is defective, in respect that it is too liable to leak after being in use for a short time. That some last for a year or more, shows that they can be well made, but there ought to be very material improvement in this particular. I have learned how to improvise a good bellows out of an India-rubber finger stall which costs two pence, but this should not be necessary. Were some one with a genius for bellows making to give his mind to the matter for a little while, all would doubtless be put to rights; and I make him a present of the suggestion not to put more than one fold in his bellows, or, better still, none at all, if he can manage it, for it is the fold that gives first. All that is wanted is extension, and preferably that in one direction only. Go at it genius! However, with even a knowledge of the weak point as it at present exists, I unreservedly advise all to become possessed of a flap-shutter, and they will find that it considerably sweetens photographic life.

### QUERIES, CONUNDRUMS, AND CONCLUSIONS.

A CORRESPONDENT desires the address of "Kehama." We are unacquainted with his present whereabouts. Please do not send any more communications to our care for him.

A. F. S. says: My landlord, in refitting my skylight, has glazed it with ground glass, the ground side out. It makes the interior of my studio blue and dead. What shall I do?

Have it changed before you begin work in it. In the first place ground glass is not fit for your work. Clear glass and inside screens are better. Second, as it is, dust will soon accumulate on it and obscure it more and more.

Broad-ribbed glass is good, but be cautioned against glass with very narrow or fine ribs. It acts like a diffraction grating and collects all the colors of the prism inside your glass room.

"FILTERER."—Try this: Coke and spongy iron are found to be the most efficient agents for the removal of microorganisms from water by filtration. But even these lose their virtues to a great extent after about four weeks' use. By agitating water with coke, and then filtering, all organisms entirely disappear, leaving the water in a state of absolute purity.

"DISINFECTANT."—If you would have your dark-room once thoroughly cleansed and then daily wiped out it would never get in "such a condition" as you describe. Some photographers are inexcusably slovenly.

A cheap and effective disinfectant can be made by dissolving a bushel of salt in a barrel of water, and with this water slack a barrel of lime. This forms a sort of chloride of lime, which may be used freely in cellars, outhouses, dark-rooms, etc.

S. C. W.—Surely you had a narrow escape from bleeding to death. A glass cut should always be guarded against. There is a powder which possesses great hemostatic powers, and is capable, it is said, of arresting the bleeding of large arteries, so that it will

prove serviceable in such cases as yours was. The powder is prepared by mixing equal parts of colophony, carbon, and gum-Arabic

"STUCK."—It is a question whether you can succeed in making anything better than good nails and asphalt will secure, but we add some recipes to help you try:

An excellent cement, for attaching metals to glass or porcelain, is said to be prepared by boiling together two ounces of thick glue solution with one ounce of linseed-oil varnish, until as perfect a mixture as possible has been effected. The pieces cemented should remain fastened together for two or three days.

To cement wood and glass together mix together some finely pulverized, well dried zinc-white with clear copal varnish in such quantities as to produce a half liquid preparation, spread this over the parts to be cemented and it will be found that they will be joined firmly together. This cement has the advantage over many others in that it does not injure the most brightly polished oak wood; it does its work well, always cementing the two materials together very firmly, and will bear the test of washing with warm water, if the cement is first thoroughly dried.

"CAN I make and sell photographs from a negative of mine which I made of a Catholic priest who is now dead? I sold some copies to an agent, and the sister of the priest in question tells me I cannot sell them without *her* consent. How is this? I understand the negative is my property or stock in trade, but do not know whether or not I have a right to sell such pictures. You probably understand this point, and you would confer a favor by setting me right."

As a rule, photographers consider it a breach of confidence or courtesy to dispose of prints from negatives of private persons. Clergymen are considered exceptions to this rule. If, however, in an individual case, like the one quoted, the relatives object to the sale of the pictures, it is for the artist to determine whether it is policy or not for him to regard the request not to sell. One offended relative has it in her power to injure more than the profits on many a picture could make whole.

A CORRESPONDENT writes us (no stamps inclosed) as follows:

"I inclose you a print, and would like you to touch out the spark in the pupil of the eye as you think it should be. By so doing you will settle a small wager."

Our inexperience as a retoucher and as an umpire must be an excuse for declining to accede to such requests.

### PRINTING ON SILK.

The following recipe for preparing silk for printing upon is given:

<i>No. 1.</i>	
Tannin . . . . .	40 grms. (1 oz. 2 drs.)
Water . . . . .	1000 c. em. (34 fl. ozs.)
<i>No. 2.</i>	
Salt . . . . .	40 grms. (1 oz. 2 drs.)
Arrowroot . . . . .	40 grms. (1 oz. 2 drs.)
Acetic acid . . . . .	150 c. em. (4 ozs. 7 drs.)
Water . . . . .	1000 c. em. (34 fl. ozs.)

No. 1 is mixed with No. 2, well shaken, and filtered. The older the mixture, the better it is for use. In this bath the silk is thoroughly immersed, and allowed to remain for three minutes, when it is taken out and hung up to dry.

Sensitizing solution is composed of a silver bath, one to ten, acidified with nitric acid.

#### *Toning Bath.*

<i>No. 1.</i>	
Chloride of gold . . . . .	1 grm. (15 grs.)
Water . . . . .	200 c. em. (6 fl. ozs. 6 drs.)
<i>No. 2.</i>	
Sulphocyanide of ammonium . . . . .	20 grms. (5 drs.)
Water . . . . .	500 c. em. (17 fl. ozs.)

No. 1, after shaking, is mixed with No. 2. In a few days the mixture will become clear, when it is ready for use. It is preferable to dilute with from two to four times the quantity of water. Fixing and washing as usual.

### PRODUCTION OF GRAINED GELATINE SHEETS.

NEGATIVES in which the half-tone of the picture has been converted into a grain, and which then are adapted to the production of printing plates with the half-tone transferred for photo-engraving, etc., can be

readily manufactured in the following manner, according to A. Borland:

A light-printed plate, made with chrome-gelatine layers, can be prepared in the usual way, dried in proportionately low temperature (about 22° C.), and exposed under a negative. Now it must be thoroughly washed off, laid for 30 minutes in a mixture of 4 c. em. of sulphuric acid, and 320 c. em. of water; washed in several different waters, and allowed to soak a short time before each change of water. Then it should be laid for 15 or 20 minutes in a saturated solution of alum, and afterwards washed in two or three changes of water. Now the plate should be put in a vessel which contains just so much water of 32 to 38° c. as will suffice to cover the plate. The operation will be ended in nearly five minutes; the instant the plate shows a uniformly smooth surface, it should be taken out and plunged into cold water. After a short time, it is to be taken out, drained slowly, and then remove the water still remaining upon the layer with fine blotting paper, since it is easily torn.

If bromo-silver-gelatine plates are used, the same method is pursued, with the exception of lighting and developing. With these it is necessary to light plentifully and develop quickly, to produce sufficient detail, and not have too great density.

Should one wish to produce only grained layers, and no negatives, then it is necessary to expose only the parts to the light and proceed as above. However it is particularly necessary with gelatine plates to guard against over-lighting.

The nature of the grain can be modified by mixing different acids with the water (as lemon, tartar, or muriatic acid), or by mixing acid with the alum solution, and by varying the washing time of the plate. If the grain should happen to be uniform, the plates must be equally thick all over; a thick film gives a coarser, a thin film a finer grain.

### SALTS OF IRON PRINTING PROCESSES.

BY W. E. WOODBURY.

NOTWITHSTANDING the great intrinsic merits of iron printing processes, compara-

tively little of the attention they deserve has been bestowed upon them in this country. On the continent of Europe, however, they are much better known, and in civil engineers' and architects' offices, these processes are largely used for obtaining copies of plans, etc. Not only for plans are these printing methods useful, but also for quickly obtaining a print from a negative without all the trouble involved in suddenly undertaking the usual operations necessary to produce a silver print. From soft negatives very good prints can be obtained. The general principles involved in these processes are not new discoveries, the process called "Cyanotype" being described by Sir John Herschel during the very earliest days of photographic invention. Since that time, however, many improvements have been effected. The probability that the attention of experimentalists in England may be directed to these methods, and the hope that further improvement may be the result, have together led me to undertake to bring before you a review of the methods already discovered and in use.

Certain ferric salts are sensitive to light, in consequence of the exposure which reduces them to ferrous salts. Upon those properties are based all the methods under consideration.

*White lines upon a blue ground* first claim our attention as being the simplest, and therefore the most-used, method. In 1842, Sir John Herschel first made public a process under the name of "Cyanotype" with ammonio-ferric-citrate and ferrid-cyanide of potassium. Two solutions are made—12 parts of red prussiate are dissolved in 100 parts of water; and 10 parts of iron salt in 60 parts of water. These two solutions should be mixed immediately before using, and the operation must be performed in the dark. Paper is floated on this solution, or applied with a broad camel's-hair brush, and then hung up to dry. If it is well dried and carefully preserved from light, moisture, and air, this paper will keep for some considerable time. After printing—which, when sufficient, should show the lines copied of a yellow color upon a blue ground—the prints should be washed in several waters; and if a few drops of chlo-

rine water or dilute hydrochloric acid be added to the washing water, the blue ground will appear much darker, and the lines rendered clearer and whiter. By this method the commercial paper is mostly prepared. The prints so obtained can, if desired, be changed from a blue to a beautiful black by being immersed in a four per cent. solution of caustic potash, until the blue is changed to yellow; after being well washed, they are laid in a four per cent. solution of tannin.

Dr. Vogel gives as an improvement on the above recipe the following: 10 parts of potassio-ferric oxalate in 100 parts of water, and 10 parts of ferrid-cyanide of potassium in another 100 of water; the remainder as before. With the above methods, the red prussiate, instead of being added to the mixture, can be used in dilute form as a developer after exposure. Paper that is prepared without it can also be developed after printing in the usual way with a one per cent. silver bath. Prints so developed are of a deep sepia tone.

It often happens, especially in summer, that pictures printed on these ferro-prussiate papers become over-printed, the blue color assuming a dirty dark greenish tint. Herr Himly recently published a method of effectually saving such prints. He prepares a weak solution of caustic potash, and places the over-printed picture in it until the lines become clear, and the ground of a gray color. The print is then immersed in a weak solution of hydrochloric acid, when it once more appears of a fresh blue color. It is then washed and dried in the usual way.

*Blue Lines upon a White Ground.*—To obtain this effect, it is necessary that the action of the light should be to convert the iron compound into one that can be discharged from, instead of being fixed in, the paper, as in the other methods.

*Pellet's Method (1877).*—Paper is coated with boiled starch, so that the solution will remain upon the surface, and not sink into the paper. This is then floated upon a solution of 10 parts chloride of iron, 5 parts of citric acid, and 100 parts of water. After drying, the paper is pressed flat, and kept from light and air. As in printing, the visible change is very slight; a few strips of the paper should be placed under a piece

similar to the paper upon which is the tracing or other design from which you are printing. One of these strips should be from time to time taken and placed in the developer, which is composed of a 24 per cent. solution of yellow prussiate. When these strips develop perfectly white, the print has been sufficiently exposed. In direct sunlight, one minute may possibly be sufficient; but on a dark day, from ten minutes to an hour may be required. After developing, the prints are rinsed with water, washed with a dilute solution of hydrochloric acid, and again washed and hung up to dry.

Blue spots, which sometimes appear upon the white ground, can be afterwards removed by touching with a solution of potash. This solution can also be effectually used for removing stains from the hands, etc.

Pizzighelli's method requires three solutions:

<i>A.</i>	
Water . . . . .	50 parts.
Gum-arabic . . . . .	10 "
<i>B.</i>	
Water . . . . .	50 "
Ammonio-citrate of iron . . . . .	25 "
<i>C.</i>	
Water . . . . .	50 "
Perchloride of iron . . . . .	25 "

The solution *A* becomes useless in a very short time. *B* and *C*, however, remain good for weeks if kept in closely stoppered bottles. For use, 20 parts *A*, 8 parts *B*, and 6 parts of *C* are mixed together in the order named, otherwise the gum will coagulate. This mixture after a short time becomes thick and tenacious, but in a few hours will be found to flow quite freely. When in this state it can be applied by means of a brush to paper that must be well sized. It must then be dried quickly in a well-warmed room from which both light and damp are excluded, and after drying must be pressed flat. Development is effected with a solution of 2 parts of ferrocyanide of potassium in 9 parts of water, which is either applied with a brush, or the print floated upon the surface. In either case care must be taken that no portion of the developing fluid touches the back, as it would cause a stain. If floated, the exposed side of the paper should be carefully laid upon the developer,

and the hand passed lightly over the back to remove the air-bubbles. After a few seconds the paper should be quickly drawn from the solution, and held in a vertical position till sufficient density is obtained; it is then rinsed with water, and immersed in an 8 per cent. solution of hydrochloric acid, and finally well washed and hung up to dry.

*Dark Violet-black Lines upon a White Ground.* The sensitizing solution required is composed of the following:

Water . . . . .	16 ounces.
Gelatine . . . . .	4 drachms.
Perchloride of iron in a syrupy condition . . . . .	1 ounce.
Tartaric acid . . . . .	1 ounce.
Sulphate of iron . . . . .	4 drachms.

The necessary exposure is about the same as the others. When sufficient, the greenish-yellow color will become white, excepting the lines, which should be somewhat dark. The developing solution is composed of one part of gallic acid in ten parts of alcohol and fifty of water. When immersed in this solution, the lines will be found to immediately turn blacker. The print is then finished by being well washed in water.

In conclusion, I see no reason why we should not, by improving upon these methods, be able to obtain a printing process equal to platinotype in the results, and at far less the cost and trouble of working.

### SOCIETY GOSSIP.

EVERY little while we are cheered by some new proof of the growth in influence and esteem of our art. The latest testimony is the report of the Secretary of the Amateur Photographic Association of Victoria, Australia. It shows that the society is flourishing, and, best of all, reaching out eager hands, not entirely empty either, for help and exchange. The society has seventy members. During the year it has had demonstrations of new processes, exhibits of apparatus, papers both technical and descriptive, and lantern shows. It sent, moreover, to the Colonial Exhibition in London ten large frames containing about 120 prints, and some 300 stereoscopic views and lantern slides.



THE first regular fall meeting of the Philadelphia Amateur Photographic Club was held at their room on Monday evening, September 20th.

The Executive Committee reported the election of S. D. Hopkins and E. Bancroft to active membership. Mr. Haines called attention to the fact that during the summer the club had forwarded a frame of pictures to the Minneapolis Amateur Photographic Club to be exhibited at the Minnesota Industrial Exhibition.

Mr. Haines announced that the Committee offered a purse for the best example of home portraiture—*i. e.*, not in a studio—by a member.

Mr. H. L. Roberts showed some views taken with Gray's Vest Camera, and Mr. Clements exhibited his McKellen Camera, which he had brought with him from England.

Our exhibition of lantern slides from negatives made by members during the summer was then given. The exhibition was more than usually interesting on account of the large variety of subjects presented, embracing, as it did, views of Niagara, Canada, England, and France, together with numerous local views.

W. W. RANDALL,  
Secretary.

EDITOR PHILADELPHIA PHOTOGRAPHER.

MY DEAR SIR: To-day I received official notice from W. H. Potter, President of Photographers' Association of America, that Charles T. Stuart, of Hartford, Conn., had been awarded the one hundred dollar cash prize for best essay presented at the Convention held in St. Louis, June 22 to 25, 1886.

Fraternally,

H. MCMICHAEL,  
BUFFALO, N. Y., Sept. 25, 1886. Secretary.

### STELLAR PHOTOGRAPHY.

WE have received from Prof. Edward C. Pickering, Astronomer of Harvard College, a work describing his investigations in stellar photography—a part of Vol. XI. of the *Memoirs of the American Academy of Science*.

The following subjects are discussed in turn:

History of Stellar Photography; Pre-

liminary Experiments, 1882 to 1885; Description of the Apparatus; Theoretical Consideration; Trails formed by Stars when their Apparent Motion is not wholly Connected by the Telescope; Construction of Charts by Photography; Stellar Spectra; Brighter Stars in the Pleiades; Close Polar Stars.

The work is illustrated by a photograph of the photographic telescope used, by a sectional map of the trails of circumpolar stars, and by photographs of spectra. It is a magnificent contribution to photographic science, and must become a part of our photographic literature, although science claims the talented professor who has accomplished such wonderful results, aided by Mr. Wm. H. Pickering, of the Massachusetts Institute of Technology, Boston.

It is only rarely that one can find fifty pages of scientific photographic details containing so much of thrilling interest.

Volumes have been given us on the adventures, trials, perils, and death of many noble men who have risked all in their unsuccessful searchings for the north pole. And while their followers are yet engaged in such hazardous work, the one acute, searching eye of photography, pointed by the hand of science, lays upon our office table a map of the stars which circulate around that much-searched-for spot, and shows us the very routes over which they move round and round at their dizzy height.

Is it not marvellous?

After a quarter of a century of dry plates, imperturbably slow, and wet plates, not very quick, except to spoil, the world has suddenly been donated with dry plates very much more sensitive than the best wet, and capable of keeping indefinitely, either under exposure or out of it.

It is upon these qualities, now being given into their hands, and they not having to prepare their own plates, that astronomers are now doing such great things amongst the stars, by exposures not of a second or two, but an hour or two, or three.

We have already made our readers acquainted with some of the results of Mr. W. H. Pickering and of the Henry Brothers, of Paris, with an engraving from a star negative.

It occurs at once to a photographer that such plates may not always present the truth, because a defect in the plate would show the same as a star. This difficulty is headed off by Prof. Pickering, who, by long exposure, secures the trails or tracks of the stars, which appear on the plate as fine lines, forming a part of a circle, having the north pole as a centre.

This is illustrated by the photo-engraving below, which is made direct from one of Prof. Pickering's plates, of which he kindly sent us a glass positive.

clock-work (*i. e.*, the telescope camera was permanent, and did not follow the movements of the stars), and only shows the central part of the original plate, which is 8 x 10 inches, and is not enlarged."

The plates used were made by Messrs. Allen & Rowell, Boston, and developed with Cramer's pyro and soda developer.

The first stellar photographs ever taken were made at Harvard in 1850.

And now photography is used for making charts of the sky, for picturing the spectra of the stars, for fixing their positions, for

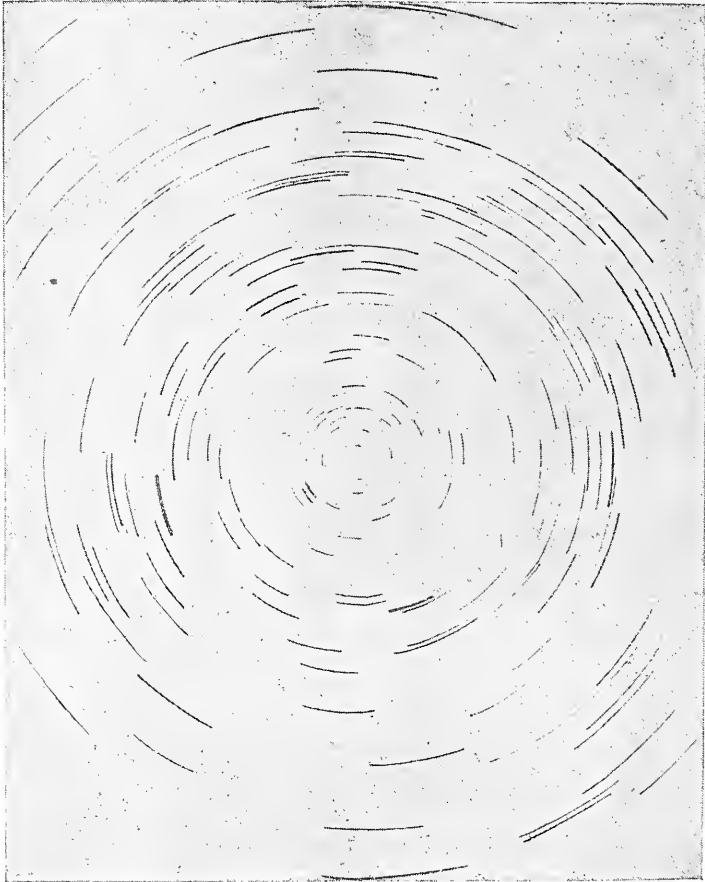

The irregularities of the lines are due to the photo-engraving process, and do not appear in the positive.

In his letter accompanying his interesting picture, he says: "This was made without

determining magnitude, and for tracing their movements and deviations.

But, on bright moonlight nights, and near large cities brilliantly lighted by electricity, these experiments cannot be con-

ducted, on account of the extreme sensitiveness of dry plates.

If photography thus continues to be so spry, it must itself be sent to the north pole to do its wondrous work. Thus much concerning the north pole.

At the suggestion of our helpful friend, Prof. C. Piazzi Smyth, Astronomer Royal of Scotland, we are interceding with Dr. Gill, of the Cape of Good Hope, for a plate of the stars which move around the south pole.

If Prof. Smyth prophecies correctly, in due season we shall have such a map of trails to present to our readers.

---

### OUR PICTURE.

THE charming little study which embellishes our current number is from a negative by Mr. F. Gutekunst, the famed Philadelphia photographer, and is a phototype printed by him at his branch establishment.

As a lovely child picture, simple in pose, yet so artistically composed; lighted so deftly, and, with accessories chosen so harmoniously, it can hardly be excelled. And yet, it is only an ordinary example of Mr. Gutekunst's careful, skillful work, for as in art, so in technique, he stands at the head.

When the first picture for this magazine, an engraving of Mulready's ("The Loan of a Bite") was made, October, 1863, the unflinching editor was an employé in Mr. Gutekunst's establishment. So far back as then, our esteemed employer far outrivalled his compeers; and some of our first subscribers were won after we had shown the parties through the establishment, where they came to learn "what lens you use," and "how you fix your light," for the Gutekunst establishment was even then a place of pilgrimage, whereto earnest photographers came from long distances to study from the master in our art.

And yet, with all its fame, when "The Loan of a Bite" was copied, the entire staff of the establishment, from the head down, was puzzled to know how to get rid of the "ghost" which haunted the Harrison globe lens used. But this was not the worst difficulty. How, in the midst of dark autumnal days, were enough prints to be produced in

time to supply even our then meagre edition?

It puzzled and perplexed us all, and a devout wish was expressed deep and loud for some more rapid process of printing.

That wish never died in Mr. Gutekunst's breast. For years he watched with keen interest the various reproductive processes which arose from photography, and became himself a pilgrim, repeatedly going to Europe to learn and understand what was produced there.

To make the story short, he now has attached to his establishment one of the most complete departments for photo-mechanical printing in the world.

The peculiar method he uses he calls "phototype." Our readers will agree that the example before them is a magnificent specimen of photo-press-printing. We think we hurt no one's feelings when we aver that no one produces portraits by any kindred process that excel those made by Mr. Gutekunst.

*Skill* is the great ingredient which enters into the production of such works, and it seems to us, even Mr. Gutekunst himself must be satisfied with *such* results.

With his direction, a staff of expert help goes on, day after day, sending off from the steady hand presses and from several gourmand steam presses, results that were not even dreamed of when the PHILADELPHIA PHOTOGRAPHER was born.

But this is only one of the marvellous accomplishments of our art with which our veteran friend and old employer has in every direction kept pace.

He has made his portrait establishment a public resort and a national necessity, for there are the portraits not only of the majority of our own great men, but of the great who come to our country from foreign lands.

Mr. Gutekunst was one of the first to take up photography, first doing a large ambrotype business. He is not yet an old man—past the fifties, only—and displays the same enthusiasm which he did a quarter of a century ago, and which has made his fame and his ample fortune.

Long may he live to produce such sweet little studies as "our picture."

**PHOTO. FACTS AND FANCIES.**

THE following, from an "admirer of consistency," is a well put fancy. Thanks.

*To the Editor of the World:*

I see in your answer to "Leon" in last Sunday's *World* you say, "It is never the custom to ask the return of photos once given." I confess surprise to think that you—so fastidious a critic—should use the word "photos!" I consider the abbreviation of the word "photograph" to "photo" on a par with calling an omnibus a "bus;" as both styles of expression are common! As it will be optional with you to publish my criticism regarding the bad form I consider you guilty of, I do not much expect this note to be published. But I could not refrain from expressing my impression on reading the word "photos" written in your usual corrective, self-satisfied style.

AN ADMIRER OF CONSISTENCY.

NEW YORK, September 8, 1886.

Your criticism is a perfectly proper one, and even if deserved would be appreciated. But this time you must hold us guiltless. They wrote "photographs," but the compositor preferred "photos," and the change was not detected in time.—*N. Y. World:*

**A PRACTICAL SOLUTION OF SOME OLD PROBLEMS.**—It is gratifying to notice that within the last few months the use of the incandescent lamp in the photographic dark room has been made practical for those who are unable to get their electricity from a central station.

There is no one thing about photography which is so disagreeable and unhealthy as the heat and stifled odor and vitiated air peculiar to all dark rooms where gas or kerosene is used for the purpose of producing artificial light.

We understand that the Chemical Electric Light and Power Company, of Boston, are furnishing to photographers small isolated plants of their Volta Pavia Battery, and that during several months of constant use they have given perfect satisfaction, the cost of light being within figures which photographers are willing to pay for a good light. The ease with which the dark room (so-called) can be illuminated with either

white or ruby light, by the will of the operator, by simply touching a switch, is a great convenience to members of the photographic profession.

We understand that the above-named company has taken a contract to illuminate the cabin and state-rooms of one of the finest yachts afloat in New England waters. The battery will furnish a good light all through the yachting season, it is expected, with one or two charges of Volta Pavia solution.

A WATER-PROOF PAPER can, it is said, be made by passing paper rapidly over and in contact with the surface of a solution of oxide of copper in ammonia, by means of properly placed rollers moving with speed. The paper on leaving is pressed between two cylinders, and next dried by drying cylinders similar to those in use in paper mills. The action of the solution is to dissolve the cellulose of the paper to a very slight degree, and to form an impenetrable varnish.

MAGNESIUM, which has more than once been abandoned as a source of light, appears likely to be employed again, a process having been discovered for producing pure magnesium by electrolysis, and at a price much less than that at which it was formerly obtainable. At the works in Bremen, where the manufacture of magnesium is carried on, prizes are offered for the construction of the best magnesium lamps having clock-work movement.

---

**HEPWORTH'S FOUR POSTER.**

BY T. C. HEPWORTH.\*

I WILL now describe my "photographic four-poster," which I have found the most useful piece of apparatus that my dark room possesses. It was suggested to my mind after trying a number of different ways of drying plates, and, after some two years' experience of it, I see no reason to alter its design in any way whatever. The accompanying sketch of the erection, together with a few plain directions, will enable any one to make it for himself, unless he prefer to employ a regular carpenter for the pur-

---

\* From *Photography for Amateurs*, by T. C. Hepworth, Esq., editor of *The Camera* (London).

pose. I will give the size of mine, but, of course, other sizes may be more convenient to others.

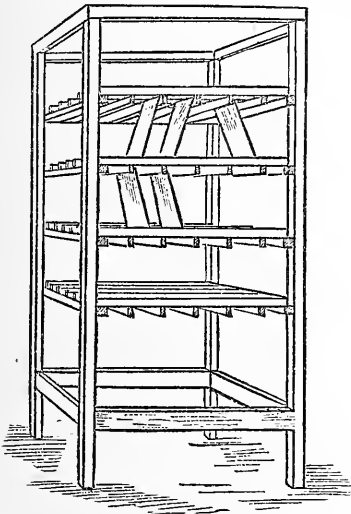

Photographic four-poster.

The four posts are six feet long and one inch and a half square. The first operation is to place these posts in pairs, and mark upon them lines indicating the places where the supports for the shelves are to be screwed. The intervals between these supports must be according to the size of the plates which are to stand upon the finished structure. My shelves are placed at different distances, so as to accommodate different sized plates. The supports, two feet long, and made of stuff one inch by three-quarters of an inch thick, are now screwed into their places, when the pair of posts have the appearance of two ladders. The shelves must now be taken in hand, and are conveniently made before being put into position. They are made of laths, about one inch by three-eighths of an inch, which can be bought by the dozen at any sawmill. These can be carefully measured off with pencil-marks, the upper laths being spaced out according to the size of the plates which are to stand upon them, the lower ones being intended for the top edge of the leaning plates to rest upon. At each point of crossing, the junction must be made good by one French wire nail.

When the shelves are all in position, the general structure can be screwed together with tie-pieces, the back and sides filled in with black glazed calico, and a blind of the same material fitted to a roller in front. In my four-poster, a closed gas-stove is fitted to the lower part; but this is not necessary for gelatine plates, which will soon dry if the room itself be not damp. The skeleton arrangement of the shelves permits a constant current of air to circulate round about the plates; but a better current can be insured by taking advantage of the rising property of warm air, in a manner first suggested by myself in the *Photographic News*. I quote the passage in question:

“SUGGESTION FOR A DRYING-BOX.”

“Sir: In your recent very welcome ‘Seasonable Hints to Emulsion Workers,’ you rightly remark that ‘the real difficulty in making satisfactory and clean dry plates begins when the emulsion has been made.’ I have long been of the opinion that a perfect drying apparatus has still to be contrived. If the plates are left dry spontaneously, it is often thirty-six hours, or even more, before the last obstinate wet patch disappears. During all this time, the plates are liable to be covered with the dust which is present in the cleanest room, and opaque spots in the finished negative are the result. The many drying-boxes which have been planned and described in your columns possess one disadvantage in the requirement of a flame from which not only light can steal, but from which there is chance of danger from fire. These difficulties have led me to devise a plan whereby a steady heat and draught may be maintained without actual fire or flame. The solution of the problem is found in a solution not unknown to photographers, namely, one of acetate of soda. It is well known that the admixture of certain salts with ordinary water raises the boiling-point of the liquid far above the stereotyped 212 degrees. Acetate of soda stands, I believe, at the head of the list in raising the boiling-point to 256 degrees..

“My suggestion is, that at the bottom of the drying-box (which should be pierced with holes for the admission of air) should stand, on four short feet, a metallic vessel

filled with a boiling solution of the soda. This hot box would cause a constant draught of warm air to rise to the plates standing in racks above it, and the retained heat would dry the thickest film in a few hours. This method of heating has already been applied in France to railway foot-warmers, and the following experiment recently tried with one of them will show how such a vessel is capable of holding heat for a long period. A foot-warmer, on being charged with its hot solution, registered 253 degrees. At the end of some hours, when again tested with a thermometer, it registered 211 degrees, or only one below the boiling-point of water. I see that a Dresden chemist has lately constructed a stove on the same principle; but the mixture he uses (for which an improvement is claimed) is one part of acetate to ten of hyposulphate. This stove is said to act well.

"I must apologize for the crude form in which my suggestion is offered, and I trust that those who have time to experiment in this direction will publish, for the benefit of others, the results obtained."

The four-poster is highly useful for other purposes than the mere drying of newly made plates. It can be used as a rack for glasses when they have received their final rinse under the tap after washing. It will serve the same purpose for negatives, which will quickly dry in such a position, particularly if the erection be brought close to a fire. At other times it will form a nest of useful shelves, where cardboard, paper, glass, and other things can be conveniently stored. It may be modified in various ways to suit individual wants. Thus it may be convenient to shorten the legs, so that the thing can stand on a vacant table. Or the same kind of shelves can be fitted to an existing cupboard, in which case efficient light-tight ventilation must be strictly enforced. Altogether, I am well pleased with the success of the contrivance, and trust others may be the same.

It is advisable not to move the plates until they are quite dry. In favorable weather this will occupy about thirty-six hours, sometimes longer. When dry, they must be carefully packed away for future use.

### DEVELOPERS FOR INSTANTANEOUS PRINTS.

A.—Neutral sulphite of soda . . . . .	25 grammes.
Pyrogallic acid . . . . .	10 "
Sulphuric acid . . . . .	3 to 8 drops.
Water . . . . .	100 c. c.
B.—Carbonate of potash, pure . . . . .	90 grammes.
Neutral sulphite of soda . . . . .	25 "
Water . . . . .	200 c. c.

At the moment of using, mix 100 c. c. of water with 3 c. c. of A and 3 c. c. of B. The image is softer if the quantity of water is increased and the development slower. As a reducer for overexposure, a little citrate of potash may be added, or some bromide of potassium, which is more active.

The sodic developer, first introduced into America by Cooper, Newton, and others, has also given proofs of very high qualities.

A.—Sulphite of soda . . . . .	100 grammes.
Pyrogallic acid . . . . .	14 "
Sulphuric acid . . . . .	5 to 10 drops.
Water . . . . .	500 c. c.
B.—Crystals of soda . . . . .	50 grammes.
Water . . . . .	500 c. c.

In using, mix 20 parts of A, 20 parts of B, and 20 parts of water. The developed plates are well washed in water, placed for a few minutes in a strong solution of alum, again washed, and then fixed in a solution of hyposulphite of soda (1 to 5).—*Moniteur*.

### A PHOTOGRAPHIC FEAT EXTRAORDINARY.

OUR readers will remember our noting the celebration of the 100th birthday of M. Michel-Eugene Chevreul, the celebrated French scientist, in our last number. For some days the centenarian savant was without doubt the most prominent figure in France. The scientists of the nation assembled to honor his fête, and the papers were filled with accounts and pictures of its ceremonies and the illustrious old man who was their cause. But it was reserved for the *Le Journal Illustré*, of Paris, to satisfy the popular interest by a feat which marks an advance in journalism, and is at once a journalistic marvel and a photographic triumph.

It devoted the entire space of its issue of September 5th to a series of photographic interviews with the scientist, in which, while the famous Parisian photographer, M. Paul Nadar, conversed with him, a stenographer took the conversation and an operator a



1. "I have never drunk anything but water, and nevertheless I am president of the Society of Wines, of Anjou—but honorary president only."

2. "We have here the trouble with this philosophy of to-day, of this philosophy of the rhetoricians, of great sayers of nothings. Hollow words and phrases suffice. . . ."

3. "Note that I am far from blaming what I cannot explain; but I will say to you that I must have the proof, that I must see."

4. "Now since they affirm that they can direct their balloon at will, let them come for me here, at this window, on the days on which the Institute has its meetings, and carry me back! That would save me having to go up and down two flights of stairs."

5. "I met Mr. Hersent, the painter, in 1840, at the Institute, after the meeting of all the united academies, at which Arago had made known the process of Daguerre, without making mention of Nicephore Niepce, the veritable inventor. In the course of the conversation I was led to say to Mr. Hersent, that the yellow

alongside of the blue would produce difficulties hard to overcome."

6. "M. Hersent, who was slightly excited by our dissertation, replied to me: 'If any other but M. Chevreul had said this to me, I would say that he had told a lie. But M. Chevreul saying so, I must see it to believe it.' I at once invited him to visit my laboratory at the Gobelins to witness the proof."

7. "He died twenty years afterwards without ever having come to see me at the Gobelins, as I had invited him. . . ."

8. "I have not told you all. It does not suffice to say we must prove, we must *show*! I must *show* you. You must see! I must show, because it is when I SEE that I BELIEVE!"

9. "I will write for you the first principle of my philosophy. It was not I who formulated it; it was Malebranche. I have sought much but never found a better one: 'One should strive to attain infallibility without pretending to it.'"

series of instantaneous photographs of the talkers. The *Journal* prints twelve plates, reproduced by the Krakow Photogravure process, bringing before us in vivid reality the fleeting expressions and the personality of M. Chevreul, and setting forth, as has never been done before, the range and varieties of human expression. The result is one of the most striking things we have ever seen. Nothing like it, in its entirety, has ever been done before; it is, both from the journalistic and artistic point of view, an unique achievement.

We are happy to be able to let our readers judge for themselves. Nine of the twelve plates of M. Chevreul we reproduce, with a translation of the conversations at the times of the exposures. It is needless to dilate on the interest of these pictures, and their value as studies. We can trust our readers to appreciate them. Everyone concerned in this wonderful piece of work deserves high praise, but from our photographic standpoint we feel a special admiration for M. Nadar. His artistic skill, and his enterprise shown in his other photographic achievements, more especially in his balloon voyages, are known to many of our readers. In this latest work, where in three separate interviews he studied and evoked the different expressions which his plates record, he has added another flower to his wreath. And it is to be noted also that with all this skill the thing would have been an impossibility save by grace of the new Eastman films, whose rapidity enabled such successful instantaneous portraits to be taken. The reproductions of the plates were made by the Levytype Co. of Philadelphia, by whose promptness we are enabled to reproduce them so early.

The *Journal* editorially says: "Far from us now is the time when Niépce and Daguerre found a fifteen minutes' exposure necessary, in full sunlight, to secure an image; photography is now able, by the aid of Eastman, to catch an impression in the *two-thousandth* of a second. Making use with a skill that we can hardly praise too much, of these prodigious improvements, and honored by the kind friendship of M. Chevreul, who granted him three interviews, M. P. Nadar has reproduced in-

stantaneously all the attitudes, and, so to speak, all the physiognomies of the illustrious scientist. whilst, according to the subjects discussed by him, his features and his expression changed. The portraits, of an interest and value that none will deny, we now offer to our readers."

### ARGENTIC DRY PLATES FOR POSITIVES.

SOME months ago we made the announcement that the Phenix Plate Co., Worcester, Mass., had succeeded in producing a new plate for positives—an emulsion-coated iron plate.

It was believed then that all the difficulties entailed in the manufacture of such plates had been mastered. But so soon as the great demand came for them at once after they were announced, causing them to be made in large quantities, *new* drawbacks arose, and their production had to be suspended.

Instead of continuing to produce an inferior article and forcing it upon buyers, as some of the earlier dry-plate makers did, the Phenix Plate Co. adopted the more manly and straightforward course, and called a halt. Not only this, so far as they could learn of losses from the use of their plates, they made the parties whole, and destroyed the faulty plates.

Being assured by the unexpected demand for them, they were satisfied that there is a place for the Argentic Dry Plate, and therefore went persistently at work to produce a first-class article.

They now come to us again, with the assurance that all the difficulties are ended, and that nothing stands in the way of the continuous production of just what is wanted—a perfect plate.

Not only this, they have favored us with some portraits made upon Argentic plates, which are of excellent quality, and leave nothing more to be wished for.

And, still further, several portraits of one person show that any effect desired can be had by the simple twirl of the developer.

Yet more, the Phenix Plate Co. guarantee every plate, so that if you do not get twelve good results out of each dozen plates, it



must be because you do not follow the directions which accompany each box of plates.

In looking over these instructions, we notice several important changes from what were given on page 58 of our current volume.

It is possible now to fix the plates with hypo if preferred to cyanide.

Immersion in alum follows fixation.

The developing formula is so simple that "1" and "2" may be used, like weights and wares on a scale, to drive the balance of power quickly in the desired direction.

It is a delight to make pictures upon the Argentics, and to feel that after development and cleaning and varnishing, there, before you, face to face, it is possible in ten minutes after exposure to have the finished picture ready for delivery.

For emergency work, this will be a great help to the regular photographer whose subjects cannot wait for the slow process of silver printing.

To the amateur, the Argentic will prove "a big find."

Heretofore they have been, owing to the necessities of the case, confined almost wholly to out-door subjects—pictures of places and things, but not many of persons, except where they could be grouped on the lawn, upon the portico, or awkwardly placed in whatever position circumstances dictated. The prime reasons for this were the want of a place where a proper and pleasing light could be controlled to fall upon the face of such power and quality as would enable the aspiring operator to "secure the shadow ere the substance" grew tired and restless, spoiling the work; and, more than all, secondly, because of the *long time* required by the ordinary "negative" process to produce copies for distribution.

The great charm of all these "occasion" pictures is the facility with which everybody concerned can be supplied with copies. The old process is too slow. There are occurring in every family occasions inviting the use of the camera—the calling of friends, the visit of relatives, the family reunion, the birthday party, the charming kettle-drum, the wedding visit, and many others.

If you could only secure copies *at once*—in a few moments—how fine it would be,

and especially so to produce pictures which would rival those of any studio.

At last the *home camera* can be fitted for winter portrait souvenirs as readily as for summer landscapes and outdoor groups. The new "Argentic Dry Plate" supplies the means, and millions of them are ready for the "sacrifice." They are always ready, rapid, clean, permanent, unbreakable, reliable, certain, simple in manipulation, and free from pinholes, stains, fog, frilling, and other dry-plate difficulties.

We congratulate all concerned upon the existence of an honorable company, so willing to persist until the perfect article is produced.

### ON THE "TRIENNIAL."

EDITOR PHILADELPHIA PHOTOGRAPHER.

MY DEAR SIR: In *Photographic Times*, dated September 27, 1886, I notice an article by Gayton A. Douglass, of Chicago, relative to Triennial Exhibitions of the Photographers' Association of America.

I am well aware that the writer has the best interests of the Association at heart, but I cannot see why the Association should take any steps in the matter, as it is purely a business transaction with the dealers. If they choose to come in with us every year, or every three years, is a matter for them to decide.

This is a subject where the opinions may widely differ, as some manufacturers have told me they would make an exhibit if they did not sell a dollar's worth. They said the expense was a good deal but it was the most direct way to reach many photographers who would not buy so many new goods if they did not see them on exhibition, and the many fine photographs showing their use.

If, as he says, it is apparent that each succeeding meeting has added to the value of this grand organization, beginning with a mere handful of earnest workers, it has grown to nearly a thousand, don't you think it would be better to let well enough alone rather than make a change which must necessarily be an experiment to a considerable extent.

I am well aware there is a great deal of expense and labor connected with each ex-

hibition, but that is the case with everything progressive.

He also says it must be admitted that one of the greatest attractions of these conventions is the display of appliances for photographic work, then why deprive the members in smaller cities where the intervening educational and legislative conventions would be held of having the advantages of seeing and studying the appliances as those living in Chicago and vicinity? We are well aware that many photographers cannot attend except when they are held near where they reside.

Suppose the next convention were to be held in some city far east, there would be very few from the west comparatively, but those who might attend it would want to have all the advantages the same as those who attend the Chicago meeting, besides very few dealers who exhibit in Chicago would make a display at the eastern meeting, consequently the labor and expense would not come on the same ones for a number of years.

I think there should be many changes in the general government of the Association, that it might be strengthened and productive of a greater amount of good in the future than in the past. I believe there should be a complete revision of the Constitution and By-laws and the Association incorporated by a committee composed of all the past and present executive officers, then we should have a legal foundation to work upon. If, in the judgment of this committee, it would be for the best interests of the Association to hold the convention at greater intervals, it could be incorporated in the Constitution and By-laws and officers elected accordingly.

At the last convention there was a resolution adopted and a committee appointed to incorporate the Association under the laws of the State of Illinois.

As I understand it, there must be a permanent officer in the State where it is incorporated, and our Constitution does not provide for any such officer, consequently the resolution cannot be carried.

For one, I should be glad of any change that would be for the best interest of the

Association and make it a permanent and prosperous organization.

Very truly yours,

H. McMICHAEL.

BUFFALO, NEW YORK, October, 1886.

---

### CONCERNING CARDBOARD.

THIS is a sample, one out of many, of a complaint we often receive:

"MY DEAR SIR: I am much troubled with the color of my cardmounts coming off under the burnisher. The heated lubricator seems to dissolve it, and it spreads and smears over the rollers and print, ruining more than the mounts are worth. Is there any remedy? The prints are the usual maroon color. I inclose a sample, and would be greatly obliged if you can suggest any means of preventing this nuisance.

"Very truly yours,

\_\_\_\_\_."

Unhappily, for this disease, the photographic herb-garden holds no cure. Manufacturers assure us that it is not possible to make a maroon color which will not act thus in the burnisher. We are sorry for those who have a large stock of these mounts on hand, but we can only tell them that they must take to a dry lubricator or suffer in silence. We have tried to head off the too-prevailing taste for the maroon mount by precept and example. We do not see how anyone could desire handsomer mounts than some of those in our last few months' issues. The maroon mount is a palpably proven sinner, and really ought to go. There are many others quite as good to look at, and without its hidden faults.

---

### PRACTICAL POINTS FROM THE STUDIO.

It seems a doubtful chance to take the varnish off a flat negative to intensify it. Many never care to try it. Yet we have been shown by Mr. Lulu Farini a print which was from a negative thus treated, as successful as any of the others. The varnish had been on a year. If prints like his can be secured thus, we think it would pay to try the experiment.

**WEAKENING THICK PLACES IN GELATINE NEGATIVES.**—In taking a picture of a rocky cave, with an outlook upon the sea (Torgate, in Norway), I as usual overexposed the light opening and secured a dense halo of light. To weaken, I dipped the negative in water until the film was saturated, then dried the parts which were not to be weakened, rubbed off the blotting-paper, and moistened the parts to be weakened with a mixture of 100 parts hypo-solution (1 : 10) and five parts dragon's blood solution 1 : 5 put on with a brush. The plate was held horizontally, while I marked the effect with a mirror placed underneath. This was so striking that, after several minutes, not only the halo had disappeared, but the whole overexposed landscape came into view. Finally, wash the plate thoroughly.

(Translated for the Philadelphia Photographer.)

## ON THE USE OF HYDROQUINONE IN PHOTOGRAPHY.

BY M. E. JOLY.

CAPTAIN ABNEY was the first to make known the possibility of replacing, in alkaline developers, pyrogallie acid by another organic product, and notably by hydroquinone. M. Davanne mentions this fact in his excellent treatise on photography; he advises the use of a hydroquinone solution at six per cent. at the maximum, with the addition of ammonia, and says that by this means are obtained negatives that are dense and free from fog; but the high price of hydroquinone does not allow this process to be brought into general use. I have made some experiments with hydroquinone, and I think that this product can be used in practical photography, in which it is called to render veritable service, without much cost.

Hydroquinone is found in the form of hard and crystalline scales, not very soluble in water; its aqueous solution rapidly takes a purple-black color when in contact with the air. I easily obtained developments with this solution, freshly made, at a strength of 4 per 100 and diluted with ammonia. There would be no advantage in operating in this manner; the process would be, as M. Davanne has said, much too expensive.

The solution of hydroquinone in alkaline sulphites, on the contrary, remains perfectly white for a certain length of time, and it is with it that I propose to operate. In 100 parts of a solution of sulphite of soda at 10 for 100, I dissolve 1 part of hydroquinone; I steep my impressed plate two or three minutes in this bath, and, without draining it I plunge it into an ordinary ammoniacal pyrogallie developer without sulphite. The image appears with all its details and the bath does not acquire a dark color. If the negative is a little gray, I add a few drops of an aqueous solution of hydroquinone at 1 for 100, that I make at the time, and in very small quantity. In this manner I obtain negatives that are perfectly clear, of a beautiful red-brown color, eminently favorable for printing. The sulphite bath may be used until exhausted. The pyrogallie bath may serve several times, and, moreover, the addition of a few drops of the hydroquinone solution of 1 for 100 increases but very little the cost. I have not tried hydroquinone with the alkaline carbonate developers, but I believe that it would render great service in intensifying the negatives, after the appearance of the details in the pyrogallie bath, especially in the process recently recommended by M. Balagny. I have also made some experiments with resorcine, but without obtaining satisfactory results. In regard to the isomeric pyrocatechine of the two preceding substances, I did not think it necessary to undertake with it experiments which could not lead to any practical results on account of the high price at which it is sold.—*Moniteur.*

## WORLD'S PHOTOGRAPHY FOCUSED.

FOR the year past, it will be found in *Photographic Mosaics* for 1887. Fifty cents.

*Photographic Mosaics*, 1887, will be embellished by a beautiful photogravure print as frontispiece, and contain several illustrated articles.

MR. DALLMEYER has announced "a new single rapid lens," called the "2 R. P." The agents in this country are Messrs. E. & H. T. Anthony & Co.

For some time past the Catholic order of the Christian Brothers have been making use of photography in teaching the deaf and dumb to talk. The results exceeded all expectation, and their success has led them to make use of the same means to teach very young children to correct their faults of speech and to pronounce distinctly. For this purpose, in the primary schools, charts are used, in which is seen, for each letter, the photograph of a child showing the contraction of the lips required in the pronunciation of each letter, and which he is taught to imitate exactly.

WE read in *Cosmos*: "It appears that the production of books in China is now undergoing an important transformation. The greater part of the publications that come each year from the Chinese presses are reprints or new editions of old books. They are reproduced by a process of xylography, which often gives rise to errors or falsifications of the original text. To avoid this objectionable feature, and to reduce the price of the reproductions, photolithography has been substituted with great success. Two houses, one Chinese, the other English, have just been established at Shanghai, and they have already published classical and other works of great value, at prices which astonish the natives."

IN Germany, the oxalate of iron developer is almost exclusively used. When the iron developer is made use of, it has been often recommended to immerse the plate, after exposure and before development, in a preliminary bath. The best for the purpose consists of a solution of hypo at from 1 part of hypo to 2000 parts of water; the plate is allowed to remain from two to three minutes. The advantages to be derived from this bath are the following:

1. The image appears almost immediately, with all its details.
2. The developer is more energetic.
3. The negative obtained is softer.

The principal advantages among these three is especially the abundance of detail which the hypo bath aids the oxalate of iron in producing, and which it could not produce alone.

M. GOUDMAN has published in the *Bulletin de l'Association Belge de Photographie* the result of his investigations on the question of stops. The author, after discussing the different systems in connection with the principle which has guided their makers, arrives at the conclusion that the simplest is the best, that is to say, the ordinary drop shutter. If the sky is to be a little less exposed than the ground, the action may be accelerated by means of a rubber spring placed horizontally. The form of a trapezium is given to the opening, whose narrowest part is on top, and the desired effect is obtained.

WE are informed that the inauguration of the facade of the cathedral at Florence has been postponed until next spring, and that the intended photographic exhibition will take place at the same time; that is to say, about the month of May. In all probability this exhibition will be an international one.

ECLIPSE OF THE SUN ON THE 29TH OF AUGUST.—Despatches have been received from Granada relative to the observations made at the time of this eclipse. It was intended to obtain several photographs of the corona of the sun, with different times of exposure, as well as spectroscopic prints or the corona. It has been ascertained that good photometric observations have been made by M. Thoro, and good photographic prints of the corona were obtained by Messrs. Darwin & Schuster; but the details have not yet been received.

THE Voigtländer portrait eurycope is being focussed in all the principal galleries of the old countries.

THE Glasgow Photographic Exhibition was a grand success.

THE Eastman film has been unrolled before nearly every photographic society in Continental Europe. It "takes" wherever it is exposed.

"THE Handy Map of the Moon" is announced by Messrs. Horne, Thornewaite & Wood, London, from photographs taken from the earth. Shall wonders never cease?

PRESIDENT POTTER sends an answer to "Kehama" to the *Amateur Photographer* (London), which, in our humble opinion, he had better withheld.

In commenting upon it, the editor says: "Americans can 'give themselves away' with a right royal generosity."

And, further: "We await the personal explanations of Kehama that are called for, but we await them with considerable confidence."

Alas! there are a number of persons in this city who are waiting "the personal explanations" of Kehama on matters which are not quite clear.

THE "Woodbury Tissue" is now advertised for sale in London. It is also supplied in rolls, we understand.

The company manufacturing it supply a tissue slide and an album for the registration and preservation of the tissue negatives.

GERMAN copyright law as to photography, although weak, still holds enough virtue to restrain the wholesale piracy of the works of the photographer by the copyist. An important case has been tried in Altona, recently, whereupon the court decided that "a mere direct mechanical copy of a photograph is a piracy, against which the original photographer is protected; but the utilization of photographs for transference into artistic designs, which may, in themselves, come fairly into the category of new creations, is a permissible use." A queer ruling. Paint wings upon a photograph of Mrs. Cleveland, and, although it may be copyrighted, it is "artistic" (on account of the wings), and can therefore be copied and sold by the "pirate"—according to German justice.

Bismarck is badly libelled by the copyists. They decapitate him and paste his head on the bodies of uniformed beer giants.

AT the late meeting of the British Association, at Birmingham, Mr. Howard Grubb, the eminent Irish optician, exhibited and described a working model of his design for working the telescope and dome of the Lick Observatory, in San Francisco, by hydraulic power. It is to be controlled by electric currents. The pressure of a button drives

the great lens, face front, to any part of the heavens.

THE annual exhibition of the Photographic Society of Great Britain opened on the 4th inst.

The corona of the sun remains as much a problem as ever, the photographs of the late total eclipse not having revealed any new points to the astronomers, much to their disappointment.

MR. W. H. CHADWICK, Hon. Secretary of the Manchester Photographic Society, revealed some of the points he had gained while in America, at the last meeting of the Society.

THE "Sunday question" is being discussed with great warmth in England. One good amateur proposes to "brighten the homes of those condemned to live in the darkened and dismal slums of the great cities" with prints from his negatives, provided he is allowed to photograph on Sunday.

A RUSSIAN professor (an amateur) claims to have succeeded in photographing seventeen eminent personages of hell. We understand he copied them for an illustrated edition of Dante's *Inferno*.

The next thing we know, his Satanic Highness (or lowness) will be ordering an amateur outfit. He will need no tripod, for all he will have to do will be to stiffen his tail, spread his legs, lean back, and place his camera on his head.

We recommend a "hat camera" to his Sulphuretted Majesty.

Query.—Can he use gelatine plates? Mr. Eastman will please answer.

ON closely examining a light-weight silver dollar presented at the sub-treasury in Boston, the other day, a piece of handiwork of a high order was discovered. The coin had been hollowed out in the centre, so as to allow the placing within it of the photograph of a child, while the face of the coin formed a sort of cover, which was held in position by hinges and a clasp. So fine was the work that probably no one but an expert could detect it. It is thought that the

coin found its way to the treasury by mistake.

MR. WILLIAM H. WALKER (of the Eastman Dry-plate and Film Co., now resident in London) is holding a discussion with the Autotype Co., of that city, who have made rather unwise and unjust insinuations as to the permanency of bromo-gelatine enlargements. Mr. Walker rather gets the better of it. Carbon prints were long ago proven fadeable.

At the last meeting of the Academy of Natural Sciences, instantaneous photographs of lions in motion were shown. The animals were represented as being spotted, although such spots, it was stated, could not be seen on the animals themselves without, at all events, very close observation. It was stated that photography frequently revealed characters which could not be detected by the eye.

A LADY living in West Thirty-first Street, possessed of a considerable fortune, and well known in New York society, who spent much time with Mme. Blavatsky, in those days, and who is still active in the Theosophical organization, avers that she saw the seer produce instantly, by simply laying her hand on a sheet of paper, an excellent photograph of a relative of this lady whom Madame had never seen, and who was then in a distant city.

THE German law concerning reproductions is interesting. In general terms, it holds that one copy may be made for the private use of one person, without injury to the lawful interests of the author. But if more than one copy is made, or if more than one person uses the copy, the author's rights *i. e.*, pecuniary interests—are held to have been infringed upon, and an action will lie.

To many people, sitting for a photograph is a delicate task, for the reason that in their endeavors to assume a pleasing expression they generally overdo the thing and appear as though simple. Stage performers are, as a rule, artistic photographic subjects. They act well even before the camera. Accustomed to exercise facial expression in their avocation, they can assume at will a counte-

nance at once so bright and charming as to delight the operator and enable him to produce excellent negatives in a fraction of the time required by ordinary sitters.

### GRAY'S VEST CAMERA.

MR. R. D. GRAY, the inventor of the "vest" camera, is a practical photographer, well known in St. Louis. He has greatly improved his camera of late, reduced its weight and added to its powers. Outwardly it now resembles a nickel-plated circular bon-bon case, scant six inches in diameter, and just an inch thick at the centre.

But within that case are great possibilities. It is a dark chamber; it contains an instantaneous shutter, and the apparatus for working it, with the means of holding a circular sensitized plate in place, capable of receiving six exposures. Outside, at one edge, the tiny lens, looking like a horn vest-button, is placed, and at the centre is a knob with a dial-hand, by means of which the exposures are numbered—1 to 6—as made. Each exposure secures a picture  $1\frac{3}{4}$  inch in diameter.

When "loaded," the camera is hidden under the vest, the lens protruding through the button-hole. From one edge leads a string, downward. The pulling of this string causes an exposure to be made. A little thump is the only response you get, but thus you know the deed is done. The drawings make the thing plainer, perhaps.

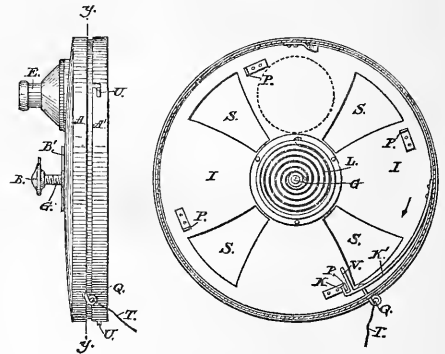

We need not go into the possibilities of such an incendiary apparatus as this. It can do more mischief than its weight in

dynamite, or more good than its weight in gold, according to the disposition and will of the person whose hand pulls the string.

It is the only really invisible detective camera. Anything not closer than six feet is subject to its grasp, sharp and clean. We have before us elephants, street arabs, policemen, State capitols, washer-women, a strike, promenaders, and what not. Six negatives on a plate as sharp and clear and good as can be.

Mr. J. Carbutt has already met the want for circular instantaneous plates, and supplies them; and the Scovill Manufacturing Company have a special "vest-camera developing and printing outfit."

It is always ready, it is hidden, like the tongue of scandal, but it is going to impart a great deal more pleasure and do good. Already we see people walking straighter when a suspicious amateurish sort of a character halts near or follows them.

## Editor's Table.

MR. LEON VAN LOO, the famous photographer of Cincinnati, sailed for home on the Belgenland from Antwerp, on September 25th. His proposed Italian trip was given up on account of the cholera, and he returned instead, to his old home, Ghent. We wish him a safe return after his pleasant rest.

WE have received an interesting account of the researches in the photography of the stars, lately carried on at the Harvard College Observatory, by Prof. EDWARD E. PICKERING and his assistants. The instruments used are described and illustrated. The dry plates used in an exposure of thirty minutes gave a photograph of all the stars down to the eighth magnitude. Valuable results were obtained, especially stellar charts and spectra.

THE photo-engravings of this number were made by Mr. L. E. LEVY, of the LEVYTYPE Co., Philadelphia. Mr. LEVY was one of the pioneers of photo-engraving—among the very first to work it. That he has kept up with its wonderful progress, and still stays in the front, his pictures prove.

FROM Mr. W. S. PERKINS, of Colfax, Cal., we have received a beautiful "bit of nature" in the Maine woods, photographically preserved, and also some pictures of the G. A. R. reunion in San Francisco. From Mr. FLICKINGER, of Bethlehem, Pa., comes a taking picture of a "dog and basket," well caught.

It is officially announced that the first number of the new *Scribner's Magazine*, issued by CHARLES SCRIBNER'S SONS, will appear on December 15th. It is awaited with very much interest. It is believed that its publishers will avail themselves more freely in its illustrations of the many new photo-mechanical processes than our other two great magazines have done.

THIS is the sort of letter we like to receive. It is brief but to the point:

MANCELONA, MICH.

DEAR SIR: I want the best, so continue to send the PHILADELPHIA PHOTOGRAPHER right along. A photographic magazine is a necessity with me, and yours is by far the leader of them all. I enclose Post-office order for subscription and for latest edition of *Photographics*.

Respectfully,

W. JUDD.

AND Mr. N. M. WILCOX, of Austin, Tex., adds his little word, saying: "It has done more to fire my ambition than anything else."

MR. R. D. GRAY, inventor of the "Vest Camera," has opened an establishment for making bromide enlargements, at 1430 Broadway, New York. Mr. GRAY is a skilled photographer, and from our knowledge of his ability, and also from its evidence in the samples we have seen, we can cordially recommend him to the trade.

WE have received a cabinet reproduction of the six splendid pictures by DECKER & WILBER, of Cleveland, O., which took the first prize at Braunschweig. In pose and lighting they are superb, bearing the stamp of individuality that makes genuine art.

A GOOD EXAMPLE.—A new subscriber writes: "I have read your magazine as an employé for over twelve years. Now I am in business for myself, I want it sent direct to me. I enclose the money.

THE *Boston Times* in a late number, contains a long account of the studio of Mr. RITZ, the artist-photographer of that city.

THE gelatines of F. DRESCHER & Co., of Oberndorf-Schweinfurth, Germany, are famous abroad. Their circulars contain testimonials from many firms of plate-makers and from individuals. We are glad to call attention to their advertisement on another page, and endorse their goods.

SOME days ago we were pleasantly surprised by the entrance into our office of Mr. I. W. TABER, of San Francisco, who had just returned from a trip to the yacht races. Mr. TABER long since earned for himself the title of "The Photographer of the Pacific Coast." He left a copy of his little pamphlet, "*Hints to Strangers*," which is a condensed guide to points of interest in and near San Francisco.

FROM GAYTON A. DOUGLASS & Co., of Chicago, come notices of two of their new specialties, "Doane's Non-actinic Compound," which can be used like an ordinary water-color, and the "Venetian Pressed Ruby Glass," which absolutely excludes all but the red rays of light.

ON another page will be found the advertisement of the PHELPS ENAMELLING COMPANY, of Muscatine, Iowa. It is to be noted that gelatine is not used in their process. As is well known, pictures in which gelatine is used invariably turn yellow with time. We have seen samples of the work of the PHELPS Co., which are very good.

THE SCOVILL MANUFACTURING COMPANY offer an excellent holder for the studio, in their new "Waterbury Dry Plate Holder." By a simple system of ledges and two adjusting screws, it holds securely any ordinary size plate whatever.

JAMES W. QUEEN & Co., the opticians, of 924 Chestnut Street, Philadelphia, have issued a new 135 page catalogue of "photographic lenses, cameras, apparatus, and material." They have in stock everything needful to the photographer, and roll-holders, films, and the other very latest improved appliances are well represented.

OUR genial friend, Mr. G. G. ROCKWOOD, of New York, has returned from his European tour, and we have interviewed him. The results of the interview will appear in our next number.

WILSON, HOOD & Co., send us a series of original and taking circulars of the goods of the BLAIR CAMERA COMPANY. In their fall list we notice the "Marcellus Shutter," which is said to be the best in use.

WE have received from DECKER & WILBER, of Cleveland, some very flattering correspondence in regard to their recent exhibit at Braunschweig. We congratulate them.

OUR MAGAZINE.—"I am much pleased with your journal and hope for a long and profitable acquaintance with it."—Prof. LEROY C. COOLEY, Vassar College, New York.

WE have word from Mr. JAMES INGLIS, that the ROCHESTER DRY PLATE COMPANY is now in full swing and ready to fill any size order promptly.

SECRETARY CARLISLE corrects our figures in regard to the Convention, printed in our last number. It should be 335 instead of 235 old members who were at St. Louis. The result of this correction is to increase the estimate of the cost of a Convention by \$8000.

WITH the October issue, the enterprising Buffalo magazine, *Queries*, was enlarged by the addition of sixteen pages of reading matter. The new features consist of miscellaneous reading matter, critical essays, poetical extracts, readings from new books, and a number of superior illustrations. An excellent full-page engraving of Constance Fenimore Woolson, and portraits of Locker, E. W. Howe, and Tolstoi, the Russian novelist, are also given. The publishers now claim *Queries* is the largest and best dollar magazine published. Buffalo, N. Y.: C. L. SHERRILL & Co.



# Specialties.

## ADVERTISING RATES FOR SPECIALTIES.

25 cents for each line, seven words to a line—in advance. *Operators desiring situations, no charge.* Matter must be received a week before issue to *secure* insertion. Advertisers will please not ask us for recommendations. ~~33~~ We cannot undertake to mail answers to parties who advertise. Please always add your address to the advertisement. **Postage-stamps taken.**

**MAKE OUT YOUR OWN BILL,** and remit cash with your advertisements, or they will not be inserted.

RETOUCHING BUREAU.—Under the direction of Mr. H. Harshman. None but skilled help employed. Quality of work guaranteed. Prices moderate. Send your negatives in wooden box with cover screwed on, and prepay charges. Address GAYTON A. DOUGLASS & Co.,

Merchants in Photo. Supplies,  
185 & 187 Wabash Avenue,  
Chicago, Ill.

“Long’s Art of Making Crayons on Solar Enlargements.” Price 50 cents.

EDWARD L. WILSON,  
853 Broadway, N. Y.

A first-class gallery on Broadway for sale. Good business. *For cash only.* For particulars address

F. H.,  
226 E. Fifteenth St.,  
New York.

SECOND CHOICE.

### DOUBLE ALBUMEN PAPER.

Extremely cheap. Samples sent.

W. HEUERMANN,

49 CEDAR STREET, NEW YORK.

### FOR SALE! LENSES AT A BARGAIN!

One Morrison 11 inch Rapid Rectilinear Lens. Will cover a 11 x 14 plate sharp to the edges. An excellent instantaneous lens. In good condition.

PRICE, \$50.

Two 8 x 10 Morrison Wide-angle Lenses, as good as new. 8 inches focal length.

PRICE, \$20 each.

One Euryscope, in good condition. Will cover a 11 x 14 plate.

PRICE, \$50.

Address “W. K.,”

Photographic Times Office.

EVERY photographer in want of excellent lenses, for *any purpose*, will best serve his interest by consulting the new illustrated price-list of Messrs. BENJAMIN FRENCH & Co. before purchasing.

## DOWN SHE GOES!

NEW PRICE-LIST

OF THE

ROCKWOOD SOLAR PRINTING CO.

17 UNION SQUARE NEW YORK.

Size.	Unmounted.	Mounted.
11 x 14.....	\$1 00	\$1 25
13 x 16.....	1 00	1 25
14 x 17.....	1 00	1 25
16 x 20.....	1 00	1 25
18 x 22.....	1 20	1 50
20 x 24.....	1 35	1 50
22 x 27.....	1 40	1 90
25 x 30.....	1 40	1 90
27 x 32.....	2 25	3 00
29 x 36.....	3 00	4 00
30 x 40.....	4 00	5 00

No charge for negatives. All orders must be accompanied by the cash. Make all P. O. orders payable to ROCKWOOD SOLAR PRINTING Co.,  
17 Union Square, New York.

PRINTING AND TONING FOR AMATEURS  
A SPECIALTY.

PLATES DEVELOPED.

Try our freshly made photographers' paper. Made fresh daily, and fumed ready for use. 25 cents per sheet, 18 x 22, cut any size, and sent by mail without extra charge.

Our Concentrated Toning Solution is pronounced the *best* by all who have used it. Price, seventy-five cents.

Photographic supplies of all kinds. Largest variety of stock in the city. Send for catalogue.

LOEBER BROS.,  
119 & 121 Nassau St.,  
New York.

825 REVISED LIST. 825

We call attention (circular free) to our revised price-lists of *albumen papers, Magee's nitrate of silver, dry plates, and pyrogallie acid.* Consult it before you buy. WILSON, HOOD & Co.,  
825 Arch St., Phila.

**WILSON, HOOD & CO.,**  
**825 Arch St.,**  
**PHILADELPHIA.**

We have now in stock  
**THE NEW EAGLE DRY PLATE.**

ALSO  
**THE INGLIS TRIUMPH PLATE.**

A new brand of  
**GERMAN PYRO ACID.**  
 (35 cents per ounce.)

**POCKET GLASS CUTTER.**  
 (15 cents each.)

**NEW STYLE CORNER CHAIR.**  
 (\$10.00 each.)

**PAPIER MACHÉ STUMP.**  
 (\$6.00 each.)

**SUNSHINE MAILING ENVELOPE.**

THE STUDIO REGISTER furnished by Smith & Pattison, Chicago, seems to be growing in popularity. It is a very complete and well arranged system of keeping record of orders, etc., in the studio. Every gallery should have one. They furnish sample leaves free.

FOR SALE.—An excellent opportunity for a good photographer to purchase the leading gallery in a city of 60,000. Address,  
 Gallery,  
 Care of **GEORGE MURPHY,**  
 250 Mercer St., N. Y.

FOR SALE.—A photographic gallery, situated in Brockton, Mass. Everything of first-class appointment; doing large business. For cash only. Address  
 "S."  
 P. O. Box 1214,  
 Boston, Mass.

Another preserver of neatness is Anthony's Artist's Cuffs. The engraving makes the article

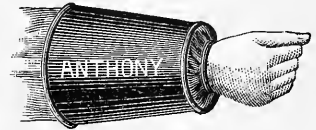

and its use plain. No more spoiled shirts or soiled wrists.

**GRAY & STAMMERS'**

Reduced Price-List of

**BROMIDE ENLARGEMENTS.**

Size.	Unmounted.	Mounted.
11 x 14.....	\$1 00	\$1 25
14 x 17.....	1 25	1 50
16 x 20.....	1 50	1 75
18 x 22.....	1 75	2 00
20 x 24.....	2 00	2 50
22 x 27.....	2 25	2 75
25 x 30.....	2 25	2 75
24 x 36.....	3 00	3 75
30 x 40.....	5 00	6 00

Our facilities to do good work on short notice are unexcelled. Prints made on either smooth or mat-surface paper and vignettted when so ordered. Send cash with order, and 25 cents, extra, for packing each lot of mounted prints. Samples furnished at the above rates.

**GRAY & STAMMERS,**  
 1430 Broadway, New York.

**THE LIGHT RUNNING**

**NEW HOME**

**SEWING MACHINE**

**HAS NO EQUAL.**

**PERFECT SATISFACTION**

**New Home Sewing Machine Co.**  
 —ORANGE, MASS.—  
 30 Union Square, N. Y. Chicago, Ill. St. Louis, Mo.  
 Atlanta, Ga. Dallas, Tex. San Francisco, Cal.

**FOR SALE BY**

THE AGENTS, at the above named places.

**THE DUPLEX NOVELETTE CAMERA**

Is a marvel of Camera architecture. In an instant a "vertical" camera may be turned into a "horizontal," and in another the change made from the 5 x 8 to the 8 x 10 size, and *vice versa*. It is supplied in two carrying cases, so that you may leave one part at home if you desire. The same platform and one front serves for both sizes. It is as complete an equipment as ever was invented. One holder, each size, goes with the "Duplex" at \$35. Messrs. E. & H. T. Anthony & Co. are the makers.

Among all the photographic lenses of various makes and styles which have been introduced during the past ten years, the euryscopes, of which Voigtlander & Son are the sole manufacturers, loom up conspicuously. The success of these lenses has been unparalleled, and the demand is as lively as ever. They can be found in nearly every gallery in the land, and the amount of satisfaction and profit they produce is difficult to calculate. Most convincing proof of their superiority over other lenses is the exquisite work done with them, and the fact that it is simply impossible to get along without them.

**SPECIAL CARD.**

Talcott's Improved Mounting for photographs softens the lines, gives much strength and great brilliancy to the picture, and is the only process by which a photograph may become indelible.

Patented March 23, 1886.

For preserving from all soiling engravings, etchings, crayons, diplomas, certificates, etc., this mounting has no equal, the picture or parchment being hermetically sealed.

Pictures thus mounted can be displayed or packed in less than one-half the space required by pictures with other framings, as by this process all other framing becomes wholly unnecessary, yet it is so constructed that if desired it can be placed in any ordinary picture frame intact, free from all interference.

E. K. TALCOTT,  
216 Northampton St.,  
Boston, Mass.

Our dark-room and laboratory are under the charge of Dr. John Nicol, photographic chemist, late of Edinburgh. None but purest chemicals used in our preparations. All the standard dry-plate developers kept in stock. Your patronage desired.

GAYTON A. DOUGLASS & Co.,  
Merchants in Photo. Supplies,  
185 & 187 Wabash Avenue,  
Chicago, Ill.

Reed's Common-sense Negative Washing-box.  
New. Send for circular.

WILSON, HOOD & Co.,  
825 Arch St., Phila.

FOR SALE OR RENT.—Gallery in West Point Clay County, Miss. Only gallery in the county. Town contains 3000 inhabitants. Doing a good business. Best of reasons for selling or renting.

Address Jno. F. BURNETT,  
West Point, Miss.

**USED "DAISY," AND "NEW" HOLDERS FOR SALE.**

From holders used at New Orleans Exhibition, I have

24 of 5 x 8 . . .	\$1 35
12 of 10 x 12 . . .	3 00
1 of 14 x 17 . . .	8 00

Cheap. Good as new.

EDWARD L. WILSON,  
853 Broadway, N. Y.

WANTED.—At once, a first-class operator. None but one with a good character and steady habits need apply. Wages \$18 at start. Address, with sample of work, to be retained.

BASS PHOTO. STUDIO.,  
Brockton, Mass.

**SITUATIONS WANTED.**

*No charge for advertisements under this head; limited to four lines. Inserted once only, unless by request.*

In a first-class gallery as retoucher, painter, and assistant operator. Address J. L. Jones, Box 105, Blossburg, Tioga Co., Pa.

As printer, toner, or assistant operator; can also retouch. Reference or sample. Three years experience in good galleries. Address G. C. Haugh, 307 Huron St., Akron, O.

By a young lady, as retoucher and printer; can make herself generally useful about a gallery. Address 576 Pine St., Lockport, N. Y.

By a first-class retoucher, operator, printer, and toner. Best recommendations; wages no object; eight years experience. Prefers the south. Address O. M. Brown, Chagrin Falls, O.

By a young lady, at present having charge of a large eastern gallery, a position in a western city, prefers Cleveland, Columbus, or Cincinnati. Can retouch or take charge of a reception-room. Address Miss L. Blair, care Robt. Blair, Sandusky, O.

By a first-class operator, printer, and manipulator. Has had long experience. Address PHILADELPHIA PHOTOGRAPHER, 853 Broadway, New York.

ASK FOR THE  
BLUE LABEL.

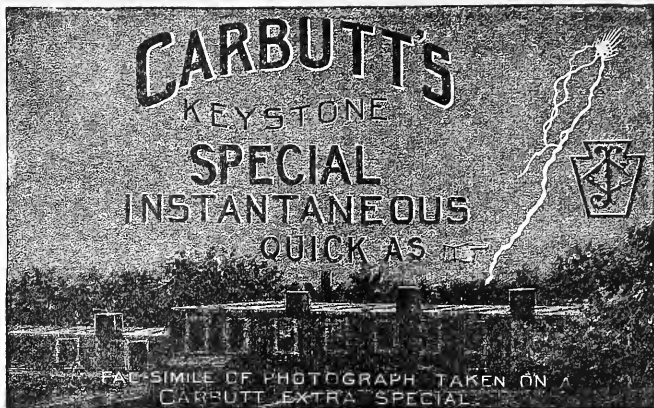

TRY THEM.  
and you will continue to  
USE THEM.

Pronounced the "Ne Plus Ultra" of Dry Plates.

UNSOLICITED TESTIMONIALS.

MR. JOHN CARBUTT, Wayne Junction, Philadelphia.

WORCESTER, MASS., December 25, 1885.

DEAR SIR: I have been using some of your new plates, emulsion 1024, sensitometer 24. I think they are, without exception, the finest and best plates I ever used. They are not only very fine and delicate in their structure, but, when properly manipulated, result in a blooming negative, possessing all the desirable qualities that any artist could wish for. I could most appropriately christen them the "Ne Plus Ultra Dry Plate."

Yours truly, E. R. B. CLAFLIN.

DETROIT, MICH., January 16, 1886.

MESSRS. HARRIS & KITTLE.

GENTLEMEN: I am very much pleased with the Carbutt Plate; in fact, I call them the best plate *by far* that I tried so far. I find them especially useful for my theatrical subjects, as the quick emulsions are *absolutely instantaneous*.

Yours truly, A. B. TAYLOR.

For Sale by all Dealers in Photo. Materials.

JOHN CARBUTT, Keystone Dry Plate Works, Wayne Junction, Philada., Pa.

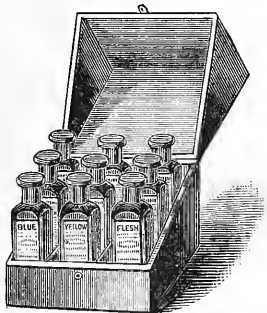

Send for Catalogue.

**JANENTZKY & WEBER,**  
MANUFACTURERS OF  
**ARTISTS' MATERIALS**

- J. & W.'s Superfine Artists' Oil Colors in collapsible tubes,
- J. & W.'s Artists' Canvas, Fine Brushes for Oil or Water Colors, Academy Boards, Water Colors in cakes and pans, Soft Pastels,
- Monochromatic Boards, Pastel Canvas, Pastel Plaques, Liquid Photograph Colors, Blue Print Papers, plain and sensitized, Solar Printing Papers.
- Crayon Drawing Materials,
- Everything required for Drawing, Painting, Etching, Modeling, etc.
- Wax and Paper Flower Materials.

No. 1125 Chestnut Street, Philadelphia.

**PHOTOGRAPHERS' ART VINE.**

Beautiful and durable Ivy Vine for scenic effects; manufactured especially for photographers. All natural vines and leaves imitated. Send for circular. Special rates to dealers in photographers' supplies.

**S. G. SHERWOOD,**  
232 Vermont St., Buffalo, N. Y.

**RENEWED.**

AS THE READING SEASON IS AT HAND, WE RENEW FOR  
A MONTH OR SO OUR



IG OFFER OF

**\$8.00 WORTH OF BOOKS FOR \$4.00.**

SECURE A SET BEFORE THE OFFER ENDS.

“How doth the little busy bee  
Improve each shining hour,  
And gather honey all the day  
From every opening flower!”

When Isaac Watts wrote that immortal verse, which for generations has served to shame many a laggard into photography or some other honest effort for a living, he only used the bee as a figure to represent the amateur and adept photographer, and to “gather honey” meant to read carefully from the “opening flower,” which is plain English for photographic books.

And now, as the season of reading and study approaches, is the proper time to follow the injunctions of the wide-awake and observant bard.

To enable the enterprising “busy” ones to do this, we have combined with the Scovill Manufacturing Company to offer, with theirs, certain of our publications at one-half price—i. e., four dollars will purchase eight dollars’ worth of books, postage paid to any American address. Dr. Vogel’s *Progress of Photography*; Tissandier’s *Hand-book of Photography*; Robinson’s *Pictorial Effect in Photography*; *Gihon’s Guide*. A few words as to these:

Dr. Vogel’s *Progress* is the best instructor on dry-plate manipulation there is; no library is complete without it. It treats of all classes of work, including the æsthetic department and finishing and printing the negative. It is profusely illustrated, handsomely printed, bound in cloth, gilt, and is exhaustive on the subjects of light, chemistry, optics, apparatus, processes, technique, and amateur photography. It is published at \$3.00.

Mr. H. P. Robinson’s *Pictorial Effect in Photography* teaches wrinkles and dodges that you would never dream of in your photography. It is as full of bright, brilliant ideas—told so pleasantly—as a film is of molecules. It is the best art authority you can study. It is amply illustrated, is bound in paper (cloth 50 cents extra), and is published at \$1.00.

*Gihon’s Guide*, though called the *Colorist’s Guide*, is by no means confined to instruction in coloring. Its chapters on linear perspective should be memorized by every one who can

focus. Every page instructs. It is bound in cloth, finely illustrated, and published at \$1.50.

Tissandier’s *History and Hand-book of Photography* is one of the most attractive books on photography that has ever appeared in any country.

Part first gives a history of photography, from the discovery of the camera obscura by the Italian philosopher, Porta, including all the interesting details of Daguerre’s and Niepce’s experiments, their partnership, the death of the latter, the final perfection and publication to the world of the daguerrotype process, the discovery of photography on paper by Talbot, and down to the taking of negatives.

Part second treats of the operations and processes of photography, describing and illustrating the studio and apparatus, the manipulations of the negative process; all the operations of the printing department; theory and practice, including the modifications required by various kinds of photography, such as landscapes, portraits, skies, and instantaneous photography, retouching, enlargements, dry processes, etc.

Part third enumerates the applications of photography, such as heliography, the Woodbury process, photosculpture, photographic enamels, photomicrography, microscopic dispatches during the siege of Paris, astronomical photography, photographic registering instruments, the stereoscope, photography and art, and the future of photography.

The appendix describes panoramic photography, the heliotype process, the photoint process, the most approved formulae of the wet collodion process, a simple method of repairing dry plates, and English weights and measures.

The book is beautifully illustrated throughout with fifteen full-page engravings and sixty woodcuts. It comprises three hundred and twenty-six pages, and is printed on heavy tinted paper. It is bound in cloth, and published at \$2.50.

These four books, whose aggregate publication price is \$8.00, we offer for \$4.00 until our joint stock is exhausted. Any two of them to one address, one-third discount from publication price. No discount on a single publication.

**EDWARD L. WILSON, 853 Broadway (Domestic Building), New York.**

**F. DRESCHER & CO.'S  
IMPROVED GELATINE FOR EMULSION.**

Made by a new and improved method, is the purest, the most reliable, and gives the best results.

**UNRIVALED FOR THE PURPOSE.**

Also **IMPROVED GELATINE FOR LICHTDRUCK AND OTHER PHOTO. WORK.**

Obtainable from the **SCOVILL MANUFACTURING CO.**, and all  
Dealers in Photographic Materials.

Or from the Manufacturers: **F. DRESCHER & CO.**, Oberndorf-Schweinfurt-on-the-Main, Germany.

---

**GAYTON A. DOUGLASS & CO.**

MERCHANTS IN

**SUPPLIES FOR PHOTOGRAPHY,**

**185 & 187 Wabash Ave.,**

**CHICAGO.**

---

**PHELPS ENAMELING CO.**

**Practical Photographers,**  
Inventors and Proprietors of the

**NON-GELATINE PROCESS OF ENAMELING,**

AND ENAMELERS FOR THE TRADE.

We respectfully invite any photographer to send us two cabinets unmounted with cards, which we will enamel free of charge, and return to them by mail. It will pay you to investigate this. Correspondence solicited. Patent applied for.

**The Most Important Discovery of the Age to Photographers.**

**Nos. 307, 309 & 311 East Second Street,**

**MUSCATINE, IOWA.**

*The Eagle Paper Keeps its Place as Leader.*

Try the New Colors of the Leading

**DRESDEN ALBUMEN PAPER.**

**IMPROVED**

**EXTRA-BRILLIANT PENSEC,**

10 KILOS.



10 KILOS.

**EXTRA-BRILLIANT NEW ROSE.**

**It Possesses the Highest Durability of Color.**

It Never Blisters. It Keeps Well after Silvering.

It Tones Easily. It Gives the Most Vigorous  
and Brilliant Prints. It is the Best

Selected Paper.

It is Always Uniform and Reliable, and has the Least  
Objectionable Water-Mark. The Majority  
of Artists will Have It.

**SAMPLES FREE ON APPLICATION.**

For Sale by all Stockdealers in the United States  
and Canada.

**G. GENNERT,**

Importer,

**No. 54 EAST TENTH STREET,**

**NEW YORK.**

# THE DUBOIS FILING CASES.

*For Preserving Photographic Negatives, Prints, &c., Letters, Bills, and Miscellaneous Papers.*

PATENTED SEPTEMBER 2, 1884.

**Economical! No Binding! Either a Temporary or a Permanent File.**

Made in  
five sizes and cabinet  
form.

AGENTS WANTED.

Write for Descriptive  
Circular.

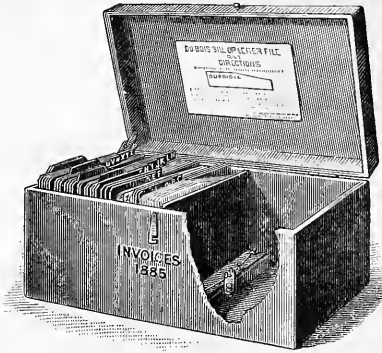

NEW YORK,  
April 27, 1886.  
Mr. FRANK G. DuBOIS,  
No. 512 W. 30th St., N.Y.  
DEAR SIR: Your File supplies a need that I have felt for some time past. It is the best thing of the kind that I have ever seen, and I shall be much pleased to recommend it to all my friends for preserving bills, notes, receipts, recipes, unmounted prints, photographs, and all kinds of miscellaneous papers to which easy reference may be wanted at any time. Respectfully,  
Miss SOPHIE L. MAURER.

Sent by Express, on receipt of \$3.00, or with lock and key, \$4.00.

PATENTEE AND SOLE MANUFACTURER,

FRANK G. DuBOIS, 512 W. 30th St., New York.

TO THE TRADE ONLY.

## HYPOSULPHITE OF SODA

FOR PHOTOGRAPHERS.

### CHAS. A. W. HERRMANN,

16 Cedar St.

New York.

TO THE TRADE ONLY.

THE LARGEST ESTABLISHMENT IN THE WORLD

SIXTEEN YEARS PRACTICAL EXPERIENCE

**MOSS ENGRAVING CO.**

535 PEARL ST. COR. ELM. NEW YORK

MOSS' NEW PROCESS Superior to Any Other Method.

ILLUSTRATIONS OF EVERY DESCRIPTION For Books, Magazines, Newspapers, Catalogues, CIRCULARS, &c. IN THE MOST ELEGANT STYLE OF THE ART

SEND GREEN STAMP FOR 24 PAGE CIRCULAR -- SEND PHOTOGRAPH, DRAWING OR PRINT FOR ESTIMATE.

### C. H. CODMAN & CO.

## Photographic Stockdealers

Sole Agents for the NEW ORTHO-PANACTINIC LENS, Moor's Photographic Enamel, the Perfect Mounting Solution for mounting Photographs on the thinnest mount without wrinkling.

New England Agents for American Optical Co.'s Apparatus. The best in the world. Send for Price List.

34 Bromfield Street.

BOSTON, MASS.



720 (5 gross) of these trimmers were sold to one party in July.

# ROBINSON'S NEW MODEL PHOTOGRAPH TRIMMERS!

This drawing is of the full natural size and shape of the New Model Revolving Trimmer. The Straight Cut is of same size, varying but little in shape.

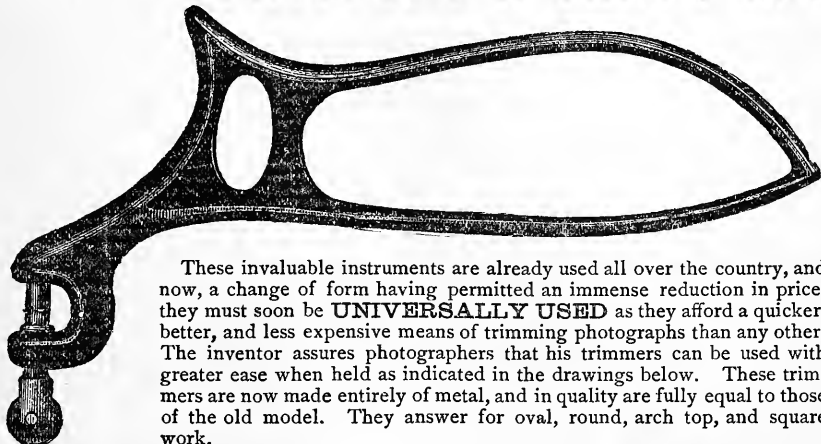

These invaluable instruments are already used all over the country, and now, a change of form having permitted an immense reduction in price, they must soon be **UNIVERSALLY USED** as they afford a quicker, better, and less expensive means of trimming photographs than any other. The inventor assures photographers that his trimmers can be used with greater ease when held as indicated in the drawings below. These trimmers are now made entirely of metal, and in quality are fully equal to those of the old model. They answer for oval, round, arch top, and square work.



Plan of holding the *Straight Cut* Trimmer when in use. PRICE, 50 CENTS.

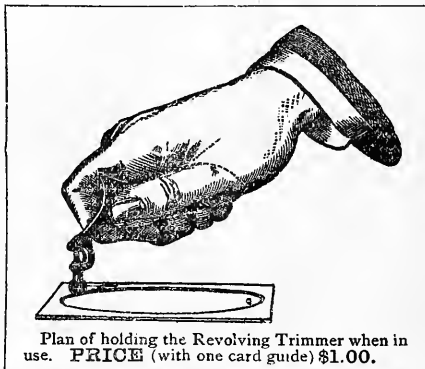

Plan of holding the Revolving Trimmer when in use. PRICE (with one card guide) \$1.00.

## ROBINSON'S GUIDES.

MADE OF SHEET-IRON.

We have the following Regular Sizes always on hand at 10 cents per inch the longest way of the aperture.

OVALS.				SQUARE OR ROUND CORNERED.			
2 x 2 $\frac{1}{2}$	3 $\frac{3}{8}$ x 4 $\frac{3}{8}$	5 x 7	6 $\frac{1}{2}$ x 8 $\frac{1}{2}$	2 $\frac{1}{8}$ x 3 $\frac{3}{8}$	2 $\frac{5}{8}$ x 3 $\frac{3}{8}$	2 $\frac{3}{4}$ x 4 $\frac{1}{2}$	4 x 5 $\frac{3}{8}$
2 $\frac{1}{2}$ x 3	3 $\frac{3}{8}$ x 4	5 $\frac{1}{2}$ x 7 $\frac{1}{2}$	6 $\frac{1}{2}$ x 8 $\frac{1}{2}$	2 $\frac{1}{4}$ x 3 $\frac{3}{8}$	2 $\frac{5}{8}$ x 3 $\frac{7}{8}$	2 $\frac{7}{8}$ x 4 $\frac{3}{8}$	4 $\frac{1}{2}$ x 5 $\frac{3}{8}$
2 x 3	3 $\frac{3}{8}$ x 4 $\frac{1}{2}$	5 $\frac{1}{2}$ x 7 $\frac{1}{2}$	7 x 9	2 $\frac{1}{2}$ x 3 $\frac{1}{8}$	2 $\frac{3}{4}$ x 4 $\frac{1}{2}$	3 $\frac{3}{8}$ x 5 $\frac{1}{4}$	3 $\frac{3}{8}$ x 6
2 $\frac{1}{2}$ x 3	3 $\frac{3}{8}$ x 5	5 $\frac{1}{2}$ x 9 $\frac{1}{2}$	7 $\frac{1}{2}$ x 9 $\frac{1}{2}$	2 $\frac{1}{2}$ x 3 $\frac{1}{2}$			4 x 6 $\frac{1}{2}$
2 $\frac{1}{2}$ x 3	4 x 5	5 $\frac{1}{2}$ x 9 $\frac{1}{2}$	7 $\frac{1}{2}$ x 9 $\frac{1}{2}$	FOR STEREOGRAPHS.			
2 $\frac{1}{2}$ x 4 $\frac{1}{4}$	4 $\frac{1}{2}$ x 6	6 x 8	7 $\frac{1}{2}$ x 9 $\frac{3}{4}$	Arch Tops. Round Cornered. Round.			
				3 $\frac{1}{16}$ x 3 $\frac{3}{4}$	3 x 3	3 $\frac{1}{16}$ x 3 $\frac{3}{4}$	3 x 3

The above sizes suit the Collins Card Mounts, and photographers knowing that they can be always had at the low price of ten cents per inch, would do well to make their sizes accord, as orders can also be filled more quickly. Ten days are required to make special sizes.

Special Sizes made to order, at 15 cents per inch, the longest way of the aperture.

**ROBINSON'S PHOTOGRAPH TRIMMERS** are substitutes for the Knife for Trimming Photographs, and do the work much more expeditiously and elegantly. They Save Time, Save Prints, and Save Money.

They do not cut, but pinch off the waste paper, and leave the print with a neatly bevelled edge which facilitates adherence to the mount. Try one, and you will discard the knife and punch at once. For ovals and rounded corners they are worth their weight in gold.

For sale by all Dealers.

**ROBERTS & FELLOWS,**

Successors to E. L. WILSON,

1125 Chestnut St., Philadelphia, Pa.

"Tasteful, well edited, and crammed full of technical information is THE PHOTOGRAPHIC TIMES."—The Journalist.

# The Photographic Times

Is a WEEKLY JOURNAL devoted to the

**THEORY, PRACTICE, AND ADVANCEMENT OF PHOTOGRAPHY.**

ITS DEPARTMENTS ARE:

**EDITORIAL.**

**CONTRIBUTED AND MISCELLANEOUS,** articles by the best photographic writers of both hemispheres. **COMMUNICATIONS FROM SOCIETIES,** Including Papers, Lectures, etc.

**MEETINGS OF SOCIETIES.** Stating date and place of meeting of all Photographic Societies, both professional and amateur, and giving full proceedings of all meetings.

**CORRESPONDENCE.** Scientific and practical discussion by practical photographers of important and interesting questions, and letters from all quarters of the globe by intelligent and observing correspondents.

**OUR EDITORIAL TABLE.** Reviews of books, exchanges, etc.

**PICTURES RECEIVED.** Impartial criticism and notice of all photographs sent in.

**NOTES AND QUERIES.** Answers by the Editors to correspondents in search of knowledge.

**COMMERCIAL INTELLIGENCE.** Description of new photographic appliances, studio changes, and a record of photographic patents.

## A PARTIAL LIST OF WRITERS TO THE PHOTOGRAPHIC TIMES.

CAPT. W. DE W. ABNEY.....	England	W. H. WALMSLEY.....	Philadelphia
W. M. ASHMAN.....	"	FREDERICK A. JACKSON.....	New Haven
W. K. BURTON.....	"	PROF. RANDALL SPAULDING.....	Montclair, N. J.
W. E. DEBENHAM.....	"	PROF. WM. HARKNESS, U. S. N.....	Washington, D.C.
H. P. ROBINSON.....	"	DR. JOHN H. JANEWAY, U. S. A.....	Governor's Island
G. WATMOUGH WEBSTER.....	"	C. D. CHENEY, D. D. S.....	Hoboken, N. J.
ARNOLD SPILLER.....	"	PROF. KARL KLAUSER.....	Farmington
W. JEROME HARRISON.....	"	GEO. H. JOHNSON.....	Bridgeport
ANDREW PRINGLE.....	Scotland	MISS ADELAIDE SKEEL.....	Newbergh
CHARLES SCOLIK.....	Vienna	CHARLES WAGER HULL.....	New York
KARL SCHWIER.....	Germany	REV. G. M. SEARLE.....	"
VICTOR SCHUMANN.....	"	C. W. CANFIELD.....	"
W. J. STILLMAN.....	Athens	P. C. DUCHOCHOIS.....	"
PROF. H. D. GARRISON.....	Chicago	HENRY M. PARKHURST.....	"
PROF. S. W. BURNHAM.....	"	REV. C. E. WOODMAN, Ph. D.....	"
HENRY L. TOLMAN.....	"	H. EDWARDS-FICKEN.....	"
GAYTON A. DOUGLASS.....	"	S. H. HORGAN.....	"
A. HESLER.....	"	WM. KURTZ.....	"
GUSTAV CRAMER.....	St. Louis	J. M. MORA.....	"
J. F. EDGEWORTH.....	"	PROF. L. C. LAUDY.....	"
W. H. SHERMAN.....	Milwaukee	A. BOGARDUS.....	"
GEORGE EASTMAN.....	Rochester	CHAS. D. FREDERICKS.....	"
DAVID COOPER.....	"	A. MORENO.....	"
PROF. H. W. LORD.....	Columbus	C. W. DEAN.....	"
H. McMICHAEL.....	Buffalo	DR. O. G. MASON.....	"
JOHN CARBUTT.....	Philadelphia	ERNEST EDWARDS.....	"

The Photographic Times { Monthly edition issued on the } Issued Every Friday  
 { last Friday in the month. }

### —••—SUBSCRIPTIONS.—••—

One copy Weekly issue, postage included, to all points in U. S. or Canada.....	\$ 3 00
One copy Monthly issue, postage included, to all points in U. S. or Canada.....	2 00
Weekly issue to foreign addresses, postage included.....	4 00
Monthly issue to foreign addresses, postage included.....	3 00

Single copy, Weekly, 10 cents

A month's trial (four weeks), of the Weekly for 30 cents.

A specimen number free.

Single copy, Monthly, 25 cents.

Remit by Express, Money Order, Draft,

P.O. Order or Registered Letter.

Subscriptions to THE PHOTOGRAPHIC TIMES received by all dealers in photographic materials in this Country, Canada, West Indies, Great Britain, Australia, New Zealand, and by the publishers,

## SCOVILL MFG. CO.

W. IRVING ADAMS, Agent.

No. 423 Broome Street, New York.

The Weekly Photographic Times and Philadelphia Photographer to one address, \$6.50.

Subscribe now and Secure the back numbers before they are all sold.

# PERMANENT BROMIDE ENLARGEMENTS.

Having equipped an Enlarging Department for testing our Permanent Bromide Paper, we are prepared to make enlargements from Photographers' Negatives, promptly and of the best quality. When *good original* negatives are furnished, these enlargements require little or no finishing, and are far superior to those made by any other process whatever.

Permanent Bromide Enlargements can be finished in India ink, crayon, water colors, or oils.

Pack negatives carefully, and specify whether to be *vignetted* or *solid*. *Plain* enlargement signifies unfinished.

Specify whether stretcher or card mount is desired.

## PRICES OF PERMANENT BROMIDE ENLARGEMENTS.

### ON CRAYON PAPER.

	Unmounted.	Mounted.
10 x 12, each.....	\$1 00	\$1 50
11 x 14, " .....	1 25	1 75
14 x 17, " .....	1 50	2 00
16 x 20, " .....	1 75	2 25
18 x 22, " .....	2 25	2 75
20 x 24, " .....	2 50	3 00
22 x 27, " .....	2 75	3 50
25 x 30, " .....	3 00	3 75
24 x 36, " .....	4 00	4 75
30 x 40, " .....	6 00	7 25

## PRICES OF PERMANENT BROMIDE ENLARGEMENTS.

### MATT SURFACE ON OPAL GLASS.

10 x 12, each.....	\$3 00	
11 x 14, " .....	3 50	
14 x 17, " .....	4 00	
16 x 20, " .....	5 00	

Terms: Cash with order. Specimens furnished from our own negatives at the above prices.

## The EASTMAN DRY PLATE AND FILM CO.

ROCHESTER, N. Y.

# SWEET, WALLACH & CO.

## Photographers' Supplies,

229 & 231 STATE ST., CHICAGO.  
 Best Goods! Lowest Prices! Complete Stock!  
 ORDERS PROMPTLY FILLED. SATISFACTION GUARANTEED  
 Your Patronage Solicited. Send for Catalogue.

MANUFACTORY OF  
 STEAM PRINTING PRESSES OF SCHMIERS, WERNER & STEIN,  
 OF LEIPZIG.

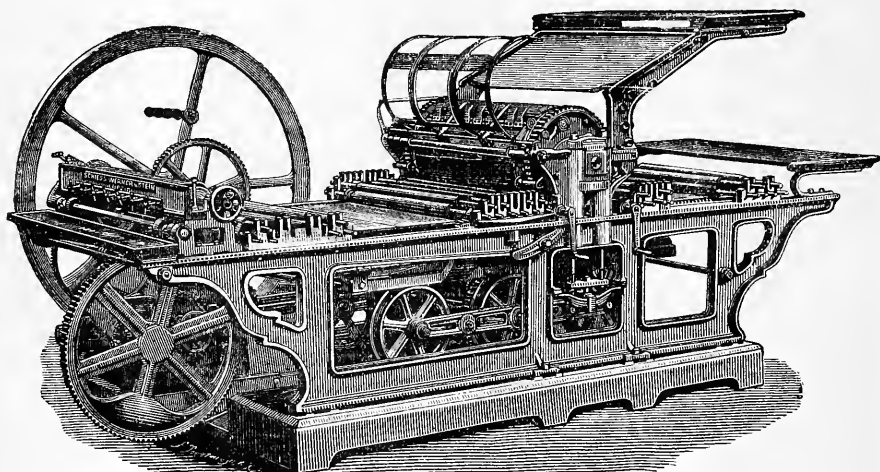

### PHOTATYPE OR HELIOTYPE STEAM PRESSES.

These Steam Presses, which are admitted to have given the most satisfactory results in every respect, are as yet unsurpassed, and have been in use, by preference to all other systems, in all first-class Heliotype Establishments all over the world for the last ten years. They are supplied by the undersigned manufacturers in four sizes, and absolutely warranted with respect to their working capacity. The comfortable and easy working of the machine, and their solid and excellent workmanship, are the principal advantages of our phototype steam presses. These steam phototype presses are also supplied with the contrivance for lithography, and with or without automatic uncovering frame, and feeding table, etc. For full particulars apply to the

STEAM PRINTING PRESS MANUFACTORY OF SCHMIERS, WERNER & STEIN,  
 LEIPZIG, GERMANY.

**G. W. WILSON & CO.**

(By special appointment Photographers to Her Majesty the Queen),

MANUFACTURERS OF MAGIC LANTERN SLIDES,  
 St. Swithin Street, Aberdeen.

Catalogue of 12,000 subjects in England and Scotland, and Price Lists, post free on application.

# THE ARGENTIC DRY PLATE.

## A Splendid New Picture.

Among the desirable advantages are rapidity, cleanliness in manipulation, permanency, certainty of good results, absence of all pinholes, metallic stains, discoloring, fog, frilling, and other dry-plate ills. Pictures deliverable ten minutes after the sitting. Full directions with each box.

### LIST OF SIZES AND PRICES.

2 dozen $3\frac{1}{4} \times 4\frac{1}{4}$ , per box, . \$0 90	2 dozen $5 \times 8$ , per box, . \$2 25
2 " $4 \times 5$ , " . 1 25	2 " $6\frac{1}{2} \times 8\frac{1}{2}$ , " . 3 75
2 " $4\frac{1}{4} \times 5\frac{1}{2}$ , " . 1 50	2 " $7 \times 10$ , " . 4 00
2 " $4\frac{1}{4} \times 6\frac{1}{2}$ , " . 1 80	2 " $8 \times 10$ , " . 4 50
2 " $5 \times 7$ , " . 2 00	1 " $10 \times 14$ , " . 4 00

A splendid opportunity to increase business is offered by the New Argentic Dry Plate. Every plate guaranteed.

**FOR SALE BY ALL DEALERS.**

# PHENIX PLATE CO.

Manufacturers,  
WORCESTER, MASS.

VENI, VIDI, VICI!

THE WONDER OF THE P. A. of A. CONVENTION  
AT ST LOUIS



Only Five Months in Existence, and Carried off the  
Honors from All Comers

The judges at the St. Louis Convention awarded the exhibitors **Seven Medals**, gold and silver, for work done on the **EAGLE DRY PLATE**, the photographs being, without exception, the gems of the exhibit.

How could it be otherwise with such a plate, when for **Reliability, Rapidity, Delicacy of Detail, and Extreme Brilliancy**, they surpass all other makes of Dry Plates in the market.

Their reception by the photographic profession at large, speaks volumes in their favor, they being now used by the leading lights of the photographic world, both professional and amateur.

Came, saw, and conquered! Truly, such was the case, and in the future our aim will be to lead them to further conquest.

EAGLE DRY-PLATE CO.

**G. GENNERT,**  
**54 East Tenth Street, New York,**  
**GENERAL AGENT**

## ANTHONY'S SATCHEL DETECTIVE CAMERA.

**I**N outward appearance, and to the ordinary observer, this latest modification of the Detective Camera looks exactly an alligator hand-satchel that is carried by a shoulder-strap at the side of the pedestrian. Upon closer observation, one sees that it consists of an artfully-concealed Detective Camera, in which all the movements to secure a picture are situated upon the under side.

For use the camera is held so that the base of the satchel rests against the body of the operator. By means of a brass pull at the side the shutter is set. A plate in the regular holder is placed in position at the back of the camera and the slide is drawn ready for exposure. The release of a short catch exposes the front of the shutter ready for action, and by raising a small leather-covered lid the little camera obscura called the finder, on the (now) upper side of the camera, shows the position that the object will occupy on the plate. The slightest touch upon a small brass button releases the shutter, and the exposure is made. Replacing the slide in the plate holder, reversing the holder, and setting the shutter again, leaves the apparatus in readiness for another shot, when the plate-holder slide is withdrawn.

By removing a screw that takes the place of the spring lock of an ordinary satchel the camera proper can be removed from its cover,

and the screw removed serves to attach the camera to a tripod for ordinary use. This last form of the Detective Camera allows the operator to carry with him twelve plates in the interior of the apparatus, and so carefully packed away that no light can strike them. It is

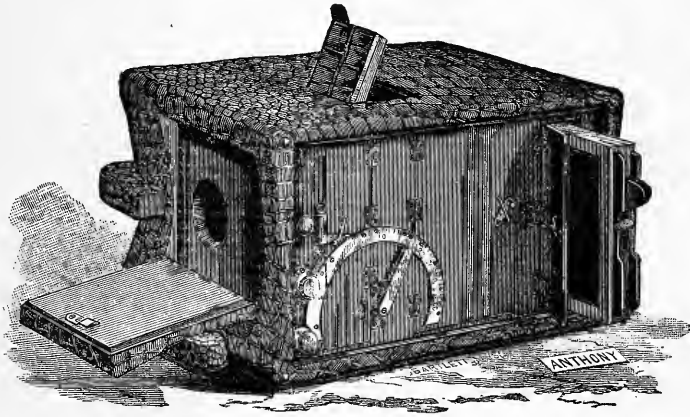

also furnished with an ingenious attachment by which the speed of the shutter can be regulated to suit the speed of the objects, moving with greater or less velocity; while, by simply releasing a catch, time exposures can be made at the will of the operator. In fact the whole affair is the latest achievement in ingenious and compact light photographic apparatus.

Size 4 x 5 in Imitation Alligator or Grained Leather, with one Patent Double Dry Plate Holder.....	\$80 00
" 4 x 5 in Genuine Alligator, with one Patent Double Dry Plate Holder.....	85 00
" 4 x 5 in Imitation Alligator or Grained Leather with rear compartment containing six Patent Double Dry Plate Holders.....	95 00
" 4 x 5 in Genuine Alligator, with rear compartment containing six Patent Double Dry Plate Holders.....	100 00

LARGER SIZES MADE TO ORDER.

FOR SALE BY ALL DEALERS.

**E. & H. T. ANTHONY & CO., Manufacturers.**

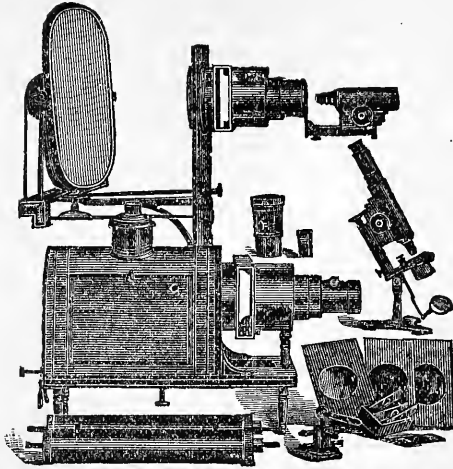

# OPTICAL AND ELECTRICAL INSTRUMENTS.

We desire to call the attention of  
TEACHERS, SCIENTISTS, LECTURERS, and  
those interested, to our

**Stereopticons, Microscopes, Dr. McIntosh's Solar Microscope and  
Stereopticon Combination Apparatus for  
the Oxy-hydrogen and Ether-oxygen Lime Light, Photographic  
Transparencies, Microscopical Preparations, etc.**

Our Instruments and Apparatus are new in design and have many improvements  
that overcome difficulties heretofore considered unavoidable. We also manufacture

**Static Electric Machines, Batteries, Magnets, and a Full Line of  
Electrical Apparatus for Practical and Experimental  
Purposes.**



We received the highest  
award at the New Orleans  
World's Exposition, on  
both Optical and Elec-  
trical Apparatus, in com-  
petition with the best of  
home and foreign manu-  
facturers.



Illustrated Catalogue of Optical and Electrical Apparatus sent free on application  
by mentioning this journal.

**McIntosh Galvanic and Faradic Battery Co.**

Nos. 300 & 302 Dearborn Street,

CHICAGO, ILL., U. S. A.



Number 285.

30 Cents.

THE  
PHILADELPHIA  
**Photographer.**

AN ILLUSTRATED SEMI-MONTHLY JOURNAL,  
DEVOTED TO PHOTOGRAPHY.

## SUMMARY OF CONTENTS.

	PAGE		PAGE
Notes from London. By T. C. HEPWORTH,		The World's Photography Focussed, . . .	657
F. C. S., . . . . .	641	Our Picture, . . . . .	659
The Powell Print. By DR. J. H. JANEWAY,		Subterranean Photography, . . . . .	660
U. S. A., . . . . .	642	Tissandier's Balloon Experience, . . . . .	661
Pertaining to the P. A. of A., . . . . .	644	Feeling, the Life of Art. By E. K. HOUGH,	662
On Local Reduction of Gelatine Plates. By		Photographic Mosaics, 1887, . . . . .	662
Prof. KARL KLAUSER, . . . . .	646	Is Photography "Gone Down?" By A	
An Amateur's Album. By MARCUS H.		RATIONAL OBSERVER, . . . . .	663
ROGERS, . . . . .	646	A Good Tray. By C. L. JUDD, . . . . .	663
Something About Paper Negatives. By C.		Some Animal Photographs, . . . . .	664
M. FRENCH, . . . . .	647	The Blair Camera Co., . . . . .	665
Your Dealer. By ONE OF THEM, . . . . .	648	Are Permanent Bromide Prints Perma-	
Correct Exposures and the Area System of		nent? . . . . .	666
Marking Lenses and Stops. By FRED.		Talcott's Method of Mounting and Finishing,	667
EVANS, . . . . .	649	An Easy Way to Make Portraits in Oil, By	
Comparison of Iron and Pyro Development.		JAMES INGLIS, . . . . .	668
By J. GADICKE, . . . . .	653	To Water-tight Your Tanks. By X. Y. Z.,	669
Backgrounds and Accessories: Their Use		Editor's Table, . . . . .	669
and Abuse. By Mrs. CLYDE EHINGER, 655			
OUR PICTURE.—"Bavarian Beauties." By FRANZ WERNER, Munich. Negatives on "Eagle" Plates. Prints by Messrs. Roberts & Fellows, Philadelphia.			

EDWARD L. WILSON,

853 Broadway, New York.

SUBSCRIPTIONS RECEIVED BY ALL NEWS AND STOCKDEALERS

Five Dollars per Annum, in Advance.

## ADVERTISEMENT S.

AIR BRUSH.  
 ALLEN BROTHERS. The Suter Lens.  
 ANTHONY & CO., E. & H. T. The New N. P. A.  
 Pensé Extra Brilliant Dresden Albumen  
 Paper.  
 BUCHANAN, SMEDLEY & BROMLEY. Photo.  
 Stockdealers.  
 CARBUTT, J. Gelatine Dry Plates and Improved  
 Dry Plate Lantern.  
 CARPENTER, H. F. Analytical and Manufact-  
 uring Chemist.  
 CODMAN, C. H. & CO. Photo. Stockdealers.  
 CRAMER, G. Lightning Plates.  
 COOPER, CHAS. & CO. Photo. Stockdealers.  
 COLLINS, A. M. MFG. CO., Photograph Cards.  
 DEALERS' DIRECTORY.  
 EASTMAN DRY-PLATE AND FILM CO.  
 ENTREKIN, W. G. Patent Eureka Burnisher.  
 Duplex Rotary Burnisher. Duplicating Print-  
 Cutter.  
 FRENCH & CO., BENJ. Voigtlander & Son and  
 Darlot Lenses. The Wonderful Euryscope.  
 HANCE'S SPECIALTIES.  
 HYATT, H. A. New Brand of Dry Plates.  
 HODGE & HUSTON. Solar Printers.  
 INGLIS, JAMES. Dry Plates.  
 MAGEE & CO., JAS. F. Photographic Chemicals.

McINTOSH GALVANIC AND FARADIC BAT-  
 TERY CO.  
 MOORE, ALBERT. Solar Enlarger.  
 MOSS ENGRAVING CO.  
 PHOTOGRAPHIC TIMES.  
 PHOTOGRAPHIC MOSAICS.  
 SCOVILL MANUFACTURING CO. New Dres-  
 den Albumen Three Crown Paper. Gihon's  
 Cut-Outs. Photo. Apparatus.  
 STANLEY DRY PLATE.  
 STEINHEIL LENS.  
 ST. LOUIS DRY PLATE COMPANY.  
 SWEET, WALLACH & CO. Photo. Supplies.  
 THE ARGENTIC DRY PLATE.  
 THAYER, N. C. & CO. Photo. Stockdealers.  
 TALCOTT, E. K. Patent Mounts for Photog-  
 raphers.  
 THE BLAIR CAMERA CO.  
 VOIGTLANDER & SON. New Portrait Eury-  
 scope.  
 WILSON, HOOD & CO. Ross and Steinheil  
 Lenses, Photo. Frames, Goods, Stereoscopes,  
 and Views.  
 WILSON'S PHOTOGRAPHICS.  
 WILSON, G. W. & CO. Magic Lantern Slides.  
 WALMSLEY & CO. Beck's Rectilinear Lens.

## ADVERTISING RATES.

THE PHILADELPHIA PHOTOGRAPHER is acknowledged to be the best advertising medium in the trade.

Its circulation is among the first class, at home and in nearly every foreign country.

Its rates, all advantages considered, are the most favorable, and it will bring you fine returns.

	One Issue.	Six Issues.	Twelve Issues.	Twenty-four Issues.
1 Page.....	\$20.00	\$110.00	\$200.00	\$350.00
1-2 " .....	12.00	66.00	120.00	200.00
1-4 " .....	7.00	38.50	70.00	120.00
1-8 " .....	4.00	22.00	40.00	70.00

Special contracts made with bona-fide dealers and manufacturers. Address

**EDWARD L. WILSON,**  
 853 BROADWAY, NEW YORK.

## NOTICE TO SUBSCRIBERS.

In remitting by mail, a post-office order, or draft, payable to the order of EDWARD L. WILSON, is preferable to bank-notes. Postage stamps of the denomination of two and five cents each will be taken. Clearly give your Post-Office, County, and State.

Foreign subscriptions must be accompanied by the postage in addition.

**FIRE!** Our books having been all destroyed by fire at and with our establishment, all who owe us will confer a great favor by remitting at once.

**CROSSCUP & WEST ENGRAVING CO.**  
 907 Filbert St., Philadelphia.

SOLE AGENTS FOR THE AMERICAN CONTINENT.

DETROIT, MICH.

# ALLEN BROTHERS,

In the above letters, where blanks occur, the Lenses referred to are the best known on both Continents. Mr. E. Suter was awarded a silver medal for invention and construction of Lenses at the recent International Inventions Exhibition at London, England. Her Britannic Majesty's Government has purchased a set of Suter Lenses for the use of the South Kensington Museum. Count Schouvaloff, Russian Ambassador at Paris, uses a Suter Lens. Andrew Pringle, Esq., the British professional Photographer, gets fine effects with a Suter Lens. A. L. Henderson, the English professional Photographer, uses Suter Lenses. We commend these facts to the people who assert that because the Suter Lens is sold at a low price, it must be an inferior instrument.

Dear Sir: Your price current has reached me and I thank you for it. My friend and Photographic Colleague, Prof. W. Donkin, Honorary Secretary of the Photographic Society of England, has said to me that in the opinion of Captain W. De W. Abney, your photographic lenses are perfect, giving negatives extremely fine. I send you my cheque, praying you to send me at the earliest possible moment your Aplanatic Lens, No. 8 B. I intend taking with this Lens some large views on the high Alps. Hoping to receive soon a perfect instrument. Please accept the assurance of my highest consideration.

This from a prominent Italian amateur:

Mr. E. SUTER, Bâle: I await with impatience the two lenses you have promised to make me. Observe the beautiful season, and I am anxious to make some instantaneous views. The lens No. 5 A, which you have sold me is *excellent* and above all, very rapid. I rely on your kindness, and pray you to accept my best regards.

A. ASTRUA.

Mr. Dear Mr. SUTER: At last I have received your price list (the second one), as the first letter has been lost on the way. To-day I send you from Kailowitz, Silesia, a photograph of myself taken at Warsaw, by Brandel. The picture was taken with an Aplanatic made by—, with fourth stop, in two seconds (omission). I would have bought one of these instruments if Mr. H. Warnetke, who owns an emission factory in London, had not dissuaded me. This gentleman spoke about your instruments which were unknown to me and Mr. Brandel, as follows: "The instruments of— are quicker and stronger than the— instruments, but far better than either of these are the same can do as good work as the enclosed picture shows. I would therefore like to have an Aplanatic No. 8, provided the plates not matter than 40 x 50 centimeters. Mr. Brandel will undoubtedly also become your customer as soon as he has sufficient proof of the excellency of your instruments. I intend to take a good picture in—, Lenses I return mail what you would advise me to do. May be that an Aplanatic No. 6 would be better. In—, Lenses I put no confidence, neither does my friend, because neither of us was able to take a good picture with same. I remain, your obedient servant, P. S. I would like to get one of your Objectives sent to Vienna on trial. I will be there during January.

The following is from an Austrian officer:

Mr. SUTER, Bâle: Mr. Warnetke, of London, England, tells me that you manufacture an Objective marked "Series A," which greatly excels in the instantaneous process, especially in photographing in the public streets, with movable objects. Wilson, who has used your instruments with the best success. We intend to take Street Photographs (size 13 x 18 centimeters), in this city, but must have the picture clear and strong up to the very edge of the plate. We use neutral (largest) stop.

Extract from a letter from the noted Polish firm of Karoli & Pusch, Warsaw:

From personal information gained in England and Continental Europe, we make the unqualified assertion that the Suter Lenses are now the Best in the World. We submit a few testimonials from eminent sources.

# THE SUTER LENS IN EUROPE.

# THE ARGENTIC DRY PLATE.

## A Splendid New Picture.

Among the desirable advantages are rapidity, cleanliness in manipulation, permanency, certainty of good results, absence of all pinholes, metallic stains, discoloring, fog, frilling, and other dry-plate ills. Pictures deliverable ten minutes after the sitting. Full directions with each box.

### LIST OF SIZES AND PRICES.

2 dozen $3\frac{1}{4} \times 4\frac{1}{4}$ , per box, . \$0 90	2 dozen $5 \times 8$ , per box, . \$2 25
2 " $4 \times 5$ , " . 1 25	2 " $6\frac{1}{2} \times 8\frac{1}{2}$ , " . 3 75
2 " $4\frac{1}{4} \times 5\frac{1}{2}$ , " . 1 50	2 " $7 \times 10$ , " . 4 00
2 " $4\frac{1}{4} \times 6\frac{1}{2}$ , " . 1 80	2 " $8 \times 10$ , " . 4 50
2 " $5 \times 7$ , " . 2 00	1 " $10 \times 14$ , " . 4 00

A splendid opportunity to increase business is offered by the New Argentic Dry Plate. Every plate guaranteed.

**FOR SALE BY ALL DEALERS.**

# PHENIX PLATE CO.

Manufacturers,  
WORCESTER, MASS.

# UNSOLICITED TESTIMONIALS.

COR. BROAD AND MARKET STS., NEWARK, N. J., July 3, 1886.

EASTMAN DRY-PLATE AND FILM CO., Rochester, N. Y.

GENTS: The enlargements came duly to hand. We are very much pleased, and they give satisfaction to the customers who ordered them. We must say that this class of work *must take*, and we think it is one of the most beautiful results that we have as yet seen. Will you kindly return the paper negative of men on top of Tally-Ho coach, and oblige, as we have some silver prints to take from it. The glass negatives came all O. K.

Yours truly, THOMAS & CO

P. S. If we had thought, we could have sent you some elegant paper negatives and prints, which we think would have done credit to the process, for exhibition at St. Louis, but we suppose it is too late now.

25 NEW STREET, TRENTON, N. J., June 28, 1886.

EASTMAN DRY-PLATE AND FILM CO., Rochester, N. Y.

GENTS: Please send me circular and sample print of your Permanent Bromide Paper. I have been using your Eastman-Walker Roll-Holder, and it gives me complete satisfaction. Yours respectfully,

CHAS. J. RODGERS.

NIAGARA FALLS, N. Y., May 17, 1886.

EASTMAN DRY-PLATE AND FILM CO., Rochester, N. Y.

GENTLEMEN: I have been making a few paper negatives last week, with perfect success. Have not printed them yet, but will to-day.

Yours truly, CHAS. BIERSTADT.

208 FULTON STREET, BROOKLYN, N. Y., July 2, 1886.

EASTMAN DRY-PLATE AND FILM CO., Rochester, N. Y.

GENTS: Enclosed you will find my check for the Roll-Holder. It is attached to my 8 x 10 compact camera, and the two work so well together that one is led to think that each was intended for the other. As a trial for paper negatives and Roll-Holder (the first I have made), while in a pleasure party, I made nine exposures, and secured nine good negatives, which I consider very satisfactory; and with an experience of thirty years, I feel confident that in a very short time, your invention for making negatives on paper, either on rolls or sheets, will supersede all other sensitive mediums. Congratulating you on the perfection of your negative paper, also the roll-holder, I am,

Very respectfully, G. F. E. PEARSALL.

42 JOHN STREET, NEW YORK, June 18, 1886.

EASTMAN DRY-PLATE AND FILM CO., Rochester, N. Y.

GENTLEMEN: We were much pleased with the results obtained on the last lot of negative paper sent us. The grain seems to be entirely absent, and the rendering of the negative translucent by means of the preparation "Translucine." It seems both effective and easy.

Very truly, E. W. SMITH & CO.

CAZENOVIA, N. Y., June 18, 1886.

EASTMAN DRY-PLATE AND FILM CO., Rochester, N. Y.

GENTLEMEN: Please make two more enlargements from same negatives, same size and style as the first and return negatives as soon as done. Mail enlargements unmounted. We are very much pleased with the work. It finishes perfectly in crayon.

Yours truly, MARSHALL BROS. & CO.

MONTICELLO, IND., June 12, 1886.

EASTMAN DRY-PLATE AND FILM CO., Rochester, N. Y.

GENTLEMEN: We have been very successful with the bromide paper, and think it is just the thing for enlargements.

Very truly yours, LIGHTY BROS.

230 ST. LOUIS ST., SPRINGFIELD, MO., May 28, 1886.

EASTMAN DRY-PLATE AND FILM CO., Rochester, N. Y.

GENTLEMEN: The two prints, or enlargements, came safely, and I am delighted with them. Think I will want the material to use in my gallery. Hope to see you at the Convention. Very respectfully,

G. W. SITTLER.

DELAVAN, ILL., June 25, 1886

EASTMAN DRY-PLATE AND FILM CO., Rochester, N. Y.

GENTLEMEN: The 24 x 36 Permanent Bromide print and smaller prints at hand. Thanks. The G. A. R. Post seem very well pleased. It is much better than I thought the negative would make. I find I am, by comparison getting along all right with my prints. Just as soon as I can save the wherewithal, I shall have one of your enlarging outfits. I shall probably send you some more negatives in a few days.

Yours truly, E. D. SHAW.

# BENJ. FRENCH & Co.

No. 319 WASHINGTON STREET, BOSTON,

Sole Agents in the United States for the Celebrated Lenses  
Manufactured by

## VOIGTLÄNDER & SON.

ALSO, THEIR FAMOUS

# EURYSCOPE,

Which is unrivalled for groups, full-length figures, and other demands in the gallery, and every species of out-door work, including instantaneous photography.

THE EURYSCOPE is made *exclusively* by Voigtländer & Son, and their name is engraved on the tube.

FOR PORTRAITS. **DARLOT LENSES** FOR VIEWS.

IMPORTERS, ALSO, OF THE CELEBRATED

TRAPP & MÜNCH

## ALBUMEN PAPER,

AND DEALERS IN ALL KINDS OF

*Photographic Materials and Magic Lantern Slides.*

SEND FOR OUR NEW ILLUSTRATED PRICE LIST OF LENSES.

# H. F. CARPENTER,

29 & 31 Page St., Providence, R. I.

## ANALYTICAL AND MANUFACTURING CHEMIST.

Refiner of PHOTOGRAPHIC WASTES.



## Assayer and Sweep Smelter.

Nitrate of Silver and Chloride of Gold.

Chemically pure gold prepared especially for Photographers' use at \$1.10 per dwt.

Information given on application in regard to methods of saving waste.

## ANTHONY'S PATENT TRIPLEX TRIPOD.

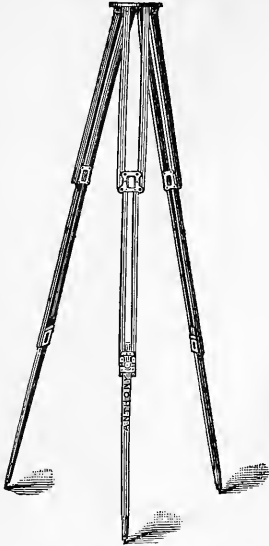

This is the finest finished in the market and is perfectly rigid, combining both the folding and telescopic, besides which it occupies little space, and for transportation can be packed with clothing in a large grip-sack. It is made of cherry throughout, and has the patent springs on under side of top, by which it is impossible for the legs to become unfastened accidentally. When the leg is fully extended, it is held automatically by a spring, saving necessity of using thumb-screw for clamping same.

PRICE, . . . \$4.00

## ANTHONY'S HELIOS DARK-ROOM LANTERN.

This is a new Lantern for the dark-room for those who desire more light than can be had from the ruby lamp. This lantern or lamp will be found to be all that can be desired. The draught is as perfect as can be. It has a glass  $6\frac{1}{2} \times 8\frac{1}{4}$  inches, with a burner capable of great volume of light when desired. It is intended to fill a want long expressed by many for a good dark-room lantern at a reasonable price.

PRICE, \$4.00

For sale by all dealers. Manufactured by

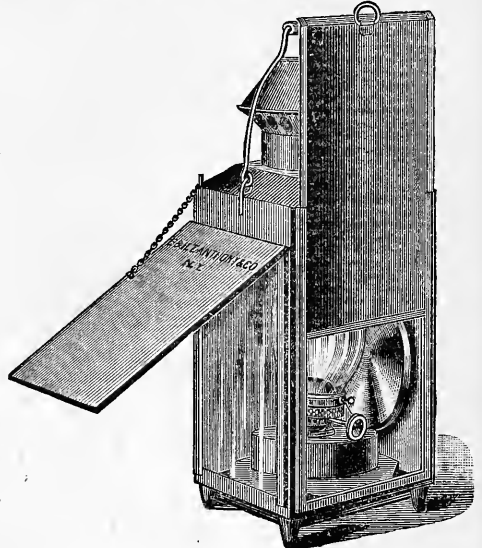

**E. & H. T. ANTHONY & CO.**  
**591 Broadway, NEW YORK.**



# THE STANLEY DRY PLATE

Has passed through the ordeal of its first summer, and its manufacturers have almost entirely escaped the usual trials of fogging, frilling, and other perplexities. In fact, the quantity sold in July exceeds that of any former month.

Its *unusual combination of sensitiveness and brilliancy* have made it a general favorite, and the territory into which it penetrates grows constantly larger.

## AMONG ITS RECENT ACHIEVEMENTS ARE

*Instantaneous Views of the Decoration Day Parade* (3d size stop), taken without sunlight, used as a Bulletin Illustration.

*Views of Horses and Carriages entering Central Park*, trotting rapidly across the field of view, sharp and clear cut. These will appear in the Bulletin.

*Views of Steamboats* going twenty miles an hour directly across the field, taken at 5.30 P. M. Sharp and clear as if standing still.

*The Life-size Portrait of J. F. Ryder*, by McMichael, shown at the Buffalo Convention, was made on an 18 x 22 Stanley Plate in five seconds, with a Dallmeyer Rapid Rectilinear Lens.

*Instantaneous Views*, by Mr. Henry J. Newton, President of Photographic Section of the American Institute, about which he writes:

"I found that sunshine was not absolutely necessary for instantaneous negatives on these plates, and I think a majority of the negatives I send you were made when there was not sufficient sunlight to cast a visible shadow. I think it is due that I should say that the plates worked satisfactorily in every respect, exhibiting extreme sensitiveness, responding readily to the developer, and going steadily on to the finish.

P. S. I used the Prosch Shutter at its full speed."

(Signed),

H. J. NEWTON.

And now to crown the whole, Mr. Parkinson writes as follows:

E. & H. T. ANTHONY & Co.:

PARKINSON PHOTO. PARLORS, 29 W. 26TH ST.,  
NEW YORK, August 12, 1885.

"GENTLEMEN: I take pleasure in assuring you that I made a group portrait in my gallery of an old lady of eighty years, with child of four years, a month or two since, on a Stanley 18 x 22 plate, in one second, with Dallmeyer Rapid Rectilinear Lens. A little more time would have done no harm; but the picture in question has elicited as many words of praise from visitors to my studio as any other in same length of time."

Yours truly,

W. B. PARKINSON.

The Stanley Dry Plates can be had from any dealer, or direct from

**E. & H. T. ANTHONY & CO.,**  
591 BROADWAY, NEW YORK.

Another thing that has gone rapidly to the front is the

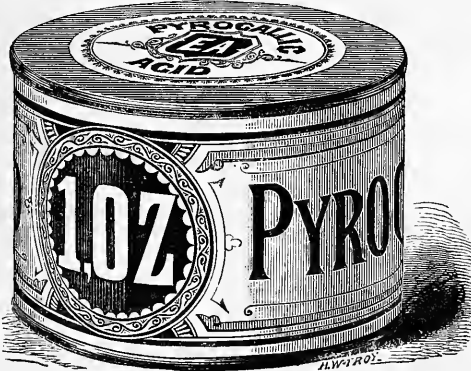

When Dry Plates were first introduced it *was not yet on the market*, and the old stereotyped developing formulas do not mention it; but in the developing formulas of the more recent *popular plates*, as the STANLEY and the ST. LOUIS, the E. A. Pyro is recommended as most desirable, and in the EASTMAN DRY PLATE CO. formulas the same preference is given ever since they *knew of its merits*.

It is always used by the veteran "Roche," and constitutes one of the main elements in the popular Cooper's Developer.

Every photographer should try the E. A. Pyro. Every dealer has it, or ought to have it, or it can be had direct from

**E. & H. T. ANTHONY & CO., 591 Broadway, N. Y.**

# A CARD.

75 STONE ST., ROCHESTER, N. Y., July 26, 1886.

GENTLEMEN: About three months ago the business of Inglis & Co., of this city was formed into the Inglis Dry Plate Co.

In the articles of agreement, a clause was inserted giving the I. D. P. Co. the exclusive use of the name of "Inglis," and also that James Inglis would not connect himself with any dry plate business using the name of "Inglis."

Matters have taken such a form since then, he has been compelled to leave the I. D. P. Co. And being thus debarred from the use of his own name, adopts this means of making known to his numerous customers where they may still obtain his plate. **And the Only Place.**

A new firm taking the name of the **ROCHESTER DRY PLATE CO.** have engaged his services, and under his supervision a new factory has been fitted with the most modern improvements required for the production of **clean and spotless** plates, with all the other extra qualities that his plate has become so renowned for. The fraternity may therefore depend upon the very finest plate ever yet produced, from the **ROCHESTER DRY PLATE CO.**

## JAMES INGLIS,

Late Manufacturer of the Inglis Dry Plate, and President  
of the Inglis Dry Plate Co.

---

**ALBERT MOORE** THE **SOLAR ENLARGER,**  
THE LONGEST, LARGEST, AND BEST.  
**828 Wood Street, Philadelphia.**

---

## JAMES F. MAGEE & CO.

522 Race St., Philadelphia,

**Manufacturers of Pure Photographic Chemicals,**

**Specialties: NITRATE OF SILVER and CHLORIDE OF GOLD.**

❖REFINERS OF GOLD AND SILVER WASTE.❖

Waste sent through Stockdealers will receive prompt attention.

---

## G. W. WILSON & CO.

(By special appointment Photographers to Her Majesty the Queen),

**MANUFACTURERS OF MAGIC LANTERN SLIDES,**  
St. Swithin Street, Aberdeen.

Catalogue of 12,000 subjects in England and Scotland, and Price Lists, post free on application.

# SWEET, WALLACH & CO.

## Photographers' Supplies,

229 & 231 STATE ST., CHICAGO.  
 Best Goods! Lowest Prices! Complete Stock!  
 ORDERS PROMPTLY FILLED. SATISFACTION GUARANTEED  
**Your Patronage Solicited. Send for Catalogue.**

N. C. THAYER,  
 President and Treas.

HENRY G. THOMPSON,  
 Vice-President.

W. T. JONES,  
 Secretary.



SEND FOR OUR \$500.00 PRIZE CIRCULAR.

**FINEST STORE. LARGEST STOCK. LOWEST PRICES.**

—SEND TRIAL ORDER.—

SEND FOR FINEST CATALOGUE EVER ISSUED.

# THE AIR BRUSH.

This New Art Tool applies color by a jet of air. It is invaluable to any photographer who produces his own large work. Portraits may be made over solar or contact prints, on plain or Albumen Paper, in India Ink, or Water Colors, etc.

*Lights built up on Flat Negatives, Cloud Effects in Backgrounds for View Work, etc., all can be accomplished by this Tool,*

with the greatest rapidity, and with a perfection bounded only by the capacity of the artist. Full particulars FREE. Address

**AIR BRUSH MFG. CO., 50 Nassau St., Rockford, Ill.**

ALFRED M. COLLINS,  
*Secretary and Treasurer.*

HENRY H. COLLINS,  
*President.*

EDWARD COPE,  
*Vice-President.*

A. M. Collins Mfg. Co.

*MAKE ALL KINDS OF*

**CARDS AND CARDBOARDS**

FOR

**P** PHOTOGRAPHERS **S**

AND

**MATS, MOUNTS, AND ENVELOPES**

FOR

**FERROTYPES.**

---

OFFICE AND WAREHOUSE,

**No. 527 ARCH STREET,**

**PHILADELPHIA.**

---

Price Lists may be had by intending purchasers on application to us, or to all Photographic Merchants, through whom your favors are respectfully solicited.

JOHN G. HOOD.

ESTABLISHED 1865.

WM. D. H. WILSON.

# WILSON, HOOD & CO.

825 Arch St., Philadelphia,

SOLE AGENTS IN THE UNITED STATES FOR THE



Centennial, 1876.



Centennial, 1876.

## Ross' Portrait and View Lenses.

Portrait Lenses, from 1-4 to 8 x 10.  
Cabinet Lenses, Nos. 2 and 3.  
Card Lenses, Nos. 1, 2, and 3.  
Triplets, Nos. 1, 2, 3, 4, 5, 6, and 7.  
Symmetricals. Rapid Symmetricals.

Instantaneous Doublets, all sizes.  
Medium Angle Doublets, all sizes.  
Large Angle Doublets, all sizes.  
Stereographic Lenses, all sizes.  
New Universal Lens.

Numerous testimonials pronounce them to be the *best* as well as the *cheapest* Foreign Lenses ever offered to the American Photographer. We will mail price list on application, and promptly fill all orders. Always in stock,

## CAMERA BOXES,

Made by AMERICAN OPTICAL CO., ANTHONY, BLAIR, and ROCHESTER OPTICAL CO.

WE KEEP IN STOCK FULL ASSORTMENT OF

## AMATEUR PHOTO. OUTFITS

DRY PLATES OF ALL MAKES.

N. P. A., EAGLE, and S. & M. PAPER, PER REAM, \$34.00.

Any article needed we can supply, as

WE MANUFACTURE, IMPORT, AND DEAL IN ALL KINDS OF

*Photo. Goods, Frames, Stereoscopes and Views,*

At prices as low as are consistent with the quality of goods furnished. We are indebted to our customers for the patronage during the past *Twenty Years*, and our efforts shall be to merit a continuance of it.

Illustrated Price Lists supplied free. Correspondence solicited.

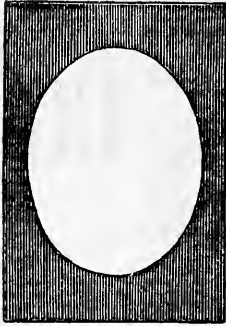

# GIHON'S CUT-OUTS

An Entirely New Variety for  
PRINTING MEDALLION PICTURES.

Are the very best that are made, and are now without a rival in the market. They are clean cut, most desirable shapes and sizes, and made of non-actinic paper, manufactured specially for the purpose. Each package contains 30 Cut-Outs, or Masks, with corresponding Insides, assorted for five differently sized ovals and one arch-top.

*Price, \$1.00 per Package. Sent by mail on receipt of price.*

Parties wishing special sizes, or large lots of a few sizes, may have them cut to order promptly by addressing the manufacturer. No lot costing less than \$1.00 made at a time.

*No printer should attempt to make Medallion Pictures without them.*

## THEY HAVE NO EQUAL FOR QUALITY.

Beware of spurious imitations made of common paper, full of holes, badly cut, and odd shapes and sizes. Ask your Stock-dealer for GIHON'S CUT-OUTS, and see that they are in his envelope, with instruction circular included. The recent packages are composed of an entirely new variety and of a new paper. **TRY THEM.**

Promenade Size now Ready. Sold Separately at 50 cents per Dozen.

# GIHON'S OPAQUE

Is designed for Completely obscuring the Imperfect Backgrounds of Copies, Retouching Negatives, Faulty Skies in Landscapes, Coating the Inside of Lenses or Camera Boxes, Backing Solar Negatives, Covering Vignetting Boards, And for Answering all the Requirements of the Intelligent Photographer in the Production of Artistic Results in Printing.

Wherever you want to keep out Light, use Opaque.

**IT IS APPLIED WITH A BRUSH, DRIES QUICKLY AND STICKS.**

**CUT-OUTS (thirty), \$1.00. OPAQUE, 50 Cents.**

**FOR SALE BY ALL DEALERS.**

**ROBERTS & FELLOWS, Makers, Philadelphia.**

Address all orders to

**SCOVILL MANUFACTURING CO., New York.**

# "THE MOUND CITY" Photographic Stock House



Offers the Most Complete line of  
Photographic Apparatus, Chemicals,  
Picture Frames, Mouldings, Mats,  
Albums, Etc., in the market,  
at bottom prices.

Professional and Amateur Outfits a Specialty.

AGENT FOR

KUHN'S LIGHTNING DRY-PLATE INTENSIFIER,

AND

KUHN'S SENSITIZED PAPER STRETCHER AND DRYER.

Address

**H. A. HYATT,**

8th & Locust Sts.,

ST. LOUIS, MO.

Send for Illustrated Catalogues of Photographic Goods and Picture Frames.

## BECK'S AUTOGRAPH RECTILINEAR LENSES.

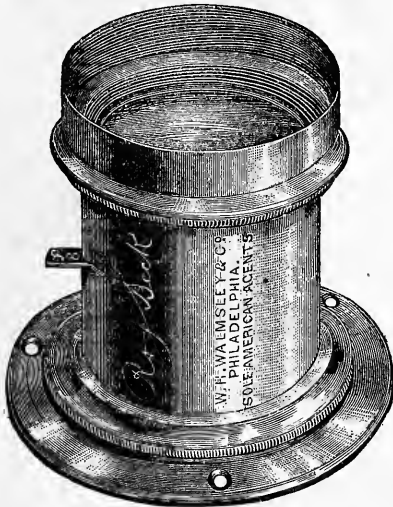

THESE extraordinary lenses attracted universal attention at the late St. Louis Convention; the specimens of work in Portraiture, Groups, Landscapes, Instantaneous Views, etc., executed by them being of unequalled excellence. A life-sized head, made with the 8 x 10 lens of 13 inches focus, was considered by the experts present, as being far ahead of any similar performance ever seen. A full description of these and our other specialties will be found in our full catalogue. *Mailed Free.*

**W. H. WALMSLEY & CO.,**

*Photographic Stockdealers.*

**1016 Chestnut St., Phila., Pa.**

**ENTREKIN'S**  
 IMPROVED  
**DUPLEX ROTARY BURNISHER.**  
 PATENTED.

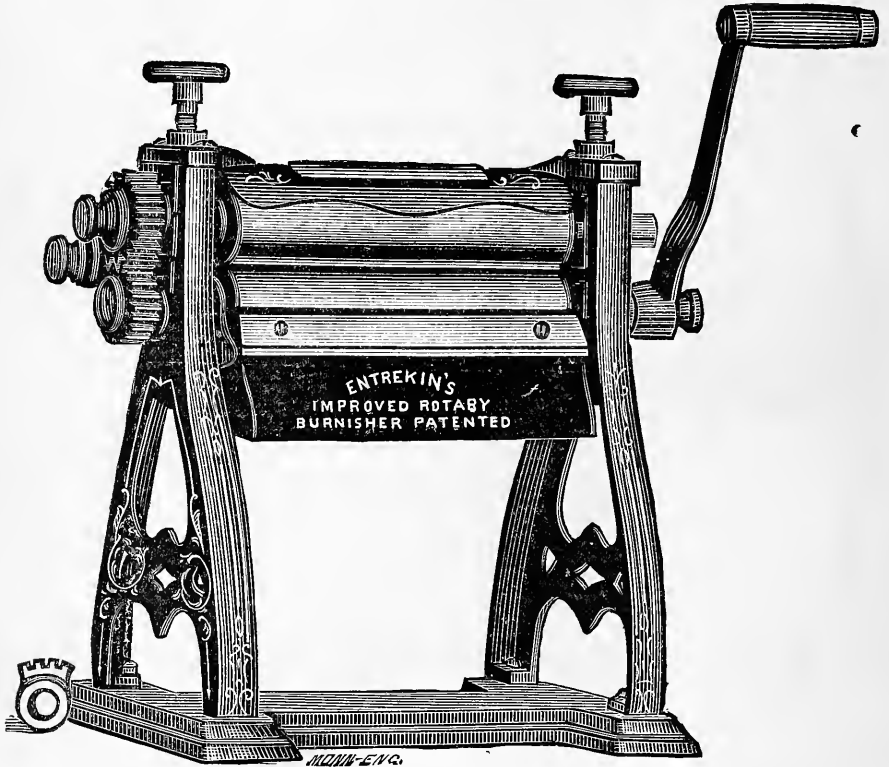

10 in., \$25.00. 15 in., \$35.00. 20 in., \$45.00. 25 in., \$60.00.

This Machine is an improvement on our old Duplex Rotary Burnisher, invented by us in 1874.

It is so constructed that by changing the Large Gear or Cog-wheel, from the stud to the end of the draw-file or upper roll, you reverse and change the speed of the lower or polishing roll, thus getting the same result as in the old Duplex Rotary; but to secure the best polishing surface, use the machine with the large cog-wheel on the Stud, by so doing you secure three times the polishing surface. All the machines will be sent out with gearing so arranged as to give this result. It is optional with the Photographer how he may use the machine. The Fire-Pan is so arranged that it is impossible for it to come in contact with the surface of the polished roll, and it can be turned away to cleanse the roll.

**EVERY MACHINE WARRANTED PERFECT.**

FOR SALE BY

**W. G. ENTREKIN, Inventor and Sole Manufacturer,**

4384 Main St., Manayunk, Philadelphia, Pa.

AND BY ALL PHOTOGRAPHIC STOCKDEALERS.



# ENTREKIN'S PATENT EUREKA BURNISHER.

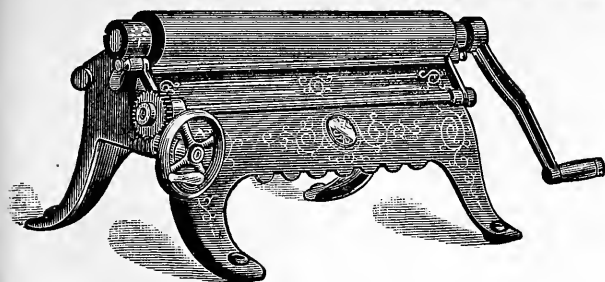

The above cut represents our 25 inch Eureka.

The unprecedented popularity of this Burnisher is wonderful. Over seventeen thousand (17,000) sold in less than five years. Agencies in London, Berlin, and Vienna, and sold by all stockdealers in the United States. The machines are built in first-class style, and warranted to do the work claimed.

Full directions accompany each machine.

## PRICES:

6 inch Roll, . . . . .	\$15 00	20 inch Roll, . . . . .	\$60 00
10 " " . . . . .	25 00	25 " " . . . . .	70 00
14 " " . . . . .	35 00		

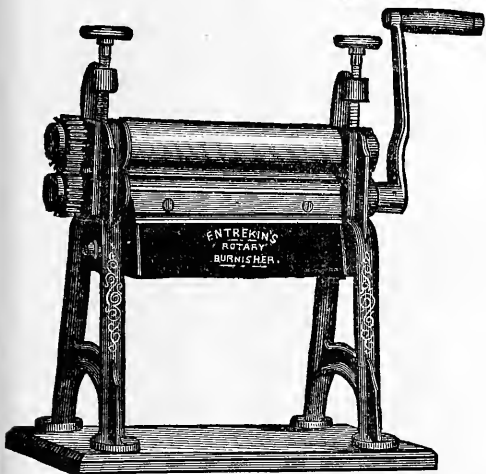

# ENTREKIN'S Duplex Rotary Burnisher.

PATENTED JUNE 1, 1875.

## PRICES:

10 inch, . . . . .	\$15 00
15 " . . . . .	25 00
20 " . . . . .	35 00
25 " . . . . .	45 00

# ENTREKIN'S DUPLICATING PRINT CUTTER.

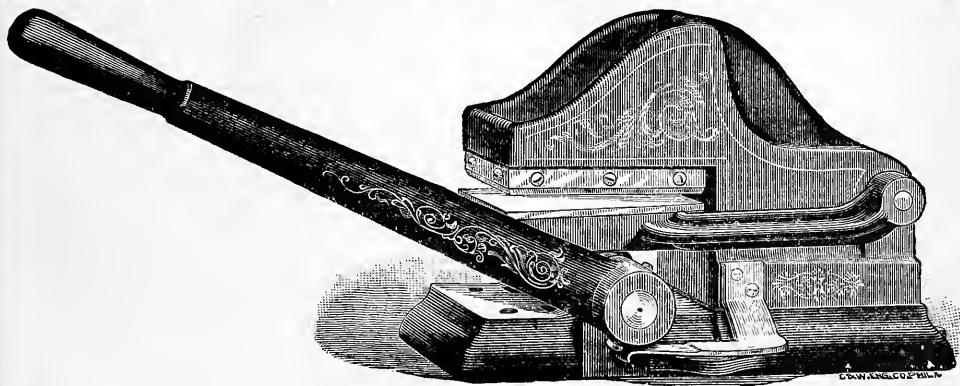

Cabinet and Stereo. Sizes, \$25.00

Small Panel Size, \$35.00.

Size 6½ x 8½, \$40.00.

MANUFACTURED AND FOR SALE BY

W. G. ENTREKIN, 4384 Main St., Manayunk, Phila., Pa

"Tasteful, well edited, and crammed full of technical information is THE PHOTOGRAPHIC TIMES."—The Journalist.

# The Photographic Times

Is a WEEKLY JOURNAL devoted to the  
THEORY, PRACTICE, AND ADVANCEMENT OF PHOTOGRAPHY.

ITS DEPARTMENTS ARE:

**EDITORIAL.**

- CONTRIBUTED AND MISCELLANEOUS**, articles by the best photographic writers of both hemispheres.
- COMMUNICATIONS FROM SOCIETIES**, including Papers, Lectures, etc.
- MEETINGS OF SOCIETIES**, Stating date and place of meeting of all Photographic Societies, both professional and amateur, and giving full proceedings of all meetings.
- CORRESPONDENCE**, Scientific and practical discussion by practical photographers of important and interesting questions, and letters from all quarters of the globe by intelligent and observing correspondents.
- OUR EDITORIAL TABLE**, Reviews of books, exchanges, etc.
- PICTURES RECEIVED**, Impartial criticism and notice of all photographs sent in.
- NOTES AND QUERIES**, Answers by the Editors to correspondents in search of knowledge.
- COMMERCIAL INTELLIGENCE**, Description of new photographic appliances, studio changes, and a record of photographic patents.

## A PARTIAL LIST OF WRITERS TO THE PHOTOGRAPHIC TIMES.

CAPT. W. DE W. ABNEY.....	England	W. H. WALMSLEY.....	Philadelphia
W. M. ASHMAN.....	"	FREDERICK A. JACKSON.....	New Haven
W. K. BURTON.....	"	Prof. RANDALL SPAULDING.....	Montclair, N. J.
W. E. DEBENHAM.....	"	Prof. WM. HARKNESS, U. S. N.....	Washington, D. C.
H. P. ROBINSON.....	"	Dr. JOHN H. JANEWAY, U. S. A.....	Governor's Island
G. WATMOUGH WEBSTER.....	"	C. D. CHENEY, D. D S.....	Hoboken, N. J.
ARNOLD SPILLER.....	"	Prof. KARL KLAUSER.....	Farmington
W. JEROME HARRISON.....	"	GEO. H. JOHNSON.....	Bridgeport
ANDREW PRINGLE.....	Scotland	Miss ADELAIDE SKEEL.....	Newbergh
CHARLES SCOLIK.....	Vienna	CHARLES WAGER HULL.....	New York
KARL SCHWIER.....	Germany	Rev. G. M. SEARLE.....	"
VICTOR SCHUMANN.....	"	C. W. CANFIELD.....	"
W. J. STILLMAN.....	Athens	P. C. DUCHOCHOIS.....	"
Prof. H. D. GARRISON.....	Chicago	HENRY M. PARKHURST.....	"
Prof. S. W. BURNHAM.....	"	Rev. C. E. WOODMAN, Ph. D.....	"
HENRY L. TOLMAN.....	"	H. EDWARDS-FICKEN.....	"
GAYTON A. DOUGLASS.....	"	S. H. HORGAN.....	"
A. HESLER.....	"	WM. KURTZ.....	"
GUSTAV CRAMER.....	St. Louis	J. M. MORA.....	"
J. F. EDGEWORTH.....	"	Prof. L. C. LAUDY.....	"
W. H. SHERMAN.....	Milwaukee	A. BOGARDUS.....	"
GEORGE EASTMAN.....	Rochester	CHAS. D. FREDERICKS.....	"
DAVID COOPER.....	"	A. MORENO.....	"
Prof. H. W. LORD.....	Columbus	C. W. DEAN.....	"
H. McMICHAEL.....	Buffalo	Dr. O. G. MASON.....	"
JOHN CARBUTT.....	Philadelphia	ERNEST EDWARDS.....	"

The Photographic Times { Monthly edition issued on the } Issued Every Friday  
last Friday in the month.

### —SUBSCRIPTIONS.—

One copy Weekly issue, postage included, to all points in U. S. or Canada.....	\$ 3 00
One copy Monthly issue, postage included, to all points in U. S. or Canada.....	2 00
Weekly issue to foreign addresses, postage included.....	4 00
Monthly issue to foreign addresses, postage included.....	3 00

Single copy, Weekly, 10 cents  
A month's trial (four weeks), of the Weekly for 30 cents.  
A specimen number free.

Single copy, Monthly, 25 cents.  
Remit by Express, Money Order, Draft,  
P.O. Order or Registered Letter.

Subscriptions to THE PHOTOGRAPHIC TIMES received by all dealers in photographic materials in this Country, Canada, West Indies, Great Britain, Australia, New Zealand, and by the publishers,

## SCOVILL MFG. CO.

W. IRVING ADAMS, Agent.

No. 423 Broome Street, New York.

The Weekly Photographic Times and Philadelphia Photographer to one address, \$6.50.

Subscribe now and Secure the back numbers before they are all sold.

**PHOTOGRAPHIC MOSAICS,****—1887—****READY NOV. 10th. 23d YEAR.****144 PAGES.****50 CENTS. CLOTH, \$1.00.****144 PAGES.****BEATS ALL ITS PREDECESSORS.****CONTENTS.****A Photogravure Picture by ERNEST EDWARDS,  
and the following:**

Retrospective. Edward L. Wilson, Editor of Mosaics.  
Coming Back to Good Sense in Developers. Thomas  
Pray, Jr. [x amatoor], Hartford, Connecticut.  
Development of Overtimed Plates. L. Farini, Bridge-  
port, Connecticut.  
The Flap Shutter. G. G. Mitchell, Edinburgh, Scot-  
land.  
The Simplest Enlarging Process. Dr. E. A. Just,  
Vienna, Austria.  
Hydroxylamine as a Developing Agent. W. E.  
Woodbury, Dusseldorf, Germany.  
Lantern Slides. Dr. Thomas W. Drinkwater. Edin-  
burgh, Scotland.  
Developing Dodges. Harold Sands, Nottingham,  
England.  
The Art-education of Photographers. Charlotte Adams,  
New York.  
Habits of Life. W. H. Clark, St. Louis, Mo  
Photographing Interiors. W. I. Lincoln Adams,  
New York  
Photography for the Papers. F. H. Wilson, New York.  
Development of Dry Plates. E. M. Estabrook, New  
York  
A Printer's Collation. Young Chloride  
Call from an Old Foggy. W. J. Baker, Buffalo, N. Y.  
On the Development of Very Short Exposures in the  
Studio. W. E. Truesdell, Springfield, Illinois.  
What We Want. John W. Hallenbeck, New York.  
The Use of Photography in Wood Engraving. M. V.  
Roux, Paris, France.  
Developing—A Lesson. A 5 x 8 Tramp, Boston, Mass.  
My Experience. William McComb, Muskegan, Mich.  
Three P's Photographically Considered. J. Pitcher  
Spooner, Stockton, Cal.

Shade Your Lenses. Karl Klausner, Farmington,  
Conn.  
My Printing Methods. C. P. McDannell, Titusville,  
Penna.  
Photography as an Art. One Who Observes.  
Scaled Prices. G. M. Carlisle, Providence, R. I.  
The Grade System of Prices. G. L. Hurd, Providence,  
R. I.  
Millions Wanted, and Money in It. A Retired Watch-  
maker.  
Eyes. C. J. Billingham, Orange Heights, Florida.  
How Shall We Aim? J. F. Ryder, Cleveland, Ohio.  
Developing with Pyrogallol. Arthur H. Elliott, Ph.D.,  
New York.  
The Disposition of the Hands in Portraiture. W. T.  
Mozart, New York.  
Our Picture.  
Stopping Down the Eye. Dr. D. Garrison, Chicago,  
Illinois.  
Make Your Own Rustic Furniture. H. G. Parcel,  
Kirksville, Maine.  
A Surprise. Col. Octavio Barrati, Piverone, Italy.  
Carbon Solar Prints. F. H. Sherman, Milwaukee,  
Wisconsin.  
Odd Points. C. F. Moelk, Edina, Missouri.  
Backgrounds and Accessories, Their Use and Abuse.  
Mrs. Clyde Ehinger, Quincy, Ill.  
Enlarging and Magic Lantern Slides. A. R. Dresser,  
London, England.  
Stop to Consider. H. McMichael, Buffalo, N. Y.  
An Item in Oil. J. Hegyessey, Paris, Texas.  
Dots. "Aunt Dottie."  
Many Mites from Many Minds.

**OVER 2000 SOLD BEFORE ISSUE.****EDWARD L. WILSON, Photo. Publisher, 853 Broadway, N. Y.***Mailed on receipt of price. For Sale by all Dealers.*

## BLAIR'S " PERFECT " ( R. B. ) CAMERAS.

THIS  
Carrying Case  
ONLY  
Five Inches  
THICK.

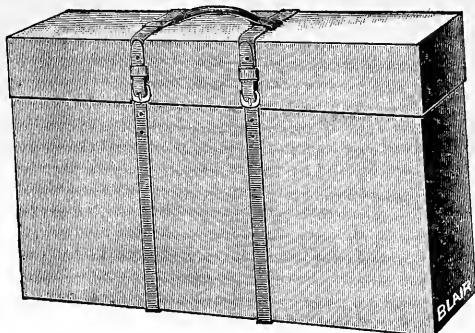

CARRYING  
6 F. W. Holders  
and 6½ x 8½  
PERFECT  
CAMERA.

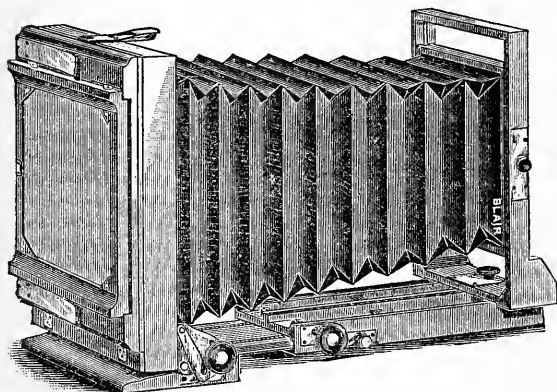

OPEN FOR USE.

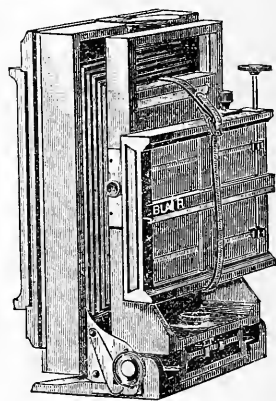

CLOSED.

The model instrument has been under progress in our factory for several months, and has undergone every change to our mind possible, to make it the most compact, combined with strength, possible.

1. By the ingenious method of constructing the " swing-back," greater swing is allowed, while the camera occupies no additional space by this important advantage.

2. By the method of constructing the telescopic bed the standard carrying the lens is quickly carried out to about the focal distance of lens in use, and then by the use of the Rack and Pinion the fine focus is attained. The thumb-nut and rod operating the Rack and Pinion is situated midway between the camera back and standard carrying the lens, which overcomes the objection of reaching forward when using long-focus lenses. The telescopic bed leaves no detachable parts. When using lenses of shorter focus than (5) inches the movable portion of the bed is not used; above that focal length the telescopic bed will not interfere with the view. *No clamping screws are used to make the bed rigid when attached.* There are two attaching nuts for the tripod screw, thereby enabling the operator to balance the camera when using long and short focus lenses

*Bear strongly in mind that all of our Reversible Back Cameras possess greater focussing capacity by several inches than any other Cameras of a similar pattern.*

The double swing occupies no more space than the single It is of our best manufacture, highly polished, with with nickel mountings. Fitted with feather-weight holders, unless otherwise specified.

### PRICE LIST OF PERFECT ( R. B. ) CAMERAS.

Size of Plate.	Size of Lens Board.	Capacity for Length of Focus.	Single Swing.	Double Swing.
5 x 7 .....	4½ in. sq. ....	17 in. ....	\$32 00 .....	\$34 00 .....
5 x 8 .....	6 " " .....	18 in. ....	36 00 .....	38 00 .....
6½ x 8½ .....	6 " " .....	18 in. ....	36 00 .....	38 00 .....
8 x 10 .....	7½ x 6 in. ....	18 in. ....	45 00 .....	48 00 .....

## THE BLAIR CAMERA CO.

Office and Factory, 471, 473, 475, 477 Tremont Street,

BOSTON.

Warerrooms, 318 Broadway, NEW YORK.

BLAIR & PRINCE, 148 W. Fourth St., Cincinnati, Ohio.

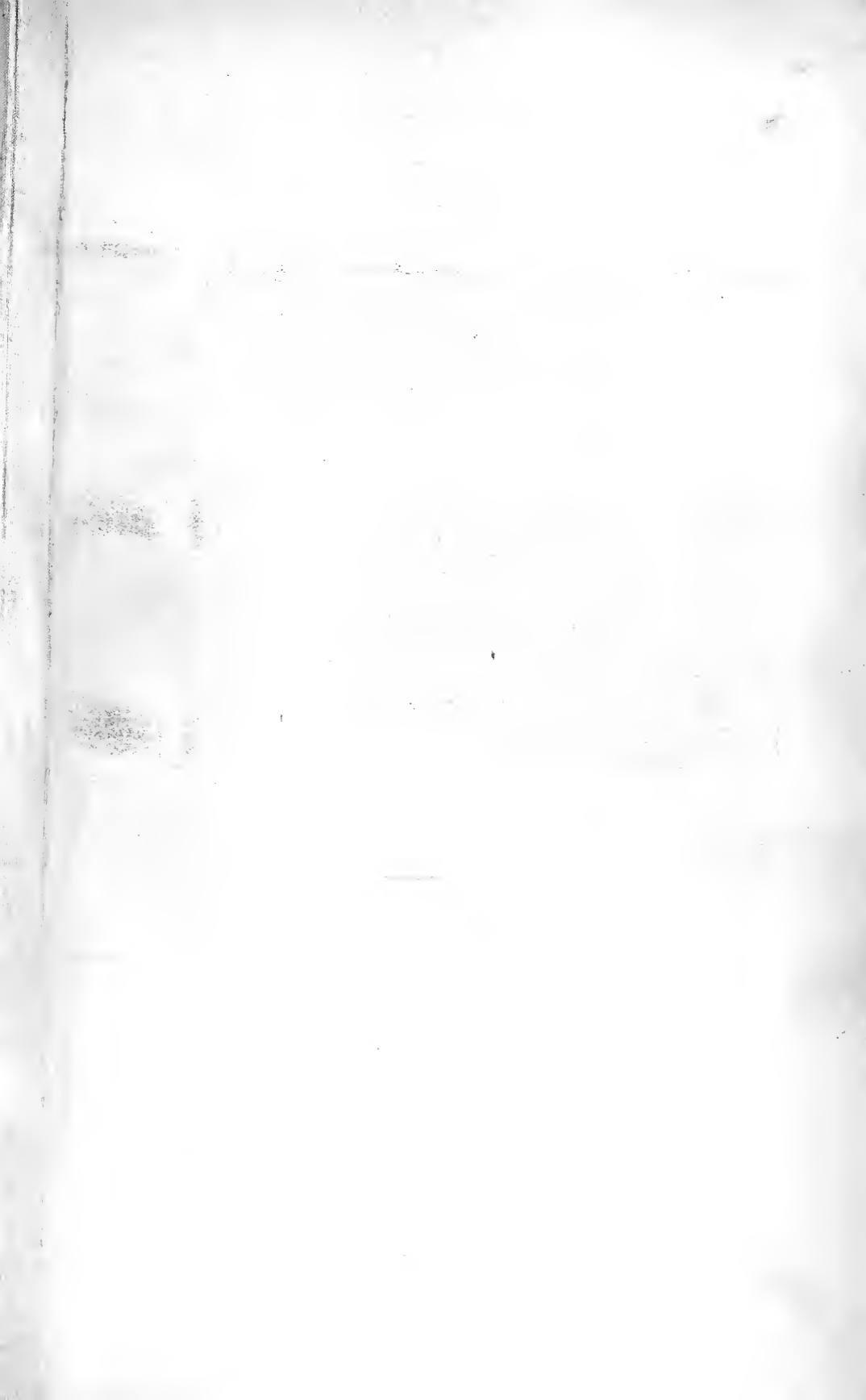



FRANZ WERNER,

MUNICH.

BAVARIAN BEAUTIES.  
SELECTED FROM THE ST. LOUIS EXHIBITION.

THE

# Philadelphia Photographer.

EDITED BY EDWARD L. WILSON.

Vol. XXIII.

NOVEMBER 6, 1886.

No. 285.

## NOTES FROM LONDON.

BY T. C. HEPWORTH, F.C.S.

Now has arrived that time of year when the days are getting chilly, the leaves which have not fallen are dry, hard, and brown, and outdoor photographic work generally is a pastime not to be pursued except by those of iron constitution. Now and again a warm sunny morning comes upon us as a pleasant surprise, and we can once more fancy that "summer is a coming in," and we are tempted to go out for a day's sport with that now slaughtering apparatus, the camera. But the majority of amateurs are packing up their traps—affectionately tucking them up for their long winter sleep until the dawn of another season.

But the mind of the ardent photographer sleeps not, and his hands are sure to find something to do, although the gloomy days seem to have entered into a conspiracy against him. He is sure to have put away in odd nooks and corners of his laboratory, certain things which have for a long time been waiting for the proverbial "more convenient season." When these are done he will probably try that quick-printing paper, or those opals which were sent to him for trial many weeks ago. Failing in these, he may try a few enlargements by means of his lantern. But when all these postponed matters have been duly executed, the photographer has still matters indoors which will hold him in pleasant bonds during the

dark days of winter. One of these is photo-micrography, and the other is the production of lantern slides from the negatives which have accumulated during the year.

Photo-micrography seems to have a future before it, and some English manufacturers of apparatus are preparing for the demand for instruments—camera and microscope combined—which they believe will presently arise. Matters are thus getting simplified for that enviable being, the well-to-do amateur, who finds everything made easy for him, while such beings as Newton, Faraday, and many others had to potter about contriving their own apparatus before they could do anything. But it must be conceded that many of the amateurs are good, hard workers, and that they often lead the van in a field of enquiry which the busy photographer has no time to pay attention to. One enthusiast whom I know, produces the most wonderful photo-micrographs which I have ever seen. He is about to try what can be done with a  $\frac{1}{30}$ th immersion lens which is being made for him. With low powers the work is comparatively easy, more especially as most of the microscope makers are now issuing them corrected for photography.

In the preparation of lantern slides some amateurs are very successful indeed, and this is perhaps mainly due to the commercial production of gelatino-chloride plates. More lately, bromide plates of the slow and

sure kind have been introduced for the same purpose, and from what I have seen of them, give very good results. Indeed, we may say that in this particular class of work the professional producer is rather hardly pressed in friendly rivalry by the ubiquitous amateur. This will in the end do no harm, for some of the lantern slides sold in the streets of London are of a most second-rate kind. One or two workers, I know, who produce their slides by the old albumen process, which used to be worked so successfully in stereoscopic transparencies by Ferrier, of Paris. But the majority of slides sold are done by the wet process, and toned to a tint as black as pitch with platinum. These will not compare in any way with gelatine pictures. They are in comparison very hard in appearance, and there is often very little relief between the chalky whites and the pitchy blackness of the shadows.

THE ever fresh ingenuity of the late Mr. Woodbury is once more called to mind by the introduction, commercially, of the tissue which was the subject of so much experiment during the latter years of his useful life. This new material for negatives, is produced by the Woodbury Tissue Company, and although it has only just been launched upon the English market, we learn that the company are overwhelmed with applications for it. It has the appearance of flexible glass, and when used with the Vergara patent dark slide—obtainable from the same source as the tissue—it represents a very convenient, light, and portable method of taking photographic pictures. This dark slide is simplicity itself. It has the appearance of an ordinary double back of very narrow depth; there is a shutter on each side of the usual pattern, but the arrangement does not open for the insertion of the tissue. Instead of this, there is a middle shutter which draws out entirely. Over this is folded a piece of tissue large enough for two pictures. It is then replaced and carries the tissue with it into position ready for two exposures.

THE annual exhibition of the Photographic Society of Great Britain has just been inaugurated as usual by a conversazione. The exhibition is now open to the

public, and remains so until November 13th. On three evenings in each week transparencies will be shown by the Society's optical lantern. I hope to have something to say about the pictures exhibited, in my next letter.

---

### THE POWELL PRINT.

BY DR. J. H. JANEWAY, U. S. A.

THE cyanotype or blue print from the ease of its production, both in regards to time and simplicity of manipulation, has long been, from the want of a better, a favorite with the photographer, especially amateurs, who are pardonably anxious to see the results of their work at the shortest space of time. But the eye soon tires of the objectionable color of the iron picture, the want of delicacy in the gradations or half tones, and lack of purity in the whites. So, almost coincident with the introduction of the "blue print," efforts were made by many an able worker to improve the print, in some way to discharge the iron and reproduce some other tint or shade more pleasing to the eye and at the same time increase the beauties of the half tones and brilliancy of the whites, without diminishing the permanency of the picture. Many were the attempts made and with as many failures; apparently successful in some cases, the prints soon faded or rapidly became badly discolored and worthless and the experiments were given up in disgust, or, as in one or two cases where success seemed to crown the efforts of the experimenter, the process was so complicated as to render it almost impossible for an ordinary man to continue it, and it therefore fell into disuse.

After many attempts continued during a series of years, and after numerous failures, the late Mr. Samuel Powell, of Newport, R. I., perfected a process which crowned all his labors with success, and resulted in the production of beautiful prints in a variety of agreeable tints or colors and durability. His process is as follows: He passes any good hard sized-paper suitable for the cyanotype picture through a bath of dilute gelatine, which he prepared as follows: Two and a quarter grains of gelatine



to each ounce of water; after passing the paper through the gelatine bath it is hung up to dry and drain, using all precautions to avoid unevenness of coat, streaks, and marks; when quite dry the sized-paper should be, in the dark, evenly coated with a solution composed, say, of seventy grains of ammonio-citrate of iron, with sixty grains of ferridecyanide of potash in two ounces of water, which should be prepared and kept in the dark. This is then the prepared paper, which, when duly exposed under a negative to light, may produce the variety of image desired. When printed it is washed in two or three changes of clear water and we have the developed print no longer sensitive to light. This print needs now only to be blotted off from superfluous water, when it is ready for immersion in the discharging bath. The discharging bath may be composed of a variety of agents such as

(A.) The carbonate, bicarbonate, sesquicarbonate of soda.

(B.) The soluble alkaline silicate of potash and soda.

(C.) Biborate of soda, known as borax.

Any of the above reagents dissolved in the proportion of ten grains to the ounce of water will discharge the color of the "blue print," still leaving the salt of iron in the form of a nearly invisible and perfect image on the paper.

He preferred to combine the discharging bath of ten grains of efflorescent sesquicarbonate of soda with each ounce of water. In this bath immerse the "blue print" till the color is discharged and the paper loses nearly all trace of the picture, except a rusty color more or less distinctly marked with the image in the strong shadows. When the blue color has vanished in the discharging bath the paper is washed in two or three changes of clear water and is then blotted off to remove any remaining traces of soda salts, which, if left in the print, would modify final color. The print is now discharged and ready for the toning bath, for which we may employ gallic, tannic, or pyrogallic acid, or any other suitable compounds of tannin or such other agents as are known and employed to produce color reactions with salts of iron. Mr. Powell prepared his coloring bath of four

grains of gallic acid to the ounce of water, in which immerse the print and then watch carefully for the development of the desired color, which, when it appears, is the signal to remove the print from the coloring bath and to pass it once rapidly through one bath of clean water so as to wash it fairly, then immediately blot off all superfluous water and dry it in full daylight, and preferably in the sun, which strengthens and increases its brilliancy. There can be no doubt by the above process very brilliant pictures, with varied and agreeable tints and tones, can be produced; sharp, and at the same time pleasantly graded. By the old process with the alcoholic solution of caustic potash, there was almost always a blurring effect produced, which no doubt caused it to fall in disuse. The time elapsing between the printing and drying of these prints, together with the ease of manipulation, variety of tones, and I think durability, would seem to recommend this process.

A PATENT of Messrs. Woodbury & Verrara has just been published for the production of a transparent paper intended, it is said, to take the place of glass in photographic operations, and which, besides, may be used for various other purposes. This process consists in taking a rather thin paper of a very homogeneous texture, which is passed successively in the following baths:

1. Benzine, 32 ounces; gum dammar, 61 ounces; these substances are well mixed for twenty-four hours, until the gum dammar is entirely dissolved.

2. Benzine, 2 ounces; gum,  $\frac{1}{2}$  an ounce; mix as above.

These two resinous solutions are mixed together, and the product is filtered through a fine cloth. The paper is treated one sheet at a time, and dried at a temperature of about 80° Fahr. Thus prepared, it is passed into a second bath consisting of gelatine, 2 ounces; water, 40 ounces. The paper is now dried at a moderate temperature.

A sheet of paper rendered transparent by this process may be used to receive a coating of emulsion in the same manner as a glass plate. Moreover, it may be used for making tracings, etc., and for ordinary drawings.—DR. PHIPSON, in *Moniteur*.

## PERTAINING TO THE



## REPORT OF THE TREASURER.

*G. M. Carlisle, Treasurer, in account with the Photographers' Association of America.*

<i>Dr.</i>	<i>Cr.</i>
1886.	1886.
Cash in bank January 1, 1886 . . . \$1913 59	January 30, Paid—
June 22-25, Received from—	Draft 1, J. Landy, expense attend-
321 new members @ \$5 each . . . 1605 00	ing Ex. Committee meeting . . . \$39 50
335 new members @ \$2 each . . . 670 00	Draft 2, H. McMichael, expense at-
For 508 tickets @ 25 cents . . . 127 00	tending Ex. Committee meeting . . . 70 00
H. McMichael (Entrekin donation	Draft 3, W. A. Armstrong, expense
to medal fund) . . . . . 10 00	attending Ex. Com. meeting . . . 41 60
Joshua Smith (balance of medal	Draft 4, D. R. Clarke, expense at-
fund) . . . . . 40 65	tending Ex. Committee meeting . . . 34 50
H. McMichael (floor space) . . . 1485 35	Draft 5, W. H. Potter, expense at-
August, H. McMichael (floor space) . 116 40	tending Ex. Committee meeting . . . 35 00
	Draft 6, G. M. Carlisle, expense
	attending Ex. Com. meeting . . . 104 30
	April 9, Paid draft 7, H. McMichael,
	on account . . . . . 100 00
	June 23, Paid draft 8, R. Benecke
	on account . . . . . 100 00
	June 24, Paid
	Draft 9, R. Benecke, on account . . 125 00
	Draft 10, Cyrus Morgan, stenog. . . 300 00
	June 25, Paid—
	Draft 11, F. W. Sachse & Co., car-
	penters . . . . . 40 15
	Draft 12, E. & H. T. Anthony &
	Co., expense foreign exhibit . . . 48 66
	Draft 13, Sowders & Benecke,
	flowers . . . . . 40 00
	Draft 14, F. W. Sachse & Co., car-
	penters . . . . . 16 92
	Draft 15, C. Gentile, R. R. advert'g . 65 50
	Draft 16, P. W. Rounds, Badges . . 150 00
	Draft 17, Joshua Smith, medal acct. 200 00
	Draft 18, G. M. Harding, carpenter . 56 93
Carried forward . . . . . \$5967 99	Carried forward . . . . . \$1568 06

1886.	<i>Dr.</i>	
Brought forward . . . .	\$5967 99	
		\$5967 99

1886.	<i>Cr.</i>	
Brought forward . . . .	\$1568 06	
Draft 19, O'Neil Lumber Co., use of lumber . . . . .	82 27	
Draft 20, H. S. Bellsmith, committee expense . . . . .	3 10	
Draft 21, William Miller, police service . . . . .	30 00	
Draft 22, R. Benecke, labor acct.	250 00	
Draft 23, L. B. Pierce, rent of hall	685 00	
Draft 24, R. Benecke, salary . . . . .	250 00	
Draft 25, R. Benecke, bal. labor account . . . . .	46 97	
Draft 26, H. McMichael, due from 1885 account . . . . .	10 10	
September 4, Paid—		
Draft 27, H. McMichael, 5 per cent. of receipts . . . . .	202 72	
Draft 28, G. M. Carlisle, 5 per cent. of receipts . . . . .	202 72	
October 6, Paid—		
Draft 29, C. T. Stuart, essay prize	100 00	
For postage stamps . . . . .	7 30	
For exchange on 10 drafts . . . . .	2 50	
For express . . . . .	2 70	
For stationery . . . . .	73	
Total . . . . .	\$3444 17	
Cash on deposit Oct. 12, 1886 . . . . .	2523 82	
		\$5967 99

*Recapitulation.*

Received for dues, 1886 . . . . .	\$2275 00
Public admissions @ 25 cents . . . . .	127 00
For floor space . . . . .	1601 75
Mr. Entrekim, donation to medal fund . . . . .	10 00
Balance of medal fund returned to treasury . . . . .	40 65
Total receipts, 1886 . . . . .	\$4054 40
Disbursements as per vouchers . . . . .	3444 17
Net gain, 1886 . . . . .	\$610 23
Balance on hand January 1, 1886 . . . . .	1913 59
Cash on deposit October 12, 1886 . . . . .	\$2523 82

Respectfully submitted,  
G. M. CARLISLE,  
Treasurer P. A. of A.

## ON LOCAL REDUCTION OF GELATINE PLATES.

BY PROF. KARL KLAUSER.

A PHOTOGRAPHIC negative ought to be perfect if exposed correctly and developed judiciously, and there should be no after-work necessary for good printing conditions.

Unfortunately, in practical experience, a "perfect" negative of this sort is a rare thing, especially when the subject photographed is one of strong contrast, as *f. i.*, white painted houses surrounded by dark foliage, etc. Harmony may be somewhat restored by printing under a mask (which is a tedious process), or by local reduction of the too dense parts.

Local reduction is done by chemicals, and these being liquids, it is very difficult to keep them from overrunning—overflowing the parts to be reduced and very often more mischief than benefit is the result.

I have often tried, and with good effect, simply grinding the too dense parts, after drying the plate, with some soft grinding powder; such for instance as is used to "matt" varnished negatives for retouching purposes. With some patience the most obdurate parts may be subdued into good printing condition. Wipe away the grinding powder when it has become dark and use fresh.

Some negatives when developed in a too often used developer will show a dark deposit after drying. This is certainly a fault, but one which can be turned to advantage. The local reduction in these cases will clear and clean the too intense spots by means of an often renewed tuft of cotton—dry, of course, as all these suggestions are.

---

## AN AMATEUR'S ALBUM.\*

BY MARCUS H. ROGERS,  
East Brimfield, Mass.

EVERY amateur photographer is presumed to make an album of his pictures, and if he aims at perfection, as all amateurs should, the chances are that he is disappointed at the result. It is exasperating, after one has

taken great care with a lot of pictures, and pasted them in an album with every precaution against their curling, to find that each particular leaf takes every shape but a flat one. In making my first album I bought one of the books sold by the stockdealers, with gilt lines around the pages, and I used the utmost care in pasting in the pictures. Some I dried, and brushing over rapidly with a broad brush dipped in the paste, put the picture in position, and placed the album in a letter-press before the paper had time to expand. Others I pasted and allowed to dry, and then dampened the page with a wet piece of blotting-paper cut to the exact size, and put the book in press as before. I was so careful not to allow any dampness to penetrate to the other leaves that I had two sheets of tin between which the newly pasted leaves were kept in press until quite dry. In a few weeks after being removed from the press, the leaves of that album assumed all sorts of crooks and curves—and it was not good in my sight. Then I obtained some cards of proper size, pasted photographs on each side and burnished them, and kept them in the press for a month, intending to have them bound afterwards. But burnishing did not prevent their curling, though it improved the pictures, and the plan was pronounced a failure.

"Thirdly," as the ministers say, I bought some double-weight albumenized paper, cut to 8 x 10 size, which I sensitize as required. My negatives are 5 x 8, and are printed nearly in the middle of the 8 x 10 sheets in this way: A plain glass is put in an 8 x 10 printing frame, and upon it a piece of cardboard about the thickness of a negative, with a 5 x 8 hole cut in it to receive the negative to be printed. Then a mask made of needle-paper, and attached to the card-board at one side, is cut with perfectly true edges overlapping the negative a quarter of an inch all around. This leaves a sharply defined outline around the pictures, which adds much to their appearance when finished. The leaves are to be bound at the side—not at the end—so the pictures are not placed exactly in the centre, leaving a little margin for binding, every other negative being put in, in a reverse way, so that the pictures will all "face" in one direction. The photographs

\* Written for *Mosaics*, but received too late.

are then printed, toned, and dried, and the name or description, with date—an important feature—printed on them with a type writer. The pictures are then pasted together, back to back, without any mount between them, only a strip of thin cotton cloth at one edge, to aid in binding. They are then carefully bur-nished, using an old mount to protect the upper picture from the roll, and to make of sufficient thickness. The leaves thus made remain perfectly flat, and are not so bulky as when put upon a heavy mount, and the photographs look very handsome with the pure white border and sharp outlines. The only great difficulty attending this plan of making an album is the blistering of the double-weight paper. I have tried all known remedies to prevent blistering, and a good many things by way of experiment, but nothing has been of much use. When the blisters are small they do little harm, except to the temper of the amateur while making the pictures, as they disappear while drying. Some thin negatives made during a camping trip in Florida, and therefore highly valued, have been printed on bromide paper, in the same manner, with very beautiful results. These were dried on plate glass, producing a brilliant finish, and, as mounting destroys it, they were only pasted at the edges. All my pictures are not yet completed, but so far the work is a success, and when finished, and the leaves trimmed and bound, it promises to be pretty near perfection.

---

### SOMETHING ABOUT PAPER NEGATIVES.\*

BY C. M. FRENCH,  
Oneonta, N. Y.

As my work is largely in the line of paper negatives, I may be excused for confining myself to this subject.

Not unfrequently have I read of various mediums being recommended for drying the negative upon, to enable one when they are dry to strip them off straight and smooth, and it has led me to believe that others may have as much trouble as I have had. It

cannot be questioned that polished hard rubber is the best known medium, but where a large number of prints are to be mounted at one time, rubber is too expensive. I have always used glass, but many a good negative have I scraped off with my knife, being unable to pull it off, even though it was well greased. I have tried ferrotype plates, as has been recommended, but without success.

I have discovered that polished glass is much better than ordinary French glass, and I have also found that it is better to rub them thoroughly with whiting, let it dry, and then polish clean, than to wash them. I use an oil made by combining sperm oil and fresh lard to the consistency of cream.

But with almost any support they are apt to dry uneven, the upper part (if set in a rack) will dry first, and leave the support, causing the paper to cockle up and prevent it lying flat in the printing frame. This is very annoying, as I have been obliged in some instances to wet them and mount them over. This difficulty is very much lessened by setting the negatives up in a rack until surface-dry, then place one or two blotting-pads between them, lying flat on the table over night; in the morning, set them up in the rack again, and dry slowly. This is the best way I know of to proceed with oiled glass.

I have recently discovered what I believe to be a more satisfactory way than oiling, although I speak from less experience. In experimenting with Eastman's stripping films I used a rubber solution which they supply; it is usually flowed over each plate, and allowed to set before the negative is adjusted; but this being too tedious for a number of prints, I took one of my oiled plates and wiped it off as thoroughly as I could, and with a piece of chamois skin, dampened with the rubber solution, I went quickly over the plate and adjusted the negative at once. It remained in perfect contact until thoroughly dry, and then I cleaned the glass with a fine surface and without a wrinkle. I have no doubt it would have done the same had not the glass been previously oiled. I shall investigate further, and if what I have written will help any one, I shall feel repaid for giving my experience.

---

\* Written for *Mosaics*, but received too late.

## YOUR DEALER.

BY ONE OF THEM.

DURING the last fourteen years it has been my lot to be classed among those who are so fortunate (?) as to be called upon to supply the wants of the photographic public. The amiability of the class of photographic servants to which I belong is apparent to all familiar with the almost constant annoyances to which we are subjected, as a result of the quite unpardonable carelessness of those with whom we do business, together with so much indifference to, and disregard of the most commonplace rules and customs of ordinary commercial intercourse on their part, which so far as I know have never before called forth publicly a single wail from any of the unfortunate victims of this condition of things.

I have long withheld any public protest against the causes of our annoyances, hoping that as our patrons must themselves share in a measure the inconveniences they occasion, that the difficulties would in time work out their own cure, but have looked and waited in vain for any marked improvement. The greatest annoyance to the average dealer doubtless comes from the carelessness of his patrons in writing their orders, this carelessness being generally manifest in a failure on the part of the patron to give explicit and complete directions as to what he wants. For instance, a customer sends in an order which includes "1 dozen dry plates" (*no size given*), or "5 dozen ex. brill. alb. paper," naming the brand, but *fails to mention the tint desired*. Or he calls for "1000 No. 42 cab't cards R. C.;" *no color given*; or "50 8 x 10 pebbled mats;" *no opening given*, or if size of opening is given the shape is omitted. And so these examples may be multiplied and varied almost indefinitely. The very nature of all such cases of omission to state exactly what is wanted, compels us to adopt one of three courses, viz., to ship the balance of the order leaving out the doubtful article, or to hold the shipment until we can write and get the desired information, or *guess* at the unexpressed portion of the order. Either course must result in an annoyance to our patron as well as to ourselves unless we

adopt the "guessing" plan and *happen* to guess right.

Another very common and very annoying oversight on the part of our correspondents, is a failure on their part when heading their letters or orders to mention the *State* in which they reside. It is the height of egotism for the average photographer to presume that his name is so generally known to the average stockdealer, and known too in connection with the town or city where he resides, as to make it unnecessary for him to mention his State. I venture the assertion that there is not one in one hundred that enjoy such distinction. Even while writing this article a letter comes to me from a stranger with just this omission, and the writer will doubtless censure my firm severely for lack of courtesy and enterprise on account of not answering his letter, when his own carelessness has rendered it impossible for us to do so, as the name of his town is found in nearly every State in the Union, and this is by no means an exception. Scores of towns could be mentioned whose names are duplicated in a dozen or more different States.

Another common oversight is a *failure to sign* the orders, etc. sent to us. We have, during our business experience, received several orders which were not signed, neither was there a word to indicate the town, county, or State from which they were sent, and the stamp of the post-office on the envelope where mailed was illegible, rendering it utterly impossible to tell *who* or *where* they came from, or to do anything with them. The writers doubtless busied themselves for weeks after in heaping imprecations upon our innocent heads, because we paid no attention to their orders.

Another common annoyance results from receiving orders from strangers having no commercial rating, who wish goods sent on open account, promising to remit in ten or thirty days, yet failing to give reference, or in case references are given, wishing goods *immediately*, making no allowance for time it takes for us to get the necessary information as to their character and commercial standing, through correspondence with the persons they name or otherwise. Others ask credit of us who would not for a

moment think of asking their local banker for a loan of an equal amount, though he is much better acquainted with them than we can be. Why is this? Our goods are our capital just as much as the banker's cash is his capital. Where is the difference, or why should not we be just as careful about crediting out our goods as is the banker about his cash? Or granting that the loan or the credit has been made, you expect to pay the bank on the very day it is due, why not be as careful to pay your dealer just as promptly? Our debtors often write us, "Please give me a little more time on my bill, I have my rent to pay this week," or "I have a payment to make on my place," or one of a score of other excuses equally weak; as though they regarded it as our duty to wait till all other obligations of theirs were met, then, if there was any cash left not particularly needed for other purposes our claims would be attended to.

Many other grievances might be named, but I will rest my diagnosis of the ills of the average "dealer," or rather of his patrons, and if the evils pointed out, which by the way suggest their own remedies, shall in any measure result in working a cure of the numerous patients, I may venture to continue the case at some future time.

---

### CORRECT EXPOSURES AND THE AREA SYSTEM OF MARKING LENSES AND STOPS.

BY FRED. EVANS.

THE question of correct exposure being of such vital importance in all photography that aims in its results at being considered as "fine art," a few notes on a recent holiday with the camera, having this end specially in view, and working with lenses and stops on the new "Area System," recently introduced by Mr. George Smith, may be found of interest and value to your readers. That the general feeling is for a more scientific, speedy, and exact method of determining exposures, as against "rule-of-thumb," and other guess-work approximation, is evident from the numerous plans for systematic exposure that have been advocated and discussed lately. I am the more desirous,

therefore, of advocating what I think have proved by careful testing to be as perfect and scientific, though simple, a system as we can, at least at present, hope for. It is equally well adapted for all, from the hopeless amateur, wedded to his one-lens camera, to the amateur or professional bent on turning out only such work as can be honestly considered as artistic, combined of course with the utmost technical perfection attainable.

Before adopting this system, my exposures, though very fairly successful, were always felt to be largely arrived at by guess-work; though I carefully worked by Mr. Burton's most excellent tables, the difficulty was very great in arriving at the correct exposure for the various stops, the fractions occurring in almost every result made any feeling of satisfaction or exactitude impossible. The fault was not in Mr. Burton's tables, but in the system of marking or naming lenses and stops or apertures, and the unit on which calculations were based;  $f/4$  is simply absurd as a unit for any figures to be based on for landscape work. The prime virtue of the area system is that its basis or unit is that of  $f/16$ , the maximum aperture allowable in any good landscape work. It was a very happy inspiration that coupled this desirable unit with the simple though scientific ratio between lenses and stops as introduced to us in this area system, the exposure for *any* stop with *any* lens being now ascertainable at a glance. Another virtue is that all existing stops and lenses can easily be measured and marked in accordance with the system, and all its advantages at once and easily be utilized.

The difficulty has been to establish such a ratio between lenses and stops as that the exposure for any stop used with any lens can be easily and quickly ascertained, and this without recourse to any elaborate worked-out tables, but simply and solely by a glance at the numbers engraved on the lens-mounts and on the stops; this the area system completely accomplishes. Put simply, it is as follows: a more scientific explanation must be sought in Mr. Smith's own article in the photographic papers recently. The first thing to do is to very carefully ascertain the focal length of the

lenses in use; taking a 6-inch focus lens as an example, this in *quarter-inches* is 24, the square or area of 24 is 576, called for greater convenience in after working, No. 58; mark this number plainly and permanently on the lens cell.

Now as to the stops, for the area system is of course only applicable by the conjunction of both lenses and stops marked on a similar plan. It is well known that all holes are technically measured in sixty-fourths of an inch, a drill making a hole of  $\frac{1}{2}$ -inch diameter being numbered and known as 32; all stops used in this area system have to be marked with the area number resulting from such measurement. For example, a  $\frac{2}{3}$  inch stop equals 24 sixty-fourths of an inch (the same number, 24, be it observed, as the 6-inch lens stated in quarter inches), the square of 24 is (as above stated) called No. 58. Now, the ratio of  $\frac{1}{64}$  of an inch (the measurement of the stops) to the  $\frac{1}{4}$  of an inch (the measurement of the lenses) is 1 to 16,  $\frac{1}{64} \times 16 = \frac{1}{4}$ ; the number, therefore, of this  $\frac{2}{3}$  stop—*i. e.*, 58, being equal to the number of the lens—*i. e.*, 58, the proportion of aperture to focus is as 1 to 16, for  $\frac{2}{3} \times 16 = \frac{32}{3} = 10\frac{2}{3}$  inches; this stop, used with this lens, therefore, will be working at  $f/16$ .

The admirable simplicity and effectiveness of this system is at once apparent, for if when the number of the lens and stop are the same, the working aperture is  $f/16$ , then it follows that when any stop of a *less* number than the lens number is used (as should almost always be the case in landscape work), the lens number must be divided by the stop number, and the exposure required for  $f/16$  multiplied by the result. Thus, I was using the lens, area number 52, and the subject being landscape and foreground, nearest shadows about 40 feet distant, a smaller aperture than  $f/16$  was of course essential. I selected, therefore, stop area No. 20 ( $\frac{1}{4}$  inch); the light being dull I decided first that the exposure for  $f/16$  would have to be 2 seconds; the lens number 52 then divided by the stop number 20, gave a multiplier of  $2\frac{1}{2}$  times the two seconds for  $f/16$ , that is 5 seconds for the lens and stop in use, the result being as perfect a negative as I was ever happy enough to secure.

The stops I find most useful are, in area Nos. 2.5; 5; 10; 20; 40; 78; 160. It is plain to the "meanest capacity" that there is no necessity for carrying a stop or stops giving exactly  $f/16$  for any or every lens; this system of marking lenses and stops is on the unalterable basis of  $f/16$ , therefore, whatever stop, large or small, be used, it *must* be working on the ratio of  $f/16$  by the simple plan as above exemplified; the stops above quoted, ranging from  $\frac{1}{12}$  of an inch to  $\frac{5}{8}$  of an inch, give every desirable degree of aperture for any possible subject. This beautifully simple rule of having only to decide the exposure requisite for the *hypothetical*  $f/16$ , and the ratio to that, of whatever lens and stop is in use, being instantly ascertainable, does away for ever with the vexatious doubts and calculations as to what  $f/$  the stop used is actually working at, whether *quite*  $f/22$  or perhaps nearer  $f/32$ , or how much to allow in exposure for the difference between the two; the area system abolishes these worries completely, while giving a far greater degree of accuracy than is attainable by any other method. Of course it is apparent that if the stop number in use is *greater* than the lens number (as should very rarely be the case), as for instance, the above quoted lens 52 used with stop 160, the rule would be reversed, and 52 being about  $\frac{1}{3}$  of 160, this lens and stop would require an exposure of  $\frac{1}{3}$  that necessary for  $f/16$ . Again, when "two single lenses"—I quote from Mr. Smith's circular—"are combined in one mount, the numbers of each lens are added together, and the product divided by 8 gives the area number of the combined lens." For instance, I want a  $4\frac{1}{2}$ -inch focus lens. I take my lenses Nos. 102 and 144, these added together and divided by 8 give area No. 31 for the lens wanted; these few combinations are soon learnt or better recorded at end of note book with the exposure table for  $f/16$ .

It will at once occur to all that the area system does not profess to provide a guide to exposures for  $f/16$ , but given a reliable table for this—which all must make themselves according to the plate they use—the area system provides a speedy, exact, and simple method of ascertaining the exposure



required for any lens with any stop. With a view to arriving at this very desirable exposure table for  $f/16$  permit me to draw attention to a modification of Mr. E. Howard Farmer's Distance Table (in *British Journal Almanac*, 1886, page 186)—10 feet distant, 4 seconds; 20 feet, 2 seconds; 40 feet, 1 second; 100 feet,  $\frac{1}{2}$  of a second; this was found on my recent holiday to be very valuable as a guide when applied to the nearest shadows in the landscape.

The question of exposure depends on the character of the picture, and particularly on the value of the shadows. For instance, the same range of distant hills or mountains may serve as a background to many

wooded lane which would be most effective with the sunlight breaking up the road, the exposure will not be materially less than in bright diffused light.

No table, however elaborate or simple, will ever do away with the necessary employment of individual judgment in every exposure made; the ever varying quality of the light alone will always impart a fluctuating quantity into the most scientific and exact of tables, and prevent their ever being anything beyond approximate. The notebook ruling adopted for this table, together with the area system of marking the lenses and diaphragms, is as follows. I use a  $4\frac{1}{4} \times 3\frac{1}{4}$  camera only:

JUNE, 1886.

Neg. No.	Dark slide. No.	Subject.	Distance.	Light.	Time.	Lens.	Stop.	Quality of			Exposure	Remarks.
								$f/16$ exp.	Light.	Stop ratio.		
23	2-1	Shady nook in field.	40 feet.	Dull.	10 A. M.	52	20	1 sec.	2	$2\frac{1}{2}$	5 sec.	Brilliant.
18	3-2	Henneld Church, Sussex.	$\frac{1}{4}$ mile.	Sun.	4 P. M.	250 ( $12\frac{1}{2}$ in.)	20	$\frac{1}{6}$ sec.	1	12	2 sec.	Good.

different pictures, and while the correct exposure for the hills remains the same the exposure for the whole picture will be varied by that required for the deepest shadows in foreground. The object of interest may be a comparatively near white-washed cottage requiring very little extra exposure beyond that for the hills; while the object of interest might be a very near and comparatively shady tree or bush, which would require considerably more exposure than the hills. *The surest guide therefore is to expose for the nearest important shadows.* The  $\frac{1}{2}$  second—100 feet—was found to include near objects, such as cattle, etc., in a really open landscape.

If no object of interest under 100 yards, exposure =  $\frac{1}{3}$  of a second; while the same at a quarter of a mile =  $\frac{1}{6}$  of a second is ample. This was for bright diffused June light, 9 A.M. to 3 P.M., for plates known as thirty times. These figures were further verified by other exposures on fifty times plates at proportionately reduced figures. *Sunlight reduces exposures one-half if it also lights up the nearer shadows;* in the case of a deeply

With reference to lenses, I have a set of five, which interchange at either end of the same mount, and can consequently be used either as single lenses or as doublets; these lenses, by a very ingenious adaptation of the bayonet joint, are instantly fixed by a quarter-turn only, the mount being also as quickly and safely fixed in the camera, one cap and set of stops sufficing for the whole set of lenses is as follows:

*As Singles.*

Area No. 250 = $12\frac{1}{2}$ inches.
“ 168 = $10\frac{1}{4}$ “
“ 144 = $9\frac{1}{2}$ “
“ 102 = 8 “
“ 84 = $7\frac{1}{4}$ “

*As Doubles.*

Area Nos. 168 + 250 = No. 52 = $5\frac{3}{4}$ inches.
“ 144 + 168 = No. 39 = 5 “
“ 102 + 144 = No. 31 = $4\frac{1}{2}$ “
“ 84 + 102 = No. 23 = $3\frac{3}{4}$ “

I thus get a battery of nine foci available from these five lenses, and am therefore adequately equipped for every possible class of work. The stops used with them I have

before quoted. It may possibly be objected that results cannot be obtained from such lenses equal to those obtained from the expensive symmetricals and rectilinears of Messrs. Ross, Dallmeyer, *et seq.* All I can say is, that the difference in results under the severest tests is quite inappreciable. It would be quite impossible for the acutest critic to say that my negatives had not been obtained by a Ross or a Dallmeyer lens. So long, therefore, as I can obtain such satisfactory results, I shall remain content with the admirable set of lenses supplied me by the Sciopticon Company, at the moderate cost of five guineas.

Another objection may be, why carry so many lenses for use, with but one and so small a camera? For the very adequate reason that when I unship my camera, it is to obtain a certain picture—not view merely—one that I have previously studied, grouped, and composed as artistically as possible. If, then, I was possessed of but a couple of lenses, it would be ten chances to one if either of them gave me on the ground glass exactly the picture, *neither more nor less*, I wanted to carry away a permanent record of. But with my battery of lenses, of from four to twelve and a half inches foci, in so absurdly little bulk, it is but at the trouble of selection to get to a certainty the exact picture I want, and—be happy!

If the lens used be of a wider angle, and give the view *and something over*, it is useless to say that the redundant portions can be trimmed away in the resulting print. The artistic effect is never the same as if the full plate had been filled with the subject by using a lens that gave the picture wanted and that only; to say nothing of so useless and fatal a loss in size, more especially in small cameras. Besides, who, amongst ordinary amateurs or professionals, has the resolution to pare down the print in this way, merely for the sake of artistic balance and effect? *It is never done*, I verily believe, if we are to judge by the tales so eloquently told by exhibition walls, scrap albums, etc.!

"Get all you can," seems to be the all but universal motto, in the commercial world at the expense of morality, and in the photographic at the expense of artistic worth.

This matter of a proper set of lenses of various foci is really a serious one in its art aspect; the taking of a photographic picture should never be at the mercy of accident, and it is pure accident to the man with but two lenses (the one lens-camera man is simply and utterly hopeless) to get the artistic picture desired; no artist goes out water-color sketching with but a couple of colors or a single brush in his box; he must have the proper equipment of tools, or he cannot do work worth looking at; the restrictions of the photographic artist are so much more stringent, as his grouping and composing is purely attained by choice of point of view, and not as with the painter, who can put this tree a little nearer or farther, etc., that the photographer must, therefore, be equipped with such a set of lenses as will at choice give him one that shall give precisely the picture he desires (or should desire!) on the ground glass. I have frequently found it necessary to use in a single morning's work so divergent foci as 4 inch and 12 inch, finding that they only could give me the pictures, *neither more nor less*, I was desirous of securing. The great houses of opticians do not seem to have sufficiently considered this vital question as they still go on advertising, and therefore advocating, one lens for a camera, making no provision for a proper *set* of lenses for any one camera, though the cost of a set of symmetricals or rectilinears would be simply appalling!

The question of optical performance before alluded to is very easily tested; I am perfectly satisfied, myself, as to the thorough efficiency of the lenses I am using, as I wanted for a special purpose a study or two of portions of our lovely English hedge-rows, and the negatives taken by these lenses are full all over of microscopic detail, and are in every respect technically flawless. The lenses used were the No. 52 (a doublet made up of Nos. 168 and 250) and the 10 inch single, No. 168, used with stops Nos. 5 and 10 ( $\frac{7}{8}$  and  $\frac{1}{8}$ ). With such small stops some authorities (?) say that all depth and perspective must be quite destroyed, but these negatives are absolutely true to nature, the light and shade and the stereoscopic effect being, as I think, wonderful. I enclosed a couple of

proofs of these hedge-row studies for your inspection.

Of course, the great difficulty in this, as in all focussing, is to decide which plane is the right one to focus for before stopping down; if the wrong plane be chosen with full or nearly full aperture, too close to or too far from the camera, no amount of after stopping down, even to a pinhole aperture, will secure the desired sharpness. This refers to all subjects, for though I do not prefer all over sharpness to atmospheric, pictorial effect, yet the right degree of sharpness, crispness, must be present or there will be no enjoyable picture, more especially when enlarged. This does not in the slightest degree prejudicially affect the due preservation of perspective, distance, relief as it were, without which no negative can be considered perfect, technically or artistically; these essential qualities can only be secured by this scrupulous care in focussing for the right plane before stopping the lens down to whatever degree is thought desirable. It is this difficulty that makes my particular hobby, photomicrography, such a continual failure in most hands; and it is a difficulty that nothing but practice and careful observation of results can remove.

I hope the day is not far distant when this most admirable Area System, which I have tried to make clear and practical in these remarks, will be universally adopted by opticians as well as by photographic workers; it is, to my thinking, and after practical testing, one of the most valuable discoveries in connection with photography ever made; though, as with so many other useful inventions, one necessarily common property, and therefore capable of yielding little or no profit, save in honor, to its ingenious inventor; I also trust that the various points in my paper will lead to some healthy discussion in your columns.—*Amateur Photographer.*

(Translated for the Philadelphia Photographer.)

## COMPARISON OF IRON AND PYRO DEVELOPMENT.

BY J. GADICKE.

THE opinions of photographers about iron and pyro development differ greatly.

Whereas the proverbial "practical" American develops almost exclusive with pyro, yet in Germany the iron-oxalate development is the predominant one.

In order to discover whether the one method of developing surpasses the other in its effects, comparative experiments should be made, and, first of all, trials with the sensitometer.

1. *Test of Sensitiveness.*—A large dry plate of my manufacture was cut up into a number of small plates of two inches square. Some of them were placed under a sensitometer of 1-16 tissue paper, about two feet distant from a benzine flame one and a half inches high, with a quarter of an inch of exposed wick, lighted ten seconds, and half of the plates developed with pyro, the others with iron oxalate.

For the pyro developer was used :

### No. 1.

Pyrogallic acid . . . . .	3	grs.
Sulphide of soda . . . . .	20	"
Water . . . . .	40	"

### No. 2.

Potash . . . . .	5	grs.
Water . . . . .	40	"

Of these fluids were used, No. 1 thirty-two minims, No. 2 one drachm, and one ounce and two drachms of water. This experiment can be simplified by mixing one part of the No. 1 solution with two parts of solution No. 2, and keeping it in a bottle for future use. This mixture keeps well, and only needs to be diluted with water in the ratio of 1 : 6, in order to give the developing fluid. Seven parts of the mixture should then be taken and diluted with water to fifty parts. An ounce and a half is sufficient for a 5 x 8 plate.

The oxalate developer should be formed, as is well known, thus: No. 1, potash-oxalate solution, 1 : 4; No. 2, iron-vitriol solution, 1 : 3, acidified with citric acid.

For development 3, Vol. 1 and Vol. 2:

The sensitometer tests, as described above, should be developed five minutes—thus long in order to produce the utmost possible effect of the light. By this it was shown that the first sign of the picture appeared, with pyro, in twenty-four seconds, with iron in four-

teen seconds. Pyro develops, therefore, more slowly than iron.

The result was that the plates developed with pyro Nos. 8 and 9 were more distinctly discernible than those developed with iron. A higher number than nine would not be observed with either of the two developing methods, that is: The pyro developer does not bring out more than the iron developer, but it brings it out in another character. One and the same plate, therefore, does not show any greater sensitiveness when developed with pyro than when developed with iron.

2. *Character Test.*—For the closer determining of character, a number of plates should be placed at a distance of one foot from a constantly burning fish-tail jet during one to six seconds under a sensitometer of layers of the finest writing paper, numbered 1-16, and exposed to the effect of gaslight. Again, half the plates were developed with pyro, the rest with iron-oxalate, and were quite legible up to No. 16. What required with iron two and a half minutes, required with pyro four minutes. Here the following distinctions were made:

Plate developed with

<i>Iron.</i>	<i>Pyro.</i>
1, 2, 3, 4, the strongly lighted parts are extraordinarily black and differ little from one another.	1, 2, 3, 4 are less dark, and are well diversified from one another.
13, 14, 15, 16, the weakly lighted parts are little covered.	13, 14, 15, 16 are covered more strongly.
Color of the negative bluish-black.	Color of negative brown.

Now, to find out which of the pictures was the more correct, two plates developed at the same time were placed upon each other, so that 1 rested upon 16, 2 upon 15, 3 upon 14, etc. These double plates were observed in transmitted light.

The following conclusions were deduced:

If two similar paper sensitometers were placed upon each other so that 1 rested upon 16, 2 upon 15, etc., and they were viewed by transmitted light, then in the first case the light has to penetrate through a thickness of paper of  $1 + 16 = 17$ , in the second case through  $2 + 15 = 17$ , etc.—*i. e.*, 17 thicknesses in all cases. Consequently, sensitometers

placed two upon each other have the same tone. If, now, two similar negatives were made from one of these sensitometers, and reproduced truthfully the light-value of the single view, then they must also, if placed upon each other in a similar way, show a uniform tone for all views.

If the emulsion works too hard—*i. e.*, shows too much light, and too little shadow, then the views 1, 2, 3, 4 become too dark, the middle tones work too bright—*i. e.*, the face of the negative placed together will be too dark on both sides and bright in the middle. But with a harmonious working emulsion, which produces sixteen different tones, nearly an equal tone will arise. The emulsion used here produced sixteen well-graduated tones, which reflected in its appearance nearly the true picture of the sensitometer.

The foregoing observations were applied to the negatives developed with iron and pyro, in order to ascertain which method produced the most faithful picture of the sensitometer, for both came near the truth. It was seen that the negatives developed with pyro, when laid one upon another, nearly the same intensity, whereas those developed with iron, in rows, those consisting of 1, 2, 3, 4, were much darker than the middle ones—*i. e.*, pyro develops the half tones truthfully, and iron develops the well-lighted parts very strongly, and gives thus too hard a negative.

3. *Practice.*—These results were put to practical proof in the studio of W. Fechner. Two pictures were made upon a dry plate directly after each other, and under exactly the same conditions. The plate was cut in two, and one-half developed with pyro and the other half with iron. With a card portrait, and exposure of four seconds, the iron negative showed a black color, appearing, by contrast with the brown pyro negative, much harder. The relation of black clothing to the flesh and to the linen appeared more harmonious in the pyro negative than in the iron. In developing with iron, the flesh appears so dark that it is difficult to distinguish the separate tones, and it becomes necessary to trust more to good luck and to one's experience than to the evidence of one's senses.

The pyro negative, on the other hand, is so diaphanous, that it is quite clear to the photographer, when he has developed enough, without losing too much of the tones of the flesh. The fixing in the pyro development lasts a little longer than in the iron; but, for that reason, the layer is firmer, because the pyrogallic possesses tanning qualities.

After the fixing, the pyro plates often show a purple-red or violet color; but this color disappears by laying the plates in a solution of alum for a few minutes.

The positives obtained verified what appeared in the negatives. The seemingly much thinner pyro negative, though covered more from the light, required a copying time of 35 minutes, while the iron negative was copied in 30 minutes.

4. *Calculation.*—An important fact to be considered in this matter is the calculation.

Take the following prices for an estimate:

Pyro . . . . .	per kilo	60.00 marks.
Sulphide of soda . . . . .	"	1.50 "
Oxalate . . . . .	"	1.50 "

So that

2 pints oxalate developer costs	0.28 marks.
2 pints pyro " "	0.21 "

The pyro developer is, therefore, 25 per cent. cheaper than the iron-oxalate developer. Accordingly (taking into consideration the results obtained and the prices) the pyro developer deserves the decided preference. However, I will not lay down my opinion as conclusive (not yet, at all events), for I intend to continue my experiments, particularly to find out whether the oxalate developer cannot be brought to the same perfection as the pyro developer.

Might I suggest that photographers join me in experimenting?—*Mittheilungen.*

## BACKGROUNDS AND ACCESSORIES: THEIR USE AND ABUSE.<sup>1</sup>

BY MRS. CLYDE EHINGER,  
Quincy, Ill.

SINCE backgrounds and accessories of such elaborate nature have come to be so extensively used in photography, there fol-

lows the necessity for the study of such laws of use, beauty, and fitness as pertain thereto.

Experience alone will not always give to the photographer that nice discrimination between truthfully artistic effects and those which at first thought seem quite appropriate and satisfy the sitter. Culture will do much, very much; but a little natural endowment is essential.

Truth, Mr. Ruskin teaches, is the first consideration in art; harmony and beauty will follow.

As the importance of finely executed backgrounds in the production of artistic photographs is so universally recognized, we must give some attention to the hand that fashions them. Our scenic artists are—many of them—mere novices, and their productions are sold cheap, because they are bad pieces of workmanship, false both in outline and perspective.

There is unlimited room at the top of the artistic ladder for the scene painter who thoroughly understands his work. It is a study requiring much thought and careful handling. If our grounds *could* be painted so they would not be so very suggestive of brush and canvas, what a boon would be conferred upon the photographic fraternity and their patrons. Trees too often look as though they had been turned at a second-rate planing mill, instead of being the product of earth, air, and sunshine; the rocks seem anything but nature's own; in fact, all lack finish and detail.

To be sure, backgrounds must not be obtrusive, but their treatment can be accurate without being too pronounced.

Look, for example, at a person standing in the woods, with trees and shrubbery all about him; when you look at the man, you see as well every tree and shrub in the line of vision, and those nearest the figure will present to the eye every detail, even though the beholder be unconscious of it. He would be conscious at once, however, if for any reason the details should become blurred or blended, as they are in a great many of our scenic backgrounds; he would quickly be aware that something was wrong, and seek an explanation of the phenomenon.

The background in a picture stands in the same relation to the camera that the trees do

<sup>1</sup> From *Mosaics*, 1887.

to the eye, in this instance; and when placed a few feet behind the sitter, a clearly cut, finely executed ground has the same effect of nature that Nature herself shows to the eye which contemplates her as a background. On the other hand, a background poorly detailed and full of inaccuracies, has the effect in a photograph of attracting the attention from the figure to the ground, to discover, if possible, where the fault lies which creates in the observer a feeling of unexplained dissatisfaction.

When the camera is focussed on the sitter, only the figure will be clearly defined, any object a few feet in the rear will of necessity be a little dimmed to the vision. If, therefore, a background is painted with blurred effects, how much more uncertain and unnatural will it appear in a photograph, where it is still more blended from the fact of its being out of focus.

The most glaring faults of the average scenic backgrounds lie in their foreground. The objects are nearly always too small; trees, especially, are diminutive and wholly lack character, both in bark and foliage; they are neither elm, oak, birch, or apple trees, so far as any of their natural characteristics are discernable. Perhaps it may seem trivial to pay attention to these matters, but a *real* artist is he who either *truthfully* imitates nature, or originates from his own mind that which represents some principle, thought, or emotion; while he who mixes the attributes of several objects of nature neither imitates nor originates.

Photography is no longer a trade; it is an art. The last few years have witnessed wonderful achievements, and the next few will not fall short in this march toward true art. And if photographers could have the aid they deserve in accurate, truthfully painted grounds and accessories, to what excellence could they not attain?

We require that our landscape artist shall give us pictures truthful to the last detail. If he is painting Venetian scenery, it must be strictly Venetian. If he is portraying a cluster of birch trees, they must be birch in contour, color, bark, and foliage, and, in some instances, even to the fibre. And his background of grass, ferns, trees, sky, or water, must be equally perfect imitations of

nature, or his picture is not true, and our critics must ever withhold the praise and acknowledgment which they accord only to the masters of art.

Photography will eventually reach the same lofty plane and become a fine art, but it must be through the strict adherence to the same laws and principles which govern the other branches of art. Therefore, until our background artists have perfected their work, we must either resort to plainer grounds, aided by *natural* accessories to complete the design, or meekly submit to the unsparing criticisms the work will call for.

The best way to remedy this evil is to demand first-class work from our scene painters, and absolutely refuse anything devoid of real merit. This will compel them to study their subject and methods of work as they should. Scene painting, of course, is an art peculiar to itself, and requires different handling from a painting which is to be viewed from a short distance; and in speaking of details, I do not refer to the minutæ of these points, in the painting of which the landscape artist spends so many weary hours, but to the exact and truthful drawing of such minor parts as shall leave no room for doubt as to what was intended to be portrayed.

Our accessories, many of them, look artificial—look “painted,” and there is equal need of improvement here, as these play quite as important a part in the photograph as the background. How often do we see a window, for instance, that looks as though it was made of paper, instead of being part of a substantially built, inhabitable abode—which impression the artist intended to convey in this piece—and we unconsciously find ourselves hoping that it will not topple over while the subject is seated in it.

Much ingenuity is being brought to bear in the construction of accessories, and many which appear in our best photographs show thought and careful workmanship, while others appear to have cost their maker neither of these qualities.

Some photographs which find their way into my hands attest that even good accessories are frequently so misplaced as to appear quite absurd; pictures which otherwise

are very fair, having proper lighting, easy posing, and with finish fully up to the average, are utterly ruined by a poor choice of accessory combinations. As an instance, I recall a cabinet photograph of a young couple whose dress suit and orange blossoms bespoke a recent wedding; the background was a forest scene, with a winding foot-path leading off into the distance. The long "matted" grass at their feet was another proof of sylvan surroundings. But the first thing which arrested my attention was the very plump, handsomely upholstered gallery chair in which the groom was seated, and I vaguely wondered what power had transported this wholesome-looking product of civilization into that rural wilderness.

Another most unfortunate piece of background absurdity which came under my notice, consisted of a single, twisted, unnatural-looking tree trunk, supposedly resting on *terra firma*, which had two equally unnatural limbs, without so much as a twig or leaf to break the severity of outline against what was undoubtedly meant for a cloudless sky. A man, neatly attired, stood in such a position that one limb of the tree appeared to have passed through the crown of his hat, the other to have grown into his shoulder. This made up the background entire. Think of it!

Still another represented a garden scene. A child was seated upon a ponderous rock, or what was intended for one; a small patch or two of grass was also visible; while, underneath all was—a carpet.

One more displayed a finely carved staircase, apparently the outer entrance of a dwelling; a huge boulder was tilted at uncomfortable angles, directly at the foot of the stairs—not at the side, where it might have figured as an ornament, but exactly in the middle, blocking the way. On this sat a frightened-looking little girl—an artistic error sufficiently preposterous to intimidate an older and wiser head.

Instances innumerable of lesser artistic sins might be cited, but these will suffice.

With the difficulty of poor backgrounds to contend with, the photographer is sometimes doubly perplexed by the sitter, who not infrequently is minus artistic culture and a true perception of photographic effects,

insisting on having a certain background or accessory brought into use, despite the operator's gentle remonstrance and quiet bringing out of other and more suitable articles.

Many people have an idea that the more pieces of furniture and knickknacks appear in the picture, the more effective it is, and this is true, but "effective" only in so far as to render it a matter for conjecture which is the accessory, the sitter or the furniture.

One great difficulty under which the average photographer labors is the expense of procuring such an array of scenic accessories, and the amount of room requisite for their storage; as an alternative, therefore, he must see that the few he considers necessary are of the best—and the best are nature's own work. For example, instead of using an upholstered chair with a forest background, take a holiday trip out into the woods, some day—photographers work hard enough to earn many such luxuries—and bring back enough wild grape-vine and suitable tree limbs to make a graceful rustic chair; then use the spare hours and construct one for gallery use. Improvise something that will take the place of those painted rocks on castors. Study nature and the pretty indoor designs which are found in one's own home, and those of the various friends, and discourage the use of all accessories which savor in the least of artificiality when seen in the photograph.

Strive to remodel imperfect backgrounds. If a first-rate scenic artist can be engaged for a few hours, he can do much to help the flatness of the average ground, even in so short a time, and the satisfaction of producing really artistic effects will more than repay the money thus expended.

### THE WORLD'S PHOTOGRAPHY FOCUSSED.

THE exhibition of the British Photographic Society was lately opened and the remarks upon it in the *Photographic News'* critique might well be applied to many of our own exhibitions. The *News* says:

"Perhaps some of our readers will be indisposed to agree with the *Times* critic, who says: 'The scientific improvements of the past few years have facilitated produc-

tion, but they have not increased either the pictorial capacities of the art itself, or the artistic powers of those who practise it.' We think that the more thoughtful of our readers will agree with this.

"When an automatic recording process like photography is in the hands of every one who desires to practise it and who is a few grades above the level of the absolutely incapable, the artistic character of the general result must be looked upon as a reflex of the general condition of art culture in the nation, and this cannot be expected to move quickly; in fact, capable authorities are at issue whether we are advancing or whether we are receding.

"The first impression is the collection is too large, the walls being crowded to so high a part as to render it difficult to see, and also crowded down to the ground. In fact, the collection would have been far better, and probably much more interesting, if it had only been half as large. The average is, perhaps, lower—and this because there are so many bad photographs; but possibly the fifty best would be, on the whole, better than the fifty best of last year."

The above remarks cover the situation very thoroughly. The mass pulls down the average. That is the office of the crowd in this world of mediocrity. The generous idea that a man is to be judged by his best work does not seem to be applied to photography. This is in part excused, however, by the haystack of poor work which must be tossed over to find the good. Yet, after all we are not sorry to have the crowd. It is better they should struggle than sit still. If they only labor they will work out their own artistic salvation. But they should not be too free in exhibiting their experiments. Remembering that to the last day of our lives we are still learners, they should not haste to show their photographic pot-hooks as specimens of calligraphy.

It is a maxim that the artist's severest critic should be himself.

Let the exhibitor filter more thoroughly, and rather send a single fine picture than half-a-dozen doubtfuls.

STELLAR PHOTOGRAPHY AT THE BRITISH ASSOCIATION.—Astronomical photography

was well represented at the British Association which has just terminated its meetings. Professor Pickering, who has made himself a name in the United States by his numerous observations, gave a description of the work being done at Harvard College in optical and photographic stellar spectroscopy. He tells us that the spectrum of ordinary stars, examined directly by the eye, or studied indirectly by the aid of photography, presents but little variation. The rare cases in which exists a deviation between the visual and the photographic result, have, therefore, a great interest, and call for explanation. The appearance of brilliant lines in the spectrum, is the most extraordinary thing which has yet been observed. All the brilliant stars, visible in the latitude of Harvard College, have been thus reproduced by photography, and only four have shown the brilliant lines referred to.

Mr. Isaac Roberts, one of the most distinguished English observers, and formerly president of the Liverpool Astronomical Society, read a very interesting paper on Stellar Photography, and exhibited to the members five plates representing a chart of sixteen degrees square, of the heavens, in the region of the constellation *Cygnus*, obtained in August last by means of a reflecting telescope (silvered mirror) of twenty inches. In these experiments, the photographic plate was exposed for fifteen minutes, which was sufficient to reproduce stars of rather weak brilliancy, the comparative size of which has not yet been determined. Stars of the ninth magnitude were reproduced faintly in one second of time. The author has compared his results with those obtained at the Observatory of Paris by the Messrs. Henry, by means of a refraction telescope of thirteen and a quarter inches. In these last, the disks of the stars are round, with a well-defined circumference, whilst the reflection telescope gave edges slightly irregular, or badly defined. In the prints of the Messrs. Henry, it is remarked that the stellar disks are all equally brilliant, whilst in those of Mr. Roberts, a well marked graduation exists between the most brilliant stars and those of lesser brilliancy. It is asserted, moreover, that the reflection telescope gives on the photographic plate a greater number of stars in



a given time. Without wishing to offer a categorical opinion for the present, on this question, we prefer the refraction telescope; but much depends on the time of exposure.—DR. PHIPSON.

THE USE OF MUSIC IN THE PHOTOGRAPHIC STUDIO.—Those photographic artists whose success in this world depends almost exclusively on successful portraiture, find it more and more difficult to obtain, at the time of exposure, an agreeable expression in the features of their customers. At the present time, when everybody, more or less, is complaining of the general bad condition of things, those persons who for some reason or another are obliged to have their pictures taken, come to the studio with sad faces and melancholic expressions, calculated to bewilder the most skilful photographers. The Spaniards and the Germans, the sternness of whose lines is the general rule, contrasting strongly with what is ordinarily observed among the French and Italians, have, particularly, much to suffer in this respect. The gravity of the Spaniard, whose features are as long as his name, disconcerted so gravely a Seville photographer that this last announces that *in future there will be music in the studio at the time of posing*; that this music will be of a light and lively character, inasmuch as the influence on the features of the sitter are truly marvellous! The idea is not a bad one, and we are reminded of an experience which justifies it.

RELATIVE SENSIBILITY OF BROMIDE AND CHLORIDE PLATES.—At the last meeting of the London Photographic Association, Mr. Cowan showed an interesting experiment touching the relative sensibility of a bromide and chloride plate. The last was found to be *thirty thousand times* less rapid than the bromide plate. The chloride plate was exposed at twelve inches from a gas jet for *eighty minutes*; the bromide plate was exposed at a distance of ninety-six inches during *ten seconds* only. In both cases the ferrous citrate developer was used. In diffused daylight the bromide plate is 25,000 times more rapid than the chloride plate.

TO PREVENT BLISTERING OF GELATINE FILMS.—Mr Wilde, of Gorlitz, says that he

has prevented blistering in gelatine films, during very hot weather, by adding chrome alum to the developer. Here is his formula:

No. 1.	
Water . . .	800 c.c. (27 fl. ozs.)
Pulverizedchrome alum . . .	20 grms. (5 drachms.)
Neutral oxalate of potash . . .	200 " (6 ozs. 3 drms.)
No. 2.	
Water . . .	450 c.c. (15 fl. ozs. 3 drms.)
Pulverizedchrome alum . . .	12 grms. (3 drachms.)
Sulphate of iron .	150 " (4 ozs. 7 drms.)
Sulphuric acid .	8 drops.

Four parts of No. 1 are mixed with one part of No. 2. The alum, it is said has no influence on the development. Mr. Cowan showed to the British Photographic Society a transparent print which, after development, had been placed for a night in a solution of chrome alum, and which had been fixed in a boiling solution of hyposulphite of soda and washed in boiling water. This print, says the publication from which we borrow this item, was *immaculate*.

### OUR PICTURE.

FROM the lovely collection of prints exhibited at the St. Louis Convention by Mr. Franz Werner, of Munich, Bavaria, we were permitted by Mr. G. Gennert, who had them in charge, to select the four Bavarian Beauties, which embellish our current number.

In attitude, lighting, and technique, it occurred to us that they were among the best which came to the exhibition from Germany. We know they will be carefully studied and appreciated by our artistic readers, and prove to be useful studies.

The makers claim that a great deal of their excellence is due to the Eagle plates which were used, sent over for the purpose. The reproductions were made from the original 11 x 14 prints by Messrs. Roberts & Fellows, Philadelphia, to whom we are also indebted for the carefully made prints. For the latter the well and favorably known N. P. A. paper, imported for us by Messrs. E. & H. T. Anthony, New York, was used.

Our December picture will be a *View from Our Office Window*.

**SUBTERRANEAN PHOTOGRAPHY.**

On October 22, 1885, part of the Chancelade Quarries, near Perigneux, France, caved in, entombing in the lower drifts five miners. As it was considered quite probable that they had been imprisoned unhurt, efforts were at once made to reach them. Attempts to dig down only increased the cave-in. Finally, those in charge had a

distance, might be let down the well, the needful light being furnished by electric lamps. Such an apparatus the ingenuity of M. Langlois, a Parisian photographer, devised. It is represented, entire and in detail, in the two cuts below, which show how well M. Langlois overcame the difficulties in his way.

The complete apparatus, as seen on the right, was contained in a metallic case, three

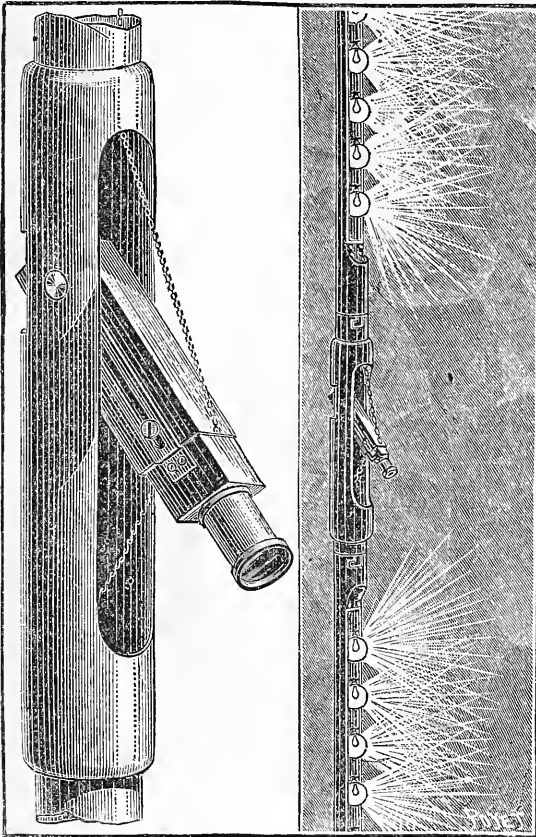

and a half inches in diameter, which was let down into the bore-hole by iron rods. By means of chains drawn at the well's mouth, the camera could be made to rise from its vertical sheath, and the whole affair to turn on its axis, so as to take views in different directions. The upper and lower parts were provided with rows of electric lamps, also lit or extinguished from above.

The dark-room was a shanty built over the boring. The apparatus was let down until it touched bottom, the camera drawn up from its sheath, and a few moments given for oscillation to subside. The little dry plates used were about two inches square. The camera, as it was in the dark, needed neither cap or shutter. The electric lamps, turned on, made the exposure, which lasted from four to five minutes. Then the apparatus was hauled up, and the plate developed. As many views as desired could, of course, be taken, and a lever

boring, twelve inches in diameter, sunk to a depth of twenty-three feet, reaching the gallery in which the miners had been. No sign, however, came from them to the watchers above. How was positive intelligence of the condition of things to be gained? It was finally suggested that a photographic apparatus, which could be worked from a

at the upper end enabled the camera to be swung through any angle.

The plates were very satisfactory. One, however, which created a sensation by bringing up the picture, apparently, of a young miner's head, in ghastly relief against the black rock, did not tell its story truly. The dead face was found merely to have

been a strongly illuminated point of rock. We are indebted to the *Scientific American* for the cuts of M. Langlois's apparatus.

(Translated for the Philadelphia Photographer.)

### TISSANDIER'S BALLOON EXPERIENCE.

A VALUABLE use for the shutter and instantaneous plate is found in balloon photography. The use of air-balloons in military reconnaissance was recommended in the year 1783 by Lieut. Meussiner, and again, in 1793, at the siege of Valenciennes; but it was the well-known aëronaut, Nadar, who took the first photographic picture from a balloon, in 1859.

In the Austro-Italian campaign of 1859, Godard and Nadar, at the command of Napoleon III., spied out the movements of the Austrians at Solferino, and brought back records of them by means of photographs taken from a balloon. The result was not distinct, and consequently not useful. In 1860, Nadar continued his experiments in this direction, and obtained better, though still unsatisfactory, results; but, unfortunately, in one of his many ascents he fell and crushed the bones of both his feet.

In 1860, King and Black attempted to take a picture of Boston from a balloon; and in 1863, a certain Negretti experimented in balloon photography in London.

It was not until the year 1878, that these experiments in balloon photography were revived by the attempt of Dagron to portray the panorama of Paris from a balloon situated 500 metres above the earth; and, in 1880, Desmarests made an attempt at a distance of 1100 metres. The

pictures of the latter are to be found in the Conservatory of Arts and Sciences in Paris.

Shadbolt, in London, and Tissandier, in Paris, from 1880 to 1885, surpassed greatly the efforts of their predecessors.

The principal difficulty in taking photographic pictures from a balloon lies in the rotating movement of the balloon, and in the shaking or trembling of the basket. The least movement of the person inside communicates itself to the balloon. Therefore, the most unfavorable time for taking a picture is in a first ascent. At the instant that the balloon rises from the earth, a rotating motion is experienced, which makes it impossible to obtain accurate pictures, even with a very short exposure. The balloon is, moreover, moved by the currents of the air in the direction of the wind. When at a height of 1000 meters, with a moderate wind of only ten or fifteen miles per hour, it is necessary to expose only one-tenth second; when 500 metres high, one-twentieth second suffices, if a tolerably accurate picture is desired.

On June 19, 1885, Tissandier undertook an aëronautic expedition for photographic purposes in his air-balloon, "Le Commandant Rivières." The amateur, J. Ducomb, manipulated the photographic apparatus, while Tissandier was busy with the

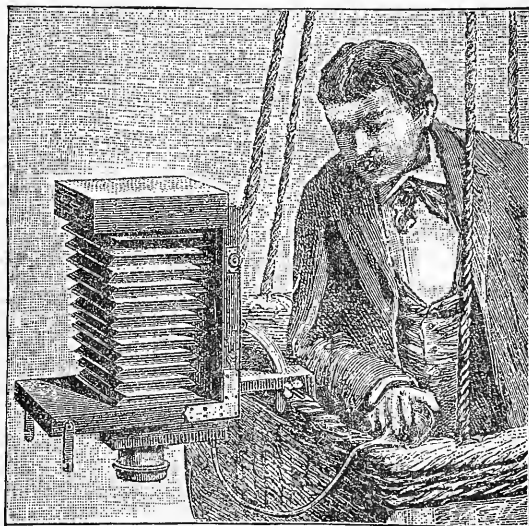

guidance of the balloon. The photographic apparatus, which was turned by an axle, consisted of a tourist's camera by Macken-stein, and was fastened to the side of the basket, as seen in the accompanying cut.

The objective was a rectilinear of François, with a focal distance of 35 mm. The instantaneous shutter, the slide of which was pneumatically released, was also François's, and the exposure with it required one-fiftieth of a second only.—*Correspondenz.*

Many of our readers will feel acquainted with M. Tissandier, through reading his admirable *History and Hand-book of Photography.*

---

### FEELING, THE LIFE OF ART.\*

BY E. K. HOUGH,  
Winston, N. C.

WHAT conscience is to religion, feeling is to art. Without conscience, religion becomes a cold mannerism, the formal doing of certain specified commands, ignoring the spirit. The kind of Christians who, as Burns says,

“Display to congregations wide,  
Religion's every grace, except the heart.”

Of such were the Pharisees of old. And there is much Phariseism in art as well as religion now. There are those who try to teach that no form of art is right except theirs. It is less than a century since all art was bound and hampered by such formalism, which declared that all forms of art must be after the Greek ideal, with Greek drapery, etc.

In deference to that spirit, the statue of Washington was made like a Greek or Roman senator; and when West dared to paint American riflemen and British soldiers in their natural uniforms, he was warned that it would ruin him as an artist. But, instead, it was the first step toward common sense and true art, which two are much nearer related than is generally supposed. West felt that it was true art to paint things as *he* saw them, and he did so, and made a new departure.

No great artist ever painted after any set of rules. True artists make rules—or, rather, the rules are deduced from their works by the critics. He was a true artist, and he did so and so; *you* must do so, they tell us; and then follow a legion of imitators, who degenerate finally into mere

formalists, without a particle of the true art feeling, until another true artist comes who does things in quite a different fashion, from whose works the critics deduce a new set of rules and lay down the law to a new set of followers.

True artistic feeling is inborn and cannot be acquired. It may be developed, encouraged, guided, but never created.

Great artists paint as they do because they *feel* that it is right. Very often, when asked, they can give no better reason than it seemed best so, they *felt* sure that was the best way. And there is no better reason. If the artist has any of the true art feeling, and is honestly guided by it, he will surely produce something valuable. All may not like it, but some surely will, and they will appreciate him, and he will have his following, his customers whom he can always please, because they like his way.

The moral is, that if photographers, in their form of art, will have the courage of their opinions, and instead of trying to apply a set of hard and fast rules, with which they are not in sympathy and don't understand, will be guided more by what they think is good, what they feel to be right, regardless of rules, we should get more diversity and originality, and less imitation and servile copyism. Try it.

---

### PHOTOGRAPHIC MOSAICS, 1887.

OUR twenty-third annual will be in the hands of the early purchaser about as soon as this is. The photographer and his help are usually so busy during the holidays that in order to secure greater usefulness for it, we issue *Mosaics* earlier than usual this year.

It is crowded with good. Among its contributors a number of new foreign names will be found—from England, Germany, France, and Italy. The editors of several of our magazines are represented; the veteran and the young operator tell us of their practice. Miss Charlotte Adams and Mrs. Ehinger (*nee* Miss Long) cheer and help us in the Art Department; Dr. Just, of Vienna, Mr. Mozart, of New York, and Mr. A. L. Dresser, the genial Secretary of the Camera Club, all contribute splendidly illustrated papers, and Mr. Ernest Edwards, President

\* Written for *Mosaics*, but received too late.

of the Photogravure Company, has made for the frontispiece an example of work from one of his own negatives, that will cause every one who looks at it to regret that "the harvest is past, the summer is ended," because they cannot go out into the open fields and equal it.

We have endeavored, for our part, to review carefully the work and growth of the past year, and to bring up the rear with a systematic selection of "Many Mites from Many Minds." Please read the advertisement.

No one need deny himself *Mosaics*, 1887, for want of a postal note. Two-cent or one-cent postage stamps to the amount of fifty cents, will cause us to mail a copy promptly.

## HAS PHOTOGRAPHY "GONE DOWN?"\*

BY A RATIONAL OBSERVER.

Is photography *really* so degraded, so down in the dust, as some of the pessimistic croakers would make us believe? Not a bit of it—any more than hardware is.

Ten years ago there was a big change in the hardware business. The manufacture of pig iron was so improved that any tasteful moulder could open a foundry, and from a "ton of pig" turn out enough tiny articles of hardware to bring him a hundred dollars. Such small shops starting up all over the country, set the manufacturers to thinking. With high rents, and expensive labor, they could not compete. Did they get down and howl? No! But putting their brains to work, and hiring even more skilled labor, they tried the decoration dodge—*i. e.*, the match-safes, and boot-jack, and turn-buckles, and scissor-handles, were all produced in new and really pretty designs. They *charged* for this, and beat their competitors, who could not reach them. The public taste for "pretty things" was catered to, and it was a strike. "*Style*" won. A hundred were sold where ten were previously asked for. Prices were lower, but the demand was greater. It is so in a hundred trades. Even the pickle-bottle is improved in style, and "parlor-

paste" comes with a label worthy of being placed among your oriental bric-a-brac.

*Every one* must do more to get a dollar than he did ten years ago. Why should we expect photography to be an exception? Improve your style, and improve your business. Photography gone down? Humpf!

## A GOOD TRAY.\*

BY C. L. JUDD.

DISHES of a good many kinds are in use for photographic purposes, but the following is so good, clean, and cheap, that I think it worthy of publication:

Take good dry thin boards, and make the dishes of any desired size or shape; it is not necessary that the joints should even be tight. Next lay over the dish a piece of unbleached cotton cloth, and with a hot laundry iron spread the cloth over the inside of the dish with melted beeswax, folding in the corners, and running the wax thoroughly into the cloth and wood. Run a sharp knife around the edge of the dish, cutting off the extra cloth, and fasten down the edges with the melted wax.

Give the outside of the dish a coat of boiled linseed oil, and one or two coats of asphaltum, varnish to keep out the water, and you have a dish that will last for years. Should the wax get thin, or wear off in spots, melt a little more on with the hot iron, and the dish is as good as new. The wax, applied in this manner, fastens the cloth to the wood very firmly, and strengthens the same so that it may be made very light, and, of course, bees-wax is proof against most of the chemicals used in photography, is easily kept clean, and is so cheap that a man can afford to have good dishes for all sizes and kinds of his work.

Although not entirely original, I have never seen the above idea in print, and hope it may be of as much benefit to others as it has been to me.

At Baltimore, on October 11th, the new Camera Club was inaugurated under promising auspices. There is also a new Camera Club at Portland, Oregon. We wish both success.

\* Written for *Mosaics*, but received too late.

\* Written for *Mosaics*, but received too late.

**SOME ANIMAL PHOTOGRAPHS.**

THE subject of animal photography does not receive much attention from the ordinary photographer. An occasional four-

splendid things may be made. One good picture will draw other opportunities, and bring an honest penny, very welcome in these times, to the clever photographer. We have seen some real gems of our

FIG. 1.

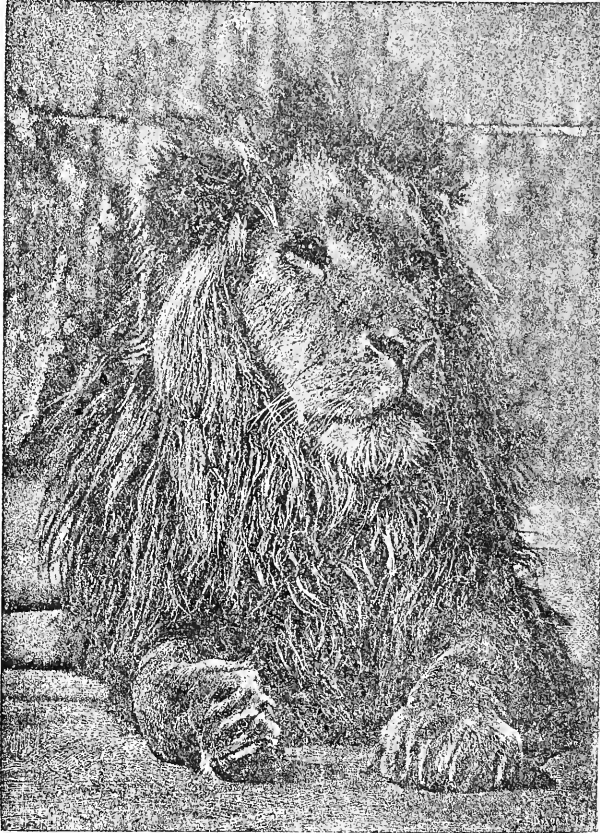

legged idol, some precious pug, or pampered puss strays into the gallery, under the influence of its admiring owner. The artist isn't sure it is not rather *infra dignitate* to be called on to take the pet, but he spreads a cloth on his table, the subject is set thereon, and his quickest plate does the rest under a running fire of admonition from the subject's companion.

Yet animal photography offers some magnificent artistic results. Many artists find its studies invaluable in their work; and, even where its range is limited, some

common farm-yard animals, and a splendid dog is inspiration for anyone. We need not go further for an example than to the mid-August issue of our magazine, where the faithful eyes of Mr. Abell's setter look out from the frontispiece.

The subject receives a good deal more of attention in Europe than here. There the court photographer, Uhlenluth, of Coburg, has taken some very fine animal photographs of deer, pheasants, turkeys, etc. So, also, Boissonas, of Geneva, who has shown some splendid pictures of lions, giraffes

elephants, etc. Among his best-known pictures are those of "Miss Cora," a rather famous young woman who "goes into the lion's den" and does wonderful things with the inhabitants. The cuts herewith are re-

some animal paintings by a German artist. Here we have our own Beard and Church, both painting the mute creation, with very dissimilar treatment, yet much common sympathy.

FIG. 2.

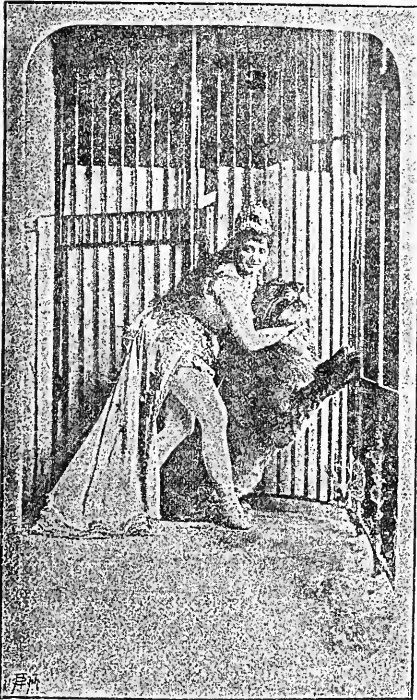

FIG. 3.



productions from photographs by M. Boissonas, showing her at home among her lions, and making a tiger display the expressiveness of his countenance.

Long ago, in 1870, Ruskin called the attention of English painters to the splendid field offered them in animal portraiture, and exhorted them to enter it. He suggested that the only animals that had been at all generally painted, the worked-to-death stag, dog, and horse, be given a holiday, and their wilder fellows be attempted for a change. His exhortations were acted upon by several artists, and helped to bring about the somewhat better state of things that now exists among artists. A recent number of the *London Art Journal* contained, as its leading article, a finely illustrated account of

Let our photographers try, in their humbler way, what they can do. The field is large, open, and inviting.

### THE BLAIR CAMERA CO.

WHILE in Boston, a short time ago, it was our fortune to be able to inspect the establishment of the Blair Camera Co. We were led by the able manager, Mr. T. H. Blair, from the salesroom to the finishing-room, and found much to interest us. The new lucidograph particularly pleased us. Few camera-users think, when using their nicely fitted, strongly made, and light apparatus, what labor and skill are required to prepare and put together the many tiny pieces which compose it, or consider the importance of

having every part of wood well seasoned and guaranteed against warping and splitting at some unforeseen moment. As we went through the works we witnessed "stacks" of camera parts filled up in the different stages of finish.

The busy, clean-cutting saws; the enterprising planers; the brass-workers; the bellows-makers, where "Sarah" presides; and the polishers, not to mention the deft artisans who combined the various parts, all "worked together for good," for, as many of our readers know, the apparatus of the Blair Camera Co. has long stood among "the best."

And yet there was no large quantity of it stored here. It is ordered before it is done, and there has been difficulty in meeting the demand.

More expert workmen have become skilled in their departments, however, and the works enlarged; so, it is believed, there will no longer be any complaint.

Moreover, in order that greater opportunity may be given buyers to see the apparatus before purchasing, arrangements have been made for placing a variety of goods at several points, as follows: With George R. Angell, Detroit; Messrs. Reimers & Katz, Milwaukee; and Mr. W. T. Gregg, 318 Broadway, New York. At the latter place a wholesale stock is also arranged, under the care of Mr. E. C. Blair, who, for several years, has had charge of the shipping department at the Boston factory. These, in addition to Messrs. Blair & Prince, Cincinnati, and the Boston headquarters, should make things hum like the clear, smooth-cutting "buzz" saws of the Blair Camera Co.

### ARE "PERMANENT BROMIDE PRINTS" PERMANENT?

PERSONALLY, we never question this. When a house of such strict integrity as the Eastman Dry Plate and Film Company makes an assertion, we feel free to accept it, especially when we personally know how on one or two occasions they have held back from announcing certain articles now in great use, until they were *sure* they were all they desired to claim for them.

Much as we regret it, however, we cannot

place any confidence in the permanency of any of the work of a careless, "slouch" photographer who is too indifferent to wash the deleterious chemicals from it, including his "permanent bromide" prints.

The question has been raised, however, and it is our duty to place the matter rightly before our readers.

In England, the Autotype Company, printers of carbon prints, have asserted that bromide paper prints are fugitive; of course, such an assertion is "business" for them. But they must acknowledge, as all will, that their attacks fall futile to the ground when such testimony against them appears as the letter of Messrs. Morgan & Kidd, in the *British Journal of Photography* of October 8th. These gentlemen have for a long time made *permanent* bromide prints. We quote from their letter, viz.:

"GENTLEMEN.—We have had our attention called from time to time to strong and scarcely fair attacks made on the argentic gelatino-bromide process in *Autotype Notes*, a trade circular issued by the Autotype Company to their patrons. This circular is presumably distributed chiefly amongst customers of the Company, and, therefore, enjoys a somewhat restricted circulation, since, on their own admission, 'Autotype printing has not found favor with the general body of the photographic profession.' And as unless the 'noble exceptions to this rule' are more credulous than the generality of photographers, such unfair and interested disparagement is not likely to seriously injure the process of which we were the originators, we did not think it necessary to give the matter much attention. That the Company should take every means in their power to retain their trade, is natural, and some license may be allowed them for that purpose; but no doubt their readers will recognize the unfairness of *privately* circulating hostile assertions unsupported by any solid evidence.

"Many theories are better aired, if they must be aired, in public, where absurdities can be sooner corrected. We were, therefore, glad to see the controversy promoted to a place in your columns, especially as the responsibility of publicity might be expected to constrain to a little fairness.

"But those who counted on a too scrupu-



lous nicety should be disappointed, certainly, after they have read the first paragraphs of the Autotype Company's letter in your last issue, and note the attempt to force a parallel between the argentic gelatino-bromide process and albumenized silver paper, and the artifice by which this ill-sorted couple are harnessed together. The poor bromide process is hustled into bad company, and for its very light touch of the pitch is defiled indeed.

"And why should the Autotype Company go so far afield for a bad parallel, when an obvious and better lies so ready at hand. Here is a closer comparison, possibly less to their taste—an ordinary dry plate. We do not know that there is any great apprehension amongst photographers that a properly washed and manipulated negative will fade, and what is a bromide print but the same article on a different base? Paper—a material not even disdained of autotype.

"And now let us turn from strained analogies to actual experience. It must be remembered that, although it may be held that sufficient time has not yet elapsed to test the permanency of bromide enlargements fully and finally, it is now six years since we have made bromide prints commercially, and they had been made experimentally many years before. We are ourselves responsible for a large proportion of the very great number of these prints in existence, we have had most exceptional opportunities of watching their behavior under all manner of trying conditions, and in many where a silver print could not have lasted a month, and we have never in the whole course of our experience found a case of actual fading of the image. Prints carelessly washed, or insufficiently fixed, we have seen turn yellow in time, but prints by any process may be ruined by bad manipulation, not excepting autotype. We have also often heard prints blamed when the paper only on which they were made was discolored by exposure.

"How easily paper loses its purity when exposed to the action of strong light, or in time to the atmosphere, can easily be seen by exposing a sheet of the best and whitest note or packing paper to strong light, and examining it in a few weeks' time, and may cause a little surprise. We have known

prints to be hastily accused of instability on the evidence of a slight tinge of yellow being detected, when the paper beneath them has been slightly discolored by time. The discoloration of the raw paper beneath the image is a trouble with all photographs on a paper support, and as bad examples of it can be found in autotype enlargements as in those by any other process.

"That the paper discolors and not the film is amply proved by the fact that no case of discoloration of bromide enlargements on opal, that have been properly fixed, has been known.

"By the concluding paragraph of the Autotype Company's letter in your last issue we expected that we were at least to be confounded by an unmistakable and shocking example of the instability of our process. We were eager, though somewhat sceptical, and hastened to claim your courtesy, gentlemen, to be allowed to examine these prodigies. But it was not an altogether unexpected disappointment when we found them simply examples of the discoloration of the raw paper enhanced by contrast with parts shielded from light and remaining pure—a rather meagre result for elaborate and hostile tests, and a phenomenon they might easily have produced in their own autotypes instead of going to the expense of obtaining bromide prints for the purpose. We repeat, we have yet to see our first example of the actual fading of the image of a bromide print.

"That the test of time only can put the question wholly beyond dispute for bromide as well as autotype we agree, and can afford to await its judgment with equanimity. But the test of time suits a drowning man ill, and he must needs clutch at the straws nearest at hand, and here the most seductive straw is the want of permanency of bromide prints, and we imagine the Autotype Company will find this as unsubstantial a straw as need be.

"We remain, yours, etc.,  
MORGAN & KIDD."

---

### TALCOTT'S METHOD OF MOUNTING AND FINISHING.

Two fond dreams keep alive the spirits of the earnest photographer. One is that

some day he may look his patron in the face, and declare without a qualm that his work is permanent, and the other that some method may some day come that will reproduce in his prints all the loveliness of detail, softness, and half-tone which his artistic eye may discover in his negative. While he has been working to this end—living on these hopes, a gentleman and lady in Boston, who are not photographers at all, but invalids in fact, with the artistic sense within them, have, together, perfected a method which promises to bring about a very practical realization of the artist's dream.

We allude to the Talcott method of mounting and finishing. So far as we can see, a strong, rich print is first sealed to a sheet of thick plate glass with a wide bevelled edge, so that no air or moisture whatever can come between. A strong binding of leather follows, a heavy backing of prepared card being included. In this card fastenings are set of such form as to make it impossible to remove them, and of such strength as to bear three or four hundred pounds. A removable metallic rest is also attached, thus enabling the happy owner of the picture to hang it upon the wall, or stand it upon the mantel, easel, or table. No frame is needed. No white margin is left upon the picture.

The effect, then, is most beautiful and artistic. Whatever compound is used brings out the full tone and color of the print, softly, and giving every possible detail.

We have at our hand prints varying in subject from statuary, of boudoir size, to a life-size head of a child on a 16 x 20 plate. We do not see how any reasonable person—any æsthetic dreamer—could expect anything more perfect. Surely here is a means placed in the hands of our fraternity for securing to their patrons choice works of their art, freed from the suspicion of being fugitive, and altogether unique.

The inventors speak for their cause in their advertisement in this issue, and modestly too. They offer a liberal share to the trade, and should be well patronized.

Those who first introduce the novelty will be the first to reap the reward.

It has one *great* advantage which should not be overlooked. It never can become a "*cheap*" picture.

## AN EASY WAY TO MAKE PORTRAITS IN OIL.\*

BY JAMES INGLIS.

In the days of wet plates I used to make a positive enlargement, tone it with gold, and when dry give it a coating of gelatine (this was to give a foundation to work on), allow the gelatine to dry, then paint on this gelatine surface, observing the progress of the work from the face side through the glass. With but very little skill in coloring, a very nice portrait can be made, and in a very short time. Should it be wanted to finish as ink work, in black and white, grind the surface of the gelatine as you would a negative for retouching, and with a pencil sharpen up the picture; by using the stamp and crayon the border shades can be strengthened, and a strong, bold, and vigorous picture is easily made. After the work of pencilling and crayoning is done, it will be necessary to run the plate over steam just sufficient to open the gelatine enough to fasten the pencil and crayon work for the subsequent treatment, otherwise it might be washed off in the mounting. To mount it, wet a sheet of albumen paper, or any other kind; if not albumen, then give it a slight coating of gelatine; flood the picture with water, and lay on the paper; squeegee it into good contact, then mount it finally with a cardboard, just in the same way it has been done with the paper; set it aside to dry, and then strip it from the glass, and you will have a highly finished portrait, either in color or black and white, as you prefer.

It might be said that all this is out of date; to a great extent it is; but I don't see any reason why dry plates may not be made for this purpose as well, and even to much better advantage than the wet were. The plate would necessarily require to be one giving quite a thin image, so that the color would show fairly well through it. There would be no toning required, as the plate developed with oxalate would give a good color at once to work on. The plates, of course, would have to be stripped.

In these days, when everyone is racking

\* Written for *Mosaics*, but received too late.

his brain how to increase his business, I offer these suggestions as a means to this end, especially for the photographer who does not do enough of colored work to engage an artist. Paper might be made to do the same as the plate, by the double transfer process.

### TO WATER-TIGHT YOUR TANKS.\*

BY X. Y. Z.

PHOTOGRAPHERS who are away up and must depend upon roof-tanks for their water-supply, and who are in constant dread lest their washing-tanks leak and ruin the tenants below, will find the hints below useful to them—if applied:

Paint thickly on the inside with a mixture composed of eight parts of melted glue and four parts of linseed oil boiled with litharge. In forty-eight hours the application will have hardened, so that the cistern or tank can be filled with water.

The boiling of the linseed oil with the litharge (of which about 30 parts are neces-

\* Written for *Mosaics*, but received too late.

sary for every 1,000 parts of the oil) has for its object to render the linseed oil more rapidly drying. In fact, it makes it what is generally called and sold by the druggists as "boiled linseed oil." "Melted glue" means glue that has been soaked first in cold water, then drained, and afterward melted. It is impossible to melt dry glue by heat. If this is attempted, the glue will turn to whitish bean-like lumps, caused by a sudden dissipation of excess of moisture, and afterward will become dark colored, give out offensive odors, and burn.

The glue having been soaked and melted, should then be raised to a temperature considerably above the boiling point of water, care being, however, taken that it does not become burned. When quite hot, the boiled oil is stirred in, and in a few minutes afterward the mixture will be ready for application. It must be kept hot, since it becomes solid and tough as it cools. I have tried it on pasteboard boxes, and have found it to make them water-tight.

I am indebted for the wrinkle to an old magazine.

## Editor's Table.

OUR good friend, Mr. H. McMICHAEL, of Buffalo, has kindly sent us some splendid 16 x 24 heads and full-length photographs. Some of our readers are already familiar with them, as they were at the St. Louis Convention. The quality of Mr. McMICHAEL's work is well known, and some of these examples of it are nothing less than superb. One head of an old lady in a Quaker cap is a study for an artist, with its splendid lighting and the wonderful textures of lace and silk, subordinate to, yet accenting the fine old face, unspoiled by the retoucher. This is the day of large work, and these pictures show that their artist has come to it with rare knowledge and skill, insuring marked success.

FROM BUCHANAN, SMEDLEY & BROMLEY, the enterprising stockdealers of Philadelphia, comes a red-inked circular, with edges torn and stained, emblematic of the effect of the fire that lately burnt them out. They have wasted no time in rising from their ashes. The day after the fire they opened temporary offices with an increased

force, and went right on with business. Now the carpenters have finished their new building at 1030 Arch Street, which they propose to make the most complete and the most attractive stockhouse in America. "A Palace Stockhouse" they mean to have it. We hope that, as indeed it seems, their late misfortune will only prove a stimulus to their energy, and that they will come out of it farther on their way to success. Their customers need have no fear of delay in their orders, for the new place is already in the best of running order.

PICTURES RECEIVED.—Mr. J. L. GRISWOLD, of Lyme, Conn., sends us a bright sunny picture of four small boys on top of a rock. Mr. J. A. PATTERSON, of Pulaski, Tenn., sends us a very successful moonlight view of a house taken with five hours' exposure on an Eagle plate. Miss A. A. MEAD, of Kingman, Kan., sends a pleasant arrangement of a lace curtain and a cat. Messrs. BALDWIN & SON, of Wichita, Kan., send a number of pictures very remarkable for their correct drawing, the perspective in a long

iron bridge being quite unequalled by anything we have lately seen. Views away under shrubbery and among trees, and many-buttressed houses are caught and held with an evenness and regularity that are marvellous. The lens used was a Beck 4 x 5, rapid. Mr. S. Y. RICHARDS, Danville, Pa., sends some cabinets with dark background. The relief and accentuation of the head secured by this make it seem strange that it is not more often used. Mr. A. J. LE BRETON, of San Francisco, sends some views, one of an old mission being very picturesque. From Mr. E. LONG, Quincy, Ill., come some interesting stereoscopic views of that pleasant town.

Those who appreciate the picturesque ideas of Mr. C. M. FRENCH will be glad to learn that he has ready a new series of foregrounds. An open circle for the head is surrounded by daisies, apple blossoms, butterflies, and similar accessories, giving very novel effects.

MR. J. P. CHEYNEY, of 636 Arch Street, Philadelphia, has lately refitted his store, and is now on the first floor of his building, with a large and varied stock of photographers' supplies, which we recommend to the attention of the fraternity.

MR. BENJAMIN FRENCH, of Boston, was caught by us a few days ago at his Boston office, examining fondly a new lot of Voigtländer Portrait Eurycope Lenses. He finds it impossible to meet the demand, since the coming supply is always sold before the arrival of the invoices. The No. 5a P. E. is capital for a short studio, for it will make a three-quarter or full-figure panel size; a large head and a cabinet *quick*. It will do more than a 4 x 4 portrait and a No. 4 eurycope put together, therefore it supplies the place of two lenses, and at much less cost. Mr. FRENCH knows more of the good points of the new eurycope than anyone living, and he likes to explain them.

THE SCOVILL MANUFACTURING Co. issue circulars of the new Waterbury Dry-plate Holder and of Scovill's Universal Safety Shutter, which can be arranged with a variety of openings. These are two great conveniences, concerning which your own dealer can give you object lessons.

THE Argentic Dry Plates for positives have met with a cordial reception, as they did before. They are pretty generally distributed among

the dealers now, and there should be no more difficulty in getting them or in working them. They will prove a great convenience to the amateur and a good business bringer to the practical artist. Every plate is guaranteed perfect.

MR. J. BAECKER, who advertises for a situation in our current issue, embodies a good deal of talent in his make up, and would prove a valuable adjunct to a studio frequented by people who speak many tongues and like good work.

MR. EDWARD ANTHONY returned to his desk at 591 Broadway a few weeks ago, completely rejuvenated by his summer residence at his villa at Alexandria Bay. All of his numberless friends will be glad to know this, for they value his friendship and his usefulness. At an interview with him we found him as full of vim, brightness, and hope as ten years ago.

WHEN the Photographic Section of the American Institute collated at Fort Lee a few weeks ago, Dr. OSCAR G. MASON made some admirable negatives of groups of the pioneers. Among others we recognize portraits of rare excellence of MESSRS. VANDERWEYDE, BECKER, NEWTON, GARDNER, GARDEN, JANEWAY, ESTABROOKE, LAUDY, ELLIOTT, and others which will be of great value to posterity as historical likenesses. All are hard workers yet.

WE went over the other day to interview Mr. G. G. ROCKWOOD, who has just come back from Europe. Up to his ears in work we found him, and had to set down behind his screen and talk to him between times. He said his trip had done him good in every way. Commenting on his observations of the photographers on the other side, he remarked that he was surprised at their conservatism. "I was astonished," he said, "to go into some of the largest galleries in Europe and find that they were working about as we worked here ten or fifteen years ago. In Berlin, Munich, Dresden, Vienna, I found in almost all the establishments the same condition of things. They do not rush sitters through in the style they follow in our club galleries, but they grind the portraits out in the same style, only with more deliberation. Little attention is paid to the individual peculiarities of the sitter. I believe that one should diagnose the physical form and temperament of his client, like a physician. But there was a steady uniformity about everything."

Here an interruption came from the other side of the screen, and Mr. Rockwood hurried off. One secret of his success is his consistent carrying out of this principle—giving the same care and attention to the serving maid that he does to the President's wife, both of whom he once had in his chair in the course of a single half hour.

He said that the portraits he saw were as a rule chemically good but poor artistically. In landscape and composition photography, however, they were vastly better; the work of Mr. STURCLIFFE he mentioned especially. He told of an English amateur whom he met on the Rigi, to whom in conversation he gave some hints on stops, selection of the views, etc. "Do you American professionals talk that way to amateurs who ask your advice?" asked the Englishman. Mr. Rockwood said yes, of course. Said the other "You would have to apply a corkscrew to get such hints from English professionals, and you would have to fasten a guinea on the bottom of the cork."

WE are pleased to announce that Mr. T. C. HEPWORTH, Editor of *The Camera*, will give the latest news from London to the readers of the PHILADELPHIA PHOTOGRAPHER for 1887. As our London correspondent he will doubtless prove as progressive and interesting as he is in his own journal. In order to give our readers a foretaste of the good things to come we have persuaded Mr. HEPWORTH to begin his letters at once, and the first of them appears in this number. Photography is growing fast across the water, and there will, without doubt, be many things to tell.

PROF. KARL KLAUSER, of Farmington, Conn., kindly writes a few words of praise: "Your speedy reproduction of the Chevreul pictures," he says, "does you great credit. They are the most wonderful feat of instantaneous photography on record. The PHILADELPHIA PHOTOGRAPHER still seems to walk in seven-league boots."

It gives us much pleasure to announce that Miss CHARLOTTE ADAMS, whose art criticisms have been so valuable to our readers, has been chosen as the American editor of the *Magazine of Art*. We heartily congratulate her on her well-deserved elevation.

MR. G. GENNERT has returned from Braunschweig, where he did, as is his constant en-

deavor, good work for American photographers. He is the better for his trip, and comes back in good trim for his fall and winter work. The fraternity will be the better of it, too, by many new things. He says that the prizes awarded at the German Convention are now in the Custom House. We will by and by have more to say about these.

MR. GEORGE HANMER CROUGHTON, whose art papers have made him known and appreciated by the readers of our magazine, has been engaged by the EASTMAN DRY-PLATE AND FILM Co. as the head of their enlarging department. Mr. CROUGHTON is thoroughly fitted for his work. He is an artist not only in feeling but practice, and knows photography in every detail, from the cleaning of a plate to the finishing of a portrait. We must congratulate both Mr. CROUGHTON and the Eastman Co. on what must prove a happy and prosperous alliance.

MR. W. H. BIGALOW, who is a travelling photographer during the summer season, writes for his numbers, and says: "I expect many delightful hours in perusal of my back numbers." And Mr. S. Y. RICHARDS, of Danville, Pa., writes: "Your welcome journal comes to our place, and all enjoy its benefits." That means all, from the glass-cleaner to the retoucher and operators, for we have a word for each.

EVERYBODY knows what "N. G." means. It might very appropriately be stamped in place of a trademark on many of the interesting novelties that are rushed out upon photographers, but as a pleasing example of quite the opposite thing is the new brand of pyro imported by Mr. G. GENNERT. It is marked "G. G.," which may well stand for great good, for it is a thoroughly reliable and even article. Its novel box, with its ends of tin and its chocolate-colored label, will no doubt soon be a familiar friend of the craft, to whom we commend it.

GIBON'S cut-outs have become indispensable to the printing-room. The manufacturers, Messrs. ROBERTS & FELLOWS, 1125 Chestnut Street, Philadelphia, have just placed upon the market several new patterns—the Maltese cross, the keystone, the crescent, the palette, the arch, etc., all of which are now included in the regular package of thirty sold for one dollar. They are well and cleanly cut, and will prove a new help in ornamental and tasteful printing.

"ONE OF THEM" has done a timely and thoughtful thing in writing his letter—"Your Dealer"—printed in this number. The photographer who complains may be brought by it to a sense of the fact that it isn't all on his side, and that the dealer has his grievances and difficulties also. Mr. SMITH's sensible letter ought to help both to more sympathetic relations.

MESSRS. LOEBER BROS, 119 & 121 Nassau Street, New York, have shown us a very ingenious combination camera and plate-holder. It is very compact and carefully made, and so light as to please the most tried. Twelve exposures may be made without any change. The plate first exposed may be quickly turned into a receiving case and another made to take its place by the same motion. In fact the plate that has "fired" steps to the rear, and another advances ready for "a shot." It has an "indicator," so there can be no mistake.

SUCH a trio of testimonials as appears below, sent us by Messrs. ALLEN BROS., should convince anyone of the excellences of the Suter Lens. But what can we add when the studio workers speak so strongly and with such exact focus? Read:

UPPER SANDUSKY, O., Sept. 4, 1886.

MESSRS. ALLEN BROS.

GENTS: The No. 5 B Suter is indeed very fine. I am fully satisfied that I could find no superior, and doubt if I could find its equal.

MR. JOHN HODGES, of Paw-paw, Mich., says: "The 6 B Suter is a little giant; the most wonderful instrument that I have ever seen."

CHARLOTTETOWN, PRINCE EDWARD ISLAND,  
September 26, 1886.

MESSRS. ALLEN BROS.

GENTLEMEN: Having tried the No. 6 B Suter Lens you sent, it is to my entire satisfaction. For groups and large heads it is splendid, having a flat field and great depth of focus. It works much quicker than I expected it would. I will keep it, and you can draw on me for amount of bill.

Yours truly,

THOMAS COOK.

THE firm of N. C. THAYER & Co., 257 & 259 State Street, Chicago, has been incorporated with the following officers:

*President and Treasurer.*—N. C. Thayer.

*Vice-President.*—Henry G. Thompson.

*Secretary.*—W. T. Jones.

Everybody knows Mr. THAYER, and nearly the entire trade of the West knows Mr. H. G.

THOMPSON, formerly of the firm of DOUGLASS, THOMPSON & Co., whom we are sure will welcome his many friends at his new quarters, and serve well and faithfully all the newcomers.

THE new ground-glass transparency plate of Mr. JOHN CARBUTT will prove a great boon to the makers and lovers of that most lovely product of the negative, the glass positive. Finely ground glass is coated with CARBUTT'S transparency emulsion, and thus the trouble of getting good ground-glass for the backing and the non-reversal of the subject are both overcome. An example before us is a most artistic landscape—"The Artist at Work," by Mr. W. D. H. WILSON, of WILSON, HOOD & Co., Philadelphia, and is 4 x 4 size. It was enlarged from a one-quarter size negative, and is *perfect* in every sense. When such marvels of excellence as this can be produced with such little labor and expense, one may well say that photography has been "made easy." The choice of subject in this case also proves Mr. WILSON to be a true artist in feeling. Now comes the season for transparency making.

A TIMELY SUGGESTION.

BUFFALO, October 27, 1886.

EDITOR PHILADELPHIA PHOTOGRAPHER.

MY DEAR SIR: Until my attention was called by the editor of the *Bulletin*, I was not aware that there was a committee appointed to revise the Constitution and By-laws of the P. A. of A. On examining the stenographic report I find the names of the following gentlemen appointed on that committee by President POTTER: Messrs. G. CRAMER, Dry-plate Man., St. Louis; GAYTON A. DOUGLASS, Photo. Stockdealer, Chicago; RANGER, Man. Burnishers, Syracuse; H. M. BELLSMITH, Rep. Eastman Dry-plate and Film Co., Rochester; C. GENTILE, Editor *Photographic Eye*, Chicago; J. LANDY, Photographer, Cincinnati; G. M. CARLISLE, Providence; and BRAND, Photographer, Chicago. Since it is so nearly in the hands of the dealer, why not change the name and call it the Man. and Dealers' Photographic Association of America?

To even it up, I think Mr. DAVID TUCKER, President of Merchants' Board of Trade, should appoint a committee of photographers to arrange their business, which might be of inestimable value to the photographer.

Very truly yours,

H. C. McMICHAEL.

# Specialties.

## ADVERTISING RATES FOR SPECIALTIES.

25 cents for each line, seven words to a line—in advance. *Operators desiring situations, no charge.* Matter must be received a week before issue to *secure* insertion. Advertisers will please not ask us for recommendations. We cannot undertake to mail answers to parties who advertise. Please always add your address to the advertisement. **Postage-stamps taken.**

**MAKE OUT YOUR OWN BILL**, and remit cash with your advertisements, or they will not be inserted.

### HOLD!

With but one exception our sales at St. Louis were larger than at any previous convention. Having but just completed the Convention orders, we are now ready for the fall trade, and invite attention to our popular and attractive novelties and specialties.

### RICH HOME INTERIORS.

QUAINT DESIGNS, ESPECIALLY FOR CHILDREN.

USEFUL AND REALISTIC ACCESSORIES

AT

PARTICULARLY CLOSE PRICES.

THE LARGEST LINE OF BACKGROUNDS  
IN THE WORLD.

Correspondence solicited. Samples to the profession. LAFAYETTE W. SEAVEY,

Studio 216 E. 9th St.,  
New York.

A first-class gallery on Broadway for sale. Good business. *For cash only.* For particulars address F. H.,

226 E. Fifteenth St.,  
New York.

SECOND CHOICE.

DOUBLE ALBUMEN PAPER.

Extremely cheap. Samples sent.

W. HEUERMANN,

49 CEDAR STREET, NEW YORK.

WANTED.—A strictly first-class retoucher. Will pay \$20 per week. Send samples with photograph of self. Must work large negatives elegantly. Address 2220 Indiana Avenue, Chicago, Ill.

FOR SALE.—An excellent opportunity for a good photographer to purchase the leading gallery in a city of 60,000. Address,

Gallery,  
Care of GEO. MURPHY,  
250 Mercer St., N. Y.

## DOWN SHE GOES!

NEW PRICE-LIST

OF THE

ROCKWOOD SOLAR PRINTING CO.

17 UNION SQUARE NEW YORK.

Size.	Unmounted.	Mounted.
11 x 14.....	\$1 00	\$1 25
13 x 16.....	1 00	1 25
14 x 17.....	1 00	1 25
16 x 20.....	1 00	1 25
18 x 22.....	1 20	1 50
20 x 24.....	1 35	1 50
22 x 27.....	1 40	1 90
25 x 30.....	1 40	1 90
27 x 32.....	2 25	3 00
29 x 36.....	3 00	4 00
30 x 40.....	4 00	5 00

No charge for negatives. All orders must be accompanied by the cash. Make all P. O. orders payable to ROCKWOOD SOLAR PRINTING Co., 17 Union Square, New York.

PRINTING AND TONING FOR AMATEURS  
A SPECIALTY.

PLATES DEVELOPED.

Try our freshly made photographers' paper. Made fresh daily, and fumed ready for use. 25 cents per sheet, 18 x 22, cut any size, and sent by mail without extra charge.

Our Concentrated Toning Solution is pronounced the *best* by *all* who have used it. Price, seventy-five cents.

Photographic supplies of all kinds. Largest variety of stock in the city. Send for catalogue.

LOEBER BROS.,  
119 & 121 Nassau St.,  
New York.

SPECIAL OFFER FOR THIRTY DAYS.

Upon receipt of \$2.00 cash, with order, I will send one of my Automatic Retouchers on fifteen days' trial; balance of \$5.00 not to be paid unless satisfactory.

E. A. GILBERT,  
Jamestown, N. Y.

WANTED.—To rent photograph gallery furnished, in an usually good location. No postals.

Address LINK & LEWIS,  
Easton, Md.

TREASURY DEPARTMENT,  
OFFICE OF THE LIGHTHOUSE BOARD.  
WASHINGTON, October 18, 1886.

To PHOTOGRAPHERS.—Sealed proposals will be received at this office until 2 o'clock on Saturday, the 13th day of November, 1886, for printing and mounting six hundred copies (more or less) photographic views of light-stations. Specifications and blank forms for proposals can be obtained on application at this office. The right is reserved to reject any or all bids, and to waive any defects.

S. C. ROWAN,  
Vice-Admiral U. S. N., Chairman.

Gilbert's Metal Retouching Pencils, in two grades, 25 cents each. For sale by dealers or by  
E. A. GILBERT,  
Jamestown, N. Y.

**THE LIGHT RUNNING**

**NEW**

**STRONG**

**HOME**

**SWIFT**

**SURE**

**SEWING MACHINE**

**HAS NO EQUAL.**

**PERFECT SATISFACTION**

**New Home Sewing Machine Co.**

**—ORANGE, MASS.—**

30 Union Square, N. Y. Chicago, Ill. St. Louis, Mo.  
Atlanta, Ga. Dallas, Tex. San Francisco, Cal.

**FOR SALE BY**

THE AGENTS, at the above named places.

## FIRE!

TO PHOTOGRAPHERS.

PHILADELPHIA, October 15, 1886.

We will stop and chat with you a few minutes, but are too busy to say much to you to-day. We want to inform you of the destruction of our store by fire, and tell you where you can find us now. First we will speak about the fire.

At an early hour Tuesday morning (12.10), September 21st, fire broke out at 25 N. Seventh Street, and in a few minutes our entire stock was in ruins. It was not all burned, but what was spared by the flames was either destroyed or damaged by water. The fire was under control in about an hour's time, but during that hour the second, third and fourth floors had suffered to the extent of \$25,000. Eight fire engines can destroy nearly as much photographic stock in an hour as a blazing fire—more stock than you could use in ten years' time—and they did it too.

Thousands of dozens of dry plates and nearly two hundred reams of albumen paper were left soaking wet. The stock was not fully covered by insurance, hence we will sustain a considerable loss. The cause of the fire is unknown, but most likely it originated from a defective flue, as the fire was most destructive in this portion of the building.

On the following day we opened a temporary office and storeroom, increased our corps of efficient assistants, purchased a new stock, and commenced filling orders as usual. Having bade No. 25 North Seventh Street adieu, we have secured a large and commodious warehouse in the *new building* at 1030 Arch Street.

### A PALACE STOCKHOUSE.

Carpenters are now pushing forward their work, and will have everything in readiness for us by November 1st. We will spare no expense to have this the most attractive, and are determined to make it the most complete photographic stockhouse in the States of America. Meantime don't forget that *B. S. & B.* are at 714 Arch Street, wide awake and ready for business.

BUCHANAN, SMEDLEY & BROMLEY.

P. S.—Letters for us may now be addressed to

1030 ARCH STREET.

FOR SALE.—Two good galleries cheap and on easy terms if sold within thirty days. Don't write unless you have some money and mean business. Address

E. B. RADABAUGH,  
Huntington, Ind.



OFFICE OF

**THE BLAIR CAMERA CO.**FACTORY 471, 473, 475 and 477 TREMONT ST.,  
BOSTON, MASS.

TO THE TRADE.

(PHOTOGRAPHIC SUPPLIES.)

BOSTON, October 9, 1868.

To accommodate our customers and more thoroughly care for the requirements of the New York trade in photographic apparatus, we have made arrangements with Wm. T. Gregg to open in a portion of his store, 318 Broadway, a wholesale department, which will be in charge of E. C. Blair, who for the past three years has been in charge of the order and shipping department at our factory.

The retailing of goods will, as heretofore, be under the charge of Wm. T. Gregg, whose reputation for attention to the wants of his customers is well known. By this arrangement we feel confident that wholesale as well as retail customers will be well and justly cared for. We take pleasure in referring all communications and our old friends and patrons to

THE BLAIR CAMERA CO.,  
318 BROADWAY, N. Y.

(Goods delivered free in New York City.)

*Address all communications as above.*

FOR SALE.—One of the best galleries in the city of Worcester, Mass. This room has been fitted up this month with a new light, and has everything in it to do first-class work, and it is doing a good business. Reason for selling, change of business. Sold very low for cash.

Address G. P. CRITCHEESON,  
Box 235, Worcester, Mass.

**SEASON OF 1886-87.**

NEW DESIGNS IN

BACKGROUNDS AND ACCESSORIES.

Including Interior Slips in Profile. Winter, Backgrounds, Set Pieces, etc., from the Studio of

PACKARD BROTHERS, Scenic Artist.  
JAMAICA PLAINS, BOSTON, MASS.

*Send for illustrated catalogue.*

FOR SALE.—Two galleries; one in North Carolina, and one in a large city in Mexico.

Address W. H. ZOLLER,  
Box 83, Tarboro, N. C.

TO OUR PATRONS.

St. Louis, October 23, 1886.

GENTLEMEN: During the last ten months we have been enlarging our factory in order to meet the growing demand for our plates, and succeeded in doubling our working capacity. Still our supply is not half sufficient to fill our orders. We have, therefore, commenced the building of a new factory, much larger than our present one, and have taken steps to secure its completion by the 1st of February next.

We again beg your patient forbearance and the continuance of your good will toward us, and trust that with the beginning of another year we shall be in shape to fully supply all demands.

Respectfully,

M. A. SEED DRY-PLATE CO.,  
A. R. HUISKAMP, Manager.

**SITUATIONS WANTED.**

*No charge for advertisements under this head; limited to four lines. Inserted once only, unless by request.*

By a lady, to retouch and attend reception-room. Address Emma Graham, care St. John's Reading Room, Buffalo, N. Y.

As operator in some first-class gallery, by a man of experience. Address A. J., Box 1065, Oneida, N. Y.

As printer, toner, or general assistant. Address Fred. Hummerley, 340 Breck Alley, Scranton, Pa.

By a first-class photographic printer, of fifteen years' experience, who can make himself generally useful. Address B. R. Powers, 804 W. Main Street, Richmond, Va.

As dark-room operator or toner, by a young man thoroughly acquainted with dry-plate work. Address W. Von Glazer, 238 N. Eighth Street, 2d Floor, Philadelphia, Pa.

In large gallery, by a young man who can take entire charge of a gallery. Ten years' experience in all branches. Address L., care W. J. Baker, Buffalo, N. Y.

As retoucher. Address Miss C. L. Phillips, Box 389, West Newton, Mass.

As assistant to run a gallery on shares. Can furnish two cameras, lenses, and other things too numerous to mention. Address Artist, Jenningsville, Pa.

By a young man, to finish trade. Samples given if required. West preferred, but will go anywhere if in a good gallery. Address L. B. Jayne, Jenningsville, Pa.

By a young man twenty-one years old, with two years' experience, as printer or general workman. Will work for ten dollars per week and board. No Sunday work. Address W. E. Swartz, Van Wert, O.

At once, by a thorough and efficient artistic operator and retoucher of twenty years' experience, who understands working India-ink. Speaks several languages. Address J. Baecker, 235 Spring Street, New York City.

In a city of from 20,000 to 50,000, by a German of temperate and steady habits, who is capable of taking entire charge of a gallery. Is a good operator, crayon, artist, and an A No. 1 retoucher. Wages \$20 per week. Address H. Kruger, 97 Stanton Street, New York,

As retoucher and reception-room lady in a first-class gallery. Is under the instruction of a first-class retoucher. Address L. A. B., Box 204, Lebanon, Pa.

<p>THE LARGEST Photo-Engraving ESTABLISHMENT IN THE WORLD</p>	<p>SIXTEEN YEARS PRACTICAL EXPERIENCE</p> <p><b>MOSS ENGRAVING CO.</b></p> <p>535 PEARL ST. COR. ELM. NEW YORK</p>	<p>ILLUSTRATIONS Every Description For Books, Magazines, Newspapers, Catalogues, CIRCULARS, &amp;c. IN THE Highest State of the Art</p>
<p>Moss' New Process Superior to Any Other Method.</p>		
<p>SEND GREEN STAMP FOR 24 PAGE CIRCULAR -- SEND PHOTOGRAPH, DRAWING OR PRINT FOR ESTIMATE.</p>		

## C. H. CODMAN & CO.

### Photographic Stockdealers

Sole Agents for the NEW ORTHO-PANACTINIC LENS, Moor's Photographic Enamel, the Perfect Mounting Solution for mounting Photographs on the thinnest mount without wrinkling.

New England Agents for American Optical Co.'s Apparatus. The best in the world. Send for Price List.

34 Bromfield Street.

BOSTON, MASS.

## OUR SPECIALTIES.

BROMIDE AMMONIUM, Chem. Pure.

BROMIDE POTASS., Chem. Pure.

NITRATE SILVER, Chem. Pure.

### FOR DRY PLATES.

CROSS-SWORD DRESDEN ALBUMEN PAPER,  
Single and Extra Brilliant. The Best in the Market.

ALSO A GENERAL LINE OF

## PHOTOGRAPHIC CHEMICALS.

A circular, "How to Save Waste," sent on application.

## CHAS. COOPER & CO.

194 Worth St., New York.



[TRADE MARK]

TRY THE NEW

## 3 KINGS EXTRA BRILLIANT ALBUMEN PAPER.

*Vio-Pensee*, a most delicate violet tint, and  
*Pearl-Email*, a beautiful shade of pearl.

SUPERIOR PRINTING QUALITIES.

Price per Ream, \$34.00.

Sample dozen post-paid to any address on receipt of \$1.00.

**BUCHANAN, SMEDLEY & BROMLEY,**  
Importers. New Store, 1030 Arch St., Phila.

THE PLATINOTYPE (Patented).

Send ten cents for instructions and sample,  
portrait or landscape.

WILLIS & CLEMENTS,  
1112 HUNTER ST., PHILADELPHIA,  
BUCHANAN, SMEDLEY & BROMLEY,  
General Agents for the sale of materials.

## HODGE & HUSTON, THE SOLAR PRINTERS, 622 ARCH STREET, PHILADELPHIA.

*Permanent Prints by the Platinum Process. Electric Light.*

### SOLAR PRINTERS, TAKE NOTICE.

The busy season is close at hand, and with it short days and poor light. It will pay you to investigate the merits of the **Platinotype Process**. You can save time and money by using it. Send ten cents for specimen print and latest instructions.

**WILLIS & CLEMENTS,**

1112 Hunter Street,

PHILADELPHIA. PA.

THE best artists and solar printers in the United States and Europe use **PLATINOTYPE PAPER** for large and small pictures. This paper is manufactured for Willis & Clements' **Platinotype Process**, and is the *purest and most desirable* grade of paper made in the world for ink, crayon, or pastel. Samples free.

**BUCHANAN, SMEDLEY & BROMLEY,**  
Importers, 1030 Arch St., Phila.

*The Latest Achievement in Portrait Lenses.*

**VOIGTLANDER & SON'S**  
**NEW**

**PORTRAIT**

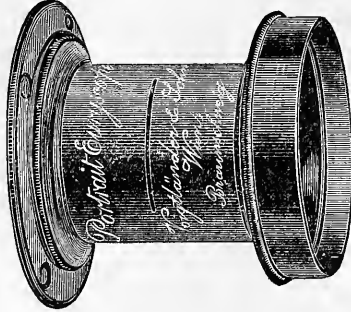

**EURYSCOPE**

**THE IDEAL LENS FOR PORTRAITS, GROUPS, AND FIGURES.**

Unlike the regular Portrait-Lenses, the front combination which consists of one compound lens and the rear combination of two separate lenses of quite dissimilar shape, these new lenses are composed of two perfectly symmetrical and cemented combinations, similar to the Euryscopes, and offer several important advantages. By sealing the two separate lenses of the rear combinations, the number of reflecting surfaces is reduced, thus saving a considerable amount of light formerly lost, and as, moreover, all diffusion of light is obviated, the new lenses produce more brilliant pictures and improved definition.

The front and back combinations being perfectly symmetrical, superior marginal definition and perfectly even illumination of the plate can be obtained, and, with the same length of focus as heretofore, a larger field is covered and the size of the image increased, the resulting picture being absolutely free from distortion.

The **PORTRAIT-EURYSCOPIES** are divided into two series as regards their working rapidity. The first corresponds in ratio of aperture to focal length to the Portrait-Lenses of normal speed, but excels them in covering capacity, depth of focus and powers of definition.

The second series—and these will be found the most useful—have an increased length of focus, and are consequently less rapid, but sufficiently quick-working for all ordinary portrait work in the studio. Possessing too, greater covering capacity (increased size of field), and greater depth of focus than the first series, this second series is specially adapted to taking groups and full-length figures in short studios where the regular Euryscopes, on account of their longer focus, may not be available. They are also excellent for instantaneous work, inasmuch as the flare characterizing portrait-lenses, when used out of doors, does not exist. In point of fact, this construction of the **PORTRAIT-EURYSCOPIES** will fill a gap in the series of existing portrait-lenses and as they are lighter and shapelier than the old long-focus Portrait Objectives, they will become great favorites. Each lens is provided with central stops.

We would state, furthermore, that no change will be made in the present style of Euryscope lenses. Send for price list which also contains the official report of the Photographic Society of Vienna on the above lenses.

**BENJ. FRENCH & CO.**

*Sole Agents for the United States,*

**No. 319 WASHINGTON STREET, BOSTON, MASS.**

# 500 UNSOLICITED TESTIMONIALS AND MORE.

PLEASE READ THE LAST ONE.

A New Edition, with a twenty-four page appendix, giving all new processes practically useful, is now ready—  
THE CHAUTAUQUA EDITION.

*Northwestern Business College,  
Saginaw City, So. June 14, 1886.  
E. L. Wilson, Esq.  
Dear Sir:—I am highly pleased with the  
Photographic. In an experience of over 30 years teaching,  
I have used and examined many text books, but have  
found none more ably written, or more exhaustive  
of the subject treated, in so small a compass.  
Containing, as it does, a clear exposition of the  
methods tried and proved by the long experience of  
the Author, together with notes from over 200 eminent  
practitioners. It cannot fail to prove a valuable aid,  
not only to the Amateur, but to the professional  
as well. Theory and Practice follow each other so  
closely, that the student can know and do  
at once.*

If your old copy is worn out, get  
THE CHAUTAUQUA EDITION.  
If you have never owned *Photographics*, get  
THE CHAUTAUQUA EDITION.

*W. C. Cochran*

\$4.00

## WILSON'S

\$4.00

NEW  
EDITION.

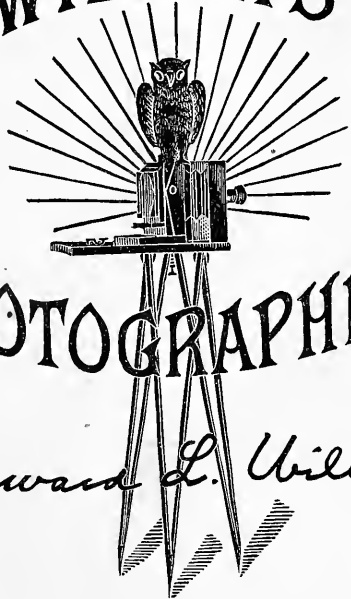

NEW  
EDITION.

JUST  
READY.

## PHOTOGRAPHICS

JUST  
READY.

*Edward L. Wilson.*

\$4.00

\$4.00

### THE BEST PHOTOGRAPHIC LESSON-BOOK

By EDWARD L. WILSON,

Editor of "The Philadelphia Photographer," "Photographic Mosaics," etc.

The author believes it to be the best effort he has ever made, and begs to call attention to a few of its peculiar advantages as  
A STANDARD WORK FOR ALL WORKERS IN PHOTOGRAPHY.

- A. Treatment of the Subject.
- B. The needful apparatus.
- C. The Objective or Lens.
- D. The Dark Room.
- E. Preparation of the Glass.
- F. Chemicals and Solutions.
- G. The Manipulations.
- H. Manipulatory Miseries.
- I. Retouching the Negative.
- J. The Glass Studio.
- K. Accessories and Light.

- L. Managing the Model.
- M. Printing on Albumen Paper.
- N. Printing on Plain Paper.
- O. General Remarks on Printing
- P. Printing on Various Surfaces.
- Q. Printing Perplexities.
- R. Art in Printing.
- S. Mounting and Finishing.
- T. Photography Outside.

- U. Bromo-Gelatine Emulsion Work.
- V. Vogel's Collodion Emulsion.
- W. Enlargements and Lantern Slides.
- X. Photographs, Platinotypes, and Collodion Transfers.
- Y. Wastes and their Worth.
- Z. Metrical Measuring.
- & Concluding Confab. Index (six pages).

The index added is very full and will enable the reader to quickly find almost any subject needed on every practical department of the art Sent post-paid for \$4.00 by

EDWARD L. WILSON, 853 Broadway, New York.

ASK FOR THE  
BLUE LABEL.

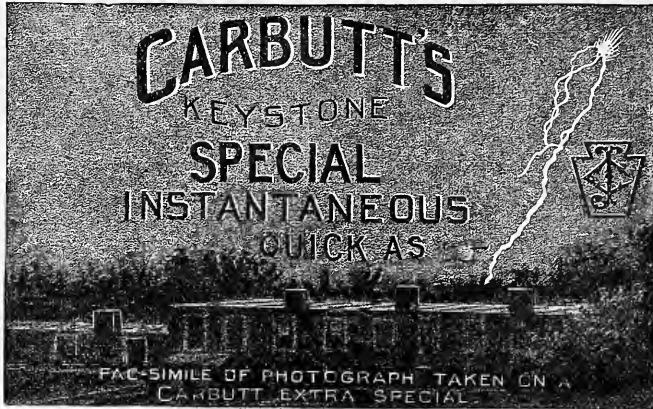

TRY THEM!  
and you will continue to  
USE THEM!

Pronounced the "Ne Plus Ultra" of Dry Plates.

UNSOLICITED TESTIMONIALS.

MR. JOHN CARBUTT, Wayne Junction, Philadelphia.

WORCESTER, MASS., December 25, 1885.

DEAR SIR: I have been using some of your new plates, emulsion 1024, sensitometer 24. I think they are, without exception, the finest and best plates I ever used. They are not only very fine and delicate in their structure, but, when properly manipulated, result in a blooming negative, possessing all the desirable qualities that any artist could wish for. I could most appropriately christen them the "Ne Plus Ultra Dry Plate."

Yours truly,

E. R. B. CLAFLIN.

DETROIT, MICH., January 16, 1886.

MESSESS. HARRIS & KITTLE.

GENTLEMEN: I am very much pleased with the Carbutt Plate; in fact, I call them the best plate *by far* that I tried so far. I find them especially useful for my theatrical subjects, as the quick emulsions are *absolutely instantaneous*.

Yours truly,

A. B. TAYLOR.

*For Sale by all Dealers in Photo. Materials.*

JOHN CARBUTT, Keystone Dry Plate Works, Wayne Junction, Philada., Pa.

## THE UNRIVALLED STEINHEIL LENSES.

In Six Different Series and Forty Numbers, for  
Every Description of Work.

These Lenses not only maintain their old-established reputation, but continue to lead in the field of progress.

Special attention is called to

**Series No. II.**, Patent Aplanatic, the newest conception in lenses. For Instantaneous Portraits, Large Heads, Full Figure Groups, Architecture, and Landscape. A marvel of illumination, depth, and rapidity. No Photographer or Amateur should purchase a lens before testing a Steinheil, Series No. II.

**Series No. III.**, the famous Aplanatic tube, the illumination of which has been increased, and which is recommended for large Portraits, full-size Figures, Groups, Architecture, and Landscape.

**Series No. VI.**, Wide Angle Aplanat, which has no rival for copying Maps, Charts, Paintings and Engravings. It is the Photo-lithographer's favorite.

Send for Illustrated Catalogue and Price-List to your dealer or to

H. G. RAMSPERGER & CO., Sole Agents,  
180 Pearl Street, New York.

## DEALERS' DIRECTORY.

*The following houses are to be recommended as the best for photographers in their localities.*

S. T. BLESSING, New Orleans, La. And Dallas, Texas.	GEORGE MURPHY, EAGLE STOCKHOUSE, 250 Mercer St. New York.	SMITH & PATTISON, NEW LOCATION, 145 & 147 Wabash Avenue, Chicago.
H. A. HYATT, Mound City Photo. Stock House, 8th and Locust Sts. St. Louis, Mo.	WILSON'S PHOTOGRAPHICS, \$4.00.	GAYTON A. DOUGLASS & CO. 185 & 187 Wabash Ave. CHICAGO.
SCOVILL MAN'G CO. 323 Broome St. New York.	D. TUCKER & CO. Buffalo, N. Y.	ALLEN BROS. Detroit, Michigan.
C. H. CODMAN & CO. Boston, Mass.	WILSON, HOOD & CO. 825 Arch Street, Philadelphia, Pa.	B. FRENCH & CO. Boston, Mass.
BUCHANAN, SMEDLEY & BROMLEY, 1030 Arch Street, Philadelphia.	A. B. PAINE & CO. Fort Scott, Kansas.	MULLETT BROS. Kansas City, Mo.
OSCAR FOSS, San Francisco, Cal.	E. & H. T. ANTHONY & CO. 591 Broadway, New York.	SHEEN & SIMPKINSON, 166 Race St. Cincinnati, O.

# TALCOTT'S PATENT MOUNT

FOR PHOTOGRAPHS, ETC.

IS NOW MEETING A LONG FELT NEED.

---

A unique invention constituting a picture and frame combined, complete for the easel, mantel, or wall, by which all framing may be dispensed with.

---

**Patented March 23, 1886.**

---

The Talcott mount softens the lines, adds much strength and great brilliancy to the picture, and is the only process by which a photograph may become indelible, rendering it practically indestructible. Picture frames are expensive, go out of fashion, and take up room.

*A picture mounted by our patent mount* can be displayed or packed in one-half the space required by a picture with ordinary framing, as by this process all other framing becomes wholly unnecessary, yet it is so constructed, that if desired it can be placed in any ordinary picture frame, intact, and free from all interference.

Our invention relates to a mounted picture such, for instance, as a photograph, the object being so to mount the picture, as to *dispense with ordinary picture frame*, to preserve the picture, and secure a stronger, richer, and more brilliant and more life-like effect than has been heretofore produced by ordinary modes of mounting, and to afford when so mounted means for support and suspension of the same.



As specimens of our improvement in mounts for pictures, photographs, etc., have been placed for inspection, which must naturally be subject to more or less criticism, it may be well for us to give some *description of the method* and its merits.

Upon superficial examination, some may say: "It is merely a picture placed back of plate glass; but this is far from the case, as herein, to a great extent, exists the cause of the fine effect produced by this mount. The picture being pressed firmly upon the transparent plate is made to adhere fast thereto by a transparent enamel of great strength and fine gloss, made by us expressly for this purpose, and is of singular purity.

The compound used gives much gloss, and in connection with the transparent plate *produces a soft and brilliant appearance*, bringing out the subject in relief to a surprising degree so life-like.

In this manner the picture becomes so closely identified with the plate as in appearance being one and the same. The considerable length of time we have experimented with this process and noted the results makes us feel confident in asserting that *any photo print may be preserved in all its strength and freshness an indefinite period if* subjected to our process before chemical change begins, for it will arrest a picture from fading, and prolong its strength far beyond its usual existence.

*The glass plate is of the finest quality* than can be procured, shaped and finished to each individual print, which print is securely enclosed, and hermetically enclosed in a neat and durable manner.

The mount is provided with a strong suspension and support, the whole presenting a finish and richness to correspond with any surroundings, however elegant.

With increased facilities we are now prepared to receive orders from photographers, art dealers, and the trade generally, to mount pictures, photographs, etc., at the shortest notice, and to all such in the trade who may desire, we will, upon application, send sample mounted, C.O.D., at trade prices.

For further particulars and price list, address

**E. K. TALCOTT,**

216 Northampton St.

BOSTON, MASS.

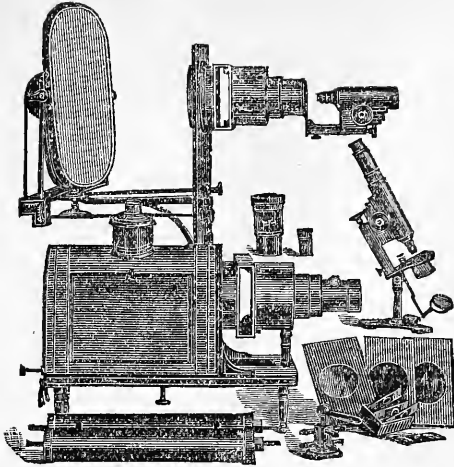

# OPTICAL AND ELECTRICAL INSTRUMENTS.

We desire to call the attention of  
TEACHERS, SCIENTISTS, LECTURERS, and  
those interested, to our

**Stereopticons, Microscopes, Dr. McIntosh's Solar Microscope and  
Stereopticon Combination Apparatus for  
the Oxy-hydrogen and Ether-oxygen Lime Light, Photographic  
Transparencies, Microscopical Preparations, etc.**

Our Instruments and Apparatus are new in design and have many improvements  
that overcome difficulties heretofore considered unavoidable. We also manufacture

**Static Electric Machines, Batteries, Magnets, and a Full Line of  
Electrical Apparatus for Practical and Experimental  
Purposes.**



We received the highest  
award at the New Orleans  
World's Exposition, on  
both Optical and Elec-  
trical Apparatus, in com-  
petition with the best of  
home and foreign manu-  
facturers.



Illustrated Catalogue of Optical and Electrical Apparatus sent free on application  
by mentioning this journal.

**McIntosh Galvanic and Faradic Battery Co.**

Nos. 300 & 302 Dearborn Street,

CHICAGO, ILL., U. S. A.

# THE PHILADELPHIA PHOTOGRAPHER.

TWENTY-THIRD YEAR, 1886.

*Devoted to the Advancement of Photography and the Dissemination of Art Principles.*

SEMI-MONTHLY: issued the First and Third Saturday of each month.

\$5.00 a year, \$2.50 for six months, \$1.25 for three months—in advance. 30 cts. per copy.

## CONTENTS OF THE THIRD QUARTER.

**JULY 3.**—The St. Louis Convention. An Answer to Mr. W. J. Stillman's Opinion of Photo-Art, by CHARLOTTE ADAMS. Photography as an Art Educator. Printing Positives on Gelatino-chloride Paper, by M. CHARBO. Photography in Newfoundland. Is Photography an Art? by F. H. WILSON. Gelatine, a Substitute for Albumen in Silver Printing, by W. M. ASHMAN. Very Slow Gelatino-bromide for Landscape Work, by W. K. BURTON. The World's Photography Focussed, The New Studio of MR. P. H. ROSE, at Providence, R. I. What an Old Teacher says of "Wilson's Photographics." Our Picture. Yesterday and To-day, or Justice to All, by MRS. E. N. LOCKWOOD. Brains and Judgement most Needed in Photography, by C. F. MOELK. On the Business Management of a Photographic Establishment, by C. M. CARLISLE. The Progress of Photography in Germany and Austria, by DR. J. M. EDER. Practical Points from the Studios. Editor's Table.

EMBELLISHMENT.—"Merry Wives of Windsor," by REICHMANN & Co., New York.

**JULY 17.**—Figures in Landscape, by XANTHUS SMITH. Report on the Progress of Photography in America, by ARTHUR H. ELLIOTT, P.H.D., F.C.S. Report on the Progress of Photography in Great Britain, by J. TRAILL TAYLOR. A Tribute to Photography, by CHARLES T. STUART. Pertaining to the P. A. of A. Convention Items. The Humor of It. Improvement in Photographic Printing and Enlarging, by DAVID COOPER. A Simple Device for Accurately Timing an Exposure, by WINFIELD A. FRENCH. Our Picture. Queries, Conundrums, and Conclusions. Editor's Table.

EMBELLISHMENT.—"On the Pennypack," by XANTHUS SMITH, Philadelphia.

**AUGUST 7.**—The St. Louis Convention. Pertaining to the P. A. of A. The Decline of Prices, and the Remedy, by A. ST. CLAIR. Art Censorship, by L. H. SCHUMAN. Money Making, by W. J. GUILD. Convention Notes. Mr. George Barker's View of Niagara Falls and Florida. The Canada Convention. A Chautauqua Photographic Day. Our Picture. Editor's Table.

EMBELLISHMENT.—"The Valentine," by H. P. ROBINSON, Tunbridge Wells, England.

**AUGUST 21.**—The Uses of Rainy Days, by CHARLES T. FELLOWS. Process for Developing Negatives with Very Short Exposures, by M. BALAGNY. Rambling Remarks, by RANALD DOUGLASS. Views from My Office Window. Useful Hints. Photo. Facts and Fancies. Alaska Correspondence. Practical Points from The Studios. The Humor of It Chattering of This and That. A Camera Without a Lens, by M. MEHEUX. Open Corner. Bleaching Overprinted Photos. for Photo-Engraving. Mr. T. R. Burnham's Large Negative. Society Gossip. Queries, Conundrums, and Conclusions. Our Picture. Paper Coated with Gelatine Emulsion for Direct Printing. Instantaneous Portraiture. Answer to a Question Concerning the Toning of Albumen Paper. The World's Photography Focussed. Editor's Table.

EMBELLISHMENT.—"After Play," by Messrs. ABELL & SON, Portland, Oregon.

**SEPTEMBER 4.**—Photography from a Balloon. Art and Photography, by G. HANMER CROUGHTON. A New Method of Obtaining Enlarged Negatives. On the Action of Ferric Salts Employed in Conjunction with Sodium or Ferric Hyposulphite in Reducing Overdensity. The Humor of It. On Photographic Interiors, by VALENTINE BLANCHARD. Practical Points from The Studios. Our Picture. The Use of the Centrifugal Separator in Preparing Gelatine Emulsion, by JOSEPH PLENNER. Queries, Conundrums, and Conclusions. Photographic Day at Chautauqua. A Piece of Presumption. The World's Photography Focussed. Facts and Fancies. The Open Corner. Editor's Table.

EMBELLISHMENT.—"The West," by H. BUTLER, Vermillion, Dakota.

**SEPTEMBER 18.**—A Pleasant Field Day. Practical Points from the St. Louis Exhibition. On the Use of Aristotypic Paper. Photographs of South Africa. On Framing Photographs, by PORTE-CRAYON. The Spectroscopic Detection of Alkaloids. Remarks on the Process of Direct Reproduction in Black Lines on a White Ground of Plans, Drawings, Maps, Engravings, etc., by M. DE SAINT-FLORENT. Official Report of the Committee Appointed by the Photographic Society of Vienna to Test Voigtländer & Son's New Portrait Eurscope. The Canada Convention. Queries, Conundrums, and Conclusions. The Photographic Convention of the United Kingdom. On Men's Heads, by WILLIAM ADCOCK. Success, by H. P. ROBINSON. The Treatment of Negatives after Development—a Mystery Unravell'd, by W. B. BOLTON. Photographing the Late Eclipse. Our Picture. Practical Points from The Studios. Elimination of Hyposulphite of Soda by the Salts of Lead. Photo. Facts and Fancies. The World's Photography Focussed. Editor's Table.

EMBELLISHMENT.—"A Ramesian Studio," by EDWARD L. WILSON.

The above six numbers to one address for \$1.25, prepaid. The numbers for January, February, and March, or for April, May, and June to one address, post-paid, \$1.25.

Our Invaluable Back Numbers for 1886 are Equivalent to Several Volumes on Our Art.

EDWARD L. WILSON, 853 Broadway, New York.

OFFICE OF

# G. CRAMER DRY PLATE WORKS,

Shenandoah and Buena Vista Sts., St. Louis.

---

The enlargement of my factory being now completed, I am able to serve my patrons more promptly than heretofore.

Thanking the fraternity for their kind patronage; and soliciting a continuance of the same, I am                      Fraternaly yours,



DRY-PLATE WORKS, ST. LOUIS, MO.

---

**THE**

## ST. LOUIS DRY PLATE COMPANY

Beg to announce that under their New Management they have recently made Important Improvements and Increased their Facilities, so that they are now making better and more uniform plates than heretofore.

---

ALL ORDERS WILL RECEIVE PROMPT ATTENTION.

---

## ST. LOUIS DRY PLATE CO.

No. 827 Chouteau Avenue,

ST. LOUIS, MO.

34

Number 286.

30 Cents.

THE  
 PHILADELPHIA  
**Photographer.**

AN ILLUSTRATED SEMI-MONTHLY JOURNAL,  
 DEVOTED TO PHOTOGRAPHY.

SUMMARY OF CONTENTS.

PAGE	PAGE
Points on Printing. By CHAS. T. FELLOWS, 673	How Scientific Literature is Studied. By
Some Radical Points at Random. By D.	J. L. MÖRCH, . . . . . 689
BACHRACH, JR., . . . . . 674	Grouping Under the Sun. By C. WALTER
Instantaneous Work. By HENRY BUTLER, 675	HILL, . . . . . 691
An Orthochromatic Idea. By GEORGE M.	Naturalism and Photography. By H. P.
BRADSHAW, . . . . . 676	ROBINSON, . . . . . 693
Errors and Helps. By WELL. G. SINGHI, . 676	A Veteran's Answer. By JEX BARDWELL, . 694
Items of Practice. By R. DOUGLASS, . . 677	Photographing Abraham Lincoln, . . . . 694
The Proof. By L. FARINI, . . . . . 678	The American Exhibition in London, . . 695
Did You Ever Try It? By F. M. ROOD, . 679	Our Picture, . . . . . 696
Questions and Answers. By "OLD ARGEN-	The World's Photography Focussed, . . . 696
TUM," . . . . . 679	Pertaining to the P. A. of A., . . . . 697
The Position of Portrait Photography as a	Report of the Committee on Science and the
Plastic Art. By WALTER KUHN, . . 682	Arts on Ives's Process of Isochromatic
A Few Words About Negatives for Enlarg-	Photography, . . . . . 699
ments. By M. HERAUD, . . . . . 686	On the Rapidity of Images in Chrono-
A German Horse in Motion, . . . . . 686	Photography. By M. MARCY, . . . . 702
A First Step Towards the Photographing	Editor's Table, . . . . . 702
of Colors, . . . . . 688	

OUR PICTURE.—"The Midnight Sun at the North Cape." Photo-engraving by F. E. IVES.

EDWARD L. WILSON,  
 853 Broadway, New York.

SUBSCRIPTIONS RECEIVED BY ALL NEWS AND STOCKDEALERS  
 Five Dollars per Annum, in Advance.

## ADVERTISEMENT S.

ANTHONY & CO., E. & H. T. The New N. P. A.  
Pensé Extra Brilliant Dresden Albumen  
Paper.

ANTHONY'S BULLETIN.

CARBUTT, J. Gelatine Dry Plates and Improved  
Dry Plate Lantern.

CODMAN, C. H. & CO. Photo. Stockdealers.

COLLINS, A. M. MFG. CO., Photograph Cards.

CRAMER, G. Lightning Plates.

COOPER, CHAS. & CO. Photo. Stockdealers.

DOUGLASS, GAYTON A. & CO. Photo. Stock-  
dealers.

DRESCHER, F. & CO.'S. Improved Gelatine for  
Emulsion.

EASTMAN DRY-PLATE AND FILM CO.

FRENCH & CO., BENJ. Voigtlander & Son and  
Darlot Lenses. The Wonderful Euryscope.

GENNERT, G. Eagle Dry Plates.

HERRMANN, CHAS. A. W. Hypo. Soda.

INGLIS, JAMES. Dry Plates.

JANENTZKY & WEBER. Artist Materials.

McINTOSH GALVANIC AND FARADIC BAT-  
TERY CO.

MOSS ENGRAVING CO.

PHELPS ENAMELING CO. Non-gelatine Pro-  
cess of Enameling.

PHOTOGRAPHERS' ART VINE.

PHOTO-GRAVURE CO.

PHOTOGRAPHIC TIMES.

PHOTOGRAPHIC MOSAICS, 1887.

ROBERTS & FELLOWS. Photo. Stockdealers.

SCHMIERS, WERNER & STEIN, Phototype or  
Heliotype Steam Presses, Leipzig, Germany.

SCOVILL MANUFACTURING CO. New Dres-  
den Albumen Three Crown Paper. Gihon's  
Cut-Outs. Photo. Apparatus.

SMITH & PATTISON. Photo. Requisites.

ST. LOUIS DRY PLATE COMPANY.

SWEET, WALLACH & CO. Photo. Supplies.

THE ARGENTIC DRY PLATE.

THE BLAIR CAMERA CO.

TALCOTT, E. K. Patent Mounts for Photog-  
raphers.

THE DU BOIS FILING CASES.

WILSON, G. W. & CO. Magic Lantern Slides.

## ADVERTISING RATES.

THE PHILADELPHIA PHOTOGRAPHER is acknowledged to be the best advertising medium  
in the trade.

Its circulation is among the first class, at home and in nearly every foreign country.

Its rates, all advantages considered, are the most favorable, and it will bring you fine  
returns.

	One Issue.	Six Issues.	Twelve Issues.	Twenty-four Issues.
1 Page.....	\$20.00	\$110.00	\$200.00	\$350.00
1-2 " .....	12.00	66.00	120.00	200.00
1-4 " .....	7.00	38.50	70.00	120.00
1-8 " .....	4.00	22.00	40.00	70.00

Special contracts made with bona-fide dealers and manufacturers. Address

**EDWARD L. WILSON,**  
853 BROADWAY, NEW YORK.

## NOTICE TO SUBSCRIBERS.

In remitting by mail, a post-office order, or draft, payable to the order of EDWARD L.  
WILSON, is preferable to bank-notes. Postage stamps of the denomination of two and five  
cents each will be taken. Clearly give your Post-Office, County, and State.

Foreign subscriptions must be accompanied by the postage in addition.

**FIRE!** Our books having been all destroyed by fire at and with our establishment, all  
who owe us will confer a great favor by remitting at once.

**CROSSCUP & WEST ENGRAVING CO.**

907 Filbert St., Philadelphia.

ALFRED M. COLLINS,  
*Secretary and Treasurer.*

HENRY H. COLLINS,  
*President.*

EDWARD COPE,  
*Vice-President.*

A. M. Collins Mfg. Co.

*MAKE ALL KINDS OF*

**CARDS AND CARDBOARDS**

FOR

**PHOTOGRAPHERS**

AND

**MATS, MOUNTS, AND ENVELOPES**

FOR

**FERROTYPES.**

---

OFFICE AND WAREHOUSE,

**No. 527 ARCH STREET,**

**PHILADELPHIA.**

---

Price Lists may be had by intending purchasers on application to us, or to all Photographic Merchants, through whom your favors are respectfully solicited.

# TALCOTT'S PATENT MOUNT

FOR PHOTOGRAPHS, ETC.

IS NOW MEETING A LONG FELT NEED.

---

A unique invention constituting a picture and frame combined, complete for the easel, mantel, or wall, by which all framing may be dispensed with.

---

**Patented March 23, 1886.**

---

The Talcott mount softens the lines, adds much strength and great brilliancy to the picture, and is the only process by which a photograph may become indelible, rendering it practically indestructible. Picture frames are expensive, go out of fashion, and take up room.

*A picture mounted by our patent mount* can be displayed or packed in one-half the space required by a picture with ordinary framing, as by this process all other framing becomes wholly unnecessary, yet it is so constructed, that if desired it can be placed in any ordinary picture frame, intact, and free from all interference.

Our invention relates to a mounted picture such, for instance, as a photograph, the object being so to mount the picture, as to *dispense with ordinary picture frame*, to preserve the picture, and secure a stronger, richer, and more brilliant and more life-like effect than has been heretofore produced by ordinary modes of mounting, and to afford when so mounted means for support and suspension of the same.



As specimens of our improvement in mounts for pictures, photographs, etc., have been placed for inspection, which must naturally be subject to more or less criticism, it may be well for us to give some *description of the method* and its merits.

Upon superficial examination, some may say: "It is merely a picture placed back of plate glass; but this is far from the case, as herein, to a great extent, exists the cause of the fine effect produced by this mount. The picture being pressed firmly upon the transparent plate is made to adhere fast thereto by a transparent enamel of great strength and fine gloss, made by us expressly for this purpose, and is of singular purity.

The compound used gives much gloss, and in connection with the transparent plate *produces a soft and brilliant appearance*, bringing out the subject in relief to a surprising degree so life-like.

In this manner the picture becomes so closely identified with the plate as in appearance being one and the same. The considerable length of time we have experimented with this process and noted the results makes us feel confident in asserting that *any photo print may be preserved in all its strength and freshness an indefinite period* if subjected to our process before chemical change begins, for it will arrest a picture from fading, and prolong its strength far beyond its usual existence.

*The glass plate is of the finest quality* than can be procured, shaped and finished to each individual print, which print is securely enclosed, and hermetically enclosed in a neat and durable manner.

The mount is provided with a strong suspension and support, the whole presenting a finish and richness to correspond with any surroundings, however elegant.

With increased facilities we are now prepared to receive orders from photographers, art dealers, and the trade generally, to mount pictures, photographs, etc., at the shortest notice, and to all such in the trade who may desire, we will, upon application, send sample mounted, C.O.D., at trade prices.

For further particulars and price list, address

**E. K. TALCOTT,**

216 Northampton St.

BOSTON, MASS.

Read page 667 of Philadelphia Photographer, Nov. 6, 1886.

---

# BENJ. FRENCH & Co.

No. 319 WASHINGTON STREET, BOSTON,

Sole Agents in the United States for the Celebrated Lenses  
Manufactured by

## VOIGTLÄNDER & SON.

ALSO, THEIR FAMOUS

# EURYSCOPE,

Which is unrivalled for groups, full-length figures, and other demands in the gallery, and every species of out-door work, including instantaneous photography.

☞ THE EURYSCOPE is made *exclusively* by Voigtländer & Son, and their name is engraved on the tube.

---

FOR **DARLOT LENSES** FOR  
PORTRAITS. VIEWS.

IMPORTERS, ALSO, OF THE CELEBRATED

TRAPP & MÜNCH

# ALBUMEN PAPER,

AND DEALERS IN ALL KINDS OF

*Photographic Materials and Magic Lantern Slides.*

---

SEND FOR OUR NEW ILLUSTRATED PRICE LIST OF LENSES.

# A CARD.

75 STONE ST., ROCHESTER, N. Y., July 26, 1886.

GENTLEMEN: About three months ago the business of Inglis & Co., of this city was formed into the Inglis Dry Plate Co.

In the articles of agreement, a clause was inserted giving the I. D. P. Co. the exclusive use of the name of "Inglis," and also that James Inglis would not connect himself with any dry plate business using the name of "Inglis."

Matters have taken such a form since then, he has been compelled to leave the I. D. P. Co. And being thus debarred from the use of his own name, adopts this means of making known to his numerous customers where they may still obtain his plate. **And the Only Place.**

A new firm taking the name of the **ROCHESTER DRY PLATE CO.** have engaged his services, and under his supervision a new factory has been fitted with the most modern improvements required for the production of **clean and spotless** plates, with all the other extra qualities that his plate has become so renowned for. The fraternity may therefore depend upon the very finest plate ever yet produced, from the **ROCHESTER DRY PLATE CO.**

## JAMES INGLIS,

Late Manufacturer of the Inglis Dry Plate, and President  
of the Inglis Dry Plate Co.

---

## OUR SPECIALTIES.

---

BROMIDE AMMONIUM, Chem. Pure.

BROMIDE POTASS., Chem. Pure.

NITRATE SILVER, Chem. Pure.

### FOR DRY PLATES.

CROSS-SWORD DRESDEN ALBUMEN PAPER,

Single and Extra Brilliant. The Best in the Market.

ALSO A GENERAL LINE OF

PHOTOGRAPHIC CHEMICALS.

A circular, "How to Save Waste," sent on application.

**CHAS. COOPER & CO.**

194 Worth St., New York.

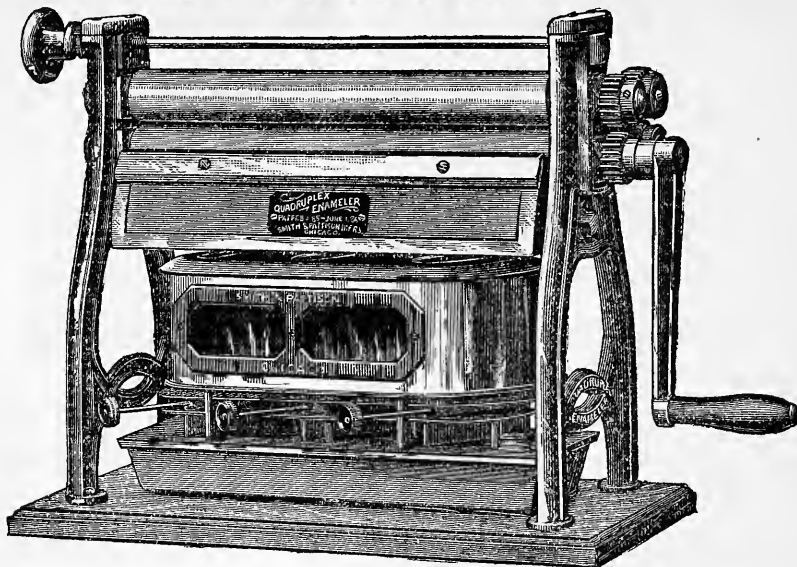
**THE LATEST!**

Patented Feb. 3, 1885, and June 1, 1886.

**THE QUADRUPLEX ENAMELER.**

A GREAT IMPROVEMENT OVER ALL DUPLEX ROTARY MACHINES  
HERETOFORE MADE.

**IMPROVEMENT No. 1** consists of a new device for regulating the pressure on the cards by means of one *hand screw* instead of two as heretofore used, making the pressure *uniform and positive* the whole length of the roll, while with all "Duplex" machines it takes a great deal of *time and care* to maintain a *uniform pressure*.

**IMPROVEMENT No. 2** consists of such an arrangement of *4 cogs* as enables the operator to adjust the distance between the rollers to accommodate any thickness of card, from the very thinnest to the heaviest made, without visibly *disconnecting or separating the cogs from each other*, causing the rollers to revolve just as smoothly, and the gearing to operate just as perfectly on thick as on thin cards. *This is impossible when but 2 or 3 cogs are used.*

**IMPROVEMENT No. 3**, covers the general construction of the machine. It is *new in design*, and more perfect *mechanically* than any of the "Duplex" machines, one of the most noticeable improvements being in the roller bearings.

**IMPROVEMENT No. 4** consists of the *beautiful finish* given these machines. *They are full nichel plated, all over.* They are a *handsome ornament* for any studio.

**IMPROVEMENT No. 5** consists of a new Kerosene Heater of our own design, which will heat them up fully one-third quicker than those heretofore used.

The finish given to photographs with this machine is superior in brilliancy to many "enameled" pictures we have seen, and much more durable than enamel. NO LUBRICATOR USED. NO SCRATCHES POSSIBLE. NO SPOILING OF PRINTS.

**IT IS THE BEST. TAKE NO OTHER.**

**PRICES.**

GAS OR OIL HEATERS INCLUDED.

10 Inch, . . . . .	\$25 00	20 Inch, . . . . .	\$45 00
15 " . . . . .	35 00	25 " . . . . .	55 00

MANUFACTURED BY

**SMITH & PATTISON,**

145 & 147 Wabash Ave., CHICAGO.

# The Photo-Gravure Company,

853 Broadway, New York.

PHOTO- { GRAVURE  
LITHOGRAPH  
CAUSTIC  
GELATINE } PRINTING

## PROCESSES OF THE PHOTO-GRAVURE COMPANY.

**PHOTO-GRAVURE.**—By this process the highest artistic effects are produced. Metal plates are engraved (in intaglio) by photography and printed in copper-plate presses. The effects produced by photography may be altered by the hand of the artist, values may be increased or diminished, and almost any omission or addition made. The work may be carried on till the desired effect is produced and the edition is always uniform. The plates can be supplied when desired, or the Photo-Gravure Co. will do the printing. The results obtained by the Photo-Gravure Co. equal the best results obtained abroad, and reference to this effect is permitted to leading Publishers and Artists who have used these plates. All classes of subjects, whether in half-tone or line, can be produced by this process.

**PHOTO-GELATINE PRINTING.**—The results produced by this process are similar to what is known as Albertype, Artotype, Heliotype, Autoglyph, Phototype, Lichtdruck, etc. The particular method used is that patented by Mr. T. C. Roche, and is believed to give the best results at the least cost. The Photo-Gravure Co. has in this department the best staff of printers in the country and a most extended experience of the treatment of gelatine for the purposes of printing. All classes of subjects are suitable for reproduction by this process, and it is especially suitable for portraits, views, architecture, art catalogues, scientific and natural objects, book illustration, town, county, and family histories, theatrical and general advertising, reproductions of engravings, machinery, animals, and still life, copies of deeds, instantaneous effects, scientific records, mill labels, etc.

**PHOTO-CAUSTIC PRINTING.**—This term is applied to a modification of the results produced by Meisenbach, Ives, and others. By this modification the photographic effect is produced from stone. No attempt is made to produce engraved plates, but the printing is done by the Photo-Gravure Co., and by this means greatly better results are obtained than where plates are made and placed in the hands of the ordinary printer. The results are not as good as those obtained from Gelatine or by Photo-Gravure, but they are sufficiently good for a number of purposes where the quality of the higher grades of work is not necessary. It is applicable to all the purposes of the other processes, but is lower both in cost and quality.

**PHOTO-LITHOGRAPHY.**—The results of this well-established process are well known. It is the oldest of the photo-mechanical processes, but is only adapted to the reproduction of original drawings or engravings which are made in a black or other non-actinic color on a white or light ground. We have in our employ on this work the most skilful staff in the country, who for many years have made it a specialty. Photo-Lithography is unrivalled for the reproduction of maps, plans, tracings, surveys, patents, and other drawings, engineers' and architects' designs, *fac-simile* letters and circulars, exhibits in law cases, miniature catalogues, copies of line engravings, reduction or enlargement of line work, etc.

A Book of Specimens of our various processes will be forwarded on receipt of One Dollar, and all inquiries will be promptly answered. Special arrangements made with photographers.

THE PHOTO-GRAVURE CO.,

853 Broadway, New York.

**BUY THE BEST!**

No other will give you half so much satisfaction.

FOR DRY PLATES  
ANTHONY'S Patent Perfect PLATE HOLDERS  
ARE SUPERIOR TO ALL.

DALLMEYER

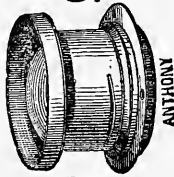

FOR WET

OR DRY

WIDE-ANGLE RECTILINEAR

E. A.  
SINGLE COMBINATION, RAPID,  
WIDE ANGLE, PLATYSCOPE,  
PORTRAIT AND VIEW LENSES.

DALLMEYER LENSES,  
SUCCESS CAMERAS,  
THE FAIRY CAMERAS,  
THE NOVEL CAMERAS,  
SCHEMID'S DETECTIVE CAMERA

SEND FOR OUR CATALOGUE, AND GET THE BEST Of Everything.

APPARATUS OF ALL KINDS.  
Chairs,  
Neg. Boxes,  
Camera Stands  
Printing Frames,  
Etc., Etc.

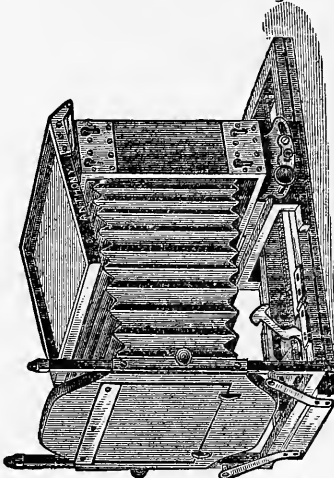

DALLMEYER

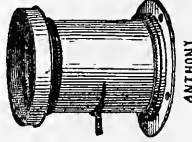

NOTHING

COMPARES

RAPID RECTILINEAR

THE FAIRY CAMERA.  
*The Lightest and Best for Out-door Work.*  
FOR EITHER DRY OR WET PLATES  
NOTHING EQUALS  
THE BENSTER PLATE HOLDER.

O. I. C.  
PORTRAIT, COPYING, CLIMAX  
PORTRAIT, GEM, AND  
COMPACT VIEW CAMERAS.

**E. & H. T. ANTHONY & CO., BROADWAY, NEW YORK.**

--591--



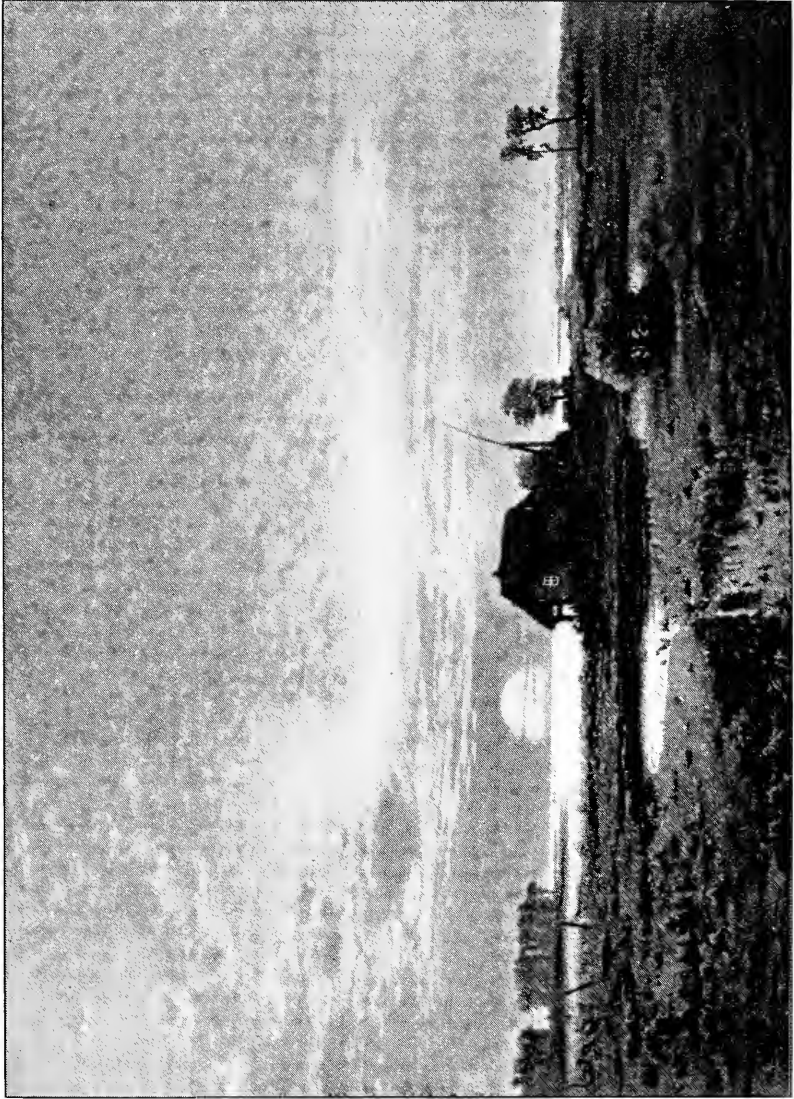

*“The Midnight Sun at the North Cape.”*

ORTHOCHROMATIC PHOTOGRAPH OF PRANG CHROMO, BY IVES' CHLOROPHYL PROCESS.



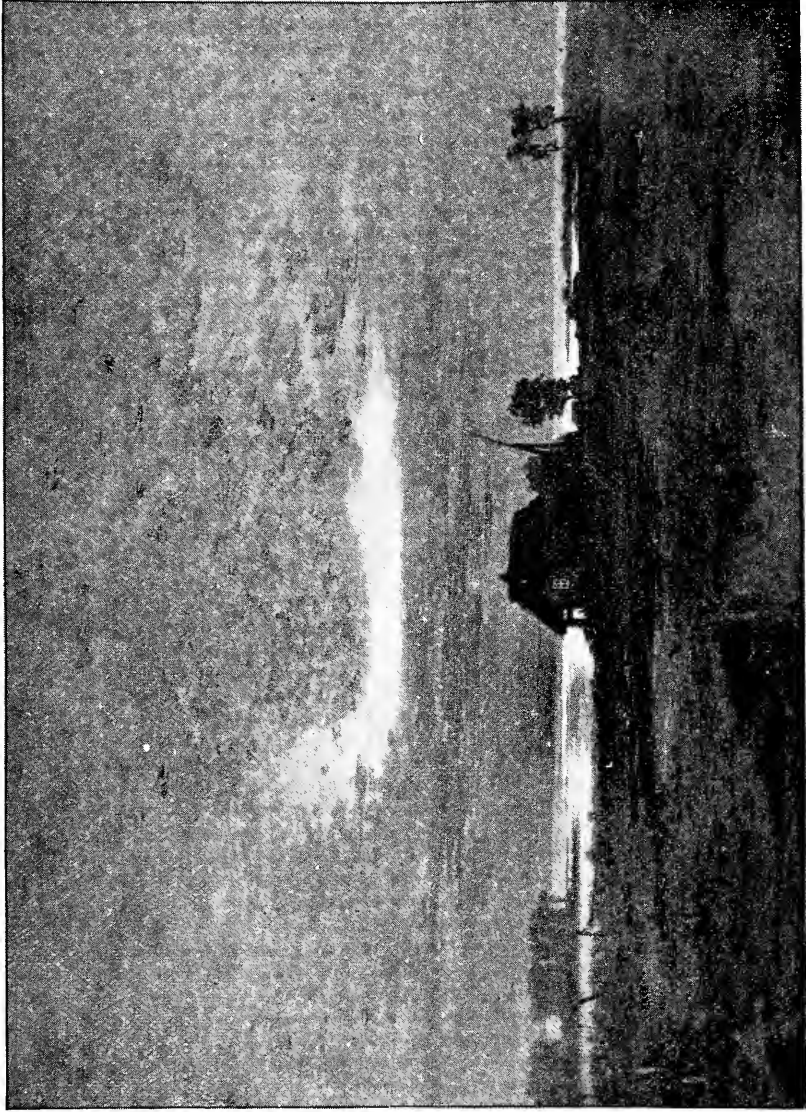

*“The Midnight Sun at the North Cape.”*  
ORDINARY PHOTOGRAPH OF PRANG CHROMO.



THE

# Philadelphia Photographer.

EDITED BY EDWARD L. WILSON.

Vol. XXIII.

NOVEMBER 20, 1886.

No. 286.

## POINTS ON PRINTING.\*

BY CHARLES T. FELLOWS.

SINCE there has been so much said about the dry plates and formulæ, perhaps it would be better to speak of the production of positives on albumen paper; this part of the picture-producing art seeming to be somewhat neglected.

While many amateurs prefer having the pictures made for them, yet there are those who are ambitious to make a picture from beginning to end (except the gelatine plates), and, for their benefit in particular, we will turn our attention to the subject mentioned. Many of them may find some hints in the following paragraphs, which may be of some practical value to them. Heretofore they were obliged to depend largely upon the ready sensitized paper, which can never produce the results most to be desired. Chemical mixtures rarely improve by age, how then can we expect perishable paper prepared with a sensitive salt of silver to preserve its quality?

To secure the best result, the paper should be prepared the same day as used, then we can expect rich, beautiful pictures. There are a great many formulæ given in the different text-books for printing or toning baths. I am an advocate of the simplest methods where the most desirable can be obtained by simple means. But it must be

borne in mind that, although there are many formulæ given by different authorities, it requires a power behind the throne as well, and the amateur must not expect to secure perfection of finish at once, only to be obtained through experience.

The first essential is a good quality of paper, then sensitize in a bath of 64 ounces of water, 60 grains of silver nitrate to the ounce of water; test for acidity; if too acid, neutralize with ammonia or carbonate of soda. This bath can be kept in a bottle and sunned when not in use. Paper to take the silver nicely, should be slightly damp; to do this take a box a little larger than the paper sheet, place in the bottom several damp blotters, in fact, quite wet; above these, place a few slats; then place the paper, to remain over night, and in the morning it will be found quite limpid. While in this condition it should be floated on the silver bath from one and a half to two minutes, then dried thoroughly, and fumed about fifteen minutes, after which, with good quality negatives, and proper care, one should have no trouble in having good prints.

For toning, use

Water . . . . .	32 ounces.
Gold—3 grain solution . . . . .	1 ounce.

Make slightly alkaline with carbonate of soda; add a pinch of salt. This will tone six or seven sheets of paper; tone until the prints assume a rich brown, and then stop

\* Written for *Mosaics*, but received too late.

immediately. This will give the rich warm tones so popular throughout Europe. Fix as usual in hypo about ten minutes, and then immerse in a strong salt solution for about ten minutes, and then wash thoroughly. Of course, all these operations require care, or good work is out of the question.

#### A FEW POINTS.

Tear-drops are produced on paper by the low temperature of the silver bath. The silvering-room should be kept warm, and the bath kept at an even temperature as near as possible. They are also sometimes caused by the excessive dryness of the paper, hence the importance of a dampening-box.

If there should be any paper left over after printing, to preserve it, place it between two blotters which have been previously saturated with a strong solution of carbonate of soda, and place under pressure.

Another method is to float the paper, back down, in a weak solution of citric acid, and, after drying, float as usual on the silver bath a little longer time. Dry thoroughly, but do not fume. But avoid these preservatives whenever possible.

A three-grain solution of gold means three grains of pure gold to one ounce of water; one pennyweight of pure gold dissolved in aqua regia will make eight ounces of three-grain solution.

---

### SOME PRACTICAL POINTS AT RANDOM.\*

BY D. BACHRACH, JR.

MANY of us, practical workers, would like to know when dry plate manufacturers will become conscientious and practical enough to file off the keen razor-like edges of their large plates. That men who get a fair price for their product, should subject the hands of the manipulator to constant and severe cutting, is an outrage on those who pay for them. The suggestion may be made that we should do this ourselves. I will only answer that it takes up valuable time at the very period when expedition is desirable; and, besides, one half the danger lies in taking such plates out of their box. One day I de-

veloped half a dozen 20 x 24 plates, and, though the utmost care was used, my hands were so cut up that I could handle no plates for several days, and I find that this occurs frequently with others as well as myself. We have a right to *demand* a reform of this abuse, until that happy time when paper, or some kind of flexible films will totally displace every plate above 8 x 10 inches at least, for which let us devoutly pray.

Now something about wet plates. On this subject I am willing to be classed an "old fogy." I will freely confess that I am unable to make any dry-plate negative up to 8 x 10 in size, that will compare with a *good wet plate* in every desirable quality. I will go further, and say I never saw anybody else who made *first-class wet plate work*, ever equal it in quality up to 8 x 10 in size with dry plates. Of course, in the large sizes the advantages of sensitiveness with slow lenses is so great as to practically exclude wet plates from competition. Now, this is no theory merely, but we carry it out in every-day practice. Whenever we have a subject who can sit, we use wet plates for small work. Not only does it *pay*, but our clients seem to appreciate it.

I do not know anything very definite about the business of others, but, judging from the size of our force and pay-roll, in comparison to what I know the others to have, I think we must be doing the largest amount of photographic work of any one studio in Baltimore. This was not the case five or six years ago. Perhaps a partial reason for this is, not that our work is materially better (except in the very large sizes), but because that with which we are in most direct competition is *materially worse*. Most notably is this the case with two or three of the leading studios. I have a good method of judging by the photographs brought into our solar printing department, of which, probably twenty to thirty every week are from the studios in Baltimore.

Now let us look at it in a practical way. Let us say that our operating day commences at nine o'clock; from that time until three we make wet plates for small work of every sitter, except children and those who are nervous, or whose expression is extremely

\* Written for *Mosaics*, but received too late.

changeable; this gives us about two-thirds wet plates. *They are then done with*, no more sweating over them for hours in a ruby light and close dark room. After three o'clock (or four in spring and summer), the dry plate displaces the others. At the end of a month we may safely say we have made the equivalent of twelve dozen 8 x 10 wet plates at the least, and some months nearly double that number. Twelve dozen 8 x 10 dry plates cost at lowest retail prices \$27.00. Twelve dozen 8 x 10 wet plates (allowing for coating two dozen extra for failure by moving), \$13.00 at most; saving \$14.00 per month at least. But we find it pays far more to us in more rapid and regular printing, more juicy quality of prints, *and our customers like them*, and don't object to the sitting. We have a good light, of course, otherwise the dry plate would have the advantage. And, I will say further, that if a photographer wants to look ahead, he will shun any studio that has *not* a good light. Of course, travelling manipulators for dry-plate manufacturers will say that *the two cannot be worked together*, etc. One very urgent and sapient individual contending that the *smell of the acetic acid* (?) spoiled the dry plates, but as we find our large dry-plate negatives to be fully as good in every quality as those of the best studios around us, those objections fall to the ground.

Of course, these views will not be relished by those fellows who never could make a decent wet plate. The dry plate was their godsend, by which they were able to crowd out, with cheap prices, the better and abler class of photographers. That is, they are able to make, *mechanically*, good work by the aid of the dry-plate factory, which they never could do before, but *artists* they never will be, and I can see that they are rapidly losing their hold, and the better men again taking the lead.

Gentlemen, would it not be well to cultivate your old wet plate friend *just a little*? *It will pay*.

N. B.—After concluding the above, I find I have made one omission on the question of *saving*, which is important. In our own studio we have such a large stock of old negatives to clean annually that we save the cost of the glass in addition; so, on twelve

dozen 8 x 10 negatives, we may count \$5.00 additional, making \$19.00 *per month* at least, that we save in money alone by this policy.

### INSTANTANEOUS WORK.\*

BY HENRY BUTLER,  
Vermillion, Dak.

In complying with your request for an article describing my mode of making instantaneous views, lightning pictures, and so on, I hardly think I can tell you anything new.

I always use Cramer's lightning plates for instantaneous views, and Prosch's Eclipse shutter, No. 5 Boehmke lens, and diaphragm according to the strength of the light. Always wash the plate before development *under the tap*, commence development with a *small* amount of pyro and plenty of water, that is weak in soda; as it begins to develop you can add soda or pyro as needed, remembering soda produces softness, and pyro strength and contrast. Developer is made as follows:

#### No. 1.

Carbonate of Soda . . .	1 ounce.
Sulphite of Soda . . .	1 "
Water . . . . .	60 ounces.

#### No. 2.

Pyro . . . . .	1 ounce.
Water . . . . .	6 ounces.
Salicylic Acid . . . . .	6 grains.

Salicylic acid to be dissolved in one drachm of alcohol and added. To develop a 5 x 8 plate, take four ounces of No. 1 and from a half to one drachm of No. 2; be sure to commence with a small amount of pyro, and add if needed to give intensity and contrast. Develop until shadows are well covered.

To make a picture of lightning, choose a dark night, point your camera toward the point where the bolts are most frequent, uncap the lens, and wait for the bolt to come; as soon as it comes cap the lens, and if it is in the right part of the plate you will probably have a satisfactory negative. In waiting for a bolt, there may be several flashes, if so you will probably bring out all in the line of vision, trees, houses, etc., as I have done on several occasions. I have made pictures

\* Written for *Mosaics*, but received too late.

by moonlight, with snow on the ground, with seventy-five minutes exposure, and brought out details in the shadows, I used next to the smallest diaphragm.

### AN ORTHOCHROMATIC IDEA.\*

BY GEORGE M. BRADSHAW,  
Philadelphia.

PEOPLE who attend theatres are sometimes at a loss to know how an actor can change from one facial "make-up" to another so quickly, as he often is obliged to do. He uses *grease-paints*, which are quickly applied. An actor friend who frequents my studio, gave me this information, and put me up to the practice of keeping a few *grease-paints* "constantly on hand" for use upon the faces of my patrons. It is a comical idea, but I often find them more useful than *face-powder* for red and white, because not dry and dirty; splendid for working up black eyebrows; and often useful for putting in a bit of brown for contrast here and there in very pale and smooth doll-baby faces. When the skylight circus is over, a little vaseline, followed by a wet rag, will remove all trace of the color. Delicately and politely applied, these colors are a fine thing. If you want to use too much, then orthochromatic plates must be employed. I give the receipts below for some of the colors.

The principle is to make a dry powder somewhat darker than the desired tint, and then thoroughly mix this powder with some bland oil (as almond oil), or some fat (as perfumed benzoated lard), or some perfumed paraffinoid (as petrolatum), in the proportions necessary to produce the required color and consistency. Here are several formulæ for dry powders frequently used alone:

#### White Powder.—

Powd. Venetian Talc . . . . .	300	grammes.
Bismuth Oxychloride . . . . .	50	"
Carmine . . . . .	0.05	gramme.
Oil Bergamot . . . . .	10	drops.
Oil Peroli . . . . .	2	"

#### Red Powder.—

Powd. Venetian Talc . . . . .	100	grammes.
Carmine . . . . .	2.5	"
Water of Ammonia . . . . .	20	"

Digest the carmine in the water of ammonia until dissolved, mix the solution with a portion of the powdered talc, and this with the remainder, and dry by exposure to the air.

#### Black Face Paint.—

Best Lampblack . . . . .	1	gramme.
Cacao Butter . . . . .	6	grammes.
Oil Peroli . . . . .	5	drops.

Melt the cacao butter, add the lampblack, and while cooling make an intimate mixture, adding the perfume toward the last.

In a similar manner, you can prepare *brown face paints* by using, instead of lampblack, finely levigated burnt umber; or, for a reddish-brown, sienna, or similar dry powders. The cost of the cacao butter being considerable, you can easily devise a base, being careful to guard against rancidity, if lard is a component, by carefully benzoinating it.

#### White Paint.—

I.

White Meal . . . . .	2	parts.
Olive or Almond Oil . . . . .	2	"
Powdered Talc . . . . .	1	part.
Oxide of Zinc . . . . .	$\frac{1}{2}$	"

II.

Oxychloride of Zinc . . . . .	5	parts.
White Wax . . . . .	2	"
Sweet Almond Oil . . . . .	5	"

*Red Paint.*—About 1 part carmine to 40 of finished paint is the proper proportion. Dissolve 1 part carmine in sufficient aqua ammonia (4 to 8 parts). Mix with 6 parts of powdered talc; dry, powder, and mix with:

White Meal . . . . .	13 $\frac{1}{2}$	parts.
Olive or Sweet Almond Oil . . . . .	20 $\frac{1}{2}$	"

Try them on.

### ERRORS AND HELPS.\*

BY WELL G. SINGHI.  
Poughkeepsie, N. Y.

A FRIEND of mine said to me, "The idea of salt preventing blisters is erroneous. I will silver a sheet of paper in such a manner that a barrel of salt will not prevent it from blistering; or I will silver a sheet so one

\* Written for *Mosaics*, but received too late.

\* Written for *Mosaics*, but received too late.

half will blister and the other half print and tone all right, without a sign of blistering. Now, if you want to prevent blistering, do not dry the paper too hard, for if you do you will loosen the albumen, and that will cause blistering, and salt will not save it." Everyone who is troubled with tears on the albumen paper should remember this little idea, or, better yet, pin it up in your silvering-room, and that is this: Rub the albumen side of your paper just before silvering with a tuft of cotton, and don't float it on the solution when it is agitated, and I venture to say you never will have tear drops on your paper.

Some photographers think it is no use to advertise that they are in the manufacture of faces, and want the public to know where they are, how long they are going to stay, etc. That is where they make a mistake. If your rent is two hundred dollars per year, just spend another hundred in printer's ink. Don't try to get in as much as you can for the money. What is the use of a man buying a pair of boots No. 10, when his size is No. 6, just because he gets more leather? In advertising, say as few words as you can, but excite their curiosity, so that they will want to come and see for themselves.

I read in one of our daily papers the other day "How to Sit for your Photograph," and think it too good to be lost, and will bear repeating here:

#### HOW TO SIT FOR YOUR PHOTOGRAPH.—

In the first place you want to have your mind thoroughly made up that the thing has got to be done. Dress yourself carefully in something you know you would like. Fix your hair in the most unbecoming style possible, and calmly wend your way to the studio. Tell the artist you have come to have your picture taken, but you know you won't like them, as you never had a picture fit to be seen. Also tell him you are afraid you will break the glass, and that you would a great deal rather have a tooth pulled. It will be something new for him to hear, and will probably make him good-humored, and bring out his best efforts in your behalf. Have several different styles and positions taken, and then, because there is some little thing about the hair or dress that does not just suit you, don't give any order, or even

offer to pay the artist for his trouble, but fix yourself up and go to some other gallery and sit over again. That's the way a good many folks do.

---

### ITEMS OF PRACTICE.\*

BY R. DOUGLASS.

YEAR before last, in making up a few batches of plates, I took the precaution of cutting off the thick edges of the strips of gelatine, and using other precautions which I have so often remarked before, the plates came out clear and practically free from opaque spots.

Last year I made another lot, and did not trim off the thick edges, though all other precautions were observed: plates were full of spots. This seems to show that grease or injurious matters were collected about the edges of the dry gelatine, while at the inside it is reasonably pure. This dodge, I hope, will help those who wish to make their plates occasionally.

The manufacturers each, evidently, have their own way of clarifying gelatine, which, probably for various reasons, they prefer to keep secret. Some plates in the market are very clear now-a-days.

To the amateur or newly-made printer, if you find trouble in good tones, be sure your silver bath is all right before you blame your gold. A foul bath will not yield good tones with any kind of gold. The best remedy, and the simplest as well, is to boil it down until nearly dry every time two dozen sheets have been floated on it. Supposing you use a half gallon bath, after boiling, filter it and put in fresh silver, and make up with water to the bulk and strength required; keep it slightly alkaline, and it need never turn red as an acid bath will. This plan never fails with me. Ammonia is better than soda, because in boiling down the nitrate of ammonia decomposes into laughing gas and water, both of which pass off as steam, but soda is a fixed salt and cannot be got rid of short of fusion or other means.

The amateurs are now thick everywhere; more than half of them may be counted as bogus men, or photographic tramps, and they

---

\* Written for *Mosaics*, but received too late.

are doing their best to kill the outdoor branch of the business. They go from town to town, taking everything right and left, and sell the pictures for whatever they can get; get all you can, is their motto. In Washington they are so thick that we can no longer work in some of the parks there without a permit; the keeper of the White House Park told me that so many of them came that if permits were not required there would be all of them in and nobody else. However, they seem to do at least one good, if not more: they are quickly bringing people to discriminate between good and bad work. It need not now take long for the public to recognize merit in pictures. As the bogus men have killed trade for both themselves and the professionals, we can only hope that the time will soon arrive when they will retire, like flies in winter. The true amateur is always welcome, but the bogus men need to be rid of before business will pay well.

---

### THE PROOF.\*

BY L. FARINI,  
Bridgeport, Conn.

FINDING so much misunderstanding on the part of the public with reference to the meaning and intention of the proof, I have tried to correct it. I supply only an untuned proof. I deliver it in a strip of buff post-office paper, large enough to keep the proof from the light. On the outside I print "Rough proof. When examining this do not expose it to strong daylight." I place it in an envelope, and deliver it with a little four-page leaflet, unperfumed, but on tinted paper, which speaks for itself, viz.:

#### SOME REMARKS OF INTEREST TO SITTERS.

It has ever been the rule to submit to persons who have been photographed, a "Rough Proof" from their negative. The object of this is, that the sitter may have a chance of forming an estimate of what the finished result will show. Whether the lighting, the expression of the face, position of the head or figure, have been so managed as to produce a pleasing effect.

It is an unfortunate fact, however, that few persons know to what extent a "Rough Proof" is capable of affording them the information they desire.

There can be nothing more *unsatisfactory* than a "Rough Proof," especially so when the best lenses have been employed in producing the image. It may, therefore, not be considered out of place to explain *why* this "proof" confronts us with exaggerated defects in every feature. It even brings to light blemishes in the skin that our own eyes have not had power to detect. It makes us look much *older* than we really are. We are disappointed, and we declare "we would rather go to a dentist, than sit for another portrait!"

It is not surprising, since optical science has brought photographic lenses to such perfection and power, that the time occupied in taking our portrait did not exceed *one second*. And now that we have secured all we want (and even more), let us explain that our negative falls into the hands of a skilful artist, who is known as the "retoucher." This individual is frequently dubbed a *base flatterer*; but let us do him justice, not only by bringing his valuable services to the front, but by confessing that owing to his skill we find our negative freed from every blemish. He has patiently worked until he has obliterated every defect, modified the exaggerated lines we saw in our "proof," and when we behold our picture again we find it represents us as we are seen under the most favorable conditions. In short, a skilfully retouched negative is "a thing of beauty and a joy forever."

It must not be inferred from this that there is no limit to the retoucher's power. He cannot alter or change the position, nor can he make persons look pleasant if they looked sad at the time of sitting. It should be the photographer's aim to call forth the desired expression when *taking* the portrait, but if he has been unsuccessful in this, or in any other respect fallen short of the mark in aiming at perfection, his professional pride should be sufficient excuse for his *insisting* on making another trial.

In accordance with a time-honored custom, Mr. Farini furnishes you with this "Rough Proof," from which (together with the fore-

---

\* Written for *Mosaics*, but received too late.



going remarks) you will be able to form some idea of how the finished pictures will look.

It works well.

---

### DID YOU EVER TRY IT?\*

BY F. M. ROOD.

TAKE a penknife with a very small, pointed blade, sharpen the point well, and with it, using a magnifying glass, you can remove, by scraping, small opaque spots on gelatine negatives, when dry. You can also modify or remove an objectionable light in the eye, or any little defect of that kind. Your first trials will probably be failures, but practice will show you the proper shape of blade needed. Of course, care and patience are essential to success, but it can be done. Did you ever try it?

It is very unsafe to print from gelatine negatives without first protecting the film with some sort of varnish. The film gets stained from the silvered paper; a drop of water or other liquid may ruin it; the flies may think it isn't retouched enough, and their "stippling" isn't so fine as yours, and you don't like it. Flow with plain collodion, if nothing else, after retouching; it does very nicely where but a dozen or so of prints are required from a negative; indeed, a careful printer can make a thousand prints from a negative varnished with plain collodion only, without injuring it. Did you ever try it?

Retouch on the gelatine film by grinding with resin, fine pumice-stone, or any of the methods in use; coat with plain collodion, as above, and when dry and hard, coat with good varnish; when hard, grind again carefully, and retouch off those black freckles or moles that you could not fill up on the first film, and soften those heavy lines about the eyes and mouth that would not "yield" on the gelatine, and that stray lock of hair that refused to "budge" before can now be made to vanish. Scan the whole work over, and put on the finishing touches, and you will be pleased with the result. Did you ever try it?

Clean the back of your negatives before

printing, with dry pumice-stone (powdered), using the ball of the finger; perhaps a knife will be needed to scrape the largest gelatine stains or spots that may happen to be there, but the pumice-stone will make them shine and print clean. Did you ever try it?

In silvering albumen paper, when the first corner touches the surface of the silver solution, begin to raise it instantly, while lowering the rest of the sheet—that is, let it first touch the solution with a slightly rolling motion, and then you will find it impossible to get any air-bubbles under it. Did you ever try it?

In spotting prints before burnishing, rub up your India-ink (first quality) and neutral tint or opaque (or whatever you use to give the proper tone) with oil of spike, on the ground side of a piece of fine ground glass; use no water; dip the brush in a small bottle of the spike oil, as you work, and when you burnish your spotting will "stay there Eli." Did you ever try it?

---

### QUESTIONS AND ANSWERS.\*

BY "OLD ARGENTUM."

It is pleasant to know that I am "yet useful to the craft," as our editor puts it, but I am behind the age. "Othello's occupation's gone" from me, for I have not followed up the "dry" since it drove us old "wet" people from the field." Instead of writing you my usual article, therefore, I will hunt out a dozen or so of such questions as come to me every day, and give the answers I returned to the writers, trusting they may be useful to other "practicals." Q. shall stand for the name of the querist, and A. for Argentum's answer. Are we understood?

Q. I am after a substitute for glass for emulsion negatives. How can I make "flexible" glass?"

A. Paper of proper thickness is rendered transparent by soaking in copal varnish. When dry, it is polished, rubbed with pumice-stone, and a layer of soluble glass (had at all drug-stores) is applied and rubbed with salt. It is stated that the surface is as perfect as glass.

---

\* Written for *Mosaics*, but received too late.

---

\* Written for *Mosaics*, but received too late.

*Q.* I am trying to get rich on making some of my own accessories, such as rocks, etc. Can you tell me how to contrive a good, strong glue?

*A.* A very strong paste for pasteboard and other similar articles may be produced as follows:

4 parts of glue are soaked in 15 parts of cold water until soft. The mixture is gently warmed, until the solution is clear, and then mixed with 65 parts of boiling water. In another vessel, 30 parts of starch are mixed with 20 parts of cold water to a perfectly smooth paste, and this is gradually added to the solution of glue, which must be kept near the boiling point. When all is added, the heat is continued a few minutes longer and then withdrawn. The mass may be prevented from souring for some time by adding a little carbolic acid.

*Q.* How may I fix crayon drawings, and so on, so that when framed for specimens, dampness will not injure them?

*A.* India-ink for drawing plans may be prevented from running by adding a little sugar to the ink.

Probably the best and most convenient way of fixing pencil-marks is to immerse the paper containing the markings to be preserved in a bath of clear water: then flow or immerse in milk a moment, and hang up to dry. This treatment will preserve both the ordinary pencil-marks and crayon drawings as well.

*Q.* What will keep my dry plates from being affected by moisture *en route*—say on a sea or river voyage?

*A.* Asphalt paper is worth its weight in gold for such purposes. You can make it by "painting" strong manilla paper with melted asphalt.

*Q.* How can I keep my nicely polished camera looking "as good as new"?

*A.* The subjoined simple preparation will be found desirable for such work: Over a moderate fire put a perfectly clean vessel. Into this drop two ounces of white or yellow wax. When melted, add four ounces of pure turpentine, then stir until cool, when it is ready for use. The mixture brings out the original color of the wood, adding a

lustre equal to that of varnish. By rubbing with a piece of fine cork, it may, when it fades, be removed.

Or this:

Spirit of Turpentine . . .	1 pint.
Rectified Oil of Amber . . .	1 "
Olive Oil . . . . .	1 "
Oil of Lavender . . . . .	1 ounce.
Tincture of Alkanet . . . . .	$\frac{1}{2}$ "

A cotton rubber is saturated with this polish, which is thus applied to the wood. The latter is then well rubbed with soft, dry cotton rags, and wiped dry.

*Q.* What will produce a good black varnish for obscuring the inside of the camera, and so on?

*A.* Dissolve 50 parts of powdered copal in 400 parts of oil of lavender by the aid of a gentle heat, then add 5 parts of lampblack and 1 part of powdered indigo.

*Q.* Can I make a stopper or cork air-tight, to preserve my solutions from evaporation, etc.?

*A.* You can make corks air-tight by soaking them for some hours in a solution of 15 grammes gelatine and 24 grammes glycerine in  $\frac{1}{2}$  litre of water at 44° to 48° C., and drying them. They may be made acid-proof by introducing into a mixture of 2 parts vaseline and 7 parts paraffine at 40° C.

*Q.* How may I keep eggs fresh?

*A.* Unless you live "out West," or on a mountain, the best plan is to buy eggs fresh and often. At a recent dairy exhibition in England, it was shown that eggs which had been rubbed with a mixture of boiled olive oil and beeswax, or with clarified suet, had been preserved in excellent condition for a considerable time.

*Q.* What are good remedies for cuts and burns, to be kept handy in the dark-room, where glass edges and acids play tricks?

*A.* It is well to know that a solution of bicarbonate of soda (baking soda) promptly and permanently relieves all pain. The points to be observed are: 1. bicarbonate of soda must be used; washing soda and common soda are far too irritant to be applied if the burn is serious. 2. The solution must

be saturated. 3. The solution must be ice-cold.

Powdered rice is said to have a great effect in stopping bleeding from fresh wounds.

*Q.* Is there not some simple way of quickly cutting bottles and glass tubes?

*A.* To cut glass jars, fill the jar with lard oil to where you want to cut the jar; then heat an iron rod or bar to red heat; immerse it in the oil. The unequal expansion will check the jar all round at the surface of the oil, and you can lift off the top part.

A simple method of cutting thick glass tubes, even of large diameter, is, viz.: Wind an iron wire, of half a millimetre in thickness, around the glass tube, and connect it with a galvanic battery of sufficient power to raise the wire to a red heat. Then put a few drops of water near the wire upon the glass. The latter will then crack in the direction of the wire, and the thicker the glass, the more exact will be the fracture.

*Q.* Please tell a lady amateur how to keep her hands clean.

*A.* To clean the hands after work, rub with a little petroleum jelly and wash with warm water and castile soap.

For removing silver stains from the hands, Dr. Vogel recommends the application of a solution prepared by dissolving a few crystals of potassium ferricyanide in a solution of sodium hyposulphite.

*Q.* How can I toughen paper for use on my dark-room shelves, etc.?

*A.* Parchment paper is made by dipping ordinary unsized paper for five or six seconds in dilute sulphuric acid, and then washing.

*Q.* I live in the country. When I build a fire in the morning, the gases from my stove affect my emulsion plates. Can I avoid it?

*A.* The following is a very simple way of avoiding the disagreeable smoke and gas which always pours into the room when a fire is lit in a stove, heater, or fireplace on a damp day: Put in the wood and coal, as usual, but before lighting them ignite a handful of paper or shavings placed on top of the coal. This produces a current of hot air in the chimney, which draws up the smoke and gas at once.

*Q.* Two or three times my "den" has been imperilled by fire. Is there a good "extinguisher chemical" within the scope of your knowledge that is both handy and easily applied in such cases made and provided?

*A.* An eminent German physicist recommends for the extinguishment of fire in closed places, where the use of water or other liquids would be likely to do great damage, a dry compound, which, by its burning, absorbs the oxygen and quickly renders combustion impossible. The compound is composed of powdered nitrate of potash (saltpetre), 59 parts; powdered sulphur, 36 parts; powdered charcoal, 4 parts; colcothar (brown-red oxide of iron), 1 part. This preparation is one that can be cheaply made. It is recommended that it shall be, when thoroughly dried and mixed, put up in tight pasteboard boxes, holding about five pounds each, with a quick fuse in the side of the box—protruding six inches, with four inches inside—to facilitate and insure lighting it.

*Q.* I believe in nice specimen cases in the gallery and at the door, but in winter they are a job to keep clean. What is your experience?

*A.* To keep the silvered sash clean, try this paste: Grind (dry) 12 parts silver nitrate, 50 parts sodium chloride, and 30 parts cream tartar, very finely in a mortar, then triturate with a little water to form a homogeneous paste; keep the paste sheltered from the light. To silver, rub the copper or brass article with the paste, previously separating the verdigris from the copper, until it is thought that the layer of silvering is thick enough; then wash and wipe hard with a chamois skin. In replacing nitrate of silver by cyanide of silver, a dry powder is obtained, which is to be moistened when used. But it is more dangerous to use.

To keep show-windows clear and bright and to prevent frost, try this: Wash the glass all over with a sponge and clean, lukewarm soap-suds, mixed with about a gill of pure alcohol. When dry, rub it bright with a buckskin and a little prepared chalk, finely powdered. Finish with a silk handkerchief.

Q. How may I mend glass and porcelain dishes? I like them best for their cleanliness, but they do so break.

A. Try the following: Glass, porcelain, and metals can be soldered by an alloy made as follows: Copper dust, obtained by precipitation from a solution of the sulphate by means of zinc, is put in a cast-iron or porcelain-lined mortar, and mixed with strong sulphuric acid, specific gravity 1.85. From 20 to 30 or 36 parts of the dust are taken, according to the hardness desired. To the cake formed of acid and copper there is added, under constant stirring, 70 parts of mercury. When well mixed, the amalgam is carefully rinsed with warm water to remove all the acid, and then set aside to cool. In ten or twelve hours it is hard enough to scratch tin. When required for use it is to be heated so hot that when worked over and brazed in a mortar, it becomes as soft as wax. In this ductile form it can be spread on any surface, to which it adheres with great tenacity when it gets cold and hard. This alloy is intended to be used to solder such articles as will not bear high temperatures.

Or this:

*Diamond Cement.*—Soak isinglass in water until soft; then dissolve it in proof-spirits, and add a little resin. Good for china and glass.

[Translated for *The Philadelphia Photographer.*]

## THE POSITION OF PORTRAIT PHOTOGRAPHY AS A PLASTIC ART.

BY WALTER KUHN,  
Leipzig.

PORTRAITURE has become so general since the invention of photography, and particularly since the important technical improvements in that art, that it is quite rare now to find a person, living in civilized lands, who has not had his picture taken in some form or other. Formerly, it was the privilege of the rich to have portraits of themselves, but now, thanks to photography, this luxury is permissible to all classes of people.

It is the invention of photography, also, that has prompted the taking of portraits in quite other directions, and in a way differing greatly from former methods. Before the invention of photography, pictures were

taken by painters, or draughtsmen all in a manual way, and without the aid of mechanical means. What the eye perceived, and how this affected the mind, was reproduced by the hand. In strong opposition to this *modus operandi*, the photographer uses his machine, and by bringing the person sitting for his portrait into proper relations to the instrument, obtains the desired picture. The difference then between the portrait of a painter and that of a photographer, consists in this—the picture produced by a painter is the result of his mind operating through his hand, while that of a photographer is the result of his mind operating through the machine.

To examine more closely this distinction between painter and photographer, and their several ways of producing portraits, as well as to discover the special advantages and disadvantages which accrue to a photographer by following the mechanical method of producing pictures, shall be the theme of this article.

The first, and principal thing to be obtained in a portrait, is a likeness to the person it is intended to represent. In all probability, it is the photographer who possesses the greatest advantage in this respect by means of his machine, which presents a perfect image of the person—thus the truest, most life-like picture imaginable is the result.

If the photographic apparatus is properly arranged, so that the picture appears distinct and without perspective notings upon the dim disk, and if the person sitting for his portrait has not stirred during the proper time of exposure, so that in the development of the plate, an accurate picture appears, then a distinct and clearly reflected picture is obtained, and this must necessarily be exactly like the person.

And yet how few really true pictures there are, notwithstanding this technical accuracy. It may be mentioned at this point, that there is an agent that comes into consideration, which prevents the photographic picture from being an exact image. This is the peculiar action of different colors of the spectrum as light values. In consequence of this prejudicial circumstance, there may not be a great resemblance; an insufficient or

excessive retouching, occurring sometimes in lieu of real artistic discernments, is still more detrimental to the resemblance.

But a portrait ought not only to be a complete image of the person, but it should be intellectually alive, it must be *speakingly* like. This, then, is the conclusion of the matter—the picture must give the impression that it could speak, or, at least, that it could be spoken to, just as if it were the living person. Also, a portrait must be life-like, but not only life-like but true to life, *i. e.*, the individuality of the person must be represented in the picture. Moreover, it is not enough that a portrait be both life-like and true to life, but it should also present the pleasing peculiarities of the individual—it must appear to advantage, be pleasing and winning. These are the principal things, the fulfilment of which are, without exception, necessary to the obtaining of a good portrait.

A photographer finds many difficulties in obtaining a life-size portrait. These difficulties may be due to limitations in the management of his apparatus, or to the changeable disposition of his model. As great progress as instantaneous photography has made, it has not yet drawn portraiture into its compass. Portraits taken in the studio are here referred to. Were one to determine an average time of exposure for this purpose, five seconds would be considered a very short time. But it is not so easy to sit perfectly still and yet look natural, even for five seconds; and yet this is necessary for a photograph. With the exception of children, who do not understand what is taking place while they are being photographed, and of actors, who have acquired from the practice of their profession a certain control over the muscles of their face, it is not possible for any one to be unconstrained or to appear so; and even should a person possess the qualities of a mimic, yet in his picture would be noticed a certain strangeness, affectation, or stiffness. Usually there is apparent the so-called photographic look—a look which shows that the person has taken pains to sit perfectly still and to appear very pleasant. This convulsive pleasantness is generally crowned by a smile, which is abnormal to

most people in life, and thus opposed to the effect aimed at being untrue and repulsive in the extreme. Herein lies the great distinction between painting and photography, and the advantage in this matter rests with the painter, because the photographer is hindered by his instrument. Both painter and photographer study their models with care, and endeavor to find out the most favorable motive in the person for a portrait; but the painter can make his observation *at every sitting* and alter it at will; whereas the photographer must have the absolute coöperation of his model at the time of exposure, without which it would be impossible for the most skilful photographer to produce any kind of a favorable result.

It must be clear to the photographer that he is dependent upon his apparatus, and must continue to be so. He must also be aware that this apparatus places a limit for him, and prevents him from making a freer, more artistic use of his skill. To limit this dependence upon the apparatus to a minimum, must be the aim of every photographer; at least, if he tries, he can govern his machine completely—*i. e.*, he must understand thoroughly its technical treatment, as well as the advantages and disadvantages it possesses, and skilfully make use of the former, while endeavoring to remedy the latter.

Again, the photographer must turn his attention to a continual improvement in his working materials, and connive in some way to reduce the time of exposure to a minimum. At present the photographer strives to expose long enough, but it will come to pass that the photographer's art will consist in exposing as short a time as possible—*i. e.*, the photographer will find himself in the condition of being obliged to calculate his exposing time to the fraction of a second.

Every one knows that the objective and plate materials are far from perfect enough to allow the exposure in the department of portraiture to be reduced to so short a time; yet such great progress has been made in this respect in the past, that it can readily be believed that this point will sometime be reached.

The advantages of this shortened exposure

will be apparent to all. As before mentioned, it is difficult for a person to sit as still as is necessary even for five seconds. This is, in part, due to the fact that man is compelled by physical causes to be in continual, even if only very slight, movement. Therefore it requires the greatest bodily exertions to maintain a given position a longer time. Whoever has had the opportunity to know about standing for a model in the academies, or possibly to have stood for one himself, will know that the unnatural repose of body required is a great demand on the strength of the model. It is usual for the model to become exhausted in a short time, and even rarely to result in faintness, and, indeed, this may happen to people the strongest and accustomed to the most fatiguing labor.

Yet it is proper and necessary to man that even in his repose there should be a certain movement, and how much more apparent is this exercise of the muscles in a man of lively and intellectual nature.

For the "alive" expression of countenance lies not in any fixed position of the muscles, but in the continual exercise of the same. It is the play of thought which passes over the countenance and expresses speech—eloquent though silent—that constitutes an attractive face. Thus, for instance, a smile, if natural and merry, is beautiful, when it follows closely upon a foregoing quiet, and in the same way any change whatever, be it an increase or decrease of laughter, shows in the play of thought passing over the countenance. It is impossible, however, to laugh naturally five seconds without causing a change of expression in the countenance. Of course, the mouth could be kept that long in the same position, but man does not laugh with the mouth alone, but with the whole face, and, in the same way, the position of the body is acted upon (to which then the position of the body also corresponds).

As has just been remarked, the charm of a countenance lies in its change of expression and constant exercise of its muscles. If the condition of a person's mind is peaceful, then the changes on his face will be less, and will follow each other more slowly. But the more active the mind, the more fre-

quently does the expression change, and the more rapidly do these changes flit across the face. For example, a countenance may appear very beautiful while laughing most heartily, but only because quietness preceded it and will follow it. Thus it is the change of expression which beautifies a face. In a picture of a peaceful countenance, we will miss the change of expression less because there is less to miss, and by its non-expressiveness has a greater inclination to stolidity; but, on the other hand, in a picture representing an impassioned countenance, the absence of expression caused by a rapid change of thought, would be much more noticeable.

In this very respect is there a limit set for all *plastic* (from *plasso*, to shape, to form) arts.

*The moment* can be easily represented, but not the change of several moments. Since our aesthetic sense, however, is accustomed to show the highest expression of mind in the countenance for only a short time, and in life is followed immediately by repose of countenance, therefore the artist must be on the watch to catch these momentary phases, for in their rapid changes they form a direct contrast to the immovable works of the artist. It is not the object of this treatise to discuss how far the plastic art can go in this matter without violating the aesthetic. We have to deal especially with taking portraiture of people. In order to have the picture appear *lively*, nothing should be sacrificed in the matter of life truth. The portrait must not represent the person in any affectation, but as one is accustomed to see the person in every-day life. To represent the character of the individual is the object of the portrait.

Let us suppose a case: An earnest man, busied with deep thought, accustomed to carry his head downward, his eyes shaded by half-closed lids, comes to have his picture taken. The photographer places him in position, head erect, eyes wide open, profile, Rembrandt illumination, while a smile (occasioned by the photographer's enthusiasm) plays on the man's lips. The picture is produced sharp, uncommonly plastic, perfect in technique; and, conscious of the good result, the photographer exhibits the picture, and is exceedingly astonished that

no one recognizes a resemblance to the original. The picture is physically like but not individually so, and the blame of the failure is thrown wholly upon the photographer.

One of the chief hindrances to a photographer is due to just these kind of mistakes, and this also explains the fact that portrait photography has risen to no great artistic height, though it might easily do so were it not for the deficient working materials now attainable. This is the reason that portrait photography is carried on as a business of the masses. This is its drag-chain, limited by its mechanical technique. It happens in most cases that the person who comes to have his picture taken is a perfect stranger to the photographer, and only a few minutes are allowed him for the usual course of procedure in taking a picture. How can any one in so short a time get acquainted with a totally strange countenance, or enter into intimate relations with a person so as to discover his characteristic peculiarities in looks, manner, and movement. Even were the photographer a particularly good reader of character or of human nature, still it would be impossible for him to determine the individuality of his model; for people come just with the intention of having their picture taken, and in most cases an unusual manner is assumed which does not give a correct impression of the person. The artist ought to be able to observe his model's conduct in daily life, in speech, etc., and seek to discover his distinguishing characteristic. Just as the painter endeavors to fasten the result of this observation on the canvas, so must the photographer strive, by giving a suitable position, and by means of entertaining the sitter, to keep his model during the exposing time in just such a position and state of mind as will appear most characteristic, natural, and pleasant.

Again, in another respect, a purely artistic effect is not possible, for even supposing that most photographers can quickly and easily discover the distinguishing traits of their models, yet the most artistic talent must give out and become stupefied, owing to the great number of persons coming and going. Therefore, because the photographer cannot enter into any degree of intimacy in so short

a time, he must undertake to group and classify his models according to age, position, and other external marks; and will, in consequence, handle these according to a certain plan in arrangement of position, expression, lighting, etc., then what is there to hinder him from reaching the highest pinnacle of art?

Many will reply: this is only so in the case of photographs no great pretensions are made in these. But the reason that nothing much is expected of photographs is because we are not accustomed to anything better in them, since by far the greatest number are produced in haste and by the dozen; but it is by no means because photographic technique permits no better result, for this is well adapted to a high, yes, even the highest degree of art. Then in art, it does not depend upon the materials used. Whether the picture is drawn with charcoal or lead-pencil, or painted in colors, or whether it is a photograph, makes no difference in its valuation as a work of art. And just as little does art question concerning the time necessary for its execution, or whether there were particularly great difficulties to be overcome. Also, whether a picture was made in a day or a year; whether it needed extra exertion to produce it, whether many journeys enjoining trouble and danger were undertaken to accomplish it, none of these things are taken into account at all, it is only considered perfect when all the results which can be laid claim to in regard to the given materials are fulfilled. But what will this lead to? many a one will say, if every portrait is going to require such a long and careful observation of the original, what will be the cost of a photograph picture? But art does not make any question of time or money, therefore, so long as photography remains as a *business* for the masses it keeps itself from reaching the highest degree of art altogether.

Theory and practice are not so very distinct in art matters, in fact, in pure art, they are united. The only troublesome point is *money*, which separates them, and makes them so antagonistic to each other. Every artist, painter as well as photographer, must determine for himself how he can best settle this matter of theory and practice.

How different the position of a photog-

rapher is in this respect, every one can see. It is not possible for him to leave off on account of the competition going on in his business, so he is constrained to make a certain arrangement. Though he is not in the position to observe his model long and carefully, yet he should try at least, from time to time, to work on a model in this studious way. A photographer, just as every other artist, has to pursue his studies. By this is not meant the production of the so-called head-studies, but making clear to himself all those things embraced in the department of photography; for instance, the organic position and motion of the human body, physiognomy in physical and psychological respect, the laws of illumination, etc., in short the search after the wherefore.

It is seldom that a photographer succeeds so well with a picture that he finds nothing to rub out in it, for usually something has been overlooked that cannot afterwards be altered. To produce a picture free from faults, obtained by studious observation of different characteristics of model made with the greatest care and true resignation, the position, illumination, etc., chosen with regard to the smallest details, should be the aim of every photographer. Of course, he must not be deterred by this from taking more portraits, but must try to shun in the latter ones the faults of the preceding ones, and keep on trying until he believes he has achieved success. But for all that, he must sometimes work otherwise, as his practice obliges him. Sometimes rest; artistic work must not be done in haste. Then there are hours of recreation needed for the fatigued mental ability, which will give to him the requisite strength and desire to proceed in the pathways of his art with courage and ardor.—*Deutsche Photographen Zeitung.*

[Translated for the Philadelphia Photographer.]

## A FEW WORDS ABOUT NEGATIVES FOR ENLARGEMENTS.

BY M. HERAUD,  
Photographer at Aix.

I THINK I can be of some service to many of my colleagues by pointing out the operations to which I submit the gelatine bro-

vide negatives intended for enlargements. Let me say at first that the negatives that are daily made by the photographer to be used in the pressure-frame for printing one or several dozen prints, are not suitable for enlargements, and this for three reasons: they are generally very strong; they are varnished; they are alumed. An intense negative is indispensable for printing in the pressure frame, whilst for an enlargement this intensity is an obstacle. The varnish is also prejudicial; and, finally, the alum prevents the gelatine from stretching. Exposed in the enlarging apparatus for some time to the action of the sun, the film of alum gelatine invariably splits, and the negative is lost. To obviate this three-fold trouble, I proceed as follows:

The removal of the varnish from the negative is done with the greatest ease by immersing it in alcohol at 40°, containing two per cent. of caustic potash. In about two minutes the varnish is completely dissolved, and the negative is then washed under the tap. This first operation being ended, I proceed to reduce the intensity of the negative by placing it in a bath of cyanide of potassium at ten per cent. I have been successful in this bath in rendering some portions less intense than others, by injecting the liquid by means of a small glass syringe on the parts that are too intense. When the negative has reached the desired point it is washed and dried. Finally, to neutralize the action of the alum, in other words, to restore to the gelatine its faculty of dilation, I cover the negative with normal collodion at one per cent. of cotton, and containing two drops of glycerine for 100 c.c. (3 fl. ozs. 3 drs.) of collodion. By this means I obtain a brilliant negative, having all the desired transparency, and that can be exposed without danger in the solar apparatus.—*Le Progress.*

## A GERMAN HORSE IN MOTION.

IN a late number of *Photographische Correspondenz* appeared some reproductions of the best photographs of "the horse in motion" we have ever seen. They were taken by Herr Ottomar Anschütz, of Hannover. We are glad to be able here to place before our readers these pictures of a horse



taking a leap. The entire leap lasted about  $\frac{3}{4}$  of a second, the exposure about  $\frac{1}{1000}$  of a second, and there was an interval of  $\frac{1}{10}$  second between each exposure. The *Correspondenz* says :

"Photography has made great strides of late, especially in two directions, viz., in reproduction and in instantaneous pictures. Muybridge has used the latter process to portray the movements of a galloping horse

horse was eleven millimetres, so that these are enlargements.

"The most difficult task in photography is the reproduction in a series of the positions of rapidly moving bodies, and it has long been a problem which the most prominent photographers, such as the American Muybridge and the French Marey, have endeavored in vain to solve to their complete satisfaction, for they obtained, instead of

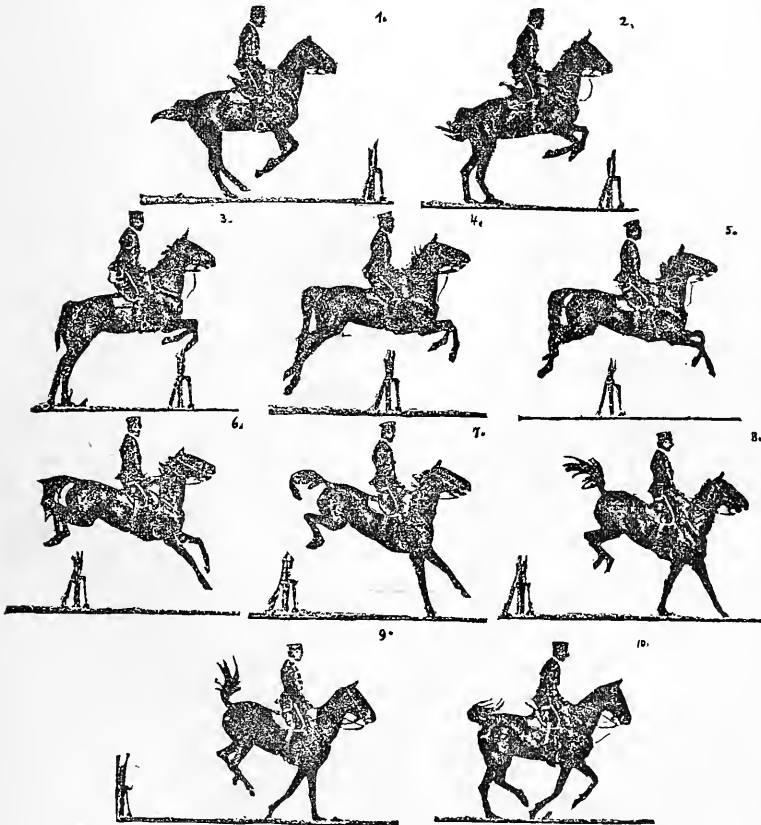

and rider, while Ottomar Anshütz has published, in Prussia, the picture of a stork family. The Prussian government has commissioned Mr. Anschütz to take pictures of horses when walking, trotting, galloping, leaping, and on the racecourse, by means of a new apparatus. The figure represents pictures of a horse and his rider in the act of jumping, taken in ten consecutive exposures. In the original picture the length of the

plastically modelled bodies, mere silhouettes or outlines. The special technical skill and great energy necessary for such work, have been found in the German photographer, O. Anschütz, and, without doubt, he has achieved that which will prove very beneficial to science. As is seen in these pictures of the horse jumping, the camera is designedly placed very low, in order to get a good view of the hoof as it is placed on the

ground at the end of the leap. There is also photographed with each picture a horizontal measuring rod. We notice in these pictures that the horse's forefeet do not touch the ground at the same time, at the conclusion of the jump, but one at a time, which fact is quite at variance with our preconceived notions. The positions of the leg during the jumping, in spite of their apparent oddness, are nevertheless quite correct."

(Translated for the Philadelphia Photographer.)

### A FIRST STEP TOWARDS THE PHOTOGRAPHING OF COLORS.

BY M. CONSTANT GLISENTI,  
Of Brescia, Italy.

I COMMENCE by declaring that I do not pretend to have discovered the photography of colors; nevertheless, I think it useful to communicate to the *Progrès Photographique* the result of my modest labors, having the conviction that my experiments will become the starting point of more important discoveries in this direction.

The prints that I submit to your appreciation were obtained by means of a process that I am about to describe. I call your attention to the direct collodion positive representing a landscape; you will remark in this print four well defined shades of green; the trees are of a beautiful dark green, the grass, the shrubbery, etc., of a green more or less light. The other prints have divers colorations; carmine-red, orange-red, orange, orange-yellow, and yellow; properly speaking, there is not here a reproduction of colors as in the landscape mentioned above; these prints, however, present some very curious effects. Let me remark in passing, that the clichés colored by my processes are excellent for the reproduction of engravings, plans, geographical charts, etc.; they give brilliant whites and intense blacks. My mode of proceeding is very simple. First prepare the two following baths:

#### *Bromide of Copper Bath.*—

Distilled Water . . . 50 c.c. (1 fl. oz. 5½ drms).  
Bromide of Ammonium . . . 7 gms. (108 grains).

In another bottle place 26 grammes (7 drms.) of pulverized sulphate of copper, and pour over it the bromide solution; agitate

strongly the bottle, and after from 20 to 30 minutes add 450 c.c. (15 fl. ozs. 3 drms.) of distilled water; filter after complete solution.

#### *Iodide of Mercury Bath.*—

A.

Distilled Water . . . 240 c.c. (7 fl. ozs. 6 drms).  
Iodide of Potassium . . . 6 grms. (92 grains).

B.

Distilled Water . . . 240 c.c. (7 fl. ozs. 6 drms)  
Bichloride of Mercury . . . 2 grms. (31 grains).

After complete solution, mix these two last together and filter. The collodion print, after fixing and washing, is plunged into the bath of bromide of copper; in about from 20 to 30 seconds it is completely discolored; it may, however, be allowed to remain without injury, according to the intensity of the negative; it is now withdrawn, washed, and immersed in the bath of iodide of mercury; it at once commences to take color; at the expiration of fifteen seconds, this coloration is already very apparent; it is complete at the end of thirty seconds, but the action of this bath may be slightly prolonged. We may remark that a collodion print that has just been made, submitted while yet wet to the successive action of the two baths, is colored very quickly; this is not the case when the prints have been made for some time; these are much longer in taking the color. Care must be taken to varnish the edges of old negatives, to avoid the raising of the collodion film; this being done, the plate is passed through water, then placed in the copper bath, in which it should remain from three to ten minutes, according to the tone desired. The plate is now plunged, after washing, in the mercury bath, where the coloration takes place, less quickly, however, than the wet plate. The aspect of the colored plates presents singular differences, according as they are examined by transparence or reflection. Let us suppose four prints of different intensities, obtained on the same plate by means of a multiplier, starting from a weak direct positive, and going gradually up to a strong negative: seen by reflection, the first—the weakest—will be of a carmine-red, whilst the last—the most intense—will be orange-red. By transparence, the first will be of a pinkish-yellow, and the two intermediates, red; the last will preserve its

orange-red tint. The application of gum lac varnish seems to diminish a little the brilliancy of the colors; amber varnish appears to me to be preferable; the amber should first be melted, then, after powdering, dissolved with the aid of heat in rectified benzine; after filtration, this varnish is ready for use. These processes are not applicable to gelatino-bromide plates.

[Translated for the Philadelphia Photographer.]

## HOW SCIENTIFIC LITERATURE IS STUDIED.

BY J. L. MÜRCH.

"ARE YOU a learned photographer?" Such was the question asked me some years ago by a prominent German photographer in England, when I made his acquaintance. This is also the question with so many of our craft when they read an article in some scientific journal, and, alas! only too often fail to understand it. And why? Just because they have never studied their art, but have only "learnt" it—and these are practical workmen. I use the term "learnt" advisedly, for photography in our times can be practiced in a purely manual way, and may be acquired in a superficial manner; but that photographer will never be called a scientific man who has not *studied* his profession, and also followed up eagerly all its improvements. And in order to do this, it is necessary to make use of the periodical literature of the profession, as well as the latest scientific works on the subject. So many photographers affirm that this is not necessary; that it is sufficient to produce commercially good pictures. These people are then surpassed by their intellectually superior comrades. I have met such "learned" photographers, to whom the newer, permanent copying processes, the charcoal prints, platina prints, the aristotype, were all so much Greek, and likely to remain so. Their deficiency, in comparison with their colleagues, produced an inability to create new and better arrangements. A scientific journal, in the hands of this class of "learned" photographers, would cer-

tainly be an unusual sight, for this is only for people who do not understand their business yet!—not for finished, well informed workmen.

Again, another class of photographers subscribes diligently, buys often, and possesses a fine technical library. The works of Eder, Liesegang, Vogel, etc., stand forth in elegant bindings, and the various annuals of photographic journals are exhibited; for a "cultured" photographer, and who, belonging to the profession, would not be that, must possess the professional literature. But question these people upon the contents of all these volumes, and you will soon see that the happy possessor thereof knows no more of them than their titles. "I have no time to read," complains one. "There is nothing practically useful in them," says another. A third makes this charge against the authors of scientific articles: "They delude the scientific public with receipts and descriptions which are not available; a receipt taken from a newspaper is never serviceable." How often have I heard this statement made! And yet it is an accusation which every author must consider as an insult, and must deny.

We are now brought to the source of the ignorance; it is insufficient study of the literature of one's art! But says one to me, "I do not belong to that class which do not cut the leaves of their journals, or lay them aside unread; I read each article conscientiously every time." Do you really do that, my good friend? But do you comprehend thoroughly what you read? Scarcely aright, I fear, as the result of your work proves.

How, then, to study, we question ourselves? How ought we, to whom the week, with its seven days, is too short to study the literature of our art? I will answer this question by briefly describing my own system of study. In the first place, I have a book arranged with an alphabetical index. This book I have kept regularly for the past ten years, and I consider it more important than any other separate volume of my professional library, for it contains the *proved* contents of the others, and shows the results. To keep such a book as this I pursued the following plan: As soon as I received a journal

I made an effort to read it through hurriedly. For this there is time enough, for the operator has some minutes to spare mornings and evenings, as also has the retoucher and printer. These are quite sufficient for a glance over the contents to pick out, as a nut from its shell, the gist of the matter, minus its wordy encasement. I do this and mark the principal parts with a blue pencil. Whatever subject the article treats of, I enter it in succinct form under its proper class and number in my book, with author and origin given. With receipts, which are given for ordinary practice, I add a clause containing the exact formula as prepared and used, just as soon as an opportunity offers itself without interfering with business interests. The operation is most carefully watched, and the results compared with that obtained by other solutions or processes. One's own experience can now be added to the receipt or described method, and the decision reached whether it is valuable or worthless. Moreover, observation has perhaps shown that the method or solution shows an inclination to work in a certain direction. Then I ask myself, why is this? and endeavor to find out. If I can do so, then I make a note of it and add it to the receipt or description of the method. Subject and classification are now entered in the index, while at the same time the mind is impressed with the subject, and will remember what has been observed in time of need: thus an important advantage is derived therefrom. Yet I am not satisfied with this, but place the directions of different authors upon the same subject together in a special book, and add thereto my own experience which I had with each receipt. In this way I obtain a result of the highest importance—the abstract, or summary, of the whole matter. I see wherein the directions are deficient; I notice the heterogeneity in the working of different materials, and so master conclusively the whole matter.

Perhaps some will say that all this sounds too particular; that it requires an unusual activity, a strong will. Very true; but nothing is obtained without effort, and does it not bring its own reward?—a pure and lofty sense of satisfaction at greater perfec-

tion and mastery of one's business. The practical man is often right that he does not believe in what the theoretical man says, or trust implicitly in his directions; what appears logical in theory is not always serviceable in practice. But this only confirms what I have been saying concerning the inadequate study given to professional literature by practical men. A workman who makes use of scientific literature in the manner described will make at first imperceptible progress, but later his advance will be strikingly noticeable. All fruits require time to ripen, and so it is in professional life.

When a man has reached a certain point in his profession, he finds that certain duties devolve upon him as a member of human society, and he is called upon to give his opinions on professional matters as a cultivated and well-informed practitioner. Then are his works welcome to an editor, and quite important; and to the struggling young artist they serve as true guides, on which he can safely rely.

But to the man who has studied his profession in the manner described by me, and yet perhaps is not a learned photographer, the question I mentioned in the beginning may appear as a ridiculous prejudice. Alas! prejudice prevails in all graphic arts. Thus I know good old practitioners to whom a wet negative which has not a certain precipitate in the limpid places is a horror. That may be the sign of "ripeness." To me it was always a sign that the plate was overexposed, overdeveloped, or overstrengthened, or that the silver bath did not work faultlessly, and I anxiously avoid this suspicious ripeness which permits lights in the deepest shades.

Of course, the younger members of our art who study in the above way will never continue using certain receipts and methods, but will improve upon them by their own experiments; perhaps they will find that the same qualities may be made to produce better results, or it may be that new methods save time, or that expensive materials may be replaced by cheaper ones. In the professional journals, however, practice cultivated by theory will best speak for others.—*Photo. Archiv.*

## GROUPING UNDER THE SUN.\*

BY C. WALTON HILL,  
Littleton, N. H.

THE tendency of photographers to study art principles is one of the most cheering signs of the times. I was born with a paint-brush in my mouth, instead of with a silver spoon, as the *lucky* child usually is, and had art painted in me by my paternal from the time I could understand what he said.

At the same time I will leave my easel on the slightest provocation and shoulder my camera for a hunt among the good people who get their living from the cracks in the rocks up in this White Hills land.

I am one of the artists—nay, *painters*, for we are all artists, more or less—who is willing to acknowledge that photography is invaluable to me in my vocation. And since I feel so good toward you who get your bread and butter and maple molasses by

will touch the feelings of all classes, if possible, or as Lord Bacon has said, "come home to the business and bosoms of most men." In doing so the mind, as much as the eye, came into play. Let me illustrate by a picture that it is possible to imitate wherever harvest fields grow. It is called "The Harvesters at Rest," by Mr. Wyatt Eaton, one of the choicest compositions of its kind I ever saw.

Suppose you were going to photograph the "Harvesters at Rest" You would choose the shady side of a shock of sheaves; you would pose the tired husbandman in a restful attitude; you would send the housewife to him with his noon-day lunch, and, of course, she must bring the baby, because there is no one at home to leave it with. The mother and child should be placed where the husbandman can admire them, and thus help him rest better, where they

will help most in your diagonal composition.

The basket you would use also to complete the exterior lines and toss the old hat down where it would best break up the empty foreground, and break up a rather too broad expanse of light; would you not? Or, if you are in a grass-growing country, where it is the custom to blow the horn to call to lunch the mower and the good wife, who tosses the new-mown hay, that it may dry in the sun, another group would come to

FIG. 1.



means of the camera, I trust you will take a few suggestions kindly as to the composition of outdoor groups. I shall apply to some of my fellow-artists for my illustrations, rather than copy from my own picture.

One of the first things to look at, of course, is to invent the story you want to tell. It should always be something that

your mind, such as "Answering the Horn," by Mr. Winslow Homes. Now you might see a dozen such couples as this in a day's ramble, looking awfully picturesque, and yet you would be puzzled to know how to pose them, unless you could invent a story to work them into. "Answering the Horn" does it. The parties halt at the sound; the answering hand goes up with a shout from the mouth of the man, which closes that of

\* Written for *Mosaics*, but received too late.

the woman, and the picture is worthy of the camera.

FIG. 2.



In attempting larger groups, such as "The Washing Place—Brittany," by Mr. Edgar M. Ward, or any group where the figures are numerous, the effort should be

FIG. 3.



to give variety to the occupation of the persons, and with them all and what accessories

you can—tell the story to the best of your ability. This is not an American or English picture, or one likely to be found in either America or England, but it is full of suggestion all the same.

As Burnet says, "the form or plan of any composition is the first process the painter practically commences with. The nature of the subject having been settled, he weighs in his mind the effect to be produced upon the spectator. He therefore arranges his figures and objects accordingly, and endeavors to distribute his materials in that form which will best accord with his intention. The illustration of his story, the distribution of his light and shade, the localities of the scene, all present their individual interests to his notice; while his imagination embodies them into that congregated form which seems best calculated for his purpose." But to do all these things well, he must have the principles of art instilled within him. To them I commend you.

The next illustration will be more "to the manor born." It is Mr. Edward Gay's "Penfield's View," and is from a celebrated spot beloved by artists near Mount Vernon, New York. I am sorry the reduction is so small, but there is enough of it to show that

the painter was influenced by the rules of art, though he has applied to nature to give him the means of securing variety and originality in his work. The arrangement of the wagons and carts and people and sheep was by no means accidental, but intentional in a great measure, though he has evidently a quick eye enough to guide him in taking advantage of accidental arrangements, and the power of methodizing his ideas. All these you must acquire by study and hard practice.

"Cannot drive sheep where you want 'em in a photograph," you say?

Well, I have seen sheep better grouped in a photograph than these are. It is this

FIG. 4.



class of photographs, my friends, that is going to lift your art up to the top of its ladder. Remember what I say.

### NATURALISM AND PHOTOGRAPHY.\*

BY H. P. ROBINSON.

FASHION changes in art as well as in other things. Pre-Raphaelitism was a protest against the classicism that was in its decadence. The art of the period, when it arose, was all but devoid of purpose, thought, or imagination. The Pre-Raphaelites added all these qualities to wonderful manipulative excellencies, but now the whirligig goes round and naturalism protests against thought. It is the protest of grammar against poetry; Lindley Murray is preferred to Shakespeare. In all arts but the photographic, craftsmanship is taking the place of imagination and design. In painting, the artist has no further use for the higher qualities of his nature. He need not think; he has only to sit down and copy nature by a fashionable recipe, which does not leave much likeness to her in the result. The clever suggestion of the first impression of a scene is made to do duty for all the better qualities that once went to the making of a picture; in music, execution is superseding melody; in poetry, the way it

is said is more considered than the thing said; the proper relation of the sestet to the octave in a sonnet has a greater value than all the prodigal wealth of imagination in *Paradise Lost*. The craze has extended even to the libraries, and it is now difficult to get a sound tale, such as those in the *Waverly Novels*; the interest is not now in the plot, but in psychological analysis and the way the philosophy of human life is presented. It is fortunate that there is now little room for skill in craftsman-

ship in our own art. It would be a curious instance of time bringing round its revenges if photography, once the most prosaic and mechanical of all the arts, should become the most poetical. But processes are so simplified that there is little room for the ambitious photographer to shine, except in the intellectual side of his art. It is only by the addition of those qualities which begin where photography properly ends, such as selection, choice or invention of subject, composition, light and shade, and expression, that the clever operator can show any real skill beyond his fellows. This is always observable in exhibitions. Visitors pass quickly by the ordinary portraits and landscapes, and linger only to enjoy themselves when they come to a picture embodying a thought, however poor the thought may be, and, to some extent, however indifferently the thought may be expressed.

In keeping to the old, well-tried rules of art, the photographer need not neglect what is good in the new. He must study "values," now the fashionable study in art; not that he may render them accurately as they are in nature, for that is mechanically and absolutely done for him in a properly exposed and developed plate, but that he may create them before he renders them, a thing that an orthodox, naturalistic painter would disdain to do. For instance, he has to photograph a gray landscape; he must exercise his invention and ingenuity to introduce

\* Written for *Mosaics*, but received too late.

some dark or light object in the foreground to give value to the misty scene. This is the use which a study of values can be to a photographer.

Study art, if you want to make pictures; you cannot learn by studying nature only. Nature does not teach art, but she will make suggestions to you when you have learnt to see them. Any one who has not studied from books and pictures does not see one tenth of the beauties of nature; he does not know how to see them. Let your picture look as if you wanted to do the best with your subject. You may not succeed, but it will be plain to an expert whether you have tried or not. When you fail, hunt down the failure. The subject might have been delightful, but was badly lighted; it is evident you might have done better by waiting. A figure might have pulled the composition together; you have neglected this. The negative is too intense and chalky; reducing might have remedied the fault. Never be satisfied if you want to succeed. Above all, try to fix this admirable definition of art in your memory: "Art is interpretation by means of a creative idea, and never a stupidly exact copy."

---

### A VETERAN'S ANSWER.

BY JEX BARDWELL.

IN No. 289 of the PHILADELPHIA PHOTOGRAPHER, page 615, I notice Mr. Styles's remarks—"By the way, I claim to be the first person who used dry plates in everyday practical photography in the United States. If there is any one ahead of me, bring him out."

I suppose this is intended as a sort of challenge. I know of a party in Philadelphia, and one in Boston, that worked the albumen dry process as early as 1851 and 1852; in 1853 I experimented some myself, but not of any account; in 1854 I tried to take some collodion negatives by flowing it on paper, and have now in my possession a print from one of them, but could not succeed in working them dry; but I did use a moist process in 1855 or 1856. Mr. Anthony, of New York, constructed for me an outdoor camera, with six holders, for dry-plate

work, which camera and holders I have now. The camera is in use to-day in making collodion transparencies, and I very much doubt if there is to be found a camera of its age and having been in continued use for the same length of time. This camera, Mr. Anthony told me, was the first made for its especial use. After the honey and meta gelatine process, I took to the tannin, then the coffee, which I continued to use up to the advent of the bromo-gelatine. I moved to Detroit in 1859, and commenced to do stereo-commercial work. I have now in my collection negatives from the honey, raisin, tannin, and coffee, from that date having done most of my outside work on dry plates. I think I am one of the men Mr. Styles has asked for.

The above is not of much account, so I will close with an observation or two that may be of some account to somebody. I have found that a small quantity of *bisulphite of soda* will keep a solution of pyrogallie acid absolutely white, and I may say indefinitely, for I have kept it over a year in perfect condition. I recommend Powers & Weightman's bisulphite. Sulphite of soda, made up in solution with pyro, if kept any time, soon loses its good qualities. If made up in solution by itself, and in small quantity at a time, and the required quantity added to the developer at time of using, I have found it to be an improvement.

When I require a negative of more density than is usual, especially in black and white work, where density and clearness is needed, I find a few drops of phosphoric acid added to my developer to give me all I desire.

---

### PHOTOGRAPHING ABRAHAM LINCOLN.

THE November *Century* magazine begins a new volume of that unrivalled monthly and the edition printed is a quarter of a million. The frontispiece is an admirable engraving of Abraham Lincoln from a negative made by the veteran, Alex. Hesler, of Chicago.

Mr. Hesler sends us some characteristic notes on his experiences with Mr. Lincoln as a model, which should be placed on record.



Mr. Hesler writes us as follows:

In February, 1857, some lawyers came to my studio, then in Metropolitan Block, Chicago, and stated that a number of them wanted a good photograph of Lincoln; and as they felt he was not able or could not well afford to buy and give them away, would I make a negative of him and let all who wanted come and buy them? To which I readily consented, although up to that time I had never seen him that I could remember.

In due time a tall lank person presented himself, and said: "The boys at the Court House wanted him to come and sit for his picture, and he couldn't imagine what any one wanted with such a looking picture as he would make." As is my rule, when he was seated I began studying his face, and found that what at first struck me as a plain, uninteresting face was really a remarkably fine one, beaming with kindness and intelligence. As he seated himself, his long hair fell over his forehead covering its magnificent lines. I ran my fingers through it, throwing it back, and letting it fall loosely as you see in the copy I send you. All his friends were delighted with the result and thought it fully represented the man in action, habit, and character.

After his nomination for the Presidency, in 1860, I published his and Douglass' picture together. Douglass was dressed and barbered up to the utmost, and when placed by the side of Lincoln's made it look untidy to the unartistic eye, and a request came to me that I make a new picture, "more dressed up." Accordingly I wrote to Mr. Lincoln asking that he give me a sitting the first time he came to Chicago, and received a very kindly letter stating, his friends with himself had decided that he remain at Springfield during the campaign; and if I would come there he would give me the dressed sittings. I went down (taking the night train), called at 8 A.M. at his house, and was told by Mrs. Lincoln that he was at the State House, where I found him, surrounded by portrait artists all eager to get his picture first. On stating my mission Mr. Lincoln kindly said he would go with me to the photograph gallery and give me all the time I wished for. I

made three negatives; a copy of one of them I enclose to you.

The time in which this occurred was the last day of June, 1860, the day of the "Great Comache Cyclone" that swept over Iowa and Northern Illinois with such fearful destruction of life and property.

The original negatives then taken were destroyed in the great Chicago fire, October 8 and 9, 1871, together with forty thousand other valuable negatives.

Respectfully, A. HESLER.

### THE AMERICAN EXHIBITION IN LONDON.

THE American Exhibition in London opens on May 2, 1887. The directors have given photography a place among the arts, and Mr. John Sartain, whom those happy enough to have been at the Centennial Exposition will remember as head of the Department of Fine Arts there, holds the same position in this Exhibition. He has written urging us to call on American photographers to contribute and make their art's exhibit an honorable and a representative one. We would join him in earnestly asking the fraternity to take an interest in this Exhibition, and to send their best work to it.

Much should not be sent by any one man, as space is very precious. Send the gems without the gavage. There has lately been too much of a disposition in exhibiting photographers to be generous—to themselves. Therefore send only the very best. That this brings no lack of appreciation is proved by such exhibits as Decker & Wilber's, which was cream of the cream, as an exhibit should be. Fine landscape or characteristic groups or similar artistic subjects should be sent, not mere portraits, which are not interesting unless of celebrities.

The generous conditions offered by the Directors ought to call forth as generous a response. They assume all charges for freight, packing, and insurance; there is no charge for storage or space.

"All works of art submitted," also says their circular, "must be of a high order of merit, and will be admitted to the exhibition only on the approval of the Committee

on Selection, composed of artists," Other conditions are :

"Packages forwarded by exhibitors in the United States for admission to this Department must be marked "Art Department." There must also be attached to the outside and inside of each package a label giving the name and address of the exhibitor, and the title and number of articles in the package.

"All pictures whether round or oval, should be placed in square frames.

"Works of Art intended for sale will be so designated in the Official Catalogue.

"Works not intended for competition must be so stated by the exhibitor, and they will be excluded from the examination by the jury on awards.

"All works of Art must be in London prior to April 1, 1887, and after having been admitted under the rules, cannot be removed before the close of the Exhibition. Applicants will be notified of the time and place to present their works to the Committee of Selection for examination."

There is in sober fact the generous offer of a splendid opportunity for American photography to show what is in it. Let the American Exhibition hear from you!

For particulars and circulars address, John Sartain Esq, No. 702 Chestnut St., Philadelphia.

---

### OUR PICTURE.

For a number of years a great deal has been written on the subject of securing negatives which would render the proper color-value of the object photographed.

A most industrious experimentalist in this direction is Mr. F. E. Ives, of Philadelphia, who from time to time has generously recorded his experiments in our pages. Our readers, therefore, are familiar with the subject of orthochromatic photography, and quite prepared to see the splendid result presented now as our picture.

In nearly all of the art stores may be seen the splendid chromo published by Messrs. L. Prang & Co., Boston, entitled "The Midnight Sun at the North Cape." It is in the richest imaginable tints of red and yellow, brown and black, only the sun,

the water, and the reflected light supplying the lights of the composition. Scarcely a more difficult subject could be chosen as a test for the orthochromatic method, than "The Midnight Sun," and yet Mr. Ives has proven his process to be equal to the occasion.

Our picture, a double one, is photoengraved by a process which is a second ingenious invention by Mr. Ives. The first impression is by ordinary photography, and the second by the Ives orthochromatic process. For expert photographers we need hardly point out the differences, or make claim for the superiority of the new method. The exaggerated rendering of the handling of the painter in the sky and the marking of the image of the golden sun only by a dim, dark spot in one, contrasted with the lovely delicacy of the clouds and the soft rendering of the sun-disk in the other, need only to be alluded to in order to interest our readers in the many other advantages secured by Mr. Ives. It is a wonderful triumph and marks a great advance in photographic technique. As will be seen by the report on another page a committee of the Franklin Institute, Philadelphia, has honored Mr. Ives with a medal which is only awarded once a year for the most important improvement or invention of the year in all directions.

Our picture represents not only one, but two of the most useful inventions which have grown out of our art during the past few years. Certainly the young inventor is to be congratulated.

---

### THE WORLD'S PHOTOGRAPHY FOCUSED.

THE French Academy of Sciences has recently been much occupied with the development of photography, and M. Chevreul's theory that, in order to obtain the most rapid impression, the plate should be of the *noir absolu*, has received a great deal of attention. At their last meeting M. Maray placed before the Academicians the result of experiments made on plates as recommended by M. Chevreul, by means of which he has obtained a series of photographs, each of which was taken in the

two thousandth part of a second by a process, M. Maray explains, which, when fully developed, will only take half the time; or the four-thousandth part of a second. It is not surprising that the honorable Academician considers that at present the development of the mechanical part of photography has reached its utmost limits, at which science makes a stand against her votaries, saying, "So far and no farther."

THE National Library, the library of the Ecole des Beaux Arts and similar institutions in Paris, are about to inaugurate a new measure, that of photographing all the books and manuscripts, of which they have only one or at most two copies on their shelves. In case of accidents, by fire or theft, they will thus be able to reproduce any original lost; and more than this, libraries outside of Paris, be it in the provinces or abroad, may easily procure copies. From the probable sale of the latter, in fact, the expense of the undertaking is likely to be partly, if not wholly, defrayed.

A NEW APPLICATION OF THE PHOTOPHONE.—M. Léon Esquille has found it possible to employ photography and electricity together, for the purpose of recording and reproducing speech in a more direct manner than has hitherto been done. M. Esquille's method consists in speaking in the first instance to the photophone transmitter. Our readers will remember that this is merely a diaphragm with a highly polished surface from which a ray of light is reflected. The record of this speech is then obtained by simply photographing the ray of light upon a travelling band of sensitized paper. After having been developed, the articulation may be reproduced by projecting the image of the trace by means of an electric arc or oxyhydrogen light upon a selenium receiver, preferably one of the form due to M. Mercadier. The speech is then heard through the telephone in the usual manner. It seems highly probable that, although this method is certainly more troublesome, it will give results superior to those of instruments which, like Edison's phonograph and Professor Bell's more recent "graphophone," depend initially upon

a mechanically formed trace of the sound vibrations.—*Electrician*.

PHOTOGRAPHY IN INDIA.—Amateur photography has so advanced in India that a flourishing photographic society has been formed in Calcutta, and has just held its first meetings. The members will make excursions to collect material for an album to be published by the society, and it is further proposed to organize an exhibition of their work in the cold season. Lady Dufferin is a patron of the society, being herself a very successful amateur "Lady of the Sun."

A BERLIN photographer recently met with an accident while performing a noble action. He happened to see a little girl run right in front of the horses of a brewer's wagon. He hastened to the rescue and, at the last moment, pulled the child, who was even then under the horse's hoof, to one side, saved her, but at his own expense, for his left hand was run over by the front wheel and two of his fingers crushed. The pain must have been intense for the strong man acted like a madman. A physician rendered him assistance.

#### PERTAINING TO THE

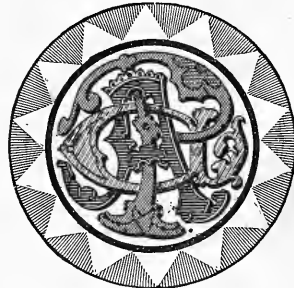

MANY things are being said concerning triennial exhibitions, cost of conventions and their management, the giving of medals, and radical changes in the financial policy of the Photographer's Association of America. Having been closely connected with the fraternity the last two or three years, perhaps a few facts gathered from my experience would not be out of place at this time.

Let us consider first the reduction of fees

and dues of members together with the price of floor space to dealers and manufacturers. President Potter recommends a reduction of the initiation fees to two dollars for proprietors and one for employers, annual dues one dollar each, with the exhibit of both art and stock department to be open to the public for the last three days, admittance twenty-five cents.

Taking the last two conventions as bases, let us compare the receipts with the expenditures and see the result.

At the Buffalo Convention 194 new members paid \$5.00 each, in all \$970; 431 paid dues of \$2.00 each, \$862. With floor space of \$2000, we have a total of over \$4000. Receiving from Mr. Armstrong the former Treasurer \$600, we have in the treasury \$4612. Deducting the expenses of the convention, \$2718.69, we have a balance in the treasury of over \$1900 making a net gain of over \$1300.

Now reduce the floor space one-third and we have about \$1334. The amount of dues of 194 members at \$2.00 each is \$388. With 431 members at \$1.00 each (\$431), admitting the public at 25 cents each (\$200), we have a total of about \$2353. Adding to this the \$600 in the treasury and we have \$2953. With expenses amounting to \$2718 there would be a balance of \$235 in the treasury, rather a small amount to start the St. Louis Convention.

At St. Louis, the receipts from 321 members at \$5.00 each is \$1605. Dues paid by 335 members, \$2.00 each, \$670. Received from public admissions \$127, and from floor space \$1628, making a total of \$4020. The expenses, \$3444, deducted from this leaves a net gain of \$576 or about \$700 less than the Buffalo Convention. This added to the money in the treasury gives \$2500 to the credit of the Association.

Now let us make a reduction on the cheap scale for St. Louis, 321 new members at \$2.00 each, \$642; 335 members at \$1.00 each, \$335; admissions from the public \$127; making a total of \$1104. Adding to this the amount in hands of treasurer from reduced rate in Buffalo and we have \$1425. Taking from this the expenses of the St. Louis Convention, \$3444, the Association would be in debt over \$2000.

Shall we return to the financial policy of the brethren who had in charge the management of the old N. P. A. and fill our photographic journals with the cry of give, give, for our National Association must have assistance or perish for want of nourishment. Many will remember the time when our lamented Rulophson stood upon the auction block in the city of Chicago and sold picture frames and other articles donated by the members to pay the indebtedness and uphold the honor and dignity of the fraternity, but all of no avail. A few more struggles and the old N. P. A. became a thing of the past and was heard of no more. Or shall we continue a policy which has made this P. A. of A. incorporation self-sustaining, an honor to the craft, and, if rightly managed in the future, cannot but have a great influence toward the elevation and advancement of photography?

Any changes in the management of the Association should be approached with due thought and caution so as not to interfere with its workings. The Association if carefully conducted might be more liberal to the dealers with advantage to both itself and them.

I believe all help necessary for the handling and sale of goods at our convention should be admitted free. As a rule they are of no benefit to the Association and have no interest in it. Then as to the price of space it seems to me that the charge per square foot should be regulated according to circumstances.

The dealers are willing to contribute liberally to the support of the Association when all have an equal footing and are governed by sound business principles, but, after they have paid their honest debts, they do not want to be hunted down with subscription papers as if for a charity organization for some fund that can and ought to be paid out of the treasury.

I am a firm believer in the giving of medals. There is something about them that inspires a man to greater efforts. The soldier on the field of battle faces death a thousand times for honor to his country and himself and the medal on his breast tells the story of his victories to the world. Our friend J. F. Ryder says they are be-

getters of jealousies, destroyers of harmony, and bones of contention over which to wrangle. When I look on his cabinet cards, and count the many medals, I cannot but think what a destroyer of harmony he must have been. No, brother Ryder, give the boys a chance to win laurels like those you have so honorably won.

Some say conventions are too expensive for the returns they afford. We may count the costs to attend them but who among us shall estimate the value of our Association to its members or to the future of photography?

It would be ungrateful in me not to acknowledge the assistance and pleasure derived from these yearly meetings and I hope each member feels that he too has acquired some good from attending. Nothing would contribute more directly to bring about the Golden Age of this Association than the harmony and persevering operations of its members. "But we must take the current when it serves."

Trusting to the indulgence of the readers of this article and feeling sure of the consideration of the critics, who, while they find many faults, are at the same time conscious of the difficulty of doing such a subject justice.

Very truly yours,  
H. McMICHAEL.

---

**REPORT OF THE COMMITTEE ON SCIENCE AND THE ARTS ON IVES'S PROCESS OF ISOCHROMATIC PHOTOGRAPHY.\***

HALL OF THE FRANKLIN INSTITUTE,  
PHILADELPHIA, November, 1885.

The Sub-Committee of the Committee on Science and the Arts, constituted by the Franklin Institute, of the State of Pennsylvania, to whom was referred for examination

FRED. E. IVES'S IMPROVEMENTS IN  
ISOCHROMATIC PHOTOGRAPHY,

*Report*: That they have carefully considered the process published by Mr. Ives in the PHILADELPHIA PHOTOGRAPHER, p. 365,

---

\* Reprinted from the *Journal of the Franklin Institute*, October, 1886.

No. 192, December, 1879, under the title "On Photographing Colors."

In this paper attention is called to the fact that colors which, to the eye, seem light, will often photograph dark; while some colors looking dark, photograph light. He claimed at that time to have perfected a process of value in copying oil paintings, and also in making pictures of natural scenery, when a long exposure is possible; and he proceeds to describe the process as follows:

"I place the object to be photographed in a strong light, if possible, and use a quick-working objective, directly in front of which is placed a lantern tank, having thin plate-glass sides, nearly half an inch apart. Fill the tank with a solution of bichromate of potash, containing one part of bichromate to 1000 parts of water; focus as usual. Then prepare a plate with 'Newton's Emulsion' (I always manufacture it myself, and find it uniform and perfectly reliable, as follows:

"As soon as the emulsion is set, pour upon it a little alcoholic solution of chlorophyl (formula below), and float it backwards and forwards for about thirty seconds, after which wash until smooth. Then flow with tea organifier (tea, one-half ounce; water ten ounces); rinse and expose about two and one-half times as long as required with plain emulsion without tank of yellow.

"Develop with the sal-soda developer (I make this double the strength recommended by Mr. Newton, and dilute where over-exposure is suspected). If the bichromate of potash solution is too intense, blue and green will photograph too dark. I have given the proportions I find perfectly adapted to my tank, lens, and chemicals.

"To prepare the chlorophyl, first extract everything soluble in water from myrtle or tea leaves, by treating with a number of changes of hot water; then dry the leaves, and the chlorophyl may be extracted at any time by treating about one ounce of leaves with four ounces of hot alcohol.

"Myrtle leaves yield the most chlorophyl, the solution of which should be a deep pure green color, and will remain good a long while, *if kept in the dark*. It spoils very soon if exposed to a strong light."

Mr. Ives submits to your committee photographs taken from highly-colored pictures,

in comparison with photographs made from the same highly-colored pictures by the ordinary wet collodion process. He submits also a chromo of two men playing cards, this is highly colored with plenty of bright yellow and red in contrast with blue. This chromo has been photographed by Mr. F. Gutekunst of this city, using a colored glass before the lens, but not using the chlorophyl as recommended by Mr. Ives.

The result is unsatisfactory; yet, from the well-known skill of the operator, your committee is convinced that it represents the best result obtainable by the ordinary methods of photography, aided by the colored glass. The same chromo photographed by the Ives process, substantially as given in the PHILADELPHIA PHOTOGRAPHER in December, 1879, is perfect in detail, and in the gradation of light and shade, as expressed by light or dark pigments, regardless of the actinic effect of the color used. Thus, the light yellow is given light in tone, and the darker blue is dark in tone.

Your committee have examined the recorded state of the art at the time of Mr. Ives's publication of his process, and have satisfied themselves that it is the first working, practical process of photographing colors in their relative degree of light and shade as they impress the eye, and that Mr. Ives is entitled to high commendation for complete publication, in all its details, of his process, as well as the high degree of perfection of the results obtained, certainly unequalled up to that time, and unsurpassed, if equalled, up to the present time.

The principle of rendering colors photographically according to their visual intensity had been proposed before Mr. Ives's publication. Mr. Ives seems to have been the first who made successful application of the principle, in his perfected and published process, which deserves recognition by reason of its novelty, its completeness, and the publication of it without any reservation of information or of rights. In consideration of which, and as a fitting recognition of the benefit bestowed on the art by Mr. Ives, your committee recommend the award of "THE SCOTT LEGACY MEDAL AND PREMIUM" to Mr. FRED. E. IVES, for his

chlorophyl process of photographing colors according to their visual intensity.

All of which is respectfully submitted.

Coleman Sellers, *Chairman*, John Sartain, Samuel Sartain, Jos. M. Wilson, John G. Bullock, W. Curtis Taylor, Fredk. Graff, Chas. F. Himes.

Approved, August 4, 1886.

H. R. HEYL, *Chairman*.

#### APPENDIX.

*Notes upon Ives's Process of Isochromatic Photography, comprising the record of experiments on the same conducted by F. E. Ives, in presence of Fredk. Graff, Jos. M. Wilson, and John G. Bullock, June 16, 1886.*

#### PROCESS.

*Emulsion Used.*—Newton's collodio-bromide. Preferably ripe. Fresh apt to fog. The rapidity of this emulsion is about one-third that of a bath plate in sunlight.

*Chlorophyl.*—That obtained from blue myrtle or common plantain is preferred. That from the plantain appears to be relatively more sensitive for red than that from myrtle, although the admixture of eosine seems to correct it.

Upon this occasion Mr. Ives used about equal parts of each, probably one ounce altogether, cut and digested in five ounces Atwood's ninety-five per cent, alcohol, on water bath for about fifteen minutes. Filtered and ready for use; should be allowed to cool.

The plate having been coated with the collodio-bromide emulsion is allowed to set; it is then flowed over five or six times with the alcoholic solution of chlorophyl and immersed in a dish of water, which seems to precipitate the chlorophyl in a very finely divided condition upon the collodion, rendering thereby the plate very sensitive, which it is not, if exposed without the immersion in water.

That chlorophyl remains upon the plate is demonstrated by the fact that after coating a plate so treated with an alcoholic varnish, the last drippings are of a green color.

Fresh myrtle leaves should be used, as the sensitizing properties decrease with age.

*Eosine.*—About one drachm of a stock solution of eosine, blue shade, thirteen grains to the ounce, ninety-five per cent. alcohol are added to three pints of water, giving a pale cherry red color to the same. The plate is immersed in this solution for about one minute, for the plain eosine plate, and *directly* after flowing with the chlorophyl in the chlorophyl-eosine plate, *without previous washing*, that the two coloring matters may be deposited together.

It does not answer the purpose so well to add the eosine to the chlorophyl solution and then flow the plate.

The yellow sensitiveness in the plain eosine plate may be somewhat increased by a slight action of silver nitrate, *but not where chlorophyl is present*. Free silver salt is destructive to chlorophyl sensitiveness.

An excess of eosine slows a plate. It renders an emulsion sensitive to yellow and green, but not to red, and requires a darker shade of yellow screen for the best results.

*Screen.*—A solution of picric acid in a small tank, with sides of plate glass: thickness about one-fourth inch between glasses; such was used in the following experiments. A more convenient screen is made by flowing a piece of plate glass with gelatine, staining it with picric acid, and covering with glass, previously flowing with Canada balsam. Such may also be introduced between the combinations of double lens.

*Development.*—Soda carb. and soda sulphite with *dry pyrogallic acid*.

The usual stock solutions of pyro, made with sulphurous acid, etc., should not be used. A little bromide is also added. All forms of these plates develop very quickly, are likely to fog, and may be intensified, but still give good prints. Fumes of  $H_2S$  are very destructive. A dark, yellow-green glass, gives the safest light for development of chlorophyl plates.

*Subject.*—A lithograph containing red, blue, yellow, and green in pure colors, and combinations thereof.

## FIRST EXPOSURE.

*Plate.*—Plain collodio-bromide emulsion. Time, one minute; diffused light by window and under skylight. *No color screen.*

Developed quickly, about correct time.

## SECOND EXPOSURE.

*Plate.*—Plain collodio-bromide, *with color screen*. Time, one minute; in sunlight reflected from mirror.

Developed. No trace of image. Entirely underexposed.

## THIRD EXPOSURE.

*Plate.*—Chlorophyl. Time, seventy seconds; reflected sunlight. Overexposed. Yellow screen used.

## FOURTH EXPOSURE.

*Plate.*—Chlorophyl. Time, forty-five seconds; reflected sunlight. Correct exposure. Screen used.

## FIFTH EXPOSURE.

*Plate.*—Eosine. Screen used. Time, forty-five seconds; reflected sun. Correct exposure.

## SIXTH EXPOSURE.

*Plate.*—Eosine and chlorophyl. Screen used. Time, *fifteen seconds*, reflected sunlight. Exposure correct. Best negative of all.

*Comments.*—A chlorophyl plate exposed without a yellow screen would be full of detail, but the reds would be too dark and the blues too light.

Mr. Ives claims to be the first to *prove* that the chlorophyl plate produces all colors in their correct relations. The first to prove blue myrtle chlorophyl to be the best of chlorophyls. The first to *combine* eosine and chlorophyl. The only one to give the process to the public.

The relative values of the different sensitizers are demonstrated by the accompanying prints, and those of the spectrum.

Their effect upon the length of exposure rendered necessary, is shown by the list of exposures above given.

In our opinion Mr. Ives demonstrated, with satisfactory results, all that he claims for his process, which we believe to be an eminently useful one, and one, which, with ordinary care and attention to the instructions, is by no means difficult to manipulate.

[Signed]

FREDK. GRAFF,  
JOS. M. WILSON,  
JOHN G. BULLOCK.

[Translated for the Philadelphia Photographer.]

## ON THE RAPIDITY OF IMAGES IN CHRONO PHOTOGRAPHY.\*

BY M. MARCY.

WHEN exposing the principles of the chrono-photographic method in analyzing motions, I pointed out the necessity of throwing a strong light on the object to be studied, and of placing behind it an absolutely black background. However small the quantity of light that the background emits in the objective, as this emission is reported at the passage of each opening of the rotary stop, the sum of light emitted by the background ends by being sufficiently important to veil the images. Our illustrious colleague, M. Chevreul, has resolved the problem of obtaining an absolute black, by means of a hole pierced in the sides of a box, the inside of which is black. It is, therefore, to him that the honor reverts of having rendered possible an extremely powerful method for the analysis of rapid motions. But great difficulties of execution are met with when, instead of a small hole opened in an obscure cavity, we must have an opening several yards in width and in height, before which a man, or an animal of large size, can go over a rather extended space. A first black background which has served me up to the present time consisted of a shed three yards in depth and lined with black velvet. This depth being insufficient, I was forced to construct another shed eleven yards deep and eleven yards wide. The height of the opening is reduced to the strictest necessity by means of movable frames, and in this way a much more perfect

\* Paper read before the Paris Academy of Sciences.

obscurity is obtained than with the primitive arrangement. But certain imperfections still exist. The ground of the screen, although covered with bitumen, reflects in the interior of the shed a certain quantity of light, so that the blackened sides are not in complete obscurity. The ideal, no doubt, would consist in excavating the ground to a depth sufficiently great for the solar light never to reach it. In the construction that I make use of, I hope to materially improve the conditions of obscurity of the black ground by covering the bitumen with strips of velvet at the time of operating. Finally, care must be taken to water frequently the ground near the dark opening, as without this precaution the dust raised by the feet of a person walking, or by the wind from the wings of a bird, often veil the images by the light which it emits. With my present arrangement I have already succeeded in reducing the time of exposure for each image to  $\frac{1}{20000}$ ths of a second, and I purpose to reduce it still further. Recent photographs show that this diminution of the time of exposure greatly increases the sharpness of the images. The Academy may perhaps remember the first trials which I submitted, and which, alongside of the new points, were nothing more than the silhouettes of birds. Here the pivoting of the feathers on their longitudinal axis is perfectly visible, as well as the motions imparted to the body of the bird by the raising and the lowering of its wings. Without entering into the details of these delicate reactions, which will form the object of a special paper, I desire to make known to the Academy the notable progress realized in the obtaining of chrono-photographic images, progress becoming greater as we, in our experimental appliances, approach nearer the conditions indicated by M. Chevreul.

## Editor's Table.

MOSAICS, 1887, is already being read by thousands of students. Do not fail to read the advertisement. Do not fail to send 50 cents at once and secure a copy, as the edition is limited, and

it is not electrotyped. Order now. Three thousand copies were sold before it was printed. A splendid present for your photographic friend. One or two cent postage stamps will do.



THE Argentic dry plate is in such demand as to meet the most sanguine expectations of the manufacturers. The results on them please beyond the expectations of the manipulators.

THE Powell process, given by Dr. JANEWAY in our last issue, should not be overlooked. It will be found practical, and of immense service in many directions.

\$400 or \$500 would not be objected to by any of our readers, we are sure. The "Diamond" advertisement of N. C. THAYER & Co. offers a chance to overcome the objection, if there is any.

The *American Annual of Photography and Photographic Times Almanac for 1887* will appear next month as a new candidate for favor among amateurs and adepts, and judging from the announcements of the Scovill Manufacturing Company, the publishers, it will be a grand book. It will not include a series of papers only, like *Mosaics*, but will supply tables, a calendar, lists of publications, societies, symbols, postal rates, lists of patents, etc. See future notices.

MOSAICS is valuable to every one. In illustration we quote from a letter of BUCHANAN, SMEDLEY & BROMLEY, the stockdealers of Philadelphia:

"We herewith enclose copy for one page advertisement in *Mosaics*. Copy for another page will follow in a day or two. We regard *Mosaics* as the best advertising medium out, having received more replies from it than in all other books combined. To receive letters in reply from Mexico and abroad is not an unfrequent occurrence."

WE were honored last week by a call from Mr. JOHN E. DUMONT, of Rochester, N. Y., whose picture, "Listening to the Birds," will be remembered by our readers. We were also pleased to see Mr. FRANK N. BLAKE, who, at North Adams, Mass., is making some very excellent dry plates.

WE learn from the local paper of Fredonia, N. Y., that Mr. E. K. HOUGH, of Winston, N. C., is about to remove to that place. This will bring him conveniently near Chautauque for next summer. He has already begun well by taking two premiums for crayon portraits at Fredonia. We are sure he will make in every sense a success, wherever he may go.

MESSRS. E. & H. T. ANTHONY & Co. announce that they are about to issue a new popular manual

of photography, written by Mr. E. M. ESTABROOKE, and entitled *Photography in the Studio and in the Field*. The new book, though small, will be very comprehensive, taking the reader through all the manipulations of wet and dry plate photography, and of the various methods of printing. It is written in a plain and practical manner, and Mr. ESTABROOKE'S familiarity with and competence to treat his subject are already known and appreciated, especially by those who possess his earlier book, *The Ferrotype, and How to Make It*. His new book will doubtless be welcomed.

FROM Mr. S. T. BLESSING, the leading Southern stockdealer, we have received a fine 100-page catalogue of the goods which he dispenses from his two houses, the "Star" and "Crescent"—one at Dallas, Texas, and the other at New Orleans, La. Next year will be his thirtieth in the business, which he has built up so successfully from its beginning, in 1857. He says, "I endeavor to put in all articles that are valuable, and keep out all those that are not. I devote all my time to supplying the wants of the fraternity."

ANOTHER foreign testimonial comes from Mr. C. C. VEVERS, of Horsford, Leeds, England: "I continue to receive the PHILADELPHIA PHOTOGRAPHER," he says, "and am better pleased with it every fortnight. It is both useful and ornamental, and I wish there was a magazine published here on the same principles. Your embellishments are perfect works of art."

PICTURES RECEIVED.—From Mr. C. G. BUSCH, of Claremont, N. H., some views of that town, his home—a pleasant quiet New Hampshire town, nestled among New Hampshire hills; also two clever groups—"Before the Joke," and "After the Joke." Mr. C. E. ORR, of Sandwich, Ill., sends a splendid picture of an express train going at fifty-five miles an hour, one of the most successful we have ever seen. We shall shortly give our readers an opportunity to judge. Mr. H. McMICHAEL sends some superb studies of "Falstaff," wonderful in their expressiveness. Mr. T. W. INGERSOLL, of St. Paul, Minn., sends a picture of an illumination, taken by the gas-light, showing a curious effect of halation.

THE Voigtländer lens was well treated at the German Convention. The concluding paragraph of the report presented to the Vienna Photo-

graph Society says: "In conclusion, it should be stated that Voigtländer's new Portrait Eury-scope marks the first great and important improvement in portrait-objectives since the introduction in 1840 of the portrait-combination with separated back-lenses, which is in use up to the present day;" and is signed by such names as these: Victor Angerer, Prof. J. M. Eder, J. Löwy, Fritz Luckhardt, Ch. Scolik, Dr. Jos. Szekely, Victor Toth, O. Volkmer, Carl Wrabetz.

"Of course I want to continue the PHOTOGRAPHER; it seems as if something was missing when we do not get it." So writes Mr. C. E. SARGENT, of Hamilton, Ohio, and furthermore says: "I have a very nice place; built, in fact, according to my plans, and some good ideas from *Photographics*. I gave my *Photographics* to the architect and told him to study all on the subject of skylights, and the consequence is, I have one of the finest lights in the country."

Mr. W. JUDD, of Mancelona, Mich., writes in regard to a recent complaint "concerning cardboard," that the Baldwin burnisher, using no lubricator, obviates entirely the running of the color.

FROM the Scovill manufacturing Company come circulars of the Acme glass bottom developing trays, and of a new and useful device, Scott's Printer's Register, a little counter that tables the number of prints, when fastened on the back of the printing frame, and which is palpably a most useful idea.

*The Photographischer Almanach und Kalender für das Jahr 1886*, by Dr. ED. LIESEGANG, Dusseldorf, Germany, is received, full as usual of excellent material for the practical photographer. A portrait of Joseph Albert and another of Fr. Manecke embellish it. It is all handsomely gotten out.

THE PHILADELPHIA PHOTOGRAPHER (now of New York) continues under the old editor and publisher, EDWARD L. WILSON, a bright, enterprising, and instructive specialty magazine. The PHOTOGRAPHER is now issued semi-monthly, and each issue contains an excellent illustration of photography or one of the photographic engraving processes. These are of great beauty and value. The text of the magazine is made up of contributions from expert photographers, societies, etc., and is always eminently practical in its character.—GEO. W. CHILDS'S *Philadelphia Daily Ledger*, Oct. 18, 1876.

*Photographic Notes* is the title of a compact little volume from M. ANTON SCHAEFFNER, Paris, France. It explains all the operations and the use of apparatus and products necessary in photography. It is published by MM. GAUTHIER & VILLARS, Paris, 1886. These notes are divided into four chapters. The contents of the chapters are as follows: Chapter I., Albuminized and Sensitized Papers (History, Use and Formule; Chapter II., Chemical Products and Specialties of My House; Chapter III., Photographic Summary and Manipulations; Chapter IV., Divers Processes. M. SCHAEFFNER has also just published a complete illustrated catalogue with two hundred and fifty cuts.

"BEAUTIFUL BABIES" come to us in a compact case from the California Coast labelled THORS, San Francisco. It is a good while since we have seen such a lot of lovely child pictures so exquisitely lighted and so judiciously posed. The individual loveliness of each child is secured admirably. One little martyr seems to have had a hard struggle to keep still, and so is allowed to brace herself up by using one tiny hand to hold the elbow of its mate, while the other hand is pressed against the cheek in support of the finger in the mouth. Great newborn tears catch the light in the eyes, and give a most natural effect to all.

#### AN OPEN LETTER.

INDIANAPOLIS, IND., Oct. 6, 1886.

E. & H. T. ANTHONY & Co.

GENTLEMEN: In the hurry and bustle consequent upon the great amount of work to be done in so short a time at the Convention, the obligation to your house for the greater part of one of the most prominent features of the Convention, the foreign exhibit, was not properly recognized.

Every one at the Convention recognized and appreciated the magnificent results of your efforts, and it was purely an unintentional oversight that the sentiments of gratitude felt by all toward you were not bodied forth in appropriate resolutions. Therefore, as you undertook the task at my solicitation, and, notwithstanding the labor and expense, greatly exceeded my expectations, I take this means to acknowledge the debt of thanks the Association owes you.

Your obedient servant, W. H. POTTER,  
*President of P. A. of A.*

H. MANDERFELD, Waseca, Minn., sends money for *Mosaics*, and says, "I wish it was issued about four times a year, instead of once."

# Specialties.

## ADVERTISING RATES FOR SPECIALTIES.

25 cents for each line, seven words to a line—in advance. *Operators desiring situations, no charge.* Matter must be received a week before issue to *secure* insertion. Advertisers will please not ask us for recommendations. ~~As~~ We cannot undertake to mail answers to parties who advertise. Please always add your address to the advertisement. **Postage-stamps taken.**

**MAKE OUT YOUR OWN BILL**, and remit cash with your advertisements, or they will not be inserted.

### HOLD!

With but one exception our sales at St. Louis were larger than at any previous convention. Having but just completed the Convention orders, we are now ready for the fall trade, and invite attention to our popular and attractive novelties and specialties.

#### RICH HOME INTERIORS.

QUAINT DESIGNS, ESPECIALLY FOR CHILDREN.

USEFUL AND REALISTIC ACCESSORIES

AT

PARTICULARLY CLOSE PRICES.

THE LARGEST LINE OF BACKGROUNDS  
IN THE WORLD.

Correspondence solicited. Samples to the profession.

LAFAYETTE W. SEAVEY,

Studio 216 E. 9th St.,

New York.

RETOUCHING BUREAU.—Under the direction of Mr. H. Harshman. None but skilled help employed. Quality of work guaranteed. Prices moderate. Send your negatives in wooden box with cover screwed on, and prepay charges. Address GAYTON A. DOUGLASS & Co.,

Merchants in Photo. Supplies,

185 & 187 Wabash Avenue,

Chicago, Ill.

#### FOR SALE! LENSES AT A BARGAIN!

One Morrison 11 inch Rapid Rectilinear Lens Will cover a 11 x 14 plate sharp to the edges. An excellent instantaneous lens. In good condition.

PRICE, \$50.

Two 8 x 10 Morrison Wide-angle Lenses, as good as new. 8 inches focal length.

PRICE, \$20 each.

One Euryscope, in good condition. Will cover a 11 x 14 plate.

PRICE, \$50.

Address "W. K.,"

Photographic Times Office.

MOsaICS, 1887, is ready. 144 pages, 50 cents. Cloth bound, \$1.00.

A first-class gallery on Broadway for sale. Good business. *For cash only.* For particulars address

F. H.,

226 E. Fifteenth St.,

New York.

"THE BEST OF SLIDE MAKERS."—Read the following and send your slide orders to Roberts & Fellows, 1125 Chestnut Street, Philadelphia. Read this:

TOLEDO, OHIO, Oct. 22, 1886.

MESSRS. ROBERTS & FELLOWS.

DEAR SIRs: Notwithstanding the short time allowed, your slides arrived a day sooner than expected or needed. I projected them across the street (over 100 feet) to a size 30 x 30, having to contend with gas and electric lights, and yet with fine effect. The general verdict was, "Magnificent!" Being alternated with 110 other views, it gave a good opportunity for all to judge of the merits of your work. In the few years I have been in the business, I can say I never saw better slides, and don't know that I ever saw just their equal. They have proved satisfactory in the highest degree. Thanking you for your promptness and the unequalled quality of work, I enclose amount of bill sent.

Yours respectfully,

L. B. LAKE.

WANTED.—To buy a good-paying gallery. Give particulars, and state amount of business done, and price. Address

Box 54,

Cooperstown,

Otsego Co., N. Y.

WANTED.—To correspond with a good crayon, India ink, and pastel artist; one who can work the air brush. Prepared to go South.

Address

G. W. DAVIS,

827 Broad St.,

Richmond, Va.

MOsaICS, 1887, is ready. 144 pages, 50 cents. Cloth bound, \$1.00.

**WILSON, HOOD & CO.,**  
**825 Arch St.,**  
**PHILADELPHIA.**

We have now in stock  
**THE NEW EAGLE DRY PLATE.**

ALSO

**THE INGLIS TRIUMPH PLATE.**

A new brand of

**GERMAN PYRO ACID.**

(35 cents per ounce.)

**POCKET GLASS CUTTER.**

(15 cents each.)

**NEW STYLE CORNER CHAIR.**

(\$10.00 each.)

**PAPIER MACHÉ STUMP.**

(\$6.00 each.)

**SUNSHINE MAILING ENVELOPE**

**THE LIGHT RUNNING**  
**NEW HOME**  
**SEWING MACHINE**  
**HAS NO EQUAL.**  
**PERFECT SATISFACTION**  
**New Home Sewing Machine Co.**  
**—ORANGE, MASS.—**  
 30 Union Square, N. Y. Chicago, Ill. St. Louis, Mo.  
 Atlanta, Ga. Dallas, Tex. San Francisco, Cal.  
**FOR SALE BY**

THE AGENTS, at the above named places.

FOR SALE.—One of the best galleries in the city of Worcester, Mass. This room has been fitted up this month with a new light, and has everything in it to do first-class work, and it is doing a good business. Reason for selling, change of business. Sold very low for cash.

Address

G. P. CRITCHEESON,  
 Box 235, Worcester, Mass.

**TO OUR PATRONS.**

St. Louis, October 23, 1886.

GENTLEMEN: During the last ten months we have been enlarging our factory in order to meet the growing demand for our plates, and succeeded in doubling our working capacity. Still our supply is not half sufficient to fill our orders. We have, therefore, commenced the building of a new factory, much larger than our present one, and have taken steps to secure its completion by the 1st of February next.

We again beg your patient forbearance and the continuance of your good will toward us, and trust that with the beginning of another year we shall be in shape to fully supply all demands.

Respectfully,

M. A. SEED DRY-PLATE CO.,  
 A. R. HUISKAMP, Manager.

MOsaICS, 1887, is ready. 144 pages, 50 cents. Cloth bound, \$1.00.

ENLARGEMENTS.—Every photographer having a Solar Camera should use the Rapid Albumen and Plain Paper. Enlargements from original negatives in ten to sixty seconds equal to contact work.

E. A. GILBERT,  
 Manufacturer and Solar Printer,  
 Jamestown, N. Y.

**PRINTING AND TONING FOR AMATEURS**  
**A SPECIALTY.**

PLATES DEVELOPED.

Try our freshly made photographers' paper. Made fresh daily, and fumed ready for use. 25 cents per sheet, 18 x 22, cut any size, and sent by mail without extra charge.

Our Concentrated Toning Solution is pronounced the *best* by all who have used it. Price, seventy-five cents.

Photographic supplies of all kinds. Largest variety of stock in the city. Send for catalogue.

LOBBER BROS.,  
 119 & 121 Nassau St.,  
 New York.

MOsaICS, 1887, is ready. 144 pages, 50 cents. Cloth bound, \$1.00.

GRAY & STAMMERS'

Reduced Price-List of

BROMIDE ENLARGEMENTS.

Size.	Unmounted.	Mounted.
11 x 14.....	\$1 00	\$1 25
14 x 17.....	1 25	1 50
16 x 20.....	1 50	1 75
18 x 22.....	1 75	2 00
20 x 24.....	2 00	2 50
22 x 27.....	2 25	2 75
25 x 30.....	2 25	2 75
24 x 36.....	3 00	3 75
30 x 40.....	5 00	6 00

Our facilities to do good work on short notice are unexcelled. Prints made on either smooth or mat-surface paper and vignettted when so ordered. Send cash with order, and 25 cents, extra, for packing each lot of mounted prints. Samples furnished at the above rates.

GRAY & STAMMERS,  
1430 Broadway, New York.

MOSAICS, 1887, is ready. 144 pages, 50 cents. Cloth bound, \$1.00.

PHOTOGRAPHERS will find it to their advantage sending orders to my Studio. First-class work; Crayons and Inks in real artistic style. Reasonable prices. C. V. SKOKAWSKI.  
9 Essex St., Cambridgeport, Mass.

EVERY photographer in want of excellent lenses, for any purpose, will best serve his interest by consulting the new illustrated price-list of Messrs. BENJAMIN FRENCH & Co. before purchasing.

"Long's Art of Making Crayons on Solar Enlargements." Price 50 cents.

EDWARD L. WILSON,  
853 Broadway, N. Y.

FOR SALE.—Two galleries; one in North Carolina, and one in a large city in Mexico.

Address W. H. ZOLLER,  
Box 83, Tarboro, N. C.

MAGIC CAMERA STANDS made by Smith & Pattison, Chicago, are certainly entitled to the wonderful popularity they are attaining. They are beautifully finished, symmetrical in design, very strongly built. The heavy weights, cogs ratchets, set-screws, etc., so objectional in other stands, are done away with. Never buy a stand without looking into the merits of the "Magic."

USED "DAISY," AND "NEW" HOLDERS FOR SALE.

From holders used at New Orleans Exhibition, I have

24 of 5 x 8 . . . .	\$1 35
12 of 10 x 12 . . . .	3 00
1 of 14 x 17 . . . .	8 00

Cheap. Good as new.

EDWARD L. WILSON,  
853 Broadway, N. Y.

GREAT BARGAINS. WHO WANTS THEM?

	List price.	Will take
1 No. 4 A. Dallmeyer Lens . . . .	\$316	\$210
1 No. 5 Voightländer Lens . . . .	90	35
1 3/4 size Usener Lens . . . .	40	25
1 14 x 17 Anthony's View Camera S.S.	80	40

These are such bargains as one dreams about, but seldom realizes. The camera is in fine condition, and shows but little use. Who will take them? W. D. GATCHEL,  
Louisville, Ky.

MOSAICS, 1887, is ready. 144 pages, 50 cents. Cloth bound, \$1.00.

SITUATIONS WANTED.

No charge for advertisements under this head; limited to four lines. Inserted once only, unless by request.

By a young man of six years' experience in all branches of photography, in a good gallery. Address J. L. Crocker, Addison, New York.

By a young man. First-class printer, retoucher, and operator. Six years' experience. First-class reference. Address Dick McCarthy, Eighth and Cherry Sts., Binghampton, N. Y.

As operator, retoucher, or printer and toner. Can speak German. Samples of work sent on application. Address J. H. Schroeder, cor. Main and Fifth St., Evansville, Ind.

As a general workman in a good gallery. Salary moderate. Address J. L. J., Painesville, Lake Co., Ohio, care of Storrs & Harrison.

By a young man, a first-class printer and toner. Address F. B. Thompson, 72 S. Salina St., Syracuse. N. Y.

By a first-class operator. One who can retouch. Address Photographer, care of F. Henson, Box 1667, New York City.

ASK FOR THE  
BLUE LABEL.

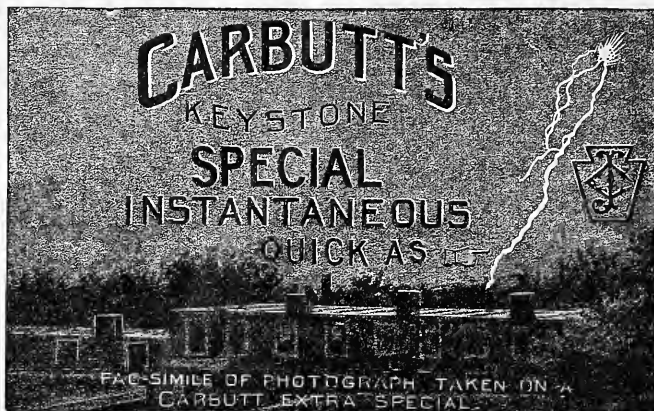

TRY THEM!  
and you will continue to  
USE THEM!

Pronounced the "Ne Plus Ultra" of Dry Plates.

UNSOLICITED TESTIMONIALS.

MR. JOHN CARBUTT, Wayne Junction, Philadelphia.

WORCESTER, MASS., December 25, 1885.

DEAR SIR: I have been using some of your new plates, emulsion 1024, sensitometer 24. I think they are, without exception, the finest and best plates I ever used. They are not only very fine and delicate in their structure, but, when properly manipulated, result in a blooming negative, possessing all the desirable qualities that any artist could wish for. I could most appropriately christen them the "Ne Plus Ultra Dry Plate."

Yours truly,

E. R. B. CLAFLIN.

DETROIT, MICH., January 16, 1886.

MESSRS. HARRIS & KITTLE.

GENTLEMEN: I am very much pleased with the Carbutt Plate; in fact, I call them the best plate *by far* that I tried so far. I find them especially useful for my theatrical subjects, as the quick emulsions are *absolutely instantaneous*.

Yours truly,

A. B. TAYLOR.

For Sale by all Dealers in Photo. Materials.

JOHN CARBUTT, Keystone Dry Plate Works, Wayne Junction, Philada., Pa.

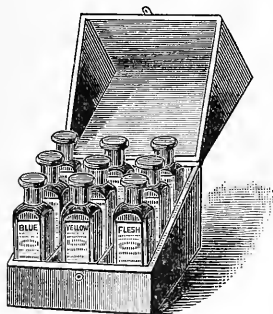

Send for Catalogue.

JANENTZKY & WEBER,

MANUFACTURERS OF

ARTISTS' MATERIALS

J. & W.'s Superfine Artists' Oil Colors in collapsible tubes,  
J. & W.'s Artists' Canvas, Fine Brushes for Oil or

Water Colors, Academy Boards, Water Colors  
in cakes and pans, Soft Pastels,

Monochromatic Boards, Pastel Canvas, Pastel Plaques,  
Liquid Photograph Colors, Blue Print Papers, plain  
and sensitized, Solar Printing Papers.

Crayon Drawing Materials,

Everything required for Drawing, Painting, Etching, Modeling, etc.  
Wax and Paper Flower Materials.

No. 1125 Chestnut Street, Philadelphia.

PHOTOGRAPHERS' ART VINE.

Beautiful and durable Ivy Vine for scenic effects; manufactured especially for photographers. All natural vines and leaves imitated. Send for circular. Special rates to dealers in photographers' supplies.

S. G. SHERWOOD,

232 Vermont St., Buffalo, N. Y.

**BLAIR'S " PERFECT " ( R. B. ) CAMERAS.**

**THIS**  
**Carrying Case**  
**ONLY**  
**Five Inches**  
**THICK.**

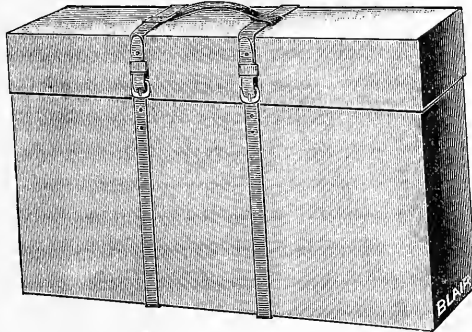

**CARRYING**  
**6 F. W. Holders**  
**and 6½ x 8½**  
**PERFECT**  
**CAMERA.**

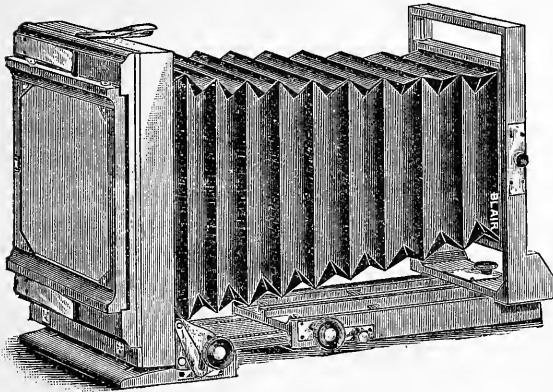

OPEN FOR USE.

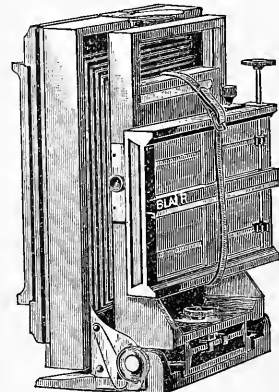

CLOSED.

The model instrument has been under progress in our factory for several months, and has undergone every change to our mind possible, to make it the most compact, combined with strength, possible.

1. By the ingenious method of constructing the "swing-back," greater swing is allowed, while the camera occupies no additional space by this important advantage.

2. By the method of constructing the telescopic bed the standard carrying the lens is quickly carried out to about the focal distance of lens in use, and then by the use of the Rack and Pinion the fine focus is attained. The thumb-nut and rod operating the Rack and Pinion is situated midway between the camera back and standard carrying the lens, which overcomes the objection of reaching forward when using long-focus lenses. The telescopic bed leaves no detachable parts. When using lenses of shorter focus than (5) inches the movable portion of the bed is not used; above that focal length the telescopic bed will not interfere with the view. *No clamping screws are used to make the bed rigid when attached.* There are two attaching nuts for the tripod screw, thereby enabling the operator to balance the camera when using long and short focus lenses

*Bear strongly in mind that all of our Reversible Back Cameras possess greater focussing capacity by several inches than any other Cameras of a similar pattern.*

The double swing occupies no more space than the single. It is of our best manufacture, highly polished, with nickel mountings. Fitted with feather-weight holders, unless otherwise specified.

**PRICE LIST OF PERFECT ( R. B. ) CAMERAS.**

Size of Plate.	Size of Lens Board.	Capacity for Length of Focus.	Single Swing	Double Swing.
5 x 7 .....	4½ in. sq. ....	17 in. ....	\$32 00 .....	\$34 00 .....
5 x 8 .....	6 " " .....	18 in. ....	36 00 .....	38 00 .....
6½ x 8½ .....	6 " " .....	18 in. ....	36 00 .....	38 00 .....
8 x 10 .....	7½ x 6 in. ....	18 in. ....	45 00 .....	48 00 .....

**THE BLAIR CAMERA CO.**

Office and Factory, 471, 473, 475, 477 Tremont Street, **BOSTON.**

Warerooms, 318 Broadway, **NEW YORK.**

**BLAIR & PRINCE, 148 W. Fourth St., Cincinnati, Ohio.**

---

**F. DRESCHER & CO.'S  
IMPROVED GELATINE FOR EMULSION.**

Made by a new and improved method, is the purest, the most reliable, and gives the best results.

**UNRIVALED FOR THE PURPOSE.**

Also IMPROVED GELATINE FOR LICHTDRUCK AND OTHER PHOTO. WORK.

Obtainable from the **SCOVILL MANUFACTURING CO.**, and all  
Dealers in Photographic Materials.

Or from the Manufacturers: **F. DRESCHER & CO.**, Oberndorf-Schweinfurt-on-the-Main, Germany.

---

**GAYTON A. DOUGLASS & CO.**

MERCHANTS IN

**SUPPLIES FOR PHOTOGRAPHY,**

**185 & 187 Wabash Ave.,**

**CHICAGO.**

---

**PHELPS ENAMELING CO.**

**Practical Photographers,**

Inventors and Proprietors of the

**NON-GELATINE PROCESS OF ENAMELING,**

**AND ENAMELERS FOR THE TRADE.**

We respectfully invite any photographer to send us two cabinets unmounted with cards, which we will enamel free of charge, and return to them by mail. It will pay you to investigate this. Correspondence solicited. Patent applied for.

**The Most Important Discovery of the Age to Photographers.**

**Nos. 307, 309 & 311 East Second Street,**

**MUSCATINE, IOWA.**



*The Eagle Paper Keeps its Place as Leader.*

Try the New Colors of the Leading

**DRESDEN ALBUMEN PAPER.**

**IMPROVED**

**EXTRA-BRILLIANT PENSEC,**

10 KILOS.



10 KILOS.

**EXTRA-BRILLIANT NEW ROSE.**

**It Possesses the Highest Durability of Color.**

It Never Blisters. It Keeps Well after Silvering.  
It Tones Easily. It Gives the Most Vigorous  
and Brilliant Prints. It is the Best  
Selected Paper.

It is Always Uniform and Reliable, and has the Least  
Objectionable Water-Mark. The Majority  
of Artists will Have It.

**SAMPLES FREE ON APPLICATION.**

For Sale by all Stockdealers in the United States  
and Canada.

**G. GENNERT,**

Importer,

**No. 54 EAST TENTH STREET,**

**NEW YORK.**

# THE DUBOIS FILING CASES.

*For Preserving Photographic Negatives, Prints, &c., Letters, Bills, and Miscellaneous Papers.*

PATENTED SEPTEMBER 2, 1884.

**Economical! No Binding! Either a Temporary or a Permanent File.**

Made in  
five sizes and cabinet  
form.

AGENTS WANTED.

Write for Descriptive  
Circular.

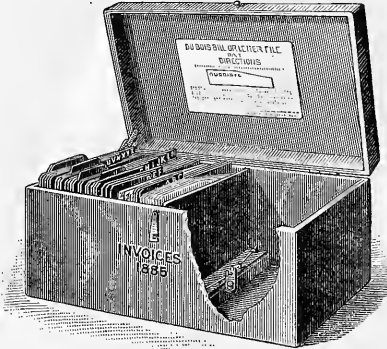

NEW YORK,  
April 27, 1886.  
Mr. FRANK G. DuBois,  
No. 512 W. 30th St., N.Y.  
DEAR SIR: Your File supplies a need that I have felt for some time past. It is the best thing of the kind that I have ever seen, and I shall be much pleased to recommend it to all my friends for preserving bills, notes, receipts, recipes, unmounted prints, photographs, and all kinds of miscellaneous papers to which easy reference may be wanted at any time. Respectfully,  
MISS SOPHIE L. MAURER.

Sent by Express, on receipt of \$3.00, or with lock and key, \$4.00.

PATENTEE AND SOLE MANUFACTURER,

FRANK G. DuBOIS, 512 W. 30th St., New York.

TO THE TRADE ONLY.

## HYPOSULPHITE OF SODA

FOR PHOTOGRAPHERS.

### CHAS. A. W. HERRMANN,

16 Cedar St.

New York.

TO THE TRADE ONLY.

<p>THE LARGEST Photo-Engraving ESTABLISHMENT IN THE WORLD</p>	<p>SIXTEEN YEARS PRACTICAL EXPERIENCE</p> <p><b>MOSS ENGRAVING CO.</b></p> <p>535 PEARL ST. COR. ELM. NEW YORK</p> <p>MOSS' NEW PROCESS Superior to Any Other Method.</p>	<p>ILLUSTRATIONS OF Every Description For Books, Magazines, Newspapers, Catalogues, CIRCULARS, &amp;c. IN THE Finest Style of the Art.</p>
<p>SEND GREEN STAMP FOR 24 PAGE CIRCULAR -- SEND PHOTOGRAPH, DRAWING OR PRINT FOR ESTIMATE.</p>		

**C. H. CODMAN & CO.**

**Photographic Stockdealers**

Sole Agents for the NEW ORTHO-PANACTINIC LENS, Moor's Photographic Enamel, the Perfect Mounting Solution for mounting Photographs on the thinnest mount without wrinkling.

New England Agents for American Optical Co.'s Apparatus. The best in the world. Send for Price List.

34 Bromfield Street.

BOSTON, MASS.

720 (5 gross) of these trimmers were sold to one party in July.

# ROBINSON'S NEW MODEL PHOTOGRAPH TRIMMERS!

This drawing is of the full natural size and shape of the New Model Revolving Trimmer. The *Straight Cut* is of same size, varying but little in shape.

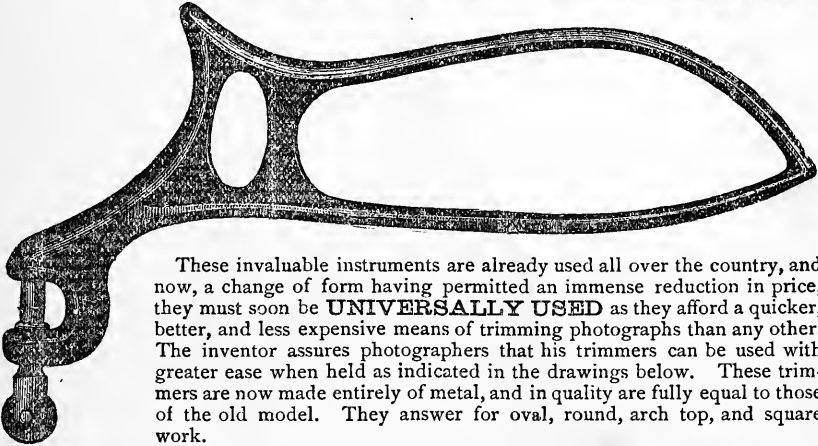

These invaluable instruments are already used all over the country, and now, a change of form having permitted an immense reduction in price, they must soon be **UNIVERSALLY USED** as they afford a quicker, better, and less expensive means of trimming photographs than any other. The inventor assures photographers that his trimmers can be used with greater ease when held as indicated in the drawings below. These trimmers are now made entirely of metal, and in quality are fully equal to those of the old model. They answer for oval, round, arch top, and square work.



Plan of holding the *Straight Cut* Trimmer when in use. PRICE, 50 CENTS.

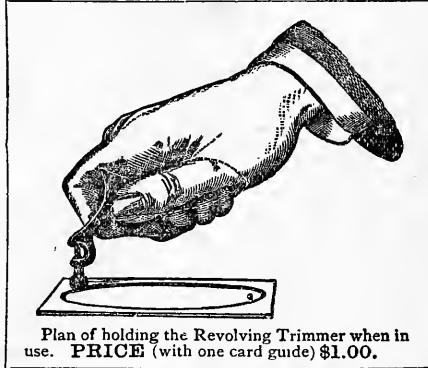

Plan of holding the Revolving Trimmer when in use. PRICE (with one card guide) \$1.00.

## ROBINSON'S GUIDES.

MADE OF SHEET-IRON.

We have the following Regular Sizes always on hand at 10 cents per inch the longest way of the aperture.

OVALS.			SQUARE OR ROUND CORNERED.		
2 x 2 $\frac{1}{2}$	3 x 4	5 x 7	2 $\frac{1}{8}$ x 3 $\frac{3}{8}$	2 $\frac{5}{8}$ x 3 $\frac{3}{8}$	2 $\frac{3}{4}$ x 4 $\frac{1}{2}$
2 $\frac{1}{2}$ x 3 $\frac{1}{2}$	3 x 4	5 $\frac{1}{2}$ x 7 $\frac{1}{2}$	2 $\frac{1}{8}$ x 3 $\frac{1}{2}$	2 $\frac{5}{8}$ x 3 $\frac{1}{2}$	2 $\frac{7}{8}$ x 4 $\frac{1}{2}$
2 $\frac{1}{2}$ x 3 $\frac{3}{4}$	3 x 4	5 $\frac{1}{2}$ x 7 $\frac{1}{4}$	2 $\frac{1}{8}$ x 3 $\frac{1}{4}$	2 $\frac{5}{8}$ x 3 $\frac{1}{4}$	2 $\frac{7}{8}$ x 4 $\frac{1}{4}$
2 $\frac{1}{2}$ x 3 $\frac{1}{2}$	3 x 5	5 $\frac{1}{2}$ x 7	2 $\frac{1}{8}$ x 3 $\frac{1}{2}$	2 $\frac{5}{8}$ x 3 $\frac{1}{2}$	2 $\frac{7}{8}$ x 4 $\frac{1}{2}$
2 $\frac{1}{2}$ x 4	4 x 5	5 $\frac{1}{2}$ x 7 $\frac{1}{2}$	2 $\frac{1}{8}$ x 3 $\frac{1}{2}$	2 $\frac{5}{8}$ x 3 $\frac{1}{2}$	2 $\frac{7}{8}$ x 4 $\frac{1}{2}$
2 $\frac{1}{2}$ x 4 $\frac{1}{4}$	4 x 6	6 x 8	2 $\frac{1}{8}$ x 3 $\frac{1}{2}$	2 $\frac{5}{8}$ x 3 $\frac{1}{2}$	2 $\frac{7}{8}$ x 4 $\frac{1}{2}$

The above sizes suit the Collins Card Mounts, and photographers knowing that they can be always had at the low price of ten cents per inch, would do well to *make their sizes accord*, as orders can also be filled more quickly. Ten days are required to make special sizes.

Special Sizes made to order, at 15 cents per inch, the longest way of the aperture.

**ROBINSON'S PHOTOGRAPH TRIMMERS** are substitutes for the *Knife for Trimming Photographs*, and do the work much more expeditiously and elegantly. *They Save Time, Save Prints, and Save Money.*

They do not *cut*, but *pinch off* the waste paper, and leave the print with a neatly bevelled edge which facilitates adherence to the mount. Try one, and you will discard the knife and punch at once. For ovals and rounded corners they are worth their weight in gold.

For sale by all Dealers.

**ROBERTS & FELLOWS,**

Successors to E. L. WILSON,

1125 Chestnut St., Philadelphia, Pa.



**PHOTOGRAPHIC MOSAICS,****—1887—**

READY NOV. 10th. 23d YEAR.

**144 PAGES.**

50 CENTS. CLOTH, \$1.00.

**144 PAGES.****BEATS ALL ITS PREDECESSORS.****CONTENTS.**A Photogravure Picture by **ERNEST EDWARDS,**  
and the following:

Retrospective. Edward L. Wilson, Editor of Mosaics.  
Coming Back to Good Sense in Developers. Thomas Pray, Jr. [x amatoor], Hartford, Connecticut.  
Development of Overtimed Plates. L. Farini, Bridgeport, Connecticut.  
The Flap Shutter. G. G. Mitchell, Edinburgh, Scotland.  
The Simplest Enlarging Process. Dr. E. A. Just, Vienna, Austria.  
Hydroxylamine as a Developing Agent. W. E. Woodbury, Dusseldorf, Germany.  
Lantern Slides. Dr. Thomas W. Drinkwater, Edinburgh, Scotland.  
Developing Dodges. Harold Sands, Nottingham, England.  
The Art-education of Photographers. Charlotte Adams, New York.  
Habits of Life. W. H. Clark, St. Louis, Mo.  
Photographing Interiors. W. I. Lincoln Adams, New York.  
Photography for the Papers. F. H. Wilson, New York.  
Development of Dry Plates. E. M. Estabrook, New York.  
A Printer's Collation. Young Chloride  
Call from an Old Foggy. W. J. Baker, Buffalo, N. Y.  
On the Development of Very Short Exposures in the Studio. W. E. Truesdell, Springfield, Illinois.  
What We Want. John W. Hallenbeck, New York.  
The Use of Photography in Wood Engraving. M. V. Roux, Paris, France.  
Developing—A Lesson. A 5 x 8 Tramp, Boston, Mass.  
My Experience. William McComb, Muskegan, Mich.  
Three P's Photographically Considered. J. Pitcher Spooner, Stockton, Cal.

Shade Your Lenses. Karl Klauser, Farmington, Conn.  
My Printing Methods. C. P. McDannell, Titusville, Penna.  
Photography as an Art. One Who Observes.  
Scaled Prices. G. M. Carlisle, Providence, R. I.  
The Grade System of Prices. G. L. Hurd, Providence, R. I.  
Millions Wanted, and Money in It. A Retired Watch-maker.  
Eyes. C. J. Billinghurst, Orange Heights, Florida.  
How Shall We Aim? J. F. Ryder, Cleveland, Ohio.  
Developing with Pyrogallol. Arthur H. Elliott, Ph. D., New York.  
The Disposition of the Hands in Portraiture. W. T. Mozart, New York.  
Our Picture.  
Stopping Down the Eye. Dr. D. Garrison, Chicago, Illinois.  
Make Your Own Rustic Furniture. H. G. Parcell, Kirksville, Maine.  
A Surprise. Col. Octavio Barrati, Piverone, Italy.  
Carbon Solar Prints. F. H. Sherman, Milwaukee, Wisconsin.  
Odd Points. C. F. Moelk, Edina, Missouri.  
Backgrounds and Accessories, Their Use and Abuse. Mrs. Clyde Ehinger, Quincy, Ill.  
Enlarging and Magic Lanter Slides. A. R. Dresser, London, England.  
Stop to Consider. H. McMichael, Buffalo, N. Y.  
An Item in Oil. J. Hegyessey, Paris, Texas.  
Dots. "Aunt Dottie."  
Many Mites from Many Minds.

**OVER 2000 SOLD BEFORE ISSUE.****EDWARD L. WILSON, Photo. Publisher, 853 Broadway, N. Y.***Mailed on receipt of price. For Sale by all Dealers.*

**SWEET, WALLACH & CO.**  
**Photographers' Supplies,**  
**229 & 231 STATE ST., CHICAGO.**  
**Best Goods! Lowest Prices! Complete Stock!**  
**ORDERS PROMPTLY FILLED. SATISFACTION GUARANTEED**  
**Your Patronage Solicited. Send for Catalogue.**

MANUFACTORY OF

STEAM PRINTING PRESSES OF SCHMIERS, WERNER & STEIN,  
 OF LEIPZIG.

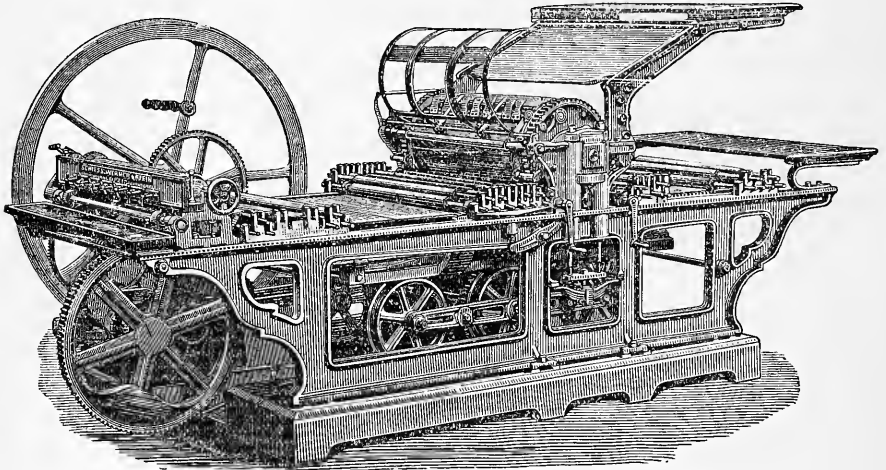

**PHOTYPE OR HELIOTYPE STEAM PRESSES.**

These Steam Presses, which are admitted to have given the most satisfactory results in every respect, are as yet unsurpassed, and have been in use, by preference to all other systems, in all first-class Heliotype Establishments all over the world for the last ten years. They are supplied by the undersigned manufacturers in four sizes, and absolutely warranted with respect to their working capacity. The comfortable and easy working of the machine, and their solid and excellent workmanship, are the principal advantages of our phototype steam presses. These steam phototype presses are also supplied with the contrivance for lithography, and with or without automatic uncovering frame, and feeding table, etc. For full particulars apply to the

**STEAM PRINTING PRESS MANUFACTORY OF SCHMIERS, WERNER & STEIN,**  
**LEIPZIG, GERMANY.**

**G. W. WILSON & CO.**

(By special appointment Photographers to Her Majesty the Queen),

**MANUFACTURERS OF MAGIC LANTERN SLIDES,**  
**St. Swithin Street, Aberdeen.**

Catalogue of 12,000 subjects in England and Scotland, and Price Lists, post free on application.

# THE ARGENTIC DRY PLATE.

## A Splendid New Picture.

Among the desirable advantages are rapidity, cleanliness in manipulation, permanency, certainty of good results, absence of all pinholes, metallic stains, discoloring, fog, frilling, and other dry-plate ills. Pictures deliverable ten minutes after the sitting. Full directions with each box.

### LIST OF SIZES AND PRICES.

2 dozen $3\frac{1}{4} \times 4\frac{1}{4}$ , per box, . \$0 90	2 dozen $5 \times 8$ , per box, . \$2 25
2 " $4 \times 5$ , " . 1 25	2 " $6\frac{1}{2} \times 8\frac{1}{2}$ , " . 3 75
2 " $4\frac{1}{4} \times 5\frac{1}{2}$ , " . 1 50	2 " $7 \times 10$ , " . 4 00
2 " $4\frac{1}{4} \times 6\frac{1}{2}$ , " . 1 80	2 " $8 \times 10$ , " . 4 50
2 " $5 \times 7$ , " . 2 00	1 " $10 \times 14$ , " . 4 00

A splendid opportunity to increase business is offered by the New Argentic Dry Plate. Every plate guaranteed.

**FOR SALE BY ALL DEALERS.**

# PHENIX PLATE CO.

Manufacturers,  
WORCESTER, MASS.

VENI, VIDI, VICI!

THE WONDER OF THE P. A. of A. CONVENTION  
AT ST LOUIS

THE  
EAGLE



DRY  
PLATE

Only Five Months in Existence, and Carried off the  
Honors from All Comers

The judges at the St. Louis Convention awarded the exhibitors **Seven Medals**, gold and silver, for work done on the **EAGLE DRY PLATE**, the photographs being, without exception, the gems of the exhibit.

How could it be otherwise with such a plate, when for **Reliability, Rapidity, Delicacy of Detail, and Extreme Brilliancy**, they surpass all other makes of Dry Plates in the market.

Their reception by the photographic profession at large, speaks volumes in their favor, they being now used by the leading lights of the photographic world, both professional and amateur.

Came, saw, and conquered! Truly, such was the case, and in the future our aim will be to lead them to further conquest.

EAGLE DRY-PLATE CO.

**G. GENNERT,**  
**54 East Tenth Street, New York,**  
GENERAL AGENT



SUBSCRIBE FOR



**ANTHONY'S**  
**PHOTOGRAPHIC**  
**BULLETIN**

EDITED BY  
PROF. CHAS. F. CHANDLER, Ph. D. LL.D.  
Prof. of Applied Chemistry in the School of Mines  
Columbia College, New York City.

**E. & H. T. Anthony & Co.**  
591 BROADWAY  
New York.

THE BULLETIN FOR 1886.

That the BULLETIN has proved a success during the past year, our long list of unsolicited testimonials bears ample witness. And we have found it utterly impossible to publish all the good things that have been said of us, owing to the wealth of material always at hand to fill our pages. What is yet more encouraging to us is the large increase in our subscription lists, on which the number of names is now almost double what it was one year ago, and is increasing with every issue of the journal.

We recall with pride the names of some of the contributors to our pages: Prof. C. F. Chandler, Ph.D., Prof. Ogden N. Rood, Dr. A. H. Elliott, Ph.D., Prof. J. M. Eder, Ph.D., Henry J. Newton, E. L. Wilson, Ph.D., L. H. Laudy, Ph.D., Victor Schumann, Prof. Chas. F. Himes, Thos. Bolas, F.C.S., M. Carey Lea, Dr. R. W. Wilcox, F. C. Beach, Dr. John H. Janeway, Prof. Spencer Newberry, A. A. Campbell Swinton, Fred. E. Ives, T. C. Roche, E. K. Hough, G. H. Loomis, J. B. Gardner, W. E. Partridge, P. C. Duchochois, J. F. Ryder, David Cooper, Abraham Bogardus, and a host of others. In addition to the contributions from the above gentlemen, we have given our readers clear and accurate reports of the photographic societies, in many cases from the stenographic notes of our own reporters. Our correspondence column has been a source of pleasure to our editors, and has become an important and unrivaled feature of our publication.

This is what we have done and shall continue to do, with this advantage, that the fund of material upon which we can draw in the future is still larger than that utilized in the past. Among other improvements we intend to illustrate every number of the BULLETIN with a specimen of the best work in both professional and amateur photography. Thus the subscribers will obtain in one year, two dozen gems of the photographic art. Various improvements in the literary part of the journal will also be made. In fact, nothing will be left undone to keep it in the front rank of American Photographic journals.

The improvements we contemplate will involve a large expenditure of money, and as we cannot be expected to furnish so much valuable material at a loss, we shall be compelled to charge three dollars for the illustrated edition of the BULLETIN, and two dollars without the illustrations. Just think of it! Twenty-four illustrations and seven hundred and sixty-eight pages of valuable photographic information for three dollars. There is not another photographic journal in America that does so much for so little. Either the illustrations alone or the literary material alone are worth the price of the subscription, and we give them both, so the subscriber gets twice the worth of his money.

We have laid out a large amount of work for the coming year, and we intend to carry it through. But to do this with energy and pleasure, we must have the encouragement of our readers and subscribers. Help us, and we will help you as much as, if not more, than in the past. Our policy will always be, *With charity for all and malice towards none*

THE PUBLISHERS.

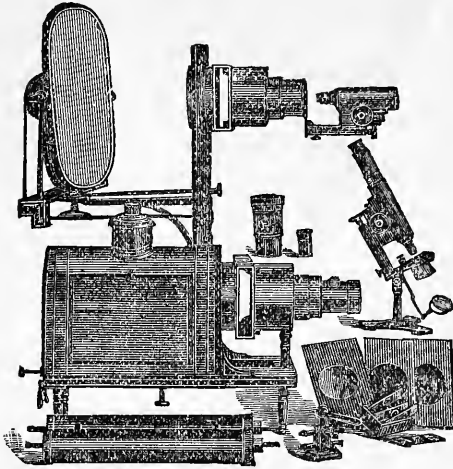

# OPTICAL AND ELECTRICAL INSTRUMENTS.

We desire to call the attention of  
TEACHERS, SCIENTISTS, LECTURERS, and  
those interested, to our

**Stereopticons, Microscopes, Dr. McIntosh's Solar Microscope and  
Stereopticon Combination Apparatus for  
the Oxy-hydrogen and Ether-oxygen Lime Light, Photographic  
Transparencies, Microscopical Preparations, etc.**

Our Instruments and Apparatus are new in design and have many improvements  
that overcome difficulties heretofore considered unavoidable. We also manufacture

**Static Electric Machines, Batteries, Magnets, and a Full Line of  
Electrical Apparatus for Practical and Experimental  
Purposes.**



We received the highest  
award at the New Orleans  
World's Exposition, on  
both Optical and Elec-  
trical Apparatus, in com-  
petition with the best of  
home and foreign manu-  
facturers.



Illustrated Catalogue of Optical and Electrical Apparatus sent free on application  
by mentioning this journal.

**McIntosh Galvanic and Faradic Battery Co.**

Nos. 300 & 302 Dearborn Street,

CHICAGO, ILL., U. S. A.

# THE PHILADELPHIA PHOTOGRAPHER.

TWENTY-THIRD YEAR, 1886.

*Devoted to the Advancement of Photography and the Dissemination of Art Principles.*

SEMI-MONTHLY: issued the First and Third Saturday of each month.

\$5.00 a year, \$2.50 for six months, \$1.25 for three months—in advance. 30 cts. per copy.

## CONTENTS OF THE THIRD QUARTER.

**JULY 3.**—The St. Louis Convention. An Answer to Mr. W. J. Stillman's Opinion of Photo-Art, by CHARLOTTE ADAMS. Photography as an Art Educator. Printing Positives on Gelatino-chloride Paper, by M. CHARBO. Photography in Newfoundland. Is Photography an Art? by F. H. WILSON. Gelatine, a Substitute for Albumen in Silver Printing, by W. M. ASHMAN. Very Slow Gelatino-bromide for Landscape Work, by W. K. BURTON. The World's Photography Focussed, The New Studio of MR. P. H. ROSE, at Providence, R. I. What an Old Teacher says of "Wilson's Photographics." Our Picture. Yesterday and To-day, or Justice to All, by MRS. E. N. LOCKWOOD. Brains and Judgement most Needed in Photography, by C. F. MOELK. On the Business Management of a Photographic Establishment, by C. M. CARLISLE. The Progress of Photography in Germany and Austria, by DR. J. M. EDER. Practical Points from the Studios. Editor's Table.

EMBELLISHMENT.—"Merry Wives of Windsor," by REICHMANN & Co., New York.

**JULY 17.**—Figures in Landscape, by XANTHUS SMITH. Report on the Progress of Photography in America, by ARTHUR H. ELLIOTT, P.H.D., F.C.S. Report on the Progress of Photography in Great Britain, by J. TRAILL TAYLOR. A Tribute to Photography, by CHARLES T. STUART. Pertaining to the P. A. of A. Convention Items. The Humor of It. Improvement in Photographic Printing and Enlarging, by DAVID COOPER. A Simple Device for Accurately Timing an Exposure, by WINFIELD A. FRENCH, Our Picture. Queries, Conundrums, and Conclusions. Editor's Table.

EMBELLISHMENT.—"On the Pennypack," by XANTHUS SMITH, Philadelphia.

**AUGUST 7.**—The St. Louis Convention. Pertaining to the P. A. of A. The Decline of Prices, and the Remedy, by A. ST. CLAIR. Art Censorship, by L. H. SCHUMAN. Money Making, by W. J. GUILD. Convention Notes. Mr. George Barker's View of Niagara Falls and Florida. The Canada Convention. A Chautauqua Photographic Day. Our Picture. Editor's Table.

EMBELLISHMENT.—"The Valentine," by H. P. ROBINSON, Tunbridge Wells, England.

**AUGUST 21.**—The Uses of Rainy Days, by CHARLES T. FELLOWS. Process for Developing Negatives with Very Short Exposures, by M. BALAGNY. Rambling Remarks, by RANALD DOUGLASS. Views from My Office Window. Useful Hints. Photo. Facts and Fancies. Alaska Correspondence. Practical Points from The Studios. The Humor of It Chatterings of This and That. A Camera Without a Lens, by M. MEHEUX. Open Corner. Bleaching Overprinted Photos, for Photo-Engraving. Mr. T. R. Burnham's Large Negative. Society Gossip. Queries, Conundrums, and Conclusions. Our Picture. Paper Coated with Gelatine Emulsion for Direct Printing. Instantaneous Portraiture. Answer to a Question Concerning the Toning of Albumen Paper. The World's Photography Focussed. Editor's Table.

EMBELLISHMENT.—"After Play," by Messrs. ABELL & SON, Portland, Oregon.

**SEPTEMBER 4.**—Photography from a Balloon. Art and Photography, by G. HANMER CROUGHTON. A New Method of Obtaining Enlarged Negatives. On the Action of Ferric Salts Employed in Conjunction with Sodium or Ferric Hyposulphite in Reducing Overdensity. The Humor of It. On Photographic Interiors, by VALENTINE BLANCHARD. Practical Points from The Studios. Our Picture. The Use of the Centrifugal Separator in Preparing Gelatine Emulsion, by JOSEPH PLENNER. Queries, Conundrums, and Conclusions. Photographic Day at Chautauqua. A Piece of Presumption. The World's Photography Focussed. Facts and Fancies. The Open Corner. Editor's Table.

EMBELLISHMENT.—"The West," by H. BUTLER, Vermillion, Dakota.

**SEPTEMBER 18.**—A Pleasant Field Day. Practical Points from the St. Louis Exhibition. On the Use of Aristotypic Paper. Photographs of South Africa. On Framing Photographs, by PORTE-CRAYON. The Spectroscopic Detection of Alkaloids. Remarks on the Process of Direct Reproduction in Black Lines on a White Ground of Plans, Drawings, Maps, Engravings, etc., by M. DE SAINT-FLORENT. Official Report of the Committee Appointed by the Photographic Society of Vienna to Test Voigtländer & Son's New Portrait Euryscope. The Canada Convention. Queries, Conundrums, and Conclusions. The Photographic Convention of the United Kingdom. On Men's Heads, by WILLIAM ADCOCK. Success, by H. P. ROBINSON. The Treatment of Negatives after Development—a Mystery Unravelled, by W. B. BOLTON. Photographing the Late Eclipse. Our Picture. Practical Points from The Studios. Elimination of Hyposulphite of Soda by the Salts of Lead. Photo. Facts and Fancies. The World's Photography Focussed. Editor's Table.

EMBELLISHMENT.—"A Ramesian Studio," by EDWARD L. WILSON.

The above six numbers to one address for \$1.25, prepaid. The numbers for January, February, and March, or for April, May, and June to one address, post-paid, \$1.25.

**Our Invaluable Back Numbers for 1886 are Equivalent to Several Volumes on Our Art.**

**EDWARD L. WILSON, 853 Broadway, New York.**

OFFICE OF

# G. CRAMER DRY PLATE WORKS,

Shenandoah and Buena Vista Sts., St. Louis.

---

The enlargement of my factory being now completed, I am able to serve my patrons more promptly than heretofore.

Thanking the fraternity for their kind patronage, and soliciting a continuance of the same, I am  
Fraternally yours,



DRY-PLATE WORKS, ST. LOUIS, MO.

---

**THE**

## ST. LOUIS DRY PLATE COMPANY

Beg to announce that under their New Management they have recently made Important Improvements and Increased their Facilities, so that they are now making better and more uniform plates than heretofore.

---

ALL ORDERS WILL RECEIVE PROMPT ATTENTION.

---

## ST. LOUIS DRY PLATE CO.

No. 827 Chouteau Avenue,

ST. LOUIS, MO.

Number 287.

30 Cents.

THE

# PHILADELPHIA

# Photographer.

AN ILLUSTRATED SEMI-MONTHLY JOURNAL,  
DEVOTED TO PHOTOGRAPHY.

SUMMARY OF CONTENTS.

PAGE	PAGE
<p>Our Next Year, . . . . . 705</p> <p>Photographic Mosaics for 1887, . . . . . 706</p> <p>A Simple Ventilator. By C. C. VEVERS, Hartsforth, England, . . . . . 707</p> <p>Mountains and Marines. By O. K. B. W. K., 708</p> <p>Practical Points from the Studios, . . . . . 710</p> <p>Hints from Guatemala. By E. J. KILDARE, 711</p> <p>The Printer's Troubles. By CHARLES P. KRAUSS, Memphis, Tennessee, . . . . . 711</p> <p>Pasting Copies Upon Glass, . . . . . 712</p> <p>How to Prevent Silver Prints from Fading. By ROBERT IRVINE, . . . . . 712</p> <p>Multiplying Negatives. By W. CRONENBERG, 713</p> <p>Finishing on Permanent Bromide Paper. By G. HANMER CROUGHTON, . . . . . 715</p> <p>The Reproduction of Old Books and Prints. By M. VERNEUIL, Paris, France, . . . 717</p>	<p>Photo. Facts and Fancies, . . . . . 718</p> <p>Hints on Lighting. By GEORGE SPERRY, Evansville, Ind., . . . . . 719</p> <p>Transfer on Wood of Carbon Prints, . . . . . 720</p> <p>The World's Photography Focussed, . . . . . 720</p> <p>The Open Corner, . . . . . 722</p> <p>Our Picture, . . . . . 723</p> <p>The Humor of It, . . . . . 724</p> <p>A Universal Sensitometer. By DR. JOHN NICOL, . . . . . 725</p> <p>Autographic and Calcographic Transfers . 726</p> <p>American Astronomers were Right, . . . . . 730</p> <p>"Forward," . . . . . 731</p> <p>Querjes, Conundrums, and Conclusions, . . 732</p> <p>Manufacture of Pellicles. By M. TONDEUR, 733</p> <p>Editor's Table, . . . . . 734</p>

OUR PICTURE.—"View from Our Office Window." Prints by MESSRS. ROBERTS & FELLOWS, Philada.

EDWARD L. WILSON,  
*853 Broadway, New York.*

SUBSCRIPTIONS RECEIVED BY ALL NEWS AND STOCKDEALERS  
Five Dollars per Annum, in Advance.

## ADVERTISEMENTS.

AIR BRUSH.  
 ALLEN BROTHERS. The Suter Lens.  
 ANTHONY & CO., E. & H. T. The New N. P. A. Pensé Extra Brilliant Dresden Albumen Paper.  
 BUCHANAN, SMEDLEY & BROMLEY. Photo. Stockdealers.  
 CARBUTT, J. Gelatine Dry Plates and Improved Dry Plate Lantern.  
 CODMAN, C. H. & CO. Photo. Stockdealers.  
 COLLINS, A. M. MFG. CO., Photograph Cards.  
 COOPER, CHAS. & CO. Photo. Stockdealers.  
 CRAMER, G. Lightning Plates.  
 DEALERS' DIRECTORY.  
 EASTMAN DRY-PLATE AND FILM CO.  
 ENTREKIN, W. G. Patent Eureka Burnisher. Duplex Rotary Burnisher. Duplicating Print-Cutter.  
 FRENCH & CO., BENJ. Voigtlander & Son and Darlot Lenses. The Wonderful Euryscope.  
 HYATT, H. A. New Brand of Dry Plates.  
 HODGE & HUSTON. Solar Printers.  
 INGLIS, JAMES. Dry Plates.  
 MAGEE & CO., JAS. F. Photographic Chemicals.

McINTOSH GALVANIC AND FARADIC BATTERY CO.  
 MOORE, ALBERT. Solar Enlarger.  
 MOSS ENGRAVING CO.  
 PHOTOGRAPHIC TIMES.  
 PHOTOGRAPHIC MOSAICS, 1887.  
 SCOVILL MANUFACTURING CO. New Dresden Albumen Three Crown Paper. Gihon's Cut-Outs. Photo. Apparatus.  
 STEINHEIL LENS.  
 ST. LOUIS DRY PLATE COMPANY.  
 SWEET, WALLACH & CO. Photo. Supplies.  
 TALCOTT, E. K. Patent Mounts for Photographers.  
 VOIGTLANDER & SON. New Portrait Euryscope.  
 WALMSLEY & CO. Beck's Rectilinear Lens.  
 WILSON, HOOD & CO. Ross and Steinheil Lenses, Photo. Frames, Goods, Stereoscopes, and Views.  
 WILSON'S PHOTOGRAPHICS.  
 WILSON, G. W. & CO. Magic Lantern Slides.  
 WILSON'S PHOTOGRAPHIC PUBLICATIONS.  
 WILSON'S LANTERN JOURNEYS.

## ADVERTISING RATES.

THE PHILADELPHIA PHOTOGRAPHER is acknowledged to be the best advertising medium in the trade.

Its circulation is among the first class, at home and in nearly every foreign country.

Its rates, all advantages considered, are the most favorable, and it will bring you fine returns.

	One Issue.	Six Issues.	Twelve Issues.	Twenty-four Issues.
1 Page.....	\$20.00	\$110.00	\$200.00	\$350.00
1-2 " .....	12.00	66.00	120.00	200.00
1-4 " .....	7.00	38.50	70.00	120.00
1-8 " .....	4.00	22.00	40.00	70.00

Special contracts made with bona-fide dealers and manufacturers. Address

**EDWARD L. WILSON,**  
853 BROADWAY, NEW YORK.

## NOTICE TO SUBSCRIBERS.

REMEMBER YOUR OPERATOR AT CHRISTMAS.

In remitting by mail, a post-office order, or draft, payable to the order of EDWARD L. WILSON, is preferable to bank-notes. Postage stamps of the denomination of two and five cents each will be taken. Clearly give your Post-Office, County, and State.

Foreign subscriptions must be accompanied by the postage in addition.

**SUBSCRIPTIONS FOR 1887 NOW RECEIVABLE.**



# PHOTOGRAPHIC MOSAICS,

—1887—

READY NOV. 10th. 23d YEAR.

144 PAGES.

50 CENTS. CLOTH, \$1.00.

144 PAGES.

**BEATS ALL ITS PREDECESSORS.**

## CONTENTS.

A Photogravure Picture from Negative by ERNEST EDWARDS,  
printed by the Photogravure Co., 853 Broadway, N. Y.,  
and the following :

Retrospective. Edward L. Wilson, Editor of Mosaics.  
Coming Back to Good Sense in Developers. Thomas  
Pray, Jr. [x amatoor], Hartford, Connecticut.  
Development of Overtimed Plates. L. Farini, Bridge-  
port, Connecticut.  
The Flap Shutter. G. G. Mitchell, Edinburgh, Scot-  
land.  
The Simplest Enlarging Process. Dr. E. A. Just,  
Vienna, Austria.  
Hydroxylamine as a Developing Agent. W. E.  
Woodbury, Dusseldorf, Germany.  
Lantern Slides. Dr. Thomas W. Drinkwater, Edin-  
burgh, Scotland.  
Developing Dodges. Harold Sands, Nottingham,  
England.  
The Art-education of Photographers. Charlotte Adams,  
New York.  
Habits of Life. W. H. Clark, St. Louis, Mo.  
Photographing Interiors. W. I. Lincoln Adams,  
New York.  
Photography for the Papers. F. H. Wilson, New York.  
Development of Dry Plates. E. M. Estabrook, New  
York.  
A Printer's Collation. Young Chloride.  
Call from an Old Foggy. W. J. Baker, Buffalo, N. Y.  
On the Development of Very Short Exposures in the  
Studio. W. E. Truesdell, Springfield, Illinois.  
What We Want. John W. Hallenbeck, New York.  
The Use of Photography in Wood Engraving. M. V.  
Roux, Paris, France.  
Developing—A Lesson. A 5 x 8 Tramp, Boston, Mass.  
My Experience. William McComb, Muskegan, Mich.  
Three P's Photographically Considered. J. Pitcher  
Spooner, Stockton, Cal.

Shade Your Lenses. Karl Klausner, Farmington,  
Conn.  
My Printing Methods. C. P. McDannell, Titusville,  
Penna.  
Photography as an Art. One Who Observes.  
Scaled Prices. G. M. Carlisle, Providence, R. I.  
The Grade System of Prices. G. L. Hurd, Providence,  
R. I.  
Millions Wanted, and Money in It. A Retired Watch-  
maker.  
Eyes. C. J. Billingham, Orange Heights, Florida.  
How Shall We Aim? J. F. Ryder, Cleveland, Ohio.  
Developing with Pyrogallol. Arthur H. Elliott, Ph.D.,  
New York.  
The Disposition of the Hands in Portraiture. W. T.  
Mozart, New York.  
Our Picture.  
Stopping Down the Eye. Dr. D. Garrison, Chicago,  
Illinois.  
Make Your Own Rustic Furniture. H. G. Parcell,  
Kirksville, Maine.  
A Surprise. Col. Octavio Barrati, Piverone, Italy.  
Carbon Solar Prints. F. H. Sherman, Milwaukee,  
Wisconsin.  
Odd Points. C. F. Moelk, Edina, Missouri.  
Backgrounds and Accessories, Their Use and Abuse.  
Mrs. Clyde Ehinger, Quincy, Ill.  
Enlarging and Magic Lantern Slides. A. R. Dresser.  
London, England.  
Stop to Consider. H. McMichael, Buffalo, N. Y.  
An Item in Oil. J. Hegyessey, Paris, Texas.  
Dots. "Aunt Dottie."  
Many Mites from Many Minds.

OVER 3000 SOLD BEFORE ISSUE.

EDWARD L. WILSON, Photo. Publisher, 853 Broadway, N. Y.

*Mailed on receipt of price. For Sale by all Dealers.*



*The Latest Achievement in Portrait Lenses.*

**VOIGTLANDER & SON'S**  
**NEW**

**PORTRAIT**

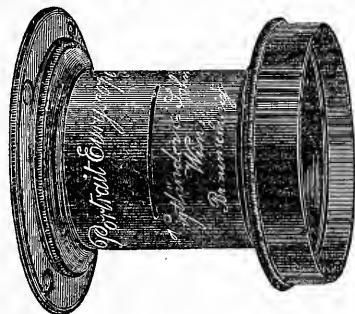

**EURYSCOPE**

**THE IDEAL LENS FOR PORTRAITS, GROUPS, AND FIGURES.**

Unlike the regular Portrait-Lenses, the front combination which consists of one compound lens and the rear combination of two separate lenses of quite dissimilar shape, these new lenses are composed of two perfectly symmetrical and cemented combinations, similar to the Euryscopes, and offer several important advantages. By sealing the two separate lenses of the rear combinations, the number of reflecting surfaces is reduced, thus saving a considerable amount of light formerly lost, and as, moreover, all diffusion of light is obviated, the new lenses produce more brilliant pictures and improved definition.

The front and back combinations being perfectly symmetrical, superior marginal definition and perfectly even illumination of the plate can be obtained, and, with the same length of focus as heretofore, a larger field is covered and the size of the image increased, the resulting picture being absolutely free from distortion.

The **PORTRAIT-EURYSCOPIES** are divided into two series as regards their working rapidity. The first corresponds in ratio of aperture to focal length to the Portrait-Lenses of normal speed, but excels them in covering capacity, depth of focus and powers of definition.

The second series—and these will be found the most useful—have an increased length of focus, and are consequently less rapid, but sufficiently quick-working for all ordinary portrait work in the studio. Possessing too, greater covering capacity (increased size of field), and greater depth of focus than the first series, this second series is specially adapted to taking groups and full-length figures in short studios where the regular Euryscopes, on account of their longer focus, may not be available. They are also excellent for instantaneous work, inasmuch as the flare characterizing portrait-lenses, when used out of doors, does not exist. In point of fact, this construction of the **PORTRAIT-EURYSCOPIES** will fill a gap in the series of existing portrait-lens and as they are lighter and shapelier than the old long-focus Portrait Objectives, they will become great favorites. Each lens is provided with central stops.

We would state, furthermore, that no change will be made in the present style of Euryscope lenses. Send for price list which also contains the official report of the Photographic Society of Vienna on the above lenses.

**BENJ. FRENCH & CO.**

*Sole Agents for the United States,*

No. 319 WASHINGTON STREET, BOSTON, MASS.

# 500 UNSOLICITED TESTIMONIALS AND MORE.

PLEASE READ THE LAST ONE.

A New Edition, with a twenty-four page appendix,  
giving all new processes  
practically useful, is now ready—  
THE CHAUTAUQUA EDITION.

*Northwestern Business College,  
Seward City, So. June 14, 1886.  
O. L. Wilson, Edg.*  
Dear Sir:—I am highly pleased with *Photographics*. In an experience of over 30 years teaching I have used and examined many text books, but have found none more ably written, or more exhaustive of the subject treated, in so small a compass. Containing, as it does, a clear exposition of the methods tried and proved by the long experience of the Author, together with plates from over 200 eminent practitioners, it cannot fail to prove a valuable aid, not only to the Amateur, but to the professional as well. Theory and Practice follow each other so closely, that the student can *know and do at once.*

If your old copy is worn out, get  
THE CHAUTAUQUA EDITION.  
If you have never owned *Photographics*, get  
THE CHAUTAUQUA EDITION.

*C. C. Cochran*

\$4.00

## WILSON'S

\$4.00

NEW  
EDITION.



NEW  
EDITION.

JUST  
READY.

## PHOTOGRAPHICS

JUST  
READY.

*Edward L. Wilson.*

\$4.00

\$4.00

## THE BEST PHOTOGRAPHIC LESSON-BOOK

By EDWARD L. WILSON,

Editor of "The Philadelphia Photographer," "Photographic Mosaics," etc.

The author believes it to be the best effort he has ever made, and begs to call attention to a few of its peculiar advantages as  
**A STANDARD WORK FOR ALL WORKERS IN PHOTOGRAPHY.**

- A. Treatment of the Subject.
- B. The needful apparatus.
- C. The Objective or Lens.
- D. The Dark Room.
- E. Preparation of the Glass.
- F. Chemicals and Solutions.
- G. The Manipulations.
- H. Manipulatory Misceries.
- I. Retouching the Negative.
- J. The Glass Studio.
- K. Accessories and Light.

- L. Managing the Model.
- M. Printing on Albumen Paper.
- N. Printing on Plain Paper.
- O. General Remarks on Printing
- P. Printing on Various Surfaces.
- Q. Printing Perplexities.
- R. Art in Printing.
- S. Mounting and Finishing.
- T. Photography Outside.

- U. Bromo-Gelatine Emulsion Work.
- V. Vogel's Collodion Emulsion.
- W. Enlargements and Lantern Slides.
- X. Phototypes, Platinotypes, and Collodion Transfers.
- Y. Wastes and their Worth.
- Z. Metrical Measuring.
- & Concluding Confab. Index (six pages).

The index added is very full and will enable the reader to quickly find almost any subject needed on every practical department of the art. Sent post-paid for \$4.00 by

EDWARD L. WILSON, 853 Broadway, New York.

# A CARD.

75 STONE ST., ROCHESTER, N. Y., July 26, 1886.

GENTLEMEN: About three months ago the business of Inglis & Co., of this city was formed into the Inglis Dry Plate Co.

In the articles of agreement, a clause was inserted giving the I. D. P. Co. the exclusive use of the name of "Inglis," and also that James Inglis would not connect himself with any dry plate business using the name of "Inglis."

Matters have taken such a form since then, he has been compelled to leave the I. D. P. Co. And being thus debarred from the use of his own name, adopts this means of making known to his numerous customers where they may still obtain his plate. **And the Only Place.**

A new firm taking the name of the **ROCHESTER DRY PLATE CO.** have engaged his services, and under his supervision a new factory has been fitted with the most modern improvements required for the production of **clean and spotless** plates, with all the other extra qualities that his plate has become so renowned for. The fraternity may therefore depend upon the very finest plate ever yet produced, from the **ROCHESTER DRY PLATE CO.**

## JAMES INGLIS,

Late Manufacturer of the Inglis Dry Plate, and President  
of the Inglis Dry Plate Co.

---

**ALBERT MOORE THE SOLAR ENLARGER,**  
**THE ONGEST, LARGEST, AND BEST.**  
**828 Wood Street, Philadelphia.**

---

**JAMES F. MAGEE & CO.**

*522 Race St., Philadelphia,*

**Manufacturers of Pure Photographic Chemicals,**

**Specialties: NITRATE OF SILVER and CHLORIDE OF GOLD.**

❖**REFINERS OF GOLD AND SILVER WASTE.**❖

❖Waste sent through Stockdealers will receive prompt attention.

---

**G. W. WILSON & CO.**

(By special appointment Photographers to Her Majesty the Queen),

**MANUFACTURERS OF MAGIC LANTERN SLIDES,**  
**St. Swithin Street, Aberdeen.**

Catalogue of 12,000 subjects in England and Scotland, and Price Lists, post free on application.

# THE PATENT BENSTER PLATE HOLDER. THE BEST

For either Dry or Wet Plate Photography  
in the Studio.

The Climax Portrait Cameras are fitted with the Benster Holder.

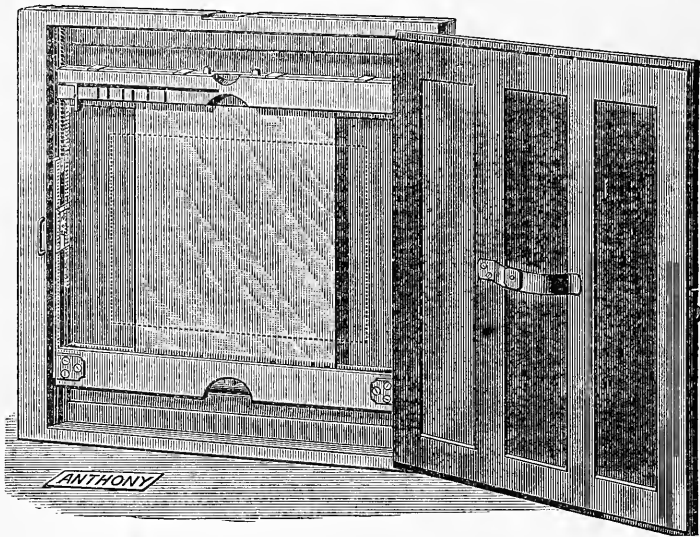

The plate rests on pure silver wire, and there is a trough, with large bottle beneath, into which all the silver waste readily finds its way. As the trough is raised, the upper ledge descends, so that the center of the plate is at all times in the centre of the holder, no matter what size is used. This obviates the use of inside kits, and adapts itself at once to any size of plate, from the largest the holder will admit to one not under three inches square. This is unquestionably the best gallery plate holder made. By a recent improvement, the horizontal bars may be instantly fastened for plates of any size, and there is also an attachment for the vertical adjustment. For dry plate studio work, it is the holder *par excellence*.

The prices of Benster Holders for Portrait Cameras are as follows:

For 8 x 10 plate and under, 12½ inches wide, 13⅝ inches high.....	\$10 00
» 8 x 10 » » 13¾ » 13¾ » .....	10 00
» 10 x 12 » » 15 » 15¾ » .....	14 00
» 11 x 14 » » 17 » 17¾ » .....	18 00
» 14 x 17 » » 20½ » 21 » .....	22 00
» 17 x 20 » » 23½ » 24 » .....	25 00
» 20 x 24 » » 28 » 28½ » .....	35 00
» 22 x 27 » » 31 » 31½ » .....	40 00

Special sizes to order, will cost 20 per cent. additional.

MANUFACTURED BY

## E. & H. T. ANTHONY & CO.

591 BROADWAY, NEW YORK.

# ANTHONY'S UNIVERSAL EASEL.

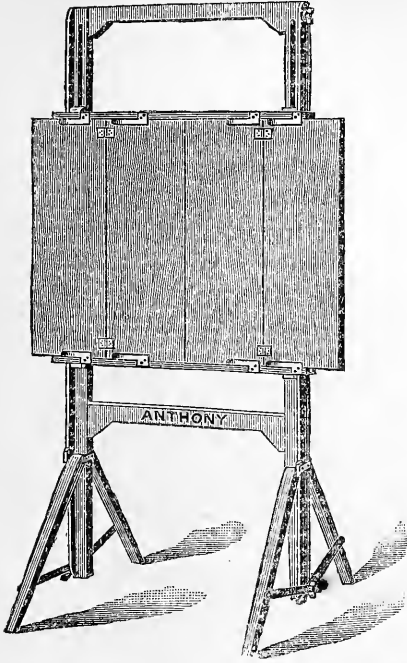

For making enlargements, holding pictures for copying, either opaque or transparent, Will take from the smallest size up to 25 x 30.

The board can be removed and folded into small space, and the entire easel can be unbolted and rolled into a small bundle in a few minutes. It can be inclined forward and backward, and meets every want for an article of its kind.

Price, \$7.50.

# NEWEST.

8 x 10 Novelle Camera, with single swing, *extra length*, for copying, enlarging, etc.

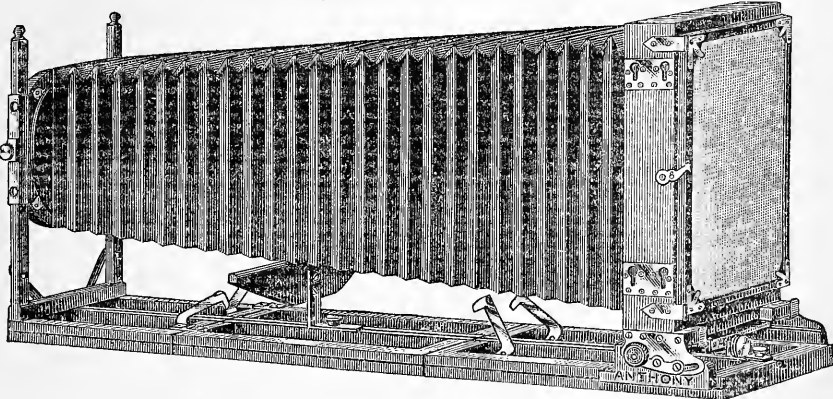

The bed is composed of three sections. By removing the rear section a regular 8 x 10 Novelle Camera is obtained. The extra section is held firmly in position by two dowel pins and our hook clamps, and can be removed in less than three seconds. A movable support is placed under the bellows to hold it in position and prevent sagging.

All is packed in an ordinary carrying case.

Length of focus..... $32\frac{1}{2}$  inches.  
 Total Weight..... 7 pounds.

Price, including one of our new style double Novelle Holders and case, \$40.00,

**E. & H. T. ANTHONY & CO.**

# SWEET, WALLACH & CO.

## Photographers' Supplies,

229 & 231 STATE ST., CHICAGO.  
**Best Goods! Lowest Prices! Complete Stock!**  
**ORDERS PROMPTLY FILLED. SATISFACTION GUARANTEED**  
**Your Patronage Solicited. Send for Catalogue.**

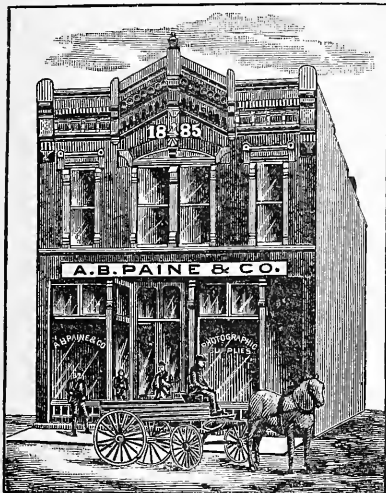

THE

## KANSAS STOCKHOUSE,

One year in business and have doubled our stock three times.

One year ago we started in a room 20 x 40 and we now occupy

### This Entire Building

from garret to basement.

We are headquarters for all photographic material of whatever make.

Send for our catalogue and "Monthly Bureau," free.

**A. B. PAINE & CO.**

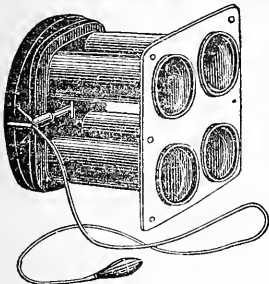

## THE BON TON SHUTTER.

For exposing four Gem Lenses at once. Absolutely necessary in using the Argentic Plates. Also

## THE FAVORITE STEREO. SHUTTER.

Constructed on the same plan.

Send for particulars to

**W. D. GATCHEL, Louisville, Ky.**



## THE AIR BRUSH

Applies Color by a Jet of Air.



Received Silver Medal Franklin Institute, 1885, Special Medal American Institute, 1884. Invaluable in every photographic studio producing large work, whether in black and white or water colors. Works on any surface. Especially successful on Bromide Prints. Excellent retoucher for large negatives, and highly endorsed by leading photographers. Sent upon trial. All particulars cheerfully furnished upon application.

**AIR BRUSH MFG. CO.**

50 Nassau Street.

ROCKFORD, ILL.

# THE WONDERFUL PERMANENT BROMIDE PAPER.

---

LABEL REGISTERED 1885.

---

A Grand Medal of Merit Awarded at the St. Louis  
Convention.

BUFFALO, N. Y., July 2, 1886

THE EASTMAN DRY-PLATE AND FILM CO.

GENTLEMEN: I take great pleasure in informing you that the Committee have awarded you a **Special Medal of Merit** for your elegant display of portraits printed on Permanent Bromide Paper. Congratulating you, I remain,

Very truly yours, H. McMICHAEL, *Secretary P. A. of A.*

---

When it is explained that of our exhibit at St. Louis, over fifty of the prints, ranging from 20 x 24 to 30 x 40, were made in *two days*, the capacity of our enlarging department for turning out first-class work will be understood.

---

## THERE IS MONEY

in Permanent Bromide Enlargements for the  
Progressive Photographer.

---

Send for Our Illustrated Circular HOW TO IMPROVISE AN ENLARGING APPARATUS.

---

**THE EASTMAN DRY-PLATE AND FILM CO.**

ROCHESTER, N. Y.

ALFRED M. COLLINS,  
*Secretary and Treasurer.*

HENRY H. COLLINS,  
*President.*

EDWARD COPE,  
*Vice-President.*

A. M. Collins Mfg. Co.

*MAKE ALL KINDS OF*

**CARDS AND CARDBOARDS**

FOR

**P** PHOTOGRAPHERS **S**

AND

**MATS, MOUNTS, AND ENVELOPES**

FOR

**FERROTYPES.**

---

OFFICE AND WAREHOUSE,

**No. 527 ARCH STREET,**

PHILADELPHIA.

---

Price Lists may be had by intending purchasers on application to us, or to all Photographic Merchants, through whom your favors are respectfully solicited.



Now at  
825 Arch Street,  
PHILADELPHIA.

United States Agents for

# ROSS LENSES

Price Lists  
Free.



**WILSON, HOOD & CO.**  
**WILL REMOVE**  
**DURING THE MONTH OF JANUARY, 1887,**  
**To No. 910 Arch Street, Philadelphia.**

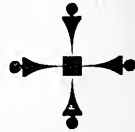

Send us  
your orders  
for

**PHOTOGRAPHIC  
MATERIALS**

OF ALL KINDS.

**OUTFITS  
FOR AMATEURS**

A SPECIALTY.

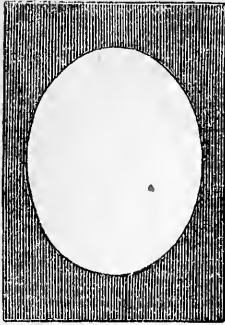

# GIHON'S CUT-OUTS

An Entirely New Variety for  
PRINTING MEDALLION PICTURES.

Are the very best that are made, and are now without a rival in the market. They are clean cut, most desirable shapes and sizes, and made of non-actinic paper, manufactured specially for the purpose. Each package contains 30 Cut-Outs, or Masks, with corresponding Insides, assorted for five differently sized ovals and one arch-top.

*Price, \$1.00 per Package. Sent by mail on receipt of price.*

Parties wishing special sizes, or large lots of a few sizes, may have them cut to order promptly by addressing the manufacturer. No lot costing less than \$1.00 made at a time.

*No printer should attempt to make Medallion Pictures without them.*

## THEY HAVE NO EQUAL FOR QUALITY.

Beware of spurious imitations made of common paper, full of holes, badly cut, and odd shapes and sizes. Ask your Stock-dealer for GIHON'S CUT-OUTS, and see that they are in his envelope, with instruction circular included. The recent packages are composed of an entirely new variety and of a new paper. **TRY THEM.**

Promenade Size now Ready. Sold Separately at 50 cents per Dozen.

# GIHON'S OPAQUE

Is designed for Completely obscuring the Imperfect Backgrounds of Copies, Retouching Negatives, Faulty Skies in Landscapes, Coating the Inside of Lenses or Camera Boxes, Backing Solar Negatives, Covering Vignetting Boards, And for Answering all the Requirements of the Intelligent Photographer in the Production of Artistic Results in Printing.

Wherever you want to keep out Light, use Opaque.

**IT IS APPLIED WITH A BRUSH, DRIES QUICKLY AND STICKS.**

**CUT-OUTS (thirty), \$1.00. OPAQUE, 50 Cents.**

**FOR SALE BY ALL DEALERS.**

**ROBERTS & FELLOWS, Makers, Philadelphia.**

Address all orders to

**SCOVILL MANUFACTURING CO., New York.**

“THE MOUND CITY”

Photographic Stock House



Offers the Most Complete line of  
Photographic Apparatus, Chemicals,  
Picture Frames, Mouldings, Mats,  
Albums, Etc., in the market,  
at bottom prices.

Professional and Amateur Outfits a Speciality.

AGENT FOR

KUHNS LIGHTNING DRY-PLATE INTENSIFIER,

AND

KUHNS SENSITIZED PAPER STRETCHER AND DRYER.

Address

**H. A. HYATT,**

8th & Locust Sts.,

ST. LOUIS, MO.

Send for Illustrated Catalogues of Photographic Goods and Picture Frames.

**BECK'S AUTOGRAPH RECTILINEAR LENSES.**

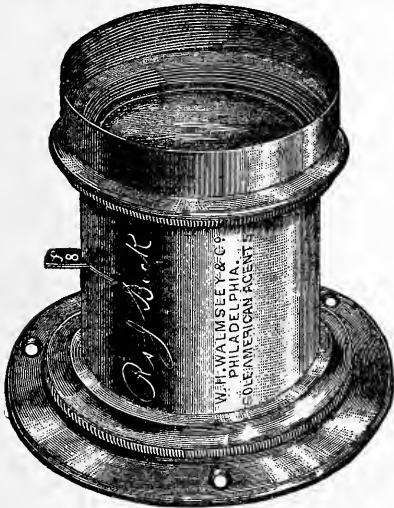

THESE extraordinary lenses attracted universal attention at the late St. Louis Convention; the specimens of work in Portraiture, Groups, Landscapes, Instantaneous Views, etc., executed by them being of unequalled excellence. A life-sized head, made with the 8 x 10 lens of 13 inches focus, was considered by the experts present, as being far ahead of any similar performance ever seen. A full description of these and our other specialties will be found in our full catalogue. *Mailed Free.*

**W. H. WALMSLEY & CO.,**

*Photographic Stockdealers.*

**1016 Chestnut St., Phila., Pa.**

**ENTREKIN'S**  
 IMPROVED  
**DUPLEX ROTARY BURNISHER.**  
 PATENTED.

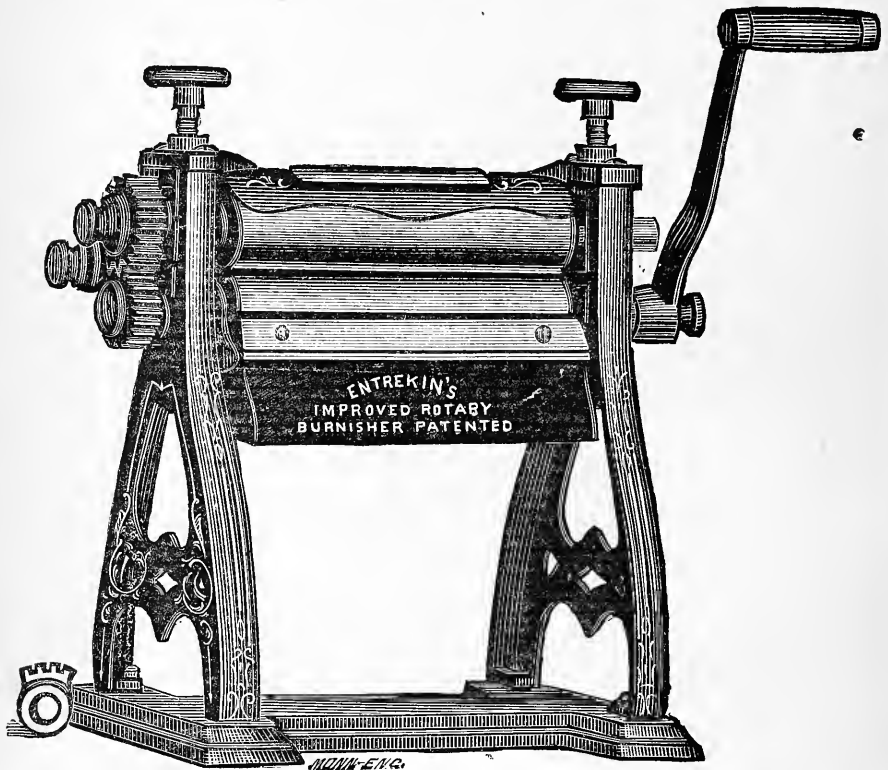

10 in., \$25.00. 15 in., \$35.00. 20 in., \$45.00. 25 in., \$60.00.

This Machine is an improvement on our old Duplex Rotary Burnisher, invented by us in 1874.

It is so constructed that by changing the Large Gear or Cog-wheel, from the stud to the end of the draw-file or upper roll, you reverse and change the speed of the lower or polishing roll, thus getting the same result as in the old Duplex Rotary; but to secure the best polishing surface, use the machine with the large cog-wheel on the Stud, by so doing you secure three times the polishing surface. All the machines will be sent out with gearing so arranged as to give this result. It is optional with the Photographer how he may use the machine. The Fire-Pan is so arranged that it is impossible for it to come in contact with the surface of the polished roll, and it can be turned away to cleanse the roll.

**EVERY MACHINE WARRANTED PERFECT.**

FOR SLE BY

**W. G. ENTREKIN, Inventor and Sole Manufacturer,**

4384 Main St., Manayunk, Philadelphia, Pa.

AND BY ALL PHOTOGRAPHIC STOCKDEALERS.

# ENTREKIN'S PATENT EUREKA BURNISHER.

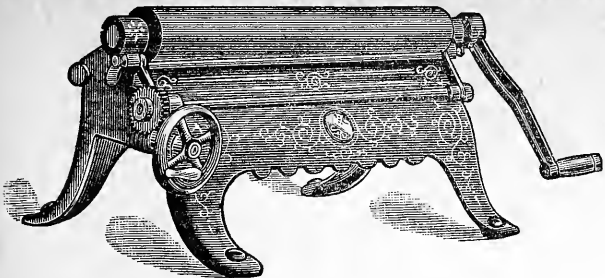

The above cut represents our 25 inch Eureka.

The unprecedented popularity of this Burnisher is wonderful. Over seventeen thousand (17,000) sold in less than five years. Agencies in London, Berlin, and Vienna, and sold by all stockdealers in the United States. The machines are built in first-class style, and warranted to do the work claimed.

Full directions accompany each machine.

## PRICES:

6 inch Roll, . . . . .	\$15 00	20 inch Roll, . . . . .	\$60 00
10 " " . . . . .	25 00	25 " " . . . . .	70 00
14 " " . . . . .	35 00		

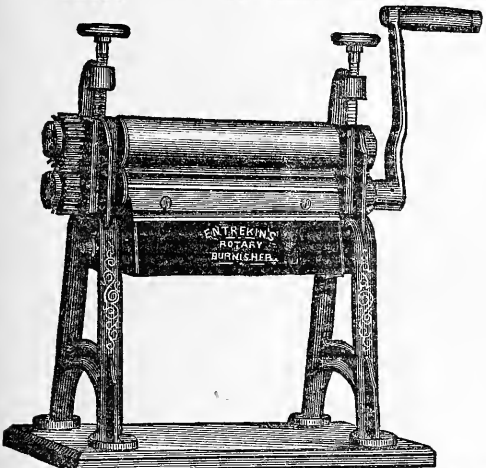

## ENTREKIN'S Duplex Rotary Burnisher.

PATENTED JUNE 1, 1875.

## PRICES:

10 inch, . . . . .	\$15 00
15 " . . . . .	25 00
20 " . . . . .	35 00
25 " . . . . .	45 00

# ENTREKIN'S DUPLICATING PRINT CUTTER.

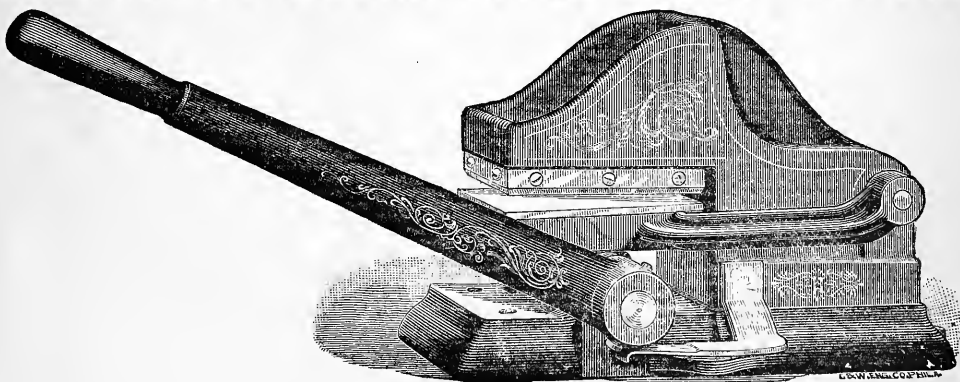

Cabinet and Stereo. Sizes, \$25.00      Small Panel Size, \$35.00.  
 Size 6½ x 8½, \$40.00.

MANUFACTURED AND FOR SALE BY

W. G. ENTREKIN, 4384 Main St., Manayunk, Phila., Pa

"Tasteful, well edited, and crammed full of technical information is THE PHOTOGRAPHIC TIMES."—The Journalist.

# The Photographic Times

Is a WEEKLY JOURNAL devoted to the  
THEORY, PRACTICE, AND ADVANCEMENT OF PHOTOGRAPHY.

ITS DEPARTMENTS ARE:

**EDITORIAL.**

**CONTRIBUTED AND MISCELLANEOUS**, articles by the best photographic writers of both hemispheres.

**COMMUNICATIONS FROM SOCIETIES**, including Papers, Lectures, Demonstrations, etc.

**MEETINGS OF SOCIETIES**, Stating date and place of meeting of all Photographic Societies, both professional and amateur, and giving full proceedings of all meetings.

**CORRESPONDENCE**, Scientific and practical discussion by practical photographers of important and interesting questions, and letters from all quarters of the globe by intelligent and observing correspondents.

**OUR EDITORIAL TABLE**, Reviews of books, exchanges, etc.

**PICTURES RECEIVED**, Impartial criticism and notice of all photographs sent in.

**NOTES AND QUERIES**, Answers by the Editors to correspondents in search of knowledge.

**COMMERCIAL INTELLIGENCE**, Description of new photographic appliances, studio changes, and a record of photographic patents.

## A PARTIAL LIST OF WRITERS TO THE PHOTOGRAPHIC TIMES.

CAPT. W. DE W. ABNEY.....	England	W. H. WALMSLEY.....	Philadelphia.
W. M. ASHMAN.....	"	FREDERICK A. JACKSON.....	New Haven
W. K. BURTON.....	"	PROF. RANDALL SPAULDING.....	Montclair, N. J.
W. E. DEBENHAM.....	"	PROF. WM. HARKNESS, U. S. N.....	Washington, D. C.
H. P. ROBINSON.....	"	DR. JOHN H. JANEWAY, U. S. A.....	Governor's Island
G. WATMOUGH WEBSTER.....	"	C. D. CHENEY, D. D S.....	Hoboken, N. J.
ARNOLD SPILLER.....	"	PROF. KARL KLAUSER.....	Farmington
W. JEROME HARRISON.....	"	GEO. H. JOHNSON.....	Bridgeport
ANDREW PRINGLE.....	Scotland	MISS ADELAIDE SKEEL.....	Newbergh
CHARLES SCOLIK.....	Vienna	CHARLES WAGER HULL.....	New York
DR. MALLMAN.....	"	REV. G. M. SEARLE.....	"
KARL SCHWIER.....	Germany	C. W. CANFIELD.....	"
VICTOR SCHUMANN.....	"	P. C. DUCHOCHOIS.....	"
W. J. STILLMAN.....	Athens	HENRY M. PARKHURST.....	"
PROF. H. D. GARRISON.....	Chicago	REV. C. E. WOODMAN, Ph. D.....	"
PROF. S. W. BURNHAM.....	"	H. EDWARDS-FICKEN.....	"
HENRY L. TOLMAN.....	"	S. H. HORGAN.....	"
GAYTON A. DOUGLASS.....	"	WM. KURTZ.....	"
A. HESLER.....	"	J. M. MORA.....	"
GUSTAV CRAMER.....	St. Louis	PROF. L. C. LAUDY.....	"
J. F. EDGEWORTH.....	"	A. BOGARDUS.....	"
W. H. SHERMAN.....	Milwaukee	CHAS. D. FREDERICKS.....	"
GEORGE EASTMAN.....	Rochester	A. MORENO.....	"
DAVID COOPER.....	"	C. W. DEAN.....	"
PROF. H. W. LORD.....	Columbus	DR. O. G. MASON.....	"
H. McMICHAEL.....	Buffalo	ERNEST EDWARDS.....	"
JOHN CARBUTT.....	Philadelphia	DR. CHAS. EHRMANN.....	"

The Photographic Times { Monthly edition issued on the } Issued Every Friday  
 { last Friday in the month. }

### —•••SUBSCRIPTIONS.•••—

One copy Weekly issue, postage included, to all points in U. S. or Canada.....	\$ 3 00
One copy Monthly issue, postage included, to all points in U. S. or Canada.....	2 00
Weekly issue to foreign addresses, postage included.....	4 00
Monthly issue to foreign addresses, postage included.....	3 00

Single copy, Weekly, 10 cents

A month's trial (four weeks), of the Weekly for 30 cents.

A specimen number free.

Single copy, Monthly, 25 cents.

Remit by Express, Money Order, Draft,

P. O. Order or Registered Letter.

Subscriptions to THE PHOTOGRAPHIC TIMES received by all dealers in photographic materials in this Country, Canada, West Indies, Great Britain, Australia, New Zealand, and by the publishers,

## SCOVILL MFG. CO.

W. IRVING ADAMS, Agent.

No. 423 Broome Street, New York.

A copy of either of the British Annuals, or of Wilson's Photographic Mosaics for 1887 will be given to every subscriber sending in \$3 00 for one year's subscription to the PHOTOGRAPHIC TIMES from January 1, 1887.

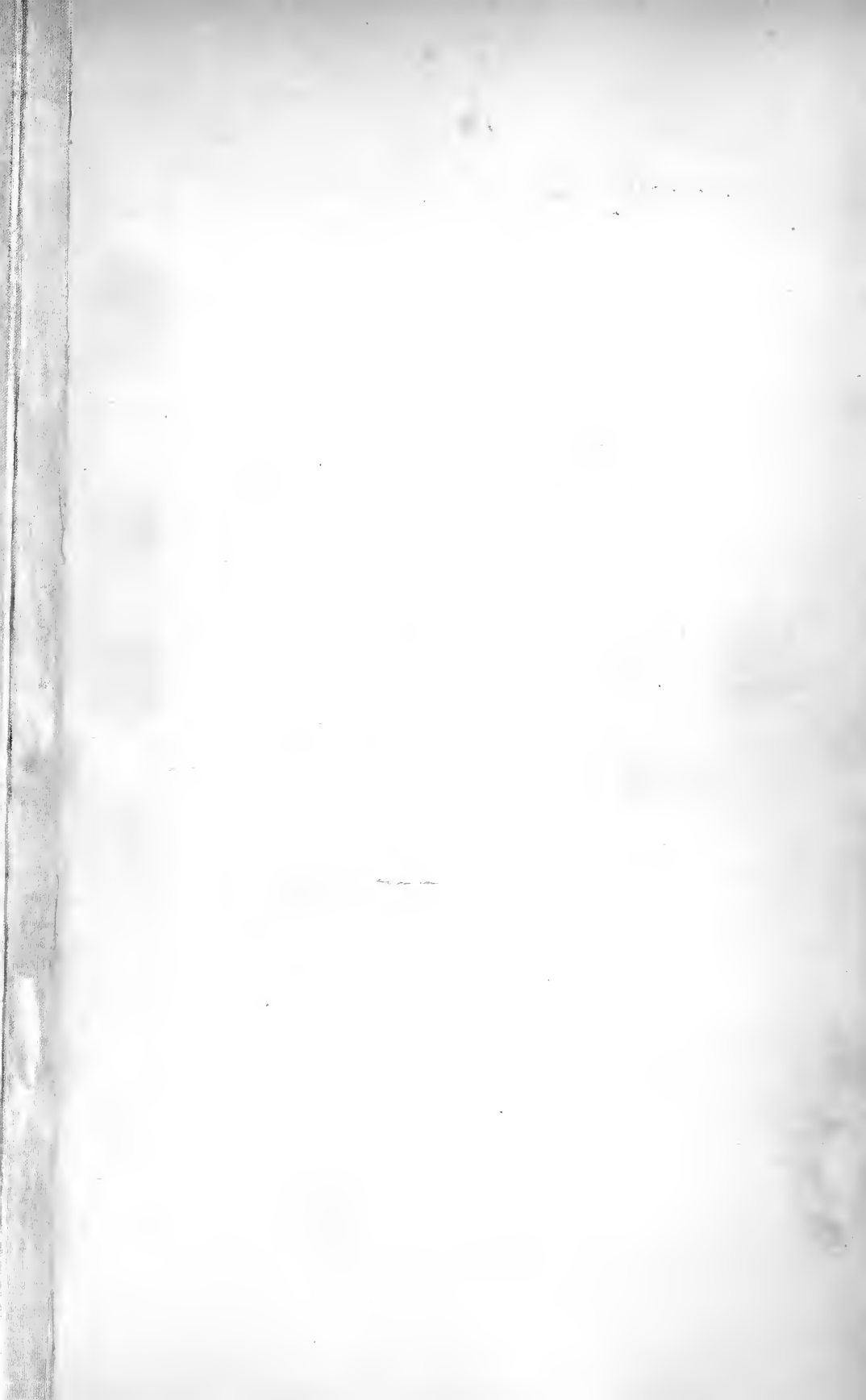



EDWARD L. WILSON,

FROM MY OFFICE WINDOW.

NEW YORK.



THE

# Philadelphia Photographer.

EDITED BY EDWARD L. WILSON.

Vol. XXIII.

DECEMBER 4, 1886.

No. 287.

## OUR NEXT YEAR.

WE all regret to see the end of anything that has been pleasant or profitable to us. We, editorially, particularly regret the ending of our subscription year. We have passed through the experience now twenty-three times, and always with the feeling that our end has come, as that of the leafless tree, and that there is a doubt whether we shall again receive the support which only can put life in us for another year.

We trust there is no doubt on the part of our subscribers, however, and that they will promptly assure us of their desire for our life and a new outgrowth of leaves by promptly renewing their own subscriptions and adding new names to our list.

And won't you all please say yes or no quickly—before our January issue is due? We do not like to discontinue sending our magazine to old, staunch friends. We dislike to be berated for sending it where it is not wanted. How are we to know? If our magazine is useful to you, we are, in all courtesy, entitled to know if you want it continued. If, for any reason, you do not want it, we are entitled to know that.

We make our terms so easy that no one should be deprived of the prompt appearance of our semi-monthly numbers. We give so much for the money now, however, that we cannot print a large number of over-copies with the uncertainty of their sale before us.

A good photographic magazine is somewhat like your water supply. You do not realize how useful it is until it stops. What would photography do if there were no good magazines devoted to it? Is it not to your interest to support them all? and if not all, the *best* one?

Please take a moment to consider these things *for your own good*.

During the past year it was our honest effort to make our magazine the best of its class in the world. No publisher gives so much for the money—12 numbers, illustrated (32 pages each, always), for \$2.50; double that number for \$5.00. Where is it equalled?

It gives you the news of the world; it is the practical photographer's devoted advocate and helper; it is not issued for the sake of catching other trade; it is open and straightforward in its policy; and it will not be beat. A splendid variety of studies is given—an unrivalled choice, and it is our constant effort and study to be of service to the photographer who must win his daily bread by his camera.

Now we propose to continue this another year. In addition, we have arranged for several new series of papers from foreign contributors; for a series of illustrated art lessons, for an entire novelty—the reproduction, in supplementary sheets, of some of the best articles of the year in the French and German languages, for our readers who cannot read English; for a grand prize con-

test; for a series of lessons from the veterans of the craft; for another series from the second generation; and for twenty-four or more such studies as were never before seen in any photographic magazine. Among these last there will be examples of work from all sections of our country and from foreign lands. For a fuller list, see the third page of our cover.

The year will be led by Mr. D. H. Anderson, of this city, with a splendid portrait of the charming actress, Miss Charlotte Behrens, in her Russian character of "Zitka." It will be followed by an example of the Vandyke style of lighting, by Messrs. Loescher & Petsch, Berlin; by that charming female subject from Peitzner, Tôplitz—in our opinion the gem of the German department at St. Louis; a whole series of lovely child pictures—some from Texas, some from California, and some from the Hoosier State; photogravures, phototypes, gelatine, and other process pictures; a group of ladies from the new studio of Mr. P. H. Rose, Providence, R. I.; a Kalahari view, by Mr. Lulu Farini, Bridgeport, Conn.; a gem from Mr. H. P. Robinson; a quartette of portrait studies from a famed London artist; an azaline reproduction of a chromo, with the original and a wet picture added; and— Well, it is not good policy, for obvious reasons, to tell *all* we are going to do; but if our old friends will come forward and help us to some new ones, reciprocal action will assure them that together we can uphold the honor of our art, make it grow under our hands, and help each other to more comfort in our work. Shall the thing be mutual? Please express your opinion by the usual sign—and our best wishes for a happy New Year go to you heartily.

---

### PHOTOGRAPHIC MOSAICS FOR 1887.

As good as ever, *Mosaics* for 1887, is at hand. Its appearance was somewhat delayed by the removal to larger quarters of our excellent printer, Mr. Dornan; but it will, we trust, be all the more appreciated for having been long expected.

The new issue of our year-book is remarkable in many ways. The photographer

who has long known it will be surprised as he takes the wrapper off of his old friend to see how much he has grown this year. However, it is only the approaching portliness of middle age—a healthy symptom. He must keep pace with the art he expounds. The number of contributions that came in has been remarkable also—so great that his hands have had no room for them all, and many bits of gems dropping from the heap, have been caught by his semi-monthly brother, in whose columns they will appear sparkling for some time to come. Notable also, is the very large number of articles sent by our friends over seas. The foreign authorities have been generous, and are well represented. And finally, an entire novelty, are the illustrated articles, which will feed the growing taste for art, or give an object-lesson on apparatus.

Taking up the book, the first things we see after turning the familiar cover, are the Moss Engraving Company's pictures. These are worth study, as showing what good work can be done direct from the photograph. The photographer is becoming more and more useful in art and illustration, through processes like these.

Then comes the beautiful little frontispiece, by Ernest Edwards, printed by the Photogravure Company, New York. It is a success all through. The view is a charming little bit of nature, well chosen and well treated. The negative was a good one, and the plate, made direct from it, preserves, indeed heightens, its excellences. The printing is remarkably even; and it is pleasant to see the good qualities of the negative thus preserved in absolutely permanent form in the skilful hands of the Photogravure Company.

Next comes the list of the good things awaiting the reader, in the table of contents. The Editor's retrospect leads off as usual. A most notable year the backward-turning eye looks over; a year of unexampled progress, with many a day marked with the white stone of some advance or invention. All are noted here, and in a thorough way the story of the year is well told. Then the different branches of the art have their chance.

Among the "art articles," we see "Photography as an Art," "The Art-Educa-

tion of Photographers," by Miss Charlotte Adams; then "The Disposition of the Hands," by Mr. W. T. Mozart. "Back-grounds and Accessories," are ably treated by Mrs. Clyde Ehinger. "Photographing Interiors," is treated by Mr. W. I. L. Adams, editor of the *Photographic Times*; "How Shall We Aim?" by J. F. Ryder; "Photography for the Newspapers," by F. H. Wilson; and "The Use of Photography in Wood Engraving," by M. V. Roux.

Then all the practical manipulations follow. Mr. G. G. Mitchell writes of "The Flap Shutter;" Professor Karl Klauser on "Shading the Lens;" Mr. Harold Sands treats of "Developer Dodges;" Mr. W. E. Woodbury, "Hydroxylamine as a Developer;" Mr. E. M. Estabrook, "Development of Dry Plates;" Mr. W. E. Truesdell, "The Development of Very Short Exposures;" Dr. Arthur H. Elliott, "Developing with Pyrogallol." So printing, toning, re-touching, and finishing. Not one is without its word. And with several articles full of "Odd Points," comes to end all a compendium of "Mites from Many Minds," giving various valuable receipts and formulæ.

*Mosaics*, after nearly a quarter-century's existence, is old enough to be a familiar and appreciated friend to the photographer. So we are less surprised than pleased to find that nearly every copy of the edition has been sold to subscribers and dealers before a number has come from the binders. In fact, the edition is so near exhausted that we would warn our friends to send in their orders very quickly if they want a copy. All the dealers have it, and we have a few left ourselves. Order early.

### A SIMPLE VENTILATOR.\*

BY C. C. VEVERS,  
Hartsforth, Eng.

MUCH ill-health arises from working in a stuffy or badly ventilated dark-room, amongst the fumes of ammonia and other noxious chemicals, and often the true cause of failing eyesight, so prevalent among the profession, may be traced to an ill-ventilated

"developing case." The annexed sectional diagram illustrates a simple but very efficient ventilator, which may be easily fixed to any existing dark-room, with very little trouble or expense. I have long had these "air-holes" attached to my dark-room, and can vouch for their utility.

It is advisable to fix one at each end of the room; the first near the floor, preferably under the sink, for the inlet of fresh air, the other near the roof, for the outlet of exhausted or heated air.

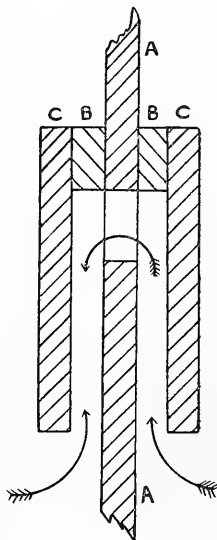

A horizontal opening is cut in the wall (A) (which in England, almost invariably, is constructed of wood), from 12 to 24 inches in length, and 3 or 4 inches deep. Directly over the opening, at each side of the partition, is fastened a strip of wood (B) an inch or more thick, about 2 inches wide, and the length of the opening. To these strips are screwed boards (C) not less than a foot wide. All that now remains to be done is to fix strips at each end, so that the air and light can only enter at the bottom, the former following the direction of the arrows, while the light finds some little difficulty in turning the corners. Dust may be entirely excluded by gluing over the opening, at the inside, a piece of fine gauze.

\* Written for *Mosaics*, but received too late.

**MOUNTAINS AND MARINES.\***

BY O. K. B. W. K.

THE ability to climb is one to be cultivated by the would be successful mountain photographer. A great many pictures I have seen made in mountain regions are imperfect and unsatisfying, because the camera was placed at too low a standpoint.

The foregrounds are filled with incongruous and badly composed rocks, or trees, or roadway it may be, and there is no feeling of atmosphere or distance whatever, though it is true there are the mountains in the beyond.

ered, the islands hidden, and the height of the hills lowered by contrast with the trees.

As it is, we have a foreground full of pictorial value, a splendid sense of expanse and distance conveyed by the islands and the lake, with a charming view of the mountains.

But to secure such a combination the artist must climb, perhaps two or three inclines before he can find a proper standpoint.

"One can not always find lakes if he climbs," you may say, and true it is, but climbing almost always helps. Look for an illustration of this, at the charming little

FIG. 1.

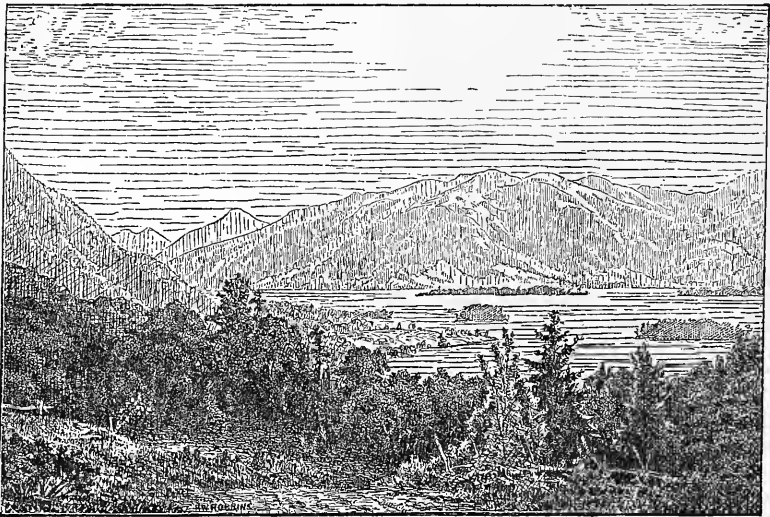

To correct these evils you must climb—climb to a point where you can overlook the immediate foreground, and secure a good expanse between you and your principal point of interest, the mountains.

I might illustrate my meaning by reference to Mr. H. W. Robbins's painting of "Harbor Islands—Lake George." (Fig. 1). With half an eye one can see that if a camera picture of this scene was ordered of the photographer, he would terribly miss it if he attempted it from a point near the level of the lake. The lake would be mostly cov-

bit by Mr. J. B. Bristol, called "Mount Equinox, Arlington, Vt." (Fig. 2.) Here is no lake, and islands would be incongruous, but it is a pretty and proper composition taken from the proper height to get the best effect.

And yet there are exceptions to all rules. There are occasions where it is best to remain lowly, but only when the best picture can be so obtained. Such an instance is exhibited by Mr. Albert Bierstadt's magnificent painting of "Mountain Lake." (Fig. 3.) This is a picture of a lake hedged in among the richest accessories of tree and

\* Written for *M. saics*, but received too late.

mountain which nature ever provides. Here are a hundred pictures possible in one; but

angered, come and where, to

rolling in as if to forewarn, get the full sense of the picture your highest tripod or the top of a bath-house must be used.

FIG. 2.



it is a picture of a "Mountain Lake" and must not yield to the things which are about it. It will be observed, however, that it was

D. M. Armstrong's painting of "The Harbor Bar, Mount Deseret." (Fig. 5.)

It is true, this is a "bar," and with such accessory objects as belong to a "bar," yet it strikes me with the feeling that there are too many objects crowded in, and the effect of the whole gives trouble to both eye and mind to puzzle out the artists reason for their introduction. The swirl of the lines is also too tame. If I had been photographing in that locality I should have chosen a different combination.

FIG. 3.

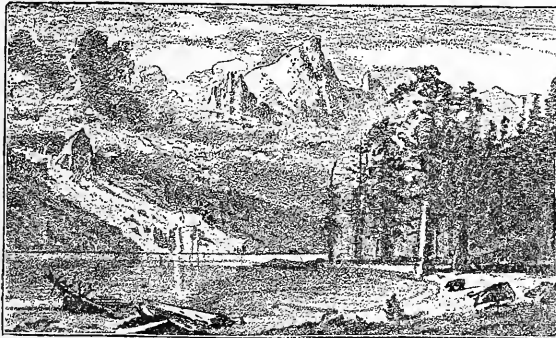

not the policy of the artist to paint "the whole" lake "or none." He has chosen one of its most beautiful curves, with a shore line decorated by such accessories only as are found there in nature. And after all somewhat of an elevation must be reached in order to get just such a combination.

Head, Grand M6nan," by Mr. A. T. Bricher. (Fig. 6.) It is full of lovely sugges-

FIG. 4.

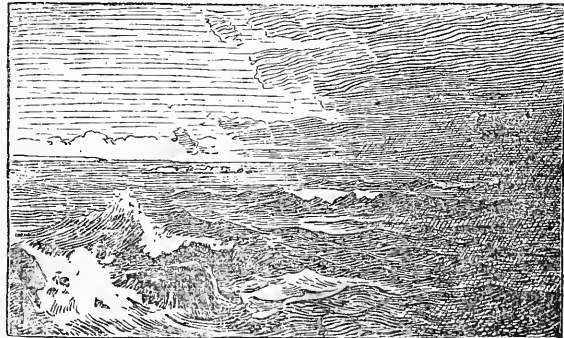

Climbing comes good also when you have to master marine pictures as well as in the mountains. "The Gull Rock," of Mr. W. T. Richards (Fig. 4) shall be used to help us here. It is one of those occasions when, just before the fog pays its visit to the shore, the waves, seemingly

tions, and would require an elevated standpoint to secure its full sense in a photograph.

Of course, I am only to be understood as making suggestions—as simply giving you

### PRACTICAL POINTS FROM THE STUDIOS.

FIG. 5.

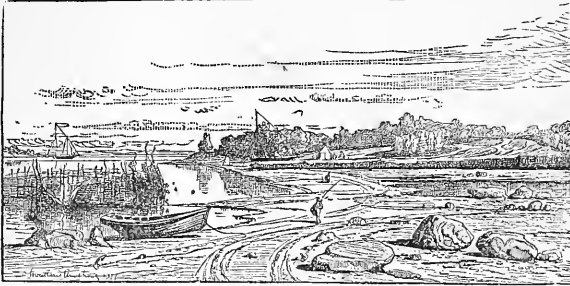

a receipt for a developer but not mixing it or manipulating it for you. I use the word climb in its literal sense, and its typical as well. You must *work* if you would secure pictures.

Even if you only stand on a wharf-pile and fire away, should you want to get, such a picture as "From a North River Pier," by Mr. Arthur Quartley, you (Fig. 7) must climb up to the art-rules and must seek a place for your camera where all incongruities and inharmonious objects will be left out.

I hope I have not led you too high.

FIG. 7.

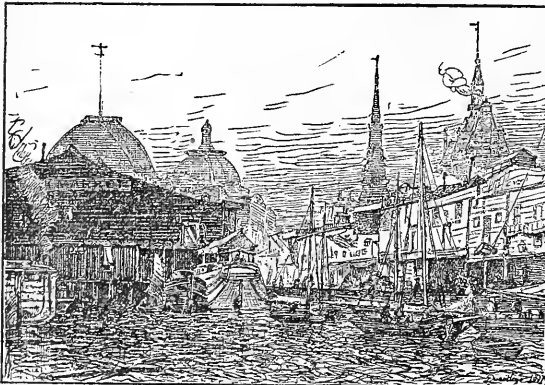

P. S.—Oh! Don't forget about the time of day.

of phosphorescent color in oil; when thoroughly dry, frame. In daytime the

FIG. 6.

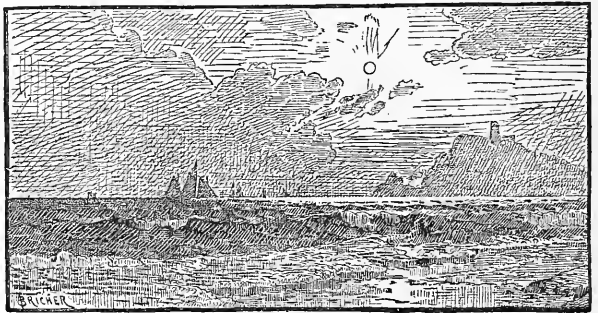

image resembles an ordinary photograph, and at night it is luminous; with large

heads the effect obtained is magical. But what is still more curious is to use instead of carbon paper, a paper containing a white coloring matter instead of carbon; a white image is now obtained, which is invisible during the day, and which, by the application of the phosphorescent color, becomes visible at night.

This idea, already given by the *Moniteur de la Photographie*, several years ago, may still be applied in another way, by printing a negative on the glass instead of a positive; in this case it is the image itself which is luminous, instead of showing black on

the phosphorescent background. Both experiments are fascinating and curious.

We are surprised that searchers after scientific curiosities have not put in practice this idea, so simple, and which would insure a large sale of subjects suitable for the purpose.—*Moniteur*.

### HINTS FROM GUATEMALA.\*

BY E. J. KILDARE.

**DOUBLE PRINTING OF PAPER NEGATIVES**—I was slightly fooled by receiving a  $4\frac{1}{2} \times 7\frac{1}{2}$  roll-holder for my  $5 \times 8$  view-box. However, it works to a charm, and I get the same size as of yore, by trimming my paper negatives to have clean edges with round corners, and in this condition is placed in the centre of the  $5 \times 8$  paper and printed. And there you are, you know—"Nice print with black border."

**TRANSPARENCY COMPOUNDS—MANNER OF USING.**—Fasten your paper negative, face down, in a carrier or similar device. Now, with a small flat bristle brush, apply your translucine, vaseline, or oil, and if you haven't a hot sun (as I have) to place them in for a few minutes, heat artificially, or use the mixtures hot. This is better than rubbing it in with your fingers, and saves soap.

### THE PRINTER'S TROUBLES.†

BY CHAS. P. KRAUSS,  
Memphis, Tenn.

RESPECTED reader, do not expect to hear something about yellow baths, mouldy paper, or broken negatives, etc., as the drift of my remarks to this popular volume is in another direction. It is important as it has been utterly neglected by all writers on photography to a large extent. The proper name for this manuscript would be "Absence of System in the Printing and Finishing Departments." Owing to the fact however, that it is devoted to the benefit of printers, and calculated to improve their positions by rendering the same more agreeable, I headed it as above.

A printer may have done a very good

day's work as far as brilliant prints, uniform tones, etc., are concerned, and feel justly satisfied with his achievements. Immediately after sending his prints into the finishing room, however, he will hear the angelic voice of the lady clerk exclaiming, "Well, I do declare, now he has gone and made plain prints off of Mrs. X's baby when I had faithfully promised her vignettes or clouded backgrounds. Oh, Mr.—you must print them all over and as soon as possible as I promised them to her by to-morrow. I am sure I mentioned the fact to you when you made the proofs." Of course there is nothing for the printer to do but to print them over. The above is a daily occurrence in most of the galleries and only too often results in unpleasantness which generally terminates in quarrels and changes of hands or quitting of situations. There are other troubles which can be discussed under the same heading; such as overprinting, incomplete orders, and not printing "in time." No matter where the fault may be—clerk, retoucher, or printer—the result is always the same, the latter is generally blamed for all blunders. There are two ways of preventing these calamities. One is to furnish the printer with an order book with columns as below:

Neg. No.	Am't wan'd.	Style.	When prom'd.	R'm'ks.
1640	12	Cab's	18th	Vig.

Another is to mark your negatives say: 23168—12 vig.—16th or 25782—6 pl.—24th, etc. Then make a print book of heavy brown paper, say  $11 \times 14$  in size or larger; rule the paper so as to leave 16 card-size openings which must be numbered regularly. Make a book print of each and every negative taken. On back of each book print the negative number, the number of prints wanted, and when wanted should be copied. This print should be pasted in its respective opening with what and when ordered, written in space below. When a batch of negatives come into the printing room the printer should assort them according to their dates and print them out accordingly. If you are still troubled, with incomplete orders it is the printer's own fault and he deserves all blame. Pictures should not be promised under ten to twelve days at any

\* Written for *Mosaics*, but received too late.

† Written for *Mosaics*, but received too late.

time, and in busy season not under twelve to fifteen days. This will give the printer plenty of time to have his orders finished when promised. If through some accident he is a print or two short let him know in time and your customers will not be disappointed.

Some photographers are in the habit of delivering unfinished orders, which is a very inconvenient practice as well as unsatisfactory to both parties. If customary, however, keep a memorandum book or slate and make note of how many are delivered. The book-print system is excellent, even with the printer's order-book, as it serves to mark prints or envelopes with negative numbers without taking the burnished prints into the printing-room, and aids the printer in finding duplicates.

Another very important point is to charge one man with the care of negatives and not let any one else touch them under any circumstances. This will avoid getting them out of proper places or turning them face about, which is the cause of scratched films and broken as well as lost negatives. If one man has charge of them, he alone is responsible for lost or misplaced negatives. This will awaken energy in his job. I will below give a good and safe way to keep negatives in stock. Have 8 x 10 boxes made long enough to hold one hundred negatives 8 x 10, cabinets, and cards. Print or mark the number of hundred therein contained on the outside of the box. When duplicates are wanted get the required box down and take out the negative wanted. Keep some very heavy paper between the negatives to preserve the film or varnish. Boxes should be kept covered to prevent the dust from getting on the negatives, as it does not improve a negative to be covered with dust. Negative envelopes are very good things, but more expensive and not any better than wooden boxes. Printed duplicates should be returned to their proper place every rainy or dull day, so they may not accumulate in the printing-room and it is certainly easier to file twenty negatives away than it is to return two hundred to their respective places. Compel printers to report every broken negative to prevent a fruitless search after negatives that are

through accident or negligence destroyed. As a general rule employers complain of enormous wastes in the printing department, not considering, however, that it is principally their own fault by not giving the above matters proper attention; in short, by not arranging their printing and finishing department systematically.

[Translated for the Philadelphia Photographer.]

### PASTING COPIES UPON GLASS.

THE full beauty of a copy is first apparent when it is pasted upon glass, upon the picture side. In Aristo, and other gelatine pictures, the process is very simple. A glass plate, colorless, and free from flaws, is cleaned, the copy laid under water as it comes from the wash-water, with the picture side on the glass, then both taken out together, and a caoutchouc cloth laid upon them, and from different directions gone over with a squeegee. The picture is then framed, of course, without a second glass.

Albumen and collodion pictures must be pasted on with gelatine. To ninety-two grams gelatine, three and a half fluidounces of cold water are added; when the gelatine has become soft, the cold water can be poured off, and replaced by the same quantity of hot water. If the gelatine should not be quite dissolved in this, set the vessel in hot water or on the fire. The solution must be nearly 200°. The glass plate is to be laid in a tin vessel, and warmed by pouring hot water upon it. When this water has been poured off, the gelatine solution is then poured on, to such an extent that it stands at least six millimetres high. The copy is laid in warm water until it softens, then the picture, side downwards, on the glass plate. Then take the glass and picture out of the gelatine solution, and press the latter on firmly with the squeegee.—*Photog. Archiv.*

### HOW TO PREVENT SILVER PRINTS FROM FADING.

BY ROBERT IRVINE.

IN response to a request made to me some time ago, I beg briefly to describe to the members the means I uniformly employ in



making and finishing my silver prints. I claim for my process that it will prevent fading under ordinary favorable circumstances, and where the prints have been kept from damp. I may say, that I have never seen any fading in my work, when it was fairly treated in the manner I am about to place before you, and I wish to impress upon any one who may desire to make trial of it, that they should be very particular to follow my method, otherwise I must not be held in any degree responsible for what failures they may meet with.

In the first place, I may state that I prepare my paper and do my printing in the usual way. I have tried many kinds of toning baths in my time, but always fell back upon chloride of lime. My bath is made in this way :

Chloride of Lime . . .	6 grains.
Common Whiting . . .	20 "
Chloride of Gold . . .	15 "
Water . . . . .	6 pints.

Allow the solution to stand aside for a few days before use. It will tone for a long time; and when it begins to show signs of exhaustion, is reinvigorated by the addition of a little gold at each time of toning. Nearly any description of tone may be had from it, ranging from warm brown to black.

I think it essential always to fix with newly-dissolved hypo. The practice of leaving some of the solution previously made use of, I consider a mistake; and though at the moment better results may be thought obtainable, still there is no question but it induces fading. After fixing, I put the prints under a tap furnished with a rose full of very small holes, which, while it helps to keep them in motion, does not break or crush them in any way. The vessel I use for the purpose is a wooden tub, the sides and bottom of which are pierced with a great many holes, which are fully a quarter of an inch in diameter—care being taken, of course, to see that the inflow is equal to the outflow, so as to keep the prints floating. After washing fully an hour, I take them out and lay them on a thick glass plate, and, with a smooth, wooden roller, press all the water out of them—at the same time, I believe, removing nearly all the hypo remaining. I then re-

turn them once more to the washing water, and put a good quantity of common salt along with them, which I think effectually helps to neutralize any traces of hypo that may be left. I let them now wash an hour or two; after which, it is and has been my practice for a year or two past, to take them out and put them into fresh water in which a small quantity of alum is dissolved. After remaining and being moved in this for a short time, I gather them singly, and wipe each print with a soft sponge and water, and then press them in mass as dry as possible—when they are ready for mounting. The mountant I prefer is gelatine. Starches and pastes easily sour, and in time cause prints to fade.

I do not pretend to be even a second-grade photographer, but I can distinctly say that during the twenty-three years I have been in business, I never saw my prints fade if I adhered to the method I have just detailed.

It has occasionally happened that when I was pushed for time, I have omitted to follow precisely the above form; but in usual circumstances it is my invariable practice. I may say, that I have prints in my show-cases, and elsewhere, that have been exposed to sun and frost for a long time, and they will stand examination as to fading and come well out of it. I have hundreds of prints in boxes that have lain by me for many years unfaded; and I shall be glad if these remarks prove of service to the profession in any degree, because it is one of the great reproaches to our beautiful art, that so far as silver printing is concerned, the effects, no matter how charming they may be to-day, cannot be depended upon to endure for any considerable length of time, and too often but for a short time indeed, compared with other productions of art and skill.—*In Transactions of the Edinburgh Photographic Society.*

[Translated for the Philadelphia Photographer.]

## MULTIPLYING NEGATIVES.

BY W. CRONENBERG.

[SOMEWHAT over a year ago, Herr Ober-netter announced a new "dusting" process of multiplying negatives. A specially prepared sensitive plate, exposed under the

negative, receives an impression which is developed by powdered graphite, which adheres to the parts affected by the light. From this positive any number of duplicate negatives may be printed off. It is very simple and ought to offer no difficulties at all to our older friends who have been trained in wet-plate manipulations. We are now glad to be able to place the process in detail before our readers.—Ed. P. P.]

I have no doubt that many a one of my colleagues has had occasion to use a great many prints of a subject of which he had only been able to secure a single negative. Besides this inconvenience, he is in danger of losing such, often valuable negatives, by breakage or other contingency. Though safety is moderately assured by a good copying frame and careful treatment, there is always fear of some accident. In these cases it is my custom to secure myself, by multiplying the negative by the dusting process.

I give the process in detail: In the hands of a capable person it is not at all difficult. The developer is, instead of fluid, powdered graphite. Any practical photographer after developing half a dozen plates, will have a tolerably clear insight into the matter, and be able to work with safety. The "dusting" renders it possible to print from the original a positive, and from this any number of negatives similar to the original. The quality of the reproductions is in no way inferior to the original, but on the contrary, a practiced operator of this process will secure negatives better than the original. Over-density or weakness may alike be remedied, and spots disappear.

The arrangements are simple. A drying case of pine, with a sheet-iron bottom like that used in the *lichtdruck* process, with oil or gaslight, can be made by any carpenter. The heat is applied at the bottom, and should be uniform; a thermometer should be placed inside to guide in regulating it. Transverse iron rods are fixed inside the case to support the plates; through these run screws, so that the exact level of the plates, which is necessary, can be secured. The manipulations are as follows:

Take the whites of two eggs, beat to a froth, let stand twenty-four hours till clear albumen collects, then take—

Albumen . . . . .	230 grs.
Silicate of Potash . . . . .	230 "
Water . . . . .	4 ozs.

Mix well and filter thoroughly; use two filters.

A glass plate well cleaned with weak acid is placed so as to be absolutely level. The albumen solution is placed upon it. It will run well, but a piece of blotting paper can be used to spread it entirely. The plate is tilted and the surplus solution poured back into the vessel. It is then placed level and allowed to dry. This is the "first plate," and can be kept as it is for a long time if in a dry place. Now take—

No. 1.

Best Gum Arabic, pulverized . . . . .	30 grs.
Water . . . . .	10 ozs.

Dissolve and filter.

No. 2.

Gelatine (Nelson's) . . . . .	45 grs.
Water . . . . .	1 oz.

No. 3.

Grape Sugar . . . . .	125 grs.
Water . . . . .	1½ oz.

No. 4.

Bichromate of Ammonia . . . . .	75 grs.
Water . . . . .	1½ oz.

Dissolve each separately. The gelatine must soak an hour, being moderately heated. When entirely dissolved pour all four together, and add nearly twenty-five grains of ninety per cent. alcohol and about five drops of chemically pure glycerine. The proportion of glycerine depends upon the temperature; in warm weather more glycerine is necessary, and less in moist weather. The solutions shaken together are heated and poured on quite hot.

The plates prepared the day before with the first solution (albumen and water) should be rinsed under running water for about two minutes, set level, and let dry.

The lamps or burners under the drying-case are lit, and when the temperature reaches 105° F. the plates are brought to it, and when well warmed nicely levelled.

Near the drying-case stands a table, with levelling blocks. The plates are taken out of the case one by one, and the warm and

well filtered sensitive solution poured over them. Rock the plate, let the surplus run off, and finally place the plate level in the drying-case. Be sure no dust adheres to it; if any is seen, remove it with a piece of blotting-paper. After the filtered solution has been poured over all the plates the drying-case is closed, and the temperature brought quickly up to 120-23° F. In ten minutes open the case for about six or eight seconds; close it again, and dry wholly. In about twenty-five minutes the plates are well dried if the heat has been kept steadily at 125°. The opening of the case for a short time contributes much to the acquirement of uniform plates. During the drying, preparations for copying can be made.

A second table is at hand, a sheet of white paper laid upon it, also finely pulverized Siberian graphite and two little cotton pads. The plate is taken out of the drying-case hot, placed upon the warmed negative in the heated copying-frame, and exposed to the light in a copying room likewise warm. A good negative can be fully copied in three or four minutes—the copying time varies from three to ten minutes, according to the negative and the light. After copying, the plate is brought back to the drying stove, heated for one minute, and then laid upon the white sheet of paper. Take the cotton pad in the hand, and with it lay the graphite with a gentle, circular movement, over the plate. Never rub it on, because the picture could be easily spoiled. After a short time the picture will appear; the dusting process is to be continued until the picture shows itself complete in all its details. If the exposure has been correct, then the picture will be uniformly developed in quite a short time. It can be watched and must be developed a little strongly, since, after the removal of the yellow chrome, the picture weakens a little. If sufficient strength has been attained, then the picture can be dusted with a second clean cotton pad to remove the surplus graphite, and negative covered with a two per cent. raw collodion solution, to which some castor oil has been added, about five parts to 250; then wash the negative in water containing alcohol, until the yellow color of the chrome is completely removed.

This will take about four hours. The washing water must be changed often; only the first water must contain alcohol, by which means the film is not raised and no blisters form on it, which latter would produce round and strongly marked spots. After the washing, dry well and varnish. From this positive, as already stated, any number of negatives can be produced.

This dusting process has to be performed in a half-dark room. If the picture comes instantly with the dusting, then the exposure was too short; and if it comes very slowly and faint, then it has been overexposed. If the plate becomes smeared too quickly, then it is too moist, and must be well warmed in the case. The picture should develop slowly, but quite evenly, and must be wholly clear and bright. I prefer a slow development to a quick, as it is more delicate and detailed. A plate spread over too thinly will always produce a more or less feeble negative; therefore the plate should be thoroughly spread over; and do not let it drip, but turn it quickly, because the fluid would otherwise run to the thickest part. The plate dried in the case must have a uniform straw-yellow color. The result shows the proper way of pouring. A competent photographer will soon find, after a few trials, the correct manipulations in this process.—*Photo. Archiv.*

---

### FINISHING ON PERMANENT BROMIDE PAPER.

BY G. HANMER CROUGHTON,

Artist, in charge of the Eastman Co.'s Finishing  
Department.

IN spite of prejudice and misrepresentation the use of permanent bromide paper for enlargements has forced itself to the front, both by the ease and simplicity of the manipulations and the superiority of its results.

But as one objection is overcome another is urged, and the last stronghold of its opponents is, that the artists cannot use it as a basis for finishing. This objection I intend to assail in this paper.

From the first introduction of gelatine bromide paper in England, about six years

ago, I have used it almost exclusively for finishing upon, until the introduction of permanent bromide paper, which being a great improvement in quality over its predecessor, I prefer it to any other, and I claim that good enlargements upon it are easier to work upon, and a higher grade of finish, with less labor, can be obtained upon them, either in crayon, pastel, ink, or water color, than upon solar, platinum, or any other enlargements.

In working upon drawing paper, from life or from photographs, the paper chosen is one that is strongly sized, because a higher degree of finish can be obtained upon such a surface. In the necessary manipulations of preparing the paper for solar prints—the developing and fixing washing—the sizing of the paper is entirely washed out; it is so with a platinum print, the hot developer taking the size out of the paper and making it as soft and absorbent as blotting paper. With a permanent bromide print, although it has to undergo all the manipulations of development, washing, and fixing the gelatine surface is not removed, and when dry serves as a strong sizing to the paper. This necessitates a somewhat different method of treatment than upon the softer paper, but all the manipulations for producing an artistic effort upon solar or platinum prints can be followed upon permanent bromide, and from my years of experience I can say confidently, that the best results can be obtained quicker and better.

*Crayon Finishing.*—The only difference is in the material used. Instead of using a stumping sauce alone, I find a mixture of No. 1 Conti crayon, finely crushed with an equal quantity of crayon sauce, the best for all stumping purposes. Most crayon artists put in their background with a chamois leather. You cannot use a chamois skin upon permanent bromide paper, but a soft tuft of cotton is just as effective and can be manipulated in exactly the same manner, then the fingers can be used as a stump, and the background graded with the above mixture, worked with the fingers quicker and better than with the stump. If you should get your background too dark or uneven, lay the picture flat, sprinkle a little pumice powder over it and rub lightly with the

fingers all over, using more powder where you wish your background to be lighter.

The stumping of hair, shadows in drapery, etc., can be done with a paper stump with the mixture above, in exactly the same manner as upon any other paper, with the difference that the print being so much more perfect in gradation and more brilliant than a solar, there is not near so much stumping needed. In fact, a good permanent bromide enlargement needs very little stumping, the principal work being sharpening and deepening with the point, and flat tints with the mixture, over drapery, etc. The shadows of drapery can be deepened with Nos. 2 and 3 Conti, in the usual manner, softening and grading with the finger or stump.

The use of rubber and ink eraser for taking out lights is well known to crayon artists. The same method of taking out the lights can be used on permanent bromide paper and with greater effect, for the lights can be taken out cleaner and with greater facility than upon absorbent paper where the crayon is rubbed right into the fibre of the paper. Another advantage is that you can use the scraper upon these prints for taking out lights and even lightening dark places. With a sharp scraper lights can be taken out in lace, white draperies, etc., giving great brilliancy without abrading the paper, for the picture being entirely upon the surface, you can scrape quite through the deepest tint before reaching the paper itself.

The finishing of the face must be done with a harder crayon than usual, as the harder surface of the paper requires a harder crayon to work upon it. The best for the purpose is No. 0 Conti, superfine, in wood. A No. 1 of the same kind will also be required for the darker touches. This work upon the face is more in the manner of mending and joining gradations than the usual work upon the solar, and it is in this respect that a permanent bromide print is so much superior to any other, and requires so much less work, while the result is much finer.

*Pastel.*—With the pastel there is no difference in the manipulations, the gelatino bromide taking pastel with the greatest facility.

*Water Color and India Ink.*—For water color or ink it will be necessary to wash the surface of the print with a weak solution of ammonia till all the greasiness disappears, and to be careful not to wash one color over another till the first is thoroughly dry, not alone surface dry, but be careful that the gelatine is dry before washing over the same place, or blisters may result.

[Translated for the Philadelphia Photographer.]

## THE REPRODUCTION OF OLD BOOKS AND PRINTS.

BY M. VERNEUIL,  
Paris, France.

PROCESS OF MESSRS. AUGUST AND PAUL DUPONT.—The experiments made by these gentlemen have shown in the most conclusive manner that the transfer of old editions of books could be made at any time, and they have been enabled to reproduce the rarest editions and to furnish a number of libraries with works which only existed in some others. Old books being reproduced with the orthography of the times at which they were published possess immense advantages, which will be appreciated by those who know how difficult it is to preserve in new editions the orthography of past ages. The utility of this discovery is especially evident in regard to books written in a foreign language and printed in foreign type, for it must be admitted, that, in general, a work can only be well printed in the country in which the language of the author is spoken.

Besides the numerous applications in which the lithographic process may be used for the reprinting of ancient works, it renders possible the reproduction with accuracy and without sensible alteration of the original, of any printed matter, however old it may be, wood engravings, vignettes, etc.

To reproduce the old originals the ink of which cannot be transferred by pressure alone, commence by steeping the printed sheet in a solution of potash, then of tartaric acid. It results from this that all portions of the paper which have not been printed on become impregnated with small crystals of bitartrate of potash. As this

salt repels the oil, the roller may be passed over the surface of the paper and the ink will only adhere to the printed portions.

The whole is now washed and the sheet transferred to stone, where it undergoes several pressures. Acidulation and gumming are done afterwards. The transfer becomes much more difficult when the originals are on un-sized paper. In this case it is easy to judge with what care it is necessary to act to reach the desired result. We have succeeded by making use of pure milk, or soapy water, as reagents of the old ink, and a number of satisfactory results have proved to us that these easy methods were certain. The use of acids often destroys the originals, for that reason baths of soapy water or milk are much preferable.

PROCESS OF M. FARADAY.—A printed or lithographic sheet, an engraving or a page written with lithographic ink is first wet with weak nitric acid. It is then strongly pressed by means of a roller on a well grained sheet of zinc. By this operation, the letters or the design are detached from the paper and adhere to the zinc, so that it represents a reversed copy of the original. A solution of gum in weak phosphoric acid is now spread over the zinc plate, this solution does not adhere to the letters formed of fatty inks, but to the uncovered portions of the metal. Now comes the roller charged with fatty ink which adheres to the letters and not to the gum, so that the plate is inked and can by a simple pressure give prints of the original sheet. With some slight modifications a smooth lithographic stone may be substituted for the zinc.

PROCESS OF M. TIERRON.—The printed sheet is wet or dampened with diluted acid, then placed between sheets of bibulous paper so as to absorb the excess of liquid. The acid does not act on the black or the fatty ink; it only attacks the white portions or those without ink, which it corrodes. If the print is not older than from six to twelve months, a few minutes suffice to obtain this effect. The print is placed upon a sheet of grained zinc, or on a pumiced lithographic stone, to which it should adhere, and it is then placed in the press. When the pressure has produced its effect, and the corroded white portions have been,

by a simple washing, delicately removed, the letters alone adhere to the plate or the stone and form a very slight relief composed of the thickness of the ink and of the paper. A second washing is made to remove the remainder of the paper. A solution of gum is now spread over the surface, which adheres to the uncovered parts and brings out the type, giving it a black tint in the ratio of its primitive intensity. The operation lasts but a few minutes. Finally, the portions surrounding the type are lightly acted upon by the acid so as to be better detached. When the roller is passed, the ink adheres to the letters and not to the metal or stone, and the prints may be made on a lithographic press if the operation was made on stone, or on a printing press if a sheet of zinc has been used.

PROCESS OF M. KNECHT.—Success is more certain with impressions made in the 17th or 18th century than with those dating back but twenty years only, from the fact that formerly better varnish and better black were used and the printing was stronger. The success of the operation, therefore, depends on the quality of the varnish and black used in printing old works. The sheet to be inked is steeped in gum arabic, placed on a marble, and caustic soda at from 55° to 60° is poured over it. The alkali is allowed to act for from fifteen to thirty minutes, examining from time to time a word to see if the fatty body commences to revive. As soon as the soda has produced its effect, rinse with water to remove the alkali, then pour on essence of turpentine, which is intended to attach itself to the type; the turpentine is allowed to remain about fifteen minutes, keeping the sheet constantly wet. Inking is done in a special manner with an ink composed of a half part of virgin wax, a half part of tallow, and as much vermilion, one part of weak varnish, a quarter of a part of Venice turpentine, and as much essence of turpentine. Use a small pledget to lightly ink this mixture over the type. Here everything depends upon the inking; if not well done the fatty body or the black will leave the paper and mix with the red ink; if the paper is allowed to dry the red will soil it; if the pledget is not carefully used the surface of the paper will

be removed. A great deal of patience and practice is required for this operation, but above all, the power of adopting the modifications necessary in this mode of inking. A small roller covered with cloth is used to clean and remove the excess of ink on the sheet. When the red ink is seen to be fixed on the type, the sheet is placed between two macules and transferred but slightly dampened. The stone is then treated in the ordinary way.—*Moniteur*.

### PHOTO. FACTS AND FANCIES.

SINCE the Centennial Exhibition in Philadelphia, in 1876, similar affairs on a smaller scale have become frequent—even annual, in many of our large cities; managing them has become a trade, and exhibiting therein an art. We need not expatiate. We all know of the advantage taken of such opportunities by bright business men who know the advantages. Photographers, as a rule, do not seem to understand the advantages, and when they exhibit, often forget the art as well.

We have received the following from the superintendent of an annual exhibition in one of our most important cities, which surprises us, as follows:

“I am sorry to say, that each year our show of photographs seems to dwindle. If it keeps on at the rate at which it has been going for a few years past, we will find ourselves without any exhibitors in that line. Why this should be, is a mystery to me, for a better advertisement, I think, it would be impossible for them to get, and the cost is so trifling that it is not worth consideration, that is, at least, so far as our charges go, which are ten dollars. Now-a-days, we even drape the walls for them, and they have nothing to do but to hang up their pictures. A few of the more enterprising are always on hand, notably \_\_\_\_\_ and some others of less note, with whom you are probably not acquainted. These men certainly find it pays. Indeed, I know it pays them and they do not hesitate to say so. But the higher-toned ones—the men who insist upon viewing photography from the art point of view (I need not name them to you), look

upon anything in the way of an exhibition as too much of a commercial matter. They cannot seem to get down to the level of doing business after the fashion of a drygoods man or, in fact, any other man who is successful in these days of ceaseless competition."

Surely this should not be so. Every time a fine lot of photographs is placed before the public, our art makes an advance. It may not always "pay" the exhibitor directly, but the returns are diffusive, and he gets his share, besides upholding our art while the battle goes on for its advancement and honor.

Now, if you make up your mind to be more public-spirited hereafter, get over the idea that making a good exhibit consists in covering an immense amount of wall space, and making a grand splurge. Exhibit only a choice selection of your very best work. Six attractive, effective pictures, will be looked at by more people, and consequently gain you more praise than will a surfeiting sixty of mediocre grade.

A CORRESPONDENT states fact and no fancy when he writes us as follows:

"Development is painting of the most delicate kind. What a scope it offers for power and feeling when swayed by the hands of a true artist. For to use it right requires all the power and feeling of a first-class painter. Its touches are more delicate, and must be more precise and sure than those of the brush can ever be."

WE have given our readers a good opportunity to see samples made by the various photo-engraving processes, made variously by the Ives, Moss, and Levytype, and we do not like to think what sort of a magazine the PHILADELPHIA PHOTOGRAPHER would be without the help which we all get from such illustrations.

As the matter is of great interest to us all, and becoming more so, it is proper that we should have some well-rooted, general name for the cross-line processes used. On this score, Mr. Louis E. Levy, of the Levytype Co., Philadelphia, writes as follows:

"Regarding cross-line work, I have found a good name for the 'Meisenbach' style of plates, which you would do well to incorporate in your published references to such re-

sult. The name I propose is AUTOGLYPHIC. The Ives and Pettit processes which produce the results by mechanical means are, indeed, more truly original than is Meisenbach's, which latter, though a marked advance, is, after all, only a clever modification of previously known and practiced processes. Now, the processes used in Paris, by Bousod, Valadon & Co., in the *Figaro Salon*; by Angerer & Göschl, in Vienna, as per the Miss Cora prints, and many other much finer examples by the Vienna firm, and by still others in Leipzig, are all based on *autographic optical* principles, as distinguished from mechanical means as by Ives, and from purely chemical means, as in the case of the 'Dallasint,' of London, etc. The latter method was, indeed, the earliest process of all, having been discovered and introduced by Paul Pretsch, as early as 1854-5.

"To revert then to the name, for these various reasons, I do not see the justice of identifying anybody in particular with this important advance in the graphic art, and I propose the term *Autoglyphic* as the proper designation of the process, and the result might thus be termed an *Autoglyph*."

This is a good suggestion. In the future then, we shall adopt Mr. Levy's nomenclature when speaking of such processes, and call them "autoglyphic," and their results "autoglyphs"

---

### HINTS ON LIGHTING.\*

BY GEORGE SPERRY.  
Evansville, Ind.

I WISH to call attention to a prevailing source of error in the lighting of white drapery, a careful consideration of which would necessitate a change in the *modus operandi* of some of our operators in handling this class of subjects.

Take a lady sitter, with little or no color in the face. Pose her some distance from the lights; draw your curtains; trundle up your head-screen, and—study that face carefully. What have you got? Marble! And marble you will get in your negative. This illumination might answer for a swarthy face; certainly not for a fair one. And if

---

\* Written for *Mosaics*, but received too late.

this be true of the face, how much more so in the case of white drapery, which must have light, and plenty of it, or you get no shadows? A few experiments with a white statue will show you that a strong light, properly controlled, will give you better detail than a weak one. Head and side screens *may be* good servants; they are certainly bad masters. A soft light is not indispensable in the production of a soft negative. Brilliancy and hardness are by no means synonymous terms.

There is another thought in this connection which may be worth considering. You sometimes notice a face on the street which fairly sparkles with animation; but when you come to photograph that face, it seems dull and insipid. Is the sitter altogether to blame for this? May not the subdued light of the studio be somewhat responsible for this lack of expression? The scale in the gamut of expression contains an indefinite number of octaves. A weak light may fail to detect the beauties that a strong one reveals.

---

### TRANSFER ON WOOD OF CARBON PRINTS.

To transfer a carbon print on veneer which is to be glued on a piece of furniture, Mr. Geldmacher says, that the wood may be prevented from warping by sticking the veneer to a sheet of paper stretched on a plate, to which it is glued by the edges. When the transfer is finished and the whole thoroughly dry, the edges are detached with a knife, the sheet thus obtained is polished after being first cut to the desired size, then glued to the piece of furniture and polished in the usual way.

Mr. Geldmacher mentions also some applications of the carbon process. For example, if a carbon print is transferred on gold or silver paper, we obtain an image whose whites present a gold or silver appearance. It is easy to obtain both metals on the same print; let us suppose a gold cup with encrusted silver medals to be reproduced. The carbon image being on a plate of collodionized glass, stick on the medals pieces of silver paper, cut out accord-

ing to the corresponding outlines, and then on the whole the gold paper, also cut out according to the exterior outlines of the vase. Such images have a fine effect and are strongly recommended by the author.—*Deutsche Photographen Zeitung.*

Truly Mr. Geldmacher ignores our own applications of these rudimentary indications. We have in our photochromy processes, not only applied the carbon prints, but also phototypic and photoglyptic images on metals, either isolated or combined, but also on colors added to different metals. We have even advised the use of these photochromics to the decoration of furniture and this industrial application is still to be created. We have here a process for making artistic furniture of an entirely new style and resembling nothing that has been made up to the present time.—LEON VIDAL.

---

### THE WORLD'S PHOTOGRAPHY FOCUSSED.

At the November meeting of the Philadelphia Amateur Photographic Club, after routine business, a vote of thanks was tendered to Buchanan, Smedley & Bromley for their gift to the Club library of a book entitled *The Magic Lantern*. The Club then proceeded to nominate officers for the coming year, with the following result:

*President.*—Wm. A. Haines.

*First Vice-President.*—H. P. Gillingham.

*Second Vice-President.*—Philip P. Chase.

*Secretary.*—Alfred Thompson.

*Treasurer.*—F. G. Stuart.

*Executive Committee.*—W. W. Randall, Wm. Super, Jr., H. G. Phillips, A. Clements, P. P. Chase.

*Excursion Committee.*—F. G. Stuart, A. Clements, Alfred Thompson.

Upon motion the Club adjourned to witness an exhibition of lantern slides, made from negatives taken by Mr. Pusey during his recent trip to Europe. The views were taken with a detective camera, and were remarkable for their general excellence and the detail shown in the shadows.

PHILIP P. CHASE,

Secretary *pro tem.*



In *The Camera*, for November 1st, the veteran photographer, Valentine Blanchard, gives some valuable points "On the Exercise of Taste in Photographic Printing." He counsels more care in cloud printing, citing an example where heavy cloud-masses were printed over an expanse of water without a ripple, so loading the top of the picture as to make it look as if hung upside down. He considers the prevailing fault to be printing the clouds too dark, so destroying the aerial perspective. "Another equally grave fault," he says, "is the use of clouds with the light on them in totally different direction to that in the landscape." He gives his own very excellent method of printing.

The same journal reprints from *Cassell's Family Magazine* a short account of "The Photography of the Heavens," by Dr. Higgins, F.R.S., which gives interesting comparisons between the retina and the photographic plate.

The English journals have been giving considerable space to criticisms of the photographic exhibition. *The Camera* reproduces three of the pictures, by autoglyphic prints. One especially, "Woodside in Winter," by Mr. E. Thurston, is particularly fine both as a print and as a picture. "Never Too Late to Mend," is also a capital study; a busted shoe, a small boy, and a shoemaker, being the chief characters.

*The Photographic News* announces that the next English Photographic Convention will be held on July 4, 1887, at Glasgow. It also notes an exhibition in aid of the Photographer's Benevolent Association—an institution which we should think there would be room for here.

Lieut. S. W. Very, U. S. N., in *The Photographic Times*, gives some interesting data on different lengths of exposure for the same plate, showing that in some cases good negatives may be secured with the same plates, in same light, with exposures varying from 2 to 15 seconds.

Mr. Lincoln Adams also finishes his pleasant accounts of his photographic excursions among the White Mountains.

The Boston Camera Club, the Society of Amateur Photographers of New York, and the Photographic Society of Philadelphia,

have combined to hold an annual joint exhibition of the work of their members in these cities. The first will be held in New York about the first of February.

The American Photographic Societies are growing so numerous, and doing so much, that they pass the limits of our space. The accounts of their proceedings which their secretaries kindly send us, sum up so extensively that we can give only the very gist of the most important. The other journals publish them fully, so that we are the better able to devote our space to practical matter, and especially the cream of late information on the art at home and abroad more *in extenso* than do our contemporaries.

At the last meeting of the Photographic Section of the American Institute, Mr. A. Bogardus gave a talk on his experiences in "Forty Years behind the Camera," giving some entertaining anecdotes of the Daguerrotype period in our art. Dr. Chas. Ehrmann gave an account of the Photographic School at Chautauqua, and predicts great good to come therefrom.

At a meeting of the Philadelphia Amateur Photographic Club, November 1st, a lantern exhibition of foreign views, taken by Mr. Pusey, was given.

The Edinburgh Photographic Society sends us their very handsome certificate of membership.

New difficulties arise in the path of the editor with the progress of the photographic art. The mass of matter offering is so great that he has to become a sort of perpetual boiler, evaporating it down—a constant centrifugal machine, whirling to mix it, and make good harmonious work—to supply the best emulsion each issue for his readers.

A paper "On Photographing Genre and Still-life Subjects" was read by Mr. John Bartlett at a late meeting of the Photographic Society of Philadelphia. There was an interesting discussion of the photography of projectiles.

The last issue of the *Bulletin Belge*, our esteemed Brussels contemporary, is a very handsome one. Besides many illustrations it presents a charming aristocratic print of a rustic cabin in Bavaria, by Mr. Joaquin Basto.

The Executive Committee of the P. A. of A. holds its next meeting in January, in

Chicago. Messrs. Cramer, Landy, and others assure us that no stone will be left unturned to make the coming convention a great success. They appreciate the care they must exercise.

In such good hands, and with such clear heads, there is not much to fear.

We hope the mistake of having an inexperienced local Secretary will not occur again. Be he ever so good, and never so earnest and faithful, unless experience is added, he will prove unequal to the task.

It is not necessary that the local secretary should be a citizen of Chicago. A few weeks residence of the proper man there will do the work.

At the last meeting of the Franklin Institute, Philadelphia, Mr. F. E. Ives read a paper giving an account of some recent experiments in photographing with phosphorescent substances. A tablet was coated with a phosphorus paint, exposed in a camera for thirty seconds, and, when placed in contact with a sensitive plate in the dark-room for about the same period of time, a brilliant negative resulted. Experiments were also made in photographs of the spectrum, it being found that the tablet was affected by the rays below the red or visible end of the spectrum. Mr. Ives concluded that dark objects may be photographed in the camera by the radiation of heat rays from them, and in this deduction he differed from the conclusions of M. Zenger, of Paris, who recently made investigations in the same line, and who held that there were certain "dark actinic rays" to which the phosphorus plates were subject.

The subject was discussed by Dr. Wahl, Prof. Houston, and others, and a slide of the negative, by Mr. Ives, was shown.

The chlorophyl process of Mr. Ives, illustrated in our last number, was never patented, but generously given to the public by the ingenious discoverer. That is the reason, perhaps, why it has not come into more general use.

### THE OPEN CORNER.

**PREPARATION OF SILK.**—Mr. Woodbury, Jr., tells us that, at present, silk for photographic printing is prepared in the following manner :

Take tannic acid 40 grammes, and water 1000 c. c. This makes the first solution. Then take chloride of sodium 40 grammes, arrow-root 40 grammes, acetic acid 150 c. c., and water 1000 c. c. This second solution is mixed with the first, the whole well agitated and filtered. The older this preparation is the better it is.

In this bath, after filtration, the silk is completely immersed and allowed to remain for three minutes. On coming from the bath it is hung on lines to dry. Sensitizing is done with silver salt at 10 per cent., slightly acidified with nitric acid.

The best toning bath is: Chloride of gold 1 gramme, water 200 c. c., which are added to sulphocyanuret of ammonium 20 grammes, water 500 c. c. In the course of a few days the mixture of these two solutions becomes limpid. When using it is well to dilute it with from two to four times its volume of pure water. Fixing and washing are done for silk as for paper.

**PACKING GELATINE PLATES.**—The packing of gelatino-bromide plates continues to engage the serious attention of our photographers. Mr. C. B. Barnes has just made a special investigation of this important subject; after having shown the injury resulting from bad packing, the author seeks a remedy for this trouble. He suggests that the outside envelope of the packages should be stronger than that usually employed; then that the interior mode of packing should be improved. In his opinion there are two ways to overcome the difficulties: The first consists in packing the plates face to face, without any intervening substance, each three pairs being wrapped in a sheet of orange paper, and each series of six plates thus treated wrapped in black paper, the whole being placed in a flat wooden box. The only essential precaution is that the gelatine of the plates should be thoroughly dry before putting them face to face.

The other method consists in making use of grooved boxes, which, once paid for, could be refilled by the manufacturer. These boxes should be made of light wood.

**USE OF BORAX IN WATER COLORS.**—Mr. Hartley, Professor of Chemistry, asserts

that the addition of a little borax to the water used for mixing colors in aquarelle painting prevents, in a certain measure, the fading of these colors under the influence of light. He also recommends to pass a solution of diluted borax over the paper before applying the colors. He thinks that the acidity of the colors and of the paper is one of the causes which affects the permanence of tints, and the use of borax makes this cause disappear.

**CARDBOARD FOR MOUNTING PRINTS.**—Dr. Stolze says that to make sure that the cardboard does not contain any hyposulphite of soda, allow small strips to macerate for a few hours in cold water, then add iodide of starch; if the last is discolored it is probable there is some hypo. But it must be still further verified by adding to the liquid a clipping of pure zinc and a few drops of pure sulphuric acid; the vessel in which the reaction is made is covered with a piece of bibulous paper, on which is allowed to fall a drop of a solution of nitrate or acetate of lead; if there is any hyposulphite of soda in the liquid, the portion wet with the lead salt will become brown in a short time by the formation of sulphuret of lead.—*Wochenblatt.*

---

### OUR PICTURE.

At the beginning of the year we agreed to embellish our magazine with a picture representing each quarter of our great Continent—East, West, South, and North. Three-fourths of the promise has been kept. Last March we crept on the ice and snow to the summit of Mount Washington to procure negatives to enable us to make our obligation whole. Nature was against us. Instead of finding the magnificent frost formations there, similar to what we had seen on four other occasions, the wind, it was found, had preceded us, and blown every bit of the winter architecture away, until the summit of the noble old mountain was as bare and sorry a figure for a picture as Milan Cathedral would be if some horrid cyclone had sent all the spires and pinnacles and statues and buttresses of white marble down in a crush into the streets below.

We come to you, therefore, with a substi-

tute, and an appeal for mercy. The thing shall be made all right. Meanwhile, look with us at the view from our office window. A better view could have been had if we had gone to the window below, and a hundred more picturesque subjects appear within the scope of this view, a changed assortment daily, when the camera is placed upon the ground.

But we design that you should see exactly what we see, when, wearied with work, or startled by the noise of a procession or the cling of the fire bells, we turn from our desk and look out of our office window.

We have from time to time given you some word bits. We fear a view of the whole exposure will render them dingy, for, first of all, and spoiling all, are the wires of the telephone and telegraph. But these "mean business," and are, therefore, as delightful to the eye of the genuine New Yorker as are the odors of the pasty to the epicure. The street directly in front is Fourteenth Street; at the right is Fourth Avenue; on the left Broadway, which, in fact, halts at the right of our window, and uses Fourteenth Street to get across to its continuation on the left side of the Square, and then runs diagonally north and west through the gap seen to the left of our picture, away far out into the country.

Then comes the loveliest of the breathing places of the city, Union Square. It was our playground in childhood, and is yet; it is a part of our daily walk. All summer we have been the happy observer of the wonderful growth of African pond lilies, lotuses, and other water plants, growing in the basin of the great fountain hidden by the largest tree. They were white and blue and pink and rose color, and came from Zanzibar and the Egyptian Delta.

At night, under the electric light, the scene eclipsed the palace of Aladdin, we are sure. Then always to be seen were the groups of people and the passers-by. Early in the morning the poor unfortunates from the station houses aired themselves there. By afternoon they were gone, and the Square thronged with babies in their carriages, and the whole picture fringed by the trimmings on the white caps and aprons of the nurses. Between the two periods the

wondrous people of the great metropolis moved to and fro continuously, while the sparrows never ceased to entertain the student of nature.

Around the Square the scene is always a marvel. It is a great Art neighborhood, and the tall buildings which you see are devoted to the studios, music stores, picture galleries, jewelry establishments, book marts, depots for bric-a-brac, five photographic studios, and all the principal sewing-machine establishments, not forgetting the building of the "Domestic"—the greatest of them all—whence we look.

In the tall building at the right of the gap the wonderful offices of *The Century* magazine are located. Of the magnificent trees we need not speak. On the right of the picture is the splendid bronze statue of Lafayette, by Bartholdi, whose "Liberty" has just been unveiled. Over on the Fourth Avenue side is the equestrian statue of George Washington, and on the left Abraham Lincoln stands in bronze.

We desist. Neither photography or pen can describe the beauty of the scene. It is a world in itself, and our view only looks like a Sunday morning attempt at it. The negatives were made with a Euryscope view lens, a Hoover shutter, and on Passavant's "C. I. P." plates, in August last.

To our taste, such expanses are never pleasing or satisfactory. We prefer the "bits." Now, while we write, the trees show their forms, for they are naked of leaves; the buildings are all exposed; the fountain is visible; the tall spar upholding the electric tower light shines in the sun and dozens of flag-staffs show, with our country's banner at half mast, in honor of the dead ex-President.

And the light has gone out of the view, too, and the cold has come. It is never *just* right for the picturesque, though always charming and full of life. Perhaps our ideals are unreasonable.

Our prints were made by Messrs. Roberts

& Fellows, of Philadelphia, on the excellent N. P. A. paper, imported for us by Messrs. E. & H. T. Anthony & Co., 591 Broadway, New York.

If our good readers will give us the encouragement we look for at this time of year, we shall continue to look out for views from our office window.

### THE HUMOR OF IT.

THE example of elongated perspective which follows, is from the *Fliegende Blatter*, and represents the old year backing in towards the setting sun. His last words, more earnest and practical than beautiful, but such as we would expect from a veteran, seem to be, "*Do not fail to subscribe early for the PHILADELPHIA PHOTOGRAPHER for 1887.*"

AN acrimonious "cheap John," who "hain't got no time to read journals, but can borrow one occasionally," suggests that our "Magazine is published too often for any good. Can't read it all." This reminds us of a little story—a German one. An old

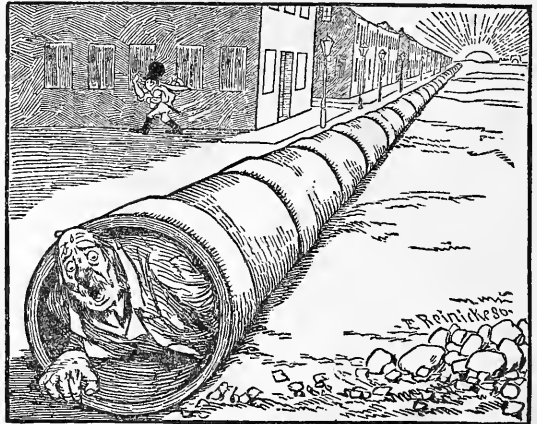

grandmother acted as "advance agent" for her amateur grandson, and going ahead of his camera, selected his subjects for him. She came to a picturesque barn, "with a lovely thatched roof, where she saw the head of a

horse looking from the window," and "the tail of a horse looking from the back door." She was astounded, and, lifting her arms, exclaimed, "My heavens, that is too much

is utterly useless: a pretty toy, and nothing more. The alkaline sulphide from which the so-called standard light is obtained varies in its power of absorption and of evo-



horse," and ran back to her baby boy to prevent him seeing such a frightful sight. If she had had any brains she would have realized that there were *two* horses in one stable. There was more in it than she could comprehend, so she suffered herself to lose it all.

Moral.—Take all of our magazine for 1887, and profit by what suits your case.

### A UNIVERSAL SENSITOMETER.\*

BY DR. JOHN NICOL.

Editor of the Photographic Beacon, Chicago.

For some time after the modern gelatinobromide dry plate came into general use, it was customary to describe the relative degrees of sensitiveness as so many times that of wet collodion; but as this standard varied in the hands of every operator, something more reliable was felt to be a desideratum. To meet this demand Mr. Warnerke, of London, England, introduced the instrument to which his name has been given, and notwithstanding its many faults, it is the only one that has received, even a limited share of public notice, or been in any degree considered authoritative. For the private comparison of various batches of one variety or make of plates, the Warnerke, or any one of the various forms of sensitometer that have been suggested, may do well enough, but as means of conveying information as to the sensitiveness of plates in general, is

lution almost as much as did collodion in sensitiveness, and the screens sent out with the instruments seem to vary as much as the luminous tablets.

The conditions essential to a really useful sensitometer are that the light employed shall be uniform in quality and quantity, from whatever source it is obtained, and that the graduated screen shall be a mathematically correct mechanical production that can be made by any one trained to exact work. The light should also approach as near as possible to that of pure diffused sunlight. It is well known that the light produced by the oxidation of magnesium approaches more nearly to ordinary sunlight than any other form of artificial light, and that the quantity emitted from the rapid combustion of any given weight is a constant quantity. I believe, then, that a convenient and thoroughly practical standard light for sensitometer purposes will be found in the flash produced by the ignition of an accurately weighed quantity of a uniform mixture of magnesium in powder of a certain degree of fineness, and chlorate or nitrate of potash in fine powder. The degree of fineness, and the proportions in which the nitrogen should be mixed, should be matter of careful experiment. It should be undertaken by one of our photographic societies, and I heartily commend the subject to the attention of the Amateur Photographers' Association of New York.

\* Written for *Mosaics*, but received too late.

The kind of screen that recommends itself to me, as likely to answer most perfectly, is a mechanical arrangement that appeared in the *British Journal of Photography* some years ago. Practically it consisted of a square box so divided as to represent any desired number of square tubes; nine, of two inches square and three inches deep, should answer admirably, and would assume the form of a box 6 x 6 x 3 inches.

One side of the box, or one end of the tubes, is fitted so as to receive a plate holder or dark slide, in which the plate is placed, and the other side, or end of the tubes, is covered by a metallic plate in which are drilled nine holes, each in the centre of one of the square tubes, and each exactly twice the value in light-admitting area of its predecessor.

In these days of exact tool-making, there need be no difficulty in drilling such holes accurate to a very small fraction; and if the instrument should be adopted by the afore-

from the slowest to the most rapid in use at present, and while a sensitometer thus arranged might not be altogether perfect, it certainly would approximate more nearly to perfection, and convey a more correct knowledge of the true sensitiveness of a plate than any form of instrument that has as yet been proposed.

[Translated for the *Philadelphia Photographer*.]

### AUTOGRAPHIC AND CALCOGRAPHIC TRANSFERS.

#### AUTOGRAPHIC AND LITHOGRAPHIC INKS.

—Lithographic ink is generally made after the following formula:

Yellow Wax . . . . .	10 parts.
Tallow . . . . .	4 "
Gum Lac . . . . .	12 "
Mastic, in Tears . . . . .	1 part.
White Soap . . . . .	4 parts.
Turpentine . . . . .	1 part.
Linseed Oil . . . . .	1 "
Lampblack . . . . .	12 parts.

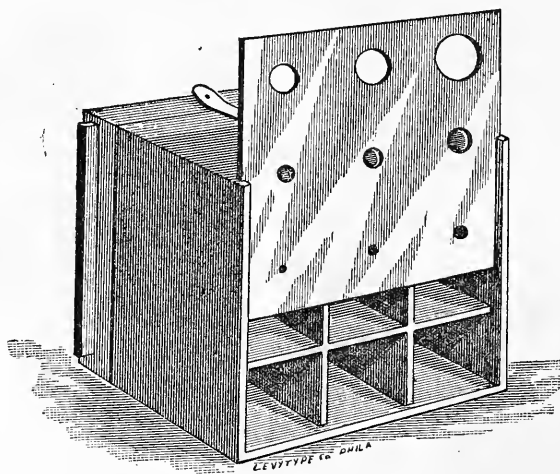

said Society as a reliable standard, I have no doubt that the manufacture of such plates would be taken up by one or more of the noted philosophical instrument makers, and supplied for a small sum.

The size of the openings, distance of the flash from the plate, and quantity of magnesium flashed, could easily be arranged, so that the nine numbers would include plates

The tallow and oil are melted together and incorporated with the lampblack, the whole forming a paste of the consistence of butter, which is removed from the vessel and rubbed up with the muller. The wax, the gum shellac, the mastic, and the soap are now melted, and the heat is increased, so as to decompose and transform the resins into resinates of soda; the turpentine is

now added, and also the lampblack ground with the tallow and oil; a spatula is used to thoroughly mix the substances, and, after heating for a short time, the whole is run on a metal plate, or on a stone greased with tallow, then, when the mass becomes set, it is cut into sticks, to be kept for use.

This ink is used in the same manner as India ink, by rubbing a stick on a saucer containing a little water. The resinates of soda contained in this ink dissolving in the water, separate the fatty bodies, oil, tallow, and wax; these last remain suspended in a very divided state, and form an emulsion.

The composition of autographic ink is almost the same as that of lithographic ink. The proportions of the substances used alone vary; the quantity of resin and wax is increased, and the lampblack omitted:

Yellow Wax . . . . .	6 parts.
Gum Lac . . . . .	4 "
Mastic . . . . .	3 "
White Soap . . . . .	2 "

Lithographic crayons have also an analogous composition. Here is a good formula:

Yellow Wax . . . . .	25 parts.
Soap . . . . .	18 "
Tallow . . . . .	4 "
Gum Lac . . . . .	1 part.
Turpentine . . . . .	1 "
Lampblack . . . . .	8 parts.

Moreover, it is easy to obtain crayons or inks possessing the properties that may be desired, by using resinates prepared separately and melting them with fatty bodies and coloring substances.

We insist upon these preliminary details; the reader will see further on the importance they have in certain cases.

**GUM ARABIC AND GELATIN.**—Gum arabic dissolved in water in fixed proportions, then spread over a lithographic stone, loses its affinity for fatty bodies; this action only occurs, however, when the gum has dried on the stone. This, properly, is applied, as we will see later, to negative prints easily retouched, especially in the case of calcographic reimpresions. Gelatin alone is not suitable for this purpose. It generally greases the stone, and leaves a slight veil; mixed, however, in equal proportions with

the gum, it preserves the whites perfectly well. As gelatin plays a great part in the negative autographic processes, we will indicate its general properties. Gelatin is insoluble in cold water, in which it swells. By raising the temperature to about 70° centigrade (158° Fahr.), it melts and yields a transparent liquid which, on cooling, becomes a jelly.

Acetic acid renders gelatin soluble in cold water. In this condition it may be spread as easily as gum. In drying, the acetic acid evaporates, and the properties of the gelatin are in no manner modified. Gelatin is also soluble in a cold saturated solution of bichromate of potash. Bichromate of potash, added to a solution of gum, albumen, or gelatin, renders these substances sensitive to light; a thin and dry film of one of these substances becomes insoluble after exposure to light.

**GENERAL APPLICATION.**—These divers properties being known, let us see the applications that may be made of them in the most usual cases. The ordinary autographic process consists in writing with a fatty and resinous ink on a paper coated with a size made of gum, starch, or gelatin. After the writing is dry, the back of the paper is wet with a sponge, and the paper placed on a lithographic stone or on a metal plate, or even on a block of wood, the writing or the drawing underneath, and, after covering with a slightly-sized paper, a strong pressure is given, either in a lithographic or printing press; the paper is again wet, and it may be then easily detached from the stone or metal. The drawing or writing is now transferred to the support, to which it completely adheres. A slight acidulation with a sponge is now given to render the ink completely insoluble, and, at the same time, to clean the stone or the plate. After gumming, allow to dry.

The divers autographic processes that we have just described are rarely used by designers, as they require the making of the drawing on the same scale as the engraving, and because they can be immediately executed on the wood, the metal, or the stone. It is, therefore, only in the case of enlargement or reduction of the original that certain portions of the work that we have previously

described may be used with advantage in connection with some one of the photographic operations mentioned in the first chapter.

According to the case, the nature of the image to be produced, the operator, after having obtained his negative or his positive, should follow, in order to obtain the transfer, one of the following methods.

**FIRST METHOD.**—Take some slightly sized paper (Rives paper is excellent for this purpose), and float it on the surface of a dish containing a solution at a temperature of about 35° centigrade (95° Fahr.), composed of:

Ordinary Water . . .	1 litre (34 fl. ozs).
Gelatine . . . . .	150 grms. (4 ozs. 6 drms).
Fish Glue . . . . .	25 “ (6 drms).
Bichromate of Potash	15 “ (4 “

The paper is allowed to float in this bath for about three minutes, care being taken to slowly agitate the dish from right to left to avoid air-bubbles which, attaching themselves to the surface, would form white spaces. The paper is now carefully withdrawn, raising it by two corners on the same side, and hung on a board and allowed to dry spontaneously, which requires about two hours in an average atmosphere of 20° centigrade (68° Fahr.). It is well understood that this operation should be made in a dark room, lighted only by yellow glass. After discoloration, the paper is exposed in a positive frame to solar light, making use of a negative if a black print is wanted on a white ground, and of a positive if a white print on a black ground is required; the average exposure with a weak negative is from two to three minutes in the sun, and from eight to ten minutes in diffused light. The print is developed by immersing it in a dish filled with ordinary water, in which it is allowed to remain until the yellow coloration due to the bichromate of potash has entirely disappeared. In this condition, and without drying the sheet, it is laid on a flat surface, wood or glass, and inked with a smooth roller with the ink already mentioned. When all the sharpness of the original has been obtained, a transfer is made on wood, or on metal, or on stone or on glass, by the process previously described.

**SECOND METHOD.**—This method differs from the preceding one by the substitution of albumen for the gelatine. Although rather more complicated, it has advantages of rapidity which may often cause it to be preferred.

The paper, as in the first method, is floated on a bath composed of:

Distilled Water . . .	150 c.c. (4 fl. ozs. 8 drms).
Fresh Albumen . . .	50 “ (1 oz. 5 drms).
Gum Arabic . . . . .	5 grms. (77 grains).
White Sugar . . . . .	3 “ (46 grains).
Bichromate of Ammonia	8 “ (123 grains).

After desiccation, expose in a pressure frame, either under a negative or a positive, according to the cases indicated, for about five minutes, to diffused light. The print, taken from the frame, is placed upon a flat, horizontal surface, the exposed side towards the face of this support; the sheet is slightly wet on the back, turned over and inked with the transfer ink mentioned above. The first method has the advantage, in case of failure, to allow several successive applications of the ink, which the fragility of the second methods only allows, after a long practice of the process and a hand accustomed to the use of the roller. Nevertheless, when it is simply a question of placing a print that is to be retouched, it will suffice, in most cases, to obtain a good result in the first inking. The rapidity of the exposure will also go a great ways in preventing failures.

**THIRD METHOD.**—Spread on the stone, the wood, the metal, or the glass to be engraved, a solution of:

Crystallizable Benzine . . .	500 c.c. (17 fl. ozs).
Bitumen of Judea . . . . .	20 grms. (5 drms).

This solution should be spread in a regular manner on the surface of the support, as is done in photographic operations. After drying, which requires from ten to fifteen minutes, expose in the pressure frame under a negative or positive for about twenty minutes in the sun, and for one hour in diffused light. The image is developed in a dish containing a sufficient quantity of dry essence of turpentine, allowing it to remain until the backgrounds are entirely freed from the matter not acted upon by the light:



now wash in abundant water under the tap, and allow to dry spontaneously. In case certain portions should be covered with a slight veil, or in case it should be wished to suppress some of them in order to assist the retouching or the interpretation of the subject, it is possible, by a partial rubbing, by means of a brush, to obtain this result either during development or after, by pouring a little of the essence on the part to be removed, rubbing with a brush until the complete disappearance of the veil or the image to be suppressed. The first two methods may be used directly on the supports to be engraved, but they may sometimes interfere with the tools used, however thin the film may be.

**FOURTH METHOD. *Calcography and Transfer of Old Prints.***—In most reproductions of old prints or drawings it is possible to make use of photographic processes for making a cliché applicable to a new engraving of the subject. Some impossibilities exist, however, due to the condition of prints partially stained, and which rubbing might injure, or which, from divers causes, are so discolored that it is not possible to obtain a perfect photographic cliché.

M. Vidal, to whom the different engraving processes owe such great improvement, made known, in 1863, the first, we believe, a process for reproducing old prints without injury to the original, and it is applicable to old prints which have not been covered with a special coating. His process depends:

1. On the want of affinity of water for fatty bodies.

2. On metal precipitations and the affinity of acids for metals.

A print is impregnated by the back with a cupreous solution, and the aqueous liquid only penetrates around the lines formed of fatty ink. All other suitable metallic salts, salt of lead, of bismuth, of silver, etc., produce the same effect. The print is now turned on the right side, placed on a zinc plate, and submitted to uniform pressure. The salt is at once decomposed, reduced and precipitated on the plate, which it entirely covers, except where the lines are, so as to give a negative image in relief, representing, with the greatest exactitude, the drawing

which has served to produce it. A few seconds suffice to obtain this effect, and photography does not act with more promptitude and more faithfulness. To obtain a copper-plate, it suffices to plunge the plate into a bath of azotic acid, which attacks the ink and respects the copper.

This process has been perfected, modified in its elements, by divers operators; here is the method that we make use of with constant success, without injury to the original, giving either a direct transfer of the image or a satisfactory photographic cliché.

The operator should have at his disposal for this work the following elements:

1. A slab of plaster (this slab is obtained by running on a plate placed horizontally a layer of plaster of Paris of the thickness of about two centimetres—five-sixths of an inch).

2. A velvet roller.

3. A box of hard lithographic ink.

4. A solution of caustic potash and alcohol.

5. A dish of sufficient size.

6. A vessel filled with filtered water, and a fine sponge.

The engraving to be transferred is first immersed for about fifteen minutes in the dish containing the following solution:

Distilled Water	. 1 litre (34 fl.oz).
Pure Caustic Potash	10 grms. (2 drms. 34 grs.).
Alcohol at 36°	. 50 c.c. (1 fl. oz. 5 drms).
Acetate of Soda	. 50 grms. (1 oz. 5 drms).

When uniformly wet with this liquid it is withdrawn with care from the dish and spread on the plaster slab. After drying a few seconds a very slight coating of turpentine is poured rapidly on the surface; now drain and ink with a velvet roller previously coated with lithographic ink. Inking should be done with the greatest care, without too much pressing on the roller, until the smallest lines, seen by reflection, have a bright and brilliant appearance. After drying for about a quarter of an hour, the print is ready for a transfer, which is done in the way indicated at the commencement of this chapter for autography.

In case it is necessary to enlarge or reduce the reproduction of the print, this result may be obtained by the photographic processes, or by those called, in lithography,

"caoutchouc frame," which belong to certain specialists and cannot be described here.

FIFTH METHOD. *Chemical Bitings of Reproductions or Transfers to Metal, Stone, and Glass.*—In all the operations that we have described—photographic, autographic, and calcographic,—the impressions may be eliminated after a slight biting, which fixes the details of the image whilst it renders free the surface of the different supports.

We must now, at the end of this chapter, point out the mordants that are to be used according to the method followed and the kind of support:

1. For images on zinc the biting should last about two minutes, with water acidulated at five per cent. with nitric acid. Copper and steel may also be bitten with the same liquid for about ten minutes.

The copper and steel may also be bitten with a solution of perchloride of iron at 40°, or still better, if the small cuts are not to be retouched, with the *glyphogène* of Lemaire, which is thus composed:

Distilled Water . . .	500 c.c. (17 fl. ozs).
Nitric Acid . . .	260 c.c. (8 fl. oz. 6 drms).
Acetate of Silver . . .	8 grms. (123 grains).
Alcohol at 36° . . .	500 c.c. (17 fl. oz).
Nitrous Ether . . .	64 c.c. (2 fl. oz. 1 drm).
Oxalic Acid . . .	4 grms. (62 grains).

When the biting is terminated, the plate is washed with essence and the gelatine and albumen coating is dissolved by immersion in a vessel filled with boiling water. After solution clean with potash, rinse in running water, and the plate is ready for the graver.

2d. For images on divers stones, bite with acidulated solution of hydrochloric acid, in the proportion of eighty parts of water and twenty parts of acid. When the biting is ended rinse rapidly in running water, and dissolve the gelatine or albumen in boiling water, as we have previously said.

3d. For glass, enamel, and porcelain the biting is done with gaseous or liquid fluorhydric acid—gaseous when a very slight image is to be obtained, to be used as a tracing for ulterior coloring, liquid when the operation has for its object to obtain sunken lines, more or less deep, destined to be filled with metallic substances or colored enamels.

In engraving on glass, the third method which we have indicated—that with bitumen of Judea,—should be exclusively used. For the complementary details of these divers branches of the work, the reader is referred to the treatises formally published by us.\*—*Moniteur de l'Photographie*.

### AMERICAN ASTRONOMERS WERE RIGHT.

PROF. RICHARD A. PROCTOR writes to the New York *Tribune*: The recent eclipse, but not during totality, brought with it what, though of the nature of a discovery, must be regarded as a disappointment. It is well known that for a long time Mr. Huggins has believed that he can photograph the corona when the sun is not eclipsed. Professor Stokes, Captain Abney, and others, after carefully examining Mr. Huggins's portraits of the sun, expressed their belief that the curious streams and rays seen around the solar disk belonged to the veritable corona. Professor Pickering and other American observers formed a different opinion. For my own part I hoped that Stokes and Abney might be justified, but I feared that Messrs. Pickering and Barker were in the right. I remember having something of the same feeling when Mr. John Brett, English landscape painter, submitted to me, then editor of the proceedings of the Royal Astronomical Society, a paper in which he explained how he could always see the solar corona through a telescope of moderate power. I was strongly tempted to hope it might be so; but optical and physical objections were too strong for my hopes, and I was fain to express my belief that what he saw was simply an atmospheric coronal glare, not the real corona at all. He was wroth with me to a degree for excluding his corona from the proceedings of the Astronomical Society, and when Mr. Huggins

\* V. Roux.—*Traité pratique de la transformation des négatifs en positifs servant à l'héliogravure et aux agrandissements*. In-18, 1881. *Traité pratique de Zincographie, Photogravure, Reports*. In-18 jésus, 1885.—*Manuel opératoire pour l'emploi du procédé au gélatino-bromure d'argent*. In-18, jésus, 1885.

began to produce photographs of the corona, Mr. Brett was fully satisfied that what Mr. Huggins photographed was what he had seen, and the true solar corona. As a matter of fact it turns out now on unmistakably decisive evidence that Mr. Huggins has been carefully and laboriously photographing matter in our own air lit up by sunlight, when he imagined he was photographing the solar corona. A test which I suggested to Mr. Brett's corona has proved fatal to Mr. Huggins's much more promising one. If his method be applied during the partial phases of the recent eclipse, it is evident that if the real corona is photographed, pictures must be obtained showing the moon's disk on the background of that corona whereas, if unfortunately the corona photographed should turn out to be merely a terrestrial phenomenon formed by the sun's rays shining in our own atmosphere, then as the moon lies beyond our atmosphere, the photographed glare would show no trace of the moon's disk. The latter, alas, was the result actually obtained when the experiment was tried. Captain Darwin, at Grenada, and Mr. Gill, at Cape Town, photographed the partial phases, the latter employing Mr. Huggins's special method, which he has long been testing, and apparently with hopeful results, at the Royal Observatory there, and no trace whatever of the moon's disk can be seen on the corona photographed round the sun. The corona, then, must be on the hither side of the moon, and therefore cannot be the true solar corona. Mr. Huggins says that the result is so far unfavorable, and that he can give no explanation of Mr. Gill's failure. But, unfortunately, the result is unfavorable finally and absolutely, and can be only too simply explained. Mr. Huggins's photographs of the solar corona turn out to be, as Professor Pickering long since said they must be, "a delusion and a snare."

---

### "FORWARD."

UNDER the above wide-awake title, Mr. Andrew Pringle read a timely paper at the twenty-seventh meeting of the Edinburgh Photographic Society. Our crowded columns prevent us reprinting all of it. We clip it

of some of its points of local interest only, and give the following:

"I would fain see our society come to the front as a propagating agent of *new* work, as a foster-mother to *progression*, as the society of the *future*.

"Any new process, any fresh and marked departure from a beaten track, usually, if not always, emanates in its elementary state from the brain of an individual. In every mixed flock there is usually a hoary-headed auld tup that first loupes the dyke, but the ewes, the hogs, the gimmers, and the lambs follow, and by the time they are all over, the dyke is considerably *coupit*, and no longer presents a great obstacle to the lamest *crute*. I want our individual members to be auld tups, and the society, partly as a society, partly as committees, to follow as closely as possible every bell-wether who breaks what appears promising ground, or who butts boldly at what appears a strong obstacle to success in any field of work whatever. What one man cannot alone accomplish, a body of men may frequently carry out with little trouble.

"Let every man personally strive his utmost to work out some definite improvement on old processes, or advance towards a new process; and let this society lend a helping hand to every man who lays before the society any scheme, any idea, any suggestion, any speculation (limited liability, however), bearing upon photography, and let it help him by either showing him the errors upon which his scheme is founded, or by placing at his service the time, the brains, the hands, the experience, and the purse of the society. An incalculable amount of good would be done if people only consulted each other about their pet schemes.

"Gentlemen, our business is *to do this*. As members of this society, it is our business to bring before the society our theories, our experiences, and our experiments. As a society it is our duty to listen to, to examine, and to discuss what is brought before us by our individual members, no matter how young, how inexperienced, nay, how foolish they are; they pay their subscription, and have a right to be heard, to be discussed, to be corrected, and to be reproved if they require reproof; to be instructed, to be encouraged, and to be helped.

"They ought to be helped as I have said, and they ought to be helped by *organization*.

"I shall now venture to point to some branches of our science where I think there are opportunities for novelty and improvement.

"First undoubtedly in importance, as matters now stand, comes the question of transparent and flexible supports for the sensitive emulsion for negative making. The essentials for this are perfect transparency, flexibility, length for use on rollers, freedom from curling and cockling in aqueous solutions, and the usual points that apply to emulsions on other supports, as even coating, cleanness, etc. There are two ways of attaining ultimate transparency—first, by stripping from a temporary flexible translucent support; second, by the original support being itself textile and transparent. In the first case, the temporary support must be translucent, so that the progress of development may be examined by transmitted light—no other means of judging density being perfectly or even tolerably satisfactory. Several processes now known fulfil some of these conditions; none, so far as I am aware, fulfil all. We have several processes of building up films of collodion, caoutchouc, gelatine, and so on, and coating the resulting pellicle with emulsion. This has to be pieced together for great lengths, and so is unsatisfactory; and films so prepared are apt to curl up in water. There is a process well known in America, and largely used of late by myself, wherein the emulsion negative is stripped from the original paper support. The results when complete approach very close to perfection; but the stripping process is tedious and ticklish. There are several makes of paper films in the market, wherein the paper remains part of the negative; I do not consider any of these processes satisfactory, though for certain work they answer fairly well. I do not favor any process of oiling for paper supports; the effect *may be* to lessen the grain of the paper, and *is* to shorten printing operations, but the oil is not stable, and is apt to become troublesome after a comparatively short time. Here then is a fine field for experiment: to produce a transparent, flexible, strong, permanent support for negatives, easily coated with gelatine, and

not liable to curl in aqueous solutions. Not only would a satisfactory solution of this problem place in our hands a convenient material but the resulting negatives would be of a *higher standard* than those on glass, for reasons which here I cannot enter into.

"The gelatino-bromide system of emulsion-making is always open to investigation. In particular, I think some light might be thrown on the fundamental theories of light action; some new and well-founded arguments on this might help us to perfect the working of the process. At present I do not and cannot believe we are on the right track in our theories of light-action on "sensitive" substances. I am sure that greater rapidity can still be obtained without detracting from good qualities, but I distrust the ammonio-nitrate process for the purpose. Extreme rapidity is, I freely admit, gained most easily by ammonio-nitrate, of all known processes; but I doubt the quality, and I deny the keeping, of ammonio-nitrate emulsions. I think it has been accepted without sufficient evidence that a collodion emulsion cannot be made as sensitive as a gelatine one. I could go on longer than you would listen, giving instances of matters which might be investigated and worked out, but I feel that I have given you quite enough for once."

### QUERIES, CONUNDRUMS, AND CONCLUSIONS.

TO CARL WEISER: It is easy to remove the gelatin coating from old plates by allowing them to soak in a bath containing 2 parts of commercial chlorhydric acid for 100 parts of water. A slight rubbing of the plates will free them from the gelatin film.

"QUINTUS CLAUDIUS": You may be right in surmising that we will "stand a great deal before kicking," but we prefer you should confine your conundrums to photographic topics. However, a good impression of any article of metal having a flat, ornamental surface, may be taken by wetting some note paper with the tongue and smoking it over a gas flame. The article is then pressed upon the smoked part, when, if the operation be carefully conducted, a clear impression will appear. This

can be made permanent by drawing the paper through milk and afterward drying it.

Glass stoppers are apt to stick, and in attempting to move them the bottle is often broken. These difficulties may be avoided by holding the stopper in a cup of melted paraffine until a film clings to the glass. The only exception is that of a bottle to contain sulphuric acid.

To make a bend in glass tubing without flattening, two inches of the tube should be heated to an equal temperature. This may be done by holding the glass width-wise in the flat flame of an ordinary gas-burner.

In making a large hole in a cork by a cork-borer or any other instrument, the danger of splitting can be avoided by wrapping the cork tightly with wire.

A paste for labelling glass bottles may be made by heating starch on a piece of tin while stirring until the color becomes yellowish brown. Boil in water and make a thick paste. It may be kept from souring by adding a few drops of creosote.

When the threads of screws are fine, to start them properly without injury to the thread, the female screw should be first applied to the male screw, and turned back until the two fit each other without any canting. The motion may now be in the proper direction.

Melted ice can often be used when distilled water cannot be obtained, and with good results in all, except the most delicate operations.

To make gelatine mould, use a little bichromate of potash with the gelatine. Don't eat it.

(Translated for the Philadelphia Photographer.)

## MANUFACTURE OF PELLICLES.\*

BY M. TONDEUR.

I PURPOSE to show you my method which allows me to obtain with great facility any kind of pellicle.

1. On a plate, polished or not polished, and framed, previously greased, rubbed with nut-gall or tale, collodionized, waxed, silicated, or simply prepared, I pour a coating of organic matter emulsionized by AgBr, or

any other combination of Ag. I allow to set or dry, and I apply a sheet of paper, plain or coated, on one or on two sides, with one or several of the substances that I will indicate in speaking of the translucent pellicle.

This sheet is coated with a fatty, unctuous matter, with wax or talc. I allow to dry; at this time the paper carries away with it the pellicular emulsion film, and will only leave it after all the operations are ended. I called the product thus obtained *French pellicular paper plate*.

2. If, instead of using paper as a subjectile, I make use of canvas, I have the same result, and I call this result *French pellicular canvas*.

3. By proceeding as above, minus the talc and the wax, and in making use of a transparent canvas or paper, I obtain a *translucent pellicle paper or canvas*.

4. If, still operating in the same manner, I apply paper or textile material, I obtain, after drying, a product suitable for printing positive prints, and which has the polish of a glass plate. I call this product *French plate paper*.

Proceeding as is said in No. 1, and overlaying of new films of collodion, gelatine, glue, dextrine, varnish, albumen, gutta-percha, caoutchouc, animal or vegetable tissue, or any other translucent substance; using these substances hot or cold, liquid or dry, modified or not by physical agents, heat, pressure; by chemical agents, such as alums, azotates, acids, resins, varnishes, soaps, chlorides, sugars, glycerines to which mineral or vegetable colors have been added to increase or diminish photogenic intensity. To the products mentioned above, I add the word *colored*, if they are colored, as well as the name of the silver compound used. In all these preparations, the subjectile may precede or follow the emulsion film. I add that any one has the right to take what he pleases from the description that I have just given, and which is extracted, *in extenso*, from a portion of a patent dated January 9, 1883, No. 153,009, and which I abandon to the public.

Numerous patents have been taken since by pretended inventors; the present description will have the result to make all interested acquainted with their respective rights. I now show you pellicles 50 x 60 centimetres.

\* Communication made to the French Photographic Society July 2, 1886.

One obtained a few years ago, the other before spreading the emulsion, absolutely impervious; a pellicle on paper obtained in two operations; I poured the emulsion and applied the paper; I will now detach it before you. If talc has been used, the pellicle will separate after the last washing; if not, the film will remain adherent; a translucent pellicle also in two operations; I poured the emulsion and applied a sheet of gelatine; a pellicle without polish to take the place of ground-glass in the camera for outside work. We also have here numerous pellicular clichés, positives and negatives, on different translucent substances. Paper and transparent stuffs, positive paper, silk, canvas, to be painted, wood for engraving or painting,

metal for engraving. They are the clichés of artists destined to be used as references; by printing the front and back, I have obtained two documents instead of one.

I purposely made these pellicles of different thickness and rigidity; many are impervious, inextensible, and elastic. I obtained the first two qualities by treating the gelatine with chrome alum, azotate of uranium, picric acid, gum lac, dextrine, albumen, silicate; the second by the use of sugar or glycerine. The antiseptic agent used was bichloride of mercury. You see, gentlemen, that it is possible to obtain similar results by very different processes. A pellicle measuring 50 x 60 centimetres can be obtained in two minutes.

## Editor's Table.

MESSRS. A. B. PAINE & Co., Fort Scott, Kansas, have just completed an enlargement of their quarters, and write us a cheerful account of their rapidly growing trade. It now extends widely into Kansas, Colorado, New Mexico, Old Mexico, and Texas. They occupy the whole building, from basement to loft, the latter being devoted to bromide enlargements, and lower floors to frames, mouldings, and photo. goods. Stock all new and clean. Such enterprise deserves all the success it gets. Speak for their forthcoming catalogue.

MESSRS. D. LOTHROP & Co., the publishers, of Boston, Mass., issue a promising prospectus of *The Pansy* for 1887. Their little monthly is full of entertainment and information for their young subscribers, and will be even better than heretofore, in 1887. Some good serials are promised, with small biographies of great men and women, articles on plant life, and other good things.

WE have received from Mr. T. H. BLAIR the *Art Gems from the American Architect*, a neat book, containing some of the *Architect's* best sketches, bound together. A handsome page is devoted to the goods of the BLAIR CAMERA COMPANY.

THE M. A. SEED DRY PLATE COMPANY, of St. Louis, are proceeding rapidly with the completion of their new factory, they write us, and expect soon to be able to promptly meet all demands for their admirable plates.

Two more lovely landscape studies could not be caught than are the presentation prints of the Photographic Society of Philadelphia. "May Days," by Mr. F. G. Cauffman, and "By Quiet Waters," by Mr. R. S. Redfield, are their titles. Woods and waters, light and shade, flowers and children are the chief ingredients which produced this choice camera couplet—and our congratulations.

THE German (Braunschweig) prizes have arrived, and we have seen them at the store of Mr. Gennert. A full description in our next.

POSTAGE STAMPS for *Mosaics* will be taken at this office—if they come soon.

\$5.00 is the subscription price of our magazine for 1887—twenty-one cents per number. Where can you get so much good for so little money? Did you ever think of that?

*The American Annual of Photography and Photographic Times Almanac* promises to be the "autocrat of the annuals."

MR. JOHN CARBUTT, maker of the Keystone Dry Plates, has issued a new circular, in which, besides listing a number of new qualities and sizes of plates, he gives detailed instructions as to development and making transparencies.

THANKS to F. C. BEACH, Esq., President, for a copy of the Constitution, list of members, and Calendar of the New York Amateur Society.

"I forward the postage stamps for *Mosaics*, 1887. I have had the little annual for many years, and cannot afford to drop it now.

"GEORGE N. MOORE."

SEATTLE, W. T.

PHOTOGRAPHS OF LINCOLN.—MR. A. HESLER has sent us five different photographs of Mr. Lincoln, from the negatives alluded to in his letter in our last issue. They are very interesting, indeed.

WILSON'S LANTERN JOURNEYS. VOL. III.—Of this, Rev. W. C. Winslow, Ph.D., of Boston, and treasurer of the Egyptian Exploration Fund, says: "It must do much to enlighten the many, while even the few catch fresh and brighter beams than before of the sites and sights of old Europe and the older East."

"BEAUTY'S CALENDAR" is the name of a publication by the American Photolithographic Co., New York—a Calendar for 1887, headed by fifteen portraits of the most celebrated beauties in the world. It is lovely, and is sold to the trade by Messrs. E. & H. T. Anthony & Co., N. Y.

THE AMERICAN OPTICAL COMPANY, N. Y., has just completed for Mr. Massey, of Philadelphia, a first-class camera box for dry plates, 38 x 38 inches. It uses a six-foot bed; four sets of bellows are inflated when it is stretched out at full length; its face raises and lowers; its back swings right and left, and so does its front. It can see as well at 10 inch focus as it can at 32 inch, and its movements are as skilfully adjusted and therefore as easy as those of the 2 x 2½ inch camera, which stands near it. Its holder has a curtain slide. After some adventurer has crossed Niagara Rapids in it, it is to be mounted on wheels and used as a travelling photo. establishment. A dark-room will be in one corner, and shelves for photo. stock. The first test made of it will be jumping off Brooklyn Bridge. It looks strong enough to be a giant of Bashan.

CORRECTION.—DEAR SIR: By the transposition of a punctuation mark, my letter made me make a mistake. It was my mistake; the printers never make them. Thus: "But I did use a moist process in 1855 or 1856." It should read: "But I did use a moist process. In 1855 or 1856 Mr. Anthony, of New York, constructed for me," and so on.

JEX BARDWELL.

THE sale of *Mosaics* for 1887 has been phenomenal. There is hardly a copy of the edition left unsold.

MOAICS.—The *Mosaics* is one whose annual coming is always welcomed, and whose absence would be sadly missed. With it there is but one disagreeable condition, and that is that almost a quarter of a century has elapsed since I received the first number, which is a fearful evidence of advancing years, by no means a very agreeable subject for contemplation.

Yours, etc.,

CHARLES WAGER HULL.

A PHOENIX FROM THE ASHES.—When a noted landmark in our art is burned down, things do not seem to go right until it arises from its ashes and again takes its place among us. Messrs. Buchanan, Smedley & Bromley, Philadelphia, did not allow the ashes of their destroyed store to cool before they were "ready for business" at a temporary stand close by. And in only a few weeks more we find them established permanently at their new store, No. 1030 Arch St. A recent visit there revealed to us one of the best arranged and best lighted stock stores there is anywhere. The visitor halts at the front door, attracted by the display of platinotypes and other choice pictures. Ascending to the second floor, the well filled shelves of new goods attract his eye, and at once churn him into a disposition to buy. And there is everything there needed by the enthusiastic photographer: A counter devoted to books and publications; a case to lenses; cabinets of apparatus and the general offices occupy the Arch Street front. Following these are the counters and general merchandize apartments, all lighted at the west side; and then at the rear is the packing-room, connected with the back street by an elevator. Many ingenious methods are adopted for storing the goods and for showing them. The windows of the door between front and rear are of yellow, blue, ruby, green, and other colors of glass—samples from which to select for the dark-room. Platinotype paper in huge rolls is kept covered clean in a receptacle made for it; glass baths, trays, etc., are kept on edge in bins; tripods are in drawers; crystal chemicals in bins under cover; and the dry-plates (labels of various colors) are arranged harmoniously on edge.

A convenient dark-room is one of the advantages of the establishment. Everything looks prosperous and bright and clean as a new year, and we trust prosperity will attend it all.

A NEW Baltimore headquarters for the amateur talent has just been opened by Mr. W. C.

Russell, at No. 106 N. Charles Street. It is a photographic and stock establishment combined. A large society or club-room and a splendid dark-room, with every convenience of lockers, etc., are among the attractions provided by Mr. Russell, added to his ability to instruct and help. It will be an undoubted success.

AMONG the most interesting of the exchanges that come to our table is *Queries*, edited by Mr. C. W. Moulton, and published by Shewell & Co., Buffalo, N. Y. It is a monthly collection of little gems and bits of art, literature, and science, gathered by its editor's careful hand. Then, in its question department, are printed series of questions on different subjects, which are answered in the issue following, giving always matters of educational value, and often bits of fact most precious and timely. Another interesting feature has been a number of writings from the most popular authors, poets, and others. The journal gives altogether a wonderful mass of information for the very modest subscription price of \$1.00 per year.

Besides its literary and educational value, the art side of the journal is well kept up. The last number is especially notable in containing a very fine and characteristic portrait, by an autolythic process, of John Ruskin, with a number of well chosen extracts from his writings. *Queries* is also not without an occasional reference to our art. But Mr. Ruskin perhaps takes a very one-sided view of photography when he speaks of it thus:

"My chemical friends, if you wish ever to know anything rightly concerning the arts, I very urgently advise you to throw all your vials and washes down the gutter-trap; and if you will ascribe, as you think it so clever to do, in your modern creeds, all virtue to the sun, use that virtue through your own heads and fingers, and apply your solar energies to draw a skilful line or two, for once or twice in your life. You may learn more than by photographing the entire population of the United States—black, white, and neutral tint."

MR. JOHN CARBUTT generously issues a four-page circular of "Instructions and Formulæ," which should be carefully read by all who can get it. From such an eminently practical man the demand should be great.

OUR "Pictures Received" have been of a remarkably high order. From Mr. C. E. ORR, of

Sandwich, Ill., comes a picture of a train running fifty-five miles an hour, already noticed, and with it a splendid farm composition, showing the whole process of threshing the grain crop, and making, moreover, a picture of it. Our colleague, Mr. W. H. H. CLARKE, sends us a photograph of the beautiful banner presented at St. Louis, which we are most glad to have as a permanent record of the occasion and of its officers. With it come two photographs of Mrs. Clarke's niece, Mrs. Gregory, who embroidered the banner—one of them taken in her ball dress, which she embroidered herself, and which took the first prize at the fair at St. Louis. From Mr. W. D. H. WILSON, of WILSON, HOOD & Co., come a series of most artistic amateur work. Their quality is most creditable, and the result very excellent selection and treatment. A charming lot of little bits they are, and the little plates have room for a good deal of thought and a corresponding amount of beauty caught. Some of the work of his new studio, doubtless remembered by our readers, is sent to us by Mr. P. H. ROSE, from Providence. Some pictures show the studio itself, which is a sort of photographic palace. Others show the splendid portrait work he sends out, and especially some beautiful group studies of two young girls. In the series of these there is a whole lecture on treatment and composition. Notable especially is the tone Mr. Rose gets over his pictures, doing away with the exaggerated perspective the lens will often give, rounding his figures, and melting them into the background naturally, and giving a wonderfully artistic effect. Mr. Rose's work bears the seal of the artist's individualism. It is his own—easily recognizable, not like anything else. It would be pleasant if more of other work could be like it. Style is rather rare in the run of photographs; such masterly style as these show rare, indeed. Dr. H. G. PIFFARD, of this city, kindly sends us a wonderful lightning flash photograph, taken by himself at Indian Harbor, Conn., last July. It shows three flashes, one triple, and up in the foreground, the hull quite perceptible, and the masts sharp against the sky, a ship—the United States Coast Survey schooner "Polinarus." It is a very remarkable photograph. Mr. J. F. RYDER has favored us with a cabinet and boudoir picture of his German Honor Prize. Mr. FRITZ, Lambertville, N. J., has sent us some excellent examples of his work, a "speaking likeness" of a "bonnie boy." MESSRS. ALLEN BROTHERS have already prepared us for the New Year with a pretty Suter Lens Calendar.



# Specialties.

## ADVERTISING RATES FOR SPECIALTIES.

25 cents for each line, seven words to a line—in advance. *Operators desiring situations, no charge.* Matter must be received a week before issue to *secure* insertion. Advertisers will please not ask us for recommendations. ~~☞~~ We cannot undertake to mail answers to parties who advertise. Please always add your address to the advertisement. **Postage-stamps taken.**

**MAKE OUT YOUR OWN BILL**, and remit cash with your advertisements, or they will not be inserted.

### TO OUR PATRONS.

St. Louis, October 23, 1886.

GENTLEMEN: During the last ten months we have been enlarging our factory in order to meet the growing demand for our plates, and succeeded in doubling our working capacity. Still our supply is not half sufficient to fill our orders. We have, therefore, commenced the building of a new factory, much larger than our present one, and have taken steps to secure its completion by the 1st of February next.

We again beg your patient forbearance and the continuance of your good will toward us, and trust that with the beginning of another year we shall be in shape to fully supply all demands.

Respectfully,

M. A. SEED DRY-PLATE CO.,  
A. R. HUISKAMP, Manager.

### RICH INTERIORS.

WINTER BACKGROUNDS, new and beautiful designs. Accessories for the season at *cut rate prices.*

L. W. SEAVEY,

Studio, 216 E. Ninth St., New York.

MOZAICS, 1887, is ready. 144 pages, 50 cents. Cloth bound, \$1.00.

A first-class gallery on Broadway for sale. Good business. *For cash only.* For particulars address

F. H.,  
226 E. Fifteenth St.,  
New York.

RETOUCHING BUREAU.—Under the direction of Mr. H. Harshman. None but skilled help employed. Quality of work guaranteed. Prices moderate. Send your negatives in wooden box with cover screwed on, and prepay charges. Address

GAYTON A. DOUGLASS & Co.,  
Merchants in Photo. Supplies,  
185 & 187 Wabash Avenue,  
Chicago, Ill.

Mozaics, 1887, is ready. Cloth bound, \$1.00. Paper cover, 50 cents.

## DOWN SHE GOES!

### NEW PRICE-LIST

OF THE

ROCKWOOD SOLAR PRINTING CO.

17 UNION SQUARE NEW YORK.

Size.	Unmounted.	Mounted.
11 x 14.....	\$1 00	\$1 25
13 x 16.....	1 00	1 25
14 x 17.....	1 00	1 25
16 x 20.....	1 00	1 25
18 x 22.....	1 20	1 50
20 x 24.....	1 35	1 50
22 x 27.....	1 40	1 90
25 x 30.....	1 40	1 90
27 x 32.....	2 25	3 00
29 x 36.....	3 00	4 00
30 x 40.....	4 00	5 00

No charge for negatives. All orders must be accompanied by the cash. Make all P. O. orders payable to ROCKWOOD SOLAR PRINTING Co., 17 Union Square, New York.

### PRINTING AND TONING FOR AMATEURS A SPECIALTY.

#### PLATES DEVELOPED.

Try our freshly made photographers' paper. Made fresh daily, and fumed ready for use. 25 cents per sheet, 18 x 22, cut any size, and sent by mail without extra charge.

Our Concentrated Toning Solution is pronounced the *best* by *all* who have used it. Price, seventy-five cents.

Photographic supplies of all kinds. Largest variety of stock in the city. Send for catalogue.

LOEBER BROS.,  
119 & 121 Nassau St.,  
New York.

FOR SALE.—\$1000 will get control of two good galleries. Sickness cause for selling.

Address W. G. COSS,  
Box 131, Kenton, Ohio

PUBLISHER'S NOTICE.

UNDER this head, in the *Mosaics* for 1886, I asked, "Now, what for next year?" The answer is in the pages of *Mosaics*, 1887.

From them the observant reader will readily discover that, since our art was born, there has not, in one year, been such rapid growth or so many important advances.

And as to the good people who have helped me verify this truth, they have sent in their gems of thought in such abundance as to make it impossible for me to place them all. A large overflow finds usefulness in the PHILADELPHIA PHOTOGRAPHER'S ISSUES.

Many thanks to all the writers and to the reading ones interested in our art, who have so swollen the orders, before *Mosaics* was in type, as to make its issue unprecedented.

Best greetings to all for the quickly coming New Year.

EDWARD L. WILSON.

**THE LIGHT RUNNING**

**NEW**

**STRONG**

**HOME**

**SWIFT**

**SURE**



**SEWING MACHINE**

**HAS NO EQUAL.**

**PERFECT SATISFACTION**

**New Home Sewing Machine Co.**

—ORANGE, MASS.—

30 Union Square, N. Y. Chicago, Ill. St. Louis, Mo.  
Atlanta, Ga. Dallas, Tex. San Francisco, Cal.

**FOR SALE BY**

THE AGENTS, at the above named places.

MOSAICS, 1887, is ready. 144 pages, 50 cents. Cloth bound, \$1.00.

THE CENTENNIAL CHAIR, made by Smith & Pattison, Chicago, is a great improvement over the old style wire frame. The frame made by Smith & Pattison is of wood, and the upholstering is a great improvement, while the prices have been placed way down.

WANTED.—A first-class reception-room lady, who understands retouching and spotting; also one accustomed to retouching large heads. A first-class operator can likewise find a good position.

P. H. Rose,  
Conrad Building,  
Providence, R. I.

WANTED.—A young man as general assistant, who has had experience in a first-class gallery, to do spotting, assist in printing, etc. Send photo. of self. References and particulars to  
ADT & BROTHER, Photographers,  
Waterbury, Conn.,

MOSAICS, 1887, is ready. 144 pages, 50 cents. Cloth bound, \$1.00.

FOR SALE! LENSES AT A BARGAIN!

One Morrison 11 inch Rapid Rectilinear Lens Will cover a 11 x 14 plate sharp to the edges. An excellent instantaneous lens. In good condition.

PRICE, \$50.

Two 8 x 10 Morrison Wide-angle Lenses, as good as new. 8 inches focal length.

PRICE, \$20 each.

One Euryscope, in good condition. Will cover a 11 x 14 plate.

PRICE, \$50.

Address "W. K.,"  
Photographic Times Office.

USED "DAISY," AND "NEW" HOLDERS FOR SALE.

From holders used at New Orleans Exhibition, I have

24 of 5 x 8 . . .	\$1 35
12 of 10 x 12 . . .	3 00
1 of 14 x 17 . . .	8 00

\* Cheap. Good as new.

EDWARD L. WILSON,  
853 Broadway, N. Y.

EVERY photographer in want of excellent lenses, for any purpose, will best serve his interest by consulting the new illustrated price-list of Messrs. BENJAMIN FRENCH & Co. before purchasing.

**WILSON, HOOD & CO.,**  
**825 Arch St.,**  
**PHILADELPHIA:**

We have now in stock  
**THE NEW EAGLE DRY PLATE.**

ALSO

**THE INGLIS TRIUMPH PLATE.**

A new brand of  
**GERMAN PYRO ACID.**

(35 cents per ounce.)

**POCKET GLASS CUTTER.**

(15 cents each.)

**NEW STYLE CORNER CHAIR.**

(\$10.00 each.)

**PAPIER MACHÉ STUMP.**

(\$6.00 each.)

**SUNSHINE MAILING ENVELOPE.**

"Long's Art of Making Crayons on Solar Enlargements." Price 50 cents.

EDWARD L. WILSON,  
 853 Broadway, N. Y.

**Two-Horse Power Engine. \$150.**

WITH STEEL BOILER.

**Cheap, Reliable, Safe.**

Automatic Boiler Feed. Automatic Pop Safety Valve Steel Boiler. Cost of running guaranteed not to exceed one and one-half cents per horse power per hour. Less than half that of any kerosene engine of equal efficiency. Nothing equal to it ever before offered for the price. Send for free descriptive circular.

CHAS. P. WILLARD & CO.  
 284 Michigan Street, Chicago, Ill.

825 REVISED LIST. 825

We call attention (circular free) to our revised price-lists of *albumen papers, Magee's nitrate of silver, dry plates, and pyrogallie acid.* Consult it before you buy. WILSON, HOOD & Co.,

825 Arch St., Phila.

FOR SALE.—Two good galleries, cheap and on easy terms, if sold within thirty days. Don't write unless you have some money and mean business. Address E. B. RADABAUGH, Huntingdon, Ind.

GRAY & STAMMERS'

Reduced Price-List of

BROMIDE ENLARGEMENTS.

Size.	Unmounted.	Mounted.
11 x 14.....	\$1 00	\$1 25
14 x 17.....	1 25	1 50
16 x 20.....	1 50	1 75
18 x 22.....	1 75	2 00
20 x 24.....	2 00	2 50
22 x 27.....	2 25	2 75
25 x 30.....	2 25	2 75
24 x 36.....	3 00	3 75
30 x 40.....	5 00	6 00

Our facilities to do good work on short notice are unexcelled. Prints made on either smooth or mat-surface paper and vignettted when so ordered. Send cash with order, and 25 cents, extra, for packing each lot of mounted prints. Samples furnished at the above rates.

GRAY & STAMMERS,  
 1430 Broadway, New York.

MOSAICS, 1887, is ready. 144 pages, 50 cents. Cloth bound, \$1.00.

**SITUATIONS WANTED.**

*No charge for advertisements under this head; limited to four lines. Inserted once only, unless by request.*

In a first-class gallery. Can operate, retouch negatives, print, tone—in fact, do all work connected with a gallery. Besides, do portrait work in ink, crayon, and pastel. Address A. G. Arrasmith, Roann, Wabash Co., Ind.

By a young lady, as retoucher. Address Miss N. E. Tanner, Box 258, Groton, N. Y.

As printer and retoucher. Can assist at operating. Address George H. Stone, Box 453, Canton, N. Y.

A valuable man, with highest references, desires a situation as operator, or operator and retoucher. Competent to take charge. Address O. & R., S. E. cor. Sixth and Elm, Cincinnati, O.

As printer, retoucher, or general assistant. Address W. J. Vialow, Vinton, Benton County, Iowa.

As printer, toner, and general assistant in a gallery. Has had three years' experience. Good work guaranteed. Good references. Address F. Ward, Box 202, Oneida, N. Y.

THE PHILADELPHIA PHOTOGRAPHER.

As general assistant. Four years' experience. Good reference from former employer as to ability to take charge of any part of gallery work. Please state salary. Address H. S. Fudge, Blossburg, Tioga Co., Pa.

As first-class crayon artist, in a gallery where he could make use of his knowledge of photography, New York City or country. Address Artist, care of Uthoff & Butterly, 852 Broadway, New York City.

By a first-class operator, dry or wet plates portrait work; good poser, and reliable. Can give best reference, if desired. Can come at once. Fifteen years' experience. Address H. Geisinger, 1624 N. 13th St., Philadelphia.

A gentleman, artist in ink, crayon, and water colors, of acknowledged ability, and with many years' experience in photography, is now open for an engagement. Address, with stamp, Perseverance, Box 106, Stoneham, Mass.

**C. H. CODMAN & CO.**  
**Photographic Stockdealers**

Sole Agents for the NEW ORTHO-PANACTINIC LENS, Moor's Photographic Enamel, the Perfect Mounting Solution for mounting Photographs on the thinnest mount without wrinkling.

New England Agents for American Optical Co.'s Apparatus. The best in the world. Send for Price List.

34 Bromfield Street.

BOSTON, MASS.

**OUR SPECIALTIES.**

BROMIDE AMMONIUM, Chem. Pure.

BROMIDE POTASS., Chem. Pure.

NITRATE SILVER, Chem. Pure.

**FOR DRY PLATES.**

CROSS-SWORD DRESDEN ALBUMEN PAPER,

Single and Extra Brilliant. The Best in the Market.

ALSO A GENERAL LINE OF

**PHOTOGRAPHIC CHEMICALS.**

A circular, "How to Save Waste," sent on application.

**CHAS. COOPER & CO.**

194 Worth St., New York.



[TRADE MARK]

TRY THE NEW

**3 KINGS** EXTRA BRILLIANT  
ALBUMEN PAPER.*Vio-Pensee*, a most delicate violet tint, and  
*Pearl-Email*, a beautiful shade of pearl.

SUPERIOR PRINTING QUALITIES.

Price per Ream, \$34.00.

Sample dozen post-paid to any address on receipt of \$1.00.

**BUCHANAN, SMEDLEY & BROMLEY,**  
Importers. New Store, 1030 Arch St., Phila.

THE PLATINOTYPE (Patented).

Send ten cents for instructions and sample,  
portrait or landscape.WILLIS & CLEMENTS,  
1112 HUNTER ST., PHILADELPHIA,  
BUCHANAN, SMEDLEY & BROMLEY,  
General Agents for the sale of materials.**HODGE & HUSTON,**  
**THE SOLAR PRINTERS,**  
622 ARCH STREET, PHILADELPHIA.*Permanent Prints by the Platinum Process. Electric Light.***SOLAR PRINTERS, TAKE NOTICE.**

The busy season is close at hand, and with it short days and poor light. It will pay you to investigate the merits of the **Platinotype Process**. You can save time and money by using it. Send ten cents for specimen print and latest instructions.

**WILLIS & CLEMENTS,**  
1112 Hunter Street, PHILADELPHIA. PA.

THE best artists and solar printers in the United States and Europe use **PLATINOTYPE PAPER** for large and small pictures. This paper is manufactured for Willis & Clements' Platinotype Process, and is the *purest and most desirable* grade of paper made in the world for ink, crayon, or pastel. Samples free.

**BUCHANAN, SMEDLEY & BROMLEY,**  
Importers, 1030 Arch St., Phila.

# WILSON'S PHOTOGRAPHIC PUBLICATIONS.

→ \*A TREATISE ON EVERY BRANCH OF PHOTOGRAPHY.\* ←

## THE PHILADELPHIA PHOTOGRAPHER,

A Semi-monthly Magazine, illustrated by photographs of superior merit. \$5.00 a year; \$2.50 for six months.

Stands ahead of all its kindred. Twenty-one years of success is a sufficient guarantee of its value and use to the practical, working, growing photographer. Do not go without its valuable help. See Prospectus.

### WILSON'S LANTERN JOURNEYS.

By EDWARD L. WILSON. In Three Vols.  
Price, \$2.00 per vol.

For the lantern exhibitor. Gives incidents and facts in entertaining style of about 2000 places and things, including 200 of the Centennial Exhibition.

### WILSON'S PHOTOGRAPHICS

THE NEWEST AND MOST COMPLETE

#### PHOTOGRAPHIC LESSON-BOOK.

COVERS EVERY DEPARTMENT.

352 Pages. *Finely Illustrated.* Only \$4.00.

By EDWARD L. WILSON.

### BIGELOW'S ARTISTIC PHOTOGRAPHY.

For lovers of the art. Beats his "Album of Lighting and Posing." Suberb! With twelve photographs and instructions. Price reduced to \$4.00.

#### THE FERROTYPYER'S GUIDE.

Cheap and complete. For the Ferrotypyer, this is the only standard work. Seventh thousand. Price, 75 cts.

### THE PROGRESS OF PHOTOGRAPHY

A NEW BOOK.

By Dr. H. VOGEL. Price, \$3.00.

A splendid work.

### STUDIES IN ARTISTIC PRINTING.

By C. W. HEARN. Price, \$3.50.

Embellished with six fine cabinet and promenade portrait studies.

### PICTORIAL EFFECT IN PHOTOGRAPHY.

By H. P. ROBINSON. For the Art Photographer. Cloth, \$1.50. Paper cover, \$1.00.

THE

### PHOTOGRAPHIC COLORISTS' GUIDE.

By JOHN L. GIBON. Cloth bound, \$1.50.

The newest and best work on painting photographs.

### PHOTOGRAPHIC MOSAICS, 1887.

Cloth bound, \$1.00; paper cover, 50 cents.  
Back volumes, same price.

Better than any of its predecessors.

COPIES MAILED POST-PAID ON RECEIPT OF PRICE.

## EDWARD L. WILSON,

Photo. Publisher.

853 Broadway, New York.

ASK FOR THE  
BLUE LABEL.

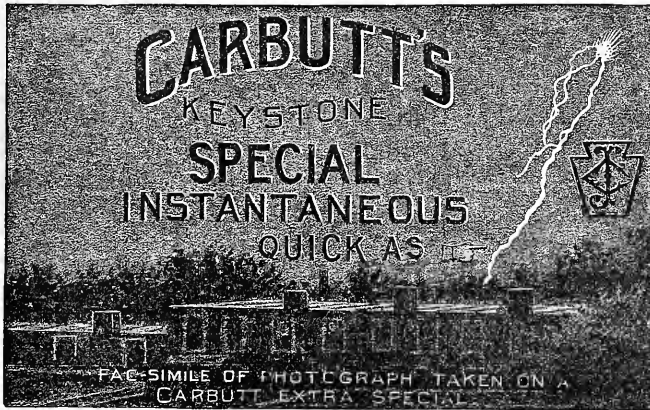

TRY THEM!  
and you will continue to  
USE THEM!

Pronounced the "Ne Plus Ultra" of Dry Plates.

UNSOLICITED TESTIMONIALS.

MR. JOHN CARBUTT, Wayne Junction, Philadelphia.

WORCESTER, MASS., December 25, 1885.

DEAR SIR: I have been using some of your new plates, emulsion 1024, sensitometer 24. I think they are, without exception, the finest and best plates I ever used. They are not only very fine and delicate in their structure, but, when properly manipulated, result in a blooming negative, possessing all the desirable qualities that any artist could wish for. I could most appropriately christen them the "Ne Plus Ultra Dry Plate."

Yours truly,

E. R. B. CLAFLIN.

DETROIT, MICH., January 16, 1886.

MESSRS. HARRIS & KITTLE.

GENTLEMEN: I am very much pleased with the Carbutt Plate; in fact, I call them the best plate *by far* that I tried so far. I find them especially useful for my theatrical subjects, as the quick emulsions are *absolutely instantaneous*.

Yours truly,

A. B. TAYLOR.

*For Sale by all Dealers in Photo. Materials.*

JOHN CARBUTT, Keystone Dry Plate Works, Wayne Junction, Philada., Pa.

THE UNRIVALLED

# STEINHEIL LENSES.

In Six Different Series and Forty Numbers, for  
Every Description of Work.

These Lenses not only maintain their old-established reputation, but continue to lead in the field of progress.

Special attention is called to

**Series No. II.**, Patent Antiplanatic, the newest conception in lenses. For Instantaneous Portraits, Large Heads, Full Figure Groups, Architecture, and Landscape. A marvel of illumination, depth, and rapidity. No Photographer or Amateur should purchase a lens before testing a Steinheil, Series No. II.

**Series No. III.**, the famous Aplanatic tube, the illumination of which has been increased, and which is recommended for large Portraits, full-size Figures, Groups, Architecture, and Landscape.

**Series No. VI.**, Wide Angle Aplanat, which has no rival for copying Maps, Charts, Paintings and Engravings. It is the Photo-lithographer's favorite.

Send for Illustrated Catalogue and Price-List to your dealer or to

H. G. RAMSPERGER & CO., Sole Agents,  
180 Pearl Street, New York.

# WILSON'S LANTERN JOURNEYS.

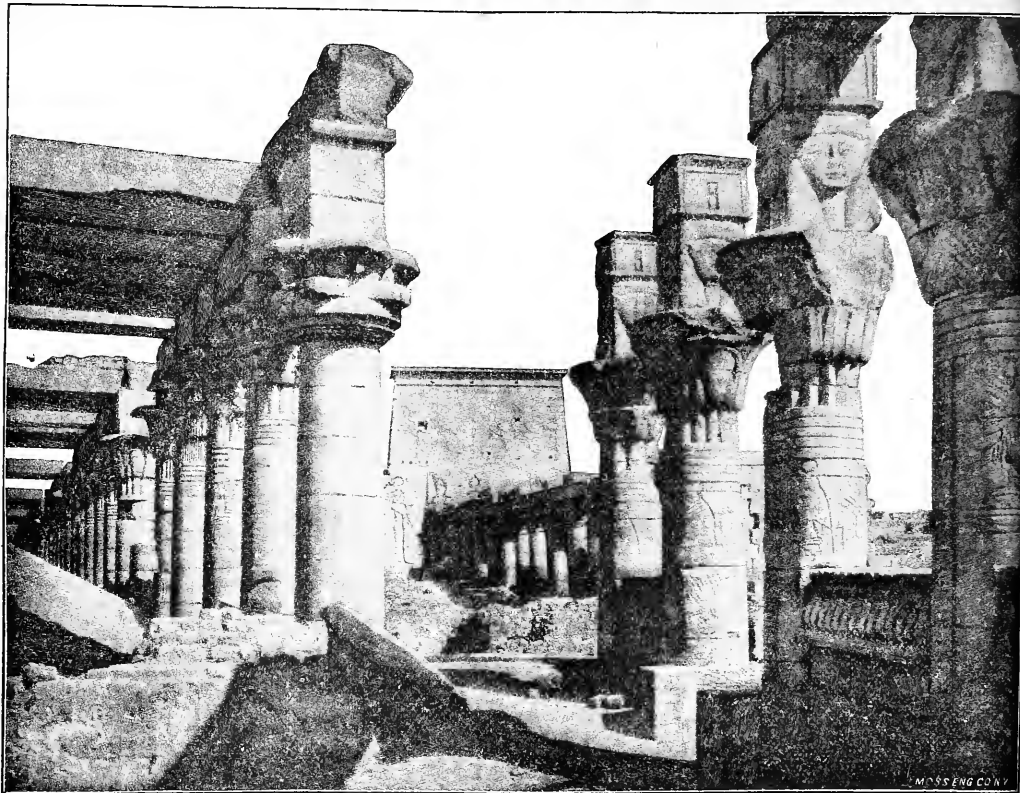

"Splendid summer reading for 'can't-get-aways' and 'can't-travels.' It is lovely travel and description combined."—*Herald*.

**3 Volumes. SEE WHAT COUNTRY THEY COVER. 3 Volumes.**

## VOLUME I. 306 PAGES, CONTAINS NINE JOURNEYS:

A—France and Switzerland. B—Belgium, Germany, Austria, Saxony, and Bavaria. C—Italy—Lakes, Cities, and the Italian Art Galleries. D—Holland, Denmark, Norway, Sweden, Russia, and Spain. E—Egypt, Palestine, Syria, Turkey, Greece, and India. F—England, Scotland, and United States of America. G—Centennial Exhibition, Phila. H—Centennial Exhibition, Phila. I—Paris Exposition, 1878.

**IN ALL OVER 900 SUBJECTS.**

## VOLUME II. 331 PAGES, CONTAINS TWELVE JOURNEYS:

J—Germany and Russia. K—Belgium and Austria. L—France—Cities and Provinces. M—Spain and Portugal. N—Switzerland—The Four Alpine Routes. O—Italy, Ischia, and Sicily. P—Turkey, Greece, and Egypt. Q—Palestine and India. R—Scotland—Cities and Ruins. S—Ireland. T—England—Cities, Museums, and Ruins. U—United States of America.

**IN ALL 1073 SUBJECTS.**

## VOLUME III. 323 PAGES, CONTAINS ELEVEN JOURNEYS:

Sinai Peninsula and Petra. From Hebron to Bethel. Round about Jerusalem. Picturesque Palestine. From Damascus to the Sea. A Thousand Miles in Nile Land. Nile, Tombs and Temples. How They Live in Egypt. Egypt and the Egyptians. Egypt, Old and New. New Pictures of Old Places.

**IN ALL 700 SUBJECTS.**

*Gives descriptions of all slides made by Mr. Edward L. Wilson of his personally taken views of The Sinai Peninsula; The Desert of the Exodus; The Route of the Israelites to the Promised Land; and the*

## TAKING OF PETRA.

Readers of The Philadelphia Photographer cannot put better books on their reception-room tables than this for waiting patrons.

**PRICE \$2.00 PER VOLUME, POST-PAID.**

For Sale by all Dealers. **EDWARD L. WILSON, Photo. Publisher, 853 Broadway, N. Y.**



## DEALERS' DIRECTORY.

*The following houses are to be recommended as the best for photographers in their localities.*

S. T. BLESSING, New Orleans, La. And Dallas, Texas.	GEORGE MURPHY, EAGLE STOCKHOUSE, 250 Mercer St. New York.	SMITH & PATTISON, NEW LOCATION, 145 & 147 Wabash Avenue, Chicago.
H. A. HYATT, Mound City Photo. Stock House, 8th and Locust Sts. St. Louis, Mo.	WILSON'S PHOTOGRAPHICS, \$4.00.	GAYTON A. DOUGLASS & CO. 185 & 187 Wabash Ave. CHICAGO.
SCOVILL MANF'G CO. 323 Broome St. New York.	D. TUCKER & CO. Buffalo, N. Y.	ALLEN BROS. Detroit, Michigan.
C. H. CODMAN & CO. Boston, Mass.	WILSON, HOOD & CO. 825 Arch Street, Philadelphia, Pa.	B. FRENCH & CO. Boston, Mass.
BUCHANAN, SMEDLEY & BROMLEY, 1030 Arch Street, Philadelphia.	A. B. PAINE & CO. Fort Scott, Kansas.	MULLETT BROS. Kansas City, Mo.
OSCAR FOSS, San Francisco, Cal.	E. & H. T. ANTHONY & CO. 591 Broadway, New York.	SHEEN & SIMPKINSON, 166 Race St. Cincinnati, O.

# TALCOTT'S PATENT MOUNT

FOR PHOTOGRAPHS, ETC.

IS NOW MEETING A LONG FELT NEED.

---

A unique invention constituting a picture and frame combined, complete for the easel, mantel, or wall, by which all framing may be dispensed with.

---

**Patented March 23, 1886.**

---

The Talcott mount softens the lines, adds much strength and great brilliancy to the picture, and is the only process by which a photograph may become indelible, rendering it practically indestructible. Picture frames are expensive, go out of fashion, and take up room.

*A picture mounted by our patent mount can be displayed or packed in one-half the space required by a picture with ordinary framing, as by this process all other framing becomes wholly unnecessary, yet it is so constructed, that if desired it can be placed in any ordinary picture frame, intact, and free from all interference.*

Our invention relates to a mounted picture such, for instance, as a photograph, the object being so to mount the picture, as to *dispense with ordinary picture frame*, to preserve the picture, and secure a stronger, richer, and more brilliant and more life-like effect than has been heretofore produced by ordinary modes of mounting, and to afford when so mounted means for support and suspension of the same.

As specimens of our improvement in mounts for pictures, photographs, etc., have been placed for inspection, which must naturally be subject to more or less criticism, it may be well for us to give some *description of the method* and its merits.

Upon superficial examination, some may say: "It is merely a picture placed back of plate glass; but this is far from the case, as herein, to a great extent, exists the cause of the fine effect produced by this mount. The picture being pressed firmly upon the transparent plate is made to adhere fast thereto by a transparent enamel of great strength and fine gloss, made by us expressly for this purpose, and is of singular purity.

The compound used gives much gloss, and in connection with the transparent plate *produces a soft and brilliant appearance*, bringing out the subject in relief to a surprising degree so life-like.

In this manner the picture becomes so closely identified with the plate as in appearance being one and the same. The considerable length of time we have experimented with this process and noted the results makes us feel confident in asserting that *any photo print may be preserved in all its strength and freshness an indefinite period if* subjected to our process before chemical change begins, for it will arrest a picture from fading, and prolong its strength far beyond its usual existence.

*The glass plate is of the finest quality* than can be procured, shaped and finished to each individual print, which print is securely enclosed, and hermetically enclosed in a neat and durable manner.

The mount is provided with a strong suspension and support, the whole presenting a finish and richness to correspond with any surroundings, however elegant.

With increased facilities we are now prepared to receive orders from photographers, art dealers, and the trade generally, to mount pictures, photographs, etc., at the shortest notice, and to all such in the trade who may desire, we will, upon application, send sample mounted, C.O.D., at trade prices.

For further particulars and price list, address

**E. K. TALCOTT,**

216 Northampton St.

BOSTON, MASS.

Read page 667 of Philadelphia Photographer, Nov. 6, 1886.

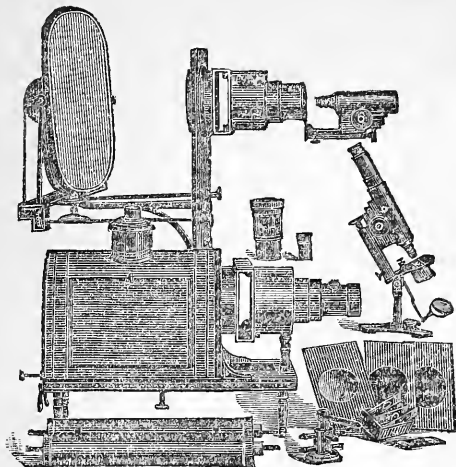

# OPTICAL AND ELECTRICAL INSTRUMENTS.

We desire to call the attention of  
TEACHERS, SCIENTISTS, LECTURERS, and  
those interested, to our

**Stereopticons, Microscopes, Dr. McIntosh's Solar Microscope and  
Stereopticon Combination Apparatus for  
the Oxy-hydrogen and Ether-oxygen Lime Light, Photographic  
Transparencies, Microscopical Preparations, etc.**

Our Instruments and Apparatus are new in design and have many improvements  
that overcome difficulties heretofore considered unavoidable. We also manufacture

**Static Electric Machines, Batteries, Magnets, and a Full Line of  
Electrical Apparatus for Practical and Experimental  
Purposes.**



We received the highest  
award at the New Orleans  
World's Exposition, on  
both Optical and Elec-  
trical Apparatus, in com-  
petition with the best of  
home and foreign manu-  
facturers.



Illustrated Catalogue of Optical and Electrical Apparatus sent free on application  
by mentioning this journal.

**McIntosh Galvanic and Faradic Battery Co.**

Nos. 300 & 302 Dearborn Street,

CHICAGO, ILL., U. S. A.

# SUBSCRIBE NOW

TO

# THE PHILADELPHIA PHOTOGRAPHER.

TWENTY-FOURTH YEAR, 1887.

*Devoted to the Advancement of Photography and the Dissemination of Art Principles.*

SEMI-MONTHLY: issued the First and Third Saturday of each month.

\$5.00 a year, \$2.50 for six months, \$1.25 for three months—in advance. 30 cts. per copy.

OLD SUBSCRIBERS please inform us now if you want to renew.

NEW SUBSCRIBERS please order early and get all the numbers for 1887.

During the year it will be our honest effort to make our magazine the best of its class in the world. No publisher gives so much for the money—12 numbers, illustrated (32 pages each, always), for \$2.50; double that number for \$5.00. Where is it equalled?

It gives you the news of the world; it is the practical photographer's devoted advocate and helper; it is not issued for the sake of catching other trade; it is open and straightforward in its policy; and it will not be beat. A splendid variety of studies is given—an unrivalled choice, and it is our constant effort and study to be of service to the photographer who must win his daily bread by his camera.

Some of the features of our new volume of THE PHILADELPHIA PHOTOGRAPHER, will be a new series of papers from foreign contributors; a series of illustrated art lessons; the reproduction, in supplementary sheets, of some of the best articles of the year in the French and German languages, for our readers who cannot read English; a grand prize contest; a series of lessons from the veterans of the craft; another series from the second generation; twenty-four or more such studies as were never before seen in any photographic magazine. Among these last, the year will be led by Mr. D. H. Anderson, of this city, with a splendid portrait of the charming actress, Miss Charlotte Behrens, in her Russian character of "Zitka." It will be followed by an example of the Vandyke style of lighting, by Messrs. Loescher & Petsch, Berlin; by that charming female subject from Peitzner, Tóplitz—in our opinion the gem of the German department at St. Louis; a whole series of lovely child pictures—some from Texas, some from California, and some from the Hoosier State; an aristotype on Liesegang's new paper; photogravures and phototypes, gelatine, and other process pictures; a group of ladies from the new studio of Mr. P. H. Rose, Providence, R. I.; a Kalahari view, by Mr. Lulu Farini, Bridgeport, Conn.; a gem from Mr. H. P. Robinson; a quartette of portrait studies from a famed London artist; an azaline reproduction of a chromo, with the original and a wet picture added; and— Well, it is not good policy, for obvious reasons, to tell *all* we are going to do; but if our old friends will come forward and help us to some new ones, reciprocal action will assure them that together we can uphold the honor of our art, make it grow under our hands, and help each other to more comfort in our work. Shall the thing be mutual? Please express your opinion by the usual sign—and our best wishes for a Happy New Year go to you heartily.

A good photographic magazine is somewhat like your water supply. You do not realize how useful it is until it stops. What would photography do if there were no good magazines devoted to it? Is it not to your interest to support them all; and if not all, the *best* one?

Please take a moment to consider these things *for your own good*.

\$1 IN BOOKS, PREMIUM FOR NEW SUBSCRIBERS.

Our Invaluable Back Numbers for 1886 are Equivalent to Several Volumes on Our Art.

EDWARD L. WILSON, 853 Broadway, New York.

OFFICE OF

*G. Cramer.*

DRY PLATE WORKS,

Shenandoah and Buena Vista Streets., St. Louis.

---

The enlargement of my factory being now completed, I am able to serve my patrons more promptly than heretofore.

Thanking the fraternity for their kind patronage, and soliciting a continuance of the same, I am                      Fraternaly yours,

G. CRAMER DRY PLATE WORKS,  
ST. LOUIS, MO.

---

**THE**

**ST. LOUIS DRY PLATE COMPANY**

Beg to announce that under their New Management they have recently made Important Improvements and Increased their Facilities, so that they are now making better and more uniform plates than heretofore.

---

ALL ORDERS WILL RECEIVE PROMPT ATTENTION.

---

**ST. LOUIS DRY PLATE CO.**

No. 827 Chouteau Avenue,

ST. LOUIS, MO.

Number 288.

30 Cents.

THE  
PHILADELPHIA  
**Photographer.**

AN ILLUSTRATED SEMI-MONTHLY JOURNAL,  
DEVOTED TO PHOTOGRAPHY.

SUMMARY OF CONTENTS.

	PAGE		PAGE
1887, . . . . .	737	As in our 1886 Volume, . . . . .	754
Our Index for 1886, . . . . .	737	Photography at the Exhibition of the American Institute, . . . . .	754
Notes From London. By T. C. HEPWORTH, F.C.S., . . . . .	738	Society Gossip, . . . . .	754
About Exhibits. By M. L. CORMANY, . . . . .	739	Woodbury Tissue, . . . . .	756
Photographing with Phosphorescent Substances, . . . . .	740	The German Prizes, . . . . .	758
Some Developer Dodges, . . . . .	740	The Humor of It, . . . . .	759
Kruse's Negative Numberer, . . . . .	741	Our Picture, . . . . .	760
The Ives Autoglyphic Process, . . . . .	742	Photography Threatened, . . . . .	761
Measels Again. By FRANK ROBBINS, Bradford, Pa., . . . . .	743	Prof Abbe's New Optical Glass, . . . . .	761
A "Dry" Christmas Collation, . . . . .	743	Practical Points from the Studios, . . . . .	763
Our Young Men, . . . . .	754	Zinc Etching—Asphalt Process, . . . . .	763
		The World's Photography Focussed, . . . . .	765
		Editor's Table, . . . . .	767

OUR PICTURE.—"Gems of the Rhine." By J. WINTER, JR., Syracuse, New York.  
Prints by the Photogravure Co., New York.

EDWARD L. WILSON,  
*853 Broadway, New York.*

SUBSCRIPTIONS RECEIVED BY ALL NEWS AND STOCKDEALERS

Five Dollars per Annum, in Advance.

## ADVERTISEMENT S.

ANTHONY & CO., E. & H. T. The New N. P. A.  
 Pensé Extra Brilliant Dresden Albumen Paper.  
 CARBUTT, J. Gelatine Dry Plates and Improved  
 Dry Plate Lantern.  
 CODMAN, C. H. & CO. Photo. Stockdealers.  
 COLLINS, A. M. MFG. CO., Photograph Cards.  
 COOPER, CHAS. & CO. Photo. Stockdealers.  
 DOUGLASS, GAYTON A. & CO. Photo. Stock-  
 dealers.  
 DRESCHER, F. & CO.'S. Improved Gelatine for  
 Emulsion.  
 FRENCH & CO., BENJ. Voigtlander & Son and  
 Darlot Lenses. The Wonderful Euryscope.  
 GENNERT, G. Eagle Dry Plates.  
 INGLIS, JAMES. Dry Plates.  
 JANENTZKY & WEBER. Artist Materials.  
 McINTOSH GALVANIC AND FARADIC BAT-  
 TERY CO.

MOSS ENGRAVING CO.  
 PHOTOGRAPHERS' ART VINE.  
 PHOTOGRAVURE CO.  
 PHOTOGRAPHIC TIMES.  
 PHOTOGRAPHIC MOSAICS, 1887.  
 ROBERTS & FELLOWS. Photo. Stockdealers.  
 SCHINDLER'S POSING CHAIR.  
 SCHMIERS, WERNER & STEIN, Phototype or  
 Heliotype Steam Presses, Leipzig, Germany.  
 SMITH & PATTISON. Photo. Requisites.  
 SWEET, WALLACH & CO. Photo. Supplies.  
 THE ARGENTIC DRY PLATE.  
 THE BLAIR CAMERA CO.  
 TALCOTT, E. K. Patent Mounts for Photog-  
 raphers.  
 THAYER, N. C. & CO. Photo. Supplies.  
 WILSON, G. W. & CO. Magic Lantern Slides.

---

## ADVERTISING RATES.

THE PHILADELPHIA PHOTOGRAPHER is acknowledged to be the best advertising medium in the trade.

Its circulation is among the first class, at home and in nearly every foreign country.

Its rates, all advantages considered, are the most favorable, and it will bring you fine returns.

	One Issue.	Six Issues.	Twelve Issues.	Twenty-four Issues.
1 Page.....	\$20.00	\$110.00	\$200.00	\$350.00
1-2 " .....	12.00	66.00	120.00	200.00
1-4 " .....	7.00	38.50	70.00	120.00
1-8 " .....	4.00	22.00	40.00	70.00

Special contracts made with bona-fide dealers and manufacturers. Address

**EDWARD L. WILSON,**  
 853 BROADWAY, NEW YORK.

---

## NOTICE TO SUBSCRIBERS.

### REMEMBER YOUR OPERATOR AT CHRISTMAS.

In remitting by mail, a post-office order, or draft, payable to the order of EDWARD L. WILSON, is preferable to bank-notes. Postage stamps of the denomination of two and five cents each will be taken. Clearly give your Post-Office, County, and State.

Foreign subscriptions must be accompanied by the postage in addition.

---

## SUBSCRIPTIONS FOR 1887 NOW RECEIVABLE.

FOR SALE—A STUDIO.—Owing to the recent death of Mr. Milton T. Carter, Worcester, Mass., his studio is for sale. It is considered the best in the city, and represents in negatives and patronage 23 years of business with the best citizens of the city and country. The territory covered is extended and thickly populated. New light and furnishings. Easily approached. Very prominent location, overlooking park. Expenses low. These statements not exaggerated. Studio continues open.



ALFRED M. COLLINS,  
*Secretary and Treasurer.*

HENRY H. COLLINS,  
*President.*

EDWARD COPE,  
*Vice-President.*

# A. M. Collins Mfg. Co.

*MAKE ALL KINDS OF*

**CARDS AND CARDBOARDS**

FOR

**PHOTOGRAPHERS**

AND

**MATS, MOUNTS, AND ENVELOPES**

FOR

**FERROTYPES.**

---

OFFICE AND WAREHOUSE,

**No. 527 ARCH STREET,**

**PHILADELPHIA.**

---

Price Lists may be had by intending purchasers on application to us, or to all Photographic Merchants, through whom your favors are respectfully solicited.

# TALCOTT'S PATENT MOUNT

FOR PHOTOGRAPHS, ETC.

IS NOW MEETING A LONG FELT NEED.

---

A unique invention constituting a picture and frame combined, complete for the easel, mantel, or wall, by which all framing may be dispensed with.

---

**Patented March 28, 1886.**

---

The Talcott mount softens the lines, adds much strength and great brilliancy to the picture, and is the only process by which a photograph may become indelible, rendering it practically indestructible. Picture frames are expensive, go out of fashion, and take up room.

*A picture mounted by our patent mount can be displayed or packed in one-half the space required by a picture with ordinary framing, as by this process all other framing becomes wholly unnecessary, yet it is so constructed, that if desired it can be placed in any ordinary picture frame, intact, and free from all interference.*

Our invention relates to a mounted picture such, for instance, as a photograph, the object being so to mount the picture, as to *dispense with ordinary picture frame*, to preserve the picture, and secure a stronger, richer, and more brilliant and more life-like effect than has been heretofore produced by ordinary modes of mounting, and to afford when so mounted means for support and suspension of the same.

As specimens of our improvement in mounts for pictures, photographs, etc., have been placed for inspection, which must naturally be subject to more or less criticism, it may be well for us to give some *description of the method* and its merits.

Upon superficial examination, some may say: "It is merely a picture placed back of plate glass; but this is far from the case, as herein, to a great extent, exists the cause of the fine effect produced by this mount. The picture being pressed firmly upon the transparent plate is made to adhere fast thereto by a transparent enamel of great strength and fine gloss, made by us expressly for this purpose, and is of singular purity.

The compound used gives much gloss, and in connection with the transparent plate *produces a soft and brilliant appearance*, bringing out the subject in relief to a surprising degree so life-like.

In this manner the picture becomes so closely identified with the plate as in appearance being one and the same. The considerable length of time we have experimented with this process and noted the results makes us feel confident in asserting that *any photo print may be preserved in all its strength and freshness an indefinite period if* subjected to our process before chemical change begins, for it will arrest a picture from fading, and prolong its strength far beyond its usual existence.

*The glass plate is of the finest quality* than can be procured, shaped and finished to each individual print, which print is securely enclosed, and hermetically enclosed in a neat and durable manner.

The mount is provided with a strong suspension and support, the whole presenting a finish and richness to correspond with any surroundings, however elegant.

With increased facilities we are now prepared to receive orders from photographers, art dealers, and the trade generally, to mount pictures, photographs, etc., at the shortest notice, and to all such in the trade who may desire, we will, upon application, send sample mounted, C.O.D., at trade prices.

For further particulars and price list, address

**E. K. TALCOTT,**

**BOSTON, MASS.**

For any one sending \$1.00 and a Cabinet print, rich and strong, I will mount and return the picture.

# BENJ. FRENCH & Co.

No. 319 WASHINGTON STREET, BOSTON,

Sole Agents in the United States for the Celebrated Lenses  
Manufactured by

## VOIGTLÄNDER & SON.

ALSO, THEIR FAMOUS

# EURYSCOPE,

Which is unrivalled for groups, full-length figures, and other demands in the gallery, and every species of out-door work, including instantaneous photography.

THE EURYSCOPE is made *exclusively* by Voigtländer & Son, and their name is engraved on the tube.

FOR PORTRAITS. **DARLOT LENSES** FOR VIEWS.

IMPORTERS, ALSO, OF THE CELEBRATED

TRAPP & MÜNCH

## ALBUMEN PAPER,

AND DEALERS IN ALL KINDS OF

*Photographic Materials and Magic Lantern Slides.*

SEND FOR OUR NEW ILLUSTRATED PRICE LIST OF LENSES.

# A CARD.

75 STONE ST., ROCHESTER, N. Y., July 26, 1886.

GENTLEMEN: About three months ago the business of Inglis & Co., of this city was formed into the Inglis Dry Plate Co.

In the articles of agreement, a clause was inserted giving the I. D. P. Co. the exclusive use of the name of "Inglis," and also that James Inglis would not connect himself with any dry plate business using the name of "Inglis."

Matters have taken such a form since then, he has been compelled to leave the I. D. P. Co. And being thus debarred from the use of his own name, adopts this means of making known to his numerous customers where they may still obtain his plate. **And the Only Place.**

A new firm taking the name of the **ROCHESTER DRY PLATE CO.** have engaged his services, and under his supervision a new factory has been fitted with the most modern improvements required for the production of clean and spotless plates, with all the other extra qualities that his plate has become so renowned for. The fraternity may therefore depend upon the very finest plate ever yet produced, from the **ROCHESTER DRY PLATE CO.**

## JAMES INGLIS,

Late Manufacturer of the Inglis Dry Plate, and President  
of the Inglis Dry Plate Co.

---

## OUR SPECIALTIES.

BROMIDE AMMONIUM, Chem. Pure.

BROMIDE POTASS., Chem. Pure.

NITRATE SILVER, Chem. Pure.

### FOR DRY PLATES.

CROSS-SWORD DRESDEN ALBUMEN PAPER,

Single and Extra Brilliant. The Best in the Market.

ALSO A GENERAL LINE OF

## PHOTOGRAPHIC CHEMICALS.

A circular, "How to Save Waste," sent on application.

## CHAS. COOPER & CO.

194 Worth St., New York.

MAGIC CAMERA STANDS. THE BEST MADE.

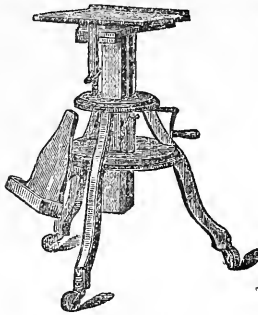

No. 1, 8 x 10, \$12 00

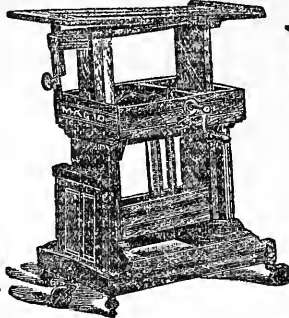

No. 2, 8 x 10 to 11 x 15, \$15 00

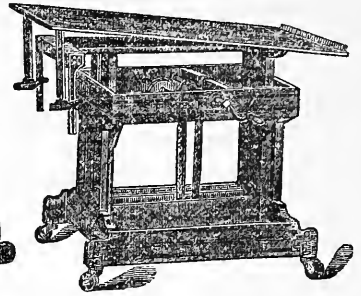

No. 3, 14 x 17..... \$20 00  
No. 4, 18 x 22 and 20 x 24.... 25 00

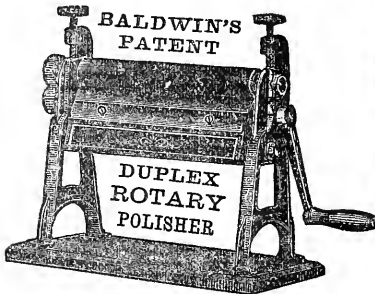

THE BEST IN THE WORLD.  
Prices, \$18, \$25, \$35, and \$45.



CENTENNIAL CHAIRS.  
Very Popular and Cheap.



BALDWIN'S BABY HOLDER.  
Has no Equal.

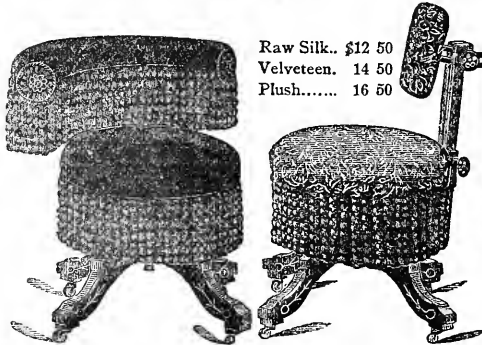

THE PATENT QUEEN POSERS.  
The most useful Chair ever invented. Prices include  
Circular Arm and Back Rest.

Raw Silk.. \$12 50  
Velveteen. 14 50  
Plush..... 16 50

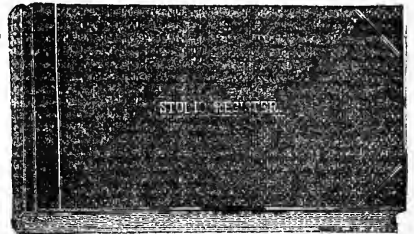

No Studio Complete without it.  
Send for Sample Page.

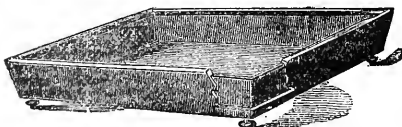

THE COMMON SENSE TRAY.  
Is the Best and Cheapest Large Tray Made.

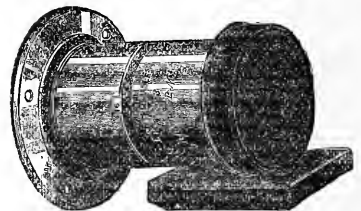

THE WONDERFUL SUTER LENS.  
Has no Superior in Quality, and no Equal  
in Price.

The above represents a few of our leading specialties, all of which (except Suter Lenses), we manufacture and control. All these items are the best in the class they represent. Take no other. Send for complete descriptive circular of any or all these items, or any article needed.

SMITH & PATTISON,

Wholesale Photo Supplies  
of every description

145 & 147 Wabash Ave., Chicago.

# The Photo-Gravure Company,

853 Broadway, New York.

PHOTO-  $\left\{ \begin{array}{l} \text{GRAVURE} \\ \text{LITHOGRAPH} \\ \text{CAUSTIC} \\ \text{GELATINE} \end{array} \right\}$  PRINTING

## PROCESSES OF THE PHOTO-GRAVURE COMPANY.

**PHOTO-GRAVURE.**—By this process the highest artistic effects are produced. Metal plates are engraved (in intaglio) by photography and printed in copper-plate presses. The effects produced by photography may be altered by the hand of the artist, values may be increased or diminished, and almost any omission or addition made. The work may be carried on till the desired effect is produced and the edition is always uniform. The plates can be supplied when desired, or the Photo-Gravure Co. will do the printing. The results obtained by the Photo-Gravure Co. equal the best results obtained abroad, and reference to this effect is permitted to leading Publishers and Artists who have used these plates. All classes of subjects, whether in half-tone or line, can be produced by this process.

**PHOTO-GELATINE PRINTING.**—The results produced by this process are similar to what is known as Albertype, Artotype, Heliotype, Autoglyph, Phototype, Lichtdruck, etc. The particular method used is that patented by Mr. T. C. Roche, and is believed to give the best results at the least cost. The Photo-Gravure Co. has in this department the best staff of printers in the country and a most extended experience of the treatment of gelatine for the purposes of printing. All classes of subjects are suitable for reproduction by this process, and it is especially suitable for portraits, views, architecture, art catalogues, scientific and natural objects, book illustration, town, county, and family histories, theatrical and general advertising, reproductions of engravings, machinery, animals, and still life, copies of deeds, instantaneous effects, scientific records, mill labels, etc.

**PHOTO-CAUSTIC PRINTING.**—This term is applied to a modification of the results produced by Meisenbach, Ives, and others. By this modification the photographic effect is produced from stone. No attempt is made to produce engraved plates, but the printing is done by the Photo-Gravure Co., and by this means greatly better results are obtained than where plates are made and placed in the hands of the ordinary printer. The results are not as good as those obtained from Gelatine or by Photo-Gravure, but they are sufficiently good for a number of purposes where the quality of the higher grades of work is not necessary. It is applicable to all the purposes of the other processes, but is lower both in cost and quality.

**PHOTO-LITHOGRAPHY.**—The results of this well-established process are well known. It is the oldest of the photo-mechanical processes, but is only adapted to the reproduction of original drawings or engravings which are made in a black or other non-actinic color on a white or light ground. We have in our employ on this work the most skilful staff in the country, who for many years have made it a specialty. Photo-Lithography is unrivalled for the reproduction of maps, plans, tracings, surveys, patents, and other drawings, engineers' and architects' designs, *fac-simile* letters and circulars, exhibits in law cases, miniature catalogues, copies of line engravings, reduction or enlargement of line work, etc.

A Book of Specimens of our various processes will be forwarded on receipt of One Dollar, and all inquiries will be promptly answered. Special arrangements made with photographers.

**THE PHOTO-GRAVURE CO.,**  
853 Broadway, New York.

## BLAIR'S "PERFECT" (R. B.) CAMERAS.

THIS  
Carrying Case  
ONLY  
Five Inches  
THICK.

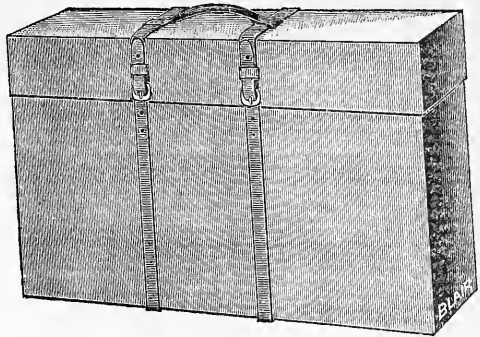

CARRYING  
6 F. W. Holders  
and 6½ x 8½  
PERFECT  
CAMERA.

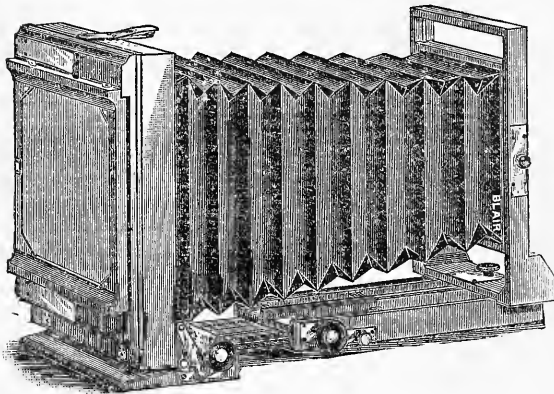

OPEN FOR USE.

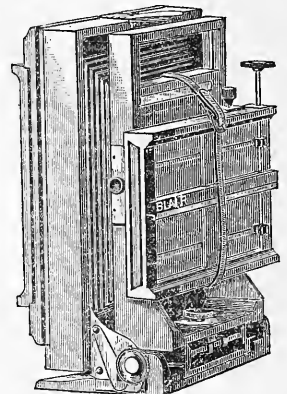

CLOSED.

The model instrument has been under progress in our factory for several months, and has undergone every change to our mind possible, to make it the most compact, combined with strength, possible.

1. By the ingenious method of constructing the "swing-back," greater swing is allowed, while the camera occupies no additional space by this important advantage.

2. By the method of constructing the telescopic bed the standard carrying the lens is quickly carried out to about the focal distance of lens in use, and then by the use of the Rack and Pinion the fine focus is attained. The thumb-nut and rod operating the Rack and Pinion is situated midway between the camera back and standard carrying the lens, which overcomes the objection of reaching forward when using long-focus lenses. The telescopic bed leaves no detachable parts. When using lenses of shorter focus than (5) inches the movable portion of the bed is not used; above that focal length the telescopic bed will not interfere with the view. *No clamping screws are used to make the bed rigid when attached.* There are two attaching nuts for the tripod screw, thereby enabling the operator to balance the camera when using long and short focus lenses.

*Bear strongly in mind that all of our Reversible Back Cameras possess greater focussing capacity by several inches than any other Cameras of a similar pattern.*

The double swing occupies no more space than the single. It is of our best manufacture, highly polished, with with nickel mountings. Fitted with feather-weight holders, unless otherwise specified.

## PRICE LIST OF PERFECT (R. B.) CAMERAS.

Size of Plate.	Size of Lens Board.	Capacity for Length of Focus.	Single Swing.	Double Swing.
5 x 7 .....	4½ in. sq. ....	17 in. ....	\$32 00 .....	\$34 00 .....
5 x 8 .....	6 " " .....	18 in. ....	36 00 .....	38 00 .....
6½ x 8½ .....	6 " " .....	18 in. ....	36 00 .....	38 00 .....
8 x 10 .....	7½ x 6 in. ....	18 in. ....	45 00 .....	48 00 .....

## THE BLAIR CAMERA CO.

Office and Factory, 471, 473, 475, 477 Tremont Street,

BOSTON.

BLAIR &amp; PRINCE, 148 W. Fourth St., Cincinnati, Ohio.

Warerooms, 318 Broadway, NEW YORK.





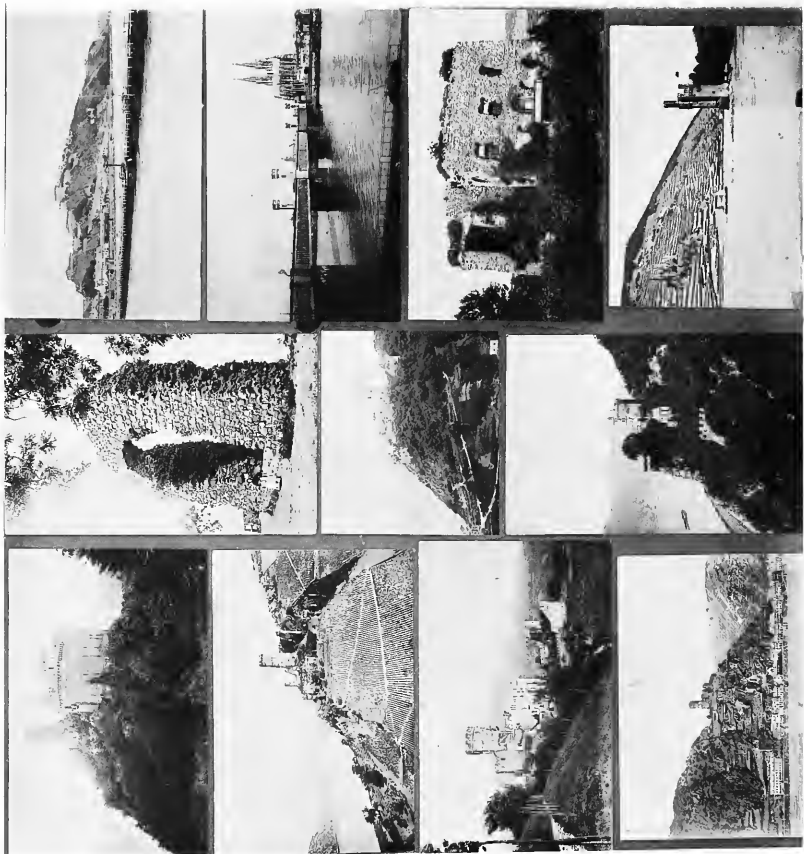

THE

# Philadelphia Photographer.

EDITED BY EDWARD L. WILSON.

Vol. XXIII.

DECEMBER 18, 1886.

No. 288.

1887.

THE leading article in our last number seems to have caused many of our readers to make it "a case of conscience," for the renewals for 1887, have been rolling down upon us like a glacier, but with much more heart-warming effect.

This is *good*, good gentlemen and ladies, and leaves us in no doubt as to your intentions towards us for 1887. But there are a great many yet who have neither said "yes" or "no."

Will you not please decide the point now, and let us have your decision?

It is better to go without some want or desire of the time, than to go without the semi-monthly help of the PHILADELPHIA PHOTOGRAPHER.

We do not wish you to miss a single number. Therefore, if you will apprise us of your wish to that effect we will print enough to supply you presently. Otherwise, the supply may be exhausted, and the tardy ones have to go without.

It will be allowed, we think, that our magazine is the most expensive one of its class to manufacture. Moreover, we give double for the money what we did a year ago. We cannot, therefore, make up a large edition twice a month, on the risk of selling them.

To conduct our magazine to any profit for ourselves, we should know very closely what demands for copies will be made two or three

months in advance, that we may order paper and print pictures. Will you not consider *us* a little in the matter, therefore?

Our efforts in your behalf are to be continued. If you failed to read our leader to you in our last issue, please do so now, or refer to the third page of the cover.

There are nine reasons why our magazine should be preferred to any other. A. It gives you *all* the important practical items concerning our art, from all parts of the world. B. None of its space is wasted in empty discussion on local proceedings. C. It is essentially and notably the practical photographer's magazine. D. It provides twenty-four splendid studies to help you in your work. E. It does all this at a less cost per number than any other magazine of its size. F. It is going to excel itself in 1887. G. You lose if you don't receive it.

It is important to both of us that you let us know *now* how long we shall continue to send you—*this magazine*.

Meanwhile, a Happy New Year to all.

## OUR INDEX FOR 1886.

WE have tried, at considerable trouble, and some expense, to make the index of Vol. XXIII. a good one. The mass of information which the journal for the past year holds we hope is by it made easily and surely available. We make it a present to our subscribers. Others we would like to

have examine it, and see if it does not hold something for them.

A new feature is the classified collection of fugitive receipts, under "useful hints." These are as valuable as anything in the journal—the very freshest, richest cream of home and foreign photographic information and progress. They are not in the books, for they are too new to have yet been gathered there. Many a one of them alone will save or gain the photographer more than the subscription price of the journal. Many were answers to some of the innumerable letters we receive, so we feel sure they fill a need.

In using the index, look always for the important word; as, *e. g.*, don't seek "A Few Points on Pyro Development," under A, but under D.

We can still supply complete sets of back numbers for 1886, at 30 cents per number, or \$5.00 for the complete year, so that duplicates can be bought easily, or whole files secured. The amateur, and the writer of puzzled letters, we would ask especially to notice this. Each number contains exactly thirty-two pages. The first issue of 1886 was No. 265. Hence, if you desire a number containing a certain article, look up the title in the index; see how many times its page contains 32, add this to No. 265, and you have it.

---

### NOTES FROM LONDON.

BY T. C. HEPWORTH, F.C.S.

THE exhibition of the Photographic Society of Great Britain, which all dwellers in the Kingdom look upon as an annual authoritative record of progress of the art, has been a most successful one; not only with regard to the quality of the works shown, but also with reference to the number of visitors attracted to the galleries. As usual, there have been heartburnings in many quarters, which have found expression in the technical journals, regarding the hanging of several of the pictures. One exhibitor complains that his frames have been skied, and with gentle irony suggests that ladders should be provided with which to view them. Another with equal vehemence calls out for cushions, so that visitors may

lie down to look at those gems of his which are lying on the floor. As one who has had some little experience in exhibition management, I must say that I sympathize with these forlorn ones, but still more do I sympathize with the hanging Committee. With a surfeit of pictures, they are anxious to reject as few as possible, and the men who do the work of hanging are instructed to lose no available space. With this one thing in view, they fill up every nook on the walls. If there is a vacant space left on the line, measuring say ten inches in width, a picture of that size is searched for and found, quite irrespective of the name of the exhibitor. It is a pity that some system of balloting for the best places cannot be instituted. Failing this, the wall space might be charged for at different rates, so that those whose works are hung too high or too low would have the comfort of knowing that they have not to pay first-class fare for third-class accommodation.

The pictures exhibited show a marked improvement on previous exhibitions, and their subjects are of the most varied nature. Three of the Society's medals go to foreigners, and very well is their success deserved. One of these is won by Mr. K. Brandel, of Warsaw, who exhibits an extraordinary number of small pictures taken instantaneously with a "photo revolver" of his own invention. These pictures cover every phase of life in movement, and are wonderfully perfect examples of photography. I had a glance at the "photo revolver," which seemed to be an ordinary camera for hand use, with a finder attached, and a quick shutter concealed behind the lens. Why it is described as a revolver I know not, for it certainly does not revolve.

Another feature in the exhibition which marks a forward step in the art of photography is the award of a medal to Messrs. Dixon & Gray for a series of pictures produced on their orthochromatic plates. These pictures are in many cases placed beside the colored original from which they were copied, together with a photograph of the same subject, but taken on an ordinary gelatine plate. Messrs. Dixon & Gray now supply these plates for instantaneous work, and we may therefore look in the near future

to a great improvement in the rendering of color by photography.

I think that just now the photographic world is rather mad on the subject of films. It is quite certain that many experiments are going forward in this direction. I hardly dare to call upon any photographer, in case he should entice me with mysterious signs into a dark corner to show me a specimen, under vows of secrecy, of some bit of limp stuff which he calls a film, and which he tells me is to beat everything else out of the market. One thing I have noticed is this: that the specimens shown are always positive, not negative pictures. To my suspicious nature this fact is full of significance. A man can easily produce a positive in the quiet of his dark-room from a perfect negative, for he can try, try, try again, until he adjusts both light and developer to the particular requirements of that negative. But a series of good negatives of different subjects, instantaneous and otherwise, would at once show what the films can do.

The Camera Club, London, is a young institution, but a very flourishing one, and a visit to its hospitable rooms will generally acquaint one with the newest events in the photographic world. One of its members—I am sorry that for the moment I forget his name—has proposed a very simple and ingenious camera “finder.” He raises the focussing screen until it stands upright on the top of the camera, and there it is held vertically by means of a side strut. A simple lens of the same focus as the lens used in the camera is supported above the camera front, and the focussing cloth is thrown over all. It is evident that with this arrangement he has under his eye the same picture as that which will be thrown upon his sensitive plate directly exposure is made. For instantaneous pictures involving moving objects, no better arrangement could be devised.

I had occasion lately to make two or three diagrams for use in the lantern, and as the work had to be completed with great speed or left undone altogether, I cast about for some means of quickly accomplishing my object. I do not know whether my plan is an original one, or whether it has been adopted by others before me; but it is

a good one, and may be useful to others, so I give it publicity. Upon a school black-board I rapidly sketched my diagrams in white chalk. These I photographed upon quarter plates, the resulting negatives being really positive—that is to say, the white lines on black resulted in black lines on a white ground. The plates were washed and dried, cut down with a diamond to lantern size, and were then ready for use. When seen magnified upon the screen, no one could have guessed that they had not been produced in the usual way. I think that this method of procedure might often be adopted to preserve the valuable and elaborate drawings that teachers in our medical and other schools often make upon the black-board. It seems a pity that these drawings, often executed with masterly skill, are rubbed off as soon as the lesson is finished, and lost forever.

---

### ABOUT EXHIBITS.

BY M. L. CORMANY.

At the Convention at St. Louis I suggested to the Committee on Awards and Exhibits that a certain style of exhibit be adopted; that the man who comes from a long distance, and who finds it difficult to bring elaborate frames and fine ornaments for his exhibit, may, if his work merits it, be on a footing with his moneyed neighbor who lives near by and deludes the eye by fine gilt and silk plush. If the committee find it impracticable to adopt this idea, they should at least agree, before making the rounds of the exhibits, not to allow for fine frames, etc. One of the committee there told me they were obliged to allow for those things. I say they have nothing to do with a man's skill as an artistic photographer, and should have no weight with the committee. It may be that it is the intention of the gentlemen appointed for the Chicago Convention to follow some such order, or have a special medal for fine decorations and tasty arrangements. No doubt such an able committee as was appointed for the coming convention will see and appreciate the position we who live so far away occupy. Many are looking forward to the coming convention as the grandest and most

profitable, and I see no reason so far why it should not be.

### PHOTOGRAPHING WITH PHOSPHORESCENT SUBSTANCES.

At the stated meeting of the Franklin Institute, November 17th, Mr. Frederick Ives read a preliminary communication on this subject, giving the result of some investigations, which he had undertaken at the suggestion of Dr. Wahl.

After making a photograph of a street scene by exposing in the camera for thirty seconds, a tablet coated with Balmain paint and then placing it in contact with a photographic sensitive plate for about the same length of time, Mr. Ives made exposures on the lime-light spectrum, to determine to what kind of light the tablet was sensitive. He found that phosphorescence was produced only by exposure to the violet rays, and that the light given out by the excited tablet was chiefly the indigo-blue, to which photographic sensitive plates are more sensitive than to any other color. But he also observed that a tablet exposed to sunlight, and then given a rest of several hours in total darkness, in a cool place, became quite sensitive to the dark heat rays at the opposite end of the spectrum, which caused a temporary exaltation and corresponding rapid exhaustion of the feeble phosphorescence remaining in the tablet. He succeeded in obtaining strong photographic negatives showing this action, and concluded that by this means it would be possible to obtain camera photographs of perfectly dark objects which radiated or reflected sufficient heat, provided that the lenses used were capable of freely transmitting such dark heat rays.

M. Ch. Zenger, in a recent communication to the French Academy of Sciences, asserted that he had obtained a photograph of towers and other objects at midnight on a dark night, by the aid of a phosphorescent tablet, and attributed the result to the action of dark "actinic" radiations, which he supposed that the objects gave out at night. Mr. Ives pointed out that, as the tablet proved to be insensitive to such rays, Zenger's explanation was certainly incorrect.

Mr. Ives's investigation had proved that bodies intensely heated by exposure to the sun during a hot summer day might under certain conditions, be photographed at night by the action of heat which they radiated, —but the method did not seem sensitive enough to give such results with glass lenses, and he thinks Zenger's photograph may have been due to unsuspected feeble phosphorescence remaining from a previous exposure in daylight, several hours or even a day or two before.

Mr. Ives offered explanations of other phenomena observed by M. Zenger, and concluded by claiming to be the first to discover that photographs of dark objects may be made in the camera, by the action of heat which they radiate or reflect.

### SOME DEVELOPER DODGES.

At this season of the year many of our readers have more leisure than they fairly know what to do with, and are glad to have some suggestions that will employ their time. We follow with one or two that may serve those who have mechanical genius enough to avail themselves of them.

The first is a plate tongs (plattenzangen), a contrivance for handling the plate during development, and other operations wherein it is desirable to keep the fingers clean, or

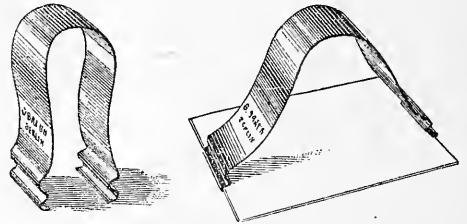

to preserve them from the action of the solutions.

A band of silver is so bent as to answer the purpose, strong enough to secure the safety of the plate during the handling.

The other is a contrivance for rocking the plate during the development. Its construction is made very plain by the drawing. This machine (Schankelapparat) may be large or small, according to your requirements. The dish containing the plate is set

upon the bed-plate, fastened in place, the pendulum started, and the operation goes on automatically.

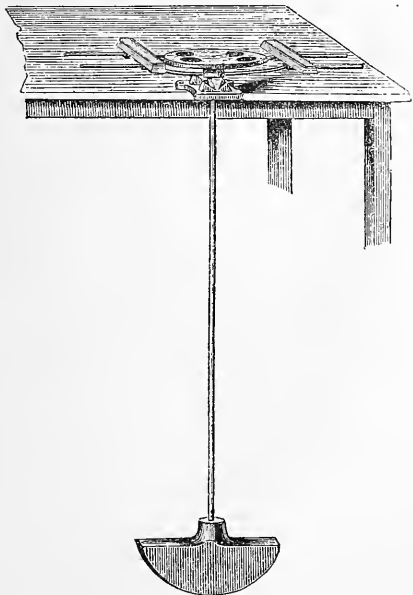

We are indebted to our German friends for both of these useful inventions, if we are not mistaken, and trust that during the coming season some of our ingenious patrons will give us something of their store of handy things with which to pay back our co-workers across the water.

[Translated for the Philadelphia Photographer.]

### KRUSE'S NEGATIVE NUMBERER.

MR. KRUSE, of Berlin, has invented an ingenious negative numberer, which may be thus described: A small benzine light (or candle) is placed in a metal lantern, so constructed, both with regard to the admission of light and the letting out of smoke, that no white light can escape. One side of this lantern is made light-tight by means of a wooden box attached to it, and this box contains the contrivance for numbering the negative. On the outside of this box, in the right-hand corner, there is a groove cut, into which the yet unnumbered negative can be inserted. Close to the edge of this negative—in the middle of the side of the wooden box—is a narrow slit parallel to the edge of

the negative through which the light issuing from the lamp within the lantern can reach the negative. The slit is covered by three small hoops of thin copper sheathing placed together. Two of these hoops, or bands, have on them the numbers 00 up to 99, the third one has from 0 up to 9, and these numerals are cut as patterns, so that by a judicious turning of the bands, the numbers from 00000 up to 99999 can be seen

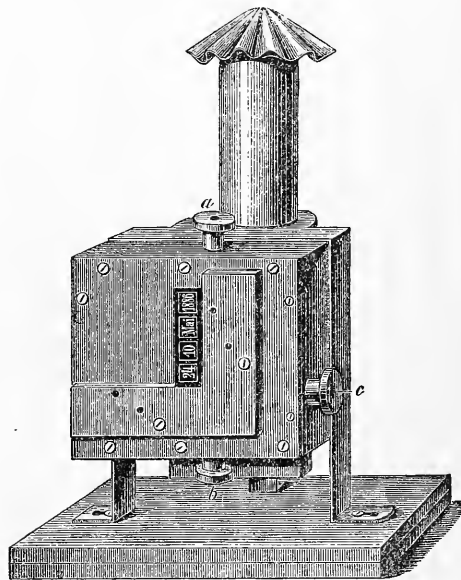

in looking through the slit. The turning of both those bands, which, numbered from 00 to 99, form the last four figures, is caused by moving a button up or down, by which means the bands referred to are wound off from one small wooden cylinder on to another, whilst the band bearing the numbers 0 to 9, which indicates the 10-thousands of the number, is changed by every movement of the hand from 10 to 10-thousand numbers. In using the instrument, the light is shut off by means of a red glass brought to view from within when looking for the controlling number; the negative is inserted in the slit before mentioned, and then by a sudden turn the red disk is drawn away. The exposure for the number is therewith at an end, and the latter appears in the development black upon a bright ground. Mr. Kruse has also arranged the apparatus so as

to cause firm name, date, and year to appear on the negative.

### THE IVES AUTOGLYPHIC PROCESS.

WE have already made our readers very familiar with the name of Mr. F. E. Ives, of Philadelphia, who is one of the most useful and prolific inventors connected with our art.

When we first knew him he was connected with Cornell University as photographer and assistant in the Physical Department. With natural taste and talent for the work and with such splendid facilities as his position afforded him, it was not wonderful that his mind and experiment ran in many useful directions.

We owe him much for his researches in orthochromatic photography; phosphores-

and was introduced to our helpful engravers, Messrs. Crosscup & West. An alliance was formed, and soon after Mr. Ives perfected his splendid process. For a long time we presented an example engraved by him on each cover of our magazine monthly. Since then Mr. Ives has made many advances and so improved his results as not only to increase the size of his plates but to apply his method to almost any class of subject. One of the finest specimens we have seen, thanks to the kindness of the parents of the sweet little model and the Crosscup & West Engraving Co., we are enabled to give below.

Nothing more choice than this has been done by any kindred method. We say kindred, because Mr. Ives has many followers. *His* process, however, is radically different from others, as we explained in our last.



cent photography; lantern appliances—notably the “ether saturator,” and, perhaps most generally useful of all for his original method of securing half-tone in photo-engraving or autoglyph work.

Leaving Cornell, he came to Philadelphia,

Moreover, it was the first half-tone block process introduced into successful commercial operation (patented and introduced more than three years before Meisenbach's, the first in Europe). Again, although it was the first commercially successful method,



and many efforts have been made to improve upon it, we notice that it is preferred by many leading publishers for the illustration of their works.

Some similar work that we have seen, especially from abroad, is miserably bad, not only, but it is wretchedly printed. The greatest care on the part of the printer is necessary in order to secure the full value of the engraving.

Our readers will agree that our own excellent printer, Mr. Dornan, is able to give us all that we could reasonably expect from our "process cuts."

**MEASLES AGAIN.\***

BY FRANK ROBBINS,  
Bradford, Pa.

THE season has come that generally brings an attack of measles on albumen paper. I believe I have tried every known remedy, and every precaution to guard against them; such as thorough drying of the paper before and after fuming, in a fuming-box that is warm and dry, etc., and yet on some days we get a trace of measles on the first sheets that are used in the morning, but none in the afternoon.

My remedy is this, silver the paper the evening before it is to be used; dry and fume it, and lay it on an open shelf in a dry room. This plan enables the printer to get his frames filled early the next morning, and thus utilize all the light we get on these short, dark days. And at this season the paper keeps perfectly.

I have no theory to offer for the above statement, but it works well in practice, and that is the essential point. Should you have an attack on some of the cold mornings, don't throw your paper away in disgust, but lay it aside on a dry shelf until next day, and the chances are that it will print smoothly.

Let me also remind you of an old dodge to prevent paper from curling up when first placed on the silver solution. Get a flat curtain stick, and cut it in two, put a tack in each stick to lift it up by, and as soon as

the sheet is placed on the solution, quickly lay a stick at each side, on top of the sheet, so near the edge that it cannot curl. Try it, and save your breath, for you will need do no more blowing in that direction.

Thirdly, should you be troubled with those very large blisters or bubbles that sometimes put in an appearance in the fixing bath, put some salt right into the fixing bath when you mix it. It will prevent blisters, and if harmful to the finished prints, let some photo-chemist speak.

**A "DRY" CHRISTMAS COLLATION.**

At the suggestion of several readers we have "boiled" from the pages of our current volume a collation of choice suggestions, very dry, but which, placed here at the end, will be easily found when the appetite for them occurs. They make a little volume by themselves, far more to the point than some more ambitious publications. We trust they may be found worth repeating.

*On Exposure.*

One thing experience has taught me—that is, whenever it is possible to overtime a picture do it, and when you come to develop you won't regret it.

Make the following solutions:

No. 1.

Pyro . . . . .	1 ounce.
Sulphite of Soda . . . . .	2 ounces.
Bromide of Potassium . . . . .	40 grains.
Citric Acid . . . . .	40 "
Water . . . . .	12 ounces.

No. 2.

Carbonate of potassa . . . . .	3 ounces.
Sulphate of Soda . . . . .	2 "
Water . . . . .	12 "

Take one drachm of No. 1 to one ounce of water, and add ten drops of (ten grammes to ounce) solution of bromide of potassium. Let the plate be in it for a minute, then pour off its solution, and cautiously add No. 2, beginning with one-quarter of a drachm to every ounce of the solution; wait two minutes before you get frightened at the non-appearance of the image; be assured if you

\* Written for *Mosaics*, but received too late.

have overtimed there is plenty of what the philosophers call potential energy to work out its own salvation. After the two minutes are up, you may add another one-quarter of a drachm of No. 2, and keep right on developing not too rapidly. If, in adding the first one-quarter, the image comes up in less than a half minute, lift the plate immediately from the solution, and lay it in a bath of bromide of potassium, one drachm to the ounce (ten grain solution), and keep it there a couple of minutes; then, without washing, put it back in the solution, and it will work out slowly and beautifully.

Always begin with the weak developer—keep a stock on hand for the purpose. Another thing which I have learned, don't be stingy or saving weak developer; you may have to pay for it in the loss of a negative. Overtimed negatives are beautiful and soft if managed in this way. I have used the most rapid plates, and given them ten times too much exposure, and yet by this method obtained the finished negatives I have; but, sometimes, you cannot overtime. Well, then, this is the way I manage: I take the plate from the holder, lay it in plain water for two minutes, covering it up of course; I then wash it by pouring water over it, place it in solution composed of one ounce of water, one drachm of No. 1 or No. 2, and go on with the development. In nine cases out of ten it will come up like a fulltimed negative. It is strange, but it is a fact, that the washing after removal from the plain water facilitates the development. If the plate should still lack details in the shadows, I lift it out and transfer it to a dish containing one ounce of water to one drachm of No. 2, and let it lie half a minute, then return it to the mixed developer. I prefer this to adding the accelerator directly to the developer.

Be sure to let the plate lie in the developer till it has density enough, but be careful not to get it too dense.

It is a good plan to develop one plate, and fix it, and see how far you have gone in intensification, then, with that experience, go back and develop the rest.

My parting advice is, use the quickest plates for all subjects, and overtime them, and you will be happy.—EUGENE ALBERT.

It has always been a matter of surprise to me that no maker of dry plates has thought of issuing a brand of really slow plates. I mean by slow plates, such as have a speed little, if at all, greater than that of collodion.

In landscape work pure and simple, leaving out of the question, on the one hand, figure subjects, on the other, instantaneous work, what does it matter to us whether our exposure be two seconds or twenty, or even sixty? It matters not at all, and there are great, I may say enormous advantages in the very slow plates. There is, in the first place, a quality to be got which cannot be had with rapid plates. Certainly quite as good quality of negative as could ever be got with collodion. I don't mean here to infer that we cannot get all round as good prints from rapid dry plates as we can from wet plates, but I am quite certain that we cannot get negatives which will give the prints as rapidly and as easily. Now, with a very slow plate we can get negatives which will give the very highest class prints, and which may be printed from in as short a time as a wet plate.

Then the ease in manipulating slow plates is so great an advantage. Not because of the ease and comfort itself, but because this ease and comfort lead to a higher average quality and to a smaller percentage of failures. I need scarcely point out that, other things being equal, our success in development, etc., will increase with the amount of light that we may safely work it in. I do not now talk of ease in the preparation of the plates; that I shall consider afterwards. But besides the greater percentage of successful negatives due to increase of light allowable, we have an increased probability of success, from the fact that with a slow plate there is very much more—even proportionally—latitude of exposure than with a rapid plate.—W. K. BURTON.

It frequently happens that amateurs, and particularly beginners, lose many valuable plates by not correctly determining the amount of exposure, the method of counting "seconds" differing very greatly. Many conscientious workers are under the impression that anything less than ten seconds can be calculated by means of an ordinary

watch, and thus, for instance, two seconds are measured off, when in reality three, or even one, were given. When, because of failure, the exposure is advised to be doubled (four seconds), this unreliable method of counting would yield anywhere from two to six seconds, and with results generally disastrous. Then the lens, plates, etc., come in for their share of condemnation. It requires but little practice to be able to measure off a minute without varying more than a second, and in that case both stop-watch and the device I am going to recommend may be dispensed with entirely, though a novice is liable to become disconcerted by any sudden excitement. I therefore suggest the use of a time-ball, which consists of a half-inch bullet firmly attached to a cord twelve inches long, in which a knot is made just nine and three-quarter inches from the centre of the bullet. Swing the ball, not violently, holding the cord *at the knot*, and the intervals will be exact half-seconds, though for seconds every other beat only should be counted. This principle is based on the fact that the length of a pendulum, beating seconds, measures 39.37 inches, which is a metre, the French standard of linear measure. If one wishes, however, to be quite certain in determining the amount of exposure, one should not commit the common mistake of sacrificing one count, which is done by calling the removal of the cap "one," and for twelve seconds replacing it at "twelve." That is but eleven seconds, twelve seconds being from one to thirteen. —WILFRED A. FRENCH.

For photographing snow and ice views, the following will come good:

The great danger to guard against is *underexposure*. Most tyros think that because there is such an expanse of white, the exposure will be short; but it is not so. I have frequently given more than double the exposure for a particular snow landscape than I have given the same scene in full foliage. The reason is this: the white, if exposed for a short time, will be overdense and without gradation. But gradation is the only thing which makes a snow scene of any value. Give it long exposure, and the density gives place to a thin but spark-

ling image, with only the highest lights on the snow dense enough to print white, while the trunks of the trees, buildings, etc., will get gradation without that heavy blackness seen when the snow is represented by a white patch. But to get out this overexposed image, a special treatment in development is required. First, the plate should be soaked in water containing a good proportion of bromide,  $\frac{1}{2}$  an ounce of 60 grain solution in 10 ounces of water. Soak for at least five minutes. Then commence development with weak developer. If you use the pyro and potash developer, use little potash till you see how your plate is developing, and, above all, do not push the development. Keep your negative thin; it will print all the better. For the benefit of those who have not used the potash developer, I give the formula:

## No. 1.

Carbonate of Potassa	. . .	3 ounces.
Sulphite of Soda	. . .	2 "
Water	. . .	12 "

## No. 2.

Sulphite of Soda	. . .	2 ounces.
Bromide of Ammonium	. . .	40 grains.
Citric Acid	. . .	60 "
Pyrogallie Acid	. . .	1 ounce.
Water	. . .	12 ounces.

The usual normal developer is 1 drachm of each of above Nos. 1 and 2 to each ounce of water used in development; but for snow scenes I use 1 drachm of No. 2 and  $\frac{1}{2}$  drachm of No. 1 to each 4 ounces of water, adding No. 1, if wanted, till the full drachm is used, but *no more*. If the negative requires more than the normal developer, it is underexposed, and you will not get the best effects from such a negative.—G. HANMER CROUGHTON.

*On Developing.*

As to development, much diversity of opinion exists in regard to this, and every one has his own pet formula. Suffice it to say that as much science, or art if you will, pertains to this stage of making a good negative, as at any other. In old days, for overexposure, double the pyro was recommended. I do not agree with this, quite the reverse; by using a weaker all-around developer, you have the plate more under control, and can

keep back the shadows until the high lights attain sufficient density to insure good gradation. Of course, the development is very slow, but so much the better; the shadows, while developing, keeping quite clear, having an underexposed look; but you are all right, go on. Just here let me make a suggestion (not a new one): that it is a good plan to have a small aperture giving more light in one side of the lamp or window. This can be uncovered, so that you may judge of the density by the transmitted light, and if you think more detail desirable, wash under the tap, and apply a normal developer.

Having had considerable experience in plate-making, I find it is absolutely impossible to get clear shadows in the quickest plates without careful development. Rapidity in plates means a close approximation to decomposition of the gelatine, either by heat or by ammonia. A plan has often been suggested to look at the back of the plate to judge of development, but your subject and plate will have a great deal to do with how much or how little you see of the image, as with some coatings you cannot judge of density by this means. Slow plates do not require so much care in development, as more latitude in exposure is allowable.—*Edinburgh Photo. Society.*

**FERROUS OXALATE DEVELOPER IN CONCENTRATED SOLUTION.**—By following the indications given by Dr. Eder, we have made the following concentrated solution:

Boiling Water . . .	500 grammes.
Neutral Oxalate Potash	300 “

This solution made, and to the same liquid at 95° C. (203° F.) we have added

Sulphate of Iron . . .	100 grammes,
------------------------	--------------

when all was dissolved we filtered this liquid into well-stoppered bottles. In use this is what we observed: An exposed plate plunged into this developer gives but faint traces of the image to be developed, but the intensity increases when water is added to the concentrated liquid. By adding an equal volume of water, and even double the volume of the solution, we have obtained very complete development. When developing plates that have had a normal exposure, we can at once use three times the volume of the con-

centrated solution. If, on the contrary, overexposure is feared, the water should be added gradually. A prolonged stay in the concentrated solution retards the coming of the image, instead of rendering it more intense. A plate immersed in water, before being treated with the concentrated developer, does not develop any better in it, unless at least the proportion of the additional water be increased twofold. To resume, this concentrated solution offers the advantage of reducing to a *minimum* a solution of ferrous oxalate ready for use; by the addition of more or less ordinary water, it is possible better to conduct the development of overexposed negatives.—LEON VIDAL.

**DEVELOPMENT WITH PYROGALLIC ACID AND ALKALINE CARBONATES.**—Recently the use of sulphite of ammonia has been recommended instead of sulphite of soda for developing with pyrogalllic acid and with carbonates of soda or potash. I have tried it, and I have obtained excellent results, especially as regards the color of the negative and the intensity of the image. I would not speak, however, of this experiment, which many others have made before me, were it not that I wish to call your attention to the fact that, in using sulphite of ammonia to which carbonate of soda or of potash has been added, we are simply making a development with carbonate of ammonia. In fact, the sulphite of ammonia being always in great excess in the developer when the carbonate of soda or potash is added to it, is partly converted into sulphite of soda or potash, and into carbonate of ammonia, the odor of which is very strongly apparent. It is, therefore, this last product that causes the development, as the soda or potash is gradually added. I have been particularly successful with this mode of operation when developing plates in two successive solutions of pyrogalllic acid and of carbonate. One more word, not on development, but on the use, in the manufacture of plates, of a body which might be supposed incompatible with emulsions. I allude to vaseline, with which the plates may be rubbed with advantage before being coated with the emulsion. The coating of gelatine spreads readily on the surface of

the glass slightly greased with the vaseline, and afterwards rubbed. The adherence seems perfect, and it seemed to me, after a first experiment, that no spots or depressions were formed when the film was setting. I cannot assert positively that this result arises from the use of this mineral grease, but I am rather inclined to believe that it does.

It is possible that this body may be used in the manufacture of papers or pellicles destined to receive an emulsion coating. In any event, this fact seemed curious enough to me to be mentioned, admitting even that it had no practical consequences.—M. E. ANDREA.

#### ON THE USE OF HYDROSULPHITE OF SODA IN THE DEVELOPMENT OF NEGATIVES.—

M. Villechole is desirous of simplifying the development of gelatine plates and advises invariably the use of ferrous oxalate for instantaneous as well as for all other prints. He admits that the use of alkaline developers with pyrogallic acid may give more intensity, especially in the case of instantaneous prints, than the ordinary ferrous oxalate, and sought a method to make this last developer suitable for the development of instantaneous prints. His investigations in this direction have taught him that hydrosulphite of soda, introduced into the gelatino-bromide films in suitable quantity, materially modifies the coming of the image without producing too much fog. This fact which has often been pointed out and experimented with, was investigated anew by M. Villechole, and in the following manner: Sensitive plates were immersed for a few moments in a bath containing 1 for 1000 of hydrosulphite of soda, and 10 for 1000 of bromide of ammonium, as has been indicated by M. Andrea. These plates, after rinsing and drying, were kept for a few weeks before exposure. On the other hand, at this time were exposed other plates of the same nature, but which had not been previously treated with the hydrosulphite of soda. Before developing these last were immersed in the diluted hydrosulphite bath, and they gave a result more intense than the preceding ones, at least in the same space of time, as the plates previously impregnated with the hydrosulphite of soda were less

rapid in giving these effects, which they seemed afterwards to overtake. M. Villechole infers from his experiments that it is better to proceed by immersion in the hydrosulphite, at the time of the development, and he thinks that owing to this treatment, so extremely simple, that in every case it will be possible to use the ferrous oxalate.

SODA AND POTASH DEVELOPER.—Prepare the three following solutions:

- |                     |                        |                                  |
|---------------------|------------------------|----------------------------------|
| A. Water            | . . .                  | 200 c.c. (6 fl. oz., 6 fl. dr.). |
| Pyrogallic Acid     | 15 gr. (4 drachms).    |                                  |
| Sulphite of Soda    | 100 gr. (8 oz., 2 dr.) |                                  |
| B. Water            | . . .                  | 200 c.c. (6 fl. oz., 6 fl. dr.). |
| Carbonate of Potash | 50 gr. (1 oz., 5 dr.). |                                  |
| C. Water            | . . .                  | 200 c.c. (6 fl. oz., 6 fl. dr.). |
| Carbonate of Potash | 25 gr. (6½ drachms).   |                                  |

In using these solutions remark that 25 parts of potash are equivalent to 50 parts of soda, and that when 1 part of A. is mixed with 1 part of B. or C., adding 6 parts of water we have a very strong developer, since it has been shown that the soda developer is from five to seven times more powerful than the oxalate to bring out the details of the parts that have been feebly lighted. The potash developer is equal to that made with soda.—DR. F. STOLZ.

A NEW SULPHITE OF AMMONIA DEVELOPER.—I have fully recognized the value of a potash developer for rapid plates and short exposures; but, notwithstanding this, I recommend a new developer, containing ammonia and ammoniacal sulphite, which is excellent for almost all commercial plates.

A. Dissolve 10 parts of pyrogallic acid and from 25 to 30 parts of ammoniacal sulphite in 100 parts of water.

B. Dissolve 5 parts of ammoniacal bromide in 150 parts of water, and add 50 parts of liquor ammonia.

To make the developer, take 100 c. c. of water, 4 c. c. of the pyrogallic solution A., and 4 c. c. of the alkaline solution B.

The development is very quickly made, and if slower action is required, add 50 c. c. of water, which gives softer images. On the other hand, if we wish to obtain stronger images, add a few drops of a ten per cent. solution of ammoniacal bromide.

The ammoniacal sulphite developer gives well-modelled and brilliant negatives, in which the high lights are well rendered and the deep blacks well defined: the negatives have a very agreeable dark-brown tone. The ammoniacal sulphite renders the pyrogallic solution more permanent than does the sodic sulphite, and with this developer there is not much danger of fogging.—DR. J. M. EDER.

My process consists simply in using separately the pyrogallic acid bath and the alkaline bath. Of the mother solution of pyrogallic acid already mentioned, and prepared as follows:

Sulphite of Soda	. 25 parts.
Distilled Water	. 100 parts.
Sulphuric Acid	. 3 or 4 drops.
Pyrogallic Acid	. 10 drops.

I take from 10 to 15 parts (according to the results that I wish to obtain), to which I add 100 parts of water, and immerse my exposed plate in this bath. I allow it to remain at least one minute or more, even from 10 to 15 minutes would cause no injury; the image commences to appear in this bath on account of the presence of the sulphite; but it is quite useless, although without danger, to await this result. In the meanwhile, I prepare in another dish the following alkaline bath:

Solution at 25 per cent. of	
Sulphite of Soda	. 10 parts.
Saturated Solution of Carbonate of Soda*	. 3 "
Ordinary Water	. 100 "

I now withdraw the plate from the pyrogallic acid bath, and after having allowed it to drain two or three seconds, I at once plunge it into the alkaline bath. The development is made with very great rapidity and with a clearness explained by the very small quantity of pyrogallic acid in the alkaline bath. In fact, the gelatine film has absorbed in a manner the quantity of pyrogallic acid necessary for its development,

\* The proportion of 3 per cent. of the solution of carbonate of soda is a minimum which it would be well to increase twofold, and even threefold if the strength of the gelatine film can bear it.

and nothing more, from which it results that the alkaline bath is not sensibly colored, neither is the sensitive film.

When the exposure has been normal the development is ended in one or two minutes, at the most, but it may be prolonged if it is observed that the intensity increases with the duration of the immersion. It is very rare that anything else is necessary than to wait in order to obtain a perfect negative. In case the exposure has been much too short, it may be necessary to add to this last bath in succession a little pyrogallic acid, then a little carbonate of soda, in order to force the tardy details to appear; but I repeat, this should only be done in exceptional cases, when very quick stops have been used, such as those of Thury and Amey. With exposures in the full summer sun of from one-twenty-fifth to one-fiftieth of a second, I have obtained excellent negatives, using a little patience, without having recourse to any addition of pyrogallic acid or of carbonate.

The proportions that I have just given, as well as the formula itself, are not absolute and may be modified to a very great degree. Instead of the mother pyrogallic solution, this acid may be in powder in the specified proportion, more or less according to the desired intensity, and dissolved in acidulated water to which the sulphite has been added. If it is thought that the plates are liable to fog easily, a few drops of a two per cent. solution of bromide should be added. But I have very seldom had need to do so. Finally, and this is not the least important point, this pyrogallic solution may be used until exhausted, provided it is done in the two or three hours following its preparation. Thus, I have developed as many as twelve negatives, 13 x 18 centimetres, with one gramme of pyrogallic acid, and if care has been taken to prepare this bath with distilled water, which is not indispensable, it may be used the greater part of a day.—LEON VIDAL.

ONE of the most desirable qualities to be sought for in sensitive plates or the preparations used in making instantaneous negatives, is that these preparations should be capable of undergoing the strongest develop-

ment. We should not have to fear an accident whilst the developing bath acts, as in that case we are stopped short, and the negative cannot be brought to the necessary point to give finally a good positive print.

I make a solution of carbonate of soda at 25 per cent.; I also make a solution of sulphite of soda at 25 per cent., say 250 grammes (8 ounces Troy) of one or the other of these two salts, for a quart of water. I allow it to settle, and decant for use. To develop, place in a glass from 25 to 30 c. c. (7 fluidrachms to 1 fluidounce) of carbonate of soda, and from 15 to 20 c. c. (4 fluidrachms to 5½ fluidrachms) of sulphite of soda, the two solutions being mixed together. The flexible plate is placed in a moulded glass dish, so as to be able to follow the development by transparency. (I use moulded glass because the developer is so strong that it entirely dissolves the marine glue with which are made the wood-and-glass receptacles for the bath.) The liquid is thrown on the pellicle, which is well wet and allowed to remain in this state for about two minutes.

During this time of waiting, place in the glass, which is now empty, from 10 to 15 c. c. (4 fluidrachms) of pyrogallic acid dissolved in alcohol in the proportion of 10 grammes (3 drachms) to 150 c. c. (5 fluidounces) of alcohol. A large pinch of pyrogallic acid in powder may also be put at the bottom of the glass. Whether the acid is used in powder or in an alcoholic solution, the mode of operating is the same and the result will be identical. All the alkaline liquid which is in the dish is poured on the acid and the most intimate mixture is obtained. The whole is again poured on the flexible plate which has remained adhering to the bottom of the dish. After agitation, and in a very short time, the image appears, but at first with a rather grayish tint; then it is the blacks alone that come up without intermission, until it is deemed that the action is sufficient. During all the time of development the whites are very well preserved; I may say that I did not miss one, and always without bromide. But a little bromide may be added with advantage when the slow stop has been used. In this case add, at the start, to the mixture of carbonate and sulphite, from 5 to 10 drops of a

solution of bromide of ammonium in water in the proportion of 10 per cent.

When the development is ended wash well, especially if pyrogallic acid dissolved in alcohol has been used. When the greasy streaks have entirely disappeared give an alum bath—60 grammes (2 fluidounces) for 1000 grammes (34 fluidounces) of water—and after remaining two minutes in this bath, fix with hyposulphite.—M. BALAGNY.

IF any of you—only one of you—think that an unfixed plate will stand with impurity exposure to daylight, try the following experiments: Cut an unexposed quarter-plate into strips, and place one of them in daylight for half a minute or a minute with one-half covered with a card. A certain amount of discoloration takes place, which many people suppose disappears in fixing; but if you fix this exposed strip you will see that this is not the case. Next dip half of another strip into water, and take it into daylight; the wet portion will blacken much more rapidly, and take a deeper color than the dry; and with some plates exposed in sunlight, a depth sufficient for the shadows of a transparency can be attained, and, what is more, will not be very greatly reduced in hypo. If the plate be moistened with sulphite of soda, dilute ammonia, or anything having a slight solvent action on silver bromide, a still deeper discoloration will take place.

I do not imagine that very many photographers are in the habit of taking their negatives into the open air before fixing, but I know that many like to examine the image by daylight, "just to judge its density before fixing." It is a rather useless and illogical proceeding truly, for if the density be wrong it cannot be remedied without fixing; and then if intensification be required there is a little unnecessary veil to intensify along with the picture. On the other hand, a plate that has been kept from white light until it has been fixed *and washed*, will be in the best possible condition to undergo any subsequent treatment.—W. B. BOLTON.

WASHING GELATINO-BROMIDE OF SILVER NEGATIVES.—Opinions vary greatly in re-

gard to the time necessary to eliminate thoroughly by washing the last traces of hyposulphite of soda from gelatino-bromide negatives. Some operators think that the sooner a plate is fixed the less washing it requires. M. Joop is of the opinion that with a small flow of water running slowly and constantly, three hours at least are necessary, whilst with a strong flow of water, fifteen minutes are sufficient.

We believe that by placing the plates in a bath of weak javelle water, say a tablespoonful in a quart of water, it is possible to eliminate the last trace of hyposulphite. Care must be taken not to use too much of the javelle water, as in this case the negative might be injured; many operators only use a teaspoonful in a quart of water. If the plate has been well washed, twenty drops will suffice. There exists a solution of labarraque for washing, containing dry chloride of lime, which acts in the same manner as the solution of javelle water; its effect is almost instantaneous. The solution of javelle water is made as follows:

Dissolve four ounces of dry chloride of lime in a quart of water; close well the bottle and shake from time to time. In another vessel dissolve four ounces of dry common potash in a quart of water; allow these two solutions to rest from six to ten hours, then slowly pour the potash solution into that of the chloride of lime, agitating the vessel evenly. Allow the mixture to repose for a half-hour, then filter through paper; the product obtained is a pure javelle water, which, in a well-stoppered bottle, and kept in a cool place, will not deteriorate. In using, before taking the prints from the hyposulphate bath, pour in three quarts of water as many times five and a half fluidrachms of the solution as there are prints in the fixing bath. The prints taken from the hyposulphite bath are carefully drained and gently placed in the javelle water, in which they are allowed to remain three minutes, keeping them constantly in motion; after which the bath is again renewed for three minutes. The prints, well rinsed, are now ready to be mounted.—LEON VIDAL.

#### *On Fixing.*

Now, to be certain you are right.

Be sure your hypo bath is alkaline, and, if not so, make it so with water of ammonia or carbonate of soda, and this applies to plates or prints; then do not use a hypo bath one moment after it becomes yellow; put it into a bottle, and add sulphuret of potassium in solution, and let it settle; add the sulphuret solution as long as the hypo turns black, and then pour off the yellow fluid, and keep the black precipitate for re-finer. In this way you will be sure of clean, good negatives, and they will never turn yellow, or disgust you by coloring in the film, so as to prevent printing.

Let every process be thoroughly and cleanly done; a negative once done and dry is not a tractable subject for any future experiment; but if it is done well it becomes a matter of pleasant reference, and the record is beautiful prints.

Saturated solutions of hypo are not advisable for gelatine plates—one ounce of hypo to five of water is about the right thing—it does not pay to *rush* a plate either in development or fixing, and we *never* should be hurried in washing; and a dry plate should never be set on its end to be dried—set in a rack or on pins so that the corner shall drip, and let the corner be an inch or two clear of anything; so the film may dry and harden evenly and be clean when done.—THOS. PRAY, JR.

#### *Use of Alum.*

The proper use of the alum bath in connection with the dry plate is this: When the plate is fully developed wash it under the tap, or sousé it in a dish of water; wash it well, then plunge it into an alum bath for half a minute. Why? If the developer goes over into the hypo a little on each plate, the hypo gets stained, and in the dark-room you can't see it, and then the film on the plate gets stained; the washing will get off most of the developer, and the alum is a scavenger, and it readily picks up the pyro and the alkali, and cleans off what you cannot see, but what will show in the bottom of the alum bath, very prominently, after six or eight plates have been through; then wash again, and place in the hypo; now your plate will not "cockle, frill," or run off the hypo; when through with it, it



can be washed off best by a *soak* of five minutes in still water, and then back into the alum bath, where it can lie five minutes or half an hour, and then let it go to the wash for three to five hours. Don't mix the developer into the alum; don't mix alum and hypo; don't mix hypo and alum. Don't carry a plate from one bath into any other *without well washing* each one every time.

Don't develop a dozen plates with an idea you can fix them just as well.

Gelatine is more peculiar than those who are workers in it; if you allow a slouchy washing, and then let the plate stand, look out for stains, *bye and bye*.

Develop, wash—alum, wash—hypo, wash a considerable—more alum, and then wash several hours. Wash in this case does not mean a shiftless soak, or a lazy slouch imitation. What you do, do well; perhaps some of the younger ones don't understand why all this pains must be taken; the old ones, "who know it all," can skip this.—THOS. PRAY, JR.

#### On Negatives.

To prevent the loosening of the gelatine film in the fixing bath, which happens very easily during the warm weather of summer time, and to harden the film, one part of hypo solution (1 to 4) is mixed with one-half to two parts of saturated aqueous alum solution. The mixture will pretty soon become muddy by separation of sulphur and sulphurous acid but for all that it acts satisfactorily.

The negatives easily become milky, which is no hindrance in their printing qualities, but it does not look very well, and is the reason for using the mixed hypo and alum baths only in exceptional cases. The first negatives are washed, dried, varnished, and, according to requirement, strengthened or reduced.

Of the various intensifying methods, the mercury intensifier has maintained its place. Besides the well-known methods with chloride of mercury, there is a process, introduced from England in 1884, which meets with much favor. The fixed and washed negative is placed into a solution of

Chloride of Mercury . . .	2 parts.
Bromide of Potassium . . .	2 "
Water . . . . .	100 "

until it has attained the necessary strength. The color of the negative is then white, but is blackened by washing with water and flowing on a solution of

Neutral Sulphite of Soda, . . .	1 part.
Water . . . . .	6 to 8 parts.

The silver negative is transformed into bromide of silver and chloride of mercury by the mercury solution; sulphite of soda reduces the chloride to metallic mercury, and thus darkens the negative.

The advantage of this process is that there is no necessity for careful washing between the treatment with chloride of mercury and sulphite of soda. Further, the intensified plate is very constant, and does not change during printing, which latter evil sometimes happens to some of the mercury methods.

For the reduction of too dense parts of gelatine negatives, a simple mechanical process serves, proposed by Lenhard, of Vienna, in 1885, and which can be recommended. The dense parts are rubbed with a linen rag steeped in alcohol. It will be seen that the rag will soon become black, the picture clears up, and the softness of delineation will not suffer in the least.—DR. J. M. EDER.

REDUCING NEGATIVES THAT ARE TOO INTENSE BY MEANS OF FERRIC CHLORIDE.—At the Edinburgh Photographic Society, Mr. Brebner read a paper upon the reduction of negatives that are too intense, which he accomplishes by the addition of a little ferric chloride to the hyposulphite bath. Another member of the Society remarked that when but a slight reduction is required, the plate may simply be left in contact with the air for some time whilst it is still wet coming from the hypo bath. Mr. Whaithe said that it is possible to reduce the intensity of a negative by pouring over the plate a little ferric chloride when coming from the fixing bath.

Dr. Eder has recently published some valuable notices concerning the reduction of too strongly developed plates with chloride of iron and oxalate of potassa. Dr. Eder employs the mixture as follows:

- A. 1 part Chloride of Iron, diss. in 8 parts water.  
 B. 2 " neut. Oxalate Potassa in 8 " "

Both solutions keep a long time without deteriorating. Immediately before using equal parts of A and B are mixed, forming a bright green solution, which keeps well for several days in the dark, but decomposes in one day in the light. Of this mixture a little is added to a fresh and strong solution of hypo. In difficult cases 1 part hypo and  $\frac{1}{4}$  to  $\frac{1}{2}$  of iron solution are employed. The plate to be reduced is placed in this solution. The image weakens quickly and uniformly. The plate is taken out and washed just before the desired reduction is reached, because the action continues during the washing, gradually diminishing under the stream from the tap. This reducer acts on plates developed either with pyro or oxalate, and does not destroy the details in the shadows, like cyanide. There is also less tendency to frill than with the cyanide bath. The reducing process of Mr. Lenhard for weakening certain portions of the negative is most excellent. A pad of linen is dipped in alcohol, and rubbed over the dry film until the dark parts brighten up. This is effected without any loss of detail, and without the slightest injury to the film. The finer strap may be rubbed with a flexible piece of wood dipped in alcohol. I saw, at the establishment of the Court photographer, Herr Burger, difficult retouching effected in this manner.—DR. H. W. VOGEL.

FOR STRENGTHENING FIXED GELATINE NEGATIVES.—

No. 1.

Saturated Solution Bichloride of Mercury, in Water.

No. 2.

Water . . . . . 100 c. cm.  
Sulphate of Soda, . . . . . 2 grammes.  
Carbonate of Soda . . . . . 2 “

The well-fixed and thoroughly washed negative, after drying, is laid in No. 1, until it gets of a silvery-white color. It is then thoroughly washed in water and laid in No. 2, in which it must be kept in constant motion until it becomes dark. Instead of solution No. 2, ammonia and water may be employed, taking care not to use it too strong.

Intensifying may also be effected with iron for this purpose:

Water . . . . . 80 c. cm.  
Sulphate of Iron . . . . . 12 grammes.  
Chrome Alum . . . . . 2 “

The negative, if developed with pyro and fixed with hypo, may be laid in this without washing; in a few minutes it will be cleaned and, at the same time, intensified. If it is strengthened too much, it may be reduced by placing it in a solution of

Water . . . . . 30 c. cm.  
Muriatic Acid . . . . . 6 drops.

—G. W. W.

TO REMOVE THE FOG OF OXALATE OF LIME FROM THE SURFACE OF PLATES.—

For the baths and washings, use ordinary water; then, after fixing, plunge the plate in a bath of

Ordinary Water . . . . . 100 parts.  
Ferrous Sulphate . . . . . 20 “  
Alum . . . . . 8 “  
Tartaric Acid . . . . . 2 “

The fog rapidly disappears, and ordinary water is used in the washing. This process will be especially useful for prints intended for projections.—M. SIMON.

One of the most eminent photographers, Mr. W. England, has published a very useful paper on the spots which so very frequently show themselves on plates, and which are only seen after it is too late—that is to say, after the development. In truth, it is during development that these spots are produced, as everybody knows they are transparent, and many negatives have been ruined by them.

Mr. England shows us that these spots are caused by the dust which adheres to the plates, and which is found there before exposure. A speck of dirt on the exposed plate acts as a screen, prevents the action of the light, and disappears in the developing bath, leaving in its place a small transparent spot. The grooved boxes so generally used for carrying gelatino-bromized plates when travelling are very liable to allow the dust to penetrate, which attaches itself to the film, and it is necessary, says the author, to pack these plates with a sheet of paper be-

tween them. They should only be placed in the holders at the time of using them, and these, as well as the interior of the camera, should be well dusted.

**LIGHT FOR THE DARK-ROOM.**—I have read in the February number of the *Progrès* the article concerning the use of varnish, colored by dragon's blood, to take the place of glass in dark-rooms. As the coloring property of this substance is very weak, to obtain the proposed results, I give you here with an extract from Chapter II. of the second edition of my process for the automatic development of gelatino-bromide negatives, giving a coloration as intense as may be desired.

Red light, being the one having less chemical action on bromide of silver, and good red glass being expensive, here is a way to obtain it at very little expense. The window of the dark-room, glazed with ordinary white glass, for an opening measuring  $1\frac{1}{2}$  yards of surface, dissolve 5 grammes (77 grains) of carmine, in 40 grammes (1 oz. 2 drs.) of liquor of ammonia. On the other hand, dissolve 2 grammes (31 grains) of picric acid in 458 grammes (14 oz. 3 drs.) of water, to which 7 grammes (2 drs.) of glycerine have been added; introduce into this yellow water 50 grammes (1 oz. 5 drs.) of gelatine, which is allowed to swell for an hour, and then dissolve over a water bath. When the gelatine is melted, the ammoniacal carmine coloring is carefully added to it, and kept hot over a water bath; this mixture is spread with a flat brush over the glass. As soon as the first coat of the colored gelatine is sufficiently set, it may be covered with a second and then a third coat; by this means it is possible to obtain a coloration as intense as may be wished.

In order that this brilliant red light should not fatigue the operator's eyes, place before the glass, instead of curtains, two strips of yellow paper, and the light of the dark-room will then be in the best possible condition.—M. CASSAN.

Take a flat wick kerosene-oil lamp, and get oiled paper, colored on both sides with a strong solution of picric acid in alcohol, acid, or water (alcohol is best, it stains the

paper all through), and oiled, say, with common sperm oil. This paper will be of almost perfect yellow; the coloring matter is so pure that, if you have a strong solution in a bottle six inches in diameter, it hardly shows any more color than a hair-tube with a diameter of one millimetre and less, filled with it. It is, therefore, pretty nearly a pure yellow. Any good manilla paper brushed both sides with the picric acid solution, and then oiled, will answer the purpose. I constructed a lantern 7 inches square and about 4 feet 9 inches high. The lantern skeleton consists of four pieces of pine, 1 inch square, 4 feet 9 inches long, held in position by eight pieces 7 inches long, put inside the frame, four on top and four on bottom. The colored and oiled manilla paper is 30 inches wide. I now cover what will be the upper part of the lantern with a double thickness of this paper, which will give quite a good light; then cover the lower part on three sides, two thicknesses. This overlaps the upper part 3 inches, so the back side is open. Then I fit over the lower part two more thicknesses of this paper all around the frame, so that it will slide easily over the upper part. The bottom is a pasteboard box  $2\frac{1}{2}$  inches square, the sides  $1\frac{1}{2}$  inches high. Into this I set the lantern frame. The top is covered with thin sheet-iron, so that there is plenty of room for the warm air to escape, and at the same time it is so constructed that not a streak of white light is to be seen through any of the necessary openings. I find plenty of fresh air for combustion is admitted, because the lower sliding part of the lantern is fitted very loosely. To put the lighted lamp into the lantern, I simply raise the movable portion of the covering and put the lamp in so that it is edgewise toward the side I want to use most. Therefore I call it the front opposite from where I left the opening to put the lamp in and drop the lower part of the covering again. Now in front of the edge of the flame I put a narrow (about  $\frac{3}{4}$  inch wide) opaque object (say a piece of tin, brass, or copper), so that the rays of light can only impinge at oblique angles on the paper screen, and I should think the sifting of the chemical rays would be complete if they can be entirely separated at all.

I have not seen any signs of fog, and my room is illuminated so that I can see all around very plainly.—C. G. BUSCH.

### OUR YOUNG MEN.

OUR issue of October 2d was opened by some remarks on Mr. President Potter's address at St. Louis, with reference to our young men. It was followed by "a reply" from Mr. Potter of great length, but in our judgment the subject was not of sufficient interest to give it further discussion. Our remarks were intended more to soothe the young men who had expressed themselves as "snubbed," than as strictures upon Mr. Potter, who has doubtless, worked the best he knew how. No fair reader will discover any injustice in what we said, except Mr. Potter, who writes our non-publication of his "reply" was "ungenerous, unjust, and lacked moral courage." This we regret, since it is in *est waste basketibus* (to use a legal term).

An editor is supposed to be the best judge of what is worth while to put before his readers. And if they cannot understand him—he is a long-suffering person and a little more censure wont hurt him. An editor must never be "ungenerous." Justice is his right-hand man and "moral courage" he has to show every hour of the day. Our record is public property.

Seriously, however, the real truth is Mr. Potter meant one kind of "metal" and we meant another. We tried to divert "Our Young Men" from Association politics and to turn their minds more to the production of good work. And we practice this in the conduct of our magazine, as history will tell.

### AS IN OUR 1886 VOLUME

THERE never was, in the history of photography, such a marvellous amount of photographic information gotten together. Seven hundred and sixty-eight pages of closely printed reading matter and twenty-four photographic examples of work, all for \$5.

Besides this there are several distinctive features about the volume which should not be overlooked. During the year we published several series of papers, each one of

which, separated, would equal in size many of the books on photography sold from fifty cents to one dollar a copy. In *one number* we give a whole volume on "How to Print," by Mr. Krauss. It thoroughly and entirely gives the whole process from end to end. Then there are the articles on "Composition, Light, and Shade" by Mr. Xanthus Smith; "Art and Photography," by Mr. G. Hanmer Croughton; "The Department of Art," by the Editor; the selected articles from the French magazines, by our own translator; the selected articles from the German magazines, by our own translator; "The World's Photography Focussed;" "Practical Points from the Studios;" "The Open Corner;" "Photo. Facts and Fancies;" "Queries, Conundrums, and Conclusions;" nearly thirty original papers from the *Mosaics* overflow; the Convention papers never chopped up into two or three numbers but always entire in one issue, and, finally, a copious index on a new plan. As we have said, there never was such a volume published (and there never will be another, for next year's will be better).

Another distinctive feature of 1886 is its illustrations. We believe in pictures and in boiled down articles. We have spent money lavishly in securing the first and much time in accomplishing the last, for our busy, wide-awake readers. Now, we have a few volumes only of 1886 to sell at \$5, post-paid. When they are gone there will be no more. Those whose sets are broken can secure odd copies to fill in as long as they last. Be enterprising.

### PHOTOGRAPHY AT THE EXHIBITION OF THE AMERICAN INSTITUTE.

ALTHOUGH the managers of the Exhibition devote the best lighted side of their grand building to our art and handsomely drape the alcoves ready for hanging the pictures, offer special awards, and charge only the nominal fee of ten dollars for space, yet the display of photographs this year is a very meagre one. This is a great mistake on the part of somebody. For the good name of our art it would seem to us that

more interest would be taken in this grand opportunity, to say nothing of the business advantages. Another season we shall have more to say upon this subject and try to present it properly before our readers.

Notwithstanding the fewness of the exhibits there were, nevertheless, some very excellent photographs on exhibition.

Perhaps the best variety of plain work was that of Pach. Besides portraits of excellent quality he exhibited fine interiors, out-door groups, marines, landscapes, and animal pictures, all showing fine feeling and artistic sense throughout. Mr. Rockwood's bromide enlargements, untouched, were unequalled. His frame of children's pictures would be recognized as his work anywhere because of the impress of his individuality upon them. C. D. Fredricks & Co. exhibited some superb pastels, wondrous in delicacy and careful choice of color.

Mr. Parkinson's "I'll Take Care of You"—an old grandmother and a loving grandchild caressing her, was the admired of all admirers and touched the public sentiment as well as the hearts of the judges, who gave Mr. Parkinson a first award.

Dana's collection was a good advertisement for his club system, and a creditable display it made.

There were a good many collections of "crayons," which gave but little show of photography. Such work seems as abusive as the habit the Mohamedans have of whitewashing the splendid malachite and porphyry columns of some of the old Christian churches in the Orient, in order that the Christianity on them may be hid. In our case photography is æsthetic Christianity and crayon artising is the Mohamedanism of picture-producing. The 1886 fair of the American Institute is a thing of the past now, but we trust it will be remembered hereafter as a good opportunity.

The only display of apparatus was made by the Scovill Manufacturing Co., and, of course, it was an unusually fine one.

---

### SOCIETY GOSSIP.

Editor of PHILADELPHIA PHOTOGRAPHER.

DEAR SIR: From the long silence that has existed on photographic matters on the

Pacific Coast, you may think that the ambition of the Pacific Coast Amateur Photographic Association was of an ephemeral nature, and that the Association which showed promise of much growth had languished, or died a natural death; but, if such be your thoughts, let me by this letter change them, and inform you that the child, you erst-while knew, has grown to be a vigorous and lusty youth, and hardly recognizable, especially in the character of its work. Nothing shows how much progress it has made as a comparison of its early productions with what is now being monthly shown at its interesting meetings.

During the last summer, the Association moved from its one small room which it had occupied for a couple of years, and has now exceedingly comfortable quarters, with a general reception and meeting room, connecting by folding doors with a second room, which has a twelve-foot screen for showing lantern slides, and off of this room a large and well fitted up dark-room. The rooms have fine light in the daytime, having windows to the North, East, and South, giving opportunities for copying and printing, and are well furnished; provided with burnisher, trimmer, an enlarging box made here, and a fine copying camera, the generous contribution of the Scovill Manufacturing Co., of New York; and, above all, a reading table covered with all of the current literature of the day on photographic matters; and on the walls pictures, all photographic work that show pure artistic sense and feeling. On occupying the new rooms, the Association made a request that its members should each contribute a *framed* picture, and the response was generous, and the varied work, silver prints, bromides, platinotypes, and enlargements, make a splendid showing, and the names of many of our Association are gaining more than a mere local reputation.

The Association each month holds a regular meeting, at which the attendance is large. This shows a continued interest in its affairs, and a strong desire to learn, and do anything that tends towards increased excellence of its work, and to contribute funds necessary towards keeping up the Association. At the last meeting, Mr. Virgil Williams, artist and director, gave a series of

lectures on Composition and Art as expressed by photography, giving illustrations by blackboard drawings and suggestions, the result of years of study. He was listened to with great pleasure and closest attention.

The frequent attendance of professionals at the meetings of the Club, shows that relations are not strained with that body, and that we are still, as we started, purely amateurs.

Yours truly,

SIDNEY M. SMITH,

Corresponding Secretary Pacific Coast  
Amateur Photographic Association.

SAN FRANCISCO, NOV. 22, 1886.

## WOODBURY TISSUE.

BY C. C. VEVERS.

OVER here—England—Eastman's negative paper has at length found no insignificant rival in the Woodbury tissue, which promises, in a short time, to run the Eastman paper very close for first place; while Vergara's dark slide is intended to displace the wonderfully ingenious roll-holders for exposing the flexible paper or tissue.

While allowing that the Eastman Company were first in introducing (since the days of Fox-Talbot) a really successful flexible substitute for glass, and a slide for exposing the same, there can be no doubt that Woodbury Tissue is a great advance in modern photography. Perfect as the Eastman Company have rendered their negative paper it must be admitted that it has many disadvantages, the greatest, of course, being the necessity of rendering the paper translucent for printing by means of castor oil, vaseline, or other equally messy and disagreeable stuff; and when thus made translucent it requires three times as long to print as a glass negative, and even then its translucency is not permanent. What printer, then, would discard glass for paper on such terms? Walter B. Woodbury occupied the last seven years of his valuable life in a determined endeavor to make paper as transparent as glass; that he succeeded is proved by the fact that as a test a piece of his tissue was placed over one-half of a negative and on a print being made from it, the whole of the paper was of equal den-

sity, it being impossible to distinguish at which end of the negative the tissue had been placed. Unfortunately Woodbury's death occurred before he had succeeded in making his tissue a marketable article. It, however, fell into the hands of Mr. Vergara, who, with a few modifications of the original formula made it perfect, and, after erecting extensive works at Woodbury's former residence, Java House, Norwood Junction, S. E., is now offering it for sale along with his dark slide and album.

The tissue itself, a thin, tough, even-textured paper, is immersed, after being attached to thin laths, in bands some three or four yards long, in a solution of certain gums dissolved in rectified benzole, composed like the following, where it remains from ten to forty-eight hours, until the gums have thoroughly permeated the tissue and rendered it perfectly transparent.

Benzole . . . .	68 parts.
Gum Damar . . . .	31 "
Gum Elemi . . . .	1 part.

On being removed from this solution the transparent band is suspended in a warm room to dry, which occupies some twenty-four hours, when it is sized by immersion in a weak solution of gelatine—about 1 to 20.

The sheets of tissue are now attached together so as to form one continuous band and the whole, by means of an ingenious contrivance patented by Mr. Vergara and driven by a 1-man power gas engine, through a trough or tank containing gelatino-bromide emulsion, thus being coated on both sides, which, besides making the paper very tough, permits of its being exposed on either side. On leaving this trough it is at once drawn, by an endless chain driven by machinery, into the drying-room above, where it is suspended till dry.

It will be observed that the tissue is brought into a vertical position before the emulsion has had sufficient time to set, and this is probably the cause of the unevenness of film observable on all the tissue I have used. This fault will, no doubt, be rectified when Mr. Vergara becomes aware of it.

When dry the sensitive tissue is cut into sizes from  $3\frac{1}{2} \times 4\frac{1}{2}$  to  $10 \times 12$  suitable for

Vergara's dark slide, or into bands of various widths for use in roller slides.

I think, by this time most of our brother "shadow-catchers" on your side of the water will have experienced many disadvantages of the roller slide. Suppose, for example, when on tour one day's work amounts to eighteen exposures and the operator probably intends to expose a similar number on the day following, which course shall he adopt? waste one-fourth of a roll of paper or be content with half a dozen negatives for his next day's work? Again, if we wish to make only one or two exposures, it is rather a nuisance being obliged to carry a slide (which certainly is heavy) made to hold sufficient paper for twenty-four exposures. Suppose, again, we wish to develop but one of our twenty-four exposures, and this happens to be in the middle of the roll, what then? Yet again, suppose we are rather careless—many of us are over here—and in the dim ruby light mistake three punctures for four and cut our tissue accordingly, what then?

Mr. Vergara saw these difficulties, and designed a very simple slide, which he has patented, and now supplies in mahogany or cardboard—the latter are about one-third the price of the wooden ones, and will stand a good deal of knocking about without fear of breakage. The tissue is put up in boxes sufficient for twenty-four exposures, each sheet being double the size of the plate—thus, the sheets for a  $\frac{1}{4}$  slide measure  $8\frac{1}{2} \times 13$ , and cost 15*d.* per box. A sort of division is drawn out of the slide, inserted *between* one piece of the tissue and the whole returned to the slide, which is then charged for two exposures. The sensitive tissue is about the rapidity of an "ordinary" plate, and is, of course, exposed in the camera exactly the same as a glass plate or Eastman negative paper.

In the developer the tissue must be very carefully handled—or rather not *handled* at all. The Company recommend the following formulæ, which, it will be seen, is slightly modified from Beech's potash, and which, by the way, is becoming exceedingly popular over here. I find, however, that almost any well restrained developer will yield satisfactory results.

## No. 1.

Warm Water (distilled) . . . 4 ounces.  
Sulphite of Soda . . . 4 "

When cold add

Pyrogallic Acid (avoirdupois) 1 ounce.  
Sulphurous Acid . . . 4 ounces.

## No. 2.

A { Water (distilled) . . . 4 ounces.  
  { Carbonate of Potash . . . 3 "  
B { Water (distilled) . . . 3 "  
  { Sulphite of Soda . . . 2 "

## No. 3.

Potassium Bromide . . . 1 ounce.  
Water . . . . . 10 ounces.

To develop, to each ounce of water add 30 minims of No. 1 and 20 minims of No. 2. For underexposure increase quantity of No. 2, overexposure add a few drops of No. 3. The tissue is placed, with dry fingers, in a dish and flooded with water until soft. About half the developer is poured into another dish and the tissue tenderly lifted with a pair of ebonite forceps by the corner and placed in the solution, and the other half of the developer immediately poured over it. Air-bubbles are certain to collect on the surface of the tissue and must be removed from both back and front with a camel hair brush. The remaining operations are the same as for a glass negative, with the exception of the alum bath being omitted. After washing, it should not be blotted as advised in the Company's instructions, but suspended to dry, when it is ready for printing from.

Should the tissue show a tendency to curl, it may be left for a few days in the printing-frame or in a press. After use the negatives are to be stored in the "album" provided for the purpose and any memoranda with reference to exposure, etc., made upon the leaf to which each is attached.

The price of the tissue is somewhat high—almost twice the cost of dry plates—but it is to be hoped this will be considerably reduced when its use becomes more extensive and its makers find that the profession cannot adopt it until the price is nearer that of glass.

**THE GERMAN PRIZES.**

By invitation of Mr. G. Gennert, 54 East Tenth Street, New York, we visited his

photographers at the late photographic exhibition in Braunschweig, Germany.

It will be remembered (see PHILADELPHIA PHOTOGRAPHER, October 2, 1886, p.

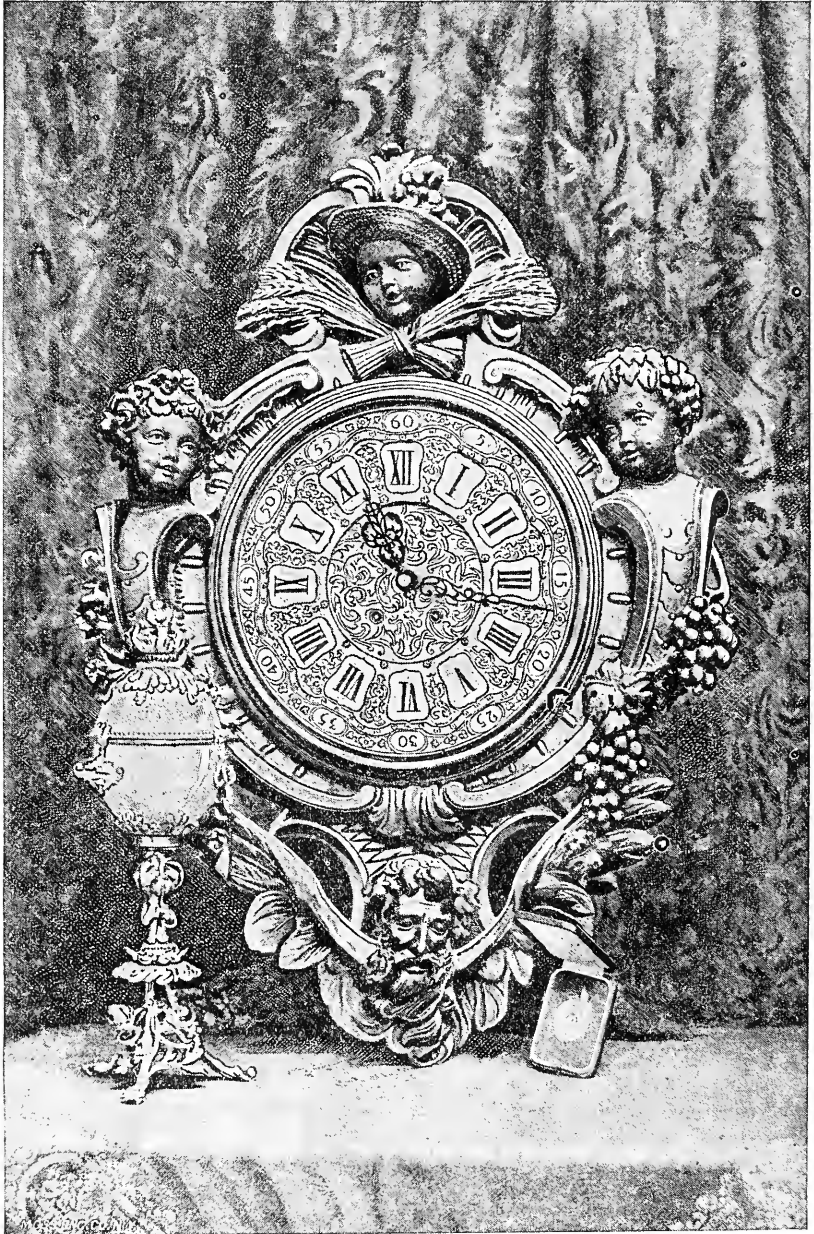

store recently to witness the unpacking of the prizes which were awarded to American (598), that a handsome clock was offered by Mr. F. Eilender, of Cologne; a cup by Mr.



F. Müller, of Munich, and a medal of silver by the Society at large, as first, second, and third prizes for American exhibits. The successful competitors, of a very respectable number, were Messrs. Decker & Wilber and J. F. Ryder, Cleveland, Ohio, and George Barker, Niagara Falls.

The fine engraving, shown on page 758, is a Mosstype of the prizes, made for us by the Moss Engraving Company, 535 Pearl Street, New York, from a negative made on an Eagle plate by Mr. D. H. Anderson, 785 Broadway, New York, by permission of Mr. G. Gennert, who has shown so much public spirit in the present affair.

The recipients of the prizes will forgive us for delaying the reception of their awards for a day in order that we might secure this picture *en route*.

Our object was two-fold. First, as a representative of American photography, to give evidence of our appreciation of the efforts of our German co-workers to promote fraternal feeling and an interchange of thought between us, and second, to enable our readers to have some understanding of the beauty of the awards.

The cup is a real gem of art. The bowl and cover are the sections of an ostrich egg, and the golden metal parts highly wrought.

The face of the clock is a ceramic with burnt-in blue figures. The massive carving is in the dark wood of the black forest, and, as you see, rich in design.

The medal, of silver, is engraved on the obverse side with a laurel wreath and the following inscription:

Ehren-preis  
für  
Vorzügliche  
Leistung  
in der  
Photographie  
George Barker.

On the reverse side, the image of the sun shining in all directions, and the inscription:

Deutscher  
Photographen  
Verein  
Braunschweig  
1886

All the prizes are inscribed.

Well done for all concerned, we say. May the new year still more earnestly promote harmony, fraternity, and generous rivalry between the noble artists of the sun in Germany and America.

### THE HUMOR OF IT.

WHY SATISFACTION IS NOT GUARANTEED.—Photographer's boy.—“No, ma'm, we never take pictures unless we get pay in advance.”

Old Maid.—“But suppose I pay for them and don't like them?”

“Don't know, ma'm; the boss is out, but he'll be in soon an' will tell you.”

“Seems to me a very queer rule; you ought at least to guarantee satisfaction.”

“Yes, but you see, ma'm, there ain't no way to keep pictures from lookin' like the people.”—*Omaha World*.

A PARTY called at a famed studio here a few days ago to see the head poser. “The lady at the desk” said he was operating and could not be disturbed. Thereupon the visitor wrote a note to the operator thus:

DEAR NED: “Awful sorry. Please lend me a V.”

DAVE.

The answer came back:

DEAR DAVE: “Am V-airy sorry. I send you a negative. Best I can do,”

NED.

A STUDY FROM THE ANTIQUE.—Photographer.—“Then I'll not marry you my pretty maid.”

Model.—“Nobody asked you sir,” (she said.)

Photographer.—“Well, you need not develop such a growl or be so intense with your vocabulary. I only wanted to fix you nicely for life.”

TOO MUCH WATER.—Lady.—“All your views of the sea represent it so calm and still. Why do you not photograph a storm occasionally?”

Photographer.—“Too much water for my new instantaneous process, madam. Would dissolve everything. I use the dry method; don't chew know?”

Lady.—“Oh! yes! I've read about the wonderful action of the drop, but I had no idea it was so destructive as that.”

#### A CROOKED LIE-EN.

When a man doth go to view it,  
In time like this he says he 'll do it.

He has a lens both good and strong,  
But slow; and taking just so long—



Ere he gets home the time decreases,  
He tells his ma, his aunts and niece thus:



But his friends who have a viewing been  
Know that the man hath lied like sin.  
And they simply sit and smile and grin.



#### OUR PICTURE.

WE present our readers with something entirely novel to wind up the year—a Mosaic picture of “Gems from the Rhine.” Very brilliant gems they are, and must make many of us wish that we, too, could do as did the artist, Mr. J. Winter, Jr., of Syracuse, N. Y. This gentleman spent three weeks in a trip up the Rhine, and the gems he has kindly allowed us to use are a selection from 160 negatives made in that time. Some of them are so extremely beautiful as to almost give rise to wishes for a few ruins here, which our country proverbially lacks.

The rough old Teuton barons who built their towers upon these crags, thinking solely of their own present security, seem to have been unknowingly controlled by a guiding hand to set them on sites that could hardly have been bettered artistically. Thus they worked for the pleasure of future generations, building far better than they knew.

The first of Mr. Winter's pictures is Ehrenbreitstein, one of the oldest of all the Rhine castles, that has been standing for centuries, and is a stronghold still. This, like the Cat tower in the last picture, is

wonderfully isolated, and lifted up by the houses of the little town clustering around its base. In strong contrast to it comes the crumbling arch in the second picture—all that is left now of the castle of Rolandseck. The third is Schönburg, and beautiful towers they are, their light stone rising out of the bark woods. A somewhat similar effect, a little finer still, perhaps the most perfect pictorially of them all, is the tenth, the Rheinstein. The richness and breadth and distance, the contrasting play of shadow, are marvellous in this picture. An unusual but impressive composition is the fourth in the series, showing the bridge over the Rhine, with the towers of Cologne Cathedral in the distance. Gutenfels, the next, is similar as a picture to Schönburg, its towers perhaps a little too faint, the wood along the foot of the hill being well brought in. Next comes Fürstenburg, which has an unfortunate foreground, and yet holds its own on the picture, and shows finely against the sky. The seventh picture is of the ruins of Brömserburg; following it another splendid composition, the great castle of Lahneck, which shows extreme good judgment and thought in the choice of its view point. Following comes the odd square Mouse tower, on an island in the river, with Ehrenfels in the distance. The Cat tower, last of all, was so named from the watchful position it occupied over the river and the town below.

We commend these pictures to the thorough study of our readers. Each one is the product of careful choice, and holds long and precious lessons to the landscape photographer if properly studied. He may not be so happy as to be able to produce their exact like, but he can consider and apply their principles.

The prints were made by the gelatine process of the Photogravure Company, 853 Broadway, N. Y. For reference, we add a numbered list of the subjects:

- No. 1. Ehrenbreitstein.
- “ 2. Rolandseck.
- “ 3. Schönburg.
- “ 4. Cathedral, Cologne.
- “ 5. Gutenfels.
- “ 6. Fürstenberg.

- No. 7. Brömserburg.  
 " 8. Lahneck.  
 " 9. Mouse Tower and Ehrenfels in the distance.  
 " 10. Rheinstein.  
 " 11. Cat.

---

### PHOTOGRAPHY THREATENED.

A CORRESPONDENT writing from Paris says: "I was informed the other day by a member of the Academy of Sciences, that experiments which M. Pictet and Dr. Raoul Duvernay have been making during the last five years, have at last been crowned with success, and that these two distinguished men of science are now able to construct mirrors in which old impressions can at any time be reproduced at will, and the mirrors be forced to yield up the history of all that has taken place within a room since one of them has hung there in such a position as to command a fair view of the apartment. The full secret of the process through which these tell-tale contrivances are constructed has not fully been made public, though it is pretty generally understood that the mirrors depend for their effect upon the peculiar action of light upon selenium, the metal by means of which, when fortified by the aid of electricity, it is now possible to reproduce in light and shade, at one end of a long wire, a photograph exposed at the other extremity. The latter contrivance has been perfecting for the last 100 years at least, but now, as I recently read in *La Nature*, it has been brought so near to the end desired that it will come to work satisfactorily and cheaply when a little more ingenuity shall have been expended upon it. Both in the recording mirror and the reproduction of the photograph the results are due to the dynamics of that all-pervading substance which is commonly, though without any peculiar propriety, called the 'luminiferous ether,' or 'æther,' as De Volsom Wood names it in his recently published brochure, and indeed as it ought always to be named, since the word 'ether' is already appropriated by a common chemical, and 'æther' is nearly akin to the Greek *aither*, by which was meant a sub-

stance very like what we understand the æther to be."

The God Sol help photography if such a calamity as this is to come upon us. The "concealed" camera and the "detective" will all go out of fashion, for one need only carry a mirror on the person to outwit and outdo them.

Dynamite backed by a host of Chicago anarchists could not do a tithe of the damage in the power of only a fragment of one of these new mirrors.

Lovers; villains; congressmen; aldermen; gossipers; eavesdroppers; amateur photographers; all! your occupation is gone. Seek in the auction stores amid the bric-a-brac collections, for all the mirrors you have ever looked in and destroy them ere it be too late, and then—"get thee to a nunnery—go!" You are watched; no longer shadowed by the "detective's" glare, but each move reflected by the mirror's stare!

*Licht!* How uncomfortable it makes one feel. Every looking-glass one sees seems to point a finger and say—"I could a tale unfold," etc. And we expect they could. But what is to become of photography if this thing is allowed to proceed?

We hope the Executive Committee of the P. A. of A. will abandon all prize schemes for 1887, and try and bring up this reproducing mirror business instantaneously. President Cramer, you are defied!

---

### PROF. ABBE'S NEW OPTICAL GLASS.

EVERYTHING that falls from the pen of Prof. Abbe, of Jena, relating to optical matters commands respect. His announcement, therefore, of the discovery of new kinds of glass, specially adapted for the manufacture of lenses, has been received with peculiar interest, and although details of information on various points are still wanting, enough has been published respecting the new optical glass to be worthy of more than passing notice.

All who have had anything to do with optical instrument making know only too well the existence of the defect termed "irrationality of dispersion." When Hall

and Dolland had independently shown that the chromatic dispersion of a crown glass lens might be corrected by combining it with a second lens of flint glass, a new impetus was given to optical research. The so-called "achromatic" lens in the hands of successive generations of opticians constituted the basis both of the modern microscope and of the modern telescope. But as greater and greater perfection in the construction of the "achromatic" lens was attained, it became apparent that perfect achromaticity was very far from being realized; for though two lenses might be found which should perfectly bring together two widely differing rays, such, for example, as the red of the line C of the spectrum and the blue of the line G of the spectrum, it by no means followed that this pair of lenses would bring together to the same focus all other rays. On the contrary, owing to the "irrationality" of dispersion, a "secondary spectrum" would always remain uncorrected.

The relation between the chemical constitution of a medium and its action on waves of light of different periods is one of those matters about which we are still profoundly ignorant. We know that a prism of glass does not spread out the waves in proportion to their wave length or to the frequency of their periods. A simple case of irrationality is afforded in the fact that a green ray which, when viewed through one prism, may lie exactly half way between C and G in the spectrum, will not lie exactly half way when viewed through a prism of a different kind of glass.

All that a combination of two lenses can do is to achromatize for two rays of the spectrum; it may very nearly achromatize for the neighboring rays, but, strictly speaking, it only achromatizes for two. For ordinary optical purposes, we seek to achromatize for the red and the blue, so reconciling the end regions of the visible spectrum. For photographic purposes we achromatize for green and violet (or even ultra-violet) rays, reconciling the end regions of the photographically active spectrum.

To Dr. Blair, whose observations were published in the *Transactions* of the Royal Society of Edinburgh for 1721, we owe the

suggestion to achromatize for three rays by using compound lenses of three different media.

What Blair proposed to effect with his liquid combinations Prof. Abbe claims to have now achieved by his discovery of new kinds of optical glass. To Abbe we owe the remark that, in addition to the secondary chromatic aberration of our so-called achromatic lenses, there exists a second defect, termed by him the chromatic difference of the spherical aberrations. This term he uses to denote the fact that with the crown and flint glasses used by opticians, though the curves of the lenses be calculated to correct the spherical aberration, taking in each case the mean refractive power, there will be a slight residual spherical aberration for all rays not of mean refractive index, the lens being spherically under-corrected for red rays and spherically over-corrected for blue.

Having realized, so far back as 1880, that these defects were inherent in the use of such glass as opticians had at their disposal, Abbe determined to make a resolute attempt to discover new kinds of glass which should be free from these vices. The research involved no less a field of work than the examination of the optical properties of all known chemical substances which undergo vitreous fusion and solidity in non-crystalline transparent masses, together with a detailed comparison of their physical and chemical properties. The work was begun so far back as January of the year 1881, by Prof. Abbe and his coadjutor, Dr. Schott, then of Witten in Westphalia, now of Jena.

Dr. Schott undertook the chemical portion and the melting processes. Prof. Abbe and his assistant, Dr. Riedel, conducted the optical examinations of the products. At first only small quantities, from 20 to 60 grammes in weight, were melted at once, all kinds of chemical elements being tried with the view of ascertaining their influence on the refractive and dispersive powers.

Pending the publication of these very valuable scientific investigations, only a very brief account can be given of the actual results. The first problem has been satisfactorily solved, with the result that achromatic lenses of a much more perfect

kind than has ever been attainable are now in the market; and the second has also been successfully carried out, a whole series of new glasses of graduated properties having been introduced into the optical trade.

Whether these new appliances are found to fulfil under the test of experience all that their inventor claims for them remains yet to be seen; but it cannot be doubted that a great step has been taken. It ought also to be recorded to the credit of all concerned that no attempt is being made to secure to one firm a monopoly of the new materials, but that the new optical glass is offered to the optical trade without any restriction or patent to stand in the way of further development.—*Nature*.

---

### PRACTICAL POINTS FROM THE STUDIOS.

**SALICYLIC ACID IN EMULSION.**—During the hot weather the editor of one of our best photographic reviews made some experiments on the use of salicylic acid in the emulsion. We know that in damp heat gelatine undergoes a slight decomposition the nature of which is not very well known, but which prevents the emulsion from setting rapidly in a solid and dry film on the plate. It appears that a very small quantity of salicylic acid corrects this state of things: 1 part of acid for 1000 parts of emulsion. It is added with the last quantity of gelatine during the manufacture, and this addition (the salicylic acid being thoroughly distributed by an intimate mixture) has no influence whatever on the ulterior photographic operations.

**THE WHARTON-SIMPSON PROCESS.**—The collodio-chloride process invented by the late Wharton-Simpson, formerly editor-in-chief of the *Photographic News*, a process which has never made much headway with us, has been adopted by some distinguished photographers in England and in Germany. In the latter country it is now proposed to substitute absolutely the Wharton-Simpson process for the albumen process. This was good some time ago, and we have nothing to say against this process in regard to its results; *it is certainly it that pointed out the*

*way to the inventor of emulsion.* But at present we may bid adieu to collodion; this preparation always more or less dangerous becomes more and more useless in photography; soon, perhaps, surgery will do without it. All are now looking forward to the emulsion paper or the *negative tissue* of Woodbury.—*Moniteur*.

**PRESERVATION OF POSITIVE PAPER.**—Mr. C. B. Barnes publishes a note on the preservation of sensitive paper. When after sensitizing the paper has been thoroughly dried, the author recommends the rolling of it in a tight manner on a wooden roller which has previously been covered with an old sheet which has already been exposed to the light. (Why?) It is rolled tightly so as to exclude the air, for, according to Mr. Barnes, the action of the air (damp?) is ten times more injurious than that of the light. The author understands, doubtless, the accidental light which can reach the sheets. When all the sheets have thus been rolled, the whole should be covered, says he, with a sheet of paper which has been exposed to the light (why?) and then enveloped in ordinary thick brown paper. In this manner the paper may be kept more than eight days, says Mr. Barnes, without the slightest coloration.

**TONING AND FIXING BY MR. BARNES'S PROCESS.**—The toning bath that Mr. Barnes uses with the most satisfactory results, for albumenized paper, contains: hot water, 9 quarts, acetate of soda, 1 oz,  $3\frac{1}{2}$  grains, chloride of gold, 23 grains. This bath should be prepared at least one week before using. Each day the necessary quantity is taken for the toning to be done. His fixing bath is: hot water, 9 quarts, hyposulphite of soda,  $3\frac{1}{2}$  pounds.—**DR. PHIPSON'S** *Correspondence in the Paris Moniteur*.

---

[Translated for *The Philadelphia Photographer*.]

### ZINC ETCHING—ASPHALT PROCESS.

THE photo-chemical process with asphalt is much less known than the method with chromates. Geymet has well described the process in a pamphlet entitled *Traité pra-*

*tique de Photogravure sur Zinc et sur Cuivre* (Practical Treatise of Photogravure on Zinc and on Copper), and which was published in Paris. He was engaged in working this process for a long time, and the writer of this article has for twenty years been practising the process with him. The results are so satisfactory that a statement of the method will doubtless prove of interest.

Geymet names the following requisites for the process :

Transferring color, nitric acid, muriatic acid, chlorate of potash, chlorate of iron, sulphuric acid, solution of gum, lavender oil, oil of turpentine, benzine, chloroform, brown shellac varnish, asphalt, pulverized resin, etching chalk, modelling wax, chalk (or crayon) paper, a plane, two round dusting brushes (or pencils), two fine sponges of medium size, funnel and filter, rags, dishes, steel-gravers, zinc plates, three polishing rollers, a stove, a saw, scissors, hammer, pair of compasses, and iron ruler. The steps of the process are as follows :

1. Preparation of the asphalt solution ;
2. Polishing and coating the zinc plate ;
3. Drying the layer over the fire ;
4. Exposing ;
5. Developing the picture ;
6. Re-touching the picture before and during the etching ;
7. Etching ;
8. After-etching ;
9. Cleansing ;
10. Levelling the irregularities in the relief ;
11. The printing.

Asphalt solution :

Asphalt . . . .	77 grains.
Benzine . . . .	3½ fl. oz.
Lavender Oil . . . .	2 drops.

This solution should be filtered into a dry bottle, and well corked. Since this substance soon loses its sensitiveness, it is best not to dissolve too much at once. In winter the solution can be somewhat thinner, in summer somewhat thicker, otherwise a thin layer is preferable to too thick a one, because the latter peels off easily.

The negative must be very dense in the lights and clear in the lines. The collodion furnishes the best negatives.

The zinc plates can be obtained from the trade smoothly polished. They are polished with chalk and alcohol, to which a few drops of ammonia have been added to remove

every vestige of grease. The quite dry, but unheated, plate must be very carefully dusted off. The asphalt solution, filtered the day before, is now to be poured upon the plate, and the surplus allowed to run into a clean, dry bottle. The layer must be even and protected from dust. The lower thick edge must be rubbed away with a rag to the breadth of one-third of an inch. Then the plate is to be heated over the spirit-lamp. For the most part talc powder is used upon the plate so as to avoid adhesion.

The copying frames must be much stronger than for ordinary prints, with double the number of pins, and a thick, smooth cover, without hinges. The pan must also be particularly thick.

The negative for the asphalt print must be reversed and made either upon plate-glass or upon gelatine. The negative is developed with iron, fixed and washed, and then laid in the mercuric solution.

Dissolve 77 grains of chloride of quick-silver in some alcohol and pour this into two parts of water. When the layer has become white, it must be washed and a mixture of 7 fluidounces of water and 1¾ fluidounces of ammonia poured upon it.

Over the dry negative the following solution is poured :

Benzine . . . .	20 drachms.
Caoutchouc . . . .	2 "

This varnish dries within a half an hour, but remains sticky. Raw collodion (two per cent.) is poured upon it and the plate dipped in a dish of water mixed with sulphuric acid. After some minutes the layer dissolves around the edges. The water should now be replaced by fresh and the film laid inverted upon an albumenized or gelatinized dry glass plate. With gelatine plates the same process is pursued, only instead of sulphuric acid fluoric acid is added to the water in the proportion of two per cent. The vessel used for the bath must be of gutta-percha. Pure fluoric acid is very dangerous, but diluted to two per cent. not so much so.

The exposure in the copy-frame lasts in a bright sun about twenty-five minutes ; in weaker sunlight about forty-five minutes. The photometer must be used when expos-

ing with dispersed light. As in carbon print, it is impossible to perceive the progress of the picture, since this first becomes visible in the development. If the copying is done in the sun, the zinc plate must be heated; then let cool before laying it in the developing vessel, since otherwise the oil of turpentine would dissolve the lighted parts. If the development takes place in bright daylight, it is, of course, necessary to follow exactly the different steps of the work.

Of the various developers tried, such as naphtha, benzine, petroleum, chloroform, different sulphides of carbon, none has proved so good as oil of turpentine. It mixes better with water, so that no greasy spots remain after washing. Of course chloroform and benzine dissolve much more quickly, wherefore one might think to succeed better with them, especially if the layer has been lighted too long.

It seems as if the picture would gain by the use of the more violent means of solution, since lines that would be otherwise lost come out distinctly; but the final result is seldom better, for if some lines are gained others are lost, the picture fogs, and is spotted in the etching, while a very thin asphalt layer, which is dried before the washing, resists in the etching solution. It is therefore judged best to keep simply to the oil of turpentine and not try any others. If only the negatives are good, the artist will come out all right.

The zinc plate, having become cold, is now placed in a dish and oil of turpentine poured over it, which is kept in uniform motion. With the proper exposure the picture is instantly developed, while the parts left unexposed dissolve themselves. If the lines appear clearly in brownish or yellowish color against the metal, the plate must be taken out of the dish and rinsed properly under the tap, the stronger the water-pressure the better.

By washing, every particle of the asphalt remaining soluble must be removed, since these would show afterwards in the etching. The development is then only entirely successful when the negative is good, *i. e.*, quite clear in its lines, opaque in its lights.

A portrait photographer, even a competent one, seldom produces a good negative

for etching just because he is accustomed to half-tones, and with these the etcher can bring nothing to perfection. It is thus necessary to be exceedingly particular in taking the negative. If the asphalt picture does not appear quite clear and clean upon the zinc plate the etching must not be attempted for it will not be successful.

With good negatives the developer is absolutely certain and simple. The plate can lie as long as one pleases in the oil of turpentine as the asphalt will not dissolve, because it could be exposed long enough. A good negative can only be exposed by a too short, never by too long, an exposure. It is also well in every case to expose quite a long time, supposing, of course, that a good, strong negative has been obtained. But if the negative is not very dense, then it must not be over-exposed, because the light would go through and would also make it insoluble. With such negatives it is not necessary to continue the exposure too long, not over half an hour in the sun.

As has already been said, the zinc plate must be thoroughly rinsed after the development, so that no soluble asphalt may remain. Afterward a sheet of smooth bibulous paper, without folds, should be laid on it, and pressed on it with a cotton pad. Then the paper must be taken away and the plate warmed so that the hand can barely stand it, in order to dry and at the same time harden the asphalt. The zinc plate can be etched, when the drawing stands out freely in yellow upon the gray zinc ground.

If a darker tone is desired, it can be obtained by adding a few drops of lavender oil to the asphalt solution. But this is not necessary. The plate can be examined with a lens, especially if the ground is quite clean.

---

### THE WORLD'S PHOTOGRAPHY FOCUSSED.

HERE is a receipt to make a black varnish for wood: Dissolve, with the aid of gentle heat, two pounds of asphaltum in four quarts and a half of essence of turpentine; when all is dissolved, and the solution somewhat cool, add one pound of copal, one pound of boiled linseed oil, and a little lampblack.

A VERY practical object-lesson was given the privileged members of the New York Society recently, by Mr. J. Wells Champney, the artist. As lantern slides were projected, he commented upon them, and with mask and mat so moulded and modified the 'scapes as to make them appear to best advantage as lessons. Capital! Practical!

DR. JANEWAY is making the "Question Box" a very great help too, and gives the members who hear him great advantages. He knows whereof he speaks.

PROOF OF PROSPERITY.—A number of our subscribers have written us recently, "We have taken your magazine for over twenty years, and do not propose to drop it yet, either."

PAPER may be rendered impervious by placing it rapidly in contact with the surface of a solution of oxide of copper in ammonia, by means of rollers suitably placed, and revolving with rapidity. On leaving the bath, the paper is pressed between two cylinders, then dried over cylinders like those used for drying letter paper. The action of the solution is to slightly dissolve the cellulose of the paper, and to thus form an impervious varnish.

To diminish the density of negatives that are too hard, the following method may be resorted to:

The negative is steeped in water until the coating is saturated, and with a brush the plate is coated with a mixture of 100 parts of a hypo solution (1:10), and 5 parts of dragon's blood (1:5). After a few minutes, the effect is striking, and the plate rapidly diminishes in intensity.

It is often desirable to have a solution to remove the yellow tint which sometimes soils the coating of negatives. The following bath is very good, and is used after developing and intensifying:

Alum . . . . .	1 ounce.
Sulphate of Iron . . . . .	1 "
Citric Acid . . . . .	1 "
Water . . . . .	24 fl. ozs.

In about fifteen minutes the plate has been cleaned; the bath will last for a long time.

PAPER MILLS IN SAXONY.—An article reproduced from the German papers in those of London, says that in Saxony, in which there are many manufactories of paper, a number of the mills in which the wood is reduced to pulp, were forced to stop on account of the scarcity of water, and that, consequently, it is very probable that this winter they will not be able to furnish the quantity of paper ordered from them for books, newspapers, and photography; and, therefore, Germany will be obliged to take her paper from abroad.

PHOTOGRAPH ALBUMS FOR HOSPITALS.—At the Liverpool Amateur Society a letter was received from a philanthropic person requesting the members of the society to send to him all the prints for which they have no use, in order to fill photographic albums to be sent to the hospitals. This is a good idea.

PRINTS ON ALBUMENIZED BLUE PAPER.—At the same meeting Mr. Dearle showed some prints on blue albumenized paper; these prints showed a moonlight effect, it is said; other prints presented by the same gentleman were on ordinary albumenized paper. The most interesting points in these communications is, that all the prints mentioned above were printed from negatives on paper, and that they do not show any more grain than prints obtained from negatives on glass.

POISONING BY IODIDE OF POTASSIUM.—Medical journals report two deaths owing to the administration of iodide of potassium. In the last case, but four spoonfuls of a three-per cent. solution were taken in thirty-six hours. The unfortunate victim died after eight days. The doctors do not well understand how these accidents could have occurred, but setting aside the fact that iodide of potassium is more dangerous than is supposed, this salt often contains iodate of potash, of which, small quantities are very poisonous, as Professor Malzens, of Brussels, has shown, when given to dogs. The chloride of potash is also a very poisonous salt, but happily it is never found mixed with the chloride, otherwise we would often hear about it.



## Editor's Table.

*Mosaics* for 1887 has gone ahead of all previous record. Mr. W. IRVING ADAMS, of the SCOVILL MANUFACTURING Co., writes: "I am duly in receipt of the advance copy you kindly sent me. It has more than the usual complement of good things, and will, therefore, be received by its thousands of readers with even more than its usual hearty welcome. Unless your first edition is a very large one, you will doubtless be called upon to issue a second soon after the book reaches the public."

The last prophecy has been fulfilled, for the paper edition is already exhausted.

MESSRS. BUCHANAN, SMEDLEY & BROMLEY, the plucky and enterprising stockdealers of Philadelphia, have settled to steady work in their new store, at 1030 Arch Street. Now they send us their "list of 100 bargains," that is interesting to every photographer, and their new catalogue, containing, they say, "a few prices of our own," a fine list of chemicals and apparatus. Subsequent experience leads us to repeat and heartily endorse what we said of them two years ago: "They are an enterprising firm, and all who deal with them will find that they may safely depend upon their representations."

MR. C. C. VEVERS, of Horsforth, Leeds, England, sends us an advance circular of his forthcoming little work, *Practical Amateur Photography*, which his experience will make valuable. We have also to thank him for some very pretty little bromide prints.

PICTURES RECEIVED.—From Mr. H. BUTLER, of Vermillion, Dak., we have some of his excellent instantaneous views, some of them showing his town already deep in snow, others a few of its beautiful summer aspects. From Mr. CHARLES BUTTERWORTH, of Wilmington, O., we have received one of the finest head studies we have ever seen. It is called "La Magdalene," and is, artistically and photographically, a splendid picture. Mr. BUTTERWORTH is one of our young men who are growing up to make a new generation—new and advanced, in many ways—of photographers. He says; "I do not claim for it *perfection*, either in conception or execution, but, I think it will show you that I appreciate your late article on 'Feeling.'" We have Mr. BUTTERWORTH's picture in our office as a proof and example of the advance of artistic photogra-

phy; and the only difficulty is that, owing to the splendid arrangement of his light, the ordinary observer is hard to convince that it is not from a painting. Yet this, too, is a compliment. From Mr. C. E. ORR, of Sandwich, Ill., comes a series of his fine instantaneous pictures. Horses trotting, a baseball in mid-curve, dogs and boys swimming, are cleverly caught. Some very excellent landscapes are sent, and in one the shutter has been used to secure a bright and interesting picture—a little boy in mid-stream in pose to throw, while his dog looks up anxiously, ready to plunge into the water after the object and bring it back. This is a real picture. The figures are placed exactly right, adding interest to the landscape, yet not unduly prominent, and their pose is most effective. Besides all this, Mr. ORR sends us examples that show his portrait work to be good; also, soft and clean. We shall shortly give our readers an example of his instantaneous work. In a late issue of the *Chicago Herald* seven of Mr. ORR's instantaneous pictures are engraved, accompanied by a two-column descriptive article.

Under the above heading we made a sad mistake in our last issue, in attributing Mr. INGERSOLL's photographs of the ice palace to Minneapolis instead of St. Paul. St. Paul is the true and only ice-palace town, and to it is the credit due. We feel a little less guilty in view of the fact that Mr. INGERSOLL addressed us at Philadelphia.

CHRISTMAS brings with it a perfect feast of artistic good things. The artistic photographer couldn't do better than send a *carte blanche* order to his bookseller for *all* the Christmas periodicals, each of which is more delicious in its embellishments than the last. The art journals, especially, come out strongly. The *Art Journal*, published in New York by the INTERNATIONAL NEWS Co., besides issuing a charming annual, gives a fine lot of articles in its current number. It shows its progressive spirit by a generous use of the new photographic processes in its illustration—the frontispiece being a splendid reproduction of Meissonier's possibly most famous picture, "1814." Other articles are "How to Design," by Charles G. Leland; "Japanese Art," "Ruskin's Notes on Bewick's Birds," and "Suggestions in Decorative Design from the Works of Great Painters."

We want to impress on the craft the ripening,

widening effect they would find in a little genuine art-thought and study, fresh and living, such as these magazines serve up so bountifully.

THE very latest claimant to favor is *The Art Review*, published by Mr. GEORGE KELLY, New York. It is by long odds the best, too, of the several new art-magazine ventures that have lately been started. Its frontispiece is one of CHURCH'S exquisite, thoughtful etchings, "Dreamers"—girl and storks, both pensive, lost, deep in day-dreams. The other full-page illustrations are three photogravures, some of the best of the splendid work done lately by the PHOTOGRAVURE Co., of New York. The literary portion is of equally high standard, and the new journal, as a whole, promises exceedingly well.

OUR esteemed contemporary, *Queries*, of Buffalo, N. Y., says, kindly: "Mr. EDWARD L. WILSON, the enterprising publisher of the PHILADELPHIA PHOTOGRAPHER, has just issued the twenty-third number of *Photographic Mosaics*. Mr. WILSON is known throughout the fraternity to which he belongs as one of its leading and best-informed members." This volume records the progress of the past year, and the accumulated volumes have become a cyclopedia of photographic information. A good photographer must, of necessity, be an artist, and must keep abreast of the progress of his art, and we know of no source where so much information can be obtained for the outlay as in this volume."

And Prof. A. C. HERRICK, of Sacramento, Cal., writes: "Volume III. of *Lantern Journeys* is a perfect gem. So helpful, so concise, so clear."

THE new *Scribner's Magazine* promises to take hold on public favor at once. The first number was issued on the 15th. That its sales will be large is assured by the fact that its English agents, F. WARNE & Co., have bought outright 20,000 copies. The first number, with glimpses at the French Revolution and the Siege and Commune of Paris, given by Gouverneur Morris and Ex-Minister Washburne, its pictures of "Babylonian Seals," its fiction by Bunner and Janvier, is most interesting, and there is the promise of still better things to come.

*The American Annual of Photography and Photographic Times Almanac* will shortly be issued. It brings a show of valuable matter. Among its contributors are such names as Abney, Spaulding, H. P. Robinson, Schumann, Hull, and Janeway; and besides its contributions it contains a number of most useful tests, tables, and formulæ. It will be in fact useful to

everyone, and should be assured of a hearty welcome.

MESSRS. WILSON, HOOD & Co. will remove during January to No. 910 Arch Street, Philadelphia, and promptly send us notice in advance. We hope they will continue in favor at their new stand as at the old.

WE would call attention to the advertisement, in another column, of the small steam-engine offered by CHAS. P. WILLARD & Co., of Chicago. Such an engine, at this very moderate price, will be within the reach of many photographers, and ought to be useful to them in many ways especially to some of them who find it hard to keep up a good and sufficient water supply, also for the electric light.

MESSRS. ROBERTS & FELLOWS send us the circular of their new self-centering lantern slide holder, which insures the exact centering of each slide, and, consequently, perfect focus. It is a very useful device.

AMONG the extra efforts for the holiday season among the journals, one that is really valuable artistically is the *Art Annual*, issued by the INTERNATIONAL NEWS Co. of New York. This year's issue gives a complete account of the life and work of ALMA-TADEMA, with copious illustrations, several of them full-page etchings of his most famous pictures. It is an excellent record of a famous artist, and commends itself at once to the artistic amateur, while to the student it is full of hints on composition and costume especially. Its very moderate price, 75 cents, places it easily within their reach.

RENEWING AND REWARDING.—The renewal of your subscription for our magazine rests with you. As a part of our reward comes the following, which we quote from a letter enclosing seven dollars "for the *Photographer*, *Times*, and *Mosaics* for 1887":

"In renewing my subscription, I wish to express my thanks for much pleasure and the many useful hints that I have received from it."

We challenge all our old subscribers to express it more gracefully.

NEVERTHELESS IT IS SO.—A little extra push this year has placed our entire edition of *Mosaics* in the hands of the dealers, who well know its worth. We must, therefore, ask you to send your orders to them, as we have only cloth-bound copies for sale. We give a list of the dealers whom we know to be supplied, in the advertisement. You should order early if you desire to secure *Mosaics* for 1887

# Specialties.

## ADVERTISING RATES FOR SPECIALTIES.

25 cents for each line, seven words to a line—in advance. *Operators desiring situations, no charge.* Matter must be received a week before issue to *secure* insertion. Advertisers will please not ask us for recommendations. ~~25~~ We cannot undertake to mail answers to parties who advertise. Please always add your address to the advertisement. **Postage-stamps taken.**

**MAKE OUT YOUR OWN BILL**, and remit cash with your advertisements, or they will not be inserted.

### TO OUR PATRONS.

ST. LOUIS, October 23, 1886.

GENTLEMEN: During the last ten months we have been enlarging our factory in order to meet the growing demand for our plates, and succeeded in doubling our working capacity. Still our supply is not half sufficient to fill our orders. We have, therefore, commenced the building of a new factory, much larger than our present one, and have taken steps to secure its completion by the 1st of February next.

We again beg your patient forbearance and the continuance of your good will toward us, and trust that with the beginning of another year we shall be in shape to fully supply all demands.

Respectfully,

M. A. SEED DRY-PLATE CO.,  
A. R. HUISKAMP, Manager.

RETOUCHING BUREAU.—Under the direction of Mr. H. Harshman. None but skilled help employed. Quality of work guaranteed. Prices moderate. Send your negatives in wooden box with cover screwed on, and prepay charges.

Address GAYTON A. DOUGLASS & Co.,  
Merchants in Photo. Supplies,  
185 & 187 Wabash Avenue,  
Chicago, Ill.

### FOR SALE! LENSES AT A BARGAIN!

One Morrison 11 inch Rapid Rectilinear Lens Will cover a 11 x 14 plate sharp to the edges. An excellent instantaneous lens. In good condition.

PRICE, \$50.

Two 8 x 10 Morrison Wide-angle Lenses, as good as new. 8 inches focal length.

PRICE, \$20 each.

One Euryscope, in good condition. Will cover a 11 x 14 plate.

PRICE, \$50.

Address "W. K.,"  
Photographic Times Office.

MOsaics, 1887, is ready. 144 pages, 50 cents. Cloth bound, \$1.00. All dealers have it.

A first-class gallery on Broadway for sale. Good business. *For cash only.* For particulars address F. H.,  
226 E. Fifteenth St.,  
New York.

"THE BEST OF SLIDE MAKERS."—Read the following and send your slide orders to Roberts & Fellows, 1125 Chestnut Street, Philadelphia. Read this:

TOLEDO, OHIO, Oct. 22, 1886.

MESSRS. ROBERTS & FELLOWS.

DEAR SIR: Notwithstanding the short time allowed, your slides arrived a day sooner than expected or needed. I projected them across the street (over 100 feet) to a size 30 x 30, having to contend with gas and electric lights, and yet with fine effect. The general verdict was, "Magnificent!" Being alternated with 110 other views, it gave a good opportunity for all to judge of the merits of your work. In the few years I have been in the business, I can say I never saw better slides, and don't know that I ever saw just their equal. They have proved satisfactory in the highest degree. Thanking you for your promptness and the unequalled quality of work, I enclose amount of bill sent.

Yours respectfully, L. B. LAKE.

### USED "DAISY," AND "NEW" HOLDERS FOR SALE.

From holders used at New Orleans Exhibition, I have

24 of 5 x 8 . . .	\$1 35
12 of 10 x 12 . . .	3 00
1 of 14 x 17 . . .	8 00

Cheap. Good as new.

EDWARD L. WILSON,  
853 Broadway, N. Y.

MOsaics, 1887, is ready. 144 pages, 50 cents. Cloth bound, \$1.00. All dealers have it.

**WILSON, HOOD & CO.,**  
 825 Arch St.,  
 PHILADELPHIA.

We have now in stock  
**THE NEW EAGLE DRY PLATE.**

ALSO  
**THE INGLIS TRIUMPH PLATE.**

A new brand of  
**GERMAN PYRO ACID.**

(35 cents per ounce.)  
**POCKET GLASS CUTTER.**

(15 cents each.)  
**NEW STYLE CORNER CHAIR.**

(\$10.00 each.)  
**PAPIER MACHÉ STUMP.**

(\$6.00 each.)  
**SUNSHINE MAILING ENVELOPE.**

**THE LIGHT RUNNING**

**SIMPLE STRONG**

**NEW HOME**



**SWIFT SURE**

**SEWING MACHINE**

**HAS NO EQUAL.**

**PERFECT SATISFACTION**

**New Home Sewing Machine Co.**

**—ORANGE, MASS.—**

30 Union Square, N. Y. Chicago, Ill. St. Louis, Mo.  
 Atlanta, Ga. Dallas, Tex. San Francisco, Cal.

**FOR SALE BY**

THE AGENTS, at the above named places.

**Two-Horse Power Engine. \$150.**

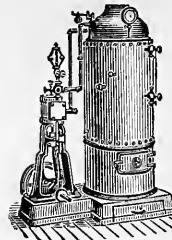

WITH STEEL BOILER.  
**Cheap, Reliable, Safe.**  
 Automatic Boiler Feed.  
 Automatic Pop Safety Valve  
 Steel Boiler, Cost of running  
 guaranteed not to exceed  
 one and one-half cents per  
 horse power per hour. Less  
 than half that of any kero-  
 sene engine of equal effi-  
 ciency. Nothing equal to it  
 ever before offered for the  
 price. Send for free descrip-  
 tive circular.  
**CHAS. P. WILLARD & CO.**  
 284 Michigan Street, Chicago, Ill.

MOSAICS, 1887, is ready. 144 pages, 50 cents.  
 Cloth bound, \$1.00. All dealers have it.

**PRINTING AND TONING FOR AMATEURS**  
 A SPECIALTY.

PLATES DEVELOPED.

Try our freshly made photographers' paper.  
 Made fresh daily, and fumed ready for use.  
 25 cents per sheet, 18 x 22, cut any size, and  
 sent by mail without extra charge.

Our Concentrated Toning Solution is pro-  
 nounced the best by all who have used it. Price,  
 seventy-five cents.

Photographic supplies of all kinds. Largest  
 variety of stock in the city. Send for catalogue.

LOEBER BROS.,  
 119 & 121 Nassau St.,  
 New York.

EVERY photographer in want of excellent  
 lenses, for any purpose, will best serve his interest  
 by consulting the new illustrated price-list of  
 Messrs. BENJAMIN FRENCH & Co. before pur-  
 chasing.

"Long's Art of Making Crayons on Solar  
 Enlargements." Price 50 cents.

EDWARD L. WILSON,  
 853 Broadway, N. Y.

MAGIC CAMERA STANDS made by Smith &  
 Pattison, Chicago, are certainly entitled to the  
 wonderful popularity they are attaining. They  
 are beautifully finished, symmetrical in design,  
 very strongly built. The heavy weights, cogs  
 ratchets, set-screws, etc., so objectional in other  
 stands, are done away with. Never buy a stand  
 without looking into the merits of the "Magic."

MOSAICS, 1887, is ready. 144 pages, 50 cents.  
 Cloth bound, \$1.00. All dealers have it.

---

 The Lithographer Publishing Co.,

PUBLISHERS OF THE

"American Lithographer and Printer,"

HAVE IN COURSE OF PUBLICATION

## A DIRECTORY

OF THE

Lithographic &amp; Allied Trades,

COMPRISING A COMPLETE LIST OF ALL

Lithographers, artists, designers, photographers, photo-litho, and photo-engravers, printers in all graphic arts, engravers in all branches, electrotypers, book-makers, art-publishers, paper-makers, lithographic and printing ink manufacturers, all firms and persons engaged in lithographic and photographic supply-houses, manufacturers of and dealers in lithographic and printing machinery, stationers, and in fact all who are engaged in these and kindred trades.

Although such publications are issued annually in England and Germany, yet there is absolutely nothing of this character in this country.

The success of our Directory is already assured. Our first edition is guaranteed by contracts to be 5000 copies.

Advertisers will please send in their ads. as early as possible.

For particulars and circulars address:

THE LITHOGRAPHER PUB. CO.,  
12 Centre St., New York.

---

LENS FOR SALE.—One Harrison 18 x 22 Orthoscope, with patent diaphragm. A good lens for life size portraits. \$45.00 cash.

R. D. GRAY,  
1430 Broadway, N. Y.

---

FOR SALE.—A Scovill View Camera for 14 x 17 dry plates; one double dry plate holder. Camera has double swing back and side swing, with raising front-board, perfect, and as good as new. Never used for a dozen plates. With Suter Clens, No. 5; covers 16 x 20 plate all over, and is a beauty. Will be sold at \$125 cash, complete, and delivered at office of PHILADELPHIA PHOTOGRAPHER,

J. P. T.,  
care PHILADELPHIA PHOTOGRAPHER.

MOSAICS, 1887, is ready. 144 pages, 50 cents. Cloth bound, \$1.00. All dealers have it.

BARGAINS.—One No. 9 Boehmke Aplanat (same size, depth of focus, rapidity, etc., as No. 7 Euryscope), cutting a full 20 x 24 plate for groups or life-size heads—list price \$230—only \$1.85. This lens has been used in our studio one year, a new lens; samples of work will be sent, and money refunded after four days' trial, if not as represented.

Also one portrait camera box (made to order), double swing, for 26 inch plate, bonanza holder, all as good as new, solid and serviceable, only \$75; cost nearly double the price.

Full particulars for both these articles on application, and a written guarantee sent with same. Terms cash with order, and money refunded on return of same in good order, after inspection, if not as represented.

One  $\frac{1}{2}$  size H. B. & H. lens, excellent instrument, only \$15.

One  $\frac{1}{2}$  size Lewis lens, only \$8.

One No. 1 Darlot Wide Angle Hemispherical lens, only \$12.

Address  
BACHRACH & BRO.,  
Baltimore, Md.

---

## SITUATIONS WANTED.

No charge for advertisements under this head; limited to four lines. Inserted once only, unless by request.

---

As printer and toner, or general assistant. Had some experience in operating. Address George Junod, Sanquoit, Oneida Co., N. Y.

By a young man of good habits and large experience in first-class gallery, as printer or retoucher, or any part of gallery work. Would rent or buy a good gallery, or buy one on shares. Address W. L. H., 505 West Ave., Buffalo, N. Y.

A young man (28)—good operator—and young lady (20)—good retoucher—would like to have situations in some good gallery, from January 1 to May 1. Address Box 195, Bedford, Pa.

A first-class operator and retoucher, also working up in India ink, of long, practical experience, wants a situation at once. Salary moderate, if position permanent. Baecker, 15 Beach St., New York City.

A photographer of twelve years' standing wishes a position for 1887. Best of references given by the artists of New York City. Address John de Banes, Sumner, Bremer Co., Iowa.

ASK FOR THE  
BLUE LABEL.



TRY THEM!  
and you will continue to  
USE THEM!

Pronounced the "Ne Plus Ultra" of Dry Plates.

UNSOLICITED TESTIMONIALS.

MR. JOHN CARBUTT, Wayne Junction, Philadelphia.

WORCESTER, MASS., December 25, 1885.

DEAR SIR: I have been using some of your new plates, emulsion 1024, sensitometer 24. I think they are, without exception, the finest and best plates I ever used. They are not only very fine and delicate in their structure, but, when properly manipulated, result in a blooming negative, possessing all the desirable qualities that any artist could wish for. I could most appropriately christen them the "Ne Plus Ultra Dry Plate."

Yours truly, E. R. B. CLAFLIN.

DETROIT, MICH., January 16, 1886.

MESSRS. HARRIS & KITTLE.

GENTLEMEN: I am very much pleased with the Carbutt Plate; in fact, I call them the best plate *by far* that I tried so far. I find them especially useful for my theatrical subjects, as the quick emulsions are *absolutely instantaneous*.

Yours truly, A. B. TAYLOR.

*For Sale by all Dealers in Photo. Materials.*

JOHN CARBUTT, Keystone Dry Plate Works, Wayne Junction, Philada., Pa.

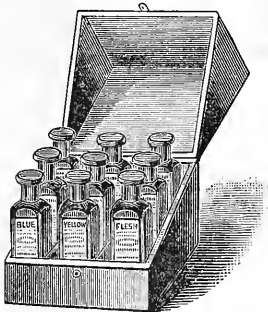

**JANENTZKY & WEBER,**

MANUFACTURERS OF

**ARTISTS' MATERIALS**

J. & W.'s Superfine Artists' Oil Colors in collapsible tubes,  
J. & W.'s Artists' Canvas, Fine Brushes for Oil or  
Water Colors, Academy Boards, Water Colors  
in cakes and pans, Soft Pastels,  
Monochromatic Boards, Pastel Canvas, Pastel Plaques,  
Liquid Photograph Colors, Blue Print Papers, plain  
and sensitized, Solar Printing Papers,  
Crayon Drawing Materials,

Everything required for Drawing, Painting, Etching, Modeling, etc.  
Wax and Paper Flower Materials.

**No. 1125 Chestnut Street, Philadelphia.**

Send for Catalogue.

**PHOTOGRAPHERS' ART VINE.**

Beautiful and durable Ivy Vine for scenic effects; manufactured especially for photographers. All natural vines and leaves imitated. Send for circular. Special rates to dealers in photographers' supplies.

**S. G. SHERWOOD,**

232 Vermont St., Buffalo, N. Y.

**BUY THE BEST!**

No other will give you half so much satisfaction.

**FOR DRY PLATES**  
**ANTHONY'S Patent Perfect PLATE HOLDERS**  
**ARE SUPERIOR TO ALL.**

**DALLMEYER**

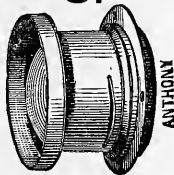

**FOR WET**

**OR DRY**

**WIDE-ANGLE RECTILINEAR**

E. A.

**SINGLE COMBINATION, RAPID,  
WIDE ANGLE, PLATYSCOPE,  
PORTRAIT AND VIEW LENSES.**

**DALLMEYER LENSES,**

**SUCCESS CAMERAS,**

**THE FAIRY CAMERAS,**

**THE NOVEL CAMERAS,**

**SCHMID'S DETECTIVE CAMERA**

**SEND  
FOR OUR  
CATALOGUE,  
AND GET  
THE BEST  
Of Everything.**

**APPARATUS OF ALL KINDS.**



Chairs,  
Neg Boxes,  
Camera Stands  
Printing Frames,  
Etc., Etc.

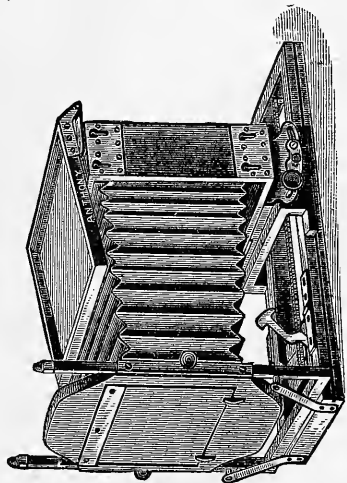

**THE FAIRY CAMERA.**

*The Lightest and Best for Out-door Work.*

**FOR EITHER DRY OR WET PLATES**

**NOTHING EQUALS**

**THE BENSTER PLATE HOLDER.**

**DALLMEYER**

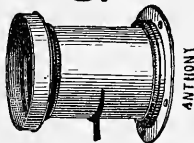

**NOTHING**

**COMPARES**

**RAPID RECTILINEAR**

O. I. C.

**PORTRAIT, COPYING, CLIMAX  
PORTRAIT, GEM, AND  
COMPACT VIEW CAMERAS.**

**E. & H. T. ANTHONY & CO. --591-- BROADWAY, NEW YORK.**

# F. DRESCHER & CO.'S IMPROVED GELATINE FOR EMULSION.

Made by a new and improved method, is the purest, the most reliable, and gives the best results.

UNRIVALED FOR THE PURPOSE.

Also IMPROVED GELATINE FOR LICHTDRUCK AND OTHER PHOTO. WORK.

Obtainable from the **SCOVILL MANUFACTURING CO.**, and all  
Dealers in Photographic Materials.

Or from the Manufacturers: **F. DRESCHER, & CO.**, Oberndorf-Schweinfurt-on-the-Main, Germany.

## GAYTON A. DOUGLASS & CO.

MERCHANTS IN

# SUPPLIES FOR PHOTOGRAPHY,

185 & 187 Wabash Ave.,

CHICAGO.



*Send for our Illustrated Catalogue, finest ever issued.*



*The Eagle Paper Keeps its Place as Leader.*

Try the New Colors of the Leading

**DRESDEN ALBUMEN PAPER.**

**IMPROVED**

**EXTRA-BRILLIANT PENSEC,**

10 KILOS.



10 KILOS.

**EXTRA-BRILLIANT NEW ROSE.**

**It Possesses the Highest Durability of Color.**

It Never Blisters. It Keeps Well after Silvering.  
It Tones Easily. It Gives the Most Vigorous  
and Brilliant Prints. It is the Best  
Selected Paper.

It is Always Uniform and Reliable, and has the Least  
Objectionable Water-Mark. The Majority  
of Artists will Have It.

**SAMPLES FREE ON APPLICATION.**

For Sale by all Stockdealers in the United States  
and Canada.

**G. GENNERT,**

Importer,

**No. 54 EAST TENTH STREET,**

**NEW YORK.**

1849

SCHINDLER'S

1886

# PICTURESQUE AND EASY POSING CHAIRS,

## STUDIO FURNITURE, AND ACCESSORIES.

Of our latest, the No. 72 "Elité" Posing Chair, Mr. Kent says: "It is ever so much better." Mr. D. R. Clark, Indiana, is very much pleased with the "Elité," the plastic interior background decorations, the revolving album, the No. 71 vignetting chairs, velvet cushions, etc. Mr. Noble, Nebraska, finds the "Elité" very pleasing and useful, adopted to a large variety of positions, both sitting and standing. Mr. Falk, New York City says: "It is far superior in design," etc. All others are pleased.

**CAUTION.**—Since several members of the Photographic Merchants Board of Trade made a fraudulent use of a copy of the electros of chairs, designed, patented, and introduced by us, and substituted worthless abortive trash as our make, we sell our *Genuine No. 53, Centennial Chairs* in manilla or velvet, for \$18.00. Packing in crate, \$1.00. No discount.

### DECEIVED PHOTOGRAPHERS.

DEAR SIR: We ordered through a dealer such a Centennial Chair as we bought of you for our Altoona, Pa., Gallery some years ago, and supposed we were getting the same, but find it is an imitation, and will not keep it. It has not the iron back; is clumsy and common looking, and has a poor cover; a trimming of bad color. Please send one of your No. 53 chairs, in the *double-thick velveteen*, usual color, at \$20.00, and we will remit at once. Refer to Mr. J. P. C.

MINNEAPOLIS, MINN., July 27, 1886.

To C. A. SCHINDLER, West Hoboken, N. J.

DEAR SIR: Enclosed sight draft on N. Y. for \$21 00. We are greatly pleased with the chair, and more so every day; the counterfeit we would not keep at any price; being badly made, clumsy and awkward, in fact the worst looking chair I ever saw pretending to be good. I would not exchange yours for half dozen of the bogus. For our own use, I must say yours is even better than I expected at that price, and I like it better than the one we have in the East. Send catalogue for further orders.

MINNEAPOLIS, MINN., August 16, 1886.

Yours respectfully, BISHOP BR S.

<p>THE LARGEST ESTABLISHMENT IN THE WORLD</p>	<p>SIXTEEN YEARS PRACTICAL EXPERIENCE</p> <p><b>MOSS ENGRAVING CO.</b></p> <p>535 PEARL ST. COR. ELM. NEW YORK.</p>	<p>ILLUSTRATIONS OF Every Description For Books, Magazines, Newspapers, Catalogues, CIRCULARS, &amp;c. IN THE Finest Style of the Art</p>
<p>MOSS' NEW PROCESS Superior to Any Other Method.</p>		
<p>SEND GREEN STAMP FOR 24 PAGE CIRCULAR -- SEND PHOTOGRAPH, DRAWING OR PRINT FOR ESTIMATE.</p>		

## C. H. CODMAN & CO.

### Photographic Stockdealers

Sole Agents for the NEW ORTHO-PANACTINIC LENS, Moor's Photographic Enamel, the Perfect Mounting Solution for mounting Photographs on the thinnest mount without wrinkling.

New England Agents for American Optical Co.'s Apparatus. The best in the world. Send for Price List.

34 Bromfield Street.

BOSTON, MASS.

720 (5 gross) of these trimmers were sold to one party in July.

# ROBINSON'S NEW MODEL PHOTOGRAPH TRIMMERS!

This drawing is of the full natural size and shape of the New Model Revolving Trimmer. The Straight Cut is of same size, varying but little in shape.

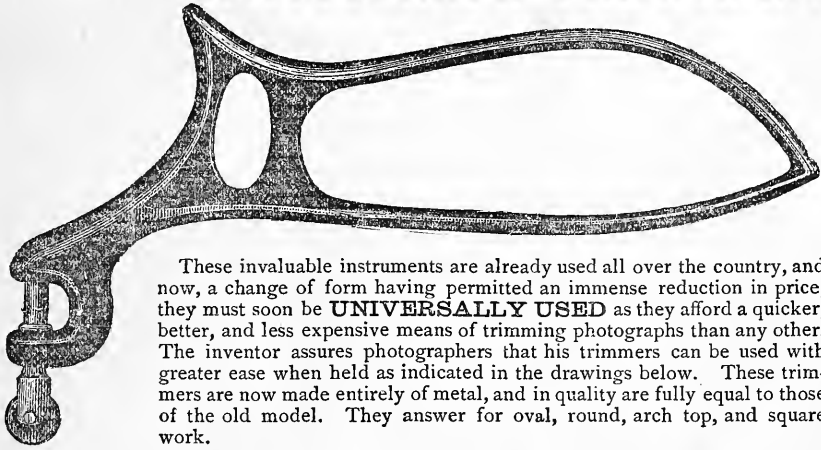

These invaluable instruments are already used all over the country, and now, a change of form having permitted an immense reduction in price, they must soon be **UNIVERSALLY USED** as they afford a quicker, better, and less expensive means of trimming photographs than any other. The inventor assures photographers that his trimmers can be used with greater ease when held as indicated in the drawings below. These trimmers are now made entirely of metal, and in quality are fully equal to those of the old model. They answer for oval, round, arch top, and square work.



Plan of holding the Straight Cut Trimmer when in use. PRICE, 50 CENTS.

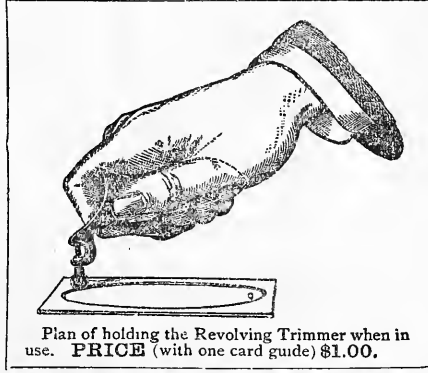

Plan of holding the Revolving Trimmer when in use. PRICE (with one card guide) \$1.00.

## ROBINSON'S GUIDES.

MADE OF SHEET-IRON.

We have the following Regular Sizes always on hand at 10 cents per inch the longest way of the aperture.

**OVALS.**

$2\frac{1}{2} \times 2\frac{1}{2}$	$3\frac{3}{8} \times 4\frac{1}{8}$	$5 \times 7$	$6\frac{1}{4} \times 8\frac{1}{4}$
$2\frac{1}{2} \times 3$	$3\frac{3}{8} \times 4\frac{1}{4}$	$5\frac{1}{4} \times 7\frac{1}{4}$	$6\frac{1}{2} \times 8\frac{1}{2}$
$2\frac{1}{2} \times 3\frac{1}{2}$	$3\frac{1}{2} \times 4\frac{1}{2}$	$5\frac{1}{2} \times 7\frac{1}{2}$	$7 \times 9$
$2\frac{1}{2} \times 3\frac{3}{8}$	$3\frac{3}{8} \times 5$	$5\frac{3}{8} \times 7\frac{3}{8}$	$7\frac{1}{4} \times 9\frac{1}{4}$
$2\frac{1}{2} \times 3\frac{1}{2}$	$4 \times 5\frac{1}{2}$	$5\frac{1}{2} \times 7\frac{1}{2}$	$7\frac{1}{2} \times 9\frac{1}{2}$
$2\frac{1}{2} \times 4\frac{1}{4}$	$4\frac{3}{8} \times 6$	$6 \times 8$	$7\frac{3}{4} \times 9\frac{3}{4}$

**SQUARE OR ROUND CORNERED.**

$2\frac{1}{4} \times 3\frac{3}{8}$	$2\frac{5}{8} \times 3\frac{3}{8}$	$2\frac{3}{4} \times 4\frac{1}{2}$	$4 \times 5\frac{3}{8}$
$2\frac{1}{4} \times 3\frac{1}{2}$	$2\frac{5}{8} \times 3\frac{7}{8}$	$2\frac{7}{8} \times 4\frac{5}{8}$	$4\frac{1}{2} \times 5\frac{7}{8}$
$2\frac{1}{4} \times 3\frac{3}{4}$	$2\frac{3}{4} \times 4\frac{1}{4}$	$3\frac{7}{8} \times 5\frac{1}{4}$	$3\frac{3}{8} \times 6$
$2\frac{5}{8} \times 3\frac{1}{8}$			$4 \times 6\frac{1}{4}$

**FOR STEREOGRAPHS.**

Arch Tops.	Round Cornered.	Round.
$3\frac{1}{8} \times 3\frac{3}{4}$	$3 \times 3$	$3\frac{1}{8} \times 3\frac{3}{4}$
$3 \times 3$	$3 \times 3$	$3 \times 3$

The above sizes suit the Collins Card Mounts, and photographers knowing that they can be always had at the low price of ten cents per inch, would do well to make their sizes accord, as orders can also be filled more quickly. Ten days are required to make special sizes.

Special Sizes made to order, at 15 cents per inch, the longest way of the aperture.

**ROBINSON'S PHOTOGRAPH TRIMMERS** are substitutes for the Knife for Trimming Photographs, and do the work much more expeditiously and elegantly. They Save Time, Save Prints, and Save Money.

They do not cut, but pinch off the waste paper, and leave the print with a neatly bevelled edge which facilitates adherence to the mount. Try one, and you will discard the knife and punch at once. For ovals and rounded corners they are worth their weight in gold.

For sale by all Dealers.

**ROBERTS & FELLOWS,**

Successors to E. L. WILSON,

1125 Chestnut St., Philadelphia, Pa.

# THE PHOTOGRAPHIC TIMES FOR 1887

WILL BE ILLUSTRATED

At frequent intervals by the different Photographic Printing Processes. Among other subjects for these illustrations will be a series of

Portraits of Eminent Photographic Writers to the Photographic Times.

In addition to the regular Editorials and leading articles by our immense staff of prominent photographic writers, the PHOTOGRAPHIC TIMES for 1887 will contain

**“CHAPTERS IN THE HISTORY OF PHOTOGRAPHY.”**

By W. JEROME HARRISON.

**“LETTERS ON LANDSCAPE.”**

From H. P. ROBINSON.

A series of valuable articles on

**“GELATINE: Its Manufacture, Characteristics, and Practical Uses in Photography.”**

By W. M. ASHMAN.

Several papers on

**“ALBUMEN PRINTS.”**

By ANDREW PRINGLE.

**“THE AMERICAN BIBLIOGRAPHY OF PHOTOGRAPHY.”**

By C. W. CANFIELD.

And a Photographic Story entitled,

**“SPIRIT PHOTOGRAPHY.”**

By W. J. STILLMANN.

The series of illustrated articles on

**“REJLANDER'S PHOTOGRAPHIC STUDIES.”**

By A. H. WALL.

The Society News, Letters to the Editor, Notes and Queries, and Commercial Intelligence, will be continued as heretofore, and

**THERE WILL BE NO INCREASE IN THE SUBSCRIPTION PRICE.**

A copy of either of the British Annuals, or of Wilson's Photographic Mosaics for 1887, will be given to any one sending in \$3.00 for one year's subscription to the Weekly PHOTOGRAPHIC TIMES previous to January 1st.

**PHOTOGRAPHIC MOSAICS,****1887****144 PAGES.****50 CENTS. CLOTH, \$1.00.****144 PAGES.****BEATS ALL ITS PREDECESSORS.****CONTENTS.**

**A Photogravure Picture from Negative by ERNEST EDWARDS,**  
 printed by the Photogravure Co., 853 Broadway, N. Y.,  
 and the following:

Retrospective. Edward L. Wilson, Editor of Mosaics.  
 Coming Back to Good Sense in Developers. Thomas  
 Pray, Jr. [x amatoor], Hartford, Connecticut.

Development of Overtimed Plates. L. Farini, Bridge-  
 port, Connecticut.

The Flap Shutter. G. G. Mitchell, Edinburgh, Scot-  
 land.

The Simplest Enlarging Process. Dr. E. A. Just,  
 Vienna, Austria.

Hydroxylamine as a Developing Agent. W. E.  
 Woodbury, Dusseldorf, Germany.

Lantern Slides. Dr. Thomas W. Drinkwater, Edin-  
 burgh, Scotland.

Developing Dodges. Harold Sands, Nottingham,  
 England.

The Art-education of Photographers. Charlotte Adams,  
 New York.

Habits of Life. W. H. Clark, St. Louis, Mo.

Photographing Interiors. W. I. Lincoln Adams,  
 New York.

Photography for the Papers. F. H. Wilson, New York.

Development of Dry Plates. E. M. Estabrook, New  
 York.

A Printer's Collation. Young Chloride

Call from an Old Foggy. W. J. Baker, Buffalo, N. Y.

On the Development of Very Short Exposures in the  
 Studio. W. E. Truesdell, Springfield, Illinois.

What We Want. John W. Hallenbeck, New York.

The Use of Photography in Wood Engraving. M. V.  
 Roux, Paris, France.

Developing—A Lesson. A 5 x 8 Tramp, Boston, Mass.

My Experience. William McComb, Muskegan, Mich.

Three P's Photographically Considered. J. Pitcher  
 Spooner, Stockton, Cal.

Shade Your Lenses. Karl Klausner, Farmington,  
 Conn.

My Printing Methods. C. P. McDannell, Titusville,  
 Penna.

Photography as an Art. One Who Observes.

Scaled Prices. G. M. Carlisle, Providence, R. I.

The Grade System of Prices. G. L. Hurd, Providence,  
 R. I.

Millions Wanted, and Money in It. A Retired Watch-  
 maker.

Eyes. C. J. Billingham, Orange Heights, Florida.

How Shall We Aim? J. F. Ryder, Cleveland, Ohio.

Developing with Pyrogallol. Arthur H. Elliott, Ph.D.,  
 New York.

The Disposition of the Hands in Portraiture. W. T.  
 Mozart, New York.

Our Picture.

Stopping Down the Eye. Dr. D. Garrison, Chicago,  
 Illinois.

Make Your Own Rustic Furniture. H. G. Parcell,  
 Kirksville, Maine.

A Surprise. Col. Octavio Barrati, Piverone, Italy.

Carbon Solar Prints. F. H. Sherman, Milwaukee,  
 Wisconsin.

Odd Points. C. F. Moelk, Edina, Missouri.

Backgrounds and Accessories, Their Use and Abuse.  
 Mrs. Clyde Ehinger, Quincy, Ill.

Enlarging and Magic Lantern Slides. A. R. Dresser,  
 London, England.

Stop to Consider. H. McMichael, Buffalo, N. Y.

An Item in Oil. J. Hegyessey, Paris, Texas.

Dots. "Aunt Dottie."

Many Mites from Many Minds.

**NOTE BY THE PUBLISHER.**

I am obliged to make the unprecedented announcement, that in less than two weeks after its issue, all my paper bound copies of Mosaics, 1887, were sold. I have only a few cloth-bound copies left. The 50 cent edition may be had of the dealers named below, who had a full supply.

J. W. MORRISON.  
 PAUL & SHAPE.  
 REIMER & KATZ.  
 H. LIEBER & CO.  
 W. S. BELL & CO.  
 P. SMITH & CO., CINCINNATI.  
 SWEET, WALLACH & CO.  
 H. J. THOMPSON.  
 G. A. DOUGLASS & CO.

SMITH & PATTISON.  
 ZIMMERMAN BROS.  
 D. TUCKER & CO.  
 F. HENDRICKS & CO.  
 J. C. SOMERVILLE.  
 H. A. HYATT.  
 W. D. GATCHEL.  
 SHEEN & SIMPKINSON.  
 SARGENT & CO.

B. FRENCH & CO.  
 C. H. CODMAN & CO.  
 R. BROUDE & CO.  
 SAM C. PARTRIDGE.  
 G. W. SITTLER.  
 BUCHANAN, SMEDLEY & BROMLEY  
 WILSON, HOOD & CO.  
 E. & H. T. ANTHONY & CO.  
 GEO. MURPHY.

**EDWARD L. WILSON, Photo. Publisher, 853 Broadway, N. Y.**

*Mailed on receipt of price. For Sale by all Dealers.*

# SWEET, WALLACH & CO.

## Photographers' Supplies,

229 & 231 STATE ST., CHICAGO.  
**Best Goods! Lowest Prices! Complete Stock!**  
**ORDERS PROMPTLY FILLED. SATISFACTION GUARANTEED**  
**Your Patronage Solicited. Send for Catalogue.**

MANUFACTORY OF  
**STEAM PRINTING PRESSES OF SCHMIERS, WERNER & STEIN,**  
**OF LEIPZIG.**

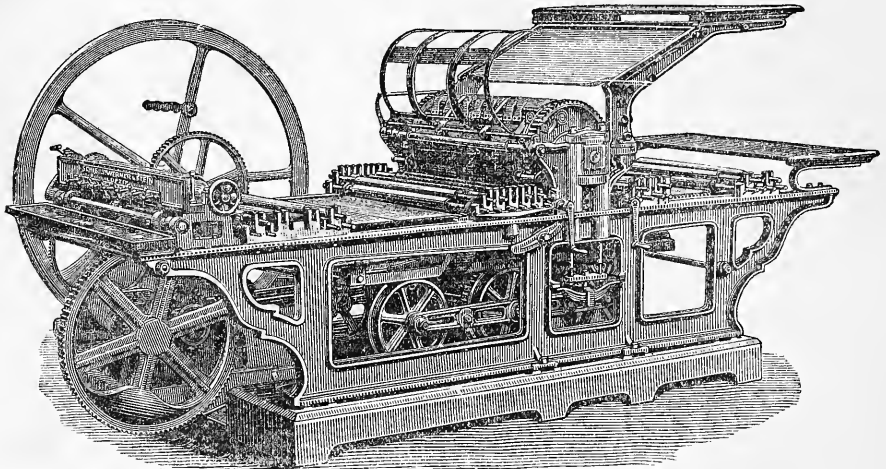

### PHOTOTYPE OR HELIOTYPE STEAM PRESSES.

These Steam Presses, which are admitted to have given the most satisfactory results in every respect, are as yet unsurpassed, and have been in use, by preference to all other systems, in all first-class Heliotype Establishments all over the world for the last ten years. They are supplied by the undersigned manufacturers in four sizes, and absolutely warranted with respect to their working capacity. The comfortable and easy working of the machine, and their solid and excellent workmanship, are the principal advantages of our phototype steam presses. These steam phototype presses are also supplied with the contrivance for lithography, and with or without automatic uncovering frame, and feeding table, etc. For full particulars apply to the

**STEAM PRINTING PRESS MANUFACTORY OF SCHMIERS, WERNER & STEIN,**  
**LEIPZIG, GERMANY.**

### G. W. WILSON & CO.

(By special appointment Photographers to Her Majesty the Queen),

**MANUFACTURERS OF MAGIC LANTERN SLIDES,**  
**St. Swithin Street, Aberdeen.**

Catalogue of 12,000 subjects in England and Scotland, and Price Lists, post free on application.

# THE ARGENTIC DRY PLATE.

## A Splendid New Picture.

Among the desirable advantages are rapidity, cleanliness in manipulation, permanency, certainty of good results, absence of all pinholes, metallic stains, discoloring, fog, frilling, and other dry-plate ills. Pictures deliverable ten minutes after the sitting. Full directions with each box.

### LIST OF SIZES AND PRICES.

2 dozen $3\frac{1}{4} \times 4\frac{1}{4}$ , per box, . \$0 90	2 dozen $5 \times 8$ , per box, . \$2 25
2 " $4 \times 5$ , " . 1 25	2 " $6\frac{1}{2} \times 8\frac{1}{2}$ , " . 3 75
2 " $4\frac{1}{4} \times 5\frac{1}{2}$ , " . 1 50	2 " $7 \times 10$ , " . 4 00
2 " $4\frac{1}{4} \times 6\frac{1}{2}$ , " . 1 80	2 " $8 \times 10$ , " . 4 50
2 " $5 \times 7$ , " . 2 00	1 " $10 \times 14$ , " . 4 00

A splendid opportunity to increase business is offered by the New Argentic Dry Plate. Every plate guaranteed.

FOR SALE BY ALL DEALERS.

## PHENIX PLATE CO.

Manufacturers,

WORCESTER, MASS.

## VENI, VIDI, VICI!

THE WONDER OF THE P. A. of A. CONVENTION  
AT ST. LOUIS.



Only Five Months in Existence, and Carried off the  
Honors from All Comers.

The judges at the St. Louis Convention awarded the exhibitors Seven Medals, gold and silver, for work done on the **EAGLE DRY PLATE**, the photographs being, without exception, the gems of the exhibit.

How could it be otherwise with such a plate, when for **Reliability**, **Rapidity**, **Delicacy of Detail**, and **Extreme Brilliancy**, they surpass all other makes of Dry Plates in the market.

Their reception by the photographic profession at large, speaks volumes in their favor, they being now used by the leading lights of the photographic world, both professional and amateur.

Came, saw, and conquered! Truly, such was the case, and in the future our aim will be to lead them to further conquest.

EAGLE DRY-PLATE CO.

**G. GENNERT,**

**54 East Tenth Street, New York,**

GENERAL AGENT.



# ANTHONY'S SATCHEL DETECTIVE CAMERA.

IN outward appearance, and to the ordinary observer, this latest modification of the Detective Camera looks exactly an alligator hand-satchel that is carried by a shoulder-strap at the side of the pedestrian. Upon closer observation, one sees that it consists of an artfully-concealed Detective Camera, in which all the movements to secure a picture are situated upon the under side.



For use the camera is held so that the base of the satchel rests against the body of the operator. By means of a brass pull at the side the shutter is set. A plate in the regular holder is placed in position at the back of the camera and the slide is drawn ready for exposure. The release of a short catch exposes the front of the shutter ready for action, and by raising a small leather-covered lid the little camera obscura called the finder on the (now) upper side of the camera, shows the position that the object will occupy on the plate. The slightest touch upon a small brass button releases the shutter, and the exposure is made. Replacing the slide in the plate holder, reversing the holder, and setting the shutter again, leaves the apparatus in readiness for another shot, when the plate holder slide is withdrawn.

and the screw removed serves to attach the camera to a tripod for ordinary use.

By removing a screw that takes the place of the spring lock of an ordinary satchel the camera proper can be removed from its cover,

This last form of the Detective Camera allows the operator to carry with him twelve plates in the interior of the apparatus, and so carefully packed away that no light can strike them. It is

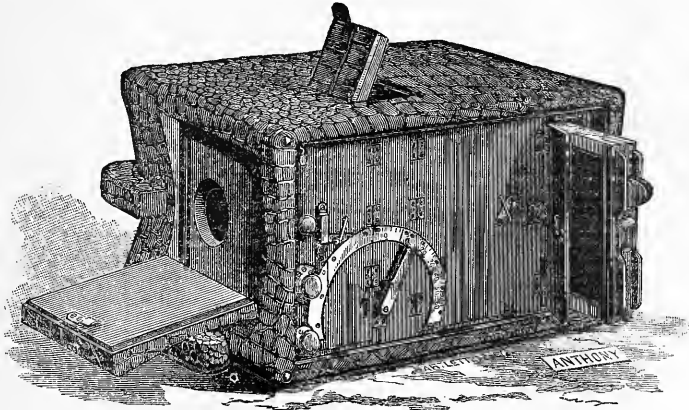

also furnished with an ingenious attachment by which the speed of the shutter can be regulated to suit the speed of the objects, moving with greater or less velocity; while, by simply releasing a catch, time exposures can be made at the will of the operator. In fact the whole affair is the latest achievement in ingenious and compact light photographic apparatus.

Size 4 x 5 in Imitation Alligator or Grained Leather, with one Patent Double Dry Plate Holder.....	\$80 00
" 4 x 5 in Genuine Alligator, with one Patent Double Dry Plate Holder.....	85 00
" 4 x 5 in Imitation Alligator or Grained Leather with rear compartment containing six Patent Double Dry Plate Holders.....	95 00
" 4 x 5 in Genuine Alligator, with rear compartment containing six Patent Double Dry Plate Holders.....	100 00

LARGER SIZES MADE TO ORDER.

FOR SALE BY ALL DEALERS.

**E. & H. T. ANTHONY & CO., Manufacturers.**

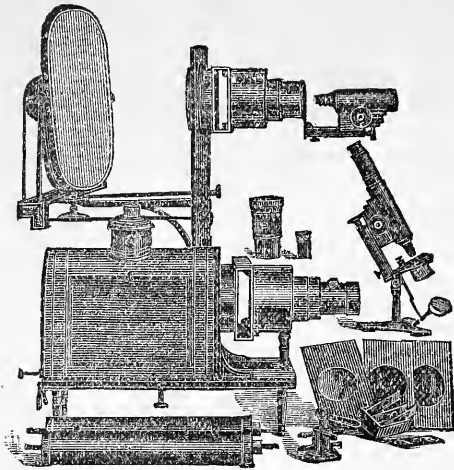

# OPTICAL AND ELECTRICAL INSTRUMENTS.

We desire to call the attention of  
TEACHERS, SCIENTISTS, LECTURERS, and  
those interested, to our

**Stereopticons, Microscopes, Dr. McIntosh's Solar Microscope and  
Stereopticon Combination Apparatus for  
the Oxy-hydrogen and Ether-oxygen Lime Light, Photographic  
Transparencies, Microscopical Preparations, etc.**

Our Instruments and Apparatus are new in design and have many improvements  
that overcome difficulties heretofore considered unavoidable. We also manufacture

**Static Electric Machines, Batteries, Magnets, and a Full Line of  
Electrical Apparatus for Practical and Experimental  
Purposes.**



We received the highest  
award at the New Orleans  
World's Exposition, on  
both Optical and Elec-  
trical Apparatus, in com-  
petition with the best of  
home and foreign manu-  
facturers.



Illustrated Catalogue of Optical and Electrical Apparatus sent free on application  
by mentioning this journal.

**McIntosh Galvanic and Faradic Battery Co.**

Nos. 300 & 302 Dearborn Street,

CHICAGO, ILL., U. S. A.

**SUBSCRIBE NOW**

TO

# THE PHILADELPHIA PHOTOGRAPHER.

TWENTY-FOURTH YEAR, 1887.

*Devoted to the Advancement of Photography and the Dissemination of Art Principles.*

**SEMI-MONTHLY:** issued the First and Third Saturday of each month.

**\$5.00 a year, \$2.50 for six months, \$1.25 for three months—in advance. 30 cts. per copy.**

**OLD SUBSCRIBERS** please inform us now if you want to renew.

**NEW SUBSCRIBERS** please order early and get all the numbers for 1887.

During the year it will be our honest effort to make our magazine the best of its class in the world. No publisher gives so much for the money—12 numbers, illustrated (32 pages each, always), for \$2.50; double that number for \$5.00. Where is it equalled?

It gives you the news of the world; it is the practical photographer's devoted advocate and helper; it is not issued for the sake of catching other trade; it is open and straightforward in its policy; and it will not be beat. A splendid variety of studies is given—an unrivalled choice, and it is our constant effort and study to be of service to the photographer who must win his daily bread by his camera.

Some of the features of our new volume of THE PHILADELPHIA PHOTOGRAPHER, will be a new series of papers from foreign contributors; a series of illustrated art lessons; the reproduction, in supplementary sheets, of some of the best articles of the year in the French and German languages, for our readers who cannot read English; a grand prize contest; a series of lessons from the veterans of the craft; another series from the second generation; twenty-four or more such studies as were never before seen in any photographic magazine. Among these last, the year will be led by Mr. D. H. Anderson, of this city, with a splendid portrait of the charming actress, Miss Charlotte Behrens, in her Russian character of "Zitka." It will be followed by an example of the Vandyke style of lighting, by Messrs. Loescher & Petsch, Berlin; by that charming female subject from Peitzner, Tôplitz—in our opinion the gem of the German department at St. Louis; a whole series of lovely child pictures—some from Texas, some from California, and some from the Hoosier State; an aristotype on Liesegang's new paper; photogravures and phototypes, gelatine, and other process pictures; a group of ladies from the new studio of Mr. P. H. Rose, Providence, R. I.; a Kalahari view, by Mr. Lulu Farini, Bridgeport, Conn.; a gem from Mr. H. P. Robinson; a quartette of portrait studies from a famed London artist; an azaline reproduction of a chromo, with the original and a wet picture added; and— Well, it is not good policy, for obvious reasons, to tell *all* we are going to do; but if our old friends will come forward and help us to some new ones, reciprocal action will assure them that together we can uphold the honor of our art, make it grow under our hands, and help each other to more comfort in our work. Shall the thing be mutual? Please express your opinion by the usual sign—and our best wishes for a Happy New Year go to you heartily.

A good photographic magazine is somewhat like your water supply. You do not realize how useful it is until it stops. What would photography do if there were no good magazines devoted to it? Is it not to your interest to support them all; and if not all, the *best* one?

Please take a moment to consider these things *for your own good*.

**\$1 IN BOOKS, PREMIUM FOR NEW SUBSCRIBERS.**

**Our Invaluable Back Numbers for 1886 are Equivalent to Several Volumes on Our Art.**

**EDWARD L. WILSON, 853 Broadway, New York.**

OFFICE OF

*G. Cramer.*

DRY PLATE WORKS,

Shenandoah and Buena Vista Streets., St. Louis.

---

The enlargement of my factory being now completed, I am able to serve my patrons more promptly than heretofore.

Thanking the fraternity for their kind patronage, and soliciting a continuance of the same, I am                      Fraternally yours,

G. CRAMER DRY PLATE WORKS,  
ST. LOUIS, MO.

---

**THE**

**ST. LOUIS DRY PLATE COMPANY**

Beg to announce that under their New Management they have recently made Important Improvements and Increased their Facilities, so that they are now making better and more uniform plates than heretofore.

---

ALL ORDERS WILL RECEIVE PROMPT ATTENTION.

---

**ST. LOUIS DRY PLATE CO.**

No. 827 Chouteau Avenue,

ST. LOUIS, MO.





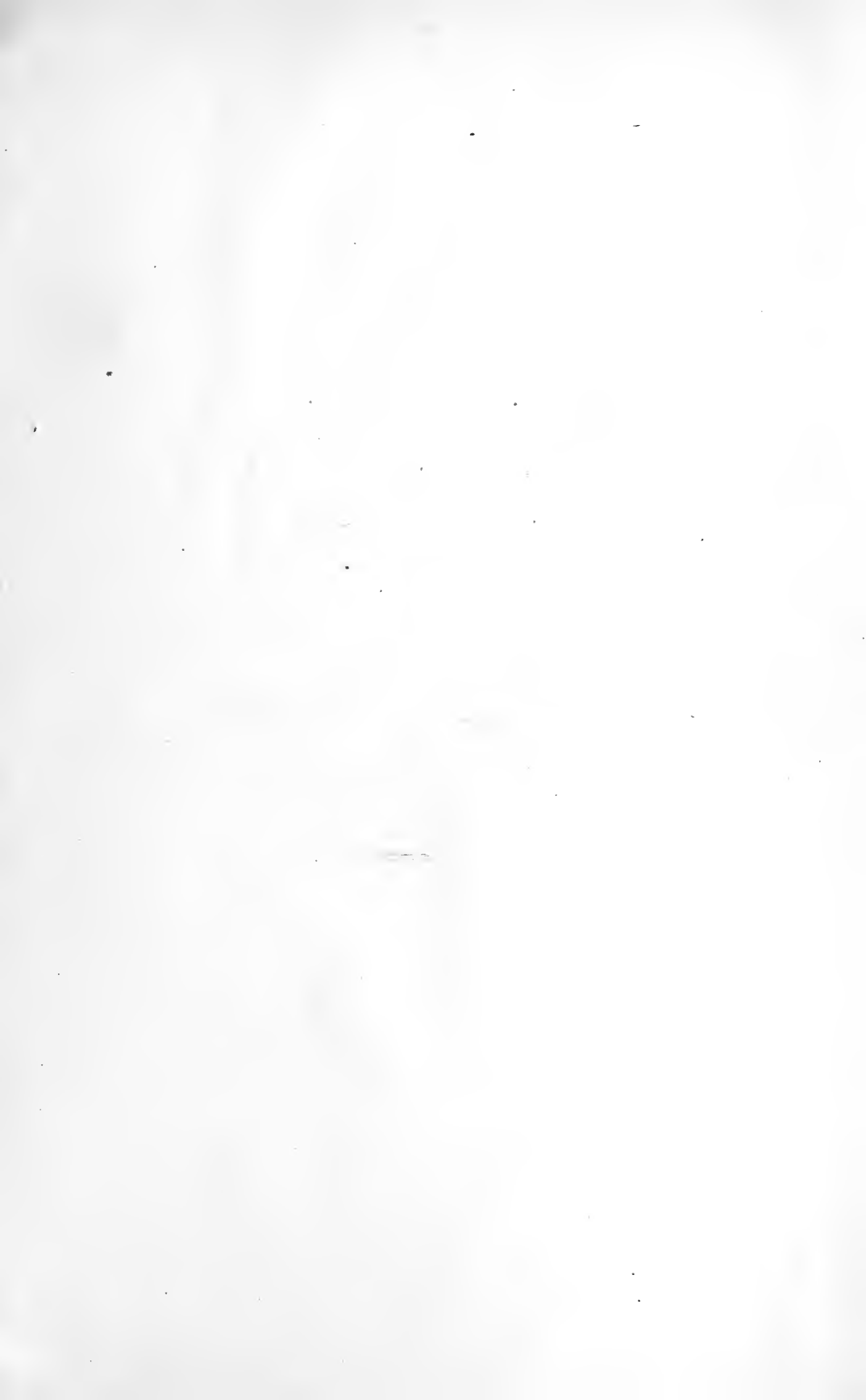





(Sept., 1886, 20,000)

## BOSTON PUBLIC LIBRARY.

---

One volume allowed at a time, and obtained only by card; to be kept 14 days (or seven days in the case of fiction and juvenile books published within one year) without fine; not to be renewed; to be reclaimed by messenger after 21 days, who will collect 20 cents besides fine of 2 cents a day, including Sundays and holidays; not to be lent out of the borrower's household, and not to be transferred; to be returned at this Hall.

Borrowers finding this book mutilated or unwarrantably defaced, are expected to report it; and also any undue delay in the delivery of books.

\*\*\*No claim can be established because of the failure of any notice, to or from the Library, through the mail.

---

The record below must not be made or altered by borrower,

