



L. R. 1.





Postering Room, 5, 11

Published the Last Day of every Month.—Price 2s. 6d.

THE
**PHILOSOPHICAL MAGAZINE
 AND JOURNAL:**

COMPREHENDING
 THE VARIOUS BRANCHES OF SCIENCE,
 THE LIBERAL AND FINE ARTS,
 AGRICULTURE, MANUFACTURES,
 AND COMMERCE.

NUMBER CCCXI.

For MARCH 1824.

WITH TWO PLATES,

Illustrative of Dr. WALCHNER's Examination of a new Mineral
 named Hyalosiderite; and of Mr. BAILY's and M. FRAUEN-
 HOFER's Accounts of the Circular Micrometer.

By ALEXANDER TILLOCH, LL.D.

M.R.I.A. F.S.A. EDIN. AND PERTH; CORRESPONDING MEMBER OF THE ROYAL
 ACADEMY OF SCIENCES, MUNICH; AND OF THE ACADEMY OF SCIENCES,
 LITERATURE AND ARTS, LEGHORN, ETC.

And RICHARD TAYLOR, F.L.S.

MEMBER OF THE ASTRONOMICAL SOCIETY OF LONDON, AND OF THE ASIATIC SOCIETY
 OF GREAT BRITAIN AND IRELAND.



LONDON:

PRINTED BY RICHARD TAYLOR, SHOE-LANE:

Sold by Cadell; Longman, Hurst, Rees, Orme, Brown and Green; Baldwin,
 Cradock, and Joy; Highley; Sherwood, Jones, and Co.; Harding; Under-
 wood; Simpkin and Marshall; London:—and by Constable and Co. Edin-
 burgh; and Penman, Glasgow.

TO CORRESPONDENTS.

Mr. J. E. GRAY'S Zoological Notices, and Mr. STURGEON'S Experiments on Thermo-magnetism, &c. are under consideration.

We have been favoured with some interesting communications from Professor HARE, of the University of Pennsylvania, which will appear in our next.

This day is published, in 8vo, with a Plate and a new Map constructed from the best authorities, price 12s. boards,

SELECTIONS from the WORKS of the BARON DE HUMBOLDT, relating to the Climate, Inhabitants, Productions, and Mines of MEXICO, with Notes and an Introduction.

By JOHN TAYLOR, Esq.,
Treasurer to the Geological Society, &c.

Printed for Longman, Hurst, Rees, Orme, Brown, and Green.

This work is intended to communicate information on these interesting subjects, and particularly to those who may be investing Capital in the Mines of New Spain, or to others who may contemplate a residence in the country. Some recent and original communications will be found in the work.

THE SECOND EDITION OF THE CAMBIST,
Essentially improved by the aid of Government.

Published in two vols. 4to, price 4l. 4s. in boards,

THE UNIVERSAL CAMBIST, and COMMERCIAL INSTRUCTOR; being a full and accurate Treatise on the Exchanges, Moneys, Weights and Measures of all trading Nations and their Colonies,

By P. KELLY, LL.D.

Master of the Finsbury-square Academy, London; and Mathematical Examiner to the Trinity-House.

The Second Edition, corrected and enlarged.

This edition comprehends the results of the late comparison of foreign weights and measures with those of England, effected for the first time on a general and systematic plan, by order and aid of the British Government.

A Supplement on Indian Weights and Measures is in preparation, by order of the Honourable Court of Directors.

These volumes also contain an entire revision of foreign exchanges from recent operations, and of foreign coins, from verified assays. An explication of the coins is added, with a translation of their legends; and the work concludes with a copious index and commercial dictionary.

Printed for the Author: and sold by Lackington and Co., Finsbury-square; by J. M. Richardson, 23 Cornhill; and by the principal Booksellers of the United Kingdom.

Of whom may be had, by the same Author,

An INTRODUCTION to SPHERICS and NAUTICAL ASTRONOMY, the 5th Edition. Also,

The ELEMENTS of BOOK-KEEPING, the 7th Edition.

Published the Last Day of every Month.—Price 2s. 6d.

THE
PHILOSOPHICAL MAGAZINE
AND JOURNAL:

COMPREHENDING
THE VARIOUS BRANCHES OF SCIENCE,
THE LIBERAL AND FINE ARTS,
AGRICULTURE, MANUFACTURES,
AND COMMERCE.

NUMBER CCCXIII.

For MAY 1824.

WITH A PLATE

Containing two new Species of *Ascidia*; and *Amphiuma means*,
a new Batrachian Animal.

By ALEXANDER TILLOCH, LL.D.

M.R.I.A. F.S.A. EDIN. AND PERTH; CORRESPONDING MEMBER OF THE ROYAL
ACADEMY OF SCIENCES, MUNICH; AND OF THE ACADEMY OF SCIENCES,
LITERATURE AND ARTS, LEGHORN, ETC.

AND RICHARD TAYLOR, F.L.S.

MEMBER OF THE ASTRONOMICAL SOCIETY OF LONDON, AND OF THE ASIATIC SOCIETY
OF GREAT BRITAIN AND IRELAND.



LONDON:

PRINTED BY RICHARD TAYLOR, SHOE-LANE:

Sold by Cadell; Longman, Hurst, Rees, Orme, Brown and Green; Baldwin,
Cradock, and Joy; Highley; Sherwood, Jones, and Co.; Harding; Under-
wood; Simpkin and Marshall; London:—and by Constable and Co. Edin-
burgh; and Penman, Glasgow.

TO CORRESPONDENTS.

Want of room has compelled us to defer till next month some communications which we had hoped to be able to give in the present number.

Our Correspondent XX will hear from us within a few days.

Mr. Wiseman's Paper on Dr. Young's Report on Improvements in Gauging has come to hand, and shall receive attention.

In the Number for February last, in Mr. Sturgeon's paper, page 97, line 17, for "the platinum is positive to the silver," read "the silver is positive to the platinum."

In the Number for April, page 268, line 5, for "400°," read "100°."

PHARMACOPŒIA LONDINENSIS,

Iterum recognita et retractata, 1824, p. 6.

"*ACIDUM ACETICUM FORTIUS,*"

vel

"*Acidum Aceticum è Ligno destillatum.*"

PURE CONCENTRATED ACETIC ACID, agreeable to the Sample furnished at the request of the Committee of the Royal College of Physicians, may be had of the Manufacturers, BEAUFOY & CO. South Lambeth, London.

THE SECOND NUMBER of the ZOOLOGICAL JOURNAL will be Published on the 15th June by W. PHILLIPS, George Yard, Lombard Street.

ENGRAVINGS.

Vol. LIII. A Plate illustrative of Dr. URE's Experiments on Caloric, Mr. LUCKCOCK's Paper on the Atomic Philosophy, and Mr. BOLTON's on the Purification of Coal Gas.—A Plate representing Mr. RENNIE's Apparatus employed in his Experiments on the Strength of Materials; and the Marquis RIDOLPHI's Improvement on the Gas Blow-pipe.—A Plate illustrative of Mr. MEIKLE's Paper on Calorific Radiation; Mr. LOWE's on the Purification of Coal Gas; and Mr. HUGHES's on ascertaining Distances. — A Plate illustrative of Dr. OLINTHUS GREGORY's Paper on the different Rates of PENNINGTON's Astronomical Clock at the Island of Balta, and at Woolwich Common.

Vol. LIV. A Plate illustrative of the MENAI BRIDGE.—A Plate illustrative of Mr. LOWE's Description of a Mercurial Pendulum.—A Plate illustrative of Mr. HARE's Calorimotor, a new Galvanic Instrument.—A Plate illustrative of Captain SABINE's Paper on Irregularities observed in the Direction of the Compass Needles of the Isabella and Alexander in the late Voyage of Discovery; and Mr. SCORESBY's Anomaly in the Variation of the Magnetic Needle as observed on Ship-board.

Vol. LV. A Plate exhibiting Sketch of the Comer's Path of July 1819.—A Plate illustrative of the Annular Eclipse of the Sun on the 7th of September next.—A Plate illustrative of Mr. LANE's Instrument for gathering Fruit; Mr. YOUNG's Mode of preparing Opium from the *Papaver somniferum*; and of Captain FORMAN's Essay on a Property in Light which hitherto has been unobserved by Philosophers.—A Plate descriptive of Mr. CUTHBERT's improved Hydro-pneumatic Apparatus, &c.—A Plate illustrative of Capt. FORMAN's Essay on the Reflection, Refraction, and Inflection of Light, &c.; and Mr. CHARLES BONNYCASTLE's Communication respecting the Influence of Masses of Iron on the Mariner's Compass.

Published the Last Day of every Month.—Price 2s. 6d.

THE
**PHILOSOPHICAL MAGAZINE
 AND JOURNAL:**

COMPREHENDING
 THE VARIOUS BRANCHES OF SCIENCE,
 THE LIBERAL AND FINE ARTS,
 AGRICULTURE, MANUFACTURES,
 AND COMMERCE.

NUMBER CCCXIV.

For JUNE 1824.

By *ALEXANDER TILLOCH, LL.D.*

M.R.I.A. F.S.A. EDIN. AND PERTH; CORRESPONDING MEMBER OF THE ROYAL
 ACADEMY OF SCIENCES, MUNICH; AND OF THE ACADEMY OF SCIENCES,
 LITERATURE AND ARTS, LEGHORN, ETC.

AND *RICHARD TAYLOR, F.L.S.*

MEMBER OF THE ASTRONOMICAL SOCIETY OF LONDON, AND OF THE ASIATIC SOCIETY
 OF GREAT BRITAIN AND IRELAND.



LONDON:

PRINTED BY RICHARD TAYLOR, SHOE-LANE:

Sold by Cadell; Longman, Hurst, Rees, Orme, Brown and Green; Baldwin,
 Cradock, and Joy; Highley; Sherwood, Jones, and Co.; Harding; Under-
 wood; Simpkin and Marshall; London:—and by Constable and Co. Edin-
 burgh; and Penman, Glasgow.

TO CORRESPONDENTS.

The following communications have been received :

Mr. J. **UTTING** on an Analogy between the Projectile and Gravitating Forces in the Planetary System.

Mr. **SQUIRE** on the great Difference in the Quantity of Rain about the 15th of May at Boston, London, and Gosport; with his Meteorological Summary for 1823. And

Mr. T. **EXLEY** on the Theory of Parallel Lines.

AN ORIGINAL WORK.

On the 16th of July will be published, in Quarto, Weekly Numbers, price 6*d.* Monthly Parts 2*s.* each, got up in the first style of workmanship, and with correct and highly finished Copper-plate Engravings,

THE MECHANIC'S ORACLE; or, ARTISAN'S COMPLETE LABORATORY AND WORKSHOP. Explaining, in an easy and familiar manner, the General and Particular Application of PRACTICAL KNOWLEDGE to the different Departments of SCIENCE and ART. Illustrated by appropriate Engravings, executed by the first Artists.

————— "So work the honey-bees,
Creatures that, by a rule in nature, teach
The art of order to a peopled kingdom."

Edited by eminent Scientific Gentlemen of great mechanical talents, who would rather the Public should judge of the work by its *own* merits, than be influenced by the sanction of their names.

Communications, Drawings, &c. &c. are solicited; to be addressed to the Editors of the Mechanic's Oracle, 38, Newgate Street, London. Sold by all Booksellers and Publishers.

PHARMACOPŒIA LONDINENSIS,

Iterum recognita et retractata, 1824, p. 6.

"*ACIDUM ACETICUM FORTIUS,*"

vel

"*Acidum Aceticum è Ligno destillatum.*"

PURE CONCENTRATED ACETIC ACID, agreeable to the Sample furnished at the request of the Committee of the Royal College of Physicians, may be had of the Manufacturers, **BEAUFOY & CO.** South Lambeth, London.

This day is published, No. II., price 10*s.* of

THE ZOOLOGICAL JOURNAL, to be continued Quarterly; conducted

By **THOMAS BELL**, Esq., F.L.S. **JOHN GEORGE CHILDREN**, Esq. F.R. and L.S. **JAMES DE CARLE SOWERBY**, Esq., F.L.S. and **G. B. SOWERBY**, F.L.S.

Printed and published by **W. Phillips**, George Yard, Lombard Street. Sold also by **G. B. Sowerby**, 156, Regent Street; where communications are to be addressed; **W. and C. Tait**, Edinburgh; and **A. A. Royer**, au Jardin des Plantes, à Paris.

THE
PHILOSOPHICAL MAGAZINE
AND JOURNAL:

COMPREHENDING
THE VARIOUS BRANCHES OF SCIENCE,
THE LIBERAL AND FINE ARTS,
AGRICULTURE, MANUFACTURES,
AND COMMERCE.

By *ALEXANDER TILLOCH, LL.D.*

M.R.I.A. M.G.S. M.A.S. F.S.A. EDIN. AND PERTH; CORRESPONDING MEMBER OF
THE ROYAL ACADEMY OF SCIENCES, MUNICH; AND OF THE ACADEMY
OF SCIENCES, LITERATURE AND ARTS, LEGHORN, ETC.

And *RICHARD TAYLOR, F.L.S.*

MEMBER OF THE ASTRONOMICAL SOCIETY OF LONDON; AND OF THE ROYAL
ASIATIC SOCIETY OF GREAT BRITAIN AND IRELAND.

“Nec araneorum sane textus ideo melior quia ex se fila gignunt, nec noster
vilior quia ex alienis libamus ut apes.” *Just. Lips. Monit. Polit. lib. i. cap. 1.*

VOL. LXIII.

For *JANUARY, FEBRUARY, MARCH, APRIL, MAY, and
JUNE, 1824.*

LONDON:

PRINTED BY RICHARD TAYLOR, SHOE-LANE:

AND SOLD BY CADELL; LONGMAN, HURST, REES, ORME, BROWN, AND GREEN;
BALDWIN, CRADOCK, AND JOY; HIGHLEY; SHERWOOD, JONES,
AND CO.; HARDING; UNDERWOOD; SIMPKIN AND
MARSHALL, LONDON:—AND BY CONSTABLE
AND CO. EDINBURGH: AND PENMAN,
GLASGOW.



ALERE FLAMMAM



CONTENTS

OF THE SIXTY-THIRD VOLUME.

<i>ON two new Species of Narcissus</i>	Page 7
<i>On the irregular Indications of Thermometers. By J. HERAPATH, Esq.</i>	8
<i>On the apparent Magnetism of Metallic Titanium. By WILLIAM HYDE WOLLASTON, M.D. V.P.R.S.</i>	15
<i>Chemical Examination of a Fragment of a Meteor which fell in Maine, August 1823. By JOHN W. WEBSTER, M.D.M.G.S. Lond. &c.</i>	16
<i>A new Theory of Telescopes founded on rational Principles and interesting Experiments. By J. READE, M.D.</i>	20
<i>Description of certain Gangues of Spinelle brought from the Island of Ceylon by M. LESCHENAULT DE LATOUR. By M. le Comte de BOURNON, Chev. de St. Louis, F.R.S. &c.</i>	30
<i>Description of an improved Gauge for ascertaining with Precision the Pressure of highly compressed Steam, Gases, and Fluid Bodies. By Mr. SAMUEL SEAWARD</i>	36
<i>Description of some new Cacti and Mammillariæ, recently brought from Mexico by Mr. BULLOCK of the Egyptian Hall, Piccadilly; and now preserved, with many other very rare Plants, in the Nursery of Mr. TATE, in Sloane-street. By A. H. HAWORTH, Esq. F.L.S. &c.</i>	40
<i>An Account of the Effect of Mercurial Vapours on the Crew of His Majesty's Ship Triumph in the Year 1810. By WILLIAM BURNETT, M.D., one of the Medical Commissioners of the Navy, formerly Physician and Inspector of Hospitals to the Mediterranean Fleet.</i>	42
<i>Account of a Work entitled "Storia de' Fenomeni del Vesuvio avvenuti negli anni 1821, 1822, e parte del 1823," etc. "History of the Phænomena of Vesuvius during the Years 1821, 1822, and Part of 1823; accompanied with Observations and Experiments. By J. MONTICELLI, Perpetual Secretary of the Royal Academy of Sciences of Naples; and N. COVELLI, of the Royal Institute of Encouragement." By M. MENARD DE LA GROYE</i>	46

CONTENTS.

<i>On the ensuing Opposition of Mars.</i> By F. BAILY, Esq. F.R.S. <i>Read before the Astronomical Society of London, January 9,</i> 1824	50
<i>Remarks on the Position of the Upper Marine Formation exhibited in the Cliffs on the North-east Coast of Norfolk.</i> By Mr. RICHARD TAYLOR of Norwich	81
<i>On the Mode of manufacturing Salt by Evaporation on Faggots.</i> By R. BAKEWELL, Esq.	86
<i>Description of a Pressure Gauge recommended for its Simplicity of Construction and Principle; with Observations on the Gauge proposed by Mr. SEAWARD.</i> By Mr. H. RUSSELL	92
<i>Electro- and Thermo-magnetical Experiments.</i> By Mr. WM. STURGEON	95, 266
<i>On Parallel Straight Lines.</i> By JOHN WALSH, Esq.	100, 271
<i>A technical Description of Chloraster, a new Genus of Narcisseæ.</i> By A. H. HAWORTH, Esq. F.L.S. &c.	102
<i>Papers relating to the Earthquake which occurred in India in 1819</i>	105, 170
<i>On White Copper.</i> By C. KEFERSTEIN. <i>Read at a Meeting of the German Explorers of Nature at Halle, September 18,</i> 1823	119
<i>Experiments on the Deviation of the Magnetic Needle, as effected by Caloric, &c.</i> By JOHN MURRAY, Esq. F.S.A. F.L.S. F.H.S. Member of the Geological and Wernerian Societies, &c. &c.	130
<i>Description, Analysis, &c. of a Lamellar Pyroxene.</i> By LARDNER VANUXEM	131
<i>On the Application of Algebraic Functions to prove the Properties of Parallel Lines</i>	161
<i>Experiments on the Adhesion of Nails.</i> By B. BEVAN, Esq.	168
<i>On the Circular Micrometer.</i> By F. BAILY, Esq. F.R.S.	177
<i>Mineralogical and Chemical Examination of Hyalosiderite, a new Mineral.</i> By Dr. WALCHNER, of Freiburg in the Breisgau	181
<i>On High-pressure Gauges.</i> By Mr. SAMUEL SEAWARD	190
<i>Memoir on the Variations of the reflective, refractive and dispersive Powers of the Atmosphere, &c.</i> By T. FORSTER, M.B. F.L.S. Member of the Astronomical and the Meteorological Societies of London, and Corresponding Member of the Academy of Natural Sciences at Philadelphia, &c.	192, 328
<i>Description of a new Micrometer.</i> By M. FRAUENHOFER of Munich	210
<i>Letter from ROBERT HARE, M.D. Professor of Chemistry in the University of Pennsylvania, to B. SILLIMAN, Professor of Chemistry in Yale College, on some improved Forms of the Galvanic Deflagrator; on the Superiority of its deflagrating</i>	

CONTENTS:

<i>Power: also, An Account of an improved Single-leaf Electro-meter; of the Combustion of Iron by a Jet of Sulphur in Va-pour; and of an easy Mode of imitating native Chalybeate Waters</i>	241
<i>Further Remarks on the Theory of Parallel Lines</i>	246
<i>On the Mathematical and Astronomical Instrument Makers at Paris. By Lieut. ZAHRTMANN</i>	252
<i>Suggestions regarding some probable Sources of Error in the usual Modes of ascertaining the Force of Steam</i>	259
<i>Remarks on an Article published in No. 23 of the Journal of Science, and treating of the New Tables of Refraction. By J. IVORY, Esq. M.A. F.R.S.</i>	261
<i>Description of a Rotative Thermo-magnetical Experiment. By Mr. WILLIAM STURGEON</i>	269
<i>Zoological Notices. By Mr. JOHN EDWARD GRAY</i>	274
<i>Analysis of Professor HAUSMANN'S Essay on the Geology of the Apennines</i>	278
<i>Chemical Examination of Green Feldspar from Beverly, Massachusetts. By J. W. WEBSTER, M.D.</i>	283
<i>Descriptions of several new Species of Ascidia. By C. A. LESUEUR</i>	321
<i>Dissection of a Batrachian Animal in a living State. By RICHARD HARLAN, M.D. Professor of Comparative Anatomy to the Philadelphia Museum</i>	325
<i>Remarks on the Theory of the Figure of the Earth. By J. IVORY, Esq. M.A. F.R.S.</i>	339
<i>Examination of the Divisions of REICHENBACH'S Circle at the Observatory of Königsberg. By M. Bessel</i>	348
<i>On Mr. BABBAGE'S new Machine for calculating and printing Mathematical and Astronomical Tables. From FRANCIS BAILY, Esq. F.R.S. & L.S.</i>	355
<i>A brief Account of some Electro-magnetic and Galvanic Experiments. By ROBERT HARE, M.D. Professor of Chemistry in the University of Pennsylvania</i>	367
<i>On the Circle. By JOHN WALSH, Esq.</i>	368
<i>On a Method of finding the Limits of the Roots of the higher Powers of Numerical Equations. By Mr. J. ROWBOTHAM</i>	369
<i>On the Application of the Term "Infinite"</i>	372
<i>Two Lines from the Nautical Almanac, addressed to Mr. IVORY.</i>	374
<i>An Account of some Experiments made in order to determine the Velocity with which Sound is transmitted in the Atmosphere. By OLINTHUS GREGORY, LL.D., Secretary of the Astronomical Society of London, and Professor of Mathematics in the Royal Military Academy at Woolwich</i>	401

CONTENTS.

<i>On the New Method of Gauging proposed by Dr. YOUNG. By Mr. W. WISEMAN</i>	415
<i>Letter on the Astronomical Refractions. By J. IVORY, Esq. M.A. F.R.S.</i>	418
<i>On some Errors in Dr. HUTTON'S Tables of the Products and Powers of Numbers. By Mr. JAMES UTTING</i>	427
<i>Introduction to the Sixth Section of BESSEL'S Astronomical Observations</i>	427
<i>Some Account of the Binomial Calculus. By J. WALSH, Esq.</i>	443
<i>On Black Currant Wine. By C. G. HARLEY, Esq. . . .</i>	446
<i>Notices respecting New Books</i>	52, 135, 219, 284, 375, 447
<i>Proceedings of Learned Societies</i>	59, 136, 224, 299, 378, 452
<i>Intelligence and Miscellaneous Articles</i>	63, 140, 230, 307, 392, 459
<i>List of Patents</i>	75, 148, 239, 319, 399, 471
<i>Meteorological Tables</i>	75, 149, 240, 320, 400, 473

PLATES.

- I. Section of Cromer Cliff.
- II. Dr. WALCHNER'S Figures of the Crystals of Hyalosiderite.
- III. FRAUENHOFER'S Micrometer.
- IV. Dr. HARE'S Single-leaf Electrometer, and improved Deflagrators.
- V. Amphiuma means: Ascidia plicata: and Ascidia ovalis.

ERRATA:

- Page 60, line 20 from bottom: for "William Scores, Jun. Esq." read "William Scoresby, Jun. Esq."
- Page 60, line 6 from bottom: for "Walross" read "Walrus."
- Page 97, line 17: for "the platinum is positive to the silver" read "the silver is positive to the platinum."
- Page 236, line 20 from bottom: for "Meissin" read "Meissen."
- Page 268, line 5: for "400^o" read "100^o."
- Page 305, line 4 from bottom: for "M. Guillon" read "M. Gaillon."
- Page 306, line 22: for "M. Le Galloias" read "M. Le Gallois, Jun."
- Page 306, line 12 from bottom: for "M. Giraud" read "M. Girard."
- Page 306, line 5 from bottom: for "M. Remain" read "M. Romain."
- Page 307, line 5: for "Arnaud Reynaud" read "Arnaud Reynaud."
- Page 307, line 7: for "M. Tilerier" read "M. Tilorier."
- Page 394, last line: for "Irkutak" read "Irkutsk."

THE
PHILOSOPHICAL MAGAZINE
AND JOURNAL.

31ST JANUARY 1824.

I. *On two new Species of Narcissus.*

To the Editors of the Philosophical Magazine and Journal.

Gentlemen,

WHEN you published in your last Number, p. 440, Mr. Haworth's excellent account of a new Genus of *Narcisseæ*, you were not aware that the two species there noticed had been described, and one of them actually figured, in The Botanical Register, as new species of *Narcissus*, with specific names under which they have been known and distinguished for the last two years, and which I am persuaded Mr. Haworth has no desire to change. The *Diomedes minor* of Mr. Haworth is *Narcissus Macleayi* of the Botanical Register. This plant appears to have been long lost to our gardens until recently imported by the Secretary to the Linnæan Society, among other bulbs, from Smyrna. Mr. Haworth's *D. major* is figured in the Botanical Register, and named *Narcissus Sabini*, in honour of the worthy Secretary of the Horticultural Society, whose thorough knowledge of the genus fully entitles him to this distinction, independently of the circumstance of his having recently restored this species to the notice of British botanists. Whether the beautiful genus of *Narcissus* ought to be divided into many genera, must be left to botanists to decide; but I suspect that *Diomedes* will not be considered a good name for a genus of plants, as being not sufficiently distinct from the genus *Diomedea* of Linnæus.

Yours &c.

E. E.

II. *On the irregular Indications of Thermometers**. By
JOHN HERAPATH, Esq.†

THE first time I noticed any irregularity of thermometrical indication, was in the summer of 1820. Holding the thermometer of a friend obliquely, with its bulb in boiling water, and then raising the stem to a vertical position, I repeatedly observed that the latter position gave a higher indication than the former. This, as far as I remember, happened only when the thermometer was first put in the water obliquely, and then brought to a vertical position; but I do not recollect whether any difference happened when the position was first vertical and then oblique; nor do I indeed remember that such a case was tried. My friend having at the time treated my observation as accidental, and due to the greater influence of the ascending steam on the vertical than on the oblique tube, turned my attention to a different object; though the least consideration of the thickness of the glass and the very slow transmission of heat by this body, ought to have convinced us that such a reason was incorrect. I have no precise recollection of the obliquity of the tube, or of the amount of the difference of the indications; but I rather think the declination from the vertex was about 30° , and the difference of the indications a degree or two. The thermometer, as far as I remember, was rather large in the calibre.

Some months after this I observed, in the course of some experiments on the resulting temperatures of equal portions of mercury differently heated, that the thermometer with which I took the higher temperature often sunk, in taking immediately afterwards that of the mixture, from a half to a whole degree lower than that to which it quickly rose and settled.

My attention being shortly afterwards more particularly directed to the correction of thermometers, I resolved to undertake a few experiments for the purpose of discovering a guide to a more practically accurate correction than that usually given.

Exp. 1.—I put the bulb of a thermometer which was about

* It has been imagined by some scientific gentlemen into whose hands a friend put this paper, that my object is to support the theory of Bellani. This opinion they formed from my having made, as they say, an erroneous quotation of his experiment; owing to my relying on a hasty mental impression enfeebled by a considerable lapse of time. I beg however to observe, that I never had an idea of supporting Bellani's views. My present ideas of thermometrical corrections had occurred to me some years before Signor Bellani published, or perhaps made, his experiment; and my allusion to it was for the purpose of showing, that, from the impression I had of the experiment, Bellani erred in discovering the cause of his phænomenon.

† Communicated by the Author.

50° Fahr. gradually into mercury at about 350°. After the thermometer had risen as high as it would, I took it out, and rapidly cooled down the bulb by means of a wet cloth to within about 50° or 70° of 212°. Plunging the bulb immediately into water rapidly boiling, I observed the mercury descend to a certain point; and then regularly, but somewhat quickly, rise and settle from a degree to a degree and a half higher. I could not ascertain the exact ascent, in consequence of the divisions of the scale comprehending each not less than two degrees.

Exp. 2. Having first cooled down the stem and bulb, by immersing the instrument for some time in water of about 50°, I put the thermometer as before into mercury of 400° or upwards. Suffering it to become stationary, it was taken out, and the bulb cooled, by similar means to that in the last experiment, to about 300°, and then immersed in the same water boiling very fast; a like rise took place, after the mercury had sunk to its minimum, but as I fancied a little greater approaching nearer to two degrees.

An accident at the close of this experiment unfortunately destroyed the thermometer I used, which happened to be the last I had left that extended to a high range. This prevented me from trying other similar experiments on a more careful and varied plan.

The instrument ranged from about -100° to nearly $+500^{\circ}$; and its bulb extended 3-4ths of an inch or more below the scale.

After the lapse of a considerable period, I recollected that I had a thermometer by me, which, though not very good for measuring great intervals of temperature, on account of the irregularity of its calibre, was nevertheless, from its sensibility and range, well suited for delicate experiments of this kind. It extended from about -44° to $+106^{\circ}$, and was so sensible, that the temperature might be read off to the 1-15th of a degree, or even to the 1-30th with great care. Its bulb projected three inches beneath the scale.

With this instrument I made the following experiments*:

Exp. 7. Leaving my thermometer and 16865 grains of mercury in a glass tumbler, weighing 2835 grains, for about twelve hours in the same room, I took the temperature of the mercury at $51^{\circ}27$, the air being 52° . Putting the bulb immediately afterwards in water of a much higher temperature, I allowed the thermometer to ascend to 105° . As I could not safely venture to raise the mercury higher, I took out the instrument, suffered it to cool a few degrees, and then reimmersed it. This I did

* The intermediate experiments, and the 11th, have been struck out by the author for the sake of brevity; but their mean results are included in the general balance.

two or three times, by which I thought I should produce the same effect on the thermometer as if I had allowed it to reach its maximum in water of about 105° or 106° . Cooling down the bulb considerably, I observed the mercury to be $51^{\circ}47$, exceeding apparently its former temperature by $^{\circ}2$.

Exp. 8. Being apprehensive that I might have raised the temperature of the mercury a little, by the excess of the temperature in the bulb at the time of the re-immersion, I repeated the experiment at the distance of 12 or 24 hours in precisely the same way, except that I brought the bulb, previous to taking the second temperature, to as near as I could this mercurial temperature, by putting it in water and then quickly wiping it dry with a handkerchief. The air being 50° near the wall, the numbers were $48^{\circ}53$ and $48^{\circ}67$.

Exp. 9. Twenty-four hours afterwards the same apparatus and precautions gave $45^{\circ}93$ and $46^{\circ}10$, the air being $46^{\circ}7$.

Exp. 10. At the end of 12 or 24 hours more, in an atmosphere of 47° , I obtained $46^{\circ}2$ and $46^{\circ}4$.

Exp. 12. Being desirous of trying the experiment so as to ascertain whether immediate repetitions with mercury would be attended with successive augmentations of temperature, I put my glass containing the mercury in the same room with my thermometer. About four hours afterwards, the air near one of the walls being $48^{\circ}5$, I repeated the experiment with all the preceding precautions, to which I added that of cooling the thermometer's bulb, previous to the last immersion, a degree lower at least than the mercury. The numbers were $48^{\circ}5$ and $48^{\circ}73$. A few minutes afterwards I raised the thermometer again to 105° ; and, with the same care in cooling the bulb a degree or more beneath the mercury, took the mercury at $48^{\circ}83$. Another repetition with like precautions gave $48^{\circ}9$, and another $48^{\circ}97$. These experiments altogether occupied about 20 minutes.

Half an hour after I had finished I observed the same thermometer near the wall stand at $48^{\circ}8$; the mercury indicating by this instrument a temperature of $48^{\circ}87$.

Exp. 13. Twenty-four hours afterwards, the air being $48^{\circ}47$, I repeated the experiment with the same care and precautions. The numbers were at

8 ^h 40'	A.M. before heating thermom.	47 ^o 47
8 43	... after ditto	47 77
8 47	... after 2d ditto	47 93
8 50	... 3d ditto	48 07
8 55	... 4th ditto	48 20
9 0	... 5th ditto	48 40
9 5	... 6th ditto	48 60
9 10	... 7th ditto	48 77

the bulb having at each repetition, after being raised to 105° , been cooled down to 47° or lower, and quickly and carefully wiped with a silk handkerchief before retaking the temperature of the mercury.

In consequence of the weather being fine, its temperature manifestly increasing, and the mercury at first so much colder (one degree) than the atmosphere, I concluded that the successive augmentations of temperature observed in the mercury at the several repetitions of the experiment, were due rather to the gradual rise of this body's temperature than to any continued increase in the indications of the thermometer. As a confirmation of this, I observed that the temperature of the air and mercury taken at $9^{\text{h}} 40'$, or one hour after, was $49^{\circ} \cdot 8$; which, compared with the temperature of the mercury at the first and last of the preceding observations, shows nearly a uniform increase of $2^{\circ} \cdot 2$ per hour after allowing for the excess of the apparent above the real indication in the observation at $9^{\text{h}} 10'$.

Deducting therefore from all the observations except the first a quantity proportional to the time, at the rate of $\frac{1}{300}$ of a degree per minute, the observations will stand, corrected for the increase of the mercury's temperature, as below :

1st . . .	$47^{\circ} \cdot 47$	5th . . .	$47^{\circ} \cdot 65$
2d . . .	$47 \cdot 66$	6th . . .	$47 \cdot 67$
3d . . .	$47 \cdot 67$	7th . . .	$47 \cdot 68$
4th . . .	$47 \cdot 70$	8th . . .	$47 \cdot 67$

This experiment seems to show that the difference of indications in the thermometer is produced at the first heating of the bulb, and not increased by any following similar operations.

Exp. 14. During the preceding experiments I was near the mercury at the times only of my taking its temperature; at other times I was many feet from it; and not unfrequently several things stood between me and it, so as to cut off all rectilinear communication. But having after the last experiment observed that the heat of the body, when standing within about two feet from the unprotected glass, raised the temperature of the mercury in one instance as much as 3-10ths of a degree in $5'$, I was desirous of repeating the experiment under circumstances in which this proximity could have no effect, or at least no sensible effect. For this purpose I obtained the assistance of my friend Mr. Mervyn Crawford, to whose precision the accuracy of the following experiments is much indebted.

The mercury having been for several days in our experimenting

menting room, I formed about three hours before we began all round the glass, but not touching it, a close thick wall of books, rising from two to three inches above it. At 8^h 22', the mercury was 46° 23', and at 9^h 10' the air 46°·13. At this time we commenced our experiments, going through the usual process of heating and cooling the bulb (to 46°·2) before taking each temperature after the first.

Times.	Mercurial Temp.
9 ^h 10' $\frac{1}{2}$	46°·17
9 15	46 ·33
9 19	46 ·30
9 23 $\frac{1}{3}$	46 ·33
9 27	46 ·33

Wishing to know whether the air and mercury for a short time afterwards varied their temperatures much, I observed with the same instrument, without any heating or cooling, at

9 ^h 32'	the merc. was 46°·33	the air 46°·13
9 37	46 ·40	. . 46 ·80 going out and
returning at 9 52	46 ·53	. . 46 ·80

Exp. 15 and 16. Another experiment made with a closer and higher wall of books gave a similar result ·13. Varying the experiment so as to measure the temperature of the mercury with the thermometer in the same state a second time, before each repetition of heating, had the advantage of showing the real alteration of the mercurial temperature at equal intervals, during the course of repetitions. No difference however having been found in the general value of anomalous indication, it is unnecessary to enter into details.

In this last experiment I used water for heating the thermometer, which was only 106°; in which I put the bulb, and let it remain for about 5 minutes to see whether any difference in the result would arise from the water being of a less temperature than before. The difference of indication came out, however, nearly the same, ·17 or rather more.

The mean difference of indication in all these experiments, after allowing in the 12th for the advance of temperature, is about ·174; the air and thermometrical tube being about 50°·7, or in round numbers 50°.

During the making of the preceding experiments I made one or two efforts likewise to ascertain whether any difference existed in the indications, by first immersing the bulb in water of 105° with the stem oblique, and then raising it to a perpendicular; but, for want of a steady temperature in the water, I could not succeed.

On inquiring into the cause of the phenomena I have detailed,

tailed, we are instantly led to attribute it to the recommunication, from the glass of the stem to the colder descending portion of mercury, of a part of that heat which had been communicated from the warmer portion of the ascending column. Were the bulb at every instant uniformly of the same temperature, the successive portions of mercury which ascend into the stem from the bulb would be successively higher in temperature than those which precede or are above them; and the temperature of all that had ascended from the bulb would be less almost in the precise proportion to the distance from the bulb. But, from the quick conductivity of mercury, it seems probable that there is a rapid and continued transmission of temperature from the bulb to the higher parts. And, in consequence of the little affinity between mercury and glass, this transmission may be aided, when the stem is vertical, even by the ascent of the warmer portions, on account of the difference in the specific gravity. However this may be, it is plain that the mercury being warmer than the stem, must communicate a portion of its excess of temperature to the glass. The loss thus sustained by the mercury will be shortly made up by further transmission from the bulb. In the course of a very few transmissions in this way, that is, in a very short time, the interior of the glass to a small depth from the column of mercury, will attain a temperature equal or nearly equal to that of the adjacent mercury; provided the temperature of the bulb remain nearly the same.

Suppose now the bulb to be cooled, the mercury in the stem which occupied the higher will descend to the lower and warmer parts, and if this descent be very rapid it may exceed in celerity the tardy communication of heat from the surrounding glass; so that the column of mercury at the instant it becomes stationary, is colder than the glass enveloping it. An expansion, therefore, and a consequent rise in the mercurial column will gradually ensue by the communication of a part of the excess of heat in the contiguous glass. This phenomenon would be similar to that in the first two experiments.

Should the bulb be brought back after being heated to its primitive temperature, it is plain that the suspended column of mercury, though precisely the same in quantity, yet being by the heated glass raised in temperature, will settle to a higher indication than before. This is the phenomenon contained in the 14 last experiments.

The amount of this variation of apparent temperature manifestly depends, in either case, on the difference of the second and last temperatures of the bulb, and the length of the column of mercury in the last temperature. If these remain the same,
a repetition

a repetition of the heating and cooling process immediately afterwards would therefore produce no difference in the amount of the variation, provided sufficient time was given in the first process for the mercury to obtain from the bulb, and communicate to the glass, the necessary quantity of heat, according to the distance from the bulb. For like reasons a third, fourth, &c. process immediately afterwards would not alter the value of the variation. Hence the reason that the 12th and subsequent experiments did not exhibit any difference in the apparent temperatures at the 3d, 4th, &c. observations; proper allowance being made for the real variation of the mercurial temperature during the intervals.

With respect to the time required in the first heating and cooling of the mercury to give the maximum effect, I have not made any observations; but, from a circumstance or two that occurred in the course of my experiments, a much shorter period than I took would produce a sensibly less variation. Nor have I determined in how long after such an experiment a like variation may be observed with the same instrument; but I conceive that a half hour's careful cooling of the stem would be sufficient, or less if the stem could be well cooled in a less time.

It can hardly be expected of me, with so few experiments, to enter into a theoretical computation of the value of this variation under all circumstances. If however the views that I have taken of it be nearly correct, the variation would be about half the mercurial correction for the same column of mercury at the 2d and 3rd temperatures of the bulb.

Now the correction given by the Royal Society's Committee

is = $\frac{\text{range out of wat.} \times \text{excess temp.}}{10000}$ minus $\frac{1}{8}$ of this value. Call-

ing, therefore, in round numbers the range of the last thermometer from -40° to $+100^{\circ}$, and supposing the mean temperature of the bulb to have been 50° , we shall have for the general correction

$$\frac{7}{8} \cdot \frac{(40+50) \times (100-50)}{10000} = \frac{7}{8} (45) = 3938;$$

the half of which, or 0.197 , ought to be the amount of variation. Our experiments give 0.17 .

Again: supposing in the first experiment there were about 20° or 22° of the lower degrees immersed, which I should think there were though I did not attend to it carefully, the correction would be

$$\frac{7}{8} \cdot \frac{(78+212)(352-212)}{10000} = \frac{7}{8} (4.06) = 3.553.$$

Half of this $1^{\circ}77$ should be the amount of ascent, which does not differ much from the experiment — a degree or a degree and a half. The difference is also on the right side; for we might easily conceive that the mercury is heated a little as it comes down, and consequently does not sink so low as it otherwise would, nor therefore afterwards rise so much.

A like calculation for the second experiment would give about $2^{\circ}4$. This differs also from observation on the side we might expect, but more than the preceding calculation.

It is remarkable that if we take a number to $1^{\circ}77$ as $\cdot17$ to $\cdot197$, it will be $1^{\circ}5$, as nearly as possible that which was observed in the first experiment; and if we take a number to $2^{\circ}4$ as $\cdot17$ to $\cdot197$, it will be $2^{\circ}1$, differing also but very little from the second experiment. From this it appears that our theoretical value is too high by about an eighth. Before, however, much can be said with certainty, other and more extensive experiments are wanting. But enough, I hope, has been advanced, to show the danger of relying, in delicate experiments, on the correction usually employed for that part of the tube not immersed in the fluid.

London, Cranford, May 7, 1823.

III. On the apparent Magnetism of Metallic Titanium.

By WILLIAM HYDE WOLLASTON, M.D. V.P.R.S.*

IN an account that I lately gave of the properties of metallic titanium, which is printed in the First Part of the volume of the Philosophical Transactions for the present year†, there is an oversight, which I am desirous of rectifying as soon as may be. I have there stated that the cubic crystals of titanium, when first detached from the iron-slag where they are found, were all attracted by a magnet, but that when they had been freed from all particles of iron adherent to them, they appeared to be no longer acted upon by it.

Having since that time been led, by the observations of M. Peschier of Geneva, to examine this question more accurately, I find that, although the crystals are not sufficiently attractile to be wholly supported by the magnet, yet when a crystal is supported by a fine thread, the force of attraction is sufficient to draw it about 20 degrees from the perpendicular, and consequently that the force of attraction is equal to about one-third the weight of the metal.

When a piece of soft iron of about the same size was made of a cubic form (weighing half a grain), the attractive force

* From the Philosophical Transactions for 1823, Part II.

† See Phil. Mag. vol. lxii. p. 18.

of the iron to the same magnet was found, in successive trials, to lift from eighty to ninety times its weight of a silver chain adapted to this inquiry.

By a similar mode of trial, I found that cobalt carried from fifty to sixty times its weight, and that a similar quantity of nickel supported from twenty to thirty times its own weight by the same magnet.

From the above comparison of the magnetic forces, it is evident that the presence of about $\frac{1}{250}$ part of iron as an alloy in the metallic titanium, would be sufficient to account for this power, without regarding titanium itself as a magnetic metal; and its origin in the midst of iron gives every reason to suspect that it would be contaminated by some proportion of that metal.

It is, however, extremely difficult really to detect the presence of so small a proportion of iron, on account of the high colour of the precipitates of titanium. For though it may be easy to produce an appearance of blue by using a prussiate, which already contains iron, and is consequently better adapted to prove the absence of iron where no blueness appears, than to ascertain its presence, it is by no means easy to obtain the more indisputable evidence of iron by infusion of galls. It is only by repeated evaporation of the muriatic solution, and continued exposure of the residuum to the temperature of boiling water, that I have succeeded in separating enough of the titanium to allow the blackness of gallate of iron to appear, when the efflorescent edges of the dried salt are touched with infusion of galls.

Although the quantity thus rendered sensible does not appear in proportion sufficient to account for the magnetic force observed, there seems more reason to ascribe it to this impurity, than to suppose titanium possessed of that peculiar property in a degree so far inferior to the other known magnetic metals.

IV. *Chemical Examination of a Fragment of a Meteor which fell in Maine, August 1823.* By JOHN W. WEBSTER, M.D.
M.G.S. Lond. &c.*

THIS aërolite fell at Nobleborough in the State of Maine, on the 7th of August 1823, between four and five o'clock P.M. The only information which I have been able to obtain of the attending phænomena is from the papers of the day,

* For this communication we are indebted to the kindness of the author, in the ensuing Number of whose Journal of Philosophy and the Arts, published at Boston, U.S., it will be inserted.

and from a communication of Professor Cleaveland, which is published in the *American Journal of Science*, vol. vii. p. 170; this account he informs me was obtained at his request by a gentleman of intelligence in a personal interview with Mr. A. Dinsmore, who was at work near the place where the aërolite struck. "Mr. Dinsmore's attention was excited by hearing a noise which at first resembled the discharges of platoons of soldiers, but became more rapid in succession. The air was perfectly calm; and the sky was clear, with the exception of a small whitish cloud, apparently about forty feet square, nearly in his zenith, from which the noise seemed to proceed. After the explosion, this little cloud appeared to be in rapid spiral motion downwards, as if about to fall on him, and made a noise like a whirlwind among leaves. At this moment, the stone fell among some sheep, which were thereby much frightened, jumped, and ran into the woods. This circumstance assisted Mr. D. in finding the spot where the stone struck, which was about forty paces in front of the place where he was standing. The aërolite penetrated the earth about six inches, and there meeting another stone, was broken into fragments. When first taken up, which was about one hour after its fall, it exhaled a strong sulphureous odour. The whole mass previous to its fracture probably weighed between four and six pounds; other fragments of the same meteoric stone are said to have been found several miles distant from Nobleborough."—*Amer. Jour.*

To the politeness of Dr. George Hayward I am indebted for a fragment of this meteor.

Externally the specimen was in part covered with a thin semivitrified crust or enamel of a black colour, the surface of which was irregular and marked with numerous depressions, presenting every appearance of having been subjected to intense heat. The crust was hard, yielding with difficulty to the knife. The quantity of this crust which the small fragment I obtained afforded, was not sufficient to allow of any separate analysis of it.

The mass of the specimen had a light gray colour interspersed with oblong spots of white, having the aspect of decomposed leucite, and giving it a porphyritic aspect. Throughout the stone minute points of a yellow substance, resembling olivine, were distributed, with microscopic points of a yellow colour, which I imagine were sulphuretted iron. The cement by which these substances were united was of an earthy aspect, and soft texture, readily broken down by the fingers. The general appearance of the mass was precisely like that of some of the volcanic tuffas.

The specific gravity was remarkably low, being but 2·05*.

Before the blow-pipe it exhaled a sulphureous odour, but was not fused.

The specimen was reduced to powder and submitted to the action of a magnet of considerable power, but no attractable particles were separated. A portion was heated to redness on a platina spoon; it emitted the sulphureous odour, and its weight was diminished rather more than 21 per cent.; the residue acquired a brown colour; it was again presented to the magnet, but nothing was attracted.

(1.) One hundred grains of the stone were introduced into a tubulated retort with dilute muriatic acid; the beak of the retort was plunged into a solution of acetate of lead, slightly acid, and contained in a small tubulated receiver. A moderate degree of heat was applied, and the digestion continued for twelve hours. A slight quantity of sulphuret of lead was formed, but not sufficient to admit of being collected and weighed.

All action upon the powder having ceased, the fluid was turbid, apparently holding a substance which I imagined to be the sulphur in suspension; at the bottom was an undissolved residuum.

(2.) The fluid was carefully separated and filtered; the substance remaining upon the filter was washed with distilled water, and thoroughly dried; it proved to be sulphur, and weighed 18·3 grains.

(3.) The insoluble residuum was mixed with pure potash, and exposed in a silver crucible to heat sufficient to cause the fusion of any siliceous earth. The crucible being placed in an evaporating dish, hot distilled water was poured upon it until the contents were completely removed. The resulting fluid was treated in the usual manner with muriatic acid, with the addition of the acid which had been digested upon the stone in the first instance. The quantity of silex obtained after calcination amounted to 29·5 grains.

(4.) The solution, the bulk of which had been considerably augmented by the addition of the water with which the precipitate (3) had been washed, was carefully evaporated to rather less than a pint. Carbonate of potash was added until it ceased to produce any precipitate; the whole was moderately boiled. When the precipitate had completely subsided, the supernatant liquor was decanted, and distilled water substituted. The precipitate was collected and boiled with pure potash; the liquor after filtration was treated with muriatic

* The lowest specific gravity of any meteorolite on record, is that of the St. Etienne specimen, which is but 1·94.

acid in excess, from which carbonate of ammonia threw down a flaky precipitate, and was added until the alkaline taste predominated. The precipitate thus obtained, after ignition weighed 4·7 grains. To satisfy myself of the nature of this substance, it was treated with sulphuric acid and potash; crystals of alum were obtained, and it was therefore alumina.

(5.) The residuum which had resisted the action of the potash was digested in diluted sulphuric acid; after expelling the excess of acid, pure water was poured upon the remaining solid, in order to dissolve any sulphate of magnesia and metallic sulphates.

To discover if any lime was present in the solution, it was treated with alcohol, which afforded a slight trace of that earth.

(6.) The solution, after the addition of more water, was acidulated with sulphuric acid, and the metallic oxides were precipitated by the bicarbonate of potash. The magnesia was separated by pure potash, and after ignition weighed 24·8 grains.

(7.) The precipitate (6) was boiled in nitric acid, in order to convert any chrome present in it into an acid, which was afterwards by the addition of potash converted into a soluble chromate. On adding muriatic acid, the chrome was obtained in the state of an oxide, sufficiently characterized by its beautiful colour. After being well dried it weighed 4 grains.

A portion of this substance was subsequently exposed on charcoal with borax to the action of the blow-pipe, and its nature satisfactorily proved.

(8.) The matter remaining after the separation of the chrome was redissolved in muriatic acid, and the iron was thrown down by ammonia. After washing and drying, it weighed 14·9 grains.

(9.) The remaining solution was now evaporated, the ammonia driven off, and the precipitate, which proved to be nickel, weighed 2·3 grains.

The composition of this meteoric mass is therefore

Sulphur	18·3
Silex	29·5
Alumina	4·7
Lime	a trace
Magnesia.....	24·8
Chrome	4·
Iron.....	14·9
Nickel	2·3
	<hr/>
	98·5
Loss.....	1·5
	<hr/>
	100·

V. *A new Theory of Telescopes founded on rational Principles and interesting Experiments.* By J. READE, M.D.*

LOOKING on the corneal theory of vision as established, in this paper I shall endeavour to apply that theory to practical advantage in the science of astronomy. Although I have shown, by numerous and I may venture to say conclusive experiments, that our ideas of objects are produced by erect images painted on the pupil, still I by no means argue that the retina is not the nerve communicating with the sensorium, in a similar manner as the nerves minister to feeling, hearing, tasting and smelling. Indeed, the five senses may be all reduced to one, the sense of feeling. So long as philosophers believed that inverted images painted on the retina produced the phænomena of vision, so long the most inconsistent opinions were advanced of long- and short-sightedness, and the theory of telescopes, spectacles, &c. "If the cornea or crystalline (say authors), or either of these, be too flat, a pencil of light coming from an object at an ordinary distance will have its focus at some point beyond the retina, and therefore vision will be indistinct, as in the case of an object too near for a common eye." Let us for a moment examine this reasoning. It is admitted on all hands, that no inverted image is ever formed, until the rays cross after arriving at the focus; consequently, if the focal point were situate beyond the retina, no image could ever be painted on that substance, and we must be driven to the absurdity, that the mind could perceive an object without an image. Dr. Porterfield has some strange metaphysical ideas on this subject, at one time talking of pictures on the retina, and the next moment denying their existence. Having examined the eyes of many short-sighted persons with much accuracy, I find them not to differ in the least from long-sighted eyes; hence the flatness or plumpness of the cornea can have nothing to do with the disease, however necessary it may be to the refracted theory of philosophers.

Here I may enlarge on this subject, but must refer to a former paper in your valuable Journal†, wherein I have experimentally demonstrated that focal images are not formed by any crossing of the rays, when passed through a lens, but that the focus is produced by reflected images uniting, and sent from the concave sides. Indeed, I am inclined to think that we must look to the nerves for the cause of short-sightedness, and not to any fanciful flatness or plumpness of

* Communicated by the Author.

† See Phil. Mag. vol. lviii. p. 249, and vol. lix. p. 200.

the cornea. For on an analogy with the other senses, such as feeling, hearing, tasting, &c., we find extreme stimuli act so as for a time to injure the organ, and in a manner to paralyse sensibility. Thus a soldier returning from the field of battle, and deafened by the roar of cannon, for a time becomes insensible to minor sounds. The fingers accustomed to rough usage, are incapable of nice works; and in like manner the retina accustomed to the stimulus of light sent from very close objects, by degrees adapts itself and becomes insensible to those more remote, and consequently less powerful. On similar principles, a person with the best sight may make himself short-sighted, by merely wearing concave glasses. I have met with some simple young gentlemen at College, who produced the disease by this affectation, and became perfectly short-sighted. It is well known that watch-makers are short-sighted, and sailors the reverse. A long-sighted person may become short-sighted in a week, or after a fever, or a nervous disease, without any change of the cornea or crystalline lens. Nor can I conceive that wearing a concave glass could after any time change the shape of the cornea.

For the purpose of particularly investigating this subject, I requested a very short-sighted gentleman to seat himself opposite the letter T pasted on the window, as already mentioned in my paper *On Vision*, published in the *Annals of Philosophy*; and on looking at the correct reflected image on the pupil, and comparing it with that of a long-sighted person seated at the same distance, I could not perceive the least difference either in the size or strength of colouring; yet the long-sighted gentleman saw the letter distinctly, while the other said that he only saw a very confused and large outline. Hence we must infer that the disease lies not in any plumpness or flatness of the cornea, but in either the humours or the nerves, or both. A convex glass increases the confusion with a short-sighted person, and therefore is never used; with a long-sighted person it renders the object more distinct. By the interposition of a concavo-concave glass, an image is formed very near the eye, which, although small, sends the rays with as much force to the cornea, as if the object itself were in the same place: short-sighted people choose a small print, write a small hand, and take off their spectacles when reading. Much has been written to very little purpose on the means of finding the foci of spectacles, and philosophers have exerted all their ingenuity; yet the practical optician, however qualified to read their learned essays, throws them aside for the old-fashioned and purely mechanical method of holding the lens before a wall, and measuring the focus with
a rule:

a rule: yet it must be allowed that on a subject of such importance to the happiness of mankind, such a method is very unsatisfactory, and often leading to an injury of sight, for two convex or concave spectacle glasses may be very dissimilar in transparency or quality of glass without in the least affecting the focal images; this may be shown by scratching a lens or soiling the surface without in the least altering those focal images. The following method, arising out of the discovery that the cornea is the true seat of vision, is preferable. Procure two glass globes somewhat larger than the human eye, fill them with pure water, and place them in a case at about one inch from each other to represent the human eyes. The glasses for examination, whether convex or concave, should now be placed in their frames and held in front of these globes, and before the letter T pasted on the window. On comparing the magnified or diminished images of the letter on the convex faces of these globes, the practical optician may immediately say whether they are similar in their powers, whether they magnify or diminish equally, and likewise whether the images are clear and distinct. In making this experiment, we should take care to have the globes perfectly similar. Hereafter I shall resume this subject, and shall now proceed to the theory of telescopes.

As the Galilean telescope is the most ancient, most simple, and most generally used, I shall begin with it. For a good history of this instrument I must refer to an excellent article in Brewster and Rees's Encyclopædias, and in a concise manner shall give the present theory from Mr. Wood's Elements of Optics, one of the best works I have seen on the subject, and I am informed the one used at Cambridge, perhaps the first mathematical university in Europe. "Galileo's telescope consists of a convex object-glass, and a concave eye-glass, whose axes are in the same line, and whose distance is equal to the distance of their focal lengths. A distant object may be seen distinctly through Galileo's telescope, and the angle which it subtends at the centre of the eye when thus seen, is to the angle which it subtends at the centre of the naked eye as the focal length of the object-glass to the focal length of the eye-glass.

"Let L and E be the centres of the glasses, PQR a distant object towards which the axis of the telescope is directed; pqr its images in the principal focus of the glass L, and therefore in the principal focus of the glass E.

Then since the rays tend to form an image in the principal focus of the concave lens E, after refraction at that lens they will be proper for vision, or a distinct image of the object

PQR

PQR will be formed upon the retina of a common eye.

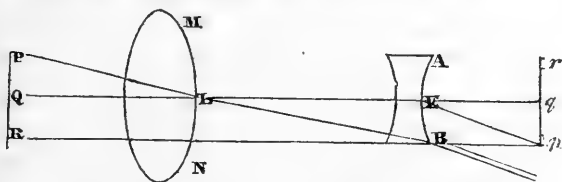

Also, the angle under which the object QP is seen through the telescope is equal to the angle $q \hat{E} p$; and the angle under which it is seen by the naked eye at L is QLP , which is equal to $q \hat{L} p$. Therefore the visual angle in the former case : the visual angle in the latter :: $Lq : Eq$." From this reasoning Mr. Wood infers the corollary that the magnifying power of the Galilean telescope is measured by $\frac{Lq}{Eq}$.

Before I enter on a mathematical examination, I shall beg leave to call the attention of my readers to what I conceive to be a metaphysical absurdity attending this theory: I shall quote a passage from Dr. Young, an able mathematician and experimental philosopher; who says in his Lectures on Natural Philosophy, p. 428, "In the Galilean telescope or opera-glass, a concave eye-glass is placed so near the object-glass that the first image would be formed beyond it and near its principal focus, and the second image formed by the eye-glass, which is the vertical image viewed by the eye, being on the opposite side of the centre, is inverted with respect to the first image, and erect with respect to the object." And in page 427, he continues, that "in almost all telescopes and compound microscopes the image formed by one lens or mirror stands in the place of a new object for another. The operation of such instruments may be illustrated (say Dr. Young and other authors) by placing a screen of fine gauze in the place of the image, which receives enough of light to make the image visible in all directions, and yet transmits enough to form the subsequent image."

Here let us pause, and mark the gross metaphysical absurdity, in supposing that an inverted image painted on the retina could enable the observer to see both an erect object through the telescope, and an inverted object or image at the piece of gauze. Again: Dr. Young supposes that this inverted image at the gauze transmits enough of rays to form the subsequent image on the retina. Now it is evident this retinal image would be erect in respect to the image on the gauze,

gauze, and therefore the observer should see it inverted: but why see the object erect? I am inclined to hope that Dr. Young will agree with me, not only that this experiment and reasoning involve a metaphysical absurdity, but that they strike at the retinal theory of vision. For to perceive an object both erect and at the same time inverted, by means of one image on the retina, is impossible. But there is no difficulty with respect to the corneal theory of vision; for on holding a concave and convex glass before the eye of an observer looking at the letter on the window, I distinctly perceived a small erect image of the letter on the pupil, and likewise an inverted image produced by the refracted rays as they are called. 2dly, The eye of the observer is always placed close to the eye-glass. If the magnitude of the object seen through the telescope depended on the visual angle $q E p$, the object should appear larger the further the eye was removed from the eye-glass; but direct experiment teaches that the contrary is the fact. Indeed, the idea of an inverted image floating in the air, invisible, yet visible, and measured by a visual angle beyond the influence of the nerves, which visual angles are measured by the calf as well as the cow, by the idiot as well as the philosopher, is more than we can believe: even the learned Berkeley, late bishop of Cloyne, who advanced many strange things, could not believe in this. The next object is, that these focal and vertical images, from which our ideas are supposed to be derived, are ten or twenty times as large as the area of the pupil itself, and consequently a conjurer may as well get into a quart bottle as these images through the pupil. This is a strong objection, and I conceive an insurmountable one, to the present theory of telescopes. Indeed I am surprised it should have escaped notice. How is it possible that the extreme rays coming from a vertical image one inch or more in length and half an inch in breadth, could not only enter the pupil, but a hole the size of a pin's head, such as that used by surveyors? We must either admit, what opticians do not allow, that rays converge after passing through the concave eye-glass so as to form a very sharp cone at the pupil, and do away with the magnifying power, illustrated by the angle $q E p$, otherwise the cone would be at the wrong end. Having unscrewed the eye-glass of an opera telescope about three inches long, I held it before the window, and, on placing a card at the principal focus, found that focus to be about five inches from the object-glass. The letter T on the window, being ten feet distant when the eye-glass was again screwed on, the focal image became somewhat enlarged, but very indistinct. What I principally wish to impress is the

fact,

fact, the incontrovertible fact, that this focal image when intercepted by the card was nearly two inches in breadth, and yet the pupil through which they were to pass was not 1-4th of an inch, nor the eye-hole of the telescope 1-20th of an inch. And, as already mentioned, if $q E p$ measured the magnifying power, the further the eye was removed from the eye-glass the larger the object should appear: that the reverse is the fact must be known to every experimenter; indeed at a little distance the extreme rays coming from Q and P and crossing at L and then diverging, would not only clear the pupil itself, but the very ears of the spectator; consequently to argue that we see the object by means of these rays, is absurd.

The fourth objection I have to bring forward is, that focal images are always painted immediately in the axis of the lens, and no where else. Therefore, if these inverted images were the cause of vision, the pupil of the observer's eye should be always placed in the axis of the lens, and no where else. However, direct experiment informs us that we can see through a refracting telescope, when the eye is removed considerably to the right or left of the axis. Indeed I have been enabled to see the inverted image of an object painted on the bull's eye, when my pupil was at right angles with the axis, where it was impossible that any of these rays could enter the eye.

Having thus shown, I hope to the satisfaction of my readers, that this mathematical theory of the Galilean telescope is fallacious, I shall now endeavour to substitute a more rational theory, and one founded on direct experiment. I must refer to my former paper on Vision for those experiments which prove that rays diverge in passing through a convex lens, and converge in passing through a concave one. I have also shown in a former paper that rays never form focal images by crossing, which forms another strong objection. Having procured a convexo-convex lens, whose focus was about two feet, and a concavo-concave lens for an eye-glass, Number 17, I covered half the concave lens or eye-glass with a piece of white paper. I now held these two lenses opposite a lighted candle so as to form a telescope without the tube, and on removing the object-glass to the proper distance from the eye-glass, I perceived the candle erect and considerably magnified in all its dimensions; and I also perceived an inverted image of the candle, painted on the paper of the eye-glass. Here I again assert, that it would be metaphysically absurd to say that rays coming from this inverted image produced both the sensation of an erect and at the same time of an inverted image.

The following conclusive experiment will explain the true theory of the Galilean telescope. Having placed a glass globe filled with water in a wine glass resting on a table, immediately opposite the letter T on the window, the letter was distinctly painted by refraction on the convex surface. I now held the convex object-glass already described at about a foot and half distance over this image, and perceived it to be considerably magnified, and surrounded with confused colours. I now interposed the concave eye-glass at about one inch before the image, and perceived the image to be diminished to nearly half its size; but the colours at the margin vanished, and it became, although smaller, much more distinct and black. This image could be either increased or diminished by approaching or distancing the object-glass. I now pasted a piece of white paper on the globe in the vicinity of the reflected image, and could perceive that the rays which went to form the inverted virtual image, as it has been named, had nothing to do with the erect image formed on the convex side of the globe by reflection. From this experiment, and numerous others, I would infer that in the Galilean telescope the eye-glass diminishes the image formed on the pupil by the object-glass; so that a small well-defined image is painted close to the pupil, which standing in place of the object, and magnified by the object-glass to the proper standard of distinct vision, I now made an assistant seat himself opposite this letter on the window; and on holding the glasses in the same manner before his pupil, I perceived similar effects; and when the white paper was pasted on half the eye-glass, on his looking at the letter, I perceived the erect image in the pupil, and the inverted image painted on the paper at the eye-glass. I now instead of the white paper put on a piece of white cloth, so as to hinder those rays from going at all to his eye; yet he perceived the object through the telescope. After this experiment, can any person contend that this virtual image is the mean of vision through the telescope? The field of view in the Galilean telescope depends on the distance of the object-glass, for the size of the image is inversely as the distance.

Thus having shown by numerous experiments that these gross refracted rays, with all their twistings and turnings, have nothing to do with the phænomenon of vision either naked or armed with the telescope, further than by throwing a quantity of light into the pupil, I shall now give a figure.



a, the letter T pasted on the window, sends an image to the object-glass BC, where two more images are formed in
each

each surface: hence they are sent magnified to the eye-glass DE, which again transmits the image to the eye F; thence



to the retina, and finally to the sensorium. This is a correct outline of the Galilean telescope, supported in every stage by direct experiment. I have particularized Dr. Young's opinions, both because that gentleman is justly celebrated in the scientific world, and because I preferred the living to the dead. The pleasure I feel at having discovered the corneal theory of vision, is somewhat diminished by considering that it strikes at some of the most interesting theories in astronomy. For if the theory of refraction be proved fallacious, it follows as a consequence, that the greatest astronomers have no idea of the distances of the planets, &c., all their calculations being built on visual angles and virtual images.

On looking over the Philosophical Transactions for 1821, I find a paper written by a very intelligent experimenter, Mr. J. F. Herschel, On the Aberrations of Compound Lenses and Object-glasses. This gentleman, -- seemingly unacquainted with the experiments I have published some years ago, both in your Journal and in the Experimental Outlines, -- after remarking on Euler and Dalember, from whose exertions he says nothing resulted beyond a mass of complicated formulæ, he gives a number of algebraic calculations, entirely built on the gratuitous assumption that Newton really separated the whole light into seven coloured rays. Was Mr. Herschel unacquainted with my experiments? If so, I would beg leave to call his attention to the following.

If a square piece of black cloth with a small semicircular piece cut from the lower part in the following manner,  be pasted on a pane of glass at the window, on looking at it through the lower refracting angle of the prism, we perceive the bottom to be fringed with red and yellow rays; if we now paste another similar piece some little distance below it on the same pane, and in an inverted position, as thus represented  we perceive, on looking through the prism, the upper  part to be fringed with blue and violet: thus we have three simple and one compound colour produced by these fringes, derived from the black light reflected

from these two pieces of cloth, and rarefied by sticking on the pane. The violet is evidently compounded of the orange blending with the black light of the lower piece of cloth, and the reader is to notice that when these two pieces are kept asunder, we never perceive more than four colours,—blue, red, yellow and violet: but if we now direct an assistant to approximate the pieces, the yellow fringe of the upper one immediately passes over the blue fringe of the lower piece, and forms a vivid green; and until this takes place, no green is ever formed. The *rationale* of this interesting experiment is too obvious to require much observation. The square piece of black cloth represents the dark window-shutter of Sir Isaac Newton's experiment; and the two semicircular cuts, when united, represent the circular hole through which the sunbeams passed. The black light reflected from the edges of the hole was rarefied by striking the plane of the prism into colours, and mixing gave the spectrum of seven colours to the eye.

Here we have to remark, that the light passing through the centre of this hole was colourless, not mixing with the fringes, entirely produced by rarefied black light, as is easily shown by passing the shadow of a knitting-needle through a prism placed in the sunbeams. Here we are also to remark, that the green is formed after emergence by a mixture of the blue and yellow, and by no means a simple colour as Newton supposed. Thus did Sir Isaac Newton compound what he calls seven with the three simple and primary colours,—blue, red, and yellow. I am fully confident that no unprejudiced person, after repeating this easy experiment, can for one moment doubt that this great philosopher was entirely mistaken in his inference; and however we may admire the ingenuity of that reasoning, which for centuries could make the world believe that transparent light was a compound of opaque rays, yet we cannot extend our approbation to those gentlemen, however learned or respectable, who in the face of direct experiment, and I will venture to say common sense, continue to uphold false principles. If the experiments I have published can be refuted, I am ready to give them up and acknowledge myself in error; if not, I call on those gentlemen to act with candour and liberality,

I now varied this experiment in the following manner: I allowed the sunbeams to pass through the hole, and placing a prism behind it, so as to pass them through the lower refracting angle, I perceived a beautiful oblong spectrum of the hole, not the sun, on the opposite wall: that this spectrum was oblong and not circular, by no means surprised me, as I had al-

ready

ready remarked, that the straight shadow of a knitting-needle became curved by striking and passing through the prism; consequently a circle would become oblong: but what at first did surprise me was, that the entire colours of the spectrum were reversed from what I saw on looking at the hole through the prism. The violet was now at top, the orange at the bottom. This fact escaped the notice of Newton and his followers: had they noticed it, the theory of repulsion and attraction must have undergone some slight modification. At some future time I shall endeavour to account for this phænomenon. And I again repeat, that any person performing this experiment must be satisfied that the colours are produced by those fringes, and also that those fringes are produced by the rarefaction of black light, and by no means from any separation of the solar ray.

I shall now say a few words on the astronomical telescope. Mr. Woods has the following description, p. 160:—

“ Let L and E be the centres of the two glasses; Q P an



object towards which the axis of the telescope is directed, and so distant that the rays which flow from any one point in it, and fall upon the object-glass L, may be considered as parallel. Then qp , an inverted image of QP , will be formed in the principal focus of the glass L, and contained between the lines QLq and PLp ; and because LE is equal to the sum of the focal lengths of the two glasses, pq is in the principal focus of the glass AB; consequently pQ may be seen distinctly through the glass, if the eye of the observer be able to collect parallel rays upon the retina. Produce pL till it meet in the eye-glass in B , join pE , and draw BO parallel to pE . Then the rays which flow from p in the object on p its image, enter the eye placed at O in the direction BO ; also the rays which flow from Q enter the eye in the direction EO . Thus the angle which QP subtends at the centre of the eye, when viewed through the telescope, is the angle BoE , which is equal to PEq . The angle which QP subtends when viewed with the naked eye from L , is PLQ , which is equal to pLq ." The same objections I have already brought against the Galilean telescope are equally strong here; I therefore

fore shall merely give a figure of what I conceive to be the true theory of this instrument.

a, the letter T pasted on the window, sends an image to the

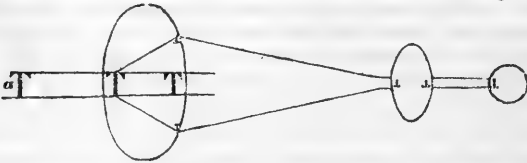

convex object-glass, which is too much rarefied to pass to the eye, but two inverted images are formed at *b* and *c*, which uniting at the eye-glass *CD*, form one inverted image *d*. This again is magnified and sent to the eye at *E*, whence it travels to the retina and sensorium. In both telescopes the image at the eye-glass stands in place of an object.

As this paper is intended as a mere outline, I have not given the exact foci of the glasses, choosing those of high powers. The experimenter is to distinguish between the converging rays and those which form the image. Let him make the following experiment:—Place the glass globe filled with water in the sunbeams, and holding a convex lens over it, he perceives an image of the lens with the sun painted on the convex surface, and he also perceives the gross refracted rays form an image of the sun which can be thrown to some distance, having nothing whatsoever to do with vision. This I proved by the following experiment: I desired a friend to look at a lighted candle, and holding a convex lens opposite his pupil, I perceived the lens with a magnified image of the candle to be painted on his pupil, while by holding the lens a little obliquely, I threw the refracted rays on the side of his nose or on his forehead.

I remain your obedient servant,

Cork, April 22, 1823.

JOSEPH READE, M.D.

VI. *Description of certain Gangues of Spinelle brought from the Island of Ceylon by M. LESCHENAULT DE LATOUR. By M. le Comte de BOURNON, Chev. de St. Louis, F.R.S. &c.**

IN a memoir on Corundum which I presented to the Royal Society of London, and which has been printed in the Philosophical Transactions for 1802, after having fulfilled the

* Extracted from *Observations sur quelques-uns des Minéraux, soit de l'Île de Ceylon, soit de la Côte de Coromandel, rapportés par M. LESCHENAULT DE LATOUR, Par M. LE COMTE DE BOURNON. Paris. 1823.*

end

end which I had proposed to myself, which was to make this substance more perfectly known than it then was, by determining at the same time its intimate connexion with all the stones to which jewellers apply the term *oriental*, such as the oriental ruby, topaz, amethyst, sapphire, &c., I took advantage of this circumstance to insert some details relating to other substances, and more particularly to spinelle. Mr. White, an officer in the English army, whom, on his departure for Ceylon, I strongly recommended to procure some stones from that island, sent us, in a collection otherwise of little value, two fragments of rocks, in which I observed, for the first time, the spinelle of Ceylon in its gangue, and not from the sand of the rivers of that island.

It is twenty years since this observation was made; and since that period we have received no addition to our first knowledge upon this subject respecting the corundum of nearly the whole of India, and that, more interesting on account of its transparency and purity, of the island of Ceylon. Notwithstanding that the English, masters of nearly the whole of India, and at present of the whole of Ceylon, carry on a regular correspondence between every part of India and the metropolis of their country, they are still, I think, liable to reproach in this respect; which opinion arises from the interest which I take in science, and in its progress in a country where it has procured me so many gratifications*.

M. Leschenault de Latour, sent into India by the French Government, with a particular commission to procure for our colonies the vegetables which appear to be useful to their agriculture, as well as to the extension of their commerce, is the inquirer to whom we are indebted for the most extended knowledge of the mineralogy and geology of some of the most interesting districts of India; on account of the information which he has collected concerning these two sciences, though he

* This reproach, perhaps, may seem severe, the Geological Society of London, of which I had the honour to be one of the founders, having printed in 1821, in the second part of the fifth volume of its Transactions, a letter addressed from Ceylon by Dr. John Davy to Sir James MacGregor, and which was read to the Society on the 4th of December 1818. But the details contained in that letter, relating as much to the mineralogy as to the geology of Ceylon, can only be considered, it appears to me, as those of a slight glance thrown over the island. The indications and descriptions which accompany the substances therein named, are so short and incomplete, that they seem but to convey a promise, speedily to be fulfilled, of a work of more importance, containing more instructive details, and so arranged as to arrest the attention of the mineralogist and geologist. I cannot help expressing my regret, that Dr. Davy, so well qualified for this undertaking, has not carried this work to perfection. Perhaps, however, my regret is premature.

was at the time almost a stranger to them. M. Leschenault, remarkable for his extensive knowledge in different branches of natural history, and especially for his zeal and activity, which are equalled only by his great modesty, during a stay of six years in India, scarcely seven months of which were devoted to the researches which he made in the island of Ceylon*, has enriched the French colonies, and principally the Jardin Royal of the Isle of Bourbon, with a great number of plants, useful to the agriculture of the island, as well as to the amelioration, in this respect, of its commercial relations. After having enriched the Jardin du Roi at Paris with many plants, birds, quadrupeds, insects, fishes, and crustacea, which furnish several new species, he has returned to his own country, bringing with him an extremely interesting collection of minerals and rocks, which he collected in the different parts of India through which he travelled. After having first submitted this collection to the choice of the professors of the Jardin du Roi, M. Leschenault presented to the private mineralogical collection of the King, the specimens which were subjected to a second choice made by me. Though I had to regret the loss of a great number of minerals, of which he had no duplicates, this second choice has nevertheless been very useful to the collection, by the facts which their study has put me in possession of. These facts enable me to add some new details to those which I formerly gave relating to corundum and to spinelle; they likewise enable me to make known some others, which the different mineral substances, brought home by this traveller, have introduced to our notice.

I shall commence these details with the description of the various gangues of the spinelle of the island of Ceylon, which are among the minerals presented to the private collection of the King by M. Leschenault.

The first gangue is a carbonate of lime and magnesia, or, more simply, a dolomite. It is colourless, and composed of distinct parts crossing each other in different directions. It contains, thinly disseminated, some small crystals of phosphate of lime of a deep beryl blue, sometimes placed between the particles of dolomite, but more frequently contained in its substance, and which are only discovered by the fractures made to determine the characters of the mineral. These crystals are

* M. Leschenault arrived at Ceylon at the end of July 1820, and quitted it in February 1821, after having been obliged to return to Columbo by a dysentery; and in the short time of his residence in the interior, the science of botany, the special object of his mission and researches, was in consequence that to which his chief attention was directed.

generally of a rounded and indeterminate form; nevertheless, on one of the specimens in the King's collection I observed among them a complete hexahedral prism, and another with many small facets on the edges of its terminal planes. These crystals are but few in this gangue, which likewise contains, in still smaller quantity, some small crystals of spinelle of a pale-red or flesh-colour. They are even contained in the substance of the dolomite; their form is either a regular octahedron, a cuneiform octahedron, or an octahedron the edges of which are replaced by a plane. The dolomite of this gangue dissolves in nitric acid, without any sensible effervescence, and with extreme slowness: a small fragment requires forty-eight hours for its complete solution. It was found by M. Leschenault very near Candy. It is likewise found, as well as the two following gangues, in the isolated rocks at the feet of the elevated mountains which separate Candy from Colombo, and upon the road which joins those two towns.

The second gangue is likewise dolomite, in a lamellary state, and formed, in the same manner as the preceding, of particular masses, but smaller and crossing each other in different directions. When first placed in nitric acid, it produces a very lively effervescence, which becomes weaker by degrees, and at last very feeble. In a short time after it has been placed in the acid, it becomes disintegrated into an infinity of small particles, the greater number of which continue to dissolve very quickly. The analysis which has been made of it gives more carbonate of lime than is necessary to the composition of dolomite. I strongly suspect this rock to contain some particles of carbonate of lime interposed in its substance; from which would arise the lively effect of the acid upon coming into contact with it, its quick solution, as well as the disintegration which it undergoes. This second gangue contains, in rather greater proportion than the preceding, some flesh-coloured crystals of spinelle. It also contains some very small crystals of mica of a very deep yellow colour. Here and there likewise may be observed some small crystals of pyrites, of the icosahedral variety; but I have not observed any trace of phosphate of lime. This gangue was found by M. Leschenault seven leagues east from Candy.

Although the third gangue of spinelle is from the same district as the former, it is essentially different, and of a very particular nature. It consists of very coarse grains, the texture of each of which is lamellated. Of these grains a very great number are white, and their fracture has a very brilliant

lustre; they belong to the dolomite. The others have a gray tint, and their fracture is less bright; they belong to carbonate of lime; but they are mingled with interposed particles of dolomite.

In this gangue are disseminated some small icosahedrons of pyrites, some crystals of mica, of an orange yellow; some amorphous particles, and also some regular crystals of apatite, resembling in their green colour the variety called spargelstein of Spain. It likewise contains a still greater quantity of this substance in small flattened hexahedral prisms, very difficult to recognise on account of a thin white layer which entirely covers them; but when this is removed, the green colour of the apatite appears. I am ignorant whether this white layer arises from an alteration of the apatite, or whether it belongs to another substance which would be completely insoluble in acids; for it was in dissolving this rock in nitric acid that I obtained these crystals. This gangue contains, besides, many minute particles of magnetic pyrites, and likewise a considerable quantity of small crystals of spinelle, of a fine rose colour. I observed among the latter some complete octahedrons, some with the edges replaced, and some, each of the solid angles of which was replaced by four planes, placed upon the faces, as frequently seen in the pleonaste spinelle of Mount Somma, and which I have also observed in the red spinelles found in the sand of the Ceylon rivers. Some of the yellow crystals of mica have a brilliant lustre, on which account they might be very easily taken for some of the hard stones called gems.

The memoir on Corundum, which I presented to the Royal Society of London, having been printed in the *Journal des Mines* for 1803, by referring to pages 97 and 98 of the Number for May of that Journal, it will be seen that this gangue is absolutely of the same nature as those sent to London, from the island of Ceylon, in 1801 or 1802, for the first and the last time*.

The fourth gangue of spinelle is extremely interesting: it is composed for the most part of spinelle and of mica. The spinelle is in octahedral crystals of a brown colour approaching to violet, and they are much larger than those contained in the gangues above described. The colour of some of them is so deep, that they appear to be black; they form one of the varieties of the pleonaste spinelle of Ceylon. These crystals, which are extremely abundant in this gangue, are very close to each other, and often form considerable masses, in which

* See also Phil. Trans. for 1802, p. 308-311.—EDIT.

some of them are in contact with others, and even penetrate them.

The mica is of a brown yellow colour, slightly orange by refracted light; it forms, in this gangue, considerable masses, to which we may give the name of "*mica en masse lamellaire.*" The detached parts of these masses are perfectly transparent, and have a very brilliant lustre. By means of nitric acid I have extricated one of them, of the dimensions of two inches by one inch and three lines, from the carbonate of lime, which constitutes a part of the gangue; this mass is perfectly pure, with the exception of some insoluble particles which it contains; among which are particles of magnetic pyrites. I have never yet seen mica in such considerable masses presenting so beautiful and brilliant an aspect. The mica, which in this specimen is very pure, has sufficient solidity to resist pressure, and is consequently very suitable for the illustration of what I asserted for the first time in 1813, in the summary catalogue of my collection, now become that of the King, that the integrant particles of mica are of themselves of very great hardness, and that this substance is so easily broken on account of the weakness of the cohesive force which unites these particles to each other; but that, when small fragments or crystals of mica have sufficient thickness to resist pressure, they cut glass with facility, and will even scratch quartz, or at least deprive it of its polish, a fact which is further confirmed by the nature of its refraction, as well as by that of its reflective power*. The King's private collection possesses a suite of specimens of mica for study, which presents this extremely interesting substance under a great variety of aspects very little known. This suite, which in my opinion is unique, should be consulted in order to obtain a complete knowledge of this substance.

The fifth gangue is very particular: it is a *girasol*, mixed with particles of a slightly grayish white, with some of a yellowish green, and with others in the state of *girasol jasper*, on account of the hydrate of iron which is interposed in them. The specimen placed in the Royal collection has adhering to it a small piece in an earthy state, mixed with much brown

* All these characters induce me to believe that this fourth gangue of Ceylon spinelle is the same as that, which, according to Dr. Davy, forms hills in the vicinity of Candy, and in which he likewise observed crystals of ceylanite, which he seems to consider as a different substance from spinelle. I am ignorant of his reasons for making this distinction: ceylanite, it is true, contains a large proportion of iron, but the quantity of that metal varies in the different analyses which have been made of spinelle; I think, therefore, that it is merely interposed in the ceylanite.

mica, of which there are some small plates interposed, even in the substance of the girasol. This gangue contains, in the interior of its substance, a considerable quantity of pale-blue crystallized spinelle, among which, however, there are some crystals of so deep a blue that they appear black. M. Leschenault only found this rock on the bank of a river seven miles to the north-east of Candy, on the route to the province of Fassagram, where he met with it in isolated masses.

The sixth gangue of Ceylon spinelle, which is still more particular, is a rock of a granitic aspect, in which the mica is replaced by molybdena in small thin laminæ. This rock is principally composed of transparent granular felspar, and of these laminæ of molybdena. One may observe, besides, some little plates of brown mica, which are thinly disseminated, and a great number of very pale-red crystals of spinelle. This rock was found by M. Leschenault, seven miles to the north-east of Candy, in the same district as the preceding, and likewise in isolated masses upon the bank of the same river.

I may add to the description of these gangues of spinelle, that of a seventh, which is the second of those I have described in the paper on Corundum, printed in the Philosophical Transactions for 1802. This gangue consists principally of transparent felspar or adularia, pure in one part, and mixed in the other with magnetic pyrites and a little carbonate of lime. Some small crystals of spinelle are disseminated in it, but more thinly than in the other gangue mentioned in the same memoir.

VII. *Description of an improved Gauge for ascertaining with Precision the Pressure of highly compressed Steam, Gases, and Fluid Bodies.* By Mr. SAMUEL SEAWARD.

To the Editors of the Philosophical Magazine and Journal,

Gentlemen,

PERMIT me to offer you the accompanying description of a gauge for measuring the pressure of highly compressed fluids or gases, which I shall feel gratified by your introducing into your valuable Magazine, if you consider it deserving of that distinction.

I am, gentlemen, yours, &c.

3 Charles Street, City Road,
Jan. 14, 1824.

SAMUEL SEAWARD.

Description, &c.

Considerable difficulty has been experienced in ascertaining in a satisfactory manner the exact pressure of highly condensed gases or fluids.

The usual method of accomplishing this object is by the rising of a column of mercury in a glass tube hermetically sealed at the top; the tube being previously filled with air at the ordinary pressure of the atmosphere. For as the mercury rises by the pressure of the gas, the air confined in the tube above the surface of the mercury will be compressed to the same degree as the gas itself, making proper allowance for the weight of the column of mercury. But it happens that when fluids are required to be compressed to 30 or 40 atmospheres, it becomes necessary to have the tube of the mercury gauge of very great length, say from 30 to 45 feet, otherwise the divisions of the upper part of the scale will be much too small for useful reference; but this great length renders the apparatus exceedingly inconvenient for practical purposes.

The accompanying drawing represents a gauge on an improved principle, which it is expected will be found much more convenient and correct than the gauge in common use. The gauge consists of two small cylindrical chambers A and B, and the glass tube C. The communication between the two is by the small tube *d*, which reaches nearly to the bottom of the lower chamber.

The glass tube C we will suppose to be about eight feet long: the chamber B is to be filled with mercury as high as the line *cc*; the tube *e* is to admit the compressed gas or fluid, which acting on the surface of the mercury forces it up the tube *d*, which after filling the chamber A will rise in the tube C.

Now, supposing the apparatus to be previously filled with air of the common atmospheric pressure, and that the chamber A be equal to 19 times the capacity of the

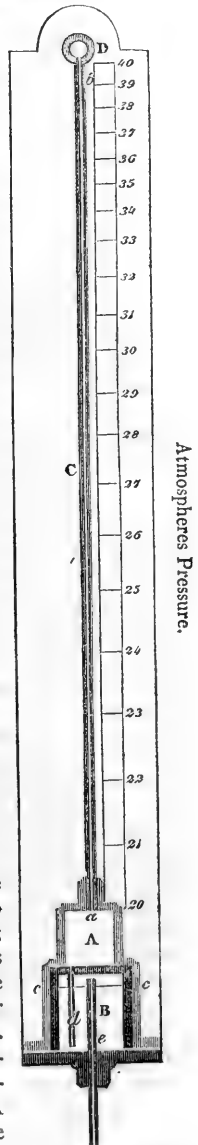

tube

tube *c*; it is quite plain, that when the mercury is forced by the pressure of the gas or fluid into the chamber *A*, and rises up to the bottom of the glass tube, the air in the tube *C* must then be compressed 20 times, and will consequently indicate a pressure of 20 atmospheres; and if the mercury is then raised half way up the tube *C*, the air will then be compressed 40 times, and will indicate a pressure of 40 atmospheres. We have considered that the glass tube *C* should be eight feet long; but if, instead of eight feet, we make this tube only four feet long, and fix to the top a small hollow ball *D*, of equal capacity with four feet of the tube; then if the mercury rise four feet high in the tube, or up to the ball, the apparatus will still indicate a pressure of 40 atmospheres, as if the tube eight feet long had been employed.

By this means we have a compact instrument, which will indicate in a satisfactory manner the various pressures within the range of 20 and 40 atmospheres; for the divisions on the scale for the whole of this range will be as large as if a tube of the common form 70 feet long had been employed.

But it may be objected that this instrument is imperfect, because it will not indicate any lower pressure than 20 atmospheres, nor any higher than 40. To this it should be observed, that in all practical applications of a gauge of this sort, as the compression of gases, &c., it is only within certain limits that it is desirable to ascertain the exact pressure: for instance, in the case alluded to, it is of no consequence to ascertain the pressure when below 20 atmospheres; nor is it ever required to be elevated above 32 atmospheres; therefore a range, as here proposed, of from 20 to 40 atmospheres is quite sufficient for practical purposes in working the apparatus of a portable gas establishment, &c. Perhaps it is unnecessary to observe, that the various ranges may be altered at pleasure, from the lowest pressure up to the greatest; for by properly arranging the different sizes of the ball *D* and chamber *A*, it may be made to indicate from 1 to 20—from 20 to 40—from 40 to 60, and 60 to 100 atmospheres. And if it should ever happen to be necessary to ascertain the exact pressure of the fluids from 1 atmosphere to 100, which is a thing perhaps never wanted, it can still be done with the same degree of exactness throughout; for, by using two or more of these gauges graduated for different ranges, we thus obtain a correct scale of reference, which it would be impossible to do in the old method; say from 1 to 15—15 to 45—and 45 to 100.

It is here proper to observe, that the weight of the column of mercury in the chamber *A*, and in the tube *C*, should be
 taken

taken into account as well as the pressure of the air in the tube C; otherwise it will not be a correct indication of the force of the gas or fluids acting upon the surface of the mercury in the chamber B. Therefore, in the following calculation for graduating the scale attached to the tube C, a proper allowance is made for the weight of the column of mercury.

Annexed is the investigation of a theorem for graduating the scale. The table was computed therefrom, and a scale agreeable thereto is made to be attached to an instrument which I am now making, for the purpose I have described.

Calculation for the Scale.

Ascertain nicely the capacity of the chamber A, together with the tube C and its ball D, and let that quantity be denoted by M. Then ascertain the capacity of the tube and ball only, and denote that by m: and let the ratio of these two quantities be denoted by r; that is $r = \frac{M}{m}$.

And let a denote, in inches, the whole length of the tube C, including a length of tube equal in capacity to the ball D; and let x represent the height, in inches, of the mercury in the tube C, from the bottom of the tube at a. Then when the mercury just reaches the bottom of the tube at a, it is plain that the pressure must be equal to r atmospheres. And when the height of the mercury in the tube is equal x, then the pressure on the inclosed air will be equal $\frac{a}{a-x} \times r$ atmospheres.

But in order to ascertain exactly the force of the gas acting upon the surface of the mercury in the chamber B, we must add to the above the weight of the column of mercury above the level in the said chamber B. Let b denote the number of inches that a, the bottom of the tube, is above the level of the mercury; and let c represent the height of a column of mercury equal in weight to one atmosphere, say 29.5 inches. Then the weight of the column of mercury in the tube C will be $= \frac{x+b}{c}$. Therefore putting y equal the required number of atmospheres, we shall have

$$\frac{a}{a-x} \times r + \frac{x+b}{c} = y. \quad \text{Or,}$$

$$x = \frac{a+cy-b}{2} \pm \sqrt{\frac{(a+cy-b)^2}{4} + car + ab - acy}. \quad (\text{No. 2})$$

Now put r the ratio = 20 and a = 76.8, the whole length of the tube including the ball at top; and put c = 29.5 the height

height of a column of mercury that will balance the pressure of the atmosphere; and put $b=7.3$. Thus, if these values be substituted in the equation No. 2, and different values taken for y , we shall thereby obtain the corresponding values of x , or the height of the column of mercury in the tube C, indicating the several pressures. Thus, put $y=30$ atmospheres; then

$$x = 477.25 - \sqrt{227767.5 + 45312 + 560.64} - 67968$$

$$x = 23.74 \text{ inches.}$$

That is, the altitude of the mercury in the tube will be 23.74 inches, when the pressure is equal to 30 atmospheres pressing upon the surface of the mercury in the lower chamber B. And in this manner have been computed the different values of x , corresponding to different pressures, as shown in the following table:

Table for graduating the Scale.

Pressure.	Values of x or height of the mercury.	Pressure.	Values of x or height of the mercury.
21 atmospheres	2.49 inches.	31 atmospheres	25.42 inches.
22 ditto	5.57	32 ditto	26.99
23 ditto	8.43	33 ditto	28.48
24 ditto	11.10	34 ditto	29.89
25 ditto	13.57	35 ditto	31.21
26 ditto	15.88	36 ditto	32.48
27 ditto	18.04	37 ditto	33.67
28 ditto	20.07	38 ditto	34.80
29 ditto	21.96	39 ditto	35.88
30 ditto	23.74	40 ditto	36.91

VIII. *Descriptions of some new Cacti and Mammillariæ, recently brought from Mexico by Mr. BULLOCK of the Egyptian Hall, Piccadilly; and now preserved, with many other very rare Plants, in the Nursery of Mr. TATE, in Sloane-street. By A. H. HAWORTH, Esq. F.L.S. &c.*

To the Editors of the Philosophical Magazine and Journal.

Gentlemen,

ALLOW me to transmit to you herewith technical descriptions of some new and very remarkable plants of the family of *Cacti* Juss., which I hope you will admit into an early Number of your valuable Miscellany. And I remain

Your most obedient servant,

Queen's Elm, Chelsea, Nov. 1823.

A. H. HAWORTH.

CACTI

CACTUS. *Linn. aliorumque.*

senilis. C. oblongus; subviginti-angularis; spinarum radiis
1. capilliformibus elongatis.

Obs. Unam plantam semipedalem solum vidi, angulis profundis viridibus. *Spinarum* radii inter se dense flexuosi sive intertexti depresso-recurvuli; in singulo fasciculo circiter 12, omnino capillacei 4-unciales plantamque tegentes præsingulares; uti comam albicantem in capite senili. Nullo, mihi noto, affinis, at forte cum *Cacto multangulari* Willd. sectionem propriam formavit. *Flores* non vidi, neque in sequentibus.

latispinus. C. depresso-sphæroideus; sub 21-angularis; spinarum radiis variantibus, una infimo deflexo latissimo plano.

Obs. Cacto recurvo *Milleri* proculdubio proximus, at angulis numerosioribus, et spinâ latâ, non erectâ nisi in juventute. Valde depressus, angulis porcisve validissimis duris viridibus. *Spinarum* radii variantes sordide lutei, circiter 12 exterioribus in singulo fasciculo ordinariis, subuncialibus, circiter 4-6 aliis 10-20-plo majoribus, subduplo longioribus (horum ultimorum), sub 3 superioribus subulatis sordidè pallescentibus, elevatim densè annulatis fere ad apicem lævem, demum rufam, annulis (in lente) rufescentibus, 2-3 infimis spinis (in singulo fasciculo) plus minus planatis, ipsa infima (spina) omnino plana deflexo-incurvula 3 lineas lata apice recurvo subulato.

Obs. Spinæ omnium validissimæ primo fulvo-rufescentes, demum superne rufæ, denique sordidæ.

MAMMILLARIA. *Nob. in Synops. Pl. Succulent.—*
Aliorum Cactus.

magnimamma. M. mammis magnis perviridibus apice tomentosis, spinis subquatuor validis expansis, 2-3 recurvis lutosi apice nigris.

Obs. Plantam unam bifidè germinatam subglobosam pugno minorem solum vidi. Tomentum ad basin spinarum breve ac densum est.

lanifera. M. simplex tereti-obovata, mammis apice lanosis plus 20-spinosis, spinis radianter patentibus variis.

Obs. Spinæ exteriores in singulo fasciculo minores albæ (mortuis nigris) subsex interiores 3-5-plo longiores quam ultimis et 3-7-plo validiores, fulvo-fuscescentes, supernè nigræ seu nigricantes. Plantam 3-4-uncialem solum vidi.

geminispina. *M. columnaris*; mammis exiguis numerosissimis,

5. spinis parvis intertextis albis; duabus in singulo fasciculo cæteris multoties longioribus.

Obs. Plantæ plus quam semipedales fere omnino simplices teretes, superne sensim crassiores apice vix convexo. *Mammæ* pallidè virides spinis recurvo-radiantibus capillaceis albis; duabus in singulo fasciculo validioribus geminatim semierectis pungentibus apice nigris.

Obs. Spinarum fasciculi radiantes et inter se confertim patentés, fere totam plantam eleganter tegentes.

IX. *An Account of the Effect of Mercurial Vapours on the Crew of His Majesty's Ship Triumph in the Year 1810.* By WILLIAM BURNETT, M.D., one of the Medical Commissioners of the Navy, formerly Physician and Inspector of Hospitals to the Mediterranean Fleet. Communicated by MATTHEW BAILLIE, M.D. F.R.S.*

IT has long been known, that in the vacuum of the barometer, mercury rises in a vaporous state at the usual temperature of this climate, and that persons employed in the mines from whence this metal is procured, as well as those who are employed in gilding and plating, have suffered paralytic and other constitutional affections, from inhaling the air saturated with mercurial vapours: had any doubt remained of mercury existing in the state alluded to, it would be effectually removed by the experiments made by Mr. Faraday, detailed in the twentieth number of the *Journal of Science*, &c.

An unprecedented event, which occurred in one of His Majesty's ships of the line, at Cadiz, in the year 1810, a short time before I took upon me the charge of the Medical Department of the Mediterranean Fleet, has afforded me an opportunity of illustrating this subject on a very extensive scale, the details of which may not, perhaps, be uninteresting to the Royal Society.

The *Triumph*, of 74 guns, arrived in the harbour of Cadiz in the month of February 1810; and in the following March a Spanish vessel, laden with quicksilver for the mines in South America, having been driven on shore in a gale of wind and wrecked under the batteries, then in possession of the French, the boats of this ship were sent to her assistance, by which means, during many successive nights, about one hundred and thirty tons of the quicksilver were saved and carried on

* From the *Philosophical Transactions* for 1823, Part II.

board the *Triumph*, where the boxes containing it were principally stowed in the bread-room.

The mercury, it appears, was first confined, in bladders, the bladders in small barrels, and the barrels in boxes. The heat of the weather was at this time considerable, and the bladders, having been wetted in the removal from the wreck, soon rotted, and the mercury, to the amount of several tons, was speedily diffused through the ship, mixing with the bread, and more or less with the other provisions. The effect of this accident was soon seen, by a great number of the ship's crew, as well as several of the officers, being severely affected with ptyalism, the surgeon and purser being amongst the first and most severely affected, by the mercury's flowing constantly into their cabins from the bread-room; their cabins being, as is usual, on the orlop deck, separated from this store by partitions of wood. In the space of three weeks from the mercury's being received on board, two hundred men were afflicted with ptyalism, ulcerations of the mouth, partial paralysis in many instances, and bowel complaints. These men were removed into transports, where those more slightly affected soon got well; but fresh cases occurring daily, Rear-Admiral Pickmore, then in command of the squadron, ordered an inspection to be made by the surgeons thereof, and, in consequence of their report, sent the *Triumph* to Gibraltar to remove the provisions, and purify the ship by ablution, the affected men being sent to the Naval Hospital; which order was strictly attended to; the provisions, stores, and likewise the shingle ballast, being removed on shore.

Notwithstanding the removal of the provisions, &c., and afterwards frequent ablution, on restowing the hold, every man so employed, as well as those in the steward's room, were attacked with ptyalism; and during the ship's passage, and on her return to Cadiz, the fresh attacks were daily and numerous till the 13th of June, when the *Triumph* sailed for England.

After their departure from Cadiz they experienced fresh breezes from the N.E.; and the men being kept constantly on deck, the ship aired night and day by windsails, the lower-deck ports allowed to remain open at all times, when it could be done with safety, allowing no one to sleep on the orlop deck, and none affected with ptyalism on the lower deck, a very sensible decrease in the number daily attacked soon became apparent; but, nevertheless, many of those already affected became worse, and they were under the necessity of removing twenty seamen and the same number of marines, with two serjeants and two corporals, to a sloop of war and

the transports in company. On their arrival in Cawsand Bay, near Plymouth, on the 5th of July, not one remained on the list for ptyalism.

The effects of the mercurial atmosphere were not confined to the officers and ship's company; almost all the stock, consisting of sheep, pigs, goats, and poultry, died from it; mice, cats, a dog, and even a canary bird, shared the same fate, though the food of the latter was kept in a bottle closely corked up.

The surgeon (Mr. Plowman) informed me, in conversation, that he had seen mice come into the ward-room, leap up to some height, and fall dead on the deck.

The *Triumph*, previous to this event, had suffered considerably, by having a number of her men attacked with malignant ulcer, which at one time prevailed to a considerable extent in our ships, both at home and abroad; and in many of the men who had so suffered, the ulcers, which had long been completely healed, without even an erasure of the skin, broke out again, and soon put on a gangrenous appearance.

The vapour was very deleterious to those having any tendency to pulmonic affections; three men died of phthisis pulmonalis, who had never complained, or been in the list before they were saturated with the mercury; and one man who had suffered from pneumonia, but was perfectly cured, and another who had not had any pulmonic complaint before, were left behind at Gibraltar, labouring under confirmed phthisis. Two only out of so large a number affected died from ptyalism, gangrene having taken place in their cheeks and tongue: they had previously lost all their teeth. In the case of a woman, who was confined to bed in the cockpit with a fractured limb, not only were all the teeth lost, but many exfoliations also took place from the upper and lower jaws.

The mercury showed its effects upon the ship herself, by the decks being covered with a black powder; but quicksilver was not discovered at any time in this powder in a native or globular state, though the brass cocks of the boilers, and the copper bolts of the ship, were covered with the metal, the last to some extent within the wood; a gold watch, gold and silver money kept in a drawer, and likewise some of the iron-work of the ship which had been kept bright, evidently showed the influence of the prevailing atmosphere, being in some places covered with quicksilver.

In a communication with which Mr. Plowman, surgeon of the *Triumph*, has obliged me, he states, that those who messed and slept on the orlop and lower decks, with the exception of the midshipmen, suffered equally, while those on the main or
upper

upper deck were not so severely affected: the men who lived and slept under the fore-castle escaped with a slight affection of the gums. The only reasons which can be assigned for the partial escape of the midshipmen, are, that the windsails were kept always in action, and that these gentlemen were almost constantly on deck, or were more frequently employed on service out of the ship, in proportion to their numbers, than the men.

Various opinions were entertained of the manner in which the systems of the sufferers were brought under the influence of the mercury. By some, it was supposed to have originated from the use of the bread and other provisions, with which the mercury had mixed itself: and to such an extent was this opinion carried, that I find, by reference to official documents in the Victualling Office, seven thousand nine hundred and forty pounds of biscuit were condemned as unserviceable from having *quicksilver mixed with it*.

By others, amongst whom was Mr. Plowman, the surgeon, it was considered to have arisen from inhaling the mercurialized atmosphere; and from the preceding details, I think there cannot remain a doubt that this opinion was the true one.

It is well known that mercury, in its native state, has often been administered in very large doses, in cases of obstinate constipation, without producing any specific effect on the system, merely removing the affection by its specific gravity. I have, however, reason to believe, from the accounts of Orfila, and others, that if the mercury was to be retained in the intestines for some time, and thus subjected to the action of the contents of the stomach and bowels, a part might become oxidated, and being conveyed into the system by means of the absorbents, would there show its specific effects.

But after the removal of the provisions, &c. at Gibraltar, many fresh cases occurred, and many relapses amongst those who had been cured out of the ship, took place on their return to duty on board, which effectually destroys the probability of this having been the cause of the succeeding ptyalism, and other morbid affections.

It only remains for me to offer my opinion, of the manner in which the system became saturated by the mercury; and this I conceive to have been effected by inhaling the mercurial vapours; the quicksilver being then in the most perfect state of division, was readily taken up by the absorbents of the lungs, and soon showed its influence on the system generally. This idea is very much strengthened by the effect which was
produced

produced on the animals on board, already mentioned, as well as by the circumstance of a great number of men being attacked after the ship was cleared at Gibraltar, and till she arrived in a more northern latitude.

It may be considered out of place here, to give any detail of the curative means employed. I shall therefore only briefly state that sulphur given in large quantities internally, produced no alleviation of the symptoms; on the contrary, it greatly augmented the bowel complaints, with which many of the men were affected, and brought on a most severe tenesmus; consequently, it was laid aside; applied externally, it was of no use.

The only plan which produced effectual relief was removal from the ship, with the frequent use of small doses of neutral salts and detergent gargles.

W. BURNETT.

X. *Account of a Work entitled "Storia de' Fenomeni del Vesuvio avvenuti negli anni 1821, 1822, e parte del 1823," etc. "History of the Phænomena of Vesuvius during the Years 1821, 1822, and Part of 1823; accompanied with Observations and Experiments. By J. MONTICELLI, Perpetual Secretary of the Royal Academy of Sciences of Naples; and N. COVELLI, of the Royal Institute of Encouragement." By M. MENARD DE LA GROYE*.*

THE general form of this work is nearly that of a journal, that is to say, the facts are recited in the natural and successive order in which they were collected. If we judge of the ultimate celebrity of M. Monticelli, by that which he has for several years enjoyed, arising from his former labours, we shall be induced to believe that he will occupy the first rank among the historians of this celebrated volcano, which we always consider as in some sort a *volcanic archetype*.

The new work which we announce was preceded by a description of the eruptions of 1812 and 1817. The same author likewise published in French, in conjunction with M. Covelli, some "Observations and Experiments made at Vesuvius during Part of the Years 1821 and 1822."—(See *Bulletin*, tom. ii. p. 435.) The first section of the work which now occupies our attention, is for the most part a repetition,

* From the *Bulletin des Annonces Scientifiques*, tom. iv. p. 34. M. de la Groye's analysis of the former work by MM. Monticelli and Covelli above alluded to by him, will be found in vol. lxii. of the *Philosophical Magazine*, p. 90.

in Italian, of that just mentioned. The new eruption in the month of October last, not only one of the most considerable which have occurred since that so celebrated in 1794, but even of the grandest which have ever been witnessed, having presented to the authors an extensive field for new experiments and observations, induced them to resume and enlarge that work by the addition of two sections, a preface, a table of contents, and figures.

The most remarkable of the principal facts contained in this work, are enumerated by the authors themselves in the preface. These are the formation of earthy pisolites among the pulverulent lava; the particular and oblique ejection of a fine sand, or, as it is vulgarly named, volcanic ashes, which also produces small and extremely singular currents, having at a distance the appearance of streams of hot water; that of other currents formed entirely of substances much more bulky, but equally incoherent; the examination made with new and peculiar interest of the discontinuance or intermission, and of the partial fits of the eruptions, which are compared by the authors to the paroxysms of violent diseases; the positive observation of sulphurous acid, and of sulphur itself, in the lava which has ceased flowing; that of carbonic acid in fumeroles of lava, before it is completely cold, and especially of a considerable evolution of this acid, after great eruptions, giving place to large and numerous *mofettes* which are manifested around the base of the mountain. This fact is so remarkable and of such importance, that the celebrated Sir Humphry Davy thought that it might lead to the discovery of the origin of the various calcareous rocks in which volcanic substances are contained, either in cavities or in the substance of the rocks themselves.

Among the newly recognised productions of Vesuvius, will be remarked the sulphates and chlorides of manganese, which characterize a number of saline metallic sublimates, and the existence of which in the mineral kingdom has been hitherto unknown. This work likewise offers several considerations concerning the diversity of temperature, which the different volcanic vapours require in order to their attaining a solid state. The veracity of Pliny the younger, in the description he gives of the eruption which occasioned his uncle's death, has been frequently questioned; but MM. Monticelli and Covelli prove, by comparing several passages of his relation with the effects which they have themselves observed, that he is entitled to complete confidence. They have also observed the formation of the last cone, and seen it gradually disappear in part, in the same manner as that which, according to the description of Strabo, existed

existed before the horrible catastrophe of the year 79. The first section is entitled "The State of Vesuvius from the Eruption of 1820 and 1821 to the Commencement of October 1822; with Observations and Experiments." It contains an article on the state of the volcano from the 11th of May 1822 to the beginning of October, not inserted in the work which preceded it; from which it also differs in some other respects towards the end. The second section is a "Journal of the Eruption of October 1822." The authors first speak of the state of the atmosphere during the spring, summer, and autumn which preceded that eruption; a state rendered more remarkable by the excessive drought which prevailed. They mention some movements of the volcano precursory to the eruption; and then proceed to the description of the phenomena observed in the interval between the 21st of October and the 11th of November; during which time occurred the various paroxysms of that eruption. The zigzag lightning began to appear on the 22d, at two o'clock in the afternoon, not proceeding from the *pine* of ashes, or from the great cloud of smoke arising from it, but in a part of the atmosphere between both and occupied only by the ashes. The lightning was not accompanied with any detonation. This electric phenomenon, which increased as the violence of the eruption diminished, did not take place in the middle of a paroxysm, but at the edges of the clouds of ashes. At a later period the lightning was seen to emanate not only from the dusky clouds or the air, but also from the earth, and even to traverse the roads.

Our authors discovered, by very simple but decisive experiments, that the falling cinders were strongly and vitreously electrified. Electric discharges were still seen from the summit of the mountain; and the cinders, which were at first gray, notwithstanding that their electricity remained the same, altered to brown, and finally became of a reddish colour. These red ashes falling in great abundance, and spreading themselves thickly to a considerable distance, caused great darkness. In addition to this, they observed a strong smell of muriatic acid and of muriate of iron, which reached as far as Naples: had this not been the case, they would yet have discovered from other effects the existence of this acid in the ashes, which had the same day been the subject of their experiments.

The *pine* presented a variety and a remarkable mutability of colours, which are attributed by the authors to the refractions produced in the different currents of air through which they passed. After an abundant shower of rain and cinders, the

the trunk of this *pine*, already much weakened from other circumstances, instead of the cylindrical column presented only a series of large and small globes, which the authors attribute, in great measure, to the enfeebled state of the electric attraction of the air. At the conclusion of the eruption the volcano attracted to itself all the clouds of the atmosphere, from which was formed an immense quantity of water, which rolling down its sides in torrents, and carrying with it large quantities of incoherent matter, devastated the surrounding country. Of the pisolites, some of them, and those the largest, fell already formed; the others were formed upon the ashes which covered the ground by means of a fine rain.

Section 3d. "Observations and Experiments made during the Eruption of October 1822." This section is the longest, the most interesting, and contains the greatest variety of new facts. The following are the titles of its principal divisions:

Art. I. "Periods of the Maximum and Minimum of Violence which this Eruption presented. In this is given in detail the fact that the paroxysms appear subject to this general law, that their violence is in the inverse ratio to their duration. The shortest and most terrible are in the middle of the eruption; the longest and feeblest, at its commencement and at its close.

Art. II. "State of the Crater and of the great Cone on the 16th of November 1822.—Description of the Cone and of the actual Crater." The *Atrio* became more and more filled up, and Vesuvius, properly so called, and Mount Somma were approaching to union. The edge of the crater in question was very narrow.

The authors have given in this part a review of the observations made upon the height of Vesuvius from the year 1749 to 1822.

Art. III. "Examination of the Substances which are ejected or produced during the Eruption." These are divided into five classes: 1. incoherent solids; 2. liquids; 3. volatile substances; 4. gaseous substances; 5. imponderable substances. Each of these classes is examined separately and in detail, and the various modes and periods of their appearance are pointed out. The ashes have been carried as far as 105 miles in almost all directions; and the strata which are the result of them, as well as those consisting of other incoherent matter, are studied under various aspects, and are observed to differ greatly from those formed by alluvial deposition. The effects of these showers of ashes on organized bodies are again spoken of. The currents of lava form sub-

jects of consideration in the article on liquid substances. Water is an important agent, mechanically and chemically, among those of a volatile nature. Among the gaseous substances, muriatic acid is evolved at all periods of the eruption, and at all temperatures.

Art. IV. Of the Currents of incoherent Lava.

Art. V. Of the Currents of Ashes.

Art. VI. Of the Aggregates formed by those Substances.

Art. VII. Of the Mofette produced by the Carbonic Acid.

Art. VIII. Of Obsidian, a rare Species of Lava at Vesuvius.

In Art. IX. is given A Catalogue of the Products of the Eruption of October 1822: In Art. X. the Details of the chemical Processes, which they followed in their Analytical Examination of the Substances produced in this last Eruption.

Art. XII. contains two tables of Meteorological Observations made during the months of October and November 1822, at the Observatory of Naples, at the distance of about eight miles from Vesuvius. It also contains a recapitulation of the most remarkable facts observed in the course of the last eruption, and since that period.

The figures represent, 1st, Vesuvius viewed from the road of the Hermitage a few days before the eruption of October 1822; 2d, this eruption observed from the same situation at eight in the evening; 3d, the Volcano seen from Bosco-tre-Case; 4th, a drawing of the Crater made upon the spot, on the 16th of November 1822.

XI. *On the ensuing Opposition of Mars.* By F. BAILY, Esq. F.R.S. Read before the Astronomical Society of London, January 9, 1824.*

AT a time when we have two new and excellent observatories established in the *southern* hemisphere, where the celestial phænomena are watched and observed with the greatest diligence and zeal, it becomes the more important and necessary that corresponding observations of a certain class of those phænomena, of not very frequent occurrence, should also be made in the *northern* hemisphere, by such persons as are fortunately possessed of the requisite means for this purpose. Without this co-operation, the labours of those industrious observers will lose much of their value, and the advantageous opportunity of elucidating an important

* See our report of the proceedings of the Society at page 61.

branch of physical astronomy will be wholly lost to the public.

The ensuing opposition of Mars, on the 24th of March, is one of this class: a phænomenon which occurs once only in a period of about 780 days. It is well known that corresponding observations of this planet, in the two hemispheres, as compared with stars situated near its path, about the period of its opposition, will serve to determine its parallax. And the parallax of Mars being known, that of the sun may thence be deduced. This was the plan adopted by Lacaille, when he was at the Cape of Good Hope, in the year 1751: since which period, the method has fallen into disuse, for want of an observatory in the southern hemisphere, with instruments fit to be compared with those in Europe.

The present period seems extremely favourable (for the reasons above mentioned) for the revival of this method. At the time of the last opposition in 1822, I ventured to draw the public attention to the subject, by pointing out certain stars, near which the planet would pass; and with the positions of which it might be compared. Several valuable observations were made both in the southern and in the northern hemisphere, which are published in various periodical works: and which, being thus recorded, may be referred to with advantage, by those who devote themselves to this branch of physical astronomy.

At the present opposition, there are but few stars, and those of inferior magnitude, with which Mars can be advantageously compared. For ten days preceding and subsequent to the date of its opposition, Mars will not approach *near* to any star given in the large catalogues of Bradley or Piazzi. There are, however, five stars given in the catalogues of Lalande, inserted in the *Connaissance des Temps* for the years VIII. and XIII. with which the comparisons may be made. The mean places of these stars, on January 1st of the present year, are given in the following little table; together with the dates when Mars will be in conjunction with them.

Conn. des Temps.	Mag.	R.			D.			Mars.
		H.	M.	S.	°	'	"	
An. XIII.	7·8	12	10	0	2	18	44 N.	April 1
XIII.	8		14	29	1	52	2	March 29
XIII.	8		17	16	1	29	47	— 27
VIII.	7		20	8	1	8	37	— 25
XIII.	6·7		29	56	0	6	44	— 19

When Mars approaches either of these stars, the observer should, with a micrometer, measure their distance in a direct line; or take the differences, in right ascension and declination, between the planet and the star: the place and the correct time of observation being noted down.

Accurate observations of this kind are of great importance in astronomy: and as nothing tends so much to further such objects as a previous announcement of the phænomena about to take place, I trust I need not make any apology for drawing the attention of the members of this Society to so interesting a subject.

The diameter of Mars, on the day of opposition, will be 13",91.

XII. *Notices respecting New Books.*

Recently published.

A Practical Essay on the Strength of Cast-Iron and other Metals, &c.; the 2nd Edition, 8vo. By THOMAS TREGGOLD, *Civil Engineer, &c.*

THIS importantly useful Work, came under our notice too late in the last Month, to admit our doing little more in p. 451, than announcing its publication: we now therefore resume the subject, with reference to the account we gave of the 1st Edition, in p. 137 of our 60th volume, in order to notice, the new matters dispersed through the present Edition, which seems collectively to amount to about 130 pages.

Instead of the former seven *Sections*, the work now consists of eleven such, viz. an entire new sixth Section has been inserted; the matter of the former sixth Section has, with a great deal that is new, been distributed into four others, which are numbered VII, VIII, IX and X, and the former seventh Section is now the XIth. Very judiciously, as regards references, and the quotations of this Work by other Writers (which cannot fail we think of becoming numerous), no alterations have been made of the former division of the Work into 304 *Articles*, as numbered in the Margin; but between these Arts. in various places, the principal new matter has been introduced, and numbered and distinguished thus, viz. 6^a, following Art. 6; 8^a following Art. 8: 19^a and 19^b, following Art. 19, &c. And the alphabetical *Table of Data*, which follows Art. 304, might, advantageously for references, have its Articles numbered, in continuation, viz. 305, 306, &c.; and in a future Edition we hope this will be done.

In Section I. Art. 6, an important Table, as to the saving of calculation its effects, is now added, to show the load or pressure in hundred-weights, while a cylindrical Pillar, Column or Post of Cast Iron (without enlarged ends, or an attached Base or Cap) will sustain with safety, when of any of the several given diameters from 1 inch to 12, and lengths from 2 to 24 feet of Column. Art. 8^a contains the description of this third Table; and two practical Examples for explaining its use, will be found in Art. 19^b. In a *Note* in page 9, Mr. Thomas Farnolls Pritchard, a Shropshire Architect, who died in October 1777, is stated to have been the proposer and designer, in 1773, of *the first Cast Iron Bridge* which was anywhere erected, viz. over the Severn near Broseley and Colebrook-dale, and that Mr. A. Darby, to whom (by the Society of Arts) this merit has been assigned, merely, as a speculator, furnished part of the Money for carrying Mr. Pritchard's design into execution, under the superintendance of a Mr. Daniel Onions, in 1777.

In Section II, in Art. 15 is described, a new and very simple and durable *Weighing Machine*, for Waggon, Carts, &c. not exceeding 4 Tons: it is founded on the direct proportionate flexure and return, of a Cast Iron Beam (or two such) 16 feet long, 7 inches broad, 5 inches deep in the middle and $2\frac{1}{2}$ at its ends, where it is supported. The descent of the middle point, with a 4 Ton load, would be 1.7 inch: which, when multiplied 5 times by a Lever, would cause an Index to move, one-tenth of an inch for each Cwt. of load. Art. 19^a explains the use of Table II, in the case of a Load *uniformly distributed* over the length of a Beam (like that of the weight itself of a heavy Beam) and directs, *half* of this load to be considered, as acting on the middle point of the Beam, when supported at its ends: In a future Edition it may, for the satisfaction of the practical Man, be well, to explain here in words, why *half* the uniformly distributed load, is to be used in applying Table II, and why *five-eighths* of such a load is to be used, in applying Table I, Arts. 18 and 19. In this Section, the number of popular Examples is much increased.

In Section IV, Art. 34^b Mr. Tredgold explains a new principle of constructing Cast-iron Bridges, which would not be affected by contraction and expansion, such as has impaired several of our finest constructions of this kind: a large Bridge on this construction, might be put together in parts, and erected without the assistance of centering.

In Section V. Arts 59^b to 59^h, the Author's latest Experiments are detailed, on 12 Specimens, of 6 different kinds of Cast

Cast Iron : three of these kinds were run by Mr. F. Bramah, from the Pigs of different Furnaces in Shropshire and in Derbyshire; one was from re-melted old Iron scraps; another kind consisted of new Pig and old Iron, in equal parts; and the last pair, of Pig Iron $\frac{1}{10}$ th alloyed with Copper.

These experiments and the practical results which Mr. Tredgold draws from them, appear to us highly important; and so do the seven new Experiments by Mr. Bramah, on the Twisting or Tortion of Cast Iron, given in Art. 67^a.

Art. 68^a concludes this Section, with a set of new Rules, for judging of the quality of Cast Iron by the aspect of a newly fractured surface thereof, as to colour and lustre. "The colour of Cast Iron, is various shades of gray, sometimes approaching to dull white, sometimes dark iron gray with specks of black gray. The lustre of cast Iron differs in kind, and in degree: it is sometimes metallic, for example like minute particles of fresh cut lead, distributed over the fracture; and its degree in this case, depends, on the number and size of the bright parts; but in some kinds, this lustre seems to be given, by facets of crystals, disposed in rays; I will call this lustre crystalline.

"In very tough Iron, the colour of the fracture is uniform dark iron gray, with abundance of metallic lustre. If the colour be the same, but with less lustre, the iron will be soft, but more crumbling, and (will) break with less force. If the surface be without lustre, and the colour dark and mottled, the Iron will be found the weakest of the soft kinds of Iron.

"Again, if the colour be of a lighter gray, with abundance of metallic lustre, the iron will be hard and tenacious: such iron is always very stiff. But if there be little metallic lustre, with a light colour, the iron will be hard and brittle: it is very much so, when the fracture is dull white; but in the extreme degrees of hardness, the surface of the fracture is grayish white, and radiated, with a crystalline lustre.

"There may be some exceptions to these maxims, but I hope they will, nevertheless, be of great use to those engaged in a business which is every day becoming more important." In previous pages Mr. Tredgold says,

"The best and most certain test of the quality of a piece of Cast Iron, is, to try its edge with a hammer: if the blow make a slight impression, denoting some degree of malleability, the iron is of a good quality, provided it be uniform: if fragments fly off, and no sensible indentation be made, the iron will be hard and brittle."

"The Tables in this work and Rules, are calculated for
soft

soft *gray* cast Iron: metal of this kind yields easily to the File, when the external crust is removed, and is slightly malleable in a cold state."

Section VI, Arts. 68^b to 68^l, contains Experiments on malleable Iron, English and Swedish, on Steel, on Gun-metal or Bronze, and on Brass: wherein, as to Iron, the effect of hammering and the decrease of force by heat, are experimentally examined, and the cause of English Iron being inferior to Swedish, for particular purposes, is pointed out. The novel and important object which Mr. Tredgold has had in view in all his Experiments, has been, to ascertain the exact strain that Materials would bear, and with what flexure, without impairing their elasticity, so that on removing the strain, this might cause them to recover perfectly, the flexure which the strain had occasioned; whereas almost all previous Experiments were carried, from 3 to 4 times as far, as to strain, in order to observe, the almost useless point, at which actual breaking took place.

In Section VII, and the others which follow, wherever Fluxions have been used by other Writers, in the investigation of the general Formulæ, the Author has instead, had recourse to the method of progression, which he first described in 1821, in three papers in our 57th volume. In Art. 121^a is now given, a Table of the Thickness, Breadth, and Pitch of the *Teeth of Wheels*, followed by ample directions and examples of its use; and it is ascertained, that the proportions here theoretically assigned, agree very nearly with those, long in use by the most esteemed of our makers of Machinery in the large way.

In Art. 139^a is now inserted a Table of the proportions of *Gudgeons* or *Pivots*, for different degrees of strain or stress: the diameters of the gudgeons in this Table, are from $\frac{1}{2}$ to 10 inches, their lengths 43 to 85 inches, and strain from 213 to 85,000 lbs. In Art. 156^a the addition is made, of a Table of Cast Iron *Joists for Fire-proof Floors*, when, besides the flat Brick Arches, the extraneous Load is not to be greater than 120 lbs. on the superficial Foot: At the conclusion of the directions for using this Table, the Author observes "The construction of these Floors, renders a place secure from Fire, without loss of space, and with very little extra expense: it may be of infinite use in the preservation of Deeds, Libraries, and indeed of every other species of property. In a public Museum, devoted to the collection and preservation of the scattered fragments of literature and art, it is extremely desirable that they should be guarded against Fire: otherwise, they may be involved in

one common ruin, more dreadful to contemplate than their widest dispersion."

Section VIII treats of the *stiffness* of Beams, to resist lateral Strains, with its application to some interesting practical cases.

Section IX is on the strength and *stiffness* of Beams, to resist Tortion or Twisting, with its application to machinery.

Section X treats of the strength of Columns, Pillars and Ties, with several new Examples. What Euler, Lagrange, and other continental mathematicians obtained, from the most refined methods of analysis, is here arrived at and exceeded in accuracy, simplicity and adaption to use.

Section XI has been spoken of (as the 7th) in our account of the 1st Edition, before referred to.

The Table of *Data* will be found considerably improved. And at the end is a very copious alphabetical *Index*, which will serve to direct the unlearned or the casual consulter of this useful volume to the particular Table, Example in numbers, Rule in words at length, or algebraical Formula or Equation, adapted to any required case; calling at the same time his attention to the other cases and conditions, of the same or some nearly similar Problem, from which, the one in hand must be carefully distinguished, in order to avoid error, by the application of a wrong Rule. We deem every Book, materially defective, which appears without a good alphabetical Index.

We are glad to observe, at the end of the Preface, that a second Volume or Part of this Work on Cast-iron and other Materials, is in preparation, treating on the strength of Pipes, Mains, Tanks, Boilers, &c.: of Chains to resist impulsion and pressure: of Suspension and other Iron Bridges: and of framed work for Roofs, Bridges, Mills, and Machinery.

At the end of this Volume, we observe also, that Mr. Tredgold has in advanced progress, "*Principles of Warming and Ventilating Public Buildings, Dwelling Houses, Manufactories, Hospitals, Stores, Conservatories, &c., and of constructing Fire-places, Boilers, Steam Apparatus, Grates, Drying Rooms,*" &c.

A Synopsis of the Prices of Wheat and of Circumstances affecting them; particularly of the Statutes which relate to it from the Commencement of the Thirteenth Century to the End of 1822: Exhibiting in one view the Market Prices as they occurred and as expressed in the present Value of Money. Together with Statements which indicate the Situation of the Country

Country as to its Agriculture, Commerce, and Manufactures, Population, Public Revenue, &c.

These Tables are evidently the result of extensive research and careful calculation. They form a body of valuable documents on the main branches of our national wealth, and they can never fail being referred to with advantage on subjects of similar inquiry. The Author we understand to be recently deceased. He must have been a man of great industry, and of no common powers of mind. He seems to have flinched from no labour in the prosecution of his subject, and he has certainly bequeathed to his country a very important collection of facts in our political economy. The price of the work, considering its details, its size, and execution, is unusually low.

Works in the Press.

The following Works are preparing for publication, in quarterly numbers, by Mr. J. F. Stephens, F.L.S., &c.

A Catalogue of British Insects, or an Attempt to arrange them according to the Natural System; with the Synonyma of the principal Authors inserted.

Illustrations of British Entomology, in which it is proposed to give the generic and specific characters of all the Insects which have hitherto been discovered in Great Britain and Ireland, and observations on their metamorphosis, food, economy, &c.; accompanied by Figures of the more obscure and interesting Species.

A Monograph on the British Species of the Linnæan Genus Sphinx, embellished with correct representations of *all* the known Species, their larvæ and pupæ; to which will be added an Appendix, containing a notice (with the characters and figures) of such congenerous Insects of this group as are usually, from bad taste, placed in British Cabinets, either *as authentic indigenous specimens* or in lieu thereof, to the utter confusion of our knowledge of their geographical distribution.

The Author's intention, we understand, is to publish the 1st number—of the Catalogue on the 1st of May next—of the Illustrations on the 1st of June—and of the Monograph on the 1st of July, following, and to proceed quarterly with each work until completed. The last work will be in 4to, the others in 8vo.

ANALYSIS OF PERIODICAL WORKS ON NATURAL HISTORY.

Curtis's British Entomology. No. 1.

In the present improving state of Entomology in this country, when so much attention has been drawn to this curious and interesting branch of Natural History by several distinguished labourers in this field of science, a work on British
: Vol. 63. No. 309. Jan. 1824. H Insects,

Insects, in which the Genera should be established and elucidated by elaborate dissections, was certainly much to be desired. This want seems likely, if we may judge from the first Number now before us, to be well supplied by Mr. Curtis; whose accurate and beautiful Figures are accompanied by full descriptions and elucidatory observations, which evince a critical acquaintance with their subjects. Mr. Curtis's plates also contain representations of the Plants upon which the insects feed, or to which they are attached, executed with the scientific accuracy which has long distinguished his drawings for the Botanical Magazine.

It may be observed, that no one could expect to see the completion of a work upon *Species* in the present advanced state of science; whereas a work limited to *Genera* may be perfected in a reasonable time, and will be of more real utility.

The following are the subjects of the five plates in the first Number:

Cicindela sylvicola. This is a beautiful species, unique as British, and has only been figured on the continent by Megerlé.—*Velia rivulorum* has, we believe, never before been figured: it is a pretty insect, and has been considered very rare.—*Deilephila Euphorbiæ* is a most beautiful and rare species of Sphinx, and a British specimen of the caterpillar has never before been figured. *Euphorbia Paralias*, embellishing the drawing, is a most luxuriant specimen of that local plant.—*Peltastes Pini*, a new species of a genus proposed many years ago by Illiger, which Mr. Curtis has endeavoured to establish by very elaborate dissections. The Ichneumonidæ being ill understood, the information contained in this article will be very useful.—*Ctenophora ornata* is also unique in Britain, and is very beautiful compared with most of the Tipulidæ of authors; which, however, are all elegantly formed, although the pain which some of them inflict makes them dreaded in warm countries: but this does not apply to the genus *Ctenophora*. The palpi are described as being flexible like the trunk of an elephant, which is very uncommon, and has, we believe, not before been noticed.

The Botanical Magazine. Nos. 442, 443.

Pl. 2441. *Melastoma granulosa*.—*Oxylobium arborescens*.—*Cissus quinquefolia*, "foliis quinatis: foliolis utrinque attenuatis acuminatis serratis pedicellatis, ramis teretibus nodosis lævibus:" from Rio Janeiro.—*Biscutella hispida*.—*Erodium Gussonii*, "pedunculis longissimis multifloris, foliis petiolatis cordato-ovatis inciso-lobatis crenatis, utrinque villosis, caule ascendente hirta:" sent to Professor Tenore, from Avellino in Sicily, by his pupil Gussoné, who is engaged upon a new Flora Sicula.—*Ipomœa speciosa*, *Convolvulus speciosus* Willd.

Pl. 2447. *Protea grandiflora*, α *latifolia*.—*Amethystea cærulea*.—*Phlomis Herba venti*, of which it is strange that there should have been no figure but the wood-cut of Lobel.—*Ononis hispanica*.—*Coreopsis lanceolata*.—*Ocimum canum* "stamineum; foliis oblongo-ellipticis serratis canis longe petiolatis, spicis verticillatis, verticillis subsexfloris, staminibus corollâ bis longioribus."—*Ionidium Ipecacuanha*, β . (*Viola* Linn.).—*Desmanthus virgatus*.

The Botanical Register. Nos. 105, 106.

Tab. 748. *Erinus Lychnidea*.—*E. capensis* Linn., distinguished by Mr. Lindley from *africanus* by the pubescent tube of its corolla.—*Tillandsia flexuosa*

flexuosa v. *pallida*, "floribus pallidis, spicâ sub-simplici:" probably, Mr. L. thinks, a distinct species.—*Erythrina speciosa*.—*Diurella strumosa*, "foliis lætè viridibus, omninò lævibus (latitudine, ubi latioribus, subunciali): paniculâ laxâ, numerosâ, decompositâ: corollæ penulo-cernuæ laciniis reflexis, alternè saturatiùs 3-5-lineatis: filamentis cum strumâ obesâ saturatiùs coloratâ antheriferâ apice articulatis: pedicellis flore paulò brevioribus," lately observed in New South Wales by Mr. Cunningham, and does not seem reducible to any of the seven species of Mr. Brown.—*Schizopetalon Walkeri*, introduced from Chili by Mr. Francis Place; an elaborate character by Mr. Brown accompanies the description.—*Ocymum febrifugum* suffruticosum pubescens, "foliis ovato-lanceolatis crenatis petiolatis, verticillis terminalibus racemosis, bracteis rhombeis deciduis, corollâ calyci subæquali." From Sierra Leone. Very similar to *O. heptodon* of M. de Beauvais.—*Curculigo latifolia*.

Pl. 755. *Stapelia normalis*.—*St. hirsuta*, var. *atra*. We are glad to see this genus preserved entire.—*Gnidia denudata*, "foliis oblongis quadrifariam imbricatis pilosis trinerviis: nervis denudatis, floribus terminalibus villosis: villis sparsis patentibus."—*Allium Cowani*, "scapo nudo semiterete, foliis lanceolatis acuminatis flaccidis ciliatis vaginantibus, umbellâ fastigiatâ, petalis obtusis." From Peru.—*Pleurothallis punctata*.—*Ponthieva petiolata*, "spicâ laxâ erectâ, foliis petiolatis erectis crispis glabris, floribus discoloribus:" brought from St. Vincent's by Mr. M'Rae.—*Polygala paniculata*.

Sowerby's Mineral Conchology. Nos. 75, 76.

No. 75, Pl. 432, &c. *Pileolus*, a new genus of fossil shells, of which two species are represented, *P. plicatus* and *lævis*: the plate, we observe, is the same that was employed in No. 19 of the Genera of Shells by Mr. G. B. Sowerby: their descriptions are of course somewhat enlarged beyond the limits of a work solely illustrative of Genera.—*Turbo conicus*, and *T. rotundatus*, from the green sand.—*Murex peruvianus*, and *M. tortuosus*, crag fossils. the first has a recent analogue in the West Indian seas.

Pl. 434, 435, 436, contain ten species of *Terebratulæ*, of which the descriptions are promised in No. 76.

No. 76, Pl. 438, &c. *Terebratula obesa* and *bucculenta*; *Mytilus edentulus*, *lanceolatus*, and *sublævis*; *Inoceramus cordiformis*; *I. Cuvieri* and *Brongniarli*; *I. mytiloides*. These are several species of a remarkable gigantic Genus, formerly considered, from the fibrous structure of its shell, to belong to *Pinna*: it is peculiar to chalk, and one or two contiguous strata. The reference made by Mr. Sowerby to the mountain limestone seems rather too hasty.—*Crenatula ventricosa*. This Genus has not before been observed among fossils.

G. B. Sowerby's Genera of Recent and Fossil Shells.

No. XX. of this useful work contains the following Genera: *Cardita*, united to *Venericardia*; *Cypricardia*; *Thecidium*, a new genus of *Brachiopoda*, separated from *Terebratula* by M. de France, and distinguished from it by the manner of its adhesion, and to which two or three very singular Maestricht fossils belong; *Rostellaria*; *Strombus*; and *Pteroceras*.

XIII. *Proceedings of Learned Societies.*

ROYAL SOCIETY.

Jan. 8 **R** EAD, Observations on the Positions and Distances and 16. **R** of 380 double and triple Fixed Stars, made in the years 1821, 1822, and 1823; by J. F. W. Herschel, Esq. F.R.S., and J. South, Esq. F.R.S.

Jan. 22.—A paper was read, On the Cause of the Corrosion and Decay of Copper used for covering the Bottoms of Ships, by the learned President, Sir H. Davy, Bart., in which he pointed out a simple and æconomical method of remedying this evil. The cause, he ascertained, was a weak chemical action, which is constantly exerted between the saline contents of sea water and the copper, and which, whatever may be the nature of the copper, sooner or later destroys it. The same general principle of the manner in which chemical changes may be exalted, destroyed, or suspended, by electrical powers, which led him to the discovery of the decomposition of the alkalies and the earths, likewise afforded him this new and more practical discovery. He finds that a *very small* surface of tin or other oxidable metal any where in contact with a *large* surface of copper, renders it so negatively electrical that sea water has no action upon it; and a little mass of tin brought even in communication by a wire with a large plate of copper, entirely preserves it. By the desire of the Lords of the Admiralty, he is now bringing this discovery to actual practice on ships of war. It is needless to point out the uses and æconomical advantages of a result which must add so much to the permanency and strength of our navy and shipping, and be so beneficial to our maritime and commercial interests.

The reading was commenced, likewise, of a paper On the Development of Magnetism in Iron and Steel, by Percussion; Part II; by William Scores jun. Esq. F.R.S.E.

LINNÆAN SOCIETY.

Jan. 21.—A communication from Mr. Jonathan Couch, F.L.S., was read, "On a new Species of the Genus *Gadus*." This diminutive species, called by fishermen the Mackarel Midge, is only an inch and a quarter in length, the proportions being near to those of the Whiting.

Part of a paper, communicated by the Zoological Club of the Linnæan Society, was also read, On the Natural Affinities that connect the Orders and Families of Birds. By N. A. Vigors, Esq., M.A. F.L.S.

The following were among the presents on the table:—A Collection of Birds, including several species of Gull, among which was a specimen of *Larus Sabini*; a box of Minerals, and a skull of the Walross, *Trichecus rosmarus*, presented by Mr. Mogg, one of the gentlemen who accompanied Capt. Parry in his late voyage. Also, a specimen of *Syren lacertina*, and a new species of *Cyprinus viviparus*, from Don Vincente de Cervantes, Professor of Botany in the University of Mexico.

ASTRONOMICAL SOCIETY.

Jan. 9th.—The Papers read at the Meeting of this evening were as follow :

1st. Observations of the Comet of 1811, taken at the Havannah, by Don Joseph Joachim de Ferror, of Cadiz, deceased, communicated by the President.

These observations were accompanied by computations of the Comet in an elliptic orbit, and the elements are very nearly the same as those brought out by M. Argelander.

2d. On the Constants of Deviation occurring in the Reduction of Astronomical Observations. By Benjamin Gompertz, Esq., F.R.S. and M. Ast. Soc.

This paper examines the causes of deviation, and proposes formulæ for their more easy reduction: it is however so purely mathematical as not to admit of abridgment within our limits.

3d. On the ensuing Opposition of the Planet Mars on the 24th of March next. By Francis Baily, Esq., F.R.S., V.P. Ast. Soc.

As this paper contains some valuable observations upon an interesting phænomenon shortly about to take place, we have obtained permission to print it at full length, and it will accordingly be found at page 50 of our present number. We understand likewise, that the Society have come to the resolution of printing all papers read before it monthly, after the ensuing Anniversary, instead of withholding them for an annual volume.

HORTICULTURAL SOCIETY.

Jan. 6.—His Majesty the King of Wurtemberg was elected a Fellow of the Society; and the following communications were read:—On the Classification of Peaches and Nectarines. By Mr. George Lindley, Corresponding Member of the Society.—Description and Plan of a Pine Stove constructed in the Garden of Richard Forman, Esq. F.H.S.

Jan. 20.—The following communication was read:—On the Treatment of the Banyan Tree, in the Conservatory, so as to give it its natural mode of growth. By Capt. Peter Rainier, R.N., F.H.S.

METEOROLOGICAL SOCIETY.

A Third General Meeting of this Society was held on Jan. 14, when the Code of Laws alluded to in our last number was adopted; and the Meeting having been resolved into an ordinary one, a Preliminary Report from a Committee was read, on the objects to which the Society's attention should first be directed; a Paper on the Vernal Winds, by
John

John Gough, Esq. of Kendal; and various other communications.

MEDICO-BOTANICAL SOCIETY OF LONDON.

This Society held their Anniversary Meeting on Friday the 16th of January, when the following Council were elected for the ensuing year, viz. *President*.—Dr. Bree, F.R.S. *Vice-Presidents*.—Dr. Paris, F.R.S.; Dr. E. T. Monro; Joshua Brookes, Esq. F.R.S.; Wm. T. Brande, Esq. F.R.S.; Sir James M^cGregor, M.D. F.R.S.; Sir Alex. Crichton, M.D. F.R.S. *Treasurer*.—Wm. Newman, Esq. *Secretary*.—Mr. C. Holdstock. *Professor of Botany*.—John Frost, Esq. *Council*.—Thomas Jones, Esq.; Wm. Yarrell, Esq.; Thos. Andrews, Esq.; Anthony White, Esq.; Dr. John Elliotson.

ROYAL INSTITUTION OF GREAT BRITAIN.

The Lectures at this Institution will commence early in the month of February, and the following Courses are announced for delivery in the season, viz.

On Electricity, Electro-Chemistry, and Electro-Magnetism. By W. T. Brande, Esq., Sec. R.S. and F.R.S.E., Prof. Chem. in the Royal Institution.—To commence Saturday, 7th February, and continue each Saturday.

On Mechanical Philosophy and its recent Improvements, particularly in Optics and Hydraulics. By John Millington, Esq. F.L.S., Sec. Ast. Soc., Prof. Mech. in the Royal Institution.—To commence Thursday, 12th Feb., and continue each Thursday.

On Botany and Vegetable Physiology. By John Frost, Esq., Prof. Botany to the Medico-Botanical Society of London.—To commence after Easter.

On Plane Geometry. By John Walker, Esq., of Trin. Coll. Dublin, M.R.I.A.—To commence after Easter.

On Music. By W. Crotch, Mus. Doc., Prof. Music in the University of Oxford.—To commence after Easter.

All the Lectures commence at 2 o'clock.

ROYAL ACADEMY OF SCIENCES OF PARIS.

July 7.—The Academy received from M. Becquey, director-general of bridges and roads, some Researches on the uniform Motion of incompressible and homogeneous Fluids, by MM. Lamé and Clapeyron; also a new Memoir from M. Arnoul senior on Equations of three Terms of the second Degree.

M. Moreau de Jonnes read part of a third Memoir on the Geography of American Plants, entitled, Researches on the Conditions of Vegetable Organization necessary for the geographical Transfer of Plants by Animals and by Men.

M. Gay-

M. Gay-Lussac read a Memoir by MM. Boussingault and Rivero on the Milk of the Cow Tree. MM. Humboldt and Arago mentioned that those gentlemen, Professors of Chemistry at Santa Fé de Bogota, had just sent some interesting observations on the mean height of the barometer at the level of the sea between the tropics; on its hourly variations; on the hot springs of the Cordilleras; on the geographical positions of various places, &c. &c.

M. Becquerel read a Memoir on the electric Effects developed in various chemical Actions. The Sitting finished by the reading of a Memoir by Mr. H. M. Edwards, on the elementary Structure of the principal organic Tissues of Animals.

July 14.—Specimens were received from the director-general of mines of the Sal gem, from the mine lately discovered in Lorraine; he requested that an analysis of it should be made by a Commission of the Academy; and stated that the Minister of Finance would publish their Report.

M. Arago communicated a new Note of M. Becquerel on his electro-magnetic experiments.

M. De Ferussac read a Note on the Shells found in the Nile by M. Caillaud, and which had been erroneously regarded as oysters; they are *hétéries* of Lamarck.

M. Gaynard read a Memoir on the Growth of Polypi geologically considered.

M. de Jussieu jun. read a Memoir on the Family of Euphorbiaceæ.

XIV. Intelligence and Miscellaneous Articles.

THE COMET.

Gosport Observatory, Jan. 26, 1824.

THE following observations on the present COMET are at your service, if you think them worth a place in your Journal, and have not received a more satisfactory account from any of your Correspondents. It was first observed here in the morning of the 29th of December, 1823, when its *nucleus* appeared ill defined, and no larger than a star of the third magnitude, and its train was only $2\frac{1}{2}$ degrees long. The following memoranda will show its position from time to time, and its progressive antecedental motion under the fixed stars.

Monday Morning, Dec. 29th, 1823,	}	1824,	its Right Ascension was 251° 15'
			its Declination 8 30 north.
Sunday Morning, Jan. 4th,	}		its Right Ascension was 249 00
			its Declination 18 12 north.
Monday Morning, Jan. 12th,	}		its Right Ascension was 243 30
			its Declination 32 50 north.
Friday Evening, Jan. 23d,	}		its Right Ascension was 217 20
			its Declination 63 45 north.

For

For the first 13 days, that is, from December 22d 1823 to January 4th 1824, its motion under the fixed stars was at the rate of $1^{\circ} 31'$ per day. From the 4th to the 12th of January its daily motion was $1^{\circ} 58'$; and from the morning of the 12th, to the evening of the 23d of January, its velocity through the heavens increased to $2^{\circ} 36'$ per day. These certainly are great inequalities. Its present motion is *twice* as great as when it was at its perihelium, and its nucleus gets larger and its tail longer as it recedes from the sun, which are anomalies not easily to be accounted for; as they do not seem to arise from any inclination the comet has towards the earth, because it is approaching its aphelium.

The speed of this comet outstrips all that have been observed here for many years past, not excepting that of the brilliant comet in the autumn of 1811.

It now being a circumpolar object, at least in this latitude, it may therefore be seen soon after sunset, and throughout the night in clear weather.

It is now (January 26th) in the tail of *Draco*, between the head of *Ursa Minor* and the tail of *Ursa Major*, and by the end of the month it will be at or near the last star in the tail of *Draco*, and about 21° under *Polaris*, in the evening.

From the preceding remarks I have found that it must have crossed the Equinoctial about the 22d of December 1823, when its distance from the sun was about $27\frac{1}{2}$ degrees, which may be considered as its perihelion point. WM. BURNEY.

Inchbonny, Jan. 13, 1824.

The comet a few days hence will be within the circle of perpetual apparition, and will be continually above the horizon, and so never set. At present it rises between the N.N.E. and N. by E. about 15 minutes past 10 at night, and comes to the meridian about 45 minutes past 8 in the morning, and sets between the N.N.W. and N. by W. at 35 minutes past seven at night. Its correct distance was, on the 10th January, 17 hours 30 minutes mean time; from *Arcturus* 32 deg. 48 min. 16 sec.; from *Lyra*, 26 deg. 38 min.; and from *Rasalhagus*, 22 deg. 50 min. The earth travels nearly at the rate of one million and a half of miles per day in its annual course round the sun, and the earth's mean daily motion is nearly 59 minutes and eight seconds; but the daily motion of this comet at present is 112 minutes, which is nearly double that of the earth round the sun. About six o'clock in the morning the planet *Venus* will be seen on the south-east, and the planet *Mars* a little past the meridian, and nearly in conjunction
with

with the star marked gamma in Virgo, and Jupiter near his setting in the west.

JAS. VEITCH.

P.S.—On the 13th instant, about thirty minutes past six, a large fiery meteor, with an oval head larger than the full moon, and a long and sparkling tail, appeared to come from the west, and moved toward the south-east, in a curve line, with its convex side to the north.—J. V.

The comet on the 7th of January was in the right shoulder of Hercules, taking a direction towards the tail of the Dragon. It moves with astonishing velocity, as it has since passed midway between the back of Hercules and the northern crown, through the right leg of Hercules, and is now continuing its course between the right knee of Hercules and the right hand of Bootes, and at the present time does not set. If the brilliancy of the comet continue, we may expect a more favourable opportunity of seeing it about the 30th of this month, when the moon will be absent; and should the atmosphere be clear, it will then be distinctly visible between the Pole and the extremity of the tail of the Ursa Major, at any hour of the night.

ASTRONOMICAL INFORMATION.

M. Schumacher's *Astronomical Tables* for 1824 have at length arrived, and may be had of Messrs. Treuttel, Wurtz and Co.: accompanied with an English translation. They contain the usual tables, which will be found of constant use in an observatory.

M. Schumacher has communicated to the Astronomical Society of London, the elements of the present comet, deduced from his own observations and those of M. Bouvard at Paris. M. Mossotti, who is now in England, is engaged in a similar undertaking from observations made in this country.

COMET OF SEPTEMBER 1822, OBSERVED AT PARAMATTA.

The following are the elliptic elements of the comet observed at Paramatta by Sir Thomas Brisbane and Mr. Rumker, as communicated to the Royal Society of Edinburgh.

Time of passing the perihelion, mean time,	Oct. 24, 221201
Log. of perihelion on the orbit,	} from mean { 271° 36' 18".3
Log. of descending node	
Inclination	52 40 41
Logarithm e ($\delta = 82^\circ 53' 11''$)	9.9966440
Log. $\frac{1}{2}$ parameter	0.3585731
Sidereal revolution in days	663554.3

Edinb. Phil. Journ., vol. x. p. 179.

ANOMALY IN THE FIGURE OF THE EARTH.

So many ships touch at Madeira, and take a new departure from it, that the longitude of the island is a matter of considerable importance. Dr. Tiarks was therefore sent out by the Board of Longitude to ascertain it, with sixteen watches, in the summer of 1822; and a remarkable circumstance occurred, which was not within the object of his original mission. For, in going from Greenwich to Falmouth, a difference of longitude was found equal to $20' 11'' 49$; and, in returning from Falmouth to Greenwich, a difference of $20' 11'' 13$. Now the difference, as determined from the Trigonometrical Survey (given in the third edition of the requisite tables), is only $20' 6'' 9$; and this variation made it expedient to engage Dr. Tiarks to verify his observations in the Channel. He was furnished with twenty-nine chronometers, and was employed from the latter end of last July till the middle of September in sailing between Dover and Falmouth. His results are as follows:

Longitude of Dover station	$0^h 5' 17'' 54$ E.
Portsmouth Observatory	$0 4 24 \cdot 77$ W.
Pendennis Castle	$0 20 10 \cdot 85$ W.
Madeira	$1 7 39 \cdot 08$ W.

From hence it is clear that the figure of the earth must be somewhat different from that assumed for determining the longitudes from the Trigonometrical Survey, and that about $5''$ must be added, in the latitude of the Channel, for every $20'$ of longitude which is deduced from it.—*Edinb. Phil. Journ.*, vol. x. p. 179.

REMARKS ON PROFESSOR STRUVE'S OBSERVATIONS TO DETERMINE THE PARALLAX OF THE FIXED STARS. BY J. POND, ESQ., ASTR. ROYAL.

Of the various attempts to discover the parallax of the fixed stars, the observations of Professor Struve must be regarded as among the best and most judicious. [*Obs.* Vol. II. III.]

His object is, by means of an excellent transit instrument furnished with seven wires, to determine the sum of the parallaxes of several fixed stars, differing nearly 12 hours in right ascension from each other.

The results which he obtains seem to verify a remark which I have often had occasion to make; that in proportion as any improvement takes place either in our instruments or our processes, the resulting parallax becomes proportionally less.

Of fourteen sets of opposite stars thus compared, Mr. Struve finds seven, which give the parallax *negative*: this circumstance alone should suggest great caution in attributing to the effects

effects of parallax the small positive quantities that are derived from the remaining seven. Mr. Struve however is inclined to assign $0''.16$ of space as the parallax of δ Ursæ Minoris, and $0''.45$ for the sum of the parallaxes of α Cygni, and ι Ursæ Majoris. His learned coadjutor, M. Walbeck, who, it appears, has undertaken the calculations, is disposed to attribute the greatest portion of this parallax to the smaller star: a circumstance so improbable requires very strong evidence for its support.

But whatever reasonable doubt we may entertain as to any one given result* relating to such extremely minute quantities, yet the mean of the whole must be admitted to deserve very great confidence; and it is to this view of the subject (omitted by the learned author) that I wish to direct the attention of astronomers.

If we take the mean of the fourteen results as relating generally to stars from the 1st to the 4th magnitude, it will appear that the mean sum of the parallaxes of two opposite stars is equal to $0''.036$ of space, or the parallax of a single star equal to $0''.018$.

If any reliance can be placed on these observations, every attempt to determine the parallax of these stars in declination must be entirely hopeless; since in this case we can only measure the shorter axis of the ellipse, and the uncertainty of refraction must amount at least to twenty times the quantity we are in search of.—*Quart. Journ. of Science*, vol. xvi. p. 365.

M. DE LAPLACE'S GREAT WORK.

The fifth and last volume of the *Méchanique Céleste* has made its appearance, in which the question of the form of the earth is discussed in various new points of view: namely—1st, The dynamic effect of the presence and distribution of the waters on the surface of the globe. 2dly, The compression to which the interior beds are subjected. 3dly, The change of size, which may result from the progressive cooling of the earth.—The author has arrived at the following results: That the great mass of the earth is by no means homogeneous; that the beds situate at the greatest depth are the most dense; that those beds are disposed regularly round the centre of gravity of the globe, and that their form differs little from that of a curved surface generated by the revolution of an ellipsis; that the density of water is nearly five times less than the mean density of the earth; that the presence and distribution of the

* It should be remembered, that in a series of observations, it generally happens that some results will be erroneous by a greater quantity than the mean probable error.

waters on the surface of the earth do not occasion any considerable alterations in the law of the diminution of the degrees, and in that of weight; that the theory of any considerable displacing of the poles at the surface of the earth is inadmissible, and that every geological system founded on such an hypothesis will not at all accord with the existing knowledge of the causes which determine the form of the earth; that the temperature of the globe has not sensibly diminished since the days of Hipparchus (above 2000 years ago), and that the actual loss of heat in that period has not produced a variation, in the length of the day, of the two hundredth part of a centesimal second.

TO MATHEMATICAL CORRESPONDENTS.

To the Editors of the Philosophical Magazine and Journal.

Since the invention of fluxions, it has generally been customary among the mathematicians of this country to denote the fluxion of any quantity, as x , by the symbol \dot{x} , its second fluxion by \ddot{x} , its third fluxion by \dddot{x} , &c., as was done by Sir I. Newton: while those on the continent, following the example of Leibnitz, have expressed the same by dx , d^2x , d^3x , which they have called the several orders of *differentials* of the quantity x . Of late years, however, some of our first mathematicians, from a conviction of the latter notation being in many respects superior to the former, have adopted it in their writings; and from the circumstance of its not having been long ago adopted by the mathematicians of Great Britain, some of them even attribute to this cause the comparatively slow progress which the mathematical sciences have made in this country during the last century, to what they have made in France and Germany. Now as the cause of this alleged superiority has never been satisfactorily explained, so far as I can learn, by any English author, except in telling us that it cannot be understood by any but those who have attained a great proficiency in the study of the calculus; I should, therefore, feel much obliged to any of your dx correspondents to endeavour to furnish something which may throw further light on this subject. Indeed, it has always appeared to me, that if a preference could be given to either of these arbitrary symbols, the Newtonian ought to be chosen, as being more definite in its signification, and less apt to produce confusion in the mind of a learner, as the other is apt to convey the idea of a product as well as a differential.

I am your most obedient servant,

\dot{x} .

NEW NORTHERN EXPEDITIONS.

His Majesty's discovery ships *Hecla* and *Fury* have been recommissioned at Deptford by Captains Parry and Hoppner. The latter officer was the first lieutenant on board of Captain Lyon's ship on the recent voyage. Such is the confidence felt in the intrepidity, judgement, and conduct of the distinguished officer in command of the expedition, and in the attention paid by the different naval departments to the comfort of the men, that no sooner were the ships commissioned, than one-third of the crew belonging to the *Fury* on the former voyage again volunteered for the *Hecla*, the ship bearing Captain Parry's pendant. Captain Lyon at the same time commissioned His Majesty's ship *Griper*, which ship is destined for Repulse Bay, whence Captain Lyon proceeds over land to the back of that Bay, to survey the coast thence to the "Cape Turnagain" of Captain Franklin's recent discoveries. Captain Franklin proceeds by the way of New York to Fort Enterprize, with a view to survey the coast on the American Continent to the westward, connecting, if possible, the survey between Fort Enterprize and Icy Cape.

TEMPERATURE OF THE CARIBBEAN SEA AT THE DEPTH OF
6000 FEET.

The following is Captain Sabine's account of an experiment on this curious subject, as given by him, in a transcript of the original memorandum written at the time, in a letter to Sir H. Davy, published in the second part of the *Philosophical Transactions* for 1823, p. 207.

"H. M. S. *Pheasant*, on passage between Grand Cayman Island and Cape St. Antonio, in Cuba, lat. $20\frac{1}{2}$ N., long. $83\frac{1}{2}$ W., November 13, 1822.

"At 2 P.M. hove to, and sounded with 1230 fathoms of line, being 11 coils of 113 fathoms each, and three fathoms of a 12th coil; at the end of the line was attached a strong iron cylinder of 75 lbs. weight, inclosing a Six's self-registering thermometer: the top of the cylinder screwed down upon leather, being designed, by excluding the water from the interior, to obviate any effect which might be supposed to arise from the increased pressure of water at great depths: the thermometer fitted into spiral springs at the top and bottom, which kept it from contact with other parts of the cylinder, and preserved it from injury, in case the apparatus should accidentally strike against the sides of the ship, or against rocks at the bottom: another iron cylinder, of much less strength and weight than the preceding, was attached two fathoms above the end of the line, and being pierced with
holes

holes in the top and bottom, admitted free access of the water to a second thermometer, of similar construction to the first. The opportunity was very favourable for the object, the weather being fine, with light airs and but little swell: the 1230 fathoms run out in rather more than 25 minutes, at the expiration of which time the line was fairly on the quarter, the ship's drift having been bodily to leeward, without her having had either head or stern way; there was consequently much less stray line than had been anticipated. The best practical judgement which Captain Clavering could form on the spot was, that the depth to which the thermometers had actually attained must have exceeded a thousand fathoms, as an allowance of the remaining 230 fathoms for stray line would certainly be more than ample, if no bight of consequence existed in the rope, which, from the appearance, and from the rapidity with which the weight drew out the line, might be judged the case: 230 fathoms would equal a drift to leeward of $\frac{2}{3}$ ths of a mile in 25 minutes, whereas that of the ship did not exceed $\frac{1}{2}$ a mile an hour; it is more than probable, therefore, that the depth is underrated when it is estimated at 1000 fathoms, or 6000 feet. The line was hauled in in 53 minutes, and the thermometers came up in good order; the one in the cylinder to which the water had free access had registered $45^{\circ}5$; the attempt to exclude the water from the other cylinder did not in this instance altogether succeed, in consequence of the top not having been screwed down sufficiently close upon the leather; this thermometer had registered $49^{\circ}5$; the difference of 4° may be attributed, perhaps, partly to the latter not having been so long in contact with the cold water as the other thermometer, as the water appeared to have had great difficulty, and was probably some time in forcing its way into the interior of the closed cylinder; and partly to the heat which so great a thickness of metal would retain for a considerable time; the surface water was from $82^{\circ}5$ to $83^{\circ}2$ in the course of the afternoon; the difference of temperature between the surface, and a depth exceeding 1000 fathoms, was therefore $33^{\circ}3$ by one thermometer, and $37^{\circ}3$ by the other, the indication of the latter being entitled to the most reliance.

“It may be reasonably inferred, that one or two hundred fathoms more line would have caused the thermometer to have descended into water at its maximum of density, as depends on heat, below which, consequently, no further diminution of temperature would take place; this inference being on the presumption that the greatest density of salt water occurs, as is the case in fresh water, at several degrees above its freezing point.”

DÆBEREINER'S EUDIOMETER.

“The very remarkable discovery of Professor Dæbereiner concerning the relation of the metallic powder of platinum to a gaseous mixture of hydrogen and oxygen,” observes Prof. Gmelin, “I found confirmed in a splendid, but at the same time in a dangerous manner. I caused a few cubic inches of hydrogen gas to enter into an eudiometer two inches in width, and the glass of which was one line in thickness; and then brought the platinum-powder, wrapped up in white blotting paper, through the quick-silver, into contact with the gas. I then caused oxygen gas to enter into the eudiometer, and when but few bubbles had ascended, a terrible explosion took place, which shivered the glass into a thousand pieces, which were thrown about to the distance of ten feet. It is remarkable that neither myself nor Prof. Bohnenberger, who stood by, was in the least injured. I do not consider it superfluous to communicate this experiment to you, since it proves that great caution is required in attempting it. In Prof. Dæbereiner's experiments, no explosion appears to have taken place. I afterwards made the experiment with hydrogen and atmospheric air, and found that a considerable diminution of volume followed; but it appeared, at the same time, that much of the oxygen remained; for the residue still exploded strongly by means of the electric spark; and a considerable diminution of volume again took place. It appears, therefore, that this method will not answer the purpose of an eudiometer.

The further results I obtained are as follows:—

1. It is indifferent whether the hydrogen be first brought into the vessel, the platinum-powder afterwards, and then the atmospheric air; or whether the hydrogen gas and the atmospheric air be first mixed in the vessel, and the platinum-powder then introduced.
2. Much humidity prevents the absorption.
3. Silver-dust (obtained from nitrate of silver by copper) and gold-dust (obtained from muriate of gold, precipitated by iron, and purified by hot muriatic acid and water) do not produce the least effect, not even with oxygen gas.”

The above is translated from a letter of Prof. Gmelin to Prof. Schweigger, published in the October number of the *Neues Journal für Chemie*, &c. of the latter, who makes the following remark on Prof. Gmelin's conclusion as to the inapplicability of Dæbereiner's discovery to eudiometrical purposes:—“Under what conditions this may notwithstanding be the case, will be seen in our next, in which will appear an account of the proceedings of the German Explorers of Nature,

to whom, on the 20th of September, Prof. Dæbereiner communicated his remarks and experiments."

From Schweigger's Journal for November, we accordingly extract the following:—

"At a meeting of the Society of the Explorers of Nature, held on the 20th of September 1823, Professor Dæbereiner fulfilled the promise he made at the first meeting; viz. to communicate something more respecting his new and important discovery, so far as it is applicable to eudiometry, and to exhibit it by experiments.

"The platinum is kneaded up with clay into small balls, which are then brought to a white heat before the blowpipe. If such a ball, suspended by a platinum-wire, is dipped into an open glass vessel filled with hydrogen and oxygen, the ball rapidly becomes red-hot; during which a cloud of vapour forms itself around it; it then becomes white-hot, and the explosion immediately takes place. Such balls answer best for eudiometrical experiments made over quicksilver. The decomposition would certainly not be completely effected if the platinum-powder, moistened by the water which is formed, ceased to remain hot. But how easy is it in such a case to let another ball be carried through the quicksilver, in case the first is not sufficient!"

No. XXXII. of the *Quarterly Journal of Science* contains the following article on the same subject:—

"Professor Dæbereiner has suggested the use of finely divided platina for the purpose of detecting minute portions of oxygen in a gaseous mixture, in which hydrogen also is present. Its effect is immediate; the moment the substance rises above the surface of the mercury in the tube containing the mixture, the combination of the oxygen and hydrogen begins, and in a few minutes is completed; and, as Professor D. has stated, it seems capable of detecting the smallest quantity of oxygen. Its utility in the analysis of atmospheric air, and compounds containing oxygen, is obvious, provided no combination also takes place between the hydrogen in excess, and the nitrogen (or other gas) that may be present, as does in fact happen, according to Dæbereiner, when protoxide of platinum is so employed.

"Messrs. Daniell and Children mixed 20 measures of atmospheric air with 37 measures of hydrogen gas, and passed up to the mixture a small portion of the platina powder, procured by heating the ammonia muriate to redness, and made into a ball with precipitated alumina. The pellet was heated red by the blowpipe, immediately before it was used, its size about that of a small pea. The absorption amounted to 13 measures = 4.3 oxygen, being 0.1 of a measure more than the quantity of oxygen in 20 measures of atmospheric air, which
may

may probably have arisen from a slight impurity in the hydrogen, or from some minute unperceived bubbles of air entangled in the mercury.

“Another mixture of common air and hydrogen, in which the latter was in considerable excess, was deprived of its oxygen by the pellets, and when the absorption was complete, 38 measures of the residual gas were taken, and a fresh pellet, heated to redness, immediately before it was used, passed up. After standing about a quarter of an hour, no absorption had taken place. The tube and the mercury were then placed before the fire, till the whole apparatus was too hot to be touched with the naked hand. It was then removed from the fire, and, when cooled to its original temperature, the mixture occupied, as before, exactly 38 measures. The powder of platina with hydrogen seems, therefore, to be admirably calculated for eudiometrical purposes. Its application is extremely simple and easy; it is speedy in its effect, and no error need be apprehended from the formation of ammonia, even at considerably elevated temperatures. It appears also to be well calculated for ascertaining the purity of simple gases, at least as far as regards admixture of atmospheric air. The oxygen of a very minute portion of common air, mixed with carbonic acid gas, and a little hydrogen, was immediately absorbed, on passing up one of the little pellets to the mixture.”

BENZOIC ACID IN THE RIPE FRUIT OF THE CLOVE TREE.

The clove is the flower bud of the *Eugenia caryophyllata*, and the ripe fruit was formerly used in medicine under the name of *Antophylli*. In the latter, Mr. W. Bollaert has observed crystals of benzoic acid lining the cavity between the shell and the kernel.—*Quart. Journ. of Science*, vol. xvi. p. 378.

CRANBERRIES.

A correspondent who has read Mr. Milne's paper on the Cultivation of the English Cranberry, printed in *Phil. Mag.* vol. lxii. p. 382, from the Horticultural Transactions, wishes to be informed if the Cranberries which are said to be sold in such large quantities in the town of Langtown, in Cumberland, be really the fruit of the *Oxycoccus palustris*, or *Vaccinium Oxycoccus* of Linnæus. He suspects otherwise, because he has ascertained beyond a doubt, that what are commonly called Cranberries in Scotland, are the fruit of the *Vaccinium Vitis-idaea*, or Cranberry, which is a much more common plant than the *Oxycoccus*, and is in the opinion of many persons not less worthy of cultivation.

THUNBERG'S CABINET OF ENTOMOLOGY.

Professor Thunberg, of Upsal, has proposed to sell his large and valuable collection of Insects. It includes every class and order, and is in very good condition. It is one of the most extensive, containing at least between 25 and 30,000 specimens: it commenced 60 years ago, and has been continued till the present time; the names of the subjects, and notes on them, are affixed. They are preserved in 84 cases, which contain neat boxes or drawers covered with glass, and having cork at the bottom. Of each species there are in many cases two or more specimens. The class of butterflies is unusually complete, handsome, and enriched with specimens and species the largest and most rare. The new and as yet undescribed species are many. There are specimens of some which are not in any other collection; the collection is rich in those from Japan, Java, Ceylon, the Cape of Good Hope, and South America.

This formation has cost the proprietor 10,000 rix dollars, Hamburgh currency, for collections purchased, exclusive of those which he has collected himself. For the whole the proprietor expects 2000*l.* sterling.

 EARTHQUAKE.

Ceylon, Feb. 15, 1823.

On Sunday last, about three minutes after one P.M. (mean time), two distinct though slight shocks of earthquake were felt at Colombo, following each other in the course of half a minute. No damage has been sustained either here or in the several other places in the island where it was also felt. We have accounts of the occurrence from Kandy and different places in its neighbourhood, Ratnapora, Matura, Hambantotte, and Negombo. The phænomena, as described, seem to have been nearly the same every where, and were accompanied by a rumbling noise as of heavy ordnance moving along the ground. It appeared to move in a direction from the north-west to south-east. Though our correspondents have given us the times at which they observed the occurrence at different places, yet as they have not always distinguished whether the time was solar or mean time, and as the accuracy of watches at out-stations is not always to be relied on, we do not think the data in this respect are given with sufficient accuracy to be useful. The sky was clear, but no greater heat, or other difference of temperature observed from what is usual at this period of the year.

LIST OF NEW PATENTS.

To Thomas Greenwood, of Gildersoun, near Leeds, machine-maker, and Joseph Thackrah, surgical mechanist, of Leeds, both in the county of York, for their improvements on or substitutes for pattens and clogs.—Dated 27th of December 1823.—2 months allowed to enrol specification.

To John Vallance, of Brighton, Sussex, esq., for his improved method or methods of freezing water.—1st January 1824.—6 months.

To Francis Devereux, of Cheapside, London, merchant, for certain improvements on the mill or machine for grinding wheat and other articles, commonly known by the name of the French Military Mill.—8th January.—6 months.

To Joseph Foot, of Charles-street, Spitalfields, Middlesex, silk manufacturer, for his improved umbrella.—15th January.—6 months.

To John White, of the New Road, in the parish of St. Mary-le-bone, Middlesex, architect, for his floating breakwater.—15th January.—2 months.

To John Finlayson, of Muirkirk, Ayrshire, farmer, for certain improvements on ploughs and harrows.—15th January.—6 months.

To Jean le Grand, of Lemon-street, Goodman's Fields, Middlesex, vinegar manufacturer, who, in consequence of a communication made to him by a certain foreigner residing abroad and discoveries by himself, is in possession of certain improvements in fermented liquors and the various products to be obtained therefrom, and that the same are new in this kingdom 15th January.—6 months.

To William Gutteridge, of Dean-street, St. Fin Barrs, county of Cork, musician and land-surveyor, for certain improvements on the clarinet.—19th January.—2 months.

To George Pollard, of Rupert-street, in the parish of St. James, Middlesex, brass-founder, for certain improvements on machines or machinery for levigating or grinding colours used in the various branches of painting, which machinery may be worked by any suitable power and is applicable to other useful purposes.—19th January.—2 months.

To James Russell, of Wednesbury, Staffordshire, gas-tube manufacturer, for his improvement in the manufacture of tubes for gas and other purposes.—19th January.—2 months.

To Simeon Broadmeadow, of Abergavenny, Monmouthshire, civil engineer, for his improved method of manufacturing and purifying inflammable gases by the admission and admixture of atmospheric air.—19th January.—4 months.

To Howard Fletcher, of Walsall, Staffordshire, saddler's ironmonger, for certain improvements in tanning hides and other skins.—19th January.—2 months.

—◆—

Meteorological Observations at Great Yarmouth, by
C. G. HARLEY, Esq.

[Continued from vol. lxii. p. 238.]

1823.	Days.					Winds.					Thermom.		Rain.		
	Dry.	Wet.	E.	SE.	S.	SW.	W.	NW.	N.	NE.	Low.	High.	Med.	In. $\frac{1}{2}$.	
Sept.	20	10	—	1	4	9	6	4	1	5	54	70	62	2	—
Oct.	18	13	6	2	10	7	1	2	—	3	47	64	53	3	—
Nov.	18	12	1	3	2	11	5	1	4	3	40	54	48	1	—
Dec.	16	15	—	—	6	12	6	5	1	1	37	52	43	2	2

SUMMARIES OF METEOROLOGICAL OBSERVATIONS FOR THE PAST YEAR;

(Continued from vol. 61, p. 148.)

Results of a Meteorological Register kept at New Malton, in the N. R. of Yorkshire, in the Year 1823,
by JAMES STOCKTON, Esq.

1823.	Barometer.				Spaces de- scribed in Inches, &c.	No of Changes	Thermometer.			Winds.										Weather.			Rain. Quantity in Inches, &c.	
	Max.	Min.	Mean.	Range.			Max.	Min.	Mean.	Range.	N.	N.E.	E.	S.E.	S.W.	W.	N.W.	Var.	Brisk.	Boist.	Wet Days.	Hail.		Snow.
Jan.	30.17	28.59	29.574	1.58	●	43	9	31.887	34	212	9	5	1	0	0	1	1	2	2	2	4	1	9	4.56
Feb.	30.45	28.38	29.184	2.07	47	18	25	35.785	22	4	4	2	5	2	7	4	0	6	7	11	1	12	7.04	
March	30.69	28.64	29.706	2.05	57	13	23	40.209	34	3	3	2	3	0	7	4	7	2	5	1	7	0	5	1.76
April	30.57	28.83	29.856	1.74	62	10	32	44.033	32	4	13	1	0	2	3	4	1	2	5	2	4	1	0	0.94
May	30.67	29.27	29.895	1.40	77	11	39	54.419	38	1	4	2	2	1	8	6	1	6	6	1	9	0	0	2.80
June	30.44	29.22	29.920	1.22	70	8	42	54.916	28	6	5	0	0	10	4	3	2	1	0	7	1	0	0	2.11
July	30.20	29.30	29.711	0.90	73	43	58.774	30	3	1	1	1	0	5	16	3	0	4	0	16	1	0	0	4.94
August	30.17	29.19	29.780	0.98	71	17	44	57.645	27	1	1	1	1	5	11	5	1	5	7	0	20	1	0	4.45
Sept.	30.42	29.03	29.868	1.39	66	15	30	52.316	36	3	2	0	2	7	6	2	1	4	7	10	0	0	0	3.52
Oct.	30.53	28.35	29.680	2.18	59	15	34	45.741	25	8	7	0	2	8	7	3	0	1	2	4	12	0	0	4.40
Nov.	30.88	29.07	30.083	1.81	55	10	27	42.750	28	4	3	2	2	4	7	5	2	1	4	2	4	0	0	2.20
Dec.	30.45	28.60	29.514	1.85	51	15	26	36.710	25	0	0	0	1	10	12	8	0	0	11	8	10	1	1	3.68
Annual Means, &c.	30.88	28.35	29.732	2.53	77	9	46.282	68	31.56	20.23	45.94	53.18	25.55	34.114	7.25	42.40								

ANNUAL RESULTS.

<i>Barometer.</i>		Inches.
Highest observation, Nov. 10th.	Wind N.E.	30·880
Lowest observation, Oct. 11th.	Wind S.E.	28·350
Range of the mercury		2·530
Mean annual barometrical pressure		29·732
Greatest range of the mercury in October		2·180
Least range of the mercury in July		·900
Mean annual range of the mercury		1·597
Spaces described by the mercury		93·180
Total number of changes in the year		154·000

Six's Thermometer.

Greatest observation, May 7th.	Wind var.	...	77·000
Least observation, Jan. 18th.	Wind N.W.	...	9·000
Range of the mercury in the thermometer			68·000
Mean annual temperature			46·282
Greatest range in May			38·000
Least range in February			22·000
Mean annual range			29·918

Winds.

North and East	51·000
North-East and South-East	79·000
South and West	98·000
South-West and North-West	112·000
Variable	25·000

Rain.

Greatest quantity in February	7·040
Least quantity in April	0·940
Total amount for the year	42·400

REMARKS.

Pressure.—The mean annual barometrical pressure (notwithstanding the extraordinary wetness of the period) is greater than for many years past.

Temperature.—The mean annual temperature fully confirms what has been before advanced, that wet summers are generally cold. The whole of the monthly means, with the exception of May and December, are unusually low; indeed, the actual deficiency as to the annual amount exceeds $2\frac{1}{2}$ degrees.

Winds.—These nearly agree with their respective numbers in 1822; and, what is more strikingly remarkable, those of the S.W. exactly correspond.

Rain.—As to rain and snow, the amount is nearly unprecedented; and for the three last years it has been rapidly increasing.

Summary, for the Year 1823, of the Quantity of Rain, State of the Barometer, and Thermometer, &c. kept in Kendal by Mr. SAMUEL MARSHALL.

1823.	Maximum of the Barometer.	Minimum of the Barometer.	Mean Height of the Barometer.	Maximum of the Thermometer.	Minimum of the Thermometer.	Mean Height of the Thermometer.	Quantity of Rain in Inches.	Number of rainy Days.	Quantity of Rain in Inches for 1823.
January	29.90	29.20	29.51	42°	17°	31° 38'	2.900	6	1.547
February	29.91	28.88	29.18	51	26	35.4	5.516	14	7.284
March	30.00	27.70	29.35	52	22	39.5	3.053	10	9.016
April	29.98	28.98	29.55	56	26	41.51	3.228	17	2.344
May	30.26	29.15	29.67	71	31	51.03	7.043	18	2.277
June	30.15	29.17	29.72	71	35	52.8	3.414	12	1.584
July	30.02	29.28	29.58	68.5	39	55.4	7.858	24	8.340
August	29.97	29.21	29.61	69	37	54.79	7.750	27	4.297
Septemb.	30.13	28.98	29.71	68	30	52.4	5.742	17	2.869
October	30.26	28.62	29.52	60	30	44.8	6.218	18	8.487
Novemb.	30.43	29.00	29.89	54	23.5	42.65	3.403	13	10.876
Decemb.	30.20	28.61	29.45	50	18.5	38.35	6.624	22	3.805
							62.749	198	62.726

The town of Kendal, where these observations were made, has long been a point of interest to meteorologists. It is situated nearly at the south extremity of the mountainous district of Westmorland and Cumberland, in the west side of a valley bounded by two chains of hills running from north-east to south-west. Its height above the high-water mark is about 42 yards, calculating from the canal which runs between this town and Lancaster.

The prevalent winds in this valley are the north-east and south-west. The latter is the most prevalent. The former, which may be styled the vernal east wind, prevails here, in common with other parts of the north of England, in the month of April to the 7th or 8th of May, and sometimes much longer. Not much dependence, however, can be placed on observations for meteorological purposes, made on the directions of the winds, from the local situation of Kendal, as they will be governed, or at least materially affected, by the direction of the hills which bound the valley. For the last seven months the winds have been remarkably stationary, their direction having been, with very little variation, south-west or veering from south to west.

The summer and autumnal months have been marked by an unusually low temperature, and by frequent rains. More than the average quantity of rain has fallen during that period, viz. from the beginning of June to the end of November. The total quantity in this and the last year has exceeded the average, which, calculating from observations made in Kendal for 16 successive years, may be stated at 49.86 inches.

METEOROLOGICAL TABLE.

Extracted from the Register kept at Kinfauns Castle, N. Britain. Lat. 56° 23' 30".—Above the level of the Sea 129 feet.

1823.	Morning, 10 o'clock. <i>Mean height of</i>		Evening, 10 o'clock. <i>Mean height of</i>		Mean Tempr. by Six's Ther.	Depth of Rain. Inch. 100	N° of Days.		
	Barom.	Ther.	Barom.	Ther.			Rain or Snow.	Fair.	
January ..	29.704	34.387	29.701	33.581	33.935	3.50	16	15	
February...	29.295	35.393	29.294	33.464	34.357	3.50	14	14	
March....	29.585	40.613	29.577	38.355	40.350	1.30	12	19	
April.....	29.737	44.830	29.745	41.600	43.500	1.00	8	22	
May.....	29.704	52.900	29.750	48.290	51.710	2.20	14	17	
June... ..	29.741	55.330	29.725	49.700	53.533	1.00	11	19	
July.....	29.565	57.090	29.545	52.900	56.390	6.35	24	7	
August ...	29.720	56.680	29.640	52.807	55.480	3.50	20	11	
September.	29.729	54.333	29.704	49.930	53.100	1.65	14	16	
October...	29.570	46.420	29.570	44.350	45.870	3.55	10	21	
November.	29.902	46.300	29.886	45.760	46.333	1.45	8	22	
December .	29.415	39.193	29.403	37.580	38.581	4.45	18	13	
Average of the year.	29.639	46.955	29.628	44.026	46.095	33.45	169	196	

ANNUAL RESULTS.

MORNING.

<i>Barometer.</i>	<i>Wind.</i>	<i>Thermometer.</i>	<i>Wind.</i>
Observations.			
Highest, 10th Nov. W.	30.53	11th August, SW.	63°
Lowest, 30th Dec. W.	28.40	5th February, NW.	26°

EVENING.

Highest, 10th Nov. SE.	30.53	11th August, SW.	64°
Lowest, 29th Dec. W.	28.43	5th February, NW.	17°

<i>Weather.</i>	<i>Days.</i>	<i>Wind.</i>	<i>Times.</i>
Fair	169	N. and NE.	4
Rain or Snow	196	E. and SE.	122
		S. and SW.	59
	365	W. and NW.	180
			365

Extreme Cold and Heat, by Six's Thermometer.

Coldest, 6th February . . .	Wind SE.	14°
Hottest, 12th & 30th June .	Wind E.	68°
Mean Temperature for 1823		46° 1'

RESULT OF TWO RAIN GAUGES.

	In. 100
Centre of the Kinfauns Garden, about 20 feet above the level of the Sea	33.45
Kinfauns Castle, 129 feet	26.31

A METEOROLOGICAL TABLE: comprising the Observations of Dr. BURNET at Gosport, Mr. CARY in London, and Mr. VELL at Boston.

Days of Month, 1823 and 1824.	Gosport, at half-past Eight o'Clock, A.M.										Clouds.				Height of Barometer, in Inches, &c.		Thermometer.			RAIN.		WEATHER.	
	Barom. in Inches, &c.	Thermo.	Temp. of Sp. Water.	Hygrom.	Wind.	Evapora- tion.	Rain near the Ground.	Cirrus.	Cirrostr.	Stratus.	Cumulus.	Cumulost.	Nimbus.	Lond. 1 P.M.	Bost. 8 1/2 A.M.	LONDON.		Boston.	London.	Boston.	London.	Boston.	
																London.	Boston.						
Dec. 26	29.81	44	50 1/2	92	SE.	...	0.175	1	1	1	1	1	1	29.78	29.63	45.47	47.40	...	0.50	Fine
27	29.24	43	...	81	SW.020	1	1	1	1	1	1	29.24	29.07	43.47	40.41	Rain	
28	29.49	45	...	82	SW.	0.06	.410	29.40	29.27	39.47	37.37	Fine, storm at night	
29	29.22	42	...	73	SW.140	29.23	28.96	42.47	40.38.5	Fine [with light-	
30	29.18	45	...	74	SW.050	29.18	28.80	41.46	43.42.5	Fine [ning and rain	
31	29.48	42	...	74	NW.	.09	.420	29.59	29.20	39.47	42.38.5	Fine, rain at night	
Jan. 1	29.35	48	50 1/2	86	W.010	1	1	1	1	1	1	29.32	29.05	44.49	46.44	Fine, stormy night	
2	29.47	45	...	65	NW.	1	1	1	1	1	1	29.53	29.02	46.47	40.45	Cloudy	
3	30.15	41	...	63	NW.	.17	...	1	1	1	1	1	1	30.29	30.0	39.43	35.53.5	0.45	Fine	
4	30.47	33	...	69	N.020	1	1	1	1	1	1	30.61	30.35	30.38	37.39.0	Cloudy	
5	30.45	35	...	74	N.	1	1	1	1	1	1	30.43	30.33	37.42	40.39.0	Cloudy	
6	30.23	34	...	72	E.	1	1	1	1	1	1	30.47	30.10	35.42	37.35.0	Fine, rain a.m.	
7	30.30	34	...	72	W.	.08	...	1	1	1	1	1	1	30.37	30.20	32.41	37.31.0	Fine	
8	30.28	31	49 1/2	73	N.	1	1	1	1	1	1	30.33	30.20	33.40	35.30	Misty	
9	30.21	42	...	77	SW.025	1	1	1	1	1	1	30.22	30.0	40.46	42.40.5	Cloudy	
10	30.14	44	...	78	SW.	.04	.240	30.14	29.90	42.45	43.46	0.00	Cloudy, rain p.m.	
11	30.20	39	...	74	N.	1	1	1	1	1	1	30.31	30.15	40.44	35.33.5	Fine	
12	30.42	29	...	78	NW.	1	1	1	1	1	1	30.49	30.30	30.37	30.30	Fine	
13	30.45	26	...	76	NW.	.10	...	1	1	1	1	1	1	30.50	30.33	26.32	28.28	Fine	
14	30.36	26	...	78	NW.020	1	1	1	1	1	1	30.41	30.20	26.31	30.31	Fine	
15	30.33	36	...	82	N.010	1	1	1	1	1	1	30.35	30.25	34.37	30.31	Cloudy, snow p.m.	
16	30.53	32	49 1/2	76	N.	1	1	1	1	1	1	30.60	30.45	34.36	32.32	Fine	
17	30.52	26	...	71	N.	1	1	1	1	1	1	30.52	30.35	28.35	31.27.5	0.05	Fine	
18	30.40	36	...	74	N.	1	1	1	1	1	1	30.40	30.25	35.41	32.33.0	Cloudy	
19	30.24	41	...	76	NW.	.10	...	1	1	1	1	1	1	30.23	30.10	37.44	42.37.0	Fine	
20	30.12	59	...	91	NW.	1	1	1	1	1	1	30.11	29.97	39.43	42.36	Cloudy	
21	29.71	42	...	80	SW.350	1	1	1	1	1	1	29.62	29.55	42.46	42.36.5	Fine [vy rain p.m.	
22	29.28	42	...	83	NE.	.04	.170	29.18	29.15	42.46	48.37	Fine, rain a.m. hea-	
23	28.94	46	...	77	W.030	1	1	1	1	1	1	28.82	28.60	43.48	41.41.5	Fine, rain p.m.	
24	29.70	38	...	75	NW.005	1	1	1	1	1	1	29.85	29.50	38.45	47.35	0.05	Fine, rain at night	
25	29.97	48	49 1/2	84	SW.	.04	.010	1	1	1	1	1	1	30.04	29.65	47.54	50.47.5	Cloudy	

*mation
forfolk.*

nal.

section
to the
office of
the di-
r posi-

ment at
d. clay
ist, for
ds two
diately
surface
uation
about
t-water
aving,
talities,
ous and
or less
ratum ;
ments ;
which
le cha-
exten-
usually
which
August

of recent

The

SECTION of part of CROMER CLIFF, showing the remarkable Contortions of the Diluvial Formations.

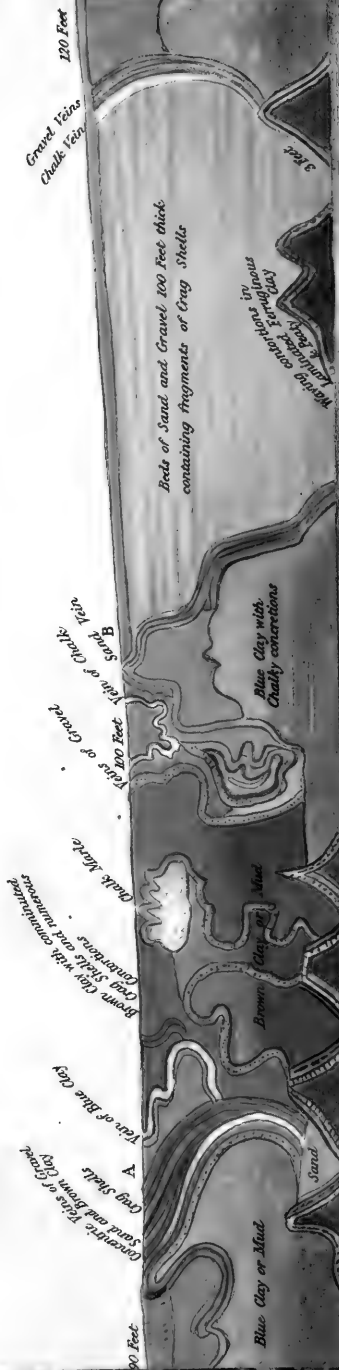

G E R M A N O C E A N

Stacks of Gneiss at Low Water

100 Yards

Drawn by R. Taylor.

THE
PHILOSOPHICAL MAGAZINE
AND JOURNAL.

29th FEBRUARY 1824.

XV. *Remarks on the Position of the Upper Marine Formation exhibited in the Cliffs on the North-east Coast of Norfolk.*
By Mr. RICHARD TAYLOR of Norwich.

To the Editors of the Philosophical Magazine and Journal.

THE accompanying sketch (Plate I.) represents the section of about a quarter of a mile of the cliff immediately to the west of Cromer Jetty, at a point which attracts the notice of the geological observer to the singular contortions of the diluvial beds; and is further remarkable by the singular position and expansion of the crag strata.

In pursuing the line of cliffs from their commencement at Weyburn Hope, a thin bed of ferruginous gravel and clay may be traced, almost uninterruptedly, along the coast, for about seven miles, to this spot. This bed seldom exceeds two feet in thickness, and for the most part is visible immediately overlying the upper chalk series, which rises to the surface about three miles west of Cromer. An apparent continuation of the same bed may be traced from hence southward, about fifteen miles; appearing in general, just above the high-water mark, sometimes laminated and often contorted or waving, and varying at every hundred yards its component qualities, through every modification and combination of ferruginous and ochreous sand, gravel, clay, peat* and loam, with more or less of compressed wood; stumps of trees rooted into the stratum; ochreous nodules and nuclej; shelly and bony fragments; teeth, tusks and horns of elephants and deer; in all which properties it preserves a certain general and remarkable character by which it can be identified throughout an extensive line of the eastern coast, occupying the position usually assigned to the crag or upper marine formation, and which I have previously noticed in the article in volume lx., August 1822.

* In one of these peat beds I observed a numerous colony of recent and living *pholades*.

The opinion there entertained that this osseous stratum is an extension of the Harwich bed, containing similar remains, has been very recently confirmed by the knowledge that large bones have been collected at Ormesby in Norfolk, and Corton in Suffolk; elephants' teeth near Southwold; and recently elephants' teeth are stated to have been raised by the fishermen in their nets off Yarmouth. It was to be expected in the low ground, between Caister and Gorleston, originally covered by the sea, that this stratum, although continuous, was situated considerably below the low-water mark. The same observation applies in passing Winterton, northward, towards Happisburgh; along which line this stratum is in general only to be traced by its *debris* thrown upon the beach.

Besides the bones which are above noticed and those formerly mentioned in *Phil. Mag.* vol. lx. p. 82, a small tusk has been recently taken out of the ferruginous stratum near Happisburgh. I have also in my possession many mineralized bones, which at different times have been entangled in the nets of the fishermen, at a considerable distance at sea, opposite the Norfolk cliffs, towards Happisburgh; affording an additional proof of the great space over which this osseous deposit has extended. Of these animal remains no arrangement or scientific examination has at present been attempted; nor can I here venture to describe them but in general terms. They appear to be referable, chiefly, to species of the elephant, the ox, and the elk; consisting of

Two vertebræ, about six inches in diameter.

Fragment of a tusk which, if entire, would have measured six inches diameter.

Twelve teeth, or fragments of teeth, of elephants.

One fragment—probably the superior part of the femur of the elephant, the greatest width being eight inches.

Several portions of bone, detached fragments of the larger bones, perhaps, of elephants.

One horn, eleven or twelve inches long, and about ten inches in its greatest circumference; probably of an animal of the ox kind,—but I am not able to determine.

The upper portion of the skull apparently of the large fossil elk, the "*cerf à bois gigantesque*" of M. Cuvier; width of the front six inches; circumference of the beam of the horn about nine inches.

A part of the horn of a similar animal, the brow-antler broken off; measures eight inches and a half.

Part of the forehead and commencement of the horns of a smaller species of elk.—In four specimens of this portion
of

of the skull of the stag or elk, a material difference in their size and proportions is observable.

One or two small portions of the leg-bones of the elk or stag.

To return to the more immediate subject of this communication. Near the base of the cliff, represented in the Plate, indurated beds of crag sand, with abundance of its peculiar fossil shells, here consisting chiefly of small *Maetra arcuata*, *Cardia*, *Mya lata*, *Turbo littoreus*, and fragments of *Balani*, are exposed at low water upon the beach.

It is remarkable that at this spot the crag suddenly enlarges, from a small bed a foot and half in thickness, to a series of beds occupying almost the entire cliff more than a hundred and twenty feet high, and about two hundred yards wide; filling up a sort of gap in the accumulated deposits of the diluvial clay formation.

There is a further peculiarity: whilst the thin stratified crag, which appears at low water at the base of the cliff, contains chiefly perfect or unbroken shells, the whole of these extended superior beds contain comminuted fragments only; a fact which, in conjunction with other circumstances, leads at once to the conclusion that a great disruption of the regular strata, through the powerful agency of currents of water, has taken place since the deposition and consolidation of the chalk. Numerous instances corroborative of such an opinion may be observed within the space of a few miles; some of these may perhaps be particularized in a future article.

The crag shells are here dispersed, in fragments, throughout a series of horizontal beds, alternating with gravel and whitish sand, and occasionally with thin seams of loose peat.

The dry and loose nature of these, like all the other crag sands wherever noticed, subjects them to the continual operation of slipping down the cliff and forming heaps at its base.

The position of the formations bounding this unusual accumulation of crag, is best understood by a reference to the plate.

Here some singular curvatures, inversions and contortions of the strata present themselves; but are with difficulty represented on a scale so limited. Detached masses, lumps and veins of chalk; contortions and tortuous veins of blue clay, gravel and sand, arrange themselves in a variety of forms; passing through the thick formations of consolidated mud of which the cliffs are chiefly composed along nearly 25 miles of the Norfolk coast. This mud is divided into two beds, chiefly distinguished by the difference in their colour and density.

At the base lies the bed of ferruginous, peaty and laminated clay, before adverted to; here, as in frequent instances, disposed in an irregularly waving or serrated line. Above this is heaped a mass of dark blue mud or clay varying from ten to near a hundred feet thick; frequently containing small chalky concretions, and sometimes pyrites and rounded fragments of the older rocks, but possessing no peculiar organic remains; none, indeed, save a few solitary pieces of belemnites or gryphea, and the shells contained within the bouldered fragments of indurated clay. Over the blue clay is the brown mud or clay, less compact than the former, full of springs, and remarkable throughout its course for the contortions which it exhibits. This also, for the most part, is barren of organic deposits, except a few diluvial waterworn fragments: at the spot we are describing, we have to notice a remarkable departure from this character. A large portion of the brown mud, occupying the space between the great contortion at A and the crag sand at B, contains comminuted crag shells dispersed through the mass. These, and the detached masses of chalk in the position shown in the sketch, afford further proofs of the local disruption and partial dispersion of portions of the preceding older deposits.

I am acquainted with no corresponding instance of the dispersion of crag shells through the adjoining clay beds in the progress of this stratum through the interior of the county of Norfolk.

Since the sketch was placed in the engraver's hands, a more attentive examination has convinced me that broken portions of crag shells are abundantly interspersed through the mass of the clay formation, particularly of the upper beds, for a mile or two of the cliffs on each side of Cromer. These fragments are so small, although abundant, that it is not surprising that they were so often overlooked before.

Traces of the crag formation are plentifully exhibited, at that part of the cliffs upon which Foulness light-house is situated. Here the diluvial clay or mud formation attains its greatest elevation during the whole of its course along this coast. The section of the exposed clay beds was measured by the writer, and found to be 270 feet of perpendicular height; above which are horizontal deposits of gravel and sand, 40 to 50 feet more. The whole of this accumulation of 270 feet contains comminuted crag shells intermixed with small chalky fragments*.

The sand beds at Foulness light-house are probably 150

* Messrs. Conybeare and Phillips consider 30 feet as the thickness of this stratum at Harwich and Walton Naze; and this, perhaps, is more than an average thickness.

feet thick; but I have not detected therein any traces of crag fossils, although they abound in the clay, in an extensive gap of which these horizontal beds are deposited.

At A commences the most extensive contortion hitherto displayed in the diluvial formations of this district. It consists of concentric bands of gravel, sand, and brown mud; the external mud vein contains minute fragments of crag shells. There are few visitors to Cromer, probably, but are struck with this singular feature in its cliffs. The foot of this contortion rests upon a bed, 15 feet thick, of yellow sand without shells, overlying the waving laminated and peaty clay bed before described; and the entire section exposed was found on admeasurement to be 90 feet.

The general composition of the cliffs, for many miles to the west and south of the portion here represented, is chiefly an accumulation of the consolidated diluvial mud; varying in thickness from 20 to 250 feet; occasionally divided by vertical gaps, which have been subsequently filled with chalk, marle, or sand, but chiefly the latter. Some instances occur, where the beds of mud and other diluvial deposits assume a vertical position. These, and the gaps alluded to, often cut through the mud cliffs from the summit to the base, at the particular part where the accumulation is the greatest and the elevation is the loftiest. The most remarkable examples of this occur at Paston Hill, at Beck Hythe, at Cromer, Runton, Beeston, and Sherringham.

Extensive slips of enormous masses of the diluvial clay are constantly occurring; and avalanches of mud are continually in operation, particularly between Cromer and Mundesley. They are occasioned rather by the numerous land springs and by interruptions to the natural drainage, than by the undermining action of the waves; and the accumulating mass forms an inaccessible and impassable border of soft boggy mud, often several hundred yards in width, and 100 or 150 feet in thickness, destitute of vegetation, and presenting a gloomy and desolate aspect for some miles.

The annexed drawing is chiefly copied from a section constructed on a large scale, by the writer of this article, of the entire line of cliffs on the Norfolk coast; from the point where the diluvial beds rise from beneath the Marum sand hills, north of Winterton, to where the high land recedes from the shore near Cley at Weyburn Hope.

Yours &c.

Norwich, Dec. 15, 1823.

RICHARD TAYLOR.

XVI. *On the Mode of manufacturing Salt by Evaporation on Faggots.* By R. BAKEWELL, Esq.*

THE salt-works at Montiers in the Tarentaise are particularly deserving attention, being perhaps the best conducted of any in Europe with respect to economy. Nearly three million pounds of salts† are extracted annually from a source of water which would scarcely be noticed, except for medical purposes, in any other country.

The springs that supply the salt-works at Montiers rise at the bottom of a nearly perpendicular rock of limestone, on the south side of a deep valley or gorge through which the Doron runs before it joins the Isere. The distance of the salt-works from the spring is about a mile; the water runs in an open canal, but is received in a reservoir, where it deposits part of its ochreous contents. The water rises from the rock with considerable force, and emits much gas, which is principally carbonic with a mixture of sulphuretted hydrogen; it has an acidulous and slightly saline taste. The temperature of the strongest spring is 99° Fahrenheit; it contains 1.83 per cent. of saline matter. The second spring has the temperature of 95°, and contains 1.75 of saline matter. Besides common salt, the water contains in small proportions sulphate of lime, sulphate of soda, and sulphate and muriate of magnesia; together with oxide of iron. During the great earthquake that destroyed Lisbon in 1756, the salines at Montiers ceased to flow for forty-eight hours; and when they flowed again, their quantity was increased, but the saline impregnation was weaker‡. It may seem extraordinary that the waters at Montiers, which have only half the strength of sea water, should repay the expense of evaporation; but the process by which it is effected is both simple and ingenious, and might be introduced with great advantage on many parts of our own coast, should the salt duty be entirely removed. The salt-works at Bex in the Pays de Vaud are nearly similar to those at Montiers, but not on so extensive a scale, and a very useful part of the process at Montiers is not adopted at Bex.

* Extracted from volume i. of "Travels in the Tarentaise, and various Parts of the Grecian and Pennine Alps, and in Switzerland and Auvergne, in the Years 1820, 1821, and 1822." In 2 vols. octavo.

† In this quantity are comprised common salt, Glauber's salt, and the alkaline salts sold to the glass manufacturers.

‡ The geological position of these springs, and the numerous thermal waters of the central chasim of the Alps, are described in the latter part of the volume.

I shall endeavour to give such a description of the process as will enable any person to imitate it in this country; indeed so little is known of this mode of evaporation by faggots, that it has been often stated by English writers, and has recently been gravely repeated, that it consists in throwing salt water upon burning faggots, and gathering the salt that remained! This would be a mode of making salt as wise and practicable as the nursery method of catching birds by putting salt on their tails. It is obvious that water so weakly impregnated with salt as to contain only one pound and a half in every thirteen gallons, could not repay the expense of evaporation by fuel in any country. The water of the North Sea contains $2\frac{1}{4}$ per cent. of salt; and yet it has never been attempted, I believe, to make salt from it with coal fires, even on the coast of Northumberland or Durham, where refuse coal suited to the purpose might be purchased for 1s. 6d. per ton.

The first attempt at Montiers, in 1550, to make salt by atmospheric evaporation, was by arranging pyramids of rye straw in open galleries, and letting the water trickle through gradually and repeatedly. By this process a portion of the sulphate of lime was deposited on the straw, and the water became concentrated to a certain degree. It was then carried to the boiler and further evaporated by fuel. In 1739 the present buildings were erected by order of Charles Emanuel the Third.

There are four evaporating houses, called *Maisons d'Epines* (literally, houses of thorns). Nos. 1 and 2 receive the water from the reservoir, and concentrate it to about three degrees of strength, viz. they evaporate one-half of the water they receive. These houses of evaporation are 350 yards in length each, about 25 feet in height, and seven feet wide. They are uncovered at the top. They consist of a frame of wood, composed of upright posts, two and a half feet from each other, ranging on each side, and strengthened by bars across; the whole is supported on stone buttresses, about three feet from the ground, under which are the troughs for the salt water to fall into. The frame is filled with double rows of faggots of black thorn, ranged from one end to the other, up to the top; they are placed loosely, so as to admit the air, and supported firmly in their position by transverse pieces of wood. In the middle of each *Maison d'Epines* is a stone building, containing the hydraulic machine for pumping the water to the top of the building; it is moved by a water-wheel. When the water is raised to the top, it is received in channels on each side, which extend the whole length of the building; from these
long

long channels it is made to pass into smaller ones by the side, from which it trickles through a multitude of small holes, like a very gentle shower, upon the faggots, where it is divided into an infinite number of drops, falling from one point to another. Being thus exposed to the contact of the air, it gains one degree of strength in falling, and, by the action of the pumps, it is raised again, and falls in other showers, till it has acquired the strength required for passing to the evaporating house, No. 3.

The process is conducted with less nicety in Nos. 1 and 2 than in the others, and, as I mentioned before, the houses are not covered. The pumps moved by the machine in the centre of the building, are distributed at equal distances on each side of the *Maison d'Epines*. The water is not always let to trickle down on both sides of the thorns, but only on that exposed to the wind. The two buildings, Nos. 1 and 2, are placed at different angles, to catch the different currents of wind that rush down the valley. No. 3 is constructed on the same principles as Nos. 1 and 2; it receives the water from them both; it is 370 yards long, and is covered, to preserve the salt water from the rain. There are twelve pumps on each side in this building, and more care is taken to distribute the water equally; here it is concentrated to the strength of twelve per cent., and deposits most of its remaining sulphate of lime, in incrustations on the twigs.

The water being now reduced to about one-seventh of the original quantity, and raised to the strength of twelve degrees, is passed along channels to the *Maison d'Epines*, No. 4. This is only seventy yards in length: here it is further concentrated by a similar process, till it nearly reaches the point of saturation, but this depends on the season. In dry weather, it is raised to twenty-two degrees; but in rainy, moist weather, to eighteen degrees only. In summer-time the whole process of evaporation, in passing through the different houses, is about one month; in wet seasons it is longer. The stream of water that sets in motion the hydraulic machines for raising the saline water to the top of the buildings, is brought by a small aqueduct from the river *Doron*. When once in motion, the process goes on and requires little further attention, or manual labour, till it is completed. When the water is nearly saturated, it passes to a large building, where are the pans for boiling, and the salt is crystallized in the usual method. That the reader may form an idea of the quantity of water evaporated before it comes to the pans, I will state the reduction at each of the evaporating houses:

8000 hogsheads, when received at Nos. 1 and 2, contain about 1½ per cent. of salt	hogsh. 4000
4000 hogsheads, when received at No. 3, contain about 3 per cent. of salt	reduced to 1000
1000 hogsheads, when received at No. 4, contain about 12 per cent. of salt	reduced to 550
550 hogsheads, received at the pans, contain near 22 per cent. of salt.	

Thus, out of every 8000 hogsheads, passing through the Maisons d'Epines, 7450 are evaporated by the air in summer, and about 7000 in winter; and only one-sixteenth part of the fuel is consumed, that would be required for evaporating the whole quantity of water by fire.

The faggots are changed at periods of from four to seven years. Those in Nos. 1 and 2, where the saline impregnation is weak, will decay sooner than in Nos. 3 and 4. In No. 3 all the twigs acquire so thick a coating of selenite, that when broken off, they resemble stems and branches of encrinetes.

The Maison de Cordes was invented by an ingenious Savoyard named Buttel. It is forty yards in length and eleven wide: it is much stronger than the Maison d'Epines, the roof being supported by six arches of stone work; the intermediate spaces on the sides being left open. In every one of these divisions are twelve hundred cords, in rows of twenty-four each, suspended from the roof, and fixed tight at bottom. The cords are about sixteen feet in length. The water is raised to a reservoir at the top of the building, and distributed into a number of small transverse canals, each row of twenty-four cords having one of these canals over it, which is so pierced as to admit the water to trickle down each separate cord, drop by drop. The original intention of this building was to crystallize the salt itself upon the cords, for which purpose the water was made use of from the pans after it had deposited a quantity of salt in the first boiling, to save the expense of fuel in a second boiling; the residue-water of the first boiling, by repeatedly passing over the cords, deposited all its salt in about forty-five days, and the cords were incrustated with a cylinder of pure salt, which was broken off by a particular instrument for the purpose*. This process is at present abandoned for crystallizing; but the cords are still used for evaporating, and are found to answer better for the higher concentration of the water than the faggots. This method did not answer for the first evaporation, because the water rotted the cords; but it was discovered that the cords

* This process might be used for sea-water with particular advantage in warm climates, and the necessity for boiling altogether avoided.

were not soon injured by it when it had acquired five degrees of strength. The cords, we were informed, had many of them remained thirty years in use without being changed: indeed, they were so thickly encased with depositions of selenite, that they were defended from the action of the water. This mode of evaporating is found to be more expeditious than that of the faggots.

A sketch of the evaporating-house No. 1 is annexed; No. 2 is similar to it in every respect.

In the covered house No. 3 there are twenty-four pumps, twelve on each side, to distribute the water more equally over the whole. This system of pumps is worked by joined bars of wood, which move backwards and forwards, and are connected by crank wheels with each piston, to raise and depress it. As I have before mentioned, they take care to evaporate on the windward side of the building. When I was on the top of No. 3, though the air was very warm, I felt an intense degree of cold, the consequence of speedy evaporation.

In the *Maison de Cordes*, it is found that the evaporation goes on more speedily in windy weather than in the *Maisons d'Epines*, as might be expected from the more ready access of air to the surface of the water. The cords are double, passing over horizontal rods of wood at the top and the bottom, to keep them firm in their positions, and at regular distances from each other. I did not see the cords without their envelope of selenite; but I was informed that they were not thicker than the finger. With the incrustations they were become as thick as the wrist.

Near the salt-springs there are the remains of a large reservoir, into which the water was formerly made to fall from a considerable height by a machine; but this mode of evaporation was only found to answer in very hot weather, and the process is given up.

The saline water is received into reservoirs from the springs, where it remains some time before it passes to the *Maisons d'Epines*, and here it deposits a considerable quantity, or nearly all, of its ferruginous matter: the canal along which it runs to the reservoirs is also lined with a red ochereous incrustation.

The total length of the *Maisons d'Epines* is as under:

	Yards, English.
Nos. 1 and 2, together . . .	700
3	370
4	70
Total,	1140,

or nearly two-thirds of a mile.

The

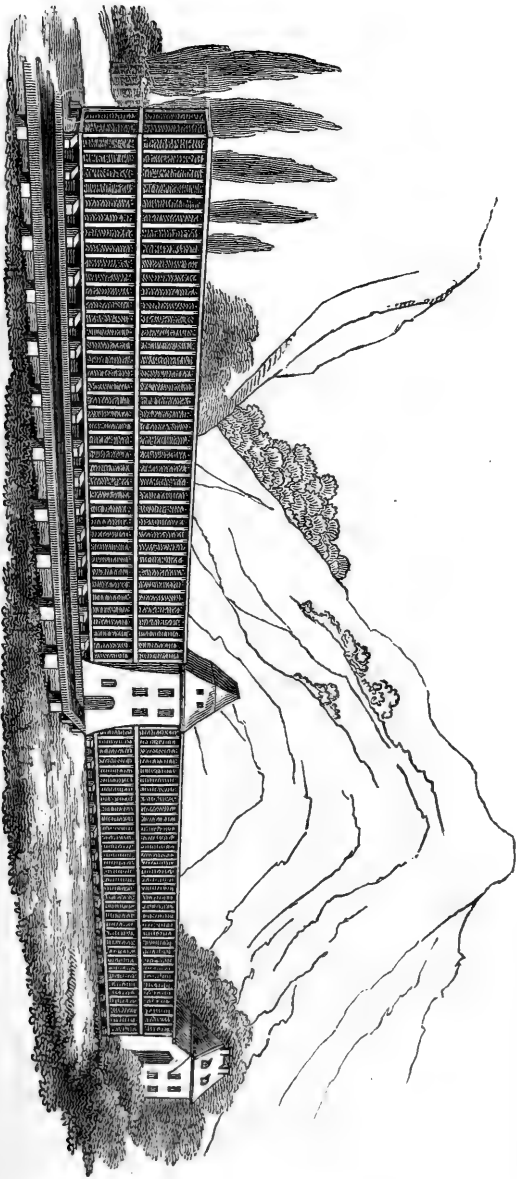

The fuel used at the pans for the last process is partly wood, and partly anthracite from the neighbouring mountains. The anthracite answers remarkably well when once ignited, as it preserves for a long time a regular degree of heat. The consumption of wood was formerly so great that it has denuded many of the higher mountains in the Tarentaise, and exposed them to the action of the atmosphere, which has occasioned vast *eboulements*; for it is found that forests are of the greatest utility, in preserving precipitous mountains from destruction. The fact is now so well ascertained, that the Government, for this cause alone, has lately paid particular attention to the preservation of the wood. The quantity of salt made here annually, is estimated at 100,000 myriagrammes, or about 2,250,000 lbs. avoirdupois, and about 9000 myriagrammes of sulphate of soda, or about 187,000 lbs. The other alkaline matter which adheres to the pans is sold to the glass-makers. The Government receives, on the average, 150,000 francs for the products, out of which it is estimated that 30,000 are expended for wood and fuel, 8000 for materials employed in the buildings, and for the faggots &c., and 62,000 for the wages and the salaries of the different officers, leaving an annual profit of 50,000 francs. In some of the mountains of the Tarentaise, the gypsum is intermixed with rock salt *en masse*, and was worked by the peasants; but the places are now closed up, and so strictly guarded by order of the Government, that I found it difficult to procure specimens.

These mines were formerly worked, the salt being separated from the gypsum by solution, and subsequently evaporated by fire; but the great *eboulements*, caused by clearing away the wood from the sides of the mountains, obliged the Government to abandon the mines, and undertake the manufacture of salt at the Salines. These mines are mentioned by the Roman historians.

XVII. *Description of a Pressure Gauge recommended for its Simplicity of Construction and Principle; with Observations on the Gauge proposed by Mr. SEAWARD**. By Mr. HENRY RUSSELL.

To the Editors of the Philosophical Magazine and Journal.

Gentlemen,

AN examination of the instrument proposed by Mr. Seaward, and described by him in your Magazine, No. 309, at pages 36 and following, has induced me to lay before your

* See p. 36 of this volume.

notice a description of a pressure gauge which I have constructed for my own amusement, and which I have no doubt will ultimately be considered as remarkable for its accuracy and simplicity, as Mr. Seaward's will for its inaccuracy and complexity.

The gauge which I am now about to describe, and which is here represented, consists of a glass tube sealed at one end with a ball blown very near the other, leaving only as much tube beyond the ball as may be necessary for connecting it with the pipe leading from the vessel containing the condensed gas, steam, or other elastic vapour. This ball, when the tube is filled with air and subject only to atmospheric pressure, should be about three quarters full of mercury, and the whole capacity need not exceed that of the tube more than as two to one. That the divisions on the scale may be in geometrical progression, the tube is placed in a horizontal position: this renders the instrument altogether so simple in appearance, that persons totally unacquainted with instruments of this description, may at once be brought to understand its nature, and be enabled to affirm with confidence the degree of pressure to which it is subject.



To determine the degree of pressure at any given point, ascertain the distance of that point from the sealed end of the tube, and by that measure divide the length of tube contained between the sealed end and the bulb; the quotient will be the number of atmospheres. Thus, in general terms, where T represents the whole tube, P the part into which the column of air is compressed, and A the number of atmospheres; we have $\frac{T}{P} = A$. Thus suppose the tube eight feet long, and the column of air compressed into half that length, then we have $\frac{8}{4} = 2$ atmospheres. If this column be again compressed into half its volume, it will be represented by $\frac{8}{2} = 4$ atmospheres. If again compressed into half its volume, we have $\frac{8}{1} = 8$ atmospheres. If again (8 feet = 96 inches) $\frac{96}{3} = 32$ atmospheres. And lastly $\frac{96}{6} = 16$ atmospheres. In the annexed figure is represented my own gauge

gauge complete (except that there are given only the geometrical divisions) with the mercury chamber blown in the tube itself; so that on this plan we have no joints whatever to make in the instrument: and being placed in a horizontal position at a convenient distance from the floor, all parts of the scale may be examined with equal facility.

For the internal diameter of the tube, perhaps $\frac{1}{16}$ th of an inch will be found preferable.

The following numbers represent, in inches and decimal parts, the spaces between each division representing a number of atmospheres and the top of the scale.

Atmospheres.	Inches.	Atmospheres.	Inches.
1	= 96·000	17	= 5·647
2	= 48·000	18	= 5·333
3	= 32·000	19	= 5·052
4	= 24·000	20	= 4·800
5	= 19·200	21	= 4·571
6	= 16·000	22	= 4·368
7	= 13·714	23	= 4·173
8	= 12·000	24	= 4·000
9	= 10·666	25	= 3·840
10	= 9·600	26	= 3·692
11	= 8·727	27	= 3·555
12	= 8·000	28	= 3·428
13	= 7·384	29	= 3·310
14	= 6·857	30	= 3·200
15	= 6·400	31	= 3·096
16	= 6·000	32	= 3·000

I shall now endeavour to point out to you, that the gauge proposed by Mr. Seaward is not so good an instrument as the one in common use, upon which he seems to think that he has made so much improvement. The first article in what Mr. Seaward calls his description runs thus: "Considerable difficulty has been experienced in ascertaining in a satisfactory manner the exact pressure of highly condensed gases or fluids." Now I would ask Mr. Seaward, where has he met with this difficulty? or, how can we possibly meet with any difficulty when guided by an instrument of perfect simplicity, as is the pressure gauge in common use? He knows what the common pressure gauge is, for he clearly describes it.

He next says, "But it happens that when fluids are required to be compressed to 30 or 40 atmospheres, it becomes necessary to have the tube of the mercury gauge of very great length, say from 30 to 45 feet, otherwise the divisions of the upper part of the scale will be much too small for useful reference." How far Mr. Seaward is justified in this assertion,

I leave

I leave others to determine; I shall only say that the smallest space which is between 31 atmospheres and 32, on a scale adapted to an eight foot tube, is equal to $\frac{1}{10}$ of an inch — $\frac{1}{310}$ only; a quantity as great as the nature of the case can possibly require. Mr. Seaward has not informed us how he will make the joint between the glass tube and the metal box, so that it shall remain perfectly tight; and that under a pressure of from one to twenty atmospheres: and I think he will admit that a leakage in this part, however trifling, would be fatal to his plan.

The difficulty and trouble of ascertaining *nicely* the capacities of the chamber, tube and ball, is no very agreeable employment, particularly when we consider that in using a tube without these incumbrances there is no occasion whatever for measuring capacities. Another very material objection to this complex plan, is the immense trouble of substituting a new tube in case of accidentally breaking the original one; the same difficulties oppose which we meet in adjusting a thermometer tube to an old scale. Upon the whole, instead of being “more *convenient and correct* than the gauge in common use,” as its inventor has endeavoured to represent it, I am satisfied that the complexity of this instrument will render it unworthy of our confidence, and, if relied on, will lead to erroneous conclusions, which the adoption of a simple tube would certainly have avoided.

Fearing I have trespassed on your pages too much for a subject of this simple description, I am anxious to subscribe myself

Yours truly,

City Road, Feb. 10, 1824.

HENRY RUSSELL.

XVIII. *Electro-magnetical Experiments.* By Mr. WILLIAM STURGEON.

To the Editors of the Philosophical Magazine and Journal.

BEING desirous to understand the relation that subsists between the chemico- and thermo-electric phænomena, as influenced by the magnet, so as to form a comparison of the widely different apparatus for exhibiting those phænomena; and likewise, if possible, to ascertain some general law to be observed in thus comparing the two modes of exciting this influence; the few following simple experiments suggested themselves as the most likely to give satisfaction on this point. As this investigation and comparison* seems to have escaped the

* There may be said to be one objection; for a comparison has certainly been made by a philosopher of acknowledged skill; and it is with due deference that I cannot subscribe to the conclusions of that gentleman.

attention

attention of every other experimenter, perhaps a detail of those experiments with their results, and a description of an instrument which I have been led to invent and construct, upon a simple principle, for the purpose of carrying on the comparison to any required extent, may not be thought uninteresting to some of your readers.

Exp. 1. I charged in the usual way with dilute nitric acid an Amperé's rotating cylinder, and placed it on a table. I now placed the north pole of a bar magnet on the upper edge of the outer rim of the copper part of that apparatus. I likewise imagined myself "coinciding in position with the wire about which the machine turns," and "looking towards the magnet." On bringing one of the wires of the zinc cylinder between me and the magnet, that wire was projected to the left.

Let the line ED, fig. 3, be the horizontal part of the wire in this and the following experiments, moveable on a pivot *o*; then, when the wire is said to be projected to the right, it is meant that the point E is projected towards R, as *oR*; and when to the left, the point E is projected towards L, as *oL*.

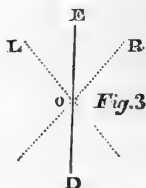

Exp. 2. I now presented the south pole of the magnet to the wire. The latter was projected to the right.

Observation. This chemico-galvanized wire was evidently the ascending wire from the zinc to the copper; or (which is the same thing) the descending wire from the copper to the zinc.

Exp. 3. I now suspended by a piece of untwisted silk a semicircular copper wire, with a zinc diameter, as in fig. 4:

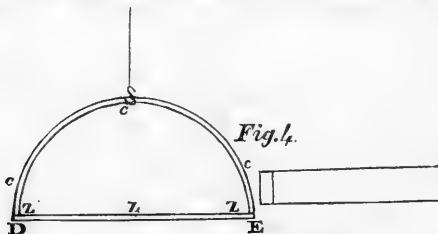

ccc is a fine copper wire; and *zzz* a fine slip of zinc, soldered to the former at the extremities *zz*. The north pole of the magnet was now placed close to one arm of the semicircular arc, as shown in the figure, and the lamp applied at E. The wire was projected to the left.

Exp.

Exp. 4. The semicircle adjusted as before, the lamp was now applied at D. The wire was projected to the right.

Exp. 5 and 6. In these experiments the lamp was applied as before, but the south pole of the magnet was now presented to the wire. The motions were the reverse of the two former experiments.

I have tried rectangles instead of semicircles, but there is no difference in the results.

If a semicircle or rectangle be made of platinum and silver wires, the former supplying the place of the copper, and the latter be substituted for the zinc, in the above thermo experiments, the results of the two machines are exactly alike; hence the copper and platinum wires are possessed of the same kind of electricity, and so are the zinc and silver each to each; but of the contrary kind of the other two wires: so if the copper be positive to the zinc, by this magnetic test we must necessarily conclude that the platinum is positive to the silver.

But this is not all that is to be observed in these experiments; we must compare the results of the chemico with those of the thermo experiments, and endeavour to trace the relation that subsists in the phænomena exhibited by those two modes of exciting the electrical influence.

We will therefore compare our chemico experiment 1, with our thermo experiment 3. We here find the wire projected to the *left* in both cases.

We will now suppose the immersed plates of the chemico apparatus to correspond with the heated union of the thermo wires; and the most remote extremities of the chemico conducting wires, with the coldest junction of the thermo machine. It will follow, that as the copper wire (by the supposition) is as evidently ascending in the thermo machine, as the zinc wire is ascending in the chemico cylinder; and as they are both propelled in the same direction (*left*), by the approximation of the north pole of the magnet; the forces of the two galvanized wires must of necessity be exerted in contrary directions. For although they are both propelled the same way, yet they are of contrary kinds or names.

Again: Let us now suppose the immersed plates of the chemico apparatus to correspond with the coldest union of the thermo wires; and the most remote extremities of the chemico conducting wires, with the heated junction of the thermo machine. In this case, the two wires nearest the magnet, of the chemico and thermo machines, will in all respects correspond with each other; for they are now both descending from the copper, or both ascending from the zinc (by the supposition). Hence the forces of the two galvanized wires are ex-

erted in the same direction; for the wires are of the same kind, and are propelled the same way.

The conclusion still holds good, when the junction of the wires is heated at D instead of E.

Having thus ascertained, by the former supposition, that the forces of the chemico and thermo galvanized wires are exerted in *contrary directions*, and that by the latter supposition these forces are exerted in the *same direction*; I shall leave the theorizing philosopher to adopt which side of this dilemma he may think fit; for it is not my province to predict whether we are to have a thermo-electric force acting in a contrary direction to our old galvanic force, by the former supposition, or whether we are to have these two forces reconciled to each other by the latter;—my business being only to ascertain some general law, whereby to regulate my subsequent experiments.

I have since made experiments, both chemico and thermo, with combinations of other metals; and the results have given me the greatest satisfaction that the above law is general; for the comparison is, in all that I have made, the same as with copper and zinc.

Here follows a description of the instrument I have made for the purpose of exhibiting and comparing chemico and thermo phænomena as influenced by the magnet; by means of which I can make the experiments with the greatest facility and exactness. I have named it the Comparing Galvanoscope.

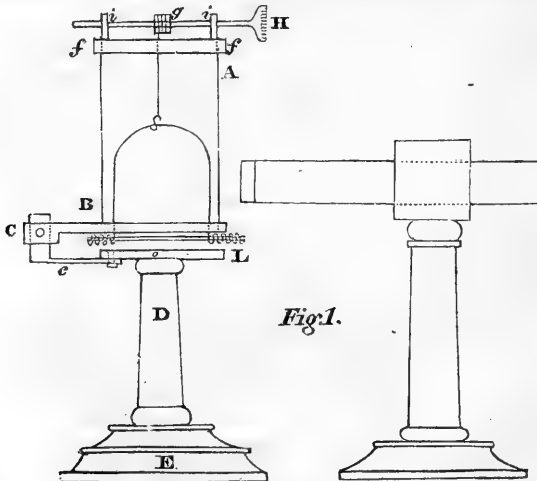

Fig. 1.

Fig. 1. A cylindrical glass tube supported by the arm Cc of

of the brass stand DE; on the top of the cylinder is a moveable brass cap *ff*. To the upper side of this cap is adapted a thick wire, with its bobbin *g* and milled head H. This wire turns in two spring sockets at *ii*. One end of a piece of untwisted silk is fixed to this bobbin; the other end is supplied with a fine silver wire hook, which descends through a small hole in the centre of the cap into the glass cylinder. The circular plate *o* at the top of the stand has a flat moveable rim, which is graduated from 0 to 90° each way. This is for measuring the quantity of deflection; and hence the instrument in some measure answers the purpose of a galvanometer.

Fig. 2 shows a chemico combination out of the instrument. A is a small glass vessel containing dilute acid. The parallel slips or wires *aabb* are the dissimilar metals for the experiment. The conducting wire *ccc* is soldered to their extremities at *a* and *b*.

To make the experiment: the glass cylinder is taken off the stand by unscrewing the nut *c*, fig. 1. The combination is then hooked on and drawn to the top of the inside of the cylinder by turning the pin H. The glass vessel with its acid is placed on the circular plate *o*; and the cylinder replaced, and the nut screwed tight. The metals may now be let down into the fluid to any depth the experimenter thinks fit. The circle may now be adjusted by bringing *o* under one of the wires, and the magnet being applied outside of the cylinder will deflect the wire.

To make a thermo experiment: the glass cylinder is taken off as before; the combination hooked on, and the whole replaced; when the wire is at rest (which soon will take place, for the cylinder entirely cuts off the undulations of the external air). The graduated circle is now adjusted, and the lamp applied at L, and the magnet as in the figure.

This method of detecting the galvanic influence in delicate chemico combinations is so efficacious, that a piece of fine silver wire, such as forms a part of what is called gold lace, with a piece of zinc of the same dimensions let into the dilute acid not more than 1-10th of an inch, will cause the connecting wire (on the approach of the magnet) to be deflected 40°, sometimes 50°.

I have a great variety of combinations ready, which are placed between the leaves of a small book made for that

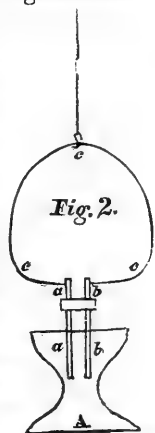

purpose, with the names of the metals on their respective leaves.

The whole apparatus packs up in a neat mahogany box.

This instrument differs from the galvanometers I have seen described. I use a powerful magnet for detecting and determining a slight galvanic influence; whereas in the galvanometer a feeble needle is used for that purpose. Many other differences might easily be pointed out, whether advantages or not is not for me to determine.

I am, gentlemen,

Yours, &c.

Artillery Place, Woolwich.

WM. STURGEON.

XIX. On Parallel Straight Lines. By Mr. JOHN WALSH.

A SOLID is that which resists the touch. Surfaces are the boundaries of solids. Lines are the boundaries of surfaces. Points are boundaries of lines. When the surfaces of two solids are such, as that any one surface of the one being placed any where on any one surface of the other, there shall be no space between them,—these are called plane surfaces, and their boundaries are called straight lines. If such surface is placed any where on any other surface any how bounded, and that there is no space between them,—this other also is a plane surface. Two straight lines cannot inclose space. Two straight lines that intersect each other are in the same plane; and three straight lines that meet each other are in the same plane.

Let x and y be two straight lines intersecting each other, and let the plane of the triangle ABC be so placed on the plane of x and y as that AB shall always fall on x ; and let $A'B'C'$, $A''B''C''$ be any two positions of the triangle ABC ; then shall $A'C'$ be parallel to $A''C''$. This follows from the invariability of the angles of the triangle ABC .

Axiom. When a straight line intersects any one of two parallel straight lines, it cannot be parallel to the other.

This is the same as Euclid's axiom. It appears to me to be more evident in this form. It is not however so logical as that of the Greek geometer, as it is intended to elucidate a property of angles.

When a straight line falls on two parallel straight lines, it makes equal angles with them both. (Preceding prop. and axiom.)

Professor Leslie, in a note to his Elements of Geometry, second edition, shows that M. Legendre has failed in his attempt
to

to demonstrate, by the theory of functions, the property of plane triangles, depending on the preceding proposition, that the sums of the three angles are equal to two right angles. M. Legendre, though vanquished, continues to argue still, and is supported in his defence by a foreign geometer of eminence, M. Maurice, as well as by the celebrated British geometers Dr. Brewster and Professor Playfair. When such authorities contend, it were perhaps presumptuous to interfere. It appears to me extraordinary that M. Legendre, a geometer so deeply acquainted with the properties of numbers, should really mistake the nature of number itself. This circumstance is, I believe, common to most geometers. Number expresses the relation between two homogeneous magnitudes. It cannot represent magnitude. Numbers are therefore abstract things. To say "*abstract numbers*," is to say "*abstract abstract things*!" It is as correct language to say "straight right line."

At the origin of grammar, men, then not acquainted with the real nature of numbers, arranged them very improperly under the head of adjectives. We say, "The money is one pound sterling;" "The distance is three metres;" "The right angle is one," &c. We ought to say, "The money has the relation one to the pound sterling;" "The distance has the relation three to the metre;" "The right angle has the relation one to the right angle," &c.:—the pound sterling, the metre, the right angle, &c., being the bases of comparison.

Let $A B C$ be the angles of any plane triangle, and c the side adjacent to the angles $A B$. It is required to determine the angle c . For this we have $C = \theta(A B c)$. Now M. Legendre says, in a note to the tenth edition of his *Elements of Geometry*, that "the side c is of a nature heterogeneous to the angles $A B$, and cannot coalesce with them in the equation $C = \theta(A B c)$. The right angle being the natural unity of angles, it is therefore a number. The angles A and B are therefore numbers. They cannot then coalesce with the side c , which is a straight line; then C is entirely determined by the angles A and B alone; therefore, when two angles of one triangle are equal to two angles of another, the third angle of the one is equal to the third angle of the other."

Now I shall demonstrate that the preceding reasoning fails in three different ways. 1st. It is said the right angle is the natural, that is to say, the necessary unity of angles. I have shown that a number cannot be put for magnitude. The right angle is not the necessary, but is made the arbitrary base of comparison in respect to angles. In respect to the sides, I shall make the metre the base of comparison; then instead of the side c I shall substitute its relation to the metre, and substituting

stituting for the angles $A B C$ their relations to the right angle, the equation $C = \theta(A B c)$ is an equation entirely between numbers, and consequently the number c cannot be excluded.

2dly. If the side c is excluded from the equation $C = \theta(A B c)$, then in this equation we have $c = 0$; but when $c = 0$, then $A = 0$, $B = 0$, $C = 0$, then $0 = \theta(0, 0 \cdot 0)$. Here the reasoning fails altogether.

Finally: M. Legendre asserts that the side c is of a nature heterogeneous to the angles A and B . Now the number of degrees in the angles of any plane triangle is determined by the circumferences of the circles of which the angular points are the centres. I have demonstrated elsewhere, that $\frac{N}{y} h = T$ is the equation of the tangent straight line to any curve; N being the normal, y the ordinate, and h any arbitrary increase or decrease of the abscissa; and that it is homogeneous to the equation which determines the length of the arc. Therefore the circumference of a circle and the side of a plane triangle are homogeneous quantities.

When we have to demonstrate a general property which necessarily involves in it notions of infinity, we must rest the demonstration as a postulate which must involve notions of infinity. The difficulty encountered in this theory of parallel straight lines, arises therefore from the constitution of the human mind, and cannot be overcome.

“Men learn the elements of science from others: and every learner hath a deference more or less to authority, especially the young learners, few of that kind caring to dwell long upon principles, but inclined rather to take them upon trust. And things early admitted by repetition become familiar. And this familiarity at length passeth for evidence. Now to me it seems there are certain points tacitly admitted by mathematicians, which are neither evident nor true. And such points or principles ever mixing with their reasonings, do lead them into paradoxes and perplexities.”—(*Berkeley, Defence of Free Thinking in Mathematics*, sec. 21.)

JOHN WALSH.

XX. *A technical Description of Chloraster, a new Genus of Narcisseæ.* By A. H. HAWORTH, Esq. F.L.S. &c.

To the Editors of the *Philosophical Magazine and Journal*.

Gentlemen,

ALLOW me to reply to E. E. in page 7 of your Miscellany for January last, and to say that the account of the two *Narcisseæ* there mentioned was published in the Botanical Register

Register for the month of January 1824; consequently *after* you had published my descriptions in p. 440 of your December Magazine: but a figure of one of them, or a plant allied to them, without name, appeared in the Register for the month of December, which however, without dissection or description, could not be determined. Old Parkinson, in his way, enumerates six species.

As to the names of these plants, I never heard of or saw either of them until they were published as above in January.

And with respect to these plants forming a good genus, I have no fear on that score, nor even of the admissibility (into the classic group to which it belongs) of the name *Diomedes*; because *Diomedea* is one syllable longer, and because many generic names are now in print which differ in gender only: and even these must pass* in the vast sciences of natural history, where such inconceivable numbers of generic and subgeneric appellations are wanted; not fewer than ten thousand of which will be occupied by Entomology alone!

As the above is but a very meagre communication, gentlemen, I will endeavour to make it more worthy of your attention, by subjoining to it a botanical description of what I consider to be another new genus of *Narcisseæ*, of two species, and which, from its remarkable green starry flowers, I call *Chloraster*, and remain

Your most obedient servant,

Queen's Elm, Chelsea, Feb. 9, 1824.

A. H. HAWORTH.

CHLORASTER. *Narcissus auctorum*.

Spatha 1—pluriflora. *Corollæ* lacinix lineares in gracillimam stellam patentes. *Corona* minima, integra, vel hexapetalo-partita, singulis partibus incurvatim cochleatis incrassatis. *Filamenta* omninò tubo adnata, 3, tubo breviora, 3 ejus longitudine.

Herbæ submaritimæ Africanæ bulbosæ nudifloræ unifoliæ, viridibus floribus autumnalibus, Jonquillarum habitu odoreque, alio modo florendi.

Specierum Characteres.

fissus. CHL. (The cloven-cupped) coronâ hexapetaloideâ.

1. *Narcissus viridiflorus*. *Bot. Mag.* l. 1687.

Descriptio. Gracilis omni parte. *Scapus* dodrantis aliquid compressus basi crassitie calami corvini

* Surely they might and ought to be avoided, as names may be varied *ad infinitum*.—EDIT.

laevigatus lucens caeruleo-viridis. Spatha in nostro vivo exemplari uniflora (an semper?) vix uncialis erecta striatula valde marcescens subferruginea. *Pedunculus* 2-uncialis erectus parum angulatus. *Germen* (ratione magnitudinis plantæ) magnum grossè ovale obtusissimè trigonum. *Tubus* vix uncialis teres lævis sordidè prasino-viridulus. *Corollæ laciniae* loratæ 8-lineares acutæ lineam latæ basi distinctæ tubi colore stellato-semireflexæ. *Corona* primulina sexpartita (quasi hexapetala) singulis partibus incrassatis erecto-incurvulis sive concavo-cochleariformibus rotundo-obovatis laciniis corollæ concoloribus at septies brevioribus. *Filamenta* omnia omninò tubo connata, tria tubo 2 lineas breviora, tria longitudine tubi. *Antheræ* (defloratæ in nostro) erectæ grossè ovales sive ellipticæ sulcatæ luteæ, tres tubo altè inclusæ harum media aliquantillum altior, tres e tubo paululum progredientes præcipuè harum ultimarum media. *Germen* (florendi tempore) habet semina varia incipientia, alba at majuscula. *Stylus* gracilis teres viridis antherarum altitudine, *stigmatibus* in lente tribus horum duobus (in nostro) incompletis. *Folium* solitarium in singulo bulbo non vidi; at secundum auctores, scapo omninò conforme, at solùm post florescentiam viget. *Floret* (in nostro exemplari) in Decembre. *Habitat* in Barbariæ maritimis.

integer. CHL. (The entire-cupped) spathâ 2-3-florâ, coronâ integrâ. Narcissus Juncifolius autumnalis flore viridi. Park. Parad. 94. 11. t. 93. f. 6.

Hanc plantam non vidi, et fidelis Parkinsoni fide solùm admisi. A priore differt coronâ integrâ nec hexapetalo-partitâ. *Habitat* in Barbariâ. Parkinson in loco. *Floret* Octob. ibid.

P.S. It is apprehended that as both the above described plants have green flowers, no apology is necessary for relinquishing the specific name of *viridiflorus* for the former, as names which have any tendency to mislead or delude, are ever objectionable, and the green flowers are common to both.

XXI. *Papers relating to the Earthquake which occurred in India in 1819.**

To William Erskine, Esq. &c. Bombay.

My dear Sir,

AS it was at your suggestion that I attempted to draw up the following account of the earthquake which occurred in India in June 1819, I beg that, should you consider it as at all interesting, you will do me the favour to present it to the Society. It consists of a plain description, and no circumstance has been admitted that has not been well certified; at the same time it must be observed, that the whole is written from memory, or very scanty memoranda.

I remain, my dear sir, yours very faithfully,

Camp at Bhooj, Jan. 27, 1820.

(Signed) J. MACMURDO.

P.S. At noon this day we had a very strong shock, attended by a loud noise like distant thunder. Several shocks have likewise occurred since the accompanying details were written.

On the 16th of June 1819, between fifteen and ten minutes before seven o'clock P.M., a shock of an earthquake was felt in Cutch; and as it appears to have been remarkable in India for the great extent of its range, and also for the very confined limits of its severe effects, I shall attempt to describe the course and results of the phænomena as they appeared in this province, without offering any scientific speculations, for which I am totally unqualified, or even stating opinions on the subject which I have heard advanced by others.

The shock was foretold by no uncommon appearance in the heavens; at least nothing was remarked previously, either in the heavenly bodies or in the atmosphere, to indicate the approach of any convulsion of nature. The hot months had passed on with the clear and serene sky, the burning sun, and the westerly wind, which commonly prevails at that season of the year. It was observed that the month of May was extremely hot, perhaps more so than usual, but the thermometer seldom higher than 108° or 110° of Fahrenheit in the shade of a tent, and generally not above 105°. On the evening of the 3d June we experienced a severe storm of rain and wind, with thunder and lightning from the north-east quarter, an occurrence by no means uncommon at the same season; the storm lasted about two hours, with rain through the night,

* From the Transactions of the Literary Society of Bombay, vol. iii., for 1822.

was pretty general through the province, and was felt in some places to the eastward of Bhooj in a degree approaching to a hurricane.

In the description of the shock it will be necessary to speak in the first person, because I can only pretend to describe with correctness my own feelings, thoughts, and observations. In the subsequent observations, however, I shall avail myself of those felt and made by others under different circumstances and in different situations.

At the moment already mentioned, after a hot day, I was sitting with a party of friends on an earthen terrace, in front of a house in which we were about to dine. The evening was remarkably serene, not a cloud to be seen, and a light and cool breeze from the west. The situation was on a ridge of slate rock in the town of Anjar, and close under a large round tower with four heavy guns mounted on it. Our notice was first attracted by a slight motion of our chairs, as if they had been lifted up, and a noise from the doors and windows, as if they had been moved by the breeze: before the question of "What is that?" could be uttered a second lifting of the chairs took place, and the motion became too evident to be mistaken even by me, who had never before experienced a shock. Every person made what haste he could to leave the tower, which, after rolling and heaving in a most awful degree, gave way at the bottom, on the western face, and crumbling down, buried guns and carriages in the rubbish: a moment after, the towers and curtains of the fort wall, and upwards of fifteen hundred houses, were reduced to ruins; but as I was within thirty yards of the round tower, my attention was particularly drawn to it.

The opinions with regard to the length of time which this shock lasted are various, but appear to be limited to from two to four minutes: my own conviction is that the first is nearest the truth, and perhaps even a little beyond the mark. On subsequently observing the time by a watch, it seems to me that if the motion had continued for more than two minutes, no building could have been left entire. Allowances must be made for agitation at the moment, and the general voice seems to fix the duration of the severe shocks at two minutes and a half. A philosopher, who had been in the habit of observing and speculating on the great convulsions of nature, might have coolly taken out his watch and been delighted with the opportunity of adding to the knowledge which the experience of the shock might have afforded. For my own part, however, my feelings at the moment were such as for an instant to deprive me of all presence of mind and power of reflection;

and

and when self-possession did return, my mind was too deeply occupied with the awful and appalling spectacle of the face of nature in a state of excessive agitation to admit of other thoughts or impressions. It certainly was terrific to behold hills, towers, and houses, the stability of which we had been in the habit of considering as proof against every power, and against the lapse of centuries, rocking to and fro, or rising and sinking, while the former sent forth clouds of dust, or perhaps smoke, and the latter crumbled into rubbish.

With regard to the nature of the motion there is likewise a variety of opinions. Some persons with whom I have conversed feel convinced of the action of the shock being directly upwards, as if the earth was on the point of opening under their feet; a few assert that it was vibratory, whilst others attribute to it an undulating motion. I confess I am one of those who favour the last-mentioned opinion, although the slight motion at the commencement did certainly feel as a direct elevation of the chair attended by a blow as if under its feet. When the shock was at its height, the motion of the earth was so strongly undulatory that to keep our feet was no easy matter. The waving of the surface was perfectly visible, and in attempting to walk, the motion has been most aptly compared by a gentleman to that felt when walking quickly on a long plank supported at both ends;—when one foot was elevated, the earth either rose and met it, or sunk away from it in its descent.

The shock was attended with a violent gust of wind and a noise like that of a numerous flight of birds; but this did not precede the event; I think, on the contrary, that the noise was heard even after, or at all events towards the conclusion of the motion. Both of these occurrences have been denied, although, for my own part, I feel convinced that they did happen; more especially as the noise has been frequently heard to accompany subsequent shocks.

The night of the 16th proved extremely serene and beautiful; and as we slept in the open air, we had a favourable opportunity of remarking any thing extraordinary that might occur. We observed, as we thought, a more than usual number of the meteors known by the name of falling stars; but whether we might not have been biassed by what we had read of such phænomena having been supposed to attend earthquakes, I will not venture to affirm. Before 11 o'clock P.M. we experienced three shocks; and, according to the statements of the sentinels and townspeople, there were many in the course of the night. These were however trifling, and their effects were confined to shaking the tiles and bringing to the

ground loose stones from the ruined houses. The next day, the 17th, the earth was frequently in motion, attended by gusts of wind and a noise like that of wheeled carriages. For some time before 10 A.M. these symptoms intermitted only for a few minutes, until about a quarter to 10, when a severe shock was experienced; this lasted for about fifty seconds, and brought down a number of shattered buildings.

As no register has been kept, or could well have been preserved, of the number of shocks felt, it is impossible to furnish particulars on this head. Until the beginning of August, no day passed without one or more shocks; and subsequently they became less frequent, only occurring every third or fourth day. During the whole of this time the shocks were generally very slight; many persons did not feel what was sensibly felt by others. Subsequently to this period shocks became still less frequent, occurring at uncertain periods of many days interval, until the 23d of November, which seems to be the last distinct one we have had.

It would be hazardous to state a decided opinion of the number of shocks felt, both in consequence of the cause before assigned, and because motions of the earth appear to have been felt in one spot and not in others; but as it is necessary to give some vague idea to enable a judgement to be formed by the reader, it may be observed that probably until the 1st of July there were not fewer than two or even three shocks every day; one daily throughout that month; one every three days in August and September; and perhaps six in the course of October; and three in November. This calculation, which is made avowedly on no solid grounds, gives short of 100 shocks in all; and it is probable that the number is at least a third within the truth.

I know not how to class the shocks, unless in the fanciful manner of 1st, 2d, 3d and 4th, implying the degree of their severity. Of the 1st, we had only the first and most violent; of the 2d, which were such as could be felt by a person while standing, but without affecting buildings in any material degree, we had, I think, about four; these occurred as follows: 17th June, 10 A.M.; 29th June, 2 P.M.; 4th July, 3 A.M.: and another at midnight in the same month, but the day forgotten: the longest of these did not last more than 50 seconds. The third class, which is the most numerous, are those shocks evident to persons sitting or reclining; few of these lasted longer than perhaps 30 seconds, and did no damage. The fourth class is that in which are included slight motions of the earth, felt by some and disputed by others.

The motions of the different classes were by many considered

sidered as undulatory and vibratory; although in some instances direct perpendicular shocks were certainly felt. The second class was remarked to be attended by a noise like that of a flight of birds and gusts of wind, and in some cases similar noises to those already mentioned followed or preceded the third class. Noises were frequently heard as if proceeding from the earth, and the expectation which they occasioned of the usual shock was never disappointed.

The direction in which the motion travelled was, as almost every other part of this phenomenon, disputed; many (of which I was at first one) believed that the direction was nearly from N.E. to S.W. The most general opinion, and which appears since to be corroborated by circumstances, was, that it was from S.W. to N.E.

The severe effects of the shock of the 16th were principally confined to the province of Cutch, the damage done to other countries even bordering on it being comparatively trifling; and it is remarkable that the shock appears to have been more severely felt in many distant countries than it was in those intermediate, and even in some closely bordering on Cutch. The great shock was felt at Calcutta about twenty minutes past eight o'clock; which, when corrected to the longitude of Bhooj, will give six minutes past seven o'clock P.M., or eighteen minutes later than the shock was felt in Cutch.

At Chunar the severe shock was felt at seven minutes past eight o'clock P.M. on the 16th, equal to $7^h 15^m 16^s$ Cutch time.

At Pondicherry it was experienced at eight P.M., equal to twenty minutes past seven o'clock Bhooj time.

At Ahmedabad the shock occurred about seven o'clock; but at Broach, which is little more than 3° E. of Bhooj, it occurred at nineteen minutes past seven o'clock, corrected by observation*. This extraordinary variation in the moment of the occurrence of the great shock can hardly be accounted for by neglect or error in fixing the moment, or from errors in the watches.

	E. Long.		E. Long.		E. Long.
Calcutta,	$88^\circ 28'$	Chunar,	$82^\circ 54'$	Pondicherry,	$79^\circ 58'$
Bhooj,	$69 58$	Bhooj,	$69 58$	Bhooj,	$69 58$
	<hr/>		<hr/>		<hr/>
	$18 30$, or diff.		$12 56$, or diff.		$10 0$, or diff.
	Time.		Time.		Time.
	$1^h 14^m$		$0^h 51^m 44^s$		$0^h 40^m$
	$8 20$		$8 7 0$		$8 0$
	<hr/>		<hr/>		<hr/>
	$7 6$		$7 15 16$		$7 20$

* Bombay newspaper.

The utmost limits within which this earthquake was felt, as far as we have yet learned, may be fixed at Catmandoo in the north, Pondicherry to the south, Calcutta to the east, and the Mountains of Billoochistan to the west. In Nepal it was felt sensibly on the evening of the 16th June, the exact time not specified. At Calcutta the shock was felt very sensibly, but apparently not so severely as at Chunar, and more so than in Malwa and Khandesh, in many parts of which it was not felt at all. At Pondicherry it was severely experienced, and described as much more awful than in many intermediate provinces. In Sindh it was felt very partially and slightly; and similarly at Shikarpoor on the southern frontier of the Peshawar country.

The range of the great shock is therefore known to have embraced a space of 18° of lat. and 20° of long. In many particular spots in this extent of country, of course, the motion was either not noticed or did not occur; but it was severely or sensibly felt at these limits on the evening of the 16th June.

The ocean extending S. and S.W. from Cutch will prohibit our ever knowing the limits of the shock in those directions; but it may be remarked that early in June a severe earthquake occurred at Mockha on the Red Sea; but I have never heard that it was experienced (or that of ours of the 16th) at Muscat, which is nearly due west of Cutch*.

What forms, in my opinion, one of the most striking circumstances connected with this phænomenon is, that it should have been felt over such an extensive surface, and that its severity should have been confined to the limited space of 200 miles or less. The damage sustained by Bulliaree, Amercote, and Jesilmer, which all lie in the Desert and north of Cutch, points out that the severity of the motion extended beyond Cutch in that particular direction; yet Sindh, Marwar, and Guzerat, including the peninsula of Kattewar, all of which border on this province, suffered nothing †. The destructive motion, therefore, seems to have been confined to a narrow space, running in a direction of N.N.E. from Bhooj, as far as Jesilmer. How far it extended in an opposite point it is impossible to say; but taking Cutch as a centre, the radius

* It may not be superfluous to remark, that about the beginning of June 1819, Mount Etna was threatening to bury in its lava the cities in its vicinity; Vesuvius was in a similar state of violent agitation; and earthquakes were felt in different parts of Italy, and I believe in Sicily, although not in the vicinity of these mountains.

† Poorbundor, Moorbee, and Amrun, are exceptions; but those people who have seen its effects in these places and in Cutch declare the former to be comparatively insignificant.

should

should have extended into Persia and Arabia, and nearly to the equator. As we know, however, that the shock of the 16th was not felt in these countries, it follows that Cutch was not the centre of motion, because, if the cause of this phenomenon had its origin in Cutch *, the power which agitated the earth must have acted nearly entirely to the eastward of a line extending north and south through the centre of the province.

That the cause of the shock, wherever it had its seat, must have been at a vast depth below the surface of the earth, may perhaps be admitted, when we reflect on the immense surface moved; but, as I have already observed, my want of knowledge on the philosophical branch of the subject warns me to stop.

We come now to speak of the effects of this awful occurrence. And first of all it may be proper to advert to our own feelings, and the state of our minds, on witnessing, for the first time, such a visitation. If I were to say that the impression, after the shock had subsided, was an agonizing fear, it might perhaps offend, although the strong oppression at the heart, a kind of gasping anxiety, weakness in the limbs, and, in some cases among Europeans, and generally throughout the natives, a slight sickness of stomach †, certainly cannot be interpreted in more appropriate language.

For a long time, and indeed I believe up to the present day, among natives, similar symptoms in a less degree are felt on the occurrence of the slight shocks; but for a short time after the 16th there was a restlessness and disinclination to be alone, or to attend to usual occupations, visible in both European and native societies. In the latter, despair and helplessness were strongly depicted in their countenances, and their language and actions both corroborated the fact of these feelings being the sole tenants of their minds. They insisted to a man that there was almost a constant undulatory motion in the earth, and frequent vibrations between the shocks, for ten days after the 16th; and this last feeling among Europeans was, I believe, confined to myself and one or two other persons.

The brute creation in general did not appear to show much sensibility to the motion; but it was remarked that horses in

* From the circumstance of the shocks still continuing in this province alone up to this day, now nearly eight months, I confess that, ignorant as I am of the theory of earthquakes, I am inclined to think that the causes are to be found in the structure of the country.

† The information from Pondicherry states a similar feeling to have been excited there on the 16th.

action partially lost their equilibrium, and that pigeons and other birds roosting were delicately sensible of the least motion. The elephants in Bhooj broke from their pickets, and seemingly in great alarm attempted to rush through the street, till obstructed by the falling of houses.

The shock of the 16th was the only one by which the face of nature or the works of man were materially injured or changed. In the province of Cutch it may be fairly asserted that no town escaped feeling its effects, either in the fall of houses or in that of its fortifications. It would be difficult to particularize the damage done to each. I shall therefore confine myself to general remarks.

The capital naturally attracts our first attention; and, as fortune would have it, Bhooj suffered in many respects more severely than any other town; nearly seven thousand houses, great and small, were overturned, and eleven hundred and forty or fifty people buried in the ruins. The houses were built of stone and chunam, or in many cases mud instead of this cement. Such houses as were built of mud alone, were little or no ways affected by the shock. Of the original number of houses which escaped ruin, about one-third are much shattered. Bhooj stands in a plain of sand-stone covered with a thin soil of sand and clay, but in many parts the rock is exposed. To the north-eastward about half a mile rises an abrupt hill, apparently composed of solid rock, on which are extensive fortifications. The north-eastern face of the town wall, which is a strong modern building, on an average four and a half and five feet broad, and upwards of twenty feet high, was laid level nearly to the foundation; whilst the hill works suffered in a very trifling degree. The south and western sides of the town are situated upon a low ridge of sand rock, and the water from the town finds its way out to the northward, where is an extensive swamp of low and springy ground. This face has also been overturned in many places, and not a hundred yards of entire wall left. The town has been utterly destroyed in the N.N.E. quarters, while the S. and S.W. quarters stand comparatively little injured. I have entered thus particularly into minutiae, to explain what I conceive to have been the case every where, that buildings situated upon rock were not by any means so much affected by the earthquake as those whose foundations did not reach the bottom of the soil, which I conceive to have been the case with those houses on the swampy and low sides of Bhooj*.

At

* There are some strong exceptions to this observation: Roha, which is a fort on a rocky hill, was laid in ruins, while the lower town, on the plain, escaped

At Anjar, half of the town, which is situated on low rocky ridges, suffered comparatively nothing; whilst the other half, upon a slope to a plain of springs and swamps, into which the town is drained, was entirely overturned. About 1500 houses were destroyed from the foundations, and about a similar number rendered uninhabitable. The loss in lives amounted to 165, besides a number who afterwards died of their bruises. The fort wall consisted of 3000 yards of masonry in circumference, not more than three feet and a half thick, and in some places forty feet high; and in this extent are included 31 towers, round and square. Of this 1000 yards are level with the ground, 1333 yards destroyed to within ten feet of the bottom, and only 667 yards standing to the rampart, and the greatest part of this split in half*. All the houses excepting four are cut as it were in two; in some the inner and in others the outer half has crumbled into ruins. The east and swampy face is down to the very surface of the earth.

There are, or rather were, a great number of fortified towns throughout Cutch: in general their works are destroyed. Thera, which was esteemed the best in the province, has not a stone unturned; the town fortunately did not suffer in the same unparalleled degree, although few or no houses were left securely habitable †.

Kotheree, another town of the same kind five or six miles from Thera, was reduced to a heap of rubbish, only about fifty or sixty gable ends of ruins left standing. The fortifications down, but not so utterly destroyed as those of Thera.

Mothora, a similar place to those described, suffered equally in houses and ramparts, and more in lives than any place of its size. Nulliah, Kotharee, Venjan, and many other towns of the same size and description, suffered nearly in the same manner; but it would be a much easier task to enumerate those that escaped. Among the latter, Mandvee, Moondra, Sandhan, Poonree, Buchao, and Adooee, may be recorded as the most fortunate. The total of lives lost, according to the

escaped undamaged. Moondra, Mandree, and Sandhan, close to the sea shore, situated very low, and in sandy plains, escaped with little damage. It is probable, however, that their foundations are on the strata of sandstone, which at different depths appear to be the support of the soil of the whole province.

* The walls of Anjar were remarkably bad, and in most places off the perpendicular: they are not more than one hundred and ten years old.

† The towns mentioned do not contain more than 5 or 6000 inhabitants.

best information I have been able to procure, does not exceed two thousand: of these,

	Bodies.
In Bhooj,	1140*
In Anjar,	165
In Mothora,	73
In Thera,	65
In Kotherec,	34
In Nulliah,	8
In Mandree,	45
In Luckput,	13

Total, 1543

The rest are chiefly sufferers in villages and small towns, of which no very authentic account can be procured. Many very distressing accidents might be related; but I know of none so much so as that of a whole family of women and children male and female, to the number of eleven people, the wives and offspring of a Jhareja family of rank in Mothora, being smothered in one room (where they had hastily assembled) by a lofty bastion being precipitated directly upon their apartment. An aged grandfather and one son, I believe, are alone left of the stock. It is remarkable that under the heaviest misfortunes of mankind there is generally some cause for congratulation; and in the case of this calamity, had the accident occurred in the night time, perhaps a third of the population of the province would have been buried in the ruins of their own dwelling-houses.

As far as comes under our notice, the face of nature has not been much altered by the shocks. The hills, which are most likely to show its effects, although from their abruptness and conical or sharp ridgy summits, and from the multitude of half-detached rocks with which they are generally covered, they might have been expected to have displayed strong marks of the convulsion by which they were agitated, have in no instance, to my personal knowledge, suffered more than having had large masses of rock and soil detached from their precipices. I have seen none with the cones flattened, or in any remarkable degree altered.

At the moment of the shock vast clouds of dust were seen to ascend from the summits of almost every hill and range of hills. Many gentlemen perceived smoke to ascend, and in some instances fire was plainly seen bursting forth for a mo-

* Registered and discovered; but upwards of 300 bodies never found in the ruins.

ment. A respectable native chieftain* assured me, that from a hill close to one on which his fortress is situated, fire was seen to issue in considerable quantities. A ball of a large size was vomited as it were into the air, and fell to the ground, still blazing, on the plain below; where it divided into four or five pieces, and the fire suddenly disappeared. On examining the hill next day (the chieftain stated) it was found rent and shattered, as if something within had sunk, and the spot where the fire-ball was supposed to have fallen bore marks of fire in the scorched vegetation. In the neighbourhood of Murr, where alum is made, and where an entire hill is formed of a bituminous earth†, fire is stated by the inhabitants to have issued to an alarming extent. The Government Agent on the spot reported the circumstance, and that the hill had been shattered, and rent into ravines: the height was likewise asserted to have been obviously reduced‡.

The rivers in Cutch are generally dry (excepting in the monsoon), or have very little water in them. Native accounts seem to confirm the fact of almost the whole of their beds having been filled to their banks for a period of a few minutes, and, according to some, for half an hour. They are said to have subsided gradually. I was not in the way of observing this part of the phænomenon, but have no reason to doubt it. Two chieftains were sent by me to settle a dispute among the Sandhan Bhyaut; and as they travelled in a rath, they knew nothing of the shock. After it was dusk they reached the Sandhan river, in which, to their utter astonishment, they found a strong stream from bank to bank; nor did they learn the cause till they reached the town. It is remarked that rivers in the valleys, and those with sandy beds, were alone affected. Wells every where overflowed, many gave way and fell in, and in numerous places spots of ground in circles of from twelve to twenty feet diameter threw out water to a considerable height, and subsided into a slough. I saw none of these actually forming, but frequently met with them in their sloughy state. The colour of the waters sent forth gave great alarm to the natives, many of whom affirmed that the rivers had run in blood, doubtless from the colour of the soil through which they had been forced.

* Jharejah Vijerajjee of Roha: which place is twenty-six miles W. of Bhooj.

† I have the pleasure to send a specimen of this earth to the Society. It is burnt as an incense by the rajpoots, and those who worship the goddess Asshappoorra.

‡ A letter from my friend Captain Elwood states, that an appearance of fire was perceived by him near Poorbunder; and the earth on examination proved to be scorched, and to bear marks of fire.

This convulsion of nature has affected the eastern and almost deserted channel of the river Indus, which bounds Cutch to the westward, and the Runn or desert, and swamp called the Bhunnee, which insulates this province on the north, in a more remarkable manner than it has any other part of the country. I myself have seen this branch of the Indus forded at Luckput, with water for a few hundred yards about a foot deep. This was when the tide was at ebb; and when at flood the depth of the channel was never more than six feet, and about eighty or one hundred yards in breadth: the rest of the channel at flood-tide was not covered in any place with more than one or two feet of water. This branch of the river Indus, or, as it may now with more propriety be termed, inlet of the sea *, has since the earthquake deepened at the ford of Luckput to more than eighteen feet at low water; and on sounding the channel, it has been found to contain from four to twenty feet from the Cutch to the Sindh shore, a distance of three or four miles. The Allibund has been damaged; a circumstance that has re-admitted of a navigation which had been closed for centuries. The goods of Sindh are embarked in craft near Ruhema Bazar and Kanjee Kacote; and which, sailing across the Bhunnee and Runn, land their cargoes at a town called Nurra on the north of Cutch. The Runn, which extends from Luckput round the north of this province to its eastern boundary, is fordable but at one spot, at this period of the year, at which it has heretofore been dry; and should the water continue throughout the year, we may perhaps see an inland navigation along the northern shore of Cutch: which, from stone anchors &c. still to be seen, and the tradition of the country, I believe to have existed at some former period.

Sindree, a small mud fort and village belonging to the Cutch Government, situated where the Runn joins the branch of the Indus, was overflowed at the time of the shock. The people escaped with difficulty, and the tops of the town-wall are now alone to be seen above the water.—The fate of Sindree was owing to its situation, for there cannot be a doubt of all the Runn land having during the shock sent forth vast quantities of water and mud. The natives described a number of small cones of sand six or eight feet in height, the summits of which continued to bubble for many days after the 16th.

The sea must have been affected by the motion of the earth;

* It is many years since the eastern branch of the Indus has been almost deserted by the waters of the river.

but nothing material or positive has been discovered on this part of the subject.

Although the appearance of the country in Cutch bespeaks that it has suffered at some period from convulsions of nature; and although there are strong signs of volcanic matter thickly scattered over its surface, still there does not exist even a tradition of an earthquake* of any violence having occurred. The natives, therefore, were perfect strangers to such a phenomenon, and were terrified in proportion to their ignorance. The instantaneous and firm belief adopted by all sects and descriptions was, that the world was at its end; and their minds were impressed accordingly†. After the first alarm had subsided, advantage began to be taken of the circumstance. The Brahmins enjoined charity to the Hindoos; and placards were issued from unknown quarters, foretelling misfortunes to those who did not feed their priests, or who persevered in sin. One of these papers was stated to have come from Kasse (Benares); and as it had a remarkable effect upon all classes of Hindoos, I am induced to submit a verbal translation of it.

“ A letter has been received in the name of Shri Ramjee. It has come from Kassi Benares. In the middle of this Iron Age, the Golden Age will make its appearance: Shri Bhudajee will appear. Of the iron age have elapsed 4912 years‡; and after Sumvut 1876 (A.D. 1819) the golden age will last 13,033 years. On the 5th Asonsood (or 24th September 1819), after twenty-two ghurries of the night have elapsed, at that moment will Bhuddajee appear, and the golden age commence. The earth will shake for seven ghurries and thirty pulls. The earth will open: then will false and uncharitable people be swallowed up. They who are charitable and religious, depend upon Bhugwan, give alms, do virtuous actions, and fear bad actions,—these will be saved. The golden age will last 13,033 years: the age of man will be 250 years. There will be universal friendship and peace. Every month will consist of forty-five days; every day consist of ninety ghurries. There will be thirty-six mansions of the moon:

* The slight shocks felt of late years in Guzerat were also experienced in this province.

† A few minutes after the shock, I walked through the streets of Anjar, which were crowded with people sitting on the ruins of their houses and shops which had fallen into the road. They appeared to me to be in a state little short of mental derangement; and to a question put, the only answer to be got was “*Ram Krushn*,” which they repeated constantly and loudly, apparently unconscious of what they were saying.

‡ This appears to be a mistake, as 4920 years have elapsed.

there will be twelve planets: there will be fifteen signs in the zodiac. At night, when thirteen ghurries remain, then will the golden age commence: Bhuddajee will appear. This event has been extracted from the Vedes after much study. From the Shri Bhud Maha Grunth, after intense study, has it been extracted. Whosoever reads, hears, or causes to be heard, copies, or spreads abroad this letter, will be fortunate. Believe in it, for he who denies its truth kills a Brahmin or a cow. He who has not faith will be damned: he who believes will be saved, he will be happy, he will attain to the presence of Bhugwan. Shri Krushan Damotherjee is truth."

This paper was written in the Bridge Bhakha dialect, and Balbood character. At the hour appointed in it for the destruction of sinners, almost every Hindoo of respectability purified himself, and sat with the toolsi leaf in his mouth, patiently expecting a fate which he had endeavoured to evade by liberal donations to Brahmins*.

The Moosulmans were equally alarmed, and abundance of threats of punishment to the wicked were fulminated from the musjeeds; and a paper asserted to have come from Mecca, with the usual seals attached, foretold the approach of the day of judgement. The Moolahs and mendicant Sijeds stated the cause of the earthquake to be, that the horse *Dooldool* was pawing for his food, and strict injunctions were issued to all good Mahomedans to send a certain quantity of grain and grass to the Moolahs &c. to satisfy *Dooldool*, which supplies were appropriated to the pious Moolah's own private emolument.

The Hindoos attributed the earth's motion to a quarrel among the Dyets and Dewas, and fabricated the most ludicrous stories on the subject. Prophets sprung up from all classes, casts and sects: some asserted that they had foretold the calamity which had occurred; others boldly pointed out the hour and moment at which still more calamitous events were to happen; and in short there was a superabundant display of every thing absurd or extravagant that could be advanced by ignorance and presumption, deceit and superstition.

It may be remarked that the monsoon commenced about the 11th of July in some places of the province, and later in others. The memory of any person living can furnish no example of so severe a season. The rain in the western parts

* Even the Banians are said to have sold their goods at just rates and with fair weights for some time previously to the dreaded day. A circumstance so extraordinary, as honesty in a Banian retailer, is certain proof of the impression which the prophecy had made on his mind.

of Cutch fell in such torrents for hours successively, that, combined with occasional shocks of the earthquake, it excited the most alarming fears in the minds of the inhabitants. To the eastward we had it less severe, though equally constant; and were I to say that for two months we never had a day without some rain, I believe I should not be exaggerating. In consequence, the crops have either failed, or could never be sown; and grain is now selling at the rate at which it sold in Cutch in the famine of 1812-13. We have always much thunder and lightning in Cutch during the monsoon, this season I think more than common; and the heavy clouds, which for a period of three months never ceased to travel close to the earth from the S.W., obscured the sun for many days successively. We had also a storm of wind from the westward, which amounted to a hurricane in the western parts of Cutch. These occasionally have happened before, and are called by the natives *hoowah*.

Such are the details of the circumstances attending the earthquake of 1819. I have much reason to solicit the pardon of the Society for having descended to such trifling particulars; and the only apology I have to offer, is the circumstance of such a phenomenon having so seldom occurred in India with similar violence.

(Signed) J. MACMURDO,
Captain 7th regt. N. I.

Camp at Bhooj, Jan. 27, 1820.

[To be continued.]

XXII. *On White Copper.* By C. KEFERSTEIN. Read at a Meeting of the German Explorers of Nature at Halle, September 18, 1823*.

FOR a considerable period white copper has been made and manufactured at Suhl, in the Henneberg country, and the neighbouring places, particularly for the mounting of guns or firelocks, but likewise for other purposes, as for spurs and the like†. This metal strongly resembles silver, even to deception, keeps excellently without tarnishing, has the colour of silver on the touch-stone, is not brittle, but on the contrary extremely malleable, contains no arsenic like the metallic compound usually called white copper; and is therefore very useful in the manufactories at Suhl.

* From Schweigger's *Neues Journal*, band ix. p. 17.

† The French and Spanish gun-manufacturers are said to ornament their finest guns with the same metal, as it is peculiarly adapted to that purpose. They say they obtain this metal from the East Indies. More particular data on this subject have not come to my knowledge.

Of what does this metallic substance consist? Whence is it obtained? How is it treated? On these points scarcely any thing has yet been known; for which reason, some time ago, I requested my brother M. Adolphus Keferstein, at Suhl, who directs much of his attention to natural history, to institute the most exact inquiries that could be made respecting these subjects, which appeared of considerable interest with respect to the arts, and to mineralogy.

The Society for Exploring Nature, at Suhl, likewise became interested in the inquiry; my brother sent some of the ore, from which the white copper is made, at Suhl, to M. Brandes at Salz-Uffeln, who is distinguished as a chemist, in order that he might analyse it; and my brother also undertook, in conjunction with M. Müller of Suhl, to make inquiries on the spot respecting the sources of the ore.

The results were laid before the Society for Exploring Nature, at Suhl, in a Report of which I have just received a copy, and from which I am enabled to give an account of them to the honourable meeting of German Explorers of Nature; and to this I beg leave to add some observations of my own.

Analysis of the Ore from which the White Copper of Suhl is made, by the Aulic Counsellor M. BRANDES of Salz-Uffeln.

A.

On 100 grains of the ore were poured 2 ounces of nitric acid, which was kept for some hours in gentle digestion, after which the fluid was poured off, and the undissolved part again digested with another half ounce of nitric acid. After the digestion was finished there yet remained a trifling residue, which gathered on a filter, previously weighed, amounted to 2.5 grains. In this residue small particles of sulphur could be plainly perceived; when it was heated before the blowpipe, no arsenical vapour was perceptible, but a smell of burning sulphur was produced. The whole heated in a crucible lost 0.75 grain of sulphur; besides which a small quantity of sublimate of a white substance, becoming yellowish afterwards, appeared on a copper plate with which the crucible was covered; this sublimate had the properties of oxide of antimony. The residue of 1.75 grain was heated with a few drops of nitric acid, by which a solution was formed, which gave a brownish precipitate with ammonia, evidently oxide of iron. The remainder of the residuum proved to be a slag of siliceous earth, and clay, in which the metal occurs.

B.

The nitric solution A was now supersaturated with ammonia,

monia, by which the precipitate first occasioned was almost entirely redissolved; the fluid however still appeared a little turbid, and was filtered on that account, by which a residuum of 1 grain was found, proving to be oxide of nickel, which had probably escaped the action of the ammonia, and which must be reckoned as 0·787 of metallic nickel.

C.

The ammoniacal liquid B was again supersaturated with nitric acid. Although there are different methods of separating oxide of nickel from oxide of copper, yet that by which the copper is first separated by iron, or that by which the oxide of nickel is precipitated by caustic potassa, has not enabled us to effect the separation of those oxides, so perfectly as the method in which sulphuretted hydrogen is employed: for this reason the acidulated fluid was precipitated by sulphuretted hydrogen, and a precipitate of bi-sulphuret of copper of 132·8 grains was obtained, indicating 88 grains of metallic copper.

D.

The fluid C was now heated, and caustic potash added to it, by which means 10·25 grains of anhydrous oxide of nickel were obtained = 7·966 grains of metallic nickel. The fluid separated from the oxide of nickel now contained no other substance, except a trifling portion of copper, which does not appear to be always completely separated when a solution of that metal is supersaturated.

E. *Results.*

The ore examined, therefore, according to the above analysis, contains

Copper (C)	88·000
Nickel (B 0·787 + D 7·966)	= 8·753
Sulphur, with a little antimony (A)	0·750
Silex, clay, and iron (A)	1·750
	<hr/>
	99·253

This ore, in its pure state, appears to be nothing but an alloy of copper and nickel. The other substances are probably to be considered as appertaining to the slag.

It yet remains to be observed that this cupreous mineral, of a bright copper colour, exists in small globules, and also in large roundish pieces, in plates and similar forms, in a black slag-like mass;—the analysis was made with such pieces as had been purified in the most careful manner from the slags, but the black slag itself likewise contains copper and nickel.

Report of MM. MÜLLER and KEFERSTEIN to the Natural History Society of Suhl, respecting the Locality of White Copper.

About five hours' journey from hence are the two places, Unterneubrunn and Ernstthal, in the Hildburghausen territory, at about the distance of a gun-shot from each other. The Schleuse flowing from the former to the latter village carries the white copper in its sand; and the ore is partly massive, partly, in appearance, in brownish yellow grains, partly finely disseminated in slags, and, finally, occurring partly as cement copper. The metal shows itself only in this confined space, and is perceived by the practised eyes of several persons, who search for it at the clear bottom of the Schleuse; and it is frequently brought up in particles by means of rakes.

The source of this metal, however, is becoming more and more exhausted, so that at present but little is found, and the price of a pound of such white copper slag costs, on the spot, two dollars Prussian currency. Some years ago it was found more abundantly, as the slag had been used for filling up buildings, and also was met with frequently here and there, in the same manner, as is still the case with such slags as are thrown away as useless. As every repository however, in which such slags were supposed to exist, in Unterneubrunn, as well as in Ernstthal, has been searched and exhausted, the present source is merely the Schleuse.

This metal occurs, for the most part, as has already been mentioned, inclosed in slags, but partly also as cement copper; and as we have not been able to meet with any records respecting its origin, we are obliged to content ourselves with what tradition has preserved. According to this, there has been at some early period a copper smelting work at Unterneubrunn, as well as at Ernstthal, which latter had in later times been converted into a wire-mill, where not long ago a vessel was dug up filled with different sorts of wire, but half decayed. These copper-works were owned by merchants of Nurnberg, (as was the case with most of the similar works in the Thüringerwald,) who there smelted the ores, which were obtained from the following copper-mines, not far distant, viz. 1, the Gabel, on the Prussian side; 2, the lower Gabel; 3, the upper Gabel; both in the Hildburghausen territory: 4, the Bohrbach; 5, the Tanne. It is said that at all these places there are old mines to be met with, and undoubted traces of mining works. We ourselves have examined the old mine at the Gabel on the Prussian side, which, by its extent, plainly shows that there must have been a large produce of ore. We have endeavoured,

endeavoured, but in vain, to meet with pieces of copper ore found there; we only obtained some malachite; from this, however, as well as from the legend, it may be concluded with certainty that copper-works formerly existed there. Some few copper ores, apparently not very poor in metal, were laid before us at Ernstthal, which were said to have been collected partly at the old mine, and partly from that at the Bohrbach. Arrangements have likewise been made for investigating the remaining old mines above named, in order to obtain such copper ore as it may yet be possible to find in them. M. de Hoff relates of these copper-mines, in his Description of the Thüringerwald (No. II. on the south-easterly division, p. 287) "in what manner the village of Gabel probably owed its existence to a mining work now deserted, which had been situated a little distance higher in this valley. It is said that they had worked for copper there, and that blackish-gray slate, primitive clay slate with calcareous spar and gray sulphuret of copper, red copper ore and malachite are still found there. In ancient descriptions of this country, there are in general several mines noticed, which have been worked for copper, sulphur, and iron, particularly at the Avelsberg, the Gabel and the Tanne."

Geognostically considered, the predominating rock-mass through which the Schleuse flows, consists of primitive clay-slate, with layers of quartz; but it shows by some intersecting members a near relation to the slaty hornblend rock. It is covered by porphyry; forms on the western bank of the Schleuse, or on the Prussian side, the Greifenberg; on the eastern shore, the mountains between the Tann and the Biber, extends towards the Avelsberg, where large masses of quartz are met with in it; is covered with trap-porphyry, and appears again in the valleys of the other side of the mountain, beneath the lower strata of the Wahlrose, above Gehren, below the above-mentioned porphyry.

The copper ores found here were smelted, as above mentioned, at Unternebrunn and Ernstthal; but, according to a tradition, copper ores from Salzburg were likewise carried to those places.

Although it cannot well be doubted, but that the white copper slags found at present are the produce of former copper-works, yet their appearance likewise informs us that this white copper, which in great measure occurs in a reguline state in the slags, was considered, during the earlier smelting operations, as a useless educt, and was thrown away.

The quantity in which this white copper has been found, will not permit us to consider it as the accidental product of a failure in the process of smelting. We should rather be of

opinion, that at each smelting a quantity of white copper was formed, besides the usual red copper, and that the former was not thought worth the trouble of separating from the slags, in which of course it remained.

How this white copper became formed, is difficult to determine. The result of the chemical analysis is, that it consists merely of a mixture of copper and nickel; and this mixture may have been produced in three ways: one is, that the copper brought from the above-named five mines also contained nickel, and that by means of the nickel thus naturally present, white copper was formed; another, if we ascribe it to the ores said to be brought from Salzburg; and the third, by supposing that the white copper was formed by means of an artificial addition, made in the process of smelting, in former times. We should declare ourselves for the first way, partly because it is improbable that copper ores should have been brought from Salzburg to Ernstthal, and partly because in several other places not far distant, at Brimmeisel for instance, copper-works have also existed, but no white copper has been produced in them. But whether white copper can be at present produced from the copper ores of the five mines above named, and in what manner, can only be decided by collecting the copper ores from the old mines, and subjecting them to experiments, by which it would also be ascertained whether they contain nickel. It is indeed maintained at Ernstthal and Unterneubrunn, that many workmen of those places, now deceased, understood the art of producing white copper, indirectly, from the copper ores collected from the old mines. This however is merely traditional; and those who work in white copper generally like to envelop themselves in a certain mystic darkness respecting their modes of operating. Thus it is usually maintained, that the white copper, in the form in which it occurs, is much too brittle for working, and that in order to render it useful it must first be submitted to a secret process. After minute inquiries, however, we have been informed, that it is found of various qualities, and that every piece is not of equal goodness for working; that much was brittle, but that the best and most pure could be used immediately, and at once showed the characters of genuine white copper,—whiteness and malleability. Thus much is certain, that even the most clever workmen in white copper at Unterneubrunn and Ernstthal, as well as here, and in Zelle, can only produce good white copper from good slags; and if bad white copper is talked of, it may be owing partly to the slags not having been good for much, and partly to there being an artificial compound in imitation of it, made of a mixture of arsenic
and

and copper. The period at which the value of the white copper was first known and estimated, is said to be from 60 to 80 years ago. At that time there was a copperas-work at the Tanne, not far from Ernstthal. One of the workmen wanted, for the purpose of forming common copperas, to make an addition of iron; and, mistaking the white copper slags for iron slags, he took a quantity of these under the idea of their containing that metal, and was greatly surprised on obtaining blue vitriol from them. He now examined the mass more particularly, and knew not what to make of it, until he submitted it to a certain M. Homburg at Hildburghausen, who, after a closer examination, found it to be white copper; since which discovery it has been used for various purposes, chiefly in the manufacture of spurs, and of mountings for fire-arms.

Suhl, Aug. 26, 1823.

MÜLLER. KEFERSTEIN.

From the chemical and mineralogical results thus reported, it appears that the white copper ore of Suhl is a combination of copper and nickel, found in the slags of former copper-works; but that this supply will soon be entirely exhausted; and the application of so useful an alloy, which greatly contributes to the prosperity of the manufactures at Suhl, must be totally abandoned, if we cannot succeed in producing the combination by means of art, or in discovering the ores which yield it.

The name *white copper* is applied to various substances, and is therefore somewhat indeterminate.

1. In mineralogy, an ore is so called, which, at an earlier period, was once found in compact masses in the Halsbrücker district, near Freiberg; Werner placed it in his mineralogical system as a peculiar genus, from which it has been transferred into most other systems; according to Hoffman's Mineralogy, it occupies a place between copper pyrites and arsenical pyrites. No chemical analysis of it is extant; it is only affirmed to contain from 30 to 40 per cent. of copper, with a little silver. Patzier, in his Metallurgical Chemistry (iv. 293), calls this ore arsenical copper pyrites, observing, that it contains oxide of copper, oxide of iron, sulphur, and arsenic; but it cannot be made out from his description whether he means the genuine white copper of Werner. From the scarcity of this ore, and our slight acquaintance with it, it is probable that it will hardly continue to be cited as a peculiar genus in mineralogy.

2. A combination of copper and arsenic is also called white copper. The metal obtained from this alloy (formerly known by the names of *white Tombac*, *Cuivre blanc*, *Argent haché*) is of a silver-white colour, bright, close-grained, hard, and takes a polish;

polish; but it is brittle, and it soon tarnishes. On the touchstone it has the colour of 12 fine silver. It is used in harness-making.

The white copper of Suhl is altogether different from this, and might more properly be called *nickel-copper*, by which every mistake might be avoided.

A combination of nickel and copper, analogous to the ore of Suhl, has indeed, according to different Manuals of Chemistry, been formed in small quantities by art, and is known in theory; but nickel, which in its pure state approaches near to silver with regard to its colour, is very difficult of fusion, and this is probably the reason that an alloy of it with copper has not been manufactured on a large scale.

White copper was indeed known in former ages; but, alas! very few accounts of it have reached posterity, and it remains doubtful whether nickel-copper or arsenic-copper was made use of.

Pliny several times mentions *æs candidum*; once, when he speaks of the Corinthian ore, he seems to point to an alloy of silver: at another place (34, § 48), he cites, as the best metal for specula, an alloy of copper with tin, and $\frac{1}{3}$ d of *æs candidum*. Now, according to modern experience, a composition of copper, tin, and arsenic, produces the best speculum-metal; and we may therefore believe, that the *æs candidum* was rather an arsenic-copper than a silver-copper. Aristotle (*de Mirabilibus*, cap. 53) speaks more plainly of white copper, when he says, "The *χαλκος Μοσσυνοικων* is stated to be extremely shining and white; it is made, not by adding tin to copper, but by smelting an earth, found in that country, with the copper. It is related, that the first inventor did not inform any one of his composition, whence it happened that the earlier vessels of this metal were more beautiful than those which were made afterwards." The Mosynöeci, from whom this metal indisputably received its name, were no particular nation; but, as Strabo tells us, those people of Asia Minor living on the northern shore of the Black Sea, in Colchis, Pontus, Paphlagonia, &c., commonly went by that appellation. Now in Paphlagonia lies Pompejopolis, where, from the most ancient times, very important mines were worked for copper and iron, and particularly for arsenical ores.

The ruins of this place, so important for antiquity, have, according to Malte-Brun (*Annales des Voyages*, t. xiv. p. 30), been lately discovered near Tasch Kouprou, eight hours' journey from the large place Voyavat, situated on a clay-slate rock; which may be the Sandarracurgium of Strabo, where the chief mines for arsenical ores were situated (*σανδαραχη* and *αρρενικον*).

ρευικον). Near Tasch Kouprou enormous heaps of slags are even to be found, a sign of a former extensive mining concern. Several literati, particularly Beckmann, in his Annotations on Aristotle, consider the χαλκος Μοσσυνοικων to be our brass; and support their opinion by the circumstance, that, amongst other things Strabo alludes to, he says that brass is prepared from copper and an earth which is found in Asia Minor. But brass was a metallic combination well known to the ancients; and Aristotle speaks (cap. 59) of ορειχαλκος in particular; the silver-white copper mentioned by him must therefore be something totally different: to this may yet be added, that the calamine which is mentioned by Strabo as coming from Asia Minor, and which was employed in the manufacture of brass, came from Ardira on the Ægean Sea in the district of Mysia; the earth for the white copper from Paphlagonia; and therefore the places where they were found do not agree.

Of the antique white copper, various pieces still exist; for Winkelmann alleges, in several parts of his works, that amongst certain antiquities a white metal was found, which at first sight appeared like silver (Works, vol. ii. p. 272). In annotation No. 70 the Editor observes, that, in digging in the year 1779 in the Pontine marshes, a handsomely-worked instrument of this kind was found, on which was the name and likewise the mark of the artist. Further accounts on this subject have not come to my knowledge; but, after the facts which have been quoted, we shall probably be justified in affirming that the ancients were acquainted with white copper, that they employed it in the arts, and that they obtained it from a particular ore. It still remains uncertain, however, whether the metal was an alloy of copper and arsenic, or of copper and nickel.

In modern times, the Chinese are the only people who understand the art of preparing white copper, and of applying it in various ways to useful purposes. Our scanty knowledge of this country and its literature, interesting in so many respects, is the cause why the preparation of this substance, as well as that of so many others, is still a secret to us. The Chinese fabricate several metallic combinations, which are usually called white copper, as Lauder has lately detailed. (Edinb. Phil. Journ., Jan. 1823.) One species of it is the Tutenag, which forms an article of commerce between China and India; it is exported in slabs of from 8 to 9 inches long, and $5\frac{1}{2}$ wide, of a grayish colour, not malleable, but very brittle. No analysis of this metal has hitherto been made; from trials made by Keir, it is said to be a white alloy of copper, zinc, and iron; according
to

to de Guignes, it consists of iron, lead, and bismuth, without containing either copper or zinc.

The real white copper is only used in China itself, and its exportation is contraband. Dr. Howison of Lanarkshire was so fortunate, when in China, as to procure a basin and ewer of this metal, a part of which he sent to Dr. Fyfe in Edinburgh, who analysed it, and published an account of it in *The Edinburgh Philosophical Journal* for July 1822.

The basin is of a whitish colour, approaching to that of silver, and is very sonorous. When held in one hand, and struck with the fingers of the other, the sound is distinctly heard at the distance of an English mile. It is also highly polished, and does not seem to be easily tarnished.

The metal is malleable both when cold and when red hot, but in a white heat it becomes brittle. By great caution it was rolled into thin plates, and was drawn into fine wire. When fused in contact with the atmospheric air, it oxidated, and burned with a whitish flame like zinc: its specific gravity was = 8.432.

The analysis gave, in 100 parts,

Copper.....	40.4
Nickel	31.6
Zinc	25.4
Iron	2.6

100

This result agrees, as to the ingredients, with Engestrœm's analysis; he says, in the *Stockholm Transactions*, "that the Chinese white copper or *pakfong* consists of copper, nickel and zinc, in the proportions of 5 : 7 : 7." This *pakfong* bears a considerable price in China, since the above-mentioned basin cost about $\frac{1}{4}$ of its weight in silver. The method by which it is prepared is unknown; but Dr. Howison mentions that Dr. Dinwiddie, who accompanied Lord Macartney to China, showed him, when at Calcutta, specimens of the ore from which he was told the white copper was procured, and which he obtained at Peking. The dear price of this metallic combination renders probable this method of obtaining it.

An ore was lately found, also, containing only nickel and antimony, which could be employed in this country. (*Annales de Chim.* t. xx. p. 421.)

It results from the above considerations, that the white copper of Suhl, and the Chinese *pakfong*, are similar alloys, which consist principally of copper and nickel, and that this alloy,

alloy, which will soon cease to be obtained, would be of great value in the arts, if we were enabled to produce it in Germany upon the same large scale as in China.

With regard to experiments for this purpose, there are two ways: viz. the chemical and the mining. Perhaps chemistry may succeed in producing the nickel-copper on a large scale; and it certainly is desirable that more accurate experiments should be instituted with this view by philosophical chemists as well as by practical metallurgists.

But as it is probable that the *pakfong* is smelted in China from its peculiar ores, as the same was probably the case with the white copper of the ancients, and as there is the greatest probability that the nickel-copper was formed accidentally, but in considerable quantities, which is not the case at other copper-works, from the ores which were smelted in the old copper-works at Suhl;—we may conclude that the deserted mines contained peculiar ores, from which the nickel-copper became formed with readiness. It would thence be important to institute further inquiries concerning those old mining works, in order, if possible, to discover the ores again.

How great would be the profit, if a metal could be worked upon a large scale, which so strongly resembles silver, and which is so peculiarly distinguished by its clear sound!

It is not yet known from what cause those old copper-mines were given up; deficiency of ore may have occasioned it; but it is equally possible that other circumstances, such as war, and the like, had that effect. Perhaps even riches of copper may still be found here; but the most important object would be, that the masses which were formerly thrown away as useless, should now be, as far as possible, the chief objects of mining and smelting.

It is to be wished, then, that the Ducal Government of Saxe Hildburghausen, as well as the Prussian Government, together with its mining officers, who, in a technical as well as in a scientific point of view, are so extremely active, would take into consideration the patriotic subject here treated of, and make arrangements for more exact inquiries respecting those mines, as well as the obtaining and working of the white copper at Suhl. Some of the Explorers of Nature here collected might interest themselves for this object: then, perhaps, we should have the pleasure of seeing preserved a material for the arts, now almost entirely exhausted, and new trades arise, in a country which has suffered much from the circumstances of the times.

XXIII. *Experiments on the Deviation of the Magnetic Needle, as effected by Caloric, &c.* By JOHN MURRAY, Esq. F.S.A. F.L.S. F.H.S. Member of the Geological and Wernerian Societies, &c. &c.

To the Editors of the *Philosophical Magazine and Journal*.

Gentlemen,

I TRUST the following detail of experiments on the deviation of the magnetic needle as effected by caloric, &c. will prove not uninteresting. They at once corroborate and extend some remarks of mine you did me the honour to introduce in a former Number of the *Philosophical Magazine and Journal*.

It may be only necessary to premise, that for the subsequent experiments I used a very delicate magnetic needle, about six inches long, the point on which it moved entering an agate cap. So extremely mobile was the magnetic bar, that *simple pressure by the finger* on the sealing-wax was sufficient excitement, and a ribbon of silk once drawn over the glass tube quite enough for the vitreous or positive electricity.

In the comparison of the phænomena, the heated zinc plate will be found to accord with the excited glass, and the silver plate with the sealing-wax. The flames of a wax taper and spirit lamp are analogous, but the aphlogistic platinum-wire peculiar.

The north pole, in these experiments, moved usually about the *octant of a circle eastward* of north, and the south pole about the same number of degrees (45°) *westward* of south.

1. *Excited Glass.*

Posited east of north, *repelled*: and on removal, the needle moved eastward, and returned to its station.

On the west of north, *attracted*: moved eastward.

On the east of south, *repelled*: moved westward.

On the west of south, *attracted*: ditto.

2. *Excited Sealing-Wax.*

On the east of north, *attracted*: moved eastward.

On the west of north, *ditto*: ditto.

On the east of south, *ditto*: moved westward.

On the west of south, *ditto*: ditto.

3. *Inflamed Wax Taper.*

On the east of north, *attracted*: moved eastward.

On the west of north, *ditto*: ditto.

On the east of south, *ditto*: moved westward.

On the west of south, *repelled*: ditto.

4. *Spirit*

4. *Spirit Lamp.*

On the east of north, *attracted* : moved eastward.
 On the west of north, *ditto* : ditto.
 On the east of south, *ditto* : moved westward.
 On the west of south, *repelled* : ditto.

5. *Aphlogistic Lamp.*

On the east of north, *attracted* : moved eastward.
 On the west of north, *repelled* : ditto.
 On the east of south, *attracted* : moved westward.
 On the west of south, *repelled* : ditto.

6. *Heated Plate of Zinc.*

On the east of north, *repelled* : moved eastward.
 On the west of north, *attracted* : ditto.
 On the east of south, *repelled* : moved westward.
 On the west of south, *attracted* : ditto.

7. *Heated Plate of Silver.*

On the east of north, *attracted* : moved eastward.
 On the west of north, *ditto* : ditto.
 On the east of south, *ditto* : moved westward.
 On the west of south, *ditto* : ditto.

The zinc and silver plates, *merely heated*, prove that positive and negative electricity may be excited apart from chemical action, and that the *increment of temperature*, superinduced by the chemical action of the acid on the Voltaic plates, may be the source of the communication of electric power.

On the theory of these phænomena I at present forbear to touch; an extension of such experiments appears to me, however, fraught with the solution which involves the variation of the compass. The thermo-electricity of the globe, as produced by the march of the sun in the plane of the ecliptic toward the tropics of Cancer or of Capricorn, may occasion the grand outlines of variation. Local peculiarities will give rise to particular deviations from the general law.

Your obliged and obedient servant,

Chesterfield, Feb. 7, 1824.

J. MURRAY.

XXIV. *Description, Analysis, &c. of a Lamellar Pyroxene.*

By LARDNER VANUXEM.*

THIS mineral was brought last year from West Point by Professor Keating and myself; the locality, hitherto unpublished, having been shown to us by Captain Douglass, Mathematical Professor of the Military Academy.

* From the Journal of the Academy of Natural Sciences of Philadelphia, vol. iii. p. 68.

The lamellar pyroxene is found about three miles above West Point, on the western side of the river, and near to the water's edge. It is associated with hyaline quartz, black and bronze coloured mica, and feldspar; the latter but in small quantity. These minerals form an aggregate of limited extent, which is a dependant of our sienitic formation, which there covers the whole of the country included under the name of the Highlands of the North River.

The lamellar pyroxene of West Point is identical in all its characters, both external and chemical, with that mineral of Brandywine (Delaware State) which was first considered to be hypersthene, from similarity of colour, and from its presenting the same lamellar structure in one direction, as exhibited by the Labrador mineral; the same which subsequently was analysed and described as an amphibole by Mr. H. Seybert; whose account was published in the *Journal of the Academy*, vol. ii. p. 139; and to which, more recently, Mr. Nuttall and Dr. Torrey have proposed to give the name of *Maclureite*, supposing it to be a new mineral. (See *Silliman's Journal*, vol. v. p. 246.)

Those to whom the characters of these minerals are familiar, will have much less difficulty in identifying the mineral in question with pyroxene, than with either of the other two minerals, with which it has been confounded; and further, will have no reason for believing that it should not be classed with pyroxene, in the present state of our mineralogical knowledge: this being admitted, its new name of *Maclureite* becomes superfluous and objectionable. To American mineralogists this circumstance cannot but be a subject of regret; for it is not the only attempt* that has been made to confer this merited tribute of respect to our illustrious president; and to no one is it more justly due than to Mr. Maclure.

The West Point mineral occurs principally in lamellar masses; also, but more rarely, in crystals, which though not very perfect, yet are sufficiently well characterized to enable an observer to refer them to the species to which they belong.

The form of the crystals is an octagonal prism, whose angles are about 136° and 134° ; the terminations are too imperfect

* Vide *Silliman's Journal*, vol. v., No. 2, for Mr. H. Seybert's account "of the *Maclureite*, or Fluo-silicate of Magnesia, a new mineral species." This is the substance called *condrodite*, which, as Mr. Seybert found it to contain fluoric acid, he judged to be different from the *condrodite* of Europe. Since that paper was sent for publication, the same chemist has discovered that this acid likewise exists in the European mineral; so that his proposed name of *Maclureite* is inadmissible, the substances being the same.

to ascertain their nature. There are several cleavages, two of which are parallel to four of the alternate sides of the octagon, producing a prism with a rhombic base; these two cleavages are not very easy to obtain, their surface being rough, with but a feeble lustre; the angles which these cleavages form, as determined by the solid so generated, and the measure of their corresponding faces in the crystals, are about 92° and 88° . This prism may again with ease be divided in the direction of the *smaller* diagonal; the surfaces produced are very smooth, and of considerable lustre; *this is the cleavage to which the mineral owes its highly lamellar structure.* In the direction of the larger diagonal, there are indications of a fourth cleavage, but none parallel with the base.

The lamellar masses rarely exceed two inches in their greatest dimension, generally elongated and prismatic, of a dark green colour with a tinge of yellow and bronze. The shades of these colours frequently vary in the same specimen. Scratches glass with ease; fusible before the blowpipe into a shining black globule. Specific gravity about 3.24.

To the result of the analysis* of the lamellar pyroxene of West Point, is adjoined that of Delaware by Mr. H. Seybert, in order to show the complete chemical identity of the two minerals.

	West Point.	Delaware.
Silex	51.00	52.166
Lime	21.00	20.000
Magnesia	11.50	11.333
Alumine	3.50	4.000
Deutoxide of iron with a trace of manganese }	11.53	10.733
Water.....	1.00	1.266
Loss	47	502
	<hr/>	<hr/>
	100.00	100.000
	<hr/>	<hr/>

The mineral of West Point differs from hypersthene in the angles given by their cleavages, which are different; those of hypersthene being as the numbers 100, 80, and 50; and also

* The analysis of the mineral was made in the following manner, having previously ascertained that it was composed of silex, lime, magnesia, alumine, and oxide of iron, with a trace of manganese:—Pulverised and calcined a portion of the mineral for water; fused another portion with potash in order to decompose the mineral; dissolved the whole in nitro-muriatic acid, then evaporated to dryness; added acidulated water, and filtered, this gave the silex; precipitated the metals and alumine by hydrosulphate of ammonia; separated the alumine by potash; threw down the lime by oxalate of potash, and obtained the magnesia by boiling the liquor with potash.

in the latter being infusible and different in its composition. From amphibole, because there are but two cleavages in this mineral, obtainable with the same ease, and both possessing the same degree of smoothness and lustre, in short, absolutely identical. The angles which they form are those of $124^{\circ} 34'$, and $55^{\circ} 26'$, angles which do not occur in the West Point mineral. The chemical elements of amphibole and pyroxene are the same, the difference being in the proportion of their constituents.

The essential character of pyroxene is derived from its crystallization. The primitive form determined by its cleavages, and with the aid of its secondary forms, is an oblique prism with a rhombic base; angles of the prism, by the common goniometer, 92° and 88° , or more accurately by the secondary forms, joined to certain theoretical considerations, $92^{\circ} 18'$, and $87^{\circ} 42'$. The cleavages of pyroxene, as given by its several varieties, are parallel to the faces of the prism and diagonals of the base. One of the secondary forms of the pyroxene is an octagonal prism, with angles of 136° and 134° by the goniometer, or corrected in the aforementioned manner $136^{\circ} 09'$ and $133^{\circ} 51'$. The degree of smoothness and facility of obtaining the different cleavages of pyroxene, vary considerably in the different varieties of this mineral. Sometimes a cleavage which is very evident in one variety is indistinct or scarcely to be perceived in another. Thus in certain volcanic pyroxenes the cleavage parallel to the larger diagonal is the most lamellar (according to Häüy), and none exists in the direction of the base, whilst in other pyroxenes that of the base is pre-eminent; so that this character, in all cases, must be considered as very secondary in value to the character which depends upon the angles of the cleavages and those of the crystals.

Thus the mineral of West Point and of Delaware corresponds with pyroxene in the *form and value of the angles of the primitive form, and those of the octagonal prism; in the cleavages parallel with the sides of the primitive form, and diagonals of the same: in hardness, action with the blowpipe, specific gravity and chemical composition.* The only difference being this, that its *lamellar structure* is parallel to the smaller and not to the larger diagonal, as in volcanic pyroxene, a circumstance which cannot be considered of specific importance.

XXV. *Notices respecting New Books.**Recently published.*

UEBER *neu-entdeckte merkwürdige Eigenschaften des Platins, &c.*—On the newly discovered remarkable Properties of Platinum, &c. By J. W. Döbereiner. Iena, 1823. The following remarks on this work are given by Professor Schweigger, on the wrapper of his Journal for November: “We direct the reader’s attention to this brief but instructive treatise. Whoever is desirous of making practical use of Döbereiner’s discovery, so remarkable in a theoretical point of view, either for the purposes of eudiometry, or for its commodious application to a pneumatic apparatus for producing fire, will find in its pages the necessary instruction.”

A Translation of the New Pharmacopœia of the Royal College of Physicians of London; with a specification of the doses of each article, and the diseases for the cure of which they are employed, a table of the new names, a copious index, &c. &c. By a Scotch Physician residing in London.

In the Press.

Dr. T. Forster is preparing for the press, “Observations on the local and casual Variations of the reflective, refractive, and dispersing Properties of the Atmosphere, in order to illustrate the necessity of having different tables of refraction for each particular observatory; together with an attempted analysis of the variously composed light of different fixed stars, considered as rendering necessary still further corrections for each, in order to ascertain their real place by the observance of that of their spectra; together with other prismatic experiments, and rules for igniting various metallic and other substances, in order to imitate different coloured starlight.”

British Galleries of Art, now first arranged in one volume. By Charles Westmacott, author of the “Annual Critical Catalogue to the Royal Academy.” Published by Authority. This work will contain a critical and descriptive Catalogue to each Collection, with a History of the choicest Treasures of the Fine Arts, ancient and modern, in the possession of His Majesty and other noble and distinguished persons; including the Dulwich Gallery and British Museum. Illustrated with interior views of the principal galleries, drawn and engraved by Cattermole, Finlay, and Le Keux; with eight elegant engraved portraits of illustrious and noble patrons and academicians, by Wageman, Hawksworth, and Philips.

ANALYSIS OF PERIODICAL WORKS ON NATURAL HISTORY.

Curtis's British Entomology. No. 2.

Nebria livida. A fine insect, which has never before been figured in any English work: it varies considerably from the continental specimens.—*Odenesis Pini*, Pine Lappet, from an unique specimen in the British Museum: the figures hitherto published have been from German specimens.—*Chrysis fulgida*, a rare species of this splendid genus, which can vie with the Humming Birds in the brilliancy of their colouring.—*Anthrax ornata*, a very beautiful species from Hampshire of this rare genus: the accompanying plant is the Chamomile, from whence the officinal variety is obtained.—*Notonecta maculata.* We only know of a wretched figure of this handsome insect in Coquebert's *Illustratio Insectorum*; it is mentioned in the Entomological Transactions as having been taken so long back as 1807.

The Botanical Magazine. No. 444.

Pl. 2455. *Momordica Charantia.*—*Cyrilla racemiflora.*—*Echinops strictus*; "caule simplici stricto unifloro, foliis eroso-pinnatifidis spinuloso-dentatis supra glabris subtus tomentosis:" raised by A. B. Lambert, Esq., from seeds sent from Russia by Dr. Fischer.—*Nicandra physaloides.*—*Ammobium alatum*; discovered by Mr. Brown in New South Wales, and the genus (which is undescribed, and belongs to the same tribe with *Gnaphalium*) so named by him from its growing in sand.—*Plectranthus ternatus*; "caule sexangulato, foliis ternatis petiolatis ovatis crenatis rugosis, radicibus tuberosis, spicis terminalibus verticillatis:" this plant, which is from the Mauritius, has only been brought into flower amongst us at Bury Hill, the seat of Mr. Barclay.

The Botanical Register. No. 107.

Pl. 762. *Narcissus Sabini*, "spathâ uniflorâ, scapo ancipite, nectario columnari erecto plicato eroso petalis imbricatis patentibus brevioribus, stylo columnæ æquali antheris paulò longiore, tubo petalis subæquali:" from a valuable collection of hardy bulbs formed by Mr. Sabine and given by him to the Horticultural Society. With this we have the description of another species, *N. Macleanii*, "spathâ 1-2-florâ, scapo compresso subancipiti, petalis patentibus imbricatis tubo nectarioque cylindrico truncato integerrimo paulò longioribus." These have been the subject of discussion in our Magazine, vol. lxii. p. 440 and pp. 1 and 102 of our present volume. We would observe here, that the descriptions in the Bot. Reg. and Phil. Mag. appeared at the same time, the latter being published on the last day of the month.—*Cenothera acaulis*, raised by the Horticultural Society from seeds sent by Mr. F. Place from Chili.—*Cassinia aurca*, found by Mr. Brown near Port Jackson.—*Euphorbia cyathophora.*—*Bromelia melanantha*, "ebracteata? foliis ligulato-oblongis cæsiis spinâ nigrâ ciliatis cuspidato-obtusis, spicâ obeso-strobiliformi hexastichâ? distanter laxatâ, verticillis trifloris alternis, floribus rigidis fundo lanâ immerso, calyce tripartito."—*Hedychium heteromallum*, a Scitamineous plant from Calcutta.—*Curculigo recurvata.*

XXVI. *Proceedings of Learned Societies.*

ROYAL SOCIETY.

Jan. 29. **T**HE reading of Mr. Scoresby's paper was resumed and concluded: and a paper was also read, entitled "Observations on the *Iguana tuberculata*, the common Guana;"

Guana;" by the Rev. Lansdown Guilding, B.A. F.L.S. Communicated by Sir E. Home, V.P.R.S.

Feb. 5.—A paper was communicated, entitled "A finite and exact Expression for the Refraction of an Atmosphere nearly resembling that of the Earth;" by Thos. Young, M.D. For. Sec. R.S.: and the reading was commenced of "The Bakerian Lecture, On certain Motions produced in Fluid Metals by transmitting the Electric Current;" by J. F. W. Herschel, Esq. F.R.S.

Feb. 12.—The Bakerian Lecture was concluded.

Feb. 19.—Various Meteorological Journals and Astronomical Observations were communicated, by Sir Thos. Brisbane, K.C.B. F.L.S. Governor of New South Wales: and a paper was read "On the Semi-decussation of the Optic Nerves;" by W. H. Wollaston, M.D. V.P.R.S.

LINNÆAN SOCIETY.

Feb. 3.—A notice was read from Mr. John Hogg, of Norton, Durham, stating that a fine specimen of *Falco Chrysaëtos*, Golden Eagle, was lately shot near the mouth of the Tees; being the fifth known to have been killed in England.—Among the presents was a Collection of Plants made in a journey through Circassia, Persia, and Georgia; by Lieut. Col. Wright of the Royal Engineers.

The reading of Mr. Vigors's interesting paper on the Natural Affinities that connect the Orders and Families of Birds, was continued this evening, and also on the 17th.

GEOLOGICAL SOCIETY.

Jan. 2.—A paper was read "On the Geological Structure of St. Jago, one of the Cape de Verd Islands;" by Major Colebrooke.

From the observations of the author and the accompanying specimens, it appears that at the landing-place near the town of Porto Prago, in St. Jago, the rock of the cliff is composed of fragments of trap imbedded in a pure white carbonate of lime. The fragments of this breccia are generally small, and none of them rounded by attrition. The cliff, on which stand the batteries and town of Prago, is regularly stratified, and at the bottom are beds of a calcareous sandstone alternating with others which contain specimens of a large oyster; in both of these beds occur pebbles of trap. The stratum which crowns the cliff is from eight to twelve feet in thickness, and consists of trap.

Jan. 16.—A paper entitled "Outline of the Geology of Vol. 63. No. 310. Feb. 1824. S the

the South of Russia," by the Hon. William T. H. Fox Strangways, M.G.S., was read in part.

On the 6th of Feb., being the Anniversary of the Society, the following gentlemen were chosen as Officers and Council for the year, viz. *President*: Rev. William Buckland, F.R.S. Prof. Geol. and Min. Oxford.—*Vice-Presidents*: Arthur Aikin, Esq. F.L.S.; John Bostock, M.D. F.R. and L.S.; George Bellas Greenough, Esq. F.R. and L.S.; Henry Warburton, Esq. F.R.S.—*Secretaries*: Charles Lyell, Esq. F.L.S.; Philip Barker Webb, Esq. F.L.S.; Thomas Webster, Esq.—*Foreign Secretary*: Henry Heuland, Esq.—*Treasurer*: John Taylor, Esq.—*Council*: Sir Thomas Dyke Acland, Bart. M.P.; John Duke of Bedford, F.L. and H.S.; William Clift, Esq. F.R.S.; Henry Thomas Colebrooke, Esq. F.R. and L.S.; Major Thomas Colby, LL.D. F.R.S. L. and E.; Thomas Horsfield, M.D. F.L.S.; Sir Alexander Crichton, M.D. F.R. and L.S.; Charles Stokes, Esq. F.R.A. and L.S.; Thomas Smith, Esq. F.R. and L.S.; William Hæsel dine Pepys, Esq. F.R. L. and H.S.; Rev. Adam Sedgwick, M.A. F.R.S. Woodwardian Prof. Cambridge; William Henry Fitton, M.D. F.R.S.—*Keeper of the Museum and Draughtsman*: Thomas Webster, Esq.

Feb. 20.—A notice was read of the discovery of a perfect skeleton of the fossil genus hitherto called Plesiosaurus, by the Rev. W. D. Conybeare, F.R.S. M.G.S.

The Plesiosaurus which is the subject of this notice was found in the blue lias of Lyme Regis in Dorsetshire. In the whole exterior portion of its vertebral column the skeleton is entire, and of the remaining parts of the animal few are wanting. In the Transactions of the Geological Society, vol. v. and vol. i. 2d Series, the author had attempted to assign to the various dispersed and disjointed remains of this animal which were then known, their relative places in the skeleton; and his opinions, he observes, have now in all essential points received full confirmation. After pointing out those errors into which he had fallen, Mr. Conybeare describes the osteology of this remarkable fossil animal; the most characteristic and distinguishing features of which are, the extraordinary length of the neck, which fully equals that of the united body and tail; and the number of its vertebræ, which very far exceed that of any animal previously known.

ASTRONOMICAL SOCIETY.

Feb. 13.—This day being the fourth Anniversary of the Society, a numerous meeting of the members took place at their apartments in Lincoln's Inn Fields, when a very satisfactory Report

Report upon the state of the Society's affairs and proceedings during the last year was read, and ordered to be printed. This Report paid a due tribute of respect to several members which the Society has lost by death in the last year, and particularly to Col. William Lambton of Madras, and Dr. Walbeck of the Observatory at Abö. It gives a succinct account of the measurement of the largest continuous arc of a meridian yet measured, which occupied the former gentleman upwards of twenty years in India.

The chairman (Mr. Colebrooke) then proceeded to distribute the honorary rewards of the Society, viz. the Society's Gold Medal to Charles Babbage, Esq. F.R.S., as a token of the high estimation in which it holds his valuable invention of an engine for calculating mathematical and astronomical tables, being the first medal awarded by the Society. A similar Gold Medal to Professor J. F. Encke, director of the observatory at Seeberg in Gotha, for his investigations relative to the comet which bears his name, and which led to the re-discovery of it in 1822. The Silver Medal of the Society to Professor Charles Rumker, for the re-discovery of Encke's comet: and a similar Medal to M. Jean Louis Pons of La Marlia in Italy, for the discovery of two comets, on the 31st of May and 13th of July 1822, and for his indefatigable assiduity in that department of astronomy.

The chairman prefaced the presentation of each medal by a most eloquent, learned, and interesting address of considerable length, all of which were delivered in the most impressive manner. They were replete with information on the successive improvements in machinery for assisting calculation, as well as on cometary astronomy; and we were happy to find that in consequence of a motion made by Davies Gilbert, Esq. M.P., and seconded by John Fuller, Esq., they will be printed for circulation among the members.

The election for the Officers and Council of the Society for the ensuing year then took place; when the following appeared to be the unanimous choice of the meeting, viz.

President: Henry Thomas Colebrooke, Esq. F.R.S. L. & E. & F.L.S.—*Vice-Presidents*: Charles Babbage, Esq. M.A. F.R.S. L. & E.; Francis Baily, Esq. F.R.S. & L.S.; Sir Benjamin Hobhouse, Bart. F.R.S.; The Rt. Hon. George Earl of Macclesfield, F.R.S.—*Treasurer*: Rev. William Pearson, LL.D. F.R.S.—*Secretaries*: Olinthus G. Gregory, LL.D., *Prof. Math. Roy. Mil. Acad. Woolwich*; John Millington, Esq. F.L.S., *Prof. Mech. Phil. Roy. Inst.*—*Foreign Secretary*: J. F. W. Herschel, Esq. M.A. F.R.S. L. & E.—*Council*: Major Thomas Colby, *Roy. Eng.* LL.D. F.R.S. L. & E.; George Dollond,

Dollond, Esq. F.R.S.; Bryan Donkin, Esq.; Captain John Franklin, R.N. F.R.S.; Davies Gilbert, Esq. M.P. V.P.R.S. F.L.S.; Benjamin Gompertz, Esq. F.R.S.; Stephen Groombridge, Esq. F.R.S.; Daniel Moore, Esq. F.R.S. S.A. & L.S.

Several new Members and Associates were nominated, and the greater part of the Society adjourned to Freemasons' Tavern, where a dinner was provided.

METEOROLOGICAL SOCIETY.

Feb. 11.—A communication from Dr. W. Burney, of Gosport, was read; also a Note on some curious Effects of the Radiation of Heat; by Luke Howard, Esq. F.R.S. Memb. Met. Soc. And the reading was commenced of a "Memoir on the Variations of the refractive and dispersive Powers of the Atmosphere; by T. Forster, M.B. F.L.S. Member of the Society.

XXVII. *Intelligence and Miscellaneous Articles.*

SILVER MINES OF MEXICO.

GREAT public interest has been excited of late by the formation of companies in London, whose object it is to work the silver mines of Mexico, and who have raised large capitals for that purpose. We have made the best inquiries in our power upon this subject, and we are enabled to lay before our readers some correct information, which will we have no doubt be acceptable, as it relates to undertakings which may have great influence on political events, may enlarge our commercial relations, and extend the field of scientific research.

The mines of Mexico, though rich, have been abandoned, owing to the joint operation of natural causes and of others arising from long-continued domestic contentions. The first of these causes relate principally to the difficulties arising from increasing depth, and the consequent insufficiency of the means possessed to extract the water and the ore: these it is expected will be easily overcome by the application of our machinery, directed by competent skill to be supplied by persons sent from this country: the other obstacles are likely, it is hoped, to be removed by the settlement of differences among the provincial governments and the arrangement of a legislative body agreeable to the whole.

The first company which has actually contracted for mines, is called the *Anglo-Mexican Mining Association*, and possesses a capital of one million sterling in shares of £100 each. The mines

mines which are engaged are principally in the Real of Guanaxuato, near the city of that name, about 200 miles N.W. of the city of Mexico; they include that of Valenciana, which is stated to have been carried to the extraordinary depth of 350 fathoms. This mine is spoken of at large by Baron Humboldt in his interesting works upon New Spain, and is reckoned by him to have alone produced one fourth of the silver of Mexico. It was originally quite free from water, but has been inundated by the influx from an adjoining mine, Tepryac, and has been nearly filled in the last 12 years, owing principally to the neglect caused by civil commotion. There are other mines also situated upon the same vein (the veta madre of Guanaxuato), some of which will be worked by the company.

Several steam engines, as well for pumping out the water, as for drawing up the ores, and for stamping and reducing them to a proper state for amalgamation and smelting, are already constructing in this country, and a select body of miners from Cornwall are engaged to go out and conduct the various operations. The enterprize will be intrusted to Colonel Robinson, an officer of distinguished activity and merit, who will shortly leave England to commence operations. The directors in London have been chosen from among gentlemen of great respectability and influence; and the establishment, which will be of an extent commensurate with the magnitude of the object, is arranging under the direction of John Taylor, Esq., whose connexion with the largest mines in this country is very well known.

The second company consists principally of individuals engaged in mining in England, who have undertaken to work the mines in Real del Monte, about 60 miles N. of the city of Mexico, belonging to the Conde de Regla, a distinguished Mexican nobleman; and also the mine of Moran, nearly adjoining, the property of Thomas Murphy, Esq., who was long resident in the country, and of Don Fausto d' Elhuar, formerly president of the mining college of Mexico. This company has raised a capital of £200,000 in 500 shares of £400 each. Their arrangements here are also intrusted to Mr. Taylor; but we have not heard whether their foreign appointments are made, although it is understood that their preparations are in great forwardness. The mines of Real del Monte are not represented as so rich as those of Guanaxuato, but they are spoken of by Humboldt as having been very productive. They are more troubled with water than the others, from which they have from time to time been relieved by levels driven through great distances and at enormous charges; the works

works were extended below these adits as far as the skill of those employed could carry them, but the depths to be drained by machinery are not very great. The mine of Moran was selected many years ago as a proper place for trying the effect of a water pressure engine which was erected by a German engineer; but after it had drained the mine in a rainy season, it was found that in the long droughts the supply of water to keep it in motion was insufficient to produce any regular effect, and the working was discontinued.

The prospectus of another company has also lately appeared, whose capital is to be £240,000 in 6000 shares of £40 each. This association is formed to work mines, to raise or purchase gold and silver ores or metals, and to smelt, reduce, refine, and separate the same, by the combination of European skill and capital with Mexican interests, through the medium of Don Lucas Alaman, a native of and residing in Mexico; but it has not been deemed expedient to enter into actual contracts for working mines, until the association be formed and the extent of its capital ascertained.

The above is, we believe, a tolerably correct outline of the three great establishments formed for the purposes we have described, and they seem likely to possess the means of making the experiment with energy and effect. If no injudicious rivalry should take place, which would be absurd where the field for exertion is so large, they may mutually support and assist each other, and the chance of ultimate success may thus be much increased.

As far as we can form an opinion, we should think that these speculations offer bright prospects of advantage, but that they are attended with many and obvious risks.

To the two countries the benefits are sufficiently apparent: Mexico must gain by the re-opening of the principal sources of its wealth, by the increase of skill and experience, and by the profitable employment of its population; all tending to settle and improve the circumstances of the Government.

As far as England is concerned, the prospect of a trade with such a region, where the distance is not formidable, where the interchange of the valuable metals for the British manufactures may be to a great and almost unlimited extent, cannot but be esteemed most important to our commercial interests; while the very employment of capital from this country is thrown into a channel that may create a source of profitable intercourse hardly to be anticipated.

The risks are principally to be classed under the following heads: political events, the uncertainty of all mining operations,

tions, the difficulty of procuring a faithful administration so far from home, and the obstacles to be expected from the prejudices, the cupidity, or the bad faith of the Mexican proprietors.

Some of these appear to us to be formidable, and to deserve serious consideration, and they will be appreciated differently by various persons as their minds may incline them, or their information may be greater or less.

The political question we do not intend to examine, as it involves considerations foreign to the objects of our publication. As to the uncertainty attendant on mining, it appears to us, from the authority of the highly respectable traveller before quoted, that it is less in Mexico than in most places; and as we know that the principal miners of this country have been consulted, we conceive that their advice is satisfactory on this point. The distance from home, when urged as an objection, has been met by the remark, that great affairs are managed satisfactorily in more remote countries, such as in the East Indies, and that by a judicious selection of respectable officers, with a system of proper checks, what is required in this respect may be accomplished. With regard to the interference of Mexican influence to the detriment of the English companies, supposing the desire of it to exist, it is obvious that self-interest must be esteemed as the strongest motive; and as the mines will continue to exist only by the exertion of a peculiar skill in the supply and management of complicated machinery, and which skill must for a long time be vested in the English part of the establishment only, so it will be evidently the interest of the Mexican, to support and aid those upon whom the success of the mines will depend.

As to what advantage may accrue to the shareholder in London, it is of course at present not easy to form conjectures: but there is evidence enough of the great profits which these mines formerly made; those who know them best speak with confidence of the future; and if the chances which we have alluded to do not interfere injuriously to any formidable extent, we do not see why the result should not be a prosperous one.

In a scientific point of view much may be expected: mining establishments of such magnitude must necessarily include many men capable of making observations of varied character and research, and we hope that they will record and communicate them. The interests of Geology, Mineralogy, and the other studies more immediately connected with the object in view, may not only be served, but, as it may be possible to include in the establishment persons devoted to other branches

of science, we may expect also good service to the cause of natural history, astronomy, and the arts: from the known character of the gentlemen who patronize and manage the undertaking, we have a right to look forward to satisfactory results of this kind.

We understand that a work consisting chiefly of selections from the writings of Humboldt is in the press, which will contain the most interesting information upon Mexico and its mines: it will be edited and revised by Mr. Taylor, who has engaged to add some explanatory notes to render it useful to those who may be desirous of inquiring particularly into the subject.

IMPROVEMENT ON THE PRINCIPLE OF MAKING ANCHORS, BY
MR. G. HAWKES (THE PATENTEE).

To prevent the difficulty and danger attending welding the shank and the flukes of the anchor, and the hazard of burning them a little distance from the part so welded, and where anchors most frequently break, it is proposed to make half the shank and all the fluke in one piece; and if the bars of iron should not be manufactured in lengths sufficient for large anchors, those bars can be welded, and the welds separated from each other in making up the bars in sufficient numbers to make the fluke and half the shank. This being done, leaving iron sufficiently large to make the crown, it is turned with the greatest possible ease to the form of half the anchor. This process does not require the heat approaching to burning, and will give the anchor such a trial as in all probability it will never receive after; and the difficulty in making those pieces is no more than making iron knees, only that the iron must be faggoted, which will ensure its strength, and will allow of an eye being opened in each half of the shank to admit the wood-stock passing through the anchor. Two pieces being made this way, they are brought together and reconciled to the size, and to suit each other; leaving iron out at the crown to admit the opposite ring of the palm, to clinch over each other, and bolt on to the fluke: thus the palm gives collateral support to each half of the anchor; and a sufficient number of hoops are welded on the shank of the anchor, and driven down each way till it is sufficiently strong: this allows the stock to be made much smaller; and as the cutting one-third out to let it over the anchor is saved, it will be much stronger, and will only require a thin plate of iron with a shoulder screwed on each half of the stock in wake of the anchor (which will prevent the anchor cutting the wood); the shoulder is placed contrariwise on the half stocks; when hooped with one hoop and a toggle through at each end,
the

the stock can only turn round, and cannot possibly get out while the hoops remain at the ends: the stock will thus be less liable to break than by the old method of hooping and bolting it over the anchor, and will prevent the cutting away the strongest part of the wood to make the stock square. This method will make it unnecessary to take spare anchors with the stocks, which take up so much room, besides adding so much weight to the fore extreme of the ship, which is the more detrimental as the ship becomes in the greatest danger: those pieces can be prepared to be put together in two pieces with an iron stock with hoops prepared, and will only require warming and driving down, in much less time than is required to stock the old anchor. And by putting three or four of these pieces together, they will make the most effective anchor without a stock, and the chain can be passed through the shank if required, or make it fast to the shank.

Mr. Hawkes rests all his hopes on the importance of bending iron in preference to welding, which cannot be performed without the greatest hazard of burning; and however ingenious the late contrivances may be, the welding difficulty has never been attempted to be dispensed with. There have been all manner of welding scarfs proposed; but on considering that the thin part of those scarfs (whatever shape they may be) is equally subject to the same heat as the thick part, consequently must be destroyed, provided the thick part is sufficiently hot to weld,—and as to the clinching the shank of the anchor through, and on the crown of the flukes, the immense wring or strain anchors are liable to sideways, must make this very dangerous,—the bending two pieces of iron and securely uniting them, must be considered stronger than one piece of the same size, even if welded securely, and not burnt. And to do away this great danger, that has been so destructive to the lives and property of all nations, is the object Mr. H. hopes to obtain; and though the price should exceed from 5 to 10 per cent. other anchors which are made with all those hazards attached to them, independently of their being made without fag-goting the iron, which is frequently done, time will prove that anchors made on the principle proposed, will be found much superior to the present mode of making them.

No. 9, Lucas-place, Commercial-road.

IMPROVEMENT ON THE PERPENDICULAR AND HORIZONTAL
CAPSTANS, BY MR. G. HAWKES, SURVEYOR OF SHIPPING.

These capstans are either to be made of wood or cast iron, with from three to six segments of circles (as will suit best), secured with bolts sideways through each other, and with

hoop-wheels on the drumhead and pallhead, with a winch in midships, which is to turn these segments round the spindle, or the spindle with them.

To prevent the shock occasioned by the surge of the ropes (all other capstans are liable to) from having play between the deck and pallhead, there are rollers fixed in sockets at the inside of the pallrim, which rim is so constructed as to keep the capstan always palled; and those sections which make the barrel, whelps, pallhead, and drumhead, are suspended to the upper part of the spindle in a turned groove, being square excepting at that place, and resting on the live rollers within the pallrim, bearing on the upper part of the hoop let over the spindle at the deck, so that on the slightest strain they become a diagonal shore to the support of the spindle.

As the drumhead and pallhead of these capstans, either of wood or iron, need not be more than half the thickness of other capstans, it allows room for two powers on the same barrel, so that two ropes can be worked at the same time without interfering with each other; and ships that have double capstans, one on each deck, the upper part of the upper capstan is made to work independent of the other part, by dividing the segments a little above the middle, making the division between the two powers, the pallhead and pallrim, to the upper power; this will allow of four hawsers being worked at the same time, without the least confusion with each other, and must present a great advantage in case of ships getting on shore, or requiring an additional purchase, as both capstans can be applied to one object.

The spindle of the upper capstan is securely fixed into the spindle of the lower one, so that the upper capstan can be removed on getting clear of harbour: as this capstan is only used on the old principle for transporting the ship and for turning the capstan below, while the lower capstan on this principle is turned with a winch in midships, independently of the upper capstan, the winch is made to work the hand and chain pumps at the same time if found necessary.

The horizontal capstans are effectually secured with three (unless the capstan is wanted to be in the wake of the mast), then four, iron pallbits, secured to the upper deck (to prevent partaking of the contrary working of the deck below) with iron knees before and abaft, let through carlings let up from the under part of the beams, and toggled on plates to the under part of those carlings, which are firmly attached to three beams: those bits so secured receive the spindle, which is the whole length of the capstan, and will turn on sockets fixed to the pallbits: from three to six segments of circles are bolted
sideways

sideways round the spindle on each side, and the same number on the ends (the same as the perpendicular capstan), which are made to turn round the spindle, or to turn the spindle in case of using the bars. This capstan is also double palled, and friction is destroyed, and is worked with wheels on the heads, the same way as the perpendicular capstans: indeed, the difference in these capstans is only in as much as the pallbits of the horizontal capstan become the pallhead of perpendicular capstan, and offers twelve palls—six above, and the six below in a direction from the deck, which will save the old practice of chocking from the deck for its security or safety, which is the principal object the inventor has in view, and has no doubt, if the late improvements on capstans are considered, they can only give ease, and no additional speed can be obtained beyond the step or run of a man with the old palls, and play underneath allow of the same shock by the surge of the ropes as is the case in the old capstan; while the one proposed not only has the advantage of two powers on each capstan, but three different speeds by the winch and wheels, which are all external, and can be removed in a very short time to use the bars, is always palled, and is unaffected by the surging of the messenger or ropes, and if used by the bars will turn with the greatest ease, not excepting the late improvement.—The anchor and capstan are in progress at Messrs. Taylor and Martineau's for the *Triumph*, Captain Green, and the *Exmouth*, Captain Owen, both of the East India service.

FURTHER OBSERVATIONS ON THE COMET,

Gosport Observatory, Feb. 25, 1824.

Wednesday Evening, Jan. 27th,	} 1824,	its Right Ascension was 200° 10'
Friday Evening, Jan, 29th,		its Declination . . . 71 00 north.
Saturday Evening, Jan. 30th,		its Right Ascension was 181 30
Tuesday Evening, Feb. 2d,		its Declination . . . 73 00 north.
		its Right Ascension was 171 00
		its Declination . . . 73 40 north.
		its Right Ascension was 143 00
		its Declination . . . 71 50 north.

In the evening of the 27th of January, the Comet being nearly at its greatest apparent distance from the sun, as shown by the celestial globe, it had no tail, and appeared very much like the nebula in the constellation Cancer. In the evening of the 2d of February it was about 125° distant from the sun, and was scarcely perceptible by the naked eye; and at this time its daily motion under the fixed stars was about 2° 50'. Subsequent evenings proved that it had gone too far into space to make further observations on it.

WM. BURNEY.

LIST OF NEW PATENTS.

To Thomas Bewley, of Mount Rath, in Queen's County, Ireland, cotton manufacturer, for certain improvements in wheeled carriages.—Dated 24th January 1824.—6 months allowed to enrol specification.

To John Heathcoat, of Tiverton, Devonshire, lace manufacturer, for certain improvements in the method of figuring or ornamenting various descriptions or kinds of goods manufactured from silk, cotton, or flax.—24th January.

To John Jones, of Leeds, Yorkshire, late of Gloucester, brush manufacturer, for certain improvements in machinery and instruments for dressing and cleansing woollen, cotton, linen, silk and other cloths or fabrics, and which improvements are also applicable to the dressing and cleansing of machinery of various descriptions and other articles or substances.—27th January.—6 months.

To Sir William Congreve, of Cecil-street, Strand, Middlesex, bart., for his improved method of stamping.—7th February.—6 months.

To John Arrowsmith, of Air-street, Piccadilly, Middlesex, esq., who, in consequence of discoveries by himself, and communications made to him by certain foreigners residing abroad, is in possession of an improved mode of publicly exhibiting pictures or painted scenery of every description, and of distributing or directing the day-light upon or through them so as to produce many beautiful effects of light and shade, which he denominates Diorama.—10th February.—6 months.

To Robert Lloyd, of the Strand, Middlesex, hatter, and James Rowbotham, of Great Surry-street, Blackfriars Road, Surry, hat-manufacturer, for their having invented and brought to perfection a hat upon a new construction which will be of great public utility.—19th February.—6 months.

To Henry Adcock, of Summer Hill Terrace, Birmingham, Warwickshire, gilt-toy manufacturer, for his improvement in making waistbands, or umbilical, ventral, lumbar and spinal bandages or supporters to be attached to coats, waistcoats, breeches, pantaloons and trowsers, to be either permanently fixed or occasionally attached and supplied.—19th February.—6 months.

To William Church, of Birmingham, Warwickshire, esq., for certain improvements in machinery for printing.—19th February.—6 months.

To Augustus Applegath, of Duke-street, Stamford-street, Blackfriars, Surry, printer, for certain improvements in machines for printing.—19th February.—6 months.

To the Rev. Moses Isaacs, of Houndsditch, London, for certain improvements in the construction of machinery, which, when kept in motion by any suitable power or weight, is applicable to obviate concussion by means of preventing counteraction, and by which the friction is converted into an useful power for propelling carriages on land, vessels on water, and giving motion to other machinery.—19th February.—6 months.

To John Vallance, of Brighton, Sussex, esq., for his method of communication or means of intercourse, by which persons may be conveyed, goods transported, or intelligence communicated, from one place to another with greater expedition than by means of steam-carriages, steam or other vessels, or carriages drawn by animals.—19th February.—6 months.

METEOROLOGICAL RESULTS

Of the Atmospheric Pressure and Temperature, Rain, Wind, &c., deduced from diurnal Observations made at Manchester, in the Year 1823, by Mr. THOMAS HANSON, Surgeon.
 Latitude 53° 25' North—Longitude 2° 10' West of London.

1823.	Barometrical Pressure.						Temperature.				Rain.		Wind.														
	Mean.	Highest.	Lowest.	Range.	Greatest Variation in 24 hours.	Spaces in Inches.	No. of Changes	Mean.	Highest.	Lowest.	Range.	Greatest Variation in 24 hours.	Inches.	Wet Days.	N.	N.E.	E.	S.E.	S.	S.W.	W.	N.W.	Var.	Calm.	Brisk.	Boist.	
Jan.	29.66	30.14	28.90	1.24	.39	3.15	8	34.7	48	15	33	12	1.290	8	0	6	8	7	3	4	1	0	2	0	4	0	
Feb.	29.34	30.38	28.70	1.68	.88	5.18	14	38.4	50	27	23	15	3.275	14	0	2	1	7	0	12	0	3	8	0	5	1	
March	29.67	30.32	28.95	1.37	.65	5.60	8	42.9	54	29	25	18	2.664	9	0	2	0	8	0	8	4	6	2	1	1	1	
April	29.75	30.30	28.95	1.35	.45	4.30	8	46.2	60	35	25	18	1.705	10	1	0	3	1	5	5	3	5	1	0	1	1	
May	29.76	30.30	29.26	1.04	.32	3.10	6	54.4	71	42	29	24	2.730	15	0	3	1	0	5	12	7	2	1	0	5	0	
June	29.79	30.18	29.20	0.98	.42	4.00	10	55.6	68	42	26	20	2.170	16	0	7	0	0	0	12	4	4	3	0	1	0	
July	29.64	29.95	29.30	0.65	.38	2.90	10	59.1	71	47	24	22	5.060	20	0	0	0	0	3	14	1	2	1	0	0	0	
August	29.69	30.02	29.28	0.74	.30	2.15	11	59.1	70	50	20	15	4.680	24	0	0	0	0	0	9	12	7	0	0	0	0	
Sept.	29.78	30.15	29.00	1.15	.57	3.90	11	55.7	69	39	30	16	3.900	18	0	2	0	0	1	6	11	8	2	0	0	0	
Oct.	29.55	30.25	28.70	1.55	.44	5.40	12	49.5	62	39	22	14	3.060	20	0	9	1	2	1	15	0	1	2	0	0	0	
Nov.	29.92	30.40	29.06	1.34	.62	3.50	8	46.6	57	30	27	16	1.685	16	0	0	0	10	0	12	0	5	3	0	0	0	
Dec.	29.48	30.26	28.60	1.66	.76	6.50	11	42.1	53	28	25	13	3.860	13	0	1	0	2	0	14	6	5	3	0	4	2	
Annual Means, &c.	29.67					49.48	117	48.7					35.979	189	1	42	14	40	16	121	59	48	23	1	20	5	

Mean annual temperature $48^{\circ}\cdot7$, which is three degrees colder than the annual mean of 1822, but about an average mean of a series of years: the mean of the first three months $38^{\circ}\cdot7$; second $52^{\circ}\cdot1$; third $57^{\circ}\cdot9$; fourth $46^{\circ}\cdot1$: of the six winter months $45^{\circ}\cdot1$; six summer months $54^{\circ}\cdot5$. The highest state of temperature, which may be recognised in the above Table, was 71° ; it took place on the 31st of May, and 20th of July: and the lowest 15° on the 19th of January: variation of these extremes 56° .

Mean annual barometrical pressure $29\cdot67$ inches; highest $30\cdot40$ occurred on the 10th of November; lowest $28\cdot60$ on the 4th of December: variation of the extremes $1\cdot80$ inches. Mean of the six summer months $29\cdot73$; of the six winter months $29\cdot66$. Spaces described by the courses formed from the mean daily pressure $49\frac{1}{2}$ inches; number of changes 117. Prevailing winds as usual, south-west and west.

January was particularly remarkable for a severe frost. An average mean temperature of the highest extreme from the 11th to the 22d was $33^{\circ}\cdot7$; and the mean of the lowest extreme for the same period $27^{\circ}\cdot3$: the coldest state was on the 19th; there was a fog at the time, and the barometer rose during the day about 18 hundredths of an inch. The thermometer in the morning indicated the cold of 15° —that is, 17° under freezing: in the course of the day the temperature rose to 27° . The wind blew a gentle breeze from the north and north-east, the barometer gradually fell from the 11th to the 19th, and became stationary about the very low temperature, when it began to rise. The ground, for the most part of the month, was clothed with snow, and rivers and canals frozen over. My friend's thermometer at Crumpsall indicated a cold of 13° on the morning of the 19th; the mean of the two extremes on that day in town was 21° ; in the country probably 19° : mean of the means of the two extremes of the above twelve days $30^{\circ}\cdot5$. A gentleman (Mr. Buchann) in the neighbourhood of Ardwick noticed the thermometer on the morning of the 19th to be 13° , the same as at Crumpsall. On the 23d and 3 following days the wind blew strong from the S.-E. There was a general breaking-up of the frost on the 27th; the mean daily temperature got up to 45° , and the wind changed to south-west.

February was noticed for almost daily falls of rain, snow, sleet, or hail; and sometimes all at once. The temperature fluctuated from 27° to 50° . Strong winds from the S.-W., on the 1st, 11th, 12th and 22d: on the 23d the wind was very strong from the south-east; and during the night and following day blew a hurricane. Barometer for the most part low.

March

March commenced with strong south-west winds, which blew a hurricane during the whole of the night of the 3rd, and part of the following day: the pressure, during the time, low, and temperature rather high. On the 7th there was a strong south-east wind with snow and sleet: on the 20th and following night, a copious fall of snow; but which soon disappeared, as it was succeeded by rain. The weather now continued warm and open to the end, with occasional sun-gleams.

April. April showers, which usually characterise this month with mildness, were in the present instance attended during the first ten days with the blustering west and piercing east winds of March. The north-east winds, which commenced on the 5th and continued to the 14th, felt more cold than the thermometer indicated, and were particularly distressing to persons disposed to the tooth-ache. On the 18th and 19th there was a strong north-west wind with hail and snow, and the following night a sharp frost: ice on the ground a quarter of an inch thick, yet the reporter's thermometer only fell to 35°, that is three degrees above freezing. The same uncongenial weather prevailed to the 27th, which retarded vegetation much: but on the 28th, circumstances changed, as the temperature rose, the sky became clear and mostly cloudless, the barometer high and steady, and the wind changed from an east to a south course, which terminated the month.

May commenced with summer weather, and increased in heat to the 7th: the highest state of that day was 71°, which was one of the greatest extremes of the year; there were loud claps of thunder about two in the morning, with rain: on the 8th, gradual fall of the barometer, and sudden one of the temperature, attended with frequent heavy showers of rain, and hail at intervals. The 11th was a very rainy day in and about Manchester, but in Liverpool no rain fell: 13th, strong south-west wind, with frequent rain and hail showers; the hail was uncommonly large and indurated: 15th, a few swallows were noticed on the wing for the first time this season. About this time it was fine but cold for spring, but from the 19th to the end, warm and showery.

June: fine and warm to the 14th, with frequent showers of rain: 15th, nimbus, or thunder clouds, which deposited much rain; wind variable, but which finally settled and blew keenly from the north-east; the consequence was, much damage done to garden shrubs and tender vegetables, by annoying them with insects of the aphis tribe. The wind remained northerly to the 26th, when it changed to west, and on the 29th there were loud peals of thunder, with lightning and rain.

July upon the whole was cold, gloomy, and wet; on the 23d there

there was hail, with rain : three days before, the temperature was 71°, the same as in May ; but the mean of the day was 2° higher. The rain that fell measured upwards of five inches.

August. The average temperature was just the same as that of July ; and the rain, which measured nearly five inches, was pretty evenly distributed throughout. An observer of rural affairs says, about the 9th, that “the weather most unfortunately still continues unfavourable to the ripening of corn, which, on the whole, presents a very healthy and full appearance. The hay is only partially got in ; and a great deal of grass is yet to cut. Very fortunately, this wet state has not been common throughout the country ; on the contrary, many places south have been in great want of rain.” He also remarks, “It is observed, this summer, in point of wetness, is equal to 1816.” This certainly is not correct ; for on referring to that year, I find only about *nine* inches of rain fell in the three months of June, July, and August ; but in the three months of the following year there fell upwards of *fifteen* and a *half* inches : in the corresponding months of the present year near twelve inches.

September: weather generally gloomy, cloudy and wet, with occasional sun-gleams. Mr. Cobbett was enabled to state from his rural ride through Kent, &c., in the beginning of the month, that the result of his observations and inquiries, is, the crop is a full average crop of every thing except barley, and that the barley yields a great deal more than an average crop.

October. Partial showers of rain almost daily to the 10th ; on the 12th, hail. First indication of winter at the close of the month, by a decrease of temperature, and a slight fall of snow.

November. The temperature on the second under freezing : gloomy and foggy state of the atmosphere now prevailed. Rain fell on sixteen days, but very slightly except on the 30th, when it continued the whole of the day.

December commenced with strong wind, showers of hail, and a falling barometer. On the 3d, in the morning the barometer stood at 29·24, wind blowing strong from the southwest ; in the evening the pressure was lowered to 28·78, wind west, and approaching to a gale ; and in the course of the night and following morning blew quite a hurricane, nearly equal to the storm that took place on the 4th of December, 1822. On the 12th, gusts of eastern wind with hail ; the 17th was very stormy and rainy ; pressure much agitated ; in the course of the day it lost ·76 of an inch ; indeed, the barometrical pressure has been much disturbed throughout the month. Temperature high for the season.

Bridge-street, Feb. 16th, 1824.

Results of a Meteorological Journal for the Year 1823, kept at the Observatory of the Academy, Gosport, Hanits.

By WILLIAM BURNLEY, LL.D.

Latitude 50° 47' 20" North—Longitude 1° 7' West of Greenwich. In time 4' 28".

Months.	Barometer.										Self-registering Thermometer.								De Luc's Hygrometer.						
	Max.	Min.	Media.	Range.	No. of Changes.	Spaces described.	Greatest Variation in 24 hours.	Media at 8 A.M.	Media at 2 P.M.	Media at 8 P.M.	Max.	Min.	Media.	Range.	Gt. Var. in 24 hours.	Media at 2 P.M.	Media at 8 A.M.	Media at 8 P.M.	Mean Temp. of Spring Water.	Max.	Min.	Mean Range of the Index.	Media at 2 P.M.	Media at 8 A.M.	Media at 8 P.M.
January	30·10	28·96	29·625	1·14	19	5·02	0·46	29·628	29·612	29·625	52·18	34·64	34	18	37·61	32·29	35·10	48·00	97·50	47	73·1	77·6	78·0	76·2	76·2
February	30·20	28·52	29·433	1·68	21	10·24	0·68	29·431	29·418	29·442	50·28	41·16	22	17	44·78	39·89	40·57	48·54	92·54	38	72·2	79·8	78·1	76·7	69·0
March	30·37	28·85	29·801	1·52	20	8·13	0·93	29·793	29·796	29·809	57·30	43·79	27	20	48·65	41·39	43·26	48·18	93·40	53	60·6	72·0	74·4	65·1	61·1
April	30·48	29·02	29·836	1·46	20	7·33	0·62	29·839	29·828	29·839	61·32	47·53	29	20	55·47	47·07	46·93	48·33	83·38	45	54·6	63·5	65·1	62·1	56·0
May	30·40	29·55	29·939	0·85	26	4·83	0·36	29·937	29·947	29·938	73·42	56·71	31	24	63·03	58·23	56·64	49·18	84·32	52	49·7	56·1	62·1	56·0	51·2
June	30·35	29·33	29·934	1·02	15	4·47	0·42	29·937	29·934	29·929	76·42	58·07	34	24	64·43	59·13	58·63	50·27	80·31	49	44·7	50·9	58·1	51·2	59·1
July	30·13	29·60	29·866	0·53	31	5·30	0·43	29·865	29·874	29·870	75·50	62·08	25	23	67·26	61·58	60·06	51·29	90·42	48	52·9	59·4	65·0	59·1	64·3
August	30·26	29·55	29·928	0·71	24	4·50	0·38	29·928	29·933	29·929	74·49	62·63	25	18	67·90	63·00	61·23	52·12	93·45	48	56·3	64·2	72·5	64·3	57·6
Septemb.	30·39	29·32	30·027	1·07	21	5·80	0·64	30·033	30·022	30·022	71·44	58·43	27	17	64·35	57·90	57·70	53·21	90·39	51	49·1	59·7	63·9	57·6	66·1
October	30·44	28·70	29·795	1·74	19	9·08	0·76	29·684	29·713	29·721	63·38	51·42	25	19	55·55	50·26	50·39	53·25	95·43	52	58·9	69·2	70·1	66·1	69·6
Novemb.	30·60	29·50	30·107	1·10	16	4·92	0·76	30·107	30·101	30·107	56·31	47·22	25	23	50·33	45·43	46·93	52·25	90·52	38	66·2	71·0	71·8	69·6	74·5
Decemb.	30·51	28·97	29·769	1·54	22	10·26	0·99	29·753	29·767	29·754	53·28	42·86	25	20	45·87	41·32	43·32	51·04	94·58	36	70·9	76·6	76·0	74·5	65·1
Averages for 1823.	30·60	28·52	29·831	14·36	254	79·88	0·99	29·828	29·829	29·832	76·18	50·54	27·4	24	55·27	49·79	50·06	50·47	97·31	46·4	59·1	66·6	69·6	65·1	65·1

Months.	Scale of the Winds.								Modifications of Clouds.						Weather.						Atmospheric Phenomena.								Evaporation in Inches, &c.	Rain in Inches, &c.			
	North	North-East.	East	South-East.	South.	South-West.	West.	North-West.	Total Number of Days.	Cirrus.	Cirrocumulus.	Cirrostratus.	Stratus.	Cumulus.	Cumulostratus.	Nimbus.	A clear Sky.	Fair, with Clouds.	An overcast Sky.	Foggy.	Rain, &c.	Total Number of Days.	Anthelia.	Paraselenæ.	Solar Halos.	Lunar Halos.	Rainbows.	Meteors.			Lightning.	Thunder.	
January ..	1	12	5	6	1	2	0	4	19	8	29	4	1	12	19	2	7	15	1	6	31	0	1	0	1	3	1	6	0	0	0	3-365	
February ..	3	4	2	0	2	7	4	6	16	12	22	0	13	18	23	1	10	5	1	11	28	1	1	0	2	8	1	2	0	1	0	4-585	
March ..	4	3 $\frac{1}{2}$	2	3 $\frac{1}{2}$	1	4	6	7	21	13	29	1	16	18	18	2	12	11	1 $\frac{1}{2}$	4 $\frac{1}{2}$	31	0	0	1	3	0	2	0	0	0	0	2-095	
April ..	1	9 $\frac{1}{2}$	1 $\frac{1}{2}$	4	1 $\frac{1}{2}$	5	3 $\frac{1}{2}$	4	20	10	22	0	17	18	14	3 $\frac{1}{2}$	12 $\frac{1}{2}$	8	0	6	30	0	6	0	3	3	1	4	1	2	0	2-140	
May ..	1	3	4	5	3	10	2	2	28	17	31	1	20	18	17	4	15	7	0	5	31	0	1	2	8	1	1	4	1	2	0	1-125	
June ..	7	5	1	1	1	9	4	3	25	18	24	1	27	27	20	4 $\frac{1}{2}$	13	9	0	3 $\frac{1}{2}$	30	0	3	0	6	0	1	2	3	3	2	0	2-230
July ..	1	1 $\frac{1}{2}$	0	2	1	14 $\frac{1}{2}$	7	5	23	23	29	0	20	26	26	2	12	8	0	8	31	0	0	0	3	0	3	2	3	2	0	2-755	
August ..	1	5 $\frac{1}{2}$	0	1	3	14	8 $\frac{1}{2}$	2 $\frac{1}{2}$	24	19	31	1	17	20	8	6	17 $\frac{1}{2}$	4 $\frac{1}{2}$	0	9	31	0	1	1	2	0	7	1	1	0	0	1-720	
September ..	2	5 $\frac{1}{2}$	1	2	3	5	6	3	25	15	24	0	21	14	15	21	13	7	0	8	31	0	5	0	3	2	24	1	0	1	0	4-820	
October ..	2	4	4	2	3	6	5	5	21	12	29	0	14	15	11	3	8	12 $\frac{1}{2}$	0	6	30	0	2	0	3	0	5	1	1	1	0	2-220	
November ..	3	6	3	5	3	3	3	4	10	6	30	0	4	5	5	11	8	10	0	9	31	0	0	2	0	3	0	5	1	1	0	1-10	
December ..	2	0	1	1	1	9	8	9	16	15	27	0	11	9	23	2	10	10	0	9	31	0	2	0	1	4	3	2	3	3	0	4-385	
Averages for 1823.	27 $\frac{1}{2}$	54	24 $\frac{1}{2}$	32 $\frac{1}{2}$	21 $\frac{1}{2}$	91 $\frac{1}{2}$	56	57 $\frac{1}{2}$	248	168	327	8	181	200	225	35	143	105	4	78	365	2	20	5	31	29	12	99	14	13	24	28	34

ANNUAL RESULTS FOR 1823.

<i>Barometer.</i>	Inches.
Greatest pressure of atmosphere, Nov. 11th. Wind E.	30·600
Least ditto ditto Feb. 2d. Wind N.E.	28·520
Range of the mercury	2·080
Annual mean pressure of the atmosphere	29·831
Mean pressure for 181 days, with the moon in North declination	29·887
Mean pressure for 204 days, with the moon in South declination	29·810
Annual mean pressure at 8 o'clock A.M.	29·828
_____ at 2 o'clock P.M.	29·829
_____ at 8 o'clock P.M.	29·832
Greatest range of the mercury in October	1·740
Least range of ditto in July	0·530
Greatest annual variation in 24 hours in December	0·990
Least of the greatest variations in 24 hours in May	0·360
Aggregate of the spaces described by the alternate rising and falling of the mercury	79·880
Number of changes	254·

Self-registering Day and Night Thermometer.

Greatest thermometrical heat, June 1st. Wind S.	76°
_____ cold, Jan. 19th. Wind E.	18
Range of the thermometer between the extremes	58
Annual mean temperature of the external air	50·54
_____ of do. at 8 A.M.	49·79
_____ of do. at 8 P.M.	50·06
_____ of do. at 2 P.M.	55·27
Greatest range in January and June	34·00
Least of the monthly ranges in February	22·00
Annual mean range	27·40
Greatest monthly variation in 24 hours in May and June	24·00
Least of the greatest variations in 24 hours in February and September	17·00
Annual mean temperature of spring water at 8 A.M.	50·47

DE LUC'S Whalebone Hygrometer. Degrees.

Greatest humidity of the atmosphere on the 27th Jan.	97
Greatest dryness of ditto on the 17th June	31
Range of the index between the extremes	66
Annual mean of the hygrometer at 8 o'clock A.M.	66·6
_____ at 8 o'clock P.M.	69·6
_____ at 2 o'clock P.M.	59·1
_____ at 8, 2, & 8 o'clock	65·1

Greatest mean monthly humidity of the atmosphere in February	76·7
Greatest mean monthly dryness of the atmosphere in June	51·2

<i>Position of the Winds.</i>	Days.
From North to North-East	27½
— North-East to East	54
— East to South-East	24½
— South-East to South	32½
— South to South-West	21½
— South-West to West	91½
— West to North-West	56
— North-West to North	57½
	—365

Clouds, agreeably to the Nomenclature; or the number of days on which each modification has appeared.

	Days.
Cirrus	248
Cirrocumulus	168
Cirrostratus	327
Stratus	8
Cumulus	181
Cumulostratus	200
Nimbus	225

	Days.
<i>General State of the Weather.</i> A transparent atmosphere without clouds	35
Fair, with various modifications of clouds	143
An overcast sky, without rain	105
Foggy	4
Rain, hail, snow, and sleet	78
	—365

	No.
<i>Atmospheric Phenomena.</i> Anthelia, or mock-suns diametrically opposite- to the true sun	2
Parhelia, or mock suns on the sides of the true sun	20
Paraselenæ, or mock-moons	5
Solar halos	31
Lunar halos	29
Rainbows, solar and lunar	12
Meteors of various sizes	99
Lightning, days on which it happened	14
Thunder, ditto ditto	13

	Inches.
<i>Evaporation.</i> Greatest monthly quantity in May	3·80
	Least

Least monthly quantity in January	0·63 In.
Total amount for the year	24·28
<i>Rain.</i> Inches.	
Greatest monthly quantity in October	4·820
Least monthly quantity in May	1·125
Total amount for the year near the ground	34·665
Total amount for the year 23 feet high	31·165

N. B. The barometer is hung up in the observatory 50 feet above low-water mark; and the self-registering horizontal day and night thermometer, and De Luc's whalebone hygrometer, are placed in open-worked cases, in a northern aspect, out of the rays of the sun, ten feet above the garden ground. The pluviometer and evaporator have respectively the same square area: the former is emptied every morning at 8 o'clock after rain, into a cylindrical glass gauge accurately graduated to $\frac{1}{100}$ th of an inch; and the quantity lost by evaporation from the latter is ascertained at least every third day, and sometimes oftener, when great evaporations happen, by means of a high temperature and dry northerly or easterly winds.

BAROMETRICAL PRESSURE.—The *maximum* pressure was not so high by $\frac{1}{10}$ th of an inch this year, as it was in the genial year 1822; the *minimum* was nearly $\frac{5}{10}$ ths of an inch less, and the mean 0·103 inch less. The mean pressure for the present year corresponds very nearly with that for 1816. The aggregate of the spaces the mercury has described in its alternate rising and falling, is 10·58 inches greater; yet the number of changes is 18 less than that of last year. For 181 days in which the moon ranged in North declination, the mean pressure was $\frac{77}{1000}$ ths of an inch higher than that in the 204 days she ranged in South declination.

TEMPERATURE.—The annual mean temperature of the external air a few feet from the ground, is nearly $3\frac{1}{2}$ degrees less than that of the preceding year, and less than it has been since the year 1820: but it corresponds exactly with the annual mean temperature for the years 1817 and 1819. It is a remarkable circumstance in the temperature of the air, when the *maximum* height for the year does not exceed summer heat, or 76 degrees, which was the case this year; and, what is equally as remarkable, it happened on the *first* day of June. Even the cold and wet year 1816 produced a *maximum* temperature of 78 degrees, which also happened in June. The annual *maximum* temperature of the air has occurred in June five years out of the last nine, viz. in 1816, 1817, 1820, 1822, and 1823.

The annual mean temperature, and the mean at half-past 8 o'clock A.M. this year, correspond within three quarters of a degree;

a degree; and the mean at 8 A.M. and 8 P.M. within a quarter of a degree.

The annual mean temperature of spring water, as taken at 8 o'clock A.M., coincides with the annual mean temperature of the external air within $\frac{7}{100}$ ths of a degree. The difference between the mean temperature of the air and that of spring water for the last three years does not amount to three quarters of a degree; which serves to point out the analogy there is between the mean temperature of the air and that of the ground.

The mean state of the air by De Luc's whalebone hygrometer, this and the preceding year, coincides within $\frac{1}{10}$ th of a degree.

WIND.—In comparing the scales of the prevailing winds for 1822 and 1823, there will be found a remarkable coincidence, the greatest difference in point of numbers, from the eight divisions of the compass, being only $9\frac{1}{2}$ days, which was *minus* in the south-east wind. The south-west wind, which frequently comes across the Atlantic Ocean, has been more prevalent this year than for the last nine years, and the most prevalent for the three preceding years. The following is the number of strong gales of wind, or days on which they have prevailed this year, viz.

N.	N.E.	E.	S.E.	S.	S.W.	W.	N.W.	Days.
4	11	2	2	5	57	6	8	95

Hence it appears that the south-west wind here, is not only the most prevailing in light breezes, but in brisk and strong gales; which is also generally observed at sea.

CLOUDS.—Of these the *cirrostratus* was the most prevalent, and the *cirrus*, from which it is produced, the next: but it is impossible that we can always perceive the *cirrus* in its descent, before it is transformed into *cirrostratus*; because, in the absence of the sun, or when it is under the horizon, the *cirri* quickly descend, and put on the appearance of linear *cirrostrati*. The cirrose crowns of *nimbi* are not noticed here, but are included in the latter modification. In a series of years the *cirrus* and *nimbus* are pretty equal in the numbers of their appearance, or days on which they have prevailed.

WEATHER.—The difference in the cloudless and fair days this year and last, is 31 days; and the difference in the overcast and rainy, is 30 days: both in favour of 1822.

ATMOSPHERIC PHÆNOMENA.—Nothing peculiar in the appearance

pearance of atmospheric and meteoric *phænomena* has been observed here this year, except a FIERY METEOR of an extraordinary size, which appeared about 20 minutes past 6 o'clock in the evening of the 26th of January. The extent of its sudden light, and of its fiery train, was terrific, from which proceeded some degree of warmth while passing over this neighbourhood in a westerly direction. This meteor was seen nearly at the same time by some of the inhabitants of the Isle of Wight, Southampton, Salisbury, Blandford, Dorchester, and other places to the westward. The air was frosty, and the sky mostly overcast; and much rain fell on the following day.

On the 5th of February, at mid-day, a large semi-halo, 45° from the sun's centre, appeared over the sun, accompanied by a concentric semi-halo of the usual extent, from which it is probable the large one was formed by reflection. The colours of both were conspicuous in an attenuated *cirrostratus* cloud.

The most perfect of the *antheia* appeared at 1 P. M. on the 25th of June, in the side of a slow-passing *cumulostratus*, or compound cloud; it was 90° from the sun's centre, within a few minutes, and in an opposite direction to that luminary; and considering it was the *imago solis*, it showed but a mild silvery light, which occasionally contracted its circular shape, and expanded into a long and irregular diameter, arising from the slow motion and uneven surface of the cloud from which it was reflected. The sun's altitude then, was about 59° , consequently the height of the anthelion was 31° nearly.

The rain is rather more than an inch in depth this year than it was last. The evaporation this year is nearly *one-third less* than the quantity of rain at the ground; but last year it was upwards of *one-fourth more* than the rain, on account of the copious falls in the summer months, and the high unprecedented mean temperature: and it is from this latter circumstance that we have been more minute in our meteorological comparisons of the last two years.

DAMP DETECTOR.

An useful application of hygrometry to the purposes of good housewifery and the preservation of health has lately been offered to the public, in Essex's Portable Damp Detector, a small and neat instrument for ascertaining the humidity of the atmosphere, and for enabling travellers to detect the damp in beds and linen.



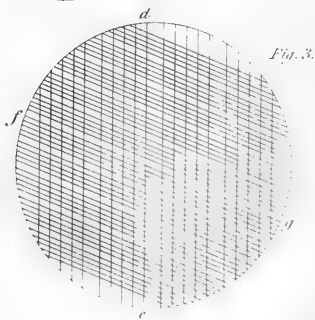
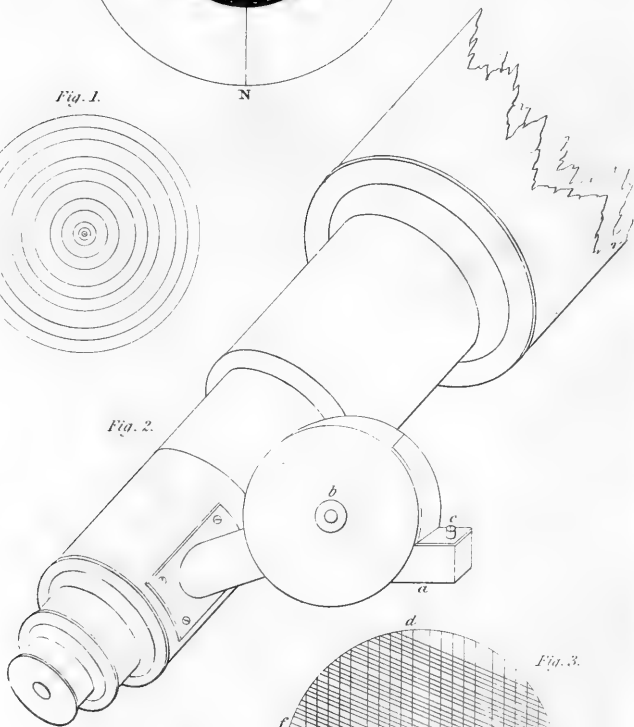
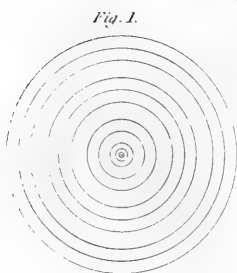
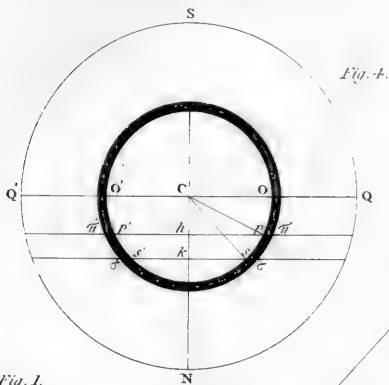



Fig. 1.

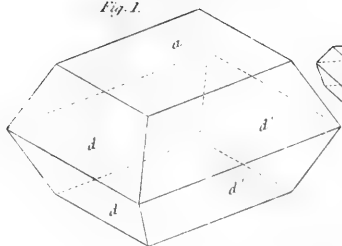

Fig. 2.

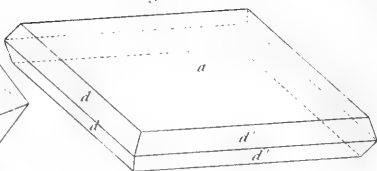

Fig. 3.

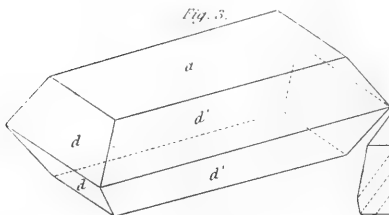

Fig. 4.

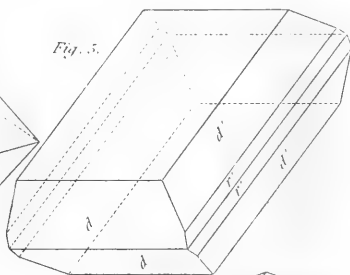

Fig. 5.

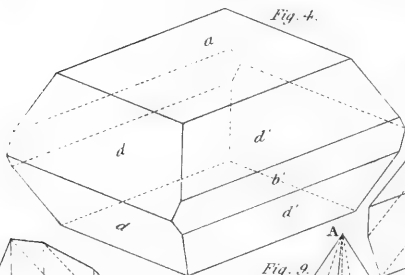

Fig. 6.

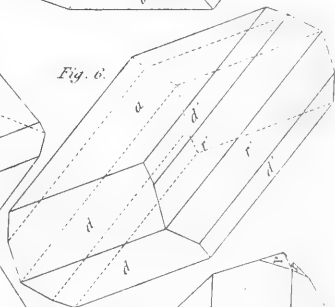

Fig. 7.

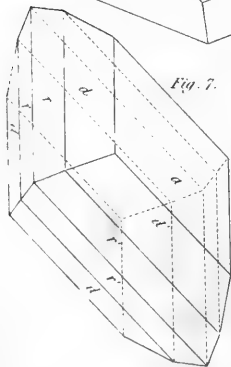

Fig. 8.

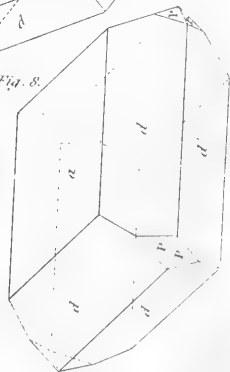
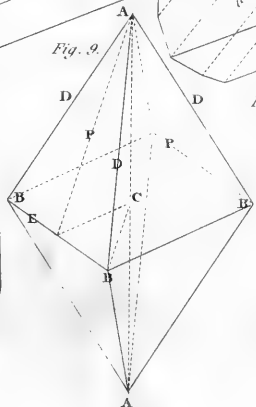

Fig. 9.



THE
PHILOSOPHICAL MAGAZINE
AND JOURNAL.

31ST MARCH 1824.

XXVIII. *On the Application of algebraic Functions to prove the Properties of parallel Lines.*

A TRANSLATION of Legendre's excellent Elements of Geometry has lately appeared, under the care of Dr. Brewster of Edinburgh. The principal novelty in this work is a defence, furnished by the author himself, of his celebrated demonstration of the fundamental property of parallel lines drawn from the doctrine of algebraic functions, which Professor Leslie has attacked in the last editions of his Geometry. It is much to be regretted that a discussion of this kind should degenerate into a contestation. On the present occasion there is no intention to mingle in the controversy. But it must be interesting to every one, who has paid any attention to geometrical studies, to inquire, how it happens that a difficulty, which has been found insurmountable in geometry, has nevertheless been so easily overcome by the methods of the modern analysis.

In laying down the elements of geometry, Euclid comes, in the 17th of his first book, to prove that any two angles of a triangle are less than two right angles. The plan of his work required that the author should demonstrate the converse of the same proposition; namely, that two straight lines will meet, and form a triangle with a third line, whenever the sum of the two angles which they make with the third line, is less than two right angles. But of this proposition no demonstration could be found; and the efforts of geometers, continued incessantly for more than two thousand years, have failed in supplying the defect. The most candid method of proceeding would therefore have been, to put down the converse proposition in the place it ought to occupy, fairly stating that, although it was not proved, it would be assumed as an admitted truth in the subsequent part of geometry. And this is, in effect, what Euclid has done, by placing the defective proposition at the head of his work in the form of an axiom, or more properly of a postulate.

When the circumstances in which two lines will meet one
Vol. 63. No. 311. March 1824. X another

another are accurately defined, the conditions of their not intersecting, or of their being parallel, are immediately inferred. And again, the properties of parallel lines being known, we arrive at the famous theorem, the 32d of book 1st; namely, that the sum of the three angles of every triangle is equal to two right angles. Now, if we could prove this last proposition independently of parallel lines, and without referring to the undemonstrated postulate, we should, by inverting the order of investigation, be able to lay down the elements with the strictest accuracy, and to remove the blemish which has always been viewed by geometers with so much regret. There is no doubt that, in this manner, geometry may be treated with all the rigour of ancient demonstration, without any peculiar axiom relating to parallel lines; and it is some satisfaction to know that this may be done, although the process of reasoning may be too long and cumbersome to be introduced in an elementary treatise. It is by pursuing the same rout that the analyst professes to demonstrate the properties of parallel lines by means of the theory of functions.

Legendre's demonstrations respecting parallel lines are founded on what is called the law of homogeneity in algebraic functions. In the problems of plane geometry, where lines and angles are combined in the same equations, the quantities depending on the angles invariably contain in their expression nothing else but ratios, or the quotients of homogeneous magnitudes; which renders the equations independent of the manner in which the angles are themselves compared or measured. It is not the same with regard to lines; for the algebraic symbols of these always involve an arbitrary unit. Hence we may lay down this general rule, that the expression of an angular quantity, deduced from an equation, can involve the ratios only of the lines concerned; for otherwise it would be dependent on the arbitrary measures of the lines, and would have no determinate value. But in the expression of a line no conditions are required with respect to angular quantities, their values being in no respect arbitrary. As the principle of homogeneity is clear, and liable to no difficulty or objection, we shall not extend further our remarks upon it.

Two functional equations are employed by Legendre to prove that the third angle of a triangle depends wholly upon the other two. Put c for the base of a triangle, C for the opposite angle, and A, B for the other two angles; then the first of the equations is thus investigated.

It is proved by superposition, that two triangles are identical when their bases, and the angles at their bases, are respectively equal. It follows that the vertical angle of a triangle

angle will be of the same magnitude in all cases when the base and the other two angles have the same values. Therefore, in every triangle, the first of these quantities must be the same function of the other three; which may be thus expressed analytically, viz.

$$C = \phi(c, A, B).$$

If the foregoing process seem clear when we consider it as an algebraic calculation, it becomes clouded with obscurity when we apply it to geometry. It is so shortly expressed, that the geometrical grounds of the demonstration cannot be brought into view, without expanding the steps of the reasoning. For this purpose, conceive another triangle of which the vertical angle is C' , the base c' , and the other two angles the same as in the first triangle; and suppose that, in this instance, we have this equation, viz.

$$C' = \psi(c', A, B),$$

the form of the function being different from what it was in the former case. But when the two bases c and c' become equal, the triangles will be identical, and the angle C will be equal to C' : wherefore by putting $c=c'$ and $C=C'$, we have

$$C = \phi(c, A, B)$$

$$C = \psi(c, A, B);$$

and this proves that the function must be the same for all triangles.

The real ground of the demonstration is now apparent. The force of the reasoning turns upon this assumption; that the base of a triangle may vary from c' to c , while the angles at the base remain the same. This is assumed, not proved. If any one deny it, there is no argument to compel his assent. Now if we follow the laudable example of the ancient geometers and state separately the principles of our reasoning, we shall be led to this postulate: Let it be granted that upon any proposed base a triangle can be constructed having the angles at the base equal to two angles of a given triangle. If this postulate be admitted, Legendre's demonstration will be legitimate and conclusive; otherwise, it will lose all its force.

But the postulate is deducible from, and therefore subordinate to, Euclid's 12th axiom. What then does geometry gain by the functional process?

We shall next give the investigation of the second functional equation. It has already been proved that

$$C = \phi(c, A, B),$$

the form of the function being the same in all triangles. But the angle C is a determinate ratio, or a value independent of all arbitrary measurement; and, since the measure of the line

c is arbitrary, it follows, from the law of homogeneity, that the line cannot enter into the expression of the angle. Wherefore the equation must simply be,

$$C = \phi(A, B).$$

And this proves that the angle C is determined by the other two angles independently of the sides of the triangle.

In this investigation triangles that have the same angles at their bases are compared together; and the existence of such triangles is therefore assumed.

It is not difficult, it may be argued, to admit that the base of a triangle may vary, while the angles at the base remain the same; and when this is granted, the functional demonstrations are not liable to objection. But the present question relates solely to what is consonant to the principles of geometry; and that science does not permit the gratuitous assumption of related figures. You may draw one triangle, for instance that upon the base c ; and you may assume as many bases c' , c'' , &c. as you please; but you cannot be allowed to suppose that, upon these bases, triangles exist which have two angles in common with that already drawn. In this manner we might be led to reason about figures that have no existence; an absurdity which is guarded against in geometry by the postulates*. You have all the data necessary for constructing the figures about which you are to reason; and you must construct them by the admitted postulates, without the help of Euclid's 12th axiom, which you propose to prove. But the triangles cannot be so constructed; and therefore the functional demonstrations cannot be held good in geometry.

The difficulty about parallel lines lies in the strictness of geometrical principles. The least relaxation of these would open a door to innumerable solutions. If the analyst, by a latent assumption, evade any of the rules imposed on the geometer, the different results of the two modes of investigation can occasion little surprise.

Without objecting to Legendre's mode of reasoning, we have endeavoured to show that his analytical demonstrations cannot be applied in geometry, unless it be assumed, that the base of a triangle may vary while the angles at the base remain the same; a proposition which is deducible from Euclid's

* In the Greek geometry the postulates are not to be considered as having a reference to practice. They are theoretical principles precluding the geometer from introducing arbitrary figures and constructions in the course of his reasoning. Legendre does not enumerate the postulates. And even Professor Leslie has degraded from its place, and thrown into the shade, this important and essential part of the geometry of Euclid.

12th axiom. But we may also object to the soundness of his reasoning.

Since the symbols A, B, C denote ratios, by the law of homogeneity, there cannot be an equation between them and the single line c ; for, on account of the arbitrary measure of c , such equation would have no fixed or determinate meaning. Therefore the equation

$$C = \phi(c, A, B)$$

is absurd. But from an absurd equation, or rather from no equation at all, you cannot, in a legitimate manner, infer that another equation is true, viz.

$$C = \phi(A, B).$$

A process of reasoning ought to be stopped whenever the relation between the magnitudes concerned implies contradiction, or can no longer be clearly understood. It seems to be an odd argument to infer that there must be an equation in one form, merely because there cannot possibly be an equation in another form. The proper conclusion seems to be, that, in analysis as well as in geometry, there is, in the present instance, a peculiar difficulty, or a failing and breaking off in the usual train of investigation.

Professor Leslie has attacked Legendre's demonstrations on other grounds. He objects to the law of homogeneity: but, in a case so very clear and undeniable, his arguments have no weight. He contends likewise that the measure of an angle estimated by its proportion to a right angle is just as arbitrary as the measure of a line in yards. This is more specious. It is urged with great confidence, and clothed, as usual, with the imposing garb of philosophical accuracy. Perhaps Legendre and his supporters have not furnished the proper answer to it. But there are few mathematicians who would oppose the opinion of that eminent geometer on a point of the modern analysis, without great diffidence; and some reflection will show that the functional equations may be vindicated from the charge brought against them by the learned Professor.

Conceive that A, B, C , instead of denoting angles simply, are the arcs subtending the angles in a circle of which the radius is r ; and let Q be the quadrant of the same circle; then $\frac{A}{Q}, \frac{B}{Q}, \frac{C}{Q}$, which are no other than Legendre's angles, are ratios, or quantities of no dimensions, that remain the same in all circles, and however the arcs are measured or compared. Now we can obtain equations between the sides of the triangle and the trigonometrical quantities $\frac{\sin A}{r}, \cos$

$\frac{\cos A}{r}, \frac{\sin B}{r}, \&c.$; and if we suppose that the same quantities are changed into the equivalent values expressed in terms of $\frac{A}{Q}, \frac{B}{Q}, \&c.$; we shall obtain the functional equations of Legendre, between the sides of the triangle and the angular quantities $\frac{A}{Q}, \frac{B}{Q}, \frac{C}{Q}$. It must be acknowledged, however, that this is some abatement in the simplicity of the equations. Yet it seems difficult to conceive any other way in which the ratios of the angles of a triangle to a right angle, can find their way into the same equations with the length of the sides. It deserves to be particularly noticed that there is no trigonometrical equation corresponding to the case

$$C = \phi(c, A, B),$$

which is a mere symbol without meaning, or rather an absurdity, marking an impossibility in the course of investigation pursued, and from which no certain conclusion can be drawn.

But it may be questioned whether, in sound philosophy, the algebraic analysis can be applied to investigate a really fundamental principle in any science. Analysis treats of number, and of measured magnitude, and of these alone. Some previous discussion founded on the peculiar nature of the magnitudes we have to consider, seems therefore to be necessary; their elementary properties must be explored at least to a certain extent; in order to enable us to compare and measure them, without which they cannot be brought within the scope of analysis. The excellence of the modern method of mathematical investigation consists in reducing the first principles in every case to the least number possible, not in dispensing with any one that is essential. This may be illustrated by referring to what so often happens in physical science. When observation and experiment have failed in discovering sufficient data, the analyst has recourse to the most probable hypotheses for obtaining the requisite number of equations. We are not now to discuss the proper use of such hypothetical investigations in promoting physical knowledge; our intention is merely to show that without sufficient data analysis is a useless instrument. Fundamental principles there must be, either legitimately obtained, or assumed hypothetically, or mixed up in a latent manner in the process of investigation. Whether there be any general character that distinguishes the principles inherent in the nature of things, which we should in vain endeavour to deduce from a foreign source; and whether the difficulty about parallel lines in geometry do not belong to that class; are points which we do not undertake to settle.

The

The modern analysis, from the universality of its application, has the supremacy of the mathematical sciences. It is the most powerful instrument of investigation that has yet been invented. But this potent engine cannot put forth its strength, until a proper fulcrum has been prepared for it.

Professor Leslie has himself attempted to improve the theory of parallel lines, and we shall add a few observations on his manner of treating this difficult subject. His definition is most faulty, involving the idea of infinity. For what notion can we have of two lines with no mutual inclination, except we conceive that they make at first a small angle which decreases to zero. But the definition is set down only *pro forma*, and may be blotted out without being missed, since it is doubtful whether it be once referred to in the whole treatise. In reality we are left to gather the sense we must affix to parallel lines from the descriptive and illustrative writing in Prop. 22. book 1st; for demonstration it cannot be called. All this may be very elegant, but it is not in the spirit of the Greek geometry. It is directly opposed to the example of Euclid, who has taken so much pains to avoid whatever is vague, and to exhibit every point to the understanding of his readers in a definite form. But the learned Professor has not been successful in removing any difficulty, or in throwing light upon any obscure subject, in elementary science. If new proofs of this were wanting, we might refer to the manner in which he has treated the composition of forces; the permanent axes of rotation; and other matters, in his late volume on Natural Philosophy.

Legendre complains that a part of a private letter of his to the learned Professor was published without leave asked and obtained. But the anonymous correspondent who has been dragged before the public in so notable a manner in this dispute, has a much more grievous cause of complaint. His opinion with respect to these demonstrations, communicated in a private letter, was partially published without his knowledge: the part of his letter which seemed to corroborate the opinion of the Professor being laid before the public, while no notice was taken of another part which coincided with the opinion of Legendre and was opposed to that of the Professor.

March 3, 1824.

DIS-IOTA.

XXIX. *Experiments on the Adhesion of Nails.* By
B. BEVAN, Esq.

To the Editors of the *Philosophical Magazine and Journal.*

Leighton Bussard.

NAILS of various kinds have been used for many centuries, in almost every part of the world, and constitute one of the most general modes of fastening substances together. Every carpenter is familiar with the use of the nail, and possesses a practical knowledge, more or less accurate, of the force of adhesion of different nails and in different substances, so as to decide without difficulty, what number, and of what length, may be sufficient to fasten together substances of various shapes, and subject to various strains. But so far as my inquiries have been made, I have not been able to find any authentic experiments, of the real force of adhesion of different nails, when driven into wood of different species; or to learn the actual weight, without impulse, necessary to force a nail a given depth into wood, and also the proper force required to extract the same when so driven. With a view to obtain some useful knowledge upon this elementary mechanical question, I had a machine constructed to measure the force of pressure and tension with extensive power, and applied it to the extraction of nails of different lengths, from a quarter of an inch to two and half inches.

Theoretical investigation points out an equality of resistance to the entrance and extraction of a nail, supposing the thickness to be invariable; but as the general shape of nails is tapering towards the points, the resistance to entrance becomes of necessity greater than that of extraction:—in some of my experiments I have found the ratio to be about 6 to 5.

The following abstract will exhibit the relative adhesion of nails of various kinds, when forced into dry Christiana deal, at right angles to the grain of the wood.

	Number to the pound avoirdup.	Inches long.	Inches forced into the wood.	Pounds required to extract.
Fine sprigs	4560	0·44	0·40	22
Ditto.....	3200	0·53	0·44	37
Threepenny brads	618	1·25	0·50	58
Cast-iron nails...	380	1·00	0·50	72
Sixpenny nails...	73	2·50	1·00	187
Ditto.....	1·50	327
Ditto.....	2·00	530
Fivepenny.....	139	2·00	1·50	320

The percussive force required to drive the common sixpenny nail to the depth of one inch and half into dry Christiana deal, with a cast-iron weight of 6·275 lbs., was four blows or strokes falling freely, the space of 12 inches; and the steady pressure to produce the same effect, I found to be 400 lbs.

A sixpenny nail, driven into *dry elm* to the depth of one inch across the grain, required a pressure of 327 lbs. to extract; and the same nail, driven endways or longitudinally into the same wood, required a force of 257 lbs. to extract.

The same nail driven two inches endways, into dry Christiana deal, was drawn by a force of 257 lbs.;—to draw out one inch, under like circumstances, took 87 lbs. only. The relative adhesion, therefore, in the same wood, when driven transversely and longitudinally, is 100 to 78, or about 4 to 3 in dry elm; and 100 to 46, or about 2 to 1, in deal. The relative adhesion under like circumstances to elm and deal is found to be about 2 or 3 to 1.

The progressive depths of a sixpenny nail into dry Christiana deal by simple pressure, were as follows:

One quarter of an inch a pressure of	24 lbs.
Half an inch	76
One inch	235
One and half inch	400
Two inches	610

I may observe, that in the above experiments great care was taken to apply the weights steadily, and that towards the conclusion of each experiment the additions did not exceed 10 lbs. at one time, with a moderate interval between, generally about one minute, sometimes 10 or 20 minutes. In other species of wood, the requisite force to extract the nail was different. Thus, to extract a common sixpenny nail from a depth of one inch

Out of dry oak, required	507 lbs.
dry beech	667
green sycamore	312

A common screw of 1-5th of an inch diameter, I have found to have an adhesion about three times that of a sixpenny nail.

From these experiments I am able to infer, that a common sixpenny nail, driven two inches into dry oak, would require a force of more than half a ton to extract by steady pressure!

I am, gentlemen, yours &c. &c.

B. BEVAN.

XXX. *Papers relating to the Earthquake which occurred in India in 1819.*

[Concluded from p. 119.]

Extracts from Letters of Captain BALLANTYNE, Agent in Kattivar, for his H. S. the Guicwar, concerning the Earthquake.

Letter addressed to Lieut.-col. BARCLAY.

Jooria, June 17, 1819.

WE have had a complete earthquake since yesterday evening at half past seven o'clock. The shocks have been numerous and severe, and the tremulous sensation does not yet cease.

The whole town is literally a ruin: the works are shaken from the foundation, and in many places thrown down. The old tower, which I had given up to Dr. Roy, is a complete ruin: the roof falling in, crushed all his things, and it is almost miraculous that we happened to be out. My sitting bungalow and sleeping apartments are one shattered ruin.

The Dewanjee has quitted the town, and lives outside, it being really not safe remaining in buildings so much injured as those here are.

Letter addressed to Mr. WILLIAMS.

Jooria, June 18, 1819.

YESTERDAY morning we went out to the westward of the town to see some rents which had been caused by the earthquake in the fields there. The earth separating, had in some places emitted water and fire. On examining the different rents, we found them to be of various extent, from an inch to a foot in breadth; the depth however in all of them was considerable, being to 10, 15, and 20 feet. In some places a black sandy and gravelly soil had been thrown out; in others, a black wet earth.

The shocks during the night of the 16th were frequent, but not very severe, and the tremulous motion of the earth scarcely ceased.

On the morning of the 17th the weather was close, and the tremulous motion continued in a very sensible and disagreeable degree: about 10 A.M. a distinct and severe shock was felt, but it did not last long.

We have had no rain, thunder, or lightning, for these six or eight days. The thermometer has ranged from 86 to 90 and 92 degrees. We had remarked on the 18th that the thermometer had risen two degrees.

The dreadful noise accompanying the earthquake was of a
rumbling

rumbling kind, and resembled sometimes that produced by the quick motion of wheeled carriages, and sometimes of a distant cannonade.

It is now between five and six o'clock (morning of the 18th): I have felt the motion frequently during the night, and am anxious as to what may yet happen. The morning is close, and appearances unfavourable. My table and chair are at this moment shaking under me.

We have already had accounts of this earthquake's having been severely felt and committing great havoc at Nowanuggur, Zoonabunder, Moorvee, Tunkaria, Dhewrole, Amrun, &c.; at the last place much of the fort has been thrown down, and eight or ten persons have been killed, besides many horses and cattle.

P.S. June 19th, another considerable shock has been felt; the weather is unusually hot, and appearances unfavourable.

*To GEORGE OGILVY, Esq. Secretary to the Medical Board,
Bombay.*

SIR,—I have the honour to report, for the information of the Medical Board, all the circumstances which have come to my knowledge regarding the earthquake which took place in Cutch on the 16th instant; and which, if we take into consideration the severity of the shock, and the damage sustained within the range of its operation, has seldom been equalled in modern times. This subject, I am aware, is but little connected with medical science; but as forming by far the most interesting and awful part of the natural history of the globe, I have no doubt every thing relating to it will be acceptable to the Board.

Different from what has generally been observed in the greater number of severe earthquakes, nothing in this previously occurred, in the state of the atmosphere or otherwise, to indicate the probability of any unusual phænomenon taking place. The months of March and April were extremely hot and oppressive; but during May the weather became milder, and remained much the same as it generally is in that month. About the second or third of June, at night, there was a severe squall of thunder and rain, which lasted for about an hour and a half. After this the temperature of the air became mild and agreeable; and till the very moment that the earthquake took place, nothing could be observed to indicate even the smallest change in the weather, far less the approach of such a dreadful convulsion.

The first and great shock took place a few minutes before seven o'clock in the evening of the 16th, and the general
Y 2
opinion

opinion is that it lasted nearly two minutes. The motion of the earth during this period was most awful and alarming, giving to most people the feeling as if it was about to open and swallow every thing up. In this short space the town of Bhooj, nearly three miles in circumference, became almost a heap of ruins; most of the houses were thrown down, and the greater part of the ramparts and towers, with the guns, were precipitated into the ditch. Nothing was seen by those at a distance but a thick cloud of dust. The same occurred in a greater or less degree in every town and fort from the eastern extremity of Wagur to Luckput on the Indus; and even the smallest villages have been levelled with the ground.

The shock appeared to increase in violence as it continued, and suddenly to stop, leaving a kind of tremour; some people said it was preceded by a noise like thunder or the rattling of a number of carriages, but this was not generally observed. Difference of opinion also exists as to the kind of motion that took place; some people considering it was undulatory, others as a kind of tremour, and others again as coming directly upwards. The last kind of motion appeared to me very evident, though being at the time surrounded by houses and walls falling in every direction, I might not be so well able to judge. I felt as if the force was acting directly where I stood, and as if the earth was making an effort to burst immediately under my feet. People appear to differ as much as to the quarter from which the shock came; nor is it to be ascertained from any general direction in which the walls of the towns or houses have fallen: they appear to have tumbled in every direction indiscriminately, and frequently one half of the same wall has fallen on one side and the other half on the other.

As far as I have been able to ascertain, in no place has the surface of the earth suffered any important alteration from the shock. There are reports of fire having issued from hills to the westward of Bhooj, but I do not think they will be found correct. On the 17th I travelled between Bhooj and Anjar, a distance of twenty-seven miles, and part of the road through hills; and though I looked carefully in every direction, I could perceive no recent changes. In the bunds of tanks and the steep banks of ravines, small rents could be perceived: in the hard rocky soil, which forms the general surface of the country, no alteration was to be seen. After the shock several dry rivers became filled with water, which afterwards gradually subsided. About Anjar the water in the wells became of a milky colour, but was not altered in taste.

With respect to the places affected by the shock, Anjar
and

and Bhooj appear to have suffered much more than any other I have yet heard of; in the former nearly 200 dead bodies have been dug out of the ruins, and in the latter 1000 are supposed to have perished, besides numbers in both towns miserably maimed. It would be impossible even to guess at the number of victims throughout the country: it will be sufficient to remark that not only in large towns the fatal effects of the shock have been felt, but even in the smallest villages some lives have been lost. In Anjar the effects of the shock appear to have been greatly modified by difference of situation; the quarter of the town towards the east, and which is the lowest, has been reduced to one mass of ruins. Neither street nor lane is to be discovered, and literally there is not one stone remaining on the top of another: the town wall on this side has suffered in an equal degree. The other part of the town, with the wall, though dreadfully shattered, does not appear to have suffered one tenth part of the injury. This must be accounted for from the lower part being situated at a considerable distance from the rock, upon a bed of white aluminous earth, while in the higher part the foundations of the houses are situated immediately upon the rock. It could not be owing to the shock being more severe in that particular place, as, extending over such a considerable tract of country, its force could not have differed in such a small space.

Since the 16th constant shocks have been felt, perhaps all together nearly thirty in number. The weather continues much the same as might be expected at this season. The wind is very variable: heavy squalls are suddenly succeeded by dead calms. The atmosphere is cloudy, with a hazy horizon. There is nothing peculiar in the appearance of the sun at rising or setting; only one meteor (a ball of fire) has been observed since the occurrence of the earthquake, and that was on the night on which the first shock took place.

I have to apologize for the unconnected manner in which the above account is detailed; but the mind cannot be quite at ease in the midst of so much desolation, and while the awful phænomenon that produced it is still in some degree impending. Should any thing additional worth reporting come to my knowledge, I shall immediately communicate it to the Board. I have the honour to be, sir,

Your most obedient humble servant,

(Signed) JAMES M'ADAM,

Assistant-Surgeon.

Anjar, 29th June 1819.

P.S. I had no opportunity of forwarding the above letter till to-day. Shocks still continue to be felt, and there was a very smart one yesterday evening. The earthquake appears

to

to have been felt all over Kattiwar, and as far east as Kaira and Baroda; also at Radhunpoor, and I believe in Sind. Cutch, from all accounts, appears to have been the centre of its operations, and especially the western part of it. Moondra and Mandavi, two large towns on the sea-coast, have suffered in comparatively a trifling degree; but the inland towns and forts towards the Indus have been almost completely destroyed. There has been a heavy fall of rain at this place, and the weather continues cool and pleasant.

(True copy)

(Signed) GEORGE OGILVY,
Sec. Medical Board.

Copy of a Letter from Captain ELWOOD.

Poorbunder, June 7, 1819.

WE yesterday evening experienced in this fort and city one of the most awful scenes in nature, that of a violent and destructive shock from an earthquake.

The weather was close and sultry: the thermometer ranged at 86° at sunset, and a light air, scarcely perceptible, was sometimes felt from the southward. An officer and myself were taking an evening walk on the ramparts of the fort, and had gone nearly all round, when, at 40 minutes past six, we observed to each other how excessively close and oppressive the atmosphere was; and five minutes after, I heard a distant sound not unlike that of a cannonade at sea. A thought had scarcely passed the mind as to what could give rise to the sound, when I felt a violent shock beneath my feet, and instantly exclaimed, "An earthquake!" Looking at the same time forwards, I saw the stone parapet at two yards distance violently agitated by a quick, short, wave-like motion, bending in and out with the greatest pliability, and with the vibration of about a foot, and attended with an incessant hissing cracking noise. I thought it impossible that the works could stand, and, expecting their immediate fall, I instantly determined on descending as quickly as possible; but as the rampart was a perpendicular height of masonry of about 20 feet, I was obliged to run back towards the nearest ramp, which was a flight of stone steps at some distance. The officer I was walking with followed; and as we passed along at a quick rate, the sensation felt was similar to that dangerous and disagreeable one of running along an elevated and elastic plank, the ends alone of which are supported. I every instant expected to fall with the works, or to be precipitated from them; but, reaching the steps, ran down as fast as I could, each lower step apparently meeting the descending foot (which I really

really believe was the case, as the whole flight of steps was violently agitated).

While passing down, I expected to be overwhelmed by the works, which were touching my right shoulder, and above my head.

Although the rampart and parapet are about twelve feet thick, and twenty-five feet in height, yet this wall of masonry waved to and fro.

Fortunately the steps were broad; had they been narrow, as is frequently the case, so great was their agitation that it is doubtful if we should have got down without being thrown over the side. Arrived at the bottom of the ramp, we did not cease running until we had got to a sufficient distance from the works to prevent their falling on us. On halting, we were surprised to find that the works had not fallen after so extraordinary an undulating motion.

On reaching a place of comparative safety, for there was no place absolutely safe, the attention was attracted by a vast cloud of black dust arising at about three hundred yards distance, and from the sea face of the fort, which ran at right angles with the one we had quitted. The danger being past, my curiosity became excited; and approaching the cloud of dust, I found it to be occasioned by the fall of towers and of large portions of the curtain, leaving several breaches, some forty and some sixty yards wide. This devastation extended for five hundred yards, and over a part of the fort which I had been walking on not five minutes before.

I do not imagine that a twenty-four hours' fire from ten pieces of heavy ordnance could have produced so extensive a destruction as was thus effected in the space of a minute and a half. We conjectured that the awful shock had not lasted more than that short period. Short as it was, it was powerful enough to destroy the work of ages.

We now directed our attention towards home, and the first occurrence that was met with near it, was the horse-keepers with the horses in their hands standing in the open air; having been apprehensive, as they said, that the stables would have fallen and killed the horses.

On entering the house, my servant informed me, that while making my bed in one of the upper apartments he had been thrown down on the floor, and that before he could make his escape he was thrown down a second time.

A gentleman and lady, on hearing all the tiles of their house in motion, and crackling as if in a fire, and observing the whole of their furniture shaking, immediately got down stairs into the open air. The gentleman informed me, that
although

although his stairs were broad and built of very solid masonry, such was the agitation they were thrown into by the earthquake, that he experienced much difficulty in descending.

An officer's house, a very substantial stone building about forty feet high, which stands by itself, appears to have been affected by the shock more than the other houses. The sepoy's describe it as having rocked from side to side as a tree in a high wind. On examination, so many rents were found in the walls that it was deemed inadvisable to sleep under its roof.

I believe there are few houses throughout this large city which are not more or less injured. Some have fallen so as to block up the streets in which they were situated.

The rajah and the principal inhabitants are now encamped outside; which they prefer to trusting themselves in their own houses, the fall of which would prove very destructive, as they are made of a thick terrace supported by stone or weighty timber.

The earth opened, and water issued from the cavity, in a plain fourteen miles hence.

The atmosphere to-day has been impregnated with a strong smell of sulphur; and between 10 A.M. and 2 P.M. there were several other shocks, which brought down some old houses: but these shocks were not to be compared with yesterday's awful phenomenon.

It was observed that all animals were much frightened: the dogs lay down on their bellies and would not be moved.

The earthquake in the interior appears to have been less violent than near the sea-shore.

I am this moment informed that fifty men have been killed by the fall of walls at Mangarole, which is distant hence 80 miles in a S.E. direction.

Copy of a Letter addressed to Captain KENNEDY.

Camp, Sirdas, June 17, 1819.

SIR,—Being a Member of the Literary Society, I deem it a kind of duty that attaches to me, to record for the information of the Society any fact or circumstance of considerable interest which may fall under my observation connected with the objects of the Society.

In these sentiments, I now have to mention the occurrence of the shock of an earthquake here yesterday evening. It occurred about seven o'clock. It was such as to alarm every one who felt it. The earth under us seemed to rise and fall very considerably; so considerably, indeed, that I myself could not stand steadily. Every one who felt it became in
some

some degree giddy. It was not felt by any one who was on horseback; and this was the case with several of our officers. Every one, however, who was on the ground felt it to be very alarming.

The duration of it was not measured by any one, but I think it lasted about two minutes. It was at first slight, and towards its termination the motion became less and less violent.

We have had no accounts of it from neighbouring towns; so that I am led to suppose it has not been so violent as to do much mischief in other places.

This country, Kattiwar, is rocky and rugged. The rock is of the trap kind, containing great quantities of agate and crystallized quartz.

I have observed nothing of a volcanic nature, unless the trap be considered such.—I now have the honour to remain,

Sir, your very obedient servant,

(Signed) G. A. STUART,
Assistant Surgeon, 1st Light Cavalry.

XXXI. *On the Circular Micrometer.* By F. BAILY, Esq.
F.R.S.

THE circular micrometer is an instrument which has been, for many years past, much used on the continent, and is still held in high and deserved estimation there by astronomers of the first rank. From the simplicity of its construction, and the facility with which it may be used in any position of the telescope, it is frequently preferred, even in public and national observatories, to micrometers of a more complex nature, which require to be adjusted to the equatorial motion of the star. Moreover, there is no necessity for its being illuminated; on which account it is peculiarly adapted to the observation of comets and small stars: and it is indeed to these two classes of the heavenly bodies, that its application is now principally confined; although some astronomers of great eminence have considered that it is capable of equal accuracy to the wire micrometers. To voyagers and others, who are travelling for the improvement of astronomy and geography, it will prove of considerable advantage. The smallness of its size (it being not much larger than a shilling) renders it very convenient for carriage; and the simplicity of its construction prevents any liability to injury. On this account it ought to form a part of the apparatus of every person travelling under the circumstances above alluded to.

Astronomy is indeed more indebted to this little instrument

ment than is perhaps generally known. Three out of the four new planets which have been discovered in the present century, were discovered with *very small telescopes*, and their motions watched, and the elements of their orbits deduced *from observations made with the circular micrometer only*: whereby astronomers were enabled to look out for them with certainty, at the time of their re-appearance at the next oppositions. And at the present hour it is almost the only instrument used on the continent for the observation of comets. To the labours of Olbers, Bessel and Fraunhofer, we are indebted for the high reputation which this little instrument enjoys. To the two former, for the talent which they have displayed in explaining the analysis, by which the observations may be reduced: and to the latter for the recent improvement which he has introduced in the construction of the instrument. In a communication like the present, it cannot be expected that I should enter very minutely into a subject of this kind: my object being merely to draw the attention of practical astronomers in *this* country to an instrument which appears to be very little known here: but which is capable of doing much useful work at a very little expense; and of assisting the observations of those who are fortunately possessed of more splendid and powerful instruments.

By the kindness of Professor Schumacher, who is ever zealous in promoting the interests of astronomy, I have obtained one of M. Fraunhofer's circular micrometers, of the most improved and recent construction. This instrument is the same that was exhibited at the last meeting of the Astronomical Society of London*; and is called by M. Fraunhofer the *suspended* circular micrometer, from the circumstance of its appearing (in the telescope) as if suspended in the heavens without any support. It consists, in fact, of nothing more than a circular piece of plate-glass about one inch in diameter, in the centre of which a circular hole is cut, of half an inch in diameter. To the inner edge of this glass circle a narrow ring of *steel* is firmly and securely fastened; and, the whole being put in a lathe, the steel ring is turned perfectly circular, and reduced to a very *thin* edge, both at its exterior and its interior circumference. The glass, with its steel circle, is then burnished into a brass ring or cap, by means of which it may be placed, when required, in the focus of the telescope.

The advantages attending this construction are, 1° the preservation of the circular form of the ring, as it comes from the lathe, without the risk of its being injured in attaching it

* See the proceedings of this Society, at the end of the present Number of our Journal.

to the telescope in the usual manner: 2° in the use of *steel* instead of brass, whereby a finer edge may be given to the circumferences*: 3° in rejecting the metal arms by which these rings were formerly attached to the sides of the telescope, from the unequal expansion of which (or any external violence given thereto) the perfect form of the circle might be injured, without being immediately detected: 4° in thus avoiding the obstructions which those arms might in some cases, by their position, occasion in the observations of the passage of a star before it entered the interior of the ring.

In Plate III. fig. 4, I have given a drawing of this micrometer, on a scale just *double* its real dimensions: the whole instrument, in fact, not being larger than the broad inner circle there delineated. By means of the outer glass circle, the star can be seen, from the time that it enters the field of view, until it reaches the steel circle; at which time the observer must be prepared to make the observation required. But, previous to the application of this instrument to any useful purposes, it will be necessary to determine with accuracy the radius of the inner circle (which I shall denote by r) in the following manner. Let the telescope be turned towards any known star, situated as near to the equator as possible; and as nearly in the direction of the meridian as possible, in order to prevent the errors arising from refraction. In the diagram (fig. 4) I have presumed that the telescope inverts; and that the star makes its appearance in the field of the telescope on the right-hand side at Q. If we suppose the path of the star to be along the line QQ', then will this line be one of the parallels of declination, and the line NS, perpendicular thereto, one of the horary circles: N being to the north and S to the south. A very few trials will enable the observer to place the telescope in such a manner that the star may pass *exactly through the centre* of the field of the circle. Note, by the clock, the time of the ingress of the star, from behind the broad circle at O; and also the time of its egress at O'. Let t denote the former, and t' the latter; then will

$$15 \times \frac{t' - t}{2} \times \cos \delta = r$$

be the radius of the *inner edge* of the broad circle; and will be a constant quantity to be used in all the subsequent computations. In this equation I have assumed δ equal to the declination of the star observed; which, in this case, is the same as the declination of the *centre* of the circle.

* As *steel* may be liable to rust, particularly on sea voyages, probably *gold* would be preferable on such occasions.

When an observation is to be made with this micrometer, let the telescope be directed towards the object (a new planet, a comet, or other small body) which may be made to describe any chord of the inner circle; and note the time of its ingress at p , and its egress at p' : let us represent the former by τ , and the latter by τ' . The telescope remaining perfectly steady, note also the ingress and egress of any known star, contiguous thereto, at s and s' : and represent the respective times, as shown by the clock, by θ and θ' . Then will

$$\frac{\tau'+\tau}{2} \text{ and } \frac{\theta'+\theta}{2}$$

be the respective times of the transit of the planet and the known star at h and k , or at the horary circle NS. Consequently the difference in the right ascension of these two bodies will be

$$dR = \frac{\theta'+\theta}{2} - \frac{\tau'+\tau}{2} \quad (\text{A}).$$

The method of determining the difference of declination is somewhat more complex.

It is evident that the semi-chord $ph = \frac{\tau'-\tau}{2} \cdot 15 \cdot \cos \Delta'$: and that the semi-chord $sk = \frac{\theta'-\theta}{2} \cdot 15 \cdot \cos \Delta$: Δ being the declination of the known star, and Δ' the estimated declination of the small planet or comet. Make

$$\sin x = \frac{sk}{r} = \frac{7.5}{r} \cdot (\theta' - \theta) \cdot \cos \Delta$$

$$\sin x' = \frac{ph}{r} = \frac{7.5}{r} \cdot (\tau' - \tau) \cdot \cos \Delta'$$

then we shall have

$$Ck = r \cos x = \text{the dist. of } k \text{ from the centre } C$$

$$Ch = r \cos x' = \text{the dist. of } h \text{ from the centre } C$$

whence we obtain the difference of declination

$$dD = r (\cos x - \cos x') \quad (\text{B})$$

These computations are founded on the supposition that the known star and the comet both pass through the circle, on the *same* side of the centre C: that the known star is situated to the *northward* of the comet; and that it passes through the circle *after* the comet. But it is easy to apply the same principles to any other relative position of the bodies observed: since it is only necessary to attend to the *signs* of the respective quantities. Sufficient has been here stated to point out the general mode of computation in such cases. The reader who is desirous of pursuing this subject more at length

length may consult the *Monatliche Correspondenz* by Baron Zach, vol. xvii. xxiv. and xxvi.; where he will find formulæ adapted, by M. Bessel, to almost every case that can arise in practice. See also Santini's *Elementi di Astronomia*, vol. i. page 261.

Although I have, in this communication, alluded only to the immersion and emersion of the bodies with respect to the *inner* circumference of the ring, yet it is evident that the same principles may be applied to the immersion and emersion of the bodies with respect to the *outer* circumference of the ring, at π , σ , and π' , σ' , respectively. And these double observations will tend to ensure greater accuracy. M. Fraunhofer however considers that the edge of the inner circle is more perfect than that of the outer one.

It must be evident that the correctness of any results, deduced from a micrometer of this kind, will depend on the accuracy with which the circles are turned and finished. In this respect M. Fraunhofer's micrometer seems as perfect as human skill can make it: and it certainly does credit to the talents of this distinguished artist.

XXXII. *Mineralogical and Chemical Examination of Hyalosiderite, a new Mineral.* By Dr. WALCHNER, of Freiburg in the Breisgau.* (With a Plate of Crystals.)

I. *Mineralogical Description.*

§ 1.

THE mineral, of which I now communicate an examination, is found on the Kaiserstuhl in the Breisgau, a rock belonging to the trap formation, in the neighbourhood of the village Sasbach, in a basaltic amygdaloid, of a reddish and liver-brown colour, accompanied with augite and bitter spar.

I found it so long ago as the year 1819, when on a mineralogical excursion which I undertook upon this interesting mountain. The opinions concerning it were very various: sometimes it was declared to be olivine, and sometimes it was pronounced to be augite. Both assertions appeared to me improbable, and I felt inclined to look upon it as a mineral hitherto unknown. A more particular examination of its form and composition strengthened my opinion. At Göttingen, where I afterwards continued my studies, I resumed my investigation of the subject, and communicated the re-

* From Schweigger's *Neues Journal für Chemie*, &c. band ix. p. 65.

sults of it, together with the mineral, to my honoured teacher M. Hausmann; who acknowledged it to be a new mineral, and was so good as to direct my attention to the analogy between it and crystallized iron slag.

§ 2.

Hyalosiderite occurs for the most part in crystals; but likewise in small blunt-edged, friable, loosely coherent grains. The crystalline forms hitherto observed in it are the following:

(1.) The rectangular octahedron, having its terminal solid angles replaced by tangent planes (fig. 1).

This form varies,

a.) By the different proportions of the terminal planes to those of the octahedron. The former are sometimes so large in proportion to the latter, that the crystallization acquires the appearance of a rectangular four-sided tablet bevelled on each side (fig. 2).

b.) By the elongation in either direction of the edges of the base, which is sometimes so considerable, that the form becomes prismatic (fig. 3).

(2.) The same crystallization (1) with the greater edges of the base replaced by tangent planes, those planes generally small (fig. 4).

(3.) The same crystallization (1), with the greater edges of the base replaced by two planes. The size of the new planes varies in proportion to that of the others. They are sometimes small (fig. 5), and sometimes so enlarged that the planes of the octahedron on which they rest almost disappear (fig. 6).

(4.) The same crystallization (1), with the solid angles of the base replaced by two triangular planes, usually very small (fig. 8).

(5.) The same crystallization (1), with all the edges of the base replaced by two planes (fig. 7).

Twin crystals I have not met with.

§ 3.

The crystals are very small, scarcely of the size of lentils; they appear when the amygdaloid has become disintegrated, as they resist the action of the elements for a greater length of time; they are either attached to augite, or freely disseminated in the amygdaloid; and are, for the most part, imperfectly formed. Their surface is smooth, and exhibits, in an oblique light, sometimes a brass yellow, or a gold yellow colour, sometimes the colour of tarnished steel; which is owing to a thin coat of perhydrate of iron, investing most of the crystals. Their proper colour is reddish- or yellowish-brown.

Fracture

Fracture small conchoidal; external lustre metallic, of the fracture vitreous; hardness, in newly exposed crystals, between that of felspar and that of apatite; cleavage at right angles to the axis of the octahedron AA' (fig. 9), not very perceptible.

Transparent on the thin edges, or in small splinters, with a hyacinth red colour passing into a wine-yellow; the streak of a cinnamon colour. Specific gravity 2.875; temp. 70.7 F.

Single crystals are sometimes attracted by the magnet; but always after they have been made slightly red hot, by which they are rendered black.

Before the blow-pipe they immediately become black and melt into a globule, which is attracted by the magnet.

With borax they are readily and completely reduced to a transparent glass, which, while hot, has a yellowish-green colour, that almost entirely disappears on cooling if but little of the mineral has been employed; but if the borax be saturated with it, it becomes black and opaque. They are dissolved by salt of phosphorus into a clear greenish glass, leaving a skeleton of silica behind, and the glass after cooling becomes colourless.

If the boracic glass, containing a small portion of the mineral, be cautiously treated with tin, the globule, after it has become quite cold, exhibits a slight but determined beautiful green colour.

§ 4.

From the nature of the forms above enumerated we may assume, that the system of crystallization of this mineral is a trimetric one*. The planes d and d' , presenting themselves most frequently, and which form the rectangular octahedron, appear then as bounding planes, which truncate rectangularly the edges of the base of the ground form; the planes a as the horizontal, and the planes P as the primary planes, since the edges, which those planes form with the planes d' and d , are in parallelism with each other.

§ 5.

The primary planes are too small for the measurement of their mutual inclination. The inclination of the planes d and d' may be determined most exactly, although, on account of the smallness of the crystals, even these measurements remain imperfect. The inclination of d on d' was determined to be 141° , and the inclination of d' on a amounted to rather more than 130° . Now if these measurements are taken as the basis for determining the mathematical character of the primary

* Hausmann *Unters. üb. d. Form. d. lebl. Nat.* i. p. 417.

form (fig. 9), then the following proportion of inclination for the base would pretty nearly approach the truth :

$$B'E : EC : CA = \sqrt{23} : 7 : 10.$$

The inclination of the primary planes on the principal axis, or the angle EAC , would, according to this proportion, be $= 34^\circ 59' 38''$, and the angles of the base $B'B'B = 111^\circ 10' 6''$, and $B'B'B' = 68^\circ 49' 54''$.

§ 6.

Besides the primary planes, the bounding planes A, B', D, D' occur in the crystals hitherto observed, the inclinations of which may be found immediately from the proportion of inclination on the base. The planes r' and r , on the contrary, are secondary planes, from the second division of the vertical edge-zones. The inclination of the planes r' which appertain to the first vertical edge-zone, was ascertained with some exactness. They answer to the secondary proportion $2CB' : 3CA$; whence the sign $B'A\frac{2}{3}$ belongs to them. The planes r probably answer to an analogous secondary proportion in the second vertical edge-zone.

§ 7.

The denotation of the different crystalline forms hitherto observed in this mineral would consequently be,

1. 2 A. 4 D'. 4 D. (fig. 1, 2, 3.)
 $a \quad d' \quad d$
2. 2 A. 2 B'. 4 D'. 4 D. (fig. 4.)
 $a \quad b' \quad d' \quad d$
3. 2 A. 4 D'. 4 D. 4 B'A $\frac{2}{3}$. (fig. 5, 6.)
 $a \quad d' \quad d \quad r'$
4. 2 A. 4 D'. 4 D. 4 B'A $\frac{2}{3}$. 4 BA $\frac{2}{3}$? (fig. 7.)
 $a \quad d' \quad d \quad r$
5. 8 P. 2 A. 4 D'. 4 D. (fig. 8.)
 $p \quad a \quad d' \quad d$

The chief inclinations are,

P on P'	=	110°	0'	44''
a ... d'	=	130	18	56
a ... d	=	141	4	54
d' ... d'	=	99	22	8
d ... d	=	77	50	12
d' ... b'	=	139	41	4
r' ... a	=	119	29	47
r' ... d'	=	169	10	51
r' ... r'	=	121	0	26

§ 8.

On a comparison of the crystallization of the hyalosiderite with

with the crystals of slags, formed in various metallurgic processes, we find a corresponding similarity not only in the forms in general, but also in the angles of inclination of the planes. The measurement of these angles, which M. Hausmann has given in his *Specimen Crystallographiæ Metallurgicæ*, § 32, could be but very imperfect on account of their small size. The determinations here communicated, which cannot indeed boast of very great accuracy, will contribute to adjust in some measure the determinations published in that treatise.

The rectangular octahedron described by M. Hausmann (fig. 14, 15, 16) is formed by the planes which are here marked d and r' ; the planes d answer to the planes M, chosen in the definition of that treatise; so that the planes r' correspond with the planes P. Later observations have also acquainted us with the planes d' in the crystallized slag. The rectangular bases of the rectangular octahedrons in the crystallized slag, namely in that from the copper pyrites smelting works at Lauten (Hausm. *Spec. Cryst. Met.* fig. 18), answer perfectly to an octahedron formed by the bounding planes d' and d . The angles which the diagonals of the rectangular bases form with their edges, are similar to the semi-angles of the base of the ground form, consequently = $\angle CB'B$ and $\angle CBB'$. These angles measure, according to the fundamental proportion of inclination above assumed, $55^{\circ} 35' 3''$ and $34^{\circ} 24' 57''$.

II. Chemical Analysis.

§ 9.

The hyalosiderite brought to a red-heat, whether in a glass retort or in a platinum crucible, becomes black, but does not yield any perceptible quantity of water; nor is it perceptibly altered in texture or in weight.

Concentrated muriatic acid attacks the mineral even when cold, dissolves it by the aid of a gentle heat, and forms with it, on evaporation, a gelatinous mass, which after desiccation was evidently silica.

a.) A few decigrammes of the powdered mineral were now treated with concentrated muriatic acid, until their solution was completely effected; the solution evaporated to dryness by a gentle heat; the residuum extracted by water, acidulated with the same acid, and separated by a filter. The yellowish fluid thus obtained was mixed with caustic ammonia, which produced a reddish-brown precipitate. This was again dissolved in muriatic acid, in order to ascertain whether mag-

nesia was present, and the solution was carefully neutralized with carbonate of soda. Perhydrate of iron was separated, which was treated with caustic potassa and then separated by filtration from the alkaline fluid, from which muriate of ammonia precipitated a little alumina. The solution, from which iron and argillaceous earth had thus been separated, was mixed, at a boiling heat, with carbonate of soda. The copious precipitate thus obtained consisted of magnesia, which, after desiccation and exposure to a red-heat, and re-solution in dilute nitric acid, yielded a little oxide of manganese. The neutralized solution of magnesia in nitric acid became turbid, but in a scarcely perceptible degree, by the addition of oxalate of ammonia.

b.) A second portion of the mineral was treated with muriatic acid, in order to ascertain the alkali which it might contain: the solution was evaporated to dryness, the silica separated in the usual manner, and the fluid remaining after the separation of the silica precipitated with caustic ammonia and with its carbonate. The residuum obtained by evaporation, was ignited in a platinum crucible, in which muriate of potassa remained.

It will be seen from these experiments that the hyalosiderite consists of silica, oxide of iron, magnesia, alumina, oxide of manganese, and potassa.

§ 10. A.

In order to determine the proportions of the constituent parts of this mineral, it was subjected to the following analysis:

a.) 1.040 gramm. of hyalosiderite, reduced to the finest powder, were exposed to a moderate red-heat for about half an hour in a platinum crucible, with three times its weight of anhydrous carbonate of soda. The mixture, after fusion, was of a brownish-yellow colour, and gave, when softened with water and treated with concentrated muriatic acid, a clear yellow solution. By evaporation to dryness &c. 0.329 of calcined siliceous earth were obtained.

b.) After the separation of the silica, the remaining fluid was accurately neutralized with carbonate of soda. The precipitate thereby occasioned, after having been separated from the fluid, was digested, whilst yet in its moist state, with a solution of caustic potassa, so long as it became diminished in quantity; and the residual iron well dried and calcined gave 0.330 gramm. of peroxide of iron, = 0.309 protoxide of iron.

c.) The alkaline fluid of (b) was now treated with a solution of muriate of ammonia so long as precipitation took place.

This

This precipitate, after calcination, amounted to 0.023 gramm. and had the properties of pure alumina.

d.) The fluid (*b*), from which the iron and argillaceous earth had been precipitated, and which did not become turbid by the addition of oxalate of potassa, was again acidulated, evaporated to the requisite degree, and precipitated at a boiling temperature with carbonate of soda. The precipitate dried and strongly calcined gave 0.277 gramm. of magnesia, which, after being dissolved in dilute nitric acid, left 0.005 of oxide of manganese.

e.) The magnesia still contained in the remaining fluid of (*d*), after that had been previously neutralized with muriatic acid, and sufficiently concentrated, was precipitated by means of carbonate of ammonia and phosphate of soda; by which 0.164 gramm. of calcined phosphate of magnesia were obtained, which answer to 0.065 gramm of pure magnesia.

B.

In order to determine the proportion of potassa in the hyalosiderite, 0.567 gramm. of the mineral were treated with muriatic acid; the iron, alumina, magnesia, silica, and manganese, separated in the usual manner, the remaining solution evaporated to dryness, and the residuum calcined in a platinum crucible. What remained was dissolved in distilled water, and treated with muriate of platinum, and thus gave 0.055 gramm. of the triple salt = 0.016 gramm. pure potassa.

C.

As the relative effect of glass of borax in the treatment with tin seemed to indicate the presence of chrome in this mineral, a quantity of it, exactly weighed, was fused with nitrate of potassa in order to discover that metal. The melted mass was of a yellowish-brown colour with some grass-green streaks which originated from sub-manganesate of potassa. The soluble part was now properly extracted with water, the fluid thus obtained carefully neutralized with nitric acid, and then treated with a solution of protonitrate of mercury, on which a slight reddish turbidness merely took place, so that the quantity of chrome could not be ascertained.

According to this analysis, 1.040 gramm. of hyalosiderite,

yield	Silica (<i>a</i>)	0.329 gramm.
	Protoxide of iron (<i>b</i>)	0.309
	Magnesia (<i>d</i>)	0.272
	Ditto (<i>e</i>)	0.065
	Alumina (<i>c</i>)	0.023
	Oxide of manganese (<i>d</i>)	0.005
	Potassa (B)	0.029
	Traces of chrome	

100 parts of this mineral therefore contain

Silica	31.634
Protoxide of iron	29.711
Magnesia	32.403
Alumina	2.211
Oxide of manganese	0.480
Potassa	2.788
Traces of chrome*	
	99.227

§ 11.

Through the kindness of my honoured teachers MM. Hausmann and Stromeyer of Göttingen, I was enabled to submit to a chemical analysis some slags, the mineralogical similarity of which with our mineral has been mentioned above. The same method was followed in the analysis which was observed in that of the hyalosiderite, and I therefore briefly state the results.

§ 12.

An iron slag from the iron smelting works near Dax in the Pyrenees, which M. Hausmann has described †, and which M. Stromeyer kindly presented to me, had the specific gravity of 3.700 at the temperature of 73.4 F. and contained, in 100 parts,

Silica	32.959
Protoxide of iron	61.235
Magnesia	1.896
Alumina	1.560
Oxide of manganese	1.301
Potassa	0.204
	99.155

§ 13.

Another iron slag, from Bodenhausen in the Hartz, which in its external appearance bore the greatest resemblance to our mineral, was kindly presented to me by M. Hausmann. Its specific gravity was 3.529 at the temperature of 70.7 F. and it contained,

Silica	32.346
Protoxide of iron	62.042
Magnesia	1.404
Oxide of manganese	2.645
Potassa	0.285
	99.746

* My honoured friend Professor Buzengeiger directed my attention to the presence of chrome in this mineral. Chrome has probably been overlooked in many minerals. On a future opportunity I shall have occasion to point out its existence in a mineral long known and frequently analysed.

† Moll's *Ephemerides*, d. B. u. H. III. 1815, p. 39. ff.

A third

§ 14.

A third slag, which had been found many years ago at Lautenthal in the Hartz at copper-works where copper pyrites was smelted, and the crystallization of which has been described above (§ 8), I likewise obtained through the kindness of M. Hausmann. Its specific gravity at the temperature of 65·3 F. was 3·870.

As I had convinced myself by a previous analysis, that it contained copper, I directed through the solution in muriatic acid, after the silica had been separated from it, a current of sulphuretted hydrogen gas, treated the precipitate thus obtained with nitric acid, and then separated the oxide of copper by caustic potassa. The fluid remaining after the separation of the copper, was treated, whilst warm, with nitric acid, and heated for some time, so as to bring the iron to the maximum of oxidation; the analysis was then proceeded with as usual.

This slag from Lautenthal contained

Silica	29·245
Protoxide of iron	63·316
Peroxide of copper	2·646
Magnesia	1·304
Alumina	1·244
Oxide of manganese	1·460
Potassa	0·184

99·399

I consider that mineral as a slag likewise which Karsten has described, and which Klaproth analysed, under the name of volcanic iron-glass*. According to Klaproth's analysis, 100 parts of it consist of

Silica	29·50
Protoxide of iron	66·00
Alumina	4·00
Potassa	0·25

99·75

§ 16.

The crystallized slag is consequently a silicate of iron. This in the hyalosiderite appears to be combined with magnesia, which seems to replace the quantity of iron in the slag.

* *Beiträge*, V. 222 ff. Stromeyer in the *Gött gel. Anz.* 1810. st. 194. p. 1935. M. Hausmann has given further particulars of it in V. Moll's *Jahrb. d. B. u. H.* III. 1815. p. 39. ff.

From the analysis above detailed, it is evident that the mineral from the Kaiserstuhl is actually a new one. The name *hyalosiderite* has been suggested by its properties and its composition, and is derived from *ύαλος* glass, and *σιδηρος* iron. The formation of this mineral, it is probable, could not have been the result of operations like those by which the primitive rocks were produced; and we may thence assume, that the rock in which it occurs is of volcanic origin.

XXXIII. *On High-pressure Gauges.* By Mr. SAMUEL SEAWARD.

To the Editors of the Philosophical Magazine and Journal.

Gentlemen,

IT is highly creditable to the taste of your ingenious correspondent Mr. H. Russell, that he can extract so much amusement from the manufacturing of high-pressure gauges. I hope no one will be so selfish as to envy him the recreation of this harmless pursuit, more especially as he appears very prudently to confine his views to his own individual gratification.

Complexity in a machine or instrument should certainly be as much as possible avoided; but if all instruments are to be condemned which have a diversity of parts (which I understand by the term complex), we should never have enjoyed the benefits of a clock, a loom, or a steam-engine.

My idea of a high-pressure gauge is, that it should be useful; but if it is intended to be merely an amusing toy, why then I should commend Mr. Russell's choice of what he lauds so much as being simple and easy.

The instrument described by your correspondent in the last Number of your Magazine, is substantially the same as the common gauge which has been in use a long time past at the Portable Gas Works, where its defective and uncertain operation has been long known,—practically known in the way of business, not speculatively conjectured: in confirmation of which I beg to state, that the superintendants of that establishment were lately in serious contemplation of erecting a gauge 70 feet long, in order that the divisions of the scale might be of adequate length. This simple fact is, I think, a complete answer to Mr. Russell's crudities.

Mr. R. seems to entertain great fear of its being practicable to make a "tight joint between the glass tube and metal box."

It

It gives me pain to observe this display of ignorance; for I am sure I felt disposed to give credit to that gentleman for a greater share of mechanical skill than what such doubt would seem to argue. The making of such a joint is an every-day operation. However, to tranquillize his fears upon this point, I beg to say, that if a trifling escape of air should take place at this joint (which is quite absurd to suppose), it would not necessarily prove fatal to the instrument; because the defect can in a few minutes be detected and remedied by a method which for simplicity and ease will, I flatter myself, almost satisfy the fastidious notions of the worthy gentleman himself.

The method of rectifying "*my own*" gauge, I ought to have included in the description which I had the pleasure of transmitting to you; but it was inadvertently omitted: and I beg to return my grateful acknowledgements to Mr. H. Russell for affording me the present opportunity of supplying the omission.

All gauges acting by the pressure of confined air require occasional rectification, because, from the oxidation which takes place on the surface of the mercury, a portion of the air becomes absorbed; and if oil or other liquid be employed instead of mercury, there will be as great inconveniencies.

It is proposed that the chamber A (*vide* description of the gauge in your Magazine for January last) should be furnished with a small screw plug, and the induction pipe (*e*) with a small stop valve, similar to what is employed in the common gauge: by the closing of the latter the pressure of the gas will be shut off, and a communication made between the chamber B and the external air: in a similar manner, if the screw plug be removed, a communication will also be made between the chamber A and the external air: therefore, if there should be, from any cause whatever, a deficiency in the proper quantity of inclosed air, it will thus be immediately supplied, and the equilibrium restored. And with regard to any insensible escape of air at this joint, it is proper to observe that as the pressure of the gas is generally above 20 atmospheres, the mercury will therefore be some height up the glass tube; consequently the joint in question will mostly be sealed, and all escape totally prevented.

With many apologies for troubling you with such a long letter, I remain, gentlemen,

Yours &c.

London, March 8, 1824.

SAMUEL SEAWARD.

XXXIV. *Memoir on the Variations of the reflective, refractive and dispersive Powers of the Atmosphere, &c.* By T. FORSTER, M.B. F.L.S. Member of the Astronomical and the Meteorological Societies of London, and Corresponding Member of the Academy of Natural Sciences at Philadelphia, &c.*

IN the infancy of every science, the first great object to be achieved is the accumulation of phænomena appertaining thereto. In proportion as we are enabled to lay out these in their natural order and arrangement, in the same proportion we advance the science; and where we are enabled to unravel the particular causes of each, we promote a knowledge of it in the highest degree.

In the following observations it will be found that I have been enabled by observation and reflection to collect a considerable number of facts, and to place them in some sort of arrangement. And though much progress has not yet been made on the development of their precise causes, yet such as has been already known has been arranged in a way which is likely to facilitate and direct the future inquiries of more able and industrious speculators than myself; and it is with a view of thus engaging the cooperation of the many intelligent members which compose the Meteorological Society, that I have ventured to obtrude the ensuing crude observations on their notice at this early stage of our investigations.

The refractive power of the atmosphere has been long well known, and corrective tables of mean refraction intended to be applied to astronomical observations have been employed for many years. In my endeavour, therefore, to be brief, in order not to become obscure, I shall avoid as much as possible the reiteration of observations already before the public, as the reader may refer immediately to Bradley's tables, and to various works on refraction. But though the refraction of light by the intervention of the atmosphere is well known, that part of the subject which more immediately belongs to meteorologists, has been particularly neglected; I mean the *Variation in the Atmosphere's reflective, refractive and dispersive powers, resulting from the diffusion therein of different modifications of cloud at different times and places. And the various effects which this aforesaid variation produces, considered as a fluctuation in the prismatic property of the air through which the modified light of the sun, moon and stars severally is transmitted to the inhabitants of our globe.*

The object of this paper is therefore to show the liability of the

* Read before the Meteorological Society of London in February and March 1824, and published by permission.

atmosphere to great variations in this its power of reflecting, refracting and dispersing the rays of celestial luminous bodies, and consequently the necessity of some further corrective tables of refraction; and to show what particular modifications of cloud produce these properties of the atmosphere in the highest degree by being diffused therein.

Previous to entering into the ensuing inquiry, I wish to caution the general reader against ever confounding reflection, refraction, and prismatic dispersion, which are distinct properties. For example, the lightness of the sky in the day time is produced by the reflective power; while its appearing of a blue colour is an effect of a certain property which accompanies it, whereby certain blue rays are separated from the rest. As a more striking example of the dispersive power, I may instance the beautiful red, crimson, and yellow colours of the clouds produced on certain occasions by the light of the sun *reflected* by their surfaces, being *refracted* and *dispersed* by the aqueous atmosphere in its passage to the earth's surface.

I am aware that the clouds themselves may on some occasions possess the property of separating light; and to this cause I was formerly inclined to ascribe their colour; but subsequent experience and reflection have convinced me that the most brilliant tints seen in the clouds are the result of the dispersive power of the aqueous vapour existing in a state of general diffusion in the lower atmosphere, whereby the light reflected from the surface of the cloud is prismatically dispersed into separate rays in its passage through the lower atmosphere to the earth.

It must be borne in mind, that my observations below do not relate to those remarkable and special refractions which occur in certain definable clouds, as the rainbow, which results from reflections and special refractions of certain rays at a determinate angle in the *nimbus* or raincloud, producing concentric rings of colours conformable to their different degrees of refrangibility. Nor do I include those special refractions of light in its passage through the *cirrostratus*, called *halos*, whereby concentric coloured rings are produced in the order of their respective refrangibility, and reflected at an angle which equals the angle subtended by the semidiameter of the *halo*.

I allude in this paper to the ordinary effects of more thinly diffused and almost invisible cloud in the atmosphere, through which the luminous celestial bodies appear clear and distinct, but which nevertheless refracts and disperses their rays in some degree, even in apparently the clearest nights.

Refraction has been hitherto considered as so general an effect of the atmosphere, and so unconnected with any par-

ticular cloud, that universal tables of mean refraction have been made out, as if they would apply to all places. This is, however, an essential error: and in developing it I find the subject naturally divides itself into three distinct considerations, as follows:

I.

On the Variation in the refractive Power of the Atmosphere at different Times of the Night and Day and on different Occasions and Seasons.

There is one question in the history of refraction which for obvious reasons ought, if possible, to be cleared up; namely, Wherein consists the dispersive power of the atmosphere, which is found to vary at different times and in different places? To me it appears that this variation is owing principally to the quantity and nature of the aqueous particles suspended in the air. Astronomers have hitherto confined their considerations too exclusively to the refractive property of pure air, and have overlooked the circumstance that the atmosphere is seldom pure for any length of time; they have consequently not taken into account the varied effects of different sorts of diffused vapours, which, though unseen by the common observer, exist in the air in different proportions at sundry times and places, and which prevail much more at some places than at others. I was led to discover this by observing the vast disproportion between the result of my observations on the stars made at different times and seasons. In observing the planets and brightest of the stars through prismatic glasses, I found that the spectrum was less oblongated while the red colour was more distinctly apparent at the time of the first falling of the dew than at almost any other time of the same nights. Venus and Jupiter afforded a fine opportunity of ascertaining this fact last spring, as these planets could be both seen of an evening as early as the period of the vapour point*.

* The vapour point is that precise period which occurs in the progress of evening, when, from the declining temperature, the air can no longer hold in solution the same quantity of aqueous gas that it maintained during day; and when consequently the aqueosity is first deposited in the form of visible vapour or cloud, and gradually descends to the earth; on arriving at the surface of which it eventually forms a *stratus* or fog, called for this reason the fallcloud. In the morning the counterpart of this process takes place, and the gasified water being taken into the composition of the air again, ascends, till rising into a colder region it is again condensed into visible clouds which float on the vapour plane, or that precise elevation whereat the air begins to be too cold to hold the vapour in solution. At this elevation it forms clouds dissimilar in their modifications, according to electrical causes which exist in the air, but generally speaking *cumuli*, the lighter modifications of cloud occurring higher up from local electrical and other causes which disturb the equilibrium of the temperature of the atmosphere.

And

And the most common observation on the rising and setting moon will always confirm it on favourable nights.

On other occasions, at the same time of night, I found an unexpected difference in the appearance of the spectrum of the very same planets; the violet and in general the most refrangible colours being most conspicuous, and the spectrum being more oblongated than ordinary.

To reconcile this difference of effects with existing causes apparently so similar, was now an interesting object; and at last I found out that the difference was referable to a difference in the quality of the falling dew, or diffused cloudiness.

The greater prevalence of the red in the spectrum uniformly accompanied that state of the atmosphere when the *cirrostratus* or wanecloud diffused itself after sunset; while the more oblongated spectrum with the violet and most refrangible colours attended an atmosphere in which the descending dew was *stratus* or fallcloud. I will not say positively that in the first case the falling mist was itself *cirrostratus*, but it was a different kind of mistiness and less purely white, when seen in the valleys, than the common mist, and it happened when there were *cirrostrati* in the higher air. Another circumstance which confirms my explanation of the phænomenon is, that during the falling of ordinary dew in clear and settled weather, particularly with east wind, the horizontal haze shows beautiful tints of the more refrangible colours, varying upwards, so that the atmosphere becomes a sort of natural prism, of which I have cited many examples in my "*Researches about Atmospheric Phenomena.*" Whereas when *cirrostratus* prevails, particularly before wind, the red is the predominant colour of the haze, and also of the clouds above it, which appear of the finest crimson and vermilion. In some cases I believe the clouds may themselves become prismatic, and the colour of which they appear may be produced by their own structure; but it is more generally the effect of the haze through which reflected rays pass in coming down. Clouds in this case may be compared to planets viewed in a prismatic glass, their surfaces reflecting the borrowed light of the sun, which becomes dispersed by the chromatopoeitic properties of the atmosphere through which it passes.

Another circumstance which I witnessed several times in November 1822, and which is of common occurrence, strikingly corresponds with the above observations; namely, that clouds whose irregular surfaces and depending fringes were of a golden or silvery colour, that is, reflected all the sun's rays just as they received them, during a whole afternoon, were, on the occurrence of the vapour point, suddenly turned red as if

by some dispersive power imparted to the circumjacent atmosphere by the first falling of the dew.

The state of the atmosphere which shows the red colour for any length of time is a forerunner of high wind.

There is an obscurity of a denser kind which often causes an apparent dilatation of the disks of the celestial bodies, which it elevates without colouring them. The moon for instance looks pale, expanded and confused. This state is a prognostic of rain, and is contrasted to the former as well as to the clearness of the serene sky which follows an ordinary fall of dew, in a well known proverb expressive of the prognosticative colour of the moon on each several occasion:—

“ Pallida luna pluit, rubicunda flat, alba serenat.”

Another state of the *cirrostratus*, when diffused, seems to possess dispersive properties of a very peculiar nature, refracting certain coloured rays at an angle of *about* 5° ; and others at an angle of *about* 23° , so as to cause two concentric halos or rings of colours; the inner one being *about* 10° , and the outer one *about* 46° in diameter. Sometimes single rings occur which are colourless; but as all these phænomena do not properly belong to our subject, and are elsewhere treated of, I shall not dwell longer on them.

All the above circumstances show that the changes in the qualities of the diffused vapour in the air must cause a great variety in the atmospherical refraction. They also explain how the atmosphere about different places may have a different mean refractive power, according to the local prevalence of the above diversified vapours which hang in it. For I am not certain whether, independent of temperature and pressure, the pure atmospheric air differs in its refractive power all over the world: I believe the difference to arise from the vapours always more or less suspended therein and generally electrified.

Two more facts confirming my hypothesis must now be cursorily mentioned. The east wind produces changes in the appearance of the spectra of the celestial bodies, even in the field of ordinary telescopes: the spectrum seems to vibrate or dance about in the field of the glass in a way that defeats many very delicate observations. Had not this remark been confirmed by other people, I should have ascribed it to the nervousness of the observer, the east wind being very liable to produce nervous disorders of the eyes and other parts. I have not observed the precise effect of the east wind on the larger prismatic spectra, as far as respects their colours; but the whole spectrum seems often on such occasions to move, and to fluctuate more than ordinarily.

Astronomers, ever since the time of Newton, have known that

that pure atmospheric air will vary gradually in its refractive powers according to the degree of heat; and remarkable instances of the great elevation of the disk of the sun above the horizon in cold climates, when calculation showed him to be below it, have been adduced as striking examples. But it should be remembered by all, and it is already known to meteorologists, that changes in temperature are never unattended with changes in the quantity and modification of aqueous vapours suspended in the air. And this circumstance must add considerably to the effect of low temperature, and may impart to an atmosphere condensed by cold some great and peculiar dispersive properties. The inordinate elevation of the mast of ships at sea by refraction is an instance and proof of the undoubted great effect of vapours occasionally suspended in the air. The east wind is connected with the arrival of peculiar vapours in it, and the vibration or irregular movement of the star in the telescope may be owing to such vapour being agitated by the electrical commotions that so generally attend a change of wind from any other quarter to one blowing from the east.

Besides the general want of correspondence between the results of different observations, where it is necessary to subtract a given quantity of refraction, we may make a particular observation on the still greater disagreement that is found to exist in the declination of several particular stars, as published by different observers; for this disagreement, when applied to certain individual stars, is referable to a compound cause; for the light of the stars severally being composed of different proportions of the primitive colours, the red ones, as *Aldebaran*, *Arcturus*, and *Betalgeus*, are less refrangible than *Sirius*, *Lyra*, *Capella*, and the white stars in general. Of this I shall treat in the third section. It may suffice to remark it slightly here, in order that, when we are considering the varieties in the atmosphere's dispersive property, we may also take into account the compound effect produced by the various colours of the stars whose light is thus variously dispersed.

The projection of *Aldebaran* and other red stars on the disk of the moon when the conjunction happens near to her upper limb, as noticed by Mr. Lee*, is an illustration of the above fact; the greater proportionate refrangibility of her white light, than that of the red light of the star, elevating her apparent disk so as to cause the star to seem to be within it just before or after the respective points of contact.

When the wind first changes to become east, and when the

* I wish my readers to peruse the whole of Mr. Lee's ingenious paper in Phil. Trans.; for though it becomes necessary to cite it, in order to make due acknowledgements, nevertheless every individual Essay should be read entire, and not in citations.

air is encumbered with the cirrostrativeness of the wanecloud, then all the celestial bodies appear redder than at other times, from the greater disposition of the air at those times to separate and transmit the red colour, which must considerably influence the foregoing observations.

The last observation I have here to make relates to a phænomenon hitherto entirely unexplained. I allude to rapid alternations in the colour and brilliancy of the light of certain stars viewed near the horizon.

Some years ago, on looking towards the constellation of the Scorpion, I observed a remarkable changing of colour in the fluctuation of *Antares*: for a second or less of time it appeared of a deep crimson colour, then of a whitish colour; then the crimson was resumed; and so on at alternating periods. Sometimes every other twinkle showed the red colour, while the alternating twinkle appeared of the ordinary colour of starlight.

What is commonly called the twinkling of a star seems to be an apparent fit of dilatation and increased brilliancy rapidly succeeded by the opposite state of apparent contraction of surface and dulness. I have observed, also, that the twinkles are of longer or shorter duration, at different times: now, in general, the intense red light I allude to occurs in every alternate dilatation; but sometimes only in every third, and at other times quite irregularly: moreover, it lasts longer sometimes than at others, and scarcely ever exceeds two seconds of time at once. This phænomenon as viewed in *Antares* was particularly conspicuous at Clapton, in autumn 1809, at Tunbridge Wells on June 19, 1817, and during the whole summers of 1822 and 1823 at Hartwell. I saw this phænomenon also in other stars, in France, in September 1823; and I have seen it in the summer of 1822, in the atmospheres of Switzerland, Alsace, and all along the Rhine: it is evidently not confined to any local cause.

I have formerly published accounts of this phænomenon in the Journals, and have ascribed it to some sort of change in the star itself, or to a revolution round an axis, whereby different coloured portions of the luminous sphere might be presented to us: but this explanation vanishes on a moment's reflection; and I am inclined to ascribe it to some atmospherical cause. I have sometimes thought that the upper portions of the atmosphere might have some undulatory motion, and that the alternating colour might be produced by its refractive powers: for the atmosphere, in this case, acting as an imperfect prism, might present different colours, according to the varying inclinations of its wavy surface*. I have thought, too, that por-

* See Phil. Mag. vol. xlix. p. 452; and the Perennial Calendar, Jan. 16, p. 17.

tions of the aqueous atmosphere, possessing different prismatic powers, might be transmitted downwards in dew, or that there might be some other unknown motion in the real air, which might cause the appearance. *Antares*, *Betalgeus*, and some other red stars, show this change of colours very strongly, particularly the former: while *Sirius* and the brilliant white stars show this alternation of colour in a less degree. It is not observed in *Procyon*, is weak in *Capella*, but is considerable in *Vega* and in *Arcturus*, the latter being a red star. *Antares* shows this phænomenon more brilliantly than any of the others. Differences in the composition of the light of stars may explain these varieties of effect.

Nobody can, I think, reflect on all the above details, hasty and imperfect as they may be, without at once seeing the importance of extending our observations on the phænomena to which they relate, in constructing tables of refraction; and I shall still be excused, I trust, in the absence of more matured and extended details, for this imperfect attempt to excite the attention of philosophers to facts which seem calculated to produce an important influence on many of our most useful astronomical calculations.

II.

Of the Variation of the mean refractive Power of the Atmosphere in different Places.

Although the refractive and dispersing power of the atmosphere varies at different times in the same place of observation, yet by dividing the sum of a vast number of observations by their number, we shall get at a mean or average of the refractive power of the atmosphere of any particular place. This I call the mean refractive power of the atmosphere, and this *mean* differs very much in different situations, so that tables of mean refraction will not apply universally, but must be made out separately for each place of observation. Thus a correction which would be applicable to observations made at Greenwich, would not equally apply to Dublin or to Paris, much less to Palermo or the Cape of Good Hope: and they would be still less applicable in Peru, where the dispersive power of the atmosphere is prodigious. I was led to the adoption of this opinion, in the first instance, by analogy, it being strictly conformable to a thousand other corresponding instances of local variation in atmospheric phænomena. Experiment seemed to confirm it. And I have lately heard of a further corroboration which this opinion has received from the able observations of Dr. Brinkley, communicated to the Royal Society. But as I have only heard casually of that paper,

paper, and have never seen his observations, I cannot speak positively to that point.

If the opinion which I have long entertained, that the mean refractive power of the atmosphere varies in different places, be correct; its promulgation may lead to important results: it may explain certain apparent discordances in the places assigned to the fixed stars as described in different catalogues. For if corrective tables calculated for Berlin or Paris were to be applied to observations at Greenwich, there might be a considerable difference in the result.

Another very important observation results from this consideration. Suppose, for example, a given corrective table of mean refraction were to be applied to a catalogue of apparent places of the fixed stars observed at Pisa a hundred years ago, and that the same table were to be applied to a catalogue observed this year at Dublin, the result of a comparison of the two catalogues would be a positive error. For Dublin and Pisa requiring a different correction, altogether independent of longitude and latitude, and depending solely on the different refractive powers of their respective atmospheres, the consequence of applying the same corrective table to the observations of both places would be the certain error of one of the catalogues. And as one catalogue would, according to our supposition, be a hundred years older than the other, the stars would be thought to have changed their places. Some misapplication of tables of refraction seems to me to be the cause of an idea of a southern motion recently promulgated by certain astronomers. Independently of the great *prima facie* improbability of such a motion, it seemed to me, when I first heard the opinion mentioned, that it would turn out to be an error depending on the want of a proper application of corrective tables of refraction. I speak, however, on the point with deference to the better judgement of learned astronomers.

III.

Of Varieties in the Composition and Nature of the Light of different Stars, considered as still further varying the Effects of atmospherical Refraction, Reflection and Dispersion.

It must have occurred to almost every body to perceive that the colour of different stars is very dissimilar; that some appear more red or copper coloured, others yellow like brass; some of a bright and almost silvery whiteness, while yet others are of a dull white colour. These differences become much more striking when viewed through such bad telescopes as, being but imperfectly achromatic, become in a measure prismatic, and separate the primitive rays of light, producing a
coloured

coloured spectrum in the field of the glass. By the adaptation of a more perfectly prismatic lens to the telescope, we get a still more distinct spectrum, and are enabled to contemplate the particular composition of light possessed by each star respectively. I was not aware of the best means of detecting these differences, till I read the excellent paper On the Dispersive Power of the Atmosphere, by Mr. Stephen Lee, published in the Transactions of the Royal Society*. As some of my own observations coincide with those detailed in the aforesaid paper, I feel additional confidence in giving them to the public, as the acuteness and ability of that gentleman as an astronomer are well known. Mr. Lee viewed the stars through a prism adapted to the eye glass of a reflecting telescope; and, prompted by a laudable desire to ascertain how far the dispersive power of the atmosphere could produce an effect on astronomical observations, he proceeded to examine several stars, with a view to ascertain, if possible, the exact degree of separation of the several rays. As the above paper ought to be read by all observers, I shall not extract any of the observations now, but proceed to the subject under consideration,—the varieties of stellar light.

According to my observations, the stars should be classed according to their colours, into the red, the yellow, the brilliant white, the dull white, and the anomalous. For though each star may differ somewhat from every other, yet we shall be assisted by this general classification.

When observed with a prismatic glass as above described, *Sirius* shows a large brush of extremely beautiful violet colour, and, generally speaking, the most refrangible rays in great quantity. The same applies more or less to all the bright white stars.

Procyon is far less beautiful than *Sirius*, and shows more of the yellow colour.

Aldebaran, together with many of the other red stars, exhibits a very small proportion of the more refrangible colours.

Arcturus much resembles *Aldebaran*, but differs in the lesser proportion of the red to the other rays.

Betalgeus is another red star, little inferior in magnitude to the two above. This star shows also but little of the more refrangible rays; but the spectrum is always a bad one, and is for some unknown cause more liable to fluctuation than the above two.

Antares, the most extraordinary star of all, contains, like *Aldebaran* and *Arcturus*, much red light; but owing to its

* See Supplement.

greater southern declination, as well as to something very peculiar in the composition of its light, we cannot get so perfect a spectrum as might be desirable. This star, too, exhibits in the greatest degree a peculiar and hitherto unexplained phenomenon, which will always interfere with our observations on its permanent spectrum. I allude to the rapid permutations of the colour of its light, every alternate twinkling, if I may so express myself, being of an intense reddish crimson colour, and the alternate one of a brilliant white. As I have before described and speculated on this phenomenon, common, though in a less degree, to other stars when near to the horizon, I shall not further dwell on it here, but observe that *Antares*, considered with reference to its light, must be put among anomalous stars.

Atair in the *Eagle*, and also the dull white stars, exhibit a vast quantity of intense green light. This is very conspicuous in many stars of the 2d and 3d magnitudes.

The planets likewise present spectra very considerably differing from each other. *Jupiter* possesses all the colours; but from something in their respective proportions, or from some unknown cause, this planet is liable to produce, even in good and almost achromatic glasses, so bad and so coloured a spectrum, that I have always found him a disagreeable star to observe. As a prismatic spectrum, however, he is beautiful. The green colour seems somewhat deficient in his spectrum; nevertheless *Jupiter* appears green in comparison with *Sirius* when an opportunity offers of viewing both at one time*. *Venus* appears less green than *Jupiter*, but still she is not of so bright and blueish a white as *Sirius*. Her spectrum in the prismatic glass shows most of the rays, but the green colour is very pale.

Saturn seems composed chiefly of the mean rays, and has a very small quantity of the extreme colours. Mr. Lee, who also notices this, subjoins the following judicious question—Whether this may not explain why *Saturn* bears magnifying better than *Jupiter* or *Venus*?

Mars, who shines with a red light, appears as a spectral image on the prism to possess less of the middle and most refrangible colours. The red is very conspicuous in the prismatic spectrum.

Mercury is said to show a similar spectrum: I confess I have not made observations on *Mercury* myself.

* We may imitate the different colours of the spectra of the several stars and planets, by burning antimony, steel, and other metallic filings, in pyrotechnical jerbs, and viewing them through a prism. Compare the prismatic spectrum of ignited steel with that of *Jupiter*, of burning antimony with *Sirius*, of copper filings with the spectrum of *Mars*; and so on.

Of the varying spectra of the *Moon*, and the composition of moonlight, I shall speak hereafter.

The next consideration is, the effects which the above-described variety in the colour of the light of the celestial bodies will have on our astronomical observations: and it appears to me that this effect will be very considerable. Sir William Herschel has already noticed this circumstance, and has observed, that the prismatic power of the atmosphere should not be overlooked, as in observations on very low stars it must make a great difference in the correction which might become necessary. He has stated the measure of two diameters of ϵ *Sagittarii*, and from his observations thereon deduced the refraction of the extreme rays as being about $\frac{1}{4} \pm$ the mean refraction*.

To me it appears evident that the different stars will, in consequence of the different composition of their light, require very different corrections; and that tables of refraction should not only be made out for each observatory, in order to apply to the mean refractive power of the air in different places as before described; but also, that some rules should be appended for applying a correction for each particular class of stars, according to their predominant colour.

As a natural deduction from the foregoing facts, we must infer that the real declinations of *Sirius* and of *Aldebaran*, for example, cannot have been determined by the application of the same correction to the apparent places of both of them; since *Sirius* is composed of a large quantity of the most refrangible colours, while *Aldebaran* is particularly deficient in them.

We cannot, I think, easily pass by the above facts, without inquiring into their particular causes, which will be found to involve us in some exceedingly curious speculations.

The difference in the colour of the light of the fixed stars is probably owing to a real difference in the proportions in which the several rays are combined. Thus *Sirius* sends forth more of the violet; *Aldebaran* more of the red; and perhaps *Capella* more of the yellow rays. *Atair* and the dull white stars perhaps have more of the yellow and blue together, and less of the red, so as to make green light; and so on†. The stars differ too in the intensity or brilliancy of their light; the largest apparently not being always the brightest. And it is curious to observe that some stars seem

* Phil. Trans. vol. lxxv. On Double Stars, by Dr. Herschel.

† I have worded it thus on the very doubtful supposition of three primitive rays, merely in conformity to received opinion: phenomena are decidedly against that notion; for I cannot separate their green light in the spectrum.

to possess a greater power of penetrating through an imperfectly obscure atmosphere than others of equal apparent bigness, as the *Pleiades* and the *Hyades*. On the other hand, the two small stars in *Cancer*, called *Aselli* by the Romans and ὄνοι by the Greeks, were found to be obscured much before the rest during the progressive condensation of the atmosphere; and their dimness and progressive disappearance, together with that of the nebula *Presepe*, was consequently regarded as the first sign of approaching rain, as is mentioned by Aratus in his *Diosemea*, and which had been before observed by Theophrastus in his treatise *Περὶ σημάτων ὑετῶν*. The passage is exceedingly curious, and is as follows:

Ἐν τῷ Καρκίνῳ δύο ἀστέρες εἰσὶν, οἱ καλούμενοι ὄνοι, ὧν τὸ μέταξυ τὸ νεφέλιον ἢ φάτνη καλουμένη· τοῦτο δὲ ἂν ζοφῶδες γένηται, ὑδατικόν.

And afterwards he observes respecting the signs of rain:

Ἡ τοῦ ὄνου φάτνη εἰ συνίσταται καὶ ζοφερὰ γίνεται χεῖμωνα σημαίνει.

Aratus in following up this observation makes a distinction between the indications of the northern and those of the southern of the two stars, which we can hardly reconcile with any conceivable hypothesis.

Εἰς μὲν παρ' βορέαο, νότῳ δ' ἐπιέρχεται ἄλλος·
Καὶ τοὶ μὲν καλέονται ὄνοι· μέσση δέ τε φάτνη,
Ἦτε καὶ ἑξαπίνης πάντῃ Διὸς εὐδιάοντος
Γίνετ' ἄφαντος ὅλη· τοὶ δὲ ἀμφοτέρωθεν ἰόντες
Ἀστέρες ἀλλήλων αὐτοσχεδὸν ἰνδάλλονται·
Οὐκ ὀλίγῳ χειμῶνι τότε κλύζονται ἄρουραι.
Εἰ δὲ μελαίνηται, τοὶ δ' αὐτίκ' εἰοικότες ὥσιν
Ἀστέρες ἀμφοτέροι περὶ χ' ὕδατι σημαίνουσιν.
Εἰ δ' ὁ μὲν ἐκ βορέω φάτνης ἀμενηνὰ φαεῖνη
Λεπτὸς ἐπαχλυῶν, νότιος δ' ὄνος ἀγλαὸς εἴη,
Δειδέχθαι ἀνέμοιο νότου· βορέω δὲ μάλα χερῆ
Ἐμπαλιν ἀχλυόεντι φαεινομένῳ τε δοκεύειν.

The peculiarity of this observation has struck many commentators, and I find the following note appended to the above passage.

Meteorologica astronomicis confundit. Nam diversæ harum stellarum species, non a propria ipsarum atmosphæra, sed a nostro aëre efficiuntur; quare, ergo, hæ, magis quam aliæ stellæ, per obscuritatem suam tempestates portendere possint? Si quidem ab ipsarum aëre aut aliquo circa eas fieri possit speciei variatio; quis credit tantam inter tam remota sidera relationem existere, ut aliquid, in stellis visum pluviam in mundo præmoneret? Sensus est — Quod etiam confestim, cælo sereno, fit evanidum

evanidum totum; atque stellæ utrimque coeuntes, si invicem vicinæ apparent; non modica tempestate arva inundant. Si autem nigrescat, rursus vero eodem colore ambæ stellæ existunt, pluvias significant. Si vero hic (ὄνος) qui est e præsepis borea modice tenebrescens, languide splendeat, cum austrinus asellus lucidus sit, ventum Austrum expecta. Boream vero e contra tenebrescente lucenteque observare oportet.—Arat. Dios. 167.

Many corresponding quotations might be added.

Some years ago Mr. Barker published a paper in the Philosophical Transactions, tending to prove that many of the stars had changed colour in the lapse of ages; some being described as red, which are now white. I do not, however, attach any importance to the remark, because the ancients used the names for colours with the utmost latitude and variety of significations. *Rubere, splendescere, purpurascere*, and many others only signified to shine brightly*.

Nevertheless, certain remarkable changes in some stars, and the alternate disappearance and reappearance of others, while some have been actually lost, seem to warrant an opinion that the gradual work of destruction and reproduction, so conspicuous through all mundane nature, is likewise going forward on a grand scale among the ponderous systems of worlds which fill eternal space. This consideration does not bear immediately on the subject under discussion, but it ought to be kept collaterally in view.

Hitherto we have been discussing the probable causes of the colour of the fixed stars shining by their own light, and have supposed the differences of colour to result from the respective composition of the light of each. But in considering the planets which shine only by reflecting the light of the sun, we have other things to take into the account. If the planets have no light of their own, the difference observable in their respective colours must arise from a difference in the dispersive powers of their own respective atmospheres, through which the sun's reflected rays may be separated in their passage. We know, indeed, little or nothing about the composition of planetary atmospheres; but analogy would lead us to ascribe the variations of their light rather to properties of their surrounding atmospheres, than to the colour or other qualities of the substance of the planet itself. It may be observed, that the particular position of the Ring of *Saturn* does not affect the colour of his prismatic spectrum, and therefore probably it throws back the same sort of light as the body of the planet does. Of what are called the Belts of *Jupiter*, we know almost nothing; but we may conjecture that they may have some-

* See *Phil. Mag.* vol. xlix. p. 49, where I have endeavoured to refute this idea.

thing to do with the peculiar tendency of this planet to produce a bad spectrum for observation even in the best telescopes. Out of the consideration of the chromatopoeitic property of the atmospheres of the planets, a question arises, Whether that property be subject to variation? There is a manifest difficulty in ascertaining this, because the reflected light of the sun passes through our own atmosphere as well as that of the planet; and consequently we cannot always tell to which atmosphere to refer any colour which we may observe in the spectrum. Observations made on two or more planets at once, where the changes in the light of the two or more severally did *not* correspond, might lead more directly to the solution of this question. But we are getting now away from our object, and must retrace our steps before we wander too far into the wide field of speculation which lies open before us. Observations are as yet wanting to establish and systematize the facts briefly alluded to above; but it is to be hoped, from the united efforts of numerous astronomers and meteorologists now beginning to be in communication with each other all over the world, that the desiderata, *quantum possunt*, will be supplied. The present subject affords an example of the natural connection between the two sister sciences, and affords a hope that the many learned men who compose the Astronomical and Meteorological Societies will cooperate in the attainment of a common object, and that the peculiarities and variations of atmospheric refraction will be more fully known than they have been hitherto, by the multiplied observations of individuals acting in concert*.

Of the Colours of the Moon.

The *Moon* viewed in the prism seems to possess all the colours; and their proportions, as far as we can judge, are very similar to those observed in *Venus*. But the observations I am about to make on the lunar disk, are intended rather to confirm a point that I am contending for in meteorology, than to establish the proportion which her component rays of light bear to

* It appears that the ancients were not inattentive to the different colours of the planets.

Pliny thus distinguishes them; which, though not a very clear description on account of the very promiscuous use of names for colour among the ancients, shows at least that considerable differences in their light had been observed even in his time. In *Hist. Nat.* lib. ii. cap. 18. we find, "*Suis quidem cuique color est; Saturno candidus, Jovi clarus, Marti igneus, Lucifero candens vesperi refulgens, Mercurio radians, Lunæ blandus. Soli cum oritur ardens postea radians.*" He then goes on to notice the varying colours of the same planets and of the Sun at different altitudes and in different states of the atmosphere. Of the observations of the ancients I shall say more in a future Number.

each other. Viewed as I have seen her from the heights of mountains and in the clearest nights, she appears of a brilliant white light. And the varying colours of her disk seem to be caused by varieties in the colouring power of our atmosphere alone. What I am trying to clear up is, that astronomers, in considering the refractive powers of atmospheric air, have overlooked the circumstance that there is almost no state of the air in which the diffusion more or less of aqueous gases or cloudiness does not exist, though in a very small degree; and that on this diffusion of cloudiness depends in a greater degree than is imagined, the dispersive power of the atmosphere and the peculiar colours of the celestial bodies seen through it.

I shall conclude my remarks on the *Moon* with the description of a curious lunar refraction, which I observed some years ago. About seven o'clock in the evening, the *Moon* being five days old, I noticed a remarkable double refraction of her image of the following form and relative position D D , that is, two distinct crescents instead of one, and both so precisely similar as not to be distinguished; so that I said to a gentleman who was with me, "Which do you think is the *Moon*, and which the paraselene?" Neither of these images was coloured, and both were as bright as the ordinary brightness of the *Moon*. The cause of this phænomenon did not suggest itself at the time; but I have since thought that it so much resembled the double refraction by which two images are seen in certain laminated spars, that it might be referrible to the same cause, and that it might be an indication that there existed atmospherical laminæ at that time. I do not conceive that the existence of laminated air is by any means improbable, and it may be connected possibly with the various contrary currents of air, which exist contemporaneously in successive altitudes in the atmosphere, of which observations on the varying direction of small air balloons have furnished me with abundant proof.

The above subjects deserve more consideration than they have hitherto met with, and I trust many members of the Society will co-operate with me in pursuing them.

P.S. Since I wrote the above, I have repeated various observations on the stars and planets with a prismatic glass of another kind, the adaptation of a prism to the eye glass of the telescope being at all times an awkward contrivance. The results have varied, however, but little from those above stated, and I subjoin the following rude table of the spectra of the stars observed during the present month, and arranged according to the intensity of light of the stars severally.

Table representative of the Singularities of Starlight.

N.B. The signs under the names denote whether the stars require that of a mean correction of plus +, or of minus —, than the ordinary Refraction Tables; = signifies they equal it; doubtful is marked with a ?.

Name of star.	Brilliance or dullness.	Apparent colour.	Whether or not twinkles much.	Alternation of colours in the fluctuation.	Prismatic spectrum.
SIRIUS. +	Very brilliant.	White.	Considerably.	Alternates with red faintly.	Beautiful violet, and the most refr. colours.
PROCYON. + ?	Brightish.	White.	Less than the preceding.	Not discernible.	Less violet, and more yellow than Sirius.
VEGA. +	Brilliant.	Blueish white.	Considerably.	Alternates slightly with red.	Resembles Sirius, but more blue.
CAPELLA. =	Bright.	Yellowish.	Less than the preceding.	Very little.	Much yellow light, and the mean colours.
ARCTURUS. —	Bright.	Reddish.	Considerably.	Not strong.	Much red light, and the less refr. colours.
ALDEBARAN. —	Steady.	Red.	Inconsiderably.	Very slight, with a greater degree of red.	Much red light, and the less refr. colours.
BETALGEUS. —	Steady.	Red.	Rather more than the last.	Rather more than the last, and the same sort.	Much red light, and the less refr. rays.
SPICA VIRGINIS. = ?	Somewhat less bright.	Blueish white.	Very little.	Inconsiderable.	Much intense green light, and also the more refr. colours.

It may be noticed that the alternating colours observed in the fluctuation, and recorded in the 5th column of the table, are *cæteris paribus* most observable when the stars are near to the horizon; and I have observed that the maximum of the intense red colour which distinguishes the alternate change happens at the elevation of about 10 degrees above it.

The phænomena noticed by Kepler in the new star discovered by him in 1604 in *Serpentarius*, and now lost, if rightly recorded, afford a striking instance of the converse of what we usually observe. For in that large and memorable star, the colours were continually changing when the star was *high*, but when it got *near to the horizon it was uniformly white*. It is much to be wished that observations had been made on the changeable stars and on those that are now quite lost. The *Stella mira* may afford interesting observations. Comets ought also to be very accurately observed. The great comet of 1680, which is expected again in 1833, will probably be the subject of much curious research.

The ordinary distribution of stars into the 1st, 2d and 3d degrees of magnitude, and so on, though it may serve common purposes, is nevertheless very imperfect; the stars recorded as being of the first magnitude differing as much among themselves as some of them do when compared with those of the reputed 2d magnitude. In the above table of large stars, I have endeavoured to arrange them in the order of their apparent size and intensity of light, the best way of ascertaining which is by observing the relative degrees of light in which each can first be seen, either at evening or morning, measured by a photometer. But it is evident that this plan will include also their brilliancy, which is a thing quite different from their apparent size. Some small stars have a more piercing light than others for their size, as the Pleiades, for example. In order therefore to ascertain and compare the relative apparent size alone, we must trust a good deal to our own judgement.

It is my intention to pursue the above subjects, and to make as accurate comparisons as I am able between the light of individual stars, dispersed by means of prismatic glasses adapted to telescopes, and the light of various combustible substances in a state of ignition viewed through prisms.

There have appeared to me to result some very extraordinary phænomena, from the adaptation of a prismatic glass to different parts of the telescopes: but as I cannot account for them on any known principles, I only state the fact as a hint, in order that others may repeat the experiments. Finally, we must ever bear in mind that the retina, and the cerebral parts in connection with it, are a necessary part of the optical ap-

paratus which we employ in all experiments on light; and we must guard against being deceived by any peculiarities or affections in our own organs of vision, which we need not fear, provided only we make the same experiments repeatedly and with due attention.

[To be continued.]

XXXV. *Description of a new Micrometer.* By M. FRAUENHOFER of Munich.*

THERE is probably no instrument, if we except the heliometer, better adapted for determining the right ascension and declination of two stars, than the circular micrometer. To this simple instrument, which can be applied to any telescope provided with a good stand, we owe, besides many other important observations, a great part of those made on comets. Improvements in this instrument are therefore desirable.

Some astronomers still prefer the rhomboidal micrometer for determining the relative places of two stars. It cannot be denied that the calculation of observations made with such a micrometer, is more simple than that made by the circular micrometer, and that the result possesses about the same degree of exactness, whether the difference of declination of both stars be great or small; while in observations with the circular micrometer we ought to have, for a smaller difference of declination, a smaller circular micrometer also. Any one possessed of practical knowledge will soon perceive that a rhomboid, in whatever manner it may be made, cannot obtain the prescribed form to such a degree of accuracy as is required for good observations; whilst, on the contrary, there are several means of making a circle to a great degree of exactness. It cannot be expected to file out a hole exactly in a rhomboidal shape. We may indeed obtain a rhomboid with straight lines, by screwing together bars of equal breadth ground perfectly straight; but to give the required angles of the rhomboid is not very practicable. In stretching four wires, in the form of a rhomboid, we have to encounter the same difficulties, as far as regards the angles of the rhomboid; besides this, there is seldom a piece of wire exactly straight, even if ever so strongly stretched; but thin wires cannot be made use of for the purpose, because in a dark field of view they cannot be seen. This is the reason why circular micrometers have such a decided preference.

With the circular micrometer, consisting merely of the dia-

* From M. Schumacher's *Astronomische Nachrichten*, No. 43.

phram of the telescope, the *ingress* of a star into the field of view, cannot be observed with the same exactness, as its *egress*; because, since we do not know at which place it will enter, the eye is not directed to that point, and is consequently only directed towards it when the star is already in the field of view. With the open diaphragm it is likewise difficult to let the star describe any given chord of the field; which is in fact necessary, because small segments give the declination, but larger ones the right ascension, more correctly. Instead of the open diaphragm they have also frequently made use of a small ring, which, by means of four bars, is suspended in the field of view. A small ring can only accidentally succeed in being perfectly round, as in good observations it ought to be; and even from its being suspended by wires, which may be stretched, its perfect form may be lost; and even the expansion or contraction of the metal with which it is connected, may alter it.

In order to have in the field of view of a telescope a small unchangeable ring, whose inner edge is exactly round, and remains so under all circumstances, I cut a round hole in a thin plate of glass, and fixed a small steel ring into it, in the same manner as glass-lenses are fixed in brass mountings; viz. by laying over the projecting margin by means of a bur-nisher. After this ring was fixed in the plate glass the inner edge could be turned in a lathe exactly circular, which is done in a manner that leaves no doubt respecting the necessary accuracy. As the objects are seen through the glass as well as without it, we see the star approach the external edge of the small ring, and know where it is to appear at the inner edge; the observer is consequently prepared for the moment, and the ingress at the inner edge can be observed with the same exactness as the egress from it. Partly for the purpose of obtaining, at the transit of both stars, the exact difference of declination, and that of the right ascension, partly to enable me to use one and the same micrometer likewise for smaller differences of declination, I have introduced *two* small steel rings, in the above-mentioned manner, into the field of view, where the diameter of the one is considerably larger than that of the other, and both of which are plainly seen at the same position of the eye-glass.

Although the observations with this circular micrometer are more to be depended on than with the usual one, yet even these leave much more to be wished, particularly in the observation of comets; and more particularly since the differences of declination, derived from different observations, frequently deviate considerably from each other. One of the causes is, that in a comet, which is always badly defined, the

centre must be estimated ; but we cannot judge with exactness whether the half of it has made its ingress or egress, because the other half is not seen, and the mere approach of a weakly illuminated object to a proportionally broad dark ring causes easily a deception in estimating the correct time. Through the eye-glass, which cannot well be achromatic, the inner edge of the small steel ring becomes blue, but the outer one is seen to be red ; the star on the contrary is blue outwards and red inwards, so that, for instance, at the egress of the star from the inner circle of view, the blue end of it gets to the blue edge of the small steel ring, and the star lengthens itself still more, which must cause an uncertainty respecting the time of its egress. As the star always lengthens itself in the direction of the centre of the field of view, and both the passing stars usually cut different segments of the circle, the errors of observation cannot easily compensate themselves. In an eye-piece with compound glasses the colours of the star can indeed be lessened ; but the small ring would be seen the more coloured. For other reasons, too, these eye-glasses would not be advisable.

The reason why the observations in a transit instrument are capable of so great a degree of exactness, is, without doubt, because the threads are so thin, that they hardly cover the star, or do so for a moment only, and that the space passed within a second of time next to the thread can be divided. If the observations with a circular micrometer were to give a similar exactness, then the circles in the field of view ought to be as thin as those threads, but would require to be illuminated in the dark field of view, because in comets the field cannot be illuminated.

I tried to cut with a diamond fine circular lines upon a thin piece of plate glass ; and having brought it into the focus of the telescope, illuminated the cut lines in the same manner as I had formerly done in lamp-wire micrometers. But in whatever way I altered the illumination, there were always small segments only of the cut lines weakly illuminated ; viz. those segments upon which the light which came from the lamp fell nearly vertically. It is also the case with the wire-lamp micrometer, that the threads are only then illuminated strongest, when the light falls vertically upon them ; thus, for instance, the vertical wire can be splendidly illuminated, while the horizontal one is quite unilluminated. By increasing the lamps, which were used for illuminating the cut lines, the object could not be accomplished. I observed, however, that already, with one lamp, the small particles, accidentally adhering to the glass, were illuminated splendidly bright, and had the appearance

pearance of stars in the field of view. If therefore the circular lines were composed of small dots, then they would be illuminated by one lamp equally at all places. We have however to contend with great difficulties, to make a circle consisting of dots exactly round.

I recollected that a line deeply etched in glass by fluoric acid gas, examined under the microscope, consists in its depth of inequalities, and has nearly the same appearance as if it consisted of dots. The circular lines deeply etched in this manner were illuminated sufficiently and pretty nearly equal at all parts, by a lamp. The glass on which lines are to be etched is covered for this purpose with a very thin coat of etching ground, on which the lines, intended to be etched, are to be scratched with a steel point. Covering the glass with leaf-gold, instead of etching ground, as is frequently done for etching with gas, is not advantageous for circular micrometers, because the fluoric acid gas acts, next to the scratched line, also beneath the gold, and in etching deep, the polish of the glass likewise suffers in other places. With a brittle etching ground the scratched lines become impure, and the gas, in etching the lines deep, acts next to them beneath the etching ground. With a too soft etching ground the etched lines easily receive unequal strength. The etching ground must intimately cohere with the surface of the glass, and be of such a consistency, that the steel point, in scratching, cuts only fine threads, which repeated practice will teach. If the fluoric acid gas acts too short a time on the glass, then the etched circular lines are illuminated but very weakly by the lamp; too strong etching, even with good etching ground, makes the lines coarse and rough. Common plate glass is unequally acted upon at different places by the fluoric acid gas. The glass used therefore for lamp-circular micrometers must be very homogeneous. In several sorts of glass, the time which the acid takes to act, differs, and some sorts of glass, deep even as they may be etched, never give a circular line, which shall appear in all its parts strong and equally illuminated by the lamp.

In order to give the circles made by the scratched lines the degree of exactness that is required, and to scratch upon the same glass many circular lines, which are exactly concentric, I contrived a particular engine, whose description is here superfluous; with it circular lines of $\cdot 003$ to $1\cdot 3$ inch diameter can be made at any given distance from each other.

We have to contend with some difficulties, in finding a construction of eye-glasses, which at one and the same position plainly show the inner and outer circular lines in the field of view, and which are so contrived, that the light from the lamp,

lamp, illuminating the circular lines, cannot come to the eye; and that the field of view remains dark. In the eye-glasses, which I made for the lamp-circular micrometers, this has been very well accomplished. In order to keep off the light coming from the lamp as much as possible from the eye, a great deal will depend also upon the form of the setting of the eye-glass.

The micrometer with which the astronomer M. Soldner made some observations, and who under favourable circumstances will make more with it, contains circular lines, which follow one after the other, as is represented on a larger scale in Fig. 1. The smallest circular line appears to the naked eye as a small dot, and is only distinguished by the eye-glass. With a higher power, which in a telescope of 60 inches focus magnifies 110 times, 5 circular lines are seen, including the smallest: through the middle eye-piece, magnifying 63 times, 8 circular lines are seen; and with the lowest eye-piece, magnifying 45 times, eleven circular lines are seen. As with many circular lines it could perhaps not be correctly judged at the moment how many of the lines the star has cut, and an error might easily take place, I gave to the 5th and 6th, the 8th and the 9th larger distances from each other, than to the rest; so that it is known in a moment with which circular line the observer is occupied. With the magnifying power of 45 times, the largest circular lines are illuminated somewhat weaker than the rest, and are less plainly seen; for which reason the weaker one is used only in great differences of declination, where the stronger oculars cannot be made use of; and also for this reason, that with a less magnifying power the same exactness is not possible as with higher ones.

The different circular lines of the above-mentioned micrometer have the following dimensions, the Paris inch taken as unity:

Dimension of	I.	=	·0038
	II.	=	·0243
	III.	=	·0840
	IV.	=	·1678
	V.	=	·2513
	VI.	=	·3590
	VII.	=	·4426
	VIII.	=	·5264
	IX.	=	·6338
	X.	=	·7178
	XI.	=	·8012

These dimensions I measured with the microscope, with which I determined the breadth of the interstices and thickness of the threads of those squares, which appertain to the phenomena

nomena produced by the mutual action of bent rays *, so that their exactness cannot be questioned. By the same microscope I also ascertain whether the circular lines be exactly round and concentric. It is only wanted to determine the proportion of the diameters with the microscope. This proportion, and at the same time the value of the dimensions, could be derived with sufficient precision from the transit of a star near the pole, if the telescope was set sufficiently firm. If the proportion of the dimensions was determined by the microscope, then it is required only to determine the value of the dimension of one of the largest circular lines, in order to know also the value of the remaining ones. As the circular lines are exactly concentric, the values of their dimensions, which they have at the focus of any object glass, can be determined in many different ways. If the telescope were placed extremely steady, and could be at the same time very sensibly moved, then the determination of the values of the dimensions might be the most simple, by means of the pole-star. For it is only necessary to place this star in the middle of the smallest circular line, and to observe the time of its transit through the other circular lines. But this transit requires much time, for which reason a telescope might not be easily placed sufficiently firm; nor is it easy for the motions of the telescopes to be sufficiently sensible, in order to place a star exactly in the centre of the smallest circular line. If the proportion of the dimensions of the different circular lines is known, then their value can likewise be derived from the transit of a single determined star, even if it does not pass through the centre.

For a star therefore of small declination, if it passes through the centre of the field of view, the greater part of the circular lines in the above micrometer are distant from each other about 10 seconds of time; which time might perhaps suffice to note the observation. As this time is proportionally longer for northerly stars, double the number of circular lines might be made in the field of view, without incurring the danger of being uncertain with which line the observer is occupied. One might, for instance, give equal distances to the first 5 circular lines, from each other, then, for easier distinction, to make the distance from the 5th to the 6th larger; then again 5 in equal distances, &c. With this micrometer one half of these circular lines could only be made use of in stars of small declination; because the intervals of time for noting would be too short. As the declination can only be exactly derived from those observations where the star has cut a small segment

* See *New Modification of Light, &c.*, by M. Fraunhofer.

of the circular line (but where there are many circular lines, one of them at least must have an advantageous position), it might even in this respect be desirable to make as many circular lines as is advisable for other reasons. Should even in some of the circular lines the ingress merely have been observed, and the interval of time had been too short, in order to observe the egress too, yet in that case the observation is not lost; because the circular lines are concentric, and their distances are known.

The circular lines are so strongly illuminated by the lamp, that their light does not vanish, even if a large star approaches them. In very weak comets, however, this strong illumination might endanger the exactness of the observation. Without lessening the flame of the lamp, the illumination of the circular lines can be diminished, by putting into the small tube, with which the lamp is annexed to the eye-tube (fig. 2), a smaller one, which contains a diaphragm. The oil-vessel *a* of the lamp can in every position of the telescope assume, on an average, a horizontal situation, partly because it can be turned round the axis *b* of the cylinder, which forms the lamp, partly because the lamp in the small tube, with which it is annexed to the eye-tube, can also be turned. The flame is, in all positions of the telescope, in the axis of the lamp. The light of the lamp, next to the flame, falls upon a convex glass, through which it is thrown upon the micrometer. The oil-vessel can be lifted out of the lamp, by pushing back at the screw *c*. By the pushing back of this part an opening at the top of the oil-vessel takes place, through which oil may be added.

The glass on which the lines are etched, is so placed that the etched surface is turned towards the eye-glass. A reversed position of this glass produces a disadvantageous reflexion, and the circular lines are less advantageously illuminated. The three different eye-glasses can be screwed to the same frame in which the etched glass is fixed, so that the latter need not be changed or brought out of its position, while the different magnifying powers are applied. Each eye-glass has in the front towards the plane-glass a diaphragm of such an aperture that it takes in the necessary part of the field; and betwixt this and the first eye-lens still a second one, through which a part of the light, coming from the lamp, which does not strike upon the circular lines, is intercepted.

One might perhaps suppose that, if the etched glass were not perfectly plane, it might have a very detrimental influence upon the observations; but we may only imagine what would take place if this glass was in reality perceptibly concave or convex;

convex; and we shall find, that, if not thick and if it stands at the focus of the object-glass, no detrimental effect can take place. As the eye-piece is not achromatic, the stars become somewhat coloured at the margin of the field; however, they do not change their form when a circular line cuts them, and even small stars do not vanish at the moment of the transit through the illuminated circular line. I have tried to make an achromatic eye-glass, but hitherto I see no possibility of hitting upon one which shall, at the same time that the middle circular lines are plainly seen, show also the outer ones tolerably plain, without moving the eye-glass. As the eye-glasses strongly magnify, every particle which adheres to the cut glass is perceptibly seen, because it is illuminated by the lamp. It is almost impossible to keep the cut glass totally free from dust. Although the illuminated particles appear in the field of view like stars, yet we soon accustom ourselves to their presence, and they are no obstacle to the observation, because they do not change their places, but real stars are always in motion, and can therefore be easily distinguished from those dusty particles. That too much dust should not be suffered to adhere to the glass, is a matter of course.

As in all instruments, where seconds of time are of consequence, a firm position is the main object, so likewise is this the case here: and nothing ought to be neglected which is capable of producing it. If the micrometer is to give such exact observations as it is capable of, then the place where it is to be put up, must be carefully chosen, every possible draft of air avoided, and the observer must remain, during the transit of the stars, unalterably quiet, without touching the telescope with his eye, which is almost superfluous to mention. For this reason, it might be well if the observer did not note the observations himself, because he must change his position for that purpose. A considerable alteration of the instrument, during the transit of the stars, could however be often detected at the calculation of the observations.

For determining the relative place of two very near stars, for instance a double star, there might still remain a good deal to be wished for in the described micrometer. In these stars the interval of time from the transit of the one to the transit of the other, is much too short, in order to be observed with any certainty. For this purpose a micrometer, consisting of straight parallel lines (fig. 3), whose distances from each other are exactly known and which cut through one another at an acute angle, which is exactly ascertained, might be very advantageous. The glass on which these lines are etched can be so turned on the telescope, that the lines which run parallel

rallel with $d e$ stand nearly vertical upon the parallel circle of the star; the lines running in the direction $f g$ would therefore be inclined thereto. From the times of transit of the stars through the vertical and those through the inclined parallel lines, the difference of right ascension and declination can be derived with accuracy. To place the lines running in the direction $d e$ exactly vertical upon the parallel circle, might not well be accomplished, even if still another line was drawn, of which one knew that it cuts these parallel lines exactly under a right angle. As the distance of the vertical lines from each other, and also that of the inclined ones, in the same manner as the angle under which they cut each other are exactly known, the proportion of the times of transit of a star through the vertical to those of the inclined parallel lines, will make us correctly acquainted with the position of these lines with regard to the parallel circle. The calculation of these observations will always be still more simple, than what is made with the circular micrometer. Even at a transit of both the stars we always obtain several observations, which on an average give declination and right ascension equally exact, whether their difference of declination be great or small. Where the difference of right ascension is small, as for instance in double stars, the transit of both, indeed, could not be observed through one and the same vertical line; but the observer would for instance observe one at the first vertical line, the other at the second, &c. This lamp *net*-micrometer has, amongst others, this advantage; viz. that an alteration of the instrument, during the transit of both the stars, can be detected previous to the calculation. I have given to the parallel lines such a distance from each other, that the distance of the inclined to those of the vertical ones bears about the same proportion, as the cosines of the inclined angle to the radius, in order that about as many transits of the star, through the inclined as well as through the vertical lines, may be observed. Five lines always have an equal distance only; the 5th is one half more distant from the 6th, than the rest amongst themselves. From this it is easy for the observer to know with which line he is occupied.

I have constructed an engine, with which straight lines can be cut exactly parallel, and to $\cdot 0001$ of an inch at equal distances. This engine is at the same time so contrived, that the parallel lines can be cut through the others under any given angle, exactly to a minute of a degree. For this *net*-micrometer the same lamp and the same eye-glasses are used, as to the above-described circular micrometer; and it is only necessary to screw on the frame with the *net*, instead of that with the *circular* lines.

XXXVI. Notices respecting New Books.

*The English Flora, Vols. I. and II. By Sir J. E. SMITH, M.D.
F.R.S. President of the Linn. Soc. &c. &c. &c. 1824.*

THE public will accept with pleasure this portion of a work which has been long promised. These two volumes comprise about one half of the phænogamous plants, and the author purposes to proceed immediately with the remainder. The preface gives a succinct and masterly outline of the nature of a Flora, confined as it should be to botanical illustration and description, with such remarks concerning the properties of plants as may be new or important; with philosophical views arising from the nature of the subject, tending to the general elucidation of botanical science. A great improvement upon the author's *Flora Britannica* is introduced, by combining as much as possible some account of the natural affinities of each genus with the Linnæan character. Thus, not only is the individual species pointed out in the clearest way to the student by means of the artificial system, but the natural relations to other species and genera, and much of its history and physiology, which constitute the philosophy of the subject. By the plan here adopted, the repetition of the species twice over is avoided. Although English botanists have been conspicuous for their acute search into species, somewhat to the exclusion of more general views, this work, with others of the learned author, will give them a taste for the higher departments of the study, and not leave them satisfied with an acquaintance solely with the individual.

If the *Flora Germanica* of Schrader, a small portion of which has reached this country, be more minutely discriminative in the descriptions, and be aided by some illustrative figures of difficult species, the English Flora of Sir J. E. Smith surpasses all others in its critical department. The descriptions are ample for all purposes of distinction, and the diagnostic views greatly assist the inquirer. There is an amenity and candour about the whole work highly creditable to the feelings of the author and to his subject, and he does but exemplify in his own practice what he says is the tendency of all natural science:—"to enlarge the understanding by a perpetual display of the power and wisdom of God."

The language is accommodated, much beyond what we could have expected, to the merely English reader, who will not be deterred by the Latinity of the nomenclature, adopted by Dr. Hull in his "British Flora," and by some other au-

thors. The typographical arrangement claims no small share of praise; and the various heads of information under each species catch the eye in a convenient and instantaneous way. Indeed we can suggest no improvement in this department, unless the habitats, as in the *Flora Britannica*, had been expressed in a different type.

A few only of the novelties, which are to be found in perusing this work, can now be noticed. *Salicornia radicans* and *fruticosa* are said to be possibly varieties, and most of our best botanists concur in this view. *Callitriche autumnalis*, which is *aquatica* γ of *Fl. Br.*, is now first admitted on the authority of that keen observer, Dr. Wahlenberg. The lovers of Flora will be glad to see *Veronica hirsuta* established as British, and for which we are indebted to Mr. James Smith, who belongs to that useful class, the Scotch gardeners. Has the learned author ever noticed the St. Vincent Rock's specimens of *V. hybrida*? One of our lynx-eyed friends always insists that it is distinct from the Humphrey Head plant. The *V. Allionii* of Hooker is, with propriety, made a variety of *officinalis*. *Schœnus Mariscus*, on the authority of Brown, affords the type of a new genus called *Cladium*. *Fedia*, comprehending the old *Valeriana locusta* (now *F. olitoria*) and *dentata*, is immutably established. *Schœnus albus* and *fuscus* furnish another new genus, created by Vahl, called *Rhynchospora*,—the only real *Schœnus* left being *nigricans*. *Eleocharis*, again, embraces *Scirpus palustris* and some others allied in habit; but why *cœspitosus* should still be left among the *Scirpi* does not satisfactorily appear. The articulated style is the character of the new genus. *Cyperus fuscus* appears here from Hooker's *Flor. Lond.*, but its claim to be a native is probably to be suspected. *Eriophorum pubescens* is new, from Cherry Hinton near Cambridge.

The Grasses have undergone great changes, by the division of the artificial genera, and by a new arrangement of their proximities. The old *Phleum paniculatum* is now *asperum*, which is the more common and appropriate name. *Phalaris arenaria* is now a *Phleum*. The genus *Trichodium* of Michaux and Schrader, to which our *Agrostis canina* and *setacea* were supposed to belong, by habit as well as by character, is not admitted. The total absence of the inner valve does not seem essential, as may be seen in *T. rupestre*, which is considered as an indubitable species of this genus. The *A. setacea* seems scarcely to be known by the continental botanists. It is to Curtis that we are indebted for the first complete establishment of this species. His figure and description are, as usual, clear and accurate, and leave nothing to be desired. Withering mistook it for *A. alpina*, from which it differs widely in the panicle,

cle, and in the general roughness. Hudson asserted, that when transplanted into a moistish soil it became *canina*; and thus it is γ of that author. Perhaps its nearest congener is *A. rubra*, to which Hudson referred it in his first edition, and of which it is, improperly, made a variety by Wahlenberg. His remark is, "Var. β in Suecia inferiori quoque crescit, et omnino convenire videtur cum *A. setacea* Smith—paniculam satis densam habet. Flosculi vero in utraque iidem, ita et nonnisi varietate a Lapponica differt." There is this difference, however, between his plant and ours, that the valve of the corolla of the Lapland species is "apice subintegra subnervis," whereas the nerves of our *setacea* are conspicuous, and end in a *mucro*. Though this difference is but trifling to the eye, it is much more to be depended on than many more obvious appearances. *A. mutabilis* of Sibth. is rightly rejected as a synonym of *setacea*. He describes his plant as awnless, "panicula patente," &c., all of which agrees well with some of the varieties of *alba*, and not with *setacea*. There is nothing but his reference to Scheuchzer to favour the idea of his having had that plant in view, whose description and figure, however, are equally applicable to *alba*. In addition, it may be remarked, that the writer of this has sought in vain for *setacea* in the habitats mentioned by Sibthorp, and he thinks he may safely affirm, that *A. mutabilis* is not *setacea*, but most probably a variety of *alba*.

A new specific character is drawn up for *A. canina*, which was left in the *Fl. Br.* in considerable obscurity. The synonym of Leers is now added, whose character and description are completely satisfactory. In referring to Withering's *A. vinealis* as *A. canina*, some doubts suggest themselves, for which there is not room in this place. The *canina* of the 2nd edition of the "Botanical Arrangement" is probably Linnæus's plant. *Panicum*, which included a completely artificial assemblage of species, is now divided into *Panicum*, having *P. viride* for its type; *Cynodon* being the old *P. Dactylon*; and *Digitaria*, which is the Cock's-foot grass. *Aira lævigata* E. B. is here transferred to *alpina*, after Wahlenberg. *Hierochloa borealis* (sometimes spelt by the learned President, as if by intention, *Hierocle*) is a new and curious arctic species. "It is a very natural genus of grasses," as Mr. Brown observes, "natives of the colder regions of both hemispheres." It is related in some particulars to *Anthoxanthum*. *Glyceria*, comprising *Poa aquatica* and its allies, is another well authorized change sanctioned by Mr. Brown. The true *Poæ* are confined to that section which has ovate spikelets. *Poa flexuosa* is ascertained by Schrader to be *laxa*; *subcærulea* and *humilis* are brought back to *pratensis* as varieties; and *cæsia* is made a var.

of *glauca*. *Poa decumbens*, which has always been regarded as an unnatural *Poa*, is, with Brown, made into a natural genus, *Triodia*. Sir James E. Smith concurs with Schreber in making *Dactylis stricta* a *Spartina*.

Festuca cæsia, E. B., is brought back to *ovina*, which will be concurred in; but is not *F. tenuifolia* good? The absence of the awn is probably a sufficient character joined with the habit. Schrader and Hooker had abolished *F. vivipara*, but the President still retains it. *Festuca triflora* is very properly made a var. of *F. gigantea*, as *F. decidua* is of *calamaria*. It had been thought that this last-named species was confined in England to the North; but that accurate botanist Mr. E. Forster has lately found it at Harrison's Rocks near Tunbridge Wells. *Bromus pinnatus* is again joined with *Festuca*, as Hudson had done before. It is not confined to chalk, but is most abundant on the oolite; and Mr. Greenough says it is very plentiful on magnesian limestone. Schrader and Hooker are followed in *B. multiflorus*, which turns out to be a different plant from what the *Fl. Br.* had made it. *B. pratensis*, E. B., and *arvensis*, E. B. 920, are merged in *racemosus*. *B. squamosus* most botanists will think ought to be excluded as not English. Long Sleddale in Westmoreland has been ransacked often enough for *Stipa pennata*, to warrant the assertion that it is not to be found there; and Dr. Richardson, the supposed finder, is of little authority.

Avena planiculmis, a discovery of that extraordinary lucky botanist G. Don, is now *alpina*. The writer of this has endeavoured in vain to understand the *Arundo epigeios* of Schrader; many of ours answering much better to his figure of *pseudophragmites*, and none of them to his figure of *epigeios*. He relies chiefly on the insertion of the arista. *Rottbollia filiformis* is surely not worthy of notice. *Elymus* is not confined, as the present writer has observed, to chalk; and he would notice, by the by, that the learned President often incorrectly uses the word limestone as synonymous with calcareous soil. *Triticum repens* γ is treated by many good botanists as a species under the trivial name of *maritimum*, but it is here regarded still as a variety. *Holosteum umbellatum* is not made with Hooker a *Cerastium*; in which most systematic botanists will concur.

Among the *Galia*, of most difficult discrimination, are two new ones, *cinereum* and *aristatum*, still from Mr. George Don. Any one who would illustrate this difficult family would confer great benefit on systematic botany. The foreigners have many more than we have admitted. *Sanguisorba media* is new from G. Don. For *Epimedium alpinum* there are some new habitats. The one on Skiddaw should be ascertained, as that
looks

looks as if the plant were truly wild. Mr. Thomas Hutton, the well known guide to the Lakes, never could point the plant out to any of the numerous botanists who went searching for it. *Potamogeton cuspidatum* of Teesdale is admitted upon the authority of Schrader. *Sagina erecta*, so different from the rest, is here, as well as by Hooker, called *Mænchia glauca*.

The genus *Myosotis*, raised lately to some popularity under the name of Forget-me-not, is well illustrated. Three new species are added, *M. cæspitosa*, *sylvatica* (Ray's plant), and *intermedia*. The two first are not uncommon. The author follows Lehman, the great authority in this tribe, in calling *rupicola*, E. B., *alpestris*. *Lithospermum maritimum* is the old *Pulmonaria maritima*. Does it not turn out that most of the habitats assigned to *Pulmonaria officinalis* are those of *angustifolia*? The *Echium italicum* is very justly excluded. Ray's plant, brought from Jersey by Joseph Smith, Esq., F.L.S., justified, as far as the present writer noted at the time, all the changes of synonyms here made; and in addition he recollects consulting the Sherardian Herbarium to ascertain the *Echium ramosius*, &c. (Moris. sect. xi. t. 27), and he found it the Jersey plant, and not the *italicum*. It will probably be found hereafter to be a good species. Those who love the Primroses, with all their agreeable early associations, will be pleased to find the addition of *P. scotica* to our Flora. *Cyclamen europæum*, the old Sow-bread, turns out to be *hederifolium*. *Meynantes nymphæoides*, so aptly termed the Fringed Water-lily, is not, with Professor Hooker, removed to *Villarsia*. The remark that the trivial name is not meant to compare the plant with a nymph, but with a *Nymphæa*, is obviously just. The pretty *Anagallis cærulea*, which has no specific character, though all the beauty, of a noticeable species, is still retained. *Campanula persicifolia* is an addition. *Viola flavicornis* is made out of *canina* γ . Is not Sibthorp's *V. arvensis* as good as any? A very curious instance of irritability is recorded under *Verbascum pulverulentum*: if the stems be smartly struck three or four times with a stick, all the flowers then open will, in a few minutes, throw off their corolla, the calyx closing round the germen, so that after eight or ten minutes none will remain on the plant. *Chironia* has disappeared, all our species being true *Erythrææ*. *E. latifolia* is well established as a species, being the second var. of *Chironia Centaurium* in *Fl. Br.*

So much has occurred to interest us in perusing the first volume, that we have lengthened our observations much beyond our original intention. The second volume will furnish another paper for the next Number.

Recently

Recently published.

Dr. Forster has just published a work, entitled "The Perennial Calendar," being a sort of compendium of the natural history of each day in the year, arranged according to the days in the Calendar, and interspersed with numerous notices of popular customs and superstitious ceremonies and rites which belonged anciently to particular seasons, or to festivals and days. The work was the amusement of his leisure hours many years ago when a student, and having been increased by the addition of numerous essays and observations by his friends, has been arranged in a popular form and published. It contains among other things, notices of the particular days on which certain plants have been found to flower in the climate of London; deduced from journals of twenty or more years regular observation. The whole forms a very thick octavo volume.

In the Press.

Mr. R. Phillips's Translation of the New *Pharmacopœia Londinensis*, with copious Notes and Illustrations, will appear in a few days.

ANALYSIS OF PERIODICAL WORKS ON NATURAL HISTORY.

Curtis's British Entomology.

No. 3. contains the following subjects :

Pl. 11. *Molorchus minor*, a curious insect, of which Linnæus said, it had the antennæ of a *Cerambyx*, the legs of a *Leptura*, and the elytra of *Forficula*.—Pl. 12. *Lycæna dispar* (the large copper Butterfly), a most splendid species which has been discovered, in some abundance, in Huntingdonshire.—Pl. 13. *Eumenes atricornis*, a new genus to this country, discovered in Hampshire by the Rev. Wm. Kirby: this genus of *Hymenoptera* is found as far east as China.—Pl. 14. *Hæmobora pallipes*, a perfectly new genus of the curious order *Omaloptera* of Leach, found by Mr. Samouelle in the New Forest, Hants, where the forest fly abounds upon the horse to an astonishing extent; and this possibly may be attached to the deer, as those animals are found in every part of that neighbourhood.

XXXVII. *Proceedings of Learned Societies.*

ROYAL SOCIETY.

Feb. 26.—A SERIES of observations were presented "On nearly all the principal Fixed Stars between the zenith of Cape Town, Cape of Good Hope, and the South Pole;" by the Rev. Fearon Fallows, M.A. F.R.S., Astronomer at the Cape of Good Hope.

A paper was read "On the different Degrees of Intensity of the local Magnetic Attraction of Vessels in their different Parts;" by George Harvey, M.G.S. M.A.S.

March

March 4.—A letter to the President was communicated from Sir E. Home, Bart. V.P.R.S., entitled “Some curious Facts respecting the Walrus and Seal, discovered in the Examination of Specimens brought by the late Expeditions from the Polar Circle.”

A paper was also read, entitled “Some further Particulars of a Case of Pneumato-thorax, by John Davy, M.D. F.R.S.”

March 11.—A paper was read, “On the Parallax of a *Lyræ*; by the Rev. John Brinkley, DD. F.R.S. &c.”

March 18.—A paper was read, entitled “An Account of Experiments on the Velocity of Sound, made in Holland; by Dr. G. A. Moll, and Dr. A. Van Beck.”

March 25.—A communication was read from L. W. Dillwyn, Esq. F.R.S. On the geological distribution of Fossil Shells. A letter was likewise read from Thomas Tredgold, Esq. Civil Engineer, to Thomas Young, M.D. For. Sec. R.S., “On the Elasticity of Steel at various Degrees of Temper.”

GEOLOGICAL SOCIETY.

Feb. 20.—A notice was read on the *Megalosaurus*, or Great Fossil Lizard of Stonesfield, near Oxford; by the Rev. W. Buckland, F.R.S. F.L.S. President of the Geological Society, and Professor of Mineralogy and Geology in the University of Oxford, &c. &c.

The author observes that he has been induced to lay before the Society the accompanying representations of various portions of the skeleton of the fossil animal discovered at Stonesfield, in the hope that such persons as possess other parts of this extraordinary reptile, may also transmit to the Society such further information as may lead to a more complete restoration of its osteology. No two bones have yet been discovered in actual contact with one another, excepting a series of the vertebræ. From the analogies of the teeth they may be referred to the Order of the *Saurians* or Lizards. From the proportions of the largest specimen of a fossil thigh-bone, as compared with the ordinary standard of the *Lacertæ*, it has been inferred that the length of the animal exceeded forty feet, and its height seven. Professor Buckland has therefore assigned to it the name of *Megalosaurus*. The various organic remains which are found associated with this gigantic lizard form a very interesting and remarkable assemblage. After enumerating these, the author concludes with a description of the plates and observations on the anatomical structure of such parts of the *Megalosaurus* as have hitherto been discovered.

March 5.—The paper entitled “Outline of the Geology of the South of Russia,” by the Honourable William T. H. Fox Strangways, M.G.S., was concluded.

The term *Steppe* is applied to vast tracts of country in the E. and S.E. of Europe. It is neither a heath, nor a moor, nor a down; *wold* would give the best idea of it in English, and it is given by the Russians to any waste land which is neither mountainous nor wooded. The Russian Steppes are bounded on the west by the Carpathian chain of Transylvania and the Banat of Temesvar; on the S. by Mount Hæmus, the Tauric Chersonese, and Caucasus; on the E. by the Oural mountains to beyond the Caspian Sea and the sea of Aral; vaguely to the N. by a line from the mouth of the Kama to the Dniester on the frontiers of Podolia and Kherson. Their length is about 2000 miles, breadth 900. The soil is similar throughout; the geological structure very different.

A trough or basin stretching across from Perecop to the Caspian, and thence beyond the sea of Aral, forms a natural division of the Steppe into the N. and S. High Steppe; this trough or basin Pallas and others well describe as the low sandy saline steppe, the two former as the high rich calcareous and granitic steppe.

The Northern High Steppe admits of five divisions:

1. Steppe of red marl, salt and gypsum, lying on both sides the Volga above the reach of Samara.
2. Steppe of Saubof and the middle Volga, from Samara to Tzaritzin; its northern part consists of the white central limestone, its southern of sandstone which connects it with the steppe of the Don.
3. Northern calcareous steppe of the Don is composed of sandstone to between Cherkask and the mouth of the Donetz; here commences an immense tract of a peculiar modern shelly limestone; the steppe limestone probably extends across the Ukraine, and is connected with the calc. gross. of Volhynia and Galicia.
4. S. and S.E. of this occurs the primitive or granitic steppe, a singular instance of a flat tabular granitic country connected, according to Pallas, with the primitive range of the Carpathians, passing the Dniester at Doubosar, and traversing Moldavia.
5. Middle calcareous steppe, of steppe limestone separated by a sandstone from the preceding; this is a prodigious mass extending throughout Wallachia, Bessarabia, the south of Moldavia, and Government of Kherson. The trough or basin before alluded to forms the steppe of the old sea, which involves the singular problem of the connexion and extension of the Caspian and Black Seas. To the south of this lies the southern calcareous steppe, comprehending the Crimea, and stretching to the foot of Caucasus, is composed of steppe limestone resting on calc. gross. The high steppes, from the occurrence of marine plants and other causes, have been supposed to have once formed a vast sea; but

but their height, in some places 700 feet above the Black Sea, and 1000 feet above the Caspian, precludes the possibility of this.

The author, after enumerating and describing the series of the above-mentioned beds, and their accompanying fossils, concludes with remarks on the probable extension of the Caspian Sea, and the sea of Aral, and their connexion with the Black Sea by means of the low steppe.

A letter from Mrs. Maria Graham to Henry Warburton, Esq. V.P.G.S., was read, giving an account of the effects of the Earthquakes which visited the coast of Chili in 1822 and 1823.

The first shock by which the towns of Valparaiso, Melipilla and Quillota were nearly destroyed, was felt at a quarter past 10 o'clock on the evening of Tuesday the 19th of November 1822; and from this time continual shocks were felt daily until the 18th of January, when the authoress ceased to reside in Chili. These shocks are said not to have terminated wholly so late as September last. The sensation experienced during the more violent shocks was that of the earth being suddenly heaved up in a direction from N. to S., and then falling down again, a transverse motion being now and then felt. On the 19th of November a general tremour was felt, and a sound heard like that of vapour bursting out, similar to the tremour and sound which the authoress observed while standing on the cone of Vesuvius during the jets of fire at the eruption of 1818. In all the alluvial valleys in the neighbourhood of Quintero, 30 miles N. of Valparaiso, quantities of water and sand were forced up, which covered the plain of Viña a la Mar with cones or hillocks four feet high.

The promontory of Quintero, consisting of granite covered by sandy soil, was cracked in various directions down to the sea; and the cracks occasioned by the earthquake in the granite on the beach were parallel to the more ancient rents in the same rock.

On the morning of the 20th, after the first earthquake the whole line of coast from N. to S. to the distance of 100 miles was found to have been raised out of the sea; the elevation at Quintero being about four feet, that at Valparaiso about three feet, beds of oysters and muscles, adhering to the rock on which they grew, being seen lying dry on the beach.

Similar lines of beach with shells are found parallel to the coast to the height of 50 feet above the sea, which probably have been occasioned by earthquakes which have in former years visited Chili.

The earthquake of the 19th was felt along the coast to the distance of 1400 miles at least.

LINNEAN SOCIETY.

March 2.—An additional portion of Mr. Vigors's paper on the Orders and Families of Birds was read this evening, as well as on the 16th; it is not however concluded.

March 16.—Among the presents received were the first two volumes of the valuable English Flora, just published by the much esteemed President of the Society.

The following communications were read:

Description of *Erythrina Secundiflora*. By Don Felix Avelar Brotero, Emeritus Professor of Botany in the University of Coimbra, For. Mem. of the Society.

On the insect called *Oistros* by the ancient Greeks, and *Asilus* by the Romans. By W. S. MacLeay, Esq. F.L.S. Communicated by the Zoological Club of the Linnean Society. In this paper, which may interest the lovers of classical antiquity as well as of natural history, Mr. MacLeay has produced many interesting proofs that the *Æstrus* of the ancients,

"——— cui nomen *Asilo*

Romanum est, *Æstron* Graii vertere vocantes," (VIRG. GEOR. II.)

was not the insect to which this name is now given, but a *Tabanus*. Olivier first observed that it was different from the *Æstrum* of the moderns. Pliny uses the name *Tabanus* for the *Μωψ*, which Aristotle says is nearly related to *Æstrus*, both being *εμπροσθενκεντρα*; it cannot therefore be the modern *Æstrus*; he also says that both are bloodsuckers, which agrees with the Linnean *Tabani*, but is wholly inapplicable to the modern *Æstrus*. As the insect is too well known for its name to have been forgotten or misapplied, there can be little doubt that the Latin *Tabanus*, the Italian *Tabano*, Spanish *Tavano*, and French *Taon* are identical, which latter name Mouffet gives as the same with the English Breese*, Clegg and Clinger, mentioned by Shakspeare, who speaking of Cleopatra, says:

"The Brize upon her, like a cow in June,
Hoists sail and flies."

Some elucidation is also brought from Homer, and the Prometheus of Æschylus, and it is observed that Virgil describes the *Asilus* or *Æstrus* as abundant and *acerba sonans*, whereas

* This name appears to be of great antiquity in all the Teutonic dialects. The Anglo-Saxon has *Brissa*, [Ital. *Brissio*], and *Brissa*, which latter Junius gives from one of his ancient glossaries D; and Skinner says "apud Higginium solum occurrit." They render *Bræ* and *Briest*, *Æstrum*, *Asilus*, and *Tabanus*; as does Kilian the Belgic *Bremme* and *Bremse*. In the Suio-Gothic we find *Broms*, which Ihre explains by *crabro*: as our Ælfric renders *Æstrus* beaf hýpnette.—
EDIT.

our *Æstrus bovis* is a rare and silent* insect. They were first confounded by Valisnieri, who has been followed by Martyn and others. It is inferred that Aristotle did not even know the latter, from his assertion that no dipterous insect has a sting behind.

ASTRONOMICAL SOCIETY.

March 12.—The papers read at this meeting of the Society were as follows:

A letter from Sir Thomas Brisbane, Governor of New South Wales, to F. Baily, Esq., accompanied by Mr. Rumker's observations of the Summer Solstice 1823 at Paramatta; the results of which are,

For the mean obliquity of the Ecliptic $23^{\circ} 27' 44'' \cdot 39$

For the latitude of the place of observation $33^{\circ} 48' 42'' \cdot 61$

Also the mean of twelve months' meteorological observations made at Paramatta between May 1822 and May 1823.

A letter from Professor Schumacher of Altona, including Mr. Hanson's computations of the elements of the comet of 1823-4, from observations made in the month of January 1824.

Two letters from Mr. Taylor jun. of the Royal Observatory, Greenwich; the first containing the elements of the same comet as computed by himself from the Greenwich observations of January 1824, using Boscovich's method; and the second, a comparison of anticipatory ephemerides of the places of this comet, from the elements computed severally by Schumacher, Carlini, Dr. Brinkley and himself, with the Greenwich observations.

On the Rectification of the Equatorial, by J. F. Littrow, Director of the Imperial Observatory at Vienna. In this paper the author directs his attention to those errors only which depend upon the placing and use of the instrument, which the observer himself must either be able to obviate or allow for; and he therefore enumerates the greater part of them, and points out means for their rectification.

On the Utility and probable Accuracy of the Method of determining the Sun's Parallax, by observations on the planet Mars near his opposition; by Mr. Henry Atkinson, of New-

* Ihre and others derive the Teutonic names *Broms*, *Bremse*, &c. from *bronna*, *brummen*, *bremmen*, *murmurare*, *sonitum edere*, but Wachter prefers tracing them to *bremen*, *pungere*: from which he also brings

—“*brem*, *brant*, a thorn (from Otfrid, a writer of the ninth century):

brem, *brom*, *rubus*:—*brem-beren*, *bramble*:

brem, *genista*; A. S. *brōm*, *broom*.

breme, *bremse*, *crabro*, *insectum aculeatum*, A. S. *brōmja ap.* Benson. non a *βρῦβη*, nec a *brummen*, *bombum edere*, sed a *bremen*, *pungere*. Inde *ross-brem*, *musca equis infesta*, *æstrus*, *asilus*, *tabanus*.” Probably therefore all the names have a similar origin—*Οισος*; from *Οισος*, *sagitta*, and *Gad-fly*, q. *Goad-fly*, A. S. *Gaab*, *gab*, *stimulus*, *cuspis*, *goad*; *Island. gabba*, *pungere*.—*Ebrt.*

castle-upon-Tyne. In this paper the author shows that in a series of observations on Mars, taken with good instruments used in north and south latitudes, the probability of error is very small; and as the synodical revolution of Mars takes place in about 780 days, that planet will be 23 times in opposition before the next transit of Venus on the 8th December 1874. Hence he infers that if careful corresponding observations are made on each of those 23 oppositions, the probable error would be reduced nearly 4.796 times. The author concluded his paper by describing what he regards as the best means of carrying this method into effect.

A new annular Micrometer by Fraunhofer was submitted to the inspection of the Meeting by Mr. Francis Baily: but as this instrument is described at page 177 of our present Number, it is unnecessary to give any further account of it in this place.

XXXVIII. *Intelligence and Miscellaneous Articles.*

CURIOUS ASTRONOMICAL FACT.

THE *eighth* volume of M. Bessel's Observations (for the year 1822) is arrived in this country. In the preface to that work there are recorded some singular facts relative to the habits of observing, by different astronomers; which we consider worthy of particular consideration. It is known to our astronomical readers that in the Greenwich observations for 1795, page 339, Dr. Maskelyne has the following remark: "I think it necessary to mention that my assistant, Mr. David Kinnebrook, who had observed the transits of the stars and planets very well, *in agreement with me*, all the year 1794, and for a great part of the present year (1795) *began*, from the beginning of August last, to set them down half a second of time *later* than he should do, according to my observations: and in January of the succeeding year (1796), he *increased* his error to 8 tenths of a second. As he unfortunately continued a considerable time in this error before I noticed it, and did not seem likely ever to get over it, and return to a right mode of observing,—therefore, though with reluctance (as he was a diligent and useful assistant to me in other respects), I parted with him." Dr. Maskelyne then proceeds to state the manner in which the discordancies were discovered, and points out some useful hints to those who are much engaged in this branch of practical astronomy.

M. Bessel

M. Bessel has met with a similar circumstance at the observatory at Königsberg. During the visit of the late Dr. Walbeck to that place in the winter of 1820–21, these two astronomers instituted a set of comparative observations on the following stars:

954 Mayeri	α' Piscium
φ Aquarii	971 Mayeri
γ Piscium	xxiii. 136 Piazzi
b ———	——— 147 ———
962 Mayeri	979 Mayeri

The right ascensions of these stars were observed by them alternately, with the same instrument, for several days; and the result was (taking a mean of the whole number of observations) that Dr. Walbeck observed them 1".041 in time later than M. Bessel. The observations were made with the meridian circle of the observatory, and with a power of 182. We have not room, in this extract, to give more than the results: the detail of the observations occupies several folio pages in the work above alluded to.

He then proceeds to mention some comparisons that were made with M. Argelander of Abo, by which he finds that this astronomer observed the right ascensions of several stars in the constellation *Gemini*, 1".223 in time later than M. Bessel.

The comparisons made between Dr. Struve and M. Bessel are the most singular: in 1814 the difference was 0".044; in 1821 it was 0".799; and in 1823 it was 1".021. By a direct comparison of the culmination of α *Piscis Australis* on Nov. 13, 1820, the difference was 0".68.

Other comparisons were afterwards made between the observations of Dr. Struve and Dr. Walbeck; and between Dr. Struve and M. Argelander*: and the result of the whole is shown in the following table; where the names of the above-mentioned observers are denoted by their initial letters.

B—W = -1".041	B.—S =	$\left\{ \begin{array}{ll} -0".044 & \text{in 1814} \\ -0.680 & 1820 \\ -0.799 & 1821 \\ -1.021 & 1823 \end{array} \right.$
B—A = -1.223		
S—W = -0.242		
S—A = -0.202		

From some experiments which were afterwards made, M. Bessel seems to think that a part of this difference may arise from the peculiar mode, which each observer may adopt, of *counting the time* by his ear, whilst he is watching the motion of the star with his eye. For, by trying a *half-second* pendulum clock, some of these differences vanished; and

* The detail of these experiments is also given by Dr. Struve himself, in the 3rd. vol. of the *Dorpat Observations*, pages L and 42.

others were considerably reduced. The subject however demands further illustration and inquiry; as it is one of considerable importance when comparing the observations of different astronomers; and even of different observers at the same observatory.

Besides a detail of these singular phænomena, the volume contains, 1° a determination of the scale of the barometer used at the observatory: 2° observations to determine the refraction near the horizon: 3° a new table of corrections for that purpose: 4° the usual daily observations of the observatory; amongst which we observe the transits of those stars which are pointed out by M. Schumacher as culminating about the same time as the moon: and lastly above *seven thousand* additional stars, observed in zones, agreeably to the plan laid down in the former volumes; together with the elements for their reduction.

The present volume has reached this country much more early (even by many months) than usual: it has in fact arrived before the presentation copies intended for the public societies. This unusual expedition must be attributed to the exertions and activity of Mr. Bohte, bookseller, of York-street, Covent Garden; who is determined, as much as possible, to remove the impediments which obstruct the *early* transmission of German books to this country.

M. PASQUICH AND M. KMETH.

A scandalous attack has recently been made on M. Pasquich, the venerable director of the observatory of Buda, by his assistant M. Kmeth; and which has unfortunately been circulated in many respectable journals. The latter accuses the former of having forged the observations of the observatory: that is, in fact, of giving to the world a statement of observations that were never made. Some of the principal astronomers on the continent have taken up the subject, in order to convince the world of the innocence of M. Pasquich. Amongst those who have come forward on this laudable occasion are MM. Gauss, Olbers, Bessel, Encke and Schumacher.

To the Editors of the Philosophical Magazine and Journal.

OPPOSITION OF MARS WITH THE SUN.

Gosport, March 25th, 1824.

As the announcement of the opposition of Mars must have excited some curiosity among our astronomers, and as corresponding

responding observations on the place of this planet in the northern hemisphere, may be found useful with those that may be made in the southern hemisphere, I therefore beg to send you the result of some observations that I have made respecting the place of his opposition with the sun. At 8 o'clock this evening Mars was distant from γ Virginis $3^{\circ} 24' 15''$, and from η Virginis $2^{\circ} 33' 45''$; from which, and with recent observations made on his daily motion towards stars lying nearly in his path, I make the place of Mars at his opposition with the sun this morning $6^{\circ} 5' 3' 40''$ of longitude, and latitude $1^{\circ} 12' 30''$ north; or $R185^{\circ} 3' 40''$, and declination $1^{\circ} 12' 30''$ north. This will differ, but not materially, from what may be ascertained of the place of this planet in the Nautical Almanac for 1824; and not having used a micrometer, for want of stars situated nearer to the planet,—only a good sextant,—I am not certain of extreme accuracy: however, the above result will be found near the truth within a few minutes either way.

Yours &c.

WILLIAM BURNEY.

NEW ORRERY.

Mr. B. M. Forster of Walthamstow has just invented a pendent orrery to represent the solar system. It consists of globes, fixed to horizontal rods, and suspended by means of catgut, which twisting or untwisting itself slowly, as the circumjacent air dries or moistens, produces the revolutions of the imitated planetary bodies, the distances of the globes which represent the planets being calculated to correspond with those of the planets themselves. Mr. Forster considers the machine as capable of great improvement, so as to be able in time to represent the *whole* of the planetary system. The catgut strings which suspend the globe twist themselves hygrometrically by being brought into a dry room from a moist one.

AEROLITES.

The subjoined notice has appeared in the newspapers; but no information on the subject has transpired from more authentic sources:—

A letter from Molinella, in the Legation of Bologna, of the 6th of March, says, “ Within the last few days a great number of meteoric stones have fallen in the neighbourhood of the village of Arenazo. The largest of these stones is twelve pounds in weight. Its fall was preceded by claps of thunder of extreme violence, accompanied by wind, a phænomenon which much astonished the inhabitants of the country. The largest aërolite has been taken to the museum of Bologna.”

ANTHRACITE OF SCHUYLKILL IN PENNSYLVANIA.

We extract the following from the New York Evening Post for the 30th of June last:

Coal.—We are pleased to find that there is a rational prospect of this city being supplied, during the ensuing winter, with coal from the extensive mines which are now working in the great Schuylkill coal range of Pennsylvania.—Philadelphia has long enjoyed this advantage, and the effect there has been to reduce the price of wood at least one third. New Jersey appears to be following the example, by making arrangements for the transportation from Philadelphia of the Lehigh coal, which is said to have produced a saving on one trial of 50 per cent. Efforts are likewise making in this city to obtain sales for this article. When we know, as we do, that the Lehigh coal sends out nearly double the heat of the Liverpool coal, and will burn considerably longer, the propriety of its introduction to this city, in preference to the imported coal, cannot be questioned. Still we understand that there is a coal dug from the same range of mountains, called the Schuylkill coal, which we have reason to believe is superior to the Lehigh coal, and which brings in Philadelphia five cents more per bushel. The Schuylkill coal belongs to a company in this city, recently incorporated by the legislature; and we are informed it is the intention of the directors to bring 5000 chaldrons of this coal into our market next fall, with the double view of profit and to make it more generally known, preparatory to a full supply the ensuing season. We are at all times ready and willing to encourage the improvements of neighbouring states; but certainly, when these come in competition with the enterprize of our own citizens, it cannot be thought invidious, or even unreasonable, if we should give a preference to the latter; the more especially when we are satisfied, as in this instance, that that preference is founded on general utility. That the Schuylkill coal is superior to the Lehigh coal, we have had no opportunity of determining by actual experiment; but we have the testimony of those in its favour who are well skilled in these matters, and who, from having used both in various ways, have decided in favour of the former. From this source we learn, that no just and adequate conception of the Schuylkill coal can be formed from those specimens of the Susquehannah and Lehigh coal, which have been exhibited in New York. The Schuylkill coal is lighter, purer, and more inflammable. In appearance it is bright and glossy, and often beautifully iridescent. It does not pulverise and throw off a begriming dust, like the common coal.

coal. It is all taken out in large masses, and when broken up, which is necessary to prepare it for the grate, it does not pulverise, but separates into small pieces of curved or prismatic forms. It ignites with perfect facility; burns with a small flame, but with a most vivid and intense heat, leaving an ash small in quantity and white like that of hickory wood. It has no sulphur and no smell. Having no bitumen, it creates no smoke or soot. The permanence and durability of this coal is as astonishing as the strength and vehemence of its heat, which circumstances render it the most economical and cheap fire that can possibly be found. These peculiar qualities of this coal are not only established by the general voice of Philadelphia and the counties on the Schuylkill, but are attested by the published statements of the Board of Direction of the Schuylkill Canal Company, composed of gentlemen of the highest distinction and character.—They state, that from “repeated experiments,” it is found that “one bushel of Schuylkill coal goes as far as three of Liverpool; and that ten bushels are equal to a cord of the best oak wood.” The purity of this coal is without example or parallel, being 97 parts out of a 100 pure carbon. Hence it is perfectly and admirably fitted for certain valuable purposes, to which the common coal cannot be applied without a tedious and expensive process of preparation, as in smelting and air furnaces, in breweries, and in kitchens, where it is used for cooking, and answers admirably. In melting iron ore and iron, besides requiring but half the quantity of coal, and saving much time, it improves the quality of the iron—a matter of the highest importance—renders it more closely textured, tougher and more malleable.

VOYAGE OF DISCOVERY.

Accounts dated in May last have just been received in Paris from the French maritime expedition of discovery commanded by Captain Duperrey. They contain some interesting details on nautical and magnetical observations, and announce the discovery of four islands in what the French call the Dangerous Archipelago, to which they have given the names of Clermont-Tonnere, Lostanges, Angier, and Frennet. The inhabitants could not be induced to have any intercourse with the voyagers. Driven thence by stress of weather, they proceeded to Otaheite, where they witnessed the happy change that has taken place in the morals of the natives since the introduction of Christianity. Idolatry, human sacrifices, polygamy, and child-murder, are now unknown among them; and many exhibit great fervour in the profession of Christianity.

The following ANALYSES OF MINERALS are extracted from late numbers of various German and French journals.

Streifenspath. Bernhardi and Brandes. *Aluminite, from the mountain of Bernon, near Epernay (de la Marne). Lassaigue.*

Carbonic acid	42·500	Alumina	39·70
Lime	53·661	Sulphuric acid	20·06
Magnesia	0·592	Water	39·94
Oxide of iron	1·376	Sulphate of lime	30
Oxide of manganese	0·308		
Water	0·250		100·00

Or, 98·687

Carbonate of lime 94·4524

Carbonate of magnesia 1·2240

Protocarbonate of iron 2·8000

Carbonate of manga-

nese 0·4995

Water 0·2500

99·2259

Calcareous Garnet of Lindbo.

Hisinger.

Silica 37·55

Peroxide of iron 31·35

Lime 26·74

Protoxide of manganese 4·78

100·42

Pitchstone of Meissin.

Du Menil.

Silica 73·00

Alumina 10·84

Protoxide of iron 1·90

Lime 1·14

Soda 1·48

Volatile matter 9·40

97·76

Rubellite of Rozena, in Mora-
via. Gmelin of Tubingen.

Boracic acid 5·744

Silica 42·127

Alumina 36·430

Oxide of manganese 6·320

Lime 1·200

Potassa 2·405

Lithia 2·043

Volatile matter 1·313

97·582

Schorl of Eibenstock in Saxony.
Gmelin of Tubingen.

Boracic acid 1·890

Silica 33·048

Alumina 38·235

Protoxide of iron 23·857

Soda with Potassa 3·175

Lime, with a trace

of magnesia 0·857

101·062

Semi-opal, from Quegstein
(Siebengebirge). Brandes.

Silica 86·000

Protoxide of iron 2·540

Subsulphate of do. 0·843

Alumina 0·500

Carbon 0·032

Water 9·968

99·883

Ditto, with a woody texture,
from Obercassel. Brandes.

Silica 93·000

Alumina 0·250

Oxide of iron 0·375

Subsulphate of do. traces

Water 6·125

99·750

Lepidocrocite: Siebengebirge:
Brandes.

Oxide of iron 88·00

Oxide of manganese 0·50

Silica 0·50

Water 10·75

99·75

UNIVERSITIES IN THE NETHERLANDS:

The Report just laid before the States General of the Kingdom of the Netherlands by the Minister of Public Instruction, gives the following account of the present state of the Universities:—"At Louvaine the most laudable efforts are made to form good philologists, who may one day be the ornament of the *Athenées* and Colleges in which they may be placed. The clinical department of midwifery has received a very useful extension. At Liege they apply themselves particularly to modern history under a political point of view. The study of the law also, as well as other branches of science, is very flourishing. The legal part of medical education is attended to with great care. At Ghent nothing is neglected, which can tend to unite the cultivation of the fine arts and the sciences. The mathematical instruction is excellent; several excellent scholars have already left the schools. At Leyden, the instruction preserves its ancient reputation, and Oriental literature is there making great progress. At Utrecht the study of Greek and Latin is the favourite pursuit; and at Groningen, no expense is spared to improve the Clinical Hospital, and to form a brilliant Academy." At the end of the Report, the number of Students in the six Universities of the Kingdom is given, and in November they amounted to 2,127; 1,058 belonging to the Southern Provinces, and 1,069 to the Northern.

CABINET OF STANDARD WEIGHTS.

The commercial and scientific world will learn with satisfaction that the standard weights of foreign countries, which were some time since transmitted to the British Government, and compared with English Standards, have been lately deposited at the London Mint, in a commodious cabinet constructed for the purpose, where they are to be carefully preserved for permanent reference.

This National collection is the first of the kind ever made on a great scale, though long considered a desideratum. Its utility, which has been already extensively proved, may be further experienced when any of the standards in use, whether English or Foreign, shall become worn or impaired.

The following account of this important collection is inscribed on the cabinet:—

"The foreign weights here deposited, having been duly verified, were transmitted to London, in the year 1818, by the British Consuls abroad, in pursuance of a general plan, for comparing the weights, measures, and moneys of all trading countries, by official experiments on verified standards.

"The

“The experiments were made by Robert Bingley, Esq., the King’s Assay Master of the Mint; and the calculations by Dr. Kelly, who planned and conducted the general comparison, and in 1821 published the Results in the *Universal Cambist*, under the sanction of His Majesty’s Government.

“The undertaking was originally patronized and recommended by the Board of Trade. The standards were procured from abroad by circular letters issued by Viscount Castlereagh and Earl Bathurst, Secretaries of State for the Foreign and Colonial Departments; and the whole plan was essentially promoted by Lord Maryborough, Master of the Mint.”

DEATH OF MR. BOWDICH, THE AFRICAN TRAVELLER.

We lament to state the decease of this accomplished traveller and naturalist, which took place on the 10th of January, at St. Mary’s River in Gambia, Africa, in consequence of his over-exertions in making a survey of the river. A widow and three orphans survive him, who are altogether unprovided for; and we take this opportunity of announcing that a work which Mr. Bowdich completed prior to his death, entitled “*Excursions in Madeira and Porto Santo*,” will be published by subscription for their benefit. A prospectus of it, we believe, will shortly be issued.

LECTURES.

Mr. John Edward Gray’s *Course of Lectures on Natural History and Materia Medica*, will commence in the middle of April; they will be illustrated with numerous specimens, practical demonstrations and excursions, which he has found to be the only plan by which the pupil can be quickly furthered.

LIST OF NEW PATENTS.

To Abraham Henry Chambers, of New Bond-street, Middlesex, esq., for his improvements in preparing and paving horse- and carriage-ways.—Dated 28th February 1824.—6 months allowed to enrol specification.

To Richard Evans, of Bread-street, Cheapside, London, wholesale coffee-dealer, for his method or process of roasting or preparing coffee, and other vegetable substances, with improvements in the machinery employed; such process and machinery being likewise applicable to the drying, distillation, and decomposition of other mineral, vegetable, and animal substances; together with a method of examining and regulating the process whilst such substances are exposed to the operations before mentioned.—28th Feb.—6 months.

To John Gunby, of New Kent Road, Surry, sword and gun manufacturer, for his process by which a certain material is prepared and rendered a suitable substitute for leather.—28th February.—6 months.

To John Christie, of Mark Lane, London, merchant, and Thomas Harper, of Tamworth, Staffordshire, merchant, for their improved method of combining and applying certain kinds of fuel.—28th February.—6 months.

To William Yetts, of Great Yarmouth, Norfolk, merchant and ship-owner, for certain apparatus to be applied to a windlass.—28th February.—2 months.

To James Wright Richards, of Caroline-street, Birmingham, Warwickshire, metallic hot-house maker, for an improved metallic frame and lap applicable to all hot-houses, green-houses, horticultural frames and glasses, sky-lights, and other inclined lights and glasses.—28th February.—6 mon.

To William Greaves, of Sheffield, Yorkshire, merchant, for certain improvements on, or additions to, harness principally applicable to carriages drawn by one horse.—28th February.—2 months.

To William James, of Westminster, Middlesex, land-agent and engineer, for certain improvements in the construction of rail- and tram-roads or ways, which rail- or tram-ways or roads are applicable to other useful purposes.—28th February.—6 months.

To Maurice De Jongh, of Warrington, Lancashire, cotton-spinner, for his mode of constructing and placing a coke oven under or contiguous to steam or other boilers so as to make the heat arising from making coal or other intense combustion in the said oven subservient to the use of the boiler instead of fuel used in the common way, and to exclude such heat from the boiler when required without detriment to the operations of the oven.—28th February.—2 months.

To Charles Bagenell Fleetwood, of Parliament-street, Dublin, gent., for his liquid and composition for making leather and other articles waterproof.—28th February.—6 months.

To Joel Spiller, of Chelsea, Middlesex, engineer, for his improvements in the machinery to be employed in the working of pumps.—6th March.—4 months.

To John Heathcoat, of Tiverton, Devonshire, lace-manufacturer, for his method of manufacturing certain parts of the machines used in the manufacture of lace commonly called bobbin-net.—9th March.—6 months.

To John Heathcoat, of Tiverton, Devonshire, lace-manufacturer, for his improvements in machines now in use for the manufacture of lace commonly called bobbin-net, and a new method of manufacturing certain parts of such machines.—9th March.—6 months.

To John Heathcoat, of Tiverton, Devonshire, lace-manufacturer, for his economical method of combining machinery used in the manufacture of lace, in weaving, and in spinning, worked by power.—9th March.—6 months.

To William Darker Mosley, in the parish of Radford, Nottinghamshire, lace-manufacturer, for certain improvements in the making and working of machines used in the manufacture of lace commonly called bobbin-net.—10th March.—6 months.

To William Morley, of Nottingham, lace-manufacturer, for his various improvements in machines or machinery now in use for the making lace or net commonly known by the name of bobbin-net.—15th March.—6 months.

To Rupert Kirk, of Osborne-place, Whitechapel, dyer, for his method of preparing or manufacturing a certain vegetable substance growing in parts abroad beyond the seas and imported to and used in these kingdoms as a dye or red colouring matter for the use of dyers, called *Safflower* (*Carthamus*), so as more effectually to preserve its colouring principle from decay or deterioration in its passage from the places of its growth to England, and other parts of Europe.—20th March.—2 months.

A METEOROLOGICAL TABLE: comprising the Observations of Dr. BURNLEY at Gosport, Mr. CARY in London, and Mr. VELL at Boston.

Days of Month, 1824.	GOSPORT, at half-past Eight o'Clock, A.M.										CLOUDS.				Height of Barometer, in Inches, &c.		THERMOMETER.				RAIN.		WEATHER.				
	Barom. in Inches, &c.	Thermo.	Temp. of Sp. Water.	Hygrom.	Wind.	Evapora- tion.	Rain near the ground.	Cirrus.	Cirrostr.	Stratus.	Cumulus.	Cumulost.	Nimbus.	Lond. P.M.	Bost. 8 1/2 A.M.	Lond. A.M.	Noon.	1 P.M.	BOSTON. 8 A.M.	Lond.	Boston.	Lond.	Boston.	Lond.	Boston.		
																										LONDON.	
Feb. 26	29.75	38	49	70	NE.	...	0.040	1	29.65	29.74	35.37	35	37.35	33.5	Cloudy	Cloudy, rain a.m.		
27	29.60	37	...	70	NE.030	1	29.86	29.60	34.37	40	37	37	Rain, &c.	Cloudy, rain p.m.		
28	29.78	33	...	72	E.	1	29.95	29.70	36.41	36	38	Cloudy	Cloudy		
29	29.83	34	...	74	NE.	0.20	1	29.72	29.85	37.41	37	37	37.5	...	0.30	Cloudy	Fine, rain p.m.	
March 1	29.77	40	49	71	NW.100	1	29.67	29.56	36.46	33	37.5	Stormy	Stormy	
2	29.64	35	...	56	N.315	1	29.93	29.50	30.34	31	28	Rain, stormy day	
3	29.05	37	...	68	NW.	.25	1	29.62	29.74	38.38	36	26	Fine	
4	29.86	31	...	64	NW.065	1	29.86	29.74	38.53	43	42	Rain	
5	29.61	43	...	72	SW.050	1	29.55	29.64	43.53	48	41	Cloudy	
6	29.84	46	48 1/2	74	SW.	.15	.950	1	29.20	29.20	47.53	48	45.5	Stormy	
7	29.56	49	...	80	SW.210	1	29.70	29.80	52.52	37	50	Stormy with rain	
8	29.20	50	...	80	SW.	.10	.455	1	29.72	29.50	37.47	42	37	Cloudy	
9	29.70	44	...	68	SW.220	1	29.94	29.55	43.44	37	37	Rain	
10	29.60	43	...	76	SE.040	1	29.46	29.85	32.46	40	34.5	Fine, rain p.m.	
11	30.00	34	...	78	NW.040	1	29.32	29.35	35.45	38	37	Cloudy	
12	29.54	42	48 1/2	73	W.	.10	.025	1	29.95	29.15	36.42	33	35	Do. [thu.	
13	29.40	40	...	65	NW.	1	30.04	29.75	33.45	35	35.5	Fine	
14	29.80	38	...	60	N.	1	30.01	29.90	33.46	46	36.5	Cloudy	
15	30.04	41	...	63	SW.	.12	.020	1	30.20	29.74	47.55	50	47	Fine	
16	29.98	48	...	77	SW.030	1	30.26	29.92	44.54	44	44	Fine	
17	30.16	46	...	73	NW.	1	30.30	29.95	46.57	51	47	Fine	
18	30.24	46	...	78	W.	.20	1	30.20	29.92	49.58	42	47.5	Cloudy	
19	30.28	49	...	74	NW.045	1	30.21	30.04	49.58	46	43	Fine	
20	30.25	45	...	75	SE.235	1	29.59	29.65	45.47	43	45	Rain	
21	29.80	45	48 1/2	75	SW.	.15	.935	1	29.92	29.50	43.41	35	42.5	Rain	
22	29.62	42	...	74	W.	1	30.01	29.70	33.45	39	42	Fine	
23	29.79	37	...	77	N.	1	30.12	29.88	39.44	40	39	Rain	
24	29.90	38	...	78	NE.	1	29.95	30.00	38.41	39	40.5	Cloudy	
25	30.00	43	48 1/2	64	NE.	.23	1	29.62	29.62	Cloudy	
Averages:	29.77	41.17	48.79	71.7		1.50	3.80	17.10	27	15	17	21		29.62	29.62				39.2	1.39	2.16						

ZINE



essor of Che-
SILLIMAN,
ne improved
riority of its
roved Single-
by a Jet of
tating native

; power of a
ncreased by
the acid, va-
ing this ob-
ils, being all
roughs con-
I afterwards
Journal, the
that all the
ode has since
wise, edge to
cal, those of
al revolution
rich support
trough must
I, must flow
n one of the
uch as above
subjected to
nade of iron,
lization. A
ating of the
to produce
ription, and

, from Silliman's
with a copy of

another,

Between each pivot & the Galvanic series within, there is a metallic connection hence pieces of sheet copper being placed

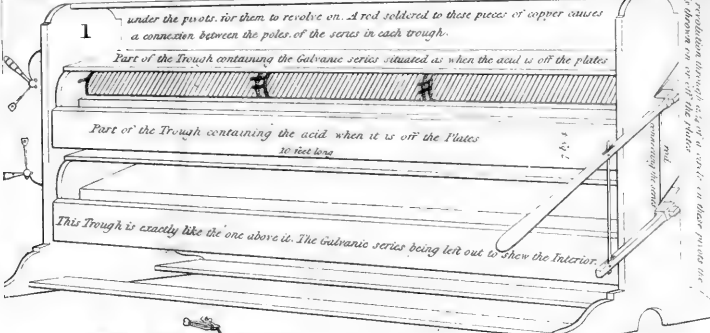

It may be seen that each trough is compounded of 2 troughs at right angles to each other, so that when 1 is full, the other is empty.

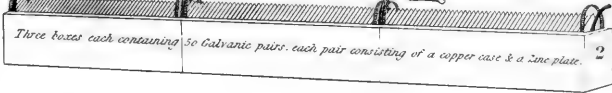

SINGLE LEAF ELECTROMETER
IMPROVED DEFLAGRATORS BY DR. HARE.

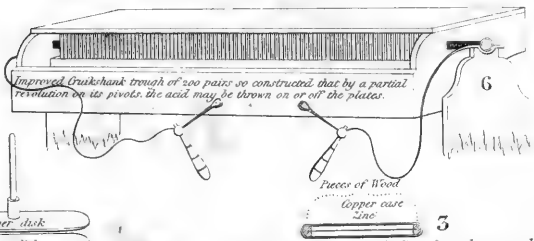
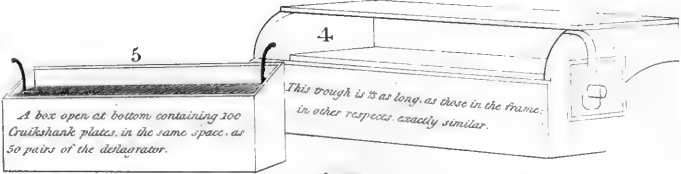

The cases are separated from each other & the Zinc from the copper by pieces of wood.

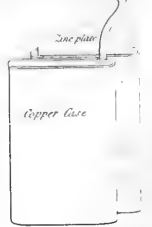
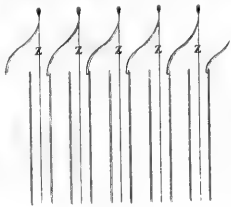
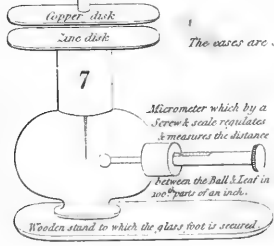

THE
PHILOSOPHICAL MAGAZINE
AND JOURNAL.

90th *APRIL* 1824.

XXXIX. *Letter from* ROBERT HARE, M.D. *Professor of Chemistry in the University of Pennsylvania, to* B. SILLIMAN, *Professor of Chemistry in Yale College, on some improved Forms of the Galvanic Deflagrator; on the Superiority of its deflagrating Power: Also, an Account of an improved Single-leaf Electrometer; of the Combustion of Iron by a Jet of Sulphur in Vapour; and of an easy Mode of imitating native Chalybeate Waters.**

AFTER I had discovered that the deflagrating power of a series of galvanic pairs was surprisingly increased by their simultaneous exposure, after due repose, to the acid, various modes suggested themselves of accomplishing this object. In the apparatus which I sent you, the coils, being all suspended to two beams, could be lowered into troughs containing the acid. In another apparatus, of which I afterwards gave you an account, with an engraving for your Journal, the troughs containing the acid were made to rise, so that all the plates might be immersed at once. A better mode has since occurred to me. Two troughs are joined lengthwise, edge to edge, so that when the sides of the one are vertical, those of the other must be horizontal. Hence, by a partial revolution of the two troughs, thus united, upon pivots which support them at the ends, any fluid which may be in one trough must flow into the other, and, reversing the motion, must flow back again. The galvanic series being placed in one of the troughs, the acid in the other, by a movement such as above described the plates may all be instantaneously subjected to the acid, or relieved from it. The pivots are made of iron, coated with brass or copper, as less liable to oxidizement. A metallic communication is made between the coating of the pivots and the galvanic series within. In order to produce a connexion between one recipient of this description, and

* From a tract reprinted, with corrections and additions, from Silliman's Journal, No. 1. vol. vii. and published at Philadelphia; with a copy of which we have been favoured by the author.—EDIT.

another, it is only necessary to allow a pivot of each trough to revolve on pieces of sheet copper severally soldered to the different ends of a rod of metal. To connect with the termination of the series, the leaden rods (to which are soldered the vices, or spring forceps, for holding the substances to be exposed to the deflagrating power) one end of each of the lead rods is soldered to a piece of sheet copper. The pieces of copper, thus soldered to the lead rods, are then to be duly placed under the pivots, which are of course to be connected with the terminations of the series. The last-mentioned connexion is conveniently made by means of straps of copper, severally soldered to the pivots, and the poles of the series, and screwed together by a hand-vice.

Fig. 1 (Plate IV.) represents an apparatus, consisting of two troughs, each ten feet long, constructed in the manner which I have described. Each trough is designed to contain 150 galvanic pairs. The galvanic series in the upper trough is situated as when not subjected to the acid. In the representation of the lower trough, the galvanic series is omitted, in order that the interior may be better understood. The series belonging to this trough may be observed below it, in three boxes, each containing 50 pairs, fig. 2. In placing these boxes in the trough, some space is left between them and that side of the trough on which the acid enters, so that instead of flowing over them, it may run down outside, and rise up within them.

The pairs of the series consist of copper cases, about seven inches long by three inches wide and half an inch thick; each containing a plate of zinc equidistant from its sides, and prevented from touching it by grooved strips of wood.—Each plate of zinc is soldered to the next case of copper on one side. This may be understood from the diagram, fig. 3. It must be observed, that the copper cases are open only at the bottom and top. They are separated from each other by very thin veneers of wood.

Fig. 4, represents a smaller trough, differing from the others only in length. This I made, with a view to some experiments on the comparative power of the galvanic pairs of the form of copper cases, with zinc plates, above described, and those made on Cruickshank's plan, or of the form used by Sir H. Davy in the porcelain troughs.

Fig. 5, represents a box, containing 100 Cruickshank plates (each consisting of a plate of zinc and copper soldered face to face) and slid into grooves, at a quarter of an inch distance from each other; all the copper surfaces being in one direction, and all the zinc surfaces in the other. In this case the

zinc

zinc plates are exposed only on one side. The sum of the surfaces on which the acid can act is therefore the same as in a deflagrator of 50 pairs, in which each zinc plate is assailable on both sides. It ought to be understood, that the box containing the 100 Cruickshank plates is open at bottom, and is of such dimensions as to occupy the place of a box, containing 50 pairs of the deflagrator, receiving the acid in its interstices from below, in the same manner, by a partial revolution of the trough, fig. 4.

Fig. 6. represents a box, containing 200 Cruickshank plates. This differs from the common Cruickshank trough only in having the interstices as narrow as those between the copper and zinc surfaces of the deflagrator pairs represented by fig. 2; and in the mode in which the acid is thrown off or on the whole series, which does not differ materially from that described in the instance of fig. 1.

On contrasting the series of 50 (fig. 4) with Cruickshank's plates in the box (fig. 5) the deflagrating power of the latter was found comparatively feeble; and even when compared with the Cruickshank trough (fig. 6) in igniting metals or carbon, the 50 pairs (fig. 4) were found greatly superior. The shock from the Cruickshank trough was more severe. You must recollect, that in former experiments I found that galvanic plates, with their edges exposed as they are in the porcelain troughs used by Sir Humphry Davy, were almost inefficient when used without insulation, as are the pairs of the deflagrator. This demonstrates that an unaccountable difference is producible in the galvanic apparatus by changes of form or position.

Being accustomed to associate the idea of the zinc pole, in a Voltaic series, with the end terminated by zinc, and the copper pole, with the end terminated by copper, I was surprised to find that, in decomposing water, the oxygen was attracted by the wire connected with the copper end of my deflagrator, while the hydrogen went to the wire connected with the zinc end. Subsequently, however, it occurred to me, that in the deflagrator the zinc pole is terminated by copper, the copper pole by zinc; and hence the apparent anomaly, that oxygen appears to be attracted by copper, and hydrogen to be attracted by zinc.

The projection from the carbon, exposed between the poles, takes place at the negative pole of the pile, and not at the positive pole, as you have alleged; and thus your observation, that the current of igneous matter is from the copper to the zinc, may be reconciled with the Franklinian theory.

The observations which are the subject of this communication,

tion, combined with those which you have made of the incapacity of the deflagrator, and Voltaic series in the usual form, to act when in combination with each other, must justify us in considering the former as a galvanic instrument having great and peculiar powers.

Since the above was written, I have tried my series of 300 pairs. The projectile power and the shock were proportionally great, but the deflagrating power was not increased in proportion. The light was so intense that, falling on some adjacent buildings, it had the appearance of sunshine.—Having had another series of 300 pairs made for Dr. Macnevin of New York, on trying it I connected it with mine, both collaterally and consecutively, so as to make in the one case a series of six hundred, in the other a series half that in number, but equal in extent of surfaces. The shock of the two, consecutively, was apparently doubly as severe as the shock produced by one; but the other phænomena seemed to me nearly equally brilliant in either way.

The white globules which you noticed were formed copiously on the ignited plumbago, especially *in vacuo*. I have not had leisure to test them, being arduously occupied in my course of lectures, and in some efforts to improve the means of experimental illustration.

Account of an Electrometer, with a single Leaf, by which the Electricity excited by the Touch of heterogeneous Metals is rendered obvious after a single Contact.

Fig. 7 represents an electrometer, with a single leaf suspended from a disk of zinc six inches in diameter, which constitutes the top of the instrument. Opposite to this single leaf is a ball supported on a wire, which may be made to approach the leaf; or recede from it, by means of a screw. Above the instrument is seen a disk of copper with a glass handle*. The electricity produced by the contact of copper and zinc, is rendered sensible in the following manner. Place the disk of copper on the disk of zinc (which forms the canopy of the electrometer): take the micrometer screw in one hand, touch the copper disk with the other, and then lift this disk from the zinc. As soon as the separation is effected, the gold leaf will strike the ball, usually, if the one be not more than $\frac{5}{100}$ of an inch, apart from the other †. Ten contacts of the same disks, of copper and zinc, will be found necessary to produce a sen-

* For the experiment with this electrometer a metallic handle would answer. Its being of glass enabled me to compare the indication thus obtained with that obtained by a condenser.

† I have seen it strike at nearly double this distance.

sible divergency in the leaves of the condensing electrometer. That the phænomenon arises from the dissimilarity of the metals, is easily shown by repeating the experiment with a zinc disk in lieu of a disk of copper. The separation of the homogeneous disks will not be found to produce any contact between the leaf and ball. I believe no mode has been heretofore contrived, by which the electrical excitement resulting from the contact of heterogeneous metals may be detected by an electroscope without the aid of a condenser. It is probable, that the sensibility of this instrument is dependent on that property of electricity which causes any surcharge of it, which may be created in a conducting surface, to seek an exit at the most projecting termination, or point, connected with the surface. This disposition is no doubt rendered greater by the proximity of the ball, which increases the capacity of the gold leaf to receive the surcharge, in the same manner as the uninsulated disk of a condenser influences the electrical capacity of the insulated disk in its neighbourhood. It must not be expected, that the phænomenon above described can be produced in weather unfavourable to electricity. Under favourable circumstances, I have produced it by means of a smaller electrometer, of which the disks are only $2\frac{1}{2}$ inches in diameter*.

The construction, as respects the leaf, and the ball, regulated by the micrometer screw, remaining the same; the cap of a condensing electrometer, and its disks, may be substituted for the zinc disk.

On the Combustion of Iron by a Jet of Sulphur in Vapour.

If a gun barrel be heated red hot at the but end, and a piece of sulphur be thrown into it; on closing the mouth with a cork, or blowing into it, a jet of ignited sulphurous vapour will proceed from the touch-hole. Exposed to this, a bunch of iron wire will burn, as if ignited in oxygen gas, and will fall down in the form of fused globules in the state of proto-sulphuret. Hydrate of potash, exposed to the jet, fuses into a sulphuret of a fine red colour.

An easy Mode of impregnating Water with Iron.

If a few pieces of silver coin be alternated with pieces of sheet iron, on placing the pile in water, it soon acquires a chalybeate taste, and a yellowish hue, and in 24 hours flocks of oxide of iron appear. Hence by replenishing with water

* I think I have seen an effect from a disk only an inch in diameter, or from a zinc disk having a copper socket to its handle.

a vessel in which such a pile is placed, after each draught, we may have a competent substitute for a chalybeate spring.

Clean copper plates alternating with iron would answer, or a clean copper wire entwined on an iron rod; but as the copper when oxidated yields an oxide, it is safer to employ silver.

XL. Further Remarks on the Theory of parallel Lines.

[See p. 161.]

NO apology can be required for resuming the discussion of parallel lines with the view of extending and completing the observations already made in the last Number of this Journal. A subject liable to many subtle distinctions must be placed in a variety of aspects, before the reader can form a decided opinion upon it. Besides, the validity of Legendre's demonstrations by algebraic functions has been so keenly contested by men of great eminence, that the full elucidation of this point must be not only very curious and interesting, but is even of some importance in geometry.

1. If we have a number of algebraic equations, viz.

$$C = \phi(c, A, B),$$

$$C' = \phi'(c', A, B),$$

$$C'' = \phi''(c'', A, B),$$

&c.

in which the letters $\phi, \phi', \phi'', \&c.$ are the marks of functions of unknown forms; and if the numbers that vary from one equation to another, be so related that when $c = c' = c''$, we must likewise have $C = C' = C''$; it will be evident that the functions cannot be of different forms, and that all the equations will be represented generally by the expression

$$C = \phi(c, A, B).$$

Now if, with Legendre, we apply the foregoing reasoning to triangles, we must conceive a separate figure answering to every equation; the bases being, c, c', c'' ; the vertical angles, C, C', C'' ; and the other angles common to all the triangles and equal to A, B : then because, by the principle of superposition, we know that, when the bases c, c', c'' are equal, the vertical angles C, C', C'' , will likewise be equal; it will follow that, in all the triangles, the vertical angle is the same function of the base and the other two angles; or, that the equation

$$C = \phi(c, A, B)$$

comprehends every case.

That we have here faithfully explained Legendre's process of reasoning is manifest from his own words: *Car, si plusieurs angles C pouvaient correspondre aux trois données c, A, B, il y aurait*

*aurait autant de triangles différents qui auraient un côté égal adjacent à deux angles égaux, ce qui est impossible**. For this means that, if the functions ϕ, ϕ', ϕ'' were of different forms in the several triangles, the vertical angles C, C', C'' would be unequal, when the bases c, c', c'' are supposed to be equal, which is contrary to what is proved by superposition.

It is manifest therefore that the reasoning of Legendre necessarily supposes the existence of triangles that have different bases, viz. c, c', c'' , and the same angles at their bases, viz. A, B ; or, which is the same thing, it supposes that the base of a triangle may vary while the angles at the base remain the same. We may therefore inquire what authority there is for this assumption.

If the base of a triangle vary, we may adopt two suppositions with respect to the angles at the base: either they may remain the same when the base varies, or they will necessarily undergo concomitant changes. Since it is admitted that the vertical angle may vary with the base, there can be no good reason for exempting the other two angles from the possibility of a like variation. The two cases we have mentioned are a complete enumeration; and it never can be maintained that one is true and demonstrated, until the other be excluded. Thus the assumption, on which Legendre's demonstrations are founded, is one of two hypotheses that seem equally possible. It is therefore certain, as we have already shown in the last Number, that the functional investigation respecting parallel lines, like the geometrical process of Euclid, rests upon a peculiar postulate, in this respect perfectly resembling almost every other method that has been proposed for overcoming the same difficulty.

2. Admitting, with Legendre, that the angles A, B, C denote ratios, or numbers independent on arbitrary measurement, it follows, from the principle of homogeneity, that there cannot be an equation between A, B, C and the side c which is measured by an arbitrary unit. Thus the two equations,

$$\begin{aligned} c &= \phi(A, B, C), \\ C &= \phi(c, A, B) \end{aligned}$$

are equally impossible and absurd: the first, because a magnitude that may be converted into a number by any assumed measure, cannot be expressed by three determinate numbers; and the second, because a determinate ratio cannot involve in its expression, a number that may be varied in an arbitrary manner. But if the equation,

$$C = \phi(c, A, B)$$

* *Elem. de Geom.* edit. 10me, p. 280.

be impossible, is not the whole of Legendre's process nugatory? What are we to think of the attempt to prove that a function, which is a nonentity, must have a determinate form, the same for all triangles?

The truth seems to be, that, in order to render the mode of reasoning imagined by Legendre intelligible, we must strip off the functional dress in which it is clothed. Since the third angle of a triangle has the same magnitude in all cases when the base and the other two angles have the same values, there must be some general relation between the four magnitudes, or between the vertical angle and some of the three things that are given. But, by the principle of homogeneity, there cannot be an equation between the base and one or more of the angles: wherefore the equation we are seeking must subsist between the three angles. And since this equation has no dependence upon the sides, it must be the same in all cases; because no reason can be assigned why it should be variable in its form. In this statement of the reasoning, nothing is brought forward except what bears conclusively upon the point to be proved; and the full force of the evidence is therefore perceived. It certainly amounts to a great degree of probability. It is such a train of thought as, in a process of invention, would lead, with great certainty, to the desired success. But the requisites of a strict demonstration are in many respects wanting; and, as the whole procedure is a comparison of triangles that have the angles at their bases common, it depends upon the postulate already mentioned.

There is one conclusion only that can be reasonably drawn from all that has been said. The same difficulty about parallel lines which has so long baffled the geometer, opposes an equally effectual resistance to the power of the algebraic analysis. The same cause operates in both cases. The definition of a straight line is indirect and imperfect, furnishing no property that will enable us by a direct train of reasoning to investigate the relation between the three angles of a triangle.

3. Legendre estimates all angles by their respective proportions to a right angle. But he might, with equal propriety, have adopted any other determinate angle as the basis of comparison. Professor Leslie has therefore argued that angles are not to be considered as numbers independent of an arbitrary unit; and that their measures are just as indeterminate as the measures of lines. In the last Number of this Journal, we proved the justness of Legendre's procedure; but it may not be improper to add some further elucidation, and for this purpose we shall choose a particular case.

Let

Let a, b denote the two remaining sides of the triangle; then the angle C opposite to the base c , must be a determinate function of a, b, c ; for the angle has always the same magnitude when the sides have the same values. But, according to the principle of homogeneity, the expression of C can contain the ratios only of the sides of the triangle; it will therefore be of this form, viz.

$$C = \varphi \left(\frac{a}{b}, \frac{a}{c} \right).$$

Again, by trigonometry, we have

$$\text{Cos } C = \frac{a^2 + b^2 - c^2}{2ab}.$$

Now the value of C deduced from this equation does not depend upon any preconceived mode of measuring. It is not the ratio of the angle to a right angle; it is the length of the arc subtending the angle in a circle of which the radius is unit. In another circle of which the radius is r , and C the length of the arc subtending the angle, the same equation will become

$$\frac{\cos C}{r} = \frac{a^2 + b^2 - c^2}{2ab}.$$

We can find $\frac{C}{r}$ in terms of $\frac{\cos C}{r}$; and by substituting the value of $\frac{\cos C}{r}$, we shall obtain an equation of this form, viz.

$$\frac{C}{r} = \psi \left(\frac{a}{b}, \frac{a}{c} \right).$$

Again, let Q denote the length of the quadrant, or any other determinate arc, in the same circle: thus

$$\frac{C}{Q} = \frac{r}{Q} \times \psi \left(\frac{a}{b}, \frac{a}{c} \right) = \phi \left(\frac{a}{b}, \frac{a}{c} \right).$$

And, since $\frac{C}{Q}$ is the proportion of the angle of the triangle to a right angle, this last equation coincides with that found by Legendre's process.

Professor Leslie is therefore not borne out in his philosophical argument respecting the similarity of the measures of lines and angles. But it is no more than justice to observe that his reasoning is very naturally suggested by Legendre's definition.

An angle is a magnitude *sui generis*. It cannot be directly compared with a magnitude of a different kind. If it enter into the same equation with the sides of a triangle, this can be effected in no other way than by the intervention of some

magnitude to which it has a relation. The transcendental quantities $\frac{C}{r}$ and $\frac{C}{Q}$ find their way into the equation by means of $\frac{\cos C}{r}$, which is the ratio of two straight lines. All

the quantities $\frac{\cos C}{r}$, $\frac{C}{r}$, $\frac{C}{Q}$ are functions of no dimensions derived from the same angle; and we know that any one of such quantities may be substituted for any other of them, in a proposed function. This proves that Professor Leslie's reasoning fails; but it does not appear that the fallacy of it could be deduced merely from Legendre's definition, which determines all angles by their proportions to a right angle. It follows from what we have shown that the angles of the triangle may be considered as ratios, or as numbers independent of arbitrary measurement, whether they be estimated in parts of a right angle, or of any other determinate angle. But Legendre's procedure is defective inasmuch as he infers inconclusively from a definition, what can be proved only by the principles we have explained.

When the understanding is made fully master of the case by acquiring distinct ideas on the disputed points, it will hardly be allowed that the functional equations are so simple as they appear to be. To reason about them with intelligence, many notions seem to be necessary that are far removed from the first principles of geometry. They cannot, with much propriety, be considered as propositions merely elementary. We are almost inclined to think that the geometer must have plodded on to the end of his science, before he has acquired knowledge enough to judge critically of the functional demonstrations of the first principles.

In this Journal for February, we observe that Mr. Walsh is a strenuous advocate for Professor Leslie's opinions. His communication is remarkable for being wrong in every point relating to geometry. What can be a greater mistake than to suppose that the angles of a triangle must be evanescent at the same time with the base? Every one knows that the angles may remain the same, while the sides increase to be infinitely great on one hand, or decrease to zero on the other. But Mr. Walsh makes ample amends by the display of his recondite researches. We are carried back to the principles of philosophical grammar; we are taught to speak accurately in the language of the schools; and the poor geometers, made the sport of every petty whipster, are utterly condemned as ignorant of the philosophy of number. If there be any doubt
whether

whether all this be in its proper place, every one must agree in admiring the writer's profound learning.

4. Every attempt to overcome the difficulty about parallel lines, uniformly leads to one conclusion; proving that it is insuperable by a direct process of reasoning. New definitions; new postulates; every mode of investigation that can be devised; only place the same difficulty in various aspects. The cause lies in the imperfect nature of the definition of a straight line; and, as in other similar cases, we cannot hope for success in this research, except by having recourse to the indirect method of demonstration.

In this Journal for March 1822, the foundation of an exact theory of parallels is laid, by proving, in an indirect manner, that the three angles of a triangle are equal to two right angles. It is shown, first, that the sum of the angles cannot be greater than two right angles; and, secondly, that it cannot be less. The first proposition is made out by transforming any proposed triangle successively into a series of others, so that the sum of the angles of every triangle shall be the same, while one angle continually diminishes till at length it is less than any given angle however small. Thus the sum of the three angles of the first triangle approaches without limit to the sum of two angles of another; and as the latter sum is always less than two right angles, the former sum cannot exceed the same quantity. We have lately seen a theory of parallel lines by a professor of the mathematics at Basle*, which, like the attempt in this Journal, follows the indirect mode of demonstration; and further resembles it in proving the proposition here spoken of by the same procedure. But in demonstrating that the angles of a triangle cannot be less than two right angles, the Professor at Basle follows Legendre in the first editions of his geometry, a new postulate being added for the sake of rigorous accuracy. We conceive that this is a blemish in the theory; because, when the indirect method of reasoning is employed, the demonstrations should be effected without any gratuitous assumption. In this respect the advantage is in favour of the proof of the same proposition given in the Number of this Journal already cited, since it proceeds upon the admitted principles of geometry. We shall briefly sketch an outline of the reasoning. If a quadrilateral figure be divided into any number of triangles that have their angles upon the sides of the figure, or at points within the figure; then, because all the angles at a point on one side of a straight line,

* *Nova Theoria de Parallelarum Rectarum Proprietatibus*, Auctore Daniele Hubero, Basileense, in Acad. patria Mathem. Professoro, et Bibliothecario. Basileæ, 1823.

are equal to two right angles, and all the angles round a point, to four right angles; it will follow that the sum of all the angles of the triangles is equal to a certain number of right angles together with the four angles of the quadrilateral. But, as the angles of a triangle cannot exceed two right angles, the sum of all the angles of the triangles will be equal to twice as many right angles as there are triangles, wanting the sum of the defects of the angles of every triangle from two right angles. Wherefore, by comparing the two equal sums, it will appear that the angles of the quadrilateral are equal to four right angles, wanting the sum of the defects of all the included triangles. Now suppose a triangle that has the sum of its angles less than two right angles by some given angle; then a quadrilateral may be constructed that shall have the sum of its angles less than four right angles by any multiple of the same angle; which is absurd, because the multiple may be so taken as to reduce the angles of the quadrilateral to zero, or so as to be less than any proposed angle. We have mentioned these demonstrations because we have never met with any other indirect proof of the equality of the angles of a triangle to two right angles, which is both unexceptionable in point of accuracy, and requires no peculiar postulate.

In taking leave of parallel lines, some apology seems to be due to the readers of this Journal for the great length of our observations. But the subject is very curious in itself; it has been keenly debated by very able men; and the contest has been lately resumed in a very high tone, and with additional forces. It therefore seemed very desirable to bring the matter to some decision; and we hope some light has been thrown upon it. On the whole we are inclined to think that much more importance has been attached to the functional investigations than they intrinsically deserve. It seems very certain that there was a time when such demonstrations would not have passed current for sterling geometry in the Athens of the North.

April 5, 1824.

DIS-IOTA.

XLI. *On the Mathematical and Astronomical Instrument Makers at Paris.* By Lieut. ZAHRTMANN.*

BEFORE I subject myself to the uncertain event of a sea voyage, I will endeavour to perform the task you have proposed to me, by communicating to you some particulars re-

* From M. Schumacher's *Astronomische Nachrichten*, No. 42.

specting

specting the most distinguished artists of Paris. These are, for chronometers the family of Breguet; for mechanical and mathematical instruments MM. Fortin, Gambey, Lenoir, Richer and Jecker; and for optical instruments MM. Lerebours and Cauchoix.

The father of M. Breguet died at the age of nearly 77 years; he was born in Switzerland of French parents, but resided at Paris for the last 60 years of his life, during the whole of which time he applied himself to the making of clocks: but it was only within about 40 years that he constructed chronometers. M. Breguet was a member of the mechanical class of the Academy of Sciences, a member of the Legion of Honour, artist to the Board of Longitude, and manufacturer of chronometers for the navy. I am unable to speak of M. Breguet without expressing the lively grief which I feel at being obliged to substitute the expression of *he was* for that of *he is*: my connection with him, while I remained at Paris, had so greatly endeared him to me, that I could not but participate in the sorrow with which all his numerous friends were overwhelmed by his sudden and unexpected death. I shall always recall him to my memory as the most amiable of men; and I am persuaded that if (which I do not suppose to be the case) there are any who would dispute with him the honour of having been the most distinguished of philosophical artists, and of possessing the utmost fertility of genius in his art, yet there are none who would deny that he possessed the best of hearts, and sustained the noblest of characters. His son, who is a man of 40, directed the business of the house during the life of his father, and will continue the establishment on exactly the same footing as formerly. M. Breguet cultivates the sciences with attention, particularly the physical sciences; and his son, a young man of 18, has already applied himself to the making of chronometers; and, as is stated, with much success. M. Breguet has for several years been engaged in concluding a work on clock-making, an undertaking by which he is much occupied and interested. I hope that it will shortly appear, and it is unnecessary for me to state the degree of attention to which it will be entitled. The address of the firm of Breguet is No. 79, Quai de l'Horloge.

After the family of Breguet, those most distinguished for clock-making, and who also are all manufacturers of chronometers, are MM. Perlet, Duchemin, M. Berthoud the son, and M. Motel; the first two of these are pupils of M. Breguet, and the others of M. Louis Berthoud; the Navy Board employ M. Motel in repairing and cleaning the chronometers of Berthoud, and are well satisfied with his performance.

M. Janvier

M. Janvier is another who is possessed of considerable knowledge in clock-making, but has not yet applied it to the manufacture of chronometers.

M. Fortin is 72 years old; he is a provincial by birth, and came when quite young to Paris, where he commenced business in some of the most humble workshops. He has always worked very assiduously, but has been unable to raise a fortune by his labours. M. Fortin first attracted notice by the perfection with which he executed balances and pneumatic machines: he still works, and with much accuracy, notwithstanding his advanced age; and in the construction of measures, barometers, and pneumatic machines, he has scarcely ever been surpassed. The most remarkable instrument which has left his workshop is the great meridian circle erected at the observatory, to which it was presented by the Duke d'Angouleme. This instrument is in imitation of the Greenwich circle, but the divisions are executed in a different manner, peculiar to M. Fortin; the fastening of the radii at the centre is more firm in his instrument, and the divided limb is formed of an alloy of gold and palladium, a sixth part of which consists of the latter metal; this combination, without becoming oxidated like silver, and without being too hard for the dividing point, as platinum is, produces a metal upon which the divisions are very easily discerned. M. Fortin possesses a dividing instrument which he has been for 40 years endeavouring to perfect, and of which he makes a profound secret; but notwithstanding all his care, his repeating circles are far from being correct with regard to division. He is a member of the Legion of Honour, and received a gold medal at the exhibition of 1819.—M. Fortin has no son, but will be succeeded by M. Herman, a man of 37 years of age, and a native of Dresden, who has married his youngest daughter. M. Herman has resided 16 years in Paris, where he has been under several masters; and he worked for a considerable time, under M. Fortin's direction, upon the meridian circle. M. Fortin lives at No. 14, Rue des Amandiers, near St. G n v ve.

M. Gambey is a native of Champagne, and is 36 years old; he began his career at Paris as a clock-maker, but has since devoted his time to the construction of instruments: he is a man of great merit, and who does not confine himself to imitation; he has made for the observatory a great equatorial, to be moved by a pendulum: the circle is three feet in diameter, and is divided upon its edge in equal divisions of 5'; the reading is effected by two microscopes furnished with micro-meters, and placed upon projecting arms from the centre
of

of the axis. The telescope is by Lerebours; its length is five feet, and the diameter of the aperture is 45 lines. The axis, which is seven feet in length, appears to be less conical than in the instruments of Reichenbach; but it is balanced by a counterpoise, by which it is supported at the end upon two wheels; the instrument is in general perfectly balanced in all its parts: the movement by the pendulum, which is communicated by a screw, is sustained uninterruptedly during a period of time rather longer than an hour; the level, or, more properly speaking, levels (for there are two) are constructed in a particular manner, so as to suffer the axis to be levelled independently of its form, being more or less perfectly cylindrical. This instrument, which was shown at the late exhibition of French industry, is without doubt the best of the kind that has ever been executed in France, and the other artists of the exhibition have subscribed to that opinion by attaching to it some lines in honour of M. Gambey. M. Gambey has constructed for the observatory a magnetic declination circle, and a heliostat. As to his repeating theodolites, of which I have already spoken to you, he has hitherto made three: the first for the Polytechnic School; the second for M. Francœur; and the third for England*. These instruments give great satisfaction, and by M. Francœur in particular I have often heard them praised. The dividing instrument of M. Gambey's invention possesses the advantage of not requiring the *centering* of the instrument that is divided,—a process which he has hitherto kept quite secret. M. Gambey obtained a gold medal at the exhibition of 1819. His address is No. 52, Rue Fauxbourg St. Denis.

The productions of M. Lenoir the elder are well known, and he now actually works no longer. He is member of the Legion of Honour, and artist to the Board of Longitude; his son, who is a man of about 40, directs the establishment at present; he works considerably, but it is rather for engineers and mariners than for astronomers; his nautical instruments appear well made. He lives at No. 340, Rue St. Honoré.

The age of M. Jecker is about 50 years. He is a native of Aix-la-Chapelle, and formerly worked at Ramsden's. Though the exterior of his instruments is in general imperfectly finished, and though they possess a certain varnish, yet I do not think that they are bad, at least there are some

* [This last instrument was made expressly for Mr. F. Baily, under the direction of M. Arago. The circles are only 10 inches in diameter, and are divided so that 2 seconds are easily distinguishable with a vernier. The execution of the various parts of the instrument does great credit to this celebrated artist.—EDIT.]

among them of good quality. M. Jecker manufactures more instruments for the navy than any other artist: but this I suppose may be attributed to his moderate prices, for he sells a reflecting circle 10 inches in diameter for 400 francs, while M. Lenoir charges 430, and M. Gambey 500; M. Jecker always makes use of the dividing machine of Ramsden. His residence is at No. 32, Rue de Bondy.

M. Richer is dead, and his son does not appear to have any intention of continuing the establishment. He was possessed of considerable merit, and invented a machine for calculating the distances of the moon from the stars; several of the instruments which M. Freycinet employed in his voyage round the world, and with which he was much pleased, were of his construction. His son, the present M. Richer, lives at the Rue Harlais aux Marais.

M. Lerebours is a man of more than 60 years of age, and is esteemed the first optician in France; his workshop has produced several excellent instruments, of which the most important is a telescope, the object-glass of which is nine inches diameter, which he has constructed for the observatory. He sent a quantity of object-glasses of different dimensions to the observatory, in order to be examined, and the greater number of them were found very good; he is a member of the Legion of Honour, and artist to the Board of Longitude. He resides on le Pont Neuf, at the corner of the Quai de l'Horloge.

M. Cauchoix, who is nearly 50 years old, is regarded as possessing a more complete knowledge of his art than M. Lerebours, though he has not brought it so much into exercise: he has constructed a telescope of 11 inches aperture, the largest which has ever been made in France; and likewise a stand of a very ingenious construction to support a telescope. M. Cauchoix lives Quai Voltaire, opposite the Pont Royal.

Among the other opticians of Paris, I shall notice only M. Soleil, who has distinguished himself by his activity in the execution of *lentilles à échelon*, which are used for light-houses: but though he has received great assistance from the glass-houses, and from M. Fresnel, who furnished him with better tools than those which he possessed, yet they still appear capable of considerable improvement. M. Soleil lives at No. 21, Passage Feydeau, and his manufactory is France Nouvelle, No. 21, Rue de Poissonnières, near the Barriere Poissonnière.

As I have never seen a large optical workshop, I am unable to give an opinion respecting them: but M. Thiele, who came to Paris after having worked a year with M. Fraunhofer, was quite astonished at the mechanical poverty which he observed

in all the optical manufactories of Paris; and remarked to me, that at Benedictbeurn no one would take the trouble to work glass with the hands, in the way in which it was done at Paris.

M. Kutsch is one of the best workmen for common measuring instruments. He lives at No. 41, Rue des Lombards.

Many of these particulars I owe to some interesting conversations which I had with M. Arago, and they are but a slight specimen of the kindness which I have received from him during my residence in Paris. But it is not myself only who am indebted to him; and I consider it my duty, before I leave France, to apprise you of your obligations to him for the care and assiduity with which he has compared and examined the instruments intended for you, as well as for the time he has devoted to them at a period when he was more than usually occupied by the exhibition of the products of French industry, of which he is one of the examiners. So that this cannot be attributed solely to the interest which he takes in every thing which relates to the sciences, but also to his desire to serve you, and to evince his friendship for you.

M. Pecqueur, the superintendant at the *Conservatoire des arts et metiers*, showed me a clock which exhibited with great accuracy sidereal time and mean solar time. He has contrived this by means of a mechanical invention, which enables him to give the same force to two different movements of the clock: for instance, to two wheels, whose movements are to each other in any given ratio. The pendulum of this clock is compensated by mercury contained in the annular space formed by two concentric cylinders, the inner one of which is made of iron, and the outer one of glass: and, as the expansion of iron by heat exceeds that of glass, this serves to augment the compensation already produced by the expansion of the mercury. The cylinder of iron is hollow, and open at both ends; and consequently enables the air as much as possible to affect the temperature of the mercury. The rod of the pendulum is made of steel. M. Pecqueur has not yet fixed the price of this pendulum; at least, I have asked him for it in vain. He has also shown me a similar contrivance for pocket chronometers. The movements of the watch being attached to this piece of mechanism, the watch will infallibly adapt itself to the motion required. This effect is produced by a spring which acts upon the spiral.

This invention was presented to the Institute some years since; but no report had been made of it, when a letter of M. Pecqueur induced the President to call for this report in

the sitting of the 8th of September, in consequence of which the reporter, M. Prony, made his report in the sitting of the 15th of the same month; the other members of the Commission were MM. Arago and Breguet. The invention of M. Pecqueur was much praised, as a thing which had already proved its utility; and the future results of which could not be foreseen: the Commission therefore proposed that the invention of M. Pecqueur should be received by the Institute to be inserted in its records; which was adopted after some discussion.

M. Pecqueur has besides exhibited an ingenious pump which requires very little force to carry water to a prodigious height.

M. Rieussec junior, the king's watch-maker, No. 13, Rue neuve des petits Champs, has exhibited a chronograph, a sort of counter by the touch, which by pressure given to a spring, makes at the same instant a black mark upon the dial-plate whilst it is in rotation. It is this invention which M. Breguet improved by applying it, but in a different manner, to chronometers:—a chronograph costs 400 francs.

M. Peschot the elder, No. 18, Rue des filles St. Thomas, has exhibited an extraordinary sort of clock, already rather common at Paris, and which consists only of a needle on a dial-plate of glass; for example, a mirror, without any visible mechanism; this consists in a rotatory weight, contained in a round box applied to the other end of the needle.

In instruments of astronomy and optics the exhibition presents nothing very remarkable, except the instruments of Gambey, of Lerebours, and of Cauchoix. There are some samples of flint glass from the royal glass-works of St. Louis, near Bitsch, Department de la Moselle.

It is said that the Minister of the Interior, M. de Corbières, has an intention to render France independent of foreigners for flint glass, by making advantageous propositions to M. Guinaud, established in Switzerland, and known by his productions in that line, to establish himself in France.

There has also been exhibited a light-house with lenses *à échelon* on the plan of M. Fresnel and executed by M. Soleil, the mechanism of M. Wagner and the lamp with concentric wicks of MM. Arago and Fresnel; the detailed description of such a light-house is to be found in M. Fresnel's memoir on this subject.—It appears beyond doubt that these light-houses with lenses are, as to intensity of light, much superior to those with reflectors: but I believe that the greatest difficulty will be to make them quite distinct from each other, especially on a coast where there are many of them. For in making them fixed they lose too much of their advantages, unless

unless they are made cylindrical, which has been projected, but which without doubt must be difficult enough in execution. By making them all rotatory, like that of Corduan, they will be distinguished only by the difference of the polygons of which they consist, producing intervals of light more or less lengthened; but this difference, if it be not very great, which it can hardly be here, will often be difficult enough to observe by sea, and the difficulty will be the greatest precisely in the circumstances most dangerous for mariners.

ZAHRTMANN.

XLII. Suggestions regarding some probable Sources of Error in the usual Modes of ascertaining the Force of Steam.

Gentlemen,

WHEN Mr. Philip Taylor published his scale for the force of steam, I was somewhat puzzled to account for its differing, especially at high temperatures, from the results obtained by Dr. Ure; and in seeking an explanation, it occurred to me, as it seems to have done to Mr. Herapath, that Dr. Ure's elasticities were increased by the vapour of mercury; but whether the like objection might not apply to Mr. Taylor's table I could not determine without knowing his mode of experimenting. If, however, the force of mercurial vapour follow a law analogous to that of steam, I should suspect it must be very small at the temperature of 310° or 320° Fahr., since it only amounts to about 30 inches at the high temperature of 680° . The separate force of mercurial vapour might surely be determined by experiment, though, for reasons which will appear by and by, I fear the task would be a difficult one; and, for aught that is known to the contrary, mercurial vapour, besides exerting its own elasticity, may so act upon or combine with steam as materially to affect the result; or, in other words, the joint effect of steam and mercurial vapour in a mixed state may be different from the sum of their separate elasticities. I would therefore suggest, as a more certain mode of proceeding, that the mercury employed in experimenting on steam be always kept at a comparatively low temperature.

But there seems to be another objection of an opposite kind which attaches to the results of several experimenters, and which does not appear to have been attended to. It is well known that, within certain temperatures at least, the particles of water attract glass and some other substances more strongly than they do each other; and Professor Leslie has shown that, for this reason, air included in a glass vessel can-

not be saturated with moisture, because the vapour is continually attracted and condensed by the glass*. Now if, as De Luc and many others allege, the quantity of vapour contained in a given space be independent of the presence of air, might we not suspect that the force of aqueous vapour not mixed with air will also be diminished by its contact with glass, since it is known to be so in the mixed state? But I have no idea of the amount of this diminution, nor how it may vary at different temperatures. However, it is probably so much the greater as the bulk of the vapour in proportion to the containing surface is less; and perhaps every sort of vessel has some effect on the tension or temperature of an included vapour. May not even the electrical states of the several parts of a complex apparatus have some influence on the elasticity?

In such an apparatus as Dr. Ure employed, this supposed effect of glass and of mercurial vapour might be in a great measure obviated by making that end of the tube which contains the vapour to consist of metal. This metallic part should be of such a length as to reach below the oil-bath, and then it may join into a glass tube; but such a joint would be a matter of some nicety. The water again ought to be continued down through the metal part and even a little way into the glass, in order that its contact with the mercury may be seen and kept at the same height in the tube. By this means the mercury may be kept away from the heat, and the pressure of the column of water and vapour resting on the mercury will remain nearly the same, except that it may vary a very little as the width of the tube is affected by change of temperature, or by change of strain proceeding from the dif-

* The peculiar agitation and fluctuation of temperature, which water exhibits while boiling in glass vessels, are probably referable to the same source, being something like the converse of the above process; the force or temperature requisite to form vapour in contact with glass being greater than what would form it in contact with metal; for vitreous surfaces are known to attract moisture more strongly than metallic surfaces: and so this vapour on leaving the bottom, being of a temperature above 212° , suddenly expands and mounts up through the water with greater violence than if only of that temperature. Hence when bits of metal are thrown in, the vapour rises from them in preference to the glass; and thus the ebullition is rendered more steady. There may, however, be something electrical in this phænomenon. And it may be remarked, in reference to the foregoing explanation, that the temperature at which vapour is formed under water must always, on account of the hydrostatic pressure, be greater than what would form it at the surface.

The particles of mercury again are known to attract each other more strongly than they do glass; but to affirm that this should *increase* the elasticity of mercurial vapour included in a glass vessel, would be going too far until it were settled by experiment.

ferent elasticities of the vapour. The longitudinal expansion of the hot part of the tube or of its contents cannot sensibly affect the results; but as the tube widens, the column of water will shorten, and consequently its hydrostatic pressure on the mercury will be diminished in a very small degree. It is curious to observe what strange mistakes regarding the effects of the expansion of the tube, one of our first-rate authors has fallen into, while playing the critic on Dr. Ure's experiments.

In making experiments on aqueous vapour at a lower temperature than that of the apartment, the whole column of water or mercury should be reduced to the temperature of the vapour; otherwise, on account of the facility with which cold descends in fluids, the result might be uncertain. But if the water be frozen, its adherence to the tube will obstruct the free motion of the mercury. It must therefore be very difficult to make accurate experiments on aqueous vapour at or below the freezing point: because the vapour may be partially condensed if in contact with glass, or the motion of the fluids may be liable to obstruction in the tube. Besides, in these cases, the mercurial column being about 30 inches long, an error in its temperature may materially affect the observed elasticity, which is then a very small quantity.

Yours &c.

H.

March 29, 1824.

XLIII. *Remarks on an Article published in No. 23 of the Journal of Science, and treating of the New Tables of Refraction.* By J. IVORY, Esq. M.A. F.R.S.

To the Editors of the Philosophical Magazine and Journal.

Gentlemen,

IF you can possibly find room, I trust you will insert, in your next publication, the following observations occasioned by an article on my Table of Refractions that appeared in the last Journal of Science.

In my paper published in the Philosophical Transactions 1823, I was particularly guarded to leave nothing uncertain or unexplained respecting the nature of the table constructed to illustrate the theory. Adopting the elementary quantities of the French philosophers, I showed that my table agreed exactly with that in the *Connaissance des Temps* as far as 81° or 82° from the zenith. I likewise proved that my refractions, to the zenith distance 86° , followed the same law with those of M. Bessel; so that his table and mine are convertible, the one

one into the other, by the addition or subtraction of a constant logarithm, or by increasing or diminishing the numbers in a given proportion. The remainder of my table is more uncertain, as I was not in possession of a sufficient number of exact observations for determining the measure of its accuracy; and of this circumstance I have sufficiently apprised the reader at the end of the table. I should therefore have been highly gratified if any astronomer had undertaken to show its defects by comparing it with good observations at low altitudes. But what has appeared in the *Journal of Science* I can consider in no other light than as a mockery, the more remarkable that, although quite uncalled for, to say no more, it professes to be undertaken in the discharge of an official duty.

The article referred to, pretends to compare my table with observations. But it is plainly a comparison of it with the table in the *Nautical Almanack*; if indeed that can be called comparing two things, which takes one of them as it is, and the other as it is not. Both the tables are computed for the same mean temperature and barometric pressure; and, in applying them to practice, nothing more is necessary than to know the heights of the thermometer and barometer at the several observations. Astronomers are divided in opinion about estimating the temperature. Some reckon by the thermometer *within* the observatory; while others think that the one *without* is more accurate. There seems to be some ground in experience for this difference of practice; for the errors of some observers are found to be less with the interior, and those of others with the exterior, thermometer. Mr. Groombridge has always found an advantage in using the exterior thermometer; and his judgement in this respect has been confirmed by Delambre, who compared the results obtained from both thermometers. There can be no doubt therefore that, with regard to the stars in my paper, p. 490, *Phil. Trans.* 1823, the exterior thermometer is to be preferred. But in comparing the two tables, the calculations should be made in the same manner from both. It can produce no other effect than to warp the judgement to a wrong decision, if one table be altered by empirical corrections made expressly to lessen the errors, while the other table remains unchanged. And if both tables be so altered, the tendency to a false estimate of their comparative merits will only be increased. If there must be a trial, the litigants should come into court upon equal terms. Why should one appear tricked out in all sorts of disguises for the purpose of ensnaring unwary judges into a favourable sentence, while the other stands at the bar without

out any adventitious advantages? I have therefore computed, by the table in the Nautical Almanack, the same refractions which are given in my paper, p. 490, as calculated both by the French table and by my own; and, reckoning the excess of the calculated above the observed quantities for the error, the results of all the three tables, when they are arranged in the order of the stars, will be as below:

N. A.	F. T.	N. T.
+ 8 ^u .5	+ 5 ^u .3	+ 5 ^u .1
+ 4.9	+ 2.2	+ 1.1
+ 7.8	+ 4.2	+ 3.8
- 10.0	+ 3.7	+ 3.5
+ 7.6	+ 3.3	+ 2.6
+ 10.4	+ 7.0	+ 1.2
+ 8.1	+ 2.9	+ 2.7
+ 22.6	+ 9.7	+ 14.2
+ 3.9	+ 2.9	- 5.1
+ 7.9	+ 6.4	- 2.3
+ 8.0	+ 6.6	- 0.4
+ 17.0	+ 0.9	+ 7.2
- 3.0	- 6.9	- 10.8
<hr/>	<hr/>	<hr/>
+ 96.7	+ 54.9	+ 41.4
- 13.0	- 6.9	- 18.6

These calculations are easily verified. The same observations are discussed in a former Number (No. 29) of the Journal of Science. The point aimed is to make the tables approach as near as possible to the observed quantities. This is effected partly by shifting the mean temperature from 50°, which is the standard degree assumed in the construction of the table, to 46½°; and partly by altering the allowance made for one degree of the thermometer in the corrections for heat. Thus, excepting what regards the barometer, the table is entirely altered as far as the corrections are concerned. It is therefore highly ridiculous to say that the results in the Journal are calculated by the table in the Nautical Almanack. In the case of Mr. Groombridge's observations, when the computations are fairly made, the errors of the table in N. A. are much greater than those of either of the other two tables. And, I apprehend, it will be found, on examination, that the table in N. A. is less accurate generally at low altitudes than the French table.

Besides the observations just mentioned, the results of nine others are given in the Journal of Science; but of these I shall

shall say nothing, as they are not contained in my paper; and I have not had time to examine the calculations.

There next follows, in the same article, what is called a table of comparative results. Whatever purpose this was intended to serve, it is certain that, as it now stands, it can only mislead. The column, headed 52° , and of course that of differences, should be both struck out. The mean temperature of my table is 50° ; and I know no reason why it should be compared with refractions at 52° , rather than any other temperature.

The column of M. Bessel's refractions is liable to be misapprehended, from the omission of a very important remark. The numbers in the column, when we refer to the table in F. A., appear to be the refractions at $48\frac{3}{4}^\circ$, 30 B; whereas they should stand at 50° , 30 B, in order to make them comparable with the other columns. But M. Bessel has very lately discovered that no error existed in Bradley's thermometer, as he formerly supposed; and that the temperature of the table in F. A., which is marked at $48\frac{3}{4}^\circ$, should really be 50° . It is indeed extremely improbable that Bradley, whose mind was, for so long a time, intensely occupied with the determination of minute quantities, should allow any inaccuracy in one of his principal instruments to escape his notice.

Very important consequences follow from this change in the temperature of M. Bessel's mean refractions. Above 10° of apparent altitude, his table is now very little different from that of the French astronomers; and it approximates in a still greater degree to my table as far as 88° from the zenith. Thus at the altitude of 45° , the refraction (50° , 30 B) is $58''\cdot36$ according to the French table and mine; and, according to M. Bessel, the same refraction is $58''\cdot27$, the difference being no more than $0''\cdot09$. And this leads me to observe that the writer in the Journal is very careless of accuracy in his strictures. He remarks that, at the altitude of 45° , it appears highly improbable that the refraction at the temperature 50° , or even 48° , can be so much as $58''\cdot36$. Yet this quantity has the authority of the French table, known for so many years, and so much approved of by astronomers. It is the result of almost innumerable observations and experiments by Delambre, Biot, Arago, Dr. Brinkley; and to these we have now to add M. Bessel.

The relation of my table to those of best authority; which I take to be that of the French astronomers, and M. Bessel's when the temperature, according to his late correction, is taken at 50° instead of $48\frac{3}{4}^\circ$; is thus exhibited:

Alt.

Alt.	F. T.	Bessel.	N. T.
80	10.30	10.29	10.30
70	21.26	21.23	21.26
60	33.72	33.67	33.72
50	48.99	48.91	48.99
45	58.36	58.27	58.36
40	1' 9.52	1' 9.40	1' 9.52
30	1 40.85	1 40.69	1 40.85
20	2 39.22	2 38.85	2 39.16
10	5 20.63	5 19.39	5 20.19
9	5 54.3	5 52.8	5 53.8
8	6 35.4	6 33.6	6 34.7
7	7 25.9	7 24.2	7 25.4
6	8 31.2	8 28.5	8 29.8
5	9 55.8	9 52.5	9 53.8
4	11 50.1	11 46.4	11 47.1
3	14 30.4	14 27.5	14 26.0
2	18 25.0	18 28.8	18 19.6
1	24 25.0	24 58.2	24 21.8
0	33 51.	36 36.1	34 17.5

All the refractions here set down are reduced to the standard quantities 50°, 30 B. It appears that my refractions are never more than 1½" different from those of M. Bessel as far as 88° from the zenith: which is a surprising degree of coincidence, when we consider that the first were calculated in the closet, and from a theory depending only upon a few elementary quantities; while the latter were originally determined from Bradley's observations, and have since been experimentally confirmed and corrected. This is an argument in favour of my theory which I could have learnt only very lately; my paper having been sent to the Royal Society about the middle of June, and the correction of M. Bessel's table being published in the beginning of September following. To this I hope soon to add another confirmation with respect to the constitution of the atmosphere adopted in my paper; by showing that it agrees with the velocity of sound as deduced from the satisfactory account of this phenomenon which we owe to Laplace.

In No. 31 of the same Journal, there is an article, p. 139, of some parts of which I have also ground to complain. By turning to p. 141, at the bottom the reader will find that the article contains some insinuations and strictures on my paper by anticipation, before it was printed and published; but what I judge must injurious is at p. 148. In the Philosophical Transactions, 1823, p. 439, if we put $m=2$, we shall get,

$$a = 3 - \lambda$$

$$\psi = z$$

$$r = \alpha(1 + \alpha) \sin \theta. \int \frac{2 dx(1-x)}{\sqrt{\cos^2 \theta + (6i - 4i\lambda)z + 2i\lambda z^2}};$$

and in this case we have an exact value of the refraction in finite terms; the formula being integrable. Now the horizontal refraction at p. 148 of the Journal is included in the expression we have just found. Again, my general equation

between the pressure y and the density z , is $y = z \frac{m+1}{m}$; and when $m=2$, $y=z^{\frac{3}{2}}$ which is the particular case in the Journal; and when $m=4$, $y=z^{\frac{5}{4}}$ which is the case I have chosen as best representing the state of the atmosphere. Yet it seems to be insinuated in the Journal that something is found out different from my theory, and about as good. Now this is nothing else than taking away from a person the result of his own labour, and turning it against himself; which is no fair way of dealing.

I have now, by such arguments as hastily occurred, endeavoured to vindicate my table from the burlesque comparison in the Journal of Science. I am far from thinking that the table is the only part of my paper by which science may, in some degree, be benefited. But if it was necessary at this time to discuss the particular results published for illustrating the theory I had to propose, the objections ought, in the discharge of a gratuitous office, to have been well-founded; and they ought to have been urged in a candid, open, and manly manner. My purpose being merely to defend myself, I have abstained as much as possible from all remarks on the table in N. A. The construction of that table may hereafter become a fair subject of discussion. But it is not impossible that it may be withdrawn, and another of a less mysterious construction substituted in its place; as it appears that a new method for the refractions was read before the Royal Society at their meeting on the 5th February last.

I remain, gentlemen, &c.

April 9, 1824.

JAMES IVORY.

XLIV. Electro- and Thermo-magnetical Experiments. By Mr. WILLIAM STURGEON.

To the Editors of the Philosophical Magazine and Journal.

Gentlemen,

ALTHOUGH the experiments I have detailed in my former paper have sufficiently satisfied myself with respect to

to

to the directive exertion of the forces of the differently excited wires or machines, yet it is not impossible that some may still doubt of the sufficiency of those experiments to determine the apparently anomalous phænomena: owing, perhaps they may say, to the difference of the construction of the apparatus employed for exhibiting them. I am persuaded, however, that the following mode of making the experiments will, in all probability, be sufficiently decisive to convince the most sceptical on this point.

Suspend the semi-circular copper arc, with its zinc diameter, as described in my former paper (the extremities of the metals need not be soldered but twisted together). Wrap one of those joinings of the metals loosely with a piece of tow or unspun cotton. Dip this part of the machine into dilute nitric acid (observe to counterpoise at the other end); present the north pole of a magnet to the same arm, and it will be projected to the right.

Take off the cotton, wash and dry the machine, and suspend it as before. Apply the lamp now instead of the acid, and the magnet as in the former experiment; that arm of the apparatus will be now propelled to the left.

I have merely pointed out this method of making the experiments, as the most likely to be understood in comparing the phænomena; but that described with the galvanoscope, for making the chemico experiment, is by far the most efficient and eligible.

The results obtained from the mode of comparing chemico and thermo phænomena, could hardly fail to suggest the idea, that chemico-excited wires would have their electrical tension increased by thermo application at the opposite extremity. And in order to try the suggestion by the test of experiment, I had recourse to the above-described simple apparatus. I twisted the copper wire a good length round the extremities of the zinc, so that as great a metallic surface as possible might be exposed to the action of the acid. After dipping the extremity wrapped with tow into the acid, I suspended the machine in the galvanoscope. On presenting the north pole of the magnet to the arm ascending from the chemico extremity, the latter was deflected to the right about 80° . From that it returned to nearly 20° : thence propelled again to nearly the same distance as before; and so vibrating several times from about 15° to 60° , when I changed the pole of the magnet. It was now deflected in a contrary direction (left) to about 70° : from thence it returned as before by the silk endeavouring to untwist itself, and was again propelled by the

magnetic influence; thus vibrating, still describing a smaller arc, and approximating nearer the magnet.

When it had become so feeble that the greatest distance did not exceed 30° , I applied the lamp at the other extremity. It was soon propelled to above 400° : and by keeping the extremity of the wires warm (it is well known that zinc would soon melt in a strong flame) I could keep it vibrating at about right angles to the pole of the magnet; for when it went further than 90° , the thermo arm became acted on by the magnetic influence, and conspiring with the reaction of the convoluted silk, the machine was frequently driven back again 40° or 50° ; but by keeping it moderately warm it was kept at between 80° and 90° from the magnet.

I now again changed the pole of the magnet, and took away the lamp. The chemico action had now become so feeble as to be just discernible. However, by applying the lamp it soon acquired between 60° and 70° , and could be kept up to nearly the lower point.

I have repeated the experiment, with the same success, in about $6\frac{1}{2}$ minutes each time. The copper wire was about 1-60th of an inch in diameter; and the zinc about twice that thickness.

When the lamp is applied before the chemico action gets too weak, this *thermo-chemical magnetic* experiment, in miniature, is most strikingly decisive. Not having it in my power at present to carry on the experiment on a large scale, I am not prepared to say how it might answer.

All the phænomena yet exhibited by the differently excited wires, seeming to be so perfectly analogous in every other respect than in the direction of their forces, I have, by parity of reasoning, found no difficulty in producing a thermo rotation by the influence of a central magnet.

As this experiment seems to have baffled the exertions of some of your scientific correspondents, it may perhaps be considered of some importance in promoting the advancement of the science.

I am yours, &c.

Artillery Place, Woolwich,
Feb. 16, 1824.

WM. STURGEON.

XLV. Description of a Rotative Thermo-magetical Experiment. By Mr. WILLIAM STURGEON.

To the Editors of the Philosophical Magazine and Journal.

Gentlemen,

HAVING promised in a former paper to communicate to your readers the method I have adopted for rotating a thermo-combination by the influence of a central magnet, the following description of the apparatus I have constructed and employ for exhibiting the experiment, with an explanation of its management, will, I humbly hope, be sufficiently plain to be understood.

NS, in the figure, is the magnet; P c P a piece of platinum wire bent into the form of a semicircle or other convenient curve; P s, P s are two pieces of silver wire twisted to the former at the extremities P P. The other ends of the silver wires are bent downwards at s s; and made quite sharp and smooth at the points. These points descend into the metallic cell F E, which contains pure quicksilver, with which the points communicate. A descending point c soldered to the platinum wire, forms the pivot on which the moveable part of the machine turns. A small concavity well polished at the bottom is made in the point of the magnet, for the purpose of containing a small globule of mercury, and likewise for the rotating pivot to work in.

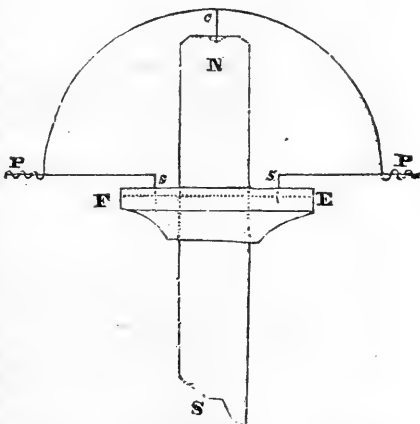

The point c being amalgamated, when it is placed in this globule of mercury, forms a communication with the magnet; and the other part of the magnet which passes through the cell communicates with the mercury in that cell: and the points of the silver wires being immersed in this mercury, the metallic circuit is thus rendered complete; first, through the platinum wire from P to c; thence through the pivot to the

the

the top of the magnet, and along that part of the magnet from the top to the quicksilver in the cell F E: and lastly, along the silver wire from the point *s* to the extremity at P, where it joins the platinum.

The other part of the wire machine being on the same principle as that described, the platinum arms of this apparatus, when heated by a spirit lamp or otherwise at the extremities PP, are in every respect assimilated to the arms of the rotating cylinder of Ampere; for the electric fluid is transmitted in the same direction through both arms of the apparatus; and hence the rotating tendency is *constant* round a central magnet; and not *impulsive*, as in other rotations with an external magnet.

The moveable part of this machine (which is the platinum and silver wires only) will rotate with a facility proportioned to the delicacy of the suspension, the difference of temperature of the parts P and *c* of each arm, the power of the magnet, and the dexterity of the experiments. And I must here warn the reader, that this last requisite is not the least to ensure success in the experiment; for had I not been satisfied that the apparatus was constructed upon principle, I probably might not have persevered sufficiently to attain my object. However, a slight modification of the apparatus considerably facilitates the experiment, and renders it more permanent and beautiful.

A circle of lamps are placed on a stage of the same figure, in such a manner that they may coincide with the periphery of the circle described by the points PP of the wire part of the machine, so that the latter may constantly be kept at nearly the same temperature in every part of their revolution. And the shoulder of those arms, or that part of the platinum wire to which the pivot *c* is soldered, is kept at as low a temperature as possible by means of ether or other cooling liquid.

If instead of lamps a circular flame of ignited hydrogen be substituted, and regulated by a stop-cock, this part of the apparatus may perhaps be considered at its acme of perfection.

Another improvement is by having a conducting wire from the pivot *c* to the metallic cell F E, in the same manner as the conducting wire of the copper part of M. Ampere's rotating cylinders; through the upper part of this conducting wire passes a screw with a milled head, made into the form of a cup. The pivot *c* runs in this cup, at the bottom of which is a small globule of mercury, for the better ensuring the contact. The cup is then filled up with ether, and may be supplied during the experiment in proportion to the evaporation.

The

The lower end of this screw rests in the hole in the top of the magnet; and by turning the milled head to the right or left, the points *ss* of the silver wires may be heightened or lowered at pleasure; and consequently their contact with the mercury in the cell *FE* may be regulated to the greatest nicety; the attainment of which was the only embarrassment I had to encounter with the original apparatus. However, by means of this improvement my anticipations were soon agreeably realized by witnessing the first thermo rotation ever produced by the influence of a central magnet.

I must here beg leave to observe, that the only attempt I ever heard of (and the only one perhaps on record) was with the apparatus of Professor Cumming, and a similar attempt by Professor Barlow with a combination upon the same principles.

The latter gentleman, however, has candidly confessed the failure of the experiment, and sufficiently accounted for the inefficacy of the apparatus upon the principle of its construction.

I am, gentlemen, yours respectfully,

Artillery Place, Woolwich.

WM. STURGEON.

P.S.—April 13. I have since succeeded in forming a sphere of galvanized wires, to rotate by the influence of both poles of an internal magnet.

This experiment was suggested on reading the late Dr. Halley on the theory of the earth; and although it may not be considered as a proof of that philosopher's notion of terrestrial magnetic variation, yet perhaps it may tend in some measure to strengthen the hypothesis. A description of the apparatus shall be the subject of another paper.

W. S.

XLVI. *On Parallel Straight Lines*. By JOHN WALSH, Esq.*

IN this paper my object is not to terminate a controversy, but to render service to science, to banish from it, as far as this is in my power, all fallacious reasoning about an elementary principle which is the basis of all mathematical science. I must observe again, that the difficulty encountered in the theory of parallels, arises out of the nature of things. It arises from this, that space has no limit. Can the geometer imagine space beyond which there is no space? Can

* Communicated by the Author.

he imagine space less than which there is no space? If he cannot, or more properly if there is not, then he cannot obviate the difficulty of Euclid's postulate. I know not how it happens that some illustrious geometers mistake the nature of number, and the manner it presents itself in mathematical investigations. I know not how it is, that the most glaring absurdities are received by geometers, even as necessary truths; and that too in a science conversant only about TRUTH. It is acknowledged to be a fact antecedent to all hypotheses, that the arc and tangent of a curve may become nearer to each other than any given difference; that is to say, there is a given difference that is less than itself. It is said to be a fact, in the theory of maxima and minima, that space can exist and cannot exist at the same time. And these two propositions are the basis of the modern mathematics. Does this arise from the nature of elementary education; from spending the important period of youth almost exclusively in the study of the languages of Greece and Rome? This is a circumstance, I suppose, which the well-being and advancement of society render absolutely necessary. But are the powers of reasoning by this means deranged, from having no fixed principles always to refer to? On the subject of this paper, I find the following observations in page 296, fourth edition of Leslie's Geometry. It appears they were advanced by M. Legendre in reply to the objections of Professor Leslie to his theory of parallels. *La loi de l'homogénéité est une loi générale qui n'est jamais en défaut.* Every body is sensible of this. In the next sentence he says: *L'angle est une quantité que je mesure toujours par son rapport avec l'angle droit.* Again he says: *L'angle droit est l'unité naturelle des angles.* That is to say, particular sounds of the human voice and linear space are homogeneous magnitudes. Locke falls into the same absurdity, when he says, "Number measures all measurables." Geometers are led away by the erroneous manner in which number presents itself in language. I define numbers to be articulate sounds used as the signs of our ideas of certain relations between homogeneous things. We measure magnitude by magnitude homogeneous to it; and number is the verbal expression of the relation found to exist by actual measurement. And figures are the written characters which as it were represent numbers, and excite in us the ideas of certain relations. The term number is generally transferred from the verbal expression to the written character. It is not until the binomial calculus shall become a general object of study among mathematicians, that reason, so long and so much distorted

distorted by the false language of the infinitesimal calculi, will have assumed its proper empire in mathematical and physical investigations.

I cannot discover in the second note, tenth edition, of his *Geometry*, where he applies functional equations to the theory of parallel lines, that M. Legendre assumes, that if at the ends of any straight lines c' , c'' &c. angles be formed equal each to each to the angles at the base c of any given plane triangle, triangles will be formed on each of those lines. In fact, his reasoning is similar to the following: "Having measured two angles of any plane triangle, it is required from these to determine the third.

"The vertical angle C is determined by the angles A , B , and the base c . For when $A=0$, $B=0$, $c=0$, then will $C=0$. But C , a number, being heterogeneous to the line c , then any particular magnitude of C cannot depend on any particular magnitude of c , then the magnitude of C can only depend on the magnitudes of A , B , and be derived from them. Therefore when any two plane triangles have two angles of the one equal each to each to two angles of the other, the third angle of the one will be equal to the third angle of the other. It follows from this, that the sum of the three angles of any plane triangle is equal to two right angles.

"The base and its adjacent angles being given, to construct the triangle?

"With the base make an angle equal to the given acute angle; then at any point in the base, or the second line, according as the other given angle is acute or obtuse, make an angle equal to the other acute angle; then a triangle will be formed, having its angles equal each to each to the angles of the triangle to be constructed. Then at the other end of the base make an angle equal to the other given angle, and the thing required is done. For if the lines forming the angles at the base, do not meet when produced, then the vertical angle will vary for particular values of the base, which is shown to be impossible."

Now I shall object to the preceding reasoning, that the arc C and the base c may both be compared to the straight line radius, and may be expressed by equations of equal dimensions, as I have demonstrated in my *Essay on the Binomial Calculus*. The reasoning of M. Legendre therefore fails altogether, as must all attempts at obviating the difficulty of the axiom of the illustrious Greek geometer.

Cork, April 15, 1824.

JOHN WALSH.

XLVII. *Zoological Notices.* By Mr. JOHN EDWARD GRAY.*On the Characters of Zoophytes.*

SINCE the discovery by Ellis, that the corals and other zoophytes were the houses of animals, there appears to have existed in the greater number of persons a considerable difficulty to draw the line of demarcation between them and the Marine Algæ; but this difficulty must have arisen from the consideration of them as animals themselves, and not as the houses of animals, in the same manner as shells are to the Mollusca. For in the consideration of them in the latter point of view, it is impossible that they can contain the animals without a space to hold them; this space, or at least its mouth, as the animals are always regularly radiated, is constantly regular and mostly symmetrical; so that let the structure be either a simple tube, or many tubes close together or separated by the intervention of cretaceous matter forming a plant-like structure, they always terminate in a regular mouth. Whereas marine plants are formed entirely of cellular structure, which is condensed on the surface to the form of a cuticle (which is sometimes, as in the Sponges, mucilaginous), and they very seldom have any apertures on their surface, or, if they have, these are always irregular.

Now since *Silex* is generally allowed to be found on the surface of many Monocotyledones, and *Tabasheer* in the joints of the Bamboo, why should not chalky matter be found in Algæ? Indeed it is to be seen on the surface and internal structure of several *Thalassiphytes* which have never been considered as *Zoophytes*.

Therefore I should consider none of the marine plant-like bodies to be of animal formation, unless cells could be discovered opening on their surface with regular apertures; and consequently there is no reason why the genera *Corallina*, *Dichotomaria*, *Penicillus*, and *Flabellaria*, of Lamarck, and perhaps even *Nullipora* of Cuvier, should not be placed with the Algæ. The first of these I have ventured to remove to their ancient habitation, on account of their bearing tubercles very similar in appearance to those of many of *Ceramiadæ* or marine conservæ; and the first section of *Flabellaria*, especially *Flabellaria pavonia* of Lamarck, bears a very great affinity to, as the above-named author justly observes, if it does not actually belong to the same genus as the *Ulva pavonia* of Linnæus, which Draparnaud the elder has formed into a genus under the name of *Zonaria*. This affinity induced me to place the *Corallinæ* so close to the *Zonariæ*, in my father's Natural Arrangement of British Plants.

On *Gadinia*, a new Genus of Patelloid Shells.

GADINIA.

Testa univalvis, non symmetrica, oblique conica; *vertice* obtuso, subpostico. *Apertura* suborbiculata, irregularis; *cavitas* simplex, sulco in latere dextro prope limbum anticum, impressionis muscularis; *impressio muscularis* elongata, arcuata, submarginalis.

Animal ignotum.

This genus is instantly to be distinguished by the peculiar groove, which is formed, there is little doubt, by the tube that directs the air to the respiratory cavity of the animal, with which unfortunately we are unacquainted.

I have only observed one species, which, having been called *Le Gadin* by Adanson, I have consequently named

1. *Gadinia afra*. *Testa* oblique conica, alba, radiatim striatocostata subsquamosa; *vertice* sublævi; *marginibus* crenulatis.

Patella afra. Gmelin 3715! *Dillwyn. Rec. Shells*, ii. 1046!

Patella n. 1. *Schroeter. Einl.* ii. 441.

Le Gadin. *Adanson Senegal*. 33. t. 2. f. 4!

Icon. Gaultier t. 9. f. 6. *Martini* i. 93 t. 5. f. 34.

Inhabits Coast of Africa. Coast of Cape Manuel and the Island of Goree. *Adanson*.

Shell white univalve not symmetrical, obliquely conical with an obtuse vertex placed towards the hinder part, rayed with many rather scaly rib-striæ diverging from the apex; the aperture is nearly orbicular, crenulated, sometimes slightly extended, on the right anterior lateral portion, just over the groove; the cavity is simple, concave with a slight groove near the front part of the right limb of the horse-shoe shaped, sub-marginal muscular impression.

Length and breadth about $\frac{1}{2}$ inch.

This shell is not uncommon in collections, and may be confounded with *Siphonaria*; but in that genus the groove is placed in the muscular impression, and divides it into two portions. I had, in a paper which it was my intention to have published the beginning of last year, called the latter genus *Liria*, believing the *Patella tristensis* of Dr. Leach to be *Le Liri* of Adanson and consequently the *Patella perversa* of Gmelin; but as Mr. G. Sowerby has lately published this shell with two or three others under the generic name of *Siphonaria*, it should be adopted.

He has however in my opinion fallen into the common error

of modern conchologists, of making too many species; for I have good reason to believe that all the specimens that he has figured, except *S. tristensis*, (with several varieties in the British Museum), belong to one species, for which I propose the name of *S. radiata*. There is, I believe, another species found in the United States, which Mr. Say has described under the name of *Patella alternata*, which, should my surmises be correct, will be a curious circumstance, as the other two species are confined to the African seas.

On some new Species of *Ampullariadæ*.

Marisa intermedia.

M. testa subdiscoidea, lævi, pallide olivacea, lata fusco-unifasciata; spira concaviusculo-plana, apice subprominente acuto; columella (axi) concavo-conica effusa.

Inhabits Brazils. Mus. J. Sowerby, Nostr.

Shell nearly discoidal, smooth pale green with a broad brown central spiral band, spire very slightly concave, nearly flat, apex slightly prominent acute, columella (axis) conical concave effused exhibiting most of the whorls; aperture narrow, half as broad again as the last whorl but one, peristome simple slightly reflexed in front, axis $\frac{1}{20}$, diameter 1 inch.

Marisa is the name which I propose for a genus of shells which has been confused with *Ampullaria*, but which differs from it in having a horny operculum and simple peristome.

This shell is very interesting as being intermediate between *Ampullaria Cornu arietis* and *A. effusa* of Lamarck; and I believe that Mr. Swainson had confounded it with the former species when he observed that Mr. G. B. Sowerby had discovered the operculum of that species, for I have reason to think that my specimen is the fellow to the one in Mr. Sowerby's collection, as he presented me with it at the time he bought them; so that the operculum of that species is still a desideratum, although I have no doubt that it is furnished with one.

This shell is instantly to be distinguished from the two former species by the flatness of the spire, and the size of its umbilicus; and the two specimens that I have seen have only one broad band, whereas the other species have five or six narrow ones, but this may be subject to variations.

The controversy that has arisen regarding the situation of the *M. Cornu arietis* is an illustration of one of the numerous errors between analogy and affinity; for there is no more reason for placing it amongst the *Planorbis* on account of its subdiscoidal form, than there would be for arranging the Bats with the Birds on account of their fluttering through the air. As to
the

the assumed absence of the columella, it is no more wanting in this than in any other species of the genus.

In fact, it only differs from them in the size of the space between the whorls; and if it is to be placed in the latter genus on that account; several other shells, such as the *Staircase Trochus*, &c. must be also added to it. I am the more astonished at the controversy, as one of the parties has travelled through the Brazils, where this genus is found, and where he might have learnt that the *Marisæ* have gills and breathe air through the medium of water; and every English conchologist knows that the *Planorbis* on the other hand breathe, by means of a closed bag, free air, which they come to the surface to procure. Consequently these two genera cannot have any affinity with each other, and their resemblance must be purely analogical, and few persons would be inclined to place genera with such different animals side by side. Again, I do not know any of the *Planorbis* to be banded, as is the case with most of the *Ampullariadæ*, and colour is not an unimportant adjunct to the natural arrangement of organized bodies, as most zoologists and botanists are well aware.

Bithinia lutea.

B. testa ovata, lævi, pallide lutea, pellucida; anfractibus quatuor, convexis; apice obtusa; columella perforata.

Ditches, East Indies. *Mrs. F. Gray.*

Shell ovate, smooth, pale yellow, pellucid; the whorls four, rather convex, the sutures distinct; the apex obtuse as if the first whorl was broken off; the axis with a narrow deep perforation, axis $\frac{5}{10}$, diameter $\frac{5}{20}$ of an inch.

Bithinia is a generic name proposed by Mr. Prideaux for the small ovate species of *Ampullariadæ* which have a shelly operculum and slightly thickened peristome, of which *Helix tentaculata* may be considered the type.

Bithinia pusilla.

B. testa ovata, lævi, alba, hyalina, anfractibus quatuor, convexis; apice subobtusis; columella imperforata.

Ditches, East Indies. *Mrs. F. Gray.*

Shell ovate, smooth, white, hyaline, with four convex whorls divided by very distinct sutures, and rather obtuse at the apex; the axis is imperforated, axis $\frac{5}{20}$, diameter $\frac{2}{10}$ of an inch.

I have transmitted both these latter species to the Baron Ferussac, who declares them to be as yet undescribed and new to him.

XLVIII. *Analysis of Professor HAUSMANN'S Essay* on the Geology of the Apennines*†.

THE first section contains an account of the general appearance of the Apennines. The most elevated point of the range is 8934 feet above the level of the sea. The second section, entitled *Apenninorum constructio interna*, embraces the geological description. From this it appears that the structure of this mountain chain is peculiarly simple, containing no rock of any consequence, except a white limestone of uniform aspect, rarely containing foreign substances or petrifications. In the immediate neighbourhood of the Alps, however, and in the southern part of the chain in Calabria, there are rocks of older formation. In the lateral chains there is considerable variety, and transverse sections of these mountains often present alternations of various rocks.

The Apennines differ from many other mountains in this, that in many places where strata of different formations are observed, the more ancient are found neither in the centre of the transverse chains, nor in the more elevated parts, but on the sides and at inferior elevations.

From analogy we should expect primitive rocks in these mountains; but from the observations of Professor Hausmann they appear to be wanting, except towards Calabria. The observations of Viviani, Spadoni, Santi, and others, are noticed; but they do not appear to be confirmed by those of our author, who however offers no decided opinion of his own, in regard to the formations of Giglio, Elba, &c., which these writers have considered granite and gneiss.

The transition formations are the most extensive and important; comprising the Apennines of Genoa, Lucca, Modena, a part of Tuscany, and various other places, always reposing on primitive rocks. The rock named *macigno* and *pietra serena*, which is extensively used in Florence for architectural and ornamental purposes, appears to be a variety of grey wacke, and occurs in all parts of Italy where the transition rocks are found. The grey wacke in different parts of Italy, observes Prof. H., is not so varied in its grain, and in other respects is more simple than that of Germany. Quartz is the predominating ingredient, together with particles of

* De Apenninorum constitutione geognostica commentatio, in consessu Soc. Reg. Scient. D. XVI. Novembr. An. MDCCCXII. ad anniversarium solenne celebrandum habito, recitata a 10. Frid. Lud. Hausmann. Gottingæ MDCCCXIII.

† From the Boston Journal of Philosophy and the Arts, Nov. 1823.

black siliceous slate, and scales of silvery mica. The cement is present in small quantity, and is even sometimes wholly wanting, in which case the portions of quartz lose the granular form, and constitute a continuous mass, making a transition from grey wacke to quartz rock. At other times it passes into clay-slate and into compact limestone.

Clay-slate, flinty-slate and talc-slate are next noticed; the latter occurring more frequently and in larger masses, passing on the one hand into clay-slate, and on the other into chlorite-slate. When mixed with quartz it forms the "saxum fornacum," or *Gestellstein* (a kind of oven-stone). This rock was noticed by Saussure* and St. Fond †, between Genoa and Finale, alternating with compact limestone and clay-slate, and is hence inferred to be of secondary formation, as is likewise the gneiss observed by Saussure ‡ near Voltri.

Compact limestone, which is so important in the geological structure of the Alps, is not less so in that of the Apennines. It alternates with grey wacke and clay-slate; in some places passing into those rocks. Its colours are various, but grey is the most common. It contains but few organic remains; a rare specimen of an ammonite was met with by Micheli§, which is preserved in the collection of Professor Targioni at Florence.

When the compact limestone is mixed with quartz and mica, it constitutes the *pietra forte*, much used at Florence and other places for paving the streets.

The transition rock of most interest in these mountains is the *brecciated limestone*. Some important observations upon this rock have been made by Brochant ||. It is apparently composed of fragments of limestone, of various shapes and colours, united by a calcareous cement, sometimes mixed with talc, clay-slate, and other matters. Its colours are strongly contrasted, and it has sometimes the character of the beautiful African breccia. In other instances it approaches the antique *Cipolline* marble. Where the nature of the fragments does not differ greatly from the cement, there takes place a transition into compact limestone, or marble, which was noticed near Carrara, where the brecciated marble alternates with the compact.

Professor Hausmann describes the appearance of the brecciated limestone of the Apennines, as rough, and traversed by numerous fissures, which are particularly conspicuous where the cement is softer than the included fragments, and being

* Voy. dans les Alps. vol. iii. p. 167.

† Voy. dans les Alps. vol. iii. p. 159.

|| Jour. des Mines. N. 137. p. 321.

‡ Annal. du Mus. vol. xi. p. 222.

§ Ferber's Briefe, p. 327.

acted upon by air and moisture, is broken down and washed away. This most beautiful breccia is known by the name of marble of Seravezza, and is much used for ornamental purposes. Our author supposes it to be the variegated stone referred to by Strabo*.

The celebrated marble of Carrara is considered by Prof. H. as belonging to the transition formation, contrary to the opinion hitherto maintained by geologists. It is connected with and passes into the brecciated limestone and grey wacke, and these rocks alternate more or less with each other. This marble forms high mountains, with steep acclivities, and narrow valleys: the rocks are destitute of vegetation, and distinguished at a great distance by their snowy whiteness.

The colour of the Carrara marble is injured by exposure, acquiring a brownish tinge probably from a small quantity of iron which it contains. Iron pyrites are found in it, together with calcareous spar and rock crystals.

Professor Hausmann observes, that when the Carrara marble is cut into long and thin pieces it is flexible like some varieties in North America.

The next rock described is the *Gabbro* of Von Buch†; this is one of the most beautiful and remarkable rocks of the secondary formation. Prof. H. observes, that, although from his examination of this rock in the Apennines, he is satisfied that it is not a primitive rock; yet he would not maintain that Gabbro is in every case a member of the transition formation. Under the term Gabbro he includes serpentine, the Gabbro of the Italians, and a rock called in Florence granitone, composed of saussurite and diallage (Euphotide of Haiiy). These rocks are shown to be but varieties of the same, often containing asbestos, in which case the hardness of the compound is diminished, and the quantity of magnesia in it is increased. Four varieties of Gabbro are described, viz.

1. Granular crystalline Gabbro, containing quartz, hornblende, prehnite, and a substance which has not been examined. This variety passes into jasper.

2. Porphyritic Gabbro, including the *Nero di Prato*. The principal part of this variety is serpentine, in which particles of schillerstein are seen.

3. Spotted Gabbro, principally serpentine with compact globules of saussurite.

4. Common Gabbro, or serpentine.

* Geog. lib. v.

† Ueber den Gabbro, von Leopold Von Buch. Magazin der Gesellsch. naturf. 1810, II. p. 128.

These observations do not exhibit any uniform regularity in the relative situation of the transition rocks of the Apennines; but they are most probably to be referred to one epoch. The direction and inclination of the strata are very various. Prof. H. thinks it not improbable that these rocks are a continuation of the secondary formations of the Alps.

After remarking that the upper Apennines exhibit a more varied structure than the other parts, Prof. Hausmann proceeds to describe the rocks between Tuscany and southern Calabria. The compact limestone already noticed, constitutes the most prominent geological feature, and is stated to resemble the white Jura limestone. It does not contain beds of oolite, which are often met with in the latter, but calcareous and argillaceous marl and hornstone. Professor Hausmann observes that it is difficult to decide whether the limestone of the Apennines is to be referred to the newest secondary formations, to which the Jura limestone belongs, as there are no super-incumbent formations, nor petrifications sufficient to determine the question. The transitions and alternations of the strata increase the difficulty. From various considerations, however, he is inclined to refer the principal part of this limestone to the same formation as the Jura limestone. If this opinion is correct, the lower part of the plain of the Po with the Adriatic sea, is to be considered as a longitudinal valley extending from N.W. to S.E. in this limestone formation. The principal boundaries of the formations have the same direction, with some little interruption. The continuation of the line of the white limestone of the Apennines above Bologna, towards the N.W., is found near Arona, in the same limestone. The line of the transition mountains, which begins in Calabria, skirts cape Circeo, and with increasing breadth stretches through the southern part of Tuscany to the upper Apennines, and thence to the Alps. The primitive rocks begin in the southern extremity of Calabria, and in Sicily, touching either the granite of Giglia and Elba, or, if this rock belongs to the transition formation, probably the primitive rocks of cape Corso in Corsica.

The tertiary mountains are next described, and, for the most part, are so completely separated from the Apennine limestone, that no transition can be discovered. There are, however, some exceptions in the territory of Otranto, where a transition was first noticed by Brocchi.

The tertiary formations are distinguished by Professor Hausmann into *more general* and *more local*.

The *more general* consist of argillaceous marl, passing on one side into slate-clay, and on the other into sandstone;

plastic and slaty clay; sandstone; conglomerate; and sand. The latter is always the newest. In these formations fossil organic remains occur, with bones of colossal animals, and shells. Bitumen, sulphur, pyrites, barytes, and strontian are also met with. The sulphur is often beautifully crystallized.

The *more local* tertiary formation consists of gypsum, calcareous tuffa, and volcanic tuffa. The alabaster which is wrought at Florence into various ornamental articles, belongs to the gypsum of this formation. The greater part of the Apennines being composed of limestone, it is easy to explain the production of the calcareous tuffa, at their base and in the valleys. The celebrated Travertina marble is a tuffa of this kind. The quantity of calcareous tuffa in Italy, and its varied appearance, are wonderfully great. Prof. H. points out some of the most remarkable localities. He remarks that different local formations of this substance can be distinguished; some having been formed at the bottom of the sea, as is proved by the marine remains found in them; while others have resulted from the sediment of fresh-water rivers and lakes. The fresh-water strata exhibit also proofs of difference in age. Those which alternate with the volcanic tuffa, as seen in some of the hills of Rome, the Aventine for example, and in the vicinity of the city, are most ancient. Those strata which cover the volcanic tuffa, and the tuffa upon which Tivoli is built, are of more recent origin. The newest formation is that daily forming, as at the baths of St. Philip, &c.

The *volcanic tuffa*, although composed of volcanic matter, in the state in which it is now observed is to be referred to the aqueous depositions, as has been proved by Von Buch in his excellent remarks upon the country about Rome*. It appears to be confined to the south-western side of the Apennines, and is separated into two portions, one of which extends from the neighbourhood of Rome to the Pontine marshes and vicinity of Bolsenna. The other portion, which is less extensive, occurs about Naples. In the first, leucites occur, but are altogether wanting in the second, into the composition of which felspar enters.

The volcanic tuffa is of later formation than the marls, sandstones, and sand before noticed; as is well seen in the neighbourhood of the Vatican, where the sand is full of marine shells and rises from under the tuffa. This fact was first described by Von Buch.

Professor Hausmann concludes his memoir by remarking, 1st, that there are no *true volcanic* rocks, nor rocks of the

* Geognost. Beob. II. p. 60, 202.

trapp formation (*Trappgebirgsarten*) in the central chain of the Apennines, although Ferber* and some other writers have advanced an opposite opinion. 2d, That the *true volcanic* formations are found only on the south-eastern side of Italy, with the exception of the extinct volcanic mountain Vulture. The greatest extent of the volcanic rocks is in the line of those of more remote origin, and but a part of them, as Vesuvius, the extinct volcanoes of Nemi and Albano, and the formation near Borghetto, approach the Apennine limestone.

XLIX. *Chemical Examination of Green Feldspar from Beverly, Massachusetts.* By J. W. WEBSTER, M.D.†

THIS mineral is peculiarly interesting, as another instance of the great similarity existing between the minerals of this country and those of the north of Europe. The only specimen which I have seen from this locality is connected with quartz and mica, constituting a perfectly characterized granite. The colour of the feldspar is of a lively verdigris green, the fracture is foliated with a high degree of lustre, and the concretions, or imperfect crystals, are from a quarter to half an inch in diameter. The intermixture of the quartz, which is white, with the brown mica and the green feldspar produces a beautiful effect.

My first object in submitting the green feldspar to a chemical examination was to ascertain the proportion of alkali it might contain. For this purpose, one hundred grains reduced to an impalpable powder were mixed with twice their weight of boracic acid, as proposed by Sir H. Davy. The mixture, after fusion in a platina crucible, was digested in dilute nitric acid. After separating the siliceous earth, the bulk of the solution was reduced by evaporation, supersaturated with carbonate of ammonia, and boiled; after filtration, nitric acid was added to the liquor, which was again filtered, and exposed to a temperature sufficient to decompose the nitrate of ammonia that had been formed. The salt obtained was nitrate of potash, and weighed 23.6 grains, equivalent to 11.1 of alkali.

Another portion of the specimen was treated in the usual manner. The details of the processes it is unnecessary to repeat, as they presented nothing peculiar. The composition of this feldspar was found to be as follows :

* Briefe aus Wälschland, p. 430.

† From the Boston Journal of Philosophy and the Arts, Nov. 1823.

Notices respecting New Books.

Silex	72
Alumina	10·1
Lime	1·2
Magnesia	3·2
Iron	2
Chrome	a trace
Potash	11·1
	99·6

In some preliminary experiments I detected fluoric acid; but on more minute examination of the specimen, small portions of distinct fluuate of lime were found connected with the feldspar; the source of the acid consequently became evident. I also noticed some metallic particles in the compound, which are probably oxide of titanium.

L. Notices respecting New Books.

The English Flora, Vols. I. and II. By Sir J. E. SMITH, M.D. F.R.S. President of the Linn. Soc. &c. &c. &c. 1824.

[Continued from p. 233.]

WE now proceed to notice the second volume of this excellent work; and we cannot forbear to express our approbation that the author should so readily, and with such a liberal spirit, have adopted the innovations of the younger naturalists; and it is the best evidence of the soundness of his scientific principles, that he has made all his early predilections, which, as possessor of the Linnæan Herbarium, cannot have been few, accommodate themselves to the advancement of science. The new modelling the genera of which Linnæus was the author, had become absolutely necessary from the vast accession of species. It was a convenience in many cases to break them down into smaller divisions, and in others it was quite irreconcilable with our present knowledge to suffer so many artificial assemblages of plants to remain combined. This was more particularly the case in all his natural orders, which, from the circumstance of their being natural, were with the greater difficulty subdivided into distinct and obvious genera. The more closely the groups of nature are related, the more difficult it is in all cases to break them down into subordinate divisions. Thus in the Umbelliferous group, which is completely natural, it is not easy to distribute the genera, and most of them in consequence are artificial. "Umbellatarum genera characteribus distinguere est res difficillima," says Linnæus; and Jussieu makes a more pertinent remark

remark still, "Umbelliferarum character generalis simplex ac facilis, difficilis generum distinctio ac distributio." On the other hand, when the genus is tolerably natural, it usually happens that the species are proportionably obscure, as for example in *Saxifraga*, *Ranunculus*, *Rosa*.

The artificial state in which Linnæus had left the umbelliferous genera rendered it very desirable that a revision should take place; and the learned author of the present work, with the assistance of Sprengel and Cusson, who are great authorities among these plants, has done well to undertake it. He has laid aside the inflorescence, to which Linnæus, contrary to his own rules, had resorted for characters in this difficult tribe, and has introduced new characters from the parts of fructification alone. In addition, he is much disposed to rely on a part which he calls the "floral receptacle," or disk, and which is "a glandular ring, under the tumid bases of the styles, and mostly united therewith, but differing in substance, and often in duration, sometimes dilated into a thin undulated margin or ruffle, in general somewhat enlarged as the fruit ripens, sometimes withering, sometimes entirely wanting, finally separated into two parts, one of which accompanies each seed." This attempt to characterize the genera is new, and, as far as a cursory study will justify an opinion, it appears likely to associate the species more naturally. The application of the principle to living plants can alone establish its validity. It has created the necessity of a fresh arrangement of the genera as to the series, and the removal of many species from their present station in the system. Thus *Caucalis Anthriscus*, *infesta*, and *nodosa* are now removed to *Torilis*, a genus of Adanson's; the *daucoides* and *latifolia* only, which are of distinct habit, remaining behind. The old *Scandix Anthriscus* is now *Anthriscus vulgaris*; the *Scandices* having the "floral receptacle five-lobed and coloured," while *Anthriscus* has the same part "slightly bordered." The genus *Myrrhis* is new, embracing the Linnæan *Scandix odorata*, *Chærophyllum temulum*, *aureum*, and a new one from Mr. G. Don, *aromaticum*. By the by, why does the present author continue the trivial name *temulentum*, without referring to the original name of *temulum*? Linnæus does not appear to have applied the epithet, as Sir James notices, from any intoxicating quality which the plant possesses, but it is probably barbarous Latin referring to the swollen joints. So Sprengel calls it *Myrrhis temula*. The Pig-nut, which has been changed and rechanged between *Bunium Bulbocastanum* and *flexuosum*, is settled down here to be the latter plant, though Ray could scarcely mean to designate the rarer plant by his common name. *Sison inundatum*

inundatum (*Hydrocotyle inundata* of Fl. Br.) and *verticillatum* are removed to *Sium*, and *Phellandrium aquaticum* to *Oenanthe*. The genus *Meum*, it appears, has no floral receptacle, and furnishes a reason why the Common Fennel (*Anethum Fœniculum*), and the Spignel, which has been an *Athamanta* of some authors and an *Æthusa* of others, and which is allied to the Fennel in habit, should be united. *Peucedanum Silaus*, distinguishable by its floral receptacle and its fruit, is now a *Cnidium*. Most of these changes, inconvenient as they are to present science, are warranted by the opinion of some of the best foreign botanists; and Sprengel, who did not adopt the part of fructification here introduced, but relied chiefly on the seeds, was led to similar conclusions.

The Linnæan genus *Juncus* is entirely remodelled, and the author, following some other botanists, has separated the "grass-leaved" species of the old herbalists, which have but three seeds, and are quite distinct in habit, from the true *Junci*. *Juncus arcticus* and *polycephalus* are new Scotch species from Professor Hooker's "Flora Scotica." The name of *J. bulbosus*, inappropriately applied by Linnæus, under a mistake, to the species bearing that name, is divided into *compressus* and *cœnosus*. *J. gracilis* of former English botanists is here called *Gesneri*, the trivial name of *gracilis* having been appropriated before by Mr. Brown to another species. *J. subverticillatus*, a species quite distinct from *uliginosus*, and long taken up by the continental botanists, is added. *J. supinus* of Don is, in the opinion of the author, only a starved variety of his *uliginosus*; but the plant noticed by some others, found by Hudson in Jersey, and first published by Mr. Symons in his useful Synopsis, he discovers to be the true *capitatus* of foreign authors, a change in which we entirely concur. The alteration of the name of the new genus from *Luzula*, which had been already adopted, to *Luciola*, was hardly warranted upon any classical scruples, especially as Jussieu has a genus of Grasses which he calls *Luziola*. The crest of the seed furnishes a sure criterion for distinguishing some of the most difficult species. The *L. campestris* β is, perhaps, rightly raised to a species under the name of *congesta*, which had been adopted in Forster's "Flora Tonbridgensis." *L. arcuata* is entirely new to our Flora, having been found by the indefatigable Glasgow Professor on the Grampian Mountains, and recently published in the continuation of the "Flora Londinensis."

The *Rumex digynus* affords the type of a new genus, which Mr. Brown has established under the title of *Oxyria*, a name, curious to relate, coined by the redoubtable knight Sir John Hill; but, as the Swedish proverb here quoted remarks,

"Sometimes

“Sometimes a blind hen meets with a grain of corn.” *Rumex pulcher* and *maritimus*, in spite of the scruples of some, are established as distinct species beyond doubt. We are, however, still in want of the plant which Hudson called *R. paludosus*. The *Alisma Plantago* β and γ , which Withering and Symons had denominated *lanceolata*, appear to us to have been worth preserving as a good species. The main object, however, is to notice these distinct states, and whether they are made varieties or species is of little consequence to science. *A. repens* is added as new from a lamented accurate observer, the Rev. H. Davies, author of the “Welsh Botany.”

Menziesia cærulea, for which we are indebted to the Messrs. Brown, gardeners at Perth, is here united to *M. polifolia* (*Erica Dabeoci* Fl. Br.), although the stamina are only eight, thus bringing it in the artificial system nearer to its natural allies the true *Ericæ*. Mr. Salisbury’s genus *Calluna* is sanctioned for the Common Ling.

Daphne Mezereum, which rested upon a single habitat of Millar, is found to grow in divers places, and may be considered as undoubtedly English. The uncertainty concerning our species of *Elatine* still continues. Mr. T. F. Forster thinks with Vaillant, that it is distinct from the true *Hydropiper* of Linn., but it is still a doubt whether his plant and the Shropshire plant are the same. He finds it plentifully, not we believe “near Binfield,” but on the Dam Head, at the Cascade, Virginia Water, Berks.

The learned and candid author has profited by Mr. D. Don’s Monograph of the Saxifrages. *Saxifraga muscoides*, the *cæspitosa* of Hudson; *S. pygmæa*, a discovery of Mr. James Donn, curator of the Cambridge garden,—a name most prolific in botanists; *S. affinis* and *incurvifolia*, discoveries of an ardent naturalist, Mr. Mackay; *S. leptophylla*, a Welsh species; and *latevirens*, are all new: but so much doubt hangs over some of them, that they require further observations to establish their titles. The *S. palmata* E. B. is made a var. of *S. cæspitosa* E. B. British botanists will be pleased to see a new habitat in Yorkshire added for the beautiful *S. Hirculus*, for which we are indebted to Mr. John Binks, a working miner in Teesdale, who possessed no ordinary taste for the productions of nature. Hudson’s *Dianthus arenarius* still remains unresolved. *Cucubalus baccifer* is rejected. It was one of Dillenius’ additions, admitted on an authority which could not afterwards be confirmed, as appears from the “Correspondence of Linnæus and other Naturalists,” lately published. *Silene paradoxa*,—the *vexata questio* of English botanists,—

turns

turns out to be nothing more than a variety of *nutans*, as *Spergula pentandra* E. B. does of *arvensis*.

The genus *Euphorbia* is removed from the class Dodecandria to Monœcia Monandria. That which Linnæus and others took for stamens appears to be distinct barren flowers, destitute of calyx and corol; and each consisting of a stamen, distinguished from its stalk by a separating joint only, occasionally marked with some discoloration.

We may be permitted, perhaps, to differ from our author in considering the *Mespilus sativa* of the old authors as our Wild Medlar, which is called the Nottingham Medlar. The *Pyrus hybrida* of his former works seems to have included two distinct plants;—the Scotch species from the Isle of Arran, being the *P. pinnatifida* of *Ehrh. Beitr.*; and Hudson's plant, which appears to be a variety of *P. Aria*. *Spiræa salicifolia*, hitherto considered so doubtful a native, now stands on the authority of several habitats, though none of those which are pointed out appear to set the question completely at rest.

Our supreme favourites, the Roses, have undergone a thorough revision; and the published labours of Mr. Woods and Mr. Lindley, as well as the important remarks of Mr. Sabine and Mr. E. Forster, have greatly contributed to the illustration of this most difficult family. The author takes the middle path between Mr. Woods, who, as he apprehends, has created too many species, and Mr. Lindley, who has been led to combine too many. In the study of a genus hitherto imperfectly understood, he considers the former as the least injurious error. "Corrected judgement may hereafter," he observes, "combine what precise observation, in the first instance, has separated;" and it is a fortunate occurrence for science, that the minute analysis to which the genus has been subjected by Mr. Woods, has been conducted by a naturalist at once acute and correct. *Rosa cinnamomea* seems to have scarcely any claim to a place in the British Flora, as it is not now to be found in the wood near Pontefract, and was probably at first only an escape from a garden. *R. Doniana*, *Sabini*, which is the finest Rose we possess, *sarmentacea*, *bractescens*, and *dumetorum* are new species added by Mr. Woods. *R. subglobosa* and *Forsteri* are additions of the present author. *R. villosa* E. B. is *R. gracilis* of Woods, and of the present work; *R. mollis* is *R. villosa*; *R. scabriuscula* is made a variety of *tomentosa*; *R. dumetorum* is *R. Borreri*; and *R. collina* is *R. systyla*.

It has been found necessary to revise the *Rubi* in a similar manner,

manner, and for the same reasons. Thus we find *Rubus plicatus*, *rharnifolius*, *leucostachys*, *glandulosus*, *nitidus*, and *affinis*, all new; part admitted on the authority of Weihe and Nees, authors of a very elaborate work, with plates, on the German *Rubi*; and part on the authority of some English botanists, who found their own views corroborated by those authors. The alterations are considerable, but they are made with peculiar sagacity; and if some of the younger naturalists suffer inconvenience from the multiplication of species, they will be compensated by the correctness of future combinations to which this minute analysis necessarily leads. In these difficult genera it is become doubly important to bring the assimilated species together under some leading characters by way of divisions, as the author has done, so that if the student is not successful in determining the species, he may at least discover its affinities.

Since the former publications of Sir J. E. Smith the *Potentillæ* have been elucidated by more than one Monograph appropriated to the subject. Like the Roses and the Brambles, they are of difficult discrimination. *P. aurea* of E. B. is *alpestris* of this work, a correction which has been suggested by M. Haller jun. We are a little disappointed not to find the *P. verna* of St. Vincent's Rocks, and other places, noticed as a variety, at least, of the Suffolk plant. *Fragaria sterilis* is removed to this genus, to which it more properly belongs than to its former station. It would have comported with the views also of many botanists, if the two states or varieties of *P. fruticosa* had been pointed out to the attention of investigators. The Teesdale plant seems to have been first discovered by Thomas Willisel, as Ray informs us in his Letters, and bore the name of "Eboracensis" among the old botanists. It was at that time considered so great a rarity, or was so little understood, that Ray published a plate of it in the second edition of his Catalogue. A second figure was published in an early volume of the Philosophical Transactions. Another state of the plant is found at the Devil's Sledgegate, Wastedale Screes, Cumberland, with broader, less revolute and less hairy leaves, and with a different ramification; and this appears to be the plant known to foreigners, and to be the origin of our garden variety. The plate in English Botany seems to be drawn from a garden specimen, as we feel persuaded that all Teesdale would not furnish an example like it. The laborious and critical Dr. Stokes records another habitat in his "Botanical Materia Medica," among Limestone, on the Banks of Loch Crib in the county of Galloway. Wade mentions other places

in Ireland in which it is found. What these may be we have no means of judging.

We omitted to notice in the proper place that *Cuscuta europæa* is found in two states, the one being intermediate between that and *Epithymum*. The scales of the corolla, which the author and Dr. Hooker deny to exist in *europæa*, in contradiction to the high authority of Mr. Brown, have been noticed by the writer of these remarks, not in the fauces, as in *C. Epithymum*, but lower down the corolla, and of a different shape, and thus furnishing a decisive specific character.

We ought also to have added, that, since the English Flora has been in the press, *Gentiana germanica* has been discovered to be a native, growing between Henham and Chickney in Essex, as far as an authentication by specimens gathered in Hanover, received by Mr. E. Forster from Mr. H. Mertens, can establish the fact.

The Indexes to the work are more copious than usual, and comprehend references to the Natural Orders, and the Synonyms of other writers.

We regret that our limits will not allow us to go more at large into the excellences of this work. To those who are engaged in the study which it embraces, it will afford abundant delight; and we feel assured that the English language can boast of a Flora, as far as it has proceeded, not inferior to any in its general scope, and in some particulars superior to all which have preceded it. As a work peculiarly English, we wish that the provincial names had been more liberally introduced. They serve to illustrate the history of the subject, and oftentimes point at relations which the more philosophic inquirer might overlook. The first step of knowledge is a rude combination of particulars, which is often to be discovered in vulgar names; the next is a minute analysis and searching into the individuals, and upon this step the science of Natural History is halting in this country at the present moment; the third and most important is the generalization of particular truths, and this is the end to which all our efforts should ultimately be directed, and from which results the most important to science may confidently be anticipated.

A Translation of the Pharmacopœia of the Royal College of Physicians of London. 1824. With Notes and Illustrations. By RICHARD PHILLIPS, F.R.S. L. & E. &c. 8vo. pp. 326.

The appearance of a new Pharmacopœia from the Royal College of Physicians after so short a lapse of time as fourteen

teen years, would seem to imply some decided improvement in one or more of the departments of Pharmaceutical Science: and if we take a retrospective view of the several branches of science which the *Materia Medica* involves, we find abundant reasons for a revision at least of the former Pharmacopœia, if not for the production of a new one altogether. The Royal College was unquestionably warranted in publishing a new Pharmacopœia in 1809, and in revising the same in 1815; but we see no grounds for regarding the present one as new, it being in fact no more than a second revision and correction of the edition of 1809, with some additions.

The practitioner in medicine having to abide by the direction of a certain body of men, in his compounding and making use of such medicines as constitute a sort of national Pharmacopœia, must naturally feel anxious that these should not only be fully adequate to the purposes for which he may wish to administer them; but also that they should allow of being prepared without difficulty or uncertainty; whilst the physician who can claim no direct interference with the concerns of the College, must necessarily exercise his undoubted right of criticising its measures; authorized as it is to propound what medicines may be employed, and thus in a manner to confine the means of cure within certain limits. We are aware that the physician is qualified to prescribe whatever he may think proper: but inasmuch as the dispenser of medicines need not have more or other remedies in his possession than are ordered by the College, this privilege is rendered of no avail, as must be felt, more especially, by such as are not resident in the Metropolis. Under these circumstances, therefore, we cannot be surprised at individuals undertaking to review and to translate the Pharmacopœia of the College; and to recommend new remedies, accordingly as science and experience discover and confirm their utility. This will also account for the appearance of new Pharmacopœias from time to time, or for new and improved editions; and both the College and private individuals are highly justified in their respective exertions for attaining greater perfection in this most important branch of the *ars medendi*.

The present Pharmacopœia owes its improvement and comparative perfection, we may say, to accumulated experience in general, and to several individuals in particular: among the latter Mr. Phillips stands very conspicuous. This gentleman, in his "*Experimental Examination of the last Edition of the Pharmacopœia Londinensis*," was unquestionably too severe in his remarks, both on the original, and on Dr. Powell's translation and annotations: but there was nevertheless so much of

truth in many of his observations, that the profession is certainly indebted to them in some measure for the present improved edition. The translation of this edition has been undertaken by Mr. Phillips, who has added to it copious notes and illustrations, so as to make a volume highly useful, and we would say indispensable, to every medical practitioner and student: the object of it being to explain the various processes, and the rationale of them, in a way that will admit neither of ambiguity nor of doubt; so that the student will find no difficulty in making himself acquainted with the intentions of the College in their directing certain processes in preference to others for the preparation of medicines. Accordingly, to each article he annexes the history and rationale of the process for preparing the same; and, wherever he thinks it requisite, points out how the process may be facilitated or improved: and it is evident that his suggestions do not proceed from an arbitrary desire to propose the adoption of any processes of his own before others; but from a wish to remove those obstacles which he himself has met with whilst subjecting the directions of the College to examination.

Every one must allow that Mr. Phillips is well qualified for such an undertaking; more especially as, with regard to subjects to the knowledge of which his own pursuits have not led him, he seeks for information from the most respectable sources; and takes advantage of their useful observations and illustrations. Although his condescending to mark the pronunciation of the names of the articles in the Pharmacopœia has been spoken of with some degree of ridicule, yet for ourselves, as we daily experience sad proofs of ignorance in this respect, with men of considerable reputation, as well as with those for whom this condescension was intended as an assistance, we think the translation is thereby rendered more useful. The external characters and more apparent qualities of the various substances are given with great accuracy, the forms even of the crystals being delineated, and the measurement of their angles as ascertained by the reflective goniometer detailed. The composition of most of the chemical substances is stated centesimally, and also according to the atomic doctrine. The adulteration to which the different articles are liable is pointed out, together with its causes, whether arising from accident or from fraudulent design; and at the same time the modes by which such adulteration may be discovered, counteracted, or removed. Next, the substances which would prove incompatible with each other on mixture, are carefully stated; and lastly, the medicinal uses of the various simples and compounds, and the extent to which they

they may be administered under all circumstances, or their doses. Much of this information has been obtained from other authors; but we nevertheless cannot but think that the profession in general is greatly indebted to Mr. Phillips for bringing it within so small a compass. It is exactly what we wished to see; and we feel much pleasure in laying before our readers one example of Mr. Phillips's translation, and of the illustrations which he has appended to it.

“ Antimōnium Tartarizātum.
Tartarized Antimony.

Take of Glass of antimony reduced to a very fine powder,
Supertartrate of potash powdered, of each one pound,
Boiling distilled water a gallon;

Mix the glass of antimony perfectly with the supertartrate of potash, and add them gradually to the boiling distilled water, stirring it continually with a spatula; boil for a quarter of an hour, and set the solution by; filter it when cold, and evaporate it that crystals may form.

“*Process.*—The method of preparing this very important medicine is materially altered, and exceedingly improved, in the present Pharmacopœia: but I think it is better to employ about one-tenth more of glass of antimony, and to boil the mixture for a longer time than is directed.

Glass of antimony is prepared by exposing the sulphuret to heat and air, by which the greater part of the sulphur is dissipated; and the antimony, by combining with the oxygen of the air, is converted into protoxide, consisting of

Antimony	84.62	or of 1 atom of metal...	= 44
Oxygen	15.38	1 atom of oxygen.	= 8
<hr style="width: 20%; margin: 0 auto;"/>			
100.00		Weight of its atom	= 52

It is afterwards strongly heated in an earthen crucible, by combining with some of the silica of which it forms a species of glass, which is transparent, and of a red colour. It consists of protoxide of antimony combined with variable proportions of silica, and a little sulphur. A specimen that I examined contained only five per cent. of silica, which is less than is generally mentioned. The state of combination in which the sulphur exists, has not been, I think, clearly made out; that is to say, it is uncertain whether it is in combination with oxide of antimony, or whether its presence is owing to a portion of undecomposed sulphuret. I suspect, however, as generally supposed, that the former is the case, for the residuum insoluble in the supertartrate of potash has a red colour, resembling that of kermes mineral.

As glass of antimony is much cheaper than it was some years since, there is only one material objection to its use, and that is, that glass of lead is sometimes mixed with, and occasionally altogether substituted for it; and their appearance is so similar, that the most experienced eye may be deceived: it is however easy to distinguish these substances by their chemical characters. I have observed that the insoluble portion of glass of antimony is of a red colour; but when glass of lead is boiled in a solution of supertartrate of potash, it is very soon rendered black, and scarcely any of it is dissolved. It is also easily detected by heating it in dilute nitric acid: if the solution contain lead, sulphuric acid will occasion a white precipitate in it.

The present process for making tartarized antimony is simple: supertartrate of potash, as already mentioned, contains excess of acid, and when a solution of it is boiled with glass of antimony, the protoxide of antimony is dissolved, while the sulphuretted oxide and silica remain unacted upon. The solution thus obtained consists of tartrate of potash and tartrate of antimony, and these combining form a double salt, called tartrate of potash and antimony, or tartarized antimony.

*Tartarized Antimony, or
Tartrate of Potash and Tartrate of Antimony.*

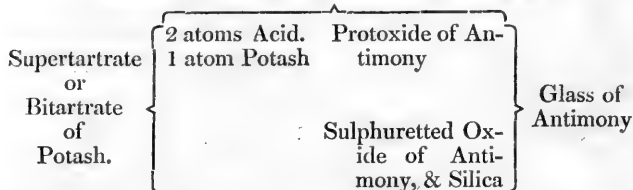

“ *Qualities.*—Tartarized antimony crystallizes with great facility, and the general character of the crystals of this compound is that of an *octahedron with a rhombic base**.

The crystals of this salt are colourless and inodorous, but have a styptic metallic taste: on exposure to the air, they effloresce slightly, and become opaque. When heated with carbonaceous matter this salt is decomposed, and metallic antimony is obtained. It is soluble in about fifteen times its weight of water at 60°, and twice its weight at 212°. The aqueous solution decomposes spontaneously after it has been some time prepared. It is insoluble in alcohol.

* In the original a diagram of the crystal as usually occurring is here given; with its cleavage and measurements. For the crystallographical illustrations in this work, Mr. Phillips acknowledges his obligation to Mr. Brooke.

“*Composition*.—This is a double salt, or a compound of tartrate of potash and tartrate of antimony; but I am not satisfied with the results of any analysis hitherto given—that which is generally quoted, is obviously incorrect.

“*Adulteration*.—This salt should never be purchased in powder, but always in crystals: in the former state it frequently contains a portion of supertartrate of potash uncombined with any oxide, and which in preparing the liquor antimonii tartarizati is precipitated. To judge if the crystals have been properly prepared, drop one or two into a solution of sulphuretted hydrogen gas, and an orange-coloured deposit will be formed on them.

“*Incompatibles*.—The solution of this salt is decomposed by acids, by alkalies and their carbonates, by some of the earths and metals, and their oxides, by lime-water, muriate of lime, and the acetates of lead. Many vegetable infusions, and especially those which are bitter and astringent, decompose it, such as cinchona, rhubarb, catechu, &c.

“*Medicinal uses*.—Tartarized antimony either sweats, vomits, or purges, according to the quantity exhibited. A *quarter of a grain*, if the skin be kept warm, will promote a diaphoresis; *half a grain* will first prove purgative, and then diaphoretic; and *one grain* will generally vomit, then purge, and lastly sweat the patient. It may be given in solution.”

We confess we were somewhat surprised at Mr. Phillips's observations on the *Pulvis Antimonialis*, which tend to impress the reader with the idea of its inutility and inertness; when thousands of practitioners are daily administering it as an efficient febrifuge, either by itself or in combination with calomel; without experiencing that universal disappointment which the observations in question would lead us to expect: indeed, we know from our own experience that it will produce nausea and sometimes vomiting, though given in no greater quantity than three or four grains; this effect is not at all uncommon in children. Inferences drawn *a priori* from the results of chemical analysis, must not be allowed to supersede the testimony of general experience.

The results of the analysis of three different specimens of this medicine, being peroxide of antimony and phosphate of lime in different proportions, and those obtained by Dr. Pearson in his examination of James's Powder, agreeing so closely with those obtained by Mr. Phillips himself, not only as to the ingredients, but also to their proportions, ought, we think, to have induced Mr. Phillips to have refrained from asserting this preparation to be altogether useless; nor should he have founded his distrust respecting the *Pulvis Antimonialis*, upon the

the authority of Drs. Latham and Duncan, who do not speak of its inefficacy or inertness, but of that of the *peroxide of antimony alone*, uncombined or not prepared with phosphate of lime. The latter, indeed, expressly states, that, "howsoever prepared," this medicine "is one of the best antimonials we possess." Mr. Phillips, we are sure, need not be told of the many instances in which the combination of two or more ingredients of different qualities, produces on the system effects which are wholly irreconcilable with their known qualities when separate. The testimony of Mr. Brande avails little against the efficacy of this powder, seeing that it is founded chiefly on the uncertainty of its genuine preparation; for it is very certain that many important formulæ might be removed from the *Pharmacopœia* on similar grounds: and it is not less possible, that Dr. Elliotson might happen to administer one hundred grains of a sophisticated article with as little effect as must the Veterinary surgeon have done, had he administered to a horse one hundred ounces of a spurious substance, which a druggist, not unknown to us, palmed upon him for so much pure opium.

We cannot but agree with Dr. Paris, (*Pharmacologia*, vol. ii. p. 357.) that "until the subject be elucidated by further experiments, it will be difficult for the chemist to persuade the physician, that he can never have derived any benefit from the exhibition of *Antimonial Powder*."

Peroxide of antimony and phosphate of lime being respectively inert, or nearly so, but the *Pulvis Antimonialis*, we confidently affirm, an efficacious medicine, may not the virtues of the latter reside in some peculiar combination existing in it of the two substances or their elements? In the process of analysis, such a combination would be resolved into the peroxide and phosphate, thus rendering the whole, apparently, a mere mixture of those bodies. We would therefore suggest to Mr. Phillips the expediency of instituting further researches on this subject.

Considering the subject just discussed to be one of much importance, we deemed it right to express our sentiments concerning it; but it is the only one, in the work before us, on which we feel disposed to animadvert: and we have no doubt that this volume will be generally sought after, and receive a large share of approbation.

The Rev. W. Pearson, LL.D. F.R.S. Treasurer of the Astronomical Society, has just published the first volume of *An Introduction to Practical Astronomy*; containing Tables recently computed for facilitating the reduction of Celestial Observations, and a popular explanation of their Construction and Use.

ANALYSIS OF PERIODICAL WORKS ON NATURAL HISTORY.

Curtis's British Entomology.

No. 4. contains the following subjects :

Pl. 15. *Omasus aterrimus* of Fab., not of Marsham's *Entomologia Britannica*: this fine insect, which a few years back only existed in the cabinet of Mr. Jos. Hooker, has been met with in Norfolk by Mr. Sparshall in sufficient abundance to supply all our cabinets.—Pl. 16. *Peronea ruficostana*, an elegant little species of the "Button Moths," only existing in the cabinet of Mr. Stone, unknown to Hubner. This new genus of Mr. Curtis's is composed of 42 British species, being a group of the extensive family Tortricidæ Leach.—Pl. 17. *Cressus septentrionalis*, a singular and beautiful species of Tenthredinidæ from Norfolk and the neighbourhood of London.—Pl. 18. *Empis borealis*. Dr. Turton first gave this as a British species, but we only know of its having been taken in Ireland; Linnæus (as Sir James E. Smith informs us in the *Lachesis Lapponica*) met with it twice in Lapland; and as it is found much further south than England, there is little doubt that it will make its appearance here alive. The singular fin-like wings give a heavy appearance to this insect; and the proboscis of many of the species, so much resembling the long bill of some of our birds, bears a still stronger resemblance in living specimens, when the labrum being separated from the lip discovers the tongue between them.

The Botanical Magazine. Nos. 445, 446, 447.

Pl. 2461. *Rhipsalis salicornoides*, Haworth Suppl. Pl. Succ.—*Malpighia luoida*.—*Crinum submersum*, an interesting plant from Rio Janeiro, described by Mr. Herbert as being "in every point of bulb, leaf, and inflorescence, intermediate between *scabrum* and *erubescens*." The writer adds, "Have we in this instance discovered a native mule in the wilderness? Have we lit upon the first origin of a new species? or, have we in this bulb an original link in the creation between two plants which have been placed by some writers in different genera?"—*Habranthus gracilifolius*, an elegant plant from Maldonado, S. A., agreeing "with no genus heretofore described," and approaches in general appearance to *Zephyranthes*: from *Amaryllis* it differs "by a hollow scape, peduncles erect, germ declined, and filaments of four lengths equally inserted."—*Erica buccinifolia*, "floribus subquaternis, bracteis a calyce remotis, foliis quaternis linearibus ciliatis;" the drawing and description furnished by E. Rudge, Esq. F.R.S. &c.—*Crinum Careyianum*. "This species," says Mr. Herbert, "forms a point of union between the first subdivision of the section *Patentes*, or Linnæan *Crinum*, and the first subdivision of the second section which has been detached from the genus *Amaryllis*, with which it does not conform."

Pl. 2467. *Eulophia guineensis*.—*Antennaria triplinervis*, "herbacea erecta, foliis oblongo-ovatis triplinerviis subtus tomentoso-incanis, corymbis compositis laxis foliosis, squamis calycinis interioribus tenuissimis radiantibus;" from Nepal. The genus was separated by Mr. Brown from *Guaphalium*.—*Lonicera punicea*, "foliis cordato-ovatis concoloribus, baccis distinctis, pedunculis axillaribus subterminalibus bifloris folio brevioribus."—*Coriaria sarmentosa*, a rare New Zealand plant.—*Cyrtanthus pallidus*, "foliis linearilanceolatis carinatis hysterantheis, corollis nutantibus infundibuliformibus, limbo tubum subæquante."—*Artemisia biennis*, from seeds gathered by Dr. Richardson on his journey to the Coppermine River with Capt. Franklin.—*Echites nutans*.—*Sedum sempervivoides* introduced from the south of Caucasus by Dr. Fischer.

Pl. 2475. *Hippeastrum subbarbatum*. It is suggested that it may
Vol. 63. No. 312. April 1824. P p perhaps

perhaps be found expedient to unite, as varieties of one species, the above, with *fulgidum*, *rutilum*, *crocatum*, and *pulverulentum*. Mules of this genus are abundant, there being now 35 hybrid crosses in the Spofforth collection, the pollen of all of which appears to be fertile.—*Dorstenia arifolia*.—*Vernonia flexuosa*, “caule stricto superne dichotomo: ramis flexuosis, floribus ad dichotomias et flexuras ramulorum sessilibus;” raised from seed sent from Brazil.—*Angelonia salicariæfolia*, Nat. Ord. *Scrophulariæ*, from the Caraccas.—*Coix Lachryma*.—*Entelæa arborescens*, discovered in New Zealand by Sir J. Banks and Dr. Solander, and flowered for the first time probably in Europe, in 1823, in the stove of Messrs. Whitley, Brame, and Milne. It is placed by Mr. Brown in his natural order of *Tiliacæ* next to *Sparmannia*.

The Botanical Register. Nos. 108, 109, 110.

Pl. 771. *Canna limbata*, “corollæ limbi interioris labio superiore tripartito; laciniis emarginatis crenatis; unguibus longis: labio inferiore bifido declinato.” The character intended for his own work is acknowledged as having been liberally communicated by Mr. Roscoe, “a writer deeply versed in the study of this natural family, and whose pen has been more than once and still is employed in its illustration.”—*Canna occidentalis*, “corollæ limbi interioris labio superiore bipartito, laciniis integris ovatis inæqualibus: labio inferiore declinato (vel rectius revoluti?)”—*Canna lutea*. “We have been prompted,” say the editors, “to insert in the present fasciculus five figures from the samples of as many species of *Cannæ*, in the hope that they might serve for exemplifications of their textuary counterparts in the forthcoming work on a portion of the Monandrous class by Mr. Roscoe. We ought to have awaited the appearance of that performance, if we had intended their complete and most authentic history.”—*Hedychium gardnerianum*, a new species from Nepal: for a fuller account than has been given of this increasing genus, we also look to Mr. Roscoe’s anxiously expected work on the Scitamineæ.—*Canna edulis*, from Peru; the *indica* of Ruiz and Pavon.—*Canna indica*. “We have not,” say the editors, “ventured to supply any of the new names and remodelled characters of the Enumeratio of Willdenow, and acknowledge that to us at least these riddles are insoluble.”—*Alpinia tubulata*, “foliis alternè bifariis remotissimis; scapo vaginato laterali; bracteis communibus divaricatis aridis acuminatis persistentibus; corollâ tubulosâ; labello incluso; antherâ sessili.”—This number, which concludes the ninth volume, contains descriptions of *Ipomœa tuberosa* and *Galega grandiflora*, which had been omitted; a Review of the genus *Jasminum*, together with a general Index, and references to enumerations of Liliaceous genera in the several volumes of the work.

Pl. 778. *Chrysiphiala flava*, a *Pancretium* of Ruiz and Pavon, from which genus this is separated; and the four species which constitute its basis have furnished Mr. Herbert with four of his new genera of *Amaryllidæ*; but the editor says, “Mr. Herbert’s distinctions are too fine for our sight.” *Chytia ericoides*.—*Plumeria rubra*.—*Grindelia angustifolia*, from Mexico.—*Ixora crocata*, given upon the judgement of Mr. Sweet as a species distinct from *coccinea*.—*Epidendrum cuspidatum* and *ciliare*, two plants which have been often confounded.

Pl. 785. *Loasa acanthifolia*, raised by the Horticultural Society from seeds from Chili.—*Maranta bicolor*, from the Brazils.—*Banksia australis*.—*Cypripedium venustum*, the first accession from the East Indies to this genus.—*Indigofera endecaphylla*.—*Calceolaria crenata*.—*Tribulus cistoides*; the genus is of the natural order *Zygophyllæ* proposed by Mr. Brown, and adopted by M. Decandolle, who describes it as coming between *Rutacæ* and *Oxalidæ*. We are happy to quote the following paragraph relative to this distinguished

distinguished botanist, which we may consider to be intended as some atonement for the illiberal insult offered to him in a former Number, and which we have had occasion to reprehend (*Phil. Mag.* vol. lxii. p. 303). "It is with pleasure we find the consummate talents, sagacity, and industry, with which M. Decandolle is indisputably endowed, directed to an object that they may accomplish to the great advantage of science, instead of struggling with impossibilities; and we congratulate our readers on the appearance of the first volume of the *Prodromus* of a general system, in which the known species will find a place in their respective divisions, with only a short notice of the distinctions, and one or two select synonyms." —*Portulaca pilosa*.

LI. Proceedings of Learned Societies.

ROYAL SOCIETY.

Apr. 1.—THE reading was commenced of "An Inquiry respecting the Nature of the luminous Power of some of the Lampyrides: *L. splendilula*, or Glow-worm; *L. halica*, or Fire-fly; and *L. noctiluca*;" by Tweedie John Todd, M.D. Communicated by Sir E. Home, V.P.R.S.

April 8.—The reading of Dr. Todd's paper was resumed and concluded; and a paper by Capt. Sabine, F.R.S., was read, containing a Comparison of the Geometrical and Barometrical Methods of determining Heights, as applied to a Hill at Spitzbergen.

The Society then adjourned to April 29th.

LINNÆAN SOCIETY.

April 6.—A letter from the Rev. William Whitear, M.A. F.L.S. of Starston, Norfolk, communicated the information that a Little Bustard had been shot by Mr. Skipper, of Little Clacton, Essex, in December last; remarking it as an extraordinary fact, that this bird, an inhabitant of a Southern climate, should have been found in this country in a hard winter.

The reading was commenced of a Description and Account of a Collection of Arctic Plants formed by Captain Sabine during a voyage in the Polar Seas in the year 1823; by W. J. Hooker, LL.D. F.R.S. Professor of Botany in the University of Glasgow; communicated by the Council of the Horticultural Society.

April 20.—Some sections of fir timber were exhibited by Sir Thomas Gery Cullum, Bart. F.R. & L.S. perforated to a great depth by the *Sirex juvencus*, together with specimens of this insect, from the woods of the Earl of Stradbroke at Henham Hall in the county of Suffolk, where two hundred Scotch firs have been already destroyed, being bored through and through by it.

The reading of Professor Hooker's Description of the Plants collected by Capt. Sabine in his late Voyage in the Polar Seas was continued: much interest is given to this Communication by the information afforded relative to the geographical range of these specimens of the Arctic Flora derived from the accounts of Parry, Wahlenberg, Scoresby, Ross, Richardson, Jameson, Swartz, Pursh, &c. &c. The lovers of natural history will feel grateful to Capt. Sabine, who was fully occupied, while on this voyage, with pursuits of a different kind, for having been so attentive to Botany and Zoology.

A part was read of a Catalogue of the Norfolk and Suffolk Birds, with remarks, by the Rev. Revett Sheppard, M.A. F.L.S., and the Rev. William Whitear, M.A. F.L.S.,—a paper which seems to possess much interest, from the particulars which it furnishes of the habits and history of the many migratory birds that visit this district from the northern part of the Continent.

HORTICULTURAL SOCIETY.

Feb. 17.—The Society's large Silver Medal was presented to Signor Antonio Piccioli, a Corresponding Member of the Society, for his present of a large collection of Models of the Fruits of Tuscany, made to the Society.

March 2.—The following communications were read:

Observations on the Effects of Age on Fruit Trees of different kinds, with an Account of some new Varieties of Nectarines. By the President.

A Note on the Pears called *Sylvanges*. By Mons. Charles François Pierard, of Manjouy, near Vendun-sur-Meuse, a Corresponding Member of the Society.

Accounts and Descriptions of some new Pears. By Mr. John Turner, the Assistant Secretary.

March 16.—The large Silver Medal was presented to Mr. Charles Harrison, F.H.S., for his newly published Work on Fruit Trees.

The following communications were read:

On Fig Trees, with a Description and Account of their Cultivation in a Fig-House in the Garden of the late Earl of Bridgewater, at Ashridge in Hertfordshire. By Joseph Sabine, Esq. F.R.S. &c., Secretary.

On the Cultivation of Early Crops of Peas. By Mr. Daniel Judd, F.H.S.

On the Preparation of Strawberry Plants for early Forcing. By the President.

April 6.—The large Silver Medal was presented to Mr. William

William Buck, F.H.S., for the Production and Dissemination of the very superior Variety of Rhubarb, called "Buck's Rhubarb."

The following communications were read:

Directions for the Management of the Hot-house Fire-places that are constructed with double Doors and ash-pit Registers. By William Atkinson, Esq. F.H.S.

Description of an Apparatus for ventilating Hot-houses. By Mr. George Mugliston of Repton, near Derby.

On a Construction Strawberry Beds. By Thomas Bond, Esq.

Description of a self-acting Ventilator for Hot-houses. By John Williams, Esq., a Corresponding Member of the Society.

April 20.—The following communications were read:

Description of a new-invented Lime-duster, with Observations on the Efficacy of Lime in Powder applied to Fruit Trees. By Mr. Samuel Curtis.

Account and Description of five new Chinese Chrysanthemums, with some Observations relative to the Treatment of all the kinds at present cultivated in England; and on other Circumstances connected with the Varieties generally. By Joseph Sabine, Esq. F.R.S. &c., Secretary.

ASTRONOMICAL SOCIETY.

April 9.—At this Meeting the following papers were read; viz.

1st. On the Elements of the Orbit of the Comet of 1823, computed from Observations made at the Royal Observatory at Greenwich. By Mr. W. Richardson, Assistant to the Astronomer Royal.

These elements were computed by Dr. Olbers's method. The paper likewise contained a comparison of his elements with the Greenwich Observations from January 1st to February 2nd; and in more than half the Observations, the results of the elements did not differ from them so much as 2' in longitude, or so much as 1' in latitude.

2d. On the Corrections requisite for the Triangles which occur in Geodesic Operations. By Capt. George Everest, of Bengal, Conductor of the Trigonometrical Survey in India.

This paper contained the solution of two problems by formulæ employed in India since 1819, and which the author thinks preferable to those given by M. Delambre for the same purpose. They require the use merely of pocket Logarithmic Tables, with four places of decimals, of which copious examples were given; and the paper concluded by the application of
these

these formulæ to the corrections of angles actually observed in the operations in India.

3d. On the Method of determining the Difference of Meridians by the Culmination of the Moon. By Francis Baily, Esq. F.R.S. V.P. Ast. Soc.

This paper was too long to permit its reading to be completed at the present sitting: we shall therefore reserve our remarks upon it till it is concluded.

Several very valuable books were presented to the Society.

MEDICO-BOTANICAL SOCIETY.

Feb. 13.—Some observations were made on the *Acacia Catechu*. A paper was read on a Bark termed the Malambo Bark lately imported from America.

Feb. 27.—Some observations were read on the alterations in the Pharmacopœia.

March 12.—A paper was read, entitled "Observations on the *Anthoxanthum odoratum*;" by Thomas Rowcroft, Esq. His Majesty's Consul General for Peru, communicated by Dr. Bree, President.

March 26.—Some remarks were made on the *Croton Tiglium* by Mr. Pope of Oxford-street.

April 9.—A paper on the *Resina Acaroides*, by Mr. W. Bollaert, was read.

MEDICAL SOCIETY OF LONDON.

The fifty-first Anniversary Meeting of this Society was holden at the London Coffee House, Ludgate Hill, William Shearman, M.D. President, in the chair.

The Officers and Council for the ensuing year are as follow: *President*: William Shearman, M.D.—*Vice-Presidents*: Henry Clutterbuck, M.D.; Henry James Cholmly, M.D.; Sir Astley Paston Cooper, Bart. F.R.S., and Thomas Callaway, Esq.—*Treasurer*: John Andree, Esq.—*Librarian*: David Uwins, M.D.—*Secretaries*: T. J. Pettigrew, Esq., and Thomas Callaway, Esq.—*Secretary for Foreign Correspondence*: Robley Dungleson, M.D.—The other members of the Council: Drs. Walshman, Hancock, J. G. Smith, Blicke, Blegborough, Hopkinson, Stewart, Ley, Darling, Haslam, Pierce, Cox, and Burne; Messrs. Sutcliffe, Drysdale, Wender, K. Johnson, Dunlap, Kingdon, Ward, Thomas Clarke, Burton Brown, Lake, Ashwell, Edwards, Handey, E. Leese, Skair, Cordell, Bell, Ellerby, Amesbury, T. Bryant, and Burrows.—*Registrar*: James Field, Esq.—The Fellow elected to deliver the annual oration, in March 1825, Eusebius Arthur Lloyd, Esq.

The

The President informed the Meeting that the time allotted for the perusal of the dissertations offered for the Fothergillian medal, during the last year, having been unexpectedly shortened, the Society had not yet adjudicated the prize: this however would be done forthwith, and the Medal would be presented to the successful candidate at a Special General Meeting of the Society to be holden on the 3rd of May, at 8 o'clock in the evening.

The annual oration was then delivered by Dr. John Gordon Smith, the Ex-Vice-President; the subject was, "The Duties and Perplexities of Medical Men as professional Witnesses in Courts of Justice."

A numerous body of Fellows and their friends, amounting in all to 86, afterwards dined together in the great room of the Tavern, the President being in the chair; and the remainder of the day was marked by harmony and conviviality.

Conditions of the Fothergillian Medal.—In conformity with the will of the late Anthony Fothergill, M.D. F.R.S., the Society resolved to give, annually, to the author of the best Essay on a subject proposed by them, a gold medal, value 20 guineas, called the Fothergillian Medal; for which the learned of all countries are invited as candidates.

1. Each dissertation must be delivered to the Registrar, in the Latin or English language, on or before the first day of December.

2. With each dissertation must be delivered a sealed packet, with a motto or device on the outside, and within the author's name and designation, that the Society may know how to address the successful candidate.

3. No paper in the hand-writing of the author will be received; and if the author of any paper shall either directly or indirectly discover himself to the Committee of papers, or to any member thereof, such paper will be excluded from all competition for the medal.

4. All the dissertations, the successful one excepted, will, if desired, be returned with the sealed packets unopened.

5. The prize medal will be presented to the successful candidate, or his representative, at the Anniversary Meeting of the Society in March 1825.

The subject of the Dissertation to be offered for the Prize Medal for March 1825, is, "The Pathology and Treatment of Periodical Asthma."

ASIATIC SOCIETY:—QUESTION RELATIVE TO THE CHARTER.

His Majesty having referred to the Attorney-general, as his adviser, the petition of the Royal Asiatic Society of Great Britain

Britain and Ireland, praying His Majesty to grant them a Charter of Incorporation, "For the investigation of subjects connected with, and for the encouragement of Science, Literature, and the Arts, in relation to Asia," he appointed the 27th April to take it into consideration. The Council of the Linnæan Society, which was incorporated in the year 1802, "for the cultivation of Natural History in all its branches," and had existed for 14 years previously, was of opinion that the establishment of a new Society, possessing the same privileges with the Linnæan Society, would materially interfere with their usefulness, and thought it their duty to protect the interests confided to their care; and in consequence they entered a *caveat* in the Attorney-general's office against the granting of the Charter in the unlimited way in which it had been sought. Each Society was represented by Counsel on the occasion; and it was urged by Mr. Grant, on the part of the petitioners, that charters were not regarded in the present day as giving any privileges of monopoly, but on the ground of their giving facilities to their proceedings. Chartered Societies were not, like others, fluctuating and ambulatory, but existed by succession and not by descent, and could transmit their property with greater ease. A Charter was supposed to give a little more dignity to their proceedings, and it was more gratifying to those who sought distinctions from them. It was acknowledged that the legal description of the Asiatic Society would enable them to prosecute the science of Natural History; but that it was not their immediate object, and it would be injurious to the higher ends they aimed at, to shut them out from even incidentally treating of the subject, while so many of the productions of the East, both animal and vegetable, might require illustration with other views than those which the Linnæan Society aimed to promote. It was a border country upon which each might make its incursions, and it would be impracticable to draw a strict line about them, without at the same time interfering with their main object.

On the part of the Linnæan Society, it was submitted by Mr. Bicheno, that it had not been the practice of the Crown to grant a Charter of Incorporation, which must be considered a privilege, to a second Society, while one already existed for the same object; and that if any privileges were to be obtained by the possession of a Charter, the Society already existing was entitled to enjoy them. It was not a question between monopoly and a more liberal principle, but between two Societies running a race for privilege, and that the one already instituted and found efficient, ought not to be injured by the establishment of another. The Linnæan Society did
not

not oppose the Charter to the Asiatic Society altogether, but merely required some security in their legal description, that should prevent them from publishing on Natural History. The Asiatic Society had, by its published addresses, declared its intention to pursue Natural History, not only as connected with the possessions of the East India Company, but in Austral Asia in general. The Linnæan Society has devoted itself to the same object, and its later volumes have been occupied in the proportion of one-half by the Natural History of the East. It has gone to a great expense in printing and engraving, and the plates illustrative of one plant only, the *Rafflesia Arnoldi*, cost about 240*l.* The collection of the natural productions of New Holland, in the possession of the Society, it was said, was the finest in Europe. The demand for publications of this kind is very limited, and it would be impossible to publish, unless great losses were sustained by somebody. These losses are made up by the Linnæan Society, and the funds to supply them are obtained from the admissions and contributions of the Fellows. If another Society is permitted to exist with similar privileges, the inducements for scientific men to join the Linnæan Society will be diminished, and the contributors of valuable papers will in some cases transfer their favours to the rival Society; and thus the literary interest of the Transactions will decrease. It was said that no country, with the exception of England, either did or could support the science of Natural History without some Government assistance; that in France the “Ouvrages des Luxes” constitutes an annual item of the Budget, and large sums are granted for the encouragement of this object; and that in Russia, Denmark and Holland, the science receives similar assistance. In our own country Professorships are endowed by Royal favour; and what the Government does not do, is in a great measure supplied by the Society whose privileges are now attacked. It is not an object that can be left to the ordinary interests of mankind, as it does not bear immediately upon their wants or pleasures; and if it is cultivated at all, it must be by the extraneous assistance to be obtained by the means this Society is enabled to furnish.

The Attorney-general having heard the parties, took time to consider his opinion.

ROYAL ACADEMY OF SCIENCES OF PARIS.

Jan. 5.—Some Observations were received from M. Guillon supplementary to his Memoir on the nutritive Animalcule of Oysters.—M. Chaptal was elected Vice-President for the year; and M. Arago commenced the exercise of his functions as

President.—M. Ampere continued the reading of a Memoir containing some new deductions of the Formula by which he has represented the mutual action of the two elements of electric currents.—M. Roche read a Memoir on Rotary Motion.

Jan. 12.—M. de Jussieu, in the name of a Commission, made a favourable Report on M. A. Richard's Memoir on the Family of Elæagneææ.—A Memoir of M. Libri, on the Theory of Numbers, was referred to a Commission.—M. Magendie gave a verbal Account of a Memoir by M. Desmoulins on the Composition of the Spinal Marrow.—M. A. St. Hilaire finished the reading of his Memoir on the genera Sauvagesia and Lavradia.—M. Bailli read a Memoir on the use of the Horns of certain Animals, particularly of the Buffalo.—M. Civiale presented a Memoir on a Lithonriptor, or new means of destroying a stone in the bladder without the operation of cutting.

Jan. 19.—A Memoir was received, On a Gazometer for condensed Gas, by M. Picquet.—Also a Memoir from Lassaigne, On the Possibility of detecting, by chemical Means, the Presence of the Acetate of Morphia in the Viscera of Animals poisoned by it.—M. le Galloias presented a Memoir on animal Heat, written by his father.—A Memoir by M. F. Runge was read, On the Means of discovering the slightest traces of narcotic substance in animals poisoned by the Atropa Belladonna and Datura.—M. Segalas presented a Kidney converted into a vast membranous sac, by the increase of a great number of calculi.—M. Desmoulins commenced the reading of a Memoir on the use of the colours of the Choroid Coat in the Eyes of vertebrated Animals.

Jan. 26.—M. Dublanc jun., apothecary at Paris, stated that he had found the Tincture of Galls to be a very sensible test of the presence of Morphia in liquids, whether alone, or combined with the acetic and sulphuric acids.—M. Navier, Engineer, was elected a member of the Academy.—M. Giraud made a favourable Report on the Memoir of MM. Seguin relative to Suspension Bridges.—M. Babinet read a Note on a new Construction of the Horse-hair Hygrometer.—M. Strauss continued the reading of his Memoir on the Anatomy of the Cock-chafer.—M. A. de St. Hilaire read some new observations on the Family of the Rutaceæ.

Feb. 2.—A Memoir was received from M. Remain on Vegetable Physiology.—Also a Memoir by M. Lamé on the Impossibility of the Equation $x^5 + y^5 = 2^d z^5$ in whole numbers.—M. Poisson presented his Memoir on the Theory of Magnetism.—M. Chevallier stated that he had detected ammonia

in many native oxides of iron.—A Report was received from the Commission relative to Gas Illumination and Gasometers. Its consideration was postponed to

Feb. 9, when it took place accordingly.

Feb. 16.—Arnaud Reynaud announced the discovery of a method of protecting the Magnetic Needle from the influence of iron.—M. Tilerier requested that a Report might be made on his mode of making elliptic parabolic Mirrors.—M. Damoiseau presented a Memoir on the Perturbations of the Motion of the Comet of 1819 in the two periods which preceded its perihelion passage in 1825.—M. Arago deposited in the Archives the astronomical observations made at Paramatta in June 1823, received from Sir Thomas Brisbane.—M. Geoffroy presented a Table of corresponding Nomenclature of the sections of the Skull of various vertebrated animals.—The Commission on Gas Illumination presented some new propositions relative to Gasometers placed at a distance from the Gas-works.

LII. *Intelligence and Miscellaneous Articles.*

BESSEL'S METHOD OF ASCERTAINING THE CORRECTIONS OF THE READINGS OF THERMOMETERS.

A CORRECT thermometer being a necessary instrument in every observatory, we consider it useful to draw the attention of the astronomers of this country to the imperfection of many of them, arising from the defective form of the tubes. With this view, we lay before our readers the detailed account of M. Bessel's method of correcting his thermometer, contained in the seventh section of his "Astronomical Observations," a book of which there are very few copies in this country, and written in a language not generally understood by our scientific men.

"There are, perhaps, no thermometer tubes, the insides of which are perfectly cylindrical; all those, at least, which were given me as such, proved on examination to be sensibly defective. Either a scale of unequal divisions, or a table of corrections, is therefore necessary to derive accurate results from thermometers constructed of such tubes. The latter deserves the preference, as it is always easier to ascertain the errors of instruments than to make them perfectly correct. Let the correction for any point x of the scale $=\phi x$; this quantity must be so determined, that for every column of mercury contained between the points x and x' of the scale, the quantity $(x' + \phi x') - (x + \phi x)$ shall be a constant quantity, to whatever part of the tube it may be moved. This being obtained, we have the following proposition:

$$Q q 2$$

$$5 + \phi 5$$

$$5 + \phi 5 - (e + \phi e) : 180 = (x + \phi x) - (e + \phi e) : F - 32$$

where 5 and e are the points of boiling and freezing water on the scale, and F the true degree of Fahrenheit's thermometer, answering to the point x of the scale.

In order to ascertain the correction ϕx , I have used the following method. At first, a part of the mercury in the tube, equal to about 50° or 60° Fahrenheit, was separated from the rest, either by shaking, or over the flame of a candle; the lower extremity of this mercury was then moved to every tenth degree of the scale, and the corresponding place of the upper extremity noted down. The mercury was then united again, and the process repeated with five or six other columns, always differing from 10° to 20° in length.

The thermometer of Schafrinsky showed the following degrees:

x	x'	x'	x'	x'	x'	x'
-20	\circ	\circ	\circ	\circ	\circ	\circ
-10	61.55	71.4	79.7	87.3
0	...	59.75	71.5	81.4	89.63	97.3
10	...	69.75	81.5	91.4	99.7	107.2
20	68.0	79.8	91.4	101.3	109.5	117.15
30	78.0	89.85	101.25	111.3	119.6	127.25
40	87.9	99.85	111.4	121.3	129.6	137.35
50	97.7	109.75	121.3	131.25	139.55	147.3
60	107.6	119.7	131.05	141.15	149.45	157.15
70	117.55	129.5	141.1	151.1	159.3	167.0
80	127.6	139.45	151.1	161.0	169.25	176.85
90	137.7	149.5	161.2	171.0	179.3	186.85
100	147.8	159.55	171.2	180.95	189.3	196.85
110	157.9	169.6	181.1	191.0	199.3	206.85
120	167.7	179.7	191.1	201.0	209.3	
130	177.75	189.6	201.1	211.0		
140	187.7	199.5	210.95			
150	197.6	209.5				
160	207.5					

In order to deduce from this table the correction denoted by ϕx , the lengths of the different columns of mercury may be so assumed as they appear in that part of the tube nearest corresponding to the scale (which, although not necessary, leads to a more speedy approximation in the calculation); this is the upper part, and accordingly the length of every column was assumed equal to the mean of all readings between 90° and 210° .

210°. By this assumption the lower parts of the scale were determined by the upper ones, the latter being supposed correct for the first approximation; the lower ones, thus approximately determined, were again compared to the upper ones, and these latter thus likewise approximately determined. These approximate values were again employed to determine the lengths of the columns of mercury, and the former calculation was repeated, by which means a second approximation was obtained, which was already so near, that a third one gave no sensible differences. In this manner, the following values of ϕx were deduced, which agree with the single readings to such small quantities as are within the limits of the uncertainty of the readings themselves.

x	ϕx	x	ϕx	x	ϕx
-20	+0.42	60	+0.02	140	-0.02
-10	+0.37	70	-0.03	150	-0.07
0	+0.35	80	-0.02	160	-0.09
10	+0.28	90	-0.01	170	-0.04
20	+0.31	100	+0.03	180	-0.02
30	+0.35	110	+0.05	190	0.00
40	+0.26	120	+0.04	200	+0.03
50	+0.11	130	+0.03	210	+0.07

I determined the freezing point by imbedding the thermometer in pounded ice, and found it, by the mean of very numerous experiments instituted in various manners, but almost perfectly agreeing in their results, = $32^{\circ}.53$: for ascertaining the point of boiling water, the height of the barometer (the temperature of which is that of melting ice) being = 0.76 ^{meter}, the apparatus proposed by Cavendish was employed, and I found it by the mean of different experiments = $212^{\circ}.71$. These results, and the above table for ϕx , give, therefore, $e + \phi e = 32^{\circ}.86$ and $5 + \phi 5 = 212^{\circ}.79$, and hence

$$\begin{aligned}
 F &= 32^{\circ} + \frac{180}{179.93}(x + \phi x - 32^{\circ}.86) \\
 &= -0^{\circ}.873 + \frac{180}{179.93}(x + \phi x)
 \end{aligned}$$

The corrections to be applied to the readings of the thermometer resulting from this formula are as follows:

x	$F-x$	x	$F-x$
-20 ^o	-0.46	50 ^o	-0.74
-10	-0.51	60	-0.83
0	-0.52	70	-0.88
10	-0.59	80	-0.86
20	-0.56	90	-0.85
30	-0.51	100	-0.80
40	-0.60	110	-0.79
50	-0.74	120	-0.79

It is evident that the following formula will nearly represent the numbers of this table,

$$F = x. 0.997039 - 0^{\circ}.538$$

at least, that the differences are within the limits of the uncertainty of the observations. I have therefore not hesitated to simplify the calculations of refractions by making use of this formula."

ELEMENTS OF THE COMET OF 1823–24. BY VARIOUS COMPUTERS.

1. The first are by Mr. J. Taylor of the Royal Observatory, Greenwich. 2. The second are by Professor Nicolai Schumacher, Astr. N. N. 48. B. 3; giving the greatest error in A.R. +18", in decl. +11". 3. The third by Mr. Hansen, A. N. 48. B. 3. 4. The fourth by Carlini. 5. The fifth by Dr. Brinkley. 6. The sixth by Mr. Richardson, of Greenwich.

Passage of Perihelium	}	1. 1823 Dec. 9.3697 ^d Greenwich.	
		2. 9.4380 Manheim.	
		3. 9.47193 Altona.	
		4. 9.4792 Greenwich.	
		5. 9.2168 Greenwich.	
		6. 9.4521 Greenwich.	
Longitude of \odot	}	1. 302 ^o 56' 34"	4. 303 ^o 4' 4"
		2. 303 1 18	5. 303 0 40
		3. 303 3 22	6. 303 1 43
— Perihelium	}	1. 28 43 54	4. 28 26 8
		2. 28 43 46	5. 29 18 50
		3. 28 29 55	6. 28 20 6
Log. nearest distance	}	1. 9.3598242	4. 9.3545000
		2. 9.3579600	5. 9.3689400
		3. 9.3553934	6. 9.3536855
Inclination	}	1. 75 ^o 55' 45"	4. 76 ^o 12' 50"
		2. 76 9 40	5. 76 1 40
		3. 76 11 22	6. 76 8 28
Motion retrograde.			

ANOMALY IN THE FIGURE OF THE EARTH.

So many ships touch at Madeira, and take a new departure from it, that the longitude of the island is a matter of considerable importance. Dr. Tiarks was therefore sent out by the Board of Longitude to ascertain it, with sixteen watches, in the summer of 1822; and a remarkable circumstance occurred, which was not within the object of his original mission. For, in going from Greenwich to Falmouth, a difference of longitude was found equal to 20' 11"·49; and in returning from Falmouth to Greenwich, a difference of 20' 11"·13. Now, the difference, as determined from the Trigonometrical Survey (given in the third edition of the requisite tables), is only 20' 6"·9; and this variation made it expedient to engage Dr. Tiarks to verify his observations in the Channel. He was furnished with twenty-nine chronometers, and was employed from the latter end of last July till the middle of September in sailing between Dover and Falmouth. His results are as follows:

Longitude of Dover Station, . . .	0 ^h 5' 17"·54 E.
Portsmouth Observatory, . . .	0 4 24·77 W.
Pendennis Castle, . . .	0 20 10·85 W.
Madeira,	1 7 39·08 W.

From hence it is clear that the figure of the earth must be somewhat different from that assumed for determining the longitudes from the Trigonometrical Survey, and that about 5" must be added, in the latitude of the Channel, for every 20' of longitude which is deduced from it.

THE RATE OF A CHRONOMETER VARIES WITH THE DENSITY OF THE MEDIUM IN WHICH IT IS PLACED.

Mr. Harvey, F.R.S. E., has lately discovered that the density of the medium in which a chronometer is placed has a sensible influence on its rate, *in most cases, producing an acceleration when the density is diminished, or a retardation when the density is increased.* In a few time-keepers he has found the reverse to take place, *viz. a decrease of rate from diminished density, and an increase from increased density;* but the former appears to be the most general effect. Mr. Harvey has proved this to be the case by an extensive course of experiments, and in which he has subjected many chronometers to pressures, from half an inch of mercury to 75 inches; and in all cases has found, that if a time-keeper *gained* by increasing the density, it *lost* by diminishing it, and *vice versâ.* A difference of density denoted by an inch of quicksilver, is sufficient to produce, in many chronometers, a visible alteration of rate.

The following are a few of Mr. Harvey's results:

A pocket chronometer which possessed a steady rate of $+1''\cdot6$, under the ordinary circumstances of the atmosphere, had its rate increased to $+6''\cdot2$, when the density of the air was diminished to a quantity represented by 20 inches of quicksilver; and on afterwards placing it in air of a density denoted by 10 inches of mercury, a further increase of its rate to $+11''\cdot0$ took place. On restoring the time-keeper to the ordinary circumstances of the atmosphere, its rate returned to $+2''\cdot1$.

In another set of experiments, with the same chronometer, Mr. H. placed it in a condenser, under an atmospheric pressure of 45 inches, when its rate changed to $-4''\cdot4$; and on increasing the density of the air to a quantity denoted by 60 inches of mercury, the daily variation further declined to $-8''\cdot2$.

In another remarkable experiment, Mr. H. found that when the rate of a chronometer was $+23''\cdot5$, under a receiver having its air exhausted to a quantity denoted by half an inch of mercury, the rate was altered to $-17''\cdot2$, when the air was increased to a density corresponding to 75 inches of quicksilver; the rate of the time-keeper, under the ordinary circumstances of atmospheric pressure, being $+4''\cdot7$.

Mr. H. has, we understand, drawn from it several important conclusions; for instance, that a chronometer constructed in London, nearly on the level of the sea, would undergo an alteration of rate, from difference of atmospheric pressure alone, if transported to Geneva, to Madrid, to Mexico, or any other place, situated much above the level of the place where it was constructed.

The whole of the results are about to be laid before the Royal Society.

NOTE ON THE EXISTENCE OF A NITRATE AND A SALT OF POTASH IN CHELTENHAM WATER, BY M. FARADAY, &C.

Having undertaken at the request of Dr. Creaser an examination of some water from Cheltenham, I had occasion to remark in it the existence of two substances not before observed in waters from that place; and though of no importance in a medicinal point of view, yet as relates to the sources from whence the waters obtain their impregnations, and to the illustration they afford of the use of two tests suggested by Dr. Wollaston, but not very frequently, I believe, in the hands of chemists, they may I think possess interest; one of these substances is nitric acid, and the other potash.

The source from which the water was obtained is called, I believe,

believe, the Orchard Well. It had been some time in disuse, but has more lately been cleaned out and deepened, and is now about fifty-six feet to the bottom. The solid contents of a pint of this water examined in London were:

Carbonate of lime . . .	1·6 gr.
Sulphate of lime	14·5
Sulphate of magnesia .	12·4
Sulphate of soda	3·7
Muriate of soda	97·0

129·2

Besides which, the water contained a portion of carbonic acid; and a small quantity of peroxide of iron had settled to the bottom of the bottle.

On adding sulphuric acid to a portion of this water in quantity abundantly sufficient to decompose all the salts subject to its action, and boiling such acidulated water in a Florence flask, with a leaf of gold for half an hour or an hour, the gold either in part or entirely disappeared, and a solution was obtained, which when tested by proto-muriate of tin gave a deep purple tint. Hence the presence of nitric acid, originally, in the water was inferred; and, that no mistake might occur, a solution was made in pure water of all the salts except the nitrate found in the water, boiled with some of the same sulphuric acid, and tested by the same muriate of tin; but in this case no colour was afforded, nor any gold dissolved.

The potash was ascertained to be present by evaporating a quantity of the water until reduced to a small portion, filtering it and then adding muriate of platina in solution. Three pints of water, evaporated until about one ounce of fluid remained, gave an abundant precipitate of the triple salt of potash and platina. In cases where small quantities of the water were tried, it was necessary to let the liquid stand an hour or two after applying the muriate of platina, but the triple salt always ultimately appeared.

Two pints of the water, evaporated to dryness in a silver crucible, gave, on re-solution of the residuum, a decided though very minute trace of silica.

THE LOGAN STONE IN CORNWALL OVERTURNED.

To the Editors of the Philosophical Magazine and Journal.
Gentlemen,

Your geological readers will hear with infinite regret that the celebrated Logan Stone in Cornwall, which has for so long a period been regarded as an object of great national interest and curiosity, and which has been visited by persons from the

remotest extremity of Europe, has within the last few days been overturned by one of the *Lieutenants of His Majesty's Navy*, now commanding a revenue cutter stationed between the Lizard and Land's End, assisted by a party of his men. The barbarous and wanton folly which could induce an officer bearing His Majesty's commission to commit so unwarrantable an act, as to remove a great national curiosity from a position in which it had stood for ages, defying the hand of time, and affording to the enlightened traveller an object of such singular interest, will, it is hoped, be visited with the severest displeasure of the Admiralty. In a tour through Cornwall in the summer of 1821, I was informed by a cottager who lived near the spot, that an attempt was made by a party of seamen some years before to remove it, but without success. Cornwall, by this wanton outrage, has lost one of its most interesting monuments.

Yours, &c.

Plymouth, April 18, 1824.

GEORGE HARVEY.

OBITUARY.—MR. JOHN FORBES.

Botanical science has sustained a severe loss in the death of this intelligent and enterprising young man. He was sent out by the Horticultural Society of London, under the sanction of the Lords of the Admiralty, with the squadron commanded by Captain William Owen; the object of which was to make a complete survey of the whole eastern coast of Africa. Such an expedition afforded too favourable an opportunity to be omitted by the Horticultural Society to send out an intelligent collector, and Mr. Forbes, whose zeal as a botanist was known to the Society, was fixed on as a proper person to accompany it.

The squadron sailed in February 1822, and touched at Lisbon, Teneriffe, Madeira, and Rio Janeiro, at each of which places Mr. Forbes made collections in almost every branch of natural history; the whole of which were received by the Society.

His extensive collections subsequently made at the Cape of Good Hope, Delagoa Bay, and Madagascar, were also received by the Society in high preservation, and by their magnitude and variety evinced the unremitting attention which he had paid to the objects of his mission. With the approbation of Captain Owen, and with a zeal highly creditable to his own character, although not instructed by the Society, he engaged himself to form part of an expedition which was proceeding from the squadron, up the Zambezi River, on the eastern coast of Africa. It was intended to go about eight hundred miles up the river in canoes, and the party was then

to strike off southwards to the Cape. It was in this progress up the Zambezi that Mr. Forbes died, in the twenty-fifth year of his age. He received his botanical education under Mr. Shepherd of the Botanic Garden at Liverpool, and had, by close application, acquired so much information in many other branches of natural science, as to justify the expectation that, had his life been spared, he would have stood high in the list of scientific travellers, and have been eminently useful to the Society whose patronage he enjoyed.

Calendar of Flora, Fauna, and Pomona, at Hartfield in Sussex. From Jan. 1. to Mar. 20, 1824.

Jan. 1.—*Tussilago fragrans*, or Shepherd of Edonia*, which flowered early in December, is still in full blow.

Jan. 25.—St. Paul's Day. Fair. Mezereon, Snowdrop, and Hepatica.

Feb. 2.—Candlemas Day has ever been regarded as critical with respect to the coming year. This year it is fair and mild, and we have a large share of the early spring plants in blow, viz. *Anemone Hepatica*, abundantly, in 3 varieties; *Tussilago alba*, the White Butterbur; *Primula vera*, the Primrose; *Primula polyantha*, the Polyanthus; *Daphne Mezereon*; *Galantha nivalis*, Snowdrop, here and there; *Lamium garganicum*; *Lamium purpureum*, the Dead Nettle; *Viburnum Tinus*, the Laurel tree; *Helleborus hyemalis*, Winter Hellebore. To these we might add a solitary Crocus, a few Stocks and Wall-flowers, all in blow ever since last year.

Feb. 14.—*Crocus vernus*, the Early Spring Crocus, in blow. This plant is in this county always in full flower by St. Valentine. *Vinca minor* is very abundant. *Leontodon Taraxacum*, the Dandelion, here and there.

Feb. 17.—A paraselene about 35° S.W. of the moon to-night.

Feb. 18.—A brilliant meteor in the N.W., descending in direction to the N.E. at midnight.

Feb. 24.—The number of Snowdrops and Crocuses increase, and together with the *Hepatica* and *Polyanthuses* render the gardens gay. *Doronicum Pardalianches* came into flower to-day, which is very unusually early. I never remember it before the middle of March.

The blackbird sang on the 25th of January, and the thrush, woodlark, and redbreast, Feb. 2d.

On the 18th of February, though the sky was very clear, and the stars apparently bright, there was some peculiarity in the atmosphere which prevented good astronomical observations. In observing Mars, in order to disperse his light

* I shall generally give the provincial names of Sussex for plants, as this may interest some readers, as well as Latin names.

in the manner I have before described, I found the spectrum vary so much from time to time in the glass that I thought it useless to record the colours. This must have been owing to some state of the air. The change of colour in the fluctuation or twinkling of the fixed stars was less than usual, and was totally invisible in *Arcturus*, and even in *Betalgeus*, where it is usually very strong. It was also faint in *Spica Virginis* and in *Sirius*, and was indiscernible in *Procyon*. This shows that that quality of the air which produces the salient and irregular spectrum, is not the same quality which seems to cause the greatest alternation in the colour of the fluctuation of starlight.

March 5.—*Anemone hortensis* and *Narcissus Pseudonarcissus* in flower.

March 7.—*Primula verna* (the Primrose) begins to flower on the banks most exposed to the sun.

March 8.—*Primula elatior* (the Oxlip) in blow, also *Blue Spring Crocus*.

March 11.—*Viola odorata*, both the white and blue variety in flower abundantly. The *Daphne Mezereon*, which was tolerably full in flower in the beginning of last month, has not continued to expand its flowers, but seems thrown back, as if by some unfriendly state of the atmosphere: and in general the plants have made very little progress, and vegetation seems at a stand. Frogs croak, and the Smallest Willow Wren appears. The titmice *Parus cæruleus* and *P. major* very noisy.

March 12.—*Narcissus lætus* in flower.

March 13.—*Hyacinthus orientalis*.

March 14.—*Daphne Mezereon* resumes the opening of its flowers.

Ficaria verna and *Tussilago Farfara* blow.

March 19.—The Butterbur, *Tussilago Petasites*, appears above ground.

March 20.—Some extraordinary change of the atmosphere took place to night, about 11 P.M. A lamp burning in my room put forth a flame of a very unusual form, otherwhere to be described; there was a sudden depression of the barometer, and a prodigious increase of moisture indicated.

The general appearance of nature is much more backward than in 1822, but less so than in 1823. What I call the equinoctial or primaveral Flora, considerably advanced. Daffodils are already numerous; the Pilewort begins to be common, and to bespangle the fields and banks with its golden star. Daisies abundant. Dandelion yet somewhat scarce. The *Hepatica* and *Polyanthuses* abundant. Primroses begin to cover every bank with their pale flowers in the greatest profusion.

I beg

I beg to append the following additional prismatic observations on the stars in March :

March 11.—I had an opportunity, during a clear interval between 11 P.M. and midnight, to resume my prismatic observation on the stars. A thin and almost imperceptible cirrostratus or wanecloud was spread over the sky, through which the light of the stars was distinctly seen, down to those of the fourth magnitude. On applying the prismatic telescope to the planet *Mars*, I found in the oblongated spectrum the following colours. The red was very abundant and strong; the yellow considerable, the orange small; and very little violet. *Spica Virginis* showed considerably less of the red colour, scarcely any yellow; an inconsiderable quantity of green, and a great deal of blue light. *Vega* or *α Lyrae* showed rather more red than the last mentioned star, though considerably less than *Arcturus*. The yellow and orange were very small, indeed almost wanting; the green very little discernible; and the blue violet very plentiful: indeed this is the bluest star I have yet examined.—March 13.—I observed most of the stars of the first magnitude visible this evening with a higher power. The Moon showed all the colours in very nearly equal proportions. *Sirius* showed rather more red than on former occasions, and some green, and also presented a large but faint brush of violet*. *Arcturus*, a large quantity of red, of orange, some green, very little of the violet. *Aldebaran* resembles *Arcturus*, but has a still larger proportion of red. *Betalgeus* like the former, but liable to assume in alternate fluctuations an augmented quantity of intense red light. *Jupiter* all the colours, but the more refrangible colours are in larger proportions than in either the *Moon* or in *Saturn*. The large and expanded violet brush has so little intensity of light, that it is soon lost by the slightest cloudiness that may intervene. *Mars*. Much red light as usual, and a considerable proportion of orange.

I cannot account for the different results of different nights' observations, slight as they are, on any other principle than that which I have elsewhere noticed, viz. a variation in the chromatopoeitic powers of the atmosphere; and it is to record other varieties, and to call the attention of others to this vari-

* The greater quantity of red light, it should be recollected, took place in an evening in which the wanecloud prevailed, and accords with what I have often before noticed. I have found on the gradual thickening of the aqueous atmosphere by the wanecloud, that the colours of the spectrum successively disappear in the *inverse* order of their refrangibility, the red being seen longest. Hence the intensity of light varies inversely as the refrangibility of the rays.

ation, that I am induced to insert these hasty and imperfect observations. In time I hope to be able to contrive instruments to give the exact proportions or breadth and intensity of each colour, in the spectrum, and also so to adapt the prism to the object glass of the telescope, as more completely to separate the different sorts of rays*. Meanwhile any hints or collateral observations, communicated through the Philosophical Magazine, will oblige, &c.

Hartwell, E. Grinstead, March 13, 1824.

T. FORSTER.

Additions to Professor HARE'S Paper.

A duplicate copy of Professor Hare's communication (Art. XXXIX.), at the beginning of the present Number, containing some additions, having reached us after it was printed, we give them separately :

P. 244, line 31, *after* screw—*add*, "There is a scale, with a vernier, attached to one since made."

P. 244 Note†, *read*, "I have seen it strike at the distance nearly of a quarter of an inch."

P. 245, *add* as a note to the account of the Electrometer the following: "If one of the condensing disks be of copper, the other of zinc, they may serve for the purpose of condensing, when not made to touch. If brought into contact, and then separated, the phenomenon will be the same as that in the instance of the Electrometer above described."

LIST OF NEW PATENTS,

To Jean Henry Petelpierre, of Chalton-street, Somers Town, in the parish of St. Pancras, Middlesex, engineer, for his engine or machine for making the following articles from one piece of leather without any seam or sewing whatever; that is to say, all kinds of shoes and slippers, gloves, caps and hats, cartouch boxes, scabbards and sheaths for swords, bayonets and knives.—Dated 20th March 1824.—2 months allowed to enrol specification.

To James Rogers, of Marlborough, Wilts, surveyor, for his method, or an improved instrument or instruments for determining or ascertaining the cubic contents of standing timber.—20th March.—6 months.

To John Lingford, of Nottingham, lace machine manufacturer, for certain improvements upon machines or machinery now in use for the purpose of making that kind of lace commonly known or distinguished by the name or names of bobbin-net or Buckinghamshire lace net.—20th March.—6 months.

To John Heathcoat of Tiverton, Devonshire, lace manufacturer, for his improvements in certain parts of the machinery used in spinning cotton, wool or silk.—20th March.—6 months.

To Henry Berry of Abchurch-lane, London, merchant, for certain improvements on a machine or apparatus for more readily producing light. 20th March.—6 months.

To Jean Jacques Stainmare, of Belmont distillery, Wandsworth-road, Vauxhall, in the parish of St. Mary, Lambeth, Surry, distiller, who, in consequence of communications made to him by certain foreigners residing

* I have, since writing the above, contrived a method of measuring the proportionate deviation in each instance; see the continuation from my paper.

abroad, and discoveries by himself, is in possession of an invention of improvements in the process of and apparatus for distilling.—20th March.—6 months.

To Charles Demeny, of Paris, but now residing in Fenchurch-street, London, merchant, who, in consequence of a communication made to him by a certain foreigner residing abroad, with whom he is connected, is in the possession of an invention of an apparatus containing within itself the means of producing gas from oil and other oleaginous substances, of burning such gas for the purpose of affording light, and of replacing the gas consumed.—22d March.—2 months.

To Namen Goodsell, late of New York in the United States of America, but now of No. 13, Leigh-street, Burton Crescent, Middlesex, engineer, for a certain machine or piece of machinery for breaking, scutching and preparing flax and hemp for use, upon an improved method, and threshing out the seed thereof, and which is applicable to the threshing of any other kind of grain, and also for shelling clover and other seeds.—25th March.—6 months.

To Edward Jordan, of Norwich, engineer, for a certain improvement or improvements in the form or construction of water-closets, or of the apparatus connected therewith.—27th March.—6 months.

To Joseph Spencer, of Belper, Derbyshire, nail-manufacturer, for certain improvements in the construction of furnaces or forges for the preparation of iron or steel, and for the process of manufacturing of nails and other articles from the said materials.—7th April.—6 months.

To Jonathan Schofield, of Rastrick, in the parish of Halifax, Yorkshire, manufacturer, for certain improvements in the manufacture of cloth or fabric which he denominates British cashmere.—7th April.—6 months.

To Thomas Ryalls, of Sheffield, Yorkshire, warehouseman, for his apparatus for shaving, which he denominates "the useful and elegant facilitator."—8th April.—2 months.

To Samuel Hall, of Basford, Nottinghamshire, cotton manufacturer, for his improved steam-engine.—8th April.—6 months.

To James Tulloch, of Savage Gardens, London, gentleman, for his improvement or improvements in the machinery to be employed for sawing and grooving marble and other stone, or in producing grooves or mouldings thereon.—12th April.—6 months.

To Henry Potter Bevet, of Devizes, Wiltshire, ironmonger, for his improvement in the construction of cranks, such as are used for bells and other purposes.—14th April.—6 months.

To William By, of Joy Cottage, Ivory-place, Brighton, Sussex, stationer and bookseller, for his method or apparatus for the preservation of books and covers.—14th April.—6 months.

To John Gunby, of New Kent Road, Surry, sword and gun manufacturer, for his improvement in the process of manufacturing of cases for knives, scissors, and other articles.—14th April.—6 months.

To David Gordon, of Basinghall-street, London, esq., for certain improvements in the construction of portable gas lamps.—14th April.—6 months.

To John Beven, of Manchester, Lancashire, dealer in cotton twist and web, and general commission agent for manufactured goods, for his apparatus for dressing various kinds of cotton, flaxen, woollen or silk manufactures.—14th April.—6 months.

To Thomas Gettien, of Henry-street, Pentonville, Middlesex, gentleman, for his improvements in the machinery and process of making metallic rollers, pipes, cylinders, and certain other articles.—15th April.—6 months.

To Daniel Tonge, of Liverpool, Lancashire, ship-owner, for apparatus by means of which an improved method of reefing sails is effected.—15th April.—6 months.

A METEOROLOGICAL TABLE: comprising the Observations of Dr. FURNEY at Gosport, Mr. CARY in London, and Mr. VELL at Boston.

Days of Month, 1824.	Gosport, at half-past Eight o'Clock, A.M.										Clouds.				Height of Barometer, in Inches, &c.		Thermometer.		RAIN.		WEATHER.			
	Barom. in Inches, &c.	Thermo.	Temp. of Sp. Water.	Hygrom.	Wind.	Evaporation.	Rain near the Ground.	Cirrus.	Cirrostr.	Stratus.	Cumulus.	Cumulost.	Nimbus.	Lond. 1 P.M.	Bost. 8 1/2 A.M.	Lond. 8 A.M.	Bost. 11 P.M.	Lond. 8 1/2 A.M.	Bost. 8 A.M.	Lond.	Bost.	Lond.	Bost.	
																								Lond.
March 26	29.98	42	48 1/2	63	N.	...	0.010	...	1	...	1	29.95	29.85	43.45	38	41	Cloudy	...	Cloudy	Rain
27	29.84	40	...	62	N.	...	0.020	...	1	...	1	29.84	29.70	39.44	35	38.5	Cloudy	...	Cloudy	Fine
28	29.84	39	...	64	N.	1	...	1	29.95	29.83	36.40	32	38	Fair	...	Cloudy	Fine
29	29.98	34	...	56	N.	1	...	1	29.99	29.77	33.45	41	37	Fair	...	Cloudy	Cloudy
30	29.74	42	...	60	NW.	...	0.010	...	1	...	1	29.66	29.55	41.47	31	40.5	Cloudy	...	Cloudy	Cloudy, rain p.m.
31	29.72	35	48 1/4	53	N.	...	0.570	...	1	...	1	29.75	29.55	37.37	30	30	Fair	...	Cloudy	Fine, snow a. & p.m.
April 1	29.93	36	...	56	W.	...	0.015	...	1	...	1	29.87	29.75	30.44	36	34	Fair	...	Fair	Fine, rain at night
2	29.22	44	...	67	NW.	1	...	1	29.28	28.90	42.40	34	40	Stormy	...	Stormy	Rain
3	30.00	37	...	60	N.	1	...	1	30.10	29.89	33.44	40	37	Fair	...	Fair	Fine
4	30.20	42	...	63	NW.	1	...	1	30.35	30.14	38.45	40	36	Fair	...	Fair	Fine
5	30.44	42	...	54	NE.	1	...	1	30.45	30.30	39.46	39	39	Fair	...	Fair	Fine
6	30.42	42	...	56	NE.	1	...	1	30.47	30.33	38.47	38	42	Cloudy	...	Cloudy	Cloudy
7	30.20	42	48	54	N.	...	0.001	...	1	...	1	30.15	30.05	38.46	39	41.5	Cloudy	...	Cloudy	Cloudy
8	30.24	42	...	55	NE.	1	...	1	30.28	30.15	39.49	41	36.5	Cloudy	...	Cloudy	Cloudy
9	30.06	44	...	58	N.	1	...	1	30.04	29.90	41.47	43	42	Stormy	...	Stormy	Rain and stormy
10	29.40	41	...	68	N.	...	0.080	...	1	...	1	29.45	29.25	42.40	34	40	Snow	...	Snow	Fine, N fall sn. a.m.
11	29.40	39	...	68	N.	...	0.050	...	1	...	1	29.44	29.20	38.40	30	32	Fair	...	Fair	Fine, snow p.m.
12	29.46	40	...	60	NW.	...	0.001	...	1	...	1	29.47	29.20	38.47	35	37	Fair	...	Fair	Fine, do. a.m.
13	29.70	42	...	56	W.	...	0.070	...	1	...	1	29.75	29.43	35.49	38	38	Fair	...	Fair	Fine
14	29.81	43	...	58	SW.	1	...	1	29.91	29.65	36.50	39	41.5	Fair	...	Fair	Fine
15	29.85	45	48	60	SE.	...	0.400	...	1	...	1	29.90	29.70	35.51	39	40	Rain	...	Rain	Stormy
16	29.19	41	...	78	E.	...	0.340	...	1	...	1	29.30	29.37	40.42	41	42	Rain	...	Rain	Stormy
17	29.43	44	...	74	NE.	...	0.015	...	1	...	1	29.57	29.37	40.40	44	44.5	Rain	...	Rain	Stormy
18	30.00	44	...	64	NE.	1	...	1	30.17	29.93	45.53	41	45	Fair	...	Fair	Stormy
19	30.24	48	...	58	SE.	1	...	1	30.20	30.05	42.59	45	47	Fair	...	Fair	Stormy
20	30.30	53	...	55	SE.	1	...	1	30.35	30.10	47.63	48	50.5	Fair	...	Fair	Stormy
21	30.08	51	48	58	SE.	...	0.150	...	1	...	1	30.09	29.90	47.61	57	54	Fair	...	Fair	Stormy
22	29.94	55	...	64	SW.	...	0.260	...	1	...	1	29.97	29.53	52.61	50	55	Shower	...	Shower	Stormy
23	29.48	51	...	83	SW.	...	0.290	...	1	...	1	29.26	29.35	50.50	47	48	Rain	...	Rain	Stormy
24	30.00	52	...	70	NW.	1	...	1	30.25	29.65	47.60	50	49	Fair	...	Fair	Stormy
25	30.10	50	48	72	SW.	...	0.25	...	1	...	1	30.15	29.90	50.60	52	51	Fair	...	Fair	Stormy
Averages:	29.880	43.29	48.12	62.2	6	2.47	2.282	18	8	26	17	16	18	29.71	29.71	41.5	41.5	1.50	1.89	1.50	1.89	...

Amphituma means.

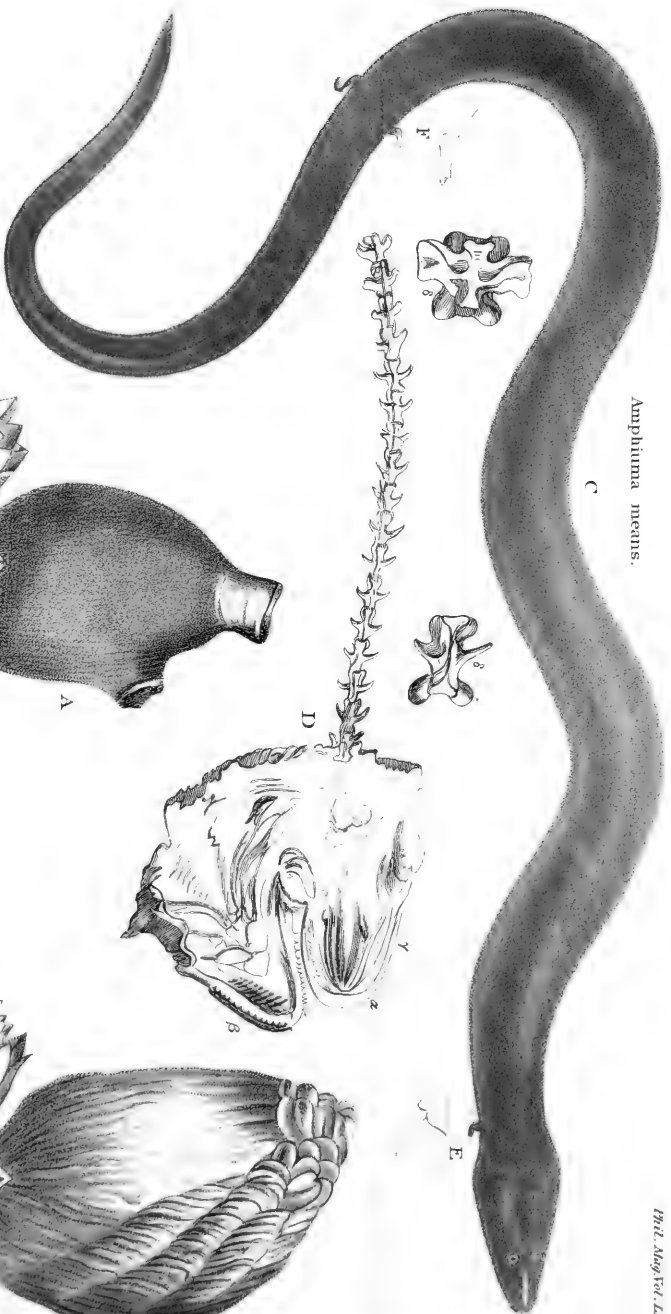

Ascidia oralis.

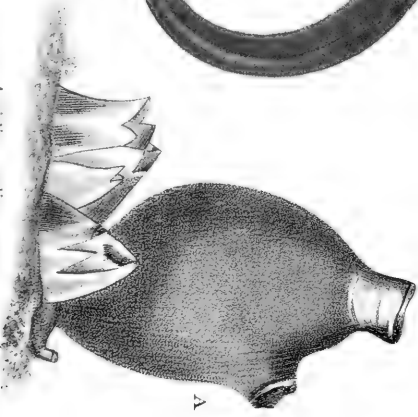

Ascidia plicata.



A METEOROLOGICAL TABLE: comprising the Observations of Dr. BURNEY at Gosport, Mr. CARY in London, and Mr. VELL at Boston.

Days of Month, 1824.	Gosport, at half-past Eight o'Clock, A.M.										Clouds.				Height of Barometer, in Inches, &c.		Thermometer.				RAIN.		WEATHER.				
	Barom. in Inches, &c.	Thermo.	Temp. of Sp. Water.	Hygrom.	Wind.	Evaporation.	Rain near the Ground.	Cirrus.	Cirrocum.	Cirrostr.	Stratus.	Cumulus.	Cumulost.	Nimbus.	Lond. 1 P. M.	Bost. 8 1/2 A. M.	Lond. 11 P. M.	Bost. 10 A. M.	Lond.	Boston.	Lond.	Boston.	Lond.	Boston.	Lond.	Boston.	
																											29-98
March 26	29-98	42	48 1/2	63	N.	...	0-010	1	1	1	1	1	1	1	29-95	29-85	43-45	38-41	London.	...	Cloudy	...	Rain	...	Cloudy	...	
27	29-84	40	...	62	N.	1	1	1	1	1	1	1	29-84	29-70	39-44	38-5	London.	...	Cloudy	...	Cloudy	...	Cloudy



THE
PHILOSOPHICAL MAGAZINE
AND JOURNAL.

31st MAY 1824.

LIII. *Descriptions of several new Species of Ascidia.* By
C. A. LESUEUR.*

GENUS ASCIDIA, *Lin.*

1. **A**SCIDIA *atra*. *Body* subcylindric, elongated, arquated, sessile; the superior part more slender, terminated by two unequal tubes, slightly separate and parallel; these tubes have each a terminal opening, which in the shorter tube is closed by five, and in the longer one by six, triangular valves; the substance of the exterior sac is very firm, almost smooth, opaque, and very deep violaceous or blackish.—It occurs attached to rocks, amongst *Opuntia*, many species of *Sertularia*, and broken shells. Its position is inclined, being adherent by the side of the base, which is a little more inflated than the other parts of the body.—We observed this species at the isles of St. Vincent and Guadaloupe, where, however, it is rather rare. Whilst dredging in the bay of Calicoua, we drew this species from the bottom of the water, with many other objects, amongst which was a beautiful *Holothuria*, marbled with brown, red, white and blackish, which had the property of dissolving so rapidly as to be observed with difficulty.

2. *A. cavernosa*. *Body* oblong, irregular, terminated by two unequal tubes; that of the branchia and mouth much longer than the other, and directed upwards; that of the oviduct and excretions situated at the base of the first and lateral; their apertures are entire, without marginal elevation, or apparent hair, and of a deep colour within; the exterior envelope is coriaceous, thick, very firm, opaque, rugous and folded, particularly towards the base, where the folds, united in fasciculi, form three points of attachment, by means of which the animal secures itself firmly to the interior of cavities in rocks and old *madrepores*; the colour is that of burnt terra-

* From the Journal of the Academy of Natural Sciences of Philadelphia, vol. iii. No. 1. for April 1823.

sienna.—This species is found only within the cavities of rocks, which are generally covered with *ulvæ* and other marine plants, at the island of St. Bartholomew. Length 2 inches 5 lines, breadth 1 inch and a half.

3. *A. albeola*. *Body* subpyriform, more inflated above, terminating in two apertures, that of the branchia rather more elevated; base destitute of a peduncle, but spreading a little outwards to increase the surface of attachment; *colour* white, diaphanous, exhibiting an interior globular, red, point. This species being small, measuring but a single line in height, presented less obvious characters than the preceding species; it is gregarious, attached to the surface of rocks, upright, and presents a peculiar aspect, which at once distinguishes it from any of the other species described in this paper; it may possibly be the young of a larger species.—Inhabits Guadeloupe.

4. *A. multiformis*. *Body* variable in form, sometimes depressed or orbicular; sometimes elongated and projecting two long unequal tubes, which, as in the other species, are distant when collapsed, and divergent when projected; the opening of one of these is furnished with four, and of the other with five, triangular lips; *base* sessile, discoidal, forming an attaching surface wider than the body; substance soft, diaphanous and tinted with red; length about 5 lines, breadth 2 lines.—Many specimens are much smaller than the size here indicated; but whether or not these are young, or varieties, can only be determined by a series of regular and constant observations. Like the preceding they are gregarious, attaching themselves to rocks on the shore of the island of Guadeloupe.

Var. α. Differs in being much larger, more solid and more opaque; the apertures are entire; the interior of the opening is black, and the general exterior colour, gray; the almost smooth surface is interrupted by a few wrinkles; it was found covered with *ulvæ*, and resembled a beautiful green *Lycopodium*; the foot was less dilated than that of the species; the apertures are terminal, conic, divergent, sometimes rectilinear and sometimes recurved.—It is a native of the coast of Guadeloupe.

5. *A. variabilis*. *Body* variable in form, oblong, sessile; *base* inflated and adherent to extraneous bodies; *apertures* large, distant, deep red, with five brighter spots within, and each placed upon a conic protuberance, with their margins hardly divided as in the other species by four or five valves; the conic protuberances are unequal, the surface in common with that of the whole body is rugous, of a grayish colour in some,

some, and brownish in other individuals, somewhat in appearance like a truffle (*Tuber*).—This species lives in society, attached to madrepores, rocks, shells, and each other; grouped with them are smaller ones, of nearly the same form, and of a beautiful red colour; but not having particularly examined these smaller specimens, I am not certain of their being the same species with their larger associates.—Length, about one inch and a half, by one inch in breadth.—Inhabits the bay of the Island of St. Thomas.

6. *A. claviformis*. *Body* small, sub-cylindric, elongated, larger towards the extremity, or sub-clavate, terminated by two small unequal approximate tubercles open at their summit; *substance* gelatinous, diaphanous, glabrous. It lives in society, attached by the base to fuci and other marine bodies, and is also found thus attached floating on the surface of the water.—Inhabits the bay of St. Vincent in the West Indies.—Length about one inch, breadth 2 lines.

7. *A. plicata*. *Body* ovate, sessile; *surface* sub-glabrous, but with many large inflated folds on the side of the inferior aperture, crossed by smaller folds, presenting on that side the appearance of small imbricated dilatations; the remaining part of the body is covered with much smaller folds; *apertures* approximate, unequal, terminal; but being much compressed by their position in the preserving liquor, I am unable to determine their natural form; *substance* opaque, readily yielding to pressure; *colour* white; when air is forcibly introduced into the body, the latter becomes inflated like a small vesicle.—Length about two inches.—Cabinet of the Academy.—This species was found attached to the bottom of a vessel in this port. See Plate V. fig. B.

8. *A. ovalis*. *Body* sessile, resembling the preceding species, but smaller, less rugged, being destitute of large inflated folds, with some slight, irregular wrinkles on the surface; *apertures* large, distant, placed at the extremity of two short, plaited tubes; the skin which margins the apertures is very thin, and apparently divided into many small obsolete angles; one of these apertures is placed lower than the other and lateral; *colour*, in the alcohol, white; nearly the size of *plicata*.—Cabinet of the Academy.

The base of this specimen is surrounded by numerous individuals of a species of *Lepas*, which covered the bottom of the vessel on which it was found. See Plate V. fig. A.

9. *A. proboscidea*. An elongated *proboscis* containing the two tubes; extremity obliquely truncated on each side; *apertures* subequal, placed on the summit of the proboscis, and separated only by a membrane, which extends the whole length

length of the tubes, and projects a short distance beyond the apertures; *colour* white; *surface* glabrous.—I have seen the proboscis only of this animal. It was drawn up from the bottom of an estuary on the coast of Georgia, by the fluke of an anchor, imbedded in mud and fragments of shells. It was communicated to me by Mr. Say, as one of the interesting objects collected by Messrs. Maclure, Ord, Say and Peale, on their voyage to Florida, and now forms part of the collection of the Academy.

10. *A. lobifera*. *Body* sessile, subglobular, with approximate, unequal apertures, concealed in the midst of many irregular fleshy lobes.—This species, which I have seen only in the preservative liquor, was contracted, and appeared to me to have been somewhat proportionably longer in the living state. It seems to have been attached to a sand-stone.—The distinguishing peculiarity of this species, is the thick, fleshy and irregular lobes which defend the apertures. I think it probable that the apertures were capable of being elevated at the will of the animal, above the lobes which protect them when at rest. The colour in its present state is a dull black, and the surface is wrinkled.—Transverse diameter, one inch and a half, height also one inch and a half.

List of additional new Species observed chiefly in the Pacific Ocean, during a Voyage of Discovery to Terra Australis; from the Manuscripts and Drawings of Peron and Lesueur.

- 1 *Ascidia marginella*, Decrés', King's and Josephine's islands, in New Holland.
- 2 *vermiculata*, King's and Decrés' islands.
- 3 *anatifoidea*, Isle of France.
- 4 *confederata*, King's island.
- 5 *trinenta*, bottom of Géographe bay, Leuwin's land.
- 6 *fragum*, Elephant bay, King's and Decrés' islands.
- 7 *truncata*, Bass' strait.
- 8 *rapuliformis*, Endracht's land.
- 9 *gigantea*, Bougainville's bay, Decrés' island.
- 10 *lithopoda*, Decrés' island.
- 11 *rhizophora*, Endracht's land.
- 12 *rosea*, Bougainville's bay, Decrés' island.
- 13 *alba*, Bougainville's bay.
- 14 *barbata*, coast of Nice, Europe.
- 15 *pilosa*, Isle of France.
- 16 *fasciata*, do.
- 17 *radiata*, coast of Havre, Europe.
- 18 *diaphana*, King's island. [islands.
- 19 *phyllostoma*, King's, Decrés' and Josephine's
20 *Ascidia*

- 20 *Ascidia tetraodon*, Josephine's island, Napoleon's land.
 21 *peniformis*, Port of King George, Nuyt's land.
 22 *australis*, Oyster bay, in Maria's island.
 23 *lithoidea*, Leuwin's land.
 24 *nigrita*, Edel's land.
 25 *rizophora*, Napoleon's land.
 26 *anthropocephala*, St. Francis' and St. Peter's islands
 and port of King George.
 27 *nasuta*, north-west coast of New Holland.
 28 *democratica*, St. Francis' and St. Peter's islands.
 29 *verrucosa*, King's island.
 30 *polystoma*, do.

LIV. *Dissection of a Batrachian Animal in a living State.* By RICHARD HARLAN, M.D. Professor of Comparative Anatomy to the Philadelphia Museum.*

THE specimen was sent from Georgia to Dr. Mease of this city. An account of a similar animal has lately been published under the name of "*Chrysodonta larvæformis*†."

Having of late been familiar in the dissection of Proteiform animals, "les reptiles douteux" of Humboldt, and having had the opportunity of observing and dissecting this specimen in a living state, I experience less hesitation in making the following observations, more especially as the account alluded to above is by no means free from imperfection and error.

The animal I dissected was eighteen inches in length (see Plate V. fig. C); the branchial cartilages are four in number, united to each other at their inferior end, but unconnected with the other parts of the skeleton; the branchial orifice is situate between the two inferior; the other cartilaginous slips are covered by the internal lining membrane: these orifices cannot be considered as connected with the process of respiration, are by no means breathing-holes, not being furnished with membranous fringes, and would appear to subserve no other purpose than to evacuate the water taken into the mouth with the food of the animal.

The nostrils are small and situated near the point of the snout, they communicate with the fauces, opening immediately behind the palatine row of teeth.

The lower jaw (fig. D. β .) contains a single row of teeth of about thirty in number; the upper jaw contains a row on the

* From the Journal of the Academy of Natural Sciences of Philadelphia, vol. iii. No. 2. for May 1823.

† Vide Medical Recorder, July 1822, No. 19.

maxillaries, and another on the palatine surface, consisting of about forty in number; they point backwards, are very minute, the tips reflect the golden rays, provided they be viewed through the medium of a microscope, they are not processes of the jaws, but are attached to the bones at their bases by a slightly moveable articulation, somewhat similar to the teeth of the shark: that is to say, neither by gomphosis or anchylosis.

On the top of the head are the orifices of two rows of glands (fig. D. α .), extending from the eyes to the tip of the nose: the eyes are covered with cuticle as in the *Siren* and *Proteus* (fig. D. γ .)

The tail is short, round at its base, and flattened vertically towards the extremity.

There are no ribs, except the motionless rudiments, resembling in this respect the *Proteus anguinus*, and differing from the *Siren* and the *Tritons*, which have moveable rudiments of ribs.

The *tongue* is cartilaginous, possessed of very little freedom of motion. In the appearance of the circulating system, the alimentary canal, the cellular lungs, and the urinary organs, this animal presents no material difference from the *Siren*.

The testicles are flat in this animal and cylindrical in the *Siren*. The parts about the region of the cloaca being somewhat mutilated, I was unable to determine exactly where the ureters entered the bladder.

This animal cannot be considered, strictly speaking, as amphibious (breathing in air or water), not being furnished with branchiæ, and is not calculated for progression upon land. Indeed the most remarkable peculiarity in its organization is its four *boneless* legs terminated by two toes, the external toe being the longest (fig. E and F).

Whatever may have been the case during the early settlements of North and South Carolina, at present this animal is certainly rare, as none of our museums contain a single specimen, nor was I aware that a specimen had ever been sent to Europe, until I was informed by Dr. De Kay of New York (after having finished this description) that a similar animal had been noticed by Dr. Garden in Smith's "Correspondence of Linnæus," under the name of *Amphiurna means*, on referring to which work I found that this animal had indeed been noticed under that name*.

It

* Extract from a letter of Dr. Alexander Garden to Mr. Ellis, dated Charlestown, May 15, 1773.

"I have not as yet been able to procure another of the *Amphiurna means*, which he (Linnæus) calls *Sireni simile*. This appeared to me to be a still more

It will be observed that the description of Dr. Garden agrees with mine, with the exception of a few minor differences as respects the tongue, the pulmonary system, &c. Dr. Garden did not seem to be aware that the *Amphiuma* respired with two cellular lungs; by his own account, the specimen he described had been *preserved in spirits*, which circumstance will sometimes give rise to inaccuracies.

From the above description, the *Amphiuma* must be acknowledged as generically distinct from the Batrachian animals hitherto described; the similarity of internal organization would place it between the *Proteus* and *Siren*.

This very curious animal lived for several weeks in the possession of Dr. Mease, by whose request a drawing of the living animal was taken by Mr. C. A. Lesueur. To the former

more singular animal than the *Siren*, as you might observe by my remarks," &c. &c.—Vol. i. p. 599.

In a letter to Linnæus, with which he sends a specimen, Dr. Garden gives the following descriptions of the *Amphiuma*:

"I must now say something of an unknown animal, which you will find in a glass bottle, and which I have no doubt will afford you much satisfaction; the specimen here sent is the only one I ever saw, and I shall think myself fortunate if it reaches you in safety.

"When I first received it, the length was 37 inches, though the animal was then become somewhat contracted. At first sight I suspected it to be another species of *Siren*; but upon nearer examination I found so many differences, that there proves to be no relationship whatever between them. Can this animal form a link between the *Lacertæ* and *Serpentes*? is it allied to *Anguis quadrupes*?

"It differs in many particulars from the *Siren*, most evidently in the following. This animal has four feet, with two toes to each, without claws. The *Siren* has only two feet. It wants the gills and their wing-like coverings. It has no scales, nor, which seems to me very singular, any tongue! all which are found in the *Siren*. I have opened the throat, and satisfied myself respecting the presence or absence of the gills. The following are the characters I have drawn up of this ugly animal.

"*Head*, rather long, depressed, tapering, serpent-like.

"*Mouth*, extending half the length of the head.

"*Lower jaw*, furnished with a single row of sharp distinct teeth.

"*Upper*, with four rows with similar curved teeth.

"*Upper lip*, covering the under one.

"*Tongue*, none. *Nostrils*, two openings at the very extremity of the upper lip.

"*Eyes*, dull, at the upper part of the head, on each side, covered with a thick tunic.

"A thin retractile membrane covers each cartilaginous lateral spiracle or orifice, by which the animal breathes.

"*Body*, thick, nearly cylindrical, tapering and keeled at each side, beyond the vent. Tail recurved. There is no *lateral line*. *Vent*, a large opening immediately behind the hinder legs.

"*Feet*, four, two of them before, close to the spiracles, each with two toes destitute of claws, two behind, at the bottom of the belly, with similar toes.

"Inhabits deep ditches and lakes of fresh water."—Vol. i. p. 333.

gentleman,

gentleman, who has shown himself on many occasions active in the cause of science, I am indebted for the opportunity of dissection.

This specimen is deposited in the Philadelphia Museum under the name of *Amphiuma means* (Garden).

[NOTE.—For Descriptions and Figures of two Species of *Siren*, see Philosophical Magazine, vol. ix. p. 118.—EDIT.]

LV. *On the Dispersive Power of the Atmosphere, and on the Peculiarities of Stars.* By T. FORSTER.

[Concluded from p. 210.]

IN a late Number of the Philosophical Magazine, you did me the honour to insert some hasty observations on the varieties observed in the refracting and dispersive properties of the atmosphere, and on the nature of the light of several stars. The opinions therein stated are deduced from a number of observations made and continually repeated by me, on the effects of refraction and dispersion. On different occasions, when I made the experiments and drew the natural conclusions from them, I was unaware that similar researches had been going forward on the continent, and also in Scotland, which I now learn to be the case; and I am also informed, that very similar facts to those which I have observed have been discovered by other persons, although, as it appears to me, by the employment of different means. At the time that I was in the southern parts of the continent in 1822, I was totally unaware that at that very time philosophers were investigating the nature and varieties of light and its refractions in the clear atmosphere of the south of Europe. And being at that time engaged in the pursuit of objects more immediately connected with meteorology, I neglected to inquire after and to collect information as to what was going on in astroscopical science in the several observatories abroad. But I find that considerable advancement has been made in the knowledge of the peculiarities of the light of stars; and though I have not at present obtained any published details of the particular observations made, nevertheless have I learnt with pleasure from private individuals, that the results of such observations, made on a most extensive scale, have in a great measure coincided with my own imperfect attempts to illustrate the singularities of different stars. I am at present unacquainted with the different methods adopted by philosophers on the continent for separating and examining the several coloured rays. But the method that I have chiefly employed

ployed is by the adaptation of the prism to the telescope and by the use of a chromatopoeitic lens. I have tried several experiments with the prism adapted to different parts of the telescope, and I have tried various methods with the lens, which it is unnecessary to detail, as they are well known. After all, I believe the best way is for each observer to pursue his own method, and to give only the result at first; for if it should turn out by a future comparison of results, that any facts be ascertained by the employment of different means, then would the said facts be established on the firmest basis. I have myself employed several modes of observation, and they have certainly all agreed in this, that they have shown the same relative degree of oblongation of the spectrum, or the same apparent proportion of the coloured rays of each star respectively; none of the different methods employed have contradicted each other*, and the variety in the results on different nights of observation has been distinctly referable to the varieties in the dispersive qualities of our atmosphere, which I have already discussed in a former part of this memoir. Making allowance for these slight varieties, which my constant attention to atmospheric phænomena has enabled me in many cases to foresee and prepare for, the same star in the following Table has always shown the same phænomena. Those stars which seem to vary in consequence as it would seem of some changes going on in their own proper light, or which are anomalous and incapable of being included in the same general view of the subject, have been put apart by themselves and will be mentioned hereafter.

In the Table, column 2, I have put down the apparent colour of the stars, not only as observed in general with the naked eyes, but by the employment of another and very simple method. I pushed the eyeglass of a four feet refractor gradually in, so as to let the rays fall on the glass before they came to a focus;—this method if applied to terrestrial objects in the day time would only produce confused images, and utterly defeat the intentions of the beholder. From this circumstance its use at night has been probably overlooked: for as applied to brilliant luminous points it is of considerable use. I usually pushed in the adjusting tube of the telescope, till I obtained a large round spectrum of the star, so expanded that it occupied a large space in the field of view. This method will answer very well for all very bright stars, because what we lose in the dazzling intensity of the light

* It was by an error of calculation that I placed *Sirius* first in the scale of refrangibility in my former paper in *Phil. Mag.* No. 311, page 208.

when brought to its proper focus, we gain in the duller and more easily observable expanded spectrum. This method, in achromatic telescopes, does not separate the different rays so as to produce an oblong and coloured spectrum; but on the contrary, the large spectral disk which I have described, corresponds in its general colour with the colour of the star viewed with the naked eye; differing only in this, that the light not being intense or dazzling, we are enabled to observe minuter differences in the colour of different stars viewed in this manner, than we could do if we let the rays arrive to the focus. This method is likewise useful for observing more accurately the permutations of colour noticed in the fluctuations of some stars, which I have before described. Since my last paper I have noticed more minutely the particular colours of the alternate changes in several stars, and have also observed some strange and unaccountable coruscations and apparent motions in the luminous striæ of brilliant white light, which sometimes seems to intersect this pale and expanded spectrum described above, either in the form of lines, of radii, or of reticular intersections, leaving frequently dark spaces and unilluminated interposing lines. These coruscations have very much the appearance of some effects produced in artificial electricity, or of certain coruscations of the *Aurora Polaris*.

I hope on a future occasion to be able to communicate some further experiments on this phænomenon, as well as on another mode of observing stars with prisms, so as to get the black lines of non-illuminating rays at the regular intervals. But at present I am desirous to confine myself to the precise object of this paper, which is, to show the comparative refrangibility of different star-light, and the necessity of tables of correction for each particular star of any considerable magnitude. I have noticed that the red colour, which alternates in the fluctuation, generally, but not in every case, alternates with the ordinary or general colour of the star, stated in the fourth column. This alternation is not distinctly observed in stars near to the zenith, but begins to be perceived very clearly at about 48° of altitude, and is greatest at between 10° and 15° above the horizon. When stars which are much subject to this alternation of colour are viewed at the above altitudes in the method above described, that is, by observing them before the rays come together in the focus, we not only observe more accurately and in an enlarged and less intensely luminous disk, the same phænomena that we can view with the naked eyes, namely, the sudden change of the whole star to deep red; but we may also distinguish that this red colour is not instantaneously

neously produced all over the star at once: it seems sometimes to ascend from the lower limb upwards, like the drawing up of a curtain, or like the progressive ascent of light thrown on to a disk by the gradual inclination of a reflecting plane mirror, occupying (though the time is perhaps a deception of our organs) on different occasions $\pm \frac{1}{3}$ " of time in passing from the lower to the upper edge of the spectrum: but it does not recede again in the same direction; it suddenly seems to vanish, either leaving the disk of the star of its usual colour and brilliancy, or giving place to a blueish colour. In *Sirius* I have noticed that indigo, violet, and greenish white change with red. I have been enabled to determine the average number of the fits of redness in *Antares* as being three in 5" of time; and generally lasting from $\frac{2}{3}$ " to 1", though sometimes longer. In *Sirius* the red is paler, there is more variety, and the fluctuations are much more rapid. Another thing observed in the expanded spectrum is, that the intensity of the alternating red light, like that of the general light of the star, varies inversely as the size of the spectrum; so that instead of a deep and intense red, such as we see with the naked eye, or when we adjust the telescope to the proper focus; we see a more diluted red or pink light, alternating with other diluted colours according to the prevailing colour of the particular star that we are viewing.

I have not devoted a separate column for the colours and relative prevalence of the fluctuations of the stars, corresponding to the fourth and fifth columns of my last table, *Philosophical Magazine*, p. 208, as it seemed unnecessary. It may suffice to observe generally, that it is only certain stars which show this phænomenon in any considerable degree, and most of those have been before pointed out. This coloured fluctuation, when observed in the prism, presents a very curious and beautiful phænomenon; and what is very remarkable is, that whatever colours any particular star may afford in the dispersive lens, the same colours will be produced by viewing the star in an ordinary telescope, and simply vibrating it at the time of observation: and this led me to discover a new method of measuring the proportions of the colours, hereafter to be described. A great degree of fluctuation interferes considerably with our endeavours to estimate the refrangibility of different stars, founded on the dispersion of their colours; because it makes the spectrum, as viewed in the glass, vary so perpetually, that we cannot easily measure the deviation of the extreme rays with the micrometer; and therefore in stars which are liable to an inordinate degree of this fluctuation we must always make greater allowance for probable error. The third

column, which is the most important, exhibits what I conceive to be the proportional refraction of the different stars severally, whose names are put down in the first column; and this scale of comparative refraction is founded on the position laid down, and which I believe repeated experiment will confirm,—that stars are more or less refracted according to the peculiar composition of their light: that is to say, in other words, the relative quantity of refraction of each star severally varies as the relative proportion of the more to the less refrangible rays of which their mixed light is composed. According to this position, it would seem that stars which appear to possess the red or less refractive rays would require a less, while those with a great proportion of violet would require a greater correction than the mean refraction as stated in ordinary tables.

I offer the following table with great deference to the results of other observations, and likewise with great caution, it being founded on an attempted measurement of the proportionate deviation and relative quantity of the differently coloured rays in the several stars stated in the table. And I request that allowance be made for the great difficulty of such observations; and that the novelty of the experiments, the few opportunities that I have had of repeating them on an extensive scale, together with the great nicety requisite where small quantities are concerned,—may apologize for the rude and imperfect manner in which the observations have been conducted.

If the future observations of more able persons should confirm my own, I shall be glad to see them in detail: if they should be confuted, the very detection of the cause of the error may lead on to the knowledge of some other fact of use in the very curious investigations now going forward as to the nature of light. At all events they have afforded me, and may afford to others, agreeable amusement during the long and dreary winter nights of this miserable country.

In the following table I assume the apparent altitude of the stars above the horizon at the time of observation to be 10° , and the barometer $0^{\text{m}}.760$:—the centigr. thermometer $+10$. Under which circumstances we may estimate the mean refraction as $5' 19''.10$, according to the formulæ determined by Laplace, and published in the *Connaissance des Temps*. Now presuming this to be the real mean refraction, and believing also that it equals the refraction of *Capella*, the figures put down in column 3 of the following table, indicate the quantities of refraction to be added to or subtracted from the above-mentioned mean, in order to get the true refraction of each of the stars

stars named in column 1. Thus the stars which I have put above *Capella* in the column require a greater, and those below him a less correction for 10° of altitude than $5' 19'' \cdot 10$, and probably in nearly the proportions indicated in the scale. The particular methods I have used, both for obtaining the spectra and for measuring the deviation of the extreme rays, being one I believe of my own discovery, and which I am not yet sufficiently confident in,—I do not at present think it necessary to disclose, because I intend to make it the subject of a future communication. It has been overlooked, I am persuaded, from its simplicity, in consequence of that fatal though common error of the human understanding, whereby we so frequently dig deep for the discovery of objects that lie near the surface and are overlooked. All I desire is, to learn from those who have better means than I possess of making the experiments, whether astronomical observations on those stars which are conveniently situated for determining the refraction, shall be found to confirm or to refute what appears to have been ascertained as probable from the employment of a very different mode of investigation.

TABLE.

Names of Star.	Apparent prevailing Colour.	Propor. Refr. at 10° alt. estimating the mean Refr. as $5' 19'' \cdot 10$.
Lyra	Blue	$6'' \cdot 50$
Spica	Blue	$6 \cdot 0$
Sirius	White	$5 \cdot 50$
Aried	Whitish	$4 \cdot 0$
Atair	Whitish	$2 \cdot 50$
Procyon.....	Yellowish white	$2 \cdot 20$
Rigel	Yellowish white	$2 \cdot$
Capella	Yellow	$0 \cdot$
Regulus.....	Reddish white	$1 \cdot$
Arcturus ...	Orange red	$4 \cdot$
Alpliard.....	Reddish	$4 \cdot 50$
Betalgeus ...	Red	$4 \cdot 50$
Aldebaran ...	Reddish	$7 \cdot$

Observe: In the above table the quantities put down are not asserted with any degree of positiveness, but are merely submitted, as being what the measurements of the various spectra seem to indicate.

The colour in the second column is merely the general appearance of the star as to colour when viewed in the manner already described, before the rays meet in a focus in the telescope; and is of no particular utility, otherwise than by reminding the reader of the general varieties of colour of stars.

I have not detailed the peculiarities of the coloured spectra, from want of time, and because the detail would take up too much space in your valuable Magazine. But I have given the results, as nearly as I could estimate them, in column 3.

The following seems to be the order of the refrangibility of the planets: but I have not been enabled to state any proportions, as the principal method employed to disperse the light of the stars will not disperse that of planets.

Planet.	Colour.	Whether the Propor. Refr. is + or - the mean.
Moon	Bright white.	+
Venus.....	Bright white.	+
Jupiter	Greenish-yellow white.	+
Saturn.....	Dull white.	=
Mercury.....	Reddish.	-
Mars	Very red.	-

} Proportions unknown.

Thus the Moon requires the most, and Mars the least correction for refraction.

I shall conclude this paper with some miscellaneous observations on a mode of producing colours by vibration of the telescope; merely to show that by almost any means that we employ to separate the rays of starlight, the results show that stars differ from each other essentially in the composition of their light, and that there is a correspondence in the results, of experiments of very different sorts; so that what we perceive is a real and not an imaginary difference.

In a future paper I hope to present you with some curious observations on extraordinary or *special refractions*, which have happened occasionally in consequence of remarkable atmospheric changes. I shall also send for a future Number, a Catalogue of Stars, on which no accurate observation can be made on their proportional refraction, and the causes why we cannot make them; as for example, *Algol, Castor, Antares*, and others. I write my observations hastily, and from my first impression of the subject, in order that I may induce others to observe and obtain information either in corroboration or refutation of my notions.

Vibration producing the primitive Colours.

I have noticed a most remarkable method of separating the light of certain stars by means of rapidly altering the position of the glass. In order the more easily to explain this method, I must be a little prolix. The experiment of producing a ring of light like a circular band or wheel, by means of twirling round a piece of lighted wood tied to a string, is well known, and is commonly practised by children. Now by causing the telescope to gyrate in such a manner, on the swivel on which it is mounted capable of being moved in all directions, as to cause the star viewed at the time to describe a circle; we obtain a luminous ring in the field of view of the telescope, instead of a luminous point. Now there is nothing very remarkable in this optical experiment, as far as it goes; for we can produce various figures very easily, according to the direction in which we move the telescope at the time we are observing a star. Thus, if we move it rapidly from one side to the other horizontally, instead of seeing a luminous point, the star will appear like a horizontal line of light. If we gyrate it round and round, we shall view a circle of light; and so on. This is easily understood, and the effect is commonly referred to *deceptio visus*. But I have now to introduce to notice a very extraordinary phænomenon connected with this simple experiment. Observing *Lyra* one evening, while I gave the telescope the gyrating motion described, I noticed that the ring of light produced was not uniform in colour, as is the case when we twirl round a blue candle or a piece of lighted wood on a string. The ring of light produced by the rapid apparent gyration of *Lyra* in the glass was separated into the prismatic colours, each colour seeming to occupy a certain portion of the circular ring of light. Now by observing which colour was most intense and occupied the largest portion of the ring, I endeavoured to ascertain the relative proportions of the primitive rays, as these coloured portions of the ring seemed to correspond to the primitive colour of which the star is composed, and which we see when the light is separated by the prism adapted to the telescope. Thus the blue was the most conspicuous in *Lyra*: for though the successive portions of the ring were red, yellow, green and indigo; yet all these colours were weak compared with the blue. I should have thought the whole of this phænomenon of no moment, had not the colours thus produced varied in the case of different stars. I tried the experiment immediately on the planet *Mars*, then favourably situated for observation; and I found that the circular

cular band of light which he produced, instead of being diversified by the various colours, was always quite uniform, and resembled the light of his disk when viewed steadily in the ordinary manner. This discovery of the *different results* from viewing the planet *Mars* and the star *Lyra* in the *same manner*, gave additional interest to the experiment, for it showed that the colours were not the mere effect of the varying inclination of the glass of the telescope. I then repeated the experiment on other stars, and on the planet *Jupiter*; the results of which are as follows:

Lyra produced the blue very strong, and the red, the indigo, the green and the yellow in successively less proportions. *Spica Virginis* showed nearly the same phenomena as *Lyra*, only the blue was still more preponderating. α *Cygni* showed a preponderance of indigo, less yellow and blue. *Betalgeus* produced yellow, and intense red and green. *Sirius* showed much indigo, violet, and portions of bright white light. *Capella* much orange, red, green, and less of the more refrangible colour. *Aldebaran* principally red, with some green and very faint orange. *Arcturus* produced a much less coloured ring than the others; indeed its portions seemed to be orange and red running into each other. The planets *Jupiter* and *Mars* showed no colours at all; the rings produced by viewing them with a gyrating telescope, being only circles of light of the ordinary and uniform colour of those planets respectively. When any identical star was observed, the same colours were always produced in whatever direction I vibrated the telescope:—thus a horizontal motion produced a horizontal rod or line, one end of which was red, the other blue, the middle green, and so on.

I trust I have made myself understood, in this short and hasty account of a phenomenon which,—whatever may be its precise cause, or whatever may be the particular hypothesis in chromatics on which we may attempt to explain it,—certainly deserves future attention. For it must strike every body immediately, that however easy the explanation of the production of colours might be on optical principles, were the effects uniform, yet the following considerations must add great importance and interest to the experiments.

1. That the planets do not produce any colour when viewed by this method.

2. That the light of some fixed stars cannot be very distinctly separated by this method into the several colours, particularly *Arcturus*.

3. That the colours produced on the above method, seem generally to agree with those obtained by the adaptation of
the

the prism to the telescope in the case of fixed stars, while in the case of the planets this method will not enable us to separate the light at all.

4. That in rapid gyrations of the telescope, dark lines are produced, which intervene between the several colours: so that the circle appears broken, the several colours seem like separate portions of a circle of the same size, closely arranged in the same orbit, and being separated from each other by narrow dark spaces.

5. That when this effect of the dark intervals between the colours takes place, we always observe other narrow spaces of intense white light, also interposed between the colours, and bordering on the dark spaces.

6. These dark spaces cannot be obtained distinctly from the light of *Arcturus*, and only in a very slight degree from that of *Aldebaran* and *Betalgeus*.

The motion of the glass of the telescope through which the light of the star passes, certainly produces the colour; and this inclined me to think that the alternate colours before noticed are produced by some motion in the atmosphere, as I have hinted at in your Number for March, p. 198.

Does the fact that *Arcturus* resembles the planets, in not affording the colours in any great degree, afford grounds for considering him as the nearest of the fixed stars, and that distance of the stars is one cause of the disposition of the light to be easily separated?

I intend to offer some observations on the effects of refraction and reflection combined, in a future Number.

I have been at the trouble, lately, of comparing the declinations of the thirteen stars of the above table, as given by seven different observers; and I find that, generally speaking, the greatest differences of results have occurred in those stars whose proportionate refrangibility is the greatest and the least; and that the differences of results have been the least in *Capella* and those stars whose refrangibility is nearest to the mean*.

P. S.

* I noticed with great interest the observation of Prof. Bessel respecting the habits of observing, as agreeing with what Maskelyne recorded of his very accurate assistant, who from August 1795 began to set down the transits $\frac{1}{2}$ '' of time later than hitherto, and continued to increase till he at length put them down $\frac{3}{10}$ '' too late. This sudden alteration in the time of recording observations has occurred before. The causes of it lie deep in the nature of the mind itself, and, I believe, do not depend on the instruments, or on any derangement of the apparatus. When, however, we speak, as we must do in ordinary language, of such errors being in the mind, we say very little as to the particular cause of them. Astronomers in general may not admit, but I am persuaded those who are physiologists will be prepared to understand what I am going to say on this subject, which has long been in my mind. The error

P. S. I should like much to know the truth of an opinion I have heard broached, that Dr. Bradley deduced his tables of

error is owing to an actual change in the brain, either from nervous disorder and from increasing age, or, as I think may happen in some instances, from a change of activity from one to the other hemisphere of the brain. All the cerebral organs are double, and the organ of time among the rest. Now, if the action of the hemispheres respectively does not exactly correspond, we may conceive an error to be invariably produced, by the left hemisphere, for example, taking the duty long performed, by the right hemisphere. For physiologists have shown strong reasons for thinking that the double organs do not both act at once; but alternate at long periods of time and thus relieve one another. Of course this explanation is conjectural, and only founded on analogies that none but phrenologists can readily enter into. Nevertheless, the discussion of these subjects is the best way to arrive at truth. And astronomers will excuse me for introducing a subject not properly belonging to that science; since it tends to show the cause of the error complained of, and since the healthy condition of our organs of sense and the brain is quite as necessary as is the perfection of optical instruments to correct observation.

I may mention here another curious fact,—that if certain persons accustomed to observe with the right eye, begin to use the left, they at first are liable to put down an excess \pm of altitude. This has been explained, though unsatisfactorily, as follows:—The two eyes are seldom so exactly alike as that they shall both give the object viewed the same elevation; although from habit when *both* eyes are open we see but one object. Now it may appear at first view, that this circumstance would not produce an error, inasmuch as *all* objects being elevated or depressed alike by each eye, the altitude of a star viewed with the left eye would appear at the same *relative* distance from the horizon, as when viewed with the right eye, with which we had been accustomed to view it. This seems good reasoning at first, but the fallacy of it consists in this: that though when we change the use of the more to that of the less elevating eye, the distances of all the objects bear the same relative proportion *to each other*, yet no particular object appears at the same relative distance, as it before did, from the place where we conceive the horizon or any other terrestrial objects to be, *by the sense of touch*. And this circumstance, unperceived by ourselves, creates a sort of confusion in the mind, that perplexes one in the record of small quantities, so as to produce error. The surplus of elevation given by one eye over and above that of the other, whatever inequality exists, may be measured, in cases where we can induce temporary double vision, or by looking alternately with each eye, or by looking through a telescope with one eye, and at the same object with the other eye naked. But the discordance varies with the particular inclination of the eyes. Now I am dissatisfied with the above explanation, because the use of the micrometer would prevent any such error from such a cause: and I am inclined to refer it to the parts of the brain in connexion with the eyes, called by the physiologists organs of space and size. For if those organs in one hemisphere did not correspond in action to those in the other, a change to the use of the other side might cause the observer actually to perceive differently the quantities of space. The organs of the left side, for example, might not perceive such small quantities of space as those on the right. All this is very obscure and hypothetical at present, and we must be very careful not to perplex our observations of phenomena, by obtruding too hastily any theoretical explanations of their physical causes.

refraction,

refraction, chiefly by observation of *Capella*? If this turn out to be the case, it would become exceedingly curious, as by numerous experiments the refractions of *Capella* appear to me to equal the mean refraction, and that of *Lyra* and *Aldebaran* the two extremes.

Hartwell, April 16, 1824.

LVI. *Remarks on the Theory of the Figure of the Earth.*

By J. IVORY, Esq. M.A. F.R.S.

IT is not my intention to trace minutely the various labours of philosophers on the Figure of the Earth, but to state concisely the present mathematical theory on that subject, and to add some observations upon it.

1. To whatever branch of the philosophical system of the universe we turn our attention, we are immediately led to the immortal author of the true theory founded on the law of universal gravitation. Newton not only laid down the principles: he, in a great measure, reared the superstructure; or, at least, he sketched out so accurately the proper view to be taken of every part of the subject, that his followers have done little else but fill up his original outlines. The modern theory of the figure of the planets, still imperfect in some respects, coincides in the main with the physical ideas of Newton, which the progress of the mathematical sciences has enabled the philosophers of the present day to develop and extend.

It is supposed in the *Principia*, that the earth is a mass of homogeneous fluid, the particles of which attract one another in the inverse proportion of the square of the distance. If there were no rotatory motion, the only figure consistent with the equilibrium of the attractive forces, would be a perfect sphere. But as the earth revolves upon an axis, a centrifugal force is communicated to the particles of the fluid, causing them to recede from the axis, and changing the sphere into a figure oblate at the poles and protuberant at the equator.

The proportion of the centrifugal force to gravity is easily found. Every point of the equator describes, in a second of time, a circular arc having its versed-sine equal to 0.67 of an inch; which is very nearly $\frac{1}{288}$ of $16\frac{1}{12}$ feet, the space through which a heavy body falls in the same time. Hence the centrifugal force is $\frac{1}{288}$ of the observed gravitation; or $\frac{1}{288}$ of the attractive force that would prevail if the earth preserved its figure and were at rest.

In the question of the figure of the earth we may therefore suppose a sphere consisting of a homogeneous fluid, at rest

and consequently *in equilibrio*; and we may inquire what change of form will ensue in consequence of a rotatory motion causing a centrifugal force very small in proportion to the gravity. The problem is considered in this view in the *Principia*; but no investigation is given of the nature of the oblate figures that will have their particles *in equilibrio* by the action of the attractive and centrifugal forces. Newton tacitly assumes that the fluid sphere, in the nascent change of its form, will become a spheroid such as is generated by the revolution of an ellipse about the less axis. The meridians of the quiescent sphere are thus, in the revolving figures, changed into ellipses having the greater axis in the equator. But whether this assumption was made merely because the ellipse is the most simple of oval figures, or for some other reasons, it would be in vain to inquire.

Supposing therefore that the oblate figures caused by the centrifugal force are elliptical spheroids, we have still to determine the relation between the protuberance at the equator, and the observed velocity of rotation. Now this research is greatly assisted by the consideration that the spheroids are very little different from spheres. For, according to the general law that regulates the small variations of mathematical quantities, the centrifugal force at the equator and the difference between the equatorial and the polar diameters, will always have the same proportions to the gravity and the polar axis, so long as we can neglect the squares and other powers of the first two quantities. It is sufficient therefore to determine what these proportions are in some given figure. Newton takes the case of the spheroid that has the polar axis equal to 100 parts, and that of the equator to 101 of the same parts; and he computes that the gravity of a particle placed at the pole, is to its gravity at the equator as 501 to 500. He next supposes two columns of the fluid reaching from the centre of the spheroid, one to the pole, and the other to the equator; and as any two particles similarly placed in these columns will have their gravities in the constant proportion of 501 to 500, it follows that the total weights will be to one another as 501×100 to 500×101 , or as 501 to 505. Wherefore, if we suppose the spheroid at rest, the equatorial will preponderate the polar column; but, if we suppose a rotatory velocity sufficient to diminish the gravity of the particles in the equatorial column by its $\frac{4}{300}$ part, the weights of the two columns will just balance one another, and the revolving spheroid will be *in equilibrio*. Thus, when the protuberance at the equator is $\frac{1}{100}$ of the polar semi-axis; the centrifugal force requisite to the equilibrium is $\frac{4}{300}$ of the gravity at the equator,

equator, the first fraction being $\frac{5}{4}$ of the other. But, in the case of the earth, the centrifugal force is $\frac{1}{2889}$ of the gravity at the equator; and hence, by applying what has just been proved, the equatorial protuberance will be $\frac{5}{4} \times \frac{1}{2889}$, or $\frac{1}{230}$ of the semi-axis of revolution. It follows therefore that the polar axis of the earth is to the equatorial diameter, nearly as 229 to 230.

Newton's determination of the figure of the earth is justly liable to objection in assuming, without proof, that the fluid sphere changes into an oblate elliptical spheroid by the action of the centrifugal force. It is also defective in considering only the extreme case of a fluid mass perfectly homogeneous. It even appears that the illustrious author had not reflected with his usual accuracy on the consequence of an increase of density towards the centre; for he supposes that it would be attended with a greater oblateness of the spheroid; which is contrary to what actually happens, as was first proved by Clairaut.

2. Huyghens considered the figure of the earth in a different point of view, which deserves to be mentioned on account of its connection with the true theory. His attention was first drawn to this subject by the variation in the length of the seconds' pendulum in different latitudes, which was discovered by Richer in 1672. Huyghens immediately perceived that this phænomenon was caused by the centrifugal force at the earth's surface; which increases in approaching the equator, lessens the power of gravity, and retards the time of the pendulum's vibrations. It also occurred to him that if the earth was a perfect sphere, a plumb-line would not be at right angles to the sea, or to the surface of standing water, but would be drawn a little aside from the perpendicular by the centrifugal force. Hence a light body in still water would not press perpendicularly upon the surface, and consequently could not be at rest; which is contrary to experience. Huyghens therefore argued that the earth was not spherical, but protuberant at the equator, in order that the terrestrial meridians might be every where perpendicular to the plumb-line. He seems not to have carried his speculations on this subject further, till after the publication of the *Principia*; when, by adopting Newton's method of equalizing the weights of all the columns reaching from the centre to the surface, he was enabled to determine the figure of the terrestrial meridians. His solution of the problem was first published in an Appendix to a posthumous tract on the cause of gravity. Rejecting the Newtonian principle of an attraction between the particles, he places, in the centre of the mass, a force attracting the particles with the same intensity at all distances: and he

he proves that a homogeneous body of fluid revolving upon an axis will be *in equilibrio* when it has the figure of an oblate spheroid very little different from a sphere, the ellipticity being $\frac{1}{2}$ of the proportion of the centrifugal force to the gravity at the equator. In the hypothesis of Huyghens the ellipticity of the earth would therefore be $\frac{1}{2} \times \frac{1}{289}$, or $\frac{1}{578}$, instead of $\frac{1}{230}$ which it is in the theory of Newton.

The centrifugal force remaining very small in proportion to gravity, if we suppose that the attractive force placed in the centre varies as some power, or even as some function, of the distance, we shall still find the same ellipticity as when the central attraction acts with the same intensity at all distances. For, on account of the near approach of the figure of equilibrium to a sphere, the variations of the central force at the surface will introduce into the equation of the spheroid no quantities but such as are of the second order, which are to be neglected.

In the Newtonian law of attraction, if we suppose a revolving fluid mass, which increases in density towards the centre, to be *in equilibrio*, it is proved that the ellipticity will be less than in the case of a homogeneous fluid; and the denser we suppose the matter near the centre, the more will the ellipticity decrease. If the matter at the centre be infinitely dense, we fall upon the hypothesis of Huyghens; which is therefore one extreme case, the other extreme being the supposition of a homogeneous fluid. The ellipticity of Huyghens, or $\frac{1}{2}$ the proportion the centrifugal force to the gravity at the equator, is therefore the least possible; and that of Newton, or $\frac{1}{4}$ of the same proportion, is the greatest. It is extremely improbable that Nature will coincide with either of the extreme cases; and accordingly all the observations agree in giving the earth a mean figure between the two limits.

3. About 48 years after the publication of the *Principia*, Mr. Stirling communicated to the Royal Society of London two elegant propositions, in which he proved the legitimacy of Newton's investigation of the equilibrium of a homogeneous fluid revolving about an axis. Two years afterwards Clairaut, in two papers sent to the same learned body, treated the same subject more fully, demonstrating the accuracy of the conclusions obtained in the *Principia*, and extending his researches to spheroids composed of strata of different densities. In 1740, or 53 years after the publication of Newton's work, Maclaurin's Dissertation on the Tides appeared, forming a remarkable epoch in the history of this department of science. He proved, by the most elegant and accurate geometry, that
a homo-

a homogeneous fluid mass, having the form of an oblate elliptical spheroid, will be *in equilibrio*, when it revolves upon its axis in a proper time. The attractive forces acting at every point of the spheroid; the rate of the diminution of gravity from the pole to the equator; and the relation between the ellipticity and the centrifugal force; are all determined with great simplicity and elegance. It follows from the researches of Maclaurin that, for every degree of ellipticity, there is only time of revolution; but D'Alembert, considering the equation between the ellipticity and the velocity of rotation, afterwards found that, when the latter quantity is given and the former is sought, the problem admits of two different solutions.

In 1743, Clairaut published his *Théorie de la Figure de la Terre*. This is a work of the greatest merit and elegance, containing many new results, and treating every part of the subject in a full and satisfactory manner. In the case of homogeneous spheroids Clairaut abandons the method followed in his first researches, and adopts that of Maclaurin. But, with respect to spheroids composed of strata of different densities, he admits the hypothesis of a small ellipticity, which simplifies the investigation, and is sufficiently exact for determining the figure of the planets.

In all these researches the oblate elliptical spheroid is alone considered; and the question is to prove that it will be *in equilibrio* when it revolves upon its axis. Maclaurin solved the problem generally and accurately in the case of the homogeneous spheroid. In all the other solutions the supposition of a very small ellipticity is admitted; and therefore the results are approximately, and not rigorously, proved. But the theory was imperfect unless the investigation could be extended so as to take in all the possible figures of equilibrium, or until it was shown that the elliptical spheroid alone fulfilled the conditions. This brings us to the researches of Legendre and Laplace; but as the discoveries of these eminent geometers were deduced from the hydrostatical theory of equilibrium, it is necessary to notice briefly the progress made in this part of the subject.

4. When the effect of the centrifugal force to shorten the seconds' pendulum in approaching the equator, was first discovered, Huyghens immediately inferred that the terrestrial meridians were not circular; and, in order to determine the true figure, he assumed the principle that they must be perpendicular to the direction of gravity. Newton investigated the figure of a homogeneous fluid turning upon an axis,

by

by equalizing the weight of all the columns of fluid drawn from the centre to the surface. There is no doubt that both these conditions are indispensable to the equilibrium of a fluid mass. But Bouguer remarked that they were not always reconcilable in the same figure; and hence he concluded that those figures only were *in equilibrio* in which both the conditions were fulfilled. Clairaut afterwards showed that the equilibrium of a fluid was not always ensured even in those cases when both the principles of Huyghens and Newton led to the same figure. Maclaurin adopted the more general and undoubted principle, that every particle is *in equilibrio* when it is pressed equally in all directions. But we are indebted to Clairaut for the discovery of the general equations of the equilibrium of a fluid mass, whether homogeneous, or composed of parts of different densities. Finally, Euler brought this theory to the more simple form in which it is now taught, by deducing the equations of Clairaut from the principle of an equal pressure in all directions.

The conditions required by the hydrostatical theory for the equilibrium of a fluid mass are these: 1°. All the particles of the same density must be arranged in distinct strata. 2°. The resultant of all the forces acting upon a particle must be perpendicular to the level stratum, or *couche de niveau*, in which the particle is placed. These conditions will be fulfilled if all the level strata be defined by the same equation, the arbitrary quantity introduced in the integration alone varying from one stratum to another; and the same quantity representing always a certain function of the density.

In the case of a homogeneous fluid, the distinction of the level strata arising from the difference of density is lost; and then the only conditions requisite to the equilibrium are contained in this proposition: The resultant of all the forces acting upon a particle in the outer surface must be perpendicular to it; and the differential equation of the same surface must be an exact fluxion.

Now if, with Newton, we suppose a sphere of a homogeneous fluid, originally at rest; and inquire what will be the nature of the oblate figures produced by the rotation upon an axis; it is manifest that we shall only have to fulfill the single condition, that the gravity be every where perpendicular to the meridians. This problem was first solved by Legendre in 1784, but only upon the supposition of a very small oblateness. After the lapse of a century, the conditions of equilibrium assumed by Newton were thus not only verified, but completely demonstrated; since it was shown that the equilibrium

brium is not possible but when the fluid has the figure of an elliptical spheroid. Laplace generalized and perfected the analysis of Legendre, which is founded on the properties of a particular kind of functions. The same illustrious geometer likewise discovered an equation in partial fluxions relating to the attractions of spheroids little different from spheres, which takes place at their surfaces. Availing himself of all these resources, Laplace was enabled to give a complete theory of the figure of the planets, and of the variation of gravity at their surfaces, which the reader will find explained at length in the third book of the *Mécanique Céleste*.

5. On reviewing all the researches relative to the figure of the earth, it is remarkable that the discoveries of Maclaurin stand apart by themselves, without much connection with the rest. His method applies only to homogeneous spheroids; but of this case it furnishes an accurate and a general solution. All the other attempts to solve the problem are merely approximations founded on the supposition that the spheroids are not much different from spheres. As was observed by Mr. Stirling, they do not accurately determine the figures of equilibrium; they only show that these figures will coincide with elliptical spheroids when we neglect the squares and higher powers of the ellipticities.

If the conditions of equilibrium assigned by the hydrostatical theory were accurate and sufficient, we should expect that the discoveries of Maclaurin would be deducible from them. Yet this has been accomplished by no geometer. Nay, when we push the approximation to the figure of equilibrium beyond the quantities of the first order, the elliptical spheroid seems to be excluded. It also appears unaccountable that the solution of Legendre, supposing that it is deduced from a sufficient theory, should bring out only by approximation a figure which we know will accurately fulfill all the conditions.

These reflections, and others which it is not important to mention, induced me to examine very narrowly the hydrostatical theory of equilibrium. I distinguished two separate cases; one, when there is no attraction between particle and particle; and the other, when the particles are endowed with mutual attractive powers.

As an example of the first case, we may take Huyghens's hypothesis respecting the figure of the earth; in which every particle of the fluid is acted upon by a centrifugal force, and a constant attraction directed to the centre. The equilibrium of the revolving mass requires that the resultant of the two

forces acting upon every particle in the outer surface, shall be perpendicular to that surface; and we may suppose that this condition is expressed by the equation

$$\phi = C;$$

where ϕ is a function of the three rectangular co-ordinates of a point in the surface, and C an arbitrary quantity introduced in the integration. All the level surfaces will be determined by the same equation, the function ϕ remaining the same, while C decreases by insensible degrees: whence it follows that the resultant of the accelerating forces will be perpendicular to every level surface; and that every level stratum will press equally upon the fluid below it. In this first case therefore, in which the level strata act upon one another only by pressure, there is no doubt that all the conditions of equilibrium are contained in the equation of the outer surface; which is agreeable to the received theory.

We may next suppose, as in Newton's theory of the earth, a homogeneous fluid mass subjected to a centrifugal force, and to an attraction between the particles in the inverse proportion of the square of the distance. The condition that the resultant of the accelerating forces is perpendicular to the outer surface, will, as before, be expressed by an equation, viz.

$$\phi = C:$$

and the several level surfaces will be determined by making C decrease by insensible degrees. In the interior of the fluid body, the gravitation, or the resultant of the accelerating forces, at any level surface, will be perpendicular to it; and hence the thin level stratum immediately above, will press equally upon the fluid below. But it is to be observed that the pressure is caused by the gravitation at the level surface acting upon the matter of the thin stratum above, and that it is independent of any active forces inherent in the matter of the stratum. Wherefore, since every particle attracts every other particle, the level stratum will act upon the fluid below it both by pressure and by attraction; and, in this respect, there is an essential difference between the present case and the former one. There are here two distinct forces independent of another; and the adjustment of the equilibrium requires that both be taken into account. The equality of pressure is a consequence of the equation of the outer surface; but the equilibrium with respect to the attractive forces of the stratum can be obtained only by supposing that the stratum has such a figure as to attract all particles in the inside with equal forces in opposite directions. The received theory is therefore defective and insufficient in the case of a homogeneous fluid

fluid consisting of attracting particles. The full conditions requisite to the equilibrium of such a fluid mass are these: 1°. The resultant of the accelerating forces must be perpendicular to the outer surface, and the differential equation of the same surface must be an exact fluxion; 2°. Every level stratum must be possessed of such a figure as to attract all particles in the inside with equal forces in opposite directions.

Let us now consider the equilibrium of a fluid mass differently; in the method of Euler, and as it is treated in most of the elementary works. For this purpose we must find the conditions requisite to the equilibrium of a rectangular parallelepiped of the fluid placed any where in the mass. The forces in action are: 1°. the pressures upon the six faces tending to compress the fluid into a less space; 2°. the accelerating forces acting upon the particles of the parallelepiped. If the latter forces be resolved into three sums perpendicular to every two faces of the parallelepiped; it is obvious that each sum must, in the case of an equilibrium, be equal and opposite to the difference of the pressures upon the same two faces. Three separate equations are thus formed; and by combining them, we deduce the value of the differential of the pressure; and again, if we suppose the pressure constant, we obtain the equation of the level surfaces. Nothing can be clearer or more simple than this procedure, when there is no attraction between the particles. In this case it is unquestionable that all the forces in action are taken into account, and no objection can be made to the accuracy of the result. But when the particles attract one another, some reflection will show that there is an omission. In estimating the accelerating forces, the attraction of the exterior matter upon the parallelepiped is alone considered, while the attraction of the particles of the parallelepiped upon the exterior matter is neglected. Although it is supposed that the parallelepiped is indefinitely small, yet, as the attraction of its particles is extended to all the fluid mass, an accumulated force is produced comparable to the pressure, and which must not be omitted in adjusting the equilibrium. When all the forces acting upon the parallelepiped; both those extrinsic to its own matter, and those inherent in its particles; are taken into account, the same conditions of equilibrium will be obtained that have already been found by the former investigation.

The proofs of the new theory of the equilibrium of a fluid consisting of attracting particles, are fully detailed in a paper sent to the Royal Society in November last, and which will appear in their Transactions for the present year. Having

obtained the true conditions necessary to the equilibrium of a homogeneous fluid, there is no longer any difficulty in deducing from them what was proved synthetically by Maclaurin. The peculiar analysis of Legendre and Laplace is no more than a modification of the exact equations of the equilibrium, when we neglect the square and higher powers of the oblateness of the spheroid.

In those remarkable propositions, which never can be too much admired, where Newton treats of the attractions of spheres and spheroids, he proves that a particle placed any where within a hollow spherical shell uniformly dense, will be *in equilibrio*, or will be attracted equally in opposite directions. The same conclusion has been extended to a hollow shell of homogeneous matter bounded by any two elliptical surfaces similar to one another. This curious property is noticed by all the writers on attraction; but it seems to be viewed as belonging accidentally to elliptical spheroids. The new theory shows its connection with the equilibrium; for the hollow shell is no other than a level stratum of a homogeneous fluid *in equilibrio*.

The paper above alluded to treats only of homogeneous fluids. But the same principles likewise apply when the mass is composed of strata of variable densities, as I shall be able to show on another occasion. A great advantage arises from knowing the true equations of equilibrium, in shortening the demonstrations, and in clearness and precision. When the equations can be solved, the exact figures of equilibrium are obtained, as in the case of a homogeneous fluid; otherwise, the analytical method of approximate solution must be employed.

JAMES IVORY.

May 5, 1824.

LVII. *Examination of the Divisions of REICHENBACH'S Circle at the Observatory of Königsberg.* By M. BESSEL.*

I HAVE applied to this instrument the same method by which I have formerly determined the errors of the divisions of Cary's circle, with such changes only as the nature of its construction required. Cary's circle is read off by microscopes, and one of them, together with another expressly constructed for the purpose of examination, is sufficient for investigating the errors of division. Reichenbach's circle has

* Translated from the viith section of M. Bessel's *Astronomical Observations*.

no microscopes, but verniers; and instead of one additional microscope, two must be applied. But these microscopes cannot be fixed any where but on the alhidade circle; and from this circumstance a change of the angle between them may arise, for the alhidade circle is attached to the principal axis of the instrument; and as there must always be a little play between this axis and its collar, their centres will not always coincide; and this accidental eccentricity will be mingled with the errors of division which are the objects of investigation, and destroy the accuracy of their determination. In order to avoid the effect of this eccentricity, it is necessary to determine the means of the errors of points diametrically opposite, which may be done by means of four microscopes so placed that two diameters determined by them inclose the angle which is to be examined. An apparatus of this description, made by M. Pistor, has been used on this occasion; the microscopes are so constructed that by proper solid clamps they may be fastened to any point of the alhidade. I have in the first place determined the angles from 15° to 15° ; next I have bisected these angles; and lastly, again bisected the angles of $22^\circ 30'$, and thereby determined all the errors of the divisions of those diameters which belong to multiples of $3\frac{3}{4}^\circ$; for every diameter I have taken the mean of the two divisions which belong to it and likewise the preceding and following ones, so that each diameter is determined by the mean of six divisions. In order to obtain the angles of the form $n \cdot 15^\circ$ with the greatest accuracy, and free from all accumulation of error, I have changed the position of the microscopes four times, making the angle between them successively 60° , 45° , 30° and 15° . In all these positions the first microscope was placed on the points 0° , 15° , 30° , ... 330° , 345° , and the other three microscopes read off; each of these four sets of observations was repeated on three different days in such a manner, that the angles were brought under the microscope, not in any regular succession, but entirely without any order, by which means I intended to destroy the effect of a change of temperature of the instrument. I denote the error of division of the point u of the circle with the sign with which it is to be added to the reading of the circle by ϕu and $\frac{1}{2}[\phi u + \phi(180^\circ + u)]$ by ψu ; agreeably to this notation the single sets of observations have given the following results.

The microscopes are on the points					The microscopes are on the points				
$u, u+60^\circ, u+180^\circ, u+240^\circ.$					$u, u+45^\circ, u+180^\circ, u+225^\circ.$				
$\psi(u+60) - \psi u$					$\psi(u+45^\circ) - \psi u$				
u	July 27.	July 28.	July 29.	Means.	u	July 22.	July 23.	July 24.	Means.
0	-0'02	-0'46	-0'15	-0'21	0	+0'39	+0'76	+0'92	+0'69
15	+1'05	+1'00	+0'95	+1'00	15	-0'17	-0'18	+0'27	-0'03
30	+1'22	+0'33	+0'69	+0'75	30	+0'89	+0'77	-0'01	+0'55
45	+0'48	+0'42	+0'52	+0'47	45	+0'44	-0'19	+0'55	+0'27
60	+1'50	+1'01	+1'52	+1'34	60	+0'88	+0'36	+0'82	+0'69
75	-0'36	-0'71	-0'11	-0'39	75	+1'35	+0'98	+1'21	+1'18
90	+0'62	+0'58	+0'32	+0'51	90	-0'06	+0'26	-1'14	-0'31
105	-0'64	-1'03	-0'79	-0'82	105	-0'65	+0'36	+0'20	-0'03
120	-0'89	-0'55	-0'61	-0'68	120	-0'59	-1'61	-1'36	-1'19
135	-0'70	-0'04	-0'97	-0'57	135	-0'40	-1'28	+0'04	-0'21
150	-1'42	-0'93	-1'19	-1'18	150	-0'93	-1'10	-1'48	-1'17
165	+0'16	+0'48	+0'47	+0'37	165	-0'09	-0'22	+0'27	-0'01
180	-0'44	-1'19	-0'34	-0'66	180	+0'59	+0'76	+0'93	+0'76
195	+1'40	+0'88	+1'03	+1'10	195	+0'83	+0'28	+0'51	+0'54
210	+0'93	+0'33	+1'20	+0'82	210	+0'31	+0'73	+0'37	+0'47
225	+0'30	+0'30	+0'36	+0'32	225	-0'50	-1'44	-0'95	-0'96
240	+1'36	+2'55	+1'19	+1'70	240	+0'86	+2'04	+0'33	+1'08
255	0'00	-0'52	+0'27	-0'08	255	+1'14	+0'33	+0'88	+0'78
270	+0'20	+0'64	-0'07	+0'26	270	+0'33	+0'51	+0'14	+0'33
285	-0'55	-1'07	-0'97	-0'86	285	+0'43	-0'15	+0'42	+0'23
300	-1'51	-1'37	-1'62	-1'50	300	-1'75	-0'53	-0'56	-0'95
315	-1'39	-0'63	-1'18	-1'07	315	-0'80	-0'36	-0'49	-0'55
330	-1'55	-0'94	-0'96	-1'15	330	-1'24	-1'61	-1'08	-1'31
345	+0'25	+0'90	+0'41	+0'52	345	-1'25	-0'46	-0'81	-0'84

The microscopes are on the points					The microscopes are on the points				
$u, u+30, u+180, u+210.$					$u, u+15^\circ, u+180^\circ, u+195^\circ.$				
$\psi u+30 - \psi u.$					$\psi u+15^\circ - \psi u.$				
u	July 25.	July 26.	July 30.	Means.	u	July 31.	Aug. 1.	Aug. 2.	Means.
0	-0'37	-1'13	-0'44	-0'65	0	-1'07	-0'98	-0'24	-0'76
15	+1'22	+0'84	+0'87	+0'98	15	+0'81	+0'34	+0'65	+0'60
30	-0'38	+0'07	-0'17	-0'16	30	+0'64	+0'52	+0'25	+0'47
45	+0'12	+0'29	+0'54	+0'32	45	-0'57	-0'51	-0'48	-0'52
60	+0'84	+1'40	+0'94	+1'06	60	+1'53	+1'06	+1'02	+1'20
75	+0'07	+0'11	+0'05	+0'08	75	-0'15	+0'26	+0'21	+0'11
90	+0'09	+0'62	+0'53	+0'41	90	+0'17	-0'01	+0'23	+0'13
105	-0'19	+0'07	-0'20	-0'11	105	+0'79	+0'10	+0'59	+0'49
120	+0'31	-0'31	-0'01	0'00	120	-0'17	-0'16	-0'74	-0'36
135	-0'51	-0'13	-0'69	-0'44	135	-0'11	+0'10	+0'09	+0'03
150	-0'64	-0'52	-0'35	-0'50	150	-0'96	-0'93	-1'08	-0'99
165	-0'22	-0'35	+0'20	-0'12	165	+0'49	+0'39	-0'03	+0'28
180	+0'08	-0'07	-0'40	-0'13	180	-0'33	-0'58	-0'99	-0'70
195	+1'33	+1'20	+1'24	+1'26	195	+0'24	+0'06	+0'09	+0'13
210	-0'31	-0'23	+0'36	-0'06	210	+0'67	+0'93	+0'95	+0'85
225	-0'54	+0'26	-0'05	-0'11	225	-0'48	-0'70	-1'01	-0'73
240	+0'92	+0'54	+0'67	+0'71	240	+0'75	+0'89	+1'19	+0'94
255	+0'29	+0'13	+0'25	+0'22	255	-0'08	+0'08	+0'15	+0'05
270	+0'32	+0'29	+0'42	+0'34	270	+0'19	+0'44	+0'47	+0'37
285	-0'74	-0'72	-0'07	-0'51	285	+0'24	+0'20	+0'18	+0'21
300	-0'38	-0'04	-0'63	-0'35	300	-1'10	-0'94	-0'69	-0'91
315	-0'77	-1'10	-1'37	-1'08	315	0'00	+0'36	+0'33	+0'23
330	-0'46	-0'62	-0'91	-0'66	330	-1'15	-1'05	-1'31	-1'17
345	-0'05	-0'62	-0'78	-0'48	345	-0'20	+0'15	+0'17	+0'04

From these observations the most probable values of the errors of division are to be deduced; their number is 24, but ψu being equal to $\psi(u+180)$ they are reduced to 12, one of which may be assumed arbitrarily; I supposed $\psi 0 = \psi 180 = 0$, and obtained, by a solution adapted to the present case of the 11 equations resulting from the method of least squares, the following values:

u.		$\psi u.$	u.		$\psi u.$
0°	180°	"	90°	270°	+0.334
15	195	-0.725	105	285	+0.476
30	210	-0.435	120	300	+0.876
45	225	+0.318	135	315	+0.171
60	240	-0.503	150	330	+0.596
75	255	+0.374	165	345	-0.416

In order to appreciate the accuracy of these determinations, I remark that every error of division is as accurately determined as if it had been derived from 30.42 observations of an angle between two diameters (referred to six divisions) or 91.26 single positions of the microscopes; I find by all observations the probable uncertainty of a single reading of the microscopes to be $= \pm 0''.1825$; and therefore the probable error of $\psi(n 15^\circ) = \pm 0''.0191$.* This great accuracy is a consequence of the clearness and neatness of the divisions, the excellence of the microscopes, the regularity of their screws, and the solidity of their fastening; but at the same time the frequent repetition of the determination of the angles and their numerous crossings was necessary, in order to carry the accuracy so far beyond the limits of the accuracy of a single observation. All errors in these observations being contingent, the accuracy may be carried to an unlimited extent, certainly much further than the artist has carried it in making the divisions: the astronomer who examines his instrument according to my method, has the great advantage over the artist who divided it, that he can repeat the operation as often as he pleases; whereas the artist has to depend on the single operation of setting the apparatus for cutting the divisions, which may be done according to the quality of that apparatus with greater or less accuracy, but never with absolute correctness.

In order to determine the angles of the form $n 15^\circ + 7^\circ 30'$, I have placed the microscopes at angles of $7^\circ 30'$ to each other, and have derived the errors from a comparison with the preceding and the following numbers of the foregoing table: in

$$\cdot \left(\frac{0''.1825}{\sqrt{91.26}} = 0''.0191. - \text{TRANSL.} \right)$$

this

this operation the circle made two entire revolutions, and every angle was determined eight times as follows :

u.		August 5 and 6.				August 7 and 8.				Means.
7° 30'	187° 30'	-0.42	-0.62	-0.60	-0.40	-0.40	-0.32	-0.39	-0.50	-0.456
22 30	202 30	-0.74	-0.82	-0.59	-0.60	-0.24	-0.51	-0.60	-0.34	-0.555
37 30	217 30	-0.41	-0.27	-0.26	-0.40	-0.39	-0.02	+0.14	-0.23	-0.230
52 30	232 30	-0.05	-0.09	-0.33	-0.30	-0.45	-0.31	-0.39	-0.54	-0.308
67 30	247 30	-0.03	+0.16	+0.44	+0.25	+0.04	-0.05	+0.27	+0.36	+0.180
82 30	262 30	+0.52	+0.43	+0.61	+0.70	+0.17	+0.49	+0.62	+0.30	+0.480
97 30	277 30	+0.35	+0.45	+0.53	+0.43	+0.60	+0.62	+0.63	+0.62	+0.529
112 30	292 30	+1.52	+1.08	+1.25	+1.60	+1.29	+1.09	+0.92	+1.12	+1.234
127 30	307 30	+0.11	+0.25	+0.25	+0.12	-0.12	-0.03	+0.46	+0.37	+0.176
142 30	322 30	+1.12	+1.09	+0.98	+1.21	+1.35	+1.20	+1.26	+1.41	+1.202
157 30	337 30	+0.46	+0.12	-0.02	+0.32	+0.37	-0.14	-0.13	+0.37	+0.169
172 30	352 30	-0.32	-0.64	-0.59	-0.28	-0.44	-0.59	-0.34	-0.18	-0.423

Probable error of each mean = $\pm 0''\cdot0396$.

For determining the angles of the form $n 15^\circ \pm 3\frac{3}{4}^\circ$, the microscopes were placed at angles of $11^\circ 15'$ to each other; the observations were not continued beyond one revolution or the fourfold repetition of the angles. I obtained the following errors of division:

u.		August 9 to August 12.				Means.
3° 45'	183° 45'	-0.16	-0.39	-0.35	-0.12	-0.26
11 15	191 15	-1.06	-1.05	-1.10	-1.11	-1.08
18 45	198 45	-1.65	-1.47	-1.33	-1.51	-1.49
26 15	206 15	-0.52	-0.40	-0.16	-0.27	-0.34
33 45	213 45	+0.19	+0.26	+0.18	+0.11	+0.19
41 15	221 15	-0.12	-0.06	0.00	-0.05	-0.06
48 45	228 45	-0.44	-0.45	-0.45	-0.43	-0.44
56 15	236 15	-0.45	-0.47	-0.42	-0.41	-0.44
63 45	243 45	-0.07	+0.03	-0.18	-0.28	-0.12
71 15	251 15	+0.26	+0.40	+0.53	+0.40	+0.40
78 45	258 45	+0.49	+0.59	+0.86	+0.77	+0.68
86 15	266 15	+0.82	+0.74	+0.72	+0.81	+0.77

u.		August 9 to August 12.				Means.
93° 45'	273° 45'	-0.11	+0.07	+0.03	-0.15	-0.04
101 15	281 15	+0.53	+0.60	+0.85	+0.78	+0.69
108 45	288 45	+0.90	+1.16	+0.97	+0.91	+0.99
116 15	296 15	+1.49	+1.03	+0.76	+1.21	+1.12
123 45	303 45	+0.49	+0.46	+0.53	+0.56	+0.51
131 15	311 15	+0.47	+0.53	+0.61	+0.56	+0.54
138 45	318 45	+1.01	+0.76	+0.62	+0.87	+0.82
146 15	326 15	+0.37	+0.32	+0.50	+0.55	+0.43
153 45	333 45	-0.72	-0.79	-0.42	-0.34	-0.57
161 15	341 15	-0.15	-0.40	-0.57	-0.31	-0.36
168 45	348 45	-0.07	-0.30	-0.13	+0.10	-0.10
176 15	356 15	-0.19	-0.41	-0.10	+0.12	-0.14

Probable error of each mean = $\pm 0''\cdot0698$.

The following table contains all the errors of division successively found:

u.		ψu.	u.		ψu.	u.		ψu.
0° 0'	180° 0'	0"00	60° 0'	240° 0'	-0"50	120° 0'	300° 0'	+0"38
3 45	183 45	-0"26	63 45	243 45	-0"12	123 45	303 45	+0"51
7 30	187 30	-0"46	67 30	247 30	+0"18	127 30	307 30	+0"18
11 15	191 15	-1"08	71 15	251 15	+0"40	131 15	311 15	+0"54
15 0	195 0	-0"72	75 0	255 0	+0"37	135 0	315 0	+0"17
18 45	198 45	-1"49	78 45	258 45	+0"68	138 45	318 45	+0"82
22 30	202 30	-0"55	82 30	262 30	+0"48	142 30	322 30	+1"20
26 15	206 15	-0"34	86 15	266 15	+0"77	146 15	326 15	+0"43
30 0	210 0	-0"44	90 0	270 0	+0"33	150 0	330 0	+0"60
33 45	213 45	+0"19	93 45	273 45	-0"04	153 45	333 45	-0"57
37 30	217 30	-0"23	97 30	277 30	+0"53	157 30	337 30	+0"17
41 15	221 15	-0"06	101 15	281 15	+0"69	161 15	341 15	-0"36
45 0	225 0	+0"32	105 0	285 0	+0"48	165 0	345 0	-0"42
48 45	228 45	-0"44	108 45	288 45	+0"99	168 45	348 45	-0"10
52 30	232 30	-0"31	112 30	292 30	+1"23	172 30	352 30	-0"42
56 15	236 15	-0"44	116 15	296 15	+1"12	176 15	356 15	-0"14
60 0	240 0	-0"50	120 0	300 0	+0"88	180 0	0 0	0"00

These errors, however small, present some regularity: the greatest part of them might be represented by the form $a \sin (A + 2u)$, and be accounted for by an elliptic form which the circle may have assumed by carriage and by being screwed to the axis. There is, however, no perfect regularity, nor could it be expected, as in each diameter the mean of the contingent errors of six divisions must considerably disturb any regularity which might exist. The value of the contingent errors of the divisions I have endeavoured to determine, by comparing the mean of the three divisions employed for every point with each individual division; by this means I have found the probable deviation of every division from any law = $\pm 0''\cdot3251$. It follows from this number, which depends on the examination of 288 divisions, that according to the laws of probability there are among the 7200 divisions of the circle,

2352	the errors of which are between	0"00	and	0"25
2192	0"25	..	0"50
1295	0"50	..	0"75
588	0"75	..	1"00
205	1"00	..	1"25
55	1"25	..	1"50
11	1"50	..	1"75
2	1"75	..	2"00

There is, therefore, only 1 division out of nearly 26, where the deviation from regularity amounts to 1 second and upwards. This extraordinary accuracy in a circle of 18 inches radius appears hardly credible, and I avail myself of this opportunity

portunity to express the admiration which this high perfection has forced from me. If the probable irregularity of a diameter determined by six divisions resulting from this contingent error, $= \pm 0''\cdot133^*$, which may be somewhat increased by the errors of my own operations, be compared with the above determined errors of division, there is, on the one hand, no doubt that there is some regularity in them; on the other hand, the irregularities which occur in them are no longer surprising. But if any advantage is to be derived from their investigation for the reduction of the observations, the irregular errors of division must be separated from the regular ones; for the latter only can be taken into account as the circle is read off by verniers, which in almost every observation coincide with different divisions of the circle.

In this respect there is an essential difference between the circles with microscopes, and those with verniers: by applying my method one may entirely do away in the former the effects of the errors of division; the latter are always affected by the irregular part of the errors of division (as it is not well practicable to examine every single division), and allow only the attainment of a certain degree of precision, the more accurate determination of which is of consequence for the valuation of the final result. On the other hand, the verniers have the advantage over the microscopes by their perfect invariability, and their giving more accurate results when the observations depend on divisions which have not been examined: with the microscopes the same contingent errors always occur; with the verniers they change almost every day.

I have endeavoured to separate the irregular errors of division from the regular ones, and to determine the latter in such a manner as to allow them to be taken into account. I have best succeeded in this by considering the parts of the circle as abscissæ, and the errors as above found as ordinates; and by drawing freely with the hand, a curve agreeing with them as nearly as was consistent with continuity, having before increased the 48 errors of division above given, by means of some more bisections, which, however, deserve less confidence. I am far from believing that the ordinates of the curve will correctly represent the law of the errors of division; but I believe myself to be warranted in assuming that the application of the curve will lead nearer to the truth, than if it were neglected. Supposing the curve to be correct, the errors of those divisions should be taken from it, which coincide with the divisions of the vernier; but if on account of the possible

$$* \left[\frac{0''\cdot3251}{\sqrt{6}} = 0''\cdot1327. \text{---TRANSL.} \right]$$

errors of the verniers, and for the sake of convenience, we suppose that the coincidence always takes place in the middle of the vernier, or $2^{\circ} 15'$ from their zero point, the errors arising from this supposition will be less than the errors of the curve itself. On this supposition the curve gives for complete observations read off by four verniers, the following corrections:

Readings of the Circle.				Errors of Division.	Readings of the Circle.				Errors of Division.
35 ^o 45'	87 ^o 45'	177 ^o 45'	267 ^o 45'	0.00	46 ^o 30'	136 ^o 30'	226 ^o 30'	316 ^o 30'	+0.33
1 30	91 30	181 30	271 30	-0.08	50 15	140 15	230 15	326 15	+0.27
5 15	95 15	185 15	275 15	-0.15	54 0	144 0	234 0	324 0	+0.19
9 0	99 0	189 0	279 0	-0.16	57 45	147 45	237 45	327 45	+0.01
12 45	102 45	192 45	282 45	-0.17	61 30	151 30	241 30	331 30	-0.03
16 30	106 30	196 30	286 30	-0.08	65 15	155 15	245 15	335 15	+0.02
20 15	110 15	200 15	290 15	+0.10	69 0	159 0	249 0	339 0	+0.08
24 0	114 0	204 0	294 0	+0.25	72 45	162 45	252 45	342 45	+0.12
27 45	117 45	207 45	297 45	+0.33	76 30	166 30	256 30	346 30	+0.15
31 30	121 30	211 30	301 30	+0.33	80 15	170 15	260 15	350 15	+0.16
35 15	125 15	215 15	305 15	+0.31	84 0	174 0	264 0	354 0	+0.11
39 0	129 0	219 0	309 0	+0.32	87 45	177 45	267 45	357 45	0.00
42 45	132 45	222 45	312 45	+0.30					

LVIII. On Mr. BABBAGE'S new Machine for calculating and printing Mathematical and Astronomical Tables. From FRANCIS BAILY, Esq. F.R.S. & L.S.*

THIS invention of Mr. Babbage's is one of the most curious and important in modern times; whether we regard the ingenuity and skill displayed in the arrangement of the parts, or the great utility and importance of the results. Its probable effect on those particular branches of science which it is most adapted to promote, can only be compared with those rapid improvements in the arts which have followed the introduction of the steam-engine; and which are too notorious to be here mentioned.

The object which Mr. Babbage has in view, in constructing his machine, is the formation and printing of mathematical tables of all kinds, totally free from error in each individual copy: and, from what I have seen of the mechanism of the instrument, I have not the least doubt that his efforts will be crowned with success. It would be impossible to give you a correct idea of the form and arrangement of this machine, or

* From M. Schumacher's *Astronomische Nachrichten*, No. 46.

of its mode of operation, without the help of various plates, and a more minute description than is consistent with the nature of your journal. But, it will be sufficient to say that it is extremely simple in its construction, and performs all its operations with the assistance of a very trifling mechanical power. Its plan may be divided into two parts, the mechanical and the mathematical.

The mechanical part has already been attained by the actual construction of a machine of this kind: a machine for computing numbers with two orders of differences only, but which I have seen perform all that it was intended to do, not only with perfect accuracy, but also with much greater expedition than I could myself perform the same operations with the pen. From the simplicity of the mechanism employed, the same principles may be applied in forming a much larger machine for computing tables depending on any order of differences, without any probability of failure from the multitude of wheels employed. The liberality of our Government (always disposed to encourage works of true science and real merit) has induced and enabled Mr. Babbage to construct a machine of this kind, capable of computing numbers with four orders of differences; and which will shortly be completed. To this machine will be attached an apparatus that shall receive, on a soft substance, the impression of the figures computed by the machine: which may be afterwards stereotyped or subjected to some other process, in order to ensure their permanency. By this means, each individual impression will be perfect.

The mathematical part depends on the *method of differences* to which I have above alluded: a principle well known to be, at once, simple and correct in its nature, and of very extensive use in the formation of tables, from the almost unlimited variety of its applications. It has been already successfully applied in the computation of the large tables of logarithms in France; and is equally applicable in the construction not only of astronomical tables of every kind, but likewise of most of the mathematical tables now in use.

But, the full and complete application of this, and indeed of every other principle in the formation of tables, has been hitherto very much impeded by the impossibility of confining the attention of the computers to the dull and tedious repetition of many thousand consecutive additions and subtractions, or other adequate numerical operations. The substitution, however, of the unvarying action of machinery for this laborious yet uncertain operation of the mind, confers an extent of practical power and utility on the method of differences, unrivalled by

by any thing which it has hitherto produced: and which will in various ways tend to the promotion of science.

The great object of all tables is to save time and labour, and to prevent the occurrence of error in various computations. The best proof of their utility and convenience is the immense variety that has been produced since the origin of printing; and the diversity of those which are annually issuing from the press.

The *general* tables, formed for the purpose of assisting us in our computations, may be divided into two classes: 1°. those consisting of natural numbers: 2°. those consisting of logarithms. Of the former kind are the tables of the products and powers of numbers, of the reciprocals of numbers, of the natural sines, cosines, &c. &c. Of the latter kind are not only the usual logarithmic tables, whose utility and importance are so well known and duly appreciated, but also various other tables for facilitating the several calculations which are constantly required in mathematical and physical investigations. I shall allude to each of these in their order.

1°. Tables of the products of numbers. The numerous tables of this species which have been published at various times and in different countries, sufficiently attest their utility and importance: and there can be no doubt that, if their accuracy were undeniable, their employment would be much more frequent. One of the first tables of this class was published in "Dodson's Calculator;" and contains a table of the first nine multiples of all numbers from 1 to 1000. In 1775 this table was much extended, and printed in an octavo size: it comprehended the first nine multiples of all numbers from 1 to 10,000. Notwithstanding these and other tables of the same kind, the Board of Longitude considered that still more extended tables might be useful to science, and employed the late Dr. Hutton to form a multiplication table of all numbers from 1 to 1000, multiplied by all numbers less than 100. These were printed by their directions; and it is to be presumed that no expense was spared to render them accurate: yet in one page only of those tables (page 20) no less than forty errors occur, not one of which is noticed in the printed list of the errata. The French Government, likewise, sensible of the utility of such tables, ordered the construction of a still more extensive set for the use of several of its departments. These are comprised in one volume quarto, and extend from the multiplication of 1 by 1 to 500 by 500: and in the year 1812, they caused a second edition of those tables to be printed. But, the most convenient tables of this kind which have yet appeared were recently published at Berlin, by M. Crelle; and

and comprise, in one octavo volume, double the quantity of the French tables. Another volume, of the same size, which is announced by the same author, will render these by far the most valuable of their kind, provided their accuracy can be relied on. The quantity of mental labour saved, in the construction of such tables, by the help of the machine, is literally infinite: for, in fact, no previous calculation is at all requisite; and it will be necessary merely to put into the machine, at the end of every two pages, the number whose multiples are required. This number will be successively 1, 2, 3, &c. . . . to 500.

2°. Tables of Square Numbers. The squares of all numbers, as far as 1000, were a long time ago published on the continent by M. Lambert. These have been since extended as far as the square of 10,000 by Mr. Barlow of the Royal Military Academy at Woolwich. The Board of Longitude employed the late Dr. Hutton to calculate a similar table as far as the square of 25,400. In computing a table of this kind by the machine, even if extended to the most remote point that could be desired, the whole of the mental labour would be saved: and when the numbers 1, 1, 2 are once placed in it, it will continue to produce all the square numbers in succession without interruption. This is, in fact, one of those tables which the engine already made is capable of computing, as far as its limited number of wheels will admit.

3°. Tables of Cube Numbers. Tables of this kind have likewise been already computed by Mr. Lambert and Mr. Barlow; and also by the late Dr. Hutton, by order of the Board of Longitude. In computing such a table by the machine, the whole of the mental labour would be in this case also saved: since it would be merely necessary to place in the machine the numbers 1, 7, 6, 6; and it would then produce in succession all the cube numbers.

4°. Tables of the higher Powers of Numbers. The Board of Longitude employed Dr. Hutton also to construct a limited table of this kind; which should contain the first ten powers of all numbers from 1 to 100. And Mr. Barlow has published, in his collection, a table of the fourth and fifth powers of numbers between 100 and 1000. Should it be thought desirable to re-compute or extend these tables, the whole labour may be performed by the help of the machine, except the few figures required to be first placed in it; and which might perhaps occupy the computer about ten minutes for each power. In fact, the computation of these few fundamental figures would not occupy so much time, nor be so liable to error, as the calculation of *one* of the tabular numbers, according to the usual method.

5°. Tables of the Square Roots and Cube Roots of Numbers. A table of the first kind has been given by Mr. Lambert: and a more extended one by Mr. Barlow, in his Collection. The latter writer constructed his table by means of differences; an advantage which may be applied with greater effect to the table of Cube Roots, on account of the greater convergency of this order of differences.

6°. Tables of the Reciprocals of Numbers. These are amongst the most simple but most useful of arithmetical tables; and are peculiarly valuable in converting various series into numbers,—thus facilitating the calculation of differences for the more ready construction of other tables. In order, however, to be employed in such operations, it is absolutely necessary that they should be infallible. Several tables of this kind have been printed: the most recent and extensive of which are those of Mr. Barlow and Mr. Goodwin.

7°. Tables of Natural Sines, Cosines, Tangents, &c. The utility of tables of this kind is evident from the variety of forms in which they have been, from time to time, printed: and it is needless to insist on their importance at the present day, since no seaman dare venture out of sight of land without a knowledge of their use. In order to be of any real service, however, they should be accurate; and diligently revised from time to time: otherwise they may be worse than useless. The labour of computing tables of this kind will vary according to the number of figures contained in the result. It appears desirable that the larger tables of this sort should be printed with their several orders of differences to a much greater extent than formerly, for the purpose of making other tables, and for executing several mathematical operations beneficial to science. It would be difficult to state precisely the quantity of mental labour saved by the machine, in constructing tables of the kind; but, I believe, it may be fairly reduced to the two thousandth part of the whole.

8°. Tables of the Logarithms of Numbers. Tables of this kind are in the hands of every person engaged in numerical investigations: and it is needless to dwell on their utility and importance. The logarithms of number from 1 to 108,000 have been already computed, with a greater or less number of figures; but this has been the work of various authors, and of several successive years: the labour is so immense that no human being has ventured to undertake the whole. The tables which now exist are chiefly copies from those original and partial computations. By the help of the machine, however, this immense labour vanishes, and new tables may be readily computed and re-computed as often as
may

may be required by the public. It is probable that the present tables, if extended from 108,000 to 1,000,000 would be of greater utility than an extension of the present tables to a larger number of figures. The quantity of mental labour saved by the machine may be estimated in the following manner. Suppose a machine constructed, capable of computing with five orders of differences; it would be necessary to calculate those differences for every thousandth logarithm only: consequently, if the table extended from 10,000 to 10,0000, there would be but ninety sets of differences to compute. Any one of these sets being placed in the machine, with its first five differences, it will deliver the 500 preceding logarithms and also the 500 succeeding ones; thus producing a thousand logarithms: at the end of which term, another set of differences must be substituted. With five orders of differences, a table of logarithms may be computed to eight places of figures, which shall be true to the last figures, and it would not require more than half an hour to compute each set of differences; particularly as the higher numbers require very little labour, two or three terms of the series being quite sufficient.

9°. Tables of Logarithmic Sines, Cosines, Tangents and Cotangents. The remarks which have been made in the preceding article, will apply with nearly equal propriety to the tables here alluded to. The mental labour required for their construction by the machine is reduced to a very insignificant quantity, when compared with the prodigious labour employed in the usual way.

10°. Tables of Hyperbolic Logarithms. Some small tables of this kind have been printed in several works, and are useful in various integrations; but the most comprehensive set was computed by Mr. Barlow, which contains the hyperbolic logarithms of all numbers from 1 to 10,000. The labour of computing them is very great, which is the cause of their not being more extended. From a slight examination of the subject, it would appear that the mental labour may, in this case, be reduced by the machine to about a two hundredth part of what was formerly necessary.

11°. Tables for finding the Logarithms of the sum or difference of two quantities, each of whose logarithms is given. This table, which was first suggested by Mr. Gauss, has been printed in at least three different forms. It is extremely convenient when many similar operations are required: the whole of it was computed by the method of differences; and consequently nearly the whole of the labour may be saved by the help of the machine.

12°. Other

12°. Other general tables might also be here mentioned, which have been of great service in various mathematical investigations, and have been computed and printed by different authors: such as tables of the powers of $\cdot 01$, $\cdot 02$, $\cdot 03$, &c.: tables of the squares of the natural sines, cosines, tangents, &c.: tables of figurate numbers, and of polygonal numbers: tables of the length of circular arcs: tables for determining the irreducible case of cubic equations: tables of hyperbolic functions, viz. hyperbolic sines, cosines, &c., and logarithmic hyperbolic sines, cosines, &c. These and various other tables which it is needless here to mention, may be computed by the machine, with very little mental labour, and with the greatest accuracy.

Besides the *general* tables above alluded to, there are many others which are applicable to *particular* subjects only: the most important of which are those connected with astronomy and navigation.—When we contemplate the ease and expedition with which the seaman determines the position of his vessel, and with what confidence he directs it to the most distant quarter of the globe, we are not perhaps aware of the immense variety of tables which have been formed almost solely for his use: and without the aid of which he dare not venture on the boundless ocean. Not only must the general tables of the sun and moon be first computed, together with the various equations for determining their apparent places; but those places also for every day in the year are prepared solely for his use; and even for different hours in the same day. The places of certain stars must likewise be given: and, as these depend on precession, aberration and nutation, tables of this kind also must be formed for each star. Then come the lunar distances, which are computed for every third hour in the day; and which depend likewise on a variety of other complicated tables. After these come the Requisite Tables, published by order of the Board of Longitude, and the usual Logarithmic Tables for facilitating the computations, both of which are dependent on other tables from which they have been deduced or copied. Now, when it is considered that an error, in any one of these multifarious tables, will affect the last result, and thereby render the navigator liable to be led into difficulties, if not danger, it must be acknowledged that it is of very essential importance that all such tables should be computed and printed in so perfect a manner that they may in all cases be depended upon. This however, in the present mode of constructing them, is scarcely possible. I have myself discovered above five hundred errors in the work containing the Tables of the Sun and Moon, from which (till lately) the annual

nual volumes of the Nautical Almanac have been computed: and a respectable author has asserted that, in the first edition of the Requisite Tables, published by order of the Board of Longitude, there were above a thousand errors. Many of the subsidiary tables, above alluded to, have not been computed since they were first printed: for, the mental and even manual labour of calculating them has been so great that the world has been obliged to remain contented with those original computations: and they are consequently subject to all the errors arising from subsequent editions and copies.

In the calculation of astronomical tables, the machine will be of very material assistance: not only because an immense variety of subsidiary tables are required to determine the place of the sun, moon and planets, and even of the fixed stars, but likewise on account of the frequent change which it is found necessary to introduce in the elements from which those tables are deduced: and which vary from time to time according to the improvements in physical astronomy and the progress of discovery.

Within the last twenty years it has been found necessary to revise almost all the tables connected with the solar system: and already many of these have been found inefficient for the refined purposes of modern astronomy. But the great expense of time and labour and money has been the principal obstacle to the advancement of this part of the science: since each revision has been attended with the introduction of new equations, which consequently require new tables. And, to this day, we have not been furnished with any tables whatever of three (out of the four) new planets that have been discovered since the commencement of the present century: nor can the places of many thousands of the fixed stars be readily determined for want of the subsidiary tables necessary for that purpose.

It perhaps may be proper to state that *all* astronomical tables (with very few trifling exceptions) are deduced by the two following methods: 1°. by the addition of certain constant quantities, whereby the *mean* motions of the body are determined; 2°. by certain corrections (of those motions) which depend on the sine or cosine of a given arc; and which are called *equations* of the mean motions. The mean motions of any of the celestial bodies may be computed by means of the machine, without any previous calculation: and those quantities depending on the sine and cosine may in *all* cases be computed by the machine with the help of two previous calculations of no great length or labour, and in *most* cases with the help of one only.

In the year 1804 Baron de Zach published his Tables of the Sun: and within two years of that date, Mr. Delambre published similar tables. In 1810 Mr. Carlini published his Tables of the Sun, on a new construction: so that within the space of six years it was considered necessary by these distinguished astronomers to publish these three interesting and highly useful works.

In the year 1806 Mr. Bürg published his very valuable tables of the moon; a work which superseded the use of Mason's tables, and was rewarded with a *double* prize by the French Government. It was received with gratitude by the scientific in every nation, and opened a new æra in the history of astronomy and navigation. These were followed by the tables of Burckhardt in 1812; which are still more accurate than those of Bürg: and at the present moment, the elements of some new tables have been deduced by Mr. Damoiseau. But it is the elements only which have yet been deduced: since it is these alone which can be expected to engage the attention of the profound mathematician. Nevertheless the laborious, yet useful, operation of computation cannot safely be left to inferior hands. The merit of each is however very unequally estimated by the world. Euler had three *hundred* pounds granted him by the English Government for *furnishing the elements*, and Mayer three *thousand* for the *actual computation* of the tables of the moon, which were published by the Board of Longitude in the year 1770.

The elements of Mr. Damoiseau have been already two years before the public: but the time and labour necessary to compute the tables therefrom are so great that they have not yet appeared. In order to deduce the place of the moon from these elements, no less than 116 different equations are requisite, all depending on the sine or cosine of different arcs. The labour of computing each equation, with the pen, would be immense; and liable to innumerable errors: but, with the assistance of the machine, they are all deduced with *equal* facility and safety, and without much previous computation.

In the year 1808 Mr. Bouvard published his tables of Jupiter and Saturn: but in 1821, owing to the progress of discovery and the advancement of physical astronomy, it was found necessary to revise the elements; and an entire new set of tables was then published by this distinguished astronomer. In order to deduce the geocentric places of these planets, it is requisite to compute no less than 116 tables depending on the sine or cosine of certain arcs.

I shall not intrude further on the time of your readers by

alluding to the tables of the other planets, which are *all* liable to similar observations: but I shall take the liberty of calling their attention to those very useful tables which have from time to time appeared for determining the apparent places of the fixed stars; and which generally assume the title of "Tables of Aberration and Nutation." Tables of this kind are of vast importance to the practical astronomer, since they save a great deal of time and labour in the reduction of observations: and it is believed that many valuable observations remain unreduced, for want of convenient tables of this sort.

The first general tables of this kind were published by Mr. Mezger at Mannheim in 1778, and contained the corrections of 352 stars. In 1807 Mr. Cagnoli extended these tables to the corrections of 501 stars: and in the same year Baron de Zach published at Gotha his *Tabulæ speciales Aberrationis et Nutationis*, which contained the corrections for 494 zodiacal stars. But, already these tables have nearly outlived their utility. Independent of their very limited extent, the elements from which they were deduced, have been superseded by others more agreeable to actual observation; which together with their exclusion of the solar nutation, and other minute quantities which cannot safely be neglected in the present state of astronomy, renders these tables of doubtful utility to the practical astronomer.

The number of zodiacal stars (without including the very minute ones) is considerably above a thousand: each of which may, in the course of a revolution of the nodes, suffer an occultation by the moon. These occultations are ascertained to be visible at sea, even from the unsteady deck of a vessel under sail: and afford the surest means of determining the longitude, provided the position of the star could be well ascertained. In order to furnish the corrections for *each* star, ten equations are requisite, depending on the sine and cosine of given arcs; so that it would require the computation of upwards of ten thousand subsidiary tables in order to produce the necessary corrections; a labour so gigantic as to preclude all hope of seeing it accomplished by the pen. By the help of the machine, however, the manual labour vanishes, and the mental labour is reduced to a very insignificant quantity. For, as I have already stated, astronomical tables of *every* kind are reducible to the same general mode of computation; viz. by the continual addition of certain constant quantities, whereby the mean motions of the body may be determined *ad infinitum*; and by the numerical computation of certain circular functions for the correction of the same. The quantities depending on these circular functions, let them arise from whatever source they

they may, or let them be dependent on any given law whatever, are deducible with *equal* ease, expedition and accuracy by the help of the machine. So that, in fact, there is no limit to the application of it, in the computation of astronomical tables of every kind.

I might now direct your attention to those other subjects of a particular nature, to which the machine is applicable; such as tables of Interest, Annuities, &c. &c.: all of which are reducible to the same general principles, and will be found to be capable of being computed by the machine with equal facility and safety. But, I trust that enough has been said to show the utility and importance of the invention; an invention inferior to none of the present day; and which, when followed up by the construction of a machine of larger dimensions now in progress (by which alone its powers and merit can be duly appreciated), will tend considerably to the advancement of science, and add to the reputation of its distinguished inventor.

I have omitted to state that this machine computes, in all cases, to the nearest figure, whatever it may be. That is, after the required number of figures are computed, if the next following figure should be a 5 or upwards, the last figure is increased by unity, without any attention on the part of the operator.

But, it is not in these mechanical contrivances alone, that the beauty and utility of the machine consist. Mr. Babbage, who stands deservedly high in the mathematical world, considers these but of a secondary kind, and has met with many curious and interesting results, which may ultimately lead to the advancement of the science. The machine which he is at present constructing will tabulate the equation $\Delta^4 u_x = c$: consequently there must be a means of representing the given constant c , and also the four arbitrary ones introduced in the integration. There are five axes in the machine, in each of which one of these may be placed. It is evident that the arbitrary constant must be given *numerically*, although the numbers may be any whatever. The multiplication is not like that of all other machines with which I am acquainted, viz. a repeated addition—but is an actual multiplication: and the multiplier as well as the multiplicand may be decimal. A machine possessing five axes (similar to the one now constructing) would tabulate, according to the peculiar arrangement, any of the following equations:

$$\begin{array}{ll} \Delta^5 u_x = a u_{x+1} & \Delta^5 u_x = a u_{x+2} \\ \Delta^5 u_{x+1} = a u_x + \Delta^4 u_x & \Delta^5 u_{x+1} = a \Delta^2 u_{x+1} + \Delta^4 u_x. \end{array}$$

If

If the machine possessed only three axes, the following series, amongst others, might be tabulated,

$$\Delta^2 u_{x+1} = a \Delta u_x + \Delta^2 u_x \quad \Delta^3 u_x = a u_x.$$

If there were but two axes, we might tabulate

$$\Delta^2 u_x = a u_{x+1}.$$

These equations appear to be restricted; and so they certainly are. But, since they can be computed and printed by machinery, of no very great complication, and since it is not necessary (after setting the machine at the beginning) to do any thing more than turn the handle of the instrument, it becomes a matter of some consequence to reduce the mode of calculating our tables to such forms as those above alluded to.

A table of logarithms may be computed by the equation $\Delta^4 u_x = c$: but in this case the intervals must not be greater than a few hundred terms. Now, it may be possible to find some equation, similar to those above mentioned, which shall represent a much more extensive portion of such tables,—possibly many thousand terms: and the importance that would result from such an equation renders it worthy the attention of mathematicians in general.

A table of sines may, for a small portion of its course, be represented by the equation $\Delta^2 u_x = c$: but it may be represented in its whole extent by the equation $\Delta^2 u_x = a u_{x+1}$. Now, this is precisely one of the equations above quoted: and if a proper machine were made (and it need not be a large one) it would tabulate the expression $A \sin \theta$ from one end of the quadrant to the other, at any interval (whether minutes or seconds) by only once setting it. It would not be very complicated to place three such machines by the side of each other, and cause them to transfer their results to a common axis, with which the printing apparatus might be connected. Such a machine would, amongst other tables, compute one from the expression

$$A \sin \theta + B \sin 2\theta + C \sin 3\theta$$

the utility of which, in astronomy, is well known. In fact, Mr. Babbage is of opinion that it would not be impossible to form a machine which should tabulate almost any individual equation of differences.

Amongst the singular and curious powers produced by small additions to the machinery, may be reckoned the possibility of tabulating series expressed by the following equations:

$$\Delta^2 u_x = \text{the units figure of } u_x,$$

$$\Delta^3 u_x = 2 \times \text{the figures found in the tens place of } u_{x+1},$$

$$\Delta^3 u_x = 4 \times \text{the figures found in the units and tens place of } u_{x+1},$$

and many others similar thereto.

Again:

Again: Let the machine be in the act of tabulating any series, a part may be attached by means of which, whenever any particular figure (a 6 for example) occurs in the units place, any other number (23 for instance) shall be added to that and all the succeeding terms: and when, in consequence of this, another figure 6 occurs in the units place, then 23 more will be added to that and all the succeeding terms. Or, if it be preferred, the number added shall be added to the term ending in 6 only, and not to all succeeding ones.

These views may appear to some persons more curious than useful. They lead however to speculations of a very singular and difficult nature in determining the laws which such series follow: and they are not altogether so remote from utility as may be imagined. I avoid alluding to many other curious properties which this machine is capable of exhibiting, as they will scarcely be intelligible till the machine itself is more known in the world. Indeed I fear I have already tired your patience with this long letter.

LIX. *A brief Account of some Electro-magnetic and Galvanic Experiments.* By ROBERT HARE, M.D. Professor of Chemistry in the University of Pennsylvania.*

SEVEN hundred feet of copper wire, nearly as thick as a knitting-needle, were made to encircle the columns of the lecture room. One end of the wire was connected with one end of a large calorimotor; the other terminated in a cup of mercury—into this, a wire proceeding from the other pole of the calorimotor was introduced. Under these circumstances, a magnetic needle placed near the middle of the circuit, was powerfully affected; and when the circuit was first interrupted, and then re-established by removing the wire from the cup, and introducing it again, the influence appeared to reach the needle as quickly as if the circuit had not exceeded seven inches in extent. The needle being allowed to become stationary in the meridian, while the circuit was interrupted, and the end of the wire being then returned into the mercury, the deviation of the needle, and the contact of the wire with the metal, appeared perfectly simultaneous.

A wire was made to circulate with great rapidity, by means of two wheels, about which it passed like a band. The wheels being metallic, and severally connected with the different poles of a calorimotor, it was found that the motion neither

* Communicated by the Author.

accelerated nor retarded the galvanic influence—and it made no difference whether the needle was placed near the portion of the wire which moved from the positive pole to the negative, or the portion which moved in the opposite direction.

If a jet of mercury, in communication with one pole of a very large calorimotor, is made to fall on the poles of a horse-shoe magnet communicating with the other, the metallic stream will be curved outwards or inwards, accordingly as one or the other side of the magnet may be exposed to the jet—or as the pole communicating with the mercury may be positive or negative. When the jet of mercury is made to fall just within the interstice, formed by a series of horse-shoe magnets mounted together in the usual way, the stream will be bent in the direction of the interstice, and inwards or outwards, accordingly as the sides of the magnet, or the communication with the galvanic poles, may be exchanged. This result is analogous to those obtained by Messrs. Barlow and Marsh* with wires or wheels.

It is well known that a galvanic pair, which will, on immersion in an acid, intensely ignite a wire connecting the zinc and copper surfaces, will cease to do so after the acid has acted on the pair for some moments—and that ignition cannot be reproduced by the same apparatus, without a temporary removal from the exciting fluid.

I have ascertained that this recovery of igniting power does not take place—if, during the removal from the acid, the galvanic surfaces be surrounded either by hydrogen gas, nitric oxide gas, or carbonic acid gas. When surrounded by chlorine, or by oxygen gas, the surfaces regain their igniting power in nearly the same time as when exposed to the air.

The magnetic needle is, nevertheless, much more powerfully affected by the galvanic circuit, when the plates have been allowed repose, whether it take place in the air or in any of the gases above mentioned.

I have not as yet had time, agreeably to my intention, to examine the effect of other gases, or of a vacuum.

LX. *On the Circle.* By JOHN WALSH, Esq.

IN my last paper in your Journal †, I alluded to a proposition demonstrated by the binomial calculus. I shall state, in this paper, the nature of that demonstration. By the principles of the binomial calculus, the part of the tangent between y and y' is the binomial of u , whatever may be dx , u being

* See Philosophical Magazine, vol. lxii. p. 321. † p. 271.

the arc of any curve. Binomiating from this term, taking dx negative, and, in the binomiation, for dx substituting x , the sinomial or arc is equal to the sum of the remaining terms of the series. If, then, for x we substitute any constant involved in the equation of the curve, the sinomial will be determined in terms of this constant. Applying this to the circle, we get for the length of the fourth part of the circumference the well known series

$$u = \left\{ 1 + \frac{1}{1.2.3} + \frac{1.3}{1.2.4.5} + \frac{1.3.5}{1.2.4.6.7} + \&c. \right\} r.$$

From which it follows, that the circumferences of circles are to one another as their diameters.

The preceding proposition does not appear to have been demonstrated before the invention of the binomial calculus. Euclid does not demonstrate it. His reasoning is founded on a lemma (the base of the method of exhaustions, of fluxions, of the differential calculus, &c.), which asserts the absurdity that a magnitude may be less than itself. And his attempt to prove this absurdity involves the assertion of the opposite absurdity, that a magnitude may be greater than itself. The second proposition of his twelfth book was deduced by analogy from the property of similar polygons; and he was obliged to heap absurdity on absurdity, to give his postulate the colour of demonstration. This is the only blemish in the most important work on science that was ever composed, or that can hereafter be composed. Every other work on science, either physical or mathematical, falls into insignificance when compared with the stupendous work of this immortal geometer.

With respect to Mr. Ivory's paper. I require of Mr. Ivory to construct the triangle, of which the base is not any thing. He is not to prove his construction by a simple appeal to "every body." Such a mode of reasoning does not belong to geometry. Neither is he to introduce the "ghosts of departed quantities." For it is demonstrated that such things are absurd. He is to prove his construction by reasoning referred to our intuitive knowledge. His paper is a very awkward surrender of the point he would maintain.

Cork, May 15, 1824.

J. WALSH.

LXI. *On a Method of finding the Limits of the Roots of the higher Powers of Numerical Equations.* By Mr. J. ROWBOTHAM.

To the Editors of the Philosophical Magazine and Journal.

Walworth, May 17, 1824.

SHOULD you think the following method of solving, or rather of finding the limits of the roots of the higher powers

powers of numerical equations* (translated from O. S. Bangma's *Dutch Algebra*) would be interesting to your readers, and worthy of insertion in your valuable publication, I shall feel happy in having communicated it to you.

I am, gentlemen, respectfully yours,

J. ROWBOTHAM.

To find the roots of the higher powers of equations, we shall begin with the following cubic equation:

$$x^3 - 14x^2 - 29x = -546.$$

Bring all the terms of the equation to one side and arrange them according to the power of x , as follows:

$$x^3 - 14x^2 - 29x + 546 = 0.$$

For x substitute three successive terms of a series of natural numbers; as, -1 , 0 , and 1 , by which the following results will be obtained:

$$560, 546, 504.$$

By subtracting the first of these numbers from the second, and the second from the third, we have

$$-14 \text{ and } -42.$$

Again: by subtracting the first number from the second, we have

$$-28.$$

The preceding numbers may be arranged as follows:

$$\begin{array}{r|l} -1 & 560 \\ 0 & 546 \quad -14 \\ 1 & 504 \quad -12 \quad -28 \end{array}$$

The lower numbers 1 , 504 , -42 , -28 , and the constant number 6 , serve to find the positive roots of cubic equations.

The upper numbers -1 , 560 , -14 , -28 , and the constant number 6 , serve to find the negative roots †.

To find the positive roots, write in a line,

$$1, 504, -42, -28.$$

* This method of solving equations will be further illustrated (should we not be too limited for space) in *A Practical System of Algebra*, by Mr. Peter Nicholson and myself, which work is now in the press, and will be published in a short time.

† The preceding method is applicable to all the higher powers, with this difference only,—that we must take for x so many successive terms of the series of natural numbers, as the highest exponent of x contains units; thus,

For cubic equations $0, 1, 2$; or $-1, 0, 1$.

For biquadratic $0, 1, 2, 3$; or $-1, 0, 1, 2$.

For 5th power $0, 1, 2, 3, 4$; or $-2, -1, 0, 1, 2$, &c.

The constant number, mentioned above, will be formed;

For the 3d power, by $1 \times 2 \times 3 = 6$.

For the 4th power, $1 \times 2 \times 3 \times 4 = 24$.

For the 5th power, $1 \times 2 \times 3 \times 4 \times 5 = 120$, &c.

Now,

Now, by adding the constant number 6 to -28 , we have -22 ; by adding -22 to -42 , we have -64 ; by adding -64 to 504 , we have 440 which is the value of the function $x^3 - 14x^2 - 29x + 546$, when $x=2$; we then write in a line

2, 440, -64 , -22 .

Now, by adding 6, and proceeding as above, we shall have 360 which is the value of the function, when $x=3$, &c.

The calculation may be arranged in the following manner:

1,	504,	-42 ,	-28
	-64	-22	6
2,	440	-64	-22
	-80	-16	6
3,	360	-80	-16
	-90	-10	6
4,	270	-90	-10
	-94	-4	6
5,	176	-94	-4
	-92	2	6
6,	84	-92	2
	-84	8	6
7,	0	-84	8

Here 0 is the value of the equation, when $x=7$; consequently 7 is one of the roots.

Now, in order to find the other positive roots, we must continue the calculation as follows, by which means we shall find that $x=13$ is also a root.

7,	0,	-84 ,	8
	-70	14	6
8,	-70	-70	14
	-50	20	6
9,	-120	-50	20
	-24	26	6
10,	-144	-24	26
	8	32	6
11,	-136	8	32
	46	38	6
12,	-90	46	38
	90	44	6
13,	0	90	44

Note. Whenever all the numbers that stand on a line with a value of x become positive, we may conclude that the equation has no greater positive roots; therefore 13 is the greatest positive root in this equation.

To find the negative roots, write the upper numbers in a line, and subtract the constant number 6.

-1,	560,	-14,	-28
	20	-34	6
-2,	540	20	-34
	60	-40	6
-3,	480	60	-40
	106	-46	6
-4,	374	106	-46
	158	-52	6
-5,	216	158	-52
	216	-58	6
-6,	0	216	-58

Note. Whenever all the numbers that stand on a line with a value of x become $- +$; $+ -$, we may conclude that the equation has no greater negative roots; therefore $x = -6$ is the greatest negative root of the proposed equation.

LXII. *On the Application of the Term "Infinite."*

To the Editors of the Philosophical Magazine and Journal.

Gentlemen,

I BEG to offer the following observations in reply to your note, appended to a proposition contained in the paper "On the Origin of Matter, and on its alleged Infinite Divisibility," which you were so obliging as to insert in the Philosophical Magazine for November last.

I am, gentlemen,

Yours respectfully,

London, January 19, 1824.

J. O. F.

If space be considered as a property of a subject existing *necessarily*, and which therefore, as proved by Dr. S. Clarke, must be necessary to the existence of all other things; such property thus existing *necessarily*, and not being a property of

of

of any created subject, must in this case be regarded as an attribute of the Deity, of which infinity may of course be predicated.

If, however, space be considered—what I believe it to be—a property of matter; as in this case also it cannot exist independent of its subject, there can be no such thing in nature as *absolute space* or *absolute vacuum*. Under this view, then, if we take away matter, we take away space. Space may indeed be nevertheless abstractedly *conceived of*, or *imagined*, as existing independently of matter as its subject: but in reality it can have no such existence, and can only be considered as a property co-existent with matter, as its subject.

Now, *universality* cannot, I apprehend, be predicated of the material part of creation, without affirming that there are no other modes of substantial existence except what are proper to material being and substance; I therefore conclude, that matter is *not universal*, and consequently *not infinite*;—thus, that *neither its qualities nor physical properties are infinite*:—and that the material universe forms, as it were, but the outwork or lowest basis of created existence, between which and the Creator there are intermediate modes of existence; although no direct *physical* proof, perhaps, can be given of modes of existence different in their nature from those of matter and space. The reality of such superior modes of existence may however be presumed from the nature of the human mind, which as it were can look into the things of space, although in itself it is not subject to or limited by space; but has a mental perception or consciousness of *an existence according to a superior mode*; and, if I may be allowed the expression, *within* the sphere of outward space and nature.

If it be true that space is proper to material nature alone, and if there be other modes of existence which are not subject to the laws that govern matter, then space cannot be universal,—thus cannot be infinite; and the same will apply to all physical properties whatever.

With respect to infinite duration: that which is *necessarily existing* must be considered as *antecedent* to that which is *created*:—thus all created things must be considered, as to duration of existence, to have *begun to be*; in this respect, therefore, their duration must be *limited*, and if *limited*, not *infinite*;—although they may nevertheless continue to exist to eternity. Infinite duration therefore can only be applied to the self-essent, self-existent, and underived being of the Creator. Considering therefore that all created subjects, by the necessity of their constitution, are limited and finite, their qualities or properties in like manner must be limited and finite;

finite; in which case the term *infinite* is strictly *inapplicable* to physical properties; as well as to moral and intellectual properties, except as these latter exist in the Creator.

With respect to infinite series in mathematics: they may be made the measure of any thing *real* or *unreal*; they may be applied to aid our conceptions of the *infinite* attributes of God, or of the *indefinite* attributes of his works; but the application, to be genuine, must evidently be with due regard to the nature of the thing to which it is made, as observed in my former remarks upon this subject.

It appears to me that *that which is Infinite must be Universal, extending through all modes of being from the first to the last.*

LXIII. *Two Lines from the Nautical Almanac, addressed to Mr. IVORY.*

“IF we employed the height of the thermometer without, which would be more consistent with the theory, it would probably be *necessary* to suppose the standard temperature of the table 48° only, instead of 50° .”—*N.A.* p. 148.

For Mr. Groombridge’s observations, it is remarked, in the 13th Number of the Astronomical and Nautical Collection, that it will be necessary to alter the supposed standard of the tables to 46° , instead of 48° .

Mr. Ivory, in the Philosophical Magazine for April, insists on employing the table of the Nautical Almanac at 50° ; and on finding the sum of its errors $+96''\cdot7$ and $-13''\cdot0$.

Now if he has computed rightly for 50° , these errors, supposing the temperature 48° , become $56''\cdot9$ and $26''\cdot0$; for 47° , $+36''\cdot3$ and $-35''\cdot8$; the sum of which is $72''\cdot1$. This is indeed a trifle more than the sum of the errors of the new table, which amounts to $60''$ only; but is still far short of $109''\cdot7$, or rather $119''\cdot7$ the sum of the errors assigned to the *N. A.* by Mr. Ivory. So inconsiderable a difference, in the neighbourhood of the horizon, can scarcely be considered as decisive of the question, even allowing the accuracy of the computation: and it has not been asserted that the New Tables are inferior to those of the *N. A.*

But the comparison which Mr. Ivory considers as *tricked out in all sorts of disguises for the purpose of ensnaring unwary judges*, does in fact prove that *both* of these tables give the correction for *accidental* changes of temperature somewhat too great; they are both founded nearly upon the same hypothesis respecting the effect of a change of temperature, and that hypothesis is not fully justified by Mr. Groombridge’s observations.

S. B. L.

LXIV. *Notices respecting New Books.**Recently published.*

PRINCIPLES of Warming and Ventilating Public Buildings, Dwelling-houses, Manufactories, Hospitals, Hot-houses, Conservatories, &c.; and of constructing Fire-places, Boilers, Steam-apparatus, Grates, and Drying-rooms: with Illustrations experimental, scientific, and practical. To which are added, Observations on the Nature of Heat; and various Tables useful in the Application of Heat. With nine Plates and several Wood Cuts. By Thomas Tredgold, Civil Engineer; Member of the Institution of Civil Engineers; Author of "Elementary Principles of Carpentry," an "Essay on Cast Iron," &c. &c. 15s.

The Character of the Russians, and a detailed History of Moscow. Illustrated with numerous Engravings. With a Dissertation on the Russian Language; and an Appendix, containing Tables, political, statistical, and historical; an Account of the Imperial Agricultural Society of Moscow; a Catalogue of Plants found in and near Moscow; an Essay on the Origin and Progress of Architecture in Russia, &c. &c. By Robert Lyall, M.D. F.L.S., Member of the Imperial Societies of Agriculture and Natural History, and of the Physico-Medical Society at Moscow.

An Essay on the Laws of Gravity, and the Distances of the Planets; with Observations on the Tides, the Figure of the Earth, and the Precession of the Equinoxes. By Captain Forman, Royal Navy. 4s.

Evils of Quarantine Laws, and Non-existence of Pestilential Contagion; deduced from the Phænomena of the Plague of the Levant, the Yellow Fever of Spain, and the Cholera Morbus of Asia. By Charles Maclean, M.D.

The Metropolitan Literary Journal, No. I.

An Elementary System of Physiology: by J. Bostock, M.D. F.R.S. L.S. M.R.I.A. &c. &c.

 ANALYSIS OF PERIODICAL WORKS ON NATURAL HISTORY.

The Zoological Journal, No. I., conducted by Messrs. T. Bell, J. G. Children, J. D. C. Sowerby, and G. B. Sowerby.

The hope we expressed on announcing the intended publication of this work, of its materially promoting the advancement of zoology, has not been disappointed by the perusal of it. We think that, with the improvements always received by a periodical publication during its progress, it will become
a standard

a standard medium of communication between the various cultivators of that delightful science. This first number contains fifteen articles, principally original; besides the usual departments of literary and scientific intelligence found in a Philosophical Journal. Among them we may particularize the following:—Art. I. *An Inquiry into the true Nature of Instinct, and of the Mental Distinction between Brute Animals and Man, &c.*: by J. O. French, Esq. In this inquiry the author proposes to account for the various actions of brutes which appear to be of a moral or of a scientific nature, by the hypothesis that moral and scientific qualities do not become objective in the minds of brutes, thus that they possess no moral or scientific consciousness; and therefore that the appearances of morality and science in their actions, are the effects of moral and scientific energies, acting upon them in a region of their minds above the sphere of their proper consciousness.—Art. II. *Monograph on the Cebrioidæ, a Family of Insects.* By W. E. Leach, M.D. F.R. & L.S.—Art. VI. *Some Observations on the Lamarckian Naiades, and the Propriety of uniting them all under one generic Name.* By G. B. Sowerby, F.L.S. Mr. Sowerby proposes to unite the genera *Alasmodonta* of Say, *Dipsas* of Leach, *Anodon*, *Hyria*, and *Castalia* of Lamarck, with some other shells, under the genus *Unio*; representing that they have been separated from it merely upon such characters as would warrant the raising of almost every strongly marked species into a genus.—Art. XI. *Monograph on the Cypræidæ, a Family of Testaceous Mollusca.* By Mr. J. E. Gray.—Art. XIV. *Abstract of a Memoir on the Physiology of the Helix pomatia.* By M. B. Gaspard, D.M.: with Notes by T. Bell, Esq. F.L.S. This is a curious memoir on the growth, habits, and physiology of the *H. pomatia*. Mr. Bell's notes correct M. Gaspard's statements on several important points.—Art. XV. *Memoir on the chemical Composition of the corneous Parts of Insects.* By M. Augustus Odier. *With some Remarks and Experiments* by J. G. Children, Esq. F.R. & L.S. M. Odier affirms in his memoir, that the substance resembling horn, obtained by treating the elytra of insects with a hot solution of potash, and which he calls *chitine*, contains no nitrogen; and he compares it to lignin. Mr. Children, however, has determined, by analysing it with protoxide of copper, that *chitine* does contain a considerable proportion of that element; thus invalidating M. Odier's inference respecting the analogy of the substance to the basis of vegetables.—The Number contains five plates, four of which, principally of Shells, are well coloured.—The Second Number is to be published on the 15th of June.

Curtis's British Entomology.

No. 5. contains the following subjects :

Pl. 19. *Rhipiphorus paradoxus*. Figures of both sexes of this insect are given, which from their dissimilarity have been considered by some authors as distinct. Mr. W. S. MacLeay, we believe, first discovered its singular economy, which has enabled entomologists to enrich their cabinets with examples of this rare and curious genus.—Pl. 20. *Pentatoma cærulea*, a beautiful little species found in the woods about London, and in Devonshire; the author has taken the opportunity of giving a complete arrangement of the British species which the genus embraces.—Pl. 21. *Eyprepia russia* (Clouded buff Moth). A genus detached from the extensive group of *Bombycidae*; *E. russula* is a beautiful species, and the dissections illustrating the *Lepidoptera* must be a great acquisition to the lovers of that beautiful order, as nothing of this kind has hitherto appeared excepting the few that were given in the early numbers of Mr. Swainson's Zoological Illustrations.—Pl. 22. *Ibalia Cullattator*. An unique specimen of this insect, which adds a new genus to the British Fauna, was taken by Mr. Edwards at Bungay, and is now in the cabinet of the author. It is allied to the Gall insects (*Diptolepidæ*), and its structure is very interesting.

The Botanical Magazine. No. 448.

Pl. 2481. *Urtica involucrata*, "caule ramoso hirsuto, foliis oppositis rotundato-ovatis crenatis trinerviis lucidis ad apices ramorum congestis, paniculis sessilibus:" brought from the island of St. Vincent, and flowered in the stove of the Horticultural Society.—*Serratula simplex*, the *Carduus mollis* of older authors.—*Oxytropis pilosa*, *Astragalus* Linn. This plant and the former were introduced at the Chelsea garden by Dr. Fischer of Petersburg.—*Nicotiana repanda* from the Havannah, said to be the plant of which the famous cigars are made.—*Habranthus versicolor*, a second species of this genus of *Amaryllideæ* proposed by Mr. Herbert (see p. 297).—*Dalea mutabilis*.—*Justicia geniculata*, "paniculis terminalibus laxis cernuis, bracteis subulatis, foliis ovato-lanceolatis glabris subtus pallidis distantibus:" native of the West Indies.—*Cissus antarctica*, New South Wales.

The Botanical Register. No. 111.

Pl. 793. *Portulaca foliosa*. "*P. guineensis*, foliis subulatis, calycibus pilosis, involucre polyphyllo, floribus subternis, petalis retusis." Lindley MSS.—*Neottia bicolor*, "foliis plurimis lanceolatis nervosis petiolatis glabris, scapo villosa infra foliolis spathaceis obsito brevioribus; racemo numero floribus cernuis, labello oblongo, laminâ summâ brevi oblatâ obsolete trifidâ undulatâ crenatâ, intus minutè papillosâ:" from Trinidad.—*Eriopermum folioliferum*: originally figured in Andrews's Repository: as well as its congener *E. paradoxicum*, it ranks among the most curious anomalies with respect to foliage in the Monocotyledones.—*Justicia pectoralis*: now first figured, though long known here.—*Justicia carthaginensis*, introduced in 1792 from the Caribbee islands.—*Lantana fucata*, "foliis ovatis rugosis crenatis obtusis pubescentibus petiolum brevem decurrentibus, capituli parvi depressi pedunculo foliis breviori:" raised from seeds brought for the Horticultural Society from Brazil by Mr. G. Don.—*Glycine vinctina*.—*Prunus paniculata*.

LXV. *Proceedings of Learned Societies.*

ROYAL SOCIETY.

April 29. A LETTER was read, from Dr. T. L. Tiarks to Dr. Young, For. Sec. R.S., as Secretary to the Board of Longitude; relating to observations made on the longitude of various places in England in 1822 and 1823*.

May 6.—The reading was commenced of a paper “On Univalves;” by C. Collier, Esq. Staff Surgeon. Communicated by Sir James MacGregor, F.R.S.

May 13.—The reading of Mr. Collier’s paper was concluded; and Davies Gilbert, Esq. V.P. R.S., communicated a paper “On the Variation of the Rates of Chronometers with the Density of the Atmosphere;” by George Harvey, F.R.S.E.†

May 20.—A letter was read from Professor Berzelius, of Stockholm, to the President; giving an account of various chemical researches in which he has recently been engaged. He has succeeded in obtaining Silicon, or the combustible base of silica, in an insulated state; and has ascertained its principal properties, which are very curious.

The reading was also commenced of a paper “On some new Phænomena effected by Magnetic Influence;” by Mr. J. H. Abrahams, of Sheffield. Communicated by Mr. Tooke, F.R.S.

LINNÆAN SOCIETY.

May 4.—A. B. Lambert, Esq. V. P. in the Chair. M. Geoffroy St. Hilaire was elected a Foreign Member.

A notice from Mr. Wood was read respecting the Golden Oriole, *Oriolus Galbula*, shot on the 26th of April, flying in company with some blackbirds, at Aldershot in Hampshire.

The reading was continued of Mr. Vigors’s paper on the Natural Affinities of Birds; and of the Catalogue of Norfolk and Suffolk Birds, by the Rev. Messrs. Sheppard and Whittier.

May 24.—On this day, being the birth-day of Linnæus, the Anniversary of the Society was held at one o’clock, in conformity with the Charter, the Right Rev. the Lord Bishop of Carlisle, Vice President, in the Chair.

The following gentlemen were re-elected Officers:

Sir James Edward Smith, *President*;

Edward Forster, Esq. *Treasurer*;

Alexander MacLeay, Esq. *Secretary*;

Mr. Richard Taylor, *Assistant Secretary*.

* See Phil. Mag. vol. lxxiii. p. 66.

† See our last Number, p. 311.

The following were elected to be of the Council for the ensuing year:—Edward Barnard, Esq.; H. T. Colebrooke, Esq.; Major-General T. Hardwicke; Daniel Moore, Esq.; and Philip B. Webb, Esq.

An extensive and interesting series of the various species of Rhubarb from Chelsea Garden was exhibited by Mr. Anderson.

The Anniversary dinner of the Society took place at Freemasons' Tavern, and a considerable number of the Fellows, including many from distant parts of the kingdom, participated in the pleasure of this meeting, which was alloyed only by the absence, owing to indisposition, of their highly esteemed President, whose excellent qualities, great attainments, and invaluable labours for the promotion of science, have long endeared him to those who know him, and especially to the lovers of Natural History. The chair was filled on this occasion by the venerable Prelate, who from the first foundation of the Society has been one of its most zealous supporters.

HORTICULTURAL SOCIETY.

May 1.—At the Anniversary Meeting for the election of the Council and Officers for the ensuing year, the following Gentlemen were chosen:—*Council*: Thomas Andrew Knight, Esq.; the Earl of Aberdeen; Edward Barnard, Esq.; Mr. Samuel Brookes; Henry Moreton Dyer, Esq.; John Elliot, Esq.; Alexander Henderson, M.D.; Charles Holford, Esq.; Robert Henry Jenkinson, Esq.; Mr. Joseph Kirke; Mr. George Loddiges; Alexander MacLeay, Esq.; Joseph Sabine, Esq.; Richard Anthony Salisbury, Esq.; John Walker, Esq.—*Officers*: Thomas Andrew Knight, Esq. President; John Elliot, Esq. Treasurer; Joseph Sabine, Esq. Secretary; Mr. John Turner, Assistant Secretary.

The President appointed the following Members of the Council *Vice Presidents* for the ensuing year:—the Earl of Aberdeen; John Elliot, Esq.; Robert Henry Jenkinson, Esq.; John Walker, Esq.

May 4.—The following communications were read:

Note on the Culture of the *Canna indica*. By Dr. Van Mons, a Foreign Member of the Society.

Note on Grafting the Rose. By the same.

On the best Mode of packing Grafts for Carriage. By the same.

On the Cultivation of Asparagus. By Mr. Peter Lindenaar, a Corresponding Member of the Society, Gardener to the King of Denmark.

Several new plants in flower, raised in the Society's Garden

from seeds received from Chili, were exhibited; also a remarkably large and fine plant, in flower, of *Cactus speciosus* from the garden of the Comte de Vandes.

May 18. The following communication was read:

Note on the Advantages of using Bunting as a Protection to Apricot Trees. By Charles Henry Rich, Esq. F.H.S.

GEOLOGICAL SOCIETY.

March 19.—A paper entitled "Sketch of the Geology of New South Wales and Van Dieman's Land," by the Rev. T. H. Scott, was read in part.

April 2.—The paper entitled "Sketch of the Geology of New South Wales and Van Dieman's Land," by the Rev. T. H. Scott, was concluded.

The coast of New Holland from Cape Howe to Port Stephens, including Botany Bay, Port Jackson, &c., as examined by Mr. Scott, consists of an uninterrupted series of the coal measures. At Illasvarro, or the Five Islands, a seam of coal is found at the surface. Between Broken Bay and Port Hunter, a horizontal seam of coal is bared by the action of the sea on the cliffs. Very good coal is worked at Newcastle on Hunter's river, thirty-seven yards from the surface, 3 feet 1 inch thick; it is intersected by trap dykes in some places; and vegetable remains of a large-leaved fern, thought by the people to be an Eucalyptus, are picked up at the base of the cliff. Limestone alternates with the sandstone, and iron ore occurs. The wells at Sidney being not more than 30 feet deep, the water is not good; one well, sunk 82 feet to a great mass of sandstone, gives excellent water. From Paramatta the coal measures continue, and are broken by trap dykes at the Nepean to Enuford, where the ascent of the Blue Mountains commences, near the summit of which the coal measures rest on the old red sandstone. The escarpment of this rock on the east side presents the aspect of a perpendicular wall, at the top of which the old red sandstone is found in contact with primitive rocks: these occur in the vale of Cleuyd and Clareneer's hilly range, where the Macquarrie rises, and after a north-east course of 300 miles terminates in a vast swamp. Returning westward, porphyritic rocks and clay slate accompany the primitive rocks near Bathurst and the Sidmouth range, to Lake George and the Cookbundoon river, which continue to the Cow pastures, where the coal measures of the colony again appear.

The geology of the island of Van Dieman's Land is conformable to that of the continent of New Holland. Both Hobart Town and George Town are upon the coal formation.

Between

Between the former and Elizabeth Town, a limestone full of shells is found, probably of the oolite series, and the same rock occurs near George Town on an island in the Tamar. In the middle of the island, at Bagdad, a rock which answers to the description of the millstone grit, and salt, is found on the river Macquarrie. To the east and the west of the inhabited tract between the two towns, high mountains and elevated primitive ridges are alone discoverable; so that the island probably contains little other fertile soil to tempt future emigration when this space shall have been peopled, which is not the case in New South Wales.

A letter was read On a Section obtained in sinking a Well at Streatham; by Mr. I. S. Yeats. Communicated by G. H. Brown, Esq.

A well having been sunk at Streatham to the depth of 285 feet, the greatest depth which has been pierced in that part of the country, the following section was exhibited. From the depth of 2 feet to 29 feet, stiff reddish brown clay; from thence to 35 feet, clays with septaria; from thence to the depth of 180 feet, blue clay, in which, in from 70 to 100 feet, were found various shells and fragments of bituminous wood with iron pyrites; from 200 feet to the depth of 230 feet, blue clay, sometimes sandy, in which numerous shells and bituminous wood occurred; at 230 feet, round black pebbles of flint like those of Blackheath were found, this appearing to be the point of junction between the London and plastic clays; next a bed of sand, and afterwards various coloured clays were pierced, at the depth of 270 feet; and continuing to 285 feet, sand and sandy clays occur, the greater part of which is full of green earth exactly resembling that of the oyster bed at Reading. The paper was accompanied by specimens of each of these strata.

A letter was read from Alexander Gordon, Esq., to D. Gordon, Esq. of Abergeldie, describing three successive forests of fir imbedded in a peat moss, accompanied by specimens.

The moss of Auldguissack in Aberdeenshire, Scotland, presents an inclined plane of rather uneven surface, and varies in depth from 18 inches to 10 feet from the lower part of the hill to the river.

Upon digging up the ground in two different parts of the moss, large roots of Scotch fir-trees were found about one foot below the ordinary average level of the moss. Below the bottoms of these roots there is a stratum of about a foot and a half of moss, below which other roots or trunks appeared; and on digging still further down (about 6 or 7 feet below the ordinary level of the moss) a third set of roots and truncated stems of trees were discovered.

It appeared to Mr. Gordon impossible that these roots could have supported different trees all growing at the same time; for the distinct ramifications of these (horizontally like Scotch firs at the present day) are bedded in moss perpendicular above each other.

April 23.—A paper was read entitled “Some Observations on the Lakes of Canada, their Shores, Communications,” &c. by Lieut. Portlock, R.E.

In this memoir the author describes the various nature of the shores of Lakes Huron, Michigan, Erie, and the other lakes of Canada, and annexes a plan, in which a tabular view is presented of the comparative level of these lakes and their communications with each other. At the Falls of Niagara, he observes that the upper stratum is a firm compact limestone resting on strata of a very schistose nature. It is not by erosion of the surface that the falls are made to recede; but the waters, after falling 150 feet, strike the bottom, and are reduced to foam; they are then driven up into the air far above the rock whence they had descended: this penetrating foam acts on the lower argillaceous strata, till the overhanging rock is undermined. Lieut. Portlock remarks, that there has been a gradual fall in the level of the Lakes at Canada. He also offers some considerations on the proximity of the sources of several rivers which flow in opposite directions.

May 7.—A paper “On the Geology of the Ponza Islands, in the Mediterranean,” by G. P. Scrope, Esq. M.G.S., was read in part.

A letter was read from Thomas Botfield, Esq., M.G.S., accompanied by a collection of bones and horns of the deer, and bones of man and other animals, found in a cleft of the rock at a quarry at Hincks’ bay, (near the Old Park iron works,) in the parish of Dawley and county of Salop. Their adhesion when applied to the tongue showed that the animal gelatine was nearly gone, which does not take place till after a long period of inhumation.

ASTRONOMICAL SOCIETY.

May 14.—The whole of this sitting of the Society was occupied by the reading of the conclusion of Mr. Baily’s paper On the Method of determining the Difference of Meridians, by the Culmination of the Moon, this paper having been commenced at the last meeting in April.

The author, after briefly alluding to the nautical methods of determining the longitude, including those by means of chronometers, adverted to five distinct astronomical methods which have been pursued, viz. 1st, By the eclipses of Jupiter’s satellites. 2dly, By eclipses of the moon. 3dly, By eclipses

eclipses of the sun. 4thly, By occultations of the fixed stars. And 5thly, By meridional transits of the moon. The first three of these, by reason of their infrequency and obvious sources of inaccuracy, are of very limited utility; while the fourth method is rendered uncertain from its involving a doubtful datum, *the compression* of the earth, as well as other difficulties which the author pointed out. He then proceeded to point out that the fifth method was greatly superior to any of the others, in which opinion he was supported by the testimony of Dr. Maskelyne, Bernoulli, and many eminent astronomers who were quoted. Notwithstanding its high recommendations, this method has not been *successfully* adopted in practice, and has even led to some awkward anomalies, on account of its having been customary to take the moon's centre reduced to the meridian, and to compare it with the apparent places of stars passing the meridian about the same time in *any parallel of declination*.

The newly proposed method consists in merely observing with a transit instrument, the differences of right ascension between the *border* of the moon, and certain fixed stars previously agreed upon, restricting the observations to *such stars as differ very little in declination from the moon*, and denominated *moon culminating stars*. The attention of astronomers has been called to this method by M. Nicolai, of Manheim, in several numbers of Schumacher's *Nachrichten*. It is quite independent of the errors of the Lunar Tables (except so far as the moon's horary motion in *R* is concerned). It does not involve the quantity of the earth's compression. It does not require a correct knowledge of the position of the star observed, nor does an error of a few seconds in the clock sensibly affect the result. Hence much trouble is avoided, many causes of error precluded; besides all which, the method is *universal*.

METEOROLOGICAL SOCIETY.

March 10.—The reading of Dr. T. Forster's "Memoir on the Variations of the Reflective, Refractive, and Dispersive Powers of the Atmosphere" was resumed and concluded.

This memoir relates to certain branches of the subject of atmospheric refraction, belonging to the province of Meteorology, which Dr. Forster states to have been particularly neglected: these are, the variations in the refractive, dispersive, and reflective powers of the atmosphere, resulting from the diffusion therein of different modifications of cloud, which are themselves affected by local circumstances, and which vary greatly at different times; and the effects of that variation on the colour of the light transmitted by the planets and fixed

fixed stars, and on the declination of the latter. After some general remarks on reflection, refraction, and prismatic dispersion, the author proceeds to consider the subjects just mentioned, in three sections. In the first, "On the variation in the refractive power of the atmosphere at different times of the night and day, and on different occasions and seasons," he ascribes that variation, principally, to the quantity and nature of the aqueous vapour diffused in the air: and he supports this opinion by various observations on the planets and stars, made at different times and seasons. In observing the planets and brightest stars through prismatic glasses, he found that the spectrum was less oblongated, whilst the red colour was more distinctly apparent, at the period of the vapour point, than at almost any other time of the same nights. On other occasions, at the same period of evening, the violet and in general the colours of the most refrangible rays were most conspicuous, and the spectrum was more oblongated than ordinarily. Dr. Forster at length ascertained, that the greater prevalence of the red in the spectrum uniformly accompanied that state of the atmosphere when the *cirrostratus* diffused itself after sunset; whilst the more oblongated spectrum, with the violet and most refrangible colours, attended an atmosphere in which the condensing vapours assumed the form of *stratus*. He infers from these and other observations, that the changes in the qualities of the diffused vapour in the air must produce great variation in the atmospherical refraction. In the second section of his memoir, he suggests that local circumstances may produce great variation in the mean refractive power of the atmosphere at different places; and that the discordances in the places assigned to the fixed stars in different catalogues of them, may have resulted from such variation. In the third section entitled "Of varieties in the composition and nature of the light of different stars, considered as still further varying the effects of atmospheric refraction, reflection, and dispersion," Dr. Forster details a number of minute observations upon those varieties; proceeds to inquire into their causes; and concludes with an account of some experiments on the decomposition of the light of the moon, the planets, and certain fixed stars.*

A Memoir by Dr. Forster was also read, "On the great Depression of Temperature which occurred in January 1820."

The remarkable depression of temperature related in this

* Part of Dr. Forster's paper was inserted in the *Phil. Mag.* for March; and the remainder will be found in the present number: both with considerable additions by the author.

paper took place at Hartfield in Sussex, to the neighbourhood of which place it appeared to be confined, during the period between sun-set on January 14th and midnight on January 15th, 1820. At 10 P. M. on the 14th, an out-door Fahrenheit's thermometer exposed to the N. E. was at zero, and at 11 o'clock it indicated -5° . Some time between the hours of 1 and 8 A.M. on the 15th, it sunk to -10° , as shown by a Six's thermometer. It thence gradually rose, until at midnight on the 15th it attained the elevation of $+23$. A thermometer exposed to the N. W. indicated 1° higher in each observation. During this period of excessive cold, the air was calm and clear, a few ill-defined cumuli only were seen on the 15th; the snow which had fallen on the 13th lay on the ground. Dr. Forster received only one notice of a distant observation, made at Canterbury, where a thermometer in-doors indicated 0° ; which was also the temperature in-doors at Hartfield on the morning of the 15th.

Dr. W. Burney communicated, through the Secretary, the Results of a Meteorological Journal for February 1824, kept at his Observatory at Gosport, Hants.

April 14.—A note was read on certain Phænomena of the late Cold Weather, and on Zodiacal Light, &c.; by Luke Howard, Esq. F.R.S. and Member of the Meteorological Society.

Dr. Burney communicated the Results of his Meteorological Journal for March; and similar communications were received from other Meteorologists.

May 12.—Dr. Burney communicated the Results of his Journal for April; and the following paper was read:

“An Account of the principal Phænomena of Igneous Meteors which were observed in the year 1823; forming part of a Review of the Progress of Meteorological Science during that period: with Remarks on the Characters of certain Meteorites.” By E. W. Brayley jun. A.L.S. and M. Met. Soc. In this paper the author first describes, from various authorities, the Fire-balls which were observed respectively on the 26th of January 1823, at Gosport; on the 23d of May, at Kiel in Denmark; and on the 20th of August, at Ragusa. The latter, being contemporaneous with an earthquake at the same place, gives occasion for an inquiry how far the appearance of Igneous Meteors may be considered as an attendant phænomenon of earthquakes: several meteors of this kind, it is observed, were seen in the province of Cutch at the time of the extensive earthquake in India in 1819, the most violent motion of which was experienced in that province and its vicinity; and two Fire-balls appeared, one at Zante, and the other at Cephalonia, on the day after the earthquake that desolated the

former island in 1820: other instances of this connexion are likewise adduced. Mr. Brayley then proceeds to an examination of the phænomena attending the fall of several meteorites at Nobleborough, in the State of Maine, in North America, on the 7th of August last. He next points out a remarkable affinity in mineralogical characters subsisting between these meteorites, and those which fell, respectively, at Loutolox in Finland in 1822, at Jonzac in France in 1819, and at Juvenas in the same country in 1821; several specimens of the latter being laid before the Society for the purpose of illustration. This affinity partly consists in the strong resemblance which they all bear to certain products of volcanoes; whilst the meteorites of several other descents connect them, by a gradual transition, with those whose characters are more peculiar: from these and other circumstances, in conjunction with that of the frequent presence of Olivine in meteorites, the author infers that the agencies which give rise to volcanic phænomena, whatever these may be, and however exerted in this case, are probably concerned in the production of Igneous Meteors and the bodies which descend from them. He concludes by recommending the investigation of this curious subject to the members of the Society; promising to lay before them, after the recess, the results of some further researches upon it.

The Society then adjourned, over the Summer recess, to meet again on Wednesday the 13th of October next.

IMPERIAL SOCIETY OF NATURALISTS OF MOSCOW*.

“The plan for forming a *depôt* for the discoveries in natural history in the vast empire of Russia; of uniting the friends of this science together, who wished to give their assistance for this purpose; and of publishing the history of the discoveries made, was conceived by professor Fischer on his arrival at St. Petersburg in 1804. It was not till the summer of the year 1805, however, that a few of the professors and literati of Moscow first assembled, and adopted the regulations proposed by professor Fischer, and established the *Imperial Society of Naturalists*. The object of the society is to encourage the study of natural history and the relative sciences, as human and comparative anatomy, chemistry, natural philosophy, rural economy, &c. The society consists of members

* The accounts of this Society, and of the Agricultural Society of Moscow, are derived from the interesting History of Moscow lately published by Dr. Lyall.

ordinary and honorary; and the ordinary members are divided into resident and non-resident.

“Shortly after the association just mentioned took place, Mr. Muravief, curator of the university of Moscow, and colleague of the minister of public instruction, informed that the society had begun to meet at the house of the director, professor Fischer, presented its regulations to his imperial majesty, the Emperor Alexander, who approved of the design, and therefore ordered Mr. Muravief to testify his high satisfaction to the professor. His excellency Count Alexei Razumofskii, lately minister of public instruction, senator, chevalier, &c., was first chosen president. The present president is prince Obolenskii. The perpetual director, Gotthelf Fischer, Aulic counsellor of H. I. M., chevalier, doctor and professor, and member of many learned societies; and vice-president of the medico-chirurgical academy.

“Soon after the institution of the society, the literati, and particularly the cultivators of natural history, whose works are too little known in England, including many of the nobility of Moscow, Petersburg, and the other towns as well as universities in Russia; and also many of the most distinguished philosophers and naturalists on the continent, chiefly through the extensive acquaintance of the founder and director, professor Fischer, were enrolled among its members. Presents were received from all quarters, of books, objects of natural history, and of money. The society was very flourishing, and by the year 1812 had published four volumes of its Transactions. All the collections of the society were deposited in the museum of the university, and, along with that extensive establishment, became a common prey to the flames in the year 1812. Among other things were lost some manuscripts, and almost the whole of the impression of their Transactions, which, however, will be soon reprinted.

“Far from being dispirited by this irreparable misfortune, the members of the society re-assembled in the year 1813, and commenced their proceedings anew; and since have continued all their efforts with unremitting vigour to recover from their losses, and have now published the fifth volume of their Transactions. The society has renovated a small museum and library. Among the foreigners, professor Fischer and Dr. Fischer, director of the botanic gardens at Gorengi*, are distinguished for their zealous services in this society. From the change in the state of Europe, a more free interchange of scientific publications is

* The Philo-Graphic Society of Gorengi was instituted by Dr. Fischer, and afterwards was united with the Imperial Natural History Society.

to be wished, and may be expected, between Russia and the Continent, as well as Great Britain. The director, professor Fischer, is a most indefatigable naturalist, and although not more than fifty years of age, the catalogue of his works and translations on different subjects occupies nearly three quarto pages; and they better proclaim his character and the extent of his erudition than any encomium I can add. A few distinguished characters of Great Britain are *honorary*; but a greater number *non-resident ordinary* members of this society. The society of natural history of Moscow is well known on the Continent, and wishes to be better known in Great Britain by an exchange of its Transactions for the Transactions of the literary societies of our island; as well as to receive donations in natural history, or of the works of its members, or of other individuals disposed to assist its views."

IMPERIAL AGRICULTURAL SOCIETY OF MOSCOW.

"The regulations of this society were published in the Russian language in the year 1820. They commence with a short historical account of its formation, which is followed by some general remarks on the pleasures and advantages of agriculture, and on its influence on a nation, in a moral, a political, and a commercial point of view. After a sketch of the opinions of the ancients regarding agriculture, its present state in Germany, France, and England, as also in America, is noticed. It is then stated that in Russia this science as yet is almost in its infancy. As contributing to the advancement of agriculture in this empire, the effects of the works of the Free Economical Society at Petersburg;—the utility of the universities in Russia (each of which has a chair for agriculture); and the observations of the Economical Society of Livonia, are alluded to.

"The difficulty of leaving off old, and of adopting new plans, is remarked;—and especially among the peasantry.

"To the *tiers état*,—the middling ranks of society, which exist in most countries of Europe,—arts and sciences, agriculture and commerce, chiefly owe their improvement and perfection. But in Russia there are no properly corresponding classes of society. The advancement of the arts and sciences, and of agriculture, principally depends upon the government, the nobility, the literati, and societies. Commerce in a great measure is in the hands of the merchants; but a few of the nobility are great speculators.

"As things are at present, by far the greatest part of the stewards upon noblemen's estates are their own slaves, and are generally very corrupt in their morals. Some of the richer

richer nobles have free stewards, and most of them are great villains: a few, however, are reputed for their honesty and good conduct*.

“The *Steward-Slaves*, as they may be called, derive their knowledge of agriculture from the peasants; so that the director and the servant are often equally wise: indeed it does not rarely occur that the latter is more learned in his profession than the former. To procure a good and honest and clever steward in Russia, is a matter of infinite difficulty: hence an adage, ‘Buy not a village, but buy a steward for yourself.’ The present society seems to have it in view, as a principal object, to form stewards at the practical school, for their estates.

“An assembly of a number of highly respectable noblemen agreed to form an Agricultural Society at Moscow in the year 1818. A correspondence took place with the Government on this subject; and His Imperial Majesty Alexander granted leave to institute a society under the name of *The Imperial Agricultural Society of Moscow*. It was permitted that this society should have its own seal with the Imperial arms, and a suitable device, and free postage of all letters and parcels.

“The Emperor made a donation of 10,000 roubles to the society; and gave the promise of an annual sum when its utility was evident:—he also presented the estate of *Tolmatchevoi-Gorbovo*, containing 70 desiatins of land, to the society. †

“The design of the society is the improvement of agriculture, and of the management of cattle, as well as of the construction of farm-houses, &c.

“Its members are divided into *active members*—who reside in or near town, and are supposed to be actively employed in some manner or other for the good of the society: to this class also belong correspondents, residing in the more distant provinces,

* “Vide p. xxii. of the History.

† “This estate is situated about 18 versts (12 miles) from Moscow. His Imperial Majesty, it appears, was badly advised when he granted it to the Agricultural Society. In the first place, it was too small for the purposes of the Society; and in the second place, it was the most arid and unproductive estate in the neighbourhood of the metropolis. The Society accepted it;—because it could not decline an imperial present: but immediately afterwards, it took a lease of another estate, called Butirka, situated about a mile from one of the Barriers (the Dmitrovskaya), which contains about 207 desiatins. Butirka is church property, but the Society intends to purchase it when rich enough. Part of this estate is now drained and cultivated, and a number of buildings are erected. Mr. Rogers, whose father has long been famous in this neighbourhood as a practical farmer, is appointed its director, and always resides on the spot. The practical school spoken of in the text, is intended to be erected here.

and in foreign kingdoms :—and *honorary* members, whose conduct has merited general approbation, and who forward the objects of the society, as by presents of land or money ; or of individuals distinguished in the sciences, and especially in agriculture.

“ The society is governed by a President, a Vice-President, a Director, a Secretary, and a Treasurer ; all of whose duties are particularly indicated. The meetings of the society are held once a month, from the 1st of November to the 1st of May.

“ The active members are formed into four divisions : 1. The Theoretical.—2. The Practical.—3. The Mechanical.—And, 4. The Pedagogical. The 1st division is to occupy itself with classical works necessary for the schools, and the translation of agricultural papers and works from foreign languages. It consists of Professors and learned individuals. The 2d division contains landed proprietors in the government of Moscow, who ought to present to the society annual reports of the results of their practice in farming, and of improvements, observations, &c. The 3d division is to engage itself with the most improved implements of husbandry used in Europe—Agricultural architecture, as of farms, of mills, of stoves for drying corn, &c. This division is to consist of engineers and mechanics. The 4th division will direct the operations of the theoretical and practical schools. A council consists of the head of each of these four divisions, the President, the Vice-President, the Director, the Secretary, and the Treasurer.

“ *Agricultural School.*—A proper site for the erection of a school, and for the formation of a garden, is to be fixed upon. Here there must be six fields, each containing four desiatins of land, for the purposes of the school. The school is to be supported by the sums annually received for the pupils, and also by their entry-money. There will be attached to it an overseer and assistant ; a surgeon, and two apprentices ; an under-officer for every eighty pupils ; a clergyman ; and teachers, 1st, for arithmetic, geometry, making of plans, mechanics, and agricultural architecture ; 2dly, for botany and the theory of agriculture ; 3dly, for chemistry and technology ; 4thly, for veterinary surgery.

“ *Pupils.*—The pupils are not to be under 15 years of age : they must know the Russian language previous to admission. If their conduct be bad, they may be sent from the school ; if they have passed six months in it, neither master nor friend can withdraw them until the conclusion of their education :—*i. e.* at the end of five years. They are to be divided into tens. During the first year, they will be taught Russian grammar

mar and writing, arithmetic and painting. In the second year, theology, agricultural book-keeping, geography and statistics, and the principles of geometry. In the third year mechanics, agricultural architecture, and taking of plans. In the fourth year, chemistry, botany, physiology of vegetables, and knowledge of woods or forests, and technology. In the fifth year, the sciences of agriculture and veterinary surgery. Those desiring it may remain longer than five years, on continuing a proper payment, and then they will be taught physics and law*.

“The annual sum to be paid for each pupil is: for food, 100 roubles; clothes, shoes, and linen, 150r.: education and wood and candles, 150r.: total 400 roubles. And for fitting out, entry, 100r. The money to be paid in advance.

“The Agricultural Society is not rich. The crown has not yet been liberal, but it is expected that other donations will be made, both in land and money. A few of the opulent members have generously contributed. General Apraksin has given a small estate near Moscow, for the use of the Society, for twelve years. The members ought to pay an annual sum of 50 roubles, but this is not enforced. Each member, except those specially exempted, pays 25 roubles for his diploma. Some of the members make an annual voluntary contribution.

“The Society has already published seven numbers of its journal in the Russian language. Hitherto it has been actively employed, and has made a rapid advancement; and I have no doubt, that if Prince Galitsin continue its president, and to reside at Moscow, even though he should resign the situation of Military Governor, it will go on in the same prosperous career. The Prince has contributed his share both in money and books. He offers an annual sum of 30 ducats; Count Rumiantsof one of 35 ducats, and the Society a third of 35 ducats, for prize essays on subjects proposed by the Society.

“The number of members in Russia is considerable. Many of the most respectable names of scientific individuals on the continent, and a number of those in Great Britain, are also enrolled in its lists.

“The plan of the Society has something in it grand and imposing:—May it lead to results extensive and useful to humanity!”

* “This is of great consequence in Russia, should the nobles make stewards of their pupils; for the half of their duty may be to manage law processes,

LXVI. *Intelligence and Miscellaneous Articles.*

NEW TABLES OF PRECESSION, ABERRATION AND NUTATION.

THE Astronomical Society of London have undertaken the formation of an extensive work, which will prove highly useful and convenient to every practical astronomer. It is the computation of Tables for determining the Precession, Aberration and Nutation of nearly 3000 of the principal fixed stars, for every day in the year; with their mean places for the beginning of the year 1830. This list will contain all the stars, not less than the 5th magnitude, which are inserted in Piazzi's catalogue; and also all the stars above the 7th magnitude, situated within 30° of the equator. The tables will be constructed on the principles detailed in our Number for October 1822; and which has been partly acted upon on the continent by M. Schumacher. This mode of arranging tables of this kind is by far the most convenient of any that has been hitherto adopted; as by the help of 4 logarithms added to 4 other logarithms (all of which will be found in the book) the correct quantities are determined without reference to any other work than a small table of logarithms to 5 places of figures. The whole will be calculated by two computers, in order to guard as much as possible against errors.

NAUTICAL MAGNETIC PREMIUM.

The Board of Longitude have conferred the Parliamentary premium of 500*l.* on Mr. Peter Barlow, of the Royal Military Academy, for his method of correcting the local magnetic attraction of ships. The great quantities of iron employed at this time in the construction and equipment of ships of war, produce so much deviation in the compass (varying according to the direction of the ship's head) as to render it almost an useless instrument in certain situations, particularly in high northern and southern latitudes. It appears by Lieutenant Foster's report of experiments made in His Majesty's ship Conway, under the superintendance of Captain Basil Hall, to lat. 61 degrees S., and under that of Captain Clavering, in the recent voyage of the Griper, to lat. 80 degrees north, that the difference in the bearing of an object with the ship's head at east and west, amounted to 28 degrees before the latter vessel left the Nore: this difference afterwards amounted to 50 degrees at the North Cape, and to 75 degrees at Spitzbergen. Great, however, as this effect was, the method recommended by Mr. Barlow was completely successful in counteracting it.

it. This is extremely simple: it consists in merely placing a small plate of iron abaft the compass, in such a direction as to counteract in any one place the effects of the other iron in the ship: after which, without removing it, it continues to do the same in all parts of the world, whatever change may take place in the dip or intensity of the magnetic needle. Three important advantages will result from this discovery. It will add greatly to the safety of vessels in our Channel in dark and blowing weather: it will tend to the general correction of our charts of variation; and will dispel nine out of ten of the supposititious currents so liberally supplied by navigators to account for every remarkable disagreement between reckoning and observation, and of which there can be no doubt the greater number have arisen from this long-neglected error in the compass.

STEAM NAVIGATION TO INDIA.

A numerous and respectable meeting has been held in Calcutta, for the purpose of taking into consideration the utility and possibility of establishing steam navigation with England *via* Suez. A committee had been previously formed, who having discussed the merit and importance of the project, opened a subscription, and recommended that the sum of one lack of rupees should be bestowed upon the first individual or company who should make two complete voyages from England to India in steam vessels, the passage not to exceed 70 days, either by the Cape of Good Hope, or the Red Sea, in vessels of British register and of not less than 300 tons burthen. The recommendation of the Committee was adopted by the meeting.

STEAM VESSELS IN THE NETHERLANDS.

The Dutch are actively employed in introducing the use of steam vessels into Holland; and one has just been established between Utrecht and Amsterdam, which performs the voyage every day in three hours and a half.

CANALS FOR UNITING THE BLACK SEA TO THE BALTIC.

A Company has just been formed, under the auspices of the Emperor, whose object is to unite the Black Sea to the Baltic by means of canals from the Dnieper and Nieman.

METEOR.

On the evening of Saturday the 17th of April, about a quarter past ten o'clock, a beautiful meteor was seen to the northward of the village of Upper Kinneil, parish of Borrowstownness. It burst forth with great splendour, illuminating the atmosphere; and proceeded with amazing velocity in a

S.E. or S.E. by S. direction, emitting a train of vivid sparks which gradually became paler until it entirely disappeared. Its duration, the writer of this, who witnessed the scene, thinks might be about five seconds, during which period it passed over about a third of the visible atmosphere.

EARTHQUAKE FELT AT SEA.

The following is from the log book of the ship *Orpheus*, bound from England to Ceylon :

Monday, 10th February, 1823.

“ At 1h. 15m. P.M. steering N.N.W. at the rate of five miles per hour, a little swell from the S.S.E., felt a motion as if the ship was running over the ground, or some other solid substance; and at the same time for from 60 to 65 seconds heard a confused grinding tremulous noise, affecting the ship in every part; we sounded with twenty fathoms of line up and down, but no ground. The sea not the least confused, nor could we perceive the smallest appearance of any thing which could occasion this noise and motion. The ship was not felt to strike once: she kept perfectly upright in her way through the water, and answered the helm; nor did she make any water in consequence of the shock received. At 2h. 5m. P.M. another shock was experienced, but much lighter than the first; and about three P.M. a third, which was only just perceptible. The first was so violent as to unship one of the compass cards from its point in the binnacle; and a pair of boots, which were hanging on a nail driven into the mainmast between decks, were shaken off. The ship's place at the first shock was 1. 10. N.; 84. 6. E.:—at the second, 1. 15. N.; 84. 4. E.”—*Medical Repository.*

EARTHQUAKES.

A pretty severe shock was felt in Trinidad on the morning of the 5th of January between three and four o'clock; but happily it did no damage.

At Bergen in Norway, on the 6th of January, about half past five o'clock A.M., a smart shock of an earthquake was experienced, accompanied with a rumbling subterranean noise, by which the houses were so much shaken that the furniture was tumbled about. The direction was from S.W. to N.E. The noise continued nearly a minute; this shock was succeeded soon after by another in the same direction, but weaker and of shorter duration.

Letters from St. Petersburg of the 7th of April announce, that in the night of the 11th of February a slight shock of an earthquake was felt at Irkutak in Siberia.

Letters received from the island of Santa Maura state, that on the 21st of February a violent shock of an earthquake was felt there about eight o'clock in the evening. It produced the greatest consternation in the minds of the people. Several buildings were much injured, and the bridge which joins Fort Alexander to the city was broken down. No lives were lost, but two females were severely wounded.

SINKING OF THE EARTH.

Naples, April 5.

Continual and excessive rains in the course of last month have caused a sinking in of the ground in the district of Avigliano, in the province of Basilicata, which has shaken a great part of the hill on which the town is built. This terrible phenomenon first manifested itself in the night of the 17th, by the fall of a house close to the barrack of the *gendarmes*. The house, which is totally destroyed, carried with it in its fall the barrack and several adjoining buildings. In the morning of the 23d, a greater misfortune followed; for a gulf opened near the inhabited parts, which swallowed up, under enormous masses of earth, two mills, of which not a vestige remains. The same day, all the young girls of the place were nearly the victims. They were going in procession to the church of St. Mary, about a mile from the place, to implore the Divine mercy in this moment of calamity, and they had hardly passed a certain spot, when the ground to the extent of five acres sunk in with a tremendous crash, overthrowing all the trees that covered it, and destroying all traces of the road for about a quarter of a mile. At the same time another gulf opened on the north side. It may be supposed that many buildings in the town have been damaged by this event. The Intendant of the province immediately sent an architect to save them from entire destruction. Happily no lives were lost except one *gendarme*. On the same night there was a dreadful storm in the Adriatic.

STATISTICS.

Paris, May 21.

It results from some tables just published by M. Benoiston, in a *Mémoire sur les Enfants trouvés*, that the number of foundlings has gone on increasing in every State in Europe, except from 1790 to 1800. During that interval the diminution amounted to a third; but after that period, and particularly since 1815, the number has constantly increased. There were 51,000 foundlings in France in 1798, 69,000 in 1809, 84,500 in 1815, and 138,500 in 1822. According to the

Annuaire du Bureau des Longitudes, there were in 1823, 932,130 births in the year, which gives one child abandoned out of every twenty-eight. It appears, from the information given by the Government, that the provinces near the sea, in which there are most populous cities, and which are the centre of arts and industry, containing 20,000,000 inhabitants, hardly give as many foundlings as the remaining 10,000,000 who occupy the centre provinces, from which Paris and Lyons are subtracted, as each of them supplies 6000.

EDUCATION IN DENMARK.

In Denmark the system of mutual instruction is making great progress; and although only a short time since it was established, there are already one hundred and forty schools where this method is followed. Count Moltke, Minister of State to the King of Denmark, is recently dead; and not content with patronizing the sciences during his life, he even wished to support them after his death. He has, in consequence, left to the University of Copenhagen 60,000 rix dollars, to be distributed as rewards to the Professors of Natural Sciences who shall treat certain questions to be proposed by the University in the best manner. He has also given 10,000 *dalers* to the Academy of the Fine Arts, and 100,000 to be employed in educating the sons of poor officers. These legacies are strongly contrasted with the regulations sometimes made in other countries in favour of monastic institutions that some people are desirous of reviving.

SOUTH AMERICA.

M. Humboldt communicated to the Academy of Sciences, at its last sitting, some very interesting observations made by Messrs. Boussingault and Reveno, two travellers whom we have several times mentioned to our readers. These gentlemen have analysed an *ærolite*, weighing several *quintaux*, which they found in the mountains of Santa Rosa, to the north-east of Santa-Fé-de-Bogota. They say, according to letters from Antioquia, that a mass of native gold has lately been found, weighing more than 190lbs. They have proved the presence of both sulphuric and muriatic acids in the waters of a small river which runs from the volcano of *Paracé*, near Popayan, and which is called by the inhabitants *Vinegar River*. The letters of these gentlemen are up to January 5, 1824. At that time a School of Mines was about to be established at Bogota, and the country enjoyed the greatest tranquillity.—*Constitutionnel*.

CANCER.

The very remarkable number of cases of cancer in the neighbourhood of East Grinstead, Hartfield, and Withyham in Sussex, has attracted the notice of several medical persons, and it is likely that this subject will undergo some regular investigation as to its causes. Upwards of ten cases of direct cancer have died at the small village of Hartfield within four years. Some persons have attributed the prevalence of this disease to the waters, which, resembling those of Tunbridge Wells, are prodigiously unwholesome; while others lay it to the air. Mr. Wallis, surgeon, who in conjunction with Dr. Forster is making out a list of the cases, states that pork and hog's flesh in general form the chief diet of the poor of the district; and we have the concurrent testimony of several physicians, that the flesh of the hog is very liable to bring on violent diseases.

—————

*Calendar of Flora, Fauna, and Pomona, at Hartfield in Sussex,
for April.*

April 1.—The spring advances very slowly, and is at least a fortnight behind the usual time in most things.

April 3.—*Tulipa suaveolens* in flower in the garden.—*Hyacinthus orientalis* begins to blow.—*Motacilla alba* very abundant.

April 5.—*Cardamine pratensis* in flower, though not common yet. Its common name of Our Lady's Smock evidently comes from its blowing about Old Lady Day. This plant flowers very abundantly throughout April and May in this our moist country.—Pilewort begins now to be abundant, and to bespangle every shady bank with its yellow stars.—*Erythronium dens canis* in blow.

April 6.—*Certhia familiaris* seen on the trees.

April 8.—*Fumaria officinalis* flowers in the garden.

April 10.—*Narcissus incomparabilis* in flower.

April 15.—*Saxifraga crassifolia* begins to flower, which is a fortnight behind its mean time of flowering.—The Snake first seen to day.

April 18.—*Lynx Torquilla* first seen at Hartfield.—*Sylvia Phœnicurus* seen.

April 19.—*Hirundo rustica* first seen at Groombridge; this bird did not become common till quite the end of the month.

April 20.—*Tussilago petasites* in flower.—*Narcissi Tazetteæ* and *N. orientales* of various sorts in full blow in the garden, together with *Hyacinthi orientales*.—*Borago officinalis* flowers.

April 22.—*Cheiranthus Cheiri*, *Lamium purpureum*, *Leu-*
cojum

cojum vernalum, and the Claimond Tulip, which I call *Tulipa præcox*, but which botanists have confounded with *T. Gesneri*, are now in blow.—This night the prodigious quantity of spiders on the walls of the house foretold the wet weather which followed. I have observed that this is as sure a sign of rain, as the much braying of the ass is of *showery weather*.

April 24.—*Cuculus canorus* first heard.—Lilacs begin to throw forth leaves.—The Cuckoo was heard at Walthamstow as early as April 21, its mean time at that place.—Cowslip *Primula veris* now abundantly in flower in the meadows. Primroses still cover every bank, and mix agreeably with Violets.—*Scilla nutans* flowers here and there.—*Narcissus bicolor* (vel *N. petalis albis nectarium flavum subæquantibus*) flowers in the garden.

April 25.—*Ranunculus bulbosus* begins to blow sparingly: during May this plant covers the meadows, succeeding the Dandelion now in profusion.—*Stellaria holostea* flowers plentifully.

April 26.—The early Daffodil still abundantly in blow in a field near Fisher's Gate in Withyam.—*Narcissus tenuifolius* in flower in the garden.

April 28.—*Erysimum Barbarca*, *E. Alliaria*, *Tulipa sylvestris*, *Fritillaria Meleagris**, and *F. imperiale*, in flower at Hale End, Walthamstow.

April 30.—*Lychnis dioica* in flower at Walthamstow.

This has been in general a most unpropitious spring for flowers, and last winter although mild has killed a great variety of plants.

April closed without having afforded one warm day. The Dandelion was still the prevalent plant that yellowed the meadows, mixed with Daisies. Harebells were as yet but few in number. Primroses and Polyanthus abundant. A single Tulip appeared here and there in warm places.†

Hartwell, May 22, 1824.

T. FORSTER.

OBITUARY.—BARON MASERES.

On the 10th of May, at the advanced age of ninety-three, died Francis Maseres, Esq. F.R.S. Cursitor Baron of the Exchequer, a profound mathematician, a munificent patron of science, and an excellent man.

* *Fritillaria Meleagris* was in flower plentifully May 10 in a mead between Billington in Bedfordshire and the church at Slapton, Bucks,—a habitat of this plant not heretofore recorded, as we believe.—EDIT.

† On the 5th of May I found *Narcissus biflorus* in flower in abundance in a field near Lingfield; and as I saw other plants of the same species blowing in the marsh far remote from any house, I have no doubt of its being a genuine habitat.

LIST OF NEW PATENTS.

To Alexander Dallas, of Northumberland-court, Southampton-buildings, in the parish of St. Andrew, Holborn, Middlesex, engineer, for his machine to pick and dress stones of various descriptions, particularly granite stone.—Dated 27th April 1824.—6 months allowed to enrol specification.

To John Turner, of Birmingham, Warwickshire, brass- and iron-founder, for his machine for crimping, plaiting, and goffering linen, muslins, frills, and other articles.—27th April.—2 months.

To George Vaughan, of Sheffield, Yorkshire, gentleman, for his improvement or improvements on steam-engines, by which means power will be gained, and expense saved.—1st May.—6 months.

To John Crosby, of Cottage-lane, City Road, Middlesex, gentleman, for his improvement in the construction of lamps or lanterns for the better protection of the light against the effects of wind or motion.—5th May.—6 months.

To James Viney, of Shanklin, Isle of Wight, Colonel in the Royal Artillery, for certain improvements in and additions to water-closets.—6th May.—6 months.

To William Cleland, of Leadenhall-street, London, gentleman, for his improvement in the process of manufacturing sugar from cane juice, and in refining of sugar and other substances.—6th May.—6 months.

To John Theodore Paul, of Geneva, but now residing at Charing Cross, Westminster, Middlesex, mechanist, who, in consequence of a communication made to him by a certain foreigner residing abroad, is in possession of certain improvements in the method or methods of generating steam, and in the application of it to various useful purposes.—13th May.—6 mo.

To John Potter, of Smedley, near Manchester, Lancashire, spinner and manufacturer, for certain improvements in looms to be impelled by mechanical power for weaving various kinds of figured fabrics, whether of silk, cotton, flax, wool, or other materials or mixtures of the same; part of which improvements are applicable to hand looms.—13th May.—6 mon.

To Jacob Perkins, of Fleet-street, London, engineer, for his improved method of throwing shells and other projectiles.—15th May.—6 months.

To William Church, of Birmingham, Warwickshire, esquire, for certain improvements in the apparatus used in casting iron and other metals.—15th May.—6 months.

To John Holt Ibbetson, of Smith-street, Chelsea, Middlesex, esquire, for certain improvements in the production or manufacture of gas.—15th May.—6 months.

To Lemuel Wellman Wright, of Welleclose-square, Middlesex, engineer, for certain combinations and improvements in machinery for making pins.—15th May.—2 months.

To Joseph Luckcock, of Round Cottage, Edgebaston, near Birmingham, Warwickshire, gentleman, for his improvement in the process of manufacturing iron.—15th May.—6 months.

To William Henry James, of Coburg-Place, Winson-green, near Birmingham, Warwickshire, engineer, for his improved method of constructing steam-carriages useful in the conveyance of persons and goods upon highways and turnpike roads without the assistance of rail-roads.—15th May.—6 months.

To Thomas Parkin, of Bache's-row, City Road, Middlesex, merchant, for certain improvements in machinery or apparatus applicable to or employed in printing.—15th May.—4 months.

A METEOROLOGICAL TABLE: comprising the Observations of Dr. BURNLEY at Gosport, Mr. CARY in London, and Mr. VELL at Boston.

Days of Month, 1824.	Gosport, at half-past Eight o'Clock, A.M.										Clouds.				Height of Barometer, in Inches, &c.			Thermometer.			RAIN.		WEATHER.	
	Barom. in Inches, &c.	Thermo.	Temp. of Sp. Water.	Hygrom.	Wind.	Evapora- tion.	Rain near theground.	Cirrus.	Cirrostr.	Stratus.	Cumulus.	Cumulostr.	Nimbus.	Lond.		Bost.		Lond.	Bost.	Lond.	Bost.	Lond.	Bost.	
														8 1/2 A.M.	1 P.M.	8 1/2 A.M.	1 P.M.							8 A.M.
April 26	29.66	53	48.00	74	SE.	...	0.175	1	1	1	1	1	1	29.64	29.40	50.59	54	Cloudy	Cloudy	Rain
27	29.80	52	...	68	W.	0.12	0.10	1	1	1	1	1	1	29.94	29.40	50.62	50	Fair	Fine	Cloudy, brisk wind
28	29.93	55	...	75	S.	...	0.65	1	1	1	1	1	1	29.95	29.54	50.56	55	Fair	Cloudy	Cloudy
29	29.80	58	...	65	S.	1	1	1	1	1	1	29.80	29.45	57.68	60	Fair	Fine	Fine
30	29.68	59	...	59	SW.	.18	.030	1	1	1	1	1	1	29.75	29.30	60.65	53	Fair	Fine, brisk wind	Fine, brisk wind
May 1	29.93	57	48.11	64	SW.	...	0.10	1	1	1	1	1	1	30.00	29.60	53.64	55	Fair	0.10	...	Cloudy	Cloudy
2	29.90	52	...	60	NW.	...	0.40	1	1	1	1	1	1	29.89	29.60	52.56	47	Rain	Rain	Rain
3	29.66	53	...	64	NW.	.25	...	1	1	1	1	1	1	29.56	29.35	47.46	45	Rain	Cloudy	Cloudy
4	29.70	52	...	60	NW.	...	0.10	1	1	1	1	1	1	29.76	29.32	45.56	44	Rain	Cloudy	Cloudy
5	29.89	56	...	60	SW.	...	0.20	1	1	1	1	1	1	29.90	29.60	50.64	51	Showery	Fine, rain a.m.	Fine, rain a.m.
6	29.92	54	...	64	SW.	.30	.230	1	1	1	1	1	1	29.90	29.60	50.64	51	Cloudy	Fine, rain p.m.	Fine, rain p.m.
7	29.88	53	48.25	62	W.	1	1	1	1	1	1	29.98	29.57	52.64	50	Fair	Fine, rain p.m.	Fine, rain p.m.
8	30.18	56	...	62	W.	1	1	1	1	1	1	30.26	29.90	50.63	50	Cloudy	0.60	...	Cloudy	Cloudy
9	30.30	53	...	64	E.	.20	...	1	1	1	1	1	1	30.32	30.10	49.61	49	Fair	Fine	Fine
10	30.03	58	...	58	NE.	1	1	1	1	1	1	30.03	29.80	51.66	51	Fair	Fine	Fine
11	29.90	53	...	60	NE.100	1	1	1	1	1	1	29.99	29.80	50.53	47	Cloudy	Cloudy	Cloudy
12	29.81	50	...	67	NE.	.20	.250	1	1	1	1	1	1	29.91	29.75	48.50	44	Cloudy	Cloudy	Cloudy
13	29.77	45	...	74	NE.	...	1.120	1	1	1	1	1	1	29.77	29.70	42.47	43	Rain	Cloudy	Cloudy
14	29.46	47	...	86	NE.	...	1.210	1	1	1	1	1	1	29.56	29.50	45.48	43	Rain	Rain	Rain
15	29.50	44	48.25	89	N.	.05	.960	1	1	1	1	1	1	29.54	29.40	43.45	44	Rain	2.10	...	Rain	Rain, stormy night
16	29.74	44	...	72	N.	1	1	1	1	1	1	29.89	29.63	43.50	41	Rain	Cloudy	Cloudy
17	30.06	55	...	48	W.	...	0.40	1	1	1	1	1	1	30.02	29.75	43.56	47	Fair	Cloudy	Cloudy
18	29.96	55	...	60	NW.	.20	0.01	1	1	1	1	1	1	29.95	29.70	50.54	50	Cloudy	Cloudy	Cloudy
19	29.80	54	...	58	NW.	...	0.70	1	1	1	1	1	1	29.85	29.60	45.55	43	Cloudy	Cloudy	Cloudy
20	29.72	48	...	50	NW.	1	1	1	1	1	1	29.77	29.50	45.50	42	Cloudy	Cloudy	Cloudy
21	29.88	45	48.25	48	E.	.45	...	1	1	1	1	1	1	29.92	29.73	45.54	43	Fair	Fine	Fine
22	29.95	49	...	46	NE.	1	1	1	1	1	1	29.99	29.80	44.52	45	Stormy	0.20	...	Cloudy	Cloudy
23	29.93	52	...	47	N.	...	0.50	1	1	1	1	1	1	29.95	29.70	45.55	50	Fair	Fine	Fine
24	29.94	54	...	56	NW.	...	0.20	1	1	1	1	1	1	29.96	29.67	45.54	50	Cloudy	Rain	Rain
25	30.16	56	48.75	50	N.	.46	...	1	1	1	1	1	1	30.00	29.94	44.54	55	Cloudy	Rain	Rain
Averages:	29.861	52.40	48.27	62.4		2.41	4.631	13	10	22	1	18	17	29.89	29.62	48	50	3.00	2.40	...

THE
PHILOSOPHICAL MAGAZINE
AND JOURNAL.

30th JUNE 1824.

LXVII. *An Account of some Experiments made in order to determine the Velocity with which Sound is transmitted in the Atmosphere.* By OLINTHUS GREGORY, LL.D., Associate Acad. Dijon, Honorary Member of the Literary and Philosophical Society of New York, of the New York Historical Society, of the Cambridge Philosophical Society, &c. Secretary of the Astronomical Society of London, and Professor of Mathematics in the Royal Military Academy at Woolwich.*

THE theoretical investigations of different philosophers, in order to ascertain the velocity with which sound is transmitted through the atmosphere, however ingenious and elegant some of them may be, seem to rest too much upon gratuitous assumptions, to allow any cautious inquirer after physical truth to receive them unhesitatingly, except so far as they may be confirmed by accurate experiment. Unfortunately, too, the results of experiment present irregularities both formidable and perplexing; since many of them cannot well be imputed to any want of skill or caution in the conductors of the inquiry.

	Feet per Second.
Thus, Mr. Roberts assigns a velocity of . . .	1300
Mr. Boyle	1200
Mr. Walker and Duhamel	1338
Mersenne in his treatise <i>De Sonorum Natura,</i> <i>Causis et Effectibus</i>	1474
The Florence Academy	1148
Cassini de Thury (<i>Mem. Paris. Acad. ann.</i> 1738)	1107
Meyer	1105
Derham	1142
Muller	1109
Pictet	1130
Arago &c., from experiments in June 1822, give 337.2 metres at the temperature of +10° centigrade	1106.32†.

* From the Transactions of the Cambridge Philosophical Society for 1824.

† This is the last result of which I had heard previously to the commencement of my own experiments.

The theoretical formula most generally adopted, especially by continental philosophers, is this :

Velocity in horizontal direction = $333\cdot44 \text{ met. } \sqrt{1 + \cdot00375t}$;
the metre being = $3\cdot2809$ English feet, and t denoting the indication of the temperature upon the centigrade thermometer.

I am inclined, however, to think that this can only be regarded as an approximative formula; and that we are not yet in a state to receive otherwise than as an approximation *any* theorem which simply includes the variations of temperature. The air is subject to various classes of changes, indicated by the barometer, thermometer, hygrometer, and anemometer respectively, as well as others probably, for the ascertaining of which we have not yet any appropriate instrument. If we could select these, one by one, *ad libitum*, and carry experiments first through a moderate range upon the barometric scale, all the other probable elements of modification remaining constant; then, through a sufficiently extensive range upon the thermometric scale, the others remaining invariable, and so on; the question would soon be set at rest: but this is impossible. It becomes desirable, therefore, to augment the number of recorded facts, as they result from accurate experiments, in order that at some future (and it is hoped no very remote) time a cautious investigator may so select, compare, and classify them, as to deduce a more comprehensive and accurate theorem than is yet known.

With a view to contribute, though in a small degree, to this purpose, I now present an account of a few experiments made by myself in the course of the present year.

My objects were, to ascertain the velocity with which the sound passed over the surface of the earth, over the surface of the water; under different temperatures; in a quiescent state of the atmosphere, and in windy weather; by day and by night; the velocities of direct and reflected sound; and the velocities of sounds of different intensities and produced by different means. As yet the experiments have not been carried to their projected extent; but while I record the results thus far obtained, I look forward with hope, that in another year or two I shall be able to complete them satisfactorily.

The instrument with which I measured the intervals of time, was one invented and made by Mr. Hardy, by means of which, with a little previous practice, I could measure an interval *accurately* to a tenth of a second, and *approximatively* to a twentieth of a second. The velocity of the wind was ascertained by means of an anemometer; and the barometer and thermometer were of the best construction.

I em-

I employed no hygrometer (much as I wished it); for as yet I am not acquainted with any in whose results I should be inclined to confide. With regard to the distances between the stations at which the sound was emitted and heard, they were in some cases taken from the Ordnance Map of Kent, and verified by new operations; in others they were determined by actual and careful measurement: in others by trigonometrical operations with accurate instruments. The whole were conducted with care; and it would be useless to enter into the detail of them.

Friday, Jan. 3, 1824.—A musquet was fired from the battery near the Royal Artillery Barracks, and the interval of time between the flash and sound was observed at two different distances on the mortar-range, direction nearly north and south.

January 3, half-past 2 P.M., barom. 29·7 inches, Fahr. therm. 45°, rather moist atmosphere, but no rain; very gentle wind blowing in direction nearly perpendicular to that of the range.

Distance from musquet to my station 3600 feet. Six rounds fired: in one the interval of time employed by the sound in passing over the 3600 feet was doubtful: in the other five the intervals were 3"·25, 3"·3, 3"·25, 3"·2, 3"·26, the mean of these is 3"·252.

$$\frac{3600}{3\cdot252} = 1107 \text{ feet, velocity of sound; therm. } 45^\circ.$$

Same day, 3 o'clock P.M., barom. 29·64 inches, Fahr. therm. 45°; atmosphere, wind and weather as before.

Distance from musquet to station 3600 feet. Five rounds fired; intervals 3"·2, 3"·2, 3"·3, 3"·3, 3"·25; their mean 3"·25.

$$\frac{3600}{3\cdot25} = 1108 \text{ feet, velocity of sound; therm. } 45^\circ.$$

Same day, half-past 3 P.M., barom. 29·64 inches, Fahr. therm. 45°; atmosphere, wind and weather as before.

Distance from musquet to station 2100 feet. Eight rounds fired. Interval between flash and report in one case doubtful: the others were 1"·88, 1"·88, 1"·9, 1"·9, 1"·9, 1"·9, 1"·91; the mean 1"·896.

$$\frac{2100}{1\cdot896} = 1108 \text{ feet, velocity of sound; therm. } 45^\circ.$$

Thursday, Jan. 9, three quarters past 7 P.M. dark, but clear, star-light, frosty night. Barom. 29·82 inches, Fahr., therm. 27°. Dry; no wind. Musquets fired from the battery, as before, distance 3600 feet.

Six rounds fired, one doubtful. The other intervals between

tween observing the flash and hearing the report, were 3''·25, 3''·28, 3''·3, 3''·3, 3''·32; mean 3''·29.

$$\frac{3600}{3\cdot29} = 1094\cdot2 \text{ feet, velocity of sound; therm. } 27^{\circ}.$$

The sound of the same charge, fired from the same musquet, was heard much more intensely on this clear frosty night than in the day-time of January 3, at the same distance, 3600 feet.

Same day, January 9. Being anxious to extend the experiments to greater distances, I had previously applied to General Ramsey, of the Royal Artillery, the Commandant of the Garrison here, for the use of cannons as well as musquets: these, with his accustomed courtesy and kindness, he immediately ordered to be at my disposal whenever I should need them in the course of my experiments.

On the morning of this day, therefore, I chose a station for the gun on the side of Shooter's Hill, between Severn-Droog Castle and the 8 mile-stone on the Dover road. I selected three other stations from which the gun could be seen with a good Theodolite telescope; one of these was at the entrance of the lane turning from the Dover road to Charlton, between "the Sun in the Sands" and the 7 mile-stone; the second in the Kidbrook Lane which turns off from the Dover road between the 6 mile-stone and "the Sun in the Sands;" and the third on Blackheath, nearly in a continuation of the western wall of Greenwich Park towards the windmills. These three stations are probably 200 feet above the high water-mark in the Thames at Woolwich; and the station at which the gun was placed is still more elevated.

The distances, as accurately measured, were, from the Shooter's Hill station to that in Charlton Lane 6550 feet; from Shooter's Hill to that in Kidbrook Lane 8820 feet; from the Shooter's Hill station to that on Blackheath, 13,440 feet.

The gun employed was a six-pounder, the charge of powder eight ounces. The serjeant-major who remained at the gun was directed to order the men to commence firing at a certain minute by his watch (which was previously made to agree with mine), and then to fire regularly a certain number of rounds at intervals of *two minutes*: this was the practice throughout the experiments, the gun was always pointed towards me, at a very small elevation, except it be otherwise expressed.

January 9th, noon. Barom. 29·92 inches; Fahr. therm. 33°; weather dry, wind scarcely perceptible, a clear cloudless frosty day.

Six rounds fired. Interval of passage of sound from Shooter's Hill to Charlton Lane, $5''\cdot9$, $6''\cdot0$, $5''\cdot9$, $6''\cdot0$, $6''\cdot0$, $6''\cdot0$, their mean $5''\cdot9\frac{2}{3}$, distance 6550.

$$\frac{6550}{5\cdot9\frac{2}{3}} = 1098 \text{ feet, velocity of sound; therm. } 33^\circ.$$

Same day, January 9, half-past 12, barom. 29.86 inches; Fahr. therm. 33° ; weather dry, wind scarcely perceptible. Six rounds fired. Result in reference to one, very doubtful. Intervals of passage of sound from Shooter's Hill to Kidbrook Lane, were $7''\cdot95$, $8''\cdot0$, $8''\cdot0$, $8''\cdot0$, $8''\cdot05$; their mean $8''$. Distance 8820 feet.

$$\frac{8820}{8} = 1102\frac{1}{2} \text{ feet, velocity of sound; therm. } 33^\circ.$$

Same day, January 9, quarter past 1 P.M., barom. 29.82 inches; Fahr. therm. 33° ; weather dry, wind scarcely perceptible. Five rounds fired; intervals of the passage of sound between the stations at Shooter's Hill and Blackheath, $12''\cdot2$, $12''\cdot25$, $12''\cdot3$, $12''\cdot24$, $12''\cdot26$; mean $12''\cdot25$, distance 13440 feet.

$$\frac{13440}{12\frac{1}{4}} = 1097 \text{ feet, velocity of sound; therm. } 33^\circ.$$

$\frac{1}{3}(1098 + 1102\frac{1}{2} + 1097) = 1099\frac{1}{6}$ feet, *mean velocity* from the sixteen rounds; therm. 33° .

Monday, February 17, noon. Barom. 29.98 inches; Fahr. therm. 35° . Air humid, but neither rain nor sleet; very gentle wind N.E. by E. Employed *bells* on the mortar-range on Woolwich Common, lying nearly north and south.

A bell rung at the north station, was heard by a soldier at the south station, who immediately rang another bell, having his arm elevated for the purpose. I stood by the soldier who rang the first bell, and measured the interval of time between the sound of the first bell, and the sound of the second bell when transmitted from the other station.

By several preceding experiments, I estimated the time which elapsed between the moment when the man with the second bell heard the sound from the other, and struck the clapper against his own bell, finding it to be *one-fifth of a second*; this, therefore, I deducted from the intervals which marked the passage of sound, before I recorded them, as below.

Distance between the two bells 1350 feet; whole distance traversed by the sound 2700 feet. Intervals elapsed (corrected as above) in five experiments; $2''\cdot5$, $2''\cdot48$, $2''\cdot44$, $2''\cdot46$, $2''\cdot42$; mean $2''\cdot46$.

$$\frac{2700}{2\cdot46} = 1098 \text{ feet, velocity of sound; therm. } 35^\circ.$$

Same

Same day, quarter past 12, barom. therm. wind and weather as before.

Distance between the two bells 1650 feet; whole distance 3300 feet. Intervals elapsed in four experiments, 3''·0, 3''·0, 3''·0, 3''·0.

$$\frac{3300}{3} = 1100 \text{ feet, velocity of sound; therm. } 35^{\circ}.$$

Same day, half-past 12, barom. therm. wind and weather as before. Distance between the two bells 1800 feet; whole distance 3600 feet. Intervals elapsed in five trials, 3''·25, 3''·24, 3''·26, 3''·25, 3''·25; mean 3''·25.

$$\frac{3600}{3\cdot25} = 1108 \text{ feet, velocity of sound; therm. } 35^{\circ}.$$

$\frac{1}{3}(1098 + 1100 + 1108) = 1102$ feet, *mean velocity* from this day's experiments; therm. 35° .

Friday, May 23. This morning there was a tolerably brisk wind blowing from the S.W. by W. nearly in the direction of my Charlton and Kidbrook stations from Shooter's Hill. Of this I gladly availed myself, as the morning was in other respects favourable, in order to ascertain what would be the effect of such a wind upon the velocity. Cloudy, air humid, but no rain.

I measured the velocity of the wind frequently with an anemometer, and found it vary between 22 and 26 feet, the mean 24 feet.

The gun a six-pounder, charge 8 oz. of powder. 11 A.M. gun at Shooter's Hill, sound heard at Charlton Lane, distance 6550 feet. Barom. 29·66 inches. Fahr. therm. 58° , air humid. Six rounds fired; the intervals were 6''·1, 6''·05, 6''·0, 6''·05, 6''·0, 6''·04; their mean 6''·037.

$\frac{6550}{6\cdot037} = 1085$ feet, velocity of sound, when *opposed* by the wind.

Same day, quarter past 1 P.M., barom. 29·67 inches, Fahr. therm. 60° ; air drier. Gun at Charlton Lane. Sound heard at Shooter's Hill. Distance 6550 feet. Five rounds fired: the intervals were, 5''·65 doubtful, 5''·8, 5''·78, 5''·76, 5''·78, omitting the first, the mean interval of the other four is 5''·78.

$\frac{6550}{5\cdot78} = 1133\frac{1}{2}$ feet, velocity of sound, when *aided* by the wind.

$\frac{1}{2}(1085 + 1133\frac{1}{2}) = 1109\frac{1}{4}$ feet inferred velocity of *sound* independently of the wind; therm. 59° .

And $\frac{1}{2}(1133\frac{1}{2} - 1085) = 24\frac{1}{4}$ inferred velocity of the wind at

at the times of the experiment, supposing it to be nearly the same at both times. This agrees quite as nearly as could be expected with the mean velocity of the wind determined by the anemometer.

Same day, May 23, half-past 11 A.M., barom. 29.67 inches: Fahr. therm. 58°: air humid; wind as before.

Before the gun was removed from Shooter's Hill, six rounds more were fired. The intervals in which the sound reached Kidbrook Lane, were 8".1, 8".125, 8".13, 8".15, 8".1, and one very doubtful. The mean of these is 8".121. Distance 8820 feet.

$$\frac{8820}{8.121} = 1086 \text{ feet, velocity of sound, opposed by the wind.}$$

Here the sound was but just audible, the wind diminishing its intensity exceedingly.

Same day, therefore, the gun was removed to Kidbrook Lane, while I went back to Shooter's Hill.

Half-past 12, barom. 29.67 inches; Fahr. therm. 60°; air drier; wind as before. Six rounds were fired. The intervals between the flash and the report were 7".8, 7".7, 7".8, 7".78, 7".78, and one very doubtful; mean 7".77.

$$\frac{8820}{7.77} = 1136 \text{ feet, velocity of sound, when aided by the wind.}$$

$\frac{1}{2}(1086 + 1136) = 1113$ feet, inferred velocity of the *sound* independent of the wind; therm. 59°. $\frac{1}{2}(1136 - 1086) = 25$ feet inferred velocity of the *wind*, nearly as before.

The same day, May 23, in the afternoon, the wind subsided, so as not to exceed 6 or 8 feet per second, while the temperature of the air remained nearly the same. I anxiously availed myself of this opportunity to ascertain the velocity of the sound, when scarcely affected by the wind. Mortars and howitzers were firing from the battery, the former at an angle of 45°, the latter at low angles for Ricochet practice. At 3½ P.M. when the barom. was at 29.68 inches, Fahr. therm. at 60°, the sun shining, I took a station 3100 feet from the battery, and in a direction nearly perpendicular to that of the wind, then gently blowing. I observed the intervals between the flash and the report, for six rounds, of which the first three were with howitzers, the next three with mortars; these were successively 2".77, 2".76, 2".79, 2".79, 2".8, 2".8; their mean 2".786.

$$\frac{3100}{2.786} = 1112 \text{ feet, velocity of sound; therm. 60°.}$$

In these latter experiments the sound was very distinct and sharp:

sharp: the result, though drawn from a short distance, serves to confirm the preceding results on the same day.

Thursday, August 7. On this day, which was cloudy, but with intervals of sunshine, I employed the same six-pounder as before, sometimes with charges of 8 ounces of powder, at others, when the distance required it, with 12 ounces. The wind was quite brisk, varying in velocity from 30 to 35 feet, as determined by an anemometer.

At eleven o'clock A.M., barom. 29·80 inches; Fahr. therm. 66°; air dry, cloudy, but sun shining; wind nearly *opposing* the motion of the sound, and having a velocity of 30 feet. Six rounds were fired from Shooter's Hill. The intervals occupied in the passage of sound from thence to Kidbrook Lane, distance 8820 feet, were 8"·1, 8"·15, 8"·16, 8"·13, 8"·13, 8"·12; their mean, 8"·13.

$\frac{8820}{8\cdot13} = 1085$ feet, velocity of sound, when *opposed* by the wind.

Same day, August 7, quarter past 1 P.M., barom. therm. wind and weather as before.

The gun being placed in Kidbrook Lane, I went to the station on Shooter's Hill. Six rounds were fired, and the intervals occupied in the transmission of the sound were 7"·7, 7"·75, 7"·68, 7"·67, 7"·72, 7"·68; their mean 7"·7.

$\frac{8820}{7\cdot7} = 1145\frac{1}{2}$ feet, velocity of sound, when *aided* by a wind of about the same velocity as the former.

$\frac{1}{2}(1085 + 1145\frac{1}{2}) = 1115\frac{1}{4}$ feet, velocity of *sound*; therm. 66°,
 $\frac{1}{4}(1145\frac{1}{2} - 1085) = 30\frac{1}{4}$ feet, velocity of the *wind*.

Same day, August 7, half-past 11 A.M., barom. 29·80 inches; Fahr. therm. 64°, the wind blowing in the same direction as before, with (an estimated) velocity of 30 feet; air dry, cloudy, no sun. The same six-pounder gun was fired from the Shooter's Hill station with a charge of 12 ounces of powder, and I took a station on Blackheath 20 feet further than on January 9, its distance being 13,460 feet from the gun.

Six rounds were fired; one of the intervals was very doubtful; the others were 12"·4, 12"·38, 12"·42, 12"·38, 12"·4, 12"·4; their mean 12"·396.

$\frac{13460}{12\cdot396} = 1085\cdot8$ feet, velocity of sound when *opposed* by the wind.

Being fearful of bringing the gun to Blackheath, in the vicinity

cinity of so many carriages as were incessantly passing, I could not *here* avail myself of the benefit of comparing the above intervals with those in which the direction of the transmission should be reversed. I venture, therefore, to *add* the velocity of the wind to that of the sound, as obtained by the experiment, and thus obtain $1085.8 + 30 = 1116$ feet nearly, for the velocity of sound, the therm. standing at 64° .

Monday, August 18. On this day, the same six-pounder gun was placed upon the wharf by the side of the Thames in the Royal Arsenal, and I took a station at the opposite extremity of the Gallion's Reach, not far from the mouth of Barking Creek; the distance from the gun was 9874 feet, the time of high water there, on that day, was about 11 o'clock A.M.

At half past 11 A.M., barom. 29.84 inches; therm. 66° ; air dry, sky rather cloudy: very gentle wind nearly perpendicular to the line of transmission of the sound. Six rounds were fired with the muzzle of the gun towards me: the intervals were $8''\cdot8$, $8''\cdot84$, $8''\cdot86$, $8''\cdot86$, $8''\cdot83$, $8''\cdot85$; their mean $8''\cdot84$.

At three quarters past 11 A.M., barom. &c. as before; six more rounds were fired, the gun muzzle being directed *from* us (up the river) in a horizontal angle of about 140 degrees: the intervals were $8''\cdot86$, $8''\cdot84$, $8''\cdot82$, $8''\cdot82$, $8''\cdot85$, $8''\cdot86$; their mean $8''\cdot841$.

$\frac{9874}{8.84} = 1117$ feet, velocity of sound; therm. 66° , over a surface of water.

Although there was no perceptible difference in the mean *intervals* occupied by the transmission of sound, in the two different directions of the gun, yet there was a considerable modification of the *intensity*; the sound being *much* weaker when the gun muzzle was directed westerly, up the river, than when it was pointed down Gallion's Reach, towards the place where I stood. In the former case, too, besides the first report, which was marked and distinct, though comparatively feeble, there was a series of audible re-percussions, at intervals of about a tenth of a second, and gradually dying away: these, I conjecture, were reflected sounds from the faces of storehouses and other buildings standing on or near the side of the river at Woolwich.

Same day, August 18, one o'clock P.M., barom. 29.82 inches, Fahr. therm. 66° ; fair, but cloudy; scarcely any wind: I took a station on the Essex bank of the Thames perpendicularly opposite the large storehouse on Roff's Wharf at Woolwich, in order to ascertain the interval occupied by both

the direct and the reflected transmission of the sound from a musquet fired by my side, and returned in an echo from the front of the said storehouse. The distance from my station to the front of the storehouse, determined carefully by a trigonometrical operation, was 1523 feet.

Of eight rounds fired from the musquet, I failed twice in the appreciation of the interval between the sound and the returning echo, from a very wrong estimate of its probable duration; and that from an erroneous impression as to the time observed by Dr. Derham in a similar experiment*. Of the remaining six rounds, the musquet pointed *across* the river, the intervals were 2''·7, 2''·75, 2''·74, 2''·72, 2''·75, 2''·74; their mean 2''·73·

Next, three rounds were fired, the musquet being pointed directly *from* the river; the intervals were 2''·7, 2''·73, 2''·76; mean as before.

Lastly, four rounds were fired *along the bank*, at an elevation of about 45°; the intervals were 2''·75, 2''·7, 2''·73, 2''·74; mean as before.

Distance occupied by the direct and the reflected sounds 3046 feet.

$$\frac{3046}{2\cdot73} = 1116 \text{ feet velocity of sound across a surface of water, half direct, half reflected; therm. } 66^{\circ}.$$

The near agreement of this with the former result on the same day, serves to confirm the opinion that *direct* and *reflected* sounds move with the same velocity.

The near agreement of this with the former result on the same day, serves to confirm the opinion that *direct* and *reflected* sounds move with the same velocity.

Thursday, August 21, three o'clock P.M., barom. 29·86 inches, Fahr. therm. 64°; clear sunshine; wind scarcely perceptible, westerly.

Mortars were firing from the battery, and I took a station 3900 feet south of it. I observed the intervals between the flash and the report in six successive rounds: they were 3''·5, 3''·5, 3''·48, 3''·52, 3''·5, 3''·5, respectively; the mean being 3''·5.

$$\frac{3900}{3\cdot5} = \frac{7800}{7} = 1114\frac{2}{7} \text{ feet, velocity of sound, therm. } 64^{\circ}.$$

These are all the experiments in reference to the velocity

* He made it 3 seconds, by means of a *half-second* pendulum. My erroneous recollection of his experiment led me to anticipate an interval of between 4 and 5 seconds. I could not account for the supposed discrepancy until after my return home, when, on examining Derham's paper, and computing the real breadth of the river from my trigonometrical operation, I found the correspondence of the two experiments to be quite as great as could be expected, considering the different natures of the chronometers employed, and the varying breadth of the river.

of sound, as transmitted through the atmosphere, which I have yet been able to make. Their chief results may be brought into one view as below.

Velocity of sound,	Fahr. therm.	27°	Feet.
_____	ditto	33	1094·2
_____	ditto	35	1099 $\frac{1}{6}$
_____	ditto	45	1102
_____	ditto	59	1107 $\frac{2}{5}$
_____	ditto	60	1109 $\frac{1}{4}$
_____	ditto	64	1112
_____	ditto	64	{ 1114 $\frac{2}{7}$
				{ 1116
_____	ditto	66	{ 1116
				{ 1117

Of these results, some have been obtained in the day-time, others in the night; some when the sound has been transmitted over the surface of the earth, others when it has been transmitted over the surface of water; some are the result of direct sound, others of both direct and reflected sound; some from the report of cannons, others of musquets, others from the sound of bells.

Were these the only experiments on the subject that had ever been made, I should not regard them sufficiently extensive to justify me in deducing from them even an *approximative* rule. But as they have been made with great care, I may at least venture to present a rule, which, while it includes with only slight discrepancies all the preceding results, is simple enough to be easily recollected by practical men; and may, perhaps, be employed in our own climate. It is this:

At the temperature of freezing 33°, the velocity of sound is 1100 feet per second.

For lower temperatures deduct } half a foot.
 For higher temperatures add }

From the 1100 } for every degree of difference from 33°
 to the 1100 }
 on Fahr. therm.; the result will show the velocity of sound, very nearly, at all such temperatures.

Thus, at the temperature of 50°, the velocity of sound is,
 $1100 \times \frac{1}{2}(50 - 33) = 1108\frac{1}{2}$ feet.

At temperature 60°, it is $1100 + \frac{1}{2}(60 - 33) = 1113\frac{1}{2}$ feet; agreeing with the experimental result quite within the limits of a practical rule.

The theorem $333\cdot44 \text{ met. } \sqrt{1 + 00375 t}$, before cited, gives nearly 1094 feet for the velocity at the freezing point; and 1114 feet for the temperature 10° centigrade, or 50° Fahrenheit: thus occasioning a greater augmentation to the velocity

in the higher temperatures, than my experiments seem to indicate.

The above practical rule, so far as it may be entitled to confidence, may be useful, 1st, to the military man in determining the distance of an enemy's camp, of a fortress, a battery, &c.; 2d, to the sailor, in determining the distance of another ship, &c.; 3d, to the land-surveyor in ascertaining the length of base lines, &c. in conducting the survey of a lordship or county; 4th, to the philosophic observer, in appreciating the distances of thunder-clouds during a storm. Yet in either of these applications the rule must be regarded as *approximative* only; because few practical men can be expected to possess a time-measurer for less intervals than *tenths* of seconds (if, indeed, so small): and an error of a tenth of a second, will occasion a mistake of from 37 to 40 yards in the estimate of the distance. Beyond this, however, the error need scarcely ever extend; because a mean of 5 or 6 careful experiments will usually give the interval to a degree of correctness far within the limits just specified. Indeed, an error of from 30 to 40 yards in a distance of three or four miles, will, on most occasions, where such approximative estimates are required, be of but small consequence. When the distance exceeds four miles, this method of approximating to it can only be employed under favourable circumstances of a very quiescent atmosphere, &c.: on which account, I felt scarcely any desire to extend my own experiments to stations more remote from each other, than those which I selected on Shooter's Hill and Blackheath.

Combining the results of experiments here recorded with those which have been formerly deduced by Derham and others, we may, I think, conclude unhesitatingly:

1st, That sound moves *uniformly*; at least, in a horizontal direction, or one that does not deviate greatly from horizontality.

2d, That the difference in intensity of a sound makes no appreciable difference in its velocity*.

3d, Nor, consequently, does a difference in the instrument from which the sound is emitted.

4th, That wind greatly affects sound in point of *intensity*; and that it affects it, also, in point of *velocity*.

5th, That when the direction of the wind *concur*s with that of the sound, the *sum* of their separate velocities gives the *apparent* velocity of sound; when the direction of the wind *op-*

* The consecution of the notes in a tune, notwithstanding the difference in their intensity, being uninterrupted when heard at a distance, furnishes an elegant and decisive confirmation of this proposition.

poses that of the sound, the *difference* of the separate velocities must be taken.

6th, That in the case of echoes, the velocity of the *reflected* sound, is the same as that of the *direct* sound.

7th, That, therefore, distances may frequently be measured by means of echoes.

8th, That an augmentation of temperature occasions an augmentation of the velocity of sound; and *vice versâ*.—(See Newton, *Principia*, lib. 2. prop. 50. Parkinson's *Mechanics*, vol. ii. p. 148.)

The inquiries with regard to the transmission of sound in the atmosphere*, which, notwithstanding the curious investigations of Newton, Laplace, Poisson, and others, require the further aid of experiment for satisfactory determination, are, I think, the following; viz.

1st, Whether hygrometric changes in the atmosphere have much or little influence on the velocity of sound?

2d, Whether barometric changes in the atmosphere have much or little influence?

3d, Whether, as Muschenbroek conjectured, sound have not different degrees of velocity, at the same temperature, in different regions of the earth? And whether *high* barometric pressures would not be found (even independently of temperature) to produce greater velocities?

4th, Whether, therefore, sound would not pass more slowly between the summits of two mountains, than between their bases?

5th, Whether sound, independently of the changes in the air's elasticity, move quicker or slower near the earth's surface, than at some distance from it?—(See Savart's interesting papers on the communication of sonorous vibration.)

6th, Whether sound would not employ a longer interval *in passing over a given space, as a mile, vertically upwards*, than in a *horizontal* direction? and, if so, would the formulæ which should express the relation of the intervals include more than thermometric and barometric coefficients?

7th, Whether or not, the principle of the parallelogram of forces may be employed in estimating the effect of wind upon sound, when their respective velocities do not aid, or oppose each other in the same line, or nearly so?

8th, Whether those eudiometric qualities, generally (whether hitherto detected or not) which affect the elasticity of the air,

* I say nothing in this paper of the transmission of sound through the gases, along metallic conductors, &c. These furnish a most interesting department of separate inquiry.

will not proportionally affect the velocity of sound? and if so, how are the modifications to be appreciated?

To the experimental solution of some of these inquiries I hope to devote myself at no very remote period: but others of them, it is evident can only be satisfactorily answered, if ever, by means of a cautious classification of skilful experiments made by various philosophers in different parts of the globe.

Royal Military Academy, Woolwich,
Oct. 25, 1823.

OLINTHUS GREGORY.

P.S. Since the above paper was drawn up, a friend has favoured me with the perusal of Mr. Goldingham's account of his experiments in reference to the velocity of sound, made at Madras. From this very interesting dissertation I shall venture to transcribe the following table of the mean motion of sound for each month of the year at Madras.

Month.	Mean height of			Velocity in a Second.
	Barometer.	Thermometer.	Hygrometer.	
	Inches.	Degrees.	Dry.	Feet.
January ...	30·124	79·05	6·2	1101
February	30·126	78·84	14·70	1117
March ...	30·072	82·30	15·22	1134
April... ..	30·031	85·79	17·23	1145
May	29·892	88·11	19·92	1151
June	29·907	87·10	24·77	1157
July	29·914	86·65	27·85	1164
August ...	29·931	85·02	21·54	1163
September	29·963	84·49	18·97	1152
October...	30·058	84·33	18·23	1128
November	30·125	81·35	8·18	1101
December	30·087	79·37	1·43	1099

These results serve, as far as they go, to confirm the suspicions which I have long entertained, that the velocity of sound is somewhat different in different climates; and that hygrometric changes have more influence than has usually been imputed to them by theorists. The velocity varies from 1099 to 1164 feet, while the barometric range does not exceed a quarter of an inch, and the thermometer varies only from about 78° to 88°. But the indications of hygrometric change are considerable, passing from 1° to nearly 28 degrees. Unfortunately,

fortunately, however, we are not able to make such satisfactory deductions from these curious experiments as they might have furnished, had Mr. Goldingham described the construction of his hygrometer, and the fixed points, or the extent of its scale.

Royal Military Academy, Nov. 8, 1823.

LXVIII. *On the New Method of Gauging proposed by Dr. YOUNG. By Mr. W. WISEMAN.*

To the Editors of the Philosophical Magazine and Journal.

Gentlemen,

IN the Journal of Science, No. 32, there appears a Report, made to the Honourable Commissioners of the Customs by Dr. Young, respecting improvements in Gauging. The matter being thus made public, I shall now take the liberty, through your permission, to offer a few observations on the occasion.

The advantages which Dr. Young states, in the Report just mentioned, would be derived from the adoption of his invention, are, the shortening the operation of casting the full content,—abolishing the practice of making a discretionary allowance in the length of each cask supposed adequate to reduce such cask to the middle frustum of a spheroid,—and at the same time attaining at least an equal degree of accuracy with the old method.

The detailed operation of casting the content, at present in use, is this:—The beginning of the first line is set to the head diameter on the second line; the number on the third line, standing against the bung diameter on the second line, is noted; against this number on the first line is found the mean diameter on the second line. Next, the end of the slide is set to the length on the fourth line; and against the mean diameter on the fifth line is found the full content on the fourth line.

The operation which Dr. Young proposes to substitute for the above, and for the method of allowances, is this:—The head and bung diameters on the first and second lines are brought together, and against the length on the third line is the full content on the fourth line.

The formula upon which this operation depends, is a most scientific and ingenious invention; and were it possible to invent a rule which would always give the content, at a single setting of the slide, sufficiently near the truth in all the varieties

ties of casks met with in practice, this would perhaps have been it. But, without corrections or allowances, the thing appears to me to be impossible.

Dr. Young's formula generalized is $b^n \times h^{2-n} \times l \div m = c$; or, in logarithms $nB + (2-n)H + L - M = C$ (m being = 294.118);

where $n = \frac{C+M-2H-L}{B-H}$. Putting this equation into numbers,

the true value of n will be found for any cask whatever whose true content is previously known. Thus the cask No. III. requires $n=1.40803$; or, if a vulgar fraction with the denominator 150 be preferred, the indices of b and h will be $\frac{211}{150}$ and $\frac{89}{150}$;—No. IV. requires $\frac{188}{150}$ and $\frac{112}{150}$;—No. 3, $\frac{202}{150}$ and $\frac{98}{150}$, and No. 8, $\frac{210}{150}$ and $\frac{90}{150}$; &c. The average of all these, $\frac{203}{150}$ and $\frac{97}{150}$, Dr. Young has adopted. But since the values of the indices will in practice vary at least from $\frac{188}{150}$, $\frac{112}{150}$ to $\frac{211}{150}$, $\frac{89}{150}$, this circumstance alone shows that Dr. Young's rule (where the indices are constant) will in many instances be necessarily very incorrect, and consequently unfit for the purposes of general cask-gauging. Those casks (port pipes, see Nos. III. and 9), which, being made in a more regular manner, are the easiest to determine near the truth, have their contents made furthest from the truth; so that there would be a certain loss to the revenue of two or three gallons on every cask of that description gauged by this method! Similar observations might be made with respect to several other varieties of casks.

It follows from what has already been said, that this new method cannot with propriety be adopted unless it can be modified in its operation by discretionary allowances in and additions to the length; something similar to the present practice: for the having recourse to tabular corrections, which Dr. Young himself seems to think may be necessary, is inadmissible; since the operation of taking such a dimension as the wake and applying its corresponding correction, would require, perhaps, tenfold the time and trouble required by those operations which this new method is intended to supersede. But if even tabular corrections could be applied consistently with dispatch, the wake, from the difficulty of obtaining it accurately, is the most improper element from which to calculate them. The obvious want of analogy between the series of wakes and that of errors given in the Report, sufficiently shows that no table of corrections calculated with the wake can be at all depended upon. If, as I said before, tabular corrections could be admitted, those calculated with the help of the middle diameter between the bung and head would be most to be depended on; and this dimension would be far more easily and

and accurately taken. But, this new method being modified by discretionary allowances, the change would not be attended with any advantages; for these allowances would be far more difficult to approximate near the truth, and more perplexing to the mind, than those in the present method.

With respect to the assertion that the new method would be at least as accurate as the old, I would observe that this question can only be decided by experiments on a large scale. But however, since the elements employed in casting the contents are (with the exception of the length) the same in both methods; and the method of casting the middle frustum of a spheroid by the sliding rule is known to be nearly true (it is not accurately true, as I have demonstrated in my small treatise on Cask Gauging); it follows that the comparative merits of the two methods rest entirely on the present mode of reducing the length. But the casks, Nos. III. and 9, if cast by the old method, would each require 9 or 10 tenths of an inch to be allowed in the length, to produce the true contents; and would require 17 or 18 tenths to be allowed to produce the contents as given by the new method; which last, since the casks are port pipes, is an allowance which no gauger in his senses would ever think of making; though he might not hit exactly upon the first. Similar observations apply to various other casks; and it is therefore only fair to infer that the old method is in general likely to be the most correct.

I have, with Dr. Young's algebraic theorems, making use of the wake, calculated the content of each of the 21 casks in the table, both by the superior and by the inferior parabolus; and the result tends to confirm my opinion that no dependence should be placed on corrections derived from the wake.

In addition to what has been said, seeing that, could this sliding rule perform all the things proposed, an additional instrument would be required (for Dr. Young's four lines would occupy the whole face of the rod, and therefore it could not be used as a head-rod), causing thereby a considerable expense to the revenue, and care and trouble to the gauger, for the sake, principally, of shortening an operation which altogether does not, in general, occupy the space of half a minute,—and that, after all, the operation of ullaging will remain as at present, subject to the settings of the slide, I think, on the whole, that the adoption of this new plan of gauging would, instead of being an advantage, be a detriment to the service.

I am, gentlemen,

Your obedient servant,

Portland Place, Hull, May 18, 1824.

WM. WISEMAN.

Vol. 63. No. 314. June 1824.

3 G

LXIX. Let-

LXIX. *Letter on the Astronomical Refractions.* By J. IVORY,
Esq. M.A. F.R.S.

To the Editors of the Philosophical Magazine and Journal.

Gentlemen,

I DO not find that there is much to remark upon in the Notice addressed to me in your last Number. I am still under no little astonishment at the critique on my Table of Refractions that appeared in the last Journal of Science. At present, I can conjecture no rational purpose it could be supposed to serve; but time, which is a great revealer of secrets, may possibly disclose what was really intended by it. I was far from wishing to put the Secretary of the Board of Longitude to the trouble of examining any of my productions; and I confess I do not see the propriety of such official interference unless specially called for, more particularly under such suspicious circumstances as attended the present instance.

In my letter in your Number for April, I used the Table in N. A. according to the directions given with it. I hope there will not be found any material errors in my calculations.

The standard temperature of a Table of refractions is fixed by that of the elementary quantities employed in its construction. In this respect there can possibly be no uncertainty. The difficulty is to find the real temperature of every particular observation. Whether the estimation is to be made by the thermometer within, or by that without, or at some intermediate degree between the two; is the question to be determined, and which every astronomer answers for himself the best way he can. The Table in N. A. has the same standard temperature with mine. Now when the S. B. L., for the express purpose of lessening the errors of his own Table, lowered its temperature from 50° to 48° or 47° , which is equivalent to bringing the exterior thermometer two or three degrees nearer the interior one; did it not occur to him that the errors of the other Table would likewise be lessened by the same device? The reason of the practice applies equally to both Tables; namely, the exterior temperature is not really that of the observations, and gives corrections that are too great. But perhaps this is one of those little advantages which the Secretary reserves to himself as a peculiar prerogative of his office.

After heaping calculation upon calculation, and trying every means of involving a very simple matter, the conclusion in the last paragraph of the Notice is just the same with what I
have

have stated at p. 490 P. T. for 1823. But no mention is made of the reason I have there assigned. The sums of the exterior and interior thermometers are respectively 567·6 and 669·9; and the difference is $102^{\circ}3$, being 8° for each star. Now this is a very great difference, and undoubtedly leaves a very considerable uncertainty about the real temperature of observation. When we consider that, at the low altitudes in question, every degree of the thermometer corresponds to an alteration of $2''$ or $3''$ in the star's place, I am persuaded that the opinion I have advanced in my Paper relative to Mr. Groombridge's observations will be found to be just. They are not a proper test of the accuracy of a Table of refractions on account of the uncertainty of the temperature. Every shifting of the standard of the Table must approach nearer the truth, or recede further from it, at the rate mentioned.

I shall now compare my Table with the same observations, on the supposition that the temperature is found more nearly when estimated, not by the exterior thermometer, but 2° nearer the interior one; or, which is the same thing, I shall lower the temperature of the Table from 50° to 48° . I have also ascertained, by sound principles as I shall show below, that no confidence can be placed in my Table, nor in any other at present in existence, passing $88\frac{1}{2}^{\circ}$ of zenith distance. Nearer the horizon the errors of every Table increase at a prodigious rate. Now, leaving out the last star and estimating the temperature as I have said, the errors of the first 12 stars by my Table are $+12''\cdot5$ and $-10''\cdot6$, or $23''\cdot1$. The error of the last star alone is $17''$; making the sum of the errors of all the 13 stars equal to $40''$. I wonder the ingenuity of the S. B. L. did not suggest some plausible argument for changing my Table from 50° to 52° , which would have given him a decided advantage.

The Table in N. A. is one of no authority. No astronomer in Europe, except the author, can tell how it was constructed. Its character rests upon a *dictum*. We know that there is no correct theory. I will not again venture to say that the formula is empirical for fear of the consequence; but it is partly empirical, as the author has admitted. The Table must therefore have been constructed either with the assistance of other Tables already in use, or by means of actual observations. Now, as no original observations are produced, except one by Mr. Pond, it is very probable that it was constructed in the first of the ways I have mentioned.

That it may not be thought I am speaking at random, I now affirm that the Table in N. A. is the same with that in the

Fundamenta Astronomiæ, from the zenith to 45° of altitude. The standard quantities of Mr. Bessel are, $48\frac{3}{4}^\circ$ Fahr., Bar. 29.6; the refraction at 45° is $57''.49$: now if this number be reduced to 50° , 30 B., there will come out $58''.118$; the number in the N. A., which does not extend beyond tenths of a second, being $58''.1$. The coincidence is equally exact in every case within the limits mentioned. I have formerly shown that the refractions in N. A. near the horizon are the same with those of the French Astronomers. It is reasonable to conjecture, nay it seems to follow as an unavoidable consequence, that the middle part of the Table in N. A. must be a mean between the other two Tables, or, at least, it must be interpolated by some rule. I throw out these observations for the purpose of showing how necessary it is to lay before the public, simply and explicitly, an explanation of the real construction of the Table.

It will readily be conceived that a Table may be constructed in the manner I have been describing, not liable to extreme errors in practice. But it would deserve little praise from the astronomer or the man of science. It would not do much honour to an exciseman*.

There is another point that stands in need of elucidation. It relates to the corrections for temperature. Without entering upon any theoretical discussion, in point of fact the corrections in N. A. are the same with Mr. Bessel's. The differences are altogether trifling. For this we have the authority of the Journal of Science †. Now the refractions in N. A. at low altitudes are almost coincident with those in the French Table. But if any astronomer should apply Mr. Bessel's corrections to the French Table, he would commit a great inaccuracy. On this ground I asserted in your last Number that the N. A. at low altitudes is more discordant with observation than the French Table.

The Table in my paper has fully answered every purpose for which it was intended. It has turned out much more correct than I could possibly have expected. I shall now direct your attention to the chief points of my Theory; briefly mention the proofs already given of its agreement with Nature; and then add other corroborative evidence that has since occurred to me.

My investigation sets out with supposing that the heat decreases equably as we ascend in the atmosphere. This is no new law. It has long been assumed in the Theory of baro-

* Sup. Enc. Brit., Article *Wakefield*.

† No. 29, p. 131.

metrical measurements as well as in that of the astronomical refractions. It is confirmed by experience to the greatest heights to which we have been able to ascend. Adopting this law, I next inquire into all the constitutions of the atmosphere in which it is fulfilled. I find that they are all comprehended in these very simple equations, viz.

$$\frac{p}{p'} = \left(\frac{e}{e'}\right)^{\frac{m+1}{m}}$$

$$\frac{1+\beta\tau}{1+\beta\tau'} = \left(\frac{e}{e'}\right)^{\frac{1}{m}}$$

The letters p' , e' , τ' , denote the barometric pressure, the density, and temperature at the surface of the earth; and the same letters without the accent, stand for the same things at any height in the atmosphere; m is an arbitrary number, and β the expansion of air for one degree of the thermometer. Now we know that every hypothesis respecting the atmosphere will give the refractions actually observed as far as 70° from the zenith; therefore if we determine the value of m that will bring out the true horizontal refraction, we shall obtain a constitution of the atmosphere, and a formula for the refractions, that must nearly coincide with Nature. But there is another way of finding m , which is preferable because it depends upon a quantity less complicated than the refractions. If we put x for the height above the earth's surface, we have this general equation, viz.

$p = f - gdx$,
 p being equal to p' when $x=0$. By combining this equation with the two former ones, it will be easy to prove this formula, viz.

$$\frac{m}{m+1} = 1 - \frac{\beta l}{\mu};$$

l being the homogeneous atmosphere, and μ the height that must be ascended at the earth's surface in order to depress the thermometer one degree. If we substitute the value of l , and take the most probable determination of μ , we shall obtain

$$m=4;$$

and thus, in the atmosphere of the earth the foregoing equations become

$$\frac{p}{p'} = \left(\frac{e}{e'}\right)^{\frac{5}{4}}$$

$$\frac{1+\beta\tau}{1+\beta\tau'} = \left(\frac{e}{e'}\right)^{\frac{1}{4}}.$$

The refractions are next computed, supposing that the relation between the pressure and density is represented by these equations.

equations. When this is done, the results are found to agree very accurately with observations, the horizontal refraction being no more than 10" above the French Table.

But the foregoing hypothesis, although it agrees sufficiently with the observed refractions, is opposed to Nature in another respect. It limits the extent of the atmosphere above the earth's surface to 25 miles, which is probably less than half the real height. It therefore becomes necessary to take a more enlarged view of the constitution of the atmosphere, not confined to the exact proportionality of the altitude ascended to the decrease of heat. This leads to the assumption of the more general equations,

$$\frac{p}{p'} = (1-f) \left(\frac{\rho}{\rho'}\right)^{\frac{m+1}{m}} + f \rho^2$$

$$\frac{1+\beta\tau}{1+\beta\tau'} = (1-f) \left(\frac{\rho}{\rho'}\right)^{\frac{1}{m}} + f \rho.$$

The letters f and m are arbitrary numbers; but they are connected by the condition that the gradation of heat at the earth's surface must agree with Nature. This is ensured by

$$\text{the formula} \quad f = \frac{1}{4} \cdot \frac{m-4}{m-1};$$

And then m alone remains indeterminate. When $m=4$, we have the atmosphere already considered in which the heat decreases uniformly. When m is made greater than 4, we obtain a series of atmospheres rising gradually above one another in their total altitude, in each of which the rate of the decrease of heat is not uniform, but continually decreasing. The height through which the thermometer must be carried at the top of the atmosphere, in order to depress the thermometer one degree, is equal to $\beta l \times (m+1)$; and it is therefore very great when m is a great number. Yet all these various atmospheres agree very nearly in giving the same system of refractions; the difference of the horizontal refractions, in the two extreme cases when m is equal to 4, and when it is infinitely great, being no more than 17". The last case, when m is a great number, is chosen as best suited to the general circumstances of the terrestrial atmosphere. The equations between the pressure and density are in this case,

$$\frac{p}{p'} = \frac{3}{4} \cdot \frac{\rho}{\rho'} + \frac{1}{4} \cdot \frac{\rho^2}{\rho'^2},$$

$$\frac{1+\beta\tau}{1+\beta\tau'} = \frac{3}{4} + \frac{1}{4} \cdot \frac{\rho}{\rho'};$$

which equations are the foundation of my Table of Refractions.

In order to place the proofs of the accuracy of my Table in a clear point of view, I shall now put

$$\frac{e}{e'} = 1 - \omega$$

$$\theta = \tau' - \tau;$$

then θ will be the depression of the thermometer at any height. The equations of the atmosphere, when the heat is supposed to decrease uniformly, will now become,

$$\frac{p}{p'} = (1 - \omega)^{\frac{5}{4}} \quad (A)$$

$$1 - \frac{\beta\theta}{1 + \beta\tau'} = (1 - \omega)^{\frac{1}{4}}$$

$$\frac{\beta\theta}{1 + \beta\tau'} = \frac{1}{4}\omega + \frac{5}{32}\omega^2 + \&c.;$$

and the equations from which the Table is constructed will be,

$$\frac{p}{p'} = \frac{3}{4}(1 - \omega) + \frac{1}{4}(1 - \omega)^2 \quad (B)$$

$$\frac{\beta\theta}{1 + \beta\tau'} = \frac{1}{4}\omega.$$

These equations very clearly point out what is common to all the atmospheres, and what causes them to agree in giving the same refractions. The first term of the development of the function $\frac{\beta\theta}{1 + \beta\tau'}$ is the same in them all and equal to $\frac{1}{4}\omega$. It is this new element which I have introduced into the problem of the refractions: and upon the exactness of the co-efficient $\frac{1}{4}$ the accuracy of my Table will entirely depend. I have proved, in my paper, that the usual formula for barometrical measurements with its equation for heat, is true in both the atmospheres defined by the equations (A) and (B). With respect to the same atmospheres I have likewise shown, by a comparison with actual experiments extended to the greatest heights to which we have been able to ascend, that the pressures and densities are the same at like distances above the earth's surface, as in the real atmosphere. To all this is to be added the very exact agreement of my refractions with observations to a great distance from the zenith. Of this I am now in possession of one proof, derived from a comparison with actual observation, that will not be disputed. I humbly hope that the examination of other unbiassed astronomers will lead to a similar conclusion; and to their determination, to which I have ever appealed, I shall very cheerfully submit.

I shall now add some additional proofs of a different description. Dalton has suggested a very remarkable law relative to the temperature of the atmosphere*. He supposes that a

* Chem. Phil. Part I. chap. 1. § 8.

given mass of air placed at any height, will always retain the same quantity of heat, either in a state affecting the thermometer, or combined with it in a latent form. Thus, if a cubic foot of air taken at the earth's surface were carried up in the atmosphere, none of its heat would be dissipated; the portion that disappears with respect to the thermometer, being wholly absorbed as the air dilates, and being necessary to maintain the expansion caused by the diminution of pressure. As I write hastily, I cannot enter upon the proofs of this law, which I adopt for the purpose of bringing down to the earth's surface the equations that have been shown to take place in the atmosphere. Suppose a portion of air at the earth's surface to be contained in a close vessel; the pressure, density, and temperature, being p' , 1 , τ' , both within the vessel and in the open air. Extract a part of the air from the vessel; what remains will dilate itself, will become colder, and then will resume the general temperature. Let $1-x$ denote the density of the expanded air, and θ the heat that combines with it in a latent form. The pressure within the vessel, after the air has resumed the general temperature, will evidently be $p' \times (1-x)$. Put p for the pressure that prevails within the vessel, the instant the air is extracted; before any extraneous heat has been communicated to the dilated air from the surrounding objects; and consequently, when its temperature is equal to $\tau' - \theta$: then the equations (A) which take place in the atmosphere, being brought down to the earth's surface by Dalton's law, will be as follows, viz.

$$\frac{p}{p'} = (1-x)^{\frac{4}{3}}$$

$$1 - \frac{\beta\theta}{1+\beta\tau} = (1-x)^{\frac{1}{3}*}$$

It is remarkable that these equations are the same with those given by M. Poisson, at p. 264 of the *Connaissance de Temps* for 1826, published six months after my paper was read before the R. S. There is a very small difference in the index of the power of the density; which instead of $\frac{4}{3}$ is found to be equal to 1.3492 by the experiments of MM. Clement and

* The densities $1-\omega$ and $1-x$ are connected by this equation, viz.

$$(1-\omega)^{\frac{1}{3}} = (1-x)^{\frac{1}{3}}$$

If a mass of air elevated in the atmosphere, and having the density $1-\omega$, be carried down to the earth's surface while its temperature remains unchanged; the pressure and density increasing in the same proportion, when the first is equal to $p' \times (1-\omega)$, the other will be equal to $(1-\omega)^{\frac{1}{3}}$; and then the pressure, density, and temperature, will be the same as in the close vessel, the instant the air is extracted, and before the accession of any extraneous heat.

Desormes,

Desormes, and to 1.3748 by those of MM. Gay Lussac and Welter.

It thus appears that there is a great connection between my Theory and the speculations of Laplace upon the Gases*. And this leads me to remark upon a point about which I am much more deeply concerned than I am about the travesty which the S. B. L. has taken the trouble to make of my labours. It may be said that I have been directed in my researches by the ideas of the eminent French philosopher. I am exculpated from this charge as far as regards what M. Poisson has written on this subject either in the *Con. des Tems* for 1826, or in the *Annales de Physique* for August 1823, by the dates. The first Memoir of Laplace on the attraction of the Gases, published in the *Con. des Tems* 1824, was read to the Academy of Sciences 10th September 1821. Now I have undeniable evidence that, at this date, I was in possession of my Theory as far as regards the present question. The proofs, gentlemen, are contained in your Journal for May and June 1821. The formula in the Number for May is derived from the equations (A); that in the next Number is obtained by a particular transformation, taking the general value m equal to 5 instead of 4.

My theory has a broader foundation and embraces a greater number of natural phenomena than the view of Laplace, which is confined chiefly to the velocity of sound. Since the equations are found to belong to an atmosphere different in some respects from that of nature, we must infer that they are approximate only, not rigorously true. All the reasonings and experiments seem to bear upon the first term of the development of a function, not upon its complete expression. It is this term only which is ascertained. The equations, as far as they are yet known to us, may be thus expressed,

$$\frac{\beta\theta}{1+\beta\tau'} = \frac{1}{3} x$$

$$\frac{p}{p'} = (1-x) \times \left(1 - \frac{\beta\theta}{1+\beta\tau'}\right) = (1-x) \left(1 - \frac{x}{3}\right)$$

It is extremely probable that my numbers are the true values of the indices; and that the experimental quantities are different only on account of the unavoidable errors attending very delicate measurements. But I cannot now enter upon any discussion of principles, and must confine myself to the statement of results. Two consequences follow from the unexpected coincidence of my Theory with the researches of Laplace on the constitution of the Gases. First, we have a direct and undeniable proof that Dalton's law actually takes

* *Mécan. Céleste*, Liv. 12.

place in the atmosphere. And secondly, the value which I have assigned to the first term of the development of the function expressing the temperature of the atmosphere, is confirmed by the experiments of the French philosophers.

Another phenomenon lends its aid to confirm the same conclusions. It is the propagation of sound in the atmosphere. Nothing can be more curious than to find the velocity of sound made a deduction from a theory of the astronomical refractions. Yet this follows immediately from the foregoing equations by applying the method of accounting for the phenomenon which we owe to the abilities of Laplace. Let l denote the homogeneous atmosphere in feet; then, according to Newton, sound, in a second of time, moves through a space equal to

$$\sqrt{32 \frac{1}{6} \times l};$$

but, according to the accurate theory of Laplace, the velocity of sound deduced from the foregoing equations is equal to

$$\sqrt{32 \frac{1}{6} \times l \times \frac{4}{3}};$$

and this agrees sufficiently well with experiment.

I have now traced an unexpected connection between many interesting phenomena that seemed to be very little related to one another. There can be no doubt that the whole investigation leads to a simple principle; by setting out from which, and following a retrograde order, all the phenomena may be deduced. But I do not now touch upon this point. The difficulty and the labour is to arrive at simple and comprehensive views. So many different facts clearly prove that the element I have introduced in the theory of the refractions, has been rightly determined. The accuracy of the table depends upon this circumstance, and is limited by it.

The horizontal refraction by my formula is greater than that in any Table of refractions except M. Bessel's. It depends entirely upon the first term of the development of the function expressing the heat of the atmosphere. Had it agreed exactly with observation, it would have followed that the refractions depend upon that quantity alone, and that the other terms of the development have no sensible effect. But the observations of M. Bessel make the horizontal refraction much greater than it is in my Table. According to the most probable determination that can at present be deduced from the labours of that distinguished astronomer, it is about 36' at 50° Fabr., 30 B. It thus appears that the other terms of the development beside the first have a sensible influence on the refractions at very low altitudes. I apprehend that this is the true reason why my Table fails in accuracy within 1½° of the horizon.

horizon. Further researches, both mathematical and astronomical, are therefore required for completing the solution of the problem of the refractions. Theory must supply the formulæ; and the astronomer, by numerous observations at and near the horizon, must furnish the data necessary for determining the theoretical quantities. Even although there should be little chance of attaining, near the horizon, all the accuracy desired by the astronomer, yet the question is still one of great interest, as it may lead to important results respecting the constitution of the atmosphere.

My chief design, gentlemen, in addressing you in this letter, is to put on record my ideas on the topics treated in it, which I have frequently mentioned in conversation. I have written hastily, and desire the indulgence of your readers.

I have the honour to be, &c.

June 14, 1824.

JAMES IVORY.

LXX. *On some Errors in Dr. HUTTON'S Tables of the Products and Powers of Numbers.* By Mr. JAMES UTTING.

Gentlemen,

ON perusing your Journal for last month, the errors mentioned in Dr. Hutton's Tables of the Products and Powers of Numbers attracted my attention. Mention is made in your Journal, of 40 errata occurring in p. 20 of Dr. Hutton's Tables. Now, Gentlemen, the number of errors in this page actually amounts to about 1700! which I discovered several years since, and of which no mention is made in the list of errata: and conceiving it will be rendering an acceptable service to such gentlemen as use Dr. Hutton's Tables, I take this opportunity of pointing them out; viz. The Products of all numbers from 361 to 380 at the head of the Table by 15 to 99 at the side are all 100 too little.

I remain, Gentlemen, yours truly,

Lynn Regis, 10th June, 1824.

JAMES UTTING.

LXXI. *Introduction to the Sixth Section of BESSEL'S Astronomical Observations.*

I SHALL first give such a short description of the meridian circle as is necessary for understanding the observations: a more detailed one would no doubt be very curious to all those who take an interest in the great advancement of the art of constructing astronomical instruments brought about by Reichenbach*; but it would require plates, and fall far

* We think it right to observe that M. Bessel has never seen the Greenwich instruments.—EDIT.

short of that description which is expected from the great artist himself. That description will not only detail the original course which this ingenious artist has pursued, but likewise contain the reasons for the whole and every part of the instrument.

The instrument is fixed between two pillars like a transit; its horizontal axis, of 32 inches (Paris) length, terminates in steel cylinders which rest on Y's of bell metal; the latter are formed of two planes meeting at an angle of 60°. Their covers have springs, by which means, when the instrument is perfectly balanced, the axis is pressed equally against the three sides of an equilateral triangle. The equilibrium is produced by levers, the supports of which are on the columns that stand on the pillars; they carry the instrument by means of friction wheels, which give to the whole an exceedingly gentle and easy motion. The horizontality of the axis is obtained by a fine level, the construction of which is such as to ensure the greatest accuracy in levelling.

On this axis are screwed the two halves of the telescope of five feet in length, and secured against flexure by a lever apparatus; the object-glass has 48·2 lines aperture; the four eye-glasses magnify 66,107,129,182 times, and in the focus there are five vertical and two horizontal wires, the latter being only 8" distant from one another, which interval the object that is to be observed bisects. Thus far the instrument is, therefore, a complete transit, with the advantage that it can be used with great ease in both positions of the axis. The reversing of the axis, which must be done without the weight of the instrument resting on the pivots, is obtained by a contrivance equally simple and secure, by which the counterpoises begin to act before the pivots reach the Y's. On the one end of the axis there is fixed a cast circle of three feet in diameter, which on the side towards the pillar is divided to three minutes on silver. An alidade circle is applied to the same end of the axis in such a manner that the axis passes through its centre and turns in a conical collar. This alidade circle has four verniers in a plane with the principal circle, by which the latter is divided to 2"; it carries a fixed level with a scale divided to lines (Paris), by which the changes of its position with regard to the horizon can be measured. By a very strong arm issuing from its centre, and an adjusting screw, it is attached to the pillar, so that the level would always retain the same position, were it not for the small changes caused by the revolving of the axis of the instrument which passes through the alidade circle, by the temperature, or by an alteration of the position of the pillars; the real existence of

of these changes consequently renders necessary the reading off of the level at every observation. An arm on the other end of the axis, with a collar through which this end of the axis passes, is firmly clamped to the axis by means of a screw, and then serves for bringing the telescope into its proper position. The artist has thus contrived that there should be no strain whatever on the circumference of the two circles, from which in other cases change of figure and considerable errors have arisen. The illumination of the wires is through the axis, which is perforated at the extremity furthest from the circle. The necessary changes of its intensity are obtained by a diaphragm attached to each pillar, the greater or less opening of which allows a proportional quantity of light to pass. A considerable increase of light has been effected since November 1820, by conical metal tubes polished in the inside and fixed in the perforated hollow of the pillar. This contrivance has been before adopted in the observatories of Munich and Göttingen.

In placing this highly perfect instrument, I have endeavoured to avoid every circumstance known to me by former experience, which might tend to produce unsteadiness;—the manner which I have used having been found to answer the purpose, I think that I ought to describe it. An excavation of six feet deep, ten feet long from east to west, and seven feet broad from north to south, was lined with a wall; in the middle of this hollow there was built a parallelopiped three feet and a quarter high, of broken rocks, forming a mass of solid masonry, leaving between its vertical sides and the surrounding wall an empty space of six inches in breadth. The two granite pillars (six feet long, two feet broad, fifteen inches thick) which were formerly the supports of the transit, were placed on this parallelopiped, in the direction of the meridian, the centres being four feet distant and walled round. On them was placed a slab of stone carefully cut, six feet long, four feet broad, and one foot thick, which was as firmly as possible attached to the pillars by means of cement and iron cramps. The upper surface of this slab is six inches below the floor; on it are placed without any other essential fastening the new pillars, six feet four inches high, 20·5 inches broad, and 15 inches thick, of very hard perfectly uniform sandstone of a very fine grain, which on account of the uniformity of its grain I have preferred to granite.

The manner of placing the supports secures them against the effects of the freezing and thawing of the ground, which only act on the surrounding wall, that goes deeper than the frost ever penetrates into the ground: they are likewise protected

tected as far as possible against the effect of a general sinking of the ground, as the firmness and solidity of the connexion of all parts render any rotatory motion very improbable; and lastly, the moving of the observer has no effect on them, as the floor does not rest on the stone slab, but on the surrounding wall, and as between the floor and both the slab and the pillars there is an empty space.

The instrument being constructed for reversing, which is indeed one of its most beautiful advantages, care was to be taken that the reversing itself should produce no change of the pillars. The end of the axis which carries the two circles is more heavy than the opposite one, and therefore requires heavier counter-weights, by which the levers exert on one side a greater pressure by 104 pounds than on the other. The axis being levelled and the instrument reversed, the pillar which before sustained the greater pressure, now suffers the less, and *vice versâ*; and it cannot be doubted that a difference of 208 pounds will produce a sensible change in the horizontality of the axis. In order to obviate the error proceeding from this circumstance, there were fixed in the wall surrounding the base, two strong iron bars, passing along the pillars from south to north without touching either the stone slab or the floor. From these bars proceeds vertically along the middle of each pillar a weak iron rod, which by means of a quadrangular frame incloses the Y's of the instrument. On the upper end of the latter rod on one end a lever may be made to act, which by a weight applied on the opposite end, exerts a pressure of 104 pounds. This lever is always applied to the side opposite to that where the circle is attached, and thus most completely removes the cause of the error. Without this apparatus there would be in the two positions of the axis a difference of $1''\cdot3$.

However perfect the meridian circle of Reichenbach may be, I did not conceive that I ought to give up the opinion, on which I had hitherto always acted,—*viz.* that all instruments ought to be subjected to an accurate and rigorous examination *after* they are placed in the observatories. In regard to this instrument, a two-fold investigation is required: first, on the curve described on the celestial sphere by the line of collimation; and next, on the points of this curve answering to various distances from the pole and zenith. Only the first of these investigations has hitherto been accomplished. I shall therefore now explain the examination of the instrument, when used as a transit; reserving for the next Section the report on its use for measuring zenith distances.

1. *Determination of the Magnifying Powers.*

I have founded this investigation on the same principle which is the basis of Ramsden's dynameter; but I have employed the divisions of the circle for measuring the diameter of the image of the cell of the object-glass formed by the eye-glass. With this view a compound microscope was horizontally placed before the telescope, which was likewise in a horizontal position, so as to show distinctly the wires in the focus, after the eye-glass of the telescope was taken out; this microscope was furnished with a wire, which, by being made to bisect the interval between the two horizontal wires in the telescope, might be easily placed horizontal and consequently parallel to the axis of the instrument. Then the eye-glass was put in, and the microscope drawn back until it showed distinctly the image of the cell of the object-glass, after which the angle was observed which it was necessary to turn the circle, in order to produce a contact of both the limbs of this image with the wire of the microscope: this angle was found for the different eye-glasses, $6' 29''\cdot00$; $4' 4''\cdot08$; $3' 23''\cdot58$; $2' 25''\cdot17$, from which the magnitude of the image may be found, if its distance from the axis of rotation of the instrument be known. In order to find this distance, I made at random a dot on the microscope, the distance of which from a dot on the telescope situate in the plane of the wires, was found without the eye-glass $40\cdot3$ lines, and with the four eye-glasses = $58\cdot4$; $52\cdot6$; $50\cdot5$; $47\cdot3$ lines; from which it follows that the four images of the eye-glass are distant from the plane of the wires $18\cdot1$; $12\cdot3$; $10\cdot2$; $7\cdot0$ lines, or from the axis of rotation $387\cdot6$; $381\cdot8$; $379\cdot7$; $376\cdot5$ lines; the latter being distant from the wires $369\cdot5$ lines. The diameter of the cell of the object-glass is $48\cdot2$ lines, and therefore the ratio of its magnitude to those of its images before the eye-glasses $65\cdot94$; $106\cdot69$; $128\cdot62$; $181\cdot90$.

These numbers would denote the magnifying powers of the four eye-glasses, if the latter were so placed that parallel rays falling on the object-glass likewise issue from them parallel; but they require a small correction when the observer has placed the eye-glasses according to his own sight. Let the diameter of the object = O ; that of the image before the eye-glass = o ; the focus of the object-glass = P ; that of the interior eye-glass = f , the exterior f' ; the distance of the two eye-glasses = d , that of the object-glass from the interior eye-glass = $F + d$, that of the image from the exterior one = δ' , that of the eye from the point of distinct vision = g , and we have

$$\delta' =$$

$$\delta' = \frac{(F+\delta)(f-d)f' + df f'}{(F+d)(f+f'-d) + (d-f')f^2}$$

$$o = \frac{O f f'}{(F+\delta)(f+f'-d) + (d-f')f^2}$$

$$\delta = \frac{(e-\delta')f(f'-d) - d f f'}{(e-\delta')(f+f'-d) + f-d)f^2}$$

Thence the magnifying power for parallel rays, or
 $m = \frac{F(f+f'-d)}{f f'}$ or (with sufficient accuracy) $= \frac{O}{o} + \frac{O}{o} \frac{F}{e}$.

I have supposed $\frac{F}{e} = 6$, and found the magnifying powers = 66.03; 106.75; 128.61; 181.93. By this method any degree of accuracy may be obtained by taking into the account the thickness and curvature of the glasses; which, however, in this case, would be entirely unnecessary. Up to the 21st of April 1820, I have alternately used the middle powers; but from the 22d of April I have exclusively employed the highest power of 182.

2. The Level of the Horizontal Axis.

This level is so constructed that it can be placed exactly in a plane with the axis, which renders the small cross level which is commonly used, superfluous, and greatly contributes to the accuracy in levelling, as the air-bubble does not sensibly change its place, if the plane passing through the axis and the level sensibly deviate from verticality. The value of the parts of the scale was determined by fixing the level to Cary's circle, and observing its changes by the microscopes. By three sets of such observations a change of the bubble of one line (Paris) was found

$$= 2'' \cdot 196 \text{ therm.} + 5^{\circ} \cdot 0 \text{ Bessel.}$$

$$2'' \cdot 120 \quad \dots \quad + 13^{\circ} \cdot 6 \text{ Argelander.}$$

$$2'' \cdot 175 \quad \dots \quad + 14^{\circ} \cdot 6 \quad \text{---} \quad \text{---}$$

Mean = 2'' · 164. Although the air-bubble in each of these sets was gradually moved four inches, there never appeared a trace of irregularity of curvature, as there never appeared an error of one second which might be ascribed to this cause.

3. Figure of the Pivots.

The examination of the horizontality of the axis instituted at each reversion of the instrument, has proved that the pivots somewhat deviate from the figure which they ought to have. This examination was repeated each time in the two opposite horizontal positions of the instrument, from which it followed, that being directed to the north, the level was 0.194 line more to the westward than when turned to the southward: this quantity is the mean of the following 62 observations from the 17th March 1820 to 1st July 1821.

Position

Position of the Circle.		East.	West.
1820.		Lines.	Lines.
March	17	0·18 E.	0·45 W.
	28	0·45 W.	0·10 E.
April	7	0·15 —	0·31 W.
	13	0·12 —	0·32 —
	21	0·07 —	0·17 —
	26	0·28 —	0·30 E.
May	3	0·50 —	0·20 W.
	15	0·02 E.	0·62 —
	25	0·30 W.	0·30 —
June	11	0·12 —	0·12 —
	27	0·60 —	0·27 —
July	16	0·42 —	0·45 —
August	1	0·20 —	0·20 —
	9	0·12 —	0·28 —
	20	0·43 —	0·43 —
Septemb.	7	0·22 —	0·25 —
	16	0·35 —	0·10 E.
October	12	0·10 —	0·48 W.
Novemb.	1	0·10 E.	0·23 —
Decemb.	16	0·15 W.	0·15 —
1821.			
January	12	0·20 E.	0·18 W.
February	10	0·08 —	0·05 E.
	28	0·14 W.	0·12 —
March	25	0·42 E.	0·25 —
	31	0·20 W.	0·83 W.
April	25	0·25 —	0·15 —
May	5	0·40 —	0·47 —
	23	0·05 —	0·40 —
June	5	0·02 E.	0·18 —
	19	0·40 W.	0·23 —
July	1	0·34 —	0·07 E.
Mean...	...	0·172 W.	0·215 W.

The probable error of a levelling of the axis is, therefore, 0·112 line = 0"·243, and consequently that of the above mean = 0·0201 line; from which it is clear, that there cannot be any doubt of the above-mentioned irregularity. The small deviation probably does not proceed from an imperfection in the cylindrical figure of the pivots, but from their axes not being

exactly in the same straight line: the points of the pivots which touch the Y's are distant from those, on which the level is suspended 9 lines; an angle of $9''$ of the axes of the two cylinders would therefore account for the small deviation. If this be really the cause, the repetition of the levelling in reversed positions of the telescope entirely destroys its effect. The diameters of the two pivots are not exactly equal, the one more distant from the circle is the thicker. Three-and-thirty reversions of the instrument have given the difference of the level in both positions = 1.286 line: viz.

1820.	Lines.	1820.	Lines.
March 7	1.50	September 7	1.61
8	1.10	16	1.39
17	1.40	October 12	1.09
28	1.02	November 1	0.89
April 7	1.14	December 16	1.52
13	1.37	1821.	
21	1.31	January 12	1.29
26	1.05	February 10	1.54
May 3	1.79	28	1.61
15	0.90	March 25	1.31
25	1.32	31	1.41
June 11	0.95	April 25	1.40
27	1.04	May 5	1.11
July 16	1.48	23	1.40
August 1	1.30	June 5	1.30
9	1.25	19	1.35
20	1.05	July 1	1.26

The hooks by which the level is hung to the pivots, form an angle of 90° , the Y's an angle of 60° . If the diameter of the thicker cylinder be denoted by r' , that of the thinner one by r , the height of the points in which the planes forming the Y's meet above the same level, that of the eastern one by h , that of the western one by h' ; the heights of the centres of the axis, when the circle is towards the east, are

$$h + 2r, \text{ and } h' + 2r'$$

and the heights of the points where the planes forming the hooks of the level meet $h + r(2 + \sqrt{2})$ and $h' + r'(2 + \sqrt{2})$. The motion of the bubble to the west is therefore, in lines (if R expresses the length of the axis)

$$= x = \frac{(h' - h) + (r' - r)(2 + \sqrt{2})}{R \sin 2'' \cdot 164} \text{ and after reversing}$$

$$x' =$$

$$x' = \frac{(h' - h) - (r' - r) (2 + \sqrt{2})}{R \sin 2'' 1.64} \quad \text{From which follows}$$

$$r' - r = \frac{(x - x') R \sin 1'' 082}{2 + \sqrt{2}} = 0.0007587 \text{ line.}$$

In examining the deviations of the axis from the horizontal position, the state of the level before and after reversing was always consulted: we have the elevation of the western end above the eastern one expressed in seconds =

$$15 b = \frac{h' - h + 2 (r' - r)}{R \sin 1''} \quad \text{and likewise}$$

$$h' - h = (x + x') R \sin 1'' 082; \text{ therefore}$$

$15 b = (x + x') 1'' 082 \pm 0.815$; where the upper figure is to be taken for the eastern, the lower one for the western position of the circle. If the level is observed in one position only, we have $15 b = x. 2'' 64 \mp 0'' 576$.

4. Examination of the Invariability of the Instrument while revolving.

After the observation of Mr. Pond, who found a considerable change of the old Greenwich transit while revolving, a more accurate investigation of this point seems to be indispensable. It has, however, no small difficulties, if it be required to find out and to take into the account even *small* constant errors. On the supposition that the deviations from the meridian resulting from a change of the instrument itself, depend on the sine and cosine of the single zenith distance, or, which is the same thing, that they take place in a great circle, the deviation of the middle wire from the meridian will be in opposite positions of the axis

$$15 (a + \alpha) \sin (\varphi - \delta) + 15 (b + \beta) \cos (\varphi - \delta) + 15 c$$

$$\text{and } 15 (a' + \alpha) \sin (\varphi - \delta) + 15 (b' - \beta) \cos (\varphi - \delta) + 15 c'$$

where a, b, c, a', b', c' denote the fifteenth parts of the deviations in azimuth, in the horizontality of the axis, and of the error of collimation, and α and β the deviations peculiar to the instrument, all expressed in seconds. The first formula I suppose to be for the eastern position of the circle, the other for its western position.

From these formulæ it is apparent that by astronomical observations in contrary positions only, the quantity $2 \beta \cos (\varphi - \delta) + (c - c')$ can be determined; but not α , which is altogether joined with the azimuth, and has no influence on the results obtained by the transit: it only causes that a vertical plane which is described by the line of collimation is not perpendicularly intersected by the horizontal axis; and there is

no means to find this out, as the direction of the axis cannot be observed independently of the telescope.

The determination of β , on the contrary, is necessary, and may be obtained either by repeating the observations after reversing the instrument, or by comparing the image of the pole-star reflected from a horizontal plane, with that seen by direct vision. The latter method appears to me to be far more advantageous, on account of the slow motion of this star, of its being independent of other errors, and on account of the greatness of the quantity by which the effect of β shows itself, especially in our high latitudes.

The observation of reflected images of stars has, as far as I know, been first employed by Tralles for finding the errors of collimation of his instrument, when measuring the height of mountains in Switzerland: it likewise affords very valuable methods for examining astronomical instruments, and is therefore frequently used in the Königsberg observatory. I have used water to obtain the horizontal plane; at first in a vessel 18 inches long and 12 broad; but this was found too small, as it did not always with perfect distinctness represent the images of stars when viewed with the highest power, while the telescope was fixed,—the distinctness of the images in a telescope of such aperture and power being the surest sign of a level surface. In a vessel of three feet diameter, from the middle of which the reflexion takes place, I found no such deviation from a plane, and have therefore, ever since the 12th of April, used such a vessel.

If the zenith distance of a star be $z = \varphi - \delta$, it is for its reflected image $= 180 - z = 180 - \varphi + \delta$; therefore the deviation of the instrument from the meridian for this image of the star =

$$15 (a + \alpha) \sin (\varphi - \delta) - 15 (b + \beta) \cos (\varphi - \delta) + 15 c$$

and $15 (a' + \alpha) \sin (\varphi - \delta) - 15 (b' - \beta) \cos (\varphi - \delta) + 15 c'$

If the times of transit of a star over the middle wire have been observed by direct vision and by reflexion $= t$ and t' , we have, the circle being to the east,

$$t + (a + \alpha) \frac{\sin (\varphi - \delta)}{\cos \delta} + (b + \beta) \frac{\cos (\varphi - \delta)}{\cos \delta} + \frac{c}{\cos \delta} =$$

$$t' + (a + \alpha) \frac{\sin (\varphi - \delta)}{\cos \delta} - (b + \beta) \frac{\cos (\varphi - \delta)}{\cos \delta} + \frac{c}{\cos \delta}$$

and when the circle is to the west,

$$t + (a' + \alpha) \frac{\sin (\varphi - \delta)}{\cos \delta} - (b' - \beta) \frac{\cos (\varphi - \delta)}{\cos \delta} + \frac{c'}{\cos \delta} =$$

$$t' + (a' + \alpha) \frac{\sin \varphi - \delta}{\cos \delta} - (b' - \beta) \frac{\cos \varphi - \delta}{\cos \delta} + \frac{c'}{\cos \delta}$$

therefore

therefore $b + \beta = \frac{t'-t}{2} \cdot \frac{\cos \delta}{\cos(\varphi-\delta)}$; $b' - \beta = \frac{t'-t'}{2} \cdot \frac{\cos \delta}{\cos(\varphi-\delta)}$;

b and b' being known by the level, β may be found, and the agreement of the determinations obtained in both positions will prove, that a great circle accords with the four observed points of the curve, described on the celestial sphere by the line of collimation.

The observations of the pole star made with this view are the following:

The Circle turned to the East.

	Passage.	$t'-t$	$15(b+\beta)$	$15 b$	15β	γ
1820. June	2 Lower	-10 ^h 10	+2 ^h 72	+2 ^h 92	-0 20	1.0
	3 —	-12.04	+3.24	+2.89	+0.35	0.5
	6 —	-11.51	+3.09	+2.82	+0.27	0.75
	9 —	-13.87	+3.73	+2.74	+0.99	1.0
	10 —	-11.39	+3.06	+2.71	+0.35	1.2
Nov. 4	Upper	+14.16	+3.66	+3.86	-0.20	1.2
1821. March	27 Lower	-31.92	+8.58	+7.54	+1.04	0.75
	29 —	-30.15	+8.10	+7.87	+0.23	0.75
April	25 —	+ 9.45	-2.54	-3.36	+0.82	1.2
	28 Upper	-12.98	-3.36	-3.13	-0.23	1.2
	29 Lower	+ 7.95	-2.14	-3.10	+0.96	1.2
May 4	—	+12.28	-3.30	-2.77	-0.53	1.2
June 1	Upper	-12.93	-3.34	-3.64	+0.30	0.75
	3 —	-11.46	-2.96	-3.43	+0.47	0.75
	23 —	-13.24	-3.42	-3.09	-0.33	0.67

Mean : + 0.274 $\gamma = 14.12$

The Circle turned to the West.

	Passage.	$t'-t$	$(b'-\beta)$	b'	β	γ	
1820, May 24	Lower	- 9 ^h 31	+2 ^h 50	+1 ^h 57	-0 ^h 93	1.2	
June 21	—	- 4.60	+1.24	+2.41	+1.17	1.2	
23	Upper	+ 6.86	+1.77	+2.75	+0.98	0.67	
Sept. 9	—	- 2.80	-0.72	-0.18	+0.54	0.75	
	13 —	- 6.96	-1.80	-0.63	+1.17	0.75	
	15 —	- 1.83	-0.47	-0.76	-0.29	1.2	
Oct. 21	—	+ 9.09	+2.35	+1.72	-0.63	1.2	
	22 —	+11.17	+2.89	+1.81	-1.08	1.2	
	1821. April 21	Lower	+21.55	-5.79	-4.80	+0.99	1.2
24	—	+19.14	-5.10	-4.94	+0.19	1.2	
May 5	—	+13.97	-3.70	-4.15	-0.45	1.2	
	5 Upper	-17.22	-4.45	-4.21	+0.24	1.2	
	8 —	-15.30	-3.95	-4.56	-0.61	1.2	
15	Lower	+18.80	-5.05	-5.31	-0.26	1.2	
	June 12	—	+15.91	-4.28	-4.89	-0.61	0.75
	13 Upper	-20.93	-5.41	-4.89	+0.52	1.2	
14	Lower	+15.34	-4.12	-4.90	-0.78	1.2	
16	—	+22.43	-6.03	-4.91	+1.12	1.2	
16	Upper	-18.34	-4.74	-4.91	-0.17	1.2	
	July 2 Lower	+15.44	-4.15	-4.34	-0.19	1.0	
	2 Upper	-17.41	-4.50	-4.34	+0.16	1.2	

Mean : + 0.013 $\gamma = 23.12$

The

The γ contained in the last column of these tables are calculated from the formula $\frac{aa'}{a+a'}$, where a and a' denote the number of wires observed by direct vision and by reflexion. The probable error for $\gamma=1$ is found $=0''\cdot453$; and hence that of the first mean $=0''\cdot1205$, that of the second $=0''\cdot094$; so that the small value of β thus found, may without great improbability be attributed to the contingent errors of observation. The mean of both determinations is $+0''\cdot112$, and its probable error $=0''\cdot0742$. This investigation rests on the supposition that the deviation of the instrument from the meridian is dependent on the sine and cosine of the single zenith distance, which is indeed not improbable, but is not proved to be true; without this supposition we should have obtained in place of β , two differences of the deviations for the direct and reflected place of the pole. But other deviations may yet exist which do not comport with a great circle, and the complete destruction of which is not necessarily obtained by the construction of the instrument, by which observations in nearly equal numbers are obtained in the two contrary positions of the axis. The errors, however, if existing, would become apparent in the right ascension of fixed stars, if observed above and below the pole in both positions of the instrument; it may be required of every transit, that either immediately, or after applying the proper corrections, it should constantly give the same right-ascension, whether the star be compared to the fundamental stars above or below the pole in one or the other position of the axis; a constant difference of these four determinations would indicate an error of the instrument, which would require further investigation.

This subject being of the highest importance for practical astronomy, I have thought necessary to undertake this investigation, which I have founded on 58 circumpolar stars almost down to the horizon. But before I communicate the results thereby obtained, I must explain my method of adjusting the instrument.

5. Corrections of the Times of Transit over the middle Wire.

The position of the transit has hitherto been adjusted in the Königsberg observatory by determining the distance of the line of collimation from the pole, by means of observations of the pole star, the line of collimation by reversing, and the deviation from the meridian in the equator by the level or the meridian mark. The first of these determinations has in certain seasons some difficulty, from the inconvenience of the moment of one of the passages, which, owing to that circumstance, is commonly not observed. In that case one must be satisfied with

with one passage, or use besides another star as pole star. For this purpose δ Ursæ minoris is very convenient: it passes about six hours before or after α Urs. min.; it is so near the pole that it may be observed with equal accuracy, and has light enough to be distinctly seen at all times. I have therefore, for all determinations of the position of the instrument with regard to the pole, employed both these stars; and have found this so advantageous and convenient, that I cannot omit recommending this practice to other observatories furnished with instruments of sufficient light. In order to give to the use of this star the same facility which that of the pole star already has, I have calculated tables for it, which are to be found at the end of this introduction. Professor Struve of Dorpat has calculated from these tables an ephemeris for the years 1820, -21, -22, which he has printed at the University press, and by which he has made to the observatories a very acceptable present.

Of the two stars, the one, the passages of which happened at convenient times, has always been used for finding the deviation of the instrument from the pole, according to the following method. The true sidereal time α of the passage over the meridian is obtained from the observed time t by the formula

$$\alpha = t + \tau + m + n \, t g \delta + c \sec \delta$$

and for another star $\alpha' = t' + \tau' + m + n \, t g \delta' + c \sec \delta'$

where α, α' denote the right-ascensions (for lower passages $+12^h$) δ, δ' the declinations (for lower passages their supplements) τ, τ' the corrections of the time of the clock. Hence

$$\frac{(\alpha - t) - (\alpha' - t') + \tau' - \tau}{t g \delta - t g \delta'} = n + c \frac{\sin \frac{1}{2}(\delta + \delta')}{\cos \frac{1}{2}(\delta - \delta')}$$

The observations which I have hitherto obtained show that the right-ascensions of α Urs. min., as taken from the tables of the Fourth Section of my observations, require at present the correction $+1''\cdot05$, those of δ Urs. min., however, require no sensible correction: the second star I have constantly taken from my fundamental catalogue, and I have calculated tables for the values of $\frac{1}{t g \delta - t g \delta'} = l$; $\frac{\sin \frac{1}{2}(\delta + \delta')}{\cos \frac{1}{2}(\delta - \delta')} = k$; of which I give here the following extract:

α Ursæ Minoris.

δ	Upper Passage.		Lower Passage.	
	<i>l.</i>	<i>k.</i>	<i>l.</i>	<i>k.</i>
+40°	+0.02952	0.987	-0.02813	1.014
30	+0.02952	0.984	-0.02833	1.017
20	+0.02911	0.980	-0.02851	1.020
10	+0.02895	0.976	-0.02866	1.024
0	+0.02881	0.972	-0.02881	1.029
-10	+0.02886	0.966	-0.02895	1.035
-20	+0.02851	0.960	-0.02911	1.042
-30	+0.02833	1.951	-0.02929	1.051

 δ Ursæ Minoris.

δ	Upper Passage.		Lower Passage.	
	<i>l.</i>	<i>k.</i>	<i>l.</i>	<i>k.</i>
+40°	+0.06301	0.972	-0.05699	1.028
30	+0.06199	0.966	-0.05785	1.035
20	+0.06118	0.959	-0.05857	1.043
10	+0.06049	0.951	-0.05922	1.052
0	+0.05985	0.942	-0.05985	1.062
-10	+0.05922	0.931	-0.06049	1.074
-20	+0.05857	0.918	-0.06118	1.089
-30	+0.05785	0.902	-0.06199	1.109

By these tables $n + kc = p$ was calculated from each observation, and the mean of all values obtained during a certain period was considered as the value of p for that period. I have endeavoured to determine the change of p by the observations; but it has always been so small and irregular that I have been obliged to give up the attempt, from which, however, no considerable error can arise, almost the same stars having constantly been observed during the whole period. Thus, for the whole period from the 12th to the 27th of June 1820, the following values obtained by the mean of 14 observations were adopted, $p = -0''.2451$, $k = -0.996$.

In order to find n from $p = n + kc$, c must be determined by reversing the instrument, and either by the meridian mark or observations of the two pole stars. In order to apply the first method with success, I have given the meridian mark

on

on the 11th of May 1820 a convenient form. This mark is a parallelepiped of granite, which has towards the observatory a face 24 inches high and 18 inches broad: this face is furnished with 5 sets of black rectangles on white ground, of 4" breadth and 2"·6 in height, which are contiguous in the direction of their diagonal lines; so that the centres of two contiguous rectangles differ 4" in azimuth. The first set begins at the (apparent) upper edge of the mark in the middle of its breadth, and determines the azimuths 0—4"—8"; the second set has five rectangles for 7", 3", — 1", — 5", — 9"; the third has four rectangles for 6", 2", — 2", — 6"; the fourth has five rectangles for 9", 5", 1", — 3" — 7"; the fifth has three rectangles for 8", 4", 0. By this construction the single seconds of the deviations of the wire are immediately perceived.

When the atmosphere is at rest and the illumination good, one may estimate parts of a second; and as one may wait for these favourable circumstances, it may be assumed, that the deviations of the wire from the mark, as given when reversing the instrument, or in the last column of the observations, are correct to 0"·2 or 0"·3. Notwithstanding this certainty in observing the deviations, I have found that this method does not perfectly determine the error of collimation; by reversing the instrument I found from 11th June to 12th October,

June 11	+	0"45		Aug. 20	+	2"·1
		27		Sept. 7	+	2·0
		July 16				16
		+				+ 1·85
		0·75		Oct. 12	+	1·7
		Aug. 1				
		+				
		1·5				
		9				
		+				
		2·25				

These observations would appear to prove a sensible alteration, which, however, as I shall show below, did not take place.

The other method of determining the error of collimation by the pole star cannot be employed with instruments of this kind, as the reversing cannot be effected quick enough to obtain a satisfactory result by one passage even of α Urs. min.: and in combining different passages one would run the risk of transferring small alterations of the pillars, &c. to the error of collimation. The same cause which in the former method causes the uncertainty, might besides be apprehended in both the latter cases.

An accurate determination of the collimation being, however, necessary, I have employed a third method, which has the advantage of being deduced from repeated observations, and at the same time considerably diminishing the contingent errors. It consists in employing for determining the collimation,

mation, all deviations observed during a certain period, of the axis from the horizon, of the middle wire from the mark, and of the instrument from the pole: it supposes the invariability of the collimation during two periods, and the success has proved that this may be done: it is besides apparent that a similar supposition must always be made for longer or shorter spaces of time. If the eastern deviation of the wire from the mark be designated by $15A$, the eastern azimuth of the mark by $15 \Delta a$, we have for the southern horizon

$$\Delta a + A = -n \sec \phi + b \operatorname{tg} \phi + c$$

astronomical observations give $p = n + kc$; n being eliminated we obtain

$$\Delta a = -A - p \sec \phi + b \operatorname{tg} \phi + \{1 + k \sec \phi\} c$$

where for A , p , b , the means of the values obtained for all passages of the pole stars must be substituted. The values of $15A$ were registered in the last column of the Journal as often as circumstances permitted; those of b are interpolated from the beginning and end of the periods. The comparison of this equation with that derived from the preceding period, gives the required determination of c . For the period above stated (from June 12 to June 27, 1820), the equation was (*for example*)

$$\Delta a = +0''\cdot574 + 2\cdot724 c$$

for the preceding one from 27th May to 10th June

$$\Delta a = -0''\cdot2855 + 2\cdot7389 c$$

Hence on the supposition of the error of collimation being during the two periods equal, but on different sides

$$c = -0''\cdot1576 \text{ and } n = -0''\cdot0881.$$

In this manner the errors of collimation from 27th May to 27th October were found as follow:

1820.	$\pm c$.	± 15
May 27 to June 10	+0''1576	+2''36
June 12 — June 27	0''1576	2''36
June 29 — July 16	0''1429	2''14
July 20 — Aug. 1	0''1262	1''89
Aug. 1 — Aug. 9	0''1312	1''97
Aug. 9 — Aug. 19	0''1351	2''03
Aug. 21 — Sept. 1	0''1452	2''18
Sept. 7 — Sept. 16	0''1496	2''24
Sept. 23 — Oct. 4	0''1611	2''42
Oct. 13 — Oct. 27	0''1455	2''18

where there is no considerable alteration. Were the correction above designated by β not $= 0$, the value of c found in this way would require the correction $\pm \beta \operatorname{tg} \frac{1}{2} \phi$.

For

For calculating the differences of right ascension n and c are sufficient; from the 27th May 1820, only $n \operatorname{tg} \delta + c \operatorname{sec} c$ was added to the observations under the head *Corrections des Instruments*, where c as immediately found was corrected by $-0''0121$ on account of the daily aberration. If, therefore, after that time the times of passage over the true meridian are required, m is to be added, which is deduced from the formula $m = n \cdot \cot. g \varphi + a \operatorname{cosec} \varphi$, where $15a$ is supposed to be the eastern azimuth of the instrument observed by the meridian marks and corrected for its deviation, for the beginning and the end of the period. The double determinations of m hence resulting, and registered in the last column of the Journal, belong therefore to the limits of the period *f. e.* from June 12 -27 $m = +0''20$ and $0''51$; the difference is involved in the rate of the clock, and has therefore no further influence.

[To be continued.]

LXXII. *Some Account of the Binomial Calculus.* By
J. WALSH, Esq.

IN the year 1815, having met with an accident which for some time confined me, I resumed the study of mathematics, of which I had before some knowledge of the elementary branches. The figure of the earth and the precession of the equinoxes first excited my attention. I did not believe the received theory of the earth; nor that the other proceeded from the action of the sun on the excess of matter at the equator: because, granting even that the sun possessed an attractive force, there could be no accumulation of matter at the equator, but an extension of the parts arising from the centrifugal force of the earth. If the equatorial parts became more extended, the polar parts became more condensed; the quantity of matter remaining the same in every section taken in any direction from the centre of the earth. Such were my opinions then: nor are they yet altered; but I was totally inadequate to investigate them, as I had no knowledge whatever of the higher mathematics. I gave up then any further thoughts upon those subjects. But to prepare myself for investigating them at some future time,—and with this intention only,—I commenced the study of the infinitesimal analysis, as it was called. I got some introductory works on this subject; but as I could not understand the principles on which they proceeded, I abandoned them as soon as I got them. I gave up then entirely the idea of prosecuting such a study any longer; especially, when I demonstrated that it was grounded on ab-

surd propositions. The first of these was invented by the ancients; the others were invented by the moderns, of which the last asserts,—that however small the variable x may be taken, the variable h may be taken still smaller; which is asserting that h may be less than itself. It is true, that however small x may be, h may be taken as small; but it is absurd to say that however small x may be taken, h may be taken smaller, or however small h may be taken, x may be taken smaller. After this I began to dabble at the binomial theorem, which appeared to me not to have received a satisfactory explanation. I thought this theorem could be demonstrated by numbers, as it may be applied to numbers: and I succeeded in demonstrating the law of its binomiation when the exponent is a negative whole number. And shortly after, I demonstrated the law of binomiation when the exponent is a positive fraction. Encouraged by my success so far, I endeavoured to apply this formula to the doctrine of curves. The most illustrious Des Cartes first represented curve lines by algebraic equations; and that impressed me with the idea that the development of these equations involved the general theory of curves. With these ideas fixed in my mind, and having demonstrated that all those propositions were absurd which were made the bases of so many theories of calculation, I devoted myself with some ardour to apply the binomial theorem in drawing tangents to curve lines. The equation $y^2 = ax$ of the common parabola, is that which I made the subject of investigation, as being the most simple. From this

I got
$$y' = (ax)^{\frac{1}{2}} + \frac{1}{2}(ax)^{\frac{1}{2}h} - \frac{1}{8}(ax)^{\frac{1}{2}h^2} + \&c.$$

h being any arbitrary increase of x . I saw clearly that the term $\frac{1}{2}(ax)^{\frac{1}{2}h}$, was the equation of a straight line. But here a question arose: What straight line it was of which that term was the equation? I saw clearly it was the tangent straight line. But then it was necessary to demonstrate this. Now I saw clearly that this would be accomplished, if I could prove that $y + \frac{1}{2}(ax)^{\frac{1}{2}}$, was greater than y' .

In order to prove this I squared those two terms, and this gave me

$$a(x+h) + \frac{1}{4}(ax)^{\frac{h^2}{2}}.$$

which was greater than $a(x+h)$, the square of the entire series, whatever may be h . This broke down the barrier which opposed itself to my advancement, and opened to my view a new field more fertile than any that was before explored, and freed the human mind from the shackles of an absurd logic by which
it

it had been for so long a time enslaved.—The manuscript containing this result was sent to Dr. Brinkley, to be revised, and published in the Transactions of the Irish Academy. But the manuscript being in a very disordered state, in consequence of my health having suffered from long and intense application, it did not meet the countenance of Dr. Brinkley. I sent notice, immediately after the refusal of Dr. Brinkley, to the French Institute; and it would appear, that this Institute thought as much about it as the Irish Institute. The authority of the Royal Academy of Sciences of Paris is no doubt great, but I am of opinion that the authority of *demonstrated truth* is infinitely greater. Truth, when opposed to long established prejudices, has always to encounter the most serious obstacles. It is a bold innovation that has demonstrated the absurdity of the principle of reasoning employed in the *Mécanique Céleste*; and the binomial calculus has accomplished this. And it appears to me too, that the physical hypothesis employed in that work is also absurd.

When any arbitrary increase is given to the independent variables, I confine the term dinomiation to the development, arranging according to the arbitrary quantities added. I call the leading term the finomial; the second, the dinomial; the third, the second dinomial, &c. I give the term binomiation to the development when no increase is given to the variables.

Dinomial Theorem.—In the binomiation, the sign of any term is the sign of this term combined with all those that follow it.

$$\text{Let } (x+h)^n = x^n(1+p)^r.$$

As x^n is evidently common to all the terms in the binomiation of $(1+p)^r$, the theorem does not depend on any determinate magnitude of x . Then p is not a determinate relation. It will be sufficient, therefore, to show that the theorem exists in the binomiation of $(+1+1)^n$, and of $(+1-1)^n$, n being any relation whatever. With respect to $(1+1)^n$, when n is any positive whole number, the theorem is evident. When n is any complex number, the terms are at length alternately positive and negative: but before this point the terms converge; and after the commencement of convergence, every term is greater than that which next follows it. Consequently the sign of any term is the sign of this term combined with all those that follow it.

Considering now $(1-1)^n$, and binomiating, I get

$$1 - n + \frac{n(n-1)}{1.2} - \&c. = 0.$$

Taking any term whatever of this series, and adding all the negative terms that precede it to both sides, and subtracting
all

all the positive terms that precede it from both sides of the preceding equation, I get

$$\mp \frac{n(n-1)\dots(n-r+1)}{1.2\dots r} \pm \&c. \equiv \mp \frac{r(n-1)\dots(n-r+1)}{1.2\dots r}.$$

And similarly it can be shown, that the theorem is true in the binomiation of any polynomial.

On the General Theory of Osculation.

Let $y = f(xz)$ be the equation of any curve or curve surface. Binomiating according to any constant in the equation, then

$$y = fy + f'y + f''y + \&c.$$

Now, $fy + f'y$, is evidently the equation of a straight line, or of a plane surface; and by the dinomial theorem, the sum of these two terms is either greater than y , or less than y , when the exponent is not unity: therefore, $fy + f'y$, is the equation of the asymptote of the first order. And for the same reason $fy + f'y + f''y$ is the equation of the asymptote of the second order, &c.

Dinomiating the equation $y = f(x, z)$, I get

$$y' = y + dy + d^2y + d^3y + \&c.$$

In this, $y + dy$ is the equation of a straight line or plane surface, and is either greater than y' or less than y' , when the exponent is not unity; therefore, $y + dy$ is the equation of osculation of the first order. And for the same reason, $y + dy + d^2y$ is the equation of osculation of the second order, &c. Taking the dinomials of the independent variables, positive and negative: then, if the sums of the terms which constitute the equation of osculation, are each greater than y' , or each less than y' , the equation is one of contact; but if one sum is greater, and this less than y' , the equation is one of intersection.

Cork, June 10, 1824.

J. WALSH.

LXXIII. *On Black Currant Wine.* By C. G. HARLEY, Esq.

To the Editors of the Philosophical Magazine and Journal.

Gentlemen,

I AM induced to send you the following statement, because your valuable Magazine is a general repository for every scientific discovery, as well as for such observations as arise out of objects commonly presented to our attention. I believe

lieve that our common fruits, with the wines made from them, have been but little examined; at least I have never met with an analysis of the Black Currant or its wine.

July 28, 1821, I boiled 2 pecks of black currants in 25 quarts of spring water (containing no metallic salts), in a copper vessel, until they were reduced to a pulp; upon measuring the liquid expressed from this pulpy fluid, it was found to have increased 10 quarts in quantity—of course, arising from the fruit used: 29 pounds of moist sugar were added, and the whole was put into a cask the second day after it was made, and allowed to ferment until the 2d of September ensuing, when it was closely stopped down, and remained so till the 14th of October 1822, when it was bottled off; its colour resembled that of new Port wine; from its sweetness it was evident that part of the sugar had not been decomposed; its flavour was considerably astringent: but its great peculiarity consisted in a very strong chalybeate taste, which was observed by several persons as well as myself; indeed, in this quality it appeared to surpass the common steel wine of the shops. But wishing to ascertain the precise quantity of iron it contained, I requested my friend Mr. Cufande Davie, of this place (in whose scientific knowledge and accuracy of experiment I could place the greatest reliance) to analyse a portion of this wine; and the result of his examination is here subjoined.

“The analysis of Mr. Harley’s black currant wine only embraced the quantity of alcohol and iron—

“Alcohol (sp. gr. 0·825) 15·25 per cent.

“Per-oxide of iron 20 grains in each pint.

“The steel wine of the present Pharmacopœia contains only 16 grains in each pint.”

Yours &c.

Yarmouth 1824.

C. G. HARLEY.

LXXIV. *Notices respecting New Books.*

Recently published.

Smith's Geological Atlas, Part VI; containing the Maps of Cumberland, Durham, Northumberland and Westmoreland: neatly coloured, and amply explained on the margins: size 22 inches by 19:—Cary, St. James's street, price 1l. 1s.; or each Map singly 5s. 6d.

WE are happy at length to have before us, another Number, completing about half the work, of the Geological County Maps of our ingenious and deserving countryman, Mr. William

liam Smith, and to observe, that immense pains seem to have been bestowed by the Author on the ample stratigraphical details which the colours on these maps portray.

The Cumberland and Westmoreland maps, in the mountainous district of the Lakes, also in the anomalous range of low hills at foot of the lofty Fells on the north-east of Appleby, and the Northumberland maps in the Cheviot Hills, exhibit parts of those more ancient and highly inclined strata, which form the general basis of our island, consisting here of masses of granite, sienite, porphyry, &c., irregular in shape, and various in position, in their slaty matrix; on which older rocks, the Author's series of strata (in which are plentifully imbedded animal and vegetable remains, affording the means of their identification) rest *in unconformable position*; that is, they cover *the edges* of the schistous strata, instead of *their planes* exclusively, which last is the manner in which regular strata rest on each other. Except in two cases, these older rocks in the maps before us, are surrounded by the carboniferous or under-coal limestone, dipping or declining from these rocks on every side: the first of these cases, include four or five isolated patches of very irregularly coarse sandstone (the *old red sandstone* of some writers); and the latter exception is made by an unconformably-overlying mass of *red marl* (locally imbedding sandstone, which some rather absurdly call *new red sandstone*) which occupies all the coast of Cumberland southward of St. Bees Head, and almost all the remainder of its coast, northward of Maryport, as well as the whole flat of the Vale of Eden, as far up as the town of Kirkby Stephen in Westmoreland.

The carboniferous limestone receives upon it, first the lower coal-measures (being without workable seams) interlaid by thin limestone rocks, and intersected vertically by veins of lead ore, particularly about Aldstone and to the eastward of it; then, on these lead-mine measures, rest conformably, the seams of coal (of an inferior and second rate quality) alternating with their shales and sandstones; and again, on these, and still further from the slaty mountains, are found, the thick and valuable seams of coal, with their alternating shales and sandstones, around Newcastle, in the Tyne and Wear district, and near Whitehaven, Workington and Maryport, on the western coast, and in a few other situations; and again, upon these coal-measures, both in the coast lands of Durham, and south-east corner of Northumberland, and also in Cumberland, south of Whitehaven, there repose unconformably, the magnesian limestone rocks, which at length become conformably covered by the *red marl*: which last, though of great thickness, and very remarkable,

remarkable, had either escaped the notice, or appeared unworthy the particular mention, of English geological writers, before the promulgation of Mr. Smith's discoveries. On the north-east of Stockton and on the south of Whitehaven, this red marl resting on magnesian limestone, occupies the highest place in the series of strata found in those four counties.

In the Northumberland and Durham maps, Mr. Smith has continued the plan, of which he first gave an example in his four-sheet Yorkshire map, of colouring the thicker sandstone rocks, interlaying the coal strata, and so has divided the Tyne and Wear coal-field into several stratigraphical divisions, corresponding with the bassets of the known seams of coal, in each of such divisions; an arrangement through the study of which, it is probable that valuable collieries may hereafter be opened in estates and places where they are now unknown.

Part I. Volume V. of The Memoirs of the Wernerian Natural History Society of Edinburgh, for 1823-4, is just published, and contains the following papers.

By Dr. R. Knox. An Account of the *Foramen centrale* of the Retina, generally called the *Foramen of Sæmmering*, as seen in the Eyes of certain Reptiles. Observations on the Anatomy of the Duck-billed Animal of New South Wales, the *Ornithorynchus paradoxus* of Naturalists. Additional Observations relative to the *Foramen centrale* of the Retina in Reptiles. Observations on the Organs of Digestion, and their Appendages, and on the Organs of Respiration and Circulation, in the *Ornithorynchus paradoxus*. Inquiry into the Origin and Characteristic Differences of the native Races inhabiting the Extra Tropical Part of Southern Africa.—By L. Edmondston, Esq. Observations on the lesser Guillemot and Black-billed Auk, the *Columbus Minor* and the *Alca Pica* of Linnæus.—By Dr. R. K. Greville, and G. A. W. Arnott, Esq. *Tentamen Methodi Muscorum*; or, A New Arrangement of the Genera of Mosses, with Characters and Observations on their Distribution, History, and Structure.—By M. Miller, Esq. Register of the Weather at Corfu, during the Months of August, September, October, and November, 1821.—By A. Marshall, Esq. Contribution to a Natural and Economical History of the Coco-Nut Tree.—By John Coldstream, Esq. An Account of a Series of Thermometrical Observations, made hourly at Leith, during Twenty-four successive Hours, and once every Month, from July 1822 to July 1823.—By G. A. W. Arnott, Esq. Notice of a Journal of a Voyage from Rio de Janeiro to the Coast of Peru, by Mr. William Jameson, Surgeon.—By David Don, Esq. A Mono-

Vol. 63. No. 314. June 1824. 3 L graph

graph of the Genus *Pyrola*.—By W. Macgillivray, Esq. Descriptions, Characters, and Synonyms of the different Species of the Genus *Larus*, with Critical and Explanatory Remarks.—By J. Atkinson, Esq. Sketch of the Geographical Distribution of Plants in Yorkshire.—By the Rev. Dr. Fleming. On a New British Species of *Spatangus*.

These Papers are illustrated by seven engravings.

Transactions of the Royal Society of Edinburgh, vol. x. Part I. containing the following Papers.

On the Existence of two new Fluids in the Cavities of Minerals, which are immiscible, and possess remarkable physical Properties. By Dr. Brewster.—Observations on the Comparative Anatomy of the Eye. By Dr. R. Knox.—Notice of an undescribed Vitrified Fort, in the Burnt Isles, in the Kyles of Bute. By James Smith, Esq.—On the Formation of Chalcidony. By Sir G. S. Mackenzie, Bart.—Notice respecting the Vertebra of a Whale found in a Bed of blueish Clay near Dingwall. By the same.—Description of Hopeite, a new Mineral from Altenberg, near Aix-la-Chapelle. By Dr. Brewster.—Astronomical Observations made at Paramatta and Sydney. By Sir Thomas Brisbane and M. Rumker.—On a remarkable Case of magnetic Intensity of a Chronometer. By George Harvey, Esq.—Remarks concerning the Natural-Historical Determination of Diallage. By W. Haidinger, Esq.—Investigation of Formulæ for finding the Logarithms of Trigonometrical Quantities from one another. By Professor Wallace.—A proposed Improvement in the Solution of a Case in Plane Trigonometry. By the same.—Some Notices concerning the Plants of various Parts of India, and concerning the Sanscrita Names of those Regions. By Dr. F. Hamilton.—On a new Species of Double Refraction, accompanying a remarkable Structure in the Mineral called Analcime. By Dr. Brewster.—On the Specific Heat of the Gases. By W. J. Haycraft, Esq.—On the Forms of Crystallization of the Mineral called the Sulphato-tri-Carbonate of Lead. By W. Haidinger, Esq.

These papers are illustrated by nine engravings.

The Edinburgh Journal of Science, No. I. has just appeared. It is conducted by Dr. Brewster, with the assistance of Dr. MacCulloch in Geology and Chemistry; Dr. Hooker, in Botany; Dr. Fleming, in general Natural History; Mr. Haidinger, in Mineralogy; Dr. Knox, in Zoology and Comparative Anatomy; and Dr. Hibbert, in Antiquities and Geology.

The Edinburgh Philosophical Journal, formerly conducted by Dr. Brewster and Professor Jameson, will now proceed under

der the direction of the latter gentleman, with the assistance of Professors Leslie and Wallace, and of other gentlemen of the University of Edinburgh.

An Elementary Treatise on Optics. By the Rev. Henry Coddington, M.A. Fellow of Trinity College, Cambridge. In one volume 8vo, with Plates, price 8s. boards.

An Inquiry into the Principles of the Distribution of Wealth most conducive to Human Happiness; applied to the newly proposed System of voluntary Equality of Wealth. By Wm. Thompson. In a thick volume 8vo, closely printed, price 14s. in boards.

ANALYSIS OF PERIODICAL WORKS ON NATURAL HISTORY.

No. II. Of *The Zoological Journal* has just appeared, containing nineteen papers, of which the following are original, or have original notes appended to them.—Continuation of Mr. Gray's *Monograph on the Cypræidæ*, with a coloured Engraving.—Mr. French *On Instinct, Essay II.* containing an Examination of the Views of that Subject taken by Dr. Fleming and M. Frederic Cuvier.—Continuation of Mr. Bell's Translation of Gaspard *On Helix Pomatia*.—Some *Observations on the Nomenclature of Ornithology*; particularly with reference to the admission of *New Genera*. By N. A. Vigors, jun. Esq. A.M. F.L.S.—*Remarks on the Animal Nature of Sponges*. By Mr. Bell.—*Conchological Observations, being an Attempt to fix the Study of Conchology on a firm Basis*. By Mr. J. E. Gray, M.G.S.—*Note on the supposed Identity of the Genus Isodon of Say with Capromys*. By Mr. Bell.—*A Revision of the Family Equidæ*. By Mr. Gray. Mr. Gray divides the family Equidæ into the two genera *Equus* and *Asinus*, describing the *Equus Zebra* of Burchell, as *Asinus Burchellii*: *A. albidus*, nuchâ dorsoque fasciis alternis nigris et fuscis, nigris latioribus, lineâ dorsali nigrâ albido-marginatis; ventre, caudâ, artubusque infasciatis. A plate is given, showing the animal itself, and also the difference between its hoof and that of the *Equus montanus* of Burchell, which is the true zebra.—*Description of two new Species of Helicina*; also by Mr. Grey.—*Description of a remarkable Fossil found in Coal Shale*. By Mr. J. D. C. Sowerby.—*On the Structure of Melania setosa*. By Mr. Gray.—*Abstract of a Monograph on a new Genus of Gasteropodous Mollusca, named Scissinella*; by M. D. Orbigny. With Notes by Mr. G. B. Sowerby. There are four plates besides those already mentioned; one of them lithographic: their subjects are, *Helicina*, *Baleæ*, *Isodon pilorides*, *Melania setosa*, the fossil bone from the coal shale, *Epeira curvicauda*, and *Nyctinomus Braziliensis*.

Curtis's British Entomology.

No. 6. contains the following subjects :

Pl. 23. *Siagonum quadricorne*. The female of this rare and curious species was unknown until now, and characters for the genus were much wanting, as a figure in the Introduction to Entomology was all that we had to help us to the knowledge of one of the most singular genera of a very intricate family.—Pl. 24. *Gastropacha quercifolia* (Lappet Moth). The larva and a male of this fine Moth are figured, together with elaborate dissections to exemplify the genus.—Pl. 25. *Psen equestris*. A pretty and rare Hymenopterous insect from the New Forest.—Pl. 26. *Atherix Ibis*. Figures of both sexes of this rare and beautiful species are given, which from their disparity have been hitherto considered as distinct species.

The Botanical Magazine. No. 449.

Pl. 2489. *Bubon Galbanum*. The observations of the Editors do not lead them to concur with Professor Schultes in referring this plant to the genus *Selinum*.—*Eucrosia bicolor*, the drawing and description of which, in the Botanical Register, are said by Mr. Herbert to be very inaccurate.—*Bossia linophylla*, discovered by Mr. Brown in New Holland.—*Campanula pulla*, a rare and elegant Alpine species.—*Centaurea spinosa*, of which it is said there has been no figure, except the indifferent one of Prosper Alpinus.—*Alpinia tubulata*, “scapo radicali laterali, bracteis scariosis corollam tubulosam subæquantibus, labello incluso.”

The Botanical Register. No. 112.

Pl. 801. *Iris furcata*.—*Cytisus nigricans*,—to this are annexed some valuable remarks by Mr. Lindley on the difficulty of defining the limits of genera, in orders the species composing which are well understood.—*Periploca græca*, one of the oldest of the climbing plants of our gardens, but never figured in any of the popular botanical works of this country.—*Rosa indica* β . *odoratissima*: some animadversions of apparently well merited severity are here bestowed on M. Trattinnick's *Synodus Botanica*.—*Columnea scandens*.—*Hibiscus hispidus*.—*Andromeda floribunda*.—*Hedysarum alpinum*

LXXV. *Proceedings of Learned Societies.*

ROYAL SOCIETY.

May 27. **T**HE reading of Mr. Abrahams' paper on “Magnetism” was resumed and concluded; and a paper waread, “On the Direction of the Eyes in Portrait-Painting;” by W. H. Wollaston, M.D. V.P.R.S.

June 3.—A paper was read, “On the Generation of Fishes;” by J. L. Prevost, M.D.: and the Society adjourned to June 17.

June 17—The following communications were read:

“On the Organs of Generation of the Axolotl and of other Protei;” by Sir E. Home, Bart. V.P. R.S.

“On the Effect of Temperature on Magnetism and the Diurnal

Diurnal Variation of the Needle;" by S. H. Christie, Esq. M.A.: communicated by Sir H. Davy, Bart. P.R.S.

"On the Preservation of the Copper Sheathing of Ships, and on some new Facts connected therewith;" by the President.

"On the Application of Dœbereiner's new Discovery to the Purposes of Eudiometry;" by W. Henry, M.D. F.R.S.

The Society then adjourned, over the long Vacation, to meet again on Thursday the 18th of November next.

LINNÆAN SOCIETY.

June 1.—A further portion of Mr. Vigors's Observations on the Natural Affinities that connect the Orders and Families of Birds was read, which proceeds in the illustration of the opinion expressed at the commencement of the paper, viz. that the system unfolded by Mr. W. S. MacLeay in his *Horæ Entomologicæ* appeared completely to hold good in Ornithology: and that following the train of affinities in natural succession we are presented with groupes, primary and subordinate, in series returning into themselves, and exhibiting analogies with corresponding groupes in the other classes of the animal kingdom. He also finds that, as has been remarked by Mr. MacLeay in the other classes, the primary division of Birds is into five groupes, viz.

Raptores, Birds of prey.

Insessores, Perchers.

Rasores, Gallinaceous.

Grallatores, Waders.

Natatores, Webfooted.

All of which are successively considered as to their natural characteristics, the families into which they are subdivided, and the relation of these to each other.

In the part of Messrs. Sheppard and Whitear's Catalogue of Norfolk and Suffolk Birds, which was also read, some confirmations were given of the fact of the Great Cinereous Shrike spitting mice and frogs upon thorns before it devours them.

June 15.—A. B. Lambert, Esq. V.P. in the chair.—Present His Royal Highness the Prince Saxe Cobourg, the Duke of Somerset, the Bishop of Salisbury, &c. &c. A part of a paper was read, entitled "Anatomical Observations on the Natural Groupe of *Tunicata*; together with the Description of Three Species collected in Fox Channel during the late Northern Expedition.—By Wm. S. MacLeay, Esq. A.M. F.L.S."—The three species described were brought home by Wm. Nelson Griffiths, Esq., and are a part of the fruits of the laudable industry with which the officers who accompanied
Capt.

Capt. Parry devoted much of their time to the collection of the natural productions of the regions which they visited.

A curious *Papilio* was exhibited by A. MacLeay, Esq. Secretary, presenting the forms and colours, we believe, of the *Laodocus* and *Polycaon* of Fabricius, which therefore are doubtless the male and female of a single species. The specimen has the wings of the former on one side, and those of the latter on the other.

GEOLOGICAL SOCIETY.

May 21.—The reading of the paper “On the Geology of the Ponza Islands in the Mediterranean;” by George Poulett Scrope, Esq. M.G.S., was concluded.

The Ponza Islands lie off the coast of Italy opposite Terracina and Gaieta. They consist of Ponza (anciently Pandataria), Palmarola, and some islets; Ventotiene and San Stefano connect them with Ischia. The harbour of Ponza is excellent. Dolomieu’s *Mémoire sur les Isles Ponces* excited curiosity, but is too general to satisfy it. These islands are composed of rocks of the trachytic series; and presenting fine sections along their coasts, enabled the author to clear up many doubts and errors which the mere investigations of inland localities have caused to be affixed to this formation.

The Isle of Ponza is long and very narrow, and is eroded by the sea into deep concavities. Harder masses left along its shores show that it once was broader, and protruding ledges mark its former connexion with Quannone and La Gabbia. Prismatic trachyte, variously coloured and disposed, forms the ossature of the island. It is constantly accompanied by, and alternates with, a semi-vitreous trachytic conglomerate formed of minute pulverulent matter inclosing fragments of trachyte. The prismatic trachyte seems to have been forcibly injected through the conglomerate; and wherever it touches the latter, its earthy base is converted from two to thirty feet deep into a pitchstone porphyry; sometimes it becomes a pearlstone, at others incloses a true obsidian. These rocks are connected with a siliceous trachyte resembling in appearance the siliceous buhrstone of Paris. Resting on the semi-vitreous trachyte and forming the base of the *Montagna della Guardia* is a rock 300 feet thick, which the author distinguishes mineralogically from common trachyte, and proposes to call Greystone.

In Jannone the trachyte overlies a limestone which Brocchi describes as transition limestone: at the point of contact this latter becomes dolomite. Having described the whole

of this groupe, the author terminates his paper by connecting their geological structure with that of the neighbouring continent of Italy.

A paper was read entitled "Notes accompanying Specimens collected on a Journey through Part of Persia and the Russian Tartaries;" by James B. Fraser, Esq. M.G.S.

A paper was read entitled "Description accompanying a Collection of Specimens made on a Journey through the Province of Khorosan in Persia;" by Jas. B. Fraser, Esq. M.G.S.

On quitting Tcheran, the road passed by the roots of the chain of Elburz through the pass Gurdunee Sirdara to Semnoon and Shahrood, over gravelly hills, having to the south a salt desert and appearances of salt on all sides; thence by Mey Amood, Abassabad, Muzeenoon, and Subzawar to Nishapore; about 40 miles west of which place are found the celebrated Turquoise mines, which are worked along the sides and ridges of a narrow valley. The principal mine is called Abdool Rezakee. The calaite is found pervading a soft yellow stone and a mouldering reddish rock, as also a rock of much firmer texture resembling quartz rock, of a grey colour with reddish streaks, and containing specular iron. A conglomerate rock occurs in the vicinity. The mineral is found sometimes in veins, sometimes mammillated in fissures, and at other times irregularly dispersed through the rock. The author describes all the mines actually worked; they are the property of the Crown, and were valued, when Mr. Fraser visited them, at the annual rent of 2000 tomauns of Khorosan, or about 3,500*l.* sterling, and are farmed to the best bidder. At Derroad, 25 miles from Nishapore, the primitive rocks of Elburz appeared similar to those seen in the lofty range between Ispahan and Cashan.

A paper was then read entitled "Geological Observation son the Sea Cliffs at Hastings, with some Remarks on the Beds immediately below the Chalk;" by Thos. Webster, Esq. Sec. G.S.

This paper commenced with a geographical description of the cliffs on each side of the town of Hastings, from the White-rock on the west, to the end of Fairlee cliff on the east, which form a very instructive natural section of an elevated tract in Sussex surrounded by, and coming out from under, the clay of the Wealds.

These cliffs consist of alternating beds of sandstone, shale and clay, more or less charged with oxide of iron and carbonized vegetable matter. The iron is most abundant in the lower part, where there are beds of two or three inches thick of rich argillaceous iron ore, that were profitably worked before

fore the fuel of this part of the country became scarce. The middle beds of the cliff have much less iron, the greatest part consisting of very white friable sandstone. In the upper part of the series there are many large blocks of a grey calciferous sandstone, the surfaces of which exhibit a mamillated structure: this rock may be considered as a variety of the *chaux carbonatée quartzifère* of Haiiy, having much analogy with the crystallized sandstone of Fontainebleau. The mamillated appearance is very well seen at the White rock, and has (though erroneously) been usually attributed to the action of the sea upon the fallen blocks.

The fossils in the cliffs of Hastings are not numerous; the shells being confined to two or three species of small bivalves, and a univalve resembling that in the Petworth marble. Thin layers of lignite are frequent, and fragments of a very singular silicified wood of the monocotyledon kind, the cavities of which are filled with minute transparent crystals of quartz.

Bones of large Saurian animals, and of birds, also occur, though rarely; together with scales of fish.

The author observed that the grey calciferous rock has not hitherto been noticed in any part of the formations between the chalk and the Purbeck, except in this district: and from its not being co-extensive with the rest of the ferruginous sand series, and the want of continuity and correspondence in many of the beds, he took occasion to remark, that it may be frequently more correct to consider the subdivisions of some formations rather as *irregularly lenticular* than as *tabular* masses.

June 18.—A paper was read entitled “Notes on Part of the opposite Coasts of the English Channel, from Deal to Brighton, and from Calais to Treport;” by Wm. Henry Fitton, M.D., M.G.S.

This paper was accompanied by a connected series of views or elevations of the coast, drawn by Mr. Webster, from the place where the chalk rises near Calais, to where, after being cut off near Blanc-Nez, the chalk again appears upon the shore near Treport; and, on the English side, from the rise of the chalk near Deal, to where it sinks at Brighton. The author expresses his acknowledgments to the Baron Cuvier, through whom he obtained permission from the French authorities to pass along the coast by sea, and experienced every where the greatest attention from the officers of the French Customs. The paper briefly describes the leading geological features of the coast, reciting the partial descriptions already published; and referring for an account of the cliffs near Hastings, to a memoir by Mr. Webster read at the last meet-
ing

ing of the Geological Society, and for a detail of the beds which form the cliffs from Gris-Nez to Equihen, to an account of the lower Boulonnois, to be read at a future meeting. From Equihen to the mouth of the Somme, the coast is altogether occupied by dunes of sand, the sand-hills being in some places, especially in the vicinity of Etaples, more than 100 feet in height. These hills are in general somewhat crescent-shaped, the back of the crescent being turned towards the prevailing wind, and the slope on the lee-side much more rapid than the opposite one. The immediate base of the dunes seems to be peat, which is found both on the land side of them, and without, just on the verge of the sea, and in some places below the level of high water: but no rocks have yet been discovered along the coast beneath the dunes. A list of heights obtained by the barometer is subjoined to this paper, and some detached sketches are annexed to it of interesting geological appearances on the French shore.

HORTICULTURAL SOCIETY.

June 1.—A paper by the Hon. and Rev. Wm. Herbert, containing "Further Observations on Hybrid Plants," was read.

June 15.—His Imperial Majesty the Emperor of Russia was elected a Fellow of the Society.

The following communications were read:

Description of a Melon Pit on a new construction. By Richard Lacy, Esq.

On the best Means of Protecting the Blossoms of Trees on Walls. By the President.

ASTRONOMICAL SOCIETY.

June 11.—The following papers were read:—

1st. On the Variation of the mean Motion of the Comet of Encke produced by the Resistance of an Ether; by M. Masotti. This comet is well known to evince a diminution of its periodic time at each revolution, and the object of this paper was to demonstrate the cause of this effect. Encke himself supposed it was occasioned by an ether diffused through space; but if so, how happens it that the planets also have not been retarded? This the author attempted to show might be the case, although the phænomenon might pass unobserved. He adopts with Encke, the hypothesis of Newton, that the density of this ether diminishes in the inverse ratio of the square of the distance from the sun; consequently that the planet Mercury would be most likely to be affected by it; and by a long series

of analytical investigation, assisted by Legendre's tables of elliptic functions, arrives at the result, that this resistance would not produce a greater change in the mean geocentric longitude of Mercury, than $31''\cdot 2$ in the course of a century. Hence he concludes that the comet may have such a resistance from an ether, as will be sufficient to account for the difference between the calculus and the observations, and yet that the planets shall not hitherto have manifested the least effect of such a medium.

2d. On a new Astronomical Instrument called the Differential Sextant; by Benjamin Gompertz, Esq. F.R.S. This paper was a further and more particular description of the construction and application of the instrument before invented by Mr. Gompertz, and partially described in his paper on Astronomical Instruments read before the Society on the 11th of January 1822. In this instrument, the index reflector is susceptible of motion on one end of the index as on a centre, being the same as that on which the index itself turns, so that the reflector may be set to make any angle at pleasure with the index; the whole being permitted to move, as a bent lever about the centre. The horizon glass also is capable of being adjusted and fixed at different angles to the fixed arm. The object proposed by Mr. Gompertz in this contrivance is to measure the *difference* of angular distances in any two celestial phænomena, occasioned by those varying circumstances which produce small changes; such as refraction, parallax, aberration, &c.: and the paper concluded with some appropriate hints as to the best manner of employing the instrument to these purposes.

3d. An Account of an Occultation of the *Georgium Sidus* by the Moon, which will take place on the 6th of August next, by Francis Baily, Esq. F.R.S. and V. Pres. Ast. Soc.—Mr. Baily begged to call the attention of the Society to this interesting phænomenon which has never yet been seen, as no occultation has occurred since the discovery of the planet. The occultation will occur within a very few minutes after the moon has passed the meridian; insomuch that those persons possessing a transit instrument will see the planet in the field of view when the moon's centre is on the meridian. This notice was accompanied by a diagram, showing that the planet would enter the western or dark limb of the moon at about half way between the moon's outer and the upper or northern part of her disk. There will be sufficient time to observe the occultation of the planet after the transit of the moon. This interesting phænomenon will no doubt attract the notice of every

every practical astronomer. This being the last meeting of the Society's present session, an adjournment took place until the 12th of November next.

ROYAL ACADEMY OF SCIENCES OF PARIS.

Feb. 16 (continued). — M. Poisson read his Memoir on the Theory of Magnetism.

Feb. 23.—M. de Humboldt gave a verbal account of a work by M. Auguste Saint Hilaire, entitled "Description des Plantes Naturelles du Bresil," Cahier I.

M. Moreau de Jonnes announced that earthquakes had been felt at the Antilles on the 11th of November and 13th of December.

M. Percy, on exhibiting to the Academy an original portrait of Copernicus, which he proposed to present to the Royal Observatory, read a biographical notice of that Philosopher. The new propositions of the Commission on Gas Illumination were approved of by the Academy. M. Dulong, in the name of a Commission, gave an account of a Memoir by M. Longchamp, on the Analysis of Phosphoric Acid, and of the Phosphates.

LXXVI. *Intelligence and Miscellaneous Articles.*

NEW SOUTH WALES.

JUNE 16, arrived off the Isle of Wight, the Competitor, Captain Ascough, in one hundred and thirty-four days from Sydney, New South Wales, with a cargo consisting of various kinds of colonial timber, seal skins, elephant oil, and two hundred and eighty bales of wool. Came through Book's Straits, New Zealand, and by way of Cape Horn. The Elizabeth, Brooks, sailed the same day as the Competitor; and the Ocean, Harrison, was to follow in ten days after, both loaded with similar cargoes.

Mr. Oxley, surveyor general, had returned in January from surveying part of the coast to the northward, and succeeded in discovering a river in Moreton Bay, lat. 28° (which he has named the Brisbane), superior to any yet known in New Holland. He ascended it for 50 miles, and saw its course from an eminence for 30 or 40 further, being compelled to return from further examination for want of provisions. It is three miles broad at the entrance, and has usually from three to nine fathoms water up to where he left off the survey; but about twenty miles from the sea it is crossed by a ledge of rocks, over which there are only twelve feet at high water. At the distance to which he penetrated, the tide rose four feet

and a half, and ran upwards of four miles per hour. The country all around was an undulating level, abounding in very superior timber, the soil rich, and well covered with grass, but rather stony. The river came from the south-west in the direction of the Macquarie marshes, of which it may probably prove the outlet, being at the termination of Mr. Oxley's survey about three hundred and fifty miles in a direct line from where he lost the Macquarie river among reeds in his former trip into the interior. The country around was not subject to flood, no marks of it being seen higher than seven feet above the then level of the river, which was considerably within the banks. It contained abundance of fish, and several parrots were shot in the vicinity, of the same species as have hitherto only been found near the banks of the Macquarie. A river of tolerable magnitude called the Tweed, was also discovered behind Mount Warning, a little to the southward of the last, with a fine bar harbour of 14 feet, and the country seemingly good around. A smaller one, called the Boyne, was also found in Port Curteis. The governor intended proceeding to survey the Brisbane in April, in His Majesty's ship *Tees* lately arrived from India. Mr. Oxley's health having been materially injured by his two former hazardous expeditions, the hardships encountered in this last had given it a still severer shock; but he had nearly recovered at the period of the *Competitor's* departure, and was anxious to set out on a further journey of discovery for the benefit of science, and the colony to which his patriotic and meritorious exertions have already been so serviceable.

Mr. Archibald Bell, junior, of Richmond-hill, had also discovered a new route over the Blue Mountains, to Bathurst, by way of Richmond, which passes through a fertile, well-watered brushy country; and besides considerably reducing the distance, the road will be comparatively level, and free from nearly all the obstacles which render the bleak and barren one now used, so uninviting to the traveller and ill adapted for the passage of carriages and cattle. The veteran corps, lately disbanded, is to be settled along this line.

A stage-coach has recently commenced running daily between Sydney and Parramatta, and a second caravan was preparing to run between Sydney and Parramatta daily; a third between Parramatta and Liverpool; and a stage-coach between Parramatta and Windsor; so that now travellers may proceed by daily stages to all the well settled parts of the colony. The five hives of bees taken out by Captain Wallace of the *Isabella*, were thriving well, and had thrown off many swarms, the greater part of which had escaped into the woods, where they will multiply

multiply fast, from the climate and country being so favourable to their propagation; so that wild honey and wax may hereafter become objects of interest to the colonist for domestic purposes and exportation, besides what will be produced from the bees in their tame state.

Mr. Hannibal M'Arthur some time ago imported six young olive trees from England, from five of which, eighty-three young plants have been raised by means of layers, while the parent stems have added a full third to their growth. The soil is a very sandy light loam, of which Mr. M'Arthur was clearing several acres with the view of planting an olive grove, from this soil appearing so congenial to them. Should the production of the olive progressively increase at this rate, Mr. M'Arthur will be able in a few years to disseminate this valuable tree over the whole colony, where all attempts at propagating it have hitherto failed.

A quantity of New Zealand flax had been imported, which the female convicts in the factory were taught to dress in the New Zealand manner by two natives of that country, after which it is spun and manufactured by the female convicts into various descriptions of cloth. Should this manufacture be properly encouraged and conducted, it may stimulate the New Zealanders to raise a commodity which they can barter for useful European articles. Tobacco has this year been so extensively cultivated, that the colonists will be independent of all foreign supply, a duty of 4s. per lb. having been laid upon imported tobacco, to encourage that of colonial growth; this measure has put a complete stop to the cultivation of tobacco in Otaheite, where it had lately been produced of very superior quality.

The country is rapidly clearing by means of the clearing gangs, the farmer paying five bushels of wheat per acre to make it fit for the plough. A large distillery has recently been erected, in the vicinity of Sydney, to distill from grain; and all the coarse earthenware required by the colony is now manufactured by two Staffordshire potters, who say that the New South Wales clay is very superior to the English for these purposes.

When the Ocean sails, no less than ten vessels will have cleared for England from New South Wales and Van Dieman's Land, with cargoes chiefly the produce of these colonies. This great increase in exportation is principally owing to the duties being taken off colonial oil and timber at home; but it is also, no doubt, partly referable to the reduction of Government expenses, and Government bills being no longer disposed of at a fixed price, but sold to the highest bidder, so that

the

the merchants find it more profitable to make their remittances in produce than in bills.—*Morn. Chron.* June 21.

RETURN OF THE RUSSIAN ANTARCTIC EXPEDITION.

This expedition, under the command of Captain Bellingshausen, has added to our knowledge of the South Polar Regions, by the discovery of two islands within the Antarctic circle, the only land hitherto known to exist so far to the southward. Both these islands lie in about 69° south latitude; one of them, named Alexander I.'s Island, in 73° west longitude; and the other, Peter Island, in 19° west. Both of them were so closely enveloped in ice, that no particular examination of them could be made. This expedition, consisting of two ships, the *Wostok* and the *Mirni*, sailed on the 3d of July 1819. They touched at Copenhagen to improve their equipment, and at Portsmouth to take on board the astronomical instruments which had been ordered for them in London, and from thence proceeded to Teneriffe and Rio Janeiro, on their way to the southward. The leading object of the voyage was to explore the Antarctic regions, and perform a circuit of the southern pole as near to it as the ice would permit; and, avoiding the track of Captain Cook, to make their highest penetration where this navigator had kept at a distance from the ice, and on the contrary to retire into a more northerly parallel in the meridians where the adventurous Cook had made the most particular examinations. On this judicious plan, they succeeded in the discovery of the two islands we have mentioned; but they could not approach within thirty miles of them for ice, and that only on the *west* side. The ice was generally found to lie so far from the pole, that their highest latitude was only 70 degrees, being short of the point reached by Cook. Within the antarctic circle they traversed a distance of near 30 degrees of longitude; and taking the latitude of 60 degrees, we find that 300 degrees of longitude were traced in the two voyages by Cook and Bellingshausen within this parallel, leaving only 60 degrees of longitude unexplored at this elevation.—*App. to Art. Polar Regions*, by Mr. Scoresby, in the *Edinb. Encyclopedia*, vol. xvii. Part I. about to appear.

MOUNT ROSA, THE HIGHEST IN EUROPE.

Dr. Brewster has published, in his new 'Edinburgh Journal of Science,' from the Memoirs of the Royal Academy of Turin, a translation of an account of the first ascent of the southern summit of Mount Rosa, by M.M. Zumstein and Vincent. Having determined, by means of the barometer, that the elevation of the southern summit, which they had

gained

gained for the first time, was 13,920 Paris or 14,83564 English feet above the level of the sea, they ascertained, by a trigonometrical measurement thence made, that the elevation of the highest summit of the mountain was 1680 Paris feet above it, or 15,600, (16,6264 English) above the level of the sea. Thus Mount Rosa is in reality the highest in Europe; the height of Mont Blanc, according to Prof. Tralles, being only 14,793 Paris, or 15,7084 English feet.

EARTHQUAKES.

On the night of the 10th of April, at a few minutes before 10 o'clock, one of the severest shocks of earthquake experienced for many years was felt at Kingston, and in different parts of the island of Jamaica. The shock was preceded by a rushing wind, and lasted 30 seconds, during which it was accompanied by a subterranean rumbling noise. Three or four houses on the north side of the island were destroyed, but fortunately no lives were lost. The Jamaica Courant mentions, on the contrary, the singular recovery of a man who had been long bed-ridden from rheumatism. In the alarm occasioned by the shock he sprang from his bed, and from that moment was able to resume the duties of his occupation as a brass-founder. Several smaller shocks were felt between the 10th and 15th of April, when they ceased.

The Bury Post says, "On Monday morning the 31st of May, about four o'clock, a slight concussion was felt by a number of persons in this town and neighbourhood, which they compare to the shock which would be occasioned by the falling of a large house at a distance, but which cannot otherwise be accounted for than by supposing it to have been an earthquake."

HOPEITE, A NEW MINERAL.

Form prismatic. Fundamental form a scalene four-sided pyramid of $139^{\circ} 41'$; $107^{\circ} 2'$; $86^{\circ} 49'$, in which the ratio of the three lines $AM:MB:MC = a:b:c$ is $= 1: \sqrt{4.443}: \sqrt{1.493}$.

Incidence of M on M over $g = 101^{\circ} 24' = \bar{P}r$;

of s on s over $l = 81^{\circ} 34' = (\bar{P}r + \infty)^3$.

Cleavage perfect parallel to $\bar{P}r + \infty (l)$, less distinct parallel to $\bar{P}r + \infty (p)$. *Surface* of $\bar{P}r + \infty$ deeply striated in a vertical direction, the other faces smooth.

Refraction double; two axes, the principal one perpendicular to the axis of P , and also to l . Action of the axis negative. Angle of resultant axes about 48° in the plane of $\bar{P} - \infty (g)$, contiguous to the obtuse lateral angle of P . *Index*

Index of ordinary Refraction nearly 1.601. *Colour* grayish-white lustre pearly upon *l*, vitreous in other directions. *Transparent, translucent*.

Hardness 2.5 . . . 3.0. *Specific gravity* = 2.76 of a perfect crystal. *Phosphorescence* and *Electricity*, none by heat.

This mineral resembles very strongly anhydrite and cryolite, being two species of the order *Haloïde* of Mohs. It is soluble in acids without effervescence. According to an examination by the help of the blowpipe, instituted by M. Nordenskiöld of Abo, it consists of some of the stronger acids, like the phosphoric or boracic acid, mixed with zinc, some earthy base, and cadmium. Hopeite occurs sparingly in the cavities of several ores of zinc, found at Altenberg, near Aix-la-Chapelle. This interesting substance has been established into a species by Dr. Brewster, who named it in honour of Dr. Hope.—*Edin. Phil. Trans.* vol. x. Part I.

EFFECT OF LIGHT ON THE COLOUR OF THE SODALITE FROM GREENLAND.

Mr. Allan observed a very interesting phænomenon in relation to the action of light upon the colour of the sodalite of Greenland. When the massive variety is broken up, many portions of it have the most brilliant pink colour; but after a day's exposure to the action of light this brilliant pink colour almost entirely vanishes. Having broken a specimen into two, Mr. Allan kept one of them in the dark, and exposed the other to light. The specimen kept in the dark retained its pink colour unimpaired, while the other lost it almost entirely.—*Brewster's new Journal*, vol. i. p. 181.

AËRONAUTIC ASCENT.

The following authentic particulars of the ascent of Mr. Graham and Captain Beaufoy, from Islington, on Thursday, the 17th of June, 1824, are extracted from "The Nation" evening paper.

The uncertainty of the weather in the morning prevented Mr. Graham's ascending at so early an hour as had been intended.

A stage about five feet high was erected, on which all the operations were carried on; so that the spectators had an opportunity of viewing the whole of the balloon and car, without inconvenience; while the absence of poles or other scaffolding secured the machine itself from any accidents.

A number of assistants stood around, to hold down the netting and half a dozen cords fastened to the top, gradually giving way to the inclination of the balloon to rise, as it filled with

with gas. When it was judged to be sufficiently inflated, a large hoop, made of strong but flexible materials, was brought; and to it were speedily fastened, by means of a number of steel swivel loops, the netting and cords above mentioned.

Four strong leather straps, fastened to staples in the platform, were attached to the hoop; and together with the united strength of a dozen men, held down the balloon while the car was being fixed.

The wind being high, with occasional gusts, induced the assistants to remove the machine (after Mr. Graham and his companion had taken their seats) by main force, as far from the trees and houses as the platform would admit; and then, watching till the balloon was perfectly upright, they let go their hold, and it rose majestically at 5 minutes past 6 o'clock.

Bar. 29 in. 8 tenths; ther. 66; hyg. 17 dry. Nothing could exceed the grandeur of the scene witnessed by the gentlemen in the car.

The balloon itself seemed stationary; not the slightest motion was perceptible; all other objects appeared to sink from it; every part of the immense metropolis, and a considerable portion of its environs, were distinctly visible; not a street, or square, or even house was concealed; most of the former being crowded with spectators whose cheers were plainly heard; and as during the first two or three minutes objects had not completely lost the appearance of height, St. Paul's and the hills near London were peculiarly interesting.

At 8½ min. past 6; bar. 27·4, or 2304 feet; ther. 46; hyg. 15 dry, the balloon was directly above Waterloo-bridge; when the beautiful distinctness with which every ship and even boat on the Thames could be traced by the eye, was extremely gratifying: but objects having now lost all distinction of height, the whole country was perfectly flat, like a military map.

At 12 min. past 6; bar. 25·5, or 4128 feet; ther. 45,—the æronauts passed through some very thin mist, which might perhaps have been only the smoke from the metropolis, and were now directly over Vauxhall-bridge.

The balloon entered a current of air, which made it revolve gently to the north; occasioning a slight sensation of giddiness and sickness to those in the car; and immediately afterwards became enveloped in clouds, when the watch was at 16 min. past 6; bar. 23 in. 3 tenths, or 6240 feet; ther. 39; hyg. 20 dry.

Until this moment every thing had been distinctly visible from the balloon; trees, houses, ships, &c. had length and breadth, but no height: roads seemed like foot-paths, of an

orange colour; fields of corn, as if ruled with lines of vivid green; the hedges looked thicker and darker.

On rising above the clouds, which had not been by any means dark, one vast expanse, like a sea of frozen snow, with masses of every shape and form rising into mountains, extended before the eye to the horizon. The sun, which shone from a clear blue sky above, gilding every pinnacle and summit in the most beautiful manner.

This sight was truly magnificent. A few very thin vapours were still seen far above our heads; and where the clouds beneath us were broken, we caught delightful glimpses of the country.

At 20 min. past 6, bar. 21·6 in. or 7872 feet, we heard the report of a cannon, but no roll or reverberation after it. The balloon now revolved, getting into another current of air; the aéronauts felt a disagreeable sensation of singing in their ears, which had come on when they were passing through the clouds, and continued during the whole voyage: the application of cotton was found useless, and therefore discarded.

At 26 min. past 6, bar. 20·2. or 9216 feet, another report of a gun was heard.—The clouds being now far below, rolled over each other into every fantastic shape, with fissures between; and their silvery points were tinged by the sun into all the varieties of light and shade. Mr. Graham recommended his companion to let loose a pigeon*, which at 31 min. past 6, bar. 19 in. 5 tenths, or 9888 feet; ther. 32; hyg. 25 dry, flew from the car with the greatest ease and rapidity, making two or three circles, and then darting through one of the openings in the clouds towards the earth.

The balloon had now attained an elevation that Mr. Graham judged could not be exceeded without throwing out ballast, which he said was always attended with the inconvenience of making the descent and landing more difficult; and as it was evident no new scenes could strike the eye, by rising higher into the blue expanse, at 20 min. to 7, bar. 19 in. 2-tenths, or 10,171 feet; ther. 32; hyg. 31 dry, he opened the valve for a moment, and the balloon began to fall very gently.

At this great height—only 384 feet short of two miles—the report of a gun was heard. To this time the metropolis had always been in view, except when clouds intervened; and the balloon had not appeared to the voyagers to make much progress except in ascending; but it now floated rapidly to the

* The first pigeon reached White Conduit House at nine o'clock the same evening.

southward,

southward, and being quite distended by the rays of the sun, some of the gas escaped through the safety valve.

At 18 min. to 7, bar. 19 in. 5 tenths, or 9888 feet, ther. 31. we caught a view of the country below; the Thames seemed diminished to a small stream, but reflecting the rays of the sun brilliantly.

This scene was interesting; yet much inferior to the sight of the vast expanse of silvery clouds.

The descent was so extremely gradual, from Mr. Graham's experience and excellent management, that it was only by constantly throwing out small pieces of silver paper, it could be ascertained whether the balloon was rising or falling.

At 9 min. to 7, bar. 22·3, or 7200 feet; ther. 38; hyg. 23 dry, the aëronauts found they were approaching the clouds; and at 5 min. to 7, bar. 24, or 5568 feet, they began to enter them; the appearance being that of a thick white mist rising up with great rapidity.

At 4 min. to 7, bar. 24·5, or 5088 feet, the balloon got into another current of air, and revolved slowly. The clouds became much thicker and of a darker colour as they more completely enveloped the voyagers, giving a disagreeable impression of space without any object to rest the eye on. The voices of the gentlemen now appeared much weaker and lower to each other, than when either above or below the clouds; but unaccompanied by any oppression on the chest.

At 7 o'clock, bar. 25 in., height 4608 feet, the machine emerged from the clouds; and experiencing a fresh current of air, it again revolved.

At 3 min. past 7, bar. 26 in. 5 tenths, or 3168 feet, objects on the earth once more became distinctly visible; so that even the sheep (appearing like white dots on the green pasture) could have been easily counted.

Mr. Graham now let down his grappling-iron with a cord of 160 yards, which thus became of a very considerable weight, at the same time giving every necessary instruction to his companion to ensure their safe landing.

At 7 min. past 7, bar. 28 in. 3 tenths, or 1440 feet; ther. 50; hyg. 22 dry, the aëronauts first perceived any difference of height on the face of the country: and descended with a rapidity that seemed the greater, because they had now an opportunity of comparing it with surrounding objects. Several persons were seen running towards the balloon, and the grapple soon after grounded, passed through a hedge, and held tight among the boughs of an oak, bringing the car almost instantaneously to the ground with considerable violence, which shock the gentlemen avoided by hanging with their

hands on the hoop, and lifting up their legs. The balloon rose again the height of the cord, with great elasticity; but the grapple holding tight, and several men coming to their assistance, Mr. Graham and his companion, after three more shocks against the ground, each less violent than the preceding, stepped out of the car on the field of Mr. M. Wilkes, in the parish of Tandridge, one mile from Godstone, and twenty-two from London, at eight minutes past seven.

The voyagers experienced the greatest civility and assistance from the crowd of individuals who had collected; and the machine, its car, and all the mathematical instruments, were soon after placed in a chaise, perfectly uninjured; another pigeon being let loose, to carry the news of their safety to London*.

He and his companion arrived in Oxford Street perfectly well, at eleven o'clock the same night.

REMARKS.—In the calculation of height, 96 feet has been allowed to each tenth of an inch the quicksilver sunk in the barometer, which is rather below than above the actual elevation.

Contrary to expectation, the atmosphere became drier as the balloon ascended, (except at the height of 2304 feet, when it was two degrees damper,) the hygrometer showing it to be 14 degrees drier when at the greatest elevation than when on the ground. The compass was of no utility whatever, as it revolved with the slightest movement in the car.

A gentleman had given Mr. Graham a small inflated bladder of Indian rubber, to be thrown out when at the greatest height above the clouds; in order to observe whether it would waft from the large balloon altogether, or continue attracted towards it, both rising and falling. Much to the regret of Mr. Graham and his companion, this curious experiment was prevented by the bladder getting damaged before the ascent.

There is nothing disagreeable or appalling in looking at objects from the car, which are not immediately under it; but to keep the eye fixed on the grappling-iron, or any thing perpendicularly below, for more than a few seconds, turns the head giddy.

When at the greatest elevation, a slight degree of cold was felt; which went off almost immediately the balloon began to descend.

After the descent, when Mr. Graham's companion had quitted the car, he had occasion to use his pocket handkerchief; when the sound in his ears was like the report of a

* Second pigeon sent up at the time of the descent, reached home the following morning.

pistol: and this he found to be the case, as often as he repeated the experiment during that evening.

It would be the greatest injustice to Mr. Graham, not to mention the scientific manner in which he managed his balloon, by always retaining such a weight of ballast, as would prevent the shock of first striking the earth from being seriously felt by the individuals in the car, and also by expending so little of his gas, as to make the descent perfectly gradual, giving him the opportunity of choosing his place of landing, by being able to ascend again at any moment.

The gas used to inflate the balloon, was $2\frac{1}{2}$ times lighter than common air.

Diameter of valve, 19 inches.

Balloon 63 feet high, by $37\frac{1}{2}$ in diameter.

Weight of balloon, car, and netting was - - - 231 lbs.

Do. of ballast, grapple, cord, instruments, &c. - 107

Do. of Mr. Graham and his companion - - - 294

632

OBITUARY.—WILSON LOWRY, ESQ.

Our numerous readers, and the friends of science and art generally, will be grieved to learn that this celebrated artist breathed his last on the 24th inst. (June) at half past two o'clock in the morning.

The mechanical branch of the art of engraving has been more indebted to Mr. Lowry than to any or all of the artists united, of which England can boast at this moment; and indeed it is but doing justice to his brother-artists to state, that they are not backward in confessing him, not merely as the improver, but rather as the father and founder of this branch as now practised. Of the exquisite and impressive manner in which he represented machinery and apparatus of every description, our friends possess many specimens in the volumes of the Philosophical Magazine. It was in this work that Mr. Lowry first exhibited his powers in this line; and the example set by the Philosophical Magazine led to all that improvement in embellishment and illustration by which our modern works of science are now characterized. Though Mr. Lowry's time was chiefly occupied with plates in the mechanical department—owing to the fame he had acquired, and the consequent pressure of business in that particular branch—his powers of execution extended to every other department, particularly to landscape engraving; though but few of those plates bear his own name, having been executed

for

for other artists, whose fame they have contributed to exalt not a little. These were chiefly executed before Mr. Lowry acquired confidence enough in his own powers to believe that he would be able to meet with constant employment should he seek it in his own name. The writer of this brief notice, who knew Mr. Lowry well, found it very difficult to persuade him to make the experiment. He did however succeed. Mr. Lowry's abilities could not long remain hidden, and from that time business pressed on him from every quarter.

It was not merely as an artist, however, that Mr. Lowry made himself distinguished. His knowledge may be said to have embraced every department of science. In mathematics and the various departments of natural history, his knowledge was extensive; and in mineralogy in particular he had few equals. His skill in this branch was of such celebrity, that but few precious stones of great value have latterly been purchased by our first-rate jewellers, without previously submitting them to his inspection.

Mr. Lowry's manners were unobtrusive, modest, and engaging; and the readiness with which he imparted to others, from his vast stores of knowledge; and the happy facility with which he communicated his instructions, will long be remembered by numbers who experienced his kindness.

Meteorological Observations at Great Yarmouth, by
C. G. HARLEY, Esq.

[Continued from p. 75.]

1824.	Days.					Winds.					Thermom.			Rain.
	Dry.	Wet.	E.	SE.	S.	SW.	W.	NW.	N.	NE.	Low.	High.	Med.	In.
Jan.	17	14	—	—	1	12	7	7	3	1	34	52	42	1 $\frac{1}{2}$
Feb.	17	12	6	4	4	5	4	2	—	4	38	52	43	1 $\frac{1}{2}$
March	9	22	2	4	4	5	2	4	6	4	30	52	45	1 $\frac{1}{2}$
April	11	19	2	6	2	5	—	4	5	6	39	65	49	1 $\frac{1}{2}$

		Therm.	Rain.
Mean temperature for 30 years	January	38 $\frac{1}{30}$	1 $\frac{2}{8}$
	February	41 $\frac{1}{30}$	1 $\frac{6}{8}$
Mean quantity of rain for 24 years	March	44 $\frac{1}{30}$	1 $\frac{6}{8}$
	April	50 $\frac{1}{30}$	1 $\frac{7}{8}$

Calendar of Flora, Fauna, and Pomona, at Hartfield in Sussex, for May.

May 1.—*Hirundo urbica* first seen at Scotts in the parish of Walthamstow. This bird was seen a few days afterwards at Hartfield. *Narcissus pseudonarcissus petalis albis* in blow at Hale End, Essex.

May

May 2.—*Doronicum plantagineum* in flower at Hartwell.

May 3.—*Pæonia tenuifolia* in blow. Tulips abundant.—*Dentaria bulbifera*, *Narcissus biflorus*, *N. poëticus*, *N. major*, *N. bicolor*, and *Orchis mascula*, flowering.

May 6.—*Trollius europæus*, *Tr. asiaticus*, and *Tr. intermedius*, at Hale End.

May 7.—*Borago officinalis* and *Papaver Cambricum*; *Dentaria bulbifera* at Hale End four days later than at Hartwell.

May 8.—*Caltha radicans* at Hale End; also *Dalibarda fragarioides*. *Iris Germanica* at Wanstead.

May 9.—*Convallaria Polygonatum*.

May 10.—*Anchusa sempervirens*.

May 12.—*Lychnis dioica*.

May 16.—*Convallaria multiflora*, *Geum rivale*, *Geum intermedium*, *Asphodelus luteus*, *Senecio squalidus*, *Papaver cambricum*.

May 17.—*Polemonium cæruleum*, *Centaurea montana*, *Valeriana Locusta*. Young gooseberries first gathered for tarts.

May 18.—*Symphytum tuberosum*, *Symphytum asperrimum*, and *Symphytum hybridum* in flower.

May 21.—*Aquilegia vulgaris*. Young chaffinches fly.

May 22.—*Papaver orientale*.

May 23.—*Geranium sanguineum*, and *Hesperis matronalis*.

May 24.—*Pæonia officinalis*, a fortnight behind its usual time. The Pink variety only out today, the crimson was some days later.

May 28.—*Pæonia peregrina*, a week later than usual, and *Pæonia officinalis* with crimson flowers.—*Hieracium Murorum* ten days too late.

May 30.—*Hieracium Pilosella*, and *Hypochæris radicata*.

Some plants have come out at their usual time, while others have been this season a fortnight later than ordinary.

Hartwell, June 22, 1824.

T. FORSTER.

LIST OF NEW PATENTS.

To John Dickinson, of Nash Mill in the parish of Abbots Langley, Hertford, esquire, for his method of cutting cards by means of machinery, and also a process for applying paste or other adhesive matter to paper, and for sticking paper together with paste or other adhesive matter, by means of machinery applicable to such purposes.—Dated 20th May 1824.—6 months allowed to enrol specification.

To James Cook, of Birmingham, Warwickshire, gun-maker, for certain improvements in the method of making and constructing locks for guns, pistols, and other fire-arms.—20th May.—6 months.

To Thomas Marsh, of Charlotte-street, Portland-place, Middlesex, saddler and harness-maker, for an improvement in the art of making saddles.—20th May.—2 months.

To James Viney, of Shanklin, Isle of Wight, colonel in the Royal Artillery, for his method of supplying water or fluids for domestic or other purposes in a manner more extensively and economically than has hitherto been usually practised.—22d May.—6 months.

To Benjamin Black, of South Molton-street, in the parish of St. George Hanover-square, Middlesex, lamp-manufacturer, for his improvement on carriage-lamps.—25th May.—6 months.

To Joseph Wells, of Manchester, Lancashire, silk and cotton manufacturer, for his machine for dressing and stiffening and drying of cotton and linen warps, or any other warps that may require it, at the same time the loom is working, either with the motion of the loom or other machinery.—25th May.—6 months.

To James Holland, of Fence House, in the parish of Aston, Yorkshire, shoemaker, for certain improvements in the manufacture of boots and shoes.—31st May.—2 months.

To John Heathcoat, of Tiverton, Devonshire, lace-manufacturer, for certain improvements in the methods of preparing and manufacturing silk for weaving and other purposes.—15th June.—6 months.

To William Ainsworth Jurup, of Middlewich, Cheshire, salt proprietor, and William Court, of Manor Hall, Cheshire, esquire, for their improved method of manufacturing salt.—15th June.—2 months.

To Richard Hooton, of the Aqueduct Iron-Works, Birmingham, Warwickshire, iron manufacturer, for certain improvements in manufacturing wrought iron.—15th June.—6 months.

To William Harwood Horrocks, of Stockport, Cheshire, cotton manufacturer, for his new apparatus in giving tension to the warp in looms.—15th June.—6 months.

To Robert Garbutt, of the town of Kingston-upon-Hull, merchant, for his apparatus for the more convenient filing of papers and other articles, and protecting the same from dust or damage, including improvements on or additions to the files in common use.—15th June.—6 months.

To William Harrington, of Crosshaven, in the county of Cork, esquire, for his improved raft for transporting timber.—15th June.—6 months.

To Charles Chubb, of Portsea, Hampshire, ironmonger, for his improvements in the construction of locks.—15th June.—2 months.

To Benjamin Ager Day, of Birmingham, Warwickshire, fire-screen maker, for certain improvements in the manufacturing of drawer, door, and lock knobs, and knobs of every description.—15th June.—2 months.

To John MacCurdy, of New York, United States of America, but now of Snow-Hill, London, esquire, who, in consequence of a communication made to him by a certain foreigner residing abroad, is in possession of an improved method of generating steam.—15th June.—6 months.

To Philip Taylor, of the City Road, Middlesex, engineer, for certain improvements in apparatus for producing gas from various substances.—15th June.—6 months.

To John Gibson, woollen draper and hatter in Glasgow, for his manufacturing or making of an elastic fabric from whalebone, and the manufacturing or making of elastic fabrics from whalebone, hemp and other materials combined, suitable for making into elastic frames or bodies for hats, caps, and bonnets, and for other purposes, and also the manufacturing or making of such elastic frames or bodies from the same materials by the mode of plaiting.—15th June.—4 months.

To William Bailey the younger, of Lane End, Staffordshire Potteries, manufacturer and ornament of lustre ware, for his improved gas consumer for the more effectually consuming the smoke arising from gas burners or lamps.—15th June.—2 months.

A METEOROLOGICAL TABLE: comprising the Observations of Dr. BURNEY at Gosport, Mr. CARY in London, and Mr. VEALL at Boston.

GOSPORT, at half-past Eight o'Clock, A.M.		CLOUDS.										HEIGHT OF BAROMETER, IN INCHES, &c.		THERMOMETER.				RAIN.		WEATHER.	
		Cirrus.	Citrocum.	Citrostr.	Stratus.	Cumulus.	Cumulus.	Nimbus.	London.	Boston.	London.	Boston.	London.	Boston.	London.	Boston.	London.	Boston.			
Days of Month, 1824.	Barom. in Inches, &c.	Thermo.	Temp. of Sp. Water.	Hygrom.	Wind.	Evapora- tion.	Rain near the Ground.	Cirrus.	Citrocum.	Citrostr.	Stratus.	Cumulus.	Cumulus.	Nimbus.	London.	Boston.	London.	Boston.	London.	Boston.	
May 26	30.40	60	48.75	50	NE.	0.28	Fair	Fine	
27	30.63	60	...	50	NW.	Fair	Fine	
28	30.59	61	...	48	SE.	Fair	Fine	
29	30.30	61	...	45	E.	0.120	Cloudy	Fine	
30	29.94	62	...	49	SW.	Cloudy	Fine	
31	29.91	64	49.00	62	SE.	.80	-.010	Cloudy	Fine	
June 1	30.12	63	...	55	N.	Fair	Fine	
2	30.34	63	...	49	NE.	.50	-.010	Fair	Fine	
3	30.35	56	...	55	NE.	Fair	Fine	
4	30.33	57	...	50	NE.	Fair	Fine	
5	30.22	56	...	49	NE.	Fair	Fine	
6	30.20	59	...	49	NE.	.80	Fair	Fine	
7	30.18	61	49.15	50	E.	Fair	Fine	
8	30.14	60	...	49	SE.	Fair	Fine	
9	30.00	62	...	47	NE.	.70	-.180	Fair	Fine	
10	29.91	56	...	54	NE.	...	-.215	Fair	Fine	
11	30.08	55	...	55	NE.	Fair	Fine	
12	30.20	56	...	55	NE.	.30	-.010	Fair	Fine	
13	30.13	60	...	56	SE.	...	-.980	Fair	Fine	
14	29.54	60	49.25	78	SW.	...	-.310	Cloudy	Fine	
15	29.20	55	...	68	SW.	.20	-.010	Cloudy	Fine	
16	29.54	63	...	62	SE.	...	-.020	Cloudy	Fine	
17	29.72	56	...	62	SE.	Cloudy	Fine	
18	30.06	55	...	46	N.	Cloudy	Fine	
19	29.72	56	...	64	S.	.40	-.260	Fair	Fine	
20	29.46	58	...	67	SW.	...	-.195	Fair	Fine	
21	29.55	61	49.70	57	W.	.20	Stormy	Cloudy	
22	29.63	64	...	54	SW.	...	-.145	Stormy	Cloudy	
23	29.36	58	...	67	E.	...	-.490	Stormy	Cloudy	
24	29.44	55	...	63	N.	...	-.030	Fair	Fine	
25	29.74	60	49.75	55	W.	.40	Rain	Cloudy	
Averages:	29.965	59.13	49.27	54.8		4.58	3.085	17	6.21	1.19	2.18	29.67	29.89	1.50	3.46	

INDEX TO VOL. LXIII.

- ACID**, benzoic, in the fruit of the clove-tree, 73
- Aëronautic ascent**, 464
- Æs candidum** of Pliny, 126
- Algebraic functions**, their application to parallel lines, 161, 246
- Algebraical notation**, 68
- Ampullariadæ**. On some new species of, 276
- Analysis of the Maine meteorite**, 19; of the ore of white copper, 120; of lamellar pyroxene, 131; of hyalosiderite, 186; of iron slags, 188; of new minerals, 236; of green felspar, 283; of Cheltenham water, 312; of black currant wine, 446
- Anchors**, improvement in, 144
- Antarctic discoveries**, 462
- Anthracite** of Pennsylvania, 234
- Antimonium tartarizatum**, 293
- Apennines**, on the geology of, 278
- Ascidia**. New species of, 321
- Asilus of the Romans**, 228
- Asinus Burchellii**, 451
- Astronomical information**, 65, 230, 252, 392, 457
- Astronomical observations**, Bessel's, 427
- Astronomical refractions**, 418
- Atmosphere**, on the dispersive power of the, 192, 328
- Babbage's calculating machine**, 355
- Baily**, (F.) on the opposition of Mars, 50; on the circular micrometer, 177; on Babbage's calculating machine, 355; on the occultation of *Georgium Sidus*, 458
- Bakewell**, on the manufacture of salt, 86
- Bangma's method of solving equations**, 369
- Barlow's variation correcting plate**, 392
- Batrachian animal**, 325
- Benzoic acid**, 73
- Bessel** on the readings of thermometers, 307
- Bessel**, Introduction to his Astronomical Observations, 427
- Bessel** on Reichenbach's circle, 348
- Bevan** (B.) on the adhesion of nails, 168
- Binomial calculus**, 443
- Black currant wine**, 446
- Books**, new, 52, 135, 219, 284, 375, 447
- Bournon** (M.) on the gangues of Ceylon spinelle, 30
- Bowdich**, (African traveller,) death of, 238
- Brandes** on white copper, 120
- Brayley** on the origin of meteorites, 385
- Breese**, or *Brize*
- Brem**, or *Brom*, a Teutonic root signifying to prick, 229
- Brisbane river**, discovery of, 459
- Burnett**, (Dr. W.) on mercurial vapours, 42
- Cacti**, new descriptions of, 40
- Canals** from the Black Sea to the Baltic, 393
- Cancer**, cases of, 397
- Capstans**, improvement in, 145
- Cast-iron**, test of its quality, 54
- Χαλλος Μοσσονοιικαν** of Aristotle, 126
- Cheltenham water**, its contents, 312
- Children and Daniell** on Dæbereiner's eudiometer, 72
- Chloraster**, description of, 102
- Chronometers**, rate of, its variation with the density of their medium, 311
- Circle**, on the, 368
- Clove-tree**, benzoic acid in, 73
- Comet of 1823-24**, elements of, 310
- Comet**, account of, 63, 147; of Sept. 1822, 65
- Copper sheathing**, preservation of, 60
- Copper**, white, 119
- Covelli and Monticelli** on the phenomena of Vesuvius, 46
- Cranberries**, 73
- Cromer Cliff**, geology of, 81
- Curtis's British Entomology**, 57
- Daniell and Childrev** on Dæbereiner's eudiometer, 72
- Davy** (Sir H.) on the preservation of copper sheathing, 60
- Denmark**, education in, 396
- Dæbereiner's eudiometer**, 71, 72
- Earth**, figure of the, 66, 339
- Earth**, sinking of the, 395
- Earthquake**, 394; at sea, 394
- Earthquake** in India in 1819, 105, 170
- Earthquakes** with meteors, 114, 173
- Earthquake** at Colombo, 74; in Chili, 227; in Jamaica, 463
- Edinburgh Phil. Trans.**, 450
- Electro-magnetical experiments**, 95, 266
- Electrometer**, single-leaf, 244
- Entomology**, Thunberg's cabinet of, 74
- Equations**, method of solving, 369
- Eudiometer** of Dæbereiner, 71, 72
- Expeditions**, Northern, 69; Southern, 462

- Faraday* (M.) on Cheltenham water, 312
- Feldspar*, green, analysis of, 283
- Fir-trees*, pierced by an insect, 299
- Flora, Fauna, and Pomona*, calendar of, 315, 397, 470
- Flora*, the English, Notice of, 219, 284
- Forbes* (John), death of, 314
- Forster* (Dr. T.) on the powers of the atmosphere, 192; on the peculiarities of the stars, 328; calendar of *Flora*, 315, 397, 470
- Fraunhofer* on the circular micrometer, 210
- Gad-fly*, 228
- Gadina*, a new genus of shells, 275
- Galvanic deflagrator*, 241
- Gauge* for compressed steam, &c., 36, 92, 190
- Gauging*, new method of, 415
- Geological atlas*, 447
- Geology* of Cromer Cliffs, 61; of Russia, 225; of the Apennines, 278; of New South Wales, 380; of the Ponza Islands, 454; of Hastings, 455; of the Coasts of the English Channel, 456
- Georgium Sidus*, occultation of, 458
- Gmelin* on Doebereiner's eudiometer, 71
- Gompertz's* differential sextant, 458
- Gray* (J. Edw.) zoological notices, 274
- Green Feldspar*, 283
- Gregory* (Dr. O.) on the velocity of sound, 401
- Hare* (Robert, M. D.) on the galvanic deflagrator, 241; on a single-leaf electrometer, 244; on the combustion of iron by sulphur in vapour, 245; on impregnating water with iron, 245
- Harlan* (Dr. R.) on *Amphiuma means*, 325
- Harley* (C. G.), on black currant wine, 446
- Hausmann* (Prof.) on the geology of the Apennines, 278
- Hawkes's* improved anchors, 144; his improvement in capstans, 145
- Haworth* (A. H.) on *Narcisseæ*, 7, 102, 136; Cactus and *Mammillaria*, 40
- Herapath* (J.) on thermometers, 8
- Hopeite*, a new mineral, 463
- Hutton's tables*, errors in, 357, 427
- Hyalosiderite*, a new mineral, 181
- James's Powder*, 295
- India*, earthquake of 1819 in, 105, 170
- "*Infinite*." On the application of the term, 372
- Iron* in black currant wine, 447
- Ivory* (J.) on the figure of the earth, 339; on the astronomical refractions, 418; on the new tables of refraction, 261
- Kefferstein* (C.) on white copper, 119
- Kmeth* (M.) and M. Pasquich, 232
- Laplace* (M. de) *Mécanique Céleste*, 67
- Lesueur* (C. A.) on *Ascidia*, 321
- Logan Stone* in Cornwall overturned, 313
- Lowry*, Wilson, Esq. death of, 469
- MacLeay* (W. S.) on *Eistrus* and *Asilus*, 228
- Magnetic needle*, effects of caloric on, 130
- Magnetism*, apparent, of titanium, 15
- Mammillaria*, new descriptions of, 40
- Mars*, opposition of, 50, 233
- Maseres* (Baron) death of, 398
- Massotti* (M.) on the motion of comets, 457
- Mathematical information*, 68
- Megalosaurus*, 225
- Mercurial vapours*, effect of, 42
- Meteor*, 393
- Meteorite of Maine*, analysis of, 16
- Meteorites*, 233; origin of, 386
- Meteorology*, 76, 80, 149, 160, 240, 320, 400, 465, 470
- Meteors*, accompanying earthquakes, 114, 173
- Mexico*, silver mines of, 140
- Micrometer*, circular, 177, 210
- Mineral*, a new hyalosiderite, 181
- Minerals*, new analyses of, 236
- Monticelli and Covelli* on the phenomena of *Vesuvius*, 46
- Mount Rosa*, height of, 463
- Murray* (J.) on the deviation of the magnetic needle, 130
- Nails*, on the adhesion of, 168
- Narcisseæ*, new species of, 7, 102, 136
- Natural History*, works on, 57, 136, 224, 297, 375, 451
- Nautical Almanac*, 374
- Netherlands*, universities in, 237
- New South Wales*, geology of, 380
- New South Wales*, discoveries in, 459
- Estrus* of the Greeks, 228
- Organic remains* from Cromer, 82
- Orrey*, new pendent, 233
- Oxley*'s (Mr.) discoveries in New South Wales, 459
- Parallel lines*, application to them of algebraic functions, 161
- Parallel straight lines*, on, 100, 271
- Pasquich* (M.) and M. Kmeth, 232
- Patents*, 75, 148, 238, 318, 399, 473
- "*Pharmacopœia of London, 1824*," 290
- Plesiosaurus*, 138
- Pond* on the parallax of the stars, 66
- Population*, 395
- Precession*, new tables of, 392
- Pulvis antimonialis*, 295

- Pyroxene lamellar*, description of, 131 ;
analysis of, 131
Reade (Dr. J.) his theory of telescopes, 20
Refractions, astronomical, 418
Reichenbach's astronomical instruments, 427 ; his circle, 348
Russel (H.) pressure-gauge, - 92
Russia, geology of, 225
Sabine (Capt.) on the temperature of the sea, 69
Salt, faggot manufacture of, 86
Sea, Caribbean, temperature of, 69
Seaward (Sam.) steam-gauge, 36, 190
Sextant differential, 458
Silver mines of Mexico, 140
Sirex juvenicus, 299
Smith (Sir J. E.) "English Flora," notice of, 219, 284
Smith's Geological atlas, 447
Society, Royal, 59, 136, 224, 299, 378, 452 ; Linnæan, 60, 137, 228, 299, 378, 453 ; Astronomical, 61, 133, 229, 301, 382, 457 ; Horticultural, 61, 300, 379, 457 ; Meteorological, 61, 140, 383 ; Medico-botanical, 62, 302 ; Royal Academy of Sciences, Paris, 62, 305 ; Geological, 137, 225, 380, 454 ; Medical Society of London, 302 ; Asiatic : Question relative to the charter, 303 ; of naturalists of Moscow, 386 ; Moscow Agricultural, 388
Sodalite, action of light on, 464
Sound, on the velocity of, 401
Spinelle of Ceylon, gangues of, 30
Steam, measure of the force of, 259
Steam navigation to India, 393
Steam pressure-gauge, 36
Struve (Prof.) on the parallax of the stars, 66
Sturgeon (W.) electro-magnetical experiments, 95 ; his electro- and thermomagnetical experiments, 266, 269
Tabanus, 228
Tables of refraction, on the new, 261
Taylor (Rich.) on Cromer Cliffs, 81
Telescopes, Dr. Reade's theory of, 20
Temperature of the Caribbean Sea, 69
Thunberg's cabinet of entomology, 74
Thermo-magnetic experiments, 266
Thermometers, irregularities of, 8 ; methods of ascertaining the corrections of the readings of, 307
Tiarks (Dr.) on the figure of the earth, 15
Titanium, magnetism of, 15
Tredgold (T.) on the strength of cast-iron, 52
Turquoise, mines of, 455
Vanuxem (L.) on lamellar pyroxene, 131
Velocity of sound, 401
Vesuvius, phenomena of, &c. 46
Vigors (N. A.) on natural affinities of birds, 453
Universities in the Netherlands, 237
Voyage of Discovery, French, 235
Utting (J.) on Hutton's tables, 427
Walchner (Dr.) on hyalosiderite, 181
Walsh (John) on parallel straight lines, 100, 271 ; on the circle, 368 ; on the binomial calculus, 443
Webster (J. W.) on the meteorite of Maine, 16
Weights, standard, 237
Wernerian Transactions, 449
Wheat, history of its prices, &c. 56
White copper, 119 ; analysis of the ore, 120 ; of China, 128
Wiseman (W.) on Dr. Young's method of gauging, 415
Wollaston on the magnetism of titanium, 15
Young (Dr.) new method of gauging, 415
Zahrtman on instrument-makers at Paris, 252
Zoological notices, 274
Zoological Journal, 375, 451
Zoophytes, on the characters of, 274

END OF THE SIXTY-THIRD VOLUME.



LONDON:

PRINTED BY RICHARD TAYLOR, SHOE-LANE.

1824.

Just published, in one thick volume, Price 10s. 6d. boards,

SKETCHES of the PHILOSOPHY of APPARITIONS; or An Attempt to trace such Illusions to their Physical Causes.

By SAMUEL HIBBERT, M.D., F.R.S.E.,

Secretary to the Society of Scottish Antiquaries, Member of the Royal Medical and Wernerian Societies of Edinburgh, of the Philosophical Society of Manchester, &c.

Published by Oliver and Boyd, Edinburgh; and G. and W. B. Whittaker, London.

PHARMACOPŒIA LONDINENSIS,

Iterum recognita et retractata, 1824, p. 6.

“ACIDUM ACETICUM FORTIUS,”

vel

“*Acidum Aceticum è Ligno destillatum.*”

PURE CONCENTRATED ACETIC ACID, agreeable to the Sample furnished at the request of the Committee of the Royal College of Physicians, may be had of the Manufacturers, BEAUFOY & CO. South Lambeth, London.

ENGRAVINGS.

Vol. LIX. A Plate illustrative of Mrs. IBBETSON's Paper On the Flower-buds of Trees passing through the Wood.—A Plate descriptive of the Instruments employed in determining Altitudes from the Trigonometrical Station on Rumbles Moor, Yorkshire.—A Plate illustrative of Mr. IVORY's Theory of Parallel Lines in Geometry; Mr. LEESON's Safety Blowpipe Appendages; Mr. MOORE's new Apparatus for restoring the Action of the Lungs in Cases of suspended Respiration; and Dr. READE's Communication on Refraction.—A Plate illustrative of a curious Electro-magnetic Experiment by Mr. BARLOW; and Mrs. IBBETSON's Paper on the Perspiration alleged to take place in Plants.—A Plate illustrative of Mr. MARSH's Paper on a particular Construction of M. AMPERE's Rotating Cylinder.

Vol. LX. A Plate illustrative of Mrs. IBBETSON's Paper On the Pollen of Flowers.—A Plate illustrative of a Paper by Mr. R. TAYLOR, of Norwich, on Fossil Bones from the Norfolk Coast.—A Plate illustrative of a Paper by F. BAILY, Esq. on the Stars forming the Pleiades.—A Plate illustrative of Prof. AMICI's New Sextant.

Vol. LXI. Engravings—1. Illustrative of Mr. TREGGOLD's Paper on the Flexure of Astronomical Instruments.—2. DEURBROUCC and NICHOLS' Apparatus for Madame GERVAIS' New Method of Fermentation.—A Plate illustrative of Mr. R. TAYLOR's Geological Section of Hunstanton Cliff, Norfolk.—A Plate illustrative of Mr. TATUM's Communication on Electro-Magnetism.

Vol. LXII. A Plate illustrative of Professor HARE's Communications on Electricity, and on the Self-acting Blowpipe.—A Plate illustrative of Mr. BRUNEL's new Mode of Tunnelling, and of his Proposal for a Roadway under the Thames.—A Plate illustrative of M. BECQUEREL's Experiments on the Development of Electricity by Pressure.—A Plate illustrative of Mr. BARLOW's Experiments on Mr. MARSH's Thermo-Electric Apparatus.—A Plate illustrative of Mr. SEAWARD's Observations on Suspension Chain Bridges.

Vol. LXIII. A Plate illustrative of Mr. GOMPERTZ's Method of defending Ships and Fortifications; and a Cut of Mr. SEAWARD's Pressure Gauge.—A Plate illustrative of Mr. RICHARD TAYLOR's Paper on the Upper Marine Formation in the Cliffs near Cromer.



CONTENTS OF NUMBER 311.

XXVIII. On the Application of Algebraic Functions to prove the Properties of Parallel Lines	page 161
XXIX. Experiments on the Adhesion of Nails. By B. BEVAN, Esq.	168
XXX. Papers relating to the Earthquake which occurred in India in 1819.....	170
XXXI. On the Circular Micrometer. By F. BAILY, Esq. F.R.S.	177
XXXII. Mineralogical and Chemical Examination of Hyalosite, a new Mineral. By Dr. WALCHNER, of Freiburg in the Breisgau	181
XXXIII. On High-pressure Gauges. By Mr. SAM. SEAWARD ..	190
XXXIV. Memoir on the Variations of the Reflective, Refractive and Dispersive Powers of the Atmosphere, &c. By T. FORSTER, M.B. F.L.S. Member of the Astronomical and the Meteorological Societies of London, and Corresponding Member of the Academy of Natural Sciences at Philadelphia, &c.	192
XXXV. Description of a new Micrometer. By M. FRAUENHOFER of Munich	210
XXXVI. Notices respecting New Books:—Sir J. E. Smith's English Flora: Dr. Forster's Calendar	219
XXXVII. Proceedings of Learned Societies:—Royal Society; Geological Society; Linnæan Society; Astronomical Society	224–230
XXXVIII. Intelligence and Miscellaneous Articles:—Curious Astronomical Fact; M. PASQUICH and M. KEMETH; Opposition of Mars with the Sun; New Orrery; Aërolites; Anthracite of Schuylkill in Pennsylvania; Voyage of Discovery: New Analyses of Minerals; Universities in the Netherlands; Cabinet of Standard Weights; List of New Patents; Meteorological Table	230–240

* * * Communications for this Work, received by the Editors, 38, Shoe-Lane, will meet with every attention.

This Day is published, in royal 4to, Price 3*l.* 3*s.* in Boards,

AN INTRODUCTION to PRACTICAL ASTRONOMY; containing TABLES, recently computed, for facilitating the Reduction of Celestial Observations; and a popular Explanation of their Construction and Use.

By the Rev. W. PEARSON, LL.D. F.R.S. &c.

Rector of South Kilworth, Leicestershire, and Treasurer to the Astronomical Society of London.

“The labour of an Astronomer, in reducing his observations, is so great, that the construction of *convenient* Tables is a matter of considerable importance.”

WOODHOUSE. [*Astron.* vol. i. p. 285.]

London: printed for the Author, and sold by Messrs. Longman, Hurst, Rees, Orme, Brown, and Green.

This day is published, in 8vo, with a Plate and a new Map constructed from the best authorities, price 12*s.* boards,

SELECTIONS from the WORKS of the BARON DE HUMBOLDT, relating to the Climate, Inhabitants, Productions, and Mines of MEXICO, with Notes and an Introduction.

By JOHN TAYLOR, Esq.,

Treasurer to the Geological Society, &c.

Printed for Longman, Hurst, Rees, Orme, Brown, and Green.

This work is intended to communicate information on these interesting subjects, and particularly to those who may be investing Capital in the Mines of New Spain, or to others who may contemplate a residence in the country. Some recent and original communications will be found in the work.

CATON ON DEBILITY, ILLUSTRATED WITH CASES.

This day was published, price 3*s.* 6*d.*, a New Edition of

PRACTICAL OBSERVATIONS on the DEBILITIES, natural and contracted, of the GENERATIVE ORGANS of both Sexes; including Remarks on Onanism, Seminal Weakness, Nocturnal Emission, Gleet, Tabes Dorsalis, Fluor Albus, &c. with the Theory of Generation.

By T. M. CATON, Surgeon,

No. 6, Norfolk-street, Strand;

Late of the United Hospitals of St. Thomas and Guy.

Printed for C. Chapple, 59, Pall-mall; Bowen, 315, Oxford-street; Callow and Wilson, 16, Princes-street, Soho; or by the Author, as above.

Where may be had,

Caton on the Venereal Disease and its Consequences, a New Edition, price 5*s.* illustrated with Cases: A Practical Treatise on the Prevention and Cure of the Venereal Disease, exhibiting the character, symptoms, and treatment of the diseases immediately or remotely connected with it; containing Observations on Gleet, Stricture, Mucal Discharges, the use of the Caustic and common Bougie, Cutaneous Eruptions, Imaginary Venereal Diseases, &c. &c. comprising an Elementary Work for Students, and a Guide to the general Reader; interspersed with select Prescriptions applicable to each division of the Disease.

CONTENTS OF NUMBER 312.

XXXIX. Letter from ROBERT HARE, M.D. Professor of Chemistry in the University of Pennsylvania, to B. SILLIMAN, Professor of Chemistry in Yale College, on some improved Forms of the Galvanic Deflagrator; on the Superiority of its deflagrating Power: Also, an Account of an improved Single-leaf Electrometer; of the Combustion of Iron by a Jet of Sulphur in Vapour; and of an easy Mode of imitating native Chalybeate Waters	page 241
XL. Further Remarks on the Theory of Parallel Lines.....	246
XLI. On the Mathematical and Astronomical Instrument Makers at Paris. By Lieut. ZAHRTMANN.....	252
XLII. Suggestions regarding some probable Sources of Error in the usual Modes of ascertaining the Force of Steam.....	259
XLIII. Remarks on an Article published in No. 23 of the Journal of Science, and treating of the New Tables of Refraction. By J. IVORY, Esq. M.A. F.R.S.	261
XLIV. Electro- and Thermo-magnetical Experiments. By Mr. WILLIAM STURGEON.....	266
XLV. Description of a Rotative Thermo-magnetical Experiment, By Mr. WILLIAM STURGEON.	269
XLVI. On Parallel Straight Lines. By JOHN WALSH, Esq.....	271
XLVII. Zoological Notices. By Mr. JOHN EDWARD GRAY. ..	274
XLVIII. Analysis of Professor HAUSMANN'S Essay on the Geology of the Apennines.....	278
XLIX. Chemical Examination of Green Feldspar from Beverly, Massachusetts. By J. W. WEBSTER, M.D.....	283
L. Notices respecting New Books:—Sir J. E. SMITH'S English Flora; PHILLIPS'S Translation of the London Pharmacopœia; Analysis of Periodical Works of Natural History.....	284—299
LI. Proceedings of Learned Societies:—Royal Society; Linnæan Society; Horticultural Society; Astronomical Society; Medicobotanical Society; Medical Society of London; Asiatic Society—Question relative to the Charter; Royal Academy of Sciences at Paris.....	299—307
LII. Intelligence and Miscellaneous Articles:—BESSEL'S Method of ascertaining the Corrections of the Readings of Thermometers; Elements of the Comet of 1823—24, by various Computers; Anomaly in the Figure of the Earth; The Rate of a Chronometer varies with the Density of the Medium in which it is placed; Note on the Existence of a Nitrate and a Salt of Potash in Cheltenham Water, by M. FARADAY, &c.; The Logan Stone in Cornwall overturned; Obituary—Mr. JOHN FORBES; Calendar of Flora, Fauna, and Pomona, at Hartfield in Sussex; Additions to Professor HARE'S Paper; List of New Patents; Meteorological Table, &c.....	307—320

* * Communications for this Work, received by the Editors, 38, Shoe-Lane, will meet with every attention.

Vol. LVI. A Plate illustrative of Mrs. IBBETSON's Paper On the Phy-
siology of Botany.—A Plate illustrative of Mr. HALL's Percussion Gun-
ck; of Dr. KITCHINER's Pancreatic Eye-Tube; and of Mr. PARK's
Improving Blocks.—A Plate exhibiting Sections, &c. of Mr. MALAM's im-
proved Gas-Meter.—A Plate exhibiting the Discoveries made by Capt.
MURRAY in the Polar Sea.

Vol. LVIII. A Plate illustrative of Mr. GEO. INNES's Calculations of
the Annular Eclipse of the Sun, which will happen on the 15th of May
1836.—A Plate descriptive of the Hydrostatic Balances of ISAIAH
WALKERS and Dr. COATES.—A Plate illustrative of "An Introduction to
the Knowledge of Funguses."—A Plate illustrative of Professor DAVY's
Spectrometer, and of Mr. JOHN MURRAY's portable Apparatus for restor-
ing the Action of the Lungs.—A Plate by PORTER, illustrative of Mr.
HOOLCRAFT's Account of the Native Copper on the Southern Shore of
Lake Superior; and of Dr. MILLAR's Observations and Experiments on
the Rose of Jericho.—With a PORTRAIT of the EDITOR, engraved by
J. TOMSON from a Painting by FRAZER;—and a Plate by PORTER, illus-
trative of Mr. LEESON's Appendage to TOFFT's Blowpipe.

Vol. LIX. A Plate illustrative of Mrs. IBBETSON's Paper On the
Growth-buds of Trees passing through the Wood.—A Plate descriptive
of the Instruments employed in determining Altitudes from the Trigonometrical
Station on Rumbles Moor, Yorkshire.—A Plate illustrative of
Mr. IVORY's Theory of Parallel Lines in Geometry; Mr. LEESON's Safety
Blowpipe Appendages; Mr. MOORE's new Apparatus for restoring the
Action of the Lungs in Cases of suspended Respiration; and Dr. READE's
Communication on Refraction.—A Plate illustrative of a curious Electro-
magnetic Experiment by Mr. BARLOW; and Mrs. IBBETSON's Paper on
the Perspiration alleged to take place in Plants.—A Plate illustrative of
Mr. MARSH's Paper on a particular Construction of M. AMPERE's Rotating
Cylinder.

Vol. LX. A Plate illustrative of Mrs. IBBETSON's Paper On the Pollen
of Flowers.—A Plate illustrative of a Paper by Mr. R. TAYLOR, of Nor-
wich, on Fossil Bones from the Norfolk Coast.—A Plate illustrative of a
Paper by F. BAILY, Esq. on the Stars forming the Pleiades.—A Plate
illustrative of Prof. AMICI's New Sextant.

Vol. LXI. Engravings—1. Illustrative of Mr. TREDGOLD's Paper on
the Flexure of Astronomical Instruments.—2. DEURBROUCC and NI-
COLS' Apparatus for Madame GERVAIS' New Method of Fermentation.
—A Plate illustrative of Mr. R. TAYLOR's Geological Section of Hun-
stanton Cliff, Norfolk.—A Plate illustrative of Mr. TATUM's Communi-
cation on Electro-Magnetism.

Vol. LXII. A Plate illustrative of Professor HARE's Communications
on Electricity, and on the Self-acting Blowpipe.—A Plate illustrative
of Mr. BRUNEL's new Mode of Tunnelling, and of his Proposal for a
Roadway under the Thames.—A Plate illustrative of M. BECQUEREL's
Experiments on the Development of Electricity by Pressure.—A Plate
illustrative of Mr. BARLOW's Experiments on Mr. MARSH's Thermo-
electric Apparatus.—A Plate illustrative of Mr. SEAWARD's Observa-
tions on Suspension Chain Bridges.

Vol. LXIII. A Plate illustrative of Mr. GOMPERTZ's Method of de-
termining Heights of Ships and Fortifications; and a Cut of Mr. SEAWARD's Pressure
Gauge.—A Plate illustrative of Mr. RICHARD TAYLOR's Paper on the
Upper Marine Formation in the Cliffs near Cromer.—A Plate illustrative
of Dr. WALCHNER's Examination of a new Mineral named Hyalosiderite;
and of Mr. BAILY's and M. FRAUENHOFER's Accounts of the Circular
Micrometer.—A Plate illustrative of Professor HARE's Single-leaf Elec-
trometer and improved Deslagnators.

CONTENTS OF NUMBER 312.

XXXIX. Letter from ROBERT HARE, M.D. Professor of Chemistry in the University of Pennsylvania, to B. SILLIMAN, Professor of Chemistry in Yale College, on some improved Forms of the Galvanic Deflagrator; on the Superiority of its deflagrating Power: Also, an Account of an improved Single-leaf Electrometer; of the Combustion of Iron by a Jet of Sulphur in Vapour; and of an easy Mode of imitating native Chalybeate Waters	page 241
XL. Further Remarks on the Theory of Parallel Lines.....	246
XLI. On the Mathematical and Astronomical Instrument Makers at Paris. By Lieut. ZAHRTMANN.....	252
XLII. Suggestions regarding some probable Sources of Error in the usual Modes of ascertaining the Force of Steam.....	259
XLIII. Remarks on an Article published in No. 23 of the Journal of Science, and treating of the New Tables of Refraction. By J. IVORY, Esq. M.A. F.R.S.	261
XLIV. Electro- and Thermo-magnetical Experiments. By Mr. WILLIAM STURGEON.....	266
XLV. Description of a Rotative Thermo-magnetical Experiment, By Mr. WILLIAM STURGEON.	269
XLVI. On Parallel Straight Lines. By JOHN WALSH, Esq.....	271
XLVII. Zoological Notices. By Mr. JOHN EDWARD GRAY. ..	274
XLVIII. Analysis of Professor HAUSMANN'S Essay on the Geology of the Apennines.....	278
XLIX. Chemical Examination of Green Feldspar from Beverly, Massachusetts. By J. W. WEBSTER, M.D.....	283
L. Notices respecting New Books:—Sir J. E. SMITH'S English Flora; PHILLIPS'S Translation of the London Pharmacopœia; Analysis of Periodical Works of Natural History.....	284—299
LI. Proceedings of Learned Societies:—Royal Society; Linnæan Society; Horticultural Society; Astronomical Society; Medico-Botanical Society; Medical Society of London; Asiatic Society—Question relative to the Charter; Royal Academy of Sciences at Paris.....	299—307
LII. Intelligence and Miscellaneous Articles:—BESSEL'S Method of ascertaining the Corrections of the Readings of Thermometers; Elements of the Comet of 1823—24, by various Computers; Anomaly in the Figure of the Earth; The Rate of a Chronometer varies with the Density of the Medium in which it is placed; Note on the Existence of a Nitrate and a Salt of Potash in Cheltenham Water, by M. FARADAY, &c.; The Logan Stone in Cornwall overturned; Obituary—Mr. JOHN FORBES; Calendar of Flora, Fauna, and Pomona, at Hartfield in Sussex; Additions to Professor HARE'S Paper; List of New Patents; Meteorological Table, &c.....	307—320

Vol. LVI. A Plate illustrative of Mrs. IBBETSON's Paper On the Physiology of Botany.—A Plate illustrative of Mr. HALL's Percussion Gun-ock; of Dr. KITCHINER's Pancreatic Eye-Tube; and of Mr. PARK's Flooring Blocks.—A Plate exhibiting Sections, &c. of Mr. MALAM's improved Gas-Meter.—A Plate exhibiting the Discoveries made by Capt. HARRY in the Polar Sea.

Vol. LVIII. A Plate illustrative of Mr. GEO. INNES's Calculations of the Annular Eclipse of the Sun, which will happen on the 15th of May 1836.—A Plate descriptive of the Hydrostatic Balances of ISAIAH WUKENS and Dr. COATES.—A Plate illustrative of "An Introduction to the Knowledge of Funguses."—A Plate illustrative of Professor DAVY's Sacrometer, and of Mr. JOHN MURRAY's portable Apparatus for restoring the Action of the Lungs.—A Plate by PORTER, illustrative of Mr. SCHOOLCRAFT's Account of the Native Copper on the Southern Shore of Lake Superior; and of Dr. MILLAR's Observations and Experiments on the Rose of Jericho.—With a PORTRAIT of the EDITOR, engraved by THOMSON from a Painting by FRAZER;—and a Plate by PORTER, illustrative of Mr. LEESON's Appendage to TOFFT's Blowpipe.

Vol. LIX. A Plate illustrative of Mrs. IBBETSON's Paper On the Lower-buds of Trees passing through the Wood.—A Plate descriptive of the Instruments employed in determining Altitudes from the Trigonometrical Station on Rumbles Moor, Yorkshire.—A Plate illustrative of Mr. IVORY's Theory of Parallel Lines in Geometry; Mr. LEESON's Safety Blowpipe Appendages; Mr. MOORE's new Apparatus for restoring the Action of the Lungs in Cases of suspended Respiration; and Dr. READE's Communication on Refraction.—A Plate illustrative of a curious Electro-magnetic Experiment by Mr. BARLOW; and Mrs. IBBETSON's Paper on the Perspiration alleged to take place in Plants.—A Plate illustrative of Mr. MARSH's Paper on a particular Construction of M. AMPERE's Rotating Cylinder.

Vol. LX. A Plate illustrative of Mrs. IBBETSON's Paper On the Pollen of Flowers.—A Plate illustrative of a Paper by Mr. R. TAYLOR, of Norwich, on Fossil Bones from the Norfolk Coast.—A Plate illustrative of a Paper by F. BAILY, Esq. on the Stars forming the Pleiades.—A Plate illustrative of Prof. AMICI's New Sextant.

Vol. LXI. Engravings—1. Illustrative of Mr. TREGOLD's Paper on the Flexure of Astronomical Instruments.—2. DEURBROUCCQ and NICHOLS' Apparatus for Madame GERVAIS' New Method of Fermentation.—A Plate illustrative of Mr. R. TAYLOR's Geological Section of Hunstanton Cliff, Norfolk.—A Plate illustrative of Mr. TATUM's Communication on Electro-Magnetism.

Vol. LXII. A Plate illustrative of Professor HARE's Communications on Electricity, and on the Self-acting Blowpipe.—A Plate illustrative of Mr. BRUNEL's new Mode of Tunnelling, and of his Proposal for a Roadway under the Thames.—A Plate illustrative of M. BECQUEREL's Experiments on the Development of Electricity by Pressure.—A Plate illustrative of Mr. BARLOW's Experiments on Mr. MARSH's Thermo-Electric Apparatus.—A Plate illustrative of Mr. SEAWARD's Observations on Suspension Chain Bridges.

Vol. LXIII. A Plate illustrative of Mr. GOMPERTZ's Method of defending Ships and Fortifications; and a Cut of Mr. SEAWARD's Pressure Gauge.—A Plate illustrative of Mr. RICHARD TAYLOR's Paper on the Upper Marine Formation in the Cliffs near Cromer.—A Plate illustrative of Dr. WALCHNER's Examination of a new Mineral named Hyalosiderite; and of Mr. BAILY's and M. FRAUENHOFER's Accounts of the Circular Micrometer.—A Plate illustrative of Professor HARE's Single-leaf Electrometer and improved Deflagrators.

CONTENTS OF NUMBER 313.

LIII. Descriptions of several new Species of Ascidia. By C. A. LESUEUR	page 32
LIV. Dissection of a Batrachian Animal in a living State. By RICHARD HARLAN, M.D. Professor of Comparative Anatomy to the Philadelphia Museum	32
LV. On the Dispersive Power of the Atmosphere, and on the Peculiarities of Stars. By Dr. T. FORSTER	32
LVI. Remarks on the Theory of the Figure of the Earth. By J. IVORY, Esq. M.A. F.R.S.	33
LVII. Examination of the Divisions of REICHENBACH'S Circle at the Observatory of Königsberg. By M. BESSEL.	34
LVIII. On Mr. BABBAGE'S new Machine for calculating and printing Mathematical and Astronomical Tables. From FRANCIS BAILY, Esq. F.R.S. and L.S.	35
LIX. A brief Account of some Electro-magnetic and Galvanic Experiments. By ROBERT HARE, M.D. Professor of Chemistry in the University of Pennsylvania.	36
LX. On the Circle. By JOHN WALSH, Esq.	36
LXI. On a Method of finding the Limits of the Roots of the higher Powers of Numerical Equations. By Mr. J. ROWBOTHAM.	36
LXII. On the Application of the Term " <i>Infinite</i> ."	37
LXIII. Two Lines from the Nautical Almanac, addressed to Mr. IVORY:	37
LXIV. Notices respecting New Books:—Analysis of Periodical Works on Natural History.	37
LXV. Proceedings of Learned Societies:—Royal Society; Linnean Society; Horticultural Society; Geological Society; Astronomical Society; Meteorological Society; Imperial Society of Naturalists of Moscow; Imperial Agricultural Society of Moscow.	37—39
LXVI. Intelligence and Miscellaneous Articles:—New Tables of Precession, Aberration and Nutation; Nautical Magnetic Premium; Steam Navigation to India; Steam Vessels in the Netherlands; Canals for uniting the Black Sea to the Baltic; Meteor; Earthquake felt at Sea; Earthquakes; Sinking of the Earth; Statistics; Education in Denmark; South America; Cancer; Calendar of Flora, Fauna, and Pomona, at Hartfield in Sussex; Obituary—Baron Maseres; List of New Patents; Meteorological Table, &c. . .	39—40

* * * Communications for this Work, received by the Editors, 38 Shoe-Lane, will meet with every attention.

SELTZER WATER.

THE Mineral Water of Seltzer in Germany has long been celebrated for its medicinal properties; and it is well known that the operation of this Water, at the same time that it gives a tone to the digestive organs, is so mild, that in Germany (where it is principally used) it forms one of the luxuries which is found at the tables of all the wealthy, who drink it, either in its natural state, or with wine and pounded sugar.

The Artificial Seltzer Water now prepared in this country by Dr. STRUVE of Dresden, to the perfecting of which he has paid an unremitting attention for several years, possesses in its minutest analysis, as well as operation on the stomach, all the properties of that taken immediately from the natural spring.

Sold retail by the Confectioners and Chemists in London; and wholesale at Dr. Struve's Mineral Water Agency, No. 23, Bucklersbury, London.

CATON ON DEBILITY, ILLUSTRATED WITH CASES.

This day was published, price 3s. 6d., a New Edition of PRACTICAL OBSERVATIONS on the DEBILITIES, natural and contracted, of the GENERATIVE ORGANS of both Sexes; including Remarks on Onanism, Seminal Weakness, Nocturnal Emission, Gleet, Tabes Dorsalis, Fluor Albus, &c. with the Theory of Generation.

By T. M. CATON, Surgeon,

No. 6, Norfolk-street, Strand;

Late of the United Hospitals of St. Thomas and Guy.

Printed for C. Chapple, 59, Pall-mall; Bowen, 315, Oxford-street; Callow and Wilson, 16, Princes-street, Soho; or by the Author, as above.

Where may be had,

Caton on the Venereal Disease and its Consequences, a New Edition, price 5s. illustrated with Cases: A Practical Treatise on the Prevention and Cure of the Venereal Disease, exhibiting the character, symptoms, and treatment of the diseases immediately or remotely connected with it; containing Observations on Gleet, Stricture, Mucal Discharges, the use of the Caustic and common Bougie, Cutaneous Eruptions, Imaginary Venereal Diseases, &c. &c. comprising an Elementary Work for Students, and a Guide to the general Reader; interspersed with select Prescriptions applicable to each division of the Disease.

ENGRAVINGS.

Vol. LXII. A Plate illustrative of Professor HARE's Communications on Electricity, and on the Self-acting Blowpipe.—A Plate illustrative of Mr. BRUNEL's new Mode of Tunnelling, and of his Proposal for a Roadway under the Thames.—A Plate illustrative of M. BECQUEREL's Experiments on the Development of Electricity by Pressure.—A Plate illustrative of Mr. BARLOW's Experiments on Mr. MARSH's Thermo-Electric Apparatus.—A Plate illustrative of Mr. SEAWARD's Observations on Suspension Chain Bridges.

Vol. LXIII. A Plate illustrative of Mr. GOMPERTZ's Method of defending Ships and Fortifications; and a Cut of Mr SEAWARD's Pressure Gauge.—A Plate illustrative of Mr. RICHARD TAYLOR's Paper on the Upper Marine Formation in the Cliffs near Cromer.—A Plate Illustrative of Dr. WALCHNER's Examination of a new Mineral named Hyalosiderite; and of Mr. BAILY's and M. FRAUENHOFER's Accounts of the Circular Micrometer.—A Plate illustrative of Professor HARE's Single-leaf Electrometer and improved Deflagrators.—A Plate containing two new Species of *Ascidia*; and *Amphiuma means*, a new Batrachian Animal.

CONTENTS OF NUMBER 314.

LXVII. An Account of some Experiments made in order to determine the Velocity with which Sound is transmitted in the Atmosphere. By OLINTHUS GREGORY, LL.D., Associate Acad. Dijon, Honorary Member of the Literary and Philosophical Society of New York, of the New York Historical Society, of the Cambridge Philosophical Society, &c. Secretary of the Astronomical Society of London, and Professor of Mathematics in the Royal Military Academy at Woolwich page 40

LXVIII. On the New Method of Gauging proposed by Dr. YOUNG. By Mr. W. WISEMAN 41

LXIX. Letter on the Astronomical Refractions. By J. IVORY, Esq. M.A. F.R.S. 41

LXX. On some Errors in Dr. Hutton's Tables of the Products and Powers of Numbers. By Mr. J. UTTING. 42

LXXI. Introduction to the Sixth Section of BESSEL's Astronomical Observations 42

LXXII. Some Account of the Binomial Calculus. By J. WALSH, Esq. 44

LXXIII. On Black Currant Wine. By C. G. HARLEY, Esq. ... 44

LXXIV. Notices respecting New Books:—Smith's Geological Atlas; Analysis of Periodical Works on Natural History 447—45

LXXV. Proceedings of Learned Societies:—Royal Society; Linnean Society; Geological Society; Horticultural Society; Astronomical Society; Royal Academy of Sciences of Paris. 452—45

LXXVI. Intelligence and Miscellaneous Articles:—New South Wales; Return of the Russian Antarctic Expedition; Mount Rosa, the highest in Europe; Earthquakes; Hopeite, a New Mineral; Effect of Light on the Colour of the Sodalite from Greenland; Aëronautic Ascent; Obituary—Wilson Lowry, Esq.; Meteorological Observations at Great Yarmouth; Calendar of Flora, Fauna, and Pomona, at Hartfield in Sussex; List of New Patents; Meteorological Table, &c. 459—47

Index and Contents.

*** Communications for this Work, received by the Editors, 38 Shoe-Lane, will meet with every attention.



