

LIBRARY
OF THE
UNIVERSITY
OF ILLINOIS

570

Il6c

no. 25-36

cop. 6

NATURAL HISTORY
SURVEY

NATURAL
HISTORY SURVEY
LIBRARY

Digitized by the Internet Archive
in 2010 with funding from
University of Illinois Urbana-Champaign



*P
L
E
A
S
U
R
E
W
I
T
H
P
L
A
N
T
S*

L. R. TEHON

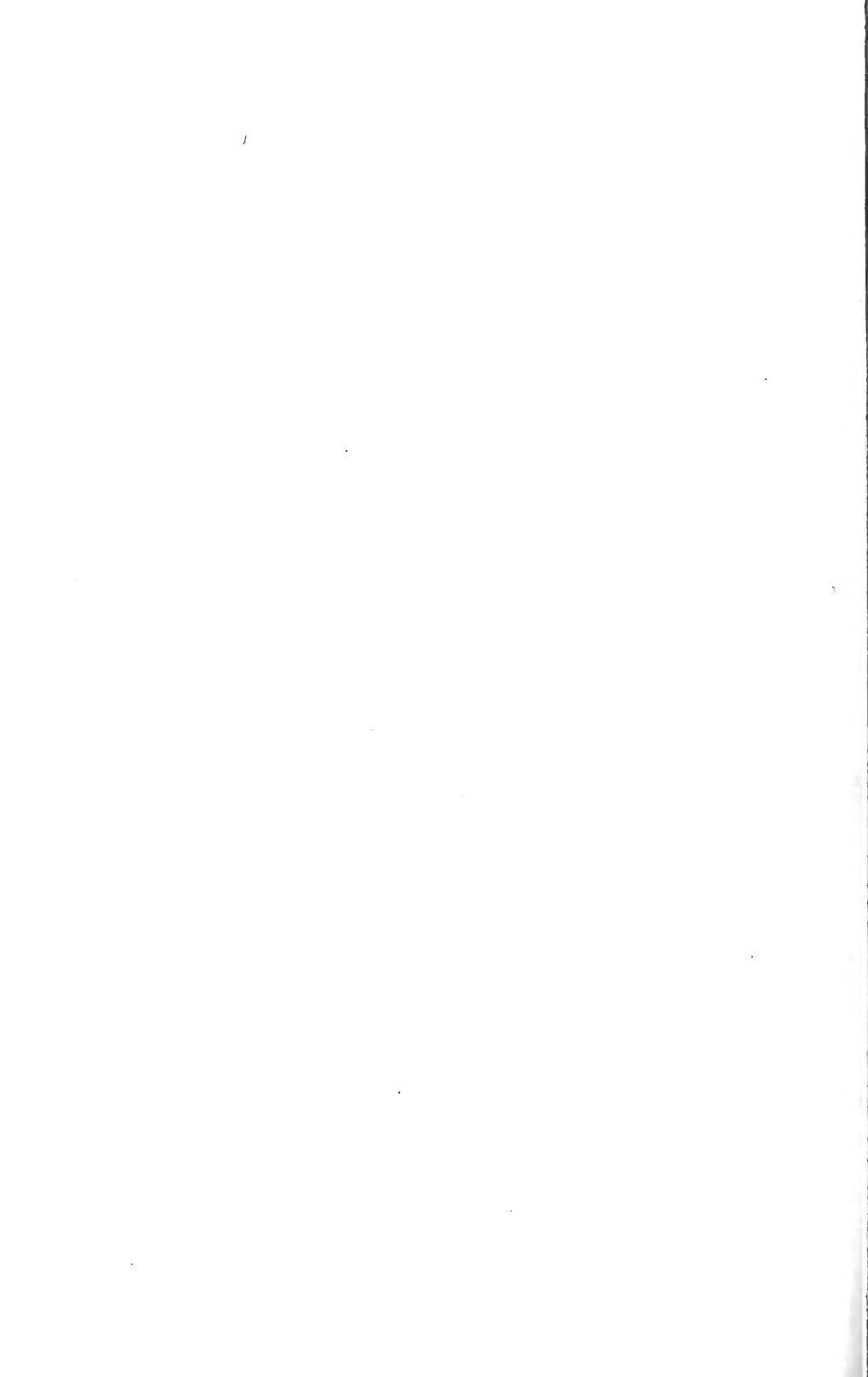

STATE OF ILLINOIS
DWIGHT H. GREEN, Governor
DEPARTMENT OF REGISTRATION AND EDUCATION
FRANK G. THOMPSON, Director

Pleasure With Plants

L. R. TEHON



Printed by Authority of the State of Illinois
NATURAL HISTORY SURVEY DIVISION
THEODORE H. FRISON, Chief

Circular 32
(Second Printing, With Revisions)

Urbana

THE UNIVERSITY OF ILLINOIS

November, 1942

JAN 23 1948

UNIVERSITY OF ILLINOIS

STATE OF ILLINOIS
DWIGHT H. GREEN, *Governor*
DEPARTMENT OF REGISTRATION AND EDUCATION
FRANK G. THOMPSON, *Director*

BOARD OF NATURAL RESOURCES AND CONSERVATION
FRANK G. THOMPSON, *Chairman*

WILLIAM TRELEASE, D.Sc., LL.D., *Biology* ARTHUR CUTTS WILLARD, D.Eng., LL.D.,
EZRA J. KRAUS, Ph.D., D.Sc., *Forestry* *President of the University of Illinois*
L. R. HOWSON, B.S.C.E., C.E., *Engineering* EDSON S. BASTIN, Ph.D., *Geology*
ROGER ADAMS, Ph.D., D.Sc., *Chemistry*

NATURAL HISTORY SURVEY DIVISION
Urbana, Illinois

SCIENTIFIC AND TECHNICAL STAFF

THEODORE H. FRISON, Ph.D., *Chief*

Section of Economic Entomology

W. P. FLINT, B.S., *Chief Entomologist*
C. C. COMPTON, Ph.D., *Associate Entomologist*
M. D. FARRAR, Ph.D., *Research Entomologist*
J. H. BIGGER, M.S., *Associate Entomologist*
S. C. CHANDLER, B.S., *Southern Field Entomologist*
JAMES W. APPLE, M.S., *Northern Field Entomologist*
B. G. BERGER, M.A., *Assistant Entomologist*
H. B. PETTY, JR., B.A., *Assistant, Entomology Extension*
J. E. PORTER, B.A., *Entomological Assistant*
C. J. WEINMAN, Ph.D., *Research Fellow in Entomology*
GEORGE F. LUDVIK, B.A., *Research Fellow in Entomology*
J. M. MAGNER, B.A., *Junior Entomologist (U.S.B.E.P.Q. and Commodity Credit Corporation, cooperating)*

Section of Insect Survey

H. H. ROSS, Ph.D., *Systematic Entomologist*
CARL O. MOHR, Ph.D., *Associate Entomologist, Artist (on leave)*
B. D. BURKS, Ph.D., *Assistant Entomologist (on leave)*
G. T. RIEGEL, M.S., *Entomological Assistant*
KATHRYN M. SOMMERMAN, M.S., *Artist, Entomological Assistant*

Section of Forestry

JAMES E. DAVIS, M.F., *Extension Forester*
LEE E. YEAGER, Ph.D., *Forester*

Section of Aquatic Biology

DAVID H. THOMPSON, Ph.D., *Zoologist*
GEORGE W. BENNETT, Ph.D., *Limnologist*
D. F. HANSEN, Ph.D., *Assistant Zoologist*
BRUNO LIMBACH, M.S., *Zoological Assistant*

Section of Game Research and Management

R. E. YEATTER, Ph.D., *Game Specialist*

Section of Wildlife Experimental Areas

ARTHUR S. HAWKINS, M.S., *Game Technician (on leave)*
F. C. BELLROSE, JR., B.S., *Assistant Game Technician*
J. B. LOW, Ph.D., *Assistant Game Technician*
W. H. ELDER, Ph.D., *Assistant Game Technician*

Cooperative Wildlife Restoration Program

(*State Department of Conservation and U. S. Fish and Wildlife Service*)

HARRY G. ANDERSON, M.A., *Junior Biologist*
L. G. BROWN, B.S., *Junior Biologist*
R. E. HESSELSCHWERDT, B.A., *Junior Biologist*
C. S. SPOONER, JR., M.F., *Junior Biologist*

Section of Applied Botany and Plant Pathology

L. R. TEHON, Ph.D., *Botanist*
D. B. CREAGER, Ph.D., *Research Pathologist*
J. C. CARTER, Ph.D., *Assistant Botanist*
G. H. BOEWE, M.S., *Field Botanist*

Section of Publications

JAMES S. AYARS, B.S., *Technical Editor*

CONSULTANT: Herpetology, HOWARD K. GLOYD, Ph.D., *Director of the Museum, Chicago Academy of Sciences*

This paper is a contribution from the Section of Applied Botany and Plant Pathology.

370
Ilbc
no. 32
1942
Cop 6

CONTENTS

	PAGE
What Is Botanizing?.....	1
Ways to Botanize.....	2
Where to Botanize.....	2
When to Botanize.....	4
How to Botanize.....	4
The purpose of collecting—Equipment for collecting—The vasculum—Use of the vasculum—The digging tool—The notebook—Keeping notes—What constitutes a specimen?—The plant press—Using the plant press	
Studying Plants.....	15
How to name plants—Botanical keys—Using analytical keys—Plant names	
Equipment for Studying Plants.....	19
Books—Tools—Magnifiers—Ruler—Dissecting Needles—Forceps—Watchglasses—Test tubes—Scalpels—How to work with dried blossoms	
The Herbarium.....	23
Preparing a herbarium specimen—Specimen labels—Arranging the herbarium—The herbarium case—Preventing insect damage	
Conclusion.....	30
Useful Books.....	30
Manuals—Handbooks and floras—Textbooks—Other books	
Maps.....	32

Frontispiece by Ray R. Hamm; line drawings by Carl O. Mohr and R. E. Favreau



The May Apple, *Podophyllum peltatum* L.

Pleasure With Plants ☼☼

☼☼☼ L. R. TEHON

THE STUDY OF PLANTS is an occupation from which many persons interested in nature derive much pleasure. The majority of these persons pursue this study in their spare time, regarding it as an avocation to which they may turn at will. They find in it, the year around, an intensely interesting employment which encourages them to spend many hours in the open, stimulates mental alertness and, in rare cases, yields some pecuniary return. And, what is more important, they find that by continuing their interest in it they are able both to make worthwhile contributions to botanical knowledge and to gain for themselves that personal satisfaction that accrues from the amassing of a collection.

The value to science of the enthusiastic devotion of these non-professional individuals to botanizing in local and even wider territories is inestimable. Indeed, it is desirable on this account that many more persons than are now so engaged should take up the study of plants. So an attempt has been made to explain in these pages what is necessary and desirable for a prospective amateur botanizer to know and do in order to achieve results gratifying to himself and useful to the world at large.

What Is Botanizing?

Although in a simple sense botanizing is merely seeking for plants, to the enthusiastic botanizer it has a much broader meaning. It includes, besides searching for plants, the entire process of learning to recognize and classify them, of collecting and preserving specimens of them, and of accumulating and interpreting information about them.

A set of rather well standardized methods has grown out of the long experience of professional and amateur students of plants. These methods have come into such general use that they constitute a sort of technique. So essential are they to a realization of the fullest possibilities of botanizing that they may reasonably be regarded as a definite part of botanizing itself.

The beginner in botanizing should master this technique, at least to the minimum extent suggested in later paragraphs but preferably in its full detail. There is a reason for each of its requirements; but it is a lenient technique, with much leeway for adaptation to individual needs. As the botanizer progresses in his work with plants, he is likely to find that no small part of his pleasure comes directly from his mastery of technique.

Ways to Botanize

A great deal of satisfaction can be obtained from studying plants even when only a small amount of time can be spent at the task. A person so restricted may find himself limited to learning to use accurately the common names of plants. But one with more time to spend may supplement this knowledge by learning the corresponding technical or Latin names and may even extend his comprehension of plants to an understanding of their classification, their habitat preferences, their life histories and their relation to and dependence upon light, soil and moisture.

If he has sufficient leisure, the amateur botanizer may go so far as to develop a personal plant collection or herbarium. He may do this quite simply, including only specimen material of outstanding value or interest. Or he may develop a pretentious herbarium which not only exhibits a multitude of plant species but also substantiates by specimens the occurrence and distribution of each species, and the character of its flowers, fruit and variations.

Where to Botanize

Perhaps the best place for a person to begin botanizing is on the grounds around his own home. Although the lawn and the garden are not usually thought of as places for wild plants, dandelions, chickweeds, plantains and many others persist there successfully. These plants are excellent material with which to practice the technique of botanizing. They also present intriguing problems in classification and manifest to observing eyes fine illustrations of biological adaptation.

After this introduction to the methods of botanizing,

the beginner should select some small area that is interesting to him and that appears to contain a considerable variety of plants. This area need not be so much as a square mile in extent, if it includes a small stream or river bank and has some distinctive physiographic feature or some variety of terrain. An unsuspectedly large number of plant species is certain to grow in such a place. Seeking out all these species will sharpen the botanizer's powers of observation. Naming and classifying them will furnish an introduction to most of the large plant families and to many interesting small families.

Many valuable botanical contributions have been made as a result of careful botanizing in such small areas. Three contributions of this kind that have been made on the basis of studies in Illinois are Pepoon's *Cliff Flora of Jo Daviess County* (1909), Thone's *List of Plants at Starved Rock* (1924) and Stover's *A Mesophytic Ravine* (1930).

As the botanizer grows in experience and knowledge, he may find it possible to attempt more comprehensive studies. This generally means that he will botanize over a larger territory, such as a region comprising several townships, a county, a unified vegetative region or even a state. The product of such work in Illinois is exemplified by Lapham's *Catalogue of the Plants of the State of Illinois* (1857), Brendel's *Flora Peoriana* (1887), Gates's *Contributions to the Flora of Hancock County, Illinois* (1925), and Pepoon's *Annotated Flora of the Chicago Area* (1927).

Knowledge gained from careful botanizing in small areas may likewise arouse curiosity regarding special groups of plants. The botanizer may be prompted to undertake a thorough study of some genus, such as the willows or the sunflowers, or of plants inhabiting distinctive kinds of situations, such as sand dunes or bogs. To carry on such studies comprehensively, he should extend the range of his collecting over the widest possible geographical territory and secure the help of other botanists in territories he himself cannot visit.

From the specialized efforts of amateur botanizers, real contributions have been made to botanical science. Many of the hawthorn species became known through the work of E. J. Hill in northeastern Illinois between 1900 and 1904. The present understanding of the taxonomy of willows is based

to an appreciable degree on the willow collection accumulated by M. S. Bebb of Rockford, Illinois, around 1860. Much of the knowledge concerning sand-inhabiting vegetation and bog floras in Illinois has been accumulated by professional botanists who, for relaxation from teaching, have turned to the stimulating occupation of botanizing.

When to Botanize

Field work, which is so important a part of botanizing, can easily be continued throughout the year. Spring usually is looked upon as the time when plants blossom, summer as their time of growth, autumn as their time for fruiting and winter as their time for rest. Actually, however, different kinds of plants come into blossom continually from early spring until late fall, and fruits are maturing throughout the year. Even in winter, when woody plants in our region are leafless, it is possible to study buds, leaf-scars and other dormant structures of trees and shrubs, which often furnish characteristics more reliable for identification than those shown by variable summer structures. Changing seasons thus present the botanizer with an almost endless variety of plants and plant conditions.

In winter the botanizer also has an opportunity to name the plant specimens he collected during the growing season, to prepare these specimens for his herbarium and to arrange them in it. He may also find leisure at this time to review the notes he made in the field, to make close and detailed comparisons of plant species he has found difficulty in distinguishing, to read some of the informative and inspiring books on botany and to plan what he will do the coming season.

How to Botanize

Even in its simplest form botanizing consists of two phases. One is finding and observing plants out of doors. The other is learning facts about them. These phases are not distinct. They overlap and are interrelated in so many ways that directions given for one phase almost invariably contain suggestions pertinent to the other.

The directions that follow are intended to be sufficient as to technique to enable an amateur to do, within his per-

sonal limitations, work as fine as could be done by the professional botanist. However, many persons will not have the time, resources or interest to be so thorough. For these persons procedures are suggested by which they still can derive a large amount of pleasure from botanizing.

The Purpose of Collecting—The botanizer collects a plant specimen primarily to identify it accurately. Since identification in the field is often extremely difficult with such equipment as the botanizer can carry with him, the specimen is taken home for close and careful study. When such a specimen is properly preserved, it becomes a permanent record of the botanizer's work in collecting and identifying.

Of course it is possible to botanize without collecting. Or, if collecting is done for identification alone, only as much of a plant need be taken as is necessary for its identification. A common method of keeping permanent memorandums of such plants is that of noting on the margin of the manual page, beside the description of the species, where and when each plant was found.

Complete specimens, if carefully taken and preserved, are far superior to written notes and, for reference, are next in exactness to living plants. Because of this, the enthusiastic botanizer collects and preserves specimens of all the kinds of plants he finds and uses them for comparison when naming species distinguished by minute or critical differences, or he refers to them as a means of refreshing his memory.

Accurate naming of plants belonging to some groups requires at the outset the critical judgment of a specialist. Specimens that have been submitted to an expert for naming serve as authoritative standards, which the amateur will find very useful in making subsequent determinations of his own.

If the botanizer has opportunity to collect in unexplored regions, is able to establish rare occurrences of plants or makes representative collections in special regions, he may be able to sell sets of specimens to museums and institutional herbaria. The returns from such sales may be sufficient to defray part of the cost of his travels, equipment or materials. Only rarely will they represent a real profit.

Equipment for Collecting—Permanent equipment for collecting usually consists of a vasculum, a notebook, a digging tool and a plant press. Although good collecting can be done

without any of these items, it can be done more conveniently with them.

The Vasculum—A vasculum is the carrying case in which a botanizer stows specimens as he collects them. The usual vasculum, shown in fig. 1, is a light metal can, gen-



FIG. 1.—The vasculum in use. The long, oval-ended metal can with a door in its side receives specimens as they are collected and keeps them from withering while they are being carried home to be pressed.

erally oval in cross section and provided with a side door large enough to permit easy insertion of specimens. It is strong in proportion to its weight, will withstand years of hard use, is shaped conveniently for carrying and prevents rapid wilting of specimens. An adjustable leather or web strap snapped into rings at each end permits it to be carried from the shoulder.

The vasculum can be purchased from some biological supply house or can be made to order. If the latter, a light metal should be specified to reduce weight, and the size should be no larger than is necessary for a good load of specimens. A vasculum 24 inches long and with diameters of 6 and 8 inches for its oval cross section is large enough for any ordinary purpose.

Use of the Vasculum—Most botanizers carry both their specimens and their collecting equipment in the vasculum. The equipment usually includes a trowel or digging knife, a pad of blank 3- by 5-inch note paper, a supply of old newspaper, a notebook and any handbook or manual the botanizer may need.

A specimen, when chosen, should be wrapped in a piece of the newspaper along with a sheet from the note pad bearing the collection number of the specimen, the place, the date and any other notes the botanizer may wish to jot down. Thus wrapped, specimens are kept separate and are further protected from wilting or drying-out until such a time as they can be arranged in the plant press.

But the botanizer ought not to pass by opportunities to collect simply because he does not have a vasculum along. Many botanizers make it a practice to carry some large-paged magazine with them when they go on trips not specifically for collecting. If they find interesting specimens, they place them between pages of the magazine and later arrange them in the plant press. The "magazine method" has been adapted to regular collecting by some botanizers, who carry large, heavy cardboards, joined like the covers of a book, between which folded newspaper sheets and a few drier sheets are arranged to accept specimens as they are collected.

The Digging Tool—The purpose of this tool—it may be a garden trowel, a putty knife, a butcher's knife or anything similar—is to dig earth away from the roots of plants desired as specimens. This tool should be used to remove the earth carefully, so that the plant can be "lifted" rather than "dug up."

Root systems and other subterranean structures are often most interesting parts of plants. Such characteristic structures as the rootstocks of Solomon's seal, which bear large seal-like scars, the large, edible tubers of the wild yam and the tubers of the Jerusalem artichoke should be represented in at least some of the botanizer's specimens of these plants.

The Notebook—The botanizer's notebook should be a journal in which he keeps a day by day account of his collecting by making note of each plant collected, where it grew, when it was collected, and all other data he desires for future reference.

The notebook may be of any type that suits the indi-

vidual botanizer's needs. Experience has shown, however, that it should be a kind readily duplicated, so that notebooks covering a period of years of collecting are uniform. It should also be well enough constructed to withstand hard handling

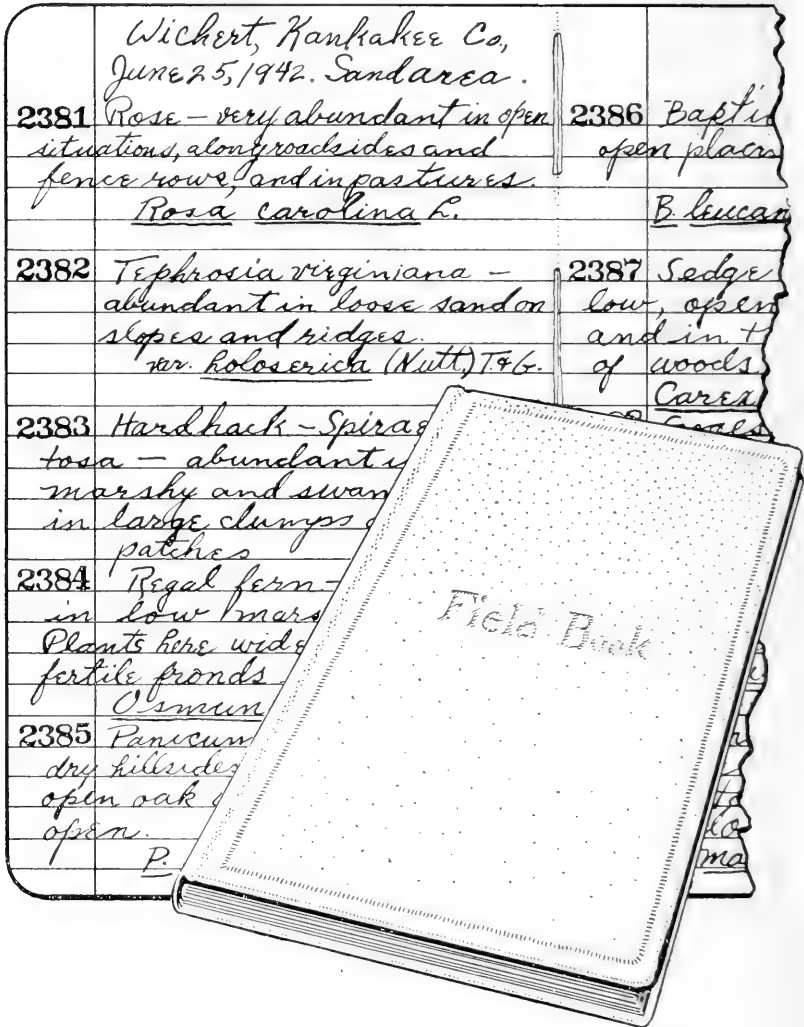

FIG. 2.—A notebook and a sample page of notes. Such a notebook has good paper and is well bound in a nearly waterproof cover. The sample page shows the method of numbering specimens and suggests kinds of notes that may be made.

in the field and long use afterwards. The cover should be sturdy, wear resisting and, if possible, waterproof. The paper should be durable and suitable for both pencil and ink. As to size, the notebook should have pages big enough to encourage the taking of full notes but should not be too large to be carried conveniently. A notebook that fills these requirements well and is readily obtainable in most places is a surveyor's Field Book, fig. 2.

Keeping Notes—Methods of keeping notebooks vary according to the individuality of botanizers. Usually, provision is made in the notebook for numbering specimens serially, as they are collected, by stamping or writing numbers serially on its pages before it is used. When a specimen is collected, it is given the next unused number in the notebook, and notes concerning that specimen are written after that number, fig. 2. Spacing of the numbers and other details can be arranged to suit the needs of the individual botanizer.

It is difficult to give directions about notes, for the making of notes is apt to be a very individual matter. For each collection number the exact scientific name should be recorded, either when the plant is collected or later when it has been carefully identified. The place and date of collecting should also be stated, either after each number or, when several specimens are collected at the same time and in the same place, above a series of numbers. Other items written down may concern the habitat, the condition of the plant or some question regarding the plant that the botanizer wishes to clear up later.

A series of notebooks, containing a multitude of observations soon lost when trusted to memory alone, is second in value only to the collection to which it refers.

What Constitutes a Specimen?—A plant chosen as a specimen should illustrate to the greatest possible extent the characteristics upon which is based the species or variety to which it belongs. Before he can select such specimens consistently, the botanizer must have long experience in collecting and much knowledge of plants. Practically it is enough at first if he collects material that illustrates typical form and structure, as he is able to observe them in the field.

Keys in botanical manuals employ flower characters to a large extent as means for distinguishing families, genera and even species. They also employ characteristics exhibited by

leaves, stems, fruits and, sometimes, roots, particularly to distinguish genera and species.

As a rule, therefore, specimens should show flowers in prime condition and should contain stems or representative parts of stems, leaves of various sizes and shapes and, whenever possible, fruits or seed. Specimens must also include roots, if roots are important for identification.

The majority of herbs can be identified by the characteristics they show when taken whole at flowering time. But large herbs cannot be preserved in their entirety as herbarium specimens, and the botanizer must select from them, as he would from trees or shrubs, representative parts that exemplify their essential characteristics.

Fruits do not mature on many kinds of plants until long after the flowers have disappeared. In order to have fruit represented in specimens of such plants, the botanizer must make a second collection when the fruit is ripe, preferably from the same plant, at least from the same colony of plants, that furnished flowers.

As his knowledge of plants increases, the botanizer may desire specimens for purposes other than that of identification. He may want to exhibit in his collection, for example, the variation between individual plants that is characteristic in some species, the different aspects that are assumed by certain species at different times of year or the dissimilarities between juvenile and mature plants. Thus the variety of material that can be collected purposefully is almost endless.

The Plant Press—This is the apparatus used to dry plants under pressure, so that they can be preserved as specimens in the herbarium. It usually consists, fig. 3, of a number of sheets of absorbent material, called driers, a pair of wooden lattices and some means of applying pressure, such as weights or straps, to flatten out the specimens. Plant presses, complete and ready to use, can be purchased from biological supply houses. They also can be made at home.

The botanizer who wishes to make his own presses can construct a number of serviceable lattices from a bundle of smoothed laths and can cut a good supply of driers from a roll of builder's felt or some similar material. He should make the lattices 12 inches wide by 18 inches long and cut the driers the same size. These measurements, which are

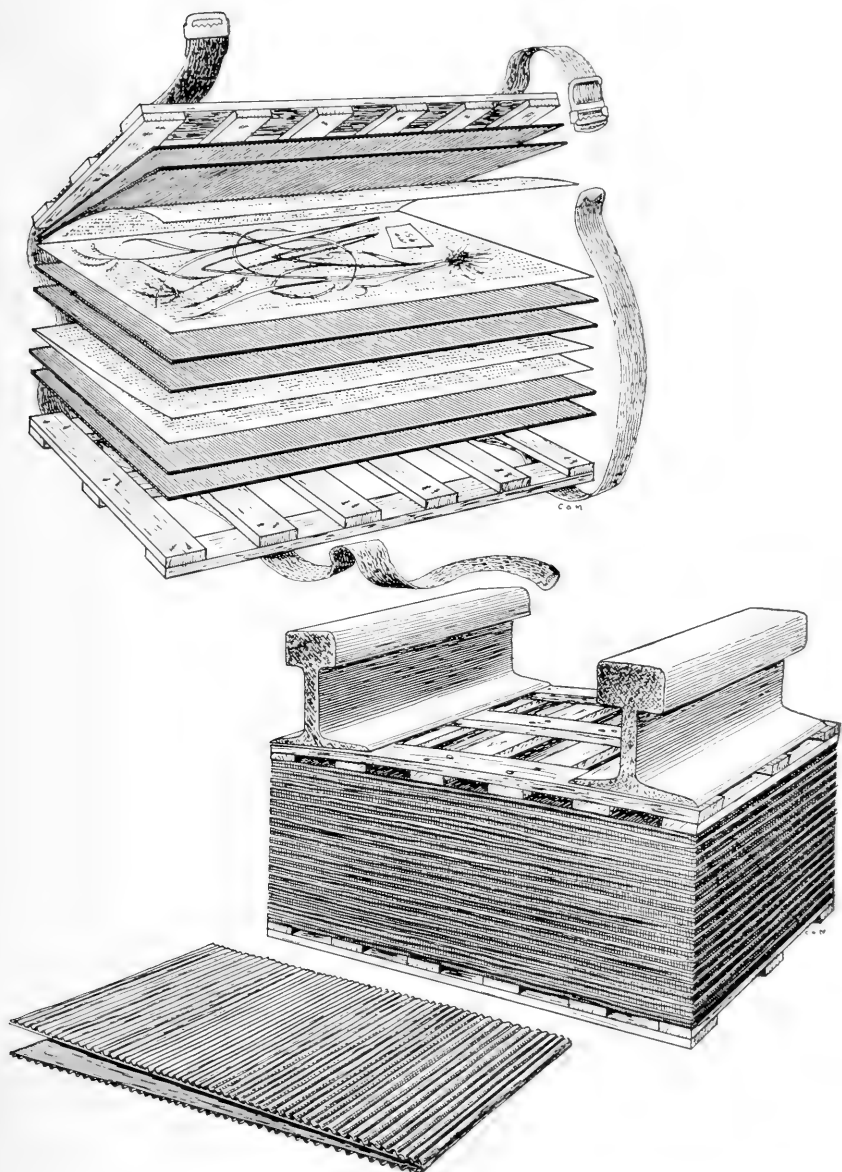

FIG. 3.—Typical plant presses. At the top, arrangement of the press—lattices below and above, driers, newspaper folders containing specimens, and straps for binding the press. In the middle, a filled press weighted with sections of railroad rail. At the bottom, the corrugated cardboard separator used between driers in the press to hasten drying.

somewhat greater than those of the standard herbarium sheet upon which specimens usually are mounted, allow a little extra space for specimens during the drying process and make it possible to dry all parts of a specimen uniformly.

Driers must be able to absorb water rapidly. The botanizer can make a simple test of the suitability of available materials. Sample sheets of each material can be cut and set on edge in an inch of water in a tub. The heights to which water rises in these sheets in an hour indicate the ability of each material to absorb moisture. The material that absorbs water most rapidly will probably make the best drier. Ability to absorb water tends to increase somewhat as a drier is used.

Corrugated cardboard separators, fig. 3, are frequently used by botanizers as a part of the plant press. These separators are inserted between the two driers that are usually placed between specimens, and the open spaces left by the corrugations allow air to flow through the packed press. When using separators, most botanizers bind their presses with straps and hang them over some kind of heater. Heated air passing through the press warms the pack, speeds up the giving off of moisture by the specimens and at the same time withdraws moisture from the driers.

Good separators can be cut from corrugated stock with the corrugation open on one side. They should be the same width, but twice as long, as the driers, should be cut so that the corrugations run crosswise, not lengthwise, and should be folded crosswise in the middle so that the corrugations are on the outside.

There are many variations possible in plant press construction. If expense is a factor, the botanizer can use numerous substitutes in place of the usual materials. For example, he can make his lattices from old crate or box lumber and he can use old newspapers as driers instead of blotting paper or felt. If he desires fine equipment, he can purchase aluminum lattices, driers cut from specially graded blotting paper, light metal corrugated separators and automatically regulated press heaters.

Using the Plant Press—Although the appearance of a herbarium depends on a number of factors, its value lies chiefly in the quality of its specimens. The botanizer should, therefore, be meticulously careful in pressing and drying his

specimens. The most carefully chosen specimen can be ruined by careless pressing, and even poor material can be given a good appearance by careful pressing.

As soon as possible after a specimen has been brought in from the field, it should be placed in the plant press. The first step in drying the specimen is to place it within a folder of lightweight absorbent paper. Some botanizers prefer a paper similar to newsprint stock, cut into sheets 23 by $16\frac{1}{2}$ inches. These sheets, folded crosswise, make folders $16\frac{1}{2}$ by $11\frac{1}{2}$ inches, the exact size of the standard herbarium sheet. Other botanizers find that single newspaper pages folded crosswise serve the purpose well enough.

The plant specimen should be arranged in the folder in the most natural position possible. And, if a quantity of specimens is to be pressed at the same time, care must be taken that the thick parts of specimens do not bunch up in the middle of the folders, or the packed press will be thick in the middle and thin at the edges. Although lattices are somewhat flexible, they usually cannot be bent enough to give the pressure necessary at the edges of a thick-centered pack. Consequently, leaves and flowers lying toward the edges of the pack will not be held flat and smooth and will come out of the press wrinkled or shriveled. Obviously, such a condition detracts from the appearance of the finished specimen.

If the flowers a specimen bears are large enough to permit handling, the botanizer should arrange them so that they will appear lifelike when dry.

Because differences between upper and lower leaf surfaces are used in keys and as technical characters of plants, specimens should be arranged before being dried so that one or more typical leaves show the bottom surface. Bulbs, thick roots and fleshy fruits may be cut in half, lengthwise, to expedite drying, improve the appearance of specimens and decrease bulk.

The appearance a specimen will make when finally mounted on the herbarium sheet should be kept in mind as the plant is being arranged for drying. Stems may be bent and the leaves, fruit and flower clusters so placed that all of a good-sized plant will show well on the herbarium sheet, without at the same time obscuring any of the characteristics the specimen should exhibit. Indeed, these characteristics

may be emphasized by the arrangement given to the plant.

When a specimen plant has been arranged to good advantage in its paper folder, the folder is laid on a drier. Then both the drier and the specimen-containing folder are laid on one of the lattices, upon which two or three extra driers have already been placed as pads to keep the imprint of the lattice from showing on the specimen. A second drier then is laid on top of the specimen folder, and a lattice is laid on top of it and held down with a weight while the second specimen is being prepared. When the second specimen has been arranged, the top lattice is removed and the second specimen, with a drier below and above it, is added to the pile. Thus the plant press is packed.

When a press is packed, the specimens at first give off moisture very rapidly, and the driers take it up and hold it. Unless corrugated separators and heated air are used, it is necessary to change driers once or even twice a day during the first two to four days. If the driers are not changed, the specimens are almost certain to become water soaked and discolored and they are also apt to heat and disintegrate or to be rotted by molds. Frequent changing of driers is an important factor in obtaining nicely prepared specimens.

Thorough drying of driers between uses is a detail that should not be neglected. If driers are stacked away immediately after being used, only their edges dry out. The center of the stack will remain damp for a long time. This condition encourages the growth of molds. Specimens can be ruined by these molds when the driers are used again. The easiest and best way to care for damp driers is to spread them out in the sunshine.

Strong pressure should be maintained on the plant press throughout the drying period. The purpose of this pressure is not to squeeze water out of the specimens but to keep them flat and smooth as they dry. Pressure may be applied by weights, such as sections of railroad rail, pieces of pig iron or paving bricks placed on the packed press, or by straps run around it and drawn tight, fig. 3. Many botanizers prefer straps, because they exert more nearly uniform pressure throughout the press. But straps must be tightened frequently to compensate for the shrinking of specimens as they lose water.

After specimens have been dried thoroughly in the press,

they may be kept in their paper folders and tied into bundles for storage until there is time to name them or mount them on herbarium sheets.

Studying Plants

Although a botanizer can learn many of the things he wants to know about plants by reading technical and popular botanical books and journals, he derives his greatest pleasure from studying plants themselves. One of the first aims in studying a plant is to learn its name.

How to Name Plants—The easiest way to learn a plant's name is to ask someone who knows. This, contrary to the advice usually given, is a good way and it is, moreover, one that will be used many times when difficult specimens have to be submitted to experts for identification.

Generally, however, the botanizer finds it necessary to name most of his specimens and he takes pride in being able to do it. For this purpose he makes use of botanical manuals and handbooks. Many such books are available, some complete for large geographical regions, but a large number limited to special groups of plants, such as trees, shrubs or grasses, or to geographical areas such as counties or states. The manual now most commonly used in the eastern part of the United States is *Gray's New Manual of Botany*, the seventh edition of which has been considered a standard reference since its publication. Other manuals and a number of useful handbooks are listed under the heading "Useful Books."

Botanical Keys—The manuals and handbooks most useful to botanizers contain "analytical keys." These keys state the most reliable of the characteristics by which plant kinds are classified and arrange them in outline so that the botanizer can start at the beginning of a key and "run down" the name of his plant.

In *Gray's Manual*, for example, an Analytical Key to the Families follows immediately after the Preface. With it the botanizer can determine the plant family to which a particular specimen belongs. Further along in the book, where that family is discussed, there is an analytical key to the genera that make up the family; and where each complicated genus is treated there is an analytical key to the species that make up the genus. Using these keys successively, the botanizer

can "key out" his specimen to its exact species, even though at the beginning it is entirely strange to him.

Botanical keys, however, are not perfect. It is therefore imperative that the botanizer compare the specimen he has in hand with the printed descriptions of the family, genus and species to which he has keyed his specimen. And if he has reliably named specimens of the species, he should compare his keyed specimen with them also. In this way he makes certain that he has named his specimen correctly.

Using Analytical Keys—Most beginners at botanizing experience difficulty in using keys. This difficulty seems to arise mainly from a lack of understanding of how keys are made and of what they are expected to do. Perhaps the best way to illustrate the construction and use of keys is to make a small key for some familiar objects.

An eraser, an automatic pencil, a fountain pen, a writing pad and a book are objects that might be seen together on any desk. Each has characteristics that distinguish it from all the others. The eraser stands out because it is flexible and because it alone is made of red rubber. Both the book and the writing pad are flat and oblong and are composed of pages. In the book, pages are bound together and bear print; in the writing pad, they are only gummed together and are clean of print. Both the pen and the automatic pencil are long and slender and are essentially cylindrical in shape. The pen has a flattish, pointed tip and writes with ink; the pencil has a conical tip and writes with lead.

When brief statements of these similarities and differences have been arranged as an outline, in the manner shown below, they form a key with which a person could identify each of the objects, even though he never had seen any of them before. From it, by following the dotted lines to the right, he would also learn the name of each object.

1. Object flexible and made of red rubber. Eraser
2. Object not flexible or not made of red rubber.
 - A. Object flat and oblong; composed of pages.
 - a. Pages bound together and bearing print. Book
 - b. Pages only gummed together, not bearing print. Writing Pad
 - B. Object long, slender and cylindrical.
 - c. Object with a flattish tip; writes with ink. Fountain Pen
 - d. Object with a conical tip; writes with lead. . . Automatic Pencil

This key to common things is similar in every respect to a botanical key, because, if there are a dozen different erasers, books, writing pads, fountain pens and automatic pencils on the desk, it will distinguish the kind of thing any one of them is. The obvious manner in which the key is used to identify the objects illustrates the exact manner in which botanical keys are used.

Keys encountered in manuals and handbooks are classified as *natural* and *artificial*. Natural keys, because they make use of characteristics important in determining whether plants are primitive or highly developed and reflect in their make-up the evolutionary order of plants, stress the natural relationships of plants. Artificial keys use, without regard for its significance, any conspicuous, constant difference that will serve to distinguish plant kinds easily and certainly. The accompanying examples, restated from two widely used books, illustrate the contrast between natural and artificial keys.

NATURAL KEY	ARTIFICIAL KEY
1. Stamens free from the corolla, as many as its lobes.....Campanulaceae	1. Leaf blades coarsely toothed, 1 to 2 teeth per cm.....Styrax
2. Stamens inserted on the corolla.	2. Leaf blades finely toothed, more than 2 teeth per cm.
A. Stamens 1 to 3, fewer than the corolla lobes.....Valerianaceae	A. Teeth rounded...Ilex decidua
B. Stamens 4 or 5, leaves opposite or whorled.	B. Teeth sharp-pointed.
a. Ovary 1-celled, flowers in dense heads.....Dipsacaceae	a. Leaves woolly-hairy on the lower surface.....Spiraea tomentosa
b. Ovary 2- to 5-celled.	b. Leaves not like that.
x. Leaves opposite, never whorled, and without true stipules.....Caprifoliaceae	x. Leaf blades oval to orbicular...Gaultheria
y. Leaves opposite and stipulate, or whorled and without stipules.....Rubiaceae	y. Leaf blades narrowly oblanceolate.Spiraea alba

Most of the keys found in manuals and complete floras are natural keys. Most of the keys encountered in handbooks

that deal with such special groups of plants as trees and shrubs are, on the other hand, artificial keys. A key can be completely artificial. It is, however, very difficult to make a completely natural key. Consequently the keys in manuals, although predominantly natural keys, usually contain numerous small sections that are definitely artificial.

The outline, illustrated above, is the typical key form found in most botanical manuals and handbooks. Another form, more economical of space and less costly to print, but less favored by botanists, is known as the bracket form, because contrasted differences are arranged together. In bracket form, the experimental key devised above appears as follows:

- | | | |
|----|---|------------------|
| 1. | Object flexible and made of red rubber | Eraser |
| | Object not flexible or not made of red rubber | 2 |
| 2. | Object flat and oblong; composed of pages | 3 |
| | Object long, slender and cylindrical | 4 |
| 3. | Pages bound together and bearing print | Book |
| | Pages only gummed together, not bearing print | Writing Pad |
| 4. | Object with a flattish tip; writes with ink | Fountain Pen |
| | Object with a conical tip; writes with lead | Automatic Pencil |

In using this kind of key, the botanizer should read the first set of contrasted descriptive lines, choose the line that applies to his specimen and then proceed to the set of differences indicated by the numeral placed at its right. He should then repeat the choosing process until he arrives at the name of his plant.

Regardless of whether they are printed in outline form or in bracket form, most botanical keys are dichotomous keys. At every point they give the user choice between two characteristics. If they were built up as diagrams, they would assume the form of a spreading tree, on which the branches always arise in pairs.

The amateur botanizer should develop a good working knowledge of the structure of flowers, fruit, leaves and stems. With this knowledge as a background he will be able to use keys easily and make determinations accurately, provided he works carefully, observes keenly and exercises good judgment in interpreting what he observes in terms of the technical descriptions in texts.

Plant Names—The names used to designate plants are of two kinds, common names and technical names.

Common names, those used in everyday speech, often

vary from locality to locality. A plant known by one common name in one place may be known by a different common name in another place, and a common name used in one place for one kind of plant may be used in another place for a different kind of plant. Technical names, on the other hand, have the advantage of being used in all parts of the world to designate the same kinds of plants.

Technical plant names consist of two parts, first the name of the genus in which a plant kind is classified and second the name of the species to which a plant belongs. For example, both the black walnut and the butternut (or white walnut) are classified in the walnut genus, the name of which is *Juglans*. The black walnut belongs to the walnut species *nigra*, and the butternut belongs to the walnut species *cinerea*. The technical name of the black walnut is, then, *Juglans nigra*; that of the butternut is *Juglans cinerea*.

Written or printed technical names customarily are followed by abbreviations that commemorate the botanists responsible for them. Thus the technical names of the pear and apple, *Pyrus communis* L. and *Pyrus Malus* L., both commemorate Carolus Linnaeus, and the technical name of the prairie rose, *Rosa setigera* Michx., commemorates André Michaux. In botanical usage, the botanist who reclassifies a species is commemorated along with the one who named it. The abbreviations following the technical name of the small Solomon's seal, *Polygonatum biflorum* (Walt.) Ell., for example, commemorate two men, Thomas Walter, who first described the species and named it *Convallaria biflorum*, and Stephen Elliott, who at a later date reclassified the species, removing it from the genus *Convallaria* and placing it in the genus *Polygonatum*.

Equipment for Studying Plants

In order to solve easily and accurately the many problems he is certain to encounter in identifying plants, the botanizer should have a certain amount of working equipment. This equipment consists partly of books and partly of tools.

Books—The botanizer will need at least three kinds of books. First, he will need a good textbook of elementary botany, from which he can obtain details relating to plant

structure. Second, he will need at least one good botanical manual that covers the region in which he works. And, finally, he will need books of a more general nature, in which, for example, he may read about the uses to which plants are put, the history of botany, the habits of plants or the lives of great botanists. A book list from which he may choose is given in the section headed "Useful Books."

Tools—The tools most useful to a botanizer are a good magnifier, a ruler, dissecting needles, forceps and scalpels, fig. 4. He will also find much use for watchglasses and test tubes.

Magnifiers, commonly called lenses, can be purchased in a variety of forms, fig. 5. Most botanizers like to have two magnifiers, one to carry on field trips and one, with some kind of support, fig. 4, to use on the study table. A good magnifier, such as a linen counter, need not cost much, and an excellent magnifier can be purchased for less than ten dollars. In the field most botanizers use a 10 X magnifier, that is, one that magnifies 10 times. A high quality triple aplanatic magnifier of 12 X magnification is often more useful. In general, the best magnifiers can be used at higher magnifications than the poorer ones.



FIG. 4.—Equipment on a botanizer's work table. The articles on the table include dissecting needles, forceps, a scalpel, a ruler, watchglasses, test tubes and test tube holders, an alcohol lamp, a tripod magnifier and two dissecting microscopes.

A satisfactory low cost magnifier to use on the study table is the tripod dissecting magnifier. The lens in this instrument can be focused by being screwed up or down in its supporting tripod. Costly dissecting microscopes and binocu-

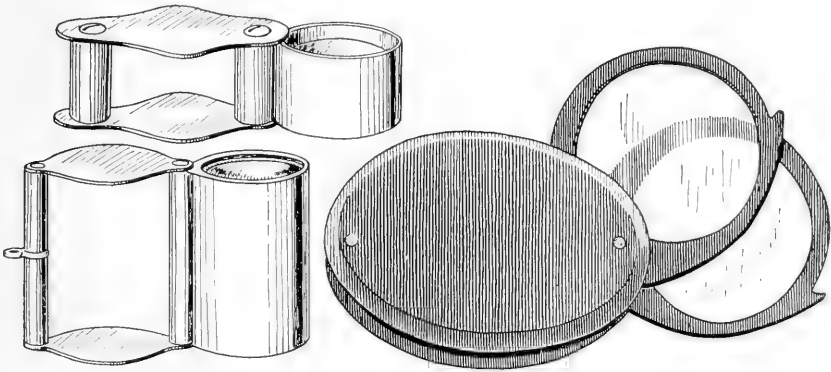

FIG. 5.—Suitable magnifiers for field use. Above, a "triple aplanatic" of the highest quality. Below, to the left, a "doublet" of good quality; to the right, a serviceable low-cost lens combination.

lar dissecting microscopes with interchangeable sets of lenses of different magnifying powers are not necessary, although they are very helpful when fine work must be done.

A ruler is a necessity. It should be small and light and it should have scales for measuring by inches and by millimeters and centimeters. A thin, white celluloid ruler about 6 inches long is easily obtainable and is in common use. Flexible, transparent rulers are available also and they possess some advantages.

Dissecting needles are almost indispensable for dissecting flowers and other minute plant parts and are especially useful for manipulating objects under magnifiers. They can be purchased at small cost, or they can be made. A factory-made dissecting needle is obtainable, the handle of which is provided with jaws so that needle points of various convenient shapes can be used as needed. Homemade dissecting needles, constructed by forcing the eye end of an ordinary sewing needle into the end of a 4-inch piece of wooden dowel, the pointed end of a wooden meat skewer or any similar piece of rounded wood, are satisfactory for almost all needs.

Forceps are useful in handling plant parts that are too

small or too fragile for the fingers. Their small cost encourages the botanizer to have them at hand in a variety of sizes and shapes.

Watchglasses are convenient dishes in which to examine boiled-up flowers and other plant parts. They are obtainable in a number of forms, but those with round bottoms should be avoided. Any other glass dish of similar size and shape will usually serve as well.

Test tubes are useful vessels in which to boil up dried blossoms for examination. They can be purchased in desirable sizes at local drug stores or from biological supply houses. A metal test tube holder is also a convenience, but a folded piece of paper will do quite well. Test tubes can be heated over a gas burner on the kitchen stove or over an alcohol lamp or Bunsen burner on the study table. Or, if the botanizer does not mind the inconvenience, he can use a cup of nearly boiling water in which to soften his specimens.

Scalpels are conveniences rather than necessities, since the sharp blade of a penknife generally will serve the same purpose. The blade of a good scalpel can be honed to a razor-like keenness for fine cutting. This fact, together with the comfortable, balanced handles provided on better grades, makes scalpels as convenient to the botanizer as they are necessary to the surgeon.

How to Work With Dried Blossoms—In the drying of a plant specimen the flowers upon which identification so greatly depends are pressed flat. To study them it is necessary to restore them to something like normal condition. The procedure commonly followed is to break off a blossom from the dried specimen, drop it into a test tube one-third full of water and hold the test tube over a flame until the water in it has boiled for a short time. This boiling should not proceed so violently as to injure or seriously disarrange any of the flower parts, but it should continue until the blossom is flexible and easily cut.

When the specimen has been boiled enough, it and the water are poured into a watchglass and allowed to cool. If the watchglass is placed under a magnifier while the water still is hot, steam will cloud the lens. A little time may be saved by transferring the blossom to a watchglass of cold water, but then there is danger of losing anthers or other small parts sometimes dislodged during boiling.

Some botanizers preserve dissected blossoms, re-drying them very carefully and gluing them to small pieces of cardboard. Mounts thus made may be covered with cellophane tissue and attached directly to the herbarium sheets from which the flowers were taken. They also may be placed in envelopes glued to the sheets. Dissections can also be preserved in small vials containing a preserving fluid, such as glycerine, that evaporates slowly.

The Herbarium

In the building of a herbarium the botanizer satisfies his desire to amass a collection. Also, he preserves the most exact record possible of his studies, accumulates reference material more concrete than the most detailed botanical descriptions and builds for himself a tangible expression of all that he learns about plants. As he progresses, he finds his herbarium constantly becoming more useful, for, serving as a convenient and always available means of comparing new and old collections, it contributes increasingly to the accuracy of his determinations and his records.

There are two essentials to a good herbarium: carefully prepared specimens and suitable cases in which to store them.

Preparing a Herbarium Specimen—When a specimen has been pressed and named, it is ready to be incorporated in the herbarium. Some botanizers prefer to keep their specimens loose in paper folders, but the majority prefer to mount their specimens on sheets of heavy paper. The first method is less costly and requires less labor, but the second gives more protection to specimens and makes them more convenient to use.

If specimens are to be kept in folders, the folders in which they are pressed may serve well enough. A degree of neatness may be achieved, however, if the specimens are transferred to fresh folders cut to herbarium sheet size. The folder itself may be labeled with the name of the specimen, or special label forms may be used as suggested later. Some botanizers spend considerable amounts for folders, selecting special papers for durability or niceness of appearance.

If specimens are to be mounted on sheets, the sheets and the mounting methods should conform to those used in established herbaria. The standard herbarium sheet measures $11\frac{1}{2}$ by $16\frac{3}{8}$ inches. The paper should be white and of such

quality that it will not disintegrate or discolor with age. It should also be so heavy and rigid that, with a specimen mounted on it, a sheet can be handled without buckling and thereby damaging the specimen. A 56-pound ledger bond paper meets these requirements well, but heavier grades are often used.

If possible, specimens should be attached to herbarium sheets with glue. Pastes and mucilages intended for paper work generally do not hold specimens permanently. Fish glues and others used in woodworking have proved more or less satisfactory. The addition of a small amount of a surface-tension-reducing chemical, such as aerosol, will often cause glue to spread more evenly on waxy or hairy surfaces.

Round stems and fruits and waxy leaves often cannot be made to adhere permanently to the sheet, even when the best glue is used. But small strips of gummed cloth tape, properly applied, will hold these parts firmly. To attach a strip of tape so that it will not break away from the paper, moisten it carefully (it must not be made too wet), center it on top of the stem and bend it down and around both sides of the stem until it nearly meets beneath the stem; then press the free ends flat on the herbarium sheet, fig. 6.

Grasses and other plants with slender cylindrical stems and narrow leaves, and also bulky specimens, are hard to mount permanently with glue. It sometimes is possible to tape them, as directed above. But a more effective procedure is to tie them to the sheets. Floss that harmonizes with the green of dried specimens is threaded in a needle and run through the sheet, first from the top and then from the bottom, so that when the ends are tied a tight loop holds the specimen to the sheet. As many loops may be made as are necessary to attach the entire specimen firmly, fig. 6. Knots should always be tied on the upper side of the herbarium sheet to avoid damaging specimens on sheets that may be stacked beneath. All three methods of attaching—tying, gluing and taping may be used on the same specimen as needed to assure additional security.

Large, hard fruits, such as nuts and acorns, may be put in small cardboard boxes, and the boxes may be glued to the herbarium sheet or stored separately. Loose seeds, small fruits and other fragments may be placed in envelopes or folded paper packets glued to the herbarium sheet.

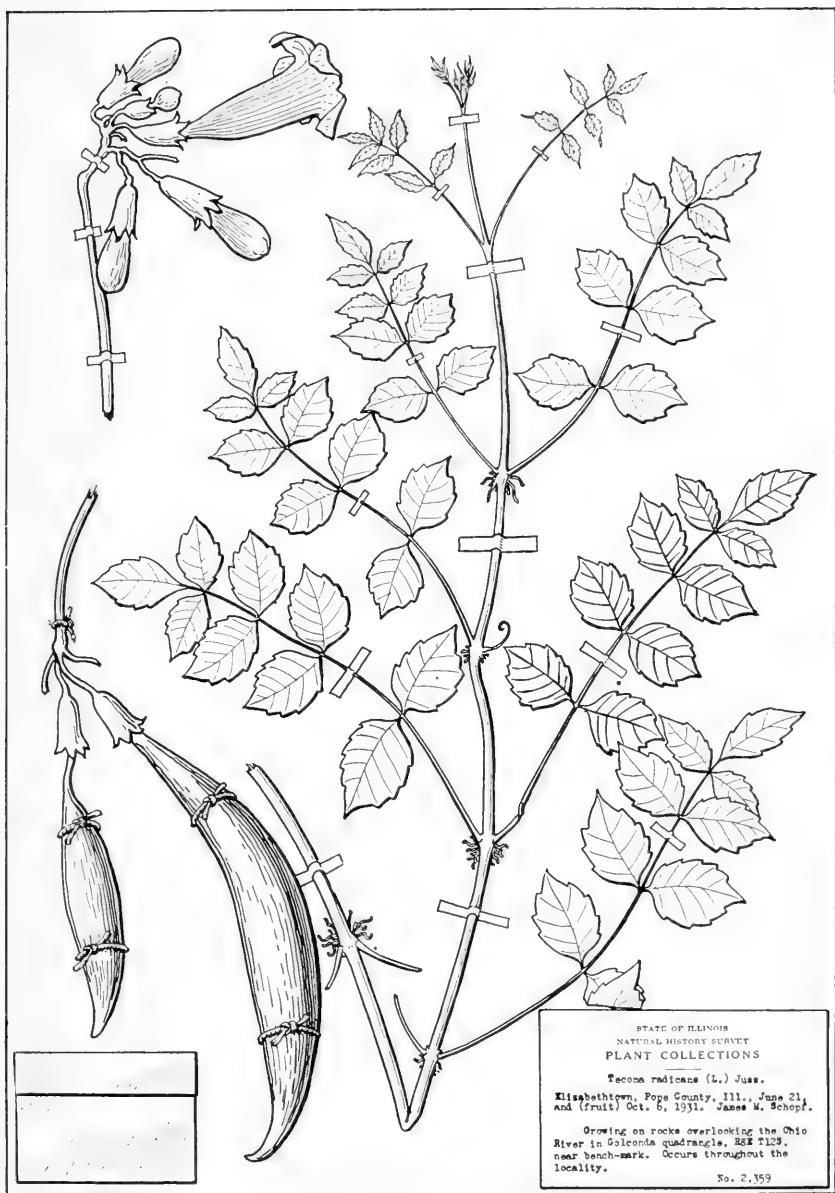

FIG. 6.—A complete herbarium specimen, with stem, leaves (one turned bottom up), flowers and fruit. The leaves and flowers are glued to the sheet, the stems are taped down and the pods are tied down with floss. The packet provides for keeping loose seeds.

As soon as a specimen has been glued and placed on a herbarium sheet, the new mount thus made should be covered with a sheet of waste paper (a half-sheet of newspaper, perhaps) and placed under a weight until the glue sets. When a number of new mounts are made at the same time, they may be stacked between driers, each mount separated from the one above it by a sheet of waste paper and a drier. The stack should be capped by a plant press lattice and pressed down by weights set on the lattice.

Specimen Labels—Labels for mounted specimens are almost as varied as are the botanizers who use them. The label commonly used is a small printed blank, fig. 7, upon which can be written the name of the species, the date and place of collection, the name of the collector, altitude of the habitat and any other desired information. The size of the

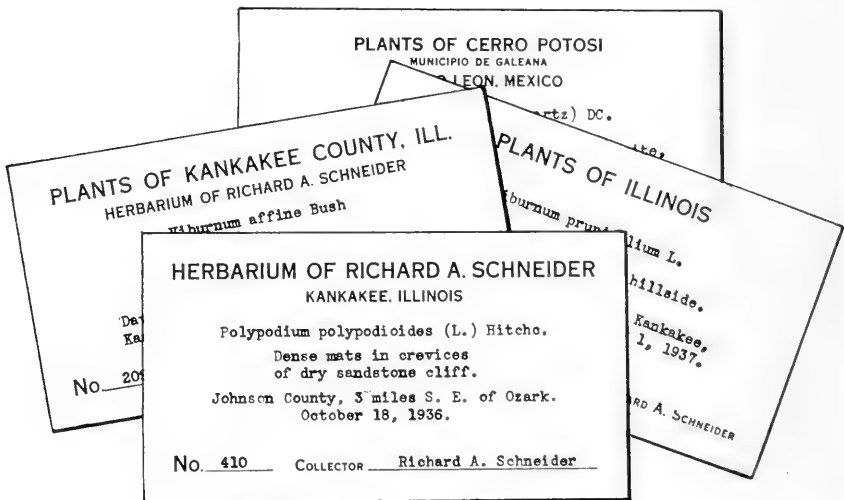

FIG. 7.—Typical specimen labels. These labels, all used by an amateur for his collections, only suggest how labels may be printed and filled in. The individual botanizer may design his labels to suit his own needs and taste.

label, the type used in printing it, and the completeness with which the items to be written on it are indicated, are all matters of individual preference.

Arranging the Herbarium—In the herbarium, all specimens representing the same species, all species belonging to the same genus and all genera belonging in the same family

should be kept together. Families may then be arranged in an order corresponding with that given in the manual the botanizer uses, or they may be arranged alphabetically. The manual order is preferred by most botanizers, since it tends to keep groups of related plants together. The genera and species of each family, on the other hand, usually are arranged alphabetically. Except in large herbaria, there is little need for a special arrangement of individual specimens.

Herbarium specimens should be filed in "genus covers," which are made by folding single sheets of heavy manila paper crosswise. A sheet measuring $23\frac{3}{4}$ by $16\frac{1}{2}$ inches makes the genus cover a little larger than a standard herbarium sheet and gives protection to the edges of the herbarium sheets filed in it.

Because of the weights of the specimens attached to herbarium sheets, it is desirable to lay genus covers horizontally on shelves rather than to stand them vertically in drawers.

The Herbarium Case—Specimens can be stored in any available box, cupboard or cabinet of suitable size, but a well designed herbarium case will give them greater protection and make them more easily accessible for use. Herbarium cases may be purchased, made to order or constructed at home. The cost ranges from a great deal for the finely manufactured steel cases used in institutional herbaria to only a very little for serviceable cases that can be made at home.

The botanizer should make certain that his herbarium case has the following qualifications. It should be practically dust- and insect-tight when closed. The shelves in it should measure not less than $12\frac{1}{2}$ inches wide by 17 inches deep, in order to accommodate standard herbarium sheets, and should be spaced 5 to 6 inches apart, so that each shelf will accommodate a reasonable but not unwieldy stack of genus folders. The case should be sturdily made, so as to give long service, and it may be finished as attractively as the botanizer desires.

For the amateur botanizer who wishes to build his own herbarium case, a plan is shown in fig. 8. The total cost of materials for this case, including lumber, hardware and finish, should not exceed twelve dollars; usually it will run between nine and ten dollars. It will be less, of course, if the case is made with one tier of shelves instead of two, and

it may be more if heavier plywood is used. The following materials are needed to construct the case shown in the plan.

- | | |
|--|--------------------------------|
| 2 4x8 ft. sheets of $\frac{1}{4}$ in. fir plywood | 3 cabinet door hinges |
| 1 4x6 ft. sheet of $\frac{1}{4}$ in. fir plywood | 1 bar sash lift, for door pull |
| 1 $2\frac{1}{2}$ x4 $\frac{1}{2}$ ft. sheet of $\frac{1}{4}$ in. fir plywood | 3 friction door catches |
| 10 ft. of 1x4 in. clear white pine | 1 lb. no. 4 finishing nails |
| 50 ft. of 1x2 in. clear white pine molding | 1 pkg. 1 in. brads |
| 16 ft. of $\frac{1}{2}$ x1 in. clear white pine molding | 1 pkg. $\frac{1}{2}$ in. brads |
| 40 ft. of $\frac{1}{4}$ x $\frac{1}{4}$ in. clear white pine stripping | 1 pt. walnut varnish stain |

In measuring and cutting the wood pieces for this case, and in fitting them together, it is necessary to work care-

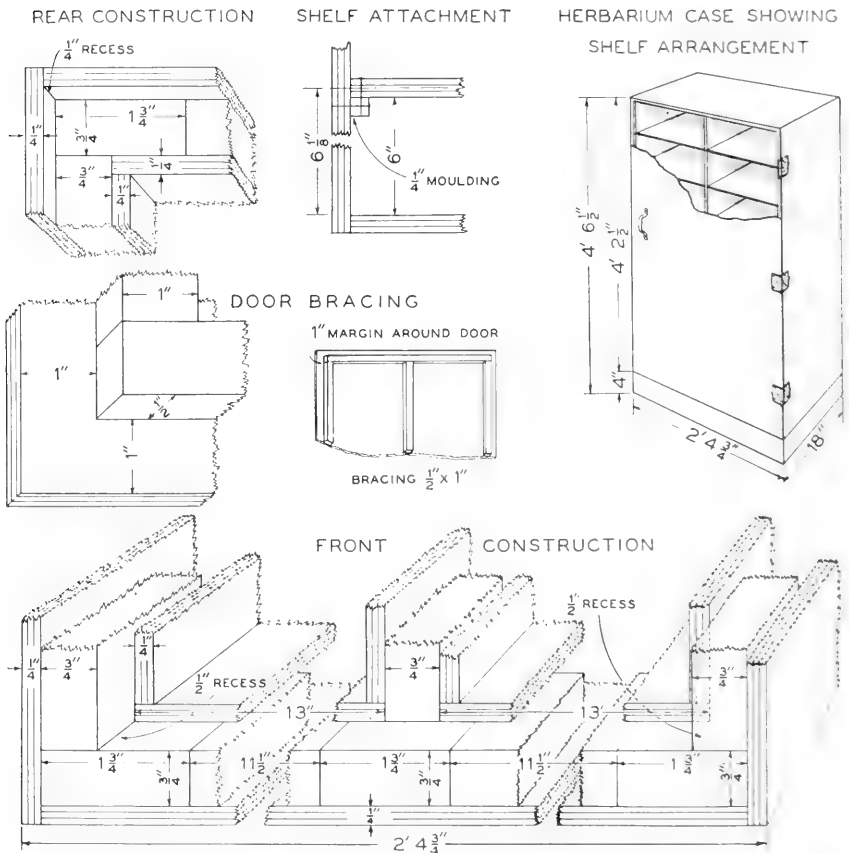

FIG. 8.—Working drawings for a satisfactory herbarium case that can be made at home.

fully, so that the joints will be tight enough to exclude dust and insects. Care in fitting the door is especially necessary.

Preventing Insect Damage—Herbarium specimens are liable to severe damage by insects which feed on dried fruits, fleshy roots, stems, flowers and leaves, and by other insects which feed on paper and the glue used in mounting specimens. Steps should be taken at the very beginning to prevent insect damage, for large numbers of specimens can be ruined before the presence of insects is detected.

The first precaution to take against insect damage is, as has been emphasized above, to make certain that herbarium cases are tight enough, when closed, to prevent the entrance of insects. It is necessary, also, to kill insects that may be carried in with specimens and to prevent development inside the case of those that enter when the doors are opened.

Specimens may be "insect-proofed" with corrosive sublimate, a **deadly poison**. Before specimens are mounted on herbarium sheets they are painted or sprayed with a 1/1000 solution of corrosive sublimate (this material is also known as bichloride of mercury and mercuric chloride) in 50 per cent alcohol. This treatment dampens the specimens and a second drying in the plant press is necessary. Although this treatment is not wholly effective, it is employed as a standard procedure in almost all large herbaria. Specimens already mounted will be protected to some extent, if the exposed side is treated. If certain parts of a collection seem especially to attract insects, a quantity of naphthalene crystals placed among the specimens loosely or in net bags will serve as a repellent.

Many of the insects that infest herbarium cases can be killed with "PDB" (paradichlorobenzene). A quantity of the crystals of this chemical may be kept in a net or cheesecloth bag fastened inside the case at the top of each tier of shelves. Directions on the container indicate the weight of crystals necessary for any cubic space. To be effective, the "PDB" must be replenished periodically.

Cyanide fumigation, which is sometimes practiced in large herbaria, should never be attempted by an amateur botanizer. It is too dangerous for anyone but an expert to use and is, moreover, only temporarily effective. A similar result can be obtained with chloropicrin (tear gas), without incurring any risk.

Conclusion

The preceding pages have dealt almost exclusively with the mechanics of botanizing. Little has been said of what may be learned about plants or of how living may be enriched through study of them. Yet the botanizer's real purpose is to learn about plants. In accomplishing it, he will encounter difficulties and face hard problems; and from overcoming the difficulties and solving the problems he may derive some of the keenest pleasures the study of plants can give.

Useful Books

The list below represents only the writer's suggestion as to which books are likely to be most useful to amateur botanizers in Illinois. Many other books might have been listed. Among the manuals, "Gray's Manual" and "Britton and Brown" have been used so generally that one of them is almost a necessity. The list of handbooks could have been extended almost indefinitely. The textbooks suggested are modern and comprehensive, but many older texts, available perhaps in local libraries, will also serve the botanizer well. Only a few other books have been suggested, for the botanizer's own inclinations are almost certain to lead him into fields of reading that could not be foreseen.

Manuals

- An Illustrated Flora of the Northern United States, Canada, and the British Possessions. By Nathaniel Lord Britton and Addison Brown. Charles Scribner's Sons. 1913.
- Field Manual of the Flora of Ohio and Adjacent Territory. By John H. Schaffner. R. G. Adams & Company, Columbus, Ohio. 1928.
- Flora of the Prairies and Plains of Central North America. By Per Axel Rydberg. Published by the New York Botanical Garden, New York City. 1932.
- Gray's New Manual of Botany (Seventh Edition, Illustrated). By Benjamin Lincoln Robinson and Merritt Lyndon Fernald. American Book Company, 1908.
- Manual of Cultivated Plants. By L. H. Bailey. The Macmillan Company. 1924.
- Manual of Cultivated Trees and Shrubs Hardy in North America (Second Edition, Revised and Enlarged). By Alfred Rehder. The Macmillan Company. 1940.
- Manual of the Flora of the Northern States and Canada. By Nathaniel Lord Britton. Henry Holt & Company. 1910.
- Manual of the Grasses of the United States. By A. S. Hitchcock. U. S. Government Printing Office, Washington, D. C. 1935.
- Manual of the Trees of North America. Second Edition. By Charles Sprague Sargent. Houghton Mifflin Company. 1922.

Handbooks and Floras

- Annotated Flora of the Chicago Area. By H. S. Pepon. Published by the Chicago Academy of Sciences. 1927.
- Fieldbook of Illinois Wild Flowers. Published by the Illinois Natural History Survey. 1936.
- Fieldbook of Native Illinois Shrubs. By Leo R. Tehon. Published by the Illinois Natural History Survey. 1942.
- Flora of Indiana. By Charles C. Deam. Published by the Indiana Department of Conservation, Indianapolis. 1940.
- Native and Naturalized Trees of Illinois. By Robert Barclay Miller and L. R. Tehon. Published by the Illinois Natural History Survey. 1929.
- Plant Materials of Decorative Gardening. The Woody Plants. By William Trelease. Published by the author, Urbana, Illinois. 1926.
- Shrubs of Indiana. By Charles C. Deam. Published by the Indiana Department of Conservation, Indianapolis. 1924. [Equally fine handbooks of Indiana trees and Indiana grasses, by the same author, will be found useful throughout Illinois.]
- The Grasses of Illinois. By Edna Mosher. Illinois Agricultural Experiment Station Bulletin 205. 1918. [Now out of print but available in many libraries.]
- Winter Botany. By William Trelease. Published by the author, Urbana, Illinois. 1918.

Textbooks

- Botany. By William J. Robbins and Harold W. Rickett. D. Van Nostrand Company, Inc. 1929.
- Elements of Botany. By Richard M. Holman and Wilfred W. Robbins. John Wiley and Sons, Inc. 1940.
- Fundamentals of Botany. By C. S. Gager. P. Blakiston's Sons and Company. 1916.
- Strasburger's Textbook of Botany. Macmillan & Company, Ltd. 1930.

Other Books

- Economic Botany. A Textbook of Useful Plants and Plant Products. By Albert F. Hill. McGraw-Hill Book Company, Inc. 1937.
- Edible Wild Plants. By Oliver Perry Medsger. The Macmillan Company. 1939.
- How to Know Wild Fruits. By Maude Gridley Peterson. The Macmillan Company. 1914.
- Methods of Descriptive Systematic Botany. By A. S. Hitchcock. John Wiley & Sons, Inc. 1925.
- Taxonomy of the Flowering Plants. By Arthur Monrad Johnson. The Century Company. 1931.
- The Book of Wild Flowers. Published by the National Geographic Society. Washington, D. C. 1933.
- The Common Names of Plants and Their Meanings. By Willard N. Clute. Willard N. Clute & Company. Indianapolis. 1931.
- Wild Flowers. By Homer D. House. The Macmillan Company. 1935.

Maps

Maps for use in conjunction with field work are obtainable from various sources. A variety of local maps may often be obtained from county surveyors' offices at small cost. County plat books, such as those published by W. W. Hixson & Company of Rockford, Illinois, contain folded county maps and page-size township maps on a larger scale, which show roads, creeks, rivers and farm boundaries. County maps showing roads, streams, towns and rural houses may be obtained from the Illinois Division of Highways. Topographic maps for many Illinois quadrangles may be obtained from the Illinois Geological Survey at Urbana. These are the most detailed maps available for large areas. Soil maps, obtainable from the Illinois Soil Survey at Urbana, frequently are useful for habitat studies.

A map too large for convenient use in the field can be cut into sections of uniform size (perhaps 6 by 6 inches). The sections can then be glued to a substantial cloth, with perhaps one-fourth inch of space between them. Thus cut and mounted, the map can be folded compactly for carrying and also be folded so as to expose any desired section.



The Jack-in-the-Pulpit, *Arisaema triphyllum* (L.) Schott.

Recent Publications

of the Illinois Natural History Survey

A.—ILLINOIS NATURAL HISTORY SURVEY BULLETIN.

- Volume 21, Article 3.—Studies of Nearctic Aquatic Insects. By H. H. Ross and T. H. Frison. September, 1937. 52 pp., frontis. + 86 figs., bibliog. 50 cents.
- Volume 21, Article 4.—Descriptions of Nearctic Caddis Flies (Trichoptera), with special reference to the Illinois species. By Herbert H. Ross. March, 1938. 84 pp., frontis. + 123 figs., foreword, index. \$1.00.
- Volume 21, Article 5.—Preliminary Studies on Parasites of Upland Game Birds and Fur-Bearing Mammals in Illinois. By W. Henry Leigh. August, 1940. 10 pp., frontis. + 2 maps.
- Volume 21, Article 6.—Preliminary Investigation of Oak Diseases in Illinois. By J. Cedric Carter. June, 1941. 36 pp., frontis. + 51 figs., bibliog. (Bound with Article 7.)
- Volume 21, Article 7.—A Needle Blight of Austrian Pine. By Robert L. Hulbary. June, 1941. 6 pp., frontis. + 3 figs., bibliog. (Bound with Article 6.)
- Volume 21, Article 8.—Duck Food Plants of the Illinois River Valley. By Frank C. Bellrose, Jr. August, 1941. 44 pp., frontis. + 35 figs., bibliog., appendix.
- Volume 22, Article 1.—The Plant Bugs, or Miridae, of Illinois. By Harry H. Knight. September, 1941. 224 pp., frontis. + 181 figs., bibliog., index. \$1.25.
- Volume 22, Article 2.—Studies of North American Plecoptera, with special reference to the fauna of Illinois. By T. H. Frison. September, 1942. 122 pp., frontis. + 126 figs., index.

B.—ILLINOIS NATURAL HISTORY SURVEY CIRCULAR.

- 33.—Controlling Peach Insects in Illinois. By S. C. Chandler and W. P. Flint. August, 1939. 40 pp., frontis. + 32 figs.
Contents: Part I. Insects attacking bark and trunk of the peach tree; Part II. Insects attacking twigs, foliage and fruit of the peach tree.
- 34.—Rout the Weeds! Why, When and How. By L. R. Tehon. January, 1940. (Second printing.) 47 pp., color frontis. + 13 figs.
Contents: The importance of weeds; Weeds as economic factors; Weeds as harbors of insects; Weeds as harbors of plant diseases; Relation of weeds to public health; Control methods; Thirteen noxious and pernicious weeds of Illinois.
- 35.—Diseases of Small Grain Crops in Illinois. By G. H. Boewe. September, 1939. 130 pp., frontis. + 47 figs.
Contents: Nature of cereal diseases; Wheat diseases; Oats diseases; Barley diseases; Rye diseases; Cereal disease control.
- 36.—Planting and Care of Shade Trees. By J. E. Davis. March, 1941. 23 pp., frontis. + 16 figs.
Contents: Introduction; Planning for shade; Planting shade trees; Care of newly planted trees; Care of older trees; Some common trees used for shade.
- 37.—Outwitting Termites in Illinois. By W. E. McCauley and W. P. Flint. August, 1942. (Second printing.) 23 pp., frontis. + 19 figs.
Contents: Termites and their habits; Structural control of termites; Control of termites with chemicals; Unified action against termites.
- 38.—Windbreaks for Illinois Farmsteads. By J. E. Davis. February, 1942. (Second printing.) 24 pp., frontis. + 19 figs.
Contents: Introduction; Planning the windbreak; Planting the windbreak; Care of the windbreak; What the windbreak trees are like; Windbreaks and wildlife.
- 39.—How to Collect and Preserve Insects. By H. H. Ross. June, 1941. 48 pp., frontis. + 53 figs.
Contents: Where to collect; What to use; Special collecting equipment; Sending insects for identification; How to handle unmounted specimens; How to mount and preserve specimens; How to label the specimens; Housing the collection permanently; Identifying the specimens; Useful books; How to ship a collection; Where to buy supplies.
- 40.—Control of Roundheaded Apple Tree Borer. By S. C. Chandler and W. P. Flint. April, 1942. 8 pp., 6 figs.

C.—ILLINOIS NATURAL HISTORY SURVEY MANUAL.

- 1.—Fieldbook of Illinois Wild Flowers. By the staff. March, 1936. 406 pp., color frontis. + 349 figs., index. \$1.50.
Contents: Introduction; Key to families; Description of species (650).
- 2.—Fieldbook of Illinois Land Snails. By Frank Collins Baker. August, 1939. 166 pp., color frontis. + 170 figs., 8 pls. \$1.00.
Contents: Land snails, what they are and where they live; Land snails native to Illinois; Land snails introduced from foreign countries; Land snails of uncertain presence in Illinois; Bibliography; Check list of Illinois species; Index.

List of available publications, over 300 titles, mailed on request.

Address orders and correspondence to the Chief
ILLINOIS NATURAL HISTORY SURVEY
Natural Resources Building, Urbana, Illinois

Payment in the form of U. S. Post Office money order made out to
State Treasurer of Illinois, Springfield, Illinois,
must accompany requests for those publications on which a price is set.

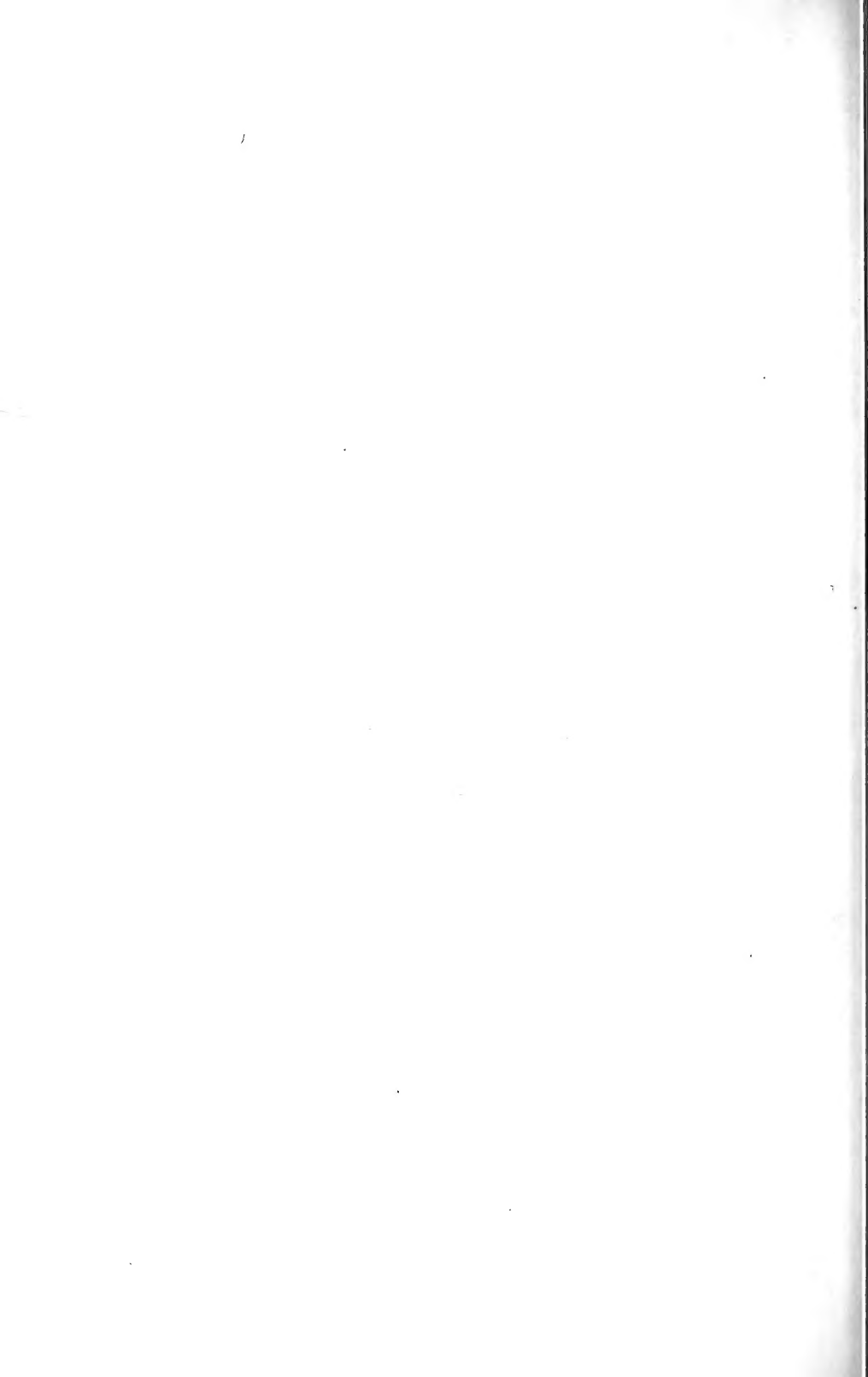



UNIVERSITY OF ILLINOIS-URBANA

57016C
CIRCULAR
25-36 1934-47

C006



3 0112 017541183