

# POPULAR SCIENCE

MONTHLY



SEPT.  
25¢

Newest "Amphibs" for Invading Japan . . . Page 121

**WHAT RADAR IS-HOW IT WORKS-P.65**

Copyright 1945



HERE IT IS

THE MOST USEFUL

Here, in one great, brand-new volume is **EVERYTHING** you need to know to do **ANY** job in or around your home—repairs, alterations, improvements, and new projects.

# The Home Mechanic's Handbook

## JUST A FEW OF THE PRACTICAL JOBS FULLY DESCRIBED

How to choose the right paint for every job  
Figure the quantity of paint needed  
Paint a house—inside and outside  
Care for brushes  
Refinish or "touch up" an auto  
Paper a room  
Put glass in windows  
Replace a sash cord  
Shingle or repair a roof  
Screen in a porch  
Tighten a loose chair, floor board, stair tread  
Fix a window, door, or drawer that sticks  
Fit screens, storm windows, doors  
Build a chicken house, cupboard, workbench, cold-bed frame, storage cabinet  
Cut, drill, grind, solder, temper, and forge metal  
Measure, cut, thread, join, and assemble pipe  
Fix leaks in faucets and valves  
Thaw frozen pipes  
Install a hot-water heater  
Make a flagstone walk, a sidewalk, a wall, concrete steps, a shuffleboard  
Build a brick fireplace  
Install glass blocks

Install a call-bell system, a front-and-rear-door system, a door-opener circuit, or a burglar alarm  
Locate a short circuit  
Repair electrical equipment and appliances

## YOU need this Book

- **HOME OWNERS!** It will help you repair, fix up, and redecorate.
- **FARMERS!** You'll find thousands of how-to-do-it instructions for improving your buildings.
- **REPAIR MEN!** It will help you work more efficiently, profitably.
- **BEGINNERS!** You need no previous experience to follow these step-by-step directions.
- **HOME WORKSHOP OWNERS!** You'll find thousands of new ideas, "kinks," practical projects.
- **HOBBYISTS!** You'll get a great kick out of the hundreds of "tricks of the trade," ingenious short cuts, helpful hints.
- **EX-SERVICE MEN!** You'll find it of great help in remodeling a house, a farm, a place of business.

THE  
**Home  
Mechanic's  
Handbook**\*

DI BERNARDO

HAINES

ADAMS

VAN TASSEL

THOMPSON

MILLER

BAILEY

NOWAK

D. VAN NOSTRAND

COMPANY INC.

815 Pages

Remarkable  
Illustrations  
show every job and  
the use of every tool

**BIG... AUTHORITATIVE...  
TREMENDOUSLY HELPFUL**



# BOOK YOU'LL EVER OWN!

## COMPLETE INFORMATION ON EVERY PRACTICAL TRADE

**The book every home owner has dreamed of**

Turn to this comprehensive HANDBOOK with confidence. You will find its helpful pages crammed with the latest, most efficient and workmanlike ways of doing every kind of job about the home and in the home workshop. Carpentry, metal work, electrical work, plumbing, masonry, painting and decorating—all explained by master craftsmen. The most detailed information about how to choose, repair, and apply the right materials in the right places.

Every move in the use of tools is shown by vivid hands-at-work photographs. All the important operations, and those "tricks of the trade" that play so great a part in good craftsmanship, are explained and made crystal clear by detailed step-by-step drawings. Complete directions, fully illustrated, for thousands of jobs, small and large—from fixing a broken window to installing a hot-water heater; from varnishing a chair to painting a house.

### PAINTING & DECORATING

Principles of paint mixing, formulas, and how to obtain any desired hue. Full directions for selection and care of brushes and other equipment. How to calculate amount of paint required, and best methods of applying to wood, metal, brick, concrete, stone, stucco, plaster. Exterior house painting—interior house painting—choice of color schemes. Complete directions, fully illustrated, for obtaining decorative effects—stippling, mottling, texturing, stenciling, striping, etc. Methods of finishing with stain, shellac, varnish, and wax. Proper stains for each variety of wood. Detailed step-by-step instructions for wall-papering. How to finish an auto, quickly, easily, and inexpensively.

### WOODWORKING

The many varieties of wood and their relative merits, working qualities, and uses. Plywoods, veneers, and wood substitutes—how to choose the materials best suited for the job. Sizes, types and functions of all carpentry tools—how to use, sharpen, and adjust them. All the basic operations and processes of woodworking—everything from how to avoid warping to full directions for cutting each of the common joints. Wood turning—the different cuts, roughing, facing, sanding and finishing; drilling, boring, morticing, spinning, polishing. Hundreds of repair jobs and new constructions—inside and outside the house—are fully explained with diagrams and every practical fact you need to get the best results.

### METAL WORKING

Complete information about the common metals, and the alloys—wrought iron, cast iron, steel, German silver, pewter, the brasses and bronzes, solders and babbitts—when to use, how to use, and how to work them. Hand tools and machine tools—their specific purposes, sizes, and the most detailed instructions for their use. Hints, ideas, and "tricks of the trade." How to use the engine lathe. Metal jobs and projects for home and shop, complete with bill of material, equipment needed, and a fully illustrated account of every step in the work.

### PLUMBING

The various kinds of pipe, pipe fittings, valves, and fixtures. All the common plumbing tools—types, sizes, functions, and how to use them. How to cut, ream, thread, and assemble iron and brass pipe. How to connect copper tubing and make lead joints. The technique of pipe fitting, and the proper sequence of steps in assembling a piping system. Household plumbing projects—installing a hot-water heater, radiator, and various other units. How to drain a plumbing system when closing the house for the winter. How to fix leaks in faucets and valves, repair a faulty section of pipe. The cleaning, and maintenance of each part of the plumbing system.

### MASONRY

Answers every practical question about concrete, plastering, stucco, brick work, concrete-block and glass-block construction. Describes all tools, and just how to use them. How to specify materials and estimate quantities. How to build forms; mix concrete, color it, make it watertight, finish it off; how to build walls, floors, steps. All the sure methods and special ways of working by which the master mason assures good results. Everything about plastering—from small repairs to doing entire rooms. Complete instructions for stuccoing—reinforcing, methods of applying different coats, and how to obtain various decorative finishes. Kinds of brick—handling and laying. Mixing and coloring mortar. Material charts. Types of construction. Various bonds. Forming cross joints. Fireplace construction. Working with concrete blocks—building the wall, corner construction. Kinds and sizes of glass blocks. Glass-block construction—mortar, full-mortar joints, set-in-wood construction.



### ELECTRICAL WORK

Practical information about every electrical job the home mechanic may undertake around the house or in the home workshop. Principles of electricity—volts, amperes, ohms. Generation of electricity. Electrical energy and power. Fuses and circuit breakers. Parallel and series circuits. Standard electrical symbols. Tools, materials, and requirements of National Electrical Code. Complete, fully illustrated explanations of every step in various operations of general electrical work—splicing, soldering, taping, testing, etc. Installation of various signalling systems—bells, buzzers, and alarms. Wiring methods for power and lighting circuits. Complete projects for the home, such as BX wiring a room, and wiring a garage in conduit and BX. Portable appliances—fans, mixers, clocks, heaters, radios. Fixed equipment—oil burners, refrigerators, lighting plants, pumps, motors, generators, and control devices; all clearly described, with practical suggestions and hints for trouble shooting and adjustment.

**Send No Money**

**Examine this Great Book FREE!**

The coupon at the right will bring you a copy of The Home Mechanic's Handbook for ten days' examination, entirely free. Look it over, spend some time with it, and decide for yourself whether or not you want to keep it. Unless you are convinced that The Home Mechanic's Handbook is the most useful book you have ever seen, you may return it to us and owe nothing; or you may keep it by making a down payment of \$1.95, plus a few cents postage, and the balance in two monthly payments of \$2.00 each, (\$5.95 plus postage). But send in the coupon NOW! The supply is definitely limited.

### MAIL THIS COUPON

D. Van Nostrand Co., Inc., Publishers, 250 Fourth Avenue, New York 3, N. Y. Please send me a copy of THE HOME MECHANIC'S HANDBOOK. Within 10 days I will either return the book, or send you \$1.95, plus a few cents postage, and \$2.00 a month for two months until the total price of \$5.95, plus postage, is paid. (If you send the entire amount of \$5.95 with this coupon, we will pay the postage. Same return privilege and refund guarantee if not completely satisfied.)

Name \_\_\_\_\_ (Please print)

Address \_\_\_\_\_

City \_\_\_\_\_ State \_\_\_\_\_

(Zone No., if you know it)

Reference \_\_\_\_\_

Address \_\_\_\_\_

PSM-945



# POPULAR SCIENCE

FOUNDED 1872

MONTHLY

VOL. 147 NO. 3

Mechanics & Handicraft

A TECHNICAL JOURNAL OF SCIENCE AND INDUSTRY

## CONTENTS *for* SEPTEMBER, 1945

Cover: *Painting by Frederic Tellander*

### *News*

<a href="#">How Radar Sees the Invisible.....</a>	65
<a href="#">Modern GI's Fight in Body Armor....</a>	74
<a href="#">Annihilation Bomb—Friend or Foe?....</a>	80
<a href="#">Toilet Soap Kills Germs on Skin.....</a>	82
<a href="#">Portable Artillery Has No Kick.....</a>	84
<a href="#">Floating Shops Keep B-29's Aloft.....</a>	90
<a href="#">Inside the World's Biggest Plane.....</a>	94
<a href="#">He Draws with Scissors.....</a>	100
<a href="#">Colonial Woodworking Shop.....</a>	108
<a href="#">Evolution of the Machine Gun.....</a>	118
<a href="#">Meet the LVT's: Beach Busters.....</a>	121
<a href="#">Patents Tell Magicians' Secrets.....</a>	126
<a href="#">A Flying Vacation (Part 2).....</a>	130

### *Automobiles*

<a href="#">Gus Cures a War Headache.....</a>	138
<a href="#">Auto Ideas .....</a>	141
<a href="#">What's Coming in Convertibles.....</a>	142

### *Home and Workshop*

<a href="#">Glass-Top Coffee Table.....</a>	146
<a href="#">Wishing for a Well.....</a>	152
<a href="#">Wood Carving in Low Relief.....</a>	158
<a href="#">How to Go Aloft Safely.....</a>	169
<a href="#">Aircraft Metals in the Home Shop.....</a>	173
<a href="#">Who Says Portraits Are Difficult?.....</a>	182
<a href="#">Trouble-Shooting A. C. Motors.....</a>	191
<a href="#">Meet Hydrogen Peroxide.....</a>	199
<a href="#">Closing Your Summer Cottage.....</a>	202



JAMES L. H. PECK (Page 65) has more than an academic interest in radar. He learned to fly in 1930 and was one of the first pilots to shoot down a modern German fighter. No stranger to Popular Science readers, he is widely known for his articles on aviation. He is now an officer in the U.S. Merchant Marine.

PUBLISHER . . . . . Godfrey Hammond  
ASSISTANT EDITOR . . . . . Fred O. Newman  
AVIATION EDITOR . . . . . C. B. Colby  
HOME & WORKSHOP EDITOR . . . . . Harry Walton

EDITORIAL ASSOCIATES: Alden P. Armagnac, B. T. Richards, Harry Samuels, Michele de Santis, Volta Torrey, Frank Rowsome, Jr., Carl W. Bertsch, Ruth Westphal, Edward F. Allen, Devon Francis, Gold V. Sanders, James L. Freeman, R. P. Stevenson, Robert Gorman, Elsie E. Brandt.

ART ASSOCIATES: Stewart Rouse, William Patrick, Samuel Dukler, Frances Cooper.

PHOTOGRAPHY: W. W. Morris.

Published monthly at 353 Fourth Avenue, New York 10, N. Y., by Popular Science Publishing Co., Inc. Godfrey Hammond, President and Treasurer; R. C. Wilson, Raymond J. Brown, Stephen P. Glennon, B. Ray Keefer, Vice-Presidents; F. W. Briggs, Secretary. Entered as second-class matter Dec. 28, 1918, at the Post Office at New York under the act of March 3, 1879; additional entry as second-class matter at Dayton, Ohio. Entered as second-class matter at the Post Office Department, Canada. Printed in U.S.A. Copyright, 1945, by Popular Science Publishing Co., Inc. All rights reserved in the United States, Great Britain, and in all countries participating in the International Copyright Convention and the Pan-American Copyright Convention. Yearly subscriptions to United States and its possessions, \$2.50; Canada, \$3.00; foreign countries, excepting Canada, \$3.50. Subscribers must notify us of change of address four weeks in advance of the next publication date. Be sure to give both old and new address.



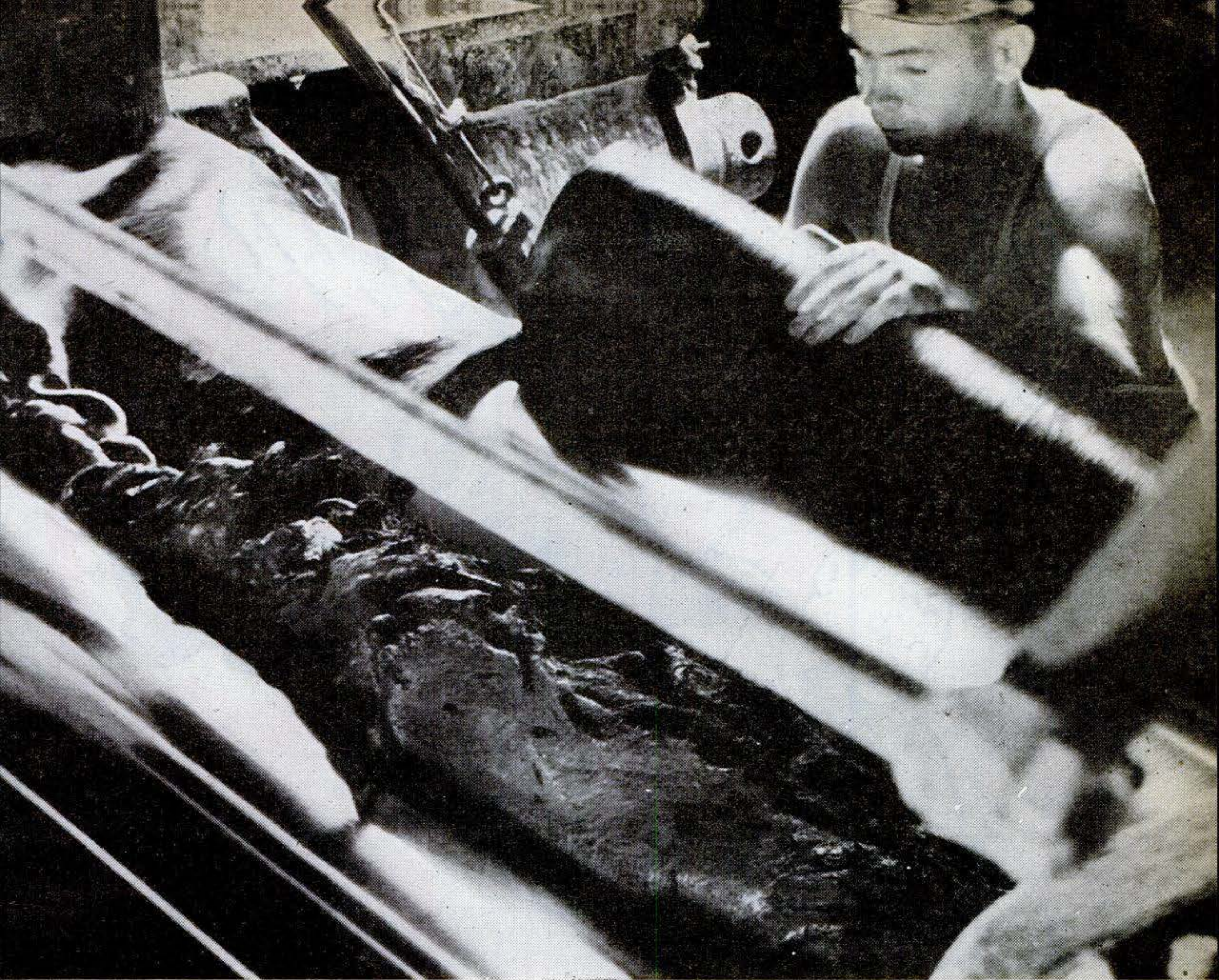

## Announcing a new, better synthetic rubber for tires

*Another example of "building for today, testing for tomorrow"*

B. F. Goodrich has announced that it is now making tires of a new kind of synthetic rubber, different from the synthetic rubber which is in general use by the tire industry.

The new rubber is a B. F. Goodrich development. Tires made of it give longer wear than those made of ordinary synthetic. They run cooler, which is especially important in big truck tires that often get hotter than boiling water under heavy loads on hot pavements.

The new rubber was actually developed months ago and made

in plants operated for the government by B. F. Goodrich. For a while it was used only in military tires, then in tires for heavy trucks. Now it is also going into new B. F. Goodrich tires for passenger cars. Tires containing it will stand up better under heat or under constant flexing, will wear longer, will even have more resistance to bruising or damage from accident. They'll also have more resistance to cracking, and they'll be able to stand higher speeds.

This new, better rubber, so important it was a military secret until recently, is one more ex-

ample of constant development at B. F. Goodrich—the kind of improvement that will bring America far better products after the war than we ever had before. Yet it's only one of dozens of tire improvements made by B. F. Goodrich in the last few years. It's another indication that you get extra value, extra economy, whenever you buy a B. F. Goodrich tire. *The B. F. Goodrich Company, Akron, O.*

*In war or peace*

**B.F. Goodrich**

**FIRST IN RUBBER**



# Up in the Air

## ABOUT WHAT BATTERY TO BUY?

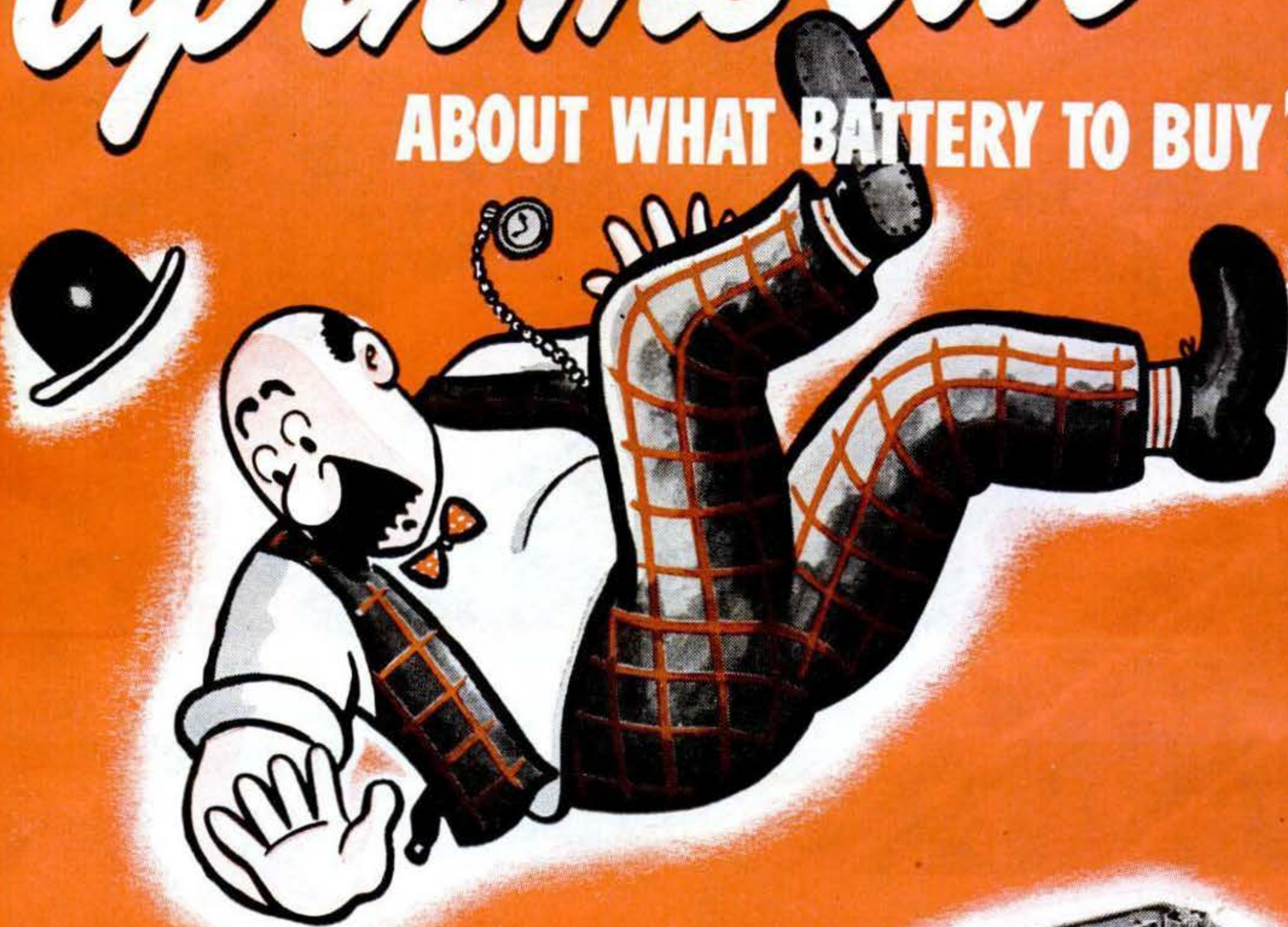

### GET THE BATTERY EXPERTS CHOOSE

You can have the help of experts when you buy your next battery. Follow their example. They choose Auto-Lite batteries for service in the million-mile ocean-spanning Clippers, for service with our fighting forces in jeeps, tanks, half-tracs and other vehicles.

**AUTO-LITE BATTERY CORPORATION • TOLEDO, 1, OHIO**

Manufacturing Plants at: Niagara Falls • Indianapolis • Atlanta • Oakland • Oklahoma City • Toronto

The qualities experts look for in a battery are the same you need in your car battery—long life, quick starts, dependable power and low-cost operation. That's what you get when you buy an Auto-Lite battery—specified as standard equipment by leading automotive engineers.

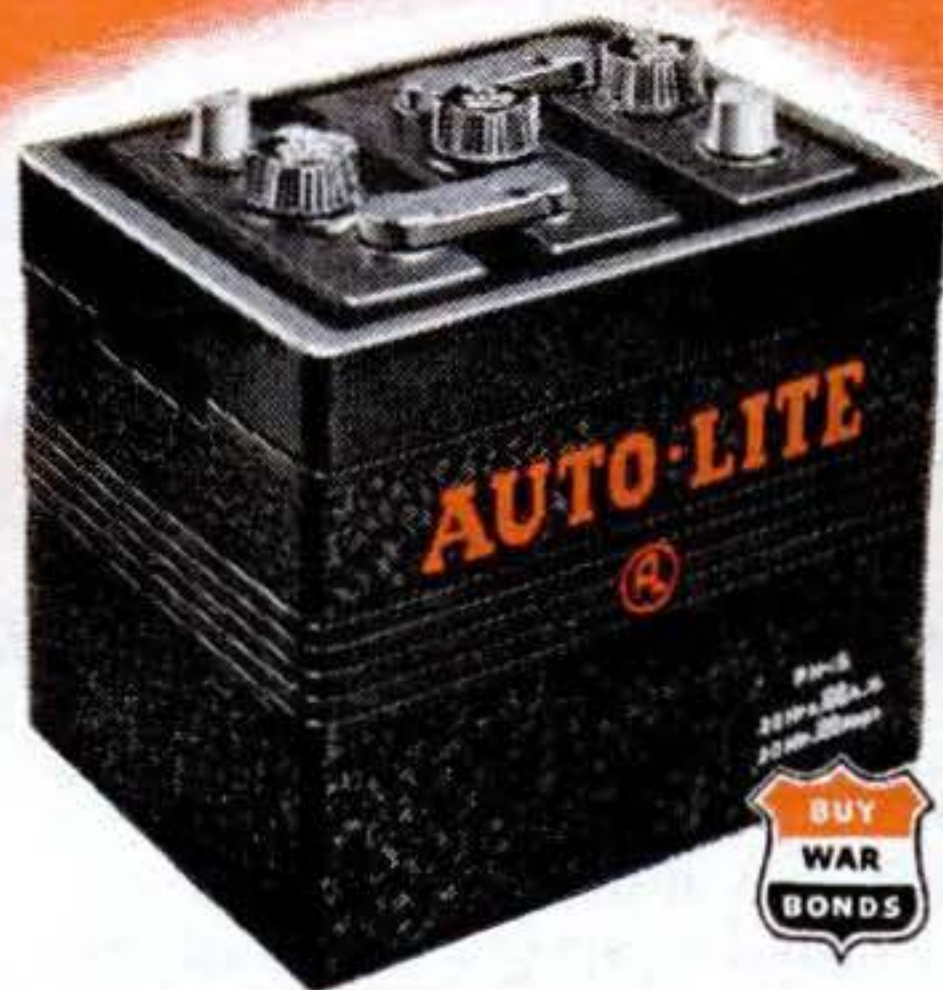

**TUNE IN THE AUTO-LITE** radio show starring Dick Haymes, with Helen Forrest, Gordon Jenkins' orchestra. Features stars of stage, screen and radio and 2-way conversations with men and women at the fighting fronts.

# AUTO-LITE BATTERIES

ENGINEERED AS A BALANCED UNIT OF THE ELECTRICAL SYSTEM





## THE BIRD WITH THE 16-MILE TAIL

The wire you see with the parachute on the end of it is a telephone wire, being payed out from a C-47 cargo plane.

Bell Telephone Laboratories, working with the Air Technical Service Command of the Army Air Forces, developed this idea. It will save precious lives and time on the battlefield.

A soldier throws out a parachute with the wire and a weight attached. The weight drops the line to the target area. From then on, through a tube thrust out of the doorway of the plane, the wire thrums out steadily — sixteen miles of it can be laid in 6 2/3 minutes. Isolated patrols can be linked quickly with headquarters. Jungles and mountain ranges

no longer need be obstacles to communication.

This is in sharp contrast to the old, dangerous way. The laying of wire through swamps and over mountains often meant the transporting of coils on the backs of men crawling through jungle vegetation, and in the line of sniper fire. It is reported that in one sector of the Asiatic theater alone, 41 men were killed or wounded in a single wire-laying mission.

Bell Telephone Laboratories is handling more than 1200 development projects for the Army and the Navy. When the war is over, the Laboratories goes back to its regular job — helping the Bell System bring you the finest telephone service in the world.



**BELL TELEPHONE LABORATORIES** Exploring and inventing, devising

and perfecting for the Armed Forces at war and for continued improvements and economies in telephone service.

SEPTEMBER, 1945

Buy War Savings Bonds and Stamps regularly.

5



## Coming Next Month

A **COLORFUL LIFE** is in store for you after the war. Homes, offices, and factories will blossom with all the hues of the rainbow as we apply new knowledge of the use of color for beauty, comfort, and safety. To help you share in this brightening-up process, Popular Science publishes a 14-page article, illustrated in color, on the scientific selection of paint shades for any given purpose.

A **BUSINESS OF HIS OWN** was what Salvatore Salvatori wanted when he got his discharge from the Navy. Now he refurbishes old furniture, and fashionable New Yorkers are beating a path to his door. GI's who are looking forward to being their own bosses "after the duration" will be encouraged by the story of this enterprising veteran's success.

**SEEING EYE OF ELECTRONICS.** Are you up to date on the cathode-ray tube? Until recently only a scientific curiosity, it has found countless new uses under the stimulus of a mechanized war. John W. Campbell, Jr., tells how it works and describes the many kinds of jobs it will perform in the postwar world.

**"LOST IN THE ARCTIC!"** Those words, once so tragic, have been robbed of much of their terror for airmen who fly above the snowy wastes at the top of the world. Our flyers know that if they are forced down, the Arctic Search and Rescue Squadron will soon be out after them—with planes, sled-pulling huskies, even Saint Bernards. Read C. B. Colby's story of these good Samaritans of the snows.

**NOW WE KNOW** just how good the Germans' weapons were. Victory has given us the chance to clear up many wartime mysteries by examining and testing guns and vehicles alongside our own. There were many surprises in store for the Ordnance men who made these tests—and for P.S.M. readers who see the results in a comprehensive article next month.

**MODEL HELICOPTER.** You'll know a lot more about vertical-lift aircraft after building the "Skyhook" model helicopter from plans by Roy L. Clough, Jr. The author has cleverly met the problems that beset all builders of helicopters, big or little, to produce a model that is easy to build—and actually flies.





**T**HERE is a definite I.C.S. type. The records of 100,000 current students . . . more than 5 million students since 1891 . . . supply the outlines. Here's how the typical enrollee shapes up at the time of beginning his studies:

He is an adult. In good times or bad times, he is an employed man. Circumstances have prevented his attending a college but he is ambitious, intelligent, determined to acquire the specialized training that will help him in his present job and prepare him for a better one.

Does the description fit *you*? Then you'll be interested in what I.C.S. helps these students to achieve. In a single 30-day period we have received as many as 635 student letters reporting advancement in salary and position. In a period of 120 days we have received 1,920 such reports.

Graduates include the presidents, board chairmen, chief engineers or chief chemists of some of the largest steel, airplane, chemical, railroad and electrical equipment companies in the country. Thousands of others have registered substantial successes in their chosen fields. Here's the kind of coupon they signed and mailed.

are you the  
**I. C. S.**  
type of man?



**INTERNATIONAL CORRESPONDENCE SCHOOLS**



BOX 7631-L, SCRANTON 9, PENNA.

Without cost or obligation, please send me full particulars about the course before which I have marked X:

- |   |  |   |  |
|---|--|---|--|
| <p><b>Air Conditioning and Plumbing Courses</b></p> <input type="checkbox"/> Air Conditioning<br><input type="checkbox"/> Heating <input type="checkbox"/> Plumbing<br><input type="checkbox"/> Refrigeration <input type="checkbox"/> Steam Fitting <p><b>Chemistry Courses</b></p> <input type="checkbox"/> Chemical Engineering<br><input type="checkbox"/> Chemistry, Analytical<br><input type="checkbox"/> Chemistry, Industrial<br><input type="checkbox"/> Chemistry, Mfg. Iron & Steel<br><input type="checkbox"/> Petroleum Refining <input type="checkbox"/> Plastics<br><input type="checkbox"/> Pulp and Paper Making <p><b>Civil Engineering, Architectural and Mining Courses</b></p> <input type="checkbox"/> Architectural Drafting<br><input type="checkbox"/> Architecture<br><input type="checkbox"/> Bridge and Building Foreman<br><input type="checkbox"/> Building Estimating<br><input type="checkbox"/> Civil Engineering <input type="checkbox"/> Coal Mining<br><input type="checkbox"/> Contracting and Building<br><input type="checkbox"/> Highway Engineering<br><input type="checkbox"/> Lumber Dealer<br><input type="checkbox"/> Reading Structural Blueprints<br><input type="checkbox"/> Sanitary Engineering<br><input type="checkbox"/> Structural Drafting<br><input type="checkbox"/> Structural Engineering<br><input type="checkbox"/> Surveying and Mapping | <p><b>Electrical Courses</b></p> <input type="checkbox"/> Electrical Drafting<br><input type="checkbox"/> Electrical Engineering<br><input type="checkbox"/> Power House Electric<br><input type="checkbox"/> Practical Electrician<br><input type="checkbox"/> Practical Telephony<br><input type="checkbox"/> Telegraph Engineering <p><b>Internal Combustion Engines Courses</b></p> <input type="checkbox"/> Auto Technician <input type="checkbox"/> Aviation<br><input type="checkbox"/> Diesel-Electric<br><input type="checkbox"/> Diesel Engines <input type="checkbox"/> Gas Engines <p><b>Mechanical Courses</b></p> <input type="checkbox"/> Aeronautical Engineering<br><input type="checkbox"/> Airplane Drafting<br><input type="checkbox"/> Flight Engineer<br><input type="checkbox"/> Foundry Work<br><input type="checkbox"/> Heat Treatment of Metals<br><input type="checkbox"/> Industrial Engineering<br><input type="checkbox"/> Industrial Metallurgy<br><input type="checkbox"/> Mechanical Drafting<br><input type="checkbox"/> Mechanical Engineering<br><input type="checkbox"/> Mold-Loft Work<br><input type="checkbox"/> Patternmaking<br><input type="checkbox"/> Reading Shop Blueprints<br><input type="checkbox"/> Sheet-Metal Drafting<br><input type="checkbox"/> Sheet-Metal Worker | <p><input type="checkbox"/> Ship Drafting<br/> <input type="checkbox"/> Ship Fitting<br/> <input type="checkbox"/> Shop Practice<br/> <input type="checkbox"/> Steel Mill Workers<br/> <input type="checkbox"/> Tool Designing<br/> <input type="checkbox"/> Welding, Gas and Electric</p> <p><b>Radio Courses</b></p> <input type="checkbox"/> Electronics<br><input type="checkbox"/> Radio, General<br><input type="checkbox"/> Radio Operating<br><input type="checkbox"/> Radio Servicing <p><b>Railroad Courses</b></p> <input type="checkbox"/> Air Brake <input type="checkbox"/> Car Inspector<br><input type="checkbox"/> Locomotive Engineer<br><input type="checkbox"/> Locomotive Fireman<br><input type="checkbox"/> Railroad Section Foreman <p><b>Steam Engineering Courses</b></p> <input type="checkbox"/> Boilermaking<br><input type="checkbox"/> Combustion Engineering<br><input type="checkbox"/> Engine Running<br><input type="checkbox"/> Marine Engineering<br><input type="checkbox"/> Steam Electric<br><input type="checkbox"/> Steam Engines <p><b>Textile Courses</b></p> <input type="checkbox"/> Cotton Manufacturing<br><input type="checkbox"/> Rayon Weaving | <p><input type="checkbox"/> Textile Designing<br/> <input type="checkbox"/> Woolen Manufacturing</p> <p><b>Business and Academic Courses</b></p> <input type="checkbox"/> Accounting <input type="checkbox"/> Advertising<br><input type="checkbox"/> Arithmetic <input type="checkbox"/> Bookkeeping<br><input type="checkbox"/> Business Correspondence<br><input type="checkbox"/> Business Management<br><input type="checkbox"/> Certified Public Accounting<br><input type="checkbox"/> College Preparatory<br><input type="checkbox"/> Commercial<br><input type="checkbox"/> Cost Accounting<br><input type="checkbox"/> Federal Tax<br><input type="checkbox"/> First Year College<br><input type="checkbox"/> Foremanship<br><input type="checkbox"/> French<br><input type="checkbox"/> Good English<br><input type="checkbox"/> High School<br><input type="checkbox"/> Higher Mathematics<br><input type="checkbox"/> Illustrating<br><input type="checkbox"/> Motor Traffic<br><input type="checkbox"/> Postal Service<br><input type="checkbox"/> Salesmanship<br><input type="checkbox"/> Secretarial<br><input type="checkbox"/> Sign Lettering <input type="checkbox"/> Spanish<br><input type="checkbox"/> Stenography<br><input type="checkbox"/> Traffic Management |
|---|--|---|--|

Name..... Age..... Home Address.....  
 City..... State..... Present Position..... Working Hours ..... A.M. to..... P.M.

Canadian residents send coupon to International Correspondence Schools Canadian, Ltd., Montreal, Canada.  
 British residents send coupon to I. C. S., 71 Kingsway, London, W. O. 2, England.

**DISCOUNT TO DISCHARGED VETERANS—SPECIAL TUITION RATES FOR MEMBERS OF THE ARMED FORCES**



## THE CHEMICAL FORMULARY

By H. Bennett  
Vol. 7—1945 Edition

The latest and most up-to-date Formulary

Here are thousands and thousands of valuable formulas for making adhesives, flavors, beverages, cosmetics, drug products, insecticides, emulsions, garden specialties, food products, inks, lubricants, oils, plastics, paints and varnishes, photographic supplies, soaps and cleaners, and almost every other important product that you use daily in the home, workshop, office, or factory. You need no knowledge of chemistry—no experience in chemical laboratories, to profit from this extraordinary book . . . you can read it as you would a cook book! The directions are so remarkably clear that you can quickly and easily produce materials on which to found an extremely profitable business. Or you can merely indulge in the important hobby of making and repairing things for yourself and your family. Imagine yourself, without any technical experience and advanced knowledge of chemistry, producing such articles as lipsticks, vanishing creams, insecticides, glue, toothpastes, etc. It does seem fantastic, but it is nevertheless possible with THE CHEMICAL FORMULARY. Behind the contents of THE CHEMICAL FORMULARY stands the integrity and scientific knowledge and experience of some of America's leading industrial and research chemists. By all odds one of the most valuable books of this decade, and should pay for **\$6.00** itself a hundred-fold.

## IT'S FUN TO DRAW

A Complete Self-Instruction Course in 9 Divisions of Art

Anyone who has learned to write can learn to draw! This helpful book removes the mysticism that has surrounded art. By reducing the elements of drawing to its simple steps, it teaches THE BEGINNER to draw, and then to advance into more difficult subjects. For the practiced artist, it is a source book and veritable mine of information. This book guides you from the first stroke on paper to selling the finished art work. Includes specific instruction, advice, tricks, on—Still Life, Animals, Human Figure, Art Anatomy, Faces and Portraits, Lettering, Layouts, Cartooning, Advertising and Commercial Art, Illustrations, Color in Art, etc., etc., includes glossary of Art Terms, Supplies, Types of Work. Profusely illustrated with over 1000 SKETCHES and DRAWINGS. **\$1.00**



## Practical Lessons in HYPNOTISM

By Dr. Wm. Wesley Cook

Teaches you the best method of hypnotic practice. It is written in plain language, and all its statements are absolute facts and its illustrations are actual occurrences. This is a big 264 page book, complete and encyclopedic in its contents, which include the following chapters: History of Hypnotism—Qualifications of a Hypnotist—What Kind of a Subject—Favorable and Unfavorable Influences—Precautions to be Observed—How to Hypnotize—Degrees of Hypnosis—Clairvoyance—Self-Hypnotism and Auto-Suggestion—The Hypnotist's Secret—Hypnotism and Disease—Hypnotism in Business and Society—Hypnotism in the Professions—Post Hypnotism—Awakening a Subject—Mind-Reading, Telepathy—Miscellany—etc. Hypnotism is today acknowledged to be an exact science. There is no restriction upon the acquisition of this knowledge. Its blessings and powers belong to all who desire them and are willing to secure them. **\$2.00**

## IT'S FUN TO BUILD THINGS

Make and Fix Things For Your Home

The simplified picture-directions in this book guide you through the ABC's of every basic step right to the finished job. So easy you can't go wrong. Clear, easy-to-understand, non-technical language and more than 500 pictures. Just one article you make—or one repair job you do—with the help of this book, can easily save you many times the cost of the entire volume. Packed with hundreds of practical projects, ideas and suggestions.

Partial List of Things To Make

Window Seats, Cupboards, Closet Fittings, Panels, Hideaways for the Family Silver, Boxes and Chests, Folding Screens, Benches, Magazine Racks, Coffee Tables, and other "furniture." Bookshelves, Trick Stuff (folding bar, secret compartment, etc.), Painting and Finishing (Oil Stain, Shellac, Brushing Lacquer, Enamel, Paint), Ideas for Desks, Dressing Tables, End Tables, Shelf Units. Plus the information of all the tools and supplies needed, how to buy lumber, information on sawing, where to build, drawing your plans, etc. **\$1.50**

## PLASTICS Scientific and Technological

By H. Ronald Fleck

In the post-war period, the demand for plastic chemists is sure to be enormous. The subject is in its infancy and there are so many thousands of kitchen utensils and other gadgets waiting, at the present time, to be manufactured from hundreds of different kinds of plastic material, that the opportunity for specialization in this lucrative field simply cannot be overlooked. PLASTICS SCIENTIFIC AND TECHNOLOGICAL is an up-to-date and comprehensive and highly authoritative treatise for the chemist and technical student, covering the very latest scientific and technological aspects of the expanding plastic industry. It is replete with useful tables, diagrams, and data designed primarily for professional men and students who are looking for a more advanced treatment of this vitally important subject. Some of the chapters include: history of plastics, theoretical principles of polymerization, the chemistry of plastic materials, manufacture of plastic materials, synthetic elastomers, physical properties of thermoplastic materials, and thermo-setting materials, synthetic resins, synthetic fibers and textiles, adhesives, manufacture of dyes and molds, chemical analysis of raw materials, etc. **\$6.50**

## WATCHES

By F. J. Camm

An up-to-date book dealing with modern methods of repair, adjustment and timing. The book represents many years of practical experience with watches and is intended as a manual for all those interested in horology, professionally or otherwise. If you have a watch that is not running properly you will be able to repair it yourself. **\$2.50**

## A SMALL BUSINESS OF YOUR OWN

With Capital Investment From \$100 to \$2,000

By Harold S. Kahn

A most timely and important book, not only for the millions of returning servicemen who will shortly be mustered out, but for countless millions of war workers and ambitious men and women who are looking forward to the era of prosperity and a better financial future. Edited by the foremost writer on small business enterprises. It includes: BE YOUR OWN BOSS (with 98 different small businesses described and explained), GET A CIVIL SERVICE JOB (how to go about getting a lifetime government job), BEST POST-WAR JOB OPPORTUNITIES (with information on the newest industries), OPPORTUNITIES IN AVIATION, A FARM OF YOUR OWN (how to buy and operate your own farm), START A MAIL ORDER BUSINESS (how to select a product, start, operate and expand a mail order business—with case histories), 200 SPARE TIME MONEY MAKING IDEAS (many ideas for everyone, etc.). **\$1.00**

## DIESEL ENGINE OPERATION

Prepared Under the Direction of E. Molloy

It is intended and written for erectors, installation, marine and plant engineers, as well as anyone concerned with the practical side of Diesel Engine operations. The two-stroke and four-stroke cycle of combustion are clearly described and illustrated with diagrams and practical considerations involved in the installation and maintenance of cold start oil engines are fully dealt with. A complete book covering the field of Diesel Engine operation. **\$2.00**

KNICKERBOCKER PUB. CO., Dept. A-102, 120 Greenwich St., New York 6, N.Y.

KNICKERBOCKER PUB. CO. Dept. A-102  
120 Greenwich Street, New York 6, N. Y.

Send me the books I have checked below:

- |  |  |  |
|--|--|--|
| <input type="checkbox"/> The Chemical Formulary . . . . . \$6.00 | <input type="checkbox"/> Plastics . . . . . \$6.50                   | <input type="checkbox"/> 3,000 Mechanical Movements . . . . . \$2.98 |
| <input type="checkbox"/> It's Fun to Draw 1.00                   | <input type="checkbox"/> Watches . . . . . 2.50                      | <input type="checkbox"/> The ABC of Physics 3.50                     |
| <input type="checkbox"/> Hypnotism . . . . . 2.00                | <input type="checkbox"/> A Small Business of Your Own . . . . . 1.00 | <input type="checkbox"/> Rubber and Its Uses . . . . . 2.25          |
| <input type="checkbox"/> It's Fun to Build Things . . . . . 1.50 | <input type="checkbox"/> Diesel Engine Operation . . . . . 2.00      | <input type="checkbox"/> Jigs, Tools and Fixtures . . . . . 2.50     |

Name . . . . .  
Address . . . . .  
City . . . . . State . . . . .

## 3000 MECHANICAL MOVEMENTS

Every conceivable kind of mechanical motion and movement is briefly explained and illustrated in this unusually valuable and helpful book. As far as known, the only work in existence which aims to provide side by side suggestion sketches of the various methods in use for accomplishing any particular movement or work. Every engineer, inventor or mechanic finds the need of devising, simplifying or improving some mechanical process or method. No need to rely on memory or experience now! SUCH AS: Accumulators, Anti-friction, Ball and Socket, Bearings, Blowings, Brakes, Cams, Chain Gear, Chopping, Chucks, Circular Motions, Clutches, Conveying, Cranes, Cranks, Cutting, Doors, Drilling, Eccentrics, Engines, Expanding, Filtering, Gears, Governors, Grips, Grinds, Heating, Hinges, Hydraulics, Indicators, Journals, Levers, Links, Lowerings, Lubricators, Measuring and Weighing, Mixing, Nozzles, Parallel Motions, Pipes, Pivots, Power, Propulsion, Raising, Ratchets, Rotary Engines, Safety Appliances, Shafting Signals, Slides, Sounds, Speed, Spindles, Starting, Striking, Swivels, Traps, Turbines, Valves, Winders, Wipers, etc.

If you work with machinery of any kind, you need this book, 355 pages, with 3000 designs, Drawings and Sketches of Mechanical Movements, Devices, Appliances, Contrivances and Details—durably printed and bound in cloth. **ONLY \$2.98**

## THE ABC OF PHYSICS

By Jerome S. Meyer

Seldom has physics been presented in such an entertaining way. You can read this book as you would a novel for it contains no complicated diagrams, no mathematics, no involved and ponderous theories and no technical language. It is written entirely for the layman in the language of the layman . . . a positive revelation to the reader who wants a clear understanding of atomic structure, the electron, the radio, television, radio-photography, the 200 inch telescope, the electron microscope and scores of other important modern inventions. From the pages of this book you will discover the magic of matter, made up of quintillions of billions of molecules traveling at enormous speeds and behaving in countless ways to produce all the solids, liquids and gases that make up our world. In addition to remarkably clear explanations of the fundamentals of mechanics, heat, light, sound, magnetism and electricity, there are numerous biographical sketches of the great pioneers of science which add to the enjoyment of the book. "A good book on physics . . . a lucid book for the reader who would gain some insight into the subject" Waldemar Kaempfert in the Book-of-the-Month Club News. Profusely illustrated. **\$3.50**

## RUBBER AND ITS USE

By Harry L. Fisher

This authoritative and practical treatment of a most important subject should be of vital interest to everyone in the rubber industry—and of interest to everyone who has ever had any curiosity concerning the many uses to which rubber is put. Written in an unusually clear, non-technical style. Not only is natural rubber discussed and described in detail, but the new developments in synthetic rubber—rubber that is made from products that never grew on a tree—are described in a fascinating way. Some of the chapter headings include: history of the rubber industry, source and production of crude rubber, properties of crude and vulcanized rubber, compounding and vulcanizing rubber, synthetic rubber, latex manufacturing processes, elastomers and rubber derivatives. RUBBER AND ITS USES also includes a valuable list of references for supplementary reading, and is profusely illustrated with line drawings and photographs. **\$2.25**

## JIGS, TOOLS AND FIXTURES

By Philip Gates

This book is indispensable to anyone interested in mechanics, and is one of the most clearly written and comprehensive volumes ever published on this fascinating subject. It covers the drawing and design of equipment for practically all modern machine tools, with chapters on special equipment and drawing office procedure. It is profusely illustrated with clear line diagrams, and gives numerous examples for practice. Some of the chapters include mechanical drawing, sketching, first considerations in design of jigs, tools and fixtures, chucks and turning equipment, including mandrels, thread chucks, tap holders, and shaving tools, cutters, and a chapter on materials. This book also includes 22 valuable tables for milling cutters, tooth cutters, button dyes, spring dyes, plug gauges, drill bushes, cone angles, cutting speeds, etc. **\$2.50**

## HOW TO ORDER

**HOW TO ORDER:** Fill out coupon and mail today. All books guaranteed satisfactory, or money back at once. All books full size, beautifully printed, durably bound. If remittance enclosed, we pay postage. If C.O.D., sent plus postage. (NOTE: Due to newly increased postage rates, minimum C.O.D. total charges amount to 38c; we suggest payment with order.) **MONEY BACK GUARANTEE:** If not completely satisfied for any reason, return books and get money back at once.



••• ARE YOU ASKING •••

# "How Can I Make Sure of My Peace Time Success?"

THAT'S a vital question for you to answer soon.

For postwar adjustment will change many things. Jobs that are good now may be very different then. War emphasis is on production in the plant—peace may shift it to the office, store, management and sales. Overalls and slacks may, for many, give way to white collars and dresses.

Now is the time to plan and prepare—to get ready for the new opportunities. By training now in spare time, you can get in on the ground floor when peace comes.

LaSalle home study training—complete, authoritative, moderate in cost—will quickly prepare you for your chosen field, ready for the preferred positions. In our 37 years, over a million ambitious men and women have found it interesting and helpful in securing promotions or better jobs.

Send the coupon at right for full, free information. Or if you are not sure which is the best field for you, write us for our frank counsel—without obligation.



**LASALLE** EXTENSION UNIVERSITY  
A Correspondence Institution  
DEPT. 983-R CHICAGO 5, ILL.

I am interested in preparing myself for permanent success. Please send me your free 48-page booklet on the training course I have checked below.



- Accounting
- Bookkeeping
- Business Correspondence
- Business English
- Salesmanship
- Law: LL.B. Degree
- Business Law
- Effective Speaking
- C. P. A. Coaching
- Industrial Management
- Executive Management
- Traffic Management
- Stenotypy

Name \_\_\_\_\_ Age \_\_\_\_\_  
Present Position \_\_\_\_\_  
Address \_\_\_\_\_  
City and State \_\_\_\_\_

**clip and mail this coupon today!**

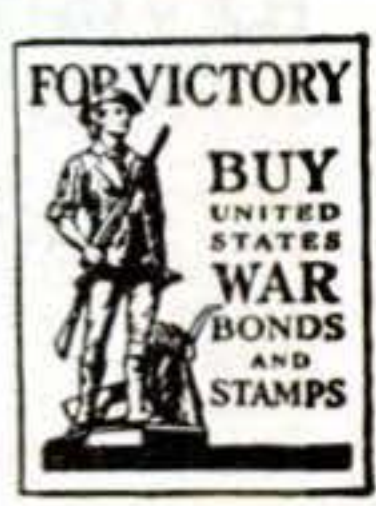





**J. E. SMITH, President**  
National Radio Institute  
Our 31st Year of Training Men  
for Success in Radio

**I WILL SEND  
A SAMPLE  
to PROVE I can Train You  
BE A RADIO**

**Good Jobs Like These  
Go To Men I Train**



**Farmer Made \$600 Extra**—"About six months after I enrolled I started making extra money in radio. I am a farmer and just work on radios evenings and stormy days. That brought me a profit of \$600 in the last year."—**BENNIE L. ARENDS**, RFD 2, Alexander, Iowa.



**\$50 a Week From Own Shop**—"Am making over \$50 a week profit from my own shop. Have another N.R.I. graduate working for me. I like to hire N.R.I. men because they know radio."—**NORMAN MILLER**, Hebron, Neb.



**Runs Repair Shop for Sears Roebuck**—"I was a barber and not working steadily. After about 30 lessons in your Course, I came with Sears Roebuck and now run their radio service shop here, at a nice steady income."—**NORMAN P. FORNOFF**, 1923 E. 13th St., Davenport, Iowa.



**\$50 a Month in Spare Time**—"I have a spare time Radio and Electrical business of my own which has been very profitable, due to the efficient training I received from your Course. Last year I averaged over \$50 a month."—**FRED H. GRIFFIE**, Route 3, Neville, Pa.



**Transmitter Network Engineer**—"I began my N.R.I. training while 16 years old and still in high school. Am now transmitter engineer here for one of the big networks."—**THEODORE CAMPBELL**, Johnstown, Pa.



**RADIO SERVICING** (picture above) pays Technicians good money, spare or full time. **RADIO OPERATORS** (picture at right) find interesting work in U. S. Broadcasting and other types of Stations.

**Get into a Busy Field With  
a Bright Peacetime Future**

**YOU MAY NEVER SEE A BETTER  
TIME TO GET STARTED IN RADIO**

I want to give every man who's interested in Radio, either professionally or as a hobby, a copy of my Lesson, "Getting Acquainted with Receiver Servicing"—absolutely **FREE!** It's a valuable lesson. Study it—keep it—use it—without obligation! And with it I'll send my 64-page, illustrated book, "Win Rich Rewards in Radio," **FREE.** It describes many fascinating jobs in Radio, tells how N.R.I. trains you at home in spare time, how you get practical experience with **SIX KITS OF RADIO PARTS** I send.



**My Radio Course Includes  
TELEVISION • ELECTRONICS  
FREQUENCY MODULATION**

Think of the **NEW** jobs that Television, Frequency Modulation, Electronics, and other developments will open in the future! I will train you to be ready to cash in when amazing wartime developments are converted to new civilian uses.

**A TESTED WAY TO**



# LESSON FREE

## at Home in Spare Time to

# TECHNICIAN



The "Sample" Lesson will show you why the easy-to-grasp lessons of the N.R.I. Course have paved the way to good pay for hundreds of other men. I will send it to you without obligation. MAIL THE COUPON!

### Good Future for Trained Men in Radio, Television, Electronics

The Radio Repair business is booming NOW. There is good money fixing Radios in your spare time or own full time business. And trained Radio Technicians also find wide-open opportunities in Police, Aviation and Marine Radio, in Broadcasting, Radio Manufacturing, Public Address work, etc. Also, there are good jobs operating, maintaining and installing Radio equipment used in schools, hotels, factories, churches, hospitals, offices, theatres, trains. Send for FREE book which pictures your opportunities.

Think of the boom coming when new Radios can be made! Think of the backlog of business built up in all branches of Radio! And think of even greater opportunities when Television, FM, Electronics, can be offered to the public! Use only a few hours of your spare time each week to get into Radio NOW. You may never again see the time when it will be so easy and profitable to get started. Mail coupon for complete information.

### Many Beginners Soon Make \$5, \$10, a Week EXTRA in Spare Time

The day you enroll I start sending EXTRA MONEY JOB SHEETS to help you make EXTRA money fixing Radios in spare time while learning. You LEARN Radio principles from my easy-to-grasp Lessons—PRACTICE what you learn by building real Radio Circuits with the six kits of Radio parts I send—USE your knowledge to make EXTRA money while getting ready for a good full time Radio job.

### Mail Coupon for FREE Lesson and Book

MAIL THE COUPON for your SAMPLE LESSON and FREE 64-page book. See how practical it is to train at home in your spare time. Read the details about my Course. See the fascinating jobs Radio offers. Read letters from men I trained, telling what they are doing, earning. No obligation. Just MAIL COUPON in an envelope or paste it on a penny postal.

**J. E. SMITH, President, Dept. 5JP3 National Radio Institute, Pioneer Home Study Radio School, Washington 9, D. C.**

**GOOD PAY**

### You Build These and Other Radio Circuits with 6 Big Kits I Send



**MEASURING INSTRUMENT** (above) you build early in Course. Use it in practical Radio work to make EXTRA money. Vacuum tube multimeter, measures A.C., D.C. and R.F. volts, D.C. currents, resistance, receiver output.

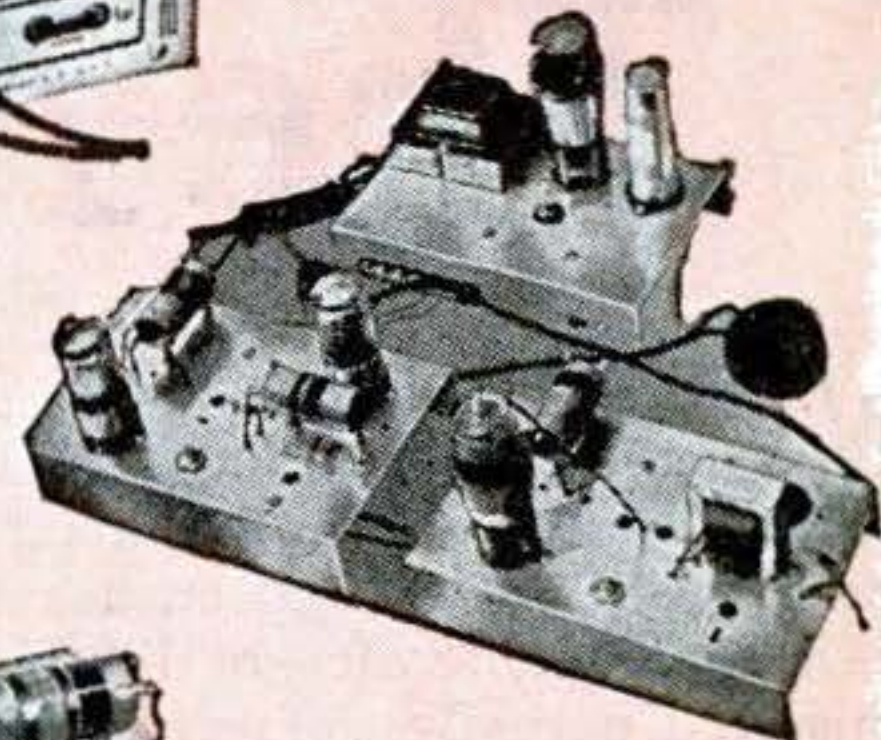

**SUPERHETERODYNE CIRCUIT** (above) Pre-selector, oscillator-mixer-first detector, i.f. stage, diode detector-a.v.c. stage, audio stage. Bring in local and distant stations on this circuit you build yourself!

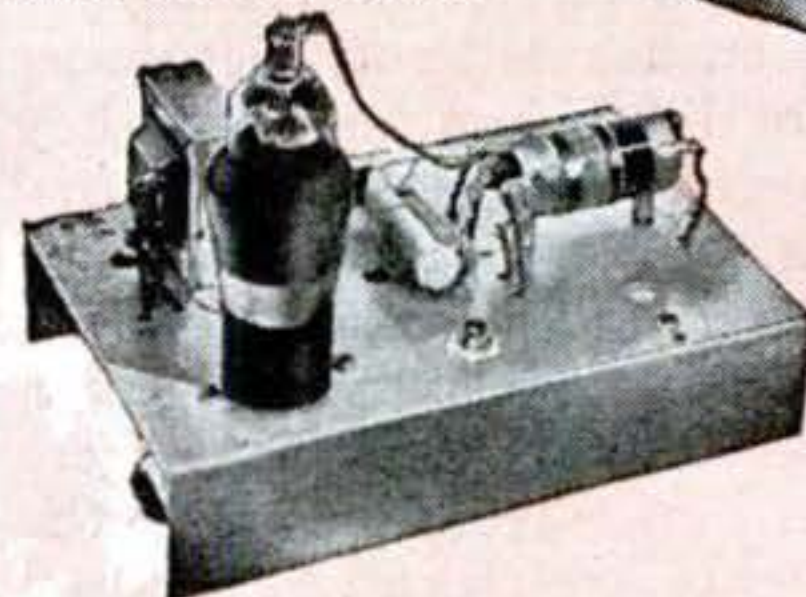

**A.M. SIGNAL - GENERATOR** (above) Build it yourself! Provides amplitude-modulated signals for test and experimental purposes. Gives valuable practice!



### GOOD FOR BOTH 64 PAGE BOOK SAMPLE LESSON FREE

**J. E. SMITH, President, Dept. 5JP3 National Radio Institute, Washington 9, D. C.**  
Mail me FREE, without obligation, Sample Lesson and 64-page book, "Win Rich Rewards in Radio." (No salesman will call. Please write plainly.)

Name ..... Age.....  
Address .....  
City ..... Zone ..... State ..... 4FR





THE GREATEST  
POWER ON  
EARTH!

# The Magic of Mind

**WERE** the great personages of the past victims of a stupendous hoax? Could such eminent men of the ancient world as Socrates, Pericles, and Alexander the Great have been deluded and cast under the spell of witchcraft—or did the oracles whom they consulted actually possess a *mysterious faculty of foresight*? That *the human mind can truly exert an influence over things and conditions* was not a credulous belief of the ancients, but a known and demonstrable fact to them. That there exists a wealth of infinite knowledge just beyond the border of our daily thoughts, which can be aroused and commanded at will, was not a fantasy of these sages of antiquity, but a dependable aid to which they turned in time of need.

It is time you realized that the rites, rituals and practices of the ancients were not superstitions, but subterfuges to conceal the marvelous workings of natural law from those who would have misused them. Telepathy, projection of thought, the materializing of ideas into helpful realities, are no longer thought by intelligent persons to be impossible practices, but instead, *demonstrable sciences*, by which a greater life of happiness may be had.

One of America's foremost psychologists and university instructors, says of his experiments with thought transference and the powers of mind—"The successes were much too numerous to be merely

lucky hits and one can see no way for guessing to have accounted for the results." *Have you* that open-minded attitude of today which warrants a clear, positive revelation of the facts of mind which intolerance and bigotry have suppressed for years? *Advance with the times*; learn the truth about your inherited powers.

*Let this free book explain*

The Rosicrucians (NOT a religious organization) have been leaders in introducing the ancient wisdom of mental phenomena. Established throughout the world for centuries, they have for ages expounded these truths to those thinking men and women who sought to make the utmost of their natural faculties. Use the coupon below—avail yourself of a pleasing book of interesting information which explains how you may acquire this most *unusual* and *helpful* knowledge.

## The ROSICRUCIANS (AMORC)

USE THIS COUPON

Scribe L.P.T.  
The Rosicrucians, AMORC,  
San Jose, California.

I am sincerely interested in knowing more about this unseen, vital power which can be used in acquiring the fullness and happiness of life. Please send me, without cost, the book, "THE MASTERY OF LIFE," which tells me how to receive this information.

Name \_\_\_\_\_

Address \_\_\_\_\_

State \_\_\_\_\_





# Will You Let Me PROVE I Can Make YOU a New Man?



## LET ME START SHOWING YOU RESULTS LIKE THESE

<p><b>5 inches of new Muscle</b></p> <p>"My arms increased 1 1/2", chest 2 1/2", forearm 7/8". —C. S., W. Va.</p>	<p><b>What a difference!</b></p> <p>"Have put 3 1/2" on chest (normal) and 2 1/2" expanded." —F. S., N. Y.</p>
<p><b>Here's what ATLAS did for ME!</b></p> <p>John Jacobs <b>BEFORE</b>      John Jacobs <b>AFTER</b></p>	<p><b>For quick results I recommend CHARLES ATLAS</b></p> <p>"Am sending snapshot showing wonderful progress." —W. G., N. J.</p> <p><b>GAINED 29 POUNDS</b></p> <p>"When I started, weighed only 141. Now 170." —T. K., N. Y.</p>

**CHARLES ATLAS**

Awarded the title of "The World's Most Perfectly Developed Man" in international contest — in competition with ALL men who would consent to appear against him.

This is a recent photo of Charles Atlas showing how he looks today. This is not a studio picture but an actual untouched snapshot.

## Here's What Only 15 Minutes a Day Can Do For You

I DON'T care how old or young you are, or how ashamed of your present physical condition you may be. If you can simply raise your arm and flex it I can add SOLID MUSCLE to your biceps—yes, on each arm—in double-quick time! Only 15 minutes a day—right in your own home—is all the time I ask of you! And there's no cost if I fail.

I can broaden your shoulders, strengthen your back, develop your whole muscular system INSIDE and OUTSIDE! I can add inches to your chest, give you a vise-like grip, make those legs of yours lithe and powerful. I can shoot new strength into your old backbone, exercise those inner organs, help you cram your body so full of pep, vigor and red-blooded vitality that you won't feel there's even "standing room" left for weakness and that lazy feeling! Before I get through with you I'll have your whole frame "measured" to a nice, new beautiful suit of muscle!

## What's My Secret?

"Dynamic Tension!" That's the ticket! The identical natural method that I myself developed to change my body from the scrawny, skinny-chested weakling I was at 17 to my present super-man physique! Thousands of other fellows are becoming marvelous physical specimens—my way. I give you no gadgets or contraptions to fool

with. When you have learned to develop your Strength through "Dynamic Tension" you can laugh at artificial muscle-makers. You simply utilize the DORMANT muscle-power in your own God-given body—watch it increase and multiply double-quick into real solid MUSCLE.

My method—"Dynamic Tension"—will turn the trick for you. No theory—every exercise is practical. And, man, so easy! Spend only 15 minutes a day in your own home. From the very start you'll be using my method of "Dynamic Tension" almost unconsciously every minute of the day—walking, bending over, etc.—to BUILD MUSCLE and VITALITY.

## FREE BOOK "Everlasting Health and Strength"

In it I talk to you in straight-from-the-shoulder language. Packed with inspirational pictures of myself and pupils—fellows who became NEW MEN in strength, my way. Let me show you what I helped THEM do. See what I can do for YOU! For a real thrill, send for this book today. AT ONCE. CHARLES ATLAS, Dept. 19, 115 East 23rd St., New York 10, N. Y.

**CHARLES ATLAS, Dept. 19**  
**115 East 23rd St., New York 10, N. Y.**

I want the proof that your system of "Dynamic Tension" will help make a New Man of me—give me a healthy, husky body and big muscular development. Send me your free book, "Everlasting Health and Strength."

Name.....  
 (Please print or write plainly)

Address.....

City.....State.....



# FREE!

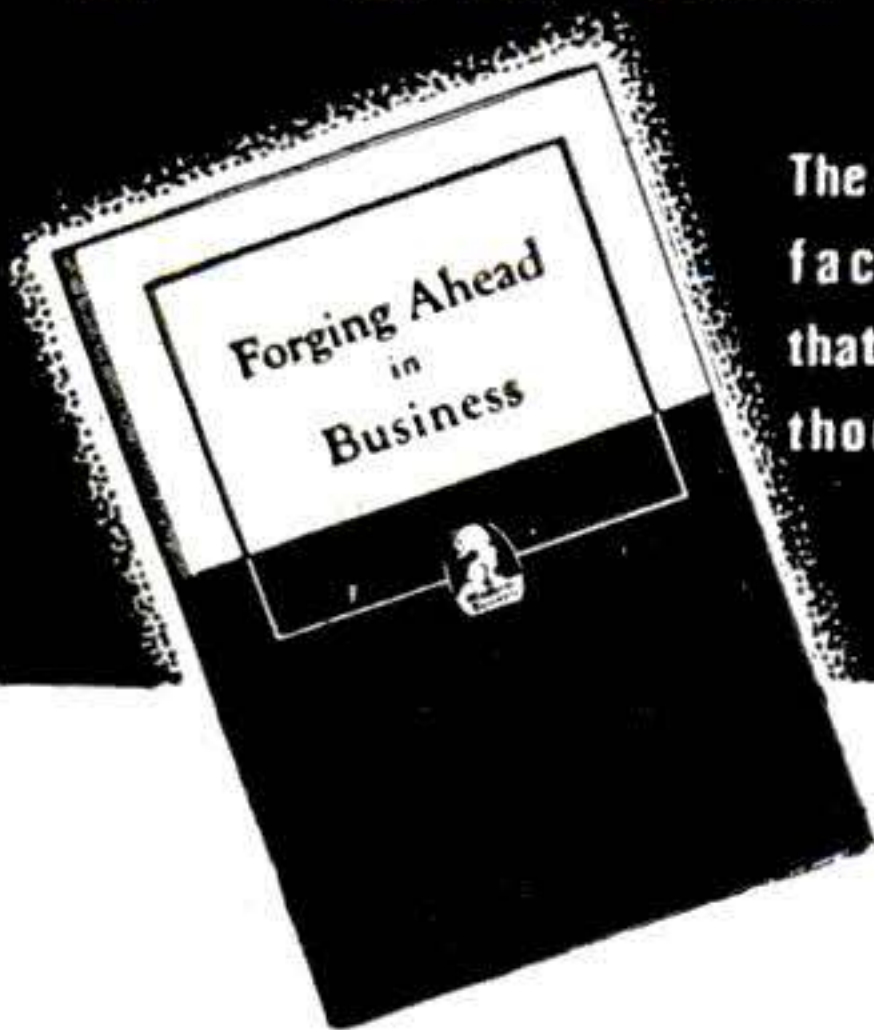

The famous 64-page, fact-packed book that has stimulated thousands of men!

"Forging Ahead in Business" is a practical, thoughtfully-written book with "punch" and common sense on every page. It carries a message of vital importance to every man who wants to make more money, get a better job and improve his station in life.

### Partial Contents:

- Law of Success
- Highway of Achievement
- Forging a Career
- Making Decisions
- Organized Knowledge
- Failure and Success

### Noted Contributors

Among the prominent men who have contributed to the Institute's training plan, which is described in "Forging Ahead in Business," are: Thomas J. Watson, President, International Business Machines Corp., Clifton Slusser, Vice President, Goodyear Tire & Rubber Co.; Frederick W. Pickard, Vice President and Director, E. I. du Pont de Nemours & Co.

Simply return the coupon below, and your FREE copy of "Forging Ahead in Business" will be mailed to you.

### MAIL COUPON TODAY

ALEXANDER HAMILTON INSTITUTE  
 Dept. 303, 71 West 23rd Street, New York 10, N. Y.  
 In Canada: 54 Wellington Street, West, Toronto 1, Ont.  
 Please mail me, without cost, a copy of the 64-page book—"FORGING AHEAD IN BUSINESS."

Name.....  
 Firm Name.....  
 Business Address.....  
 Position.....  
 Home Address.....

Buy War Savings Bonds and Stamps regularly.

## Write your own Future in Photography

Prepare now for a well-paid position today and a postwar career that is different, fascinating and profitable. Photography offers ever-increasing opportunities for both men and women. FREE book tells how N. Y. I. experts can quickly train you at home or thru resident, day or evening instruction in our up-to-the-minute N. Y. studios. Start now. ALL branches of black and white, motion picture and COLOR photography. Write TODAY!

**New York Institute of Photography**  
 Dept. 5 10 West 33 Street New York 1, N. Y.

## HIGH SCHOOL AT HOME

Most well-paid positions demand high school training. Without it, or equivalent, you can't advance to the full extent of your abilities in any trade, business or profession. Whatever your age, however you're situated, IT ISN'T NECESSARY TO STRUGGLE UNDER THAT HANDICAP. I.C.S., famous for more than 50 years, enables you to start your own high school in your own home. You're in a class by yourself—study in your spare time—acquire a high school education at astonishingly low cost. Authoritative texts! Rapid Progress! Write today for free booklet. International Correspondence Schools, Box 7632-L, Scranton 9, Pa.

## DRAFTING



More good jobs now in Drafting. Learn AT HOME in spare time (or at our Chicago School). Send postcard for FREE TRIAL LESSON and see how easy to learn and get a good job.

**CHICAGO TECHNICAL COLLEGE**  
 M-216 Tech Bldg., 2000 S. Mich. Ave.  
 Chicago 16, ILL.

## Learn this Profitable Profession



**IN 90 DAYS AT HOME**

## Money-Making Career Open to Men and Women, 18 to 50

Hundreds of men and women between 18 and 50 make \$10 to \$20 in a single day giving scientific Swedish Massage and Hydro-Therapy treatments. There is big demand from doctors, hospitals, sanatoriums and clubs. Graduates earn large full time incomes from these or in private practice in their own offices. Others make good money from home treatments given in spare time. Learn this interesting, money-making profession in your own home, through our



home study course. Same instructors as in our nationally known resident school. You can win independence and prepare for future security by qualifying for your Diploma. Course can be completed in 3 to 4 months. Many earn while they learn. Begin your training at once.

### Anatomy Charts & Booklet FREE

Enroll now and we will include, at no extra cost, many needed supplies. Fit yourself to help meet growing demand for massage now and after the war. Send the coupon at once for complete details, Anatomy Charts and 32-Page Illustrated Booklet, FREE, postpaid.

**THE COLLEGE OF SWEDISH MASSAGE**  
 Dept. 570L, 100 East Ohio St., Chicago 11, Illinois  
 Please send me FREE and postpaid, Anatomy Charts, 32-page Booklet and complete details on Home Training.

Name.....  
 Address.....  
 City.....State.....



# INVENTORS

## NOW Is the Time to PATENT and SELL Your Invention

Get  
**FREE COPY**

Now, more than ever before, is the right time to patent your invention. Why? Because manufacturers everywhere presently engaged in war production are looking ahead to the future by buying up patent rights now, so they will have new and attractive items to make and sell for civilian consumption as soon as the war is over. This is what happened during and after the last war. Hence, the smart thing for you to do is to look ahead to the future too. Protect your invention and yourself by applying for a patent now.

### Patent Guide Shows What To Do

Our "Patent Guide for the Inventor" answers many important questions concerning Patents that inventors constantly ask. It tells what facts, details, drawings, sketches, etc. are necessary to apply for a Patent; how to protect your invention through dated and witnessed disclosure; how to do this AT ONCE to safeguard your rights; how Patent Office Records can be checked to determine whether the invention is probably patentable before filing fees need be paid; discusses costs involved and a practical way these can be paid as the application progresses. It tells how some inventors secured financial backing; how many simple inventions have proved large commercial successes; how Patents covering improvements also can be profitably utilized and marketed; tells countless other facts of interest.

### Why You Need Expert Assistance

The Patent Laws were enacted for your benefit—to give you protection for the features of your invention which are Patentable. But these features must be legally and concisely set forth in the form of "claims." This phase of the procedure is so complex that the Patent Office advises the Inventor to engage a competent Registered Patent Attorney. We maintain a large staff—carefully trained registered patent attorneys—expert draftsmen—experienced searchers—to serve you. We have been serving inventors for more than 20 years.

### Take First Step Now

With the Patent Guide you will receive also Free a "Record of Invention" form which will enable you at once to establish the date of your invention, before you file your Patent application. This step costs you nothing yet may be vital to your success. Remember—in Patent Matters, ACTION is IMPORTANT. Delay can be costly. Mail the coupon in an envelope, or paste it on a penny postcard NOW.

**CLARENCE A. O'BRIEN & HARVEY B. JACOBSON**

*"Worthy of your Trust"*

Registered Patent Attorneys

52-J Adams Building  
Washington 4, D. C.

Get This  
**FREE BOOK**

**IMMEDIATELY MAIL COUPON TODAY!**

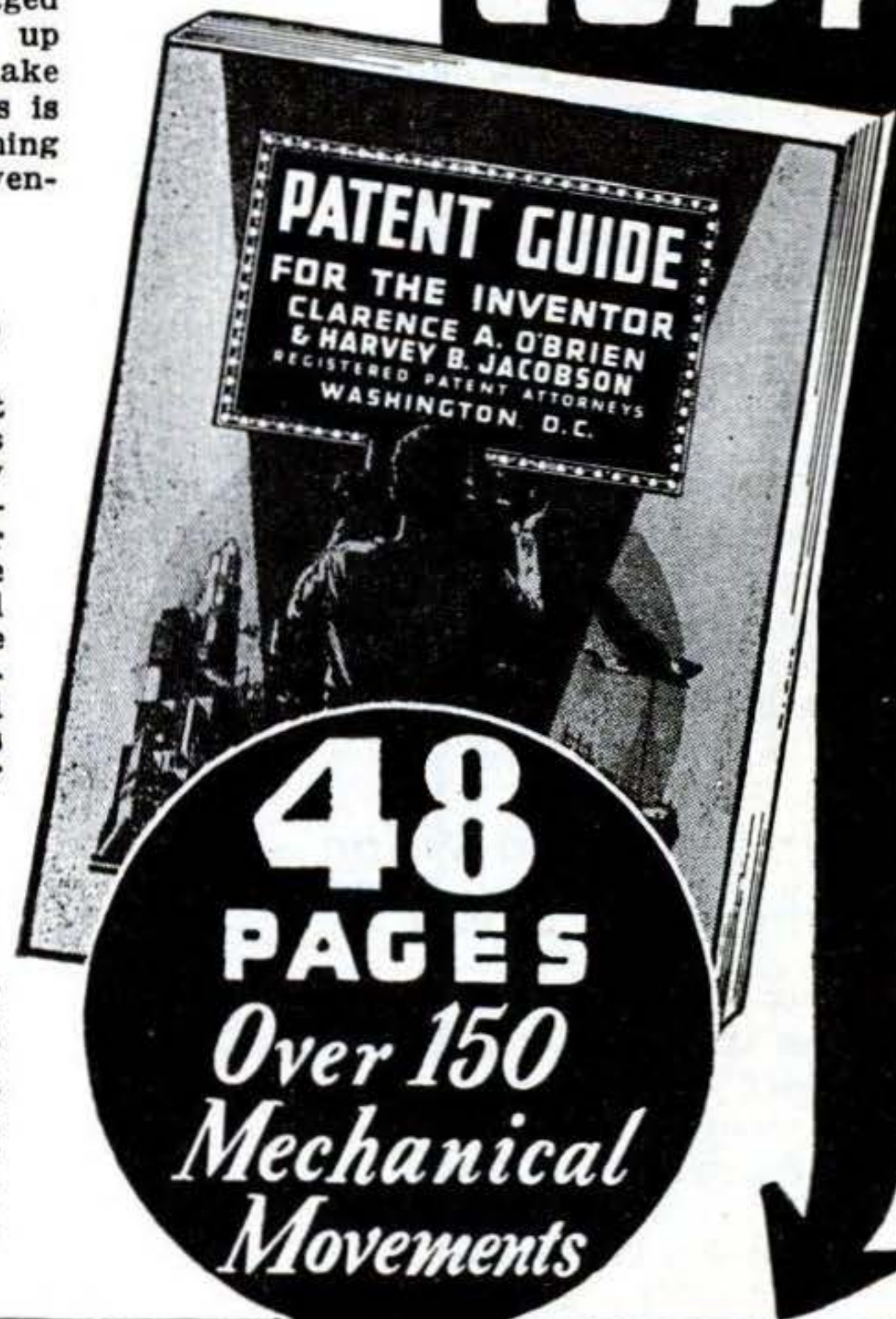

**CLARENCE A. O'BRIEN & HARVEY B. JACOBSON**

CLARENCE A. O'BRIEN & HARVEY B. JACOBSON  
Registered Patent Attorneys before the United States Patent Office  
52-J Adams Building, Washington, D. C.

Please send me your 48-Page "Patent Guide for the Inventor" and your specially prepared "Record of Invention" form FREE. This request does not obligate me.

Name \_\_\_\_\_

Address \_\_\_\_\_

City \_\_\_\_\_ State \_\_\_\_\_

(Please write or print plainly.)



# Readers Say:

## Ways to Reclaim Old Fluorescent Tubes

IN ANSWER to B.R.L., there are two uses I can suggest for burned-out fluorescent lighting tubes—one for recreation and the other for utility. Throw a tube into a swiftly flowing stream, and with a .22 caliber rifle shoot off the end. As the tube bobs up higher, keep on shooting until it sinks. For utility, the larger size might be used as the outer tube of a Liebig condenser. Cut off the ends and clean out the fluorescent material; then take two large corks and cut two holes in them. Into these place a short piece of tubing and slide the corks into a tube longer than the fluorescent one. Connect this with rubber tubing to a retort and place the other end over a flask. By running water through the outer tube from bottom to top, you can distill liquids.—W.C.N., Rock Hill, S.C.

## This Man Has a Vision of the Ideal Trailer

LIKE a lot of other men, I want to build a house trailer. Present trailers are all right in their way, but they are built primarily for use around tourist camps where electricity and water pressure are available. I want a trailer that carries an independent electric system and water system of its own. I know there are small gasoline-electric generators built, but they are heavy-duty affairs, and they weigh and cost a lot.

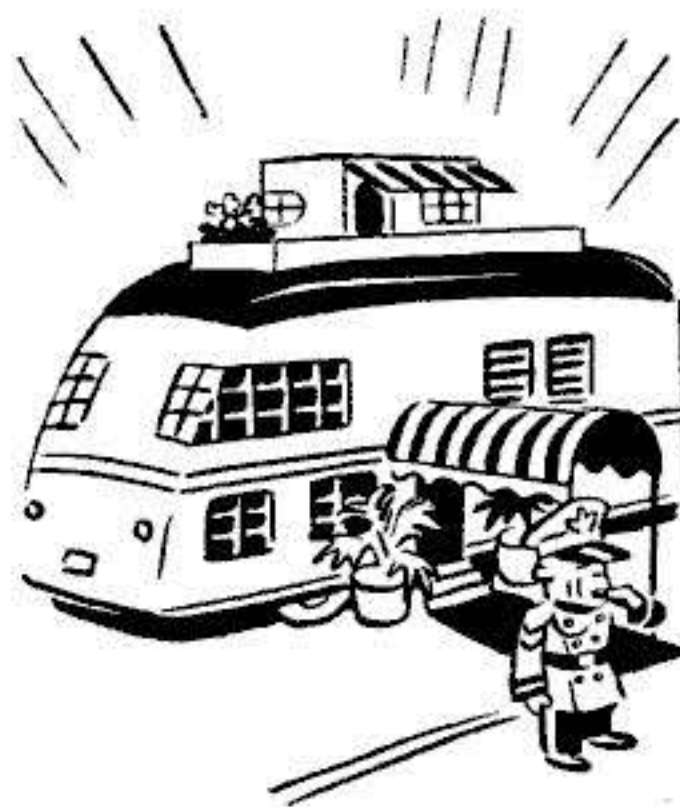

How about rigging up a very small gasoline motor to drive a car generator and battery system? I think an electric refrigerator would be convenient in a trailer. So would an electric razor.

As for water, the only thing I have thought of is a water tank with air pressure. I see that airplane oxygen bottles are for sale at the war-surplus outlet stores. How would

they do for pressure tanks? Would a built-on hand pump do for it, or could a small compressor be connected to the car motor? Maybe gasoline service stations would let you fill the pressure tank from their air hose for a price.

Butane gas is very nice for cooking. With this and water pressure, it would be simple to have a small water heater, and with hot and cold running water, a shower bath could be arranged. I have been thinking of using Plexiglas for windows, and perhaps a small bomber blister for a skylight. Outside of these things, I would like a gas-operated refrigerator, and I'd like to know if a small one could be made to use butane gas.—J. R. N., Bell Gardens, Calif.

## Here Are Suggestions for Braking Power Snow Sled

I HAVE some ideas that may help P. H. with his braking trouble on his power snow sled. The first, and probably the most efficient, way would be to mount a marine transmission between the motor and the propeller that would enable him to reverse the propeller and allow it to serve as a brake. This method would bring him to a complete stop regardless of the snow conditions. Maybe flaps would do the trick. They do all right on Army and Navy fighters and bombers. They could be closed to lie flat along the fuselage of the sled and opened either hydraulically or electrically. A search of war surpluses now for sale should reveal something usable. What I had in mind was an electrically operated device called an actuator. It would snap the flaps open in a fraction of a second and slow down the sled considerably, although it would not bring it to a complete stop.—A. R., Bedford, Ohio.



A. R. has ideas, but they bring up practical difficulties. A reversible propeller would, more than likely, snap the shaft if it were used suddenly to brake a swift-moving sled. Flaps opened toward the wind would also snap; away from the wind, they would have only a slight effect. Perhaps the drag device used on dog sleds is the best type of brake. It's simply a flexible board fixed to the forward end of the sled and suspended from the rear by a spring. When the operator steps on it, a serrated steel blade at the end digs into the snow or ice and stops the sled.—Ed.



This **FREE BOOK** Helps..

# INVENTORS

TO PROTECT THEIR INVENTIONS



### MODERN BUSINESS WANTS INVENTIONS

Practical and novel inventions are in big demand today. The opportunity for quick money is enticing. Sales sources are many if your invention has merit. But, be *sure*—before you place your device in strange hands—that it is fully protected. A United States Patent gives you this protection. *The first step toward inventive success always is—and always has been—the application for a U. S. Patent. There is no other way to protect your invention in accordance with the laws of this country.*

**MAKE THIS RECORD NOW** If you have an invention, and wish to secure it for the future, act at once. Have it dated now and recorded in our office. We will send you this **FREE Invention Record Form** fully describing the nature of your invention. Make a sketch of its main features. Mail it to us and we will record the date it was received in our office. The earlier the date the better your chance of combating rival inventors who may lay claim to your idea later. *Don't delay a single minute in taking this important step. Your whole future may depend upon it. Mail the coupon for our FREE Invention Record Blank and New FREE Book Today!*

**HOW WE SERVE YOU AS REGISTERED PATENT ATTORNEYS** The U. S. Patent Office strongly recommends—unless the inventor is familiar with such matters—that he employ the services of a Registered Patent Attorney in the preparation of his Patent Application. We are Registered Patent Attorneys fully qualified to represent you at the Patent Office. We have had long experience in studying hundreds of types of inventions. This gives us the ability to judge your invention and to describe it accurately and convincingly in technical language. It gives us the perception to center arguments upon those details of your invention which, in our judgment, will be looked upon most favorably by the Patent Office Examiner.

Mail the coupon today for our new **FREE Book**, "How to Protect, Finance and Sell Your Invention," and our **FREE Invention Record Form**—maybe this step will pave the way to future security for you and your family. Act Today!

We paint no glowing road to fortune—but if you have an invention . . . if it serves a definite new need . . . if the public accepts it—we can tell you it may provide the security and benefits you are seeking.

**McMORROW & BERMAN**  
Patent Attorneys  
142-D Atlantic Building  
Washington 4, D. C.

**FREE**  
Invention Record

**Know How Successful Inventors Protect and Sell Their Inventions**

Our new **FREE Book** is the latest volume on Inventions and Patents off the press. It's a book every inventor should have. Mail the coupon today for our book "How to Protect, Finance and Sell Your Invention" and learn these important facts—

- How to know if there is a prior U. S. patent on your invention.
- How to save steps in getting patent action.
- How we prepare your application for presentation to the Patent Office.
- How you may patent an improvement on something in use now.
- How to obtain funds to patent and promote your invention.
- How to find a buyer or backer for your invention.
- How to protect yourself in making royalty agreements.

These and many other inventive facts you'll learn by reading our new **FREE Book**, "How to Protect, Finance and Sell Your Invention."

**Mail COUPON NOW!**  
**McMORROW & BERMAN**  
PATENT ATTORNEYS  
142-D Atlantic Building, Washington 4, D. C.  
Send me your new **FREE book**, "How to Protect, Finance and Sell Your Invention",—and "Invention Record" form at once. I understand that this request does not obligate me.

NAME..... ADDRESS.....  
CITY..... STATE.....  
(Write or print name clearly)

Buy War Savings Bonds and Stamps regularly.



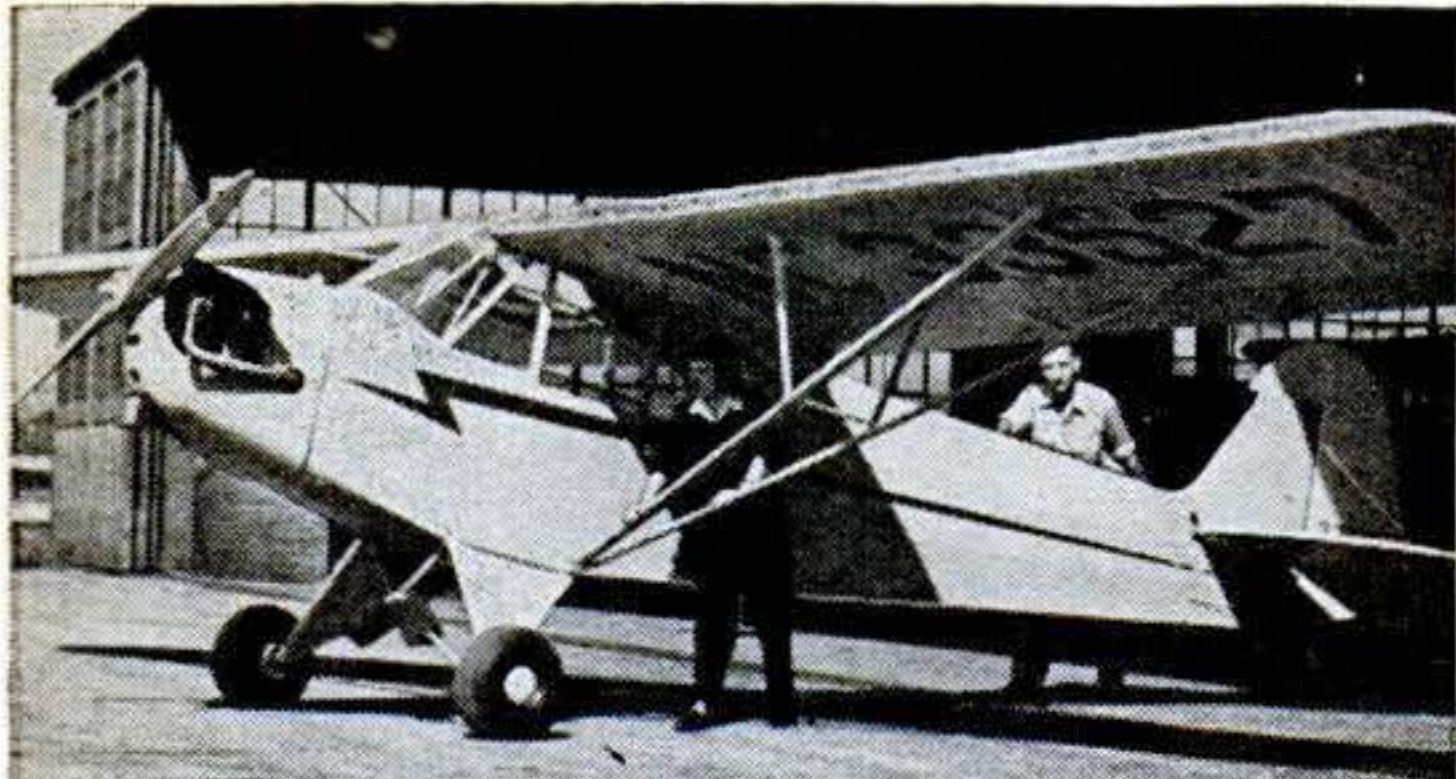

## New Booklet Shows You With Over 50 Photographs

You'll really go for the "How to Fly a Piper Cub" booklet. It takes you on a typical flight lesson . . . from pushing the Cub out of the hangar to landing it and putting it away. Written and directed by a certified flight instructor. Includes many other features and full-color pictures of Piper Cubs. For booklet send 10c in stamps or coin for postage-handling. Piper Aircraft Corporation, Dept. PS95, Lock Haven, Penna.



**Readers Say:**

### P.S.M. Spells Relaxation for This Active GI

I'VE BEEN with Patton's army from the day I hit Europe to the mopping-up process that saw the war's end in the European Theater of Operations, and your magazine has given me many moments of relaxation. I can even forget sights like Buchenwald by thumbing my worn copies of POPULAR SCIENCE.—Cpl. G. F., APO, New York City.

### Gus Wilson Saves Money for a Perplexed Motorist

MY FAVORITE article has always been the story about Gus's Model Garage. Some time ago, I read where Gus's genius for trouble shooting was put to a test in finding a short in a car's wiring system. He discovered it in a wire connecting with the trunk lid of the car. A week ago, at Delaware Water Gap, Pa., I ran into a similar difficulty. At sundown, after driving most of the day with no trouble at all, I switched on my dim lights. They were on for a second, then they flicked off and then on, and so on. Each time they went off, my ammeter flew to full discharge. When I switched them off, the ammeter registered normally until I turned on the lights again. Any position on my light switch gave the same reaction.

For a time I was at a loss for an answer. Then I remembered Gus's case. I pulled over to the side of the road, and asked my wife to look at the rear lights. There weren't any. So then I told her what I had read in POPULAR SCIENCE, and I diagnosed the case. Sure enough, when I opened my rear-deck lid, I found that my suitcase was hitting the wire that ran from the body to the deck lid. I removed the suitcase, and my troubles were over. Thanks for a swell magazine, and special thanks to Gus for saving me a repair bill and a possible fine.—J. W. C., Drexel Hill, Pa.

-IN CASE I GET STALLED





**AUDELS REFRIGERATION & AIR CONDITIONING GUIDE.....\$4**

New from Cover to Cover—1280 Pages, Fully Illus. Covering basic principles, servicing, operation & repair of household, commercial & industrial refrigeration & air conditioning. A gold mine of essential important facts for engineers, servicemen, users.

**AUDELS CARPENTERS & BUILDERS GUIDES—4 Vols. ....\$6**

A practical illustrated trade assistant on modern construction for carpenters, joiners, builders, mechanics and all woodworkers. 4 vols., 1600 pages, 3700 illustrations, flexible covers. Pocket size. Each volume sold separately \$1.50 a vol.

**AUDELS AUTOMOBILE GUIDE.....\$4**

A practical quick ready reference book for auto mechanics, service men, operators & owners. Explains theory, construction & servicing of modern motor cars, trucks, buses & auto type Diesel engines. 1540 pages, fully illustrated. 55 chapters. Indexed. A standard book for mechanics. New fluid drive covered.

**AUDELS DIESEL ENGINE MANUAL.\$2**

A practical, concise treatise with questions and answers on the theory, operation and maintenance of modern diesel engines including General Motors 2 cycle Diesel. 384 pages, fully illus., flexible binding, pocket size. All details plainly brought out, this book is of extreme value to engineers, operators & students.

**AUDELS WIRING DIAGRAMS.....\$1**

210 Pages. Illustrated. Gives practical facts on wiring of electrical apparatus. It shows clearly how to wire apparatus for practically all fields of electricity. Each diagram is complete & self-explanatory. Highly Endorsed Pocket Companion.

**AUDELS PLUMBERS & STEAMFITTERS GUIDES—4 Vols. ....\$6**

A Practical Trade Assistant & Ready Reference. Explains in plain language & by clear illustrations, diagrams, charts, graphs, pictures principles of modern plumbing practice including Marine Pipe Fitting and Air Conditioning. 4 Vols.—1670 Pages—3642 Diagrams. Pocket size. Each Vol. Sold Separately \$1.50 a Vol.

**AUDELS SHEETMETAL WORKERS HANDY BOOK.....\$1**

Practical inside information. Fundamentals of Sheet Metal Work. 388 pages. Illustrated. 11 sections. Clearly written. Essential & important facts, figures, pointers in everyday language. Ref. Index.

**AUDELS SHEETMETAL PATTERN LAYOUTS.....\$4**

Developed by Experts for Sheet Metal Workers, Layout Men & Mechanics. A Practical Encyclopedia in 10 Sections, size 7 x 10 x 2—1125 Pages—350 Layouts—1600 Illustrations. 1001 Key Facts. Fully indexed for ready reference in answering your layout problems. Covers all phases of sheet metal work including Pattern Cutting, Pattern Development & Shop Procedure.

**AUDELS ANSWERS ON BLUE PRINT READING.....\$2**

For Mechanics & Builders. Covers all types of blue print reading including ship & airplane. 376 pages, fully illustrated.

**AUDELS NEW MACHINIST & TOOLMAKERS HANDY BOOK....\$4**

Covers modern machine shop practice in all its branches. 5 practical books in 1. New from cover to cover. Tells how to set up & operate lathes, screw and milling machines, shapers, drill presses and all other machine tools. 1600 pages, fully illustrated, 5 x 6 1/2 x 2. Indexed. 5 sections. 1—Modern Machine Shop Practice. 2—Blue Print Reading & How to Draw. 3—Calculations & Mathematics for Machinists. 4—Shop Physics. 5—How to Use the Slide Rule. 60 chapters. Easy to read and understand. A shop companion that answers your questions.

**AUDELS MATHEMATICS & CALCULATIONS FOR MECHANICS \$2**

Mathematics for home study or reference. 700 pages, 550 illus. Practical mathematics from beginning. How to figure correctly. Easy, correct methods covering a complete review. Ill. & Indexed.

**AUDELS HANDY BOOK OF PRACTICAL ELECTRICITY .....\$4**

For maintenance engineers, electricians & all electrical workers. 1440 Pages, 2600 Illus. Covers important electrical information in handy form—including Marine Wiring, Radio Principles, Welding. Indexed. A Key to a practical understanding of electricity.

**AUDELS RADIOMANS GUIDE.....\$4**

A key to the practical understanding of radio including Frequency Modulation, Television, etc., Aircraft & Marine Radio. For radio engineers, servicemen, amateurs. 772 pages. 400 Illustrations & Diagrams. Photos. Review Questions & Answers, Reference Index. Authentic, clear, concise.

**AUDELS ELECTRONIC DEVICES....\$2**

Tells What You Want to Know About Electric Eye. Easily Understood. Covers photo-electric cells & their applications. Amplifiers, illumination, frequencies, voltage, photocell, tubes, Ohm's Law, wiring diagrams, etc.

**AUDELS WELDERS GUIDE.....\$1**

A concise, practical text on operation & maintenance of all welding machines for all mechanics. Over 400 pages, illustrated. Covers all methods of electric and acetylene welding including airplane work.

**AUDEL, Publishers, 49 W. 23 St., N. Y. 10**



**AN AUDEL GUIDE IS A GOOD FRIEND!**

Use the brains and experience of others in these Guides of the Trades. Save time and money with right methods, short cuts, labor saving ideas. CHECK NOW! You can look over any Audel Guide in your home. Start the Easy Payments if satisfied.

**CUT HERE MAIL ORDER**

**THEO. AUDEL & CO., 49 W. 23 St., New York 10, N.Y.**

Please mail me for 7 days' free examination the books marked (X) below. I agree to mail \$1 in 7 days on each book or set ordered, and to further mail \$1 a month on each book or set ordered until I have paid purchase price.

If I am not satisfied with Guides I will return them.

- Audels REFRIGERATION & Air Conditioning Guide . \$4.
- Audels POWER PLANT ENGINEERS GUIDE . 4.
- Audels PUMPS, HYDRAULICS & AIR COMPRESSORS 4.
- Audels WELDERS GUIDE . 1.
- Audels BLUE PRINT READING . . . . . 2.
- Audels SHEET METAL WORKERS Handy Book . . . 1.
- Audels SHEET METAL PATTERN LAYOUTS . . . . 4.
- Audels AIRCRAFT WORKER . . . . . 1.
- Audels MATHEMATICS and CALCULATIONS . . . 2.
- Audels MACHINISTS & TOOLMAKERS Handy Book . 4.
- Audels MECHANICAL Dictionary . . . . . 4.
- Audels AUTOMOBILE GUIDE . . . . . 4.
- Audels DIESEL ENGINE MANUAL . . . . . 2.
- Audels MARINE ENGINEERS Handy Book . . . . 4.
- Audels SHIPFITTERS Handy Book . . . . . 1.
- Gueths MECHANICAL DRAWING COURSE . . . . 1.
- Rogers DRAWING and DESIGN . . . . . 2.
- Audels MILLWRIGHTS and Mechanics Guide . . . 4.
- Audels CARPENTERS and Builders Guides (4 vols.) . 6.
- Audels PLUMBERS and Steamfitters Guides (4 vols.) . 6.
- Audels MASONS and Builders Guides (4 vols.) . . 6.
- Master PAINTER and DECORATOR . . . . . 2.
- Audels GARDENERS & GROWERS GUIDES (4 vols.) . 6.
- Audels ENGINEERS and Mechanics Guides Nos. 1, 2, 3, 4, 5, 6, 7 and 8 complete . . . 12.
- Audels Answers on Practical ENGINEERING . . . 1.
- Audels Aids to ENGINEERS EXAMINATION . . . . 2.
- Audels ELECTRICIANS EXAMINATIONS . . . . . 1.
- Audels WIRING DIAGRAMS . . . . . 1.
- Audels Handy Book of PRACTICAL ELECTRICITY . 4.
- Audels ELECTRICAL POWER CALCULATIONS . . . 2.
- Audels ELECTRICAL GUIDES at \$1. each . . . . 10.
- Audels ELECTRONIC DEVICES . . . . . 2.
- Audels ELECTRIC Dictionary . . . . . 2.
- Audels RADIOMANS GUIDE . . . . . 4.
- Audels NEW ELECTRIC LIBRARY at \$1.50 a Volume Vols. I, II, III, IV, V, VI, VII, VIII, IX, X, XI, XII.

Name \_\_\_\_\_  
 Address \_\_\_\_\_  
 Occupation \_\_\_\_\_  
 Employed by \_\_\_\_\_ P.S.M.



# 1 pt. of Pyroil

(IN CRANKCASE)

# 1 oz. of Pyroil

(With EVERY 5 GAL. GAS)

# ...ADDS MILES TO YOUR CAR!

It's one thing to keep your motor clean—but that isn't enough. The maintenance of proper lubrication is equally vital. That is why your gas station attendant prescribes Pyroil in regular dosages. It removes sludges, gums, carbon formations—but, even more, it maintains a clinging film of oil on piston and cylinder walls. That means less frictional wear—less rust and corrosion—more miles of carefree driving.

Manufactured and Guaranteed by Pyroil Company,

W. V. Kidder, Founder, 982 Main Street, La Crosse, Wis.

## Pyroil adds life to your car! . . .



### PYROIL COMPANY

982 Main Street, La Crosse, Wisconsin

I want my car to last and run properly. Please tell me more about Pyroil and how it can accomplish this for me.

Name.....

Address.....

City or Town.....State.....



## Handicapped Machinist Submits Better Name for Lazy Tong

ANSWERING the request for a better name for the so-called lazy tongs, I submit "extension pliers." It is the term I have used for this most useful tool for a good many years. A veteran of World War I, I was retired as a first lieutenant and rated as totally and permanently disabled. Today I depend on my extension pliers for many things, even for tying and untying my shoes.



I operate a business and do considerable work in a machine shop, where I would be lost without the extension pliers to obtain tools and parts out of my reach and to pick up items of various kinds off the floor. During World War II, our shop has been turning out parts for aircraft engines, and I have depended on this tool to help me overcome my physical handicap. It is definitely not a lazy tongs, but a decided asset in my shop.

Not being able to find them in stores, I have made extension pliers both for myself and for other shop men. I have used heavier tools of this kind to extract castings from a die-casting machine and to lift a crucible from a furnace or heat-treating oven. Perhaps the heavier tool should be called "extension tongs."—L. T. H., Lawrence, Kan.

## How to Remove a Rock Ledge from Your Driveway

SOME time ago a reader requested a method for removing a ledge of hard rock that blocked his driveway. I have not seen a solution of his problem appear in your magazine since, so I submit the following suggestions, which I hope will be helpful. Build a hot wood fire on top of the ledge, and allow it to heat the rock to a considerable degree. Haul off the coals and throw a bucket of water on top of the ledge, which will crack up into slabs that can easily be picked off. I used this method on an engineering project in Vermont many years ago, and it worked very well. The sudden uneven expansion and contraction did the work.—R. K. C., Detroit, Mich.



# I'LL SHOW YOU HOW TO SUCCEED IN RADIO

Here's the right training for Big Post-War Pay!

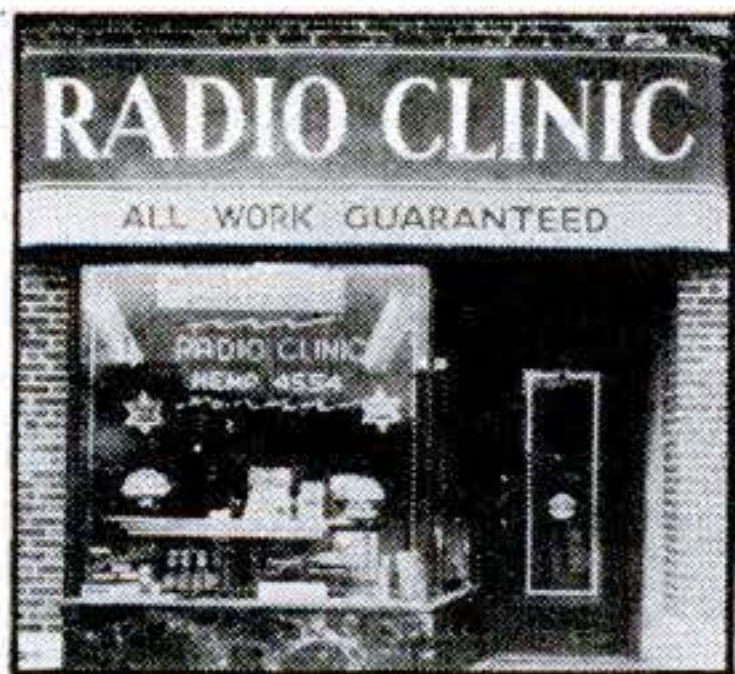

A RADIO SERVICE BUSINESS OF YOUR OWN

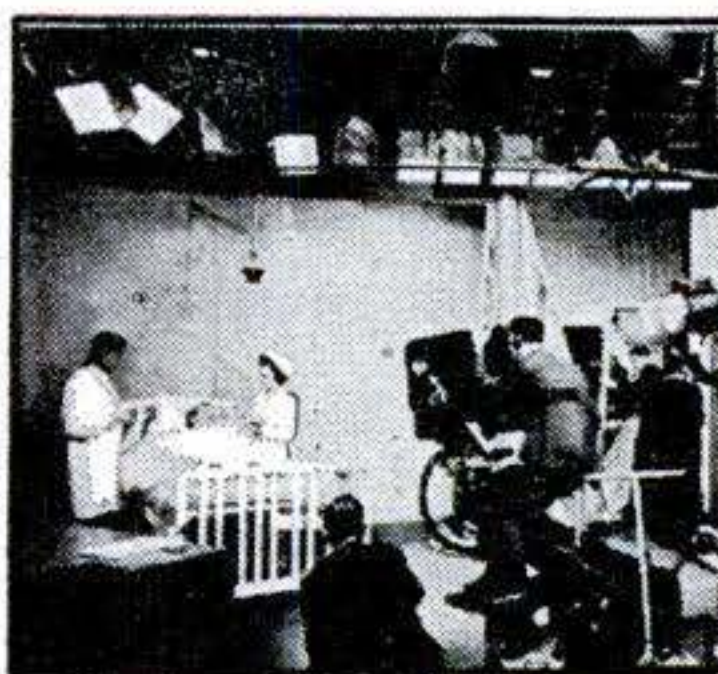

A GOOD JOB IN RADIO & TELEVISION BROADCASTING



RADIO-ELECTRONIC SERVICE ENGINEER



F. L. Sprayberry, one of the country's foremost Radio Teachers.

# BE A RADIO-ELECTRONICIAN

**NOW! YOU CAN PREPARE AT HOME IN SPARE TIME FOR AMAZING OPPORTUNITIES AHEAD IN RADIO — ELECTRONICS — TELEVISION**

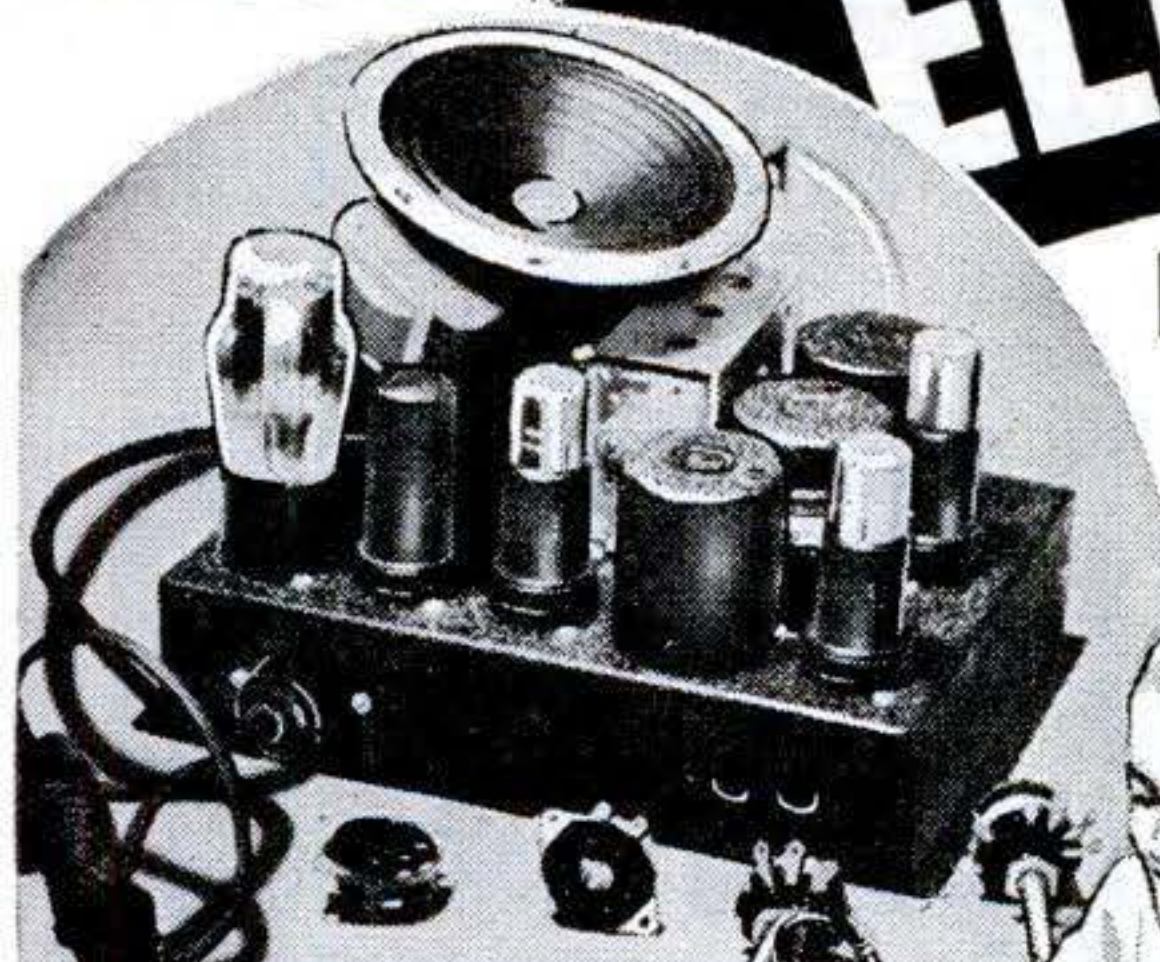

**I SUPPLY A FULL RADIO SET for practical easy LEARNING**



The offer I make you here is the opportunity of a lifetime. It's your big chance to get ready for a wonderful future in the swiftly expanding field of Radio-Electronics INCLUDING Radio, Television, Frequency Modulation and Industrial Electronics. Be wise! NOW'S the time to start. Opportunities ahead are tremendous! No previous experience is necessary. The Sprayberry Course starts right at the beginning of Radio. You can't get lost. It gets the various subjects across in such a clear, simple way that you understand and remember. And, you can master my entire course in your spare time. It will not interfere in any way

with your present duties. Along with your Training, you will receive my famous **BUSINESS BUILDERS** which will show you how to make some nice profits while learning.

**Prepares You for a Business of Your Own or Good Radio Job**

My training will give you the broad, fundamental principles so necessary as a background, no matter which branch of Radio you wish to specialize in. I make it easy for you to learn Radio Set Repair and Installation Work. I teach you how to install and repair Electronic Equipment. In fact, you'll be a fully qualified **RADIO-ELECTRONICIAN**, equipped with the skill and knowledge to perform efficiently and to make a wonderful success of yourself.

## SPRAYBERRY TRAINING GIVES YOU BOTH TECHNICAL KNOWLEDGE — SKILLED HANDS

There's only one right way to learn Radio Electronics. You must get it through simplified lesson study combined with actual "shop" practice under the personal guidance of a qualified Radio Teacher. It's exactly this way that Sprayberry trains you . . . . . supplying real Radio parts for learn-by-doing experience right at home. Thus, you learn faster, your understanding is clear-cut, you acquire the practical "know how" essential to a good-paying Radio job or a Radio business of your own.

cent of outlay for manufactured Test Equipment which is not only expensive but scarce.

**Read What Graduate Says "One Job Nets About \$26.00"**

"Since last week I fixed 7 radios, all good-paying jobs and right now I am working on an amplifier system. This job alone will net me about \$26.00. As long as my work keeps coming in this way, I have only one word to say and that is, 'Thanks to my Sprayberry training' and I am not afraid to boast about it."—ADRIEN BENJAMIN, North Grosvenordale, Conn.

### DON'T PUT IT OFF!

Get the facts about my training—now! Take the first important step toward the money-making future of your dreams. All features are fully explained in my big, illustrated FREE Catalog which comes to you along with another valuable FREE book you'll be glad to own. Mail Coupon AT ONCE!

### JUST OUT! FREE!

"How to Read Radio Diagrams and Symbols"

. . . . . a valuable new book which explains in simple English how to read and understand any Radio Set Diagram or circuit. Includes translations of all Radio symbols. Send for this FREE book now, and along with it I will send you another big FREE book describing my Radio-Electronic training.



## GET FREE BOOKS

**SPRAYBERRY ACADEMY OF RADIO**  
F. L. Sprayberry, President  
Room 5595, Pueblo, Colorado

Please rush my FREE copies of "How to MAKE MONEY in RADIO, ELECTRONICS and TELEVISION," and "How to READ RADIO DIAGRAMS and SYMBOLS."

Name . . . . . Age . . . . .

Address . . . . .

City . . . . . State . . . . .

(Mail in plain envelope or paste on penny postcard)



# INVENTORS

YOU'VE NEVER HAD A GREATER  
*Opportunity!*

GET THESE BOOKS--THEY'RE FREE--THEY TELL YOU WHAT TO DO

## Many Patents...If Secured Now...Have 3-Fold Chance to Become Profitable

Do you realize the value of your labor-saving or time-saving device . . . your improvement on a machine . . . your gadget that does some job better or does a job automatically that has never been done before? Man—then think this over!

NOW is the time to have your application prepared and prosecuted because American manufacturers are planning their coming peacetime production while they are out-producing the Axis. Thus—if your invention will help win the war, your Government may adopt it. Or—one or more war goods manufacturers may use it. Then—when peace comes—many opportunities may present themselves. Even if your invention is for peacetime use only—DON'T WAIT. Cash in on the present wave of "Post-war" thinking. **WHATEVER YOUR INVENTION—THERE IS NO BETTER TIME THAN THE PRESENT TO DO SOMETHING ABOUT IT.**

### HOW WE CAN HELP YOU

A thoroughly trained staff here at Victor J. Evans & Co., competently takes care of all the details for you . . . a procedure followed by many inventors. The experience of this staff is your assurance that your patent application will be prepared in the proper manner and speedily pushed to a conclusion. We've served men like you for nearly fifty years.

**GET THESE BOOKS—THEY'RE FREE—THEY TELL YOU WHAT TO DO**

These two big books—"Patent Protection" and "When and How to Sell Your Invention" have helped many inventors to success. They can help you! Sixty-four pages of valuable information and guidance, well illustrated. Show details of 115 mechanical movements. They may be just what you need to complete your invention.

Use the coupon NOW—while it's fresh in your mind. We'll rush the books to you with free "Evidence of Invention" form that will help you establish your claim.

**SUCCESS COMES TO THOSE WHO ACT!  
SEND THIS COUPON TODAY—**



## VICTOR J. EVANS & Co.

Registered Patent Attorneys for Nearly 50 years  
940-K MERLIN BUILDING • WASHINGTON-6, D. C.

Please send me your books "Patent Protection" and "When and How to Sell your Invention"—also important "Evidence of Invention" form, without cost or obligation.

Name.....

Address.....

City and State.....

## Get Started in Radio

### TEN "HOW-TO-DO" BOOKS

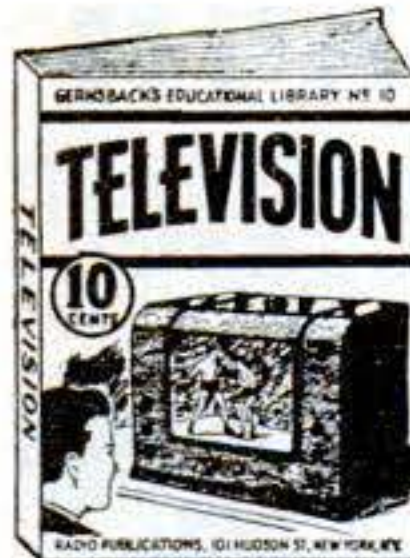

Get a solid foundation in radio by means of these 10c timely text books. Each clearly written, profusely illustrated, contains over 15,000 words. You'll be amazed at the wealth of information packed into these handy books. Excellent for reference—ideal for technical library. Your money back if not satisfied.

**10c each** 5 for 50c  
10 for \$1.00  
PREPAID

We cannot fill orders for less than 5 books.

- |  |                                     |
|--|-------------------------------------|
| No. 1—How To Make Four Doerle Short Wave Sets                      | No. 6—How To Have Fun With Radio    |
| No. 2—How To Make The Most Popular All-Wave 1 and 2 Tube Receivers | No. 7—How To Read Radio Diagrams    |
| No. 3—Alternating Current for Beginners                            | No. 8—Radio for Beginners           |
| No. 4—All About Aerials  | No. 9—Simple Electrical Experiments |
| No. 5—Beginners' Radio Dictionary                                  | No. 10—Television                   |

Remit by check or money order—register letter if you send cash or stamps.

RADIO PUBLICATIONS, 27A West Broadway, New York (7)

## STUDY ENGINEERING AT HOME

With A Chartered Educational Institution

Courses in **ENGINEERING**: Electrical, Civil, Mechanical, Drafting, Architectural, Steam, Aeronautical, Radio, Structural, Mining, Industrial, Highway, Petroleum, Marine, Chemical.  
Courses in **ARTS AND SCIENCES**: Philosophy; Education; Letters; Public Health; Medical Jurisprudence; Psychology; Sociology; Physics; Chemistry; Geology; Pol. Science; Theology; Law; Business and Commerce; Accounting; Mathematics; Statistics; Agriculture.  
McKinley-Roosevelt Incorporated, 4610-BC, Sheridan Road, Chicago 40, Illinois

## STAMMER?

This new 128-page book, "Stammering, Its Cause and Correction," describes the Bogue Unit Method for scientific correction of stammering and stuttering—successful for 44 years. Benj. N. Bogue, Dept. 1877, Circle Tower, Indianapolis 4, Ind.

GET THIS  
**FREE**  
BOOK!

## Learn PHOTOGRAPHY at Home

Splendid opportunities. Prepare in spare time. Practical basic training. Long-established school. Send for free book, "Opportunities in Photography." No obligation.

American School of Photography, 1315 S. Michigan Ave., Dept. 1366 Chicago 5, Ill.

# AVIATION Career

### DON'T WAIT UNTIL THE WAR IS OVER!

Since 1929 Cal-Aero Technical Institute has been specializing in modern, progressive training for Aeronautical Engineers and Master Aviation Mechanics. Prepare now for your Aviation Career. **BE READY!** Opportunities are great today and will be greater in tomorrow's Age of Flight. **DISCHARGED VETERANS**—Write us about Aviation Training as provided under "G. I. Bill of Rights."



**CAL-AERO TECHNICAL INSTITUTE**  
MAJOR C. C. MOSELEY PRES SINCE 1929  
FORMERLY CURTIS-WRIGHT TECHNICAL INSTITUTE

GRAND CENTRAL AIRPORT  
GLENDALE 1, CALIFORNIA  
(LOS ANGELES COUNTY)

### MAIL THIS COUPON TODAY!

Cal-Aero Technical Institute, Grand Central Airport, Glendale 1, California. Send information and illustrated catalogue on Aviation Training. **FREE . . . without obligation . . . Dept. PS-9**

Name..... Birth Date.....

Street.....

City..... State.....



Prepare Now for a Good-Pay Job in . . .

# RADIO ELECTRONICS

Learn at Home with . . .  
DEFOREST'S A-B-C  
\* *Synco-Graphic*  
TRAINING!

ONLY DEFOREST'S OFFERS  
YOU THE ADVANTAGE OF  
**MOVIES**  
TO HELP YOU LEARN  
RADIO - ELECTRONICS  
**FASTER - EASIER**  
... AT HOME

HERE'S WHAT DEFOREST'S  
A-B-C "SYNCO-GRAPHIC"  
TRAINING INCLUDES . . .

**A "LEARN-BY-SEEING" MOVIES**

To help you master important Radio Fundamentals, you use the more interesting, easier-to-understand, VISUAL method of Movie Instruction . . . with a genuine DeVry Movie Projector and Training Films!

**B "LEARN-BY-DOING" EXPERIMENTS**

You make 133 Fascinating Experiments with 8 Big Kits of Radio Parts and Assemblies. You build modern Radio Receiving Circuits, Electric Eye Devices, an Aviation Band Circuit, Public Address System, Wireless Microphone, etc. . . . all in your spare time, in your own "Home Laboratory."

**C 90 "SYNCO-GRAPHIC" LESSON TEXTS**

Prepared under the supervision of Dr. Lee DeForest, the "Father of Radio," inventor of the Audion Tube, and holder of over 300 Radio-Electronic patents.

**EMPLOYMENT SERVICE**

DEFOREST'S also provides an *Effective Employment Service* which helps you get started in this opportunity field of the future!

DR. LEE DEFOREST supervised the preparation of DEFOREST'S Training



**"SYNCO-GRAPHIC" TRAINING**

Makes learning easier because all lesson diagrams and charts are printed on sheets that **fold out**—keeping illustrations constantly synchronized to text. Eliminates confusion from frequent flipping of pages to refer back or ahead to illustrations mentioned in text. An **exclusive** DEFOREST'S feature.

DEFOREST'S TRAINING INCLUDES INSTRUCTION IN MOTION PICTURE SOUND EQUIPMENT, FM RADIO AND TELEVISION . . .

E. B. DeVry, President  
DEFOREST'S TRAINING, INC.  
2535-41 North Ashland Avenue, Dept. PS-B9  
Chicago 14, Illinois, U.S.A.

Please send me your "VICTORY FOR YOU!"  
BOOK and EQUIPMENT FOLDER

Name \_\_\_\_\_ Age \_\_\_\_\_

Address \_\_\_\_\_

City \_\_\_\_\_ Zone \_\_\_\_\_ State \_\_\_\_\_

If under 16, check here for special information.

If a veteran of World War II, check here.



Train now for the postwar Radio-Electronic job opportunities which wartime needs and experiences are developing! Use your *free time today* to store-up practical knowledge and experience for *good-pay* tomorrow! Trained men will be needed for the huge postwar requirements of Radio and Electronics, Broadcast Radio, Aviation Radio, Sound Picture Equipment, etc.—in manufacturing, merchandising, installing and servicing.

**EARN EXTRA MONEY—While You Learn**

When you learn Radio as DEFOREST'S teaches it, you can start a Business of Your Own—be your own boss, if you prefer! Even while learning, you may earn extra money doing Radio Servicing with your home as your "office." Get the facts about this fascinating home training in Radio-Electronics.

**SEND FOR FREE INFORMATION!**

Get "Victory for You!" book and Equipment folder. See how DEFOREST'S Training can help you towards good pay and a better job in a permanent industry. Also ask about DEFOREST'S Residential Training in the modern Chicago Laboratories shown at left. Mail coupon today.



**DEFOREST'S TRAINING, INC.**  
CHICAGO 14, ILLINOIS



**"I'll show YOU  
how to make yourself  
TOUGH as a MARINE**

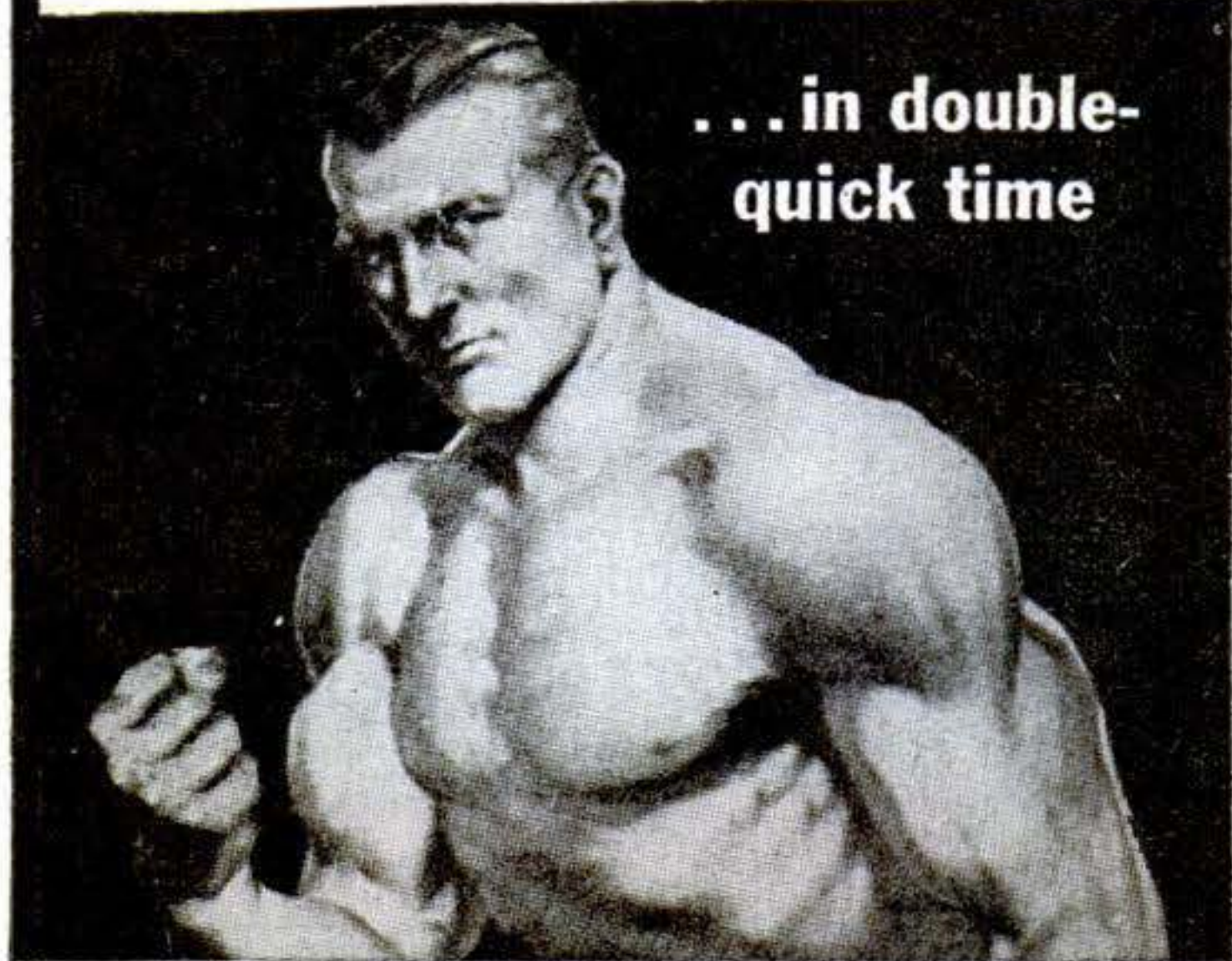

**...in double-quick time**

**...OR IT WON'T COST YOU A CENT!"**  
says *George F. Jowett*

**WORLD'S GREATEST BODY BUILDER**

Let me prove to YOU that you can put inches of dynamic muscles on your arms! Add inches to your chest! Broaden your shoulders and power-pack the rest of your body. I can do for you what I've done for thousands the world over, including many officers and men now in the U. S. and British Armed Forces!

**GIVE ME 10 MINUTES A DAY!**  
I'll Show You My Secrets Of Body Building

I'll help you learn the "Progressive Power Method" through which I rebuilt myself from a physical wreck to the holder of more strength records than any other living athlete or teacher! No matter how skinny or flabby you are, you can learn my methods right in your own home. Through my proved secrets I show you how to develop your power, inside and out, until YOU are fully satisfied that you are the man you want to be. "The Jowett System," says R. F. Kelly, Physical Director, Atlantic City, "is the greatest in the world!"

**Send Now For Jowett's Photo Book Of Famous Strong Men And Folio Of Inside Secrets**

Jowett's widely known Photo Book of Strong Men has guided thousands of weaklings to muscular power. Packed with photos of miracle men of might and muscle who started probably weaker and smaller than you are. Contains the story of Jowett, the thrilling adventure in the achievement of Power that has inspired thousands like you. This amazing book will be sent to you FREE! Also Jowett's Folio of World Famous Secrets—tells you how to gain strength and how to use your strength to astonish your friends and win success. Both FREE for limited time while they last. So Rush Coupon, before it is too late!

**Jowett Institute of Physical Culture**  
230 FIFTH AVE., DEPT. 882, NEW YORK 1, N. Y.

**JOWETT'S PHOTO BOOK OF  
FAMOUS STRONG MEN AND  
FOLIO OF INSIDE SECRETS**

**BOTH  
FREE!**



Jowett Institute of Physical Culture  
230 Fifth Ave., Dept. 882, New York 1, N. Y.

George F. Jowett:—Your offer sounds good to me. Rush me your Photo Book of Strong Men and Inside Secrets, both FREE.

NAME..... Age.....  
(Please Print Plainly. Include Zone No.)

ADDRESS .....

## START YOUR OWN REFRIGERATION REPAIR SHOP!

Exceptional opportunity for men of all ages up to 60 who like to work with tools. Learn to be a service mechanic in REFRIGERATION. Our practical, thorough home training is easy to grasp in your spare hours with a common school education. Learn how to start your own business with \$50.00 worth of tools in garage, basement or small shop. Or take a well paid job in this active field.

**FREE  
Booklet**

• Write for FREE BOOKLET today.

**MECHANICS TRAINING SCHOOL**

4701 West Pico Dept. S-9 Los Angeles 6, Calif.

## LEARN MOVIE PROJECTION THEATRE MANAGEMENT

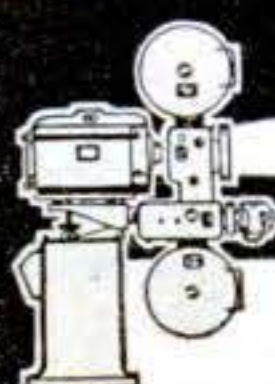

The Motion Picture Theatre Business offers big opportunities for trained men. Get into a fascinating field with a peace time future. Train at home in spare time. Free catalog. Established 17 years.

**THEATRE INSTITUTE** 385 Washington St., Elmira, New York

## MECHANICAL ENGINEERING PAYS!

This is the machine age. And back of every machine—every part—are the engineers who designed it, the trained mechanics who built it. No wonder there's high pay . . . many opportunities to advance . . . for these indispensable men. Be one of them! Don't stick in a rut! Let I.C.S. show you the way to success! These Schools, famous for more than 50 years, offer authoritative, practical Courses to meet the needs of almost any man in mechanical trades. Mechanical Engineering . . . Drafting . . . Mechanical Drawing . . . Shop Practice. Write today for free booklet.

International Correspondence Schools, Box 7632-L, Scranton 9, Pa.

## LEARN MONEY- MAKING CARTOONING

**IN SPARE TIME — by Easy Picture Chart Method**  
Same Simplified Method that has helped train creators of "Terry & Pirates," "Freckles," "Out Our Way," "Winnie Winkle," "Reg'lar Fellers," "Strange As It Seems," "The Neighbors," and many others. Earn while learning. Send 10c for Picture Chart (to test your ability). Samples of successful students, and full details. (State age.)  
Landon School of Cartooning, Dept. 4529, Philadelphia 1, Pa.



## Learn BAKING At Home

Baking is one of America's high industries in wages. Nearly depression-proof. Thorough basic home course lays sound foundation. If you have aptitude, write for FREE BOOKLET, "Opportunities in Commercial Baking."  
National Baking School, 1315 Mich. Ave., Dept. 1366, Chicago 5



**JIU-JITSU** HOW TO BECOME EXPERT, Keep Health, Have Fun. Teaching 35 years. Send 10c for sample lesson.  
Modern School Jiu-Jitsu, Dpt. AA, 5 W. 52 St., N.Y. 19

## PLASTICS TRAINED MEN NEEDED IN NEW, ESSENTIAL INDUSTRY

Plastics is a great new industry and the time to get started in it is *now*. Opportunities are unlimited. In your spare time, at home, you can prepare to enter this important field. A new, practical training plan is now ready to help you realize your ambitions and win success. Send name and address *today* for FREE information.

AMERICAN SCHOOL, Dept. P646  
Drexel Ave., at 58th St., Chicago 37, Ill.

Name.....

Street.....

City, State.....



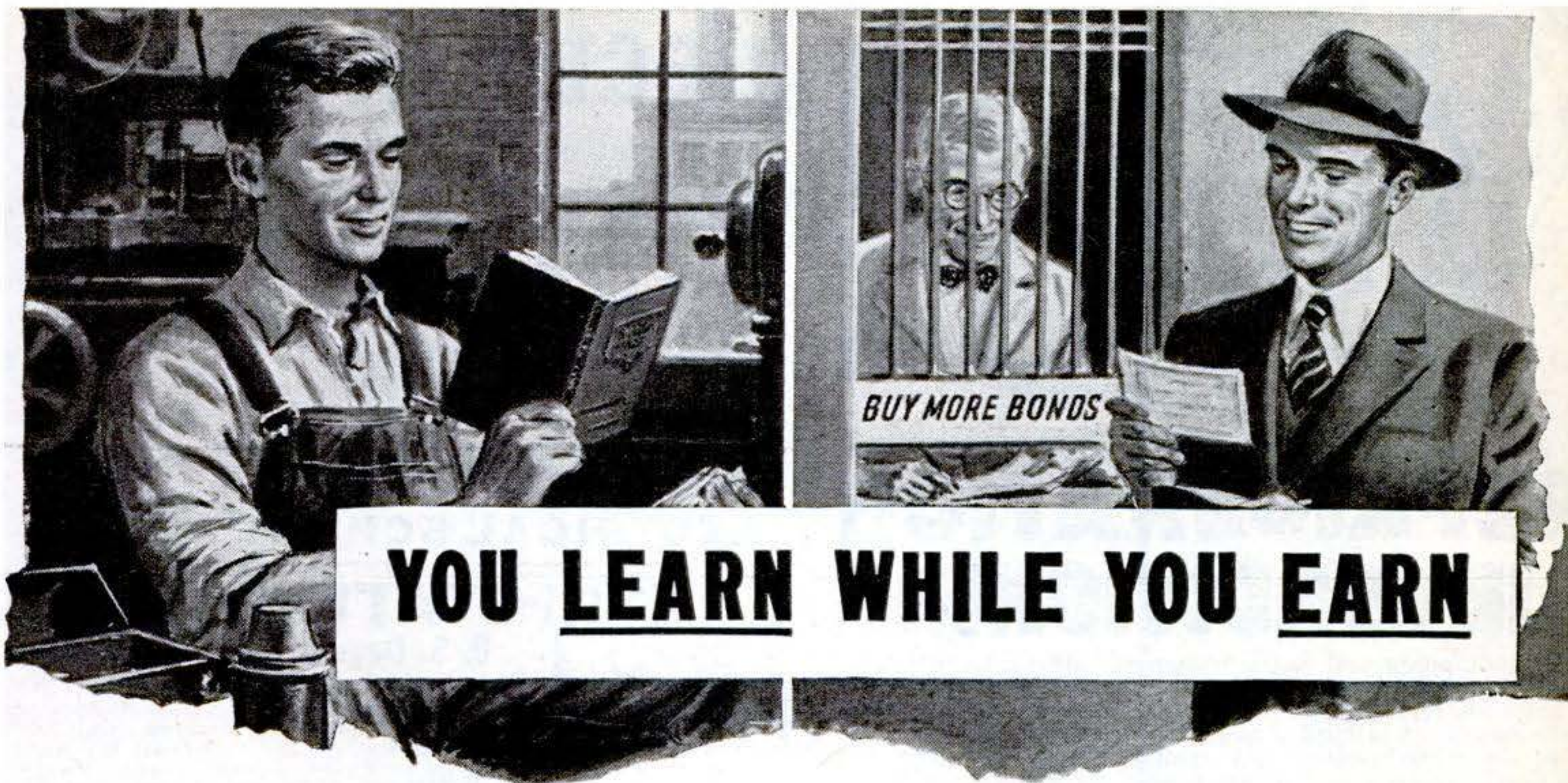

## YOU LEARN WHILE YOU EARN

**T**HERE'S rhyme and there's reason in that statement of I. C. S. advantages to *you*.

The courses of these famous schools are especially designed for study in your spare time. At work you prove and apply what you learn.

This system is backed up by 54 years of I. C. S. experience in training men in virtually every industrial and business field. It works so well that analysis shows about

99% of today's 100,000 active I. C. S. students are holding down jobs.

Many of the men and women now filling top positions in commerce and industry obtained their business or technical training from I. C. S. in just that way. What they achieved in *their* spare time, you can do in *yours*.

Start *now* — as they did — by marking and mailing this coupon:

### INTERNATIONAL CORRESPONDENCE SCHOOLS



BOX 7630-L, SCRANTON 9, PENNA.

Without cost or obligation, please send me full particulars about the course *before* which I have marked X:

- |   |  |  |  |
|---|--|--|--|
| <ul style="list-style-type: none"> <li><input type="checkbox"/> Air Conditioning and Plumbing Courses</li> <li><input type="checkbox"/> Air Conditioning</li> <li><input type="checkbox"/> Heating <input type="checkbox"/> Plumbing</li> <li><input type="checkbox"/> Refrigeration <input type="checkbox"/> Steam Fitting</li> <li><b>Chemistry Courses</b></li> <li><input type="checkbox"/> Chemical Engineering</li> <li><input type="checkbox"/> Chemistry, Analytical</li> <li><input type="checkbox"/> Chemistry, Industrial</li> <li><input type="checkbox"/> Chemistry, Mfg. Iron &amp; Steel</li> <li><input type="checkbox"/> Petroleum Refining <input type="checkbox"/> Plastics</li> <li><input type="checkbox"/> Pulp and Paper Making</li> <li><b>Civil Engineering, Architectural and Mining Courses</b></li> <li><input type="checkbox"/> Architectural Drafting</li> <li><input type="checkbox"/> Architecture</li> <li><input type="checkbox"/> Bridge and Building Foreman</li> <li><input type="checkbox"/> Building Estimating</li> <li><input type="checkbox"/> Civil Engineering <input type="checkbox"/> Coal Mining</li> <li><input type="checkbox"/> Contracting and Building</li> <li><input type="checkbox"/> Highway Engineering</li> <li><input type="checkbox"/> Lumber Dealer</li> <li><input type="checkbox"/> Reading Structural Blueprints</li> <li><input type="checkbox"/> Sanitary Engineering</li> <li><input type="checkbox"/> Structural Drafting</li> <li><input type="checkbox"/> Structural Engineering</li> <li><input type="checkbox"/> Surveying and Mapping</li> </ul> | <ul style="list-style-type: none"> <li><b>Electrical Courses</b></li> <li><input type="checkbox"/> Electrical Drafting</li> <li><input type="checkbox"/> Electrical Engineering</li> <li><input type="checkbox"/> Power House Electric</li> <li><input type="checkbox"/> Practical Electrician</li> <li><input type="checkbox"/> Practical Telephony</li> <li><input type="checkbox"/> Telegraph Engineering</li> <li><b>Internal Combustion Engines Courses</b></li> <li><input type="checkbox"/> Auto Technician <input type="checkbox"/> Aviation</li> <li><input type="checkbox"/> Diesel-Electric</li> <li><input type="checkbox"/> Diesel Engines <input type="checkbox"/> Gas Engines</li> <li><b>Mechanical Courses</b></li> <li><input type="checkbox"/> Aeronautical Engineering</li> <li><input type="checkbox"/> Airplane Drafting</li> <li><input type="checkbox"/> Flight Engineer</li> <li><input type="checkbox"/> Foundry Work</li> <li><input type="checkbox"/> Heat Treatment of Metals</li> <li><input type="checkbox"/> Industrial Engineering</li> <li><input type="checkbox"/> Industrial Metallurgy</li> <li><input type="checkbox"/> Mechanical Drafting</li> <li><input type="checkbox"/> Mechanical Engineering</li> <li><input type="checkbox"/> Mold-Loft Work</li> <li><input type="checkbox"/> Patternmaking</li> <li><input type="checkbox"/> Reading Shop Blueprints</li> <li><input type="checkbox"/> Sheet-Metal Drafting</li> <li><input type="checkbox"/> Sheet-Metal Worker</li> </ul> | <ul style="list-style-type: none"> <li><input type="checkbox"/> Ship Drafting</li> <li><input type="checkbox"/> Ship Fitting</li> <li><input type="checkbox"/> Shop Practice</li> <li><input type="checkbox"/> Steel Mill Workers</li> <li><input type="checkbox"/> Tool Designing</li> <li><input type="checkbox"/> Welding, Gas and Electric</li> <li><b>Radio Courses</b></li> <li><input type="checkbox"/> Electronics</li> <li><input type="checkbox"/> Radio, General</li> <li><input type="checkbox"/> Radio Operating</li> <li><input type="checkbox"/> Radio Servicing</li> <li><b>Railroad Courses</b></li> <li><input type="checkbox"/> Air Brake <input type="checkbox"/> Car Inspector</li> <li><input type="checkbox"/> Locomotive Engineer</li> <li><input type="checkbox"/> Locomotive Fireman</li> <li><input type="checkbox"/> Railroad Section Foreman</li> <li><b>Steam Engineering Courses</b></li> <li><input type="checkbox"/> Boilermaking</li> <li><input type="checkbox"/> Combustion Engineering</li> <li><input type="checkbox"/> Engine Running</li> <li><input type="checkbox"/> Marine Engineering</li> <li><input type="checkbox"/> Steam Electric</li> <li><input type="checkbox"/> Steam Engines</li> <li><b>Textile Courses</b></li> <li><input type="checkbox"/> Cotton Manufacturing</li> <li><input type="checkbox"/> Rayon Weaving</li> </ul> | <ul style="list-style-type: none"> <li><input type="checkbox"/> Textile Designing</li> <li><input type="checkbox"/> Woolen Manufacturing</li> <li><b>Business and Academic Courses</b></li> <li><input type="checkbox"/> Accounting <input type="checkbox"/> Advertising</li> <li><input type="checkbox"/> Arithmetic <input type="checkbox"/> Bookkeeping</li> <li><input type="checkbox"/> Business Correspondence</li> <li><input type="checkbox"/> Business Management</li> <li><input type="checkbox"/> Certified Public Accounting</li> <li><input type="checkbox"/> College Preparatory</li> <li><input type="checkbox"/> Commercial</li> <li><input type="checkbox"/> Cost Accounting</li> <li><input type="checkbox"/> Federal Tax</li> <li><input type="checkbox"/> First Year College</li> <li><input type="checkbox"/> Foremanship</li> <li><input type="checkbox"/> French</li> <li><input type="checkbox"/> Good English</li> <li><input type="checkbox"/> High School</li> <li><input type="checkbox"/> Higher Mathematics</li> <li><input type="checkbox"/> Illustrating</li> <li><input type="checkbox"/> Motor Traffic</li> <li><input type="checkbox"/> Postal Service</li> <li><input type="checkbox"/> Salesmanship</li> <li><input type="checkbox"/> Secretarial</li> <li><input type="checkbox"/> Sign Lettering <input type="checkbox"/> Spanish</li> <li><input type="checkbox"/> Stenography</li> <li><input type="checkbox"/> Traffic Management</li> </ul> |
|---|--|--|--|

Name..... Age..... Home Address.....  
 City..... State..... Present Position..... Working Hours..... A.M. to..... P.M.

Canadian residents send coupon to International Correspondence Schools Canadian, Ltd., Montreal, Canada.  
 British residents send coupon to I. C. S., 71 Kingsway, London, W. C. 2, England.

DISCOUNT TO DISCHARGED VETERANS—SPECIAL TUITION RATES FOR MEMBERS OF THE ARMED FORCES





# REFRIGERATION AIR CONDITIONING

Air Conditioning and Refrigeration are among the great industries of today and tomorrow. Installations everywhere—in restaurants, shops, homes, etc., need service. Thousands of businesses are waiting for new installations. Today, more and more homes are being air conditioned. The Refrigeration and Air Conditioning industries are headed for greater prosperity and men who have the "know how" and experience should ride along.

## Train Now Before the Expected EXPANSION Begins



Experts predict large demand for men to install and service Air Conditioning and Refrigeration equipment. . . Rise to the kind of job which requires a competent, trained man who can carry the responsibilities of installing costly equipment and maintaining it. If he knows the answer when he is called in for consultation, his reputation grows and his pay should grow also.

### Follow This Way to Knowledge

If over 17, and under 58, here's all it takes to get you ready for experience in this modern industry. Just invest a limited amount of your spare time—while you are still on your present job. Through our balanced training, you learn first through home study, how to handle Installation, Maintenance & Service Work on Refrigeration and Air Conditioning equipment. Then you can get practical training in our big shops under capable instructors—experienced men who'll take a personal interest in helping you learn. When you're through you should have knowledge that enables you to get started in this vast industry.

### WANT YOUR OWN REPAIR SHOP?

UEI training is easily understood by mechanically inclined men. You gain experience when you complete your course. Equipment, tools and personal following can accumulate as you progress. Soon you may find it wise to set up your own shop.

### GET FREE FACTS RIGHT NOW!

It costs you nothing to get all the facts about this great field. Simply mail the coupon below and we'll tell you, without obligation the whole, sensational story of what's ahead in Refrigeration and Air Conditioning. Mail the FREE coupon now.

REFRIGERATION  
TRAINING  
Since 1927

**UTILITIES ENGINEERING INSTITUTE**  
1314 W. Belden Avenue, Dept. 395, Chicago 14, Ill.

Please send me the FREE FACTS about opportunities in Air Conditioning and Mechanical Refrigeration. I have marked the one that interests me most.

Air Conditioning       Mechanical Refrigeration

NAME \_\_\_\_\_ AGE \_\_\_\_\_

ADDRESS \_\_\_\_\_

CITY \_\_\_\_\_ ZONE \_\_\_\_\_ STATE \_\_\_\_\_

# Electrical ENGINEERING, RADIO AND ELECTRONICS

8 months intensive residence course prepares for technician, engineering aides in communications, power, business machines, sales, service.

Theory and extensive laboratory practice, drafting. Graduates hold responsible technical and engineering positions. Approved for veteran training. 53rd year. Enter Oct. 1, Feb. 25, July 8. Write for catalog.

**BLISS** 109 Takoma Avenue,  
Washington 12, D. C.  
**ELECTRICAL SCHOOL**

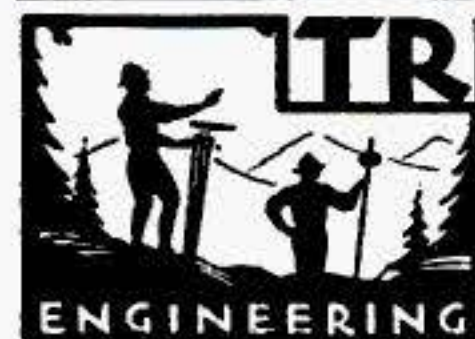

## TRI-STATE COLLEGE B. S. Degree in 27 Months

Distinguished for technical 2 1/4-year courses in Civil, Electrical, Mechanical, Chemical, Radio, Aeronautical Engineering; Business Administration, Accounting, and Secretarial Science.

EX-SERVICE MEN can complete work here in shortest possible time. Special Prep. Dep't. Also REFRESHER COURSES. 36-Week Courses in Surveying, Drafting. Low tuition. Low living costs. Cosmopolitan student body. 62nd year. Enter Sept., Jan., March, June. Catalog. 595 College Ave. **ANGOLA, INDIANA**

## DRAFTING SPRINGBOARD TO SUCCESS!

Increased salary, larger responsibilities, a real career instead of just a job—these are to be had by the trained draftsman. I.C.S. makes the way to thorough, practical training open to you. Check up and you'll find that nearly every "big name" American in engineering and production acquired experience at the drafting board. Many of them started by writing for the I.C.S. free booklet. Send for it today! It can be the most important act of your life.

International Correspondence Schools, Box 7632-L, Scranton 9, Pa.

## THERE'S MONEY IN CARTOONS!

RAYE BURNS will teach you HOW to CREATE ORIGINAL CARTOONS at home that you may SELL! Course contains 26 lessons and over 600 illustrations. All for Only.. **\$2.85**

Send name and address for free details.

RAYE BURNS SCHOOL, Dept. S, Box 3583, CLEVELAND, OHIO

## RADIO ENGINEERING, Broadcasting, Servicing, Electronics, Aviation, Marine & Police Radio taught thoroughly. 48 weeks' Engineering course equivalent to 3 years' college radio work. All expenses low. Co-educational. Catalog upon request.

Valparaiso Technical Institute. Dept. 503 Valparaiso, Ind.

## DRAW for MONEY

### BE AN ARTIST!

Trained Artists are Capable of Earning \$30, \$50, \$75 a week

Use Your Spare Time to Prepare for a Profitable Art Career! **COMMERCIAL ART, DESIGNING and CARTOONING**—all in ONE complete home study course. No previous Art experience necessary—we teach you step by step—hundreds have profited by our practical method. **TWO ART OUTFITS FURNISHED.** Full information in colorful, **FREE BOOK, "Art for Pleasure & Profit"**—tells all about our course, service, what our graduates say—and commercial opportunities for you in Art.

**FREE BOOK gives details!**

**WASHINGTON SCHOOL OF ART**  
Studio 139P, 1115 15th St., N. W., Wash. 5, D. C.  
Send me your booklet and full particulars about your course.

Name \_\_\_\_\_ AGE \_\_\_\_\_  
Address \_\_\_\_\_  
City \_\_\_\_\_ State \_\_\_\_\_



# GIANT 3 FOOT PRECISION GROUND LENS TELESCOPE



## SUPER-POWERED RANGE! BRINGS DISTANCE CLOSE-UP!

Here is the most remarkable offer that we have ever made. Now you can see most everything you want to see . . . at the ballgame . . . beach . . . sailing . . . nature study . . . stars . . . races. Bring distant objects so clearly close to your eye that they will seem almost near enough to touch. Why feel frustrated and baffled by something far away that you want to see in full detail? Why be limited in your vision when you can multiply it 13 to 15 times with this amazing 3 super-powered lens GIANT TELESCOPE. Quickly overcomes the handicap of distance . . . the magnification does it like magic. This new telescopic invention is a miracle of mass production economy and engineering ingenuity. Made to last from available war-time materials, it is the equal in performance of telescopes that sell for as much as \$15.00. Think of the wonderful fun you can have by extending your vision 30 miles in full, clear detail. Read on for full explanation of this really remarkable invention.

### IDEAL FOR SPORTS!

Don't miss half the game . . . the finish of the race . . . the winner at the beauty parade . . . the details of nature study. This miracle telescope will give you the most minute details . . . bring them close to your eye. There isn't any outdoor sporting event that you can't use one of these telescopes to improve your vision. A seat in the grandstand will become a box seat when you're carrying this SUPER-TELESCOPE. Order yours today... and don't miss a play.

### A PRECISION INSTRUMENT!

This giant telescope is not a toy . . . definitely not! It has been made with the careful precision of telescopes selling at much higher prices. Each of the 3 high powered lenses have been ground to precision by experts and carefully mounted to insure clear, far-reaching vision. Made of available war-time materials in mass production is the only reason this telescope can be sold at this low price. Adjustable to distance and perspective. Hurry and get yours.



### 5 DAYS EXAMINATION

Just send coupon with \$3.00 and get your GIANT TELESCOPE and FREE CARRYING CASE postage paid. If you prefer, just send coupon and get yours C.O.D. at \$2.98 plus C.O.D. and postage charges. If not satisfied, return in 5 days and your purchase price will be refunded. Send coupon today! Invenco Corp., P. O. Box 281, Church St. Annex, New York 8, N. Y.



### Weather Resisting CARRYING CASE

This military-looking carrying case is yours absolutely FREE with this offer. Made of heavy canvas that fits over the telescope, making it easy to carry, and protects it from dust, dirt and rain. Top fastens by a drawstring. Carrying case absolutely FREE with offer so send coupon today.

**INVENCO CORP. Dept. T-9909**  
**P.O. Box 281, Church Street Annex**  
**New York 8, N. Y.**

I am enclosing \$3.00. Send TELESCOPE and FREE CARRYING CASE immediately. You pay postage. I can return in 5 days for full refund if I am not completely satisfied.

Send C.O.D. I will pay postman \$2.98 plus new C.O.D. and postage charges on arrival. (Same money back guarantee as above).

NAME.....

ADDRESS.....

CITY & ZONE..... STATE.....

Copyrighted material





**HERE IS  
THE MODERN  
QUICK AND  
EASY WAY**

**BASIC RADIO  
LABORATORY  
INCLUDED!**

**To Master  
Radio  
Television  
and Electronics**

## **SHOP METHOD HOME TRAINING**

**By a Real, Established Resident School**

Don't just envy the man who is making such a success in Radio. Don't be on the outside looking in on America's next great industry—F.M., Television and the wonder world of Electronics. Get in there yourself, on the ground floor, with a fine, well paid job or a lifetime business of your own. This **AMAZING NEW TRAINING SYSTEM THAT DEMONSTRATES BY ACTUAL PRACTICE** makes it possible for you to take your place quickly and with absolute assurance in this great and growing industry. For details send the coupon below.

This is the practical, and sure way for you to get the training and experience necessary for a successful career in Radio, Television and Electronics. Here is a fully tested and approved method—simple, direct, easy to understand and put into practice. Fill out and send the coupon on this advertisement for a test lesson to prove to yourself how different, sure and effective this course is.

### **Results Quick and Profitable**

No longer do you have to think of Radio as a great mystery—Television as something complicated and Electronics as vague

and technical. Here it is presented as simple as A.B.C. and backed up with down-to-earth experience methods right from the National Shops and laboratories. This training is so practical **YOU START EARNING GOOD MONEY ON THE SIDE AFTER THE FIRST FEW LESSONS.**

You can get such training only from National Schools because only National—one of the oldest and best equipped technical trade schools in the world—has the shops where instructors work with students and technicians to bring you—**right in your own home—in your spare time**—the kind of instruction and practice that assures definite progress right from the start.

The way to understand how this is possible is to see it for yourself. All it takes is a penny. Fill out and paste the coupon on a post card (or if you wish put it in an envelope) and mail it right now.

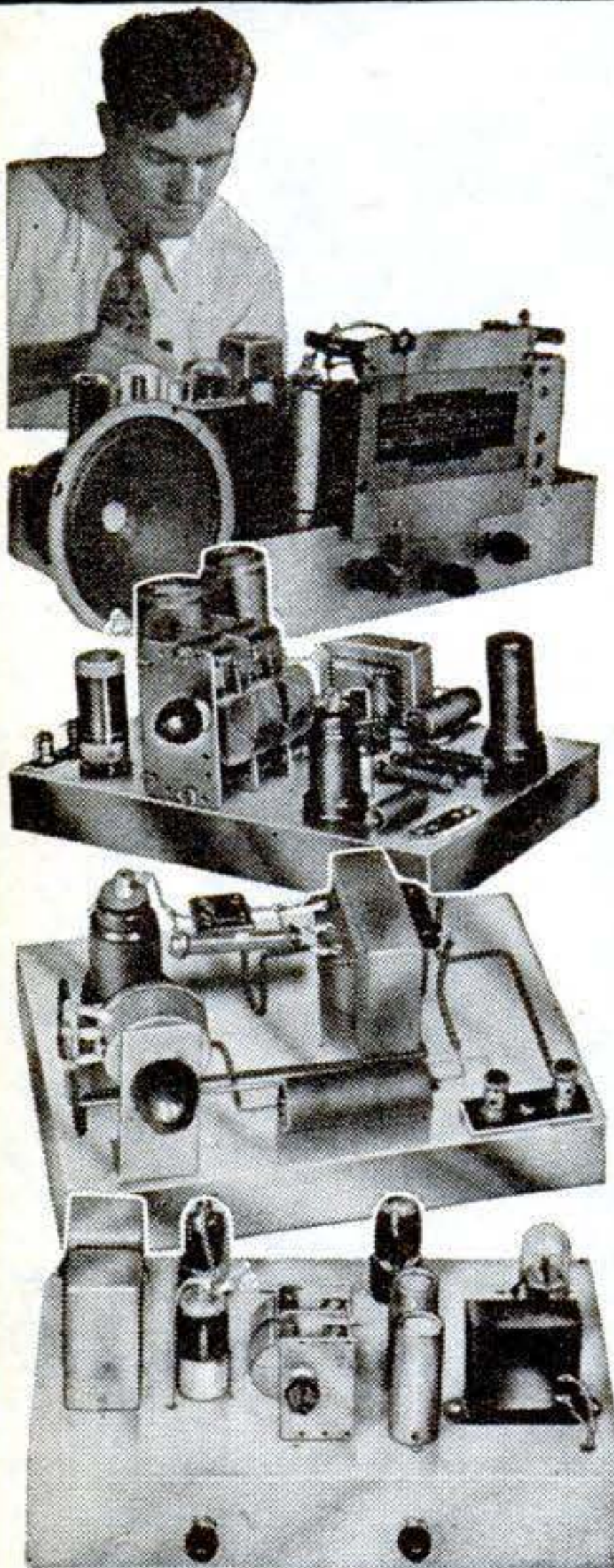

Here is some of the electronic equipment that is furnished at no extra cost with your course of National training. Build a big, long distance superheterodyne and other types of modern receivers, testing instruments, signal generators—all full sized, actual operating sets with your National equipment. In this way you really do learn by doing. You get to be a **REAL EXPERIENCED TECHNICIAN**. The test lesson that comes to you will show you how this is possible. Send the coupon for it now.



Above: Skilled instructors at National Schools developing the most effective training methods and trying them out.

Right: Testing new electronic equipment at National before releasing it to students.



**MARK AND MAIL THIS COUPON**



# GET INTO RADIO NOW

## ELECTRONICS TELEVISION ...

**SUCCESS AND SECURITY FOR YOU IN THIS GREAT, ESTABLISHED INDUSTRY**

Face facts! Radio is one of the country's great, fundamental industries with a volume of over \$5,000,000,000. It demands tens-of-thousands of skilled maintenance men, skilled operators, technicians—everywhere. Civilian production and up-keep has been practically at a stand-still during the war. Right now and for years to come RADIO WORK IS BOOMING as never before in history.

F.M., Fac-Simile and Television are in their infancy but they are only waiting for materials to get into big scale production and use. Experts estimate more than a half-million jobs in these fields RIGHT IN THE START.

Electronics is found in nearly every industry and in many new homes. Electronics will be the wonder worker of the future and so provides good pay jobs for men who know its basic principles.



Photo Courtesy of G. G.

What will you be doing when you hang up your uniform?—when your war job folds up. Before you gamble your future SEE FOR YOURSELF WHAT NATIONAL TRAINING CAN DO FOR YOU. Send your coupon now.



Above: As a National trained man you can be your own boss—start a flourishing business of your own on little or no capital. It's what you KNOW that counts. Left: In industry the better jobs and the better pay go to the man who knows what he is doing in Radio, Television and Electronics.

Get started now. You may be closer to your goal than you think. In a few short weeks you may be making your first money as a radio technician—perhaps laying the foundation of YOUR OWN PROFITABLE BUSINESS FOR A LIFETIME OF SECURITY. Take the first step now. Reach out for opportunity. Fill in and mail the coupon here, at once.

### Good Jobs Go To National Trained Men

Share in the success of National graduates. Joseph Grumlich of Lake Hiawatha writes: "My latest offer was for \$5,800.00 as Radio Photo Engineer, but I am doing well where I am and I am deeply indebted to National."



C. B. Kolb, Perry, Oklahoma worked in a hardware store while getting started in radio. Now he services more than a hundred sets a month at a good sound income.

at National and now I know it is my best chance for getting ahead in the Navy."

H. W. Schroeder, stationed in California: "I appreciate all I learned and now I know it is my best chance for getting ahead in the Navy."



Robert Adamsen, Kearney, Nebraska, National graduate, has two radio jobs—makes double pay as an instructor and as engineer at Station KGFV.



Learn a trade that will support you always—anywhere you go. Cash in on the demand for Radio, F.M., Television and Electronic operators, maintenance men, supervisors and technicians.

FREE GET THESE 2 BIG BOOKS



### Trained Men Wanted

The man who really knows modern Radio is in greater demand today than ever before—not only in Radio proper but in Television and Electronics—in Aviation, Transportation, Communications. Good jobs are wide open, WAITING FOR YOU, in the production, operation and maintenance of modern electronic equipment—in radio stations, in hundreds of industries—in homes, theatres and studios. Good, sound training in this important field is absolutely necessary. And now, National Schools brings such training to you no matter where you live or what you may be doing—not only the fundamental theory but the actual experience that comes with knowing shop practice and working with real equipment—demonstrating each step with first-hand knowledge.

Only National can offer you such practical training because only National has the plant to back it up. Sample this training yourself. MAIL THE COUPON FOR A FREE LESSON.

### NATIONAL SCHOOLS

LOS ANGELES 37, CALIFORNIA EST 1905

#### MAIL OPPORTUNITY COUPON FOR QUICK ACTION

National Schools, Dept. 9-PS  
4000 S. Figueroa Street  
Los Angeles 37, California

(Mail in envelope or paste on penny post card)

Mail me free the Sample Lesson and Opportunity Book. I understand that no salesman from National Schools will call on me.

Name.....Age.....

Address.....

City.....Zone.....State.....

GET ALL THE FACTS



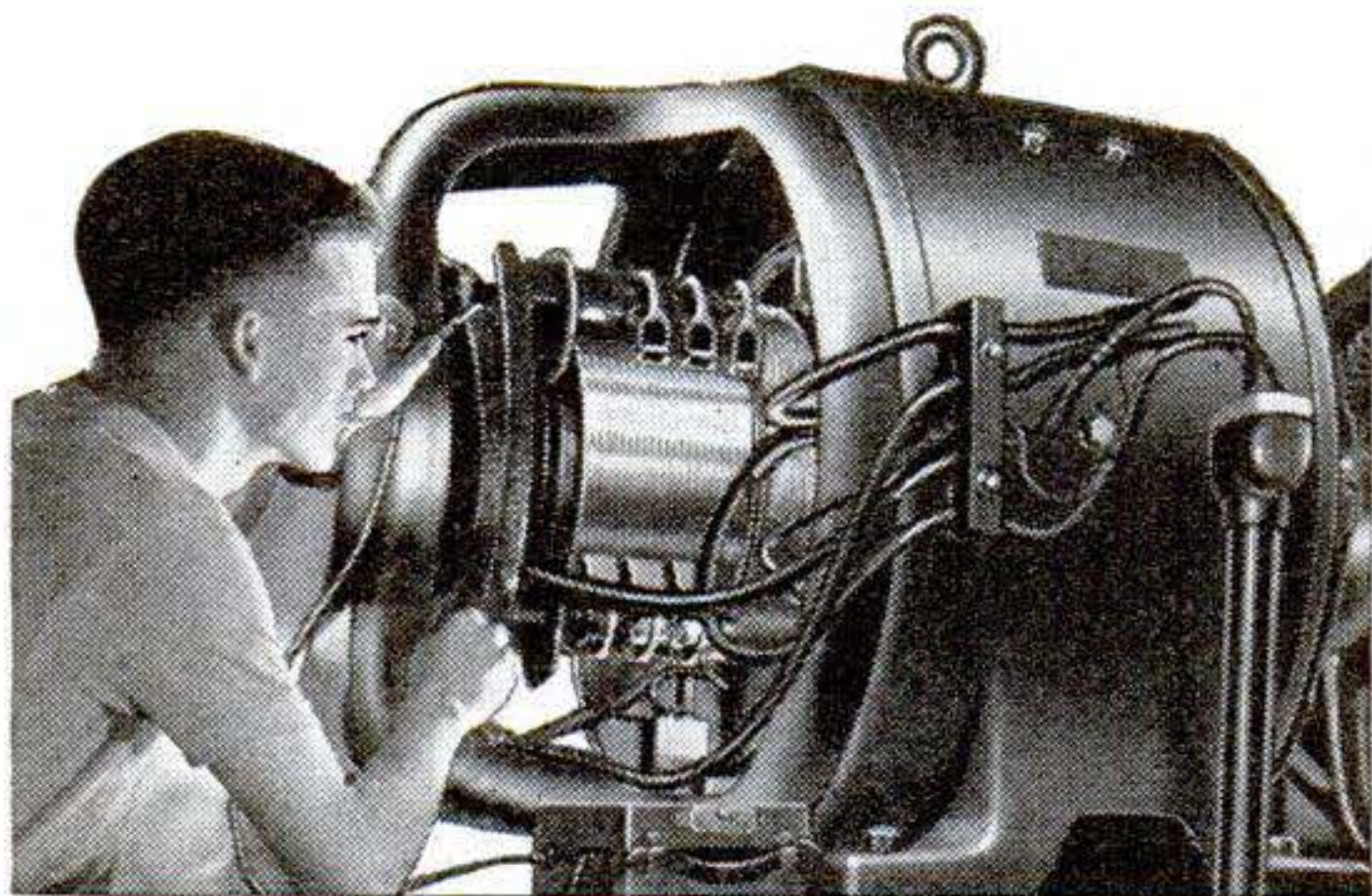

## Learn **ELECTRICITY** 12 WEEKS TRAINING ON REAL MOTORS, GENERATORS, ETC.

Trained Electrical men are needed now. It's not how young or how old you are. The question is, are YOU trained to hold a good job today—and a good job with a real future—in peace time. COYNE TRAINING is easy, practical. Located in Chicago, Coyne has 46 years experience training successful men. Mail coupon now!

### "Learn-by-Doing" in the Great Coyne Shops

Get ready for a big future the quick Coyne Way—by actual work on full-size electrical equipment, not by correspondence. Learn house-wiring, motors, power plants, switchboards, auto electricity, etc. Be an "All-Round Electrical Man"—for big opportunities.

### Train First—Pay Later

My "Pay-Tuition-After-Graduation" plan enables you to get training first, and pay for your tuition in easy payments after graduation. If you need part-time work to help defray expenses while here, I'll help you get it.

### Lack of Experience No Bar!

Many of my students have never had Electrical experience. Others have had experience in one or two branches but realize they need all-around training for the better jobs. So whether or not you have had electrical experience you need Coyne training.

### Get My Free Book!

Let me send you my big illustrated book showing how I help you get the training you need for a good Electrical job. It's FREE—no obligation—no salesman will call. Send the coupon today! We also have facilities for men with physical disabilities whether due to war or other causes. Check coupon for details.

H. C. LEWIS, Pres.  
**COYNE** ELECTRICAL SCHOOL  
500 South Paulina Street,  
Dept. 65-73, Chicago 12, Ill.



H. C. LEWIS, President, Dept. 65-73,  
COYNE ELECTRICAL SCHOOL,  
500 S. Paulina St., Chicago 12, Ill.

Send me your Free Book. Tell me about your EXTRA INDUSTRIAL ELECTRONICS TRAINING at no extra cost, and your "Pay-Tuition-after-Graduation" offer.

Send Special G.I. Bulletin  Send Physical Disability details.

NAME.....

ADDRESS.....

CITY..... STATE.....

VETERANS — Coyne is equipped to train those who qualify for training under the G. I. Bill of Rights. Check coupon for special G. I. Bulletin.

### EXTRA TRAINING

Industrial Electronics and Electric Refrigeration Now Included.

No extra cost for valuable extra training



## Learn to Service and Repair ELECTRICAL APPLIANCES

Learn to be a service mechanic on all types of electrical appliances . . . and prepare now for a permanent future, independence and security, operating a business of your own. You won't have to worry about losing your job when the next depression comes if you have your own electrical appliance repair business. There is always a demand for repair work . . . and it can't be done by a machine. Our practical, easy to learn home-training teaches you how to repair washing machines, vacuum cleaners, stoves, lamps, motors, irons, etc., and how to do house wiring. Also how to start your own business on little capital. Write today for FREE illustrated booklet which will explain in detail. No obligation. No salesmen will call.

PACIFIC TRAINING SCHOOL  
4701 W. Pico, Dept. AS-9, Los Angeles 6, California

## YOU CAN ADVANCE IN PLASTICS!

Plastics can be the next great industry . . . expanding as swiftly and largely as the automotive, radio and aviation businesses. Already, it is an important industry and a growing one. With I. C. S. training, you can take advantage of the many opportunities in Plastics today. At the same time, you prepare for the vast possibilities of tomorrow. Write for the free booklet containing full information! Do it right now!

International Correspondence Schools, Box 7632-L, Scranton 9, Pa.

## Learn Penmanship

You can learn plain, rapid writing or fancy ornamental writing for social and business advancement, right in your own home during spare time by my Simplified Method. Write for my free book, "How to Become an Expert Penman," which shows what others have accomplished by taking my Courses. Send 10c for one of my favorite Pen Points and your name with a beautiful flourished bird written on a card. Write today.

T. M. TEVIS, BOX 25R, CHILLICOTHE, MO.

## LAW

STUDY AT HOME for PERSONAL SUCCESS and LARGER EARNINGS. 36 years expert instruction —over 108,000 students enrolled. LL.B. Degree awarded. All texts furnished. Easy payments. Send for FREE BOOK—"Law and Executive Guidance"

AMERICAN EXTENSION SCHOOL OF LAW  
Dept. 57-S, 646 N. Michigan Ave., Chicago 11, Ill.

## Learn LANDSCAPE GARDENING

A thorough, interesting, home study course for those who wish to become LANDSCAPERS, GARDENERS, DESIGNERS, etc., for profit or pleasure. Write today for FREE INFORMATION to NATIONAL LANDSCAPE INSTITUTE  
Dept. PS-9, 756 So. Broadway, Los Angeles, Cal.

## BOOKS FOUND FREE!

What books do you want?

Lowest market prices on all books. No charge for locating old books. HARD-TO-FIND or OUT-OF-PRINT  
SEARCHLIGHT BOOK CENTRE 22 East 17th St. New York City 3

## DETECTIVES

TRAINING—SECRET INVESTIGATIONS—FINGERPRINTS  
Easy Method — Short Time. — Rewards.  
Home—Travel—Secret Code-Booklet FREE—WRITE  
INTERNATIONAL DETECTIVE SYSTEM  
1701-P Monroe St., N. E., Washington, D. C. 18



STUART STUDIOS

## LEARN PORTRAIT PAINTING AT HOME

Under unique Stuart System men and women with no known talent, paint exact oil or charcoal likenesses. Study the evidence in new 42-Portrait Brochure of samples. Many earn while learning. Book is free on request.

121 Monument Circle, Room 289, Indianapolis 9, Ind.

Name.....

Street.....

City..... State.....



**LEARN  
AT HOME**

# PLASTICS

**FABRICATION**

*New - Profitable Industry!*

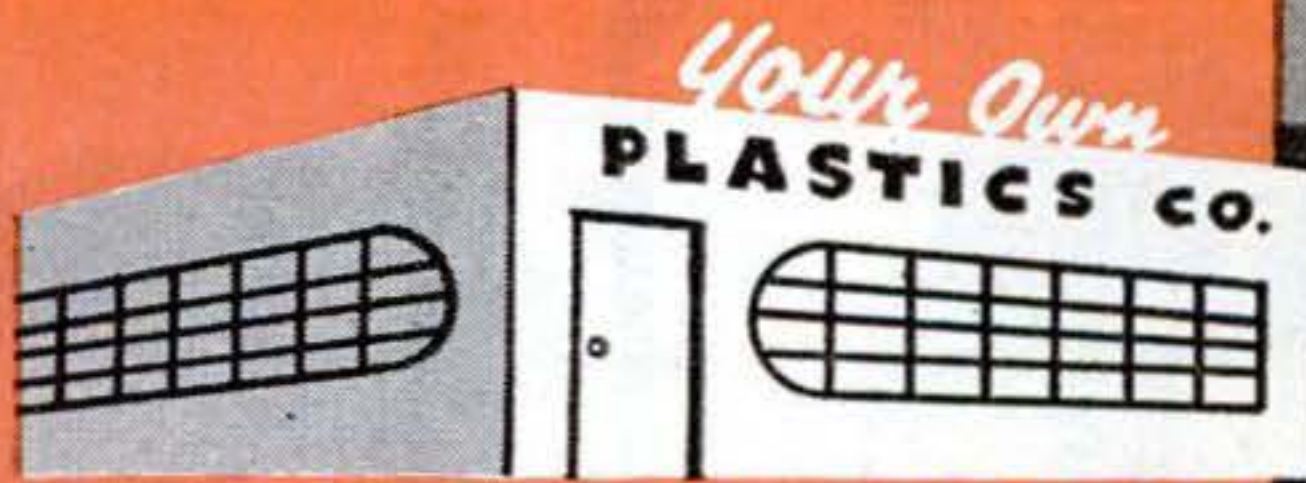

**START YOUR OWN BUSINESS**



**MAKE PRODUCTS  
LIKE THESE**



**YOU'LL** really enjoy learning plastics this new, interesting way! For you'll actually make beautiful, useful plastics articles during your home study training with Plastics Industries Technical Institute.

**NOW'S YOUR OPPORTUNITY**—Yes, the exciting age of plastics is here! Demands of war have caused phenomenal growth in the plastics industry—creating exceptional opportunities for those who know plastics. If you are a person with an eye to the future, you won't remain on the outside looking in—you'll want a choice position in the growing, expanding plastics field—or a plastics business of your own.

**WE SUPPLY MATERIALS**—For your interesting and practical work with plastics, we supply handsome, colorful, transparent rods, sheets and tubes of plastics from which you make useful, attractive creations. You saw, cement, machine, buff, form, dye, decorate, cast and laminate various types of plastics.

You also design your own plastics articles—develop your own ideas—express your originality. Earn money while learning.

**A COMPLETE COURSE**—This practical training in plastics fabrication is only *one* part of the Plastics Institute home study course. In addition, you learn about the many types of plastics, their manufacture, characteristics, properties and uses—intensive coverage of molding and mold design—testing and cost analysis—everything to help prepare you for your place in plastics.

**START YOUR FUTURE TODAY**—Mail the coupon below now! We will send you an interesting, illustrated free booklet with valuable information about plastics. We'll tell you how, at small cost, you can prepare for a future in this important industry while carrying on your present work. Don't put it off. Clip the coupon and mail it today!

**VETERANS: ASK ABOUT G.I. TRAINING**

Dept. P55-9, 122 E. 42nd St., New York 17

Dept. P55-9, 221 N. La Salle, Chicago 1    Dept. P55-9, 1601 S. Western, Los Angeles 6

**SPECIAL RATES FOR SERVICE MEN**

*Plastics*

**INDUSTRIES TECHNICAL INSTITUTE**

Plastics Industries Technical Institute.  
221 N. La Salle St., Dept. P55-9, Chicago 1

Gentlemen: Please send me the booklet "World of Plastics" and information on your training program. I understand there is absolutely no obligation.

Name.....Occupation.....

Street.....Age.....

City.....Zone.....State.....

Veterans; Check for special information.  If under 18: Check for special booklet.

Mail in Envelope or  
paste on penny postcard

**FREE BOOKLET**  
*Send For It Today!*





# SO IT NEEDS FIXING

By S. T. CHRISTENSEN  
*the "Fix-it Man"*

"**W**ELL, I guess I'm the fellow to see, for I've repaired thousands of refrigerators (home and commercial both), vacuum cleaners, radios, washing machines, irons, fans, lamps, mangles, motors, etc. In fact, many of my customers call me their "electrical appliance doctor." And, "doctoring," I might add has paid me a good substantial income for quite a few years. Funny, in a way, how I got started. Always liked to tinker and by experimenting around I found that most electrical appliances had many things in common. That, regardless of what the appliance was used for, or who the manufacturer was, the basic principles were much the same. From fixing my own appliances to fixing friends' and then for strangers at a fee, seems now to have been but a small step.

## What to Charge?

At first, I let the owner decide the charge and, frankly, I was amazed at what I earned per hour. But then, when one figures what initial costs are involved in buying most electrical appliances, one can readily see that spending extra dollars for repairs is well worth while. Before long I was making more in my spare time repairing than from my regular job. The result . . . I went into business for myself. When war came, business boomed, for new appliances were not available.

For a while, repair parts (needed on some jobs) were a little difficult to get. But that

situation seems to have adjusted itself for many repair parts have today the high priority rating of AA2. After all, we must provide for the health and well-being of our civilian population.

## The Future Offers

Friends ask me about my future. And, I think I've got a grand one. Age is no handicap in repairing. I have in my files enthusiastic letters from repairmen ranging in age from 18 to 79 years. After the war, we're bound to see hundreds of new products on the market . . . products that the average person never dreamt of. These new products and our old appliances are all going to need at some time or other "fixing." Well, I'll still be the fellow to do it. The field open for appliance repairmen is unlimited. I don't worry at all about too much competition.

## If You Are Ambitious

To the contrary, I've prepared a complete course, chuck full of simple, easy to understand photos and drawings and written in the same non-technical language as this article. I know the course is good, because I have hundreds of men all over the country writing to me telling me how the course has helped swell their pockets with cash. If you too want to prepare now for your future, I suggest you read the next page and send me the handy coupon."

Adv.





**BIG MONEY  
INDEPENDENCE**

*A PROFITABLE  
LIFETIME  
BUSINESS  
OF  
YOUR OWN!*

# LEARN ELECTRICAL APPLIANCE REPAIRING

## PREPARE NOW FOR THE FUTURE

If now in war work, start your home appliance repair business NOW in your spare time and be set with a business of your own when the war is over. You don't need elaborate fixtures or expensive equipment to be a successful repairman. Operate from your garage, basement, vacant store, etc. Work as many hours as you wish—the home appliance repairman is his own boss. It is a profitable occupation for on many types of repairs it is not unusual for a repairman to charge on the basis of \$5.00 to \$6.00 per hour. Don't gamble with your future—learn a trade that will always support you. Remember, as long as electrical appliances are used, there will be a need for electrical appliance repairmen.

If you are at all mechanically inclined—can hold and use tools—then you have all of the qualifications required for becoming a big money earning home appliance repairman. It does not matter if you have not had a great deal of schooling or had previous experience along these lines—**WE WILL TEACH YOU.** Age should be no barrier—nor should any minor physical handicap.

### New Course Tells All

Profusely illustrated, our new course shows you in simple, easy to understand language and drawings how to make each repair on refrigerators, vacuum cleaners, washing machines, motors, etc. Explains and gives you a working knowledge of electricity, welding, nickel plating, etc. Shows you how to build the power tools you need and how to solicit and keep business coming to you. Not a theory course but an honest to goodness course written by and used by repairmen the country over. Price of course is so low that the savings on your own household appliance repairs will quickly pay for it. Act now! Mail the handy coupon below today.

#### -----Read What Our Students Say About Course-----

I really believe your course the best investment a mechanically minded man can make.—Claude E. Allen, Indianapolis, Ind.

I have received your Course in Appliance Repairing and I must say I am well pleased with same. I am only sorry I did not have said Course some years ago. I have learned so much more through this course I would not part with it.—Charles Schwarz, Hamilton, Ohio.

The Course in Appliance Servicing arrived a few days ago. Want to take out a few minutes of my valuable time to let you know that this is just what I have been looking for ever since I opened up my Fix-It shop. I must admit that you told the truth when you said that it contains quite a bit more information than I bargained for.—P. J. Bretl, Sebring, Ohio.

I am a mechanic for the Western Union Telegraph Co. Three days after receiving the lessons in refrigeration I earned the exact cost of the course.—Henry S. Lee, Washington, D. C.

I work day times at the shipyard and after 4:00 P.M. I operate from my cellar and garage. I average \$10.00 to \$15.00 clear every day.—Walter Hanhy, Brockton, Mass.

### GET STARTED TODAY—MAIL THIS COUPON

**CHRISTY SUPPLY CO.**  
2835 N. Central Ave., Dept. D-3201  
Chicago 34, Illinois

Please send me free illustrated literature about America's Fastest Growing Industry—**ELECTRICAL APPLIANCE REPAIRING.**

Name.....

Address.....

City.....State.....





It's YOUR future—Make the most of it!



**Start now to earn the bigger pay in electrical repair**

WAS there ever such an opportunity to get started in electrical maintenance and repair—and at top-notch wages? Are you ready—with experience and ability—to cash in on it? Others are getting just the sort of background needed—quick! practical!—to handle the great variety of electrical maintenance and repair work TODAY—from this well-known electrical library. You can too!

**THE LIBRARY OF ELECTRICAL MAINTENANCE AND REPAIR**

5 vols., 1826 pages, 1724 illustrations

Gives you the "know-how" to tackle any wiring or motor job. Five books show you HOW—to install all types of motor and generator units—to inspect and repair motor starters and generators—to diagnose motor and generator troubles—to figure new windings for old cores—DC and AC windings—to test armature windings—test induction motors, etc., etc. One book is full of trouble-shooting charts that show quickly symptoms, causes, specific remedies, etc.

Take the first step toward improving YOUR future—Mail this coupon TODAY

No money down—special price—easy payments—FREE trial

McGraw-Hill Book Co., 330 W 42 St., New York 18, N. Y.  
 Send me for ten days' free examination the Electrical Maintenance and Repair Library. If satisfactory I will send you \$1.00 in 10 days and \$2.00 monthly until the price of \$15.00 is paid. If not wanted I will return books postpaid. (To insure prompt shipment write plainly and fill in all lines.)

Name.....  
 Home Address.....  
 City and State.....  
 Company.....  
 Position..... PSM 9-45

This 176-page

**FREE BOOK**

is also your

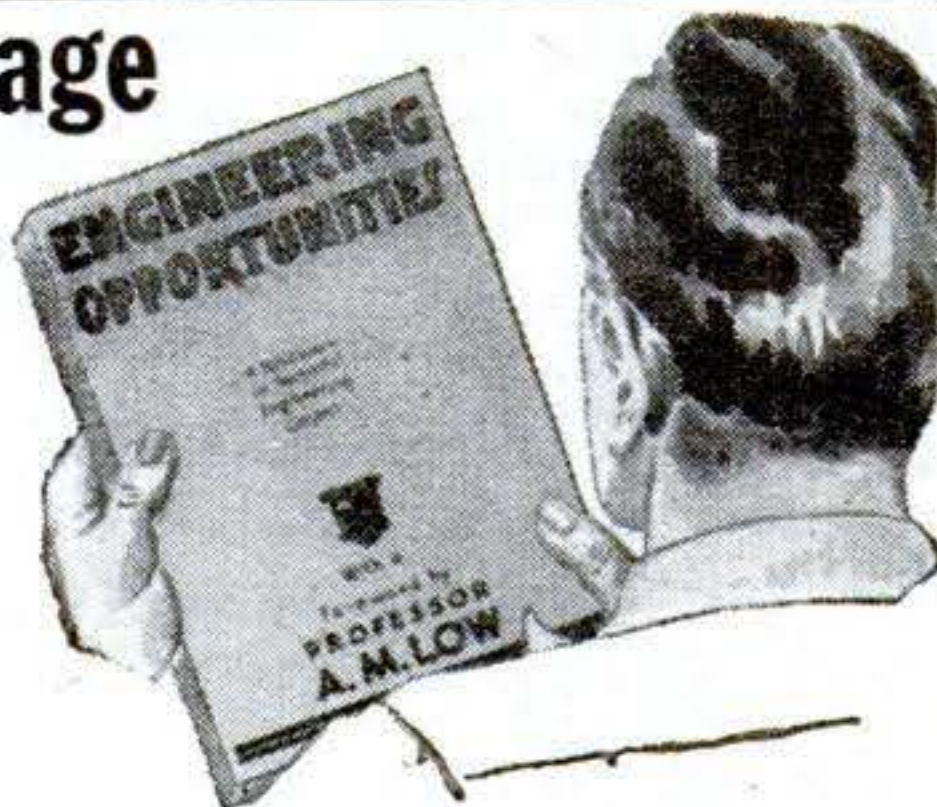

**GUIDE for the FUTURE**

Prepare for peacetime competition. Let this free book help you. It is issued by an organization known throughout the world for thorough engineering training. The examination subjects listed below are only a few of those dealt with. Without obligation write today to Canadian Institute of Science & Technology, 351 Chester Building, 219 Bay Street, Toronto 1, Canada.

- |                             |   |  |
|-----------------------------|---|--|
| A.M.I.Mech.E.<br>Mechanical | A.M.Brit.I.R.E.<br>Radio and Telegraphy | A.M.I.Struct.E.<br>Structural                |
| A.M.I.E.E.<br>Electrical    | A.M..C.E.<br>Civil                      | Automobile<br>Mining                         |
| A.F.R.Ae.S.<br>Aeronautical |   | London Matriculation<br>B.Sc. (Pure Science) |

Canadian Institute of Science & Technology Limited,  
 351 Chester Building,  
 219 Bay St., Toronto 1, Canada.

Please forward us free of cost or obligation of any kind your 176-page handbook, "ENGINEERING OPPORTUNITIES."

Name.....  
 Address..... Age.....  
 Course interested in.....

**TRAIN FOR KEY JOB OR BUSINESS OF YOUR OWN**

**REFRIGERATION and AIR CONDITIONING**

Millions of Older Units Need Expert Service. Big After-the-War-Expansion Will Create Even More Opportunities. Approved for Veterans "G. I." Training

A key job—a successful business of your own—you can have either in this vital, war-hit industry. A serious shortage of service-experts exists in every branch. Big post-war boom will open thousands of new opportunities. Get ready for your big chance. We'll give you the practical training you need—at home—and in our big Chicago shops, largest and most completely equipped in the country. No advanced schooling needed. Our unique methods make everything easy to grasp. We've trained thousands. Pay as you go. Quit when you want to. Get the full facts without obligation. Write TODAY.

**INDUSTRIAL TRAINING INSTITUTE**

2150 Lawrence Avenue, Dept. P2-1, Chicago 25, Ill.

**The MYSTERY OF RADIO**

**(HOW IT WORKS)**

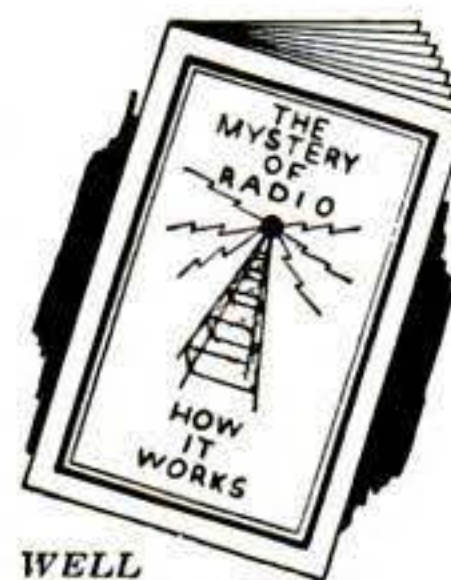

WELL ILLUSTRATED

Simplifies training procedure, by outlining T-R-F & superheterodyne principles.

EXPLAINS the NETWORK of circuits (One at a time) of an AC-DC five tube superheterodyne system.

**LEARN RADIO EASIER, FASTER**

ORDER this practical training aid without risk. If not fully satisfied, return within 3 days for refund. Only \$3. P. P. Send M. O., Bill or Check.

SCIENTIFIC RADIO SERVICE SYSTEM  
 SIOUX CITY, IOWA DEP'T-S BOX 1285

**MAKE MONEY CASTING AT HOME. FREE FACTS SENT.**



Make hundreds of Plaster Casts, quick, easy. Sell output to stores, novelty shops, etc. Enormous profits. No experience. Very little capital needed. Start in basement, garage or workshop. Complete, simple instructions anyone can follow. Start now while merchants are begging for merchandise to sell. Rush.  
 PLASTIC ARTS STUDIOS, R. R. 5, Dept. 45, Muncie, Ind.

**"How to Make Money With Simple Cartoons"**

A book everyone who likes to draw should have. It is free; no obligations. Simply address

**CARTOONISTS' EXCHANGE**

Dept. 1449-D Pleasant Hill, Ohio



Begin today. Write now for our Free Book, "How to Become a Good Penman." It contains specimens and tells how others learned to write in spare time. Enclose 10c for your name beautifully written and a pen point suitable for shaded writing. Write today.  
 THE TAMBLYN SCHOOL OF PENMANSHIP  
 N-439 Ridge Building, Kansas City, Mo.

**Correspondence Courses In RADIO and ELECTRICAL ENGINEERING LOW AS \$25**

**ELECTRICAL ENGINEERING.** Get good grasp of wide electrical field. Modern. Very understandable. Theory made easy.  
**RADIO ENGINEERING.** Extra fine course in radio, public address, photo-electric work. Trains you to be super-service man, real vacuum tube technician. Tuition ONLY \$25. either course. Deferred payment plan. Servicemen needed badly.  
**FREE** Write for free copies of school catalogs, student magazines, etc.  
 LINCOLN ENGINEERING SCHOOL, Box 931-S-81  
 LINCOLN, NEBR.



**LEARN MEAT CUTTING At Home—In Spare Time**

Get into the vital meat industry. Concise, practical Home Training based on 25 years proven instruction methods used at National's famous resident school. Prepares you for bigger pay as Meat Cutter, supervisor, market manager or more money in your own store. Go as rapidly as your spare time permits. Diploma. Start NOW to turn your spare hours into money. Send for FREE bulletin today. No obligation.

National School of Meat Cutting, Inc., Dept. O-34, Toledo 4, O.



# Learn RADIO- ELECTRONICS- TELEVISION

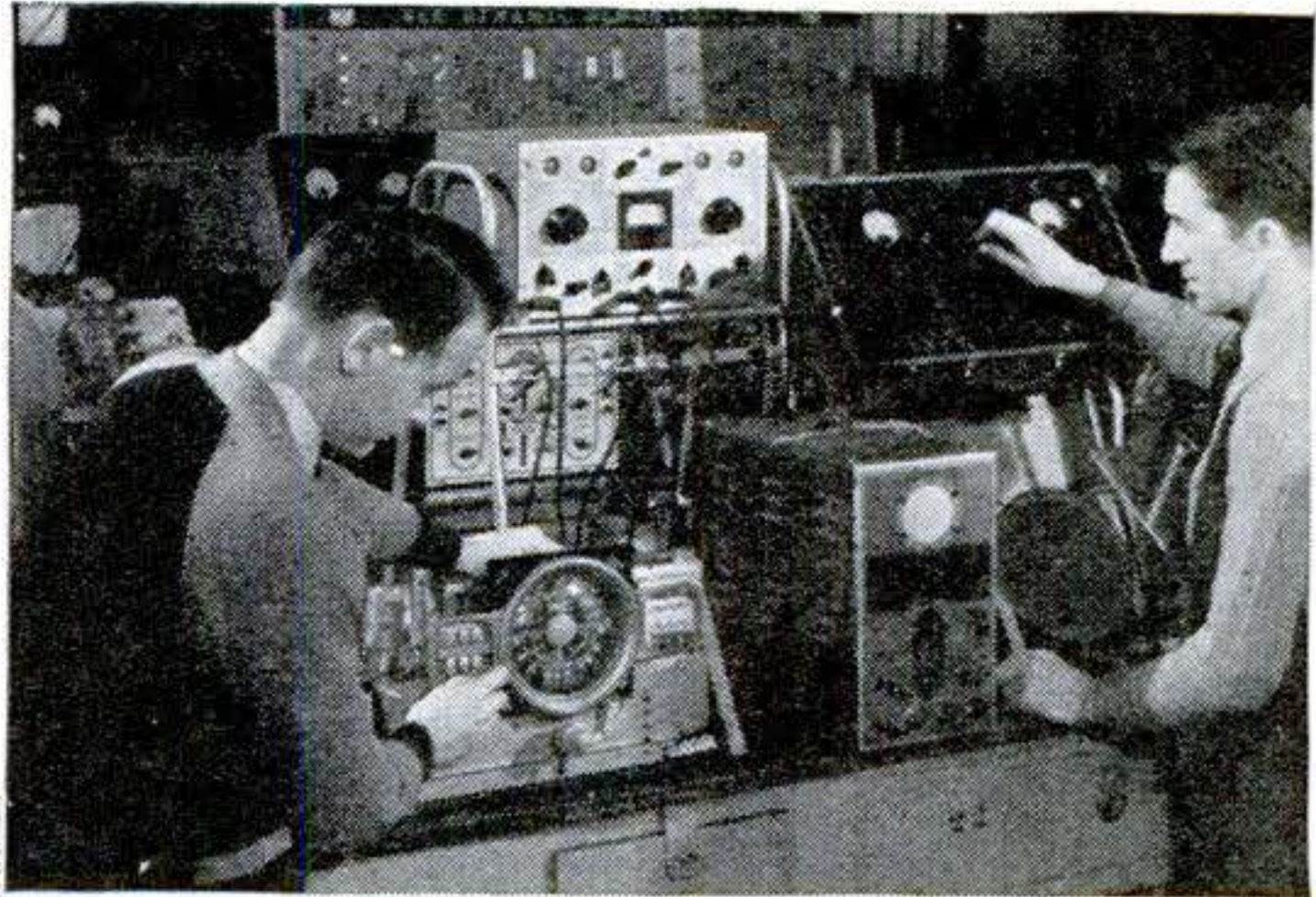

**RADIO TESTING AND SERVICING**—Students learning to locate troubles with modern radio analyzers.



**ELECTRONIC CIRCUIT TESTING** — Instructor showing students use of large Cathode Ray Oscilloscope.

## TRAIN FOR A GOOD JOB NOW *that will* *also be a* GOOD JOB IN PEACE-TIME

Don't be caught napping. Prepare for a good job now that will still be a good job with a real future when the war is over. If you are not a trained man you may have to compete with millions of other untrained men. Get into a field that offers real opportunities in war times, peace-times—good-times and bad-times. Tremendous expansion in Frequency Modulation and Television is predicted after the war. Radio-Electronics trained men are needed today—they will be needed too when final peace comes.

### Real Opportunities for the Radio Trained Man

Prepare for jobs as assembler, inspector and tester—Radio sales or service and installation work, electronics, television, sound work, aircraft-radio, auto-radio, etc. Many opportunities in the vast Radio-Electronics field.

### GET MY BIG NEW BOOK

It tells all about my big Chicago shops and my plans to help you get ahead. Packed with facts and pictures of students at work in my shops. Mail coupon for this Big New Book now! Coupon will also bring details on how I'll Finance Your Training . . . facts on how I help you "Earn-While-Learning" . . . information on FREE EMPLOYMENT SERVICE FOR LIFE . . . and other plans to help you. ACT NOW TO MAKE SURE YOU GET MY GENEROUS OFFER. Sending for this interesting free book can be your first big step to success. No obligation. No salesman will call. Mail coupon today. **H. C. Lewis**



# "Learn by Doing"

RIGHT HERE in the SHOPS of COYNE—12 Weeks Training

*All Finance Your Training*

We train you on real Radio, Television and Sound equipment—RIGHT HERE IN THE COYNE SHOPS IN CHICAGO. Whether or not you have had Radio experience you need Coyne all-around Radio Electronics training. Many of my students had no previous experience. Others had experience in one or two branches but realized they needed all-around training for better jobs and advancement.

### EARN WHILE LEARNING

If you need part-time work to help pay living expenses while at school, we will help you get it. Coyne graduates also receive a Life Membership with Lifetime Employment Service, free technical service and privilege of review without additional tuition charge.

**MEN WITH PHYSICAL DISABILITIES**—whether due to war or other causes—we also have facilities for you. Check coupon for particulars if you have a physical disability of any nature.

H. C. Lewis, Pres.

Founded 1899

**COYNE ELECTRICAL SCHOOL**  
RADIO-ELECTRONICS DIV.

500 So. Paulina Street Dept. 65-4H CHICAGO 12, ILLINOIS

### PREPARE FOR JOBS LIKE THESE

Frequency Modulation (FM)  
Radio Manufacturing  
Radio Set Serviceman  
Television Servicing  
Electronics Maintenance  
Public Address Systems, etc.

**EXTRA  
TRAINING  
NO EXTRA COST**

**Industrial Electronics  
and Electric Refrigeration**  
Extra training to help you get ready for the better jobs in these great fields . . . no additional tuition cost IF YOU ACT NOW!

THE HOME OF  
COYNE



**VETERANS!**  
Coyne is equipped to train those who qualify for training under the G. I. Bill of Rights. Check coupon for special G. I. Bulletin.

■ H. C. LEWIS, Pres., Radio-Electronics Div.,  
■ COYNE ELECTRICAL SCHOOL  
■ 500 S. Paulina St., Dept. 65-4H,  
■ Chicago 12, Ill.

Dear Mr. Lewis: Send me your Big Free Radio - Electronics Book and all the facts . . . also full details of your "Pay-after-Graduation" plan.  Send special G.I. Bulletin.  Send physical disability details.

NAME.....

ADDRESS.....

CITY.....STATE.....



## Rich diggings for DRAFTSMEN

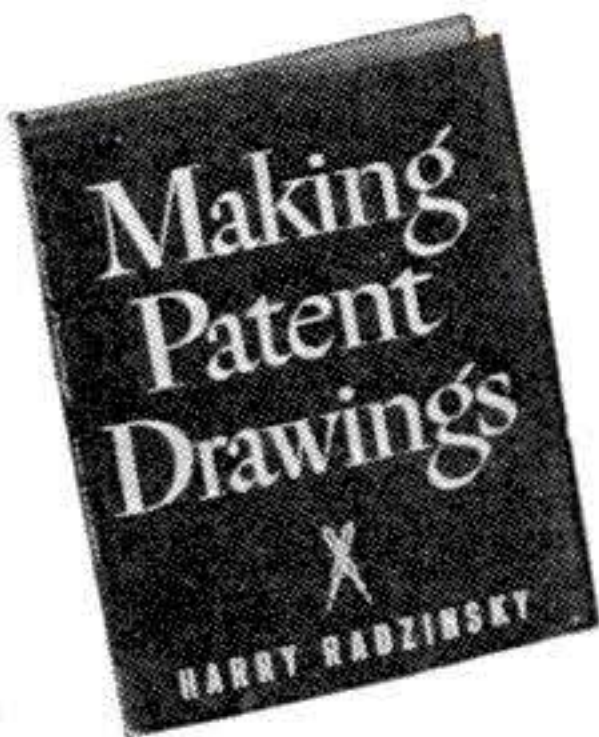

The skilled patent draftsman is *always* in demand and his work is *never* monotonous. You can learn this profitable and interesting skill from the new book, **MAKING PATENT DRAWINGS** by Harry Radzinsky for only \$3.00 It explains each step in making drawings for both patents and trademarks, with examples of all types of patents. Includes all U. S. Pat Off rules and charts.

## INVENTORS

This book will help you make sure that the drawings for your invention show exactly what you want patented, and in the exact manner required for acceptance by the U. S. Patent Office. Explains what to show in detail, what not to show. Includes many valuable pointers on how to avoid faults that might cause rejection.

### USE THIS COUPON TO GET EXAMINATION COPY

The Macmillan Co., 60 Fifth Ave., New York 11  
Please send me a copy of **MAKING PATENT DRAWINGS** by Radzinsky (\$3.) with the understanding that if I return it in good condition within 7 days my bill will be canceled.

Signed.....

Address.....

PS2

## 8 BIG BUILDING BOOKS

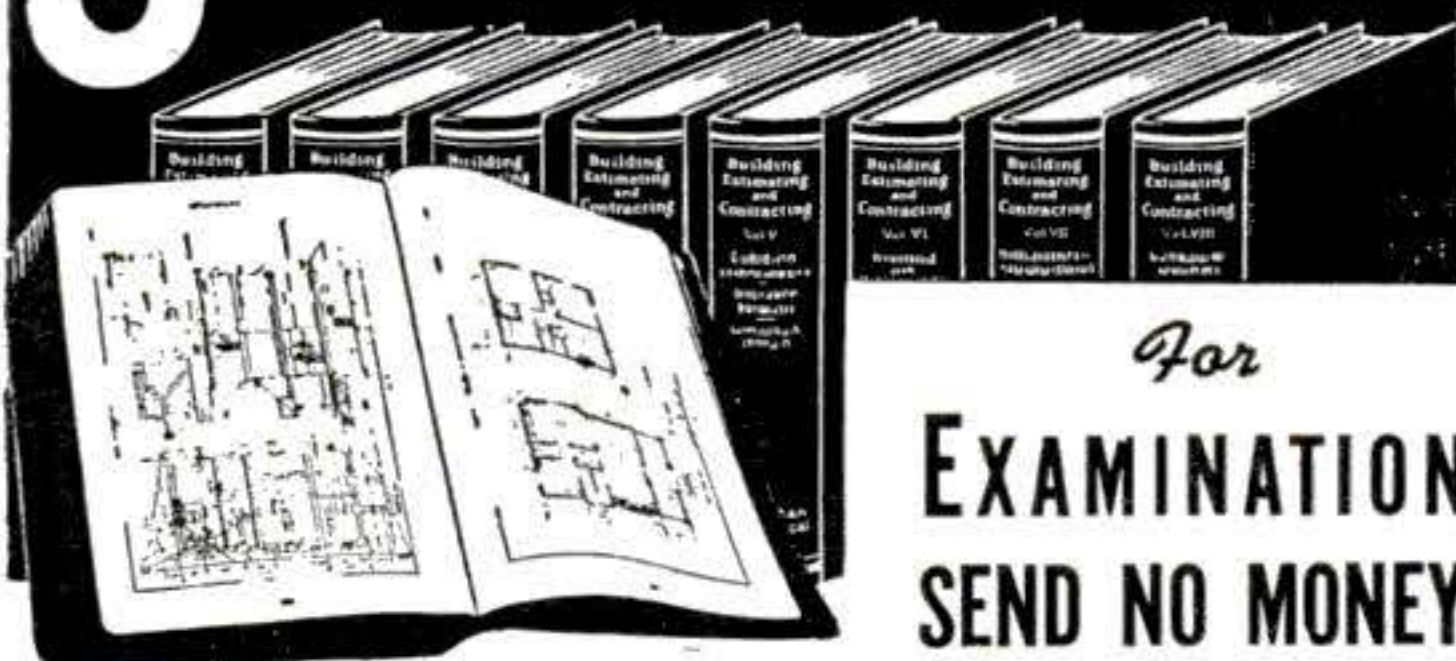

For  
**EXAMINATION  
SEND NO MONEY**

Learn to draw plans, estimate, be a live-wire builder, do remodeling, take contracting jobs. These 8 practical, profusely illustrated books cover subjects that will help you to get more work and make more money. Architectural design and drawing, estimating, steel square, roof framing, construction, painting and decorating, heating, air-conditioning, concrete forms and many other subjects are included.

### BETTER JOBS — BETTER PAY UP-TO-DATE EDITION

Keep busy now at good pay, and be prepared for after-war building boom. Big opportunities are always for **MEN WHO KNOW HOW**. These books supply quick, easily understood training and handy, permanent reference information that helps solve building problems.

These books are the most up-to-date and complete we have ever published on these many subjects.

### Coupon Brings Eight Big Books For Examination

**AMERICAN TECHNICAL SOCIETY** Vocational Publishers since 1898  
Dept. G620 Drexel at 58th Street Chicago 37, Ill.

You may ship me the Up-to-Date edition of your eight big books, "Building, Estimating and Contracting," without any obligation to buy. I will pay the delivery charges only, and if fully satisfied in ten days, I will send you \$2.00, and after that only \$3.00 a month, until the total price of only \$34.80 is paid. I am not obligated in any way unless I keep the books.

Name .....

Address .....

City ..... State.....

Please attach a letter stating your age, occupation, employer's name and address, and that of at least one business man as a reference. Men in service, also please give home address.

## LEARN AT HOME TO MOUNT BIRDS



Animals, Heads, Fishes, Pets; to TAN. Be a Taxidermist. Profit and FUN.

Hunters, save your valuable **TROPHIES**. Mount ducks, squirrels, everything. Learn to TAN for leather and furs. Wonderful **HOBBY** Have a **HOME MUSEUM**. -- **BIG PROFITS** mounting for others. **INVESTIGATE NOW.**

**FREE BOOK** With 100 fine game pictures. **NOW absolutely FREE. Write TODAY.**

Send Postal **TODAY** for **FREE BOOK**. State **AGE**. **N. W. SCHOOL OF TAXIDERMY**, Dept. 3396, Omaha, Neb.



## CHEMISTRY IS OPPORTUNITY!

There's no limit to the chemist's chances for advancement . . . in salary . . . in importance. Experiments develop into giant new industries. Established industries rely on laboratories. I.C.S. training . . . practical . . . thorough . . . opens this great field to you. Instruction papers specially written by noted chemical engineers, consulting chemists, metallurgists. And these big experts are **EASY TO UNDERSTAND**. Our editors have explained all technical terms simply, clearly. Any person of ordinary intelligence can learn and make rapid progress. You have ambition. We have the training you need. Send now for free booklet!

International Correspondence Schools, Box 7632-L, Scranton 9, Pa.

## SHORTHAND in 6 Weeks at Home

Famous Speedwriting system, no signs or symbols. Easy to learn; easy to write and transcribe. Fast preparation for a job. Surprisingly low cost. 100,000 taught by mail. Used in leading offices and Civil Service. Write for free booklet. **Speedwriting, Dept. 26095, 55 West 42 St., N. Y. 18**

## Big Money for Workers In Home or Shop



Licensed Concrete Specialists wanted. No experience needed. Make *Colorglazed* concrete pottery without molds. New, lost cost, patented method. Cemetery products, novelties, tiles, floors, etc. Basement leaksealing. Other big pay projects. Booklet, details free. Men only.

**NATIONAL POTTERIES COMPANY**  
542 West Lincoln, Fergus Falls, Minnesota

## WINDOW SIGN LETTERS

For Store Fronts and Office Windows. Anyone can put them on. Samples furnished. Genuine gold and silver. **METALLIC LETTER CO., 441 N. Clark, Chicago 10**

## MECHANICAL DENTISTRY AT HOME!

To make **Crowns, Plates, Bridgework, etc.,** for Dentists. Easy practical way to learn mechanical dentistry at home in spare time. **FULL EQUIPMENT OF TOOLS AND MATERIALS INCLUDED WITH COURSE.** Low tuition. Easy terms. Write for **FREE BOOK** about this money making profession that is not affected by the machine age.

**McCARRIE SCHOOL OF MECHANICAL DENTISTRY**  
207 N. Broad St. Dept. 842 Philadelphia, Pa.

## MONEY for MEN ALL FREE

THE PLASTEX Industry needs manufacturers on small scale and for big production of Lamp and Clock Stands, Art Goods and Novelties in Plastex and Marble imitation. Experience unnecessary. 1/2c material makes regular 10c store sellers. Rubber moulds furnished for speed production. Small investment brings good returns. Big chain store orders now being placed. Ambitious men have chance for real prosperity. Our Free booklet will interest and benefit you.

**PLASTEX INDUSTRIES, Dept. 2, 1085 Washington Av., New York 56, N.Y.**

Buy War Savings Bonds and Stamps regularly.



How to

# GUARANTEE YOURSELF A GOOD LIVING....

**T**HE only way you can GUARANTEE yourself a good living, come good times or bad, is to KNOW MORE than the average job-seeker about something important in the business world... something employers will pay you well for, or that you can use to set up a prosperous, independent Business of Your Own. ••• Here are listed just a few of the present and Post-War OPPORTUNITIES available to you. Here's your chance to choose the kind of occupation, trade or profession you'd like to master—here's that all-important practical information you require. ••• Just mail coupon for big FREE 100-page Success-Catalog showing thousands of ways to better your condition and IMPROVE and ENRICH YOUR LIFE.

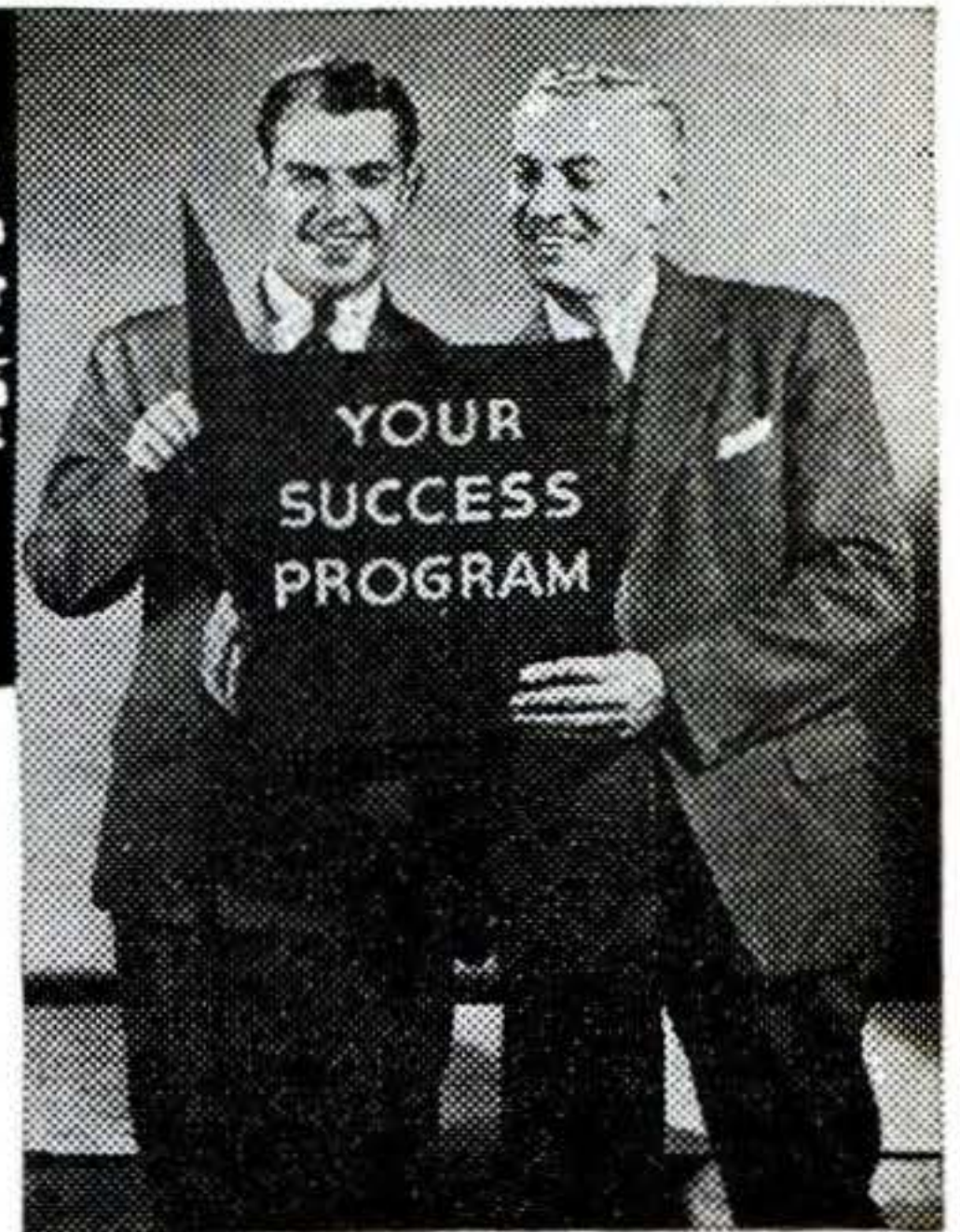

## Real Estate

### SUCCESS... be a professional man

Practical training on how to run a profitable Real Estate Business of your own. Illustrated self-study lessons on farm and suburban properties, downtown operating. Gain a working knowledge of mortgages, listings, sales techniques, appraisals, property management, commercial leasing, contracts, etc. Real estate is the foundation of all wealth! **RUSH COUPON BELOW** for NEW facts you should know about your future in real estate. There's no obligation.

## Practical REFRIGERATION

**Brand New Streamlined Course** for quick training. Authoritative step-by-step instruction on servicing household refrigerators... how to install, operate, repair. Easy-to-follow illustrated directions on troubleshooting, parts replacement, testing. Covers quick-freeze units, lockers, water coolers, freon, air-conditioning systems, etc. Amazing low prize! Free details, see coupon.

## AUTO Mechanics

Let this **Practical, Low-Priced** course get you started in the auto repair trade. Good mechanics make big money NOW... and have a great future! Self-training lessons show you exactly what to do and how to do it. It teaches servicing on all makes of cars... adjustments, tune-ups, etc. Clearly written and illustrated by expert engineers. Satisfaction or a refund! Mail coupon now for FREE details.

## Carpentry ~ Building ESTIMATING

There's a great future in the building trades for trained men. Up-to-date lessons how to plan, build, remodel houses, instructions: stair building, steel square, roofing, painting decorating, etc. Send for full information **FREE**. Use coupon.

## MAIL ORDER BUSINESS YOUR BIG OPPORTUNITY!

84-lesson course on proved, tested, up-to-date, profitable methods. Amazing treasure-house of best mail order plans and practices. How to start your mail order business on a small one-man scale, how to keep it growing more and more profitable month after month. Money-making facts. Free sensational details. Mail Coupon!

## Watch & Clock Repairing



Learn at home in your spare time. Prepare for a Happy Future of prosperity, security, and get a big-pay job now. Fascinating! You can earn while you learn. Excellent field for part-time work at home. **Practical Course in HOROLOGY**. Thorough self-instruction training in American and Swiss watches and clocks. Special section on alarm clock repairs. Learn-by-doing instruction method. Interesting. Quick. Easy. No previous experience needed. Watchmaking is basic training for Aircraft Instrument Work and other scientific precision jobs. Fast-growing field... big opportunity. Mail coupon for **FREE** information TODAY.

## Locksmithing & Key Making

### PRACTICAL UP-TO-DATE COURSE

How to pick locks, de-code, make master-keys, repair, install service, etc. New, self-instruction lessons for every handyman, home-owner, carpenter, mechanic, service station operator, fix-it shop, hardware dealer, or gunsmith. **53 Easy Illustrated Lessons** **LOW PRICE!** Satisfaction guaranteed or money back. Write now—no obligation!

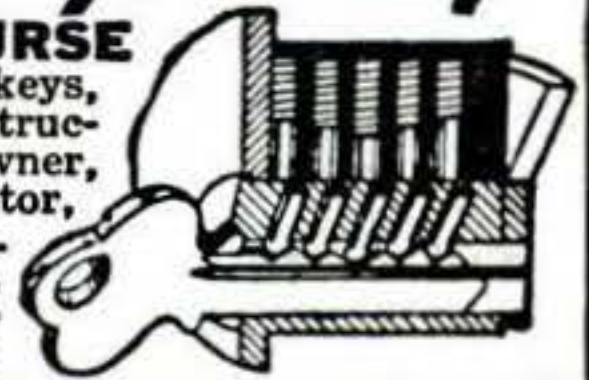

## Practical RADIO Service

**SELF-INSTRUCTION COURSE** teaches you the practical side of radio... adjustment, operation, trouble-shooting. No previous knowledge necessary. Large, clear illustrations, diagrams, charts, etc. **Interesting Steady Work!** Set up a radio repair shop of your own—or prepare for booming industrial electronics. This useful, how-to-do-it course brings you all the fundamentals including mathematics, review questions, problems, answers. Strictly up-to-date. Coupon below will bring you full information you will want. Mail it in today. No obligation.



## What to INVENT how to INVENT

**MECHANICAL DRAWING, DESIGNING, BLUE-PRINT READING**—Practical course for the wide-awake practical men. IDEAS... how to get them, develop them, protect them and promote them! Expert information on how to turn your imagination into money. Plus illustrated self-study lessons on basic mechanical movements and devices. Mail coupon below for **FREE** details. No obligation.



## FREE! 100-page book... mail this now!

**NELSON CO., DEPT. 8J01, 321 S. WABASH AVE., CHICAGO 4, ILL.** Please send me—Free, without obligation—illustrated Success-Catalog containing information about the subject (subjects) I've checked below. No salesman will call.

- |   |  |  |
|---|--|--|
| <input type="checkbox"/> Watch and Clock Repairing. | <input type="checkbox"/> Locksmithing. | <input type="checkbox"/> Refrigeration.  |
| <input type="checkbox"/> Practical Radio Servicing. | <input type="checkbox"/> Real Estate.  | <input type="checkbox"/> Auto Mechanics. |
| <input type="checkbox"/> Mail Order Business.       | <input type="checkbox"/> Carpentry.    | <input type="checkbox"/> Inventions.     |

NAME \_\_\_\_\_  
 ADDRESS \_\_\_\_\_  
 CITY \_\_\_\_\_ ZONE \_\_\_\_\_ STATE \_\_\_\_\_

**INSURE YOUR FUTURE — Mail This Coupon Now!**  
 On this coupon check the subjects that interest you. Our world-famous copyrighted Success-Catalog will bring complete details, **FREE**... no cost, no obligation.  
**NELSON CO. 321 SOUTH WABASH AVENUE**  
**Dept. 8J01, CHICAGO 4, ILL.**



# Become a REAL ESTATE Specialist

**Good Income. Pleasant Outdoor Work. Now Easy to Learn—In Spare Time at Home**

**TREMENDOUS OPPORTUNITIES!** U. S. Housing Admin. reveals 12,600,000 homes needed. Vast population shifts, Govt. loans to veterans, higher incomes on farms, in towns, cities—all mean tremendous expansion.

Prepare NOW to cash in on big profits. Learn in spare time. No need to give up present job. Start in "on side"—then build up full time business as your own boss; pleasant outside work, your own working hours.

## Mail Coupon for FREE BOOK

Practical home-study course prepares you for this money-making, big-future business. No previous experience needed. FREE BOOK tells how you can quickly learn to make excellent income. Mail coupon today. No cost, no obligation; no salesman will call. *School of Real Estate Training, Dept. 129, 126 Bedford St., Stamford, Conn.*



**School of Real Estate Training, Inc.**  
Dept. 129, 126 Bedford St., Stamford, Conn.

Send FREE BOOK describing course. No salesman is to call.

Name.....

Address.....

City..... Zone No. (if any)..... State.....



## The Big Field in Postwar Aviation

Transportation by air is still in its infancy—your opportunities for success in AIRLINES MAINTENANCE will keep right on growing as thousands of new trunk and feeder line planes start to carry more than 20 million passengers and thousands of tons of air cargo every year. Specialists in airlines maintenance are required for every plane in the air—the more planes, the more opportunities for you!

Come to Los Angeles for your training—qualify for such a career at Aero Tech, where you get the benefits of modern field and shop equipment, and close contact with the aircraft industry.

## VETERANS! SERVICEMEN!

Aero Tech is among the schools approved by the Veterans Administration, so that discharged veterans who attend are eligible for educational benefits under the G. I. Bill of Rights.



## AERO INDUSTRIES TECHNICAL INSTITUTE

HERBERT W. HARTLEY, President

5247 W. San Fernando Road, Los Angeles 26, Calif., Dept. S-9

### AERO INDUSTRIES TECHNICAL INSTITUTE

5247 W. San Fernando Rd., Los Angeles 26, Calif., Dept. S-9

Gentlemen: Please send free bulletins, and data on courses checked below.

- |  |  |
|--|--|
| <input type="checkbox"/> Master Aircraft and Engine Mechanic | <input type="checkbox"/> Master Aircraft Instrument Technician |
| <input type="checkbox"/> Airline Maintenance Engineer        | <input type="checkbox"/> Aeronautical Draftsman                |
| <input type="checkbox"/> Airline Flight Engineer             | <input type="checkbox"/> Aeronautical Engineer                 |

Name..... Age.....

Street.....

City..... Zone..... State.....

Check one: Veteran  In Service  Civilian  S-9



## THIS GREAT BOOK

# FREE!

Every farmer, every lover of horseflesh should have a copy of it. This amazing book tells how to know horses—how to break them—how to train them—how to make money as a master horseman. Write for it today—FREE, together with my special offer of a course in Animal Breeding. If you are interested in Gaiting and Riding the saddle horse check

here  Do it today—now. You'll never regret it.

**BEERY SCHOOL OF HORSEMANSHIP**  
Pleasant Hill, Ohio  
Dept. 589

## RADIO, ELECTRONICS and YOU!

There are big rewards in the communications line for the Radio man who has the answers! Too, the equipment that has made Radio communication possible is functioning now in other rewarding fields. Electron tubes in industry promise a whole new World of Electronics. I. C. S. has a variety of Radio Courses and a great new standard Electronics Course. Write for booklet, pick your Course.

International Correspondence Schools, Box 7632-L, Scranton 9, Pa.

# LAW

STUDY AT HOME for PERSONAL SUCCESS and LARGER EARNINGS. 36 years expert instruction—over 108,000 students enrolled. LL.B. Degree awarded. All texts furnished. Easy payments. Send for FREE BOOK—'Law and Executive Guidance'

AMERICAN EXTENSION SCHOOL OF LAW  
Dept. 57-S, 646 N. Michigan Ave., Chicago 11, Ill.

# STUDY AT HOME

## With A Chartered Educational Institution

Courses in ENGINEERING: Electrical, Civil, Mechanical, Drafting, Architectural, Steam, Aeronautical, Radio, Structural, Mining, Industrial, Highway, Petroleum, Marine, Chemical.  
Courses in ARTS AND SCIENCES: Philosophy; Education; Letters; Public Health; Medical Jurisprudence; Psychology; Sociology; Physics; Chemistry; Geology; Pol. Science; Theology; Law; Business and Commerce; Accounting; Mathematics; Statistics; Agriculture.  
McKinley-Roosevelt Incorporated, 4810-AC, Sheridan Road, Chicago, 40, Illinois

# Trains MAGAZINE

The illustrated monthly about railroads

Buy war bonds now . . . After the war use them to see America on the fast comfortable trains of tomorrow. Read Trains Magazine to learn what the railroads are doing and how they do it . . . Send 25 cents for recent issue.

TRAINS MAGAZINE, Dept. N, Milwaukee, 3, Wis.

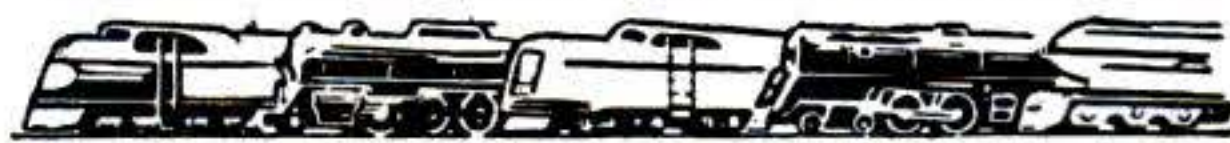

# DRAFTING

## PREPARE NOW FOR A BETTER JOB

Begin now to turn spare time into money. Become a draftsman with opportunities for advancement. Be ready to qualify for a good paying job as industry turns to peacetime production.

If you are now doing routine drafting work, prepare now for promotion to a better job in your field. Send name and address today for FREE information.

American School, Dept. DD646, Drexel Ave. at 58th St., Chicago 37

Name.....

Street.....

City, State.....



BE YOUR OWN BOSS...IN YOUR OWN BUSINESS

# LEARN PLASTICS FABRICATION AND CASTING

*"I Train You for Success"*



Paul Davis, B.S.M.E., Founder of the first Plastics Fabrication Home Training Course.

**SMALL CAPITAL . . . START IN YOUR OWN HOME**

Get into new Plastics Business. **START IN YOUR OWN HOME. SMALL CAPITAL NEEDED.** As you increase your knowledge and skill **YOU GROW WITH THIS BIG INDUSTRY.**

This opportunity is **YOURS TODAY . . .** SO get started now in what can be a **BIG PAYING** Plastics business of your own—or prepare for post-war jobs. This **NEW** educational plan gives **YOU** the sound fundamental knowledge **PLUS** the practical training you need to be **A SUCCESS IN PLASTICS.** The actual practical work consists of working with many different types of Plastics materials—teaching you **IN YOUR OWN HOME,** fabrication, shaping, forming, finishing, cementing methods, mold making, casting, compounding, dyeing, etc.

**FOR FULL INFORMATION FILL COUPON AND SEND IN ENVELOPE OR PASTE ON A PENNY POSTCARD TO DEPT. N.**

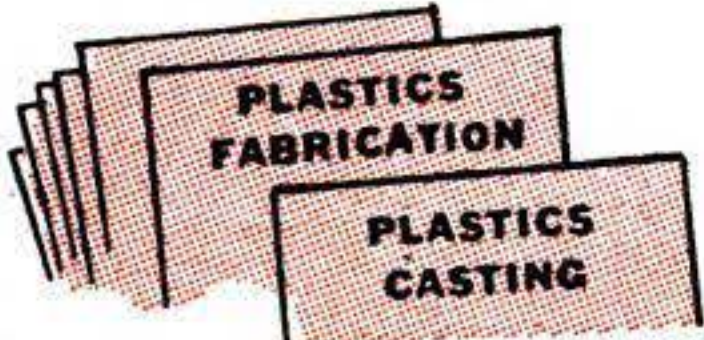

Practical Training Lessons Including



All Materials and **5** Complete Working Kits.

## PLASTICS TECH

Division of **BOSTON TECHNICAL INSTITUTE**  
**SCHOOL OF PLASTICS**, 4707 Euclid Avenue, Cleveland 3, Ohio

GENTLEMEN: Please send me **FREE** New 1946 Success Booklet'

NAME .....AGE .....

STREET .....P. O. ZONE .....

CITY .....STATE .....



Three months after taking your course  
**I STARTED TO PLAY FOR DANCES**

**"Before I took it I didn't know a note of music"**

writes Miss Rosie Montemurro of Vancouver, B. C., Canada

"Words cannot express my feelings to the U. S. School of Music. Before I took your course I didn't know one note of music. Three months later I started to play for dances. It has a clear explanation in every lesson." Miss Rosie Montemurro.

**You, too, can learn your favorite instrument quickly, easily, for ONLY 7c A DAY**

This letter is typical of many we have from pupils. Thousands who didn't know a note are now playing their favorite instruments—thanks to this simple home study way to learn music for **only 7c a day.** Learning music this famous "Print and Picture" way is easy as A-B-C! No long-winded explanations. No tiresome exercises. You play real tunes by note right from the start. If interested, send for Free Booklet and "Print and Picture" Sample. Mail coupon today, to: U. S. School of Music, 89 Brunswick Bldg., New York 10, N. Y.



**See how easy it is!**

'My country 'tis of thee, sweet land of liberty'

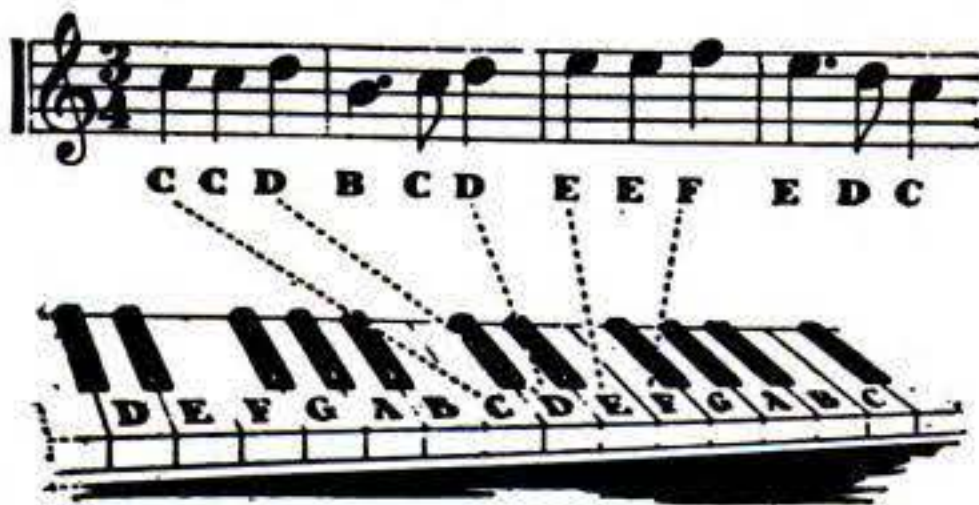

Look at the music. The first note is "C". Follow the dotted line to the keyboard and locate "C" on the piano. Find other notes the same way. Strike notes as indicated and you'll play the melody of America.

### SUCCESSFUL 47<sup>TH</sup> YEAR

U. S. School of Music  
 89 Brunswick Bldg., New York 10, N. Y.

Please send me Free Booklet and Print and Picture Sample. I would like to play instrument checked below.

- |                 |                 |                |
|-----------------|-----------------|----------------|
| Piano           | Saxophone       | Clarinet       |
| Guitar          | Trumpet, Cornet | Tenor Banjo    |
| Hawaiian Guitar | Modern          | Mandolin       |
| Violin          | Elementary      | Practical      |
| Piano Accordion | Harmony         | Finger Control |

Have You  
 Name.....Instrument?.....  
 Address.....  
 City.....State.....

Save 2c—Stick Coupon on Penny Postcard



**BE READY FOR  
A BETTER JOB  
AT BIGGER PAY**

**PREPARE Now  
FOR POST-WAR  
BUILDING  
BOOM**



**Thousands of  
Trained Men  
Will Be Needed**

● New homes and other structures to be built after peace returns will provide a tremendous number of well-paid jobs. Men trained in Architecture, Drafting, Contracting, Carpentry and related building trades will cash in BIG on their knowledge and skill. YOU can train in spare time at home, at low cost, for a big-pay job in this rich field. American School can help you to success just as it has helped others during its 48 years. Check, fill in and mail coupon NOW for FREE information.

**AMERICAN SCHOOL, Dept. B646, Drexel Ave. at 58th St., Chicago 37, Ill.**

Send me FREE information about your special training plan covering subjects checked below.

- |  |  |
|--|--|
| <input type="checkbox"/> Architecture and Building | <input type="checkbox"/> Automotive Engineering                  |
| <input type="checkbox"/> Drafting and Design       | <input type="checkbox"/> Diesel Engineering                      |
| <input type="checkbox"/> Contracting               | <input type="checkbox"/> Mechanical Engineering                  |
| <input type="checkbox"/> Practical Plumbing        | <input type="checkbox"/> Plastics Engineering                    |
| <input type="checkbox"/> Air Conditioning          | <input type="checkbox"/> Aviation <input type="checkbox"/> Radio |
| <input type="checkbox"/> Refrigeration             | <input type="checkbox"/> Business Management                     |
| <input type="checkbox"/> Electrical Engineering    | <input type="checkbox"/> High School Courses                     |

Name.....

Address.....

**JUST OUT! NEW FROM COVER TO COVER**

**AUDELS  
REFRIGERATION  
and AIR CONDITIONING GUIDE**

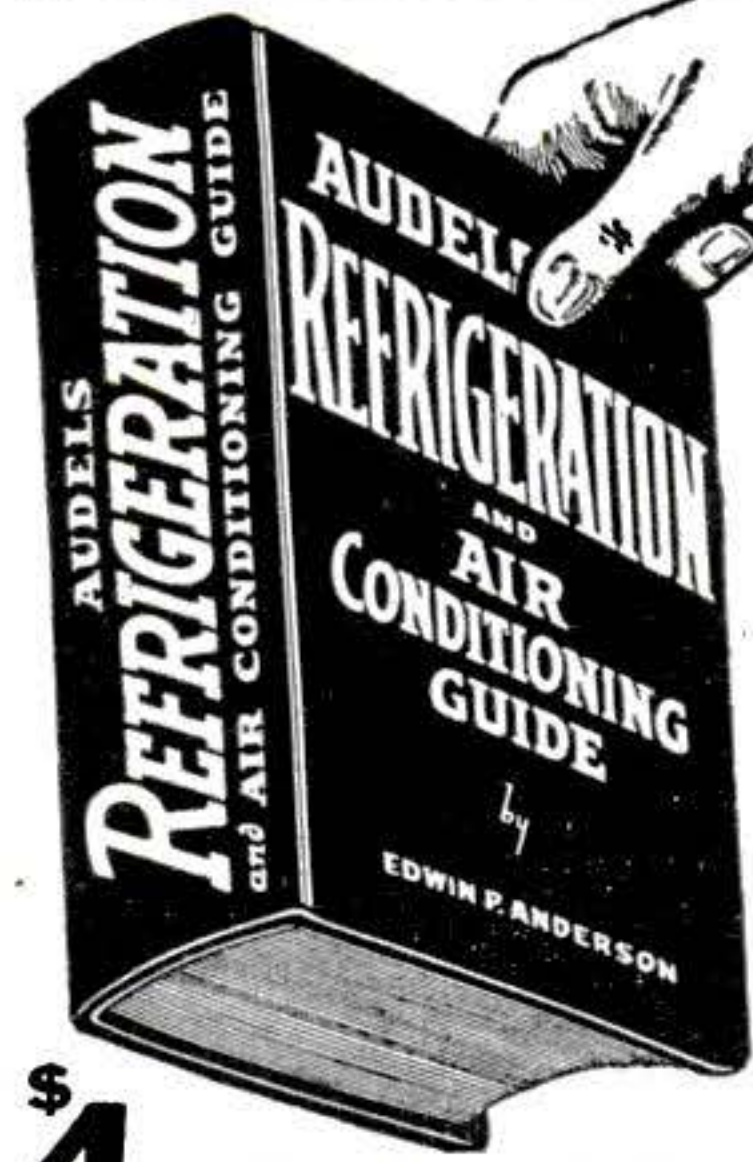

**4 Books in One! Covering:**  
Basic principles, Servicing, Operation, Repair of  
1—Household Refrigeration  
2—Special Refrigeration Units  
3—Commercial & Industrial Refrigeration  
4—Air Conditioning Systems  
A gold mine of essential important facts for ENGINEERS, SERVICEMEN & USERS.  
A Good Book is a Good Friend! Here you have at your fingers' ends a Complete Library in ONE VOLUME, the necessary data you have been looking for on: MODERN UNITS, SYSTEMS & MACHINES, REFRIGERANTS, including Freon, Lockers, Water Coolers, Quick Freezing & Air Conditioning Systems.  
1280 Pages, 46 chapters all Fully Illustrated & indexed for Ready Reference.

**ANSWERS YOUR QUESTIONS**  
Get This Information for Yourself. Mail Coupon Today. No Obligation Unless Satisfied. ASK TO SEE IT.

**\$4 COMPLETE • PAY ONLY \$1. A MONTH ←**

**AUDEL, Publishers, 49 W. 23rd St., New York 10, N.Y.**

MAIL AUDELS NEW REFRIGERATION GUIDE for free examination. If O. K. I will send you \$1 in 7 days; then remit \$1 monthly until price of \$4 is paid. Otherwise I will return it.

Name.....

Address.....

Occupation.....

Employed by..... PSM

**Get into Good Paying  
AUTO BODY and FENDER WORK**



**BIG DEMAND** in Auto Body and Fender work. Start training now spare time at home for good pay work now and postwar. Practical shop experience included. U.E.I. Training covers metal work, welding, painting, etc. Placement service—or we will show you how to start own shop. Behind U.E.I. TRAINING is a large national organization founded 1927.  
*Write today for Free Facts—No obligation*

**AUTO-CRAFTS DIVISION • UTILITIES ENGINEERING INSTITUTE  
1314 BELDEN AVENUE, DEPT. 395X, CHICAGO 14, ILLINOIS**

**Become a Doctor of PSYCHOLOGY**

Win the degree of Ps.D. Teach the secret of contentment, happiness. Solve mental worries. Experience the revelation of truth. Chartered college. Individual help. Write for FREE book, COLLEGE OF UNIVERSAL TRUTH, 5153-A North Clark St., Chicago.

**Learn TOOL DESIGN**

Qualify quickly as Machine or Tool Designer through spare-time home study. Many making \$100 to \$125 a week. Expanding industry calling for more machine and tool designers than available. Rush name and address today for facts on Machine or Tool Design. State age.

**OHIO INSTITUTE OF TECHNOLOGY, Box 267, Greenville, Ohio**

**Inventions Wanted  
Patented or Unpatented**

Inventions can now be safely sold without patenting expense. If you have a practical, useful idea for sale, either unpatented or patented, write today!

**Institute of American Inventors  
Dept. 3, 1926 Eye Street, Washington 6, D. C.**

**PATENTS  
AND TRADE MARKS  
C. A. SNOW & CO.**  
*Registered Patent Attorneys Since 1875*  
Write for Free Book and "Certification of Invention" form  
**427 SNOW BUILDING, WASHINGTON 1, D. C.**

**WATCHES WANTED BROKEN OR USABLE**

—all kinds, even Ingersolls. Highest prices paid for jewelry, rings, spectacles, alarm clocks, razors, cigarette lighters, gold teeth, etc. Cash mailed promptly.

**Lowe's, Holland Bldg., Dept. PS, St. Louis 1, Mo.**

**PATENT YOUR IDEAS  
SEND FOR FREE BOOK → HOW TO OBTAIN A PATENT**

Written by Former Member Examining Corps (1922-24) U.S. Patent Office.  
**CARL MILLER, Registered Patent Attorney**  
Former Member Examining Corps U. S. Patent Office  
Woolworth Bldg., Dept. 95-C, New York—Bond Bldg., Dept. 95-C, Washington, D. C.

**INVENTORS  
Do Not Delay!**

Have you ever been startled by seeing a successful article on the market, and exclaimed—"Why, I invented THAT 5 years ago—I didn't think it was valuable enough to Patent!"

The Patent Laws were intended for the protection of the Inventor, and the Inventor who slumbers on his rights may wake up to find someone else reaping the reward that could have been his.

The Inventor with a valuable Invention should act NOW. Send this coupon TO-DAY—to RANDOLPH & BEAVERS, 340-D Columbian Bldg., Washington, D. C.

**RANDOLPH & BEAVERS  
PERSONALIZED SERVICE**

**Registered  
Patent Attorneys  
Washington, D. C.  
340-D Columbian Bldg.**

Please send me full particulars on Patents, fees, etc., and "RECORD of INVENTION form"—Free.

Name.....  
Address.....



# WHICH OF THESE *Opportunities* INTERESTS *You* MOST?

● Today, choose the job you want—and prepare for it. Or if you are already engaged in the work you like best, start training now for quicker promotion. Acquire the knowledge that will help you to get ahead faster, make more money and have greater security.

American School, founded in 1897 as an educational institution *not for profit*, can help you to reach your goal just as it has helped others during the past forty-eight years. Check the coupon at right, add your name and address and mail it at once. The school will send you details on its training plan and outline of study prepared by specialists. There is no charge, no obligation, so send the coupon immediately.

## CHECK, CLIP AND MAIL COUPON NOW

AMERICAN SCHOOL, Dept. G646, Drexel at 58th, Chicago 37, Ill.  
*Without obligation.* Please send FREE and postpaid, bulletin and details of the Subjects checked.

- |  |   |  |
|--|---|--|
| <input type="checkbox"/> PLASTICS ENG'R            | <input type="checkbox"/> Accounting and C.P.A.              | <input type="checkbox"/> Drafting and Design for Men and Women |
| <input type="checkbox"/> Refrigeration             | <input type="checkbox"/> Bookkeeping                        | <input type="checkbox"/> Radio                                 |
| <input type="checkbox"/> Architecture and Building | <input type="checkbox"/> Private Secretary                  | <input type="checkbox"/> High School                           |
| <input type="checkbox"/> Practical Plumbing        | <input type="checkbox"/> Diesel Engineering                 | <input type="checkbox"/> Air Conditioning                      |
| <input type="checkbox"/> Automotive Engineering    | <input type="checkbox"/> Surveying & Topographical Drafting | <input type="checkbox"/> Mechanical Eng.                       |
| <input type="checkbox"/> Aviation Drafting         | <input type="checkbox"/> Sheet Metal Pattern Drafting       | <input type="checkbox"/> Shop Management                       |
| <input type="checkbox"/> Aviation                  | <input type="checkbox"/> Electrical Engin'ring              | <input type="checkbox"/> Tool Making                           |
| <input type="checkbox"/> Business Mgnment.         | <input type="checkbox"/> Electronics, Industr.              | <input type="checkbox"/> Better Foremanship                    |
| <input type="checkbox"/> Railway Training          |   | <input type="checkbox"/> Machine Shop Operations               |

### AMERICAN SCHOOL

Dept. G646, Drexel at 58th Street, Chicago 37

Name..... Occupation.....  
Address..... Age.....  
City..... State.....

# FIX ANY RADIO

## Amazing New Invention



### FOR BEGINNERS OR EXPERTS

Learn quickly to repair all radio sets. New revolutionary different comparison picture-method simplifies radio servicing. No previous radio knowledge required. Introductory training included. Find any fault with ease. Do expert radio work almost immediately. Repair radios in minutes instead of hours. Plan U.S. Copyrighted. Take advantage of this new invention.

### NO EQUIPMENT NEEDED

You can fix any radio using a screw driver, pliers, and a piece of wire—no testers needed. Simple point-to-point picture suggestions tell you where to look for defects, how to test radio circuits and parts, and how to make the repair. You may try the plan for 10 days without any risk.

### RADIO MADE EASY

Let this unique plan with its easy-to-understand diagrams, simplified illustrations, hints, job-sheets, and practical examples teach you basic radio facts. Learn important shortcuts in radio trouble-shooting. Make needed tests without testers, trace the signal, measure voltage, within the hour after receiving the plan. Follow the comparison tests given on large trouble-shooting blueprints. Over 1,000 repair hints. Data on all tubes. Covers every radio set — new and old.

PRICE ONLY  
**\$1.50**  
COMPLETE

### 10 DAYS "NO RISK TRIAL"

Examine and use Simplified Radio Servicing plan for 10 days in your own home. Apply this technique and repair one or more radios. Then decide to keep this greatest radio training bargain, or return the material and get your money refunded in full. You take no risk.

Complete plan, only **\$1.50**

In manual form, 8 1/2 x 11" Trouble-shooting charts. Data on 346 radio tubes. 76 large job-sheets. 1,000 time-saving hints Covers all receivers—new and old, portables, FM, etc. Developed by Beitman, noted engineer, teacher, and author. Order today without risk — use 10 days.

### NEW 1945 EDITION

### REPAIR RADIOS IN MINUTES

Read the introductory job-sheets, follow the step-by-step picture blueprints, and fix any radio in a matter of minutes. Do radio work for fun and profit. The complete simplified training is yours for only \$1.50, postpaid. 10 days no risk trial.

### MORE HELP — IF NEEDED

Supplement your study, clear-up all hard problems, get ahead in Radio. A companion 19 lesson Practical Radio manual will give you added assistance, help you get ahead faster, present important facts in greater detail. Include this course - manual also in your trial order. See coupon. →

## No Risk TRIAL ORDER COUPON

SUPREME PUBLICATIONS, 9 S. KEDZIE AVE., CHICAGO 12, ILL.

Ship the following manuals to me for 10 days' trial under your money-back guarantee. I am enclosing \$....., full price. Ship Postpaid.

- Simplified Radio Servicing @ \$1.50. Complete manual as described.  Practical Radio Manual @ \$2.95. Companion Volume, 19 lessons.

Name: ..... PSS

Address: .....



# BE A WATCHMAKER

Enjoy Security and a Good Income in this Skilled Profession

There is a nation-wide demand for skilled watchmakers! You can prepare for a successful career by training at American School of Watchmaking. In this respected field you enjoy clean, light work in jewelry stores—many watchmakers establish businesses of their own. Millions of timepieces require frequent service—there is always a need for skilled men to handle these delicate instruments. American School of Watch-making offers a fully accredited course, taught by experienced watch makers, with all equipment necessary to learn every phase of this



**VETERANS! SERVICEMEN!**  
Courses approved for Veterans Training under G. I. Bill.

profession. Now is the time to come to Los Angeles to prepare for a well-paid, permanent career as a watchmaker. Write for complete, illustrated booklet on this interesting field, and A.S.W. training.

## AMERICAN SCHOOL OF WATCHMAKING

Division of American School of Aircraft Instruments  
5247 W. San Fernando Rd., Los Angeles 26, Calif., Dept. 5-9



### AMERICAN SCHOOL OF WATCHMAKING

5247 W. San Fernando Rd., Los Angeles 26, Calif., Dept. 5-9

Gentlemen:

Please send me your illustrated booklet and complete information on the accredited A.S.W. Course in Watchmaking.

Name \_\_\_\_\_ Age \_\_\_\_\_

Address \_\_\_\_\_

City \_\_\_\_\_ Zone \_\_\_\_\_ State \_\_\_\_\_

Check one —  Veteran  In Service  Civilian

# ELECTRICIANS! RADIO MEN!

Earn More Money!

Get this new  
**GIANT SIZE**



**ELECTRICAL and RADIO TROUBLE SHOOTING MANUAL**  
GUARANTEED BY COYNE

*Yours 5 Days Free*

Needed by war workers, maintenance men, beginners, old timers! Nothing else like it. Saves time, helps boost your pay... **4 GREAT BOOKS IN ONE!** 1. New Step-by-Step Trouble Shooting Course. 2. 500 Shop Prints. 3. Elec.-Radio Dictionary. 4. Spare Time Jobs.

**FREE!** 1 yr. Technical Counsel by mail from COYNE staff, on trouble-shooting problems.

**SEND NO MONEY!** See offer below. Satisfaction guaranteed by famous COYNE "Learn-by-Doing" Electrical School. Rush coupon now!

**OVER 500 Large Size Electrical and Radio Shop Prints -How to read and use them**

H. C. LEWIS, Pres., Dept. 65-R8  
COYNE ELECTRICAL SCHOOL  
500 S. Paulina St., Chicago 12, Ill.

**FREE TRIAL COUPON**

Send, with all shipping charges paid, your new COYNE Electrical and Radio Trouble Shooting Manual. Within 5 days after getting it I'll either return it or send \$3, then \$3 monthly until total of \$8.95 is paid. [ ] Cash price \$8.00—you save over 10%. Same 5-day free trial and return privilege.

NAME \_\_\_\_\_  
ADDRESS \_\_\_\_\_  
CITY \_\_\_\_\_ STATE \_\_\_\_\_

# ALPHABETS

**ANCIENT**

A *New*

and modern **MANUAL**

**T**HIS is a unique collection of 124 complete alphabets—ancient, medieval and modern. Many of the alphabets are rare and very difficult to locate. Never before have all of them been included in a single volume for quick reference. This rich compilation of the letterer's art offers real inspiration in specialized layout tasks. A copy of "alphabets—Ancient and Modern" belongs in the studio of every art director. Price \$2.00, postpaid. Money back if not satisfied. Limited edition. Please order promptly. Padell Book Co., Dept. P9, 830 Broadway, New York 3, N. Y.

**BECOME AN EXPERT**

# ACCOUNTANT

Executive Accountants and C. P. A.'s earn \$2,000 to \$10,000 a year. Thousands of firms need them. About 20,000 Certified Public Accountants in the U. S. We train you thoroughly at home in spare time for C. P. A. examinations or executive accounting positions. Previous experience unnecessary. Personal training under supervision of staff of C. P. A.'s, including members of the American Institute of Accountants. Write for free book, "Accountancy, the Profession That Pays."

**LASALLE Extension University, 417 So. Dearborn St.**  
A Correspondence Institution Dept. 983-H Chicago 5, Ill.

## Get Ready for Big After War Opportunities!

**I Will Train You at Home Until You Get a GOOD PAY JOB in DRAFTING**

Act now to get a better job with more pay and pleasant working conditions. Get into Drafting—the basic profession where all post war products will start. I will train you at home—give you experience—doing the same kind of jobs you will do with the best paying firms. I furnish instruments, drawing table and all equipment when you start. Write today for vital facts and **FREE** illustrated book. Give Age.

Engineer Dobe, Div. 29, Libertyville, Ill.



Wonderful, new device, guides your hand; corrects your writing in few days. Big improvement in three hours. No failures. Complete outline **FREE**. Write C. J. Oxment, 35-B St. Louis, Mo

**LAW STUDY AT HOME**  
With A Chartered Educational Institution Men with legal training win higher positions, larger earnings, and are bigger successes in business and public life. Opportunities **NOW** greater than ever before. Complete course includes 20 college grade textbooks. Send for Catalog. McKinley-Roosevelt Incorporated, 4610-LB, Sheridan Road, Chicago 40, Illinois.

## ARTISTS MAKE MONEY

Find out your ability. Send name, age, occupation and address for Free Vocational Art Test.

**ART INSTRUCTION, INC., 9145 Art Instruction Bldg., Minneapolis, Minn.**  
(Formerly Federal Schools, Inc.)



*Thrilling Work* **COLORING PHOTOS**

Fascinating vocation learned at home by those with aptitude. Thrilling pastime. Koehne method brings out life-like colors. Free booklet.

**NATIONAL PHOTO COLORING SCHOOL**  
1315 S. Michigan. Dept. 1366, Chicago 5



**A SIMPLIFIED ART ANATOMY OF THE HUMAN FIGURE**  
by Charles Carlson. The book they're talking about! One of the most informative books of its kind for both student and professional artists. Charts, notes, and over 350 drawings show detailed studies of every part of the body, posed and in action. **ONLY \$1 POSTPAID**  
**HOUSE OF LITTLE BOOKS, 80-B E. 11 St., New York 3**

**FREE PATENTS**  
Booklet **OF COSTS and OTHER USEFUL INFORMATION ABOUT PATENTS**

**EUGENE H. PURDY, REGISTERED PATENT ATTORNEY**  
900 F. ST., N.W. ROOM 801-A WASHINGTON 4, D. C.

NAME \_\_\_\_\_  
ADDRESS \_\_\_\_\_



# SPEAK SPANISH

## THIS EASY WAY

**Big opportunities and jobs waiting** for those who speak Spanish. Millions of dollars being invested in Mexico, Central and South America. *Enjoy more—earn more. Increase social, business, travel and reading pleasures.* CORTINA Method famous for over 60 years, teaches you to  *speak like a native.* Learn quickly, easily at home "by listening" to Cortinaphone records. Thousands have, why not you? No risk under our Five-Day Approval offer. FRENCH, GERMAN, ITALIAN also taught by  *this amazing method.* Send for Free Book "The Cortina Short-Cut"—state language interested in.



**CORTINA ACADEMY—Established in 1882**

Dept. 129 105 West 40th St., New York 18, N. Y.



### GET INTO CARTOONING!

Learn Cartooning! Big Future! Our cartoon course contains 110 units in 4 sections! Shows you how to soon turn out salable cartoons! Complete course including year's criticism and drawing set only \$5.00 postpaid. Or write for details! **Hartman Studios, 2438 W St., Lincoln 3, Nebr.**

### Giro Prop — Any Child Can Fly It



America's New Exciting All Metal Toy

Retails 59c ea. Send \$1.00 for 2 samples with 2 blades each. Postpaid.

### HERMAN M. KRUSE & ASSOCIATES

301 FOREST AVENUE • ST. LOUIS 19, MO.

### GET INTO THE BIG MONEY BRACKET

Learn MODERN

## REFRIGERATION AIR CONDITIONING

**YOU CAN BE A POST-WAR LEADER IN THIS FIELD BY PREPARING NOW**

New, modern fast-growing industry offers tremendous post-war opportunity to trained men. Thousands of jobs are waiting. Get in on the ground floor by starting now. If you are mechanically inclined—if you are handy with a pliers and screwdriver, you can quickly and easily prepare yourself now for a big job, at big pay, in this big fast-growing multi-million dollar industry. Train at home or in the shop. Learn by doing. Combine theory with actual shop practice. Take your place with the leaders in this big industry. Insure your post-war future by acting now.

### GET IN ON THE GROUND FLOOR

Modern refrigeration and air conditioning are as simple as A-B-C. Work on actual machines. Big staff of expert instructors get you off to a flying start. Approved school for GI training. You owe it to yourself to investigate this waiting opportunity. Learn the facts. Judge them for yourself. Write today . . . a postcard will do.

**ALL DETAILS Sent FREE**

Send Coupon TODAY!

**ACT NOW!**

**LEARN IN YOUR SPARE TIME AT HOME**

Commercial Trades Institute, Dept. S-9  
209 W. Jackson Blvd., Chicago 6, Ill.  
200 S. 20th St., Birmingham, Ala.

Without obligation, please send me the facts. Let me judge for myself the opportunities and post-war security this training offers.

Check here if interested in GI training.

NAME.....

ADDRESS.....

CITY.....STATE.....



"A little land and a lot of living" . . . . . that's what my "Have-More" Plan tells you about. You'll certainly want to examine it. . . .

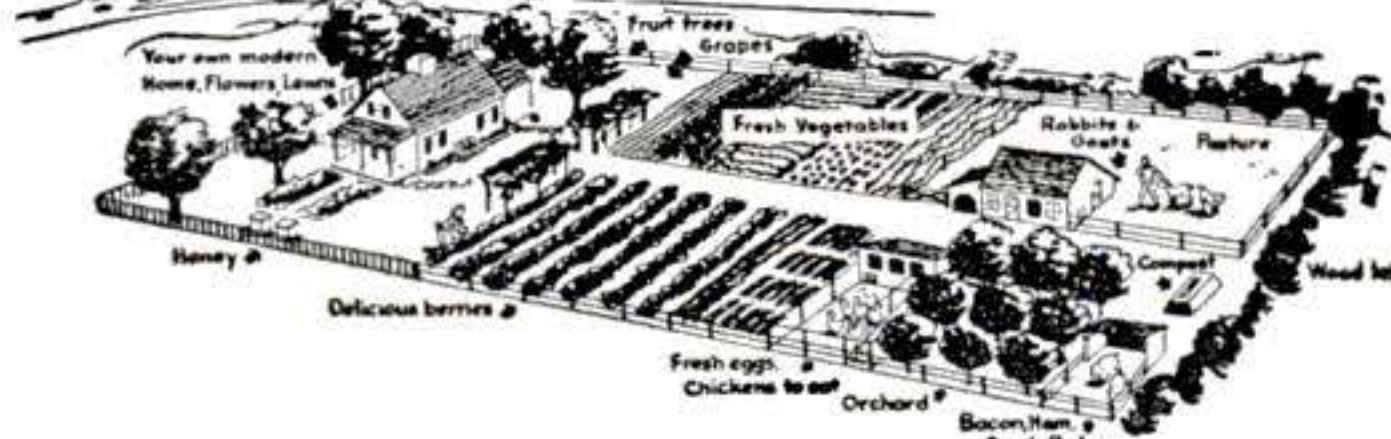

## "This is the way I want to live —the rest of my life!"



Mrs. Robison, Jackie and I aren't selling any land nor promoting anybody's products. We only want to tell you how we've learned to have more fun, more living and more security than 99% of this world's families has ever had.

We call it our "Have-More" Plan because that's how it works for us . . . we have more of just about everything that makes life worth living!

Our "Have-More" Plan is the true story of how we Robinsons moved from the city to our small place in the nearby country to find "a little land and a lot more living" while I kept a regular full-time job.

It tells how we grow most of our family's food in spare time—have fun doing it—have better living—more sunshine and fresh air—more peace and quiet—more security and independence—in fact, as I said before, more of just about everything!

### All The Details

My "Have-More" plan contains over 50,000 words, 73 illustrations, many actual photographs of our own place. And I've kept the price as low as I could, only \$1.00.

It tells just how we do things—all our short-cuts, ideas, labor-saving methods—how it takes us only an hour or so of spare time a day to have tender chicken to eat, plenty of really fresh eggs, a wonderful garden, delicious rabbit meat, rich milk, butter, cream from our miniature dairy, tasty ham, pork, bacon, sausage, geese, turkeys, squab, spring lamb, honey bees, fruit trees instead of shade trees, luscious grapes, raspberries, strawberries, etc.—how we use the latest, easiest preserving methods, including quick freezing. (Note: no one family should start all these projects at once. But we describe them all so you can take your pick.)

### No "Magic" About It

Now please don't get me wrong. This is no "crack-pot theory" on how to make an easy living. I suppose that if you absolutely had to, you could live a long time entirely off a small place like our two acres. But that would be just existing, not really living.

You've got to have some cash income—from a job or a pension or something. What I'm saying is that with my "Have-More" Plan you can make a small cash income into the best and happiest kind of a living any man could want. That's why we call it our "Have-More" Plan.

Furthermore, you and your wife have to be real partners and enjoy working together. If either of you think of the housework and the chores as just drudgery, you better go live in a boardinghouse or a two room apartment. Personally, we wish we could spend more time working around our place—it's so interesting.

### Will You Join Us?

A friend said, the other day, "Ed, why do you bother with other people? Why don't you settle down and just enjoy your own job and your 'Have-More' Homestead? Why try to spread it all over the country?" I may sound silly trying to tell you why. This is my job now. I am putting full time into gathering information on country living . . . for ourselves and others. I feel, somehow, that in the years to come, the U. S. is going to need all the help it can get toward happiness and peace and security. We aren't always going to have a war boom going on. I've got a boy I want to see grow up in a good country, and if ten or twenty million American families can get set as well as the Robinson family is, I don't think anything can hurt this nation. Do you see what I mean? That's why I've worked so hard putting this Plan together. That's why I was so careful to be truthful and sensible in everything we put in it. And that's why I've kept the price as low as I possibly could—only \$1.00 postpaid.

### Now It's Up To You

So if you are one of our kind of people, if you want to have a look at our "Have-More" Plan, just fill in the coupon here and send it to me. When you get the Plan—by return mail—look it over. If you are disappointed in it in any way or if it doesn't suit you, put it right back in the package and return it to me. I'll give you your dollar back and send you a dime for your postage.

On the other hand, if you like it, and I am sure you will, help me by showing it to your friends and getting them to start a "Have-More" Homestead also.

Yours for a "little land and a lot of living."

**Ed Robison**  
NOROTON 2809, CONN.

Send to ED ROBINSON,  
P.O. Box 2809, Noroton, Conn.



Dear Ed:—  
Here's your dollar. I want to see your "Have-More" Plan. If it's what I want I'll keep it. If not I'll send it back and you're to return my money—and we'll still be friends.

Name.....

Address.....

City.....State.....

(Please make checks \$1.05 to cover bank charge.)

Buy War Savings Bonds and Stamps regularly.



# Hunters! Anglers! You can learn Taxidermy

Here's a fascinating, profitable hobby

## WE CAN TEACH YOU TO MOUNT BIRDS

**Great Fun and Profit.** Send **Coupon** for marvelous **Free Book**. It tells **All** about taxidermy—how you can **Make Money** and have great **fun** and fascination mounting **Birds and Animals**. Save your wild-game trophies—mount for others. Also **Mount** common specimens, pigeons, squirrels, rabbits, even frogs, into humorous and useful groups—highly interesting and **sell** at sight. Wild-game **Not necessary**. Men, Women, Boys learn quickly by **Mail**. **Marvelous business, send coupon.**

**BIG PROFITS!** Turn your spare time to **Cash**. Besides **Taxidermy** learn also to **Tan Leather, Tan Fine Furs** and make them into scarfs, etc. We teach you **Genuine Chrome** method—never before revealed. 250,000 students endorse this old reliable school. We offer **You** our marvelous **Free Book**. Send for **Your** copy **Today**. In a few weeks we can teach you a **New Trade** that earns **Cash** in depression and good times, too. Then **Taxidermy** brings great fun and fascination. **Investigate!** Get the **Free Book**. Sign your name, state your **AGE**, and the **FREE BOOK** is yours. Send the coupon **Today**.

**FREE BOOK**

Northwestern School of Taxidermy,  
3396 Elwood Bldg., Omaha, Neb.

Gentlemen:—Please send me your free 48 page booklet explaining Taxidermy.

Name \_\_\_\_\_ Age \_\_\_\_\_

Address \_\_\_\_\_



**FOR COUGHS FROM COLDS,**  
cuts, aches, burns, sprains use **TAYLOR'S OIL** (Called Taylor's Oil of Life over 80 years). At your favorite store.  
35c, 75c, \$1.50  
**G. C. Taylor Co., Inc., Fairport, N. Y.**

When Writing Advertisers Please  
Mention Popular Science Monthly

# HOW TO WRITE for PROFIT

Many a former clerk, soldier, housewife, mechanic, teacher is now writing for profit. Why not you? You can learn and start making money right in your home . . . under the unique, practical methods of Palmer training . . . for writing fiction, newspaper features, magazine articles, radio scripts. Palmer is endorsed by such famous writers as Gertrude Atherton, Rupert Hughes, Katherine Newlin Burt said, "I'd have started ten years sooner . . . but there was no Palmer Institute then." Ruth Comfort Mitchell said, "You are making it possible for beginners to travel over a highway, instead of a rough road. You are proving ours is a profession . . . calling for such sound, sane, constructive training as you offer." Hundreds of successful graduates. To find out if you have writing ability, send for our "Talent Finder." Return it for our frank, confidential analysis and advice. No cost or obligation. It may start you on an ideal career.

**PALMER INSTITUTE OF AUTHORSHIP**  
5362 Hollywood Blvd., Hollywood 28, Calif. Dept. TM95

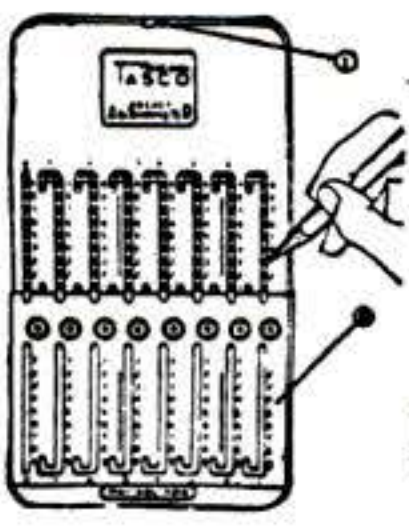

## POCKET ADDING MACHINE

Sturdy steel construction for lifetime use. Adds, subtracts, aids multiplication. Capacity 999.-999.99. A real machine—guaranteed 5 years. Thousands of satisfied users. Send name and address. We ship immediately. On delivery, pay postman \$2.50 (plus C.O.D. and postage charges). If you send \$2.50 with order, we pay postage. Leatherette case 25c additional. Your money back after 10 days' trial if not satisfied.

Free Trial **\$2.50**

**TAVELLA SALES CO., 21-MA West Broadway, New York 7, N. Y.**

## REFUSE TO GROW BALD

"GIVE YOUR HAIR A CHANCE" is the amazing book by J. W. KING, Sc. B. on dandruff, baldness, thinning and graying hair. Much usable information.—*Ohio State Medical Journal*. Best investment.—*Science Education*. Debunks hair fads.—*Scientific American*. Scientific fact.—*Sunset Magazine*. Without commercial bias.—*Teaching Biologist*. Book of a scientist.—*Home Acres*. Enormous assistance.—*Pictorial Review*. Practical.—*Science News Letter*. Send only \$2.00 today for postpaid copy of this authentic instruction, on how to save your hair. 6th printing. Prompt refund if not helped.



**BRADNER PUBLISHING CO. (Est. 1933) Dept. 32, Cambridge 42, Mass.**

## Special WHITTAKER'S Kit \$1.50

10 assorted soft white pine blanks—ready to whittle to the finished products. Also included an X-ACTO MODELLING KNIFE with complete instructions. **EASY—FUN!** Complete kit sent prepaid for \$1.50. Write now to  
Old Whittler, Dept. PS, 1402 Charles St., LaCrosse, Wisconsin



## DRAW CARTOONS BIG MONEY!

**EASY... PLEASANT WORK!**  
Let **CHAS. H. KUHN**, with 25 years actual experience in drawing a daily newspaper cartoon, teach you how to **create, draw and sell** your work. 52 complete lessons—one sent each week. **Professional criticism on every lesson.** Write today.

**KUHN SCHOOL OF CARTOONING**  
420 MURPHY BUILDING Dept. S. INDIANAPOLIS 4, INDIANA

## HOW RUPTURE MISERY MAY DISAPPEAR

Don't go on day after day suffering the tortures of a clumsy truss that presses on your hips and back, gouches your flesh, slips and slides and leaves your rupture **DANGEROUSLY UNPROTECTED**. Get the truth about rupture care and how the newly patented Vita-Pneumatic Nature-Ade (U.S. Reg.) appliance with its unique features can help your rupture, misery disappear. Write at once for **FREE** booklet containing much valuable information.  
**PNEUMATIC APPLIANCE, 103 PARK AVE., N. Y. 17, N. Y., DEPT. 72N**

## PRACTICAL BOOKS TO HELP YOU EARN MORE

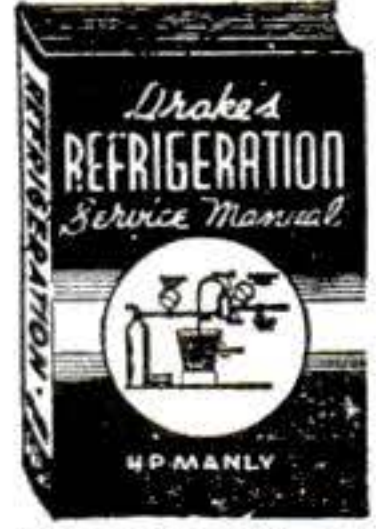

**REFRIGERATION SERVICE MANUAL**  
This new book covers refrigeration problems in conversational language. Covers operations for in the field and in the shop. Includes both domestic and commercial types, such as used in markets, milk depots, soda fountains as well as in many others. 300 pp., 138 illust. . . . **\$2.00**

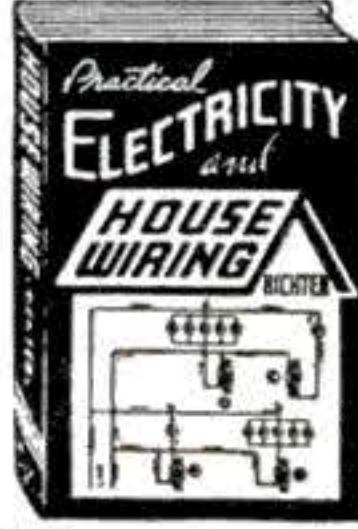

**PRACTICAL ELECTRICITY AND HOUSE WIRING**  
Discusses common electrical devices, principles of circuits, wires and insulation, grounding, fuses and circuits, wiring methods, planning installations, installing switches, fixtures, etc., wiring houses after they are built, alterations and additions, wiring farm buildings, home repairs, etc. 200 pp., 227 illust. . . . **\$1.50**



**CYCLOPEDIA OF PAINTING AND DECORATING**  
Covers methods, tools and materials for the home and workshop, including every branch of painting and decorating. Any particular job is fully explained with illustrations to clarify the text. 350 pp., 228 illust. . . . **\$3.00**

**MONEY BACK GUARANTEE • SEND TODAY • GATEWAY BOOK COMPANY, Dept. PS-9 32 N. State—Chicago 2, Ill.**



# GOOD MONEY for Your MANUSCRIPTS

How to turn Your Stories, Poems, Articles, Plays, etc., INTO CASH!

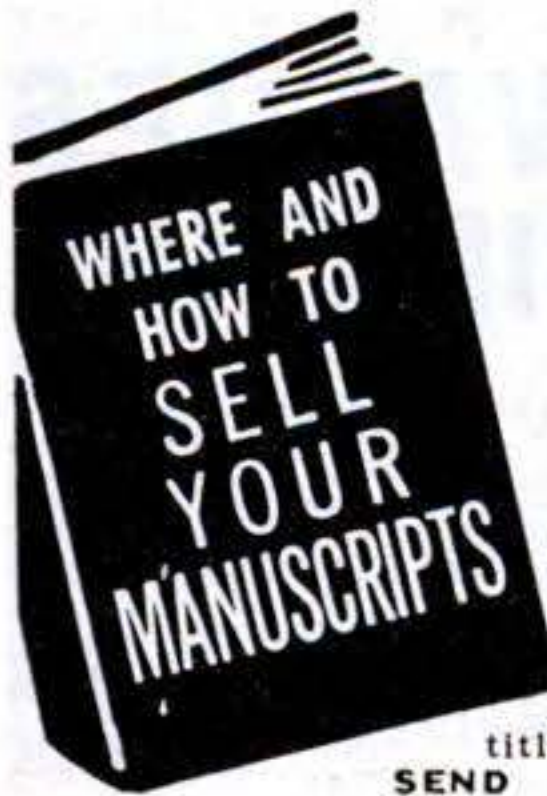

Here, at last, is a volume that gives you the shortcuts used by professional writers to win fame and fortune! Streamlined guidance that saves you time, trouble and heartache. "Where and How to Sell Your Manuscripts" is a down-to-earth writer's guide, complete in every essential detail. Covers Magazines, Newspapers, Radio, Movies, Plays, Books, Comics.

**BRIEF LIST OF CONTENTS:** What to write and where to sell it—What the editors want—How to prepare manuscripts professionally. Names and addresses of editors, publishers, agencies, producers, all kinds of magazines, etc.—Plus: What kinds of stories to send to each one. Practical Writing tips—Dictionary of "color words" (Slang, idioms, etc.)—How to choose selling titles—Copyright protection, etc., etc.

**SEND NO MONEY:** Your copy of "Where and How to Sell Your Manuscripts" will be sent to you to read and use for 10 days. If not satisfied, return the book and your money will be refunded. Full price only \$2.00, postpaid, or sent C.O.D. for \$2.00 plus postage. Same money back guarantee. Get your copy today. Write at once to

**CAMBRIDGE HOUSE, Dept. B9**  
165 West 25th Street, New York 1, N. Y.

## Good Handwriting

HELPS YOU WIN SUCCESS!

It's so important to write a good hand for business and social advancement. Poor illegible penmanship often causes costly errors and marks you for failure. Why write a poor hand? It's so easy to learn at home in spare time. Write for our new free booklet today. If you wish, send 10c for a penpoint suitable for shaded writing and your name beautifully written.

**THE TAMBLYN SCHOOL OF PENMANSHIP**  
H-439 Ridge Bldg., Kansas City, Mo., U.S.A.

DEVELOP THE POWERFUL INFLUENCE

FEUCHTINGER Method Guaranteed  
IN YOUR VOICE

DO IT YOURSELF AT HOME

Write for the Voice Book - FREE

Sent only to those over 17yrs of age

PERFECT VOICE INSTITUTE

STUDIO 1366

910 Kimball Hall Building, Chicago 4, Illinois

## MASTER MACHINIST, MECHANICAL DRAFTING, TOOL ENGINEERING

Learn by doing in completely equipped modern shops. Approved for G. I. training. Days, Evenings and Part Time. Men and Women.

**ALLIED SCHOOL OF MECHANICAL TRADES**  
1332 South Michigan Avenue, Chicago 5, Illinois

## Success in Music!

**THE ONLY HOME STUDY MUSIC CONSERVATORY OFFERING ALL COURSES LEADING TO DEGREE, BACHELOR OF MUSIC**

Personalized Instruction for Professionals, Advanced Students and Beginners by Eminent Music Teachers. Check courses which interest you and mail coupon for catalog and illustrated lessons.

### UNIVERSITY EXTENSION CONSERVATORY

765 Oakwood Blvd., Suite U246, Chicago 15, Ill.

- Piano  Violin  Cornet  Trumpet  Saxophone  Clarinet  
 Guitar  Mandolin  Voice  Ear Training and Sight Singing  
 Choral Conducting  Public School Music  History of Music  
 Harmony  Advanced Composition  Arranging

Name .....

Street .....

City & State .....

Music experience ..... Age .....

# 150 ELECTRICAL AND RADIO SHOP PRINTS

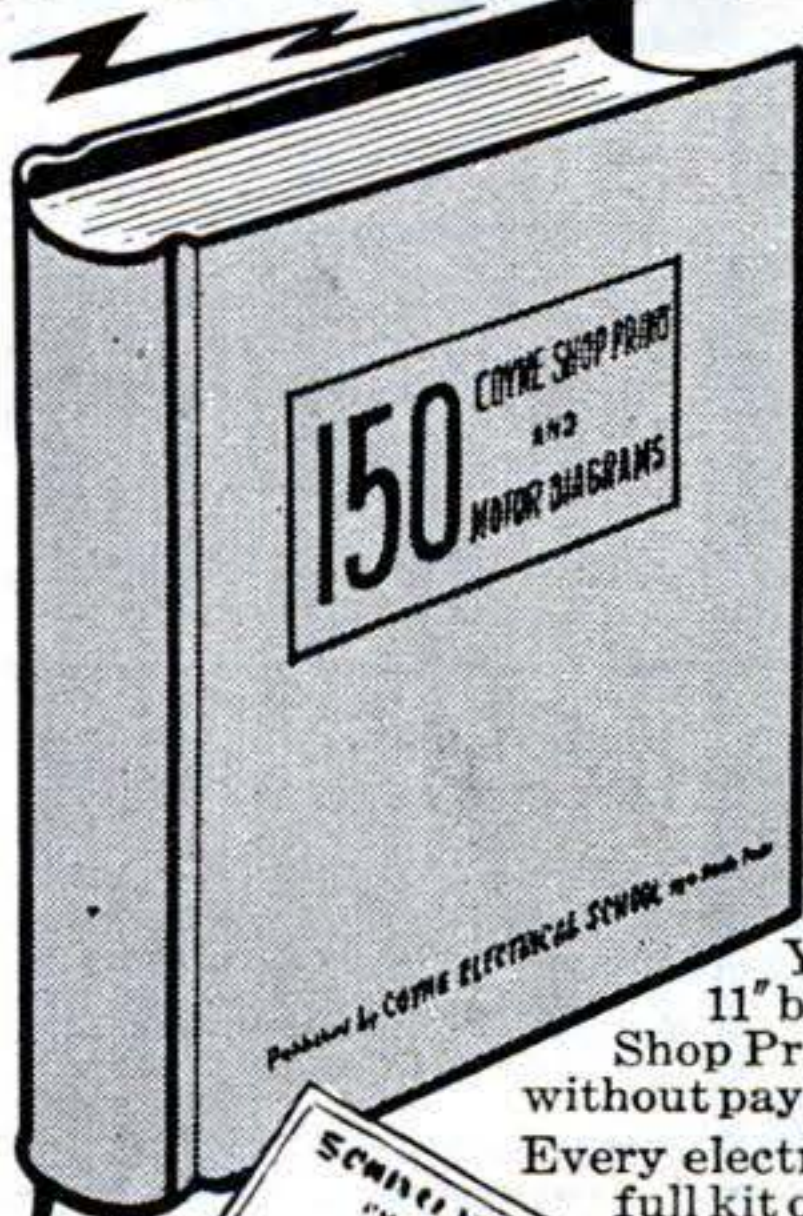

Only \$1

**NO MONEY DOWN See It FREE!**

You can get this full size 8 1/2 x 11" book of "150 Electrical & Radio Shop Prints and How to Read Them" without paying a single penny in advance.

Every electrical and radio man wants a full kit of shop prints and wiring diagrams such as these. If you bought such prints a few at a time they might cost you as much as 10c to 25c per print. Now here's a valuable collection of 150 of these useful Shop Prints for only \$1—and you pay **no money down**—Look them over for 7 DAYS FREE.

- New Electrical Ideas
- Wiring Techniques for Controls
- Wiring for Welders, Motors, etc.
- Armature Winding Diagrams
- House Wiring Circuits
- Radio Circuits

Some of the most complex electrical circuits illustrated and described in easy-to-follow instructions. Page after page of down-to-earth "show how" practical, working illustrations to show you just what you want to know.

### VALUABLE DIAGRAMS

**Easy to Understand Explanations!**

Every diagram is large, clear. Step-by-step explanations of major electrical principles of Motors, Generators, Trouble-Shooting, Welding Systems, Transformers, Radio Circuits, Frequency Modulation as well as many valuable Trouble-Shooting ideas are given.

### 7-DAY FREE EXAMINATION

Whether you're an "old hand" or a "beginner" you'll want to see this wonderful book. Without paying one penny or obligating yourself in any way, you may have a copy of this amazing volume to look over FREE for 7 full days. If, at the end of 7 days, you do not want the book, return it & you owe nothing. If you keep the book after 7 days, send us only \$1 for full payment.

### SEND NO MONEY!

The coupon below is not an order blank—just a request to see the book absolutely FREE for 7 days. Simply fill out the coupon and mail it. Then see this new, sensational book for 7 full days before making up your mind whether or not you want to keep it. You take no risk. Act today.

**H. C. LEWIS, President**  
**COYNE ELECTRICAL SCHOOL**  
500 S. Paulina St., Dept. 65-R7, Chicago 12, Ill.

### PAY NOTHING—SEE BOOK FREE!

H. C. Lewis, Pres., COYNE ELECTRICAL SCHOOL, Dept. 65-R7  
500 S. PAULINA ST., CHICAGO 12, ILLINOIS

Please send me a copy of "150 Coyne Electrical & Radio Shop Prints and How to Read Them." I may return this book to you any time within 7 days and owe you nothing. If I keep it I will remit \$1 within 7 days and the book is mine.

NAME ..... Age .....

ADDRESS .....

TOWN ..... Zone ..... STATE .....

If you want book sent C.O.D. (you pay postman \$1.00 plus small C.O.D. fee) check here—same satisfaction or money back agreement.



# WAR SURPLUS BARGAINS

★ ★ ★ ★ ★

## SENSATIONAL VALUES FOR QUICK LIQUIDATION

### SERVICEMENS GI BELTS



Of heavy canvas webbing. Adjustable in size with snap-on buckle. Eyelets all around. Used, but guaranteed.

**A131—EACH.. 98c**

### ARMY MESS KITS



Regulation Army mess kits. Ideal for campers, boy scouts, etc. Slightly used but guaranteed perfect.

**A116—EACH ONLY.. 69c**

### U. S. GOV'T CANTEENS

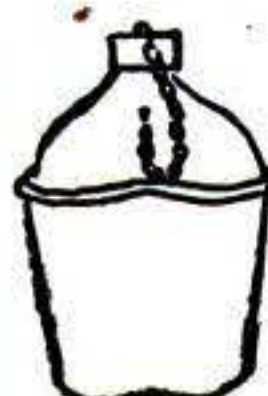

Regular U. S. Gov't issue canteens. Plastic screw top cap chained to body Slightly used.

**A117-METAL BODY 69c**  
**A118-PLASTIC BODY 69c**  
**A119-Canteen covers, Each . . . . . 35c**  
**A120-Canteen cups, ea.. 25c**

### BANDOLEERS



Army Bandoleers of heavy khaki. Used by hunters, boy scouts, etc. Slightly used but guaranteed serviceable.

**A129-11 POCKET, EA. 49c**

### U. S. GOV'T BOLO KNIFE



Extra heavy Bolo Knife ideal for home, farm or jungle use. Blade of government formula. Cutlery steel. Walnut riveted handle, 3 1/2 inch hilt, 10 1/2 inch blade. You'll find hundreds of uses for a Bolo Knife—makes a grand gift for a serviceman. Weight 2 pounds. **A112—WITH ARMY SHEATH . . . . . \$4.95**

**A212—LEATHER SHEATH, EXTRA . . . . . \$1.50**

### USED U. S. GOV'T PUP TENTS

Regulation army pup tents of durable brown canvas. Used, but in good condition. Fine for campers, outdoorsmen, boy scouts, etc.



**A100—TENT ONLY, EACH . . . \$4.95**

**A101-Ropes, wooden poles and stakes for above. Per set . . . . . \$1.00**

### 7 LB. RADIO PARTS ASSORTMENT



A "gold mine" for the radio serviceman. Hundreds of valuable radio parts, including rivets, soldering lugs, sockets, coils, resistors, trimming condensers, etc.

**A130R—7 LBS. \$1.79**

### CATHODE RAY TUBES

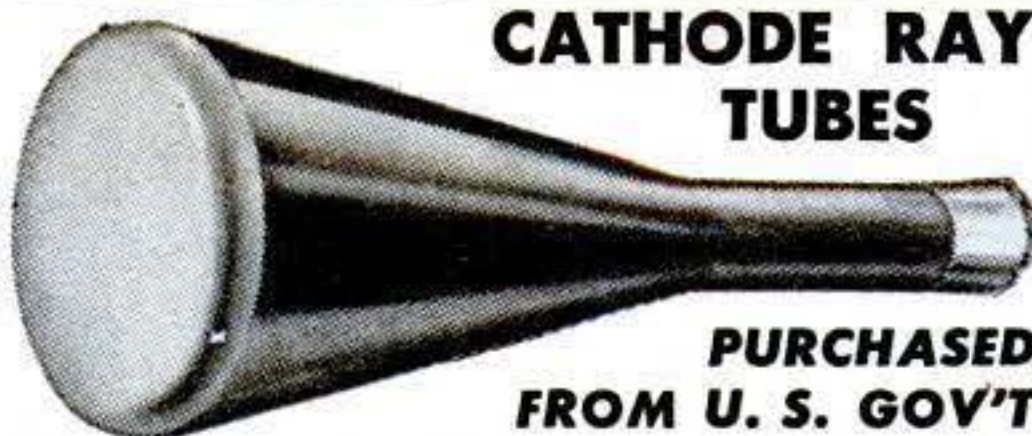

**PURCHASED FROM U. S. GOV'T**

For experimenters in radar, electronics, etc. Slightly used by Gov't for test work. Guaranteed perfect. Each tube tested before shipment. These tubes are standard Nos. 5BP1 or 5BP4 with 5 inch screen. Specify number wanted when ordering. List of other tubes on request. **EACH, exp. collect. . . . . \$12.00**

### LENS and PRISM ASSORT.



**27 LENSES, ALL NEW, PERFECT**  
 For experimental work in optics. Consists of 27 precision ground and polished prisms and lens elements in assorted diameters and focal lengths. Big variety, positives, negatives, etc. Actual value over \$100.00. **A519—27 PIECES . . . . . \$7.95**

**50 LENSES, SEMI-FINISHED**  
 Lenses similar to above but not polished. All are blanked and formed ready for polishing. Negatives, positives, and prisms in Crown and Flint glass. Worth many times this low price. **A520-50 LENSES, ONLY . . . \$1.95**

### COMB. AIR PILLOW and LIFE BELT

Every outdoorsman, hiker, camper, boy scout, etc., should have one. Made of air tight, waterproof khaki 10 x 40 inches when deflated.

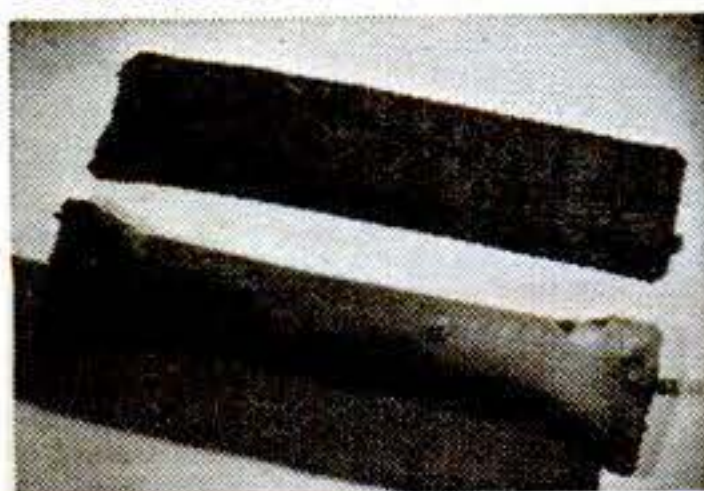

Swimmers, boatmen, etc., use them as a life belt. Quickly inflated or deflated. Used but perfect. **A127-98c EACH.**

### TANK CORPS RADIO HEADPHONES

Extremely sensitive with 4000 ohms resistance. Brand new and fully guaranteed. With moisture-proof cord and phone plug. A splendid value for the radio serviceman and experimenter.

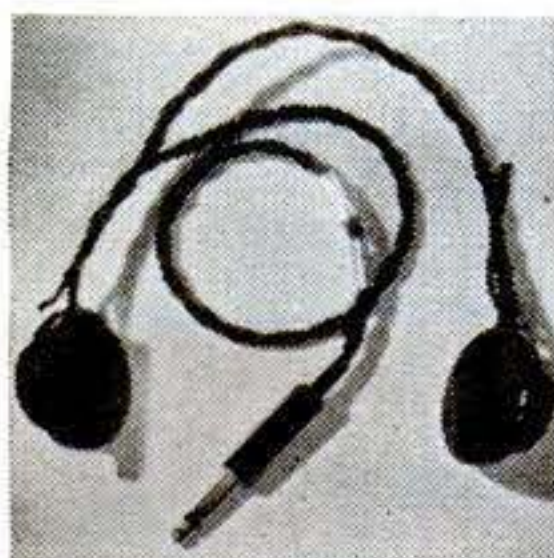

**A106—PAIR \$2.95**

### SHIPS BELLS



Purchased from U. S. Maritime Comm. Measures 10 inches high, 9 3/4 inch flare. Big 6 inch clapper. Weight 15 lbs. Fine for farms, clubs, estates, etc. All new **A-541, ONLY \$9.85**

### BLITZ CAN



Standard gov't. blitz cans. Used and scuffed but guaranteed leak proof. Measures 18 1/2 x 13 1/2 x 6 1/2 inches. Welded seams. Screw cap. Capacity 5 gal. A splendid bargain. **A-542 EACH ONLY.. 85c**

### RUBBER CUP WITH LID



Measures 3 3/4 x 3 1/2 inches—of live rubber. Makes fine tobacco humidifier, etc. All guaranteed perfect. **A-503-EA 59c**

### U. S. AVIA. GOGGLES



U. S. Aviators Goggles. Big oversize design with sponge rubber shock lining. Curved lenses, elastic headband. Fine for industrial users, motorcycleists, etc. Slightly used but guaranteed perfect. **No. A159—PER PAIR . . . . . \$5.95**

### HEAD NETS



Real protection from insects, etc. Fits over hat. Draw string in neck. Celluloid window. For campers, fishermen, etc. **A-509, ONLY . . . . . 89c**

### MILITARY SLIDE RULE



Specially designed for Army use. Measures 2 x 18 x 3/8 inches. Calibrated in yards and meters. Reversible sliding segments. Orig. value \$20.00. **A121-EACH ONLY.. 98c**

### ORDER DIRECT FROM THIS AD

Values galore! Hundreds of hard-to-find items for home, shop and outdoors. Make remittances by money-order, bank draft or personal check. Send 25% deposit on C.O.D. orders. No C.O.D.'s on orders for less than \$5.00. Include sufficient postage on parcel-post orders—any overage will be promptly refunded. All quotations F.O.B. Chicago. Used items and materials are guaranteed serviceable and as described. Your money back if not more than satisfied.

### BIG ILLUSTRATED CATALOG FREE

**STARK'S** Dept. PS9  
 509 So. State St.  
 CHICAGO 5, ILL.

### PLASTICS LUCITE AND PLEXIGLASS

In sheet form. Good workable sizes. Transparent. For costume jewelry, etc. Easy to work and polish. **A280-5 LB. \$4.75**

**CATALAN—ASST. COLORS**  
 Extruded shapes, rounds, half rounds, etc. Easy to machine. Furnished in assorted colors, shapes and lengths. **A281-5 LB. \$4.75**

### CAVALRY SPURS



Genuine wishbone type cavalry spurs. Nickered brass. **A102, Pair . . . . . 98c**  
**A103 Spur straps per set of four . . . . . 50c**

### MOSQUITO TENTS



Of marquisette with taped seams. Metal rods and bars included. Covers cot or hammock. Brand new. **A104 EACH . . . . . \$2.95**



Classified Ads only 50c per word per insertion, payable in advance. Minimum ad 10 words. White Space \$3.00 per line. To be included in October issue, copy should be in our office by September 1st. October issue on sale October 1st.

POPULAR SCIENCE MONTHLY—351 FOURTH AVE.—NEW YORK CITY 10

## 1 ADVERTISING

**ADVERTISING** Placed everywhere lowest rates. Reliable guidance on publications, expert assistance on ads without charge. Newspaper, magazine, mailing-list rate-book free. Chicago Advertising Agency, 20-MP West Jackson, Chicago 4.

**PRINTERS**, artists, draftsmen, anyone, make your own engravings at home. \$5.45 (Simple). Carson Institute, Plainview at Schoolcraft, 23, Detroit.

**ADVERTISE:** 24 words, 149 newspapers, \$6.50. Lists Free. Advertising Bureau, 4515-P Cottage Grove, Chicago 15.

**BUSINESS** letters; complete selling campaigns. Satisfying results. Nelberts, Bolton Landing, N. Y.

**RESULT** Producing Advertising—Low Cost—Connelly Agency, Rm. 622, 1328 Chestnut St., Philadelphia 7, Pa.

24 WORDS in 90 Weeklies \$4.60. J. Darnell, 730 Hays, Jackson, Tenn.

## W ADVICE

**DRUNKENNESS** Is a disease which responds to treatment. Medical skill plus human sympathy prove successful with liquor and drug cases. 60 years experience. Write for free booklet. P. S. Nelson, The Keeley Institute, Dwight, Ill.

**CONQUER** worry, discouragement. Get new life grip with friendly, confidential help. Sound, sincere, different. Details free. Write Personal Service, Box 174, Ponoka, Alberta, Canada.

## 2 AGENTS WANTED

**AMBITIOUS** School Seniors—We want Y-O-U to sell classmates the "Tops" in Graduation Name Cards. Highest commissions! Only Firm giving Free Souvenir Chest and Card Case! Your cards Gratis! Catalogs going like wildfire! Hurry! Get yours today! Craftcards, Box 235(M), Pittsburgh 30, Pa.

**START** Your Own Business on our capital. Always your own boss. Hundreds average \$6,000 to \$12,000 annual sales year after year. We supply stocks, equipment on credit. 200 home necessities. Selling experience unnecessary to start. Wonderful opportunity to own pleasant, profitable business backed by world wide industry. Write Rawleigh Co., Dept. I-U-PSC, Freeport, Ill.

**MEN, Women, Make More Money!** Cash In On Nationally Advertised Photo Stamps. Real glossy photos in amazing stamp size miniature, 100 for \$2. Made from any size snapshot, photo or negative. Gives you your own full or part time business without investment. Repeat orders insure steady income. Write for Free samples and information. Photo Specialty Co., Dept. 210, 38 W. 33rd St., New York 1.

**UP** to 100 per cent profit selling friends Christmas card assortments and Personal Stationery. Religious, Gift Wrapping, Birthday assortments 35c up. Request 21 card \$1.00 Christmas box on approval, Free 25 for \$1.00 Personal Christmas card and Stationery Portfolios. Special Offer. Elmira Greeting Card Co., M-88 Elmira, N. Y.

**SILVER** Plating Liquid. Simply Rub-On with a cloth. Cleans, Silverplates, Polishes, one rubbing. Puts on genuine 1000 Fine silverplate. Renews silverplated ware like new. Silverplates on to brass, copper, bronze, etc. Lasting finish, won't come off. Sales representatives wanted. Details free. Nuprocess Products, Dept. 184, Aurora, Ill.

**AT** last! Something new and sensational in Christmas cards. Amazing "Oilette" Cards. Like costly oil paintings. Designs never before offered. Gets orders fast. Beautiful 25 for \$1 Cards, name imprinted. 12 other assortments. Big profits. Samples on Approval. Purc Co., 3043 Locust, Dept. 240, St. Louis, Mo.

**CHRISTMAS** Cards—Beautiful 21 card assortment costs 50c in quantity. Sells \$1.00. Write for sample on approval. Large variety including new "Glitter" assortment, Currier and Ives winter scenes, Everyday assortments and Stationery. Free samples of 25 for \$1.00 personal line. Elmcraft, 5930 S. Western Ave., Chicago 36.

**CHRISTMAS** Cards. Earn big money. Take orders galore from friends. 25 exquisite folders with name \$1.25. Free Sample 10 designs. America's fastest selling 21 Christmas folder box. Costs 50c. Sells \$1.00. Request samples today. Sunshine Art, Dept. N, 115 Fulton St., New York City.

**\$1 STARTS** you in business. Sell DeLuxe five fold ties. 100% wool interlining. Costs you only \$7 per dozen, you make \$5 dozen. Send \$1.00 for special introductory offer two five fold ties. Catalog complete line Free. Phillip's Neckwear, 20 West 22nd St., Dept. K-39, New York 10.

**MAGIC** Races. At touch of lighted cigarette, six horses are Off! Watch them Run! 55 Races in mailing carton, \$1.00. Agents Commission, 40%, in dozen lots. Order direct from this ad, or send 10c for sample envelope (5 races) and complete details. Pines, Box 32, Flushing 35, New York.

**SELL** Christmas Cards. Make easy money showing gorgeous Christmas, De Luxe, Religious, Birthday assortments, Stationery. Over 100 quick sellers. Special Offer. Write today for \$1 Christmas box assortment on approval. Hedenkamp & Co., 343 Broadway, Dept. PSS, New York 13.

**CLEAR-VU** for your windshield, eyeglasses, Mirrors. Here's a glistening accent for safety. It creates a lovely sparkle to any glass and gives safe, clear vision in fog, mist, rain, snow, or steam. Agents send 50c for sample and introductory order. Clear-Vu, 3022-30th St., San Diego 4, Calif.

**GOOD** Paying Business Silvering mirrors, plating autoparts, reflectors, bicycles, bathroom fixtures, etc., by late method. No tanks or shop required, outfit furnished. Free Booklet. Gunmetal Co., Ave. G, Decatur, Illinois.

**CALL** On Friends With Sensational Personal Christmas Cards—25 for \$1.00 up. Also Box Assortments, including magnificent 21-card \$1.00 Assortment. Profit 50c. Samples on approval. Wallace Brown, 225 Fifth Ave., Dept. S-4, New York 10, N. Y.

**MAKE** more money! Begin Christmas gift sales early. Start now! Helps furnished. Opportunities unlimited. Liberal commissions. Rush request today for Free wholesale catalog. McGregor Magazine Agency, Dept. PS-5, Mount Morris, Ill.

**SCHOOL** Seniors—Sell classmates America's most beautiful, distinctive Graduation Name Cards. Positively highest commission. Largest selection. Lowest prices. Free cards and sample kit. Printcraft, 1423 E. Elm St., Scranton 5, Pa.

**PLAYER** wins pack of cigarettes for 5c. New coin operated automatic payout machine nets \$1.00 profit per pack. List price \$49.50. Send for agent deal. Webb Distributing Co., 612 N. Michigan Ave., Dept. P9, Chicago 11, Ill.

**EXCELLENT** Sideline for Printing Salesmen. Decalomania Name Plates in small quantities. Also, make money applying Initials on Automobiles. Free Samples. "Ralco", X-164, Boston (18), Mass.

**BIG** profits taking subscriptions for all magazines. Agents' Confidential Catalog listing over 2500 periodicals and complete starting supplies Free. Pines Subscription Agency, Flushing, New York.

**MAGIC** Races—At cigarette touch six horses are off. Fast seller. Big profits. 40 Races \$1.00. Dime brings samples, wholesale prices. Barkley Co., Dryden 5, Virginia.

**WHOLESALE:** Razor Blades, Laces, Excello, Texide, Silvertex and others. Write for prices and information. National Sales Company, Dept. 114, 1319 Stone Street, Flint 4, Mich.

**ROYAL** Glow in the dark, like magic. New line easy to sell, money makers. Sure repeat sales. Write today for free details. Royal glow Products, Sales Dept. P, 1472 Broadway, New York 18, N. Y.

**START** big money business on few dollars. New, successful cleaning service. Big demand everywhere. Easy, quick income. Write Americlene, 211 N. Seventh, St. Louis, Missouri.

**EVERYDAY** Cards. Make \$5.00 with every ten \$1.00 21-box assortments you sell. Also 25 for \$1.00 imprint cards. Write for samples today. Howard P. Ellis, Dept. PS, Pitman, N. J.

**SELL** big demand items—Brass Pressing Combs, Cosmetics, Hair Goods amongst Colored people. New field. Write for details. G. M. Hair Co., 339 Kings Highway, Brooklyn 23, New York.

**START** Y-O-U-R own business! Double your earnings selling flashy Costume Jewelry! Going like wildfire! Write for Free sample! Hurry! Spotlight Jewelry, Suite 207B, 25 Huntington, Boston.

**LICK** After-war layoffs; Start own business; home, office. Booklet describing "Collection of 127 Tested Plans" free. Elite Co., 214A Grand St., New York.

100 **CIGARETTE** Rollers, \$20.00; Dolls, dozen \$12.00; Pencils gross \$1.95; Aspirin, gross boxes, \$1.99. Send payment. Catalogs free. Mills Sales, 901 Broadway, New York 3.

**FREE** Water and our concentrates makes flavors, lotions, shampoos. 72 products, labels, bottles furnished. Qualco, F-20030 Russell, Detroit.

**SELL** "Petite Picture Notes." Something really different in greeting cards. Sample free. Dunbar Cards, New Brunswick 21, N. J.

**EX-O-LENE!** Powerful Mile Stretcher. Extremely profitable. Guaranteed Product. Distributors wanted. Thermopower, Peoria 4, Ill.

**DO** it with "Butter Flavor" makes Margarine and Pastry taste better. Write card for free particulars. Sample 25c. H. B. Maxwell, Rome, N. Y.

200 **MONEY-Making** Ideas, Plans. Rare formulas. Schemes. Exposed secrets. Particulars Free. Formico Co., Box 572, Dayton, Ohio.

**PRIZE** package displays. Jokes, tricks, puzzles on display cards. State your line of business. Eagle Specialty Co., Akron 11, Ohio.

**HANDY** Hair Trimmer. Sells like wild. Trims as you comb. Saves barber bills. Samples sent on trial. Kristee, 142, Akron, Ohio.

25 **WAYS** to make money with Luminous Paint. (Shines in dark.) Rush name for profitable details. Ward, 97B, Saybrook, Conn.

**SELL** Auto Body, Radiator and Soldering Trade. New Flux, Saves Time. Big Profits. Write Today. Crone Co., Parkland 3, Washington.

**BIG** Money selling Negro calendars and novelties. Commercial Ad. Inc., 464 W. 153 St., New York 31, N. Y.

\$3 **FIRE** Extinguisher sells wholesale or direct. Fire-Killer, 97 Franklin, Syracuse, New York.

**PROSPECTS**, Every car owner. Sells for \$1.50, costs you 39c. Quarter brings sample, prices. Barkley Co., Dryden 33, Va.

**GOLD** Lacquered Window Sign Letters. Beautiful Large Sizes, Penny each. Free Samples. Atlas, 7941 Halsted, Chicago.

300% **PROFIT** Selling Pep And Energy "Min-Lin". Guaranteed, best seller. Acme Pharmacal, Fairfield, Alabama.

## 4 AMERICAN POLICE, JU JITSU

**DEFEAT** A Boxer. Secret Ju-Jitsu Defense. Complete instructions 25c. Dr. Malcolm Smith, 1104 Union Ave., Montreal 3, Canada.



# POPULAR SCIENCE OPPORTUNITIES

## 5 ANTIQUES, RELICS, INDIAN GOODS

347 ANTIQUE Firearms; 4,000 Bargains. Coins, Indian Relics, Minerals, Cartridges, Rifles, Flintlocks, Fossils, Swords. Catalog with Photographs 25c. Heike, Wena, Ill.

SWORDS, rapiers, daggers, pistols, armor; illustrated catalog, 25c. Robert Abels, 860 1/2 Lexington Ave., N. Y.

ANTIQUE firearms, swords, daggers. Lists free. Nagy, K-8 South 18th, Philadelphia 3, Penna.

## RR ARCH SUPPORTS

FEET Hurt, Plastic Arch Supports made to order, Unbelievable Comfort, Impression Material Free. Archcraft Co., 600 W. 164 St., New York City 32, N. Y.

ARCH Supports Send \$1.00 and Shoe Size. Money Back Guarantee. Blairs Co., 4520 Sheridan, Chicago 40.

BIG Profits Manufacture Custom Arch Supports. Julis Corssen, 2638 Geyer, St. Louis 4, Mo.

A Cure for Fallen Arches. 25c in Coin. Lewis, 1332 Laketon Rd., Wilkinsburg, 21, Penna.

## 6 AUTHORS SERVICE

NEW writers needed to re-write ideas in newspapers, magazines, and books. Splendid opportunity to "break into" fascinating writing field. May bring you up to \$5.00 per hour spare time. Experience unnecessary. Write today for Free details. No obligation. Postcard will do. Comfort Writer's Service, 210-R South Seventh St. 2, St. Louis, Mo.

TRUE Life Stories Wanted For Publication; romantic, exciting, adventurous. Any length. Send promptly to U. S. Literary Agency, 134-136 Liberty, N. Y. 6.

HELPFUL Writing Instructions, 50c. Manuscript revision, typing. Underhill, Beebe, Arkansas.

## 7 AUTOMOBILES

MOTOR Books. "Power and Speed." World's famous racing automobiles, motorcycles illustrated, described. Engine information, cams, valves, superchargers, compression, etc. Foreign drivers, cars shown, Grand Prix race information. \$2.50

Ab Jenkins' new racing book describes Mormon Meteor, world's records, Bonneville, Utah Salt Flats, \$1.50. Auto Racing Photo Album. Action photographs famous racing drivers, cars. \$1.50. Famous Racing Motorists, Sir Malcolm Campbell's book of foreign races, his experiences, \$2.00. Motor History of America, world's wonder book automobile history. 416 pages, lists 1500 makes cars. \$3.00. All postpaid anywhere U.S. or overseas. America's most complete catalog Motor Books 10c. Clymer, 2125 W. Pico, Los Angeles 6, Calif.

CLYMER'S Motor Scrapbook. A "must" says Time Magazine. Illustrates, describes hundreds early gasoline, steam, electric automobiles, motorcycles. Includes experiences and fascinating, amusing story by the author, Floyd Clymer, one-time world's youngest automobile dealer. Editions one and two available \$1.50, each different. DeLuxe cloth bound either edition \$2.50 each. Overseas orders solicited. All postpaid. America's most complete catalog Motor Books 10c. Clymer, 2125 W. Pico, Los Angeles 6, Calif.

ARE Steam Automobiles coming back? Many think so! Book "Modern Steam Car," 160 pages, 100 illustrations. Doble, White, Stanley, others. Specifications, photographs early and latest steamers. Tells how operate steamers. Data boilers, engines, burners. Postpaid \$2.00. DeLuxe cloth bound edition \$3.00. Send 25c for folder listing 90 makes early steamers. Photos, racers, interesting, educational, ancient steamer information. Clymer, 2125 W. Pico, Los Angeles 6, Calif.

MOTOR History of America. World's wonder book automotive history. 416 pages with supplement by Floyd Clymer. 150 illustrations. All early automobiles. List over 1500 one-time automobile manufacturers in America. Postpaid \$3.00. DeLuxe cloth bound \$4.00. Clymer, 2125 W. Pico, Los Angeles 6, Calif.

UNIVERSITIES and Oil Corporation tests prove Whirlgas Turbinator, \$3, increases motor mileage and power. Users report gasoline economy exceeding 40%. Wrench installs 15 minutes. Give auto make, year. John Hanley, 5719 Loraine, Detroit 8, Mich.

AUTOMOBILE Racing Book. Fifth Edition—Revised. Tells how to build dirt track bodies, frames, engines. Records, superchargers, rules, formula, plans, stock conversions, roadster racing, fast Fords. \$1.00 postpaid; \$1.15 C.O.D. Ray Kuns, Department 274, Madisonville, Cincinnati, Ohio.

MOTOR Books. Most complete automobile, motorcycle selection in America. Historical, technical, racing. Send dime for book catalog. Clymer, 2125 W. Pico, Los Angeles 6, Calif.

AUTOMOBILE Racing Photo Album. 110 exciting photographs record cars, drivers, crashes. Famous tracks illustrated. Postpaid \$1.50. Clymer, 2125 W. Pico, Los Angeles 6, Calif.

DON'T "Go Wrong" on used cars, 20 Genuine tips—Tests that never fail, \$1.00. Satisfactory or Money refunded. Tony Gorski, 189 Semel Ave., Garfield, New Jersey.

CUSTOMIZE your automobile. Illustrated new restyling ideas, instructions, specific model changes by simple methods, \$1. Speedwheel, Box 723-C, Arcadia, California.

GARAGE doors, all types, controlled from Dashboard. Complete "Build Yourself" Plans \$1.00, refundable. Free Particulars. Kaytor Laboratories, Lynwood, California.

1945 IGNITION Supercharger, Pep, Mileage, Fast Starting. \$4.00. EG Mfg. Co., 355 E. 149th St., N. Y.

STEAMAUTO Engines, Boilers, Equipment Wanted. Steinke, RFD 4, North Brunswick, N. J.

## 8 AUTO SUPPLIES & EQUIPMENT

AMAZING new Moto-Vator injects water-vapor into motor just like newest fighter planes. Burns 15% water; saves 20% to 30% gas; Prevents Carbon; Increases power! Eliminates carbon and valve jobs. Not a gadget. Sensational performance keeps motor like new. Wonderful postwar possibilities. No investment. . . . One low price includes license to install Moto-Vator in your locality. Send 10c for booklet giving complete details. Dept. S, SX Laboratories, P.O. Box 37, Middle Village, Long Island, New York.

WATER Injection for your car! Why confine the spectacular benefits to military aircraft when anyone can make installation at very low cost, with minimum tools. All parts available to civilians. No castings! Increase power, mileage, up to 30%. Decrease carbon, engine wear. Developed and proven by our engineers, we now offer complete plans, instructions, only \$2.00 cash, check, or money order, Hughes Engineering Laboratory, 1020 Jefferson, Evansville 13, Indiana.

NON-RATIONED amazingly powerful super gallon. Get handbook with complete comparison is impossible, yet so plentiful it has never been rationed. It will not ping, knock, dilute oil, form carbon. Gas tickets never needed, average U. S. price 12 cents per gallon. Get handbook with complete information, list of necessary equipment, sketches, etc. Send only one dollar to Alberts, Box 492, Alhambra, Calif.

R AND R Mfg. Co., Box 546, Marine Division, Anderson, Indiana. Speed and Power Equipment Hicompression cylinder heads Dual intake Manifolds Camshafts Piston Lynite Flywheels for V-eight and Model A Fords. Air Pumps Gauges Tachometers Autopulses. Special Literature \$1.00.

CONVERT your auto, tractor or marine engine to burn diesel or stove oil. Proven factory method. Different and better. Costs nothing to investigate. Write for free circular No. 3. Harrington Co. 222-224 S. W. Stark St., Portland 4, Oregon.

AUTO Fuel Burners—Uses Cheap Fuel. Water Injection. DeLuxe double carburetor system. Castings for all motors. Installation Agents, wanted. Original Manufacturers since 1935. Houston & Logan, 2112 Addison, Berkeley 4, Calif.

HAVING Car Trouble? New, Used, guaranteed auto, truck parts save money. Transmission specialists. Describe needs; immediate reply. Victory, 2439-1/4 Gunnison, Chicago 25.

SPECIAL Big 15 lb. box of over 3,000 popular size assortment of steel bolts, nuts, screws, washers, cotter pins, hose clamps, etc. \$5.00 postpaid. Meltz Aircraft, Hardware Dept. New Brunswick, N. J.

UNLOCKEEZ is Patent Pending Device, guaranteed to open Push Button Auto Locks instantly, also many other cars. \$2.00 per unit with instructions. Unlockeez, B 209, White Plains, N. Y.

MORE Miles and Power or Money Back. Send \$1.00 Treat 60 gallons Gasoline. Not a pill. Hyocltube, Box 46, Long Island City, N. Y.

OIL Pumping Motors—Brought Back to Normal without Ring Job. Write for Particulars. Joe Mullner, Box 3102, I, St. Paul, Minn.

FLUORESCENT Driving Lights for any car or truck. Blueprints; instructions—\$2.00. Superior Tool, Box 1036-x, Anderson, Indiana.

PRESERVE your tires with plastic and puncture-proof your tires. Details for stamp. Betke, Box 699, Borger, Texas.

INVENTION Uses kerosene to run motors. Circular on plans. Rush name. Houston Maupin, Tipp City 37, Ohio.

ANTI-FREEZE, Noncorrosive, Inexpensive, manufacture yourself. Details for stamp. Betke, Box 699, Borger, Texas.

1945 IGNITION Supercharger \$4.00 Pep Mileage Fast Starting. EG Mfg. Co., 355 E. 149th St., N. Y.

TIRES Grad 3 6:00-16 \$6.65. Passenger Tire Reliners \$2.50. Discount to Dealers. Allied Rubber Co., E. St. Louis, Ill.

GASLESS Gas quickly, Easily, Compound Formula 25c. Duffy, G.47, Covington, Ky.

## 9 AUTO TRAILERS

BUILD your own Trailer! Save Money! Have every feature you want! Plans for House, Sport, Camp and Utility trailers. Catalog describing 9 models 10c. (15c in Canada and overseas) Jim Dandy, Box 125-B, Wausau, Wisconsin.

## 10 AVIATION

WAR-BARGAIN Airplanes now available. Send 25c for Directory of hundreds of airplanes and glider buys located all over the United States, some probably near you, with owner's price, name and address. (35c by first class mail). New Edition just out. Used Aircraft Directory, Athens, Ohio.

B-29 SUPERFORTRESS—packet containing 20 actual photographs, famous Boeing B-29's; also packets Naval Aircraft, Army Aircraft, B-17 Flying Forts, Army Trainers. Any 1 packet, 25c; 5 assorted for \$1, postpaid. Lloyds, 1411-SP Northwest 17th, Oklahoma City 6, Oklahoma.

LUSCOMBE \$65, Cub \$300. New catalog, 25c, lists thousands of sensational bargains in airplanes, motors, parts, parachutes, supplies. Aviation "Business Opportunity" section included free! National, Box 1682-Cs, Toledo, Ohio.

PROPELLERS—High grade—all types, sizes. Airliner 3 blade for sleds, boats. Fast delivery—lists free. Aircool motor diagram 50c. Standard Aircraft, Ft. Worth, Texas.

PILOTS And Mechanics. Complete Illustrated Altimeter Handbook. Included use, installation, servicing, setting testing, charts, etc., 35c. Lee Stenzel, Bellevue, Nebr.

TAYLORCRAFTS, Fairchild's & Many Other Used Aeroplanes Sold Direct For Lowest Prices. Send 20c for Latest Listings. Advanced Aircraft Service, P. O. Box 3197, Savannah, Georgia.

JET Propulsion Experiments. New Principle to drive boats, bicycles, model helicopters. Circular on plans. Rush name. Houston Maupin, Tipp City 54, Ohio.

EXPERIMENTAL Rocket, Jet Motors. Guide for model builders. Send for circular on plans. Marwood Co., 1006 E. 45th, Seattle 5, Wash.



# POPULAR SCIENCE OPPORTUNITIES

**PREFABRICATED Metal Airplane Hangars**  
Available, limited quantity. Write Taylor Company 497 So. Saginaw, Pontiac 19, Mich.

**AIRPLANES**—Used \$135 up. Also late models. Engines, wings, parts cheap. Send 25c for list. Aircraft, 2300 W. Flagler, Miami 35, Florida.

## 11 BATTERIES, GENERATORS, ETC.

**EDISON Batteries:** Power, Light. Five year guarantees. Fifteen year life. Complete lighting equipment. Free literature. See-Jay Company, 321 Yonkers Avenue, Yonkers, New York.

**BATTERY LIFE** doubled. Guaranteed Instructions \$1.00. Betke, Box 699, Borger, Texas.

## 12 BLUE PRINTS & PLANS

**RECORD Player;** Plays thru your radio; Simple and easy to make. Detailed plans and instructions only \$1.00. Jay-M Sales Company, P.O. Box 97, West Haven 16, Conn.

## 13 BOATS, OUTBOARD MOTORS, ETC.

**FULL size,** cut to shape boat patterns, blueprints. 7½—38 feet. Illustrated "Build a Boat" catalog, 10c (coin). "How to Build Boats" book, \$1.00. Cleveland Boat Blueprint Co., Dept. A-77, Cleveland, Ohio.

**CARBIDE Lights,** Carbide, Hunting Knives, Sleeping Bags, Army Blankets, Canteens, MessKits, Pistol Belts, Army Raincoats \$2.75. Boat Supplies. Alan-Clarke Co., 96 Chambers, N. Y. 7.

**MARINE Power**—Easily convert any Ford motor (domestic and foreign) with Osco parts and kits. Complete catalog 25c (coin). Osco Motors Corp., 2020 E. Orleans St., Philadelphia, Pa.

**BUILD Your Own Boat** blue prints, list of materials and instructions for 12' rowboat \$1, for 16' inboard motor boat \$4. Boreland, 250 W. 57th St., New York 19, N. Y.

**MAKE 16' Rowboat.** Blueprint, 30c. Wee-Sho-You, Box 51, Detroit, Michigan.

**MAKE simple,** nifty duckboat. Blueprint, 30c. Wee-Sho-You, Box 51, Detroit, Mich.

## 14 BODY-BUILDING COURSES

**BAR-BELLS, Dumbbells.** Exercise equipment, Courses, Special offers! Free booklet. Good Barbell Co., 3261-PS Watson, St. Louis 9, Missouri.

**HANDBALANCING** is fun! Learn at home, quickly. Write today. Power, 923 W. Vine, Kalamazoo, Michigan.

## 15 BOOKS, PERIODICALS

**100,000 POST-WAR Jobs** abroad—South America, China, India, Burma, Japan, Russia, Malaya. How and where to apply now. Post-war U. S. participation in world reconstruction and trade demands thousands of American-trained mechanics, salesmen, technicians, engineers, foremen, laborers and business representatives—every trade needed. Our 15,000-word copyrighted forecast—compiled from business, professional and government sources—lists over 200 big U. S. firms with foreign interests, gives job information, salary brackets, contract tips, application letters, passport information, climatic conditions, etc.—vital facts for your immediate application, \$1.00. Return for refund in 7 days if not satisfied. Pacific Industrial Research Bureau, 202-D Studio Building, Portland 5, Oregon.

**SOUTHWEST Pacific Pictures**—Very latest scenes, series of 11 different packets, each containing 10 actual glossy photographs, 2½x3½", of Saipan, Tarawa, Namur, Marshall Islands, Admiralties, Solomons, etc. 25c single packet, 5 assorted \$1. Special: All 11 packets, \$2. Postpaid, 3rd class. (If desired airmail, send 10c per packet additional) Satisfaction or money refunded. Lloyds, 1411-PS Northwest 17th, Oklahoma City 6, Oklahoma.

**HYPNOTIZE Anyone!** Step by step the secrets of hypnotism are revealed to you so you can hypnotize people easily. Think what this can mean to you. 264 pages of clearly written, practical instruction. No detail overlooked. Start mastering other people right away! Send for "Practical Lessons in Hypnotism" by Dr. William Cook. Only \$2.00. Ball Square Company, Dept. 55-G, 697 Broadway, Somerville 44, Mass.

**FREE Membership** in our Technical Book Club entitles you to current literature, guiding advice on all your book problems, premiums. No obligation. All books: Technical, chemistry, physics, plastics, optics, watchmaking, business, sports, photography, farming, music, languages, occultism, astrology, all homecraft, etc. Free literature, specify subject. Modern Technical Book Co., Dept 2MS, 55 W. 42nd St., New York 18.

**WANT to drive a bus** like the Greyhounds and Trailways? Get our four confidential manuals giving information about all requirements. Contains self-instruction course helping you to qualify, make your applications. Twenty complete lessons, copyrighted by a Greyhound Driver. Bus Industry needing operators! All four manuals only \$5.00. Check or money order. Acme Publishers, Dept. PSA, Box 1347, Clarksburg, W. Va.

**PORTRAITS** of gorgeous girls especially chosen for their beauty and charm. Actual clear glossy photographs of living models. Each portrait is a masterpiece of feminine loveliness. Distinctive. So different from the ordinary. Set of 12 4x5's \$1.00. Overseas orders accepted also. Eugene Baker, Box 2-SM, Merchantville, New Jersey.

**PIN-UP**—Eyefuls, Beauties in cosy poses. Glamorous, Bewitching, Feminine curves. The real thing—15—4 x 5 approximate size. Each one different. These are exciting pictures of models for adults only. Send \$1.00. No C.O.D. money order or stamps. Lin, 19 W. 27 St., New York City.

**PUBLISHERS!** Here is a profitable market to sell your books! Popular Science readers buy all kinds of books. Ask us for proof and full facts. We'll show you how to get more business! O. K. Kelly, Manager, Popular Science Classified, 353 Fourth Ave., New York City.

**OPERATE Profitable Agency** taking subscriptions to all magazines, complete supplies and wholesale catalog listing 5000 magazines 25c (Refunded first order). New York Circulation Service, 30 Church St., New York 7.

**EDUCATIONAL Books** sold cheaply or rented for small fee. Books bought. Money back guarantee. 4,000 Bargains. Catalog Free. (Courses Bought). Lee Mountain, Pisgah, Alabama.

**BIG Profits Taking Subscriptions** for all magazines. Agents' Confidential Catalog listing over 2500 periodicals and complete starting supplies Free. Pines Subscription Agency, Flushing, New York.

**TRADE Magazines**—Business, Vocational, Diversion. Current single copies. Over 200 fields. Free price-list. Commercial Engraving Publishing Co., 34S N. Ritter, Indianapolis 1, Indiana.

**MOTOR Books.** Most complete automobile, motorcycle selection in America. Historical, technical, racing. Send dime for book catalog. Clymer, 2125 W. Pico, Los Angeles 6, Calif.

**MODERN Steam Car** \$2.00. Floyd Clymer's Historical Motor Scrapbooks \$1.50 postpaid. See our advertisements under Automobiles and Motorcycles. Clymer, 2125 W. Pico, Los Angeles 6, Calif.

**MAGAZINES** (back dated)—foreign, domestic, arts, Books, booklets, subscriptions, pin-ups, etc. Catalog 10c. (refunded). Cicerone's, 863 First Ave., New York 17, New York.

**BOOKS, (out-of-print, new, used)** quickly supplied, many 35c bargains. Catalogue. Mid-West Book Service, 18870 Marx Ave., Detroit 3, Michigan.

**FREE Catalog.** Five Hundred Unusual—Interesting Books. Write, Happiness Books, PSG, 41 Union Square, New York 3, N. Y.

**SELL** some of my technical books, main subjects: electricity, applied mechanics; state subject I'll send list and price. 2369 33rd St., Astoria, N. Y.

**CHINESE Physicians Secrets,** unpublished history, peculiar healing arts, illustrations, \$1.00. Garding Lui, Box 6227 Metropolitan Station, Los Angeles, Calif.

**BEAUTIFUL, Colored, 8x10, U.S. Airplane,** Pictures, 10c each, postpaid. Nebs Bargain Store, 205 C St., Rock Springs, Wyoming.

**FREE Booklet**—The Truth About Jesus. John C. Meek—P.O. Box 512—Baltimore 3, Md.

**MARGARET Nickerson Martin's Ceiling** Unlimited, Serviceman's poems 25c. Jackson, Michigan.

**BACK** number magazines reasonable. Reedmor, 841 Intervale Ave., New York, N. Y.

**OUT-Of-Print Books** found quickly. Send Wants. Any subject. Reasonable. Clifton, Box 1377ps, Beverly Hills, Calif.

**"BOOKALOG Free Books, Opportunities.** Enclose stamp. Golden, 5730S8 Keith, Oakland 11, California.

**FINGERPRINT** course, complete, authentic \$3.00. Identifier, Box 1416, Bridgeport, Conn.

**RARE, Out-of-Print Books** located. Bookfinders, 1210 N. 11th Ter., Birmingham, Ala.

**OZARK Magazine,** Lonsdale, Arkansas. For homeseekers, sportsmen, folklorists. Year, \$1.00.

**PROOF** of Earth's Concavity, 225 pages, \$1. Theocracy, A1720 Hough, Ft. Meyer, Florida.

**SUBSCRIPTIONS** Any Magazine, Trade Journal. Printed Catalog 10c. Cassell Publishers Service, Westfield, N. J.

**LOST Treasure** 70 locations in U. S. signs, map, \$3.00. G. Patterson, 49 Elmira St., Boston, Mass.

**75 Beautifully designed book labels** 2½"x3" name imprinted 50c. Ex-Libris, 205 E. Broadway, New York 2, N. Y.

**RUBBER** molds made to order. You know our quality. Fair treatment always. Plastic Arts, Route No. 5, Muncie, Indiana.

**BOOKS** latest editions, Best sellers. Wholesale, Retail, Pacific Book Co., 2108 S. E. Taylor, Portland 15, Oregon.

**ADULT Books.** Sample and catalog 10c. Alstone, 310 Lunenburg, Mass.

**BOOK Bargains.** Illustrated catalogs free. Rialto, 349-A Sackett, Brooklyn, N. Y.

**"A RATIONAL View of Life"**—\$1. Benjamin Seibert, Urbana, Ohio.

**MAKE 70 life's prime.** Bookmaster, 104B Orchard Lane, Stillwater, Okla.

**ADULT Books:**—Catalog, Sample 25c. Lefavor, Box 229, San Bernardino, Calif.

## 16 BUILD IT YOURSELF

**MAKE** Potato Baker for electric stove or hotplate from scrap materials. Simple construction. For own use and sell to others. Good market. Complete copyrighted instructions, drawings and selling opportunities. \$1. Becker Engineering Co., 277 Broadway, N. Y. 7.

**RADIO** control equipment. Control models—doors, etc. by radio. Send 25 cents for Instruction Manual to Radio Control Headquarters, Box 214, Deal, New Jersey. No stamps.

**BUILD Tractors** from Second hand automobiles. Convert horse drawn farm equipment into tractor hook-up. Nolan's Garage, East Wareham, Mass.



# POPULAR SCIENCE OPPORTUNITIES

**BUILD Concrete Block Machine.** Easy, inexpensive. Sell blocks, build home, garage, barn, etc. at low cost. Free details. Horne, 206 W. Wilder, Tampa, Florida.

**LATHE men New toolholder Seven in one.** How To Make It, Dollar Warstamp. Allbaugh, 3318 Broadway, Huntington Park, Calif.

**PLASTIC Houses—Build yourself!** Resurface old buildings! Wonderful building material. Write Marbelizing Service, Edwardsville, Ill.

**HOME Telegraph.** Two complete sending-receiving sets! Two-way communication. Easily put together. Complete parts, \$1.00. Robert Hulet, 29A E. 39, N. Y.

**AGAIN Material available for Sun water heaters.** Get plans. Sol-Ray, Daytona, Fla.

## 17 BUSINESS OPPORTUNITIES

**"10,000 ALASKA Fishing Jobs."** Alaska's largest industry regularly employs thousands of men and women in seafoods production. Possible earnings up to \$5,000 in few weeks. Authentic 7,000-word copyrighted report gives job information, union requirements, sample application letter, names and addresses over 40 Alaska fisheries. Newest edition includes similar information on California, Oregon and Washington fisheries. Vital facts for immediate application in a permanent industry. \$1.00. 7-day refund privilege. Pacific Industrial Research Bureau, Dept. PS-9, 202 Studio Bldg., Portland 5, Oregon.

**GET The Facts concerning "My View Points"** about Mail Order Schemes, Plans, Ideas, Sales Letters, Circulars, Booklets, Formulas, Advertising, Circular-Mailing and Mailing-Lists—Know the relationship of these "Ten Vital Subjects" to the "Direct-By-Mail" Order Business. Send for Free Information to Henry E. Piltz Publications, Box 148, E. Orange, New Jersey.

**EACH Ambitious Man Should have something to sell by mail for extra income every day.** Make extra money and buy what you want. Read, "Mail Selling Is Money Business"—by Houston Maupin. Free sample service bulletin, "Tex Maupin's Letter On Speculation With Ideas." Send name on card. Houston Maupin, Tipp City 59, Ohio.

**MAKE new patented spinning toys in your shop or factory.** Turned wood or plastics. Small royalty. They sell like yoyos. Self advertising. Year around sellers. Your ticket to prosperity. Send \$1.00 for blue prints and proposition. USA only. People are toy hungry and stores are empty. Act now. Clinton Davidson, 636 "C" St., San Diego 1, Calif.

**INVENTORS Attention:** Aggressive toy manufacturer employing over 100 interested in patented or patentable mechanical devices. Product must be beyond the idea stage. Clear sketches and written description required. Your rights will be scrupulously respected. Write Box 233, Realservice, 110 W. 34th St., N. Y.

**COLORGLAZED Concrete Pottery made without molds.** New, low cost, patented method. Cemetery products, novelties, tiles, floors, etc. Basement leaksealing. Other money-making projects. Booklet, details free. Men only. National Potteries, Fergus Falls, Minnesota.

**MECHANICALLY Inclined Men—Own and operate general Appliance Repair shop.** Complete, illustrated course shows you how. Welding, Refrigeration, Motor repair. How to get business, etc., all phases covered. Free literature. Christy Supply, Dept. 755, 2835 N. Central Ave., Chicago.

**LIQUID Marble; snow-white, multi-colored. Glazed. Unglazed. Composition Flooring.** Lifetime wear. Any color. No priorities. Flexible molds. Plaster casting. Get into the big money now. Full information given free. Write—Compo-Tex, Box 786-F, St. Louis, Mo.

**COLOR Concrete with Chemicals.** Big money making Hollywood style pottery, birdbaths, without moulds. Wishing-wells, stucco-rock, benches. Marbling, cement water-paint. 10c brings sample, literature. Pictures. Hollywood Cementcraft, 8530 Wonderland, Hollywood 46, California.

**THOUSANDS of Alarm Clocks need repairing.** Jewelry stores swamped. Our simplified course with pictures and drawings teaches you how to repair these clocks. Necessary tools and supplies furnished with course. Alarm Clock Repair Service, P.O. Box 1983B, Houston 1, Texas.

**GOOD Paying Business Silvering mirrors, plating autoparts, reflectors, bicycles, bathroom fixtures, etc., by late method.** No tanks or shop required, outfit furnished. Free Booklet. Gunmetal Co., Ave. E, Decatur, Illinois.

**MAIL Order Business course shows you how to make money, spare or fulltime.** Teaches professional mail order technique—not penny-snatching schemes. New Success-Catalog Free! Write—Nelson Company, Dept. 4-01, Chicago 4.

**START Home business making statuary, plaques, art goods, pottery, garden furniture, artificial marble flooring, liquid marble.** Make flexible molds yourself. Amazing profits. Folder free. Creative Publishers, Box 236-M, Winnetka, Ill.

**ELECTRICAL Appliance Repair.** Open your own shop. Learn house wiring; electric motors, vacuum cleaners, washers, etc. Complete illustrated course shows how. Free booklet. Pacific Training School, Dept. AS-1, 4703 W. Pico, Los Angeles 6.

**START a clock shop while clock repairing is booming.** Our easy to learn home study course with pictures and illustrations teaches you how to repair all kinds of clocks. Information free. Houston Clock Shop, P.O. Box 5086B, Houston 12, Texas.

**WANT to make \$100.00 weekly? No Foolin!** Details and 64 page book tested money-making information that can mean immediate cash and assure your future independence. Rush 25c today. Now. Wilkin, 1348-P N. High, Hillsboro, Ohio.

**"100,000 jobs in Air-Conditioning."** Learn opportunities in this immense field, names, addresses of major companies, etc. Send \$1.00 for 4200-word report. 7 day refund privilege. R. A. Rasmussen, 1015 N. Milpas, Santa Barbara, Calif.

**START a home business in spare time.** Make extra money. Experience not essential. Literature free. Rolf S. Iverson, Box 916B, Grand Central Annex, New York 17, N. Y.

**JUMBO Mail! Packages full of Magazines Bargains, offers, samples from hundreds of Companies.** Name listed 25c. National Distributors, Box 57-PS, Muskegon Heights, Michigan.

**SELL by Mail to Latin-America.** Virgin, overprosperous Mailorder Field offering immense opportunities. Valuable instructions explaining how, \$1. Sample Lesson, 10c. Vallesm, 395 Broadway, New York 13.

**HEALTH First! New Drugless Method Unbelievable results!** Operate a "Health Conditioning Club." No apparatus. Metabolic System, D9128, Station S, Los Angeles.

**START Mailorder Bookshop—Everything furnished; publisher cooperation.** 25c brings booklet, exclusive setup, samples, exciting ideas. General Publications, Ossining 1, New York.

**LEARN Profitable Credit and Collection Agency Business: Earn \$5000-\$10000 annually upwards; Postcard Brings Interesting Literature Free; Write Educational Extension Service, Dept. 102, Los Angeles 36.**

**START Home Business making Novelties, Plaques, Souvenirs. Colorful Liquid Marble.** Make your own Flexible Molds. Write for Free Information. Bing Products, 621-J Tremont St., Boston 18, Mass.

**SELL Cosmetics By Mail.** Women spend millions on Beauty. You can make your share of this Cosmetic Money. Let us show you how. Details Free. Frank J. Artz, 1060 Harding Drive, Toledo 9, Ohio. Dept. B.

**MAKE and Mold genuine Plastics.** Forty illustrated work-sheets explain methods, processes. Authentic, simplified. \$1. Free circular. Plastics Digest, 3937D Tracy, Kansas City 4, Mo.

**BOOKKEEPER—Accountants.** Double your income, operate a profitable bookkeeping service spare or full time. Textbook, and particulars \$2. Tax-Saver System, Dept. F, Ft. Worth, Texas.

**MONEY Now.** After War What. Giant Collection Of Business Plans Shows How To Make Good Money At Home With Own Business. Literature Free. Strauss, P. O. Box 71, Kensington Sta., Brooklyn, N. Y.

**MAKE salable articles with real urea-formaldehyde plastic.** Only simple equipment required. Fourth pound sample \$1. Cheap quantity prices. Plastic Digest, 3937D Tracy, Kansas City 4, Mo.

**GUARANTEED powerful mailorder letters, literature, complete campaigns created.** Famous for famous results! Reasonable! Investigate! Finkle Advertising, 1201½ S. Ogden, Los Angeles.

**AT HOME—your own manufacturing business; making popular \$1.00 novelties.** Cost you 3c to 15c. Everything supplied. Write So-Lo Works, Dept. A-601, Cincinnati, Ohio.

**ESTABLISHED lifetime mail order business from your home.** No canvassing. Stamp for particulars or send two dollars for complete plans. Case, Box 172, Seattle, Washington.

**SELL Christmas Cards, Display Signs, Pictures, Calendars, Books, Greeting Cards.** Big Profits! Quick Sales! Catalog Free! Elfco, 436 N. Wells, Chicago.

**QUICK Money! "Repairing Car Batteries".** At home. Easy too. Write Batteryman, 901 South Avenue, Grand Junction 5, Colorado.

**MAKE strange new plastic, 8c gallon—sells 50c.** Makes beautiful, durable floors, walls, roofs. Amazing profits. Bays Laboratory, Oklahoma City 9.

**"OIL—DRILLING" Expert "know-how."** Leasing—Royalties, Profitable Procedures. Booklet Free. Landowner's, Caddo, Oklahoma.

**TYPEWRITER Repairing—Original Course—Simplified Home Study.** Weber Typewriter Mechanics School, Box 269, Osborn, Ohio.

**"HOW to Make Simple Molds and Plaster Plaques".** Profitable Business or Hobby! Booklet 25c. Plastercraft, 1406 E. 43rd St., Cleveland 3, Ohio.

**INVESTIGATE Mail Order Selling.** It's great opening letters containing cash, checks, money-orders. Amaze your friends. Write Young's, Kent 16, Ohio.

**IF you'd like to make \$5,000 annually or better, in an easily learned office business of your own, send for free details immediately.** G. H. Cole, Pres., Syracuse 2, N. Y.

**LIQUID rubber for making molds for plaster castings.** Finest quality. Samples? Sure! \$4.00 qt. \$12.00 gallon. W. Wooley, 405 A Howett, Peoria, Ill.

**DISTRIBUTE Health Foods, Vitamins, Vegetable Concentrates, Minerals, Fruit Powders.** Free Catalog. National Health Products, Portland 2, Oregon.

**"BUSINESS Opportunities", 5 Volumes Money Making Business Starters.** \$1. Single Volume 25c. Burke, 1345-B, Robson, Vancouver, Canada.

**BUILD Own Business Mailing penny post cards; six profitable plans with information for starting.** Gordon Publishers, Box 23, Pawtucket, R. I.

**BE independent; start own business, home, office.** Free literature describing over 100 moneymaking plans. Zbiegniewicz Co., 147P N. 8th St., Brooklyn, N. Y.



# POPULAR SCIENCE OPPORTUNITIES

GET Ready for Own Postwar Business making Venetian Blinds. Illustrated Instruction Book \$1.00. Elwert, 6900 N. Ashland, Chicago 26.

AMAZE others. Add columns instantly. Add faster than adding machine. Free details. Maths Institute, Box 633, Mobile 4, Alabama.

MAKE MONEY. Used Machinery Sales Agency. Little capital. Complete plan \$1.00. Roberts, Dept. B, 425 Beech, Arlington, N. J.

MAIL Order Mirror (Monthly), 349 B Sackett, Brooklyn, N. Y. shows how to earn extra money by mail. Sample 10c; \$1.00 yearly.

WE Start you in Business at Home, Spare-time. Earning \$10-30 Weekly Selling by mail. Stamp Appreciated. Joseph Driscoll Sales Service, Box 2771G, Denver, Colorado.

50,000 POSTWAR Job Opportunities in South America. Send stamped return envelope for Full Particulars. Pan Americana, Box 424, Hollywood 28, Calif.

MOLD-MAKING. Plaster casting. Money-making Business. Literature Free. Kemilo, Park Ridge, Illinois.

RECAST old batteries into new. Latest achievements. Battery Laboratories. Minneapolis.

\$25. Weekly working two hours daily. No canvassing. No Manufacturing. Lycke, Box 2471, Cleveland 12, Ohio.

FLEXIBLE Mould Compound, Pint \$1.00. Moulds made, send model. Winters, 9280 Yellowstone, Detroit 4, Mich.

MAIL Business Earned \$1400. Monthly. Copyrighted Instructions \$1.00. Boyd, 331 Fourth, Pittsburgh 22, Pa.

BUILD Miracle Homes. Yours. Others. Chamberlain, Fitzsimons Building, Pittsburgh 22, Pa.

GROW Dwarfed trees. Instructions 25c. McGuire, P.O. Box 628, Dept.-E, Seattle 11, Washington.

MAKE and Sell Refrigerator Deodorizer. Complete instructions 50c. Box No. 1, Toughkenamon, Penna.

24,500 RICHER; used "schemes" from "Schemer" Magazine, Alliance, Ohio. 47th year, \$1.00; Four samples, 30c.

RUBBER Moulds. Latex, models, start profitable business. Eastern Latex Laboratories, Box 153, Mattapan 26, Mass.

YOU too can learn how to make, mold and cast Real Plastics. Send stamped envelope. Box 498, Gainesville, Texas.

LARGE Profits Merchandise Imprints available. Write, Adams Exchange, 150-S W. 124th St., New York 27, N. Y.

EXTRAORDINARY Mailorder Opportunities. Literature free. Hudson Letter Shop, Box 122-D, Amsterdam, N. Y.

\$2.00 YEAR sideline easy, inventing simple items for guaranteed cash markets. Hendrixon, Argyle, Wisconsin.

1,500,000 ARTICLES wholesale, Scarce merchandise. Directory 10c. Prince, Sunnyside P, Indianapolis 44, Ind.

INSECT Spray profitable: Concentrate instructions. Kaplan, 13 S. Eden, Baltimore 31.

MAKE Big Money in spare time at home. Free particulars. Yeamans, 3305 North Ave., Richmond, Va.

BUILD Profitable Real Estate Business. Spare Time. Free Particulars. Cutt, 452 Humboldt, Buffalo 14, N. Y.

PROFITABLE Mail Order Opportunities. Vassar Service, 332-5 Washington, Hoboken, N. J.

REDHOT Mailorder Winner Make for 15c Gallon. Sell \$32.00. Progressive Service, 1412W Great Northern Bldg., Chicago 4.

MAKE flexible molds! Cast plaques, novelties, bookends! Free sample! H. Tooker, 630-R Chestnut, Hamilton, Ohio.

NEED Money? We have Cure for lean purses. Details free. Gailpeter Enterprises, Dept. 166-PS, Neillsville, Wisconsin.

SELL by mail abroad! Fifty million prospects! Details 10c. MacCormack, 9-F, Madeira, Ohio.

WHOLESALE Directory Ten cents. Volchok, 1098 S. Gerard Ave., New York 52.

STEP into Job or business you want. Write, Central, Simpson 2, Kansas.

## 18 BUSINESS SERVICE

CHICAGO Mail Service. \$1 Monthly Reliable. Confidential. Faultless Organization, 3439 Michigan 16, Chicago.

CHICAGO Mail Forwarding Confidential. Send 25c with letter. Blaire's, 4520 Sheridan 40.

MAIL Address Service \$1.00 Monthly Letter 10c. Spada, 10 Lexington, Wethersfield 9, Conn.

WASHINGTON, D. C. Receiving and forwarding your mail. Prompt Service. Service Bureau, 1401-25th St., S.E.

## 19 CAMERAS, PHOTO SUPPLIES

BASS Says: War time proves Bass leadership. Amazing selection of finest still cameras—Leica, Contax, Korelle, Reflex, Argus, new and used still available. Write for quotations. Satisfaction guaranteed or your money refunded. Bass buys 'em, sells 'em, trades 'em. 35c Postpaid for 100 page book "Military & News Photography" by Jack Price. Up to the minute information. Bass Camera Co., Dept. SP, 179 W. Madison St., Chicago, Ill.

CASH! Spot cash for cameras, lenses, binoculars, movie or still, sound projectors. Send full description by mail, or wire for prompt cash offer. Over 30 years of dependability insures honorable dealings. 35c Postpaid for 100 page book "Military & News Photography" by Jack Price. Up to the minute information. Bass Camera Co., 179 W. Madison St., Chicago, Ill.

HAVE You a camera. Improve your hobby of photography and learn how to make better pictures. Write today for our latest book catalog and sample copy of American Photography, containing articles and pictures by the world's foremost writers and photographers. Camera House, 603, 353 Newbury St., Boston 15, Mass.

WAR-BARGAIN Used Cameras. Candid Camera \$4.98, Kodak \$7.00 Graflex \$27.50, Enlarger \$15.00, 35mm, Reflex Cameras—and many others. Movie camera \$5.00, Projector \$8.00, Roll Film. Send 25c for latest list and descriptions. Used Camera Directory, Box 1031-K, Canton, Ohio.

PHOTOGRAPHY for pleasure or profit. Learn at home. Practical basic training. Long established school. Write for booklet. American School of Photography, 1315 Michigan, Dept. 1722, Chicago 5.

CANDID Camera. Build your Own Complete Kit of Parts \$3.50. Money back Guaranty. Free Particulars. Hollycam Co. Box 272-C La Jolla, Calif.

FILMS for your camera—All sizes, one to a customer. Send four dimes to Films, Box 706A, Salem, Mass.

USE any camera with plentiful 35-mm. film! Simple instructions. Rush \$1.00. Tirekop, D-9, Madeira, Ohio.

PHOTO Enlarger Kit. Free Circular. P.O. Box 148, Wall St. Station, New York 5.

## 22 CARTOONING, SIGN PAINTING

JOURNEYS With A Cartoonist, biography, travel. Cartoon Instruction, information, hundreds original illustrations, just published, \$3.00; Landscape Painting Course \$3.95; Modern Poster Art Lettering Course \$2.00; Cartoon-Drawing Course \$1.00, Catalogue 10c. Signs, Farmington, Mo.

"HOW To Make Money With Simple Cartoons"—A book everyone who likes to draw should have. It is Free; no obligation. Simply address, Cartoonists' Exchange, Dept. 1449-C, Pleasant Hill, Ohio.

LEARN Cartooning, gag creating, markets and plans! Hartman, 2438 W. St., Lincoln 3, Nebraska.

SIGNS Made Easily. Instructions and ten sets modern alphabets; numerals, patterns. Sizes up to Eight inches. All for \$1.00. Co-operative Business. Box 638, Chicago.

CARTOONING—Learn at home. 14 easy lessons. 50c. Cartoon Studio, 1402 Charles, La Crosse, Wisconsin.

HOW to Draw Funny Faces. 3 Sample Lessons 10c—. Funny Faces, Modesto 1, Calif.

CARTOON Courses—22 Easy Lessons. 200 figure sketches. 25c coin postpaid. Snack-Pack Co., 32 E. Georgia, Indianapolis 4.

## 23 CHALK TALK STUNTS

CHALK Talks. Laugh Producing Program \$1.00. Illustrated Catalog 10c. Cartoonist Balda, Oshkosh, Wisconsin.

## 25 CHEMICALS & APPARATUS

DO research work for money in any field of science. We will give you a project to work on. All necessary is some experience and laboratory. New registering fee \$2.50 you receive contract to sign stating money will receive and we pay laboratory expenses. Chemical catalogue 18c Universal Chemical Co., Rochester, New York.

THE House of Winn, the Home of Supplies for Amateur Chemists. See Winn's new idea Chemical Kits and Apparatus Outfits for Home Experimenting. Send 10c for Retail Catalog. John H. Winn, Established 1931, Dept. 607, 124 West 23 St., New York 11, N. Y.

ATTENTION Amateur Scientists—Once again club membership is open to all interested. Write immediately for full details. Membership Department, Royal Scientists of America, Box 305, Hopkinsville, Ky.

CHEMICALS and apparatus for industrial, analytical, and private laboratories. Complete supply service for correspondence school students. Send 3c for catalog. Dept. M-26, Biological Supply Co., 1176 Mt. Hope Ave., Rochester 7, N. Y.

HANDBOOK for Chemical Experimenters. Hundreds of experiments; illustrated; 50c. Experiment Booklet, 15c. Chemical Catalog, 5c. Reading Scientific Co., Reading, Pa.

NEW 36 Page chemical apparatus order book. Complete line of chemical glassware, apparatus and chemicals. Send 10c for this book. Standard Science Supply Co., 1232 N. Paulina St., Chicago.

100 DIFFERENT Chemicals. One ounce or more each. Excellent opportunity for diversified laboratory stock. \$6.90. Midwest Chemical Co., 3724 Second Ave., South Minneapolis, Minnesota.

COPPER Mirrors easily made on any glass with Myers Coppering Liquids. Send \$2.00 for four pint bottles, postpaid. Free information. Myers Chemical Co., 2134 Flatbush Ave., Brooklyn 10, N. Y.

LABORATORY Supplies at Wholesale Prices: Chemistry, Biology, Physics. Catalogue, 10c. National Scientific Co., 2204 W. North Ave., Chicago. Established 1908.

\$50.00 OFFERED by manufacturer for amateur research! 15c brings copy Amateur Scientists' Magazine, Box 73B, Memphis 1, Tenn.

LUMINOUS Paints will glow in dark. Six colors. Fairmount Chemical Co., 136 Liberty St., New York City 6.

CHEMICALS, ounce quantities, Apparatus, Catalog 5c. Fleischer's Laboratories, Everett 49, Mass.

FREE Catalog: Chemistry, mineralogy, Biology, optics. Tracey Laboratories, Evanston, Illinois.

SPECTROSCOPE for quick chemical analysis \$2.50. T. A. Cutting, Campbell 3, Cal.

UNUSUAL chemicals prepared to order. Bluco, 3031 Dauphin, Philadelphia, Pa.

CHEMIST'S Supply Catalog 5c. Arc Chemical, 1910 Arthur, Bronx 57, New York.



# POPULAR SCIENCE OPPORTUNITIES

CHEMICALS, Equipment, Books, Etc. Special Offers Free. Hallmark Technical Supply Co., Jamestown, New York.

## VV COIN COLLECTING

WE buy Indian Pennies, Lincoln Pennies, and Old Rare Coins. Highest Prices Paid. Indian Pennies worth up to \$15.00 each. Lincoln Pennies up to \$2.00 each. Other Rare Coins \$5.00 to \$2,000.00 each. Send 25c today for New 1945 Price Catalogue of all wanted U. S. Coins. American Rare Coin Co., Dept. 4, Transportation Bldg., Chicago 5.

347 ANTIQUE Firearms; 4,000 Bargains. Coins, Indian Relics, Minerals, Cartridges, Rifles, Flintlocks, Fossils, Swords. Catalog with Photographs 25c. Heike Wenona, Ill.

WILL Pay \$10.00 Each For Certain Lincoln Pennies! Indianheads \$50.00; Dimes \$1,000.00. Catalogue 10c. Federal Coin Exchange, 8-PS, Columbus, Ohio.

COMMEMORATIVE \$1/2-Columbus, Texas, Cleveland, Stone Mountain, \$1.50 ea. Illustrated Catalogue 25c. Norman Shultz, Salt Lake 9, Utah.

QUICK Service; reasonable prices. United States catalog 10c. Foreign catalog 10c. Ben's Coin Shop, 72 W. Washington, Chicago 2, Illinois.

FREE! Foreign coin, banknote and Coin Collectors' Illustrated Catalog to approval service applicants. Send 3c postage. Tatham Coinco., Springfield-D50, Mass.

THREE Foreign Bills and Two Foreign Coins Twenty cents with new Price List. Ralph E. Hirshberg, 23 Waverly Ave., Oceanside, New York.

TWENTY Different Indian Head Cents \$1.00. Price List 3c. Walton Coin, 7 Water, Boston, Mass.

WORLD Coins, Large, Itemized, Descriptive List, 10c. Harry Elsholz, Box 9014B, Pittsburgh 24, Pa.

WE Purchase Indianhead pennies. Complete coin catalogue 10c. Fairview, 277 Broadway, New York.

50,000 COINS, medals papermoney. Lists free. Coinshop, 8 South 18th, Philadelphia 3, Pa.

FREE Latest Coin Price List. Low prices. Formico, Nov-Box 572, Dayton, Ohio.

## D CONSULTING ENGINEERS

IF you want an honest, competent and confidential opinion on that radio-electronic idea or invention of yours—consult us. Electronic Standards Laboratories, 910 S. Boston Ave., Tulsa, Okla.

TECHNICAL problems invited, reasonable fee. C. W. Berger, Chemical Engineer, McPherson, Kansas.

## 28 CURIOS

100,000 GRASS Skirts Wholesale \$1.45 each postpaid: Free list Tropical merchandise. Write Air-Mail, Enterprise Inc., Box 51, Rarotonga, Cook Islands, South Pacific.

## 29 DETECTIVES

DETECTIVES. Training—Secret Investigations—Fingerprints, Easy Method, Short Time. Rewards. Home, Travel, Secret Code-Booklet Free—Write, International Detective System, 1701-P Monroe St., N.E., Washington, D.C. 18.

DETECTIVES—Work home—Travel. Experience unnecessary. Write, Wagoner P-125 West 86th, N. Y., N. Y.

DETECTIVE Training, Phillips Secret Service, 1917-C North Kenneth, Chicago 39, Illinois.

## 30 DOGS, BIRDS, PETS, RABBITS

RAISE Giant Chinchilla Rabbits. Valuable Fur. Delicious Meat. Easily Raised. Pleasant Pastime. Large Profit. Free Booklet shows amazing profits from small investment. Willow Farm, R16C, Sellersville, Penna.

A LIVING with Rabbits and Cavies. Markets Waiting. Magazine 10c. Book describing twenty breeds and magazine 25c. Book and magazine (monthly) one year 50c. Address Small Stock, Dept. 5, Pearl River, N. Y.

RABBITS—Point Free Meat—Raise delicious domestic rabbits. Small space needed. Ready market. Largest magazine in the industry tells you how. \$1 per year. Send dime for sample. No stamps. Small Stock Magazine, Lamoni 4, Iowa.

RAISE Guinea Pigs. Make money at home. Big demand. Booklet free. Taylors Cavy Farm, Hapeville, Georgia.

ST. BERNARD Pups: Champion sired beauties. Franklin Young, R. 3, Riverhead, Long Island, New York.

RABBITS: Flemish Giants, New Zealand. Reasonably priced. Franklin Young, Riverhead, Long Island, New York.

STANDARD Rabbit Journal, Milton, Pa. 3 years \$1.00. Sample dime.

JUMBO Frogs, Wild Rabbits, Cave Poles; Vol Brashears, Berryville, Ark.

RAISE Pigeons profitable business. Booklet Dime. Gebhardt Farm, Muscatine, Iowa.

30 BREEDS—Pigeons, Bantoms, Pigs. Catalogue 10c. Houck's, Tiffin, Ohio.

## KK DRAFTING INSTRUMENTS

SAVE on drafting materials. Free catalog. Draftsmen's Supply Co., 32 North Wells, Chicago 6.

## 31 EDUCATION & INSTRUCTION

GOOD Jobs and a Sound Postwar Future await you in hotel and institutional field. Men and women—all ages—needed for well-paid positions that offer color, excitement, ever-new and fascinating duties. Record-breaking business in hotels, clubs, institutions, means even greater opportunities. Lewis School receiving calls for managers, assistant managers, stewards, hostesses, purchasing agents, and 55 other types of important positions. These are not temporary jobs, but important positions in an essential business that offers splendid opportunities in war or peace, good times or bad. Previous experience proved unnecessary! No need to leave your job to qualify. A good grade school education, plus Lewis Training qualifies you at home, in spare time. Our National Placement Bureau helps to place you—and our amazing Certified Job Plan—actually guarantees you will "make good" when placed. Write today for free book! Lewis Hotel Training School, Room DS-2768, Washington 7, D. C. (First and only School of its kind—Now in its 29th year.)

PSYCHOLOGY teaches about mind. Biology teaches about body. Bio-Psychology teaches about powers of mind over body. Use powers subconscious mind. Select proper vocation. Grow. Broaden education. Develop personality. Control emotions. Succeed. Correspondence. Dept. P, Taylor School of Bio-Psychology, Chattanooga 1, Tennessee.

INVESTIGATE Auto Body and Fender Repair profits. You'll be convinced. Practical spare time home study and resident course including metal work, spray painting, welding may help you open your own repair shop or get a good job. Mechanically-minded men 17 to 57, write for free details. Utilities Engineering Institute, Dept. 34X, 1316 Belden Ave., Chicago, 14.

WRITE Short stories at home for pleasure and profit. Fame, riches and happiness of achievement are rewards to be realized by students who acquire tested technique. Get free booklet from home study school with 50 years experience. Write today! Blackstone-Sprague, Dept. 79, 307 North Michigan, Chicago 1.

FANCY Ice Cream Decorating course, easy condensed lessons \$1.00. E. Cook, 2745 N. 48th St., Lincoln, Nebraska.

WELDING—electric arc. Learn quickly by actual practice at Hobart Welding School. Individual instruction at bare cost of materials used. 75c in stamps brings valuable welding lessons post paid and full particulars. Hobart Welding School, Box P-752, Troy, Ohio.

TYPEWRITER Repairmen urgently needed. Earn \$40 to \$50 weekly spare time. Our easy to learn home study course teaches how to repair typewriters. Write for free information. Houston Typewriter Repair Service, P.O. Box 5357B, Houston 12, Texas.

GOOD "Used" self-instruction educational books on all subjects bought, sold, rented, exchanged. Satisfaction guaranteed. Complete information and 92-page illustrated bargain catalog Free. Write, Nelson Company, Dept. 2-01, Chicago 4.

FOR an extremely profitable lifetime business, operate a collection agency-credit bureau. Easily learned. Free folder. Cole Associates, Syracuse, N. Y.

CLINICAL Laboratory Technicians in great demand. We train you in your spare time, in your own home. You can practice while studying. Write for free catalogue. Imperial Technical Institute, Box 973-B, Austin 5, Texas.

LET me tell you how to develop your opportunities, get a better job, get better pay and win promotion. Tested methods. Free details. Machado, Consultant, 339-A E. 111th St., Los Angeles 3, Calif.

"UNCLE Sam" Jobs. Commence \$105 to \$175 month. Men-Women. Prepare now at home for post-war examinations. Full particulars—list of positions, Free. Write today. Dept. G-51, Rochester 4, N. Y.

SMASH worry, fear, indecision, inferiority. Wake up your mind. Be what you desire. Write for free lecture. Home Study. Personal Psychology Inc., 321 Starks Bldg., Louisville 2, Ky.

ARITHMOMETER Calculator Table that no School Child Shall be without it—send \$1.00 Cash or by P.O. Money Order to F. J. Miller, P.O. Box 266, Winona, Minnesota.

USED correspondence Courses, Educational and Technical Books, bought, sold, rented. Catalog free. Educational Exchange, Henagar, Alabama.

LEARN Profitable Credit-Collection Agency Business; Investigate Educational Extension Service Advertisement under Business Opportunities.

IQ, Logic, Vocational, Personality tests \$1.25 each. Your capacities thru interesting scientific tests. Analyst, Box 758, Beverly Hills, Calif.

HYPNOTISM—Simple Method—Full Detail—You Hypnotize or Money Refunded—Guaranteed. No Magic—\$1.00. Deekay, Box 458, Douglas 4, Arizona.

MAKE money fast—fix watches, clocks,—free bulletin. Belva Charles, Winona, Minn.

FDR in prophecy. Dime. "Pre-Dix-It" Monthly. Free copy. Nichols, Box 85, Waltham 54, Mass.

HOME Study Course, drugless therapy. Free literature. Institute of Drugless Therapy, Tama, Iowa.

ALGEBRA, plane geometry, trigonometry problems solved \$1 each. John C. Ashley, 340 Humason, Lufkin, Texas.

LOCKSMITH Course. Lock-picking, key-fitting, etc. \$1.00 prepaid. Miller's Key Shop, Canadian, Texas.

COURSES in 3 Different Traveling Trades All, \$3.00. Travel Trades Bureau, 714 Gallatin St., Jackson, Miss.

SELL By Mail. Big Profits. Magazine Teaches How. Sample 10c. Auburn Sales Co., Dept. 2ED, Auburn, Maine.

NEW, Used, Educational Books; Courses. Catalogs, dime; Refunded. Westway Educational Service, Box 58-D, Los Angeles 35.



# POPULAR SCIENCE OPPORTUNITIES

**BECOME** a Finance Man. Particulars free. George Lenhoff, Lincoln 8, Nebraska.

**LEARN** Powerful Mental Telepathy 25c. Elgin, 912 Benton, Nashville 4, Tenn.

## 32 ELECTRICAL SUPPLIES & EQUIP

**BROKEN**—Burned out Electrical Heating elements quickly repaired. Use new amazing Nichrocite Paste, simply overlap ends and turn on current. Family size \$1.00 bill. Satisfaction guaranteed. Armstrong Mfg., Box 861-Y, Minneapolis, Minn.

**ELECTRICAL** Appliance Repair. Open your own shop. Learn house wiring; electric motors, vacuum cleaners, washers, etc. Complete illustrated course shows how. Free booklet. Pacific Training School, Dept. AS-2, 4703 W. Pico, Los Angeles 6.

**NOW**—Repair your own electrical appliances with Chanite Self-welding, Electrical Heating, Element Flux. Instructions, delivered, price \$1.00. Chanite Sales Company, 914 South Main, Fort Worth, Texas.

**ELECTRICAL** Apparatus of interest to the electronic experimenter. Send for Government surplus list. Palo-Myers, Inc. 81 Reade St., New York 7, N. Y.

**NICHROME** wire and ribbon heating elements. Appliance repair parts. Dealers, repairmen send for circular B. Allstate, Box 434, Worcester 1, Mass.

**ELECTRICAL** Trouble Shooter finds leaks grounds shorts in anything electrical \$18.50 Prepaid. Free Circular, 811 Q E. 31st, Kansas City 3, Mo.

**ELECTRIC** Pencil: Writes—Engraves all Metals. \$1.00 postpaid. Beyer Mfg., 4515-C Cottage Grove, Chicago 15.

**WATTMETER** portable General Electric 1000 watts. New, Bargain. Austin Kidder, Bridgeport 4, Conn.

**NEW** Electric Fans, Rebuilt Clippers—Vibrators. Dremel Sales, Racine, Wisc.

## SS EMPLOYMENT SERVICE

**INTERESTED** Foreign employment? Thousands jobs throughout world. Names and addresses over 200 firms with sample application \$1.00. "We search the world" Wonder-World Research Bureau, Box 731, Gladewater, Texas.

## 33 ENGINES & MOTORS

**JET** Propulsion. Working drawings of three successful jet propulsion motors which you can build, \$3.50. Book—"Theory and Testing of Jet Propulsion Motors and Rockets" by Zygmunt Fonberg. Only book of its kind. Explains the fundamental principles of reaction propulsion, \$2.00. Price for drawings and book together, \$5.00. Money will be refunded without question if you return material within seven days. Aircraft Jet And Rocket Corporation, 10 W. 33rd St., New York 1, N. Y.

**MOTORS**, small 6 volt DC reversible 3000 RPM 2" diameter, short shaft extension, suitable for operating models and gadgets Postpaid \$1.25. Walthers, 235 Erie, Milwaukee, Wisc.

**MODEL** Engines, Castings, Supplies. Catalogue 25c. Howardco, P3-2417 N. Ashland, Chicago 14.

**WINDING** Data, listing 225 motors, single and three phase, \$1.00. Motor Data, Box 7631, Kansas City 3, Mo.

**150 AMPERE** generator for welding \$47.50; Extra flexible cable, 10 ft. lengths \$2.75. Butler Electric, 1885 Milwaukee, Chicago.

## 34 FARMS, OTHER REAL ESTATE

**HOMESITES**—\$300 Convenient payments. California's finest Garden Spot. On Morro Bay's wooded Shores. Wonderful fishing, hunting, boating. Fertile soil, soft water, temperate climate, congenial community. Free Literature. Richard Otto, 6560-Z Hollywood Blvd., Hollywood 28, Calif.

**WISCONSIN**, Minnesota Lake River Frontages \$7.00 acre. 3505-C S. Hope St., Los Angeles, Calif.

**GOOD** Farms—Ranches. Washington, Minnesota, Montana, Idaho, Oregon, North Dakota. Dependable crops, favorable climate. Write for literature, lists describing typical farms. Specify which state. J. W. Haw, 120 Northern Pacific Ry., St. Paul, Minn.

**STROUT'S** New Fall Farm Catalog Just Out! Hundreds of bargains from Maine to Florida, west to California & Oregon. Save Time, Gas, Money. Write today for this Book. Free. Strout Realty, 255-ZB 4th Ave., New York 10, N. Y.

**OZARK** Lands for all purposes. Actual River frontages, 5 acres \$75.00 and upwards. Free list and literature. Hubbard, 424P Minnesota Ave., Kansas City 4, Kansas.

**WORLD'S** Safest Investment! 1292 rich level acres, 1150 cultivated; substantial improvements; sure, profitable income. Grinde, New Rockford, North Dakota.

**OZARK** farms, ranches, timber, resorts. List free. Farmfinder, Lonsdale, Arkansas.

## 36 FIELD GLASSES, TELESCOPES, ETC.

**TELESCOPE**. New, powerful 5-mile range. 3 section, pre-war lifetime construction. Has scientifically ground 33mm. lens. Length closes, 4½-in., open 9-in. Only \$1.59 postpaid. Money-back guarantee. Utica Mail Order Co., 923 Eagle St., Utica, N.Y.

**LENSES**, prisms, optical specialties. Not Salvage, Not rejects. Not Junk. Highest optical perfection. Nothing like this ever offered before. Fraction original cost. Send for new optical catalog. 10 cents. Ross, 66 W. B'Way N. Y. C.

**MAKE** your own powerful, efficient astronomical telescope. Perfect lenses and instructions. 50 x \$1.00. 100 x \$2.50. 200 x \$3.50. 400 x \$5.50. Instructions alone 10c. Carl Jamer, Manorville, N. Y.

**ASTRONOMICAL** telescopes, Microscopes, Cameras, Binoculars, Books; Bought, sold, repaired; Lists 10c; Specify instrument wanted. Rasmussen and Reece, 41 Market, Amsterdam, N. Y.

**LENSES**—Prisms—Telescope Mirrors—Telescope objectives; Send for free list; Mayflor Prod., Katonah, N. Y.

**REAL** 17 power telescopes \$3. United, 2309-C Lawrence, Toledo, Ohio.

## 37 FOR THE HOME

**REPLACEMENTS**—Stoves, Furnace Grates, Firepots, Linings ? ? ? ? ? Magiprodux, Royal Oak, Michigan.

## 38 FOR INVENTORS

**INVENTORS**: Learn now—without obligation—how to protect and sell your invention. Write for free "Record of Invention" form and complete instructions for making disclosure and establishing date of your invention. We also send our new free "Patent Guide for the Inventor", containing complete information about patent procedure and how to sell inventions; giving illustrations of many successful inventions; over 150 basic mechanical movements. We assure you prompt, confidential service. Delays may be dangerous. Write today for your free "Patent Guide" and "Record of Invention" form. Clarence A. O'Brien & Harvey Jacobson, Registered Patent Attorneys, 52A-J Adams Building, Washington, D. C.

**WHERE** Can You Sell Your Ideas? Have you a new idea, an improvement, a device of utility or novelty? Want to know where to sell it? Learn the facts first about its patentability. We have letters from manufacturers wanting new patented ideas. The present emergency market has created a big demand. Get our Free Book, "How to Protect, Finance and Sell Your Invention." No obligation. McMorro & Berman, Registered Patent Attorneys, 143-V, Atlantic Building, Washington 4, D. C.

**RANDOLPH & Beavers**, Registered Patent Attorneys, 340-E Columbian Building, Washington, D. C. In order to Protect your invention and reap the reward that should be yours, Patent your invention without Delay, and at the same time have Rights to sell as Manufacturers convert to Civilian Production. Write for Information and Record Form To-day.

**INVENTORS**—We will help you if you have a good idea. We supply the finances to patent your idea in your own name. You own the patent. We also arrange profitable manufacturing connections for inventions. Write without obligation. Patent Financing Corporation, 209G Hospital Trust Bldg., Providence 3, R. I.

**INVENTORS** Take Notice. Have your invention analyzed for its potential money making possibilities. I have helped others, let me help you. Strictly confidential. Technical Service, Donald Christison, Patent Analyst, 106 22 97th St., Ozone Park 16, N. Y. C.

**INVENTORS**: I specialize in Patent Office searching. You are invited to call any evening and talk with me personally. Phone Decatur 5305, Washington, D. C., or write Raymond L. Smith, 302-A Bond Bldg. (Former U. S. Patent Office employee.)

**INVENTION** Developing, Designing, Sales Promoting, Model Constructing, Patent Searches, Authentic Manufacturers Mailing Lists, Free Literature. Invention Development, 17720 Mission Blvd., Granada Hills, California.

**WE** locate buyers meritorious patented, unpatented inventions. If will sell, reply immediately. Descriptive booklet, references, free. Invention Reporter, 3A-11106 S. Fairfield, Chicago.

**INVENTORS**—We make working models or individual parts of your invention or idea. Send sketch or blueprint for quotation. F & H Machine Co., 134 W. Broadway, New York 13, N. Y.

**INVENTORS**: New military and commercial inventions urgently needed by manufacturers. Write for particulars. Chartered Institute, Dept. 3-A, Washington, D. C.

**INVENTORS!** Have you good patentable idea? Write Mr. Metzler, 11 West 42nd, New York.

**\$2,000 YEAR** sideline easy, inventing simple items for guaranteed cash markets. Hendrixon, Argyle, Wisconsin.

**CASH** for practical ideas and inventions. Mr. Ball, BB-9441 Pleasant, Chicago.

## 39 FORMULAS, PLANS, ETC.

**RELIABLE** Formulary. 924 page illustrated book. 10000 scientific formulas, recipes, secrets, instructions for most any product. Countless profitable business opportunities, including D.D.T. new insecticide that eliminates flies, mosquitoes, moths, lice, fleas, roaches, "bbs" etc. \$2.98 postpaid (c.o.d. U.S. only). Foreign \$3.25 delivered. Adams Brown Co., Dept. 459, Chestnut Hill 67, Massachusetts.

**INDUSTRIALLY** used formulas now available! Manufacture your own products using our formulas. Any formula \$3.00. Money-back guarantee. Free consultation with each order. K. D. Harr Formula Laboratories, Dept. A, Box 296, Norwalk, Ohio.

**PREWAR** Tire carcasses everywhere, from these reclaim pure rubber, to make molds, tire-plastic, etc. Details for stamp. Betke, Box 699, Borger, Texas.

**FORMULAS**—All kinds. Latest money-makers; literature Free. KemiKal, Park Ridge, Ill.

**FORMULAS**—Latest, best Analysis. Literature free. E. Belfort, Engineering Building, Chicago 6.

**ANY** Formula or trade process supplied, 50 cents. Jackson, Newfoundland 4, Ky.

## LL FRUITS & FOODS

**WHEAT** Germ Unexcelled quality 2½ lbs. \$1.00 postpaid. Health-Wheat Co., Rochester 8, N. Y.



# POPULAR SCIENCE OPPORTUNITIES

## E FUR FARMING

**GIANT Chinchilla Rabbits.** Valuable Fur. Delicious Meat. Easily Raised. Pleasant Pastime. Tremendous Demand. Small Investment. Large Profit. Willow Farm, R16, Sellersville, Pennsylvania.

**RANCH Mink mutations and naturals,** top quality. Priced right. Carlson Mink Farm, Stromsburg, Nebraska.

## 41 GAMES, ENTERTAINMENT

**FASCINATING Fun with Thirteen Rummy Card game!** Folding Felt Board with 350 chips for \$1.98—money back if not satisfied. D'Autremont, Dayton 2, Ohio.

## AD HANDWRITING ANALYSIS

**ANALYZE Handwriting.** Unlimited opportunities in uncrowded profession. Complete Course including free handwriting analysis \$1.00. Mayer, 681 Market, San Francisco 5, Calif.

## 42 HELP WANTED

**SALESMEN—Executive type.** Sell surplus listings business men only. \$100 day. Wire-write quick. War Surplus Reporter, 20 E. Jackson, Dept. 11, Chicago.

**SELL Rayo Balm for Cold, Headaches, Rheumatics.** Other Products. 5 free samples. Rayo Chemical Corp., 334 Union Ave., Brooklyn 11, N. Y.

**SALESMEN-Saleswomen:** Seven easy sales daily pays \$200.00. Weekly commission. Royalty, Box 1060-G, Newark, N. J.

## 44 HOBBIES, COLLECTIONS

**22 BEAUTIFUL Audubon Bird Prints,** 9" x 12 1/2" full colors on finest paper. Ideal for framing, Home, Office, Club, School, Den, Stores; Also Gifts. \$2.95 Postpaid. No C.O.D.'s. Creste-Andover, 415S Lexington, New York.

**COLLECT Foreign Military Insignias and War Prisoners Emblems;** Prices, Samples 15c. Hobbyguild F-35 West 32nd St., New York.

**RADIO control—the hobby of tomorrow.** Send 25 cents for Instruction Manual to Radio Control Headquarters, Box 214, Deal, New Jersey. No stamps.

**UNUSED Match Book Covers.** 100 all different \$1.00. 35 Royal Flash Covers \$1.00. Free list. Charles Edelman, 1311 P East 84, Cleveland 3, Ohio.

**COLLECT colorful army patches.** Latest picture book and catalogue only 15c. Insignia Mart, 703 Broadway, N. Y.

**JEWELRY stones removed from rings, etc.,** 100 assorted \$2.40; 50 large ones \$2.40. B. Lowe, Holland Building, St. Louis 1, Mo.

**HOBBY catalogue 10c. Reptile List 5c. Chameleon 25c. Quivira Specialties,** Topeka, Kansas.

**EXCHANGE duplicates.** Swappers everywhere. List free. Box 2166-S, Denver 1, Colorado.

## 45 HOME CRAFTSMEN

**PLEXIGLAS and Lucite—The amazing crystal-clear plastics.** Saw, drill, bend or twist them into hundreds articles that are beautifully different! Special one-pound assortment including cement, project drawings, complete instructions—only \$1.25. Six pounds \$5.00; 25 pounds \$18.75. Masked sheets 12" x 12" (144 square inches!) 1/8" \$2.50; 3/16" \$2.75; 1/4" \$3.00. Fast-acting cement \$1.00. Red, blue, yellow dyes \$1.00 each. Polishing Compound, 65c. Send no money! Pay postman cost and charges on delivery. Satisfaction guaranteed. Carmon-Bronson, 165A E. Third St., Mount Vernon, N. Y.

**28 LAWN Ornament patterns 25c.** Other patterns: 15"-20" high; Dutch girl, Dutch boy, pirate, bull terrier, Mexican girl, Mexican boy, dwarf, penguin, flower girl, 10c each; 3 for 25c. 25 novelty patterns 30c. All 62 full size patterns \$1.00 postpaid. Strother, Box 383-HN, Bellington, W. Va.

**CATALOG: Patterns plywood Novelty Furniture - Letters - Numerals - Plaques - Frames - Weathervanes - Silhouettes - Lawn Ornaments.** 100 Books & Booklet's on Crafts & Hobbies, Picture Frame Mouldings, Tools, Large line Decal Transfers. Other lines. Hundreds articles finely illustrated. Write Wo-Met Shop, Ashburn, Georgia.

**PLASTICS—Plexiglas, Lucite, Bakelite, Lumarith, Ethocel in sheets, rods, tubes and strips.** Fine assortment of standard sizes. Cements, dyes and other plastics supplies, too! Complete lists 10c. Carmon-Bronson, 165A E. Third St., Mount Vernon, N. Y.

**PLYWOOD—Beautiful nonpriority aircraft, cabinet and paneling stock.** Thicknesses 1/16" through 1" large, small panels. Fir, Gum, Birch, Mahogany, Walnut. Reasonable! Complete lists 10c. Carmon-Bronson, 165A E. Third St., Mount Vernon, N. Y.

**TOYS Easily made from Scrap Wood,** 15 patterns 25c. Novelties made from Scrap Wood, 25 patterns 25c. 15 lawn ornament patterns 25c. Plastics, metals, and other craft supplies also available; Send for List. Lynds, Medway, Mass.

**"LUCITE," "Plexiglass" Pieces,** book of instructions and projects, 3 colors dye, cement, \$2.00 postpaid. O.K. for overseas. Barnett Specialty, 8619 W. Third, Los Angeles 36, Calif.

**TOY patterns.** Circus wagons, trucks, carts, pull toys, etc. 35 patterns \$1.00. Continental Products, 907 Birch, Eau Claire, Wisconsin.

**ARTIFICIAL Leather Fabric Remnants** suitable for home craftsmen, etc. Poundage lots. Price list on request. Lyco Supply Co., Box 214 E. Weymouth, Mass.

**WHITTLES—20 patterns, instructions,** X-Acto knife, wood. \$1.00. "Old Whittler", 1402 Charles, La Crosse, Wis.

**MAKE Shell Jewelry.** Material furnished. Tell-U-How with orders. List free. Dixie Shell Service, Sebring, Fla.

**80 PATTERNS, 40 Lawn Ornaments, 20 Novelty, 20 Silhouette,** \$1.00. Modern Woodcraft, Saginaw, Michigan.

**PICTURES For Framing.** Three Samples 10c. Curtis Specialties, Box 1916 S., Denver, Colorado.

**PLASTICS All Types Remarkably Low Priced.** Free Listings. Craft-Plastics, Box 129S Somerville, N. J.

**PLANS—30 Toys, 10 Puzzles, 10 Lawn Ornaments,** in wood. \$1.00. Winfield Hess, Dept. 10, Dover No. 1, Pa.

**MYRTLEWOOD Turning Blocks—Prices on request.** Box 7146, Multnomah, Oregon.

**ASSEMBLE plastic kits.** See Glassite's ad under Money making Opportunities.

## MM INFORMATION

**OUR 64 page directory Will Save you Money.** Lists name and address of hundreds of firms alphabetically, and other valuable information. Recommended by thousands. Satisfaction or refund. Postpaid \$1.00 U. S. only. Prompt Service. Stark Book Co., Miller, Arkansas.

**DRUNKENNESS Is a disease which responds to treatment.** Medical skill plus human sympathy prove successful with liquor and drug cases. 60 years experience. Write for free booklet. P. S. Nelson, The Keeley Institute, Dwight, Ill.

**100 BILLION Dollars of Government Surplus Goods to be disposed of.** For important information and addresses of government disposal offices, send one dollar to Consumers' Procurement Service, Post Office Box 720, Springfield, Mass.

## 47 INVENTIONS WANTED

**INVENTORS: Have you a sound, practical invention for sale, patented or unpatented?** If so, write Chartered Institute of American Inventors, Dept. 3-C, Washington, D. C.

**MANUFACTURER desires postwar products to make and sell through drug, hardware, department stores and mail order.** Or will handle sales only. Reputable, nationally-known organization capable of promoting nationwide sales as well as manufacture of items. Prefer non-electrical products of metal, glass, plastics, etc. Write, Box AM6, care Popular Science Monthly.

**INVENTORS, Attention! Large manufacturing concern employing 1400;** now entirely engaged in war work, is interested in patented and patentable electrical and mechanical devices of metal or plastic; invites correspondence with inventors having something novel and original. Lion Mfg. Corp., 135 S. LaSalle, Dept. B C, Chicago 3, Ill.

**WANTED—Patented, unpatented inventions having profit possibilities, all kinds.** If will sell, reply immediately. Descriptive booklet, references, free. Invention Reporter, 3B-11106 S. Fairfield, Chicago.

**SEND your ideas on new inventions.** 15% commission if the sale passes through our hands. Patented or unpatented. Albert G. Burns, "The Nation's Gadget Chief", Alameda, Calif.

**INVENTIONS Wanted: Patented—Unpatented—Confidential Negotiations—Patent Assistance—Substantial Royalties.** Herbert Mfg. Co., 3355 N. Olcott Ave., Chicago 34, Ill.

**NEW Items Wanted for nationally distributed Young Town Toys.** If you are a model write at once. Your rights fully protected. Box F, Youngstown Equipment Co., 111 Berkeley St., Boston, Mass.

**CASH for Inventions—Patented, unpatented.** Mr. Ball, BC-9441 Pleasant, Chicago.

**INVENTIONS Promoted, Patented or Unpatented.** Write Adam Fisher Company, 183-A Enright, St. Louis, Mo.

**WANTED—Practical inventions.** Inventors Exchange, 336-D3 Palace Bldg., Hartford 3, Conn.

**CASH for plumbing specialty inventions.** Chicago Specialty Mfg. Co., 2954 Lawrence Ave., Chicago 25, Ill.

**WANTED—Inventions including military patented since 1930.** H. H. Boger, Waynesville, Ohio.

## EE JEWELRY

**GENUINE diamonds, out-of-pawn low prices, wonderful values.** Unredeemed loans and big buying power enable us to offer beautiful gems at prices far less than original cost. Shipped Free for Inspection. Appraisal. Send for Big Free list showing fine diamonds at startling low prices. Lloyd J. Butler, Pres., Prudential Loan Association, 133-TK N. Clark St., Chicago 2.

**CERAMIC Jewelry Supplies, Bar Pins, ear screws, for ceramic and woodworkers, also, glass and sea shell assemblers.** Free catalog. Philadelphia Badge Co., 1007 Filbert St., Philadelphia, Pa.

## AA LEGAL DIRECTORY

**PUZZLED? Digest of Divorce laws every state in country \$1.00.** Liberty Co., Brookline 46, Mass.

**MEXICAN Law Practice, A. B. Flota, Box 236, El Paso, Texas.**

## 50 MACHINERY, TOOLS & SUPPLIES

**THIRD hand for \$3.00 with foot or knee operated Smith-Switch.** Frees hands for working. More production, less effort. Saves electricity! Ideal for start-and-stop operations: Drill Presses, Grinders, Bench-Pipe Machines, Photo work, X-Ray, etc. Tested to 40,000 operations daily over year, still going! Only 4 1/2 x 2 3/8 inches. Screw driver connection. Rubber case, moisture and dust proof. Tungsten contacts, 1/4 inch. Capacity 10 amps at 125 or 5 at 220 AC. \$3.00 postpaid. Diamond "R" Agencies, Box 311S Pasadena 17, Calif.



# POPULAR SCIENCE OPPORTUNITIES

**GEARS**—for Inventors, Experimenters, Model Makers, Schools, Work Shops, Laboratories, etc. Government surplus made of Brass, Bronze, Dural Steel and Stainless Steel. 12 Matched Pairs—24. Gears—Bevel, Internal, Spur & Ratchet. List Price \$12.00, Our Price \$2.50. 25 Matched Pairs—50 Gears, includes larger gears, also sets of Worm Gears. List Price \$30.00, Our Price \$5.00. 50 Matched Pairs—100 Gears, better assortment, also Crown, Helical and Worm Sets. List Price \$75.00, Our Price \$10.00. Limited Quantity, Order Now. Note, these gears are sold in sets only as listed above. Met Exchange, Dept. SM, 323 Canal St., New York.

**USEFUL.** Practical metal or woodworking tools—Mills, Shapers, Drill Presses, Vises and many others — quickly built using Lewis plain or semi-finished castings, supplied with materials and blueprints. Cost a fraction of comparable finished tools. Blueprints only available at nominal cost. Send 10c to cover cost of mailing Catalog, describing 23 items. Lewis Machine Tool Co., Box 116, Station A, Dept. S-56, Los Angeles 31, California.

**UNIVERSAL 8Pc Tool Set \$14.85—10 Pc . . . \$19.85. Wrench set 6 pc Boxend \$7.85—Openend . . . \$9.85. Combination Box & Open 8 Wrench set . . . \$14.95 . . . Midget 1/4" or 3/8" Socket Set in Case . . . \$19.85. Standard 1/2" 15 Pc Socket Set & Case . . . \$29.85. Tractor 3/4" 14 Pc Socket Set & Case . . . \$9.85. Immediate Shipment—Clip ad Mail Check Now. Universal Tool Co., 1527 Grand, PSM, Kansas City, Mo.**

**INDEX—Heads for sale.** Very inexpensive. Sixty-two different divisions. Used on small lathes, drill press, milling machines etc. Make gears, hobbs, cutters, etc. Very accurate, and durable. Not a toy. Used by defense schools and hobbyists. Write for free folder. Long's Index Heads, 2117 East B St., Torrington, Wyo.

I sell Tail Pipes and Smithy mufflers. It is nice to have a Duel on your car. I put 60 Duels on last month. Busy all the time in our shop. A complete duel job costs \$50.00 if done here but you can order all the parts and do it yourself. Write, The Alltone Muffler Shop, 2nd & Ash St., San Diego, Calif.

**EXPERIMENTERS—Repairmen — Craftsmen.** 400 valuable new springs 75 kinds, numerous sizes, 10,000 uses, \$2.00. Utility assortment, \$1.00. Deluxe assortment, \$3.00. Jumbo, \$5.00. Guaranteed. Technico, Box 246, West Hartford, Conn.

**FLAWLESS** hand tools for master instrument makers, gunsmiths, geophysical and electronic apparatus builders and servicemen. Send for catalog. Electrical Specialist Service, Box 2263, San Antonio, Texas.

**DRILL GRINDER—Grinds drills to factory accuracy.** Calipers with direct reading scales. Circle cutters. New Tool grinder. Lowest prices. Free literature. Factory. 811-A East 31st, Kansas City 3, Mo.

**BALL Bearings—all standard makes.** Can supply from large stock promptly. Save 50 to 60%. Fully guaranteed. Write for Bulletin. Met Exchange, Dept. SM, 323 Canal St., New York.

**BUILD Quickchange Gear Box for your 12" Craftsman lathe.** Complete drawings, instructions \$3.00. Stevens Engineering, 2604 Military, Los Angeles 34, Calif.

**HARDWOOD, Plywood. War Surplus!** Low Prices for Manufacturers, Toyshops, etc. Cleary Co., 56 Schubert, Binghamton, N. Y.

**HARDWARE, Machinist Tools, taps, drills, saw mandrels, steel.** Catalog 10c refunded. Terek Hdwe., 6304 Patterson, Chicago 34.

**FOR Sale Used Foley Automatic Electric Saw Filer.** Also Retooler. C. J. Lee, 215 S. Palm, Pecos, Texas.

**SEND \$1.00 Receive 5 pr. New Gears Assorted.** Max Estreich, 150-06 Liberty Ave, Jamaica 4, N. Y.

**CONCRETE Mixer Efficient Hand Power** From Oil Drum, Gearless, Plans \$2.00. A. Mitkos, 8802 Corwin, St. Louis 21, Mo.

"BRUNO Adjustable Hole Cutters". See our Ad Page 255.

## 51 MAGIC TRICKS, PUZZLES, JOKER NOVELTIES

**500 TRICKS you can do!** Douglas' famous Catalog of 500 Tricks, now only 10 cents. America's fastest service on magic for pocket, parlor, stage, professional, amateur. Douglas' Magicland, Dallas, Texas.

**ABSOLUTELY No Trick!** If You Can Memorize my "Magic" Calendar (Size 3 1/2 x 4 1/2 inches), you can (Blindfolded) tell the day of week for any date within 300 years (1800-2099). \$1. each, 3 for \$2. Roy Ginn, Rusk, Texas.

**AMAZE! Mystify! Hypnotize! Become Magician or Hypnotist!** Earn Big Money! Fascinate Friends! Half Pound Circulars Listing Hundreds Revealing Books, Startling Secrets, 25c. Nelmar, 2851 Milwaukee, Chicago, Ill.

**TRICKY Match Box, it turns around!** It stands up! And it opens, most weird, uncanny magic novelty trick. Complete ready to do 25c. The Magician, 2463-K, Kensington Ave., Philadelphia, Penna.

**AMAZE friends: Your name in light on famous Broadway theater—features as magician: Professional photography \$1.00.** Rickarby, 403-S W 115th, New York 25.

**MAGICIANS', Gamblers' secrets exposed.** Cards, Dice, Punchboards, Slot Machine. Catalog 10c. Book Co., Box 671, St. Louis 1, Mo.

**ATTRACTIVE Magic Kit of 10 tricks (\$2.50 value) \$1.00 postpaid.** Kogel's Magic Novelty Co., 6751-B Colbert St., New Orleans 19, La.

**84 CARD Tricks and our latest catalog of Magic Tricks only 25c.** Ball Square Company, Dept. 11-G, 697 Broadway, Somerville 44, Mass.

**FREE! Large catalog of magical apparatus** if you remit 25c for book "102 Easy Tricks." Robbins Co., 152-S W. 42nd St., New York.

**BE a Magician.** Large professional magic catalog of latest tricks. 25c. Ireland, F-109 North Dearborn, Chicago.

**MAGIC Package 25c, 55 easy tricks \$1.00.** Lindhorst Magic Den, 612-P.C. Pine, St. Louis, Mo.

**VANISHING Quarter and Catalog 25c.** Sterling Magic, 347 John R., Detroit, Michigan.

**BIG new magic magazine, 10c.** Lucky charm, prize contest, catalog included. Don Phoebus, Box C35, Irvington 11, N. J.

**AMAZE and mystify your friends with highest quality magic.** New catalogue 25c coin. Mazda Magic Co., Fond du Lac, Wis.

**TRICKS, Secrets, cards, punchboards, etc. explained.** Big illustrated circular free. Mack, Box 1278-P, San Francisco.

**10 MAGIC tricks and Catalog, 25c.** Magical Enterprises, Levering, Michigan.

## 52 MANUFACTURING

**MANUFACTURE Paints.** Your garage a factory. No equipment capital needed. Industrial Chemist, 1826 60th, Kenosha, Wisc.

**MODELS, small lot manufacturing, metals, plastics, etc.** Milburn, Burlington, Kentucky.

## PP MILITARY INSIGNIA

**SILK Embroidered Emblems.** Sample and price lists 10c. New Insignia Guide 10c. Insignia made to order. Hobbyguild, X35 West 32nd St., New York.

**FOREIGN decoration ribbons, insignia, lists, sample 20c.** Insigniacraft, 236-28 Ave., N. W., Calgary, Canada.

**FOREIGN Insignia Packet, and booklet, \$1.00.** Insigniacraft, 236 28th Ave., N.W., Calgary, Canada.

## O MILK GOATS

**FREE: Postcard request brings you book** about dairy goats and sample monthly magazine. (Subscription \$1 yearly). Dairy Goat Journal, Dept. 568, Columbia, Mo.

## CC MINERALS & PRECIOUS STONES

**347 ANTIQUE Firearms; 4,000 Bargains.** Coins, Indian Relics, Minerals, Cartridges, Rifles, Flintlocks, Fossils, Swords, Catalog with Photographs 25c. Heike, Wenaona, Ill.

**CUT your own gem stones with a B & I Gem Maker,** all necessary equipment, less motor and belt, \$29.50 f.o.b. factory. Write for literature, B & I Mfg. Co., Burlington, Wis., Dept. M.

"GARNETS" from Arizona Desert. Packet for Quarter. Mineral Specimens, Box 2651, Phoenix, Arizona.

**FOUR pieces colorful Agate \$1.** Rockhound, Box 555, Grand Junction, Colo.

## 53 MISCELLANEOUS

**BE The Laff Of The Party, Jokes! "Fun-Master" Gag Files—Compiled by Billy Glason.** A professional reference of Comedy Material for all branches of the theatricals. You too can now be a professional master of ceremonies, Comedian, Radio star—after dinner speaker, etc. Nos. 1 thru 10 now ready! 10 different files \$1.05 each. "How to be an Emcee" \$3.00—Paula Smith, 200 W. 54 St., Dept. A, New York 19, N. Y.

**ARMY GOODS (USED)**  
RAINCOATS \$1, Parka Suits \$3, Jeep Hats and Caps 10c. Oversea caps 10c. Dungarees 95c. Tool boxes \$1, Gas mask bags 50c. Steel Helmets \$1, Gun slings 75c, Holsters 75c. Canteens 50c. Cups 15c. Mess kits 35c. Leggings 25c. Cartridge belts 50c. Minimum shipment \$1. No C.O.D. N. Y. Salvage, 144 Chambers St., N.Y.C.

**TAILORED Homes plan-book.** Sixty floor plans one-story houses with choice of new, smart exteriors styled Colonial, English, Spanish. Moderne making hundreds of combinations. Price \$1.00! Select homes showing two-story houses in colors, \$1.50. Prepare for rationing-plan now! H. P. Jones, Architect, 486-P.S. Brandeis Bldg., Omaha 2, Nebr.

**HYPNOTIZE People Easily!** Twenty-five simple lessons fully illustrated and clearly written show the most modern methods known. Get yours today! Only 50 cents. The Archer Co., Dept. 9D, 93 Federal St., Boston 10, Mass.

**IF you have a hobby with commercial possibilities or operate a small business which developed from a hobby—I am interested in your story.** Cash awards will be paid for acceptable material. Write for particulars. Leon Cutler, Publisher, 20 E. 35th St., New York 16, N. Y.

**GOOD "Used" self-instruction educational books on all subjects bought, sold, rented, exchanged.** Satisfaction guaranteed. Complete information and 92-page illustrated bargain catalog Free. Write—Nelson Company, Dept. 2-01-2, Chicago 4.

**DRUNKENNESS** Is a disease which responds to treatment. Medical skill plus human sympathy prove successful with liquor and drug cases. 60 years experience. Write for free booklet. P. S. Nelson, The Keeley Institute, Dwight, Ill.

**BOY Scouts—Campers, U. S. Army Surplus Used Equipment, Pup Tents \$2.95, Canteens, with cover and cup \$1. Mess Kits 75c. Packs \$1. Complete set \$5, includes cartridge belt. Samet Sales Co., High Point, N. C.**

**MEDICAL Laboratory Technicians in great demand.** We train you in your spare time, in your own home. You can practice while studying. Write for free catalogue. Imperial Technical Institute, Box 973-S, Austin 5, Texas.



# POPULAR SCIENCE OPPORTUNITIES

**IMMENSE Profits Distributing Handmade Cigars, Wholesale, Retail, Under Your Own Brand. Tremendous Demand. Steady Business. Instructions Explaining How, \$2. Descriptive Literature Free. Vallesm, 395 Broadway, N. Y. 13.**

**TRADE Magazines—Business, Vocational, Diversion. Current single copies. Over 200 fields. Free price-list. Commercial Engraving Publishing Co., 34S N. Ritter, Indianapolis 1, Indiana.**

**INSOMNIA? Relief or money back. No drugs, exercise, massage or troublesome methods. Simple, natural prone position. Full instructions \$1.00. Marly, 1900 Palm, San Matio, Calif.**

**AIR Circulating Fireplace provides superior fuel utilization. Use scrap plate and weld your own or have it done locally. Complete plans, description, and photographs, \$2.00; Grapnel, Rt. 4, Putnam, Conn.**

**CLOSING Out at wholesale prices all new Duplicating (Mimeographing) Machines, Stencils, Inks. List Free. Maiden Specialty Co., Maiden 1, N. Carolina.**

**NEW toys in wood or steel wanted. Let us be your distributor or manufacturer. Send samples to City Machine Co., 868 E. Tallmadge Ave., Akron, Ohio.**

**SOMETHING to think about! The Why of Humanity? Historical, legendary, occult talk. First, Talk 10c. James Alfred Ross, Dept. E, Box 1669, New Orleans.**

**RECEIVE Mails, Moneymaking Opportunities, samples, literature. Your name in several mailing lists, 10c. Rodgowski, 3415 Broadway, New York 31.**

**JUST Your Ideas for simple household and workshop inventions can bring quick money from guaranteed cash markets. Write, Hendrickson, Argyle 8, Wisconsin.**

**PYRAMID Plan sells "anything" by mail or agents like wildfire! Working instructions \$1.00. MacCormack 9-B, Madeira, Ohio.**

**TROUSERS permanently creased. Patented process. Send trousers and \$1.00 to Evrstay Crease, 600 Joseph Ave., Rochester, N. Y. Returned promptly prepaid.**

**SPECIAL! Sun-Glasses-With-Certified-Inflexed lens. Bargain—Buy \$2.00 per Pair. Two pairs \$3.50. Summers-Summer-Glasses, Box 243 Center, Texas.**

**WELDING Instructions and sample free. Repairs broken electrical appliance heating elements. Enclose stamp. Raymond Dow, 17 Park Row (1216A1), New York 7.**

**BOOKFINDERS! Out-of-print, curious books quickly found. Send wants. Clifton, Box 1377psm, Beverly Hills, Calif.**

**MONTHLY swapper's guide sent for your list and quarter, Swap Shop, 433 Mathewson, Wichita 7, Kansas.**

**INFORMATION—Locating Articles, Products (Wholesale) etc. Rakes, Box O-5931, Chicago 80.**

**MEXICAN Miniature Pottery. Dealers list. Mexican Products Co., 126 N. Main, Tulsa 3, Okla.**

**BASHFUL? Nervous? "Fears?" Free, encouraging information. John Englund, Ironwood, Mich.**

**RECEIVE mails, literature, opportunities. Your name in numerous mailing lists 10c. Greenwood, 277 Broadway, New York.**

**CUTTERS, Dental Burs assorted, reclaimed job-lot, \$1.90 per gross. D'Wolf 1924 E. Hartlane, Philadelphia, Pa.**

**AMAZE with Supermemory! Facts, figures, names stick like burrs! Write B9, Thor Books, Box 1210, Chicago.**

**Get big list. Surplus electronic parts, instruments. Fraction original cost. Quest, 395, Great Neck 2, N. Y.**

**ALASKAN Gifts and Souvenirs. Priced accordingly. Letter forwarded 50c. Box 674, Fairbanks, Alaska.**

**UNUSUAL Novelties, samples 10c. Modern, Box 2, Station B, New York 2.**

**SHOE Shine Outfit 25c postpaid. Essential Products Co., Williamsburg 3, Mo.**

**SQUARE Dance instructions, calls, 25 sets, \$1.00. Ozarkians, Lonsdale, Arkansas.**

## 54 MODELS & MODEL SUPPLIES

**CATALOGS (Illustrated) for Modellers! Airplanes, 60 page book on Solids, Features construction data, specifications, camouflaging, 15c; Railroads: 128 page 'HO' guide. Equipment, accessories, fittings, 25c (includes refund coupon) Send coin or stamps for each profusely illustrated catalog desired. Polk's "Nation's Leading Hobby House", 314-P Fifth Ave., N.Y.C. (1).**

**SHIP model kits and fittings. Complete line Fisher model yacht equipment. All Boucher, Fisher, Marine Model and Ideal Kits, fittings and blueprints at standard prices. Most complete stock in New England. Send 10c for price lists. James Bliss & Co., Inc., 220 State St., Boston, Mass.**

**SHIP and Yacht Model fittings and blueprints. Hundreds of items to choose from. Send for our War Time Supplement. A. J. Fisher, 1002 Etowah Ave., Dept. W-S, Royal Oak, Mich.**

**MOST complete Illustrated Catalog—"O-HO OO" Model Railroad Parts ever published. Send 5c for mailing. Selly, 1377 Gates Ave., Dept. 821, Brooklyn, N. Y.**

**WORLD'S largest selection model engine castings and drawings. Illustrated catalogue 10c. Wayne Miller, Belle Plaine, Iowa.**

**RAILWAY Models complete line, informative catalog HO and O Gauge 79 pages 25c. Walthers, 269 Erie, Milwaukee, Wisconsin.**

**RADIO control for your model. Send 25 cents for Instruction Manual to Radio Control Headquarters, Box 214, Deal, New Jersey. No stamps.**

**SHIP Model and yacht supplies, complete large 64 page catalogue, 25c. Wm. Wild, 510 E. 11th St., New York City.**

**BOAT Models. P. T., Cabin Cruiser, Speedboat. Free Circular. All Star, 2003 Lincoln Ave., Chicago 14.**

**BRASS Gears and Model Supplies, send 10c for catalog. Pierce Model Works, Tinley Park, Ill.**

## 55 MONEY-MAKING OPPORTUNITIES

**MECHANICALLY Inclined Men—Own and operate general Appliance Repair shop. Complete, illustrated course shows you how. Welding, Refrigeration, Motor repair. How to get business, etc., all phases covered. Free literature. Christy Supply, Dept. 1455, 2835 N. Central Ave., Chicago.**

**BE A Novelty Manufacturer, make large profits. No expensive equipment needed, easily learned, use garage or basement, materials available, orders waiting. Plastex Products, 127 Clement, San Francisco 18, Calif.**

**ELECTRIC Clocks are every where you go, buildings, homes, parking-lots, factories. Repairs increasing. Our easy to learn course with pictures and drawings teach you how to repair these clocks. Electronic Supply Co., Box 2350-B, Houston 1, Texas.**

**GET into good paying Post-war Business now! Many opportunities open, new products—new methods. Investigate this opportunity at once! For detailed information write, William A. Shaw, Dowell 2, Maryland.**

**A NEW Mail-Order business! Nothing like it! Make \$3000-\$5000 the first year! Complete instructions only \$1.00. Opportunity Unlimited, Box 5095-B Cleveland, Ohio.**

**LEARN Metascience. Remarkable drugless healing. No manipulation. No apparatus. Unbelievable simplicity and results. Inexpensive correspondence course. Write Metascience, De Land, Florida.**

**PRIZE Contest Fans Can Win A Fortune! Free announcement service! Good news for untalented contestants! Write today! National Contest Bulletin, Box 634-M, Grand Central Station, New York City.**

**A \$100-A-MONTH hobby at home! No soliciting, no mail order, no meeting people. Easy, enjoyable pastime. Details, 25c (Refundable.) Laura Dickson, 808-PS Elizabeth St., Anderson, S. C.**

**DON'T send money. Make money. Free catalog of Glassite plastic merchandise kits and information. Judge for yourself. Glassite, 621 N. Atlantic, Monterey Park, Calif.**

**PLASTIC Engineering pays big. Home study course. Low cost. Easy terms. Free booklet. Ohio Institute of Technology, Box P-259, Greenville, Ohio.**

**GIANT big mail! Hundreds of money making propositions, home work offers, including big magazine, all for a dime. Gardenville Publishers, Gardenville 12, N. Y.**

**EARN money at home! Thousands do! "Home Worker Magazine" tells how. Sample, 25c. Sizemore, Box 6, 4917 North Kostner, Chicago.**

**WHOLESALE catalog, and directory 10c. (Refundable) over 1,500,000 articles. Stafford, Sunnyside-X, Indianapolis 44, Ind.**

**PROSPERITY—Want Financial Security? We can help You. Free details. Gailpeter Enterprises, Dept. 166-PS, Neillsville, Wisconsin.**

**CASH IN 68 page book, over 40,000 words, 25c in cash, Moneymaking business secrets, mailorder plans galore. A. G. Fisher, 572 Wilson St., Buffalo, N. Y.**

**SELL office supplies by mail. Samples, moneymaking information for 25c, refundable. Edgar W. Thomas, Barnesville 11, Ohio.**

**DETECTIVES Earn Big Money. Experience unnecessary. Particulars free. Wagoner, P-125 West 86th. N. Y., N. Y.**

**CASH Mail Order Business, Big Profits, Successful Income Builders, Hollywood 28, California.**

**\$10,000,000 FREE—Prize Contests. Win. Fortune. Bulletin, Free. Cash Register, 210 Fifth Ave., New York.**

**749 MONEYMAKING Opportunities, 25c! Free bargain lists! Hirsch, Spring Valley 3, N. Y.**

**VITAMINS at cost. Make your own. Supply others. Complete directions \$1.00. Practical Sciences, Mainesburg 1, Pennsylvania.**

**PROFITS from Plastics complete formula 25c postpaid. Gerald McNeely, 3044 Jackson Blvd., Chicago 12, Ill.**

**PUT up powder and liquid—fast repeating products under your name. Large profits. Kohn, 506 W. 45th, Chicago 9.**

**"QUARTERS Galore" by mail. Sample merchandise, ad copy, and plan 25c. Book Emporium, 327 W. Genesee, Buffalo 2, N. Y.**

**BIG Money in curtain laundry. For \$1.00 I will teach you the tricks of the trade. Mrs. Dotson, 1667 H St., Napa, Calif.**

**WANT financial Independence? I've helped thousands. Dr. Tibolt, 53A, Phila. 20, Pa.**

**1c SLOT Machines \$25.00 Force Feed Water Pumps \$5.00. Flecks, Warren, Ohio.**

**HALF pound big mail, 10c. Thomason, 857 E. Jessamine, Fort Worth 3, Texas.**

**FREE 7 day trial. Amazing Moneymaker. Box 28M, Jackson Heights, N. Y.**

## X MONUMENTS

**WRITE For Direct Prices \$14.00 Up. Freight Paid, Guaranteed, Free Catalog. Granite-Marble Factory, A49, Oneco, Fla.**

## 56 MOTION PICTURES & SOUND EQUIPMENT

**GUARANTEED fresh movie film! Three spools double 8mm, \$3.45! Six spools single 8mm for Univex cameras, \$3.50! (Limit six spools each type.) Processing free! Will ship C.O.D. on \$1.00 deposit. State make of camera. Eso-S, 4038 Broadway, Kansas City 2, Missouri**



# POPULAR SCIENCE OPPORTUNITIES

**KODACHROME** movies! Projection length sample from "Waikiki Hula", \$1.00. 8mm.-16mm. Try projecting black-white films in color with Iriscope Kit, \$5.00. Big subject catalog, 25c. World in Color, Box 392, Elmira, N. Y.

**FEATURE** sound programs—shipped anywhere \$4.95 complete. Free Catalog. National Cinema Service, 71 Dey St., New York.

**8-16mm SILENT**-sound films. Complete rental library. All latest subjects. Free catalogue. (sample film 10c). Garden Film, 317 W. 50th, New York 19.

"THE World's Greatest Passion Play". 8mm, 16mm, and 35mm. Specify Silent or Sound. Rent or Purchase, Hemenway Film Co., 33-Z Melrose St., Boston 16, Mass.

**MOVIE** Camera Films. 100' 16mm \$2.50, 25' Double 8mm \$1.25. Free Developing. Better Films, 742 New Lots, Brooklyn 7, N. Y.

**RENT—Buy—Exchange** 8/16mm; silent, sound. New money-saving plans. Free details. Midland Film Exchange, Box 429, Oak Park 3, Ill.

WE can supply Movie film in both 16mm and Double 88, write us for kinds and prices. Fromader Genera Co., Davenport, 5, Iowa.

**MOVIE** projectors bought and sold. List 10c. United, 2309-D Lawrence, Toledo, Ohio.

**BUY** Sell Trade 35mm, 16mm Films, Projectors, Equipment. Plaza Films, Bank Bldg., Secaucus, New Jersey.

**8mm DESIRABLE** Scarce others list 25c. Howard Burkhardt, 117 Roosevelt, Phila. 20, Penna.

**LEARN** movie projection, management. Free catalog. Theatre School, Elmira, N. Y.

**NEW** or Used 8-16mm Silent-Sound films. Sale, Rental, Exchange. Free lists. Circle Film Library, 12014 Prest, Detroit 27, Mich.

**8mm-16mm FILMS** for sale. Lists 3c. Rental Services-PS, Oakville, Connecticut.

**BEAUTIFUL** Kodachrome Slide and list, 25c. Art Slide Co., S-1, Canton, Ohio.

**FRESH** Movie Camera Films. Ambassador, 479-A Quincy St., Brooklyn, N. Y.

**SEND** stamp for 16mm, 8mm catalogue. Sterling's, 679 Northampton, Easton, Pa.

**FREE**, Year Subscription offer, Amateur Movie News, 3021 Narragansett, Chicago.

## 57 MOTORCYCLES, BICYCLES & SUPPLIES

**CLYMER'S** Motorcycling Manual. Illustrated, complete information, specifications, descriptions, dozens motorcycles. Engines, transmissions, carburetors, cams, spring frames, hydraulic forks, sidescars, expert riding instructions. Contains two-cycle and power bicycle information. Postpaid \$2.00. English Motorcycle Service Manual. Most popular English makes, technically described, illustrations, mechanical features. Postpaid \$1.50. America's most complete catalog Motor Books 10c. Clymer, 2125 W. Pico, Los Angeles 6, Calif.

**HUNDREDS** Of Bargains in Motorscooters, Midget Cars, Motorbikes, Motorcycles, etc. Briggs-Stratton, Lauson, Maytag Motors, some as low as \$5. New industrial tires and wheels at factory prices. 10x2.75 tire \$2.59, others as low as \$1.75. Mail order only. Send 25c for new War-Bargain catalogue Number Nine, just out. (35c by first class mail.) We have purchased the entire stock of Shipps Midgets. Midget Motors Directory, Athens, Ohio.

**MOTORCYCLISTS!** The most modern sport windshield on the market today. All transparent plastic with highly polished rust proof frame. You will be proud to own one. Fits all makes and models. Priced at \$12.50. See your dealer or send your remittance to us. Shipped Prepaid anywhere in U. S. Quick service. Your money refunded if not satisfied. Comiskey Engineering Co., 5203 Irving Park Road, Chicago 41, Ill.

**TIRES**, Tubes, Wheels, for industrial trucks, carts, wheelbarrows, scooters, midget cars, coaster wagons. Nationally known makes, first-line quality. Sizes 8" to 18" o.d. in 2, 4, and 6 ply tires, separate inner tubes, heavy duty demountable wheels. Also Caster Forks, straight and swivel types. Free illustrated circular and prices. Jahant Co., 626 E. Exchange St., Akron 6, Ohio.

**CLYMER'S** Motor Scrapbook. Hundreds early motorcycles, automobiles illustrated, described. Amusing, fascinating story of Floyd Clymer's experiences in motor business. Time Magazine called it a "must." No. 1 and No. 2 entirely different, each \$1.50. DeLuxe cloth bound edition, each \$2.50. Clymer, 2125 W. Pico, Los Angeles 6, Calif.

"MODERN Motorcycle Mechanics," manual, enlarged, revised second edition. 550 pages, 300 illustrations. The most up-to-date and complete motorcycle book published. Covers operation and servicing Harley-Davidson, Indian and British makes. Available immediately. Price \$3.00. Nicholson Brothers, Motorcycle Engineers, Saskatoon, Canada.

**WHEELS**, Tires, and Tubes for Motor Scooters, Midget Cars, Wheelbarrows, and other Industrial equipment. All sizes. Also Bicycle Parts and accessories. Largest stock in United States. Send dime for list. Cycle Transport Company, 1241 S. Michigan Ave., Dept. C, Chicago 5, Illinois.

**PROFESSIONAL** Midget Racer, Motorscooter, Midget Car and Midget Motorcycle. Plans, specifications for all four contained in illustrated handbook, 25c. Big list used motors, motorscooters, Servicycles, etc., included free! Midwest, 3839 Drummond, Toledo, Ohio.

**BOOK** "Speed—How to Obtain It." Illustrated, instructions, cams, balance, timing, valves, pistons, racing technique. World's greatest speed tuning book. \$1.50 postpaid. Clymer, 2125 W. Pico, Los Angeles 6, Calif.

**BUILD** America's lowest priced motorscooter speedster! Complete plans, specifications, Big list used motors, etc., included free! Motor Supply, Box 1682-CS, Toledo, Ohio.

**MOTOR** Books. Most complete automobile, motorcycle selection in America. Historical, technical, racing. Send dime for book catalog. Clymer, 2125 W. Pico, Los Angeles 6, Calif.

**PLANS?** Scale drawings, specifications, illustrations for building attractive Motor Scooter complete \$2.00; plans electrically driven bicycle \$1.50 postpaid. Clymer, 2125 W. Pico, Los Angeles 6, Calif.

**MOTORBIKE** Manual containing Motorbike, scooter plans, Catalog section and Motor tune-up Chart. \$1.00. Variety Enterprise Co., Box 124, Evansville, Ind.

**PARTS** accessories pistons chain Harley Davidson Motorcycles. McCann's, P.O. Box 114, El Paso, Texas.

**V-8 60 HP** Motorcycle—perfect condition—good rubber—\$885.00. Full details from Robert C. Beard, R. D. # 6, Lancaster, Pa.

**MOTORCYCLE** Parts, new and used. List 10c. Ballak, 811 N. 9th St., St. Louis 1, Mo.

## 58 MUSIC, MUSICAL INSTRUMENTS

**PIANISTS**—Quickly improve technique, sightreading, accuracy, memorizing, playing through Mental-Muscular Coordination. Free Booklet. Broadwell Studios, Dept. 95J, Covina, California.

**SONG** Poems Wanted, for musical settings. Send poems for Free Examination. Write for Free Instructive Booklet outlining Opportunities. United Music Corporation, Salem 12, Indiana.

**SONGS** arranged and scored. Melodies composed for lyrics. Workmanship guaranteed. Write for particulars. Tommy Kilbourne, Box 1253, Bakersfield, Calif.

**POEMS** Wanted! I'll compose special music. Send poem for Free examination. Eliot Wright, Box 3861-Y, Portland, Oregon.

"CROSS-note Puzzles". Interesting, instructive. Guiding parents show child to music, music-writing. Price \$1.00. D'Aleo, 145 W. 45th St., N. Y. 19, N. Y.

**MELODY**-Harmonization chord chart, together with simple, staffless music shorthand, \$1. P. Stackpole, 2112 W. Venange, Philadelphia 40, Penna.

**PLAY** Swing Piano! Send 10c for instruction bulletin. Christensen Studios, 765 Kimball Hall, Chicago 4, Ill.

**POPULAR** Piano in 12 lessons. Beginners or advanced guaranteed. Kelly School, 1734 30th Ave., San Francisco, Calif.

"GUITARS" "Band Instruments" "Bought," "Sold", Free List. P. S. Rudolph's, Atchison, Kansas.

## AC NAME LISTS

**NEGRO** Names Women or men \$4.00-1,000. Most any class names, Free Details. Dixie, King, N. Carolina.

**FLOODS** of opportunity Mail from everywhere. Write, Name Dealer, 424 Hicks Bldg., San Antonio, Texas.

## B OLD STAMPS WANTED

I WILL pay \$100.00 each for 1924 1c green Franklin stamps, rotary perforated eleven (up to \$1,000.00 each unused). Send 6c today for large illustrated folder showing amazing prices paid. Vernon Baker, PS-59, Elyria, Ohio.

**WHAT** have you to offer? A collection? A "Shoe Box" accumulation? Anything in stamps. We urgently need them. Spot cash paid. Cosmopolitan Stamp Co., 1457 Broadway (Times Square), New York.

## 61 PATENT ATTORNEYS

**INVENTORS:** Learn now—without obligation—how to protect and sell your invention. Write for free "Record of Invention" form and complete instructions for making disclosure and establishing date of your invention. We also send our new free "Patent Guide for the Inventor," containing complete information about patent procedure and how to sell inventions; giving illustrations of many successful inventions; over 150 basic mechanical movements. We assure you prompt, confidential service. Delays may be dangerous. Write today for your free "Patent Guide" and "Record of Invention" form. Clarence A. O'Brien & Harvey Jacobson, Registered Patent Attorneys, 52B-J Adams Building, Washington, D. C.

**PATENTS** Secured. Two valuable booklets, "Patent Protection" and "When and How to Sell an Invention", together with valuable "Evidence of Invention" form sent free. Write immediately to experienced patent counselors. Victor J. Evans & Co., 941-K Merlin Bldg., Washington, D. C.

**INVENTORS:** Before disclosing your invention to anyone send for Form "Evidence of Conception"; "Schedule of Government and Attorney's Fees" and instructions. Sent free. Lancaster, Allwine & Rommel, Registered Patent Attorney, 413 Bowen Building, Washington 5, D. C.

**PATENTS**—Trade marks. Preliminary advice, book and disclosure form free. Personal service. Irving L. McCathran, 316 McLachlen Bldg., Washington 1, D. C. Registered Patent Attorney.

**PROTECT** your invention through medium of my expert personal service. Preliminary information without obligation. Horace L. Beall, 902 F Street, N.W. 4, Washington, D. C.

"INVENTOR'S GUIDE" free, containing 100 mechanical movements, information about patenting, selling inventions. Frank B. Ledermann, 154 Nassau St., New York 7.

C. A. Snow & Co., S-427 Snow Bldg., Washington 1, D. C. Registered Patent Attorneys. Established 1875. Literature mailed on request.



# POPULAR SCIENCE OPPORTUNITIES

**PATENT** Protection. Write for information. Fees. Record of Invention. Free. Randolph & Beavers, 340-A Columbian Bldg., Washington, D. C.

**PATENTS** Obtained; selling service, information, recording forms free. Labiner, World Building, New York 7.

**PATENT-Particulars**, free, airmailed: Sterling Buck, P637 N. Ave., Baltimore 17, Md.

## 62 PATENTS FOR SALE

**AUTO** Direction Signal, Rotary Pontoon Safety Boat, Stooladder Shinestand, Patented necessities. Sell, Let Royalty, Exchange for Property. Welsh, Inventor, Box 205, Oakland, Calif.

**20 NEW-practical** inventions. Need reliable manufacturer, financing. Royalty. Write C. W. R., 2306B Dwight Way, Berkeley 4, Calif.

**FOR** Postwar Manufacture. Patented Clamp and Jack for sale. Nothing just like it. C. Phil Stuart, Gorham, N. H.

## 63 PERSONAL

**BE** Lonely No More! Open Destiny's Door! 50c Brings Cupid's Destiny. World's Greatest Social Publication, including nationwide names, addresses; either sex. Captivating descriptions; sparkling pictures—widows, widowers, bachelors, beautiful girls desiring early marriage. (Year, bi-monthly, \$1.00.) Mention your age. Destiny League, Aberdeen 75, Wash.

**MEET** New Friends through our Personal Service dedicated to promotion of interesting friendships. Discriminating clientele, all religious faiths. Established 1935. When in New York visit us, Grace Bowes, American Service 236-PS W. 70th St., New York City, N. Y.

**ARE** you a square peg in a round hole, unhappy at home, or in your work? For more than 15 years I have been helping men and women find themselves, their talent possibilities, aptitudes and handicaps. If you are discontented at home or at work send for "What About Your Future", which may give you a new slant on your future happiness and success. It is Free. Dr. Bunker 2, Joplin, Mo.

**DRUNKENNESS** Is a disease which responds to treatment. Medical skill plus human sympathy prove successful with liquor and drug cases. 60 years experience. Write for free booklet. P. S. Nelson, The Keeley Institute, Dwight, Ill.

**PSORIASIS** Sufferers: Has everything failed to bring even temporary relief from scales, lesions and itching? Then write today for Free important information. You needn't invest one cent! Pixacol Co., Dept. S, Box 3583, Cleveland, Ohio.

**CHESS** Players. Play Cross-Country Chess by Mail. More Fun Than Over-The-Board. Make New Friends Through This Nationwide Club. Rapid, Efficient, Personal Service. Information Free. Mail Order Chess, 714-X 19 St., Merced, California.

**NATURE'S** simple invigorating method for gaining weight, relieving many ailments without use of Pills, Tonics or especially Cooked foods. Instructive booklet price 50c, satisfaction guaranteed. C. O. Olson, Grandy, Minn.

**MAKE** Colorful Handmade Jewelry with interlocking plastic links. Popular gift item! Excellent sideline. Free details. Beginner's kit and instructions, \$1 (refundable). Hughes, 218 Sidell, Danville 2, Illinois.

**LONELY?** Plain sealed details free. Largest Club in West. Endorsed by ministers. Club Elite, Box 71, Los Angeles 53.

**WIDOW** and Widowers Club. (Confidential details 25c.) Write John Rankin, Springfield, Missouri.

**MAKE** Friends, banish loneliness, through this delightfully different, unique, correspondence circle. Sealed details free. Gotham Circle, P. O. Box 366, Times Square Station, New York 18, N. Y.

**GET** Acquainted Club—Through social correspondence thousands yearly meet their "ideal". Write for list of eligibles. Many in your State. Simpson, Box 1251, Denver, Colorado.

**LONELY** People Everywhere are finding real happiness through introductions by mail. Particulars sent Free, sealed. I'll show you proof. Nancy Jordan, G.P.O. Box 376-PS, New York.

**MAKE** new friends thru old reliable club. Free book with photos of members. Correspondence confidential. Exchange Company, 3827-PS Main, Kansas City, Mo.

**ATHLETE'S FOOT** remedy Guaranteed. Medically recommended \$1.00 bottle post-paid. Dr. W. J. Renz, D.S.C. Room 3, Chavanne Bldg., Lake Charles, Louisiana.

**LONELY?** Join exclusive club. Correspond with ladies, gentlemen seeking friendship and marriage. Write Broadway Friendship Service, 1472 Broadway, New York City.

**PIMPLES** disappear overnight. I tried everything till I found this Formula. Make it yourself \$1.00. Morean, Box 243, Lowell, Mass.

**POSTCARDS**—Trick your friends, 12 Postcards from Hollywood \$1.00. Return for remailing—Bruce Huntley, 1234 N. Sycamore Ave., Hollywood 38, Calif.

**HAIR** Thinning? Unhealthy Scalp? You Can Prevent This! Informative Treatise on Scalp Care \$1.00. Edward Mathieu, Box 507A, Purcell, Oklahoma.

**FIND** Happiness Through Astrology. Ideal Mates Everywhere. Free Details. Tressa's Social Register, Box 14, Hazel Park, Michigan.

**HYPNOTISM**. Complete 20 Method Course, 25c. Western Institute Hypnotism D-1619, Palatine, Ill.

**REJUVENATION** of Men. Also Diabetes without needle. Home treatments. Healthotel, South Whitley, Ind.

**BASHFUL?** Nervous? "Fears?" Free, encouraging information. John Englund, Ironwood, Michigan.

**LONELY?** Confidential Particulars 10c. America's Fastest Growing Club. Blair's, 4520 Sheridan 40, Chicago.

**LONESOME?** Get "Cupid's Mail". Many wealthy. (Stamp). Excel, 2149 Jackson, Chicago 12, Ill.

**CIGARETTE**-stained fingers? Use Tut-Tut Crystals. Excellent. Send 10c. Drug Dept. Box 28, Jackson Heights, N. Y.

**LONELY?** Trailsend friend awaits you, particulars, Box 2027, Madison, Wisconsin.

**HAVE** Penpals worldover. Illustrated Magazine with list 10c. World Card Club, King, N. Carolina.

**LONELY**, Have romance, companionship thru correspondence. Particulars free. Pearl Smith, Box 2732, Kansas City 13, Mo.

**LONESOME!** Descriptions and details free. Big lists. ACME, Box 192-S, Aloha, Oregon.

**"GABRIELLE"** 3 2½x4 \$1.00 not Glamour. George Wilson, 4024 Girard, Philadelphia 4, Penna.

**PROBLEMIZED?** Your problem fully analyzed, advised \$2.00. Schoenberg, 16 Carrington, Providence, Rhode Island.

**AMAZING** Discovery of the Biblical Garden of Eden. Detailed information \$1.00. The Better Way, Box 456, Lakeport, Calif.

**LONESOME?** Get acquainted this easy way. Confidential sealed particulars 25c coin. Box 310, Memphis, Tenn.

**YOUR** Letter Mailed In Any U. S. City \$1. Personal Service Bureaux, 432 Roslyn Place, Chicago 14.

**HAIR** Falling? Dandruff? Write Trichologist, 139 Lewis Street, Phillipsburg, N. J.

**COMMONWEALTH** of Israel. Literature 15c. Box 87, Station H, New York 25.

**LONELY?** Let Birds of A Feather help you. S. Dickinson, Box 142, Bangor, Maine.

**BUY** Vitamins direct. Save. Postcard. Matoska Products, White Bear Lake, Minn.

**LONELY?**—Stamp For Particulars. Francis Tower, Box 444, Kansas City, Mo.

**BANISH** Loneliness. Particulars Free. Oscar Mayes, Box 397, Elmira, New York.

## 64 PHOTO FINISHING

**SENSATIONAL** introductory offer! Send snapshot or negative, this ad, and 3c. We'll send you a beautiful 7" x 5" enlargement! Or, Kodak roll developed with 16 guaranteed deckled-edge velox fadeproof prints or 8 double-size prints, 25c! Special! From your negatives, 16 regular-size or 8 double-size reprints, 25c! Candid Rolls—36 exp. 35mm developed, vaporated, enlarged to 3x4, \$1.00! 18 exp. 50c. Reprints, 3x4, 3c each. We have new, perfect 35mm film. Low prices. Free Mailer, details on request. American Studios, Dept. 280, La-Crosse, Wis.

**BIGGEST** \$1.00 value in 35mm finishing today. 36 exposure fine grain 3¼x4½ enlargements; deckled, embossed margin and date. Eighteen exposure 75c; 16 exposure splits 55c; 36 exposure reloads 50c. Special: return this ad with \$2.00 and we will send five 36 exposure reloads. Free Mailers. 8 exposure rolls in beautiful, deckled contact finish with embossed wide margin, 25c. Mailbag Film Service, Box 5440A, Chicago 80.

**BEAUTIFUL** double size Pictures 3½c each, from 116 and 120 negatives, 3¼x4½ from all other sizes. All work guaranteed. Overnight service. Roll developed and 8 pictures 30c. Roll 12 pictures 45c. Roll 16 pictures 60c. Enlargements on double weight portrait paper 5x7—30c, 8x10—50c. Copies made from any picture 75c. Pacific Photo Service, Box 666, San Francisco, California.

**CHOICE** Film Offers—Roll developed, 8 beautiful enlarged prints (deckled if desired); or 16 brilliant "Lifetime" prints; or 8 sparkling prints plus 2 fade-proof enlargements. Pre-war quality and price—25c. Fast service. Quality guaranteed Free mailers. Dept. 18, May Studios, La Crosse, Wisconsin.

**SATISFACTION** or your money back 2 regular size prints from each good negative on 8 exposure roll complete 25 cents or 8 jumbo size prints complete 30c. The Old Reliable. Pioneer Photo Company, Box 123-PS, Wichita, Kansas.

**OIL** coloring photographs can be a fascinating hobby or profitable sideline for those with artistic talent. Learn at home. Easy simplified method. Send for free booklet. National Photo Coloring School, 1315 Michigan, Dept. 1722, Chicago 5, Ill.

**ROLL** Developed and 8 beautiful enlargements 2 to 6 times larger. Deckled Edge—High Gloss. Any 8 exposure roll 25c coin. 12 ex. 35c—16 ex. 50c—36 ex. \$1.00. Reprint Enlargements 3c each. Alden Photos, 94-4 Astor Station, Boston 23, Mass.

**MONEY** Back Guarantee—16 Sparkling double clear Nu-Art Prints, also 2 Enamel Finish Enlargements. All complete 25 cents. Rolls or negatives. Prompt, Careful, Guaranteed. Lifetone Studios, Dept. 98, Des Moines 8, Iowa.

**YOUR** 6-8 Exposure Roll Developed and Two prints each good negative 30c; Or enlarged to about Post Card size 8 Exposures 25c. 12 Exposures 40c. 16 Exposures 50c. Rapid Foto Service. G.P.O. Box 413, New York 1, N. Y.

**EVERY** picture an enlargement! 8 sparkling deckle-edge enlargements and roll developed 25c coin; 116 size or smaller; enlarge reprints 3c. Enlarge Photo, Box 791Q, Boston, Mass.



# POPULAR SCIENCE OPPORTUNITIES

AT Last! Roll Developed, all your snapshots hand-colored as beautiful as most actual colored photography 35c. Hand colored reprints 4c each—12 for 45c. National Photo Art Co., Janesville 27, Wisc.

2 BEAUTIFUL Hi-Gloss prints each good negative and enlarging coupon with each 6 or 8 exposure roll developed 25c. Owl-photo Co., Weatherford, Oklahoma.

PHOTOSTAMPS, picture yourself on postage stamps 1½c each. Free Samples. Aircraft Photo Co., 1600 Coney-Island Ave., Brooklyn 30, N. Y.

GLOSSY Prints with your 6 or 8 exposure Roll—40c. Reprints 4c—Prompt Service. Photo Art Lab, 840 S. Thomas Court, Newport News, Virginia.

BEAUTIFUL Lifelike Statuette made from your negative, \$1.00. Copies from pictures, proofs etc. 75c; 25 enlargements, \$1.00. Modern Studios, LaCrosse, Wis.

SPECIAL. Coupon for six 5x7 enlargements with roll developed and printed, up to 16 prints, only 25c, reprints 3c. Dick's Photo, Louisville, Ky.

SPECIAL—25 re-prints 50c; Suburban Studio, 1408-S Bond, Rockford, Illinois.

REPRINTS 3c each, any number, minimum order 25c. Fred A. Eastman, Bode, Iowa.

## WW PLASTICS

PLASTIC Beginners Attention Attractive kit, Plastic sand paper dye and glue. Also work sheet giving complete operations for making novelties easy simple instructive \$1.95 Prepaid. Send Money Order, Plastic Dyes, Station D, P. O. Box 141, Los Angeles 7, Calif.

PLASTIC Craft Kits—includes Lucite, dyes, cement, instruction book. Work sheet. Makes several projects. Complete \$3.00. Plastic Products Co., Box 384, Massillon, Ohio.

"PLASTICS in a Nutshell". Complete outline. Includes instructions for starting profitable plastics fabricating business. \$1.00. Plastics Information, Box 633, Stamford, Conn.

LUCITE Catalin Lumerith Plexiglas. 2 lb. package assortment \$2.00. Homecrafters, 75 Erskine Ave., Toronto, Canada.

PLASTICS—without high heat or equipment, cheap! Formulas, instructions, \$1.00. Tirekop, M-9, Madeira, Ohio.

## 66 POULTRY & SUPPLIES

RAISE turkeys the new way, write for free information explaining how to make up to \$3000.00 in your own backyard, address National Turkey Institute, Dept. 57, Columbus, Kansas.

## 67 PRINTING, MULTIGRAPHING, MIMEOGRAPHING, ETC.

QUALITY Printing 1 color 1000 each Bond Letterheads, Statements \$6.85, 6¾ Envelopes \$4.50, No. 10 \$5.75 Postpaid Remittance with order. Geo. LaDreau (C), 1222½ E. Second, Duluth 5, Minn.

\$2.00 POSTPAID; 150 8½x11 Good Bond Letterheads and 150 6¾ Envelopes. 500 of each \$5.75 postpaid. Mero Products, Box 344, Punxsutawney, Penna.

HIGRADE Letterheads 8½x11 500—\$2.95, 1000—\$4.50. Postpaid. 10% Higher West of Mississippi. William Jones, Westbury Ave., Mineola, New York.

150 8½ x 11 LETTERHEADS and 150 6¾ envelopes \$2.00 prepaid. Going, Box S-1544, Muskogee, Oklahoma.

QUALITY Printing At Lowest Cost. Samples, pricelist, free. Adams-F, 30 W. Washington, Chicago 2.

2,000 PRINTED letterheads, \$8.00, Envelopes \$6.25. Psychical Publishers, Remington, Indiana.

FREE—Your Personal Stationery. Write C. Morgan, 1310½ Third, Corpus Christi, Texas.

400 5½x8½ LETTERHEADS \$1.25. Samples Free. Mango, 555B S. 20th, Newark 3, N. J.

CARTOONING, Sketching, Drawing, Lettering. 46 Lessons, 700 illustrations, \$1.00. William Richardson, Wyoming, Pa.

SIXTEEN quality pencils with your name imprinted \$1.00 postpaid. Little Press, 5016 Thomas South, Minneapolis, Minn.

## 68 PRINTING OUTFITS & SUPPLIES

PRINT your own Postal Cards, paper, or anything on "Printomatic Self-feeding Rotary Postal Card Stencil Duplicator. Only \$9.50 with \$2.35 worth of supplies, Stencils, Ink, etc. Literature Free. Pittsburgh Typewriter Supply, 336-RA Fourth Ave., Pittsburgh 22, Pa.

PRINTING equipment, type and supplies. Send stamp for details or dime for complete illustrated supply book. Kelsey Inc. X-8, Meriden, Conn.

INEXPENSIVE home-made printing press. Details free. Novelty Shop, Downsville, Louisiana.

PRINT At Home—Send 10c for Catalogue—Type, Presses, Supplies. Barnhard Co., 6 Columbia St., Newark 5, N. J.

HOME-Made Printing Press, Duplicator, Printers' Cuts—details 10c. Tirekop, H-9, Madeira, Ohio

PRINTING Presses, Type, Supplies. Lists 3c. Turnbaugh Service, Loysville, Pa.

PRESSES, Type, Cutters, Supplies, Bulletins 3c. Levinson, Box 918, New York 8.

## 69 PROFITABLE OCCUPATIONS

"HOW To Start Your Own Business"—shows how easily you can be "your own boss", build security for yourself and your family, grow surer and wealthier year by year! Expert, easy-to-follow advice on how to choose a good location; how to display merchandise; how to figure markups, cost of sales, gross margin, etc.; what records to keep how to advertise effectively; how to stay on a money-making basis. Tested rules for success, based on years of actual experience in operating small businesses profitably. Only \$2. Ziff-Davis, Dept. PS9, Empire State Bldg., New York 1, N. Y.

ANNOUNCING home study course in commercial baking. Practical basic training. Good field for those with aptitude. Nearly depression proof. Send for free booklet. "Opportunities in the Baking Industry." National Baking School, 1315 Michigan Ave., Dept. 172-A, Chicago 5, Ill.

LOCKSMITHING—Profitable Business or Hobby! New course teaches you how to pick locks, fit keys, de-code, masterkey, etc. Easy self-instruction lessons. Bargain price. Free details. Write—Nelson Company, Dept. 7-01, Chicago 4.

\$5000 FROM Half Acre! Growing Ginseng. Seed, contract supplied. Particulars 10c. Associated Growers, Dept. 12, St. Norbert, Manitoba.

HOMEWORKERS, make, sell, shell novelties, Beginners samples, instruction, \$1.00. Burton, Box 27, Station A, St. Petersburg, Fla.

EXCEPTIONAL profits raising mink. Finest breeding stock available. Details furnished. Franklin Young, Riverhead, Long Island, New York.

\$40.00 WEEKLY. Made growing mushrooms. Fresh, Dried, Dominion Patent 331583, free spawn, North American, 169Y Yonge, Toronto, Canada.

DOUBLE your money back if not delighted with description, new mail-order profits! Rush 10c. MacCormack, 9K, Madeira, Ohio.

MUSHROOMS Grown: Boxes, Barrels. Instructions 50c. Spawn \$1.00. Gordon, 553 William, Winnipeg, Manitoba.

CASTING Plastic and instructions \$1.00. Instructions 50c. Alvin, 553 William, Winnipeg, Manitoba.

## 70 RADIO, SUPPLIES & INSTRUCTIONS

CRYSTAL Radio Experimenters. Free catalogue. Sensitive crystals. Coils. Condensers. Diagrams. Hulet, 29 E. 39th, New York.

RADIO and Hardware Kit—for repairing and experimenting—contains coils, sockets, condensers, resistors, rheostats, etc. bolts, screws, nuts, washers, rivets, spacers, springs, studs, eyelets, coppers, lugs, brackets, angles, bakelite, fiber, asbestos, rubber, etc. \$2.00 per kit. Sent C.O.D. Radioco, 1110S Marshall Bldg., Cleveland, Ohio.

YOUR New Free Catalog Is Ready! Radionic's Catalog lists hard-to-get radio parts and books. All available for immediate shipment. Send today to: Radionic Equipment Co., Dept. 9C; 170 Nassau St., New York 7, N. Y.

FOXHOLE Radio: Amazing servicemen's pastime gift, batteryless, tubeless, schoolboy thrill, made anywhere, anybody. Easy distance-getting instructions. \$1.00. Gadgets, Box 28, Dept. 507, Jackson Heights, N. Y.

2500 RADIO Tube Substitutions with change over data in handy form. 176 pages of valuable information. Send \$3.00 for prepaid copy. Radio Equipment Co., 1415 W. Franklin Ave., Minneapolis 5, Minn.

BUILD Latest, Extra-Loud Crystal Set. Instructions, 20c. Booklet, "All About Crystal Sets," 45c. Exceedingly Loud Crystals Available. Amorose, Rt. 4, Hungary Road, Richmond, Virginia.

MAKE Simple, tubeless, batteryless, distance-getting crystal radios, crystal and illustrated instructions. 25c postpaid. Allen, S-427, Clinton, Missouri.

RADIO Service men and experimenters send stamp for our giant radio catalogue. Save dollars. United Radio Co., (1000-V), Newark 1, N. J.

REVISED Plans 18 Crystal Sets (SW record 5300 miles), including "Radiobuilder" 25c. Laboratories, 2610-T 18th Ave., San Francisco 16, Calif.

RADIO—Vacuum Cleaner Parts, Tubes, Neon Circuit Tester 50c. Discounts on Quantity Orders. World Sales, Box 81, Clifton, N. J.

HEADPHONES; new lightweight sensitive 2000 ohms, complete with head band and cord—\$2.25 postpaid. Van Sickle Radio Supply Co., Indianapolis 6, Indiana.

BUILD radio complete with tubes \$10.95, details. Radio, 9418c Ave. A, Brooklyn, N. Y.

BEGINNER'S Radio Repair Booklet. Mail 25c. "Radio", Box 311-Z, Benton Harbor, Mich.

LOWEST Prices. Radio Tubes, parts. Bargain lists 3c. Potter, 1314 McGee, Kansas City 6, Missouri.

FAMOUS Razor Blade Radio! Illustrated Plans 35c. New Radio, Lohrville, Iowa.

## 72 RAZOR BLADES

SAFETY Razor Users. We have just what you need, let us prove it, write us. Smoothedge Mfr. Co., 1524 Broadway, Toledo, Ohio.

## 75 RUBBER STAMPS

SELF-INKING Pocket Stamps—2 lines \$1.00; 3 lines \$1.25; Dater 50c. Postpaid. Circular free. Press, Warm Springs 1, Georgia.

SERVICEMEN'S Kit contains stamp, ink Pad, Indelible Ink \$1.20. Excello, Box 500, Shreveport, Louisiana.

PROMPT Service cushioned indexed, 1 line 25c, 2—35c, 3—50c Guaranteed. Stampcraft, 1707 Virginia, Gary, Ind.

## 77 SONGWRITERS

SONG Writer's Attention! The amazing demand for phonograph records, accelerated by more than 300,000 Juke Boxes and the Hits accredited them warrants your immediate consideration. We are offering song-poem writers the rare opportunity of having established composers collaborate on appealing material received this month. Recola Records, Box 987S, Hollywood 28, Calif.



# POPULAR SCIENCE OPPORTUNITIES

**POEMS Wanted.** To be set to music. Send your song poem today for free examination by our staff headed by nationally famous hit composer of "Dream A Little Dream of Me". Our new 6 step plan is most liberal and complete ever offered. Write today for free booklet. Screenland Recorders, Dept. PS, Hollywood 28, Calif.

**SONGWRITERS:** Collaborate with nationally famous composer of "Boots and Saddles". Send poems for free examination. Get Free instructive booklet. Hollywood Harmony House, 126 S. La Brea, Studio L-7, Los Angeles, California.

**SONGWRITERS.** Songs Published Monthly. Advance Royalty. Send your songs or poems today for our exciting offer. Free book on songwriting. Hollywood Tune-Smiths, Dept. 10-F-C, 7024 Melrose Ave., Hollywood, Calif.

"THE Complete Songwriter". A new home study course of instruction—words, music and arrangement. Simple, practical. 96 page book. \$2.00 postpaid. M.O. Puritan Publishing Co., Dept. APS, 343 S. Dearborn St., Chicago 4, Ill.

**SONG Poems Wanted,** for musical settings. Send poems for Free Examination. Write for Free Instructive Booklet outlining Opportunities. United Music Corporation, Salem 18, Indiana.

**NEW songs and lyrics wanted** for popular radio program and professional promotion. Free examination. Transradio Music Inc., Department P.S., 1650 Broadway, New York (affiliate of B.M.I.)

**SONGWRITERS—**Before sending your poems anywhere, get the facts in our free booklet "Getting Ahead in Songwriting". Write today. Song Service, 331-J West 46th, New York.

**SONG writers:** Melodies supplied without charge by recognized Hollywood composers. Lead sheets and records furnished. Cinema Song Company, Box B-27, Beverly Hills, California.

**POEMS Wanted** to be set to music. Free examination. Send poems. McNeil, Master of Music, 510-PS S. Alexandria, Los Angeles, California.

**SONGWRITERS—**Send Poem For Immediate Examination and Free Rhyming Dictionary. Richard Brothers, 46 Woods Building, Chicago.

**SONGWRITERS—**Send Poems for immediate examination and Free Book, "Your Future in Songwriting". Radio City Music Academy, 1674 Broadway, New York 19.

**POEMS Wanted** for Musical Setting. Send poem for immediate consideration. Five Star Music Masters, 646 Beacon Building, Boston.

**WANTED!** Lyrics, melodies for songs. We arrange, publish, sell. Superior Song Studios, Passaic, N. J.

**SONGWRITERS:** Royalty Contract Free. Write for details. Puritan Publishing Co., 343 S. Dearborn St., Chicago 4, Illinois.

**YOUR Lyrics, Melody or Idea** made into complete professional song—\$3.00. Sholl, 2217 Penn St., Harrisburg, Pa.

**MUSIC** composed music printed—since 1910. Reginald Belcher, Bloomfield, New Jersey.

**SONGWRITERS** Publishing Agreement Free. Mid-West Music Press, 4737 Broadway, Chicago 40.

**OUTSTANDING** service for songwriters. Hibbeler, C15, 2157 N. Avers, Chicago.

## 78 SPORTING GOODS, GUNS, FISHING TACKLE, ARCHERY

**LIFE Belts & Rubber Boats—**(Dual Life Preserver Belts) (Seconds). Ideal for Sportsmen. Uses Sparklet Cartridges or inflate by mouth. Without Cartridges, new, \$2.98. Used \$98. Mae West Life Vests, used, repairable, with repair kit \$2.95. New \$14.95. Collapsible rubber boats. Write for circular. Karl Ort, Dept. PS-2, York, Pa.

**BRAND New Guns** available for immediate delivery in trade for your used Rifles, Shotguns, Handguns, Reels, Rods, Outboards, Cameras and other sports equipment. Save money by dealing with America's Biggest Traders who offer maximum Trade Allowances for your merchandise as full or part payment for new guns. Ship your merchandise for appraisal, or write full description today. We also pay Spot Cash for equipment. Send 25c (refunded with first order) for Fall "Guaranteed Bargain Catalog" featuring new and used guns and other "Hard-To-Find" items. Klein's Sporting Goods (Sixty years Fair Trading), 506TJ, S. Halsted, Chicago 7.

**WANTED—**Any make, size, age or condition, outboard motors, fishing tackle, hip boots, waders, binoculars, guns, ammunition, tents traps or any other outdoor sports equipment. No foolin, write your own price. Outdoor Directory, Box 707, Marion, Indiana.

**BOWS—Arrows** for Recreation—Hunting—Fishing. Beautiful Archery instruction book, 70 pages, 50 illustrations, only 50c. Illustrated catalogue Free. Archery Sales-Service, 617 South State, Chicago.

**USED Guns, Binoculars,** bought, traded, sold. Ammunition bought. Highest Cash Prices Paid. Stoeger Arms Corp., 507 Fifth Ave., New York, N. Y.

**THOUSAND Bargains,** firearms, binoculars, war relics, catalog 30c. Smith Museum, Runnemede, N. J.

**10 BASS Flies \$1.00,** Free Fly List. Frank Hudson, Box 1162, St. Petersburg, Florida.

"**AMMUNITION**" Available to Qualified Purchasers. List 10c P. S. Rudolph's, Atchison, Kans.

**SEND 10c** for list 100 used guns. Frayseths. Wilmar, Minnesota.

**USED guns,** bought, sold, exchanged. List stamp. Howe, Coopers Mills, Maine.

## 80 STAMP COLLECTING

**SPECIAL Album Free—**The United States Flag Series for twelve overrun Nations is the most unique, remarkable, impressive, and beautiful set of stamps ever issued. It fairly cries for a special album worthy of it, such as we have published. It's a very fine album of 34 pages. Cover designed by a famous artist. Arrangement artistic and practical, telling the history of each honored nation.—It is Free to sincere approval applicants. Just send 10c for mailing expenses, and state whether you desire approvals of the United States or foreign stamps or both. Approval Headquarters, Globus Stamp Co., 268 Fourth Ave., New York City 10, Dept. 217.

**FREE Iwo Jima New U. S. Dramatic First Day Cover** with 536 Different including: Australia, Centenary, Jubilee, Telephone, Proclamation; Guiana, Pictorials; Ceylon, Native Scenes; Cuba, Cigar plus Five Complete Charities; Czechoslovakia, Anthem; Djibouti, Free French; Ecuador, Golden Gate; Reunion, DeGaulle; Soviet, Complete Bondage; Spain, Columbus Air; Uruguay, Artist; Wallis-Putuna, New Issue, etc., cataloguing \$10.84 to new applicants requesting Foreign Approvals only \$1.00. Intercity Co., Dept. Y, Port Washington, N. Y.

**DESIRABLE New Falkland Island Dependancy Stamp.** MacArthur stamp from Australia, Abyssinian Wild Elephant issue, plus host of others from New Caledonia, Indo-China, Russia, Cuba, Wallis & Futuna, Dutch Indies, China, Philippines, etc., only 5c to approval applicants. Big Dime Packet List free! Methuen Stamp Service, Inc., Dept. 46, Lawrence, Mass.

**FREE—**Pick 25c worth of stamps from our first U.S. Approval Selection . . . Approximately 100 stamps to choose from . . . Excellent value . . . No obligation to buy. Lists illustrating the most popular U.S. stamps—at prices you can afford—will be included. Don't miss this opportunity! Write today. S. D. Engel Co., 38 Park Row, New York City.

**ZOWIE-E-E!** A Barrel of Fun for only a Dime! 500 United States—Absolutely unpicked and unsorted—just as received from church missions. Many varieties, including large commemoratives airmails, high denominations up to \$5.00! Stampdom's biggest package of fun—and you might find something really valuable!! Price only 10c to serious approval service applicants. Money back if not delighted. Illustrated bargain lists with each order. Mystic Stamp Company, Department 55, Camden, New York.

**WOW! \$10.00 Worth of Fun—Only 10c!** 500 foreign stamps, unsorted and unpicked, just as received from church missions, other sources. Africa, So. America, Australia, China, Philippines, Dutch Indies, and other countries. Includes few commemoratives, airmails, and stamps cataloging up to 25c or more each! Biggest value in stampdom—and you might find something really valuable! Price only 10c to serious approval applicants! Money back if not delighted. Jamestown Stamp Co., Dept. 5, Jamestown, New York.

**POSITIVELY Greatest Free Offer—**Latest Scott's International \$5.00 Stamp Album—covering entire World, contains 36,000 illustrated, descriptive spaces; Scott's 1945 Standard \$5.00 Catalogues "Philately's Encyclopedia"—absolutely Free to applicants for Foreign Approvals becoming customers. Bargain Stamp Service, Palm Springs, California.

**FREE! The Stamp Finder!** Send today for big new edition, fully illustrated, enabling you instantly to identify all difficult stamps! Also fine packet strange, fascinating stamps from Bosnia-Herzegovina, Monaco, Patiala, Cyprus, etc., including maps, ships, animals and strange scenes. All free to approval applicants inclosing 3c postage. Garcelon Stamp Co., Box 918, Calais, Maine.

**EXOTIC Pictorial Collection:** Tahiti Spear-fishing, Melanesian Idol—Carib Archer—Columbo Harbor—Reunion Produce—Jugoslavia—Philippines—Porto Rico—Malagasy Farmer—Dutch Indies—South Africa—Roman's Charity—Martinique Settlement—Newfoundland Codfish—Djibouti Locomotive—Victoria. Everything only 5c. Imperial Stamp Co., Yonkers 1, N. Y.

**FREE! Leeward Is., Cayman Is., Turks and Caicos** plus 60 different mint Geo. VI Coronation poster stamps, to approval service applicants sending 3c postage. Tatham Stampco., Springfield 50, Mass.

**VICTORY Packet Free:** Includes stamps from Tanganyika—British Cayman Islands—Animal—Scarce Babyhead—Coronation—Early Victorian—Airmail—Map Stamps—with Big Catalogue—all free—send 5c for postage. Gray Stamp Company, Dept. PR, Toronto, Canada.

**FREE—Solomon Islands "Guadalcanal"** Beauty; Caribbean Triangle; Senegal; Mukden; Czechoslovakian "Independence"; Zoo stamp; Siberia; French, British Colonies, others—all Free with approvals. Postage 3c. Bennett, 1055 E. Ocean, Long Beach 2, Calif.

**OPPORTUNITY!** Gorgeous lot with Triangles, Diamonds, Giants, Midgets Flags, Airmails, and Railroad Stamps. Also Guiana, Djibouti, Mongolia, Angola, New Caledonia, etc. Everything only 10c to approval applicants. Evden 2, 249 Woodland Dr., Kenmore, N. Y.

**WORLD'S Largest Diamond And Triangle Stamps,** Free Stamp Magazine, Stamps from Fighting Free French. 20 stamps from 20 different Countries. Pictorials. Airmails. Big Bargain 5c with approvals. Capital Stamps, Dept. 10, Little Rock, Ark.

**UNITED STATES Collection,** Fifty different mint commemoratives, very fine, unhinged condition from 1920—1939. Price \$2.00 with request for United States Approvals. Fort Orange Stamps, Albany 7, New York.



# POPULAR SCIENCE OPPORTUNITIES

**FREE** wallet. If you buy 30c worth of stamps from our colorful approvals, we give you, free, an attractive two-toned stamp wallet. Holds 75 stamps. Just the thing for your duplicates. Alpine Co., Box 536, New Rochelle, N. Y.

**SUPER Special**—Choice African Packet 50 all Different. A Galaxy of Scenes Showing Lions, Tigers, Native Chiefs and Jungle Villages. All for 10c to serious Approval applicants. Detroit Postage Stamp Co., Detroit 21, Mich.

**SMOKY** Mountain commemorative sheet, largest U. S. stamp issued, and 33 U. S. including commemoratives, airmail revenues, etc. Catalogs 75c—To approval applicants for 5c. Curhan Stamp Company, Dept. C, Gloucester, Mass.

**PREMIUMS** and premiums—but the Point-System premiums are worthwhile: Elbe albums and stockbooks, world atlases, stamps, etc. Send for Point-System foreign approvals and premium plan. Charles Horn, Santa Ana, Calif.

**GOYA** Nude 3c and postage with request for selection of moderately priced mint British Colonies approvals by serious collectors only. No penny items—references requested. Forest C. Wilson, 711 North A St., Tampa 6, Florida.

**SPECIAL**—Airmails—19 different, including Zeppelin, Triangles, Latin America, etc. 5c with approvals. Continental Stamp Co., Box 606, Dept. C, New Rochelle, New York.

**118 DIFFERENT** stamps including commemoratives, charities, airmail, sets, etc. Only 3c to approval buyers. We buy collections. Badger Stamp Co., Milwaukee 3, Wisconsin.

**SCARCE** 1880 U. S.—Hussey Local Carrier Stamp listed at 15c. Also Costarica No. 65 listed at 40c. Both sent free to approval buyers sending 3c postage. Pladon Stamps, 1717-S Idaho, Toledo 5, Ohio.

**FINE** Approvals, freshly mounted. Fast, personal service. Tell me what countries you prefer and I'll send their stamps. Milton Skinner, 345 East Ocean, Long Beach 2, Calif.

**114 DIFFERENT** stamps from far away countries including Airmail and Free Fighting French to approval applicants for 10c. Reich Stamp Co., 4647 Kenmore, Chicago 40, Dept. S9.

**FREE** 150 Stamps—Giant, Triangle, Diamond Shapes Included. To Serious Approval Applicants—Send 5c Postage, Handling. Regent Stamp, 330 Flatbush Ave., Brooklyn 17, N. Y.

**LIBERIA, Indo-China, Danzig, Egypt, Lebanon, Syria, China, British Colonies, Triangles, Airmails, Etc., Big Packet, only 5c with approvals.** Glendale Stamp Co., 2313-C Hermosita, Glendale 8, Calif.

**19th CENTURY** U. S. Commem. Civil War—Battleship revenues, \$5 and \$10. Stamps free to U.S. approval applicants. Metropolitan Stamps, 198 G. Broadway, New York.

**EXOTIC** Pitcairn Islands! Beauteous French Colonies. Gorgeous Tonga—Everything 3c with approvals! Extra! Extra! First 200 additional gift. Saxon Co., Valley Stream, N. Y.

**FREE**—Canadian Sets, Royal Visit, George VI, George V, Coronation, Jubilee, others, to approval applicants. Ensign, Box 118-P, So. Orange, N. J.

**BRITISH** Empire! 55 Different including Batum, Burma, Cyprus, Gwalior, Tasmania. 5c to Approval Buyers. Lyman, 97 Nassau St., New York 7.

**COMPLETE** "United States" catalog with 1000 illustrations! Send 10c for mailing. Harris & Co., 99 Transit Bldg., Boston, Mass.

**UNITED STATES** approvals complete coverage fine quality, attractive prices. Seminole Stamps, Box 436, Coconut Grove, Florida.

**FREE, 30 Different** including Cossack Diamond, 1/2 stamp Triangle, Gobi, others. Approvals included. Send 3c postage. Pilgrim, Waverly-18, Baltimore, Md.

**FLASH!** Super Value! Djibouti, Bechuana-land, Cameroons, Dominica, others, all 6c, Approval Applicants only, Southwest Stamp Co., Box 117, Long Beach 1, Calif.

**U. S. and Foreign** Departments, Pleases the Particular Buyer Return Postage Paid, Atwater, P. O. Box 1583, Miami 35, Florida.

**EXCHANGE** Your Duplicates, With Collectors Everywhere. Stamp brings Particulars. Kurtz, Box 1051, Allentown, Pennsylvania.

**COLLECT** And Sell! Fine Worldwide stamps on approval. Liberal confidential discount. One reference required. Harrison, Box 266, New Orleans 9, La.

**EUROPEAN** South And Central American Approvals, Arranged By Country, Henry Zimmer, 722 Culver Road, Rochester 9, N. Y.

**12 DIFFERENT** Persia—3c to approval applicants. Premiums with purchases. Brandwein Stamp Co., 167 W. 33 St., Bayonne, N. J.

**FREE**—25 different unused foreign stamps to approval applicants sending 3c postage. Universal Stampco., 1216-B Park Row Bldg., New York 7, N. Y.

"SEND me some more". You'll say that too after you receive our super approvals. E. F. Russell, 13 1/2 E. Montgomery, Johnstown, New York.

**DEALER'S** Wholesale Catalog. Postage 3c. Franksco, 5031 Queensberry, Baltimore, Maryland.

**POUND** Bag unpicked stamp mixture containing thousands \$1.00. Longacre Shop, 100-C West 42nd, New York City.

**55 DIFFERENT** United States—5c. Approvals. Utechts, 1143D N. Keeler, Chicago 51.

**55 DIFFERENT** United States 5c with Approvals. Bookman, Box 145-P, Maplewood, N. J.

**UNITED STATES, Canada, Newfoundland** Approvals. Recent British Colony Sets. Dan Hayden, Box 703, Bloomington, Ill.

**FREE!!!** British Empire Packet. Postage 3c. Williams, 601 Archerbldg. Baycity, Mich.

**FREE!** Pony Express set (facsimiles). Postage 3c. Roberts, 401 Shearerbldg., Baycity, Mich.

**FREE!** Western Hemisphere Packet. Postage 3c. Owens, 801 Welshbldg., Baycity, Mich.

**500 MEXICO** with airmails and large commemoratives \$1.00; 1000 \$1.95. Beihl, Apdo. 2887, Mexico City.

**SCARCE** Lundy Island 25c approvals. L. Arrington, 147 Hunter, Scotch Plains, New Jersey.

**SENSATIONAL** Stamp Contest, Prizes valued \$1.00 or over to all contestants. Gerhart, 2804 Rio-grande, Austin, Texas.

**UNITED STATES, \$4, \$5, and \$10** stamps and packet only 3c to approval applicants. S. Wineholt, Woodbine, Penna.

**FRESHLY** mounted approvals for collectors using Scotts International Junior Album. Wlaschim, 55 Nagle Ave., New York 34.

**FIFTY** Canadian, Newfoundland, including earlies, commemoratives 10c approvals. Reade, 696 Gerrard, Toronto.

**25 DIFFERENT** Guatemala 10c with 1/4-1/2-1c Approvals. Carroll's, 4357 C S. Hoover, Los Angeles 37, California.

**SPAIN**—Five large airmails. Send 10c. Approvals. Buchanan, 307 E. 23rd, New York 10.

**FREE!** Approval applicants select 10c worth Free—Your choice. Excel Stamp Service, Box 1315, Chicago 90.

**ADULTS** Approvals, outstanding stamps of United States and Foreigns. Discounts. Frank Carr, Jr., Pompton Lakes, N. J.

**CHINA-Burma-India** 46 Stamps including Pictorials, 10c. Approvals, Sets-Singles. Shook, Box 128, Rochester, Penna.

**APPROVALS** for adults. Unusual values, try them. H. Frank Baker, East Setauket, N. Y.

**FIFTY** British Colonies Free to Approval Applicants. Pelican Stampco, 1609 S. W. 8th St., Miami, Florida.

**EXCELLENT** Pictorial approvals. Reasonably priced. Crown Stamp Company, Box 331, Toronto, Canada.

**TRIANGLES**—(Mozambique Co.) other beauties, 10c. Approvals. Reuter, 611-D W. 40th, Los Angeles 37.

**DIFFERENT** and unusual foreign approvals. Kirklands, 7212 Farwell, Chicago 31, Ill.

**AMAZING** Value! Fifty Different Pictorials 10c With Approvals. Franciscan, 376 Oak St., San Francisco 2, Calif.

**AMAZING** Lot, includes diamonds, triangles, 10c with approvals. Deluxe Stamps, Box 4127, Los Angeles 24, Calif.

**FREE** France Packet 5c with approvals. V. Y. Walton, Porter Rd., Nashville 6, Tenn.

**10 U. S. CIVIL** War Issues 5c; Approvals: Graffam, 268 Boston, Medford 55, Massachusetts.

**25 SOUTH** American, 5c. Super Stamp Shop, 2 S. Madison, Greencastle, Indiana.

**COLORFUL, Interesting, Approvals** to Business-like collectors. See what you Buy. Johns, Box 2612, Detroit 31, Michigan.

**NEW** Zealand triangle set complete 8 cents with approvals. Logay, 1085 N. Paulina, Chicago 22, Ill.

**40 SCARCE** Philippines \$1.80, U. S. 150 Commemoratives \$2.75. Morris Stamp Co., Rockaway, N. J.

**SPECTACULAR** Approval service for collectors using International Junior album. Loewy, Aberdeen, Maryland.

**FREE!** Sensationally interesting money-saving stamp magazine. Philatelists, Aberdeen, Maryland.

**SCRIBBLE** a line—United States approvals, right price, real nice. Jarr, P.O. 711, Denver, Colorado.

**BEGINNERS** Pictorial Approvals—Premiums? Surely. Suburban Stamp Sales, 1224 Grant Drive, St. Louis 14, Mo.

**60 DIFFERENT** United States, 10c. Price-list free. Seidenberg, Cassopolis, Mich.

**PENNY** Approvals by Country. M. H. Hoerning, 102, Farmington, Ark.

**1000 WELL** mixed U. S. 25c. Monjar, 1750 Fairmount, Cincinnati, Ohio.

**LOW** Price U. S. Foreign Approvals. Scott, 30 Baker Ave., Lexington, Mass.

**FREE:** Conference Stamp. Kilby's Stamp Co., 1658 E. Olive, Compton, Calif.

**NICARAGUA**—Will Rogers set 10c. P. Gustafson, Box 1206, New Britain, Conn.

**LIBERIAN** Triangle Set—104—With Approvals. Vargo Stamps, Racine, Wisc.

## 82 TATTOOING SUPPLIES

**TATTOOING** pays big! Anyone can tattoo with our outfits. Instructions included. Free illustrated literature. Write Tatooco, 651 S. State, Chicago 5.

**TATTOO** Outfits, inks, designs. Write today. Zeis Studio, 728 Leslie, Rockford, Illinois.

## 83 TAXIDERMY

**SPORTSMEN**—Tan animal skins yourself, Indian style. Make fine buckskins, robes, furs, etc. Simple, easy, no equipment needed. Instructions, \$1.00. L. Wickizer, Dept. 6, Johnson City, N. Y.



# POPULAR SCIENCE OPPORTUNITIES

## 84 TOBACCO—PIPES

FINE Six Cent Cigars Available soon. Be first on list for first shipments. Act now. Send no money, only name and address to P. O. Box 776, Dept. F-612, Chicago 90, Ill.

CIGARETTE Papers — Finest quality, gummed or plain, 24 leaf booklets 1c. Rollers 50c, Postpaid. Pete Moberly, Box 786, Owensboro, Kentucky.

CIGARETTES, Cigars, Tobaccos. Buying Details 10c. Nelson, Sunnyside-PS, Indianapolis, Indiana.

FIFTY Quality Cigars \$3.25, \$3.85, \$4.10, \$4.85. Continental Cigars, Corning, N. Y.

## K TRAPPING

ELEVEN good Box Traps. Complete blueprints 30c. Wee-Sho-You, Box 51, Detroit, Mich.

## BB TREASURE FINDERS

SEEK Buried Treasure, Methods, mysteries, devices explained. Circulars free. Century Press, Box 151D, Glen Ellyn, Ill.

MAGIC Indicator Locates Buried Money and Mineral Deposits, \$20.00 Guaranteed, C. Horton, Bellerive, Illinois.

## 85 TREES, SHRUBS, ROOTS, HERBS

HEALTH Seekers! Learn to Live for Health. \$2.50 for 3 booklets teach you how. Dr. Chirila's Naturopathic Clinic, 706 E. Jackson, Elkhart, Ind.

## 86 TYPEWRITERS

USED Typewriters. Mimeograph, multi-graph Printing devices. Also traded and bought. DixieGraph, King, N. Carolina.

## J VOCATIONAL GUIDANCE

DETERMINE the occupation offering you the greatest opportunity for success by using scientific methods. Efficient and economical service. Write, Career Counselors, 601 S. Vermont, Los Angeles 5.

DISCOVER your best abilities through scientific aptitude tests. Information 10c. Testing Service, 507-S2 Gas-Electric Bldg., Rockford, Illinois.

## 87 WANTED MISCELLANEOUS

IF you want to Swap Buy or Sell anything, send \$1 for The National Swappers Guide. It's chock full of Swappers Sellers and Buyers from coast to coast and opportunities to Swap Buy and Sell anything under the sun. National Swappers Guide, 610 St. Joseph, Evansville, 12, Indiana.

PRODUCT suitable for chain store and wide distribution wanted by AA-1 manufacturer. Send details to R. J. Bernard, Kemper-Thomas Co., Cincinnati 12, Ohio. Quick decision.

MERCURY—Highest prices. Free Containers. Write Mercury Terminal, Norwood, Mass.

## N WATCHES

TRAIN yourself for watchmaking, repair, adjustment etc. New all inclusive "Practical Course" for beginners and professionals, also tools, materials. Fully illustrated. Sensational value. \$2.95 postpaid. Money back guarantee. Modern Technical Book Co., Dept. MS, 55 W. 42nd St., New York 18.

WATCH and clock repairing—complete practical course in modern horology. 66 illustrated self-instruction lessons. Just out! Low price. Information Free. Write—Nelson Company, Dept. 8-01-2, Chicago 4.

WATCH and clock repairing increasing, complete home study course with drawings and pictures. Information free. Houston Chronomatic and Watch Co., P.O. Box 5367B Houston 12, Texas.

GUARANTEED watch and clock re-pairing. 8-day service. Mail yours to, Rite-Time, 1318 W. 95th St., Dept. 2, Chicago, Illinois.

## 88 WELDING, SOLDERING

SUPER Welder—For home, farm, factory. Makes even beginner an expert. Improved on type used by Navy. Fully equipped with Metallic Arc and Flame Torch Handles, Carbons, Rods, Fluxes, Mask, etc. Complete directions. Operates AC-DC, 110 Volts. No extra wiring needed. Guaranteed. \$19.95. Save 2% send check with order. Super Welder Mfg. Co., Dept. BN, 23 E. 20 St., New York.

NEW Model electric welder 110 volt AC-DC; will weld all metals; easy to use, full directions. Complete with power unit, flame and metallic arc attachments, carbons, fluxes, rods, mask; all for \$19.95—Used by the Navy. Magic Welder Mfg. Co., 239-PS-9 Canal St., New York City.

RODS, 1/16", 5/64", 3/32" Assortment. 200 Rods \$1.98 Postpaid. General AC/DC Arc. Guaranteed. Little Welder Co., Dept. PS, 15766 Blackstone, Detroit 23, Mich. Six 1/4" Carbons \$1.00.

NEW and Used Arc Welders and Brazers, 220 Volt, 32 Volt, and 110 Volt. Unconditionally Guaranteed. Forney Mfg. Co., Fort Collins, Colo.

MAKE Electric Welder. Using Available Scrap. Guaranteed to weld. Information Free. Write International Incorporated, 6347 Parnell H, Chicago 21, Ill.

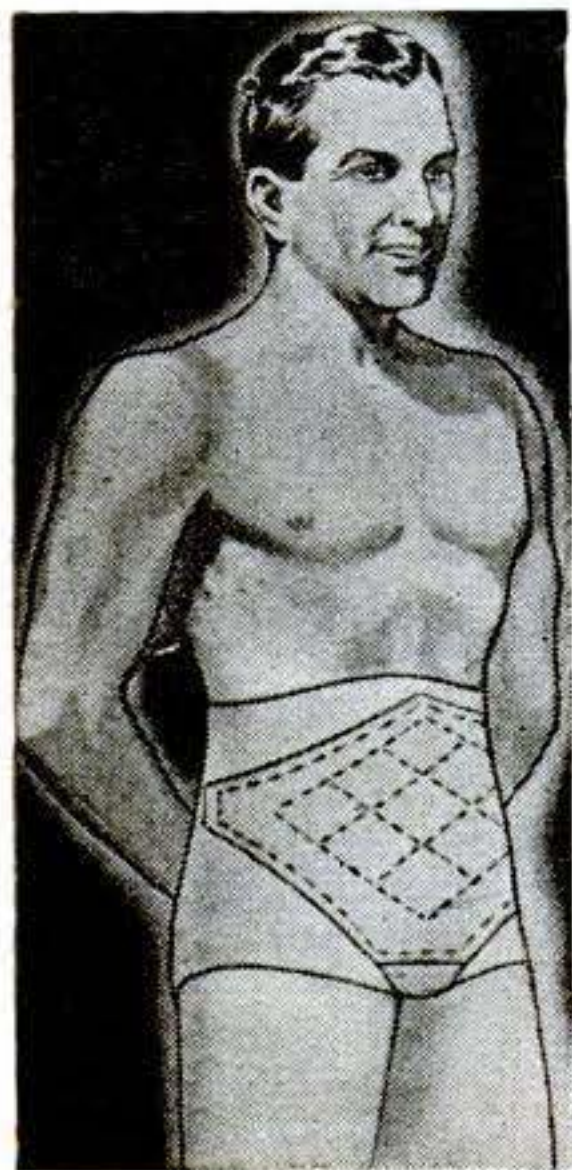

**THOUSANDS of MEN NOW**  
Appear **SLIMMER** Feel **BETTER** Look **YOUNGER**  
with Commander

Now you can get sensational results—at once—with the new **Commander Supporter**. Stay slenderized with this amazing free-action, ever comfortable, elastic woven garment! Once you try it, you'll never be without the Commander!

**"THE INTERLOCKING HANDS"**  
The Sensational NEW PRINCIPLE  
Of Abdominal Support

Clasp your hands over the abdomen, as in the picture—then raise and press gently against it—and notice how much better you feel! Sturdy porous fabric is BUILT-IN with the special stretch weave of the Commander for EXTRA DOUBLE SUPPORT across the abdomen. Instantly the Commander flattens your 'corporation'—BRACES YOUR BACK—Improves your appearance—Your clothes fit smartly—You look better, too. No binding, no riding, no sagging! Send for this famous all-purpose supporter belt today!

TRY IT TEN DAYS  
At Our Expense

Do this today! Send the coupon—wear a Commander for TEN DAYS AT OUR EXPENSE—and if you do not get all the results you expect, return it and YOUR MONEY WILL BE REFUNDED promptly.

**\$2.98**

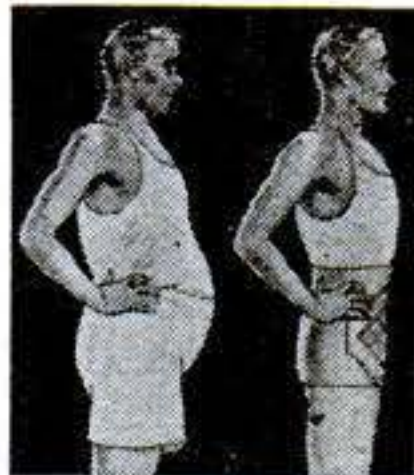

### 10 DAY FREE TRIAL COUPON—MAIL TODAY

Ward Green Company, Dept. T919  
113 W. 57 St., New York 19, N. Y.  
Send me The "Commander" for Free Trial. I will pay postman \$2.98 plus postage. (Sizes 28 to 47.) If not satisfied after wearing 10 days I may return it for a prompt refund. (Sizes 48 to 60 \$3.98.)

My waist Measure.....My Height.....

NAME.....

ADDRESS.....

We pay postage if \$2.98 is included

# Do you want

- .. to go to College?
- .. or to enter a Profession?
- (Such as Accounting, Architecture, Nursing, Dentistry, Teaching, Social Work, Osteopathy, Beauty Culture, Optometry, Embalming, Chiropody, Law, Medicine, etc.)
- .. or get an Office Position?

To get anywhere, you practically MUST finish High School FIRST. You can complete our simplified High School Course in SPARE time at home, as FAST as your time and abilities permit. Equivalent to resident school work—prepares you for college, pre-professional examinations, business, industry. Standard texts furnished. Diploma. Credit for H.S. subjects already completed. Single subjects if desired. Low tuition, easy terms. American School, Chicago, est. 1897—endorsed by educators. Finish your high school education NOW. Write TODAY!

## High School Course at Home

Many Finish in 2 Years

American School, Dept. H646, Drexel Ave. at 58th St., Chicago 37

Gentlemen: Send me FREE information covering special training in subjects checked below. No obligation on my part.

- |  |  |
|--|--|
| <input type="checkbox"/> High School Course          | <input type="checkbox"/> Diesel Engineering                    |
| <input type="checkbox"/> Electronics, Industrial     | <input type="checkbox"/> Drafting and Design for Men and Women |
| <input type="checkbox"/> Architecture and Building   | <input type="checkbox"/> Plastics                              |
| <input type="checkbox"/> Automotive Engineering      | <input type="checkbox"/> Private Secretary                     |
| <input type="checkbox"/> Business Management         | <input type="checkbox"/> Mechanical Engineering                |
| <input type="checkbox"/> Electrical Engineering      | <input type="checkbox"/> Aviation                              |
| <input type="checkbox"/> Elec. and Gas Refrigeration | <input type="checkbox"/> Salesmanship                          |
| <input type="checkbox"/> Air Conditioning            | <input type="checkbox"/> Radio                                 |
| <input type="checkbox"/> Railway Training            |  |

Name.....

Address.....



# Boys! Sportsman! Sensational New Wrist Type Luminous Dial COMPASS

Readable By Day or Night!  
**TRAIL-BLAZER COMPASS**

HERE ARE THE FEATURES THAT MAKE THIS THE GREATEST COMPASS "BUY" In All AMERICA!

- Airplane Type "Sealed In Liquid" Unbreakable Compass
- Shatterproof, Shockproof, Waterproof Construction
- Luminous "See In The Dark" Dial
- Withstands Heat, Will Not Freeze
- Latest Type Plastic Case
- Shows Degrees in All Directions
- Newest Wrist Watch Style Design
- Genuine Leather Strap



Only  
**\$1.98**  
Includes  
Leather  
Strap

Examine for  
**10 Full Days**  
at Our Risk!

• What a Compass this is! Made to give superior performance under any and all climatic conditions. Will not freeze at even 40 degrees below zero. Works perfectly under a blazing sun. Guides you accurately all hours of the day and night.

## SEND NO MONEY!

The ideal Compass for everyone—Boy Scouts, Hunters, Fishermen, Hikers, Motorists and all sports lovers. Unfailing and unbreakable. Complete with smartly styled wrist band.

Pay postman only \$1.98 C.O.D. plus few cents postage on arrival. If not delighted return in 10 days for full refund.

ILLINOIS MERCHANDISE MART, Dept. 221  
500 N. Dearborn St., Chicago 10, Illinois

Rush me the Trail-blazer Plastic Compass on your Money Back Offer. I will pay postman \$1.98 plus postage on arrival with the understanding that if I am not completely satisfied, I can return it within 10 days for full refund.

NAME.....  
ADDRESS.....  
TOWN.....STATE.....

# GIANT TELESCOPE OFFER



## BIG-POWERFUL OVER 3½ Feet Long!

The Yankee Clipper Super Telescope is by far the biggest, most powerful Telescope ever made to sell for only \$1.98 with Carrying Case included. It's guaranteed Super power and measures over 3½ feet in length from end to end. Lenses are of optically-ground polished glass. So powerful you can clearly see people and wild life miles away and watch what they're doing when they can't see you. Sensational! Exciting! Fun and adventure such as you've never known before.

Only  
**\$1.98**  
CARRYING CASE INCLUDED



Large  
Optical  
Lenses

Examine  
For 10 Days  
At Our Risk!

Just write name and address on handy order coupon and mail back to us today. Upon arrival of Yankee Clipper Telescope with Carrying Case deposit only \$1.98 plus a few cents postage with postman. If you are not positively thrilled and delighted with the way this Yankee Clipper Super Telescope helps you to see great distances return in 10 days for full refund. Rush order today and get durable Canvas Military Style Case on this special offer. Hurry—while the supply lasts.

**Send No Money!**

ILLINOIS MERCHANDISE MART, Dept. 3131-A  
500 N. Dearborn St., Chicago 10, Illinois

Please rush me the Yankee Clipper Telescope with Carrying Case. On arrival I will pay postman only \$1.98 plus few cents postage charges. If not delighted I can return in 10 days and get my money back in full.

NAME.....

ADDRESS.....

CITY & ZONE.....STATE.....

Enclosed find \$1.98. Please ship the Telescope with Carrying Case all postage charges prepaid.



# FAMILY PLANE COST CUT IN HALF

## Taylorcraft "Foursome" Already Flying!



**B**EFORE the war, 4-passenger airplanes were heavy, high-powered and costly. Prices were from \$7,500 to \$15,000 and more.

The new Taylorcraft "Foursome" takes the family plane out of this luxury price bracket for the first time in aviation history—yet provides luxury features never before obtainable in an airplane, regardless of price.

For instance: the biggest, roomiest cabin ever built into a 4-passenger plane. Electric starter—no prop spinning. Unlimited visibility—with wide windows all around and the new Taylorcraft one-piece

sunproof windshield. And performance *superior* to the heavy, costly prewar ships in many respects.

The instrument panel is compact and uncomplicated like the dashboard of your car, and the engine—what an engine! Light, powerful and smooth performing, it harnesses 125 horses—expert aeronautical engineers say it is the best all-around, most economical engine ever built for a 4-passenger plane.

See your local Taylorcraft dealer. He will gladly give you full particulars and tell you how convenient budget payments can be arranged.

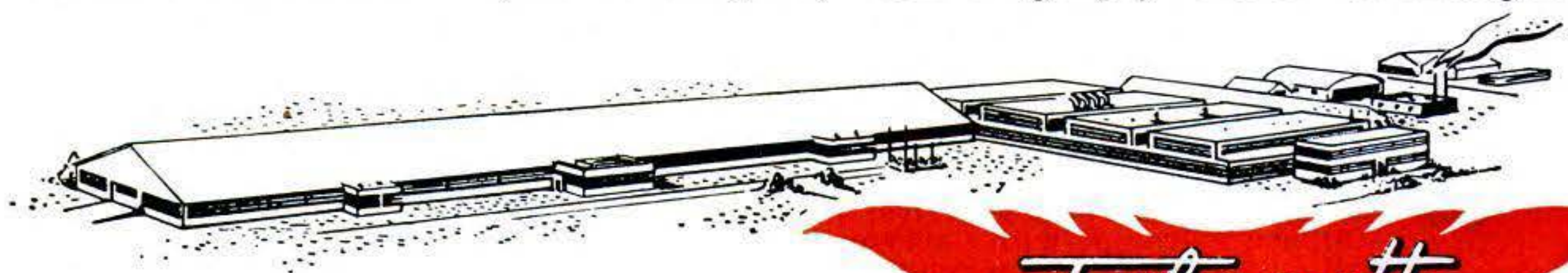

*Taylorcraft*

*World's Largest Builders of Side-by-Side Airplanes*

TAYLORCRAFT AVIATION CORPORATION • ALLIANCE, OHIO



## How Fighters Shoot Down Planes They Can't See

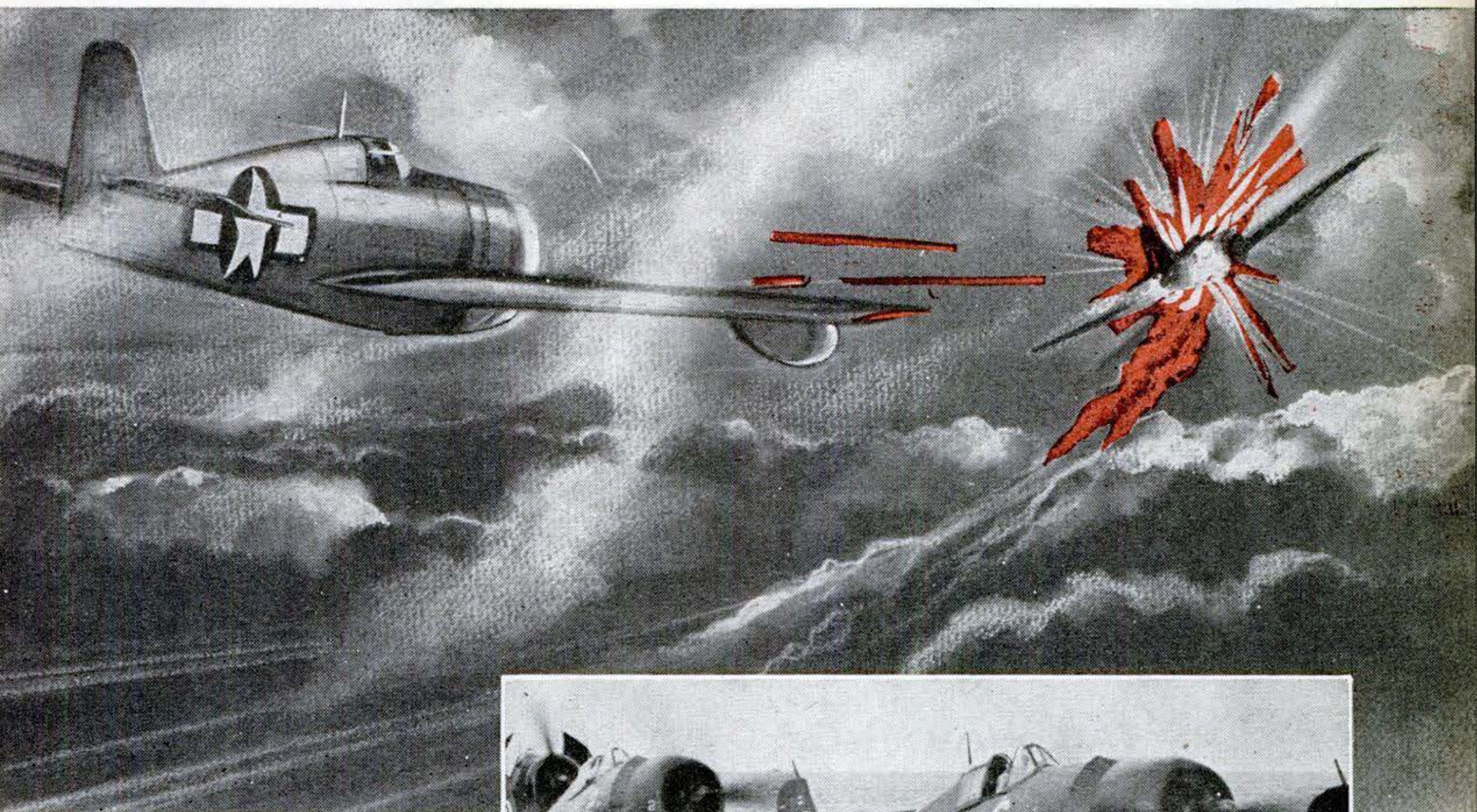

**RADAR DOES IT!** In blinding fog, a Grumman Hellcat intercepts and destroys a Jap plane. At right, a night fighter of this type rests on a carrier deck. White-nosed nacelle near wing tip is one of the radar units that guide it unerringly to its quarry.



# **RADAR... Magic Eye** **That Sees the Invisible**

**VEIL OF CENSORSHIP LIFTS TO REVEAL NEW SECRETS OF  
THE VERSATILE WEAPON IN WHICH WE LEAD THE WORLD**

By **JAMES L. H. PECK**

*Drawings by ERIC SLOANE*

**R**ADAR sees all, hears all, and tells all," an AAF pilot once remarked. "It has penetrated everything but the thick veil of secrecy behind which it has been screened." Now that the boys in the Pacific are even using radar to fish with in their spare time, its story has come crackling through censorship, too.

You've seen a searchlight throw a long, focused beam of light into the sky. It fades away into the darkness if it does not hit anything, but if the light strikes an airplane, some of it is reflected back to your eye. Suppose that this searchlight used radio waves instead of light; that it sent these waves out at rapid intervals; that it caught the waves whenever they hit an object and bounced back; and that it computed the distance they had traveled by



LOCATION OF LANDING  
FIELD, EVEN THROUGH  
CLOUDS →

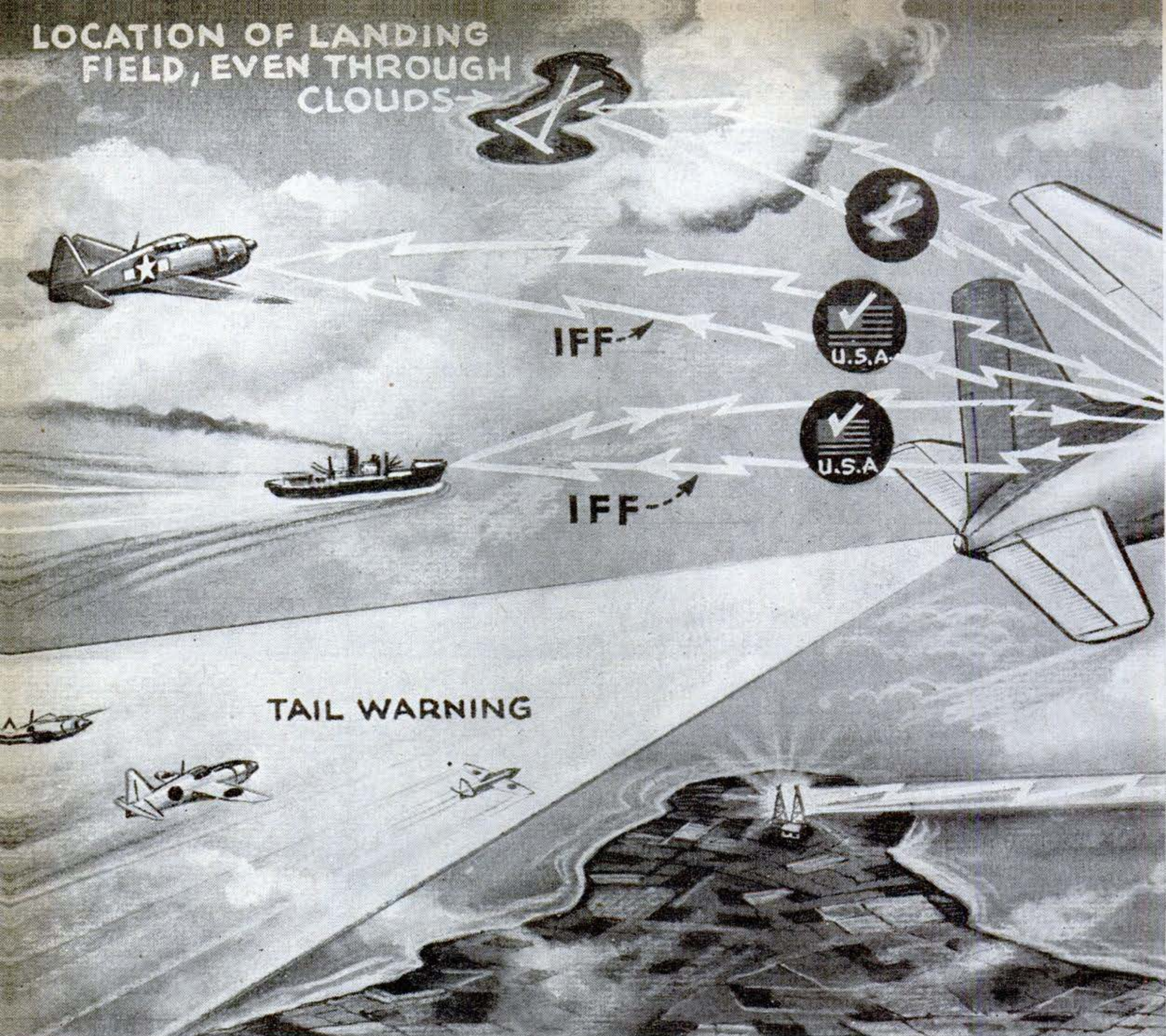

**SOME OF THE WAYS A BOMBER USES RADAR** are shown in this imaginary view. While search radar combs the sky ahead, IFF (Identification of Friend or Foe) demands an automatic countersign from unknown planes and ships; a radar long-range navigation beam gives the pilot a bearing for finding his position; another device slices through fog or clouds to reveal a target or a landing field; tail-warning beam scans a cone astern to detect hostile planes beyond the range of vision.

noting how long the round trip took them. That's the essence of radar (RADio De-tection And Ranging).

The radar operator (RO) on the ground at a fighter-control station on Okinawa announces the detection of an approaching Jap bomber by radioing one word to a Black Widow's crew: "Trade." He then tells the men in the night fighter 65 miles away the direction and distance of their foe: "Climb to 11,000. Vector, 2-9-7. Range, 42 miles."

As the Black Widow banks around to a northwest course and surges forward at 350 miles per hour, the radar operator on the ground can note its progress as well as that of the Jap plane. At the same time,

another RO in the glassed-in rear of the Black Widow's fuselage adjusts his shorter-ranged, airborne-intercept (AI) radar set.

Invisible radio detection beams are thus shot at the Jap from both the ground station and the AAF night fighter. Officers on the ground chart the courses of the two aircraft on a tablelike plotting board; as the planes come closer together, another code word is radioed to the fighter: "Punch."

The gunner in the Black Widow, meanwhile, makes the adjustments necessary to enable the fighter's radar apparatus to aim and fire its turret machine guns at the enemy.

"Pilot from radar," says the RO in the



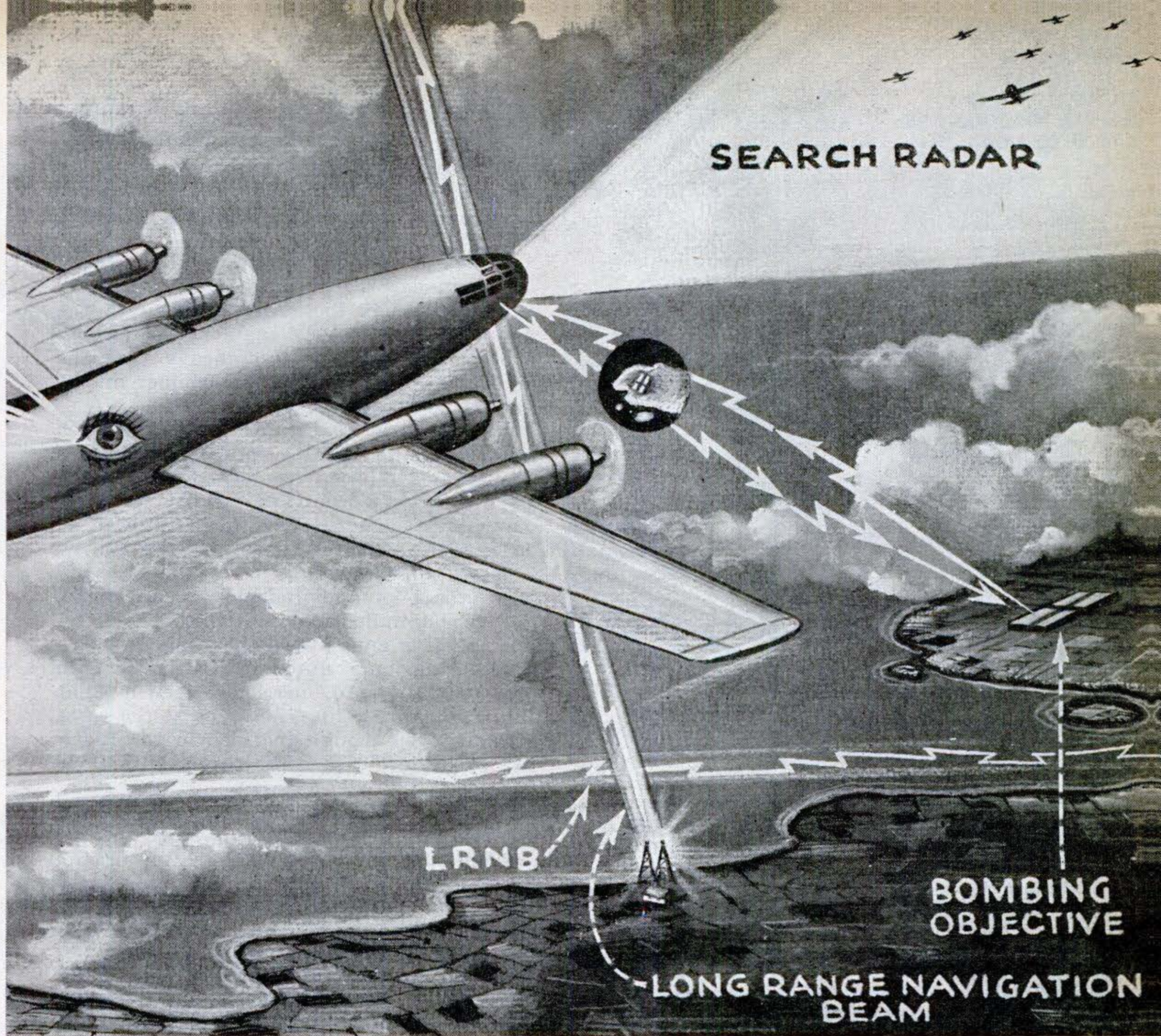

A Privateer (Navy patrol-bomber version of the B-24 Liberator) displays a load of radar gadgets. On top of the fuselage, back of the gun turret, is the IFF antenna. Under the belly, the second white "radome" is the "potato masher" for jamming enemy radar. The rounded bowl is the retractable "dish" antenna of the ASV (Air to Surface Vessel) search set. Rods behind this are antennas of the radar altimeter.



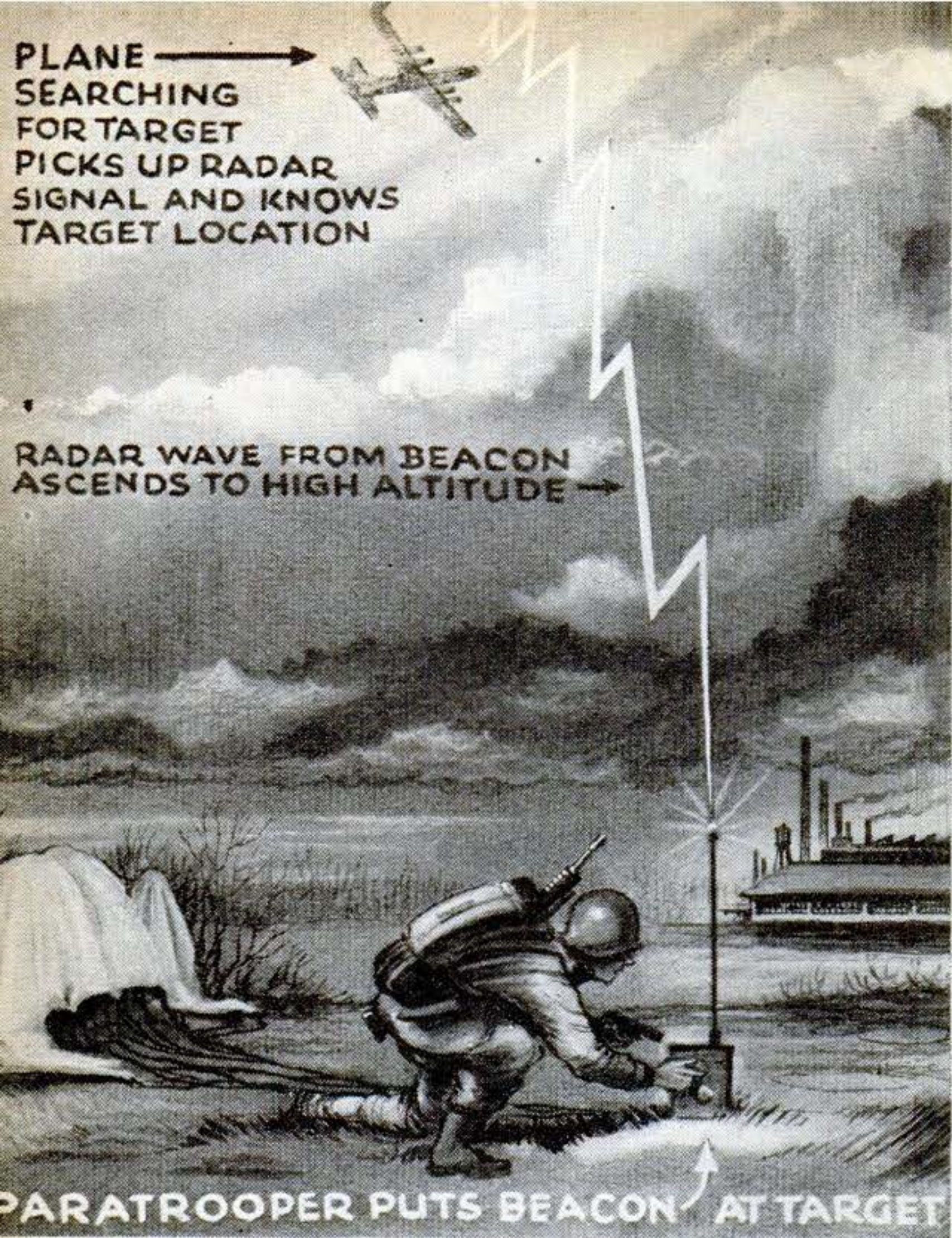

PLANE →  
SEARCHING  
FOR TARGET  
PICKS UP RADAR  
SIGNAL AND KNOWS  
TARGET LOCATION

RADAR WAVE FROM BEACON  
ASCENDS TO HIGH ALTITUDE →

PARATROOPER PUTS BEACON → AT TARGET

**SMALL RADAR BEACONS** can be planted near important targets in enemy territory by paratroopers or commandos. All that our bombers have to do is to "home" on the signals, which guide them to the spot and direct their bombing through overcast. The automatic beacon may even be dropped alone on a parachute by a fast fighter.

**RADAR SAVES LIVES** of ditched airmen. Life rafts are now equipped with "corner reflectors"—flower-shaped antennas that are set up to throw back the pulses from transmitters of search planes. Reflected pulses create a distinctive pattern on the scope, guiding rescuers directly to the scene.

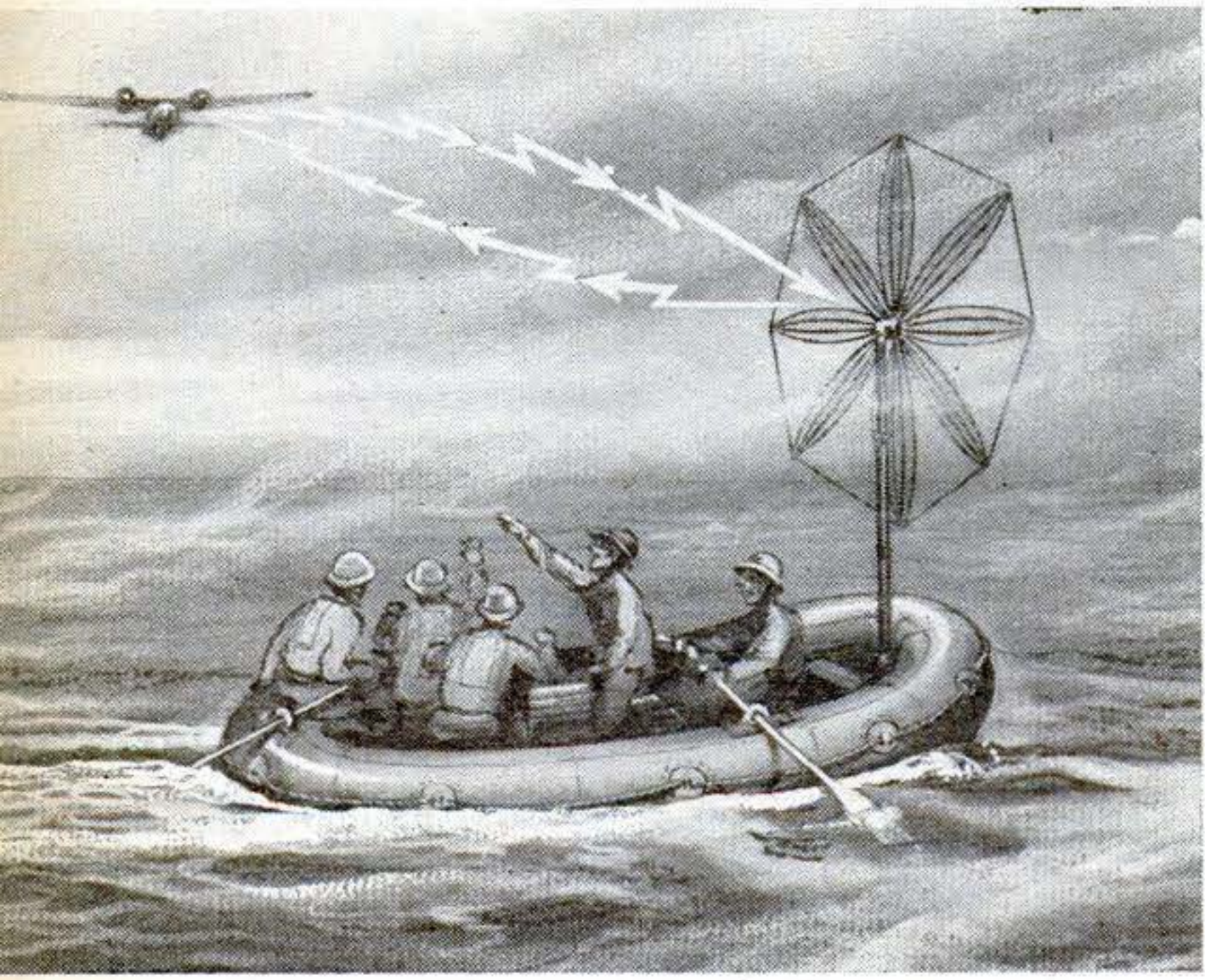

night fighter when he sees a "blip" of light on the screen of his radar that tells him the waves from his apparatus have begun to bounce back from the Jap. He speaks over the plane's intercom, "Target, 11 miles. Bearing, 20 degrees."

"Roger," says the pilot, and proceeds accordingly.

"Judy," sings the radar operator in the Black Widow to his colleague at fighter control on the ground; this means that the fighter has spotted the Jap bomber and is taking on the job of destroying it.

Now the RO in the Widow must watch the screens, or radar scopes, on his instrument panel to keep from losing the image of the target. There's a penalty for this; he will be demoted to ground duty if he loses a target three times. As the Widow closes in on the Jap in the darkness, he advises the pilot and gunner: "Dead ahead. Range, one mile. Mark, gunner."

That's the gunner's signal to flip a switch that brings the automatic airborne gun layer (AGL) into operation. It will sight and fire the four machine guns at the right instant, even though the men in the Black Widow have not seen the target with their eyes.

The roar of the two big engines is broken by two short bursts of fire from the .50 caliber guns, directed by the fighter's radar eyes. Flames reveal a Japanese Betty medium bomber, with a kamikaze, or baka bomb, snuggled beneath its belly. The Widow may swing around to let it have a few bursts of visually sighted fire from the four 20-millimeter cannons in her fuselage.

The result will be reported in one word, spoken into the microphone by the RO in the Widow and heard by the men on the ground: "Murder!"

That is how radar is used in Black Widows. The single-seater Corsair and Hellcat carrier fighters have a different kind of radar equipment (AIA instead of AI) which enables the pilot to do everything. The target appears on the radar scope of this apparatus as a large dot of light, and the pilot flies so as to keep that dot lined up in the center of his scope. The size of the dot that is the enemy plane tells him when he is within range.

The heart of radar is a cathode-ray tube, shaped like a trumpet, through which electrons are shot. These tiny negative charges of electricity we call electrons bombard and illuminate a fluorescent screen on the flared, wide end of the tube. Alterations in the current result in the formation of light patterns on the dimly glowing screen. The nature of these patterns, and the alterations in the electron stream that cause them, is determined by the very short



# MEASURES FOR DEFENSE AGAINST RADAR

**L**IKE every other revolutionary new weapon, radar has been met with defensive measures. The most common of these are artificial reflecting agencies and "jamming" with other kinds of radio sets.

"Window"—strips of paper-backed tin foil—has been used effectively by both Allied and Axis planes. As shown in these drawings, it is scattered in the air to reflect radar impulses and blur the echo pattern.

Dropped early in a mission, "window" can thwart early - warning radar, making the operator overestimate the bombing force.

German "window," good only against microwave radar, was dull black. The Allied type is silvery, like tinsel.

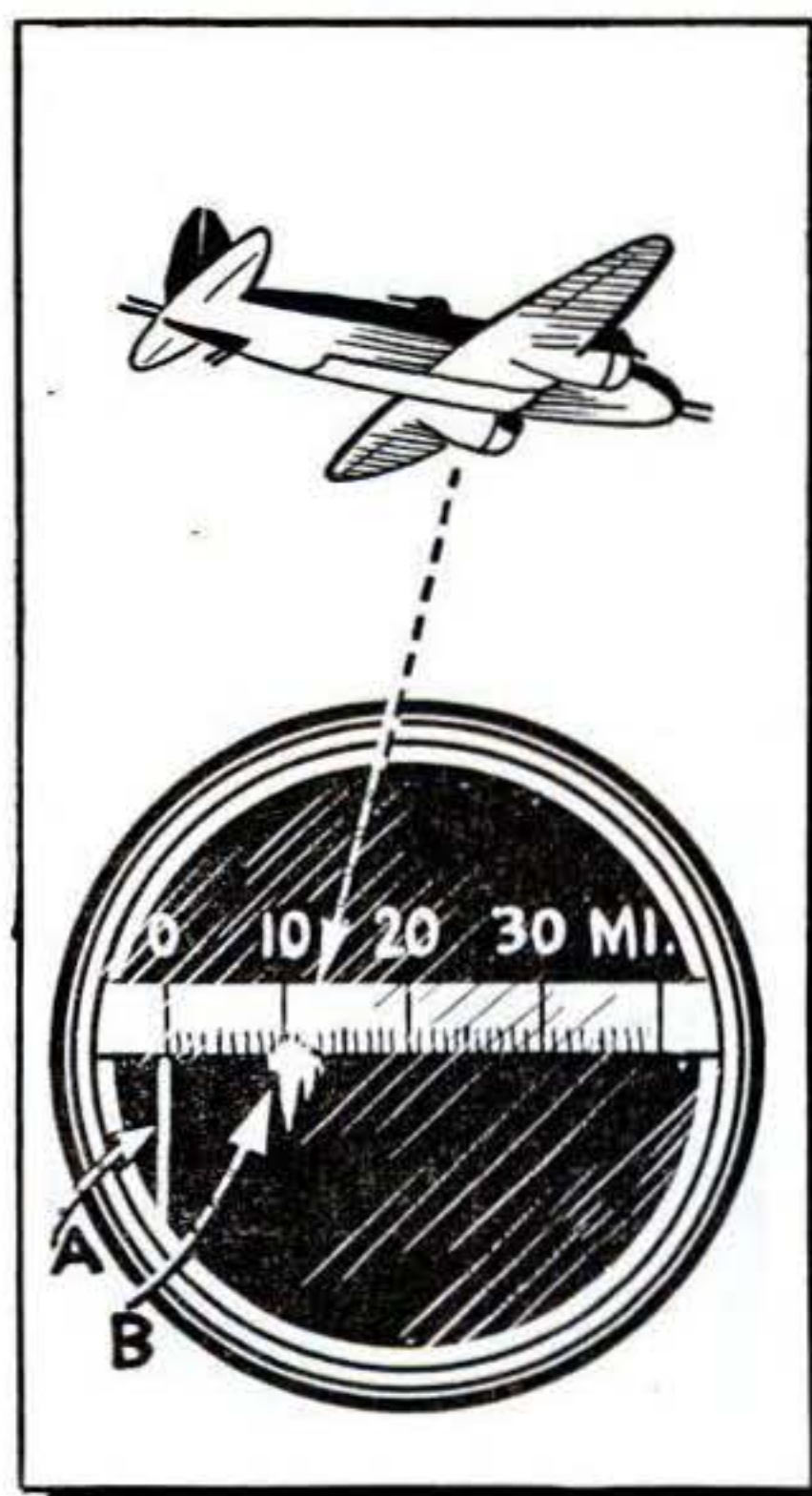

**1** A ground radar station detects a plane by the echo, or "blip," (B) on the scope. Scale shows elapsed time, and therefore the range. The anti-aircraft guns then go to work.



**2** Scraps of tin foil are scattered by planes to blur the radar echoes, producing a hazy pattern that makes range-finding impossible. This device is used by both Allies and enemy.

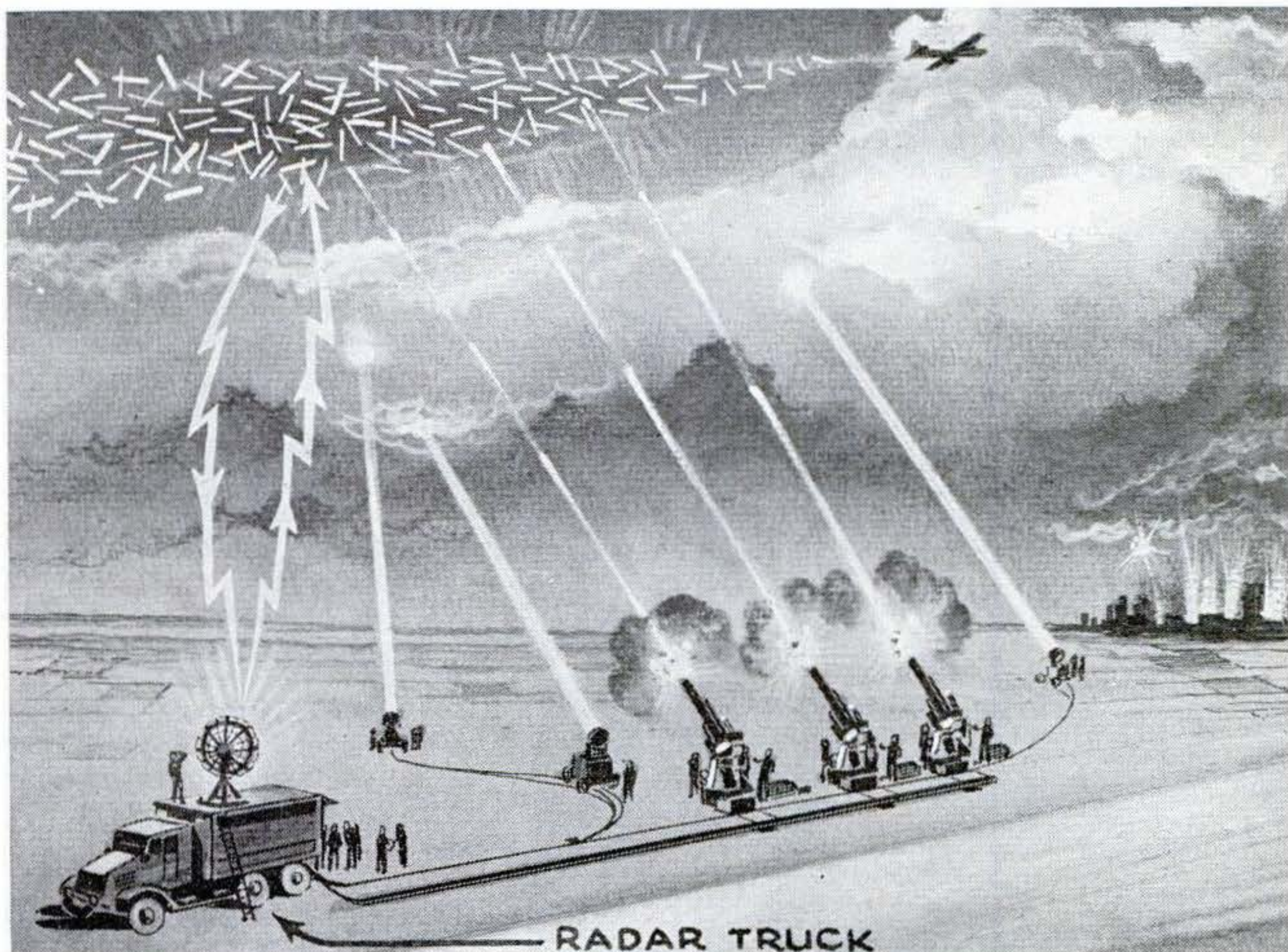

**3** The plane makes its escape as radar-controlled anti-aircraft guns are thrown off their aim. The strawlike strips of paper-backed tin foil are called "window" because, as one British radar sergeant-operator put it, "It makes a window in your scope so big that Jerry flies right through it."



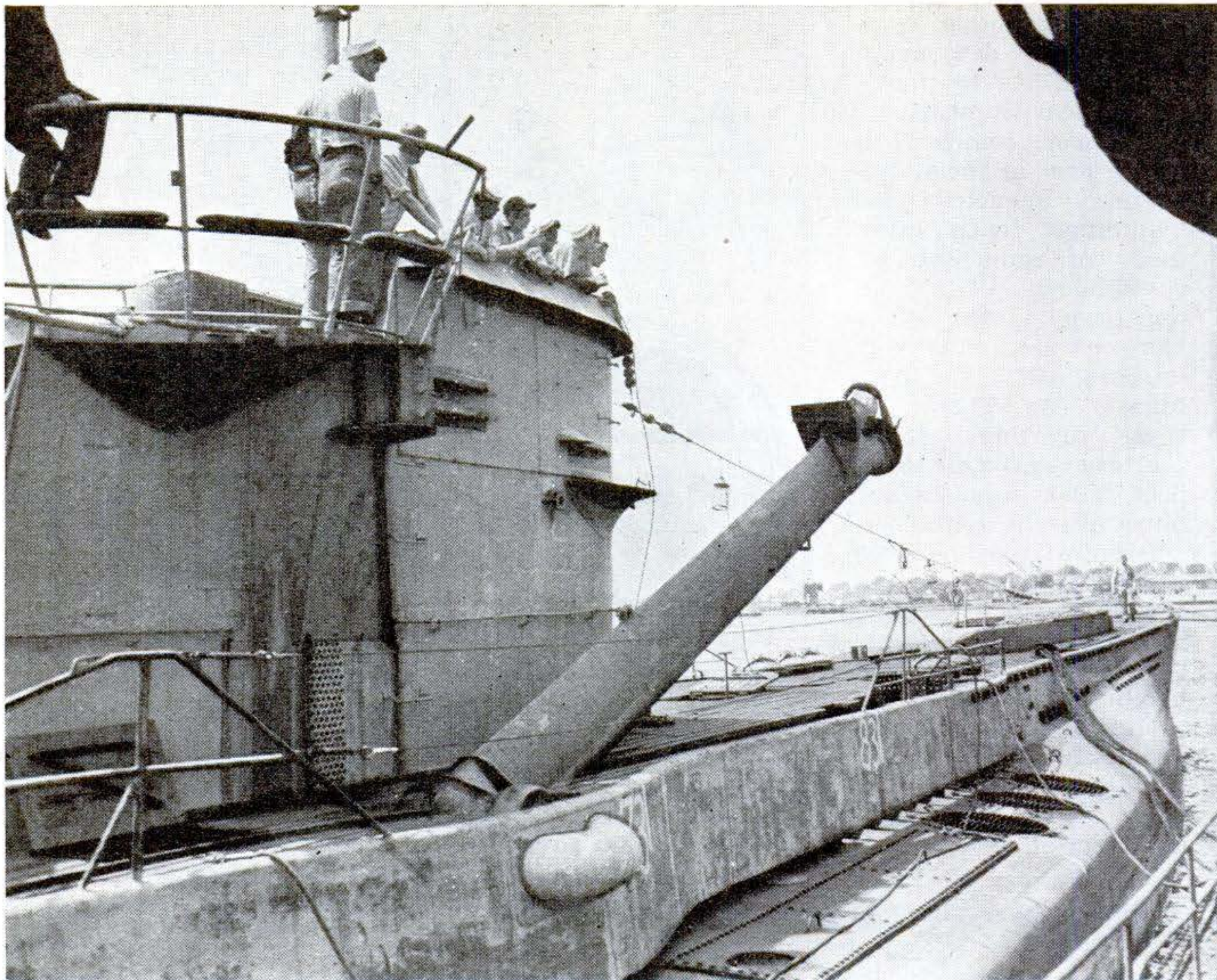

Radar detection made it so hot for enemy submarines that the Germans adopted the "schnorchel" (breather) for charging batteries while submerged. Here is one on a captured U-boat. It folds when not in use.

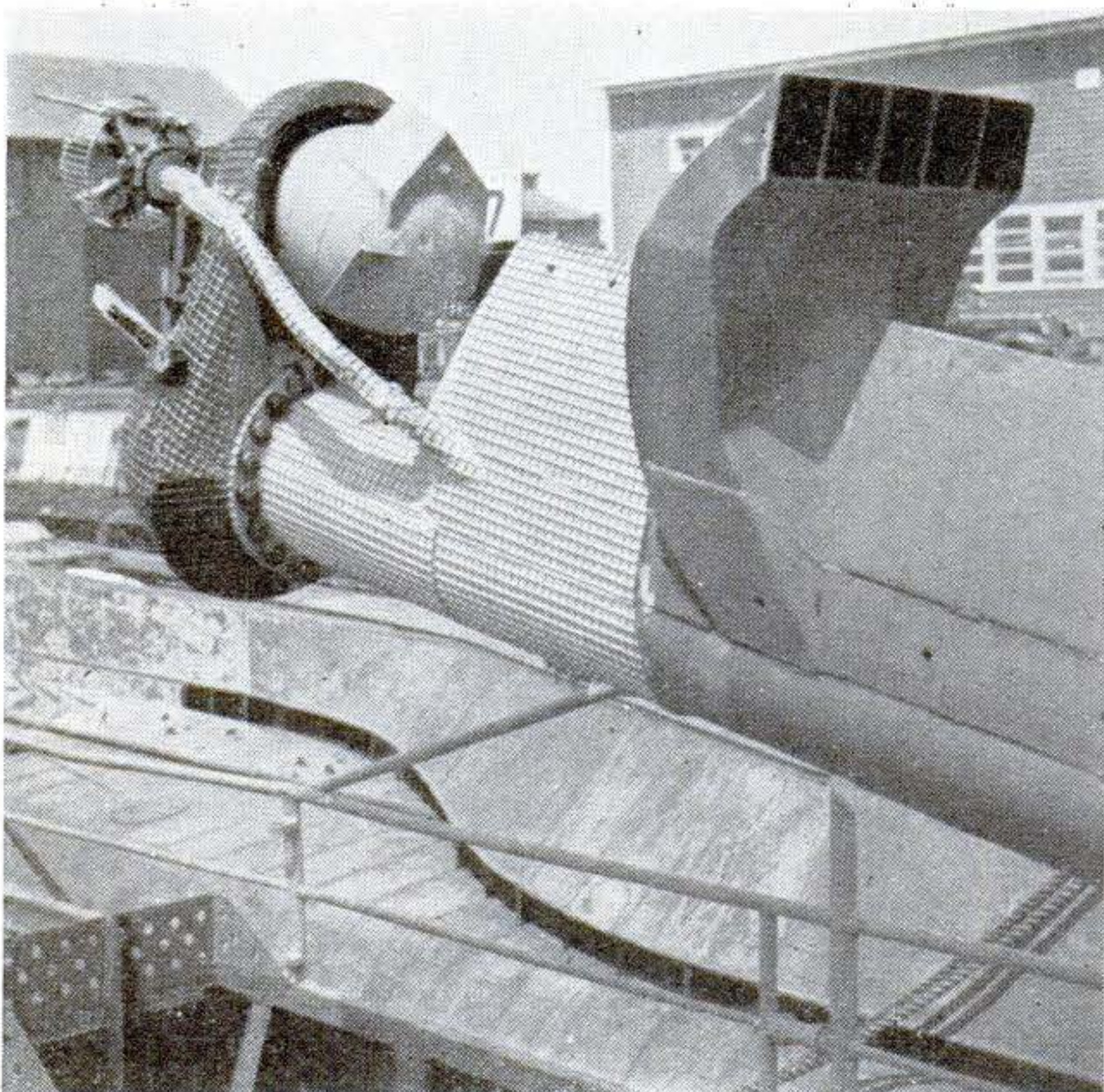

The German sub carried radar of its own, for spotting Allied ships and planes. Equipment was mounted on the schnorchel.

radio waves that bounce back from the detected object.

Since the speed of these pulses is the same as the speed of light—which can flash the 186 miles from New York to Baltimore in one thousandth of a second—the time it takes the waves to go from the transmitter antenna to a distant object and back to the cathode tube is extremely brief, but it is measurable. This measurement gives the distance, or range, of the target. The direction, or bearing, of the located object is revealed by the direction in which the radar antenna is aimed. Several types of antennas are used.

The Japs do not seem to have the laboratories and the materials to put their radar equipment on a par with American sets. Their present warning and fire-control devices compare only with early 1942 American radar. Their airborne equipment appears to be



even less efficient. However, they are making intelligent use of what they have.

The Germans, too, got off to a late start in radar development; but, when V-E Day arrived, their warning and fire-control apparatus was nearly as good as ours. The Luftwaffe did not employ airborne sets as widely as did the Allies.

The British led in the development of what they then called "radio-location." They introduced many of the present applications, such as navigation and bombing through the overcast. But their devices had many limitations, which were overcome largely by American scientists and Army and Navy technicians. Although most of our radar experimentation has been carried out as a joint operation, U. S. experts have made more rapid improvements, and more of them. Today, we are farther advanced than any other nation, thanks also to industrial plants such as RCA, Bell, General Electric, Western Electric, Westinghouse, and Philco—to name only a few.

Amazing strides have been made since we used the long-wave, broadcast-frequency types at Pearl Harbor, where Private Joseph Lockhard (officially off duty) detected the unidentified planes that turned out to be Japanese. This long-wave equipment was

also used during the epic Battle of Britain, and is credited—along with the RAF—with saving England. The long broadcast waves provided good range and a wide coverage of the sky. However, the very nature of these radio waves that permitted RO's to scan wide sectors resulted in the formation of blind spots, particularly close to the ground.

Much of the newer equipment, brought into use since 1942, is of the microwave type. These extremely short waves—measured in terms of megacycles and centimeters, instead of kilocycles as in your radio—do not scatter like broadcast transmissions and have a much better bouncing quality, or "mirror effect." The combination of long- and short-wave radar has been used with great effectiveness. The microwave apparatus covers the blind spots left by the long-wave sets. The latter, like a widely focused searchlight, is effective for finding the target; but the microwave equipment is used to better advantage, like a higher-powered, narrower-beamed spotlight, to put the finger on the enemy after he is first detected.

Such detection was the first use to which radar was put; it was purely a device with which the enemy *(Continued on page 210)*

## SEE IF YOU CAN READ THIS RADAR SCOPE

This is the viewing scope of the PPI (Plan Position Indicator). It shows the area below; center dot is plane's position. Numbers on rim give bearing; concentric circles, range. Water areas appear dark, land areas light. The luminous arm sweeps over the area.

- 1 A flight of planes. It may be identified as friendly or hostile by radar challenge (IFF).
- 2 Frontal clouds. Radar also tells the weather lying ahead of plane.
- 3 "Sea return"—echo of radar waves from rough sea—is interference.
- 4 Promontory and islands. Any shore installations?
- 5 Task force of warships. Search planes report their size and course.

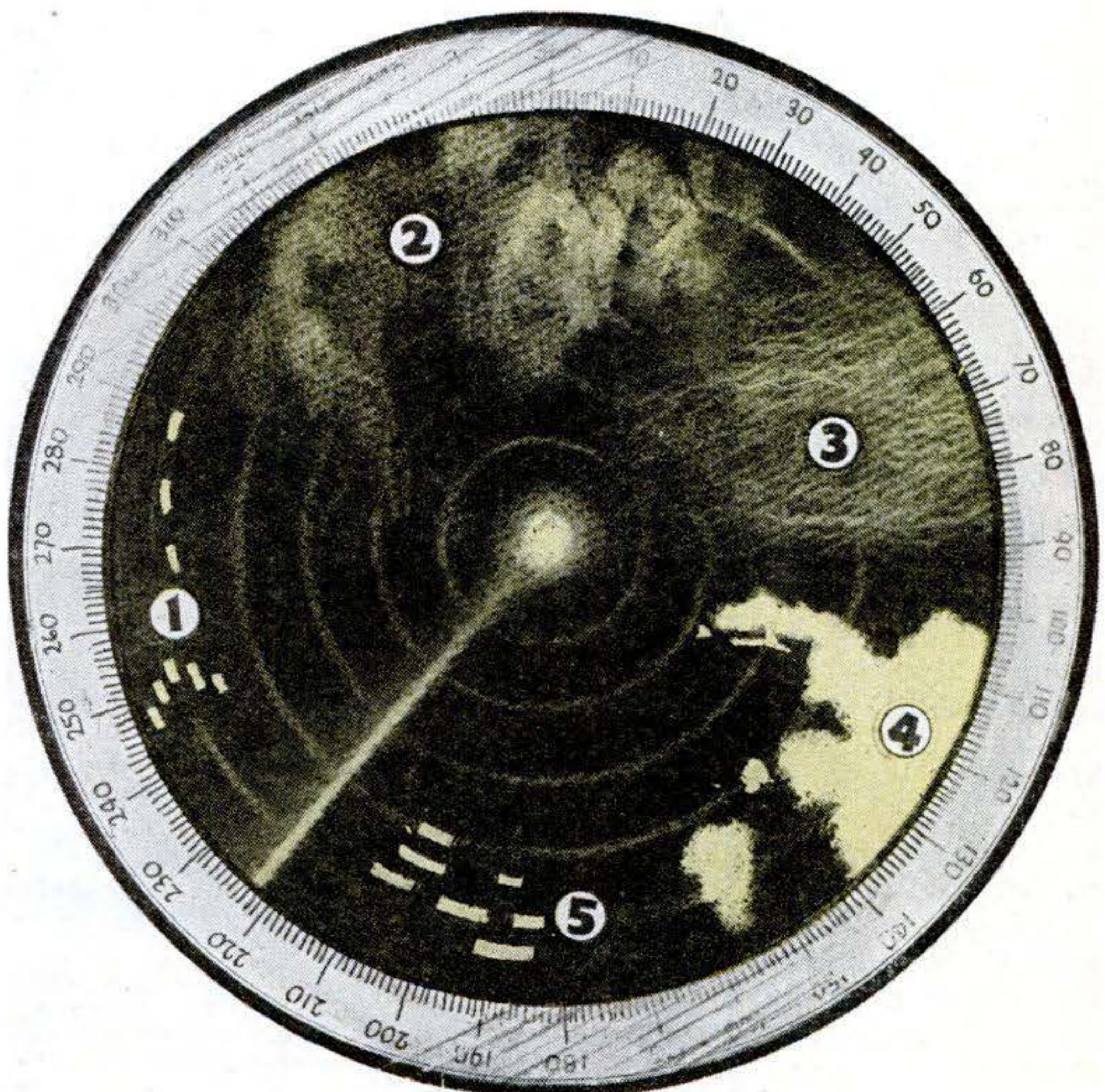



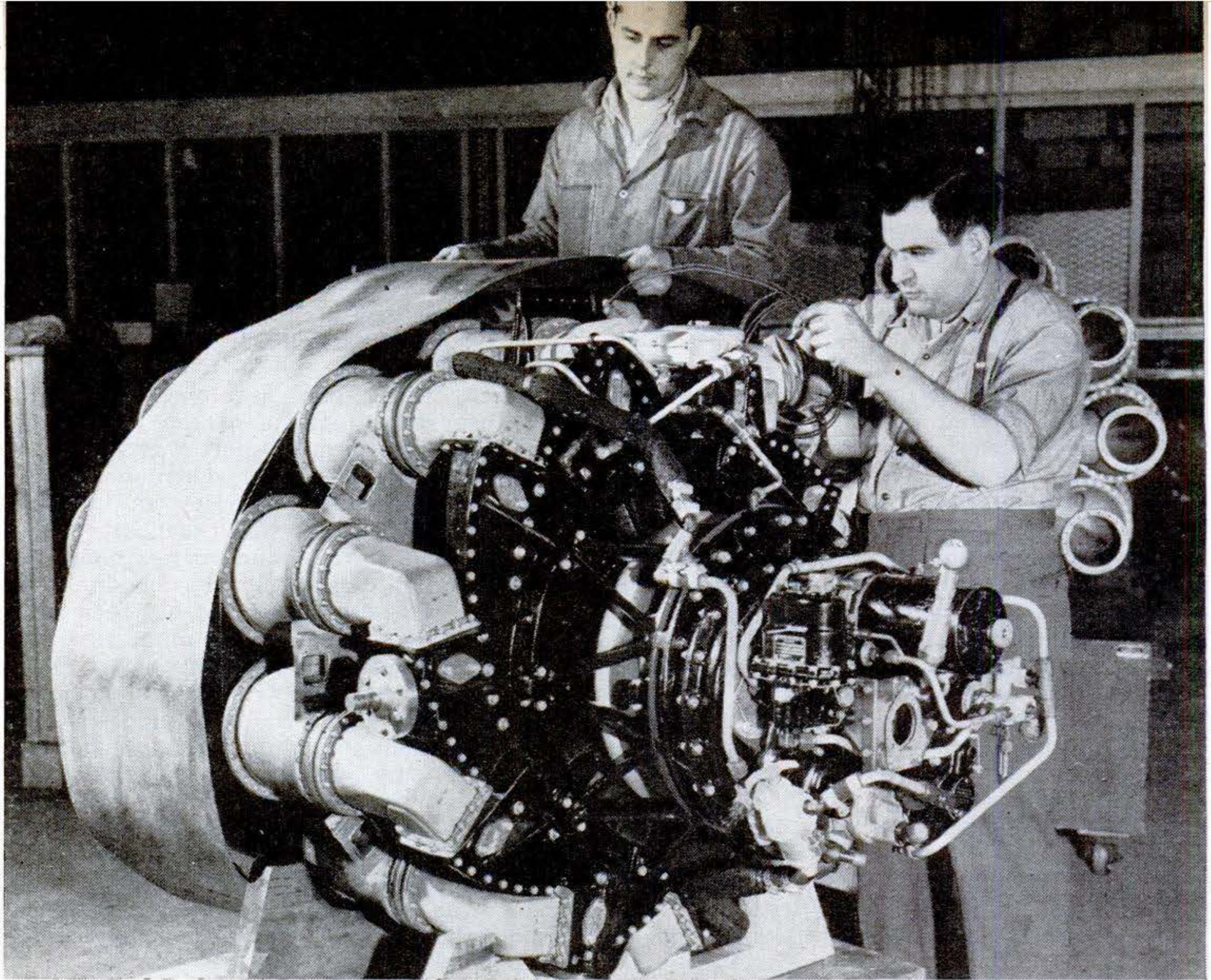

## Here's What Makes Our Jet Planes the World's Fastest Fighters

WE HAVE been reading and hearing a lot about the spectacular jet plane, but here is the first picture of a jet's power plant to be released for publication. Two of these General Electric engines propel the P-59A Airacomet, while a somewhat similar Super G-E Jet drives the P-80 Shooting Star.

Just inside the front cover shield, at the left, is a compressor, which whips air to combustion chambers. There fuel, usually kerosene, burns fiercely, increasing the velocity of the air and hot gases that pass through a turbine wheel and on out by way of the jet exhaust.

## Golf-Ball Picker-Upper Retrieves Pellets and Protects Its Operator

HERE'S a golf-ball retriever that does its job on a practice driving range even while a shower of the white pellets is falling. Towed by a motor scooter, the contraption has 52 wooden disks which turn on an axle as the machine rolls over the fairway. The balls become wedged between the disks and are carried forward. Steel fingers at the front end then knock them into a metal tray. Jerry Claps, of Newark, N. J., is the inventor; his wife, under the screen, the operator.

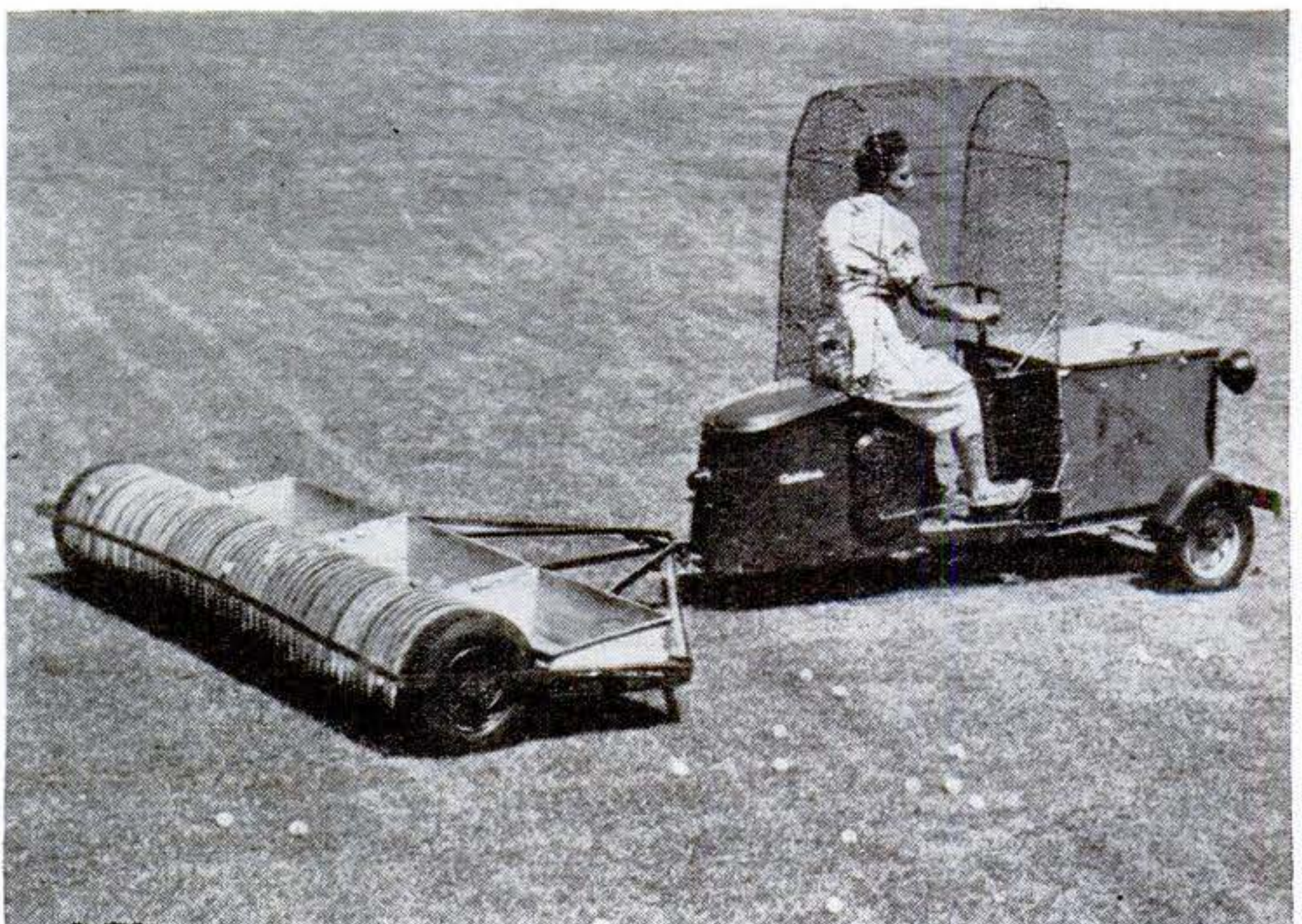



## "Baseball" Parachutes Don't Wobble Coming Down

A NEW-TYPE parachute, named "baseball" because of its similarity to half of a baseball cover, has the advantage of greater directional accuracy. The conventional parachute, launched from a fast moving plane, leaves almost parallel to the earth. As it opens, it spills air from its upper edge, causing the 'chute to swing in the opposite direction, again spilling air. This is repeated all the way down. A jumper can control this oscillation to some extent by pulling the lines on the side that spills air. The baseball parachute holds most of this air because of its hemispherical shape, thereby eliminating most of the sway. It was developed by Leonard P. Frieder, president of General Textile Mills, New York, and Walter Finken, chief engineer. The design can be used for both cargo and personnel 'chutes.

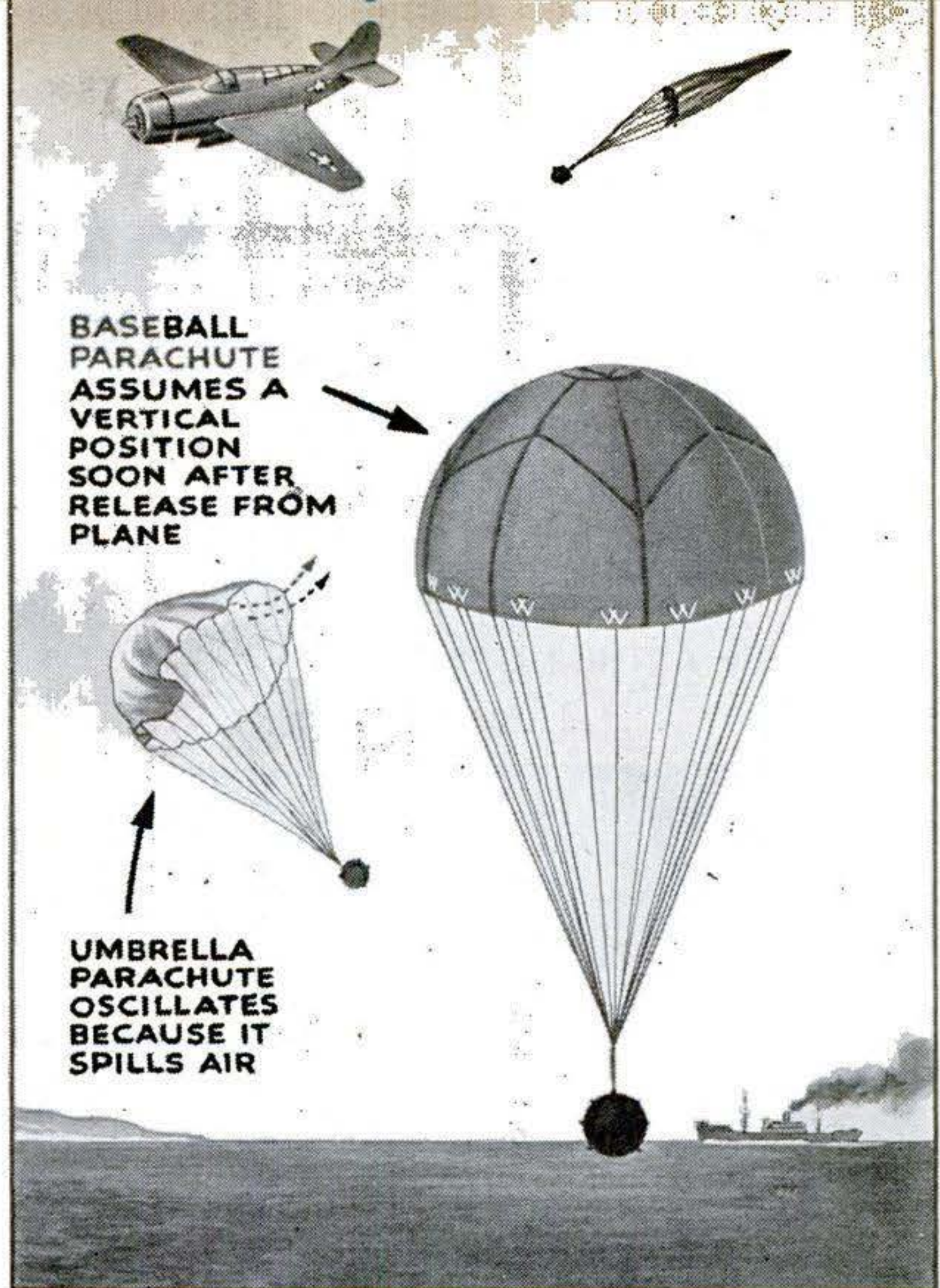

## Biggest Helicopter Carries Crew of Two and 10 Passengers

THE PV-3, first helicopter designed for air-transport operations, is also the first successful one to use two rotors in tandem. The fuselage is 48 feet long and 13 feet high, and houses the Continental-Wright

R-975 engine aft of the cabin. The PV-3 can land in a 100-foot-diameter clearing on land or water. It was designed for Coast Guard and Navy air-sea rescue and transport-service requirements.

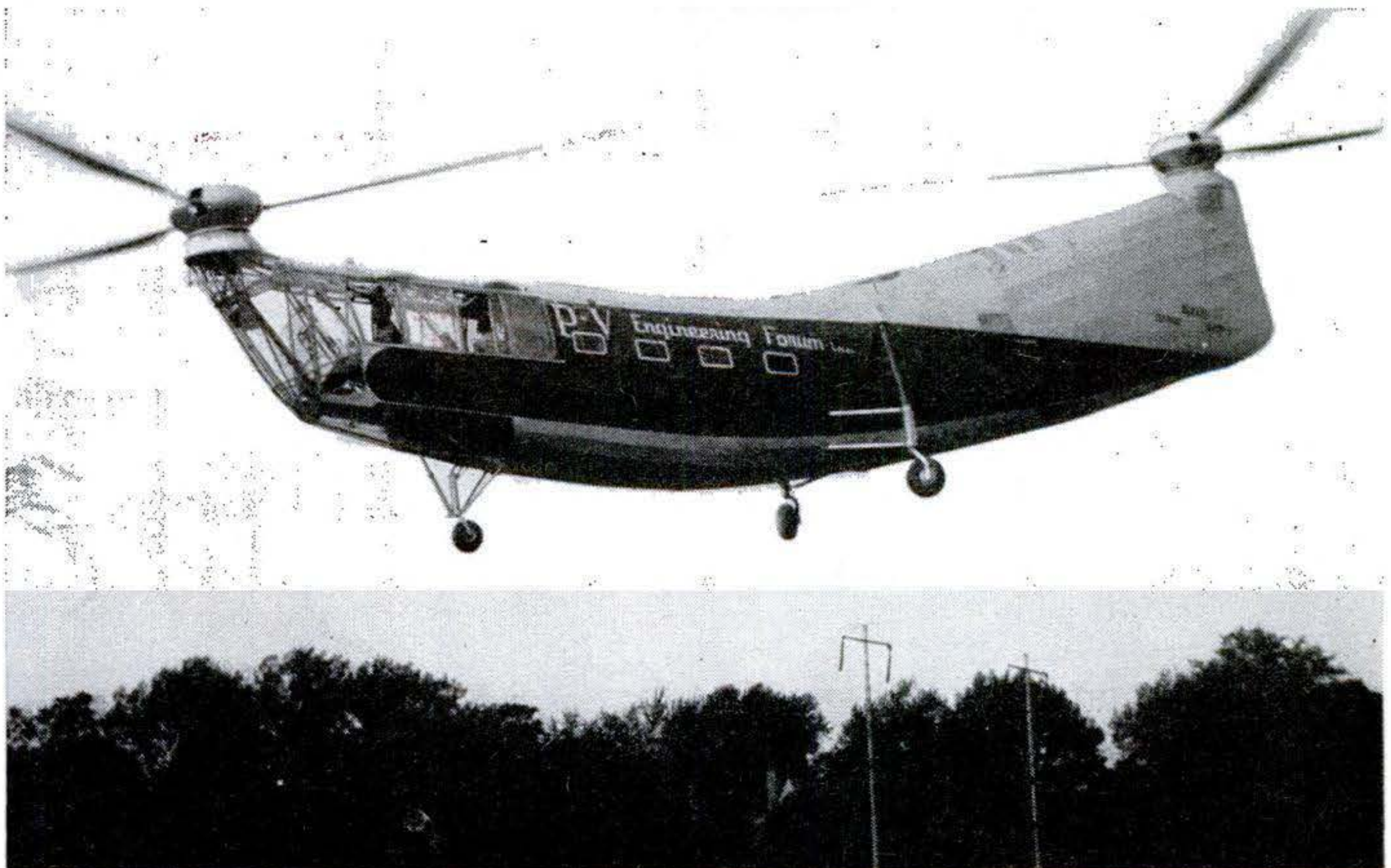



# U. S. Infantry Fights

Lightweight vests of nylon and thin metallic plates save GI's from Japanese shell fragments.

By ARTHUR GRAHAME

**B**ODY armor is reducing the number of casualties among the American infantrymen storming into the heart of the Jap homeland.

Like the knight of the Middle Ages, the GI is protected against the lance of battle—in modern war, the shell fragment. The armor is light and compact. It can be shed



Photographs by  
WILLIAM W. MORRIS  
and HUBERT LUCKETT

●  
**FRONT** view of U. S. infantryman's body armor shows the 12-pound vest that protects front and back, and the detachable 1½-pound apron. They stop shell fragments causing most wounds.

**BACK** is shielded down to the waist. The panel at the shoulders unfastens at the top for folding; lower part of back has same protection built into it.





# in Aluminum Armor

in a twinkling and packed away in his kit. Except under the most strenuous battle conditions, when ease of movement is paramount, it is worn with comfort.

The adoption of body armor by the Infantry, just announced by the Ordnance Department, means two things: fewer and less serious wounds, and fewer replacements of troops on the battlefield.

Eight percent of all battlefield casualties, and half the deaths, are caused by shell fragments (sometimes erroneously called shrapnel). When the bursting charge of a high-explosive shell detonates, the steel projectile is shattered into thousands of fragments which are thrown unevenly over an area proportionate to the size of the shell. These fragments vary widely in size and shape. Some are dustlike particles of steel; others are jagged slivers weighing a small fraction of an ounce; comparatively few are larger chunks of metal. They are projected from the bursting shell at a speed of about 3,000 feet a second, but they lose velocity

quickly and seldom are traveling over 1,500 feet a second when they strike. No body armor light enough for a soldier to wear can protect him against a direct hit by a high-explosive projectile, or even from sizable fragments from a burst close to him, but the body armor being supplied to our men can and does protect them against a large majority of fragments.

The GI's armor is designed specifically to stop most shell fragments from penetrating the skin. Most wounds occur in the torso. That's the area the armor protects.

Body armor is not new in this war. Bomber crews have been using it in the form of "flak suits." These are easy to wear because a man in a bomber doesn't move around much. Armor for the warrior with only his own feet for mobility is something else again. It has to be light. It has to leave his movements unrestricted. It has to be styled so that it can be doffed instantly in an emergency.

Army Ordnance produced just that kind

**FIT** is assured by two sets of snap fasteners on each shoulder strap. This makes it possible for one size to suit all wearers.

**CARRYING.** The new body armor can be folded compactly, placed in its kit bag, and carried in a pack. In this way, it is ready for use when combat conditions call for it.

**JETTISONING** is easy whenever the armor becomes a hindrance, as in strenuous combat. All the GI has to do is to give a yank to each of the shoulder straps, step out of armor.

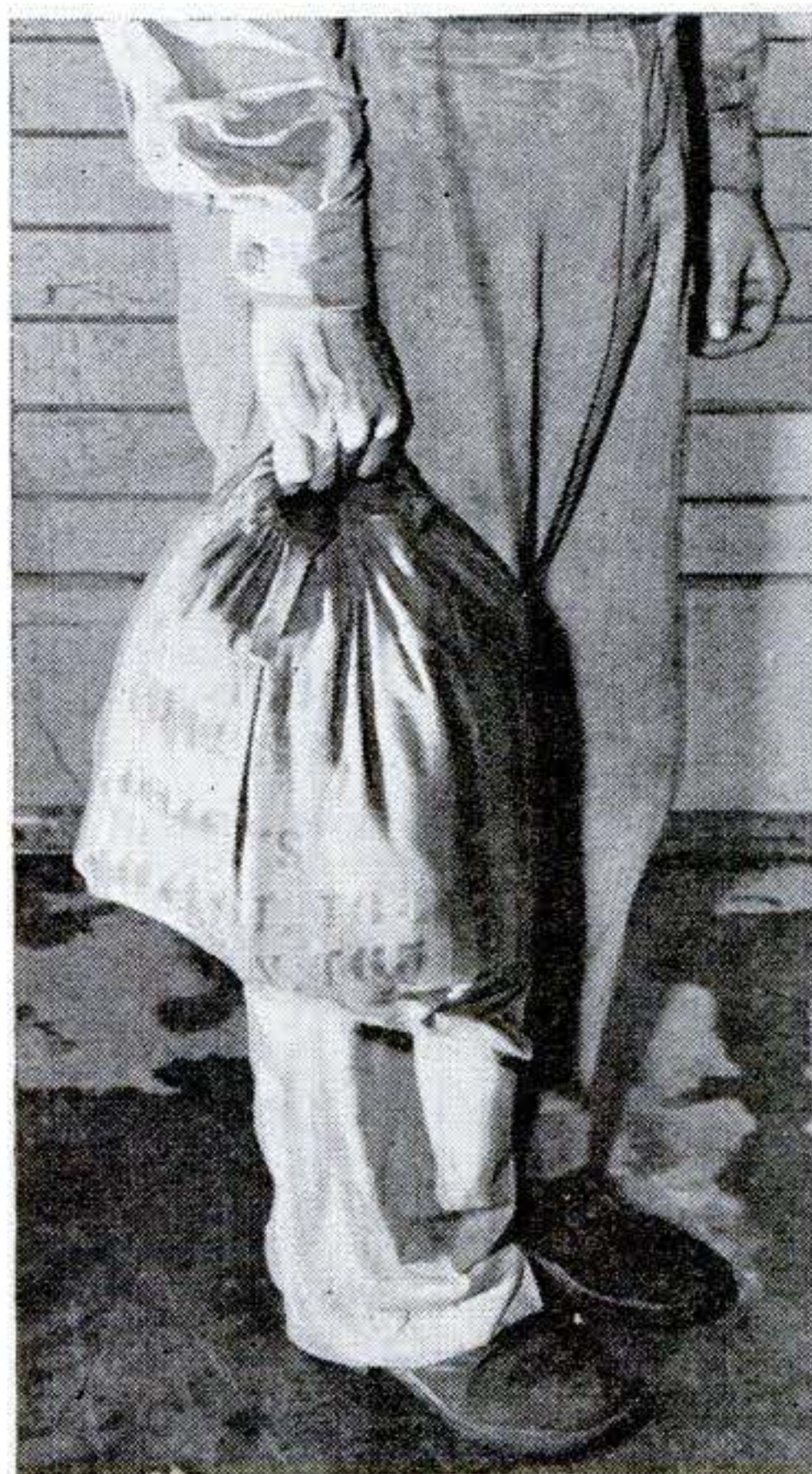



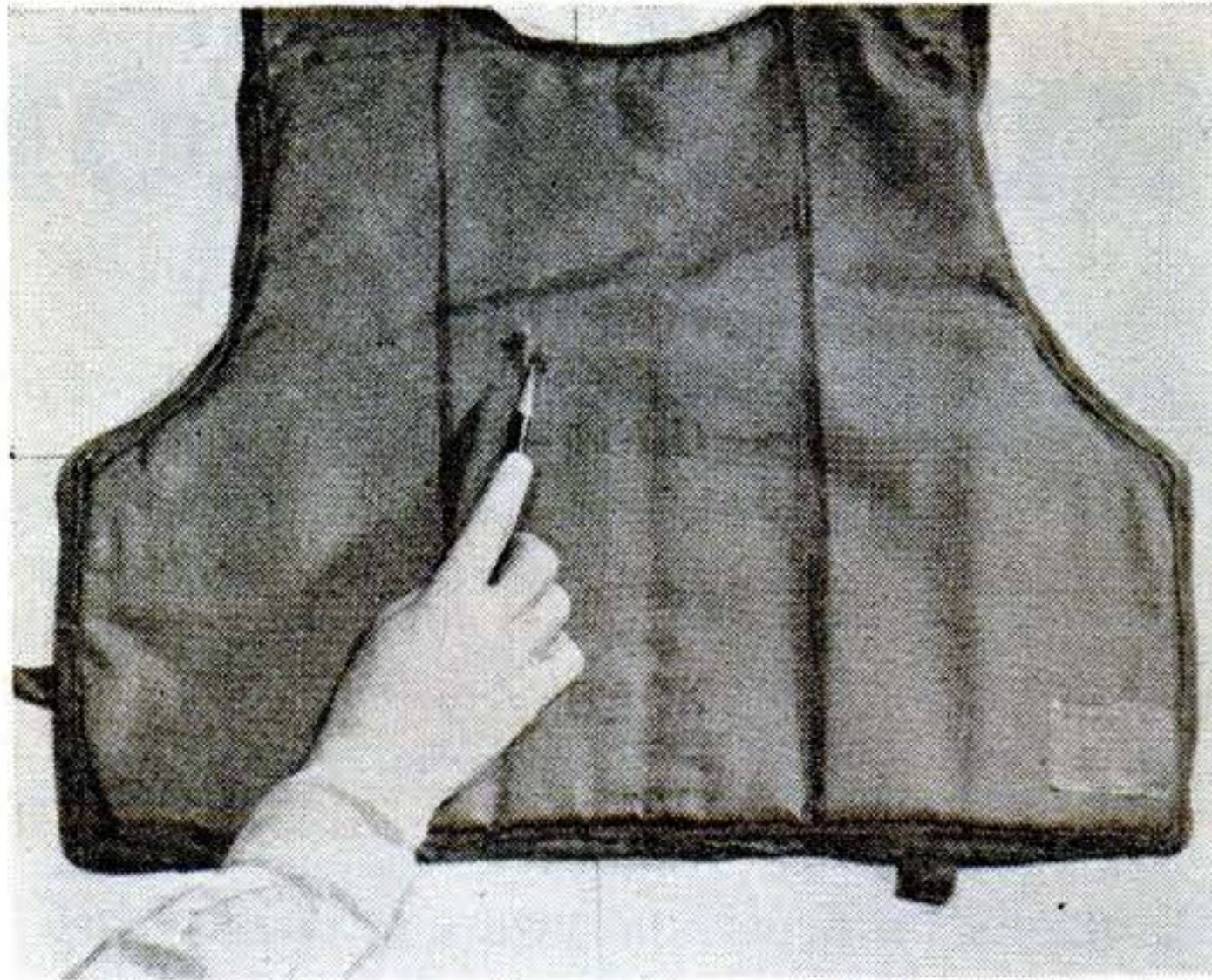

**PENETRATION** of this vest front by fragments of steel is shown by the holes indicated. Pieces that pass through the three- by five-inch aluminum-alloy plates inside are further slowed by nylon pads.



This back piece took a lot of punishment. Our body armor can't stop all shell fragments, but it protects against the kinds that cause most casualties.

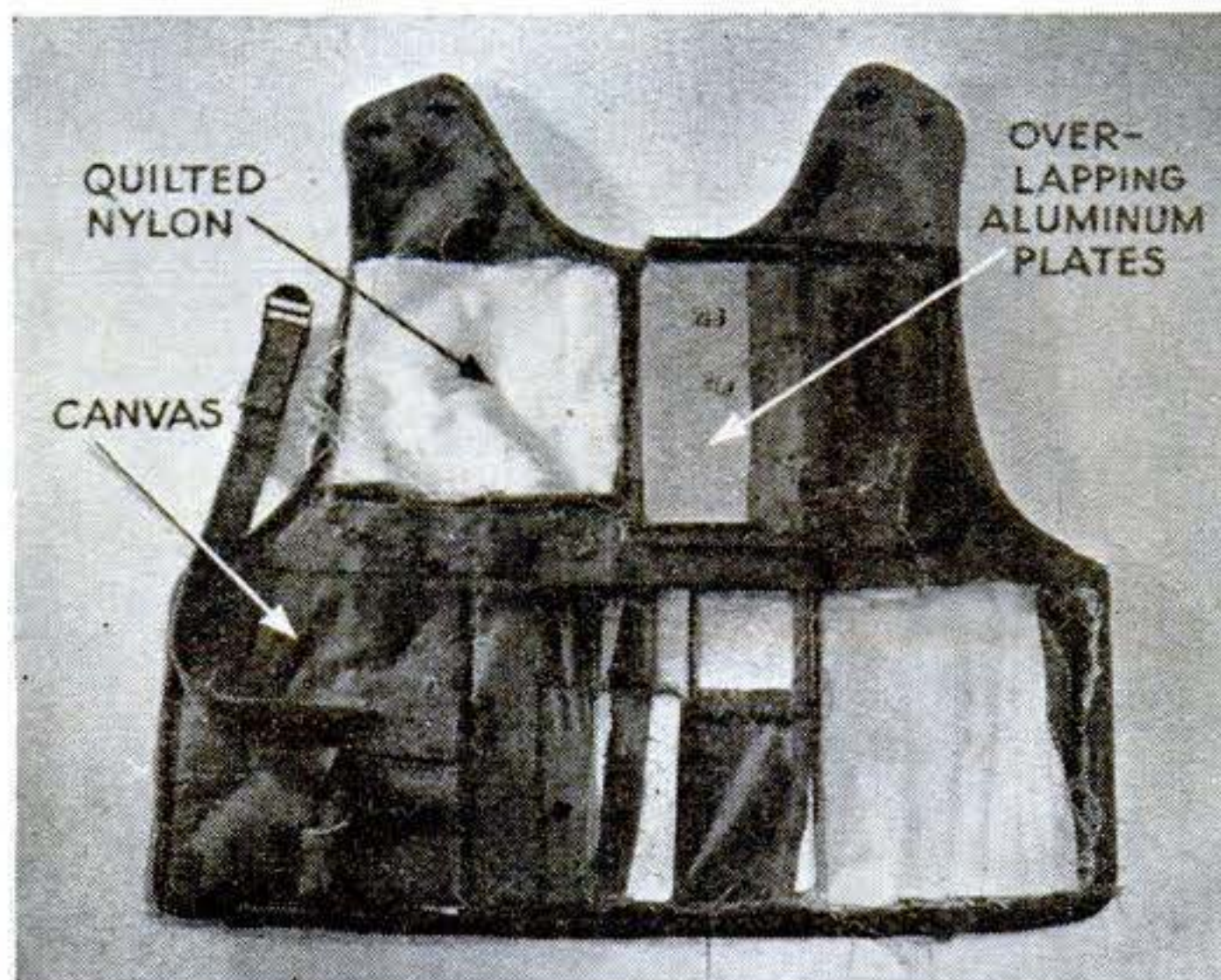

**HOW IT'S MADE.** Under the cover of the vest are overlapping plates of aluminum alloy, backed by pads of quilted nylon. The flexible apron (not shown) contains no metal but gives good protection.

of armor. Ordnance went further. By a series of painstaking tests it determined how much velocity the little pieces of metal plate, backed by quilted pads of multiple-layer nylon, would stop. While the infantryman's armor is considerably lighter than that in a flak suit, it is similar in design.

It is a vest weighing 12 pounds that affords protection for both the front and the back of the soldier. The vest consists of aluminum-alloy plates measuring three by five inches—lighter than manganese steel but equally resistant—backed by the nylon pads. Shell fragments that penetrate the plates either are stopped or their velocity is greatly retarded by the nylon fibers. Hit a pillow with your fist. Feel it yield reluctantly. That's what happens when a shell fragment penetrates the armor metal and hits the fabric.

To the vest is attached a small, flexible apron, weighing only a pound and a half and also made of quilted nylon, that protects the lower half of the abdomen.

A jerk on two shoulder straps instantly jettisons both pieces. Vest and apron may be folded compactly and carried in a pack. A man jumping from a foxhole and legging it across terrain under fire doesn't want to be encumbered. But a man standing in a landing barge and preparing to hit the beach, and even one crossing a beach under a hail of bullets and artillery shell fragments, finds his body armor the shield and buckler of modern war.

In the development of infantry armor,

**TESTING** of body-armor plate is done at Aberdeen Proving Ground with the arrangement of steel boxes pictured below. A 20-mm. high-explosive shell hurls fragments against the test plates and the standard control plate. Protective quality of a plate is gauged by the number of aluminum sheets behind it that the fragments penetrate after piercing it.

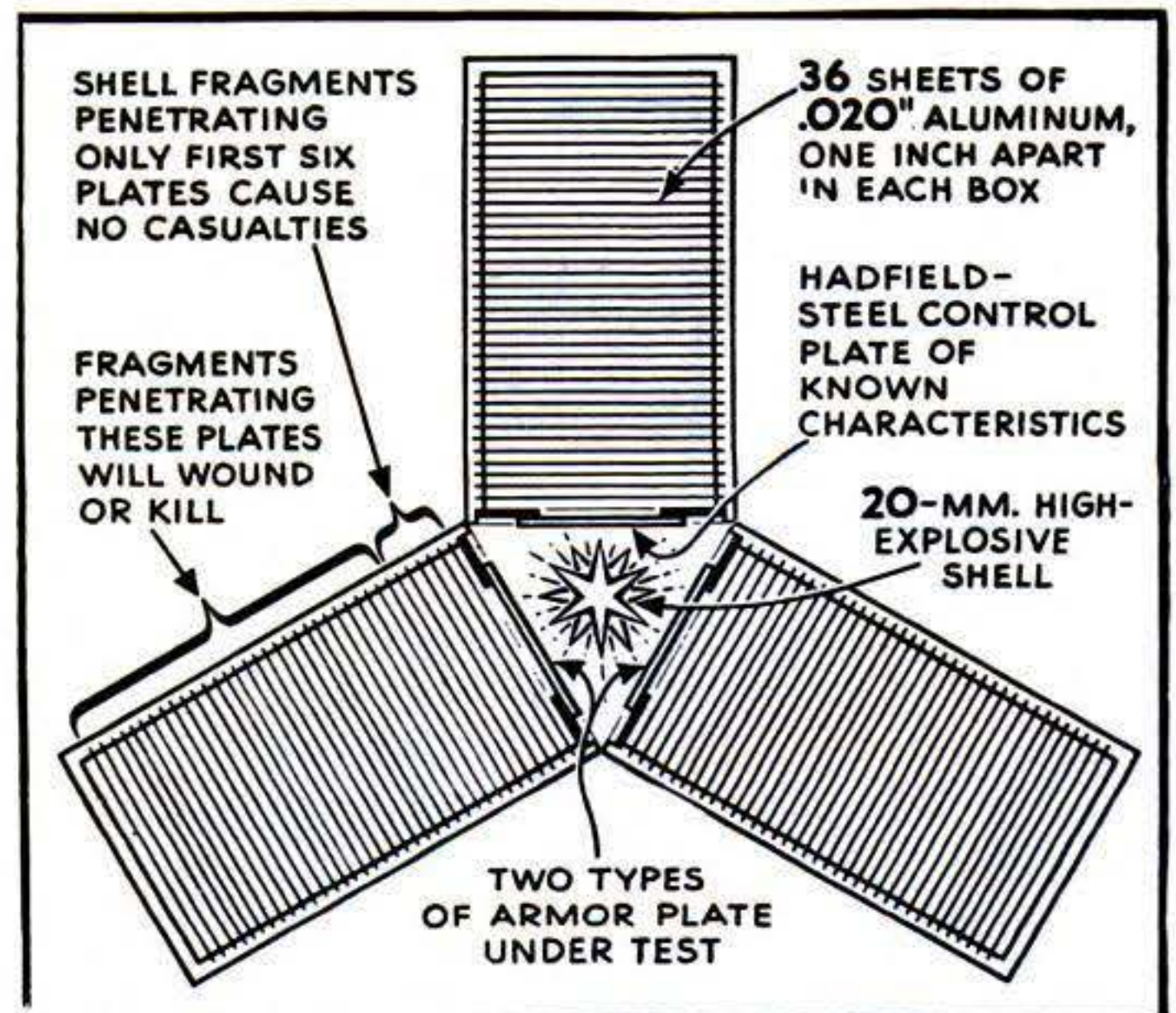



Ordnance went directly to the experience tables of the Air Forces for information. The Eighth Air Force made the first attempts to protect its flyers against the fragments of flak bursts in 1943 when strategic bombing was being stepped up in the face of determined opposition by German fighters (armed with cannon as well as machine guns) and anti-aircraft batteries. Casualties among bomber crews were becoming serious.

A type of body armor had been developed for infantrymen in World War I but it was too heavy to permit a man to move as fast as he had to in combat. The Eighth Air Force modified one of the 25-year-old suits and placed orders for a limited quantity. They worked. Casualties dropped 60 percent.

Then samples were sent home to Ordnance. Col. Rene R. Studler, chief of the Small Arms Development Division, was given the job of improving the suit and getting it into quantity production. He found that while it often was saving its wearer from death and wounds, it did show a lot of holes from shell fragments. Colonel Studler pondered that one. Then he made a decision that was to have a profound effect on body-armor design. It was this: the number of holes produced could be disregarded. It was what the shell fragments did after they made the holes that was important.

Apparatus for testing body-armor material was devised and installed at Aberdeen Proving Ground, Maryland. From what was learned in detonating explosives statically an improved flak suit was constructed. It was only a step from a better flak suit to an infantryman's armor.

Pilot models for body armor, and for steel helmets as well, are made just where you would imagine they would be made—in

the armor shop of the one place in the United States where an intimate study of devices for protecting the body against wounds has been carried on for many years. It is New York's Metropolitan Museum of Art. The Museum contains magnificent samples of armor going back to the times of the ancient Greeks and Romans. Some of the models are fashioned with the same kind of planishing hammers as were used to repair the dented steel harness of King Richard the Lion-Hearted, back in the days of the Crusaders. *(Continued on page 234)*

## Body Armor Is Not New

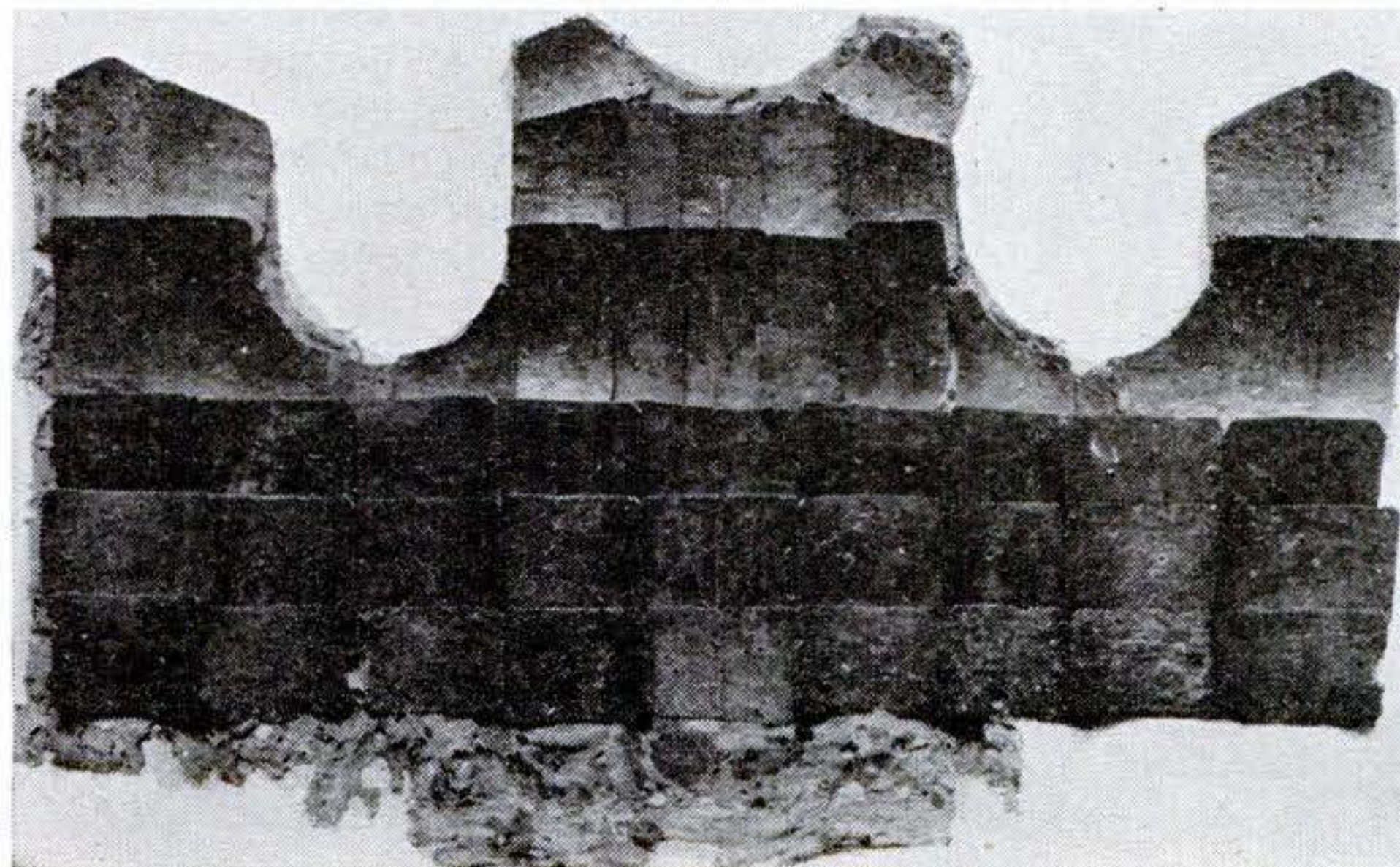
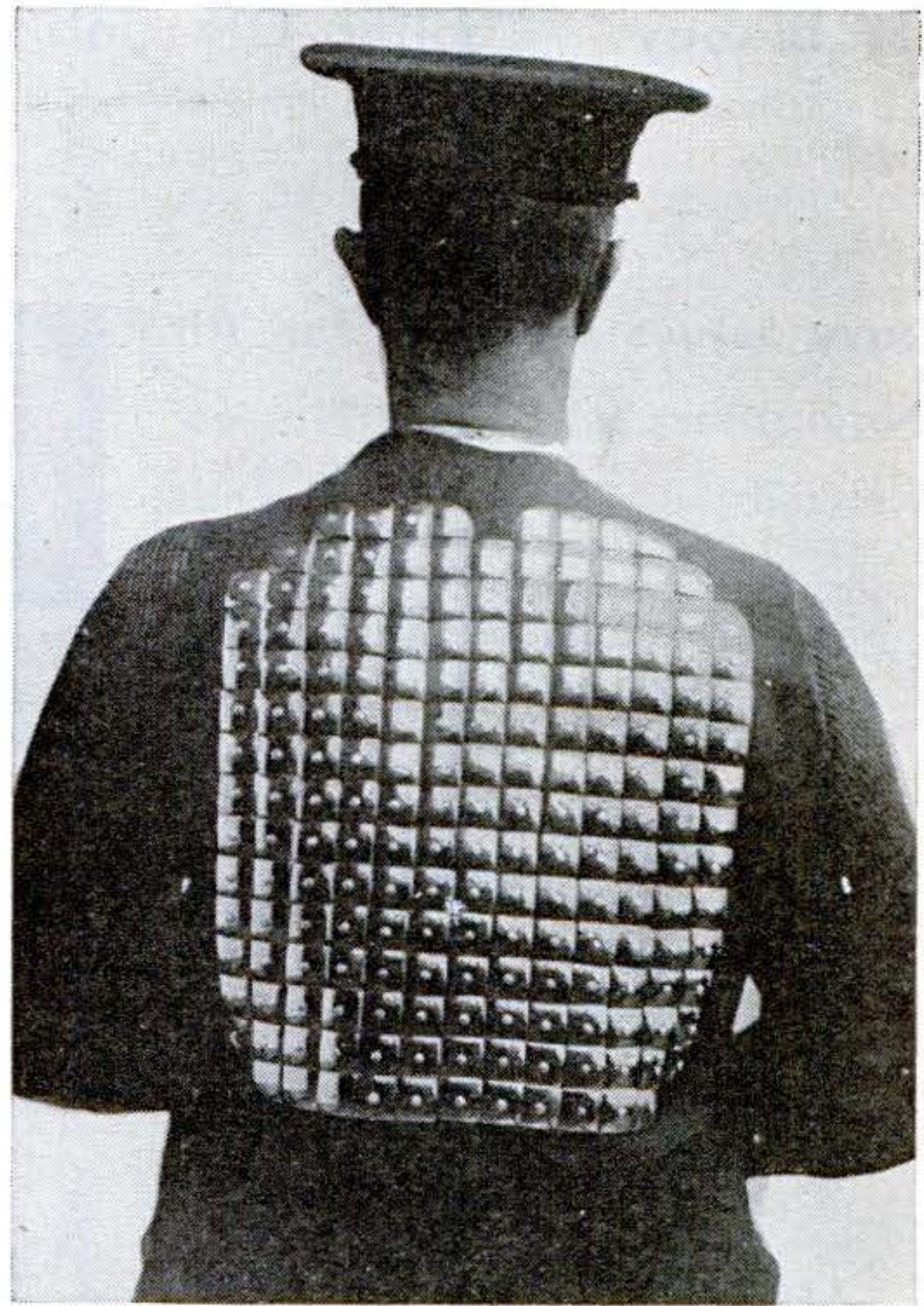

**1916** Several types of armor for infantrymen were developed in World War I. In Berkley's "flexible armor guard," above, square pieces of metal were riveted to a canvas backing. It gave inadequate protection.

Metropolitan Museum of Art

**1400** The Middle Ages were the heyday of armor. At left are the remains of an Italian "brigandine," originally consisting of 53 overlapping iron plates riveted to canvas. The length of the canvas indicates that the brigandine covered the abdomen and loins. Openings are holes for the arms.





## Stableboys' Cooling-Off Job Is Now Done by Electricity

RACE horses at the Roosevelt Raceway, Westbury, N. Y., are tied to this new electric walker so they may cool off gradually

after work on the track. Arms radiating from the motor revolve to keep horses moving at the slow pace generally used.

## Navy Issues Insignia for Air Navigators and Flight Nurses

AMONG the wing insignia recently approved are those for Naval Aviation Observers (Navigation), shown at upper right, and for Navy Flight Nurses (lower right). The former insignia, consisting of gold wings with a silver compass rose set on crossed anchors, may be worn by eligible Naval officers, including Waves. The Naval Flight Nurse insignia has gold-embossed wings and bears the anchor and oak leaf, symbol of the corps.



## Mosquitoproof Cap Protects GI's Against Malaria

DISEASE carried by mosquitoes and other insects, to say nothing of discomfort, will be lessened by the development of a "jungle cap" by the AAF Board at the Air Forces Tactical Center, Orlando, Fla. The first cap assembly was made of a snag-resisting, 14-mesh nylon netting attached to the visor and a cellulose acetate window at eye level. Preliminary tests under difficult conditions in southern Florida enabled the Army to improve the cap by extending the visor backward to keep the netting away from the ears. A soft metal ring, which permits folding, is sewed into the netting to hold it down in front and back, and a drawstring secures it around the neck.





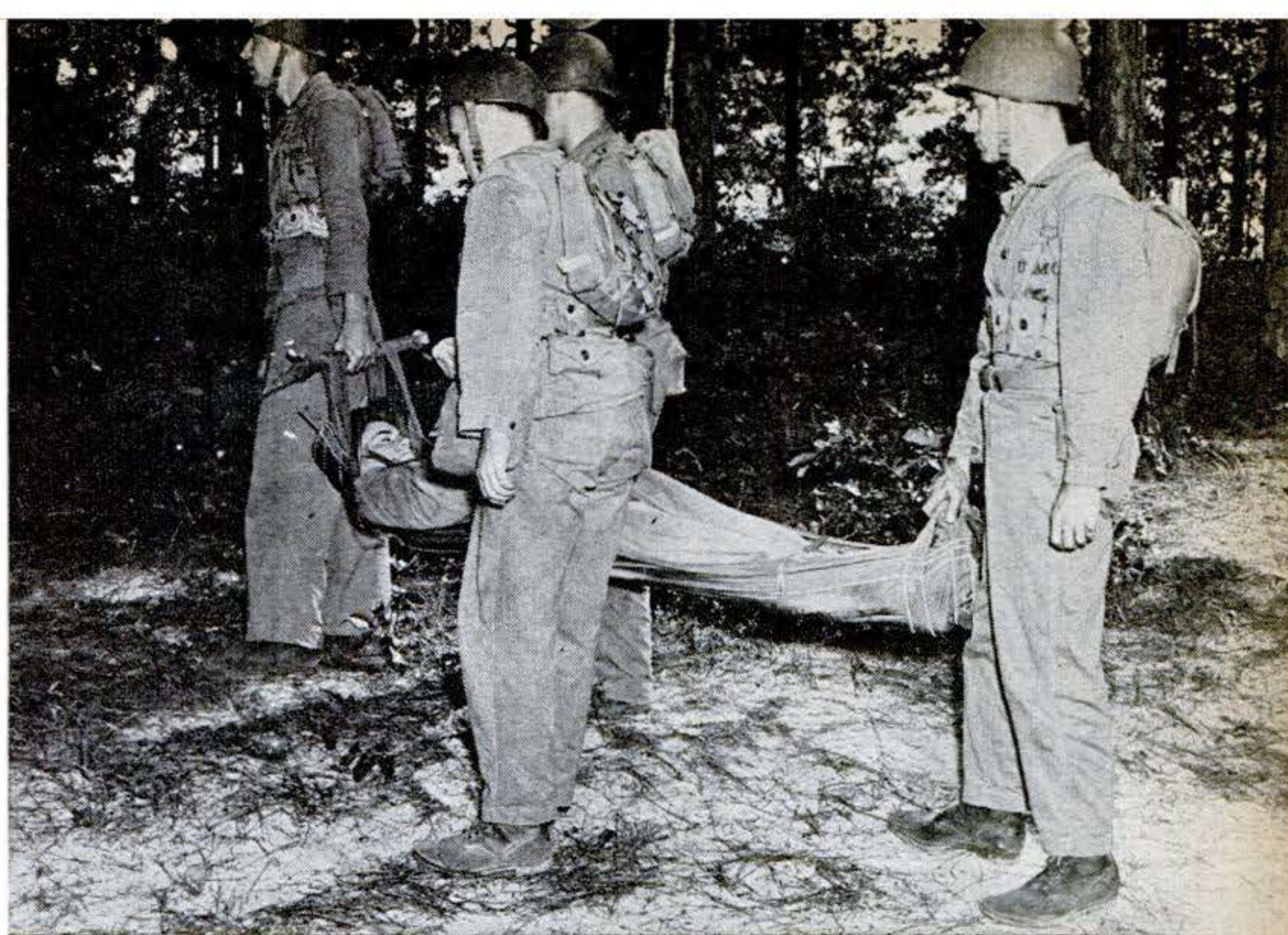

## Nylon Pocket Litter Saves Wounded Marines Under Fire

WOUNDED men are brought out of the front lines with greater ease and safety by means of a new nylon litter developed by the U. S. Marine Corps Medical Field Research Laboratory at Camp Lejeune, N. C. Measuring 78 by 26 inches and weighing less than 2½ pounds, the litter can be folded to fit in a corpsman's pocket or pouch. Five straps

hold the casualty securely in place, while loops at the head end and sides make it possible to carry him in a variety of ways. One man can drag the litter over the ground, or the wounded man can be raised or lowered over a cliff. Hems at the sides permit use of poles cut on the spot for carrying by two men like a standard semirigid litter.

## Army's Airborne Road Scraper Takes Bumps Out of the Road to Tokyo

AIRSTRIPS and roads on Pacific islands are being leveled by two-unit scrapers like the one below, which are flown out in giant air transports either assembled or in two sections. Equipped to dig, load, transport, dump, and spread the earth, the machine is powered by a 43-horsepower gasoline engine and mounts a bulldozer blade on the front and a cable-operated steel bowl scraper on a frame in the rear.

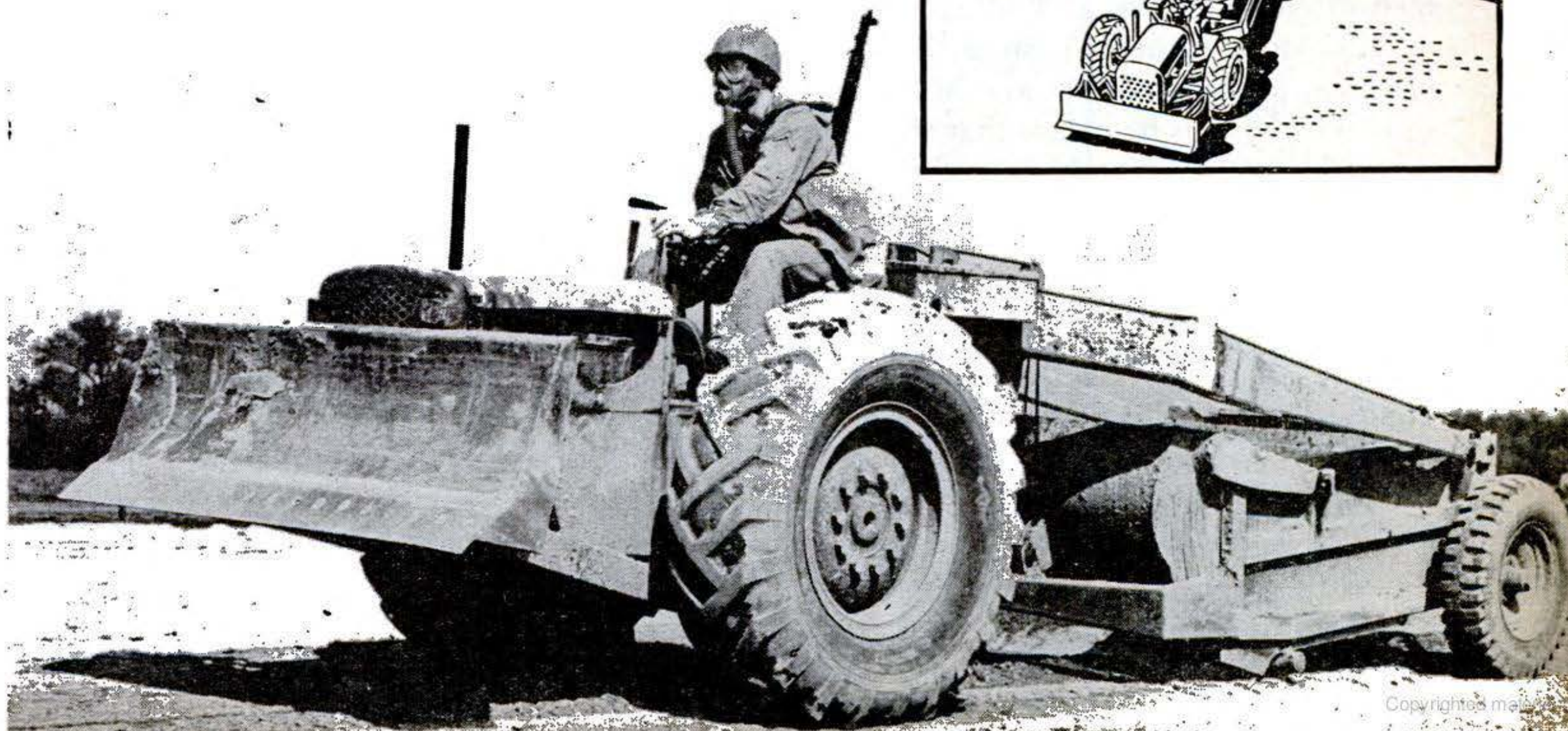
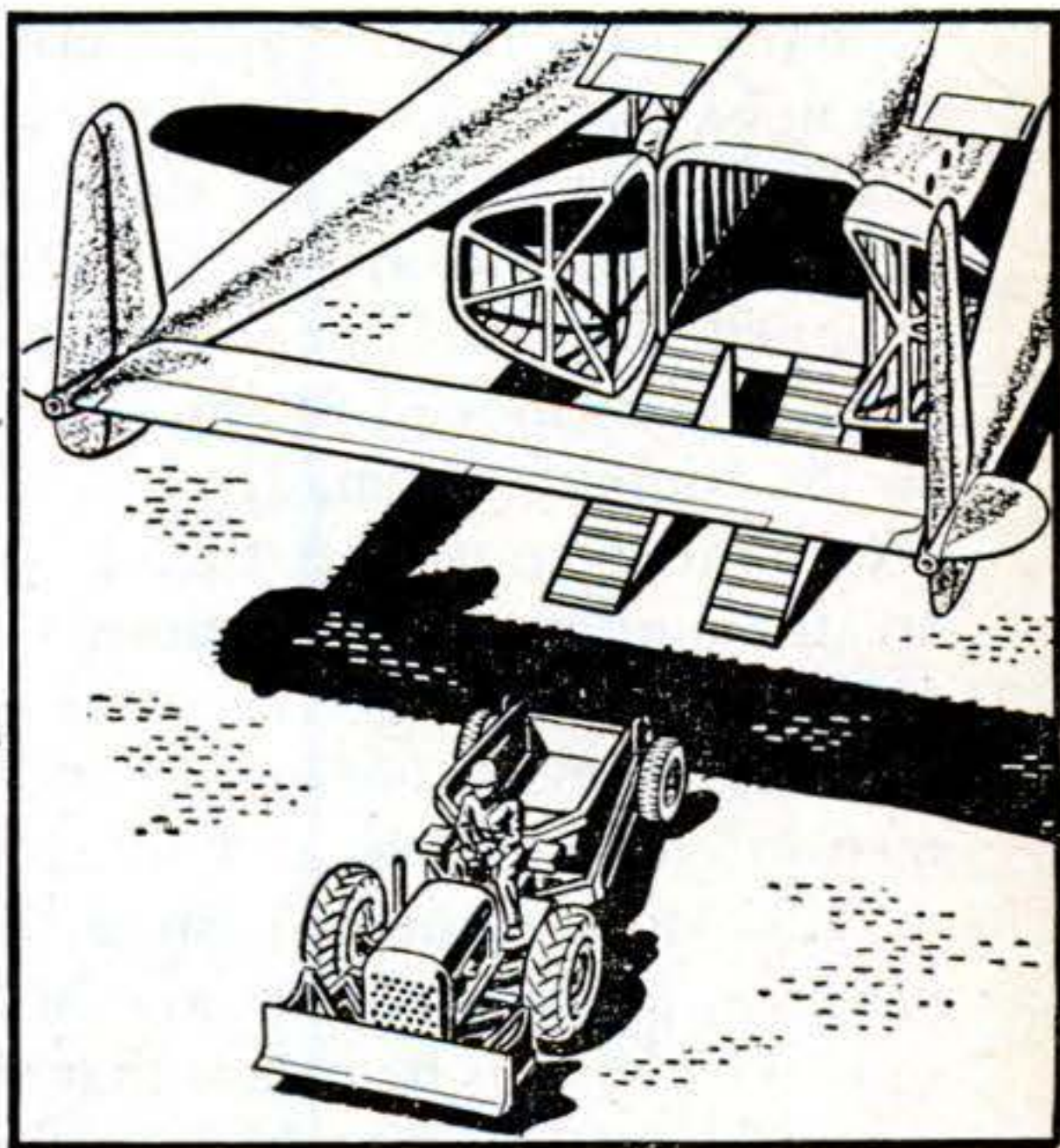



# Annihilation Bomb

## — Friend or Foe?

*A Statement by the Editors of POPULAR SCIENCE MONTHLY*

**A** CUBIC INCH of a star known to astronomers as the White Dwarf weighs about a ton, almost 6,000 times as much as a cubic inch of lead. This star may have pointed the way to atomic power—a discovery so momentous that the noted French physicist, the Duc de Broglie, calls it comparable only to primitive man's discovery of fire.

How could matter be as compressed as it is in the White Dwarf? One possibility that occurred to scientists was that this star consisted of atomic nuclei from which electrons had escaped. The supposedly indivisible atoms, in other words, appeared to have been broken apart elsewhere in the universe.

On August 6, 1945, an atomic explosion occurred within an annihilation bomb dropped on Hiroshima. *Popular Science Monthly* has looked forward to such a scientific triumph for many years; its editors are confident now that this discovery will create many more opportunities—not only for warriors, but also for physicists, chemists, astronomers, engineers, and all other men interested in the physical sciences.

Dr. Albert Einstein suggested many years ago that "E equals M times C squared." By this he meant that the energy in a unit of mass could be computed by multiplying the mass by the velocity of light squared. Such computations spurred scientists throughout the world to find a way to release the atom's tremendous energy.

A way has now been found. Even the biggest and the mightiest bombs developed previously could only hurl about familiar kinds of matter; the new atomic bomb is capable of changing minute quantities of matter into more concentrated energy

than can be obtained by any of the world's mightiest machines.

Nine million pounds of ammonium nitrate exploded near Oppau, Germany, in 1921, causing serious damage four miles away. That was the greatest weight of man-made material ever known to have exploded at one time. The exploding charge in the annihilation bomb weighed only a few pounds, but its effects were so devastating that it almost wiped out a city spread over nearly seven square miles.

Even so, Oppau and Hiroshima are scarcely comparable. In the kind of explosion that occurred at Oppau, materials such as steel have been torn into fragments, twisted and strewn over the countryside; at Hiroshima, steel appears to have been turned into gases.

You have seen corn popping in a pan. If the pan is removed from the fire the instant the first grain explodes, no more will explode. If you could see an atomic explosion, you might see something similar, but the units would go on bursting, each one setting off more explosions.

"No one knows how to halt disintegration of matter," Dr. Jean Thibaud of the University of Paris said only four years ago—but the world did not disintegrate when the atomic bomb burst on Hiroshima. Hence, it is clear that ways have been found to release predetermined amounts of atomic energy.

Conceivably, the subjection of some materials to an intensely hot atomic explosion may make them radioactive. How long this radioactivity continues depends on the nature of the material and the force to which it is subjected.

*(Continued on Page 230)*



# HEAT IS SOURCE OF ATOM BOMB'S DEVASTATING POWER



**ORDINARY BOMB** owes its destructive power to the release of hot, expanding gases produced by a chemical action in the explosive. The blast and fragments from the bomb push and pull near-by objects violently as though a hurricane had struck.



**ATOMIC BOMB** releases such tremendous heat that solid materials in the vicinity are vaporized. Force exerted is hundreds of thousands of times as great as that from the same weight of ordinary explosives. Effect on target is wholly unprecedented.

## EFFECT OF ORDINARY EXPLOSIVE AND ATOMIC BOMBS

**BEFORE**

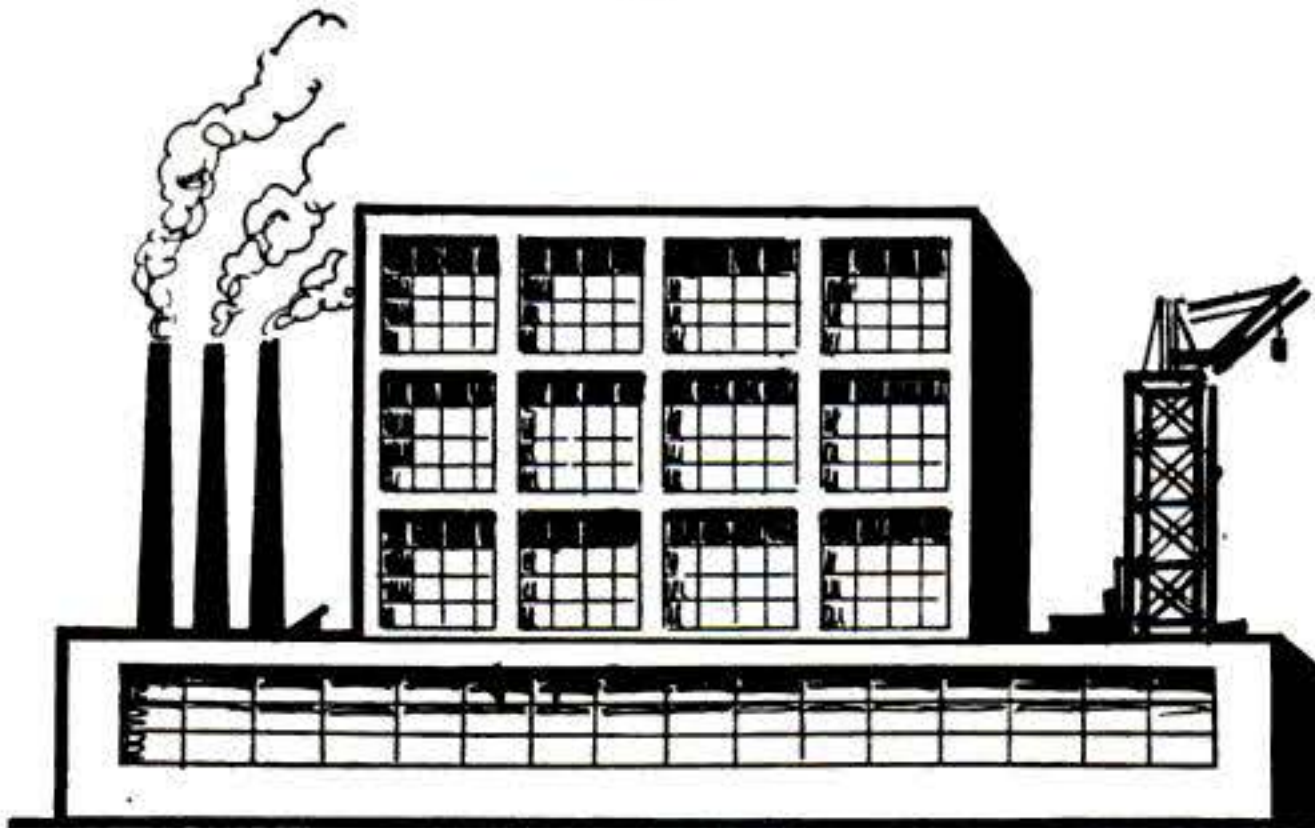

**BEFORE**



**AFTER**

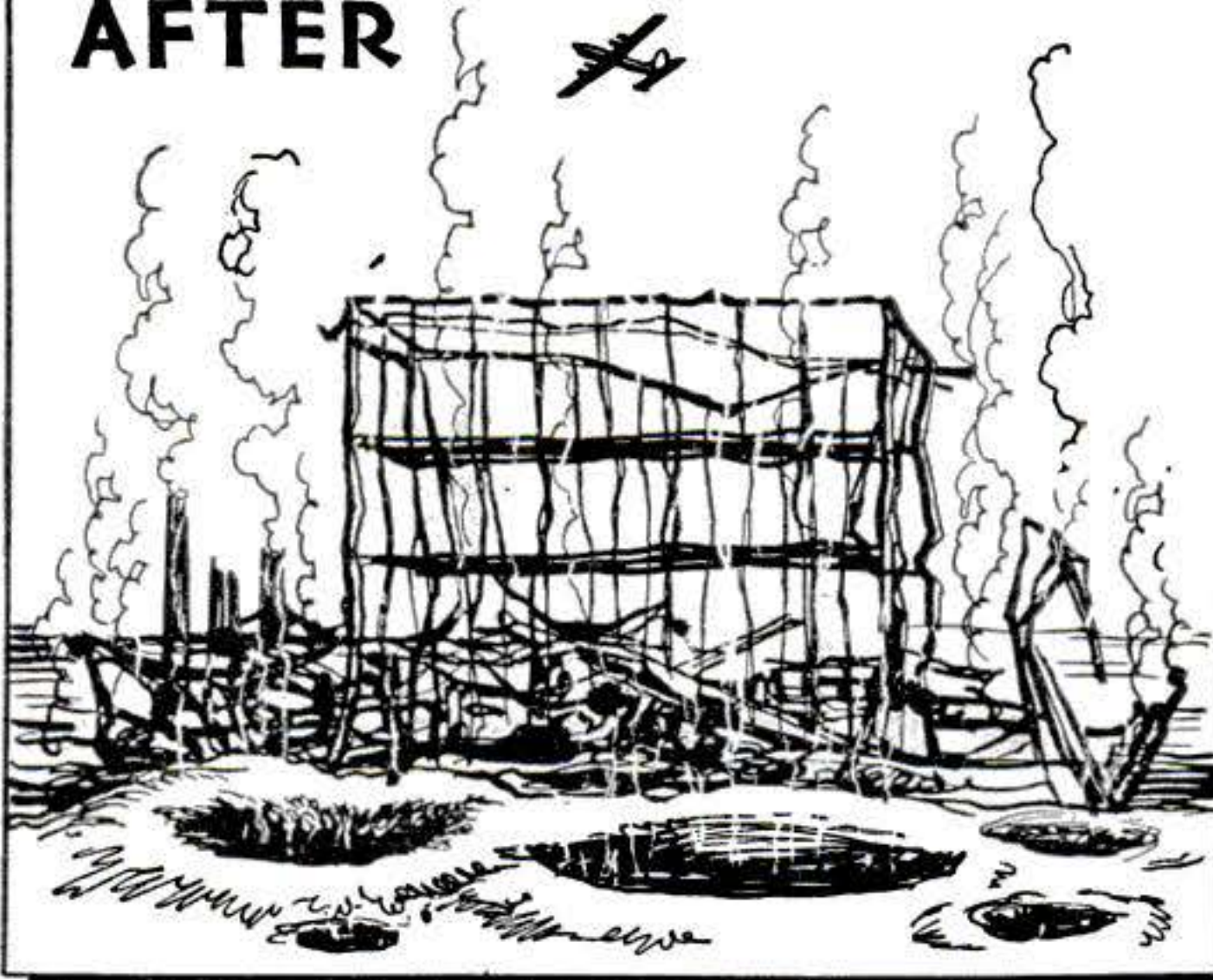

**AFTER**



When a war plant or other target is hit by high-explosive demolition bombs, damage is limited to the immediate vicinity of hits, plus incidental fires. Even with the heaviest bombardment, it is hard to damage the target beyond all hope of repair.

As proved at Hiroshima, a single atomic bomb will completely obliterate the whole target area, turning what was once a busy industrial center into a lifeless and possibly uninhabitable waste. Nothing is left with which the enemy can start over again.



WE'LL HAVE IT  
AFTER THE WAR

# Soap Washes Hands as Clean as a Surgeon's

POPULAR SCIENCE presents the first article of a series on products, created or improved by wartime research, which will transform our daily lives after the war.

THANKS to a new organic chemical with a 32-letter scientific name, your favorite toilet soap may soon take an active part in the fight against disease transmitted by bacteria on the skin. Odorless and nontoxic—except to germs—the chemical can be combined with any good soap without changing its appearance, cleansing quality, or scent.

## MIXING G-11 WITH SOAP

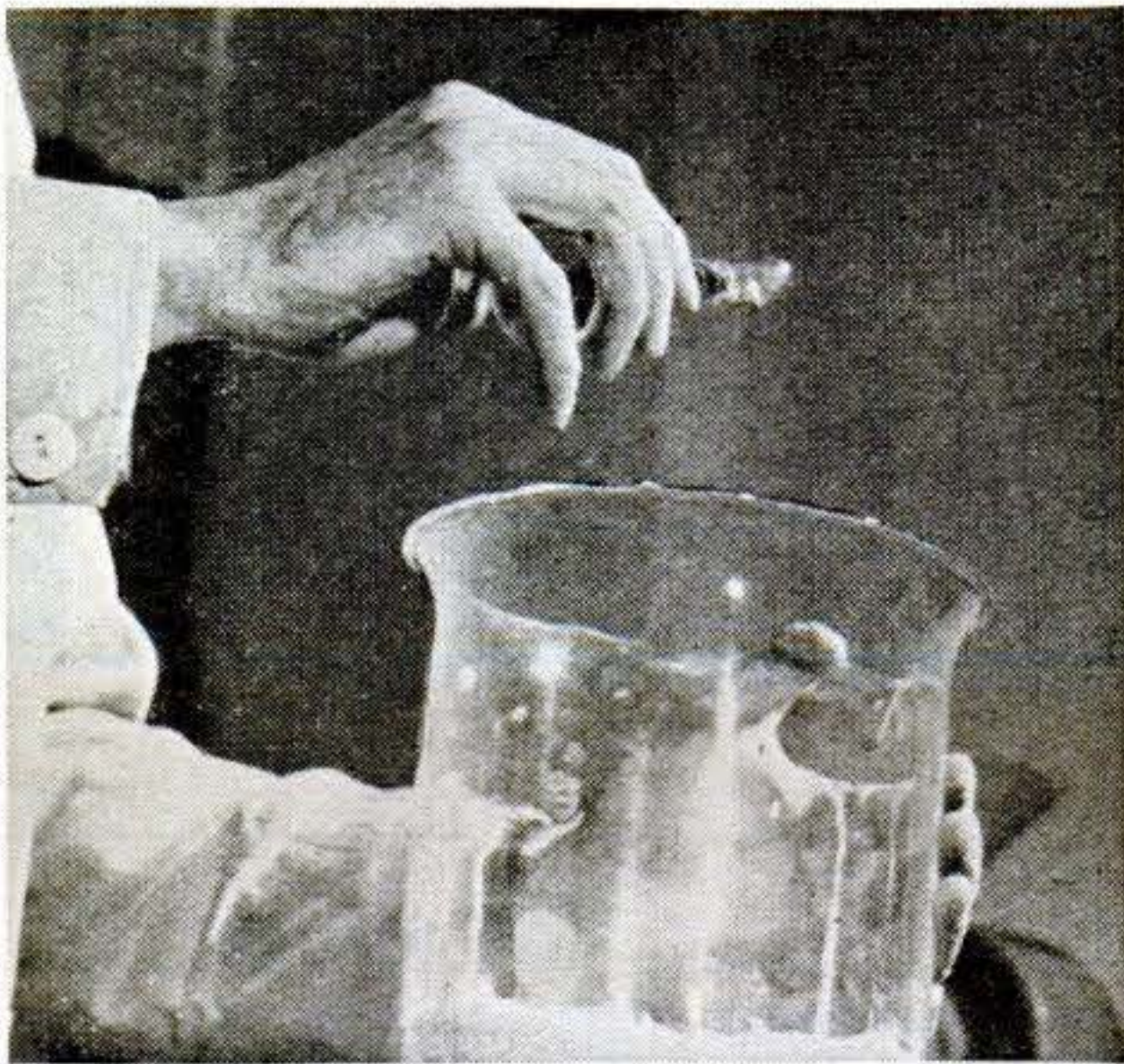

The new bacteria-killing chemical, Compound G-11, added to ordinary soap, will make it a germicide. It can be added, as in the picture above, in an alcohol solution, or mixed dry with the other soap ingredients as shown below.

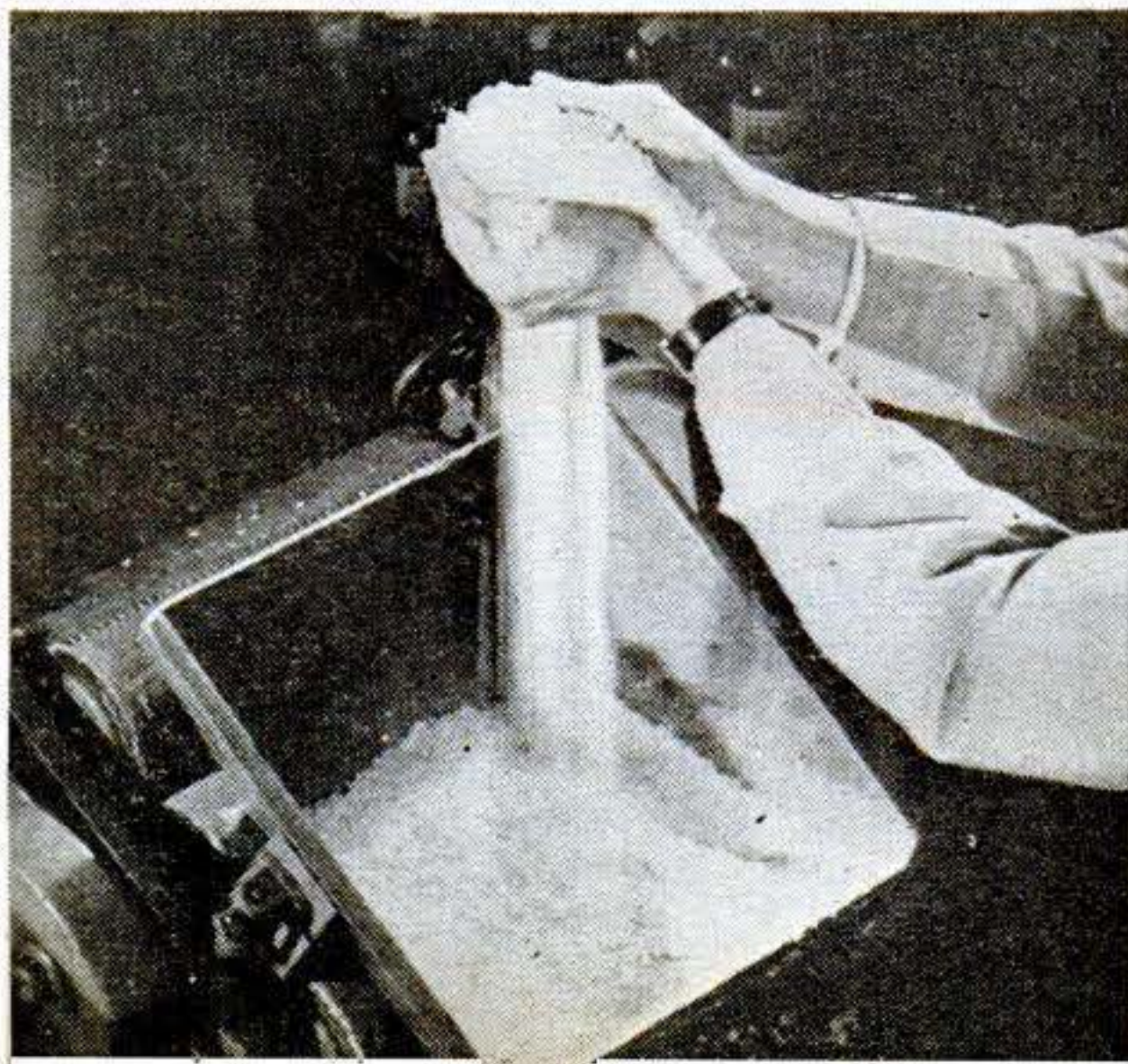

Use of soap containing this new chemical should simplify the present time-consuming scrub-up technique of physicians and surgeons. It would have decided advantages in public washrooms, Army camps, and on ships. In barber shops and beauty parlors, it would reduce skin infections; and in factories, restaurants, and hotels, it might lessen the hazard of communicable diseases. Compound G-11, as the new crystalline substance is called for short, was developed by Dr. William Gump, research chemist of Givaudan-Delawanna, manufacturing perfumers and chemists.

Washing with ordinary soap mechanically removes dirt, oil, and grease, and, along with this soil, a great many germs from the surface of the skin. These are the "transient" bacteria and fungi of all kinds that we pick up by contact with other people and things. Deeper in the skin structure lie the "resident" bacteria, belonging mostly to the group of staphylococci, which are more slowly destroyed. Fortunately, not all of these micro-organisms are harmful. As long as the skin remains healthy and unbroken, none of them, harmful or otherwise, can enter the body. But disease-producing bacteria *can* be carried on the skin from one person to another.

Although researchers had plenty of bac-

## TESTS IN LABORATORY

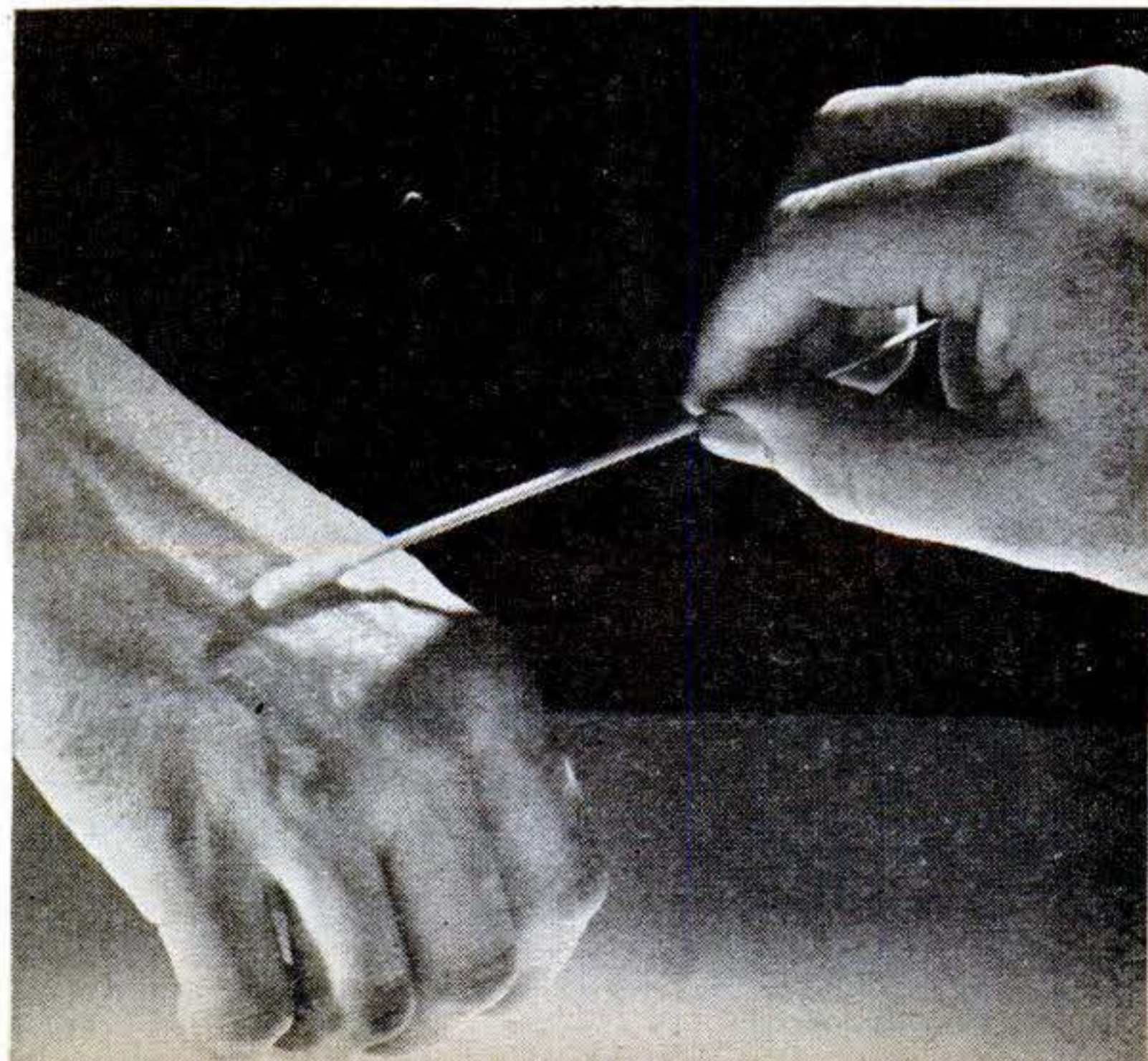



Here is the chemical that makes ordinary soap a powerful killer of germs. When it is mixed in, it does not change the appearance, cleansing quality, or scent of the soap. But a two-percent concentration spells death to bacteria, even of the deep-seated variety. Chemical name is hydroxy-hexachloro-diphenyl-methane, G-11 for short.

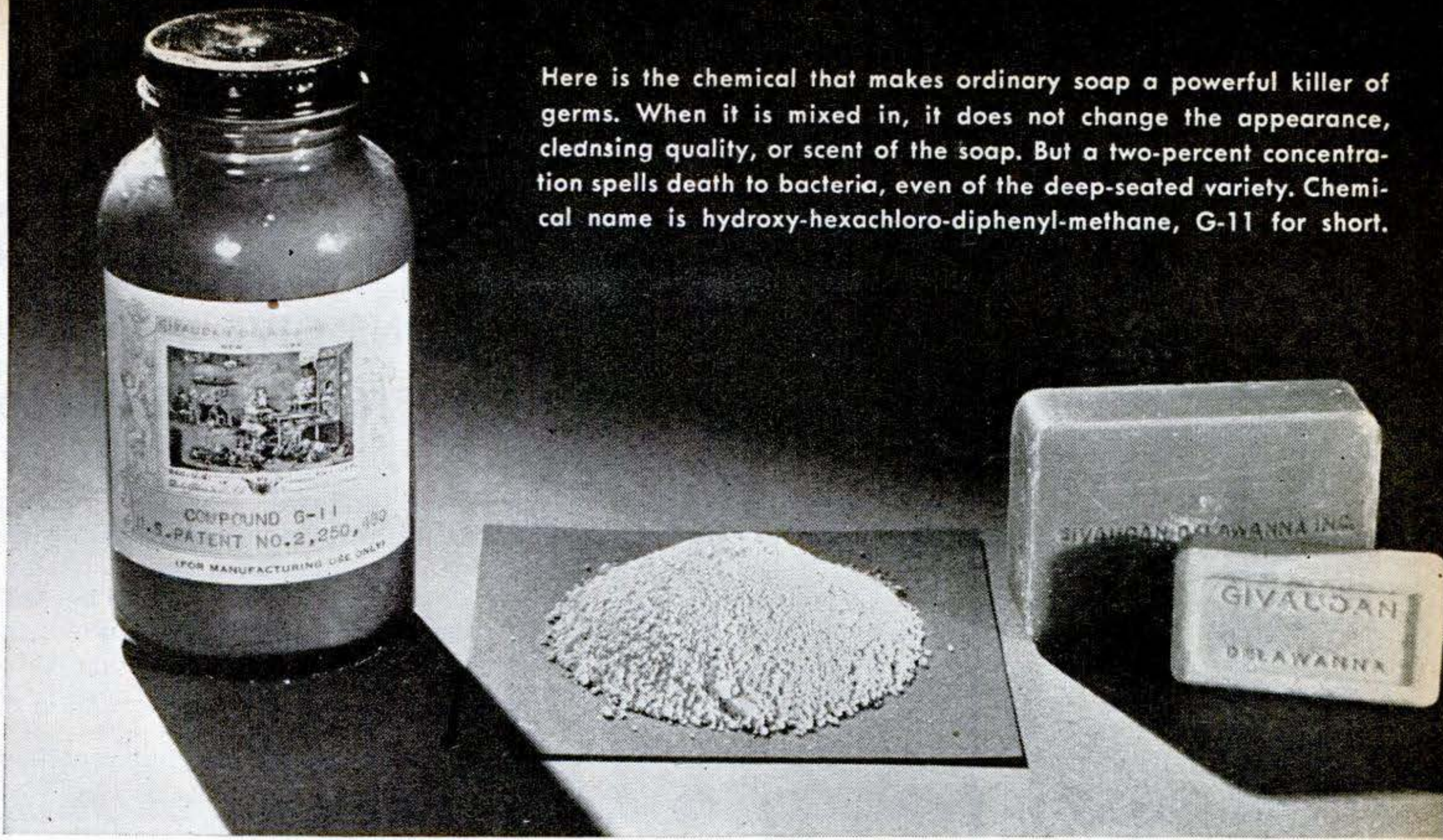

teria-destroying substances to draw from, most of these became troublesome or ineffective when mixed with soap. Iodides and organic salts of mercury were among the first tried, but these found only limited use because soap containing them was poisonous and irritating to the skin. Phenol disinfectants failed when mixed in small amounts with soap because the soap ingredients reacted with them, producing new compounds with little germ-killing power.

Besides being nonpoisonous and nonirritating, and not reactive with soap materials, the germicide must also be nonvolatile and should not stain the skin or clothing. For popular use, it must not have a disagreeable odor. G-11 is the first substance to meet all these requirements. It is made by condensing two molecules of trichlorophenol with one molecule of formaldehyde

in the presence of concentrated sulphuric acid. Although the final product is a phenol, it is a complex product that only partially decomposes in the presence of soap. The part that remains unchanged deals death to bacteria.

Although G-11 has special advantages for primarily aseptic needs, it is inexpensive enough to be incorporated into all kinds of routine soaps—for hand use, bathing, shaving, dishwashing, and laundering. It is possible that the widespread use of such germicidal cleansing might improve the general public health by reducing contagion.

Hundreds of tests made on human subjects prove that washing with soap containing two percent, or even less, of G-11 not only removes and kills most of the skin's transient bacteria, but markedly reduces those resident in the deeper layers.

## PROVE THAT G-11 KILLS HARMFUL BACTERIA

←  
The proof of the germicide is in the testing. Back-of-hand swabbings were made, as at the left, on persons who had washed with G-11 soap for a week, and on others who had used ordinary toilet soap. Then . . .

→  
Cultures were taken with the results shown. The left-hand plate shows up colonies of bacteria from the hand washed with plain soap, while that at the right shows a smaller number of colonies after the use of a soap containing the germicidal agent.

WITH  
ORDINARY SOAP



WITH  
G-11

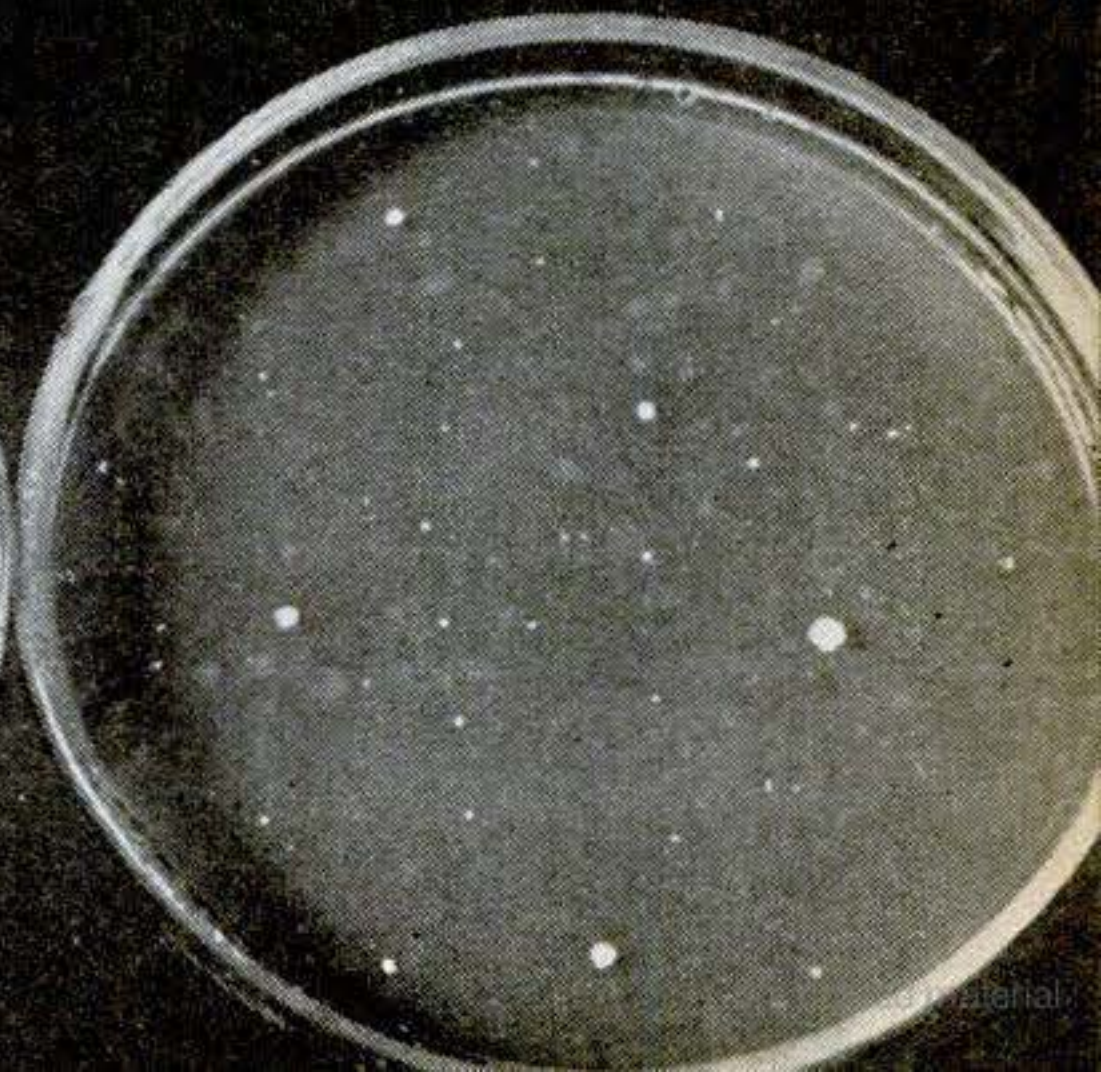



# New Kickless Cannon for GI's

## TWO-MAN RECOILLESS GUNS GIVE INFANTRY THE FIREPOWER OF FIELD ARTILLERY

Photographs by WILLIAM W. MORRIS  
and HUBERT LUCKETT

**A**FTER 600 years, armament experts finally have found a way to take the "kick" out of gunfire. The discovery has put into the hands of American soldiers in the Pacific artillery that can be carried ashore on men's shoulders in amphibious operations.

Kickless, or recoilless, guns helped root

the Japs out of Okinawa. For certain operations, a few infantrymen can lay down as heavy a curtain of fire as a whole battery of medium artillery. They can do it because the Ordnance Department has annulled, for all practical purposes, Isaac Newton's third law of motion: For every action there is an equal and opposite reaction.

Here are a few samples of what recoilless artillery has accomplished:

Two rounds from a 75-mm. gun, used by the 17th Airborne Division in Germany, knocked out a German 88 and an anti-aircraft gun concealed in a barn. A hundred Germans tumbled out to surrender.

On Okinawa, one shot from a gun of the same caliber destroyed a camouflaged machine-gun nest and killed two snipers in it at a range of 400 yards.

At a range of three quarters of a mile, 11 rounds from a 75-mm.

### U. S. KICKLESS GUN

The Germans developed a recoilless gun (below, right) for use by paratroopers, but it is bulky compared with the trim U. S. cannon shown at left and below.



**57-MM.** Weighing only 45 pounds and 61 inches long, the 57-mm. can be fired from the shoulder as accurately as the Garand. It hurls a 2 $\frac{3}{4}$ -lb. shell 2 $\frac{1}{2}$  miles.

**75-MM.** The kickless 75 can toss a 14-pound, high-explosive shell more than four miles. It is 82 inches long, weighs 110 pounds, and is fired off a machine-gun tripod. It has both a telescopic and a leaf sight.







In this U. S. Army Ordnance Department photo a group of four of the new 75-mm. recoilless rifles lays down a heavy curtain of fire. Conventional artillery shells are used, but the normal recoil is absorbed by allowing a controlled portion of the propellant gases to escape through openings in the gun's breech.

gun scored two hits on each of two caves concealing Jap artillery. All the Jap gunners were killed.

At a range of 1½ miles, seven shots from a 75 scored three hits in a cave mouth measuring five by two feet.

Recoilless guns are not tubes throwing rockets, like the familiar "bazookas." They are guns in every sense of the word. They

throw explosive ammunition or smoke shells. The shells are propelled by a powder charge. But right there the similarity stops.

All guns, except those of this particular type, "kick" when they are fired. That is because the propelling powder, suddenly becoming gaseous, expands tremendously and seeks an outlet from its confinement. The force of the expansion is exerted in two

## SURPASSES THE GERMAN MODEL

The Nazi weapon is a 7.5-cm. with a range of 7,400 yards, but it weighs 325 pounds assembled in the field. At the right is a close-up of the gun's breech and (right, below) a blowout patch used to permit gas to escape to take the "kick" out of the gun.

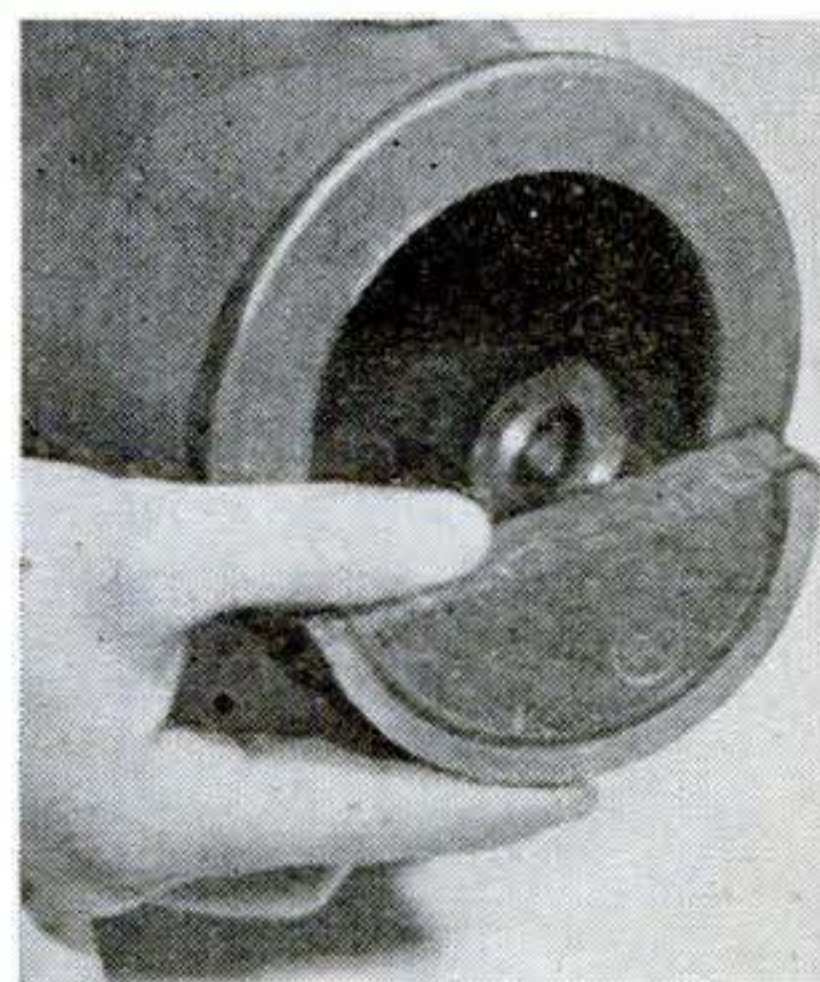
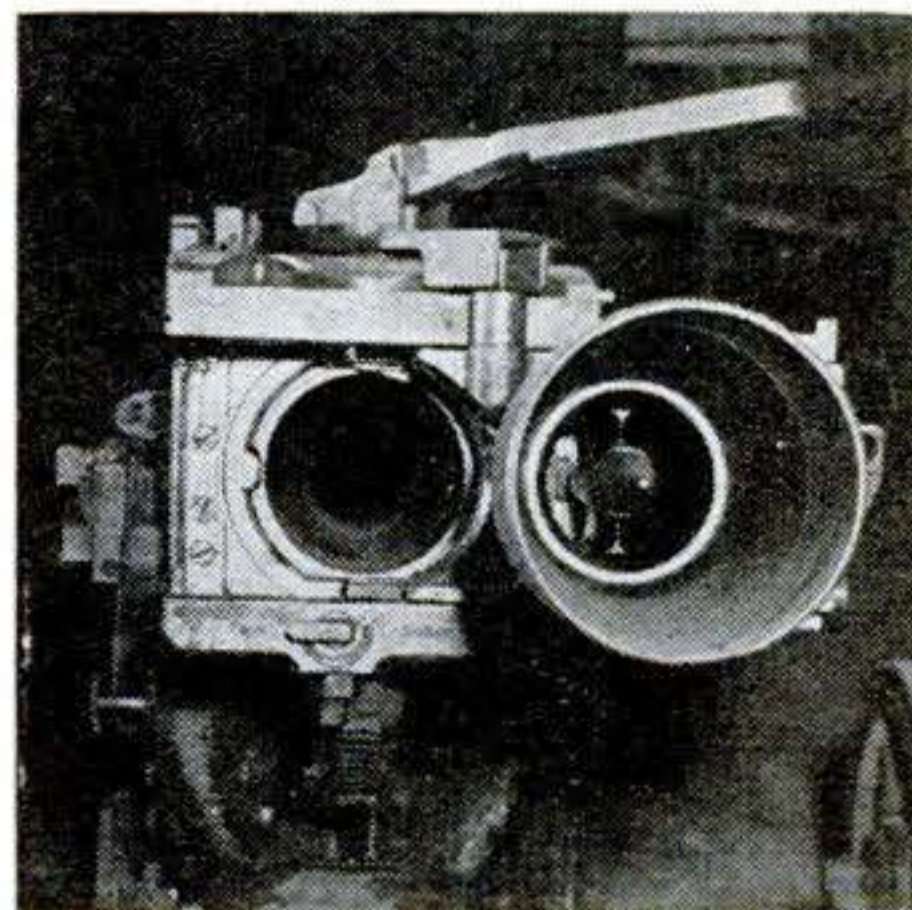



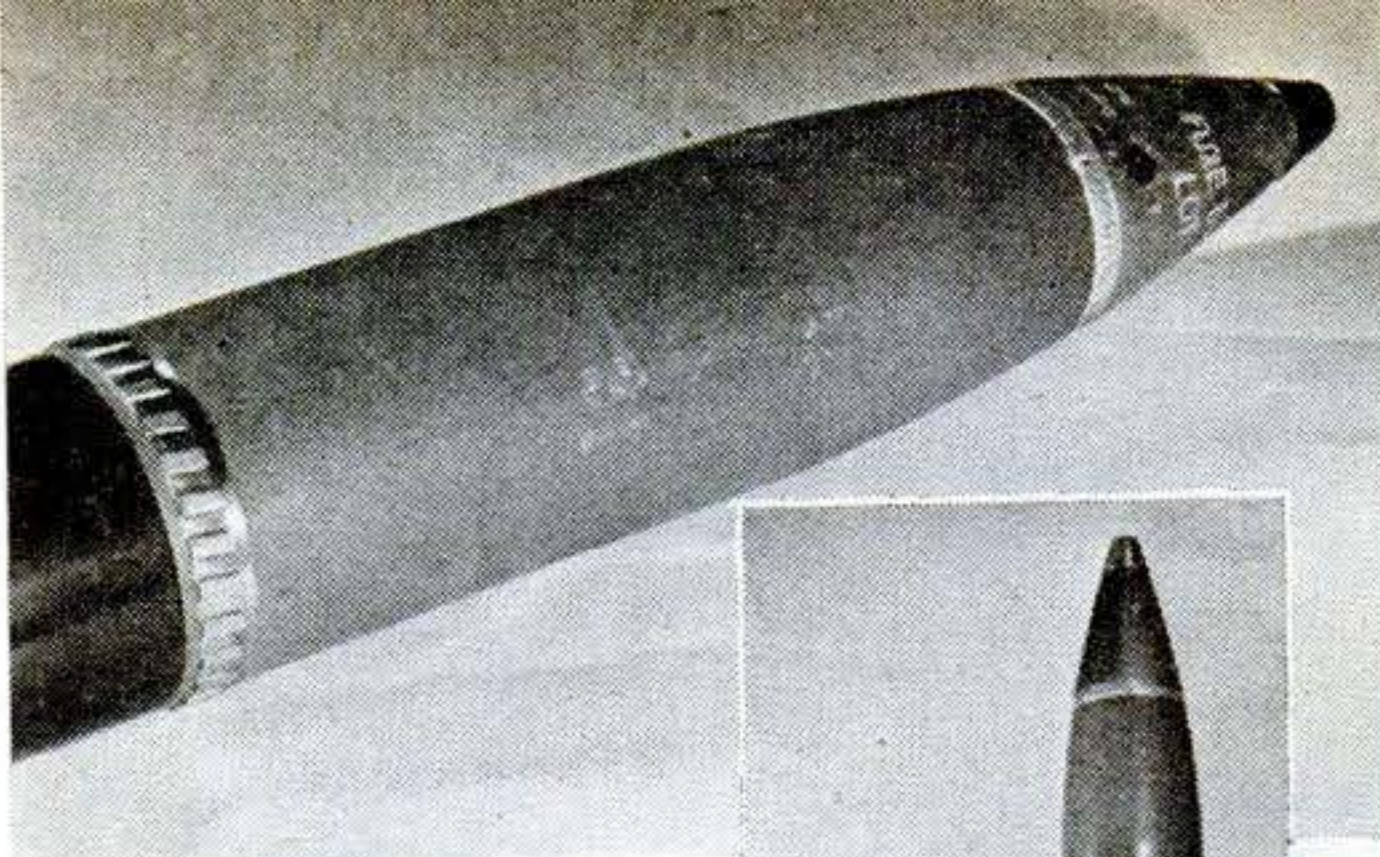

The perforations in the shell cases of the 57-mm. and 75-mm. recoilless ammunition permit escape of gases to the vents in the breech. The propellant powder is contained in a paper interlining. Note the pre-engraved rotating band on the 75-mm. shell above. This permits a thinner barrel wall, and the band must be fitted into rifling of the barrel to close the breech.

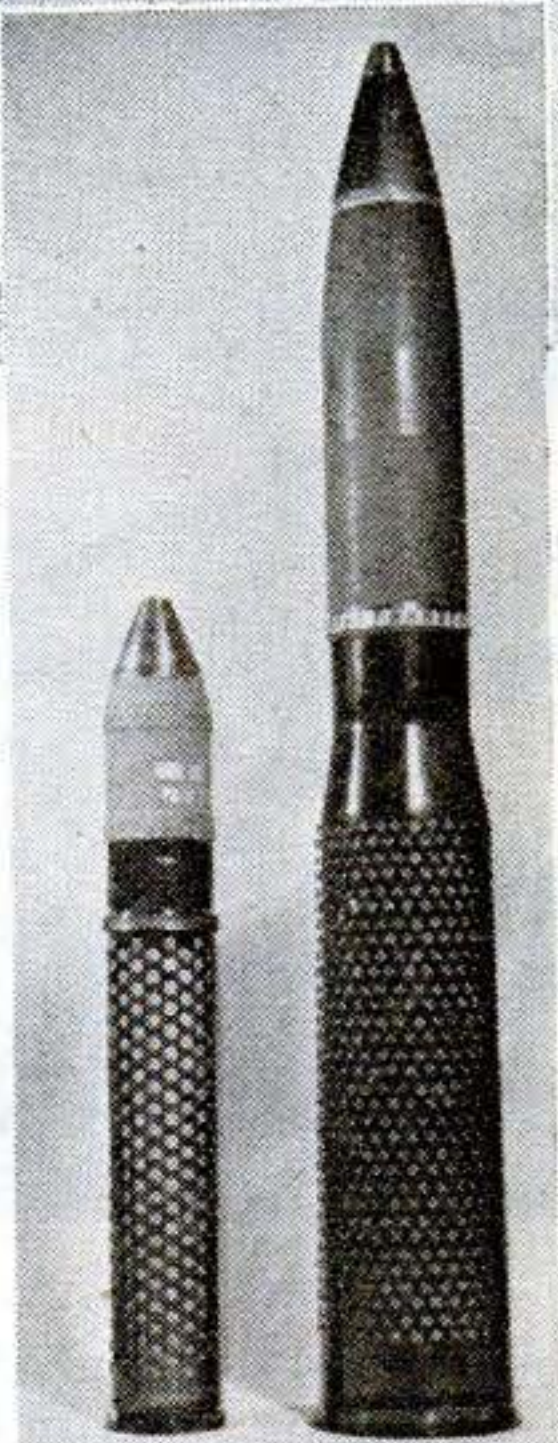

The loader of the two-man crew works from the side when inserting a shell into the milk-bottlelike breech of the 57-mm. gun. After locking the breech, he is clear of the blast that shoots back 40 feet.

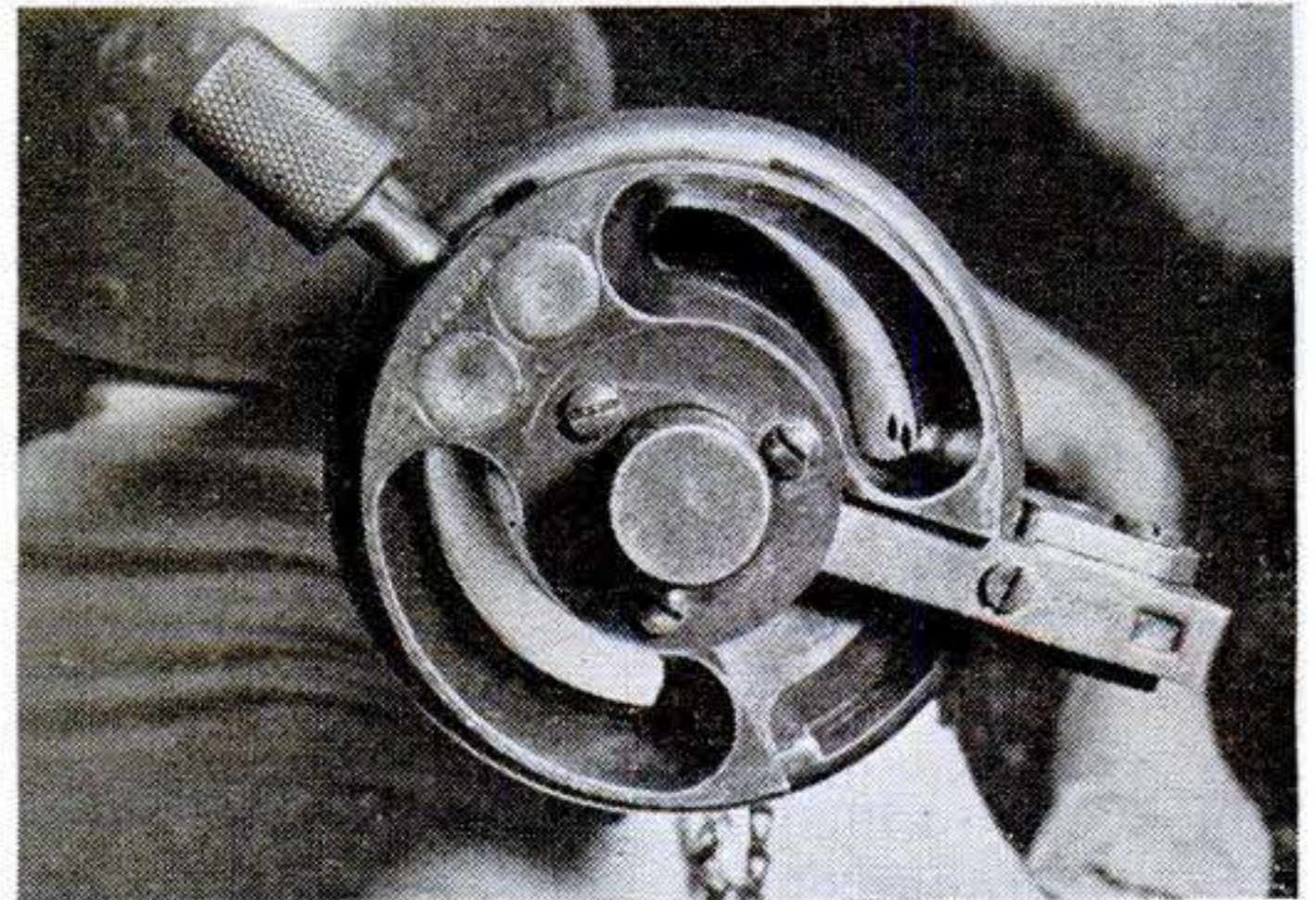

Here's a close-up showing the ports in the breech, through which the propellant gases escape, eliminating the recoil. The powder charge is twice that of the standard artillery shell, so that sufficient gases also drive the projectile out of the barrel.

directions: half of it drives the shell from the barrel, half of it kicks back to produce recoil. Much of the weight of any ordinary artillery piece is devoted to a mechanism to absorb recoil.

In obviating recoil, the U.S. Army has engineered not only one of the great developments of this war but one of the significant advancements in the history of gunfire.

## SHOULDER REST OF 57-MM. IS BIPOD FOR PRONE FIRING

A quick adjustment converts the shoulder rest into a bipod for firing from the prone position. The 57-mm. can also be set on a machine-gun tripod.

This two-man artillery team presents a small target to the enemy. Loading the weapon is fast and simple. After the loader inserts the charge, he grips handle on the breechblock to close the breech, holding projecting handle on breech to steady gun.





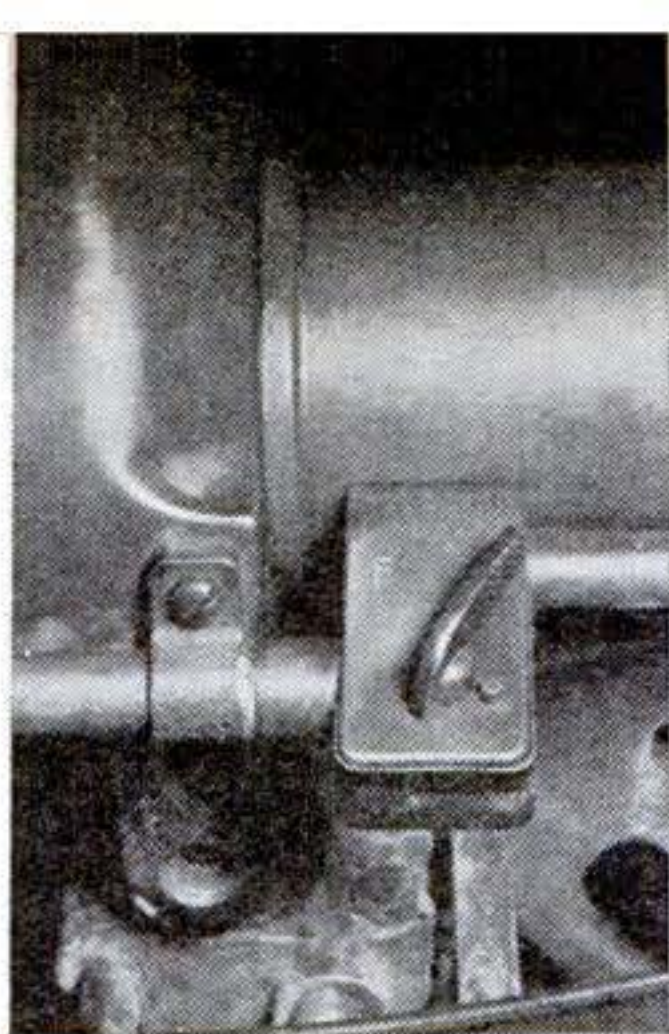

This is loader's safety lever. When he moves it to "F" he taps gunner, signaling gun is loaded.



The new-moon-shaped shoulder piece cushions the gun's weight in the sitting and standing firing positions. Right hand squeezes trigger as left steadies weapon.



Here's the trigger assembly and the leaf sight on the gun's barrel. The trigger is at the forward side of pistol grip; safety grip is at rear.



The recoilless cannon looks much like the bazooka from a distance, but, unlike the bazooka, it throws regular high-explosive ammunition or smoke shells which are propelled by a powder charge. Because of the comparatively low muzzle velocity, specially shaped projectiles are used which will penetrate most tank armor. Above, the gunner spots his target in the telescope sight of the infantry's artillery weapon.

This is how an American infantryman shoots shells up to three inches in diameter without recoil: As in an ordinary gun, the propelling gases move two ways, forward and back. But those moving back, instead of encountering the sealed breech of the gun, find ports, or holes, permitting escape. The effect is somewhat like pulling a chair out from under someone about to sit down. What should be there simply isn't.

The question naturally arises, if the gases escape from the breech, what drives the shell forward? That's the secret. The loss of gas is compensated for to a large extent by using a larger powder charge than in a conventional gun of the same size. The amount of gas escaping is a *controlled* portion. The force of the gas expended in push-

ing the shell from the barrel of the gun is exactly balanced by the force lost through the holes.

Shoulder portability for artillery is gained, but in the process something is lost, as we shall see in a moment.

Against the Japanese, American troops are using two calibers of kickless guns, 57 and 75 mm. Each can be transported from ship to shore or across practically any kind of terrain by two men. One man, in fact, can carry the 57 if need be, and fire it. Usually, however, it is handled by a two-man crew—a gunner who carries and fires the weapon and a loader who lugs the ammunition and loads it. Under normal combat conditions the loader can carry six rounds, or 30 pounds *(Continued on page 238)*



## Convair B-32 Bomber Is Hitting the Japs

NEWEST of the AAF's big bombers, the Consolidated Vultee B-32 is now in action in the Pacific. Designing of this big brother of the B-24 Liberator began before Pearl Harbor, and the production model now hitting the Japs is the result of long experimentation. The B-32's 135-foot wing span is only about six feet less than that of the Boeing B-29 Superfortress. It has a gross weight of 100,000 pounds. Four 2,200-hp. Wright Cyclone engines spin 16 $\frac{2}{3}$ -foot Curtiss electric reversible-pitch propellers, the largest-diameter props that have ever been installed in any production airplane.



The towering tail surface of the B-32 rises 32 feet above the ground in taxiing position. Its vertical surface area totals 236 sq. ft.; rudder alone, 70 $\frac{1}{2}$  sq. ft.

The B-32 in flight. Single tail and cigar-shaped fuselage differentiate it from its famous smaller sister, the B-24 Liberator bomber.



## Lights Show If Gear Is Down for Safer Landings at Night

PILOTS of Pennsylvania-Central Airlines planes, coming in for night landings, don't have to worry about whether the retractable landing gear is really down and locked. Mirrors alongside the landing lights in the wings reflect light onto the wheels, affording a positive check on the indication given by a signal lamp on the instrument panel.



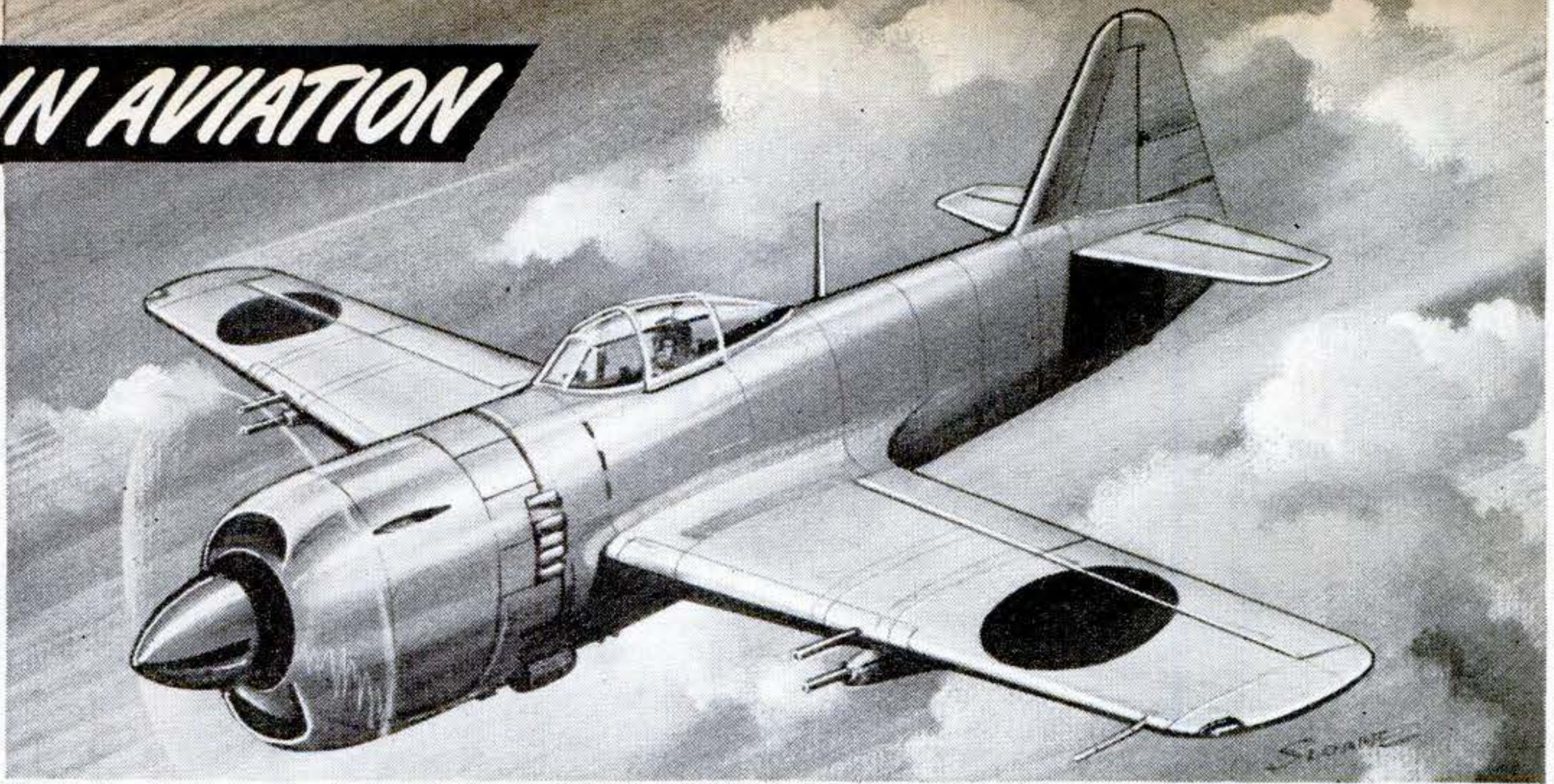

## Meet George, the Japanese Answer to the Grumman Hellcat

"LET George do it" will probably be the motto of the Japanese naval air arm, for this fast new fighter is about the best that the Nips can put into the air against our Grumman Hellcats. With its 2,000-hp. Homare 21 engine, George fights in the 400-m.p.h. class and is a little faster than most Allied carrier-borne fighters. Armament consists of four 20-mm. cannon in the wings

and two machine guns mounted in the engine cowling and synchronized to fire through the four-bladed propeller. Allied air experts who know George's potentialities expect that the new ship will be used in short-range land-based operations exclusively. Like "Betty," "Zeke," and other names for various Japanese aircraft types, "George" is a tag applied by U. S. airmen.

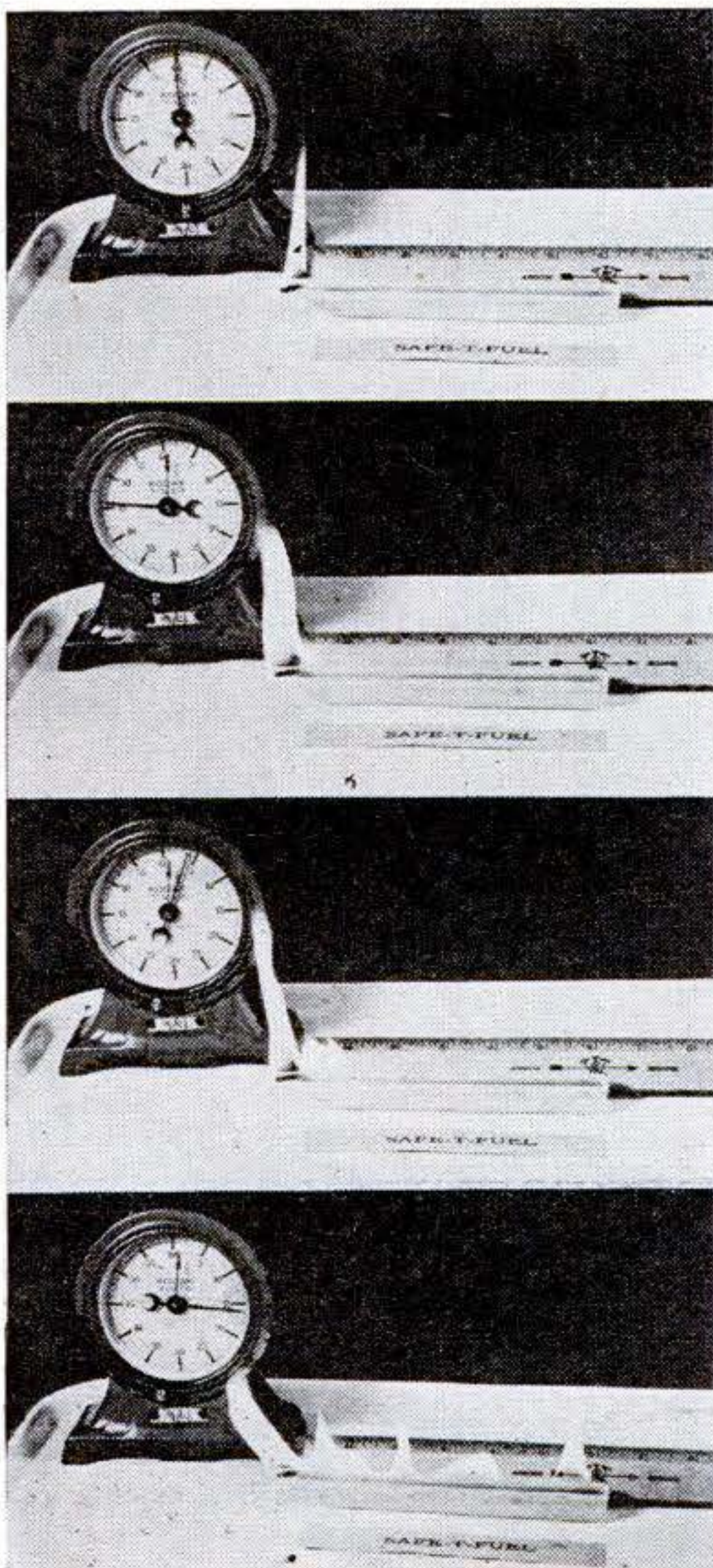

## Safety Fuel Ends Flash-Fire Peril

DROPPING a lighted match into high-octane aviation fuel needn't be fatal, if it's the new safety fuel developed by the Standard Oil Company of New Jersey. With the combustion power of 100-octane gasoline, "Safe-T-Fuel" is as safe to handle as kerosene. It must be heated to above 100 degrees F. before it produces vapors that will ignite. In use, it must be fed by direct injection instead of carburetion. The pictures at the left show a test in which it takes 76 seconds for a lighted wick to set a tray of the new fuel aflame. Below, a lighted taper is dipped in Safe-T-Fuel without igniting it, while regular aviation gasoline burns fiercely after receiving the same treatment. The new fuel actually extinguishes the flame on the taper.







A helicopter rises from a floating B-29 repair shop to fly officers to a newly won airstrip on a Pacific island. Each "floater" also carries two "duck" trucks, two jeeps with trailers, and two 30-foot work boats.

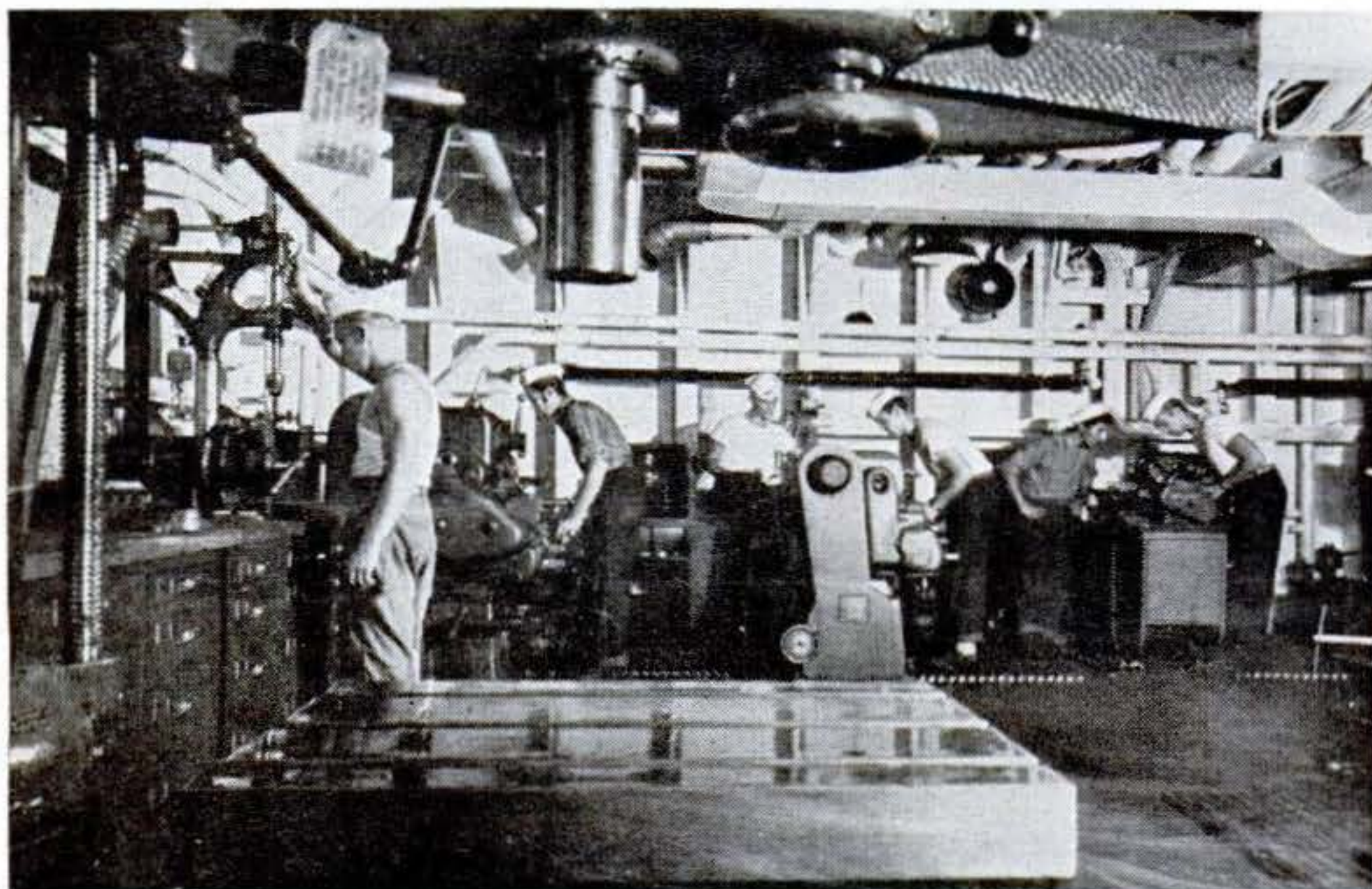

All available space below deck is crammed with machine tools. The shops are equipped to handle sheet-metal jobs and to repair airframes, superchargers, carburetors, propellers, electrical systems, radios, turrets, and other parts.

Air view (below) of a refitted Libertyship that ministers to damaged B-29's as a mother ship tends a group of submarines under its wing. These mobile depots serve until ground units reach advance bases.







Repaired parts and skilled men to install them are flown to a field ashore in a ponton-equipped helicopter. The seagoing mechanics can do just about anything in servicing the 55,000 parts of the big bombers.

## Seagoing Shops Keep the B-29's Pounding Japan

**All that our Superfortresses need is a place to land. The floating repair unit anchors near by and keeps 'em flying until ground bases can be set up.**

**By T/SGT. AMOS LANDMAN**

**B**Y BRINGING the repair base to the Superfortress, instead of vice versa, the timetable of the Pacific war has been speeded up two to six months. The Army Air Forces now reveals another of its schemes for blasting the Japs in their homelands—complete repair shops aboard Liberty ships.

Those floating repair bases simply pull up alongside a newly captured island and go directly to work to keep the B-29's in tip-

top shape for their mighty bombing attacks. They can do just about anything in servicing the 55,000 parts of the big planes. After there has been time to establish repair bases on land, the floating shops pull up anchor and move on to the next island.

The Liberty ships, which were converted to their new use by the Air Technical Service Command, are known officially as Aircraft Repair Units (Floating), but the seagoing AAF mechanics who work aboard them have boiled it down to "floater."

Not only is this new-type ship fitted with such shops as are needed for its mission, but it also is equipped with quarters and mess facilities for its personnel work, intelligence officer, finance officer, chaplain, laundry, PX, library, movies, and a complete hospital.

Floaters carry their own local transportation, for use at the scene of operations, right on their backs. Perched above the forward portion of the main deck is a 72-by-40-foot flight deck from which Sikorsky R-4B helicopters operate. Just aft of the flight deck are two "ducks" and two jeeps with trailers. On the fantail are two 30-foot work boats.

Here's how the floater works: When B-29 operations began in Saipan last November, the planes were experiencing trouble with





Finest precision work is done in this instrument shop, where compasses, bombsights, gyros, gauges, and other vital parts are completely overhauled. Many of these men were watchmakers in civilian life.

their prop governor heads. A clip which held a resistor was defective. The vibration of the engines loosened the clip, and the resistor, which looks like a cartridge-type fuse, popped out of the clip, got into the moving parts of the governor, and sometimes ripped it to pieces.

One of the floaters arrived in Saipan the day before the first Tokyo raid, and dropped anchor in Garapan harbor. Tactical outfits at Iseley Field rushed some 50 damaged prop governor heads to it for repair. Working at top speed, robbing some of the beat-up mechanisms for parts, and improvising, the men of the floater that night had a number of governor heads in serviceable condition.

The repair units are equipped with the following shops: machine shop, welding, sheet metal, heat treating, electroplating, ordnance, turret, ground and airborne radar, radio, camera repair, propeller, carburetor, turbo-supercharger, electrical, paint-dope-and-fabric, woodwork, instrument, bomb-sight, tire, fuel cell, parachute rigging, and drafting. There is a plant for the generation of aviators' breathing oxygen, the largest mobile plant of this kind overseas.

The B-29's aren't the only customers. The floaters have done work on P-51's and can handle work from any other planes, Army or Navy. One outfit even manufactured some gears for Seabee bulldozers when the Seabees were in a jam, and another capped the tires of a general's staff car.

Repairmen prime the oil pump of a B-29 turbo-supercharger. This department can overhaul 20 internal or gear-driven superchargers a month. Sandblasting of parts is done in the ship's electroplating room.

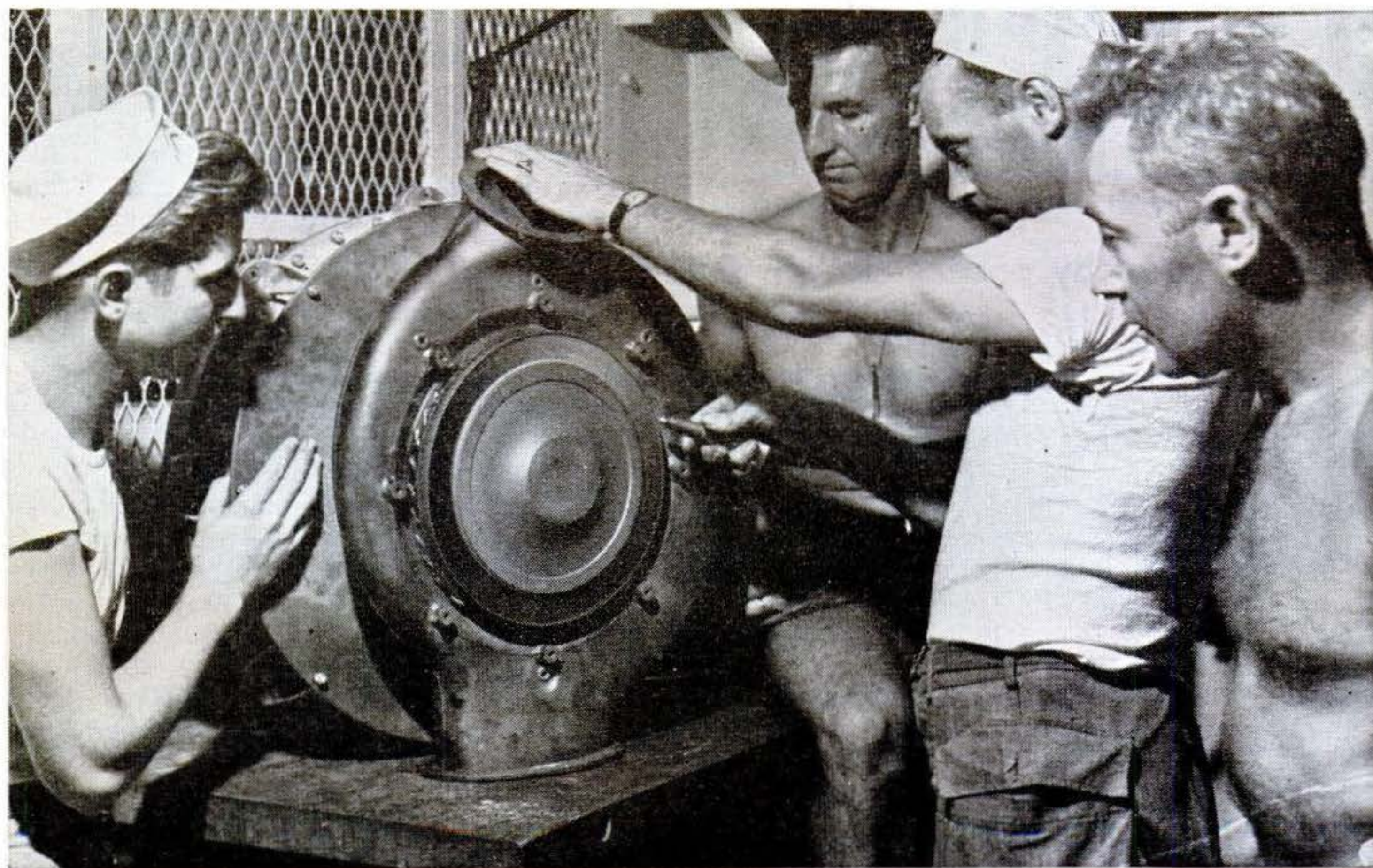



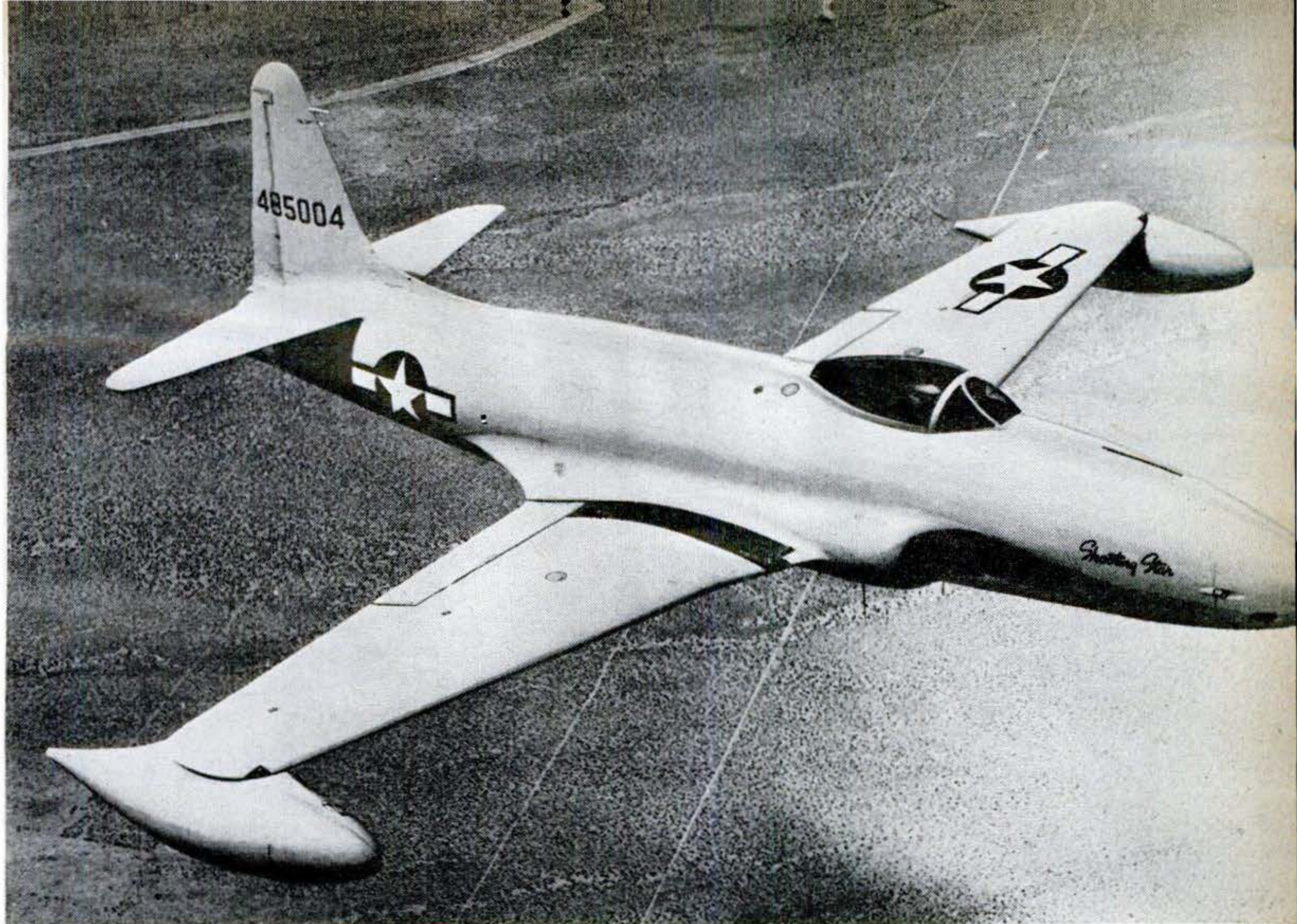

The camera catches a Shooting Star. The P-80 has a wing span of 38 feet 10½ inches and is 34½ feet long. This one is carrying auxiliary fuel tanks on its wing tips for use in long-range missions.

## P-80 Secrets Revealed

A CLEARER picture of the fastest plane in the world, the Lockheed P-80 Shooting Star, is given by photographs just released for publication and performance details now made available for the first time.

It can now be revealed that this jet fighter has a ceiling well above 45,000 feet. Armament is six .50 caliber machine guns in the nose. The pilot is protected by a bullet-resisting glass windshield and by armor plate fore and aft of his seat. Air pressure in the cockpit is automatically reduced in combat to prevent explosive decompression if a bullet hits the canopy.

Gross take-off weight of the P-80 is about 14,000 pounds, some two tons less than that of the P-38 Lightning. The kerosene-burning General Electric jet engine, which has only one moving part and requires no warm-up period, can be completely changed in less than 20 minutes. There is only one engine control: the throttle.

Because it has no propeller to clear the

ground, the Shooting Star is able to use extremely low tricycle landing gear. A "piano finish" is given the whole outside surface of the plane by the use of a special primer with baking, waxing, and rubbing.

No trail of smoke or flame is left by the blast of hot gases issuing from the jet nozzle at the tail.

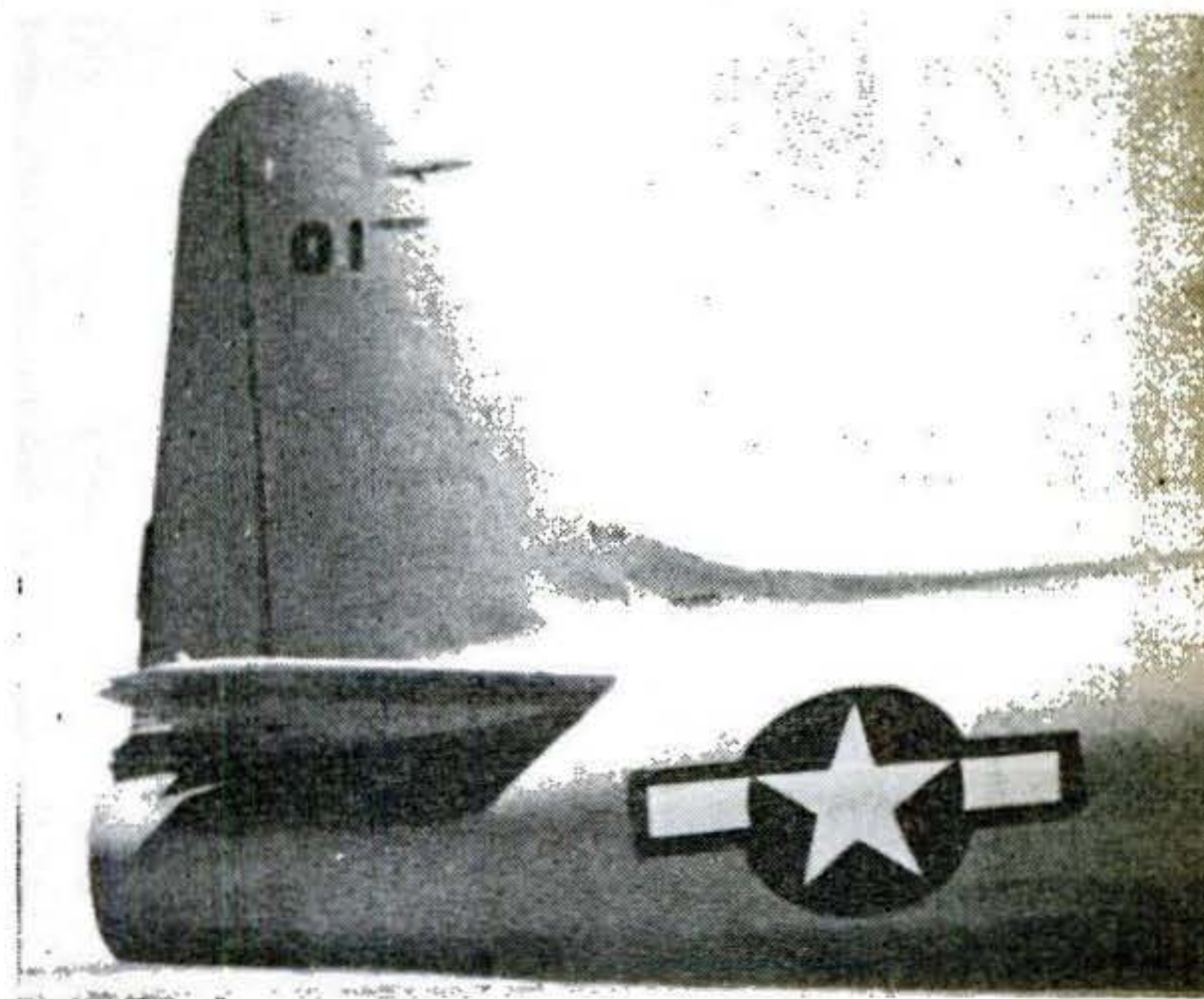



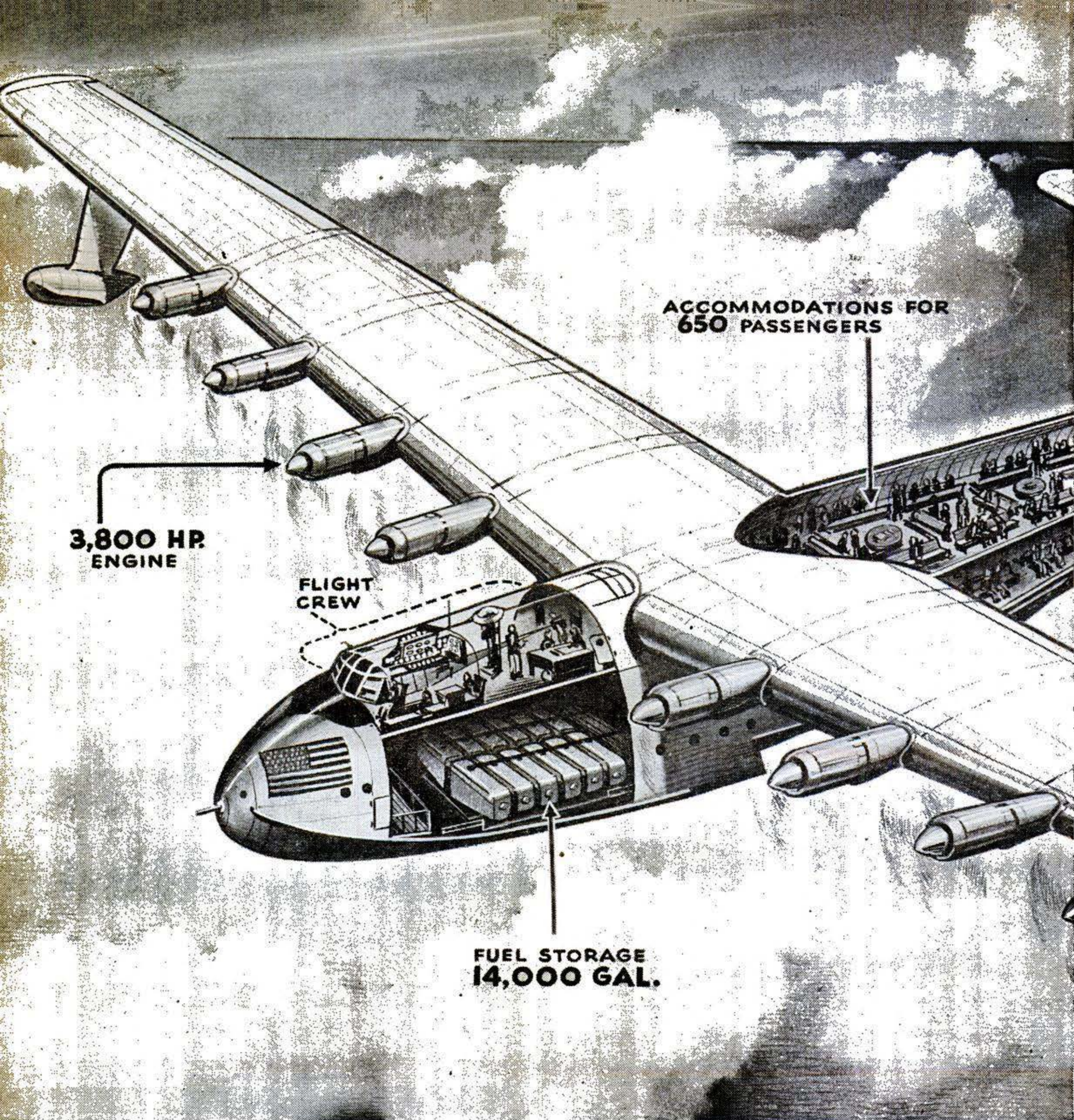

This cutaway drawing of Howard Hughes' H-4 shows the vast interior that could hold a payload of 60 tons.

## Looking Inside the

**Howard Hughes' all-plywood flying boat, with eight 3,000-hp. engines, will fly 3,500 miles fully loaded.**

*Drawings by ERIC SLOANE*

**U**NDER secret construction for almost three years, the world's biggest airplane has just been revealed in all its giant proportions. It's the \$20,000,000 mystery ship on which Howard Hughes has been working, with Henry Kaiser as a partner until a while back, and is now called merely the H-4.

We thought the Superfortress a pretty fair ship for size, with its 141-foot wing





The giant could be a cargo carrier, transport, or hospital ship, and fly nonstop from Honolulu to Tokyo.

# World's Largest Plane

span. But the H-4 is big enough to accommodate a Superfort on each wing with room to spare. It has eight engines with a total horsepower of at least 24,000.

The giant's wingspread is 320 feet—longer than a football field. Its hull—it's a flying boat—is 220 feet long and about three stories high. Gross weight will be 400,000 pounds, or 200 tons.

It will be able to carry 650 passengers, with plenty of baggage, across the Atlantic nonstop, or across the Pacific with one stop. Or it can carry a 60-ton Sherman tank, or two medium tanks, or three light tanks. It could take 400 soldiers with five tons of ammunition and equipment across the ocean and bring back 350 wounded with 40 or 50 nurses and doctors. *(Continued)*



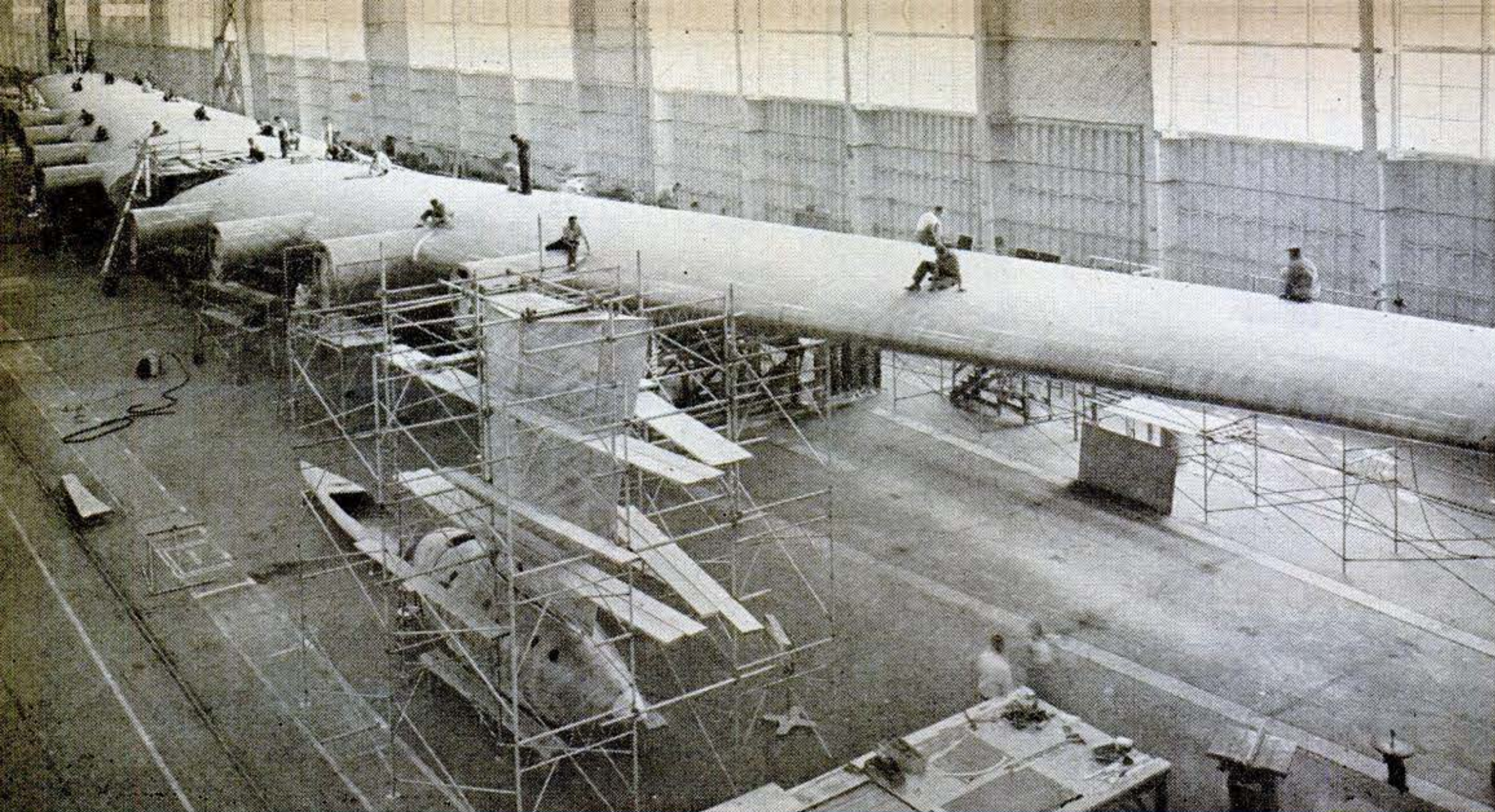

**WING SPAN** is longer than a football field, and thickness at the hull is 13 feet. In this factory scene, expert cabinetmakers have the wing almost finished. One of the H-4's two pontoons also is shown.

The H-4 is the fruit of much dreaming and planning by Howard Hughes and Henry Kaiser, followed by a remarkable construction job now nearing completion at Culver City, Calif. They got together in 1942 on the plans for this ship, and started work on it late that year.

The plane is almost entirely constructed of wood strips, glued together. The metal in it, aside from the engines, is negligible. Skin and structural parts are built up of birch and spruce, layer on layer, formed into durable units by modern techniques and the use of new waterproof glues. Thinnest parts of the H-4 are  $\frac{3}{64}$  of an inch, built up of three  $\frac{1}{64}$ -inch veneers. The thickest part is ten inches, built of 200 veneers  $\frac{1}{20}$  of an inch thick. The workers are mostly skilled cabinet-

makers, who know their wood and their glue.

Construction of wings and hull is virtually complete now. The next big job is to move them 22 miles to San Pedro Harbor, where a special graving dock and hangar are being

constructed at a cost of \$203,000. The moving job entails the removal of some 30 power lines and two buildings along the route.

The first flight of the big ship will take place some months hence. When Howard Hughes takes the controls for this flight, he will be sitting 24 feet above the water. The H-4 is not a speedy plane. Its climbing rate is 675 feet per minute, cruising speed 145 miles, ceiling 17,000 feet. Its tanks will hold 14,000 gallons of gasoline. It requires a run of 5,600 feet to obtain a speed of 86 m.p.h. for the take-off, and this takes 67 seconds.

**EACH PONTON** is taller than a man. Mounted on two such floats and the high, deep struts, the wings would clear a two-story building with room to spare.

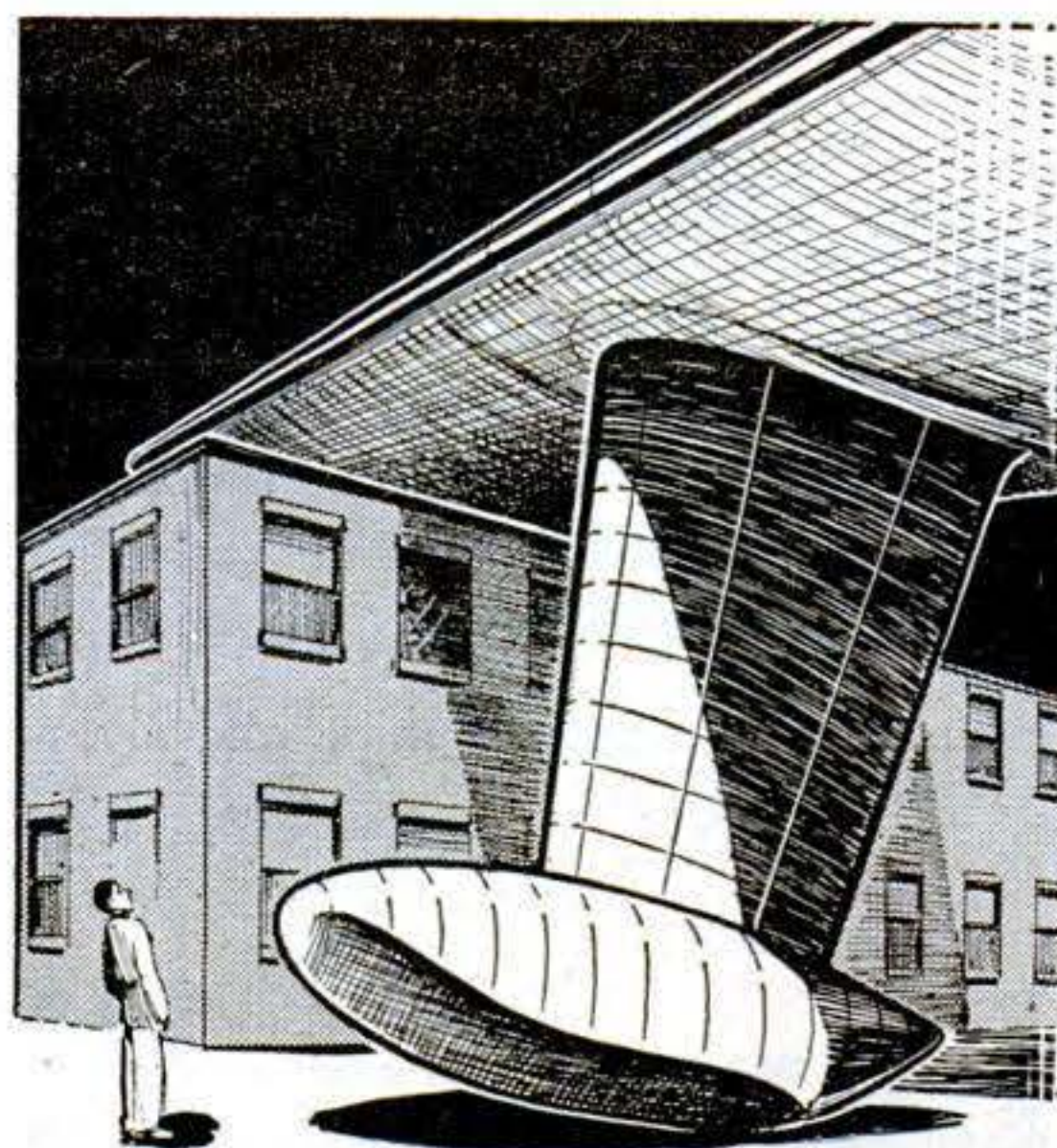

Your Pin-Up

**GRUMMAN F7F TIGERCAT NAVY FIGHTER.** With twice the power of the famous Hellcat and 50 percent more weight, this twin-engine ship is described as the most powerful fighter-bomber yet produced for the Navy. First Navy fighter to have twin engines, it is powered by two 2,100-hp. Pratt & Whitney Double Wasps that put it in the 425-m.p.h. class and give it a mile-a-minute climb. It can carry two tons of bombs, a full-size marine torpedo, or any desired combination of rockets and bombs. With heavier firepower than either the Hellcat or the Corsair, it can smash even a bomber with a single burst. A two-place model is being made for night fighting. First production goes to the Marines; later, Tigercats will fly from our 45,000-ton carriers of the new Midway class.







# NEW Tools

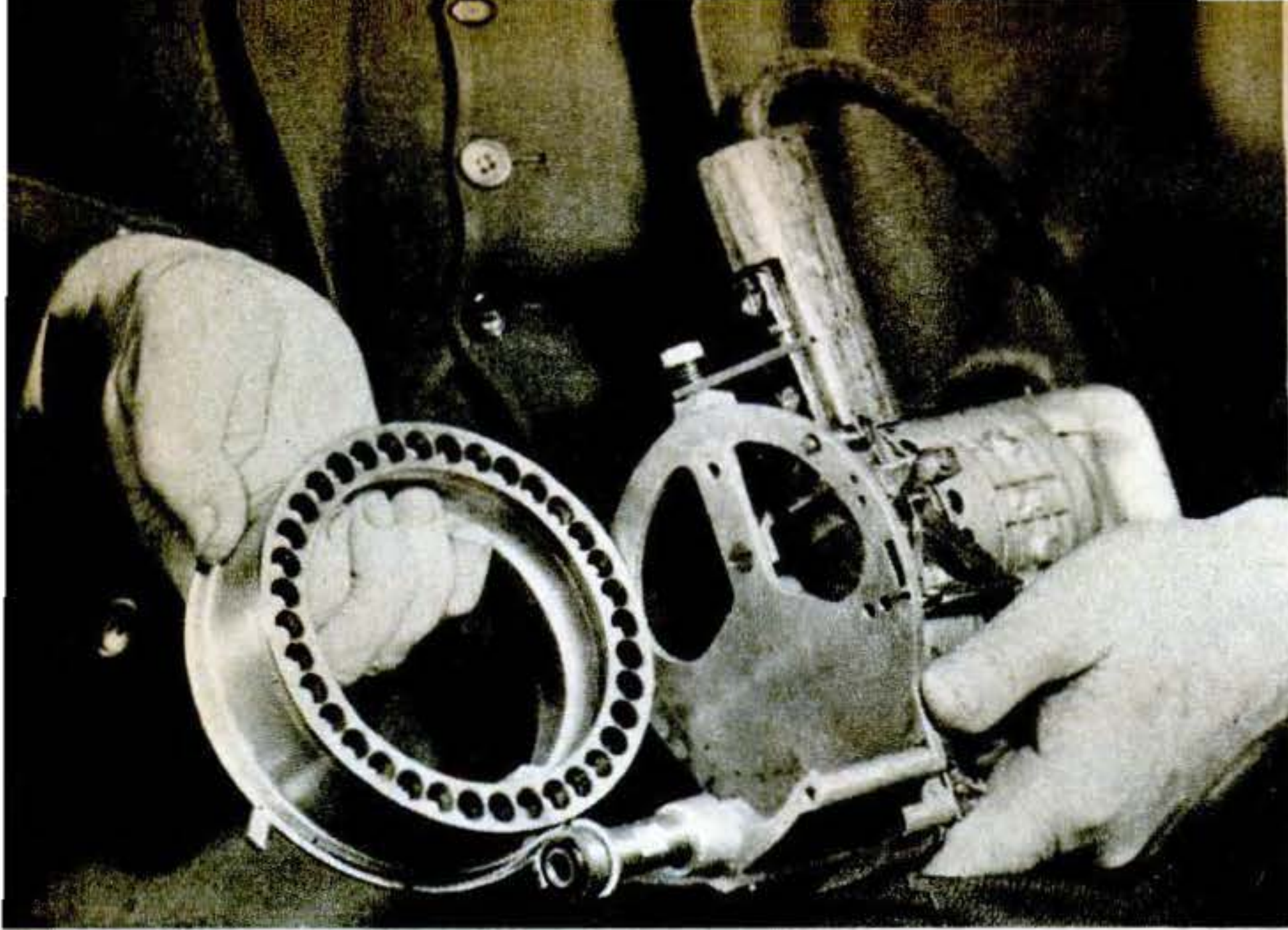

**AUTOMATIC SCREWDRIVER**, electric or air operated, drives all standard or special-head screws into wood or metal to a predetermined depth. The detachable magazine is refilled in a few seconds. Manufacturer is the Reed-Prentice Corp., Worcester, Mass.

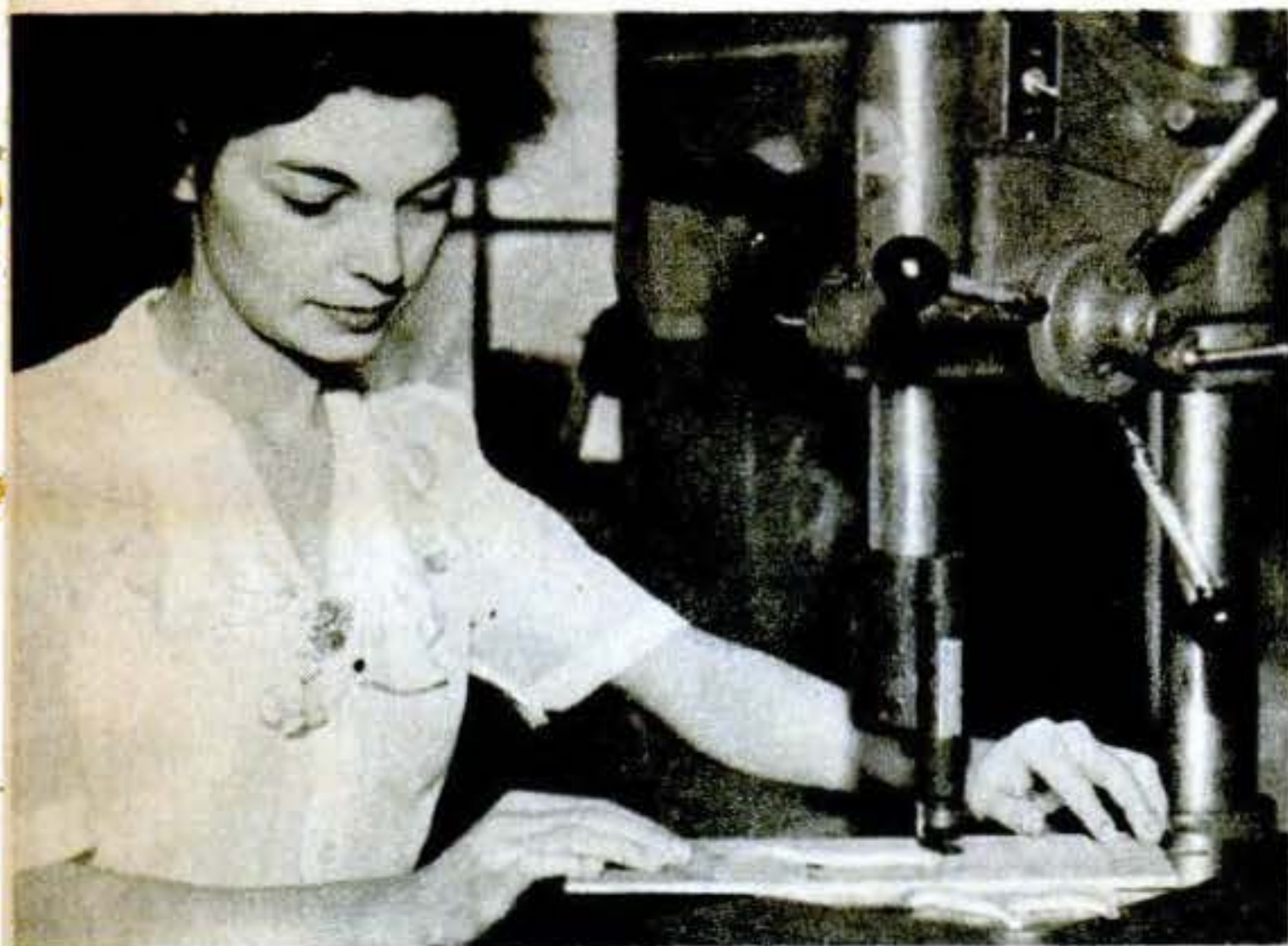
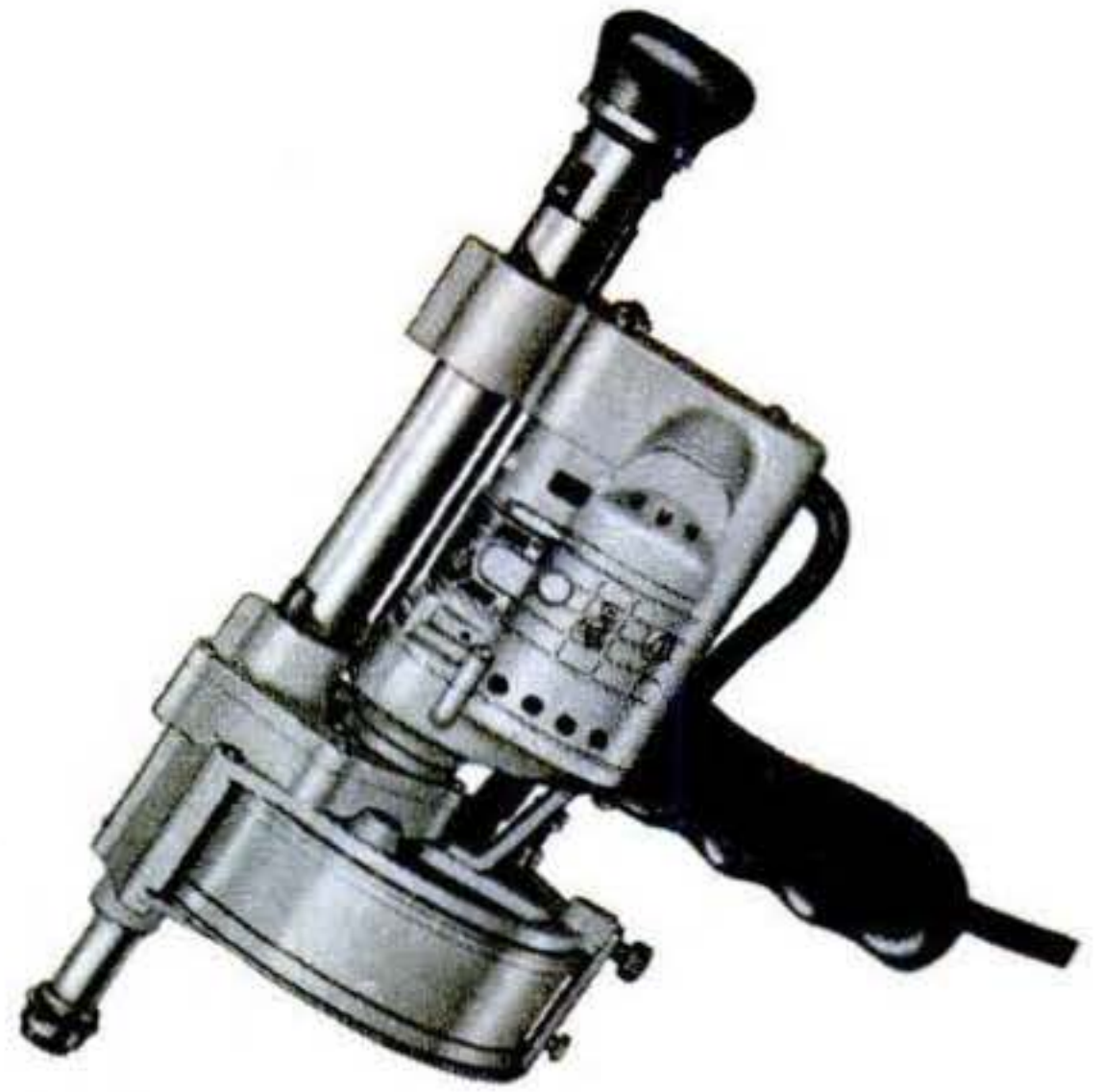

**SAWING AND FILING** with the drill press are made possible by an attachment developed by H. R. Greene, of South Bend, Ind. Attached in about three minutes, it saws the hardest wood up to an inch thick, very thin plywood, or sheet metal, besides doing various filing jobs on small castings and other work.

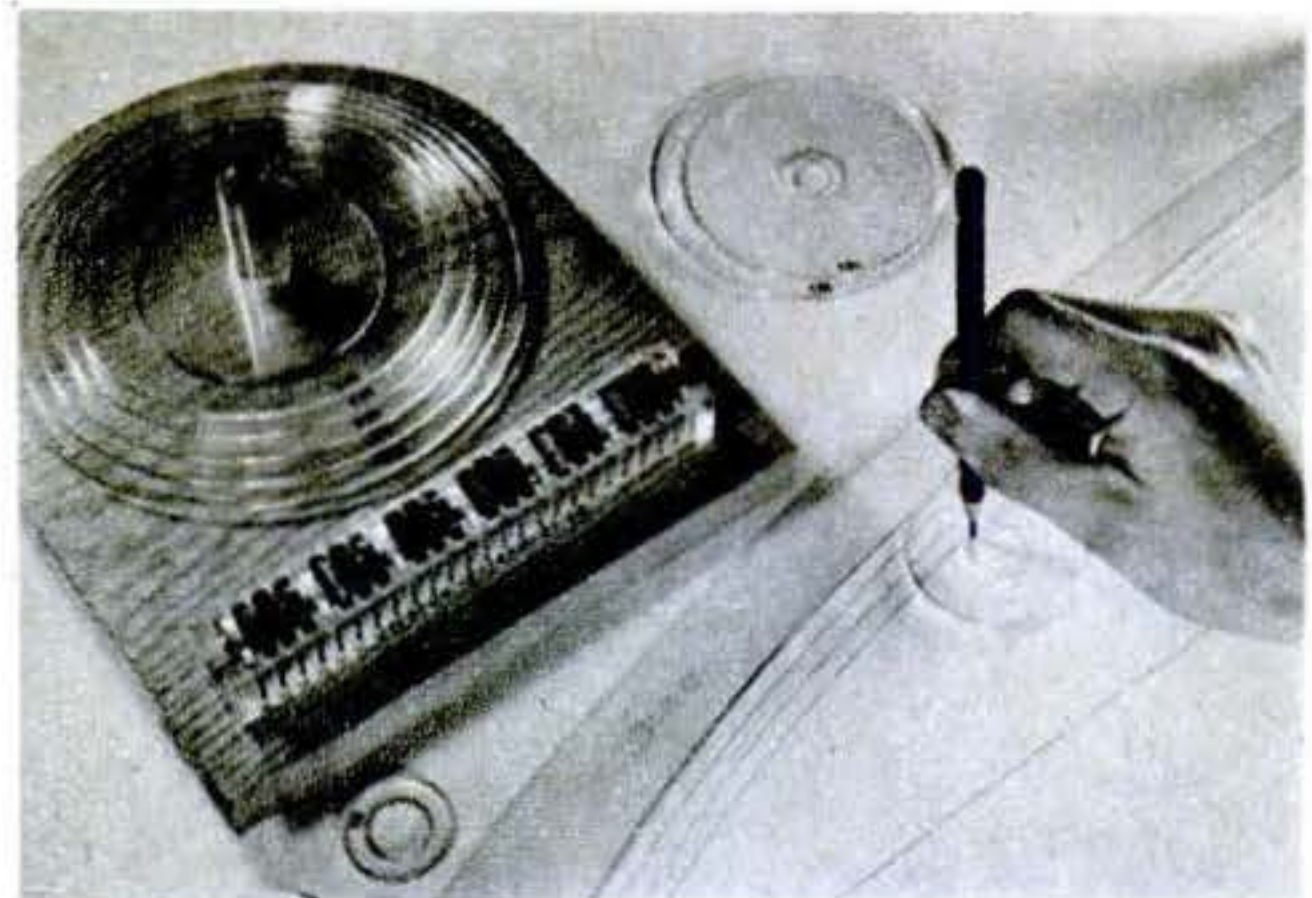

**DRAFTING AIDS.** Plexiglas disks, rolled along the edge of a curved ruler (above), draw parallel lines. The improved lettering triangle below, devised by Llewellyn Price, Fort Washington, Pa., includes fiber strips that raise it above the paper for ink work.

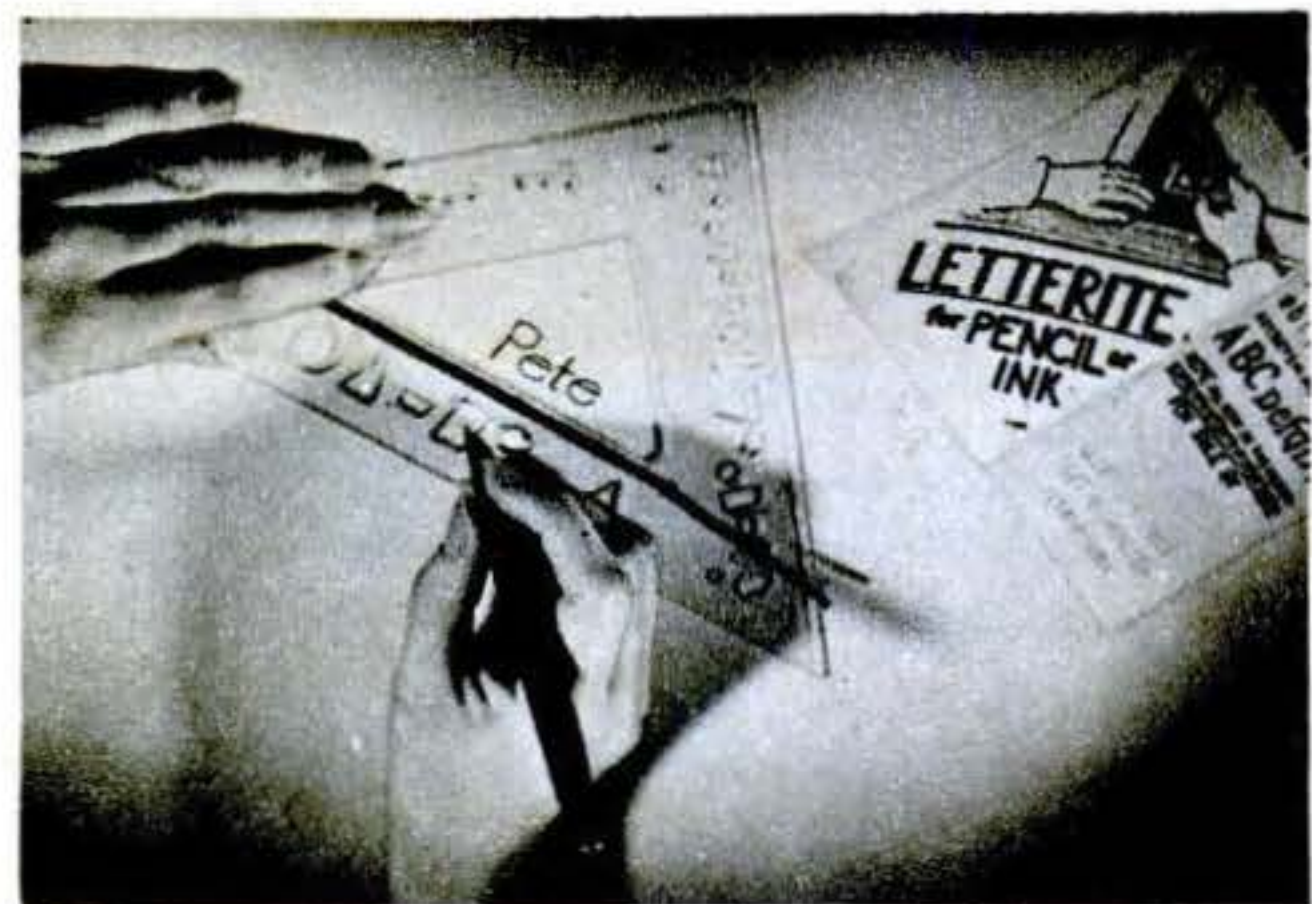

**THIS SCALE COUNTS** small parts to speed production in war plants. The parts are put in the pan, and the worker reads the number directly from the dial. J. H. Keeney & Co., Chicago, are the makers.

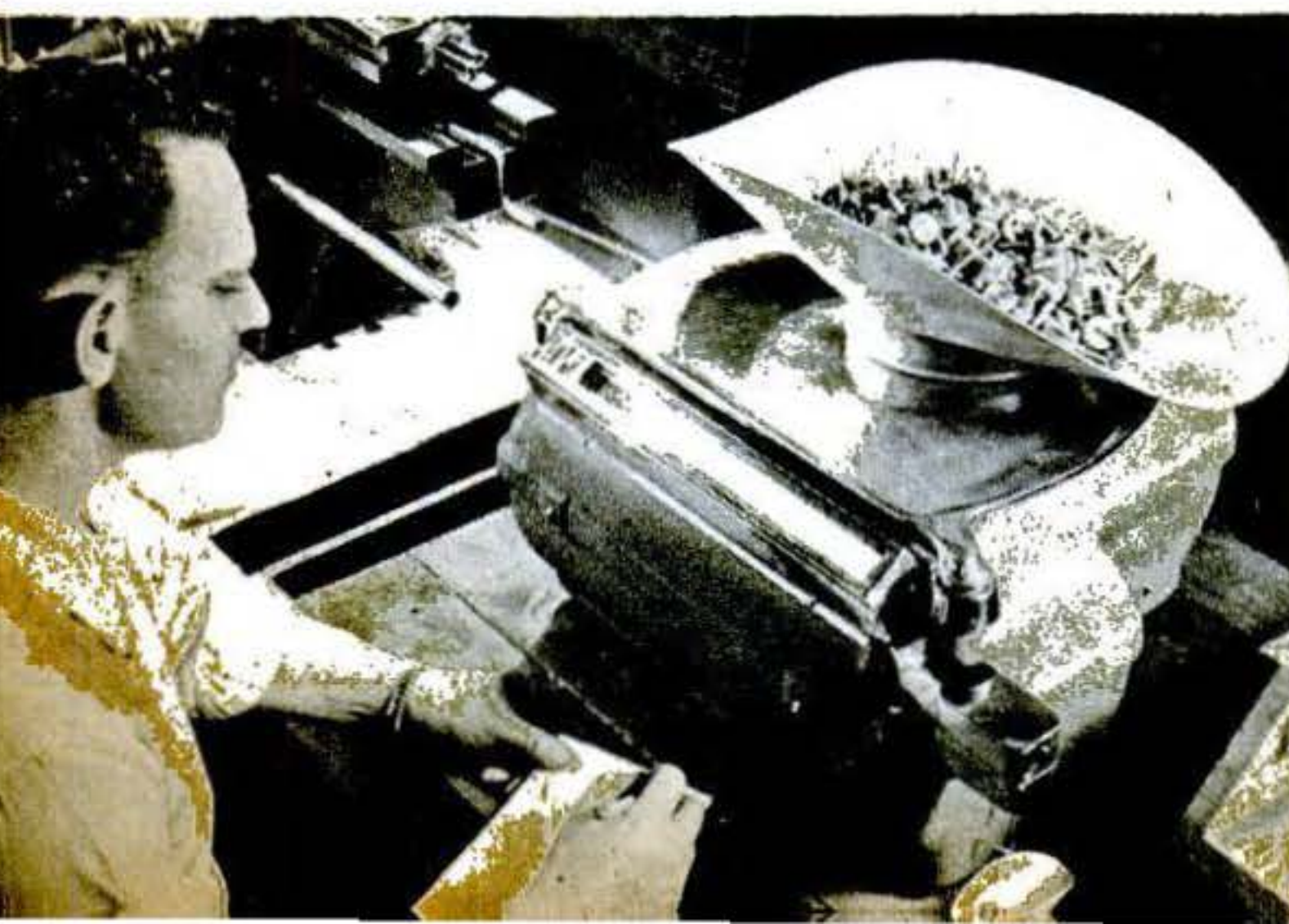



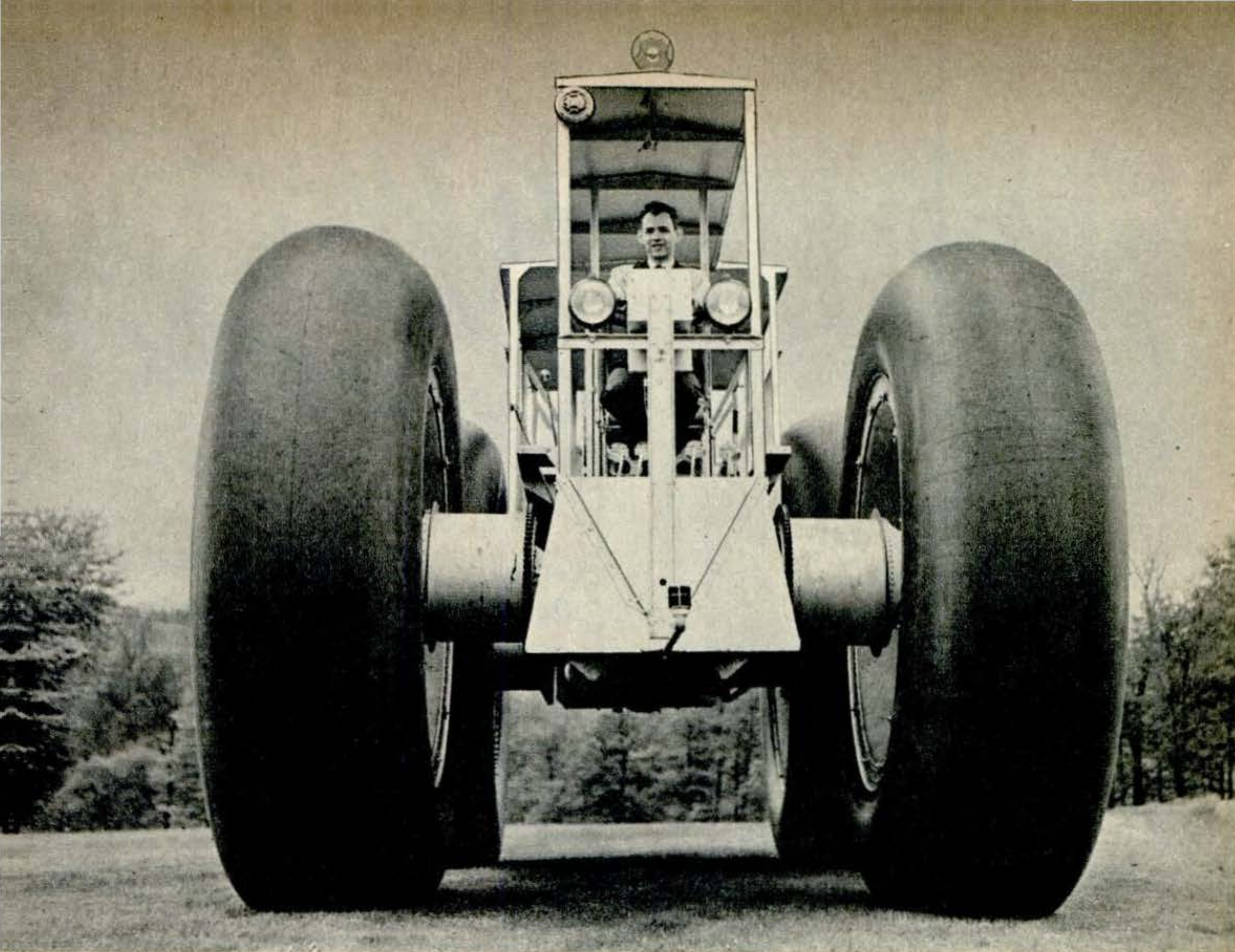

How would you like to change a tire on this "marsh buggy"? These synthetic-rubber doughnuts (size 120 x 33.50) weigh 315 pounds each, their inner tubes 125 pounds. Normal inflation is three or four pounds.

## 120-Inch Tires Carry Oil Prospectors Through Swamps

**R**OLLING across sand, swamps, and deep water, "marsh buggies" are taking petroleum hunters to places that could not be reached with boats or beasts of burden. Developed 10 years ago by the Gulf Oil Company for use in the Louisiana bayou country (P.S.M., Mar. '37, p. 40), these strange vehicles became a valuable war aid in the search for oil all around the Gulf of Mexico and the Caribbean. Their 10-foot tires are the tallest ever made by Goodyear.

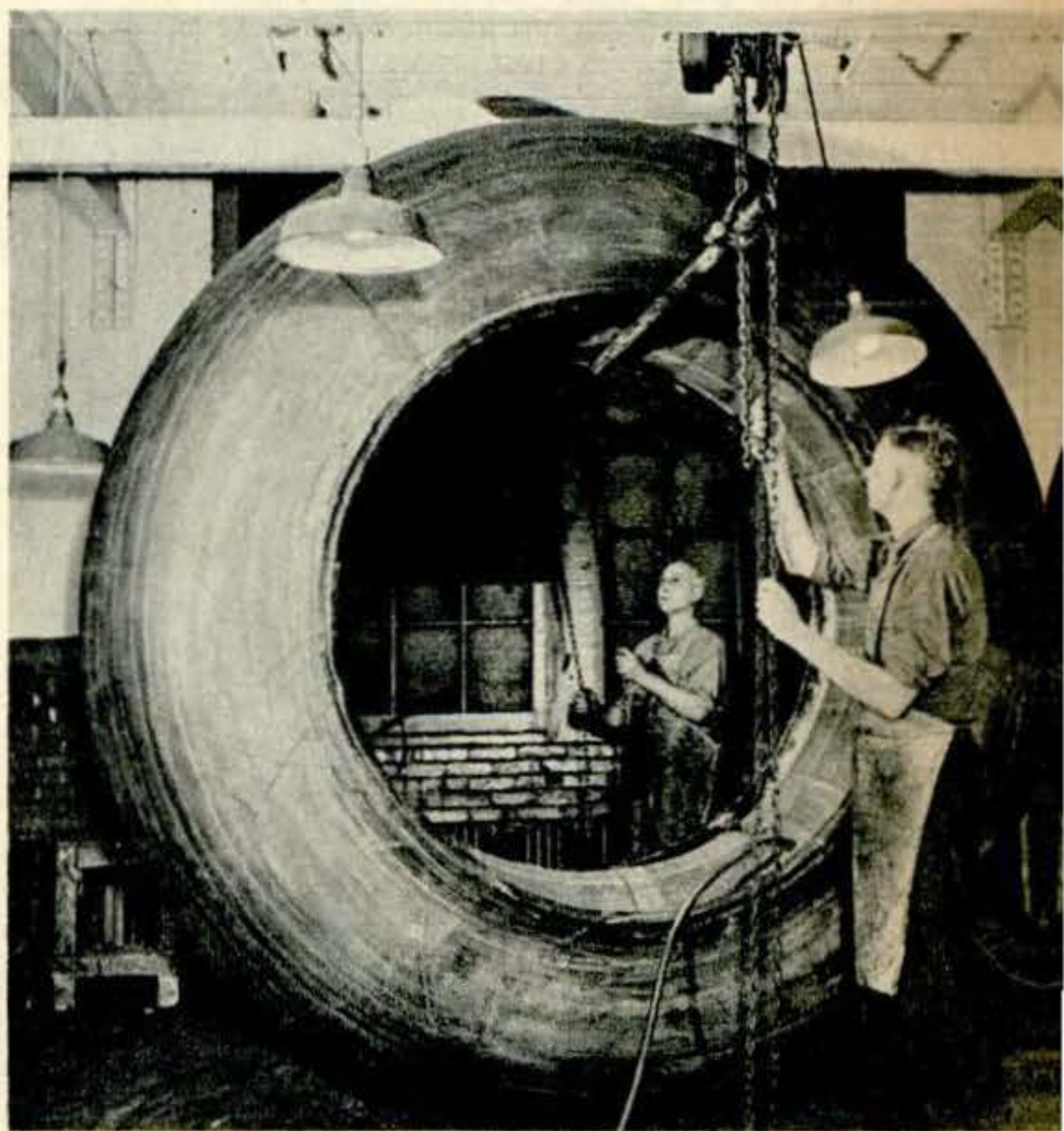

A giant tire casing begins to take form as Goodyear workmen inflate a shaping bag inside it. Air pressure in the bag molds the rubber casing, which has previously been fabricated on a building drum.

A "marsh buggy" kicks itself along in water at four miles an hour. Air in the big tires and in the hollow, drumlike wheels gives it buoyancy.





# He Draws with Scissors

## JACK EISNER MAKES FACES IN THREE DIMENSIONS

By DeVERA BERNSOHN

Photographs by ROBERT F. SMITH

Jack Eisner airbrushes the last color onto his three-dimensional paper caricature of President Abraham Lincoln.

JACK EISNER is a perfect cut-up. It's a common belief that artists are frequently that way; but here is Eisner actually making a successful business of it—or, let us say, a profession. Scissors are the backbone of his business, plus glue and paint. With these he creates three-dimensional paper caricatures of men in the news, and dramatic story-telling models for window displays.

In his whimsical studies of famous people, he pokes usually good-natured fun at such celebrities in politics, business, and the professions as Winston Churchill, the Duke

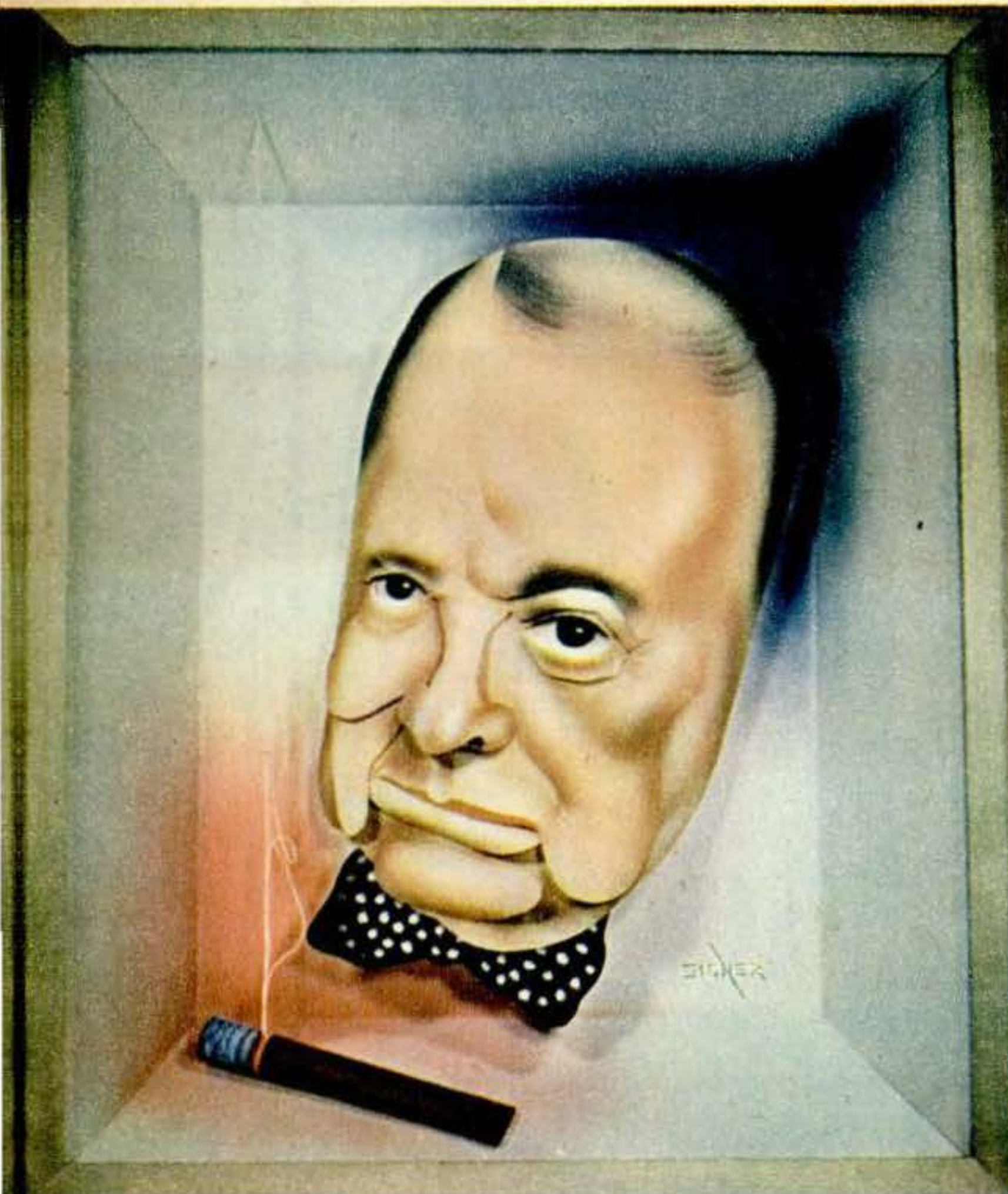

Winston Churchill, with his inevitable Havana, is a natural for paper sculpture. Frank Sinatra, at right, will probably be recognized by teen-age bobby-soxers.





In the Eisner studio, the Duke of Windsor takes a trimming. The ducal nose on the caricature is part of a wooden ball; the clothing is scraps of material glued onto paper; boutonniere, an artificial flower.

of Windsor, Henry Ford, Jimmy Durante, Frank Sinatra, and, incidentally, himself. One exception to his good nature was in his portrayal of the late (?) Herr Schickelgruber, in which he omitted his customary geniality. In fact, the thing was pretty poisonous.

Eisner creates his mischievous caricatures by using paper built out from the background in successive planes, which are bent, curved, and colored with either a bristle brush or airbrush. Thus the artist gets length, breadth, and thickness, and this achievement brings him fairly close to the classification of sculptor. Many of the spoof portraits are life-size heads, while others are made in the form of small busts or full-length statuettes.

They're based on study, too—photographs, or maybe first-hand acquaintance.

After getting the general idea in mind, Eisner goes to work and makes a rough sketch. If he is satisfied with this—and he is not easy to suit—he draws it more carefully on tissue paper. This flimsy is a diagram that shows in detail the base of the profile or full face; also the individual features, all of which have to be cut out separately.

So far, so good. Then the sketch has to be transferred to heavy drawing paper, a simple matter of rubbing the back of the tissue-paper drawing with a heavy pencil. When Eisner has accomplished this, he goes over the lines again with a sharp pencil. Then he leaves a slight margin to allow for the curvature that will be an important part of the finished work.

Now the scissors come into play, prefer-



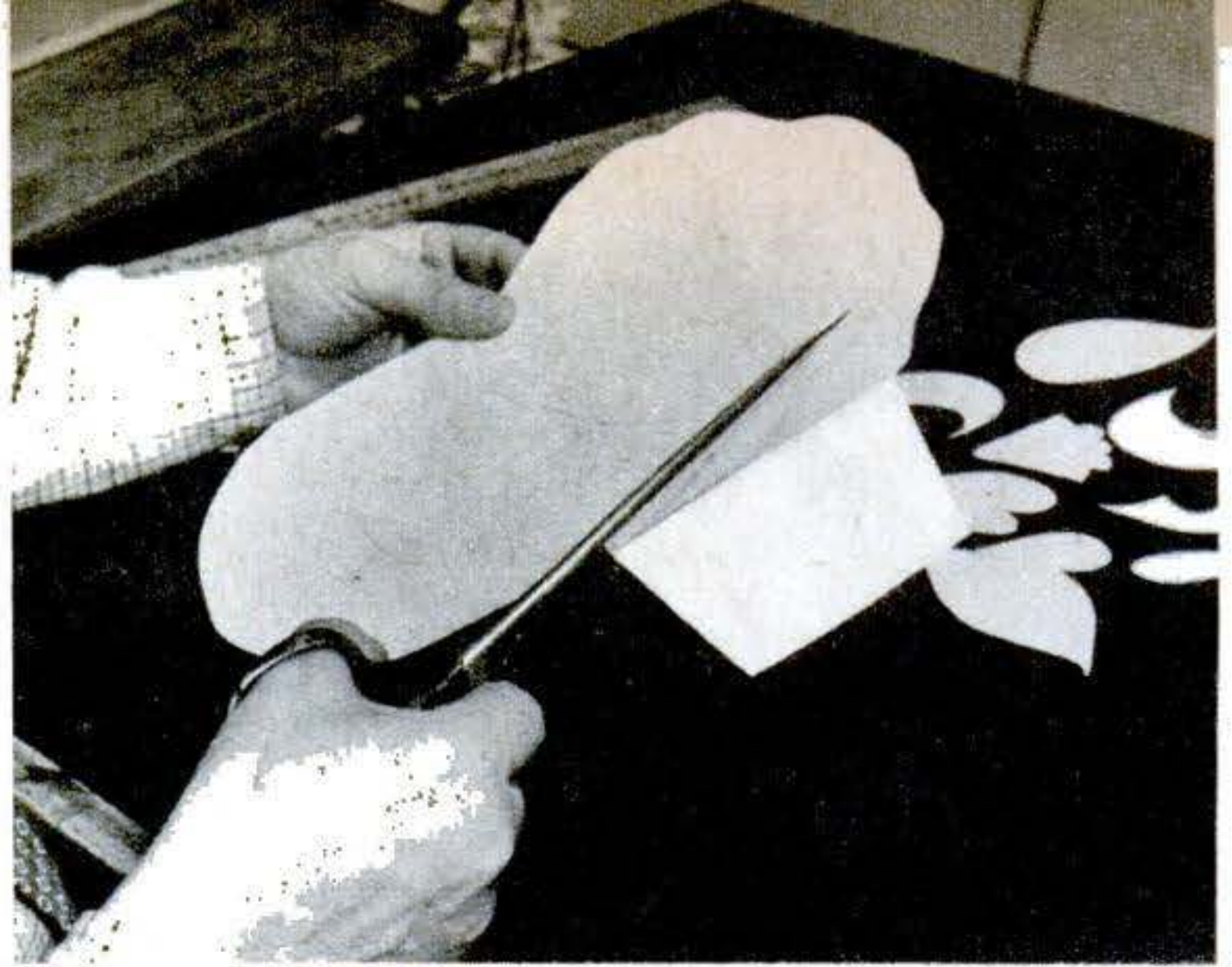
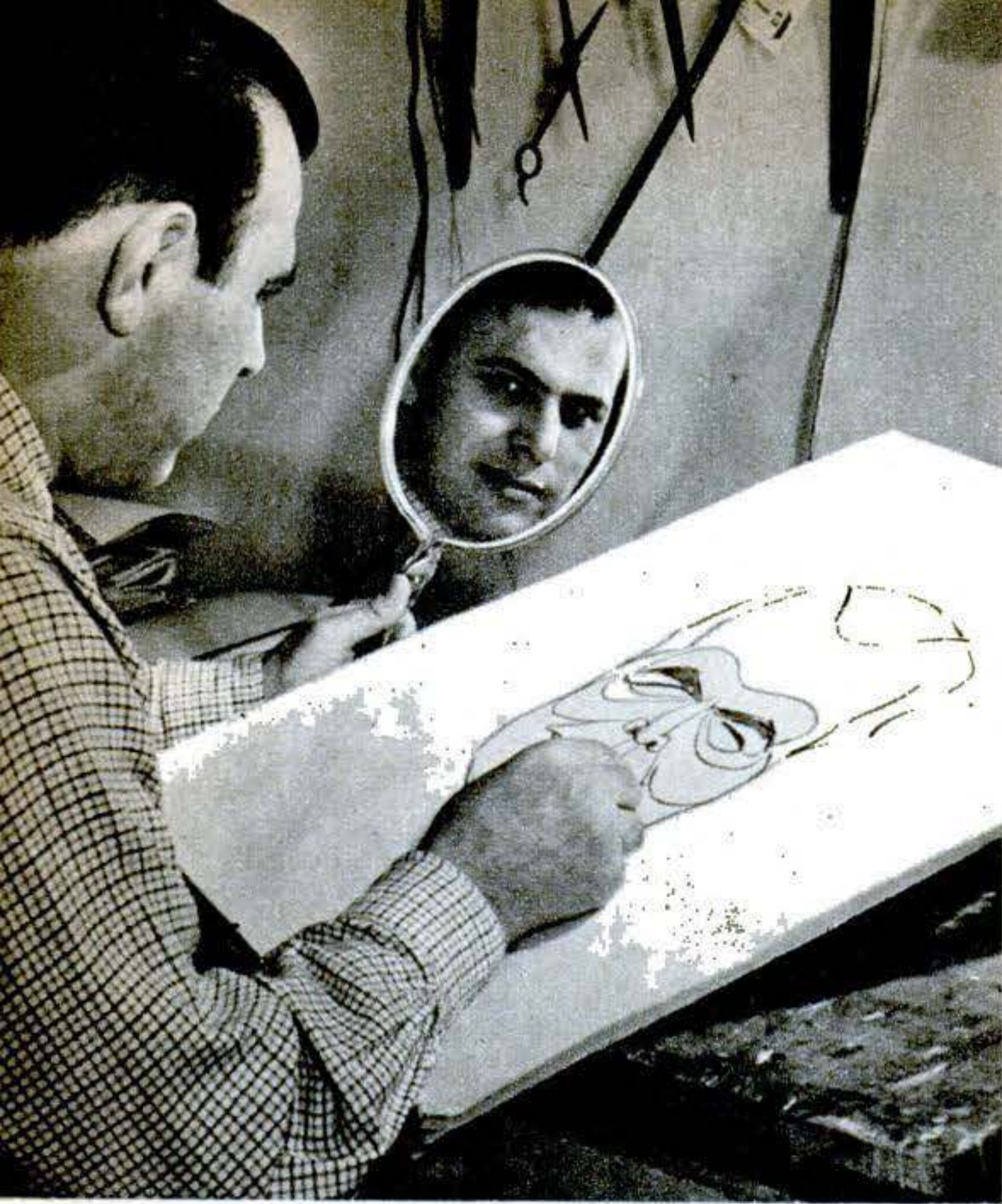

**1** To show how caricatures are made, Eisner (left) uses himself as a model. He sketches face on tracing paper, marking parts to be painted or cut out and glued onto the base in separate planes.

**2** Cutting out the sketch, after it has been transferred to drawing paper. Allowance is made so that when cut-out is glued to cardboard, the facial bulge will be permanent. Trimmings are put to use.



**3** Here the paper sculptor glues the nose onto the face. Cheeks will then be applied in the same manner. To keep such features from collapsing as adhesive dries, small cardboard props are inserted.



**4** Approaching completion, the paper caricature is airbrushed with natural skin colors, and the hair, eyebrows, and lips are painted on. Coloring seconds modeling to accent facial characteristics.

ably the type used by barbers—with the finger rest. Eisner cuts out the base drawing of the face, leaving a tab about two by four inches on each side. Later he folds these face tabs back and glues them onto a piece of heavy cardboard. Thus he rigidly fixes the curve of the paper, and helps to give a lifelike appearance to the caricature.

Features that Eisner wants to emphasize are transferred to another sheet of paper from the finished sketch and cut out separately. But before gluing these parts in place, he folds and curves the paper, rolling it over an orange manicure stick to achieve

the right degree of roundness. Then the edges of the features are stuck to the base. Eyebrow tweezers help in handling tiny parts, and sometimes a magnifying glass becomes necessary. Small cardboard props, temporarily slipped under facial parts, keep the features from falling flat while the glue is drying. Finally Eisner paints on the hair and lips with water colors and airbrushes skin tones onto the virtually completed bit of sculpture.

The artist has a good deal of fun in adapting other materials than paper to his caricatures. An automobile taillight pinch-hits





**5** The finished self-caricature by Eisner proves that he can take it as well as dish it out. After giving the model a final scissoring, all that is left for him to do is start a libel suit against himself.

At right is Eisner's conception of Henry Ford driving one of his early T-model cars. The picture below shows how paper sculpture has been used for purely decorative ends. What looks like carving is paper that has been cut out, curved, and glued onto a wooden background. Gilt applied by airbrush adds a fancy touch.

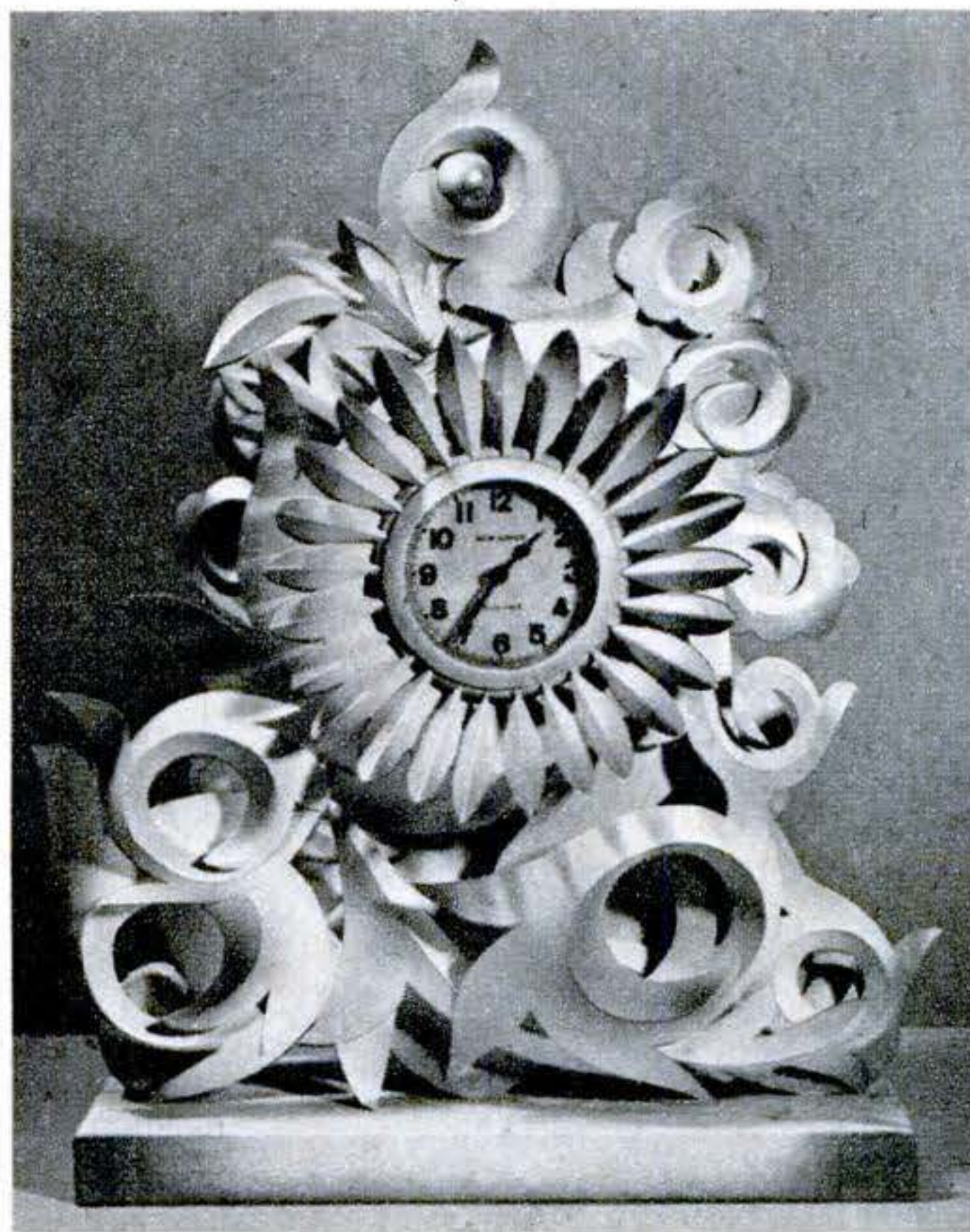
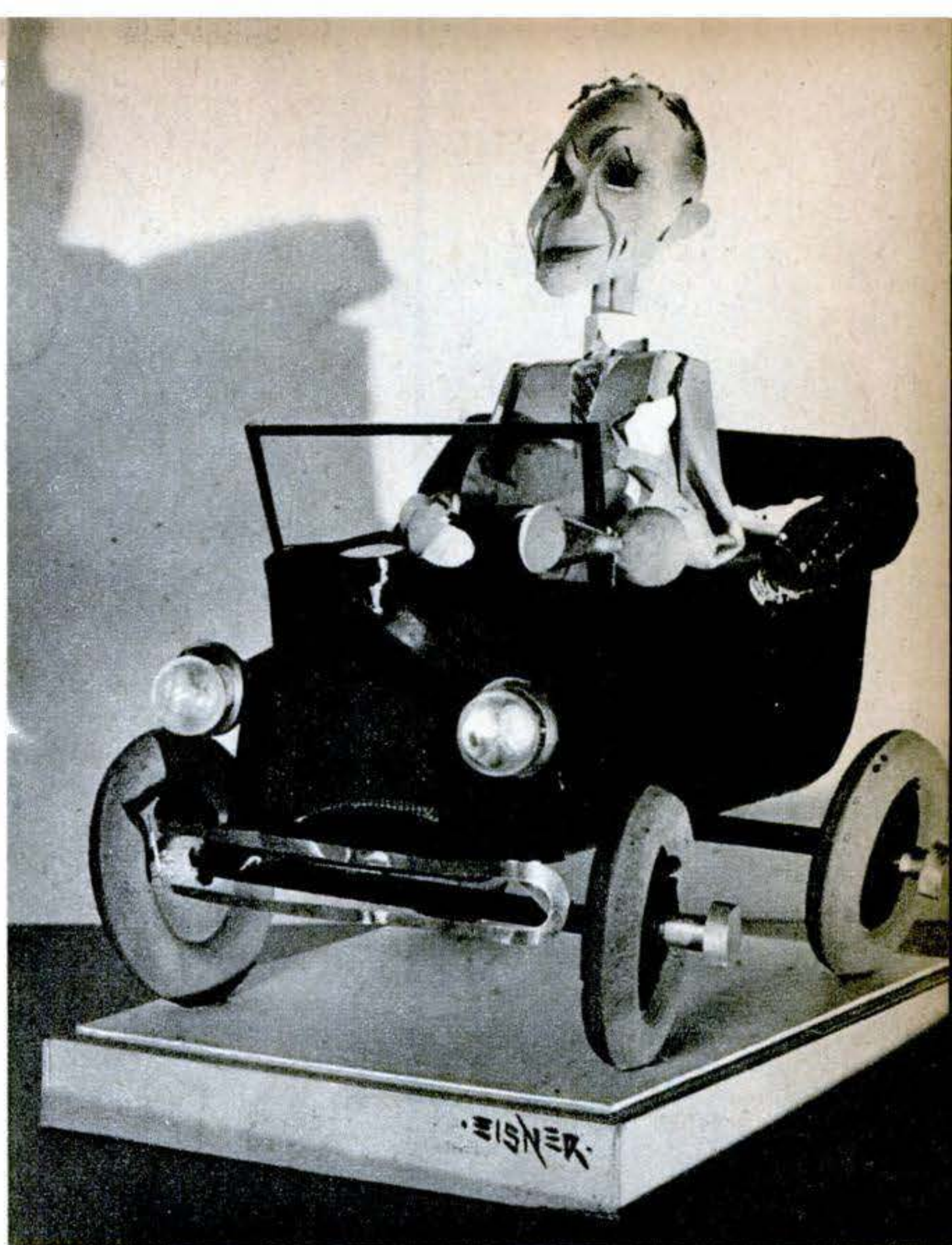

for a diamond stickpin, the tip of a shoe tree for a nose, a collar button for a motor-car horn. These are only a few of the smart subterfuges that have helped to make these caricatures what they are. In one of Joe

Louis, a particularly apt touch is the use of table-tennis balls to simulate the prize fighter's bulging shoulder muscles, biceps, and boxing gloves.

Eisner's home workshop is at Woodmere, Long Island, an hour or so distant from New York. He'd better not leave it unlocked when any small boys are around, because it contains the most wonderful collection of junk that a kid could imagine—drawers of toys, bits of yarn and wire, and paper of all sorts and colors. And all of it is grist to the mill.

Branching out from caricature into other fields, Eisner devised a way to make paper look like ornately carved wood, and Fifth Avenue merchants have made use of his work in window displays. He has also made decorations for a debutante's coming-out party, toys and books for children, and miniature buildings done to exact scale.

One of Eisner's window dressings consisted of chairs and other props made entirely of white paper to set off the very latest models of women's dark clothing. It is his firm belief that there are almost unlimited possibilities in the use of flat materials adapted to three-dimensional uses. He gives as examples preliminary studies for sheet metal designs, scale models for architectural use, stage decorations, and television-program settings.





Colorful projects like these are fashioned from cornhusks—a return to an art of our grandmothers' day.

## *Craftwork from the Cornfield*

Photographs by WILLIAM W. MORRIS

TO OUR pioneer settlers, a good corn crop always meant more than food. The husks, made into everything from mats for the floors to mattresses for the beds, were an important part of the harvest. Now that corn is at the height of its season, you may want to try your hand at this craft.

The husks come in layers—the inner fine and soft, the outer coarse and strong. Coarse husks make good floor mats and brooms; soft ones are fine for table mats, bags, lapel ornaments, and the like.

Inner husks of mature field corn turn almost white when dry and can be dyed with ordinary cloth dyes. Boiling is necessary only if they must withstand washing. Husks of sweet corn require drying, but they remain green and don't dye readily. For interesting cornhusk projects turn to page 149.



POPULAR SCIENCE



## New Wing Float for a Mariner! The Lift Truck Lends a Hand

**T**HIS handy little motor truck, with its elevator fitting on the front, hoists a new float to be attached under the high wing of a Martin Mariner. One of the mechanics rides up on the open-air lift, ready to make the necessary connections. The long-range Navy patrol bomber is getting its new boot at the Norfolk (Va.) Naval Air Station.

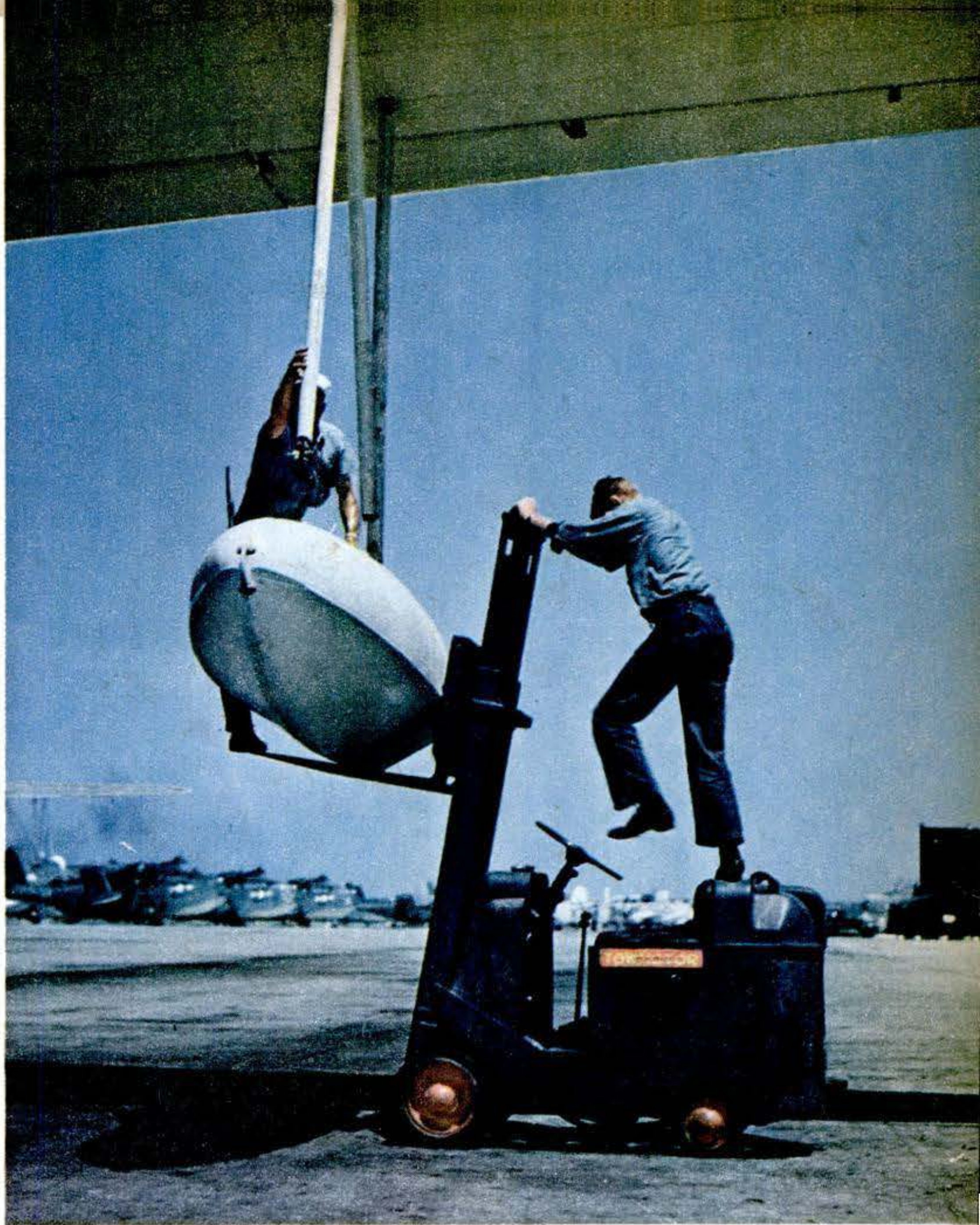

## Postwar Plastic Harmonica Has Five Parts Instead of 80

**A** NEW plastic harmonica, composed of five parts (see photo) as compared with 80 parts in the old-type instrument, makes possible the first large-scale production of harmonicas in America. Invented by Finn H. Magnus and molded from Bakelite polystyrene, the new mouth

organ is sanitary, sturdy, and inexpensive to make. It retains its tone under all climatic conditions.

In the conventional harmonica, the most difficult parts to make are the delicate reeds and the reed plates. The reeds are punch-pressed from flat brass stock and hand-ground to size. Then each reed has to be hand-riveted to the plate. In the plastic harmonica, the reed plate is molded in a single operation and contains all the reeds as integral parts of the plate. Complete assembly of the five parts, by "welding" with a hand press, takes only five seconds to accomplish.

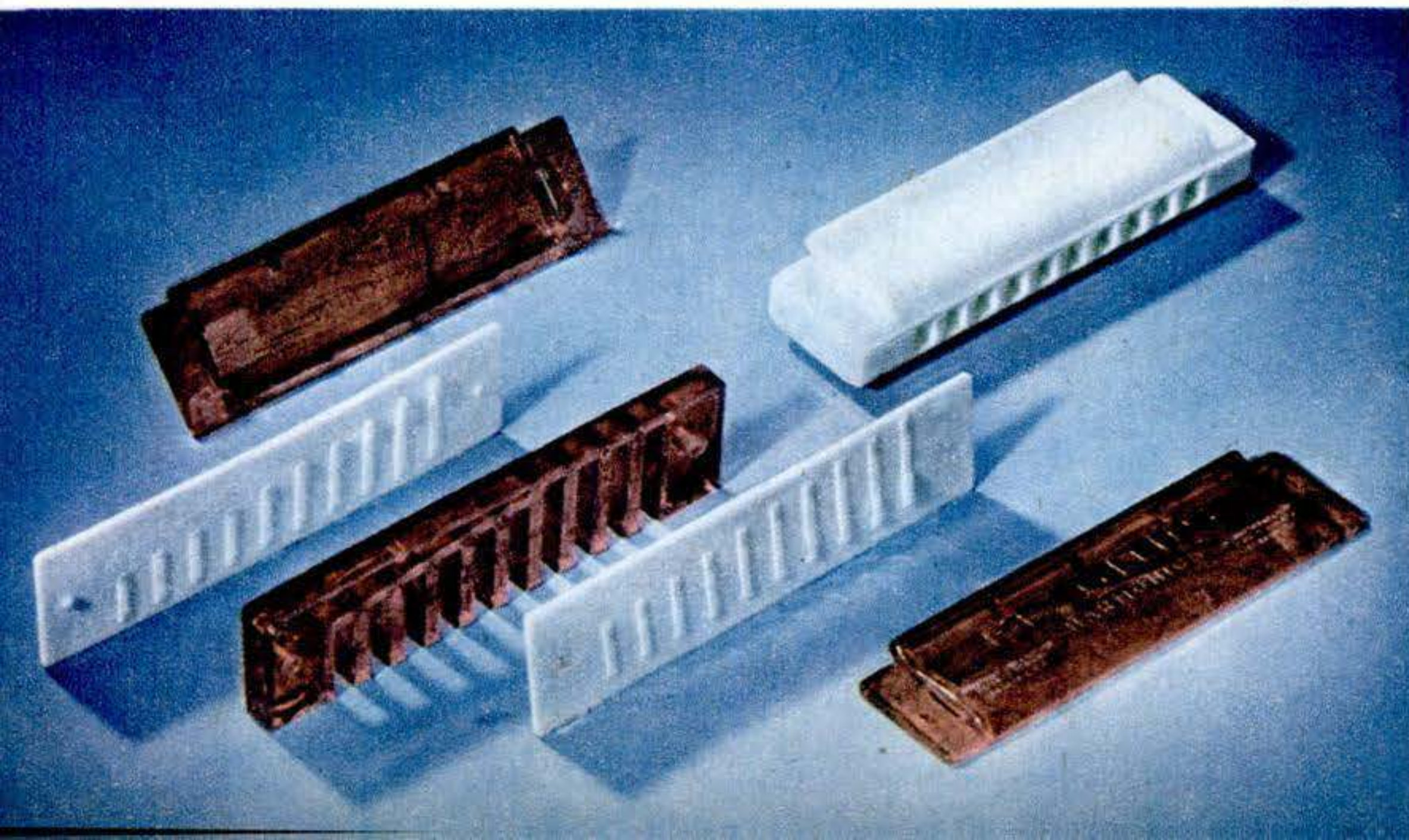





**EARRINGS** of wood, plastic, and other nonmetallic materials are held comfortably on the ear lobes by a method invented by Cheri Rich, of New York, N. Y. A strip of adhesive tape, threaded under a bar on the inside of each earring, is stuck to the lobe of the ear. This eliminates the need for a spring clip or screw to hold the ornament in place.

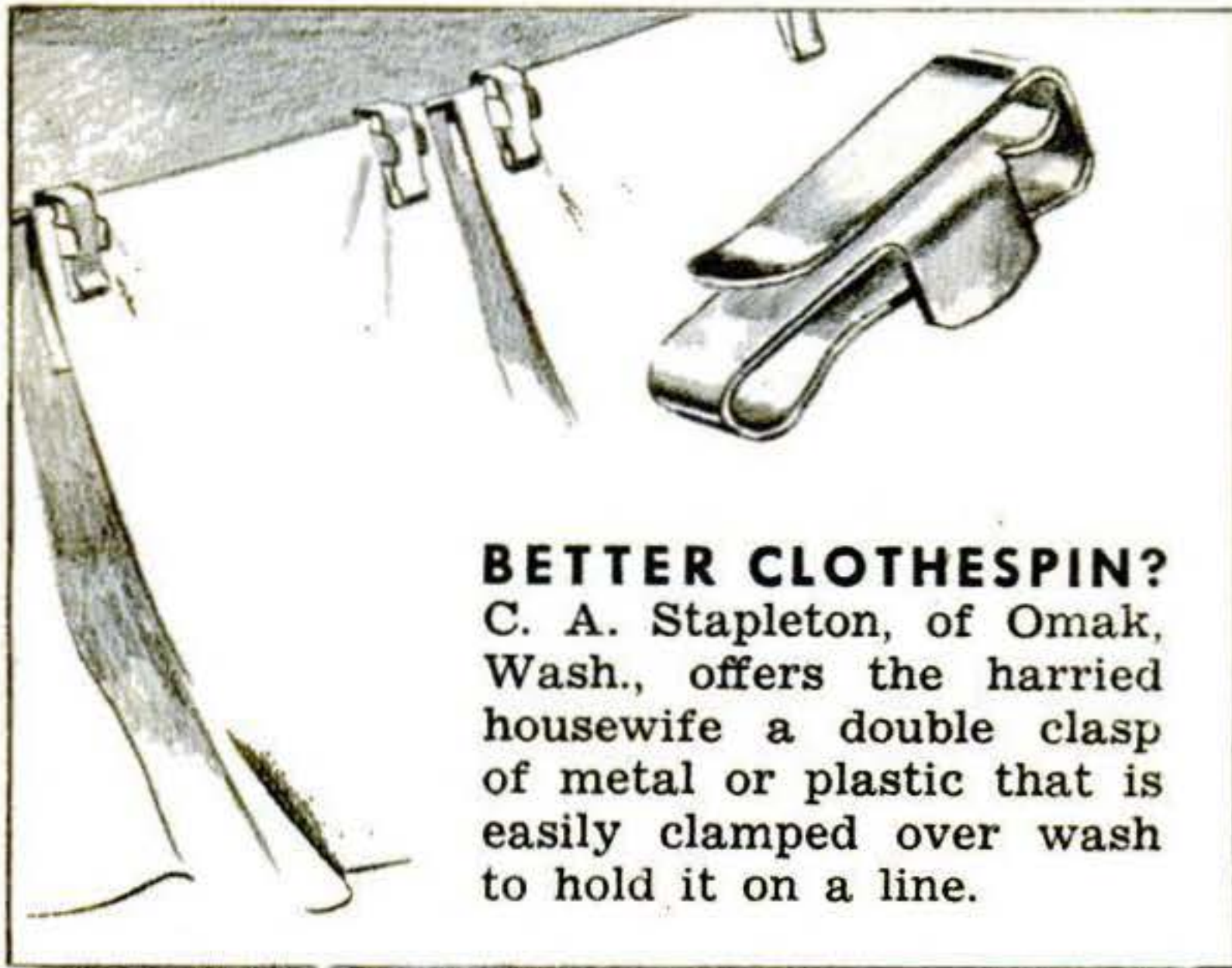

**BETTER CLOTHESPIN?** C. A. Stapleton, of Omak, Wash., offers the harried housewife a double clasp of metal or plastic that is easily clamped over wash to hold it on a line.

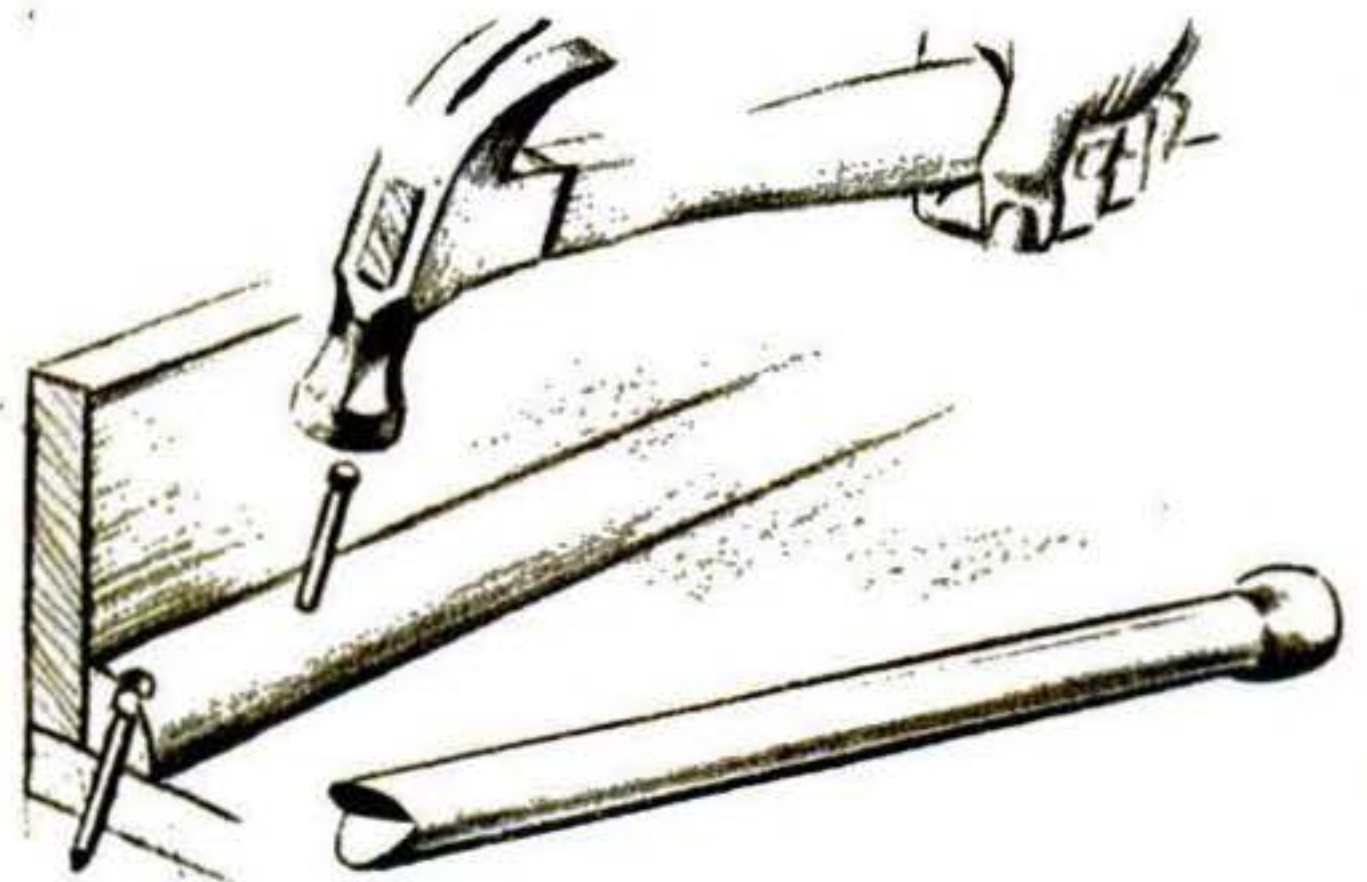

**NONSPLITTING NAIL** has a V-shaped notch at the end instead of a point. When it is driven into wood, it cuts through the fibers instead of parting them. Inventor is E. J. Gair, Snyder, N. Y.

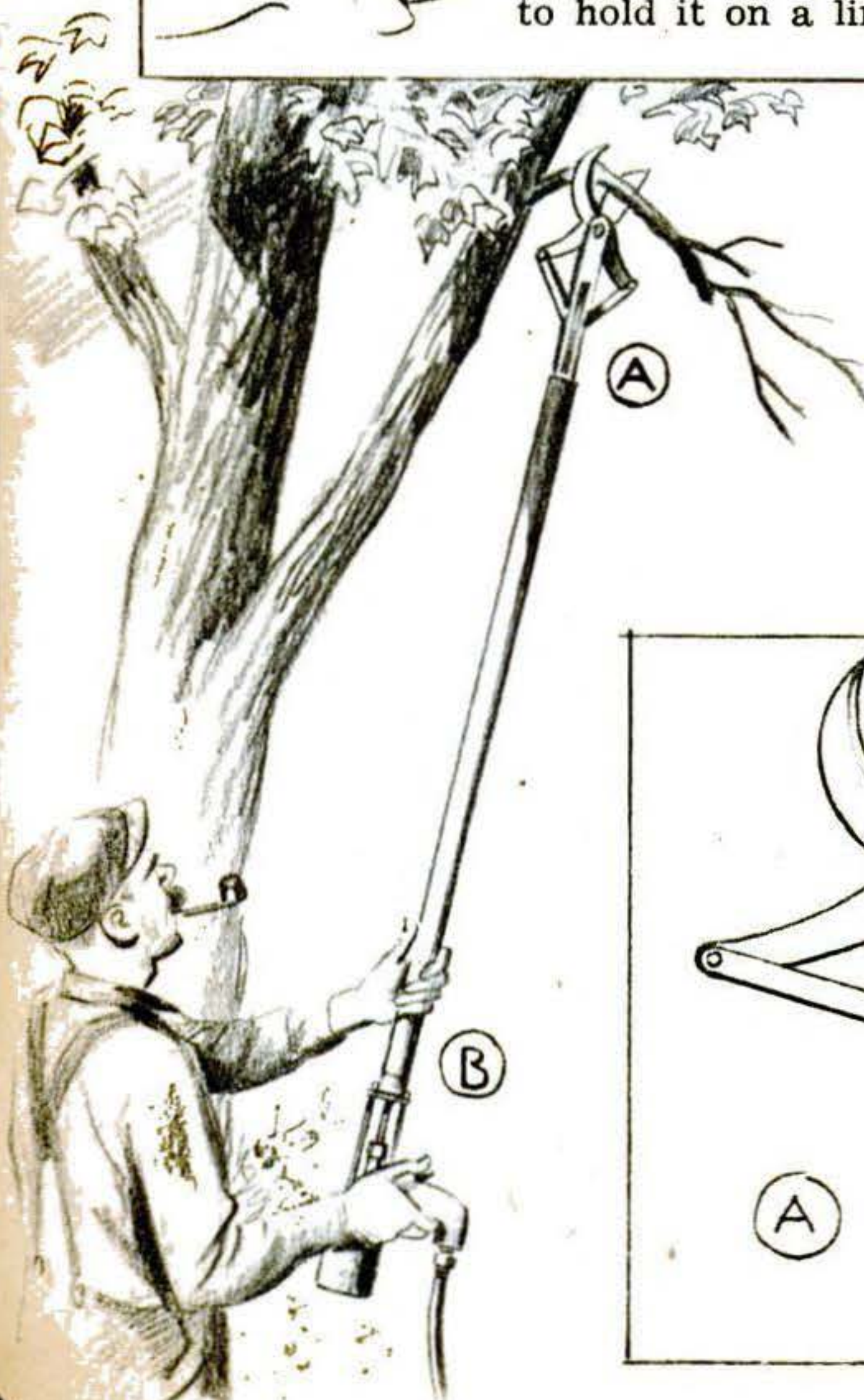

**POWERED PRUNING SHEARS.** Compressed air or liquid does all the hard work of tree pruning with these shears, designed by Charles J. Johnson, of Sacramento, Calif. Pressure fed to the tool through a flexible hose pushes down a piston in the butt of the handle. This pulls a cable extending through the hollow pole to bring the blades of the shears together. When the pressure is released, a spring opens the blades for the next cut.

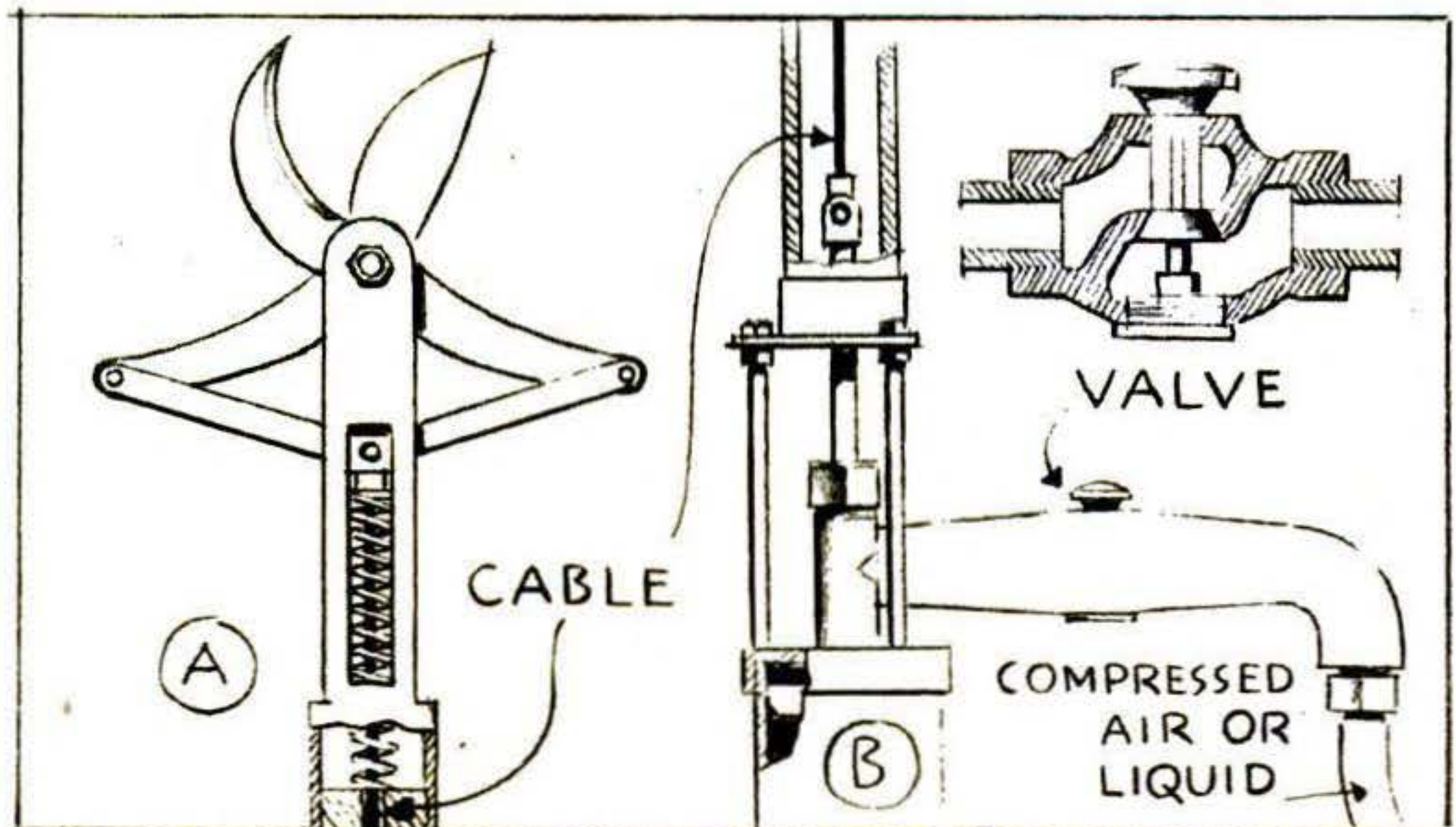



# from the inventors

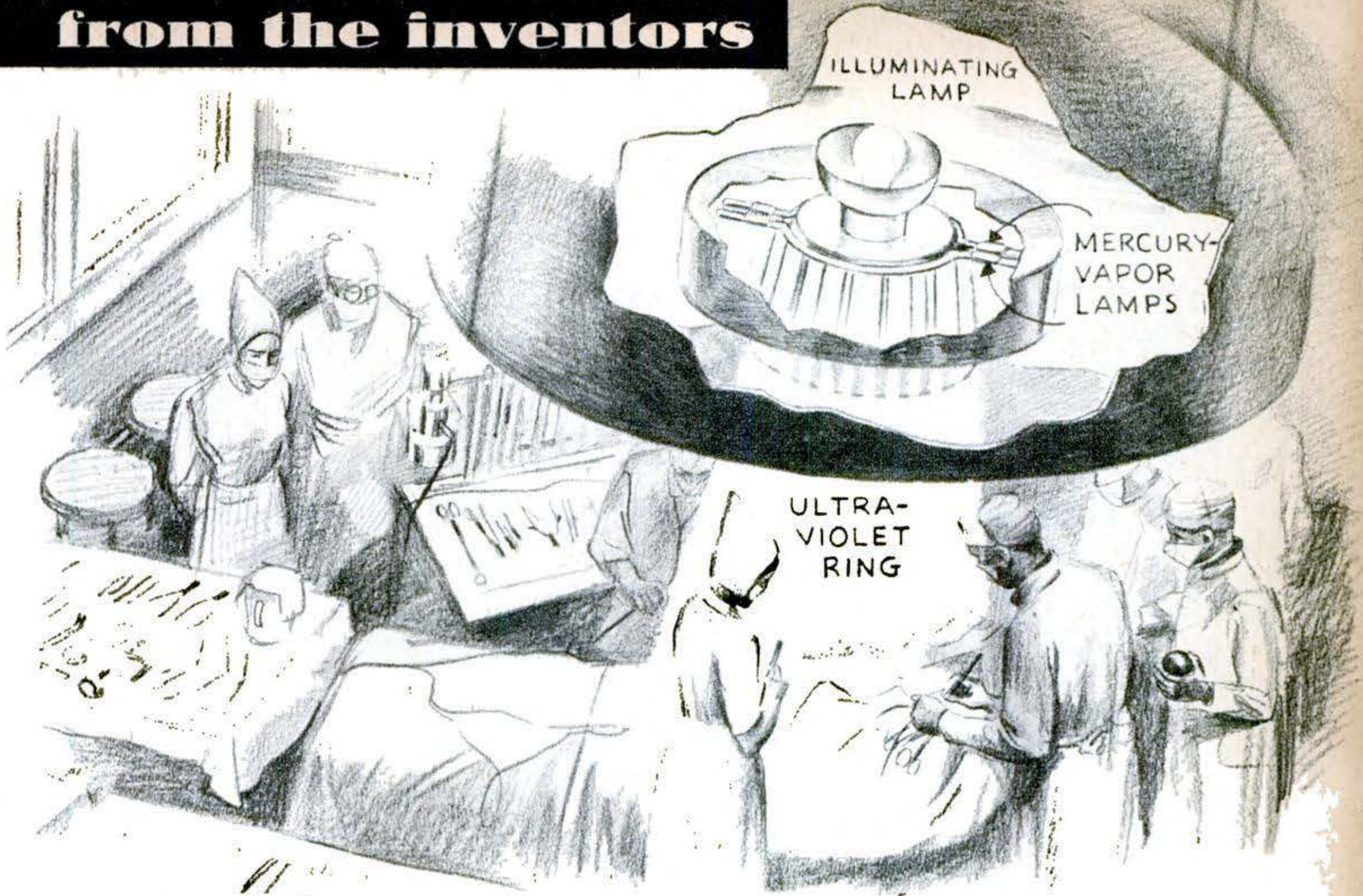

**GERMS CAN'T PASS** the magic curtain of ultraviolet radiation thrown around an operating table by the lamp shown above. Besides providing light for the surgeon and his assistants, the lamp casts a hollow cone of germ-killing rays around the working area. This prevents infection of

the wound without subjecting the exposed internal tissues to the ultraviolet radiation, which might be harmful if too long continued. The curtain of light is produced by an arrangement of reflecting surfaces. J. W. Kolbert and F. G. A. Haegele, of Slough, England, are the inventors.

**PAGE ROBIN HOOD!** The famous archer of Sherwood Forest might have chalked up an even better score if he had used this sighting device originated by Oliver H. Brown, of Waupaca, Wis. Adjustable horizontally and vertically, it is clamped firmly to the bow's upper limb.

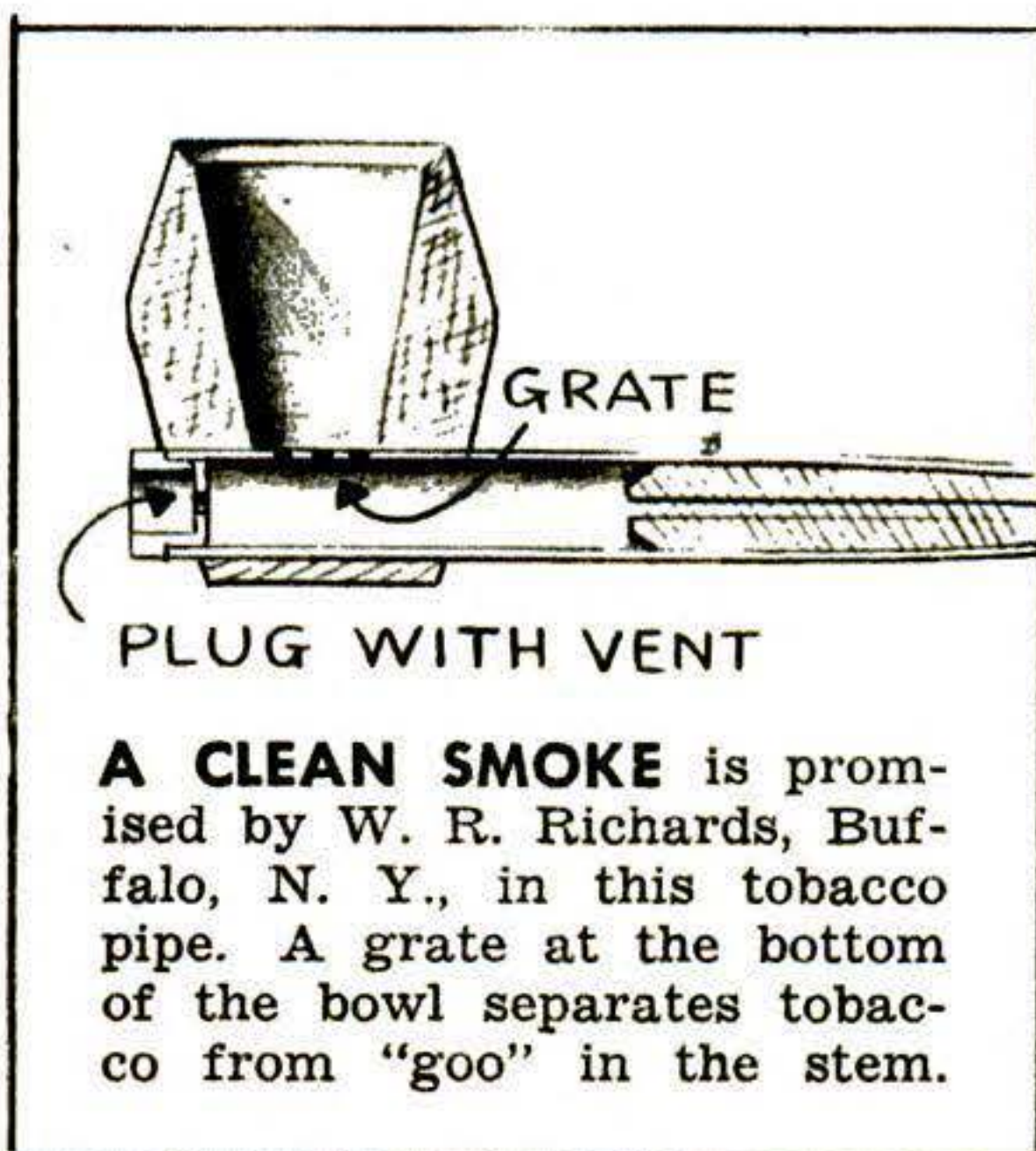
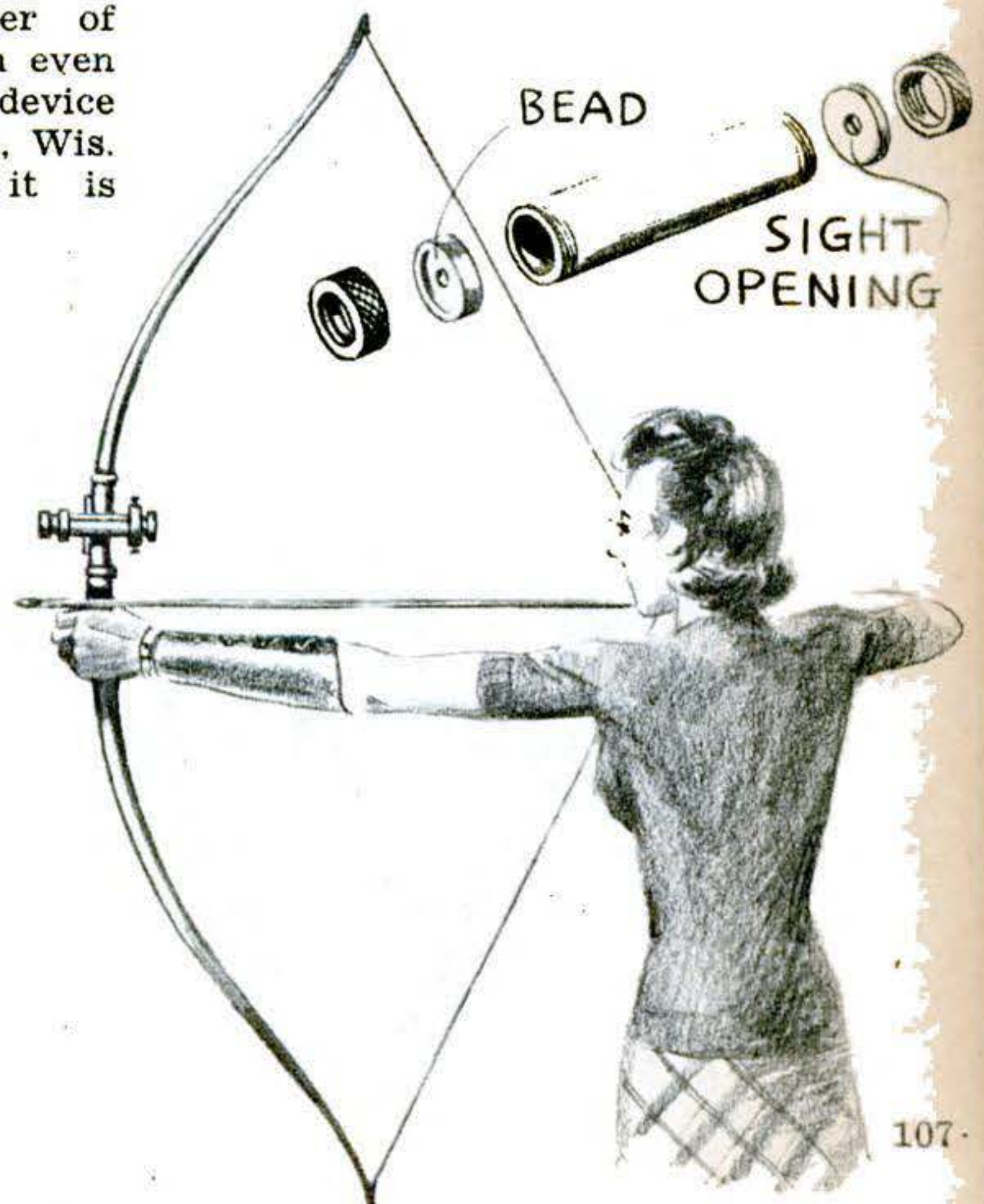

**A CLEAN SMOKE** is promised by W. R. Richards, Buffalo, N. Y., in this tobacco pipe. A grate at the bottom of the bowl separates tobacco from "goo" in the stem.



POPULAR SCIENCE TAKES YOU INTO A

## *Colonial Woodworking Shop*

Tools of 200 Years Ago Create Fine Furniture

LIKE a page out of a story book, suddenly come to life, is the scene that greets the surprised visitor who enters The Ayscough Shop in restored and reconstructed Williamsburg, Va. Nowhere else in the world, perhaps, could one see another cabinetmaker's shop like this. Workmen wearing knee breeches, white stockings, and shoes with silver buckles are busily engaged in fashioning beautiful articles out of wood, and the tools they ply with infinite skill are as ancient as their costumes. They are not permitted, in fact, to use any tool or device that was not actually employed when Williamsburg flourished as capital of colonial Virginia.

This is a unique scene in 1945, but there is a reason for it. "That the Future May Learn from the Past," is the motto of Colonial Williamsburg, Inc., the organization that is [\(Continued on page 110\)](#)

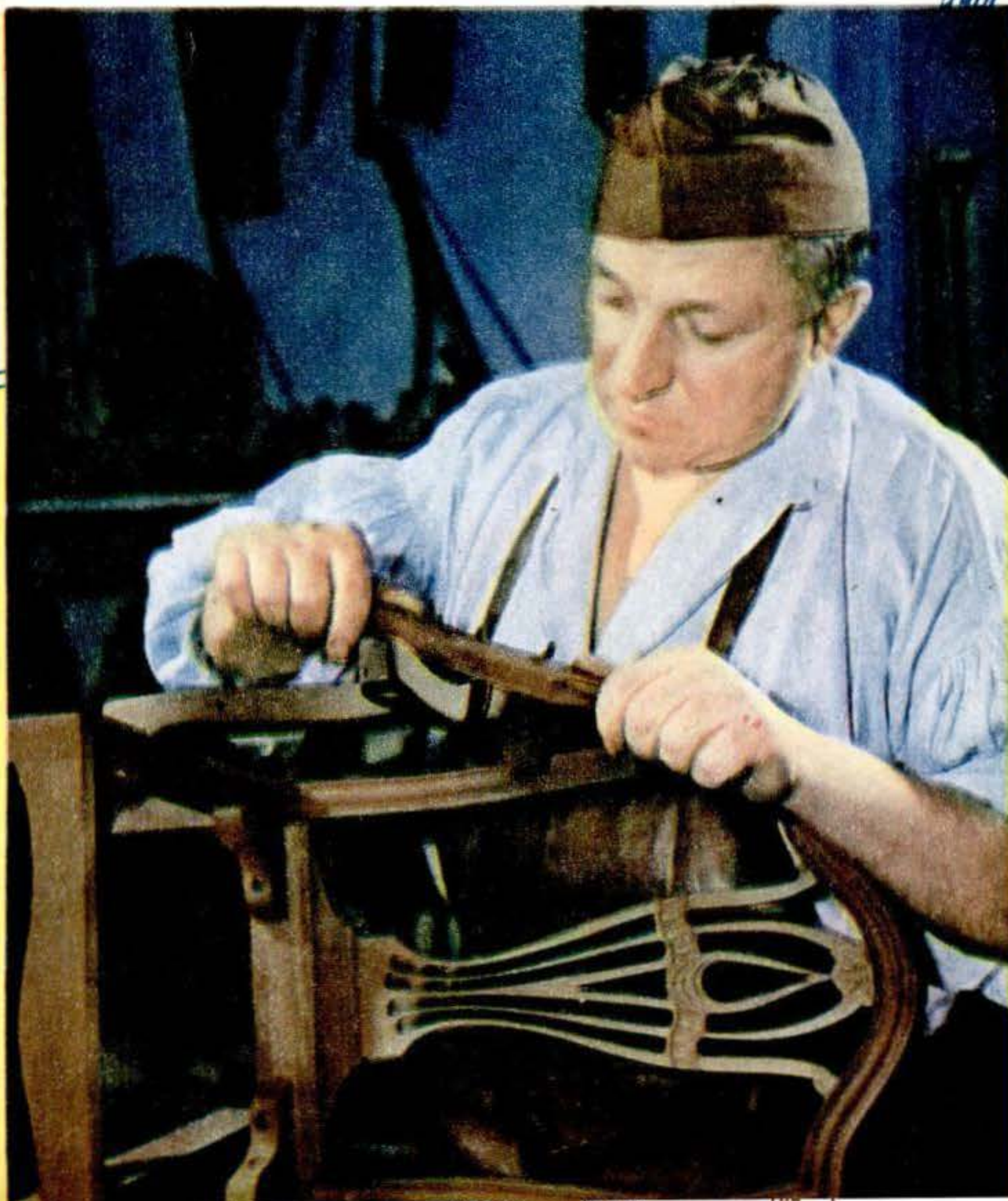

**CABINETMAKER**  
of the eighteenth century used the spoke shave to produce much of his delicate handwork. The chair being finished here is of the type used by wealthy residents of Williamsburg even long before the Revolutionary War.

Photographs by  
WILLIAM W. MORRIS





**MAHOGANY TEA CADDY**, all handmade and exactly like the tea chests in vogue in colonial times, is delivered to a "customer" by Joseph Kobelbauer, master cabinet-maker of The Ayscough Shop. Mahogany was the favorite wood of early craftsmen.





**THE OLD-TIME LATHE**, used for turning, grinding, polishing, etc., was made of heavy timbers and other pieces, and was a difficult device to adjust. The tool rest, a strip of iron fastened to sturdy wooden pieces, could be moved only by loosening a wooden wedge, then sliding the assembly into the desired position and tightening the wedge again. Above, the cabinetmaker adjusts the piece on which the tool rest is fixed. Below, he inserts the wedge to secure the piece.



re-creating a whole city that we know only from our history books.

The cabinetmaker was an important man in colonial times. He ranked with the architect. That was the day of Thomas Chippendale, himself a master craftsman of England. The cabinetmakers in colonial Williamsburg turned out furniture that ranked with his. No doubt they used his exquisite designs, as many others of the period did. To see now the crude implements with which these artisans worked is to have greater admiration for the cabinetmakers and their accomplishments, and to prize more highly the few specimens of their handiwork still in existence.

As one enters the Williamsburg cabinet shop, the whole scene gives the feeling of having stepped across the threshold into another world. Dominating the room is a great, wooden wheel, six feet high, with a crank at the hub and a rope belt passing around its rim and over a pulley on a crude wooden lathe. That is the nearest thing to machinery that one sees. The wheel is turned by manpower, and we are told this was usually the task of the apprentice.

Hand tools of the period hang on the walls and, like the lathe and its wheel, all are actual relics of the eighteenth century, gathered from far and wide through many months of painstaking search. Their handles have the unmistakable polish given them by the hands of workers long since passed on. With the dust of the years wiped off, they are in use again, turning out things of beauty, to the same designs in fact as in the old days—for only furniture of the colonial period is produced in the shop.

The workbench, too, is one that was used 150 years ago. This was found well preserved in an old barn. Its surface shows many a mark of the tool, and through its top is the hole in which the ancient type of bench clamp fitted, driven down by a hammer to hold the work, or "stuff" as they called it then. One of these clamps also has been recovered and is in use. It works well enough, although it is a far cry from the efficient bench vises of today.



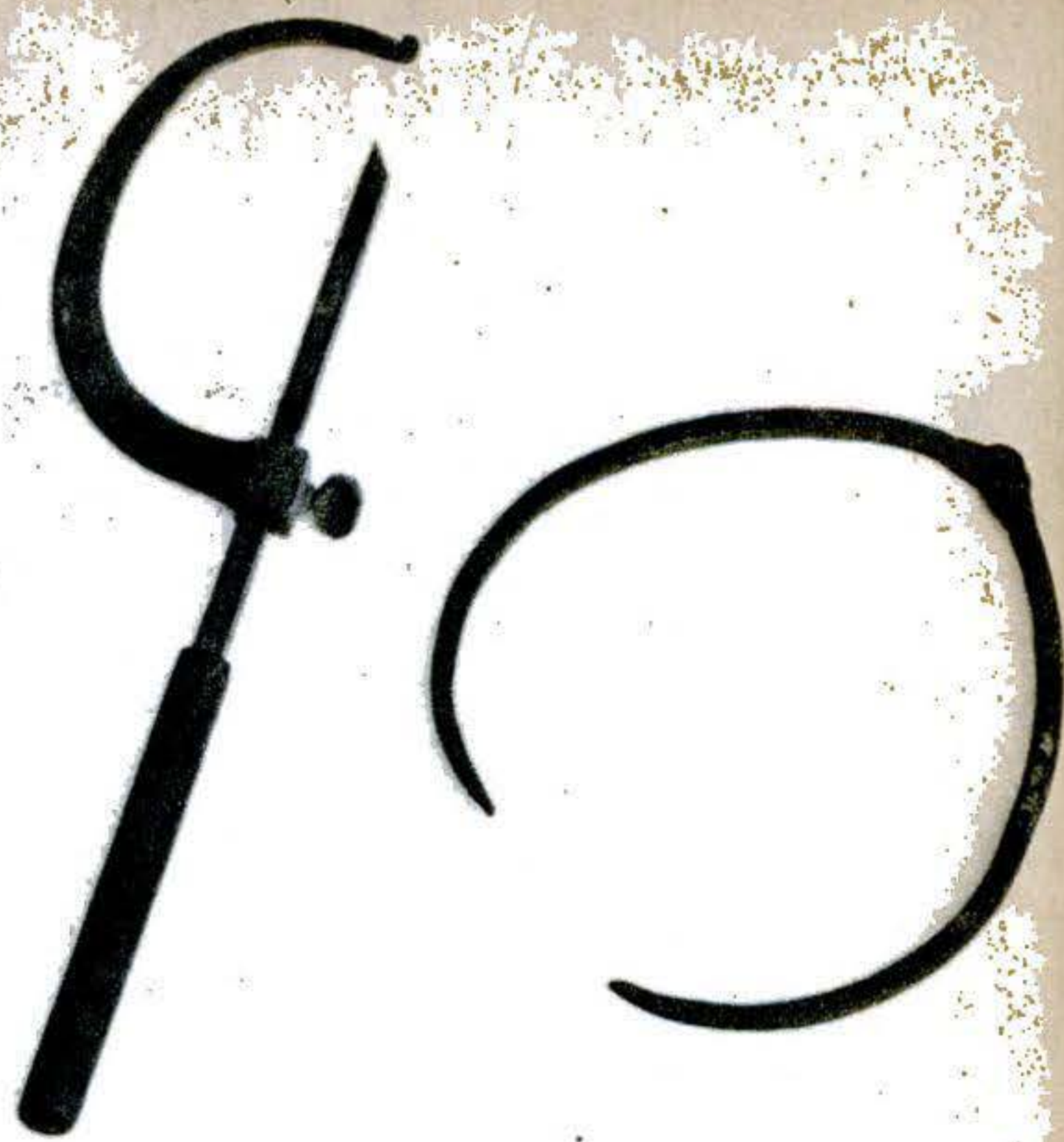
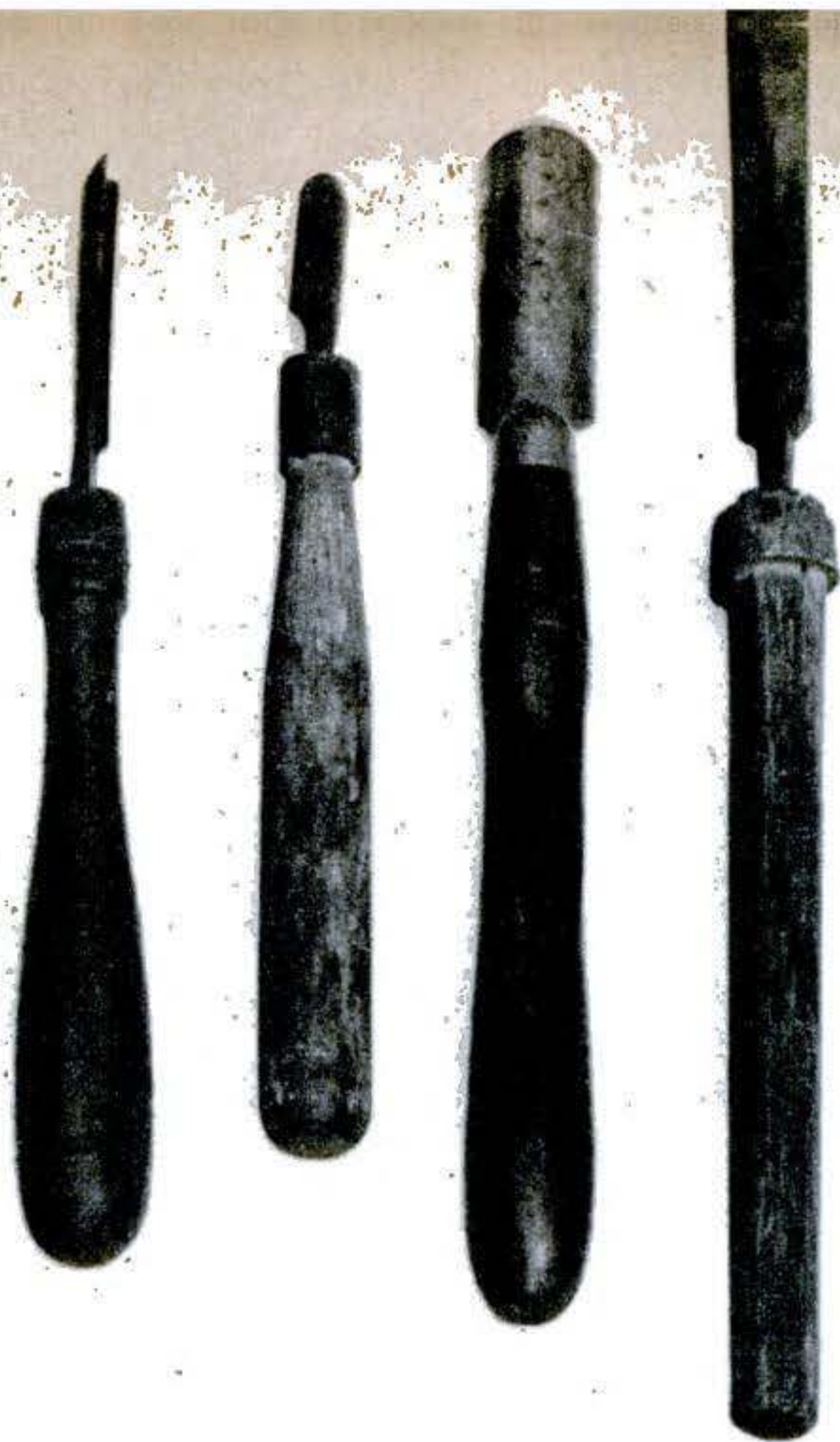

**TOOLS FOR WOOD TURNING.** Two centuries ago the tools used were not much different from those of today, except that they were cruder and heavier. Calipers were much like those now in use.

Wood-framed saws of great variety are prominent among the hand tools. They were the mainstay of the old-time worker, from the small scroll saw of quaint design to the much larger one used to saw veneers by hand. The scroll saw's blade was tightened by twisting a cord with a stick, that of the veneer saw by driving a wooden wedge that stretched it taut. The hand-saw of today, of course, is not in evidence, but something like it did exist in colonial times. It was a heavy and coarse-toothed saw, rather a tool of the carpenter than of the cabinetmaker.

Joseph Kobelbauer, master cabinetmaker of the present-day Williamsburg shop, is a worthy successor to the colonial artisans, and exhibits the same kind of skill with the tools that they must have possessed. His father and grandfather were cabinetmakers too, and he served his apprenticeship just as did the boys of colonial Williamsburg.

Love of his job shows in Mr. Kobelbauer's ruddy face as he plies the tools, one after another, on a piece of raw mahogany. Selecting one of the many block planes from a shelf, he shapes a molding along the edge. The planes are numerous, for we must remember that the old-time cabinetmaker *(Continued on page 115)*

## PREFACE.

**I** See no more Reason, why the Sordidness of some Workmen, should be the cause of contempt upon Manual Operations, than that the excellent Invention of a Mill should be dispis'd, because a blind Horse draws in it. And tho' the Mechanicks be, by some, accounted Ignoble and Scandalous? yet it is very well known, that many Gentlemen in this Nation, of good Rank and high Quality, are conversant in Handy-Works: And o-ther Nations exceed us in numbers of such. How pleasant and healthey this their Diver-sion is, their Minds and Bodies find; and how Harmless and Honest, all sober men may judge?

That Geometry, Astronomy, Per-spective, Musick, Na- ch-

**EARLY HANDBOOK** of woodworking verified the methods used in The Ayscough Shop. This is the first page of the preface of "Mechanick Exercises," by Joseph Moxon, as published in 1703.



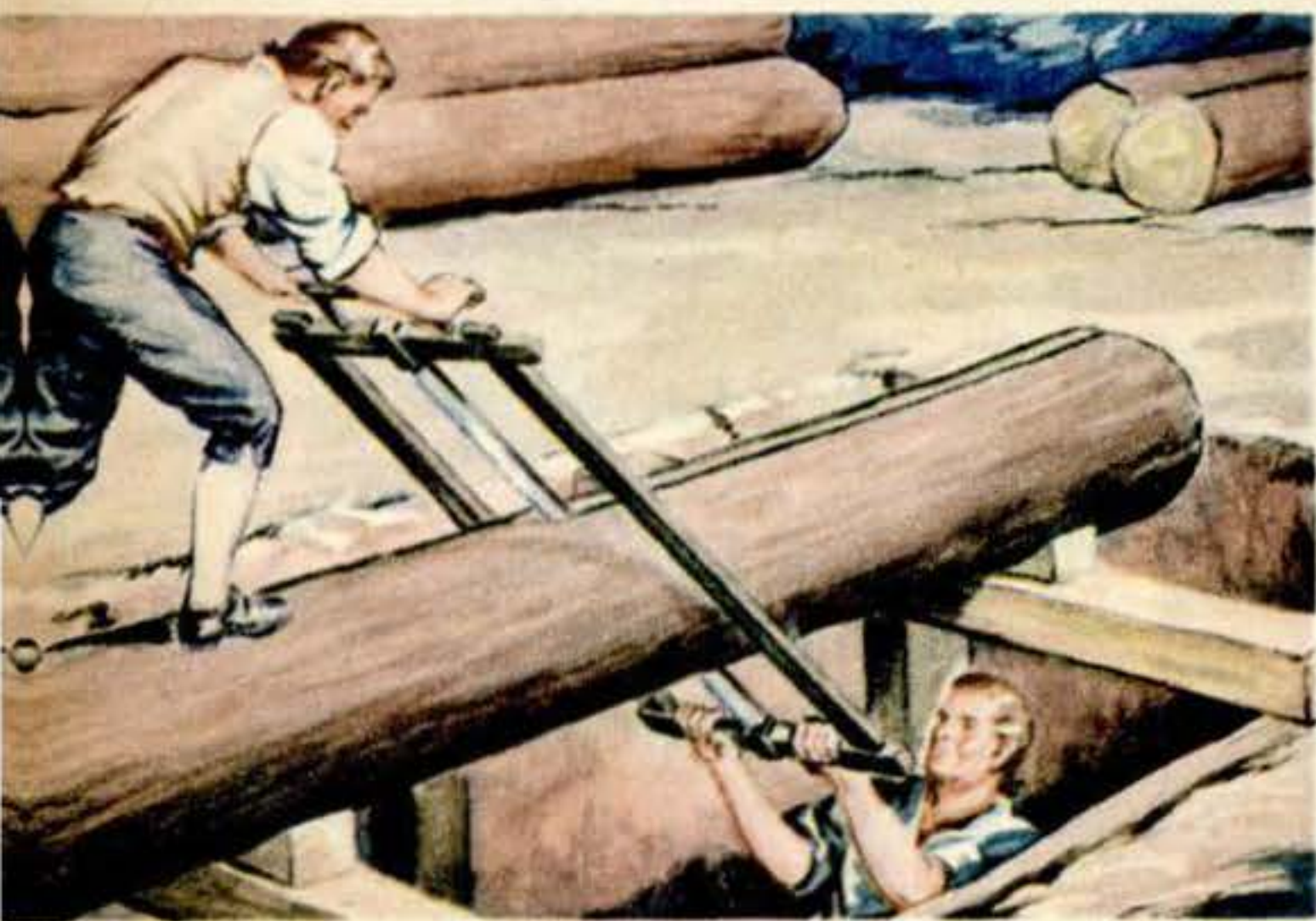

**WILLIAMSBURG SAWS** were of odd shapes and sizes—mostly narrow blades held taut by one means or another in rectangular wooden frames. The cabinetmaker of 200 years ago made his own veneers, as above, with a crude saw whose blade was tightened by means of a wedge driven through a slot in front of the handle. The pit saw, shown in the drawing at the left, was so named because, in sawing boards from logs, one man would stand in a pit to pull the saw downward while his teammate stood on top of the log to draw it back. The saw used for cutting dadoes (lower left) had half of its teeth raked in one direction and half in the other to permit a push-pull operation. The blade of the double-handled scroll saw (below) was strained by twisting the cord with a stick until it was tight.







**ONE MANPOWER** is the force used to turn this lathe, of which close-up pictures are shown on page 110. The apprentice usually got the job of turning the "great wheel," while the skilled craftsman employed the tools. A rope or other form of belt turns the driving pulley attached to the mandrel. The tailstock spindle of the lathe is adjustable by turning the handle.

**MALLET.** The old mallet seen below plainly shows its years of service. Master cabinet-makers made excellent joints, and the mallet and chisel were much-used tools. This mallet is again seeing service at The Ayscough Shop.



**WOODEN BRACE.** The brace being used below is about 200 years old but still is serviceable. Made of wood, it has brass bindings. Note the bench clamp holding the work. This is the forerunner of the vise.





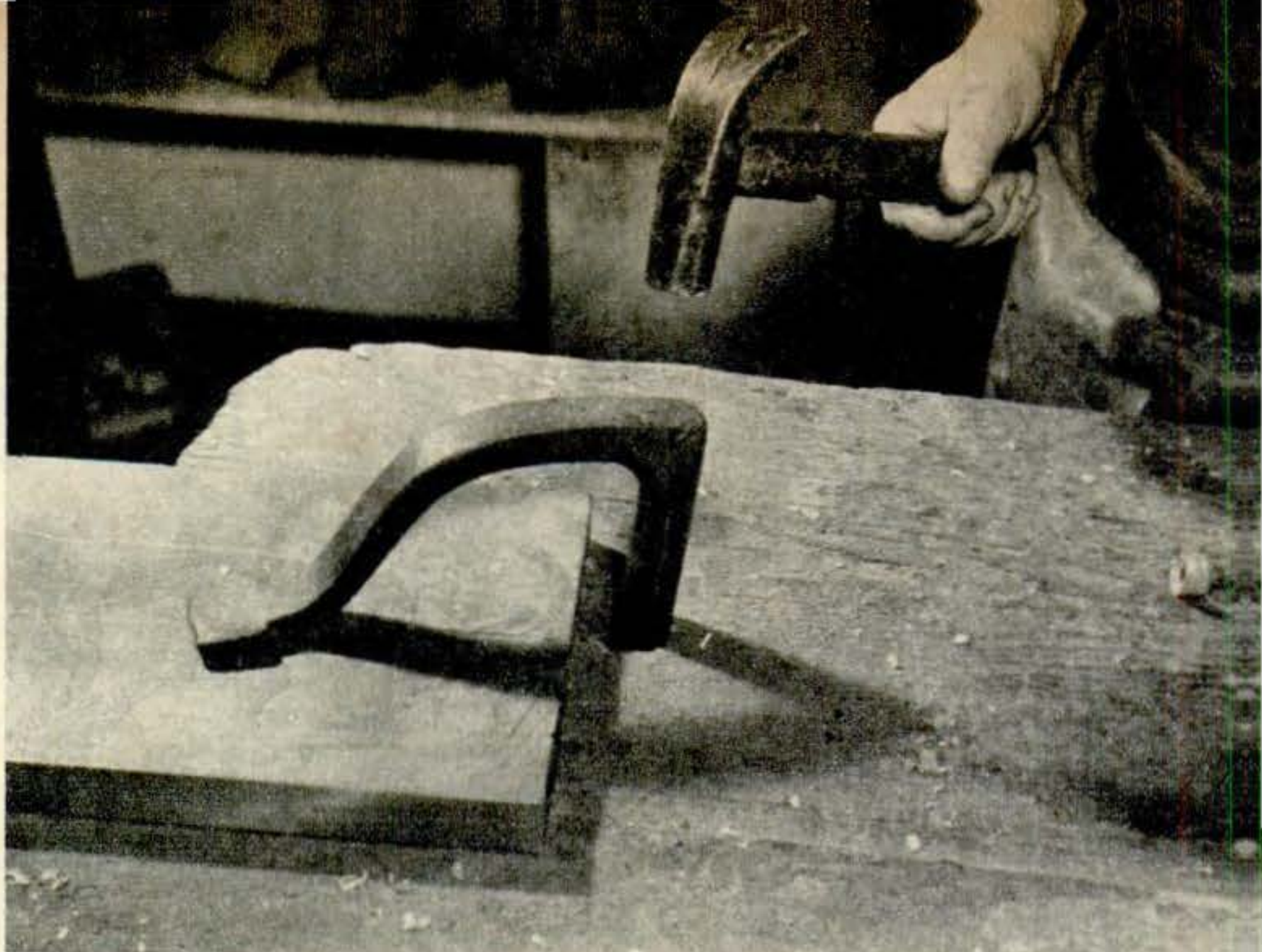

**"HOLDFAST."** The efficiency of the old-time bench clamp, also called the "holdfast," is demonstrated at The Ayscough Shop in Williamsburg. Inserted in a hole in the bench, it is driven down with a hammer, its clamping end holding the work firmly. The hammer also is of the eighteenth-century period.

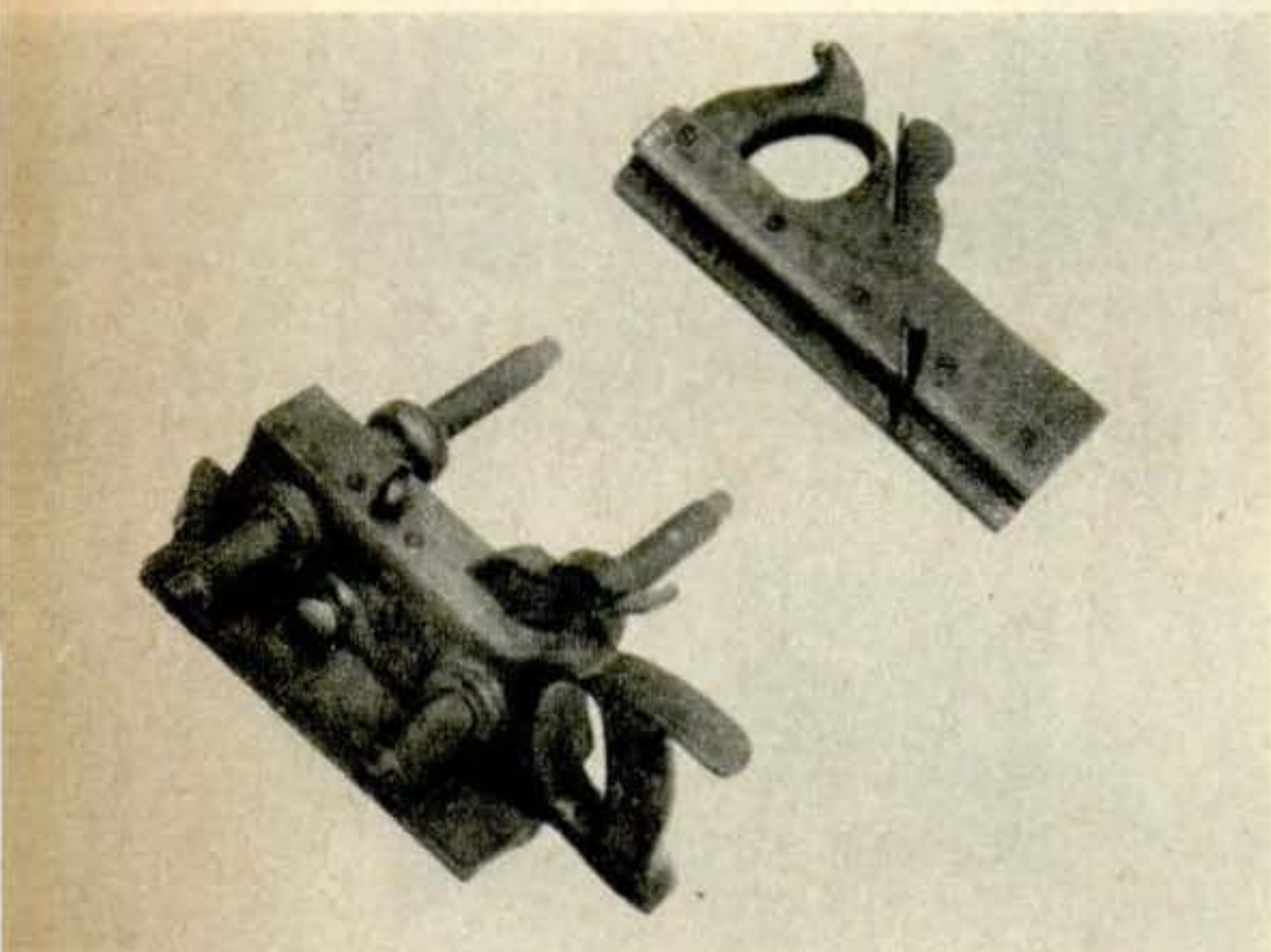

**TONGUE AND GROOVE.** The upper plane made the tongue and the lower one the groove for cabinetwork more than 200 years ago. The latter, also known as the "plow," now has wooden screws for moving the "fence" nearer to or farther from the blade so that the rabbet will be cut exactly.

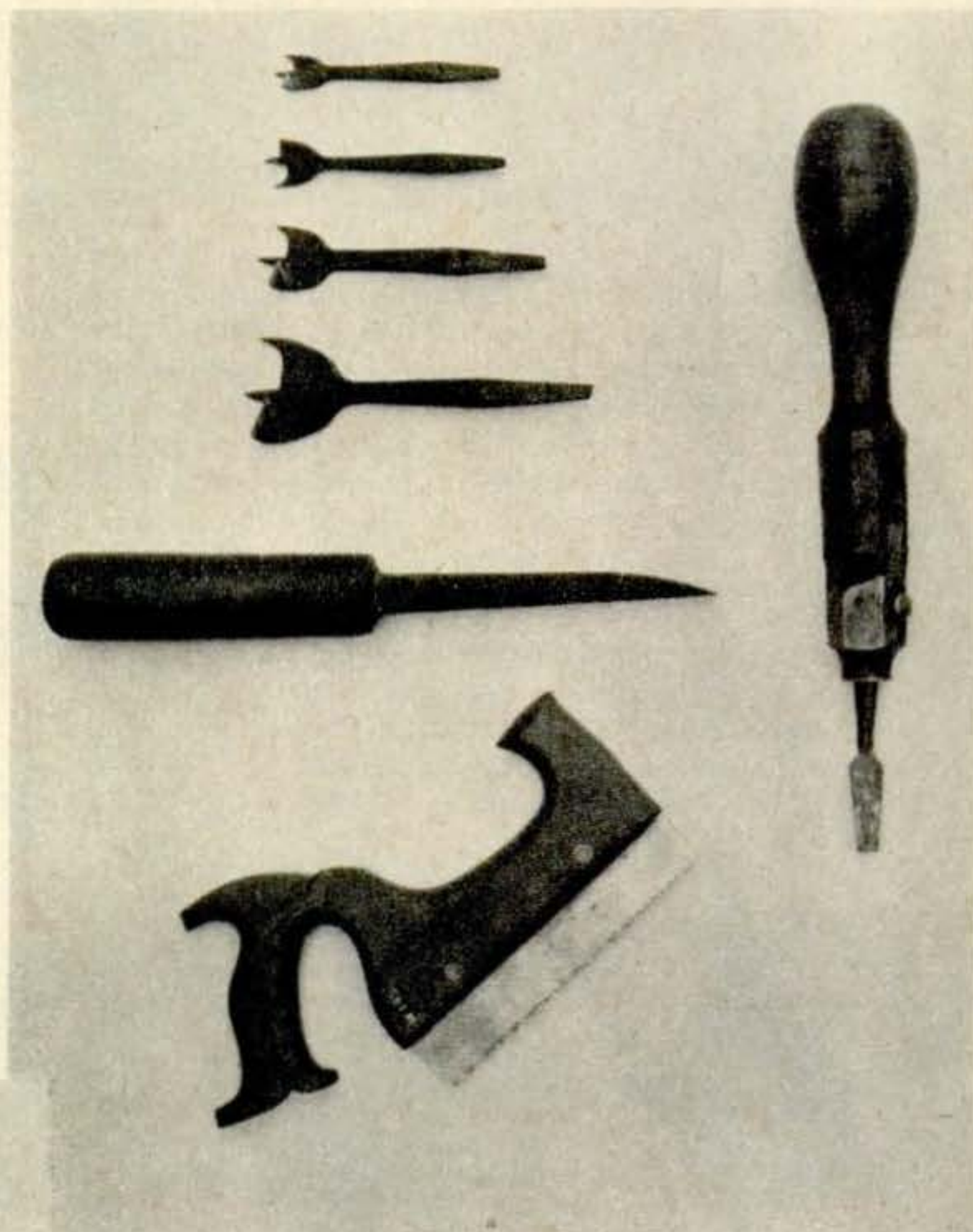

**BRACE AND BIT.** The all-wood brace at the far left dates from the sixteenth century and was the only one the colonial cabinetmaker had until the brass-bound model was evolved. Late in the eighteenth century the steel brace came into existence. The square-shanked bits (above) fit snugly into four-squared sockets of the braces. The other tools shown are a carving chisel, a dado saw, and a screwdriver.

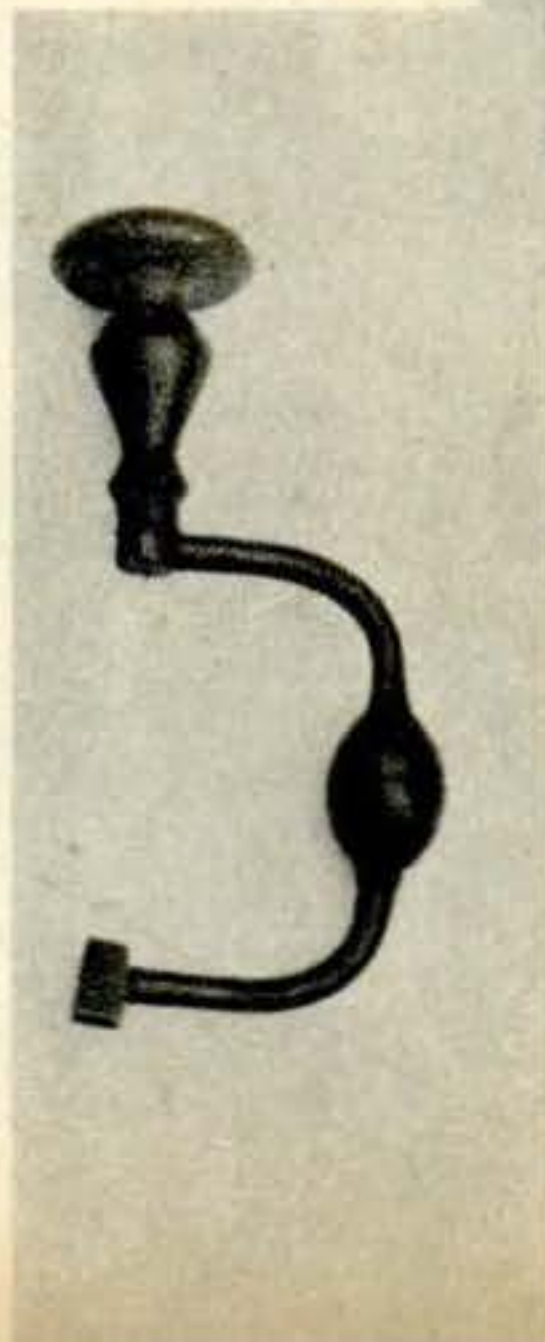
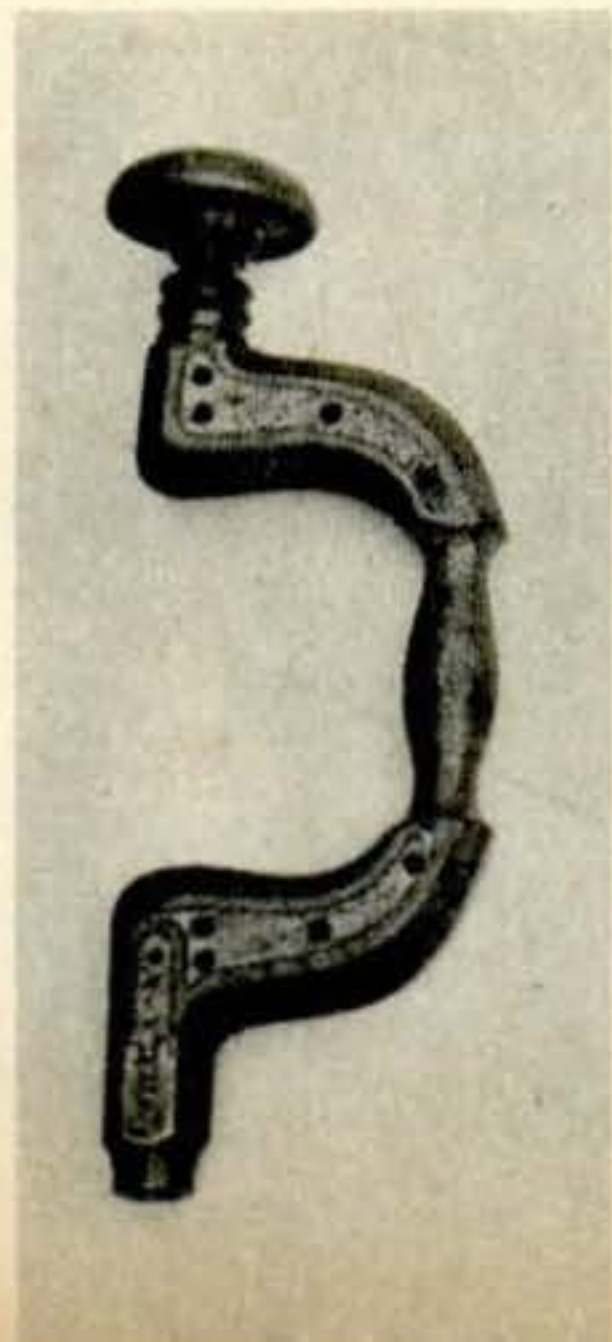



# A PAGE FROM MOXON'S BOOK

A. Joiner's Bench with bench screw, having (b) catch, (d) hold-fast, and (e) mawl (a mallet).

B. (1) Fore plane, (2) "joynter," (3) strike block, (4) smoothing plane, (5) rabbet plane, (6) plow.

C. (1 to 5) chisels and (6) gouge.

D. Try square.

E. Compass saw.

F. Bevel.

G. Gauge.

H. Brace and bit called also a "piercer."

I. "Gimblet," or "wimble."

K. Auger.

L. Hatchet.

M. Pit saw.

N. Whipsaw.

O. Bow saw.

P. Saw in clamp for filing

Q. "Saw wrest," for setting saw teeth.

R. Miter square.

Handsaw, not lettered, is shown above the bench in the lower right corner.

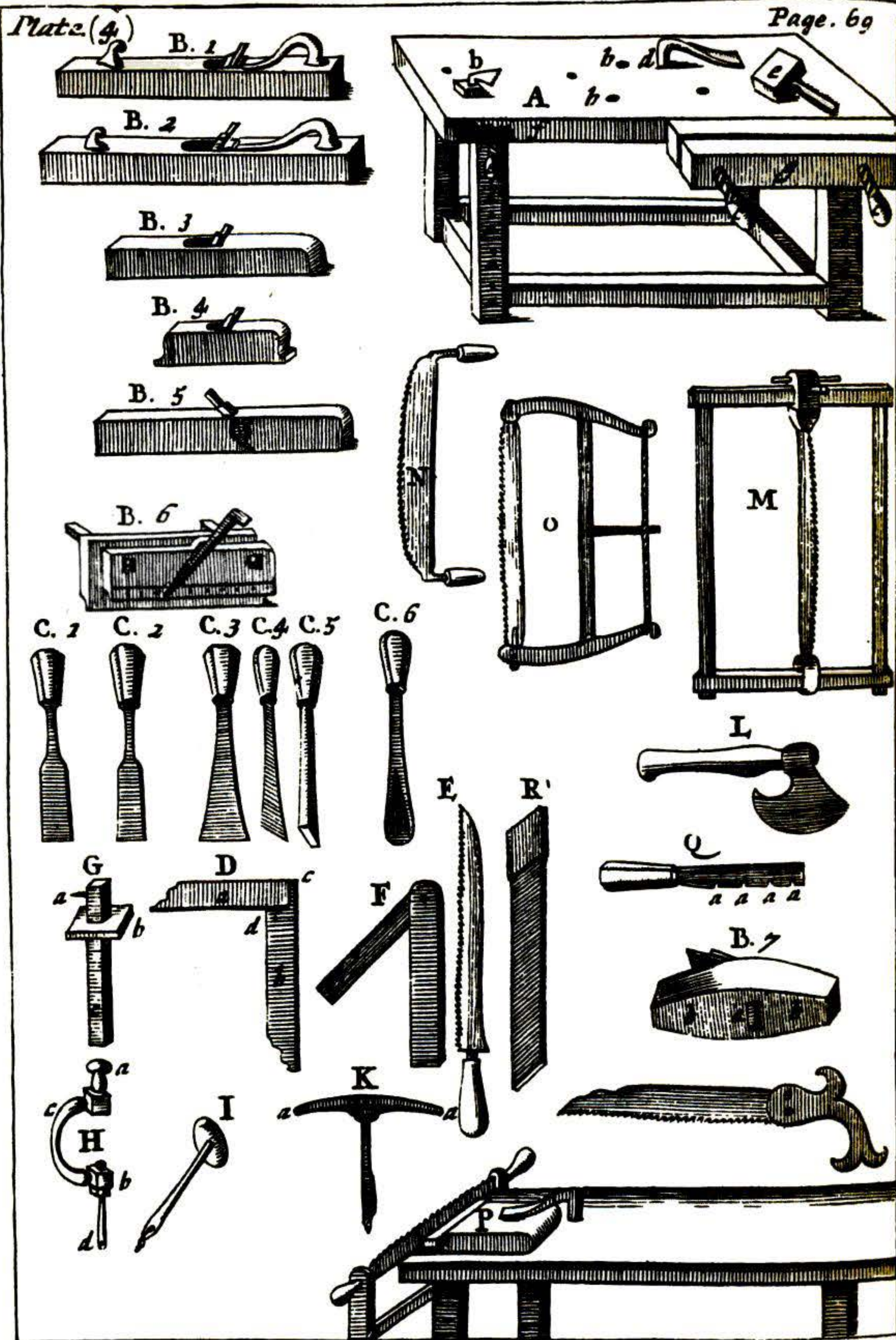

could not order a length of ogee molding from a mill, or anything else but rough, hand-sawed lumber. Whatever shape was desired had to be hewed out by hand from beginning to end. And these planes are crude ones, just a block of wood into which the blade must be adjusted and fixed by a wooden wedge.

The braces and bits are curious when compared with those of today, though they were fairly efficient for their purposes. The braces are of wood, cut roughly to the shape of the modern type. There is a free-turning knob at the top and a

square hole at the bottom to receive the bit shank. The grip for the right hand does not turn. This type of brace dates back to the sixteenth century and was all that the colonial cabinetmaker had. About the time when Williamsburg's period of glory ended, 1799, the first steel braces appeared. In the meanwhile, somebody also thought of securing the bit in the brace with a screw. The standard boring bit of the time had no threads on the center pin and no spirals on the shank. It had a blade on one side of the end for cutting around the periphery and one on the other





**ANCIENT PLANES** were much like those of today, but the blades had to be tightened by removable wooden wedges. Above, the cabinetmaker uses the long trying plane, finishing a piece of wood with exactness. Below, he manipulates a tiny plane which has a convex sole and is used to form concave parts in furniture.



**HANDMADE DUMMIES** for the wigmaker of colonial times were also products of the cabinetmaker. There is a wig shop in Williamsburg today, and the wooden heads were produced in The Ayscough Shop.

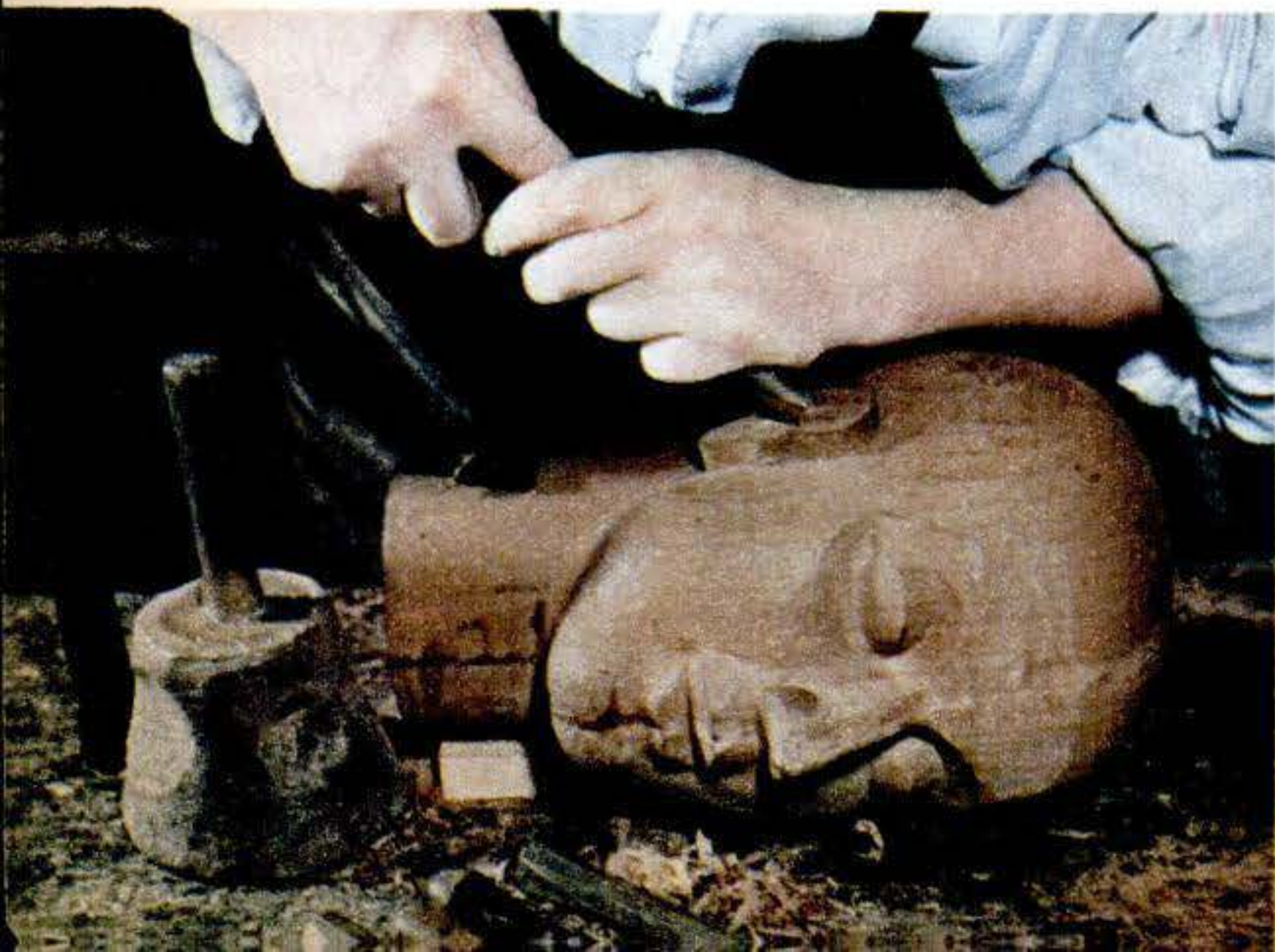

side to dig up the bottom of the hole. Such a bit did not expel the cuttings.

A modern woodworker going into The Ayscough Shop would not have to ask what the various tools are used for, as that is evident in each case. There are counterparts of all modern hand tools—saws, hammers, chisels, miter box, try squares, compasses, awls, and so on—all of them handmade and odd-looking but designed for the same uses as are the tools of today.

Mahogany is the wood used in the Williamsburg shop, and this is historically correct, for this was the choice of the master workmen and of their customers during the colonial period. Mahogany was carried back to England from the West Indies about 1725, and the cabinetmakers of the day quickly seized upon it as a wood superior to walnut because of its beauty and also because it lent itself nicely to the elaborate carving then in vogue.

According to tradition, Sir Walter Raleigh had one of his ships repaired in Cuba, and the wood used was mahogany. Queen Elizabeth saw this wood in the decking of the ship and expressed admiration for its color and smoothness. Thereupon the gallant Sir Walter had some of the planks torn out and commissioned one of the master craftsmen of the time to make a table of it for the queen. Whether or not the story is accurate, it fits into the picture nicely to explain the rapid adoption of this new cabinet wood in England, and also in the British colony of Virginia.

Designs of Chippendale, Sheraton, and Hepplewhite are prominent among the many fine pieces of furniture to be seen in the restored buildings at Williamsburg, the governor's palace and the residences of the nobility. This furniture has been laboriously gathered from many places, every piece selected with extreme care for its authenticity. Not all of it was made in this country, of course; the affluent gentry of the time imported much from London. But whether it was made here or there, the influence of Chippendale, Hepplewhite, and Sheraton was so great at the time that it was their designs that went into the finest articles on either side of the ocean.

In the restoration of Williamsburg, which has been financed by John D. Rockefeller, Jr., to the tune of millions of dollars, no labor or money has been spared in the effort to make everything authentic and historically correct. The



**ELBOW GREASE** and skill were two prominent ingredients that produced the beautiful furniture of the early eighteenth century. Every detail was finished with exactness, intricate carving being effected despite the handicap of crude implements. Mr. Kobelbauer, gives an oil finish to a clock cabinet with the same care practiced by his colonial predecessors. The ancient craftsman turned out finished products comparable with the finest that our modern tools and machinery can manufacture.



research department did a prodigious job of investigation and examination of tools so that whatever was put into the cabinetmaker's shop would belong to the period.

Williamsburg was the colonial capital of Virginia from 1699 to 1779. During those 80 years it was the social, cultural, and governmental center of a vast area, but after the government moved away it de-

clined and was almost forgotten until 1927, when the restoration project was started.

Since the cabinetmaker of that time was such an important craftsman, producing as he did the fine furnishings for the homes of the wealthy and most influential, it was fitting that restored Williamsburg should have a suitably equipped shop of this kind. —GOLD V. SANDERS.

**APPRENTICE.** A Williamsburg boy, dressed in typical costume of the early Williamsburg days, uses the bulky backsaw in cutting a piece of mahogany. The apprentice did the rough work until he could acquire the skill that could come only after many years of service under the guidance of a master cabinetmaker. In many cases the sons of woodworking craftsmen were brought into the shops to observe and to master the family trade.





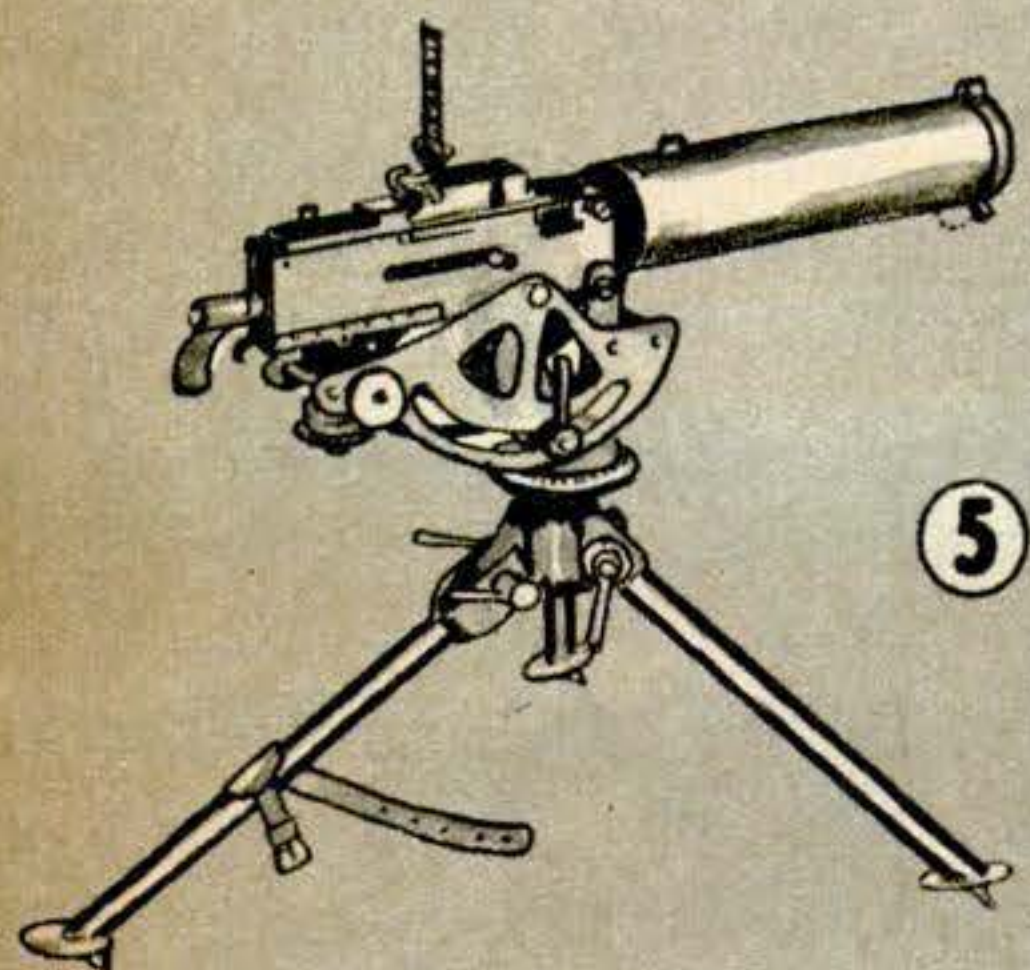
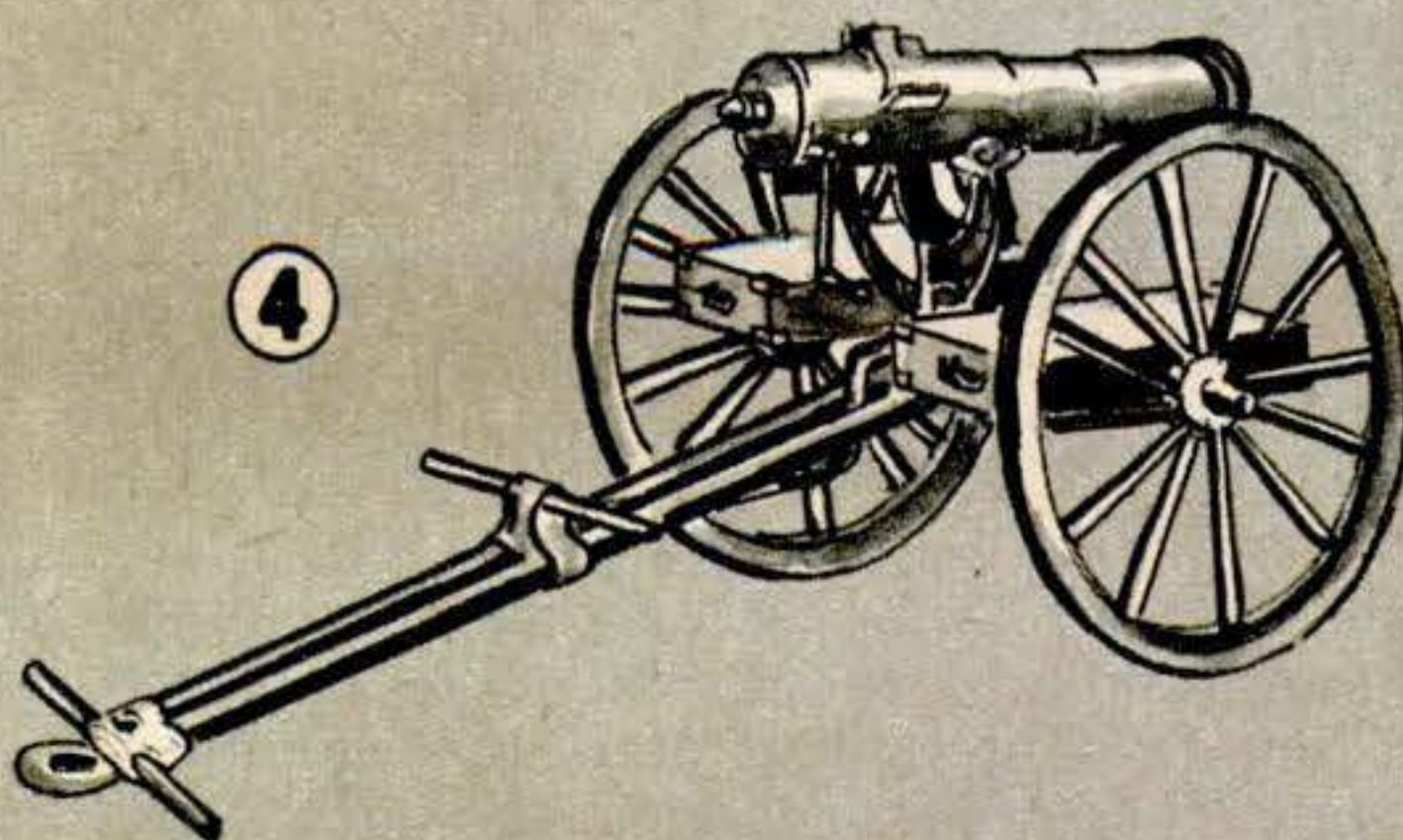
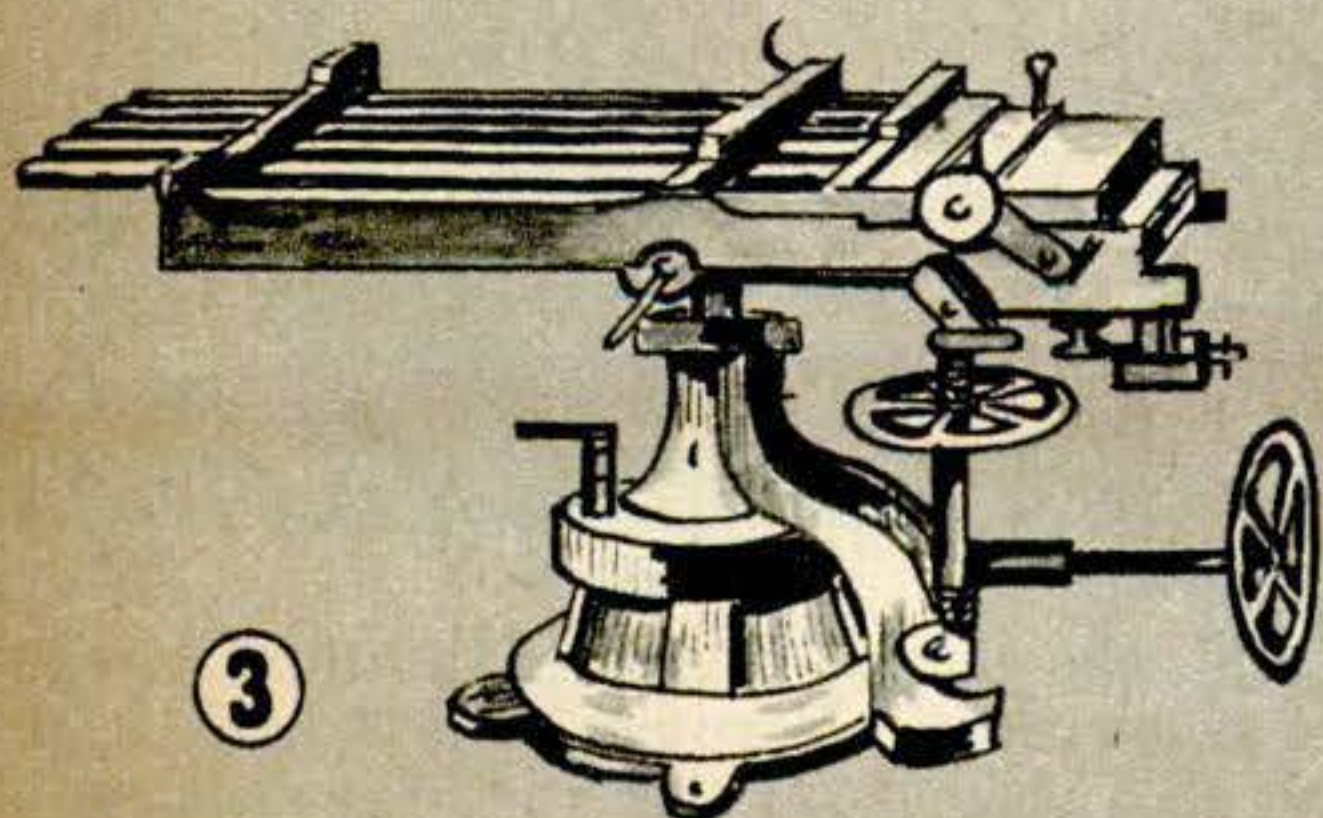
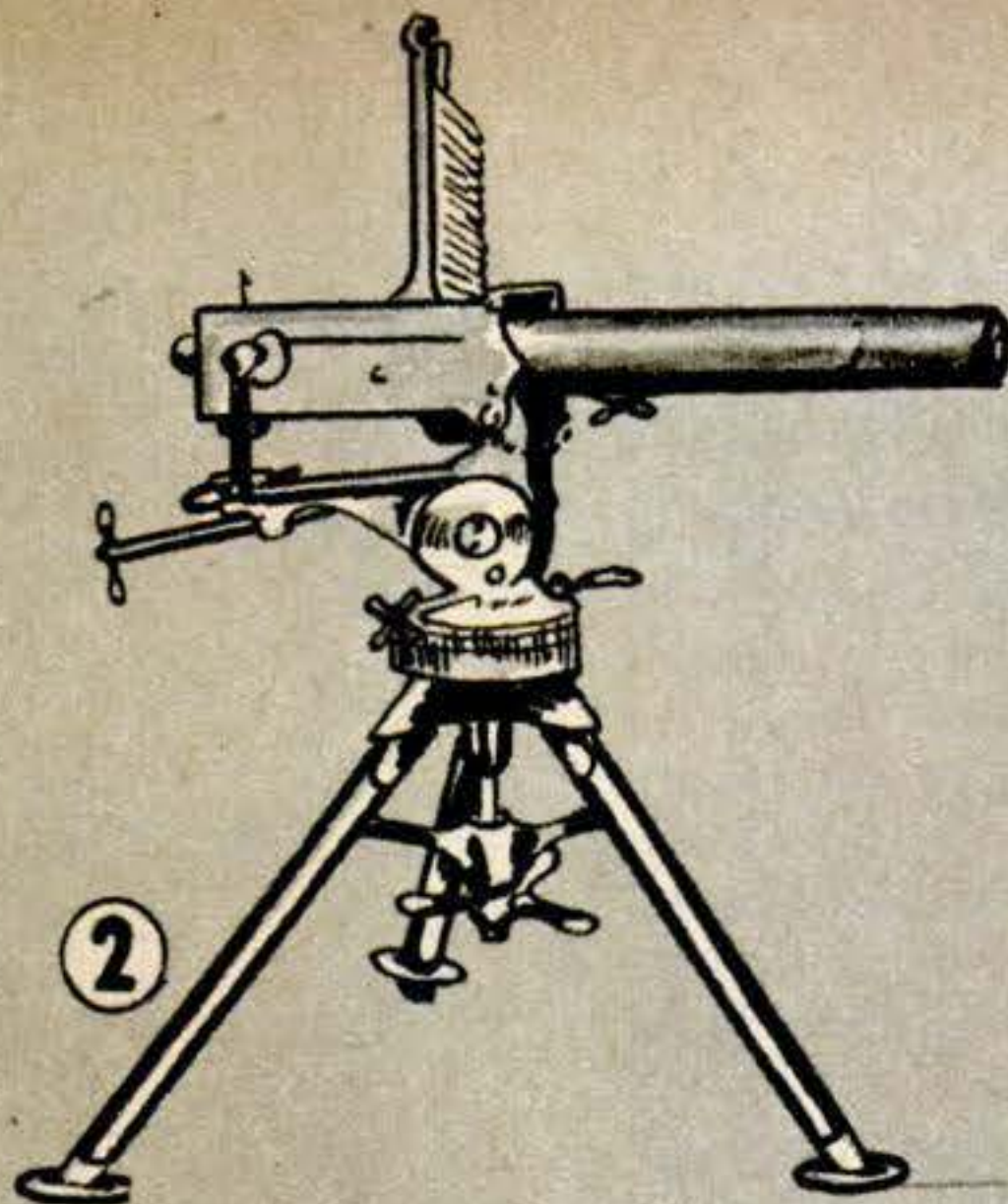
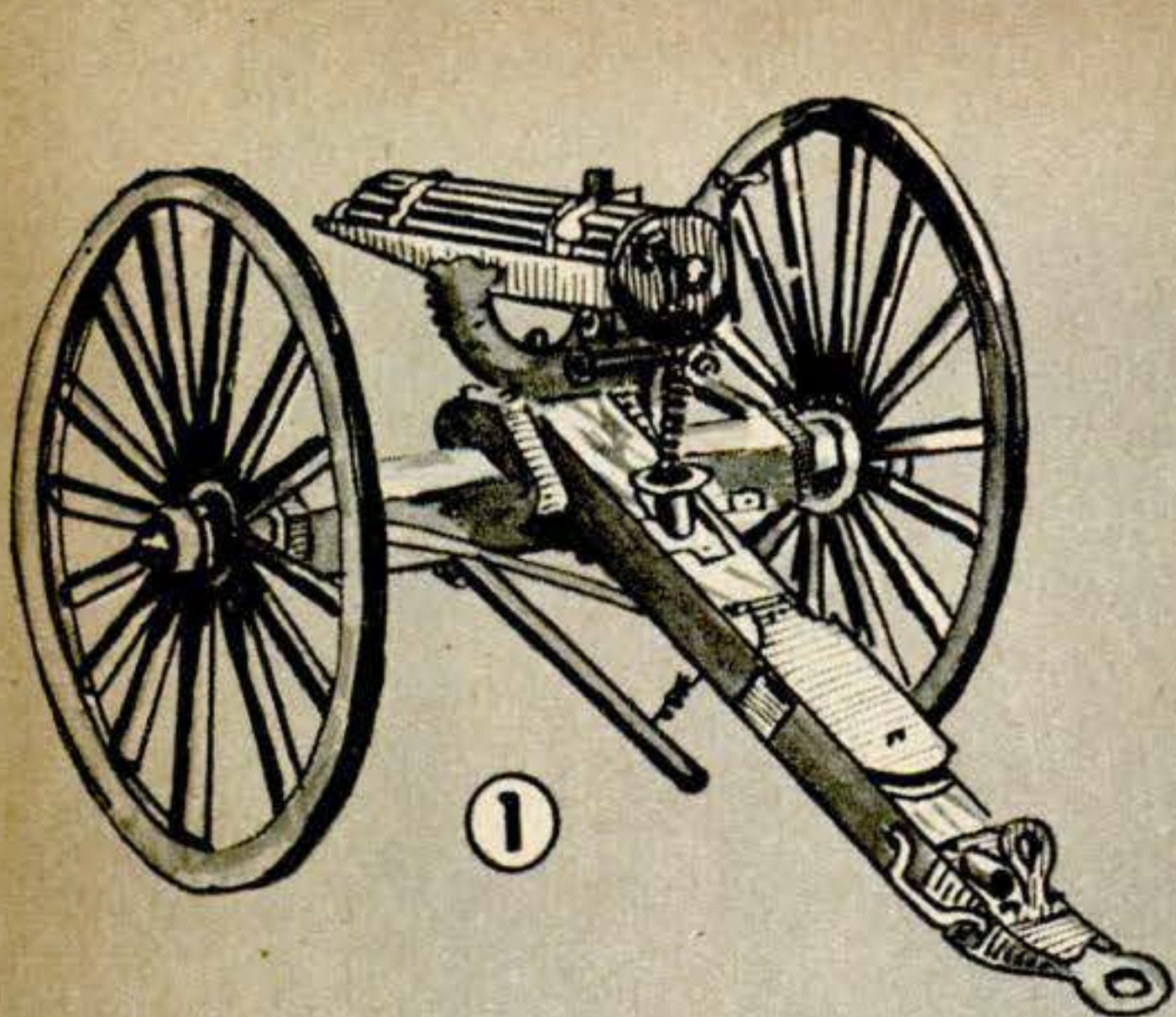

- 1 First practical machine gun was Gatling's, invented in 1862. Gun barrels were mounted on a crank-operated central shaft. Hopper above gun fed the cartridges.
- 2 The lighter Gardner gun, with tripod mount, came next.
- 3 Xylophonelike Nordenfeldt, popular in Europe 1873-1900, was Spain's ace automatic gun in Spanish-American War.
- 4 Colt-Browning, 1890. First automatic to use the gas of exploding shell to extract casing and reload gun.
- 5 Later, Browning added a water jacket for cooling the barrel; became U.S. heavy machine gun in World War I.

# Machine Guns... from

By Lt. J. T. HOLMES, AUS

Drawings by JAN HOLMES

STRANGELY enough, the American who invented the first practical machine gun, like the inventor of dynamite, hated war and hoped his invention would bring an end to all wars.

That man was Dr. Richard Jordan Gatling, born September 12, 1818. Unfortunately, the doctor's dream, born of the horrors he witnessed on Civil War battlefields, was not to be realized. He envisioned a

world held from war through terror of his death-dealing, rapid-fire gun. Instead, the machine gun became just another instrument for dealing out mass death. But, as with every development of war, a countermeasure was found—in this instance the tank, which broke the stalemate of trench warfare of 1916-18.

Gatling patented his invention in 1862 and offered it to the Federal Government, but it was viewed with suspicion. Undiscouraged even by a fire which destroyed his experimental work, Gatling hired men to take



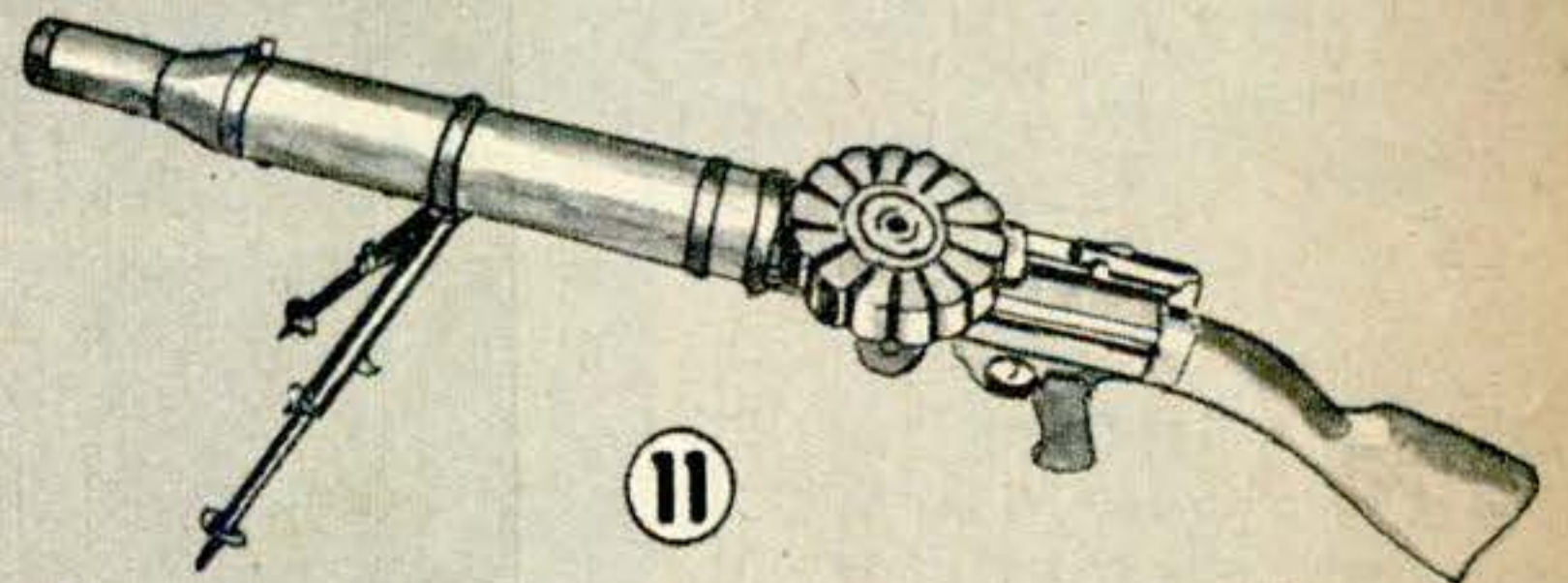
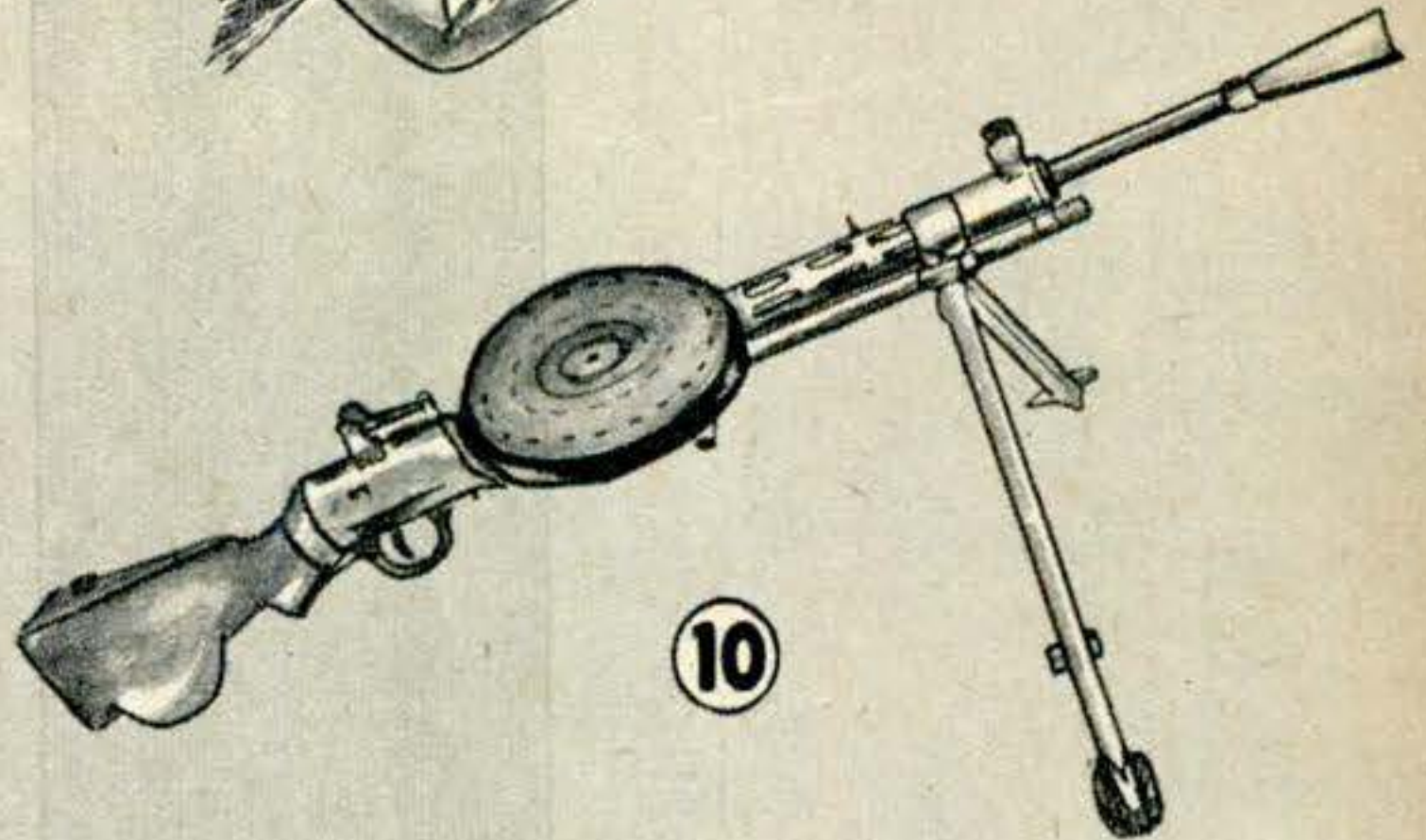
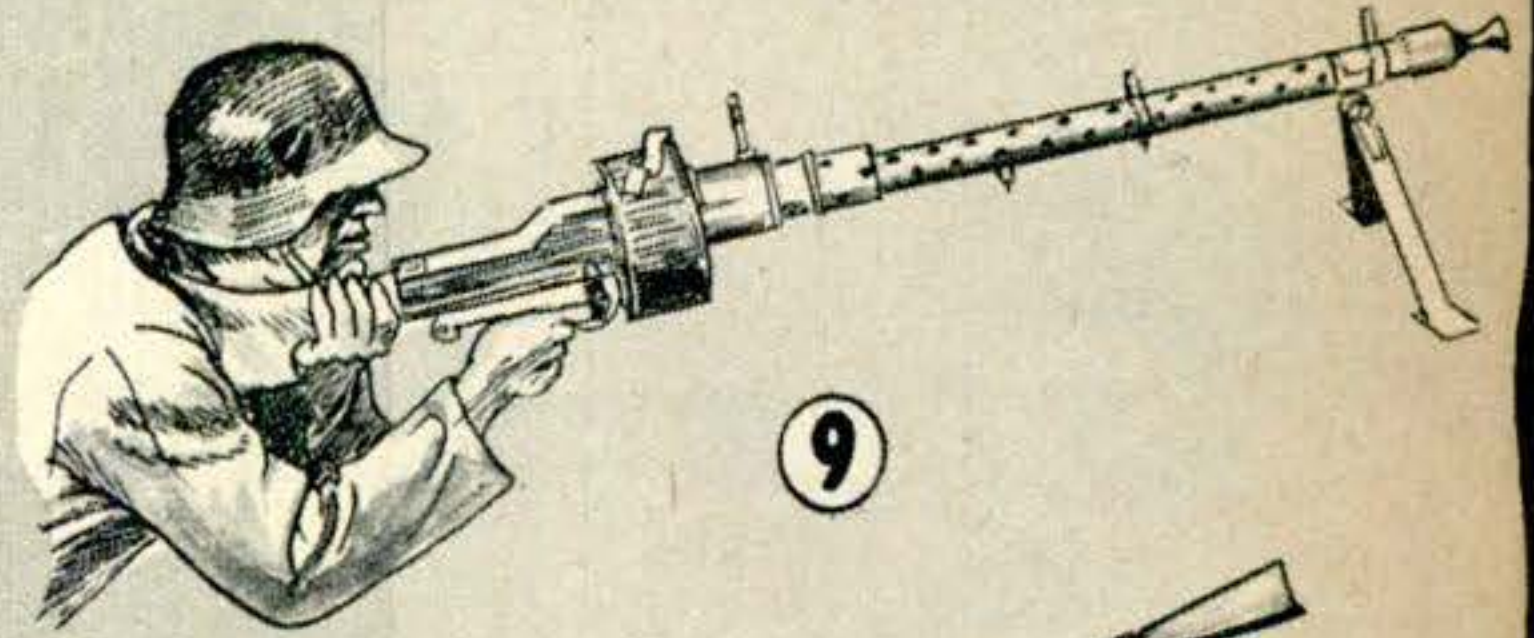
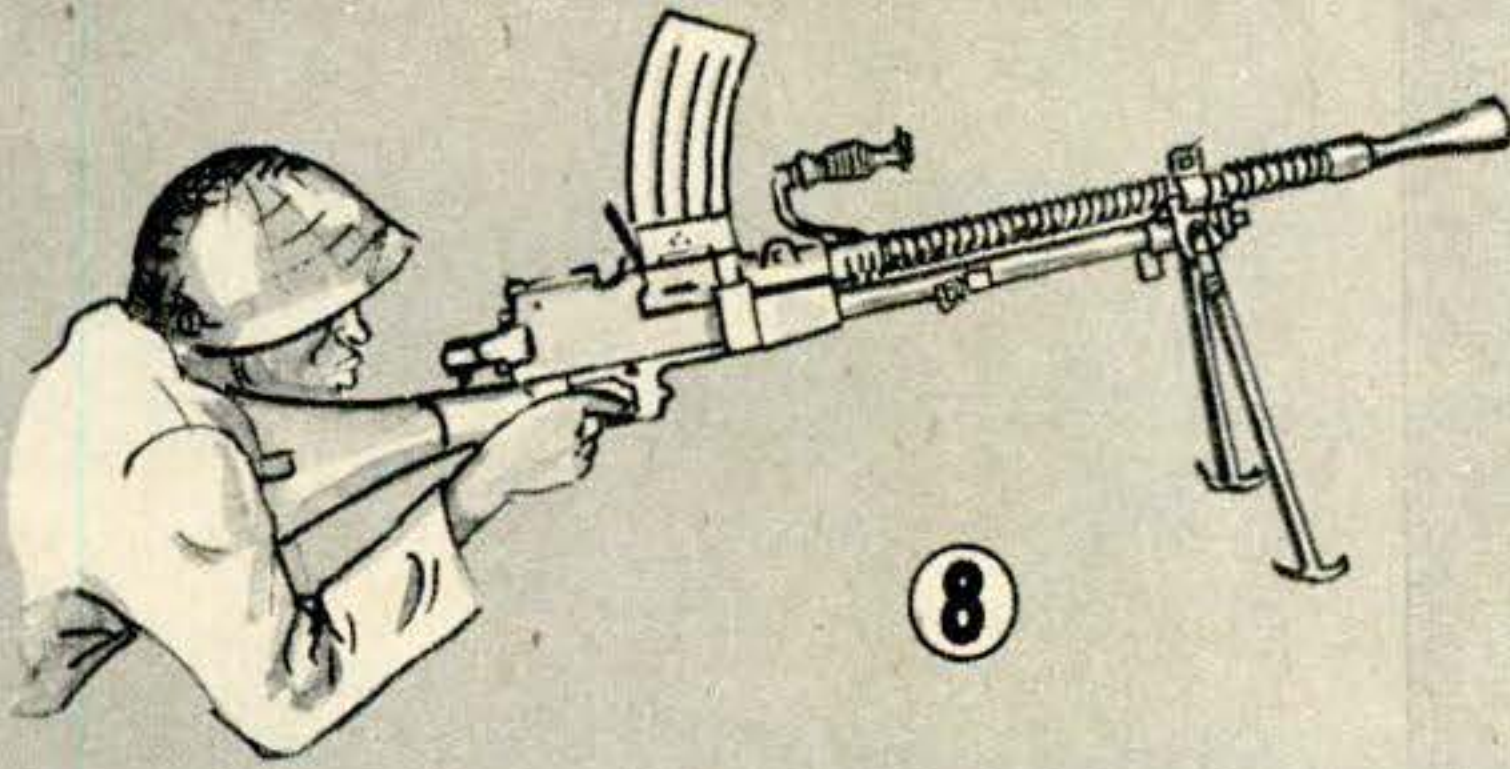
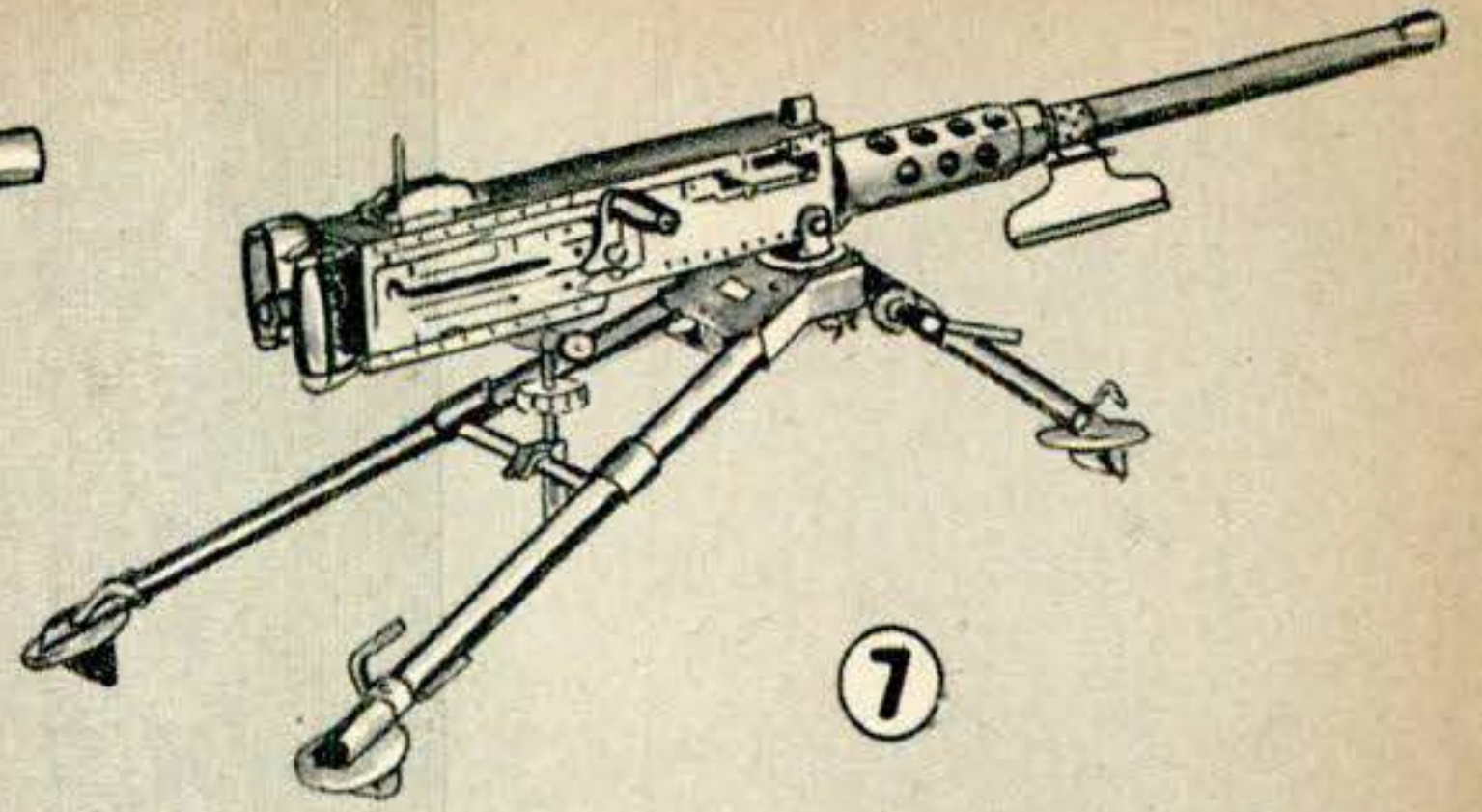
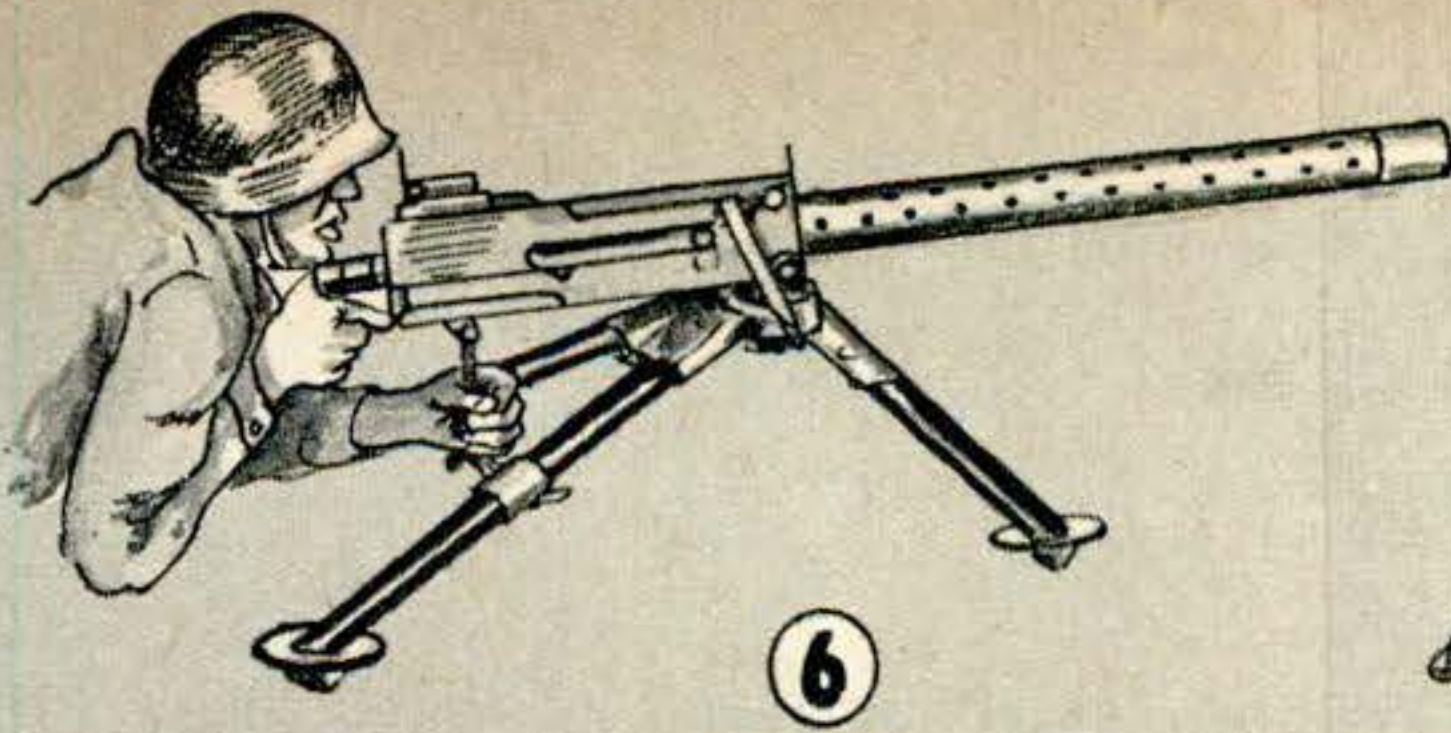

- 6 Browning air-cooled gun, lighter than water-cooled model, is standard Army equipment. Fires 60 rounds per minute for 30 minutes.
- 7 Browning .50 caliber is all-around weapon—ground gun, AA piece, and plane armament. Range is about four miles; weight, 82 pounds.
- 8 Nambu, standard Jap 7.7-mm. light machine gun; very effective, especially in jungle.
- 9 German MG 34 is recoil-operated, belt-fed, air-cooled. Used as a ground and AA weapon.
- 10 This 1937-model Russian Degtyarov weighs only 18 pounds. That's a 47-round drum magazine mounted in front of the rear sight.
- 11 The Lewis (American) gun was adopted by Great Britain in 1909, and late models are still in use. Air channels cool the barrel.

# Gatling to Browning

the weapons out on Civil War battlefields and demonstrate their use to skeptical military men. In the closing years of the war General Butler used the gun against Confederate infantry in an engagement along the James River in Virginia. An improved model of Gatling's original design was adopted as the standard machine gun of the United States Army in the early 1870's.

While Gatling was working on his weapon, the mitrailleuse, another form of machine gun, was being developed in Brussels, Belgium. This clumsy weapon was

used by the French in the Franco-Prussian War of 1870 with very poor results. The Prussians, who had a few machine guns of their own, were greatly impressed by the possibilities of automatic weapons but discarded the mitrailleuse for the Palmcrantz-Nordenfeld and several other models.

Chronologically, the Gardner, invented by an American, followed the Gatling gun. Gardner was years ahead of his time in the design of the tripod stand and the lightness of his weapon, which was widely copied by European arms *(Continued on page 208)*



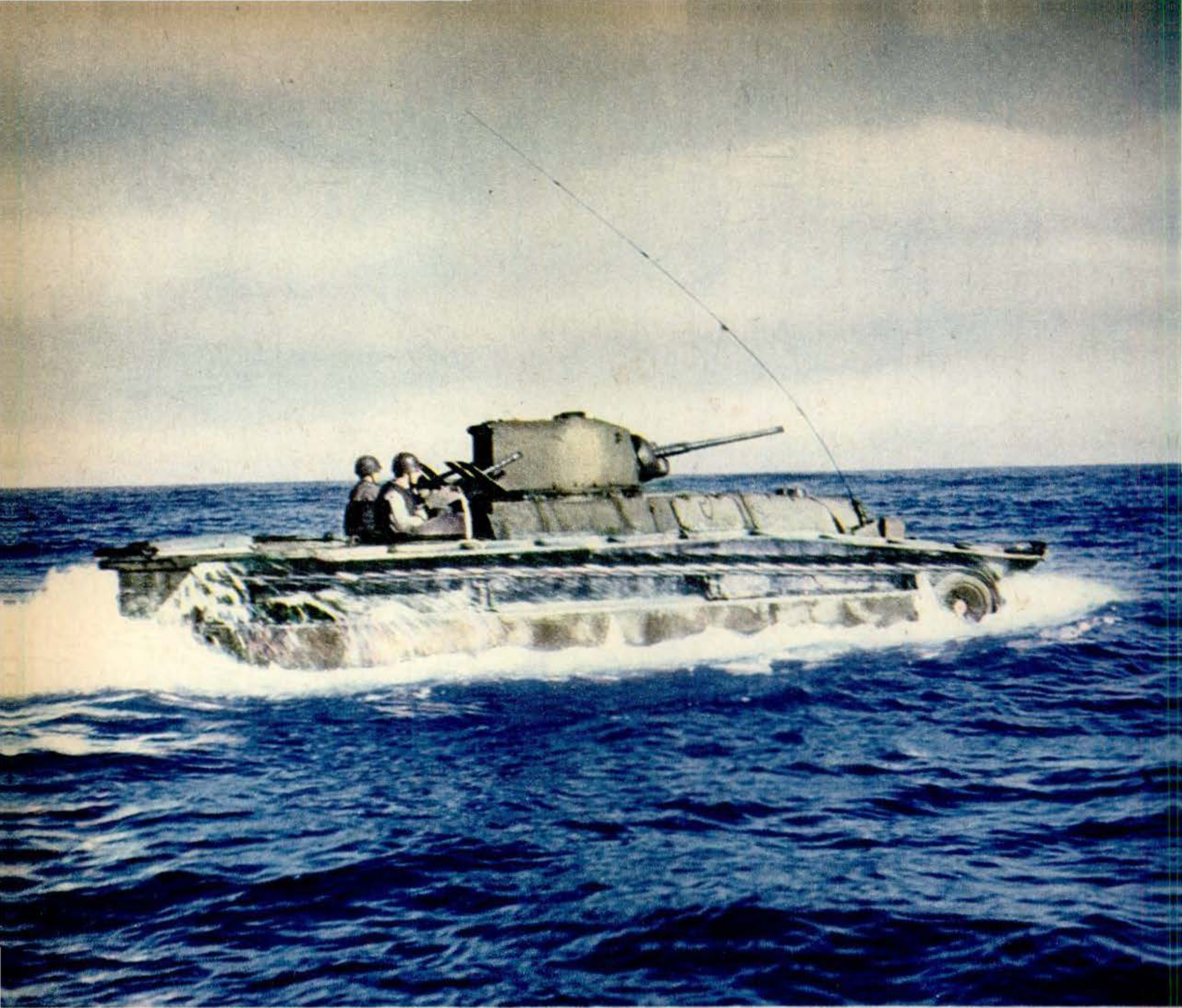

**GOING ASHORE**, an LVT(A)1 amphibian churns the blue waters with its whirling treads as it heads for the beach. Its 37-mm. cannon is ready to fire at enemy pillboxes, and the two machine guns are manned. Its low silhouette makes a poor target.

**ON THE BEACH**, the skipper and his assistant come up for a look around. The two machine gunners are on the watch for enemy planes. Radio maintains constant contact with forces ahead and behind. (Note aerial in upper photograph.) Tracked landing vehicles of this type first saw action at Kwajalein on February 1, 1944. A later model is armed with the 75-mm. cannon.





# MEET THE LVT'S

## Beach Busters

Because they can run in water, sand, or jungle, they are leading the way in the march on Tokyo.

By ALDEN P. ARMAGNAC

"THERE is not the slightest shadow of doubt that the overwhelming victories of our forces at Tarawa, Kwajalein, Saipan, Tinian, Guam, Palau, and Iwo Jima would not have been possible without the Amtracs."—Vice Adm. E. L. Cochrane, U. S. Navy Bureau of Ships.

AT OKINAWA, the newest members of America's growing family of Amtracs waddled ashore, toted cargoes up the hills

to the front line, and hauled back the wounded men. So censorship now has been lifted sufficiently to permit you to know about our newest amphibian tractors.

Like the Alligator and the Water Buffalo, these new Amtracs are officially LVT's (Landing Vehicles, Tracked). They have neither wheels nor propellers, but travel over land or water by using their endless tracks as ground grippers on terra firma and as paddles in the sea.

They are descendants of a "rescue tank" invented a dozen years ago by Donald

### AMTRACS CRAWL OVER REEFS THAT STOP REGULAR LANDING CRAFT

At Okinawa, the Japs counted on false beaches and underwater reefs to halt invaders offshore. They had not figured on our amphibian tractors, which can climb over such obstacles. What is more, these cargo, troop, and gun carriers don't stop at the beach, but crawl ashore and go after the enemy over the roughest terrain.

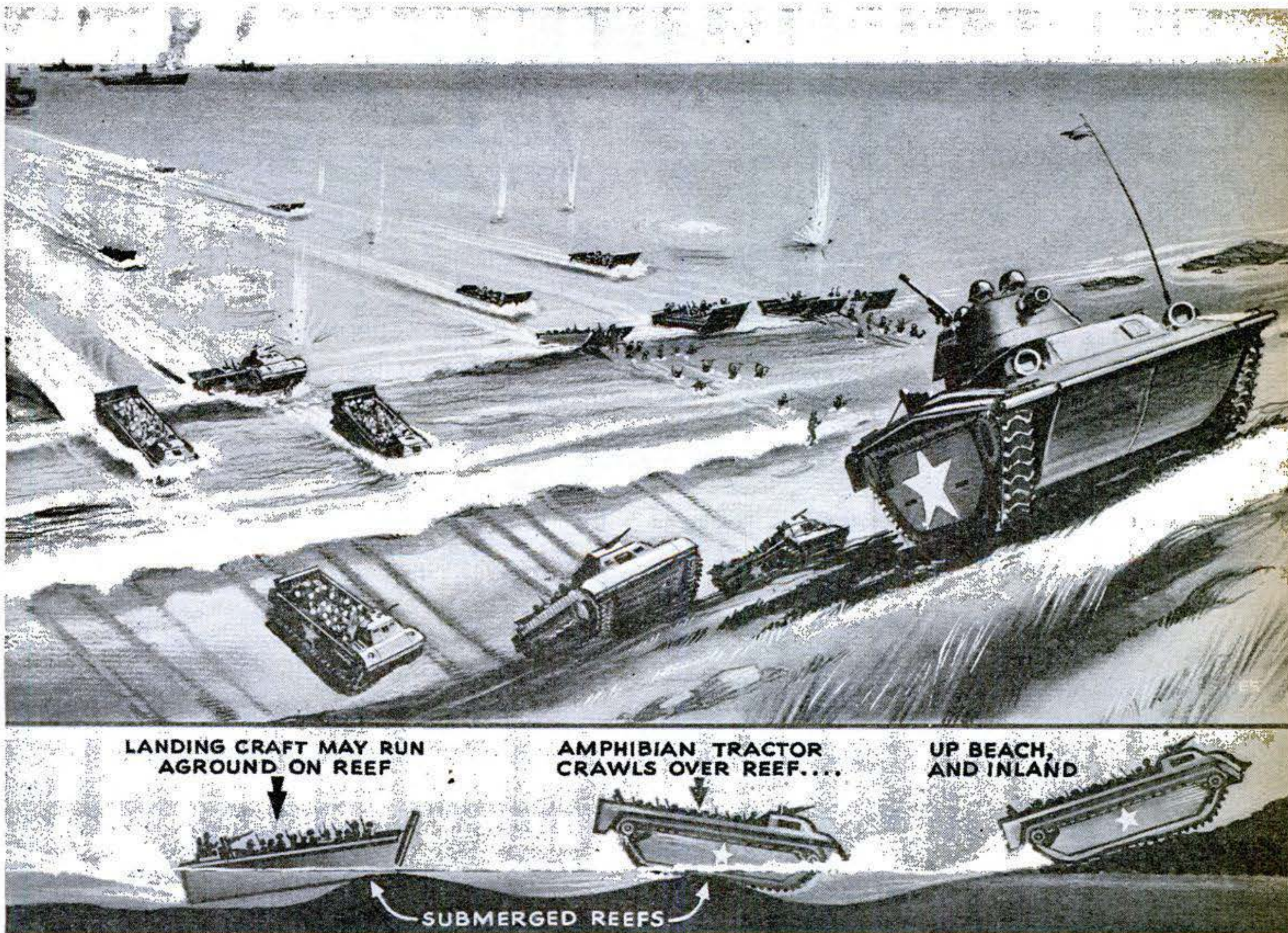



Roebing, grandson of the famous bridge builder, to save persons marooned in the Florida Everglades by tropical hurricanes. Navy and Marine Corps experts saw news pictures of Roebing's machine (P.S.M., Jan. '36, p. 42), and ordered a couple of aluminum pilot models. Few persons suspected then that Roebing's invention would help to shorten bombers' flights to Tokyo in 1945, but that's exactly what his machine's descendants have done. They've now swum and rolled to within 350 miles of Japan.

If you want to be technically correct, don't speak of an LVT as an "amphibian tank"—especially if you are talking with a certain Marine Corps officer who had three shot out from under him in a single engagement. The ones that carry troops or cargo

are "amphibian tractors," or Amtracs for short, and their thin plating stops nothing heavier than small-arms or light machine-gun fire. Therefore, their attack often is led by one or two waves of armored amphibians, a later class with more protection.

Typical armament for an amphibian tractor consists of four machine guns—either two .50's and two .30's, or all .50's. The choice depends upon a nicety of tactics. Where aerial opposition is expected, the .50 caliber weapon serves as an anti-aircraft gun and is used throughout. But when Allied airpower neutralizes the enemy's, .30 caliber bullets kill Japs on the ground just as effectively, and more ammunition can be stowed aboard. Armored amphibians mount both machine guns and comparatively heavy weapons—a 37-mm. gun or a 75-mm.

## HERE ARE SIX MEMBERS OF THE GROWING AMTRAC FAMILY

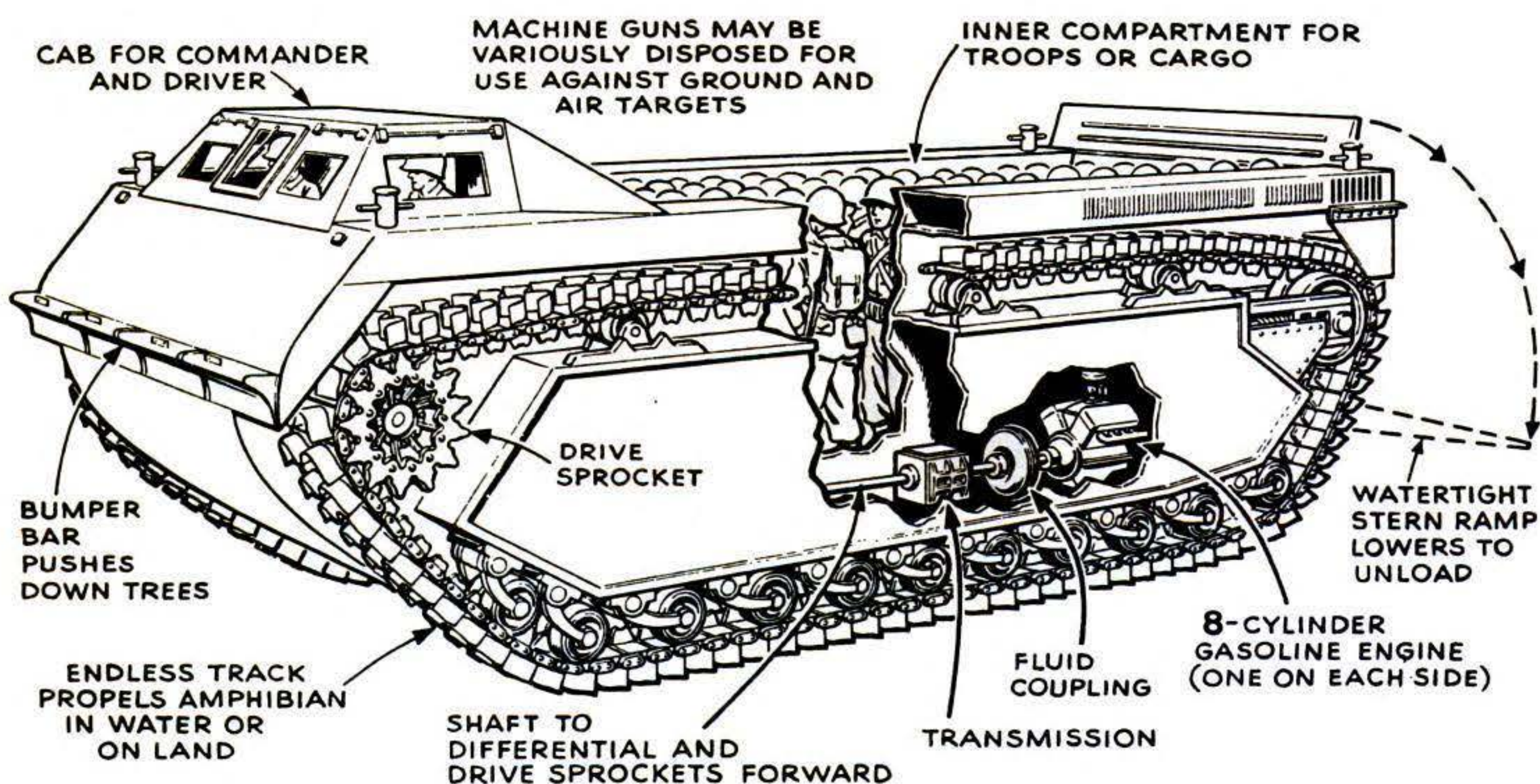

**CUTAWAY VIEW** of the LVT(3) Bushmaster shows fluid drive that makes this model easier to handle.

**LVT (1)**, the famous Alligator, was developed from a hurricane-rescue vehicle. Many of these pioneer amphibian tractors are still in use.

**LVT (2)**. Amtracs gained new size and power in the Water Buffalo, which first saw action at Bougainville in 1943. It is 26 feet long, weighs 14 tons.





howitzer—and start firing from the water as soon as the preliminary barrage from major warships has lifted.

Fuel tanks filled with high-test gasoline, invasion-bound LVT's take to the water from the lowered bow of an LST—the Navy's versatile ocean-going vessel named for its original use as a Landing Ship, Tank. By way of comparison, it takes 3¼ minutes to unload 17 LVT's from an LST; 25 to 90 minutes to unload a single LVT from a larger ship.

Taking radio orders from their group commanders, the amphibians first jockey into place on the "line of departure"—a standard assault formation, resembling that of race horses at the barrier. A second command, and they're off. Don't expect them to show spectacular speed, for they're work

horses rather than sprinters, with a pace of four or five knots in the water.

As an Amtrac nears a hostile shore, the spang of bullets against its side warns occupants not to risk a peek at what is going on, but to crouch in safety. Usually an observer in a protected position volunteers a running account of the situation.

Given sufficient notice where to land, the driver stars in the climax of the show. It is up to him to beach the machine through heavy surf, if necessary, and thorough training has taught him just how to do it. Above all, he must never let a wave catch him abeam. True, LVT's have power pumps that discharge water normally shipped aboard—but, for all their virtues, Amtracs are not submarines.

A grating noise announces that the LVT

## ... EACH DESIGNED TO DO A SPECIFIC INVASION JOB



**LVT (A) (1)** was our first armored amphibian. Built exclusively for fighting, this 18-ton vehicle looks like a seagoing tank with its turret mounting a 37-mm. gun. Its crew of six men is protected by relatively heavy armor.

**LVT (3)**, the Bushmaster, was kept under wraps until Okinawa. Its outstanding new feature is the fluid drive that takes it up hills with little shifting of gears.



**LVT (A) (4)**, the latest armored model, has a 75-mm. howitzer that can lob shells over coastal ridges. A 20-tonner, it is handled by five men. Its debut was a surprise to the Japs at Saipan.

**LVT (4)** introduced the rear ramp, a great help in unloading under fire. Twenty-six feet long, it carries 45 men, a jeep, or a fieldpiece with crew.





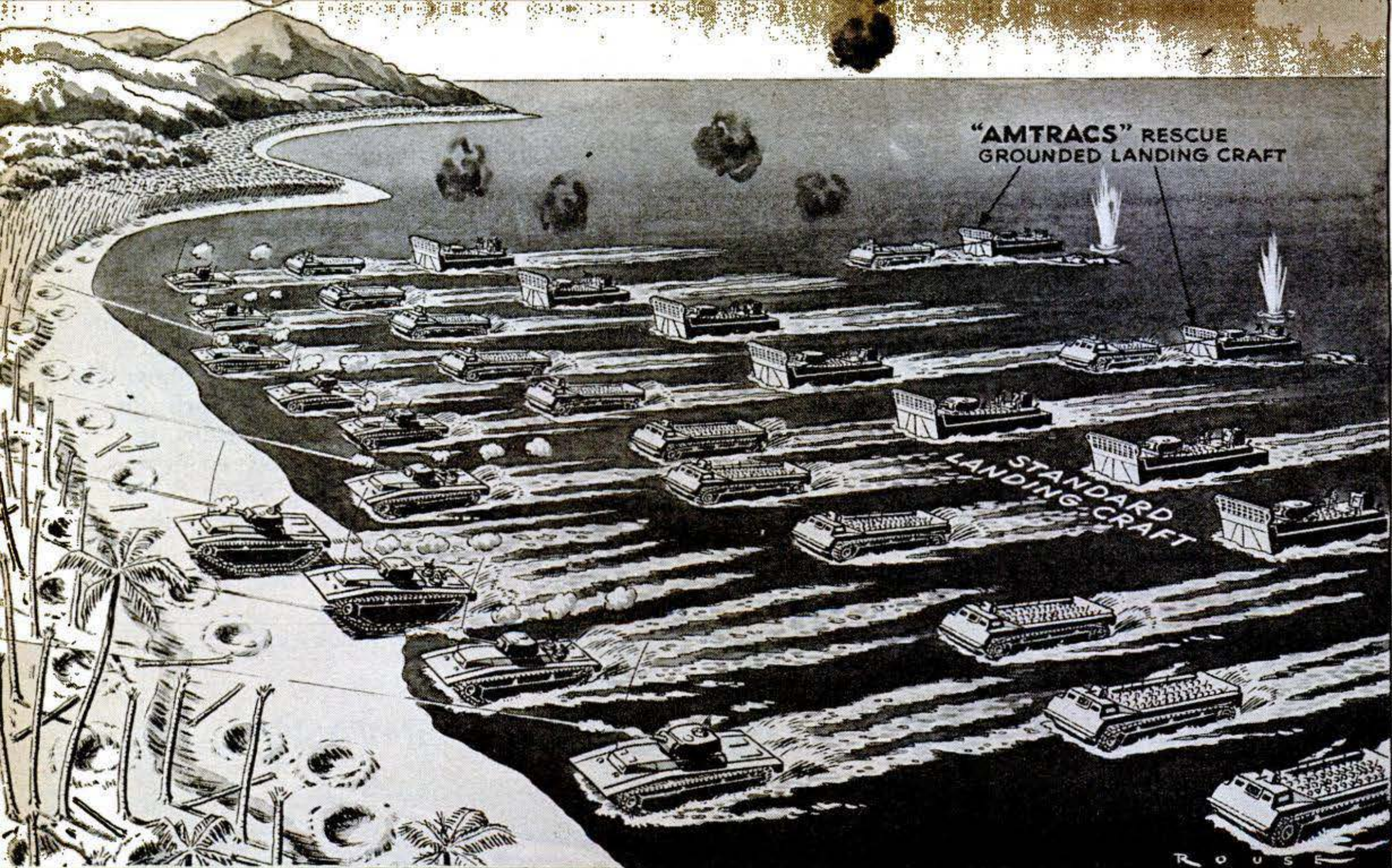

**INVASION TACTICS** usually call for one or two waves of armored amphibians to lead the way, followed by Amtracs loaded with men and supplies. When regular landing craft get stuck on reefs, the amphibians tow them off. Men in the open-top Amtracs crouch low for protection behind the steel walls, with observers in shielded positions telling them what goes on. Pennants on radio antennas identify group commanders' vehicles. All the other Amtracs fly pennants, too, and only our men know which kind marks the leader. If the Japs get wise to the code, it can be changed quickly while the fight goes on.

has reached shore, and, dripping brine, it goes into action in its terrestrial element. Incidentally, the design of its double-purpose track cleats deserves more than a passing glance; shaped like the blades of a Pelton water wheel, they have applied a classic hydraulic principle in reverse, for aquatic propulsion. Like the tracks of a land tank, they are used for steering, both afloat and ashore. To turn, the driver runs one track faster than the other; to face about, he operates them in reverse directions.

On land, the 20-mile-an-hour speed of an LVT cannot compete with that of a tank. Where it scores again is in its incomparable ability to overcome every variety of difficult terrain. Marines struck a curious type on the beach of Iwo

Jima—volcanic sand, so soft and yielding that they might as well have been struggling through a quagmire. But their amphibian tractors rode over it with ease. Likewise, as at Bougainville, tropical rains that turn roadways into beds of thick mud cannot stop them. During the Cape Gloucester invasion of New Britain, our troops received supplies in LVT's over no roads at all. Marines consider them tops among jungle machines. They have enough power to crash through the toughest thickets, and to run up hills too (*Continued on page 206*)

**NO SUPERHIGHWAYS** are needed by these first-rate jungle machines. Mud, trees, or volcanic sand can't stop them. The "duck" truck, a wheeled amphibian, could never get over terrain like this, but Amtracs take men and supplies inland and bring out the wounded.





# How's



# Your I.Q.?

**DON'T LOOK NOW**, but after you have tried to solve these problems, turn the page upside down and read the correct answer under each picture.

**THIS CUBE IS CUT AS SHOWN...**

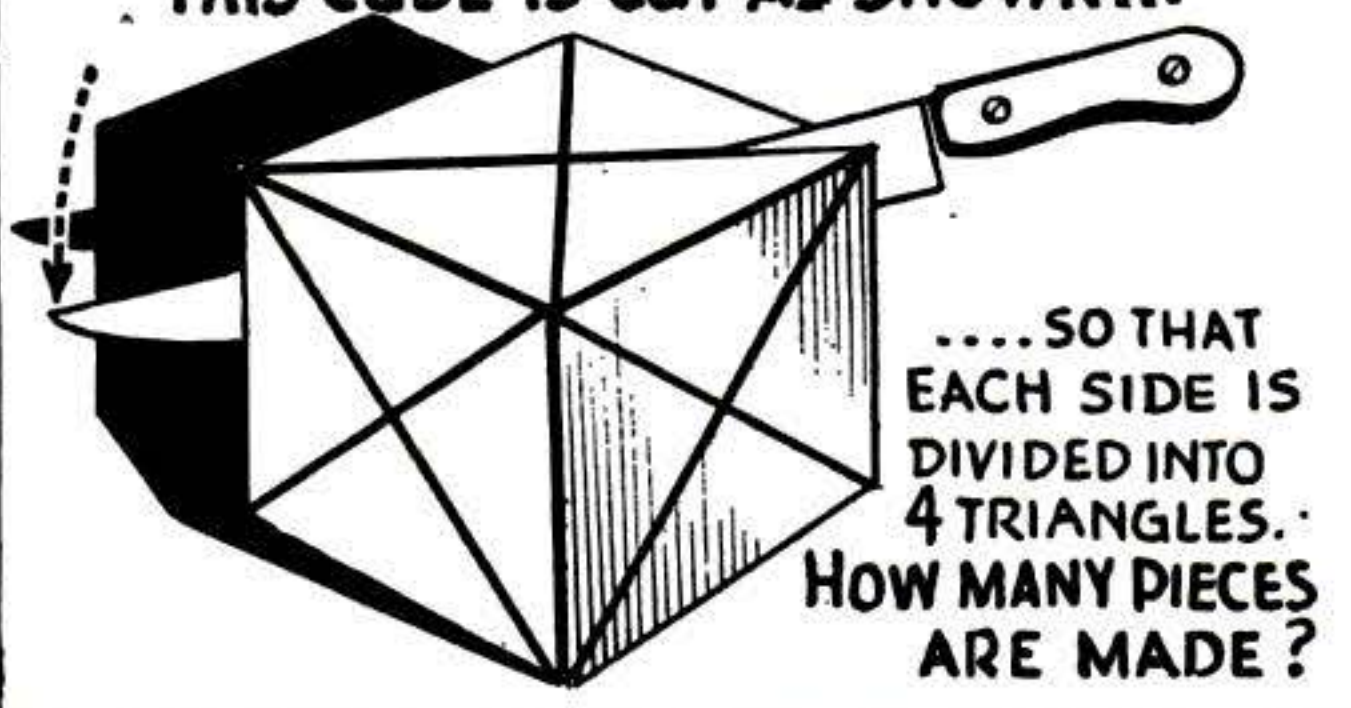

.....SO THAT EACH SIDE IS DIVIDED INTO 4 TRIANGLES. HOW MANY PIECES ARE MADE?

Since all cuts meet in the center of the cube, there are four pieces for each of the six sides—24 pieces.

**4"**  
**15"**

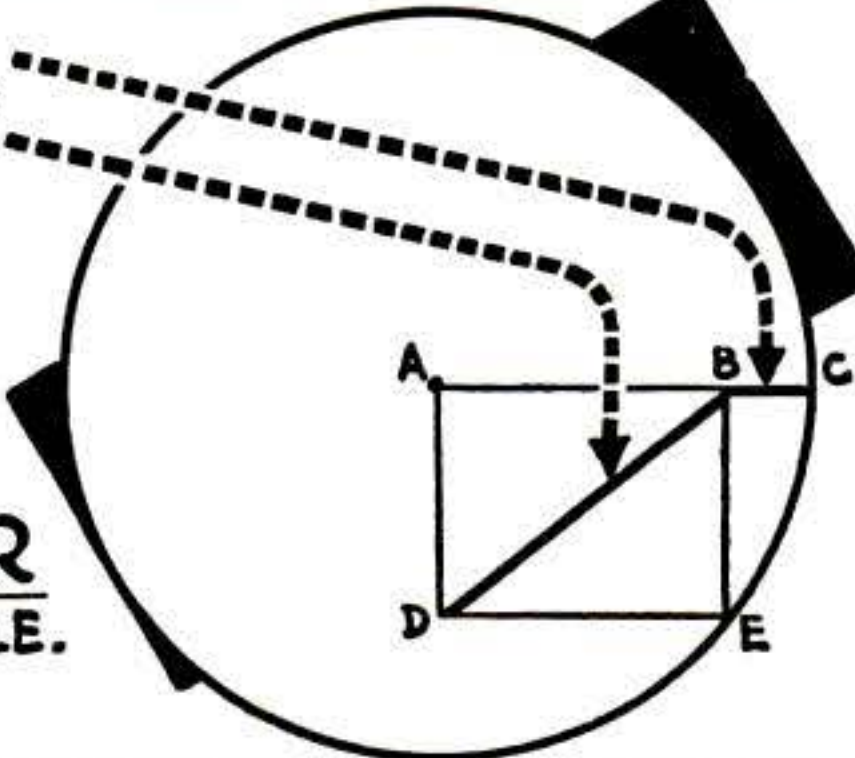

**YOU CAN EASILY FIND THE DIAMETER OF THIS CIRCLE.**  
*What is it?*

The distance AE, which is a radius of the circle, is equal to BD, or 15 inches. So, diameter is 30 inches.

**THIS CONTAINER OF WATER WITH A SHIP IN IT IS FINELY BALANCED**

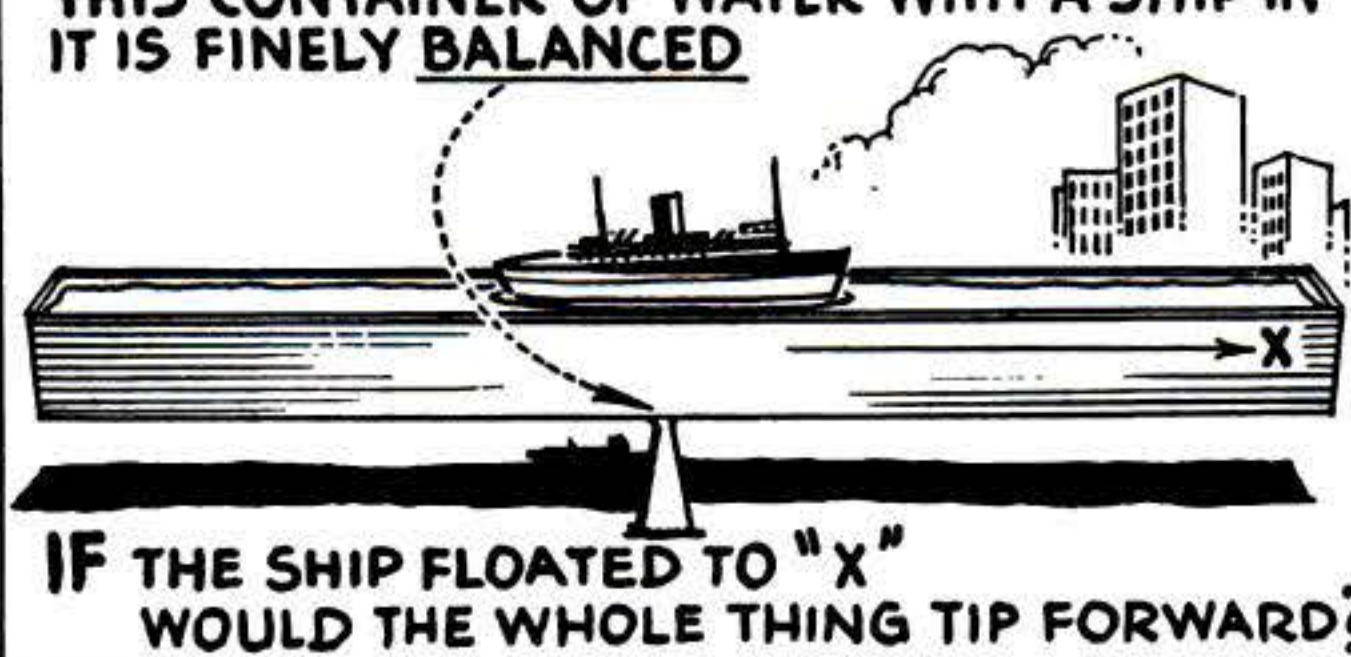

**IF THE SHIP FLOATED TO "X" WOULD THE WHOLE THING TIP FORWARD?**

Ship's position would not affect balance, because its weight is displaced and distributed throughout tank.

**\$1**



**EXTRA!**  
**CONGRESS APPROPRIATES ONE BILLION DOLLARS!**

IF PILED AS SHOWN (6 STACKS) THE PILE WOULD BE ABOUT

11 FT. HIGH ..... ?  
11 YDS. HIGH ..... ?  
11 MILES HIGH ..... ?  
111 FT. HIGH ..... ?

New dollar bills stack 233 to the inch. In one pile, a billion would reach 66 miles; in six piles, 11 miles.

**THROUGH ATMOSPHERE**



**WHICH ROCKET WILL TRAVEL FASTER?**

**THROUGH A VACUUM**



Rocket in vacuum travels faster. Air doesn't help let propulsion; its only effect is to offer resistance.

**MY BOSS WANTS ANOTHER WINDOW 2 FT. FROM TOP TO BOTTOM. IT MUST BE SQUARE BUT ITS AREA MUST BE HALF OF THAT WINDOW'S AREA**



**HOW?**

Sure, it can be done. Smaller window has a diagonal of two feet and is set with corners at top and bottom.

**BUG FLYING IN MIDAIR**



**2-OZ. BUG RESTING ON BOTTOM**

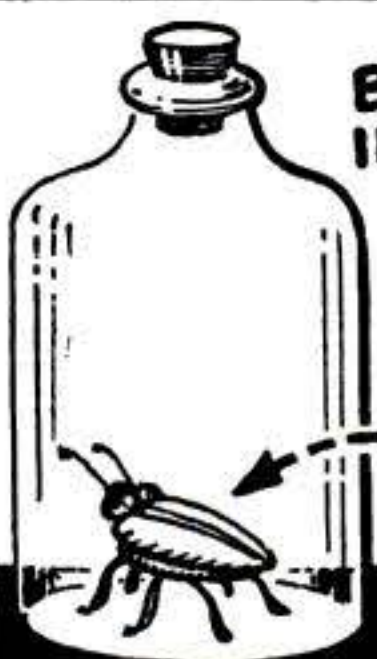

**WHICH BOTTLE IS THE HEAVIEST?**

With equal amounts of air, the bottles weigh the same. The flying bug's weight is still in the bottle.

**ST. JOHN'S (UP IN NEWFOUNDLAND)**

**IS NEAREST TO NORTH POLE, ALASKA, FINLAND, OR AFRICA**



**?**

Africa, in the region of Morocco, is closest by a long way. Check on this with a globe and dividers.



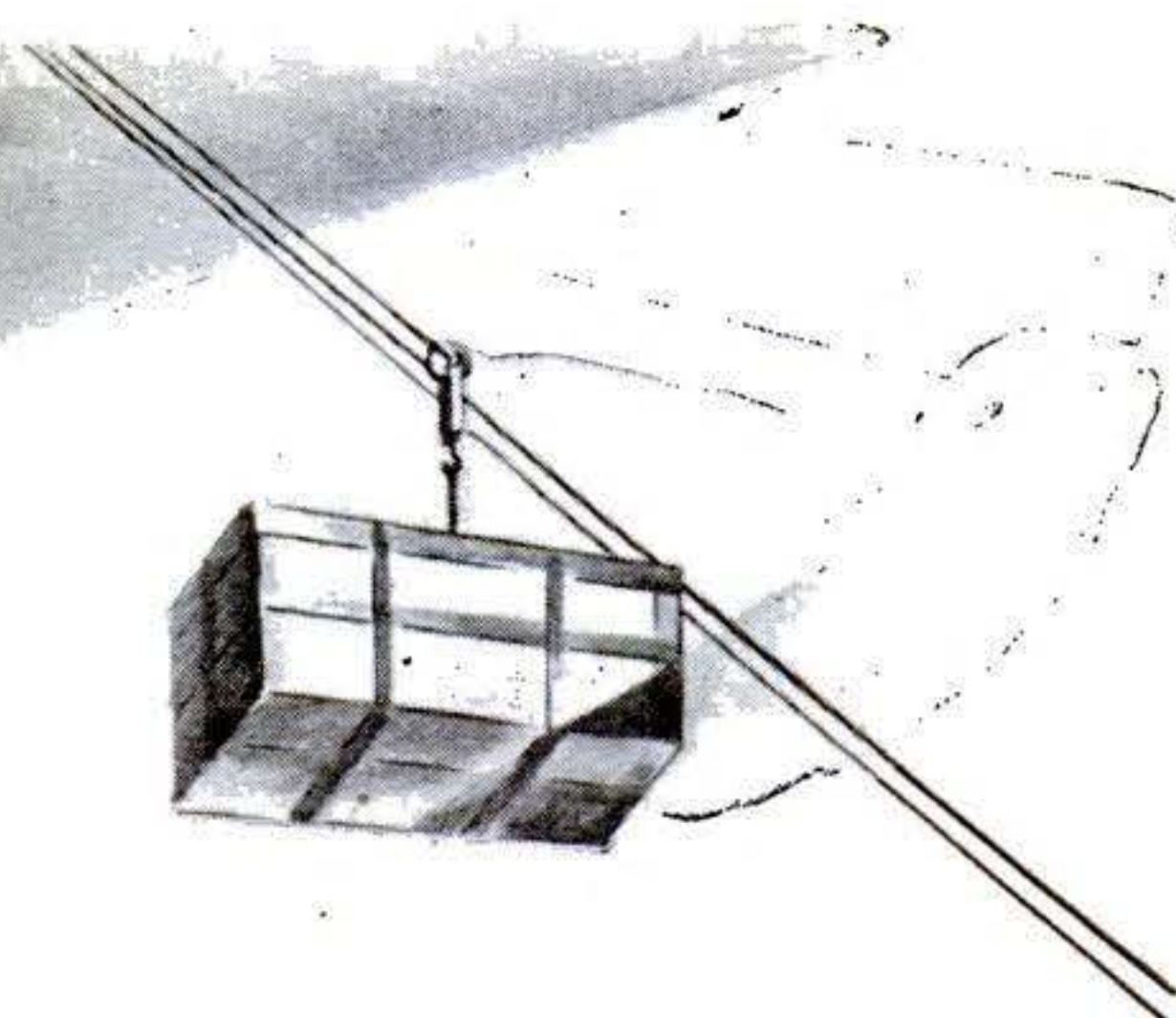
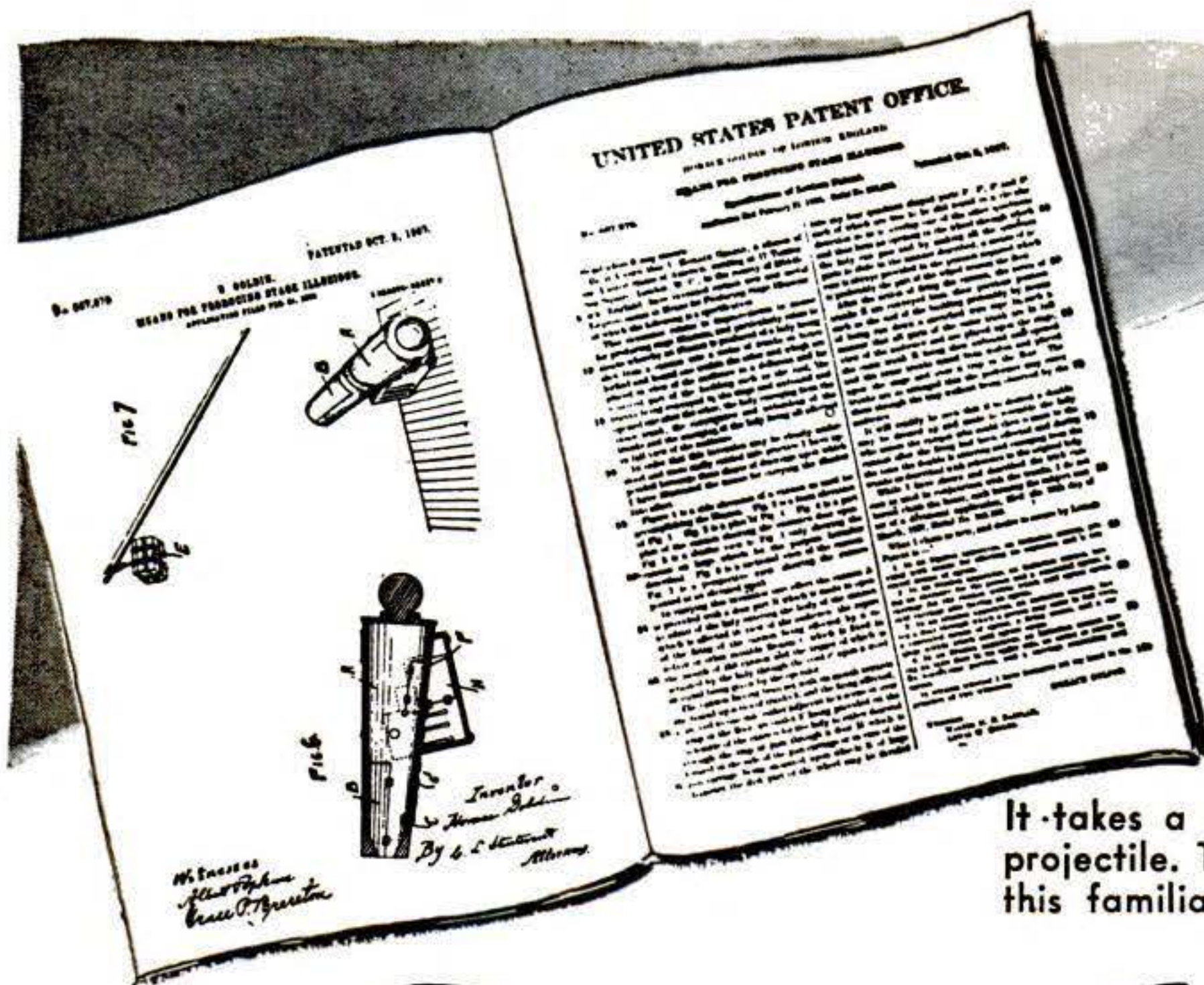

It takes a special kind of gun to use a girl as a projectile. That's why you can get the low-down on this familiar trick from Washington for 10 cents.

# Patents Give Away Magicians' Secrets

MYSTERY IS STRIPPED FROM STAGE ILLUSIONS BY PAPERS PROTECTING IMPROVED APPARATUS. YOU CAN DUPLICATE SOME OF THESE STUNTS.

By MICHEL NOSTRADAMUS

(Pen name of one of America's leading amateur magicians.)

UNLESS people ask the question, "How does he do it?" there isn't much point in an exhibition of magic. They go to the show to be mystified, and come away slightly irritated because they *are* mystified.

It's easy to find out how any trick is done if the apparatus has been patented in the United States. For a dime you can get any one of the papers issued by the U. S. Patent Office and figure out how the magician saws a lady into two pieces, causes a skeleton to appear in an empty cabinet, or loads a girl into a cannon and shoots her into a nest of three locked trunks hanging by a cable up near the roof.

Uncle Sam tells all; and since many of the big-time illusions are based on apparatus patented 17 or more years ago, you are at liberty to go ahead and reproduce these if you have the skill to build the equipment and learn the routines. The Patent Office, custodian of these secrets, lists "Illusions" under Classification 272, subclassification 8; and there are other subheads covering

various smaller appliances of similar kinds.

The chances are that the tricks are not new—and weren't when the patents were issued. In each case it was an improvement on the apparatus that was patented. The first important stage illusion on which a patent was granted was devised in England in 1863 by a Professor Pepper, of London's Polytechnic Institute, and was known as "Pepper's Ghost." It required a huge sheet of glass inclined forward on the stage at such an angle that it would reflect an illuminated pit or lower stage. Actors appeared behind the glass, which was invisible to spectators, and other actors representing ghosts or skeletons took their places on the hidden stage in front of and below the glass. Turning on the pit lights produced the intended result, which was, in the quaint phraseology of patent papers, "to associate on the same stage a phantom or phantoms with a living actor or actors so that the two may act in concert."

The Professor patented his "Metempsychosis" in the United States (No. 221,605) in 1879. In this illusion, miraculous transformations took place with the aid of a mirror set at an angle. One of its many



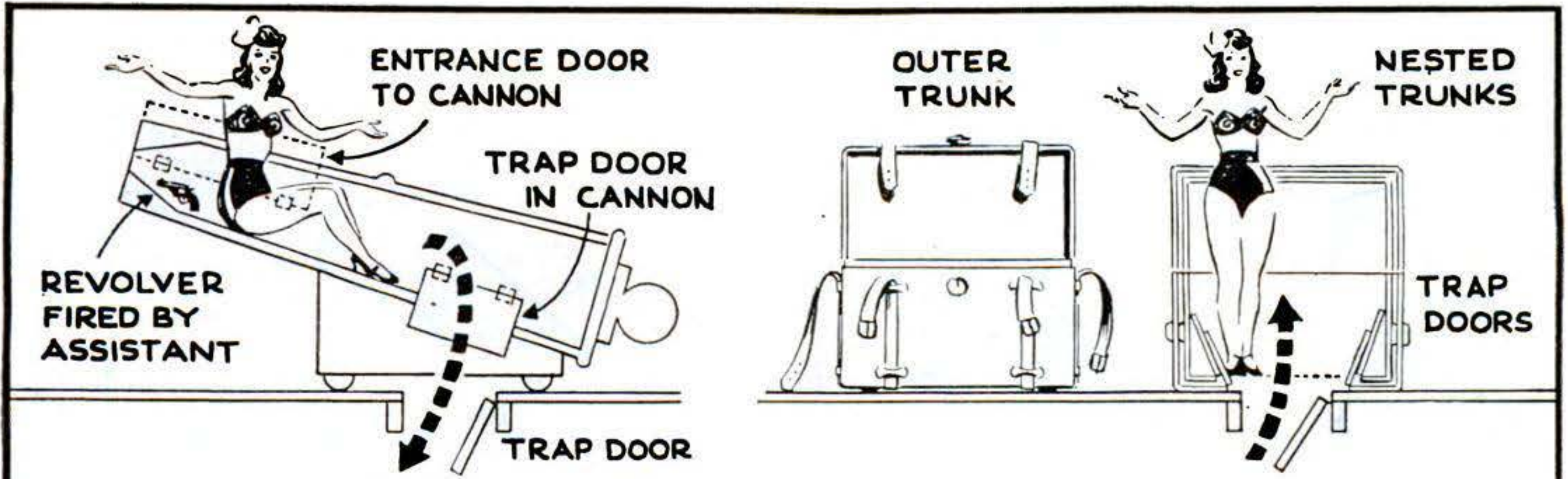

The girl slips into the cannon through an opening near the muzzle, and out again by way of a trap door concealed by the gun carriage. Before disappearing below stage, she fires the pistol shown.

When the trunk nest is lowered to the stage, the solid outer trunk is opened, and the other two are set over a trap door, under which the girl is waiting, ready to climb up and be released smiling.

## THE TRICK—AND HOW IT'S DONE ↗

**SHOOTING A GIRL OUT OF A CANNON.** Target is a nest of three trunks, all locked and strapped, hung high on a cable that reaches to the roof of the theater. The big cannon is loaded with its human ammunition. The command to fire is given. BOOM! Assistants lower the trunk to the stage, and feverishly unlock, unstrap, and open the outside trunk. They lift out the next trunk and repeat the process. Out of the third trunk steps the girl.

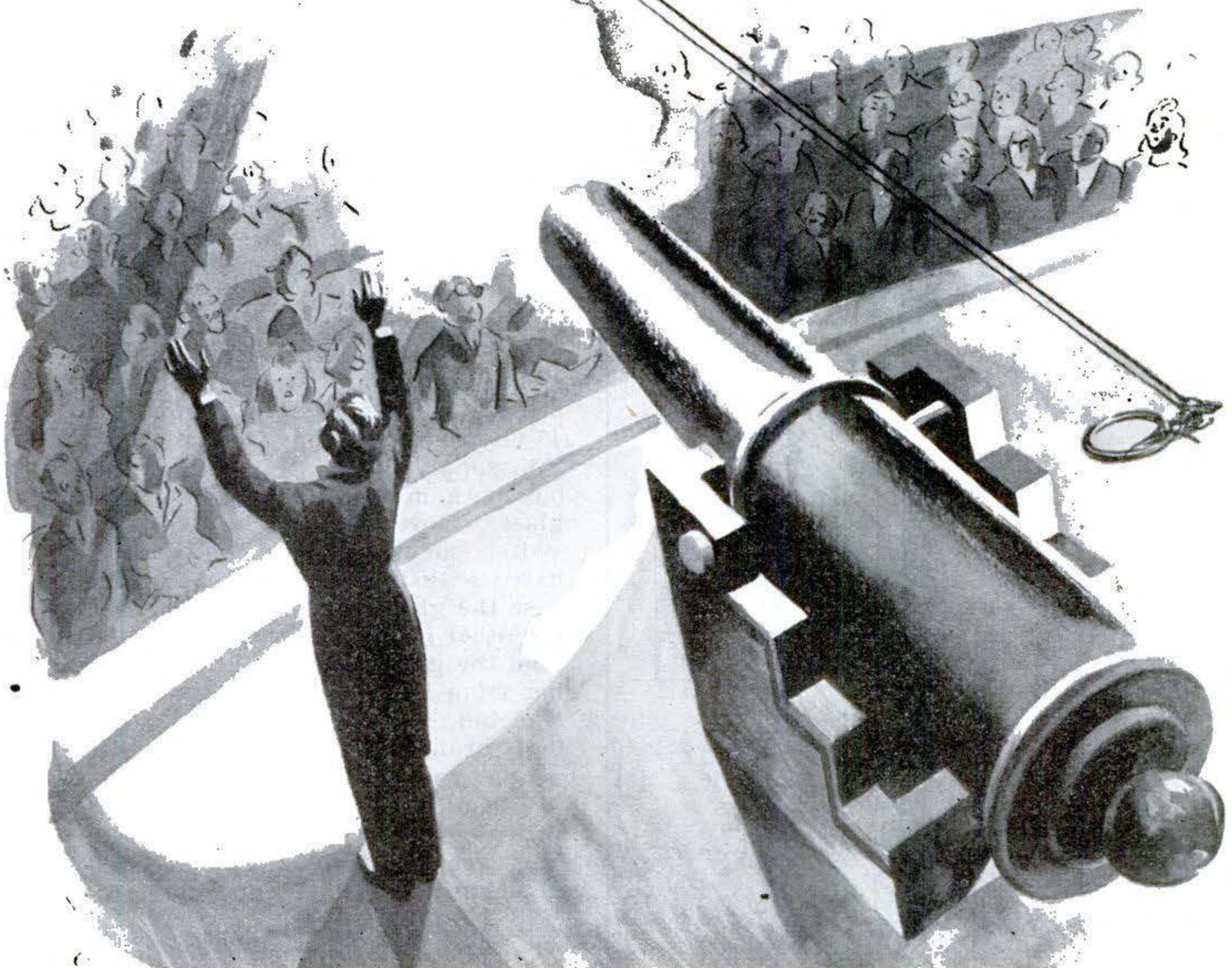



No. 726,615.

PATENTED APR. 28, 1903.

J. B. ARMSTRONG.  
TRICK TOY.

APPLICATION FILED AUG. 9, 1902.

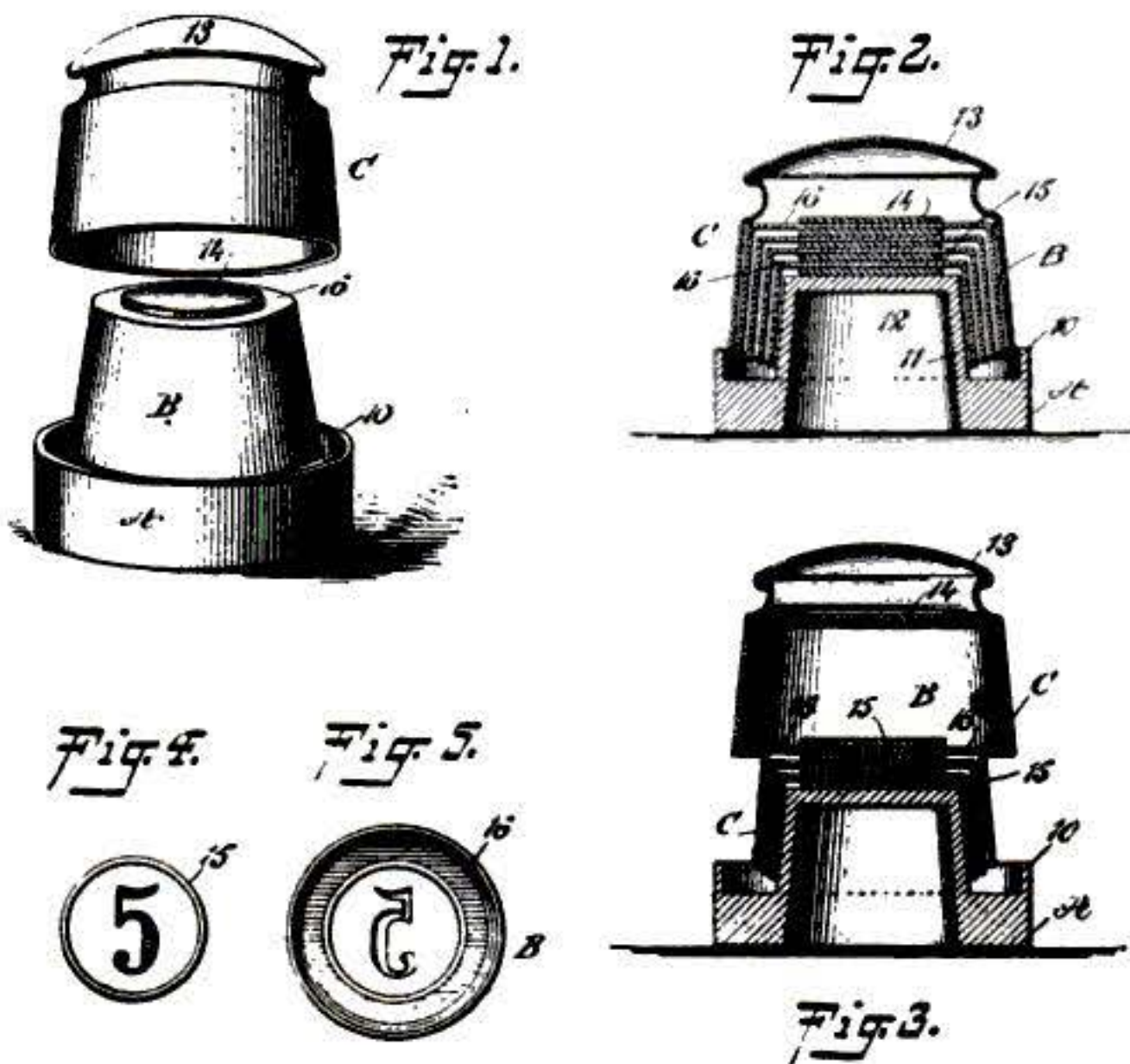

**MINT YOUR OWN.** Just put a blank metal disk in this stamper and hit the cover a blow. Then lift the lid and you'll find a real U. S. coin; that is, if you have previously loaded nested section with a dime or a cent or whatever is to be "made."

**"AMPHITRITE THE SEA NYMPH"** rises from the water and seems to twist and turn in midair. The patent drawings, made over half a century ago, reveal that she is lying on a revolving turntable and reflected in a slanting mirror seen by the spectators. Apparatus for the illusion was adapted from an earlier one by a London professor.

G. CASTAN.

THEATRICAL APPARATUS FOR APPARENTLY SUSPENDING A PERSON IN MID AIR.

No. 389,198.

Patented Sept. 11, 1888.

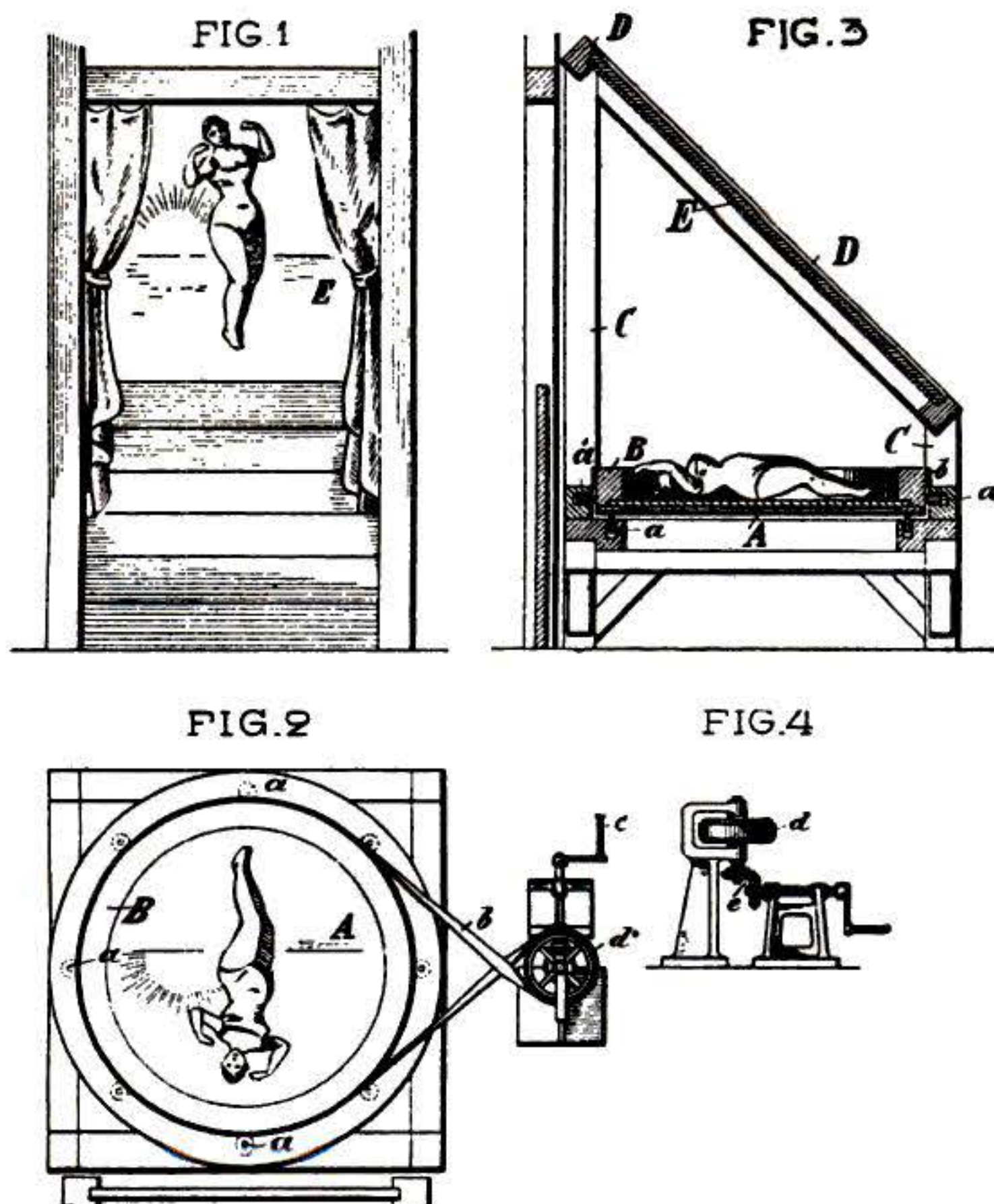

927,748.

F. L. OLESON.  
ILLUSION TOY.

Patented July 13, 1900.

APPLICATION FILED MAR. 20, 1900.

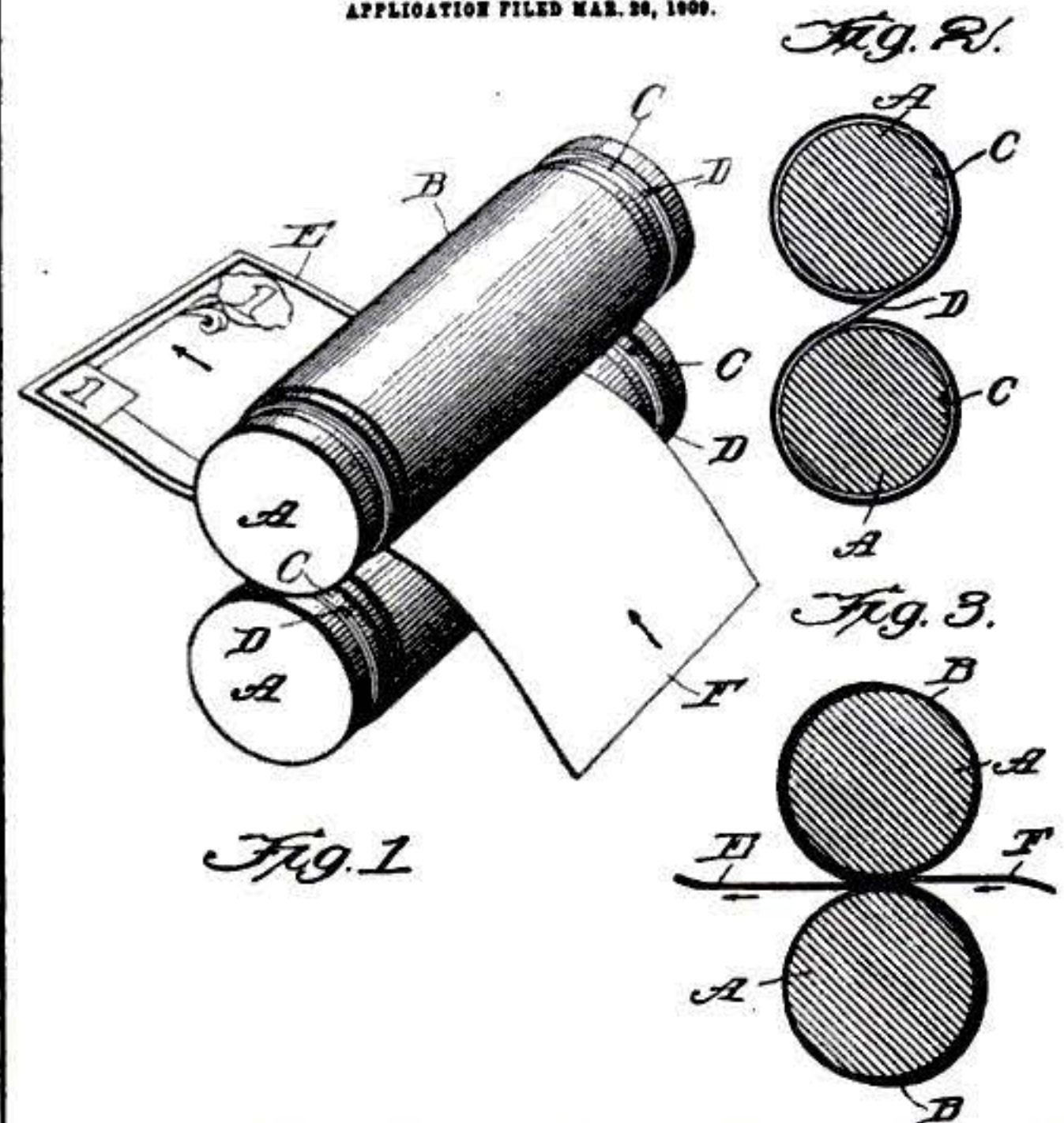

**MACHINE TURNS OUT DOLLARS.** The dollars are real, too—placed so that they will issue as blank sheets of paper are fed between rollers and go out of sight inside of the trick device. You roll out "dough" while cylinder's supply lasts.

adaptations was "Amphitrite the Sea Nymph," the patent drawings for which are shown on this page. Drawn-back curtains disclose a marine scene, in which a beautiful young goddess of the sea rises out of the water, performs graceful motions in the air, and finally sinks beneath the waves.

Of the various devices loosely classified under the head of "Pepper's Ghost," the best for miniature construction is the transformation of a dummy into a skeleton, both of which can be doll-size. For this, get a square box with an open front and provide a sheet of glass to run at a 45-degree angle from front to back. You supply lights at the top of the box both in front and back of the glass. Governed by a two-point switch, one set of lights can be alternated with the other so that in one case the glass is transparent, and in the other it becomes a reflector. Behind the glass is the doll, while facing from the side of the box is the skeleton. Switching the lights seemingly transforms one into the other at the will of the operator.

Use of a double-pointed rheostat will produce a dissolving change. In any case, the skeleton must be hidden from normal view and the light-



**SAWING A WOMAN IN HALF** need not be messy if you provide two women and a container arranged like this one. The girl whose feet show lies in the box space below, while the other one jackknifes in the forward compartment. The magician saws, the halves are drawn apart, and panels are inserted to dispel doubt. Later, a girl emerges whole.

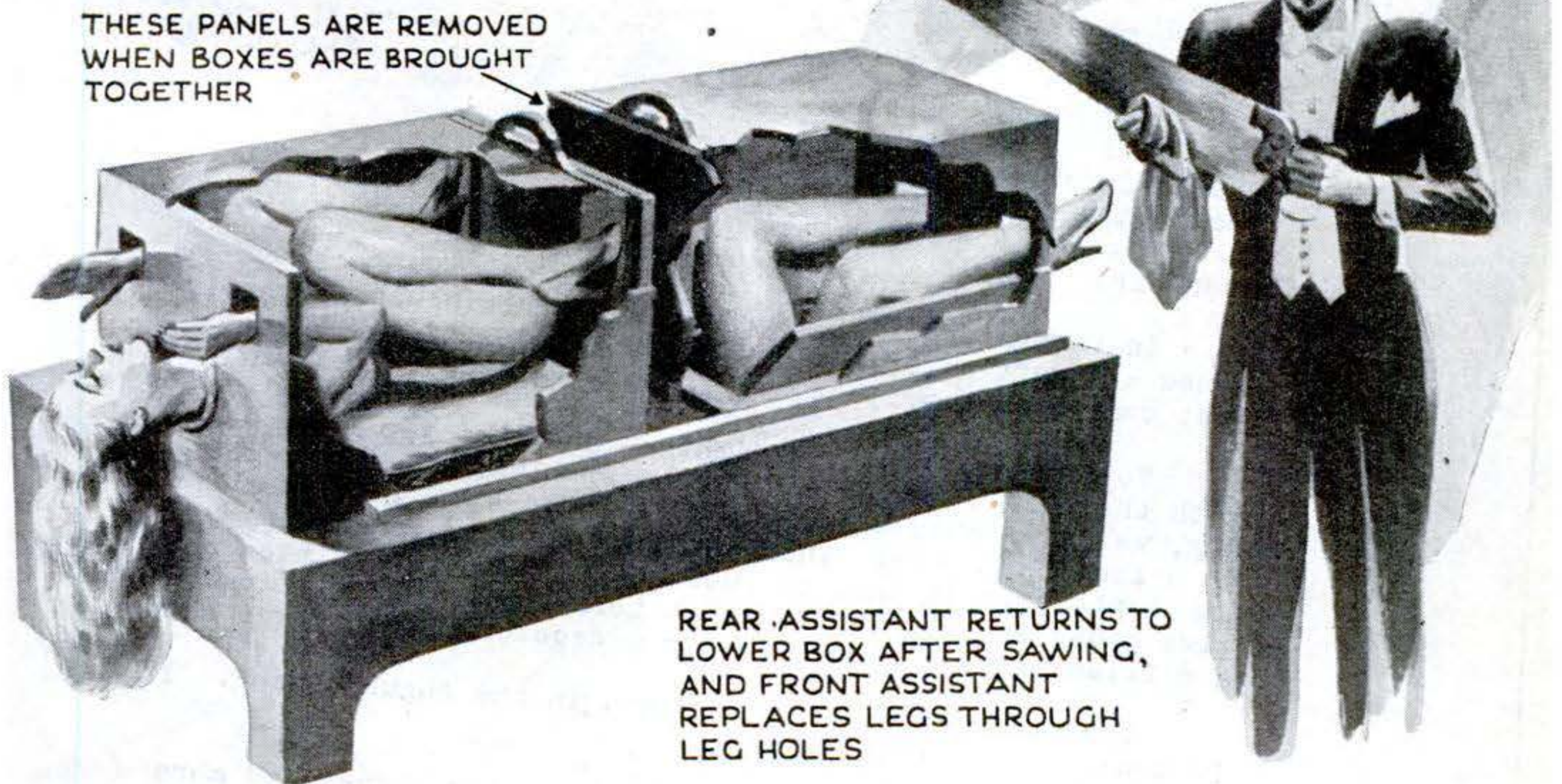

ing made indirect. This is done by closing the front of the box except for an upright aperture like a door that comes a trifle higher than the doll's head. As exhibited life-size in side shows, the two figures are often incased in upright open coffins.

Aided by the revelations of the Patent Office, you can reproduce such whimsical

little gadgets as the breakaway fan, which spreads normally when opened in one direction and practically disintegrates if pulled the other way. You can construct a machine that will turn out coin of the realm when you feed it blank metal disks, or one that will produce a crisp, spendable bill when you roll in a sheet of white paper.

**MAGIC CABINET** is shown to be empty. Curtains are drawn, doors are closed, and then things begin to happen. When it's opened, a skeleton has appeared. He was behind one of those doors, and picked up properties from floor box. Lighting helps.

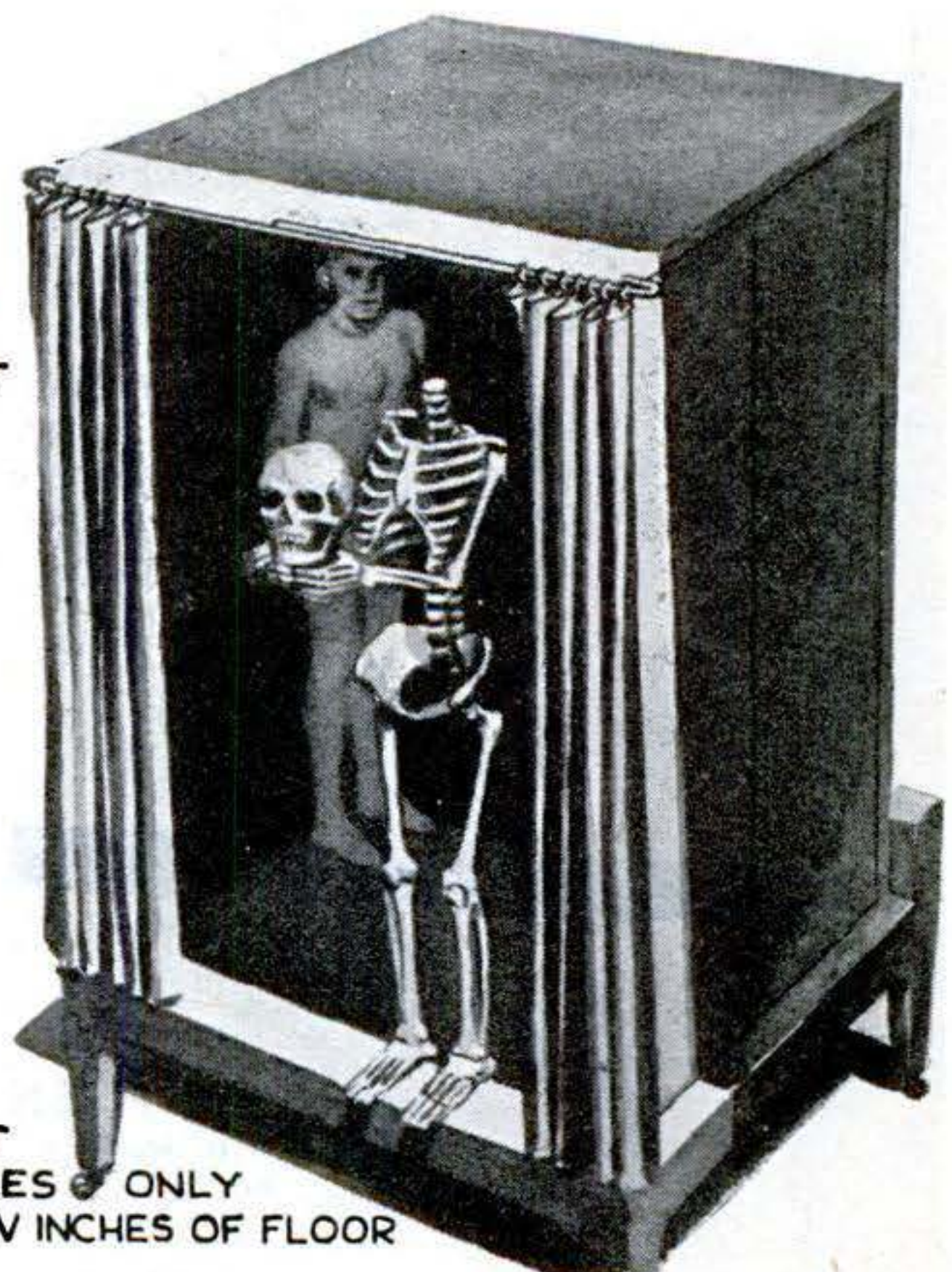
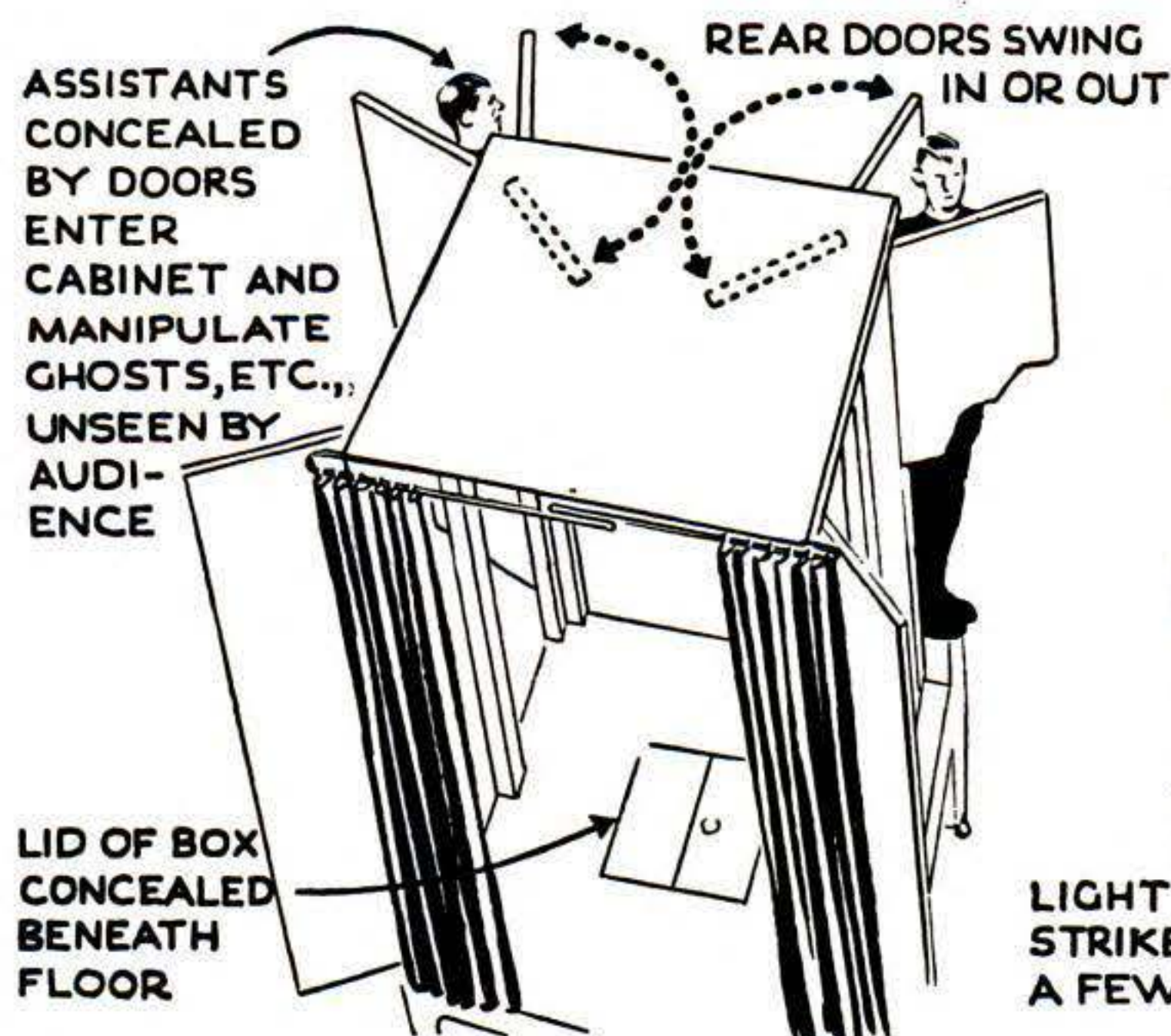



**POPULAR  
SCIENCE**  
M O N T H L Y

353 FOURTH AVENUE · NEW YORK 10, N.Y.

*The No*

Suggest a letter to  
C A A from editors  
based on experiences  
in Air Vacation  
— D. E. F.

The Administrator of Civil Aeronautics,  
Washington 25, D. C.

Dear Sir:

In the interest of more and safer flying in privately owned aircraft after the war, POPULAR SCIENCE MONTHLY has just completed a project unique in aviation journalism.

To discover what was right — and what was wrong — with the nation's approach to the problems of private flying, we dispatched two men on a trip of almost 3,500 miles in a light airplane. These men are experienced pilots of small planes, yet they encountered enough difficulties to give pause to those who talk in terms of a half million or a million private planes within a decade after the war ends.

The story of their trip began in the August issue. It is concluded in this issue.

In the years of peace to come, better planes and more landing fields will be needed if the airplane is to take its place in our transportation system as a vehicle of personal utility. But more than that is indicated. We should like to make the following recommendations:

Better navigational aids on the ground, easily visible from the air, are imperative.

No field catering to the private pilot should be marked on aeronautical maps unless it is properly maintained and readily identifiable from the air.

A means should be found for posting the periodic weather sequences at all personal-flying fields. The safety of all air traffic may ultimately necessitate grounding planes flying by contact when their pilots propose to venture into bad-weather areas.

These are our findings, submitted in a spirit of cooperation to the end that personal flying may attain the stature it deserves.

Most sincerely,

*The Editors*

**THE FLIGHT ROUTE**, like many other things about the trip, was finally decided by the weather. Francis and Groenhoff had planned to return from Denver to New York by way of Nebraska and Iowa, but they found that the best-laid plans of air tourists are subject to change by the whims of winds and clouds. ➔



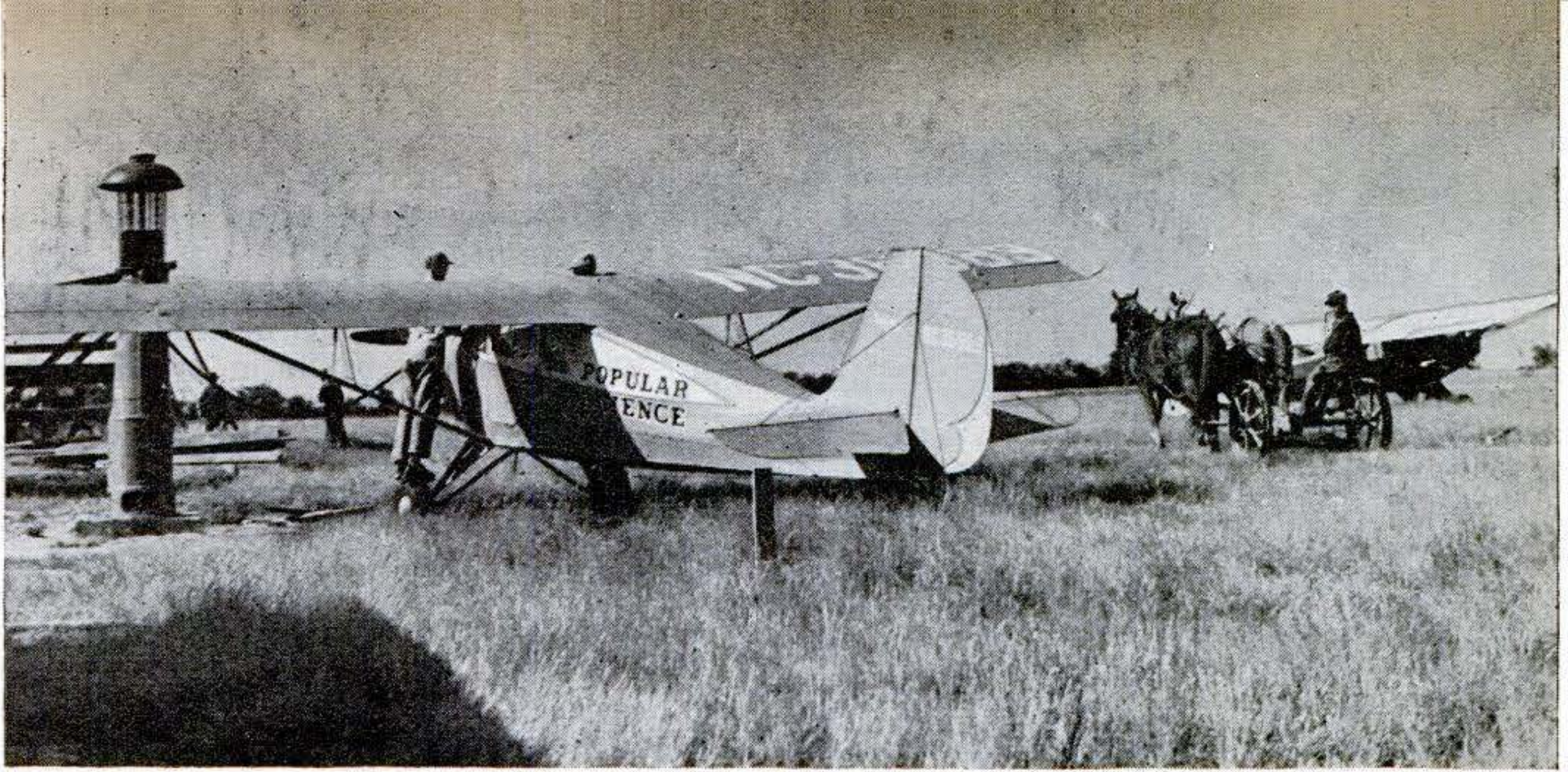

# POPULAR SCIENCE Takes You on *A Flying Vacation*

3,430-MILE JAUNT COST UNDER FOUR CENTS A MILE

By **DEVON FRANCIS**

Photographs by **HANS GROENHOFF**

**A**T THE Goodland, Kan., airport, as we voyaged westward on our lightplane vacation, the meteorologist had warned us of impending thunderstorms. And now, bent on reaching Denver before nightfall, we had become lost over the Colorado plains country.

That had been the melancholy result of flying off course to dodge a storm.

"We aren't exactly lost," I remarked cheerfully to Hans Groen-

hoff, photographer and copilot. "We just don't know where we are."

Even with our rudimentary knowledge of weather, we knew we had to keep clear of that storm. Luckily enough, it was the first one we had met in our more than 1,500 miles of flying from New York. We knew that inside it were winds of hurricane force. Even several miles away from it the air was choppy. The plane was pitching.

"If it will make you any happier," said Groenhoff, "look."

## PART 2

He pointed off in the direction op-

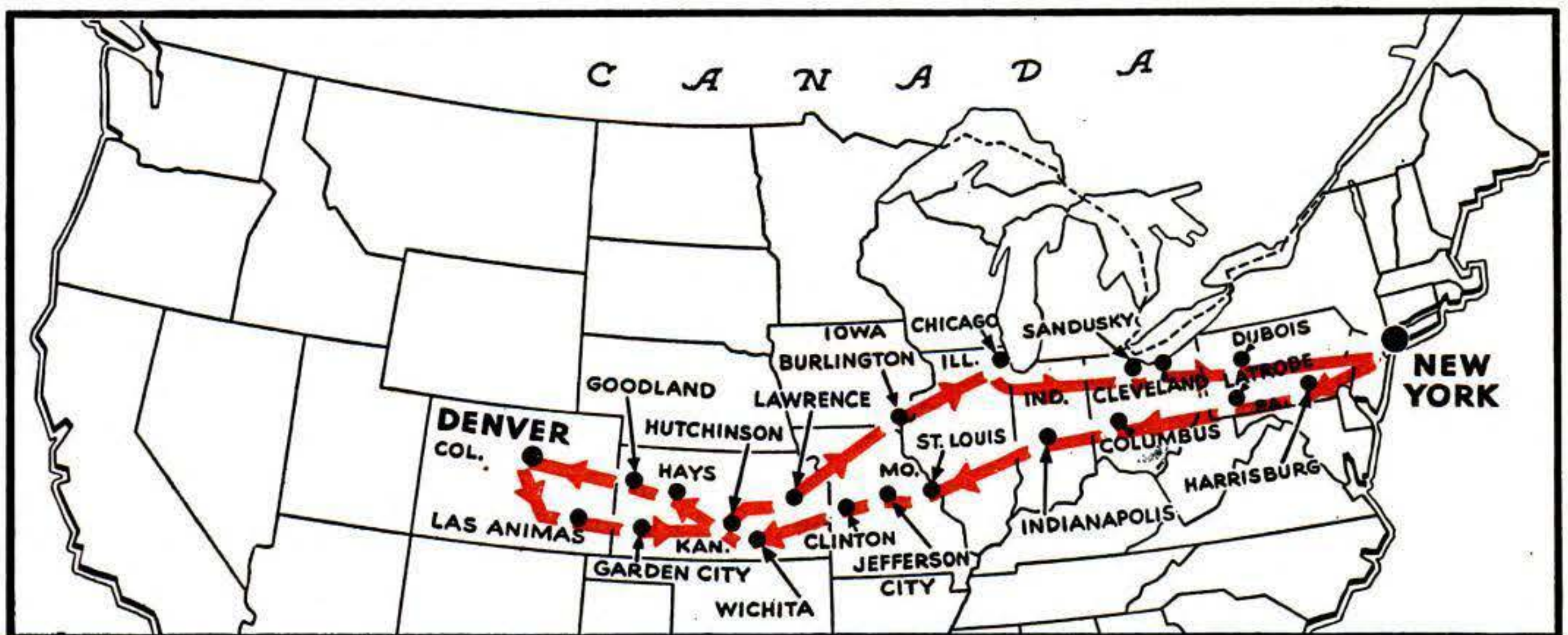



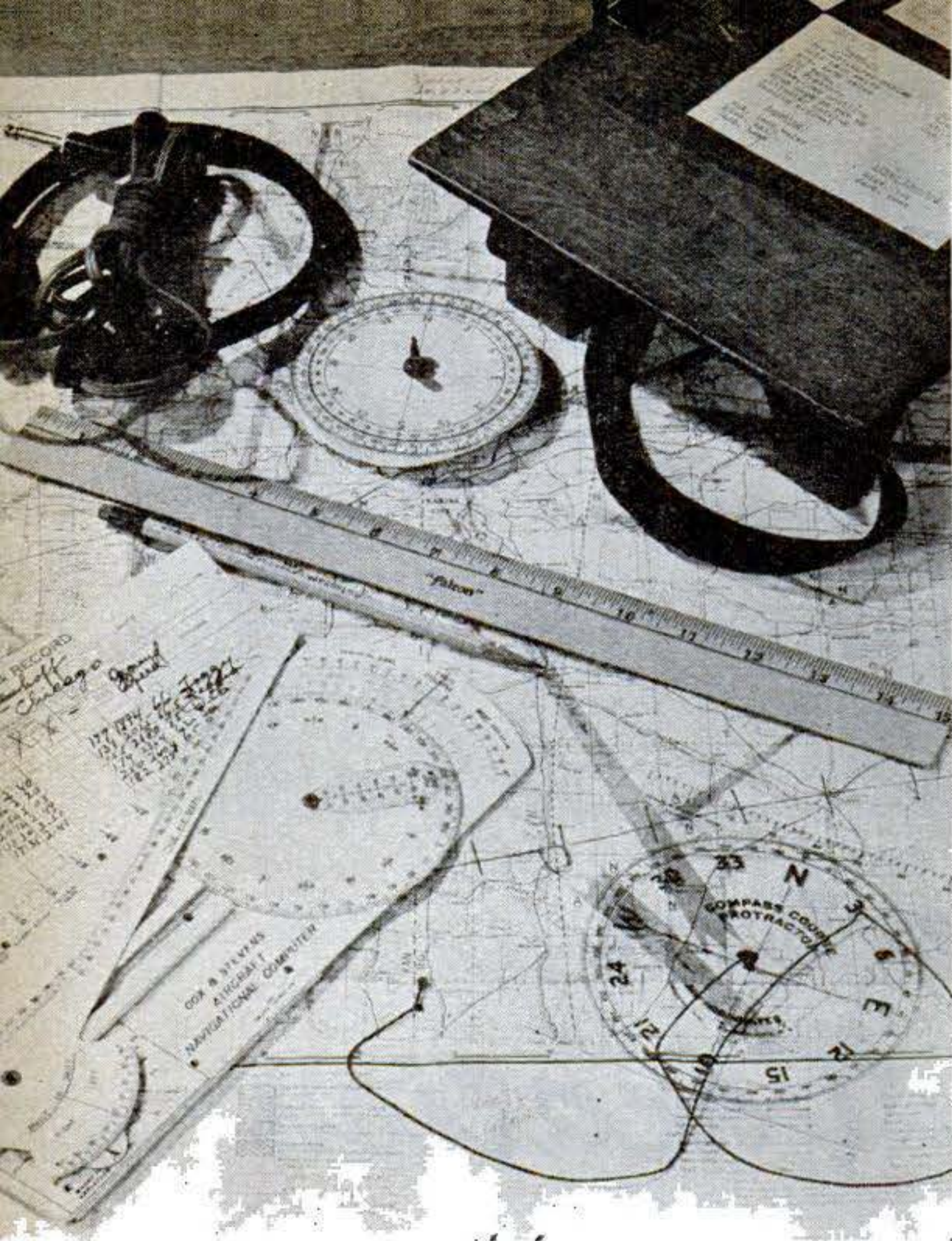

**FLYING AIDS** used in piloting the Aeronca Chief included a navigational computer, ruler, pencil, protractor, flight-record slip, airman's map, another protractor with reciprocal readings for quick compass orientation, earphones for the radio receiver, and a Francis-designed kneeboard that is strapped to the leg to keep maps in view.

posite to the storm we were skirting. There sat a pile of purple-black clouds with a narrow ribbon of dirty gray at their base. If we were to miss this second storm, we would have to alter course again. We did. Then we spotted a third storm. In several years of flying I had never encountered anything like this. It took us fully an hour to maneuver our way into the clear.

"I think we're off the map," said Groenhoff. "We must be somewhere in Wyoming."

"No, we're not," I replied. "Look ahead of you."

I used to live in Colorado. Some snow-capped peaks spired up on the horizon. They looked familiar. We rechecked our position. After all our wandering around we were 30 miles northeast of Denver, practically on course. Another thunderstorm crowned the city as we neared it, so we cruised around on the outskirts until the air cleared.

That night we celebrated.

"A nice tenderloin steak," I told the waitress at dinner. It was small talk. We knew there were no steaks.

"I'm sorry," she replied. "There's no ten-

derloin—but I can give you a sirloin." It took me five minutes to bring Groenhoff out of a dead faint.

We vacationed. We fished in a mountain lake. We did some rubbernecking from the air. We lay on our backs in the sun. And before we knew it days had gone by. It was time to start home. We checked the weather. A cold mass of Canadian air was moving down from the north and spreading across the northwestern United States.

"I'd wait," said the Denver weather man. "if I were you."

We waited. We had to. We wanted to cut northeast to Chicago. "Ceilings" were coming down all over that area. After 24 hours we got impatient.

"Let's leave," said Groenhoff. "We can cut south of our course." I was as anxious as he was to get away.

We had broken our rule again about avoiding major air terminals, because Denver Municipal Airport was the only place we could find hangar space. Now, as we sat on the concrete apron abutting the hangar, gassed up and ready to go, the control tower grew curious.

"The ceilings are down east of here," it told Groenhoff by radio. "Where are you going?"

"We'll check in at Hugo," said Groenhoff into the transmitter, naming a town 90 miles southeast of Denver.

That was just close enough to the truth not to be a fib. We would land at Hugo if we had to. The control tower had no authority to keep us aground so long as the ceiling and visibility were all right at Denver. It was just trying to be helpful. In turn, we didn't want to be a worry to anybody. We only wanted to get away.

Twenty minutes out of Denver we hit it. Fog stood like a wall from ground to sky. We turned southeast. The fog stood spread-legged in our path. We turned south. Here it was clearer. But the terrain was coming up.

"Want to go back?" asked Groenhoff.

"No."

This was the very area, east of Colorado Springs, that a Civil Air Patrol captain in Wichita had told us to shun. The hills were almost too high for us to clear them with the horsepower at our command. A 7,000-foot ridge swept by, barely 200 feet beneath us. The Aeronca, heavily laden and taxed almost beyond its capabilities, was reassuringly steady.

"I don't like this," remarked my companion. He was sweating.

"For me," I said, "you are understating the case."

We were lost again, but that was a secondary consideration. Our job was to keep



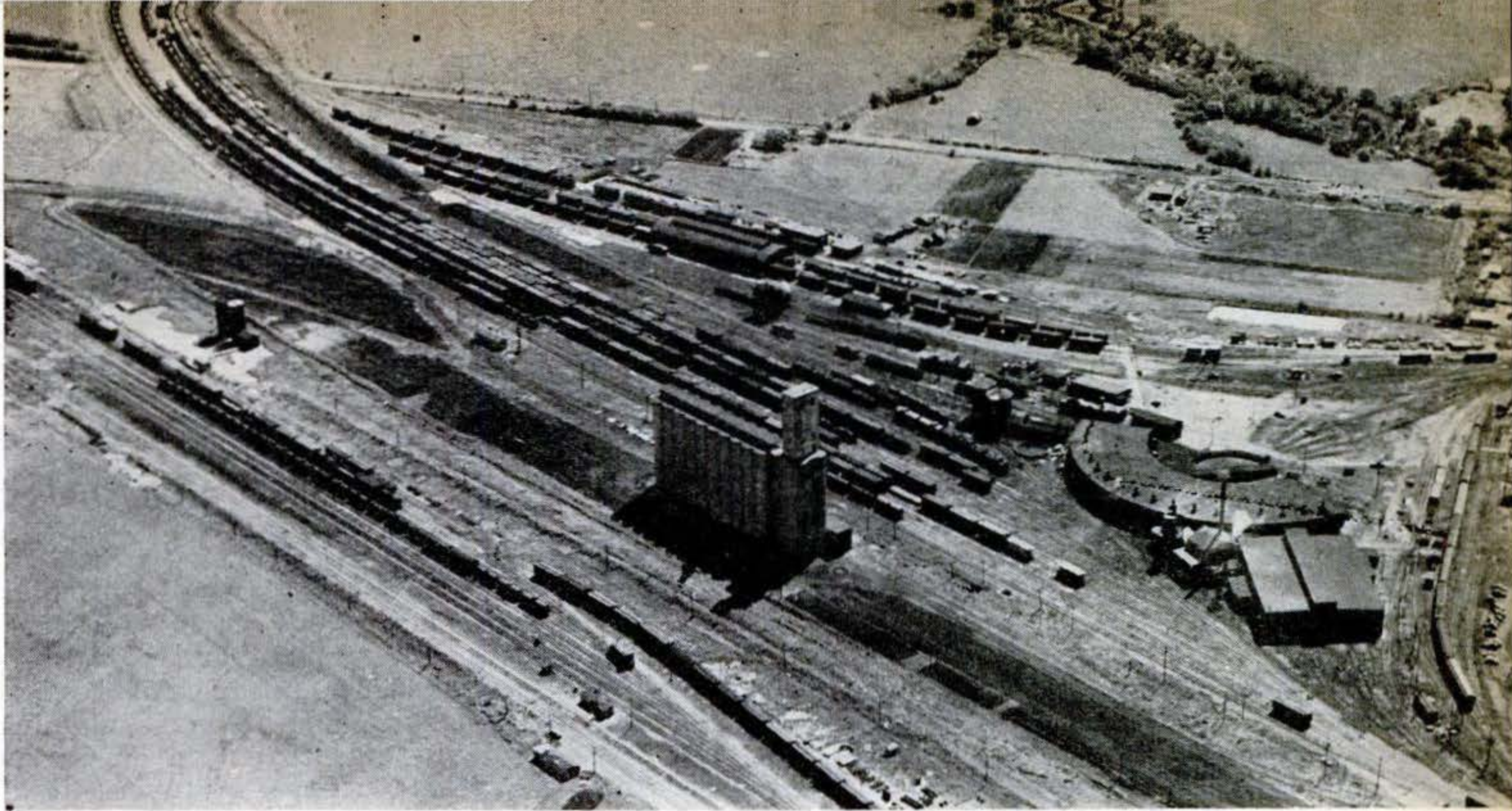

**LANDMARKS** are the guiding stars of the flyer who navigates by "pilotage." Some stick out like sore thumbs—for example, the rail yards at Wichita, Kan., (above) with an elevator and roundhouse standing out unmistakably. The oil field at right presents a characteristic pattern. To help "contact" flyers, Coast and Geodetic Survey maps prepared for airmen are filled with pictures and symbols like those shown below, identifying easily seen objects on the ground. Note that cities with more than 5,000 population are indicated by outlines representing the actual shape of the built-up area. If you follow a railroad, you must watch out that you don't get switched to the wrong track.



## HOW PROMINENT LANDMARKS ARE SHOWN ON AN AIR MAP

### Cities and Towns

-  Less than 1000
-  1000 to 5000
-  More than 5000 (actual shape)

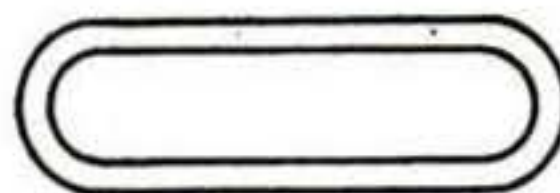

Race Track



Forest Ranger Station



Quarry or Mine



Coast Guard Station







Lookout Tower



Oil Well

### Highways and Railroads

-  Prominent Highways
-  Secondary Highways
-  Railroad (one track)
-  Two or more tracks
-  Abandoned





**HELPING HANDS** were extended almost everywhere, both by airfield personnel and by the local flyers. Here David M. Brown, the chief pilot for Mountain States Aviation, Inc., at Boulder, Colo., is helping the Popular Science flyers to patch a tire that had gone flat in landing. One hospitable airport operator even took Francis and Groenhoff out for a sightseeing trip in his own automobile.

**AIRPORTS** that could be seen and identified easily from the air were at a premium. One of the best was Norton Field, at Columbus, Ohio (below). Many of the small fields were so effectively camouflaged that our flyers had to give up after a fruitless search and go on to another. Government fields are uniformly well marked and maintained. Private airports often are poorly marked because the owners just aren't interested in transients.

out of the fog and find lower ground. We knew the Arkansas river lay south of us, and on that we could orient ourselves.

The hills got lower. Then the river, silvered by a shaft of sunlight, appeared ahead of us.

"Maybe that radio will work," said Groenhoff. He fingered the dial, listening hard at the earphones.

"I'm getting the 'N' signal on the La Junta frequency," he announced. He put a finger on the map. "We're about here."

After more than 1,700 miles the fact that the radio would pick up the beam signals was a pleasant discovery. It was sheer idiocy not to have tried it out before. We turned east, landed at Las Animas, Colo., refueled, and hurried on to make up time.

Weather forced us to put in at Garden City. We were 100 miles south of our alternate course to Chicago, but at least we were on our way. We helped roll the ship into the hangar and taxied into town. That night we took stock.

"We should have stayed on the ground in Denver," Groenhoff summed up. I agreed. "That cold air mass moving down from Canada," he went on, "is overriding a lot of warm air and causing fog and rain. This is no weather for airplane riding."

I supplemented his observations. "We crossed railroads and several highways. If they had been identified at 10- or 20-mile intervals so they could be seen from the air, with an arrow pointing to the nearest airport and the mileage specified, we wouldn't have got lost."

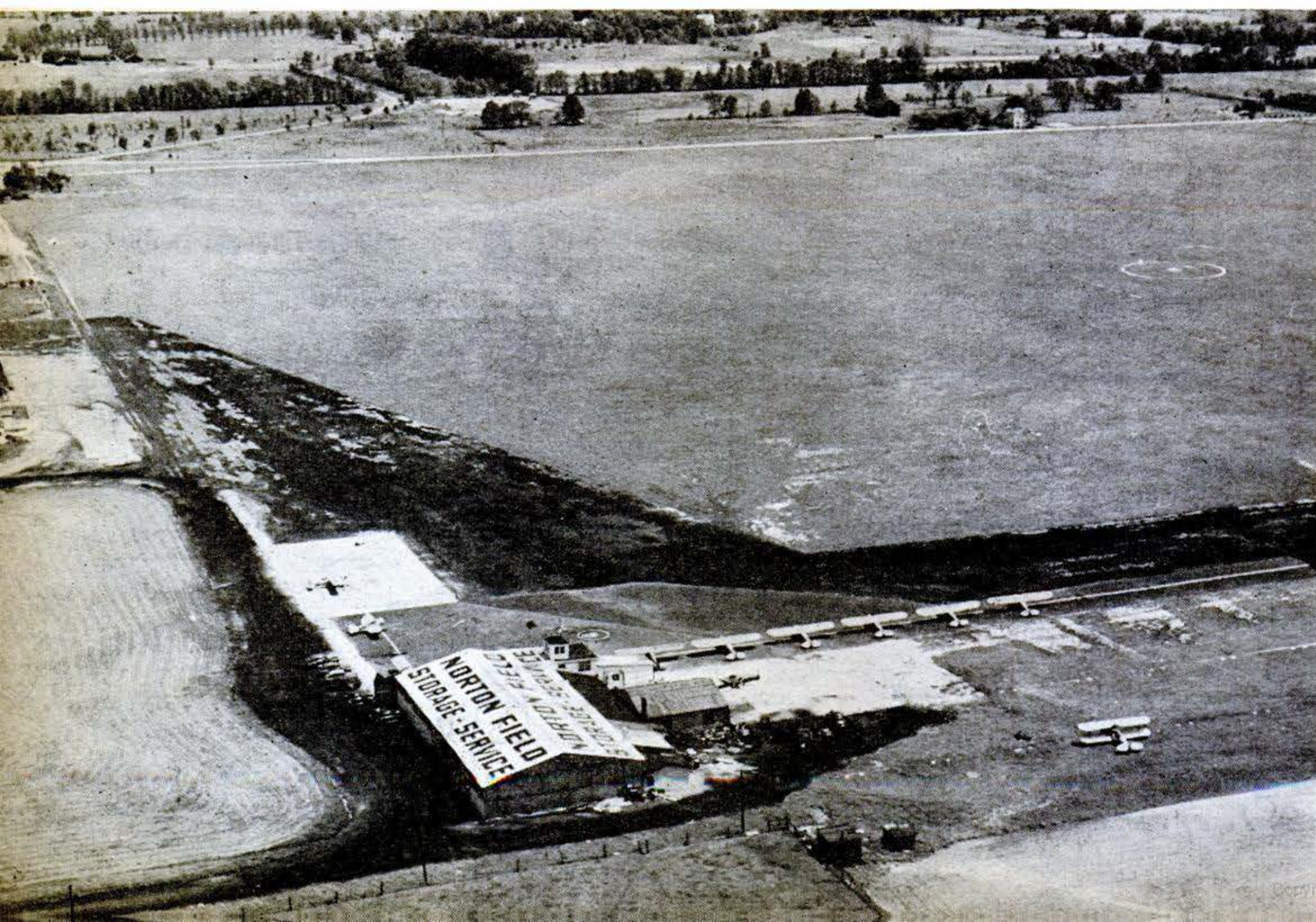



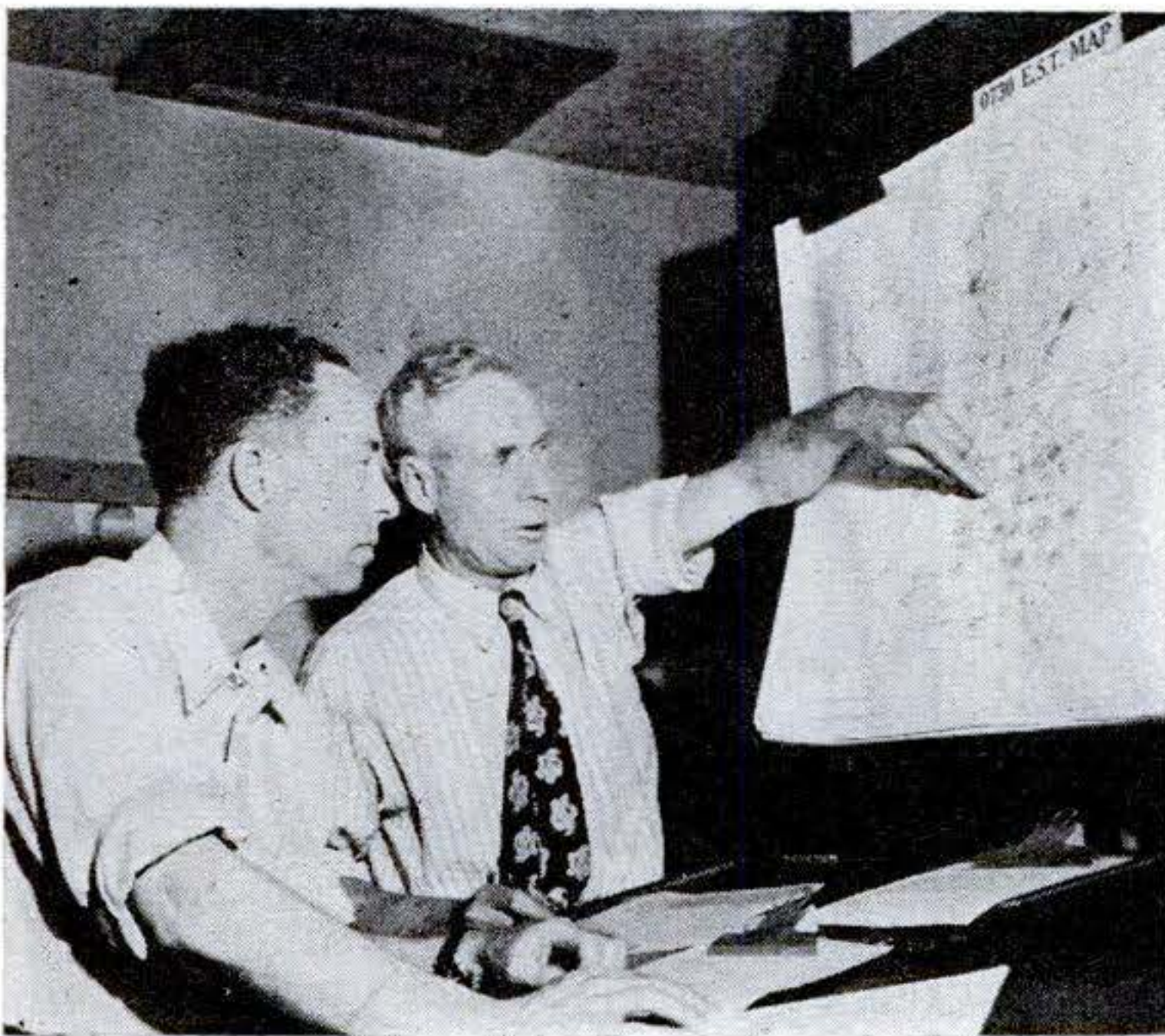

**STORM.** Here is one of the few good pictures ever made of a thunderstorm from the air. At the lower right, a ribbon of rain is seen between the cloud and the darkened earth, while the sun is shining near by. In the photo at left Arthur R. Magee, Federal meteorologist at Goodland, Kan., warns Francis of thunderstorms gathering ahead.

"Amen," said Groenhoff. "With two men in an airplane working hard at flying and navigating, and still getting lost, what is the casual flyer going to do when flying becomes more general?"

We decided something else: In addition to big identifying marks on airports themselves, each airport needed a circular fence of arrows, at least 20 miles in diameter, pointing to it. And, of course, every hamlet should paint its name in 50-foot letters on a roof or in a public park. Only then would cross-country flying become as effortless as automobiling.

If the weather didn't clear entirely, at least it was less stinko, as Groenhoff put it. We bored eastward. At Hutchinson, Kan.,

we were squared away to land when I spotted some cattle on the field.

"That can't be the airport," I said.

We found it, but only after another hunt. By now we were past the point of getting aggravated. Besides, to be truthful, we were getting too much enjoyment out of the flying itself to get irked by the inconveniences. We were watching each other like hawks on sharing the flying time.

"It's my turn in the left seat," I announced after we were gassed. "That's right," Groenhoff agreed reluctantly.

We checked the weather through the Hutchinson Navy airfield. The ceilings were not good but we played it safe. We followed railroads, confirming our visual observations with the radio receiver. If the weather had got thick, we could have raced to an airport and sat down. Carefully we marked every airport on and near our course that could serve as an emergency haven.

We passed up Topeka in favor of a small airport at Lawrence. Here we ran into a new one. A huge sign on the sloping roof of a barn read *(Continued on page 207)*



## What's New in Modern Living



**PLASTIC SCREENING**, pliable, rust resistant, water repellent, and sturdy, is being manufactured now for all household uses to which metal screening has been put in the past. That shown in the photo above is a plastic window mesh marketed under the name of Saran screen.

**NONSLIP** hangers for dish towels, aprons, and the like, promise to cure the vexing habit these kitchen items have of falling off the rack. The Ketchook, manufactured by the Plastic Die & Tool Corp., of Los Angeles, holds the article securely yet allows it to be removed simply by lifting. It is said to embody a new principle of operation and is made in a variety of colors to match kitchen color schemes. The device is fastened to the wall by means of two screws.

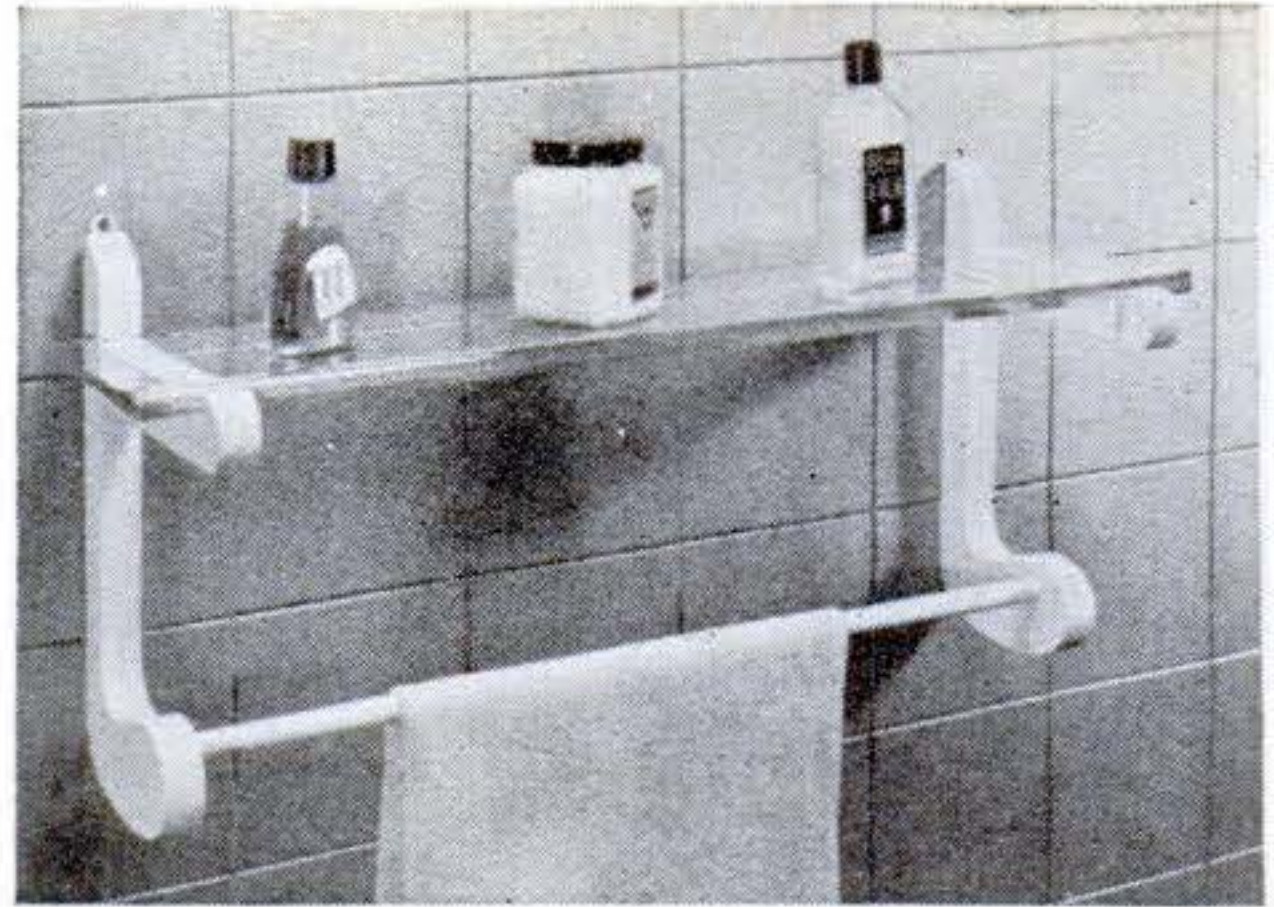

**BATHROOM AND KITCHEN** accessories now on the market include a combination 4" by 18" glass shelf and 16" wood towel rack made by George Koch Sons, of Evansville, Ind. Brackets and rod have a white, washable finish.

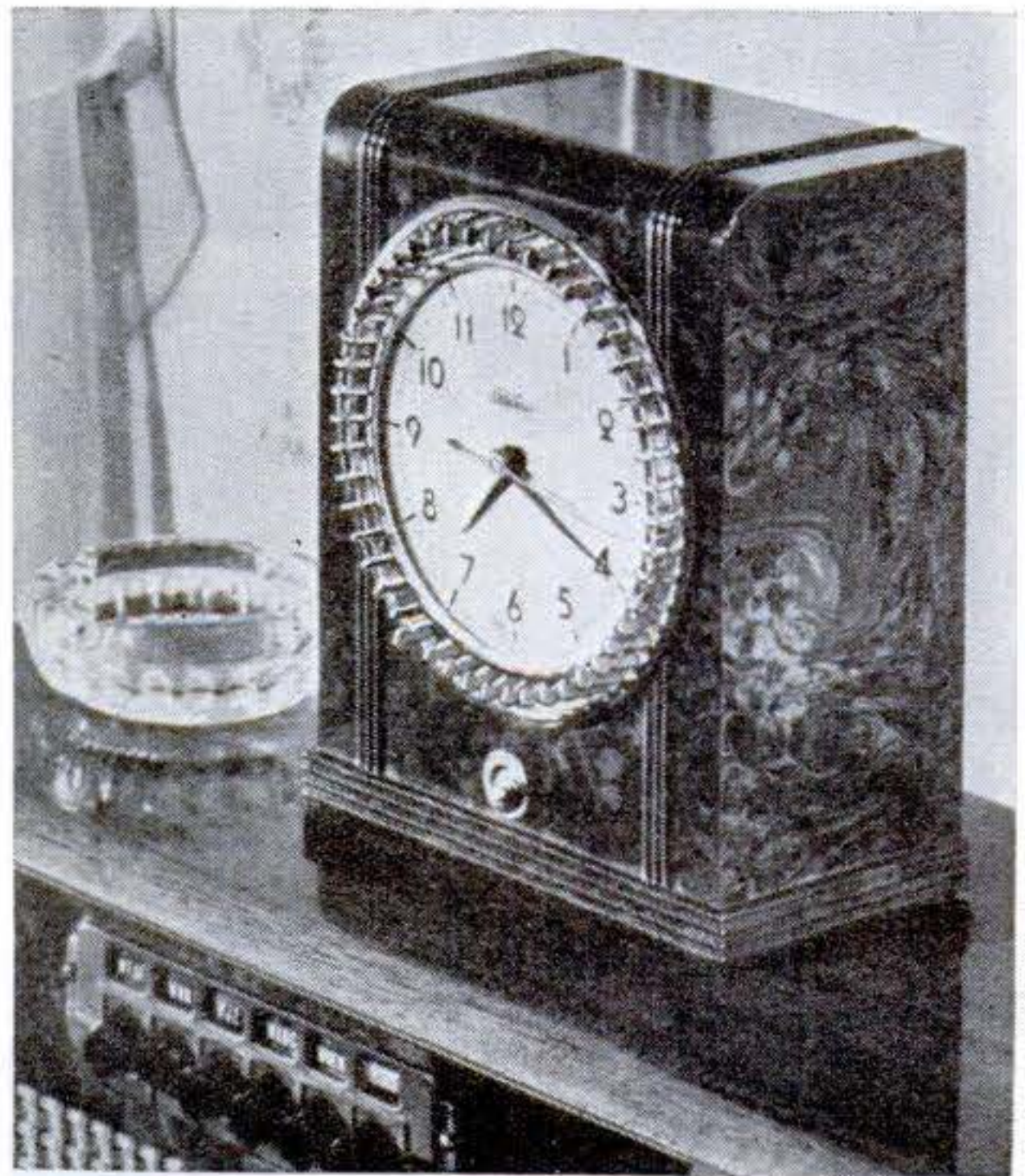

**WAKE UP TO MUSIC** with the help of this electric clock that turns your radio on or off at any preselected time. It can be used to time many household appliances, and is made by the Warren Telechron Co., of Ashland, Mass.



**GLASS SERVICE SETS** for breakfast juices include a bowl for holding ice cubes to keep the contents cold. George Sakie, of the Fostoria Glass Co., is the designer.

**DOUGHNUTS ARE SHAPED** automatically simply by pressure on a pump when dough is put in the pint-size aluminum device shown at right. The unit was developed by the Crosby Research Foundation.





OF INTEREST TO



## HOME OWNERS

**DECORATIVE** lighting methods have been getting attention from manufacturers of fluorescent lamps and fixtures, as can be seen from the typical units illustrated here. Realizing that the bare and unattractive installations now in use can be applied only to the service parts of a house, designers have turned to adaptations of concealed and circular lights. Some of the novel and interesting effects that can be obtained through the use of recessed fixtures are suggested in the composite view at the upper right. Of special importance is the trend toward employing lighting as a functional part of modern furniture. The designs pictured here were worked out by Westinghouse lighting engineers.

Panel fronts are also expected to play

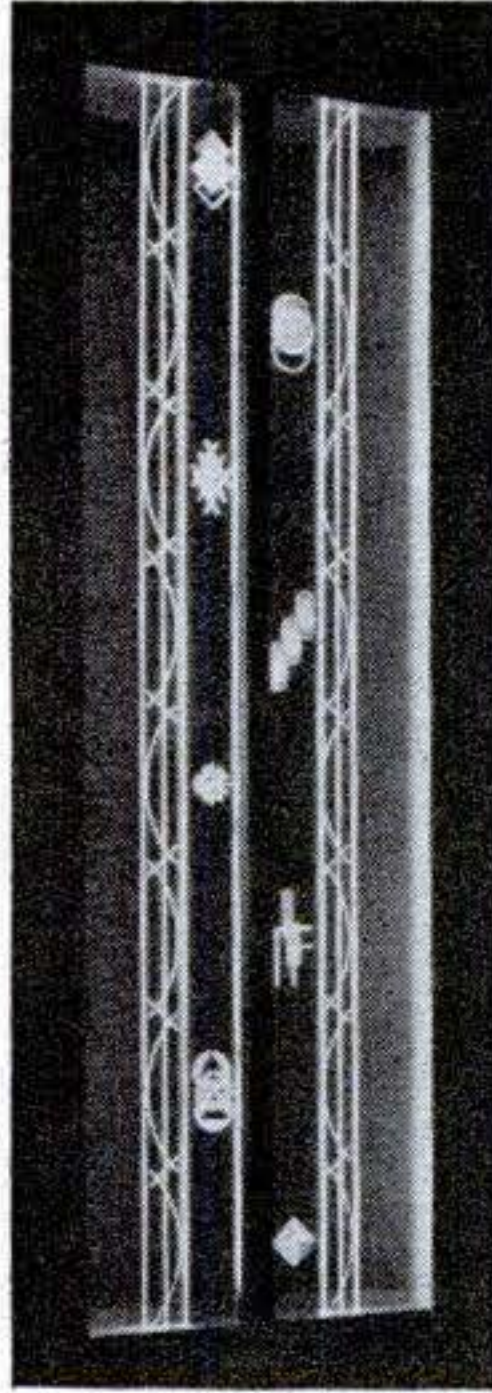

a part in softening the glare of luminous tubes and helping them to harmonize with the color scheme of a room. The picture at the left, supplied by General Electric, illustrates an interesting color-blending fixture designed by C. T. Masterson. Three types of plate glass are used to filter the light, and the bright edges are obtained by beveling the rear surface to 45 deg. All the installations shown here employ tubes of small diameter.

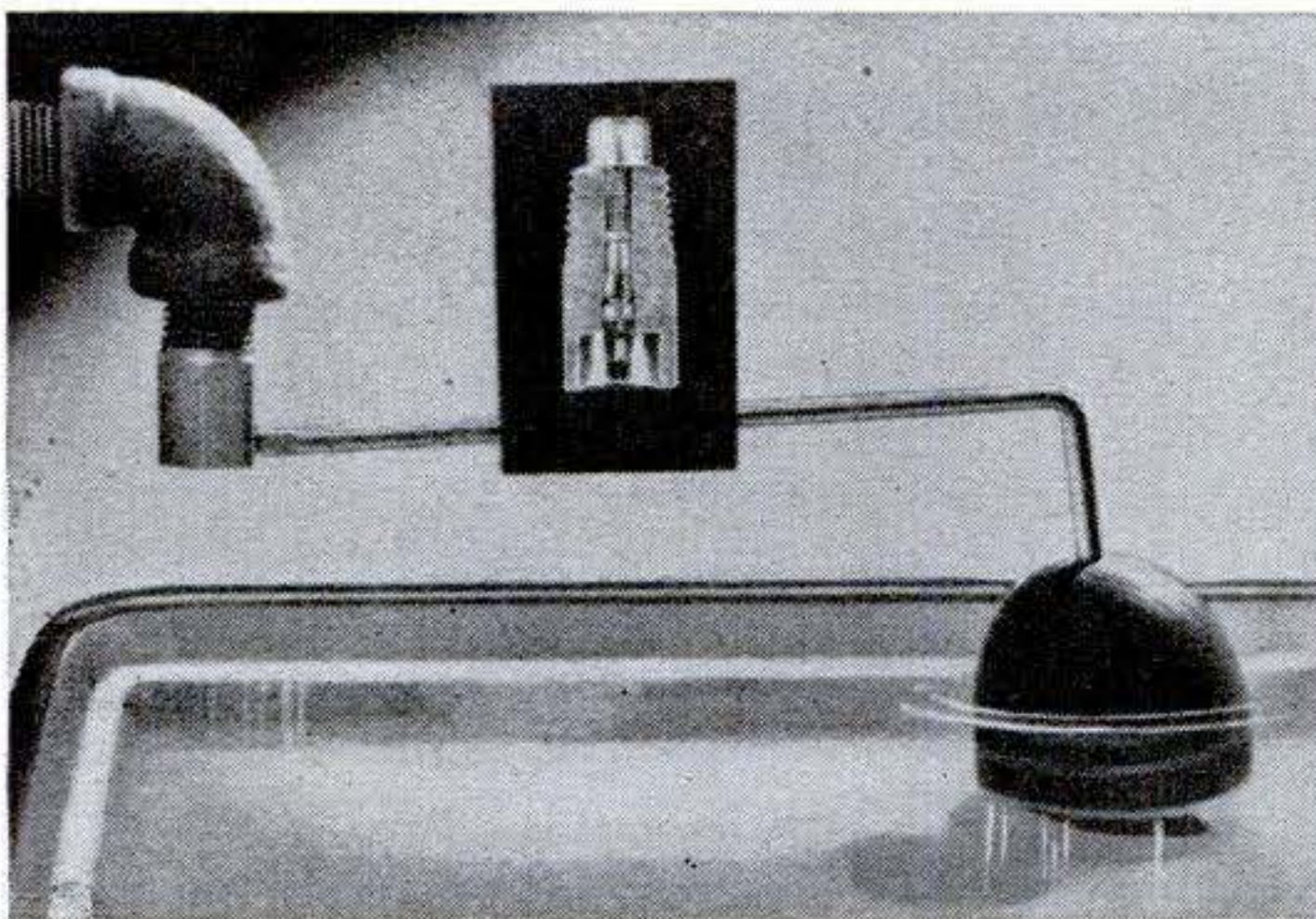

**THIRSTY PETS** will always find water in the trough if you let the Sim-Plex Automatic Float Valve remember to fill it for you. Recently announced by A. D. McBurney, of Los Angeles, the valve maintains constant water supply in pans or tanks and is suitable for poultry, farm, or household uses.

**BATTERY CASES** converted into paving blocks make an unusual back-yard walk for Fred W. Fletcher's San Francisco home. Some years ago, Mr. Fletcher took several hundred discarded storage-battery cases that were on hand at his service station, filled them with sand and cement, painted half of them white, and laid them out as shown. They have outlasted many concrete pavements in the neighborhood.

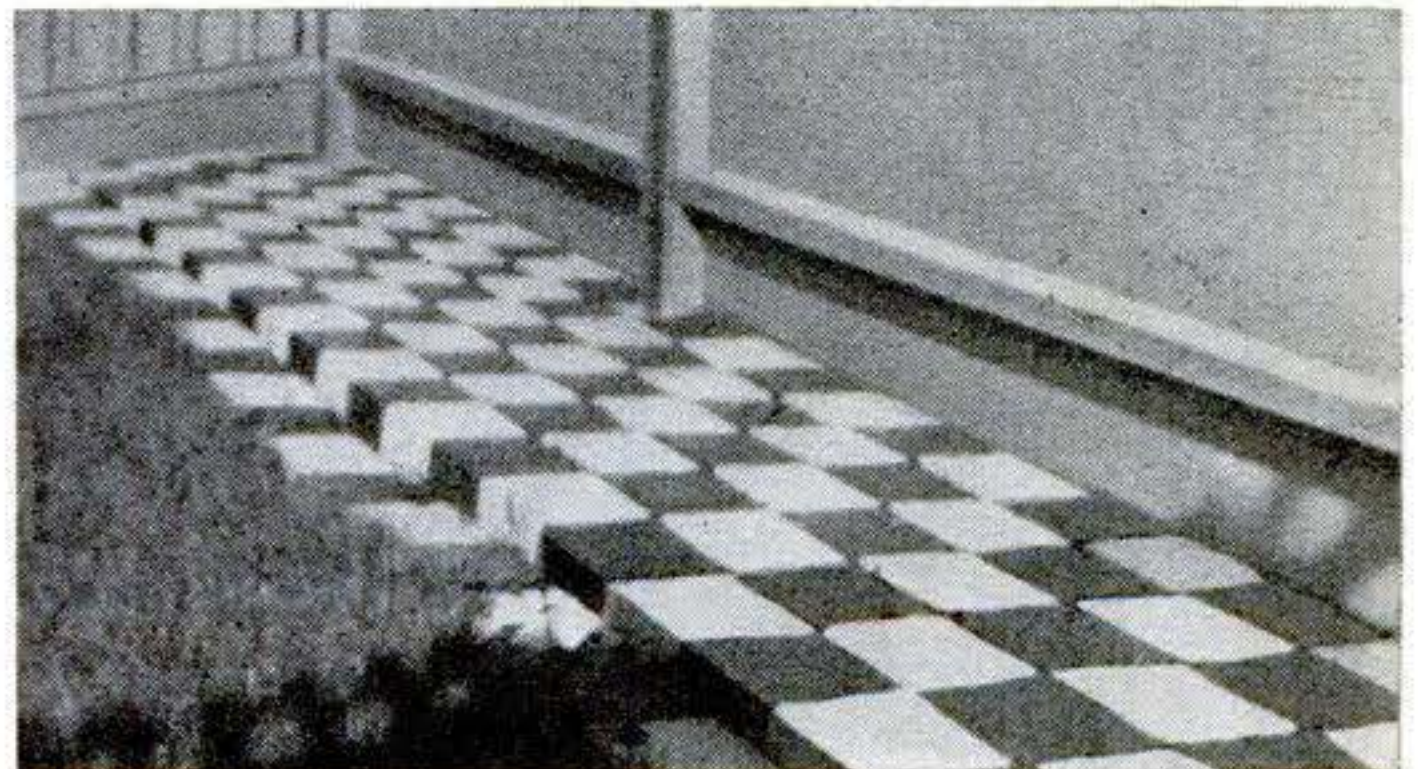



# Gus Cures a War Headache

By MARTIN BUNN

"HEY, boss," Stan Hicks said with somewhat forced breeziness. "I've dug up a new customer for you!"

Gus Wilson's expression was noticeably lacking in gratitude as he regarded the Model Garage's grease monkey and blossoming mechanic. "Well, now, that's just dandy," he told him sarcastically. "Here I am working four or five evenings a week trying to keep our regulars happy, and you go out and dig me up a *new* customer. I'll tell you what, Stan—get out your shovel and cover him right up again!"

Stan grinned sheepishly. "Well," he admitted, "maybe I'd ought to have said that this party is a sort of personal friend of mine, and would you do me a favor and take a look at—"

"Who is he?" Gus interrupted.

Stan's face got red under its habitual coating of grease. "Well," he stammered, "it ain't a he—it's a she."

"Oh," Gus smiled, "so that's it?"

"No, that ain't it!" Stan protested. "I used to go to high school with this Barbara Milligen. She's always been car crazy, and ever since she was a kid in freshman class she's been saving up her dough to get herself one. When she got a job in a war plant about a month ago she had to have a bus, so she took her coin out of the bank and bought an old sedan from one of those big used-car dealers down in the city. She ain't as dumb about cars as most girls, but it looks to me like they sold her a quince. Can I bring her in? She's outside now."

A minute later a much-shined-up 12-

year-old green sedan was driven into the shop. Gus noticed that its tires were good and that its engine was running smoothly. Stan got out on one side and a red-haired girl with a flock of freckles and an expression of concentrated fury got out on the other. She looked at Gus unsmilingly and announced: "I wish I'd never set eyes on this junk wagon, and I'll bet you will, too, after you've worked on it."

"Don't mind Barbara, boss," Stan put in diplomatically. "She's always been a sour-ball."

Barbara's green eyes blasted him. "Keep out of this, jerk!" she snapped. "I'm talking to Mr. Wilson."

Stan's feelings were outraged. "Yeah, you're talking to him because I did you a favor getting him to bother with your broken-down old bus!" he yelled. "And now the gratitude I get—"

Gus laughed. "Don't quarrel, kids," he advised. "There's no sense in getting sore at a car, miss—I've done it hundreds of times, and it never did a bit of good. Suppose you tell me just how yours has been acting up and what you've done about it."

Barbara's face crinkled into an attractive smile. "O.K., Mr. Wilson," she agreed. "Well, I knew enough about cars—mostly from always wanting to own one—not to expect to get a super-duper de luxe job for what I paid—and I didn't. I did expect something I could drive back and forth to the plant without continual trouble—but I didn't get that either."

"The first few days, it ran fine. Then the battery got weak, and one morning it didn't have enough kick to turn the motor over. I had it recharged, but the next week it ran down again, and the man at the garage said it must be the generator. He went over it and put in new brushes and everything, and nicked me plenty. Inside of a week the battery was down again, so I took the car back to the place where I'd bought it, but they wouldn't do anything—and got fresh about it, too."

"I have to be in a car pool, of course, and every time it's my turn to drive I have a lot of trouble getting started—and usually we're all late for work. The others in the

"I wish I'd never set eyes on this junk wagon," she said.







When it was her turn to drive, they were usually late. The others in the pool were beginning to get sore.

pool are sore and say they'll drop me if I don't get my car fixed. Others will hear about it and won't want me in their pools, and I'll have to give up my job—and, believe me, Mr. Wilson, those fellows fighting in the Pacific need what I'm helping to make!

"Well, while I was wondering what I could do," she went on, "I ran into Stan, and here I am. I'll have to leave the car here—my shift goes on at four o'clock. I can take a bus to the plant, and coming back tonight—"

"Never mind about tonight," Stan told her. "If we can get your car fixed, I'll drive it over and pick you up at the gate, and you can drop me at my house on your way home."

"Why, Stan, that's real nice of you!" Barbara said.

"Oh, well—I haven't got anything to do

tonight," Stan muttered in embarrassment.

Barbara's green eyes blazed again. "If that isn't just like you!" she cried. "You always spoil everything by being so—so *ungracious!*"

"Scram!" Gus shouted. "You two do your scrapping outside. I'm a busy man."

Five minutes later Stan came back grinning and found Gus checking each cell of the battery of Barbara's car with a battery voltmeter.

"They're all run down a bit, but they test even, so there can't be anything much wrong with the battery," Gus commented when he had finished. "Guess we'd better take a look at the cutout."

Finding nothing wrong there, he turned to the generator. So far as looks told, it was in excellent condition, but when he checked it he found that it wouldn't charge the battery properly until the engine was



turning over at a speed rate of 40 miles an hour.

"There it is," he told Stan. "Your friend Barbara's battery runs down because the generator doesn't charge it while she's driving. The juice that's drained out isn't replaced. Well, we've found the cause of the trouble; now we've got to find the cause of the cause. Take the generator out and put it on the test bench."

Stan did as he was told. Gus put in 10 minutes going over the generator carefully, looking for mechanical defects which he didn't find. Then he hooked it up with the test-bench drive motor for an electrical check. When the tachometer showed that the generator was being driven at a speed of about 600 r.p.m.—corresponding to a car speed of about 10 miles an hour—it began to charge, and as Gus gradually increased the drive-motor speed to 1,400 and then 1,800 r.p.m., the ammeter hand moved over to 10 and then to 12 amp.

Gus looked puzzled as he switched off the drive motor.

"There's nothing the matter with this generator," he told Stan. "It works perfectly when it's driven by the test-bench motor, so there's no reason why it shouldn't work perfectly in the car. But it doesn't! Well, we'll try again."

They reinstalled the generator in Barbara's car. Then Stan stepped on the starter and gradually increased the engine speed as Gus checked the generator output.

"Switch her off," Gus directed after half a minute. "It's exactly the same as it was before. The generator doesn't start to charge the battery until the engine is running at almost 40. There's something screwy here—and maybe it's me!"

Staring at the generator, he slowly filled and lighted his pipe. After a couple of puffs, he snapped his fingers loudly.

"That might be it," he muttered. He copied the generator serial number on the back of an envelope, went over to his workbench, and reached down his service manual from the shelf above. Then he checked the serial number against the generator numbers in the manual. Stan was peering over his shoulder.

"It's the right generator for that model car, all right," Gus said. "The same generator is used on several other makes, too—

but look here! A lot of the parts of this generator are interchangeable with the parts of other generators made by the same manufacturer. Maybe that's it!"

"Maybe *what's* it?" Stan demanded.

Gus didn't answer. He went back to Barbara's car and again examined the generator. Suddenly he laughed.

"There's the cause of Barbara's grief," he told Stan, pointing to the generator pulley. "And maybe I'm dumb not to have spotted it half an hour ago—especially since I ran up against the same thing just last year. I must be slipping."

"Huh?" Stan grunted. "I don't get you. What's the matter with the pulley? It looks O.K. to me."

"There's nothing the matter with the pulley," Gus told him, "except that it's much larger than the one called for by the specifications for this car. Naturally, the larger the pulley, the slower the generator is driven and the more engine speed is necessary to make the generator charge the battery. This pulley is so large that this generator doesn't start to charge until the car is being driven close to 40 m.p.h. Your friend Barbara probably never drives fast, so her battery never gets recharged."

"I get you," Stan said. "But what I don't get is how this oversize pulley got there."

"Like a lot of other headaches," Gus explained, "that's a result of war shortages. Auto electrical concerns are reconditioning all types of generators these days, and when you send in one for service or exchange you run the risk of getting back the right type of generator with a pulley of the wrong size on it unless you are careful to specify the car it's to be used in. Evidently when Barbara's car was reconditioned for sale, the right generator was picked up, but the man doing the assembly didn't notice the size of the pulley. That's an easy mistake to make. On a secondhand job the fan belt usually is old and stretched so much that it will easily slip over an oversize pulley before the generator is tightened."

"I'll find a pulley of the right size in my junk box. You put it on, Stan, and then take the car over to Barbara and tell her about it. That'll give you something to talk about while you're driving home."

"O.K.," Stan grinned. "You can depend on me to take all the credit."



"If we get your car fixed," Stan told her, "I'll pick you up at the gate."



## AUTO IDEAS



Sawdust spread over soft rubber in the process of retreading gives the tire greater traction.



**ORDINARY SAWDUST** eventually may relegate tire skid chains to the limbo of crank handles. Seeking a method of giving tires better traction and eliminating chains, Clarence and Lonnie Gapen, of Morgantown, W. Va., experimented with a number of materials and finally settled upon sawdust. With the cooperation of the Andy brothers, who operate a tire shop in Washington, Pa., they developed a milling process by which sawdust is worked into the camelback used for retreads. In tests, the tires carried an auto up a 12-percent snow and ice-covered grade without difficulty, and started and stopped the car on the hill without skidding. Rubber companies now are making tests to see if the process increases mileage.

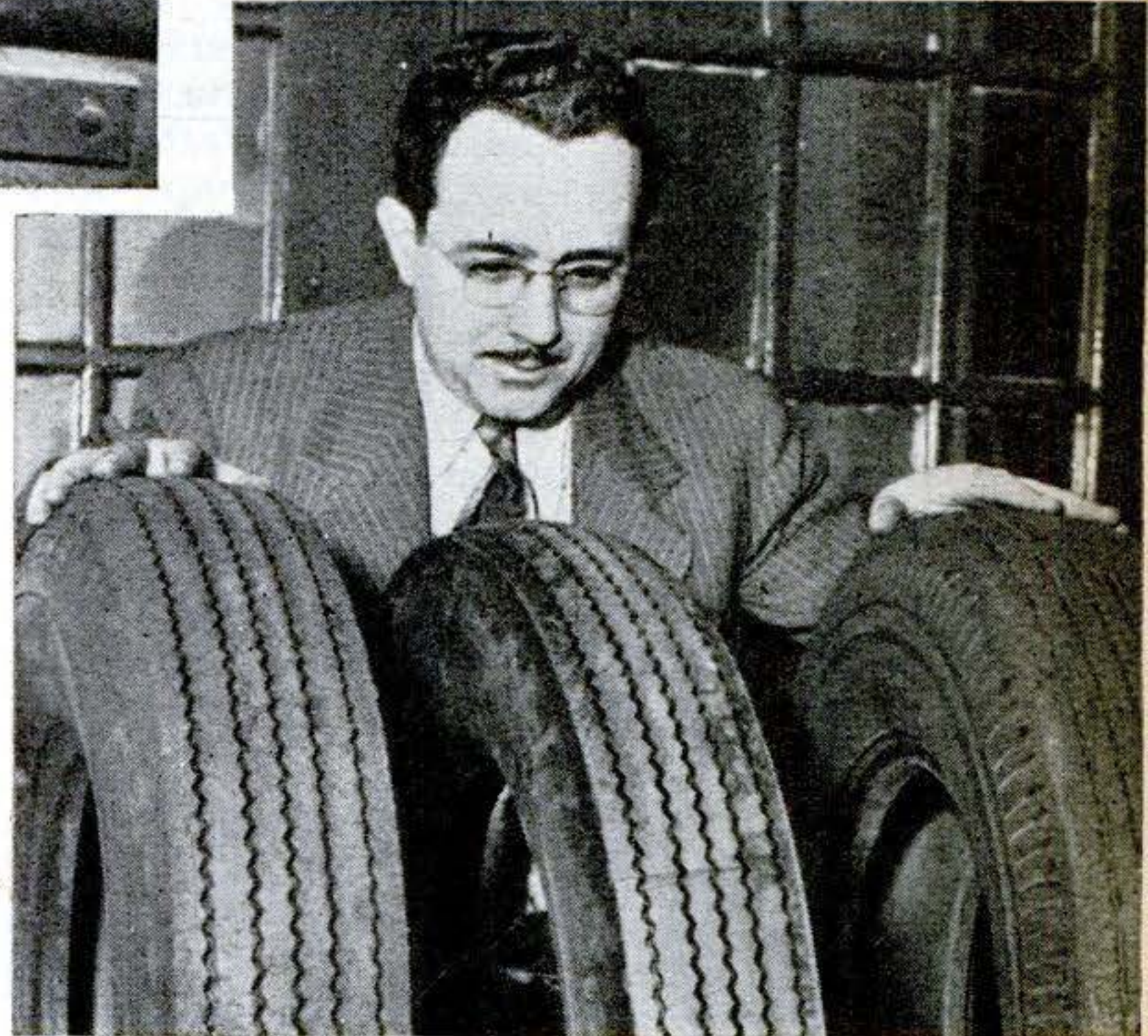

At the top, a sawdust camelback is applied. Bottom center is a normal retread. At the right, a sawdust recap after 8,000 miles, and at the left a new one.

**FORGED IN ONE PIECE**, a new jack developed for passenger cars by John M. Westrate, of Detroit, has no movable parts to slip or get out of order. After the head has been fitted against the brake drum, the auto is driven forward or backward until the

jack is resting vertically on its broad base. When the job is done, another short movement of the car frees it. There is no interference with removal of the tire or rim. Secured to the wheel with a safety strap, the device also can be used as a mud hook.



Inserted between the brake drum and rim, this one-piece jack raises the wheel off the ground when the car is driven either forward or backward.

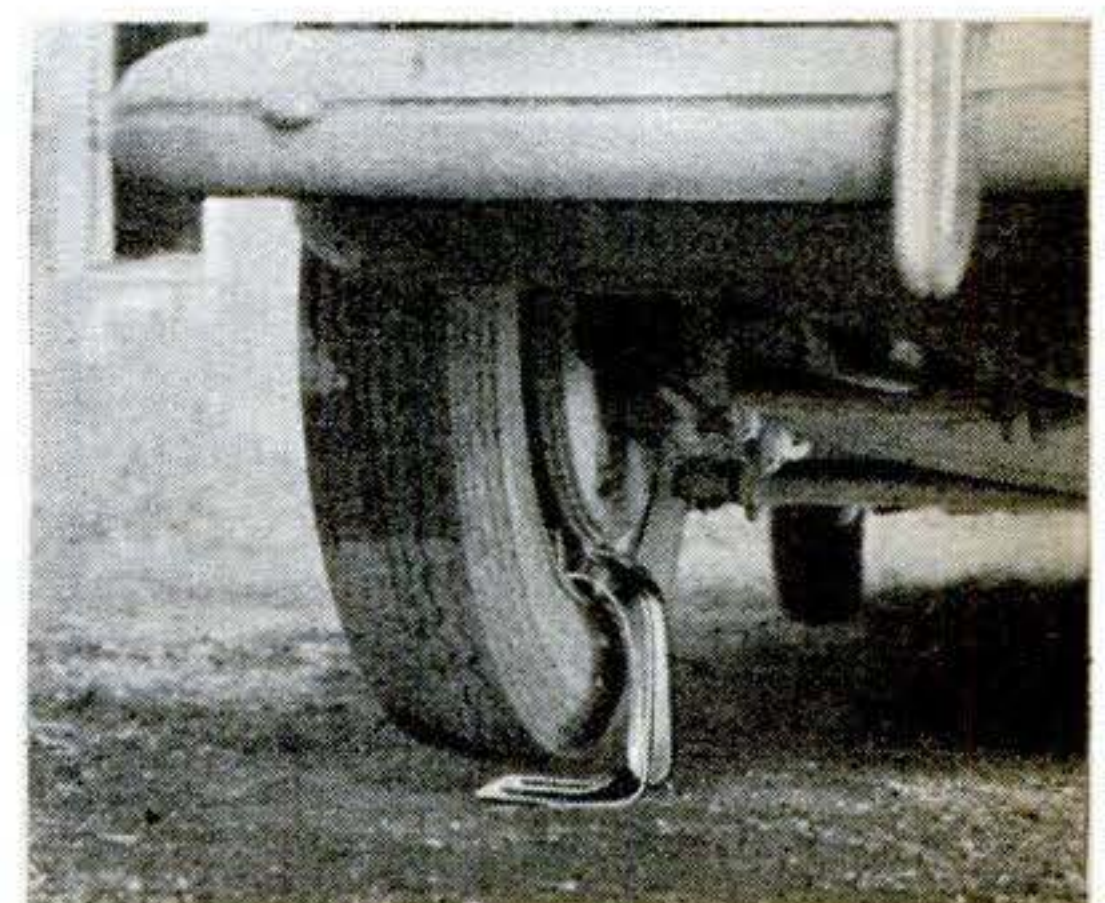



# WHAT'S COMING IN CONVERTIBLES

Will they go the way of the touring car and roadster, or will they soon join the mass-production parade?

By CHARLES T. PEARSON

CONVERTIBLES have always appealed to young drivers and to the sports-minded who like clean, racy lines and a low center of gravity. If new tops—some of them ready for production and some still on the designers' drafting boards—are any indication, this appeal is due for considerable extension into the ranks of conservatives.

Probably almost everybody likes an open car, but prewar conservative drivers often held back because of admitted disadvantages—such things as rattles, drafts, top material that faded and lost its shape, and imperfect provision for getting the top up and down.

But the new open cars will be minus most or all of these disadvantages, and many in the automobile industry think the time is coming when the convertible not only will be the second car in most garages but the only car in many. Convertibles were estimated at 2 percent of the total production before the war, and prices ranged from \$100 to \$250 above those of closed models. As-

sembly-line production is expected to bring the price down nearer that of closed cars.

The push-button or power-operated top is a certainty, with hydraulic controls bidding for first place over electric and vacuum mechanisms because of the small amount of space required for actuating cylinders and because of the ease with which the power unit can be installed. A small 6-volt motor can be put in any accessible place and oil lines run to the hydraulic cylinders that operate the top bows and linkage. Oil pressure is so controlled that motion will stop if an obstacle is struck, and the mechanism can be operated manually whenever necessary.

Top designers predict that future convertibles will be engineered as a unit instead of as in the past, when little more was done than to cut off the top of a standard model and add a cloth top. With the new top made part of the car before it leaves the drafting board, a convertible with its top up will have the sleek lines of a streamlined closed car and its own racy open-car lines when the top is down. The back will have the hard-top curve, side windows will be larger, and the rear window will be as large as that of a closed model. Designs for large rear windows

Chrysler's Thunderbolt, with its hard top down at left and partly up in the photo below. This is an experimental model. The one-piece top lowers into the rear deck where it is concealed. Up, it adds to the sleek appearance.

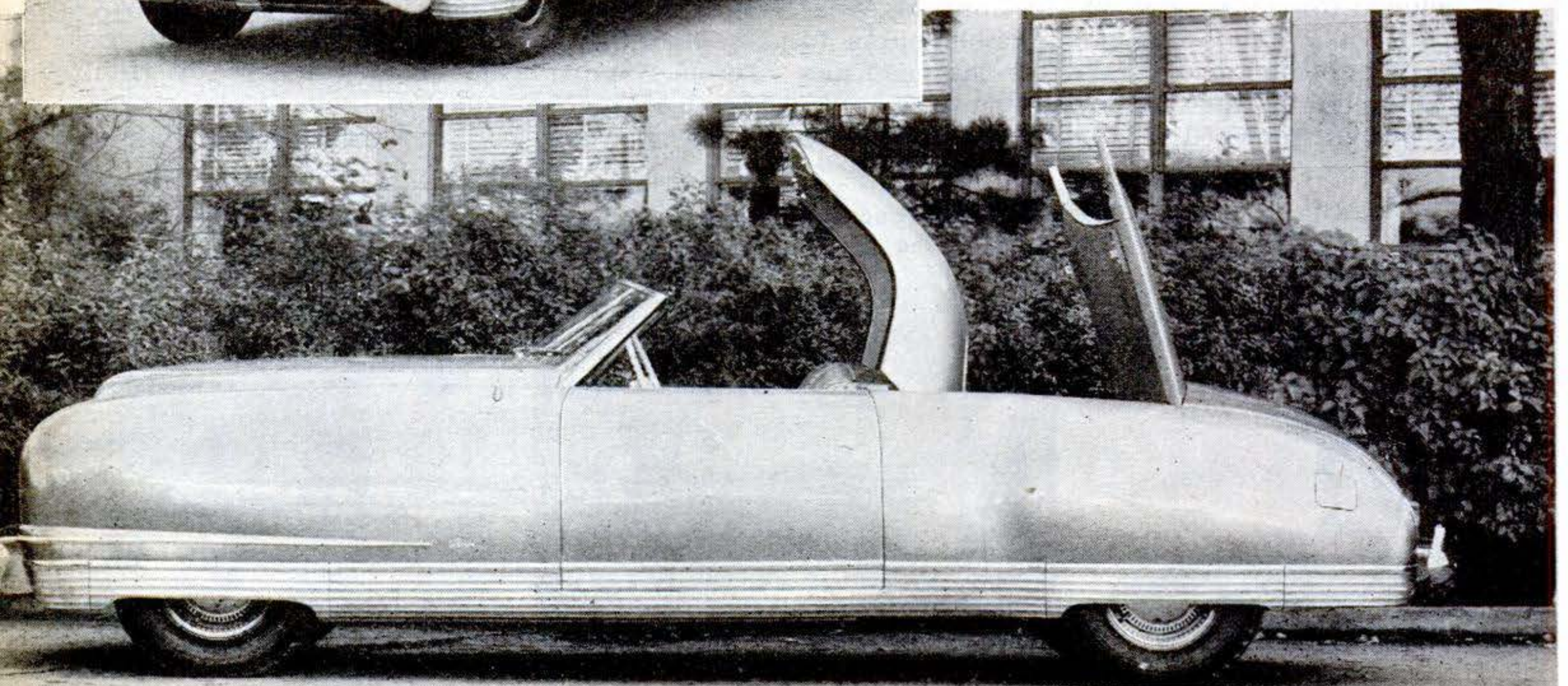
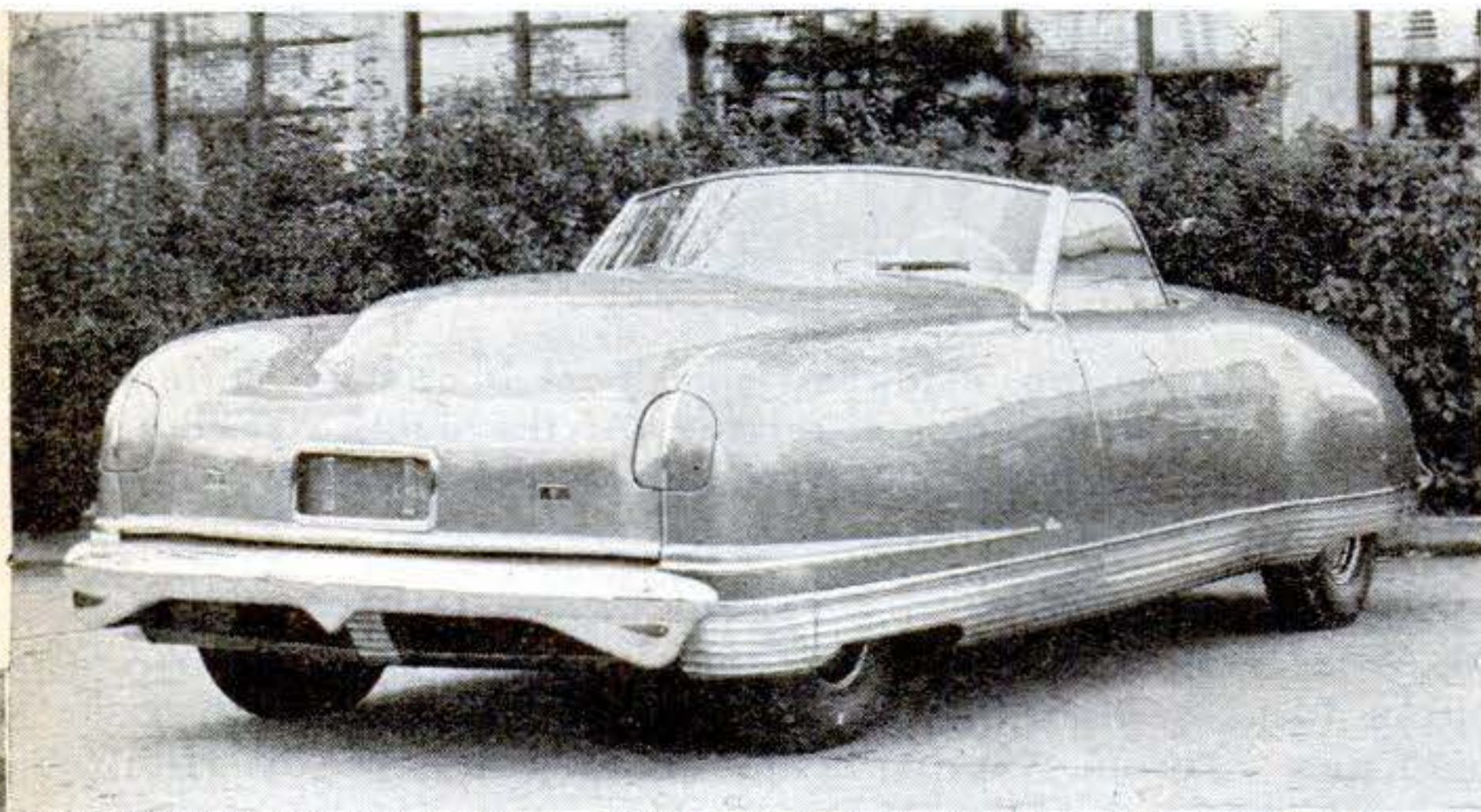



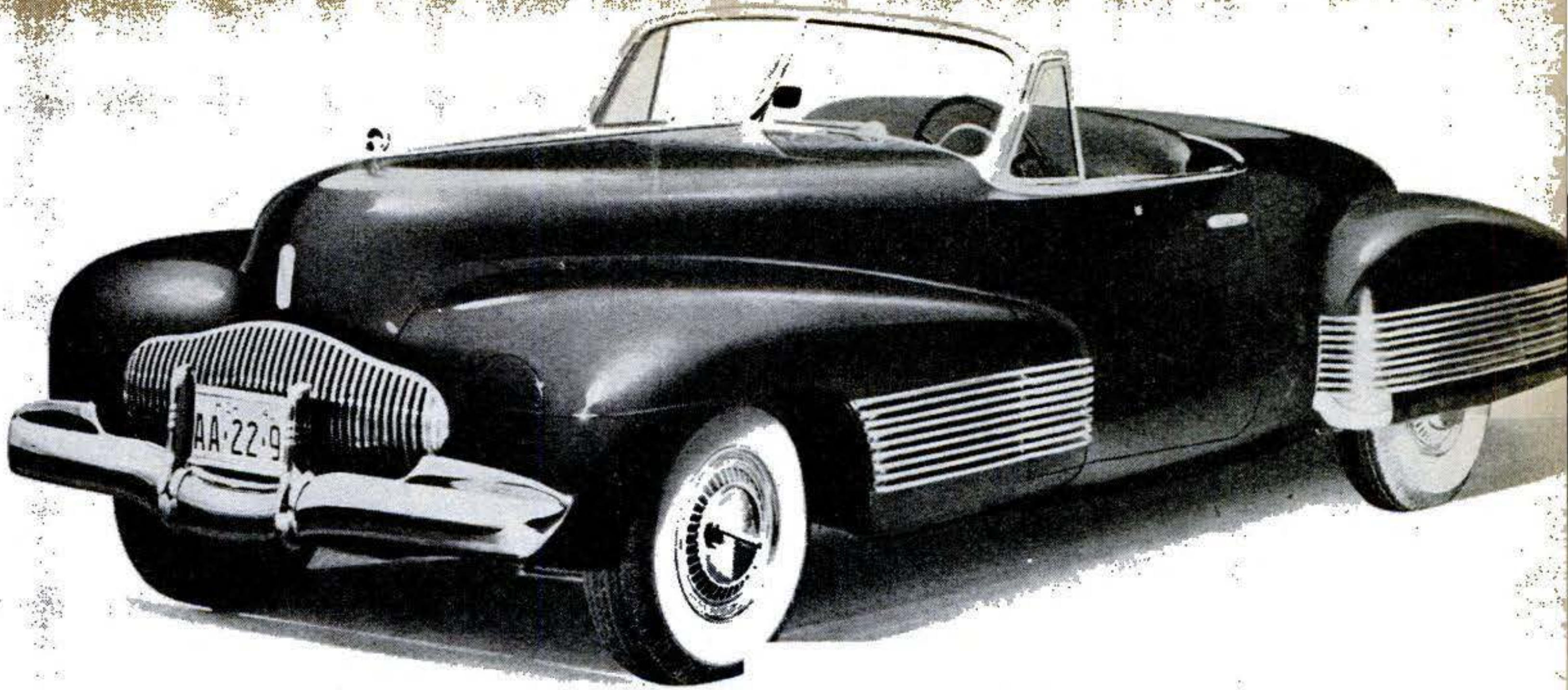

Buick's Fireball has a modern automatic folding top of the push-button type. The car was built in 1940 by Harley Earl, G.M. styling chief, and Buick engineers as a "style laboratory on wheels." At right, the top is shown partly up along with the rear-deck panel that conceals it. The panel and top work together automatically.

Below, Packard's prewar convertible by Darrin. It has an automatic top that fits almost flush with the deck when down to accentuate the sweep of the curve of the Continental-styled door.

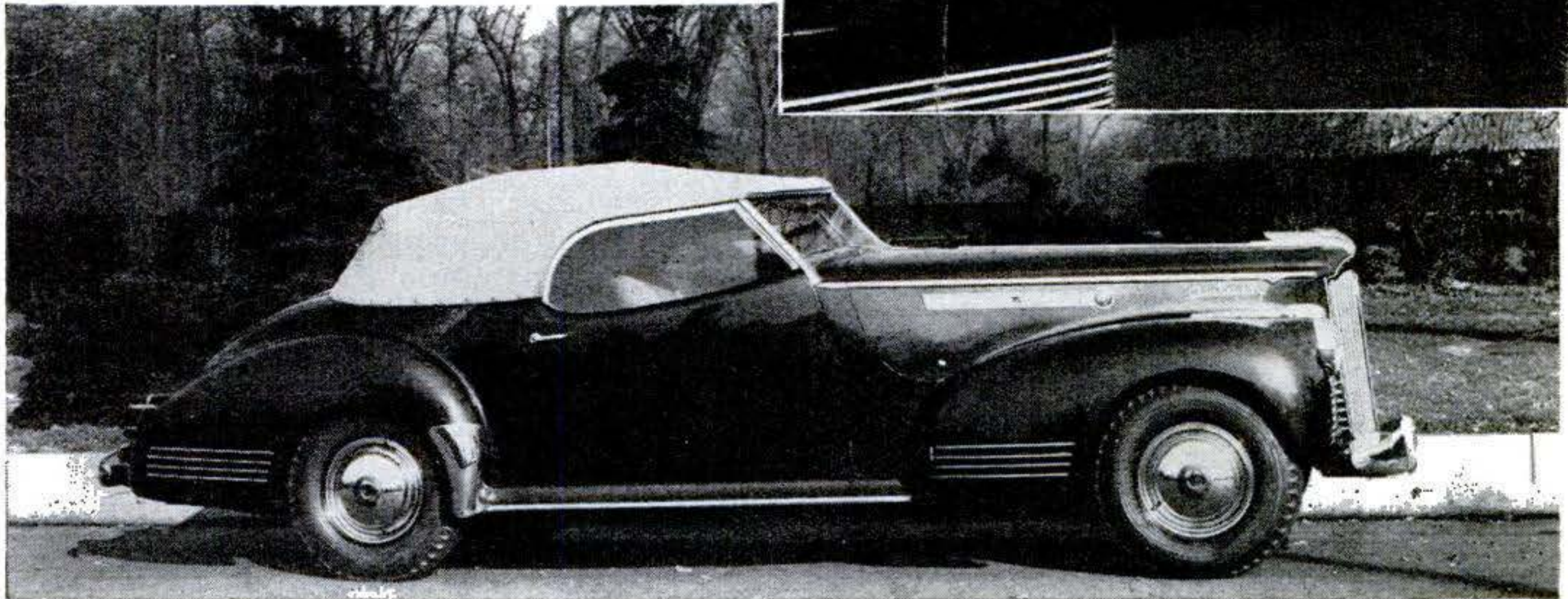
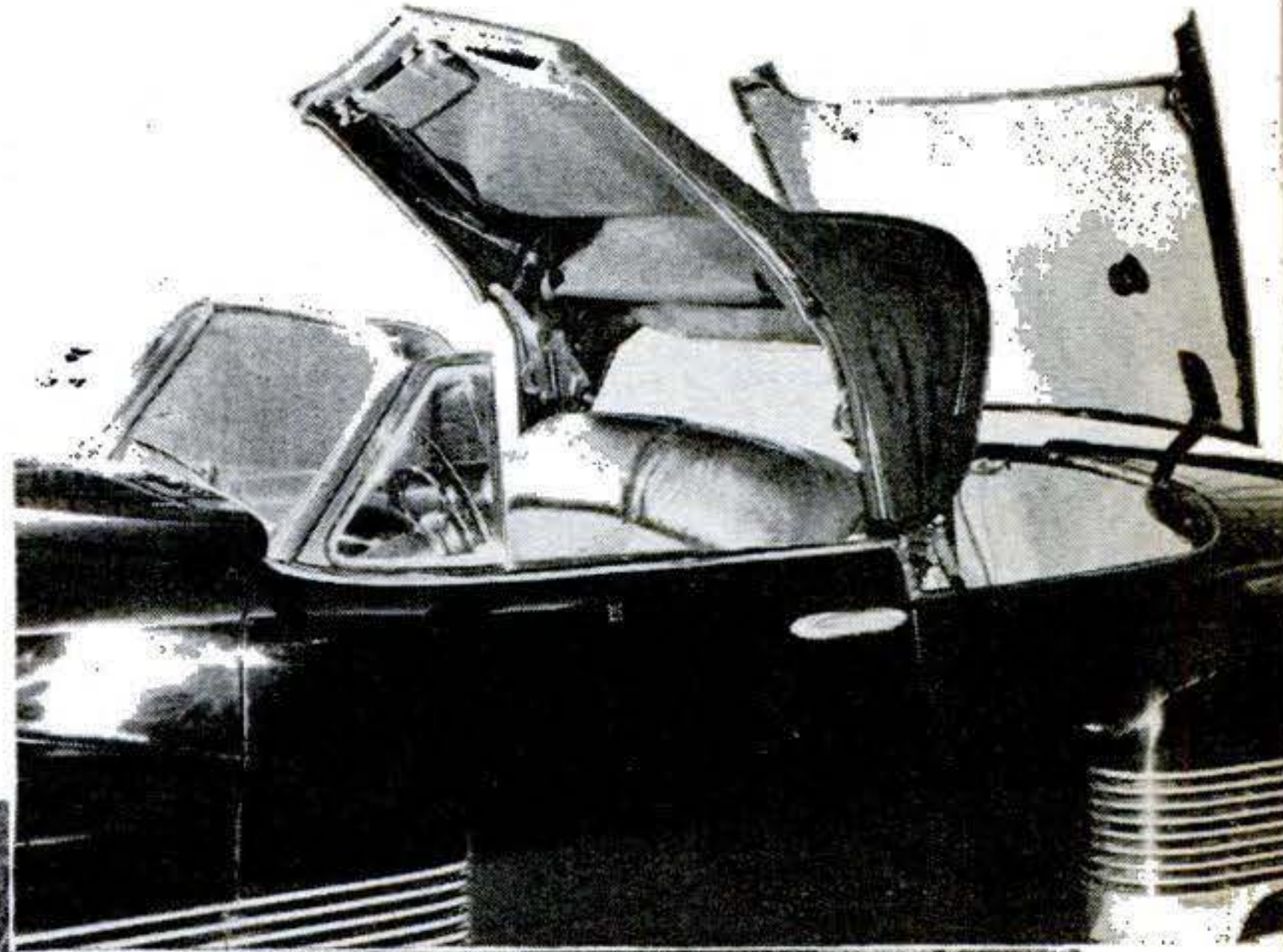

have already been perfected. Some lower into the rear deck at the touch of a button to allow open-car sweep of the breeze combined with closed-car protection against sun. One new rear window is designed for curved plexiglass and duplicates the sweeping lines of streamlined closed cars.

Control mechanisms have also undergone revolutionary changes since the day of the old "one-man" job that frequently resisted all efforts to be bent to the driver's will. Mechanically co-ordinated bows actuated by hydraulic cylinders now automatically fold

the top into place. Lighter metals, some developed in war production, reduce weight, and self-lubricating bearings stop rattles. Inside linkage is at least partially concealed, and the top is designed to make automatic, draftproof juncture with the body, windows, and windshield.

Fabrics are being improved, too, both for tops and all-weather upholstery. Synthetics and plastics are under consideration for tops, some of them opaque with bright, durable colors, some translucent, and some even transparent. The ideal top fabric will



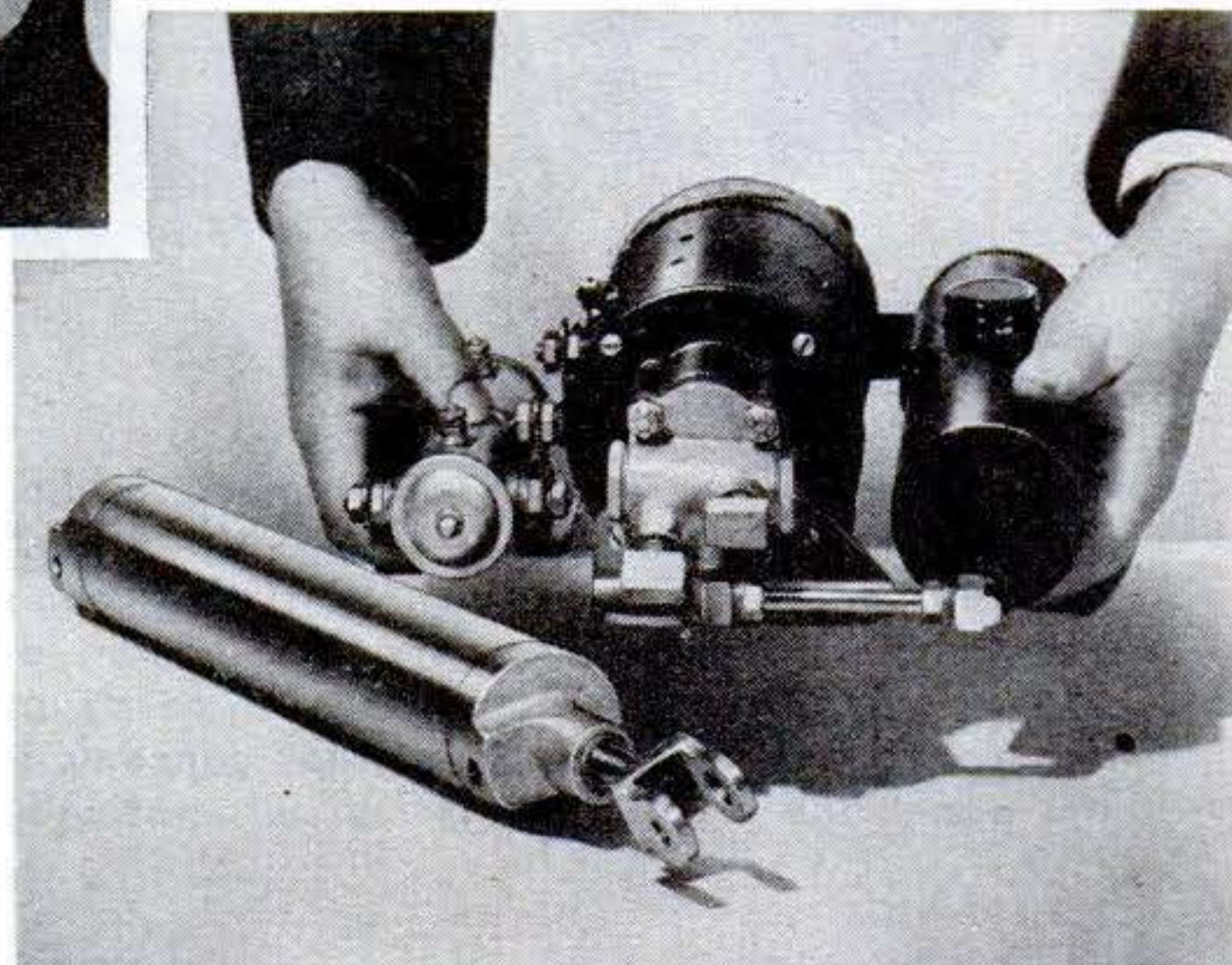
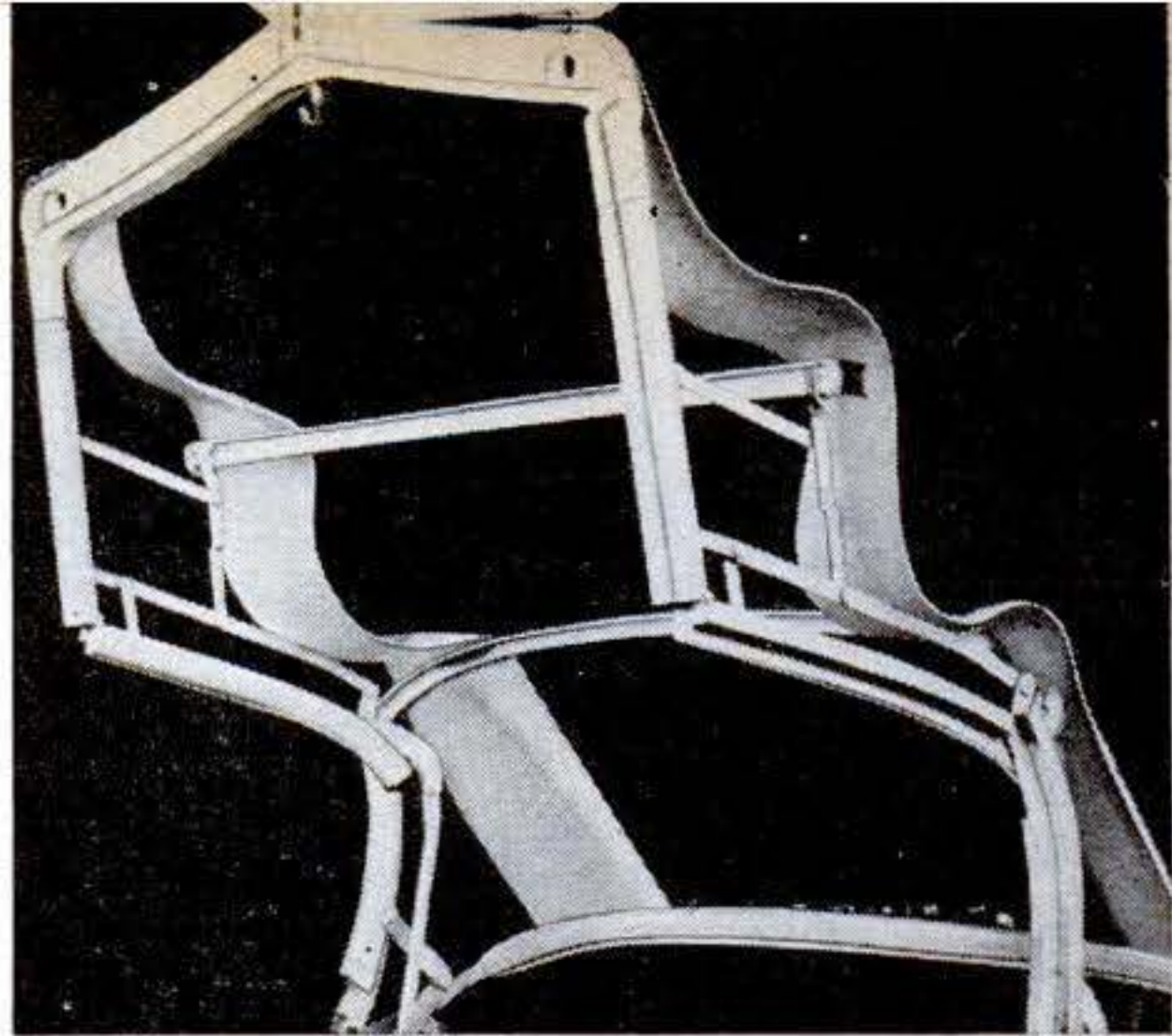
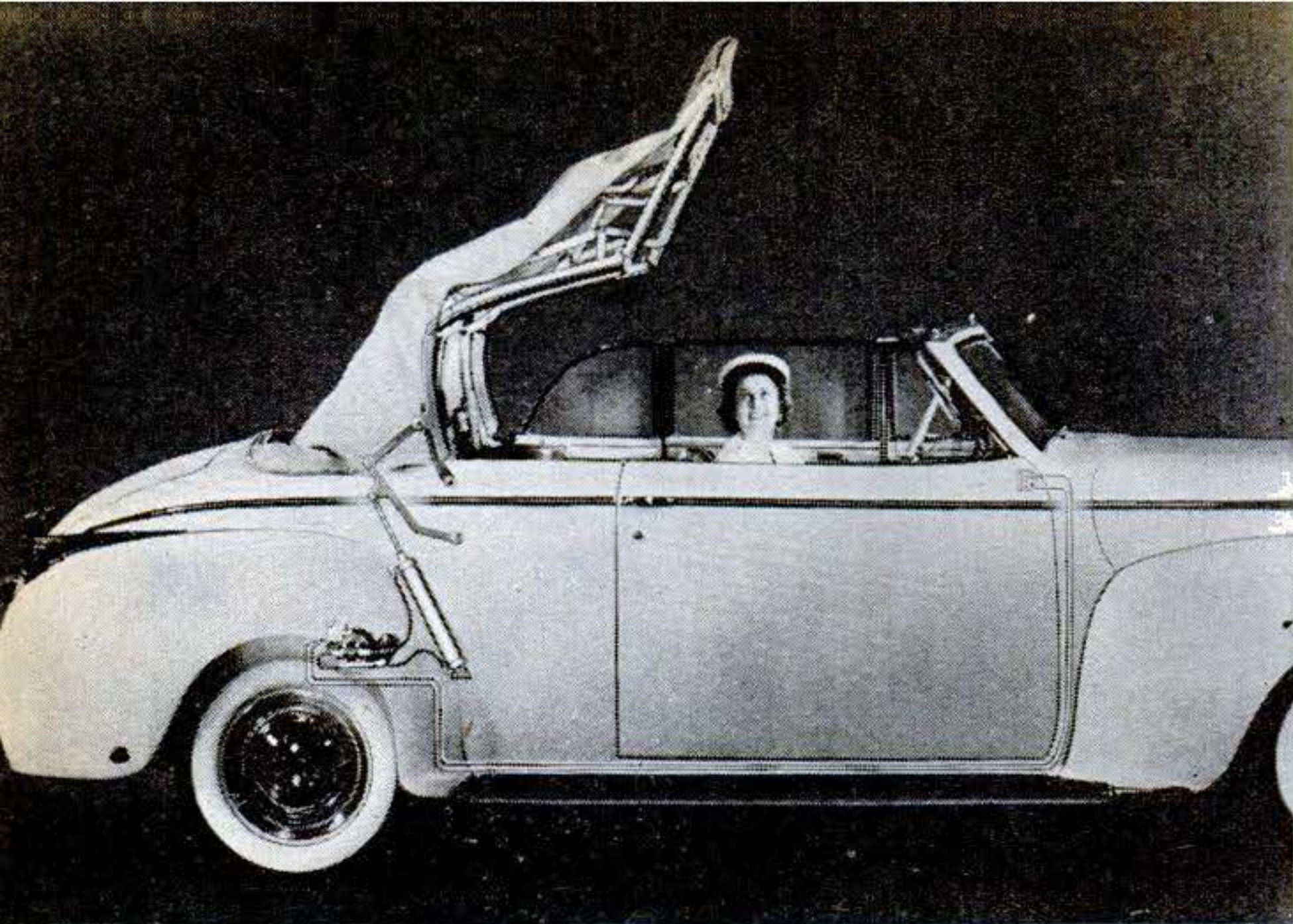

Here is how a push-button top works. The phantom view shows the motor pump under the rear deck with oil lines to hydraulic cylinders and wiring to the control on the dash. At right, new framework with channel members for compact folding, and a close-up of a pump and cylinder.

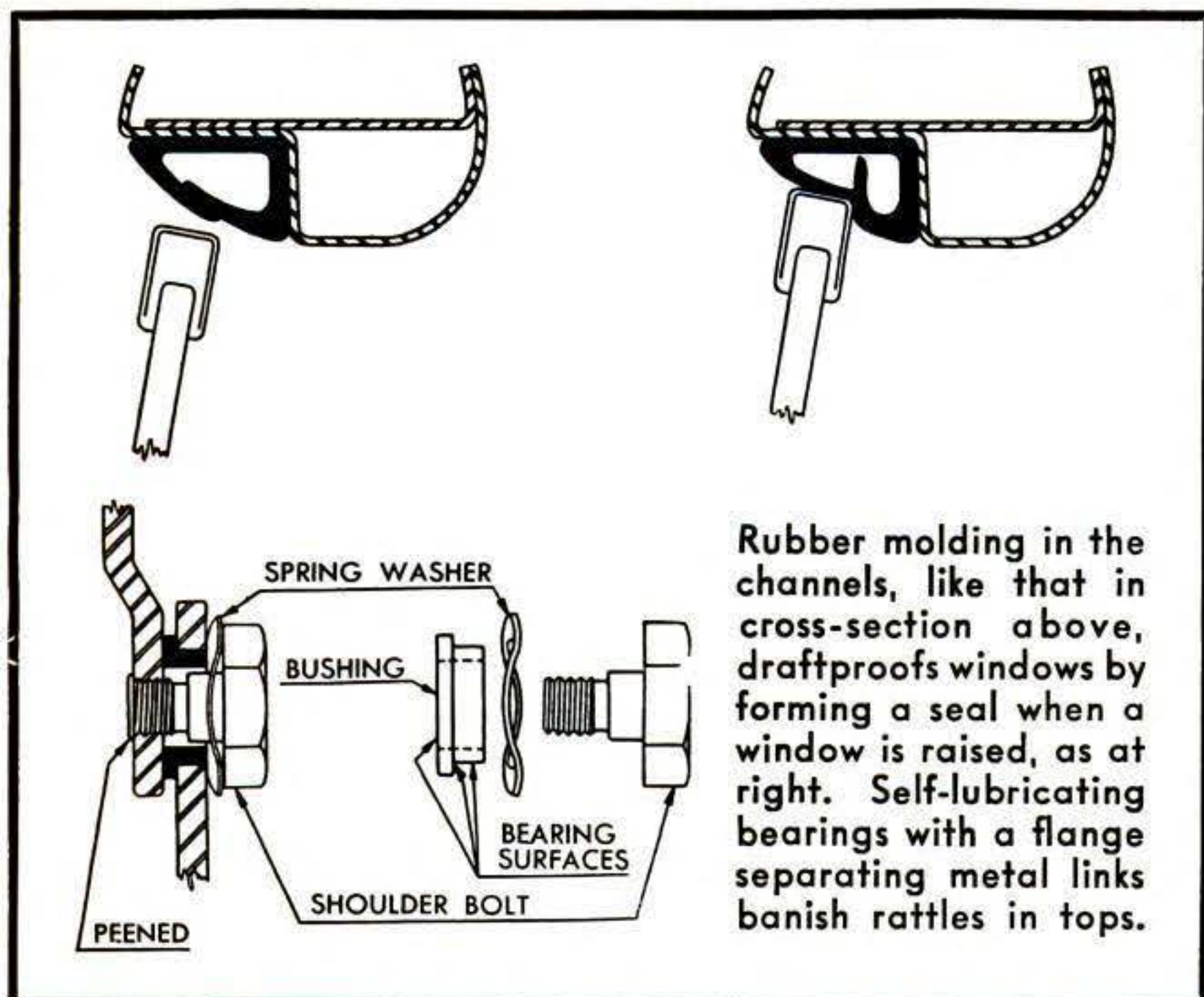

Rubber molding in the channels, like that in cross-section above, draftproofs windows by forming a seal when a window is raised, as at right. Self-lubricating bearings with a flange separating metal links banish rattles in tops.

retain color as long as the body does; it will be waterproof and dirt resistant or easy to clean; it will be wrinkleproof or wrinkle resistant, capable of withstanding repeated folding; and it will be available in a variety of weaves and colors.

Hard-top models are still in the experi-

mental stage, but they may be offered to the public when car production gets into high gear. Design has generally featured a one-piece metal top over a single seat. A single-piece hard top for a club coupe requires a lot of room when lowered into the deck, and even the single-seat experimental models use space needed for luggage. One designer is experimenting with a hard top in sections automatically folded together by hydraulic control.

Most old-line manufacturers, and many dealers, too, were inclined in the past to look upon the convertible as expensive window dressing. But returning service men and women, accustomed to the exhilarating speed of open military vehicles and the clean lines of fast planes, will probably boost demand to assembly-line proportions. The convertible is decidedly here to stay.

New fabrics, synthetics, and plastics give the postwar convertible a smart closed-car look with the top up. At left, a translucent top; at right, an opaque model with a rear window that lowers into the deck.

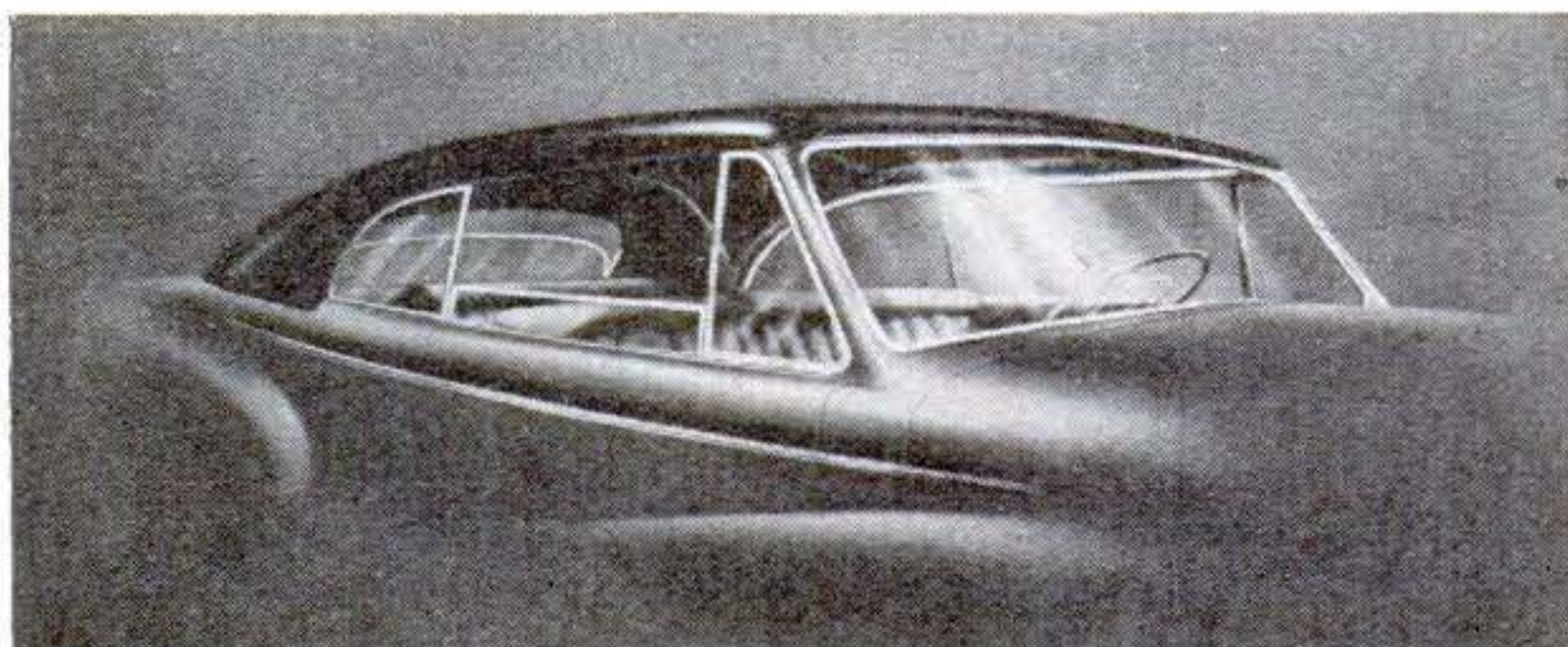
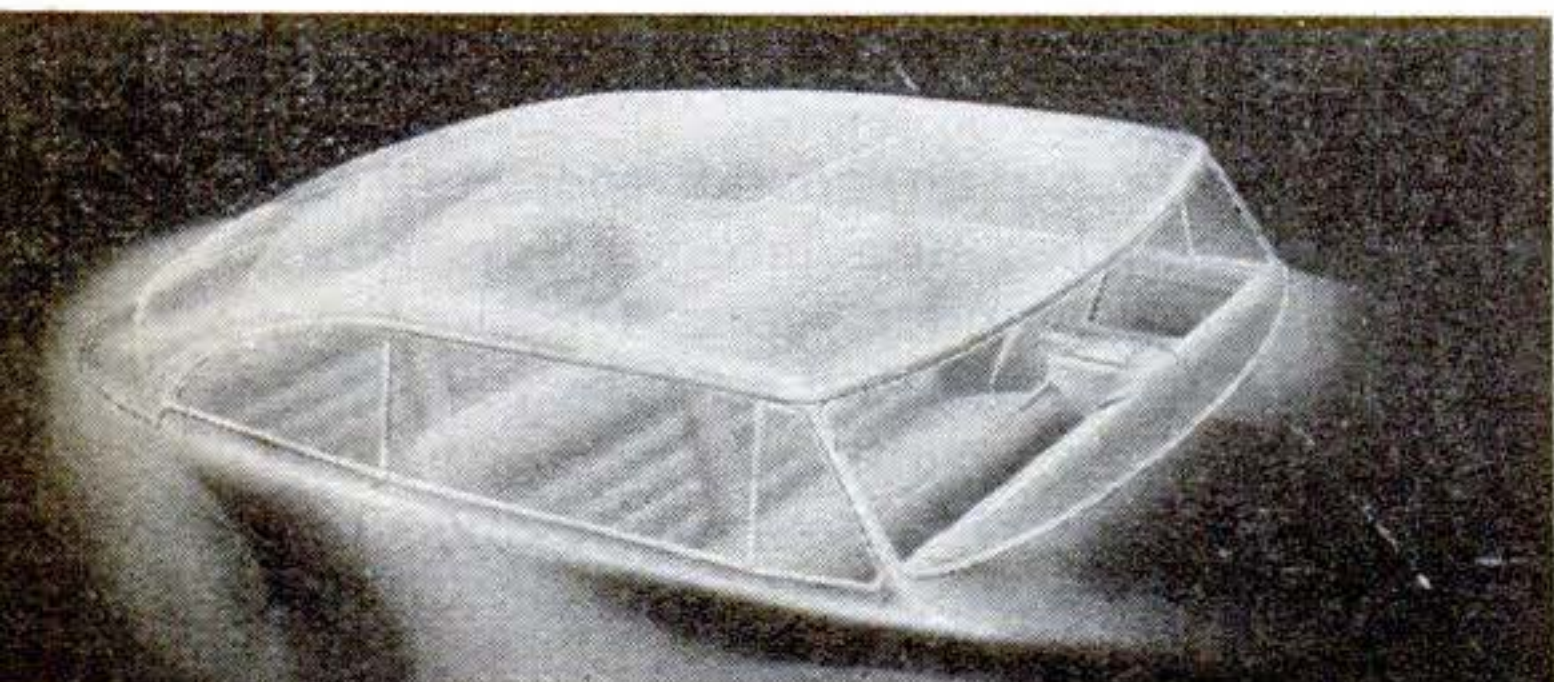



## Details of New Lincoln and Mercury Announced

WITH the 1946 Ford already in production, the Ford Motor Company has completed its first models of the 1946 Lincoln and Mercury. The Lincoln has a new grille that makes the front appear lower and broader. Bumpers are wider, and fog lights are built in. An electrically operated hydraulic mechanism for opening and closing windows has been made standard, but the mechanical lift will be available as special equipment. Oil-pump capacity has been increased, hydraulic push rods have been improved, and the oil-pan capacity has been increased to seven quarts.

A lower, heavier, and wider-appearing

Mercury is also chiefly the result of a new front grille. Mechanical changes include triple-alloy bearings, crankcase ventilation, oil-type air cleaner, an oil cleaner, an improved oil pump, four-ring aluminum pistons and interchangeable cylinder heads.

The 1946 Ford V-8 engine develops 100 hp. as compared to the 90 hp. of the prewar engine. As in the past, a six-cylinder Ford engine will also be available. Many of the mechanical features of the Mercury have been included in the Ford, along with shock absorbers that have oil seals, foot brakes requiring less pressure, a Lincoln-type hand brake, and springs with more leaves.

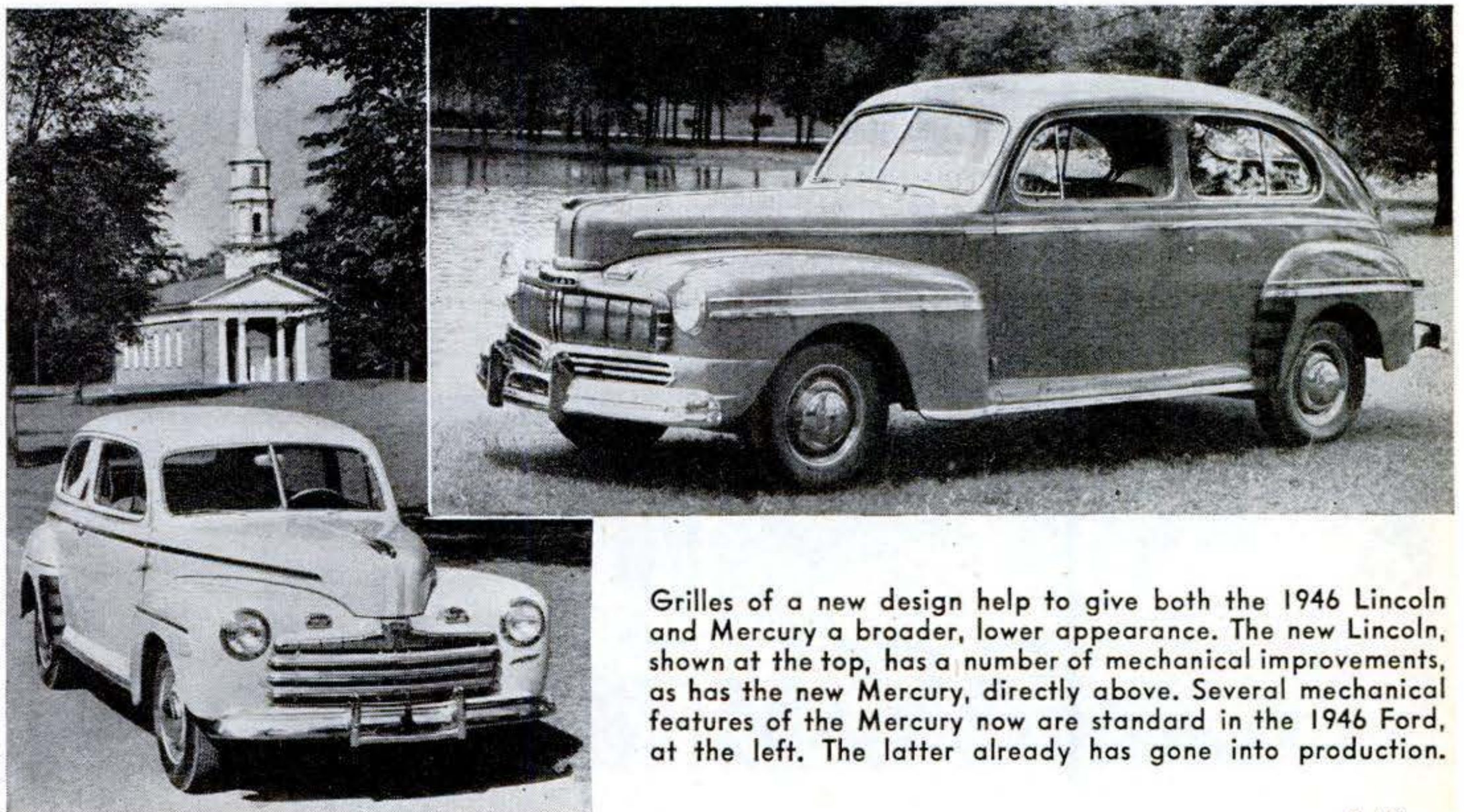
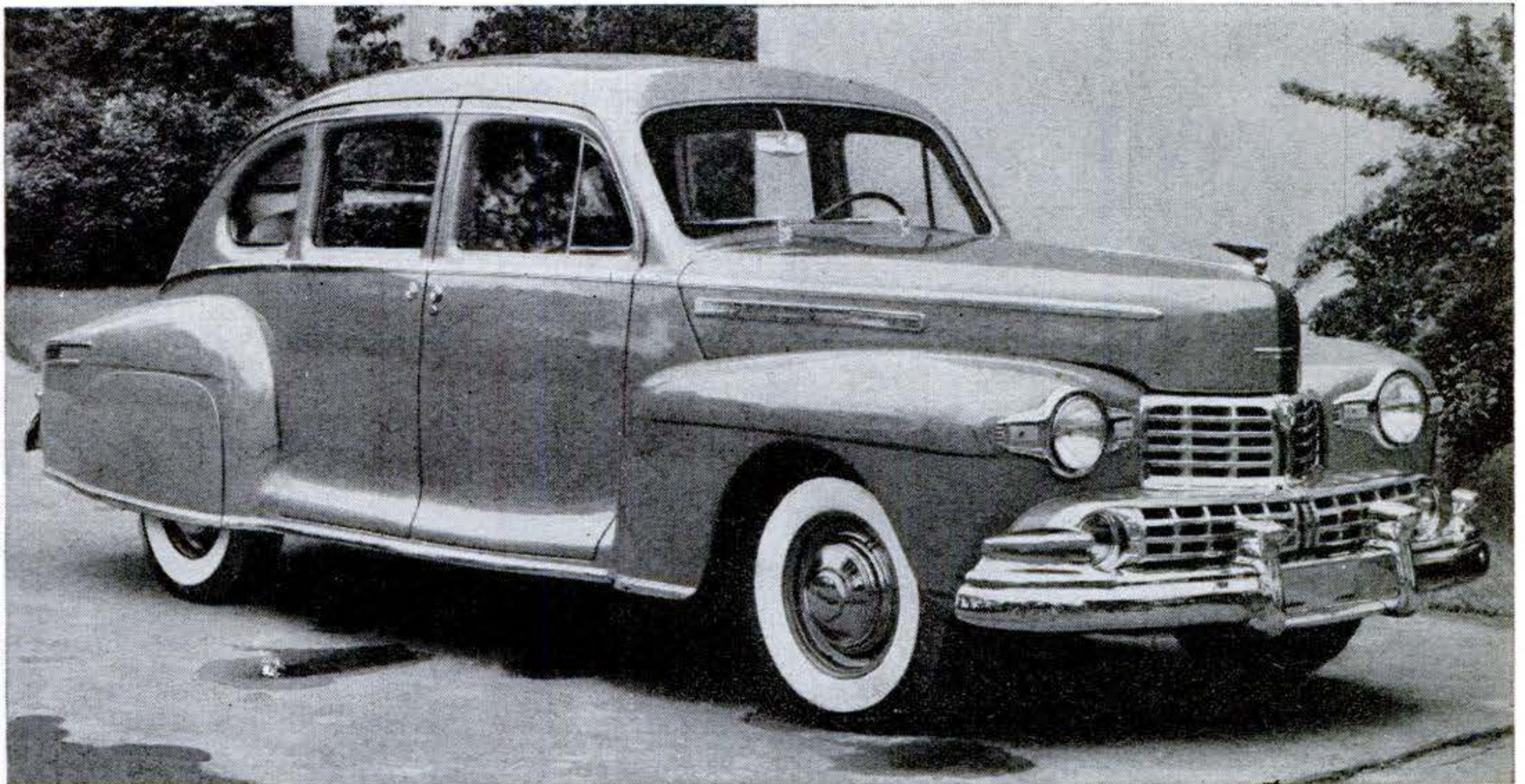

Grilles of a new design help to give both the 1946 Lincoln and Mercury a broader, lower appearance. The new Lincoln, shown at the top, has a number of mechanical improvements, as has the new Mercury, directly above. Several mechanical features of the Mercury now are standard in the 1946 Ford, at the left. The latter already has gone into production.



# GLASS-TOP COFFEE TABLE

## WITH MAGAZINE BINS

By John Hugelmeyer

FROM two large-size cardboard photo-hypo containers, some plywood and leatherette, and a glass top came the maroon and ivory coffee table shown on the facing page.

If you don't go in for photography in a big way, discarded containers can be obtained from your local photographer. With a sharp knife cut shaped openings in them, as indicated in the photos, and then cut them to height. Leave the wood bottoms in place as tops, for screws can be put through them

to hold the plywood top in place. Strips cut 2½" wide from waste parts of the containers are glued in as shown to support a plywood shelf in each of the two bases. In cutting the shelf disks allow room for leatherette covers to pull over the edges.

Measure the exact diameter of the bases and sew up two sleeves of maroon leatherette to pull over them like stockings. The leatherette will stretch, so make the sleeves a little skimpy for a good smooth covering. Trim the opening with a razor blade, drill holes ⅜" apart near the edge, and lace with ⅝" wide strips of maroon leatherette.

Cover the plywood top with ivory leatherette tacked to the underside, and edge it with a 1" strip of maroon leatherette glued and tacked on over a strip of cardboard for firmness. This binding projects ⅛" above the plywood and serves to hold the glass top in place. It is best to make a pattern of the plywood top and have an expert glazier cut the glass.



Photo-chemical containers with wooden bottoms are provided with openings and cut to a height of 15".



Disks are cut from ¼" plywood for a shelf in each container, and the insides are then painted ivory.

Strips from waste parts of the containers support the shelves, which take ivory leatherette covers.

Maroon leatherette is sewed to size, pulled on like stockings, trimmed, and laced at the edges.

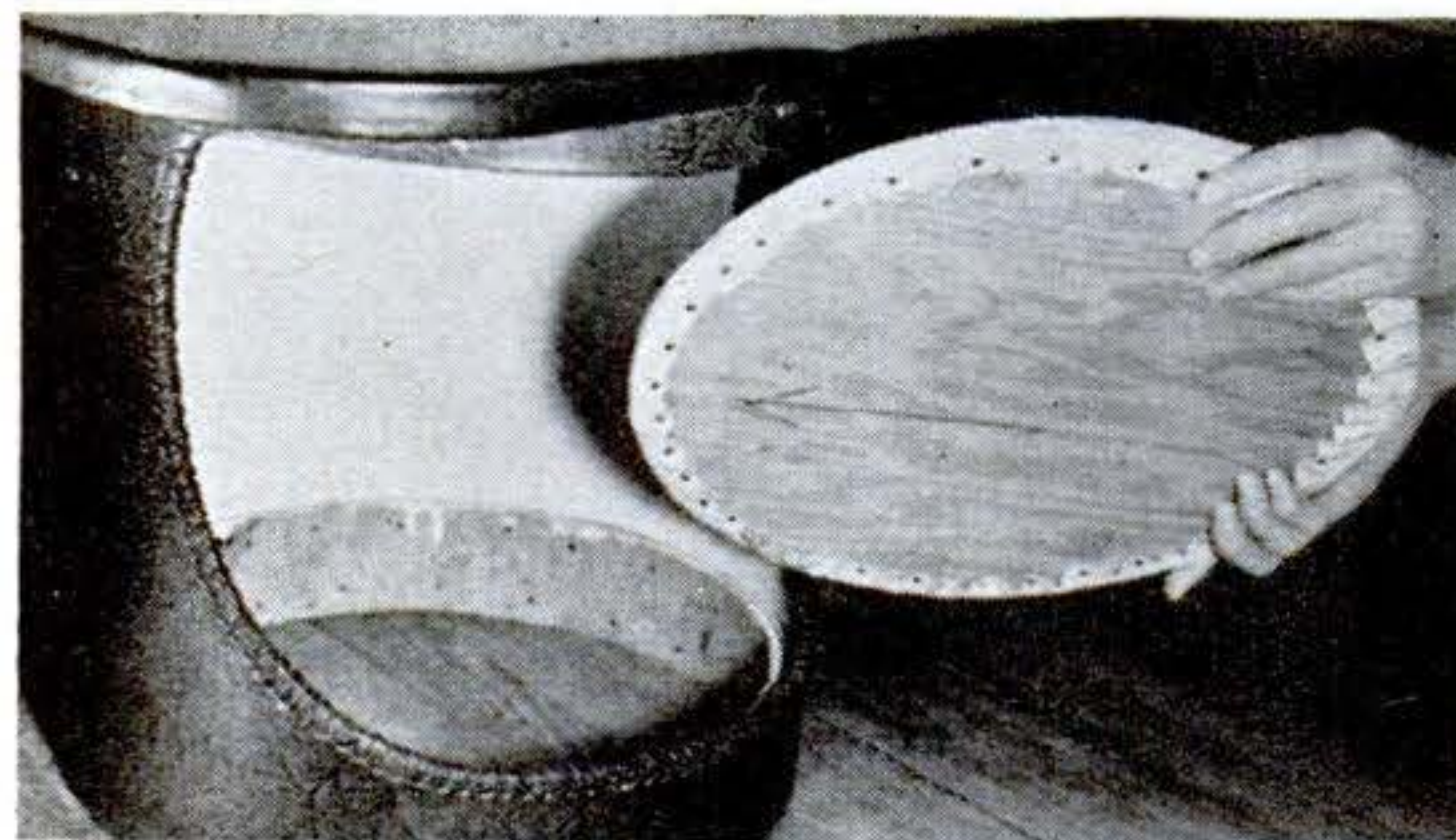





Glass over leatherette-covered plywood provides a fine, stainproof top. Bins in the base hold magazines.

Screws put through the wooden ends of the bases fasten a  $\frac{5}{8}$ " by 22" by 38" plywood top in place.

Ivory leatherette covering the top is tacked on the underside and edged with maroon leatherette.

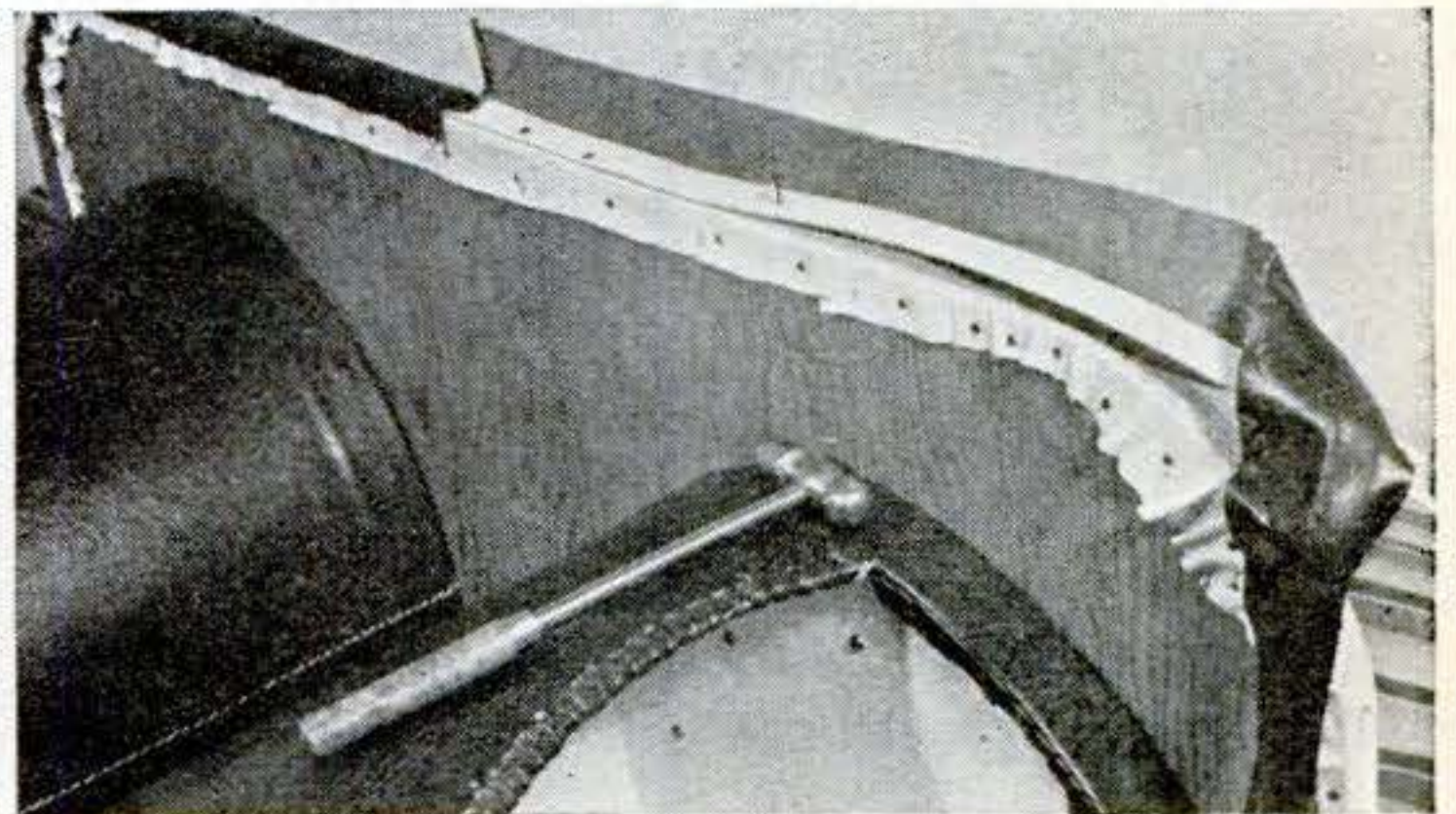
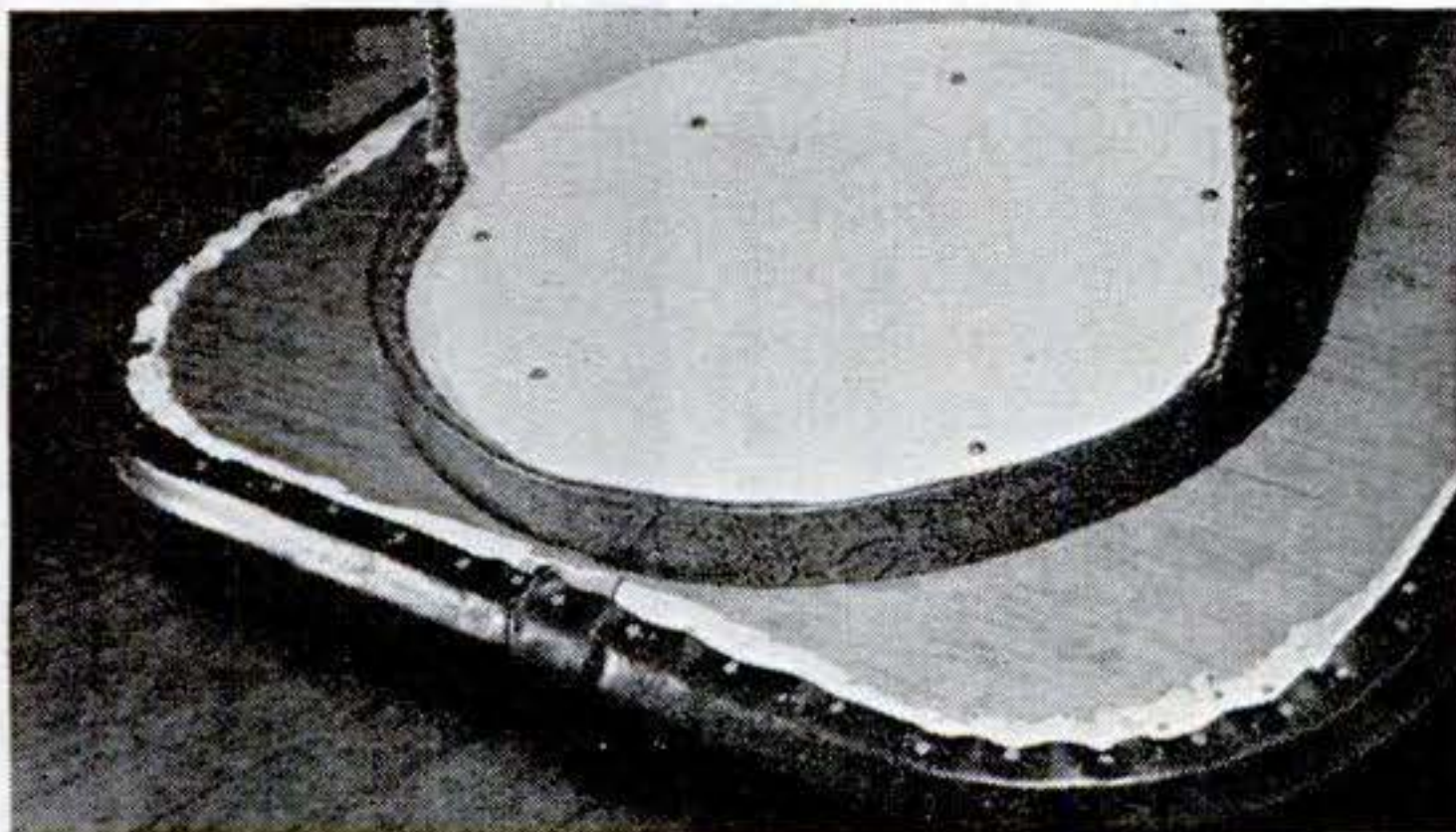



## Jar Set Provides Simple One-Evening Woodworking Project

ANY HOUSEWIFE will welcome this jar set, which holds three kinds of spices, nut meats, candied peel, or confections. Designed for three of the 4-oz. jars in which prepared baby food is sold, it consists of two lifts cut from  $\frac{1}{4}$ " wood, a door stop, and a  $\frac{3}{4}$ " dowel 2" long.

A compass is used to lay out the top. Draw a circle with a radius of  $1\frac{3}{4}$ " and use the same compass setting to divide it into six equal parts. At alternating points on the circumference, as indicated in the sketch, form three circles with a radius of  $1\frac{1}{16}$ "—a size about  $\frac{1}{4}$ " larger than the jars. Drill holes at the other three points on the circumference of the large circle to receive small spoons.

As a guide in marking the outer edge of the triangular piece, connect the outermost points of the three small circles with tangent lines. Cut out the top lift and use it to lay out the solid one for the bottom. Attach the lower lift to the dowel with a flathead screw and the upper one with the door stop, which thus serves as a handle. Paint the edges of the lifts and the tip of the handle any gay color.—VICTOR ROMING.

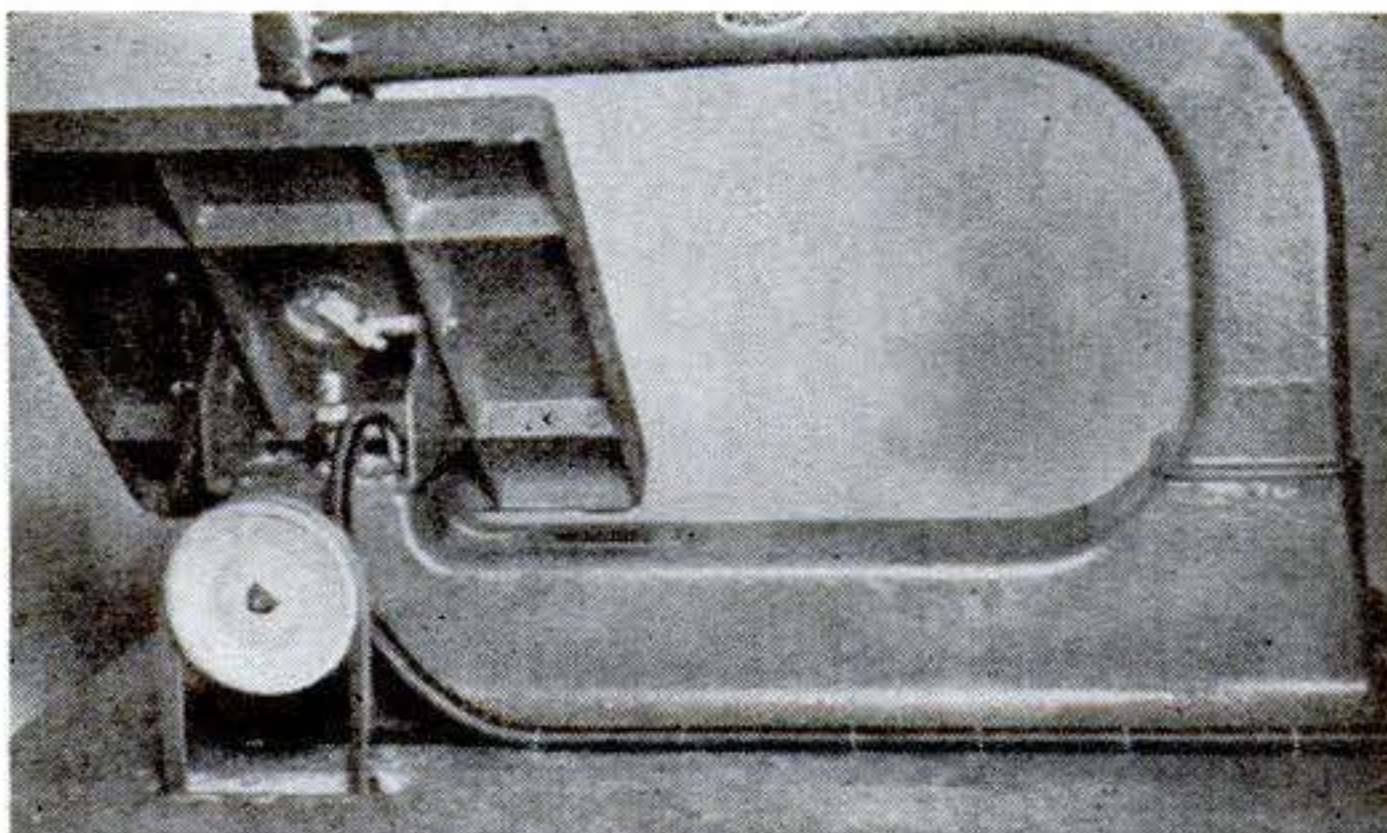
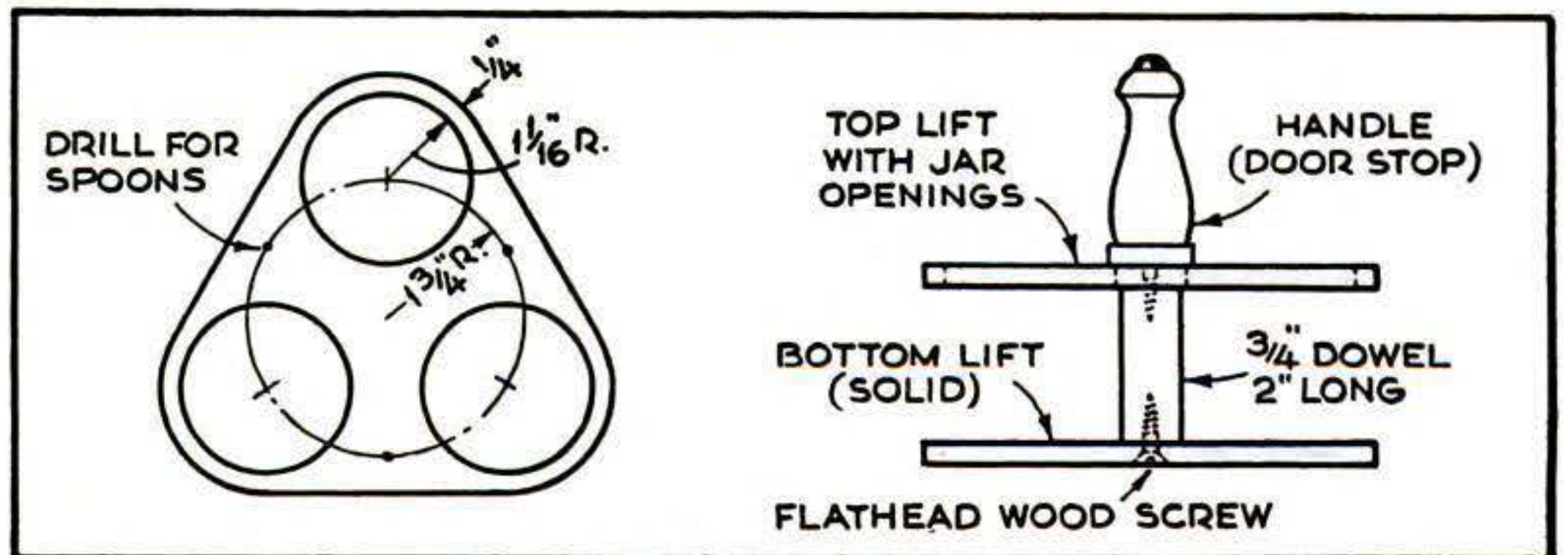

## Tube on Crankcase Air Vent of Jigsaw Keeps Out Dust

CONSIDERABLE sawdust was sucked into the crankcase of the jigsaw shown in the photo because the air vent is located near the path of the dust falling through the saw aperture. This was finally prevented by attaching a rubber tube to the pipe of the vent and running it away from the dust area. The tube was kept out of the way by fastening it to the bench with wire staples.—BERTRAM BROWNOLD.

## Your Dinner Guests Will Like This Homemade Place Favor

A POWDER puff and soda straws, cord and ribbon, and wooden beads—that's what this place favor is made of. The cord was run through the straws and knotted, then bent to provide joints for the arms and legs. From the legs the cord was extended through the skirt (a small powder puff) and the beads that form the body and head. After being tied around the hair ribbon, the cord was slipped through a hole in the top of the card. Features were inked on the head bead, and the skirt was sprinkled with sachet powder. A prop on the back holds the card upright.—B. N.

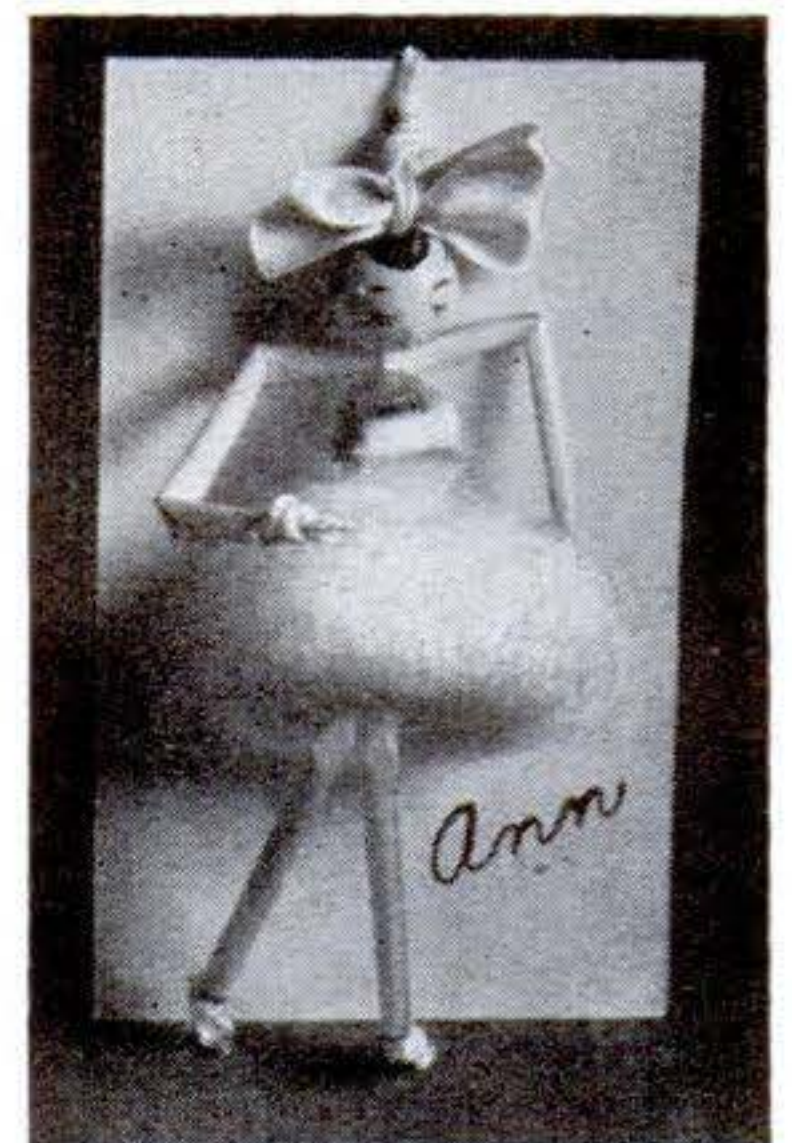



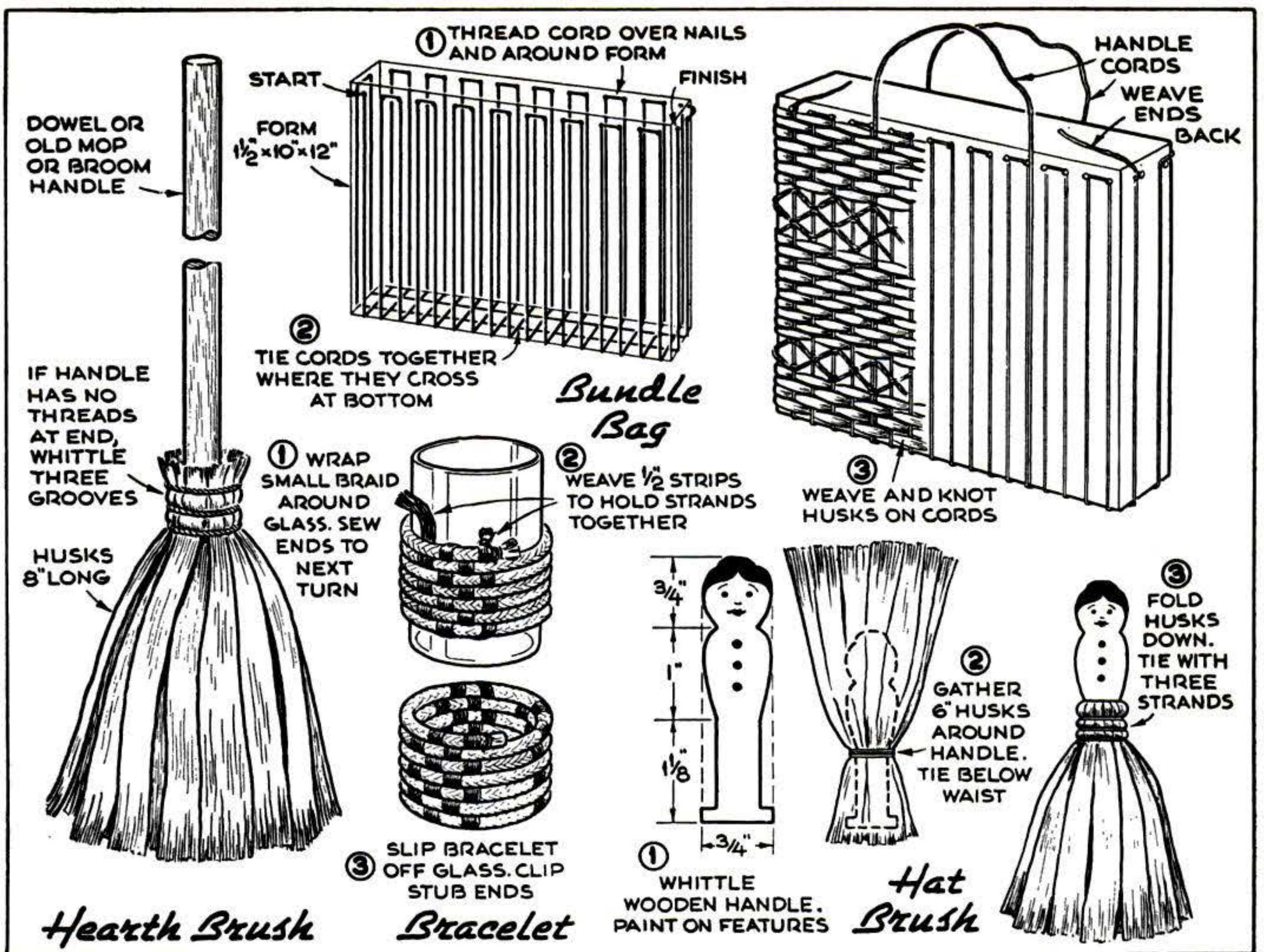

## Husking Time Provides Fun and Projects for Fall Evenings

FIELD corn is in season and its abundant husks can keep farm families busy making useful and ornamental objects. City dwellers, confined to sweet corn at a dozen ears at a time, can save up husks for projects.

Cornhusks should be used damp. Cut off the butt ends, separate the coarse outer and soft inner husks, and cut them into strips of desired widths. For dyeing, soak them a few minutes in hot water, squeeze out the surplus, and then work them in the dye bath with your hands.

Coarse husks are used in strips for brooms and brushes, as shown. Soft husks for the bracelet illustrated, chair seats, and hot pads, and coarse ones for floor mats, are braided first—loosely for thin, flat projects or tight for thick ones. New strips are braided in as necessary. Keep the stubs on the underside and clip them close when the braiding is finished. Sew the braid into the desired shape and weave with strips of husks contrasting in color.

A useful bundle bag is shown above and on page 104. Wrap the cord around the nails, from side to side and then from end to end, tie at every place it crosses, and add a heavy cord for the handles. Weave with strips, weaving the bottom first and continuing on up the sides. Strips are added as needed by knotting. The diamond pattern dividing the woven sections is made by tying strips to the cord frame. For proper weaving, strips must alternate under and over each cord for its entire length, and therefore, so there will be an uneven number of cords, one of the handle cords is treated as a separate cord in weaving and three are grouped with the cord next to them. When finished, pull out the nails and remove the bag from the wooden form.

Husks wadded and covered by a soft husk, as shown below, make heads for both the lapel doll and the boy in the whistler-and-dog bookmark shown on page 104. The dog's head is a blunt triangle.—ELMA WALTNER.

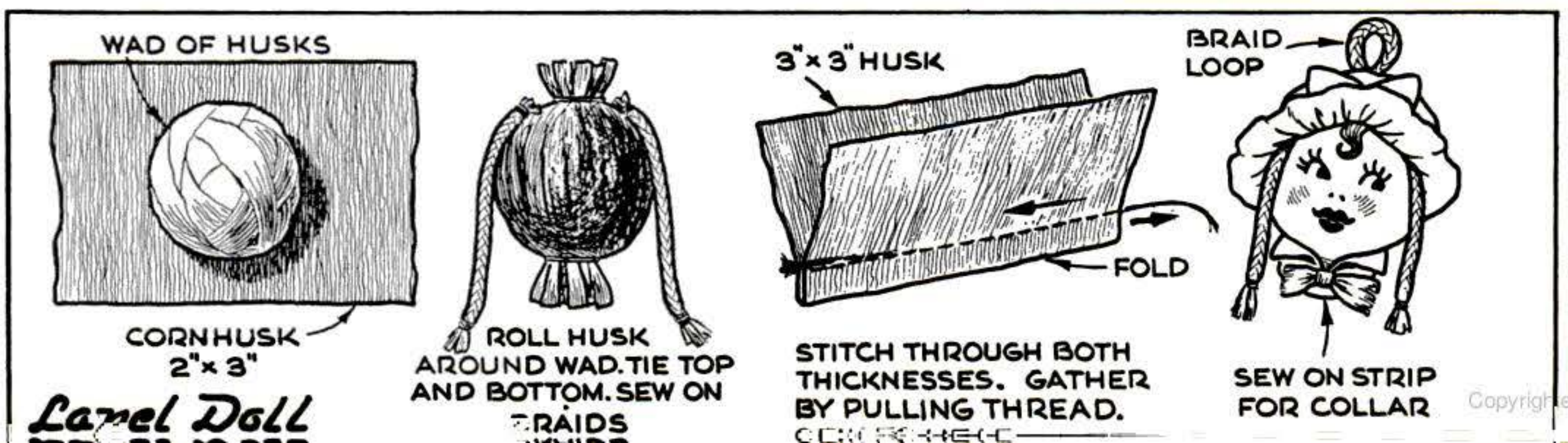



## Whittled Pig in Desk Set Has Paper-Clip Trough

PAPER clips, not truffles, fill the feed trough of Percival, but the little pig's pudgy, upturned snout remains cheerful. For all his unusual diet, he retains that well-fed look so becoming to porkers.

Lay out the figure on a  $1\frac{3}{4}$ " by  $2\frac{3}{4}$ " by  $3\frac{1}{2}$ " block of soft pine, and saw out the profile roughly to shape. The rest is done with a sharp jackknife, the stock being turned often to assure roundness and correct proportions. Sand off the rough spots, for you won't want even a young pig to be too angular. Then drill for the curlicue tail, which is a short length of pipe cleaner engagingly kinked and glued in place. Drill a small hole through the nose to hold a wire ring. Finish with a light oil stain, touching up the tail to match, and add white map tacks dotted with black for eyes.

The trough is a 1" by

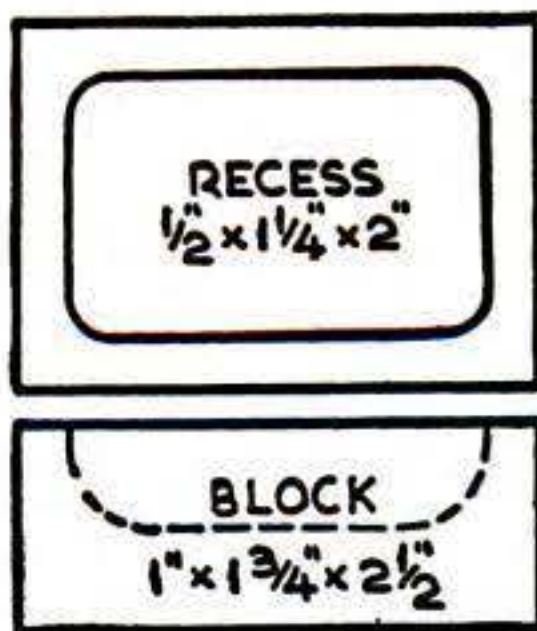
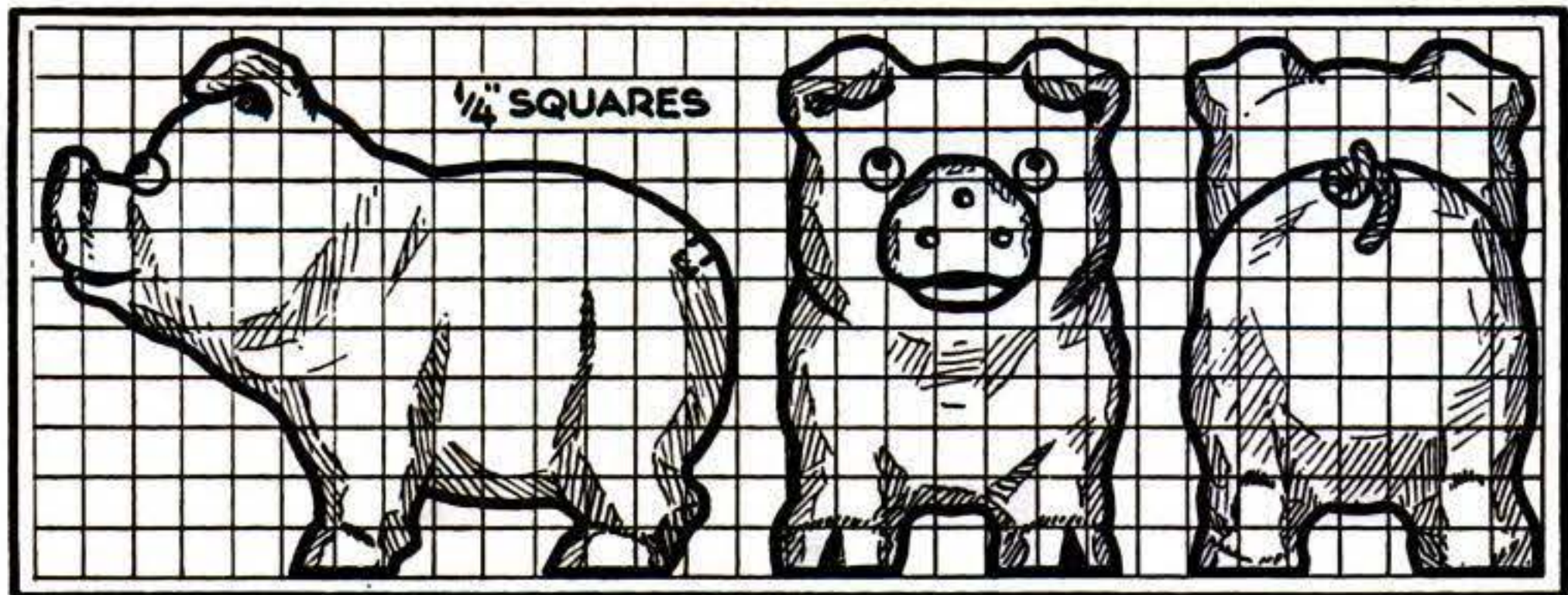
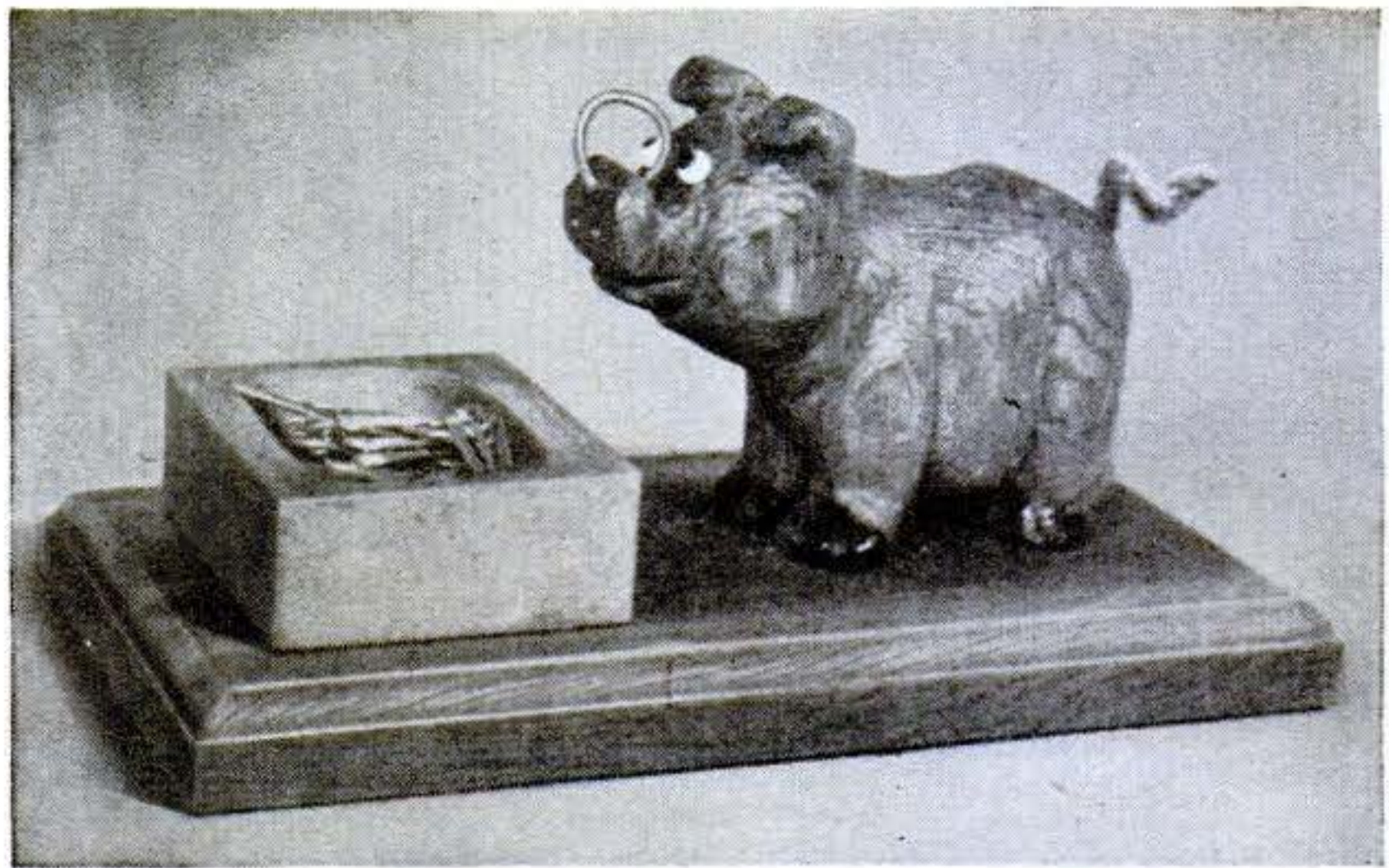

$1\frac{3}{4}$ " by  $2\frac{1}{2}$ " block hollowed out with a chisel. Sand it well, apply a coat of varnish, and then wax it. The base is a  $\frac{3}{4}$ " by  $3\frac{3}{4}$ " by  $6\frac{1}{2}$ " block with a  $\frac{1}{4}$ " bevel around the four top edges. It is also sanded smooth, varnished, and then waxed. Mount both the pig and trough with small flathead wood screws run up through the base and countersunk.—ELMA WALTNER.

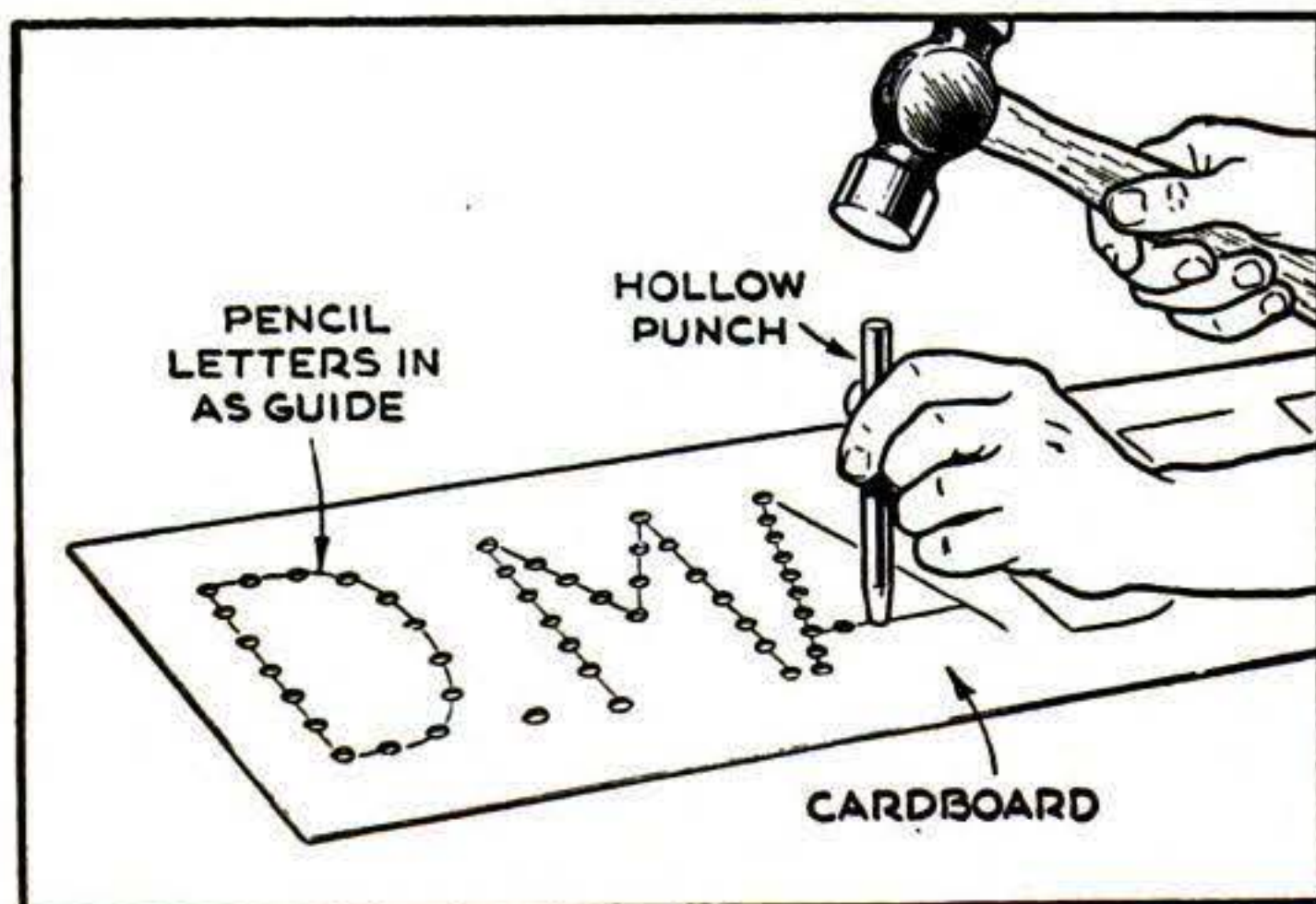

## Hollow Punch Cuts Stencils Lettered on Cardboard

WHEN a name or other lettering must be repeated a number of times on boxes, signs, and the like, a stencil can be cut quickly in cardboard with a hollow punch. Letter the name in with a pencil to guide the punch and lay the cardboard on several thicknesses of newspaper. The cardboard should be heavy enough to stand up under use, but not so thick that brushed or sprayed paint won't penetrate evenly.—BERNARD MATZEN.

## Pocket Clip Fits Flat Pencil

CLIPS for flat carpenter's pencils can be cut with tin shears from hollow curtain rods of the kind shown beside the pencil in the photo. The clip part is bent to shape in a vise or with pliers, and burrs that may be left by the shears are smoothed off with a small file—RONALD EYRICH.





**N**OT content with fashioning intricate models of ships, buildings, and the like, Segundo Garcia, of New Brunswick, N. J., surrounds each with a lifelike scene in which all items are formed to scale. For example, his model of the Morro Castle, which burned off the New Jersey coast, has passengers in lifeboats and others in the water awaiting rescue. A 5½' model of the Manhattan is docked beside a pier covered with stevedores, loading vans, and stacked cargo for local color.

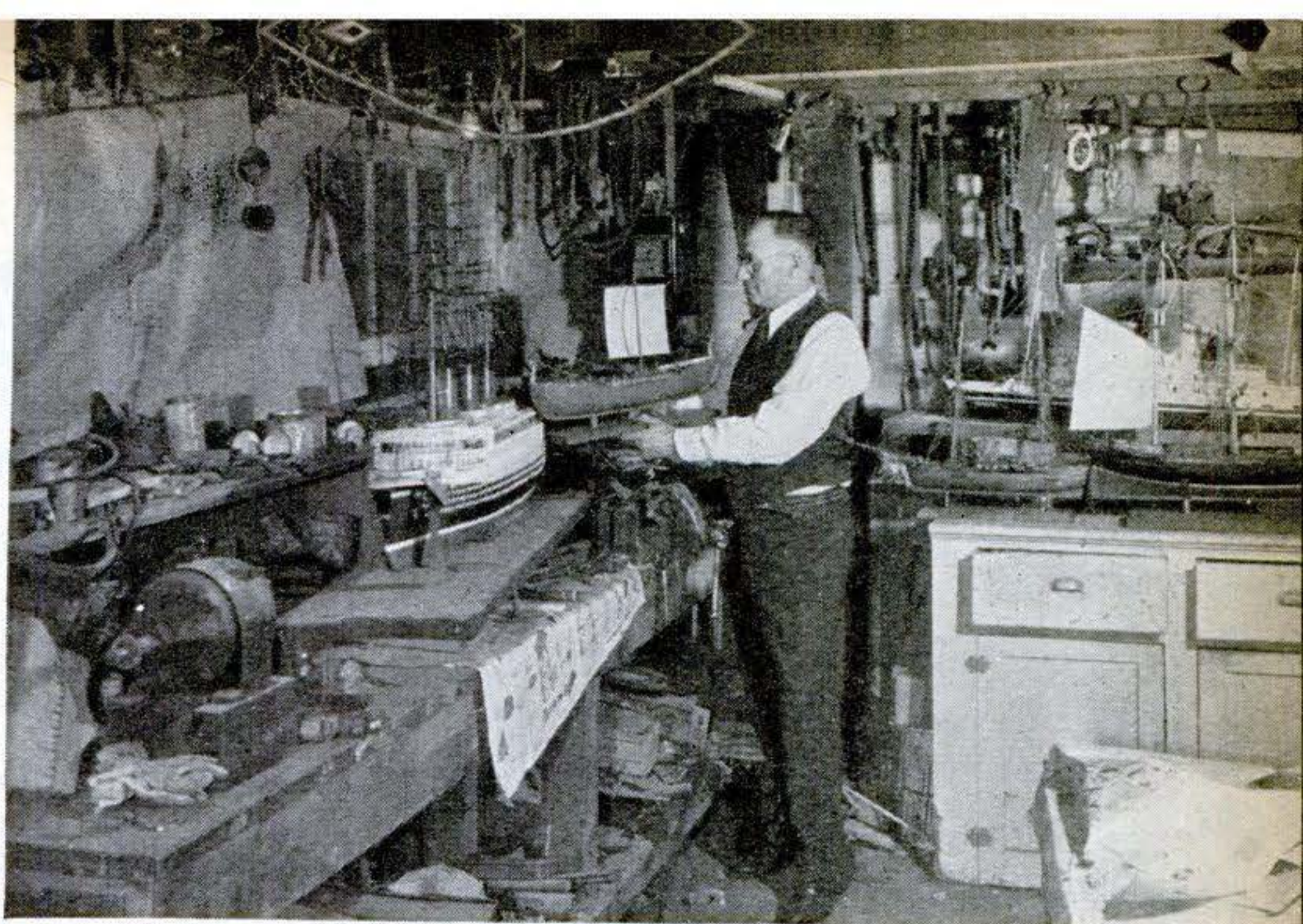

In this fully equipped cellar workshop, Segundo Garcia, a machinist by trade, finds a satisfying outlet for his creative ability by producing models of many kinds. Visible here are some of the ships he has built.

# Maestro of Modelmaking

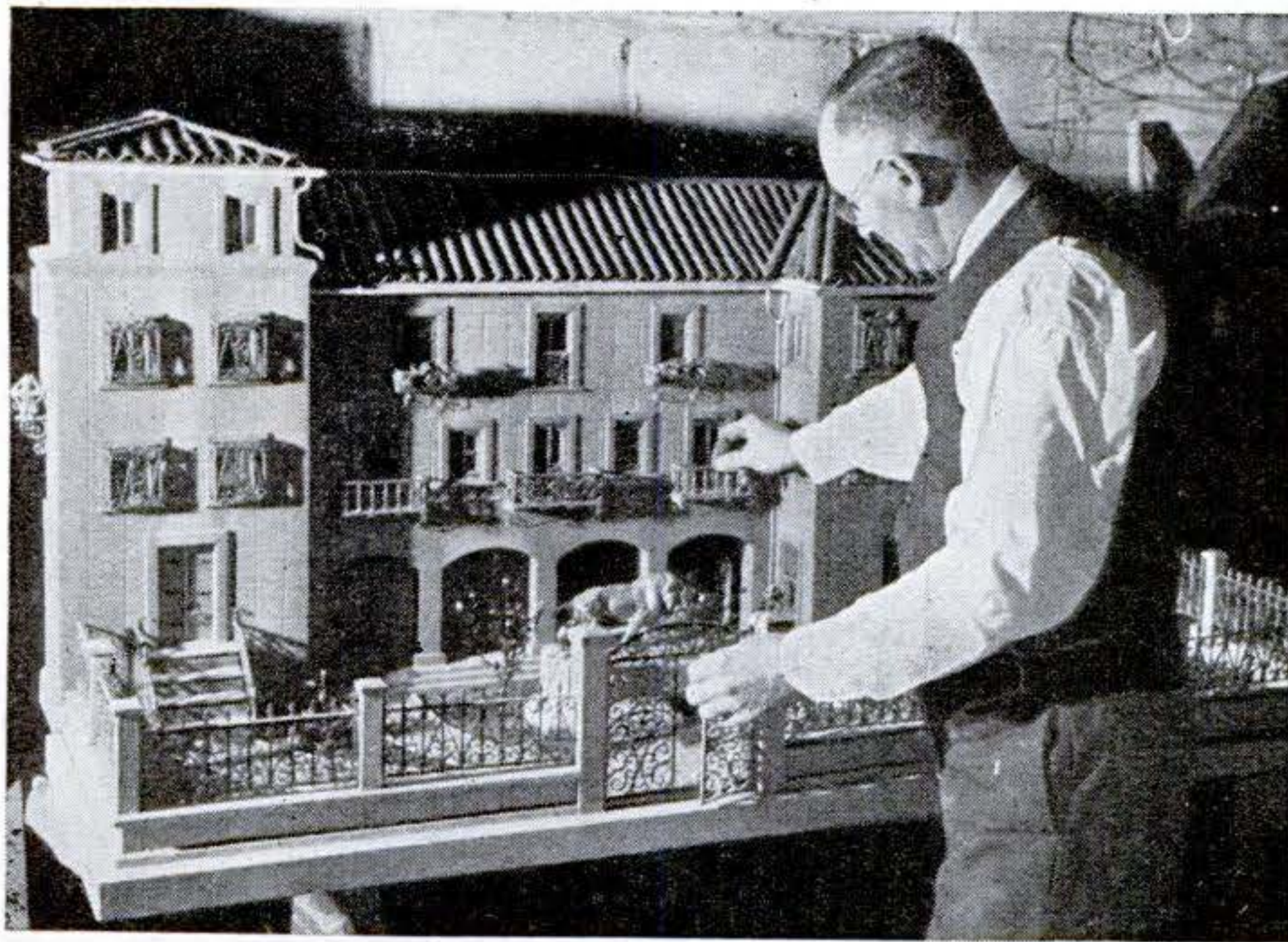

Made of wood to resemble stone, this Spanish mansion was one of Garcia's most ambitious pieces. It is 5' long and 39" high. A stainless steel gate swings on tiny hinges, the railings are of brass, and corrugated metal was painted so it would look like a tile roof. Note the small tree and carved figure in the patio.



Shaped by hand from stainless steel, the symbolic blacksmith group at left took two months to make. Its detail reflects the artist's touch inherent in all Garcia projects.

Carefully fashioned from mahogany, this 18" hull eventually will become a trim square-rigger. Like the others, it is built to scale.





# If You've Been

**A DUMMY WELL IS A DECORATIVE FOCUS OF INTEREST IN A GARDEN**

**W**ELLS like these never run dry—they are dry at the start, being intended solely for their ornamental value as a focal point in a garden. If you are so fortunate, however, as to own a real well, there is no reason why you cannot build a rustic stone wall around it to increase its beauty. Or, in the case of an artificial well, you can pipe it for a water supply and drain, cement the inside to make it watertight, and have it serve as a fish or lily pond.

Stones and timber for a wall and superstructure can often be gathered in near-by fields and woods; old bricks may be collected, if preferred; and scrap strap iron, if needed, and a suitable pulley may be found in a junk pile. A

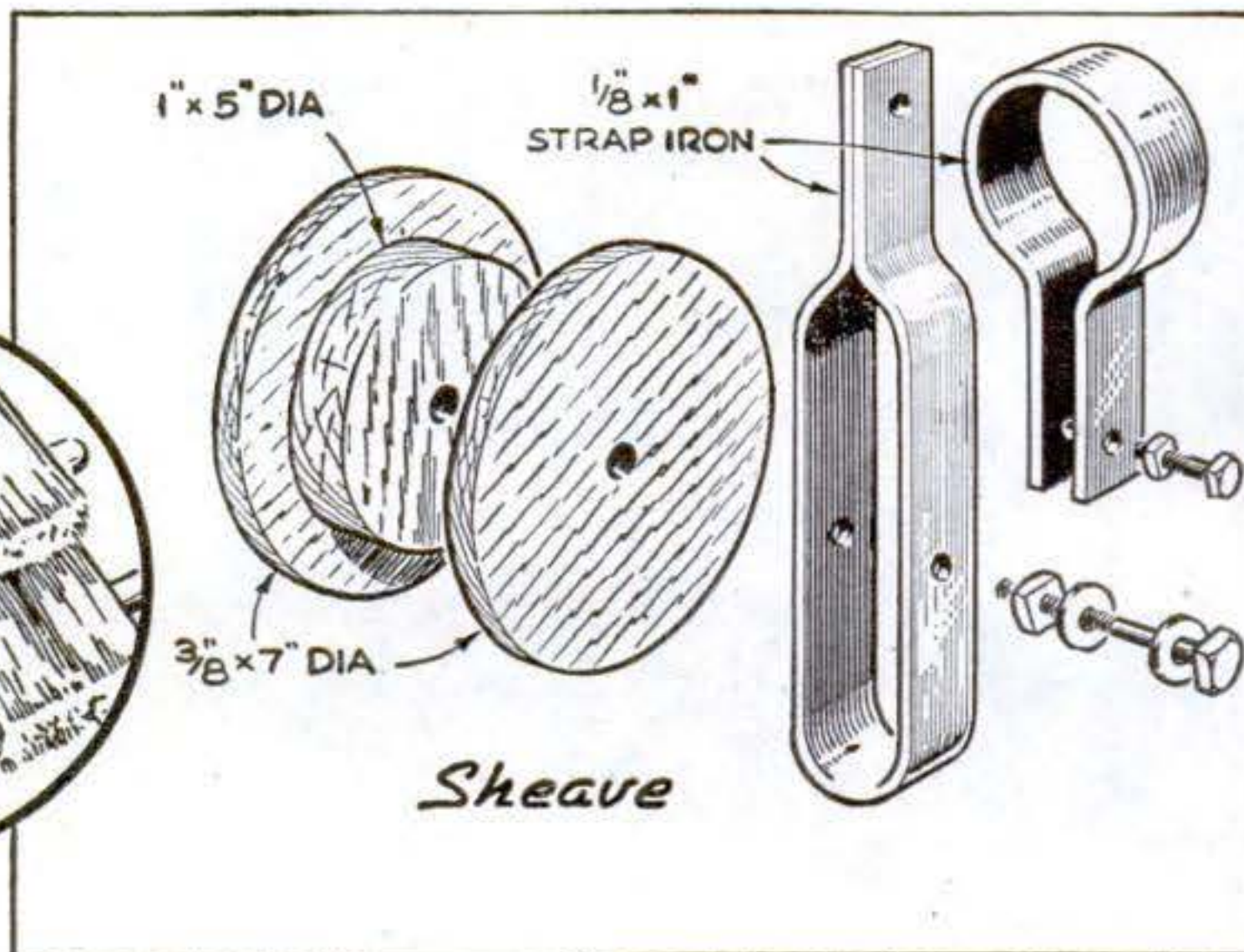
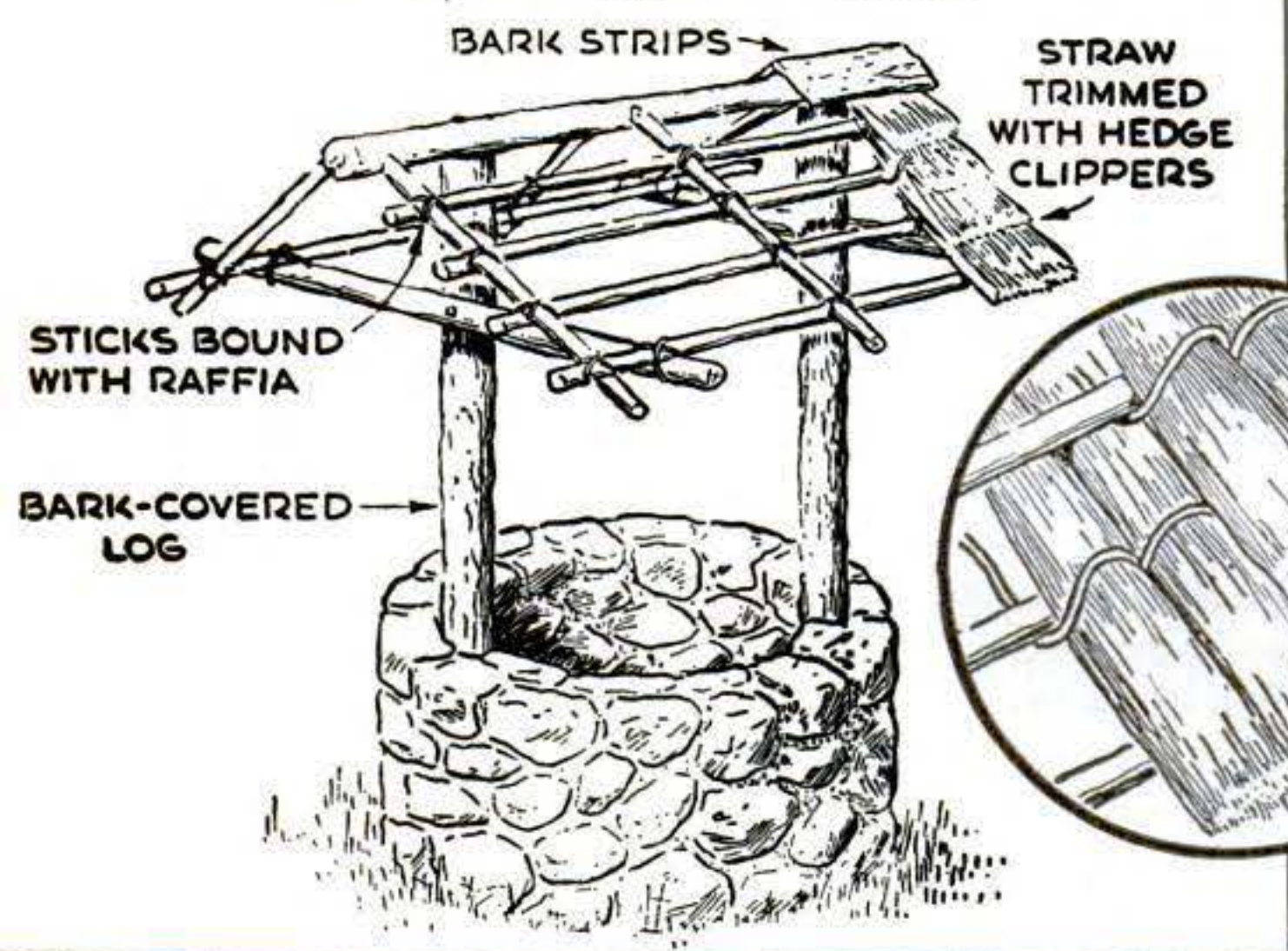
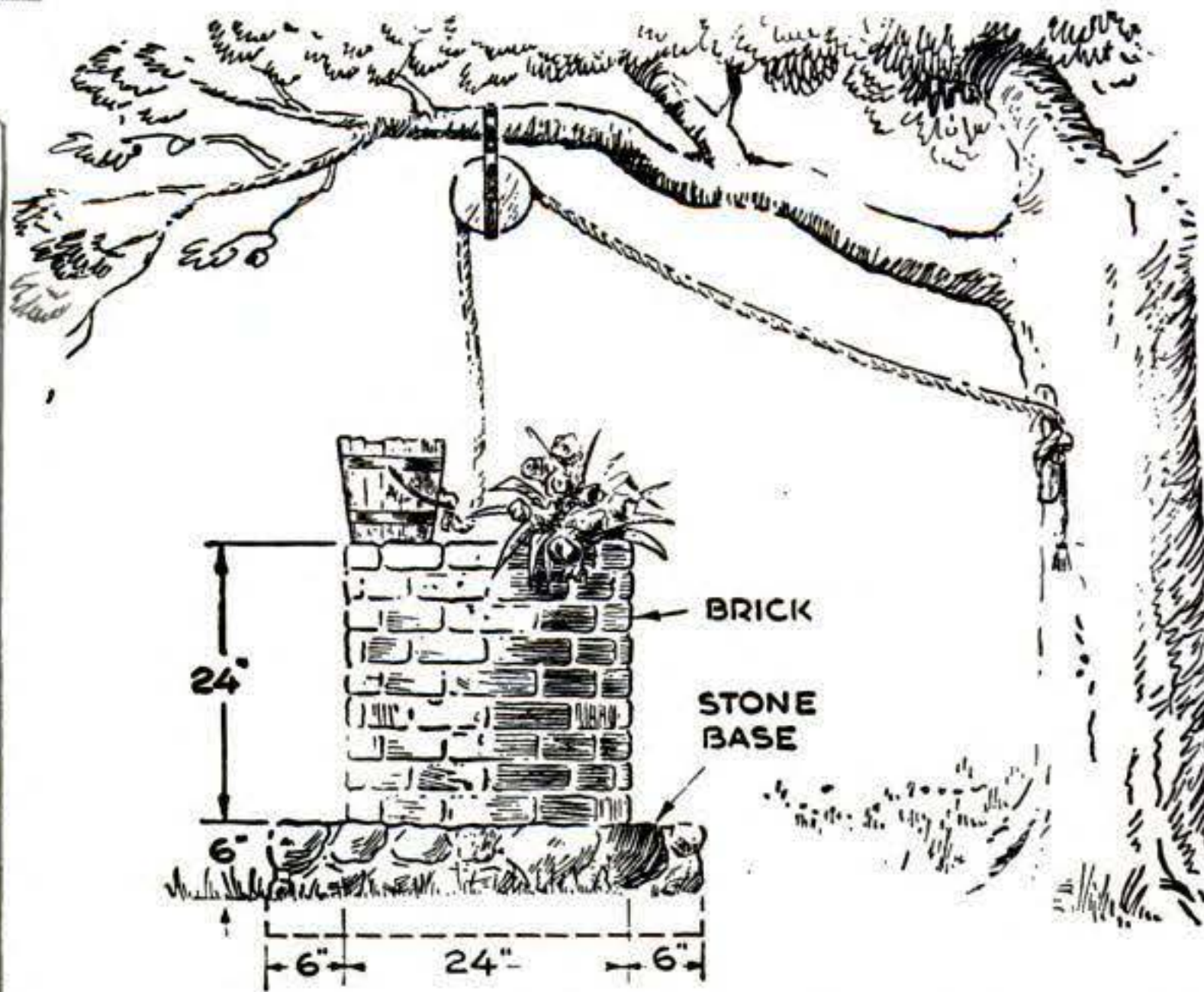
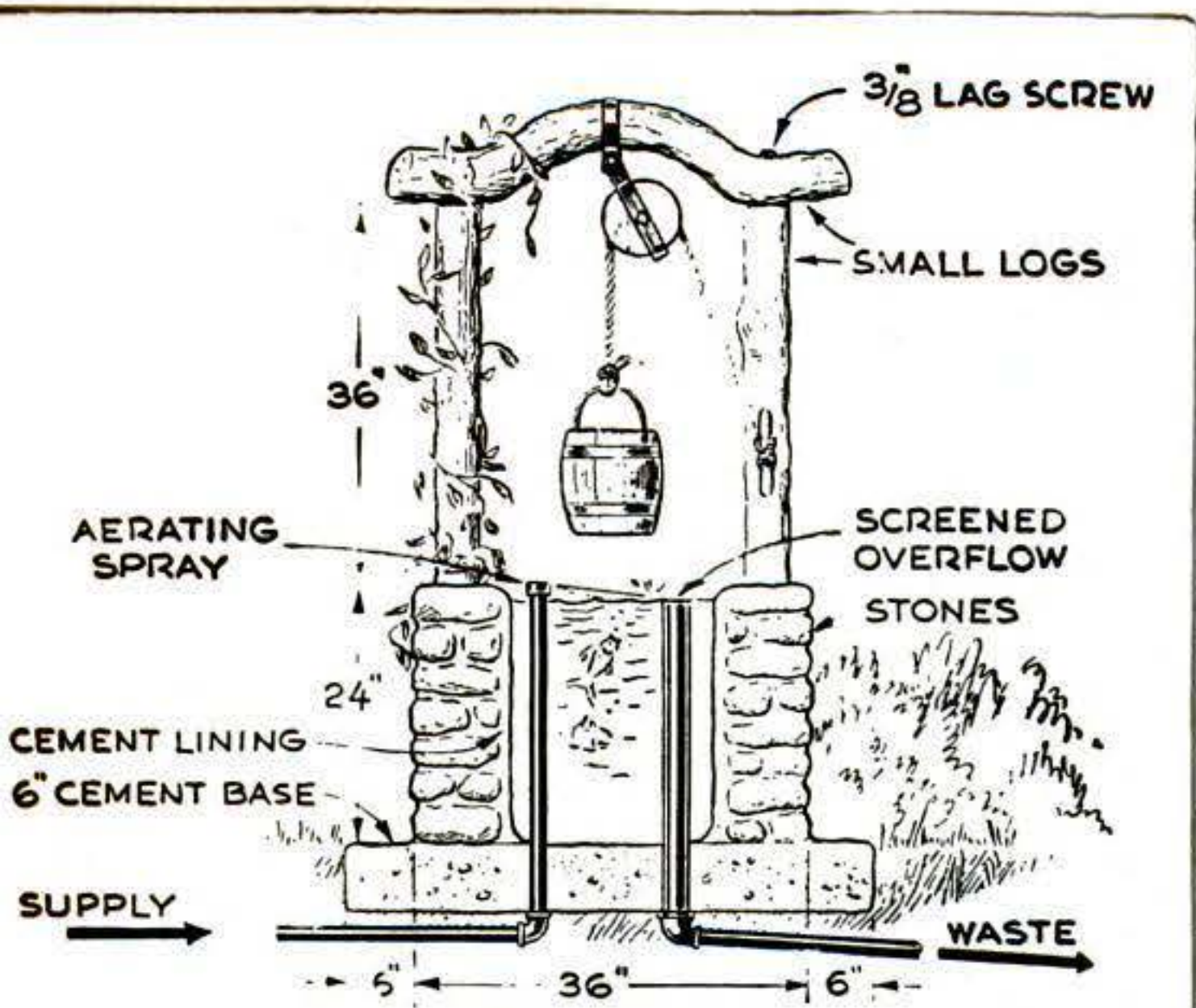



# Wishing for a Well...

wooden pulley may be built as shown in a drawing. Some sand and cement will also be required for mortar.

Several designs for rustic wells are shown in the photos and drawings. Start any of them with at least a 6" foundation, buried or exposed. Be sure to provide for drainage of any parts where growing plants are to be included.

Set the posts into the masonry of the sides, and they'll stay tight for a long time. Tree limbs, given several coats of varnish to help keep the bark on, add a rustic note. A thatched roof of raffia-tied branches may be added. Tie on large handfuls of straw with raffia, as shown in a drawing, and trim with hedge clippers when the straw is in place.

Hardware stores carry suitable wooden buckets, or a paint or wine keg can be fitted with a bail to serve.—HI SIBLEY.

Arched gracefully above a well built of cut stone, a strap-iron support holds a pulley and old bucket.

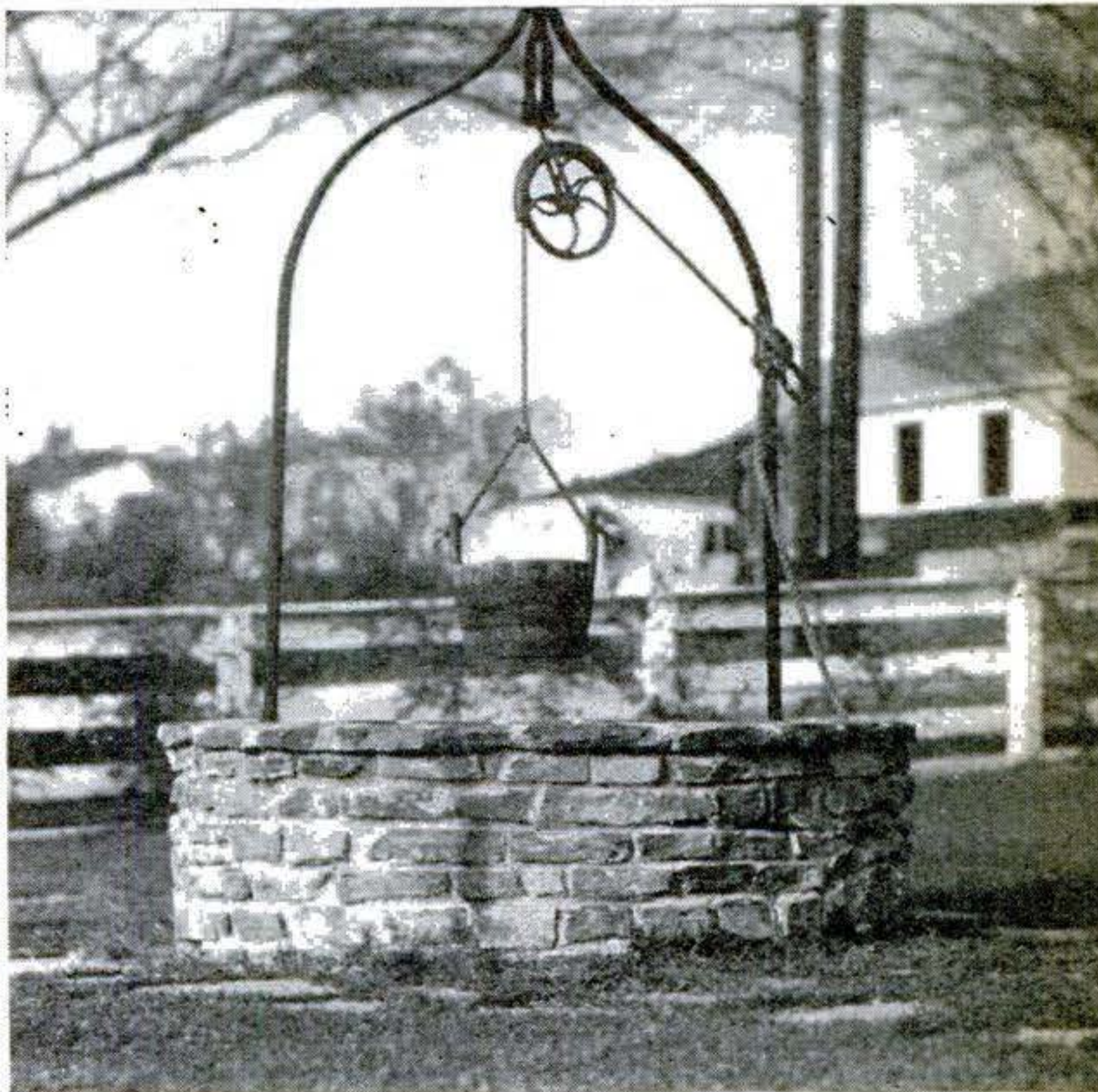

## Pair of Stirrups and Hooks on Ropes Is Tree-Climbing Aid



Above, raising one rope. A strap encircling both tree and body would add security.

ANY tree can be climbed, or even a smooth steel pole, with a rig like this. A stirrup and a hooklike clamp fitting joined with strong rope make one of a pair. Reach high, circle the tree with one rope, run it over the clamp, and put one foot in the stirrup. Your weight will anchor the device on the tree. Then reach up, attach the other rope, and step into its stirrup. Raise the first rope, which should be longer than the other, and repeat.

Put the long piece of hose on the  $\frac{1}{4}$ " rod before bending to shape and threading. Avoid nicks that may weaken the rod. The short hose sections should turn freely.—THOMAS MITCHELL.

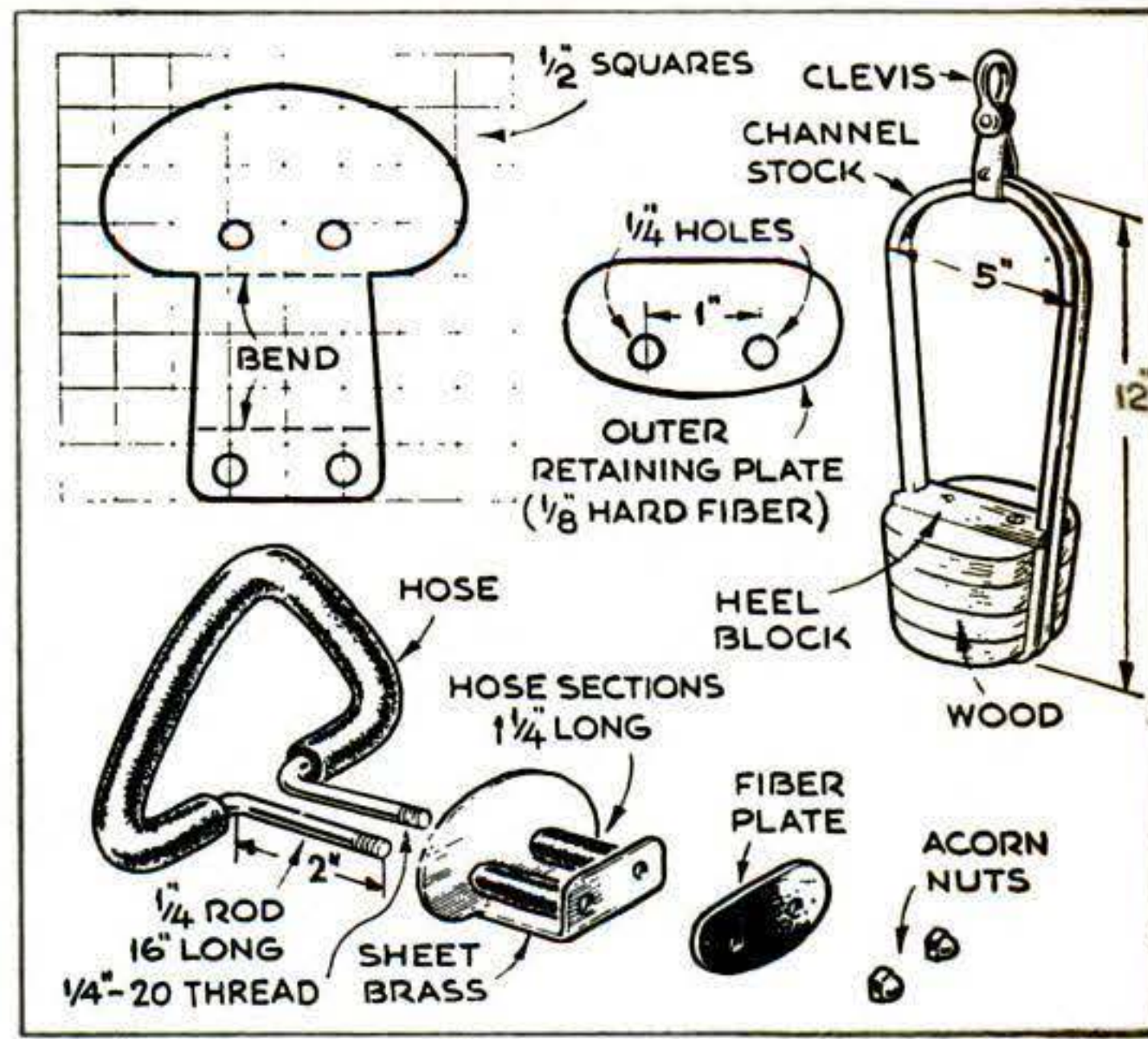



# —YANKEE INGENUITY IN UNIFORM—



**AMERICAN SOLDIERS**, always resourceful, are solving problems all over the world with the means at hand. Here, Sgt. Carl M. Perin (left), of Newport, Ohio, sheet-metal specialist at a base in Britain, and Sgt. Erwin J. Schwade, of Fort Atkinson, Iowa, use a compressed-air tank that Perin made from an oxygen container. A sheet-metal rack, fitted with pressure gauge and carrying handle, encloses the tank, which is light enough to move easily from job to job.

**HAIRCUTS** are given on Guadalcanal in a barber chair that has most of the comforts of home. It was built by men of the 282nd Ordnance Company from a discarded truck wheel, a hydraulic jack, a jeep seat, and other junked material. The jack handle was replaced with a foot pedal.

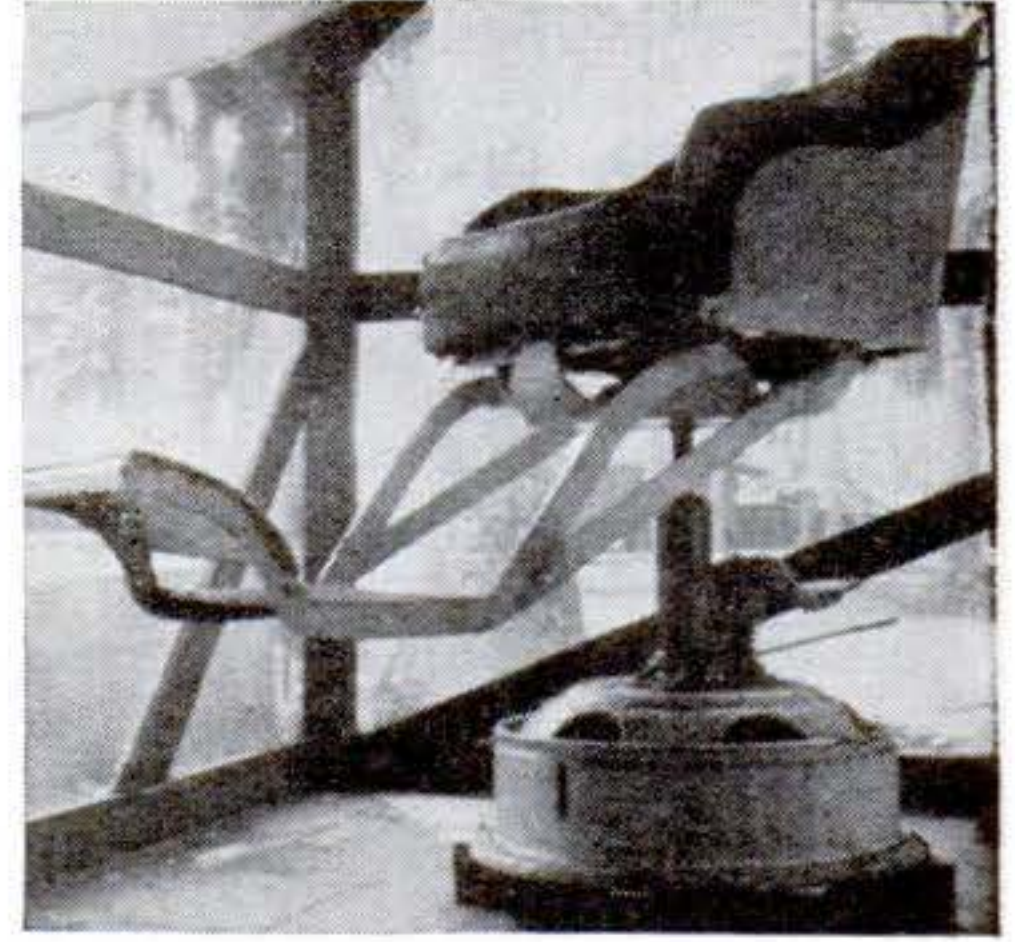

**CORRODED SPARK PLUGS** that were jammed tightly into their cylinder heads presented a problem to Master Sgt. Fred Covert, of Corsicana, Tex.—but not for long. Resorting to the technical know-how that men of the United States armed forces take along with them wherever they go, he soon evolved a procedure for extracting the plugs. He first rounded up several fire extinguishers at the Air Service Command Depot where he is stationed in England. Then he concentrated their blasts on a small surface, collecting enough carbon dioxide to form crystals of dry ice. Packing the crystals around the jammed plugs, he found that they soon contracted enough to be unscrewed.



**ALL THE PURE WATER** needed at a Pacific base, which originally had to rely on a supply distilled from the sea, now is furnished by a pump built of odds and ends. Power is supplied by an air-cooled gasoline engine. A truck winch provided the worm gear that

reduces shaft speed from 1,500 to 60 r.p.m. The reciprocating action required to operate the 55' suction rod is transmitted by means of a crank, two pitmans, and a walking beam. The long rod was pieced together from sections of concrete-reinforcing rods. All parts of the piston assembly were machined from scrap metal. Leather suction cups were tooled from a rifle boot.

Marine Gunnery Sgt. Elmer C. Wickstrom, of St. Paul, Minn., and the pump he devised to supply water at a Pacific base.

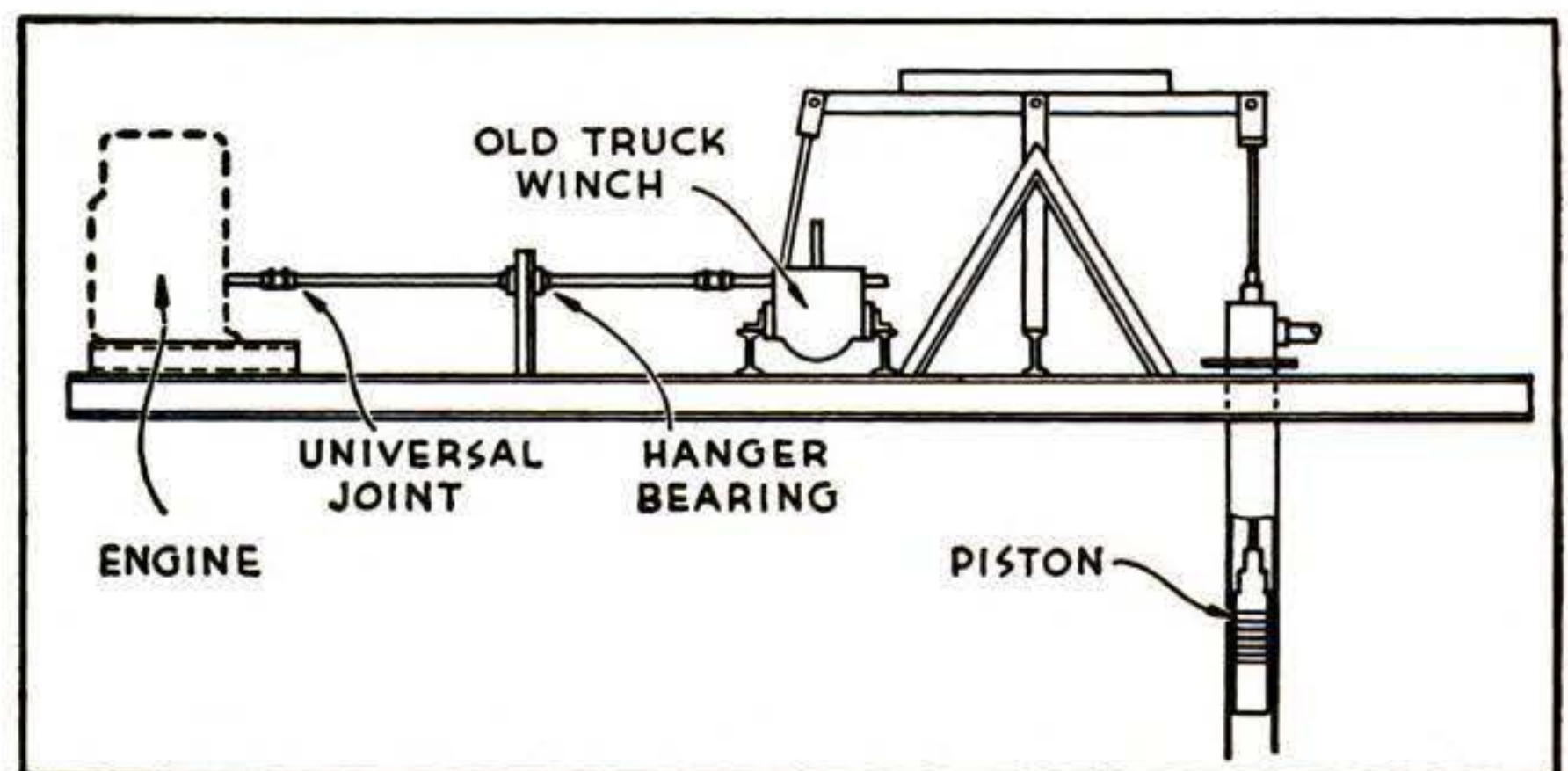



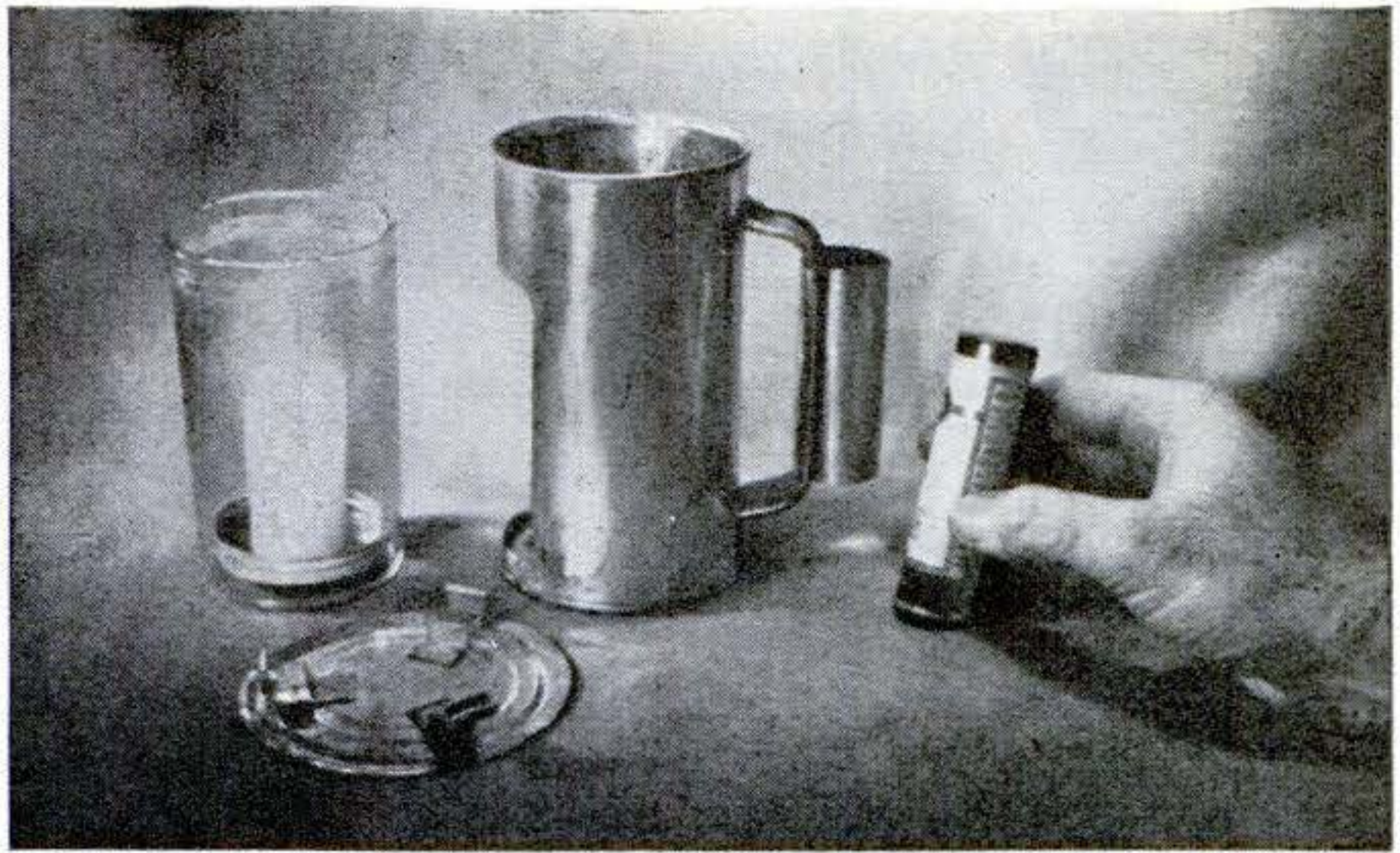

## Candle Lantern Made from Tin Can Is Useful Indoors and Out

THIS lantern has a rather old-fashioned look, but you will find it handy in an emergency if you happen to be out of flashlight batteries. Remove the top from a tin can of suitable size with a rotary opener that leaves a smooth edge, and cut a rectangular opening in one side. The candle is held in a heavy tumbler. Spike it on a nail driven through the lid of a smaller can and set it in the bottom of the tumbler. The glass and a second lid, taken from a large can and provided with clips, protect the candle flame from wind.

A handle is soldered to the back of the lantern, and a rolled piece of tin-can stock is soldered on one edge to the handle. This forms a spring clip that will hold a beef-cube can in which matches may be kept.

The outside of the lantern may be finished, but leave the inside bright for a reflector.—R. S.

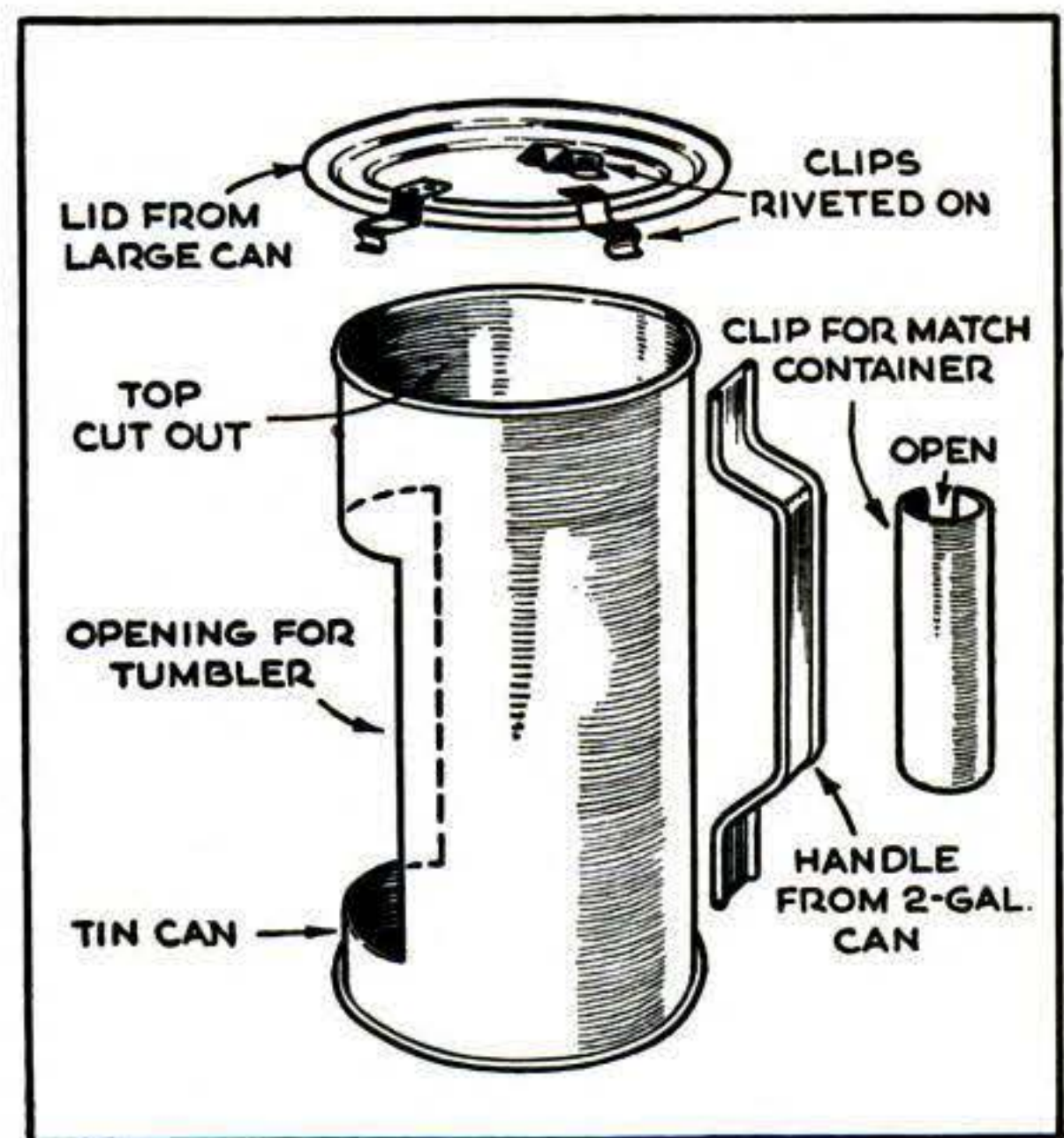

## STANDARD PLYWOOD GRADES [WOODWORKING]

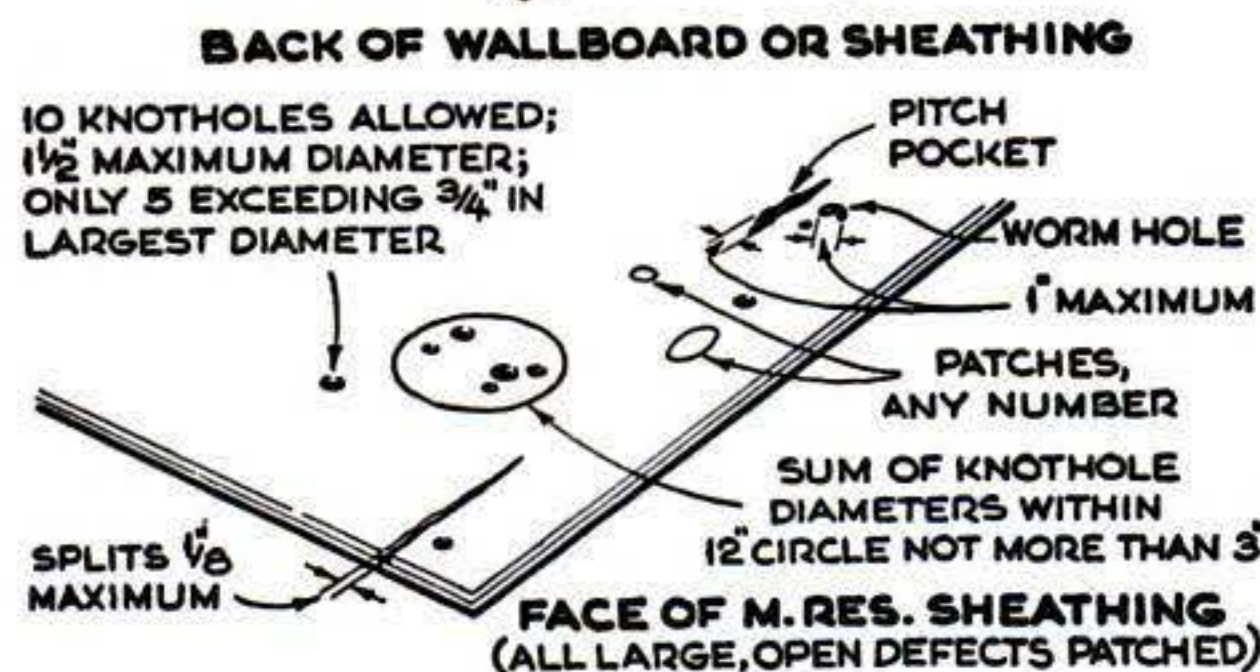
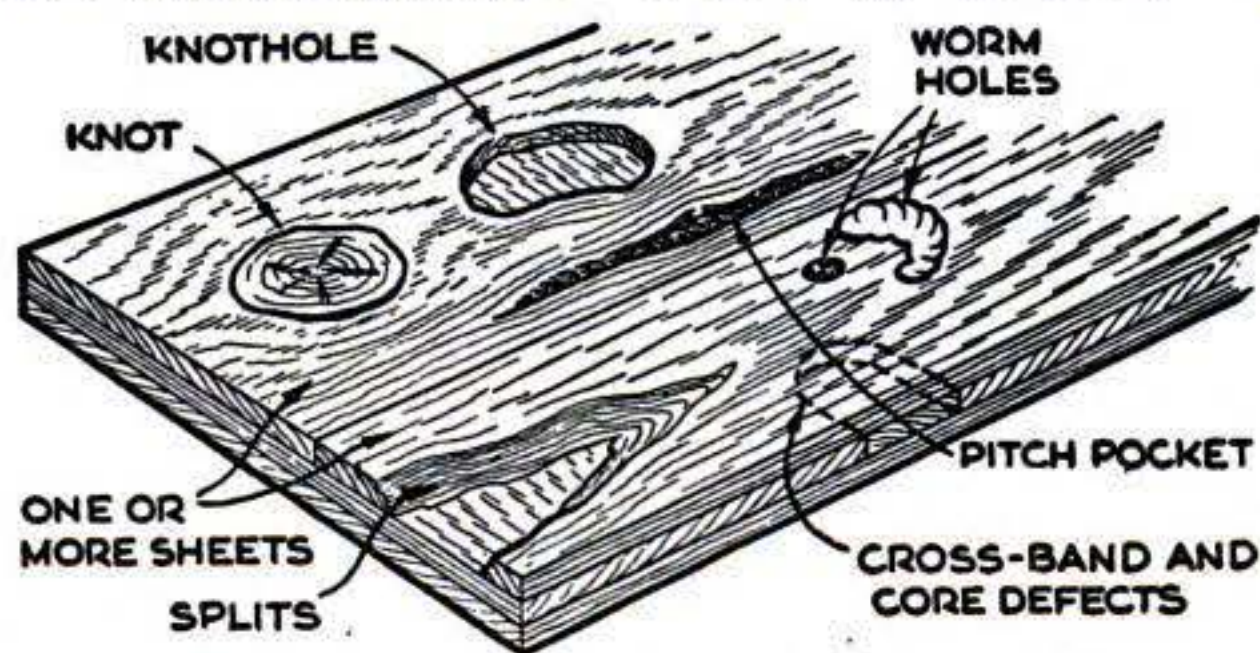

Grade	Abbr.	Face	Back	Surface	
Plypanel	Good 2 sides	G2S	Good	Good	Sanded
	Good 1 side	G1S	"	Sound	"
	Sound 2 sides	So2S	Sound	"	"
	Sound 1 side	So1S	"	Utility 1	"
Plywall	Wallboard 2	WB	"	"	"
Plyscord	Sheathing	SH	Utility 3	"	Unsanded
Plyform	Concrete form		Sound 4	Sound	Sanded

- 1 Knots or holes in back 1" or less long way.
- 2 Made only in moisture-resistant grade.
- 3 Large knotholes and other defects patched in one side. Scored with lines 16" apart for guidance in nailing to studs and joists.
- 4 Outer plies, except in 1/4" plywood, 1/8" thick before sanding. No knotholes in cross-banding. Waterproof bonding, surface mill-oiled, edges sealed with special green paint.

The permissible defects are illustrated in the drawings at left which show the back of wallboard and sheathing and the face of moisture-resistant sheathing. Specifications are those of the Douglas Fir Plywood Association. The same gradings apply in general to moisture-resistant and exterior plywood, but exterior allows neither gaps nor core voids that impair the serviceability of a panel.

POPULAR SCIENCE MONTHLY SHOP DATA





Small tools are essential equipment in the workshop of modelmaker Joseph McCord, shown at right using a watchmaker's lathe to turn a table leg. At left, a nail too tiny for the fingers is held with tweezers.

## It's the Little Things That Count

**M**ODELMAKING led to a big event in the lives of Mr. and Mrs. Joseph McCord—their marriage. They met at the New York World's Fair, where between them they had built or were in charge of more than 40 miniature exhibits. Little things still are big business with them, and the second floor of their Greenwich Village home is lined with shelves filled with a variety of tiny objects they have made.

Like many other modelmakers, the McCords always are on the lookout for small tools to add to their collection. They use surgical, dental, and watchmaking tools, altering them, if necessary, to suit the requirements of a particular job. Frequently they design and make their own. Extremely fine work is done under a magnifying glass.

Mr. and Mrs. McCord specialize in furniture, but they also have built automobiles, boats, aircraft, and other items—all work-

able and formed to scale. Furniture manufacturers often study their models to determine the feasibility of putting full-sized pieces into production, and collectors willingly pay high prices for the items.



Just the right size for a Lilliputian family, the furniture and pair of miniature brass andirons below represent many hours of patient work, each piece being formed to exact scale. Cigarettes serve as logs on the andirons. A collector paid \$65 for the pair. Note the 6" rule in the center of the tools above.

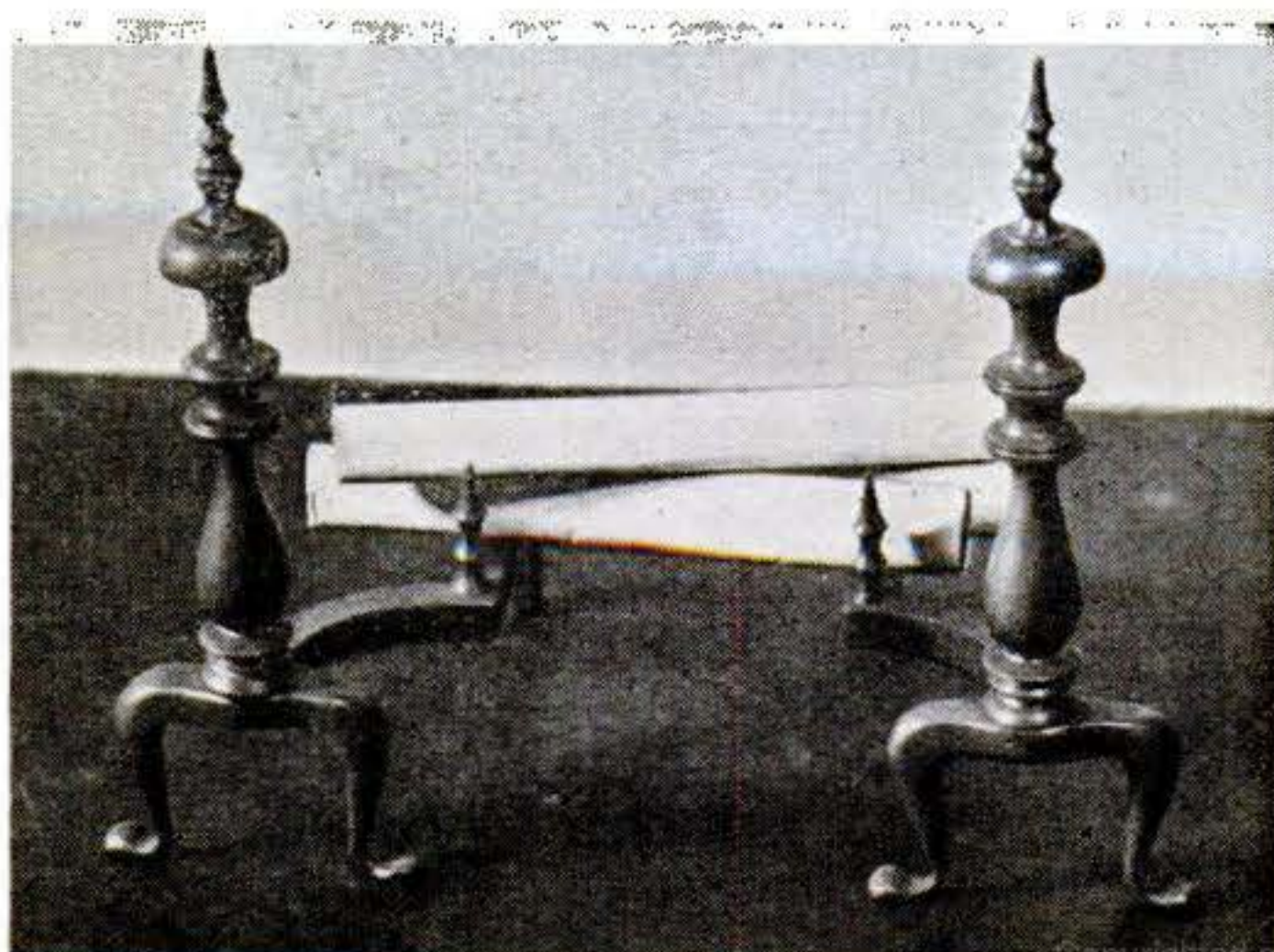



## Pocket-Size Game Is Played with Lively Bobbing Capsules

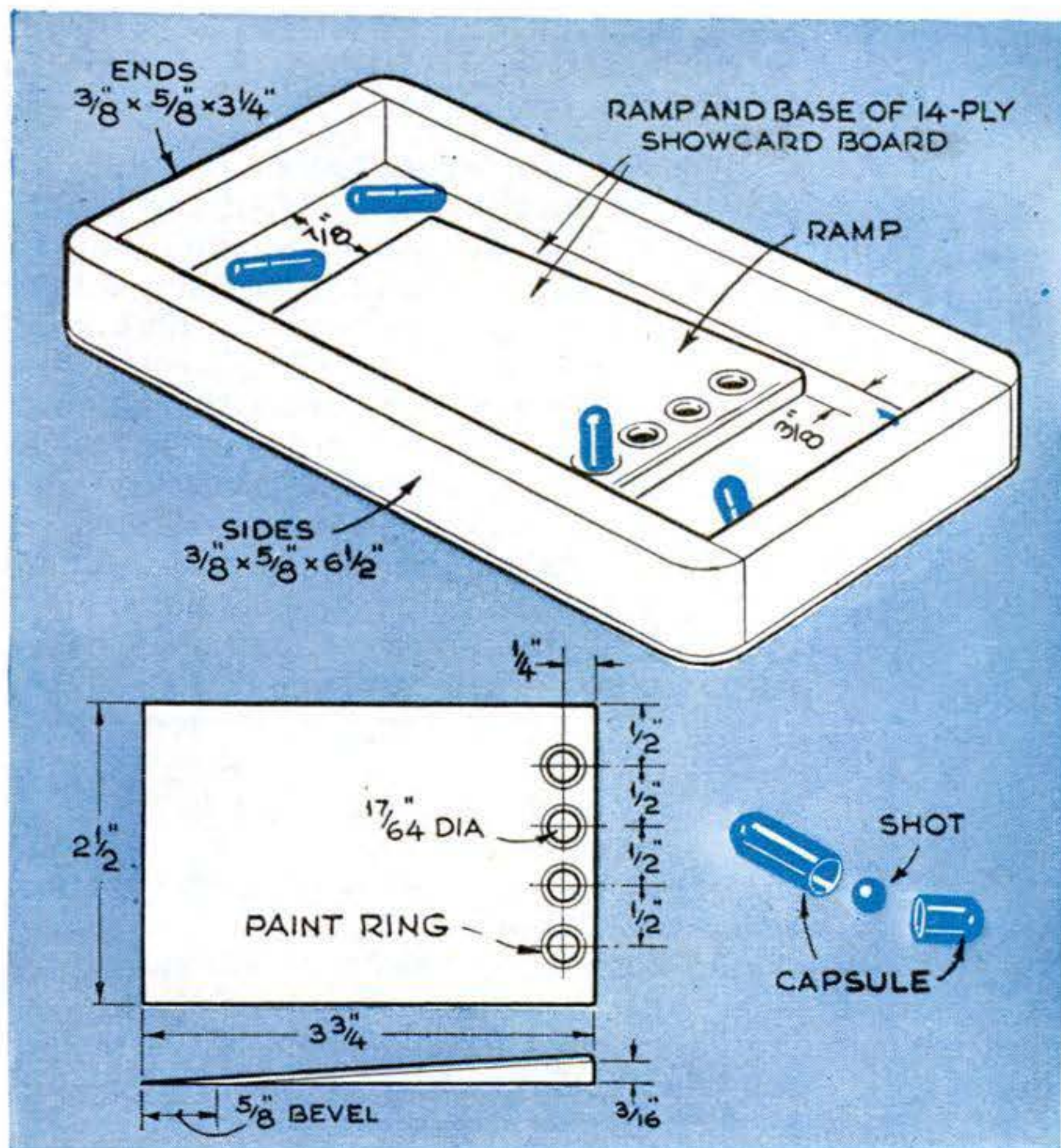

the starting point for another try, and some already in holes may fall out and have to be maneuvered in again.

Each player keeps the board until all the capsules are in

PLAYED with four capsules, each containing a lead shot, this game will send you into tailspins of excitement and exasperation. The object is to roll the capsules up the ramp and into the holes. But there's a catch. Those that fail to stop in holes must be returned along the side of the ramp to

holes. Scoring may be by time or by the number of trips capsules make up the ramp.

You can make the game harder by lacquering half of each capsule one color and half another, and then requiring them to land in holes with the same color up. Drug-gists can supply capsules—FRANK SHORE.

## Colored Beads in Test Tube Separate at "Bridge of Sighs"

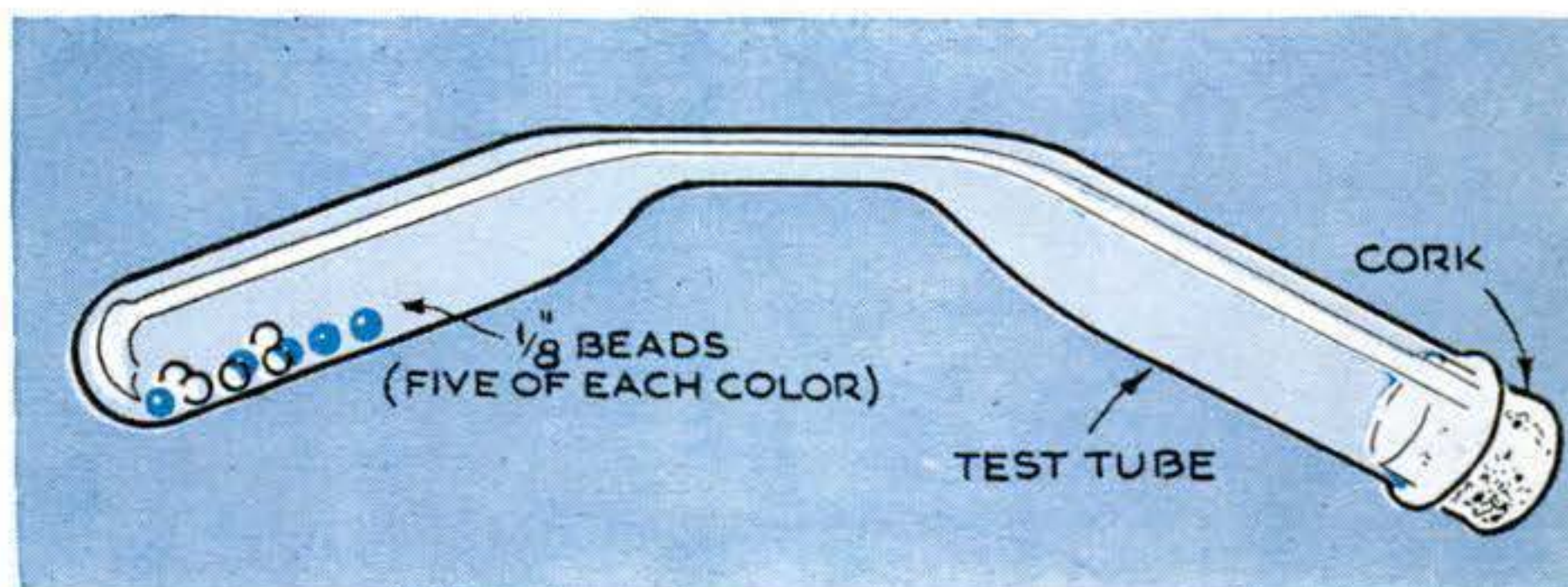

MAKING this game requires little skill in glass bending; playing it requires quite a bit more of another kind. Heat a test tube at the center by rotating it in the flame of a Bunsen burner, and remove it when the flame becomes yellow. Then pull the ends to stretch the center while the tube is hot and bend the ends down slightly.

Put five  $\frac{1}{8}$ " beads of one color and five of another in the tube and cork it. The object is to separate the colors on either side of the "bridge."—GEORGE BARR.





By EDWIN M. LOVE

**L**OW-RELIEF, or bas-relief, ornamentation was often employed by early craftsmen who enriched the surfaces of chests with chisel-cut designs. It is the next step after chip and incised carving toward advanced wood carving.

As a variant, strapwork projects cover a wide field from simple layouts to intricate all-over patterns of interlacing bands, ribbons, and leaves. Low relief itself is espe-

Scoring across the grain assures clean edges when wood of alternate hard and soft grain is carved.



# WOOD CARVING

## Chisel and Strapwork Designs

cially suited to decoration of the rails and stiles of a framed assembly, if the shallow grounding will not weaken joints, and the flatness of its ornament is a good foil for boldly modeled panels carved in high relief.

*What tools are required?* Avoid boxed sets and choose instead from the hundreds of chisels available. Wood can be carved with a very few chisels, if necessary. It is best to buy a few good ones and then add to your collection as experience demands. These 16 chisels and gouges should be ample for all but the most professional needs: skew knife;  $\frac{1}{8}$ ",  $\frac{5}{16}$ ", and  $\frac{7}{16}$ " carving chisels;  $\frac{1}{4}$ ",  $\frac{3}{8}$ ", and  $\frac{1}{2}$ " firmer chisels;  $\frac{3}{32}$ ",  $\frac{1}{8}$ ",  $\frac{1}{4}$ ",  $\frac{3}{8}$ "  $\frac{7}{16}$ ", and  $\frac{1}{2}$ " veining gouges; V-tool or veiner; and  $\frac{3}{8}$ " left and right bent-back spoon skewers.

*How is the carving done?* Take the low-relief book ends shown at the top of the facing page as an example. Draw the design with a pencil and try square, and gauge a pencil line along the edge to limit the border depth. If the material is spongy, or soft and hard grain alternate, score the edge of the raised parts across the grain to sever the hard grain and to prevent tearing of the soft wood. Experimental cuts on waste wood are advisable.

Then, with a  $\frac{1}{8}$ " veining gouge held with the handle low, follow the scored outlines,

Grounds are roughed with a large gouge and then smoothed with a flatter gouge or a flat chisel.

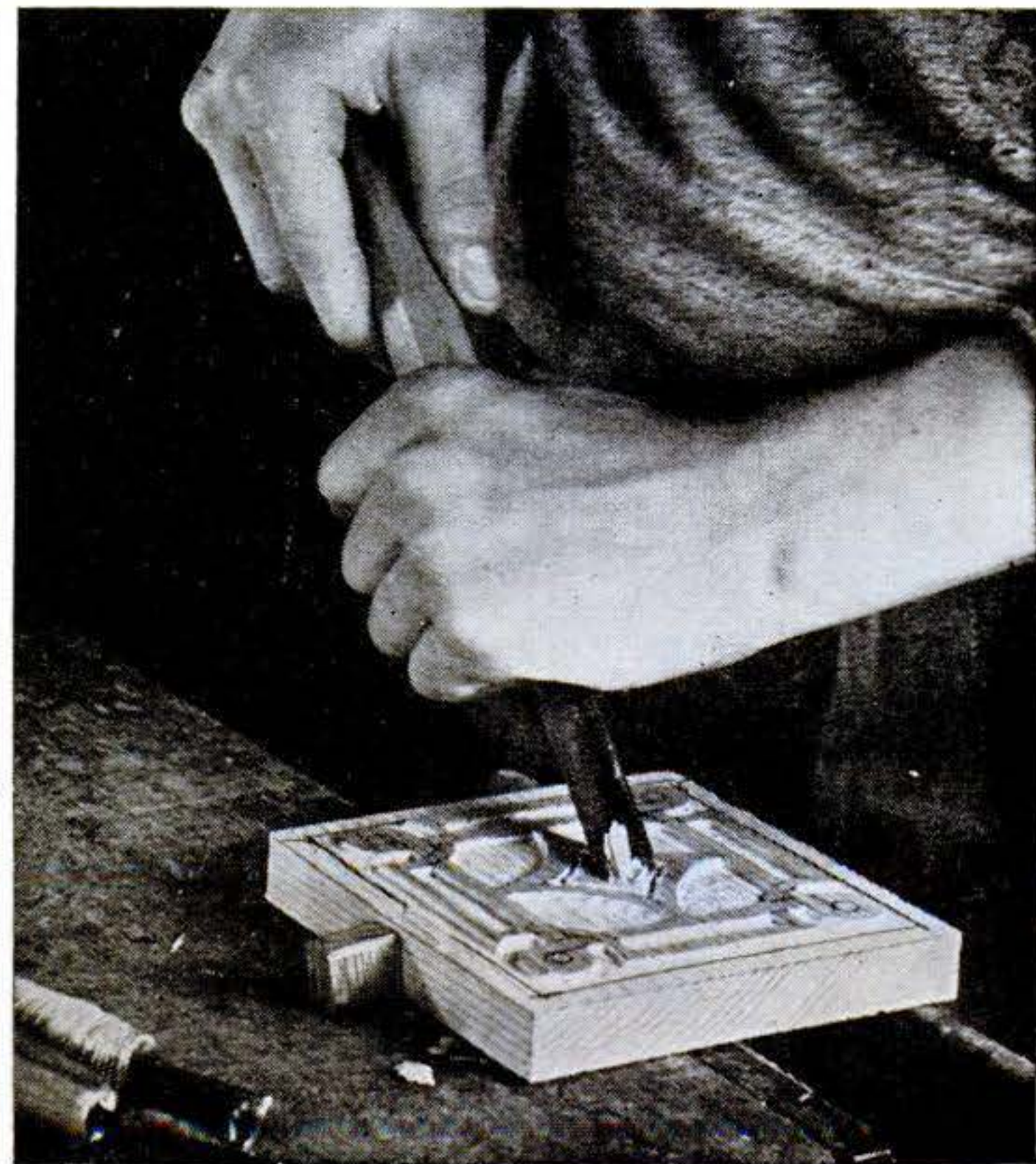



# IN LOW RELIEF

## Ornament Frames and Panels

rotating the blade slightly for a shearing cut. Trim the ends first, and then cut the edges, guiding the course of the gouge where the grain tends to lead it off the line.

Cut the tops of the T's with the same tool, and then, making a stop cut at one end and working toward it from the other, cut the long slender center flutes that cross the grain. In spongy wood such as pine, take a roughing cut and follow with a trimming cut to depth. If the lengthwise flutes are made first, their edges will splinter when the cross flutes are cut through them.

Now work the short flutes of the legs of the T's with a  $\frac{1}{4}$ " gouge, cutting from the round ends unless direction of grain prevents. Take the small gouge again and hollow the lengthwise flutes and center cross.

*Are wide stopped flutes made the same way?* Make stop cuts at the inner ends of the outer flutes; then establish the lines with light cuts of the gouge held in a vertical position, and deepen the center with a roundnose gouge or narrow flat chisel. The square in the center stops the inner flutes, but a little trimming is needed because of the greater depth of the wide flutes.

*How is the border lowered?* Carve away the ground with a wide gouge pushed diagonally across the grain with sidewise-sliding strokes. True with a flatter gouge and

Straps appear to cross over others when they are beveled. Stop cuts are made along upper straps.

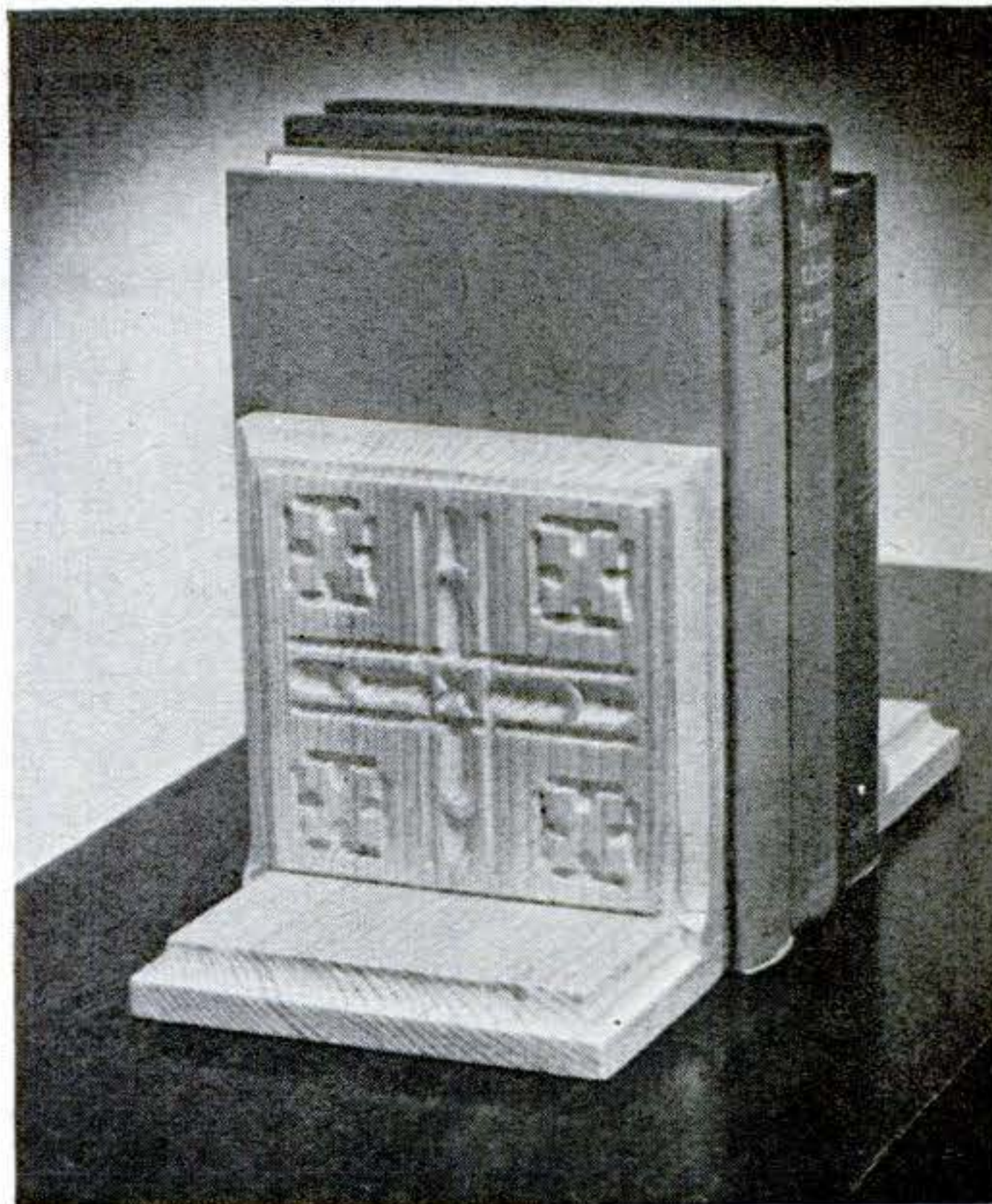

level with a flat chisel. If necessary, deepen the edge cut of the raised section with a veining gouge.

*What is done for edge coves?* Gauge guide lines on the face and edges, and chamfer with a flat chisel. Then gouge out the coves. Note the stops near the bottom edge.

*Should pencil lines be sanded off?* Use a pencil eraser. This keeps the edges sharp. Then sand, using a hard backing block.

*Is the strapwork book end more difficult?*

Grounds stippled with a stamp or punch are given a texture that contrasts with the raised design.

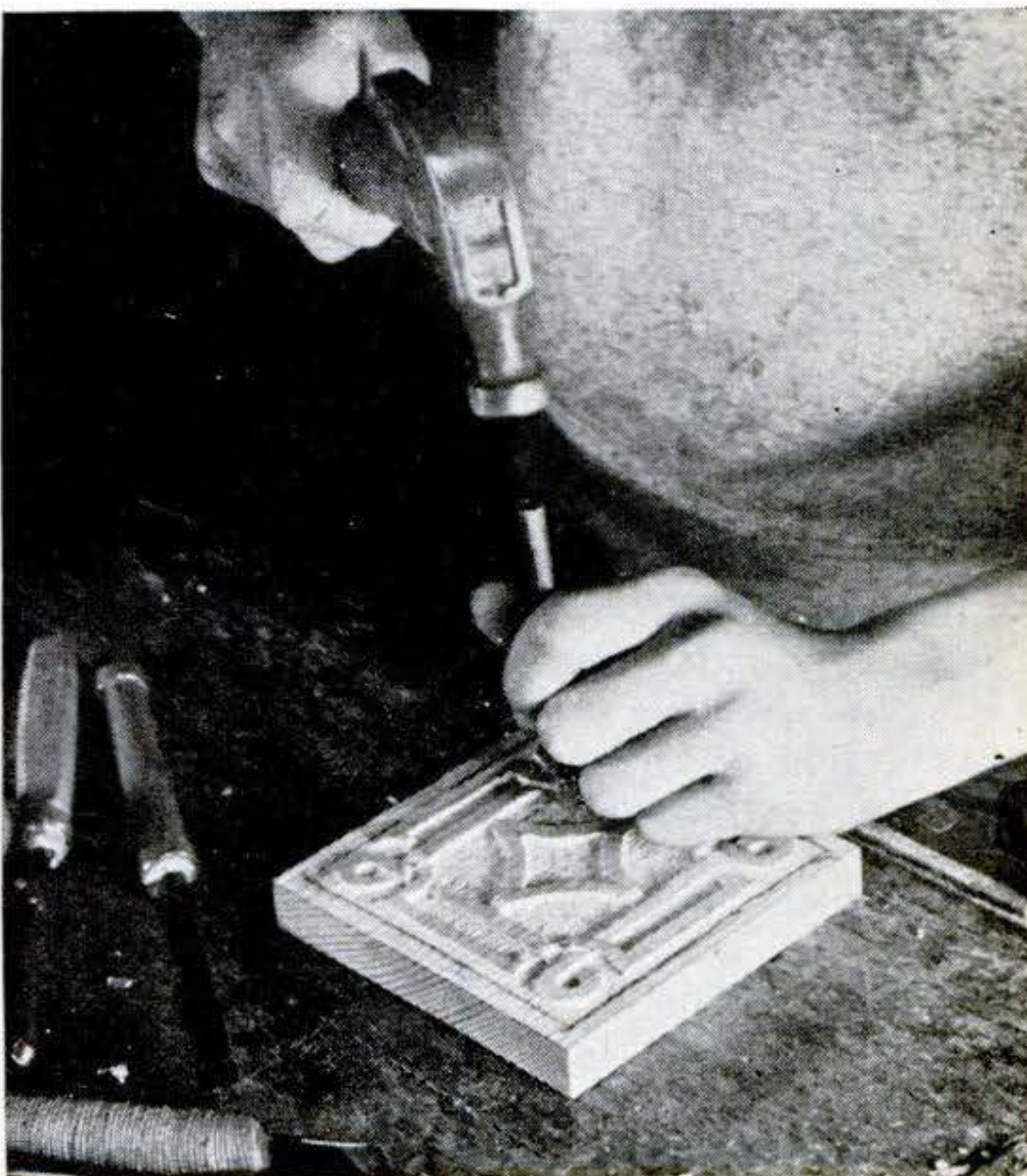
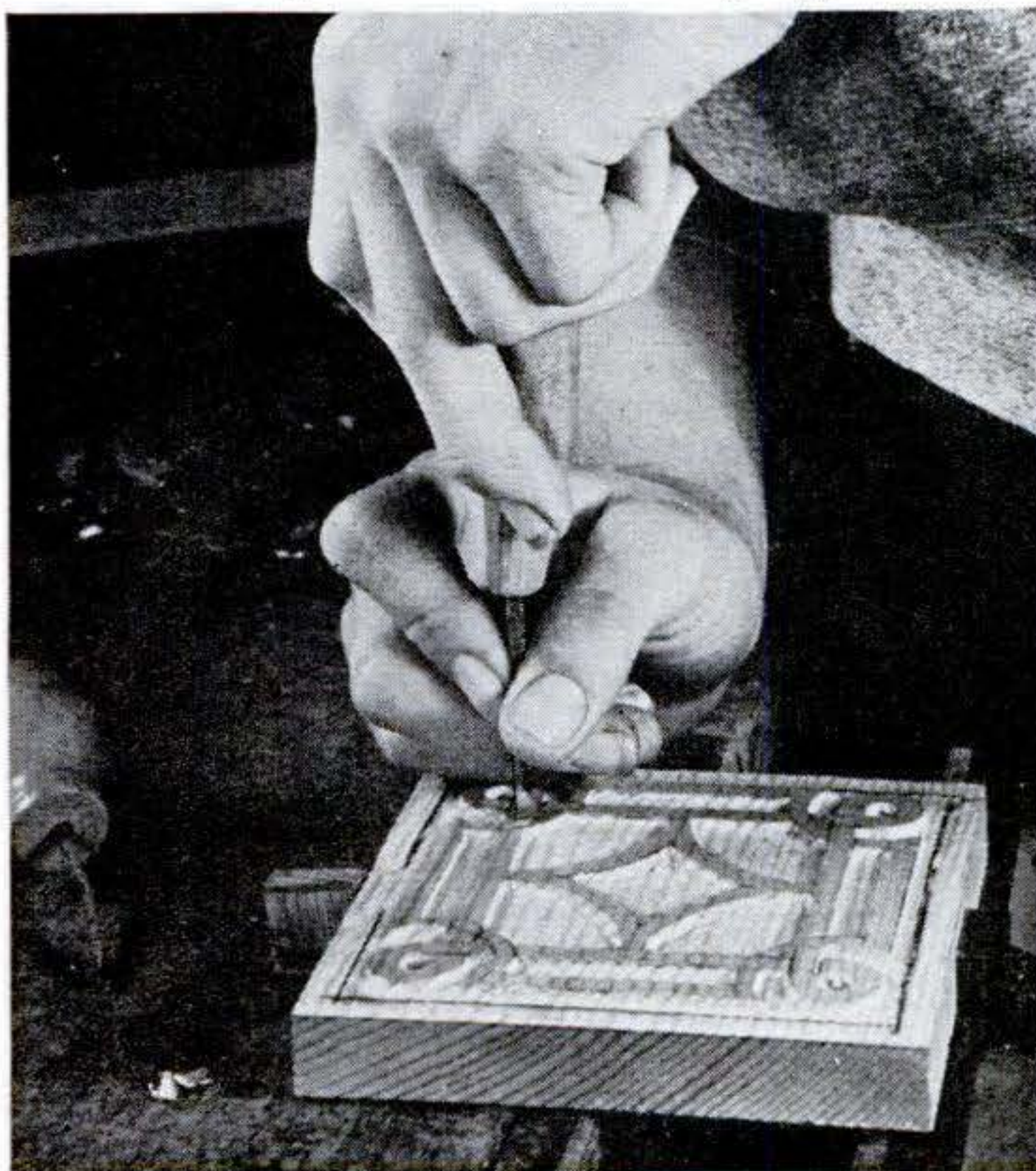



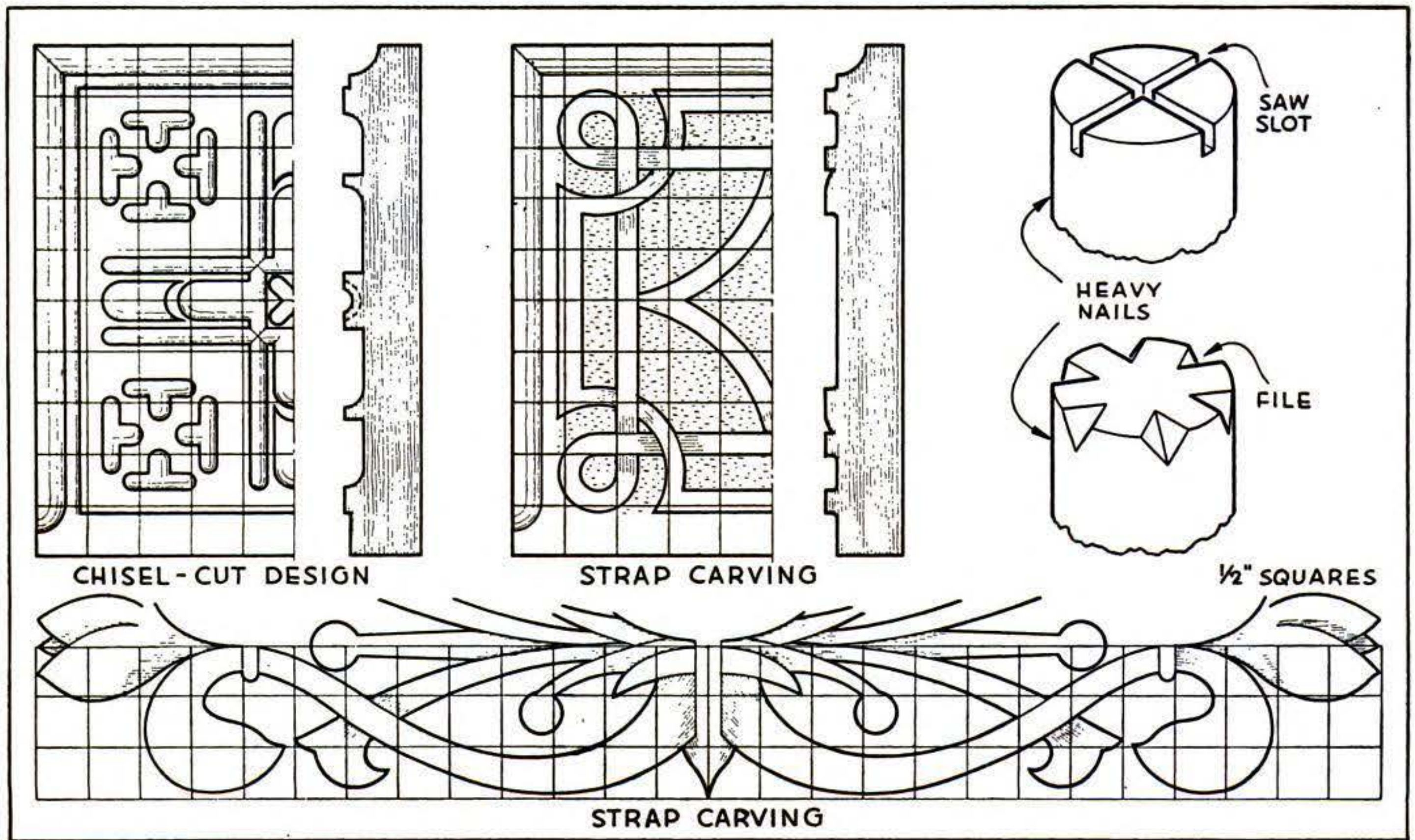

Only slightly. Lower the ground, as was done with the border of the other book end, or rout in a drill press to save time after outlining the straps with a veining gouge. The effect of one strap passing under another is obtained by beveling it smoothly down toward both edges of the upper strap. Make a stop cut on each side of the upper strap and trim the other with a flat chisel used with a shearing cut. If possible, carve with the grain across straps that run at right angles to the grain.

*How is ground stippling done?* Punches made like the two shown in the drawing are used. Ground stippling is a final leveling that gives a textured ground contrasting agreeably with the raised design.

*Is floral strapwork different?* The execution is much the same. A panel like that shown at the right is outlined with a veining gouge. Cuts are taken with the grain in one direction, and then the piece is reversed for cuts in the opposite direction. A V-veiner and narrow flat chisel are useful for trimming corner pockets.

*Can strapwork treatment be varied?* One side of the panel shown has been given a crossover treatment, while the other has been outlined with a V-tool. The piece can also be left as completed when the ground has been sunk. Such flatness gives the effect of a thin scroll-sawed piece glued to the ground, especially when the wood is without prominent grain. The ground can be left gouge-flat, it can be tex-

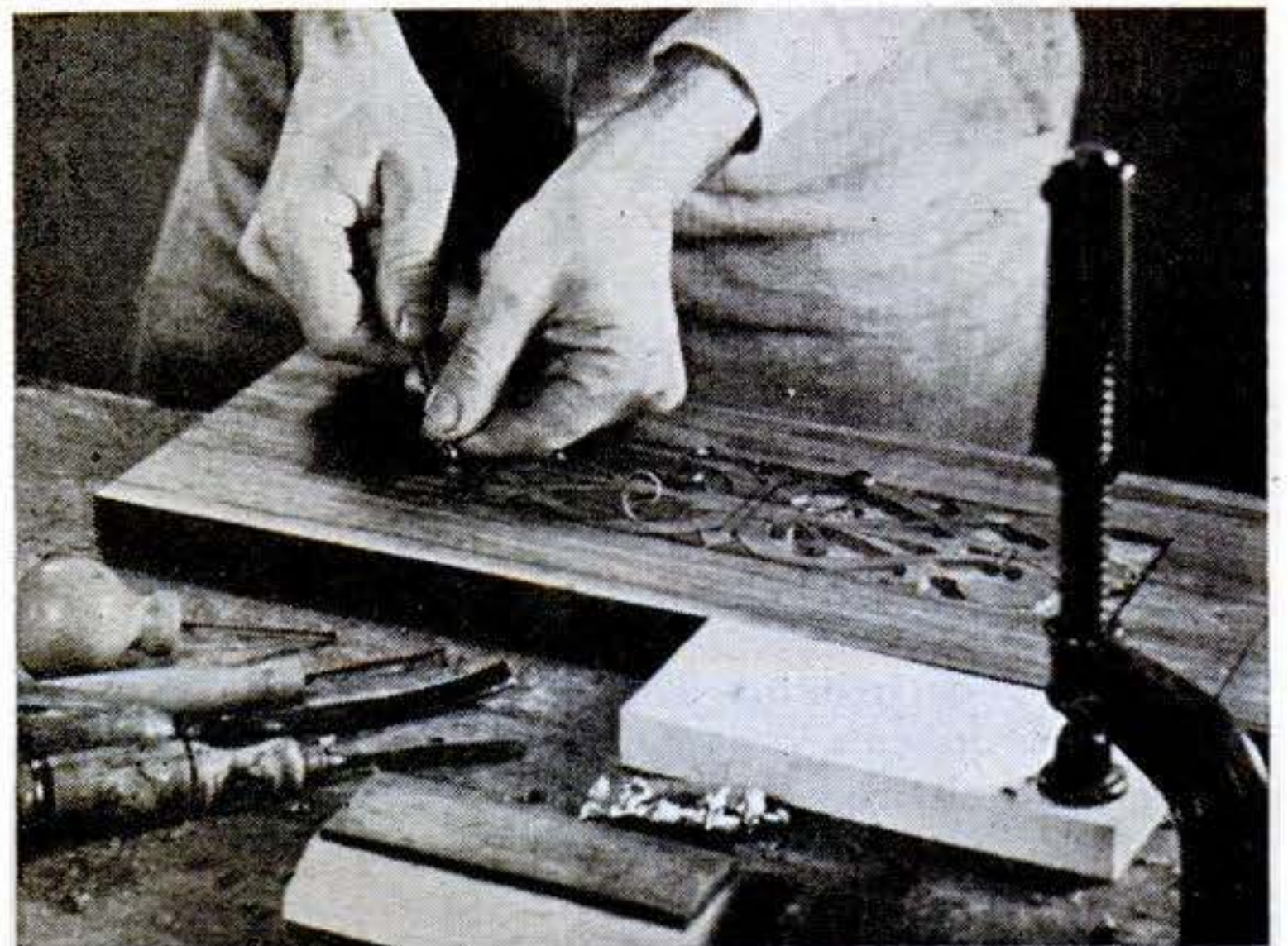

Grounds for strapwork are gouged or routed out. The straps are outlined first with a veining gouge, as in the photo above. Crossover straps are shown on one side of the panel below, outlined straps on the other.

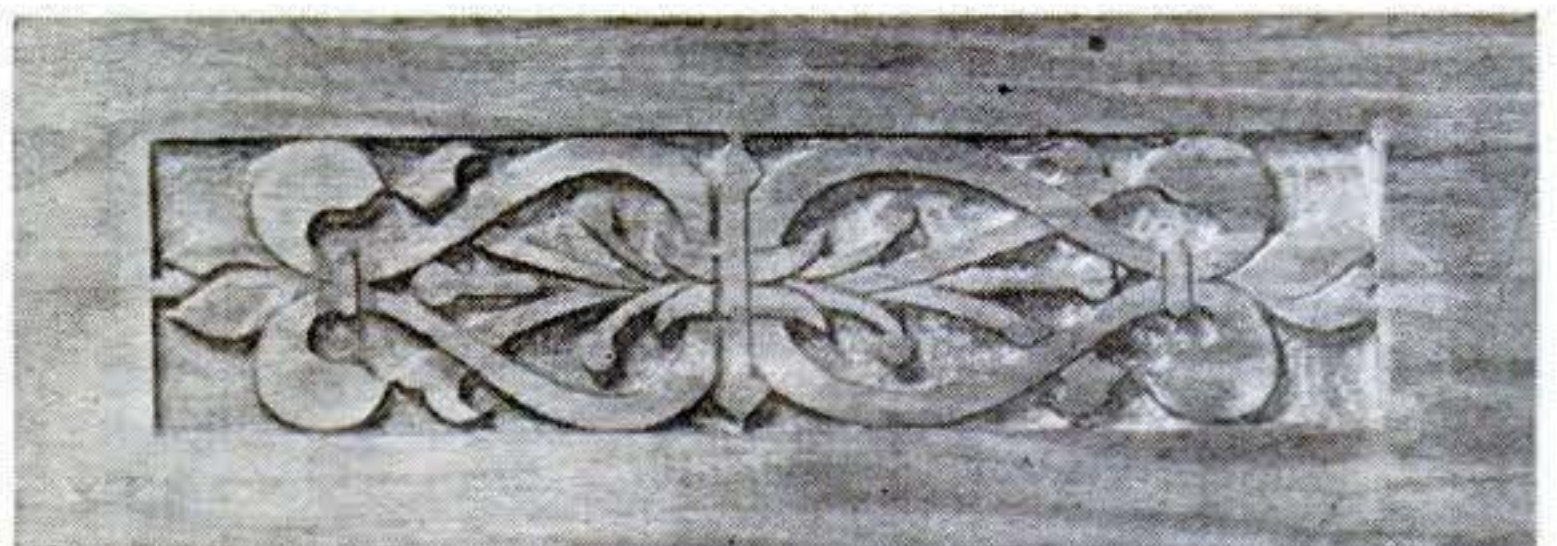

tured with small gouge cuts, or it may be stamped with a punch.

*Is color suitable for carvings?* Painted grounds and varnished patterns are effective, or polychrome treatment is good if the colors selected are harmonious and subdued.



# DOOR HINGES FOR SPECIAL PURPOSES

**H**INGES are made in many styles other than the strap and butt familiar in all home workshops. When glass doors are to be fitted with drapes, for instance, accordion butts are used. These have wide leaves that set the pivots well out and hold open doors away from the casings to leave clearance for curtain rods. Similar hinges, called parliament butts, are used on casements swinging inside.

Invisible hinges have a series of folding leaves and lugs set into mortises. They are hidden when the door is closed.

Surface spring hinges serve on flush screen doors. Some have holes into which a pin can be shifted to adjust tension. Those without adjustment are likely to let a door stand open a little after the springs weaken with wear. When a door is hung on a jamb having a projecting molding, as in a stucco wall, a half-surface hinge is required, one leaf on the door and the other mortised at 90 deg. in the jamb.

Double-acting hinges are for doors that swing both ways. The leaves go on opposite door and jamb faces.—E. M. L.

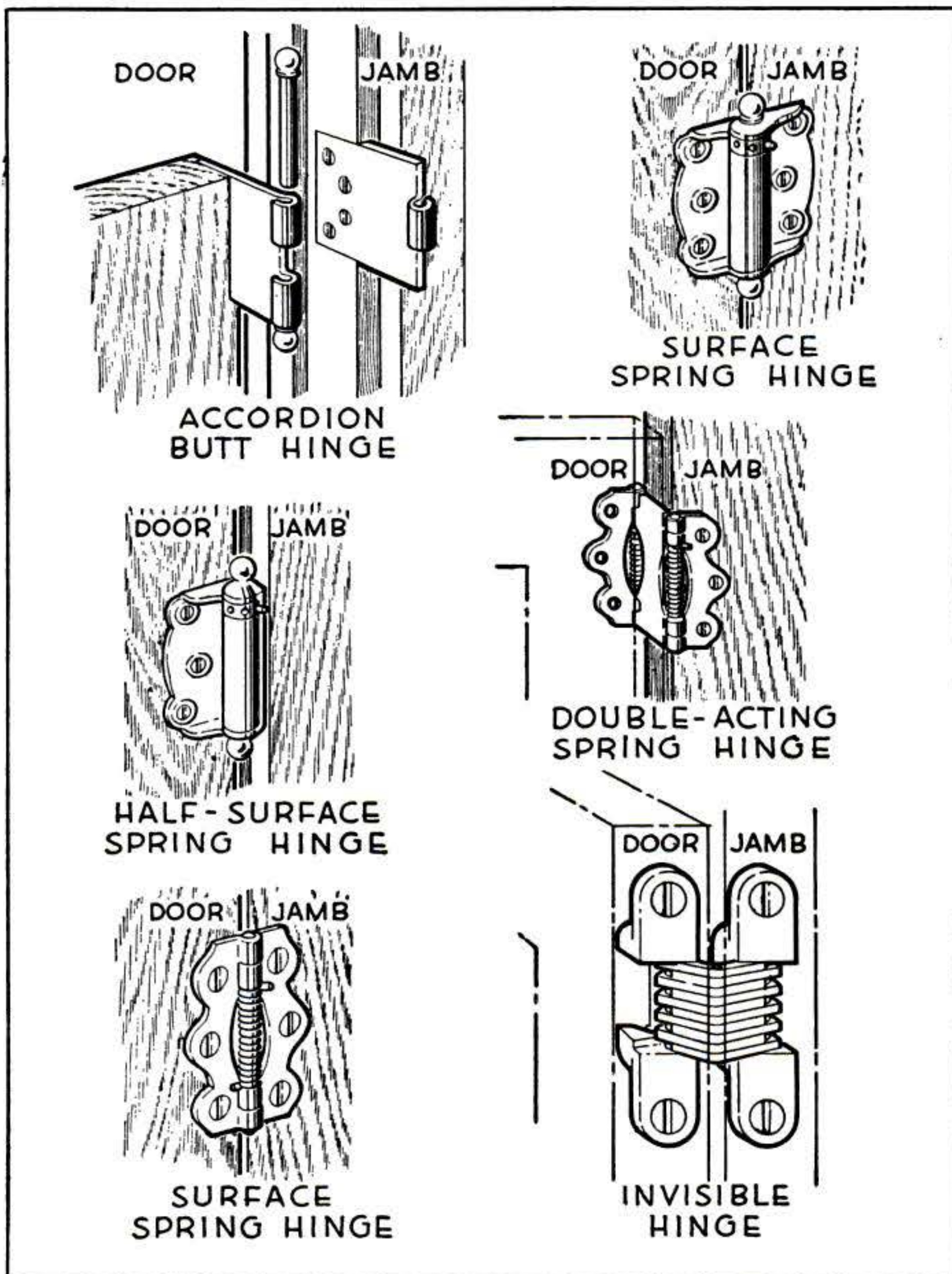

## Efficient Wood-Carving Mallet Turned from Oak

ROUND mallets are particularly favored by wood carvers, for they can strike the chisel with any face. They should be turned from oak or other hardwood.

Taper and crown the head and round the corners. Bore the head from both

ends to assure centering. Turn the handle to a snug fit and saw a kerf  $1\frac{1}{2}$ " deep in the end. Drive the handle in until it binds, drive a hardwood wedge into the kerf, and cut flush. Finish with a coat of shellac.—E. M. L.

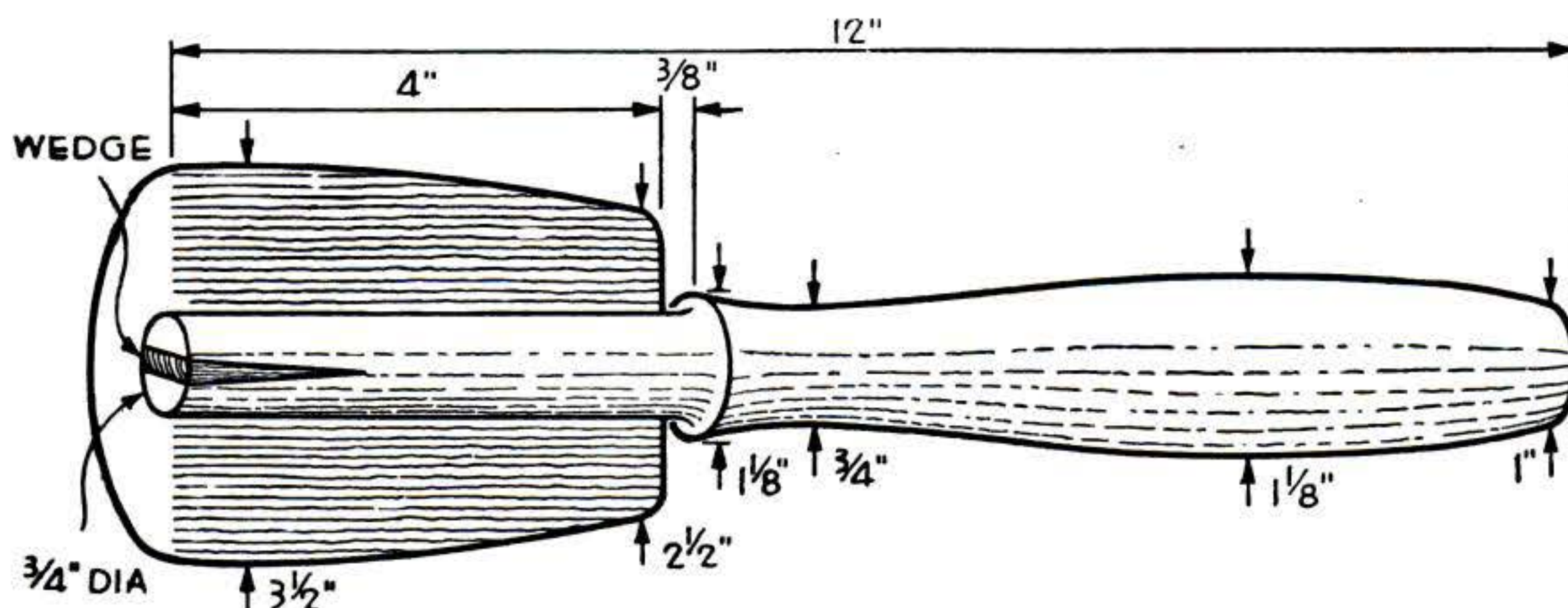



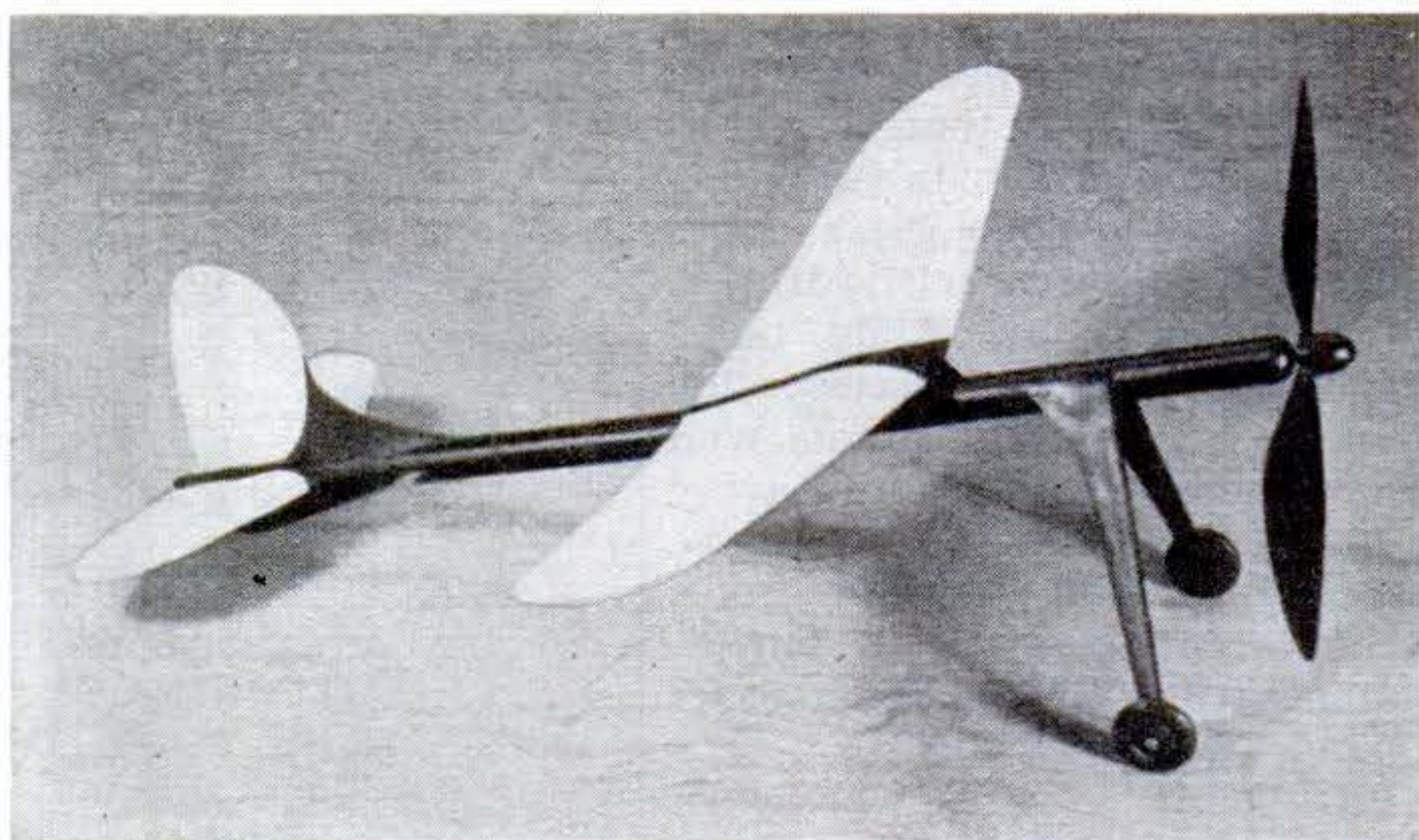
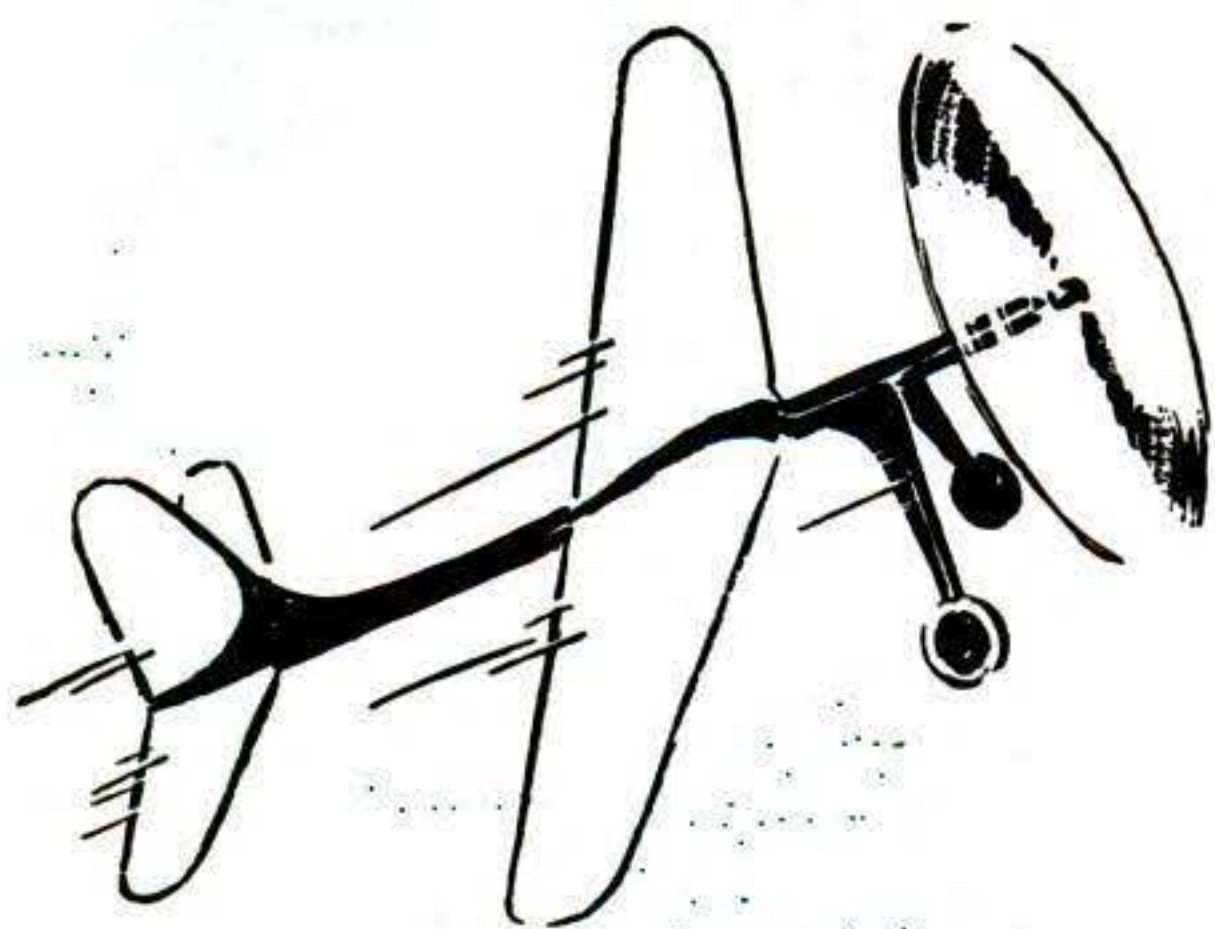

By H. A. THOMAS, Jr.

ONE of the bad things about a good thing is that it sometimes keeps us from looking for something better. Take model materials, for example. Balsa has long ruled the flying-model field because of its light weight and relative strength. So long as balsa was freely available, even its most vocal critics did very little in the way of investigating the properties and peculiarities of substitute materials.

Then came the era of shortages and modelers were forced to look around. Using heavier materials, it was sometimes found necessary to add small paper parts here and

there as a way of minimizing weight. The successful use of paper on these wartime models brought attention to its surprising possibilities. It has limitations, of course, and these must be understood from the beginning.

Improperly used, paper is weak and flimsy, but if it is shaped into tubular, box, or channel form, it is quite strong enough for our purposes. The secret of a successful paper plane lies in the use of good-quality stock. Two-ply Bristol board meets most specifications. Several layers held together with library paste produce a tough sheet; model cement is used for seams and joints.

The 12" motor tube and 3" tail section of

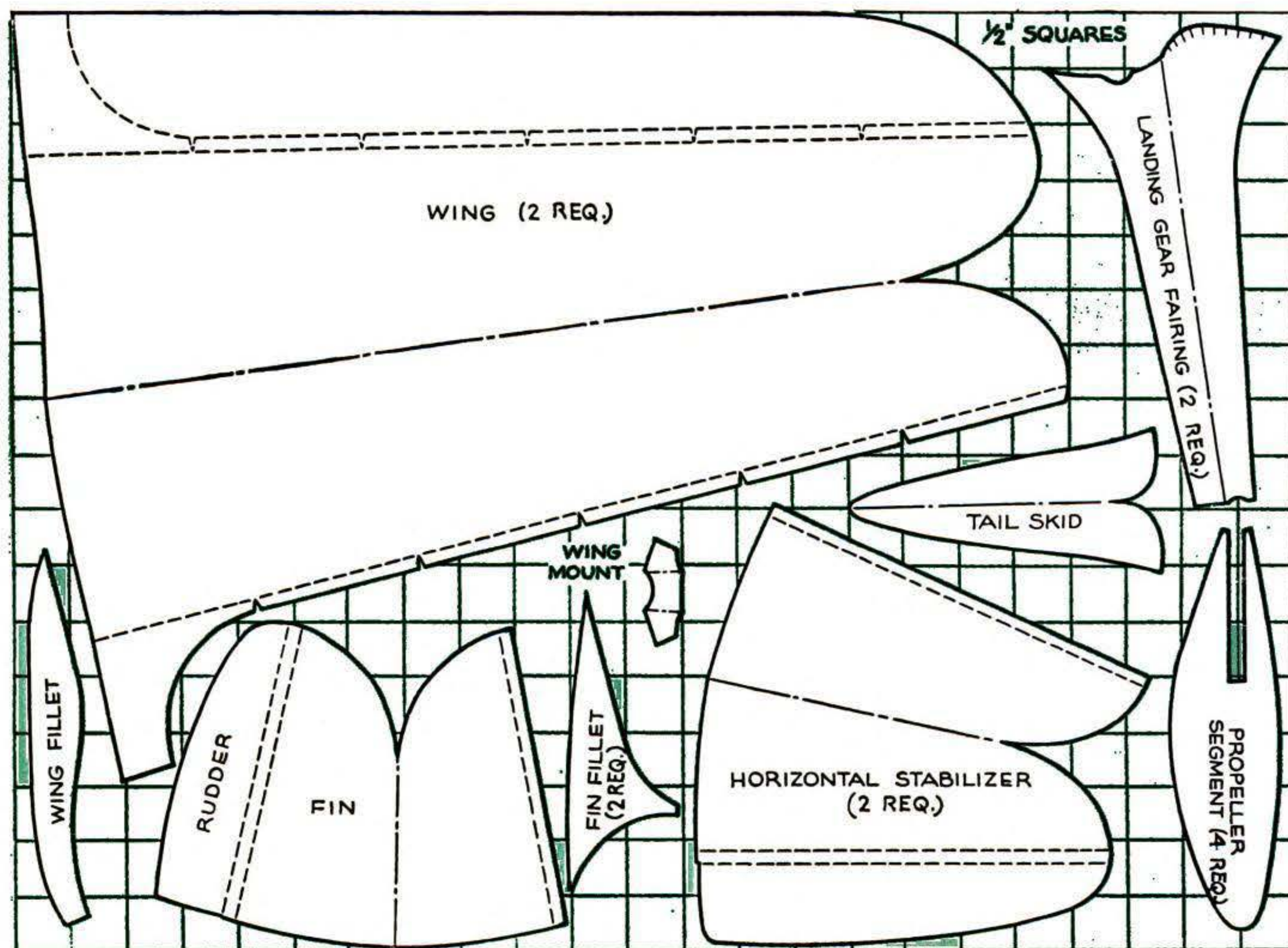



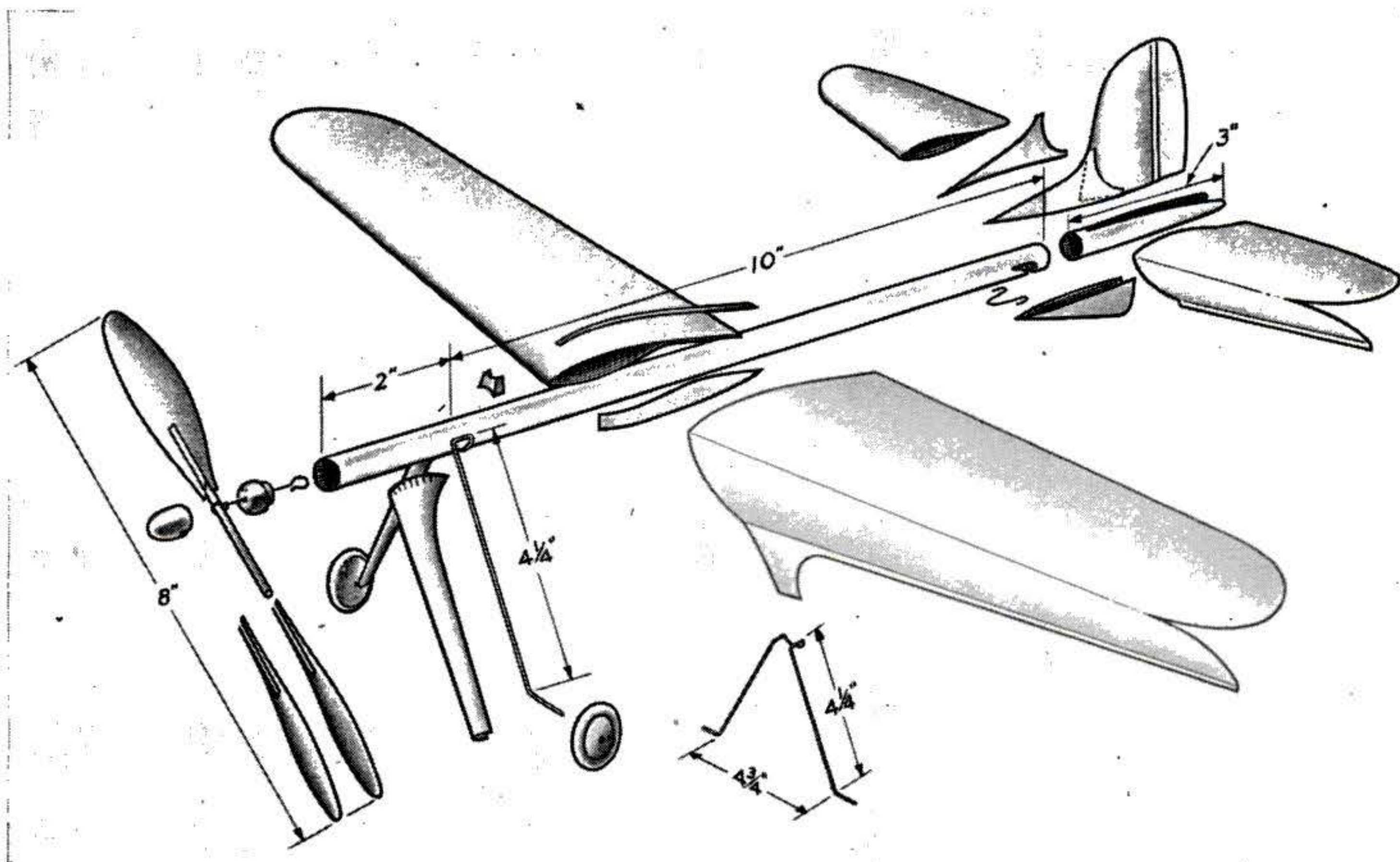

the fuselage of this paper model can be made separately or in a single operation. In the latter case you will need a 6" by 15" piece of drawing paper. Roll the sheet around a waxed  $\frac{1}{2}$ " dowel, applying library paste liberally. When dry, the tube may be slipped off the dowel, lightly sanded, and doped. Cut it into one 12" and one 3" piece with a fine saw. With the same blade cut the opening for the rear hook and the long notches for tapering the rear section.

On a grid of  $\frac{1}{2}$ " squares, lay out wing and tail-group parts. Curved surfaces can be curled by pulling them over a table edge. To get the clean bends needed at the leading edges, score the paper heavily with a sharp pencil on the inside of the bend. The dotted alleys on the drawings show where the cement is to be applied for joining the upper and lower edges. Severe warping may result from any misalignment of this seam.

Cut four propeller segments and join them in pairs with library paste. Before the paste sets, shape a  $\frac{1}{8}$ " camber in each blade and form the twist which reduces the pitch of the blades toward the tips. A  $\frac{1}{8}$ " by  $3\frac{1}{2}$ " dowel is used to connect the two blades of the propeller. Bend the wire shaft around the dowel and attach a spinner made of balsa or other wood scrap. Next, cement

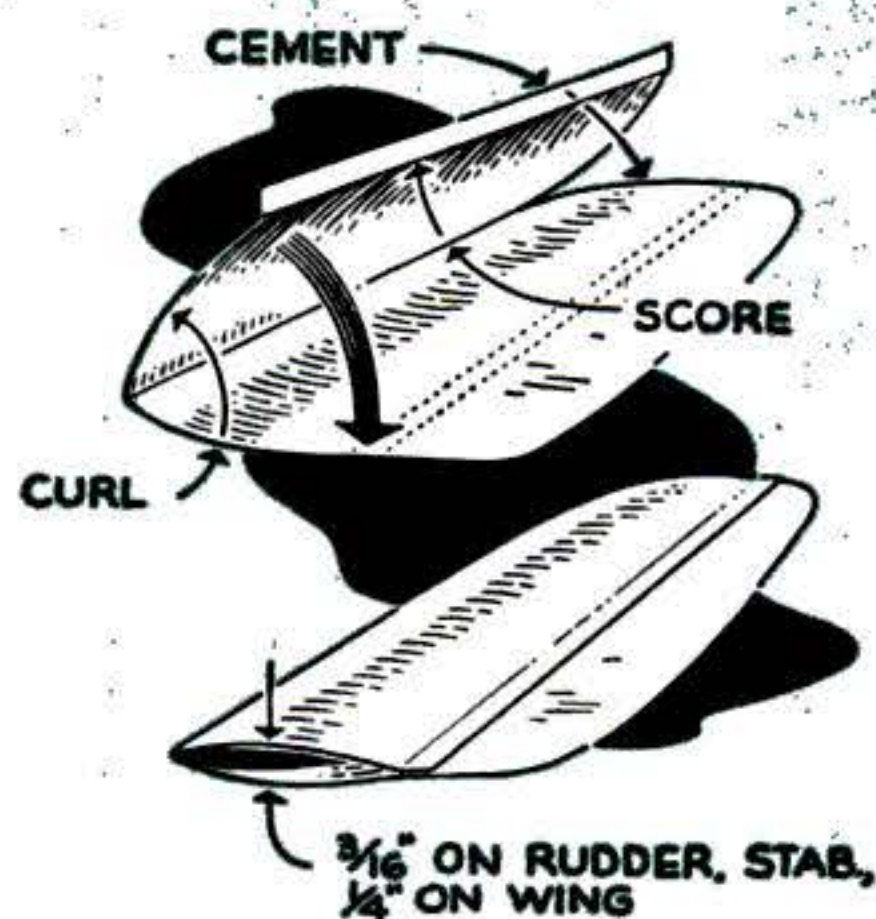

the blades to the dowel at an approximately 45-deg. angle. Finally, taper the dowel ends flush with the blade surfaces and sand and dope the unit several times. Carve the nose plug—also made of wood—to a tight fit in the motor tube. Attach the propeller and install a four-strand rubber-band motor.

Assemble the parts as indicated in the pull-apart drawing above, using cement sparingly. The wire

landing gear should be cemented in place and fitted with paper fairings. Pin the wings on to test the balance, then butt-join and cement them to the fuselage by means of the wing mount and the two wing fillets. Be sure to have the wing tips  $1\frac{1}{4}$ " higher than the roots to insure enough dihedral angle.

Fairings, motor tube, and propeller may be finished with colored dope, but the other parts had best be left alone because paint or dope may warp the paper. When the wing tips are lightly balanced between the fingers, the plane should hang level. If it doesn't, add a bit of modeling clay to the lighter end. Minor adjustments can also be made by bending the trailing edges of the rudder, stabilizers, and wings.

Fly this model as you would any other. If you don't try to use it in damp weather, you should find it a durable, capable flyer.



# TOY ROADSTER BUILT FROM WOOD

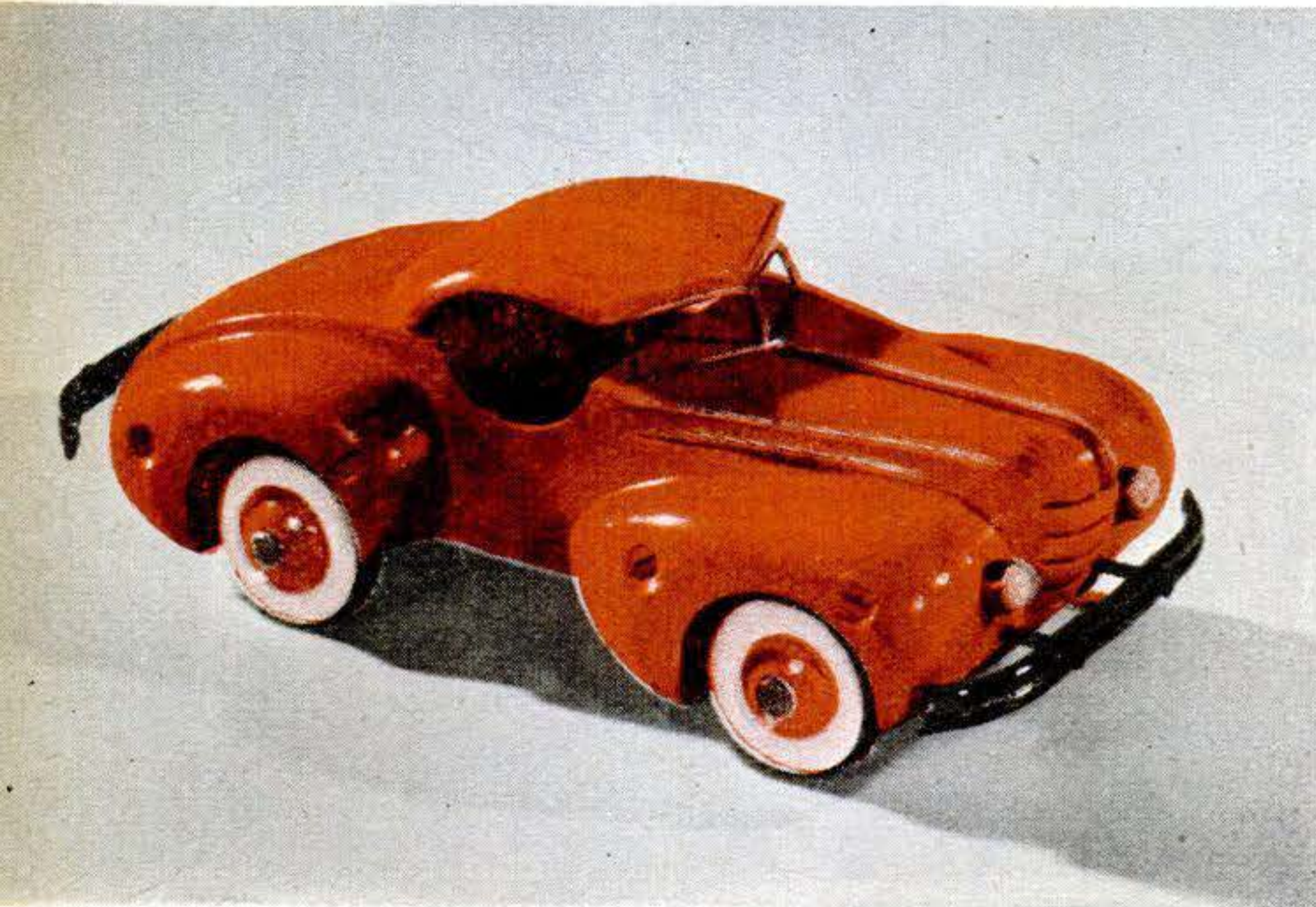

THREE blocks of  $\frac{3}{4}$ " white pine or other soft wood and two of  $\frac{1}{8}$ " stock make the body of this toy automobile. Lay out the profiles carefully and saw the blocks to shape on a band-saw or jigsaw. Make a trial assembly of the  $\frac{3}{4}$ " blocks, holding them with light nails, and file the seat slots if necessary to align them. The kerfs representing the radiator grille can be sawed during this assembly, but save tapering of the hood until the fenders have been put on. This can be done by hand with a backsaw and a rasp. The fenders help in alignment.

Shape the fenders as nearly complete as possible before assembly. Then glue all parts together, holding them with thin nails driven through the fenders until the glue has set. The nails are then drawn out, the holes filled, final shaping and sanding completed, and axle blocks glued on.

Turn the wheels as indicated in the drawing and drill them to revolve freely on nails driven into the axle blocks. The top is whittled to shape and held with dowels.

Bumpers may be any flattened tubing or metal strips drilled and attached with screws. Windshield and hood trim are tin-can stock cut into thin strips. Switchboard-lamp caps, available at electric and radio shops, make excellent head lamps. Finish with good enamel.—H. R. CORRY.

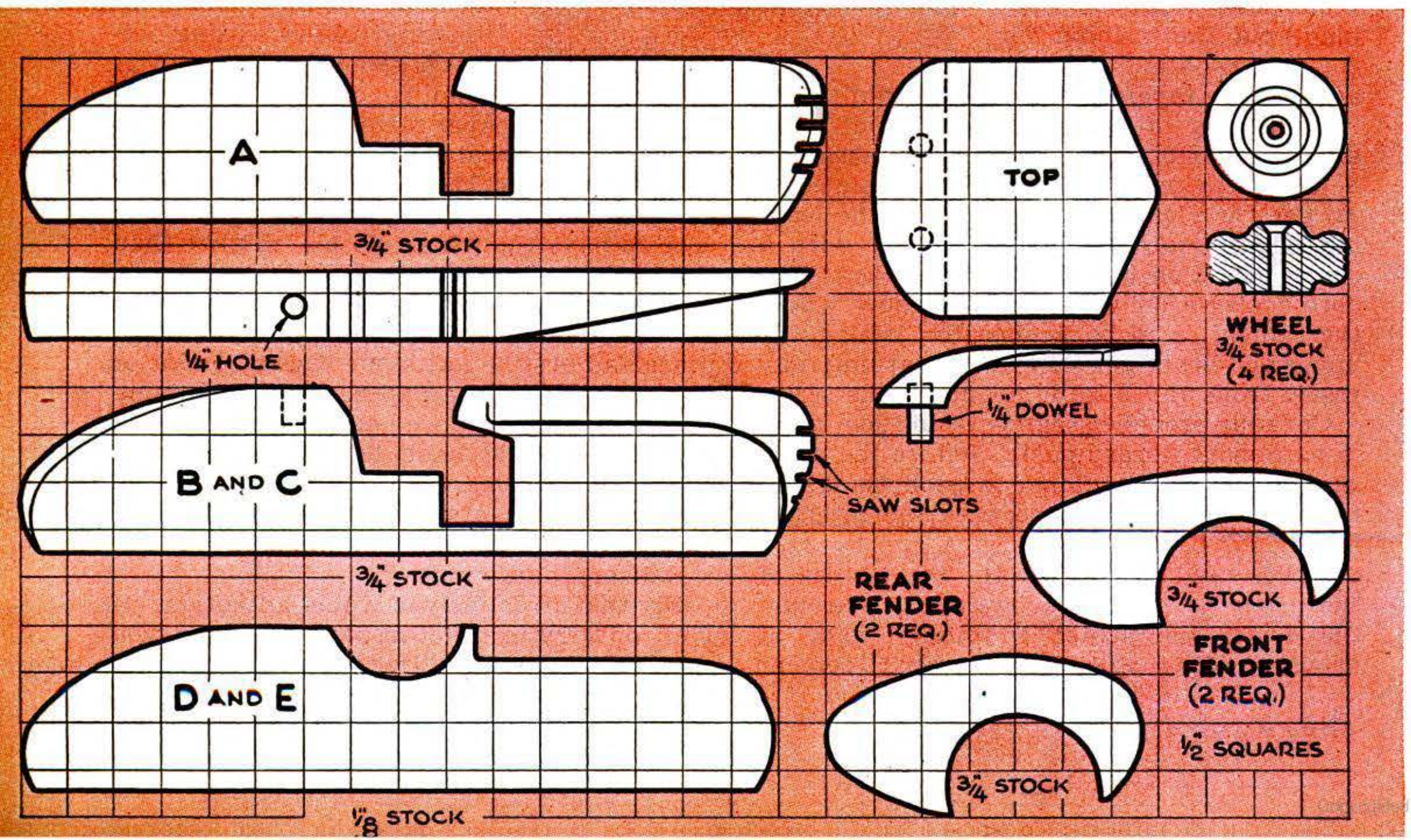
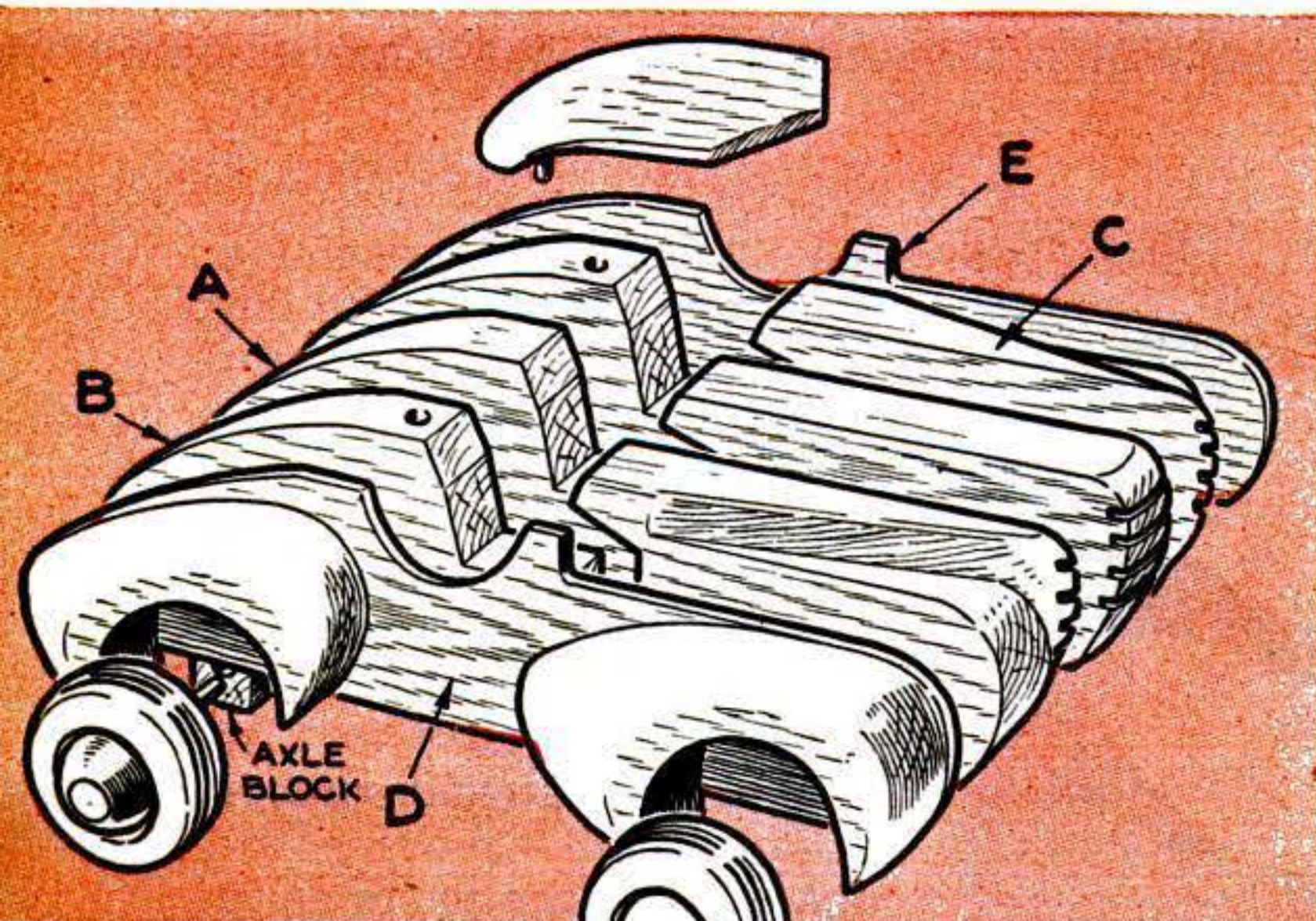



## Candleholders in Floral Designs Formed from Sheet Copper

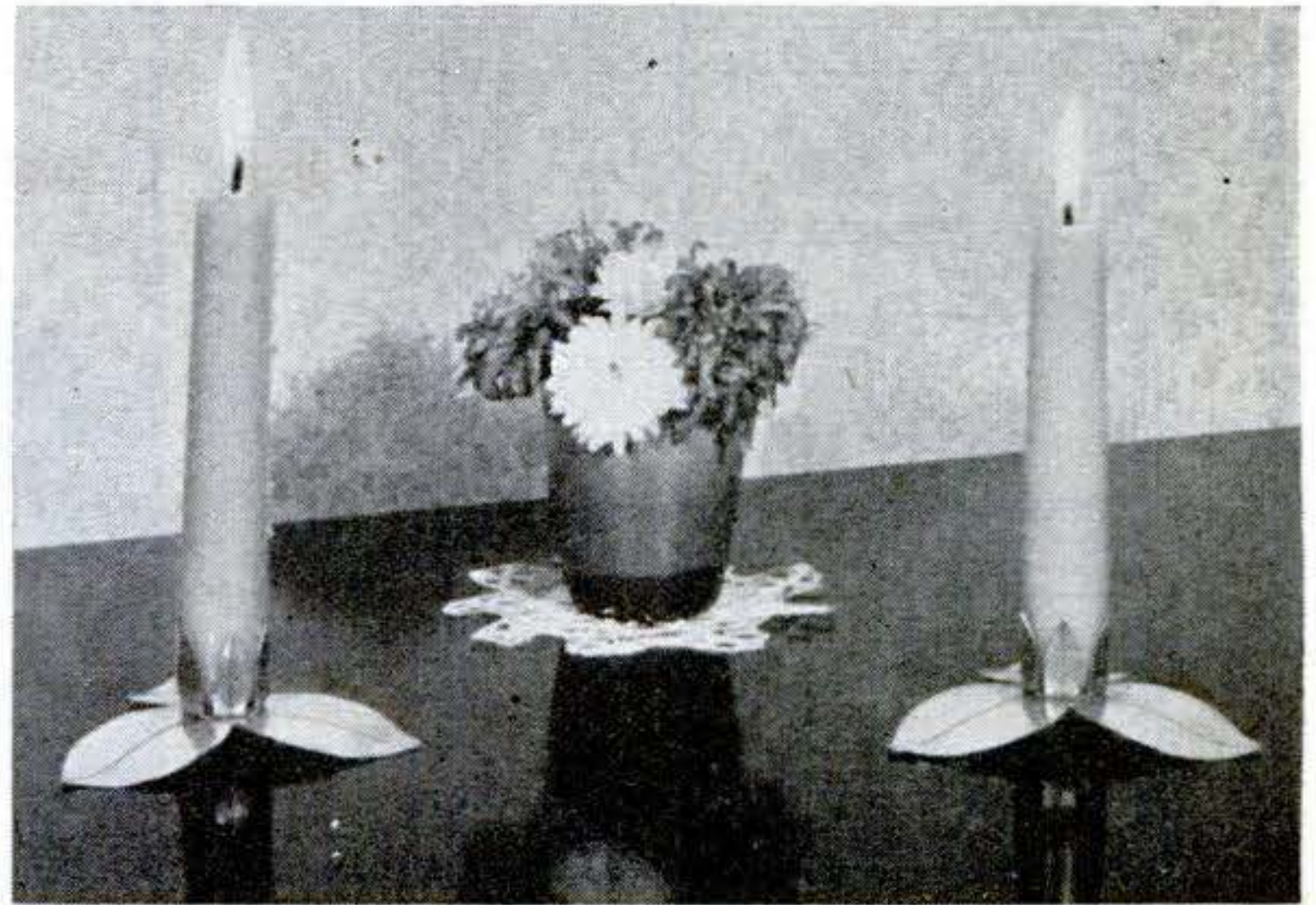
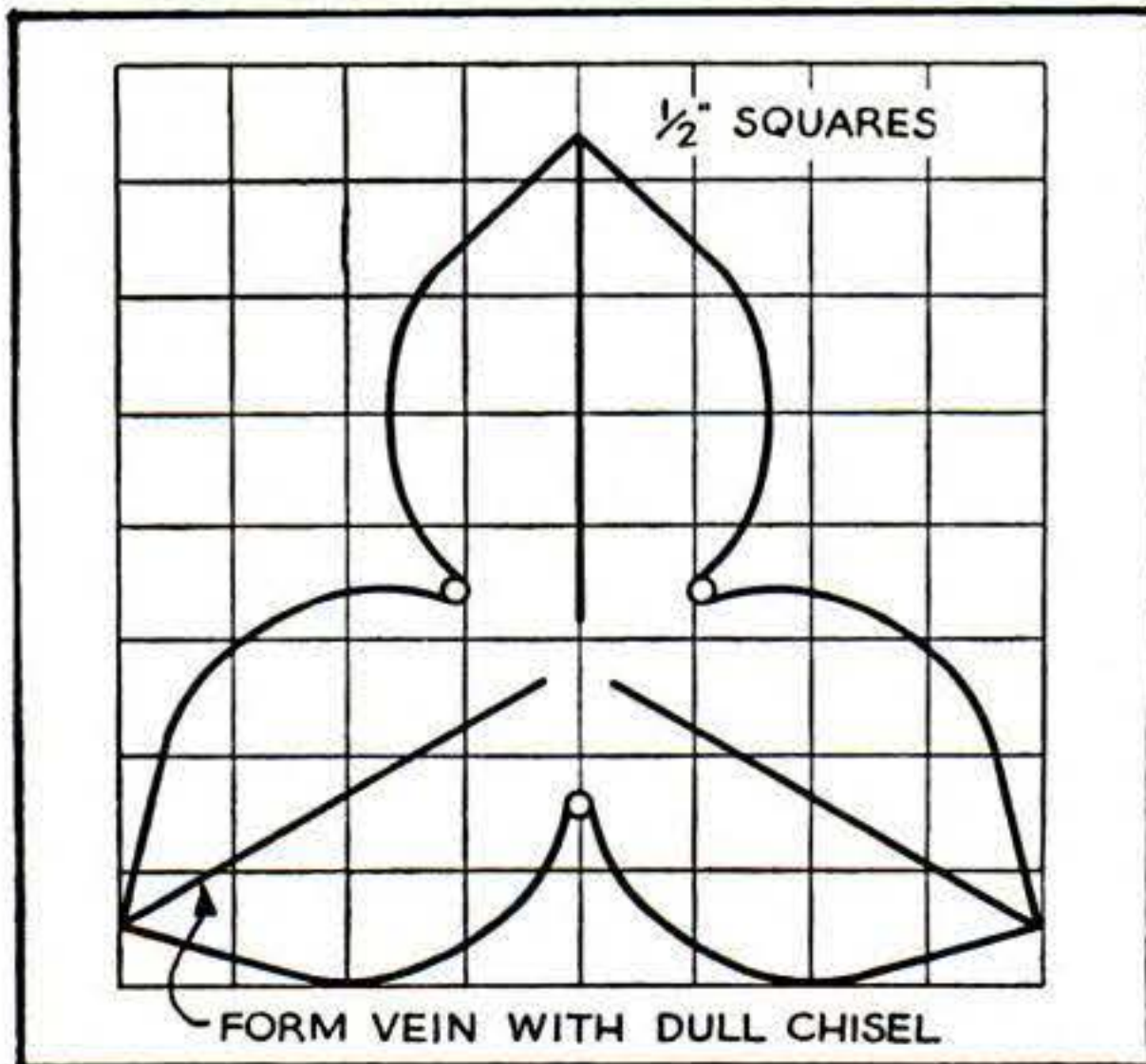

CANDLEHOLDERS in attractive floral designs can be cut and bent to shape from 22-gauge soft copper. Mark off two sections as shown. Holes drilled between the petals make a neater job of cutting out the parts with tin snips. Indent the veins with a dull cold chisel, rub down both parts with coarse steel wool, and mark the veins with black India ink. A  $\frac{7}{8}$ " steel rod will facilitate bending up the small petals. Drill a hole in the center of each piece and fasten them together with a machine screw and nut. Bend down the base petals slightly.—WALTER F. DEBOLD.

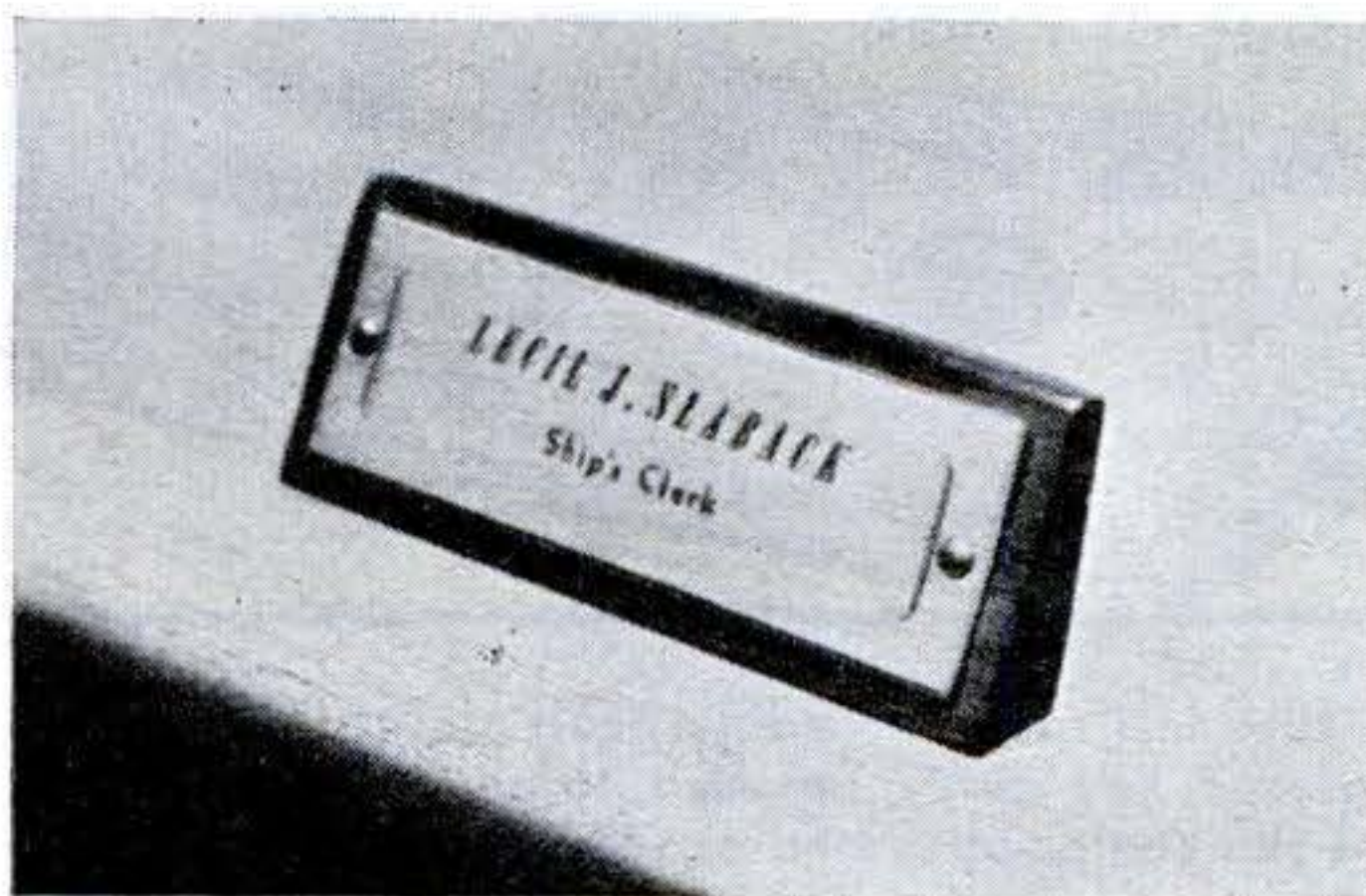
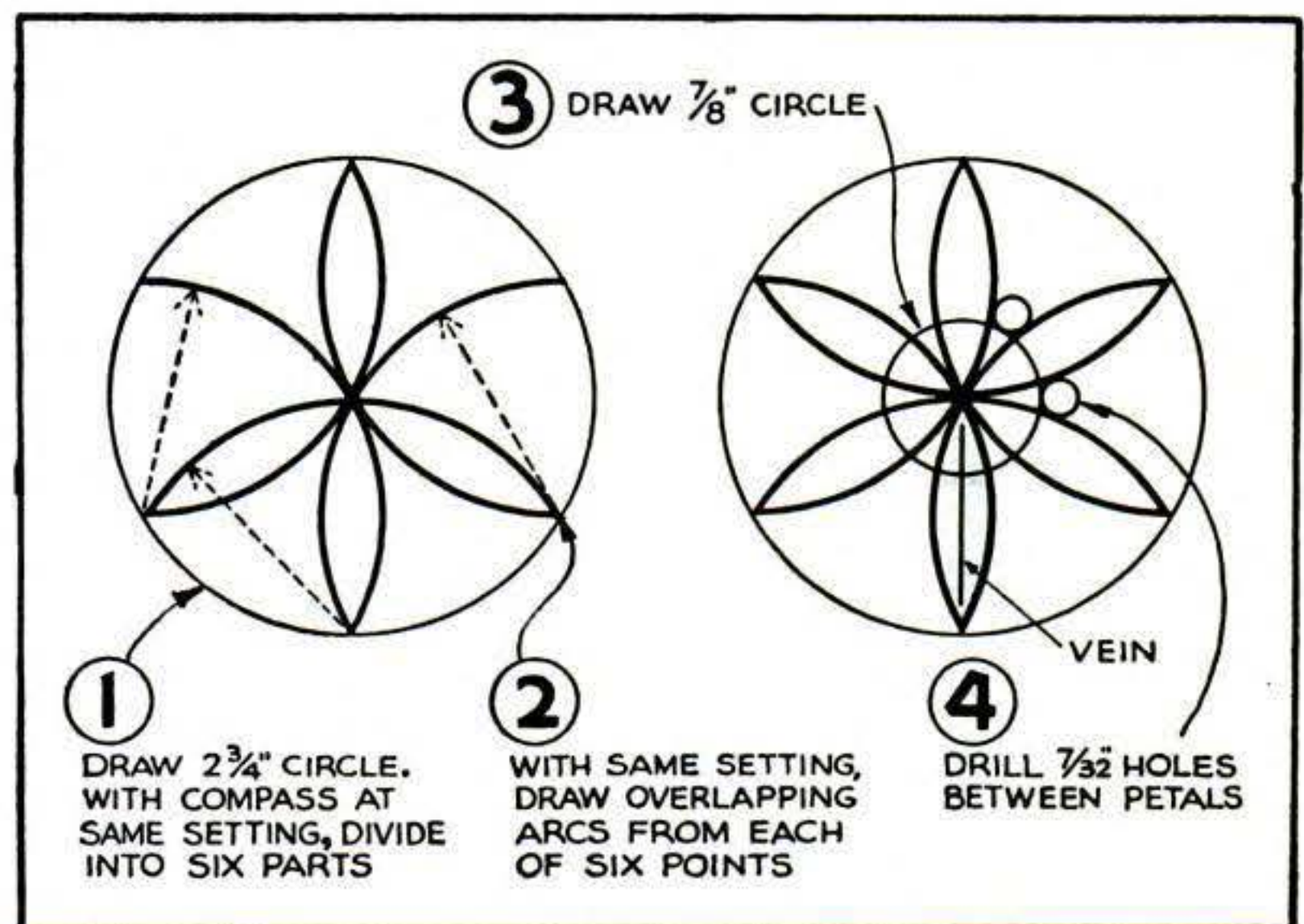

## Veneer Card on Name Plate

MOUNTED on a tapered block of well-sanded hardwood, a bit of veneer makes an impressive title card for a desk name plate. The name may be hand lettered or, if you wish, a printer will do the job at small cost. Fold a piece of clear sheet acetate around the title card before attaching it with two upholster's nails. The plate shown is a  $1\frac{3}{4}$ " by 5" piece of birch veneer on a 2" by  $5\frac{1}{2}$ " walnut block tapered from  $\frac{3}{4}$ " at the base to  $\frac{1}{4}$ " at the top.—LECIL J. SLABACK.

## Lens Holder Bent from Piece of Wire

BENT to shape from a single length of wire, this lens holder has a viewing angle of about 60 deg. from the vertical, a position often more convenient than the usual 90-deg. angle of table magnifiers. However, the lens can be placed in a horizontal position simply by changing the angle of bend between the uprights and the lens. Spring tension holds the lens in two wire rectangles. The height of the holder will depend on the best working distance of the lens.—ROBERT SCOTT.

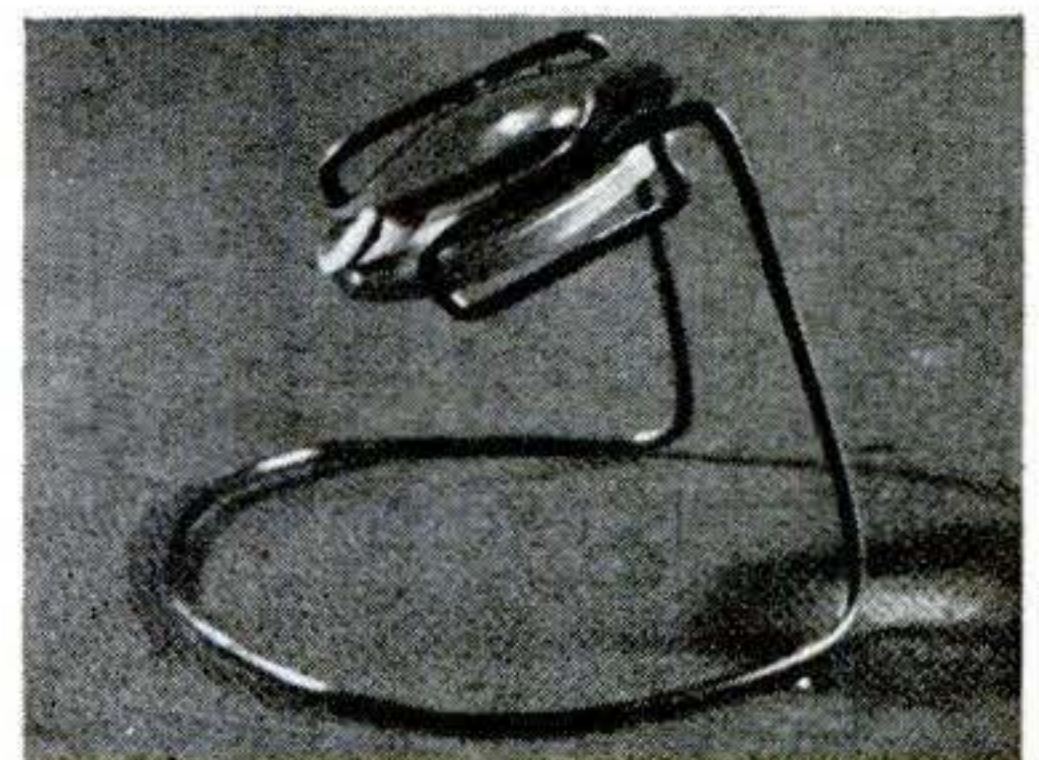



# KEEPING

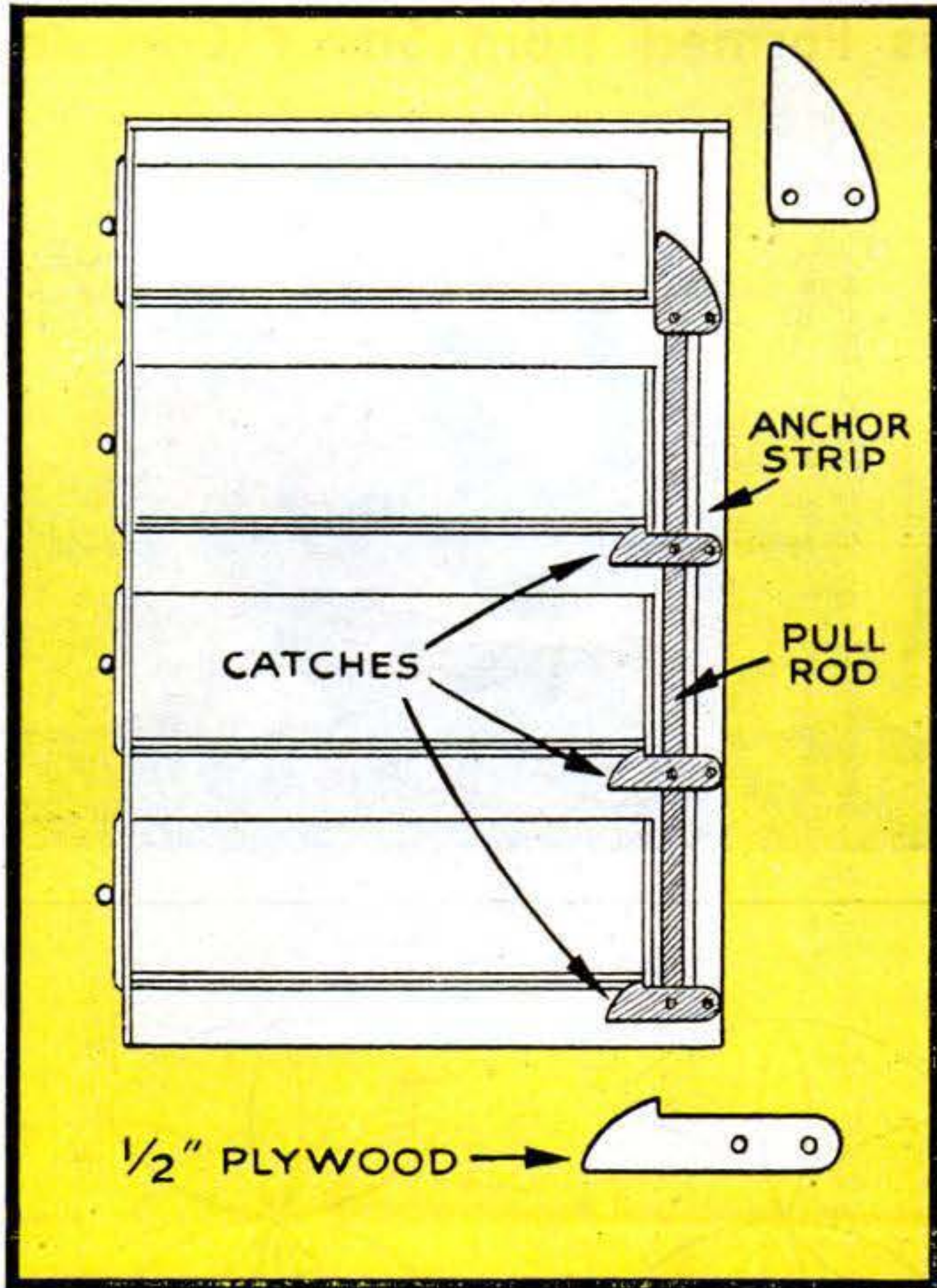

You can save your youngsters as well as your linen from harm by building into your chests an automatic lock operated by the top drawer. Make the parts of  $\frac{1}{2}$ " plywood to whatever size is allowed by the chest itself. Use loosely pivoted wood screws for all joints so that opening the top drawer will permit the catches to fall of their own weight. Sand all contact surfaces.



If your loose phonograph records are hard to find and easy to break, keep them safe and handy by gluing individual folders inside the covers of your albums. An alternative method is to hinge the folders with strips of wide adhesive tape. For safety's sake, don't add more than two extra records to any album as this may make the volume too bulky and increase the possibility of damaging the records.



Rosebush thorns make it difficult to cut the flowers as you'd like, but you can outwit them by using a spring clothespin to hold the stem while you ply your scissors.



Coat hangers will take less room in crowded suitcases if you cut and hinge them at the center as shown. A flat hook placed across each hanger locks it when open.

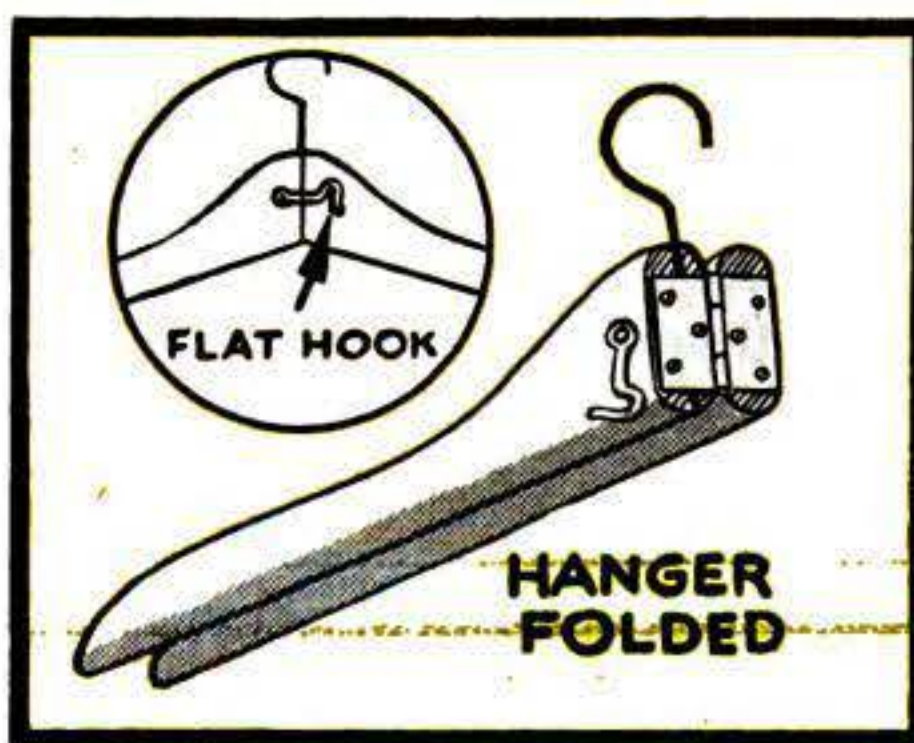

Ordinary corrugated fasteners can be used to slice pickles, olives, and similar delicacies for use in fancy salads. Hammer the fastener into a dowel or a wood strip.

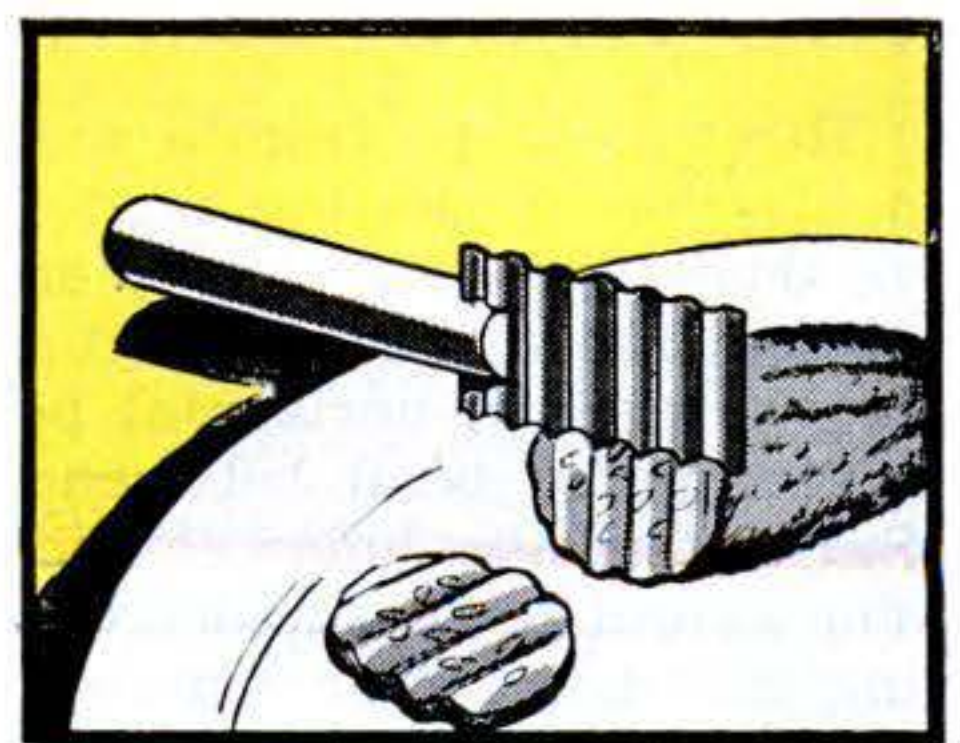



# THE HOME SHIPSHAPE



To loosen a paint-jar cap that is stuck tightly, rotate it over the flame of a match. One or two matches should suffice. Use a cloth to grip the hot metal. Repeat the treatment if necessary.

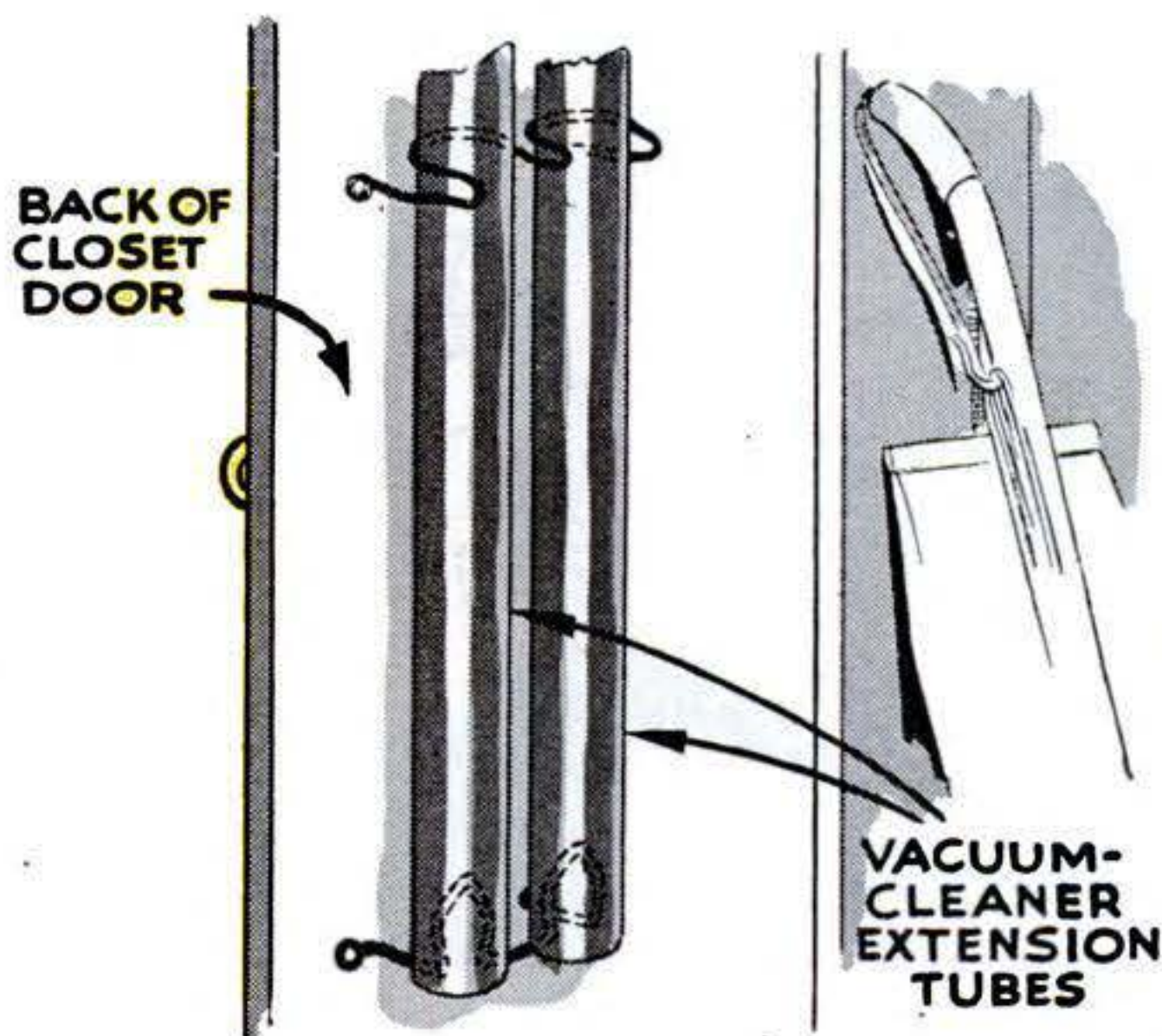

Clips made of coat-hanger wire and nailed to the back of a closet door will keep vacuum-cleaner extension tubes within reach. Bend the wire as shown in the drawing. To obtain a snug spring fit, use the tube itself as a pattern for making the clamp.

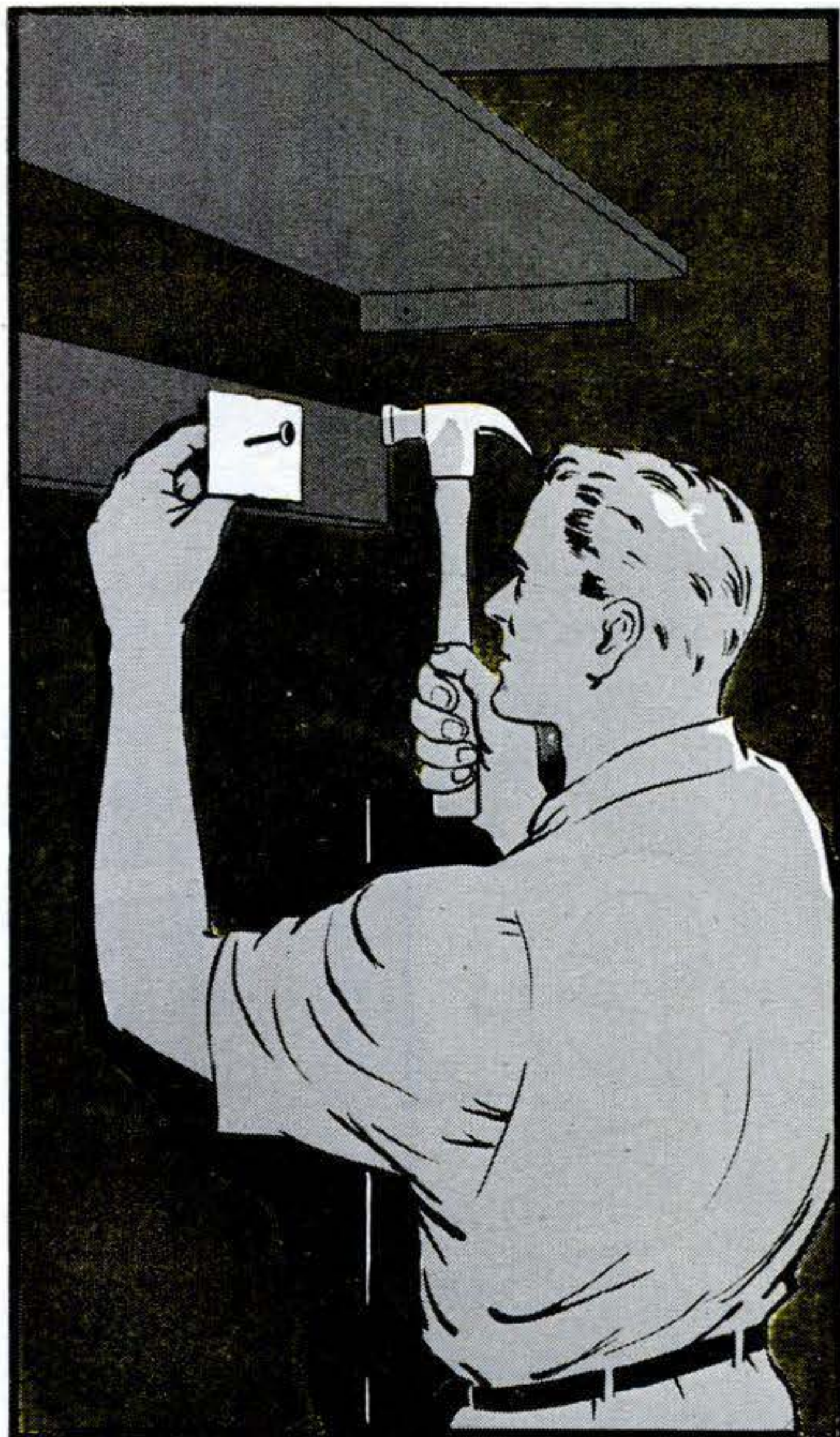

Instead of bringing up an extension light or finding someone to hold a lamp when you want to drive a nail in a dark corner, punch the nail through the center of a scrap of white paper and hammer away. The paper will provide enough contrast for vision.

Inserting a glass or metal-backed candy thermometer under the cover of your hot-water tank will enable you to keep a check on the temperature of the hot water.

If you need an emergency replacement for the porcelain handle of a kitchen faucet, shave the edges down on a large thread spool with a jackknife or rasp.

After applying paint with a spray gun, insert a pipe cleaner in the reservoir tube to keep the passage clean for the next use and to prevent clogging of the tube.

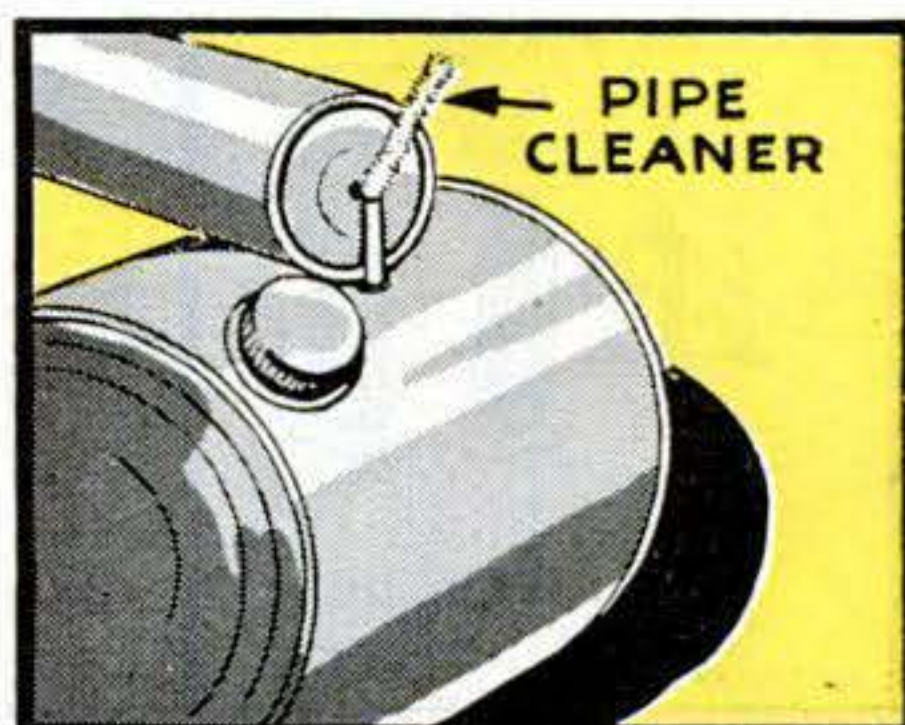
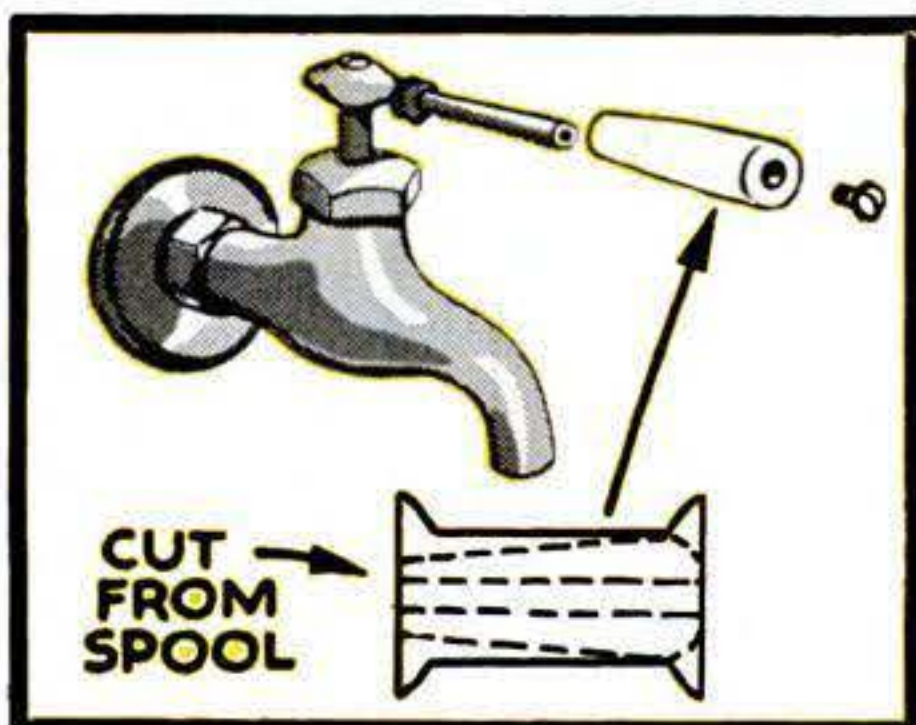
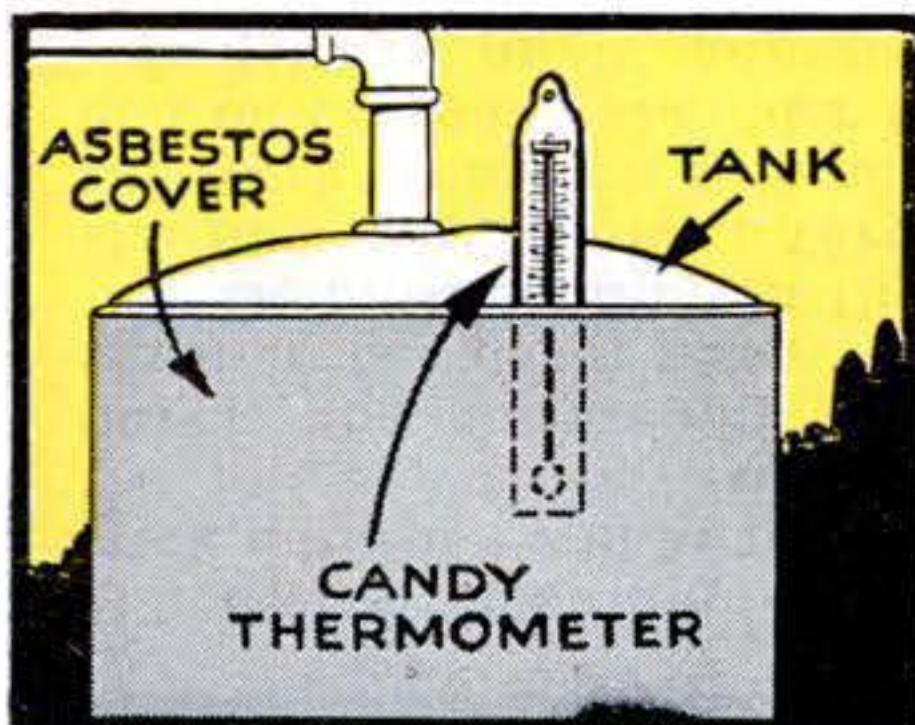



1. Pieced disks applied directly with stick adhesive will be thrown off. Back the joints with pasted cloth or strong paper, and then apply the assembled sheet in the usual way.
2. Do most sanding at the side where the disk travels downward and keeps the work from rising. Sand on the "up" end only when a shoulder requires it.
3. Always apply adhesive with the stick resting on a block of wood. This prevents fouling of the table with blobs of melted adhesive.
4. Here are two errors. Never true an end without using a miter gauge or jig and don't apply pressure that will burn the wood and clog the grit.
5. Sanding across the grain scores the stock. Take care to arrange the pieces with the grain running parallel to the motion of the belt.

CAN you find six sanding errors in the drawings—two in No. 4? The correct answers are given below.

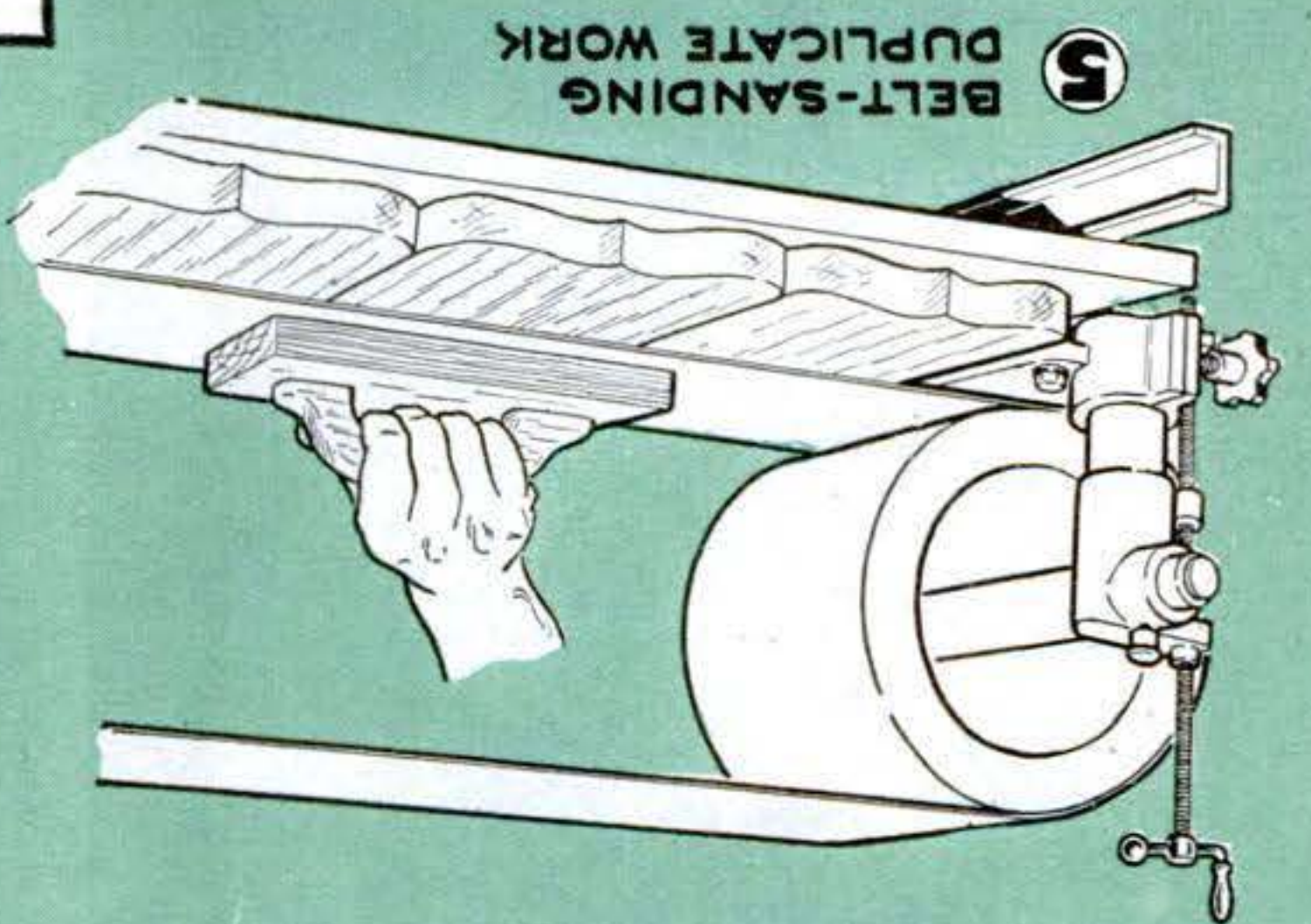

5 BELT-SANDING DUPLICATE WORK

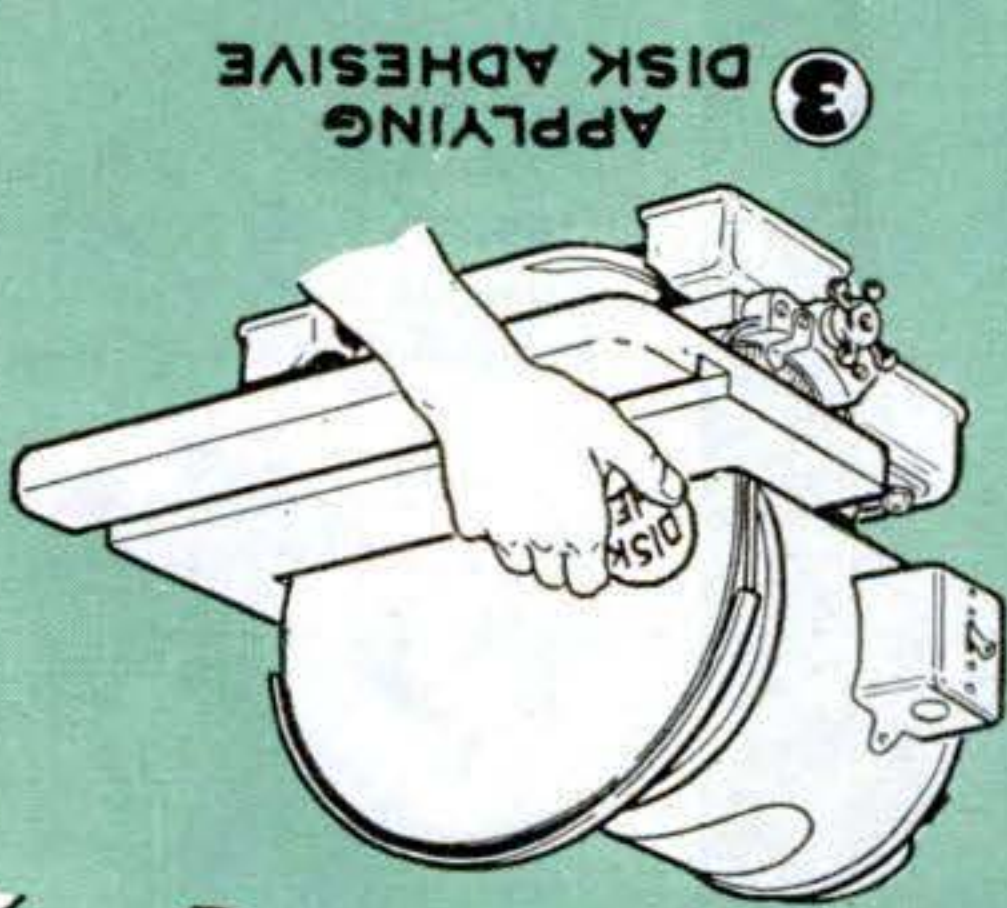

3 APPLYING DISK ADHESIVE

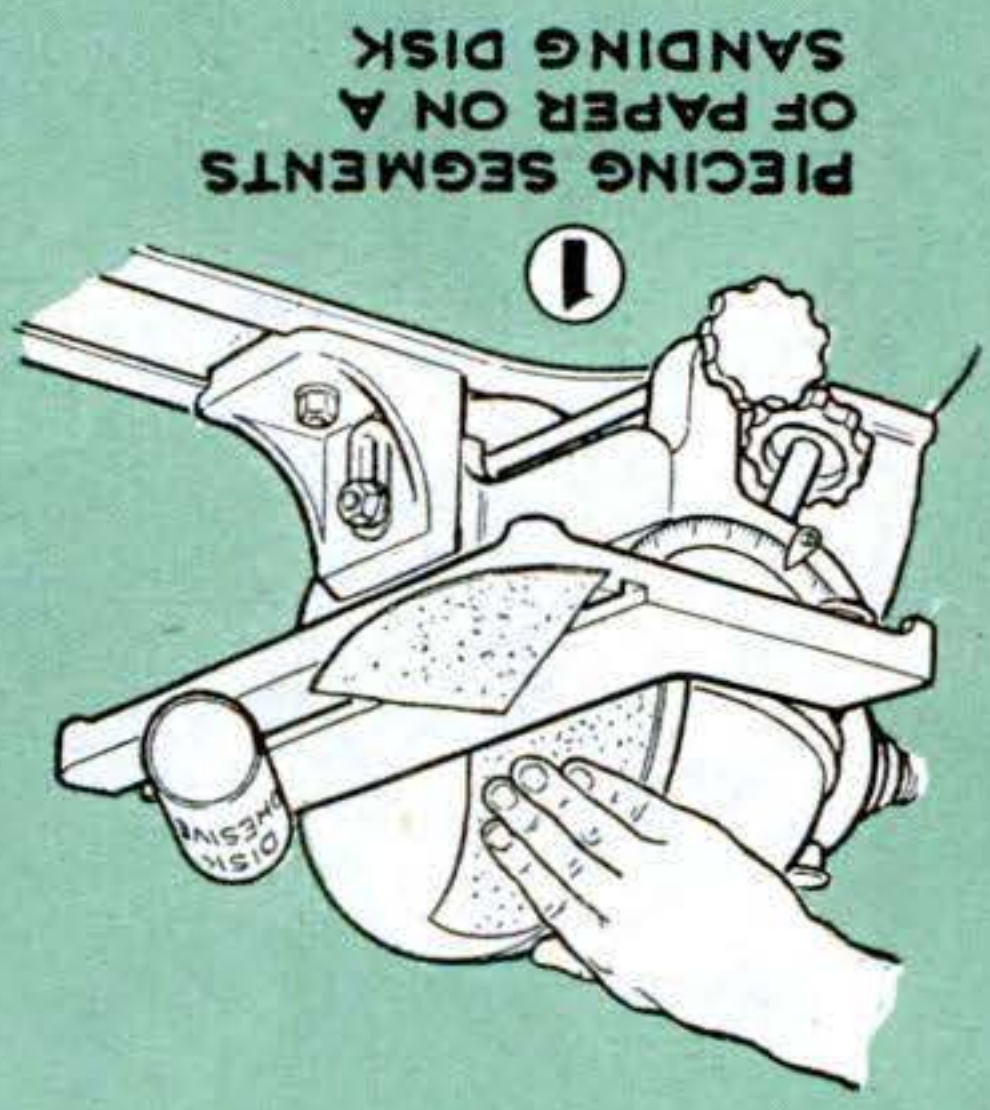

1 PIECING SEGMENTS OF PAPER ON A SANDING DISK



2 SMOOTHING A CURVE

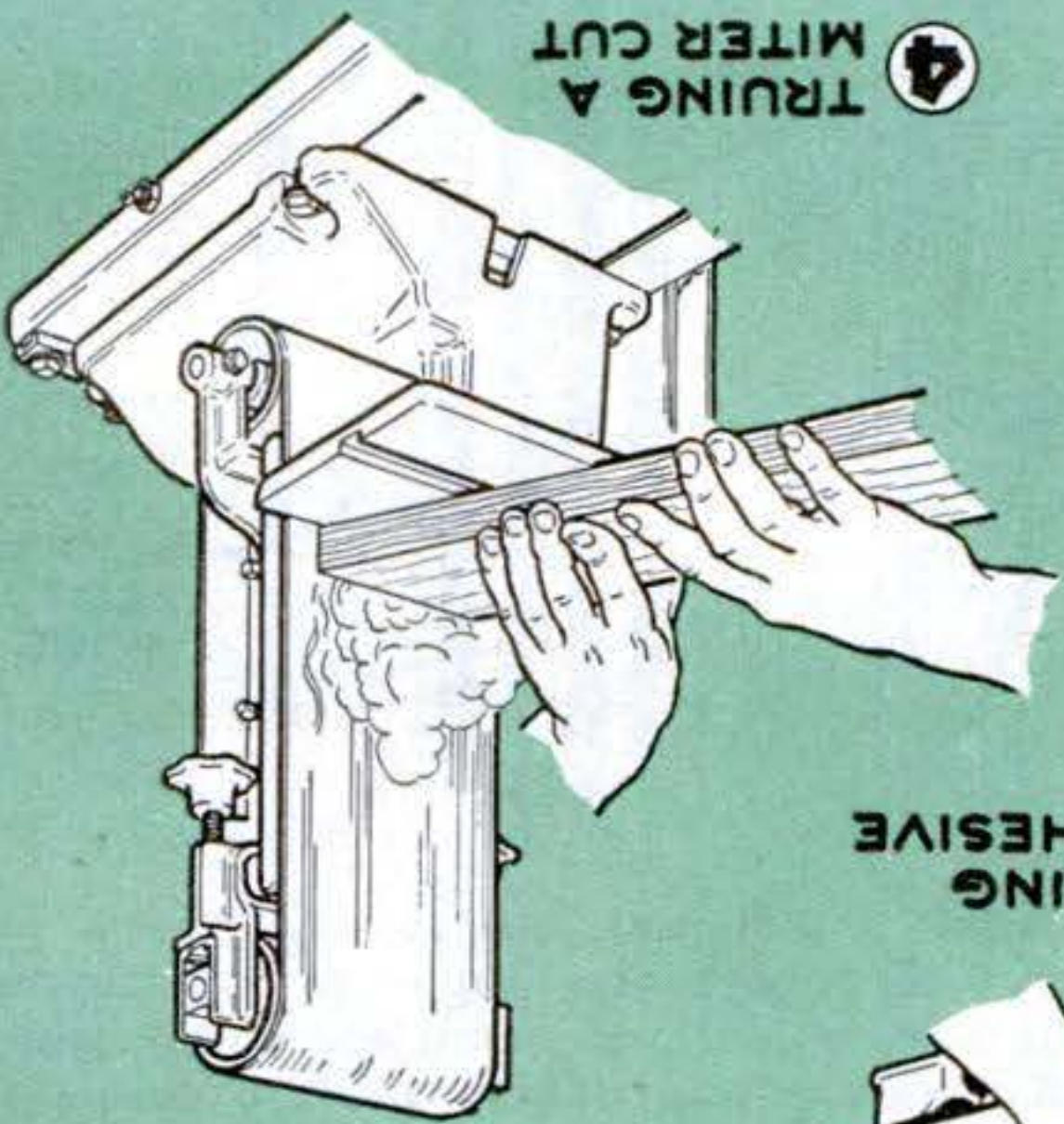

4 TRUING A MITER CUT

*What's Wrong?*



# How to Go Aloft Safely

By ELON JESSUP

**M**ASTHEAD watch for whales may be a thing of the past, but sailors are still called upon occasionally to go aloft. When gear has fouled and can't be cleared from deck, or an old halyard has let go and a new one must be reeved through the block, there is nothing else to do. This is true, too, when a mast must be cleaned and varnished.

And the masthead watch itself is staging a comeback. Not for whales, to be sure; but rather for big-game fishing and distant cruising on inland waters. A scarcity of markers and the presence of underwater obstacles could get a boat into trouble if it weren't for the masthead watch.

Methods of going aloft have always been curiously varied, but the essentially practical ones for average pleasure boating number only four. One is skinning up bare shrouds; another, shinning up the mast; a third, using a bosun's chair; and the fourth, walking up ratlines.

Any Down East deep-sea fisherman can show you how to skin up a pair of bare shrouds. Nowadays the fishermen don't practice this method so much, for the modern fishing dragger's shrouds are usually ratlined. Climbing unratlined shrouds has actually become more suitable for pleasure craft—something plenty of yachtsmen haven't overlooked.

The knack consists largely of squeezing

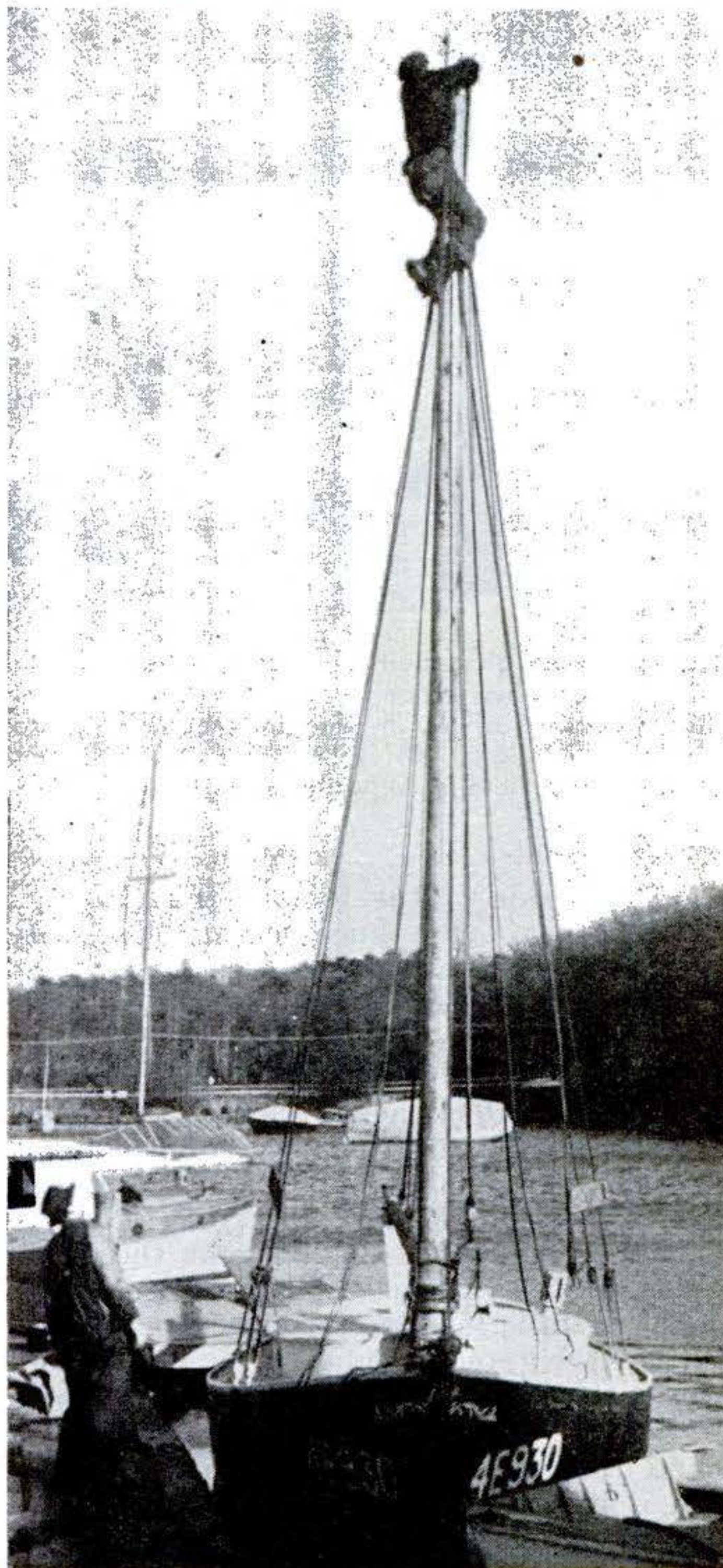

## **\$500 in War Bonds**

**TO HELP YOUR SHIP COME IN**

PRIZES for the best ideas about the boat you want to own. See page 172.

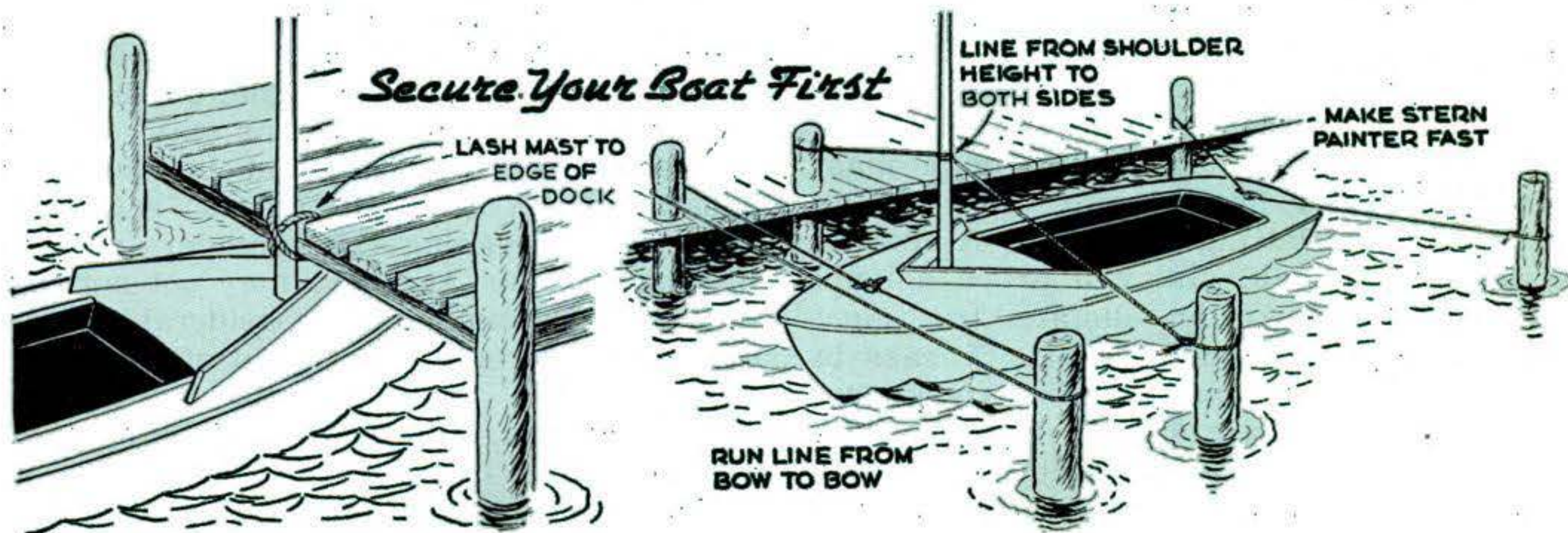





Taking it easy on a pair of shrouds. The Down East fisherman at left, up for observation, wears sea boots to help his legs grip the shrouds. Ratlines on the powerboat at center are solely for reaching the light. At right, the sailor uses the narrowed ends of shrouds for holding on while engaged in a task on the masthead.

the inner side of the foot at the toes and the outside of the knee against the wire or rope. Then the shroud crosses over the foot and in front of the leg. Overhand reaches for more altitude take care of the rest. Fishermen usually climb in their sea boots. The rubber helps their legs to stick.

Given the choice between shrouds and a smooth mast, fishermen take the shrouds every time. Many an owner of a small to medium-size sailboat will prefer the mast.

Make sure before starting up that your boat can take it. The mast becomes an up-turned weighted pendulum, and a small boat is likely to roll and may even tip over. If you have any doubts, nose her beforehand between a pile and a wharf, and then run a line to each side from the deck or low on the mast.

You will usually have a halyard to serve as a convenient handhold while climbing, or you can grasp the shrouds of a narrow boat. There is an old custom on deepwatermen that is worth bearing in mind, if you live on salt water. Try going up a mast barefooted after first dipping your feet in salt water and letting them dry. A coating of salt will remain and will prove a help.

Circumstances often dictate the most suitable method of going aloft. A case in point is the famous and familiar rig known as the bosun's chair. Don't try one in a seaway. Most sailors concede now that swinging in a bosun's chair in a seaway is

doing a job the hard way. The bosun's chair belongs in port for jobs like painting.

Aloft in a bosun's chair in its proper place, you will probably be more firmly seated than appearances suggest—but only if the seat is solid hardwood at least 1" thick, if the halyard and block can be counted on to hold you, and if the supporting bridle is adequately rigged on the seat. Criss-crossed lines under the seat are recognized as the safest rigging, for then, in the untoward event of the seat splitting, you will be left sitting on the lines.

Usually the occupant of a bosun's chair is hoisted and lowered by a shipmate on deck. Hoisting and lowering yourself is possible, but hoisting especially is not to be recommended. No matter which way you go, though, remember the old saying: one hand for the ship and the other for yourself. You can't know for certain the strength of the block aloft until you reach it, but you can keep a leg hold on the mast and one hand on a shroud or stay. A sail stop encircling your body and the mast isn't a bad idea. You can become so engrossed in a job of cleaning the spreaders or varnishing the mast that you may not notice a powerboat kicking up a considerable wave across the harbor. That kind of thing can swing a bosun's chair out and slam it back with a wallop that could seriously injure you even if it didn't unseat you.

For general fitting-out in port you may



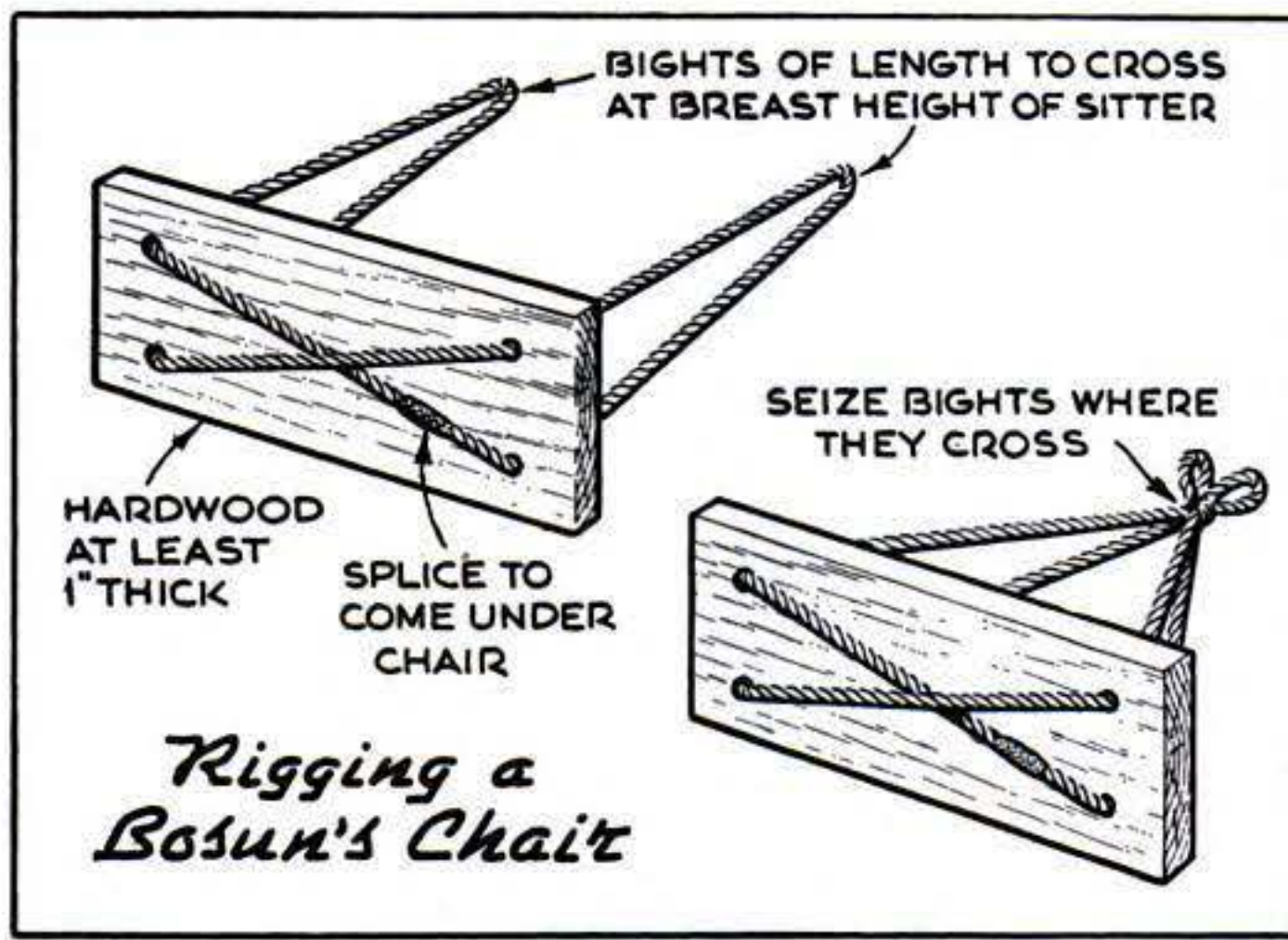

require a bosun's chair, but for observation outside and for reaching gear, ratlines are the safest, most comfortable, and most generally satisfactory means of going aloft. The shrouds are already there and, once installed, ratlines eliminate the fuss and bother of rigging up a bosun's chair.

A good many of the new sports fishing boats carry ratlines, and occasionally, too, you will find them on powerboats solely for the purpose of reaching a light. Large yachts, of course, have been carrying ratlined shrouds ever since anybody can remember. They are out of place on small sailboats, but they can prove of special value on medium and large ones. Although a certain amount of windage is inevitable, it can be halved by installing ratlines on only one side of a boat.

Pleasure craft once almost invariably used rope ratlines, but recently a number of them—especially powerboats—have taken to wood and pipe. You may prefer the appearance of rope, but wood or pipe ratlines offer firmer and more comfortable footing.

If, in spite of this, you must have rope, use a light, tarred, 12-thread line  $\frac{3}{8}$ " or more in diameter. Lengths are cut to conform to the spacing between the shrouds with enough extra allowed for making the



Aloft in a bosun's chair belayed to the deck, the seaman here employs one hand in work on the mast while keeping the other on a shroud for safety.

ends fast. Long ratlines can be shortened by twisting, but short ones can't be lengthened. To determine the number, figure 15" to 18" as a comfortable climbing step.

Before attaching the ratlines, or even cutting them, serve the shrouds with tarred marline or a few rounds of spun yarn to keep the ratlines from slipping. Friction tape can be used, but it doesn't look so well. You should also seize on a number of strong temporary battens to hold the shrouds rigid,

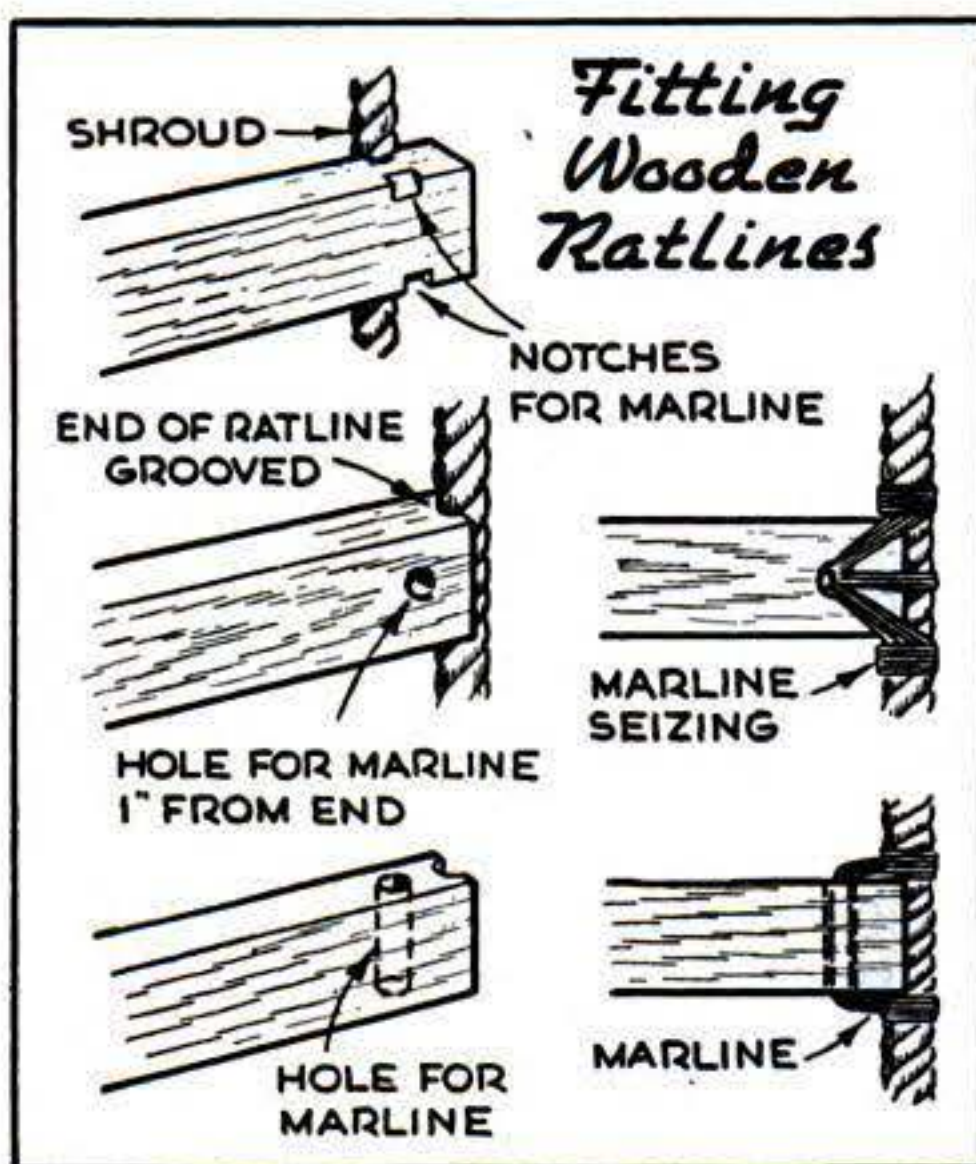

Wood ratlines are often notched near the ends, as shown below. The notches hold the turns of marline in place, as at right, when the ratlines are seized on the shrouds. Spun-yarn servings on shrouds prevent slipping under weight.

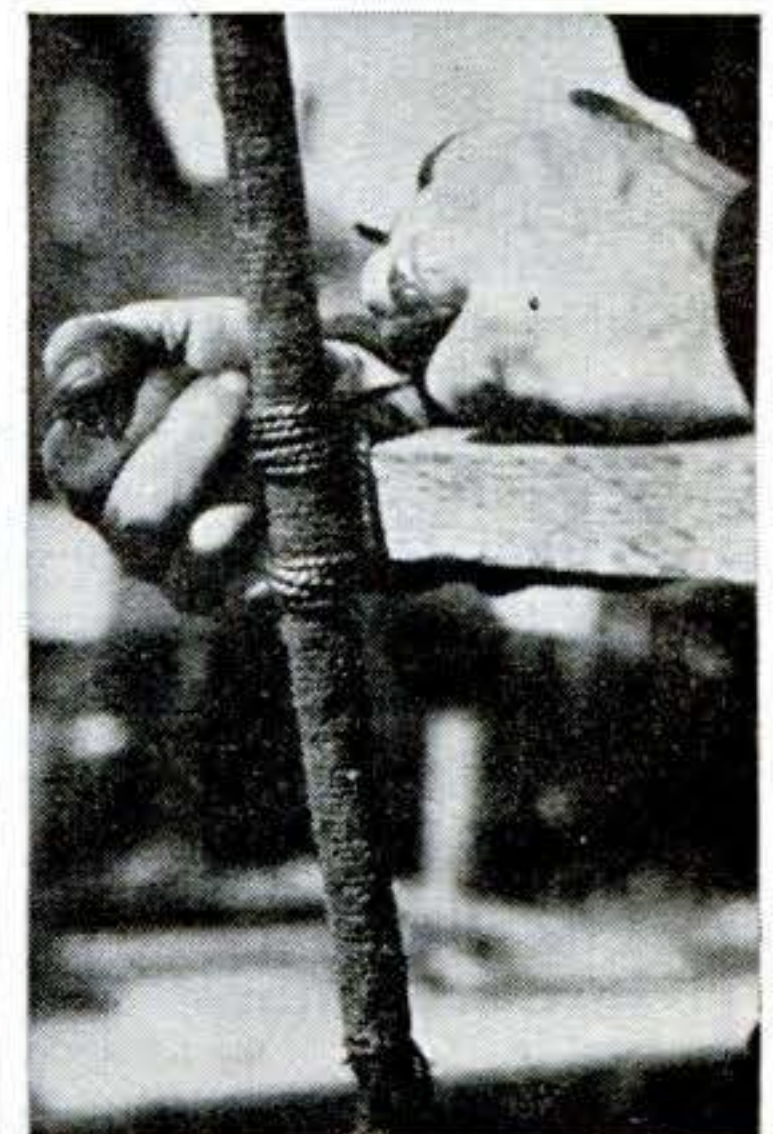



Stout ratlines are the safest and most generally satisfactory means of going aloft. Here a sailor stands on one ratline to make another fast above.

support you as you work upward, and enable you to get correct measurements between shrouds as well.

Ratlines may be attached with a clove hitch, but the more usual method—and also the more presentable—is with an eye splice. In either case, the knot is seized to the shrouds with rounds of marline. If you have a series of shrouds to deal with, use eye splices for the two outside shrouds and clove hitches for those intervening. The hitches must always face outward.

Any material used for wood ratlines should be sturdy hardwood that will take the tread of a heavy man in a rolling seaway. Rungs from a ladder are sometimes used. Down East fishermen go for oak 1" square. They set a sound example.

Serve the shrouds first with tarred marline or spun yarn, as in rigging rope ratlines. You won't need temporary battens. Methods of attachment vary. One is to notch the front and back of the ratlines about 1" from the ends. The notches on the back snug into the two shrouds, and a simple seizing on with marline takes care of the rest. Notches are not so essential on the back, but those on the face keep the marline from slipping off.

Another way is to cut grooves in the ends for the shrouds to fit into. Ratlines grooved this way do not overlap. Drill a small centered hole through the face about 1" from the ends, put several turns of marline



through, and seize around the end of the ratline and above and below on the shroud.

Ratlines of pipe are put on with linen seizing and the seizing is then shellacked. The seizing shrinks as the shellac dries and will hold with great strength.

## \$ 5 0 0 0 0 in WAR BONDS

### Prizes Awarded for the Best Design Ideas by Boat Lovers

ARE you a salt or a fresh-water skipper? Do you like to sail or do you favor powerboats? What is your idea of an ideal boat? Is it a cabin cruiser, a speedboat, a fishing smack, or a ketch or yawl? Whatever it is, just so it is no more than 35' long, POPULAR SCIENCE MONTHLY will pay for the best ideas.

First Prize.....	\$250 War Bond
Second Prize.....	\$100 War Bond
Third Prize.....	\$50 War Bond
Fourth Prize.....	\$25 War Bond
Fifth Prize.....	\$15 in War Stamps
Sixth Prize.....	\$10 in War Stamps
Ten additional prizes....	\$5 in War Stamps

You may enter as many designs as you like, but only one prize will be awarded any contestant. Entries should consist of

the following: one or more drawings, which may be in pencil; a description in not more than 500 words; an estimate of cost, stating whether the estimate includes only materials, materials and labor, or purchase price if it is the boat you'd like to buy; a declaration that the design is original with the contestant. Be sure to state what you wish to use the boat for.

Send entries to the Small-Boat Contest Editor, POPULAR SCIENCE MONTHLY, 353 Fourth Avenue, New York 10, N. Y., bearing a postmark not later than November 30, 1945. The contest is open to all except naval architects, professional boat builders and designers, employees of this magazine, and their families. Duplicate prizes will be awarded for ties. The decision of the judges will be final.



# Aircraft Metals in the Home Shop

By WALTER E. BURTON

**O**NE of the most plentiful metals in the postwar period is likely to be aluminum. It is bound to find its way into the home workshop where the craftsman will, in many cases, prefer it to steel and other metals because of its cheapness, strength, and lightness, and because of the ease with which it can be worked.

Aluminum melts at 1,220 deg. F. Scrap pieces can be melted in a crucible in almost any kind of furnace and then cast in sand or iron molds. Aluminum for casting is generally alloyed with about 8 percent copper. Another aluminum alloy, especially suitable for gears and other cast parts for salt-water craft, contains silicon and a trace of iron. One small shop, using broken-up auto-engine heads and similar scrap, had trouble getting clean-cut castings until a little scrap zinc was added. Common alloys weighing a third as much as brass have a tensile strength of about 20,000 lb. per square inch. Cast aluminum and soft sheet are rated at about 15,000 lb.

An abundance of airplane scrap and surplus materials promises to make duralumin a common word in almost every shop. This important alloy is about 95 percent aluminum with up to 4 percent copper and equal or nearly equal parts of manganese and magnesium. One of its properties is an ability to gain other qualities simply through heat treatment and cold-rolling. Tensile strength can thus be increased to 70,000 lb., as great as that of some steels.

If you should acquire sheet aluminum alloy that is too brittle to be bent without breaking, try annealing it by heating to about 700 deg. F. and then letting it cool in



Stabilizers in cathedral-like array as they await assembly on the fuselages of planes. Home craftsmen may soon be using scrap or surplus aircraft metals.

air. Aluminum is generally heated in salt baths in commercial processes, and the time and temperature are watched carefully.

Spun aluminum makes interesting projects. Bowls and similar pieces can be spun in an ordinary metal lathe. Use a fairly high speed and lubricate the tools with petroleum jelly. Bowls, platters, and the like can also be formed by hammering.

Aluminum oxide, forming naturally in a thin coating on the surface of aluminum, is one of the hardest substances known and is, in fact, an ingredient of some grinding wheels. The oxide makes aluminum difficult to solder. It may be polished off with steel wool, fine abrasive cloth, or prepared aluminum polish, but heat accompanying soldering causes renewed oxidation. A special aluminum solder is required, some makes being used with a flux and some not. Generally the best method of heating is with a torch developing a pointed flame, but soldering irons of nickel are also employed.

Welding of aluminum can be done with a



# Tips on Machining Aluminum

ALUMINUM may be machined at about the same rate as brass and much faster than steel. Comparatively low speeds are useful in roughing cuts where there is a hard abrasive outer surface, but often the only limit to cutting speed for aluminum is the top speed of the machine itself. The machining tips that follow were compiled with the aid of *Blue Chips*, a publication of the Operators Service Bureau of the Warner & Swasey Co., of Cleveland. All the drawings are from *Blue Chips*.

**1** Providing for a free flow of chips is the principal problem in drilling, and for this reason a standard twist drill having polished flutes and a thinned web is generally the most satisfactory. Deep holes are drilled best with a bit having a high spiral angle. Such a drill cuts freely and has more chip room in the flutes. Drills must be kept sharp.

**2** As much clearance as possible is essential around a boring bar to keep chips from jamming. Since the chips are work-hardened, they can spoil the finish.

**3** A reamer must actually cut aluminum because the metal is spongy, so enough stock must be left to keep the tool from squeezing and burnishing the work. Spiral-fluted reamers have a free cutting action and are often used. They should be properly ground. A speed as high as 400 surface feet per minute is possible.

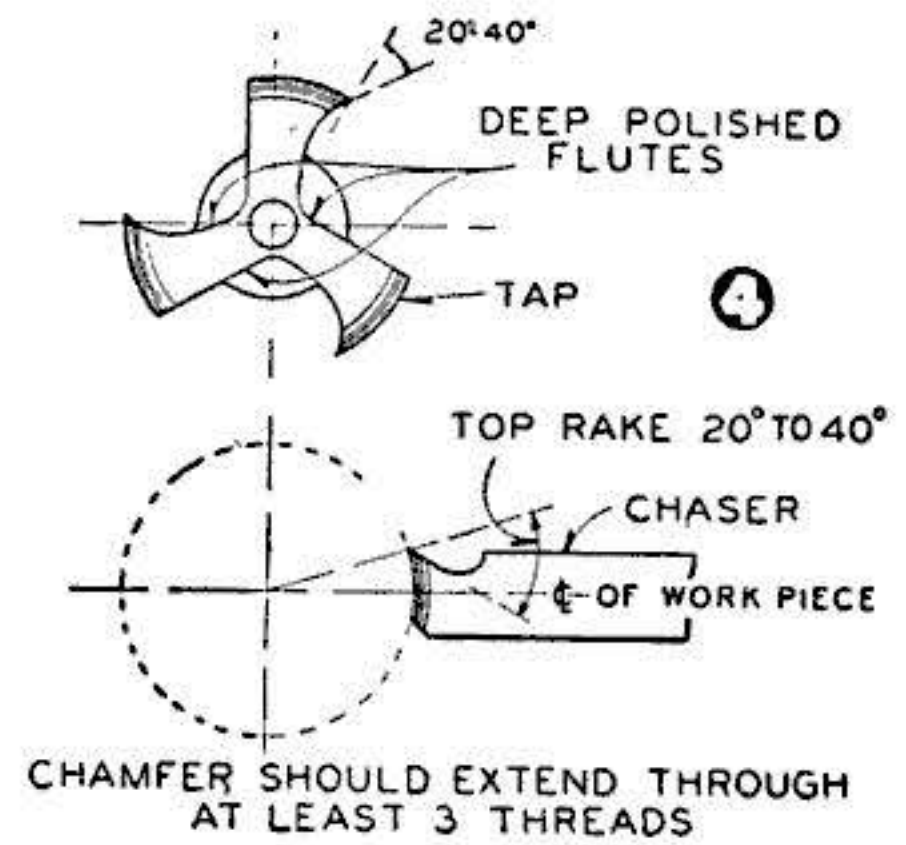
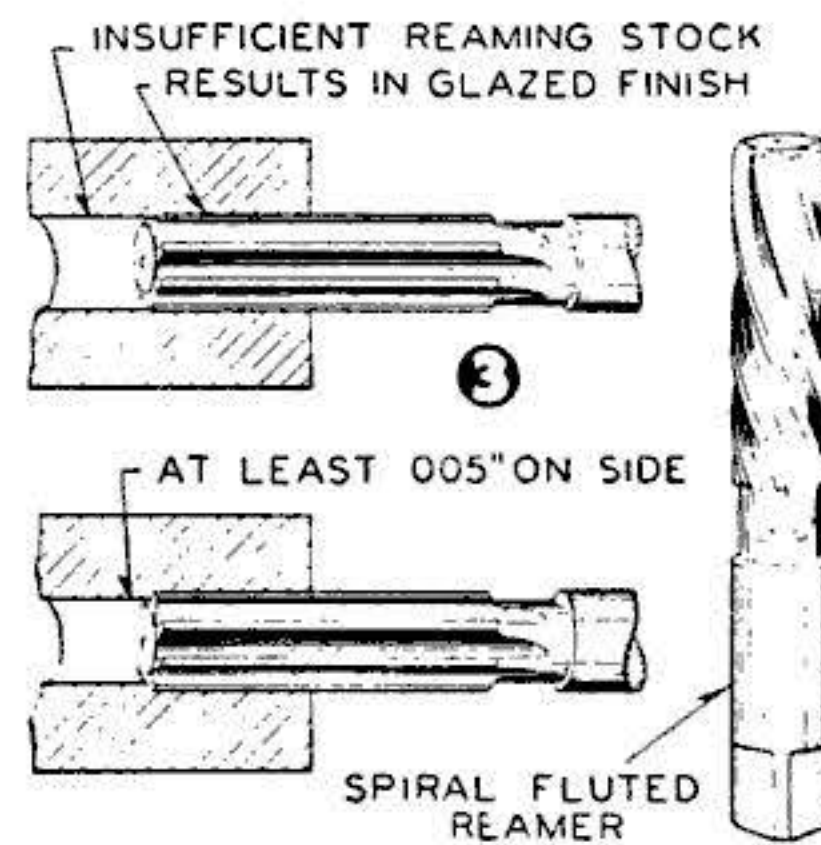
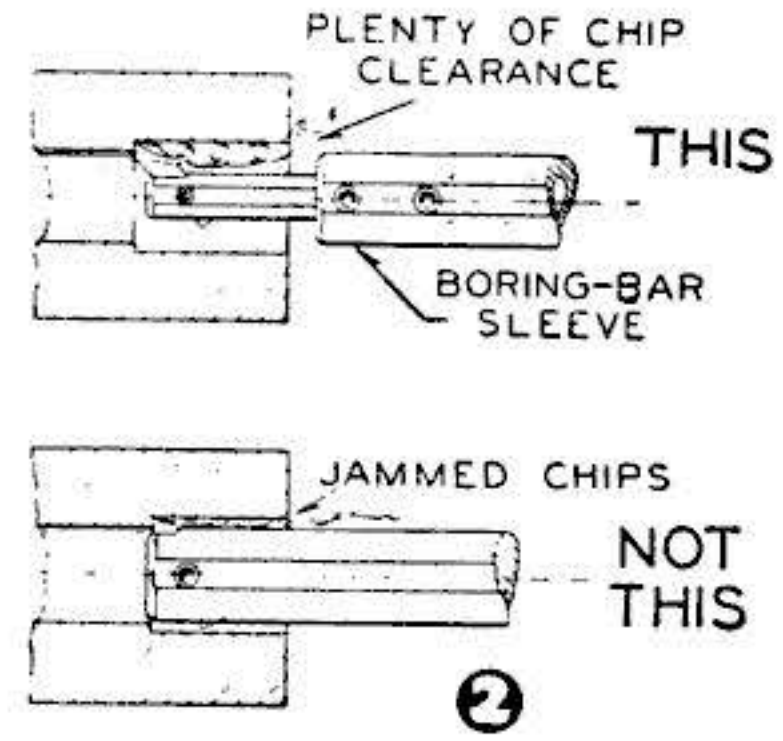
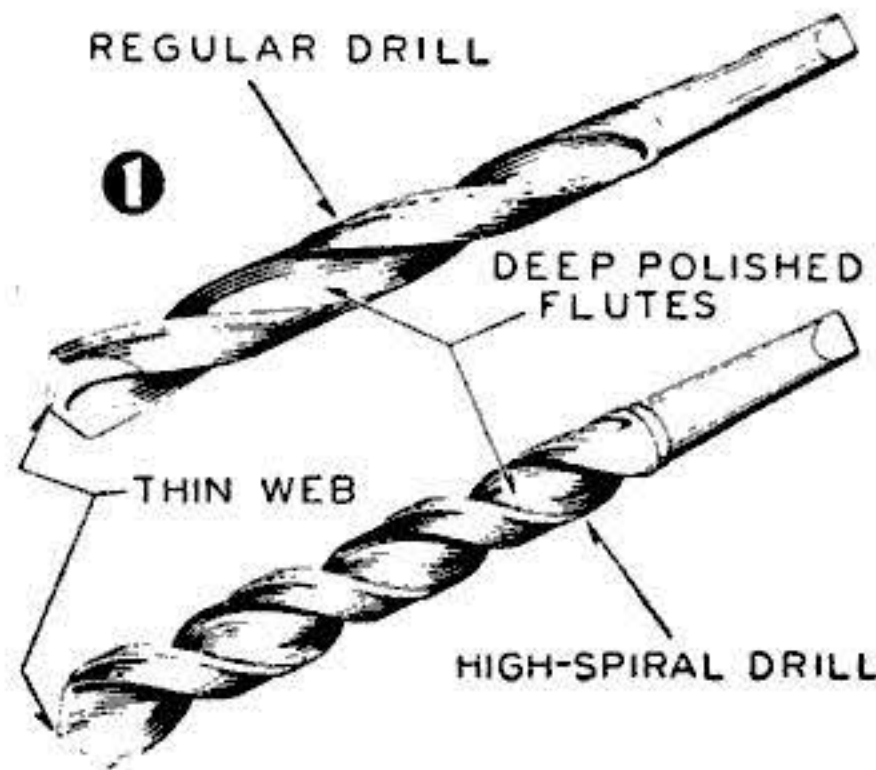

**4** Care is required in tapping and threading. Use ground-type taps with a "hook" or rake on the leading edge of the flutes. The flutes should be deep and wide to provide chip clearance and avoid jamming that may ruin the thread. Both dragging and forcing a tap or die head may destroy the accuracy of the lead.

**5** Lathe bits for machining aluminum are ground differently from those used on steel. A table of clearances and rakes is given in the drawing. For a good finish, the chips must not drag on the previously machined surface. Aluminum can be machined dry. If a lubricant is used, it may be a mixture of soluble cutting oil and water, kerosene and lard oil, paraffin (oil) and lard oil, or water or kerosene alone.

CUTTER ANGLES FOR ALUMINUM				
TYPE OF CUTTER	FRONT CLEARANCE	SIDE CLEARANCE	SIDE RAKE	BACK RAKE
H.S.S.	8°	8°	10°-20°	20°-45°
CARBIDE	6°	6°	5°-15°	5°-20°

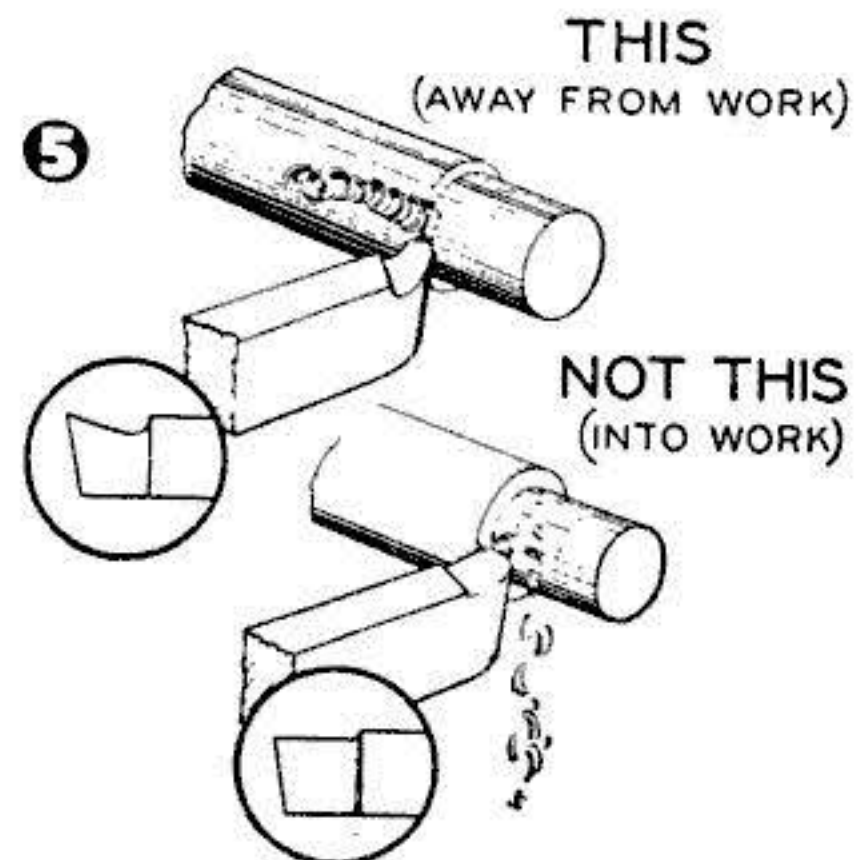



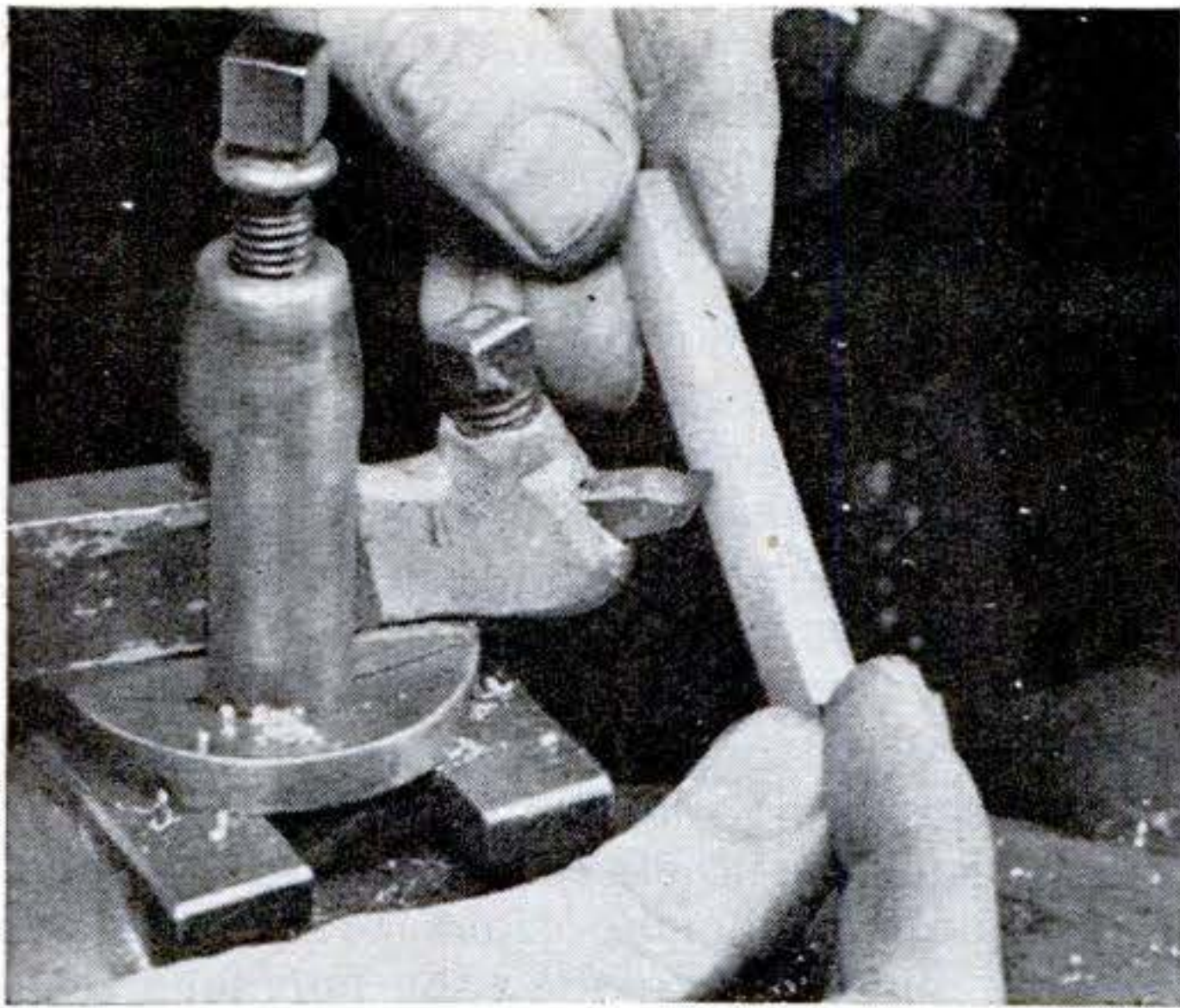

Honing the cutting edge helps to keep tools sharp for machining aluminum. As in lathe work on other nonferrous metals, keen-edged tools are required.

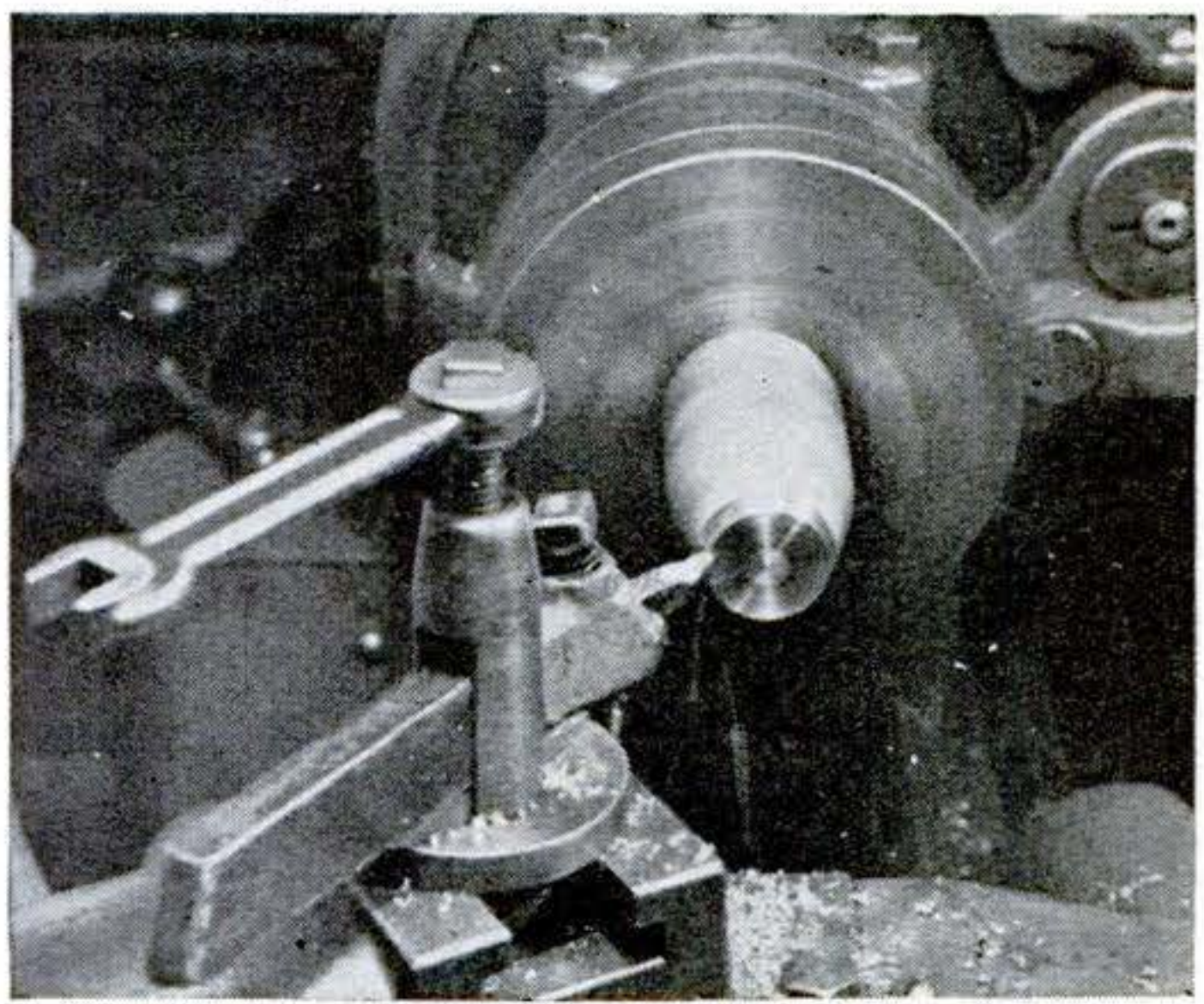

Aluminum is machined at high speeds, from 200 to 900 surface feet a minute. Note that the tool is set quite high and meets the work at a steep angle.

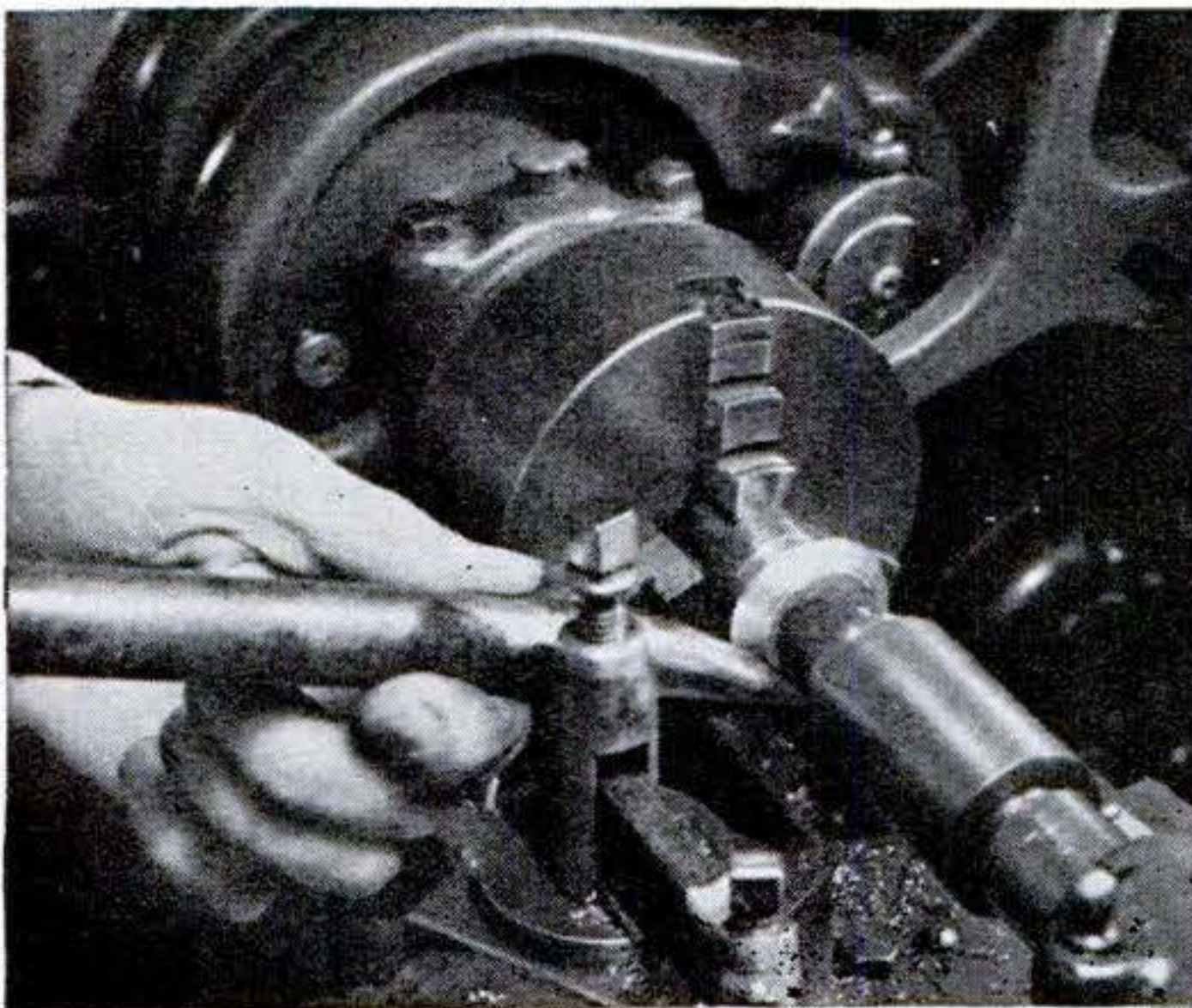

Sheet aluminum is being spun here in an ordinary lathe fitted with a rotary tailstock center. Do not try heavy spinning in a small precision lathe.

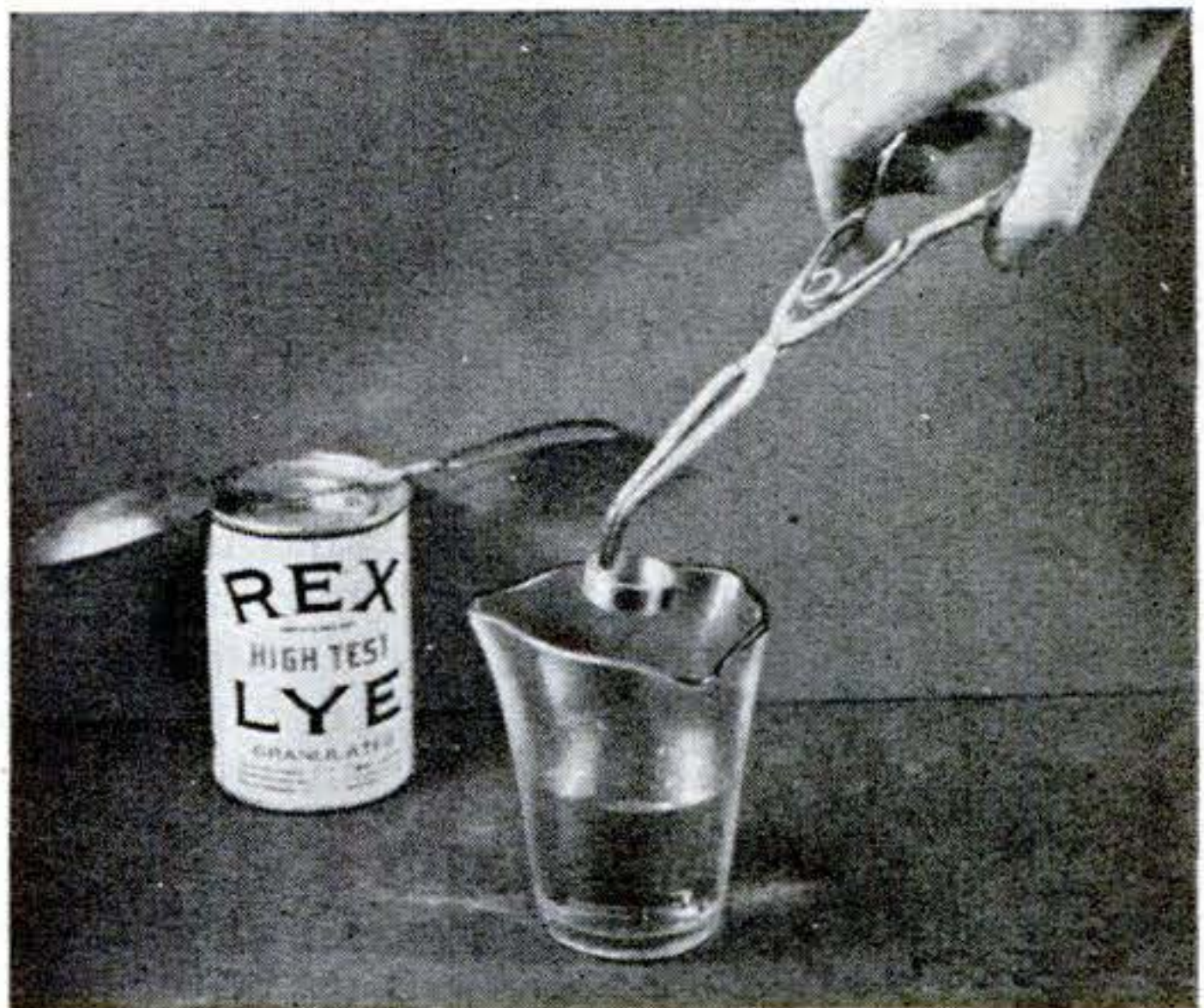

Dipping in lye gives aluminum a satin finish. The piece shown above is the aluminum lens cap being turned from a casting in the photo at top right.

torch when a suitable flux is used. Butt joints seem to be the most successful. The flux, as in all welding and soldering, should be washed off after the operation.

Aluminum articles are polished readily and require no special finish. They can be lacquered or enameled. Crackle and wrinkle-lacquer finishes are common.

An even, satiny matte can be produced by alkalis, as was found some years ago by the head photographer of a large manufacturing concern. He had experienced difficulty in obtaining reflectors for 500-watt lamps and had tried to use aluminum mixing bowls mounted on wooden supports, but they were so shiny that the distribution of light was uneven. Knowing that alkalies attack aluminum readily, he mixed a strong solution of household lye, swabbed it around inside the bowls, and let it bubble and fizz for several minutes. Washed in water,

rinsed in his acetic-acid short-stop bath, washed again, and dried, the bowls became excellent diffusion-reflection mediums. Alkaline solutions such as ordinary lye (sodium hydroxide) and potassium hydroxide are also employed in etching aluminum.

Magnesium is another important war metal likely to find favor in home workshops when extreme lightness is desired. It weighs only 109 lb. per cubic foot compared to 168½ lb. for aluminum. The melting point is slightly lower, 1,200 deg. F. Magnesium may be machined like aluminum, but the metalworker should bear in mind that fine shavings and chips will burn with a fierce heat—the flash powder used by photographers before the advent of the photoflash lamp was chiefly magnesium.

Monel metal, an alloy containing a little better than 2 parts nickel to 1 part copper and a small quantity of other elements, is



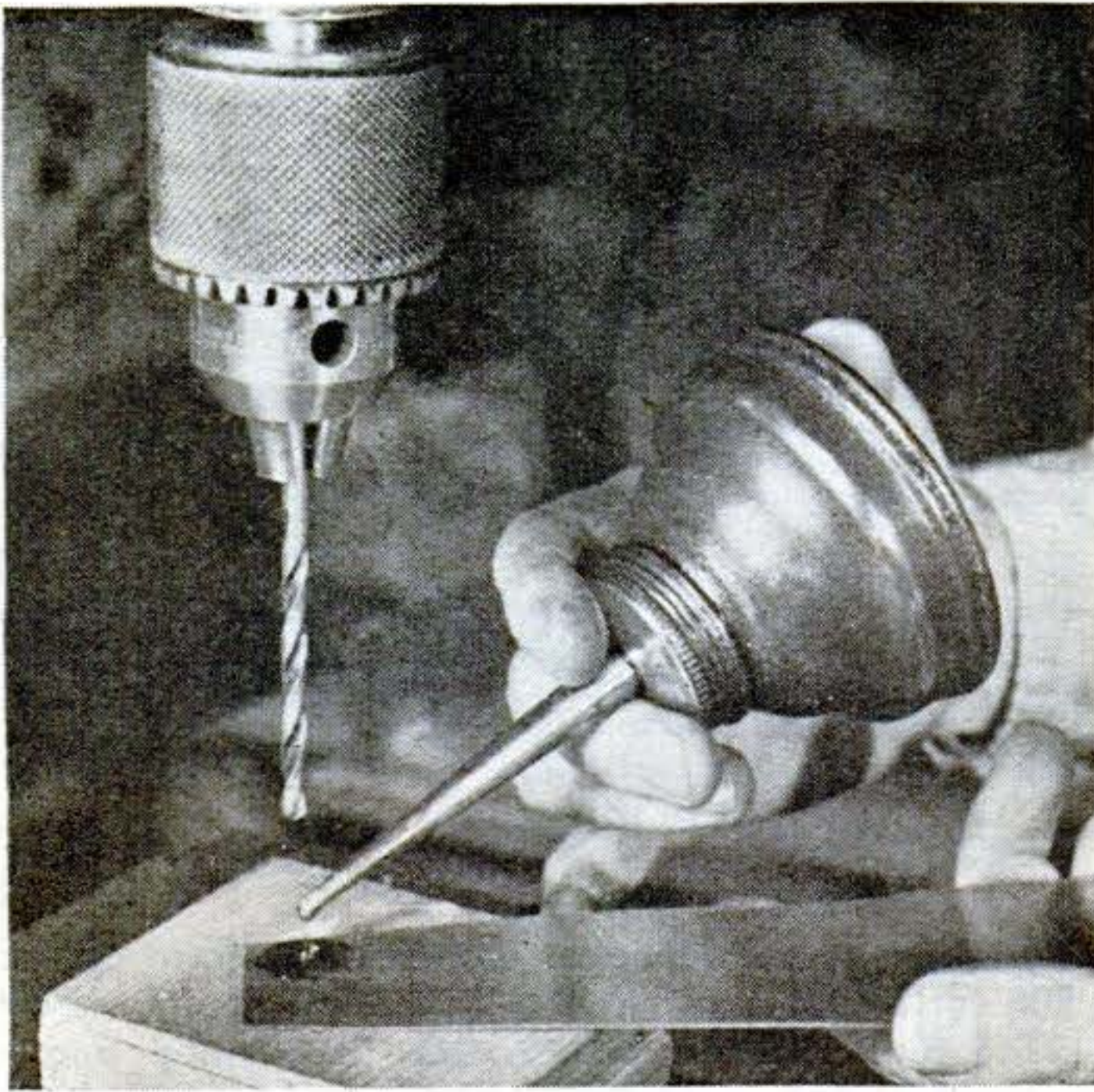

Sulphurized cutting oil is a help in drilling tough monel metal. Without it the bit may be burned. A deep punch mark encourages the bit to take hold.

one of the tough guys of the alloy world. It melts at 2,460 deg. F., has a lustrous, silvery appearance when polished, has high ductility and malleability, and resists corrosion. Some of its uses are for photographic tanks and trays, for air ducts and other equipment in factories handling salt and other corrosives, and for kitchen sinks, stove tops, work surfaces, and the like.

Its toughness makes monel sheet difficult to cut with hand snips, though if the necessary force is applied it can be done. A drill bit is likely to burn without warning when you attempt to drill monel unless you employ a trick or two. One such trick in drilling sheet stock is to make a deep punch mark first, one even deep enough to break through, which helps the drill take hold

## Old Photographic Hypo Useful for Silver-Plating Brass

THOSE who do their own film processing have a means at hand for silver-plating brass knobs, ash trays, candlesticks, and the like. They can use their old hypo. All that is necessary is to clean the surface of the brass piece to be plated to remove all dirt and grease and to immerse it in the hypo for a short time. The plated piece is then washed well, dried, and given a coating of clear lacquer to prevent tarnishing.

By a process known as chemical displacement, a thin coating of silver is deposited on the brass. This usually requires no more than a minute. Prolonged immersion may result in flaking. Be sure you employ used hypo, or there will be no silver in it.—W.E.B.

promptly instead of merely rubbing over the surface. Sulphurized cutting oil or lard oil is applied to reduce friction and produce a cleaner cutting action. Dry-cleaning fluid, applied liberally enough to prevent complete evaporation by the heat of drilling, will also work. Use a slow drill speed with just enough feed for a nicely curled chip.

Monel can be spun successfully, but it calls for more force than brass, copper, and even many steels. Whenever it becomes too hard and stiff to be spun, it should be annealed by heating to 1,440 deg. F. and cooling in air. Tallow is a good spinning lubricant, and the tools are preferably steel.

Welding, soldering, and brazing monel are not difficult provided the surfaces to be joined are clean. For soft-soldering, the best procedure is to tin the surfaces, using an iron rather than a torch when convenient, and then to sweat the joint together. The flux may be any preparation having zinc chloride as a base—the familiar zinc dissolved in muriatic acid will do, and various commercial fluxes are satisfactory. After the job has been completed, wash off the flux with hot water, scrubbing with a cloth or brush if necessary.

For hard-soldering, use a silver solder melting at 1,400 deg. F. or less and a torch with a small flame. Keep the torch moving so as not to heat the metal any more than necessary to make the solder flow. The same procedure is followed in brazing. Special fluxes for monel are made for both hard-soldering and brazing. No special brazing rods are needed with the right flux.

Monel may be welded with a gas torch, metallic or carbon arc, or spot or seam-welding equipment. Special monel welding rods are made. The current for spot-welding is higher than that needed with steel, but pressure is lighter and time shorter.





## Split Bushing in Lathe Steady Rest Protects Finished Surfaces

MARRING of polished work by the jaws of the steady rest can be prevented by a split brass bushing made up to slip over the work as shown in the photo at right. Adjust the jaws until the work is held snugly but will still revolve freely inside the bushing. Such a bushing protects the surface from chips and dirt and, when well oiled, not only guards against scoring but even increases the high polish.—C. W. W.

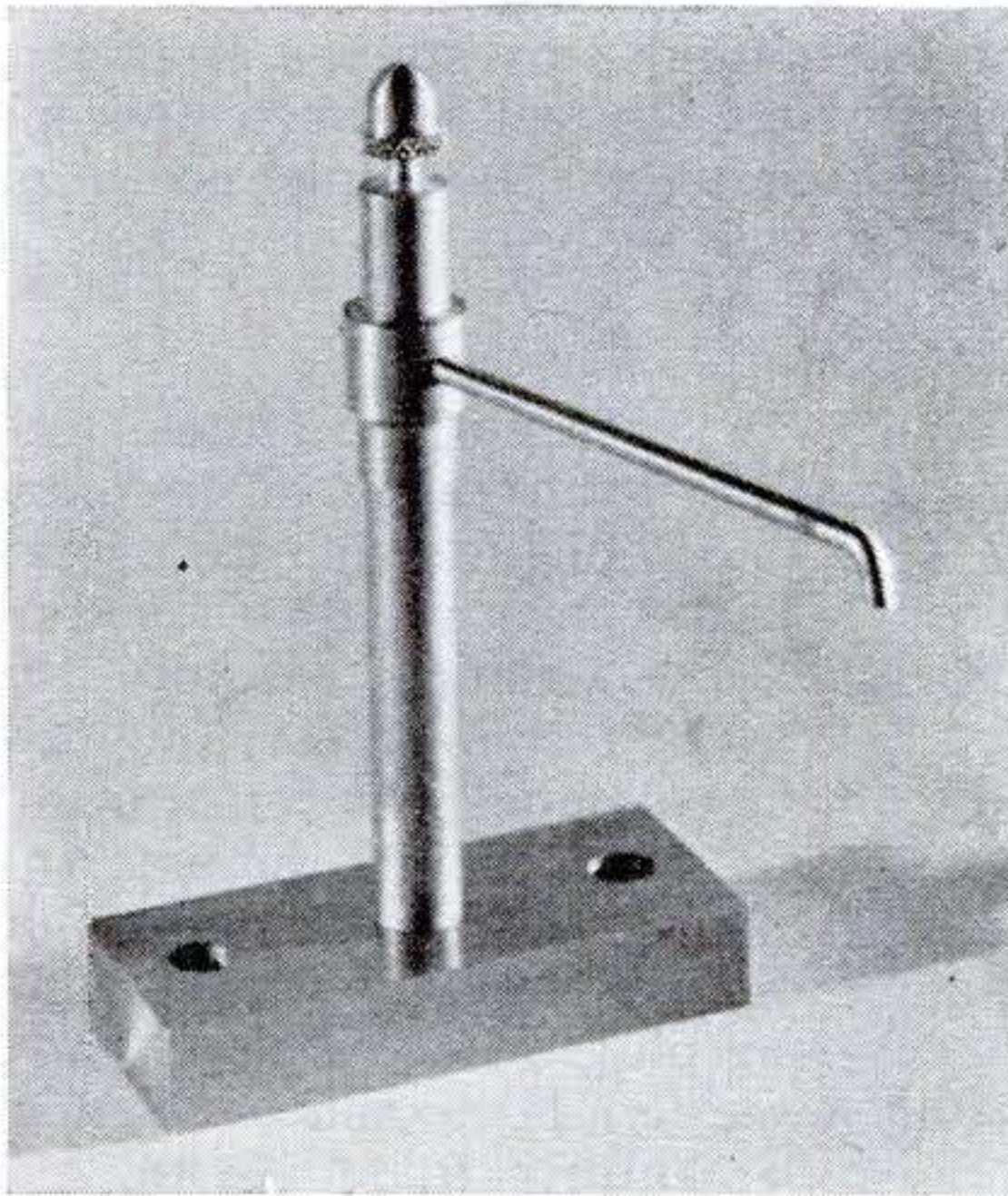
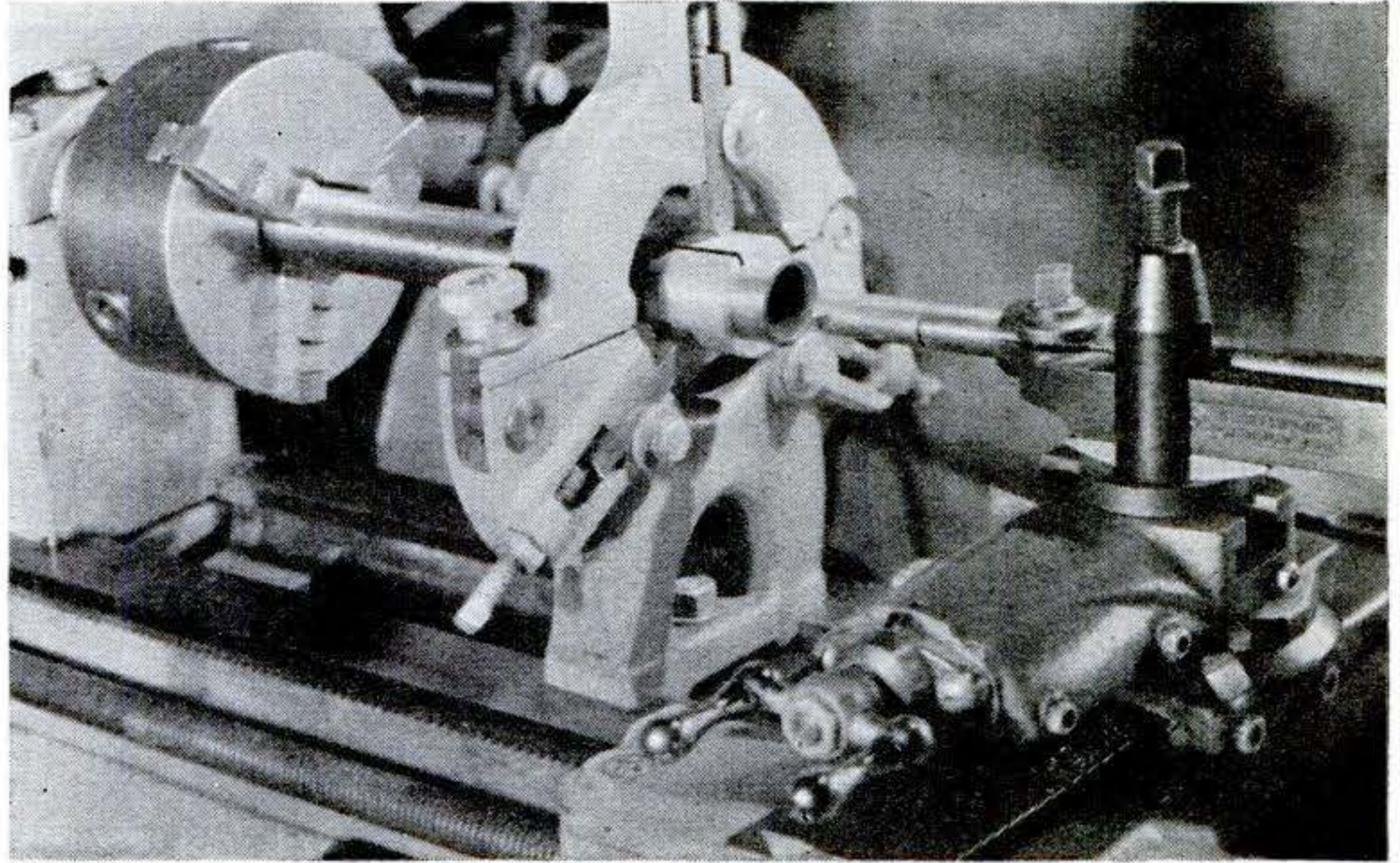

## Gauge Made from Scrap Measures Tool Height

THREADING and cutoff tools that must be adjusted to exact center or other height in a lathe can be set quickly and accurately with the aid of a height gauge made like the one shown above.

Cut the upright member from scrap bar stock, thread the end, and screw it into a suitable base. Make up a collar for a snug sliding fit, drill it clear through, and tap one hole for the height bar and the other for a setscrew. If the bent end is cut to exactly the same length as the distance from the hole to the collar bottom, the upright member can be calibrated.—C. W. W.

## Section Cut from Broken Triangle Salvages It for Many Uses

WHEN breaks or chips make a triangle worthless for drawing and layout work in its original form, cut off one unbroken side to make another handy instrument, as shown in the drawing.

Use a penknife and a metal-edged ruler to score both sides where the triangle is to be cut, and then break along the line. Sand the top edge to a bevel and smooth the cut portions. Con-

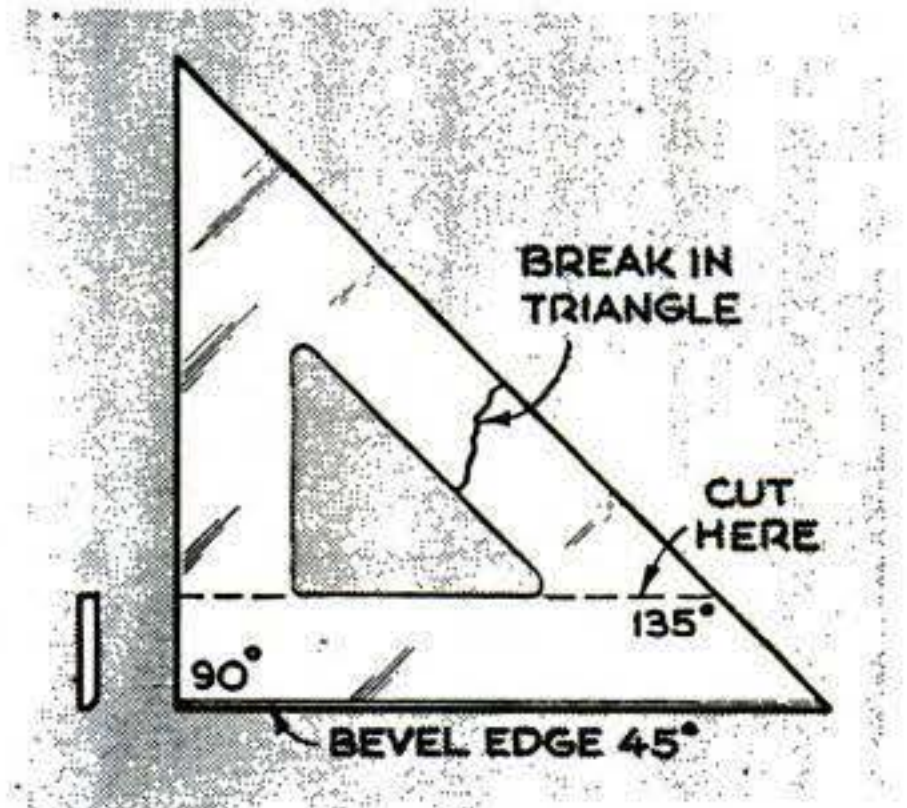

ventional divisions may be scored at the top edge, if desired, and filled with India ink.—F. S.

## Offset File Handle for Wide Work

IT IS often difficult to file a surface with an area wider than the length of the file. Fingers bump the edge of the work when the handle is left off, and uneven pressure causes poor finish. A slight alteration will remedy this.

Slip the handle off and heat the tang red hot; then make an L-shaped bend as indicated in the drawing. Be careful not to heat the cutting teeth. The bend should offset the handle just enough to give finger clearance.—JOHN KRILL.

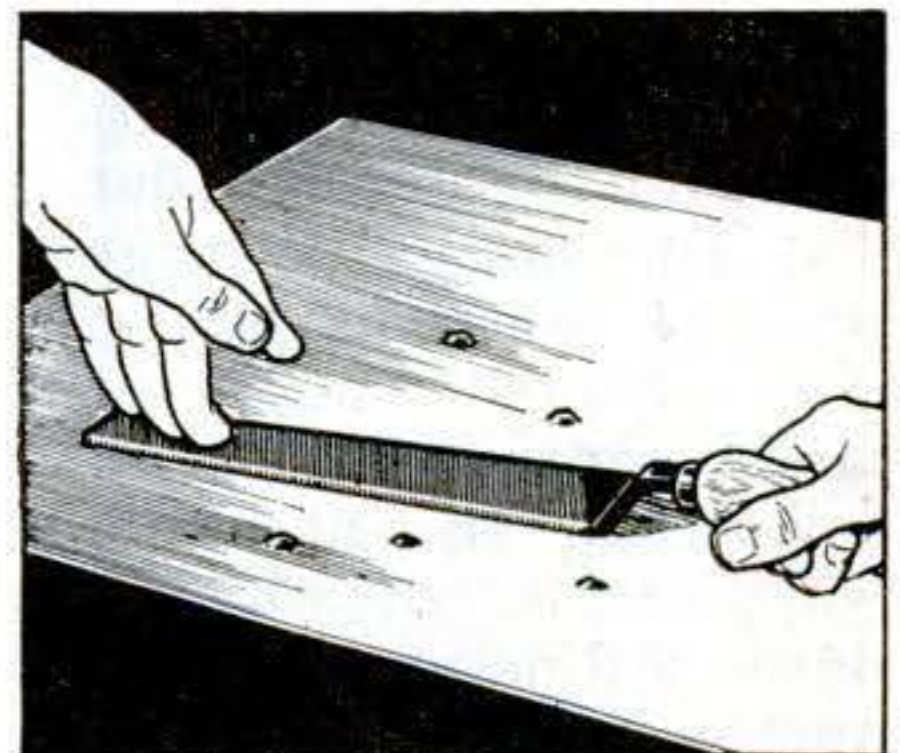



## NEW SHOP IDEAS

**SELF-FEEDING**, the device at the extreme right solved the problem of holding threaded studs against a power-driven brush. The studs fall by gravity through a tube set at an angle, and the brush contacts them through an opening cut in the tube. To keep the studs from passing too quickly, a small stationary brush is mounted to protrude into the tube through an opening opposite the larger one, its friction controlling the time the work is in contact with the rotary brush, which turns each stud until it is past and drops out of the tube.

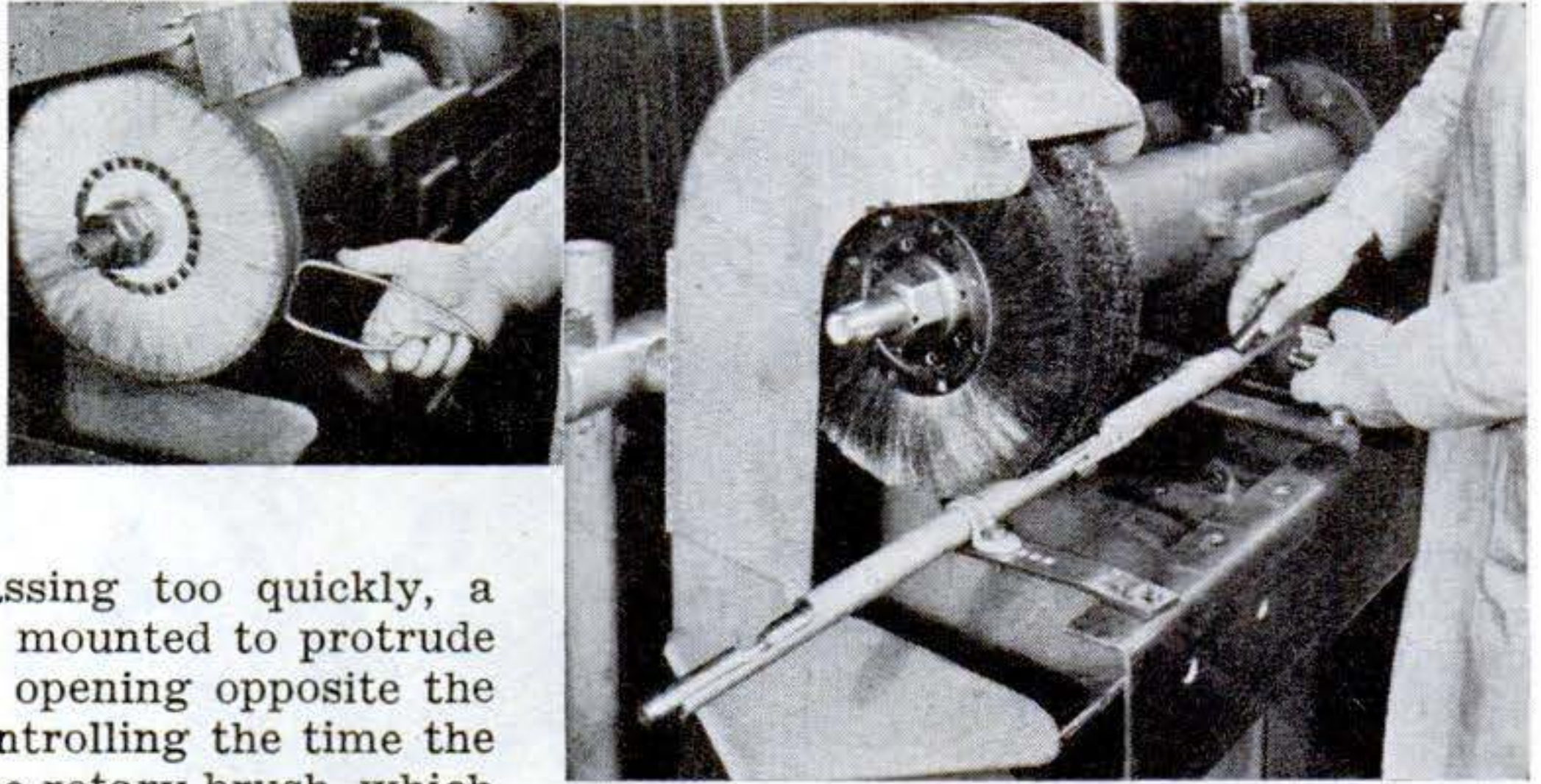

Such a holding fixture could be made from any metal pipe, but if the part being brushed is soft it would be better to use tubing of plastic or other composition to avoid damage to the external threads. This is one of two handy new shopmade devices for use with power brushes

reported to the Osborn Manufacturing Company, of Cleveland, Ohio. The other is a pair of handmade forceps (at left above) for holding tiny splines against a brushing wheel. A set of such forceps would be useful in handling parts of many sizes and shapes.

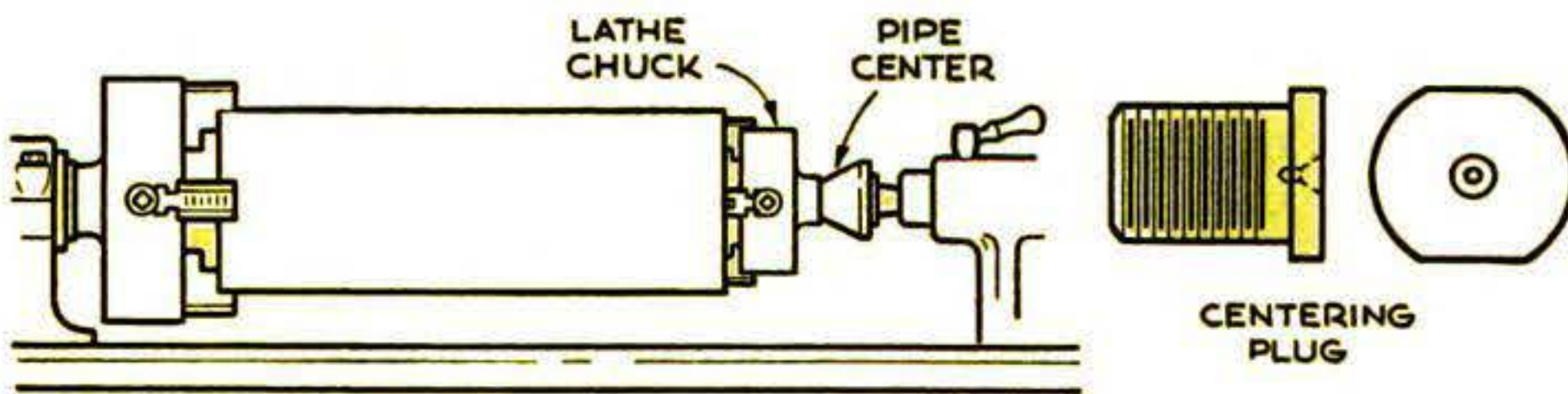

**CASING** or large pipe too big to mount on available pipe centers in the lathe can be set up securely for turning with two lathe chucks and a small pipe center. Fit the

three-jaw chuck into the inside of the casing and let it revolve on the pipe center, which is set into the tailstock. A four-jaw chuck on the headstock will support the other end of the pipe in the usual manner. For repeat work, a threaded centering plug to fit the chuck may be made and a regular lathe center used in place of the pipe center.—R. M. DYKE.

**AN AUTO TRANSMISSION** will provide speed changes for a large lathe. James W. Kemp, of Santa Fe, N. M., who installed such a system, arranged a double V-belt drive on the power-input side of the transmission by placing a double water-pump pulley on the motor and two pulleys, welded together, on the clutch shaft. On the output shaft he attached a pulley for a flat belt running to the large step of the lathe pulley. He mounted the motor and transmission in a cradle on an angle-iron support bolted to the lathe. Adjustments in the motor mount and trans-

mission support tighten the belts. A pan under the transmission collects any dripping grease. By use of the shift lever, bent down within easy reach, the operator can shift speeds without stopping the lathe.—E. H.

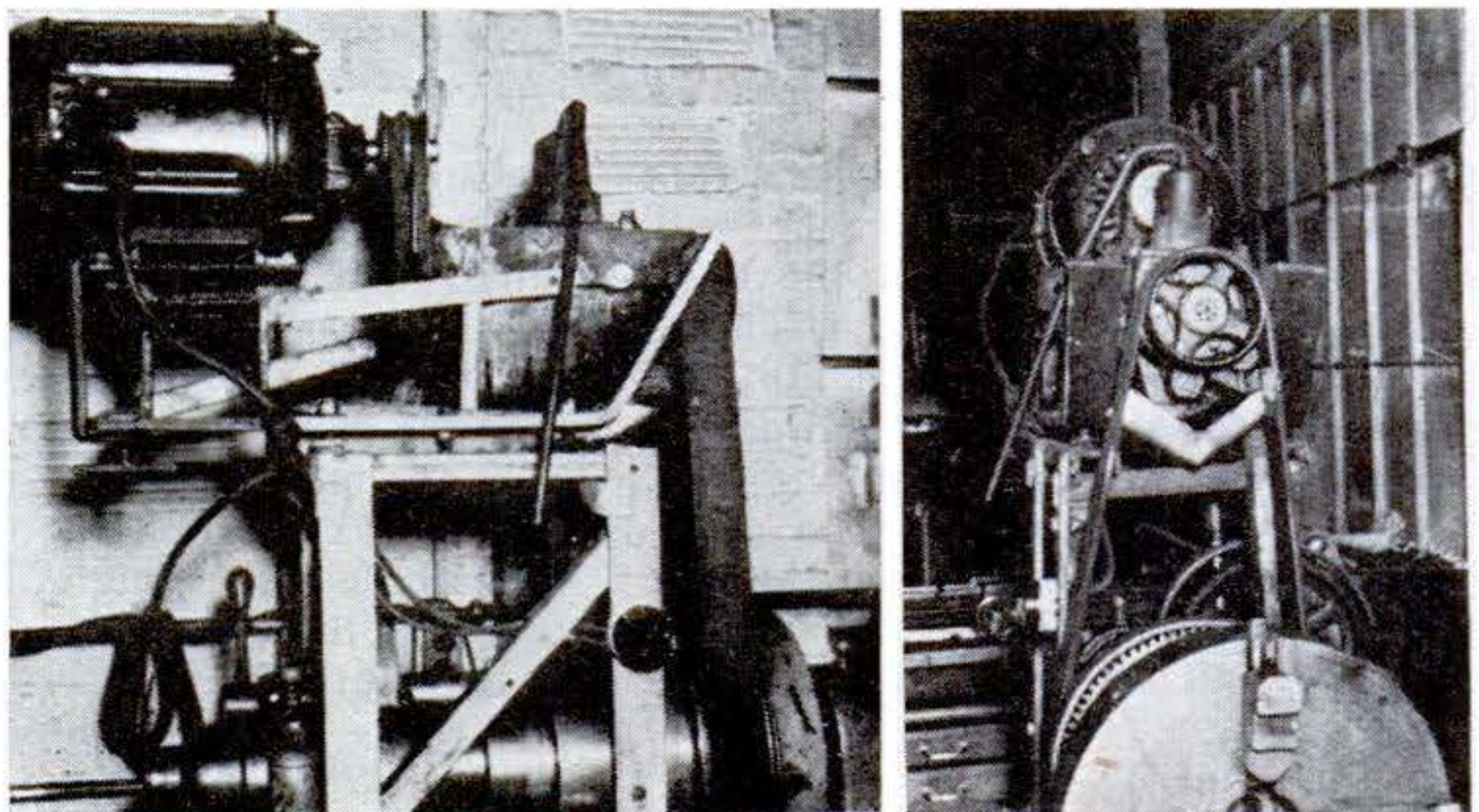



**WOOD DOWELS** are employed in an emergency method of repairing broken shear pins reported to *Army Motors* by Sgt. Robert H. Fortin. Punch out the piece of broken pin remaining in the shaft, cut it in half, and space out the two sections with a wood dowel, as shown in the sketch at the right, so that they will withstand the force between the driving and driven members. Friction tape wound around the drive shaft will keep the sections of the pin in place if necessary.

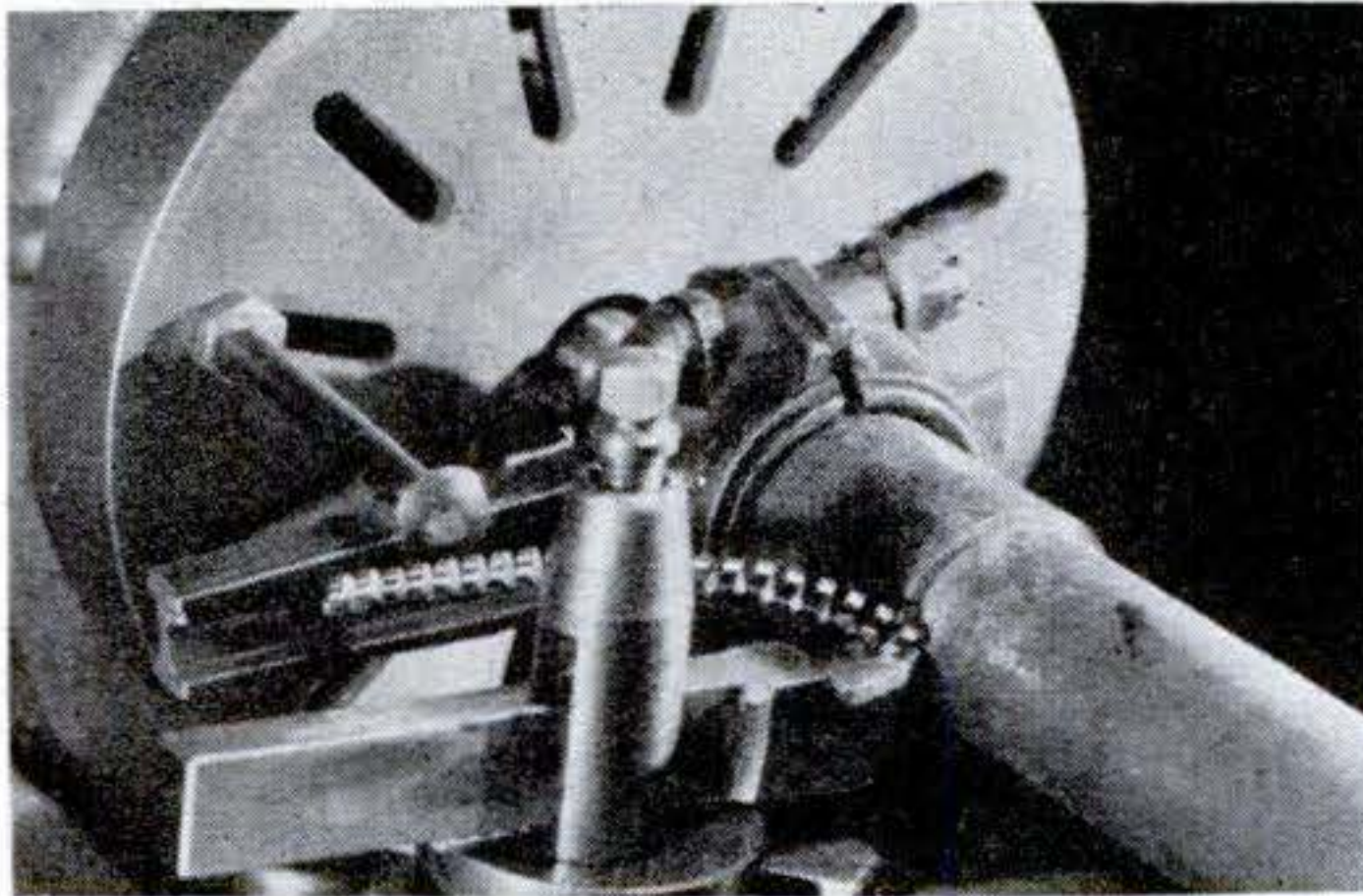
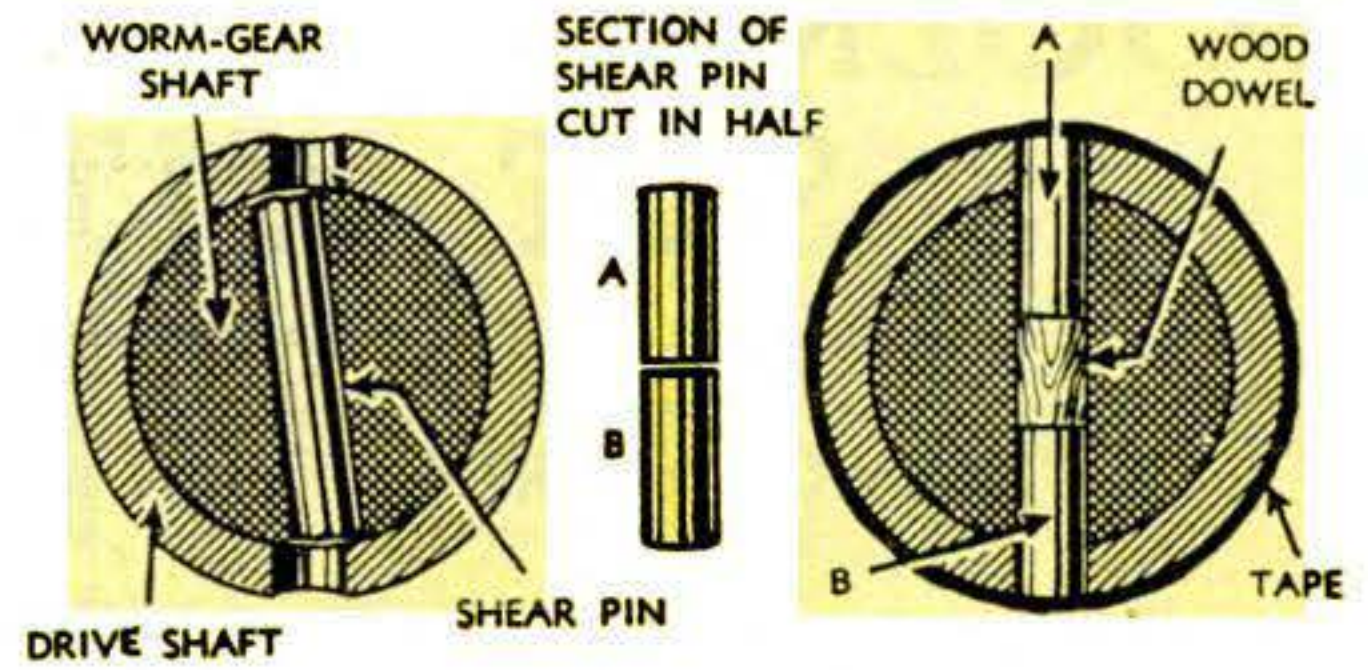

**BIG DOG.** For oversize work, the makeshift lathe dog shown above will serve the purpose satisfactorily. It was made from a discarded connecting rod with the small end cut off. A hole can be drilled in this end for insertion of a driving stud or a bolt can be fastened in the faceplate slot to drive the lathe dog and the work.—C. W. WOODSON.

**A CORK PLUG** for the headstock spindle of a metal-turning lathe stays in place better than the usual cloth or wooden stopper. If it's too large, place the cork in the lathe and turn it down with coarse sandpaper. For easy removal, the plug should protrude about  $\frac{1}{2}$ ". Insert it in the spindle and cut to that length with a sharp knife.—WILL THOMAS.

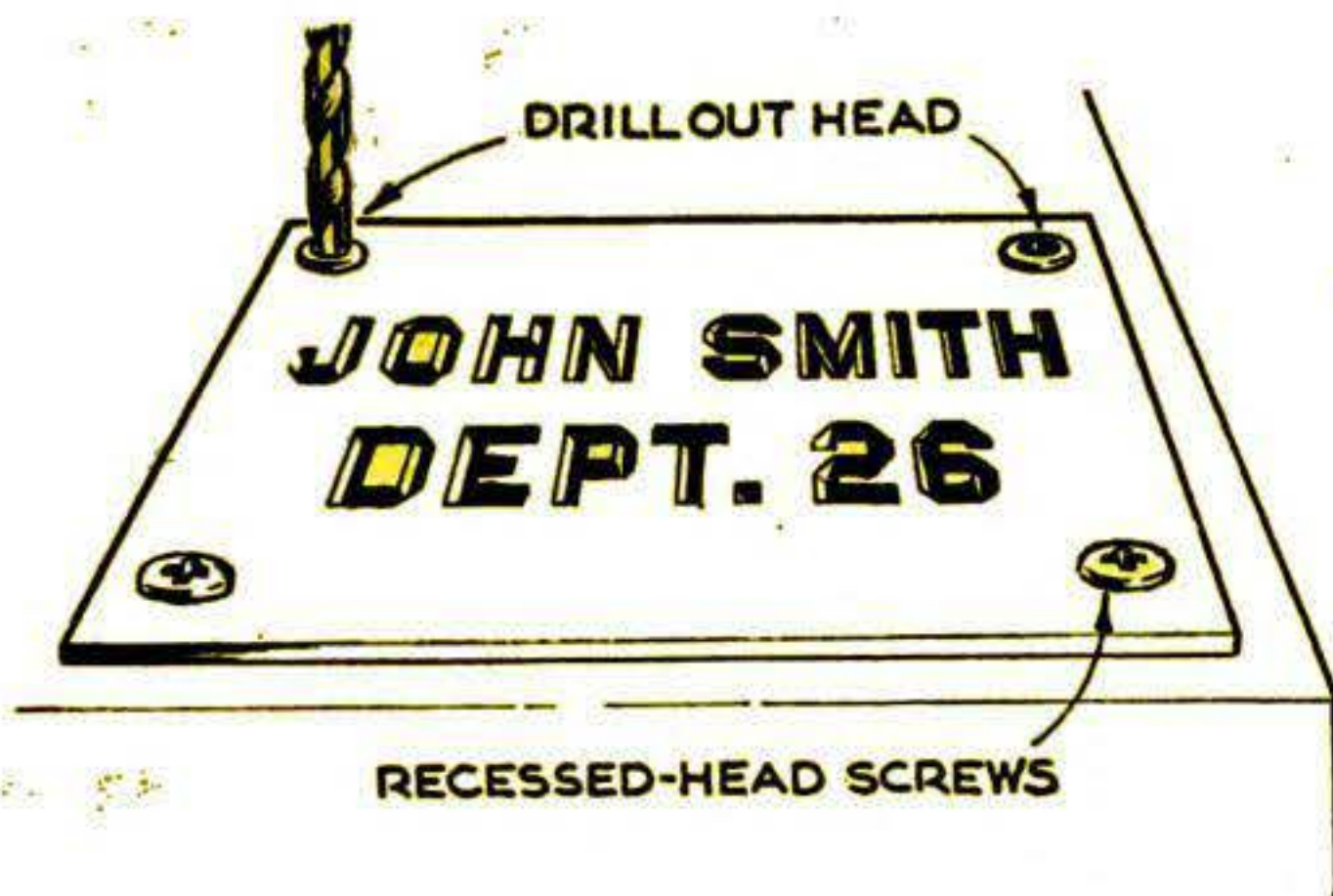
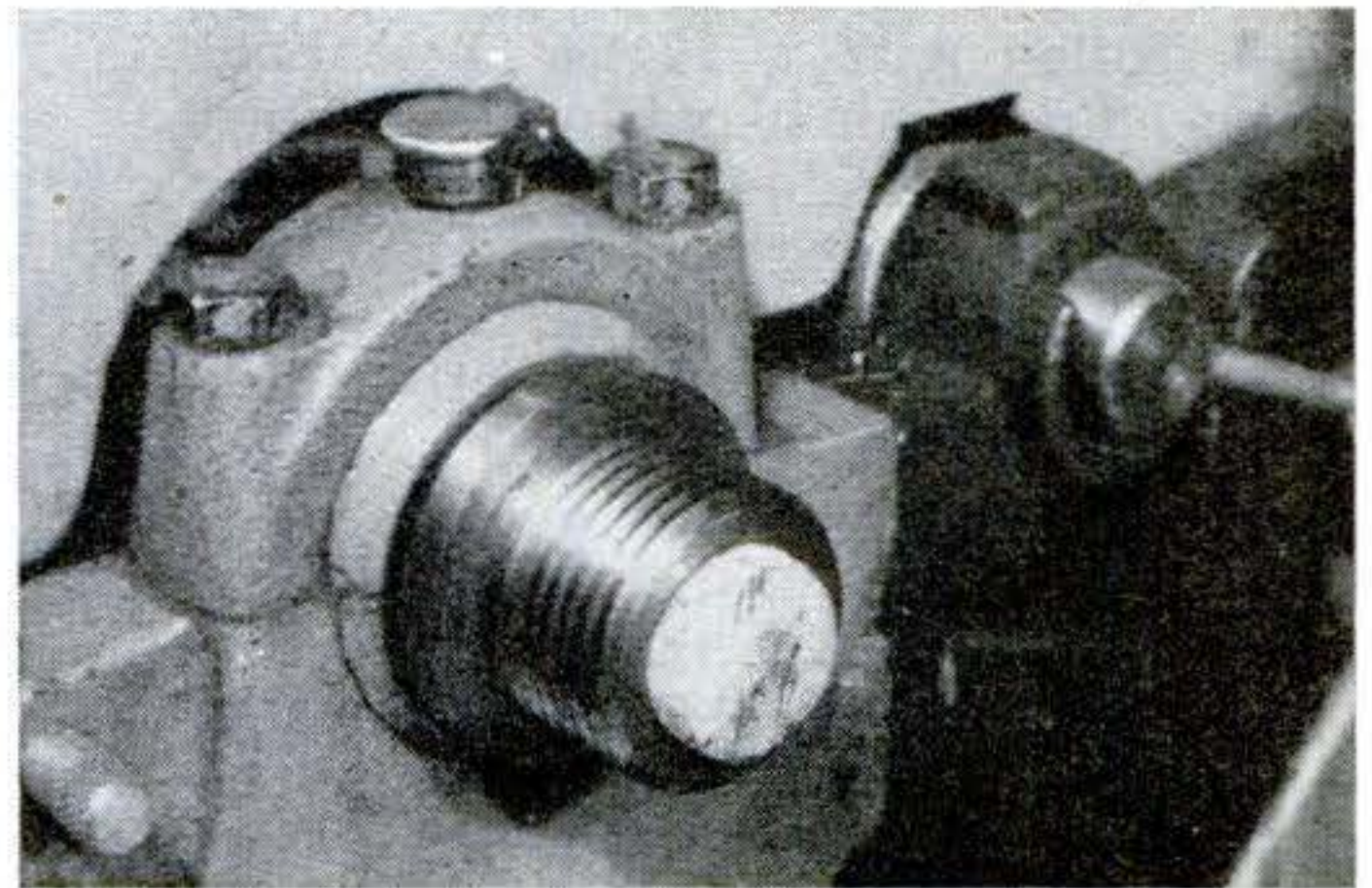

**NAME PLATES** on tool boxes, trunks, or luggage are harder to remove, and therefore make identification more permanent, if attached with recessed-head screws as at left. When the screws are in place, drill out the four-pointed recess to prevent a screwdriver from taking hold. If removal of the plate may be necessary at a later time, it is best to use machine screws so the nuts can be loosened from the inside of the door or container.—WALLACE H. MCCLAY.

**DRAWER LABELS** like those shown at the right save much time in taking inventory of small parts stored in a stock room, for it is not necessary to count each individual piece. On each card is recorded the weight of the empty drawer and the weight of one of the parts stored therein. Taking inventory thus is reduced to a simple arithmetical problem. Weigh the drawer and its contents, subtract the drawer weight, and divide by the weight of one part. The result is the approximate number of parts.—R. E.

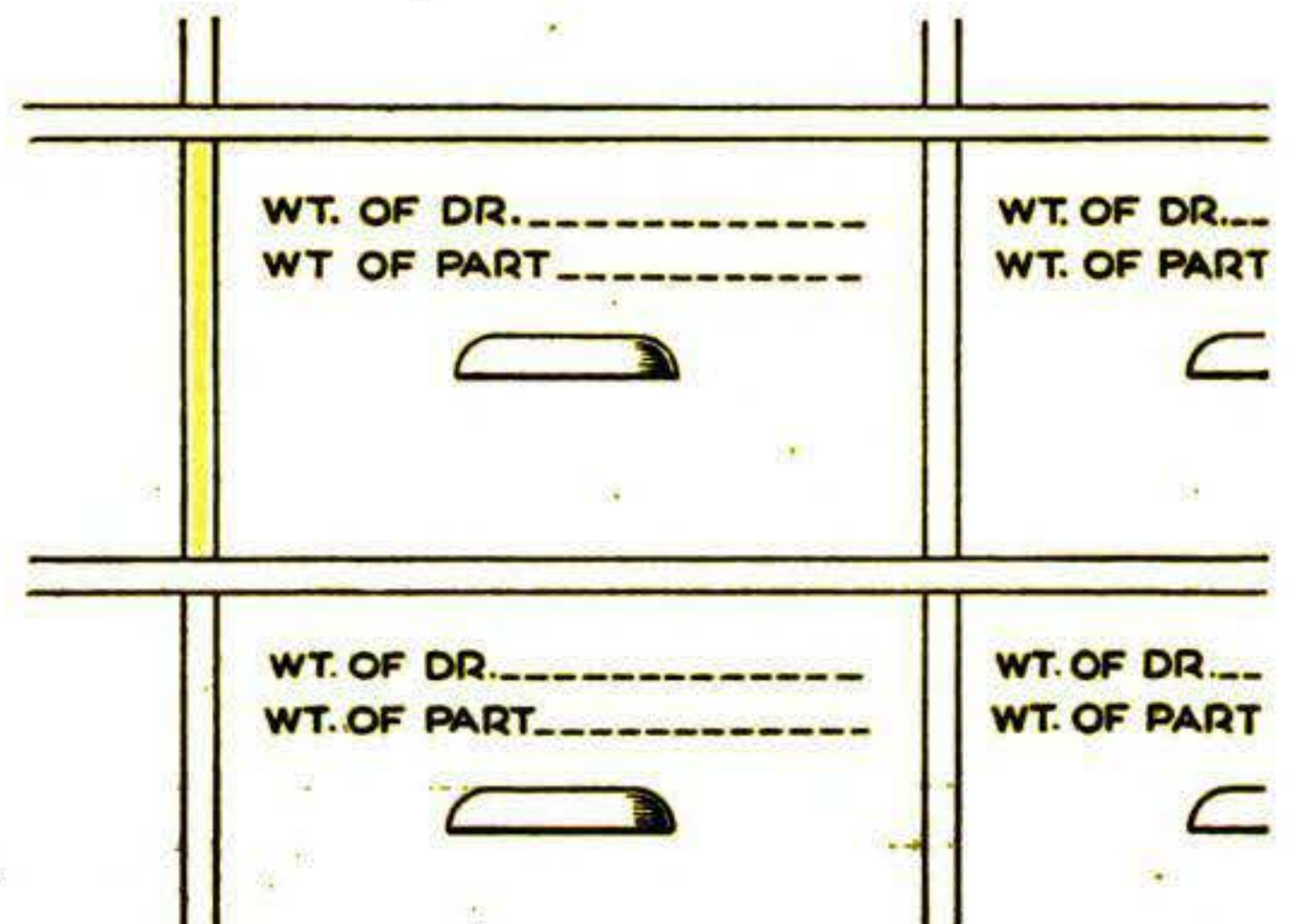



# TOOLMAKER'S PROTRACTOR IS SET WITH MICROMETER

By FRANK McCARTY

ADJUSTED like a sine bar, this miniature sine protractor enables a toolmaker to set up small work for milling, grinding, or shaping uncommon angles accurately to the minute of a degree. With the aid of two micrometers and a table of sines from a machinist's handbook, any angle up to 90 deg. can be quickly determined.

The base is shaped from a rectangular block of mild steel, squared up and drilled with a  $\frac{17}{64}$ " hole and drilled and reamed with a  $\frac{1}{4}$ " hole located as indicated in the drawing. Insert a short length of  $\frac{1}{4}$ " drill rod in the reamed hole for a test plug, and grind the bottom to exactly  $.150$ " from the underside of the plug (Fig. 1). This  $.150$ " plus the plug or hole diameter ( $.250$ ") establishes a constant of  $.400$ , which must be added to the sine of the angle for which the protractor is being set. The base is completed by trimming off excess stock and filing the  $\frac{17}{64}$ " hole to a notch.

Grind the edges of the arm parallel, and drill two holes, as indicated. A clamp screw serves as a pivot, a keyway in it receiving a  $\frac{1}{16}$ " pin inserted through the top of the base to prevent rotation when the knurled nut is tightened. The button fits loosely on its screw and can be clamped exactly  $1.000$ " from the pivot and on a common center line parallel to the edge. The length setting will be  $1.250$ " between outside diameters (Fig. 2). Make the setting from the edge with a depth micrometer.

Set the protractor by locating the sine of the desired angle, adding the constant  $.400$ , treating the figure as inches, and measuring from the bottom of the protractor base to the top of the button, as shown in Fig. 3. A  $1$ " micrometer will measure angles up to 36 deg. 52 min., while a  $2$ " micrometer will carry the measurements up to 90 deg. Figure 4 shows a lathe bit being clamped in a vise with the aid of the protractor for grinding to an exact angle.

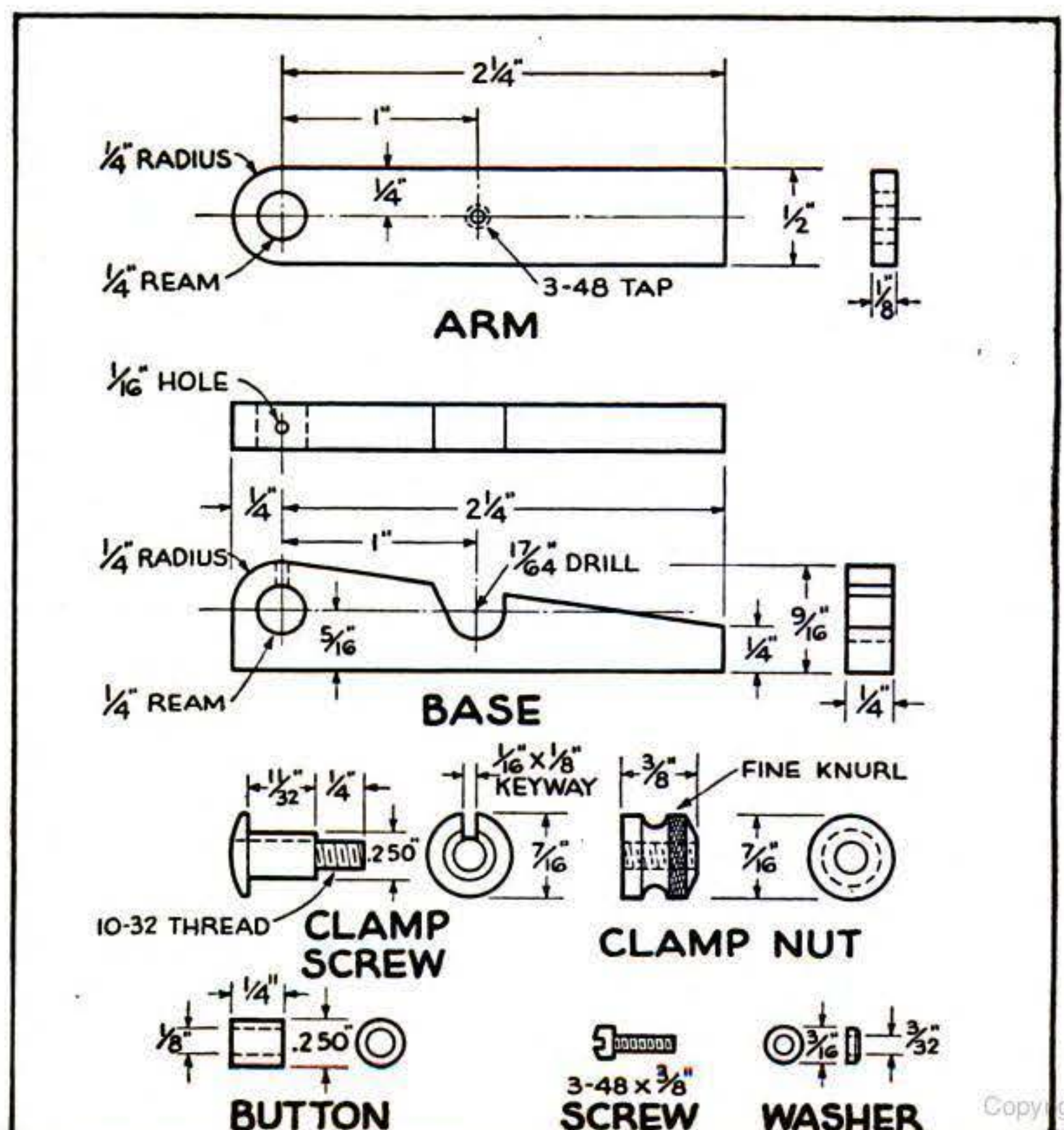
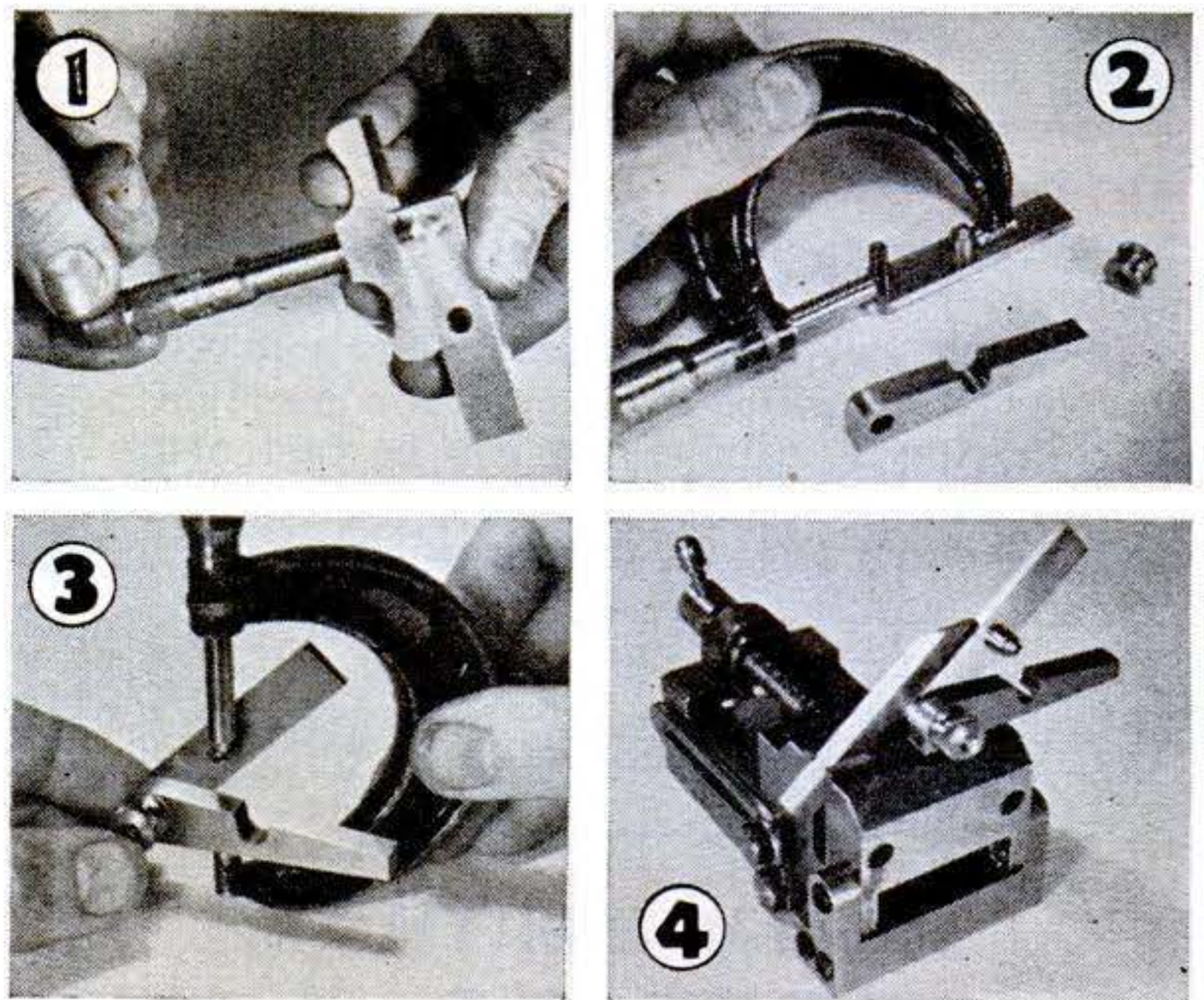
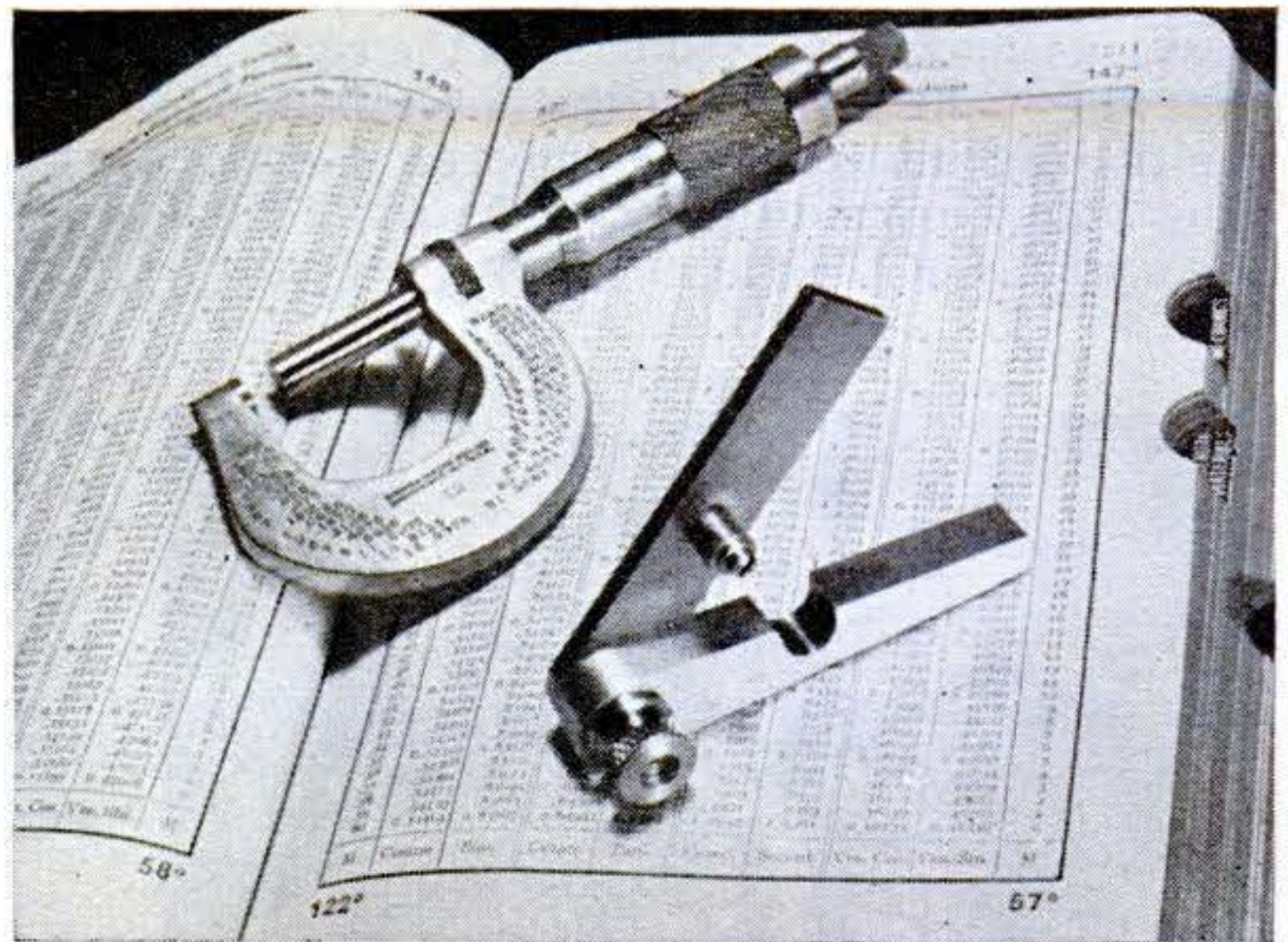



# CAN YOU BEAT THESE PICTURES?

We will pay \$5 for any photo used on this page. Write your name and address on each print. Enclose a stamped, self-addressed envelope and the negative, if it is available, and send your contribution to the Curious Photos Editor.

**NO SOLAR PHENOMENON**, these rings on the Boston courthouse. They are the result of focusing the camera through the Army's famous ring sight that picks up moving targets accurately. Rainbow rings, produced by light through a lens in the sight, are projected so that they appear to be superimposed on the target.



**MEAT IS SCARCE** when it is sold in a bank. The signs in the window are no trick photography. A meat market had moved into a bank building in Newark, Ohio, when Harry Leeper, visiting from Canton in the same state, spotted it with his camera.

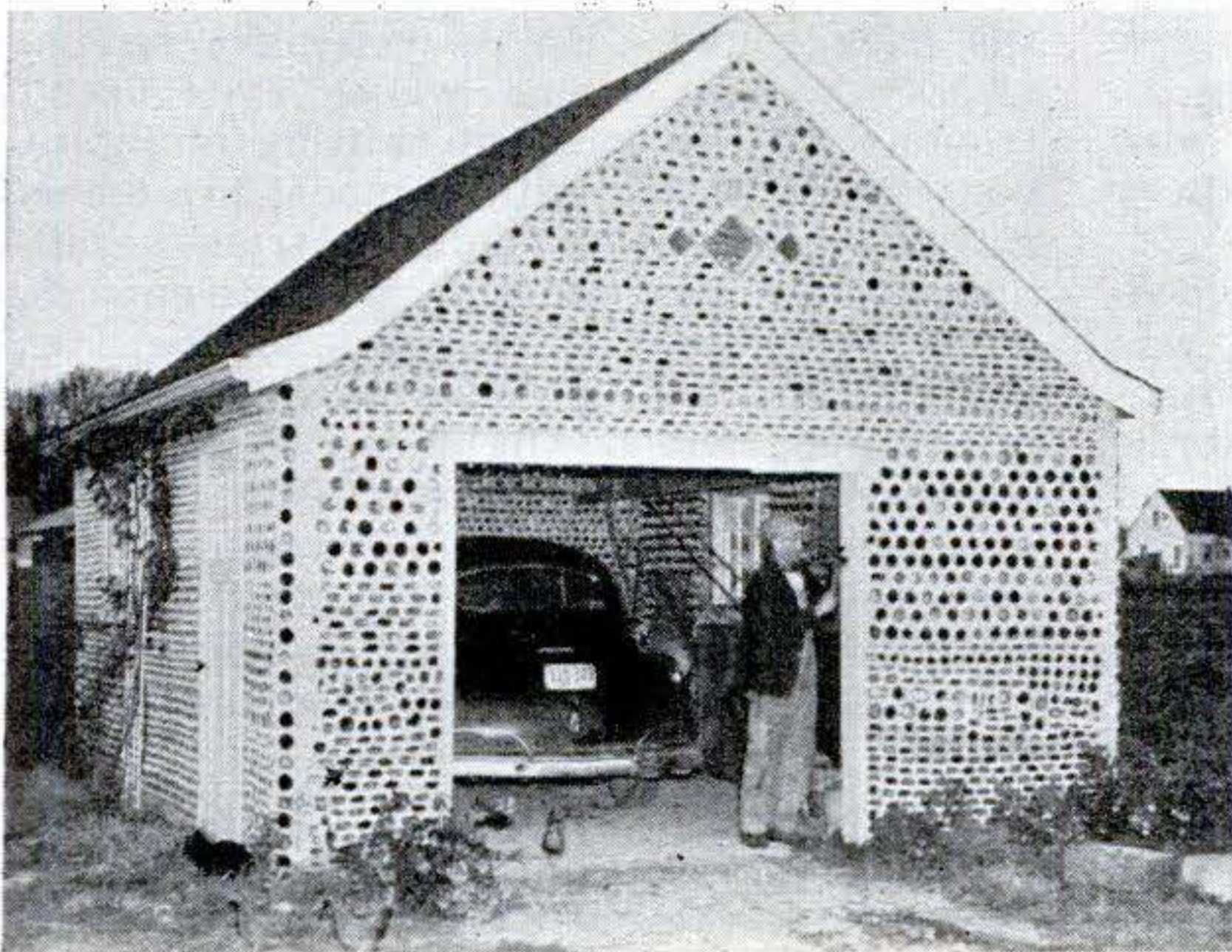
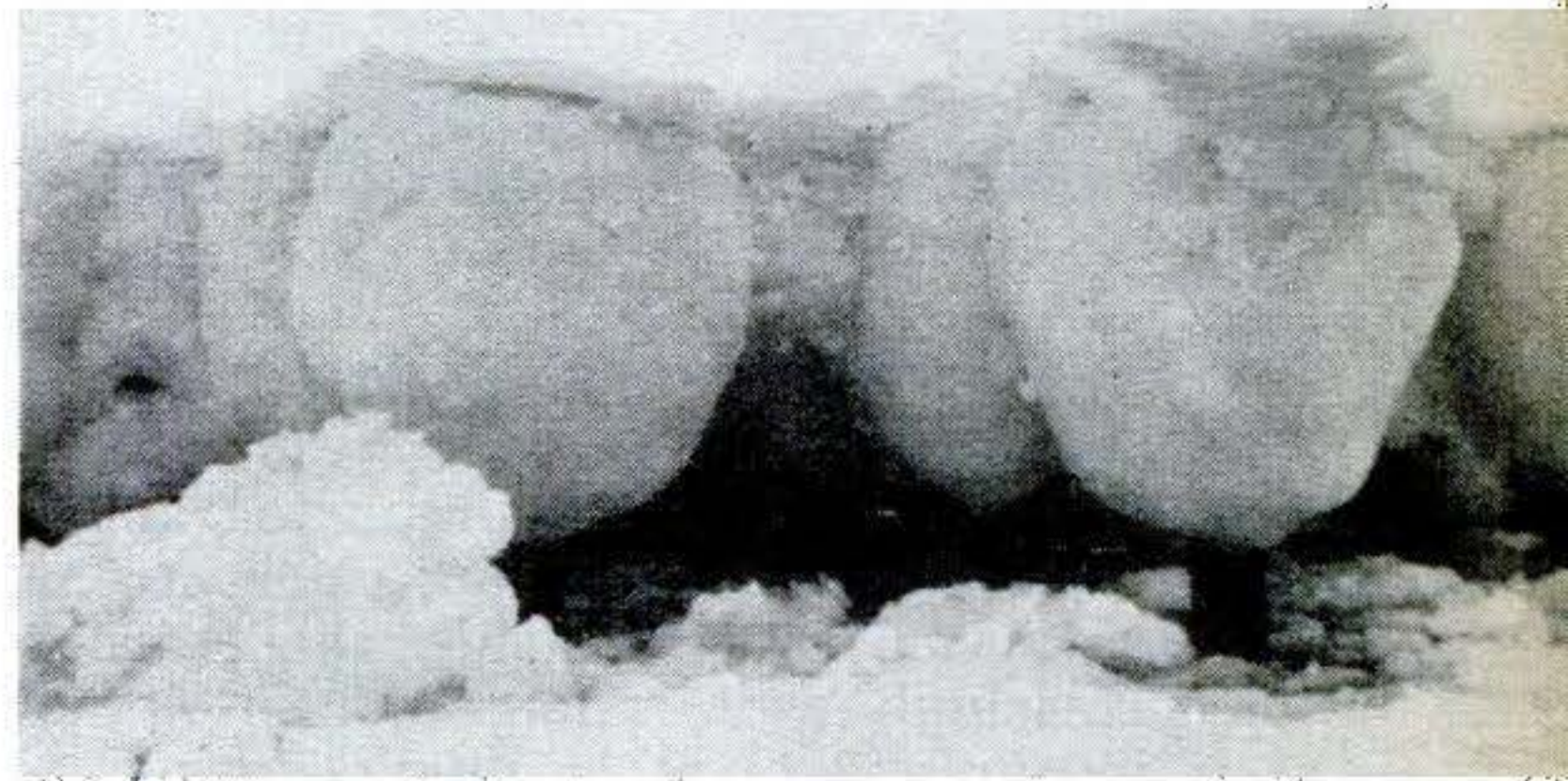

**ICED PIERS** that once held an old mill in Bath, Maine, made the odd photo above. With each rise and fall of the tide in winter, more ice is left on the piers until they look like this. Jean MacDonald, of Bath, took the picture.

**ANY OLD BOTTLES?** Neil Cornwall, a tinsmith, of Vienna, Va., saved a lot of them to build this garage. The bottles were laid in cement mortar like bricks after the framework had been put up. This interesting construction took two years—to collect bottles, not build.





## Who Says

Hardly noticeable in his hand, the stub of a cigar helped this man to relax and to assume a characteristic expression. The background is not as plain as desirable, but a large lens aperture threw it out of focus just enough to make it unobtrusive.

sistent wonders in portraiture.

Well, now that you know, there is no reason why you can't take up portraiture with assurance of success. It's as simple as that. But it does take practice and planning and the memorizing of a few easy rules. There will be discouragements at first, but don't give up. You have before you one of the most fascinating and challenging phases of the whole fascinating, challenging field of photography.

Remember, to get expression that reveals character and personality, you must take your subject's mind off having his picture made. It helps immeasurably if you handle your camera and lights automatically. So practice, practice with the camera unloaded, going over and over the picture-mak-

ing process until you do every step without thinking. Practice focusing, practice composing in the finder or on the ground glass, setting the aperture, working the shutter, winding the film or pulling the slide, checking, and double-checking. Do it over and over again.

Practice arranging your lights to see how the shadows fall and how much light reaches the background. Unless you have an unusually patient friend whose eyes aren't troubled by the constant shifting of lights, you can do better with a model head borrowed or bought secondhand from a millinery shop. Two floods or spots are enough, but if you have a third, use it on the hair. With no artificial lighting at all, you can utilize good window light and a cardboard reflector. Strive for contrast between background and subject, with more light on one than the other, so the tones won't merge. Then work out several fairly standard light placements that you like and memorize them.

When practice has perfected your tech-

By **FRANCES C. SMITH**

**A**LMOST every amateur photographer has experienced taking at least one grab-bag portrait shot that turned out surprisingly well. And too often he has been encouraged by it to plunge into portraiture with enthusiasm before he even knew what made that one shot good. The result, in most cases, has been almost disastrous, with Aunt Susan demanding to know what he did to her nose and with Cousin George offended by a rogues' gallery rendering.

Here's what made that one portrait good. By a fortunate coincidence the lighting was just right, the background was not obtrusive, and the shutter was clicked at just the right moment to get a characteristic expression on the face of the subject. The photo thus achieved the two main objectives of portraiture. It was a pleasing likeness and it revealed character and personality. If he had only known, the amateur might have gone ahead to the working of con-



# Portraits Are Difficult?

nique, you will be ready to tackle your first subject. After you have chosen him or her, do some deliberate planning. Think about him and try to decide, if you don't know already, his dominant trait or quality or the impression you want to bring out. Plan a series of poses and expressions that will bring out this trait, with or without props. Your shots may include only head and shoulders, or they may be three-quarter or full length. They may be formal or informal. Study the physical structure of your subject's face.

Plan a series of angles and lighting schemes that will subordinate such blemishes as a large nose, a prominent chin, or an extremely thin face, and will emphasize the best points, for a pleasing likeness is one of your aims.

With your plan in mind, you are ready to start on your portrait. Set up your equipment — seat, tripod, camera, and lights — before calling your subject into the room. Save a few last-minute adjustments until after he has been seated, for these sometimes serve to help take his mind off himself. Often an explanation of the photographic procedure will relieve his self-consciousness, or you might try discussing the movies, current happenings, sports, or anything in which he is interested. Some-

times a prop, like a cigarette or a book in his hand, will make him feel less stiff and posed even if it doesn't show in the finished picture.

Meanwhile, make a quick last-minute check of details such as a stray lamp shade or corner of a framed picture that might spoil the background, a crooked tie or collar, or a disorderly lock of hair.

And now you are ready to click the shutter the instant you get the expression you want on your subject's face. Often this can be achieved with a simple trick, such as asking him to smile but not to hold the smile. Make the exposure just at the end of the smile when his face is still relaxed. Other



No one need be told that everything is right in one of these photos and everything wrong in the other. At left, stiffness, bad nose lighting, collar awry, and cluttered background. Above, the same subject in a real portrait.



old stand-bys are remarks such as, "Don't look so serious. This is painless, you know—not like the dentist's." One photographer used to ask soldiers for a "furlough expression." This invariably drew an eager, "I wish I had a furlough!" The moment the lips stopped moving and before the sparkle was lost, the shutter was snapped.

One old trick that relaxes facial muscles and adds good high lights is to get the sitter, especially a woman, to moisten the lips. Click the shutter the instant the lips are still again. Try it yourself and feel how tenseness around your mouth is relaxed.

That's all except for a few rules. They might be stated this way:

Keep lighting simple. Use only 45-deg. lighting at first. There will be plenty of time later to be as daring as you wish.

Take your time. Warn your subjects at the start that picture-making is a slow process, and let nothing hurry you into a bad shot.

Have a simple background. It should be plain or at least undistracting. Seat the subject far enough in front of it to avoid



Taken with an ordinary box camera, this character-study of a girl shows that it's the photographer, rather than costly equipment, that is the crucial ingredient in picture quality. One simple trick is employed to add life to the photo at left—body and head are turned at slightly different angles.



shadows. A plain wall or unpatterned blanket will do. If you have neither, a large aperture will throw the background out of focus.

Most people look best with the face in a three-quarter pose, but there are variations. A thin face looks fuller from the front; a fat one is narrowed by a slight turn. Noses can often be straightened by taking them at just the right angle. Body and face turned in slightly different directions adds life. A high camera angle helps double chins, jowls, and long necks—but not bald heads.

If you can't get his face relaxed, take your subject smiling.

Diffuse the lights with tissue paper if your camera has an extremely sharp lens. This softens facial lines without retouching. For extreme diffusion, fasten cellophane over the camera lens with a rubber band.

Take plenty of exposures. The right expression is fleeting. Tastes differ, too, and what you like may not please your subject. Give him as many pictures as possible.



# TRY GRANDPA'S CAMERA

## THERE'RE PICTURES IN THE OLD BOX YET

TUCKED away in attics, pawnshops, and the store-rooms of photographic-supply firms are cameras long considered junk but still capable of taking good pictures. Such were the three old-timers shown here.

The 4" by 5" Eastman box is dated about 1885. I cut the box in half and mounted on it the plate back from an old 4" by 5" German Mentor press reflex. Used with high-speed cut film and a No. 20 photoflash bulb on "open" flash, its lens is amply fast for posed shots in dark interiors. The lens has remarkable depth and cuts sharply to the corners. Stopping down is done with the primitive Waterhouse diaphragm, and the shutter, an old "guillotine" type, is set by pulling up on a catgut string.

Having a lens of rather long focus, the 3¼" by 4¼" Pony Premo B makes fine portraits. Its iris diaphragm, U. S. aperture markings, and listed shutter speeds from 1 to 1/100 second date it at about 1900. The 4" by 5" plate camera of the nineties with a



double - extension bellows and tilt back has proved valuable in copying and in picturing small objects. For good definition I mounted on it a modern Zeiss f/4.5 lens in place of its old rapid-rectilinear one.

Many old cameras have double - extension bellows and a rising front, and some also have a tilt back. Lens boards are easily removed

for substitution of another objective. A portrait attachment can be used on some old lenses to achieve a wider angle.

In buying an old camera, check every detail. Look for excessive sag and broken corners in the bellows and for warp in the frame, listen to the release at each shutter speed, and open and close the diaphragm. Examine each plate holder and slide for breaks and warping; then put each holder into the camera and pull it out again to determine whether the frame is sprung.

When you get home, open every holder, wipe it out thoroughly with a cloth, scrub with a dry, stiff brush, and tap it against the palm of your hand. Clean the bellows and the rest of the camera inside and out with a cloth, and rub a little light oil or dressing into the leather. Do not oil the shutter mechanism. Clean the lens carefully with lens tissue. Check the bellows for pinholes in a strong light, shielding your eyes and the camera interior with a black cloth. Holes can be patched with adhesive tape.

Most old lever releases are stiff and inclined to jar, so it is advisable to use a rubber bulb. I believe that, because of gumming and wear, shutter speeds may be slower than indicated.—CHARLES BARR.

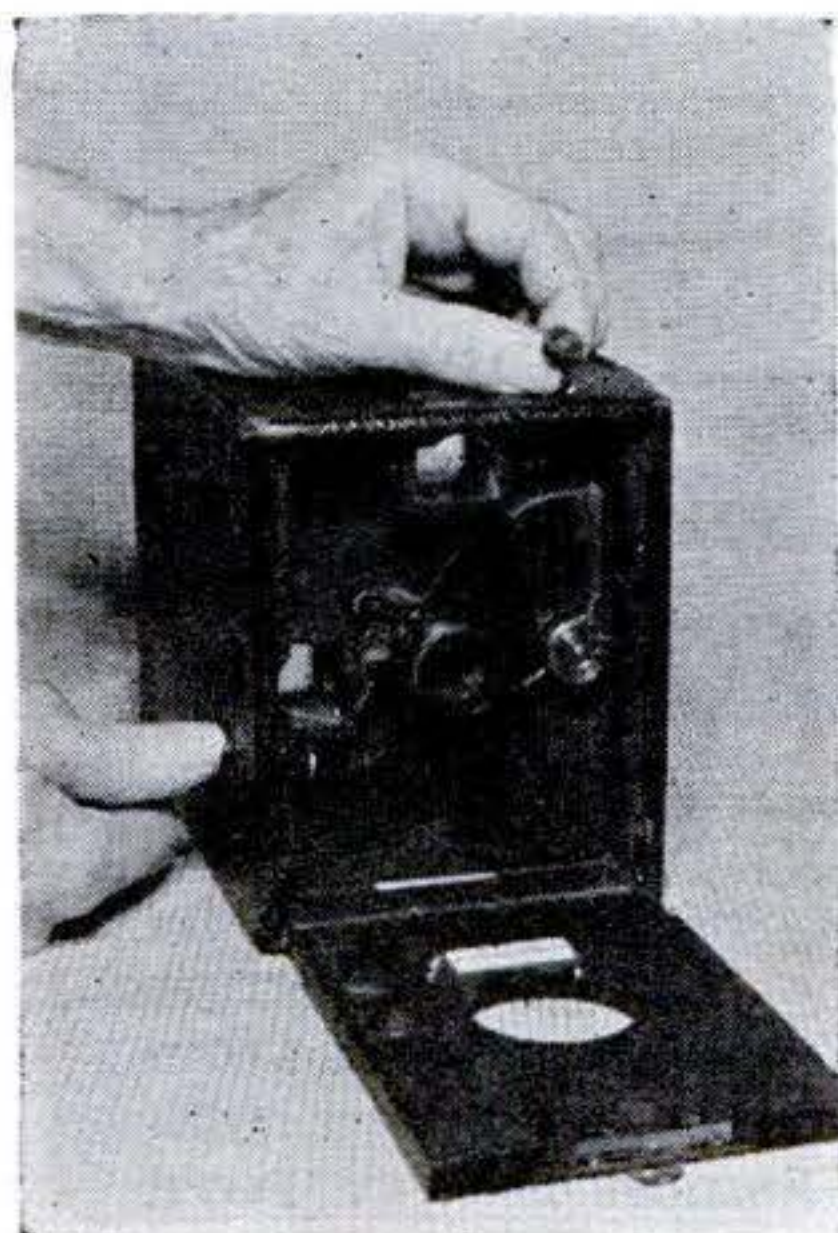

Used with modern, fast cut film, the 1885 Eastman box at left makes good pictures. A button pull draws up its guillotine shutter.

Excellent portraits are taken with the long-focus lens of the Pony Premo B shown below. The job at right has a double-extension bellows, a tilting back, and a rising-falling front.

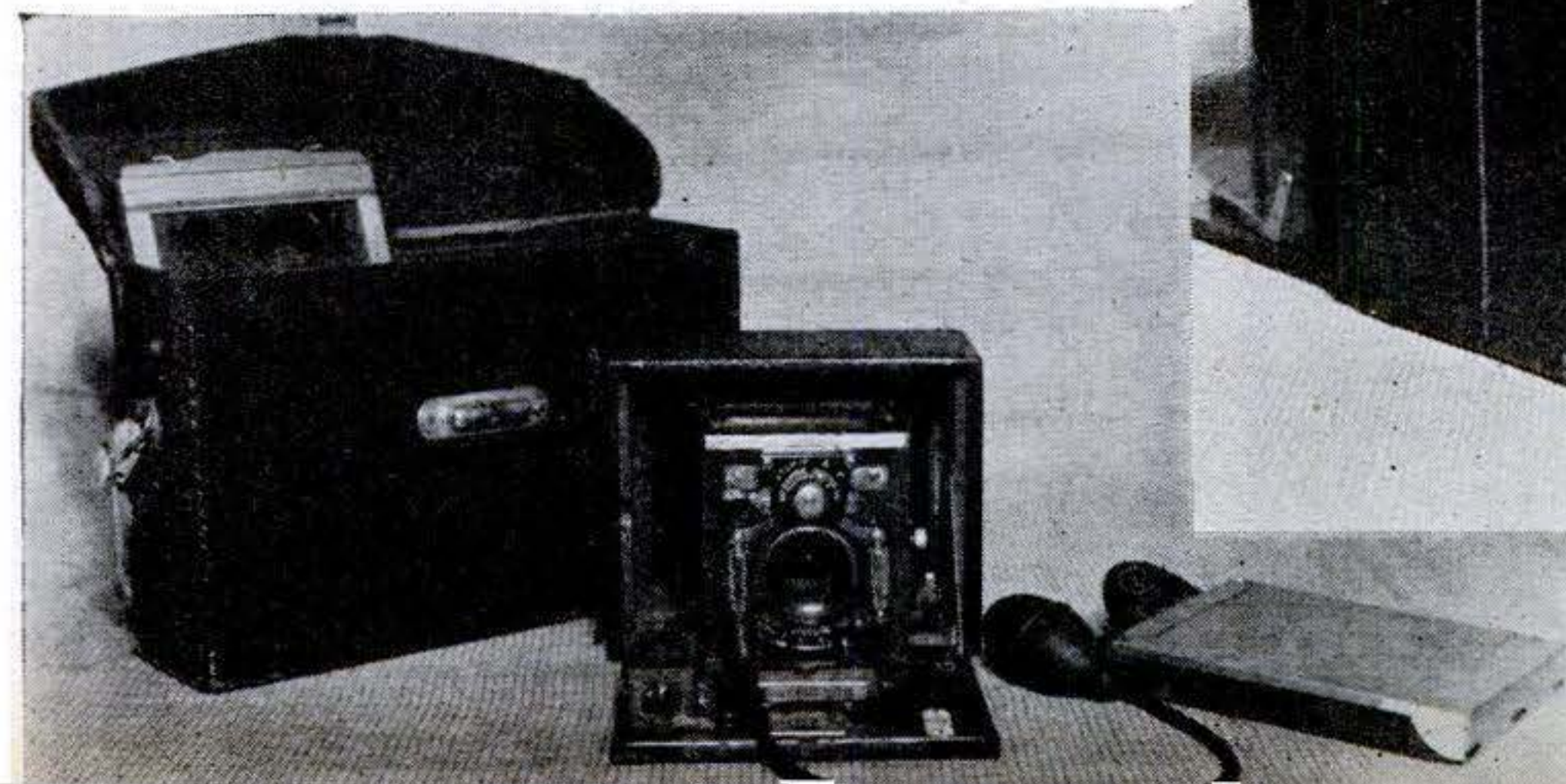
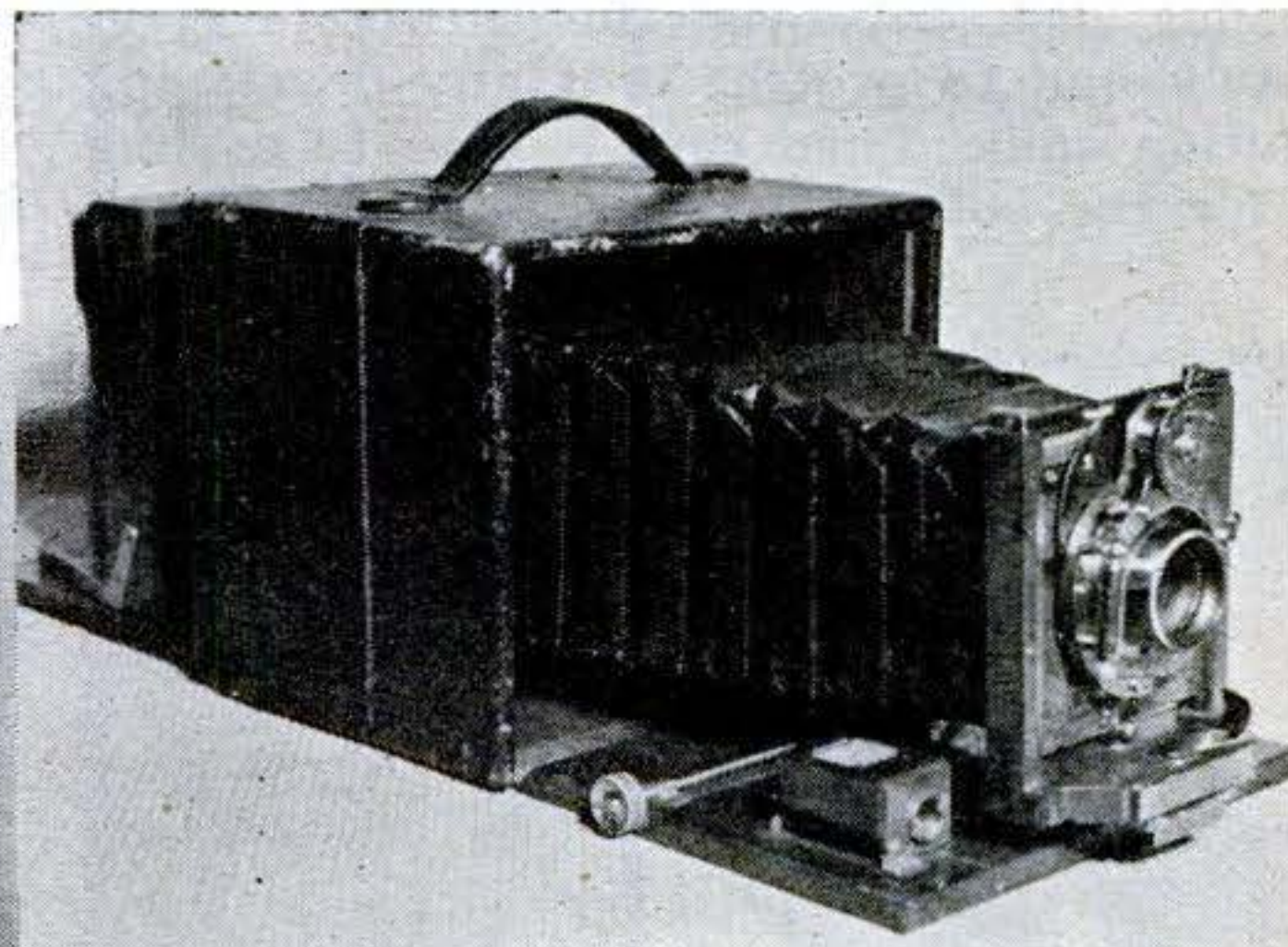



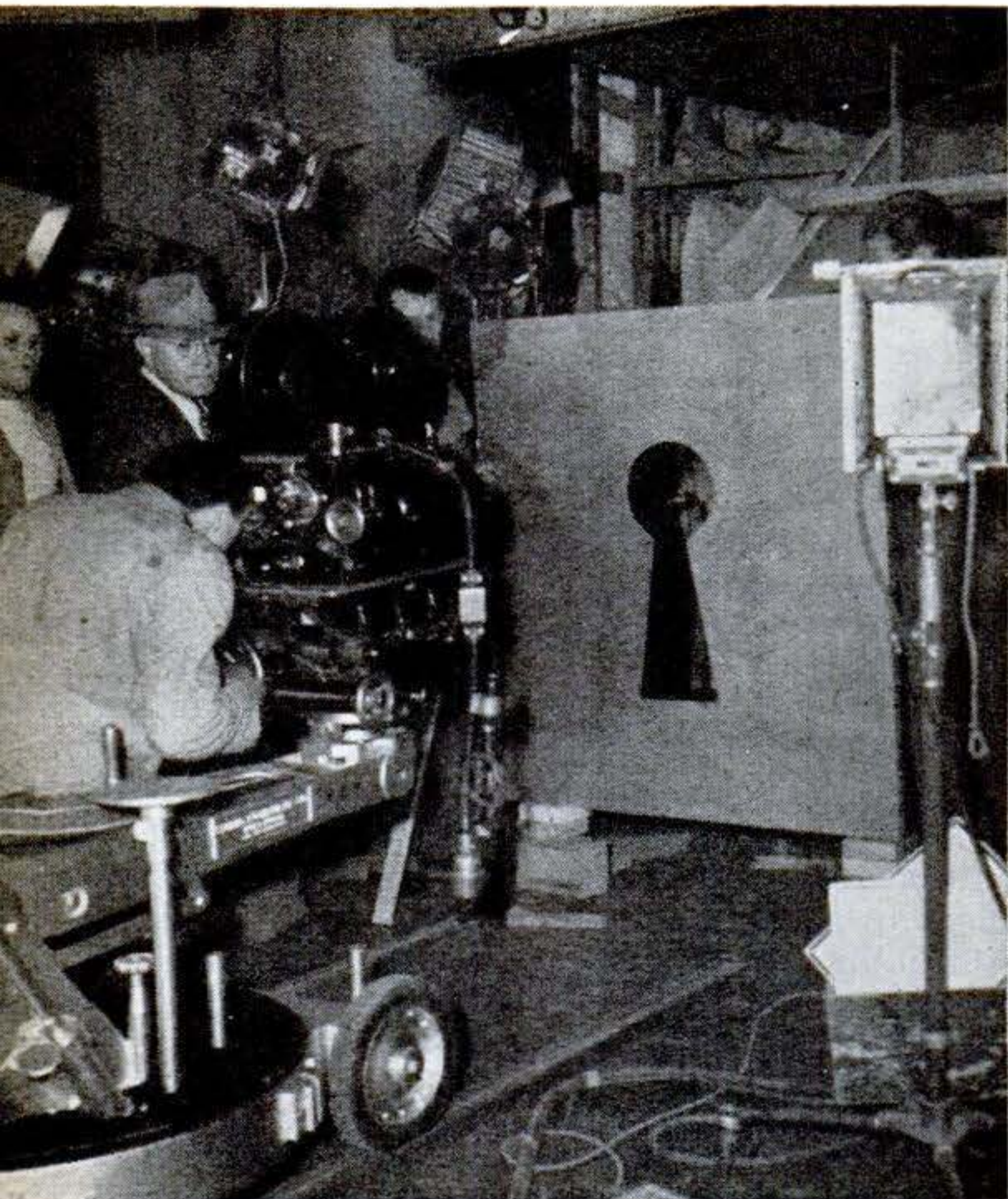

**KEYHOLE VIEWS** are taken by Hollywood cameramen through an actual keyhole—but it's a giant-size affair like that above. Similar comedy and decorative masks make unusual borders for home movies as well as for professional films. They can be cut quickly from large sheets of cardboard.

**LARGE GLASS JARS** for mixing photographic solutions can be premarked at the level of the final solution with a rubber band stretched around the circumference. Water poured in from a graduate serves as the initial guide. Several bands can be cemented on permanently, or lines may be marked with waterproof paint.—JAMES P. SAUNDERS.

**PHONOGRAPH TURNTABLES** are efficient agitators for developing tanks. Cut a wooden disk to cover the turntable completely and to protect it if any developing solution spill. Then turn a base to a snug fit for the bottom of your developing tank



**SMALL OBJECTS** to be photographed can be made to stand upright by sticking them to a table with small pieces of ropelike calking compound available in hardware stores. The material will secure light objects to sloping or vertical surfaces. Molded into tiny rods or other forms, it also permits you to support pieces above a surface for taking exploded views of mechanisms. The compound sticks well and can be removed without leaving a mark.—W. E. B.

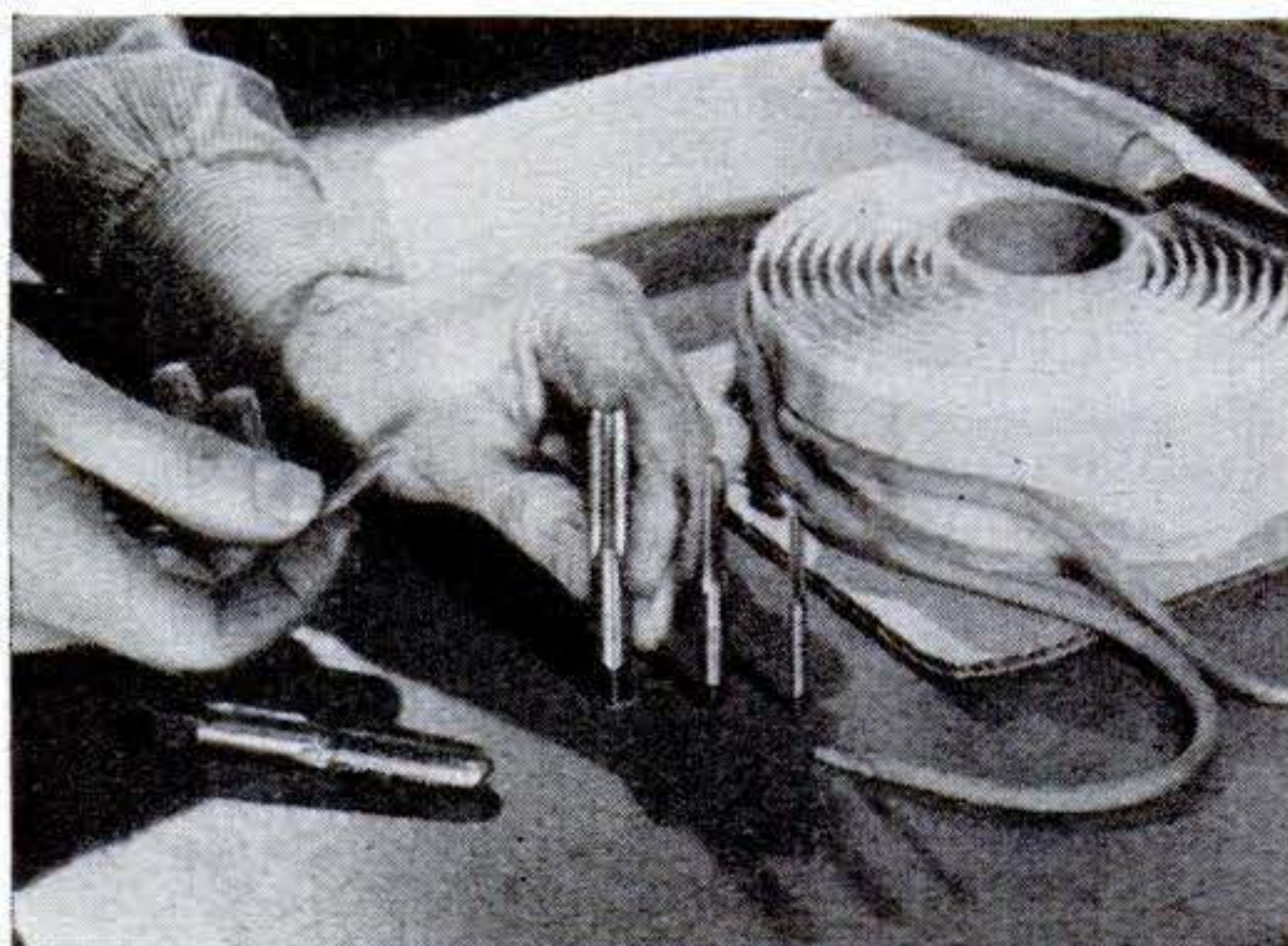

and glue or nail it to the wooden disk as indicated in the photos below. If the bottom of the base is given a slight slope before being glued on, it will keep the tank from turning too smoothly and will assure complete agitation of the liquid.—SIDNEY POTT.

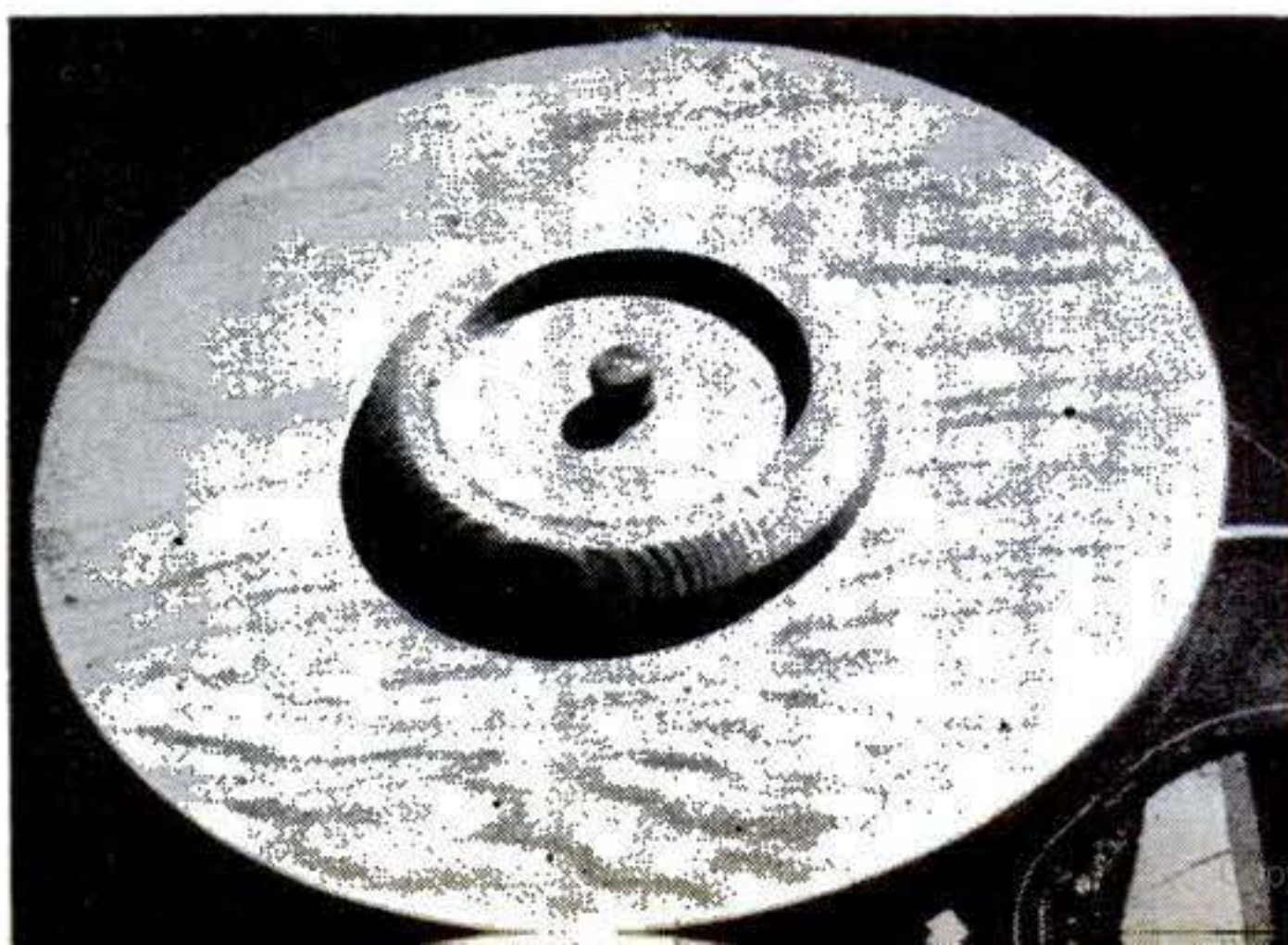



**TAXES** have nothing on this trick, right, that makes money disappear without a trace. Put a dime in the center of a handkerchief and fold the edges over the coin. Catching the corners and the coin, lift the handkerchief aloft. For the benefit of your skeptical audience, let someone feel the coin through the handkerchief to make sure it's still there. Now, shake the hanky loose. Nothing falls out! Not surprising, either, if you've done the trick right. Using a handkerchief with a wide hem, rip out a few stitches in one corner and sew a dime into the pocket thus formed. When you lift the handkerchief, drop the loose dime in your lap. Your friends feel the concealed one.



## TABLE TRICKS



**TAKE A MATCH BOX** from your pocket and open the drawer. What you see inside seems to surprise you and you can pass the surprise on to your friends by reaching into the box and pulling out a full-length pencil. How? By concealing the pencil in your left coat sleeve and cutting out the back of the box.



**THE EYE IS QUICKER** than the hand provided you know what to look for. Hold a deck of cards face down and ask a friend to draw one, look at it, and replace it without letting you see. Then shuffle and deal the cards out one by one, as below, till you come to the one he picked. You need a deck with a one-way design on the back, arranged in advance so the cards all face the same way. Turn the pack so that the right card is replaced the wrong way.



**SAND DOESN'T GET WET** even though it is dumped into a bowl of water and stirred thoroughly. To prove it, do just that. Then scoop the sand out slowly and it will be as dry as when you put it in. It won't work, of course, unless you have previously heated the sand together with a very small amount of paraffin wax. When cold, the treated sand will repel water effectively, and the paraffin coating won't be noticed.



## Oversize Soldering Lugs Made of Copper Tubing

SOLDERING-LUG terminals capable of handling heavy currents may be speedily fashioned from odd scraps of  $\frac{1}{4}$ " copper tubing. Saw off a piece about 1" long and flatten it for half its length in a vise. File corners round and drill the center hole; then clean the inside of the tubing with a scrap of emery cloth wrapped around a nail. For convenience in attaching the lug, screw it to a block of wood. After filling the open part of the lug with molten solder, preheat the wire and insert it quickly while the solder is still fluid.—F. R.

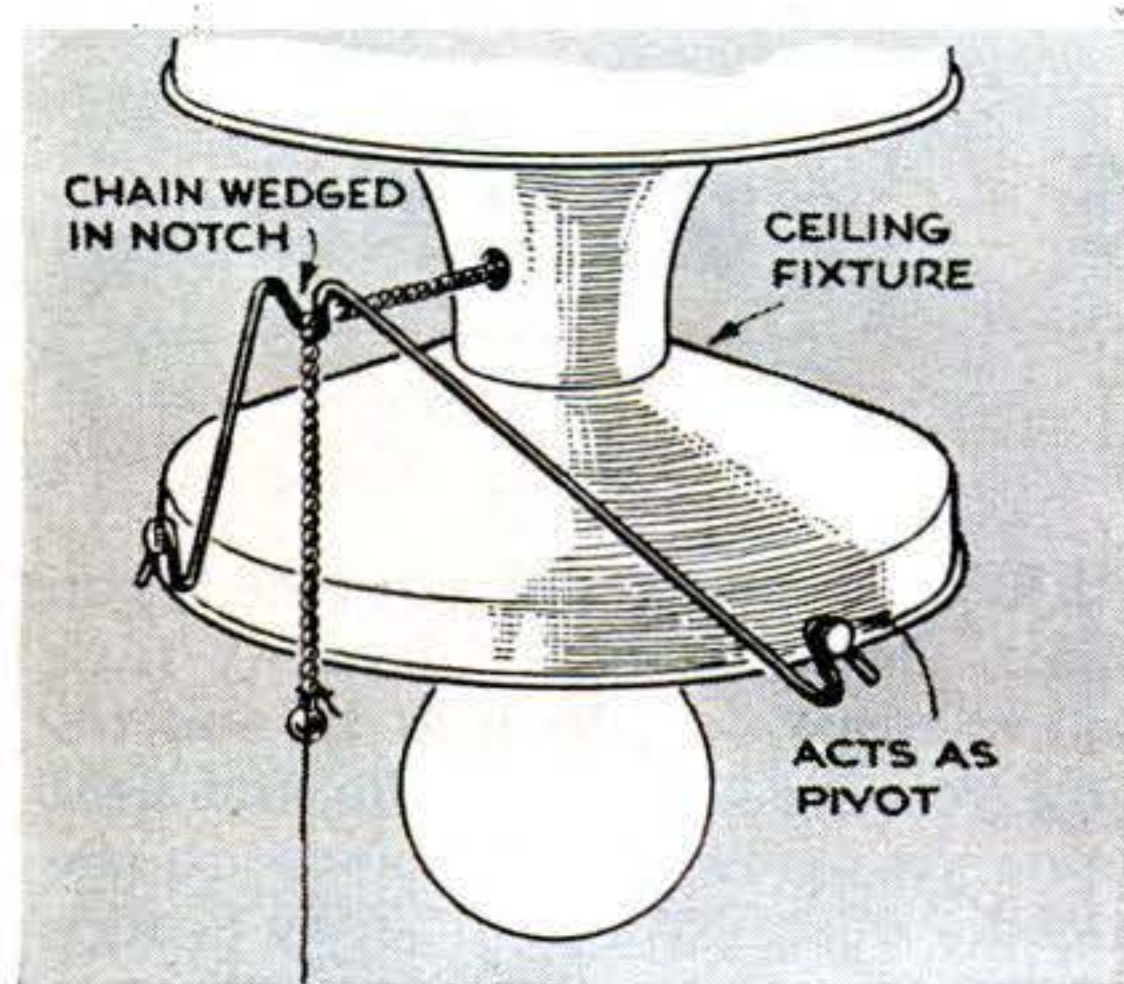
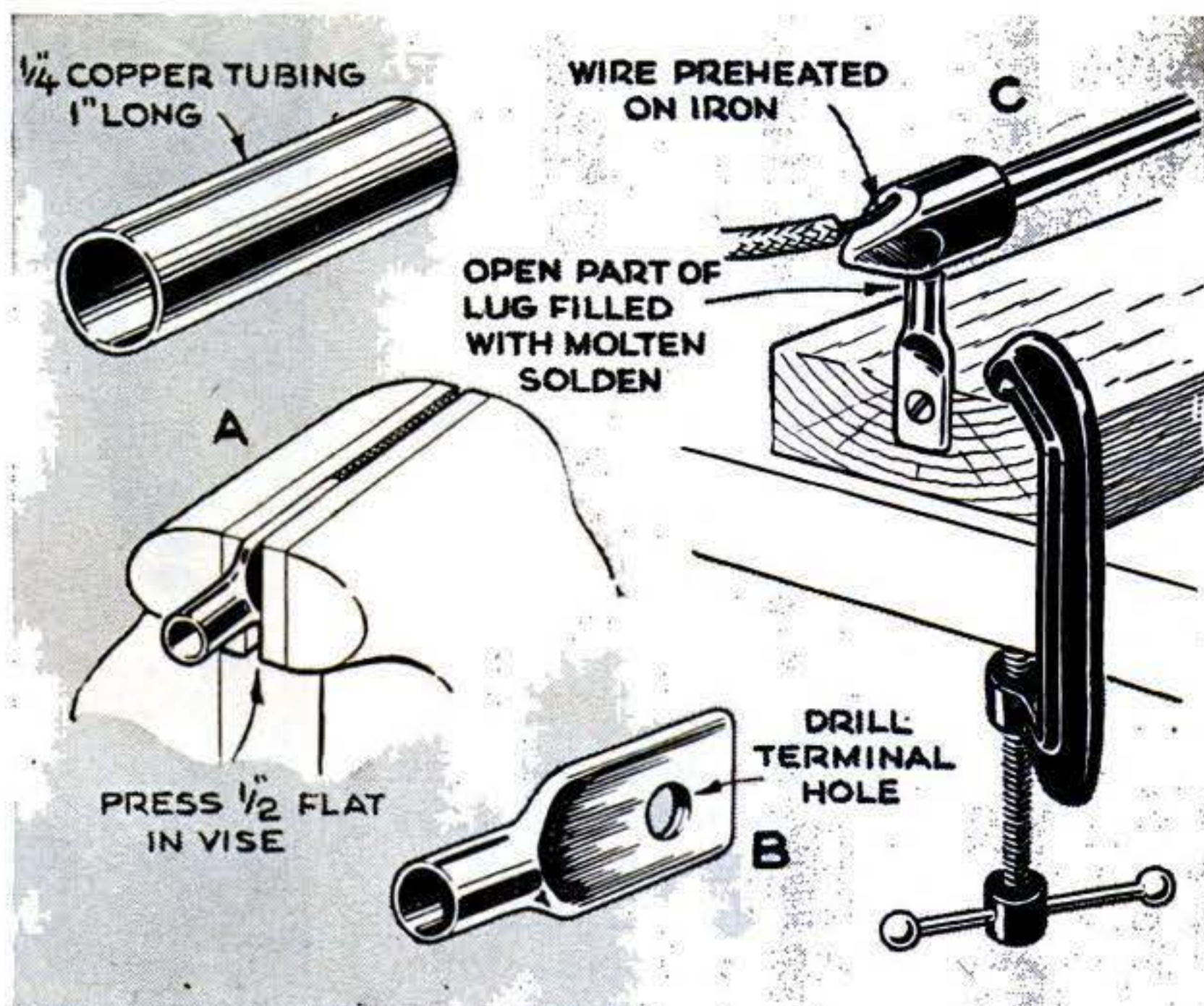

## Pull-Chain Swivel Bracket Smooths Operation of Ceiling Light Fixtures

LIGHTING fixtures often become sluggish in operation because the chain drags or scrapes against the frame and the return spring becomes too weak. When this happens—or to prevent it from happening—bend a length of coat-hanger wire as shown so that the apex of the curve forms a cradle for the chain. Hook the wire arms tightly over the screw heads in the lower lip of the fixture. The wire arm not only prevents the chain from snagging, but it helps it to spring back.—G. HAMLIN LEONARD.

## Spring Block Acts as Temporary Terminal

ELECTRICAL experimenters often have need for a terminal block to join wires temporarily while testing or hooking up circuits. Usually this is done by twisting the bared ends of the wire together, but in many ways it is more convenient and safer to use a terminal block.

Mount a short piece of spring wire—preferably bronze or brass—to a nonconducting base by means of two small angle pieces. To make contact, press the bared ends of the wires through the turns of the spring, but be sure the current is off first.—HAROLD P. STRAND.



## Sandpaper Nail Files Used to Clean Small Motor Commutator



ROUGH commutator surfaces sometimes cause otherwise perfect motors to spark badly and operate far below normal speed. Most often, to be sure, these symptoms can be traced to badly worn brushes, but if these are not at fault, hold a sandboard against the commutator while running the motor at lowest speed. Smoothing the rough edges should immediately improve the efficiency of the motor.—A. E. SCHIEVE.



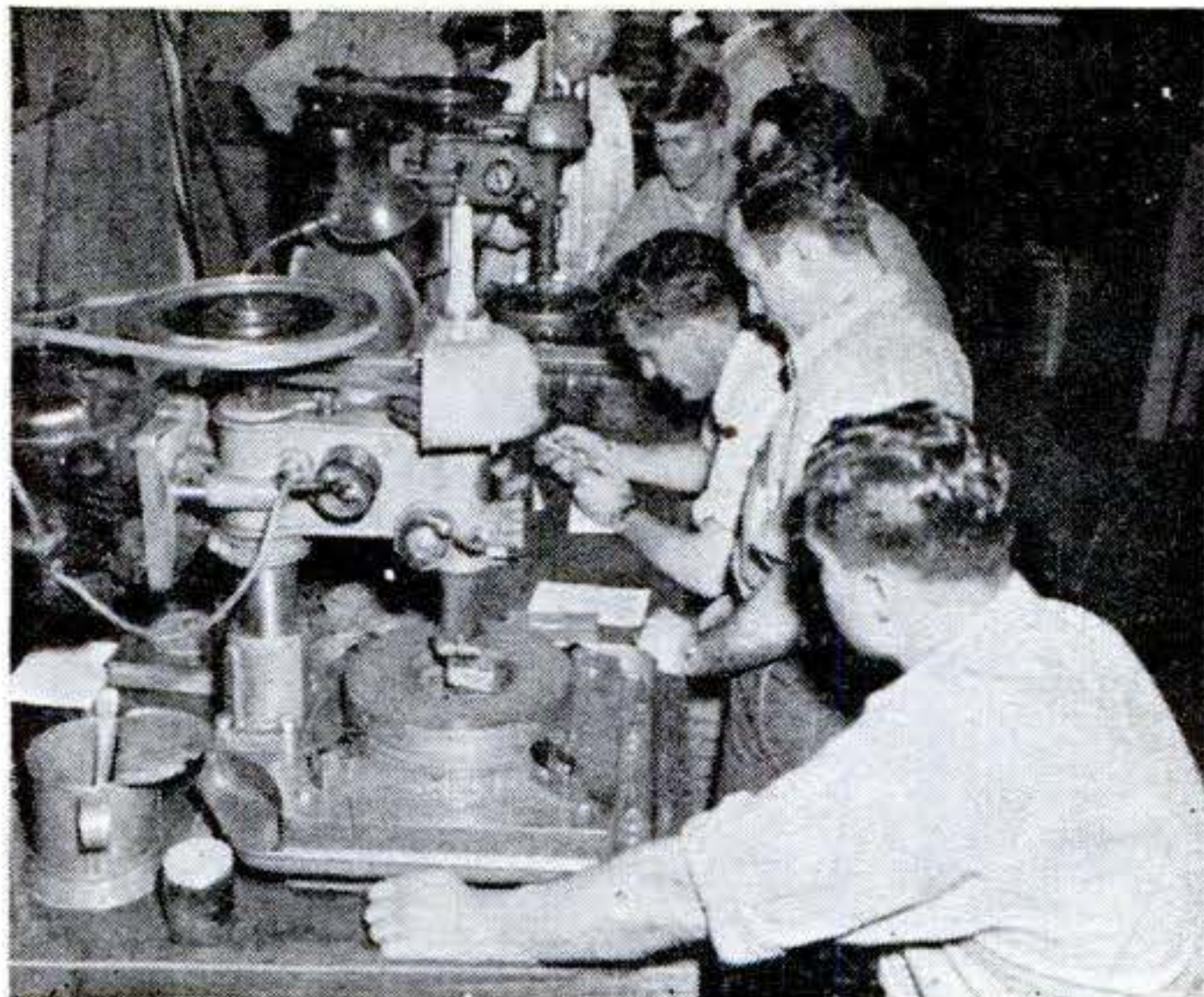

Modified drill presses, fitted with lapping plates, are used to reduce quartz chips to approximate size.



To obtain accurate frequency control, every crystal must be finished by hand (above), and tested on an oscillator (below). If it can then pass heat, shock, and vibration tests, the crystal is ready for use.

## Army Crystal-Grinding School Trains Sailors and Marines

PAPER-THIN quartz crystals, which have helped maintain military communications under the most difficult battle conditions, must be finished to within one ten-thousandth of an inch of specification—definitely not a job for amateurs. Even slight errors would affect the frequency to be selected.

The Army's only school for crystal craftsmen, a part of the Holabird Signal Depot, at Baltimore, is attended also by Navy and Marine Corps personnel. After an eight-week course, trained technicians are sent into the field to process the frequency-controlling oscillator plates used in practically all service radios.

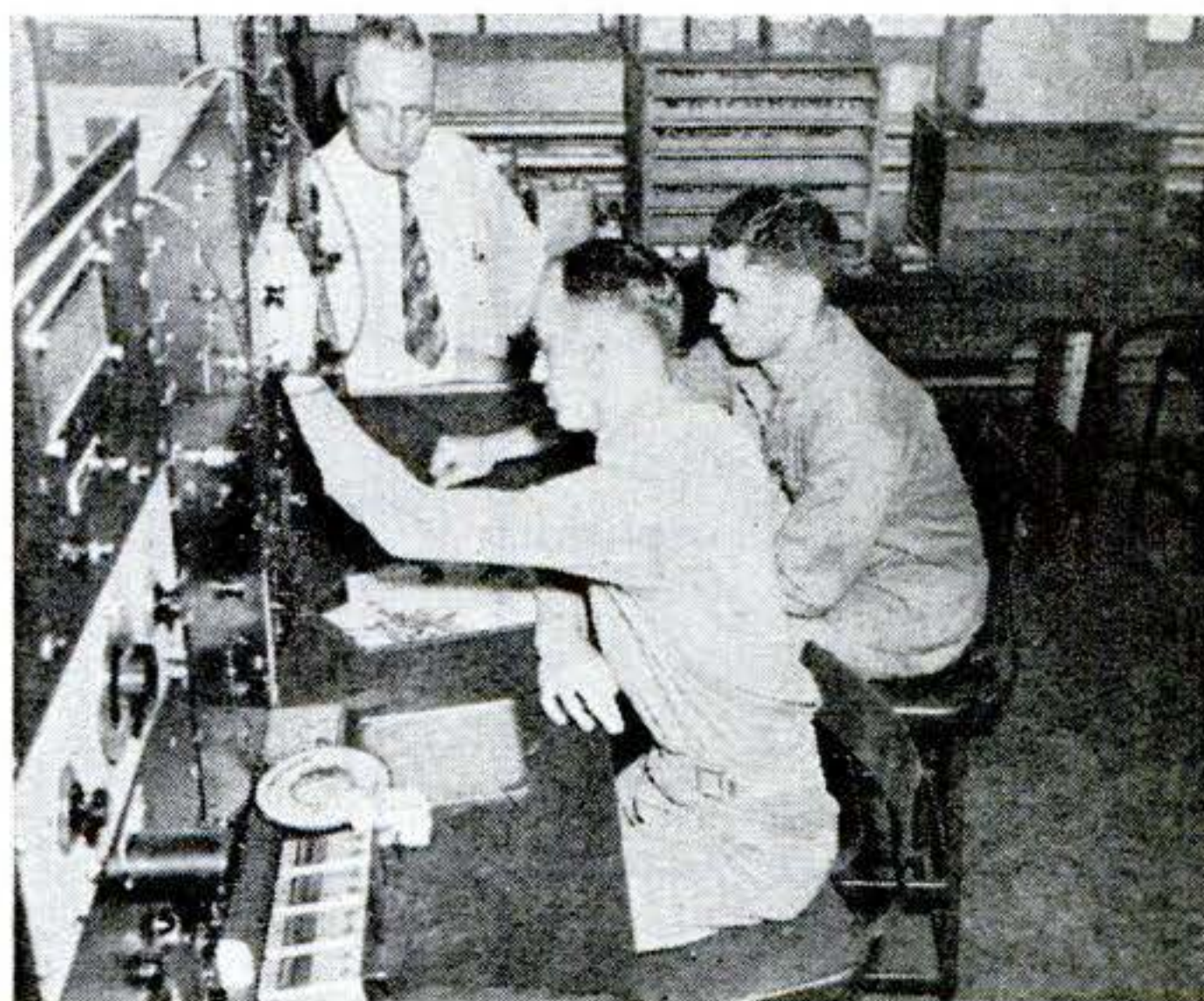

## New Canadian Station Broadcasts to World

ONE of the most powerful short-wave stations in America has been placed in operation to beam programs all over the world. The site of the station, a salt marshland at Sackville, New Brunswick, Canada, has proved doubly advantageous; the marsh acts as an "electric mirror" that augments signal strength, and the location is one of the few in Canada uninfluenced by the north magnetic pole. The station boasts a highly directional beam antenna, pictured at the right, that is said to multiply effective output many times. More than 26 miles of wire are used for the antennas, connected to towers varying in height from 170' to 380'.

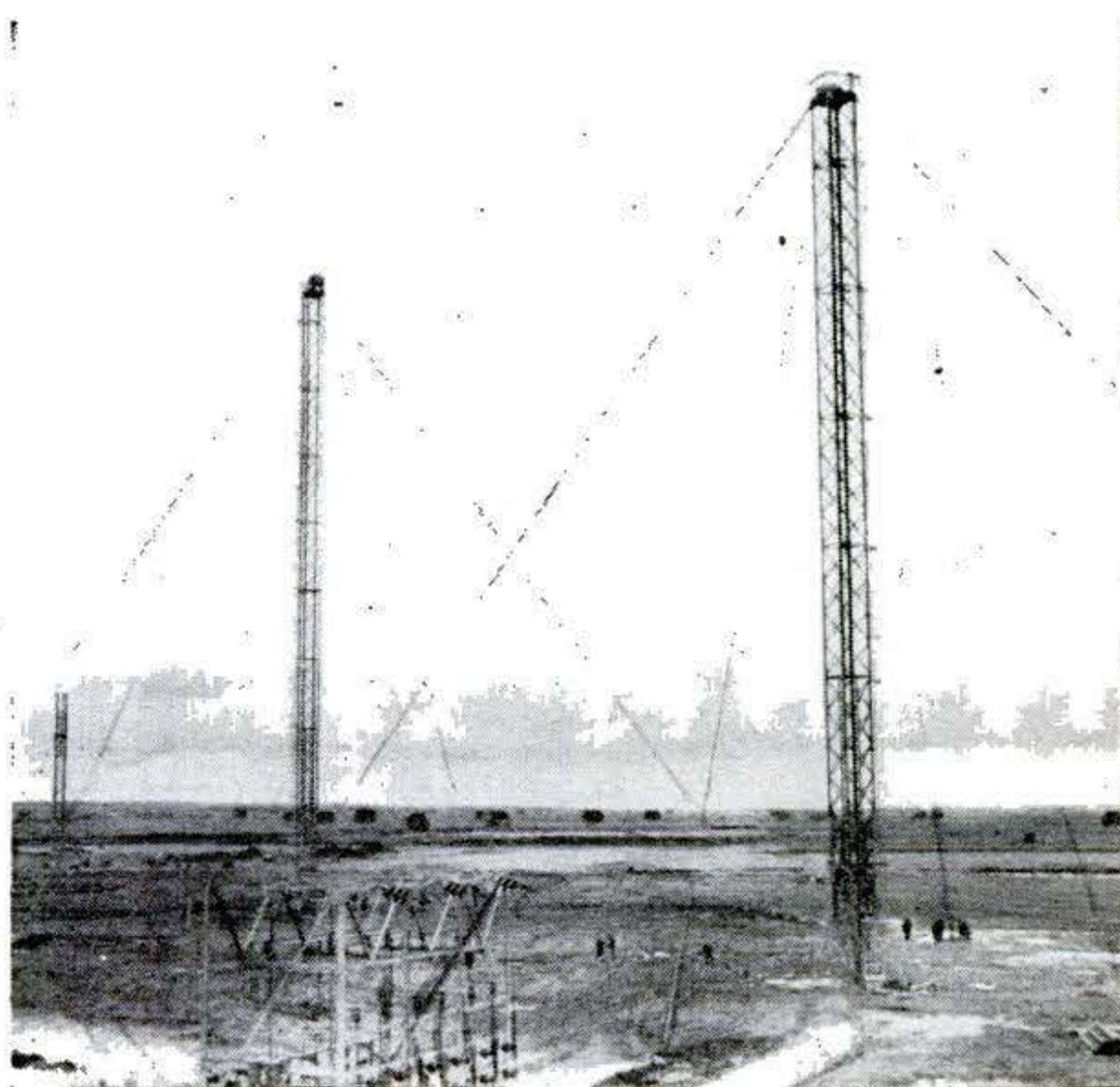



## Relaxation Oscillator Makes Portable Code Practice Set

LEARNING the dot-and-dash alphabet is only a preliminary step in code mastery, for the knack of fast operation really depends upon getting acquainted with the sound of the incoming signal. This compact practice oscillator has the advantage of being adjustable through a variety of sound frequencies and tones. The capacity of the condenser connected in series with the headphones determines the fundamental frequency of the oscillator; if a higher pitch is wanted, it may be necessary to use a smaller condenser. Some tone control can also be obtained by adjusting the potentiometer. Many types of small neon tubes will work satisfactorily in this circuit. A miniature 90-volt B battery can be used safely as the current drain is slight.—WALTER F. POWELL, JR.

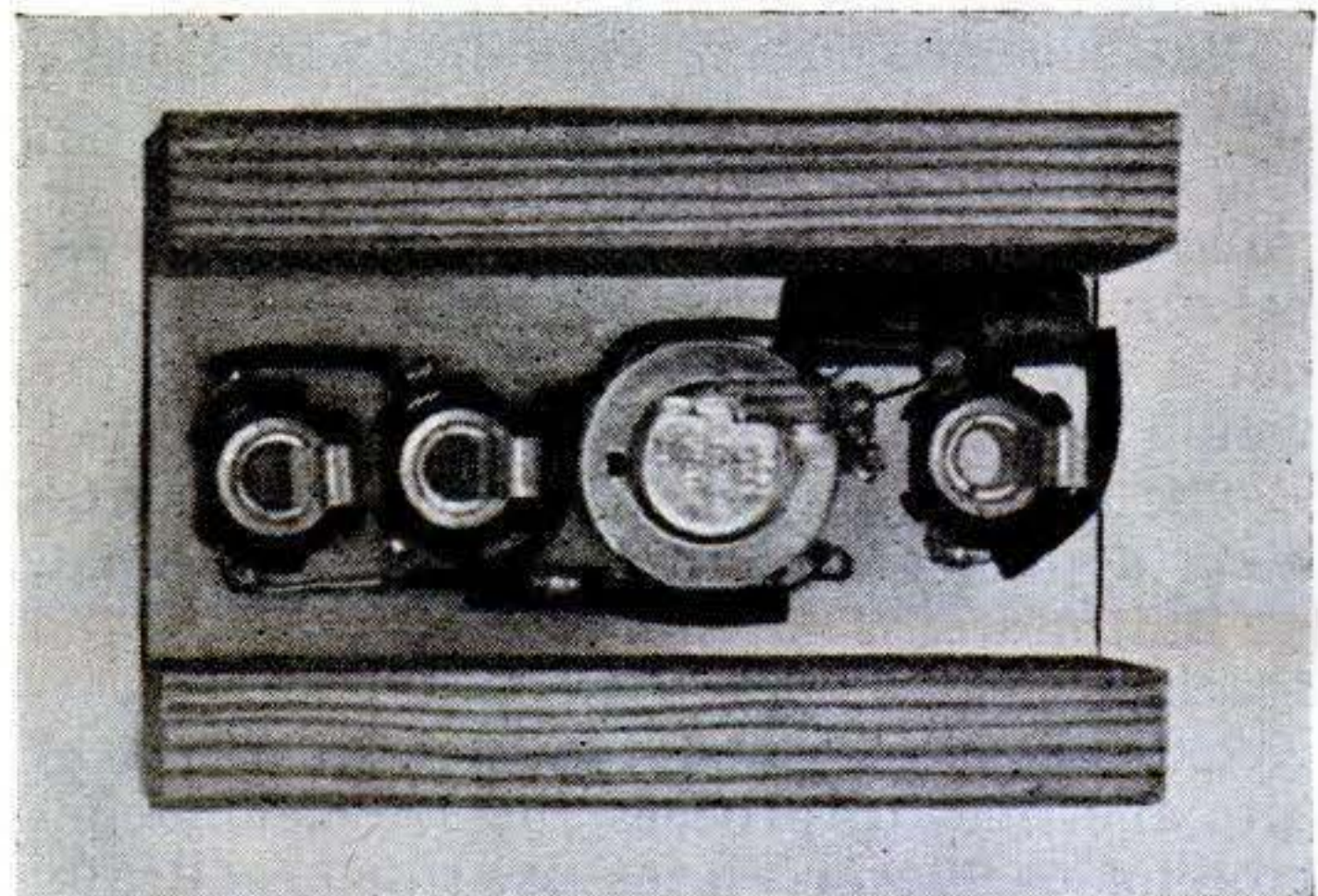
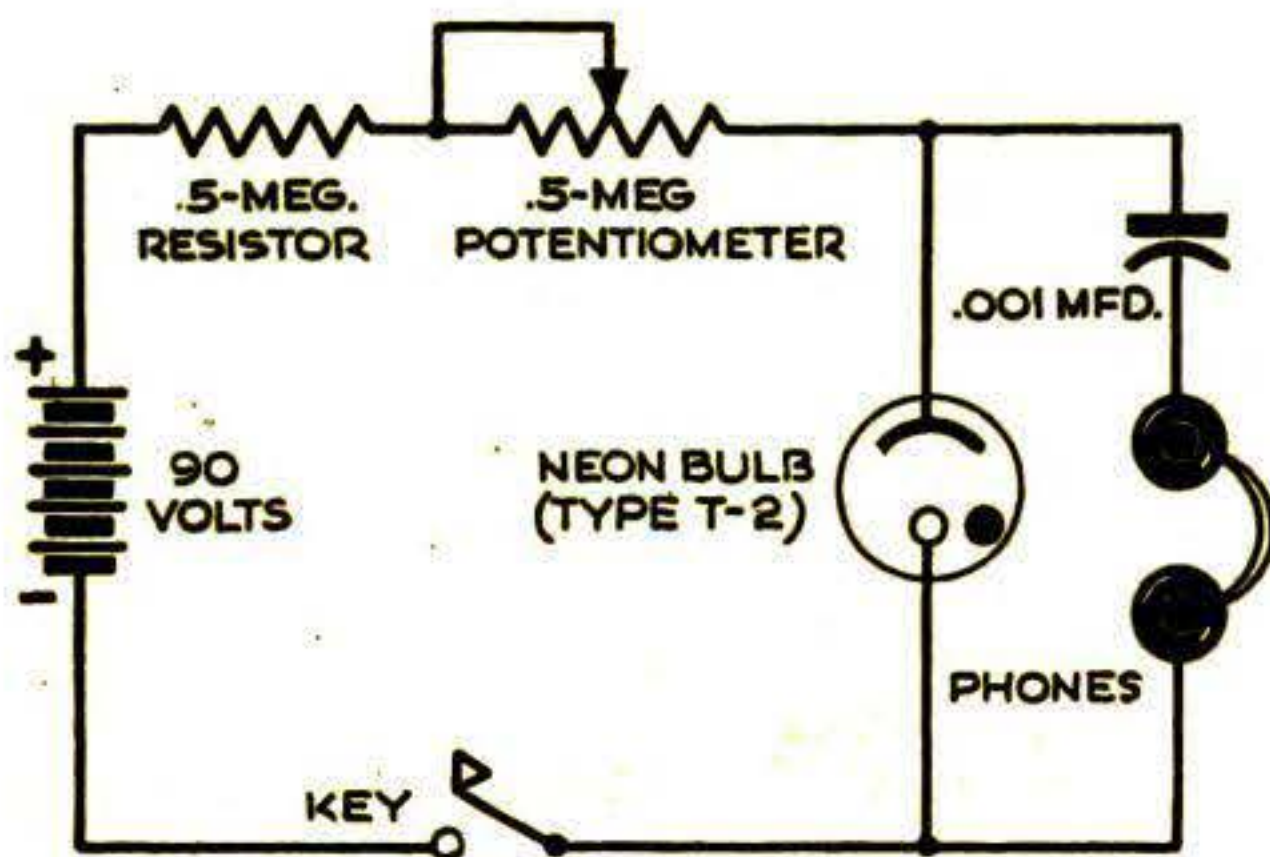
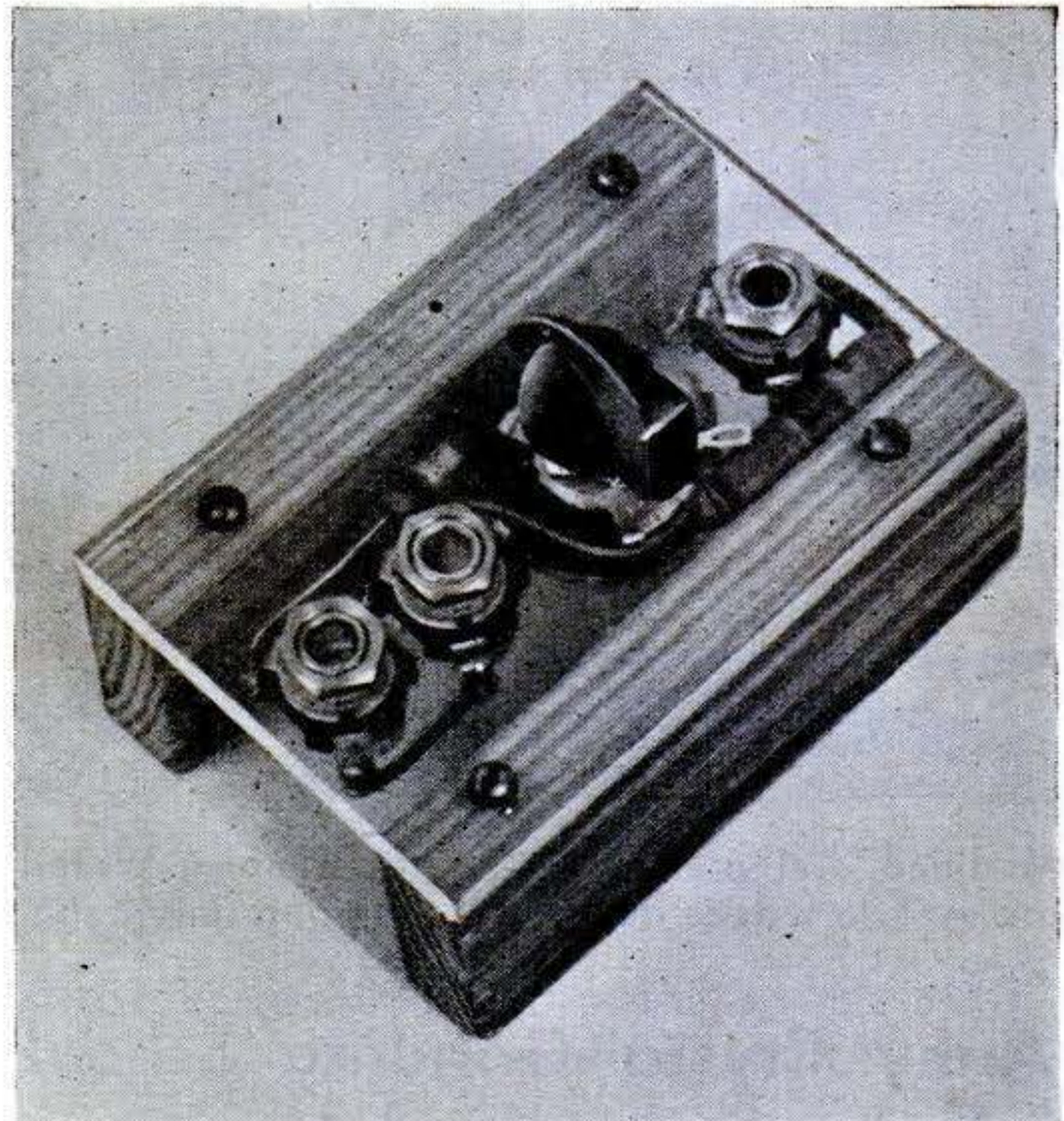

## Home Test Gives Quick Check on Burned-Out Tube Filaments

BURNED-OUT tube filaments account for a great percentage of radio failures and are worth looking for when a radio goes dead. When filaments are connected in parallel, allow the set to cool, turn it on, and touch all the tubes. If you find one that stays cool, you're hot.

In an A.C.-D.C., series-wired radio, none of the tubes will light, but an A.C. voltmeter will point out the guilty one when held across each pair of heater terminals. The meter completes the circuit and

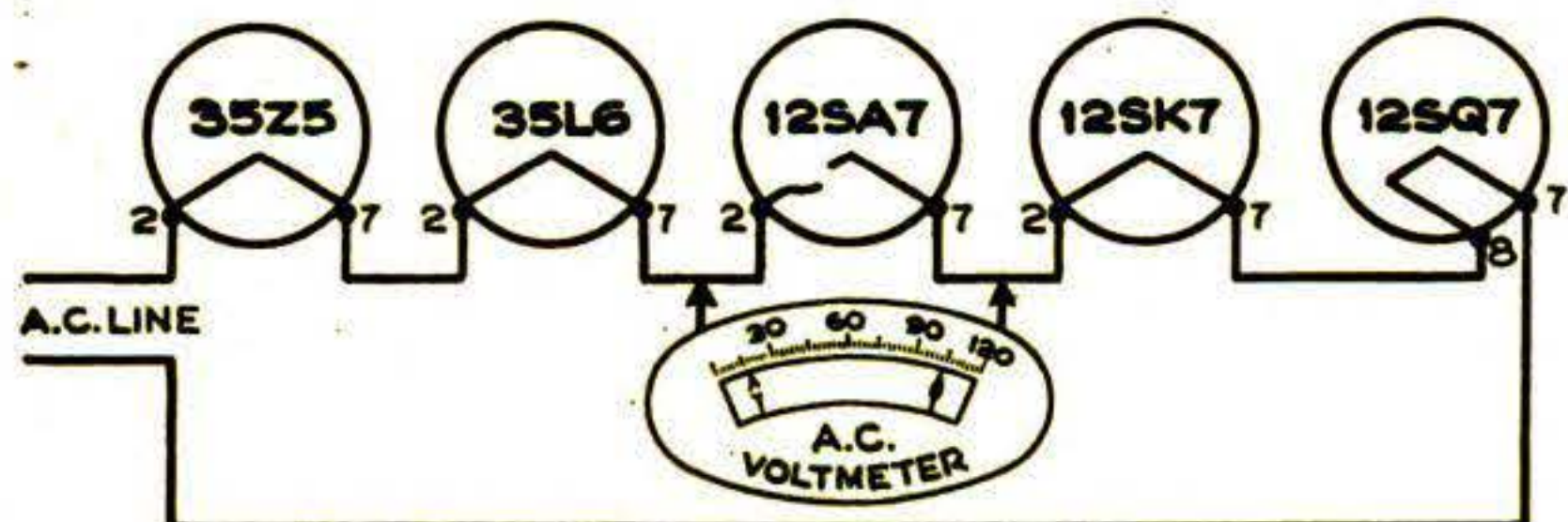

gives a reading of about 110 volts. If the filament should close during the test, the voltage will drop to its normal value for the tube.—G. BOLTON.

## High-Temperature Solder Found to Shorten Life of Fine Wire

MOLTEN solders have been found to reduce the diameter of copper wire and cause some embrittlement of the parts subjected to high temperatures. In tests conducted by engineers of the Fairchild Camera & Instru-

ment Corp., of New York, it was shown that destructiveness was greatest in fine wires and increased with the tin content of the solder. For delicate work, therefore, solders of low melting point should be used.



# Trouble-Shooting A. C. Motors

By JONAS H. WOOD

**M**OTORS of less than 1 hp. are playing an increasingly important part in the home and workshop, and yet they get little or no attention until they begin to smoke or refuse to start. The average person feels

that he has done his part when he fills the cups with oil once in a while; and then, when a motor burns out, he gets a new one and promptly treats it in the same offhand way.

This may have been all right in the days when homes had few appliances; but now, with motors for oil burners, stokers, refrigerators, washing machines, vacuum cleaners, sewing machines, food mixers, electric fans, movie projectors, and basement-workshop tools, systematic care pays off in protecting one's investment.

Proper oiling and cleaning are the best preventive maintenance. Never use too much oil and never oil too often. The manufacturer's advice, as set forth on the name plate or in an instruction booklet, should be followed. Motors having sleeve bearings and a packed wick need oiling only every 1,000 hours of use. Old-type motors having a removable reservoir at each end with a spring and wick bearing on the shaft should have their reservoirs kept filled with a good heavy oil. Ball bearings need occasional cleaning and re-packing with new grease.

A clean motor is the best insurance against burning out. Look fairly often at the windings and switch, for 90 percent of all trouble starts with dirt and oil in one or the other. Use only carbon tetrachloride for cleaning, and don't use too much of that. When you have trouble in spite of precautions, the chart at the left will help.

All appliance and home-workshop motors fall roughly into five main classes. Four are variants of the single-phase A.C. induction motor. The fifth is the universal motor designed for use on either A.C. or D.C. It is found in sewing machines, vacuum cleaners, food mixers, home-movie projectors, portable drills, saws, routers, and business machines.

Universal motors have a wound armature, two fixed brushes, and a higher speed than induction motors. It is

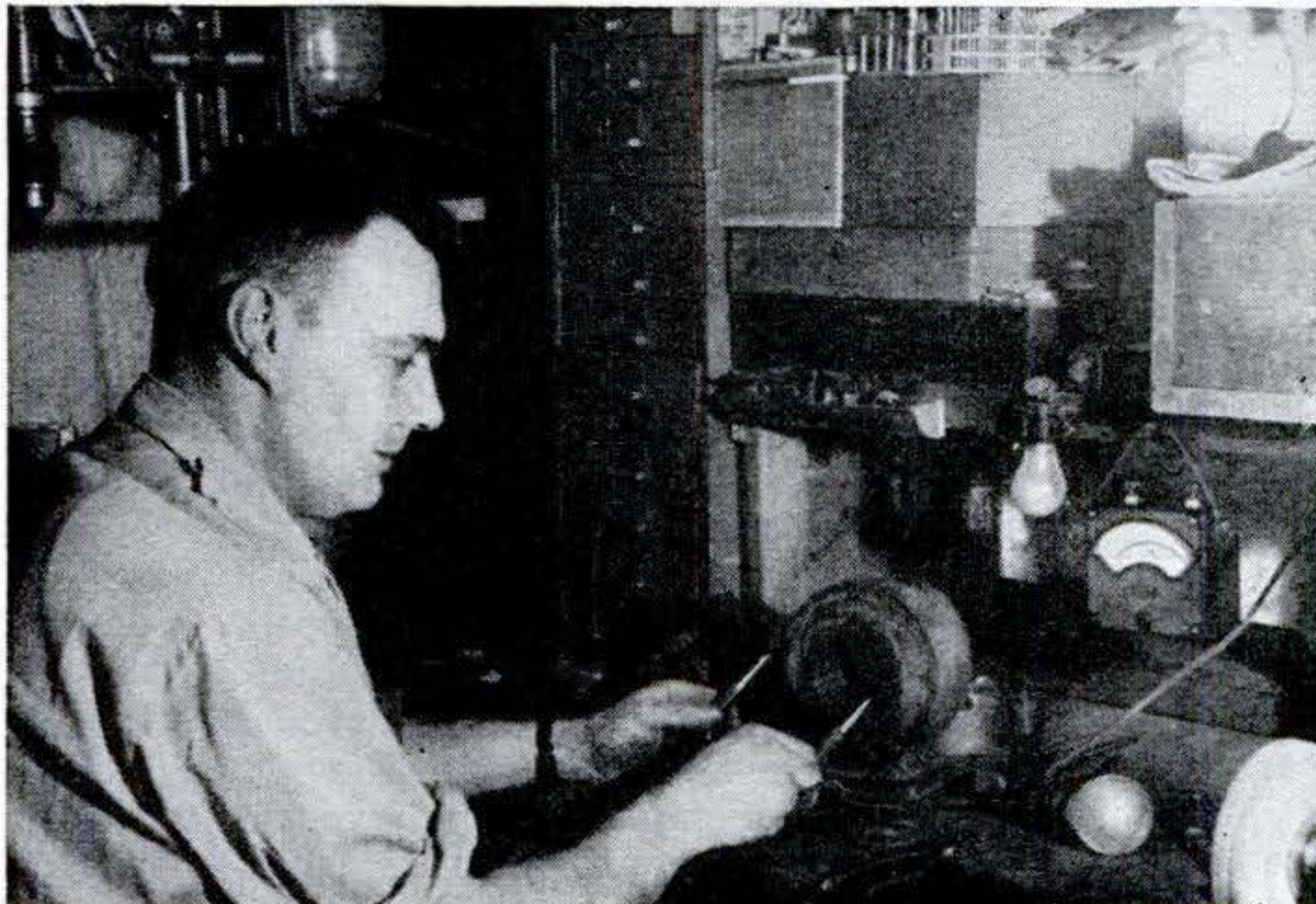

A little preventive maintenance will keep many a small motor going. The chart below will be of help in trouble-shooting.

MOTOR	TROUBLE	PROBABLE CAUSE	WHAT TO DO
Split-phase and split-phase condenser or capacitor	Will not start	Open circuit in line	Check current to motor leads
		Thermal overload out	Reset overload relay
	Hums, but will not run	Starting-switch points not closed	Clean starting switch
		Open circuit in running or starting winding	Check continuity with test light
		Defective condenser	Replace condenser
	Runs slowly and jerkily and heats rapidly	Starting-switch points not opening at proper time	Clean points; check centrifugal throw-out springs
		Bearings gummed	Clean with carbon tetrachloride; use fresh oil
	Broken or loose bars in rotor	Replace or tighten bars	
Series (D.C. and universal types)	Will not start	Open circuit in line	Check current to motor leads
		Brushes not making contact with commutator	Check brush springs and replace worn brushes
		Open circuit in field coils	Check for continuity with test light
	Runs slowly and overheats rapidly with excessive sparking at brushes	Dirty or scored commutator	Clean with carbon tetrachloride and fine sandpaper. If badly grooved, turn down in lathe
		Shorted commutator bars or high mica	Clean between bars and undercut mica
		Shorted windings on armature	Rewind armature
Repulsion-induction	Will not start	Open circuit in line	Check current to motor leads
		Brush yoke may be loose and shifted to neutral point	Move yoke to right or left and tighten setscrews
	Hums, but will not run	Brushes not making contact with commutator	Check spring tension on brush holders; replace worn brushes
		Shorting device not in contact	Check centrifugal throw-out
	Runs, but will not come up to speed; overheats rapidly	Shorting necklace broken	Replace necklace



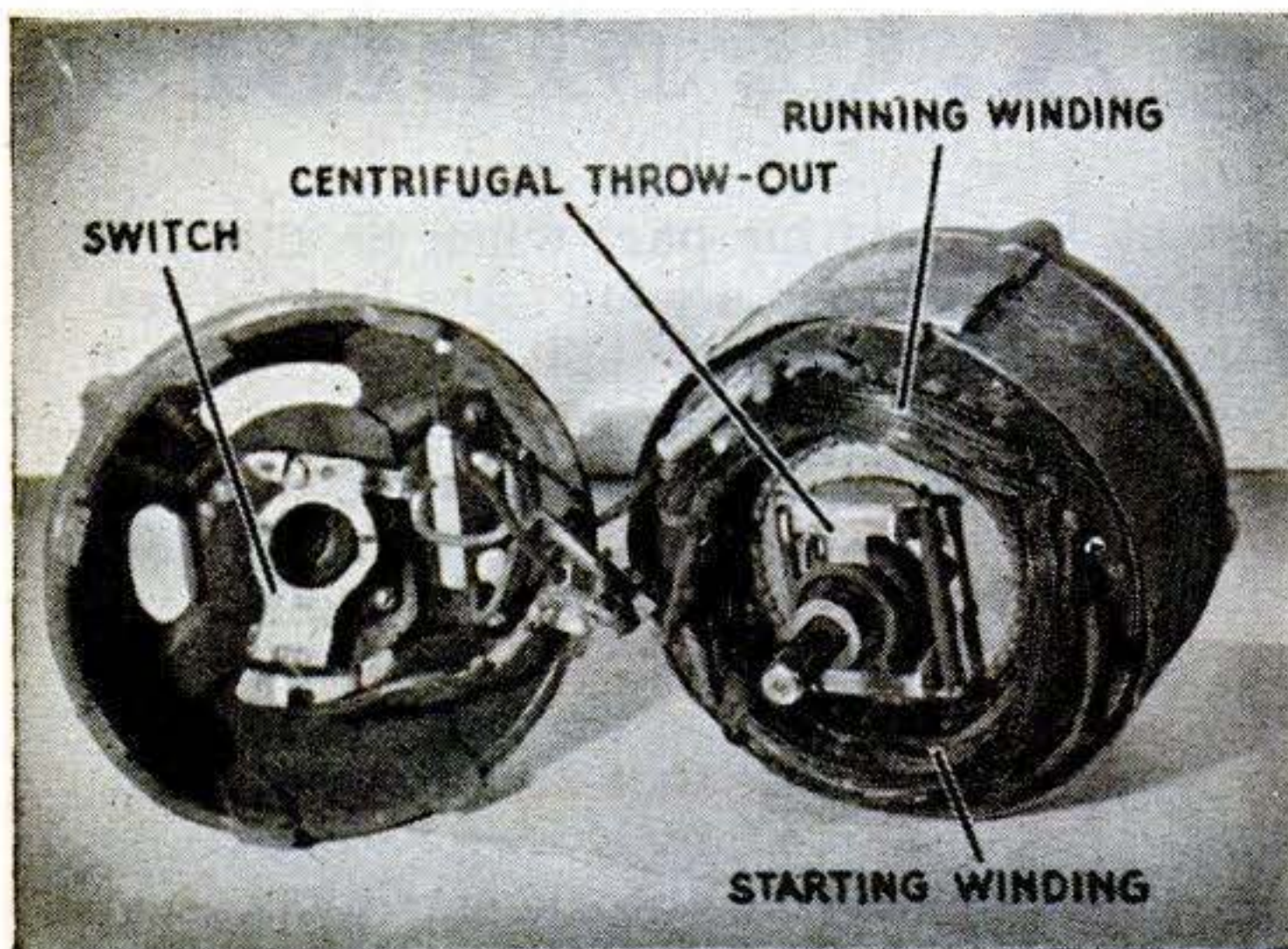

Split-phase motor.

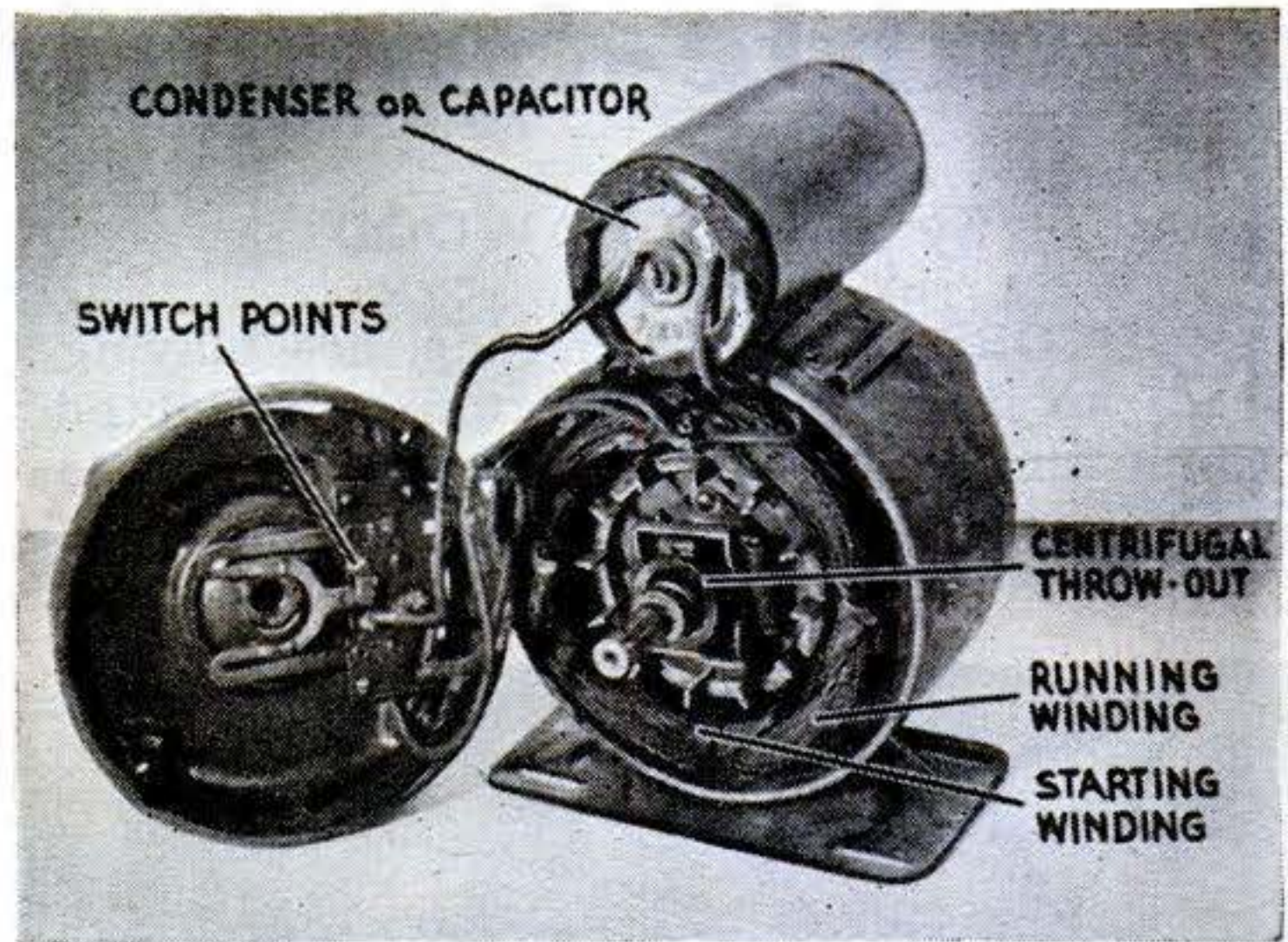

Split-phase capacitor motor.

wise to examine the brushes occasionally and to replace them before they wear down to the springs and begin to score the commutator.

Single-phase A.C. induction motors exert no turning force with a single winding and must use a secondary stator winding or wound armature to obtain the revolving magnetic field necessary for a start. As speed reaches 70 or 80 percent of normal, this auxiliary or false second phase is cut out, and the motor then operates on single phase.

Most of the motors in common use are of the single-phase induction type known as split-phase motors. They are equipped with an auxiliary winding that is displaced in magnetic position from the main winding and connected in parallel with it. These motors are found on machines with light starting loads, such as washing machines, churns, bottle washers, some business machines, oil burners, blowers, centrifugal pumps, phonographs, woodworking tools, grinders, and other machine tools.

Split-phase motors can be recognized by their solid rotor, two separate stator windings, and a centrifugally operated switch for cutting out the starting winding at proper speed. This switch is a focal point for trouble since all the dust, lint, and shavings drawn in by the internal fan collect at this point

on any excess oil that might be thrown by the shaft. As the switch opens, the arc sometimes sets the debris on fire and burns out the motor.

The capacitor or condenser motor has a round or square can, usually mounted on the top or side of the motor frame and containing the condenser or capacitor component. Some have a doughnut-shaped condenser inside the motor case. They have two windings and centrifugal cutout switches. Their use is on appliances like refrigerators, pumps, and stokers with fairly heavy starting loads. It is good practice to remove the end bells occasionally and blow out dirt and grease from the switch and windings.

Repulsion-induction motors are used for the heaviest starting loads, such as water pumps, air compressors, and some of the older refrigerators. They are characterized by a wound armature similar to a D.C. motor and two or four brushes mounted on a movable brush yoke. All have a device for short-circuiting the commutator bars as the motor comes up to speed. Governor weights on the front end of the armature in one type push through the core to bring the shorting necklace in contact with the rotor bars and to lift the brushes from the commutator face. In the brush-riding variant, the shorting device is pressed against the bars by centrifugal force while the brushes remain

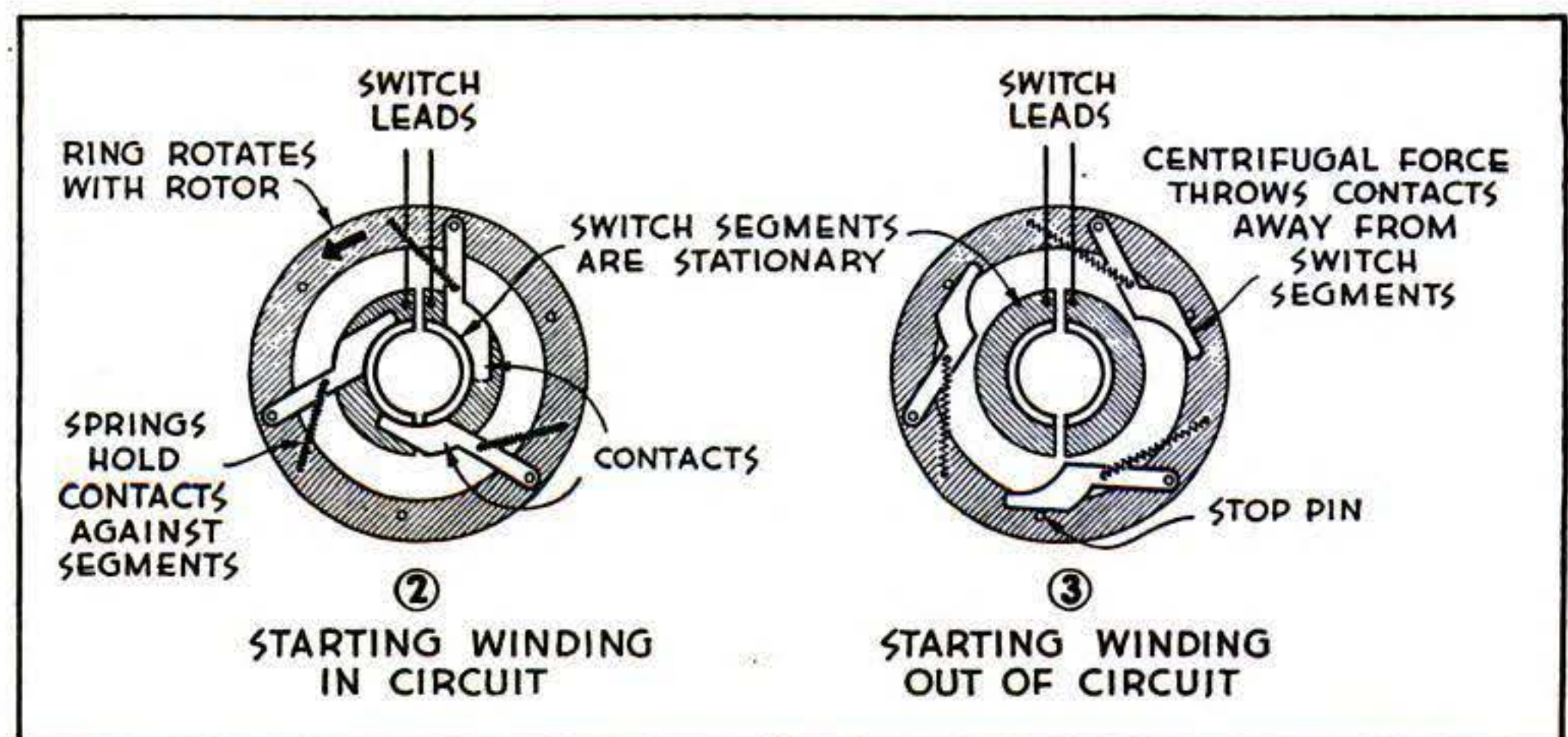
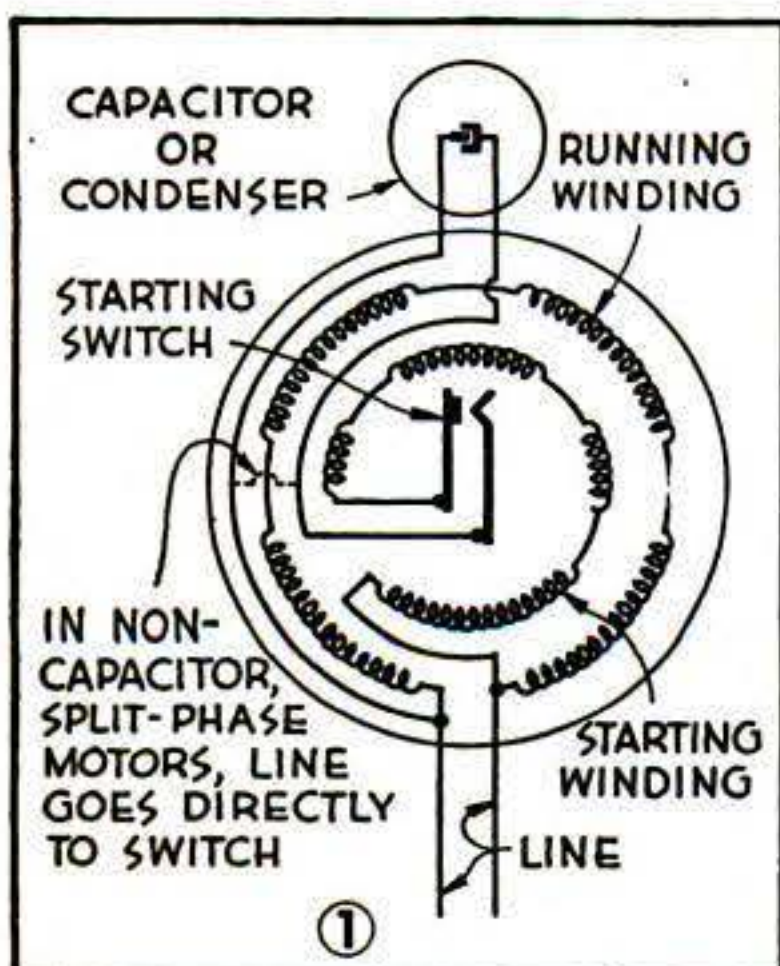



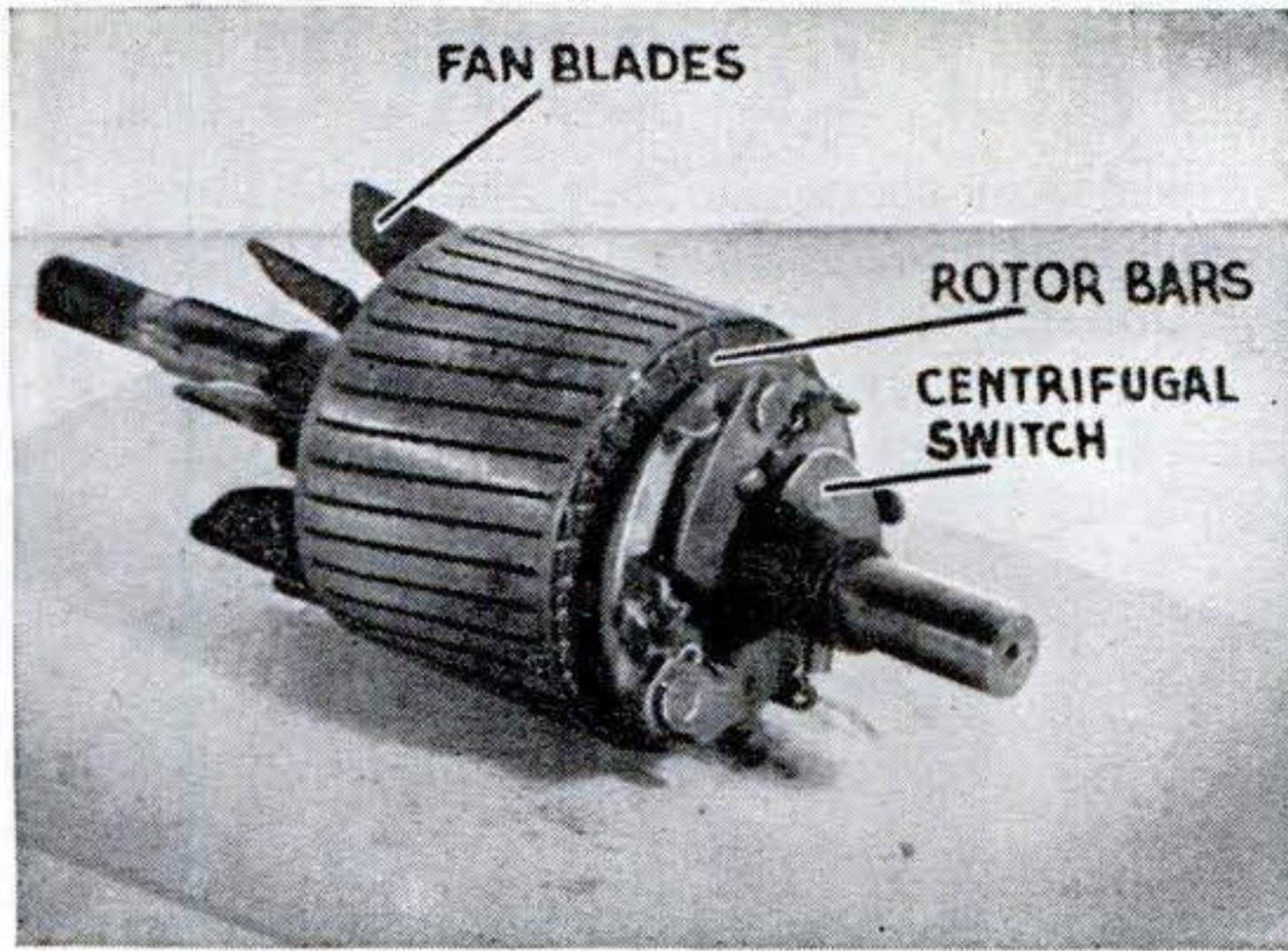

Rotor from a split-phase motor.

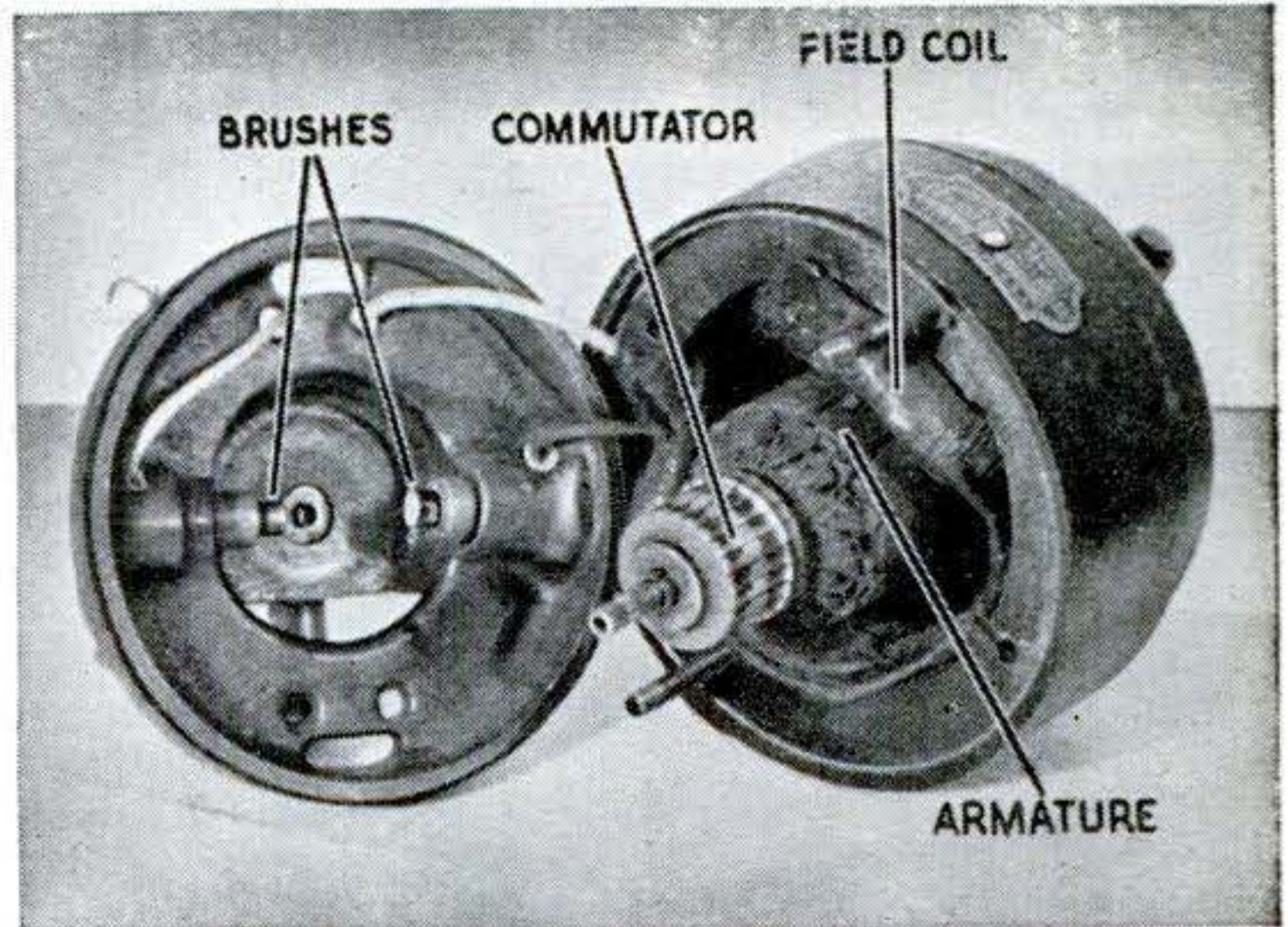

Series-type blower motor.

in contact. Trouble can usually be traced to dirt, oil, or a broken necklace in this starting mechanism.

Shaded-pole motors are the type usually found on fans and small appliances having a light starting torque. This fourth variant of the single-phase A.C. induction motor is a small motor with copper rings set in slots in the stator to assist in starting. There is no commutator, switch, or slip ring, and the shaft is the only moving part. Such motors are rugged and reliable, but on a heavy load, or if the bearings are gummed, they will stall quickly and may burn out if the current isn't cut. Because little can go wrong, they are omitted from the check list. Nothing is required in the way of maintenance except cleaning and oiling.

On heavy duty or where a motor may be loaded beyond its rating, try your hand frequently on the housing to test for overheating. A rise of 50 deg. C. is usually safe during operation. Name-plate information generally gives permissible temperature rise.

Once in a while, depending on how much the motor is run, check on the brushes, holders, and shunts, and clean the motor with compressed air. Grease should be cleaned out of ball and roller bearings and replaced every year or two.

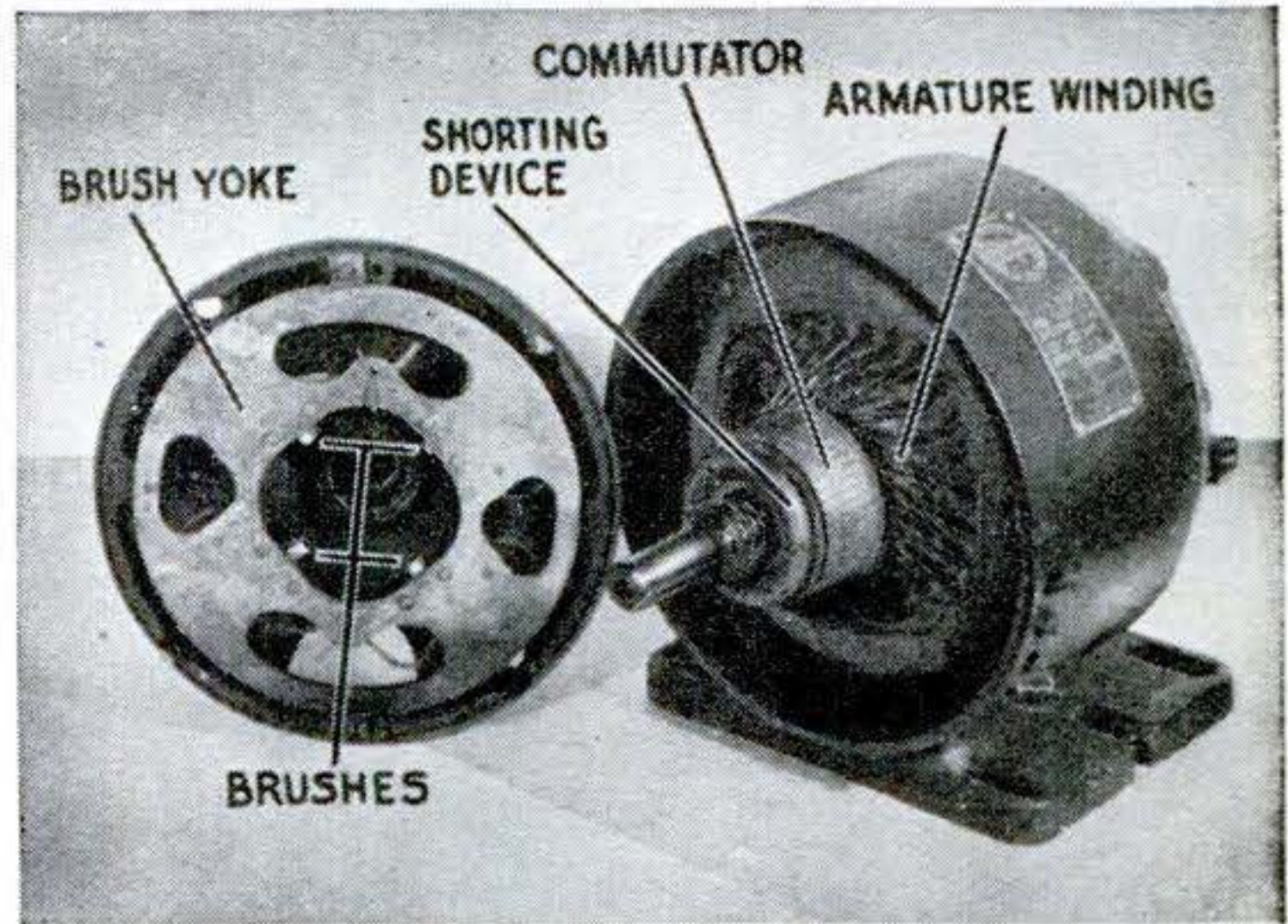

Repulsion-induction motor (brush-riding type).

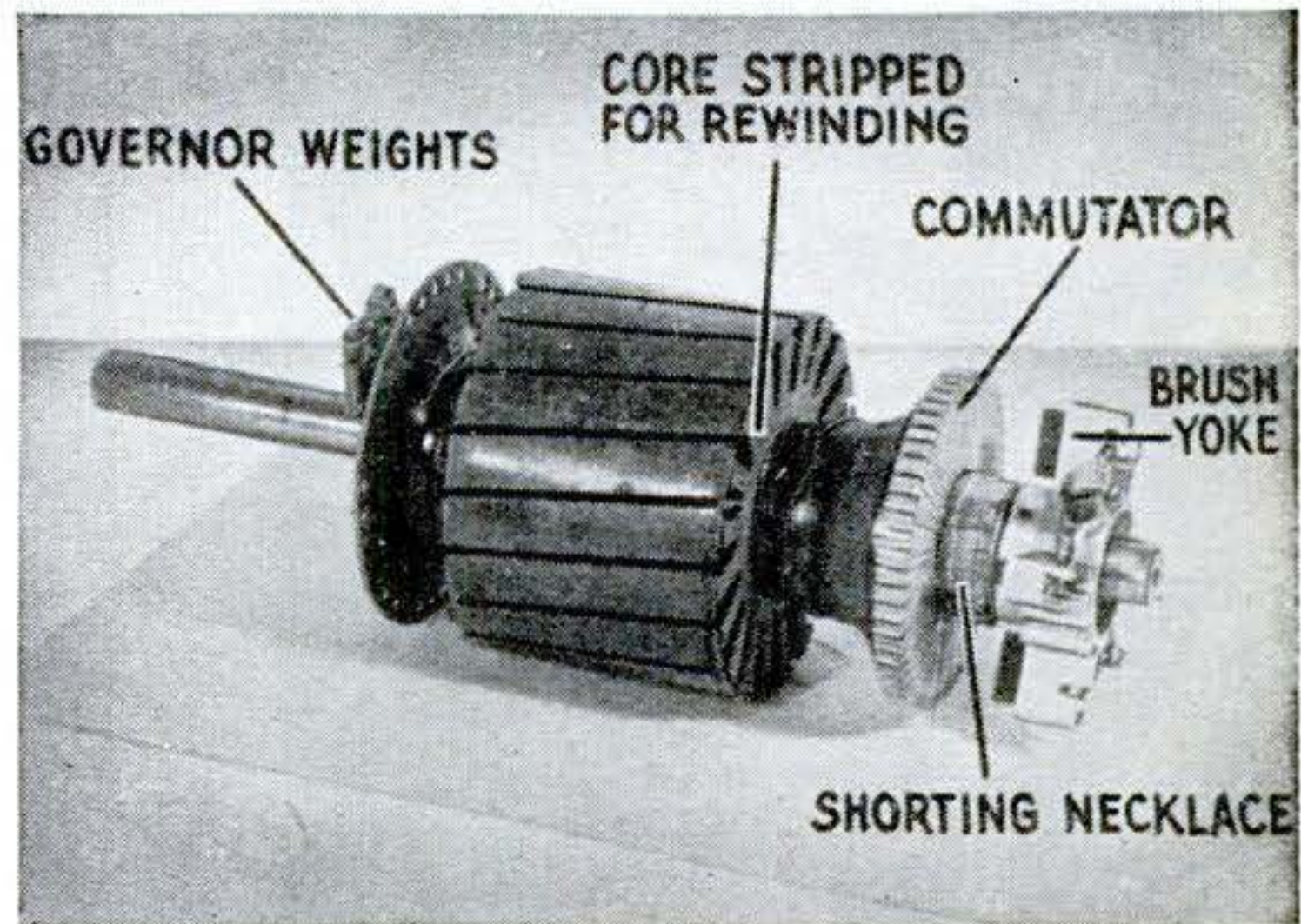

Repulsion-induction armature (brush-lifting type).

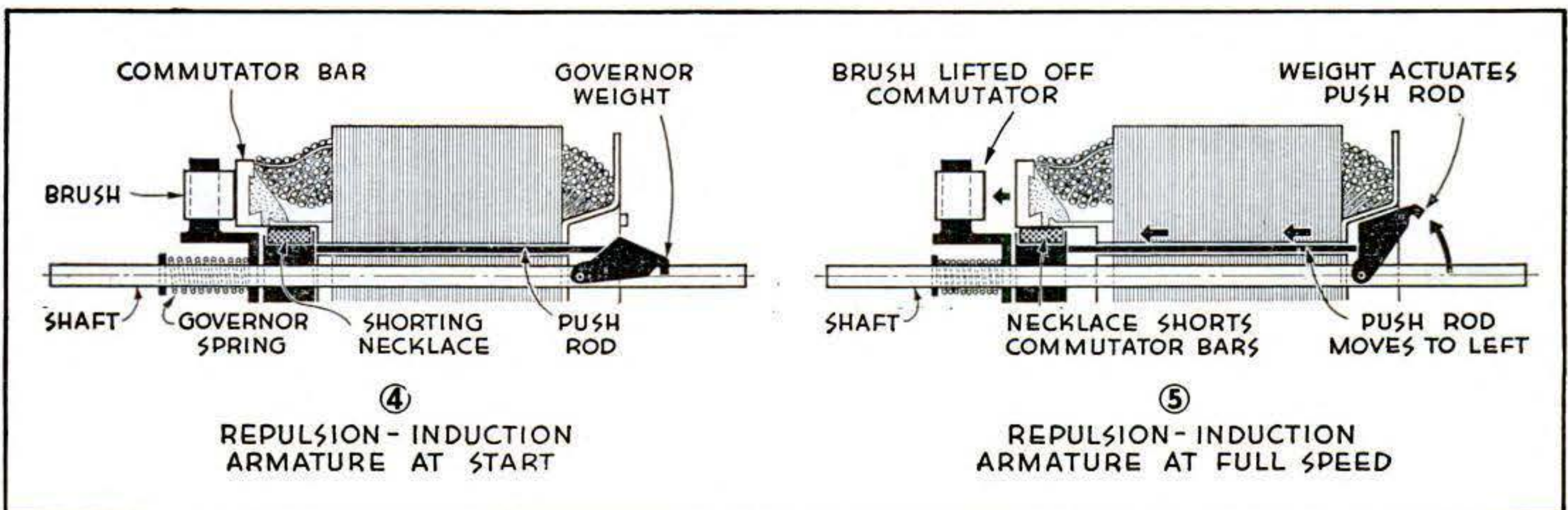



# HOW DO YOU KNOW THEY'LL SPROUT?

WHEN your flower seeds produce a ragged yield, you have plenty of reason to be sore. But that's poor consolation for a farmer or Victory gardener who has lost a season's crop. Germination tests take the guesswork out of planting.

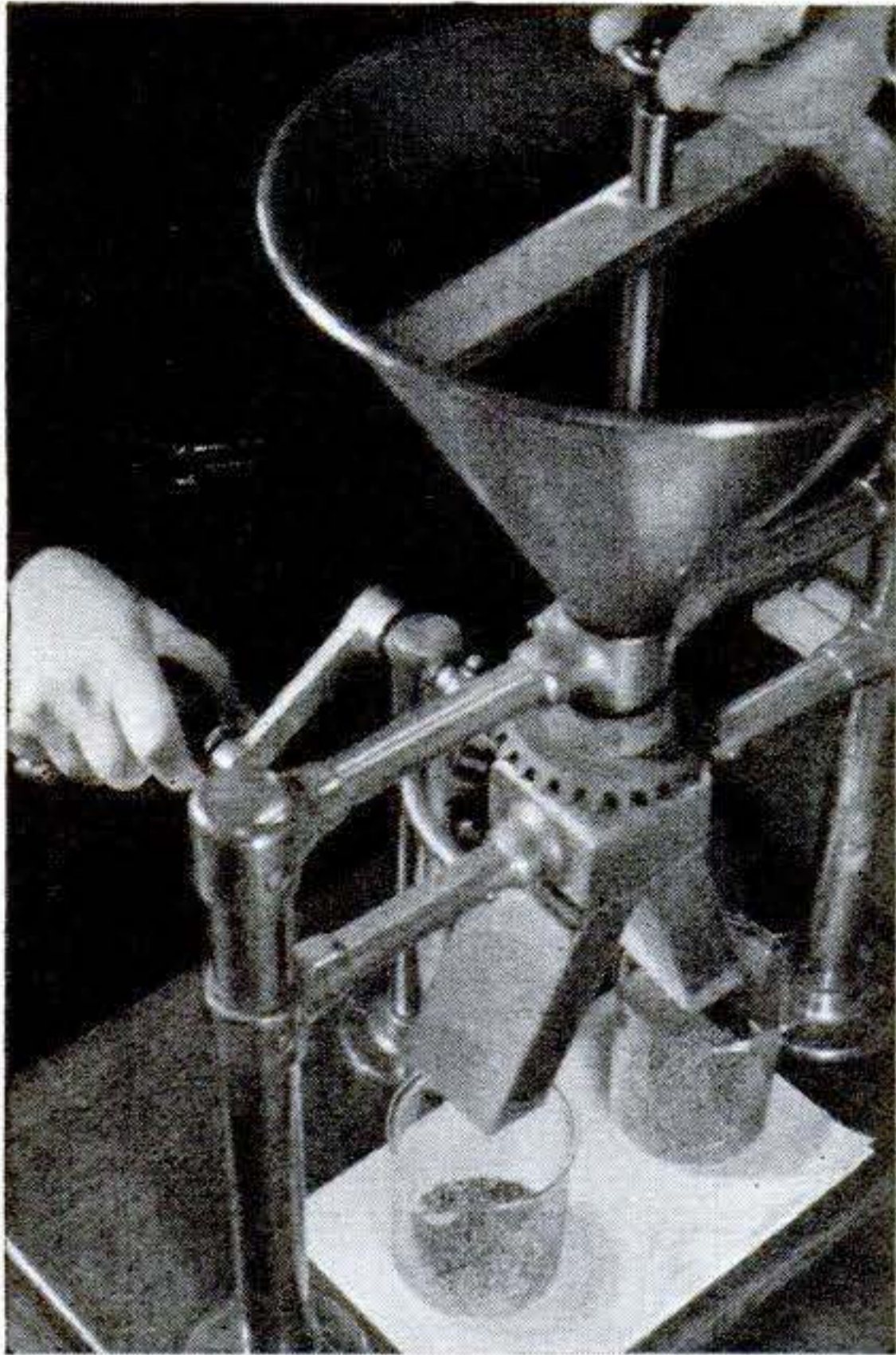

Preparing for a test at the seed laboratory of New Hampshire University. The sample is first thoroughly mixed in the machine, left, that resembles an old-style coffee grinder.

In order to forecast the size of the crop that may be expected from a given batch of seed, it is necessary to know the exact size of the specimens being tested. At the right, samples are weighed.

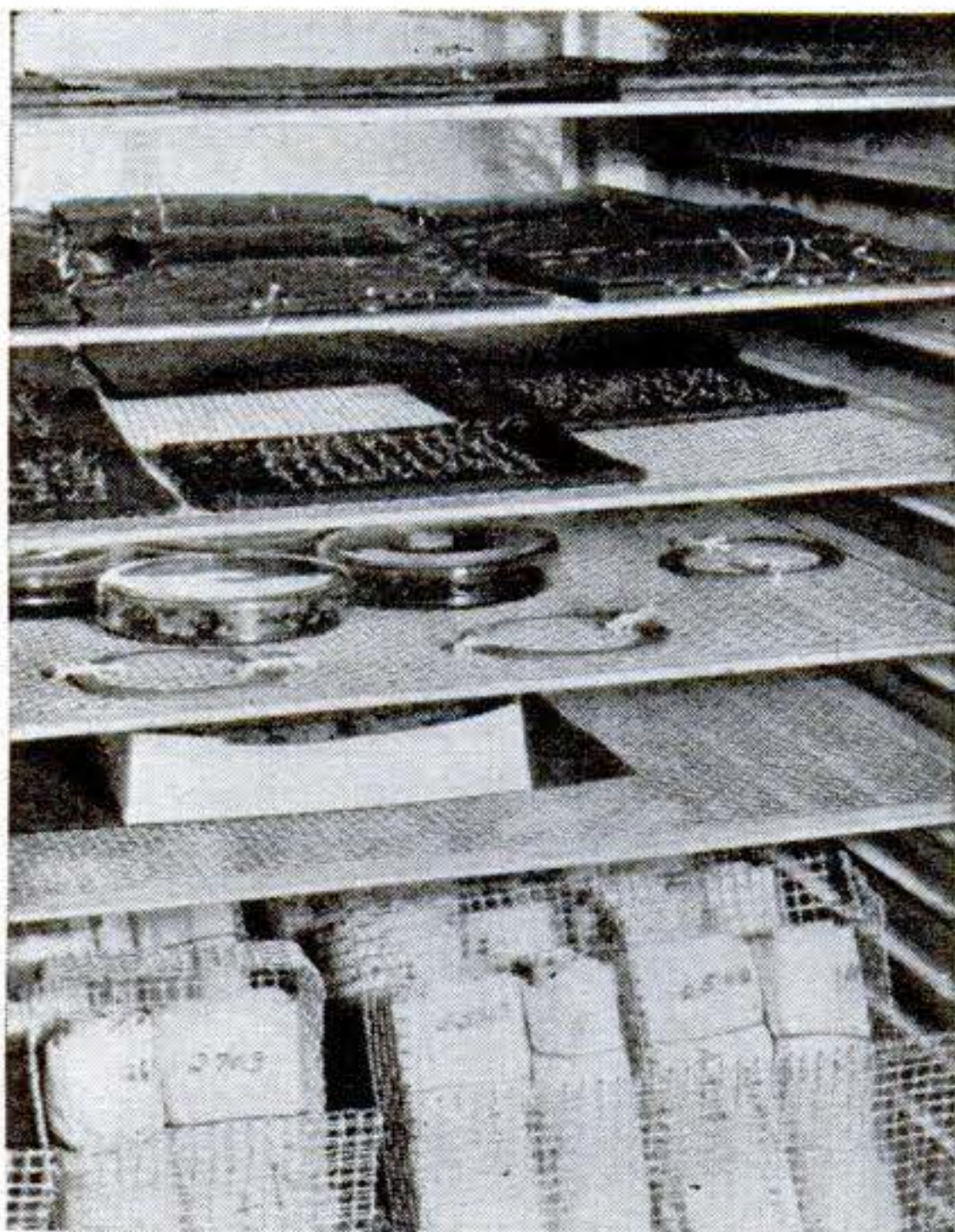
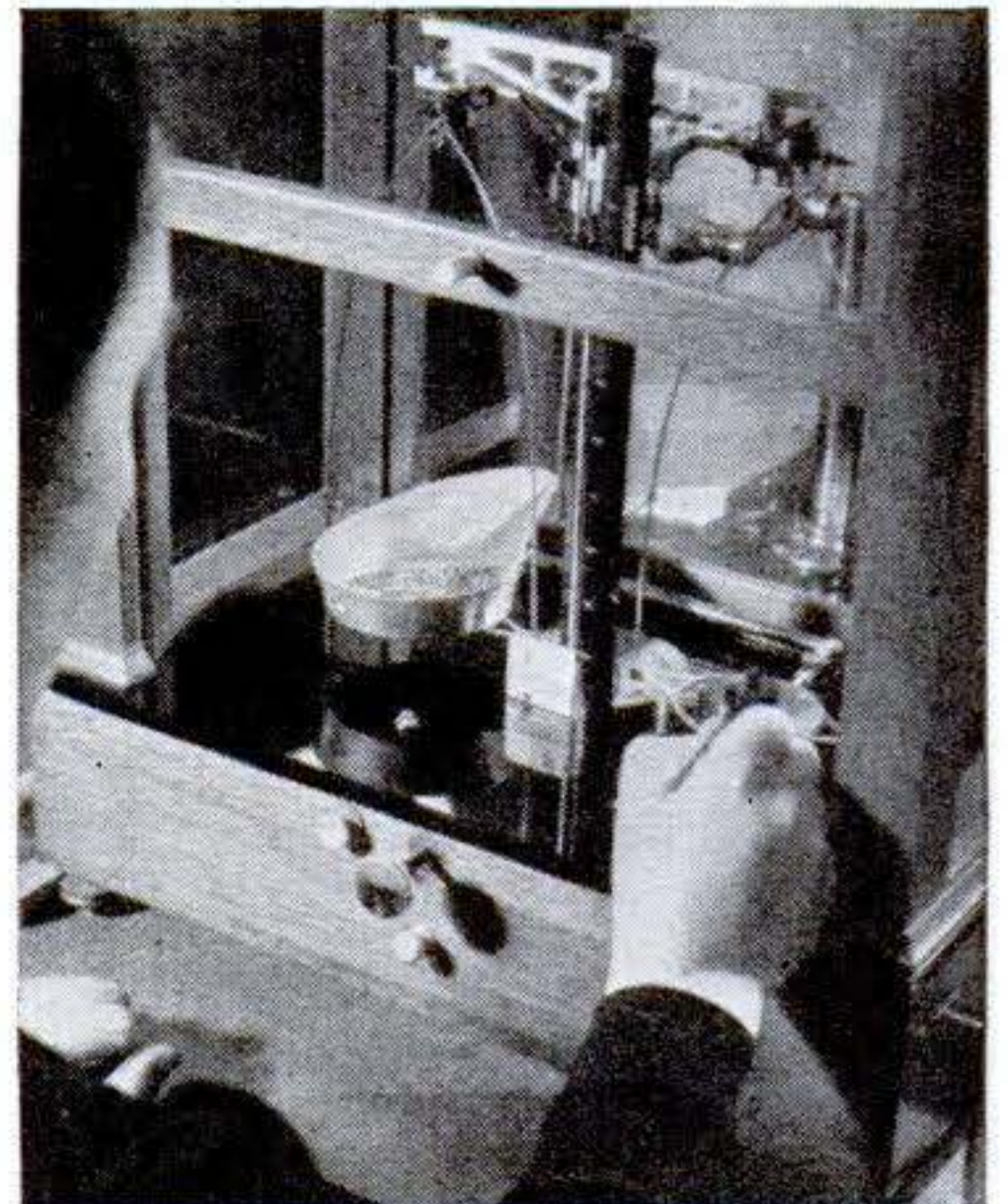

With the aid of a magnifying lens and a pair of tweezers, pure seed is separated from inert matter, other plants, and weeds. The resulting percentage is a guide to quality.

Germination tests are made by placing seeds on damp blotting paper, as shown at the left, center.

Germinated seed, left, ready to be counted. The mold-like fuzz is the root system. Time and temperature of all tests must be rigidly controlled. Percentage of germination is determined by hand-counting the sprouts, as at right.

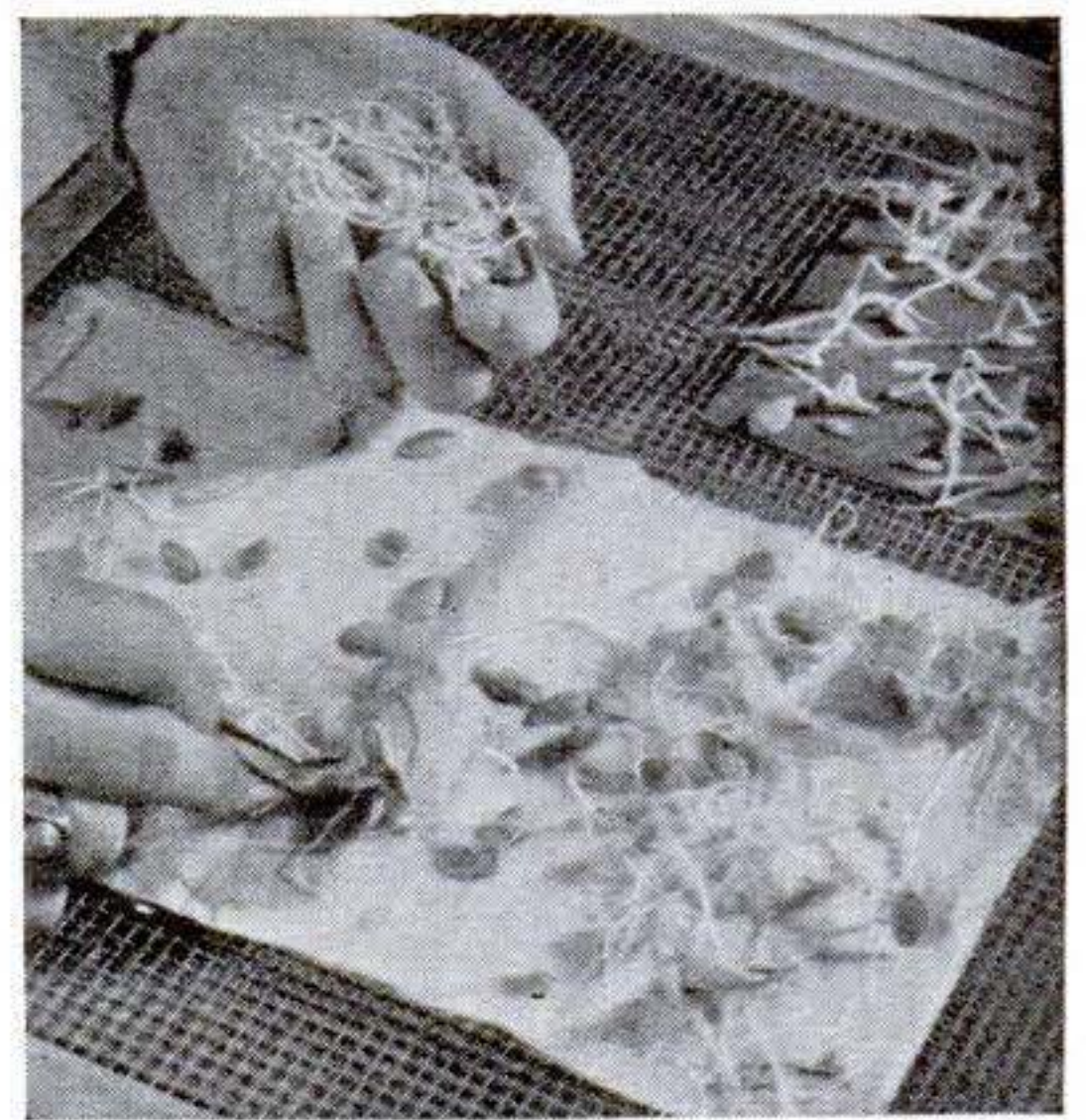
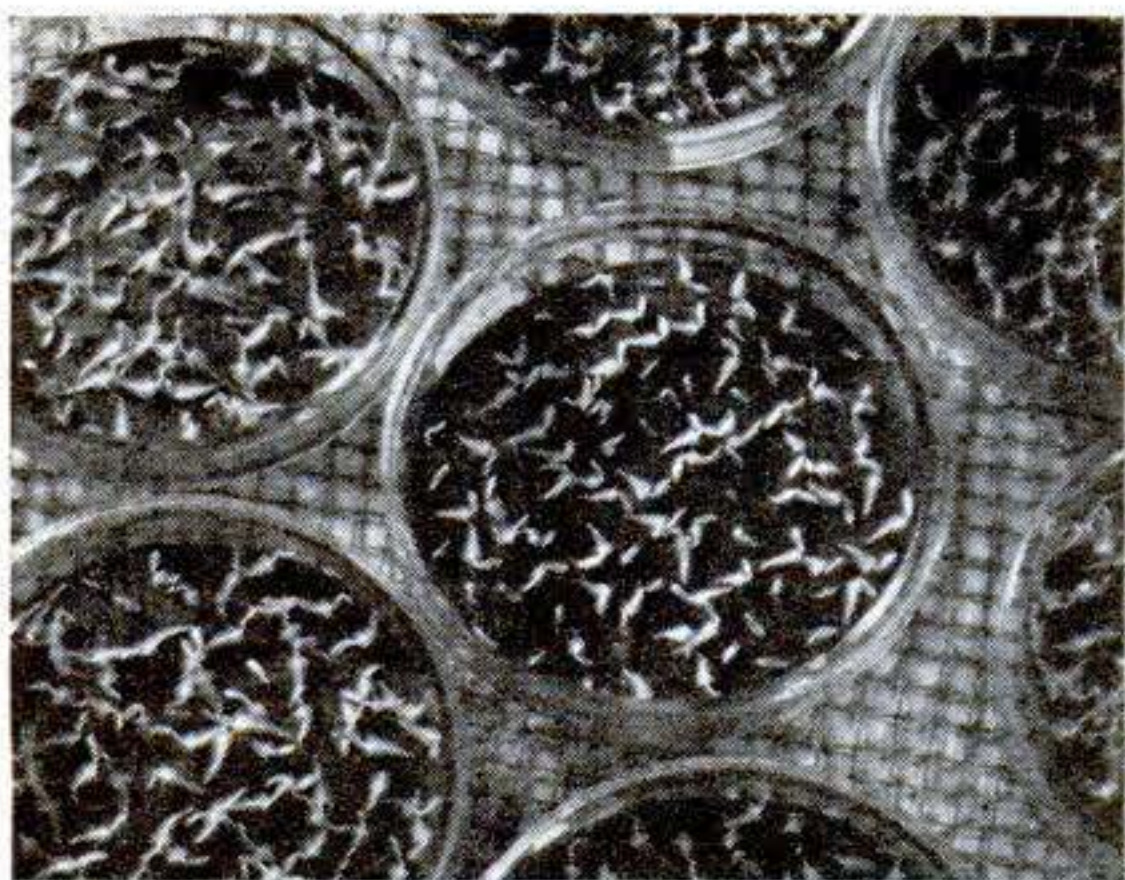



## Tracing-Paper Window Shade Takes Glare Out of Sunlight

IF YOU are bothered by glare from a window adjacent to your drawing board or other work table or bench, you can find the remedy in a large sheet of draftsman's tracing paper. Remove the original shade from its spring roller, and substitute for it a sheet of tracing paper as wide as the window and a few inches longer. Ordinary shades darken a room when drawn, but the tracing paper will admit an evenly diffused, soft light that is easy to work by.

The tracing paper may be attached to the roller with cement or adhesive tape, or the end may be folded down  $\frac{1}{2}$ " and cemented and tacked. For a stiff bottom edge, fold up  $1\frac{1}{2}$ " or 2" and cement it around a thin wood strip. Insert a screw eye and attach a pull cord. If properly attached the tracing paper can be rolled up and down like a shade, but a little extra care is required to avoid creasing or tearing the sheet.—H. DROUYN.

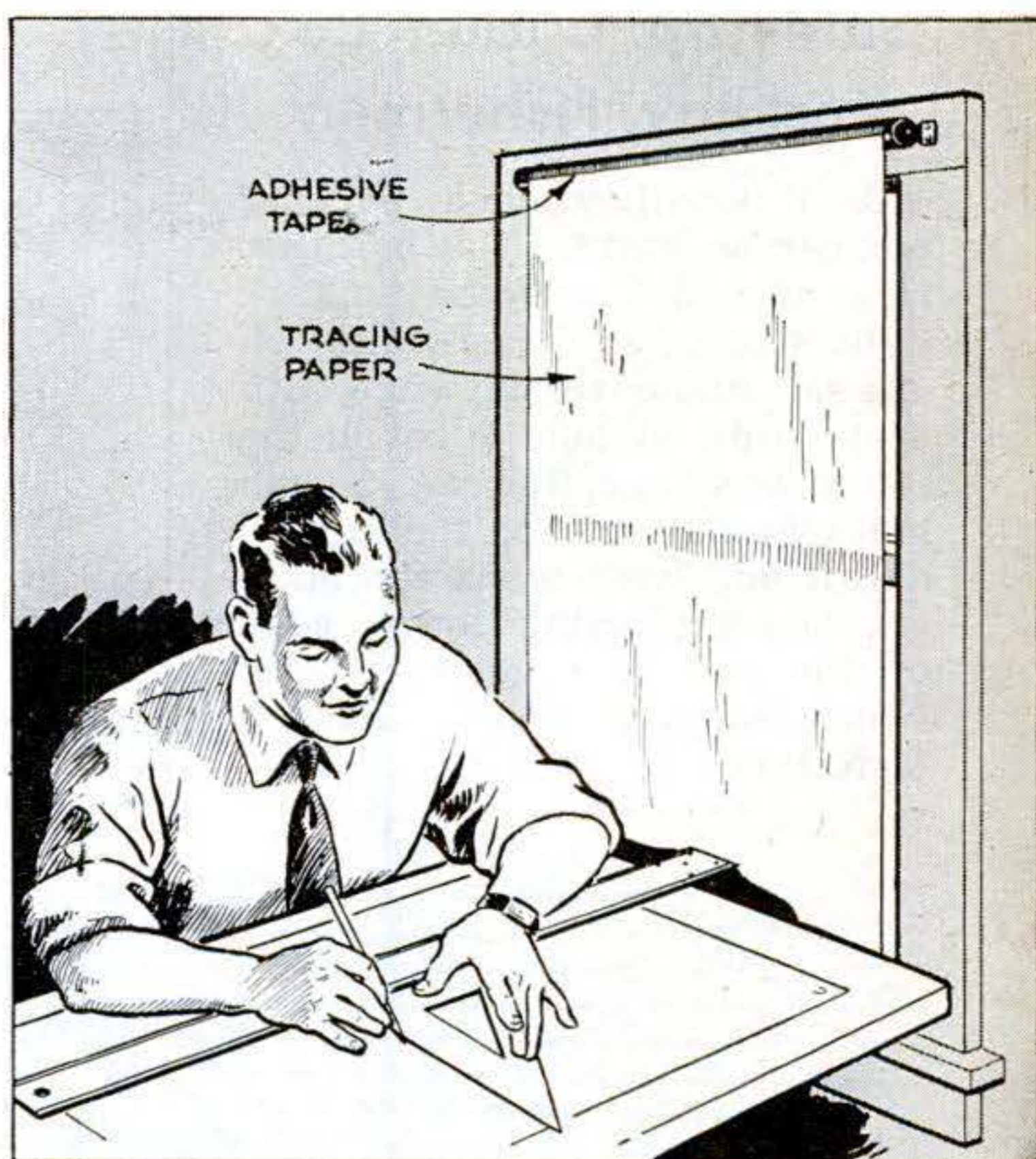

## Clamp Pressure Realigns Bristles of Reclaimed Paintbrush

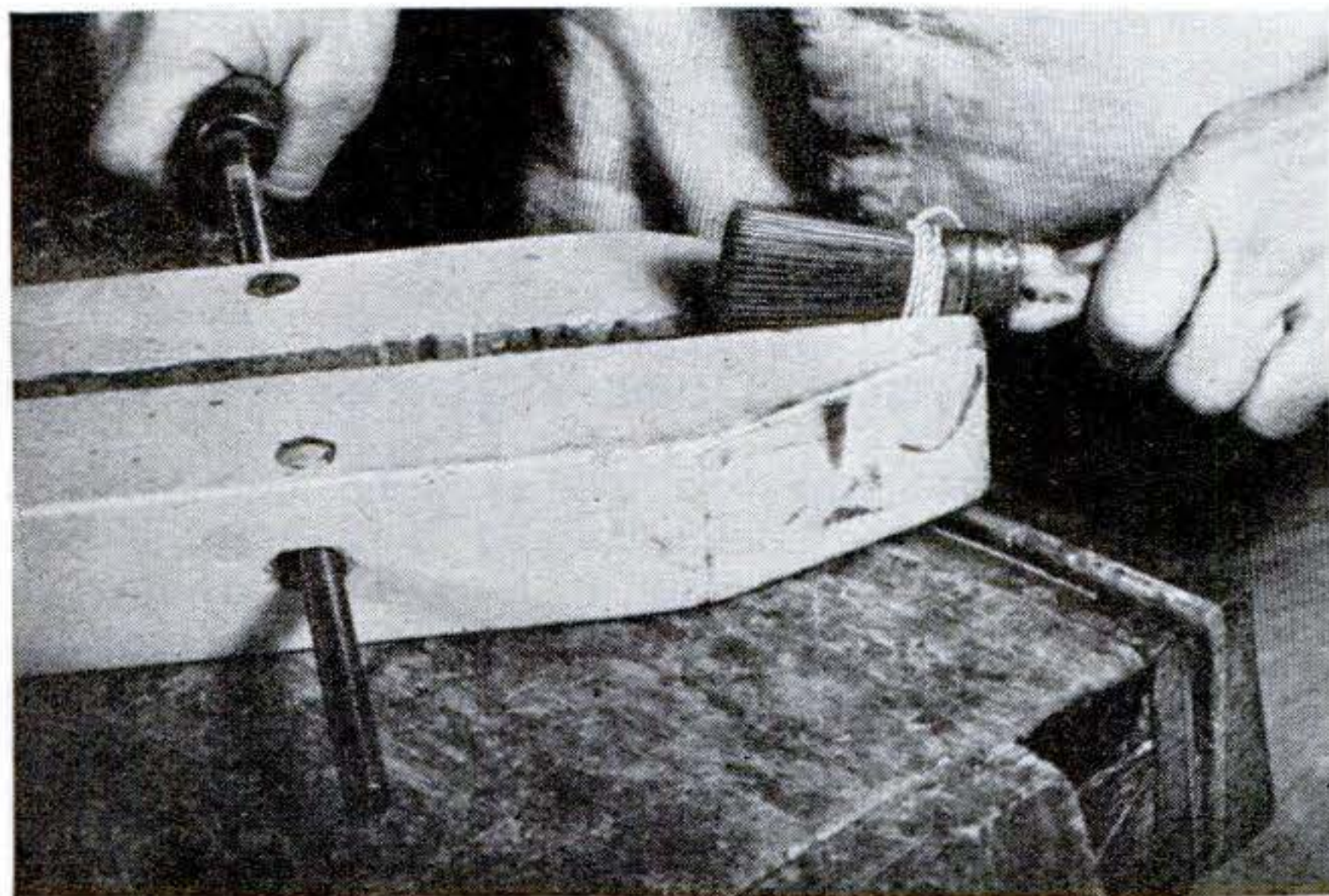

ONE great fault with reconditioned paintbrushes is the bushiness of the bristles caused by dried paint at the roots. No matter how hard you work, some dried paint stays.

This can be corrected with a  $\frac{3}{8}$ " wrapping of heavy twine starting at the ferrule. Wrap the twine tightly, tie it firmly, and then squeeze the base of the bristles in a clamp. Let the brush dry thoroughly and shape it carefully. Pressure flattens the bristles to almost normal thickness, and the twine prevents bulging edges.—E. M. L.

## Bearing for Model Plane from Electric-Light Pull Chain

A SINGLE brass ball clipped from an electric-light pull chain will substitute for a glass bead as a propeller bearing on a model plane. It already has the necessary center hole and will create little friction between the washer and the steel motor mount.

In cutting off the ball, take care not to let the small nub of protruding wire slip back into the cut. Grasp the wire with the pliers and pull it out; then smooth the ball with emery cloth. If you have trouble keeping the wire nub from getting lost inside the ball, cut off two balls together and pull them apart.—ALFRED G. MILLS.

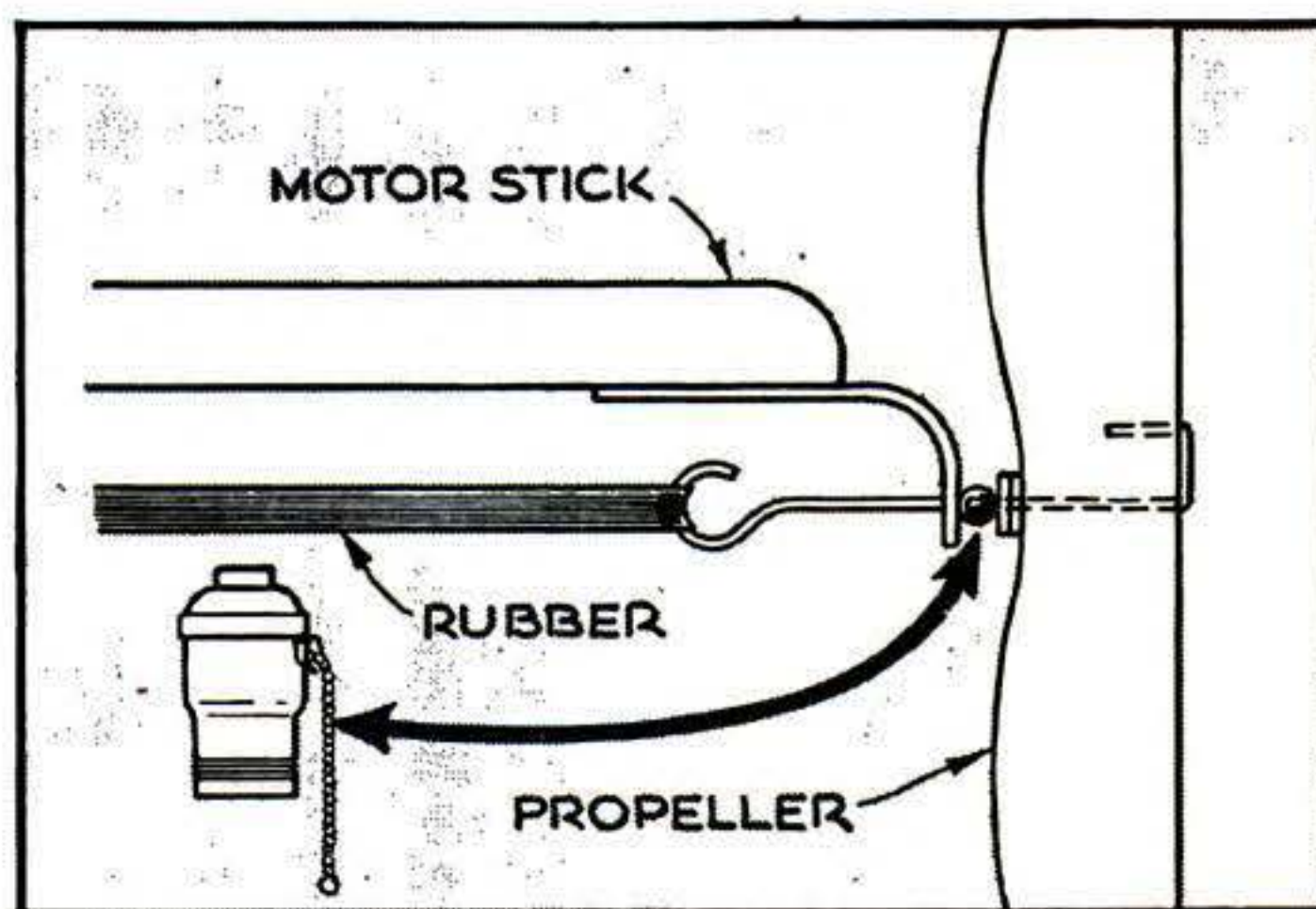



## Safe-Top Cricket Box for Boy Fishermen

ANY small wooden packing box can be used for this bait carrier, or a box may be built of light stock. Tack screening on one side and cover the edge with thin strips. A hole is cut in the top to fit a tin coffee can. Punch holes in the side of the can to nail it on. Even when the lid is off, the projecting lower edge of the can will keep crickets from jumping out. — FREDDY MITCHELL.

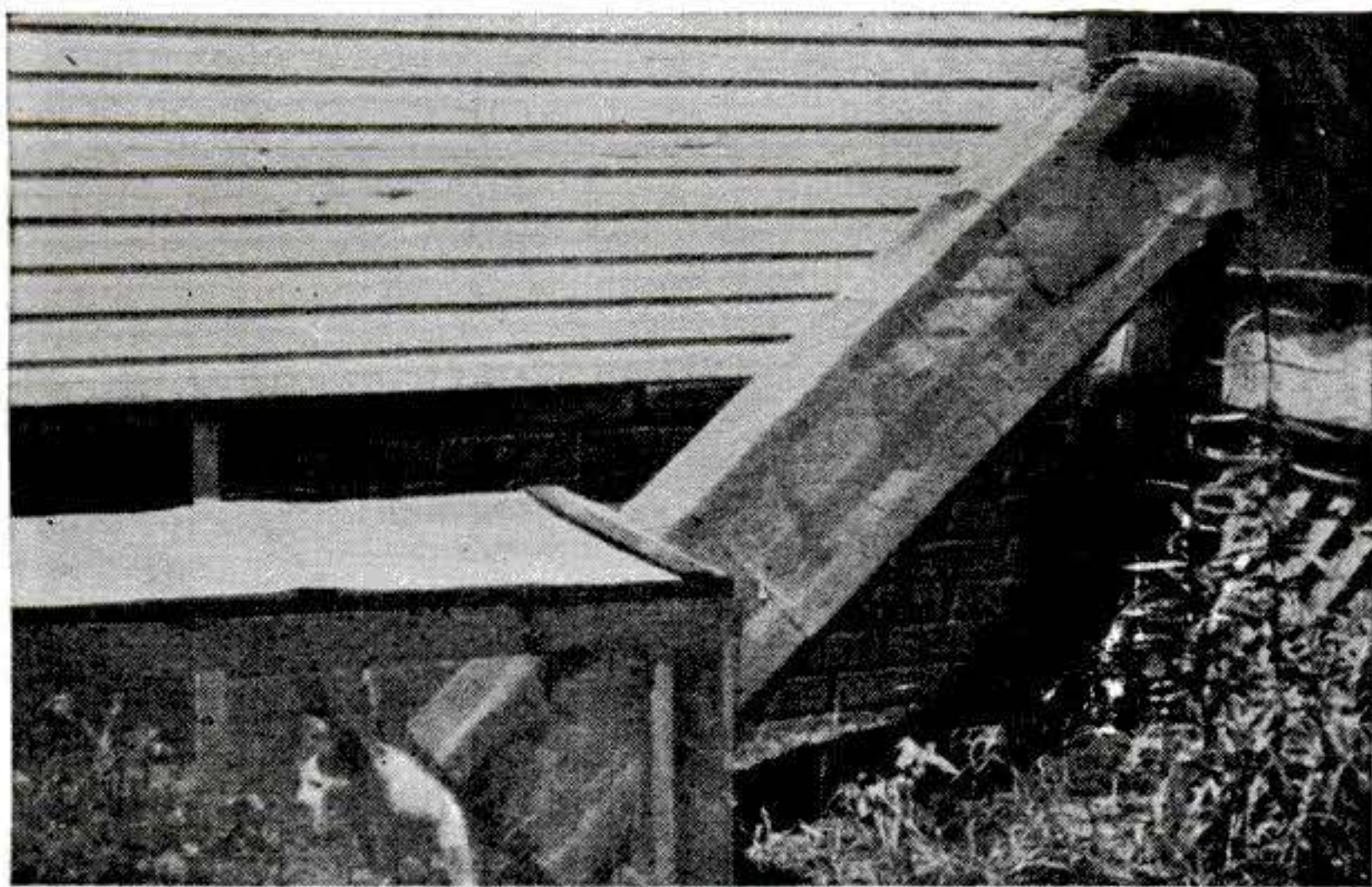
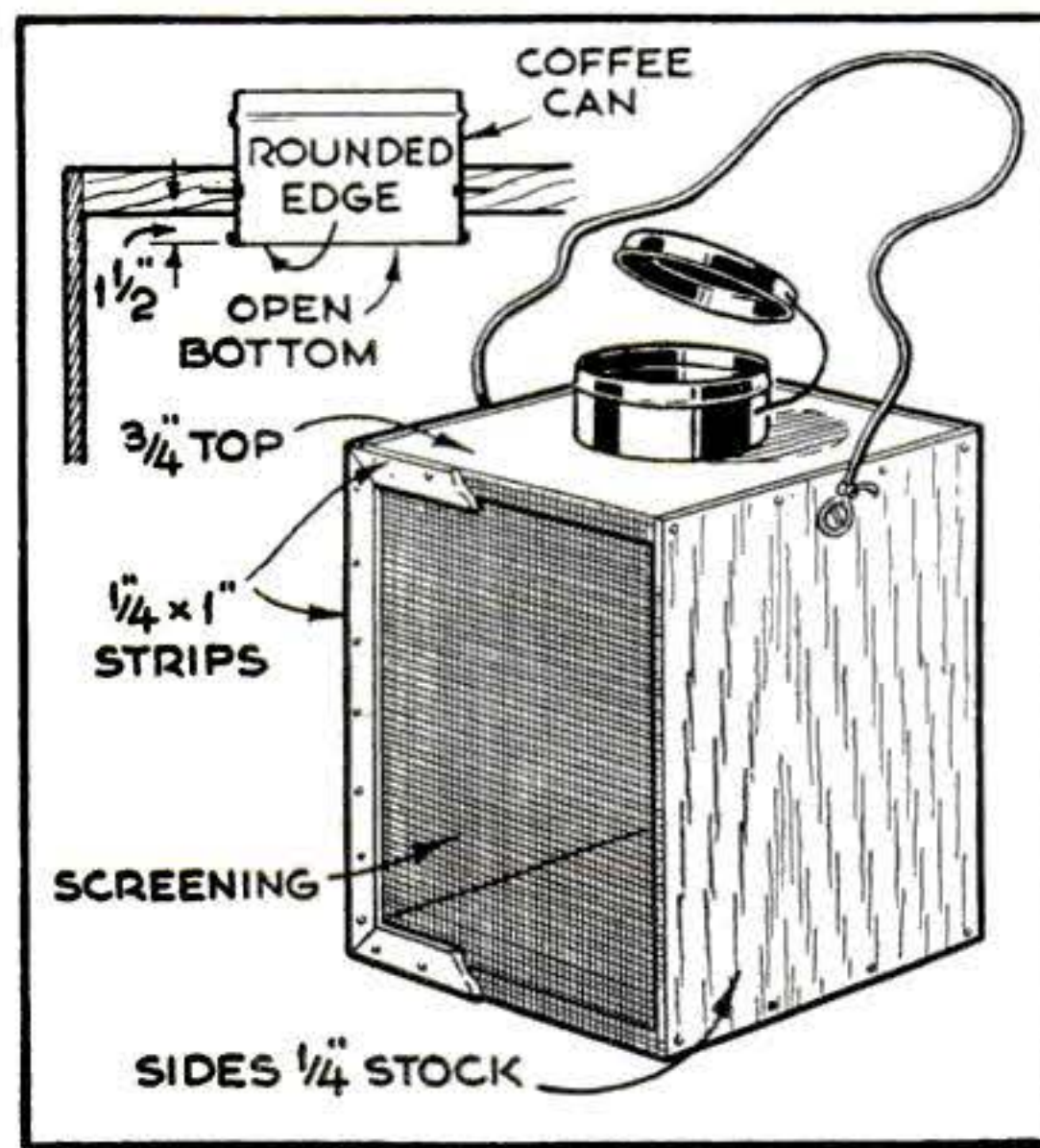

## Runway from Porch Gives Pets Access to Pen

CATS and other small pets can go outside for sunning whenever they wish, and yet be kept from annoying neighbors, with a runway leading to a pen from a rear porch. Provide an opening for the runway in the porch screen or lattice and another in the pen, and enclose both runway and pen with screening. Hinge the top of the pen so the inside can be cleaned.—H. LEEPER.

## Camouflaged Barrel Bolt Locks Garage Door Against Prowlers

IF THE hardware shortage has left your tool-shed or garage door swinging in every breeze, bend a few metal brackets to the shapes shown below and shut the door on the vexing problem. The bolt is actuated by a nail with a head that looks exactly like the surrounding ones in the outside boards.

A carriage bolt used for the barrel bolt

passes through U-shaped brackets to lock the door. Bend the end of the nail, as indicated, and hook it to a pivoted piece of strap iron bent to form a bell crank. The bolt slides as the nail is pulled or pushed.

You can unbolt the door without a key, but a small nail puller on your key ring saves your fingernails.—P. B. HORSLEY.

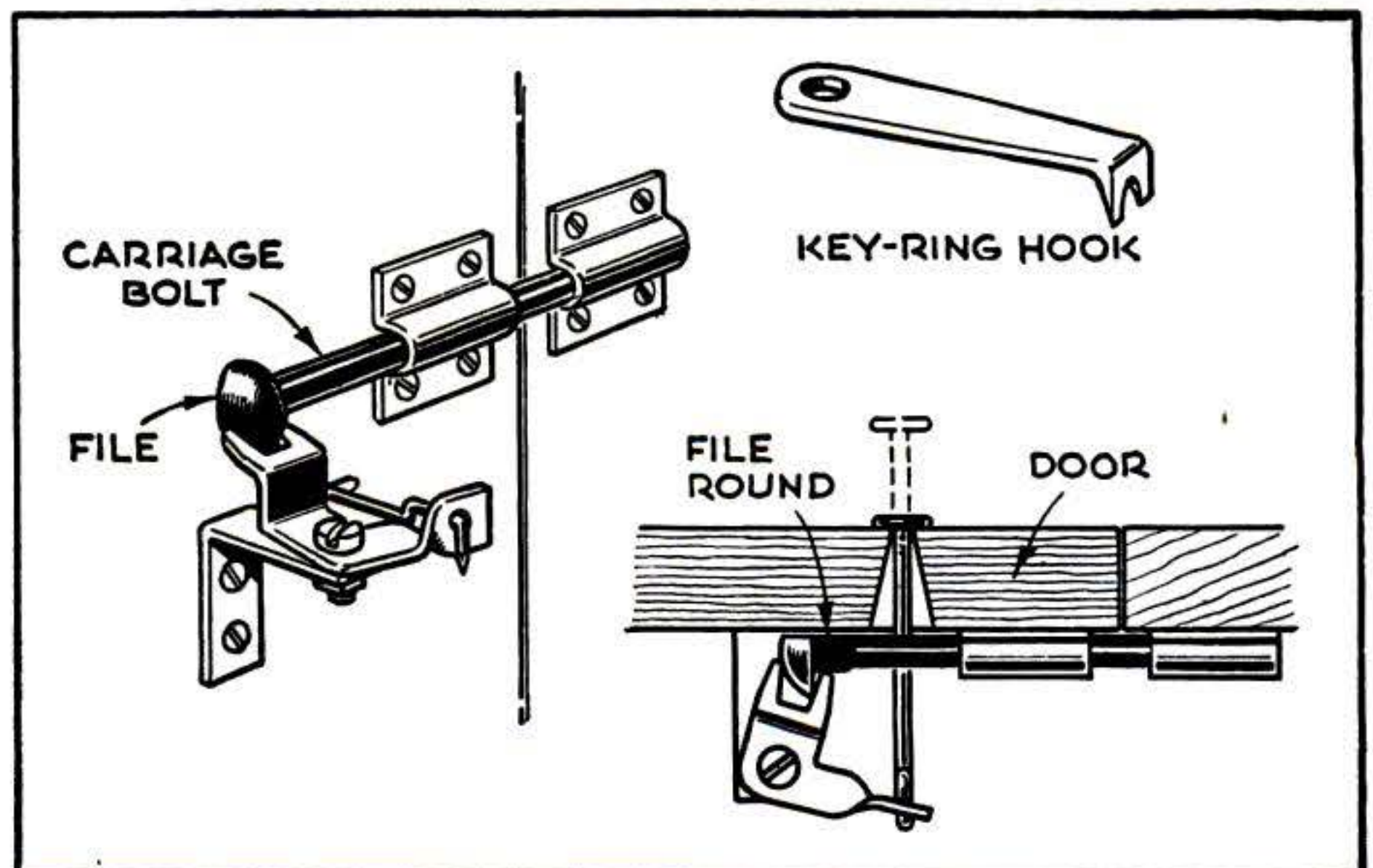
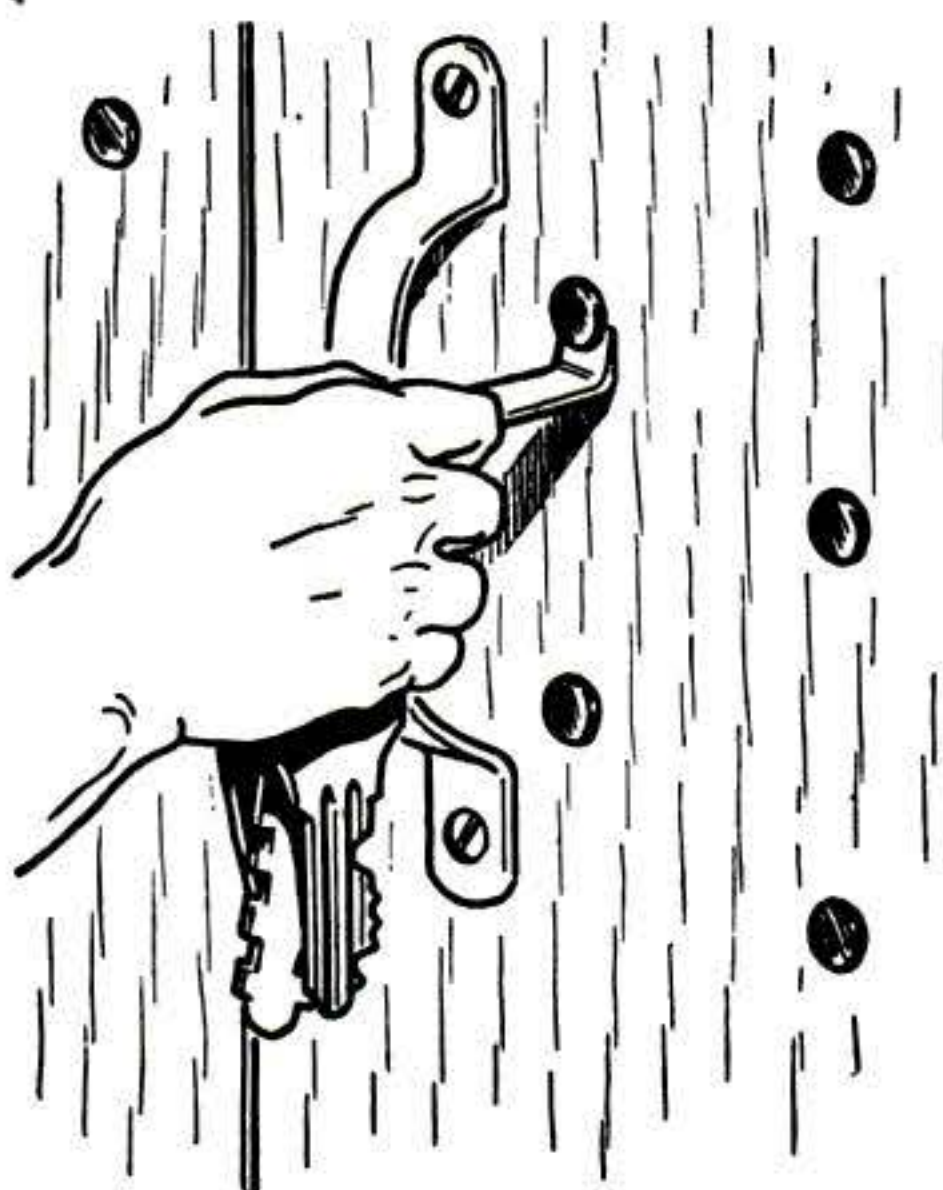



# HOME EXPERIMENTS SHOW SOME PROPERTIES OF LIGHT

**CANDLE POWER** means the luminous intensity of any light compared with that of a standard candle. A Joly photometer, an instrument for helping determine this comparative brightness, can be made by warming one face of each of two identical blocks of paraffin and pressing them together, like a sandwich, with a piece of tin foil of equal size between.

Place the composite block at right angles to a yardstick and darken the room. To illustrate the principle of the photometer, set a candle at any chosen distance, say 6", from one block. Move a similar candle back and forth along the yardstick on the opposite side of the block until the illumination of adjoining edges of the composite block is the same. If the candles are identical, the second should come to rest the same distance from the block as the first.

By the same procedure, if you know the candle power of one light, you can determine that of a second. First, find the distance from the block at which the unknown

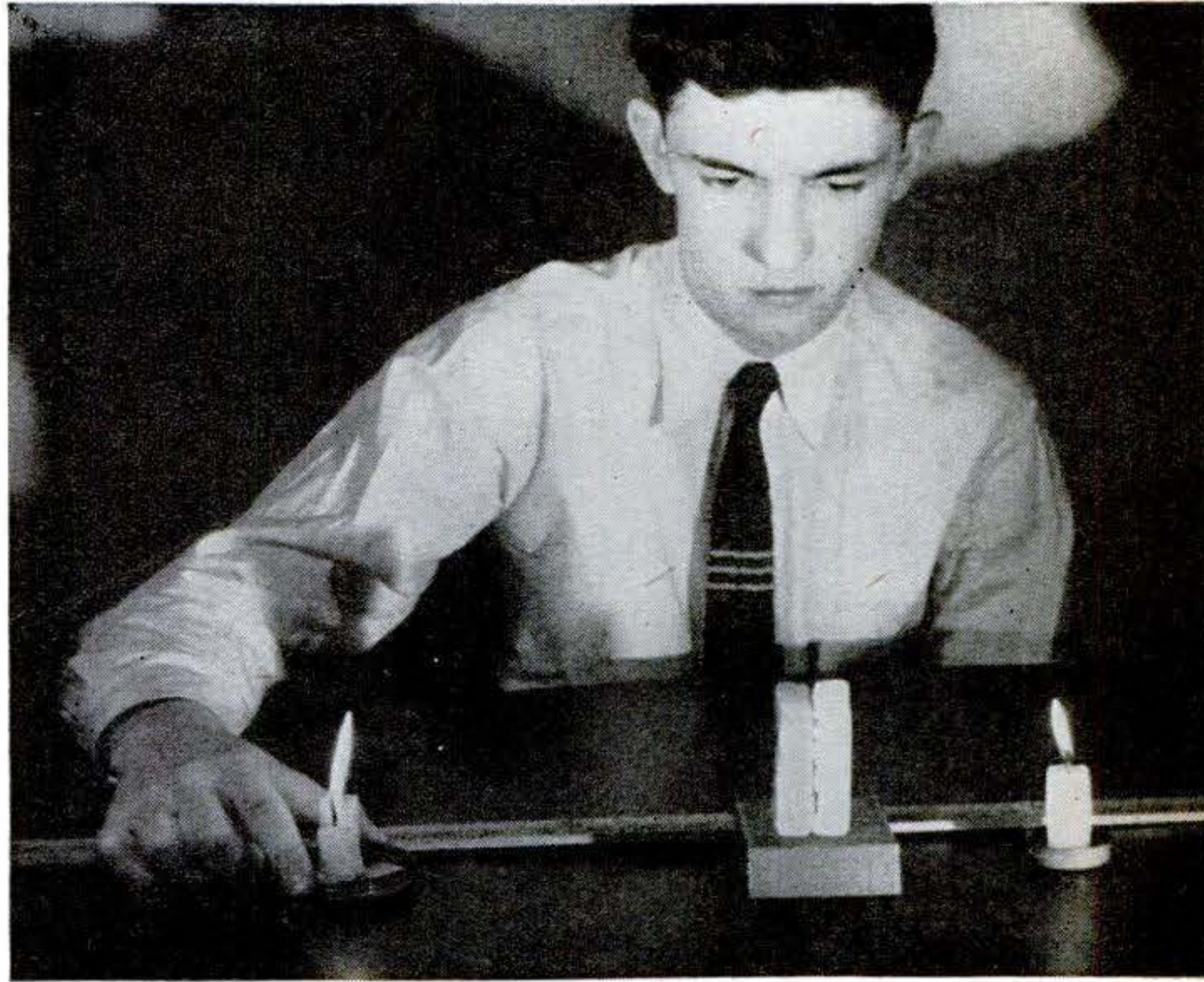

produces illumination equal to that of the known. Then divide the square of this distance by the square of the first distance and multiply by the candle power of the known light. The result is the unknown candle power.

**FROSTED BULBS** are superior to clear ones for general lighting because they reduce the shadows cast by small objects. Hold two fingers between a clear bulb and a sheet of paper, and sharp shadows result. With a frosted bulb, the shadows are smaller, grayer, and fuzzy. Why? Because the entire surface of a frosted bulb acts as the light

source. When the light source is smaller than the obstruction, as in the case of the filament of the clear bulb, the rays are blocked, producing a dense shadow that increases in size as the surface on which it falls is moved away. The reverse is true with a frosted bulb since the light (the entire bulb) is larger than the obstruction.

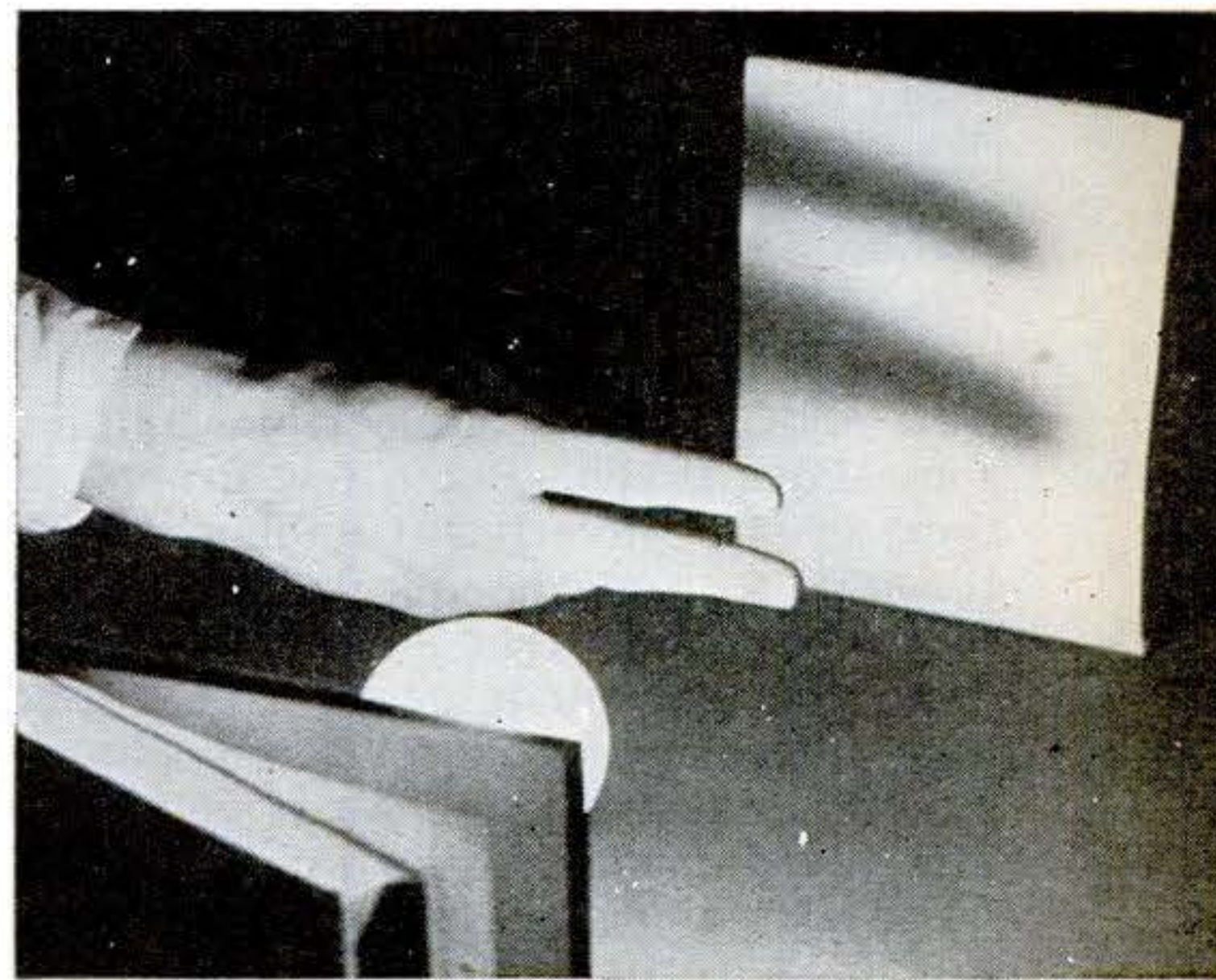
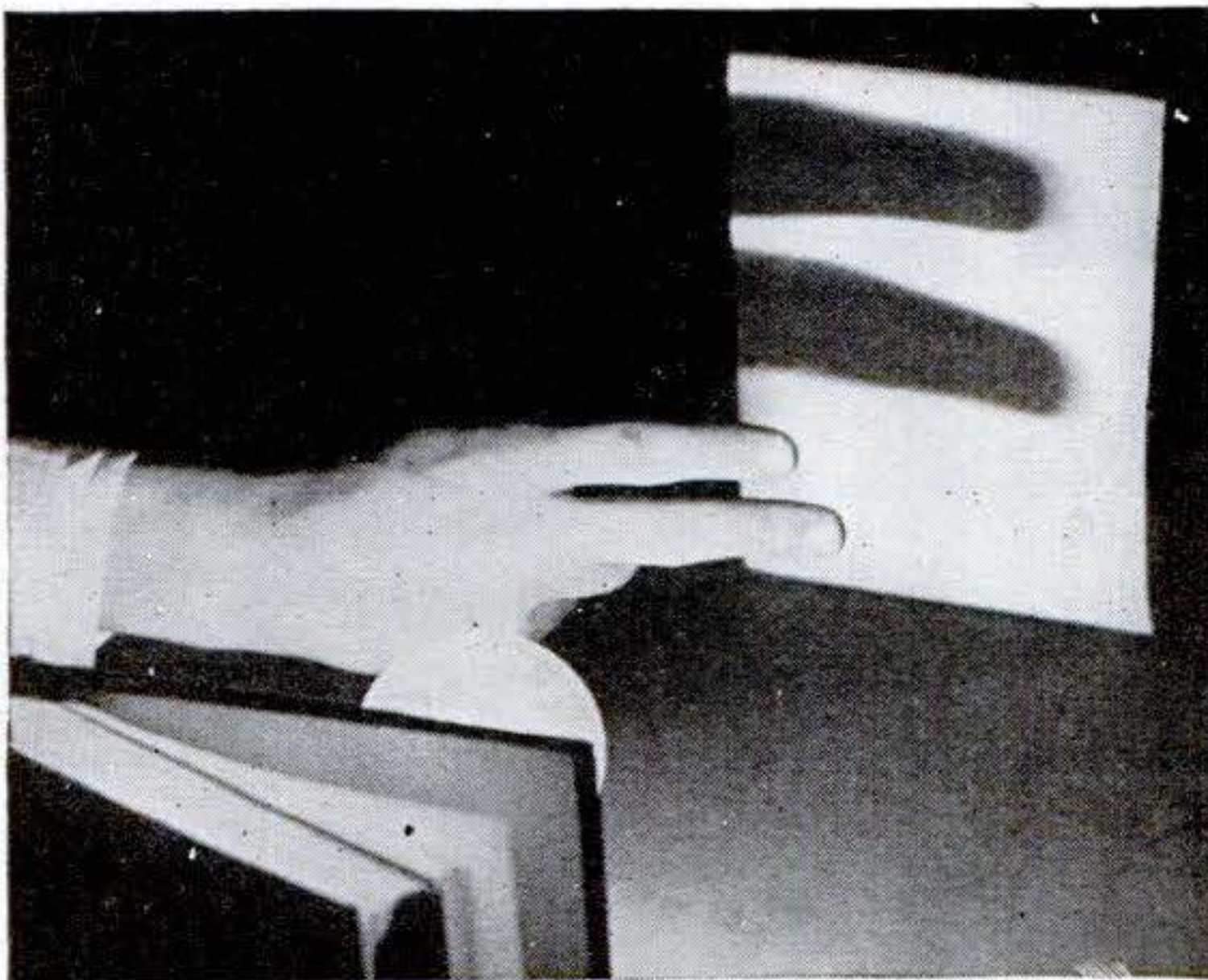



**FOCAL LENGTH.** Cut a triangular hole in the center of a cardboard shield placed over a lamp reflector. Now move the reflector and a white screen back and forth simultaneously on opposite sides of a convex lens, keeping both equidistant from the lens, until a sharp image the size of the triangular hole is formed. Measure the distance from the center of the lens to either the light or screen, divide by two, and you have the focal length of the lens.

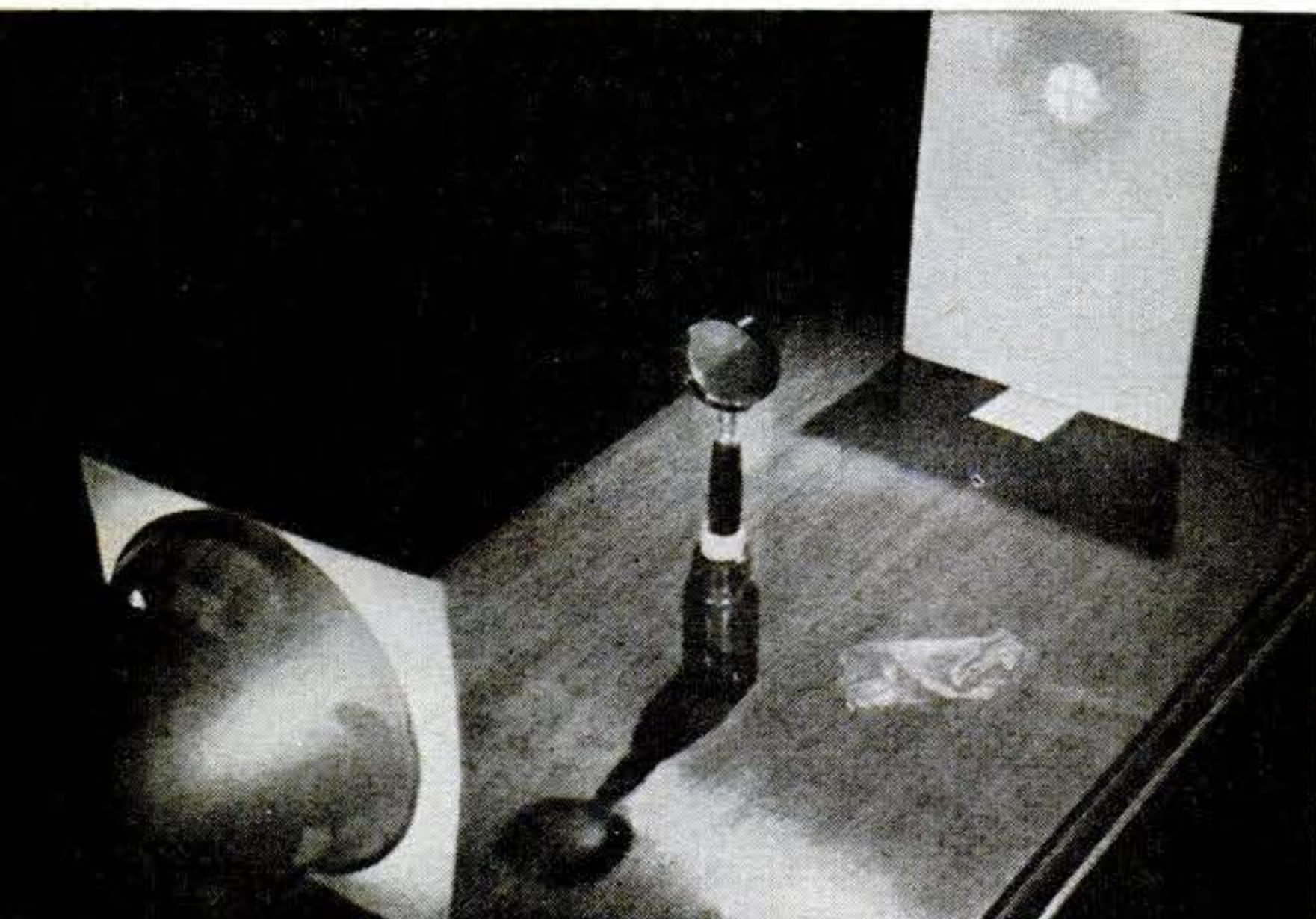

**COLOR FRINGES** mark the images formed by a simple lens. Known as chromatic aberration, this effect results because glass bends each color ray a different amount, giving each a different focus. To show this, place a light a little closer to a lens than twice the focal length (as determined above). In a cardboard lamp mask, cross two threads over a round hole. Cover the hole with red glass and focus the image by moving the screen. Now substitute dark blue glass. You'll find that the blue image will not be sharp at the same lens-to-screen distance.



**CONCAVE MIRRORS** produce real images and have definite focal lengths like lenses. You can demonstrate this with the setup shown at the left. In this case, the lamp mask used in the preceding experiment also serves as the screen. Mount the mirror so that its center is directly in front of the light and move the mirror back and forth until the image is sharpened and brought down just to the size of the hole. Then the focal length of the mirror is exactly one half the distance between the mirror and the screen.

**RED INK** made from certain aniline dyes is sometimes green. Put a few drops on the bottom of an inverted tumbler, look directly through it, and the ink is red. But hold the tumbler so that light is reflected from the surface, and the ink appears green. Likewise, a very thin sheet of gold leaf held between your eye and a strong light is not yellow but green. The mechanism of this strange effect is not definitely known, but it results from some sort of selective reflection at the surface.

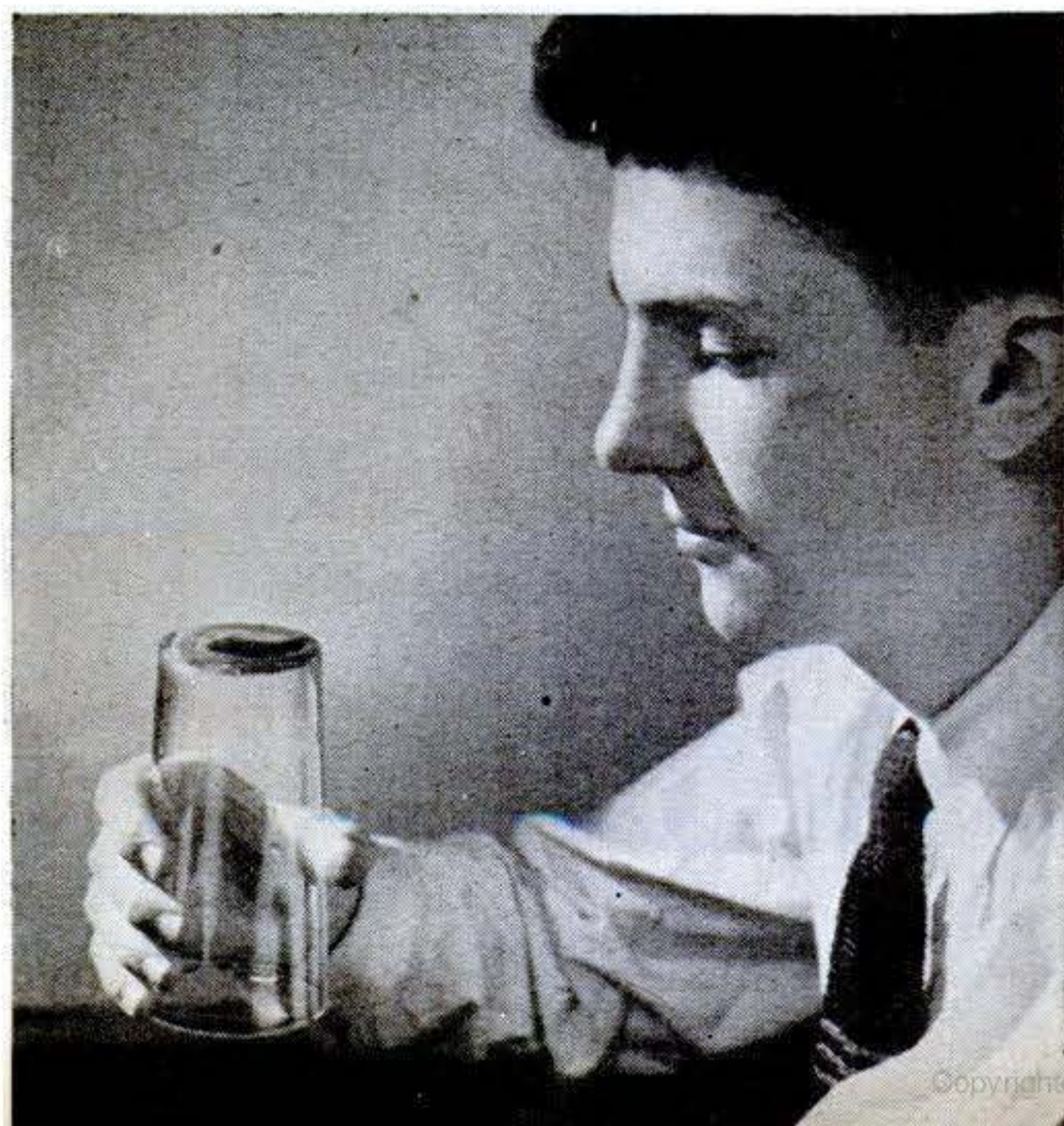



MEET  $H_2O_2$  . . . FIRST COUSIN TO WATER

# Hydrogen Peroxide

By KENNETH M. SWEZEY

NOT SO long ago a cut or bruise always meant a scamper to the household medicine cabinet for the bottle of peroxide. Dabbed or poured on the wound, this watery stuff smarted and fizzed furiously—actions which suggested that every single microbe could do no less than turn up its heels and die.

Scientific research soon proved, however, that the germ-killing power of hydrogen peroxide was greatly exaggerated; that the fizzing was caused by oxygen bubbles released by the catalytic effect of blood, dirt, tissue, and pus; and that in deep cuts such rapid evolution of gas might even cause further injury by tearing the inner tissue.

Because gentlemen (some of them, at least) prefer blondes, women long ago began turning to this interesting chemical as a hair wash. Glamorous "peroxide blondes" are the result. Because it is a strong oxidizing agent, hydrogen peroxide changes the organic pigments of the hair into colorless compounds. The "golden hair washes" now



Drop sulphuric acid into an ice-cold barium peroxide solution until it has been neutralized. This reaction produces hydrogen peroxide.

on the market are chiefly hydrogen peroxide with a trace of nitric acid added.

During the war, 95 percent of all the hydrogen peroxide produced has been devoted to essential civilian industry and secret military uses. The fact that it is distributed in tank-car lots indicates its importance.

Hydrogen peroxide always has been widely used as a textile bleach for it causes little harm to the cloth and the only residue left is plain water. Plants busy turning out cloth for military uniforms require large quantities for this purpose. Cotton cloth, a drab gray when it slides from the looms, is turned a permanent snow white before being made into underwear, shirts, and socks. Raw wool is bleached before being dyed.

Besides textiles, this liquid bleaches many other substances—raw sugar, tripe, fish, figs, furniture woods, casein for light-colored plastic articles, and cow and goat hair used in household items. It helps control the ever-present bacteria in gelatins used for foodstuffs, photographic films, and glue. It

Barium sulphate, which remains after reaction has produced hydrogen peroxide, must be filtered out, as at far left. Ether and an acidified potassium chromate solution in the tube just at left test for  $H_2O_2$ . Even a trace turns the ether dark blue.

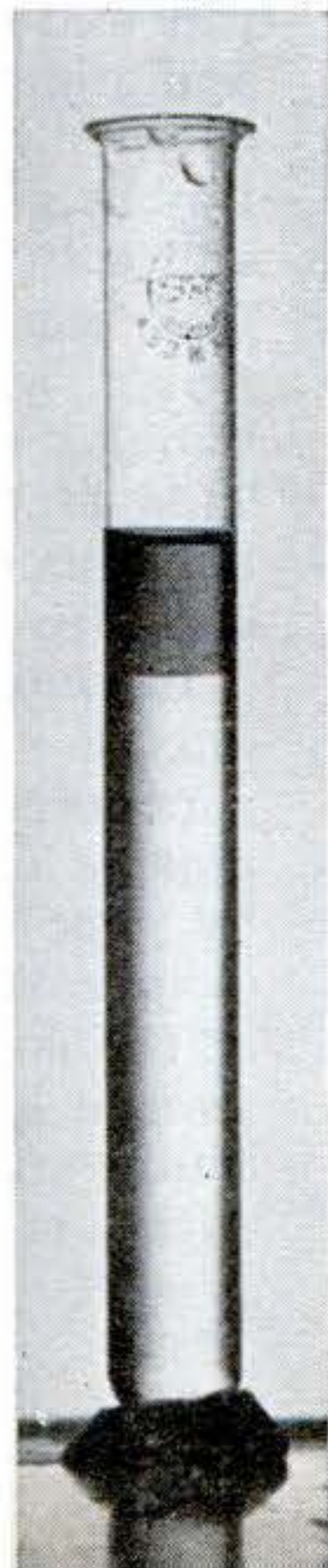
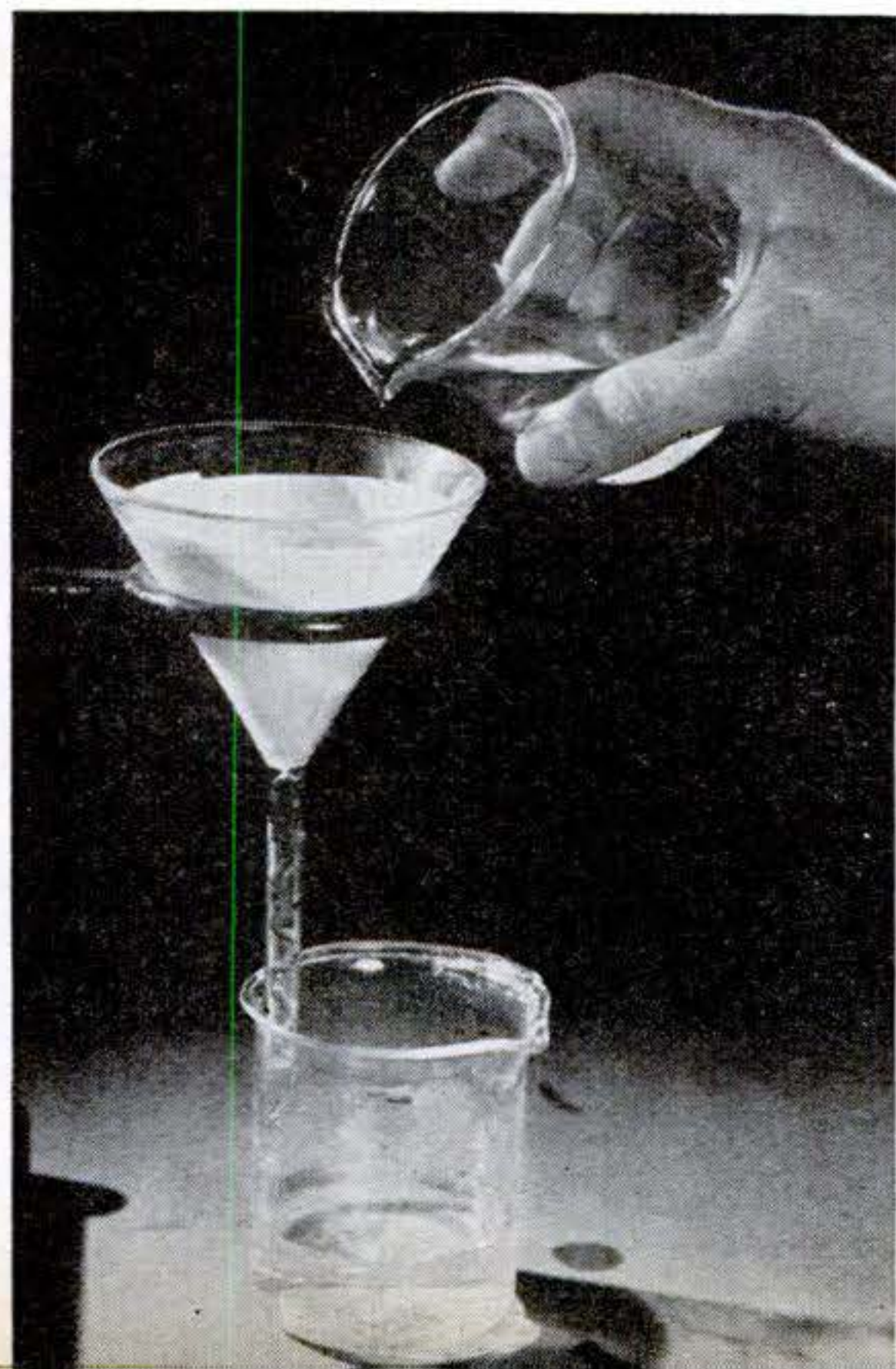



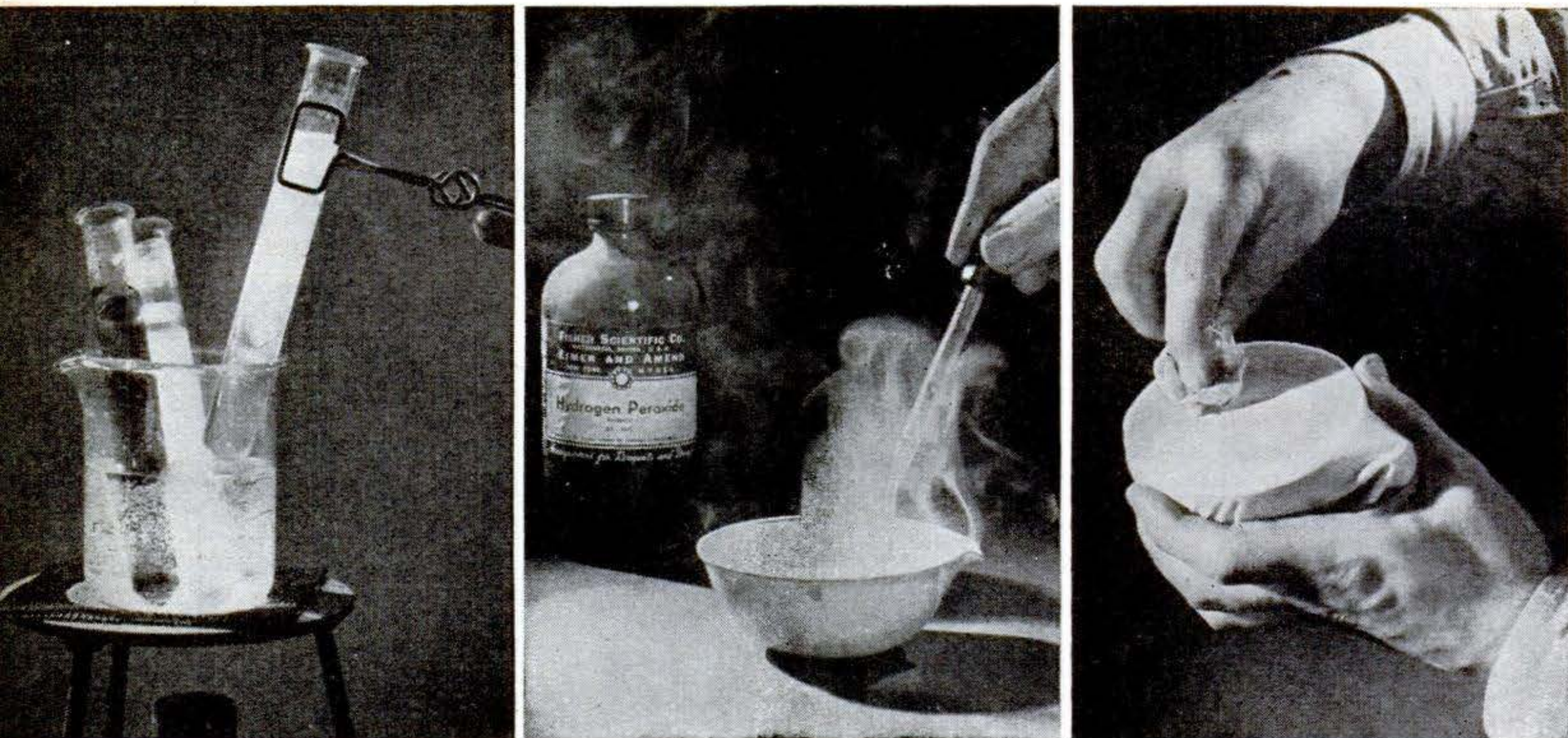

Stand test tubes containing hydrogen peroxide and various catalysts, such as powdered charcoal or chalk, in a beaker of hot water. Oxygen bubbles stream out. Center, a drop of concentrated  $H_2O_2$  explodes when it falls on manganese dioxide. Right, it is used as a bleach to remove discoloration caused by scorch.

purifies various metal salts employed in paint making and electroplating.

Hydrogen peroxide,  $H_2O_2$ , is produced commercially by reacting barium peroxide with dilute sulphuric acid—a process that can be carried out on a small scale in a home laboratory. The reaction must take place at a low temperature to prevent decomposition of the chemical. Put about 100 grams of chipped ice into a beaker, stir in 50 ml. of water, and dissolve in the mixture about 10 grams of barium peroxide and 2 drops of phenolphthalein solution (to serve as an indicator). Dilute 1 part of sulphuric acid with 3 of water, making certain that you add acid to water and not vice versa. Stir this, drop by drop, into the peroxide solution until the pink color disappears.

When your solution thus has been neutralized, it must be filtered immediately to remove the barium sulphate, for this fine precipitate, acting as a catalyst, promotes decomposition of the hydrogen peroxide.

A simple test, so delicate that it detects 1 part of hydrogen peroxide in 100,000 parts of water, will easily prove that you have really compounded  $H_2O_2$ . To a test tube half filled with water add just enough potassium chromate or bichromate to produce a light-yellow color. Also add 5 ml. of sulphuric acid, diluted 1 part of acid to 3 of water. Pour  $\frac{1}{2}$ " of ether on top of this and put in several drops of your peroxide solution. Stopper the tube and shake the contents. When the ether again has separated, you will find it colored the deep blue of perchromic acid, a sure sign  $H_2O_2$  was present.

Pure hydrogen peroxide can be made, but it is extremely unstable and may decompose with explosive violence. Commercially, fairly stable solutions of 30 percent concentration are obtainable. The drugstore variety usually is a 3 percent, or 10 volume, solution of the chemical in water. Ten volumes means 1 of solution will give off 10 of oxygen.

Light, alkalis, manganese dioxide, and many fine substances all promote the rapid breaking up of  $H_2O_2$  into water and oxygen. To demonstrate how readily it parts with its extra atom of oxygen, put a little powdered charcoal in one test tube, some powdered chalk in another, and a little sodium hydroxide in a third. Fill each of the tubes to the halfway mark with hydrogen peroxide and stand them all in a beaker of hot water. Oxygen bubbles soon begin to stream to the top in each of the tubes. But if you now add a little acid to another tube containing hydrogen peroxide and stand this in the hot water, you will notice that few, if any, bubbles are released from the fourth tube. This is because acids and certain organic substances, such as acetanilide, act as *negative* catalysts, inhibiting decomposition.

In contact with powdered manganese dioxide, hydrogen peroxide of 30 percent concentration breaks up with actual explosive violence. You can demonstrate this by placing a little of the powder in an evaporating dish and allowing a few drops of the concentrated chemical to fall upon it from a height of 6" or more. As each drop touches the catalyst, the liquid decomposes with a small explosion, releasing the oxygen



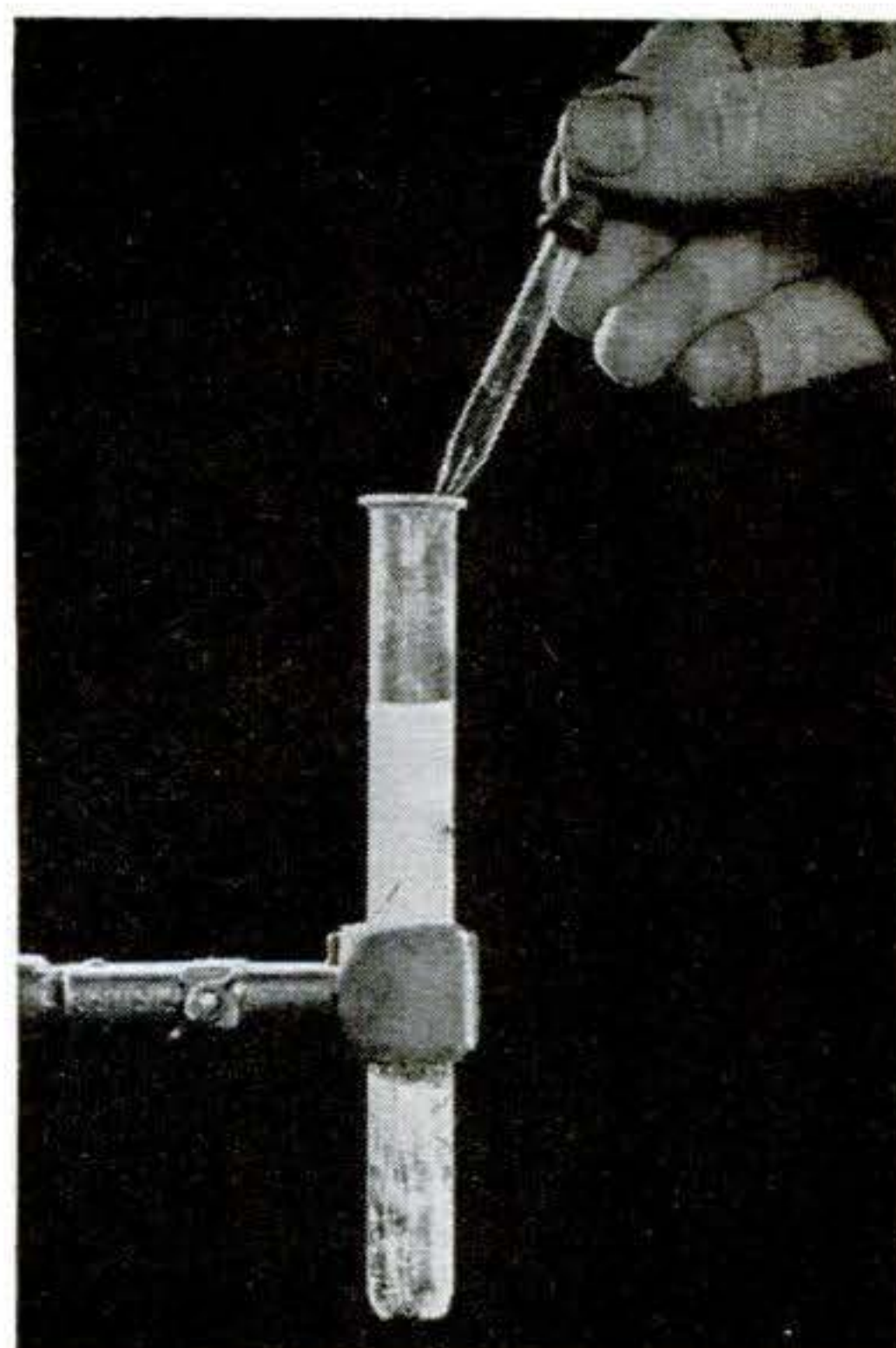

Hydrogen peroxide brushed over lead acetate darkened by hydrogen sulphide restores the original white color, left, as it will when applied to white lead paint. It also functions as a reducing agent. If a few drops are added to a solution of potassium permanganate and sulphuric acid, right, molecular oxygen evolves.

and vaporizing most of the water in a cloud of steam. *Remember that it is dangerous to decompose more than a few milliliters of such powerful hydrogen peroxide at a time. Further caution must be exercised in handling, for  $H_2O_2$  of this concentration will injure the skin almost as badly as acid.*

In the laboratory, drugstore hydrogen peroxide is an excellent source of small quantities of oxygen. A generator is easily made. Put a little powdered manganese dioxide or a warm solution of sodium hydroxide in the bottom of a small flask equipped with a two-hole stopper. Place the stem of a separatory funnel through one hole and a delivery tube through the other. Regulate the stopcock on the funnel so that hydrogen peroxide is admitted drop by drop. Oxygen will issue from the delivery tube.

Under the proper conditions, hydrogen peroxide changes black into white. You can demonstrate this by soaking a sheet of paper in a solution of lead acetate and then holding the sheet in the fumes of hydrogen sulphide—generated by pouring a little dilute sulphuric acid on a few grains of iron sulphide in a test tube. Let the paper dry after it has become completely black. Then paint over the black surface with a brush dipped in peroxide. The black turns white.

This experiment shows why hydrogen peroxide will restore the brightness of white lead paint. Such paint often turns dark because hydrogen sulphide in the air reacts with it, producing black lead sulphide. When hydrogen peroxide is applied, the dark lead sulphide changes into white lead

sulphate. This same principle often is used to brighten old oil paintings.

Around the home, hydrogen peroxide is useful for bleaching out many fruit stains and the color from organic dyes. Scorch marks may also be removed from cloth if they are not too bad. When the spotted or marked article is small, place it bodily into warm 3 percent hydrogen peroxide. Move the article about and inspect it occasionally to note the progress. In the case of larger articles of clothing, dip the spot alone into the solution or saturate a cloth and rub it.

Strange as it may seem, hydrogen peroxide not only is a strong oxidizing agent, but it sometimes is just the opposite—a *reducing* agent, or a substance that robs oxygen from a compound. For example, it does that with potassium permanganate.

Dissolve a grain or two of this chemical in a test tube half filled with water and add a few drops of sulphuric acid. If you now add hydrogen peroxide, drop by drop, to this solution, the deep purple color will gradually disappear. The reaction is accompanied by the vigorous evolution of molecular oxygen ( $O_2$ ), two oxygen atoms joined together. Although the reaction is complex, it has been proved that half of the liberated oxygen comes from the permanganate and half from the peroxide. According to one theory, the nascent or newborn oxygen liberated by the decomposition of the peroxide is so active chemically that it takes oxygen away from the permanganate in order to combine with it and form the molecular oxygen.



# Hints on Closing



By KENILWORTH H. MATHUS

**Y**OU can save yourself inconvenient trips in the early spring, and yet have everything in readiness for the opening of your summer cottage or camp next year, if you go about its closing systematically this fall.

Remove from the water all buoys, mark-

ers, rafts, and temporary wooden docks. Paint them so they will be ready for instant use next summer. Docks built in numbered sections are easy to handle.

Take up and store safely away from ice, snow, and tides all portable wooden boardwalks. Paint small boats and store them upside down off the ground under the cottage or in the garage. This keeps them dry and prevents nesting of rodents in them. Remove from the garage or sheds articles that might be damaged by an unusually high tide, heavy snow, or freshets.

Soak in kerosene and brush with grease all carpentry and garden tools to prevent rusting. Repaint and store lawn furniture, and store flagpole and awning lines.

Wash silverware, glassware, crockery, and cooking utensils. Arrange them in small piles, put each pile in a paper bag, close the bags tightly, and restore the articles to their proper shelves. They will be fresh and clean when you want them again. Wash lamp shades and bric-a-brac and wrap them in newspapers to protect them against fading, tarnishing, and dust. Remove draperies, wash and iron them, and store them or cover them with cloth or pillowcases.

If you have any windows that stick, wax or soap the edges. Then batten down or board up windows or close their blinds, paying particular attention to those on the weather or seaward side. Blinds or hinged battens should not have exposed hinges that can be removed by an intruder armed with a screwdriver. Windows that have no battens and

Antifreeze or kerosene in water traps will prevent damage from winter freezes.

## Cottage-Closing Checks ✓

- ① **PAINT:** Floors, porches, lawn furniture, docks, rafts, and small boats.
- ② **STORE:** Portable walks, buoys, docks, rafts, and small boats.
- ③ **CLEAN:** Garbage can, food containers, lamp shades, and bric-a-brac.
- ④ **COVER:** Glassware, china, silverware, cooking utensils, drapes, pillows, mattresses, vent pipes, chimney, radio, and phonograph.
- ⑤ **EMPTY:** Ink bottles, bread and cake boxes, and match containers.
- ⑥ **OPEN:** Oven, refrigerator, closets, and cupboards.
- ⑦ **SHUT:** Stove dampers and flues, blinds, and outside doors.
- ⑧ **DISCONNECT:** Electricity, gas, telephone, water, and pump.





# Your Summer Cottage

can't be boarded up should be soaped on the inside so passers-by can't see in and be tempted.

Cover cracks around thresholds with old rugs or put molding or temporary weatherstripping on the outside. This is important on the weather or seaward side.

Stop up dampers and chimney flues to keep out rodents, and tie cloth over top openings of vent pipes and chimneys to shut out birds, squirrels, and field mice. Matches, if left at all, should be in a tightly closed tin box for protection against mice.

To protect your pillows against mice and to keep them from becoming musty, they should be suspended at their corners from a line strung across a room. If mouse trouble is especially acute, even heavy mattresses can be suspended from ropes if boards are used to distribute the load and to protect the mattresses from the ropes. Old sheets will serve as covers to keep off the

Carpentry and garden tools cleaned with kerosene and greased will resist rust.



dust. Mattresses can be stored instead in a closet lined with tin to make it ratproof, but if they are they will need airing in the spring.

Leave oven, refrigerator, closet, and cupboard doors open to prevent rusting and aid ventilation. The bread box, cake box, and sugar tin should be washed and also left open. Dispose of perishable food, and clean out the garbage can. Store leftover condiments and spices in airtight tins.



Silverware, glassware, and dishes stay fresh in paper bags. Soaping the windows that aren't boarded keeps passers-by from seeing in.



Empty or throw away bottles of ink and kitchen liquids. Freezing could make them overflow or crack their containers.

If you intend to put the cottage up for rent next year, post in a conspicuous place an instruction card on operation of the water pump, stove, and other equipment. This should also list the name, address, and phone number of the milkman, iceman, garbage man, a plumber and electrician, and a doctor and dentist.

Shut off the water, gas, and electricity, and have the phone disconnected. Put anti-freeze in toilet traps and the like, or have it done by a plumber. Dispose of inflammable liquids and of gas in pressure tanks.

Paint or shellac inside floors, porch floors, and steps. Then you won't have to go through the drying period in the spring.

Leave a key to the cottage with a near-by winter resident or a State police barracks, and arrange with the neighbor or police sergeant to notify you in case of an emergency. Obtain permission to post a sign warning intruders: "This Property Protected by State Police." Post another with your name, address, and telephone number. Then enjoy your winter free from worry.





Citrus trees are fumigated under tents like these to control scale insects with measured dosages of hydrocyanic acid gas. The tents confine the fumes.

Octagonal tentlike canvas sheets are pulled over the trees by the counterbalanced device shown at right. It does the work of two hand-labor crews.

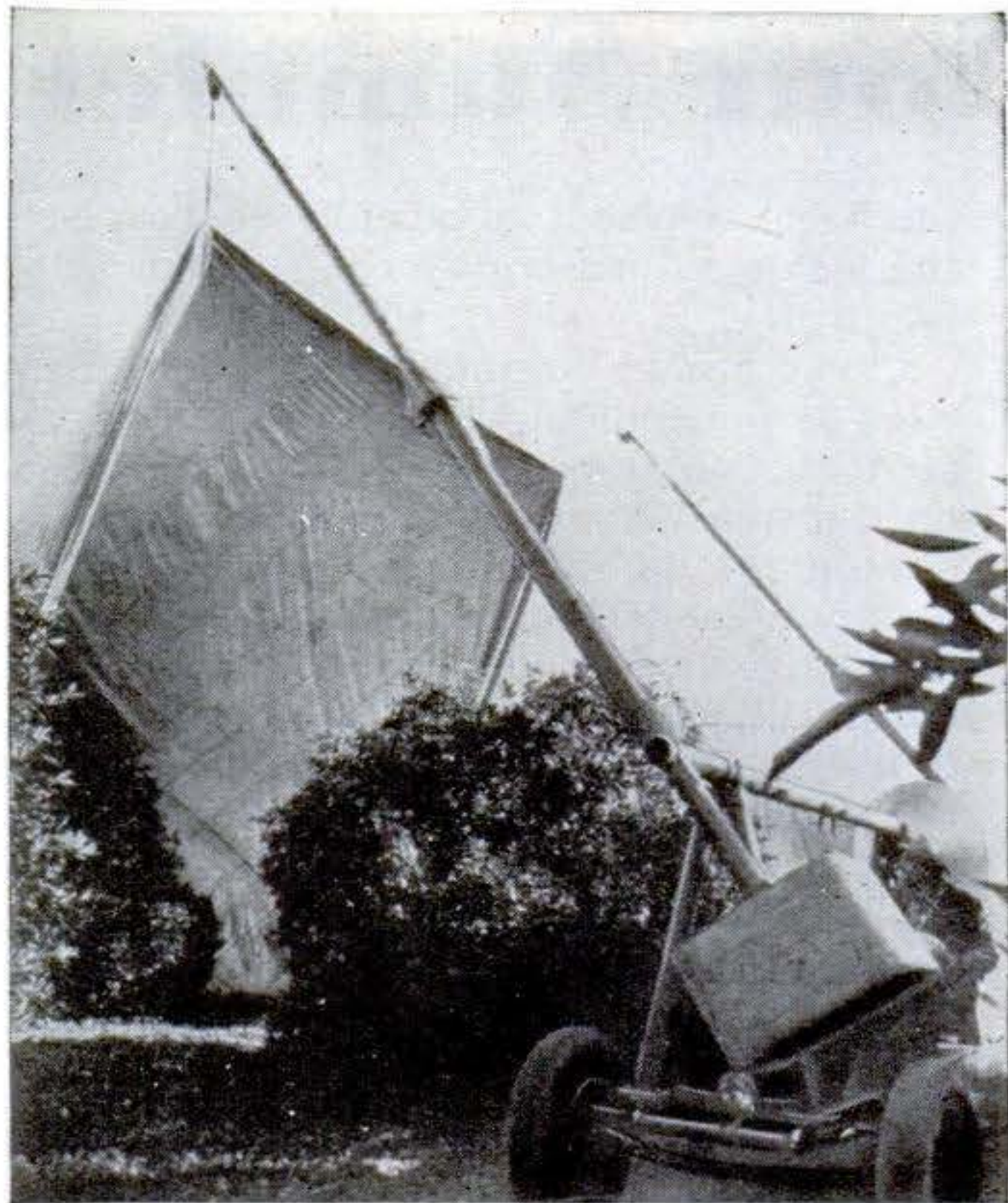

## Mechanical Tent Puller Aids in Fumigation of Citrus Trees

WHERE labor is short in citrus groves, a homemade tent puller like the one shown at right above can aid materially by doing the hardest part of the job of tree fumigation. In use in California, such machines made from scrap have pulled fumigation tents over as many as 50,000 trees per puller a season. A single puller can cover up to 80 trees with tents in an hour.

A number of different types of machines have been devised by growers. Those in use are operated on a tractor or truck chassis and, as a rule, have two long telescoping

arms that lift up, pull over, and lower two corners of the octagonal canvas sheets that serve as tents. Some have a hydraulic mechanism, but the majority have a concrete-block counterbalance pivoting on a horizontal shaft. Truck engines operate the devices by means of power take-offs.

A patent on one mechanical tent puller is held by the American Cyanamid and Chemical Corporation, of New York, which invented the device when labor shortages first struck the citrus groves. It has been released by the company for free public use.

## Caster Elevates Sickle Bar on Mower to Leave Stubble High



TECHNICIANS of the Soil Conservation Service at Elkhart, Kan., developed this adjustable mower caster for leaving a high stubble to combat wind erosion.

The caster shaft, about 4" long with a 60-deg. bend 1" from the lower end, fits into a 6" cast sleeve welded to the inside of the outer shoe of the bar. A take-up collar is installed through the top of the sleeve. The thrust collar at the bottom carries a felt washer. Notches in the coupling to the wheel permit height adjustment. A small trailer or wheelbarrow wheel is used.—ARTHUR W. EMERSON.

## Tin-Can Fruit Picker Reaches High Branches

A NOTCH in the tin can used for this picker cuts the stem of the fruit when the pole is pushed up, and the fruit falls into the cup without being bruised. The cup is emptied into a basket when it becomes filled.—NORMAN ELISBERG.

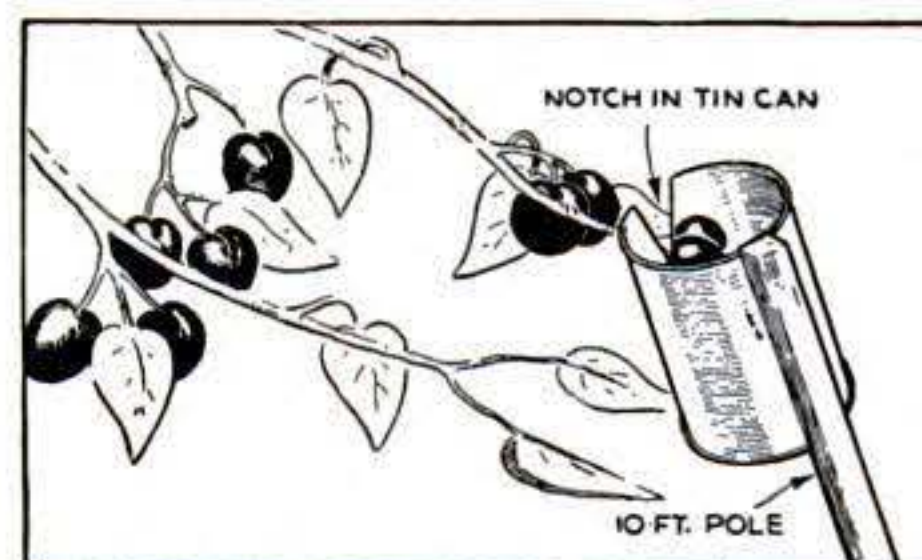



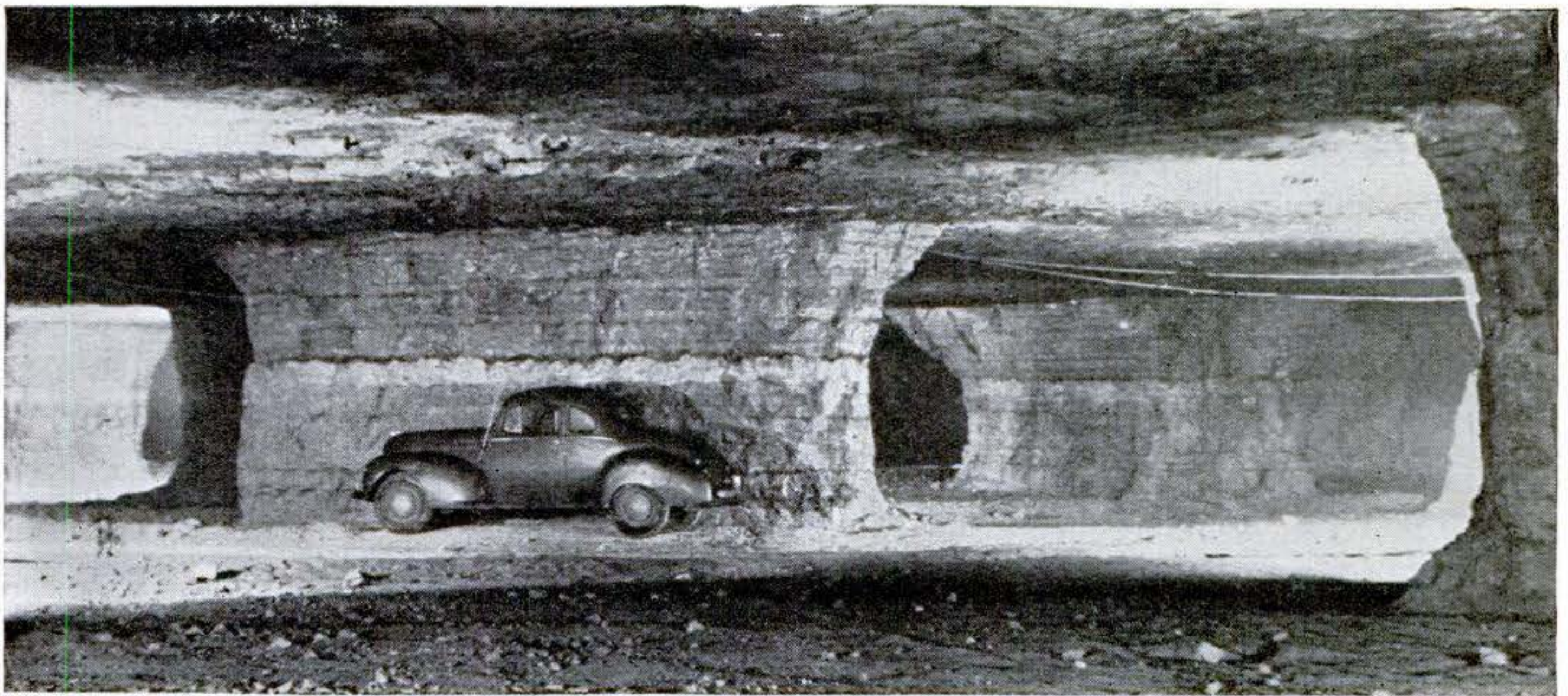

## Uncle Sam's 15-Acre Ice Box

**H**ELPED some by nature, some by limestone miners, and some by modern refrigeration, the United States has the world's largest cold-storage plant. It is a 15-acre underground unit naturally insulated by 100' of earth and stone near Atchison, Kan., not far from the geographical center of the country. Rented by the War Food Administration from the mine company that dug it, it is intended primarily for the storage of such lend-lease and rehabilitation commodities as dried fruits and eggs, cheese, lard, and cured and salt meats.

Nature gives the huge excavation a constant temperature of 55 deg. Three compressors, each having a capacity of 250 tons of refrigeration a day, bring the temperature down to 31 deg. Double doors, like the storm doors on homes but further apart, keep cold air in and hot air out. They are opened and closed by an electric eye.

Storage capacity is from 30,000 to 50,000 tons depending on the density of the food. This void is filled from processing plants throughout the Midwest. Delivered by rail, food is put on 4' by 4' wheeled platforms for transportation to the mine.

Gasoline mules draw huge quantities of foods to the door of this underground cold-storage plant, and electric engines do the rest to prevent fumes.

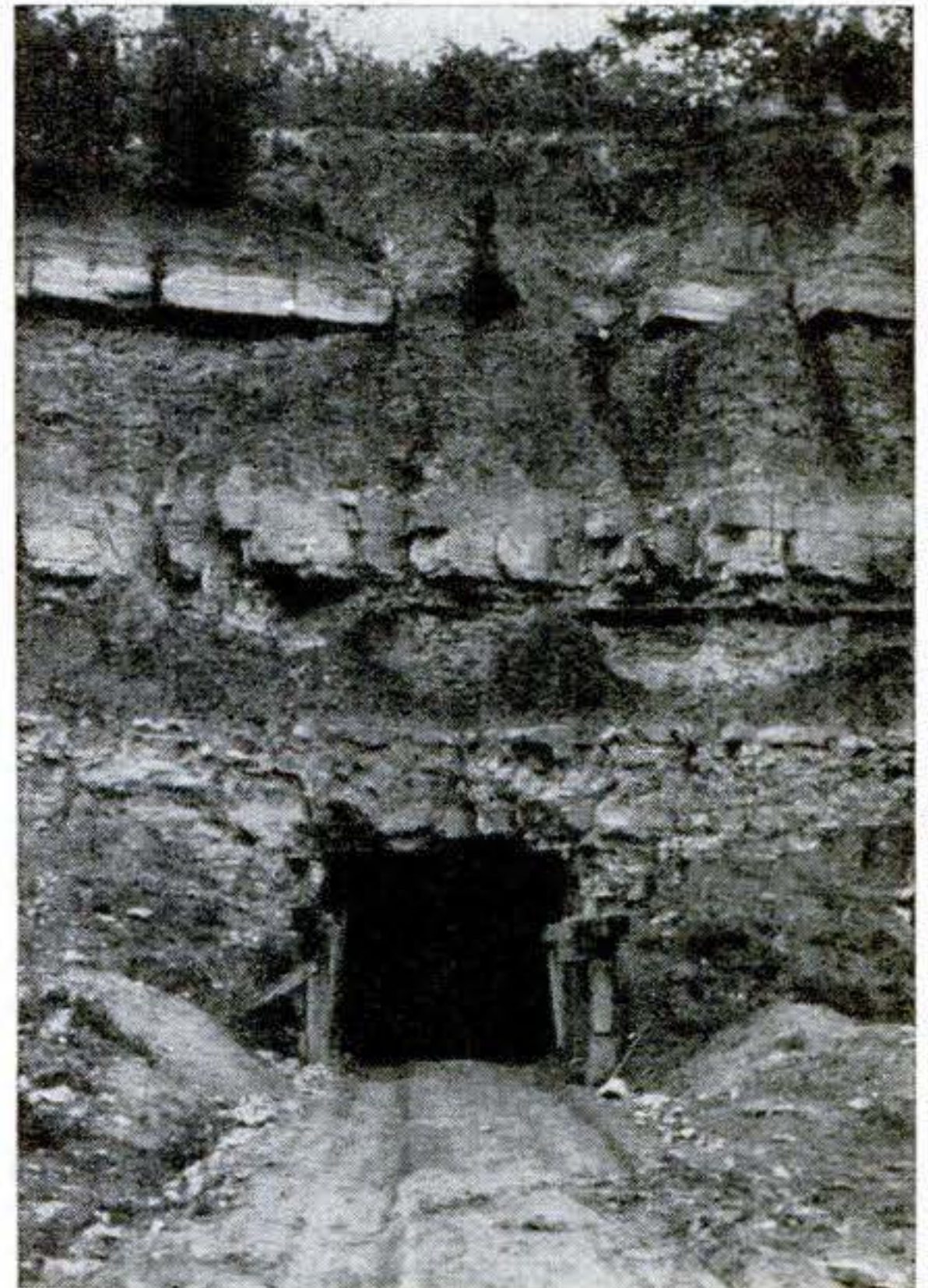

This door to the huge Kansas cave is controlled by an electric eye. "Storm doors" keep the cold in. Below, freight cars unload food for storage.

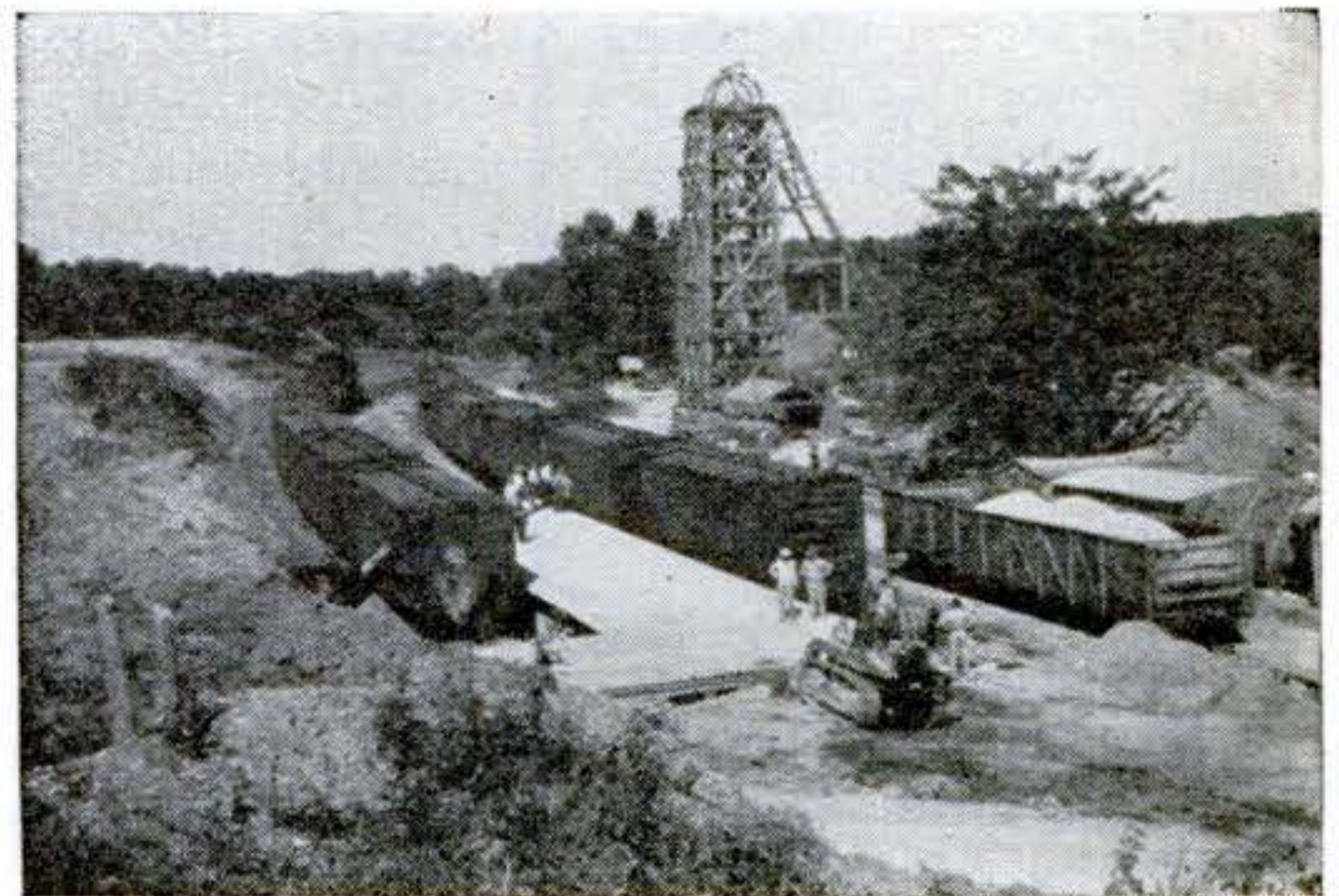



# Beach Busters: the LVT's

(Continued from page 124)

steep for land tanks. A high bumper bar, compared to that of a tank, gives the amphibians enough leverage to push over trees up to eight inches in diameter—a useful trick to clear ground for artillery aiming stakes. Armored amphibians make mobile fieldpieces. And although theoretically no match for tanks in combat, even amphibious tractors are unofficially reported to have destroyed Jap tanks.

The 21-foot, eight-ton Alligator was the first Amtrac to see combat action, taking part in the initial assault upon Guadalcanal on August 7, 1942. When the Japs got their first glimpse of these awe-inspiring machines crawling in from the sea, their dismay may well be imagined. According to a Marine officer who led one of the first waves of amphibians, the Nipponese departed precipitately and the Amtracs landed without appreciable opposition.

No one could expect a perfect amphibian on the first try, but the Alligators proved themselves so well in subsequent actions that many are still in use. Meanwhile, improved models had answered obvious demands for more size and power.

These were the LVT (2), the Water Buffalo, 26 feet long and of 14 tons, which first hit the Japs at Bougainville on November 1, 1943, and the first U. S. armored amphibian, the LVT (A) (1), which first saw action at Kwajalein, on February 1, 1944. Designed solely for fighting, this six-man vehicle bore the closest resemblance to a seagoing tank. The 18-tonner, armed with a 37-mm. gun, carried machine guns as well. Heavier armor protected the crew.

Combat experience, not theorizing, dictates changes in models. For example, men of the Alligators and Water Buffaloes had to disembark by leaping over the sides of the machine, and unload cargo the same unhandy way, while exposed to enemy fire. Thenceforth, Amtracs were fitted with built-in stern ramps. Impervious to the sea, the rubber-sealed platforms were readily lowered when the craft got ashore, making an easy task of unloading cargo and enabling troops to deploy under cover of the vehicle.

First of these ramp-type amphibians to introduce itself to the Japs was the LVT (4), an enlarged and improved Water Buffalo, 26 feet long, a ton or two heavier than its predecessor, and carrying an infantry platoon of 32 to 45 men, or a land-type jeep, or a sizable fieldpiece, complete with crew. It was the second unpleasant surprise of the day, June 14, 1944, for the Nipponese defenders of Saipan in the Marianas. The

first had been an advance assault by our latest armored amphibian, the LVT (A) (4)—a 20-ton fighting machine with a crew of five and a 75-mm. howitzer for its principal armament. Its shells, each measuring a shade under three inches in caliber, can be aimed to sail over ridges surrounding a beachhead and plop down among Japanese concentrations detected by aerial reconnaissance.

Military machines don't always appear in the same order as their model numbers. So it was with the LVT (3), a beautiful piece of engineering, which remained under wraps while the LVT (4) and other Amtracs led the march across the Pacific and some ferried American armies across the Rhine. Then, last Easter Sunday, the Bushmaster went into combat at Okinawa, with the result already described.

About equal to the LVT (4) in tonnage and capacity, a little shorter and beamier, the Bushmaster differs from the Water Buffalo in one outstanding respect. Its driver has practically been relieved from the tricky business of shifting gears in climbing a reef, a beach, or a hillside. For the LVT (3) employs a fluid transmission, similar in principle to those of modern cars, and automatically changes gears to suit the "road."

In round numbers, America has built something over 15,000 LVT's, according to best available estimates. Many more, and for new uses, are due.

Unarmed and unarmored, modified Water Buffaloes and Bushmasters are scheduled to appear soon. They will form the last link of our vast transportation system for reinforcements and supplies across the Pacific, to the forward combat zone where fighting amphibians take over.

Already talk is heard of odd postwar uses for demilitarized amphibians—ferrying logging equipment to hitherto inaccessible timber lands, or leading expeditions in search of rubber, quinine, and valuable minerals. For a while, these fascinating speculations must wait. The amphibians have another job to finish first.

**Subscribers in the armed services who notify us of change of address are requested to give us the key symbols appearing on the wrapper in which the magazine is received.**



# A Flying Vacation *(Continued from page 135)*

"LAWRENCE." An arrow under it pointed south.

"But that can't be the direction of the airport," said Groenhoff. "It doesn't agree with the map."

We found the airport, after a hunt, a quarter of a mile away. The sign on the barn top pointed to the town of Lawrence. It was for motorists.

Gradually it was dawning on us why the grass airports for private flyers scattered throughout the country were, by and large, unmarked. The local operators on them, who doubled in brass as airport managers, made their money by selling instruction time and retailing airplanes. They weren't accustomed to itinerant traffic. They were penny-wise and pound-foolish. What good was it going to do them to teach people to fly and to sell airplanes if the planes couldn't go somewhere in safety?

Yet, with one exception—at a field run by a bilious, aging gentleman who didn't want to be bothered—every one of the operators went out of his way to help us. The Hutchinson man called the weather station for us. The wife of the man at Lawrence argued on the telephone until she got us a hotel room. The operator at Garden City took us sightseeing in his car. The one at Du Bois, Pa., drove us into town for lunch, and the one at Chicago left one of his own planes out in the open overnight to give us hangar space.

On our last lap but one to Chicago I warned Groenhoff, at the controls, "Someone may have thrown a switch at the next railroad crossing. Watch out or you'll get off on the wrong track." He grinned.

We crossed a crossing. Five minutes later I glanced at the compass. "Where do you think you're going?" I asked.

Someone, sure enough, had thrown a switch. It took us ten minutes of diving on railroad stations to see if we could read the signs, of map study and radio-beam orientation, before we got back on course.

I directed him to an airport. "Where are we?" he asked, as we landed for fuel.

"Burlington."

"Burlington what?"

"Iowa."

"How did we get into Iowa?" When you fly several hundred miles between stops, your geography gets mixed up.

At Chicago we had to hunt for the airport for only five minutes. It was a record.

At Sandusky, Ohio, we swooped down on one of the finest private flying fields that we encountered in the whole trip.

"But why don't you put a big white circle on the field?" I asked the manager. "It would be good for business."

For answer he beckoned us into his car. He drove out to the center of the field. There was a circle there, all right. Time had dimmed it.

"As soon as I can get help," he said, "that circle will be fixed up."

The radio battery was going dead. We stopped at Cleveland for a new one. Jim Borton, manager of General Airmotive Corp. and an old friend, shook his head. The war, he said.

"I don't relish flying over the Alleghenies without a radio," I told Groenhoff. "You did it two weeks ago," he reminded me.

That Canadian air had moved east. The ceilings were lowering. Over mid-Pennsylvania I was doing the flying. Groenhoff was navigating.

"Let's get down," I said. "The stuff is on the mountaintops."

"There's an airport three miles ahead of us," said Groenhoff. What a navigator! We put in at Du Bois and waited for the stuff to lift.

The clouds went up just enough, no more. It was touch-and-go flying. Bits of cloud whipped by the wings. I flew generally eastward but dodged here and there, looking for clear spots in the sky.

"Go ahead," said Groenhoff. "Fly where you want to. I'll follow you on the map." If you don't think he had a hard job, try it some time.

Presently he said, "This next ridge is the last big one. We'll hit a series of nice valleys. It will be clear sailing from there on."

It was, too. Spasmodically the sun came out. I rocked the wings and did rollercoasters with the elevator.

"We never could have gone as far as we did in so short a time in an automobile," I said.

"It is generally conceded," replied Groenhoff, "that an airplane is faster than an automobile."

I looked across at him. He was sober-faced.

In our two weeks' air vacation, we had covered 3,430 miles in 52 hours and 20 minutes of flying time—which gave us an average travel speed of 65½ miles per hour. The costs chargeable against the plane (fuel, oil, hangar rent, repairs, phone calls, and taxi or bus fares) came to \$123.28. That made the operating cost per mile a little less than four cents—two cents for each of us. A bargain, we called it.



# Evolution of the Machine Gun *(Continued from page 119)*

manufacturers. The Lowell, a short-lived type, followed the Gardner. In 1885 Hiram Maxim displayed his machine gun, which was followed by the Hotchkiss.

The Maxim introduced several revolutionary features to the automatic-weapon field. The action, for the first time, was completely automatic. The gunner merely pulled the trigger; the weapon fired, recoiled, ejected the spent round, reloaded—and repeated the performance as long as the ammunition was fed.

Another feature of the Maxim was the single barrel. A water jacket completely surrounded this one barrel and cooled it. Combined with these developments was a new-type feed. All feeds previous to the Maxim had depended upon gravity, but this weapon took its shells from a canvas belt which ran through the action from a box. This combination of water cooling and belt feeding increased the sustained rate of fire. The Maxim was the forerunner of modern automatic weapons.

Closely following the Maxim, John M. Browning developed the Colt Browning automatic gun, which was adopted by both the Army and Navy and was used extensively during the Spanish-American War. The Browning was an air-cooled weapon. It used the gas of an exploding cartridge, which was diverted through a small port in the barrel, to drive a piston sliding in a cylinder attached below and parallel to the barrel. This, in turn, actuated the operating mechanism. This American weapon also was used by most of the European nations.

In 1906 the Schwarzlose machine gun, manufactured in Austria, was hailed as an innovation in automatic arms. It was modeled after the Maxim gun, but was greatly simplified.

The Lewis gun, invented by an American Army officer, was adopted by Great Britain as one of its standard machine guns in 1909. Improved models are still in use today. One of the first light machine guns, the early Lewis weighed 25¼ pounds and could be fired from the shoulder. A 49-round magazine fed the weapon, which had as one of its outstanding features a type of "forced draft" cooling of the barrel. The Vickers machine gun and the Bren gun are also used by the British Army.

Paralleling the Lewis gun was the Madsen, invented in Denmark, weighing only 15 pounds. This weapon was seriously considered for use by the American Army in the 1920's.

During the years preceding America's

entry into the First World War, it became increasingly apparent that the United States needed automatic weapons of its own design. The line of Browning automatics was the answer. The Browning Automatic, or BAR, was similar to the Madsen but has proved superior. The second of this family was the Browning water-cooled machine gun, which was the standard heavy machine gun of this country in the First World War, as it still is today.

The M1919A4 was the fourth of the series. A heavy barrel, surrounded by a ventilated jacket, dissipates heat fast enough to fire comparatively long bursts without burning out the riflings. However, it cannot fire for as long periods as can the water-cooled models.

The Browning .50 caliber machine gun completed the balanced automatic-weapons group. This long-range, heavy-hitting weapon helps to make America's warplanes among the most heavily armed in the world. Other models with longer barrels are mounted on trucks and half-tracks to battle enemy aircraft attempting to strafe motor columns and beachheads. Water-cooled models hurl luminous streams of tracers from antiaircraft mounts on ships at dive-bombing pilots.

These are by no means all the automatic weapons in America's bag of fighting weapons, but they are the basic types.

The Japanese have developed a complete line of automatic weapons. They are named after their inventor, Nambu—who, incidentally, picked up some of his ideas from foreign arms. Many of the weapons used by the Nips were captured at Singapore, Hong Kong and Manila, and the weapons of almost every nation have been found on Pacific battlefields. For lightness and efficiency in jungle areas the Japanese weapons are considered good, but in obtaining this lightness the Japs sacrificed hitting power. They began a late change-over in their weapons from the .256 caliber to .303, which is slightly larger than the American .30 caliber.

Development of the machine gun has faced certain limitations. These are primarily cooling and ammunition supply. The water-cooled barrel and the air-cooled barrel are at present the only answers to the problem of overheating.

The trend in automatic arms is toward lightness and mobility. The earlier weapons strongly resembled the cumbersome artillery of the time, while today's machine guns are streamlined and light enough for both jungle and mountain warfare.



# Outwitting the weather



How science copes with Old Man Weather is illustrated by these ideas and devices from General Electric laboratories.

How high are the clouds? A ceilometer measures this for airmen. How wet is the weather? A fungus farm in a G-E laboratory helps design military equipment to resist fungus in the world's wettest areas.

On this page are a few more examples of the way General Electric research and engineering are being devoted to this phase of human comfort and health. *General Electric Company, Schenectady, N. Y.*

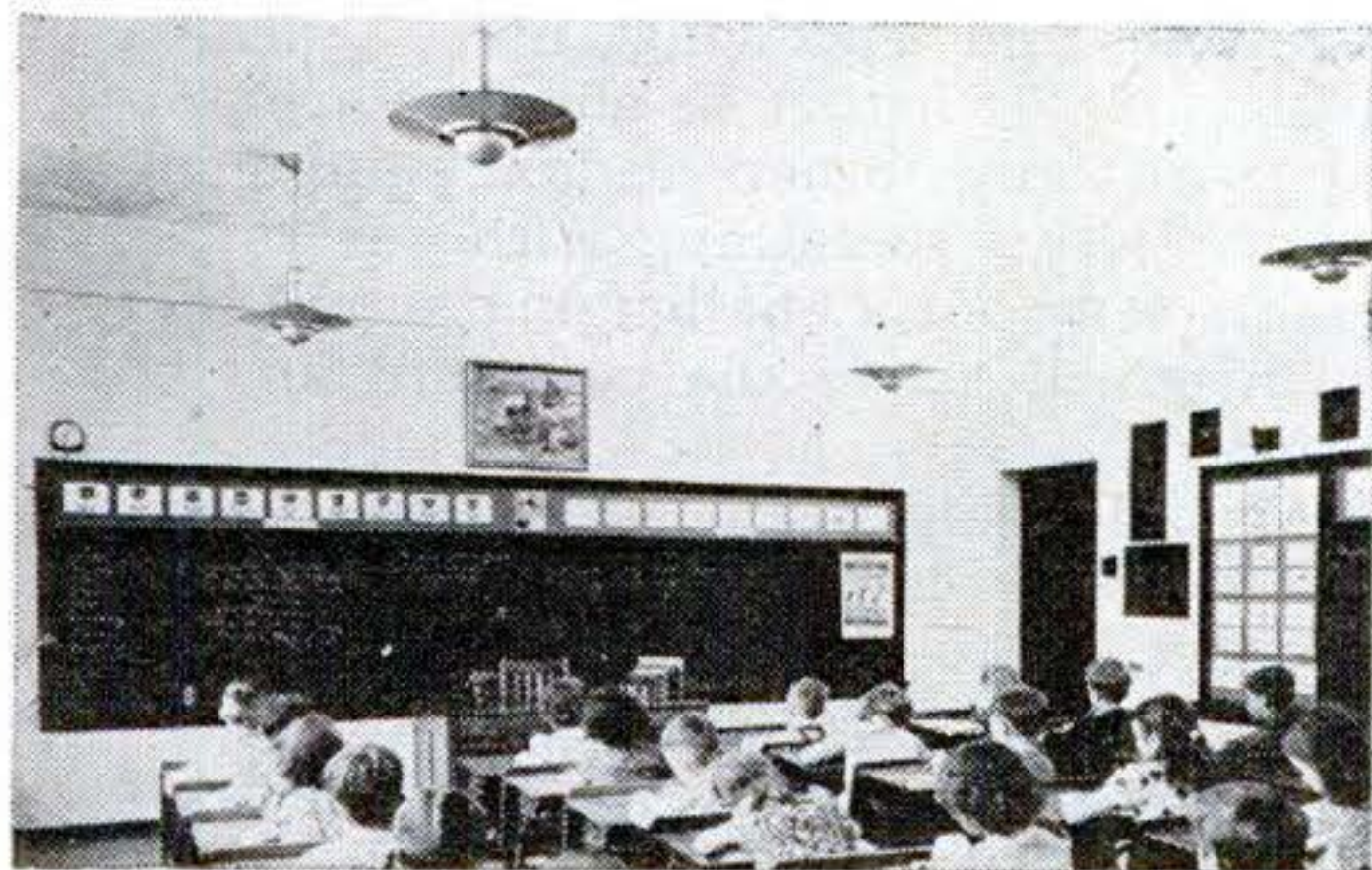

**Cloudy but bright.** When clouds darken the sky, lights come on in this schoolroom. No one has to remember; a General Electric automatic light control with an "electric eye" keeps constant watch on daylight, safeguards young eyes by turning on the lights whenever they are needed.



**Cucumber magic.** Vines in electrically heated soil (right) grew twice as tall, and bore one month earlier. The heating cable, developed by G-E engineers, is buried in the soil and thermostatically controlled. More than 15,000 commercial growers use G-E soil-heating cable.

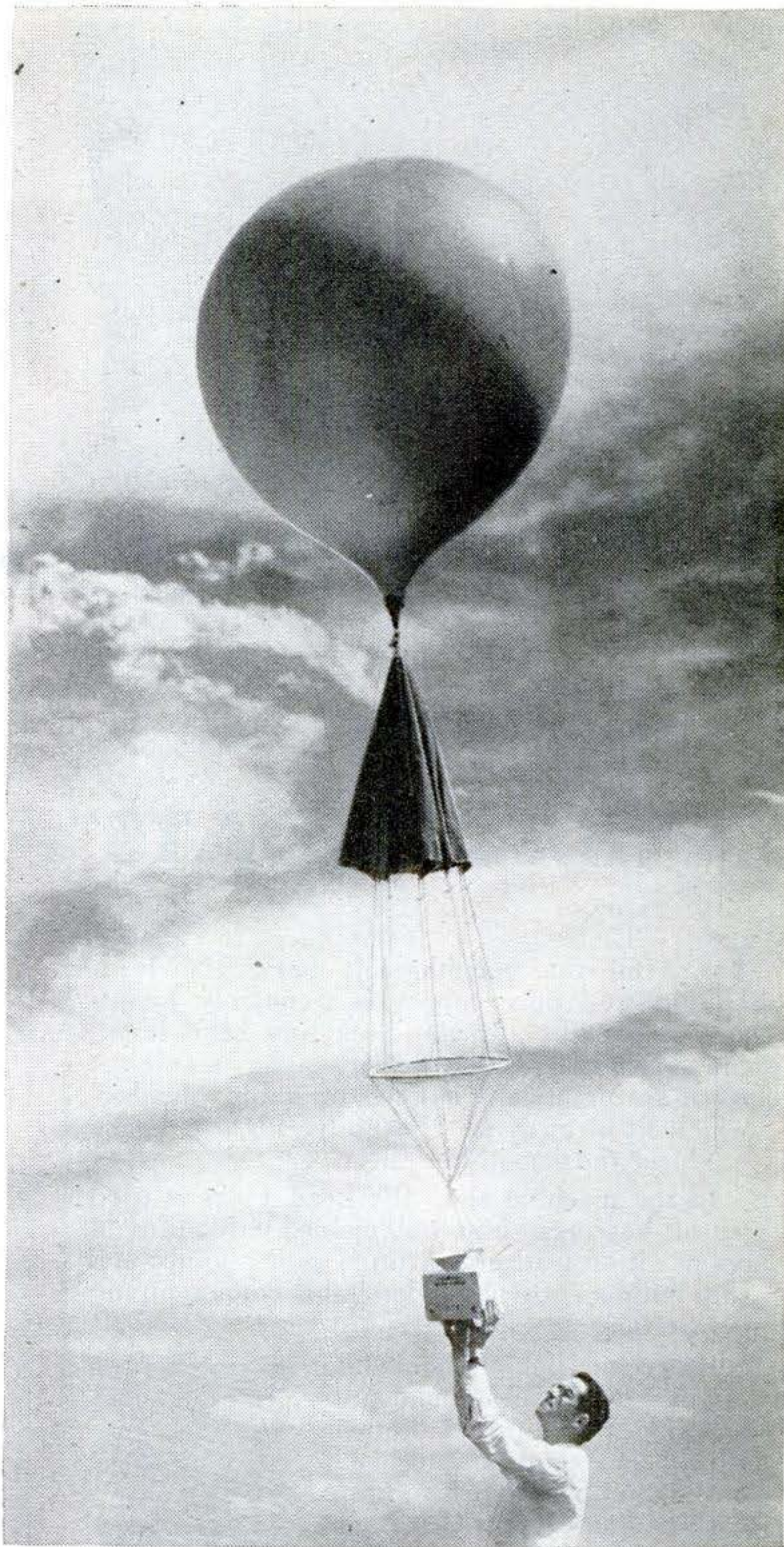

**Weather detective** goes aloft in the small box suspended from the balloon. Some 12 miles up the balloon bursts, and the box is parachuted back to earth. On the way up, this electronic device, called the G-E Stratometer, gives a running commentary on the weather—temperature, humidity, air pressure—and sends this information back to earth by radio signals. The information gathered by the G-E Stratometer can be used to help predict the weather.

★

Hear the G-E radio programs: *The G-E All-girl Orchestra*, Sunday 10 p. m. EWT, NBC—*The World Today news*, Monday through Friday 6:45 p. m. EWT, CBS—*The G-E House Party*, Monday through Friday 4:00 p. m. EWT, CBS.

**FOR VICTORY—BUY AND HOLD WAR BONDS**

**GENERAL  ELECTRIC**



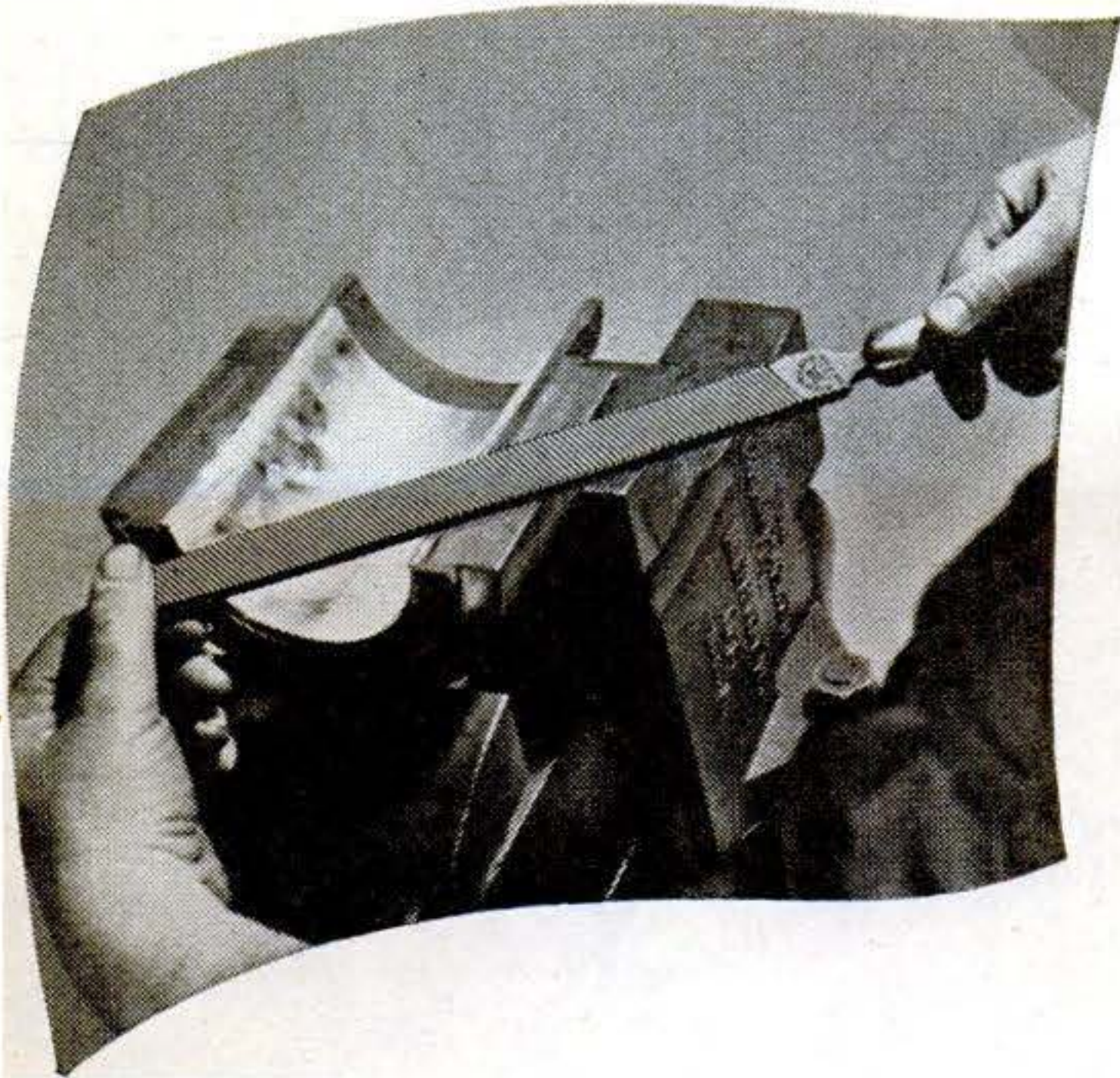

## THE FILE THAT "FLOATS"

**Y**ES, a file that smooths soft metals like lead, babbitt and pure copper is commonly known as a "float file." In the Nicholson Lead Float, the extra-coarse, extra-short-angle, single-cut teeth are practically a series of stubby "blades" which shear away metal rapidly. Light pressure produces the smoothing effect.

In the machine shop the Lead Float is used on soft bearings, shims and molded parts. Plumbers use it on lead pipe fittings, solder joints, etc. Ship-builders use it on lead and copper piping installations.

Every mechanic should be familiar with this special purpose file. . . . In Nicholson or Black Diamond brand he'll have it in unvaryingly accurate cut and finest quality. It is one of many special purpose files with which Nicholson is helping to speed industrial production and increasing mechanics' efficiency and earning capacity.

**FREE BOOK, "FILE PHILOSOPHY"**—for master mechanics, shop foremen, production and purchasing heads—on kinds, use and care of files. 48 illustrated pages.



**NICHOLSON FILE CO., 19 Acorn Street, Providence 1, R. I.**  
(In Canada, Port Hope, Ont.)

**NICHOLSON  
FILES** FOR EVERY  
PURPOSE



## Radar Sees the Invisible

*(Continued from page 71)*

bombers could be detected soon enough for defending fighters to intercept them. After the fighters took off, they had to be guided along a course of collision or interception so that they could find the bombers in the dark. During the Battle of Britain, the night fighters did their best work after making visual contact by the light of the moon or in the reflected glow of burning London.

In the Black Widow episode at the beginning of this article, part of the trick was identification. An airplane or ship looks the same in the radar operator's scope, or "scan," whether it is friend or enemy. This uncertainty is eliminated by auxiliary radar apparatus known as "IFF" (Identification of Friend or Foe). All Allied aircraft and vessels carry a specially designed radio transmitter and receiving unit called a "transponder," whether or not they are provided with any other radar equipment. When we detect something with our radar, operators send out a challenging signal that says, in effect, "Give the password and be recognized."

This challenging beam enters the receiving unit of the plane or ship being queried and passes on to the transmitting unit to spring a triggering device. The automatic action causes a friendly plane's transponder to emit a series of properly coded signals which are picked up on the challenger's scope. If it is the right code of the day, or the hour, a certain pattern is then formed on the scan of the questioning radar set. If no pattern, or the wrong one, appears, the detected object is considered hostile.

IFF sets can also be used as an aerial guide or beacon to lead other planes without the enemy's knowledge. By setting a switch, the RO causes the transponder to send forth a series of steady signals that say to other planes—merely through the pattern on the scan—"Come here," or "Follow me." Craft tuned to the proper frequency can "home" on this plane just as they would head toward a beacon on the ground. Thus, it is possible for a pathfinder or a formation leader to beckon other planes to the spot where he locates the enemy fleet in hiding without tipping his hand to the foe. When a pilot is forced down, this homing signal can also be used to attract rescuers.

Paratroopers and glider units use a condensed version of IFF for landings in hostile country. A pathfinder transport locates the most suitable drop zone and one or two paratroops are dropped carrying with them

*(Continued on page 214)*



# LIGHTER MOMENTS with fresh Eveready Batteries



"Which one of youse guys is 'cutie-pie'?"

"EVEREADY" No. 6 Dry Cells continue to provide dependable power for the vital field telephone equipment of our Armed Forces.

But you'll be glad to know they are available in increasing quantities for civilian use—fresh, full-powered, long-lived as always. Ask for them at your dealer's now.

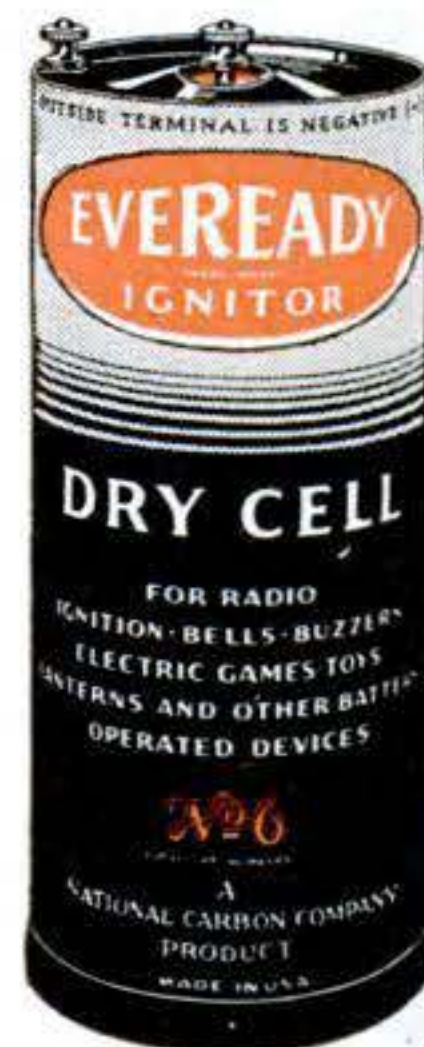

*Let's get the Jap—and get it over!*

# EVEREADY

TRADE-MARK

The words "Eveready" and "Ignitor" are registered trade-marks of National Carbon Company, Inc.



# Foundry for Featherweights

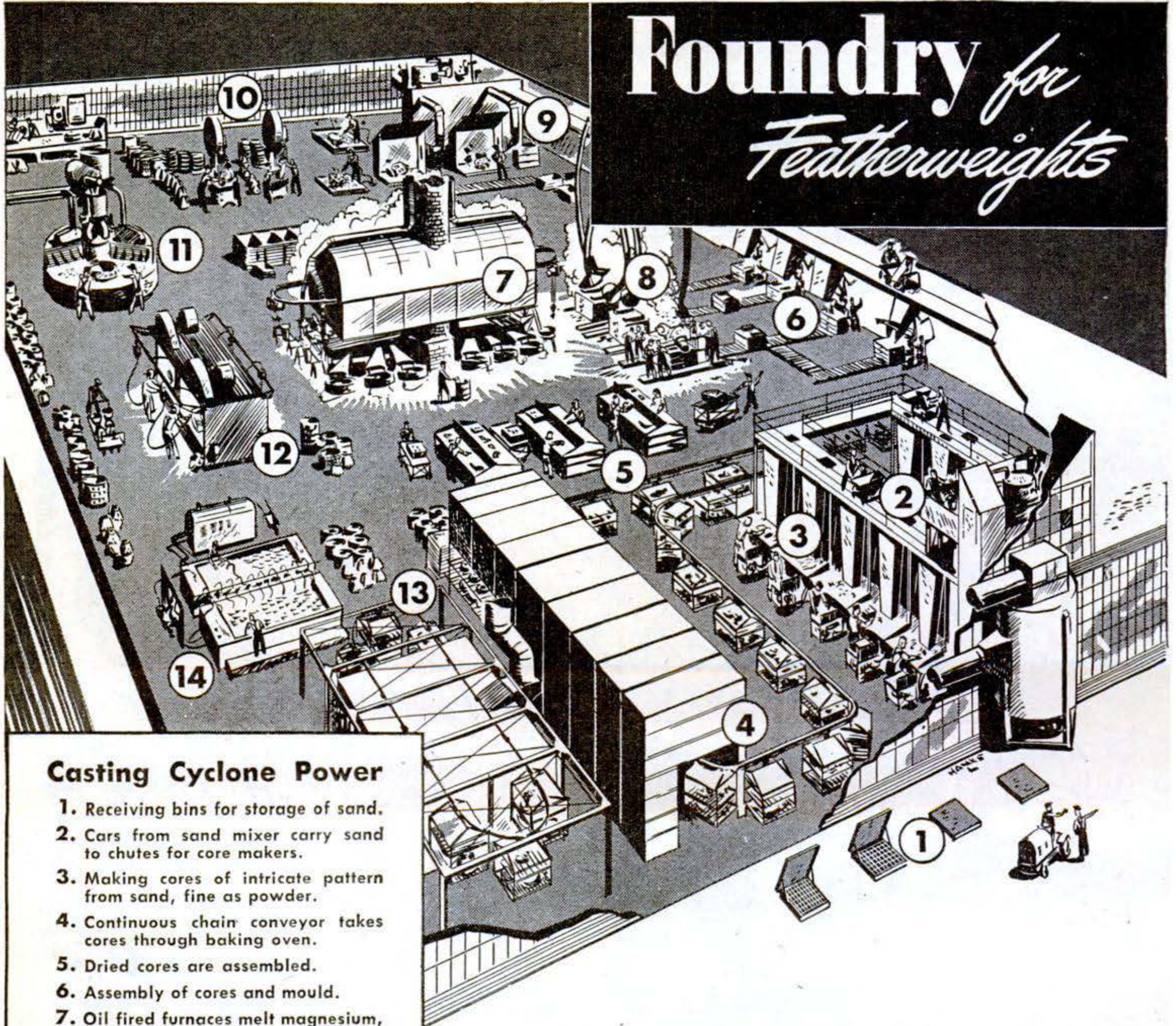

## Casting Cyclone Power

1. Receiving bins for storage of sand.
2. Cars from sand mixer carry sand to chutes for core makers.
3. Making cores of intricate pattern from sand, fine as powder.
4. Continuous chain conveyor takes cores through baking oven.
5. Dried cores are assembled.
6. Assembly of cores and mould.
7. Oil fired furnaces melt magnesium, kept covered with "flux" of borax and sulphur to prevent burning.
8. Pouring molten magnesium at exactly controlled temperatures.
9. Shake out screens remove casting, also sand for reclaiming.
10. Saw cuts excess metal from casting.
11. Sand blasting, casting inspection.
12. Burring and grinding rough spots and inspection.
13. Conveyor takes castings through heat treating furnace.
14. Compressed air test under water checks any possible flaws and cracks.

Magnesium is a metal one third lighter than aluminum, strong as iron. In this Wright Aeronautical foundry, it is melted and cast into parts for Wright Cyclone aircraft engines.

On a bomber powered by four Wright Cyclones, use of magnesium saves enough weight to add two extra gunners, or 75 more incendiary bombs, or two additional barrels of gasoline for more range.

A pioneer in casting magnesium, Wright Aeronautical uses this metal as one more means of adding speed, range and load to planes by building powerful engines without dragging weight.

## Send for "ENGINOLOGY"—25¢

Learn more about aviation's source of power. Enginology explains supercharging, combustion and engine principles in non-technical terms; describes their relation to planes and propellers. Just send 25 cents in U.S. coin to:

Wright Aeronautical Corporation  
Dept. PS, Paterson 3, New Jersey

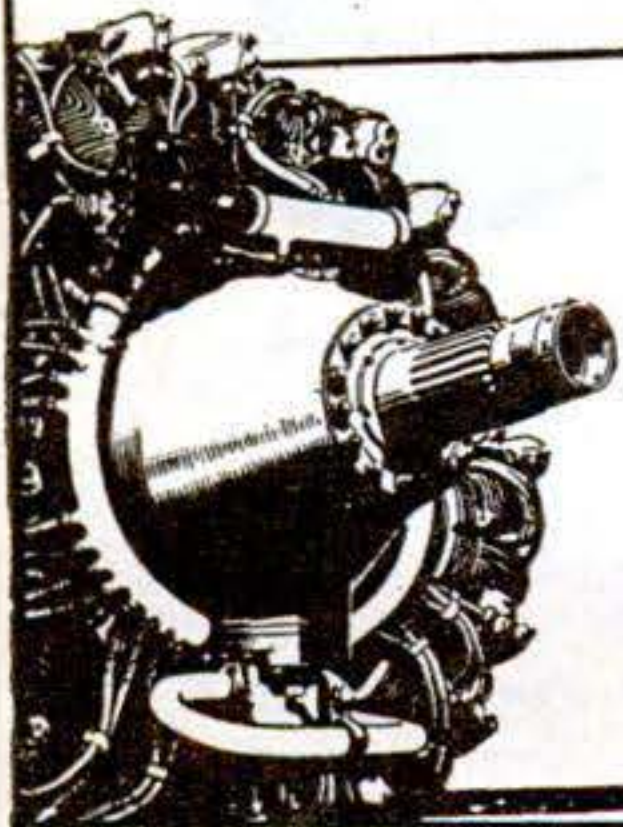

# WRIGHT

## AIRCRAFT ENGINES

DIVISION OF

CURTISS  WRIGHT

FIRST IN FLIGHT



# Here's how your car feels after MARFAK chassis lubrication

**THE REASON WHY:** Texaco Marfak lubricant provides a tough, adhesive film that cushions chassis bearings against road shocks, increasing the riding comfort of the car and adding substantially to its life. Marfak maintains its consistency at the outer edges of the bearings, sealing itself in and sealing out grit and dirt.

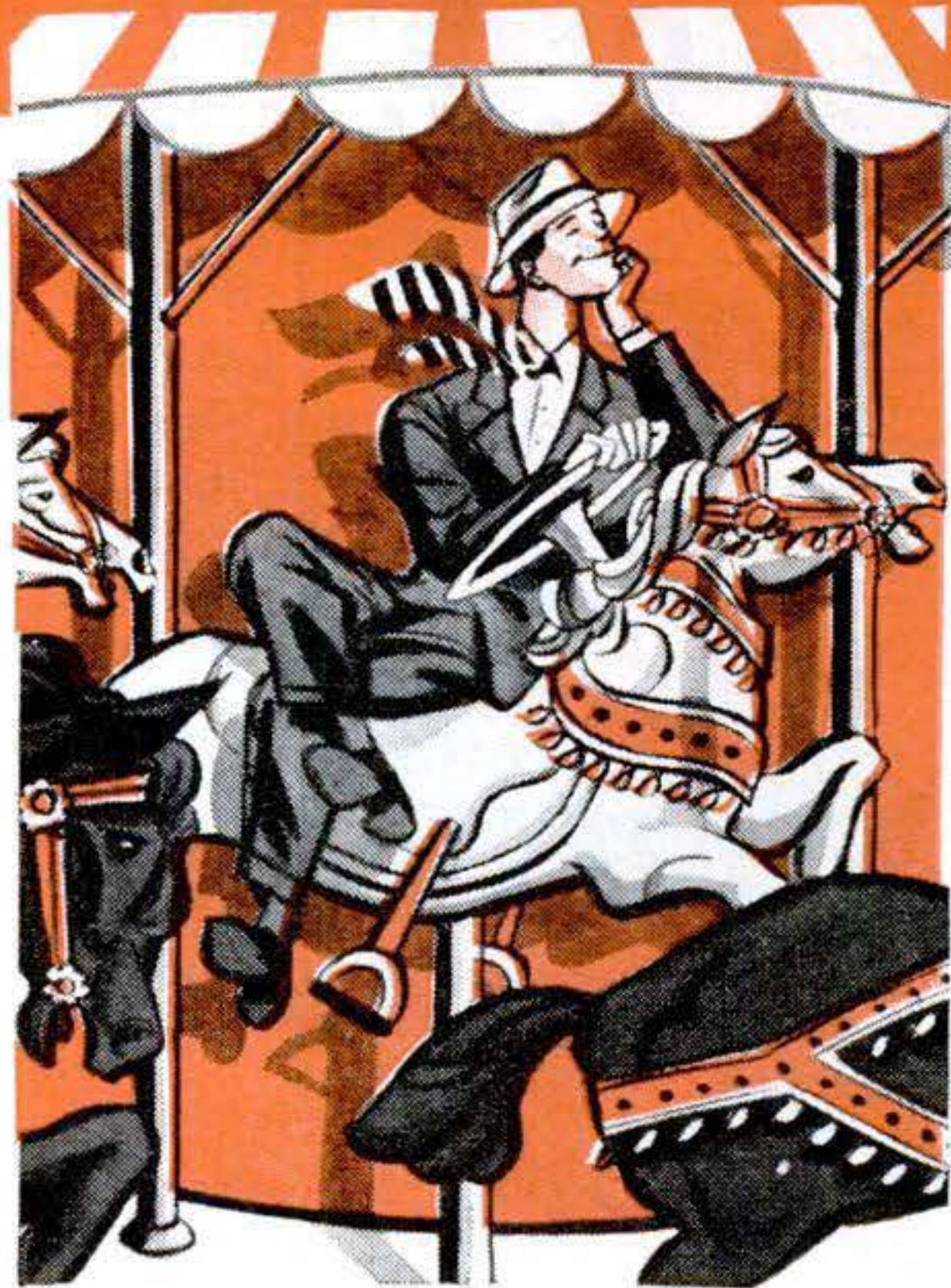

Fig. 1



Marfak cushions the blow, sticks to the job, doesn't spatter when given the hammer test. Ordinary lubricant spatters in all directions, flying away from the job.

Marfak chassis lubricant is scientifically designed to fully protect bearing surfaces against the destructive action of friction and road shock. You can feel its cushioning effect as you drive. Marfak has cohesive and adhesive qualities that make it cling to bearing surfaces

Fig. 2

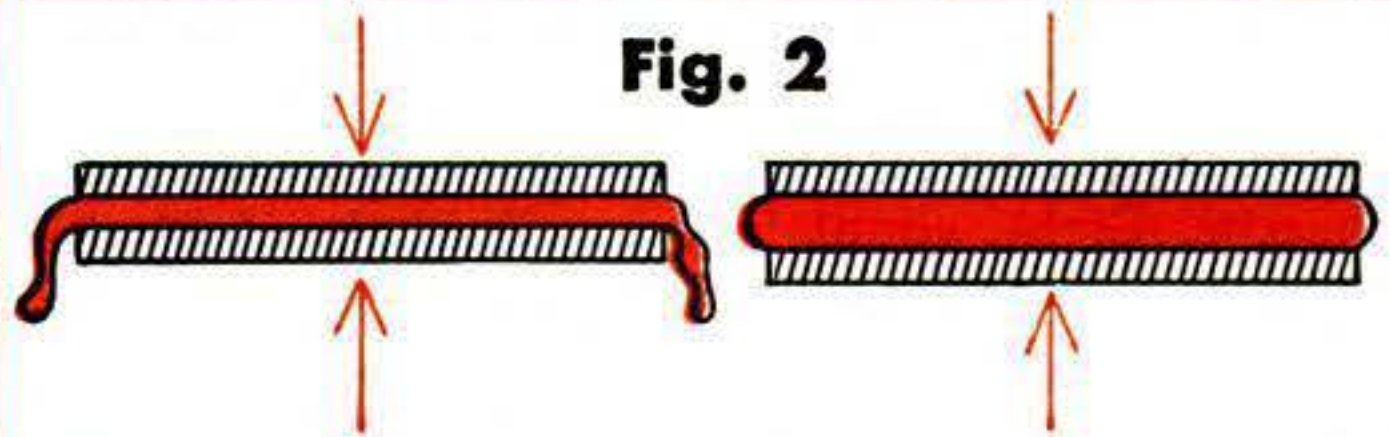

A lubricant that is lacking in cohesive and adhesive qualities squeezes out of the bearings.

The cohesive and adhesive qualities of Marfak chassis lubricant keep it together and sticking to the job.

and resist any tendency to wash-out, jar-out or squeeze-out, see Fig. 2.

Turn to Marfak protection today!

THE TEXAS COMPANY



Don't miss the **TEXACO STAR THEATRE** on Sunday nights with **JAMES MELTON** and famous guest stars. See your newspaper for time and station.

*You're welcome at* **TEXACO DEALERS**







## You'll see when you smoke I.C.

Do the gals go for the magical I.C. aroma? *You'll see!* Will your taste-buds pur-r-r over the magical I.C. flavor? *You'll see . . .* when you light up the magical Irish Castle mixture of *eight* of the world's finest tobaccos. Eight, count 'em . . . 3 kinds of Turkish, 2 choice Virginias, 1 rare White Burley, 1 Latakia, 1 Perique. Blended by the master of 'em all, *Willoughby Taylor*. To get the gals—or just to pamper yourself—get magical Irish Castle Pipe Mixture, *quick!*



**IRISH**  
**CASTLE**

### GET ACQUAINTED SPECIAL

For a limited time (and only if your dealer is out of stock) we'll send you a half-pound humidor of Irish Castle Pipe Mixture for only \$1.10. Mail coupon with cash or check to Penn Tobacco Co., Dept. PS Wilkes Barre, Pa.

Name \_\_\_\_\_

Address \_\_\_\_\_

## Radar Sees the Invisible

(Continued from page 210)

a light, battery-operated radar set. This is a small beacon, even more compact than a hand talkie, with a short whip antenna that is set up as soon as they land. Aboard the transports that follow, flashing red lights notify pilots and jumpmasters when the drop zone has been reached.

"Racons" are probably the largest RADAR beacons in use. Twin transmitter towers are permanently located so as to permit a plane to home on their signals or use them for plotting position. The beacons usually operate only when the beams from an airplane's search radar come in contact with them. These pulses automatically trigger off the beacon transmitters in the two towers.

Complete networks of racons now make possible a new system of long-range air navigation. The plane's special receiver, manned by the navigator instead of the radar operator, is tuned to catch these beacon beams. The pulses are emitted as coded signals, and each beacon has its own identifying code. In the radar scan, the plane's navigator can determine by the light traces the identifying number of the beacon station's beam. Each beam's path is represented as a curved line on a chart. The navigator then tunes in another station to get a cross bearing. Where the lines intersect is the position of the plane.

For the most part, these beacon stations are set up along coastlines; they do not function over long distances inland because of the many "permanent echoes" established by hills and other terrain features. The guiding signals can be picked up at night as far away as 1,200 miles. This new system is considered by many airmen to be just as accurate and much quicker to apply than the standard celestial navigation methods. It can be used in bad weather when there are no planets visible. The stations, each with its twin tower installation, are located from 300 to 400 miles apart. Smaller, intermediate "slave stations" with single transmitter towers are spotted between the main beacons.

There is also a short-range air-navigation system accurate enough to use for area bombing. Stations with single-tower transmitters are spaced close together and permit fixes within a matter of yards. Both the long- and short-range systems were originated by the British and improved to their present state of efficiency by American technicians.

(Continued on page 218)



**GIVES HORSEPOWER MORE ZIP!**



# CASITE

**Guarantees better and smoother performance or double-your-money-back**

**CLEANS OUT MOTORS  
KEEPS MOTORS CLEAN**

Enjoy the thrill of a clean, smoother running motor. Use CASITE! It's simple, swift, sure . . . just a pint in the crankcase every oil change and a pint through the air intake every three months. At service stations, car dealers and garages, everywhere.

## **GUARANTEE**

Add Casite to crankcase and run through air intake according to instructions, then drive your car 100 miles or for 60 days, whichever is first. If not convinced that Casite gives you better and smoother performance, you get double-your-money-back by filling out guarantee certificate and mailing it to The Casite Corporation, Hastings, Michigan. Maximum refund is \$1.30 per pint, twice the nationally advertised price of Casite.

**THE CASITE CORPORATION**  
Hastings, Michigan

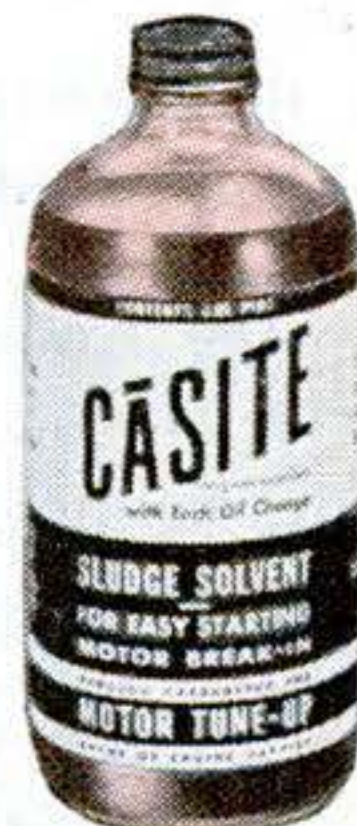

**65¢ A PINT**



# What every aircraft engineer *knows*

(The following message is taken from a recent Consolidated Vultee magazine advertisement entitled, "The Joker in Air Power," addressed to the American public.)

EVERY AIRCRAFT engineer who ever saw the inside of a wind tunnel *knows* what the joker in Air Power is.

The joker in Air Power is TIME—the heart-breaking months and years it takes to design, to build, and to perfect a plane to the point where it becomes an efficient, service-tested battle plane, ready for action.

In aerial warfare, the nation that depends on mere *quantity* and *present-day superiority* of its planes cannot win. That is one reason why Germany lost.

Progress in aeronautics is now so rapid that today's "hottest" combat plane is virtually

obsolete tomorrow. It must be replaced, with all possible speed, by new planes now on our drafting boards, in our wind tunnels, or undergoing test flights.

These are facts which an alert America should not, *must* not, forget.

Research and development in the field of aeronautics is an insurance policy on the life of the nation.

*And we must not let a single premium lapse!*

**Let's keep America  
strong in the Air!**

## CONSOLIDATED VULTEE AIRCRAFT CORPORATION

San Diego, Calif.  
Vultee Field, Calif.  
Fairfield, Calif.

Tucson, Ariz.  
Fort Worth, Texas  
New Orleans, La.

Nashville, Tenn.  
Louisville, Ky.  
Wayne, Mich.

Dearborn, Mich.  
Allentown, Pa.  
Elizabeth City, N. C.

Miami, Fla.  
Member, Aircraft  
War Production Council



THIS AMAZING FLASHLIGHT BATTERY  
**STAYS FRESH**  
 FOR WHEN YOU NEED IT -  
 EVEN FOR YEARS AND YEARS

Here's the Patented  
**RAY-O-VAC**  
**LEAKPROOF**  
**CONSTRUCTION**



**FREE**  
 FLASHLIGHT.

READ THIS  
 GUARANTEE!

"We will give you  
 FREE a new com-  
 parable flashlight  
 if yours is ever  
 damaged by cor-  
 rosion, leakage, or  
 swelling of this  
 LEAKPROOF cell."

It's **SEALED-IN-STEEL**  
 Top, Bottom and Sides  
 And it's **LEAKPROOF 2 WAYS**

- 1** Power is sealed in—your flashlight works when you need it, even for years and years.
- 2** Ingredients are sealed in—your flashlight is protected against ruinous corrosion and swelling of cells (see guarantee).

**RAY-O-VAC COMPANY**  
 MADISON 4, WISCONSIN

OTHER FACTORIES AT CLINTON, MASS. • LANCASTER, OHIO • SIOUX CITY, IOWA • FOND DU LAC, WIS. • MILWAUKEE, WIS. • KANSAS CITY, MO.



"inside story"

## of the waterproof watch you never have to wind!

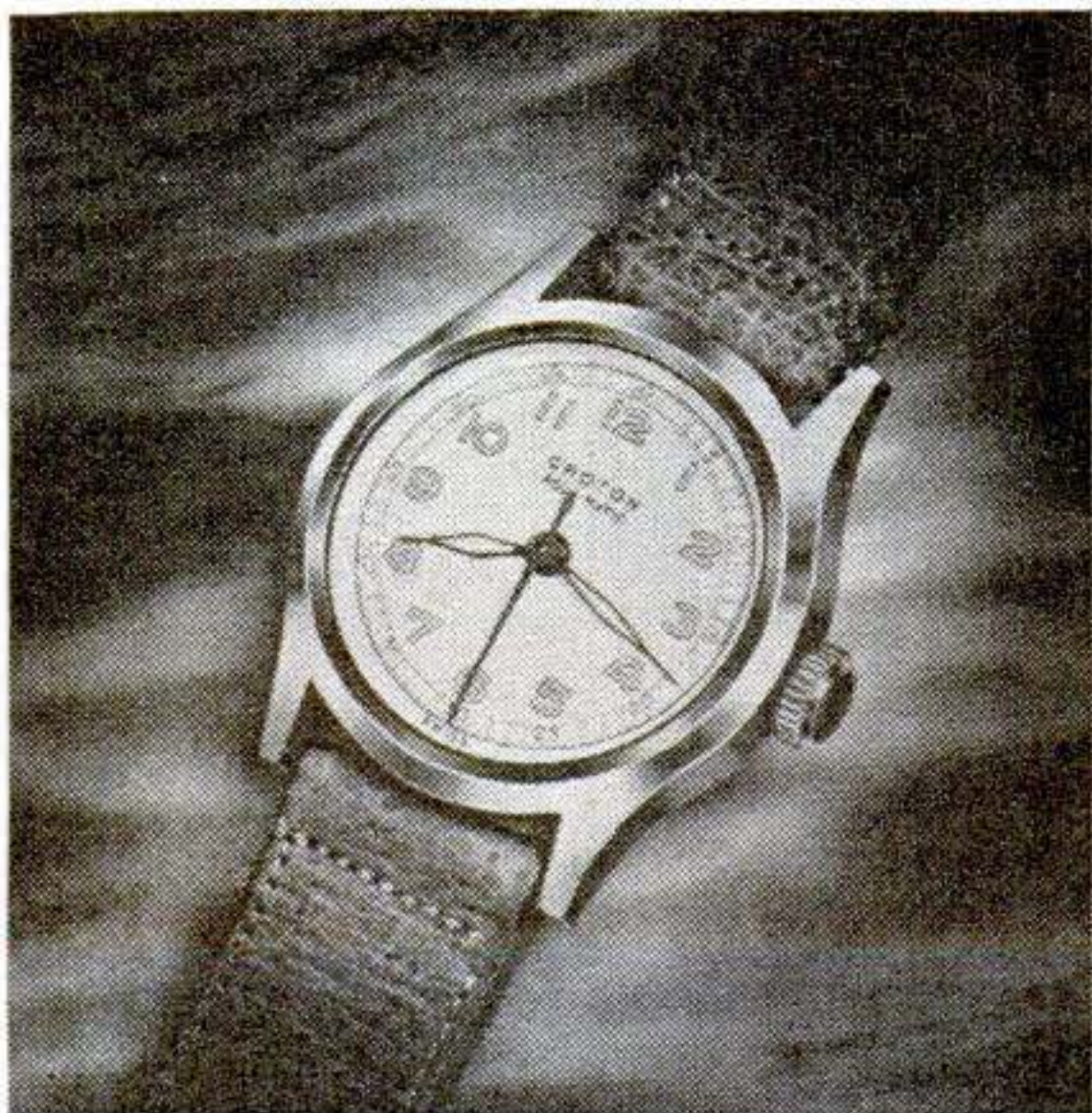

You'll tell accurate time with this Croton Waterproof Aquamatic. But you'll never have to wind it, because it winds by itself! *The natural motions of your wrist do it.* Therefore, your watch is always wound — always on time.

### ACTUALLY 13.5% MORE ACCURATE

A famous laboratory proved it. Three Croton Aquamatics in a 30-day comparison test were reported 13.5% more accurate than the average of nine well-known stem-wind watches when checked against a standard time signal. You've dreamed about this kind of "automatic" timekeeping — now you can have it!

This Croton has everything. Wear it when you bathe or swim, it's waterproof — shock resistant, tarnish proof. Also radium dial, sweep second hand, unbreakable crystal. Everything you want in a fine 17-jewel watch (plus self-winding) for only \$49.50. Fed. Tax Incl.

P. S. Write for Booklet J20.  
Croton, 48 W. 48th St., N. Y. 19

**Croton** SELF WINDING

WATERPROOF AQUAMATIC

## Radar Sees the Invisible

(Continued from page 214)

The basic radar equipment for distant reconnaissance and navigating is known as the ASV (Air to Surface Vessel) search set. This employs the fully rotating dish antenna mounted in a radome. For this type the RO has a circular PPI (Plan Position Indicator) scope that provides him with a maplike representation of the area below, clouds and darkness notwithstanding. The operator can discern land features such as peninsulas, headlands, or islands as far as 150 miles away; ships can be picked up 50 miles distant, and a fleet can be spotted at twice this distance. A switch is used to open the center of the scope to reveal the detail of targets close at hand. The newer ASV sets, are so sensitive that a well-trained RO can detect cloud formations and weather fronts.

The use to which this search set can be applied in bombing should be obvious. In the dark of night, in fog, or through heavy layers of clouds, the PPI tells the operator what is below and thus enables him or the navigator to see landmarks and spot the bombing target. The regular search set is used for these BTO (Bombing Through Overcast) operations, in combination with an H2X ranging unit and a bomb computer that is part of the Norden bombsight that accomplished such accurate visual egg-laying.

The city that is the target can be picked up 50 miles away by the radar operator in his PPI scan. He directs the pilot over the intercom during the bombing run. As the blob of yellow light and shadow that form the target's pattern slide beneath a heading line and ranging circle that are projected onto the PPI screen, the RO keeps the bomber on course. When the line and circle intersect, he releases the bombs. The "eggs" can also be set for automatic release when the proper point is reached.

In October 1944, when Flying Fortress pathfinders led the formations to raids on Vienna, Klagenfurt, and Munich, the Germans found out that no respite was to be gained from cloudy skies over the Reich. The Japs have since found out that even their foul brand of weather is no guarantee against Superfortress visits. "Micky," as the American version is called, is good for BTO missions anywhere from 12,000 feet to altitudes above 40,000 feet, if we ever have to fly that high.

Another technique was developed by the medium-bomber men of the 5th Air Force

(Continued on page 222)



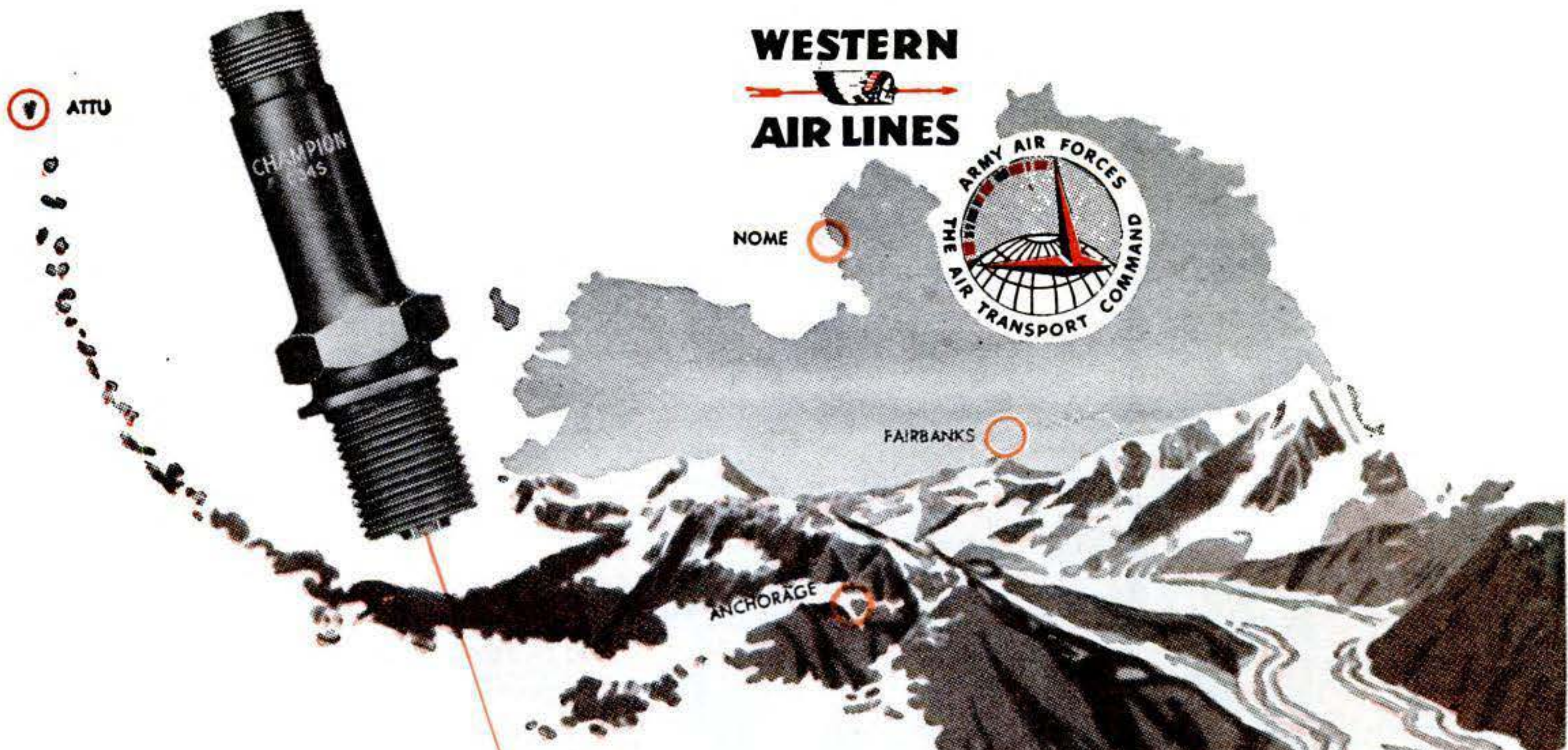

## HERE'S MORE PROOF OF CHAMPION'S PRESTIGE

● The perfect safety record established by Western Air Lines—the nation's oldest—during over three years of pioneer service to arctic war fronts under the Alaskan Division, of the AAF Air Transport Command, is officially credited to "efficient maintenance and efficient scheduling."

Moreover a plane average of 15.9 hours per day in service was set, and that over rugged U. S.—Alaska—Aleutian routes, a utilization record which again establishes the characteristic dependability of Champion Spark Plugs.

● This and hundreds of other extreme wartime services in which Champion Spark Plugs have distinguished themselves provide solid evidence of their better performance and greater dependability. For the Champions you buy for your car today are products of the same research, same basic materials and same precision and engineering standards as the aircraft types, used with such conspicuous success in military and commercial aircraft. When you need new spark plugs demand dependable Champions.

# CHAMPION SPARK PLUGS

CHAMPION SPARK PLUG COMPANY, TOLEDO 1, OHIO

TO SAVE GASOLINE—KEEP SPARK PLUGS CLEAN





# HEAT *that flows*

**TO EVERY NOOK AND CRANNY**

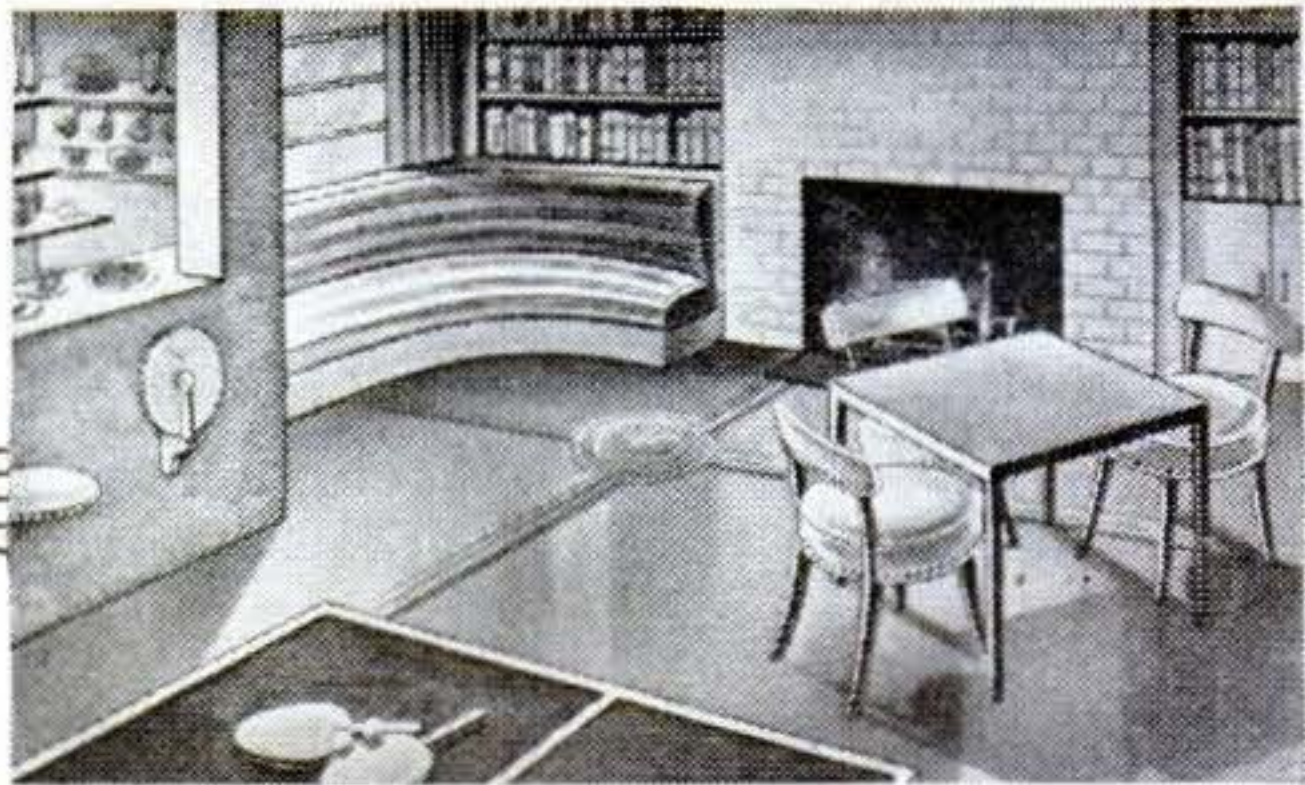
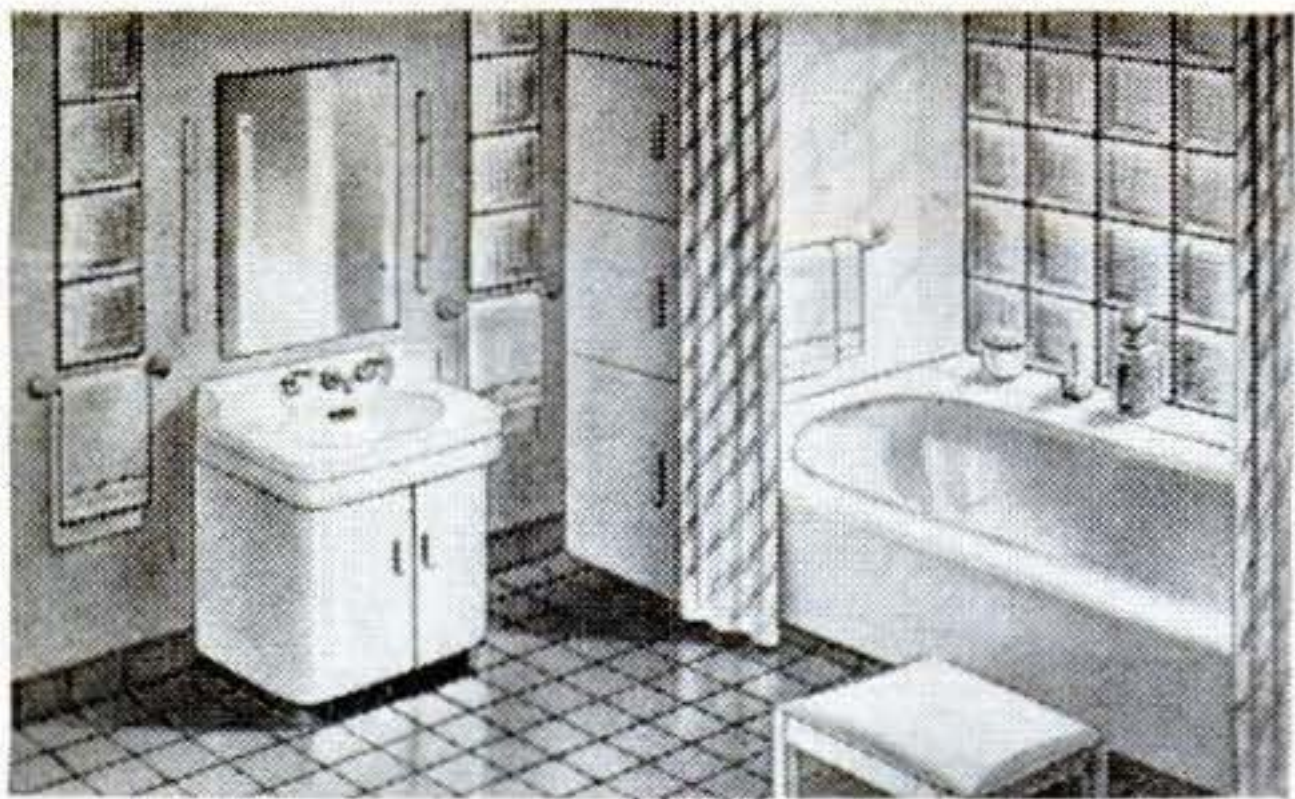

Is your bedroom colder than you like it on winter mornings? Is your bathroom as warm as you would like it for the early morning shower or the evening tub? Are your halls drafty and cold? Chances are that your home suffers from one or more of these discomforts, which are impossible to cure with the present "on and off" control of heat supply.

But cheer up! There is good news ahead. Moduflow, the amazing new control system developed by Minneapolis-Honeywell, will provide a continuous flow of modulated heat to every nook and cranny of the modern home. It can be easily and inexpensively installed in your present automatic heating system, whether coal, gas or oil.

Before you build your new postwar home, or modernize your present one, be sure to investigate Moduflow. Mail the coupon today for the interesting booklet, "Heating and Air Conditioning the Postwar Home."



SEND FOR THIS BOOK

Minneapolis-Honeywell Reg. Co.  
2912 Fourth Avenue South  
Minneapolis 8, Minnesota

**FREE**

Please send my free copy of "Heating and Air Conditioning The Postwar Home"

Name.....  
Address.....  
City..... State.....

*Let's Finish the Job — Buy MORE Bonds!*

# MODUFLOW

**THE NEW HONEYWELL CONTROL SYSTEM**



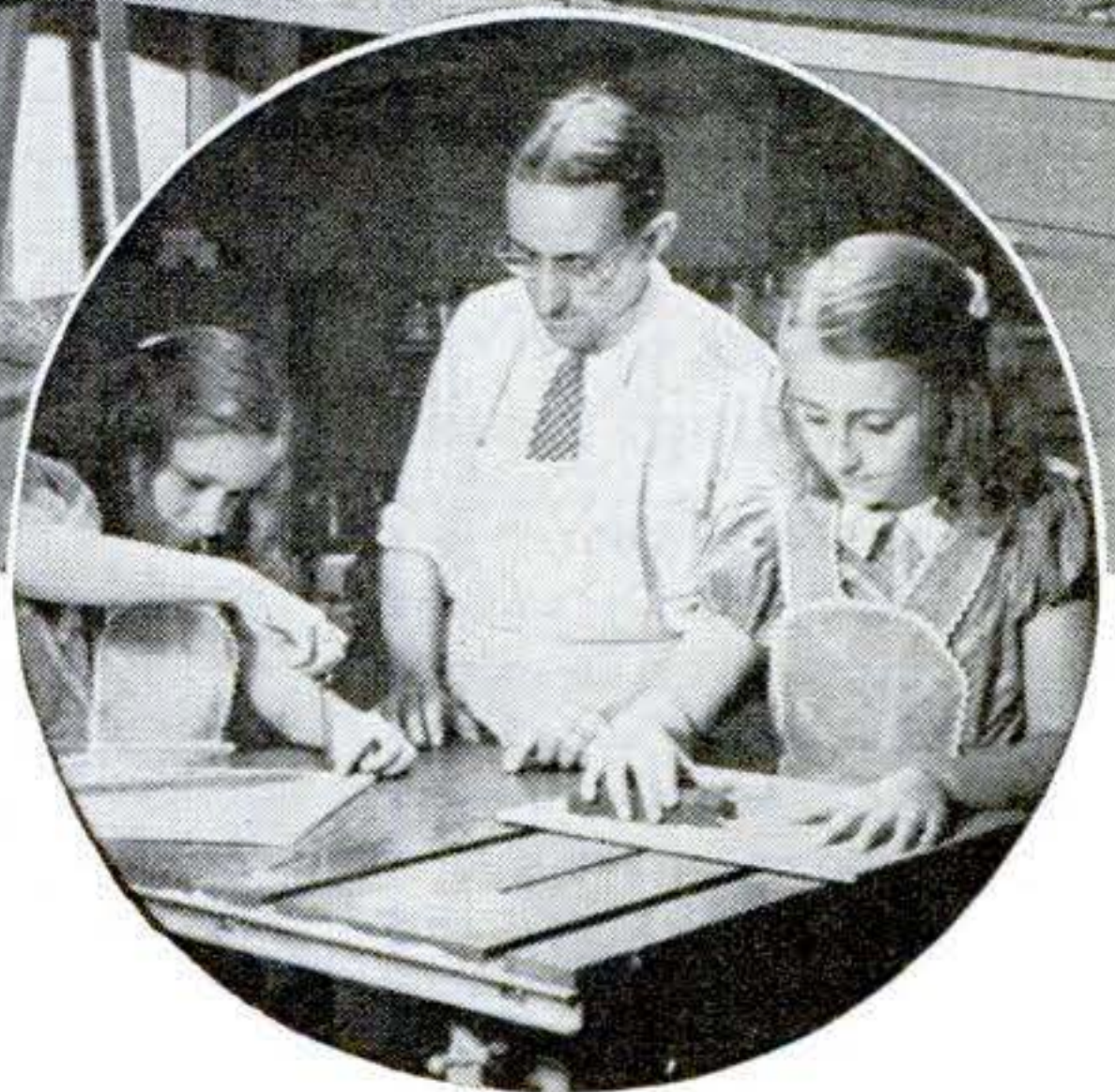
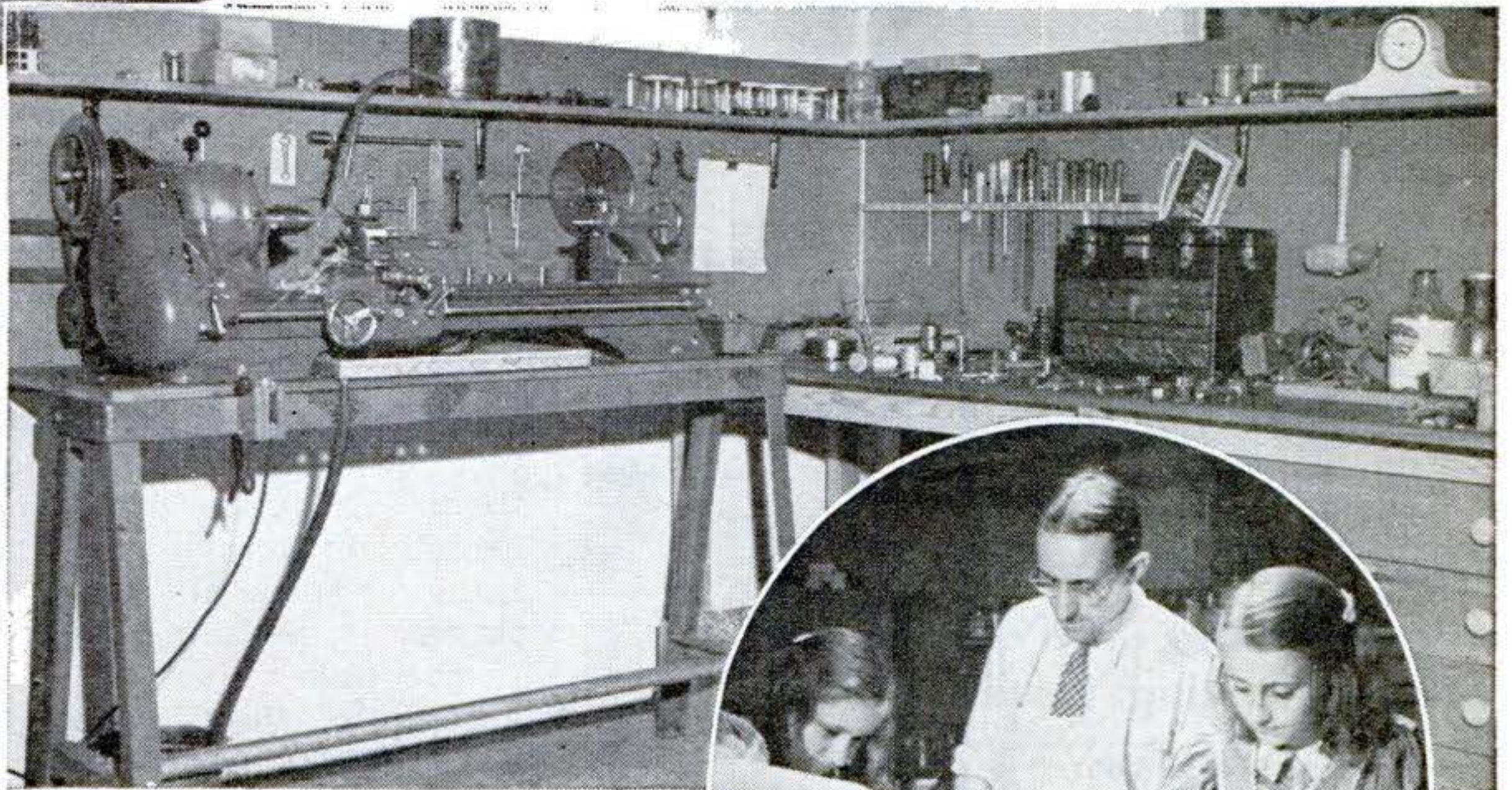
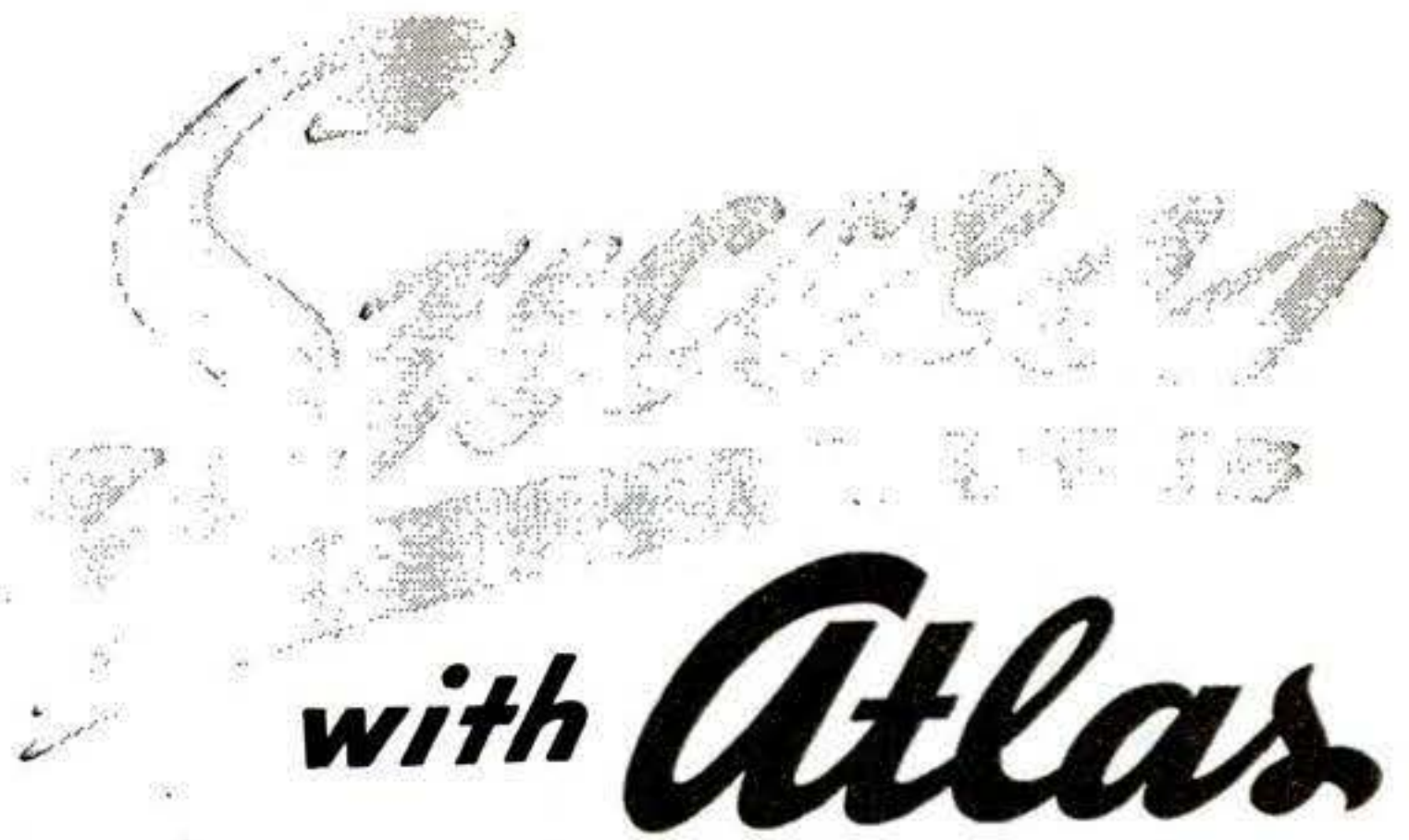
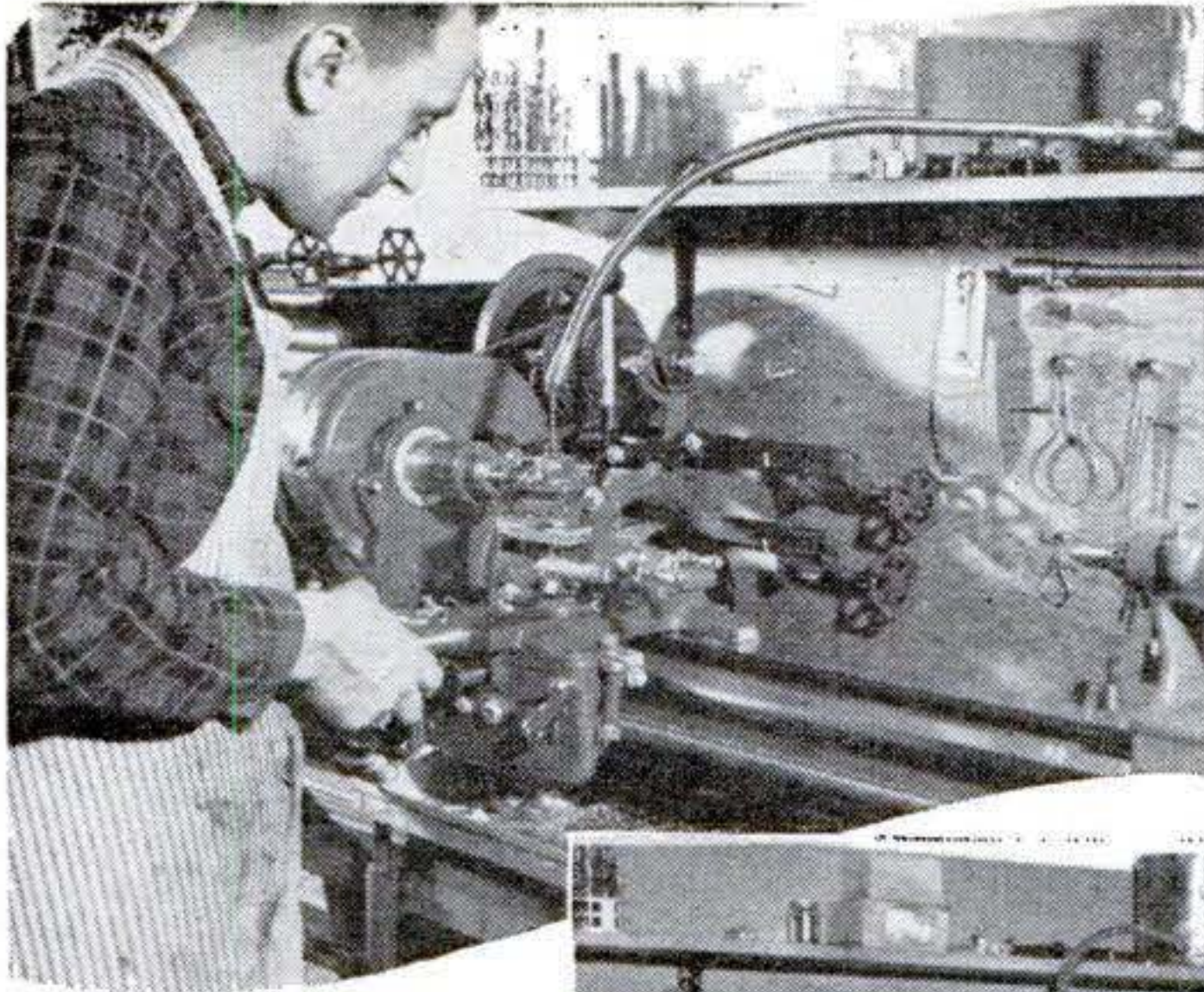

## H. C. RAPP USES HOME SHOP for VITAL WAR PRODUCTION

How a hobby was put to the good use of making over 13,000 radio and special instrument parts is the interesting story of Howard C. Rapp, Mechanical Engineer of Cincinnati, Ohio.

### "Homestead Crafters"

Before the war, Mr. Rapp spent many a pleasant and profitable hour working with his daughters on a variety of wood products, using the proceeds to add to his shop equipment. They were getting quite a reputation as the "Homestead Crafters."

When Uncle Sam asked home shop owners to use their tools and talents in war production Mr. Rapp tried, but could find nothing to do on his strictly woodworking equipment.

### Worked On Night Shift

So he made the next best contribution and for 15 months worked four nights a week and Saturdays in addition to his important daytime job. When the night shift was taken off, he was told

he could have plenty of work to do at home if he had a metal-working lathe.

With orders in hand he went to the W.P.B., secured a priority, purchased an Atlas lathe and has been busy ever since.

"My only regret," says Mr. Rapp, "is that I did not make such a purchase several years ago . . . I cannot speak too highly of my Atlas. My work calls for close tolerances and I am able to carry out this work in a fast, precise manner."

\* \* \* \*

With industry thoroughly sold on the value of subcontracting many men plan to fulfill their life's ambition—a small business of their own—after the war. If that is your plan low cost Atlas tools will help you get started with a small investment.

**SEND FOR FREE CATALOGS**  
Get full details on the Atlas  
4 Tool Team—lathe, milling  
machine, shaper, drill press.



**ATLAS PRESS CO.**  
955 N. Pitcher Street, KALAMAZOO 13D, MICH.



# SAVE WORK!

## ...Yet Have Lovelier Floors



### Self-Polishing Simoniz Shines with- out Rubbing . . . Gives Longer Lasting Luster

Don't envy others. Your floors can be as brightly spotless as the best of them—and oh so easily! Merely flow Self-Polishing Simoniz onto your floors. No rubbing—no polishing—just let it dry. Then—Presto!—Shimmering loveliness that lasts and lasts. Self-Polishing Simoniz doesn't wash off and have to be replaced every few days. It wears, in fact, much like the original SIMONIZ long famous for enduring beauty on automobiles. Cleaning's so easy, too. A damp cloth whisks off dust and dirt and your floors shine like new again. So, do try Self-Polishing Simoniz—but Soon! Sold by grocery, hardware, drug, paint and department stores everywhere. The Simoniz Company, Chicago, Ill.



# SELF-POLISHING SIMONIZ FOR FLOORS

## Radar Sees the Invisible!

*(Continued from page 218)*

in the southwest Pacific for attacks against Japanese shipping. Their LAB (Low Altitude Bombing) equipment is connected with the plane's regular set and consists of a computer, a tracking unit, and a repeater scope for the bombardier. LAB can be used from any altitude between 50 and 2,000 feet at night or in conditions of low visibility. And no one knows better than the Japs, who tried to run merchantmen and warships through our aerial blockade, the efficacy of this automatic radar bombing apparatus. LAB is operated in much the same manner as the high-altitude BTO set.

When enemy bombers attempt to attack our ships and ground installations, we put radar to work defensively. Mobile radar sets are hooked up with searchlight synchronizers called "comparators." The beams pick up the planes and aim the lights at them. Accurate anti-aircraft fire depends largely upon accurate ranging and computation of speed and direction. Radar can do this as no mechanical computers ever could. In the case of shipboard dual-purpose and automatic 40-millimeter guns, the additional factor of the ship's pitch and roll must be taken into account. This is done through the use of gyro stabilizers that are hooked up to the radar fire-control equipment. Each type of gun aboard ship usually has its own set and antennas; there is one radar for the five-inch guns, another for the 40-mm. guns, and gunnery officers and radar operators and trackers for each of the sets.

The story about radar being used to catch fish is credible because of the effect of microwaves on the delicate sense organs of fish, but radar has been accused of much that is just not so. It will not make operators baldheaded or sterile, nor will it cause RO's to go crazy after being around the apparatus for a time. One woman in the West called a major of the 4th Air Force recently to complain that ever since the AAF put radar on training planes she had been having trouble. When the planes flew over her house, she said, their radar made her telephone hard to hear, made the bedsprings squeak, the radiators get noisy, and killed all the pretty fir trees around the house.

When the time arrives for radar to cease killing either fir trees or Japs, it will become a boon to mankind in the one medium most essential to international goodwill and understanding—communication.

On land, at sea, and in the air, radar can

*(Continued on page 226)*





*Famous Ford "Firsts"*

SPECIALIZED TOOLS AND TRAINING WHICH  
ENABLE DEALERS TO OFFER FACTORY-TYPE SERVICE

**1<sup>st</sup>**

**with a factory program  
for universal service**



Henry Ford long ago declared: "A sale does not complete the transaction between us and the buyer, but establishes a new obligation on us to see that his car gives him service."

Early, the Ford Motor Company saw the need for personal service, precision tools, trained mechanics. From all over the world men came to the Ford plant for service method training. In a sense, they took with them part of the factory itself, methods and ideals, and thus Ford service became universal.

Through the development of special-purpose tools and scientific methods, Ford was first to

make it possible for dealers to give service measuring up to the precision built into the original car. Today Authorized Ford Service dealers everywhere have available a complete line of factory-approved tools that mean finer workmanship, greater economy for the car owner. And the Ford Motor Company continues to supervise the training of men who will use these tools.

Here is one more of many important Ford "firsts." It is paying extra rewards to owners under wartime driving conditions.

"THE FORD SHOW" Singing stars, orchestra and chorus. Sunday, complete NBC network. 2:00 P.M., E.W.T., 1 P.M., C.W.T., 12:00 M., M.W.T., 11:00 A.M., P.W.T.

**EXPECT THE "FIRSTS" FROM FORD!**



# Ingenious New Technical Methods

Available Now to Industry in General

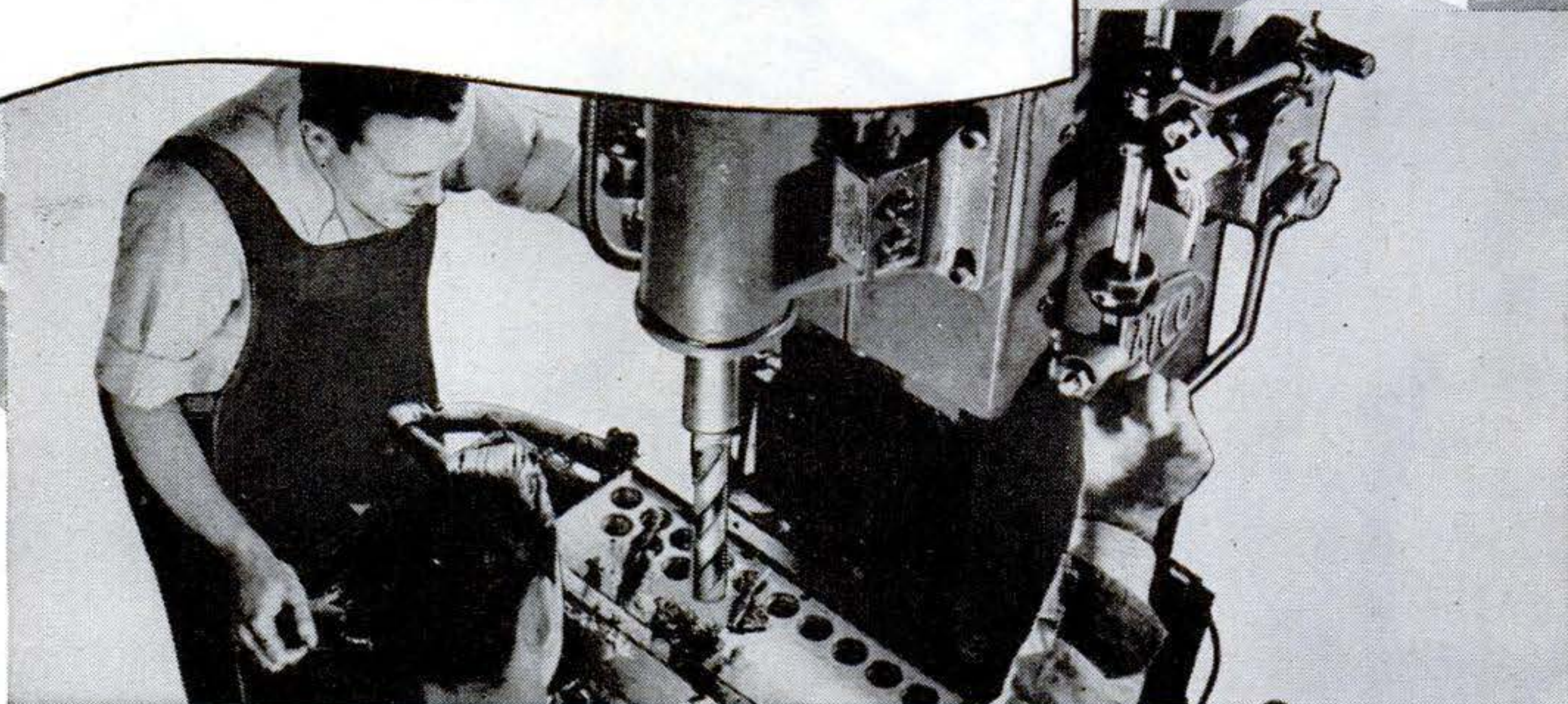

## New Shankless Roll-Forged Drill is Faster, Tougher, More Economical

Developed by Ford for wartime uses — available now to industry in general. "More holes at less cost," is the claim for this ingenious new Shankless high speed drill—made in two parts—the drill itself, and a removable taper shank, known as the "drill driver." By this separation, costs to the user have been cut 20% to 30% under conventional taper-shank drills. In the conventional drill, the shank must be discarded when the point and flutes are worn out. Here, however, the drill driver is used throughout the lives of many drills. Shankless drills are roll-forged and twisted, unlike the machined manufacture of ordinary drills, for improved structure.

Principal advantages are (1) Lower first cost. (2) Greater hole production because of greater strength. (3) Reduced breakage with tough "shock-absorber" neck. (4) Greater length of usable flute. (5) Greater scrap recovery value of unused portion of drill.

Wartime advantages of Wrigley's Spearmint Gum show how this quality product, too, can help industry—once it again becomes available. In the meantime, no Wrigley's Spearmint Gum is being made; and none will be made, until conditions permit its manufacture in quality and quantity for everyone. That is why we ask you to "remember the Wrigley's Spearmint wrapper," as the symbol of top quality and flavor—*that will be back!*

You can get complete information from  
Republic Drill & Tool Co., 322 S. Green St., Chicago 7, Ill.



Shankless Drill and "Drill Driver"



Remember this wrapper

Z-81



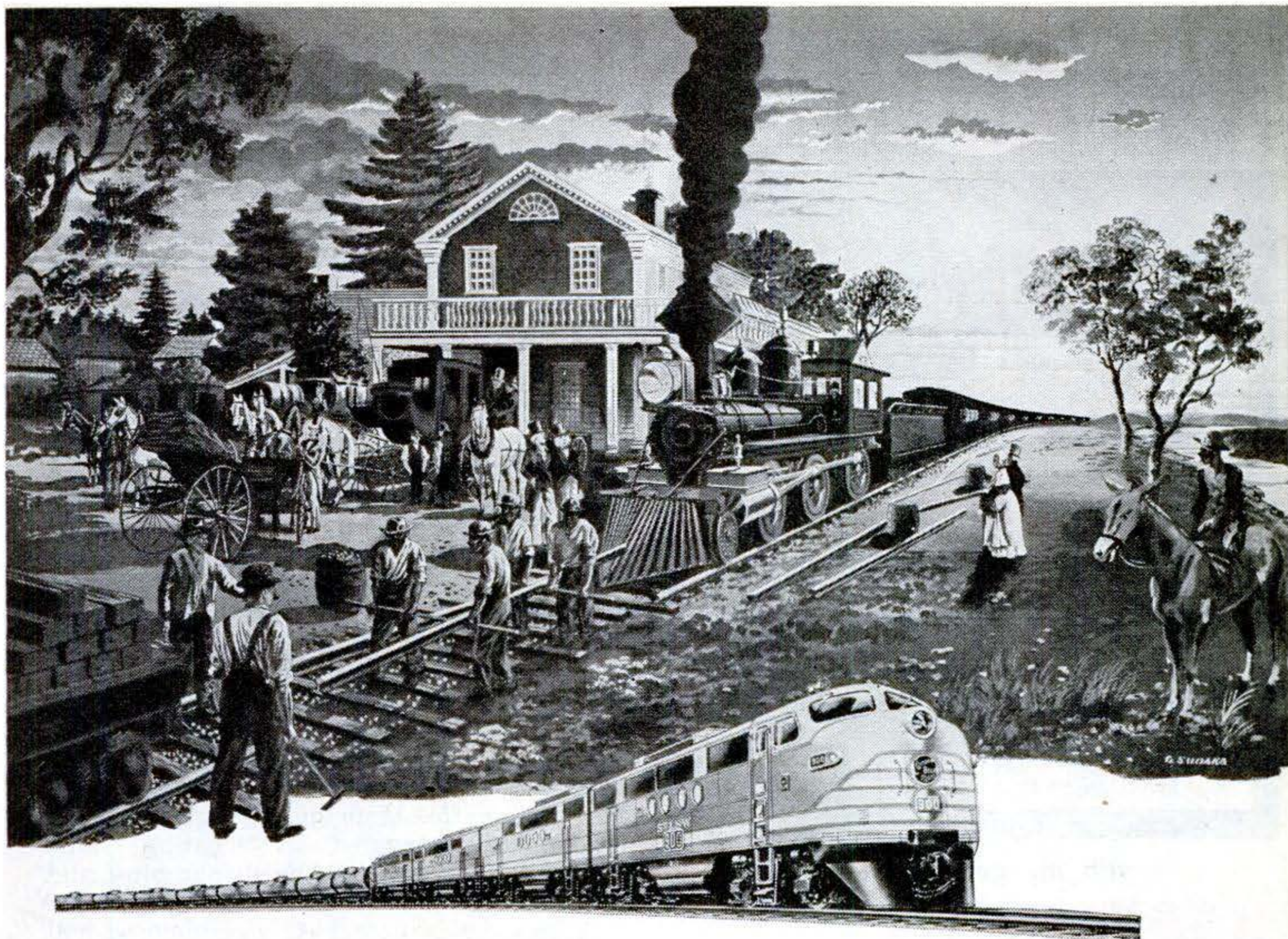

One of the great dramatic moments in railroading occurred when the Cotton Belt changed the gauge of its 419 miles of track in a single week end. The scene pictured above is our artist's conception of the closing hours of this successful old-time race against time.

## CHANGING THE MEASURE OF RAILROADING

It was September in 1886. All along the Cotton Belt, from Bird's Point, Mo., to Texarkana, old spikes came out. Rails were shifted. New spikes sank home under swinging hammers. The entire railroad was changed from narrow to standard gauge over one week end. The Cotton Belt had stepped along with the times.

This railroad is still stepping along. It is one of 83 railroads and major industries where General Motors Diesel locomotives are changing the measure of railroading.

Watch what happens when complete lines and systems are GM Dieselized. Far faster freight hauls. Quicker, more comfortable, and more reliable travel for passengers.

And reduced maintenance by sturdiness that goes a million miles or more without major overhaul!

Yes, the measure of railroading is changing — for the better. And GM Diesel locomotives are helping to bring about this new benefit for the railroads, for the country, and for you.

One More War to Win  
Buy MORE Bonds

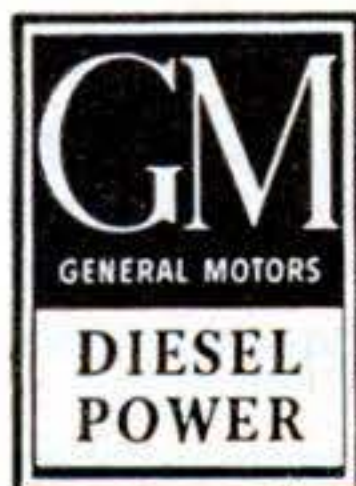

LOCOMOTIVES ..... ELECTRO-MOTIVE DIVISION, La Grange, Ill.

SINGLE ENGINES ... Up to 200 H.P. }  
MULTIPLE UNITS ... Up to 800 H.P. } DETROIT DIESEL ENGINE DIVISION, Detroit 23, Mich.

ENGINES ..... 150 to 2000 H.P. .... CLEVELAND DIESEL ENGINE DIVISION, Cleveland 11, Ohio

SEPTEMBER, 1945

Buy War Savings Bonds and Stamps regularly.

225



Make this simple test! See why you  
**GET MORE HEAT**



1. Hold a flame at the side of your finger. Feel much heat? *Very little.*

**FROM LESS FUEL**



2. Now hold your finger directly over the flame. Feel much heat? *Plenty!*

with the genuine ESTATE

**HEATROLA HEATER**

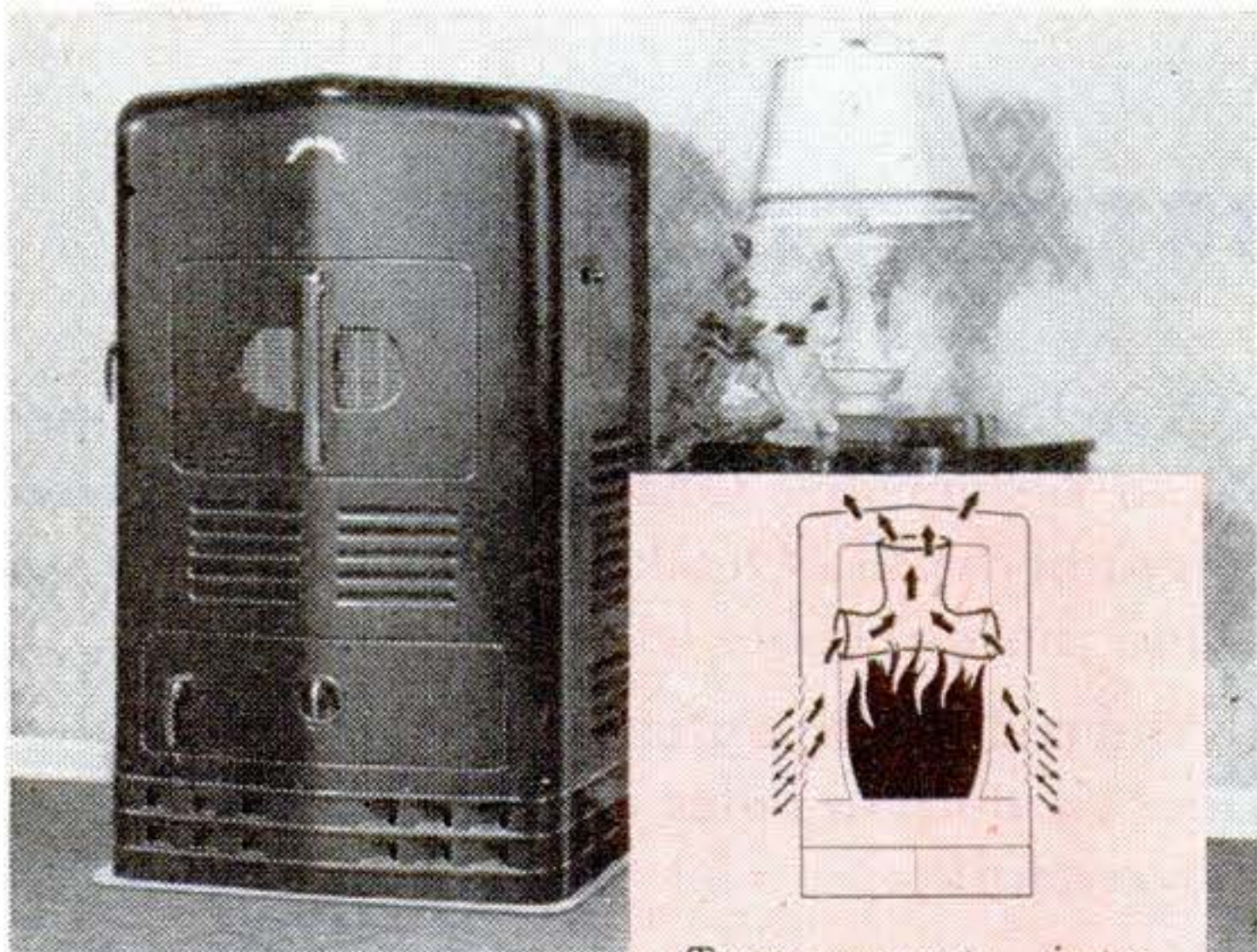

Turns waste into warmth. Only the genuine Estate Heatrola Heater has the Intensi-Fire Air Duct, built directly over the flame.

Before you buy any home heater . . . see the genuine Estate Heatrola Heater . . . the recognized leader for over 20 years. Circulates healthful warmth throughout the rooms...makes less fuel go farther.

THE ESTATE STOVE COMPANY, Hamilton, Ohio  
**Your best buy is the best you can buy**  
 . . . the genuine

**ESTATE Heatrola HEATER**  
 FOR COAL, WOOD, OIL

*Radar Sees the Invisible*

*(Continued from page 222)*

be applied to all sorts of postwar transportation. It will find its widest application in the aviation industry, because of the three-dimensional character of flying. The CAA is experimenting at Indianapolis with a commercial adaptation of the "BABS" (Blind Approach Beacon System) device used by the AAF and Navy for landing planes in the thickest pea-soup fogs. Airport control officers can be provided with a large master scope that will show, even in bad weather, all planes in the vicinity of the airport. Airlines and personal planes can carry their own navigating and detection equipment to make flying safer and easier.

Steamships equipped with radar navigational and detecting devices can maintain faster schedules in bad weather, locate icebergs and other obstructions, pick up shore lines and shoals, and check on the location of other vessels to avoid collision.

Railroads can apply radar for signaling, the automatic stopping of trains when tracks are obstructed, and locating trains on a master board in the dispatching and traffic-control offices.

Autoists may find that radar devices will enable them to drive at reasonable speeds through fog and storms. One unit might serve as a guide to keep the car on the road, flashing a warning light when the driver gets too close to the edge; another would scan the road ahead for obstructions or other cars.

Manufacturers can apply radar in a number of ways. Fisheries can make use of the devices—and certain other apparatus which is not strictly radar but closely allied to it—to locate and catch schools of fish with this "electronic bait."

Indeed, radar may be the most significant contribution to the amazing new electronics industry that bids fair to become one of the keystones of modern living.

**MAGAZINES FOR NAVY MEN**

The Navy is sending free "Overseas Edition" kits of current magazines to thousands of land stations and ships at sea, and asks relatives and friends of Navy personnel and Seabees not to send private subscriptions to the Pacific. This will (1) ease the tremendous mail load, (2) permit letter mail to go through quicker, and (3) give our fighting men newer magazines.



PICTURED—the Model 45 Link Trainer. The new Elementary Trainer will incorporate the flight-like characteristics of this standard training device.

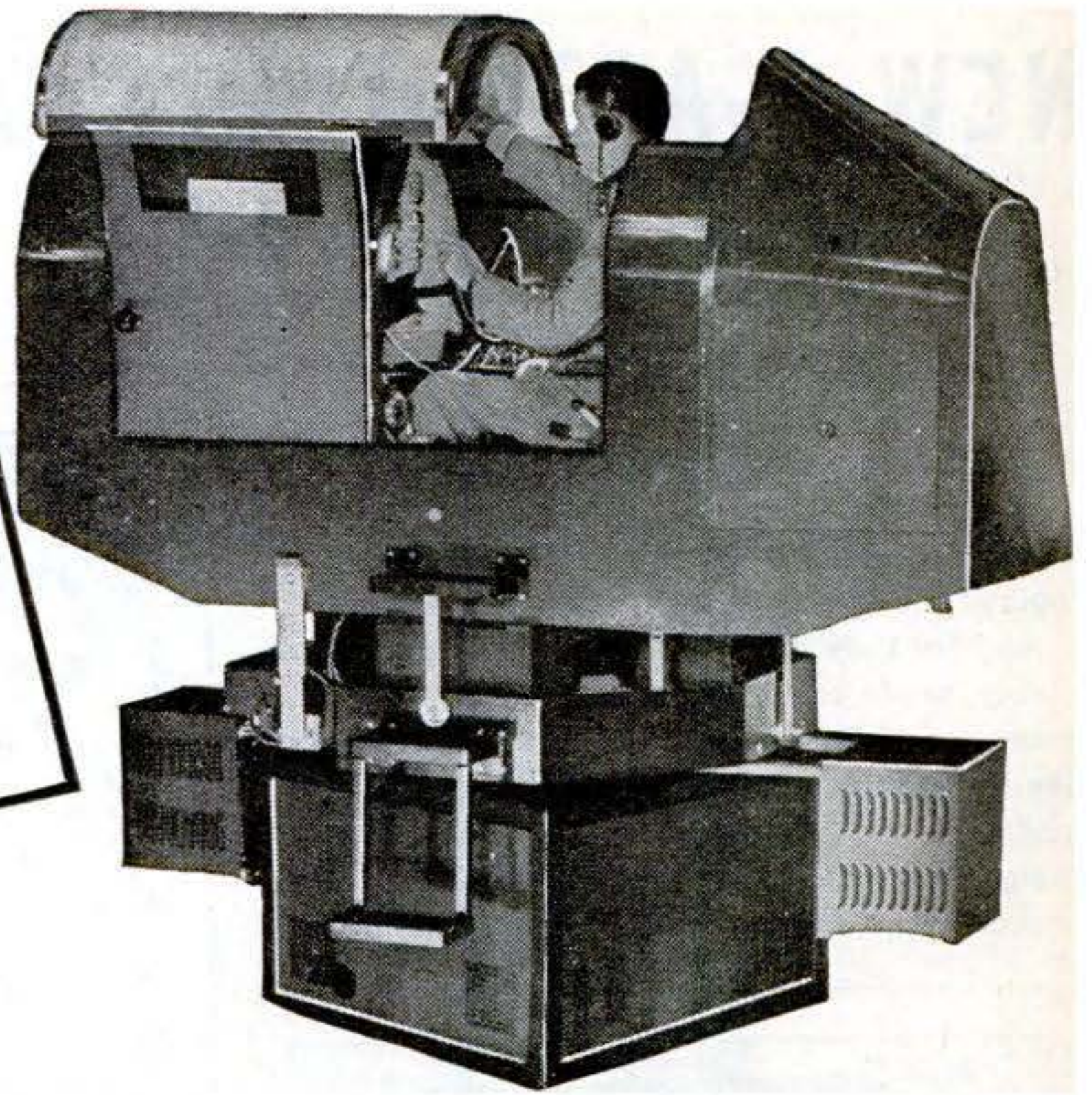

## **Coming: NEW ELEMENTARY TRAINER FOR SCHOOL USE**

**T**HIS WAR has proved the extraordinary value of training devices—in saving lives, time and money. Our fighting men are the best-trained in the world, due in no small measure to these devices which simulate military problems and help to teach their solution.

The Link was the first training device to simulate the characteristics of an airplane. It is the standard trainer for *all* pilots of our air forces and commercial air lines. Twenty years of experiment and engineering have brought it to a high degree of perfection.

Now Link engineers have developed a new Elementary Trainer, ideal for school and classroom use. It enables students to study the basic elements of aviation—*safely, on the ground*. It is a real Link, with all the flight-like features of the standard trainer. Yet its cost will be well in range for school budgets. It will be available soon after war-time restrictions are removed.

May we enter your name for descriptive literature, to be sent you as soon as it is off the press?

## **Link Aviation Devices, Inc.**

BINGHAMTON, NEW YORK

**MAKERS OF LINK TRAINERS, CREW NAVIGATION TRAINERS AND OTHER DEVICES CONTRIBUTING TO THE SAFETY OF FLIGHT.**



# NEW X-ACTO TOOLS TERRIFIC SENSATION IN HOBBY AND CRAFT FIELD

It had to come! People who once discovered the dependable exactness of X-acto Knives simply would not be satisfied till they got companion tools of the same precise perfection.

So here they are, designed with scientific accuracy, made to X-acto's topnotch standards in every detail. These are tools every handicrafter needs, whether his interests lean to model-making, carving, gadgets, or whatever. Make them standard equipment for your hobby den or workshop, and get slicker jobs done quicker.

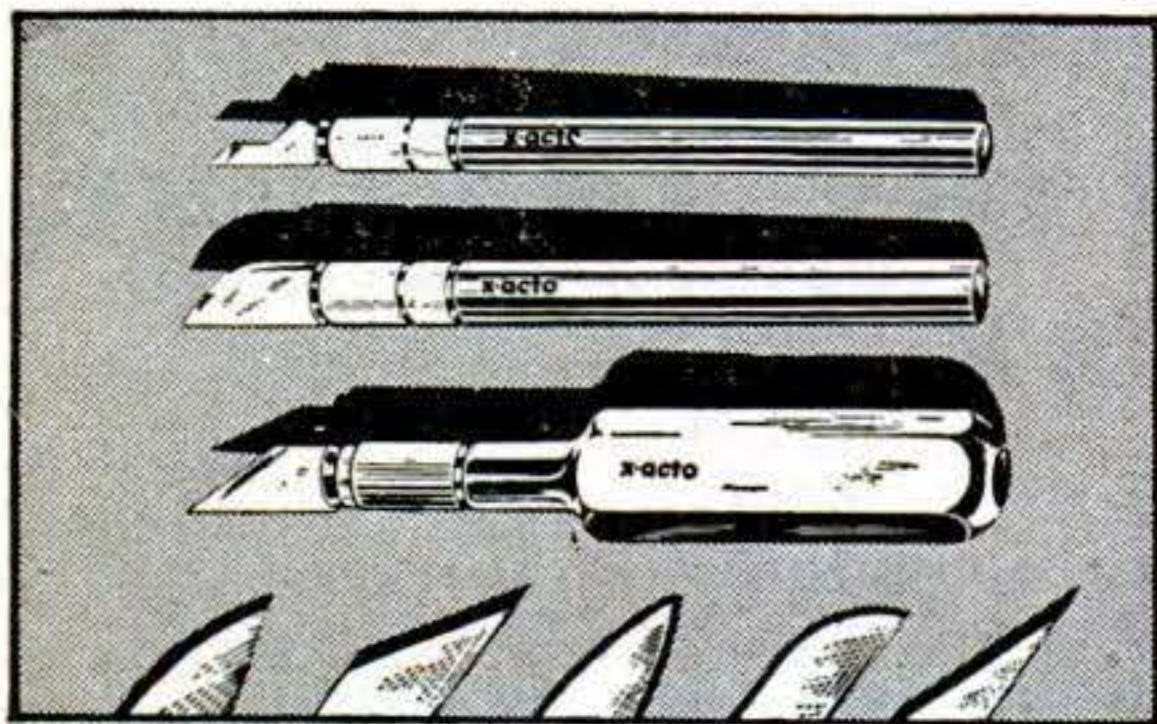

## WHEN YOU NEED A KNIFE YOU NEED X-ACTO

Always sharp, always ready. Three easy-grip knife styles. Eight scalpel-sharp blade designs, interchangeable, replaceable in 5 seconds. The knife preferred by expert modelmakers, whittlers, draftsmen, artists and photographers. Cuts paper, wood, or plastics with equal ease. Does a multitude of jobs — better, faster, safer.

# x-acto



**KNIVES  
& TOOLS**

At better hardware, hobby, and gift shops

—or if not available write direct to

X-acto Crescent Products Co., Inc.  
440 Fourth Ave., New York 16, N.Y.

X-acto Knives and Knife Chests  
From 50¢ to \$5.00

SEND FOR THESE HELPFUL HANDBOOKS

(1) Boat Whittler's Handbook. (2) How to Build Scale Model Planes. Full of helpful ideas. Only 10¢ each.



### The X-acto Sander

A good-looking, handily shaped solid block of wood, with rubber pad for round edges, and three grades of first quality sandpaper. 6 refills. Complete 50¢. Refills, 6 pcs., 10¢.

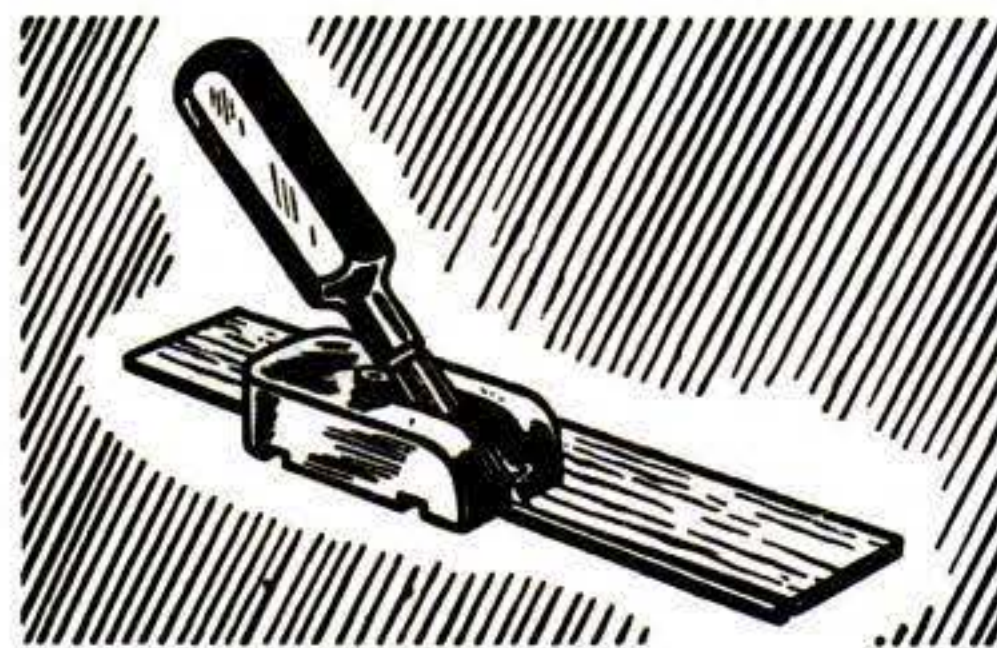

### The X-acto Balsa Stripper

Aeromodelers' indispensable. Cuts straight, square, strips; thin or heavy stock. Movable guide regulates width. Use with X-acto knife. Pays off on a single job. \$1.00 (without knife).



### The X-acto Planer

Cuts like a charm. So easy to handle. A real precision tool, shaped like a tank, fits the hand. High-temper surgical steel single-bevel blade. The craftsman's delight. Complete \$1.00.



### The X-acto Hand Drill and Pin Vise

All-metal tool takes any drill from smallest needle up to 3/32" diameter. Free wheeling knob, diamond knurling on handle assure easy manipulation with fingers. 75¢.

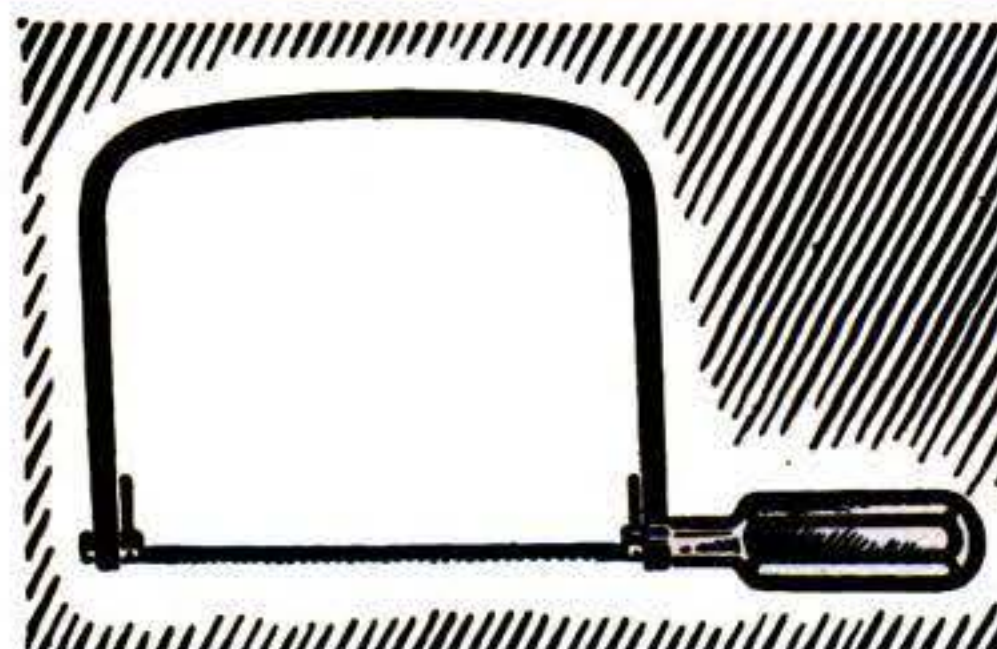

### The X-acto Hobbycrafters' Saw

Sturdily constructed, indispensable. Easy-grip dur-aluminum handle holds blade always taut. Blades are sharp and efficient, removable, quickly changed. Complete, \$1.25.



**NOW—YOU CAN "DO IT YOURSELF" WITH THE**

# **CENTURY GAS GUN**

**SELF-LIGHTING  
SELF-EXTINGUISHING  
ACETYLENE TORCH**



**Here's the trigger-quick way to do your own soldering and brazing at home. For instance: for REPAIRING ELECTRIC APPLIANCES, KITCHEN UTENSILS, PLUMBING LEAKS, RADIOS, REFRIGERATORS, GARDENING EQUIPMENT, HOUSEHOLD TOOLS, ETC. "go gunning" with the magic Century Gas Gun!**

The Century Gas Gun was developed to meet the demands of War Industry for soldering and brazing equipment to speed up production. Now, for the first time, it is available for civilian use. This Gas Gun is absolutely unique—there's never been anything quite like it. Anybody can operate it—with ease, speed, safety. And

with economy, too! For, thanks to the Century Gas Gun, you can now do 101 home repair jobs yourself. The money you'll save on just one job will more than pay the total cost of the gun. Use the handy order-coupon below for quick action!

**\$19<sup>50</sup>\***

\* Gun with enough flints for over 2,000 lightings. If you want the regulator, hose, clamps and extension nozzle, send \$17.30 additional. Your local gas distributor can supply necessary acetylene tank.



**FOR HOME REPAIR**

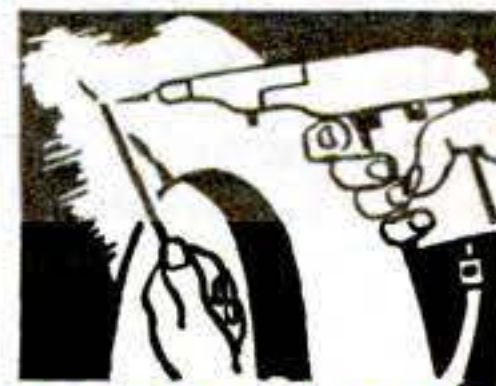

**FOR AUTO REPAIR**

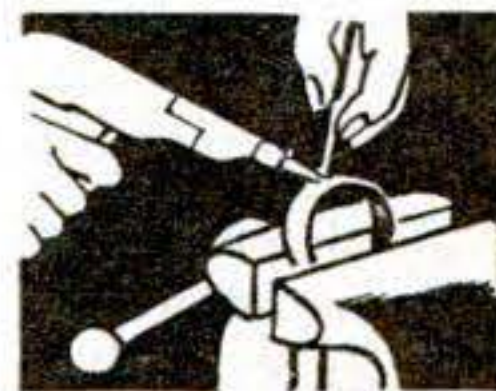

**FOR HOBBY SHOP**

**"GK"**

**SAY KAISER SHIPYARDS  
...GENERAL ELECTRIC...  
ALUMINUM COMPANY OF AMERICA...  
and hundreds of other big users. The  
Gas Gun is the SAFE way to do all  
home repair jobs that call for soldering  
or brazing. Saves gas, saves time! Be-  
cause it's automatic! Pull the trigger  
and it lights. Release the trigger and  
it shuts off. Always ready for action!**

**FOR IMMEDIATE DELIVERY  
MAIL THIS QUICK-ACTION, MONEY-BACK COUPON**

**Century Aircraft Company, Gas Gun Division  
5603 Century Boulevard, Los Angeles 43, California**

Please ship me, all charges prepaid,  
Century Gas Gun complete with flints, \$19.50   
Century Gas Gun, regulator, hose, clamps and extension nozzle, \$36.80   
Remittance attached—with the express understanding that if, after 10 days' trial, I am not thoroughly satisfied, I will return the equipment and get my money back. (If preferred, order COD. In that case, you pay shipping charges)

NAME \_\_\_\_\_  
STREET \_\_\_\_\_  
CITY \_\_\_\_\_ ZONE \_\_\_\_\_ STATE \_\_\_\_\_





## WILLIAMS BOX "SUPERRENCHES"

► Williams Box "Superrenches," with their thin head walls, permit fast and safe operation where clearances are limited. Offset handles clear obstructions that would otherwise bark knuckles and generally slow up the work. Their 12-point openings grip hex nuts on six sides . . . preventing slippage and rounding of the nuts' corners. Complete rotation of hex nuts is possible with these wrenches where handle swing is limited to as little as 30° . . . less than one-tenth of a full turn.

Williams Box "Superrenches" are made in a variety of popular patterns, including "Structural" and "Striking face" types. All are forged from tough chrome-alloy steel, heat-treated and fully guaranteed. Write Dept. S-9 for free Tool Data Sheets.

**J. H. WILLIAMS & CO.**  
BUFFALO 7, N. Y.



**DROP FORGINGS AND DROP-FORGED TOOLS**

*(Continued from Page 80)*

Radiations are known to affect living matter. Radium and X rays, for example, have been used in treating cancer. Hence, some of the biophysical effects of atomic explosions may be beneficial. But others may be gruesome. Persons far enough from an atomic explosion to escape instant death may be fatally injured internally; rescue workers hastening to the scene may also be injured, unless ways are found to decontaminate such areas. *Popular Science Monthly's* editors are confident, nevertheless, that scientists can learn to control this new source of power as they have controlled fire and electricity.

"We have been able to harness this tremendous energy in a small bomb," says Sir John Anderson, who supervised British atomic-bomb research as Chancellor of the Exchequer under Prime Minister Churchill. "That is for war. The first thing now is for the scientists to discover how it can be harnessed for the beneficial purposes of peace. That will be a long job."

As recently as June 1940, authorities estimated that it would take more than 191 years to make a single gram of concentrated uranium 238, the source of energy reported to have been used in the production of the annihilation bomb. How much has been produced is still a top secret, but this can be said: Much more than 191 years' work has been done in five years.

The combined efforts of the leaders in many scientific fields, from many nations, and facilities of many great American industries have made the employment of atomic energy to shorten this war possible. Those same efforts and facilities can contribute much more to the world.

"A door has been opened in the world of science, and what may be on the other side is still to be seen," says Sir John Anderson. *Popular Science Monthly* hopes to describe that scene to its readers as rapidly as developments make this possible. Its editors hope, too, that readers of this magazine will be stimulated to contribute to the new era of science that dawned on August 6, 1945. By splitting the atom, man may have united the world.



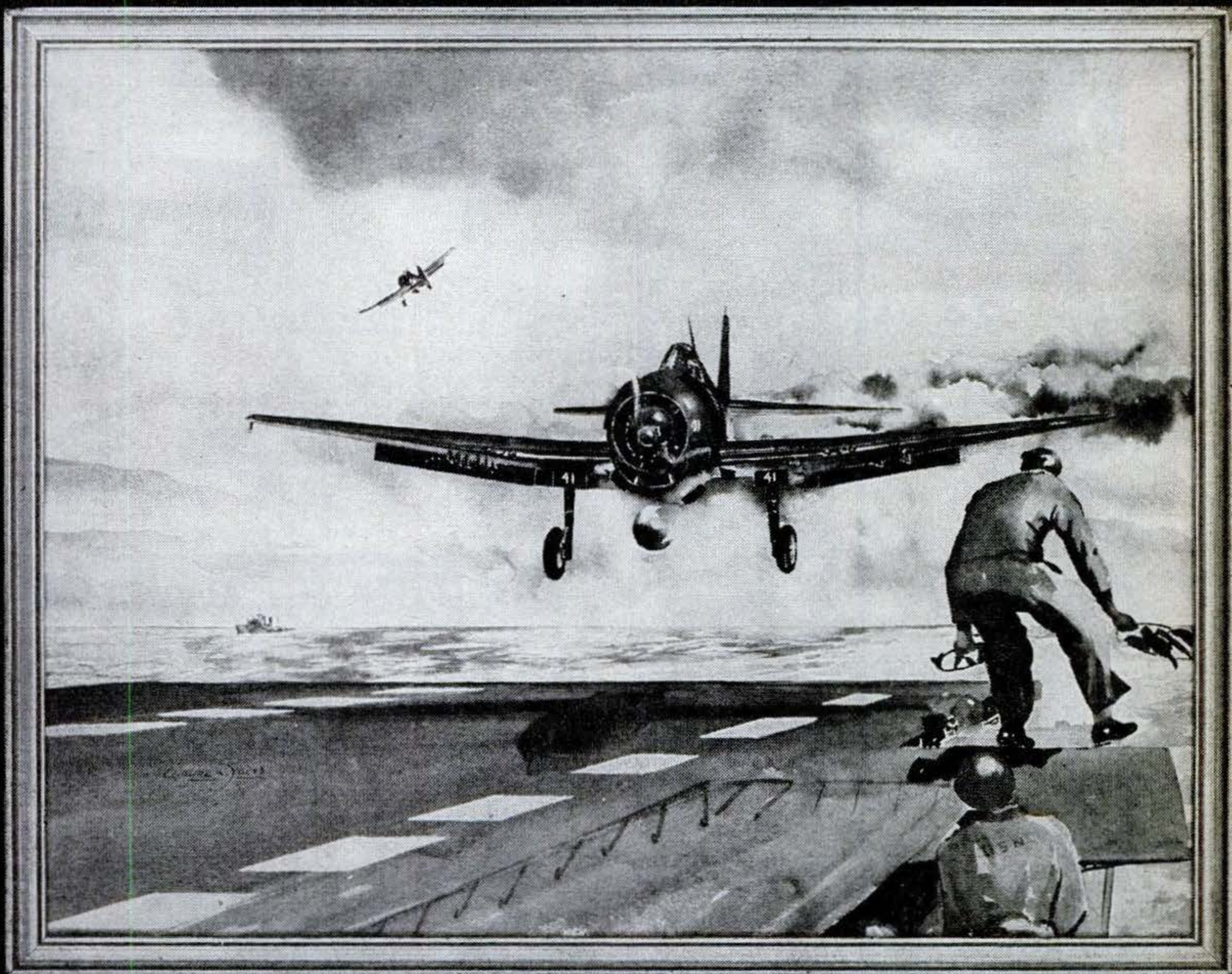

**Rugged Construction of the U. S. Navy's Grumman  
Hellcat Helped Bring This Pilot Back to Fight Again**

**Grumman**

AIRCRAFT ENGINEERING CORPORATION, Bethpage, L. I., N. Y.

Copyrighted material



# SLUDGE... RUINS MOTORS...

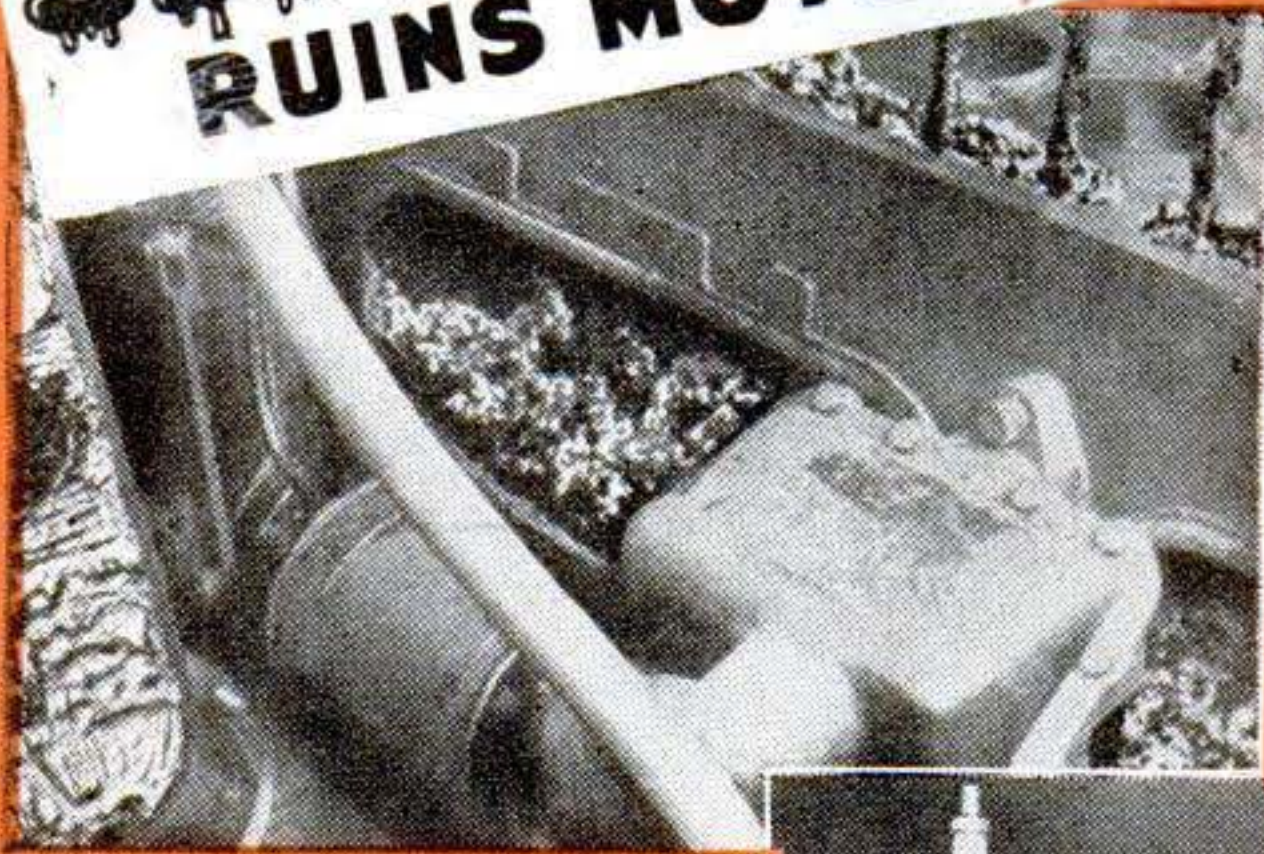

## How Does Your Motor Look Inside?

Accumulation of SLUDGE in motors causes balky engine performance, lack of pep and get-away, gas wastage, expensive repair bills.

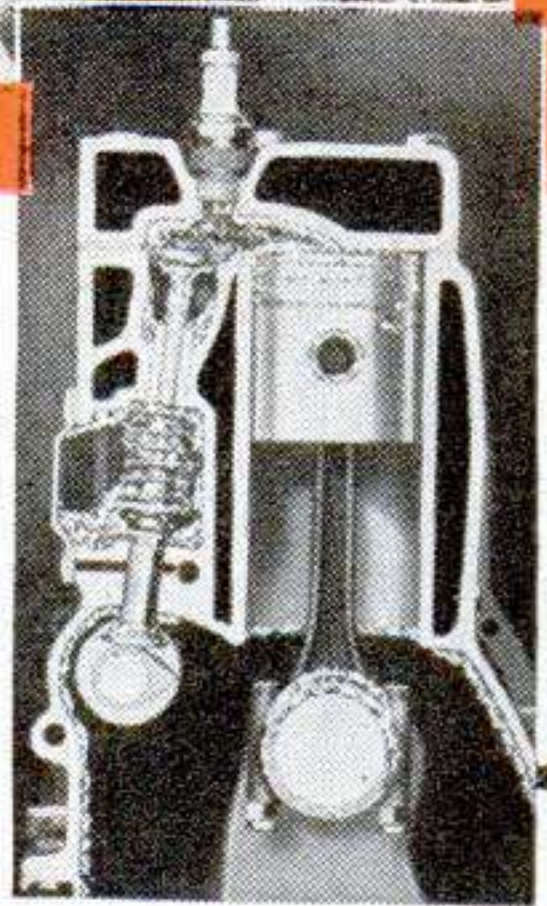

Car owners are getting wonderful results with LUBAID-T, a penetrating solvent for Desludging and Motor Tune-up; for dissolving gum, sludge and carbon binder, freeing piston rings and sticky valves, for pepping up motors.



• *Get rid of sludge. Keep your motor clean—give it new life and pep. Use LUBAID-T.*

A clean motor means longer motor life. Desludge and Tune-up your motor with LUBAID-T.

You can get LUBAID-T at service stations and garages. If not obtainable write us. 12 oz. size 60c. Quart \$1.00.

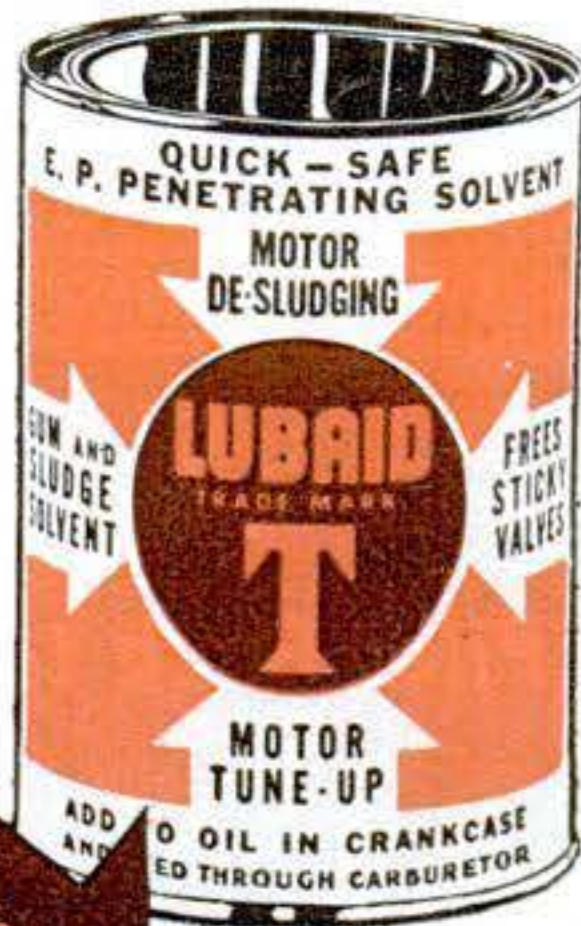

for Pep and Power...  
**DESLUDGE and  
TUNE-UP with**

**LUBAID CO.**  
Dept. 6  
Milwaukee 1, Wis.

**JOBBERs and  
DISTRIBUTORs WRITE**

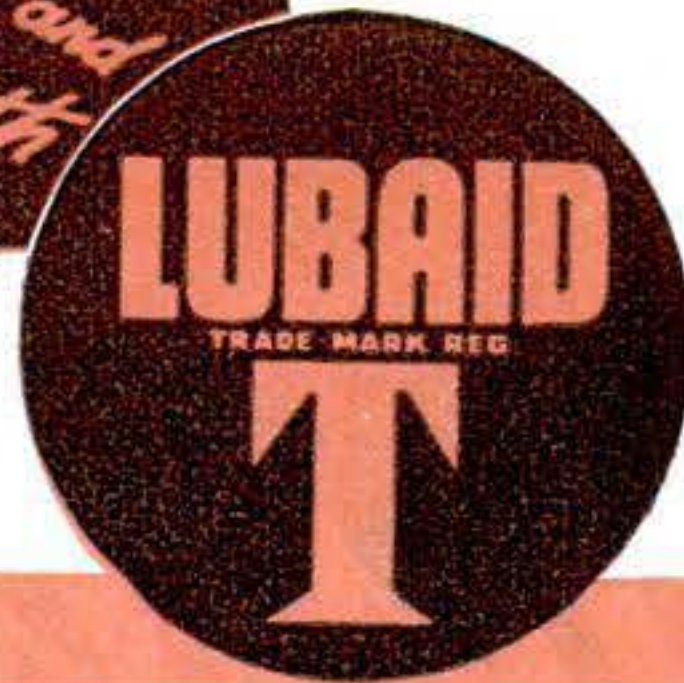

## ADD POWER to your CRAFT SKILL



Write on steel... engrave on glass, plastics... slice into wood, linoleum, cardboard, cloth... tool leather... hammer, file, chisel... do "hand quality" work with

**BURGESS  
vibro-tool**

Trade Mark Reg. U. S. Pat. Off.

Vibro-Tool complete with 20 ordinary engraving needles . . . . . \$750  
Vibro-Tool plus complete set of attachments . . . . . \$1170

We can accept priority rated orders only. Attach check or M. O., or sent C.O.D.



Tools Leather



Carves Wood



Engraves Glass



Slices Cardboard

(HANDICRAFT DIVISION)  
**BURGESS BATTERY COMPANY**

176 N. Wabash Ave., Chicago 1, Ill.

## A HOT COMBINATION! POCKET-SIZE HOTPLATE WITH "HEATAB" FIRE TABLETS

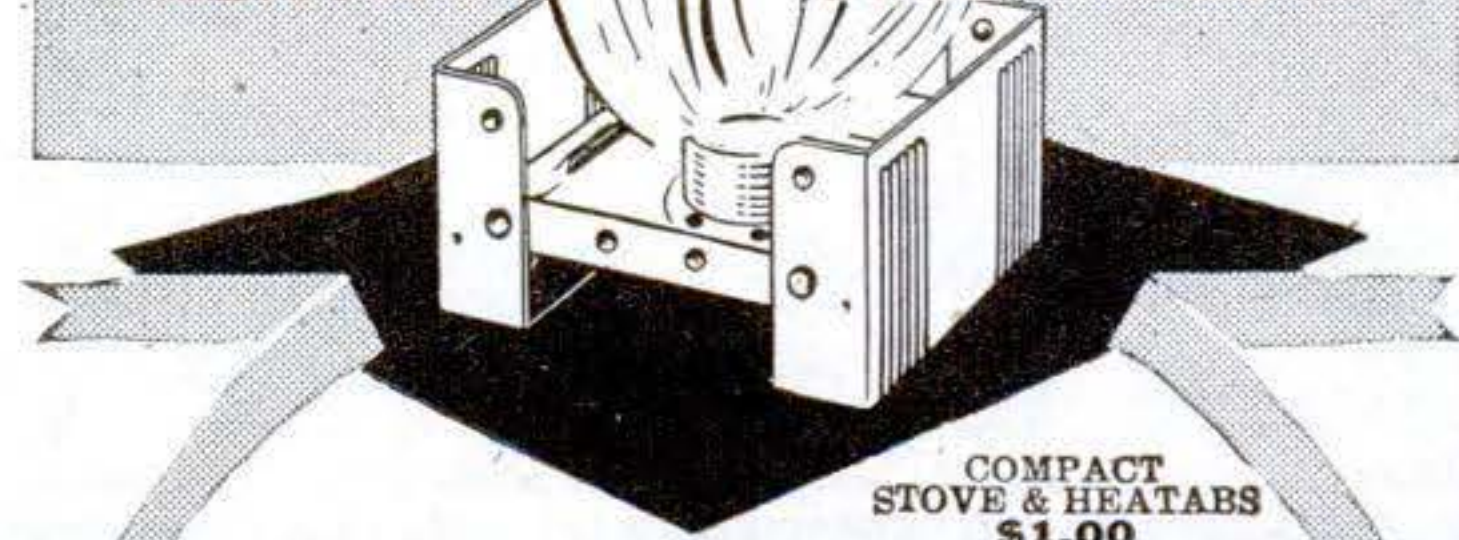

There's nothing else like this sensational COOKIT—so compact you can carry both stove and miracle fuel in your pocket or glove compartment of your car! It's amazing how many ways people are using this famous COOKIT both indoors and out.

Hundreds of uses for mechanics, hobbyists, repairmen in factories, shops, homes, and home workshops. Great for camping, hunting, fishing. Heat all foods—fry or boil—start camp and picnic fires. Handiest portable heating method for homemakers, doctors, dentists, chemists and others. Used extensively by all branches of armed forces—a "swell" gift for friends and relatives in service—Speaker COOKIT complete with hotplate and supply of HEATABS only \$1.00 at your dealer's; or order direct—\$1.00 postpaid. (In Canada \$1.55). No C.O.D.'s, please.

J. W. SPEAKER CORPORATION  
3059 N. Weil St., Milwaukee 12, Wisconsin  
Canadian Speaker Corp., Ltd., Montreal

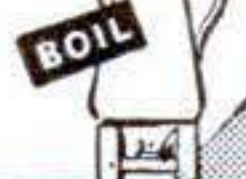

**Speaker  
HEATABS**  
TRADE-MARK REGISTERED

**FIRE  
TABLETS**



# Why Speed Nuts are *FIRST* with all five



ENGINEERING



MANAGEMENT



PURCHASING

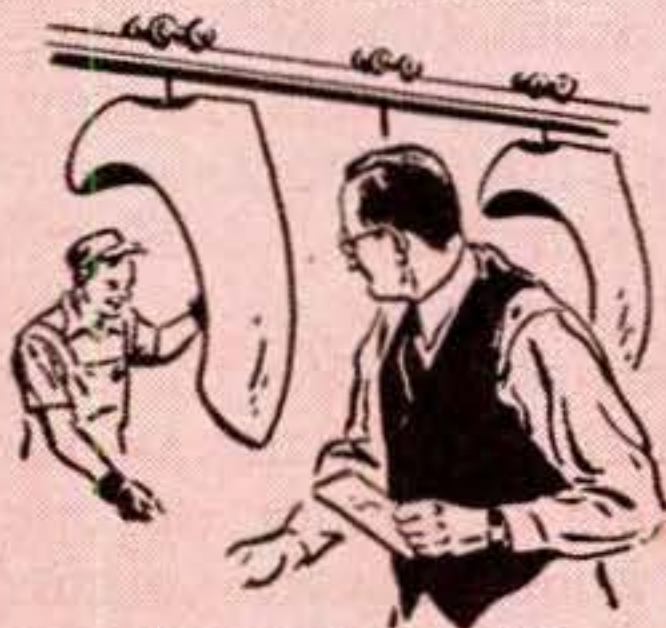

PRODUCTION



TIME STUDY AND COSTS

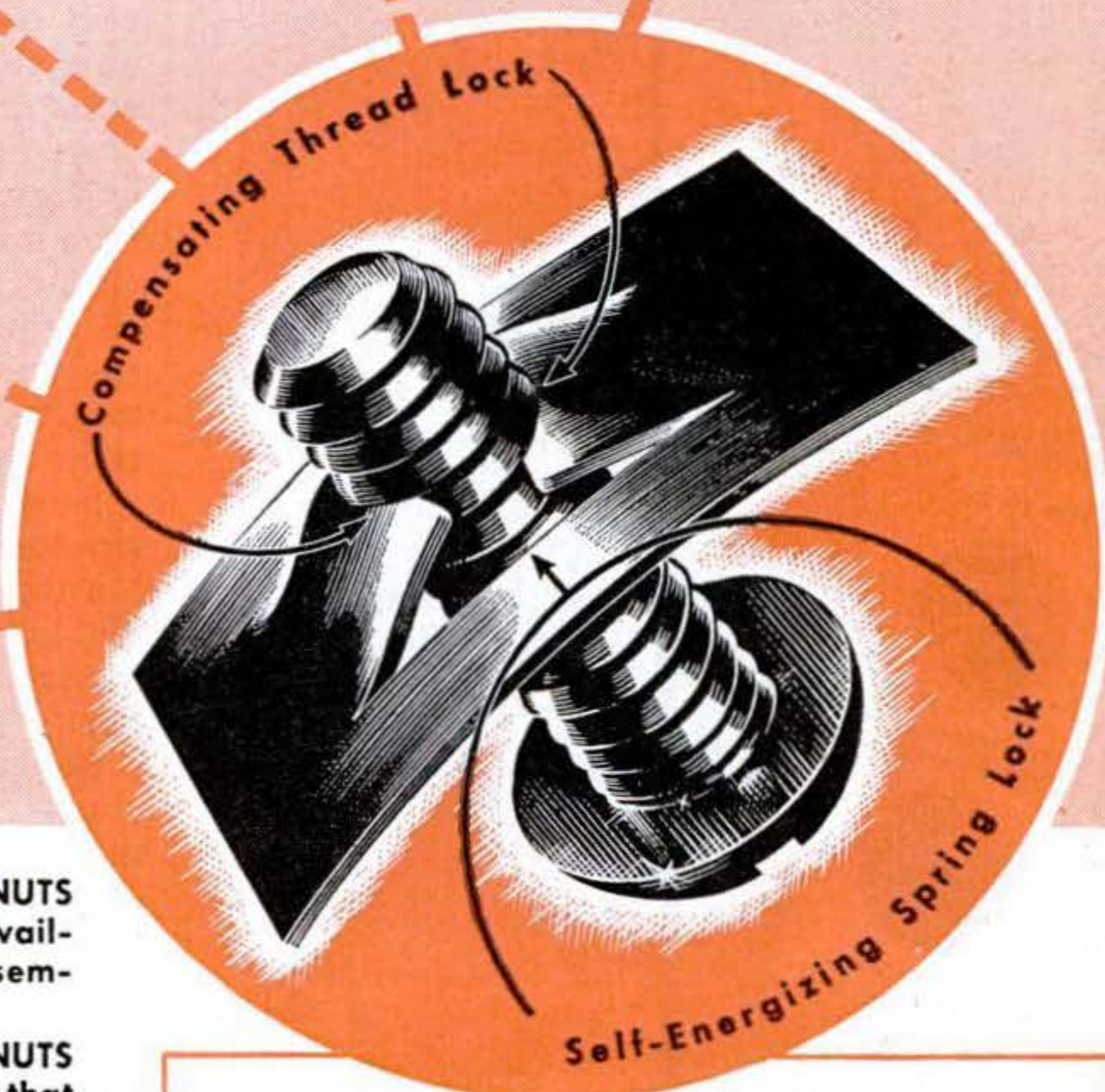

**FIRST** with Engineering because **SPEED NUTS** simplify design problems and are either available, or can be produced to meet any assembly requirements.

**FIRST** with Management because **SPEED NUTS** are time-tested, vibration-proof fasteners that improve the quality, and prolong the life of the finished product.

**FIRST** with Purchasing because **SPEED NUTS** lower inventory costs, reduce stocking problems, and are **DELIVERED** on time. Production and service facilities are unlimited.

**FIRST** with Production because **SPEED NUTS** eliminate extra handling of production parts, are applied faster and easier, and compensate for a wider range of commercial tolerances.

**FIRST** with Time Study and Cost because **SPEED NUTS** slash total net assembly costs to a fraction of other assembly methods.

Investigation will prove that **SPEED NUTS** should be **YOUR** first choice, too. Write for information today.

## NOTHING LOCKS LIKE A SPEED NUT

*TWO* distinct forces are exerted on the screw, as a **SPEED NUT** is tightened.

First, a compensating thread lock, as the two arched prongs move inward to lock against the root of the screw thread. These free-acting prongs compensate for screw thread tolerance variations.

Second, a self-energizing spring lock, created by the compression of the arch in both the prongs and base. The combined forces of the thread lock and spring lock definitely prevent vibration loosening.

**TINNERMAN PRODUCTS, INC. • 2022 Fulton Road, Cleveland 13, Ohio**



PATENTED

\*Trade Mark Reg. U. S. Pat. Off.

**FASTEST THING IN FASTENINGS... OVER 3000 SHAPES AND SIZES**



# "DUSTLESS" SWEEPING SIMPLE AS THIS



Fill the Dustless brush reservoir with Arbitrin

sweeping fluid. In the process of sweeping, this fluid filtering through the tufts makes sweeping compound out of dust on



The result:



Germ culture after ordinary sweeping



Germ culture after "Dustless" sweeping

the floor. The result: You eliminate up to 97% of the dust in the air between sweepings. You also have cleaner floors and cut sweeping costs. Thousands of factories, shops, stores, and schools now use "Dustless"

sweeping. Write for complete facts today.



- Dustless
- Speed Sweep
- Speed Wash brushes

**Dustless**  
DOES MORE FOR LESS

**MILWAUKEE DUSTLESS  
BRUSH COMPANY**

528 N. 22nd Street • Milwaukee 3, Wisconsin

## GI's Fight in Armor

(Continued from page 77)

Improvement of all body armor, including that used by flyers, is going on all the time. Two standard vests for airmen, made of overlapping two-inch-square plates of Hadfield manganese steel in fabric pockets attached to a backing of nylon canvas, now are being produced. One of them, worn by bomber navigators, bombardiers, and gunners, weighs 17½ pounds, and protects both the front and the back of the wearer's torso. The other, worn by pilots and copilots whose backs are protected by armor-plate seat backs, weighs 7¾ pounds and protects only the front of the body. Pilots and others who normally remain seated during flight wear groin armor which weighs 15¼ pounds and gives maximum protection to the abdomen and thighs. Other crew members wear either of two models of armor aprons, one of which weighs about seven pounds and the other about five pounds. The pieces making up the various protective combinations are attached to one another by quick-release fasteners which are connected by a rip cord. A single jerk frees the wearer.

One innovation now being tested in service is flyers' armor that combines an increased area of protection with an important decrease in weight.

Seventeenth-century military men who decided that improvements in firearms had made armor a useless and dangerous encumbrance must be stirring uneasily in their graves.

**FOR BEST RESULTS  
INSIST ON**



**PERFECTION**

*Inner-Flow*

**WICKS**

**FOR YOUR PERFECTION  
OIL RANGES AND WATER HEATERS**

- last longer • give clean, uniform heat perfect flame control
- patented *INNER-FLOW* construction feeds oil evenly, prevents shrinking, stretching
- easy to install, adjust and remove

**PERFECTION STOVE COMPANY  
CLEVELAND 4, OHIO**



HE DESERVES A LIFE THAT'S **BRIGHTER...**

3 CHORES **LIGHTER...**

IT'S *easy* WITH **PERFECTION!**

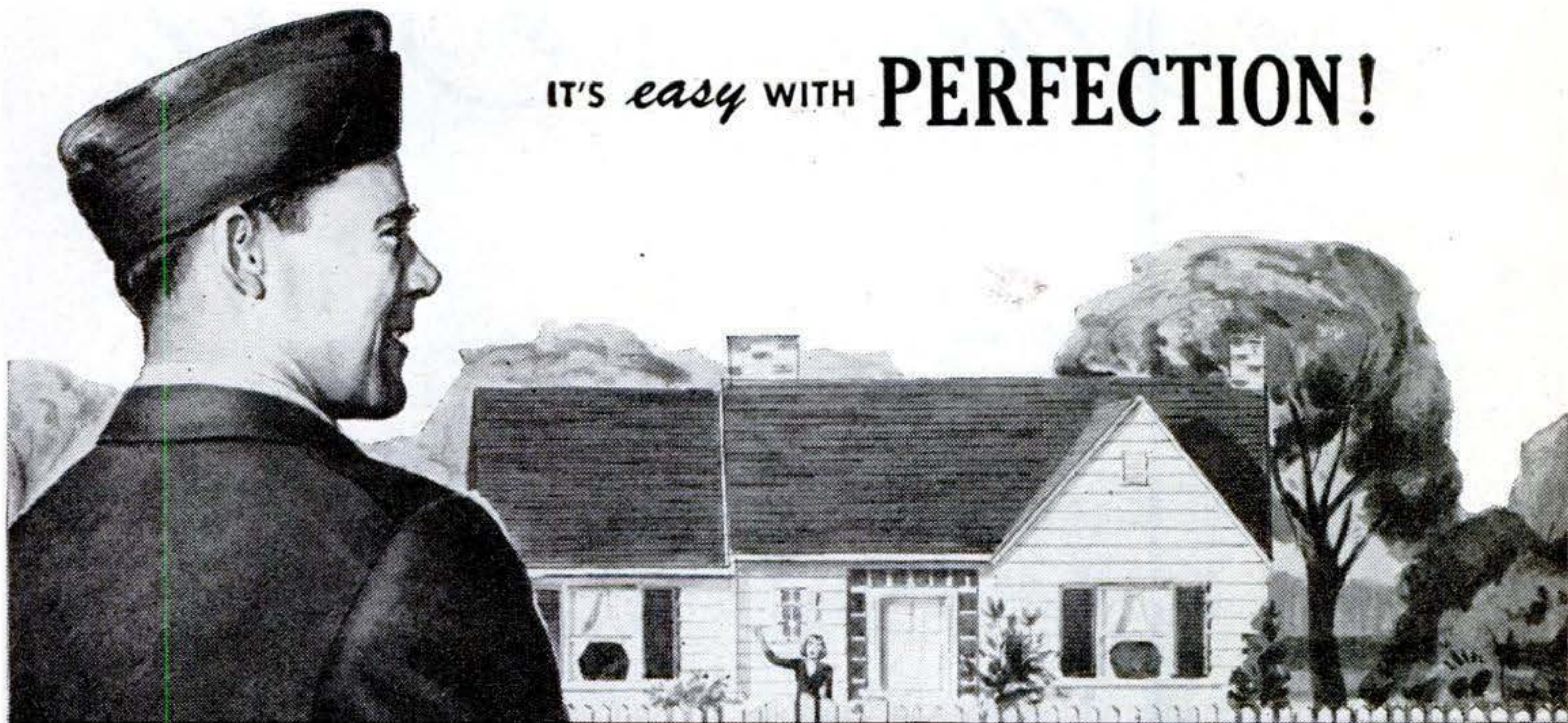

### 1-SOMETHING TO LOOK FORWARD TO..

Every room in the house warm and inviting in winter—thanks to Perfection Oil-Burning Heaters. And all the warmth without work or dirt! Dial control gives any degree of heat you want. Heat-directing shutters send heat where you want it—keep floors warmer. Blower and humidifier extend heat range and increase comfort.



### 2-WATCH HIS EYES SPARKLE...

When he sees what a Perfection Oil Range can do to the kitchen! So bright and cheery—so clean and convenient. Ashes, dirt, soot and clutter—gone forever! "High Power" burners give any degree of heat you want. "Live Heat" oven assures better baking. Perfection in the kitchen means *better living*.

### 3-PLENTY OF HEAVENLY HOT WATER...

On tap all the time for baths, housework and laundry—thanks to Perfection's modern Oil-Burning Hot Water Heater. What a comfort that will be!

*Due to our war work only limited quantities available at present.*

**PERFECTION STOVE COMPANY • 7785-A Platt Ave., Cleveland 4, O.**

Buy War Bonds

The Mark of Quality

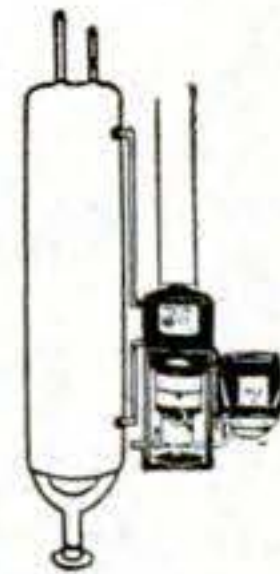

**PERFECTION**  **RANGES • HEATERS • HOT WATER HEATERS**



# Blatz Beer



THE KEY TO

Good  
Taste

BUY... Don't Sell  
War Bonds!

Fast Becoming  
America's Favorite



Copyright 1945, Blatz Brewing Co., Milwaukee, Wis. In our 95th year



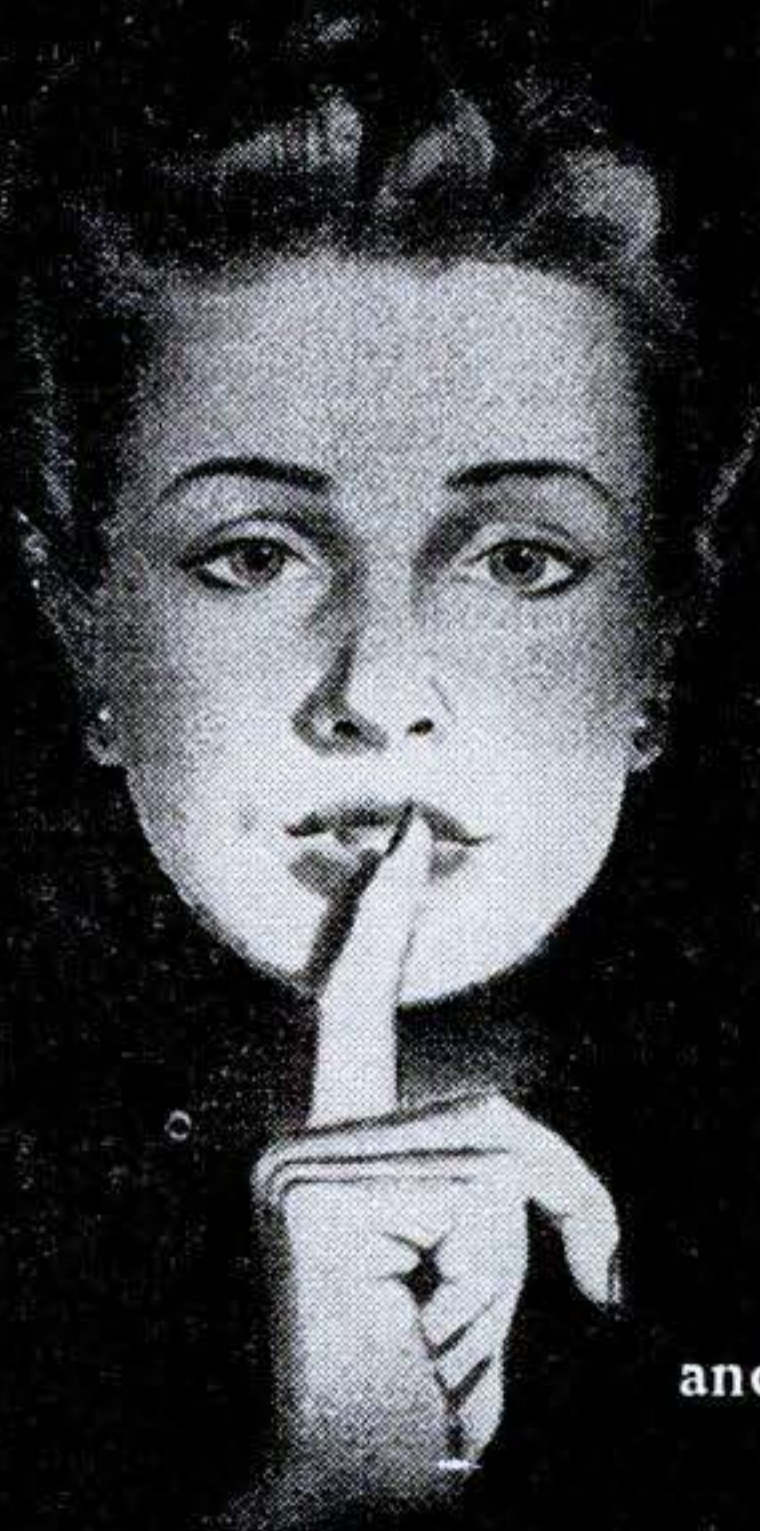

*Quiet*

Design engineers looking for peak efficiency and long life in fractional H.P. motors, will pick a QUIET motor—a BALLENTINE MOTOR. Because only skilled craftsmanship, strict adherence to close tolerances, *precision dynamic balance* plus modern manufacturing methods and equipment can produce a truly QUIET motor.

In BALLENTINE MOTORS, the engineer finds all these factors—at *their best*—combined with suitable mechanical and electrical design. *Quiet* BALLENTINE MOTORS are available in ratings from 1/1000 to 1/6 H.P.—adapted to your specific application.

Write for descriptive bulletin.

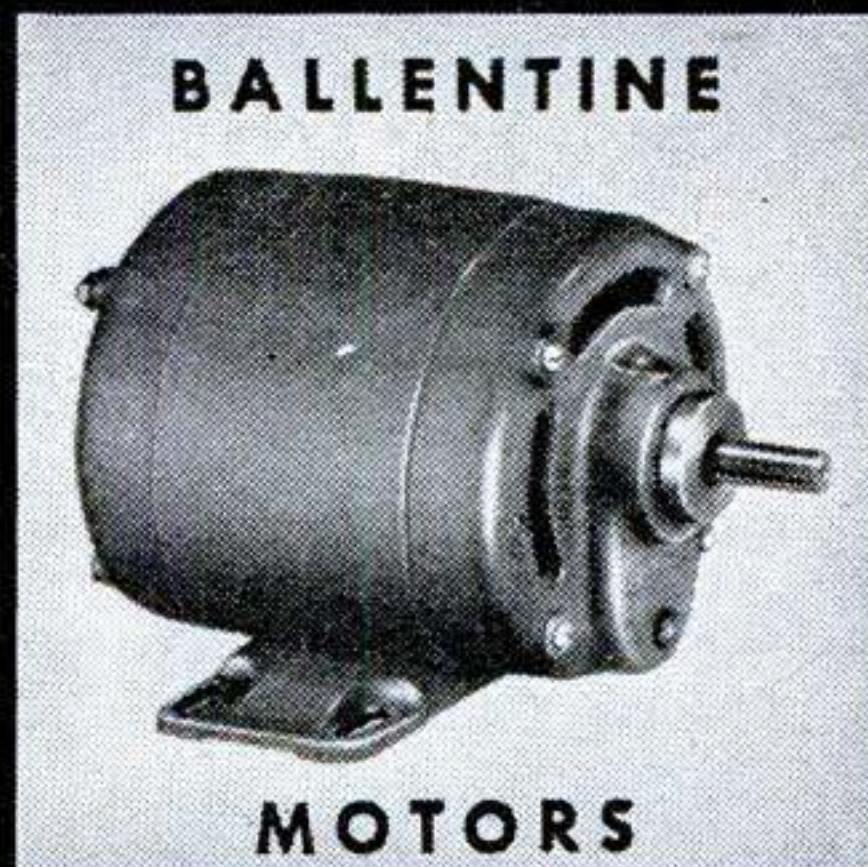

**BALLENTINE MOTORS**

*Manufactured by*

**RUSSELL ELECTRIC COMPANY**

358 W. HURON STREET, CHICAGO 10, ILLINOIS



CUSTOMBILT FROM BOWL TO TIP

**CUSTOMBILT** is a pipe for the affections... It is a treasure to handle and a friend to smoke... Bench-made by stylists who never repeat themselves... No two ever alike... Carved from the largest stummels of selected imported Bruyère, so as to give the cooler smoke of a larger bowl... Lightweight and broken-in the instant it is filled and aflame.

CUSTOMBILT  
*Pipe*

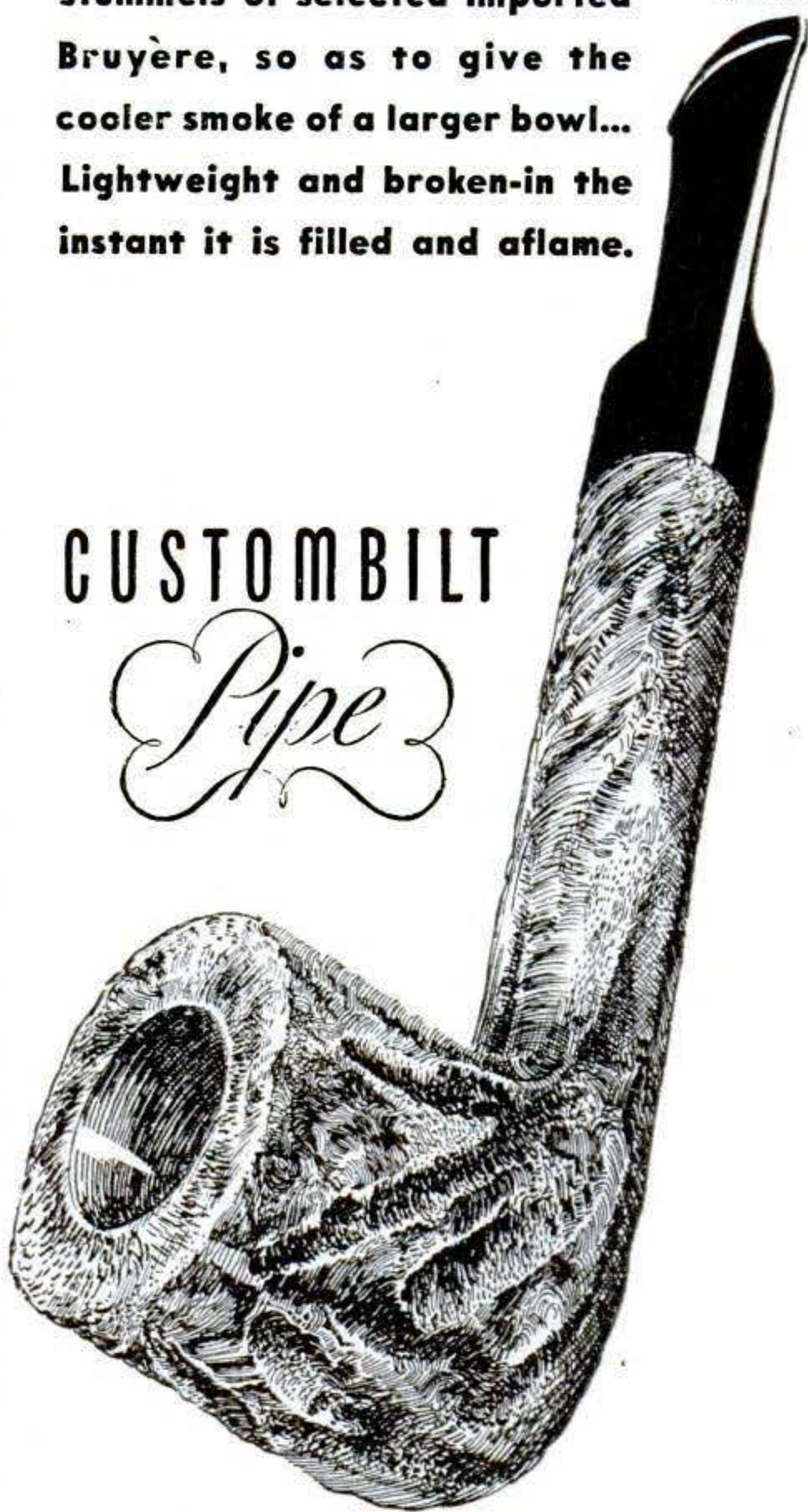

*Pipe illustrated, \$8.50. The CUSTOMBILT Pipe collection includes a wide range of styles at \$5, \$7.50, \$8.50, \$10, \$12.50 and up. All packaged in handsome gift boxes. Only at Better Stores.*

**John Hudson Moore, Inc.**, 663 Fifth Ave., N. Y. 22  
Distributors also of Sportsman Pipe Mixture, Sasieni Fine English Pipes and Sportsman Toiletries for Men.

## Kickless Cannon

*(Continued from page 87)*

The 75, too, can be loaded and fired by two men, but in many situations the heavier ammunition—each round weighs 14.7 pounds—would make the assignment of additional ammunition carriers necessary.

The 57 can be fired from the standing, sitting, and prone positions, or it can be rested on the standard .30 caliber machine-gun tripod. The 75 normally is fired from a tripod, but in an emergency can be fired from a mound of earth.

Three kinds of ammunition are being used: high-explosive, for use against personnel, unarmored vehicles, and such targets as light field defenses; high-explosive antitank shells for use against tanks, pillboxes, and the like; and white phosphorus, good both for smoke and against personnel. The high-explosive projectiles have very sensitive fuses. They will detonate on touching foliage. That makes the recoilless gun an effective weapon against tree-sitting snipers.

The idea of the recoilless gun was conceived by, and the weapon developed under the direction of, the Small Arms Development Division of Army Ordnance's Research and Development Service. Engineering assistance was given by a number of industrial concerns.

The weapon is so new that a doctrine for its tactical use has not yet been formulated. The organization of recoilless-rifle infantry platoons, with a firepower equal to, or even greater than, a field-artillery battery is possible. It may be that the application of the principle will have a profound effect on the development of all artillery weapons—for aircraft, antiaircraft, and naval as well as field-artillery fire.

The recoilless gun is not an unmixed blessing to men at war. While its muzzle velocity is far above that of the bazooka's rocket projectile, it is half or less that of an ordinary fieldpiece built to take the backward kick of propellant gases. That means a reduction in range and effectiveness in the delivery of explosives on a target.

But as a way of boosting the firepower of the infantry, its success has been unquestioned. One excited Jap officer on Okinawa, practically catapulted into the arms of his enemies by gunfire, jabbered away at the interpreter, demanding apparently that he be shown something. The interpreter and the intelligence officer finally gathered what he wanted. He was interested in only one thing—the new American artillery that popped up anywhere and everywhere on the battlefield and broke all the rules of heavy-gun mobility.—DEVON FRANCIS.







THE SPHINX USED  
TO LOOK DOWN UPON:



PIPES  
LIKE  
THESE  
IN  
EGYPT



LHS TODAY, IT'S  
**STERNCREST**  
STERLING  
IN EGYPT,  
AND EVERYWHERE OUR BOYS HAVE GONE

LHS has never turned out better pipes, nor more pipes, in the 50 years of LHS pipe-making. And yet, so great is the demand for overseas as well as civilian needs, that dealers' stocks are often depleted. But things look better. More LHS pipes are getting around. If your dealer hasn't your favorite model today, ask again tomorrow. An LHS is worth waiting for.

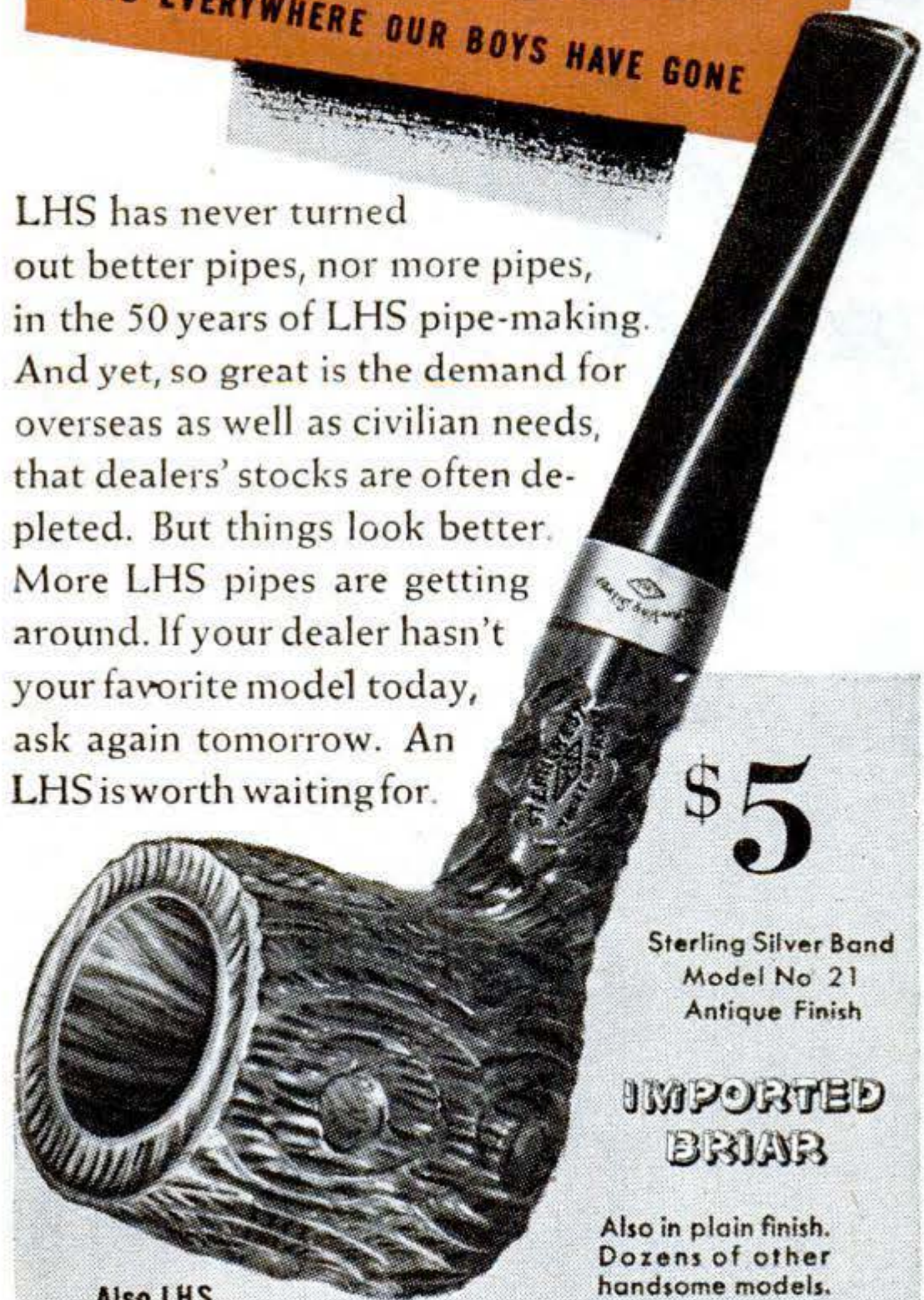

\$5

Sterling Silver Band  
Model No. 21  
Antique Finish

IMPORTED  
BRIAR

Also in plain finish.  
Dozens of other  
handsome models.

Also LHS  
Sterncrest 14K  
Specially selected  
imported briar.  
14K gold band.  
Plain and antique  
finishes . . . \$7.50

AT ALL GOOD DEALERS

KEEP ON BUYING  
WAR BONDS

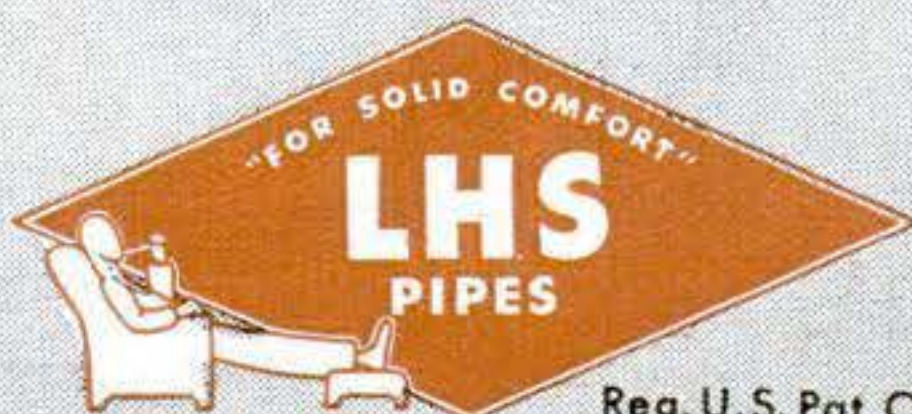

Reg. U.S. Pat. Off.

FREE—"Pointers on Pipes"—Write  
L & H STERN, INC., Stern Bldg., 56 Pearl St., Brooklyn 1, N.Y.

**A TOOLSHOP  
IN YOUR HAND!**

- GRIND • DRILL
- POLISH • ROUT
- ENGRAVE • CUT
- CARVE • SAND
- SAW, etc.

**HANDEE** TOOL OF 1001 USES

The original hand tool and today's finest for precision work on any metal, alloy, plastic, wood, horn, bone, glass, etc. Fits your hand comfortably, perfectly balanced, weighs only 12 ounces—it's the "non-fatiguing" tool. And Handee's usefulness is as extensive as the number of quick and easy-to-change accessories you own...choose from more than 300 in the Chicago line. Operates on AC or DC current at 25,000 r.p.m. With 7 accessories, postpaid **\$18.50**



Write for free new 64-page catalog  
**CHICAGO WHEEL & MFG. CO.**  
1101 W. Monroe St. Dept PO, Chicago 7, Ill.

SEAL OUT  
WINTER'S DRAFTS AND DIRT —  
CUT FUEL BILLS — WITH  
**KALK-KORD**  
SEAL CRACKS QUICKLY, EASILY,  
WITHOUT TOOLS

**Kalk-Kord**, the original non-hardening caulking compound in soft, rope-like form, enables you to effectively seal window and door frames, cracks and crevices, inside or out.

Just press Kalk-Kord into the crack or hole with fingers; no tools required. Kalk-Kord will not harden, check, or crack. It seals tightly and stays tight.

Don't wait till cold weather — use Kalk-Kord to seal out winter's cold right now. It cuts heating bills; saves cleaning of walls and drapes due to soot and dust. Use it also to plug and seal holes in wood or plaster. Kalk-Kord is waterproof and can be painted over at once, if desired.

Packed in convenient rolls, ready for use—neat and clean to work with. Anyone — and everyone — can use Kalk-Kord. Get a box today.



Buy Kalk-Kord at your nearest  
Sears-Roebuck retail store, or order by mail from Sears.

**PRESSTITE ENGINEERING COMPANY**  
3976 CHOUTEAU AVE. • ST. LOUIS 10, MISSOURI





## "That was the day you Got the Limit..."

"... Remember, Joe, it was one of the best shoots we ever had. They started coming over early and you got two sets of doubles out of the first two flights. You really folded 'em up!"

"You bet I remember... that was the day I used my STEVENS 620 Pump for the first time and found out what a difference its perfect balance, split-second speed and smooth, straight-back action made on that all-important second shot."

1 1 1 1

Joe's right! The *right* gun makes a difference! Ever since STEVENS pioneered the development of repeating shotguns nearly 40 years ago, STEVENS "pumps" have been famous for sweet handling, dependability and value. J. STEVENS ARMS COMPANY, Chicopee Falls, Mass. Division of Savage Arms Corporation. Manufacturer of STEVENS and SPRINGFIELD Rifles and Shotguns.

### Some STEVENS models Available NOW

In accordance with Government regulations, STEVENS is producing a limited number of rifles and shotguns in a few standard models for essential uses, to the extent that their production does not interfere with our war work. See your dealer about availability and remember... your new STEVENS is worth waiting for.

STEVENS 22 Cal. Automatic - three rifles in one. One of a great line of STEVENS .22's.

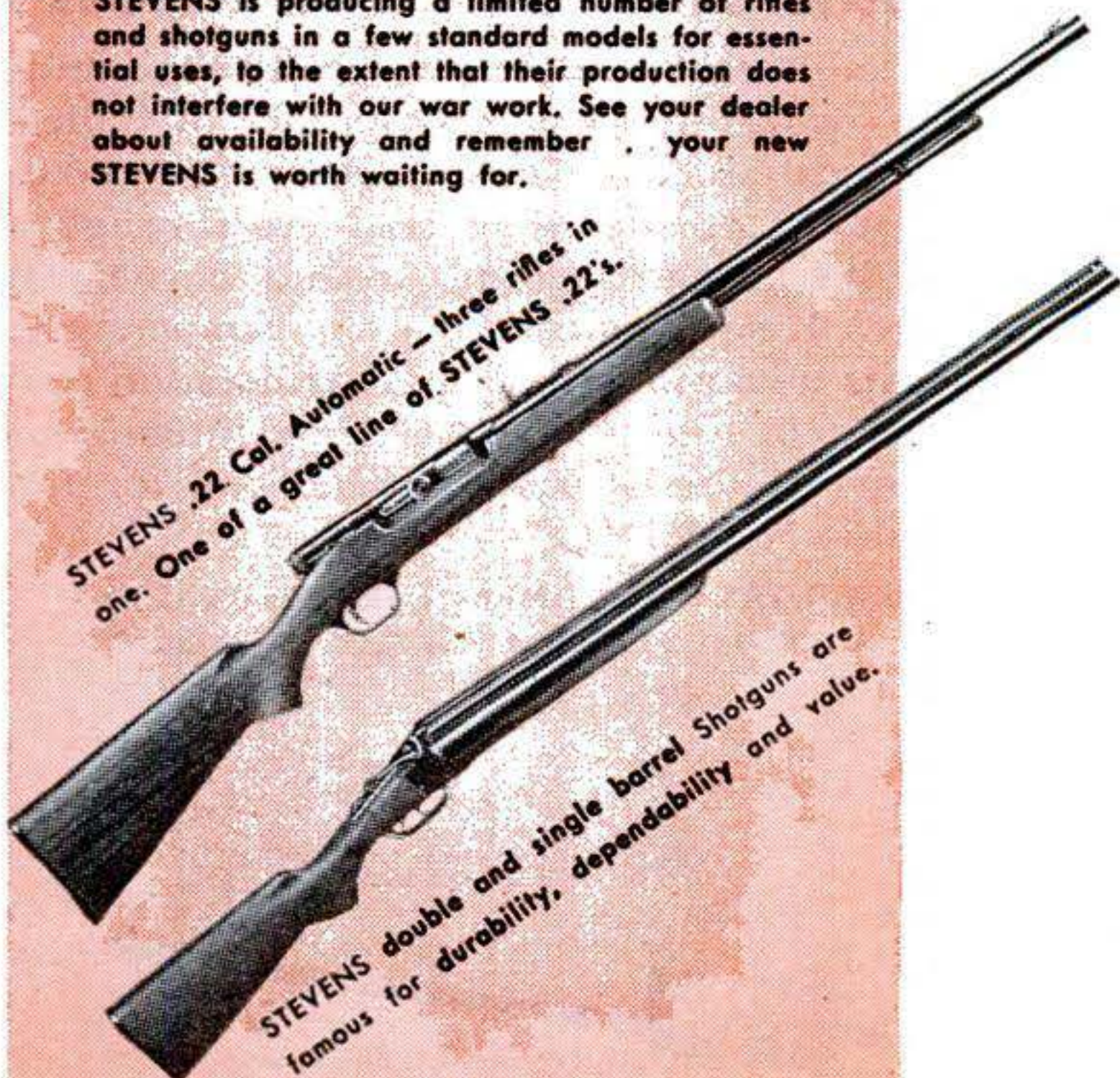

STEVENS double and single barrel Shotguns are famous for durability, dependability and value.





# ANCO RAIN-MASTER

"Dead-Locker"

WINDSHIELD WIPER  
ARMS and BLADES

BLADE SNAPS ON...  
STAYS PUT

FINGER-  
TIP  
RELEASE

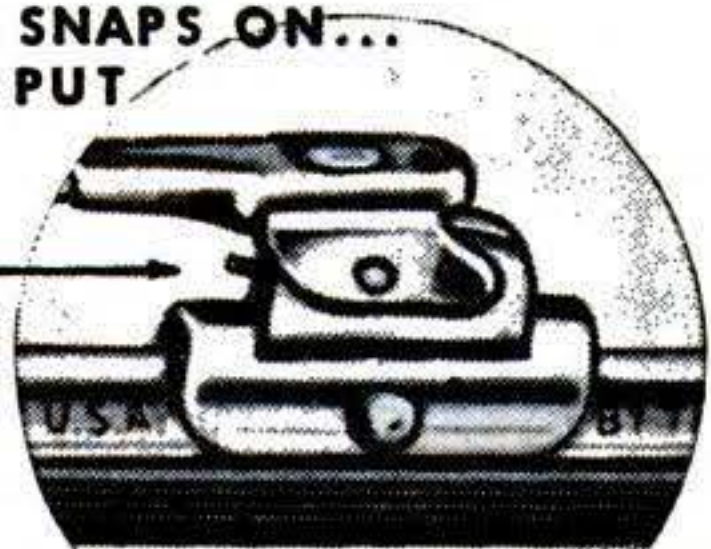

CAN'T FALL OFF  
CAN'T BLOW OFF

(A war-born invention—by ANCO—first)  
for military aircraft—now for your car.)

## DON'T SHOOT YOUR GAS-PUMP MAN!

He's doing the best he can. Sure, he knows how dangerous it is for you to drive your car... in stormy weather... with your dull old windshield wipers that smear and smear. He'd gladly put on for you quickly a pair of keen new ANCO RAIN-MASTER Wiper Blades and Arms. He has them. But he forgets to remind you? Too busy? It's the war! You can't shoot him for that.

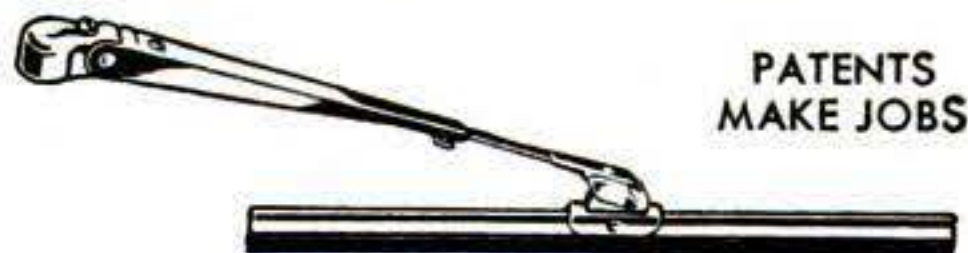

After all, it's *your* car to protect. So *you* remind *him*. Get RAIN-MASTERS... patented features... original equipment on many makes of high grade peace-time cars... used on our fighting tanks and trucks and ships and bombers too... because ANCO RAIN-MASTERS clean quicker, clean cleaner... last longer. May save you a costly smashup.

Ask for RAIN-MASTER Windshield Wiper Arms and Blades next time you buy gas.

**THE ANDERSON COMPANY**  
Established 1918  
GARY, INDIANA

# PIB NEW PENETRATING LIQUID INSULATION

Moisture-Proofs  
Ignition Systems  
USED BY ARMY AND NAVY



**PIB**, new miracle *liquid* insulation, moisture-proofs the ignition system on motor cars, motorboats, planes. It makes batteries last longer by fighting corrosion and top-surface shorts. **PIB** seals worn insulation, helps start rain-stalled engines.

**PIB** flows easily... penetrates... dries pliable... endures. **PIB** is so effective that it's used on engines of Army and Navy vehicles during amphibious operations. Use **PIB** on any gasoline or electric motor... industrial and farm machinery... home appliances.

### 1 TREATMENT FOR 6-MONTH SAFETY!

1-oz. bottle... 75¢ 4-oz. bottle... \$1.50

Send **TODAY** for **FREE** booklet on **PIB**

U. S. Industrial Chemicals, Inc., Dept. E-3,  
60 E. 42nd Street, New York 17, N. Y.

USI Product



Get **PIB** at service stations—  
hardware, electric, dep't stores!



## PULVEX FLEA POWDER

*Kills fleas*

25¢  
AND 50¢

100% SATISFACTION  
...OR MONEY BACK

## STOKER EMPTIES OWN ASH!

A remarkable stoker already used by thousands of home owners—fits into any furnace or boiler. Manufactured since 1934. So automatic it takes the coal from your present coal bin through a pipe to the furnace, going around corners if necessary. Keeps house at even temperature, empties its own ash in sealed containers, no coal to shovel, no clinkers to dig, only bituminous stoker of its kind on the market. Send for full information NOW!

POCAHONTAS FUEL COMPANY INCORPORATED  
341 EAST 131st STREET • CLEVELAND 8, OHIO





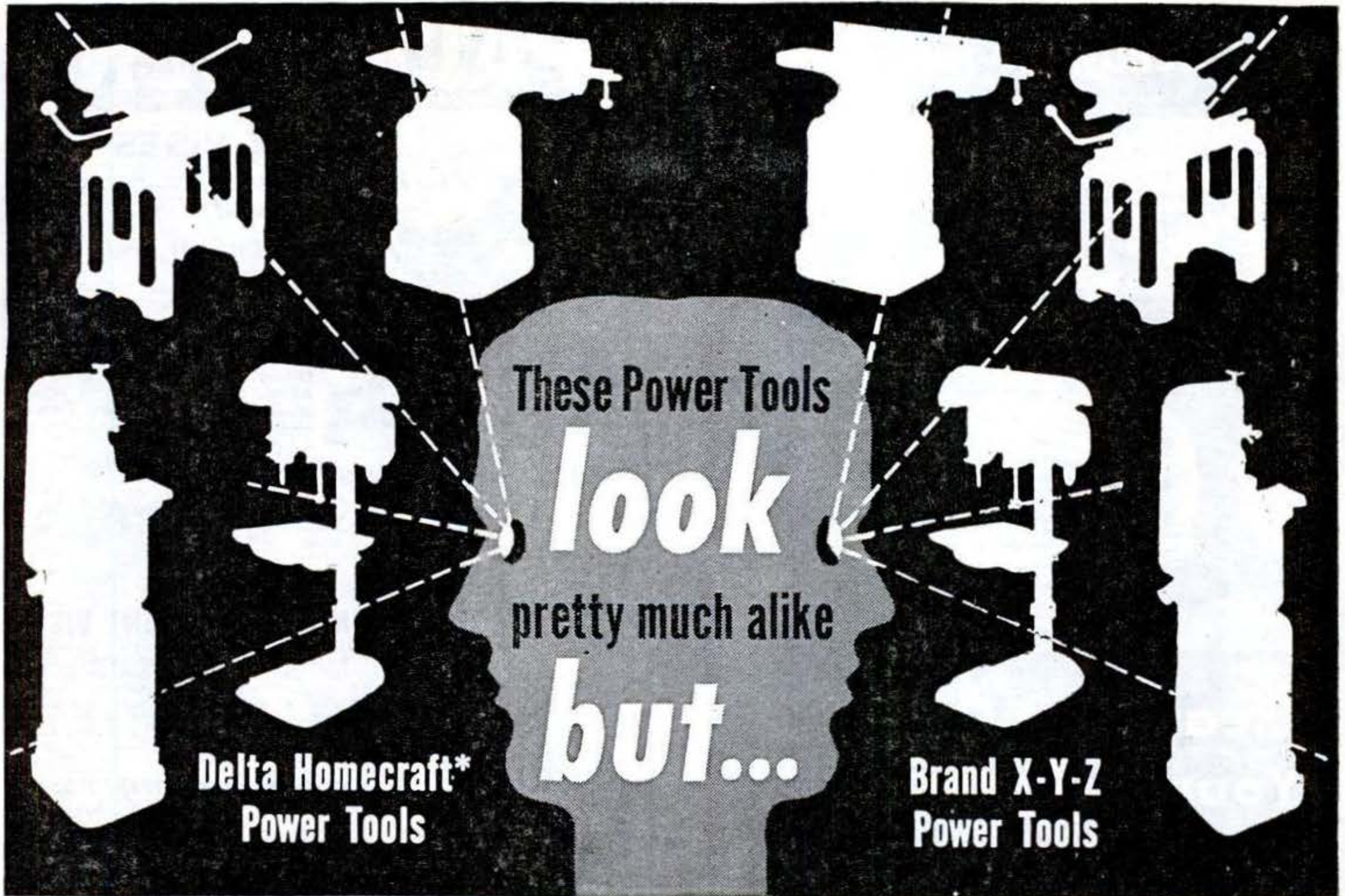

## Advanced Engineering of the Delta tools helps you get greater operating satisfaction

**Delta**  
MILWAUKEE  
REG. U.S. PAT. OFF.  
**Homecraft**  
REG. U.S. PAT. OFF.  
Power Tools

The line of Delta Tools includes Delta Scroll Saw, Delta Band Saw, Delta Circular Saw, Delta Lathe, Delta Drill Press, Delta Jointer, Delta Grinder, Delta Shaper.

*"Furniture Designs"*  
**25¢**

- 1** **Delta's industrial-type construction features help assure you of accuracy, dependability, safety, economy:**  
*Lubricated-for-life Ball Bearings.* You don't have to worry about oiling these bearings — they're *lubricated for life* when they leave the factory. And they are *double-sealed* against harmful dust, to assure you of longer bearing life.
- 2** *Pre-loaded Bearings.* This is the result of an extra manufacturing operation that reduces the "play" in the bearings, to help you enjoy long-time operating efficiency and accuracy.
- 3** *Precision-bored Bearing Seats.* These bearing seats help keep all parts lined up properly, so that you have greater assurance of producing finished pieces exactly according to dimensions.

- 4** *Precision-ground Shafts.* These are shafts built to run without any "wobbling" which might throw off your measurements.
  - 5** *Dynamically-balanced Pulleys.* The pulleys which transmit the power from your motor to your power tool are balanced to help eliminate annoying, damaging vibration.
- In selecting *any* power tool, it pays to choose *Delta*, to get built-in values like these.
- So to enjoy a full measure of the pride and pleasure that arise from the deep satisfaction of using *quality* tools, include famous Delta Homecraft Power Tools in your woodworking hobby plans.
- Right now, save for your happiness — and earn the right to enjoy it — by buying and holding War Bonds.

Tear out coupon and mail today for 56-page Delta book containing complete plans and instructions for making dozens of good-looking pieces of furniture — desk, book cases, cabinets, cupboards, etc. Enclose coin, postal note, or money order with coupon at right!

\*Trade Mark Reg. U. S. Pat. Off.



THE DELTA MANUFACTURING CO.  
682K E. Vienna Ave., Milwaukee 1, Wisconsin

I am enclosing 25¢ in full payment for copy of Delta's book, "Furniture Designs."

Name.....

Address.....

City..... (.....) State.....



## Get Ready for Anti-Freeze



## Clean Rust Out of Your Radiator

Now's the time to rid your cooling system of rust, scale and grease—before the cold weather sets in and you have to add anti-freeze. Don't wait for the big rush—do the job now. Du Pont's Cleanser actually dissolves rust—cleans thoroughly without harming the hose, packing or metal parts.

### DU PONT Cooling System Cleanser



### THEN KEEP RUST OUT

After cleaning out the cooling system, you can stop more rust forming—and prevent acid, too—by pouring in a can of

### DU PONT Acid and Rust INHIBITOR

### PREVENT RADIATOR LEAKS

Make the cooling system of your car LEAK-PROOF. Don't let your precious anti-freeze seep away this winter. You can stop the leaks, and keep them sealed, by pouring into the radiator a bottle of

### DU PONT Cooling System Sealer



BETTER THINGS FOR BETTER LIVING... THROUGH CHEMISTRY

Buy War Savings Bonds and Stamps regularly.

# PALMGREN

## ANGLE VISES

For MILLING—DRILLING—GRINDING  
FITTING—FILING

Solve Difficult Angle Jobs



No. 000  
Mt'd on  
Swivel  
Base

Quick, accurate setups at any angle. End make-shift methods—time loss—rejections. Ideal for tool rooms or home workshop. Accurately machined and graduated. Once set it stays locked. Jaws hardened steel—plain or grooved. Sizes 1 1/2" to 8" Jaws.

## DRILL PRESS VISES

For tool room, machine shop, school shop, home shop or repair shop. Accurately machined. Best semi-steel castings. Adjusting screw of hardened steel with fine pitch thread and long bearing. Jaws hardened steel, grooved or plain. Sizes 1 1/2" - 2 1/2" - 4" Jaws.



## No. 250 MILLING ATTACHMENT VISE

A most necessary fixture for small shops and even emergency work in large ones. Adaptable for South Bend, Atlas, Craftsman, Sheldon or other lathes of similar size. Has graduated vertical feed screw and 360 degree graduation for vertical angle adjustments. Easily mounted on cross slide and held by one T-slot bolt. Equipped with PALMGREN VISE, 2 1/2" Jaws opening full 2 1/2". Vise has one plain and one grooved jaw for holding round pieces.

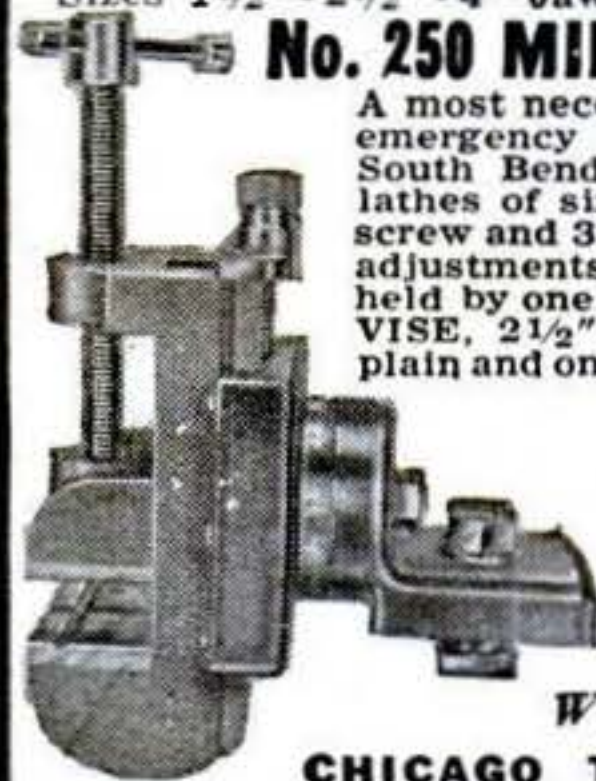

### MAKES MILLING OPERATIONS POSSIBLE ON ANY LATHE

Width Jaw	Depth Jaw	Opening Jaw	Height	Price
2 1/2"	1-7/16"	2 1/2"	10 1/2"	\$24.75

If your Dealer can't supply—order direct!

Write for Circular No. 347

CHICAGO TOOL AND ENGINEERING CO.  
8396 South Chicago Avenue Chicago 17, Ill.

### Build the World's Biggest Model Values

26 1/2" Boeing B-29 SUPERFORTRESS. Semi-solid. Line-Controlled. \$1.00 C-D Kit AU-200.



Boeing B-29 "Super-fortress" Greatest of All Bombers

Sears for hours

Huge 84" Super CONDOR Soarer. Glider. C-D Kit E-5019, \$1.00



Biggest \$1.00 Model in U. S.

If your dealer can't supply you, order direct, including 20c extra for packing - postage.

BLACK WIDOW C-D Kit T-155 \$1.50 CATALOG 5c (None Free)  
CLEVELAND MODEL & SUPPLY CO.  
★ 4508 E 86 Lorain Ave., Cleveland 2, Ohio, U. S. A. ★

## TRY THIS QUICKIE!

Cracks and nicks can be filled with PLASTIC WOOD, then refinished like new. At Paint, Hardware, 10¢ Stores.



## PLASTIC WOOD

HANDLES LIKE PUTTY • HARDENS INTO WOOD



# "HARLEY-DAVIDSONS STAND UP

**under all kinds  
of conditions!"**

Pvt. Jim O'H., writes from the Pacific area: "Just received the Enthusiast Magazine. It brings back memories of the days we all enjoyed so well. Since coming overseas, I've seen how Harley-Davidsons stand up under all kinds of impossible conditions. I've ridden your military model 45 through many miles of swamp and jungle — have seen them under enemy shell fire and not once have they failed to complete their missions. You can be sure that when the postwar Harley-Davidsons roll off the line I'll be first in line."

Thanks, Pvt. Jim O'H. — we know all you fellows are looking forward to the days when you can again enjoy race meets, hill-climbs, endurance runs and other fun-packed motorcycling events. Like you, thousands of motorcycle fans have a new Harley-Davidson on their "want first" list.



## HARLEY- DAVIDSON MOTORCYCLES

HARLEY-DAVIDSON MOTOR CO.  
Department PS, Milwaukee 1, Wisconsin

Please send at once free copy of 24-page  
"Enthusiast" Magazine, filled with motor-  
cycle action pictures and thrilling stories.

Name.....

Address.....

City..... State.....



SEND COUPON  
NOW





## EXPERT CRAFTSMANSHIP

In ages past men spent fortunes to own Damascus swords. Their fame and value were due to the expert craftsmanship of the makers whose skill could not be duplicated.

Plumb tools, too, are the work of expert craftsmen who pride themselves in turning out the finest products obtainable.

The one-piece steel head of flawlessly tempered steel, the carefully-shaped handle of shock-absorbing, close-grained hickory, the hang and perfect balance of each Plumb tool are features of craftsmanship. And these qualities have made Plumb tools the favorite of craftsmen for over 90 years. Fayette R. Plumb, Inc., Philadelphia 37, Pennsylvania.



NAIL HAMMER



BALL PEIN HAMMER



HALF HATCHET

# PLUMB

HAMMERS • HATCHETS • AXES • SLEDGES

## PICTURE OF AN OLD BRUSH



*Reconditioned  
for Duty*

This was a discarded brush, stiff with paint used in 1938. Dic-A-Doo Paint Brush Bath has reconditioned it... restored to the "100% bristle," the original flexibility and spring.

A good brush *deserves* good care and the present "War Emergency" brush *requires* it. Keep them clean the *safe* way with

## DIC-A-DOO Paint Brush Bath

Sold at Hardware, Paint, Grocery and 5-&-10¢ stores.

Patent Cereals Company  
Geneva, N. Y.

**5¢-10¢ size**



*After War*

**THE WORLD'S SAFEST ELECTRIC JIG  
SAWS** will again carry the name:

# SYNGRO

SYNGRO DEVICES, INC.  
FERNDAL 20, MICHIGAN

**REPAIR FURNITURE  
WITH HIDE GLUE**  
like the best furniture  
factories use . . . .

Liquid, ready to use with-  
out mixing or heating. No  
chilled joints.

**FRANKLIN**  
*Liquid Hide* **GLUE**

IF YOUR HARDWARE DEALER  
CANNOT SUPPLY YOU send  
30c for 1/4-pint to The Franklin  
Glue Co., Columbus 3, Ohio.





*Signet of Quality  
in Pipes*

**VanRoy**



**U**nder a star-studded sky . . . when impressions are sharply accented . . . try smoking a VanRoy. You will soon realize how profound is the difference between pipes . . . and thank your lucky stars that your smoking-companion is a luxurious VanRoy.

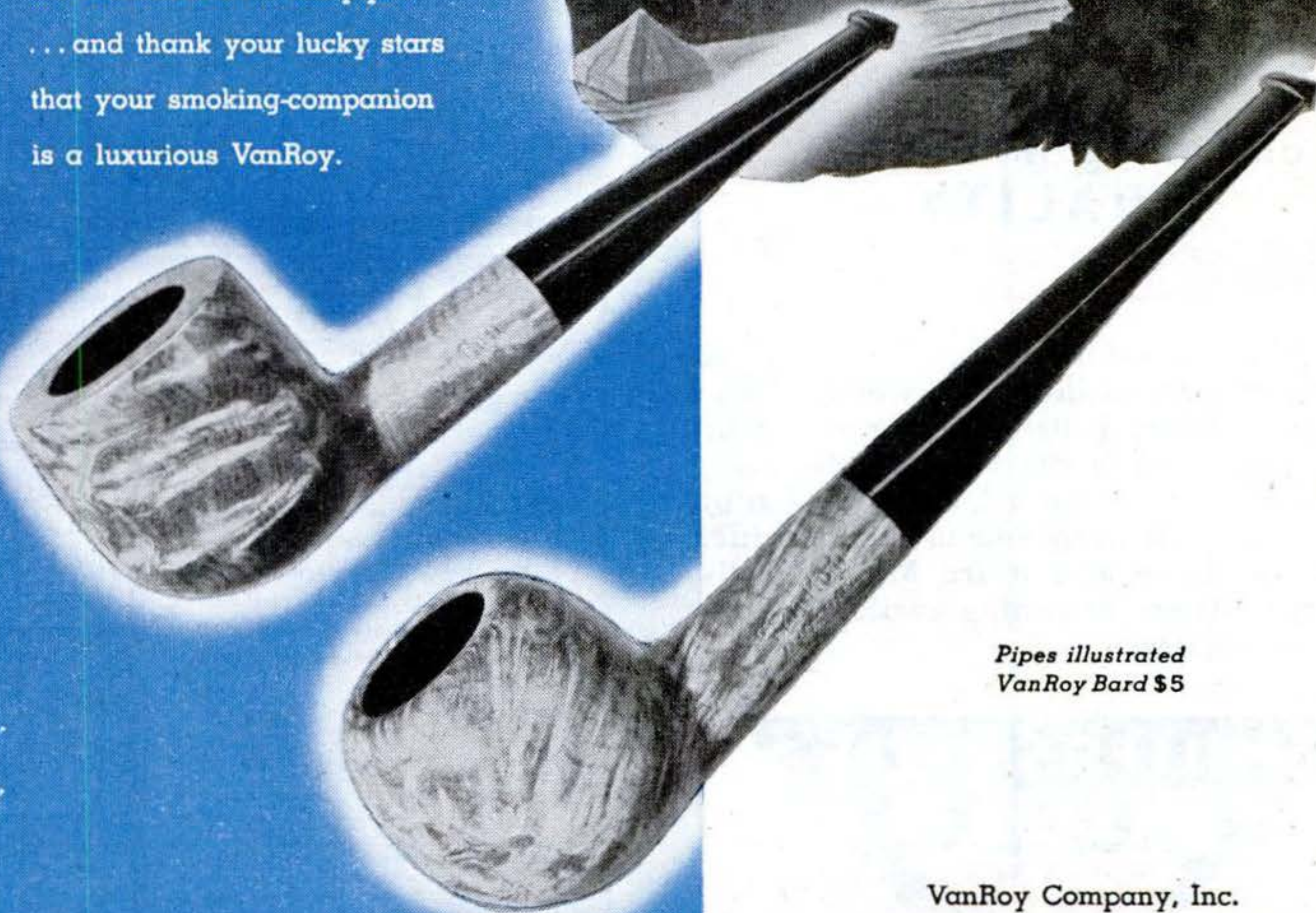

*Pipes illustrated  
VanRoy Bard \$5*

VanRoy Company, Inc.  
Empire State Building, New York 1. N. Y.



# TOOLS TO FIT THE TASK



one thing in common  
**QUALITY**

From the powerful, smooth-acting spiral ratchet models to delicate jeweler's sizes, there's a Millers Falls Screw Driver to fit every job. Each is the best for the task; each a tested, balanced, long-lived tool which you will keep and use with pride.

Today, more and more Millers Falls quality tools are becoming available. Consult your dealer.



**MILLERS FALLS CO. GREENFIELD, MASS.**

Buy War Savings Bonds and Stamps regularly.



## Shinola Shoe Polish really does a job on scarred-up furniture!

● If you've ever tried Shinola for covering up nicks or scratches on furniture, you know what a really professional-looking job it does. You apply it as you would any wax. It's simple to use, and inexpensive, too. Whether the furniture you want to touch up or refinish is old or new—cherry, maple, walnut, mahogany, or pine—there's a Shinola colored wax to do the job.

Shinola Waxes are swell for preserving linoleum . . . for finishing airplane and ship models, too. Keep these extra uses in mind when you're buying Shinola Shoe Polishes.

**SHINOLA—10¢**  
**IN ALL COLORS**



TAN (RUSSET) • BROWN  
OX-BLOOD • BLACK

(In Canada it's 2 in 1)

**HARD TO GET**  
**RADIO PARTS**  
AVAILABLE AT  
**RADIO PARTS CO.**  
612 W. RANDOLPH ST., CHICAGO 6, ILL.  
(Write for catalog—Dept. S.)

## Test-O-Lite the MODERN TROUBLE SHOOTER



### ← THE NEON GLOW

... LOCATES TROUBLE INSTANTLY in electric circuits, fuses, cut-outs, motors, radios, appliances. Tests everything electrical from 100 to 550 volts. Indicates hot or grounded wires. Tells AC from DC. Far superior to ordinary clumsy test bulb.

↑ PUTS "FINGER" ON THE TROUBLE SPOT - - QUICKLY

Saves precious time. Indispensable in shop or home. Has patented safety features. Vest pocket size with clip. Lifetime guarantee. List \$1.50. Purchase through regular electrical dealers.

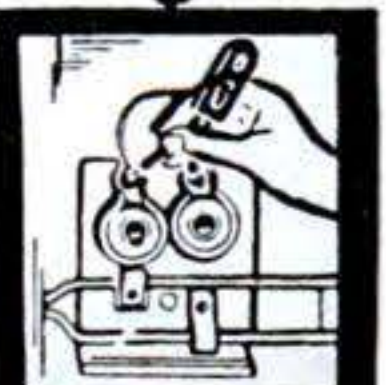

FUSES



MOTORS



OUTLETS

**L. S. BRACH MFG. CORP.**  
55 Dickerson St. Newark, N. J.



**Over a MILLION★  
Gone to War!**



★ Over a million Coleman Military Burners have gone to the military services—miniature burners for the Medical Corps—powerful 2-burner units for sterilizers, water stills, field hospitals and for 20-man cooking units—tent heater burners—and this amazing one-man "GI" Stove that enables our fighters to have hot food, hot drinks, purify water and even keep warm in foxholes!

**You'll Want This Grand Sport Stove  
for Every Outdoor Trip "Tomorrow"**

After the war, this new Coleman "Pocket" Stove will be the grandest little sport stove outdoor-loving Americans ever touched a match to... it will be the perfect portable quick-cooking pal for hunters, fishermen, picnickers, vacationers. Thousands of uses around the home.

**Burns Any Kind of Gasoline—White or Leaded**—Ready in minutes for cooking, heating drinks, purifying water. Compact—its telescoping case

provides two handy cooking utensils. Easy to carry as a quart size can of food. Only 8½ inches high; 4½ inches in diameter. Expertly designed and quality built for years of trouble-free service. Watch for

the Coleman "Pocket" Stove. You'll want one!

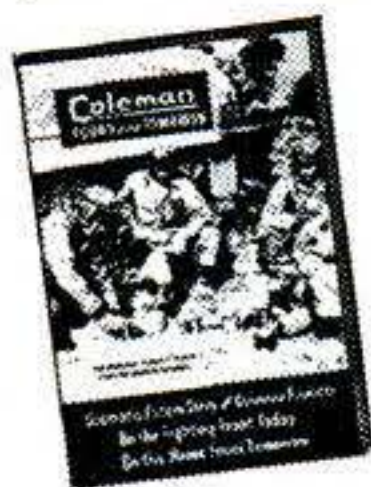

**FREE BOOK**—Write for dramatic picture story of the Coleman "Pocket" Stove in use on the fighting fronts.



**THE COLEMAN COMPANY, INC.**  
Dept. 263-PS, Wichita 1, Kansas  
Chicago 11 Philadelphia 8 Los Angeles 54  
Honolulu, T. H. Toronto, Canada

**NEW  
Coleman  
"Pocket" STOVE**





## MARLIN "39" STOPS FOUR JAPS



LATEST REPORT on the all-around utility of Marlin's famous lever action .22 cal. rifle comes from Leyte, scene of the first bloody battle in the reconquest of the Philippines.

It is also a story of courageous Filipino resistance to the Japanese invader.

Liberated from a Jap prison camp, an army man was assigned to Leyte. According to his letter to Marlin, he was one day invited to visit a small bamboo hut by a Filipino boy who looked to be about sixteen years old. The lad proudly took a rusty Marlin '39' off the wall, and described how he had killed four Japs with it up in the mountains of Leyte.

His old Marlin lever action .22 had been left behind by a couple of mining engineers. He had buried it in the dirt to keep it hidden from the Japs, which accounted for its rusty condition. Despite the abuse this Marlin '39' had taken, the action functioned perfectly upon examination.

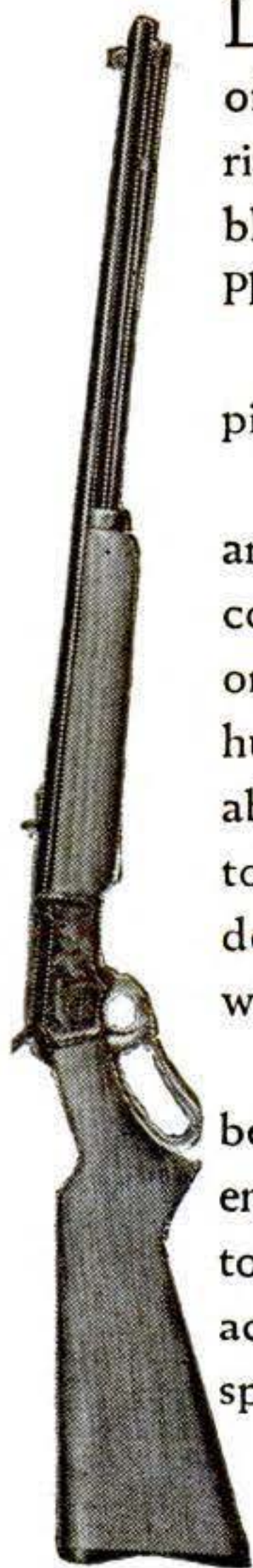

**THE MARLIN FIREARMS CO.**  
NEW HAVEN, CONN.

*Straight-Shooting Guns Since 1870*

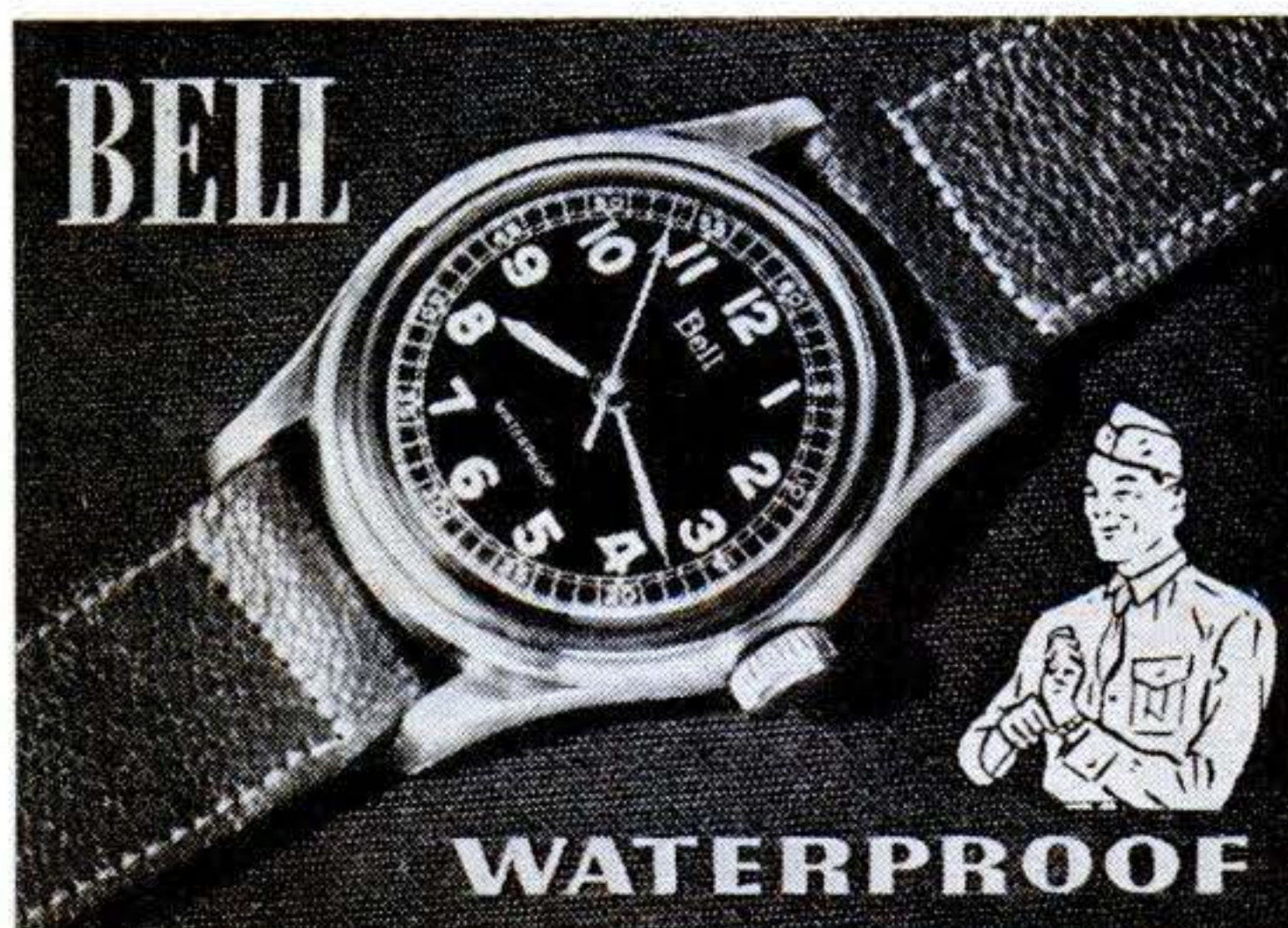

Waterproof, shockproof, anti-magnetic, radium dial and hands, unbreakable crystal, precision tested, sweep second hand.

No. BE 121 15 jewels, stainless steel back.....	<b>\$39.75</b>
No. BE 212 17 jewels, stainless steel back.....	<b>\$42.50</b>
No. BE 328 SELF-WINDING, 17 jewels, stainless steel case.....	<b>\$59.75</b>

Prices Include All Federal Excise Taxes.  
Postage Prepaid. Mail Orders Promptly Filled.

Write for Free Illustrated Booklet "BE"

**BELL WATCH COMPANY**  
Time and Life Bldg., Rockefeller Center, New York 20, N. Y.



### HUNTER'S COMPASS

Hunting Case,  
Watch Type, All **\$3.75**  
Metal, Jeweled

**Engineers All Metal Army  
Type Hand-Sighting**

**LEVELS**

**\$1.50**



**PUBLIC SPORT SHOPS**

13 S. 16th St., Phila. 2, Pa.

No COD's

**TAPE WORMS  
ROUND WORMS  
(Ascarids)  
HOOK WORMS  
WHIP WORMS**



*...you can free your dog of all these worms*

*with* **PULVEX**

COMBINATION  
TREATMENT **WORM CAPSULES**

Used by leading breeders. At leading pet, drug, department stores, 50c a package (double size, 75c). Packed two ways: for puppies, for dogs.



Enjoy Life with

*Miller's*

HIGH LIFE

*The Champagne  
of Bottle Beer*

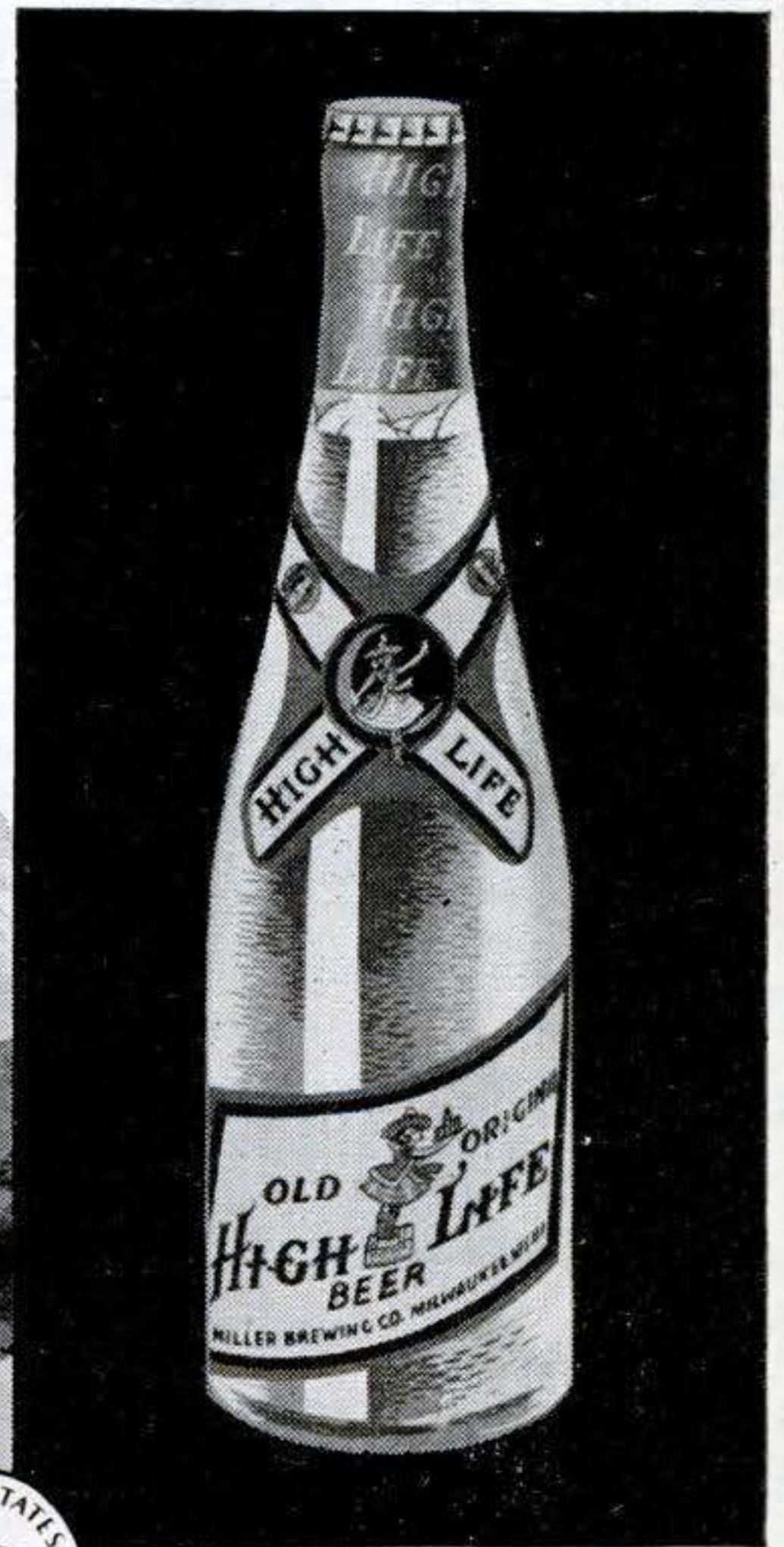

MILLER BREWING COMPANY • MILWAUKEE, WISCONSIN

SEPTEMBER, 1945

Buy War Savings Bonds and Stamps regularly.

251



# NEXT TIME SAY BRIGHT STAR

and you will get a  
**FLASHLIGHT & BATTERIES**  
famous since 1909  
for **QUALITY,**  
**STYLE** and  
**SERVICE**

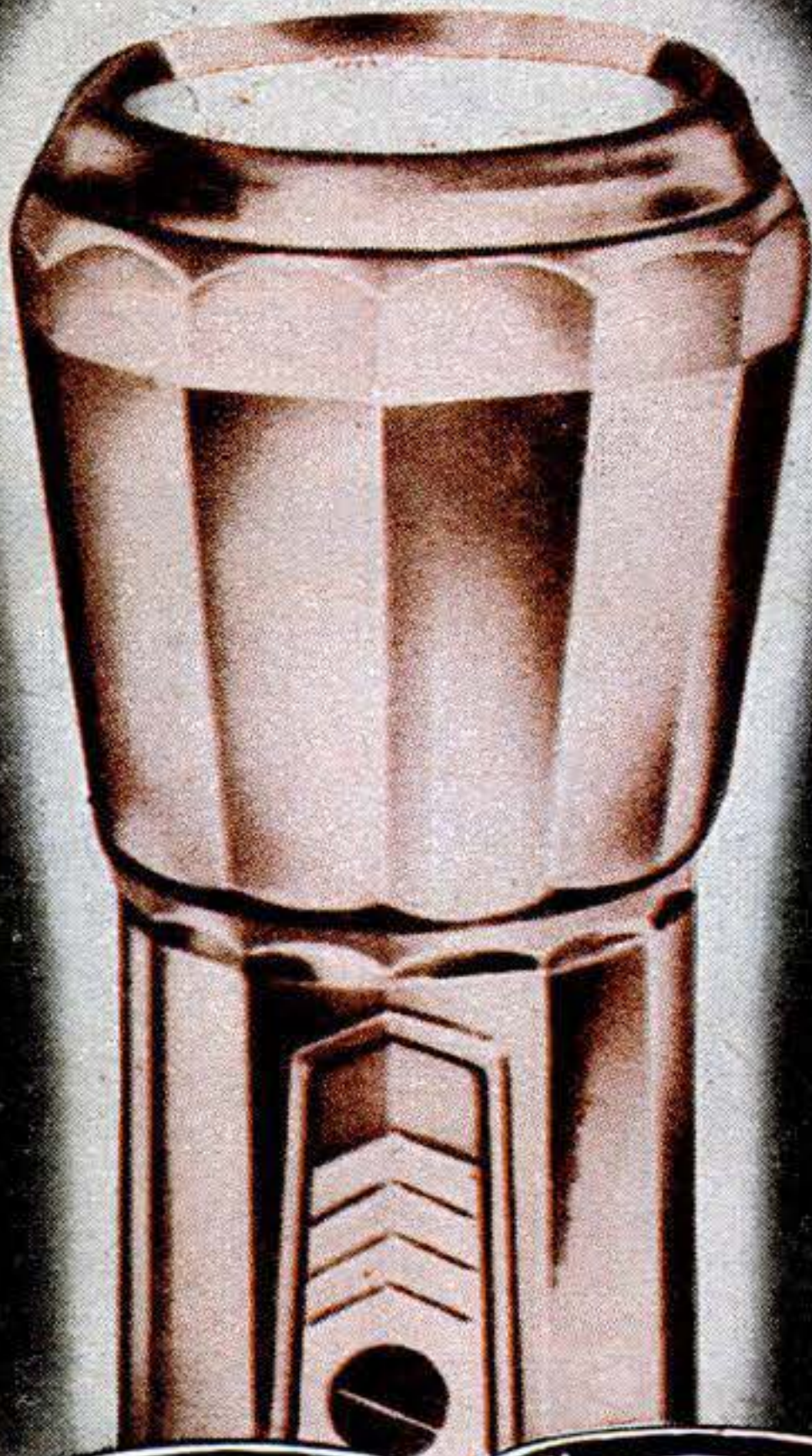

**BRIGHT STAR BATTERY CO. CLIFTON N. J.**

## A RARE BARGAIN IN PIPE TOBACCO

Surplus from compounded private formulae—\$3, \$4 and \$5 a lb. mixtures—saved in oak barrels, then aged, seasoned, counter-blended and aromatized—are now available to you at only \$1.00 per 1/2 lb. Here is a deluxe quality mixture of delicious flavor—guaranteed to give you a new thrill in pipesmoking. Will never cloy or jade the palate. Is always good—always different!



**SMOKE IT AT  
OUR RISK!**

Order a trial 1/2 lb. container of BARGAIN BARREL for \$1. Smoke a few pipefuls. Savor this delightful mixture that always pleases. If you are not fully satisfied, you can return package for complete refund. **Order TODAY!**

**Sidney P. Ram, Tobacconist for Connoisseurs**  
59 W. Monroe St., Dept. DK-612, Chicago 3, Ill.



**AFTER THE WAR IS WON**

## ARMSTRONG TOOL HOLDERS

enabled American Industry to change to war production "over night." For they are the permanent, multi-purpose tools used by 96% of the machine shops and tool rooms, on lathes, planers and shapers—the tools used to make dies and jigs, to build production machines. They are the tools you will want for your own shop after the war—ARMSTRONG TOOL HOLDERS for industry, ACE Tool Holders for home work shops.

**ARMSTRONG BROS. TOOL CO.**

"The Tool Holder People"

329 N. Francisco Ave., Chicago 12, U. S. A.



**\$2.00** Price complete at hardware or tool dealers, or send remittance direct to

## NORK WIGGLER

for *FAST* and  
*Accurate Set-Ups*

Wiggler body hardened alloy steel. Ball shaft enables you to indicate accurately from tool makers buttons, holes, ground surfaces, gauge blocks, etc. Needle-Point shaft is for finding centers and truing to layout lines. Bent shaft holds any type indicator and allows it to be positioned on any circle to 6-inch dia. The *only* Universal Wiggler of its kind.

**NORK PRODUCTS COMPANY**

Dept. 236, 5897 S. Main St.  
Los Angeles 1, Calif.



*it's fun! to make*  
**"GOOD PICTURES"**

WRITE TODAY FOR THIS 56 PAGE BOOK

IT WILL HELP YOU  
 SOLVE MANY PROBLEMS

- SELECTION OF FILM
- EXPOSURE
- DEVELOPING
- ENLARGING
- FLASH PICTURES
- FILTERS & COLOR

Send 25c to  
**ARGUS, INC.**  
 Ann Arbor, Mich.  
 DEPT. H

**argus**

Cameras and Optical Instruments

ANN ARBOR MICHIGAN

**WOODWORKING IS FUN**

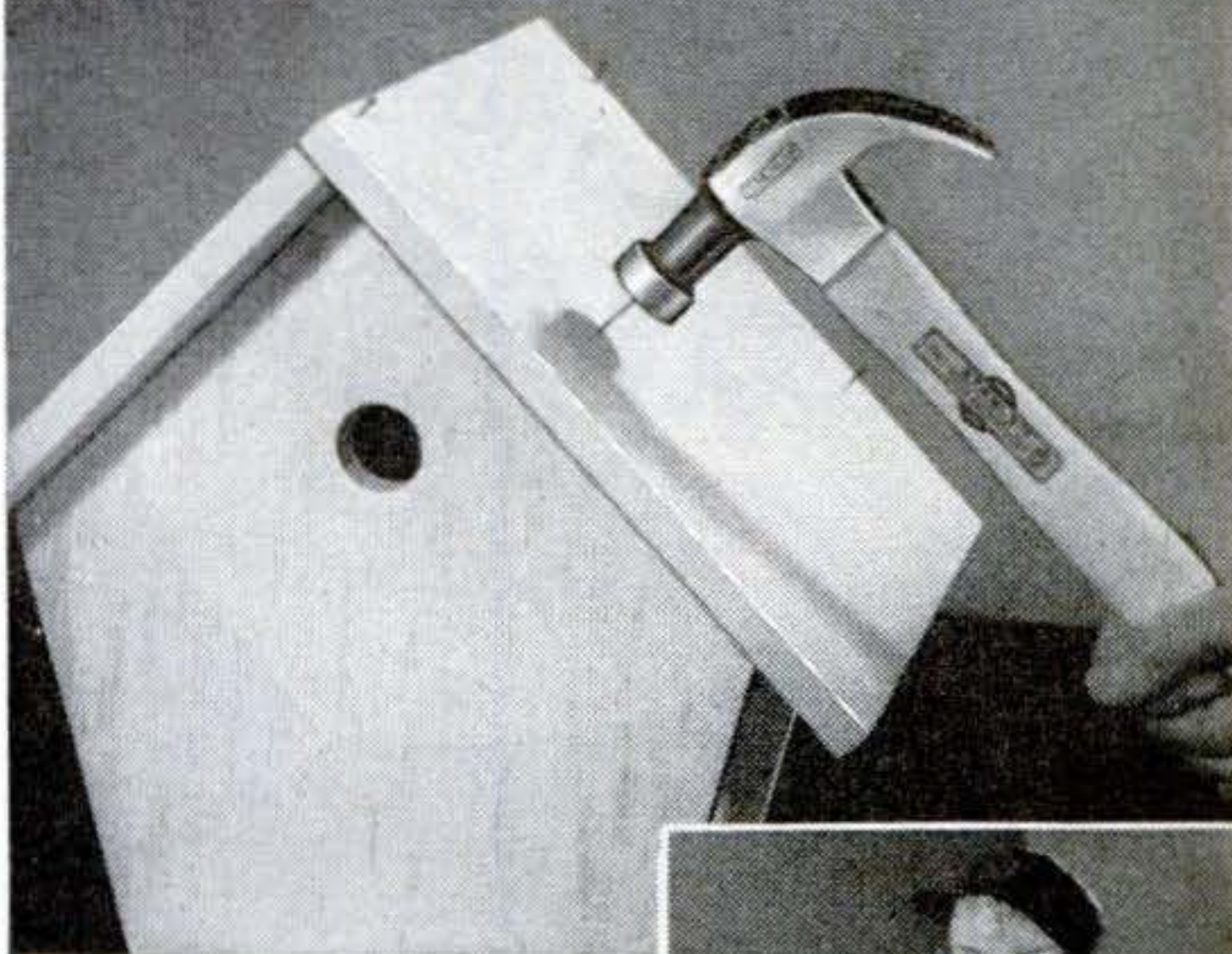

when you  
 have a

**GOOD HAMMER**

Of all the Stanley Tools you choose for your postwar home workshop, none will give you greater satisfaction than a Stanley Nail Hammer.

The heads are drop forged, heat-treated and oil quenched to eliminate strains and insure toughness throughout the steel structure. The "Evertite" handles are of sound, young, straight hickory, thoroughly seasoned and oil treated to prevent shrinking. They will not loosen and come off. There will be numerous, well-balanced models for your every need.

**Let Experts Help Select Your Tools**

Stanley has a free booklet for you, "The Joy of Accomplishment." Crammed full of helpful suggestions for the home craftsman, it contains: a primary list of tools and a special list of tools to be added as needed. You'll also find the big Stanley textbook: "How to Work with Tools and Wood," mighty useful. It's yours for only \$1.00. Mail the coupon today.



**STANLEY**

**THE TOOL BOX OF THE WORLD**

**MAIL NOW**



**STANLEY TOOLS,**  
 295 Elm St., New Britain, Conn.

Please send by return mail —

- The FREE booklet: "The Joy of Accomplishment."
- 188-page book: "How to Work with Tools and Wood." \$1.00 enclosed.

Name.....  
 Address.....  
 City..... State.....

**IT'S FREE** Don't Miss This NEW BOOKLET

**"The Age of Chemistry"**

New 1945 Chemcraft Chemistry Booklet describes many amazing experiments you can perform; and tells of the big opportunities, both now and in the future, for boys with a knowledge of chemistry... Send Today.

**THE PORTER CHEMICAL COMPANY**  
 31 Prospect Ave. Hagerstown, Md.



**WANTED!**

No, we don't want "0132057745"! But we're mighty anxious to lay our hands on that old musical instrument you're not using. We'll pay the highest prices in America for any of the following band instruments regardless of style, age or make:



**0132057745**

**TRUMPET • CORNET • TROMBONE • ACCORDION  
 ALTO OR TENOR SAXOPHONE • FRENCH HORN  
 BOEHM SYSTEM CLARINET • MELLOPHONE**

Send us your instrument for appraisal. If our offer is acceptable to you, you'll get spot cash plus shipping cost by return mail. If not we return it and reimburse you for shipping expense.

**WURLITZER**

THE NAME THAT MEANS Music TO MILLIONS

Suite 3406, 105 W. Adams St., Chicago 3, Ill.



THE FAITHFUL  
**HEART**  
OF YOUR FUEL  
SYSTEM



# AC FUEL PUMPS

Pulsing steadily, hundreds of times a mile, your AC Fuel Pump is the strong, reliable heart of your fuel system. It has given you long, faithful service because of its inbuilt quality and scientific design.

You can prolong that faithful service indefinitely, if you insist upon an AC when you replace your present pump with a new or rebuilt one.



BUY WAR BONDS • BRING VICTORY QUICKER

## INTRODUCING-New Victory Model HANDIWELD ELECTRIC ARC WELDER

FULLY  
GUARANTEED

RETAILS  
ONLY

\$1.95



### PLUGS INTO LIGHT SOCKET

Victory Model Handiweld Arc Welder operates from 110 volts, A.C. or D.C. current same as other arc welders higher priced; generates tremendous heat to weld all metals. Not a toy welder that uses carbons, but actually uses standard coated rods—sizes 1/16" and 3/32". However, due to Priorities a generous supply of 1/16" rods only are supplied with the welder. Guaranteed not to burn out. Repairs fenders, auto bodies, radiators, machinery parts, etc. Take Victory Model Handiweld anywhere to job, operate right from light socket. You'll find a thousand uses for this welder around your home, garage, workshop. Also in garages, factories, repair shops, tin shops; mechanics, inventors, plumbers, farmers, etc. Order a "Victory Model" Handiweld now. SEND NO MONEY. We'll rush one to you with rods, helmet, operating instructions, and all necessary parts with the exception of a large jar and a small piece of extension cord; these most everyone has. Pay postman only \$1.95 plus a few cents postage. If not delighted return Victory Model Handiweld in 5 days from receipt and money paid for it will be refunded promptly. Rush your order now.

KUMFY PRODUCTS Dept. Z-205, Cincinnati 26, Ohio



### INEXPENSIVE

Genuine Gerstner Tool Chests give more years of satisfactory service for lower annual cost. Free catalog for Machinists and Toolmakers.

GERSTNER TOOL CHESTS  
545 Columbia St., Dayton 7, Ohio

## Sand Casting—Forging—Heat Treating—Case Hardening BRONZE FOUNDRY

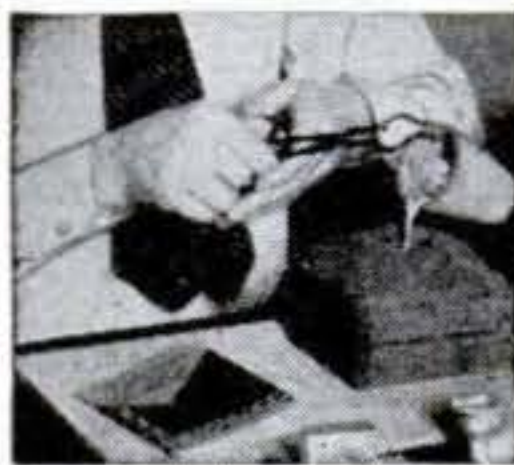

is again available in limited quantity without priority. Orders filled in sequence as received. INVENTORS-SCHOOLS-CRAFTSMEN use FOUNDRYETTE for making castings quickly for new inventions, for instruction, and general purpose. Order now for early delivery. Three sizes are available capable of making bronze castings of 1½, 3, and 6 pounds weight, aluminum, copper, brass, etc. \$17.50, \$24.00, \$34.50, f.o.b. Kansas City. Domestic gas supply and 110 volt AC or DC energy required for operation. Write for circular.

KANSAS CITY SPECIALTIES CO.  
Box 6022, Dept. S-58 Kansas City, Mo.

## UTICA TOOLS

ALL TYPES  
FOR MORE TOOL  
MILEAGE



Ask Your Dealer

U-T-I-C-A

UTICA DROP FORGE & TOOL CORP.  
★ UTICA, N. Y. ★



# REMOVES ALL FINISHES



**NO BENZOL-ACID-CAUSTIC-ALKALI-SAFER TO USE**

New type semi-paste remover quickly lifts off paint, enamel, varnish, shellac, lacquer, bakelite and other synthetic resin finishes. (Removes emulsified resin water paints, too.) Stays wet longer — stays put on upright or overhead surfaces — strips clean, quick. One coat usually enough (apply with brush or spray). Contains no benzol, acid, caustic, alkali, or wax — harmless to hands, bristles, surface stripped. All sizes (pint 65c) at paint and hardware stores.

### FREE CIRCULAR

"How to Remove Paints, Varnishes, Lacquers, etc." Also describes other Savogran Products: Heavy Duty Cleaner, Crack Filler, Wood Putty, Remover & Bleacher (renews floors), Paint Brush Cleaner, Coldfoam Soapless Soap Powder.

*It's Orange!*



**THE SAVOGRAN CO.**  
DEPT. 15. BOSTON 10, MASS.

# SAVOGRAN STRYPEEZE

IN EVERY WELL-EQUIPPED HOME WORKSHOP

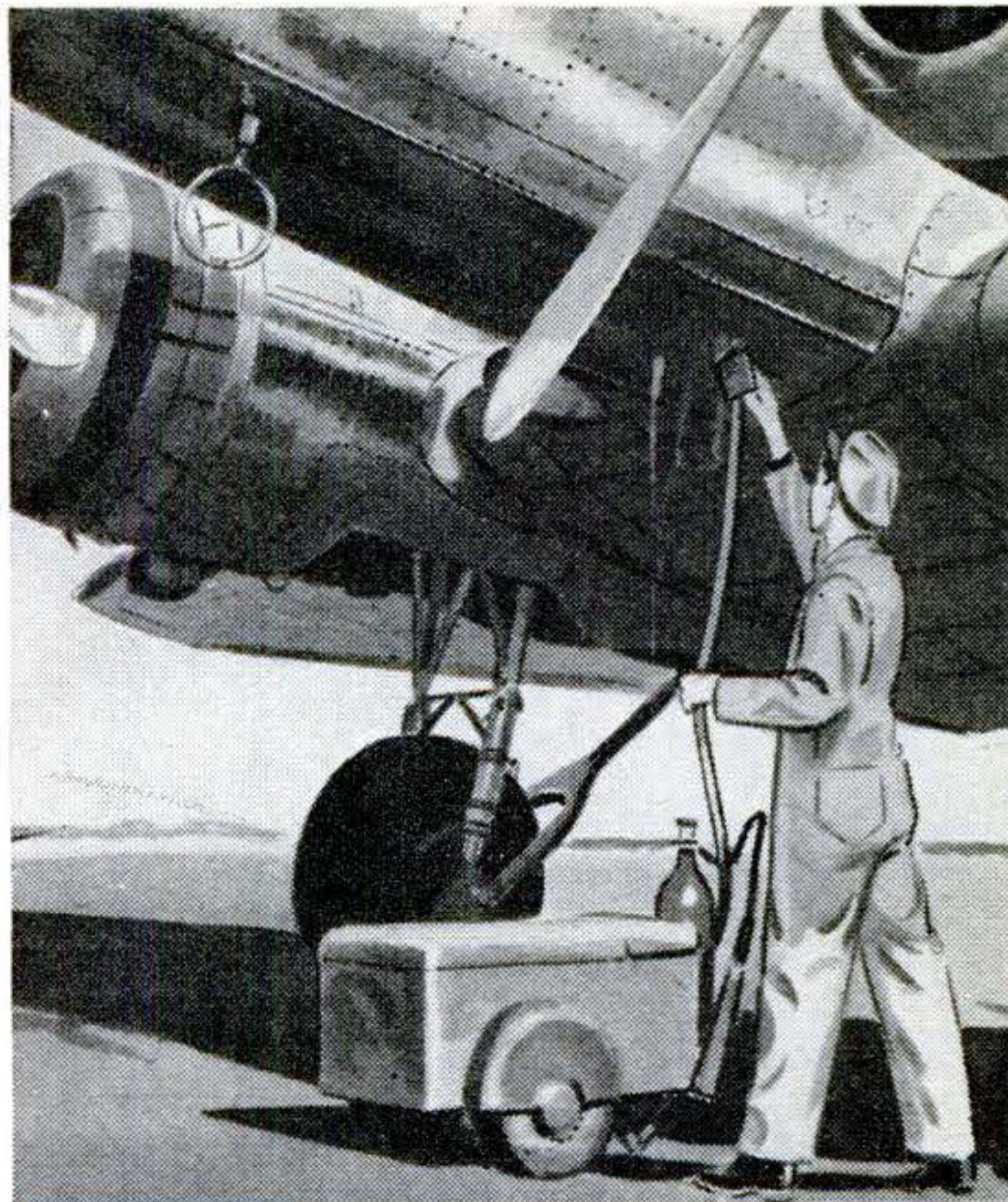

# First!



## COLLECT U. S. ARMY Shoulder Patches

Fascinating hobby. Patches 20c to 50c each. Complete set of 250 for \$50.00. Official patches available for every major Army and Air Corps unit. Send \$1 for sample assortment of patches and illustrated patch catalogue. Orders from Canada—add 20%.

### SPRINGER'S

270 San Francisco St., EL PASO, TEX.

## BUILD YOUR OWN ARC-WELDER

**For Light or Heavy Work**  
No rewinding necessary—use coils taken from old auto generators. Works on 110 or 220 A.C. Has 20 different heats. Complete plans and BIG Catalog 35c. LEJAY MFG., 3323 LeJay Bldg., Minneapolis, Minn.



**KEEP WARM! SAVE FUEL!**

# Mortite

Seal your home against drafts and cold, stop expensive heat leaks! Keeps out dust and dirt. Just press MORTITE pliable plastic tape around windows, doors, baseboards, etc. It's easy! It's sure!

A roll covers about 80 ft., enough for 5 windows . . .

At hdwe., paint, dept. stores and lumberyards.

**FREE MORTITE CIRCULAR** **J. W. MORTELL CO.**  
534 Burch St., Kankakee, Ill.



**\$1.25**

*Higher west of Rockies & Canada*



## BURGESS WINS IN NATION-WIDE POLL!

Where electronic experts and engineers use dry batteries (as in Radio Compass Test Unit above) their choice is "BURGESS 2 out of 3!" When you need batteries for Flashlights, Radio, Hearing Aid, Ignition, Telephone—choose the brand that experts prefer—BUY BURGESS!

BURGESS BATTERY COMPANY, FREEPORT, ILLINOIS.



# BURGESS BATTERIES

THE JOB AHEAD—JAPAN!





NOW THAT YOU  
CAN AGAIN HAVE  
THE  
*bullet-fast*  
LIGHT OF



**WINCHESTER**  
BATTERIES...

*Accept no other*

Typical of satisfied users of Winchester batteries everywhere, one says "I am enclosing three Winchester batteries—your unit cell #1511 for your inspection. They have distinguished themselves almost *beyond belief*. I have used them almost continuously for approximately 13 months in the flash synchronizer of my speed graphic camera. Usually batteries only last one month or two at the most but these Winchester batteries, tested regularly every week, seemed to build back up and keep going."

Thousands of other users of Winchester batteries have experienced the inherent high quality and satisfaction of these batteries. Your dealer has them now or soon will have. Tell him you *want* Winchester batteries. Winchester Repeating Arms Co., New Haven, Conn., Division of Olin Industries, Inc.

**WINCHESTER**

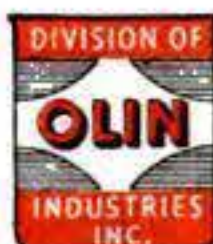

For Long-Lasting *bullet-fast* LIGHT

Watch Crystals You **CAN'T** BREAK



**PROTECT YOUR WATCH**

A watch with a broken crystal is useless. Go to any jeweler—ask him for a G-S FLEXPOLY CRYSTAL 100% BREAKPROOF. Fitted while you wait. Any size. Any shape. **Guaranteed.** GERMANOW-SIMON MACHINE COMPANY, Rochester, N.Y.

**FREE!! 40 PAGE HOBBY CATALOG**

Over 1000 items — Over 300 Photos

Our new 40 page catalog is the "bible" of wide-awake modelers. Hundreds of models to choose from! Planes, engines, boats, jeeps, tanks, gliders, supplies, etc. Send for yours today!

**AMERICA'S HOBBY CENTER**

Dept. S95, 40 E. 21 St. N. Y. 10, N. Y.

**PLASTICS**

Plexiglas, Lucite, Bakelite, Lumarith, Ethocel, Cellose, Acetate now

available in sheets, rods, tubes and strips. Fine assortment of sizes. No priority required. Cements, dyes and other plastics supplies, too! Send 10c today for complete lists!

CARMEN-BRONSON CO., Dept. 9-A

165 E. Third St. Mt. Vernon, N. Y.

**LAW**

STUDY AT HOME for PERSONAL SUCCESS and LARGER EARNINGS. 36 years expert instruction—over 108,000 students enrolled. LL.B. Degree awarded. All texts furnished. Easy payments. Send for FREEBOOK—"Law and Executive Guidance"

AMERICAN EXTENSION SCHOOL OF LAW  
Dept. 57-S, 646 N. Michigan Ave., Chicago 11, Ill.



**DRILL-INDEX**

A compact container for indexing and filing twist drills. Eliminates search. Made entirely of steel in nine sizes. Available on priority to essential users. See your dealer or write to

HUOT MFG. CO.  
436 Foot Schultz Bldg. St. Paul 1, Minn.

**120 MILES PER GALLON**

Complete motor ready to mount on ordinary balloon-tired bicycle. No mechanical skill required to install. No alteration of bike necessary. Easy to operate.



Can be pedalled by merely releasing clutch. Speed 5 to 40 M.P.H. Shipped prepaid complete with 4 cycle, 2½ H.P. motor, all attachments and heavy duty stand. Get complete facts about this low-cost, convenient transportation. . .

Write today for descriptive illustrated literature.

**WHIZZER MOTOR SALES CO.**

Dept. B, 3132 E. Washington, Los Angeles 23, California



# BARGAINS in WAR SURPLUS LENSES & PRISMS

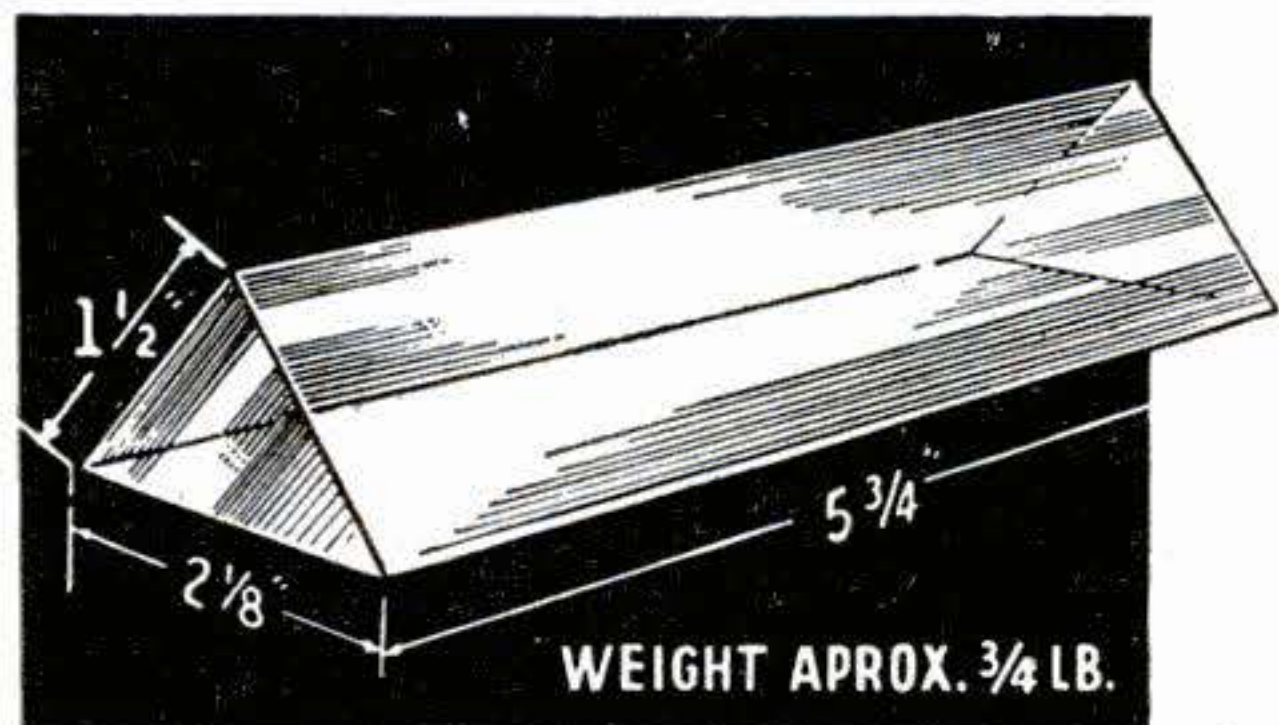

## TANK PRISMS

In order that the tank driver shall not get shot in the face, 2 of these Silvered Prisms are used to make a Periscope. We have secured a number of these, 90-45-45 degree Prisms of huge size— $5\frac{3}{4}$ " long,  $2\frac{1}{8}$ " wide, finely ground and polished. Used to build a Periscope, camera stereo attachment, range finder, etc. Excellent also for experiments, classroom demonstrations. Prism easily converted into desk name plate by affixing gold letters. 100 supplied at only 10c. (Order Stock # 3008-N). Normally these Prisms would retail from \$24 to \$30 each.

Stock # 3004-N . . . SILVERED TANK PRISM—Price \$2.00 each. Postpaid. Illustrated Booklet on Prisms included FREE.

FOUR SILVERED TANK PRISMS—Special—\$7.00 Postpaid . . . The most sensational bargain we have ever been able to offer. HOLD PRISM IN SUN'S RAYS

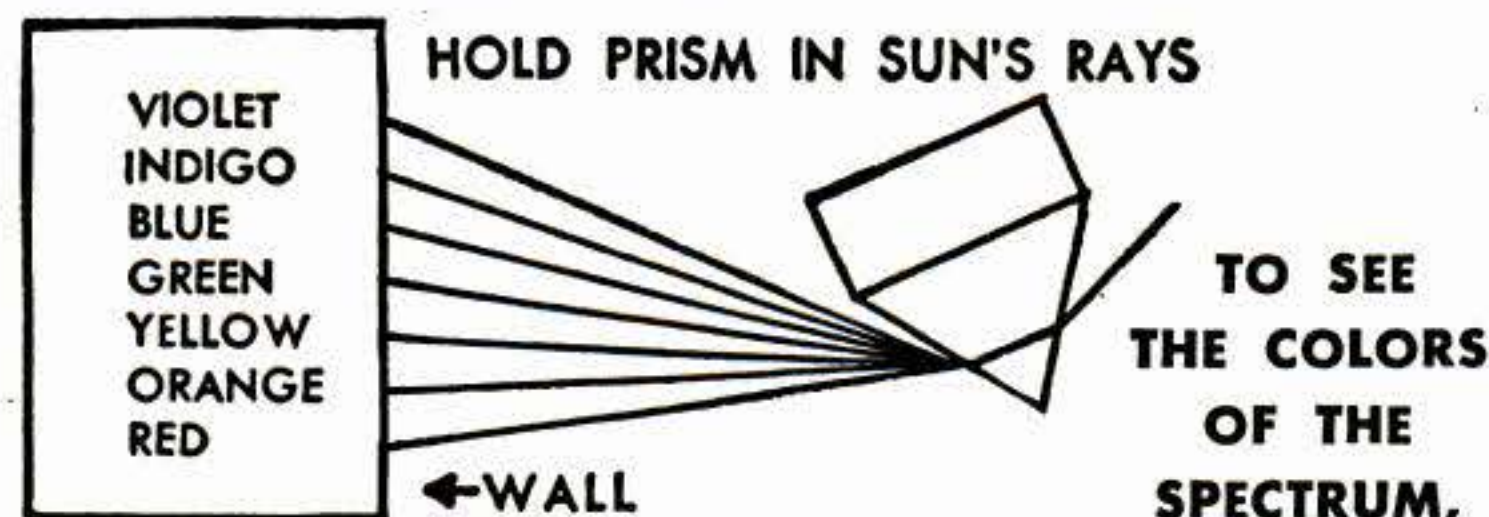

you can easily remove the silvering from these prisms and hold in sun's rays as shown in drawing. White incident light which passes through prism is thus broken up into a band of primary colors known as the spectrum—a beautiful sight!

CLEANING BRUSH SET—12" flexible plastic handle, circular construction. 4 brushes to set, range stiff to soft. Stock # 504-N . . . Price \$1.00

PORRO PRISM SET FROM ARMY'S 6 POWER BINOCULAR. Consists of 2 Porro Prisms to make an erecting system for a Telescope.

Stock # 3010-N . . . \$1.00 Postpaid

KELLNER EYE-PIECE LENSES. . . you can use in Telescopes, Binoculars, Microscopes, etc. Diam. of eye lens 16 mm. Diam. of field lens 25 mm. Eye achromat already cemented. Stock # 6108-N . . . \$1.00 Postpaid

8 MM. MOVIE PROJECTING LENS SET—Consists of 2 Achromatic Lenses, diam. 15 mm. and a F.L. when combined of approx. one inch. Each lens has the new magnesium fluoride low reflection coating. Stock # 4011-N . . . \$1.40 Postpaid

RETICLE SET . . . Five assorted, finely engraved Reticles from U. S. Gunsights. An usual group . . . just like those assisting our gunners to train sights on Tokyo. Worth several dollars each. Stock # 2035-N . . . \$1.00 Postpaid

RAW OPTICAL GLASS . . . An exceptional opportunity to secure a large variety of Optical Pieces both Crown and Flint glass (seconds) in varying stages of processing. Many prism blanks. Stock # 703-N 8 lbs. (minimum weight) . . . \$5.00 Postpaid

Stock # 702-N  $1\frac{1}{2}$  lbs. . . . \$1.00 Postpaid

MAGNIFIER SET . . . 5 Magnifying Lenses . . . Powers from 1 to 10. Various diam. for many uses.

Free Booklet on Home-made magnifiers included. Stock # 1026-N . . . \$2.00 Postpaid

PERFECT ACHROMATIC TELESCOPE OBJECTIVE LENS Diam.  $1\frac{3}{4}$  inches, F.L. 20 inches. Stock # 6091-N . . . \$5.00 Postpaid

All Items Finely Ground and Polished but Edges Slightly Chipped or Other Slight Imperfections which We Guarantee Will Not Interfere with Their Use. Come Neatly Packed and Marked.

## YOU CAN EASILY MAKE

Telescopes, Magnifiers, Photographic Gadgets and Hundreds of Experiments with these Low Cost Lenses.

To translate millimeter measurements; 25.4 mm. equals one inch.

## SPECIALS IN LENS SETS

Big 10 Page Project and Idea Booklet with all sets.

Set # 1-N "Our Advertising Special" 15 Lenses for \$1.60 Postpaid. For making your own powerful telescopes, low power microscope, strong magnifiers, drawing projector, photo cells, telephoto lens, dummy focusing camera, Kodachrome viewer, stereoscopic viewer, ground glass and enlarging focusing aids. For experimental optics, portraits of babies and small pets, copying, ultra close-up shots, and many, many other uses.

Set # 15-N—"The Experimenter's Dream"—62 Lenses, Prisms and Optical Items, and New 50-Page Book, "Fun with Chipped Edge Lenses". \$15.00 Postpaid. The variety of Lenses and Prisms in this set will enable you to conduct countless experiments, build a great variety of Optical Equipment. A sensational buy.

### NEW 50 PAGE IDEA BOOK "FUN WITH CHIPPED EDGE LENSES"

Contains wide variety of projects and fully covers the fascinating uses of all Lenses in sets listed above. \$1.00 Postpaid

## MISCELLANEOUS ITEMS

Stock No.	Item	Price
3006-N	Porro Abbe Prism . . . . .	\$ .25 each
3016-N	Pentagon Prism . . . . .	.75 each
2024-N	10 Pieces Circular A-1 Plate Glass (Diam. 31 mm.—for making Filter) . . . . .	.25
3001-N	Lens Surface Prism . . . . .	2.00 each
3021-N	Amici Roof Prism (3rd Grade) . . . . .	.25 each
4009-N	Heat Absorbing Glass 4" x 5" . . . . .	.35 each
4010-N	Heat Absorbing Glass 2" x 2" . . . . .	.10 each
2020-N	40 mm. Neg. Lens, Cross Lines . . . . .	.25 each
3020-N	Right Angle Prism 48 mm. wide (3rd grade) . . . . .	.35 each
523-N	Six Threaded Metal Reticle Cells . . . . .	.25
26-N	First Surface Aluminized Mirror, Diam. $1\frac{1}{4}$ " . . . . .	.25 each
624-N	Neutral Ray Filter size $4\frac{3}{4}$ " x $2\frac{1}{2}$ " . . . . .	.25
3022-N	Round Wedge 65 mm. Diam. . . . .	5.00 each
3036-N	Roof Prism—80 Degree . . . face $1\frac{5}{8}$ " wide	4.00 each
22-N	Inclinometer—Aircraft type . . . . .	.25 each
704-N	Lens Cleaning Tissue, one ream (480 sheets) size $7\frac{1}{2}$ " x 11" . . . . .	1.50
6002-N	Educational Set, 1 blank and 1 finished Porro Prism (3rd grade) . . . . .	.25 set
1003-N	50 Power Microscope Lens Set . . . . .	.70
1028-N	8 Power Mounted Magnifier . . . . .	.35 each
1030-N	2" Diam. Reducing Lens . . . . .	.25 each
1031-N	Perfect 6 Power Magnifier—Diam. 28 mm. . . . .	.25 each
2043-N	Standard Crossline Recticle—Diam. 29 mm. . . . .	.50 each
1034-N	Burning Glass Lens . . . . .	.25 each

(Minimum order on above—\$1.00)

POLAROID (Dyed)—Suitable for Experimentation. Consists 2 discs— $2\frac{1}{2}$ " diam. Some imperfections in glass. Stock # 622-N . . . . . \$1.00 Postpaid

LENS FOR KODACHROME EYE-VIEWER . . . Color corrected cemented lens 41 mm. diam., 66 mm. F.L. Stock # 6116-N . . . . . \$1.00 Postpaid

## TANK PERISCOPE

### Complete Set Mounted Components

Have fun! Make a real Periscope. Use it to see over the heads of crowds, to see under water, to see out windows without yourself being seen, and many other uses where observation by "remote control" is required. Originally constructed, for U. S. Army Tanks, set consists of 2 fine Periscope mirrors mounted in metal and plastic. Only plywood body frame is required to finish this exceptional Periscope. Set weighs  $2\frac{3}{4}$  lbs. Overall length  $6\frac{1}{8}$ ". width  $2\frac{1}{8}$ ". Would normally retail at \$40 to \$50. Stock # 700-N. \$3.00 Complete Set Postpaid (Two Sets (four units) . . . . . Special \$5.50 Postpaid)

Order by Set or Stock No.—Satisfaction Guaranteed

# EDMUND SALVAGE COMPANY-P.O. AUDUBON, NEW JERSEY



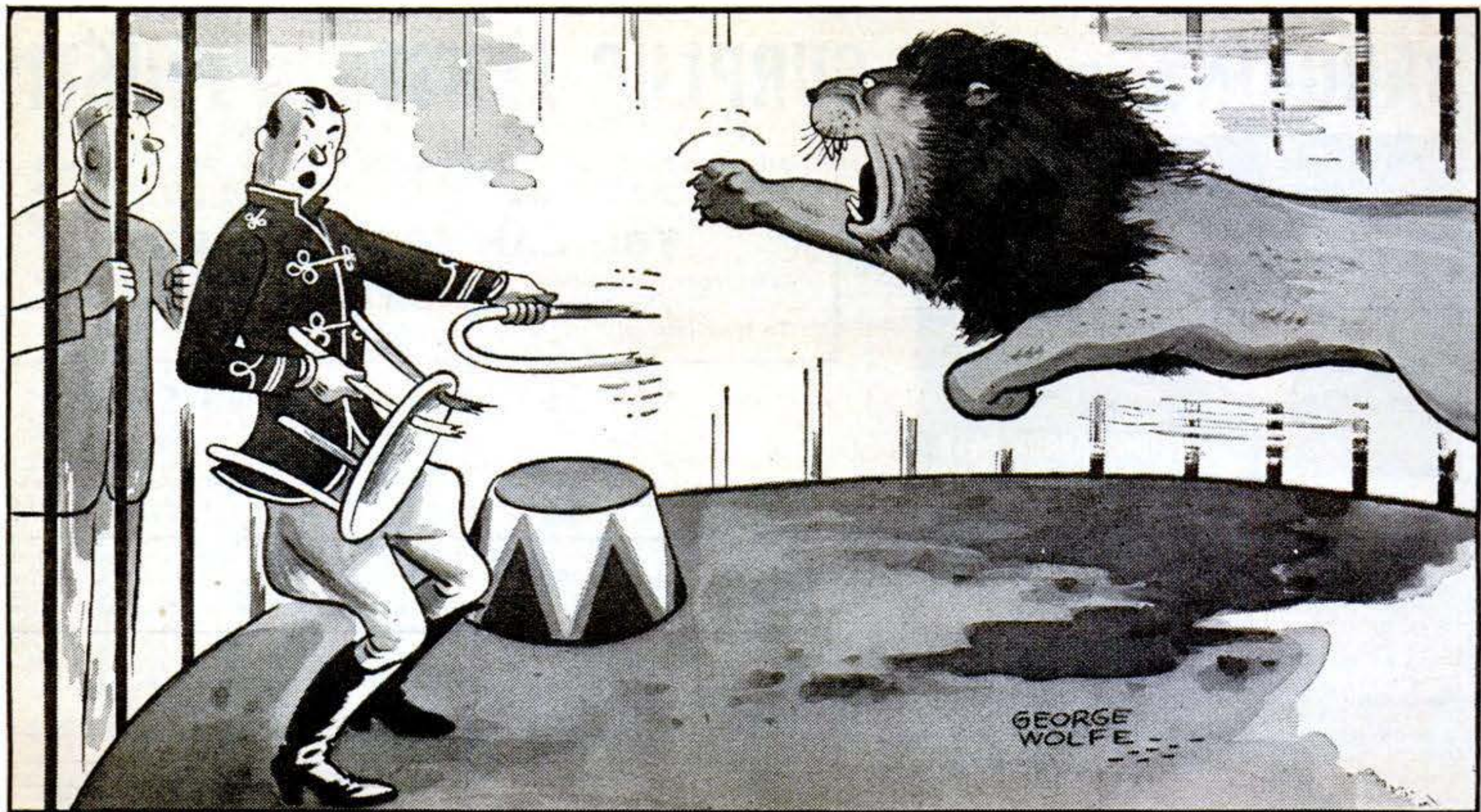

*Quick, Joe! Hand me the Weldwood Glue*

When you want to fix things fast . . . remember Weldwood Glue. It's quick to mix . . . easy to use . . . tremendously strong . . . stain-free . . . rot-proof . . . and permanent. At hardware stores, lumber yards, chain stores.



**WELDWOOD**  
PLASTIC RESIN  
WATERPROOF GLUE

**FREE BOOK Tells How To**

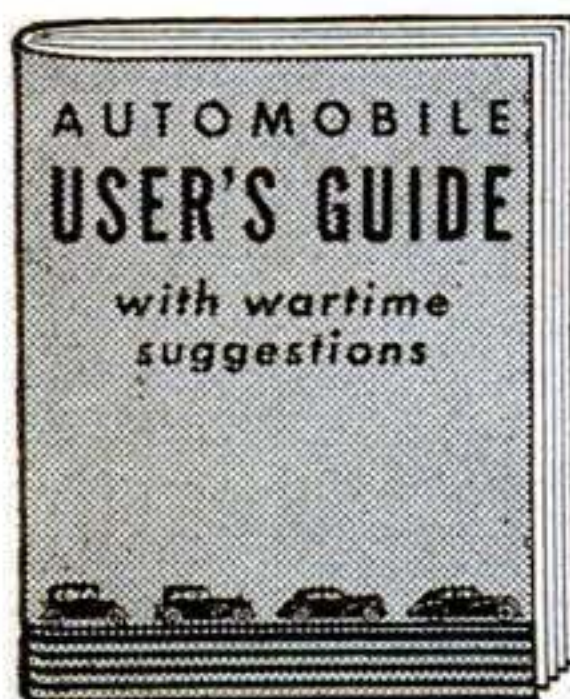

- get better gas economy**
- prolong tire life**
- preserve exterior finish**
- keep your car in the best operating condition.**

Get a **FREE COPY** from any General Motors dealer, or use coupon below.

Customer Research Dept., Room 1764  
**GENERAL MOTORS, DETROIT 2, MICH.**

Please send **FREE COPY** of new edition 64-page "Automobile User's Guide" containing 196 practical suggestions on wartime operation.

Mr. \_\_\_\_\_  
Mrs. \_\_\_\_\_  
Miss \_\_\_\_\_ *please print*

Address \_\_\_\_\_  
*please print*

City \_\_\_\_\_ Zone \_\_\_\_\_ State \_\_\_\_\_

Make of car now owned \_\_\_\_\_  
9 \_\_\_\_\_ *year model*

**HULL ENGINEERING**

Airplane-type action has been refined in the new **HULL STREAMLINE AUTO COMPASS**. Improved in performance and accuracy by wartime engineering. Limited supply at your dealer's. Write for free circular. **Price \$3.50.**



**HULL MFG. CO.**  
P.O. Box 246-E9 Warren, Ohio

***Pipe-smokers never weary of Walnut***

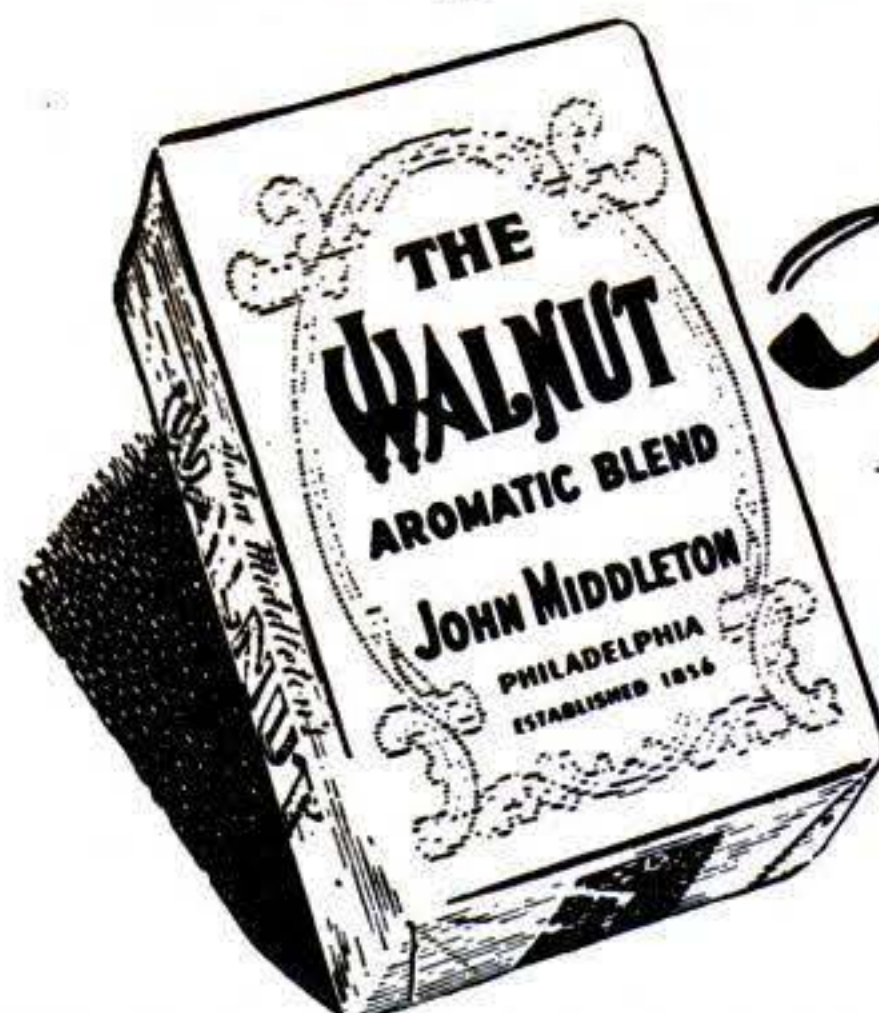

*30c the pocket-packet*

With that **RICH, NATURAL, NUTTY Flavor**  
Write for free booklet, "The Choice of Experience." John Middleton, 1203 Walnut Tobacco St., Phila. 7, Pa.  
*Custom-made for the Carriage-trade since 1856*



IT'S **PROFESSIONAL** PERFORMANCE THAT COUNTS!

SINGLE OR  
DOUBLE EDGE  
**5 BLADES**  
FOR  
**25c**



*True to Form!!*

**FOR CLEAN,  
COOL SHAVES!**

Like a plunge into the surf—cool, crisp and stimulating—that's a PROFESSIONAL shave. Smooth, clean strokes swishing through the toughest of beards with the greatest of ease... that's one way of describing it. Another is to try rust-resistant PROFESSIONAL Blades yourself! You'll get more shaves for the money—and more shaving comfort. Get them today, for the *Best Shave Ever...everytime!*

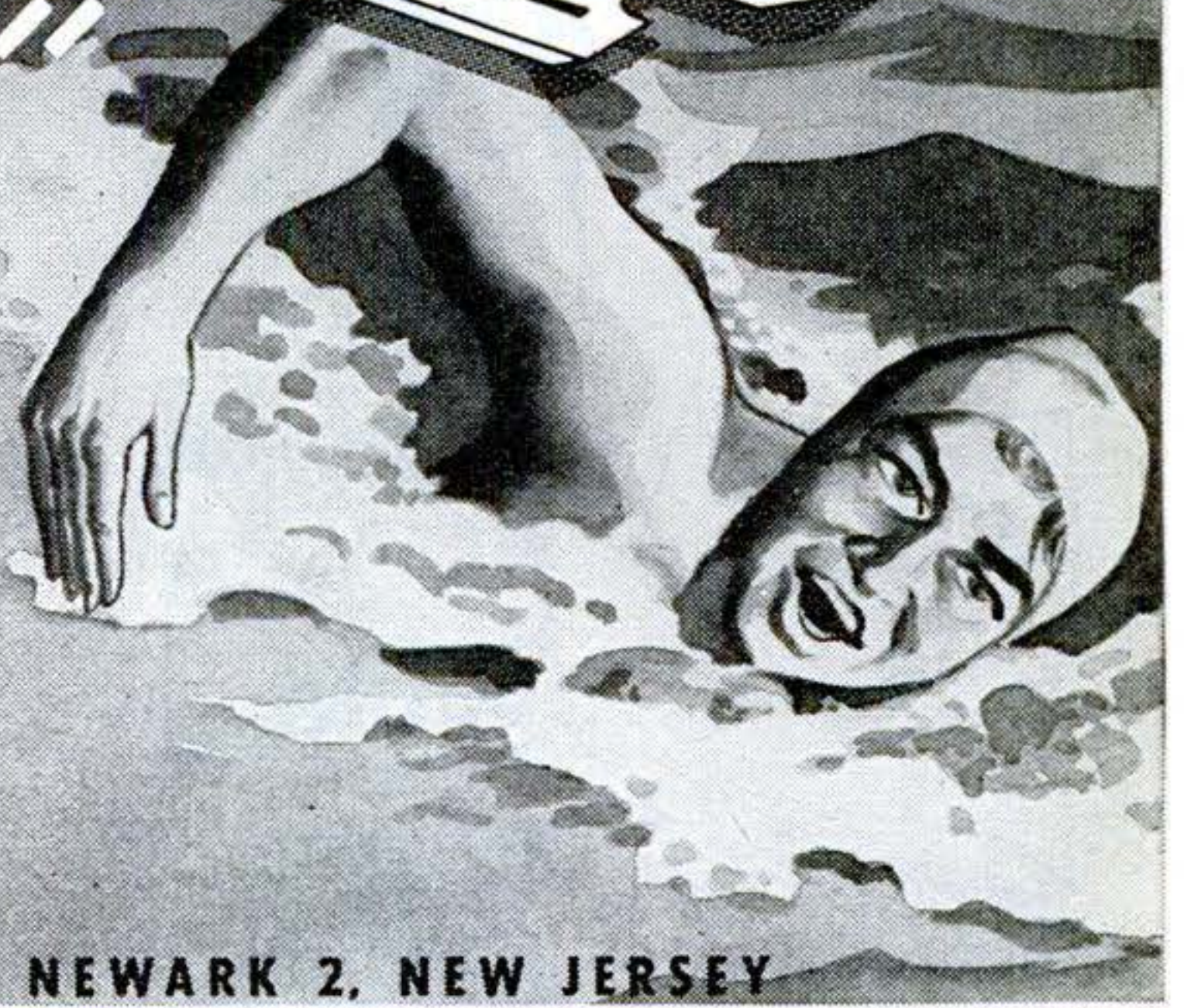

PROFESSIONAL BLADE CO., NEWARK 2, NEW JERSEY

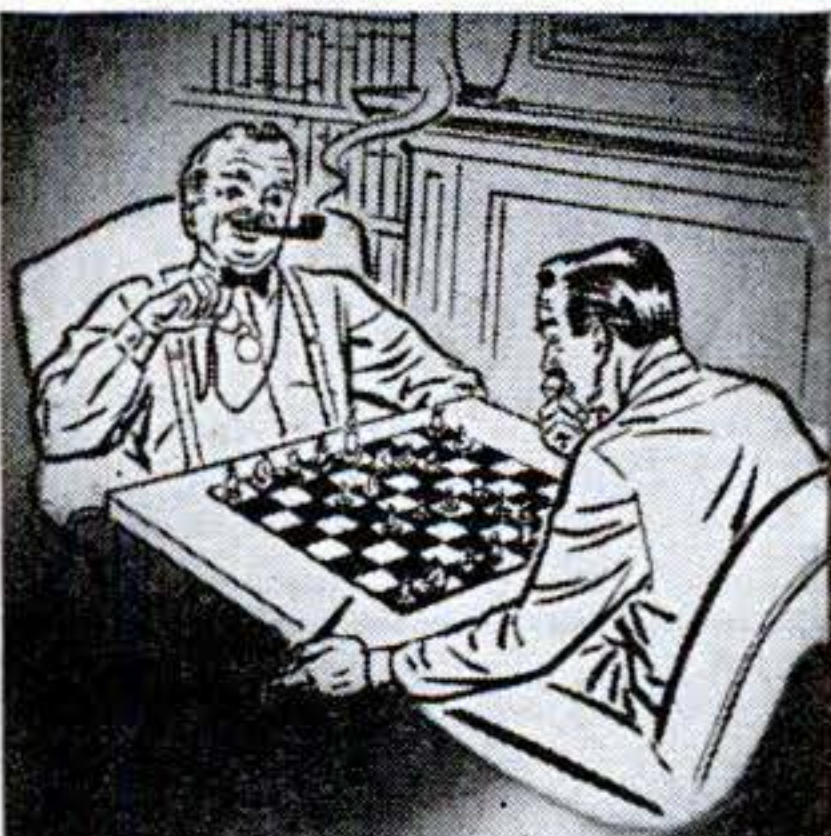

**FOR MEN who  
REALLY Know  
PIPES . . .**

**\$1.50**

Selected Briar



**MOUTHPIECE TUBE**  
prevents backflow of moisture

**CONDENSING CHAMBER**  
traps and holds bitter juices  
and sediment

**BOWL GUARD**  
keeps shank and bowl dry

**REMOVABLE SECTION**  
eases thorough cleaning

**CHAMBER GUARD**  
bars tobacco fragments from bit

Patented

*Royalton* **CROWN**

THIS PIPE REFUSES ADMITTANCE to those enemies of smoking pleasure — bitter juices and soggy flakes. They can't wriggle or ooze past Royalton Crown's condensing well and other features which guard against unwelcome intruders. This super-efficient combination of safeguards is found in no other pipe. Get a Royalton Crown and enjoy perpetually "dry-cleaned" smoking.

HENRY LEONARD & THOMAS, INC. • OZONE PARK 13, NEW YORK



# don't let sludge ruin your engine



**TO CLEAN OUT  
THE ENGINE**

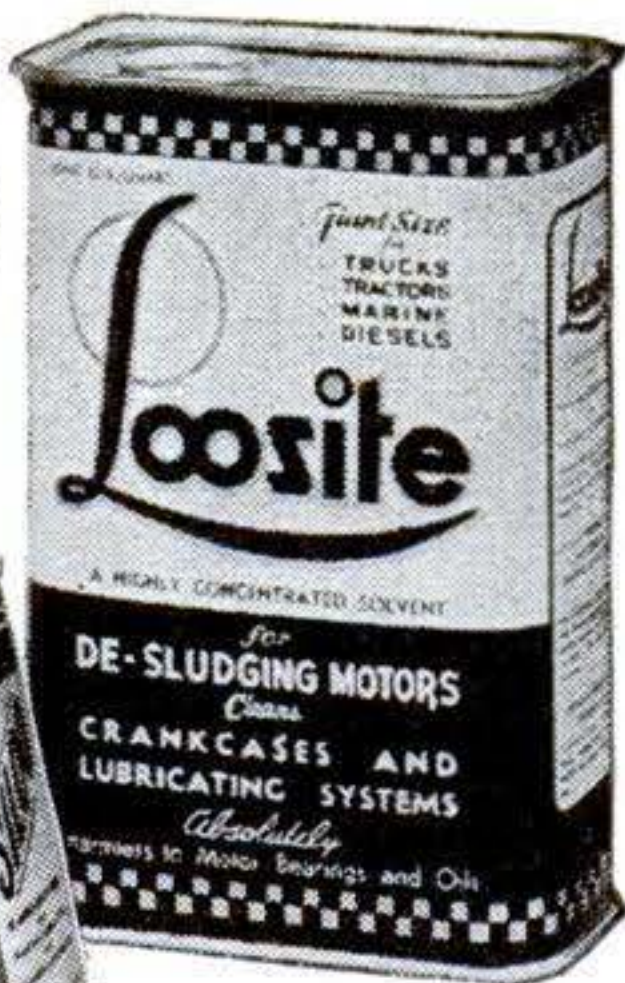

**TO KEEP IT  
CLEAN**

Sludge, gum and acid are the greatest enemies to smooth performance and long life of motors. Present in all internal combustion engines they are certain to get in their dirty work unless checked and controlled.

Fortunately these petroleum residues can be controlled and rendered harmless easily and quickly with the use of **LOOSITE** and **SILOO**. For fifteen years these safe, swift working solvents have been helping to keep millions of motors in service at full efficiency. An initial **LOOSITE** treatment cleans the motor of sludge, gum and acid. Then **SILOO** added regularly with fresh crankcase oil keeps it clean. Lubrication flows freely — assuring long, economical and smooth operation.

Get started with **LOOSITE** and **SILOO** today. Your dealer has them.

If you heat with oil — write for information on **SILOO FUEL OIL TANK SOLVENT**.

**PETROLEUM SOLVENTS CORPORATION**  
331 Madison Avenue, New York 17, N. Y.

Buy War Savings Bonds and Stamps regularly.

**LEO'S SPECIAL!**  
Immediate Delivery on this  
**Multitester**  
**\$1875**  
WRL 300 Less Leads



Handles AC and DC Voltmeter, DC Milliammeter, High and Low range Ohmmeter. Size 5 1/2 x 8 x 3 1/4. 3" meter with sturdy D'Aronsva movement. Write for priority information today.

**PHONO AMPLIFIER KITS**  
Complete with tubes, all parts, chassis, diagram, etc. Priority AA-5 or higher. No. 1059..... **\$9.50**



**We Feature Hallicrafters**

Available for immediate delivery on priority. Reserve your post-war Hallicrafters now. Write Leo for details.

These Items - Exclusive at Leo's  
44 Page Radio Parts Flyer. FREE  
Tube and Circuit Book. ....10c  
Giant Radio Reference Map. 15c  
Handy Tube-Base Calculator. 25c

Address Leo, W9GFQ Dept. PS-9  
Council Bluffs, Iowa

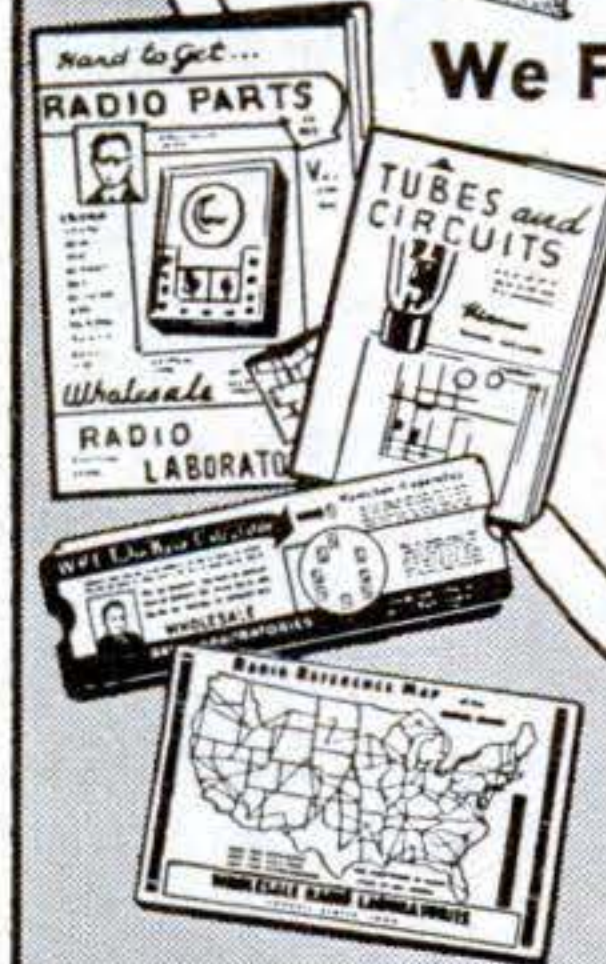

**Wholesale  
RADIO LABORATORIES**

## TELESCOPING MEASURING TOOLS

... Measure All Holes, Slots, Etc.—5/16 Inch to 6 Inches ...  
Gives You Outside Micrometer Accuracy on Inside Measurements  
**FINISH YOUR OWN SET OF FOUR TOOLS**

**Only \$2.95 C.O.D.**

Plus Usual Small Postal Charge  
PART OF THE MACHINE WORK ALREADY DONE—ONLY  
SIMPLE LATHE WORK NECESSARY TO COMPLETE. No special tools  
required—Threading, Knurling, etc., already done. Kit includes all  
material (part machined); simple drawings, and detailed instructions.  
Send \$2.95 cash with order and we pay postage.  
**ALCO SHOPS, Dept. J, 1459 Sunset Blvd., Los Angeles 26, Calif.**



## Clean Hands

Quickly remove grime and grease from hands, and almost anything, with **SKAT**, original and best Paste Soap.

At all grocers.

**Skat Co., Dept. S, Hartford 6, Conn.**

## Better Light FOR DARK JOBS ... with GENERAL BAT-LAMP



Streamlined "trouble-light" fits in tight, narrow places. Made of insulating plastic with rotating metal reflector and guard. Write Dept. 9-F.

Free-  
turning  
handle has  
plug socket  
and button  
switch.

**THE  
GENERAL DETROIT CORP.**  
2270 E. Jefferson, Detroit 7



*You're lucky you had  
Guide Sealed Beam Units*

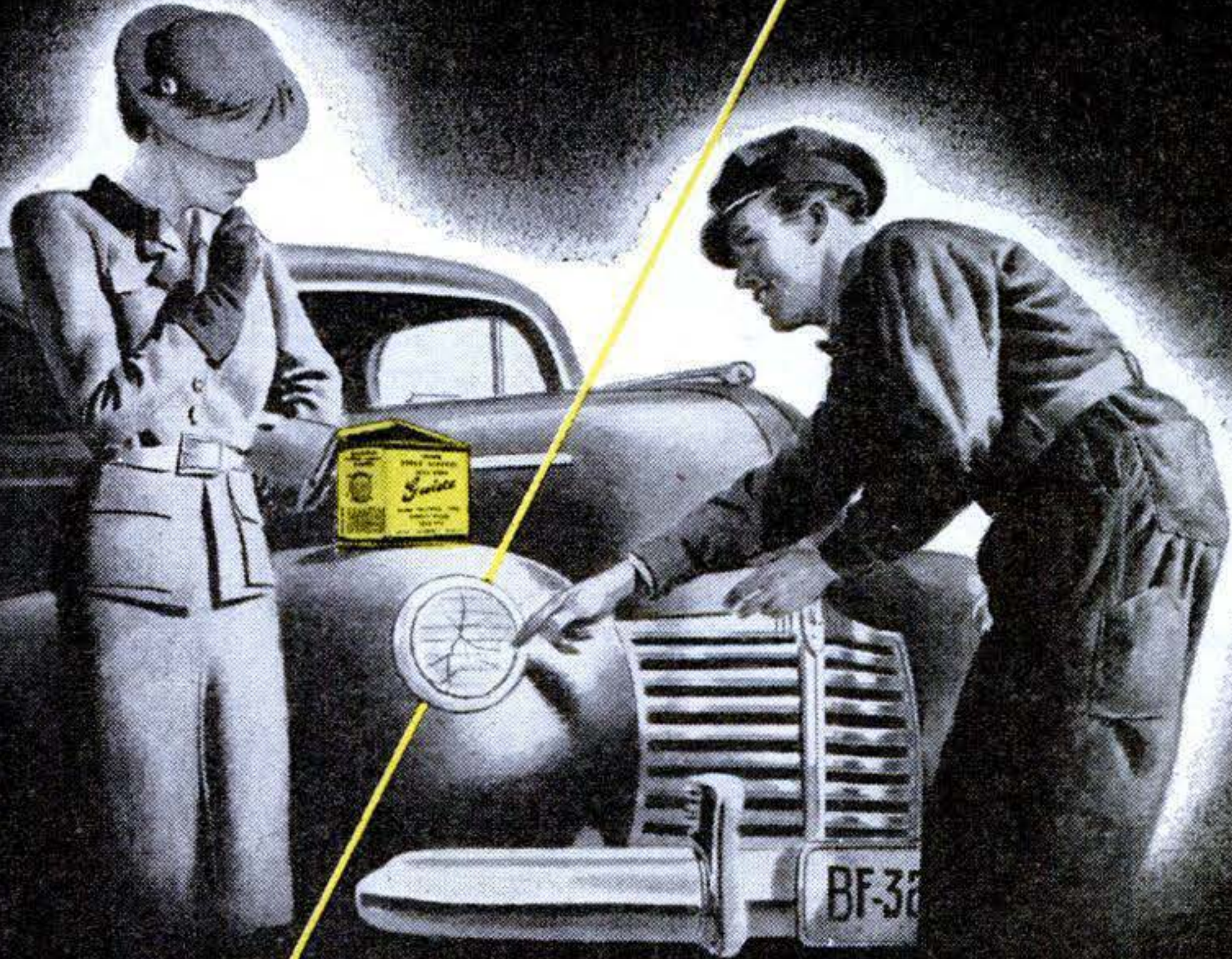

KEEP BUYING  
WAR BONDS



GUIDE LAMP DIVISION OF GENERAL MOTORS

If a lens is cracked by a stone or blow, your Guide Sealed Beam unit won't let you down. It continues to light the way even when the lens is broken . . . safeguards your ride until the damaged unit can be replaced.

Guide Sealed Beam units give you the safest lighting that money can buy . . . no dim-out, no black-out. Make sure your next Sealed Beam headlamp unit is a Guide.

**NO DIM-OUT**—because Guide Sealed Beam units are sealed against dirt, dust and traffic film. They stay bright for the life of the unit—do not lose their efficiency, as earlier-type headlamps do.

**NO BLACK-OUT**—because Guide Sealed Beam units provide the double protection of a bulb within the sealed unit. If a lens is cracked they do not fail—light the way safely until the damaged unit can be replaced.

LET SAFETY SHARE THE RIDE — REPLACE WITH GUIDE





— Any old Boat...  
and an **EVINRUDE!**

● Sure — you'd rather go fishing in a sleek modern boat — but it's fisherman's luck to find only battered old tubs on the best fishing waters! So you take what you get and like it.

● And after all it's *the motor that counts!* It means everything to have a motor that starts instantly, and purrs along smoothly and quietly, through fair weather and foul, on trip after trip and day after day. Such a motor makes a world of difference to any man's vacation!

● That is the kind of performance you can expect from your new peacetime Evinrude . . . performance that, *on any boat*, brilliantly reflects Evinrude's 36 years of *know how* in the building of fine outboard motors. **EVINRUDE MOTORS, Milwaukee, Wis.**

**—EVINRUDE—**

OUTBOARD  MOTORS

BUY MORE WAR BONDS — AND HOLD THEM!

## Fuse Puller — Circuit Tester

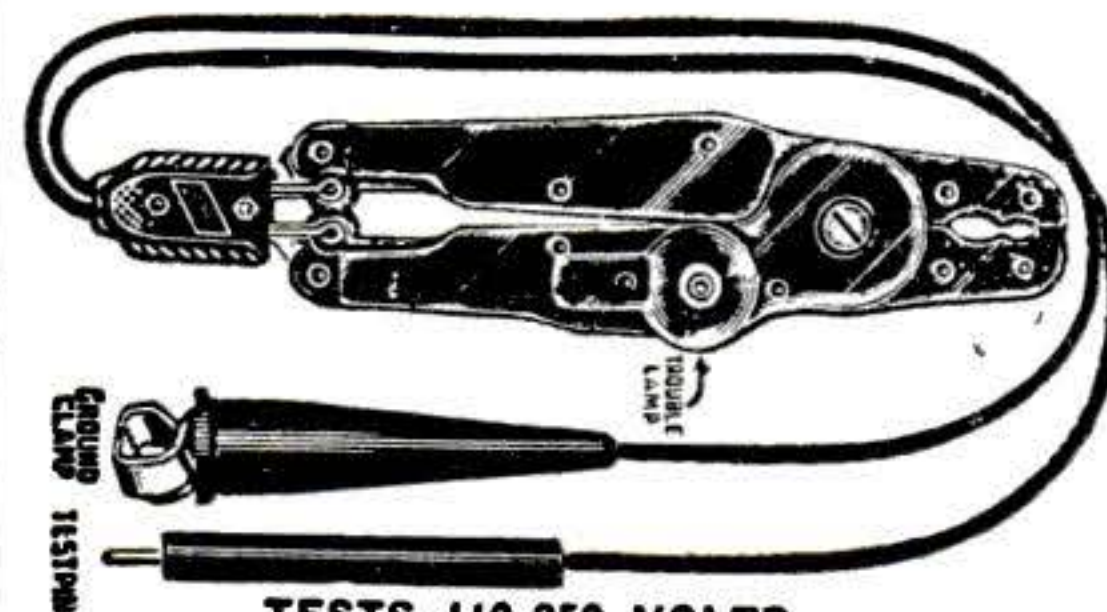

For  
Home  
or  
Factory

TESTS 110-250 VOLTS

When motors stop and lights go out, this tool quickly **LOCATES DEAD CIRCUITS** and safely removes blown Fuse. The Star Test Pocket Plier is made of a Transparent Plastic having in one of the legs a small lamp in series with a resistance and can be used to test 110 to 250 volts circuit. The Plier will pull fuses from 10 to 100 Amperes. Thousands of Electricians find this tool handier than Test Lamps. Price \$2.75 each without Leads, \$1.50 additional for Leads, plus 10c postage. Can be obtained from General Electric or Westinghouse Stores or directly from us. Order NOW. **STAR PLIER CO., 237 Canal St., New York 13, N. Y.**

## MADE FROM IMPORTED BRIAR



\$3.50 to \$10



Enjoy unmatched sweet smoking quality, outstanding fine grains, in modern designs, \$3.50 to \$10. At leading tobacconists everywhere. Write for free illustrated booklet.

**C. B. WEBER & CO., 146 Cator Ave., Jersey City 5, N. J.**



## BURNED OUT or BROKEN ELECTRIC

**HEATING ELEMENTS REPAIRED WITH NEW AMAZING NICHROCITE**

Simply overlap ends, apply Nichrocite Paste and turn on current. Used by large utility companies. Trial order, \$1.00; 4 oz., \$2.50; 1 pound, \$8.00. **Armstrong Mfg. Co., Bx. 861-B, Minneapolis, Minn.**



## DO YOU

WANT a permanent business profession of your own? Then become a foot correctionist. Earnings of men and women in this greatly needed profession

run as high as \$50.-\$100. weekly after a few weeks home training —not medical or chiropody—easy terms, no further capital needed, no goods to buy. 50th year. Write for free booklet. **Stephenson System of Foot Correction, 62 Back Bay, Boston, Mass.**

## SHAW and "Peppy-Pal" GARDEN TRACTORS

● 1 to 9 H.P. Circulars on request. War limits production—We supply repairs for all SHAW Tractors sold in our 41 years in business.

### BUILD YOUR OWN RIDING TRACTOR—"WAR HORSE"

using old auto parts, powered by 2 H.P. or larger air-cooled engine; or walking type Garden Tractor ½ to 3 H.P. or convert truck or auto into Farm Tractor. Each with steel or rubber tires; will plow, cultivate. Plans for building, in few hours, any one of above, postpaid for \$1.00 (state which wanted) or all 3 for \$2.00. Money Back Guarantee!

**SHAW MFG. CO., 5709 FRONT ST.**  
Galesburg, Kansas  
668PS North 4th St., Columbus, Ohio

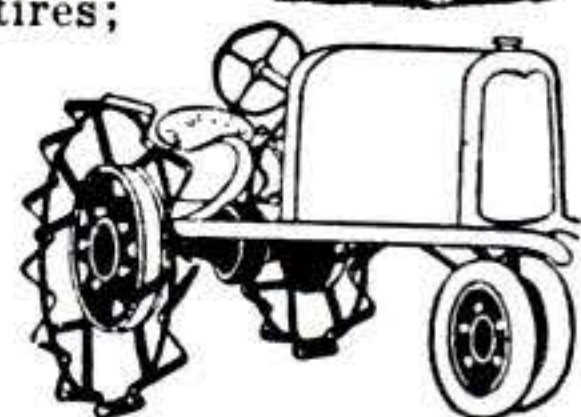
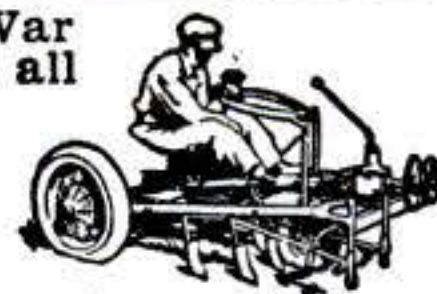



**MAKE ACCURATE PHOTOCOPIES  
OF ANYTHING! In your own shop  
—Quickly, Easily—at Low Cost!**



*The* **APÉCO**  
**PHOTOEXACT**  
*"Copies Anything!"*

**BLUE PRINTS  
PHOTOGRAPHS  
PENCIL SKETCHES  
SPECIFICATIONS  
TRACINGS; GRAPHS  
CHARTS; LETTERS  
(over 100 others)**

Photo-Copier

**\$55**

Copies up to  
18" x 22"

Also continuous cabinet models for prints  
of any length, up to 42" wide.

Make permanent, error-proof photocopies direct from blueprints (without tracings) or get *photographic tracings* direct from any blueprint, drawing or sketch. Save time, money—expedite work! APÉCO makes copies, 1-a-minute, of anything written, typed, printed, drawn or photographed—even if on both sides. No darkroom or technical knowledge needed. Get facts. Write TODAY on your business letterhead.

**AMERICAN PHOTOCOPY EQUIPMENT CO.**  
2849 N. Clark St., Dept. HU95, Chicago 14, Ill.  
(Representatives in principal cities and Canada)

**AMERICA'S MOST WIDELY USED  
PHOTOCOPY EQUIPMENT**

**"EVERYTHING Metal Items  
Need in an Oil"**

★ **THE NEW** ★

**FIENDOIL 35¢**

Lubricates— Cleans—  
Protects 2 oz. size

McCambridge & McCambridge Co.  
Baltimore 23, Md.



**IF YOU ARE INTERESTED  
in Post War FLYING**

**SEND FOR THIS  
FREE BOOKLET**



**SWITLIK**

**SAFE-T-CHUTES**

Published as a  
Public Service in the interests of Safe-T-Flying

**SWITLIK PARACHUTE CO., Dept. M-9, Trenton, N. J.**

**SWITLIK PARACHUTE CO., Dept. M-9, TRENTON, N. J.**

Please send me free copy of illustrated Booklet "For  
SAFE-T-FLYING" which includes the History of Parachutes.

NAME.....  
ADDRESS.....  
CITY..... STATE.....

# DISSTON



## The saw most carpenters use

Ask the carpenters *you* know what makes of saws they use. You will learn what many investigations have revealed—*most carpenters use Disston Saws*. They will tell you that Disston Saws are faster-cutting, stay sharper longer, and can always be depended on for clean, accurate work . . . results which can be credited to the superiority of Disston Steel, its fine temper and the rare skill of Disston Saw makers.

Take care of the Disston Saws you now have, and they will continue to serve you well until more new saws can be released for civilian needs. Many hardware retailers and saw repairmen provide a special saw sharpening service. They will be glad to help you keep your Disston Saws—or other quality make—in good serviceable condition.

If you need a new Disston Saw or other tool for *essential* work, discuss your problem with your Hardware Retailer—he may be able to help you.

**HENRY DISSTON & SONS, INC.**  
**910 Tacony, Philadelphia 35, Pa., U. S. A.**

**ASK FOR YOUR FREE COPY**



The Disston Saw, Tool and File Manual tells how to use and care for tools. FREE at your Hardware Store, or write to us for a copy.





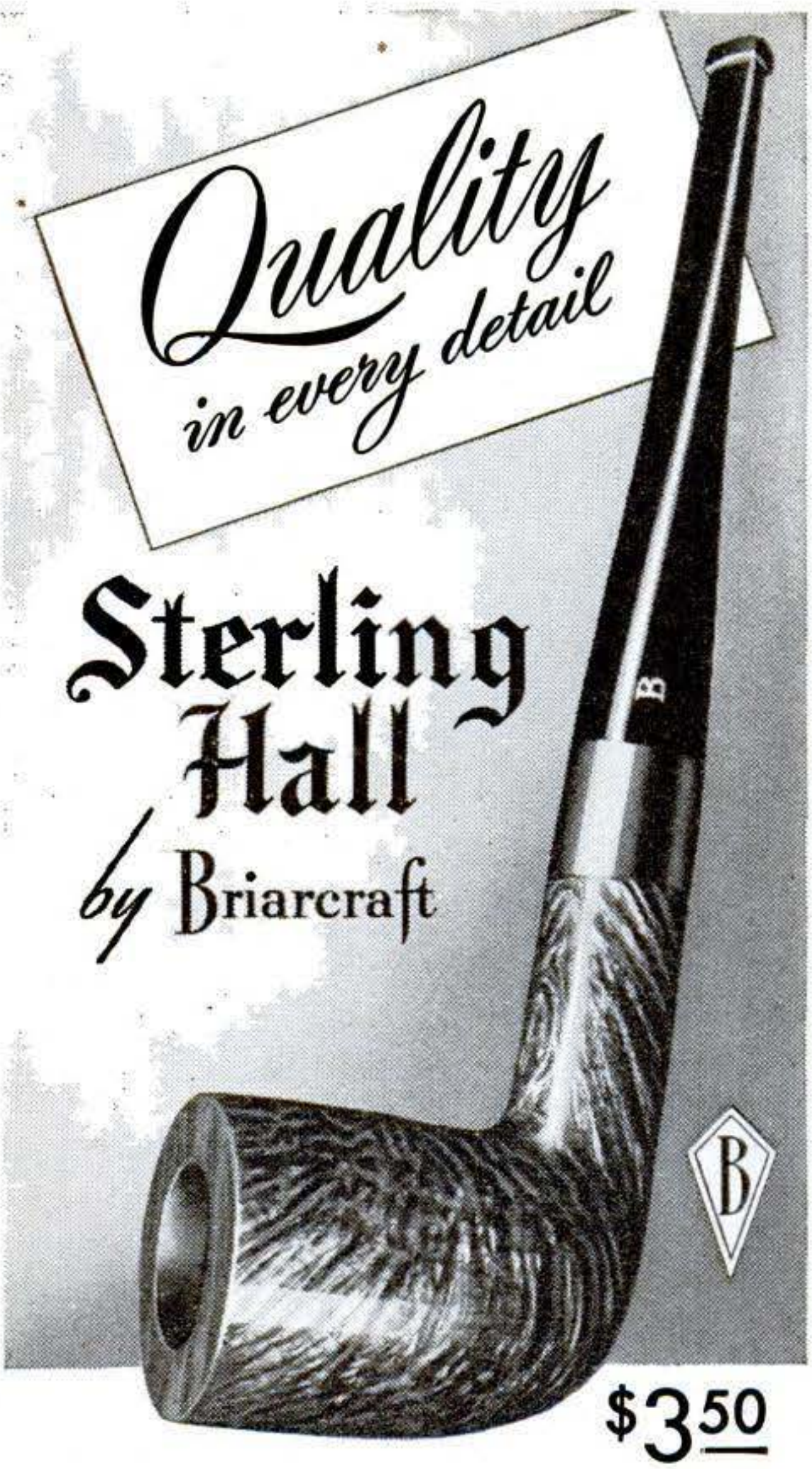

**Sterling Hall**  
by Briarcraft

**\$3.50**

You'll recognize superior quality immediately when you examine a Sterling Hall Pipe. Its perfect design, handsome grain, beautiful finish and its smart lines instantly stamp it as a de luxe product. And you'll make no mistake in assuming that a pipe made with such care can be depended upon to give years of genuine smoking pleasure.

Sterling Hall can be had at the better shops in a wide range of handsome models—with or without an inlaid sterling silver band. Individually boxed, \$3.50.

Briarcraft, Inc., 347 Fifth Avenue, New York 16, N. Y.

**Electrically Welded Endless**  
*Paramount*

**BAND SAW BLADES**



Made in widths from 1/8" to 1 3/4"

Make your band saw do more work for you. The proper width of blade will extend the scope of this important machine. Burrill's Paramount Blades are made from tough Nickel Alloy Steel properly tempered. Teeth accurately set and filed, and all saws carefully straightened. Send order and check today. Delivery will be made as promptly as war conditions permit, from a few days to a week or two. You can obtain these saws at the following prices:

- 1/8"-3/16"-1/4"-3/8" wide, 5'6" long.....\$ .90 each
- 1/8"-3/16"-1/4"-3/8" wide, 6'6" long..... .95 each
- 1/8"-3/16"-1/4"-3/8" wide, 7'6" long..... 1.10 each

Other sizes at proportional prices

Your satisfaction is guaranteed  
**BURRILL SAW & TOOL WORKS**  
405 E. Main St., Ilion, N. Y.



**HEAD PHONES LATEST TYPE**

Light Weight. Finest Quality, with plug for tuning in on radio, or intercommunication system. Also adaptable for use in making a razor blade or crystal set. Head Phones: (No head band slightly used) \$1.25; Head Phones: (No head band—New) \$1.75; Head Phones: (With leather covered adjustable head bands—slightly used) \$2.50; Head Phones: (With leather covered adjustable head bands—New) \$3.75; Plus \$.25 for shipping charges—send Money Order. Quantity Limited.

**NICO SUPPLY CO.** 540 N. 17th STREET, PHILADELPHIA 30, PA.

**USE YOUR BENCH SAW**

With Our six in. tool steel cutters. Make mouldings, casings, drop-leaf tables, grooves beading & jointing 1" wide \$1.50, 1 1/2" \$1.75 ea. Postpaid. State size hole. List & folder free.  
**John A. Sandstrom, Box 517, Stow, N. Y.**

**OTTAWA LOG SAW** Write For **FREE BOOK**

Put this **OTTAWA** to work for you. **MAKE MONEY!** Wood is bringing highest prices ever known. Ottawa does more than 10 men. Easily operated. Falls trees—Falls trees—SAWS LIMBS saws limbs. Use 5-hp. engine for other work.

**OTTAWA MFG. CO., 901 Wood St., Ottawa, Kans.**

**Get Into the MONEY via "Simplified" Arc Welding**

You'd be surprised at the number of returning servicemen that are starting job welding shops, after doing their bit for Uncle Sam. Sure, some were welders before the war, some learned while in the service and others, well, they just saw the value of welding and made up their minds it's a "must" for a profitable business. They learned a lot about building and maintaining equipment and what an important part welding plays in this game. Better get started today!

**HOBART**  
"Simplified" Arc Welders

Ask for Your Copy of *Pocket Size Arc Welder's Guide. It's FREE!*

**HOBART BROTHERS COMPANY**  
BOX P-95, TROY, OHIO

"One of the World's Largest Builders of Electric Arc Welders."



# FREE! MOST COMPLETE RADIO PARTS CATALOG

EVERYTHING in RADIO ELECTRONICS for Training, Maintenance or Repair



New R-F Resonance and Coil Winding Calculator No. 37-955. Postpaid, 25c

NEW Parallel Resistance & Series Capacitance Calculator No. X37-960. Postpaid, 25c

## RADIO'S FINEST BOOK VALUES

Specially prepared to aid radio training in schools and industry. Full of valuable data. Send for all six!

- Radio Formulas and Data Book No. 37-752.. 10c
- Dictionary of Radio Terms No. 37-751.. 10c
- Radio Circuit Handbook No. 37-753.. 10c
- Radio Builders' Handbook No. 37-750.. 10c
- Simplified Radio Servicing No. 37-755.. 10c
- Radio Data Handbook No. 37-754.. 25c
- All Six Books No. 37-799.. 75c

6 BOOKS FOR 75c

**ALLIED RADIO CORP.**

833 W. Jackson, Dept. 7-J-5, Chicago 7

# ALLIED RADIO

## LEARN ELECTROPLATING—

Complete Instructions by a practical plater, with formulas for Brass, Cadmium, Chromium, Copper, Gold, Nickel and Silver Solutions. Price \$1.00 Money Back Guarantee. **PLATER HYDE, Dept. B, P. O. Box 176, National City, California**

## NEW CHEAP OIL BURNER

FOR COOKING & HEATING STOVES-FURNACES  
HEAT YOUR HOME, COOK YOUR MEALS  
WITH CHEAP FURNACE OIL



NO MORE SHOVELING COAL OR ASHES. New Fuelizer Starter Vaporizing System turns Cheap 130 Flash Furnace Oil into Oil Gas heat without clogging up. LIFE-TIME GUARANTEE against defects. \$1.00-BONUS OFFER FOR TESTING. We will let you try it in your own stove or furnace for one month. Get Yours for introducing. Big profits.



Be first. Send in your name today. **NORTHWEST MFG. CO., 537-L 5th Ave., Mitchell, So. Dak.**

Does More Things Easier and Quicker Than Any Other Tool!

Remains locked to the work with hands removed. Holds anything, any shape, with a grip that never slips. Is actually Hand-Vise, Clamp, Super-Plier, Adjustable End Wrench, Pipe-Wrench, Locking Wrench and Toggle-Press—ALL IN ONE! Light, trim, handsome. Made of fine alloy steel. Zinc plated. 2 sizes—7" and 10".

Dept. P-9 **PETERSEN MFG. CO., DeWitt, Nebr.**

# WISE-GRIP WRENCH



Gives 1 Hand TON-GRIP



## How to Cut Any Size Hole with One Tool

Clean, fast cuts from 5/8" to 1 1/2" diameter—in steel, sheet metal, boiler plate, dural, plastics, wood, masonite, hard rubber, fibre and other materials, with

# BRUNO

Adjustable **HOLE CUTTER**  
ONLY \$2.95



Just like a compass, it's easy to set for any diameter.

For home users, mechanics, farmers, technicians—one Bruno does the work of many fixed-radius cutters.

Ideal for use in portable drill, hand brace or drill press. High-speed steel blade easy to re-sharpen. Ruggedly built. Designed by cutting tool engineers. **MONEY BACK GUARANTEE.** Bruno No. 100 has 1/4" straight shank. Also furnished as 100-B, with bit stock for braces. Cutting range 5/8" to 1 1/2". Either \$2.95. Model No. 101 has 3/8" straight shank (No. 101-B optional, with square bit stock) and priced at \$4.95. Cutting range 1" to 2 1/2".



Bruno No. 100 in electric drill cutting 1 1/2" hole in metal box.

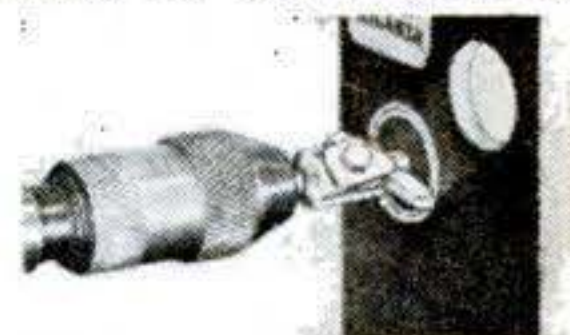

Bruno No. 100-B in hand brace cutting plastic laminate.

## SPECIAL CHRISTMAS PACKAGE

Contains Two Models: No. 100 and No. 101 Any diameter 5/8"-2 1/2" in Special Gift Package

**\$7.85**



**BRUNO TOOLS • Beverly Hills, California**

**SEND THIS COUPON NOW**

Bruno Tools — Beverly Hills, California, Department PS-9

Please send me the Bruno Hole Cutters checked below.

Enclosed Find Money Order  Ship C.O.D.

Christmas Kit of 2 Models \$7.85 (straight shank only)

No. 100 \$2.95  No. 100-B, SQ Shank \$2.95

No. 101 \$4.95  No. 101-B, SQ Shank \$4.95

Name \_\_\_\_\_

Street \_\_\_\_\_

City \_\_\_\_\_

State \_\_\_\_\_

California Purchasers Add 2 1/2% Sales Tax



**SICKNESS or ACCIDENT**  
can't rob me of my savings

**I'VE A FAMILY MUTUAL HOSPITALIZATION POLICY**

Costs **3¢** A DAY • EACH ADULT  
only **1½¢** A DAY • EACH CHILD

**FOR SICKNESS OR ACCIDENT**  
Hospital Expenses paid (beginning with the first day), up to . . . \$540.00

**FOR ACCIDENT**  
Doctor Expense paid, up to \$135.00      Loss of Wages reimbursed up to \$300.00  
Loss of Life by Accident . . . . . \$1000.00

**WAR COVERAGE and EXTRA BENEFITS**  
Childbirth Expense paid, up to . . . . . \$60.00

Sickness or accident can easily wipe out, in a few weeks, savings it may have taken years to accumulate. Don't let this happen to you. With a Family Mutual Hospitalization Policy, you'll be able to pay your hospital bills. In case of accident, you will be reimbursed for your doctor expenses and for loss of time from work. Your Family Mutual card admits you to any hospital in the United States and your own family doctor may attend you. Benefits applying to children are 50% of those paid adults.

MAIL COUPON TODAY — No Agent Will Bother You

**FAMILY MUTUAL LIFE INSURANCE CO., WILMINGTON 99, DEL.**

Family Mutual Life Insurance Co., PS-9  
601 Shipley St., Wilmington 99, Del.

Please send me without obligation, complete information on your Economical Hospitalization Plan.

NAME \_\_\_\_\_  
ADDRESS \_\_\_\_\_  
CITY \_\_\_\_\_ STATE \_\_\_\_\_

**Now for EVERY WORK SHOP!**

**NEW Invention Electroplates by BRUSH**



**Easy to Plate CHROMIUM GOLD, SILVER, NICKEL, COPPER . . . For Pleasure and Profit!**

If you have a workshop—at home or in business—you need this new Warner Electroplater. At the stroke of an electrified brush, you can electroplate models and projects—you can replate worn articles, faucets, tools, fixtures, silverware, etc. with a durable, sparkling coat of metal . . . Gold, Silver, Chromium, Nickel, Copper or Cadmium. Method is easy, simple, quick. Everything furnished—equipment complete, ready for use. *By doing a bit of work for others, your machine can pay for itself within a week.* So make your shop complete by getting a Warner Electroplater right away. Send today for FREE SAMPLE and illustrated literature. **ACT AT ONCE! Mail Coupon.** **WARNER ELECTRIC CO., DEPT. C-9 663 N. Wells St., Chicago 10, Illinois**

**FREE Details & Sample!**

WARNER ELECTRIC CO., 663 N. Wells St., Chicago 10, Dept. C-9  
Gentlemen: Send Free Sample and Details to:

Name \_\_\_\_\_  
Address \_\_\_\_\_  
City \_\_\_\_\_ State \_\_\_\_\_

**"JACKPOT"**  
**Home Model COIN MACHINE**



Get this new, colorful pay-out machine for your recreation room! Soon pays for itself! Three fruit reels. Costs player 5c per play. Pays off one quarter automatically on two cherries etc. (Retains 60¢ for house; 40¢ winnings for player). Also can be operated to pay off tokens, 25c size, bearing odds from 3 to 1 up to 100 to 1. Complete with 121 metal tokens. Size 10 x 10 x 10 in. Metal construction. Wt. 16 lbs. Send \$10.00 deposit, balance C.O.D., **\$49.50** F.O.B. Chicago. Immediate delivery . . . Each

**Webb DISTRIBUTING CO.**

612 NORTH MICHIGAN AVENUE • CHICAGO 11, ILLINOIS

**CODE SPEED SHORT CUT**

Be an expert. Learn to be a Telegraph or Radio Operator. Thousands of men needed. Intensely interesting work—good pay. Learn at home or wherever you are, quickly, easily with the famous Candler Speed System. Book of particulars Free. **CANDLER SYSTEM CO., Dept. 6-K, Box 928, Denver 1, Colo. U. S. A.**

**TRAILER BUILDERS' SUPPLIES!**

To Build, Repair or Modernize! Save money on Supplies. We are the largest and most complete trailer supply House in the States. Our new large 1945 catalog 10c; Blue prints and building instructions 25c.

**National Trailer Equipment Company 719 N. Seventh St. Milwaukee 3, Wis.**

**BEST SHAVE EVER OR MONEY BACK!**

Patented **SPEE-D-HONE**



Shave with a grin — not a groan . . . For smoother shaves — use SPEE-D-HONE! SPEE-D-HONE puts "velvet-edge" on razor blades. MILLIONS IN USE. Dozens of shaves from every blade. Only 10c. If dealer can't supply, send dime for sample. **CURTISS CANDY COMPANY DEPT. PS CHICAGO 13, ILL.**

**PSORIASIS RID YOUR SKIN**

of ugly, scaly lesions. Let Derm-K bring you satisfying relief. Not an ointment. Stainless. Excellent for **DRY ECZEMA**. Rush name and address for Special **NO RISK OFFER**. Send postal today. **Carter-Howell Laboratory, 457 Schenectady Ave., Dept. M-14, Brooklyn 3, N. Y.**



**ILLUSTRATED COMIC BOOKLETS**

**THE KIND MEN LIKE! (VEST POCKET SIZE)**

20 assorted booklets sent for \$1. Shipped prepaid in plain wrapper. No C. O. D. orders. Send cash or money order. No stamps. **GRAYKO, Dept. AB-682 Box 520, G. P. O., New York 1**



**SIMPLE EASY INVENTION AT HOME! TRIMS HAIR**

**SAVES BARBER BILLS**

Trims hair as it combs! Easy! Quick! Keeps men's, women's children's hair trim, neat, freshly-cut looking all the time! Trims, tapers, thins out uneven hair. Use like ordinary comb. Safe. Simple. No experience required. Fine for legs, underarms! **Sells like wild!**

**SAMPLES FOR AGENTS** Sample offer sent immediately to all who send name at once. A penny postal will do. **SEND NO MONEY.** Just your name. **KRISTEE CO., 699 Bar St., AKRON, OHIO**



## Floyd Clymer's MOTOR BOOKS

### Ab Jenkins' Racing Book

"THE SALT OF THE EARTH." Thrilling story of Jenkins' world's speed records with Mormon Meteor on Bonneville, Utah, Salt Flats. History of world's fastest speed course. Photos of famous English drivers—Campbell, Cobb, Eyston, and details of their racing cars. Non-technical. **\$1.50** Postpaid

De Luxe Cloth Bound \$2.50.

### The Modern Steam Car

160 pages, 120 illustrations. Interesting, practical book on steam automobiles. Complete information early and latest makes, models, both U.S. and foreign. Boilers, engines, burners described, illustrated. Articles by Stanleys, early steam ads. How to drive and care for steam automobile. Unusual, informative book. **\$2.00** Postpaid

De Luxe Cloth Bound \$3.00.

### Motor History of America

World's Wonder Book of Car History. Newly revised, authentic story of automotive industry since its inception. Lists over 1600 makes of gas, steam, electric cars. Includes historical "Scrapbook" supplement by Floyd Clymer and early details on Ford, Chrysler, Olds, Durant, all others. Valuable historical data. **\$3.00** Postpaid

De Luxe Cloth Bound \$4.00.

### POWER and SPEED

120 large pages! 200 illustrations! World's most famous racing book, automobile, motorcycle and airplane. World's speed record charts, articles by world famous speed kings, Campbell, Cobb, Eyston, others, Daytona and Bonneville record details, photos. Engines, parts described. **\$2.50** Postpaid

CLYMER MOTORS, Dept. PS, 2125 W. Pico, Los Angeles 6, Calif.



**AIRLINES,  
LIKE MOTORISTS**  
*choose AC for utmost reliability*



Aircraft Spark Plug

Northwest Airlines have now become the fourth American line to inaugurate ocean-to-ocean service. *Utmost reliability* being the watchword, it is not surprising that AC Ceramic Aircraft Spark Plugs are used.

The history of these remarkable plugs goes back to World War I, when AC built the *first and only* ceramic aircraft spark plugs, for use in Liberty engines. That was the beginning of a long series of triumphs shared by AC Ceramic Aircraft Plugs, including those of Lindbergh, Acosta, Maitland, Byrd, the Constellation and the C-97. Their war record is no less brilliant.

In automotive fields, AC pioneering has consistently shown the way to better spark plug design and performance.

Engineers of 2 out of every 4 cars and trucks specify AC's as standard equipment. In every type of motorized equipment, motor-wise people, the world over, choose AC for *utmost reliability*.

AC SPARK PLUG DIVISION • GENERAL MOTORS CORPORATION

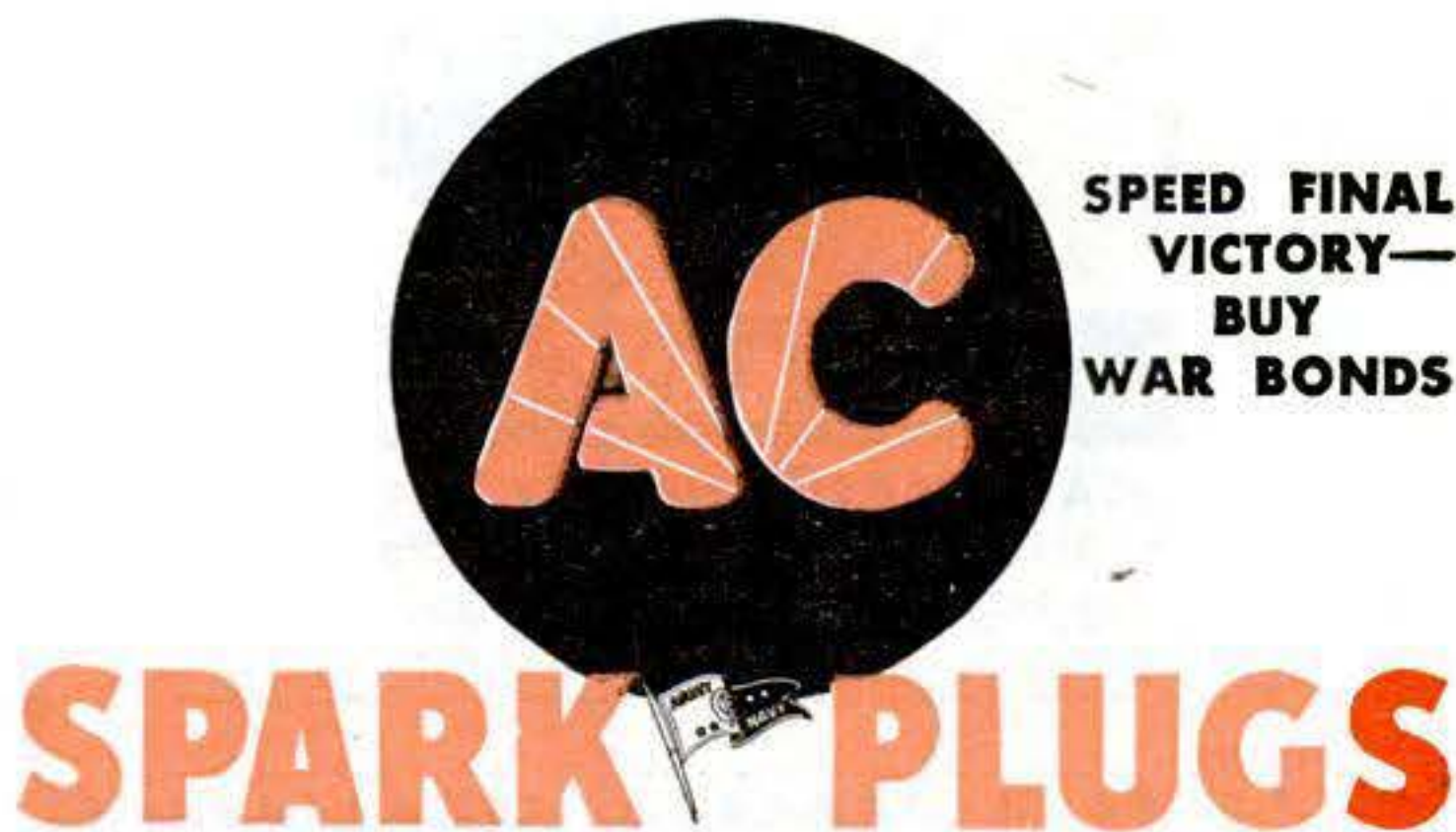

## TRADE Old Guns for Brand New GUNS

Trade Guns at KSG, America's Biggest Gun Trading Center, where you get MORE for your merchandise—and buy for less. Large selection 1945 Models (for delivery right now) and Used Bargains in Rifles, Shotguns, Handguns, from \$5—to the finest. Ship your Guns, Reels, Rods, etc., at once, or describe fully by letter.

"Where other sources fail—KSG comes through by mail"

**KLEIN'S** Famous for Guns  
Sporting Goods Since 1885

512 T J So. Halsted St., Chicago 7, Illinois



Get Your Copy: Fall "Guaranteed Bargain Catalog" and Swap List of new and used guns and other "hard-to-find" sports items—send 25c (refunded first order).



## "WONDER" ELECTRIC BUTTON

Most interesting electrical apparatus ever discovered. Make your own Telephone-Amplifier De-tectophone. Transmit your voice or music to distant rooms. Perform hundreds of fascinating experiments. So tiny it can be concealed in dozens of places. Send \$1 now for button and free 5,000 word instruction booklet with 60 illustrated experiments. SPECIAL OFFER 6 buttons and booklets sent post-paid for \$5. Write now to

BUCK MFG. COMPANY

North Aurora, Illinois

## 5 SECRETS ... OF WINNING GOLF



Easy to Learn "Dynamic Swing" Every Pro Uses

PLAY IN THE 70'S. Enjoy your game. Amaze your friends. Get out of the "dub" class by using golf's most powerful and accurate swing. **Five basic secrets** give you rhythm and power, eliminate hook and slice ... make you MASTER OF EVERY CLUB. Easy to make long drives and beautiful approach shots. Learn in a few days—10 minutes' practice a day. COMPLETE COURSE NOW ONLY \$1.00 postpaid, or \$1.00 plus 24c for postage and C.O.D. fee. Your money back if you're not amazed with results, so order NOW!

THE SYLVAN COMPANY 125 Seventh Ave., Dept. E, LaGrange, Ill.



## Free Fall Catalog

Just off the Press

Showing Hunting Footwear, Clothing, and forty-three other leather and canvas specialties of our own manufacture for campers and hunters.

L. L. Bean, Inc.  
Freeport 261, Me.



**MILDEW  
ruined  
this**

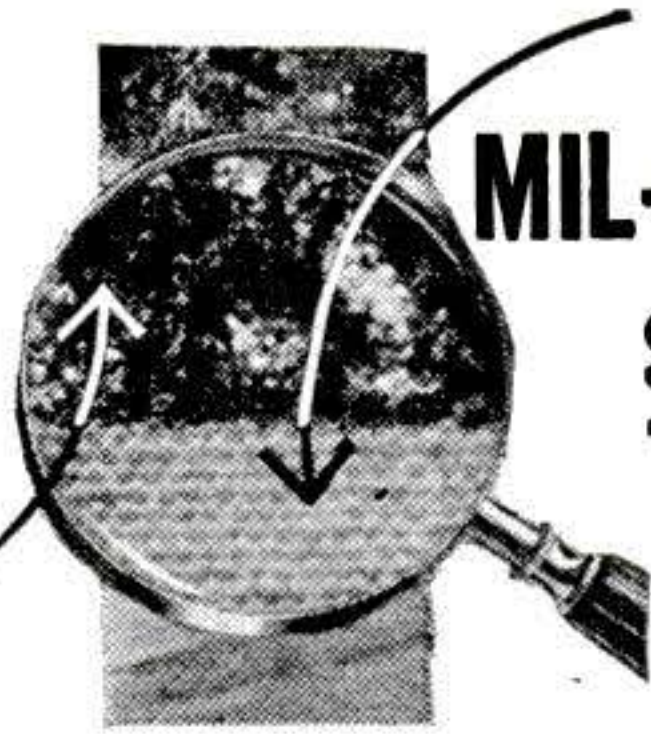

**MIL-DU-RID  
saved  
this**

● The photograph above shows a piece of fabric attacked by mildew. The top section is untreated—the bottom section is protected with a *single* application of Mil-Du-Rid!

Mil-Du-Rid can protect *your* possessions in the same way. Simply apply it to your shoes, clothes, luggage, furniture, rugs and stored equipment. Mil-Du-Rid *kills mildew instantly*, can prevent its return for months. It's safe to use on anything soap and water won't harm. Buy Mil-Du-Rid today at your department store, hardware, grocery or drug store.

**MIL·DU·RID** A Product of Interchemical Corporation



Interchemical Corporation  
Trade Sales Division, Dept. N-95  
Fair Lawn, N. J.  
Please send folder, "What is Mildew? How to Prevent it."  
Name.....  
Address.....  
My Dealer's Name.....

*This is the way to Make Money!*

**MACHINE SAW FILING** with the Foley Automatic Saw filer is the modern way to recondition saws. Anyone can do the work—no experience needed—no eye-strain. Start in spare time—Foley-filed saws cut so smooth and fast, they will advertise for you, bring you new customers and a steady repeat cash business.

The Foley is the **ONLY** machine that files all hand saws, also band and cross-cut circular saws,—enables you to handle work from schools, shops and factories as well as farmers, carpenters, etc.

**Send for FREE PLAN**  
Shows how to start—no canvassing. Send coupon today.

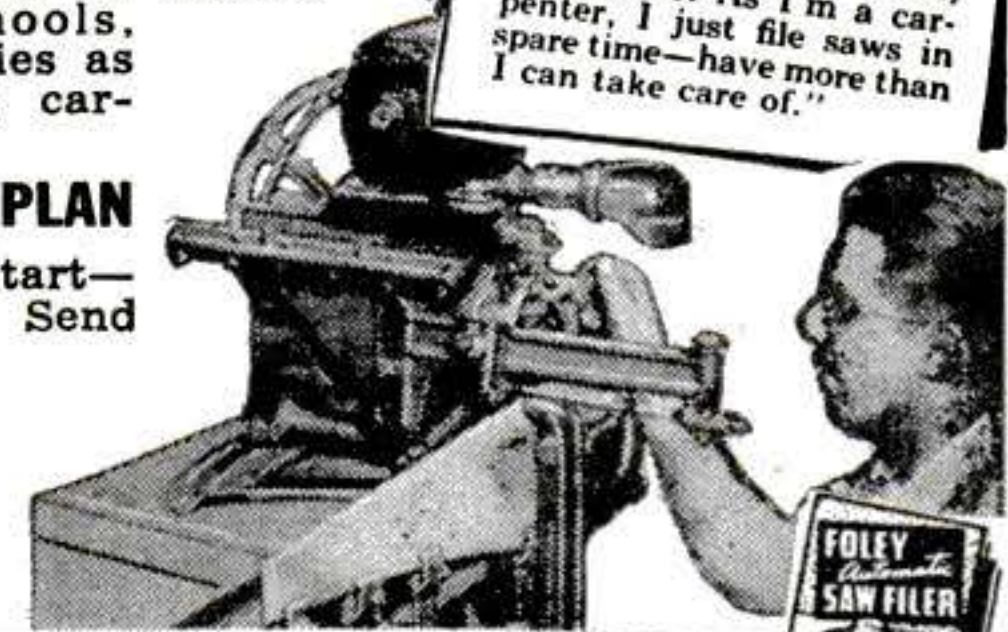

"I bought a Foley Saw Filer, one year later had all debts paid and also \$400 on a new home. Many days I earn as much as \$16," says J. H. Kellogg

W. L. Tarrant writes: "I left my old job last September and in 10 months have filed 2,159 saws. We have a lovely business worked up and cannot keep up with the work."

Thor Nedrbe, Iowa, says: "I have filed 550 saws, made \$350. As I'm a carpenter, I just file saws in spare time—have more than I can take care of."

**FOLEY Automatic SAW FILER**

**FOLEY MANUFACTURING CO.**  
919-5 Foley Bldg., Minneapolis 13, Minnesota  
Send Free Plan on Saw Filing business, no obligation

Name \_\_\_\_\_  
Address \_\_\_\_\_

**ELECTRICITY FOR ANY JOB ANYWHERE**

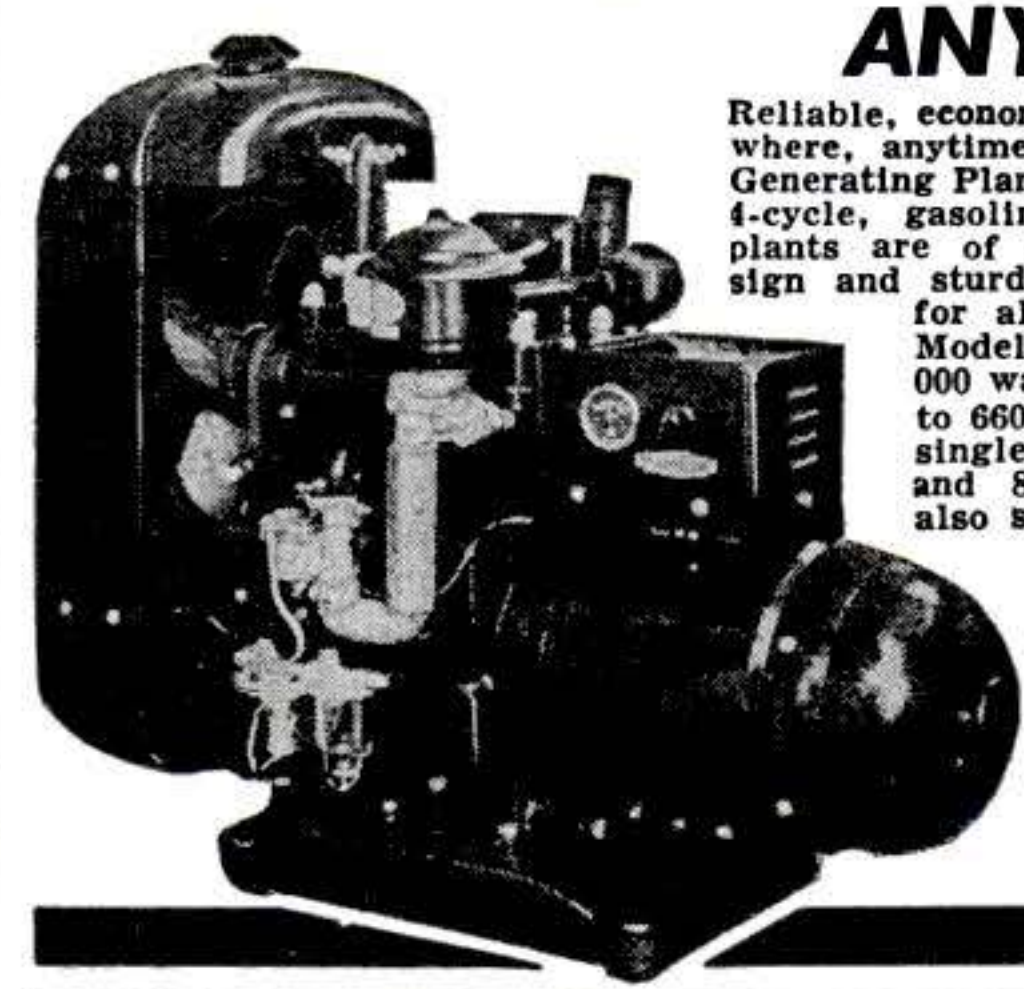

Reliable, economical electric service anywhere, anytime, with an Onan Electric Generating Plant. Driven by Onan built, 4-cycle, gasoline engines, these power plants are of single-unit, compact design and sturdy construction. Suitable for all types of service. Models range from 350 to 35,000 watts. A.C. types from 115 to 660 volts; 50, 60, 180 cycles, single or three-phase; 400, 500 and 800 cycle, single phase; also special frequencies. D.C. types range from 6 to 4000 volts. Dual voltage types available. Write for engineering assistance or literature.  
**D. W. ONAN & SONS.**  
1831 Royalston Avenue, Minneapolis 5, Minn.  
**O N A N**

**AMAZING MYSTERY**

**Startles Everybody.** With this **Electronic Button** you can make your own Telephone-Amplifier-Detectiphone. Attach this button to piece of cardboard—transmit conversation to another room. Music also transmitted to distant places. Most interesting electrical apparatus ever discovered. Enables you to perform hundreds of experiments. So tiny it can be concealed in dozens of places. A Pre-War Product. Electronic Button including 5000 word instruction booklet with 50 illustrated experiments postpaid only \$1.00.  
**Electronic Products Company, Saint Charles, Ill.**

**WOOD WORKERS**

**Lumber—Plywood Available**  
Harold Hunt wants to send you big revised No. 14 Catalog. 124 pages of woodworking ideas, 12 pages of rare woods in colors. **UNEQUALED BARGAINS** in imported and American woods, supplies. Send only 10c to cover postage and handling. Those already holding this catalog—send for revised sheets.  
**CRAFTSMAN WOOD SERVICE CO.**  
2729 S. Mary St., Dept. B-61, Chicago 8, Ill.

*only 10¢*

**HEATING Cooling Blowers**

(K.D) Metal Cabinets, Steel Wheels, Shafting, Bearings. Gas Burning Furnaces, Oil Burning Furnaces, Conversion. Gas Burners, Oil Burners, Stokers, Gas Ranges. Thermostats, Controls. Hot Water Heaters, Electric Cellar Drainers, Copper Tubing, Pumps. Wholesale & Retail.  
**PEERLESS SALES 4318 Sheridan Blvd. LINCOLN 6, NEBR**

**BUILD YOUR OWN MACHINE TOOLS!**

**Blueprints \$1.00 - Catalog FREE**

Detail construction Blueprints on 6 Lewis metal and wood-working tools postpaid for \$1.00. Includes prints for Lewis 10" Shaper, Milling Machine, Drill Press, Vise, 16" Band Saw, 6" Jointer. Plain or semi-finished castings available for these tools save up to 80% of comparable new tool cost.

Illustrated 32-page Catalog—sent free with Blueprint Order—describes 20 Lewis tools. **WRITE TODAY!**

**LEWIS MACHINE TOOL CO.**  
P.O. Box 116, Sta. A, DEPT. D-22, LOS ANGELES 31, CALIFORNIA

**ANALYZE HANDWRITING**

Qualify for Certified Grapho-Analyst Degree. Earn up to \$100 weekly, up to \$1 hourly spare time, in new uncrowded profession... Graduates in employment and credit fields, police departments, courts, and in private practice as Personal Problem and Vocational Counselors. 3,000 word test lesson and illustrated **GRAPHO-ANALYST Free**

**Free**

**ADDRESS A.I.G.A., INC., 126 JOPLIN, MO.**

**HIGH BLOOD PRESSURE A DANGER SIGNAL**

Often associated with Hardening of the Arteries, a Stroke, Paralysis, Heart Trouble, Kidney Disease, and other grave complications. Resultful treating methods of the Ball Clinic have proven dependable for nearly a quarter of a century. Send for **FREE Blood Pressure Book** today. No obligation.  
**BALL CLINIC, Dept. 5160, Excelsior Springs, Mo.**



# V-8 DUALS AND SINGLES

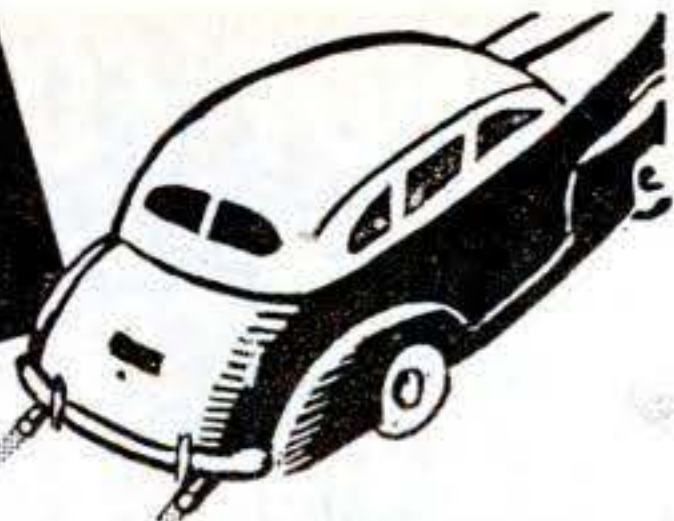

A genuine steel pack muffler WITH A BEAUTIFUL MOTORBOAT TONE. Sandee Mufflers feature improvements far in the lead, years ahead of competition. Increases mileage and power, reduces back pressure and gives better performance. Savings in gasoline will pay for a Sandee Muffler.

V-8 FORD AND MERCURY DUALS **\$17.50**

SINGLES—FIT IN PLACE OF REGULAR MUFFLER

Chev., V-8 Ford, Plym., \$5.00 Chrys., Olds., Buick, etc., \$7.00

These mufflers will outlast two regular stock replacements.

Dealers Wanted

**SANDEE MUFFLER CO.**  
7523 S. WESTERN AVE., LOS ANGELES 44, CALIF.



## MAGIC CUTTER

Cuts up to 4" hole in plastics, wood and metal. Wonder tool for amateurs and professionals developed by famous lab for own use. Send \$1 to: Tool Division ROBERTS ASSOCIATES 510 Madison Ave., New York, 22

**\$1**



## Fix Your Own ALARM CLOCKS

New, practical home course. Just out. Makes interesting hobby—profitable too. Save money by doing your own repairing at home. Easy if you know how. Price now only \$1.00. Details FREE. Send postcard.

THIES JEWELRY STORE, Genoa 5, Illinois



Send for our Catalog of TOOLS & EQUIPMENT for DEVELOPMENT WORK WATCHMAKERS TOOLS...

**FREE CATALOGUE** of Precision Tools, Equipment for Development Work, for the making of New Worlds.

"Mail Orders Only"

HENRY PAULSON & CO. CHICAGO 3, U.S.A.

## New OTTAWA WOOD SAW

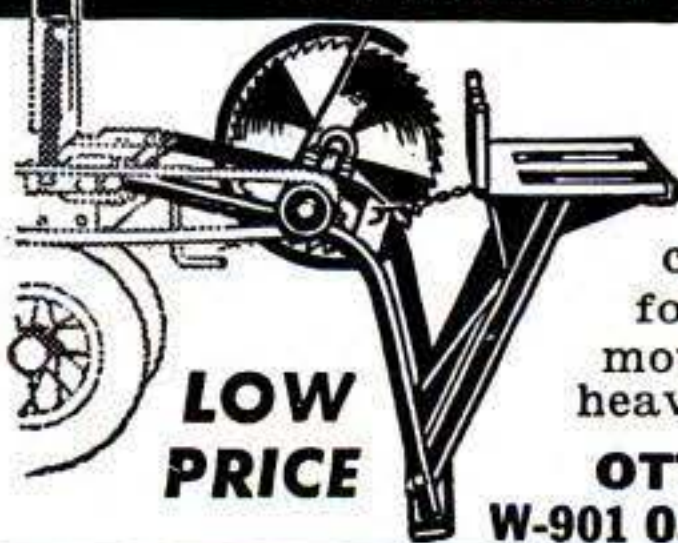

**LOW PRICE**

### For Tractors

—Makes wood sawing fast and easy. Can cut enough wood to pay for itself quickly. Easily moved while attached. Big heavy blade. FREE details.

**OTTAWA MFG. CO.**

W-901 Oak Ave., Ottawa, Kans.



What gives each file a guiding mark Like lighted street signs, after dark?

**Dennison**  
INDEX TABS

At Stationery Departments Everywhere

# WORKSHOP WISDOM

## Improving wallpaper paste



PERHAPS you plan to use extra heavy paper.

Or you want to strengthen paste for paper in rooms where air may get damp—such as in the kitchen or bathroom. To meet these special conditions, make a standard glue mix, using ½ lb. of Casco and 1 lb. water for each pail of liquid paste.

When thoroughly dissolved, stir Casco mix into the paste. It makes paste stronger and more water-resistant. You can use Casco for 1001 jobs. And here's why so many folks prefer Casco for general wood gluing:

**Unusual strength:** Casco Glue sets chemically. Doesn't just "dry out." Casco becomes as strong as wood itself and is highly resistant to dampness, heat, and time.

**Easy to mix:** You just add cold water and stir. No heating problems.

**Economical:** You use Casco as you need it. There is no waste.

For water resistant projects and special outdoor jobs, get Cascamite. It's a completely stainfree urea resin adhesive. Casco Glue and Cascamite are available in 10¢, 25¢, and larger sizes at all hardware stores.



WRITE FOR FREE Gluing Guide containing over 40 household gluing hints. Address Casein Company of America, Dept. PS-95, 350 Madison Ave., New York 17, N. Y.

# CASCO Powdered Casein GLUE

Sets chemically—hardens permanently!

Buy War Savings Bonds and Stamps regularly.



# 26 GREAT WAR PICTURES!

**Get Your Copy Now!**

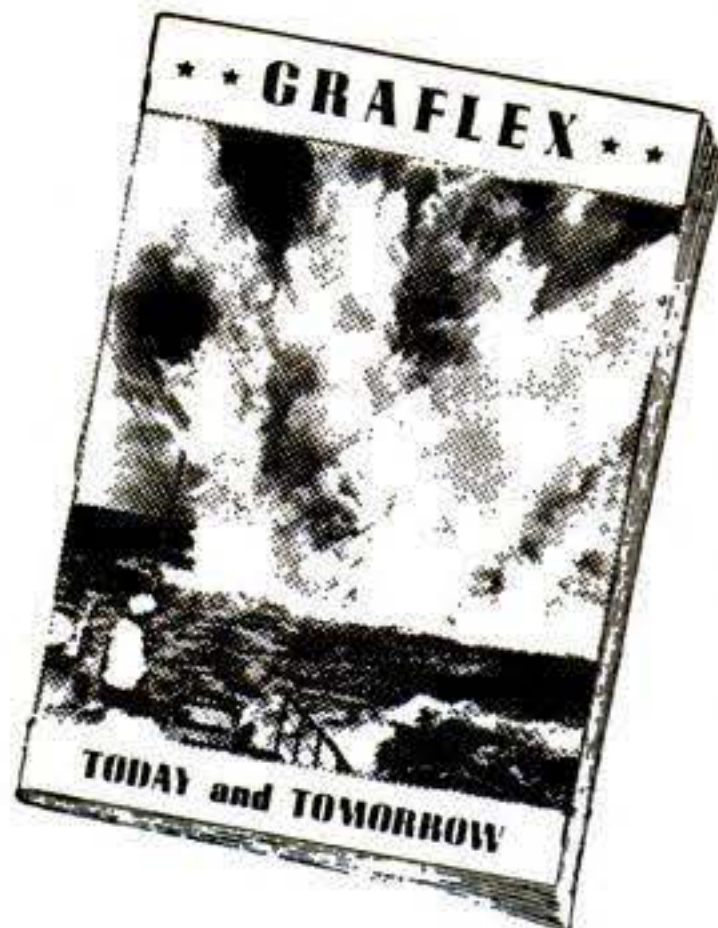

Selected action photographs by top cameramen of Army Air Force, Navy, Signal Corps, Marine Corps vividly portraying World War II on land, in air, on sea! Strikingly reproduced in attractive pocket-size brochure. Get your copy at Graflex dealer's or send 10c, to cover handling, to GRAFLEX, INC., ROCHESTER 8, N. Y.

(Formerly The Folmer Graflex Corporation)



## GRAFLEX

## HANDY FURNITURE KIT

Fixes Scratches, Dents, Nicks



You can easily restore beauty to damaged wood surfaces with this new practical kit. Enables anyone to do fast, easy touch-up jobs like a professional cabinet finisher. Repairs holes, burns, gouges, scuff marks, etc. Complete outfit—pays for itself over and over.

**Amazing Results—Easy to Use**

Kit includes 23 different items—scratch removers for slight scratches, assorted shades of shellac sticks for deep nicks, bottles of light and dark stains, shading lacquer, alcohol lamp with fuel, stainless steel spatula, touch-up brushes, scratch sticks, steel wool, sandpaper, rubbing liquid. Packed in handy leatherette finish case. Send for it today. Best investment of lifetime. Fully guaranteed. Detailed instructions supplied.

**\$3.95**  
Postpaid

**AMERICAN HOUSEHOLD BUREAU**  
Dept. A, 520 N. Michigan Ave., Chicago 11, Ill.

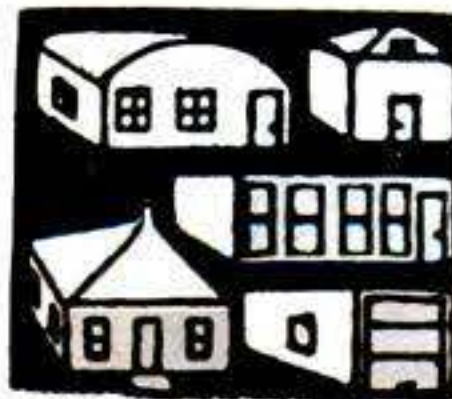

## Build with BUILD Composition

Strongly reinforced with cheap wood. Modern stream-lined roof, walls and gutters. How to build a house 22x24, three rooms, as low as \$100 for materials; garage, \$20; 20x50 poultry house, \$50. Farm buildings for a few dollars. Homemade equipment to make wall-high building blocks with inside and outside finish; roof, wall and floor tile in color, and durable wallboard of sawdust for a few cents. Several formulas. Labor saving, long lasting, no painting. Make doors and windows. Also sectional cabins. 50 moneysaving building ideas. Mixer and saw easily made from old auto. 40 War-time Plans. Earn \$10 a day. Guaranteed. Illustrated instruction book, \$1.00. **MAKE FURNITURE OF COMPOSITION** cement, sawdust, paper, asbestos. Homemade cements. Some part scrap wood and metal. Make tables, cabinets, chests, racks, shelves, inclosed sinks, lawn novelties and toys. Over 500% profit. 50c. **HOW TO MAKE ACCURATE SHOP MACHINES**, tools, electric weed cutters, band, jig, circular saws, drills, forge and many other things from old auto parts and used motors. Illustrated, 50c. **HOME MFG. ENTERPRISES**. 50 selected home shop projects. 50c. Special: All of the books described above, \$2.00 postpaid. No C.O.D. **HOME INDUSTRIES, 1318 So. 30th Ave., Dept. PS, Omaha 5, Nebr.**

## BLACK on WHITE for BETTER SIGHT

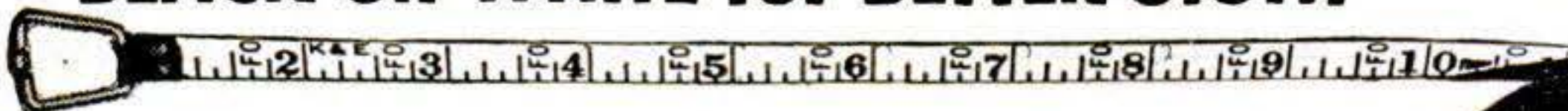

**WYTEFACE** Steel Tapes have black graduations on a crack-proof white surface. Easy to read in any light, from any angle. Faster measurements with fewer errors. Designed for hard service. Resists abrasion from rails, pipe, rocks, concrete. Protected against rust.



**WYTEFACE**  
TRADEMARK  
**STEEL MEASURING TAPES**

**KEUFFEL & ESSER CO.**  
EST. 1867

**NEW YORK • HOBOKEN, N. J.**  
**CHICAGO • DETROIT • ST. LOUIS**  
**SAN FRANCISCO • LOS ANGELES**  
**MONTREAL**

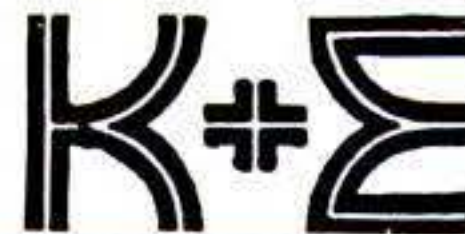

Drafting  
Reproduction  
Surveying Equipment  
and Materials  
Slide Rules  
Measuring Tapes

## Use These Arc Welding DESIGN Books to Land the "BIG MONEY" Jobs.



The war has proven that welding design is as much a part of welding as welding is itself. Only with good welding design and good welding are you sure of a sound finished product. For this reason, you need "Practical Design for Arc Welding." 3 Volumes of authoritative books of welding designs that will aid you in obtaining the better, bigger pay welding jobs. Now is the time to prepare yourself for these better post-war jobs as they become available. Order your copies today! Only \$3.50 per Volume, 3 Volumes for \$10.00 and all postpaid.



**HOBART** Brothers Co.  
Box P-951, Troy, Ohio



**Free!**  
Ask for Your Copy of "Welders' Vest Pocket Guide"

"One of the World's Largest Builders of Arc Welders."





# RIGHT TO THE POINT!



Every "Yankee" spiral screw driver is right to the point. Every part is ingeniously designed to speed work, cut down man-hours. Pains-taking design and simple strength are typical of all "Yankee" fine mechanics' tools . . . whether Tap Wrenches, Vises, Automatic Drills, or Bit Braces.

"YANKEE" SPIRAL SCREW DRIVER No. 130A  
A Size for Every Purpose

## "YANKEE" TOOLS

make good mechanics better

North Bros. Mfg. Co., Phila. 33, U. S. A.  
Established 1880

Makers, also, of "Yankee-Handyman" Tools



Balance 4"x9" Base. With either \$6.00 Metric or Avoirdupois Weights . . .

Catalog with 3000 illustrations of laboratory Apparatus sent for 75 cents. Catalog listing 10,000 chemicals, drugs, minerals, etc., and 1700 scientific books sent for 25 cents. 100 scientific books, 10 cents.  
LABORATORY MATERIALS CO.  
7317 Vincennes Ave. Chicago 21, Ill.

## 500 PERSONAL GUMMED LABELS

COMPLETE NAME & ADDRESS PRINTED ON EACH!

500 Personal Labels only 50c postpaid! Two-colors—handsome blue printing of your complete name and address on attractive white gummed label paper! Use on letters, envelopes, postcards, checks, books, tools, egg cases, etc. HUNDREDS OF USES! Wonderful for those in Service! Order today! FAST SERVICE. Limited supply. Money-back Guarantee.

WESTERN STATIONERY CO. Dept. 236-J, Topeka, Kan.

Only **50¢**

When Writing Advertisers Please  
Mention Popular Science Monthly

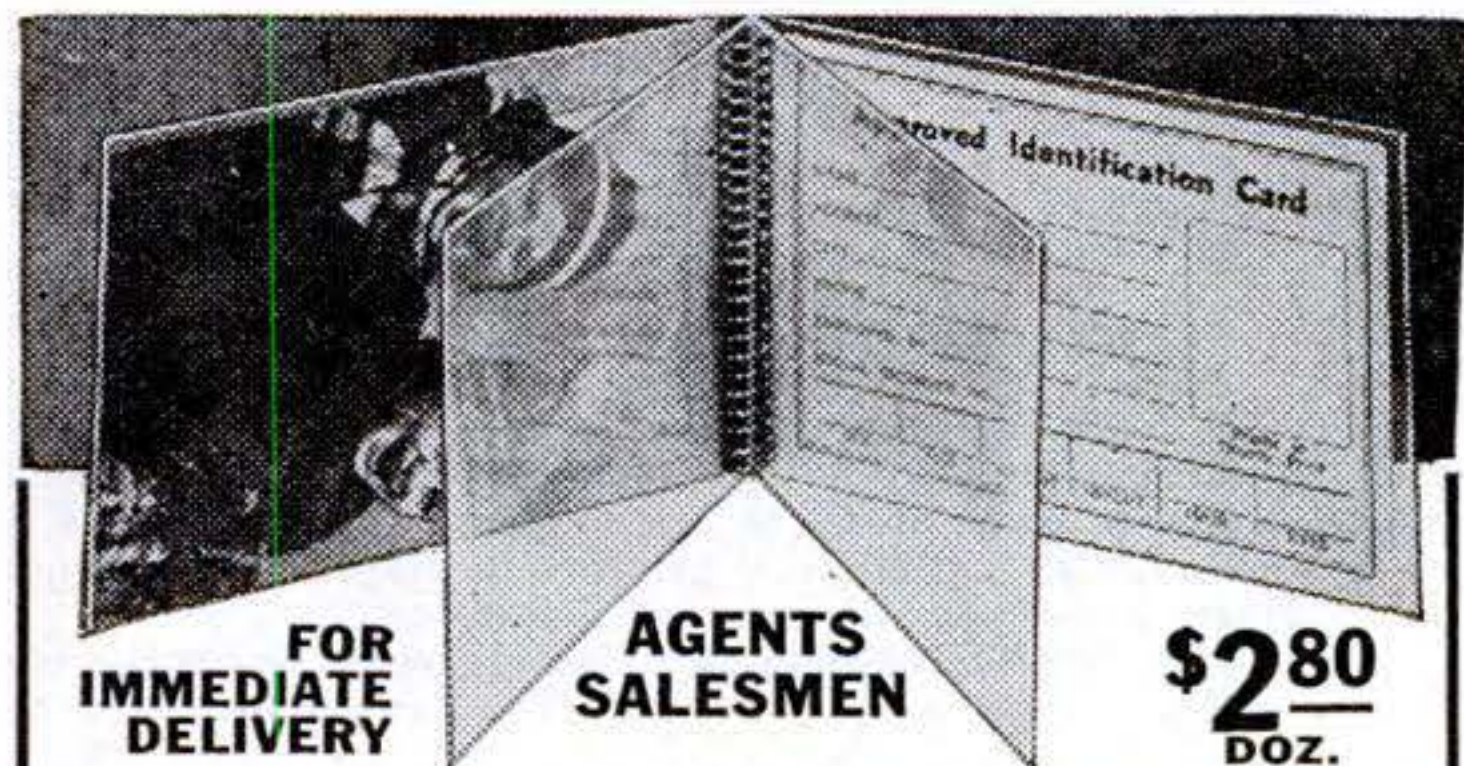

FOR IMMEDIATE DELIVERY

AGENTS SALESMEN

\$2.80 DOZ.

Timely fast selling Specialty—easy to carry. Everybody buys our Clear View Identio Case. The perfect Wallet Insert—4 Plastic pockets with two heavy plastic covers. Metal Spiral bound—fits into Wallet, Vest or Blouse pocket and Ladies purse. Sells like "Hot Cakes". Price 50c ea. Cost you \$2.80 Doz. Postpaid. Order trial Dozen today. Do not send personal checks. GUARANTEE Sale of 1st order or money refunded for unsold portion. FREE 3 color display card, sample attached, with 1st order.

BEACON SALES CORP. Dept. 5 37 S. Wabash, Chicago 3

# Tackle those Repairs Yourself...



with handy **SMOOTH-ON**



Those boiler leaks, cracked pipes, loosened joints, fixtures, handles, bolts, screws, can all be remedied promptly, inexpensively, securely — without having to wait your turn for a busy mechanic or repairman. Just get yourself a can of SMOOTH-ON No. 1—the handy Iron Repair Cement—and tackle the job yourself. No previous experience necessary. No heat. No difficult processes to learn — just follow simple directions. Smooth-On is always dependable, makes durable repairs. Popular with mechanics, plumbers, repairmen since 1895.

You'll find any number of convenient uses for Smooth-On in home, garage, shop. Little jobs and big ones. From tightening loose tool handles, casters, drawer pulls to repairing cracks and leaks in pipes, tanks, radiators, auto cylinders, crank and gear cases, etc.

## Get This 40-Page FREE BOOK

Shows you how to save time and money and get repairs done right when you need them most. Easily followed directions. 170 diagrams. Handy index. Fits the pocket. Yours for the asking — just mail the coupon.

Buy SMOOTH-ON in 1 3/4-oz., 7-oz. or larger containers from your hardware dealer, or if necessary from us.



1895-1945 Half a Century of Dependable Service

Sign and Mail Now

Smooth-On Mfg. Co., Dept. 58, 570 Communipaw Ave., Jersey City 4, N. J. Please send the Smooth-On Handbook.

Name.....

Address.....

9-45.....

Do it with **SMOOTH-ON**





• Some men are angered, embarrassed, at being thought old because they tire so quickly, get all fagged out. But, isn't there a reason for feeling like an old man at quitting time? Many men do not suspect that constant strain and drag on delicate cords in the "Vital Zone" may be to blame. Often the gentle, comforting, firm support of a Bauer & Black Suspensory brings relief.

**FREE BOOK TELLS FACTS**



Do you know why so many men say they feel years younger, livelier, with the scientific support of a Bauer & Black Suspensory? This free book gives you valuable facts every man should know about "Vital Zone" fatigue. Send for your copy today. No obligation.

**BAUER & BLACK**

**Suspensories**

Division of The Kendall Company  
Dept. S-412

2500 South Dearborn St., Chicago 16, Ill.

Yes, I want the real facts about Suspensories. Send me your FREE booklet without obligation.

Name.....

Address.....

City..... State.....

**HARD-TO-GET RADIO PARTS** ★ ★

Real bargains on hundreds of hard-to-get Radio and Electronic parts are listed in our latest FREE bulletin. Thousands of satisfied, steady customers on our lists. Send for your FREE money-saving bulletin today.

**NATIONAL ELECTRONIC SUPPLY**

622 W. Kinzie Dept. PS-9 Chicago 2, Ill.

**5 lbs. HANDY ASSORTMENT \$1.98**  
FOR MECHANICS—GARAGES—WORKSHOPS—HOME USE

SCREWS • NUTS • BOLTS • WASHERS  
RIVETS • SPRINGS • BRACKETS • MISC.

MORE THAN 1,000 PIECES

5 full pounds—a veritable treasure chest of fastening devices for every practical use. Satisfaction guaranteed. Order now. \$1.98. SPECIAL—2 assortments, over 2,000 pieces, for \$3.69.

**HUDSON TRADING CORPORATION**

The House of Handy Assortments

S-161 West Hubbard St., Chicago 10, Ill.

**FREE!** Handy List of Special Assortments: FIBER AND BAKELITE WASHERS—RUBBER WASHERS and PADS—FELT WASHERS and PADS—RADIO LUGS, CLIPS AND CONNECTORS—SPRINGS—SELF-TAPPING SCREWS—etc.

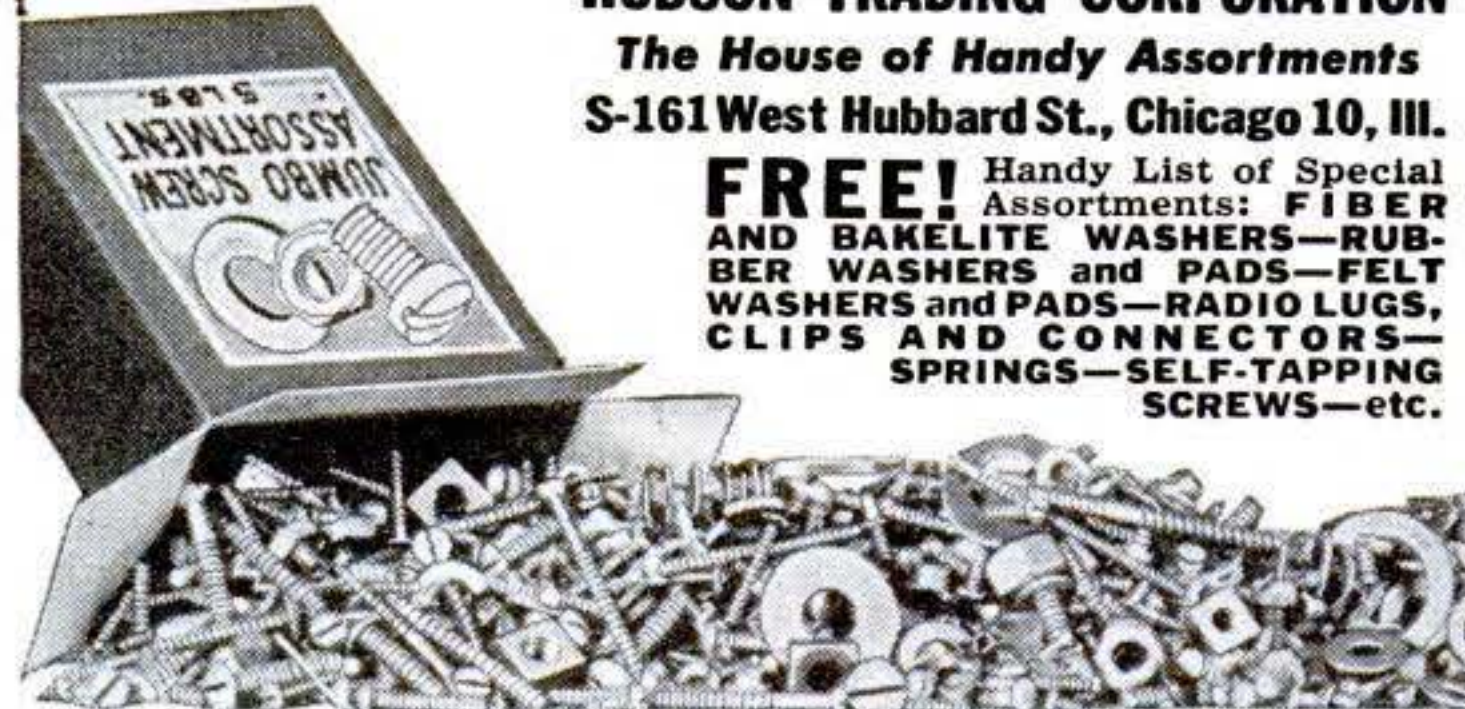

**New Designs in FRANZITE GRIPS**

Modernize Your Gun! Improve Your Score!

Most durable grips made. Positively unbreakable! For Colt, Smith & Wesson, Hi-Standard, Ortgies, Luger & Mausers in a wide choice of beautiful designs in ivory, pearl, walnut, onyx, etc. Low prices. FREE CATALOG. Dealers Wanted.

**SPORTS, INC., (Mfrs.) 5501 Broadway, Dept. S-9, Chicago 40, Ill.**

**Everything in Radio!**

Make Radolek your buying headquarters for Radio-Electronic repair and replacement needs. Large stocks assure finest, most complete selections of all available items at lowest prices. Your orders receive special attention for fastest delivery. Send today for FREE Radolek Buying Guide.

**RADOLEK CO., Dept. A-106, 601 W. Randolph St., Chicago 6, Ill.**

**FREE RADIO BUYING GUIDE**

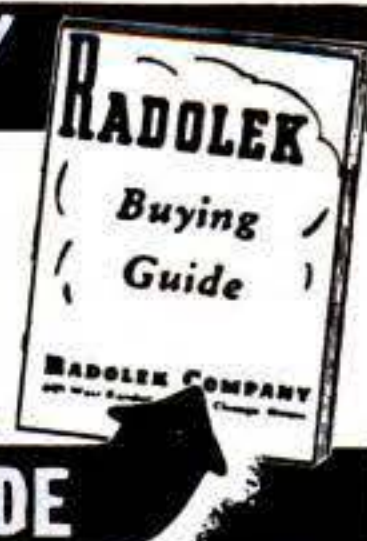

**RHEUMATISM**



**ARTHRITIS - NEURITIS - SCIATICA**

Why continue to suffer the agonizing pains of these diseases when the usual remedies have failed? Learn about a new trustworthy, modern, non-surgical treatment method. This marvelous treatment is completely explained in the Ball Clinic's FREE Book. Write today. No obligation.

**BALL CLINIC, Dept. 5100, Excelsior Springs, Mo.**

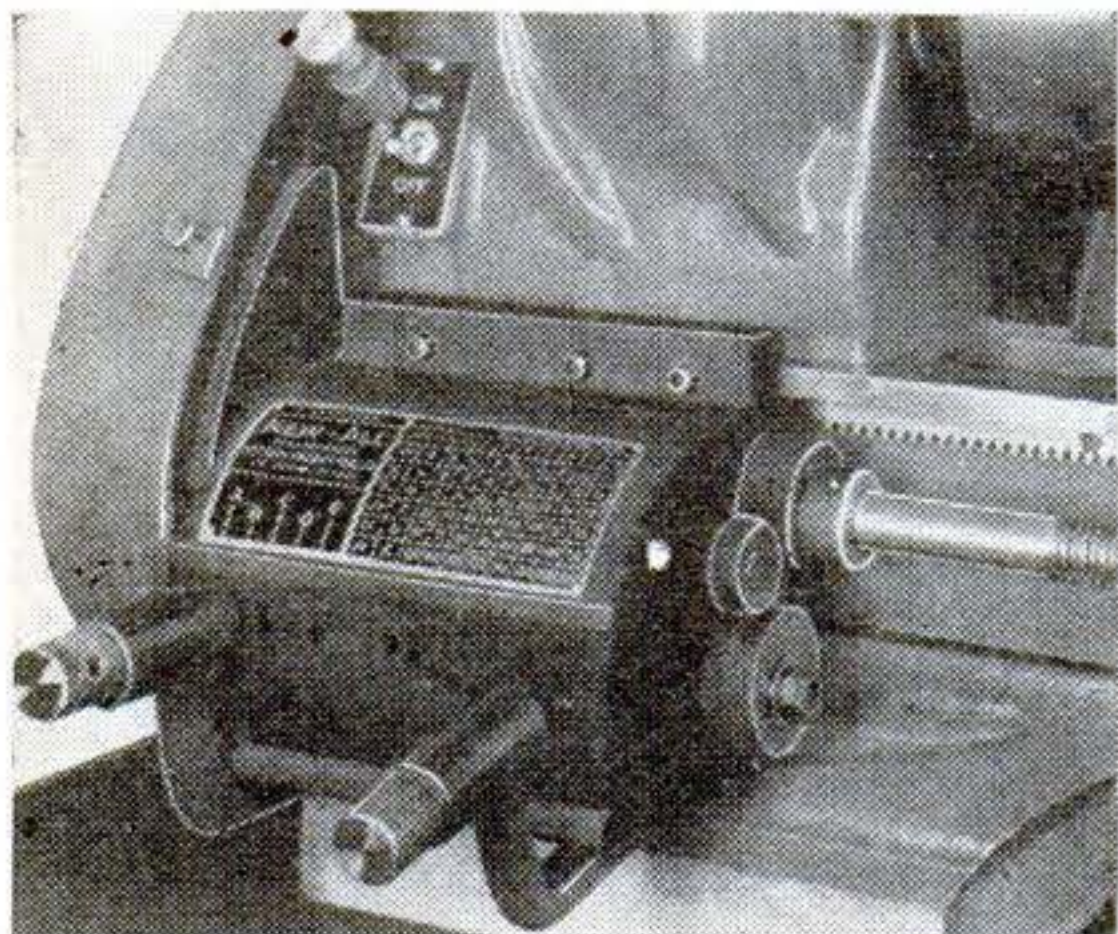

**New-All Quick Change Gear Box Increases Production Up to 1000%**

NEW—Improved Model

**PAYS FOR ITSELF IN 30 DAYS!** Sold Under 30-Day Money-Back Guarantee **GUARANTEED ACCURACY!** Is guaranteed to cut accurate threads from 4 to 224 per inch with approximately 3/1000 feed for fine turning. It safeguards entire production in process throughout the complete operation.

**DRASTICALLY CUTS LABOR COSTS!** No time lost finding gears. Inexperienced workmen easily produce top output. Easy to install. You simply drill and tap four holes.

**PRECISION CONSTRUCTED!** Precision constructed throughout with gears of quality hobbled steel. Gear Box housing is made of high grade aluminum alloy casting—with replaceable bronze bearings.

For **LOGAN, POWERCRAFT, ATLAS, and CRAFTSMAN**

**MOODY & CLAUSING.....\$135.00**

All sizes lead screws.....\$12.00

All prices F.O.B. Los Angeles

**WESTERN AIRCRAFT TOOL CO.**

650 No. Hoover St. Los Angeles 4, Calif.

NOrmandy 2-4711



# BIG MONEY NOW IN LIQUID MARBLE

**THREE** wonderful new opportunities for your own big money-making business—regardless of your age, sex, or previous experience! 1. **LIQUID MARBLE.** Make beautiful artificial Marble Slabs. Pour from liquid state. Glazed or unglazed. This marble may be mottled, veined, multi-colored or left in original snowwhite state. The color is actually a part of the marble! Does not fade or wear away. Liquid Marble is unsurpassed on kitchen or bathroom walls. Easy to make and install. 2. **PLASTIC FLOORING.** May be made in any color or combination of colors. Gives a lifetime of wear. Dust-proof, Soundproof, Verminproof. Resilient to the tread. Lay out solid from wall to wall or in pattern design of various shaped blocks. 3. **FLEXIBLE MOLDS.** For plaster casting. Make your own moulds for few cents each. \$1.00 in raw materials will make up to \$25.00 worth of finished goods. We furnish names of buyers. Write now for **FREE** information about our **BIG THREE** money-making opportunities! Get in on busy season just starting. Send penny postcard or letter. No obligation.

**COMPO-TEX, Box 786-GS ST. LOUIS 1, MO.**

## NOW ANYONE CAN FIX A WIRE ON ELECTRICAL EQUIPMENT

WITH THE **AMP Solderless ELECTRICAL REPAIR KIT**

Home Appliances, Autos, Farm Equipment, etc. Everything for attaching a wire **ONLY 595**  
 \*100 Solderless Connectors \*All-Purpose Tool \*Easy Instructions  
 Underwriters Laboratory Approved for wire sizes 22 to 10  
**AIRCRAFT-MARINE PRODUCTS INC.**  
 1525-33 North Fourth Street, Harrisburg, Pa.

# INVENTIONS FINANCED

**NATIONAL DISTRIBUTION ESTABLISHED YOUR NEW PRODUCTS DEVELOPED**

Established manufacturer desires new products to finance, develop and sell for you. Engineering advice available. **Your rights protected 100%**. Patented or not we can help you make your ideas pay. Send complete information and description.

**RICHMONT, INC.**

**215 W. 7th Street, Los Angeles 14, Calif.**

## 110-VOLTS AC from DIRECT CURRENT

with **KATO KONVERTERS.** Furnish standard 110-v. AC from 32, 110, or 220-v. DC. Good deliveries on sizes 350 through 2500 watts on priority orders. Good deliveries on 5, 7 1/2, 15 & 25 KW AC generators. Mfg'r's of motor generators, frequency changers and high frequency generators.

**KATO ENGINEERING CO.,**  
 127 Elm St., MANKATO, Minn., USA



U.S. PAT. DE. 136,736 CAN PAT. R-1-C BY N.A.MERCEZ



## EXPANDING SAFETY LEATHER WATCH BRACELET

**New Invention!** Fits watches with adjustable pins. Made from the finest Genuine Leather. No other Watch Strap at any price has these Patented advantages.

**USED BY THE U. S. NAVY SAFETY WATCH STRAP COMPANY, Dept. 16, 1944-1st Ave., N.Y. 29, N.Y.**

Rush ( ) Watch Bracelets; send prices for dealers ( )  
 ( ) I will pay postman \$1.00 C.O.D. charges & postage.  
 ( ) I enclose \$1.00. Send watch bracelet post-paid and insured. Regulated in sizes within 2 inches. For perfect fit mark size of wrist: Small ( ) Medium ( ) Large ( )  
 Name (Print).....  
 Address.....



## LOOK FIRST TO YOUR COMFORT!

Make your modernized home comfortable in coldest weather ... refreshingly cool in summer ... by applying Balsam-Wool Sealed Insulation in the attic! Balsam-Wool makes homes more livable ... provides fuel savings up to 20%.



## CREATE EXTRA LIVING SPACE WITH NU-WOOD!

New rooms or partitions are quickly built with sturdy Nu-Wood Insulating Interior Finish—with its beautiful, fade-proof colors and velvety texture. Nu-Wood also insulates and hushes unwelcome noise.

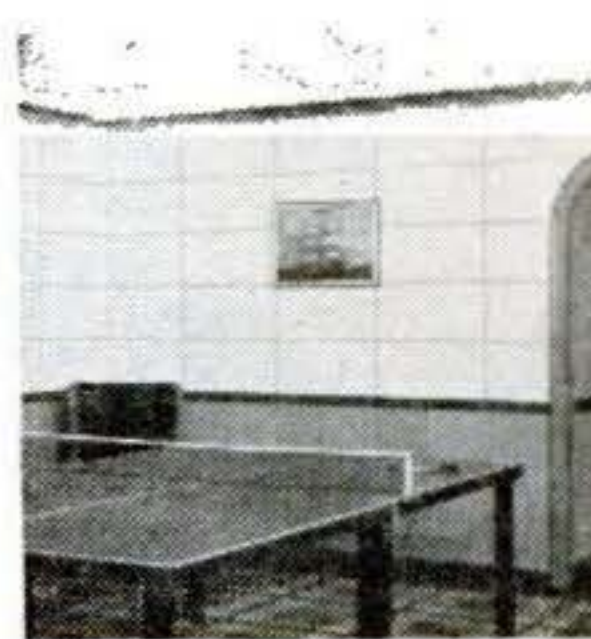

## SOLVE DECORATING PROBLEMS—ONCE AND FOR ALL!

Nu-Wood Interior Finish covers old walls and ceilings—comes in a wide variety of pattern combinations. Use with Kolor-Trim moldings—predecorated in harmonizing colors!

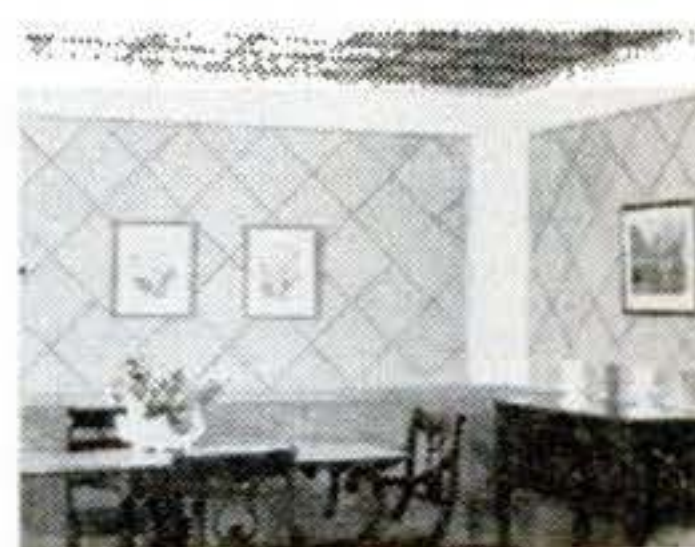

## DON'T WAIT—START RIGHT NOW!

Ask your lumber dealer for full information about Balsam-Wool Sealed Insulation and about Nu-Wood Interior Finish. For additional information and literature on Balsam-Wool and Nu-Wood, mail the coupon!



### WOOD CONVERSION COMPANY

211-9 First National Bank Building  
 St. Paul 1, Minnesota

Please send me full information on modernizing homes with Balsam-Wool and Nu-Wood. I am a  
 Home owner  Renter  Architect  Contractor  Student

Name.....

Address.....

City..... State.....

**Balsam-Wool** GUARANTEED SEALED INSULATION

**BALSAM-WOOL • Products of Weyerhaeuser • NU-WOOD**

Buy War Savings Bonds and Stamps regularly.



**GET THIS BOOK NOW!**

*The Inside Story*  
OF YOUR POSTWAR RADIO



THE INSIDE STORY of recent technological electronic developments — and what they mean in postwar radio.

Important technical improvements are continually being achieved through extensive wartime research in the radio and electronics field. Read this informative story of the results of such research before you choose your postwar radio receiver.

Written by John Meck, leading electronics engineer engaged for the duration in producing special communications devices, the booklet also includes advance information on postwar Meck Radios. Write for your free copy today.

John Meck Industries, Inc.  
Plymouth, Indiana

**MECK RADIOS**  
SOLD BY INDEPENDENT DEALERS

**Store Route Plan PAYS BIG MONEY**

**SELL COUNTER CARD PRODUCTS**

Build a good-paying business of your own: Call on dealers of all kinds; show nationally-advertised Aspirin, Vitamins, Cosmetics and 200 other necessities. Big 5c and 10c retail packages, high quality. Attractive counter displays sell goods fast. Free book gives amazing facts. Write!

World's Products Co., Dept. 83-M, Spencer, Ind.



**WORLD'S LOWEST PRICED ADDING MACHINE**

**VEST POCKET SIZE IDEAL FOR BUSINESS OR PERSONAL USE**

FREE TRIAL  
**ONLY \$2.50**  
TOTAL COST

SEND NO MONEY

**FREE!!**

Each Baby Calculator in Beautiful, rich-looking Leatherette case—at no extra cost.



Fits vest pocket or purse. Guaranteed accurate. Operated as easily, and as reliable, as machines costing many times as much. Not a toy. Substantially made of 28-gauge steel—guaranteed for life against defects in construction. You positively can't buy a calculator of equal quality for as little money. **ACCEPTED AS THE FINEST LOW PRICED CALCULATOR FOR OVER 30 YEARS!** Operates with a flick of your finger. Adds, subtracts, multiplies, divides—counts up to ten million. Pays for itself over and over in mistakes avoided, and time saved. **MAKES IDEAL GIFT.**

Sold on a positive money back guarantee. Send only name and address, pay postman \$2.50 plus postage (send full cash if outside U.S.) Money back within 10 days if not delighted. **AGENTS WANTED!**

**CALCULATOR MACHINE CO., (Mfrs.)**  
Dept. 458, P. O. BOX 1118, CHICAGO, ILL.

**PREVENT WASHDAY MISHAPS with TITE-LINE Clothes Line Holders**



String your clothes line on TITE LINE clothes line holders. It's quick. It's easy. It's the surest way to prevent that exasperating washday disaster—broken clothes lines. Each section is securely gripped—a line break affects only one section

**EASILY INSTALLED ON FLAT OR ROUND SURFACES**

TITE-LINE clothes line holders are used in attics, basements, outdoors—wherever clothes line is used. Saves line, saves time, prevents knots and kinks, holds line tight, no tying. Get TITE-LINE at your favorite hardware or variety store. If not in stock, send us your dealer's name.



**THE MIDLAND COMPANY**  
SOUTH MILWAUKEE, WISCONSIN

**NOW** Repair your own **ELECTRICAL APPLIANCES** with CHANITE Self-Welding ELECTRICAL HEATING ELEMENT flux. Generous amount, instructions enclosed. \$1.00 postpaid. Guaranteed nothing like it.  
**CHANITE SALES COMPANY, 914 South Main, Fort Worth 4, Texas**

**GUM GRIPPER**

**TIGHTENS FALSE TEETH**

**OR NO COST**

Amazing **NEW Plastic Reliner**

**LASTS FROM 4 to 6 MONTHS**

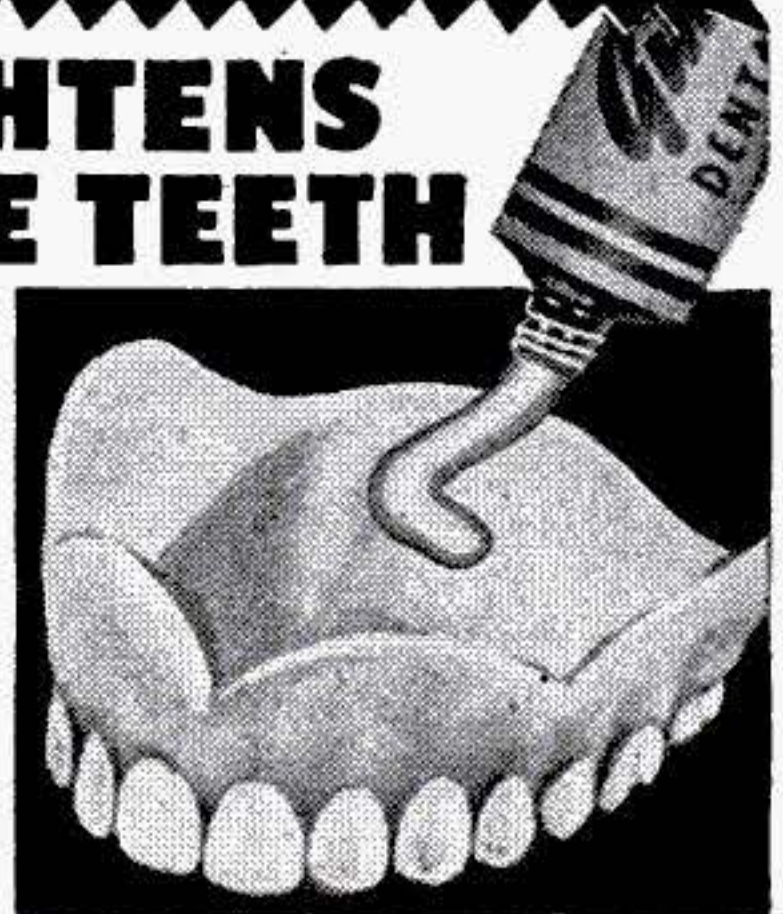

NOW—in a jiffy—you can make loose, slipping dental plates fit snug and comfortable. Eat, talk in comfort, laugh freely—for "Gum Gripper" enables you to enjoy that feeling of almost having your own teeth again!

**● APPLY IT YOURSELF—AT HOME**

"GUM GRIPPER" amazing plastic Reliner tightens dental plates quickly, makes them hold firmly and fit like new! Just squeeze from tube, spread evenly, put plate in mouth, wear it while "Gum Gripper" sets in few minutes. No heating necessary.

**● USE ON ANY DENTAL PLATE**

"Gum Gripper" will not harm denture or irritate gums. Sanitary, tasteless, odorless. Keeps mouth sweet and clean, prevents sore spots. Application of plastic "Gum Gripper" is guaranteed to last 4 to 6 months—or no cost. Can be scrubbed or washed. Rev. A. J. Wigley, Pittsburgh, Pa., writes: "Best material I ever used. I have not relined my lower teeth for 2 months."

**"Best I've Ever Used"**

**SEND NO MONEY—** Order a tube today—it's only \$1.00. Fill out and mail coupon below. You'll be delighted! Satisfaction guaranteed or your money back.

**FREE** Generous size package Dental Plate cleaner included free of extra cost. Cleanses dental plates without brushing. Will not harm denture.

**GUM GRIPPER 127 N. Dearborn St., Dept. 72F, CHICAGO**

**GUM GRIPPER, Dept. 72-F**  
127 N. Dearborn St., Chicago 2, Ill.  
Send me a tube of "Gum Gripper." You guarantee it to satisfy—or it will not cost me a penny.  
 I will deposit \$1.00 plus postage with postman when package arrives.  
 Enclosed is \$1.00—You pay postage.

NAME.....  
ADDRESS.....  
CITY..... STATE.....



# SMOKERS

Send for pamphlet telling why your pipe becomes strong . . . and how to prevent it. A penny post card will do.

**WRITE TODAY FREE!**

**TAYLOR PIPE SHOP, PIQUA 1, OHIO.**

## MAKE MONEY AT HOME

**RUBBER MOLDS**

Low as **6¢** EA.



Amazing rubber mold-making outfit makes perfect flexible molds of plaques, ash trays, book-ends, etc. Molds cost 6c to 25c each. Each mold makes hundreds of novelties and gifts to sell for \$1.00 apiece and more! No experience necessary. Everything furnished. Quick and easy. Start profitable business in your home—sell to stores, gift shops, friends, resorts, road stands, by mail. Full or spare time. Write for complete FREE details and easy instructions.

**SOLO WORKS, Dept. A-801, Loveland, Ohio**

**ANYONE CAN DO THIS IF**

**THEY HAVE OUR CHART**

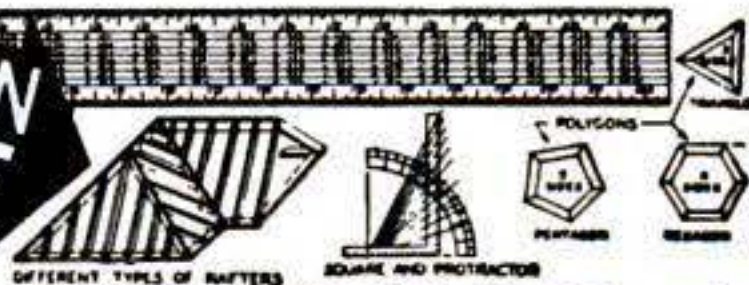

**SPECIAL OFFER FOR AGENTS**

Blue Print 27" x 36" shows how to find length of any rafter, find any angle in degrees, frame any polygon 3 to 16 sides, read board foot and brace tables, octagon scale, rafter tables and many other uses. Can be scaled down for model work as well as full scale framing. Also chart changing pitches to degrees for use with Radial Saws. Send 50c in coin or money order. No Stamps or checks.  
**MASON & PARRISH ENGINEERS**  
2031-S N. Burdick St. Dept. B Kalamazoo 81, Michigan

## PLYWOOD

Beautiful non-priority aircraft and cabinet stock. Perfect for many projects and for general construction. Thickness 1/32" to 1"; panels 6"x6" to 48"x96". Fir, gum, birch, walnut, oak, mahogany. Reasonable! Complete lists 10c. Write today!

**CARMEN-BRONSON CO., Dept. 9-A**

165 East Third St.

Mount Vernon, N. Y.

## PATENTS — INVENTIONS

We will purchase patents, inventions, processes for manufacturing in the U. S. A. and abroad. We also offer opportunities for world-wide distribution and sale of your products and inventions.

**J. J. BERLINER & STAFF**

212 Fifth Avenue

New York 10, N. Y.

## OTTAWA TRACTOR SAW



**FREE BOOK and Price List**

**350 CUTS PER MINUTE**

Make money sawing wood. Use Ottawa—fastest cutting. Cuts large, small logs easiest way. Fells trees. One man operates. Thousands in use. Built to last with heavy, stiff saw blade. Positive safety clutch control; uses power take-off any tractor.  
**OTTAWA MFG. CO., D901 Forest Ave., Ottawa, Kan.**

# HEAR

WITH

*Revolutionary*  
**COMFORT!**

Beautiful  
Black  
or  
Ivory



*Beltone*

the **QUALITY**  
**ELECTRONIC**  
**HEARING AID**

*This IS ALL YOU WEAR*

**NO SEPARATE BATTERY PACK!**

**NO BATTERY WIRE!**

About 1/2 the Weight and Bulk of Most Hearing Aids

A nationally known quality, lifetime hearing aid. Pleasant, life-like hearing. Plug in tubes, replaced as easily as a light bulb. Inconspicuous, flesh-color ear piece and cord.

MAIL THIS COUPON Today!

**BELTONE HEARING AID CO.**

Dept. PS-9, 847 W. Jackson Blvd., Chicago 7, Ill.

Sirs: Please send FREE booklet on BELTONE

NAME \_\_\_\_\_

ADDRESS \_\_\_\_\_

CITY, ZONE AND STATE \_\_\_\_\_



# Enjoy Yourself... Here's Your HOBBY!

**MAKE PROFESSIONAL-LOOKING PROJECTS**  
Worth \$5.00 to \$50.00 Each

**CHOICE OF 6 NEW HOBBIES!**

FUNDAMENTALS of PLASTIC FABRICATING

The Technic of PLASTIC CASTING

HOW TO Pressure Mold PLASTICS

Decorative PLASTIC SPRAYING

SOLDER-ARC Metal Crafting



FOLLOW A FASCINATING PASTIME WITH A PROMISING FUTURE. HAVE FUN... WHILE YOU LEARN TO EARN!



Enjoy a worth while hobby... making beautiful lamps, clocks and other gifts and furnishings for your home. No, not ordinary "school" projects... but distinctive designs equal to those sold in New York's high priced shops. *It's so easy to do now!*

**New Methods—New Materials**  
Wartime developments in Rainbow plastics, Extrusions, Onyx-like Coatings, Overlays in Colorful patterns of Rare Woods, Exotic Lizard-Skin finishes—and remarkable applications in metals and woods—are yours to enjoy in a hobby that includes everything.

Projects, materials and simple instructions created by America's leading artisans. *And yet, they are yours to enjoy at low cost.* So have fun while YOU SAVE ONE-THIRD OR MORE on attractive gifts and beautiful things for your home.

**EVERYTHING YOU NEED...**  
Projects, Plans, Instructions and Materials!

**FREE Details**

**MAIL THIS COUPON TODAY!**

HomeCrafters Guild, Dept. C-3  
360 No. Michigan Ave., Chicago 1, Ill.  
Send details of your hobby plan.

Name \_\_\_\_\_  
Address \_\_\_\_\_  
City \_\_\_\_\_ Zone \_\_\_\_\_ State \_\_\_\_\_

for **MEN and WOMEN**  
YOUNG AND OLD!

## The World's STRONGEST Adhesive!

**AMAZING Strength**

**FLEXIBLE**, yet quick-drying—and forms a practically unbreakable bond. The only cement of its kind. Exhaustive tests prove all our claims. Unexcelled for adhering metal to metal, cellophane, paper, wood, printer's cuts, plastic and hundreds of other uses.



**STA-FAST Cement**

**Almost Impossible to Pry Apart!**

**For Every Kind of Job.** Invaluable for mechanics and home craftsmen. A little goes a long way. If it's cemented by STA-FAST it stays fast. Excellent for building of model planes, ships, manufacture of novelty jewelry, model furniture. Water resistant, clean, easy to use. Satisfaction guaranteed or money refunded. At hardware, photographic and artist supply stores, and hobby shops, or direct from us, 1/4 lb. jar mailed for 60c, plus 15c for packing and postage. Order NOW.



AMERICAN WOOD TYPE MFG. CO.  
Dept. PS, 270 Lafayette St., New York 12, N. Y.

**IF COMFORT HAS BEEN A LUXURY**

# ASTHMA RELIEF

**A Modern Inhalant Method for Relieving the Symptoms of Asthma of Non-Cardiac Nature and Hay Fever**

**Money Back Guarantee**

Send for Free Book, Dept. PS

**BREATHESY DISTRIBUTORS, INC.**  
OF DELAWARE

65 Cedar St., Seattle 1, Washington

Use This or Any Similar Product Only  
As Directed by Accompanying Literature

Complete \$20

## ENGINES IN STOCK



The G. H. Q. miniature gasoline engine that really operates is still available. Over 100,000 sold to date. 1/5 H. P. Complete with fly-wheel and propeller, fuel, 15 accessories and full instructions. Fully bench tested and ready to run. Power for all models. \$20 complete. Send only \$1.00—Shipped Collect C.O.D. same day. Send for free illustrated Catalog of hundreds of hobby items.

**GHQ MOTORS, Dept. SV95, 40 East 21 St., New York 10, N.Y.**

## Burpee's Giant LARKSPUR

**SEEDS FREE**

**Plant Seeds This Fall** for biggest, best Larkspur next spring. You'll have large double flowers on 3- to 4-ft. spikes. **Easy to grow.** To try, we'll send a 15c-Pkt. Burpee's Giant Double Larkspur free, with directions. All colors mixed. **Send stamp for postage. Burpee's Seed Catalog FREE.**

**W. ATLEE BURPEE CO.**  
279 Burpee Bldg. OR 279 Burpee Bldg.  
Philadelphia 32, Pa. Clinton, Iowa

**ALL COLORS**

**PREVIEW OF 1946 MODELS!**

**MANUFACTURED TO POST WAR STANDARDS!**



**MODEL SX-45 TOOL BOX**

PRICE \$3.75 Plus Postage

Just Off the production line... for every home and workshop. Not a flimsy war-time product, but a *really rugged* tool box made of high grade, heavy gauge steel.

Large size (16" x 7" x 6 3/8") with ingenious 9 compartment adjustable tray... recessed handle for easy storing... end grips for heavy loads... long wearing hinges, catch, lock and hasp... finished in green baked enamel.



**Superior to anything on the market. Special features never before available, including —**

- Adjustable Tray Compartments
- Recessed Handle
- Easy-Lift End Grips

**Special Features**

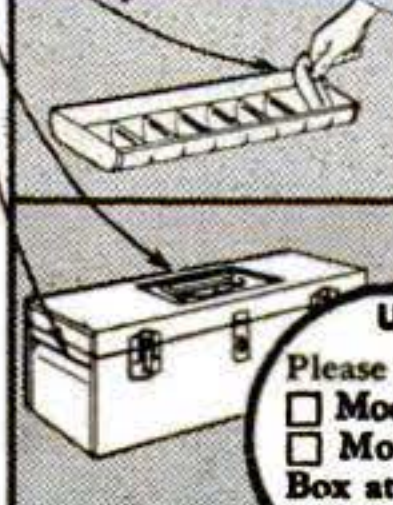

## MODEL PV-10 FISHING TACKLE BOX



PRICE \$3.95 Plus Postage

A "find" for fishermen... 9 compartment adjustable tray for any size hook or lure... packs or stacks into car easily because of recessed handle... end grips for heavy loads... rust-resistant hinges... a *real key lock*... large (16" x 7" x 6 3/8")... non-corrosive rich green baked enamel finish.

UNION DISTRIBUTORS, Inc., Box 73, Station A, Los Angeles, California

Please send immediately the 1946

Model SX-45 Tool Box at \$3.75 Signed \_\_\_\_\_

Model PV-10 Fishing Tackle Box at \$3.95 for which I have enclosed check  Money Order

Address \_\_\_\_\_

City \_\_\_\_\_ State \_\_\_\_\_

DELIVERED TO YOU IMMEDIATELY UPON RECEIPT OF CHECK OR MONEY ORDER





## 100X ASTRONOMICAL TELESCOPE LENS KIT

**ONLY \$1.95**

Thrill yourself and entertain your friends with such heavenly sights as moon craters, the beautiful rings of Saturn, comets, double stars. Fascinating hobby for you or an ideal gift for that boy of yours.

Kit includes all optical parts needed to build this powerful 6 1/2 ft. scope, a 3" dia., 75" F.L. objective lens and two assembled eyepieces of 50X and 100X, scientifically designed and matched, ready to mount. New, perfect lenses, not salvage—ground and polished. Remaining materials needed are readily found.

### EASY TO MAKE

And so simple to build too. Even a boy can follow the easy instructions furnished with each kit. An evening of easy, pleasant educational work and this wonderful scope can be yours.

Most surprising of all is the unbelievably low cost. \$1.95 check or money order brings this complete precision kit to you **postage paid**. Order immediately to get yours without delay—money back guarantee. We ship the same day order received. Address an envelope now to

**P. S. BEELERSCOPE CO.**

**Box 235 North Hollywood, Calif.**

Don't forget your return address and your remittance. By the way, if you enclose two one-dollar bills, we'll return the nickel change with your kit. **DO IT NOW.**

## FREE 32-PAGE BOOKLET ABOUT MODEL RAILROADING THE WORLD'S MOST FASCINATING HOBBY



**FREE 32-PAGE BOOKLET** tells all about this absorbing hobby for skilled tradesmen, business and professional men. Give yourself hours of satisfaction and relaxation building your own scale model railroad which performs and looks like the real thing. It's easy and relatively inexpensive. Get started now. Send at once for our free booklet "Your Model Railroad."

**MODEL RAILROADER MAGAZINE DEPT. NR MILWAUKEE 3, WISCONSIN**

## WAR SURPLUS BARGAINS



M 5 TANK PERISCOPES, new, original boxes **\$3.00**, plus 6 lb. postage. WELDING CABLE 300 amp. **\$25.** per 100 ft. 4 POWER GERMAN GUN SIGHTS **\$9.75.**

4" LENS LANTERN **\$2.75**

Many other bargains in motors, tools, hobby and sporting equipment. Send 2 dimes for French Compass and large catalog or catalog only 2 stamps.

CONVERSION of GOVERNMENT SURPLUS CO., 253 N. 3rd St., Phila., 6, Pa.

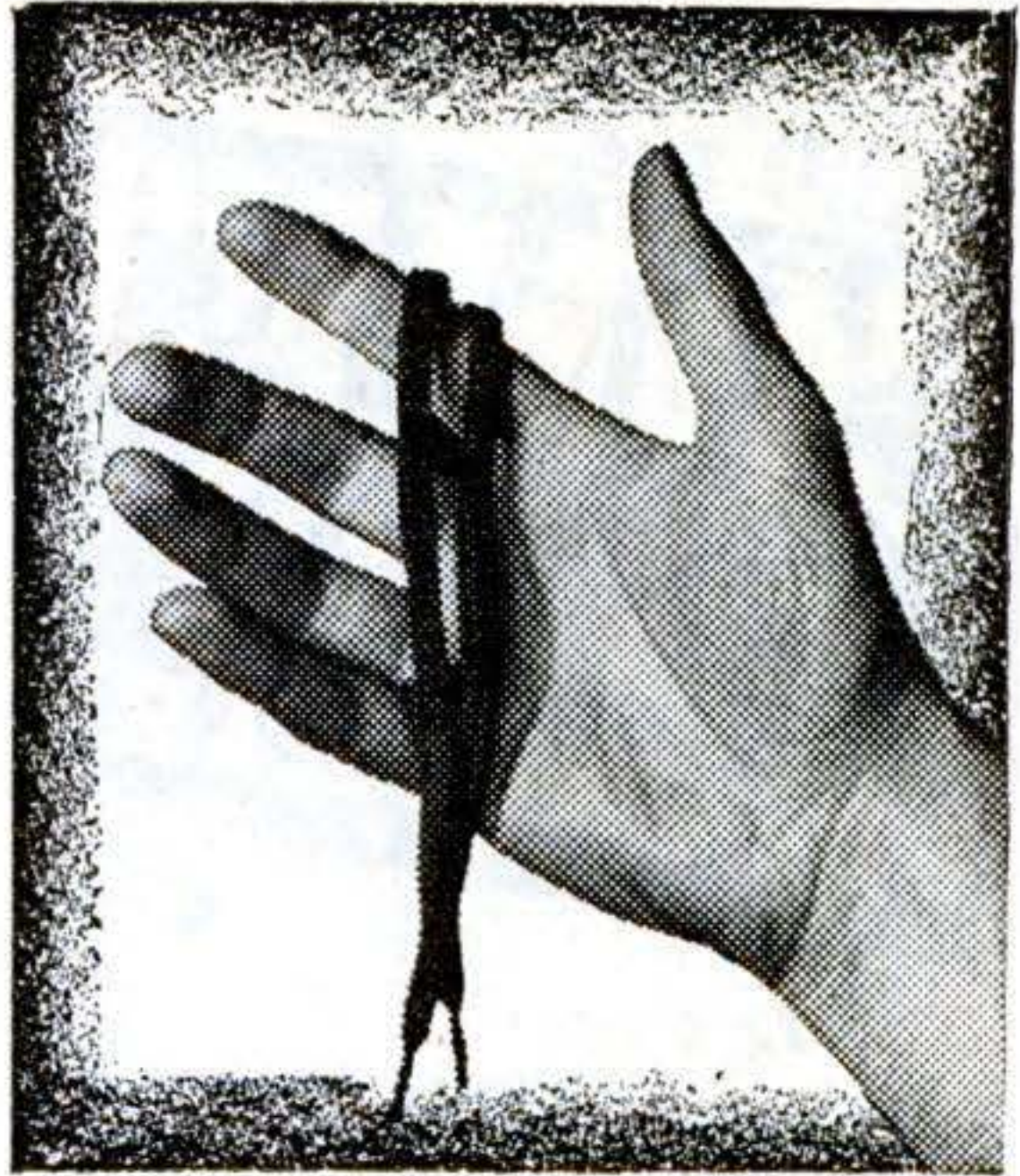

## How to Find a Business You Can Start on a Shoestring!

**SEND** today for two new **FREE** booklets revealing scores of profitable businesses you can quickly and easily launch in your own town with as little as \$1500 . . . no plant, machinery, merchandise or skilled help needed!

1. "Opportunities for Limited Capital" (48 pages) points out dozens of opportunities to go in business for yourself. 2. "Your Place in the Post War World" (64 pages) describes many of tomorrow's new jobs in 14 promising industries needing workers, distributors, salesmen and capital.

To obtain both **FREE** booklets simply return this ad **NOW** with \$4 for one year (24 issues) or only \$5 for 2 whole years (48 issues) of **FORBES**, the Magazine with the new service feature "Opportunities" giving complete details of an unusual business opening—every issue. Address Dept. E-67.

**FORBES** HEADQUARTERS FOR NEW BUSINESS IDEAS

120 Fifth Avenue, New York 11, N. Y.

## TRAILER AXLES, HITCHES, AND PARTS

● If you are interested in purchasing trailer axles, hitches, and other trailer parts, contact us promptly. Complete house trailer blue prints, \$1.00. Write for free literature



**HAMMER BLOW TOOL COMPANY, Dept. D-1 WAUSAU, WIS.**

## SHARPEN YOUR DRILLS WITH THE E-Z DRILL SHARPENER

This precision fixture was developed for factory use by aircraft tool engineers. Real shop size and not a toy. Sturdily built, attaches to bench or grinder frame. Has new **PROTRACTOR FEATURE** which enables you to adjust quickly for different drill angles. Thousands now in use—home and repair shops, garages, factories, farm shops—wherever accurate holes are drilled. E-Z is simple to operate. Gives faster drilling, perfect hole centers and clearance. Guaranteed to do the work or money back.

**SHARPENS ALL ROUND SHANK DRILLS FROM THE SHORTEST TO 11" LONG—3/32" TO 1 1/16" DIAMETER**

**SAVE MONEY WITH E-Z.** Comes complete with instructions, ready to sharpen your dull drills as good as new. Low price of \$2.80 because of our volume business on this wanted precision tool. The E-Z protractor gives you proper angles for cutting extra hard material, ordinary use, for soft material, wood, Plexiglas, Lucite, Plastics. Send check or money order for \$2.80. **WE PAY POSTAGE AND SHIP IMMEDIATELY.**

**FRED F. TEN EYCK,** Dept. S6, 758 S. Irolo St. LOS ANGELES 5, CALIF.



**ONLY \$2.80**

Complete with Protractor



**BUILD the**  
**COMET**  
**B-29**  
**SUPERFORTRESS**



- **IT'S BIG!**  
26½" WINGSPAN!
- **IT'S AUTHENTIC!**  
Right down to the last detail!

**\$2.50**

At your  
Comet  
Dealer

**ONE OF MANY OUTSTANDING COMET MODELS**

You'll find your biggest model-building thrills in Comet's ALL Balsa Solid Model of the B-29! A super-kit with many finished and semi-finished parts; finished turrets and blisters of formed plastic; scaled dual wheels, complete decal sheet, many other features! Comet Design makes it easy to build—assures better results!

**COMET MODEL AIRPLANE & SUPPLY CO. INC.,**  
 • CHICAGO • NEW YORK •

**GLOWS in the DARK**  
**MAKE BIG MONEY Selling Luminous Pictures**

**WRITE FOR FREE SAMPLE**  
 Your customers will gasp with wonder at these amazing new luminous pictures, statues, novelties. Be the first to sell them! Religious, nursery, glamour and other subjects. Sell on sight.

Madison Mills, 303 Fourth Ave., New York 10, N. Y.

**SIGNS EASILY AND EXPERTLY PAINTED WITH LETTER PATTERNS**  
**AND SHOWCARDS** MANY SIZES & STYLES WRITE FOR FOLDER!  
**JOHN F. RAHN**  
 1330-33 N. CENTRAL AVE.  
 CHICAGO 51, ILL.

**Keep your Plane Irons and Chisels SHARP as NEW!**

Unique grinding attachment insures a perfectly straight hollow grind on plane irons and chisels. Results in a sharp, keen, even-cutting edge. Adds life to tools—permits better and faster work. Enables you to do an expert grinding job. Easy to install and use. Endorsed by home craftsmen and carpenters. Satisfaction guaranteed—write for folder.  
**READ-LEWIS MACHINE CO.**  
 391 Third Ave., Troy, N. Y.

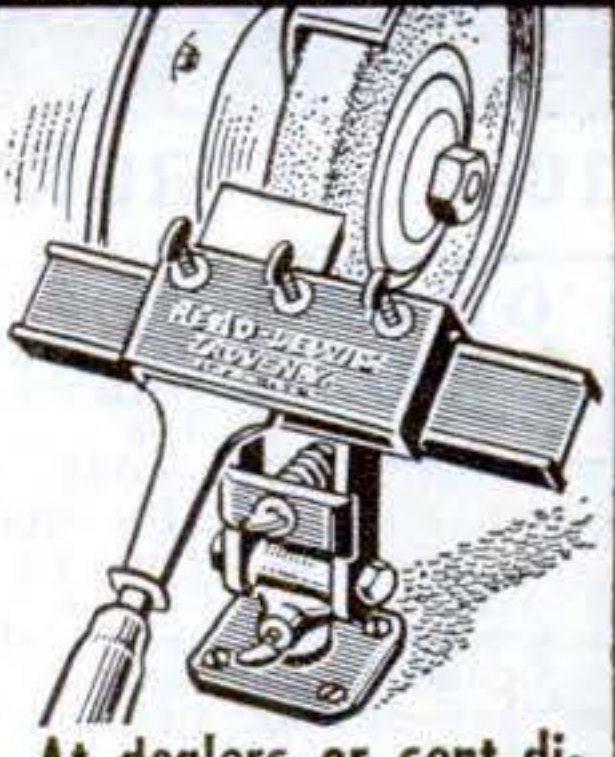

At dealers or sent direct on receipt of \$6.95.

**PERSONAL STATIONERY!**

Your Name & Address Elegantly Printed on 40 Sheets Whippet Bond & 20 Matching Envelopes... only...

We will elegantly print anyone's name and address, business or personal style, on 40 sheets of crisp, new Whippet Bond Stationery (made by Hammermill), and on 20 matching envelopes—all for only 25¢! Or, if you send \$1.00 for four sets we'll include one extra set FREE of any extra charge—or 5 sets in all postpaid! Same name, or as many as 5 different names on stationery. **Money-Back Guarantee.** Supply limited. Order Now!  
**WESTERN STATIONERY CO.**  
 Dept. 239-J Topeka, Kansas

**25¢**  
 POSTPAID



**The SUPER SYSTEM**

of Natural Physical Training builds health and strength. Send for my free booklet "Building A Better Body". Also forward to me, post-

- paid, the courses checked below.
- Fundamentals Of Exercise & Strength Building . . . . . 25c
  - Body Conditioning And Midsection Course . . . . . 25c
  - Advanced Abdominal Course Of Progressive Exercise . . . 25c
  - Arm Developing Course (Weight Training) . . . . . 25c
  - Shoulder Developing Course (Weight Training) . . . . . 25c
  - All 5 courses only \$1.00. No stamps accepted.
- HARRY GOOD, 3261-S WATSON RD., ST. LOUIS 9, MO.**

**Tired Kidneys Often Bring Sleepless Nights**

Doctors say your kidneys contain 15 miles of tiny tubes or filters which help to purify the blood and keep you healthy. When they get tired and don't work right in the daytime, many people have to get up nights. Don't neglect this condition and lose valuable, restful sleep.

When disorder of kidney function permits poisonous matter to remain in your blood, it may also cause nagging backache, rheumatic pains, leg pains, loss of pep and energy, swelling, puffiness under the eyes, headaches and dizziness.

Don't wait! Ask your druggist for Doan's Pills, used successfully by millions for over 40 years. They give happy relief and will help the 15 miles of kidney tubes flush out poisonous waste from your blood. Get Doan's Pills.



SEND FOR THIS TIME SAVING **OHMITE**  
Ohm's Law Calculator

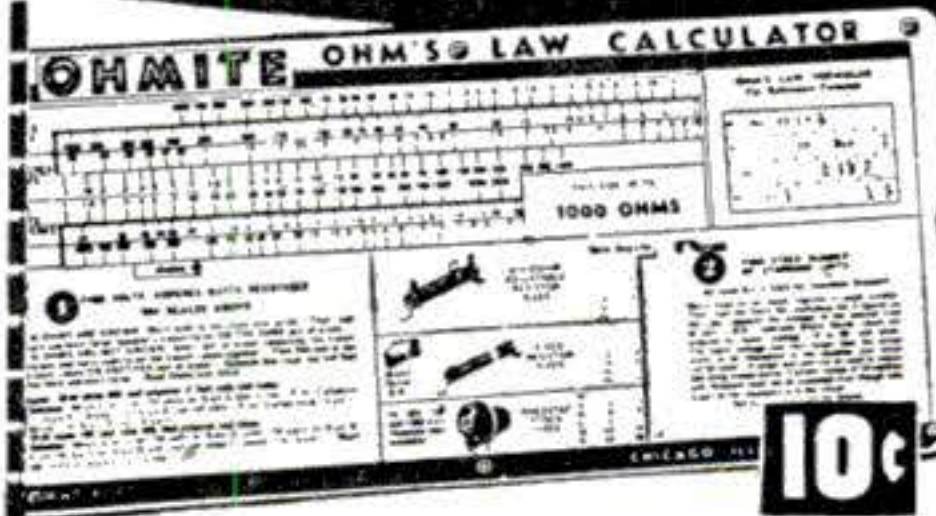

Figures Ohms, Watts, Amperes Volts... Quickly! Any Ohm's Law Problem solved with one setting

10c

of slide. All values direct reading. (4 1/8" x 9")  
Send only 10c in coin to cover cost of handling.  
**OHMITE MFG. CO., 4942 Flournoy St., Chicago 44, Ill.**

**PREVENT SMALL FIRES from becoming LARGE FIRES**



We manufacture a complete line of Underwriters' Laboratories Labeled Fire Extinguishers ranging in size from 1-quart up to 40 gallon Chemical Engines sold by our exclusive County Dealer-Salesmen.

**Opportunity for Dealer-Salesmen**

Due to war conditions we have a number of vacancies in our Dealer-Salesmen Organization in various sections of the U. S. We offer reliable men an opportunity to get into a business of their own where earnings can be increased by special effort. Write today with information about yourself and experience.

**THE FYR-FYTER CO.**  
Dept. 92 Dayton 1, Ohio

**Fyr-Fyter**

**HOW TO GET A BIG PAY JOB IN Real Estate**

Tremendous real estate boom predicted. Big-pay, permanent jobs or your own 6-profit business. Salaries up to \$2,500 to \$10,000 a year in property management, brokerage, appraisal.

loans, insurance, building. Many make fortunes selling real estate. Thousands of trained men, women, required yearly by real estate firms, insurance companies, banks, Federal agencies. Rush post-card for 32-page QUIZ BOOK—mailed FREE with full details on new and only 5-volumes library. MODERN REAL ESTATE PRACTICE! Lane Books, Dept. C-9, 100 East Ohio St., Chicago 11, Illinois.

Write for FREE BOOK!

**ASSEMBLE & SELL PLASTIC TABLE LAMPS**

COMPLETE KIT \$5.50

Today, order U-Make-It Lamp Kit \$1. You get all parts for beautiful 24" lamp; complete, easy to assemble. Enclose check or money-order.

**KOSTO HOBBY-CRAFTS PLASTICS CORP.**  
3263 M Street, N. W., Washington, D. C.

Exclusive of Shade

**New Accurate 10" Slide Rule**

Instruction Book FREE

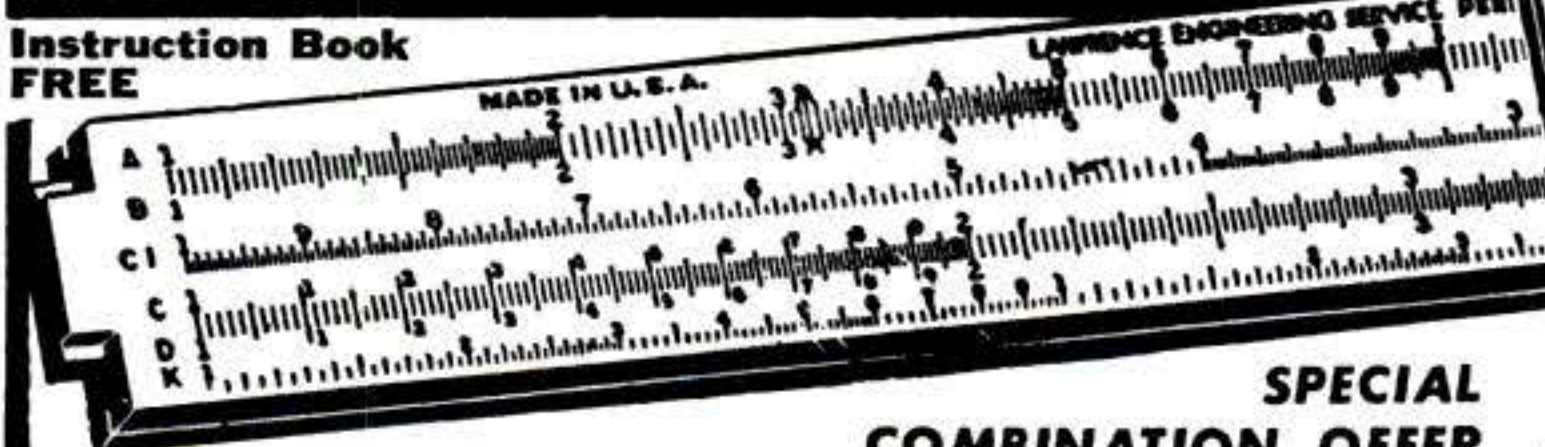

**SPECIAL COMBINATION OFFER**

Standard 10" Slide Rule and Instruction Book; Pocket Calculator for adding and subtracting up to 999,999; 6" Transparent Protractor and Graph Rule graduated in centimeters and inches —ALL 3 for \$1.00 cash (\$1.15 Foreign) POSTPAID.  
New "TRIG" 10" Slide Rule, with Pocket Calculator and Transparent Protractor. \$1.50 (\$1.65 Foreign) POSTPAID.

**Magnifying Indicator**

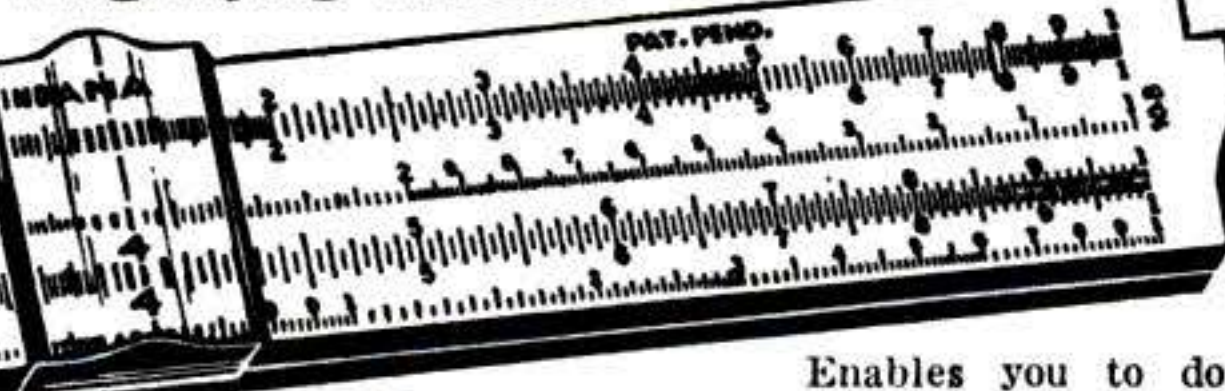

50c

Enables you to do difficult calculations instantly without paper or pencil—multiplying, proportions, division, extracting roots, etc. Accurate, white composition face. Has standard A, B, C, D, CI and K scales.

For complete outfit, including slide rule, 28-page illustrated instruction book, carrying case, send 50c (65c Foreign). New "TRIG" 10" Slide Rule, with same six scales as above plus S, L, and T scales on Reverse of Slide for problems in Trigonometry; Gunmetal Finish Indicator; complete instructions—\$1.00 (\$1.15 Foreign). Mailed postpaid. Satisfaction Guaranteed or money refunded. (See Special Combination Offer.) Order NOW.

**HEWIG CO., Box P-143, Grand Central Annex, New York City**

Open for yourself new world opportunities with another language by **LINGUAPHONE**

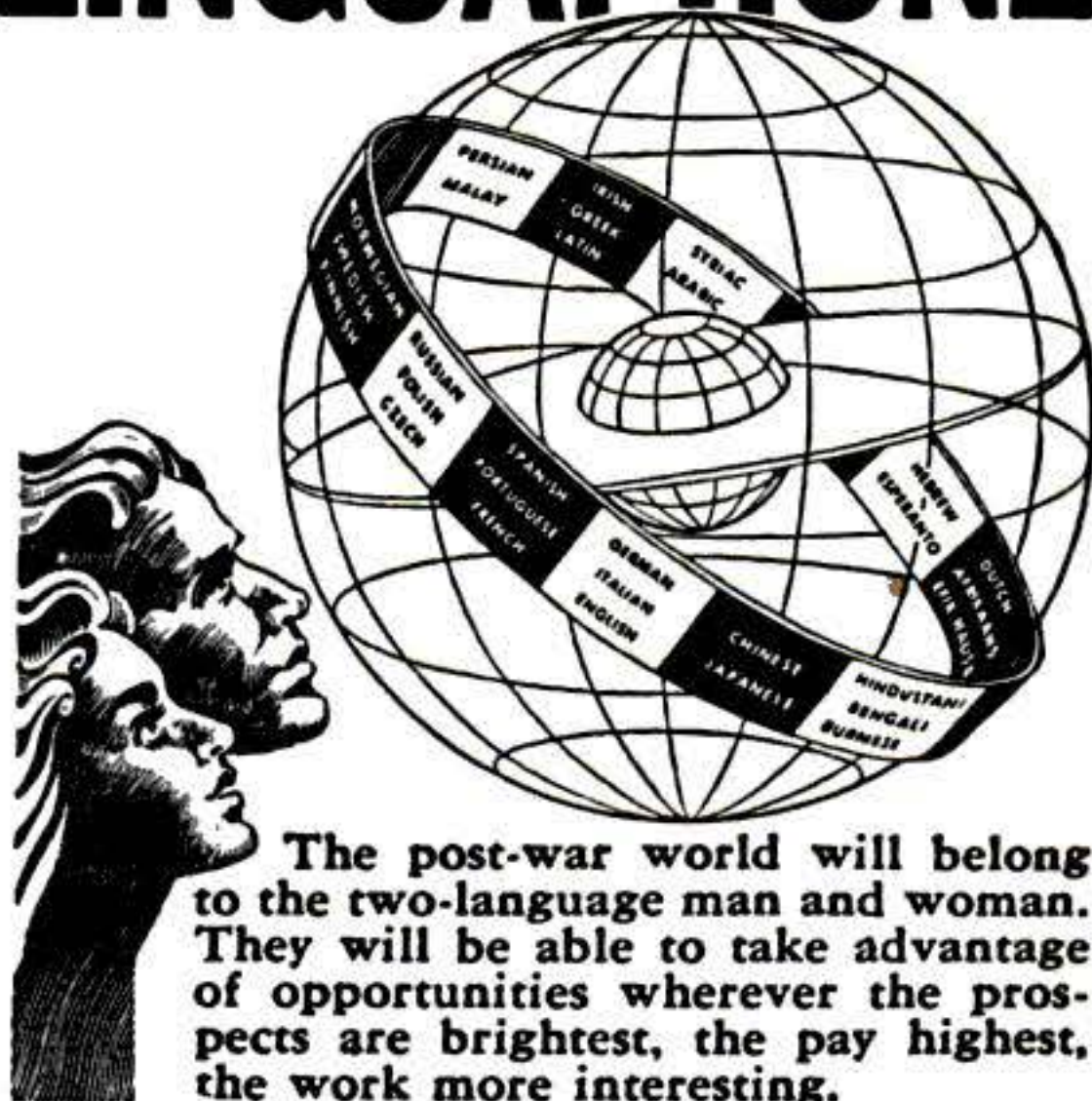

The post-war world will belong to the two-language man and woman. They will be able to take advantage of opportunities wherever the prospects are brightest, the pay highest, the work more interesting.

**LINGUAPHONE Conversational METHOD**

prepares you, in your own home, to SPEAK any one of 29 world-languages:

- |            |         |         |
|------------|---------|---------|
| SPANISH    | POLISH  | GERMAN  |
| PORTUGUESE | RUSSIAN | ITALIAN |
| NORWEGIAN  | FRENCH  | SWEDISH |

and 20 other languages

You learn through natural, everyday conversation. First you LISTEN to the clear voices of native teachers... they speak to you as often as you wish... You REPEAT what they say... ask and answer questions, and before you are actually aware, you are conversing.

Endorsed by leading educators; used in thousands of schools and colleges, and by Army, Navy, Flying, Signal and other Services. "Linguaphone is unique... it has no equal."

SEND FOR FREE BOOK. Save time, work and money—become a two-language man.

**LINGUAPHONE INSTITUTE**

LINGUAPHONE INSTITUTE  
58ARCA Bldg., New York 20, N. Y.

Without cost or obligation please send me the Linguaphone Book.

Name .....

Address .....

City ..... Zone..... State.....

Language interested .....

When Writing Advertisers Please Mention Popular Science Monthly



## Announcing—A New Drill Press Accessory

### THE BARRON ROTARY SURFACE SANDER

\$5.95 COMPLETE



#### Note these Special Features—

Made of Alcoa aluminum. Machined and balanced for smooth operation in drill press chuck. For surface sanding woods, plastics or polishing metal surfaces. Complete with 20 instantly removable sanding cup discs. No messy glueing needed. Leaves an agate smooth, absolutely true surface finish. Does not leave waves, ripples, steps or striations in work piece. The only tool of its kind. Shipped prepaid on 10 DAY MONEY BACK GUARANTEE for \$5.95.



### The IMPROVED Barron Multi-Purpose Drill Press Planer.. \$7.50

Not only surface planes toughest woods and plastics to precision limits—but rabbets, routs, tenons, panels, grooves, beads. Will

cut rabbets, tenons, panels, etc. to a depth of 1" with special Barron extra long hi-speed cutter blades. Thousands now in use. Made of Alcoa aluminum, machine finished thru-out. Vibrationless. Fits any drill press. Shipped prepaid on 10 DAY MONEY BACK GUARANTEE on receipt of cash, money order or C.O.D. for \$7.50.

### Baron ALL-METAL Auxiliary DRILL PRESS Table.. \$8.85



Hard Alcoa aluminum die casting heavily ribbed—machined both sides. Has 234 sq. inch extra large working surface. Equipped with Barron Steel Planer Fence. Can also be used for shaper operations, innumerable other drill press uses. A real buy at \$8.85, express collect.

See Your DEALER . . . Or Write For CATALOG

**BARRON TOOL CO., INCORPORATED**  
370 Architects Bldg. Detroit 1, Mich.

## BARRON PRECISION WORK SHOP TOOLS

When Writing Advertisers Please Mention Popular Science Monthly

AIR RIFLES

# BENJAMIN

AIR PISTOLS

ORDERS NOW ACCEPTED

EARLIEST POSSIBLE POSTWAR DELIVERY ASSURED—ACT NOW! ORDER Latest Models BENJAMIN AIR RIFLES and AIR PISTOLS AT ONCE. Send for our FREE ILLUSTRATED FOLDER and complete specifications TODAY. BENJAMIN H-C PELLETS ARE AVAILABLE.

BENJAMIN AIR RIFLE CO. 811 MARION ST., ST. LOUIS 4, MO.



SPECIAL BARGAIN!

## 250-FT. WIRE

High quality stranded No. 20 Wire for hookup, ground, lead-in etc. Flexible Vinylite insulation strips off easily. Waterproof and oil-proof. Our price is only a fraction of the actual value of this dandy Wire, obtained through a manufacturer's cancellation. ACT NOW! (Free Catalogs on request.)

Clip this ad, write your name and address in margin. Mail with \$1 to **OLSON RADIO WAREHOUSE, 73-K Mill St., Akron, Ohio**



## KEEP YOURSELF UP-TO-DATE ON WOOD VENEERS LUMBER & SUPPLIES

### with CONSTANTINE'S MASTER MANUAL

Published by the leading suppliers to woodworkers, the most complete book ever offered. More than a catalog, contains valuable information on lumber inlays, veneers, wood finishing, etc. 83 inlay border designs in full color, 6 pages of full color inlays plus a wood identification chart showing over 60 rare woods in natural color. Send only 25c today and we will include FREE a year's subscription to our publication, Chips & Chats.

**ALBERT CONSTANTINE & SON, INC.**  
793-S 135th STREET, NEW YORK 84, N. Y.

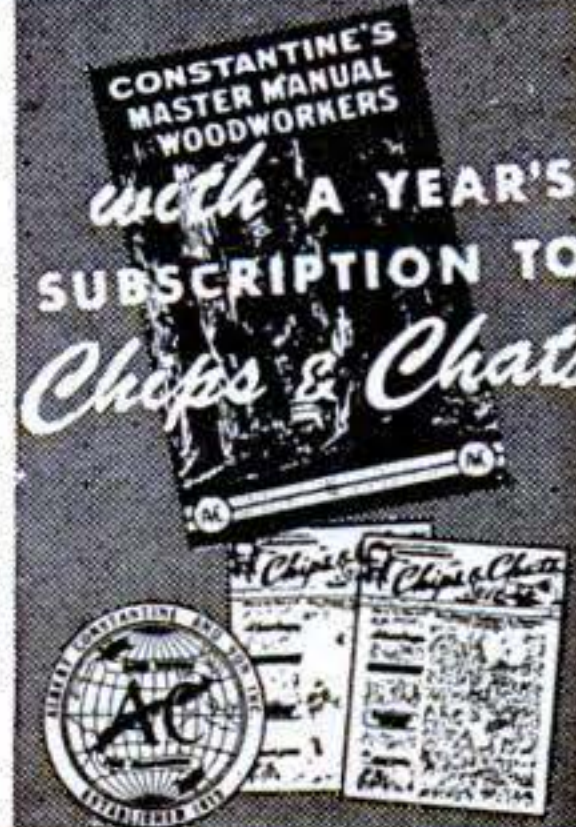

### Burn Your Name On Tools Electro Name Etcher Only

PROTECT valuable tools from thieves and tool borrowers! Electro Etcher BURNS your name, any design, permanently on tools, instruments, dog collars, any metal. Easy! Simple as writing with pen or pencil. Rush order today—supply limited—no more when these are gone! **SEND NO MONEY!** Pay postman \$1.00 plus few cents postage on delivery. Use 5 days—money back if not delighted. Electro Etcher, Dept. A-603, Strader Ave., Cincinnati, O.



# KELNOR

## AMERICA'S FINEST LINE OF LIGHTWEIGHT ELECTRIC SOLDERING IRONS

FOR CRAFTSMEN IN FACTORY AND HOBBY SHOPS. IF YOUR DEALER DOES NOT CARRY, WRITE KELNOR MANUFACTURING CO., CENTRAL TOWER, SAN FRANCISCO 3, CALIFORNIA

REG. U. S. PAT. OFF. PATS. APP. FOR

## ONE-MAN SAWMILL LESS THAN \$110.00

### Easy To Turn Trees Into Money

Makes Lumber ties, shingles, crates, lath, studding, siding.

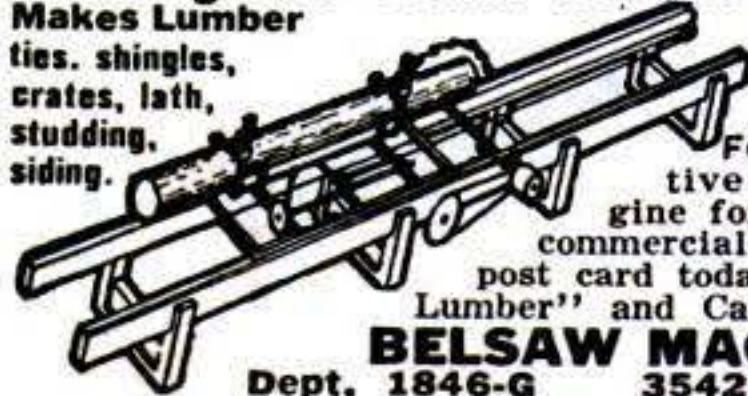

**BELSAW MODELS** in to 24 feet sawing lengths. Patented Mechanical Feed, accurate set works and positive dogs. Use tractor or old auto engine for low cost power. Thousands used for commercial sawing. Pays for itself quickly. Send post card today for FREE booklet "How To Make Lumber" and Catalog of Woodworking Equipment.

**BELSAW MACHINERY COMPANY**

Dept. 1846-G 3542 Main Street, Kansas City 2, Mo.



"The Book They're Talking About"



# ART ANATOMY & FIGURE DRAWING

For the amateur and professional artist. Contains over 350 illustrations, charts and notes, giving detailed study of every part of the body. Viewed from different perspectives. Price Only \$1

MAJOR BOOK CO., DEPT. 41-G  
72-04 Juno St., Forest Hills, New York



# LATHE OWNERS

CONVERT YOUR LATHE INTO A PRECISION MILLING MACHINE IN LESS THAN THREE MINUTES!

**GLOBE HEAVY DUTY BED TURRETS**—Adaptable to any lathe 4 1/4" travel. Precision built Rugged construction.

**GLOBE CROSS SLIDE**—Adaptable to any lathe. 3 1/2" travel Rugged construction.

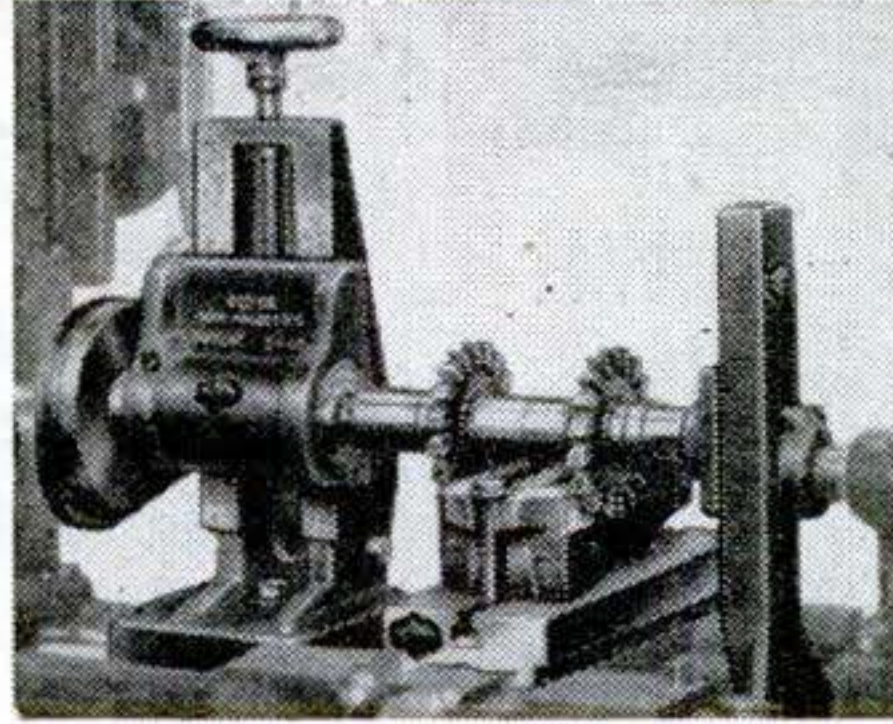
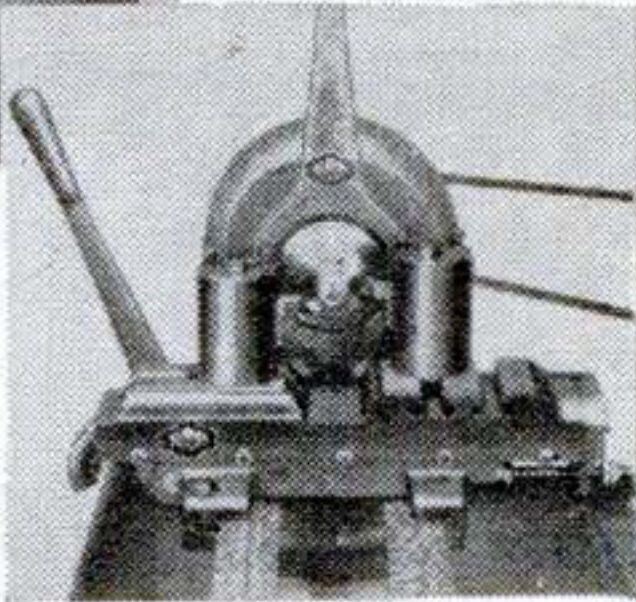

Mr. N. J. Taylor of Lakeland, Florida, says: "I don't see how I got along before I got this GLOBE MILLER. Use it nearly every day and find many time saving uses for it."

**IMMEDIATE DELIVERY, NO PRIORITY**



Costing a fraction as much as a standard miller, the Globe can perform practically any milling operation, using your lathe motor through headstock as the source of power, and employing all the speeds and feeds of the lathe.

Gang Milling      Slot Cutting      —and Many Other  
Facing              Cutting Keyways      Milling  
Gear Cutting                           Operations

**AUTOMOTIVE REPAIR MEN!**

A profitable source of new revenue is open to you with the Globe Miller in the truing of truck and passenger car brake drums. For example, it increases the swing of an 11" lathe to 19 1/2", large enough for truck brake drums. Write for particulars today.

USED EXTENSIVELY BY U. S. GOVERNMENT AS PART OF MOBILE REPAIR TRUCK STANDARD EQUIPMENT

GLOBE PRODUCTS MANUFACTURING CO.  
Dept. A1, 3380 Robertson Blvd., Los Angeles 34, Calif.

I'm interested in learning how to use my lathe as a precision milling machine.  
My lathe is a \_\_\_\_\_ (Model) \_\_\_\_\_ (Make) \_\_\_\_\_ It has  power  hand cross feed.

My lathe swing is \_\_\_\_\_"  
I have  have no  telescoping taper attachment.

Send me bulletins on  
 Globe Heavy Duty Bed Turrets      (If you request bulletins on Heavy Duty Bed Turrets or Cross Slide, please be sure to answer above questions on your lathe, model, swing, etc.)  
 Globe Cross Slide  
 Globe Hand Screw Machine

My name \_\_\_\_\_

Address \_\_\_\_\_ Zone \_\_\_\_\_ State \_\_\_\_\_

City \_\_\_\_\_

SEND COUPON FOR INFORMATION ON HOW YOUR LATHE CAN BE A PRECISION MILLING MACHINE, TOO

**GLOBE PRODUCTS MANUFACTURING CO.**  
3380 ROBERTSON BOULEVARD • LOS ANGELES 34, CALIF.

## CASTING RODS and FLY RODS

Make your own with our plans and aluminum offset handle.  
Plans \$1; Handle \$5; Cork Grip 50c;  
Line Guide Tip 50c; Line Guide 25c. NEW.  
a rigid Tubular Casting Rod with line guides on the inside (like cut) \$12.50. Also 10-foot Tubular Still-Fishing Pole with offset handle, \$12.50. Taper-Steel Casting Rod with line guides and offset handle, \$18.95—cash, or pay postman few cents extra if ordered C.O.D.

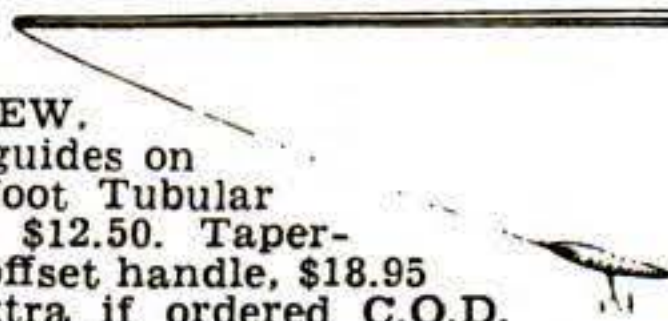

Order from this ad, no literature available.

**BISHOFF MFG. CO.**

Dept. E, 9535 Ohio St., Detroit 4, Mich.

## DURAPOINT DRILLS FOR CONCRETE, STONE GLASS, HARDENED STEEL

Style S (Standard in sizes over 3/16")

Style R (Standard in sizes 3/16" and under)

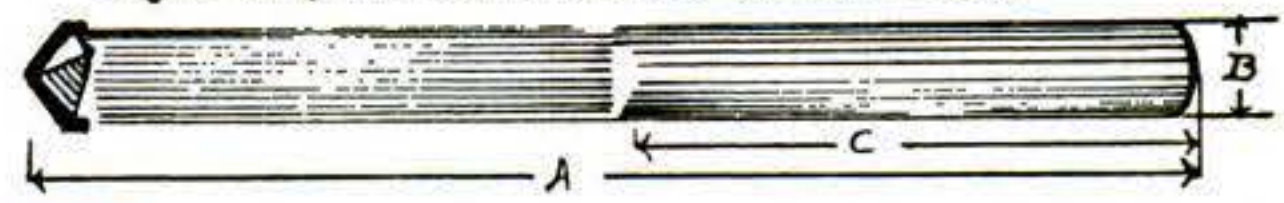
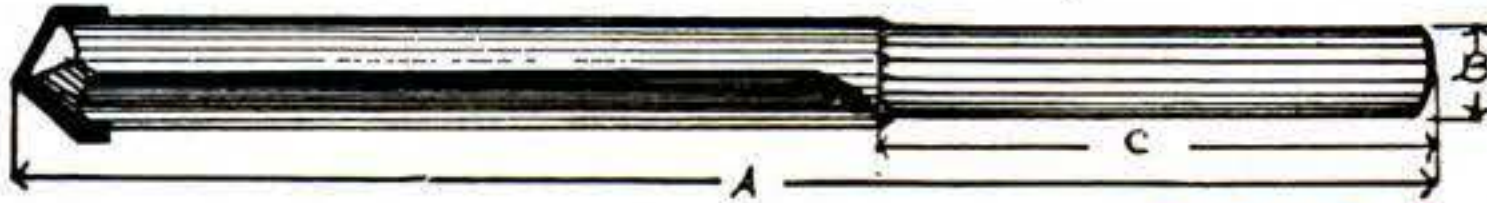

### PRICE LIST

Diameter	Net Price Each	Over-all Length (A)	Diameter (B)	SHANK Length (C)	Diameter	Net Price Each	Over-all Length (A)	Diameter (B)	SHANK Length (C)
1/8"	\$ 2.75	3"	7/64"	1 1/2"	5/8	\$ 4.50	8"	3/8, 7/16 or 1/2	2"
	3.00	4 1/2"	7/64	1 1/2"		5.00	6"	3/8, 7/16 or 1/2	2"
3/16	2.75	3"	11/64	1 1/2"	11/16	5.25	8"	3/8, 7/16 or 1/2	2"
	3.00	4 1/2"	11/64	1 1/2"		5.50	6"	7/16, 1/2 or 5/8	2"
1/4	2.75	4"	7/32	1 1/2"	3/4	5.75	8"	7/16, 1/2 or 5/8	2"
	3.00	6"	7/32	1 1/2"		6.25	8"	1/2, 5/8 or 11/16	2"
5/16	3.00	4"	1/4 or 9/32	1 1/2"	13/16	6.50	10"	1/2, 5/8 or 11/16	2"
	3.25	6"	1/4 or 9/32	1 1/2"		7.00	8"	1/2, 5/8 or 3/4	2"
3/8	3.25	5"	1/4 or 5/16	1 3/4"	7/8"	7.25	10"	1/2, 5/8 or 3/4	2"
	3.50	7"	1/4 or 5/16	1 3/4"		7.75	8"	1/2, 5/8, 3/4 or 13/16"	2"
7/16	3.50	8"	1/4, 5/16 or 3/8	1 3/4"	15/16	8.00	10"	1/2, 5/8, 3/4 or 13/16	2"
	3.75	6"	1/4, 5/16 or 3/8	1 3/4"		9.00	10"	1/2, 5/8, 3/4 or 13/16	2"
1/2	4.00	6"	1/4, 5/16, 3/8 or 7/16	1 3/4"	1	9.50	12"	1/2, 5/8, 3/4 or 13/16	2"
	4.25	8"	1/4, 5/16, 3/8 or 7/16	1 3/4"		11.00	10"	1/2, 5/8, 3/4 or 7/8	2"
9/16	4.25	6"	3/8, 7/16 or 1/2	2"		11.50	12"	1/2, 5/8, 3/4 or 7/8	2"

Sizes up to 1 1/2" obtainable at proportionate cost.  
Drills in 64ths and 32nds now in stock, tolerance normally +.005, -.000; tolerance of .001 for 5% extra; tolerance of .001 1/2 on special order. Please do not order closer tolerance than you need. Drills below 1/8" on special order. All drills from 1/8" to 1" not listed made at the price of the size next larger. Specify your largest chuck size.

Durapoint Glass Cutter, like a pencil, better than a wheel cutter for circular cutting. \$2.50, Postpaid.

**DURAPOINT TOOL COMPANY, 4342 UMATILLA STREET, DEPT. S, DENVER 11, COLORADO**



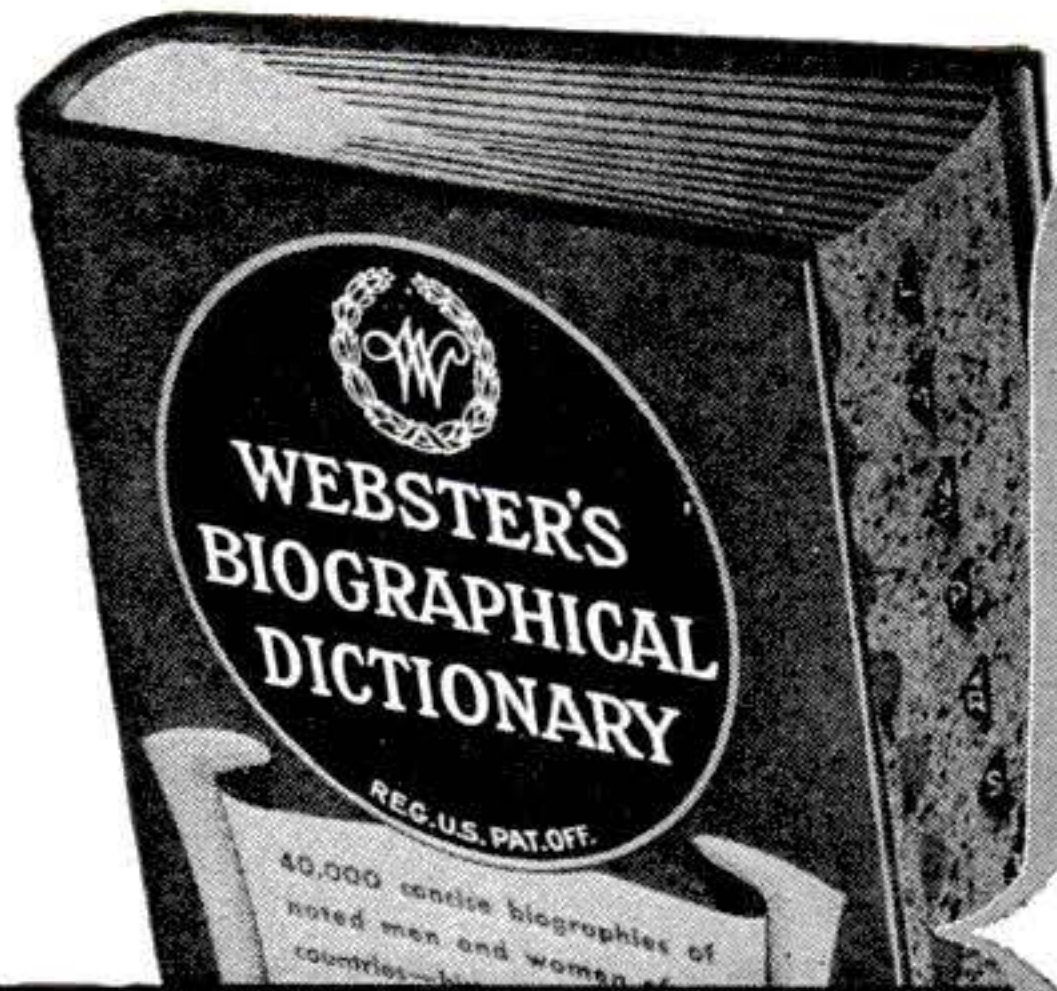

**THE MERRIAM-WEBSTER**  
Book of  
**Biographies**

**A**n entirely new work by the famed editorial staff of *Webster's New International Dictionary, Second Edition*. Contains more than 40,000 concise biographies, with pronunciation of names and all essential facts. Includes scientists, statesmen, explorers, writers, painters, actors, radio personalities, eminent figures from every other field of activity. **WEBSTER'S BIOGRAPHICAL DICTIONARY** is an invaluable source of information for writers, speakers, and readers. 1,736 pages, thumb index. \$6.50. At your bookdealer, or from the publishers.  
**G. & C. MERRIAM COMPANY**  
513 Federal St., Springfield 2, Mass.

**At Your  
Finger  
Tips—  
Essential  
Facts  
About  
40,000  
NOTED  
MEN  
AND  
WOMEN**

Historical  
and  
Contemporary  
—from Every  
Country and  
Every Field  
of Human  
Achievement!

**AUDELS**  
**POWER PLANT  
ENGINEERS GUIDE**  
WITH QUESTIONS AND ANSWERS

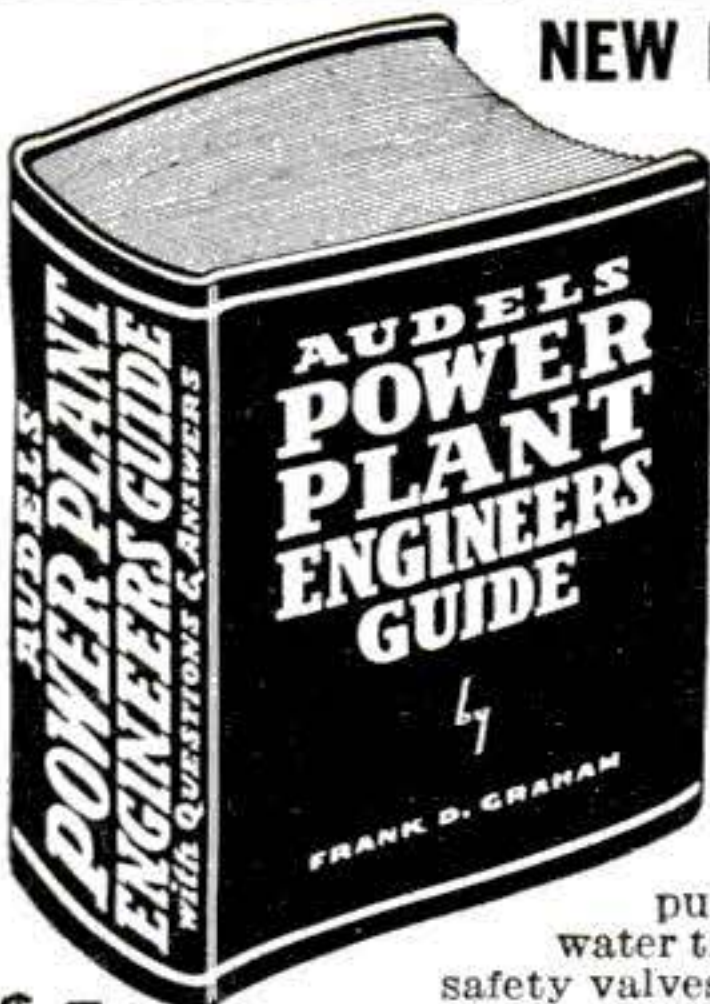

**NEW FROM COVER TO COVER!**

**JUST PUBLISHED—For All Engineers, Firemen, Water Tenders, Oilers, Operators, Repair Men and Applicants for Engineers' License Examinations.**  
A Complete Steam Engineers' Library in One Book!  
**1500 PAGES—65 CHAPTERS**  
**1700 ILLUSTRATIONS, FULL INDEX**

**1001 FACTS AT YOUR FINGER ENDS!**

**PRACTICAL INFORMATION IN HANDY FORM FEATURING:**  
Basic principles of Steam Engineering, including Boiler Construction, Operation and Repairs. Gives practical information on: Boiler Calculations, fuels, feed

pumps, water heaters, economizers, water treatment, injectors, traps, draught, safety valves, oil burners, stokers, condensers, ejectors, cooling towers, evaporators, steam and hot water heating, pipe fitting & tubing. Contains complete data on all types of Steam Engines and Turbines, Indicators, Valve gear, Valve setting, Air Compressors, Hoists, Gas and Diesel Engine Operation, Lubrication.

**\$4**

**COMPLETE** Hoists, Gas and Diesel Engine Operation, Lubrication.  
**PAY \$1 A MONTH. Get this information for yourself—ASK TO SEE IT—Mail coupon today!**

**AUDEL, Publishers; 49 W. 23 St., New York 10, N.Y.**

Mail AUDELS Power Plant Engineers Guide (Price \$4) on 7 days free trial. If O.K. I will remit \$1 in 7 days and \$1 monthly until \$4 is paid. Otherwise, I will return it.

Name \_\_\_\_\_  
Address \_\_\_\_\_  
Occupation \_\_\_\_\_  
Employed by \_\_\_\_\_ P.S.M.

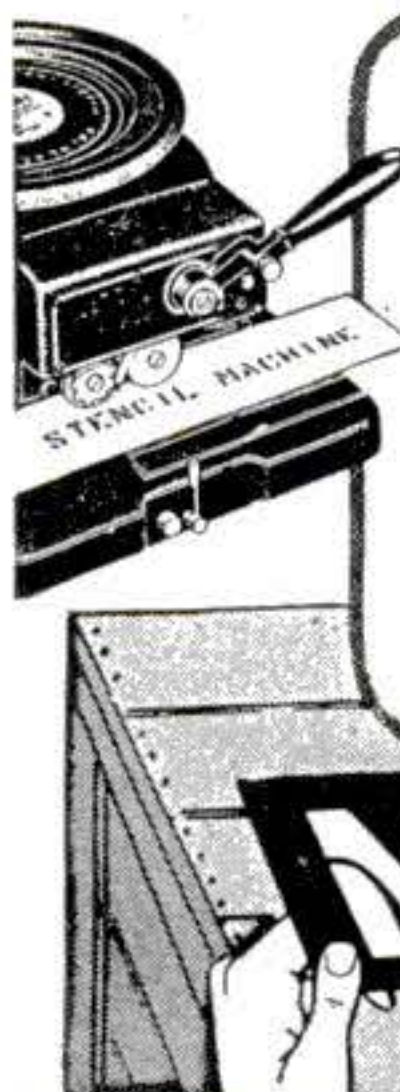

**LEADS** as a money-saver in Shipping Department," say users of Marsh Stencil Machines, Brushes, Inks! Three sizes to meet Gov't Spec., 1", 3/4", 1/2". For sample stencil, shippers' handbook and prices, pin this to business letterhead, with your name.

**MARSH**  
STENCIL MACHINE CO.  
64 Marsh Building  
Belleville, Ill., U.S.A.



★ **NEW!** *Ideal Gift for Your Service Man!*

Heavy 10K Solid Gold Souvenir Service Ring of World War II. A beautiful and authentic ring that your service man will be proud to wear and cherish forever. It plainly shows that he is a Veteran of our Armed Forces of World War II. One side of ring shows Allied Flags and World with Shield, other side shows the Great Seal of the U. S. State ring size.



No. 1541 Each.....\$18.00 Plus 20% Fed. Tax  
Send for Circular of Service Jewelry. Reliable Representatives Wanted.

**EDWIN W. LANE CO., Dept. PS, 32 W. Randolph St., Chicago 1,**

**NEW!** Sell Popular  
**ALL WOOL**  
Buffalo Check Shirt -

Every Outdoor Man a Prospect. Smartest color and style combined with warm snug comfort. Genuine ALL WOOL Buffalo Check Shirt, full cut, patented storm cuffs. Amazingly low priced, with generous profit for you.

**BIG PROFITS FOR YOU!**



**COMPLETE LINE**  
Leather and wool jackets, raincoats. 200 fast-selling shoe styles. Our salesmen making biggest profits using Actual Samples we furnish FREE. Write TODAY!

**MASON SHOE MANUFACTURING COMPANY**  
Dept. M-301 Chippewa Falls, Wisconsin

**EYEGASSES BY MAIL**

AS LOW AS 16 DAYS TRIAL  
**\$1.95** WRITE TODAY FOR FREE CATALOG SEND NO MONEY  
**ADVANCE SPECTACLE COMPANY**  
537 South Dearborn Street  
CHICAGO ILLINOIS DEPT. SP-9

**FISTULA**  
**FREE BOOK—Explains Facts**

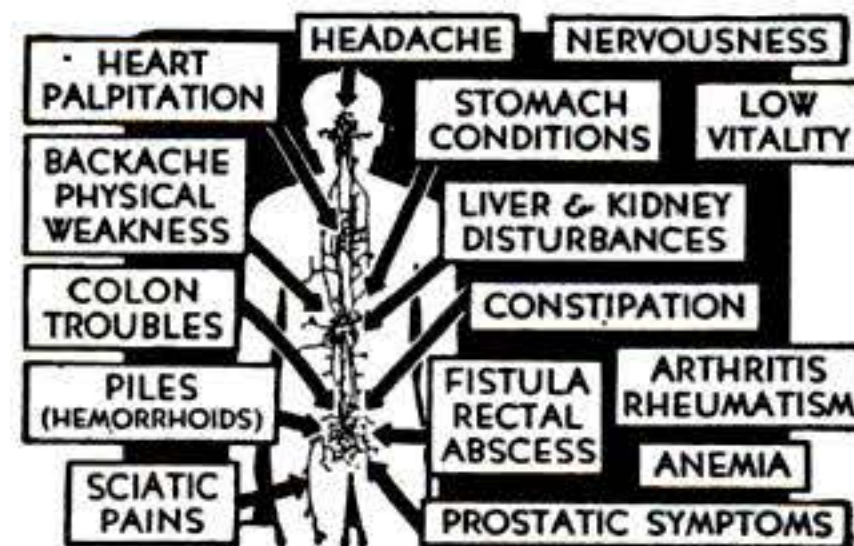

Fistula, Rectal Abscess, Piles and other rectal and colon disorders are dangerous. A new 40-page FREE BOOK explains corrective treatment. Write today. Thornton & Minor Clinic, Suite 949, 926 McGee St., Kansas City, Mo.



**SENSATION OF THE DAY—and night!**

**REX-LITE**  
TRADE MARK

Powerful...striking in design  
...built to specifications of  
U. S. Air Forces . . . 3-cell  
flashlight throws a beam  
approximately 500 feet.  
Durable all plastic case. Uses  
standard "D" size batteries.

May be carried on finger,  
hung on hook or belt, stood  
on floor. Weight only 4 ozs.  
without batteries. Three-  
position switch: steady, signal  
and safety. Plated reflector.



MAKES A FINE  
XMAS GIFT!

**\$2.65**

Sent postage  
prepaid on re-  
ceipt of money  
order . . . if C.O.D.  
send \$1 deposit.  
Write for quantity  
prices.

**AGENTS WANTED**  
Write for our attractive  
proposition today!

**RANAY CO.** Dept. **A** 21 W. 3rd St.  
Cincinnati 2, Ohio

**\$1.00 Starts you in a business  
of your own.** . . . Address post cards

**Earn big profits at home** advertising gorgeous  
monogrammed station-  
ery, Christmas Cards and name cards at money saving  
prices. Stationery sells at \$1.69 Box. Costs you \$1.00  
Box. Send \$1.00 today for 100 clever mailing cards im-  
printed with your name and address plus complete instruc-  
tions for starting a mail order stationery business. Pro-  
tected territory available. Write Dept. J9

**W. H. PETERS & ASSOCIATES, Printers, TROY, OHIO**

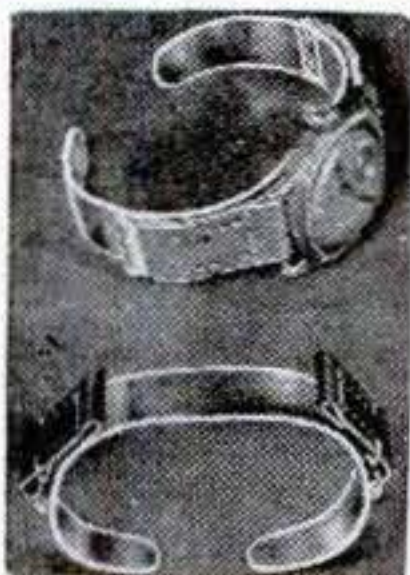

Here's the NEW  
**R-Y-T-O-N**  
SELF-ADJUSTABLE WRIST WATCH BAND  
(Patents Pending)

On or off your wrist in a jiffy. It's crystal-  
clear Plastic always clean and sanitary. Try it for  
ten days on a **MONEY BACK GUARANTEE!**  
Price \$1.50 each, with stainless steel fittings; and  
with gold plated fittings, \$2.00 each; post-paid.

**GENERAL UTILITIES (PLASTIC DIVISION)**  
Box 314 P Grand Central Annex, New York City

**12 PHOTO and INITIALED RINGS**

Only \$1.95 complete **PLAST-O-CRAFT** Ring Kit con-  
tains complete material fabri-  
cating equipment and instruc-  
tions for making 12 beautiful plastic rings  
in assorted colors. Initials, small photos,  
stones can be placed in the setting. Ideal  
for clubs, class rings, societies, gifts, etc.  
Simple to make and lots of fun. A prac-  
tical way to learn plastics. Send check or  
money order for \$1.95. We pay postage and  
ship immediately. Money back guarantee.  
**Dept. S-9 PLAST-O-CRAFT COMPANY**  
13401 Cerise Ave., Hawthorne, Calif.



**ARC WELDERS**

Post War Models now available.  
Most complete line of welding  
machines. Any size for any shop.  
From \$20 to \$200.

Brazing, preheating, cutting,  
spot welding, arc soldering, pipe  
thawing.

220, 110, 32 Volt Models

**UNCONDITIONALLY  
GUARANTEED**

Highest grade of materials used  
in construction.

There is a Forney Product in  
every town in the U.S.A.

Also have used Welders.

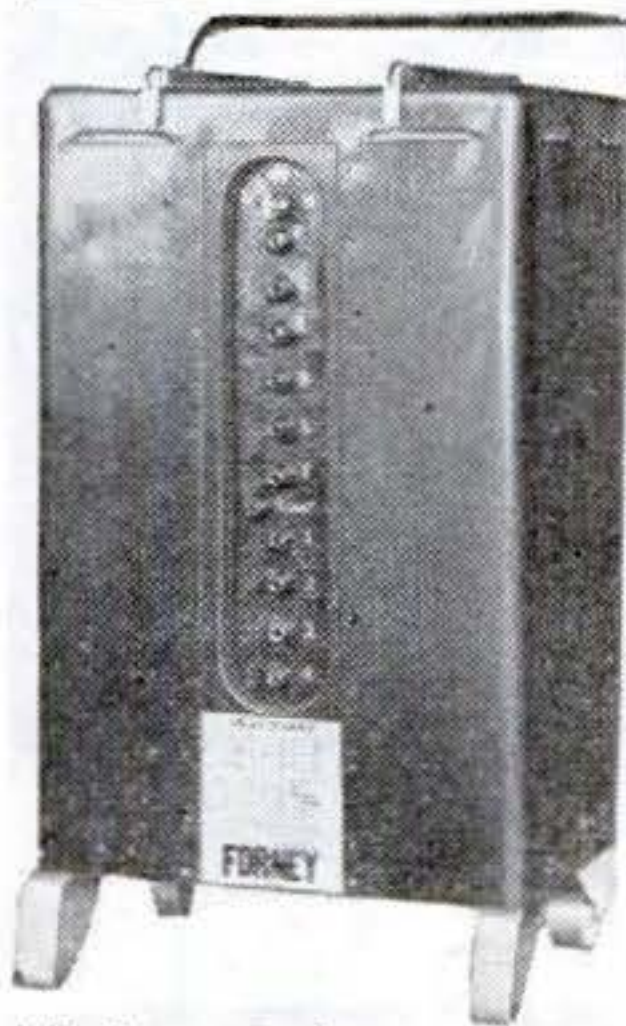

Write or wire,  
factory direct,

**FORNEY MFG. CO., FT. COLLINS, COLO.**

**ENJOY and PROFIT by  
THIS BOOK of over 100  
ITEMS**

ONLY  
**\$1.50**



**SIMPLE  
PLANS for  
PRACTICAL PROJECTS**

You will have no trouble in  
working out the plans de-  
tailed in the LeJay Manual  
and you will get a lot of  
enjoyment from them.  
Whether or not you are  
mechanically inclined, the  
projects in these plans will  
appeal to you for their use-  
fulness and practicability.  
They will save you money  
and make money for  
you, too, in jobs and  
repairs for neighbors  
and friends, because  
the plans embody all  
kinds of electrical de-  
vices.

**NO EXPENSIVE  
TOOLS NEEDED**

The tools you have  
around the house  
are all you need  
for these projects  
and most of the  
necessary material

can be found around workshops,  
garages and scrap yards. Being  
able to make your own welder  
helps a lot in doing other jobs,  
and the LeJay Manual shows

you how easy it is to do this; also, how to  
make over 100 different items. . . . **Sent on  
three days trial—money back if not satisfied.**  
Only \$1.50, Canada, \$1.75.

**THE NEW MODERN LEJAY  
FAST-FREEZER PLANS**

**FROZEN STORAGE \$1.00**

For Fish, Meat, Fruit, etc.  
From 5° above to 10° be-  
low zero.

**5 SIZES—8 to 40 Cubic  
Feet Capacity**

**NO KNOWLEDGE OF  
REFRIGERATION  
REQUIRED**

—Plans are easy to follow  
and you may have much of  
the material at hand. **FAST  
FREEZERS** made from these  
plans have been in use  
since 1938.



**MILK COOLER PLANS, too,**  
are included at no extra cost.  
Send only \$1.00 for the **FAST  
FREEZER** plans—or save 25c  
and send \$2.25 for both these  
plans and the LeJay Manual.

**BOTH  
for only  
\$2.25**

**LEJAY MFG. CO**

723 LeJay Building,

**MINNEAPOLIS - 8 - MINN.**



Men Who Make Things SAY:

**KEEP THIS HANDY!**  
you'll find it  
helps in no end  
of ways



In any type of homecraft, there's no limit to the things you can do with Durham's Rock-Hard Water Putty, the modern powdered plastic. Molds fascinating figures. Fills chipped places in antiques. Makes lasting repairs in wood, plaster, tile or similar material. Keeps indefinitely. So economical—just mix with water, and it's ready to use. Hardens quickly—then you can saw it, chisel it, paint it.

Most patching materials may shrink, chip off or fall out. But Durham's Rock-Hard Water Putty does not shrink. It sticks and stays put. Order from your lumber, hardware or paint dealer.

**SPECIAL — 4 lb. can only \$1**

To home craftsmen, we will send the big 4-pound can, postpaid anywhere in U. S., for only \$1. So many helpful ways to use it. We guarantee complete satisfaction or refund every cent of your money. Order today. Donald Durham Co., 240 School St., Des Moines, Iowa.

**MONEY-SAVING OFFER - ORDER NOW**

**FALSE TEETH**  
**FIT TIGHT**  
with Dentyte

Soften DENTYTE by warming—spread it on your plate—put in mouth and bite to make a perfect impression. Remove plate—and allow few minutes to "set." You get an absolutely perfect fit. Sore gums vanish—no more slipping or loose teeth. DENTYTE is firm but resilient. For both Uppers and Lower. Each lining lasts for months. Immediately removable with fingers. Full size jar—(a year's undreamed of comfort per plate), postpaid only \$1. Send dollar bill at our risk. Easy to order. Easy to use. Unconditionally Guaranteed.

Dental Products Corp. Dept. PS-50 Manheim, Pa.



**WHAT ABOUT**  
**YOUR Future?**

Are you a square peg in a round hole, unhappy at home, or in your work? For more than 15 years I have been helping men and women find themselves, their talent possibilities, aptitudes and handicaps. If you are discontented at home or at work send for "What About Your Future", which may give you a new slant on your future happiness and success. It is FREE. Dr. Bunker (2), Joplin, Mo.

When Writing Advertisers Please  
Mention Popular Science Monthly

**PROUD of your TOOLS? KEEP them in a SCHERR CHEST**

**SERVICEABLE —  
ENDURING**

In open top chest 20x9x13 1/4 — seven hand-fitted drawers. Built of kiln dried oak with black finish hardware. Within any mechanic's budget at

**\$13.50**



A mechanic is known not only by his tools, but by the way he keeps them. Skilled mechanics keep their tools carefully, in well-ordered chests. A really fine tool-chest is a lifetime possession. It pays to get a good one. Here are two of the Scherr line, which offers a wide choice of chests at various prices, all built to last and carefully designed to ideally serve the machinist's need.

Shipped immediately C.O.D., or on receipt of check or money order. Bulletin with specifications on full line, at request.

**The DE LUXE  
CHEST —**

Solid oak, with tray top, 20x9 1/4 x 16 3/4 in. Two locks. Fine lacquer finish. Eleven felt-lined drawers, including vertical drawer for drills. The ultimate in tool chests.

**\$18.00**



**GEO. SCHERR COMPANY, Inc.** 200-PS LAFAYETTE STREET  
NEW YORK 12, N. Y.



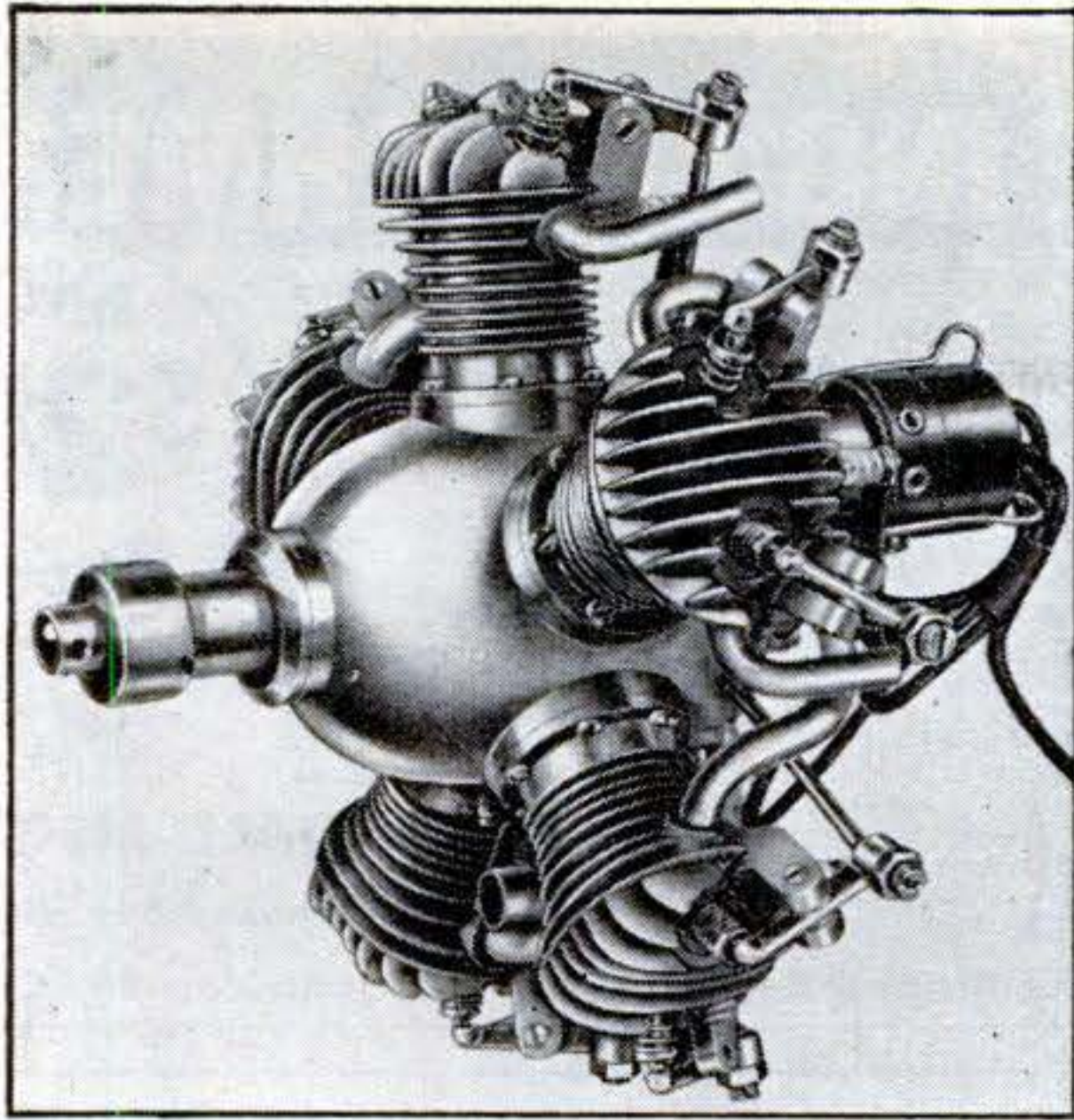

**Not Just A Model Airplane Engine . . .  
But a REAL AIRPLANE ENGINE  
Built in MINIATURE!**

Every part of this marvelous little 5-cylinder engine is built just like the big ones! It is a REAL airplane engine built in miniature. The Morton M-5 Radial Engine, is PRECISION BUILT throughout, with hardened, ground steel sleeves, cast in aluminum cylinders. Pistons lapped in individual cylinders, insuring perfect fit and maximum compression. Valves are made of special steel, and seat in replaceable valve cages. Crank shaft and lead gear are mounted in three New Departure ball bearings. Carburetor has both high and low speed jets, and will idle or take the throttle same as a full-sized engine. This exciting little engine, weighing only 22 ozs. and developing approximately ONE-HALF H.P. at 3,500 R.P.M., will enable you, for the first time to build a gas-model plane that LOOKS and FLIES like the real thing.

**Also For The FIRST TIME . . . 2 & 3 BLADED  
All-Metal, ADJUSTABLE PITCH PROPELLERS!**

Morton Adjustable Pitch Propellers can be used with any model gasoline engine. Send 10c for illustrated detailed folder on M-5 Engine and Accessories, including Assembly Chart.

**MORTON AIRCRAFT CORPORATION, Dept. C100  
3227 Harney Street, Omaha 2, Nebraska**

**AUTOMATIC RETOOTHING FOR HAND  
SAWS**

**NO PRIORITY  
REQUIRED  
(Less Motor)**

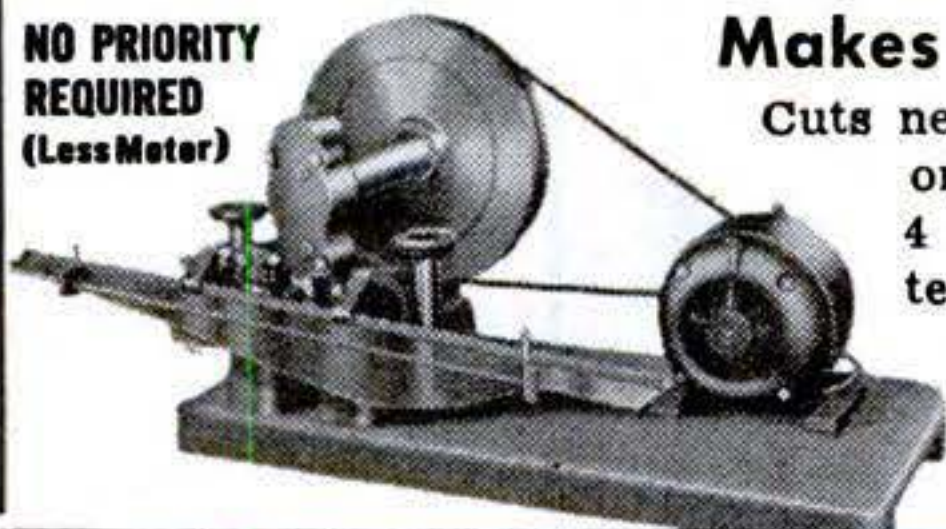

**Makes New Profits**

Cuts new teeth in 50 seconds! Any size tooth 4 to 16 points. Old teeth fall off as chips. Simple to operate. A perfect job.

**BURR MFG. CO. 8931 Venice Blvd.,  
Los Angeles 34, Calif.**

**ATTENTION!**

**ORGANIZERS - DISTRICT MANAGERS**

**The Original  
War Surplus Reporter**

**UP TO  
\$100 DAY**

requires the full time service of high-grade executive type salesmen in all states. Sensationally different plan of sales promotion secures up to \$100 day results. Contacts with business and industry only—by direct leads only. If your idea of success in selling is up to \$100 a day EVERY day, then wire or write quickly to

**EXECUTIVE OFFICES**

**THE WAR SURPLUS REPORTER**

**20 E. JACKSON, DEPT. 502, CHICAGO, ILL.**

*for treasured  
heirlooms?*

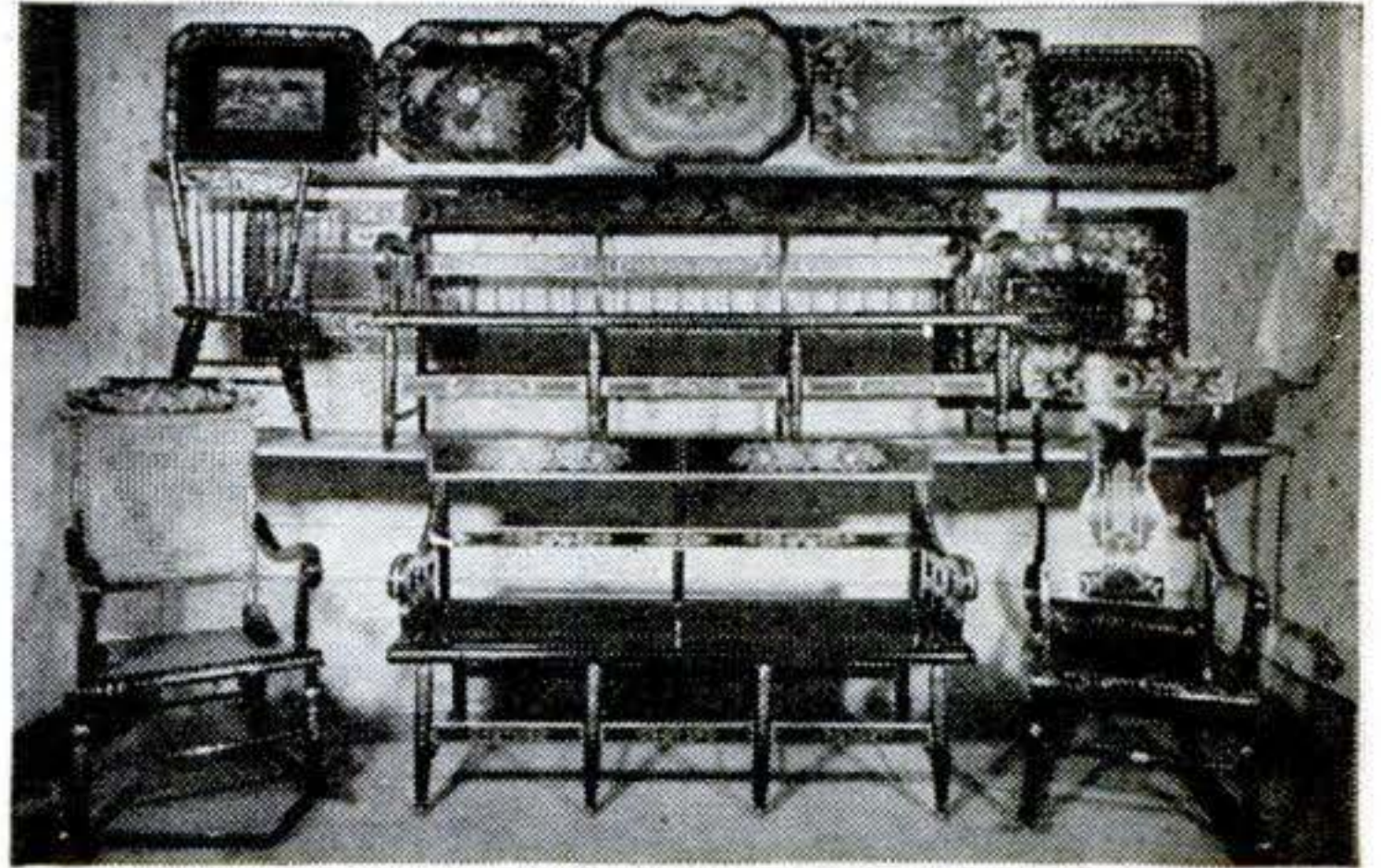

Priceless antiques restored by Ira Ebersole famous decorator of Chambersburg, Pa. The all-important finish is provided by Valspar.

*for tested durability  
and beauty?*

**VALSPAR  
STANDS UP FINE!**

Whether it's the furniture you prize most, or just the floors which the youngsters have scraped in their playing—your home deserves Valspar. Even when boiling water is poured on it, Valspar never turns white. In addition, Valspar enhances the beauty of the finish.



*Valspar—the  
Paint that  
does it right*

*Valspar—the  
Varnish  
that won't  
turn white*

Remember, Valspar stands up fine! And that means Valspar paints and enamels as well as the famous Super Valspar Varnish. Always specify Valspar.

**VALSPAR**  
PAINTS · VARNISHES · ENAMELS

VALENTINE & CO., INC., 11 E. 36th St., New York, N. Y.

Buy War Savings Bonds and Stamps regularly.



**GET THE IMPROVED**

# SUPER DRILL GRINDING ATTACHMENT

Sharpens round shank drills from 3/32" to 1-1/16" diameter. Grinds old, broken or dull drills like new in four accurate drill point angles — 49°— 59°— 69°— 88°. RECESSED ANGLE GUIDES ELIMINATE NEED FOR PROTRACTOR. Grinds short, medium and long twist drills from 1-1/2" up to 11". Attaches to bench or grinder — equally suited for hand or power-operated grinding wheels. Pays for itself the first week. **The Grinding Fixture That Gives Rounded Points!**

**USED BY ARMY — NAVY — AIRCRAFT PLANTS**

**40,000 Now in Use! Wherever Drills are Needed!**

Don't guess at drill grinding. Anyone can be an expert from the start with the Super Grinder. This precision fixture gives a true center, and clearance desired. Does work like the highest priced grinder. Grinds drills in 25 seconds — Saves drills, time and money. Built for long, hard usage. **FOUR ANGLE FEATURE GIVES PROPER POINT TAPERS FOR CLEAN FAST DRILLING IN STEEL, WOOD OR PLASTIC PRODUCTS.** No factory, machine shop, home workshop or repair shop should be without the Super Drill Grinder. Delivered with complete instructions. Mail your check or money order for only \$2.95 with your printed address. The Super Grinder will come by return mail — postage paid.

ONLY  
**\$2.95**  
COMPLETE

**CRANDALL MFG. CO.**  
1512 W. Slauson Ave. Dept. FB-10  
Los Angeles 44, Calif.

**Guaranteed To Do The Work or Money Refunded**

## Amazing NEW DISCOVERY MAKES YOUR OWN ORNAMENTS, JEWELRY, ETC. GLOW IN THE DARK

The amazing, new WONDER-GLO luminous paint which you apply easily with small brush is magic-like for making any ornament, light switch, light cord, house number, window sign, glow-in-the-dark. Have the latest things in smartness without buying new things. WONDER-GLO makes old earrings, combs, table ornaments, outdoor fixtures, etc., seem magical as they glow-in-the-dark. Lasts indefinitely. Absolutely harmless. SEND NO MONEY. Complete WONDER-GLO kit only \$1.00 (or C. O. D. plus postage). If not thrilled with results, your money back in 7 days. **Mr. Luck's Novelty Co., Dept. 451-G, 215 N. Michigan Ave, Chicago 1, Ill.**



## SHIP MODEL MAKING

New book shows how to make any model. Shows the short cuts, kinks, time-saving methods of experts. Complete plans for gorgeous galleon, clipper ship, etc. Almost 100 illustrations. Full cloth bound \$1.00. **Popular Science Monthly, Dept. 95, 353 Fourth Ave., New York.**

## EXPLORE THE MYSTERIES OF SCIENCE!

**WONDERS THROUGH THE MICROSCOPE** brings 192 pages of startling facts and information that will open up a new world of wonderment for microscope fans.

This book tells you how to set up your workshop, what a microscope consists of, what instruments and accessories you will need and how you can make them from odds and ends.

It tells you how to use your equipment, how to secure and preserve specimens, take photomicrographs, how to do dissecting and prepare cultures. It shows the beginner where to look for subjects, and how to discover new and exciting worlds in the most common objects. Over 100 illustrations. Mail the coupon below today for your copy. Satisfaction guaranteed or money back.



### SEND NO MONEY NOW!

To examine your copy of this fascinating book you needn't send a penny. Just mail the free examination coupon below, today and examine the book for 10 days. If not satisfied, money will be refunded.

**MAIL THIS COUPON TODAY!**

**POPULAR SCIENCE MONTHLY, Dept. 95**  
353 Fourth Ave., New York, New York

Please send me **WONDERS THROUGH THE MICROSCOPE**. I will pay postman only \$1.00 plus postage on delivery. You guarantee complete satisfaction or I may return book in 10 days for full refund.

NAME.....

ADDRESS.....

CITY.....STATE.....

If you enclose \$1.00 with this coupon we pay postage.

## RENEW VALUABLE EQUIPMENT CITIES SERVICE RUST REMOVER

Now you can quickly and easily clean rust from steel, iron, chromium, copper, aluminum and nickel. Cleans enamel and porcelain as well. It is non-inflammable, contains no dangerous acids. Four years' test proves it tops for all tools & equipment. Buy it NOW at these amazingly low prices. Send the coupon today.

16 oz. — 65c  
1 gal. — \$2.80



### And Its Grand Team Mate CITIES SERVICE ANTI-CORRODE

Get rid of rust, AND KEEP IT AWAY! Cities Service Anti-Corrode forms a thin, soft, transparent film on a metal surface, making it impervious to moisture from either fresh or salt water. Has exceptional lasting qualities for products of this type. Dip, brush or spray your tools and equipment—keep them bright and rust-free. This is your opportunity



1 gal. — \$1.75

FILL IN AND MAIL THIS COUPON

YOUR ORDER WILL BE SHIPPED POSTAGE PAID

**Special Order Division,**  
**Cities Service Oil Co., 401 New York Ave., Trenton, N. J.**

I enclose check or money order for \$..... Please send

NAME.....

ADDRESS.....

P.S.



# Now A DYNAMIC HEAVY DUTY INDUSTRIAL WELDER

**TO SAVE YOU VALUABLE TIME and MONEY!**

FOR ONLY  
**\$23<sup>50</sup>**

**COMPLETE**

**AMAZINGLY SIMPLE TO OPERATE!**

**Designed to Do High-Grade Welding Inexpensively**

Maintenance men, farmers, mechanics, machine shops, foundries, auto, general repair and job welding shops using the DYNAMIC WELDER find it so indispensable and useful that they cannot afford to be without it. If inexperienced you can easily learn to do a variety of high-grade welding jobs by following the practical, simplified operating and welding instructions furnished.

**WORKS ON IRON, STEEL, BRASS, BRONZE and OTHER METALS**

Has eight metallic and carbon arc welding heat stages. Does work you would think only possible with a larger, more expensive machine.

**READ WHAT USERS SAY...**

**Repair Shop Owner says, "It will do more than you say"**

"I want to say I operate a repair garage and am more than satisfied with the welder. It will do more than you say." C. P., Butler, Ohio

**It's the Greatest Portable Outfit**

"Now I am equipped for all kinds of welding and I must say it's the greatest portable outfit for welding any man could ever wish to own. I wouldn't sell mine for the cost of plenty welders I have seen which were very high in cost but not in convenience. You may put me on file as a booster of your wonderful welding product." W. J. B., St. John, N. B., Canada

**Better Than I Expected**

"I have done quite a little welding with my welder and will say it is better than I expected. The price, convenience, and variety of work that can be done with the Dynamic are the attractive points." W. R. P., Portland, Ore.

**EASY TO OPERATE!**

## DYNAMIC SUPERCHARGED WELDER

**GET DETAILS ON OUR 10-DAY TRIAL OFFER!**

Once you see a DYNAMIC in operation you won't want to be without it. Its simplicity will amaze you. In a year, the DYNAMIC only costs you about 6c a day. Comes complete, ready to operate, with helmet, rods, cables, electrode holder and operating instructions, etc. Nothing else to buy. Write today for free priority assistance and particulars on how to qualify for one of these amazingly low-priced welders. Act now while they are still available.

**DYNAMIC WELDER CO.**

**13 East 23rd. Street—DD**

**CHICAGO 16, ILLINOIS**





IF YOU'RE PLANNING  
A SHOP --

# Get This New Catalog

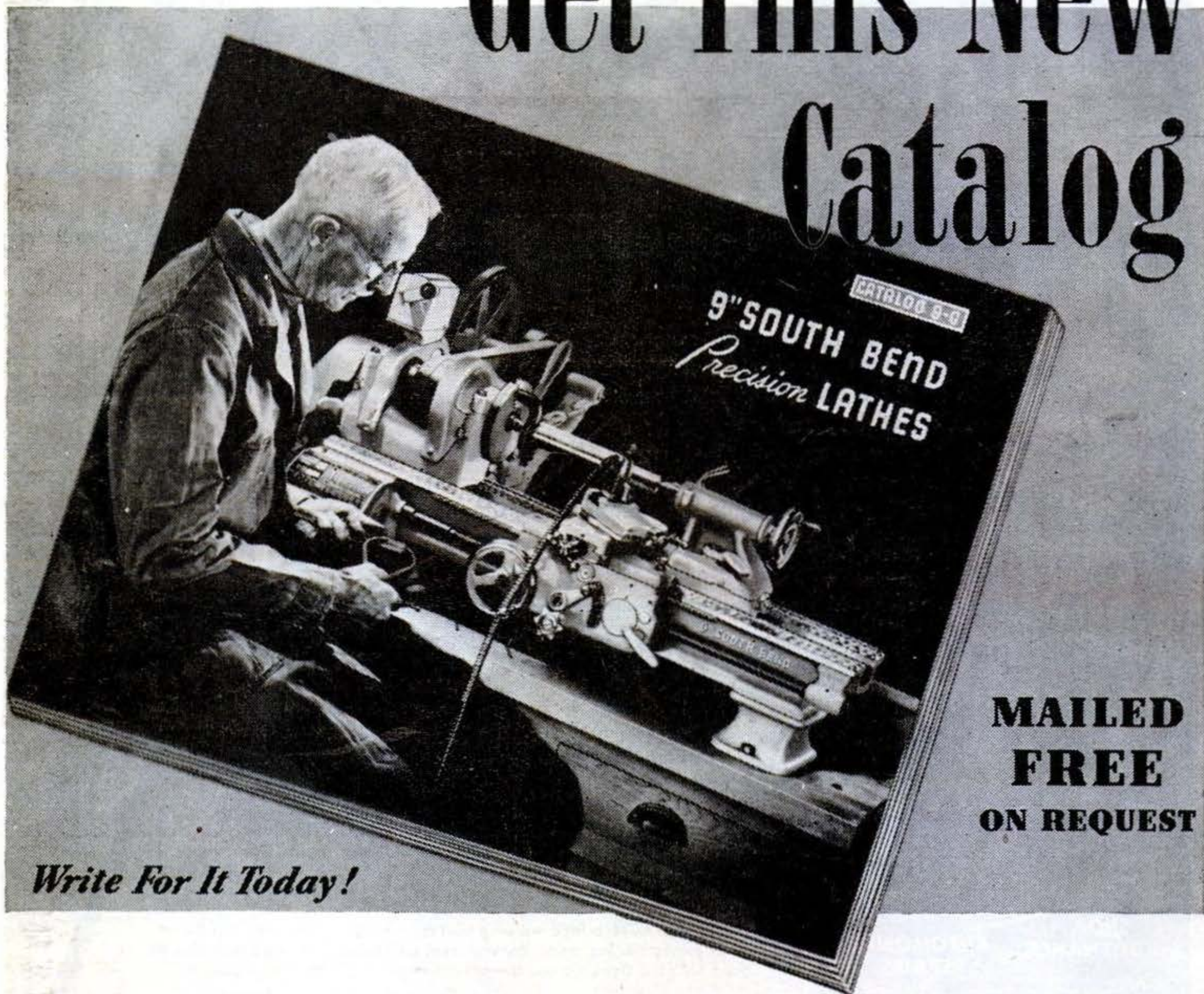

**MAILED  
FREE  
ON REQUEST**

*Write For It Today!*

Every man who owns or plans to build a shop will want this new 36-page catalog. All models of South Bend 9-inch Precision Lathes are shown in color. Complete specifications, including capacities, speeds, feeds, and weights, are printed opposite the illustration of each

lathe. Practical attachments and accessories are also shown.

The South Bend 9-inch Lathe is a *precision* tool, designed and built for fine machine work—in steel, cast iron, bronze, tool steel, fibre, plastics, bakelite and similar materials. It's the very heart of the well-planned shop. Write today for Catalog 9-G.

#### LARGER SIZES OF SOUTH BEND LATHES

South Bend Engine Lathes and Toolroom Lathes are available with 10", 13", 14½", and 16" swings. Precision Turret Lathes are made with ½" and 1" collet capacities. Information supplied on request, specify size of lathe in which you are interested.

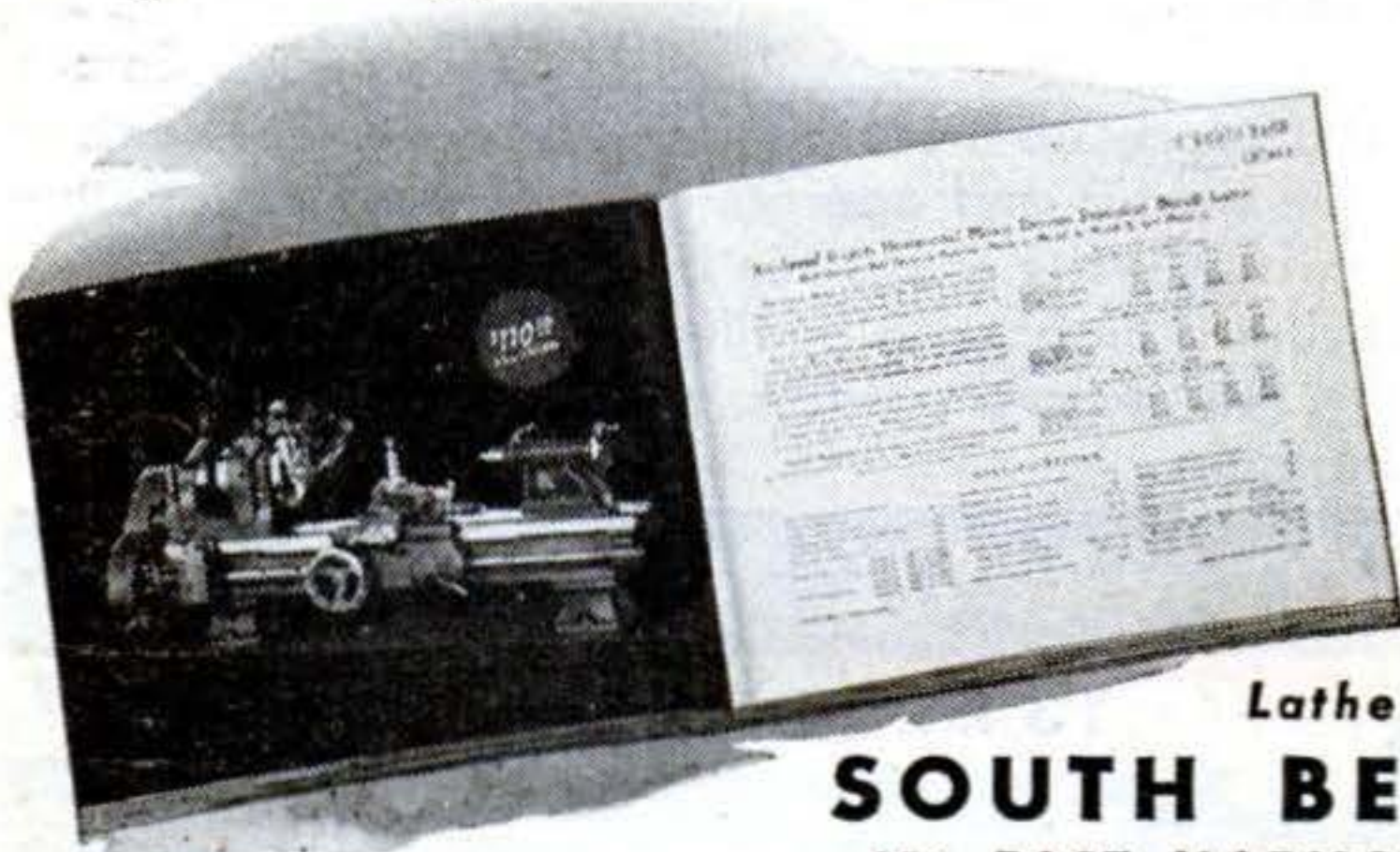

Lathe Builders For 38 Years

**SOUTH BEND, LATHE WORKS**

456 EAST MADISON ST. • SOUTH BEND 22, INDIANA





Here's Easy High-Speed  
in all 25 Useful Branches

# Mathematics

-to help you qualify for  
**jobs TODAY—and in POST-WAR**

**Brought to You by 28 Leading Experts from Columbia, M.I.T., Cornell, Carnegie Tech., Georgia Tech., many others! A Practical Mathematics Course in Four Volumes! Used by Over 100,000 Men in Shop and Office!**

**C**CLIMAXING its achievements in adult education, the NATIONAL EDUCATIONAL ALLIANCE now announces a new streamlined Course in Mathematics especially designed to answer the thousands of urgent war and post-war calls for mathematically trained men in virtually EVERY field!

On work bench, in drafting room; in the laboratory; in tool die and pattern making; in construction and engineering of all kinds; there's hardly a field where a mathematically trained man hasn't a decided advantage. He gets the better job—bigger pay—earns promotion more quickly—and will come out ahead in the post-war change-over to peacetime industry.

This New N. E. A. Course in Mathematics makes it possible for the average person to acquire—in only a few months—a practical working knowledge of all 25 branches of mathematics and their practical applications. It comes to you complete in four volumes filled with illustrated fascinating lessons designed for home study.

You receive instruction from 28 foremost instructors chosen from outstanding universities. Each instructor has been selected because of his special knowledge of a particular branch of mathematics and because of his ability to simplify and streamline his instructions.

**Over 600 Helpful, Graphic Pictures and Diagrams! Nearly 1300 Pages!**

No previous mathematics knowledge is needed under this ingenious teaching plan. You start with Basic Arithmetic and proceed by easy stages to an understanding of the most advanced branches of mathematics.

You'll learn how to use Algebra for short cuts in daily shop problems, in construction work, in tool and die making, in welding, sheet metal work and pattern making, in office and laboratory. You'll learn how to apply Geometry in chemistry, mechanics, electricity and radio, in the drafting room. You'll learn how

to employ Trigonometry in gearing, lathe centers, blueprints, die punches, etc.; in gunnery, range finding, aviation, navigation. You'll learn how to utilize Calculus in the design and production of guns, planes, tanks, ships, dams, bridges, motors.

You'll learn Practical Applications that you can use to win advancement and bigger pay, now and in peacetime.

**Yours for FREE TRIAL**

Normally, mathematical training as comprehensive as these 25-Courses-in-1 would cost you hundreds of dollars and years of study. Now you get it in these 4 volumes at

a small fraction of the cost and time! Test this Course at our risk and expense. Mail coupon below—get the set for a week's FREE Examination. After a week you may return it and owe nothing; however, if you are thoroughly convinced that it can help you advance to bigger earnings, keep it at the incredible bargain price and easy terms shown in coupon. *But you must ACT NOW!* This edition has been rigidly limited by restricted paper quota. There may not be enough to meet nation-wide demand. Avoid disappointment—mail Free-Trial Coupon NOW! National Educational Alliance, 37 W. 47th St., New York 19, N. Y. Copyright 1945 by the National Educational Alliance, Inc.

**See List of Subjects and Instructors on Outside Flap of This Cover**

**FREE!** even if you return the set!  
**this short-cut to easy figuring!**



**Does All the Work of a Slide Rule Faster, Easier and More Accurately! 160 Pages!**

This book of Logarithms is the greatest short-cut ever devised for quick and easy multiplying, dividing and all other calculating. Easier to learn; gives answers quickly and far more accurately than any Slide Rule. A complete explanation of the use of logarithm tables is given. So simple you can grasp it and begin to apply it in a few minutes. Covers logs for all numbers to the 6th place; contains much additional information including a table of circular arcs. Invaluable for mechanics, scientists, business men, etc. **FREE** even if you return the Mathematics Library!

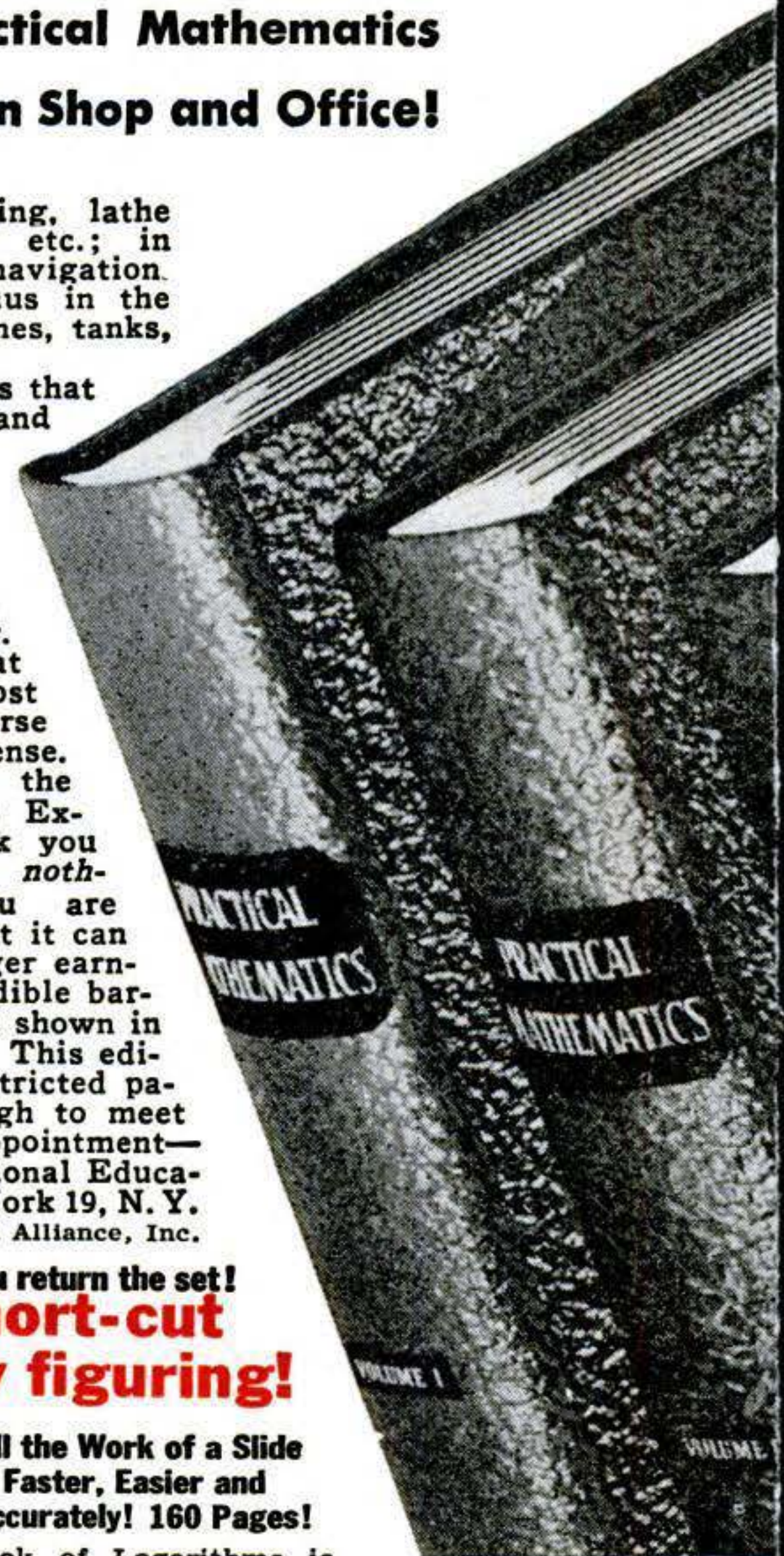

**MAIL THIS FREE-TRIAL-FREE GIFT COUPON TODAY**

Copyrighted material



# LONGER LIFE for the Heart of the Handie-Talkie

**H**eat of the handie-talkie is the dry battery that powers it. These days, it is a basically different battery, like the Mallory Tropical Dry Battery — originally developed by Mallory for the Signal Corps in response to the demand for a dry battery that can "take it" where conditions are the toughest.

In all sorts of weather conditions the Mallory Tropical Dry Battery has proved its capacity to "take it." It gives from four to six times the life of the conventional battery it replaces. It withstands high temperatures and humidity which ruin ordinary batteries. It gives greater power with smaller size. What is more, its voltage remains substantially constant throughout operating life.

The Mallory Tropical Dry Battery needs no "rest periods," possessing the same ampere hours' service-life whether operated intermittently or continuously. It has "shelf-life" sufficient to send it into action with full voltage output. It has done a job in providing more satisfactory performance for the handie-talkie.

• • •

**O**utstanding battery improvements for the handie-talkie and other military equipment foreshadow similar vital betterments for many civilian products. Hearing aids and pocket radios, for instance. Urgent



The "handie-talkie" is a front line field communications essential. The Mallory Tropical Dry Battery designed especially for it consists of seventy-two individual cells, assembled in a compact twelve inch, hermetically sealed container.



military needs have precluded the production of civilian types as all Tropical Dry Batteries now must go to the armed forces. But it seems certain that, when civilian models are available, longer operating life, smaller size and continuing "freshness" will be embodied in hearing aid batteries to greatly improve their utility and comfort to users. The realization of the much-talked-of pocket radio comes closer when these same attributes are designed into batteries that will fit the pocket as readily as a cigarette case.

*We will not make promises until we can translate promise into performance. This can happen only when we have satisfied military requirements completely.*

P. R. MALLORY & CO. Inc.  
**MALLORY TROPICAL\***  
**DRY BATTERIES**

ALSO MAKERS OF PRECISION METALLURGICAL AND ELECTRONIC PRODUCTS—AND MALLORY BEARINGS

\*Trade Mark

**P. R. MALLORY & CO., Inc., INDIANAPOLIS 6, INDIANA**

