

# POPULAR SCIENCE

Aug. 1949

25¢

Monthly



***Can Superfighters  
Stop the Bombers?***

# 2056 How-To-Do-It Pictures Simplify Every Step!

# Now

## Why Do It The Hard Way?

**Carpentry, Woodworking:** Here are all the basic techniques of carpentry, woodworking and cabinet making—made easy as A-B-C to insure best results.



## No Special Skill Needed



**Painting, Paperhanging:** Shows you how much paint to use, how to mix. How to hang paper, etc.

## Save Up To 90% On Repairs!

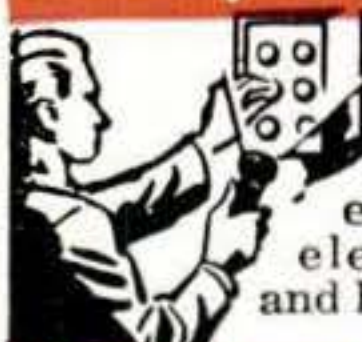

**Electricity, Plumbing, Heating:** Answers your every question about electricity, plumbing and heating systems.

## Have Fun While Doing It

**Masonry, Concrete, Plastering:** Practical facts about brickwork, concrete, stucco, cement blocks, glass blocks, etc.



## Trade Secrets of 52 Experts!

**Interior Work, Exterior Work:** Newest methods and short-cuts, estimating, materials, eliminating leaks, roofing, etc.



## Pays For Itself Many Times

You must go through this complete, illustrated guide to appreciate how much you can save by fixing things yourself. So mail coupon for **FREE 10-Day Examination—Now!**

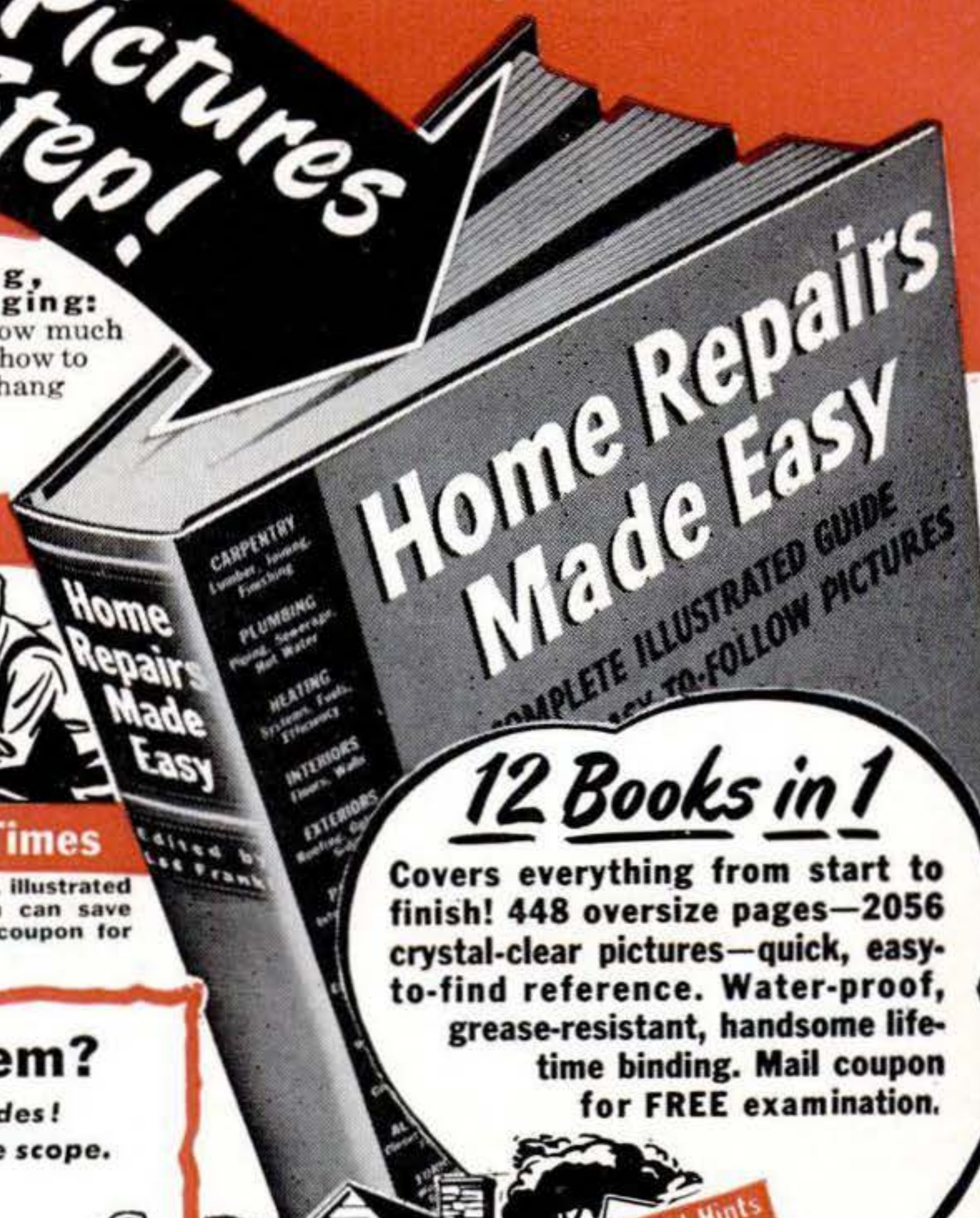

## 12 Books in 1

Covers everything from start to finish! 448 oversize pages—2056 crystal-clear pictures—quick, easy-to-find reference. Water-proof, grease-resistant, handsome lifetime binding. Mail coupon for **FREE examination.**

## What's Your Home Repair Problem?

Find the answer in a jiffy in this greatest-of-all home guides! Below is just a partial list to show its completeness and wide scope.

### WHAT TO DO WHEN ...

- lights go out
- glass pane breaks
- door lock sticks
- roof leaks
- plaster cracks
- furnace smokes
- flue backs up
- pipes freeze
- sink clogs
- toilet backs up
- plumbing knocks
- wiring short circuits
- toaster burns
- vacuum cleaner doesn't pick up
- doors swell
- windows rattle
- stairs squeak
- shingles get loose
- radiators leak
- floor boards buckle
- furniture gets rickety
- sidewalks crack
- Plumbing jobs are a cinch with this sure guide as your helper. Fix leaky faucets, install tubs, sinks. Repair gas systems, etc.
- paint blisters
- floors creak
- cellar floods
- screens rust
- fireplace smokes
- door hinge falls off

water discolors mouldings loosen  
tiles break  
termites attack  
paint fails to dry

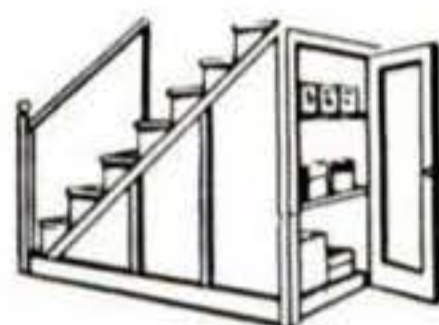

Put shelves under stairs, build corner closets, etc., just for cost of materials alone.

### HOW TO ...

- cut down fuel bills
- read meters
- change ice-box door gasket
- install locks
- add closet space
- make door keys
- lay linoleum
- refinish floor
- mix paints
- care for paint brushes
- paint over chipped paint
- shingle or reroof
- weatherproof
- repair gutters, downspouts
- build cesspool
- cure damp basement
- repair electrical appliances
- install heating systems

- get house ready for winter or summer
- build bookcases
- make screens
- cut, hang wallpaper
- build home repair center
- plaster walls
- convert attic
- install shower
- replace corroded pipe
- install new lighting fixtures

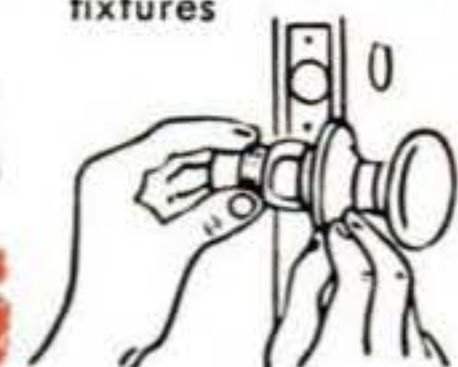

- Whether it's fixing a lock or building a workshop here's all the latest dope.
- paint over wallpaper
- enlarge windows
- clean discolored brick
- lengthen lamp cords
- finish or refinish furniture
- properly defrost
- take out, put up partitions
- make taller or smaller doorways
- enlarge kitchen storage space
- construct retaining wall
- build window cornices
- stucco outside
- put up storm windows

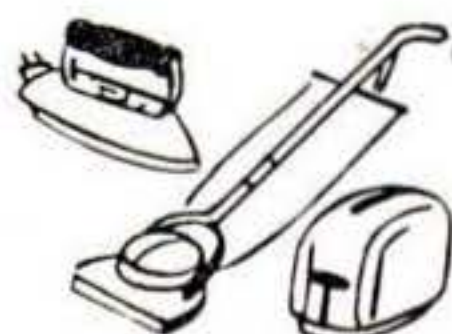

Repair irons, toaster, vacuum cleaners easily and safely.

### ENTHUSIASTIC PRAISE

"It's so easy to follow the picture instructions in this wonderful guide, my 16-year-old son is turning out repair jobs that look like a professional's."—C. V. B. — St. Louis, Mo.

"The ideas I got from 'Home Repairs Made Easy' when my house was being built saved me many hundreds of dollars and plenty of headaches."—T. J. P. — Los Angeles, Calif.

"With no man around the house this wonderful book has been a blessing. I do all the odd jobs myself and get a big kick out of it."—Miss L. V. — Boston, Mass.

But the important thing is how this new, different, and practical guide can serve you. So take advantage of our offer to send it to you for 10 days' FREE examination and use. Mail coupon—without money—NOW!

### Helpful Hints



## SAVE MONEY!

Now—Make Repairs Like An Expert—But SAVE Expert's High Prices!

### Magazines and Newspapers Applaud!

"This is, without doubt, the greatest gold-mine of up-to-the-minute ideas, short-cuts, professional secrets, and step-by-step directions ever crammed into 1 giant volume on home repair!"

"There's never been such a useful, easy-to-follow home repair guide for any housewife, as well as any man about the house."

"For those who don't relish paying today's high prices 'Home Repairs Made Easy' is surely a godsend. Any amateur can now do or supervise thousands of home repair jobs and improvements—large or small."

"Now every man who lives in a house can enjoy fun and relaxation with the help of the most wonderful guide to home repair, maintenance and improvements ever published."

You must go through "Home Repairs Made Easy" to appreciate how much time, work and money this indispensable guide can save you! And if you act now you can get it in easy installments. But first, examine and use it for 10 days FREE! Mail coupon today—without money!

Understand your home from top to bottom! Now—for the first time—"Home Repairs Made Easy" takes everything apart—then puts it together again (from foundation to roof). Shows simply and clearly the where, why, and how of keeping your home in tip-top shape. What's more it pays for itself many times over—even if you hire contractors, for it helps you check expertly on the work of others—insures getting your money's worth! You simply can't afford to be without "Home Repairs Made Easy." But you need not buy it. First, examine it—use it FREE for 10 days! So mail coupon—without money—NOW!

# Home Repairs Made Easy!

**Completely Different Illustrated Guide Shows Thousands of Ways to Save Money, Have Fun, Too! Everything Beginner or Expert Needs to Know!**

**N**OW at last—you can fix anything you want in or around your home with unbelievable skill . . . even if you never used a hammer, paint-brush, or screwdriver in your life! Save hundreds of dollars! Have plenty of fun, too!

Here's your opportunity to get for FREE examination "Home Repairs Made Easy," the entirely different and useful guide that takes apart and simplifies every step from start-to-finish; 2056 "show-all," easy-to-follow pictures, including hundreds of vivid, crystal-clear 3-dimension drawings.

### Must Be Seen To Be Appreciated

The detailed "how-to-do-it" pictures show you what to do and what not to do . . . exactly how to get started . . . what tools to use . . . how best to use them . . . how to plan and estimate every job . . . what steps to follow from very beginning to real professional finish.

Yes, you'll see that with this huge illustrated book as your expert guide and helper you need no technical knowledge,

no special skills. Every simplified picture and direction in "Home Repairs Made Easy" has been fully tested by actual use.

There's nothing like it! Nothing has been left to chance. You can't possibly go wrong. And now for the first time, these proven professional methods, latest short-cuts, newest labor and material-saving ideas, and "tricks of the trade" are yours.

### Save Hundreds Of Dollars Thousands Of Ways

Actually 12 books bound as one—this most complete, authoritative, and fully-illustrated encyclopedia covers everything you can think of—from fixing a dripping faucet to whitewashing a cellar—from making your own keys to installing a new heating system. Includes usual subjects in other "home repair" guides, as well as hundreds found in no other! "Home Repairs Made Easy" is so basic, so all-inclusive, so crammed with easy-to-do, money-saving ideas, practical suggestions, useful facts.

Imagine saving 90% on cost of papering

a room or painting your home (inside or out)—insulating your home for just the price of materials—"doing over" your porch for less than \$50 . . . fixing any plumbing or electrical appliances in a jiffy. You'll be surprised how simple all these repairs and alterations now are with the help of this voluminously-illustrated step-by-step guide.

Once you go through "Home Repairs Made Easy"—packed with thousands of usable everyday facts, ideas and suggestions, you'll agree you wouldn't give it up for anything in the world.

But you must see it to appreciate its great and permanent value! That's why we offer to send it to you for FREE 10-day examination and use. There's no risk . . . no obligation! Send no money! Pay postman nothing! Just mail coupon NOW!



Now you too, can make your own screens, storm windows, book-cases etc. Save time, money, aggravation!

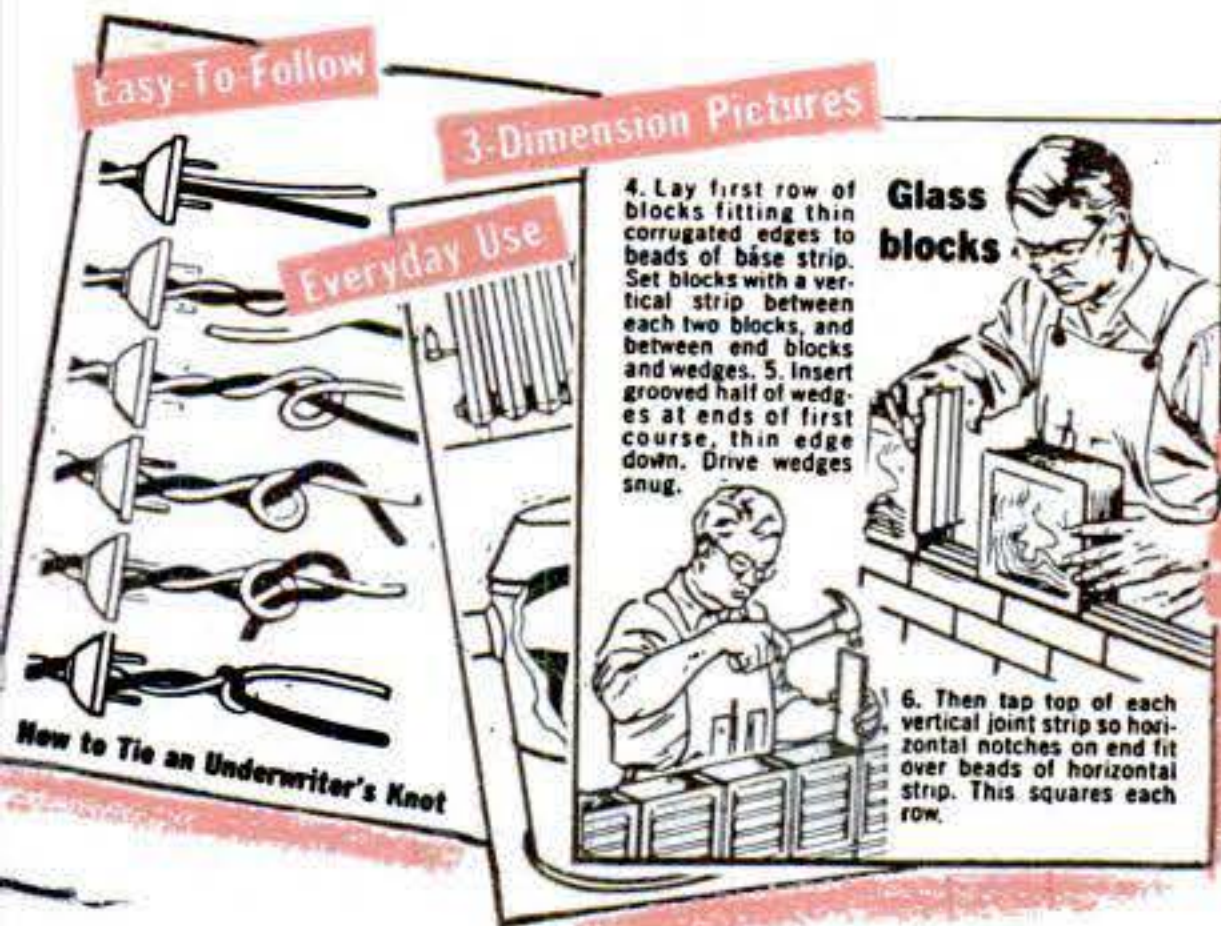

**FREE**  
10-DAY EXAMINATION  
Send No Money! Mail Coupon Now!

These typical pages show how step-by-step pictures simplify every move!

Brought To You By 52 "Training-Thru-Sight" Experts

The experts responsible for many successful wartime "Training Thru Sight" manuals have cooperated in bringing you "Home Repairs Made Easy." To appreciate how much time and money it can save you—how its many practical short-cuts make home repair and maintenance a pleasure, instead of a chore—you must see it. But you don't need to buy it. Mail coupon now!

### Send No Money! Pay Postman Nothing!

There's never been a book like "Home Repairs Made Easy." Giant 8½" x 11" size. 448 BIG, oversized pages. 2056 crystal-clear, "show-all" illustrations—thousands of easy-to-follow, "tell-all" directions take all the mystery out of home care, repair.

**No Obligation!** No one should be without "Home Repairs Made Easy." But to appreciate it you should go through it leisurely! Use it! See for yourself how just one answer can easily be worth many times its small cost. That's why we don't ask you to buy this book. Instead, let us send it to you for 10

days' FREE EXAMINATION!

You'll be surprised at the things you can do with its help . . . thrilled at all the money you can save . . . delighted with the fun you get. If not, return within 10 days. In that event, pay nothing—owe nothing! But if you agree you can't afford to be without it, send only \$2.95 (plus few cents postage and handling); then 2 monthly payments of \$2 until bargain price of \$6.95 is paid in full.

**MAIL COUPON NOW!** Send no money . . . pay postman nothing! Just mail coupon for your 10-day FREE examination.

**NELSON DOUBLEDAY, INC.**  
DEPT. PS-8, GARDEN CITY, N. Y.

Send me immediately for 10 days' FREE examination "HOME REPAIRS MADE EASY"—448 big, oversized pages with 2056 pictures—handsome, washable, grease-resistant cloth binding (8½ x 11). I will examine and use it without obligation. If I return it within 10 days—I pay you nothing—owe you nothing. If I keep it, I will then pay you \$2.95 (plus few cents postage and handling), and 2 monthly payments of \$2 until bargain price of only \$6.95 is paid in full.

Name \_\_\_\_\_

Address \_\_\_\_\_

City \_\_\_\_\_ State \_\_\_\_\_

(Please list zone number, if any)

IN CANADA: 105 Bond Street, Toronto.

# POPULAR SCIENCE

MECHANICS AND HANDICRAFT *Monthly*

AUGUST, 1949

Perry Githens, EDITOR

Fred O. Newman, Volta Torrey  
MANAGING EDITORS

Howard C. Jensen, ART EDITOR

Harry Walton, MECHANICS & HANDICRAFT EDITOR

Hartley E. Howe, Frank Rowsome, Jr.  
ASSISTANT MANAGING EDITORS

ASSOCIATE EDITORS: Howard Allaway, Alden P. Arnagnac, Devon Francis, Richard Giovine, Robert Gorman, Sheldon Gallagher, Herbert Johansen, Martin Mann, Denis Sneigr, Robert P. Stevenson.

ART DIRECTOR: Harry Samuels. ART ASSOCIATES: Herbert Anthony, Eric Karminski, Jr., Richard Meyer, Edward Hallstrom, Frances Cooper (Production).

EDITORIAL ASSISTANTS: Julia Charnif, Beatrice Eldridge, Carol Ennis, Charlotte Korch, Georgette Sparks, Ruth Westphal.

STAFF PHOTOGRAPHERS: W. W. Morris (Chief), Hubert Lockett, Orlando Guerra (Darkroom).

WESTERN EDITOR: Andrew R. Boone (Los Angeles).

WASHINGTON CORRESPONDENT: John F. Loosbrock.

EDITORIAL OFFICES: 353 Fourth Avenue, New York 10, N. Y. Manuscripts and illustrations submitted at regular rates should be so marked, addressed to "The Editors" and accompanied by stamped, self-addressed envelope. Popular Science Monthly exercises all possible care but assumes no responsibility for unsolicited material.

TRADE NAMES by which products or materials are commonly known are indicated by the symbol ©. These names may or may not be Registered Trademarks (see PS, Mar. '49, p. 294). This symbol is used only as a service to readers and Popular Science Monthly assumes no responsibility by use or omission.

Godfrey Hammond, PUBLISHER

Stephen P. Glennon, ADVERTISING DIRECTOR

Edward Roeder, Jr., ADVERTISING MANAGER

ADVERTISING OFFICES: NEW YORK—353 Fourth Avenue; CHICAGO—360 North Michigan Avenue; DETROIT—820 Book Building; SAN FRANCISCO—1003 TWA Building; PORTLAND (ORE.)—907 Terminal Sales Building; CLEVELAND—328 Citizens Building; LOS ANGELES—Granada Building.

Popular Science Monthly is published monthly at 353 Fourth Avenue, New York 10, N. Y., by Popular Science Publishing Co., Inc., Godfrey Hammond, President and Treasurer; R. C. Wilson, Raymond J. Brown, Stephen P. Glennon, Vice-Presidents; F. W. Briggs, Secretary. Entered as second-class matter Dec. 28, 1918, re-entered as second-class matter July 26, 1948, at the Post Office in New York, N. Y., under the act of March 3, 1879; additional entry as second-class matter at Dayton, Ohio. Entered as second-class matter at the Post Office Department, Canada. Printed in U.S.A. Copyright, 1949, by Popular Science Publishing Co., Inc. All rights reserved in the United States, Great Britain, and in all countries participating in the International Copyright Convention and Pan-American Copyright Convention. Yearly subscriptions to United States, its possessions and Canada, \$3.00 (2 years, \$5.50; 3 years, \$7.50); foreign countries \$1 per year extra. Subscribers must notify us of change of address four weeks before next publication date. Be sure to give both old and new addresses, including zone numbers. Vol. 155: No. 2.

## TABLE OF CONTENTS

### Science News

March of Science.....	122
Algae Work for Science.....	148
A Big Tankful of Volts.....	148

### Science at Work

Nerves of Steel.....	89
Gas Turbine to Make Power.....	109
Physicist-M.D. Engineers Tools.....	130
Cars Roll on Rubber Roads.....	132
Steam Now Cools, Too.....	136
Barge to Fix Coulee's Toe.....	137
Tester Twists Girders.....	144
Photo Eye Starts Runners.....	148

### PS Features

The Best Seat in the Ball Park.....	105
Mechanical Cow Serves Globe.....	110
Tower Splits for Trick Lift.....	116
Don't Throw that Shoe Away!.....	119
Jersey "Jungle" Is Hottest.....	124
Machine Speeds Pretzel Bending.....	138
Firemen Take Train to Fires.....	149
How Motion Pictures Are Projected.....	150
Plant Chops Old Bottles for New.....	154
Biggest Pumps to Lift River.....	156
Fast New Train Runs on Tires.....	159
Carving Houses Inside Out.....	209
Water Wizardry.....	224
Ammonia Plant Cools Home.....	231

### Aviation

Can Superfighters Stop Bombers?.....	90
What's New in Aviation.....	134
Copycat Radar.....	141

### Automobiles

\$200,000 Automobile.....	101
Dodge Revives the Roadster.....	129
New Plymouth Hauls Big Load.....	129
Truck Tests Tanks' Pull.....	144
Gus Clears an F.B.I. Suspect.....	160
What About Undercoating?.....	164
Open Car Closes in Minute.....	168
New Pinch Brakes on Crosley.....	169
Trailer Comes in a Package.....	170
Double Mirror Looks Ahead.....	172
Hints from the Model Garage.....	220
Air-Conditioning a Car.....	222

### Inventions

Boat Launcher Speeds Rescues.....	96
Spark Plug Reduces Static.....	97
New Ideas from the Inventors.....	98
Saw Cuts Casts, but Not Flesh.....	115
Car Heater Warms, Amuses.....	115
Digs Holes to Catch Rain.....	118
Ice Grows Out of Fast Freezer.....	146

# FILL THE GAPS IN YOUR TRAINING

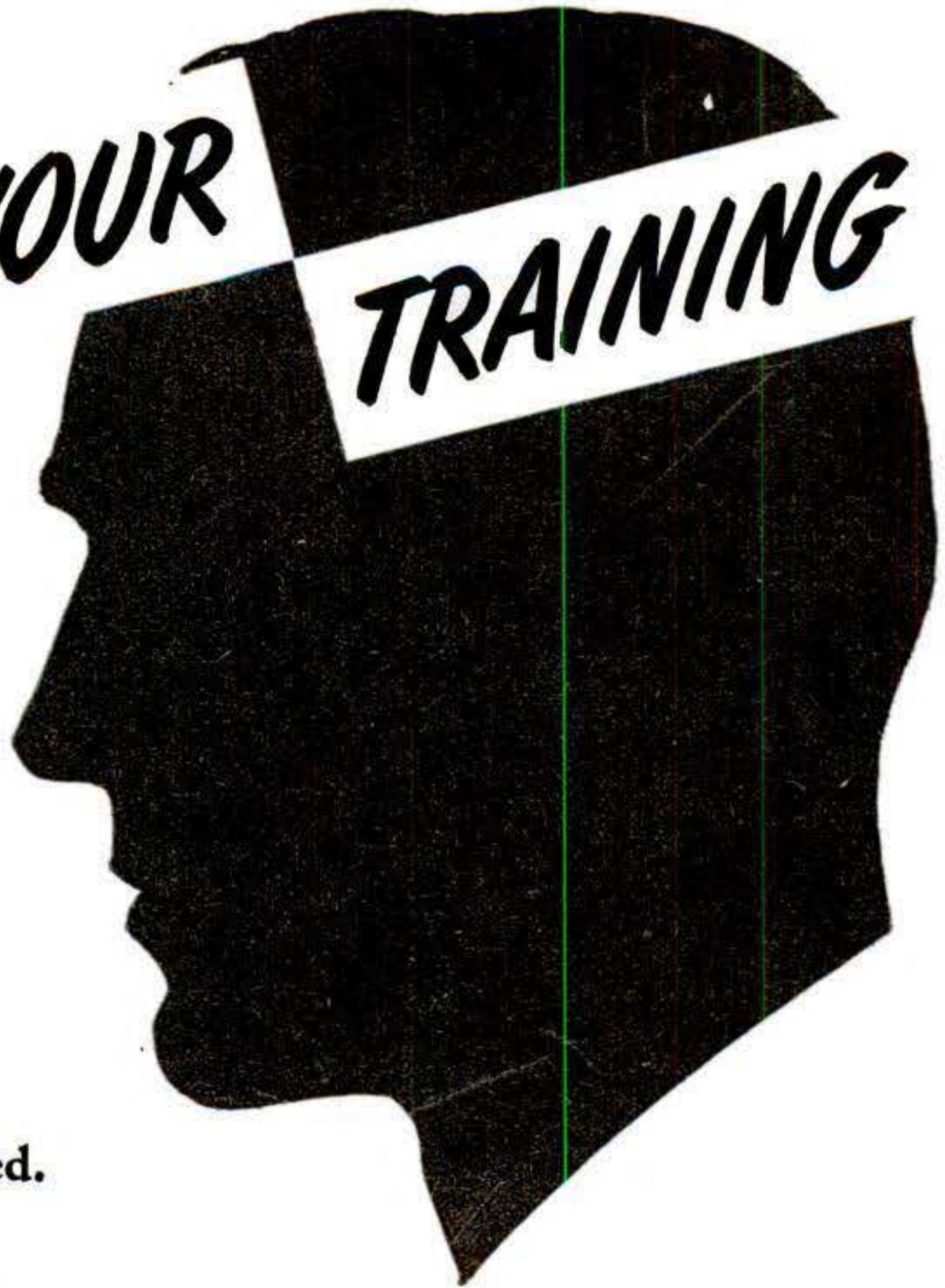

No one goes into a job perfectly prepared. Sooner or later the "weak spots" are bound to show up. And when they do, the successful man is quick to recognize them, *quick to fill the gaps.* International Correspondence Schools can help you get whatever training *you* may need. You have some 400 famous, spare-time I.C.S. Courses to choose from. Or, if you wish, brief "refresher" courses, advanced lessons, or special instruction combining one or more specific business or technical subjects can be *tailored* to fit your needs. The coupon below brings full information without obligation. Mark and mail it today!

## INTERNATIONAL CORRESPONDENCE SCHOOLS



BOX 7635-M, SCRANTON 9, PENNA.

Without cost or obligation, please send me full particulars about the course BEFORE which I have marked X:

- |                                                                                                                                                                                                                                                                                                                                                                                                                                                                                                                                                                                                                                                                                                                                                                                                                                                                                                                                                                                                                                                                                                                                                                                                                                                                      |                                                                                                                                                                                                                                                                                                                                                                                                                                                                                                                                                                                                                                                                                                                                                                                                                                                                                                                                                                                                                                                                                                                                                                                                                                                                                                                                                                                                                                                                                                                                                                                                                                                                                                                                                                                                                                                                                                                                                                                                                                                                                                                                                   |                                                                                                                                                                                                                                                                                                                                                                                                                                                                                                                                                                                                                                                                                                                                                                                                                                                                                                                                                                                                                                                                                                                                                                                                                                                                                                                                                                                                                                                                                                                                                                  |                                                                                                                                                                                                                                                                                                                                                                                                                                                                                                                                                                                                                                                                                                                                                                                                                                                                                                                                                                                                                                                                                                                                                                                                                                                                                                                                                                                                                                                                                                                                                                                                                                                                                                                                                                                                                                                                                 |
|----------------------------------------------------------------------------------------------------------------------------------------------------------------------------------------------------------------------------------------------------------------------------------------------------------------------------------------------------------------------------------------------------------------------------------------------------------------------------------------------------------------------------------------------------------------------------------------------------------------------------------------------------------------------------------------------------------------------------------------------------------------------------------------------------------------------------------------------------------------------------------------------------------------------------------------------------------------------------------------------------------------------------------------------------------------------------------------------------------------------------------------------------------------------------------------------------------------------------------------------------------------------|---------------------------------------------------------------------------------------------------------------------------------------------------------------------------------------------------------------------------------------------------------------------------------------------------------------------------------------------------------------------------------------------------------------------------------------------------------------------------------------------------------------------------------------------------------------------------------------------------------------------------------------------------------------------------------------------------------------------------------------------------------------------------------------------------------------------------------------------------------------------------------------------------------------------------------------------------------------------------------------------------------------------------------------------------------------------------------------------------------------------------------------------------------------------------------------------------------------------------------------------------------------------------------------------------------------------------------------------------------------------------------------------------------------------------------------------------------------------------------------------------------------------------------------------------------------------------------------------------------------------------------------------------------------------------------------------------------------------------------------------------------------------------------------------------------------------------------------------------------------------------------------------------------------------------------------------------------------------------------------------------------------------------------------------------------------------------------------------------------------------------------------------------|------------------------------------------------------------------------------------------------------------------------------------------------------------------------------------------------------------------------------------------------------------------------------------------------------------------------------------------------------------------------------------------------------------------------------------------------------------------------------------------------------------------------------------------------------------------------------------------------------------------------------------------------------------------------------------------------------------------------------------------------------------------------------------------------------------------------------------------------------------------------------------------------------------------------------------------------------------------------------------------------------------------------------------------------------------------------------------------------------------------------------------------------------------------------------------------------------------------------------------------------------------------------------------------------------------------------------------------------------------------------------------------------------------------------------------------------------------------------------------------------------------------------------------------------------------------|---------------------------------------------------------------------------------------------------------------------------------------------------------------------------------------------------------------------------------------------------------------------------------------------------------------------------------------------------------------------------------------------------------------------------------------------------------------------------------------------------------------------------------------------------------------------------------------------------------------------------------------------------------------------------------------------------------------------------------------------------------------------------------------------------------------------------------------------------------------------------------------------------------------------------------------------------------------------------------------------------------------------------------------------------------------------------------------------------------------------------------------------------------------------------------------------------------------------------------------------------------------------------------------------------------------------------------------------------------------------------------------------------------------------------------------------------------------------------------------------------------------------------------------------------------------------------------------------------------------------------------------------------------------------------------------------------------------------------------------------------------------------------------------------------------------------------------------------------------------------------------|
| <p><b>Business and Academic Courses</b></p> <ul style="list-style-type: none"> <li><input type="checkbox"/> Accounting</li> <li><input type="checkbox"/> Bookkeeping</li> <li><input type="checkbox"/> Business Administration</li> <li><input type="checkbox"/> Business Correspondence</li> <li><input type="checkbox"/> Certified Public Accounting</li> <li><input type="checkbox"/> Commercial</li> <li><input type="checkbox"/> Commercial Art</li> <li><input type="checkbox"/> Cost Accounting</li> <li><input type="checkbox"/> Federal Tax</li> <li><input type="checkbox"/> First Year College</li> <li><input type="checkbox"/> Foremanship</li> <li><input type="checkbox"/> Good English</li> <li><input type="checkbox"/> Higher Mathematics</li> <li><input type="checkbox"/> Motor Traffic</li> <li><input type="checkbox"/> Retailing</li> <li><input type="checkbox"/> Salesmanship</li> <li><input type="checkbox"/> Sign Lettering</li> <li><input type="checkbox"/> Spanish</li> <li><input type="checkbox"/> Traffic Management</li> <li><b>Air Conditioning and Plumbing Courses</b></li> <li><input type="checkbox"/> Air Conditioning</li> <li><input type="checkbox"/> Heating</li> <li><input type="checkbox"/> Refrigeration</li> </ul> | <ul style="list-style-type: none"> <li><input type="checkbox"/> Advertising</li> <li><input type="checkbox"/> French</li> <li><input type="checkbox"/> High School</li> <li><input type="checkbox"/> Postal Civil Service</li> <li><input type="checkbox"/> Retail Store Management</li> <li><input type="checkbox"/> Secretarial</li> <li><input type="checkbox"/> Stenography</li> <li><input type="checkbox"/> Plumbing</li> <li><input type="checkbox"/> Steam Fitting</li> </ul> <p><b>Chemistry Courses</b></p> <ul style="list-style-type: none"> <li><input type="checkbox"/> Chemical Engineering</li> <li><input type="checkbox"/> Chemistry, Analytical</li> <li><input type="checkbox"/> Chemistry, Industrial</li> <li><input type="checkbox"/> Chemistry, Mfg. Iron &amp; Steel</li> <li><input type="checkbox"/> Petroleum Refining</li> <li><input type="checkbox"/> Plastics</li> <li><input type="checkbox"/> Pulp and Paper Making</li> </ul> <p><b>Civil Engineering, Architectural and Mining Courses</b></p> <ul style="list-style-type: none"> <li><input type="checkbox"/> Architecture</li> <li><input type="checkbox"/> Architectural Drafting</li> <li><input type="checkbox"/> Building Estimating</li> <li><input type="checkbox"/> Civil Engineering</li> <li><input type="checkbox"/> Coal Mining</li> <li><input type="checkbox"/> Contracting and Building</li> <li><input type="checkbox"/> Highway Engineering</li> <li><input type="checkbox"/> Lumber Dealer</li> <li><input type="checkbox"/> Reading Structural Blueprints</li> <li><input type="checkbox"/> Sanitary Engineering</li> <li><input type="checkbox"/> Structural Drafting</li> <li><input type="checkbox"/> Structural Engineering</li> <li><input type="checkbox"/> Surveying and Mapping</li> </ul> <p><b>Communications Courses</b></p> <ul style="list-style-type: none"> <li><input type="checkbox"/> Electronics</li> <li><input type="checkbox"/> Practical Telephony</li> <li><input type="checkbox"/> Radio, General</li> <li><input type="checkbox"/> Radio Operating</li> <li><input type="checkbox"/> Radio Servicing</li> </ul> | <ul style="list-style-type: none"> <li><input type="checkbox"/> Telegraph Engineering</li> </ul> <p><b>Electrical Courses</b></p> <ul style="list-style-type: none"> <li><input type="checkbox"/> Electrical Drafting</li> <li><input type="checkbox"/> Electrical Engineering</li> <li><input type="checkbox"/> Electric Light and Power</li> <li><input type="checkbox"/> Lighting Technician</li> <li><input type="checkbox"/> Practical Electrician</li> <li><input type="checkbox"/> Power House Electric</li> <li><input type="checkbox"/> Ship Electrician</li> </ul> <p><b>Internal Combustion Engines Courses</b></p> <ul style="list-style-type: none"> <li><input type="checkbox"/> Auto Technician</li> <li><input type="checkbox"/> Diesel-Electric</li> <li><input type="checkbox"/> Diesel Engines</li> <li><input type="checkbox"/> Aviation</li> <li><input type="checkbox"/> Gas Engines</li> </ul> <p><b>Mechanical Courses</b></p> <ul style="list-style-type: none"> <li><input type="checkbox"/> Aeronautical Engineer's, Jr.</li> <li><input type="checkbox"/> Aircraft Drafting</li> <li><input type="checkbox"/> Forging</li> <li><input type="checkbox"/> Heat Treatment of Metals</li> <li><input type="checkbox"/> Industrial Engineering</li> <li><input type="checkbox"/> Industrial Metallurgy</li> <li><input type="checkbox"/> Machine Shop</li> <li><input type="checkbox"/> Machine Shop Inspection</li> <li><input type="checkbox"/> Mechanical Drafting</li> <li><input type="checkbox"/> Mechanical Engineering</li> </ul> | <ul style="list-style-type: none"> <li><input type="checkbox"/> Mold-Loft Work</li> <li><input type="checkbox"/> Patternmaking—Wood, Metal</li> <li><input type="checkbox"/> Reading Shop Blueprints</li> <li><input type="checkbox"/> Sheet-Metal Drafting</li> <li><input type="checkbox"/> Sheet-Metal Worker</li> <li><input type="checkbox"/> Ship Drafting</li> <li><input type="checkbox"/> Tool Designing</li> <li><input type="checkbox"/> Welding Engineering</li> <li><input type="checkbox"/> Welding—Gas and Electric</li> </ul> <p><b>Railroad Courses</b></p> <ul style="list-style-type: none"> <li><input type="checkbox"/> Air Brake</li> <li><input type="checkbox"/> Diesel Locomotive</li> <li><input type="checkbox"/> Locomotive Engineer</li> <li><input type="checkbox"/> Locomotive Fireman</li> <li><input type="checkbox"/> Locomotive Machinist</li> <li><input type="checkbox"/> Railroad Section Foreman</li> </ul> <p><b>Steam Engineering Courses</b></p> <ul style="list-style-type: none"> <li><input type="checkbox"/> Boilermaking</li> <li><input type="checkbox"/> Combustion Engineering</li> <li><input type="checkbox"/> Engine Running</li> <li><input type="checkbox"/> Marine Engineering</li> <li><input type="checkbox"/> Steam Electric</li> <li><input type="checkbox"/> Steam Engineer</li> </ul> <p><b>Textile Courses</b></p> <ul style="list-style-type: none"> <li><input type="checkbox"/> Cotton Manufacturing</li> <li><input type="checkbox"/> Loom Fixing</li> <li><input type="checkbox"/> Rayon Weaving</li> <li><input type="checkbox"/> Textile Designing</li> <li><input type="checkbox"/> Woolen Manufacturing</li> </ul> <ul style="list-style-type: none"> <li><input type="checkbox"/> Ship Fitting</li> <li><input type="checkbox"/> Toolmaking</li> <li><input type="checkbox"/> Car Inspector</li> </ul> |
|----------------------------------------------------------------------------------------------------------------------------------------------------------------------------------------------------------------------------------------------------------------------------------------------------------------------------------------------------------------------------------------------------------------------------------------------------------------------------------------------------------------------------------------------------------------------------------------------------------------------------------------------------------------------------------------------------------------------------------------------------------------------------------------------------------------------------------------------------------------------------------------------------------------------------------------------------------------------------------------------------------------------------------------------------------------------------------------------------------------------------------------------------------------------------------------------------------------------------------------------------------------------|---------------------------------------------------------------------------------------------------------------------------------------------------------------------------------------------------------------------------------------------------------------------------------------------------------------------------------------------------------------------------------------------------------------------------------------------------------------------------------------------------------------------------------------------------------------------------------------------------------------------------------------------------------------------------------------------------------------------------------------------------------------------------------------------------------------------------------------------------------------------------------------------------------------------------------------------------------------------------------------------------------------------------------------------------------------------------------------------------------------------------------------------------------------------------------------------------------------------------------------------------------------------------------------------------------------------------------------------------------------------------------------------------------------------------------------------------------------------------------------------------------------------------------------------------------------------------------------------------------------------------------------------------------------------------------------------------------------------------------------------------------------------------------------------------------------------------------------------------------------------------------------------------------------------------------------------------------------------------------------------------------------------------------------------------------------------------------------------------------------------------------------------------|------------------------------------------------------------------------------------------------------------------------------------------------------------------------------------------------------------------------------------------------------------------------------------------------------------------------------------------------------------------------------------------------------------------------------------------------------------------------------------------------------------------------------------------------------------------------------------------------------------------------------------------------------------------------------------------------------------------------------------------------------------------------------------------------------------------------------------------------------------------------------------------------------------------------------------------------------------------------------------------------------------------------------------------------------------------------------------------------------------------------------------------------------------------------------------------------------------------------------------------------------------------------------------------------------------------------------------------------------------------------------------------------------------------------------------------------------------------------------------------------------------------------------------------------------------------|---------------------------------------------------------------------------------------------------------------------------------------------------------------------------------------------------------------------------------------------------------------------------------------------------------------------------------------------------------------------------------------------------------------------------------------------------------------------------------------------------------------------------------------------------------------------------------------------------------------------------------------------------------------------------------------------------------------------------------------------------------------------------------------------------------------------------------------------------------------------------------------------------------------------------------------------------------------------------------------------------------------------------------------------------------------------------------------------------------------------------------------------------------------------------------------------------------------------------------------------------------------------------------------------------------------------------------------------------------------------------------------------------------------------------------------------------------------------------------------------------------------------------------------------------------------------------------------------------------------------------------------------------------------------------------------------------------------------------------------------------------------------------------------------------------------------------------------------------------------------------------|

Name \_\_\_\_\_ Age \_\_\_\_\_ Home Address \_\_\_\_\_

City \_\_\_\_\_ State \_\_\_\_\_ Working Hours \_\_\_\_\_ A.M. to \_\_\_\_\_ P.M.

Present Position \_\_\_\_\_ Employed by \_\_\_\_\_

Length of Service in World War II \_\_\_\_\_ Enrollment under G.I. Bill and P.L. 16 approved for World War II Veterans. Special tuition rates to members of the Armed Forces. Canadian residents send coupon to International Correspondence Schools Canadian, Ltd., Montreal, Canada.

# MOTORISTS WISE SIMONIZ

T.M. REG. U.S. PAT. OFF.

MAKES CARS STAY BEAUTIFUL



**Simonizing saves you time as  
it saves the finish!**

Don't waste your time with 'temporary polishings'! Simonizing gives long lasting beauty... protects the finish and keeps colors from fading. Do as millions of motorists... Simoniz your car. It's easy to do yourself.  
THE SIMONIZ COMPANY, CHICAGO 16, ILL.



Use Simoniz Kleener (liquid or paste) to clean finish.  
Then Simoniz for lasting beauty. Sold everywhere!

## New Products

Monitor Guards Atom Workers.....	97
Flag Says Stop the Water.....	104
Elevator Loads Freight Car.....	109
Plastic Coat Rustproofs Steel.....	115
Electric Fan Fits Pocket.....	115
Flip-Flop Plow Aids Farmers.....	118
Tool Rids Crops of Pests.....	132
New Liquid Dulls Pants.....	140
Jacket Floats Victim Face Up.....	140
"Dipper Stick" Made of Pipe.....	144
New Blocks Make Walls Fast.....	145
Measures Out Just One Dram.....	147
Eggs Roll into Collecting Pan.....	232

## Photography

Border Printer Brands Photos.....	226
Projector Doubles as Enlarger.....	228

## Mechanics & Shopwork

Power-Tool Shop Builds Itself.....	174
Silent Butler in Two-Toned Metal.....	178
Making Hopper Joints by Hand.....	192
Making Draw-In Collets.....	200
Motor Mount Set Two Ways.....	202
Rugged Boring-Bar Mount.....	203
Pipe Carrier Swings Out of Way.....	229

## Home Mechanics & Handicraft

Tank Makes Fire Fighter.....	104
Stringer Reinforces Scaffold.....	181
Outrigger Built in Week End.....	182
Cheese Grater Catches Crumbs.....	187
Trellises Add Glamour.....	188
Slicer Works Like Miter Box.....	191
Kitchen Bar Built Around Phono.....	204
Tank Fuels Running Outboard.....	205
Camp Cooking with Metal Foil.....	208
Chair Parts Create Wall Shelf.....	219
Carriage Becomes Carryall.....	225
Apple Crates Frame Cabinet.....	230

## Radio & Electricity

TV Helps Pull Bomb's Fangs.....	97
New TV Sets Project Pictures.....	100
You Say It, Robot Does It.....	133
Vacuum-Tube Meters.....	210
"Ham" Builds TV Station.....	215

## Departments

Letters .....	8
I'd Like to See Them Make.....	82
Voice of Science.....	87
What's Your Ingenuity Quotient?.....	180
New Tools.....	197
New Shop Ideas.....	198
Keeping the Home Shipshape.....	206
Photo Ideas and Equipment.....	227
To: Reader - From: Editor.....	254

# MORE MONEY \$\$\$ a BETTER JOB



**YOU'RE** in the biggest competition — yes, the biggest battle in the world — that of making a living. You have to work for a living—so does everyone else. Competition for

promotion is keen—people all around you are looking for more money—a better job—and so are you.

*You can get a head start.* Other men have—and in a short time you should be able to out-distance those who have no progress plan, make more money—have a better job—a more certain future.

Few people prepare themselves for that promotion—that better job and more money. Not many are making any special effort to learn outside of the time they put in each day on their work. They're taking the long, hard road to success. *How about you?* Are you, too, taking that same old, winding road—with its many disappointments and heartbreaks?

Here at LaSalle we have been training ambitious men and women for success for more than 40 years—enrolled hundreds of thousands of students—and our files overflow with grateful letters from students who have attained success and earnings far beyond their fondest dreams.

Perhaps we can help you—at any rate it will be well worth a three cent stamp to mail the coupon below. **DO IT NOW!** Just check the field of your choice and we'll send you full information on that field without obligation—plus "Ten Years' Promotion in One"—a book which has helped many men. It may be the turning point in your life to a successful career, and more money.

**LASALLE EXTENSION UNIVERSITY**  
A Correspondence Institution  
Dept. 883-R Chicago 5, Ill.

## Your Competition is Keen

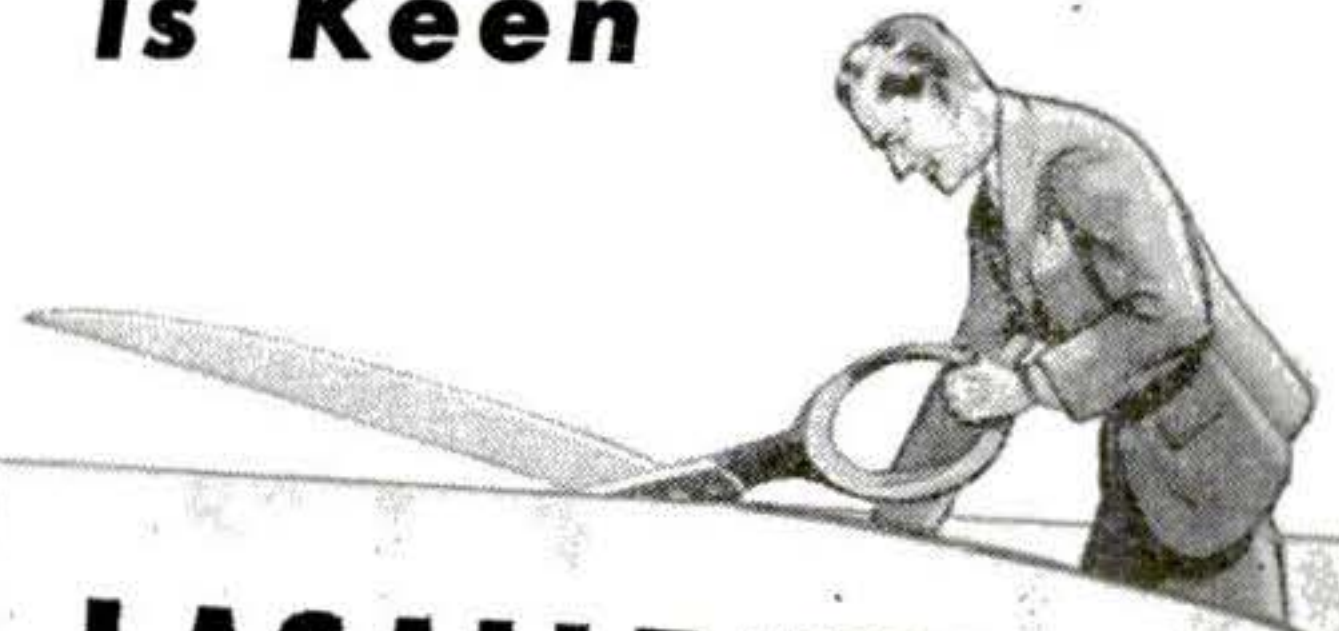

### LASALLE EXTENSION UNIVERSITY

A Correspondence Institution  
417 So. Dearborn St.

DEPT. 883-R

CHICAGO 5, ILL.

I am interested in preparing myself for a better job and more money. Please send me your free 48-page booklet on the training course I have checked below—plus "Ten Years' Promotion in One."



- Higher Accountancy
- C.P.A. Coaching
- Bookkeeping
- Law: LL.B, Degree
- Business Management
- Salesmanship
- Traffic Management
- Foremanship
- Industrial Mgt.
- Stenotypy
- (Machine Shorthand)

Name \_\_\_\_\_ Age \_\_\_\_\_

Street Address \_\_\_\_\_

City, Zone and State \_\_\_\_\_

**CLIP AND MAIL THIS COUPON TODAY!**



## THE FUTURE HOLDS GREAT PROMISE

Neither chance nor mere good fortune has brought this nation the finest telephone service in the world. The service Americans enjoy in such abundance is directly the product of their own imagination, enterprise and common sense.

The people of America have put billions of dollars of their savings into building their telephone system. They have learned more and more ways to use the telephone to advantage, and have continuously encouraged invention and initiative to find new paths toward new horizons.

They have made the rendering of telephone service a public trust; at the same time, they have given the telephone companies, under regulation, the freedom and resources they must have to do their job as well as possible.

**I**N THIS climate of freedom and responsibility, the Bell System has provided service of steadily increasing value to more and more people. Our policy, often stated, is to give the best possible service at the lowest cost consistent with financial safety and fair treatment of employees. We

are organized as we are in order to carry that policy out.

**B**ELL Telephone Laboratories lead the world in improving communication devices and techniques.

Western Electric Company provides the Bell operating companies with telephone equipment of the highest quality at reasonable prices, and can always be counted on in emergencies to deliver the goods whenever and wherever needed.

The operating telephone companies and the parent company work together so that improvements in one place may spread quickly to others. Because all units of the System have the same service goals, great benefits flow to the public.

Similarly, the financial good health of the Bell System over a period of many years has been to the advantage of the public no less than the stockholders and employees.

It is equally essential and in the public interest that telephone rates and earnings now and in the future be adequate to continue to pay good wages, protect the billions of dollars of savings invested in the System,

and attract the new capital needed to meet the service opportunities and responsibilities ahead.

There is a tremendous amount of work to be done in the near future and the System's technical and human resources to do it have never been better. Our physical equipment is the best in history, though still heavily loaded, and we have many new and improved facilities to incorporate in the plant. Employees are competent and courteous. The long-standing Bell System policy of making promotions from the ranks assures the continuing vigor of the organization.

**W**ITH these assets, with the traditional spirit of service to get the message through, and with confidence that the American people understand the need for maintaining on a sound financial basis the essential public services performed by the Bell System, we look forward to providing a service better and more valuable in the future than at any time in the past. We pledge our utmost efforts to that end.

**LEROY A. WILSON**, *President*  
American Telephone and Telegraph Company.  
(From the 1948 Annual Report.)

**BELL TELEPHONE LABORATORIES** Exploring and inventing,  
devising and perfecting, for continued improvements and economies in telephone service





**AUDELS CARPENTERS & BUILDERS GUIDES—(4 Book Set).....\$6**

A practical illustrated trade assistant on modern construction for carpenters, joiners, builders, mechanics and all woodworkers. 4 vols., 1600 pages, 3700 illustrations. Fully indexed, flexible covers. Each volume sold separately \$1.50 a vol.

**AUDELS PLUMBERS & STEAMFITTERS GUIDES—(4 Book Set).....\$6**

A Practical Trade Assistant & Ready Reference. Explains in plain language & by clear illustrations, diagrams, charts, graphs, pictures principles of modern plumbing practice including Marine Pipe Fitting and Air Conditioning. 4 Vols.—1670 Pages—3642 Diagrams & Illustrations. Each Vol. Sold Separately \$1.50 a Vol.

**AUDELS OIL BURNER GUIDE.....\$1**

384 Pages Covering Installation, Servicing & Repairs All Types Domestic & Industrial Burners. Illustrated. Highly Endorsed.

**AUDELS HOUSE HEATING GUIDE..\$4**

1000 Pages Covering Working Principles, Installation, Service of All Modern House Heating, Ventilating & Air Conditioning Systems. Explains New Radiant Heating. Fully Illustrated & Indexed.

**AUDELS REFRIGERATION & AIR CONDITIONING GUIDE.....\$4**

New from Cover to Cover—1280 Pages, Fully Illus. Covering basic principles, servicing, operation & repair of household, commercial & industrial refrigeration & air conditioning. A gold mine of essential important facts for engineers, servicemen, users.

**AUDELS SHEETMETAL WORKERS HANDY BOOK.....\$1**

Practical inside information. Fundamentals of Sheet Metal Work. 388 pages. Illustrated. 11 sections. Clearly written. Essential & important facts, figures, pointers in everyday language. Ref. Index.

**AUDELS SHEETMETAL PATTERN LAYOUTS.....\$4**

Developed by Experts for Sheet Metal Workers, Layout Men & Mechanics. A Practical Encyclopedia in 10 Sections, size 7 x 10 x 2—1125 Pages—350 Layouts—1600 Illustrations. 1001 Key Facts. Fully indexed for ready reference in answering your layout problems. Covers all phases of sheet metal work including Pattern Cutting, Pattern Development & Shop Procedure.

**AUDELS BLUE PRINT READING.....\$2**

For Mechanics & Builders. Covers all types of blue print reading including ship & airplane. 416 pages, fully illustrated.

**AUDELS MATHEMATICS & CALCULATIONS FOR MECHANICS \$2**

Mathematics for home study or reference. 700 pages, 550 illus. Practical mathematics from beginning. How to figure correctly. Easy, correct methods covering complete review. Illus. & Indexed.

**AUDELS AUTOMOBILE GUIDE.....\$4**

A practical quick ready reference book for auto mechanics, service men, operators & owners. Explains theory, construction & servicing of modern motor cars, trucks, buses & auto type Diesel engines. 1700 pages, fully illustrated. 55 chapters. Indexed. A standard book for mechanics. New Hydraulic drive covered.

**AUDELS DIESEL ENGINE MANUAL....\$2**

A practical, concise treatise with questions and answers on the theory, operation and maintenance of modern diesel engines. Over 400 pages, fully illus. All details plainly brought out, this book is of extreme value to engineers, operators & students.

**AUDELS WELDERS GUIDE.....\$1**

A concise, practical text on operation & maintenance of all welding machines for all mechanics. Over 400 pages, illustrated. Covers all methods of electric and acetylene welding including airplane work.

**AUDELS MACHINIST & TOOLMAKERS HANDY BOOK.....\$4**

Covers modern machine shop practice in all its branches. Tells how to set up & operate lathes, screw and milling machines, shapers, drill presses & all other machine & hand tools. 1600 pages, fully illustrated. Indexed. 5 sections. 1—Modern Machine Shop Practice. 2—Blue Print Reading & How to Draw. 3—Calculations & Mathematics for Machinists. 4—Shop Physics. 5—How to Use the Slide Rule. 60 chapters. Easy to read and understand. A shop companion that answers your questions.

**AUDELS ELECTRIC MOTOR GUIDE \$4**

Practical Information Covering Construction, Control, Maintenance & Wiring Hookups of All Types Electric Motors also Armature Winding. 1000 Pages Fully Illustrated & Indexed.

**AUDELS ELEC. WIRING DIAGRAMS \$1**

210 Pages. Illustrated. Gives practical facts on wiring of electrical apparatus. It shows clearly how to wire apparatus for practically all fields of electricity. Each diagram is complete & self-explanatory. Highly Endorsed Pocket Companion.

**AUDELS PRACTICAL ELECTRICITY \$4**

A key to a practical understanding of Electricity. For maintenance engineers, electricians & all electrical workers. 1440 Pages, 2600 Illus. Covers important electrical information in handy form—including wiring for Light & Power. Indexed.

**AUDELS RADIOMANS GUIDE.....\$4**

A key to the practical understanding of radio including Frequency Modulation, Television, etc., Aircraft & Marine Radio. For radio engineers, servicemen, amateurs, 914 Pages, 633 Illustrations & Diagrams. Photos. Review Questions & Answers, Reference Index.

**AUDEL, Publishers, 49 W. 23 St., N.Y. 10**

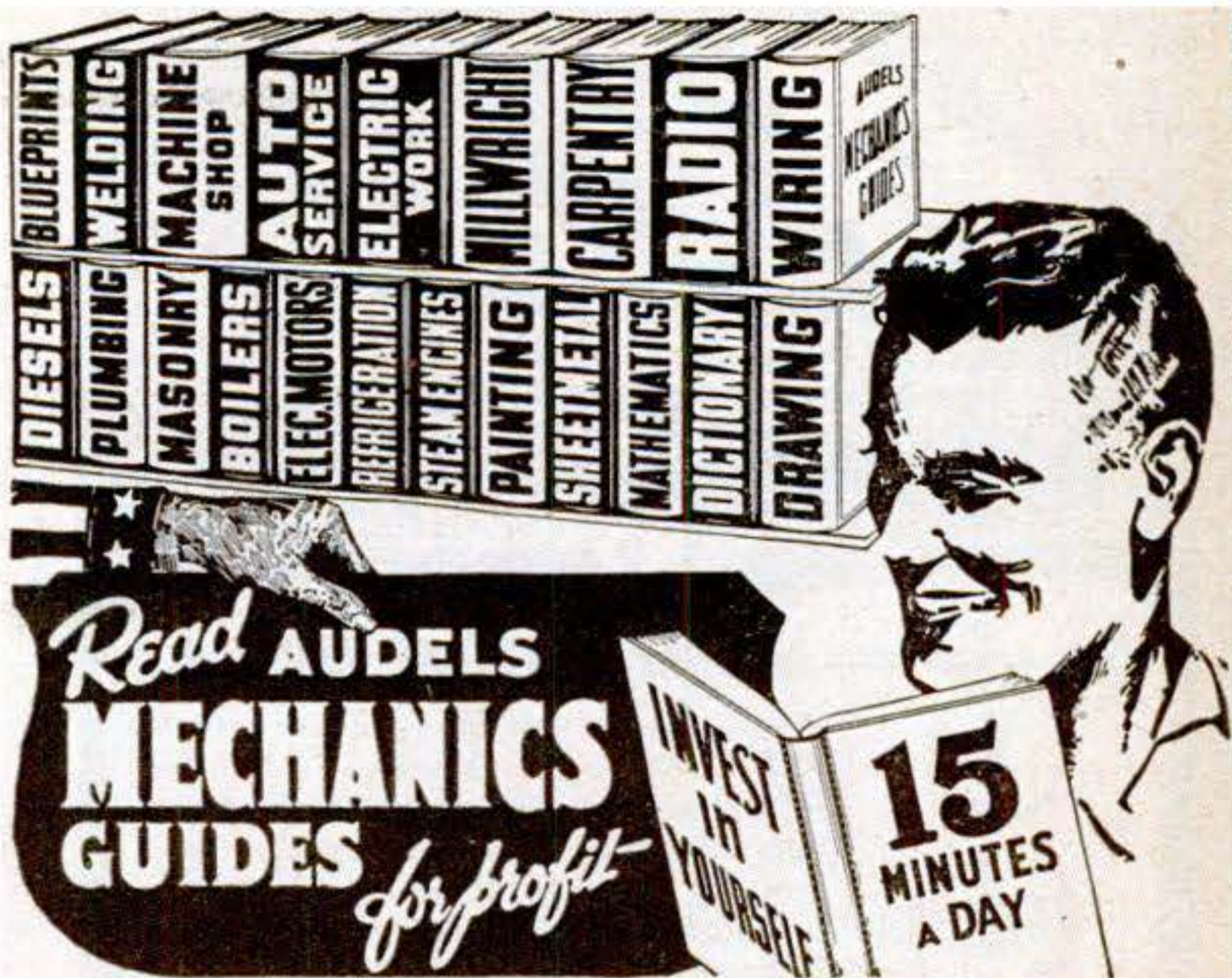

**AN AUDEL GUIDE IS A GOOD FRIEND!**

Step Up Your Own Skill with the Practical Facts and Figures of Your Trade. Save time and money with right methods, short cuts, labor saving ideas. CHECK NOW! You can look over any Audel Guide in your home. Start the Easy Payments if satisfied.

**CUT HERE MAIL ORDER**

AUDEL, Publishers, 49 W. 23 St., New York 10, N. Y.

Please mail me for 7 days' free examination the books marked (X) below. I agree to mail \$1 in 7 days on each book or set ordered, and to further mail \$1 a month on each book or set ordered until I have paid the purchase price.

If I am not satisfied with Guides I will return them.

- AUTOMOBILE GUIDE, 1700 Pages . . . . . \$4
  - DIESEL ENGINE MANUAL, 400 Pages . . . . . 2
  - WELDERS GUIDE, 400 Pages . . . . . 1
  - CARPENTERS & Builders Guides (4 Book Set) . . . . . 6
  - PLUMBERS & Steamfitters Guides (4 Book Set) . . . . . 6
  - MASONS and Builders Guides (4 Book Set) . . . . . 6
  - BLUE PRINT READING, 416 Pages . . . . . 2
  - MASTER PAINTER & Decorator, 320 Pages . . . . . 2
  - GARDENERS & GROWERS GUIDES (4 Book Set) . . . . . 6
  - OIL BURNER GUIDE, 384 Pages . . . . . 1
  - HOUSE HEATING GUIDE, 1000 Pages . . . . . 4
  - REFRIGERATION & Air Conditioning Guide, 1280 Pages . . . . . 4
  - SHEET METAL WORKERS Handy Book, 388 Pages . . . . . 1
  - SHEET METAL PATTERN LAYOUTS, 1100 Pages . . . . . 4
  - AIRCRAFT WORKER, 240 Pages . . . . . 1
  - MECHANICAL DRAWING GUIDE, 160 Pages . . . . . 1
  - MECHANICAL DRAWING & DESIGN, 480 Pages . . . . . 2
  - MATHEMATICS and CALCULATIONS, 700 Pages . . . . . 2
  - MECHANICAL DICTIONARY, 968 Pages . . . . . 4
  - MACHINISTS & Toolmakers Handy Book, 1600 Pages . . . . . 4
  - MILLWRIGHTS & Mechanics Guide, 1200 Pages . . . . . 4
  - POWER PLANT ENGINEERS GUIDE, 1500 Pages . . . . . 4
  - ENGINEERS & FIREMANS EXAMINATIONS, 528 Pages . . . . . 1
  - PUMPS, HYDRAULICS & Air Compressors, 1658 Pages . . . . . 4
  - MARINE ENGINEERS Handy Book, 1280 Pages . . . . . 4
  - ENGINEERS and Mechanics Guides (8 Book Set) . . . . . 12
  - Answers on Practical ENGINEERING, 254 Pages . . . . . 1
  - ELECTRIC WIRING DIAGRAMS, 210 Pages . . . . . 1
  - ELECTRICIANS EXAMINATIONS, 250 Pages . . . . . 1
  - ELECTRIC DICTIONARY, 9000 Terms . . . . . 2
  - ELECTRIC MOTOR GUIDE, 1000 Pages . . . . . 4
  - PRACTICAL ELECTRICITY Handy Book, 1440 Pages . . . . . 4
  - ELECTRICAL POWER CALCULATIONS, 425 Pages . . . . . 2
  - RADIOMANS GUIDE, 914 Pages . . . . . 4
  - ELECTRONIC DEVICES, 216 Pages . . . . . 2
  - NEW ELECTRIC LIBRARY, 7000 Pages (12 Book Set) . . . . . 18
- Vols. I, II, III, IV, V, VI, VII, VIII, IX, X, XI, XII—\$1.50 Each

Name \_\_\_\_\_

Address \_\_\_\_\_

Occupation \_\_\_\_\_

Employed by \_\_\_\_\_

PSM

# 4 Keys to SUCCESS IN AVIATION

Through **Embry-Riddle** Training



## AIRCRAFT & ENGINE MECHANICS

1



We have hundreds of urgent requests for A. & E. Mechanics -- key men in Aviation -- from airlines, oil companies, fixed base operators, etc., both U. S. and Overseas. Training in a C. A. A. approved school is the quickest way to get ahead. Embry-Riddle students learn fast with modern equipment . . . working on live aircraft in airline-size hangars.



## ENGINEERING

2



Embry-Riddle's Design Engineering and Maintenance course offers you eligibility for A. & E. certification plus necessary basic engineering knowledge required to fill positions such as Maintenance Foreman or Field Service, Project or Sales Engineer. If your aim is high, take this course.

## A.&E. COMBINED WITH COMMERCIAL



3

Pilot Mechanics who can test fly the ships they repair . . . executive pilots able to service their own aircraft -- airmen with dual ability are needed by aviation companies and operators. Embry-Riddle combination training offers you the most in your aviation career.



## COMMERCIAL PILOTS



4

Flying holds a real future for Embry-Riddle trained pilots. A quarter-century of experience with 30,000 students . . . the best instructors, up-to-date aircraft, superb year-round flying weather . . . qualifications unexcelled anywhere. Instrument and instructor's ratings are also available.



**Aviation needs you now!** Never has there been such opportunity for you in Aviation. Start your career now at Embry-Riddle -- living facilities directly on the Airport. Write today for full information and proof of job opportunities.

### AUTHORIZED G. I. TRAINING

Dean of Enrollments - Dept. 91  
Embry-Riddle School of Aviation  
Miami 30, Florida

Please Print

NAME \_\_\_\_\_

ADDRESS \_\_\_\_\_

City \_\_\_\_\_

State \_\_\_\_\_ Age \_\_\_\_\_

I am interested in . . .

- A.&E. Mechanic
- Commercial Pilot
- Engineering
- A.&E. Combined with Commercial Pilot
- Flying Mechanic
- Drafting & Design

Check One  Veteran  Non-Veteran

**TRAIN IN MIAMI -- AIR CAPITAL OF THE WORLD**

## Letters



### Doing It with Mirrors

Sir:

I was particularly interested in your story, "Sun Furnace in Your Attic" (PS, March '49, p. 106), as I was, at one time, part of an expedition that dabbled in experiments with solar heat, back in the middle twenties, about the time the first successful experiments were completed in California.

From my experiments and experience, one thing stands out from this account: The profitable solar hours from this type of furnace could be greatly increased with a large mirror, pivoted on a swivel, and an electrical clocklike movement designed to keep the mirror in focus with the sun and aimed at the glass heat receptacle.

Our experiments convinced us that the old trick of using the focused rays of the sun to start a fire with a magnifying glass was the best premise on which to develop solar heat, and recalling how we used to start fires with a mirror and a magnifying glass, where no sun was shining and some times with a flash-light and magnifying glass, I thought possibly those who are currently engaged in solar research might use this idea to reach a greater efficiency with their current experiments.

W. M. PACKER

St. Louis, Mo.

*Clock-run mirrors to concentrate the sun's heat have already been tried, but their complexity and high cost, at present at least, would make them uneconomical for small-home heating. Also, since high temperatures are not required for house heating, sufficient heat can be gathered from the sun without concentrating its rays. If such installations become practical, they will probably be most useful to large, solar-run, steam power plants that require high temperatures.*

### They're Both Fast

Sir:

I'll probably get my fingers rapped for beating my gums about an article written by a man who knows far more than I do. (I'm just a 4th former in high school.) Nev-

# Now Any AUTO REPAIR JOB Can Be a "Push-Over" for You!

**Free**  
7-DAY OFFER!



**IN LESS TIME—WITH LESS WORK—AND MORE PROFITS!**



**N**OW, tackle anything from carburetor to rear end on ANY car built from 1935 thru 1949. And fix it quick, easy, right the **FIRST** time! Just look up make, model, and job in quick index of MoToR's **brand-new** **AUTO REPAIR MANUAL**. Clear, illustrated instructions lead you step by step all the way.

**ONLY Manual of Its Kind!**

The engineer-editors of MoToR Magazine condensed all the meat of over 150 official factory manuals for you. They dug out all the information you need—made sure every word and picture is crystal clear—and put the whole "works" into this one big 795-page book.

Contains 200,000 service, repair, tune-up facts. 35,000 essential dimensions! More than 2100 cut-away photographs, diagrams, charts show what the clear text tells.

Used by  
U. S. Army  
and Navy

**COVERS ANY CAR BUILT SINCE 1935!**

- |           |            |
|-----------|------------|
| Auburn    | Frazer     |
| Austin    | Graham     |
| Buick     | Hudson     |
| Cadillac  | Hupmobile  |
| Chevrolet | Kaiser     |
| Chrysler  | Lafayette  |
| Cord      | La Salle   |
| Crosley   | Lincoln    |
| De Soto   | Mercury    |
| Dodge     | Nash       |
| Ford      | Oldsmobile |
|           | Packard    |
|           | Pierce     |
|           | Arrow      |
|           | Plymouth   |
|           | Pontiac    |
|           | Reo        |
|           | Studebaker |
|           | Terraplane |
|           | Willys     |

**Win Prestige! Earn More Money!**

MoToR's Manual makes every operation so easy that you'll find yourself tackling jobs you wouldn't think of doing before. And you'll win added prestige and more money in the bargain.

Beginners will find usable helpful guidance on every kind of repair and service job imaginable. Experts will be amazed by the time and labor-saving short cuts.

This **GIANT** Manual is used by Army, Navy, Technical Schools, and thousands of successful auto-repairmen. Now **YOU** can try it **FREE**—for 7 days. Learn first-hand how it can *pay for itself* the first few times you use it!

**SEND NO MONEY**

Mail coupon below — *without money!* When your book arrives — *make it show you what it's got!* Unless you agree it's the greatest time and work saver you've ever seen—return book in 7 days and pay nothing. Mail coupon **NOW!** MoToR Book Department, Desk 28, 250 West 55th Street, New York 19, N. Y.



**Just 2 of the Many Letters of Praise**



"MoToR's Manual paid for itself on the first 2 jobs, and saved me valuable time eliminating guesswork." — **W. SCHROP, Ohio**

"Instructions so clear have no trouble learning anything about any car. Now working as mechanic in big plant." — **SAM ORDONEZ, California**

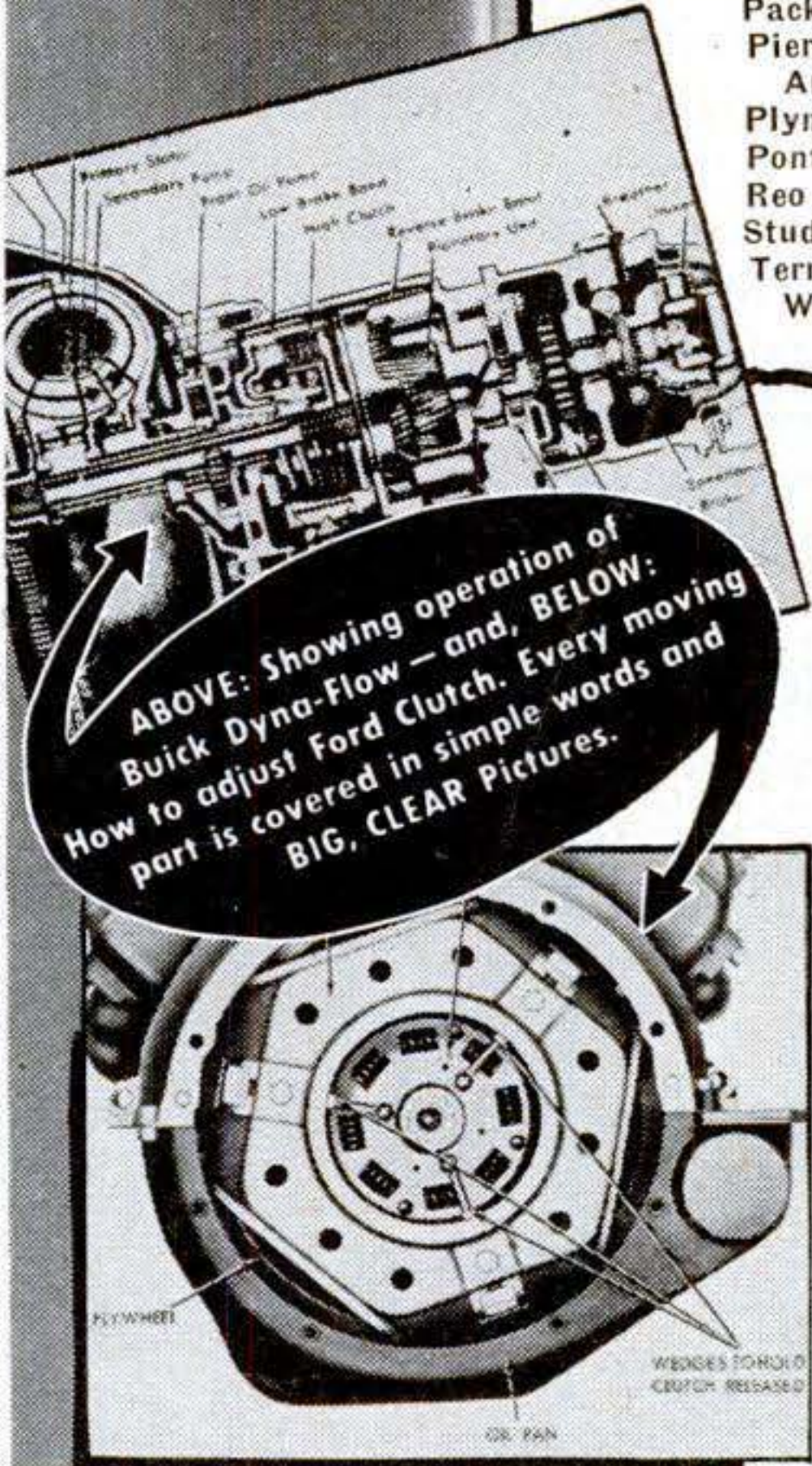

**ABOVE:** Showing operation of Buick Dyna-Flow — and, **BELOW:** How to adjust Ford Clutch. Every moving part is covered in simple words and **BIG, CLEAR** Pictures.

**Same FREE Offer on MoToR's TRUCK MANUAL**

Covers **EVERY** job on **EVERY** truck made from 1936 thru 1946! 1400 pictures, 952 pages, 300,000 facts. All types Gasoline Engines, Truck Diesels, Hesselmans, Fuel Systems, Governors, Lubrication, Ignition, Starters, Clutches, Axles, Brakes, etc., etc.

ALSO covers many buses, tractors, contractor and road building equipment, stationary power machinery. Check box in coupon at right for 7-day **FREE** trial.



Published by MoToR, The Leading Automotive Business Magazine.



**MAIL COUPON NOW FOR 7-DAY FREE TRIAL**

**MoToR BOOK DEPT.**  
Desk 28, 250 West 55th St., New York 19, N.Y.

Rush to me at once (check box opposite book you want):  
 MoToR's **NEW AUTO REPAIR MANUAL**. If O.K., I will remit \$1 in 7 days (plus 35c delivery charges). \$2 monthly for 2 months and a final payment of 95c one month after that. Otherwise I will return the book postpaid in 7 days. (Foreign price, remit \$8 cash with order.)

MoToR's **TRUCK REPAIR MANUAL**. (Described at left.) If O.K., I will remit \$2 in 7 days, and \$2 monthly for 3 months, plus 35c delivery charges with final payment. Otherwise I will return book postpaid in 7 days. (Foreign price, remit \$10 cash with order.)

Print Name.....Age.....

Print Address.....

City..... State.....

Check box and save 35c delivery charge by enclosing WITH coupon entire payment of \$5.95 for Auto Repair Manual (or \$8 for Truck Repair Manual). Same 7-day return-refund privilege applies.



## The Dark Continents of Your Mind

DO YOU struggle for balance? Are you forever trying to maintain *energy, enthusiasm,* and the *will to do*? Do your personality and power of accomplishment ebb and flow — like a stream controlled by some unseen valve? Deep within you are minute organisms. From their function spring your emotions. They govern your *creative ideas* and *moods* — yes, even your enjoyment of life. Once they were thought to be the mysterious seat of the soul — and to be left unexplored. Now cast aside superstition and learn to direct intelligently these *powers of self*.

### Accept this Free Book

Let the Rosicrucians, an age-old fraternity of thinking men and women (not a religion), point out how you may fashion life as you want it — by making the fullest use of these little-understood *natural faculties* which you possess. This is a challenge to make the most of your heritage as a human. Write for the Free Book, "The Mastery of Life." Address: Scribe J.J.B.

## The ROSICRUCIANS

San Jose (AMORC) California

ertheless, I would like to question a few points in Devon Francis' article on Ultramatic in the June issue [p. 139].

On page 140 he writes: "It (direct drive) gives extra acceleration fast," while on the next page he says: "If you need a sudden burst of acceleration, just push the pedal to the floor. Back you go to torque-converter drive." Now which does give the most positive acceleration—direct drive or torque conversion?

Another question is how can one accelerate in direct drive between 15 and 56 m.p.h.? Or can one? I saw nothing to hold the direct-drive actuating valve when the accelerator was depressed after the momentary release to shift the drive, but on page 142 it says: "This opposing hydraulic pressure . . . gives you a choice between the two drives at any speed between 15 and 56 m.p.h." If governor pressure couldn't open the valve before, how can it keep the valve open if the same governor pressure returns?

PHILIP EASTMAN

Burlington, Ontario, Canada

*At low speeds, torque conversion gives you the faster acceleration—it's like going from overdrive in a direct-drive car back into standard third gear for a sudden burst of speed. At higher speeds, however, direct drive gives you the faster acceleration.*

*Going back and forth between direct and torque-converter drive is entirely a matter of opposing hydraulic pressures. The higher the speed, the faster the governor travels, and the more pressure it exerts. Up to 56 m.p.h., this pressure can be overcome by pressure from the accelerator pedal. Beyond that speed, it cannot. What may puzzle you is that the accelerator must be depressed until it strikes an abutment on the floor to actuate the pedal hydraulic system.*

### Longue or Lounge?

Sir:

In the June issue on page 169 you have "Lightweight Chaise Longue"—which, according to Mr. Webster, should be "lounge." Is this a trade name or merely a misprint?

C. E. CHAPPEL

Mission, Kans.

*Neither Mr. Webster nor PS is at fault here. "Longue" is the French word for "long." Thus "chaise longue" means "long chair." "Lounge," despite its similarity,*

# I WILL SEND YOU BOTH FREE

**64 PAGE BOOK**

See how I give you practical experience building Radio circuits at home with BIG KITS OF PARTS I SEND. Illustrated book shows how you make extra money fixing Radios in spare time while still learn-

ing. Read letters from men I trained, telling what they are doing, earning. See the kind of fascinating jobs Radio, Television, Electronics offer. FREE with coupon below!

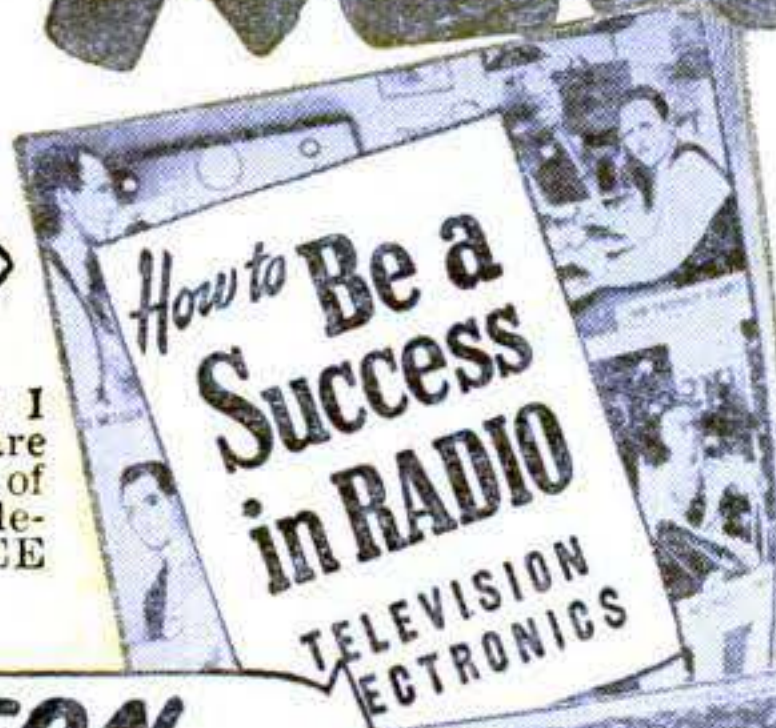

## ACTUAL RADIO LESSON

Same coupon entitles you to FREE lesson, "Getting Acquainted With Receiver Servicing." Discloses short-cuts Radio Repairmen use. Tells how

"superhet" circuits work, three reasons why tubes fail, locating defects, repairing loudspeaker. Over 80 pictures, diagrams. FREE! Send coupon now.



# See for yourself how I train you at home to BE A RADIO-TELEVISION TECHNICIAN

Want a good-pay job in the fast-growing RADIO-TELEVISION Industry? Want a money-making Radio-Television shop of your own? Here's your opportunity. I've trained hundreds of men to be Radio Technicians—MEN WITH NO PREVIOUS EXPERIENCE. My tested and proved train-at-home method makes learning easy. You learn Radio-Television principles from illustrated lessons. You get practical experience building, testing, experimenting with MANY KITS OF PARTS I send. All equipment yours to keep.

### Make EXTRA MONEY In Spare Time

The day you enroll, I start sending SPECIAL BOOKLETS that show you how to make \$5, \$10 a week EXTRA MONEY fixing neighbors' Radios in spare time. From here it's a short step to your own shop, or a good-pay Radio-Television servicing job. Or get into Police, Aviation, Marine Radio, Broadcasting, Radio Manufacturing or Public Address work. And think of the present and future opportunities in the booming Television Industry.

### See What N. R. I. Can Do For You

Act now! Send for my DOUBLE FREE OFFER. Coupon entitles you to actual lesson, "GETTING ACQUAINTED WITH RECEIVER SERVICING," absolutely free. Over 80 pictures and diagrams! You also get my 64-page book, "HOW TO BE A SUCCESS IN RADIO AND TELEVISION-ELECTRONICS." Tells how quickly, easily you can get started. Send coupon in envelope or paste on penny postal. J. E. SMITH, President, Dept. 9HP3 - National Radio Institute, Pioneer Home Study Radio School, Washington 9, D. C.

## You Build This MODERN RADIO with Parts I Send

Complete, powerful Superheterodyne Radio Receiver brings in local and distant stations. N. R. I. gives you everything . . . speaker, tube, chassis, transformer, sockets, loop antenna, and all other Radio parts you need to build set.



**MAIL NOW**

**I Also  
Send You Many  
Other RADIO KITS**

## I TRAINED THESE MEN



**Has Own Radio Business**  
"Now have two Radio shops, servicing about 200 sets a month. Highly successful our first full year." — AR-

LEY STUDYVIN, DeSoto, Missouri.



**Extra Cash In Spare Time**  
"Earned enough spare time cash to pay for my Course by time I graduated. N. R. I. training is tops!"

—ALEXANDER KISH, Carteret, New Jersey.

## Actual Lesson and 64 Page Book FREE

**MR. J. E. SMITH, Pres., Dept. 9HP3  
National Radio Institute, Washington 9, D. C.**

Mail me FREE Sample Lesson and 64-page book about how to win success in Radio and Television—Electronics. (No salesman will call. Please write plainly.)

NAME..... AGE.....

ADDRESS.....

CITY..... ZONE..... STATE.....

Check If Veteran  Approved For Training Under G. I. Bill

**MY COURSE INCLUDES TELEVISION**

YOUR OWN

# BUSINESS WITH A FUTURE!

Get the facts FREE!

a few cents worth of materials BRINGS YOU DOLLARS!!

Rich profits are waiting to be tapped in this new field. New MIRACLE finish gives a velvety, luxurious surface to radios, lamps, toys, signs, store displays, figurines, auto dashboards, and hundreds of other items. Make old objects beautiful and saleable — make new things worth much more with this soft, rich covering that can be applied to any surface, even if old and worn.



*Have*  
**Your Own Lasting, Successful Business—Be Your Own Boss—Help Fill Huge Demand ... No Experience Is Necessary**

Yes, you can learn in a few days to start **MAKING MONEY!** Everything you need is furnished, including fully detailed, illustrated instructions that are complete and easy to understand. Every point is explained, to show you how to start on the road to big money, full or spare time, right in your own home.

### EVERYTHING COMPLETE

In addition to full instructions, you get all materials that will enable you to start at once. A few cents worth of materials can mean many dollars in return. You can earn up to \$5.00 per hour and more spare or full time. Boost your present income or start your own profitable business.

### ACT NOW

Grasp this opportunity **TODAY** — start your own business. It's too good to miss! **SEND NO MONEY** — fill out the coupon and stick it on a post card or in an envelope and mail today for full details, **FREE** sample of FLOK-KRAFT covered material, and hundreds of useful and profitable **IDEAS**. Do it **NOW** — be first!

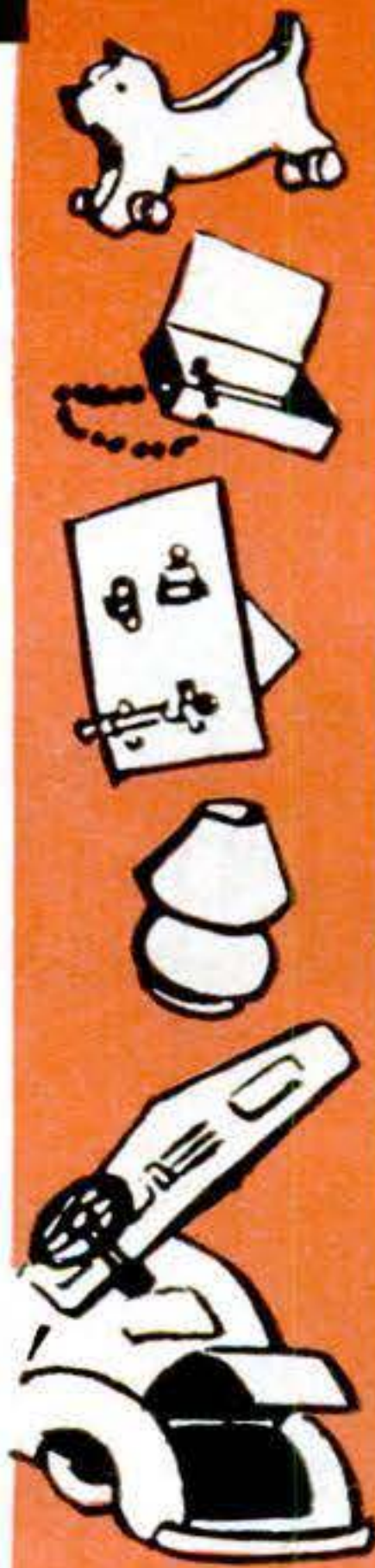

- TOYS
- JEWELRY BOXES
- DISPLAY PIECES
- LAMPS
- CAR DASHBOARDS
- CAR TRUNKS
- Covers Wood, Fabric, Metal, Plaster, Plastic, Glass, or any Surface

**USE THIS COUPON**

**SEND NO MONEY**

**COAST INDUSTRIES**

Dept. 18 1004 So. Los Angeles St., Los Angeles 15, Calif.  
Please rush me all the details!

NAME \_\_\_\_\_  
STREET \_\_\_\_\_  
CITY \_\_\_\_\_  
STATE \_\_\_\_\_



comes from an entirely different, Old French word—"lungis," which meant "lazy." Thus a lounge is also a place for lazy people. *N'est-ce pas?*

### Old Trick with a New Twist

Sir:

After reading about slit veneer, called K-Veneer, in your April '49 issue, page 172, I would like to make the statement that cooks and seamstresses have known of that principle for years.

Seamstresses place small slits or clips around curves of seams or in corners to ease the material and make it lie smooth. Cooks slit the edges of frying meat, such as ham or pork chops, to prevent it from curling.

(Mrs.) R. HILL

Ilion, N. Y.

### No Need to Window-Shop

Sir:

Thanks to you and your April issue [p. 148] for showing pix of the new Chrysler.

I am the fellow who never goes near an automobile sales floor until the moment he is ready to buy. (Like a young man purchasing a marriage license: no need to window-shop.) My mind is made up to duplicate our present job, a Chrysler Royal, within a few months. Your article assures me same will be no mistake.

FRED B. BARTON

Akron, O.

### Flood Warning Rings Bell

Sir:

Your article "How to Foil a Flood" [May, p. 190] was so outstanding I want to compliment you on it. This article well suits the season of the year, and you did a fine job.

CRAIG YEANISH

Slatington, Pa.

### Lead vs. Titanium

Sir:

We have read with considerable concern the article by George H. Waltz, Jr., in your May issue entitled, "New Paints That a Novice Can Use" [p. 153].

For instance, a new lead-free house paint was described with the comment that it resists darkening when applied to houses in or near large industrial areas where the air

*Don't miss the chance of a lifetime!*

# TELEVISION Radio - Electronics...

**OFFER YOU A PROFITABLE FUTURE!**



OSCILLOSCOPE

Get the Facts About Our

## **GREATEST OFFER in 17 YEARS**

Here's good news . . . big news . . . our **BIGGEST NEWS** in 17 years. The equipment pictured at the right gives a partial idea of D.T.I.'s remarkable new combination of shop-method, home-training aids.

Now you can use and keep ALL of this equipment—PLUS other major training aids — to prepare you at home for a grand future in the fast-moving field of TELEVISION . . . RADIO . . . ELECTRONICS.

### Send for **FREE** Information

Mail the coupon today. See how D.T.I.'s amazing, newer, training method helps you get started toward a **GOOD JOB** or your **OWN BUSINESS** in one of America's most promising, thrilling fields . . . that includes Television . . . F.M., Train, 2-Way Taxi, Aviation, and Broadcast Radio . . . Industrial Electronics . . . and other fast-developing branches.

In addition to well-illustrated lessons, you receive 16 shipments of Radio-Electronic parts from which you work over 300 instructive projects—including the building of (1) a commercial-type **CATHODE RAY OSCILLOSCOPE** that helps you get practical Television circuit training, (2) a double-range **R-F SIGNAL GENERATOR**, (3) a jewel-bearing **MULTI-METER** and (4) a quality 6-tube, **SUPERHET RADIO**. You keep all of this equipment.

**YOU BUILD and KEEP THIS EQUIPMENT**  
Work over **300** Home Experiments

### EMPLOYMENT SERVICE

When you complete your training, our effective Employment Service is available to you without extra cost, to help you get started.

MULTI-METER



R-F SIGNAL GENERATOR

### You also use **HOME MOVIES**

. . . a **D. T. I. Exclusive!**  
D.T.I. alone includes the use of modern, visual training aid . . . **MOVIES** . . . to help you learn faster, easier at home. You see electrons on the march and other fascinating "hidden action" — a remarkable home training advantage that speeds your progress.



6-TUBE RECEIVER

### You May Choose to Train in Our **MODERN CHICAGO LABORATORIES**

Train quickly, using a wide variety of commercial equipment. D. T. I.'s new labs are among the finest of their kind. Ample instructors . . . every major training advantage. Write for details!

## MAIL THIS OPPORTUNITY COUPON NOW!

DeForest's Training, Inc.  
2533 N. Ashland Ave., Dept. PS-F-8  
Chicago 14, Illinois

Without obligation, give me complete facts showing how I may make my start in Television — Radio — Electronics.

Name..... Age.....  
Street..... Apt.....  
City..... Zone..... State.....

**DeFOREST'S TRAINING, INC.**  
CHICAGO, ILLINOIS

Affiliated with the De Vry Corporation  
Builders of Electronic and Movie Equipment

contains sulphurous fumes. Users, however must realize that to have a paint that will resist darkening, they must sacrifice durability.

A virtue is also made of the fact that these lead-free house paints are self-cleaning. Here, again, it should be recognized that they are self-cleaning because they chalk off and carry the dirt off with the paint. In other words, the paint does not push the dirt off but the paint itself wears away and carries the dirt with it.

Pictures are shown of a lead-free paint and a lead paint in Morgantown, W. V., which reveal considerable darkening of the lead paint after a relatively short time. It is not brought out, however, that such conditions are relatively rare. Sulphurous gases in general do not darken lead paint. Only hydrogen sulphide does that; the ordinary sulphurous gases found in most industrial areas convert the lead compounds in the paint to lead sulphate, which itself is white.

While titanium pigments have great merit in their whiteness and high hiding power, they are not chemically active pigments like the lead pigments. The lead pigments react with the oil with which they are mixed in

a paint to form a chemical compound which results in a tough elastic paint film. No such reaction occurs when titanium dioxide is incorporated in the paint, and in that respect it acts just like all inert pigments, such as silica, magnesium silicate, barium sulphate, and other extenders.

ROBERT L. ZIEGFELD,  
Lead Industries Association  
New York, N. Y.

*Here is Mr. Waltz's reply:*

I made no attempt to recommend any paint or type of paint over any other. I merely reported on *new* paints that are now available to the workshop-minded home owner who likes to do some of his own work. If there had been a brand-new lead paint fitted to the amateur painter's needs, it certainly would have been included.

I did point out, in the text, that it is the hydrogen sulphide gas that causes the blackening of lead paints, and that the self-cleaning process is a gradual flaking or chalking off of the lead-free paint.

I used several of the new titanium paints and, in my amateur way, was able to do a pretty good, professional-looking job.

# Country Doctor



*Pipe this—for a Hit!*

Yes sir, Country Doctor comes through every time at bat with a cool, smooth smoke. TOPS in flavor. Slow-burning, as you like it. Mellowed for Mildness by a rare *blend* of the World's Finest Tobaccos. Nothing could be more satisfying!

**TRY IT TODAY! SMOKE IT FOR GOOD!**

*The Pipe Mixture  
with the KINDLY disposition*

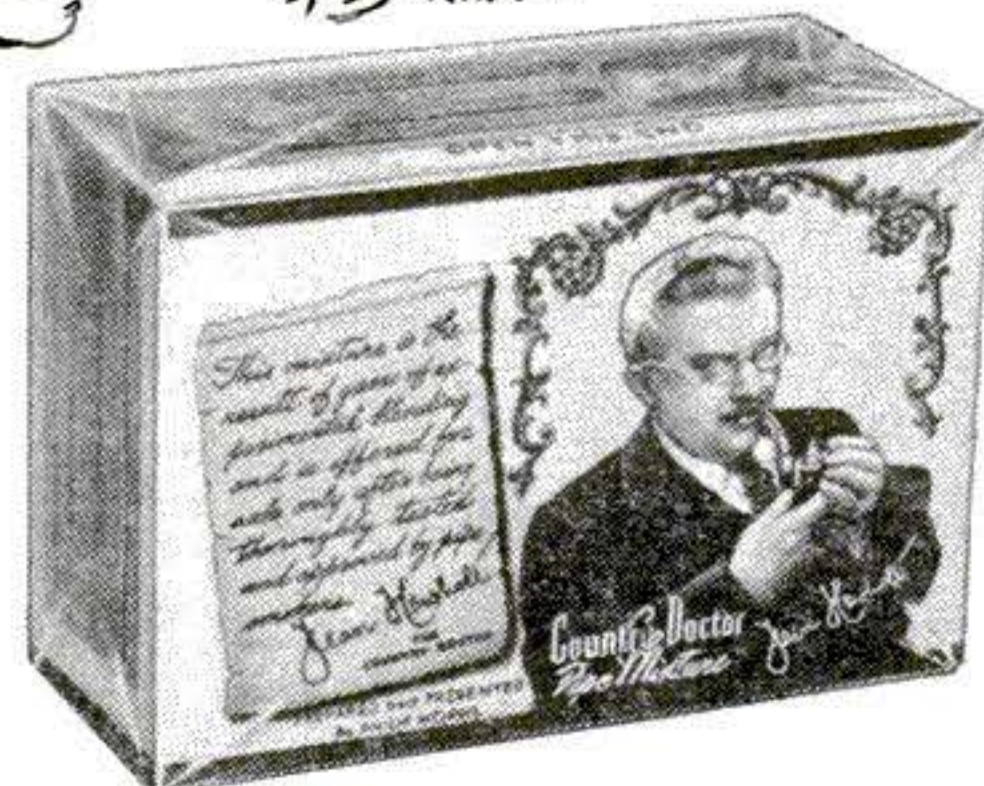
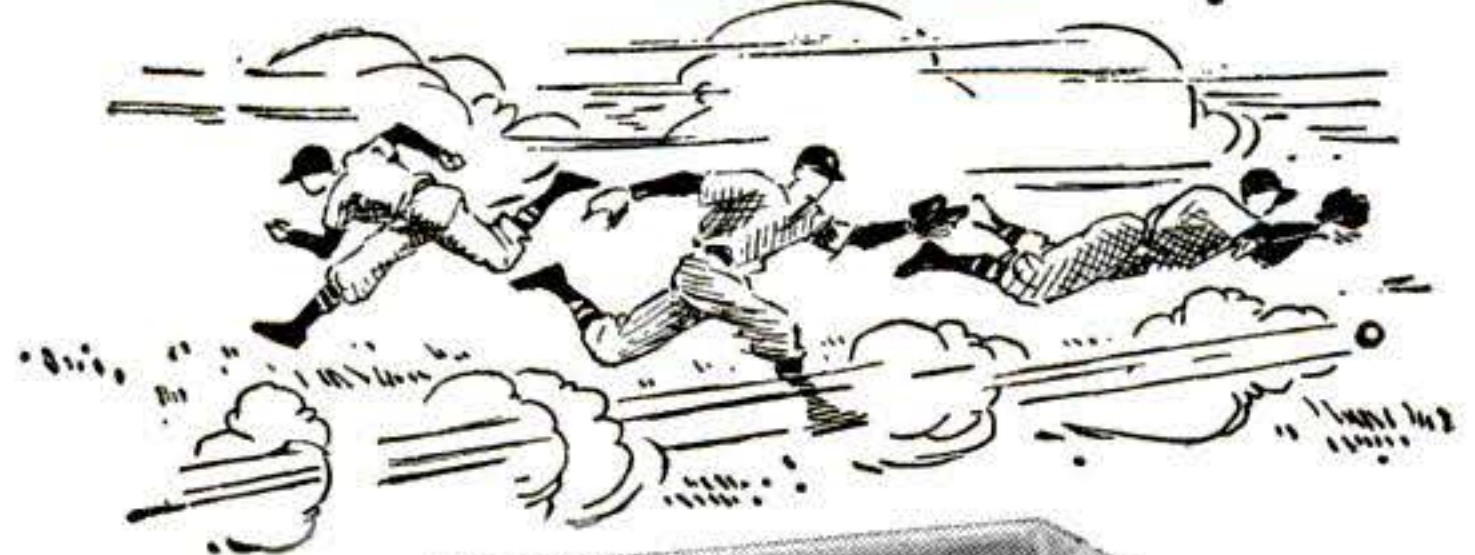

The Pipe  
Smoker's  
**ECONOMY  
LUXURY**

25  
Pleasureful  
Pipefuls for  
25¢

If your dealer does not have it — write Philip Morris & Co., Ltd., Inc., Dept. S29, 119 Fifth Avenue, New York 3, N. Y., enclosing 25¢ for full size package



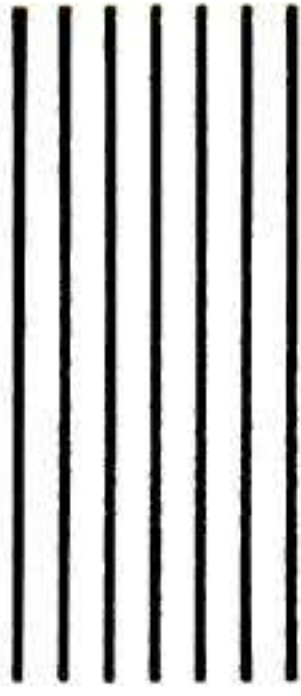

# INVENTORS

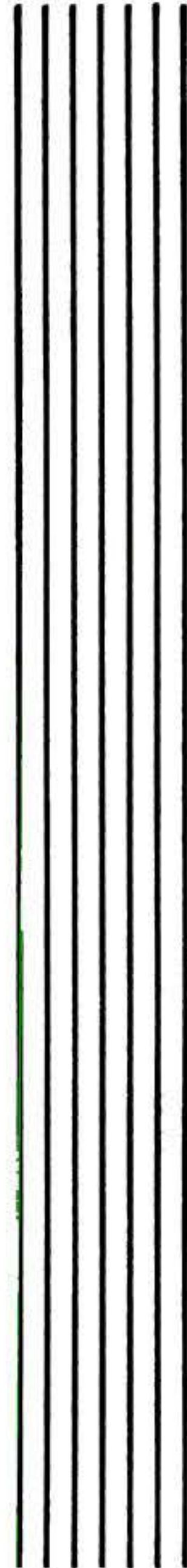

Learn how to protect your invention. The U. S. Patent Laws provide that any new and useful art, machine, article of manufacture, or composition of matter, or any new and useful improvement thereof, may be patented if the act of invention is involved. Therefore, every inventor with a valuable invention should take advantage of the Patent Laws and proceed for patent protection in order to safeguard his rights.

A patent gives the inventor the exclusive right to prevent others from making, using, or selling the invention claimed in the patent for a period of seventeen years.

The Patent Laws were enacted for the benefit of the inventor to give him protection for the features of his invention which are patentable. These features must be properly and concisely set forth and claimed in a formal application for patent, in order to comply with the requirements of the Patent Laws. For that reason, unless the inventor is familiar with patent matters, he should engage a competent registered patent attorney or agent to represent him. We are registered to practice before the U. S. Patent Office and are prepared to serve you in the handling of your patent matters.

A specially prepared booklet entitled "Patent Guide for the Inventor", containing detailed information with respect to patent protection and procedure, together with a "Record of Invention" form will be promptly forwarded to you without obligation upon request.

## CLARENCE A. O'BRIEN & HARVEY JACOBSON

*Registered Patent Attorneys*

92-H DISTRICT NATIONAL BUILDING • WASHINGTON 5, D. C.

**Patents**  
**Trademarks**  
**Copyrights**

CLARENCE A. O'BRIEN & HARVEY JACOBSON  
Registered Patent Attorneys  
92-H District National Bldg., Washington 5, D. C.  
Please send me copy of "Patent Guide for the Inventor" and also  
"Record of Invention" form. This request does not obligate me.

Name \_\_\_\_\_  
Address \_\_\_\_\_  
City \_\_\_\_\_ State \_\_\_\_\_  
(Please write or print plainly.)

# HE Mailed This Coupon

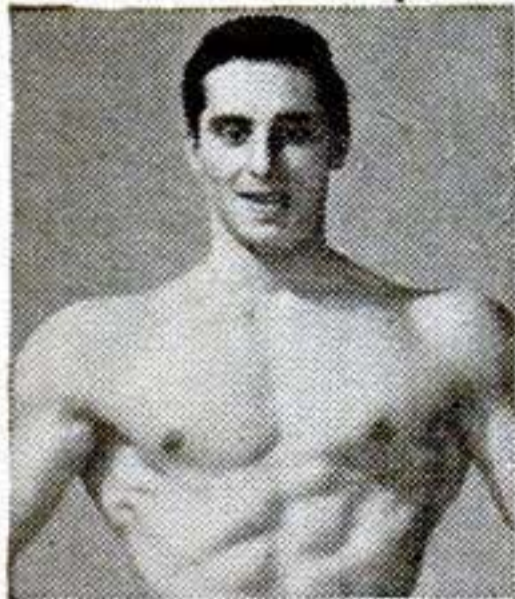

**CHARLES ATLAS**  
115 East 23rd St., New York 10, N. Y.  
I want the proof that your system of "Dynamic Tension" will help make a New Man of me—gives me a healthy, husky body and big muscle development. Send me your free book, "Everlasting Health and Strength."  
Name **THOMAS MANFRE**.....  
(Please print plainly)  
Address **275-43 St.**.....  
City **BROOKLYN**..... State **N.Y.**.....

## ...and Here's the Handsome Prize-Winning Body I Gave Him!

Thomas Manfre of New York mailed my coupon. Got my free book. Won my Atlas-Champion, Sterling Silver Cup. He says: "Look at me NOW! 'Dynamic Tension' WORKS! I'm proud of the natural, easy way you made me an 'Atlas Champion!'"

### Let Me Prove I Can Make You a New Man!

Would you like greater development—a muscular body? Then listen: I was once a 97 lb. weakling. Afraid to fight, ashamed to be seen in a swimming suit. Then I discovered the secret that changed me into "World's Most Perfectly Developed Man." My secret is "Dynamic Tension." Its purpose is to give you powerful rippling muscles you like to see in your mirror. And for those with systems sluggish from lack of exercise—to help them tone up their entire body, inside and out.

### Only 15 Minutes a Day

My method—"Dynamic Tension"—will turn the trick for you. No theory—every exercise is practical. And man, so easy! Spend only 15 minutes a day in your own home. From the very start, you'll be using my method of "Dynamic Tension" almost unconsciously every minute of the day—walking, bending over, etc.—to BUILD MUSCLE and VITALITY.

### FREE BOOK "Everlasting Health and Strength"

In it I talk to you in straight-from-the-shoulder language. Packed with inspirational pictures of myself and pupils—fellows who became NEW MEN in strength, my way. Let me show you what I helped THEM do. See what I can do for YOU! For a real thrill, send for this book today. AT ONCE.



**CHARLES ATLAS**,  
Dept. 1-W, 115 E. 23rd St.,  
New York 10, N. Y.

**CHARLES ATLAS**  
Dept. 1-W, 115 East 23rd St., New York 10, N. Y.  
I want proof "Dynamic Tension" will help make me a New Man—with healthy, husky body, big muscle development. Send FREE book, "Everlasting Health and Strength" and details about Trial Offer.

Name \_\_\_\_\_ Age \_\_\_\_\_  
(Please print or write plainly)

Address \_\_\_\_\_

City \_\_\_\_\_ State \_\_\_\_\_

### CHARLES ATLAS

An untouched photo of Charles Atlas, twice winner and holder of the title "The World's Most Perfectly Developed Man."

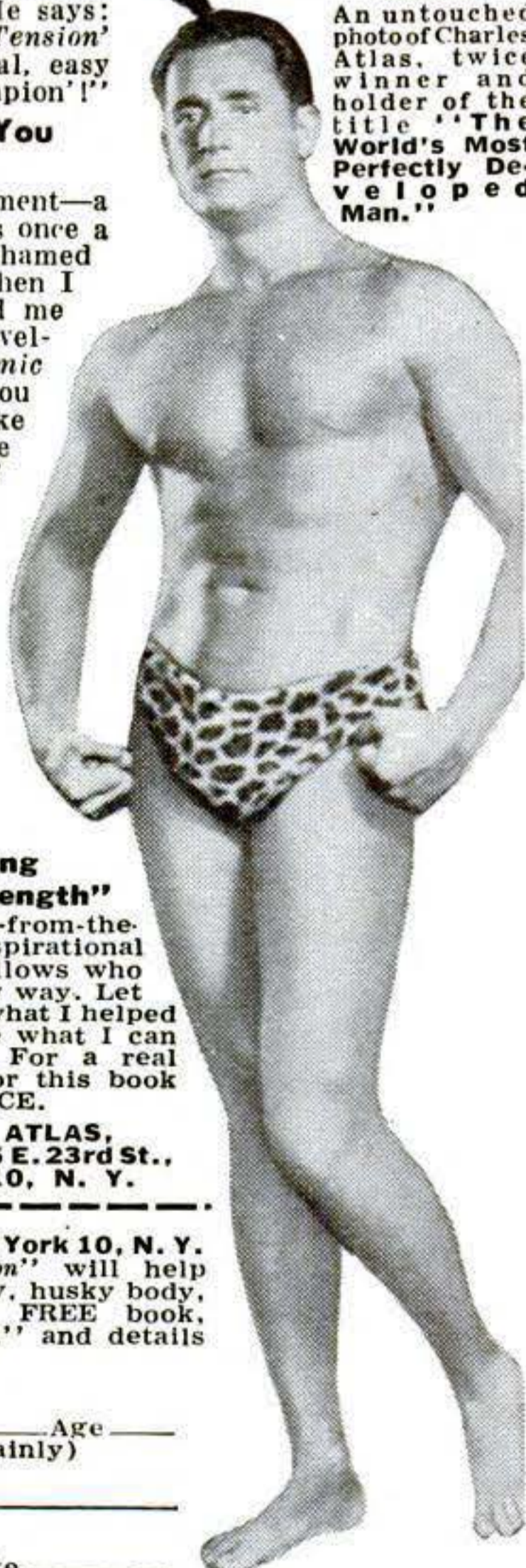

# AVIATION

Aeronautical University Approved Training meets exacting standards of aviation industry, prepares for key positions, big opportunities.

### Courses in:

**AERONAUTICAL ENGINEERING, B.S. degree**  
**AERONAUTICAL ENGINEERING DRAFTING**  
**CERTIFIED AIRPLANE AND ENGINE MECHANICS**  
**ADMINISTRATION—including sales**

**PRE-ENGINEERING:** Special course for high school graduates and veterans needing math and science. Also refresher courses for Gov't Airplane and Engine Mechanics Licenses for those with aviation experience.

Oldest fully approved aviation school. Outstanding faculty, modern equipment, outside employment, placement service. Day, evening. Approved for Veterans. Send for FREE catalog Opportunities in Aviation. 20th anniversary.

**AERONAUTICAL UNIVERSITY**  
Dept. 89, 116 S. Michigan Ave., Chicago 3, Ill.

**FOUNDED BY CURTISS-WRIGHT**

# TRI-STATE COLLEGE

**B. S. DEGREE IN 27 MONTHS**  
66th Year.  
Students from all over the world.

**ENGINEERING**—Courses in Civil, Elec., Mech., Chem., Aeronautical and Radio, Television. Also Bus. Admin., Acc't. and Sec. Science. Visitors welcome. See beautiful campus, well equipped laboratories. Graduates successful. Enter Sept., Jan., March, June. Write for Catalog.  
589 College Avenue, Angola, Indiana

## SELL EXCLUSIVE SUNSHINE CHRISTMAS CARDS

### YOU CAN MAKE MORE MONEY

● With Sunshine's exclusive CHRISTMAS LINE—MADE IN OUR OWN STUDIOS, smartly styled box and imprint creations. Low priced. DeLuxe personal line. SAMPLES ON APPROVAL. Write today. Accept FREE 10 Christmas Gift enclosure cards.

SUNSHINE ART STUDIOS, Dept. PS-8, 115 Fulton St., New York 8, N.Y.

## FREE PLASTIC TRAINING COURSE

Teaches you to make beautiful, valuable plastic articles. Free with each order for \$2.00 of plastic. Clear sparkling Lucite or Plexiglas masked sheets 1/8" x 4" x 11". Four sheets for \$2.00 prepaid and receive training course free. Order today.

PLASTIKITS . . . Lawrence 10, Mich.



## LEARN MEAT CUTTING At Home—In Spare Time

Get into the vital meat industry. Concise, practical Home Training based on 25 years proven instruction methods used at National's famous resident school. Prepares you for bigger pay as Meat Cutter, supervision, market manager or more money in your own store. Go as rapidly as your spare time permits. Diploma. Start NOW to turn your spare hours into money. Send for FREE bulletin today. No obligation.

National School of Meat Cutting Inc., Div. 0-81, Toledo 4, Ohio

## TINY RADIO—REALLY WORKS

### FITS IN YOUR HAND! Works on new

"PERMA-CRYSTAL" so it NEVER NEEDS TROUBLE-SOME TUBES, BATTERIES OR ELECTRIC "PLUG-INS"! Easy to use—Plays for nothing—Should last for years. Beautiful Red Plastic Case.



### GUARANTEED TO WORK

on local programs by following instructions. C.B. of Ala. says "Tiny Radio is just Wonderful!"

**SEND ONLY \$1.00** (bill, ck, mo) and pay postman \$2.99 COD plus postage or send \$3.99 for postpaid delivery. SENT COMPLETE READY TO PLAY on simple attachment. Has personal phone. WONDERFUL GIFTS FOR BOYS & GIRLS. Low priced. Order YOUR Tiny Radio Now!

**MIDWAY COMPANY DEPT. TPS-8 KEARNEY, NEBR.**

# INVENTORS

Patent laws encourage the development of inventions.

We recommend that an inventor employ a registered Patent Attorney or agent, if the inventor is not familiar with patent matters. This is because the value of a patent depends largely upon the skillful preparation of the specification and claims in the patent application.

The firm of McMorrow, Berman and Davidson is registered to practice before the United States Patent Office. Additionally it engages patent attorneys able to readily understand inventors' disclosures, to advise concerning patentability, and to prepare appropriate specifications and claims.

If an inventor believes he has an invention, a search of the most pertinent prior U. S. patents should be made and a report obtained relative to its patentability. Where such report indicates that the invention appears patentable, in order to secure protection, diligence should be exercised in making application for a patent.

Send for a copy of Patent Booklet entitled "How To Protect Your Invention." This booklet contains information on patent protection and procedure. You will also receive an "Invention Record" blank. This will be promptly forwarded to you upon request—no obligation.

## McMORROW, BERMAN & DAVIDSON

*Registered Patent Attorneys*

PATENTS • TRADE MARKS • COPYRIGHTS

1422 VICTOR BUILDING, WASHINGTON 1, D. C.

### McMORROW, BERMAN & DAVIDSON

*Registered Patent Attorneys*

1422 Victor Building, Washington 1, D. C.

Send me your Patent Booklet, "How To Protect Your Invention", and also "Invention Record" form at once. I understand this request does not obligate me.

Name.....

Address.....

City.....

(WRITE OR PRINT NAME CLEARLY)

**Your stepping-stone  
to a BETTER-PAYING  
MACHINIST'S JOB**

Master shop work quickly  
with these books

This big home study and reference course gives you the practical facts on machines and methods you need to advance in machine shop work. Take advantage of the other man's experience as found in books, to solve your problems, increase your efficiency with



**Revised and Enlarged**  
These 6 volumes give you not only accepted methods and practices, but latest developments in machine shop work, enabling you to meet today's shop requirements and needs.

6 volumes, 2645 pages  
2747 illustrations

**THE AMERICAN  
MACHINISTS' LIBRARY**

This library of machine shop practice was written for practical men. It gives you the best methods for every kind of machine shop work. It fully explains lathes, drills, and other machine tools and their operation, automatic screw machines, speeds and feeds, gear design and production, jigs and fixtures, punch and die work, metal surfacing, etc., etc. All plainly written and fully illustrated.

NO MONEY DOWN—Easy payments

**EXAMINATION COUPON**

McGraw-Hill Book Co., Inc., 330 W. 42 St., N.Y.C. 18, N.Y.

Send me for ten days' free examination the AMERICAN MACHINISTS' LIBRARY. If satisfactory I will send you \$3.75 and \$4.00 monthly until the price of \$23.75 is paid. If not wanted I will return books postpaid.

Name .....

Address .....

City.....Zone.....State.....

Company.....

Position..... PSM 8-49

**LEARN AERONAUTICAL ENGINEERING**  
*Aircraft and Engine Mechanics (A & E)*

Train at the Flying Wing school—New classes starting soon. Write for illustrated catalog.

*Northrop Aeronautical Institute*  
APPROVED FOR VETERANS DIVISION OF NORTHROP AIRCRAFT, INC.  
1525 E. Broadway, Hawthorne, Los Angeles County, California

**ENGINEERING DEGREE IN 27 MONTHS**

**Big Demand for Graduates**

AERONAUTICAL, CHEMICAL, CIVIL, ELECTRICAL, MECHANICAL and RADIO ENGINEERING (including Television).

Hundreds of young men are earning engineering degrees in this recognized institution each year—continuous operation. New terms start quarterly. Many students earn a major part of their college expenses in this large industrial center.

Low tuition. Competent instruction. Thorough intense practical program. Modern laboratory facilities including new physics lab. and modernized wind tunnel. Individualized instruction emphasized.

Approved for Veterans. Engineering preparatory courses. Students from 48 states and 21 foreign countries. Enter September, December, March, June. Send coupon for free catalog and full information. Enroll now.

SEND COUPON TODAY

**INDIANA TECHNICAL COLLEGE**

689 E. Washington Boulevard  
Fort Wayne 2, Indiana

Please send me free information on B. S. Engineering. Degree in 27 months as checked.

- Aeronautical,  Chemical,  Civil,  
 Electrical,  Mechanical,  Radio-Television.

Name.....

Address.....

**SHORTHAND  
IN 6 WEEKS**

**LEARN AT HOME—LOW COST**

Write 120 words per minute. Age no obstacle. Famous Speedwriting system. No signs; no symbols; no machines; uses ABC's. Easy to learn and use. Fast preparation for a position. Nationally used in leading offices and Civil Service; also by executives, writers, speakers, lawyers, scientists, students at college. Over 100,000 taught by mail. The very low cost will surprise you. Also typing. 26th year.

WRITE FOR FREE BOOKLET TO

**Speedwriting**  
Dept. 2608-9, 55 W. 42 St., N. Y. 18

**LEARN IN SPARE TIME—  
by Easy PICTURE  
CARTOONING CHART  
METHOD!**

Same Simplified Method that has helped train creators of "Steve Canyon," "Winnie Winkle," "Out Our Way," "Secret Agent X-9," "The Neighbors," "Reg'lar Fellers," "Strange As It Seems," and many others. Send 10c for Picture Chart (to test your ability), and full details. (State age.)

**LANDON SCHOOL OF CARTOONING**  
4928 Cleve. Transit Bldg., Cleveland 14, Ohio



**"YOU ARE UNDER ARREST!"**



**Help Bring Crooks to Justice Through Scientific  
CRIME DETECTION!**

We have taught thousands this exciting, profitable, pleasant profession. Let us teach you in your own home. Learn Finger Printing, Firearms Identification, Police Photography, Secret Service Methods thoroughly, quickly, at small cost. Over 800 of all American Bureaus of Identification employ I. A. S. students or graduates. We can prepare you for this fascinating work during spare time. Write today, stating age, for "Blue Book of Crime."

INSTITUTE OF APPLIED SCIENCE, 1920 Sunnyside Ave., Dept. 136-C, Chicago 40, Ill.

**Jewelry Repair Depts.**

**A GOOD BUY**

Broken Costume Jewelry—Brooches—Pins—Rings—Pearls—Findings—10 pounds..\$10.00

SEND REMITTANCE WITH ORDER

B. LOWE, Holland Bldg., St. Louis, Mo.

**Learn to Service and Repair  
ELECTRICAL APPLIANCES**

Open your own electrical appliance service shop. Complete illustrated course covering washing machines, vacuum cleaners, elec. ranges, motors, house wiring and REFRIGERATION. Appliance tools included. Send today for FREE BOOKLET without obligation.

**PACIFIC TRAINING SCHOOL**

7217 So. Broadway, Dept. S-98, Los Angeles 3, Calif.



**G. I. DIVERS!**

Don't let your training go to waste. Commercial Divers earn up to \$80 a day.

In your spare time you can do odd jobs—clean pools or tanks, retrieve golf balls or outboard motors, locate sunken boats, etc. Very LOW COST complete Gov't surplus EQUIPMENT available—either deep water or shallow water.

Catalog 15c on request

Other marine surplus—sextants, barographs, bells, life preservers, M & T barge units, anchors, etc.

**M & E MARINE SUPPLY CO.** P. O. BOX 601-G  
CAMDEN, NEW JERSEY

GET INTO

# DIESEL-AUTO MECHANICS

Master All Phases

**JOBS LIKE THESE ARE AVAILABLE TO TRAINED MECHANICS. CHOOSE THE FIELD YOU LIKE BEST**

**Get Complete Training**

- Diesel Fuel Injection
- Automotive Motor Tune-up
- Diesel Engine Rebuilding
- General Garage Mechanic
- Agricultural Implements
- Auto Engine Rebuilding
- Auto Elec. Service
- Public Utilities
- Parts Dealers
- Bus & Truck Lines
- Industrial Maintenance
- Contracting & Excavating
- Business of Your Own
- AND MANY other similar openings.

As a National Schools graduate, you are trained for ALL opportunities in the Diesel & Auto Industries.

**EARN WHILE YOU LEARN**

With our practical Master Shop-Method Home Training, you study at home in your spare time. You receive Spare Time Work Lessons, which show you how to earn while you Learn... for extra money and experience. You Learn by DOING.

**TOOLS AND EQUIPMENT**

To make your training complete, we give you selected mechanic's tools and equipment, illustrated below, including all-metal tool-box—as a regular part of your instruction.

**WE GIVE YOU TOOLS OF YOUR TRADE**

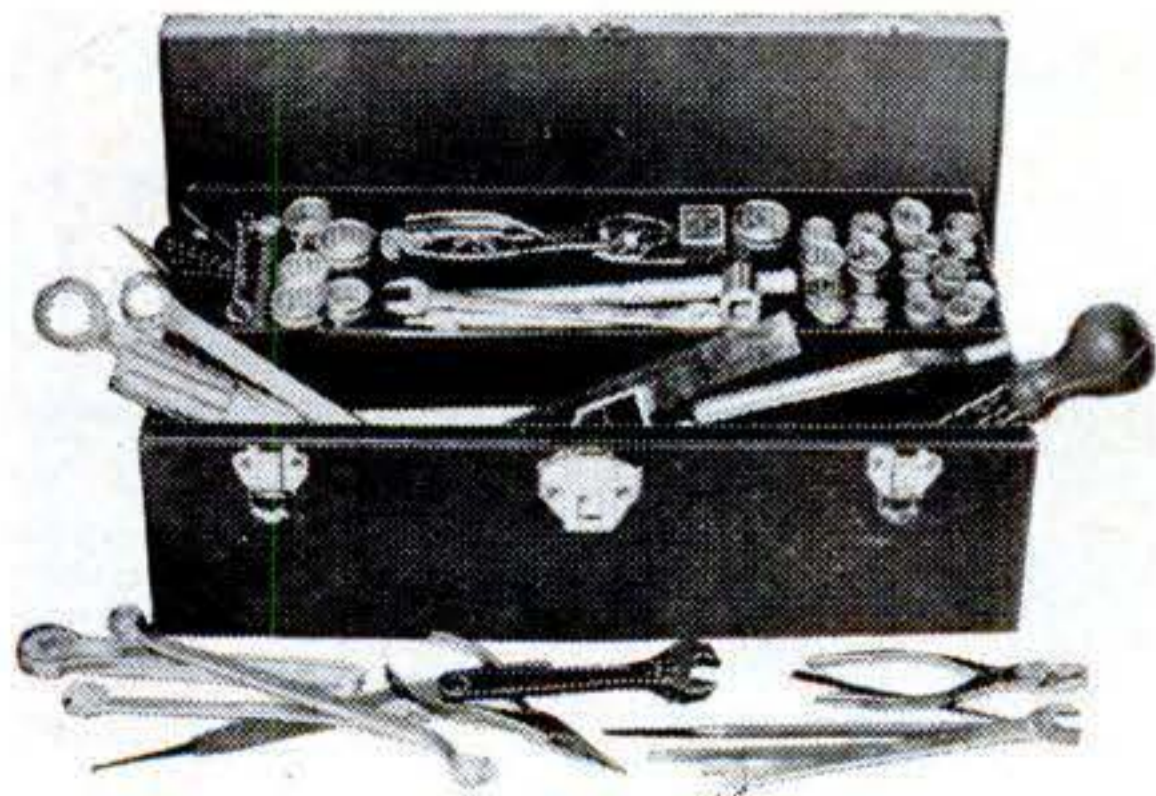

**Shop-Method Home Training by an Established Resident School Prepares you for Many Good Jobs**

Opportunity is everywhere for the trained Diesel - Auto Mechanic. Highways throng with cars, busses, trucks tractors. Garages and Service Stations are kept busy. Factories, ships, farms, railroads, general industry, are dependent upon engine power. Here's a dynamic, fast - growing field that needs trained men who know ALL phases: installation, operation, maintenance and repair. Now—National Schools offers you a practical, all-embracing Diesel-Auto Mechanic's Course, including all of these advantages:

**Complete training, covering—Diesels, High Speed and Heavy Duty; Semi-Diesels, Gasoline and Special Fuel Engines AND Allied Mechanics.**

- Basic Lesson Texts
- Diesel Installation
- Operation—Maintenance
- Diesel Chart Manual
- Spare Time Lessons
- Engine Service Manuals
- Engine Repair
- Drive Systems
- Diesel Electric Power
- Thermodynamics

**TOOLS AND EQUIPMENT INVESTIGATE**

Secure Full Information

**NEW, ILLUSTRATED BOOK & SAMPLE LESSON SHOW HOW WE TRAIN YOU... SEND FOR THEM TODAY!**

**NO COST NO OBLIGATION**



**APPROVED FOR VETERANS**

Check coupon below

**NATIONAL SCHOOLS**  
LOS ANGELES 37, CALIF. • EST. 1905



**FIND OUT NOW... MAIL COUPON TODAY**

NATIONAL SCHOOLS, Dept. 8-PSD  
4000 South Figueroa Street  
Los Angeles 37, California

(Mail in envelope or paste on penny postcard)

Mail me FREE the book, YOUR FUTURE IN DIESEL-AUTO MECHANICS, together with the Sample Lesson. I understand I may keep and use the information with no obligation.

Name..... Age.....

Address.....

City..... Zone... State.....

Check here if Veteran of World War II

# INVENTORS

A patent is a valuable right. On the basis of a provision in the Constitution of the United States, Congress has established a system under which inventors may secure the exclusive right to prevent the unauthorized use, manufacture and sale of their inventions for periods of seventeen years. The inventor secures this protection for his invention by obtaining a patent.

This firm is registered to practice before the U. S. Patent Office and is available to assist inventors in the preparation and prosecution of their cases. Detailed information and the steps to take to obtain patent protection will be furnished upon request.

Form below for mailing convenience

**VICTOR J. EVANS & Co.** *Merlin M. Evans*  
REGISTERED PATENT ATTORNEY

440-J MERLIN BUILDING, WASHINGTON 6, D. C.

• • • • •

VICTOR J. EVANS & CO.  
440-J Merlin Building, Washington 6, D. C.

• Please send me without obligation a copy of your booklet "Patent Protection For Inventors" together with your convenient "Evidence of Invention" form.

• Name.....

• Address.....

• City and State.....

• • • • •

PATENTS TRADEMARKS COPYRIGHTS

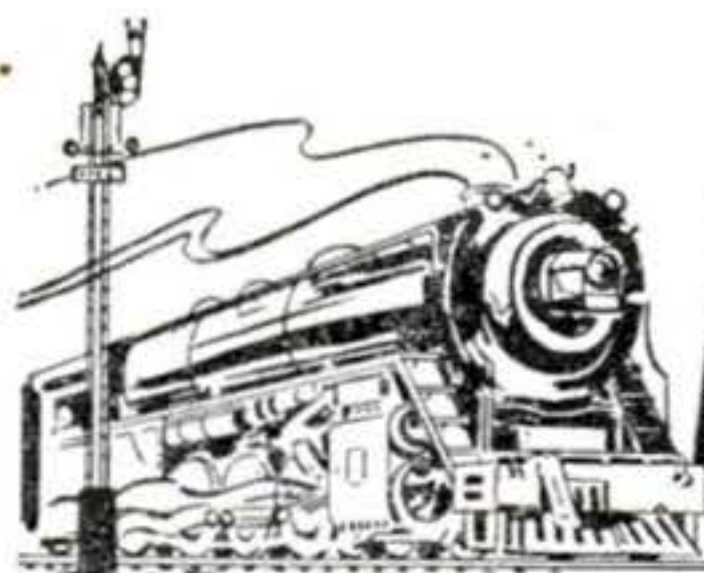

**YOU Can Earn \$280 to \$340 a Month**

More Than 3,000 R. R. Station Agents Needed Now!

Be a railway station agent in 4 to 6 months. Important, responsible work—that's why the salary is high, \$280 to \$340 per month or more. Ask your local R.R. agent about this opportunity. Our placement record of qualified men is 100%. We've placed hundreds; railroads want our trainees and need them—that's why this is one of the best employment opportunities in America today. A dependable school since 1897; located downtown. Start any Monday. Part-time work available. Get all the facts—write today for free booklet. Remember, your success tomorrow depends on your action today!

APPROVED FOR VETERANS

BOYLES COLLEGE—Dept. 18 18th at Harney Omaha, Nebr.

## RADIO ENGINEERING

Television, FM, Broadcasting, Servicing, Electronics, Aviation, Marine & Police Radio taught thoroughly. 72 weeks Engineering course equivalent to 3 years' college radio work. Approved Veteran Training. Catalog upon request.

**VALPARAISO TECHNICAL INSTITUTE**  
Dept. 503 Valparaiso, Ind.

## SHOE REPAIR OFFERS BIG INCOME

LEARN IN 12 WEEKS TIME. You can own your own shop or earn big income as skilled shoe repairman. Growing demand everywhere at top wages for men who know how. We teach you quickly by actually working on shoes and modern machines. School open to all from 18 to 60 years of age. Free Big 20 Page Book explains everything. Send for your copy today. Los Angeles & Chicago Schools only approved for Vets.

**MODERN SHOE REBUILDING SCHOOL**  
Established 1927 Dept. PS  
2937 Belmont Ave., Chicago 361-12th St., Oakland, Calif.  
806 So. Figueroa St., Los Angeles 14, Calif.

## HOW TO CUT RAFTERS

New vest pocket book gives lengths, side cuts, plumb cuts, deductions. For all rafters for any building from one inch to forty feet wide. Gives numbers to cut on square. Also degrees for same cuts for Radial Saws. All standard pitches from 1/8 to 5/8. Just open book to pitch page and there are your lengths, side cuts, etc. Anyone who knows what a jack rafter is can frame a roof if he has this great book. Price \$1.50 prepaid. Builders' Topics, Dept. S, Lock Box 828, Seattle, Washington. CARPENTERS, PLUMBERS, PLASTERERS, ELECTRICIANS, ETC., subscribe for Builders' Topics, the monthly magazine for HE-MAN CONSTRUCTION WORKERS. Only \$2.00 per year. Sample copies 25c.

## ENORMOUS PROFITS CASTING AT HOME

Write today for NEW FREE CATALOG

Learn to cast thousands of perfect figurines, plaques, book ends, ash trays, etc. Start NOW—NO EXPERIENCE, LITTLE CAPITAL needed. Earn GREAT PROFITS with X.L. RUBBER MOLDS. X.L. Rubber. Pts. \$2.00; Qts. \$3.50; Gallons \$8.95; Models and enough rubber for 3 molds \$1.30 postpaid.

PLASTIC ARTS STUDIO Route 5, Dept. 3 MUNCIE, IND.



FREE FACTS SENT

## Learn to MOUNT BIRDS

Tan SKINS, make up FURS

Be a Taxidermist. Double your hunting fun. We teach you at Home. Mount Birds, Animals, Fish, Heads, common specimens. Fun and profits. Decorate home and den MAKE MONEY. Mount game, tan for others. Big profits in spare time. WRITE TODAY. 100 game pictures in FREE BOOK. Hunters, get your copy. It's Now Free. Send post card. State your AGE. NORTHWESTERN SCHOOL OF TAXIDERMY Dept. 2608 Omaha, Nebraska

FREE BOOK

Prepare in our  
Big Training  
Shops for these

# GREAT OPPORTUNITY FIELDS!

**ELECTRICITY** OR **RADIO TELEVISION**



This big fire-proof building is occupied entirely by Coyne.

## FIVE BIG FLOORS PACKED WITH MASSIVE EQUIPMENT

Thousands of men and young men have come to our big training shops where we have floor upon floor packed with massive equipment to train with, to prepare for good jobs and real futures in the opportunity fields of Electricity and Radio-Television. For many years, these fields have offered great opportunities to trained men. With new developments, including Electronics and Television, they will continue to grow and offer even greater opportunities. Why be satisfied with a "no future" job? Many "one operation" jobs that exist today will not last. Prepare for a good job with a real future for steady pay and advancement by training NOW in the great training shops of COYNE in Chicago.

### NOT "HOME-STUDY" COURSES

Our famous Radio-Television Practical-Technical method gives you practical experience on a massive outlay of equipment. Not by correspondence, but actual shop work plus necessary technical training. You are trained right here in the great Coyne shops that have been training men and young men for over 50 years.

## ELECTRICITY RADIO-TELEVISION

### INCLUDING INDUSTRIAL ELECTRONICS

Big future in Power Plant Work, Motors, Armature Winding, Home and Factory Wiring, Appliances, Refrigeration, Maintenance, Illumination, etc. Electricians are in demand everywhere—lifetime job service to Coyne graduates. Send for BIG FREE BOOK.

A great field now, even greater growth ahead. Here at COYNE you're trained for Construction, Testing, Trouble-Shooting on Radio, Public Address, Sound Units. Training includes FM, Television Servicing, etc. Many Coyne trained men in good jobs or own well paying Radio-Television businesses of their own.

### ELECTRIC REFRIGERATION

This valuable training now included with either course means added opportunities.

### G. I. APPROVED

NON-VETERANS who are short of cash can finance most of their tuition and pay in easy monthly payments after graduation. Many earn while learning.

B. W. COOKE, President

**COYNE ELECTRICAL AND RADIO SCHOOL**  
500 So. Paulina St., Dept. C9-73H, Chicago 12, ILL.

## LARGEST, OLDEST, BEST EQUIPPED SCHOOL OF ITS KIND IN THE U.S.

### Mail Coupon for Big FREE Book!

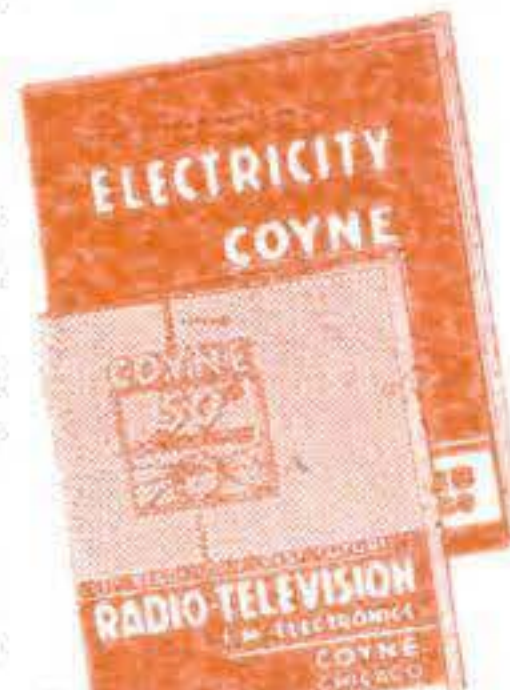

Whether you prefer Electricity, or Radio-Television, train on actual equipment at Coyne. We have a big, fully illustrated book on each course, and we'll send you the one you want, or both if you want to consider both fields, without obligation. Mail coupon—TODAY.

B. W. Cooke, President  
COYNE ELECTRICAL AND RADIO SCHOOL  
500 S. Paulina St., Dept. C9-73H, Chicago 12, Ill.

Send me the book, or books, checked below and details of your training offer. This does not obligate me and no salesman will call.

ELECTRICITY  RADIO-TELEVISION

NAME.....

ADDRESS.....

CITY..... STATE.....

BE A **WINNER** AT ANYTHING YOU TACKLE WITH **PROGRESSIVE POWER**

DARLING, THAT BULLY WON'T PICK ON YOU AGAIN.

JOE YOUR NEW ENERGY AND APPEARANCE SURE DO A GOOD JOB! YOU EARNED YOUR PROMOTION.

**10c**

Instead of \$1 For all 5 Courses



George F. Jowett

whom experts call "Champion of Champions" • World's wrestling and weight lifting champ at 17 and 19 • World's Strongest Arms • 4 times World's Perfect Body—plus other records!

**10 DAY TRIAL!** Think of it—all five of these famous courses now in one picture-packed muscle-building volume for only 10c. If you don't actually FEEL results within ONE WEEK, send it back and your money will be promptly refunded!

**PHOTO BOOK OF FAMOUS STRONG MEN!**

**FREE!**



Photos that inspire you to might and muscle. Free with order.

Let's Go, Pal! I'll prove I can make YOU an **"ALL-AROUND" HE-MAN**

**FAST—OR NO COST!** says George F. Jowett World's Greatest Body Builder

Enjoy My "Progressive Power" Strength Secrets! Give Me 10 Easy Minutes a Day—Without Strain!

I'll teach you the "Progressive Power Method" through which I rebuilt myself from a physical wreck the doctors condemned to die at 15, to the holder of more strength records than any other living athlete or teacher! "Progressive Power" has proven its ability to build the strongest, handsomest men in the world. And I stand ready to show you on a money back basis—that no matter how flabby or puny you are I can do the same for you right in your own home. Let me prove I can add inches to your arms, broaden your shoulders, give you a man-sized chest, powerful legs and a Rock-like back—in fact, power pack your whole body so quickly it will amaze you! Yes, I'll jam you with power and confidence to master any situation—to win popularity—and to get ahead on the job! Through my proven secrets I bring to life new power in you inside and out, until YOU are fully satisfied you are the man you want to be.

**PROVE IT TO YOURSELF IN ONE NIGHT** Send only 10c for my 5 easy-to-follow, picture-packed courses now in 1 complete volume "How to Become a Muscular He-Man." Try it for one night! Experience the thrilling strength that surges through your muscles.

I am making a drive for thousands of new friends fast—REGARDLESS OF COST!

**SO GET NOW MY 5 Muscle Building COURSES** (Valued at \$5 each)

All in 1 Great Complete Volume Packed With How-To-Do-It Pictures! For **10c**

Now, this "get-acquainted," extremely low price of only 10c is your chance to build a body you'll be proud of! Follow Jowett's easy method of muscle building NOW!

HOW TO MOLD A MIGHTY LEG  
HOW TO MOLD A MIGHTY BACK  
HOW TO MOLD A MIGHTY CHEST  
HOW TO MOLD A MIGHTY ARM  
HOW TO MOLD A MIGHTY GRIP

**How to BECOME A MUSCULAR HE-MAN**

With these 5 Complete Courses  
1. A Mighty Arm  
2. A Mighty Chest  
3. A Mighty Back  
4. A Mighty Leg  
5. Mighty Grip

**FREE GIFT COUPON!**

Jowett Institute of Physical Culture Dept. PS-98 230 Fifth Avenue, New York 1, N. Y.

Dear George:—Please send by return mail, prepaid, FREE Jowett's Photo Book of Strong Men, along with all 5 Muscle Building Courses. 1. Molding a Mighty Chest. 2. Molding a Mighty Arm. 3. Molding a Mighty Grip. 4. Molding a Mighty Back. 5. Molding Mighty Legs—Now all in One Volume "How to Become a Muscular He-Man." Enclosed find 10c for postage and handling. NO C.O.D.'s.

George F. Jowett  
Champion of Champions

NAME..... AGE.....

ADDRESS.....

**MODERN LAWN MOWER SHARPENER**

**FOR LAWN MOWER SHOPS**  
**GOLF COURSES • PARKS**  
**101 OTHER JOBS**

PRICE **\$241.50** less motor  
**\$263.00** with motor

Sharpens All Reel Type Mowers • Hand, Power or Gang • 10 to 20 Minutes • No Dismantling • No Extra Attachments Needed.

All reel type mowers, from 5-inch edgers to 36-inch power mowers, are quickly sharpened to extreme ends of both left and right twist blades. Handle, wheels, roller and motor remain in place when sharpening is in process. Bed knife is sharpened in same brackets. Grinding head rides on five ball bearing races. Easy to operate. Also sharpens chisels, joiner knives, planer blades. Big profit maker. Own your own business. Send Today for **FREE Illustrated Bulletin No. 11-C1**

**ORDER NOW**  
Immediate Delivery

**MODERN MFG. CO.** 160 N. FAIR OAKS AVE PASADENA 1, CALIFORNIA

**LEARN TO HYPNOTIZE**

Yes, anyone. Modern speed hypnotism. Methods revealed. Step by step you are told exactly what to say and do. Many interesting experiments. Self-hypnosis. Private & class instruction also available.

Send for **HYPNOTISM REVEALED** \$2

12" Hypnotism record inducing Group-Hypnotism & Self-Hypnosis.....\$5.

MELVIN POWERS, Professional Hypnotist, 1324 Wilshire Dept. 58, Hollywood 14, Calif

**FREE BOOKLET—For Those Who Suffer From TOOTH DECAY!**

**Tells What You Can Do About It**

Learn the amazing story of Deaf Smith County, Texas, where tooth decay is practically unknown. The booklet, "The Trail Began in Texas," will be sent you absolutely free. Just write your name and address on a penny postcard and mail to: L. M. & W. Company, Box 309-D, Marshall, Mich.

**WAR SURPLUS BARGAINS**

Substantial Savings on **WAR SURPLUS** and other MERCHANDISE **OVER 200 TIMELY ITEMS**

**SEND FOR FREE CIRCULAR**

**SIoux FALLS SURPLUS STORE**  
SIoux FALLS S.D.

**DIESEL TRAINING**

Get set NOW for steady, big-pay jobs in Diesel, Tractor and Heavy Equipment. Interstate's practical home training gives you the "know-how" for success and security. Investigate!

**SEND POST CARD FOR FREE INFORMATION**

**INTERSTATE TRAINING SERVICE**

Dept. 2-H 4035 N.E. SANDY BLVD., PORTLAND 13, OREGON

**Powerful MIDGET RADIO**  
"Outperforms them all"

No Tubes!  
No Batteries!  
No Plug-ins!

Complete, ready to play. Nothing else to buy!

Plays anywhere! No electricity needed. Carry it in your pocket. Guaranteed to play on local stations. Costs nothing to run. Lasts indefinitely. Patented electronic power unit gives sensitive big-radio clearness and tone. Handsome red plastic 6x3x1" case; single control tuning. Includes everything—radio, 50 ft. antenna, lead-in, ground wire, insulators, super-sensitive headphones. All for \$5.

**SEND \$1 ONLY** Pay postman \$4 balance, plus small C.O.D. charge and postage. Hurry, order now.

**PATRICK LABORATORIES**  
P. O. Box 5308-B Indianapolis, Ind.



# Specialize in fields of opportunity

**EVERY** course of study at this school is geared to an expanding industry. Here the young man can secure practical, specialized training in various technical fields, plus a solid educational background in the basic sciences. The curricula keeps pace with technological developments and the demands of industry.

## BUILD YOUR CAREER IN 6 TO 36 MONTHS . . .

Because of continuous year-round study, a B.S. Degree may be earned in 36 months. The unique concentric curriculum permits the student to pass step-by-step through a 6-month

service course and on to technician and professional levels. Each course is complete in itself and serves as a prerequisite for higher level study in the school.

**To Help Plan Your Future . . . You are Invited to Request This Free 48-Page Pictorial Bulletin**

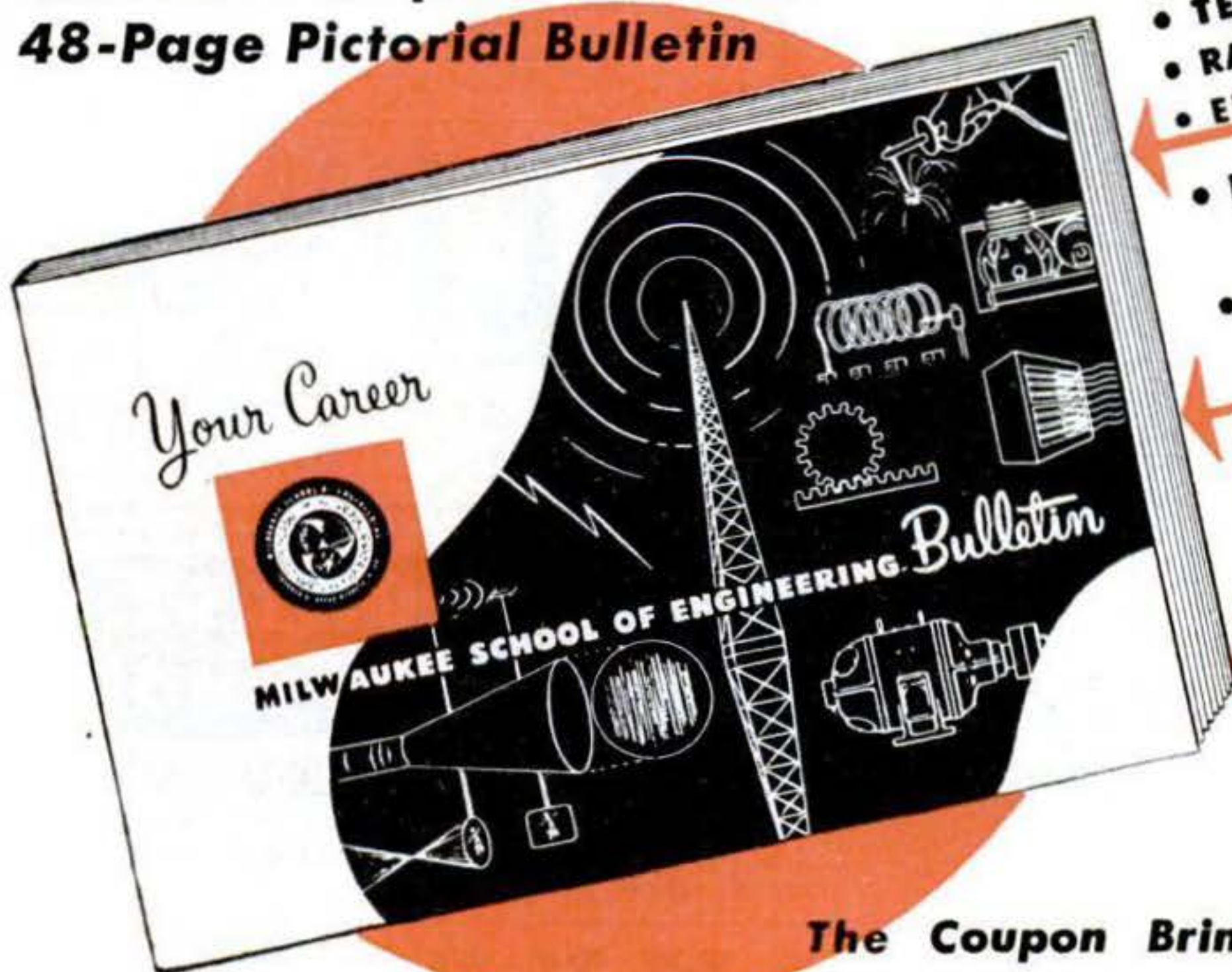

- TELEVISION
- RADIO
- ELECTRONICS
- ELECTRICAL POWER
- ELECTRICAL ENGINEERING
- AIR CONDITIONING
- REFRIGERATION
- HEATING
- WELDING
- METAL FABRICATION

### The Coupon Brings You This . . .

The above new pictorial bulletin features 103 action photos of student life, fascinating experiments and well-equipped laboratories. Helpful data is featured on career opportunities in the above mentioned fields.



**OVER 1500 STUDENTS** are currently enrolled in this non-profit institution. Faculty of 85 specialists. Experts chosen from private business serve on advisory committees. The Board of Regents comprises leaders from commerce and industry. Over 35,000 former students.

**ACCREDITATION:** The National Council of Technical Schools approves the technician's curricula. Technician courses in the Institute of Electrotechnics are accredited by E.C.P.D. Certificates and degrees conferred by authority of the State of Wisconsin Charter.

**MILWAUKEE SCHOOL of ENGINEERING**  
*Founded 1903 by Oscar Werwath*

Terms start  
 Oct., Jan.  
 April, July

**MILWAUKEE SCHOOL OF ENGINEERING**  
 Dept. PSM-849, N. Broadway & E. State,  
 Milwaukee, Wis.

Without obligation send me free bulletin "Your Career" and more details on course in

Send 110-Page Catalog

NAME.....AGE.....

ADDRESS.....

CITY.....ZONE...STATE....

Check here if World War II Veteran

# INVENTORS

When you are satisfied that you have invented a matter of value—write me, without obligation, for full information as to what steps you should take to secure a Patent. The usual first step is to have a search of the prior U.S. Patents conducted, so that I can report to you on the question of Patentability.

**PATRICK D. BEAVERS**  
(Formerly RANDOLPH & BEAVERS)  
Registered Patent Attorney

937 Columbian Building, Washington 1, D. C.

**PATRICK D. BEAVERS**, Registered Patent Atty.  
937 Columbian Bldg., Washington 1, D. C.

Please send me full information on how to secure Patents & Trademark Registration.

Name.....

Street.....

City..... State.....

## WHY DON'T YOU WRITE?

Writing short stories, articles on business, travel, shop crafts, sports, local and club activities, etc., will enable you to earn extra money. In your own home, on your own time, the New York Copy Desk Method teaches you how to write the way newspaper men learn—by writing. Our unique "Writing Aptitude Test" tells whether you possess the fundamental qualities essential to successful writing. You'll enjoy this test. Write for it, without cost or obligation.

**Veterans: This course approved for Veterans' Training.**  
**NEWSPAPER INSTITUTE OF AMERICA**  
SUITE 5729-M, ONE PARK AVENUE, NEW YORK 16, N. Y.



**AIRCRAFT MECHANICS • AIRCRAFT DESIGN**  
September Classes Filling Rapidly  
Limited Enrollment . . . ENROLL NOW!

Modern, practical courses prepare you for jobs in all phases of airplane maintenance and manufacture. Our comprehensive airplane designing course includes thorough design practice plus extensive laboratory experience.

### DAY and EVENING CLASSES

Completely equipped airline-type shops and laboratories. Living quarters available. Our graduates employed all over the world since 1932.



High School Diploma Required.  
For complete information,  
write for Catalog P

**ACADEMY OF AERONAUTICS**  
LaGUARDIA AIRPORT, NEW YORK

**"TAPPY" gives bottled beer that tangy draft beer taste!**

**ONLY \$1.50**  
FITS ALL SIZE BEER BOTTLES  
Made of shiny-clean Aluminum—unbreakable.  
Made for your satisfaction.

Here's how, with TAPPY! Open bottle, slip TAPPY on top, and pour. You get a glass of smooth, creamy-head beer, with real draft-beer tang and flavor you like. TAPPY lasts a lifetime! TAPPY is always ready for use! Rinse under faucet & it's clean! **WRITE TODAY!** Order one for yourself...order more as presents for your friends.

**MODEL PATENT MFG. CO.** 521 Majestic Bldg. Denver 2, Colorado

**PATENTS AND TRADE MARKS**  
**C. A. SNOW & CO.**  
REGISTERED PATENT ATTORNEYS  
WRITE FOR INFORMATION TO  
246 SNOW BUILDING, WASHINGTON 1, D. C.

**HELP FOR INVENTORS**  
Hundreds of manufacturers have requested our assistance in locating marketable new products.  
Complete information, free.  
**INSTITUTE of AMERICAN INVENTORS**  
Dept. 3, 1926 Eye St. N.W., Washington 6, D. C.

**HIGHEST ROYALTIES and CASH**  
**FOR YOUR INVENTIONS**  
Write for FREE booklet without obligation  
**UNIVERSAL MARKETING CO.**  
354 S. Spring St. (Suite C) Los Angeles 13, Calif.

**INVENTORS**  
Whether an invention is patentable can be substantially determined by a search of the U. S. Patent records. Without obligation, write for information explaining the steps you should take to secure a patent.  
**JOHN N. RANDOLPH**  
Registered Patent Attorney  
205 Columbian Building Washington 1, D. C.

**INVENTORS**  
IF YOU WISH TO PROTECT YOUR INVENTION, You should take steps to protect it by a U. S. Patent. Write me for "Record of Invention" form.  
**CARL MILLER**  
REGISTERED PATENT ATTORNEY  
Woolworth Bldg., 35th Floor, Dept. 89-C, New York City  
Please send me "Record of Invention" form.  
NAME.....  
ADDRESS.....



**USE IT  
OR  
LOSE IT!**

### Veterans:

This lifeline has a *deadline!* Grasp it and you're on your way to greater job security, more responsible work, higher pay. Delay and you're apt to lose out. For training under the G. I. Bill is a limited offer. To benefit you've got to *act.*

You have 400 famous I.C.S. Courses to choose from. The coupon brings full information. Take a minute *right now* to check the course that interests *you.*

## INTERNATIONAL CORRESPONDENCE SCHOOLS



BOX 7636-M, SCRANTON 9, PENNA.

Without cost or obligation, please send me full particulars about the course BEFORE which I have marked X:

- |                                                                                                                                                                                                                                                                                                                                                                                                                                                                                                                                                                                                                                                                                                                                                                                                                                                                                                                                                                                                                                                                                                                                                                                                                                                                                                                                                                                                                                            |                                                                                                                                                                                                                                                                                                                                                                                                                                                                                                                                                                                                                                                                                                                                                                                                                                                                                                                                                                                                                                                                                                                                                                                                                                                                                                                                                                                                               |                                                                                                                                                                                                                                                                                                                                                                                                                                                                                                                                                                                                                                                                                                                                                                                                                                                                                                                                                                                                                                                                                                                                                                                                                                                                                                                                                                                                                                                                                                                                                                                                                                                                                                                                                                                                                                                                                                                             |                                                                                                                                                                                                                                                                                                                                                                                                                                                                                                                                                                                                                                                                                                                                                                                                                                                                                                                                                                                                                                                                                                                                                                                                                                                                                                                                                                                                                                                                                                                                                                                                                                                                                                                                                           |
|--------------------------------------------------------------------------------------------------------------------------------------------------------------------------------------------------------------------------------------------------------------------------------------------------------------------------------------------------------------------------------------------------------------------------------------------------------------------------------------------------------------------------------------------------------------------------------------------------------------------------------------------------------------------------------------------------------------------------------------------------------------------------------------------------------------------------------------------------------------------------------------------------------------------------------------------------------------------------------------------------------------------------------------------------------------------------------------------------------------------------------------------------------------------------------------------------------------------------------------------------------------------------------------------------------------------------------------------------------------------------------------------------------------------------------------------|---------------------------------------------------------------------------------------------------------------------------------------------------------------------------------------------------------------------------------------------------------------------------------------------------------------------------------------------------------------------------------------------------------------------------------------------------------------------------------------------------------------------------------------------------------------------------------------------------------------------------------------------------------------------------------------------------------------------------------------------------------------------------------------------------------------------------------------------------------------------------------------------------------------------------------------------------------------------------------------------------------------------------------------------------------------------------------------------------------------------------------------------------------------------------------------------------------------------------------------------------------------------------------------------------------------------------------------------------------------------------------------------------------------|-----------------------------------------------------------------------------------------------------------------------------------------------------------------------------------------------------------------------------------------------------------------------------------------------------------------------------------------------------------------------------------------------------------------------------------------------------------------------------------------------------------------------------------------------------------------------------------------------------------------------------------------------------------------------------------------------------------------------------------------------------------------------------------------------------------------------------------------------------------------------------------------------------------------------------------------------------------------------------------------------------------------------------------------------------------------------------------------------------------------------------------------------------------------------------------------------------------------------------------------------------------------------------------------------------------------------------------------------------------------------------------------------------------------------------------------------------------------------------------------------------------------------------------------------------------------------------------------------------------------------------------------------------------------------------------------------------------------------------------------------------------------------------------------------------------------------------------------------------------------------------------------------------------------------------|-----------------------------------------------------------------------------------------------------------------------------------------------------------------------------------------------------------------------------------------------------------------------------------------------------------------------------------------------------------------------------------------------------------------------------------------------------------------------------------------------------------------------------------------------------------------------------------------------------------------------------------------------------------------------------------------------------------------------------------------------------------------------------------------------------------------------------------------------------------------------------------------------------------------------------------------------------------------------------------------------------------------------------------------------------------------------------------------------------------------------------------------------------------------------------------------------------------------------------------------------------------------------------------------------------------------------------------------------------------------------------------------------------------------------------------------------------------------------------------------------------------------------------------------------------------------------------------------------------------------------------------------------------------------------------------------------------------------------------------------------------------|
| <ul style="list-style-type: none"> <li><input type="checkbox"/> Air Conditioning and Plumbing Courses</li> <li><input type="checkbox"/> Air Conditioning</li> <li><input type="checkbox"/> Heating</li> <li><input type="checkbox"/> Refrigeration</li> <li><input type="checkbox"/> Chemistry Courses</li> <li><input type="checkbox"/> Chemical Engineering</li> <li><input type="checkbox"/> Chemistry, Analytical</li> <li><input type="checkbox"/> Chemistry, Industrial</li> <li><input type="checkbox"/> Chemistry, Mfg. Iron &amp; Steel</li> <li><input type="checkbox"/> Petroleum Refining</li> <li><input type="checkbox"/> Pulp and Paper Making</li> <li><input type="checkbox"/> Civil Engineering, Architectural and Mining Courses</li> <li><input type="checkbox"/> Architecture</li> <li><input type="checkbox"/> Architectural Drafting</li> <li><input type="checkbox"/> Bridge and Building Foreman</li> <li><input type="checkbox"/> Building Estimating</li> <li><input type="checkbox"/> Civil Engineering</li> <li><input type="checkbox"/> Coal Mining</li> <li><input type="checkbox"/> Contracting and Building</li> <li><input type="checkbox"/> Highway Engineering</li> <li><input type="checkbox"/> Lumber Dealer</li> <li><input type="checkbox"/> Reading Structural Blueprints</li> <li><input type="checkbox"/> Sanitary Engineering</li> <li><input type="checkbox"/> Structural Drafting</li> </ul> | <ul style="list-style-type: none"> <li><input type="checkbox"/> Plumbing</li> <li><input type="checkbox"/> Steam Fitting</li> <li><input type="checkbox"/> Plastics</li> <li><input type="checkbox"/> Electronics</li> <li><input type="checkbox"/> Practical Telephony</li> <li><input type="checkbox"/> Radio, General</li> <li><input type="checkbox"/> Radio Operating</li> <li><input type="checkbox"/> Radio Servicing</li> <li><input type="checkbox"/> Telegraph Engineering</li> <li><input type="checkbox"/> Electrical Courses</li> <li><input type="checkbox"/> Electrical Drafting</li> <li><input type="checkbox"/> Electrical Engineering</li> <li><input type="checkbox"/> Electric Light and Power</li> <li><input type="checkbox"/> Lighting Technician</li> <li><input type="checkbox"/> Practical Electrician</li> <li><input type="checkbox"/> Internal Combustion Engines Courses</li> <li><input type="checkbox"/> Auto Technician</li> <li><input type="checkbox"/> Diesel-Electric</li> <li><input type="checkbox"/> Diesel Engines</li> <li><input type="checkbox"/> Mechanical Courses</li> <li><input type="checkbox"/> Aeronautical Engineer's, Jr.</li> <li><input type="checkbox"/> Aircraft Drafting</li> <li><input type="checkbox"/> Forging</li> <li><input type="checkbox"/> Heat Treatment of Metals</li> <li><input type="checkbox"/> Industrial Engineering</li> </ul> | <ul style="list-style-type: none"> <li><input type="checkbox"/> Communications Courses</li> <li><input type="checkbox"/> Ship Fitting</li> <li><input type="checkbox"/> Toolmaking</li> <li><input type="checkbox"/> Aviation</li> <li><input type="checkbox"/> Gas Engines</li> <li><input type="checkbox"/> Flight Engineer</li> <li><input type="checkbox"/> Foundry Work</li> <li><input type="checkbox"/> Industrial Metallurgy</li> <li><input type="checkbox"/> Machine Shop</li> <li><input type="checkbox"/> Mechanical Drafting</li> <li><input type="checkbox"/> Mechanical Engineering</li> <li><input type="checkbox"/> Mold-Loft Work</li> <li><input type="checkbox"/> Patternmaking—Wood, Metal</li> <li><input type="checkbox"/> Reading Shop Blueprints</li> <li><input type="checkbox"/> Sheet-Metal Drafting</li> <li><input type="checkbox"/> Sheet-Metal Worker</li> <li><input type="checkbox"/> Ship Drafting</li> <li><input type="checkbox"/> Tool Designing</li> <li><input type="checkbox"/> Welding Engineering</li> <li><input type="checkbox"/> Welding—Gas and Electric</li> <li><input type="checkbox"/> Railroad Courses</li> <li><input type="checkbox"/> Air Brake</li> <li><input type="checkbox"/> Diesel Locomotive</li> <li><input type="checkbox"/> Locomotive Engineer</li> <li><input type="checkbox"/> Locomotive Fireman</li> <li><input type="checkbox"/> Locomotive Machinist</li> <li><input type="checkbox"/> Railroad Section Foreman</li> <li><input type="checkbox"/> Steam Engineering Courses</li> <li><input type="checkbox"/> Boilermaking</li> <li><input type="checkbox"/> Combustion Engineering</li> <li><input type="checkbox"/> Engine Running</li> <li><input type="checkbox"/> Marine Engineering</li> <li><input type="checkbox"/> Steam Electric</li> <li><input type="checkbox"/> Car Inspector</li> <li><input type="checkbox"/> Steam Engr.</li> </ul> | <ul style="list-style-type: none"> <li><input type="checkbox"/> Textile Courses</li> <li><input type="checkbox"/> Cotton Manufacturing</li> <li><input type="checkbox"/> Loom Fixing</li> <li><input type="checkbox"/> Textile Designing</li> <li><input type="checkbox"/> Woolen Manufacturing</li> <li><input type="checkbox"/> Rayon Weaving</li> <li><input type="checkbox"/> Business and Academic Courses</li> <li><input type="checkbox"/> Accounting</li> <li><input type="checkbox"/> Bookkeeping</li> <li><input type="checkbox"/> Business Administration</li> <li><input type="checkbox"/> Business Correspondence</li> <li><input type="checkbox"/> Certified Public Accounting</li> <li><input type="checkbox"/> Commercial</li> <li><input type="checkbox"/> Cost Accounting</li> <li><input type="checkbox"/> Federal Tax</li> <li><input type="checkbox"/> Foremanship</li> <li><input type="checkbox"/> Good English</li> <li><input type="checkbox"/> Higher Mathematics</li> <li><input type="checkbox"/> Motor Traffic</li> <li><input type="checkbox"/> Retailing</li> <li><input type="checkbox"/> Retail Store Management</li> <li><input type="checkbox"/> Salesmanship</li> <li><input type="checkbox"/> Sign Lettering</li> <li><input type="checkbox"/> Spanish</li> <li><input type="checkbox"/> Advertising</li> <li><input type="checkbox"/> Commercial Art</li> <li><input type="checkbox"/> First Year College</li> <li><input type="checkbox"/> French</li> <li><input type="checkbox"/> High School</li> <li><input type="checkbox"/> Postal Civil Service</li> <li><input type="checkbox"/> Secretarial</li> <li><input type="checkbox"/> Stenography</li> <li><input type="checkbox"/> Traffic Management</li> </ul> |
|--------------------------------------------------------------------------------------------------------------------------------------------------------------------------------------------------------------------------------------------------------------------------------------------------------------------------------------------------------------------------------------------------------------------------------------------------------------------------------------------------------------------------------------------------------------------------------------------------------------------------------------------------------------------------------------------------------------------------------------------------------------------------------------------------------------------------------------------------------------------------------------------------------------------------------------------------------------------------------------------------------------------------------------------------------------------------------------------------------------------------------------------------------------------------------------------------------------------------------------------------------------------------------------------------------------------------------------------------------------------------------------------------------------------------------------------|---------------------------------------------------------------------------------------------------------------------------------------------------------------------------------------------------------------------------------------------------------------------------------------------------------------------------------------------------------------------------------------------------------------------------------------------------------------------------------------------------------------------------------------------------------------------------------------------------------------------------------------------------------------------------------------------------------------------------------------------------------------------------------------------------------------------------------------------------------------------------------------------------------------------------------------------------------------------------------------------------------------------------------------------------------------------------------------------------------------------------------------------------------------------------------------------------------------------------------------------------------------------------------------------------------------------------------------------------------------------------------------------------------------|-----------------------------------------------------------------------------------------------------------------------------------------------------------------------------------------------------------------------------------------------------------------------------------------------------------------------------------------------------------------------------------------------------------------------------------------------------------------------------------------------------------------------------------------------------------------------------------------------------------------------------------------------------------------------------------------------------------------------------------------------------------------------------------------------------------------------------------------------------------------------------------------------------------------------------------------------------------------------------------------------------------------------------------------------------------------------------------------------------------------------------------------------------------------------------------------------------------------------------------------------------------------------------------------------------------------------------------------------------------------------------------------------------------------------------------------------------------------------------------------------------------------------------------------------------------------------------------------------------------------------------------------------------------------------------------------------------------------------------------------------------------------------------------------------------------------------------------------------------------------------------------------------------------------------------|-----------------------------------------------------------------------------------------------------------------------------------------------------------------------------------------------------------------------------------------------------------------------------------------------------------------------------------------------------------------------------------------------------------------------------------------------------------------------------------------------------------------------------------------------------------------------------------------------------------------------------------------------------------------------------------------------------------------------------------------------------------------------------------------------------------------------------------------------------------------------------------------------------------------------------------------------------------------------------------------------------------------------------------------------------------------------------------------------------------------------------------------------------------------------------------------------------------------------------------------------------------------------------------------------------------------------------------------------------------------------------------------------------------------------------------------------------------------------------------------------------------------------------------------------------------------------------------------------------------------------------------------------------------------------------------------------------------------------------------------------------------|

Name \_\_\_\_\_ Age \_\_\_\_\_ Home Address \_\_\_\_\_

City \_\_\_\_\_ State \_\_\_\_\_ Working Hours \_\_\_\_\_ A.M. to \_\_\_\_\_ P.M.

Present Position \_\_\_\_\_ Employed by \_\_\_\_\_

Length of Service in World War II \_\_\_\_\_ Enrollment under G.I. Bill and P.L. 16 approved for World War II Veterans. Special tuition rates to members of the Armed Forces. Canadian residents send coupon to International Correspondence Schools Canadian, Ltd., Montreal, Canada.

Here's How CREI Prepares You for a Professional Career with Industry-Recognized Training in a Minimum of Time

## RADIO-ELECTRONICS TELEVISION ENGINEERING

Graduates of CREI residence school are preferred by industry because of their *training and ability*. This recognition is the reason that CREI men quickly find good jobs. With 22 years of practical teaching experience in these highly technical fields, CREI offers an outstanding faculty, modern and complete laboratories, shops and equipment. New students are accepted twice monthly and each may advance as rapidly as he is capable. The basic course with one specialized course requires an average of 20 months to complete. CREI is recognized as one of the country's leading technical institutes. Its work is of college level. It prepares the young man for a good job in industry in a minimum of time.



Approved for Veteran's Training

### CAPITOL RADIO ENGINEERING INSTITUTE

An Accredited Technical Institute Founded in 1927

#### Mail coupon for Free Catalog

Capitol Radio Engineering Institute, Dept. 188A  
16th & Park Road, N.W., Washington 10, D. C.

Please send me your residence school catalog and complete details.  
(If interested in Home Study check below)

Name..... Age.....

Street.....

City..... Zone..... State.....

I am entitled to training under G.I. Bill

Send information on Home Study Courses

## TELEVISION SIMPLIFIED

by MILTON S. KIVER

Here is the book that brings the tremendous opportunities in the field of television within your reach. Authoritative, up to the minute, and crystal clear, this great handbook covers troubleshooting and repair. Hundreds of vivid illustrations show every part, every circuit—how they are built, the roles they play and their operating characteristics. **EXAMINE IT FREE!**

#### MAIL THIS COUPON

D. VAN NOSTRAND COMPANY, INC. Pop. Sci. 8-49  
250 Fourth Avenue, New York 3, New York

Please send me "Television Simplified." Within 10 days I will either return the book or send you \$2.00 after examination and \$2.00 a month for two months (\$6.00 in all) plus a few cents postage.

Name.....

Address.....

City..... State.....



**SUCCESS-SECURITY-RESPECT**  
as a Master Watchmaker!

APPROVED FOR VETERAN TRAINING

Learn today's top mechanical profession at the world's largest, best-equipped school of its kind. Individual instruction, day or evening classes. You graduate with complete watchmakers' tools, ready to start your own business or work for established jewelers.

SEND FOR FREE 116-PAGE INFORMATION PACKET

**WESTERN PENNSYLVANIA  
HOROLOGICAL INSTITUTE**

WORLD'S LARGEST WATCHMAKING SCHOOL



Desk 39, 808 Ridge Ave., Pittsburgh, Pa.

26 POPULAR SCIENCE

## OWN Your Own Business



PATENTED PORTABLE EQUIPMENT

## Lifetime Income

Clean and Mothproof rugs and upholstery "in the home" or public buildings. Start full or part time. Gross profits up to \$15 and \$20 a day on EACH service man. Easy to learn . . . quickly established.

**DURACLEAN** cleans by absorption! No scrubbing, soaking or shrinkage. Dirt and grease vanish . . . matted pile rises . . . colors revive. Furnishings used again same day.

**DURAPROOF** resists moths and carpet beetles. Your service backed by a National Money Back 4 Year Warranty.

We furnish enough material to return your total investment. **EASY TERMS.** Send for **FREE** booklet . . . full details. No obligation.

**Duraclean Co.** 9-188 Duraclean Bldg. Deerfield, Illinois

## Trained Men Get the Better Jobs PRACTICAL SHOP TRAINING in AUTOMOTIVE MECHANICS BODY and FENDER REBUILDING

If interested write or wire

**ATLANTA MOTIVE TRADES INSTITUTE**

Dept. C 254 IVY St., N.E. Atlanta, Georgia

Member of the Southern Association of Private Trade Schools

Veterans ask about G I Training

## REAL ESTATE BE A BROKER

**PAYS BIG! SEND FOR FREE, BIG, ILLUSTRATED CATALOG NOW!** No obligation. Graduates report making substantial incomes. Start and run **your own business quickly.** Men, women of all ages, learn easily. Course covers Sales, Property Management, Appraising, Loans, Mortgages, and related subjects. **STUDY AT HOME** or in our classrooms in big cities. Diploma awarded. G.I. approved. Nationally known.

**WEAVER SCHOOL OF REAL ESTATE (Est. 1936)**  
15 E. Pershing Road Dept. PS Kansas City, Mo.

FREE BOOK TELLS HOW

## BOMB HOIST



Ideal for garages, truck loading, machine shops, home work shops, etc. Wt. 7¾ lbs. 1500 lb. capacity—30 to 1 ratio. Dimensions, 6½ x 5½ x 5. Pulley will hold 18 ft. 3/16" 7 x 19 cable or 16 ft. ¼" cable. Rust-proof all bronze bevel cut gears. **ONLY \$9.95!** For \$2.50 extra we can furnish larger pulley that takes up to 35 ft. of 3/16" cable or 25 ft. of ¼" cable. Also available, 3/16", 7 x 19 hi-carbon galv. air craft control cable—5c ft. Same in ¼"-7½ ft. Special! Hi Power ¼" electric drill. Reg. \$18.95. Now, \$12.95. Both items postpaid. Money-back guarantee. C.O.D.s with \$1.00 deposit.

**B & M DISTRIBUTING CO., P. O. Box 1343, Dept. A 15, Tacoma, Wash.**

## ARTISTS MAKE MONEY

DO YOU LIKE TO DRAW?

Send name, address, age and occupation for **FREE ART TEST**, to find out your ability.

**ART INSTRUCTION, INC.**

8149 Art Instruction Bldg., Minneapolis 15, Minn.

## NU-WAY LAWN MOWER

Write for  
FREE Circular

Price **\$12.50**  
Why Pay More

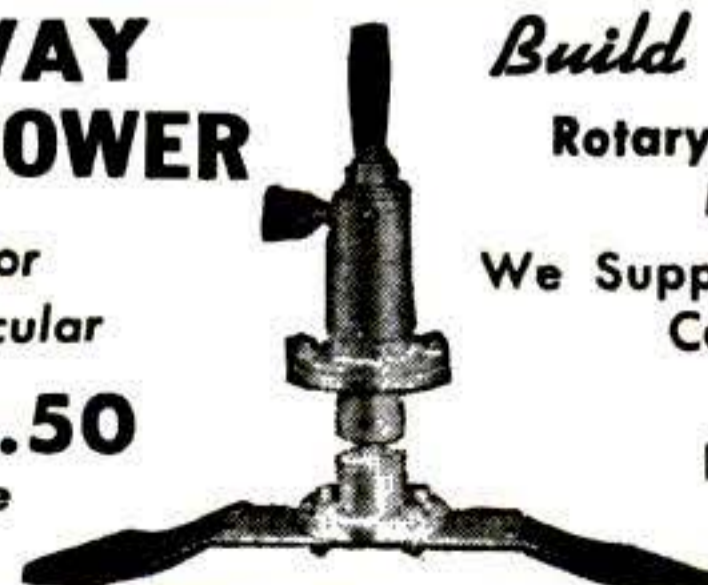

*Build Your Own*  
Rotary Type Lawn  
Mower

We Supply Cutting Unit  
Complete.

**NO INCREASE  
IN PRICE**

**TRACTOR-LITE MFG. CO., SPIRIT LAKE, IOWA**

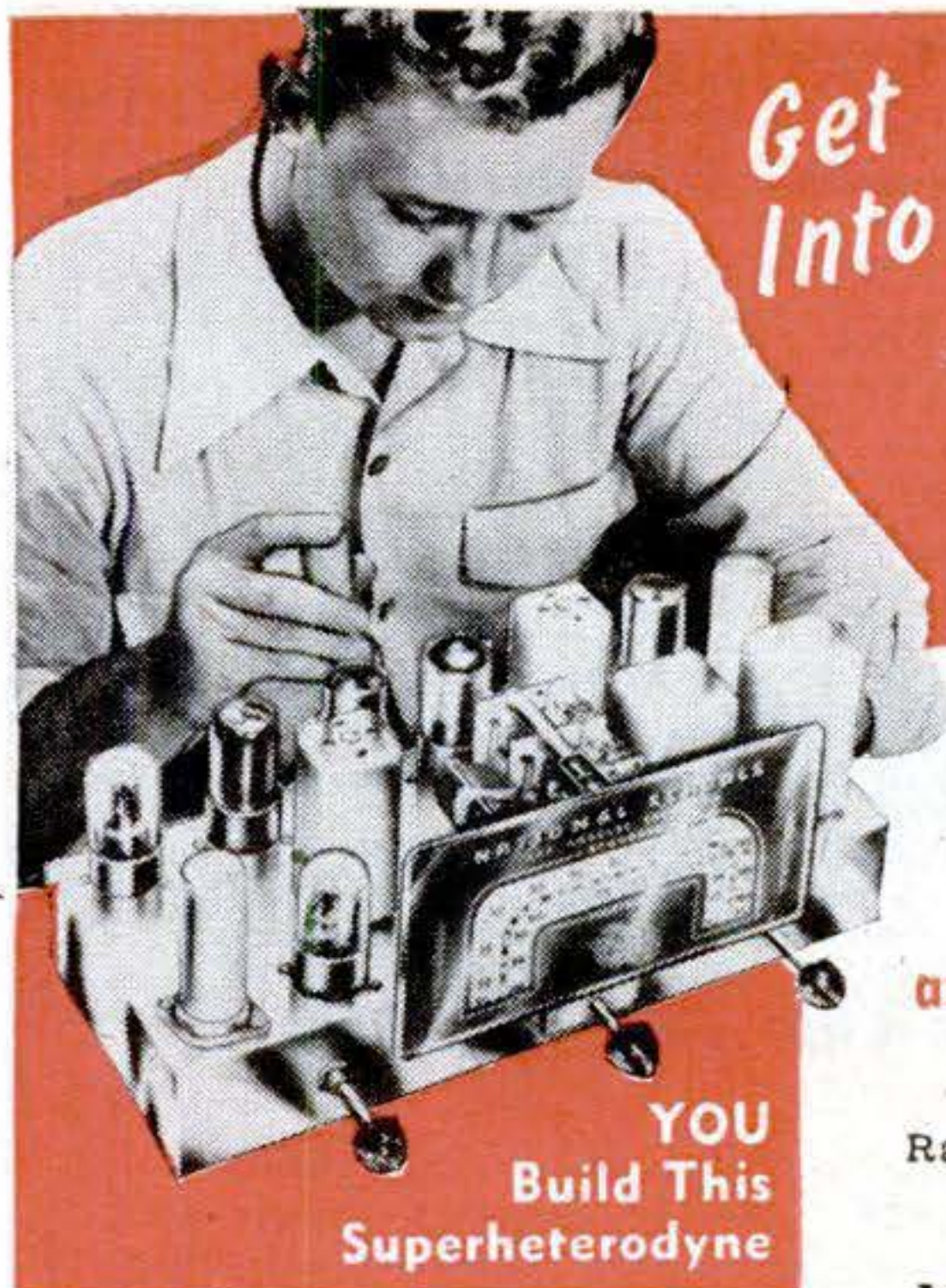

Get  
Into

# RADIO, TELEVISION and ELECTRONICS

## Master ALL Phases

**Get Complete Training. You Receive and Keep All Equipment, Parts and Lessons. No Extra Charges.**

**GOOD PAY  
and Unlimited Opportunities  
in JOBS LIKE THESE:**

Business of Your Own  
Radio Manufacturing, Sales, Service  
Broadcasting Telecasting  
Television Manufacturing,  
Sales, Service  
Laboratories: Installation, Maintenance of Electronic Equipment, Electrolysis, Call Systems  
Garages: Auto Radio Sales, Service Sound Systems and Telephone Companies; Oil Well and Drilling Companies; Engineering Firms  
Theatre Sound Systems Police Radio  
**And scores of other good jobs in many related fields**

**YOU CONDUCT MANY  
EXPERIMENTS LIKE THESE!**

Checking action of condensers  
Experiments with cathode-ray principles  
Experiments with resonance  
Producing beat frequencies  
Calibrating oscillators  
Experiments with diode, grid-bias, grid-leak and infinite impedance detectors  
Practical experience in receiver trouble shooting  
Application of visual tester in checking parts and circuits  
Experiments with inverse feed-back  
Advanced trouble-shooting  
... and many, many others

**Complete Training by Practical Resident Trade School, Est. 1905**

The same highly trained faculty, instruction materials and methods used here in our large, modern residence school, are adapted to your training in your own home. Shop Method Home Training has been proved by hundreds of successful graduates.

**Both Resident and Home Study Courses Offered**

**YOU  
LEARN BY  
DOING**

You receive special laboratory experiment lessons to show you how to build with your own hands various experimental units such as those shown at left, and how to conduct many tests.

You will find all lessons easy to understand because they are illustrated throughout with clear diagrams and step-by-step examples that you work out yourself. Every piece of the equipment and complete lesson material we send you is yours to keep and enjoy, including the multitester, experimental equipment, all parts of the Superheterodyne, tube manual, radio dictionary, and complete, modern Television texts. All parts are standard equipment.

**Shop Method Home Training . . .  
Earn While You Learn**

With our practical resident Shop Method Home Training, you study in your spare time. You receive Spare Time Work Lessons, which show you how to earn while you learn. Service neighbors' radios and TV receivers, appliances, etc., for extra money and experience. Many National students pay all or part of their training with spare time earnings!

**DON'T DELAY! The Radio-Television Industry needs trained men NOW!**

**APPROVED  
FOR  
VETERANS!**  
Check coupon below!

For quick action, mail coupon today and we'll rush you full information.

**Free!**

**NEW, ILLUSTRATED  
OPPORTUNITY  
BOOK AND SAMPLE  
LESSON SHOW YOU  
HOW WE TRAIN  
YOU . . . SEND FOR  
THEM TODAY! NO  
COST. NO  
OBLIGATION.**



**NATIONAL SCHOOLS**

LOS ANGELES 37, CALIF. • EST. 1905



**FIND OUT NOW . . . MAIL COUPON TODAY**

National Schools, Dept. 8-PS  
4000 South Figueroa Street  
Los Angeles 37, California

Send me your FREE book "Your Future in Radio" and the sample lesson of your course. I understand no salesman will call on me.

NAME.....AGE.....

ADDRESS.....

CITY.....ZONE.....STATE.....

Check here if Veteran of World War II

Mail in envelope  
or paste on  
penny postal.

**YOU  
Build This  
Superheterodyne**

You receive complete standard equipment, including latest type High-Mu Tubes, for building various experimental and test units. You progress step by step until you build a complete Superheterodyne Receiver. It is yours to use and keep.



**YOU RECEIVE THIS  
PROFESSIONAL MULTITESTER!**

You will use this professional instrument to locate trouble or make delicate adjustments—at home—on service calls. You will be proud to own this valuable equipment. Complete with test leads.

**R. F. OSCILLATOR:**

This is one of the interesting units you will build. You learn how audio-frequency energy is generated and radiated by a vacuum-tube circuit.

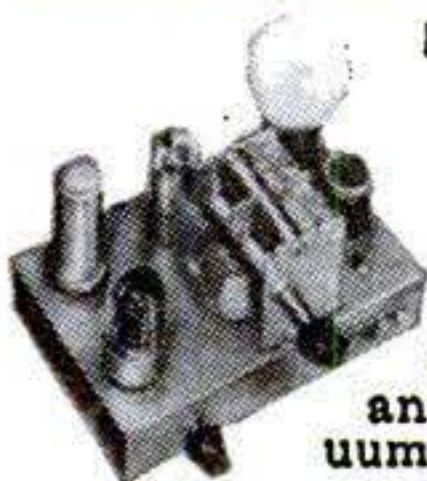

**AUDIO OSCILLATOR:**

An electronic device, which produces audio-frequency signals for modulating R.F. (radio frequency) carrier waves, testing A.F. (audio frequency) amplifiers, speakers, etc.



**T.R.F.  
RECEIVER**

You build several T.R.F. Receivers, one of which, a 4-tube set, is shown here. You learn construction, alignment, make receiver tests, and do trouble shooting.

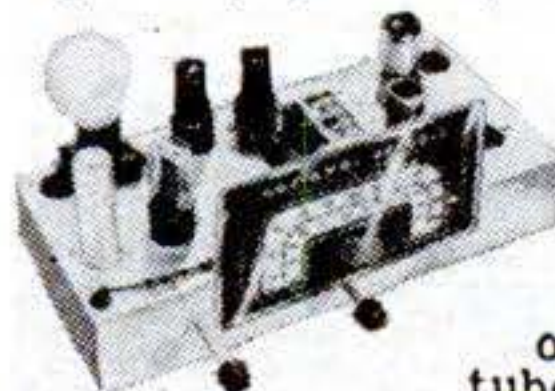



# AUTO BOOKS ON APPROVAL



**SEND NO MONEY.** Just mail the coupon for a complete set of 4 Big, Thick Auto Books. 20th Edition. Over 2700 Pages! Whether you are a mechanic or helper, expert or apprentice, auto owner or driver, take immediate advantage of this FREE EXAMINATION OFFER.

### MAKE GOOD MONEY NOW HOLD A PERMANENT JOB

America wants its automobiles kept in good repair. Men with "know how" are in demand, at big pay. These books will help you get and hold an important job, or give you a chance to go into business for yourself now or later. Any man who half tries to improve himself can learn auto servicing and repairing by this quick reference method. Use the JIFFY INDEX to find easily understood answer to any auto problem. These wonder books prepared by eleven of America's great automobile engineers. Many hundreds of valuable illustrations. Send the coupon TODAY.

**A year's consulting privileges with our engineers now given with these books without extra charge.**

*Publishers Since 1898*

**4 BIG, THICK VOLUMES**  
Over 2700 pages, 2000 illustrations, wiring diagrams, etc. Beautiful modernistic, washable cloth binding.

**AMERICAN TECHNICAL SOCIETY, Dept. AC-20**  
Drexel Ave. at 58th St., Chicago 37, Ill.

I would like to examine your 4 Volume Set of Auto Books. I will pay the delivery charges only, but if I choose I may return them express collect. If after 10 days' use I prefer to keep them, I will send you \$2 and pay the balance at the rate of only \$3 a month until \$24.80 has been paid. Include consulting service as offered above.

Name.....  
Address.....  
City..... State.....  
Please attach letter stating age, occupation, employer's name and address, and name and address of at least one business man as reference. Men in service, also please give home address.

## UP TO 80% SAVINGS ON WAR SURPLUS

**LT. WT. ALUMINUM PIANO HINGE**  
Length 72 inches, thickness .040—width 1 1/4"—Operating radius 275 degrees. Made of aluminum alloy, sold in 6 feet lengths only—\$114 per length....

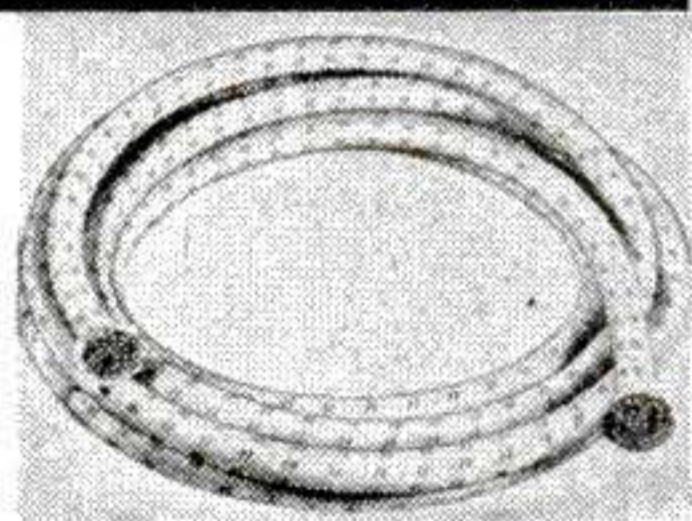

**LIVE RUBBER SHOCK CORD**  
Made in accordance with rigid army specification. Clean fresh stock. 5/8" contains approx. 500 strands of live rubber. 3/8" approx. 100 strands. 1/2" approx. 40 strands. Sold in 25 ft. lengths or more. At about 20% of original cost.

DIA.	PRICE (per 25')	Ship. Wt.
1/4"	\$1.00	2 lbs.
3/8"	\$1.25	2 lbs.
5/8"	\$1.75	3 lbs.

**HEAVY DUTY STEEL PIANO HINGE**  
Length 56"—Thickness 3/32"—Width (open) 3-5/16"—Operating radius 330 degrees—Made of heavy duty steel—Drilled ready for use. Ideal for drop tables, heavy tool boxes, heavy doors, and many other uses where heavy hinges are required. Sold in 56" lengths only. Ship. Wt. 7 lbs. At a fraction of original cost. \$145

**HEATING ELEMENTS**  
For home made photo print dryers, chicken brooders, etc. Wiring diagram for use on 110-volt. Each element 14 1/2"x2 1/4"x3/16". Set of four 96c

**NEW 10 1/2 x 4 WHEEL ASSEMBLY**  
6 ply tire 10" high, 4" wide plus new tube plus 4" ball bearing wheel with grease fitting. Uses 5/8" axle. Ideal for midget-soap-box racers, wheel-barrow, trailers, etc. Ship. wt. 8 1/2 lb. ONLY \$995

**6 VOLT DOUBLE SHAFT MOTOR**  
1/30 horse-power motor made by Delco. This is a 6 volt D.C. motor with two 1/4" shafts, used on Auto Heaters, Auto Fans, etc. Ideal for use in the shop, garage, and wherever 6 volt D.C. is available. RPM 3700. Ship. wt. 3 lbs. List price is \$4.20, our price is a real money saving buy. Our price, only \$295

Prices F.O.B. Chicago. Include approx. postage on orders paid for in advance. C.O.D. orders enclose 25%, balance sent C.O.D. WRITE FOR FREE ILLUSTRATED CIRCULAR.

**U. A. S. Corp.** Dept. PS-8 5637 W. 63rd Pl. Chicago, Illinois

## BUILD YOUR OWN POWER LAWN MOWER

### WHY BREAK YOUR BACK MOWING FIELD OR LAWN?

**WRITE FOR FREE BUILDING INSTRUCTIONS**  
The Rite-Way Mower Attachment Ball Bearing

**SAVE MONEY SAVE TIME**  
Now anyone can save time and effort mowing field or lawn by building their own whirl type power mower. Build according to your own ideas and needs at small cost. Cut close to fences, walks, buildings, etc. Build in short time with parts and instructions we furnish. Save hours of time and back breaking labor. Write today for FREE information.

**IT'S FUN TO BUILD**

**T & H MFG. CO., Dept. M-130**  
811 E. 31, Kan. City 3, Mo.

## EARN \$10,000 A YEAR

Excellent opportunities for over 100 occupations including clerks, mechanics, engineers, electricians, apprentices, laborers, etc.

**\$2,700 TO START—QUARTERS AND SUBSISTENCE FURNISHED**

TRAVEL, ADVENTURE, FUN, PROFIT, EDUCATION, CAREERS in the AMERICAN MERCHANT MARINE—absolutely NON-MILITARY.

Write for your FREE BOOKLET  
**INTERNATIONAL MARITIME INSTITUTE**  
79 Wall St. New York 5, N. Y.

## WELDING SHOP TRAINING

**G.I. APPROVED—GAS AND ARC**  
Classes start on Monday each week. Payment Plan for Non-Vets. Welders needed in practically every industry—train for a field where you have greater assurance of Steady Work, Good Pay. Write for Free Information.

**A & S VOCATIONAL WELDING SCHOOL**  
1212 E. 63rd Street, Dpt. PS-8, Chicago, Illinois

## MAKE BIG MONEY LEARN TO REBUILD SEALED REFRIGERATION UNITS

**LEARN NOW—WE TEACH YOU HOW**

MILLIONS of Sealed Units will need rebuilding. Factories usual charge is \$80.00 to \$100.00 per unit. We offer a Post-Graduate Course (16 weeks) to graduates of accredited refrigeration schools and to refrigeration service men with an equivalent background. For Veterans and Non-Veterans.

**START YOUR OWN BUSINESS . . . WRITE TODAY**  
**PRACTICAL TRADES INSTITUTE, INC.**  
25 University Ave., S.E., Dept. PS-8, Minneapolis 14, Minn.

## MONEY for MEN ALL DATA FREE

THE PLASTEX Industry needs manufacturers on small scale and for big production of Lamp and Clock Stands, Art Goods and Novelties in Plastex and Marble imitation. Experience unnecessary. 1/2c material makes regular 10c store sellers. Rubber moulds furnished for speed production. Small investment brings good returns. Big chain store orders now being placed. Ambitious men have chance for real prosperity. Our Free booklet will interest and benefit you.

**PLASTEX INDUSTRIES, Dept. 2, 3400 Third Ave., New York 50, N. Y.**

## Wear Sample Suit NOT 1¢ TO PAY!

Here's an amazing plan! Write me today and I'll show you how to get a fine, all-wool made-to-measure suit for yourself—to wear and show to friends. Just take a few orders, that's all! Here's an easy way to get your own suit without paying 1c, and also make fine cash profit on every order you take. You send no money, now or ever. Just rush name and address for Sample Woolens and Valuable Sample Suit Coupon. Act now.

**FREE**  
Costly Sample Kit containing over 100 actual fabric samples.

**W. Z. GIBSON, 500 S. Throop Street**  
Dept. V-520, Chicago 7, Illinois

# STUDY AT HOME

With An Educational Institution

Men with specialized training win higher positions, insure larger earnings, and are bigger successes in business and public life. Opportunities NOW greater than ever before. Send for our Catalog.

## ARTS and SCIENCES

Courses in Philosophy; Education; Letters; Public Health; Medical Jurisprudence; Psychology; Sociology; Physics; Chemistry; Geology; Political Science; Theology; Business and Commerce; Accounting; Mathematics; Statistics; Agriculture.

## ENGINEERING

Courses in Electrical, Civil, Mechanical, Drafting, Architectural, Steam, Aeronautical, Radio, Structural, Mining, Industrial, Petroleum, Marine, Chemical, Diesel, Automobile, Refrigeration, and Air Conditioning Engineering.

## LAW

Complete Professional Law Course includes 18 Hornbrook Series college grade textbooks. Courses also in Commercial Law, Patent Law and Medical Jurisprudence.

McKinley-Roosevelt Incorporated, 4610-AB, Sheridan Rd., Chicago 40, Ill.



**Treasure and Mineral LOCATORS GEIGER-COUNTERS**  
FOR URANIUM-ORES  
CREDIT PLAN—FREE LITERATURE  
**FISHER RESEARCH LABORATORY Inc.,**  
Palo Alto, Calif.

# DEPRESSION INSURANCE !!

Earn well even in hardest times by saving other people money! People pay up to \$5.00 or more per hour to have their vacuum cleaners, irons, refrigerators fixed, houses wired, etc. When money is tight, millions of appliances will be repaired rather than replaced. Make Money Now in your spare time with new system. Learn Electrical Appliance Repairing by making actual repairs! Pay us later for kits, illustrated lessons, etc., from earnings while learning. Write for FREE Book. CHRISTY TRADES SCHOOL, 2835 N. Central Ave., Dept. D-8001, Chicago 34.

# LAW

STUDY AT HOME for Business Success and LARGER PERSONAL EARNINGS. 40 years expert instruction—over 114,000 students enrolled. LL.B. Degree awarded. All text material furnished. Easy payment plan. Send for FREE BOOK NOW—"Law and Executive Guidance." [G.I. Approved.]

**AMERICAN EXTENSION SCHOOL OF LAW**  
Dept. 17-PS, 646 N. Michigan Ave., Chicago 11, Ill.

# HANDBOOK OF AIRPLANE MAINTENANCE & OPERATION

Easy self-study course and up-to-date reference manual in one low-priced book! Covers basic principles and functions, construction, repair and maintenance of every part of the modern airplane. 512 pages, 600 pictures, over 300,000 words! 2,500-item index! Specification data sheets of world's leading types of aircraft. Only \$5.00—refunded if not fully satisfied after week's trial.

**NATIONAL AERONAUTICS COUNCIL, Inc., Dept. 808**  
37 West 47th Street New York 19, N. Y.

Free Book



# RAISE HAMSTERS

The new wonder animals from Syria. Often called Toy Bears. Delightful pets. Everyone wants them. Laboratories need thousands. Clean, odorless. Raise anywhere. A profitable and interesting hobby or business. We furnish breeders and instructions. Write today for free book.  
**GULF HAMSTERY, 1540 BASIL ST., MOBILE, ALA.**

# MEN-IF YOU VALUE Your Future- read this FREE BOOK

SEND FOR IT  
Today!



## Tells You How to Win Bigger Pay and Real Security

This book is yours without a penny of cost. "Your Future in Refrigeration and Air Conditioning" tells you what's in store for you in this fast moving, big pay field. No obligation. We want you to have this big, fascinating book. We want you to have the opportunity to read it—and to decide for yourself whether this is the field for you. You'll see pages of interesting pictures showing men on-the-job in Refrigeration and Air Conditioning. You'll read all about the fine opportunities in this amazing industry. This can easily be the most important book you'll ever receive and read—because it concerns your own future! Refrigeration and Air Conditioning has plenty of room for trained men—to handle good paying jobs in the many branches of this great industry. Almost unlimited future for men who know this work. Now you may learn Refrigeration and Air Conditioning at home in spare time. No need to give up present job or income while preparing to step into a better job. Act now! Simply write your name and address on the coupon below and mail today. Get your free copy at once . . .

### INDUSTRIAL TRAINING INSTITUTE

2150 Lawrence Avenue, Dept. X-2, Chicago 25, Ill.

## MAIL COUPON NOW No Cost No Obligation

Mr. C. H. Smith, President,  
Industrial Training Institute, Dept. X-2  
2150 Lawrence Avenue, Chicago 25, Illinois  
Please send me a FREE COPY of "Your Opportunity in Refrigeration and Air Conditioning" by return mail.  
Name.....  
Address.....  
City and Zone.....State.....

# Learn this Profitable Profession



**IN 90 DAYS  
AT HOME**

## Money-Making Career Open to Men and Women, 18 to 50

Hundreds of men and women between 18 and 50 make \$10 to \$20 in a single day giving scientific Swedish Massage and Hydro-Therapy treatments. There is big demand from doctors, hospitals, sanatoriums and clubs. Graduates earn large full time incomes from these or in private practice in their own offices. Others make good money from home treatments given in spare time. Learn this interesting, money-making profession in your own home, through our home study course. Same instructors as in our nationally known resident school. You can win independence and prepare for future security by qualifying for your Diploma. Course can be completed in 3 to 4 months. Many earn while they learn. Begin your training at once.

### Anatomy Charts & Booklet FREE

Enroll now and we will include, at no extra cost, many needed supplies. Fit yourself to help meet growing demand for Scientific Swedish Massage. Send the coupon at once for complete details. Anatomy Charts and 32-Page Illustrated Booklet, FREE, postpaid.

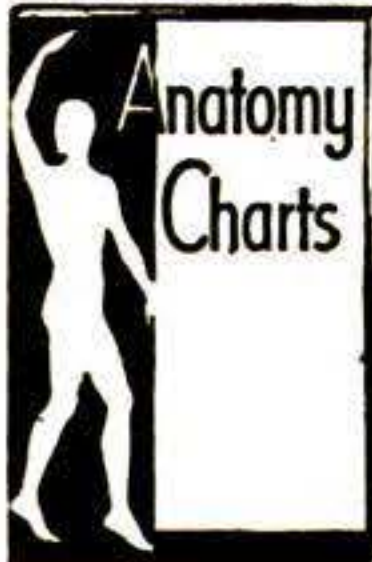

THE COLLEGE OF SWEDISH MASSAGE  
Dept. 970-K, 41 E. Pearson, Chicago 11

Please send me FREE and postpaid, Anatomy Charts, 32-page Booklet and complete details on Home Training.

Name.....Age.....

Address.....

City.....State.....

## TRAIN NOW FOR AN AVIATION CAREER IN SUNNY SOUTHERN CALIFORNIA

### MAXIMUM TRAINING IN MINIMUM TIME

Specializing in AERONAUTICAL ENGINEERING and MASTER AVIATION MECHANICS since 1929... America's Finest Aeronautical Institute... 7000 successful graduates... MAKE MORE MONEY... MAIL COUPON TODAY. APPROVED FOR VETERANS. Board and Room now available.

Without obligation, send free catalogue with full information.

NAME.....AGE..... PS-8

ADDRESS.....

CITY.....ZONE.....STATE.....

**CAL-AERO TECHNICAL INSTITUTE**  
GRAND CENTRAL AIR TERMINAL • GLENDALE 1, CALIFORNIA

## Brand new! FLEXO-MAG RETRIEVER

### The 3 in 1 TOOL with 1,000 USES

- NO MAGNETIC SIDE PULL
- FLEXIBLE AND RIGID SHAFT
- EXTENDABLE TO ANY LENGTH

Invaluable for retrieving ferrous metals weighing one pound or less. Ideal for mechanics in garages, service stations, radio, railroad or other repair shops. Useful for hobbyists, any industrial plant, retrieving lost articles in drains, lakes, rivers. Truly a tool of 1,000 uses. Permanent magnet, without side pull on 2 foot flexible and/or rigid shaft. Guaranteed.

NO SIDE PULL

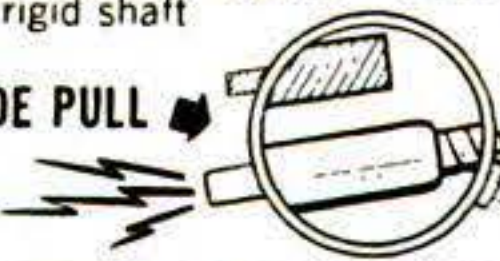

Agencies Open

Send Check or M. O. to

**MAGNETIC SPECIALTIES MFG. CO.**  
5514 W. Pico Blvd., Dept. B, Los Angeles 35

**\$2.25**  
POST PAID

## Make Ur-Own Rotary Type POWER MOWER

**\$39.95**  
F.O.B. K.C.

### KEEN MOWER

Model 49M—Just add electric motor or gas engine, concealed blade for safety, 3 cutting heights, 1½" to 3½". Ball bearing rubber tired rear wheels. 18" cut. Cuts to within ½" of sidewalk. Wght. 48 lbs. America's Greatest Power Mower value. Order Now!

Price FOB, K.C.  
Send chk. or M.O.—No COD's.

### ATLAS EQUIPMENT CO.

229 S.W. Blvd.

Dept. 5P8

Kansas City, Mo.

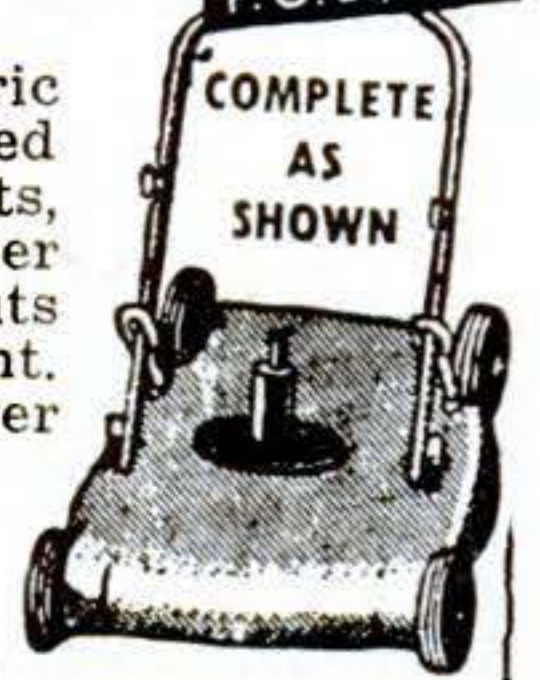

## BUILD HEAVY DUTY MACHINES

SAVE UP TO 90% You can build, using our practical, easy-to-read plans, all kinds of machines, for home, farm or shop—scooters, portable sawmills, metal working machines, concrete machinery of all kinds, printing equipment, woodworking machines, midget autos, dish washers, farm equipment, freezers, tractors.

### FREE CATALOG HANDBOOK

183 SETS OF PLANS

VALUABLE INFORMATION

NICHOLS EQUIPMENT COMPANY  
Dept. D2604 PURVIS, MISS.

## Barber's Discovery!

that checks hair loss and dandruff, now available to you in a home treatment kit. Write today for full details to

**ARTHUR R. ELSON, Trichologist**  
137 Lewis Street Phillipsburg, N. J.



## THERE'S MONEY IN CARTOONS!

DON'T COPY—LEARN TO ORIGINATE!

RAYE BURNS will teach you HOW to CREATE ORIGINAL CARTOONS at home that you may SELL! Course contains 26 lessons and over 600 illustrations. All for only **\$2.85**. Send name and address for free details.

RAYE BURNS SCHOOL, Dept. 5, Box 3583, Cleveland, Ohio

## ENGINEERING

**Chicago TECH College**

BUILDING, DRAFTING, ETC.

Degree in 27 mos. Approved for G. I. Training. Prepare in Chicago, the Industrial Hub. Earn part living expenses. 45th year. Other shorter courses in Air Conditioning, Refrigeration, Radio, Electricity. Enter Jan., March, July, Sept.

Write for catalog

K-88 TECH BLDG., 2000 SO. MICHIGAN AVE., CHICAGO 16

## EARN BIG MONEY Growing Out-of-Season Vegetables and Flowers FOR PROFIT!

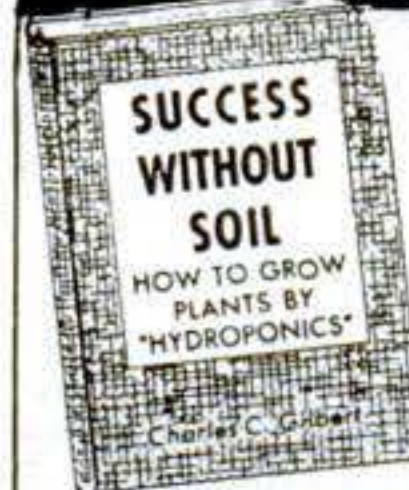

Easy - No experience or equipment needed for top results. Start in your own home or yard. Grow any plant quickly "without soil." Giant yields. Order "Success Without Soil," practical, fact-filled. Money making plans, diagrams, photos. Clear instructions—start at once. Only \$2.95 postpaid anywhere. Money-back guarantee. Send check or money order today and learn the big new opportunity methods of "Hydroponics."

Or Send Postcard for FREE Illustrated 16-page Booklet on This Money Making Plan

CHARLES C. GILBERT & CO., 840 W. IVY ST. SAN DIEGO 1, CALIF.



# WHICH OF THESE *Opportunities* INTERESTS *You* MOST?

● *Today*, choose the job you want—and prepare for it. Or if you are already engaged in the work you like best, start training *now* for quicker promotion. Acquire the knowledge that will help you to get ahead faster, make more money and have greater security.

American School, founded in 1897 as an educational institution *not for profit*, can help you to reach your goal just as it has helped others during the past fifty-two years. Check the coupon at right, add your name and address and mail it at once. The school will send you details on its training plan and outline of study prepared by specialists. There is no charge, no obligation, so send the coupon immediately.

## CHECK, CLIP AND MAIL COUPON NOW

AMERICAN SCHOOL, Dept. GC-46, Drexel at 58th, Chicago 37, Ill.  
Without obligation, Please send FREE and postpaid, bulletin and details of the Subjects checked:

- |                                                    |                                                       |                                                                |
|----------------------------------------------------|-------------------------------------------------------|----------------------------------------------------------------|
| <input type="checkbox"/> PLASTICS ENG'R            | <input type="checkbox"/> Accounting                   | <input type="checkbox"/> Drafting and Design for Men and Women |
| <input type="checkbox"/> Refrigeration             | <input type="checkbox"/> Electrical Engr.             | <input type="checkbox"/> Radio                                 |
| <input type="checkbox"/> Architecture and Building | <input type="checkbox"/> Electricity-Pract.           | <input type="checkbox"/> High School                           |
| <input type="checkbox"/> Contracting               | <input type="checkbox"/> Electronics, Industrial      | <input type="checkbox"/> Air Conditioning                      |
| <input type="checkbox"/> Practical Plumbing        | <input type="checkbox"/> Bookkeeping                  | <input type="checkbox"/> Mechanical Eng.                       |
| <input type="checkbox"/> Automotive Engr.          | <input type="checkbox"/> Private Secretary            | <input type="checkbox"/> Shop Management                       |
| <input type="checkbox"/> Aviation Drafting         | <input type="checkbox"/> Diesel Engineering           | <input type="checkbox"/> Tool Making                           |
| <input type="checkbox"/> Aviation                  | <input type="checkbox"/> Sheet Metal Pattern Drafting | <input type="checkbox"/> Better Foremanship                    |
| <input type="checkbox"/> Business Management       | <input type="checkbox"/> Railway Training             | <input type="checkbox"/> Machine Shop Operations               |

### AMERICAN SCHOOL

Dept. GC-46, Drexel at 58th Street, Chicago 37

Name.....Occupation.....  
Address.....Age.....  
City.....State.....

## EARN \$50 UP A WEEK... ON THE SIDE!

While You Learn Watch & Clock Repairing At Home

WITH OUR NEW 16 ITEM SELF TRAINING KIT ENLARGED KIT Contains: WATCH MOVEMENT for practicing (newest added feature)—PROFESSIONAL TOOLS: Loupe; 6 Watch Screw Drivers; Clock Screw Driver; Tweezers; Clock Tweezers; Material Tray; Case Opener & Knife; Movement Gauge; plus 2 COMPLETE ILLUSTRATED BOOKS: One on WATCH REPAIRING, and One on CLOCK REPAIRING. (If C.O.D., plus charges!) MONEY BACK GUARANTEE..... \$11.75 Post Paid  
MODERN TECHNICAL SUPPLY CO.  
Dept. 8 MPS 55 W. 42nd St. New York 18, N. Y.  
Tool Catalog FREE with KIT or send \$.50 credited to 1st order.

## LEARN TO WRITE

*a Good Hand!*

FOR BUSINESS AND SOCIAL SUCCESS!  
Improve your handwriting at home quickly with my new instruction books just off the press. Master all the secrets of better penmanship. Simple and easy, fully illustrated, highly endorsed. Begin today. Write for:  New Free Book, "How to Become a Good Penman", or check books wanted, \$1.00 each.  Business Writing  Artistic Writing  Card Writing  Engrossing Alphabets  Bird and Design Flourishing  Complete Set \$4.50  Enclose 10c for your name beautifully written and shading penpoint.  
S. A. Ziller, President, TAMBLYN SCHOOL OF PENMANSHIP  
439 Ridge Bldg. In Business Over 52 Years Kansas City, Mo., U.S.A.

## Learn TELEVISION RADIO—ELECTRONICS

Prepare in spare hours for good pay in Television, Radio and Electronics. Train at home with Frank L. Sprayberry, America's outstanding Radio instructor. Big Kits of equipment furnished. Build testers, sets, etc. VETERANS: Approved for Training under GI Bill. Rush name and address for details and 2 BIG RADIO BOOKS—ALL FREE! No salesman will call. Write today!  
Sprayberry Academy of Radio, Dept. 55-U  
20 North Wacker Drive, Chicago 6, Illinois

## GIGANTIC WAR EQUIPMENT MAIL SALE

Amazing Values, Fraction of Original Cost  
(We pay freight and parcel post charges in the U. S.)

- |                                  |                                  |
|----------------------------------|----------------------------------|
| ● A-C Power Plants.....\$345.00  | ● Utility Clutches.....\$ 13.95  |
| ● Compressor Sprayers..... 99.50 | ● Briggs (3.5) Engines.... 77.50 |
| ● Capstan Winches..... 24.95     | ● Briggs (6.5) Engines.... 86.90 |
| ● Multi-Speed A-C Motors 8.75    | ● Power Shaft and Stone.. 1.29   |
| ● Rotary Pump..... 3.95          | ● D-C Welding Generator 89.90    |

Also Hundreds Electrical and Radio Bargains  
Send card for complete sales catalog  
LECO ENGINEERING CO., Box 908-PS-21, Lincoln, Nebr.

## DRAW for MONEY... Be an ARTIST!



Trained Artists are Capable of Earning \$65, \$80 OR MORE A WEEK!

You can learn to draw at home in your spare time the well-known WSA way. COMMERCIAL ART. DESIGNING. CARTOONING—all in ONE complete course. No previous art experience necessary—we teach you step-by-step. Prepare now for a fascinating hobby or profitable career. For 35 years WSA graduates have been making good—WHY NOT YOU?

VETERANS!  
WSA is approved for training under the G. I. Bill

Write today for FREE BOOK, "Art for Pleasure & Profit." It fully describes our correspondence course, instruction service, and commercial opportunities for you. TWO ART OUTFITS and other features with training. Low cost—\$5 monthly.

WASHINGTON SCHOOL OF ART, Studio 138 R  
1115—15th St., N.W., Washington 5, D. C.  
Please send me full information and your Free Book, "Art for Pleasure and Profit."

Name.....AGE.....  
Street.....  
City.....Zone.....State.....  
 I am entitled to training under the G. I. Bill.

# SAVE UP TO 50% ON OUR SURPLUS

## SHOES 38% OFF!

### NEW U. S. NAVY TYPE OFFICERS BLACK DRESS OXFORDS

New, fine quality leather shoes, made by famous manufacturers on genuine U. S. NAVY lasts! Sturdy leather soles, insoles and linings, and are Goodyear welt construction! Sizes 6 to 12; widths C-D-E & EE. Very comfortable.



WORTH \$8.00  
**4.95**



### NEW ALL WOOL ARMY TYPE REGULAR 7.95 BLANKETS

Brand new, soft, fleecy-warm blankets that fit double beds! Closely woven nap, whipped ends. Ideal for cars, cabins, homes, picnics or beach!

**3.95**

Choice of  
GREY or  
KHAKI

30% Pure Wool  
70% Pure Processed Wool

### NEW ARMY TYPE ARCTIC SLEEPING BAGS

- Down & Feather filled!
- Extra large—more foot & shoulder room!
- Extra strong Talon Zipper closure!
- Forest Green color . . . easy to roll!
- Water repellent inside and out!
- Hood may be used as a pillow!
- Always keeps its shape!

Save more than \$20 on this better quality army-type sleeping bag! Just in time for hunting, camping & fishing trips . . . plenty of warmth!



WORTH \$35  
**12.95**

KINDLY SEND CHECK OR MONEY ORDER

## THE ELLIS GOLD COMPANY

Dept. P-7; 86 North Market St., San Jose 22, Calif.

# REFRIGERATION

Same Book Used by  
U.S. for G.I. Training

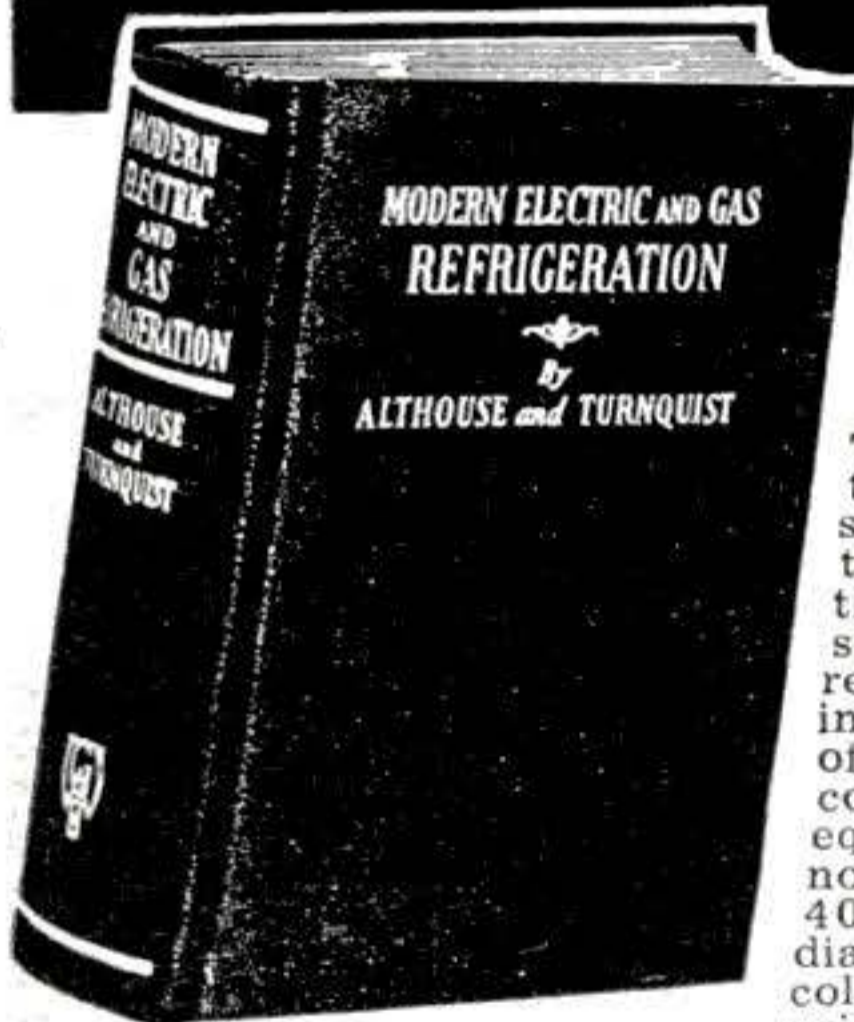

## Most Helpful, Biggest Selling Book on Subject

This is the recognized authority, used by trade schools, manufacturer's training programs and by the U.S. for training thousands of G.I.'s. It covers all repairs, adjustments, replacing parts and overhauling of every type of domestic, commercial and industrial equipment. Written in plain, non-technical language, with 408 pictures and 17 working diagrams printed in 6 to 8 colors. (These are worth the price of the book to any refrigeration man and are not available from any other source.) There are over 20 million refrigerators in the

928 Pages • 408 Illus.  
Revised, Enlarged Edition

U.S. now, which means steady employment at good pay or a profitable spare or full time business of your own with this book to help you. Send for book on coupon now. Use it 5 days, then if not O.K. send it back and we will refund purchase price.

Goodheart-Willcox Co., Dept. 53B  
1321 S. Michigan Avenue, Chicago 5

## MAIL ORDER COUPON

Send Modern Gas and Electric Refrigeration ( ) C.O.D., I will pay postman plus charges (C.O.D. in U.S. only). ( ) Remittance for \$5.00 enclosed. Send postage paid. If not O.K. I will return in 5 days and you will refund purchase price.

Name.....  
Address.....  
City..... State.....

# Learn How to HYPNOTIZE!



**Develop your personal POWER!** NOW... revealed for you... are the secrets of **practical hypnotism**... that strange, compelling force by which an expert operator can bring others under his power. He can sway people at will—issue commands and be obeyed—virtually cast a spell over his subjects. This sensational knowledge may make YOU a more dominant, masterful personality.

## Illustrated SELF-INSTRUCTION COURSE in Useful Hypnotism

Amazing lessons in simple, easy-to-understand language. How to select a subject—how to hypnotize by telephone—how to make money from hypnotism—mental telepathy—stage hypnotism—self-hypnosis—how to use modern hypnotism to conquer inferiority complex, timidity, etc. Clear helpful pictures show operating positions, movements. **Startling low price. Satisfaction guaranteed or money back.**

COMPLETE  
**ONLY \$1.95**

SEND NO MONEY! Simply pay postman \$1.95 plus C. O. D. postage—or send \$1.95 and we pay postage; same money-back guarantee. Order "Hypnotism Course" today!

Nelson-Hall Co., 1139 S. Wabash Avenue, Dept. 2H-1, Chicago 5, Illinois

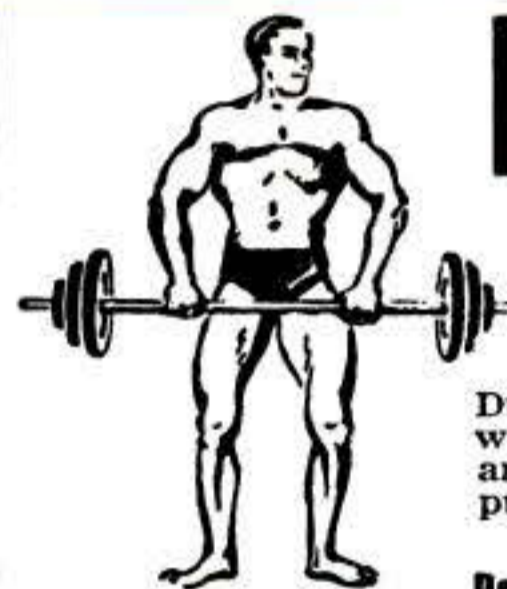

# BARBELLS

Finest Quality.....\$8.98 up  
FREE CATALOG

Send today for big new 4 color fully illustrated free catalog of BARBELLS, Dumbbells and Health equipment. Free—world famous \$15.00 Dan Lurie Barbell and Dumbbell training courses with every purchase.

DAN LURIE BARBELL CO.  
Dept. 170 H, 1729-S8 Rockaway Parkway, Brooklyn 12, N.Y.

## Learn How to RAISE rare CHINCHILLAS For PROFIT

● We teach you how to raise these profitable fur-bearing rare Chinchillas in your own home. Spare or full time. A billion dollar industry you can enter with small investment. Equipment is simple, inexpensive. No previous experience needed. Chinchillas are clean, gentle, easy to handle. Fun to raise. **FREE INFORMATION**—Send postcard for complete illustrated details on how you can make money raising Chinchillas. No obligation. Write today for the facts!

ALLIED DISTRIBUTORS, Inc. 2227-A West 182nd St.  
Gardena, California

## LEARN DIESEL AT HOME the famous HEMPHILL WAY

Get big, FREE, illustrated catalog  
**Shows opportunities in growing Diesel Industry—**  
Trains, trucks, construction equipment, ships, drilling rigs, logging equipment, etc., all use Diesels. Get the training to enter the field of your choice.  
**HEMPHILL DIESEL AND AUTOMOTIVE SCHOOLS**  
Department of West Coast University  
1601 S. Western Ave., Dept. PS-89, Los Angeles 6, Calif.



## SUMP PUMPS 2,200 GALLON CAPACITY

**1 1/4 outlet — No screen to clog — fool proof**  
The time tested Lokomona sump pump is absolutely automatic—has a special fool proof trap at the intake—rubber bearing at the bottom. Made of aluminum castings, it's 42" high and carries a 1/4 H.P. 110 V. A.C. heavy duty motor. The pump is designed for continuous dependable service. Any standard motor will fit this pump. Order yours today. COD, or cash with order, we pay postage.  
**MONEY BACK GUARANTEE**

**\$36.00 COMPLETE \$22.00 LESS MOTOR \$18.00 PUMP ONLY**  
LOKOMONA PUMP CO., Box 86, Royal Oak 2, Michigan



## HOLLYWOOD CHROME TRIM

RAILS to doll up each side after running boards removed. SHIELDS for inside fender ends. '35-'40 Fords, '39 & '40 Mercury, '39 & '40 Chev., also most cars with slight adaptation. Complete sets \$26.00. Rails only \$12.50 pr. Shields only \$6.95 pr., Front or rear. **SOLID HOOD PANELS—Ford '28-'36 \$9.95 pr.**

**FORD HYDRAULIC BRAKE KITS**  
A-B & thru '38. Install Hydraulic Brake system now—Be SAFE. Complete kit includes everything needed—Cylinders, backer plates, lines, brackets, hoses, easy to follow instruction. Easy to install in 8 hours. Satisfactory operation guaranteed. Order Direct! Complete kits only \$75.00. Los Angeles. \$25 deposit on C.O.D. Return old backer plates collect for \$10.00 refund.

**STREAMLINE MODERNIZE YOUR CAR**  
Lower body with our special shackles. Set of 4, \$1.50 (Fords) (Specify 4" or 6" and year). For other cars \$8.00 set. **FREE** History of Hot Rod & Midget Racing. We supply everything to build your own Track Cars—Hot Rods and Boats—RACING HISTORY and CATALOG 25c without order.  
ANSEN, 3805 W. Jefferson, Dept. PS-8, Los Angeles, Calif.

# ITS EVEN EASIER THAN IT LOOKS



to learn to play your favorite instrument in your own home without a private teacher

Look at the diagram at the right. The first note on the music is "D." Following the dotted line to the keyboard, "D" is the white key between the two black keys near the middle of the keyboard. From that you can find the other notes. As you strike them on the piano you'll be playing the melody of the famous "Merry Widow" Waltz. Easy, isn't it?

**SIMPLE AS A-B-C**  
the famous "Merry Widow" Waltz

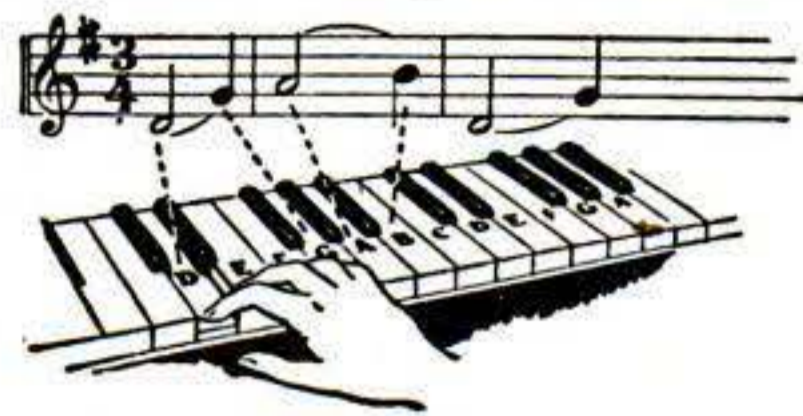

**AND IT COSTS ONLY A FEW CENTS A DAY!**



**LEARNED QUICKLY AT HOME**

"I didn't dream I could actually learn music without a teacher. People hardly believe I learned to play so well so quickly."  
\*H. C. S. California

**YOU'LL** get a big surprise when you start your U. S. School of Music lessons. You'll see how easy it is to learn to play this simple Print and Picture way. It's even easier than it looks!

Here is the secret! You learn to play by playing. No long-winded explanations. No boresome exercises. You play real tunes by note with the first lesson. Simple melodies at first, but you gradually go on to more advanced pieces. And sooner than you ever expected you should be playing popular numbers by note.

If you really want to learn music quickly and easily, send today for our **FREE** 36-page Booklet and Print and Picture Sample. They'll tell you the whole story. Instruments supplied when needed, cash or credit. U. S. School of Music, 88 Brunswick Bldg., N. Y. 10. N. Y. 51st Successful Year.

\*Actual pupil's name on request. Picture by professional model.

**FREE PRINT AND PICTURE SAMPLE**

U. S. School of Music, 88 Brunswick Bldg., New York 10, N. Y.

Please send me free booklet and Print and Picture Sample. I would like to play instrument checked below.

- |                 |                 |                   |
|-----------------|-----------------|-------------------|
| Piano           | Saxophone       | Modern Elementary |
| Guitar          | Trumpet, Cornet | Harmony           |
| Violin          | Reed Organ      | Clarinet          |
| Piano Accordion | Tenor Banjo     | Other Instrument  |

Name..... (PLEASE PRINT)

Street.....

City..... State.....

Note: If you are 16 years or under, parent must sign coupon.

Save 2c. Stick coupon on penny postcard.

Send for this **FREE BOOK** on

## RHEUMATISM

ARTHRITIS • NEURITIS • SCIATICA



If you suffer the agonizing pains of these diseases when the usual remedies have failed, learn about a specialized system proven for treating. This marvelous treatment is completely explained in the Ball Clinic's **FREE BOOK. No Obligation. Write Today.** Ball Clinic, Dept. 36, Excelsior Springs, Mo.

## Be A MASTER PLUMBER

**Earn \$15 To \$50 A Day**

**DON'T ENVY THE PLUMBER—BE ONE**

Every skilled workman will tell you that Plumbers have the best of it. WINTER and SUMMER the Plumber is busy at top wages. No skilled Plumber is ever out of a job—compare his opportunities with any trade, plus the opportunities of having your own shop. We teach you Plumbing with **TOOLS** (not books) under Licensed Master **PLUMBERS** in one of the finest equipped schools in America. We make you a Plumber, every branch is taught thoroughly—Lead Work—Blueprint for plan reading—all other tricks.

**LEARN IN 32 WEEKS WITHOUT PREVIOUS EXPERIENCE**

If you like to work with tools you owe it to yourself to investigate. No need to ever work as an apprentice. Get free bulletin. Write now! G.I. APPROVED. Our 24th year.

**UNIVERSAL PLUMBING SCHOOL**  
819 HOLMES STREET KANSAS CITY, MO.

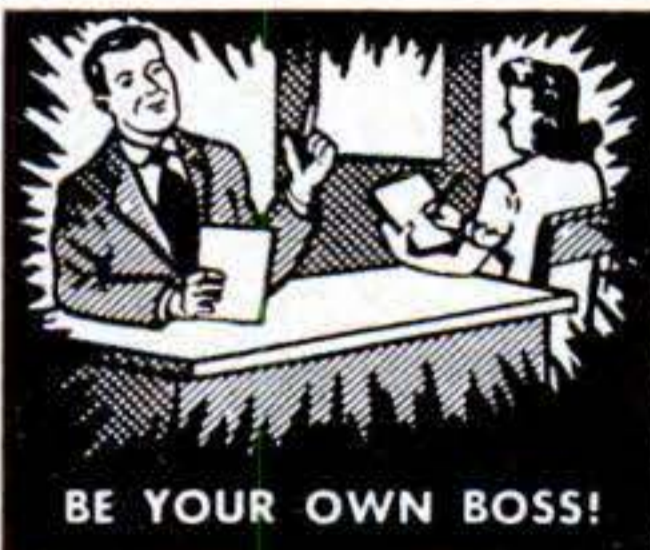

**BE YOUR OWN BOSS!**

## ADVERTISING MEN MAKE BIG MONEY!

**NOW IS THE TIME TO PLAN YOUR FUTURE!**

Big earnings of men and women in this profession—many make \$5,000 to \$10,000 yearly. Our Course makes it easy to learn at home in your spare time. Want a fine salaried job or the security and independence of your own business? Now is the time to start. No previous experience necessary. Learn Direct Mail, Mail-order, Copy, production methods—complete plans for operation of your own business. Get Full Details Now! Send no money. A post card will do—but hurry!

**ARMSTRONG SCHOOLS, 7217 S. Broadway, Dept. PS-8, Los Angeles, Calif.**

- DIRECT MAIL
- MAIL ORDER
- LAYOUT
- COPY
- PRODUCTION METHODS

# BLISS ELECTRICAL SCHOOL

## Electrical Training

Intensive 32 weeks' residence course in fundamentals of **industrial electrical engineering**, including radio and electronics. Extensive laboratory, shop work, drafting. Prepares for electrical technician and engineering aides in

communications, power, manufacturing, business machines, sales, service. G.I. approved. 56th year. Enter Sept. 6, March 6. Catalog. 7614 TAKOMA AVENUE, WASHINGTON 12, D. C.

## Thousands of Parts For Military TRUCKS

Purchased from U. S. Govt. Our prices can't be beat.

We have for immediate delivery genuine parts for all makes and models, 4x2 - 4x4 - 6x4 and 6x6. All models from 1/4 ton to 20 tons. All makes: Autocar, Biederman, Brockway, Chevrolet, Diamond T, Dodge, Federal, Ford, GMC, International, Mack, Oshkosh, Reo, Studebaker, White, Willys, and Jeeps. We have parts lists available on most models. Write stating model of Truck.



### JEEP TOPS and CURTAINS

(Weatherizing Kit), complete top with back curtain and side curtains with zip-in-doors. 5 windows, Waterproof O.D. color, shipping weight 40 lbs. Wonderful value. F.O.B. **\$39.50** K.C.

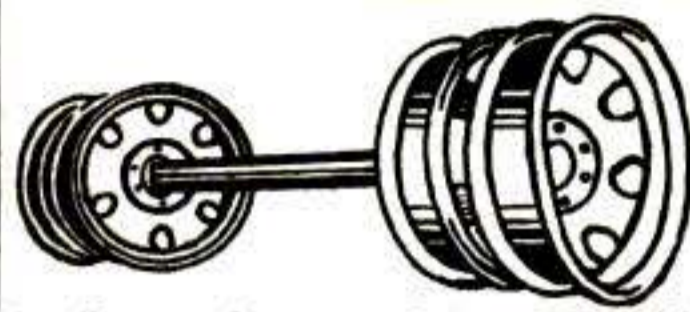

### TRAILER AXLE

Heavy duty trailer axle suitable for many types of trailer construction. Also excellent for building of heavy farm trailers and wagons. It is a 12,000 lb. capacity square type straight trailer axle complete with Timken roller bearings, hubs, and 6 hole 750 x 20 Budd Wheels. Without brakes. Axle is 2 inches square and 69 inches between wheel mounting flanges. Std. width. AN EXCELLENT BUY.

With Single Wheels **\$59.50** With Dual Wheels **\$69.50**

### Save \$30.00 On JEEP Spare Parts KIT

Originally packed for Amphibious Jeeps. Also adaptable for all military and some civilian jeeps. Offered at our low price of **\$8.95**

Kit consists of the following parts:

- 4-#1177 Retainer Wheel Grease
- 1-#2078 Hose Assy.—Rear Brake
- 1-#2079 Hose Assy.—Ft. Brake
- 1-#2197B Hose Assy.—Axle—Vent
- 2-#3135 Seal—Frt.—Axle—Pivot
- 1-#4022B Plug Assy.—Axle Vent
- 1-#5666 Belt Capstan
- 1-#8620 Belt—Fan
- 1-#12405 Spark Plug
- 1-#13466 Bulb (Black-Out Marker Lamp)
- 1-#13485 Unit Assy. (Rear Lamp Stop)
- 1-#13491 Unit Assy. (Rear Lamp Lower)
- 1-#13494 Unit Assy. (Rear Lamp Service)
- 1-#15480 Belt—Bilge—Pump
- 1-#17008 Container Assy. Spare Parts (Waterproof)
- 1-#17058 Tape—Friction (3/4"—8 oz.—Roll)
- 1-#17060 Wire—Annealed (No. 22—Ga—1/4 No. Roll)
- 1-#18318 Kit—Cotter Pin (asst.)
- 1-#18320 Kit Tire Valve Core (5-B-1725)
- 1-#18322 Kit Tire Valve Cap (5-GPW-1720)
- 1-#1711340B Seal Transfer Case Output Shaft Collar
- 1-#1711344 Seal—Drive Shaft Housing Gear
- 1-#1711346 Seal—Drive Shaft Housing Front
- 1-#1711356 Seal—Front Floor Tunnel Drag Link
- 1-#1752960 Strap Assy.

### Brand New HYDRAULIC JACKS

Walker, 3 ton. Complete, limited supply. **\$9.95** Each.

**UTILITY GAS TANK** 6 quarts—New Surplus, Cylindrical 5 1/2"x15 1/2". Brackets for mounting. Complete with Filler cap, drain plug and pet-cock. Ideal for small gas engines, stoves, etc. **\$1.50**

**SURPLUS POWER WINCHES** All are brand new and suitable for front or rear mounting. GARWOOD OR HEIL—15,000 lb. capacity. **\$150.00**

**Surplus WINCH CABLE While They Last**

200 ft. length 1/2" cable	<b>\$25.00</b>	300 ft. length 1/2" cable	<b>\$35.00</b>
250 ft. length 1/2" cable	<b>\$30.00</b>	300 ft. length 5/8" cable	<b>\$40.00</b>

HUNDREDS OF OTHER TRUCK PARTS AND SUPPLIES.

All prices quoted good 30 days FOB, Kansas City. 25% deposit required on COD orders.



**UNITED AUTO PARTS CO., INC.**  
1901 TROOST GR. 1800 KANSAS CITY, MO.

## AMAZING NEW NOVELTY

# BLONDE

in . . (out)  
of the

# BATH TUB!



Imagine ONLY **98¢**

• Fascinating! • Tantalizing! • Intriguing!  
Keeps everyone guessing. The lovely Blonde will stay in her bathtub for you—but not for others. She always pops out. Your friends will marvel that you're the only one she obeys. It's a thrilling new novelty that will be the life of the party. Send for yours today—and learn the amazing secret of how to make the lady behave. **SEND NO MONEY.** Rush your order today! Remit with order and we pay postage or C.O.D. plus postage. **SPECIAL PRICES TO DEALERS**

### NOVELTY MART

59 East 8th Street Dept. 194 New York 3, N. Y.

## 1.98 SPEEDMASTER TRAILER HITCH AND BALL



POSITIVE THUMB LOCK

Hooks Up FAST Worth \$4.00



### MONEY BACK GUARANTEE

Try it at our risk.

Send only \$1.98 with order and we will pay postage anywhere in the U. S. A.

### FRIENDLY EAGLE

1045 Millbrook Ave.

Fresno 3, Calif.

## COMMERCIAL TRADES' GRADUATES GET THE BETTER JOBS because they are PROPERLY TRAINED!

Practical Shop Training In  
Air Conditioning—Refrigeration  
and/or

Electricity Major Appliances  
Service, Maintenance & Installation

Write for Catalog PS4

**COMMERCIAL TRADES INSTITUTE**  
200 South 20th St. Birmingham, Ala.  
Member: Southern Association of Private Trade Schools  
An approved school to TRAIN Veterans & Non-Veterans



## DUST-O-VAC FOR ALL MACHINES

For Home Workshops & Industry. DUST-O-VAC collects & bags wood & plastic chips, wood & metal dust, wood shavings. Free Bag. Attaches to circular saw, planer, band saw, grinder, belt or disc sander, shaper, drill press with shaper or sander attachment, spindle shaper, wood lathe, jig saw, 110 A.C., D.C. Send for mounting instr. for all machines.

**\$19.95**

Free Ship. east of Miss. West of Miss., add \$1. Check, M.O.

### HEAVY CAST ALUMINUM BLOWER—ONLY \$10

110V, AC 50-60 cycles, cont. duty motor, deliver app. 100 C.F.M. For workshop, lab, kitchen, cellar, etc. Install yourself. Send for circular. **UNIVERSAL YONKERS CORP., 137 Alexander St., P-8, Yonkers 2, N. Y.**

## LAW FREE BOOK



Your FREE copy of "The Law-Trained Man" shows how to gain prestige and greater earnings through Blackstone home law study. All instruction material furnished including 18-volume Law Library written by 65 well-known law authorities. Lawyers, judges among our graduates. LL.B. degree. Low cost; easy terms. Write today.

**BLACKSTONE COLLEGE OF LAW** 225 N. Michigan Ave. Dept. 120-C, Chicago 1, Ill.  
A Correspondence Institution Founded in 1890

## Jet Performance for Your Car with VAPOJET

This aircraft developed water-oil vapor injector gives your car faster pick-up, smoother running power and eliminates carbon, vapor lock and overheating. Many users of the sensational new Vapojet report up to 25% more mileage per gal. of reg. gas. Complete, easily installed kit fits all car, tractor or boat engines.

### MONEY BACK SATISFACTION GUARANTEE

(If returned within 30 days)  
Order today. Only **\$9.75** ppd. Send check or money order & save postage. \$1 deposit on C.O.D.  
**VAPOJET MFG. CO., 11424 Biona Dr., Dept. PS-8, Los Angeles 34, Calif.**

### MAIL COUPON TODAY

Rush me.....Vapo-Jet Kits including carburetor adaptor, copper tubing, fittings, etc. and illustrated instructions. Enclosed is my check or money order for \$.....  
Car.....No. of cyl.....Year.....  
Name.....  
Street.....  
City.....State.....

U.S. Patent No. 2,188,175

AGENTS WANTED

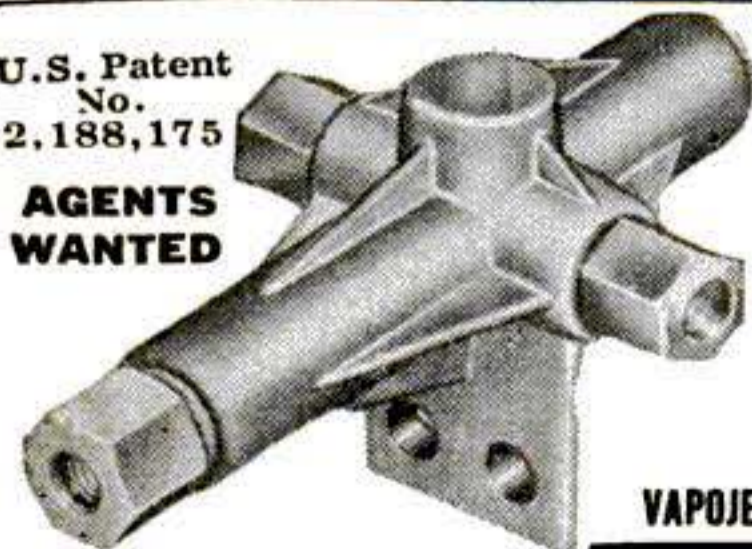



**HERE'S EVERYTHING YOU NEED TO LEARN THE MATCHLESS ART OF LEATHER CARVING—AT HOME**

Now carve your own beautiful bags, billfolds, belts, moccasins, key cases—anything from leather—at one-tenth the cost. We supply everything: patterns, tools, leather, fittings, instruction books for craftsmen. Turn hobby into a business. Send \$1 for big set patterns, or **SEND ONLY 25c FOR NEW CATALOG #102**

**BURTONS LTD., 1755½ Glendale Blvd., Los Angeles 26, Calif., Dept. H**

**101 Uses For Model TX-8 QUINCY COMPRESSORS**

All sizes available. Complete Compressors—Tank Mounted Units—Compressor Units Only—Electric Motors—Gasoline Engines—Air Pressure Tanks—Painting Equipment Portable and Stationary—Farm Compressors—Special Air Compressor Equipment Built to order. Write for FREE information. State your specific requirements. Compressor as illustrated, price only..... **\$4280**

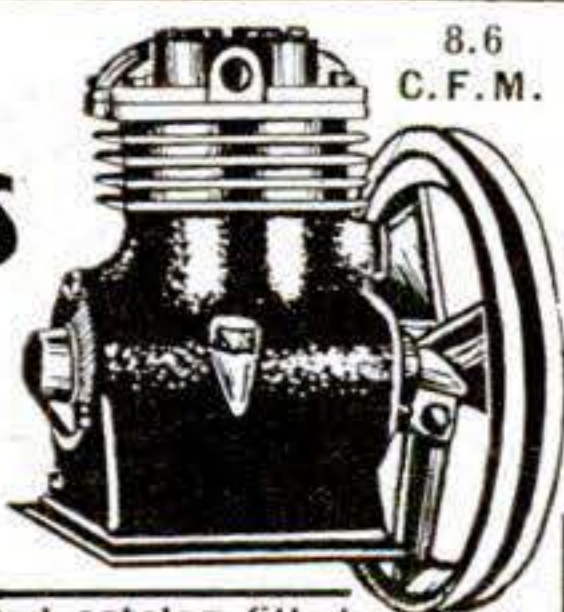

8.6 C.F.M.

Write for new 1949—52 page illustrated catalog filled with thousands of new items and War Surplus Bargains. Send 10c to Cover Handling and Mailing Costs.

**MIDWEST SALES CO.**

2533 INDIANA DEPT PS8 KANSAS CITY, MO.

**Build YOUR OWN BOAT**



Build a better boat than you can buy for the money! Save 35-55%. Exclusive laminated ribbed construction, prefabricated for easy assembly. All popular types from simple car-top models to mahogany-decked runabouts, from \$39.50 to \$199.50. Send 10c for literature.

**\$39<sup>50</sup>**  
and up

**OZARKA**

789 BORDEN LANE  
WOODSTOCK, ILL.

**EVERYTHING IN PLASTICS AT ONE PLACE!**

Sheets—Rods—Tubes. Cements, Dyes, Carving Drills—Supplies, etc. Casting Plastics. Everything you need. Write for Free Catalog.

**FRY PLASTICS COMPANY**

Dept. 18, 7608 S. Vermont Ave., Los Angeles 44, California

**EARN MORE IN DRAFTING**



**STEADY EMPLOYMENT**  
**MORE OPPORTUNITIES FOR PROMOTION**

"Here I am at work making good money as a draftsman. I'm glad I sent the coupon to Chicago Tech for that Free Trial Lesson and found out how easy it is to learn Drafting in spare time at home. Today I feel secure in my job because the draftsman's work comes first on any new project. And, in addition, draftsmen can't be replaced with machines. What's more, I feel I'm slated for promotion and more pay, because I see so many draftsmen advancing to high-pay jobs."

**LEARN IN SPARE TIME—AT HOME!**

(or at the College in Chicago)

A few hours of pleasant home study every week—that's all. No interference with your present job. All the tools you need; drawing outfit included. With Chicago Tech's help, you train yourself step by step. This tested method—developed over 45 years of C.T.C. progress—prepares men quickly for good positions in industry.



**FREE INFORMATION—SEND COUPON**

To prove to you how easy it is to learn Drafting at home by the Chicago Tech method, we will send you this FREE TRIAL LESSON. No charge for this lesson, now or later. Fill out and mail coupon, or send post card today.

**CHICAGO TECHNICAL COLLEGE**

K-226 Tech Bldg., 2000 So. Michigan Ave., Chicago 16, Illinois

Mail me FREE Lesson with information about big opportunities in DRAFTING.

Name.....Age....

Address.....

City.....Zone...State.....

**Learn PHOTOGRAPHY**

Win success in photography by spare time Home Study or at our famous Resident School in the heart of New York. Commercial, Advertising, Portrait, Color, etc. 39th year. Write today!

**NEW YORK INSTITUTE OF PHOTOGRAPHY**

Dept. "5", 10 W. 33 St., N. Y. 1, N. Y.

**WRITE FOR YOUR FREE COPY OF THE NEW KRW HYDRAULIC PRESS BOOK**

Describes all manner of Production and Shop Work on KRW Hydraulic and Bench Type Presses. Illustrates the new KRW Hand-operated, Electric-operated and Air-operated Hydraulic Presses. 25 to 100-ton capacities.

Write for your copy today.

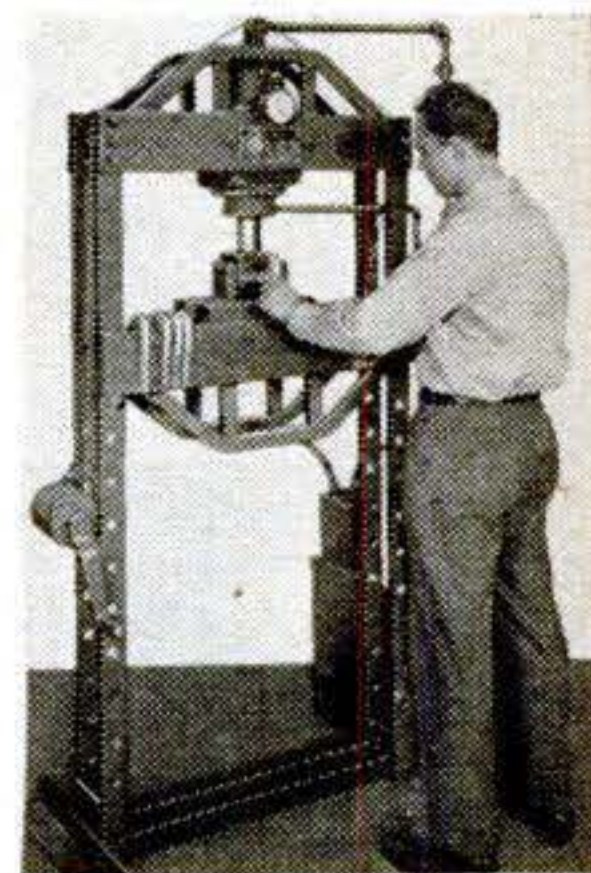
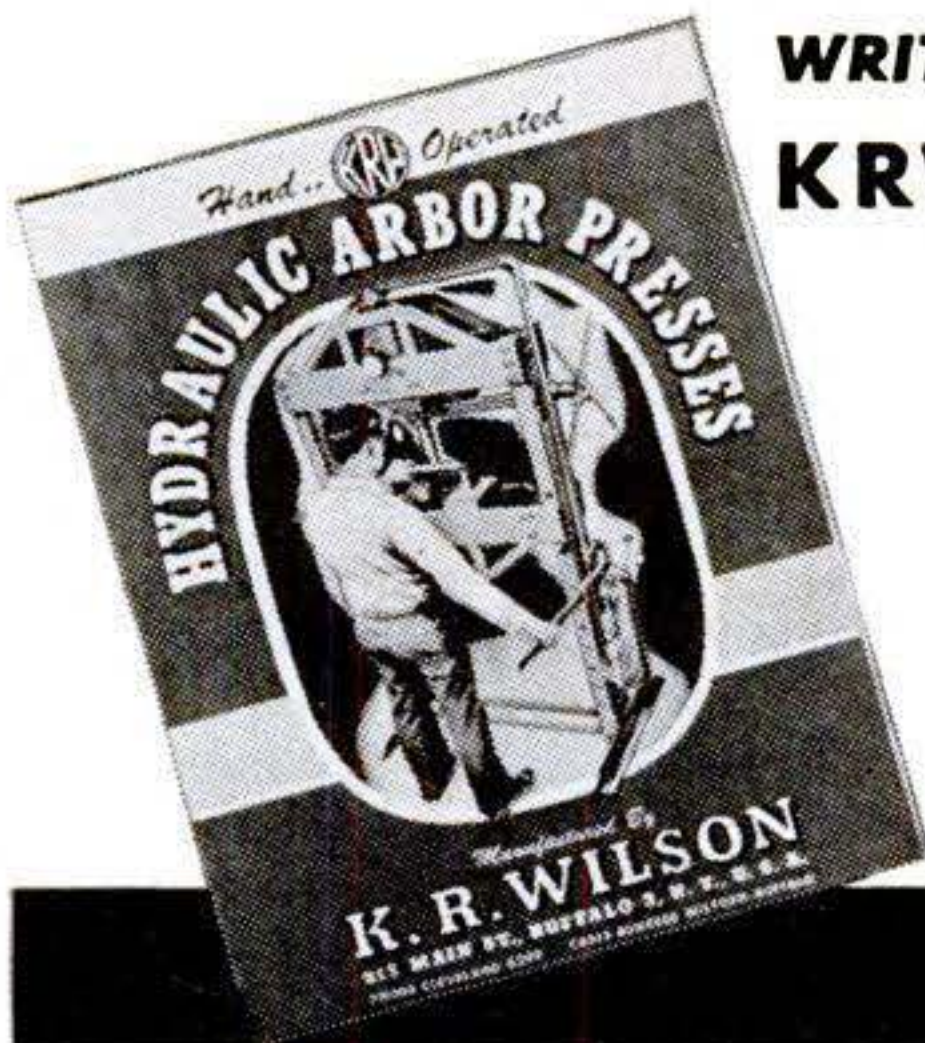

**K. R. WILSON, DEPT. 54, 215 MAIN ST., BUFFALO 3, N. Y.**

# DRAFTING

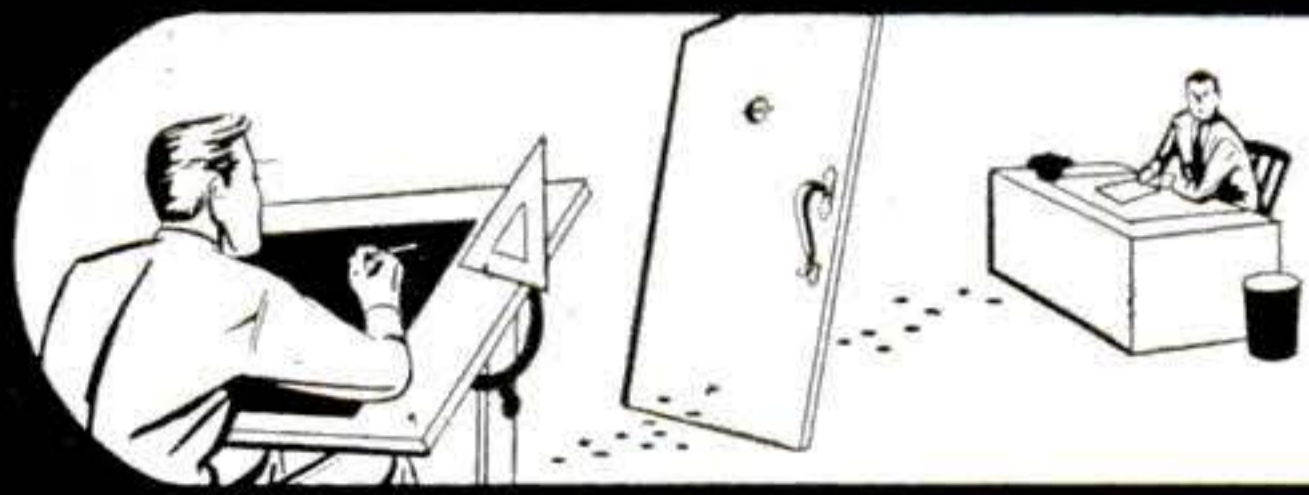

**DOORWAY TO SUCCESS!**

It's **EASY** to learn  
**DRAFTING**  
in a few short weeks with  
**CEI SIMPLIFIED**  
**TRAINING AND COACHING**

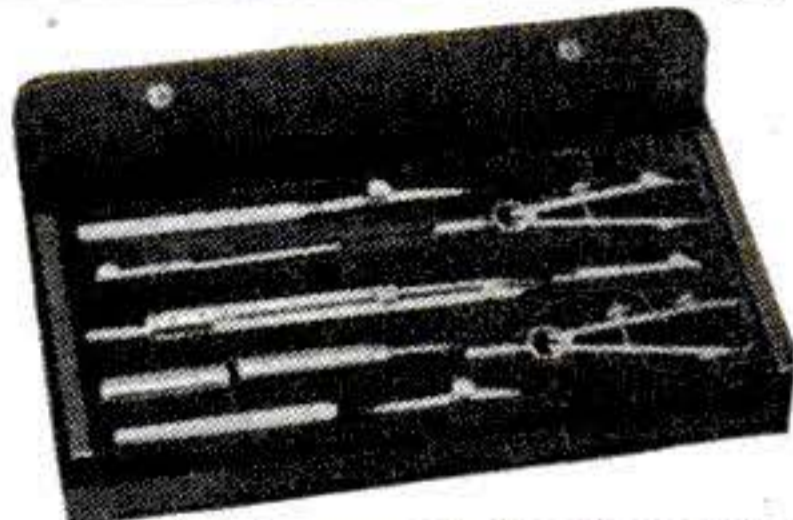

Be like industry's leaders who have used Drafting as their springboard to success! You want security, a home, a car, a bank account, freedom from money troubles—they all come with success. CEI will teach you Drafting **EASILY** and **QUICKLY** in your spare time at home, and will help you get a job! You get professional instruments and complete drafting equipment at no extra cost.



GET FREE 1949  
Success Book

## MAIL COUPON NOW

**CLEVELAND ENGINEERING INSTITUTE**  
Extension Div. PS-8  
2325 Chester Ave., Cleveland 14, Ohio  
Rush your FREE 28 page Success Book showing  
how Drafting is the Doorway to Success.  
 Veterans check here

NAME .....  
ADDRESS .....  
CITY..... STATE.....  
No obligation—No salesmen

**FREE BOOK**  
TELLS HOW  
TO BE AN ...

*Accountant  
Salesman  
Secretary  
Stenographer*

## SECURED FUTURE . . . FREE EMPLOYMENT SERVICE

Enter one of the "substantial earnings" fields through Hill's "Success Plan" training. A lifetime opportunity to join thousands of successful graduates in positions secured through our nation-wide employment service. No matter where you live, what you are doing now, Hill's can train you by study at home or in the resident school. Big Free book shows you the way to substantial earnings and an assured future. G. I. Approved.

Hill's Extension School & Business University  
Dept. PS-89, 619 W. Main St., Oklahoma City 2, Okla.  
Please send your free book. "Through Hill's to Success."

NAME .....  
ADDRESS .....  
CITY..... STATE.....  
 Check here if eligible under G.I. Bill.  
Please check course and training plan preferred.  
Course.....  Resident  Home Study

MAIL THIS EASY-TO-USE COUPON TODAY



**Pixie**

Whittaker Micro 16  
**CAMERA**  
FAIR  
TRADED

Pixie is a Precision-built camera so tiny you can wear it on your wrist. Simple, easy-to-use, and easy-to-load, Pixie makes big clear pictures in **COLOR and Black & White**—at a sensationally low cost!

**\$4.95**



ACME NOVELTIES  
Order direct TODAY or see your Dealer!  
1238 W. 59th STREET • LOS ANGELES 44, CALIF. Precision Built and Guaranteed!

## MALL SAW ATTACHMENT

SAVE TIME AND LABOR BY EQUIPPING  
YOUR MALL SAW MODEL 60 with a

### ZMCO ANGLE-DEPTH ATTACHMENT



WIDE RANGE FOR  
ANGLE OR DEPTH CUTS:  
Maximum Cut at 90° 1-31/32"  
Maximum Cut at 45° 1-3/4"  
Minimum Cut at 90° 7/32"  
Minimum Cut at 45° 1/8"

Light Weight (only 1 lb. 14 oz.) Compact (10 5/8" x 6")  
Make perfect fitting straight and bevel cuts quickly and easily. Regulate cuts with hairline accuracy. Fastens securely to your Mall Saw with no holes to drill. Sturdy Steel construction.

**\$6.75**

postpaid  
Money Back Guarantee  
Dealer Inquiries Invited

Send ad with check today to  
**ZIEROLD MFG. CO.**  
Box 509-R, Burbank 8, Calif.

## INSTANT NICKEL

NO CURRENT OR BATTERIES USED

COMPLETE  
**\$2.50 POST PAID**  
1948 PATENT  
AGENTS  
WANTED

Just Patented—Now everybody can nickel plate. No equipment, electricity or copper plating needed. Just rub. A blessing to Doctors, Hobbyists, Auto, Machinery and Home Owners and practically everybody. No poisonous cyanides or quicksilver. It will plate to a practical thickness, Steel, Iron, Copper, Brass, etc. It's new, different, practical, economical—By following easy directions a matte or brilliant "chromium like" finish is obtainable—fascinating hobby—plate for neighbors and friends. Money-back guarantee. C.O.D.'s few cents extra.  
INSTANT PLATING PRODUCTS, Dept. S-7 3438 So. Michigan Chicago 16, Ill.

**EYE-  
GLASSES  
BY MAIL**  
16 Days Trial



Write Today for Free Catalog. Send no Money  
**ADVANCE SPECTACLE COMPANY**  
537 South Dearborn Street, Dept. SP-8, Chicago, Illinois

## Learn SHOE REPAIRING

ALSO COURSES IN HAT CLEANING AND BLOCKING  
PRACTICAL SHOP TRAINING

● Excellent opportunities for good jobs or a successful business of your own. Prepare quickly—practical shop work and shop management taught by experts. Here is a field for a man who wants to be his own boss. Approved for Veterans. Help in finding part time work while a student, employment service to graduates. Write today for FREE information.

**CHICAGO SCHOOL OF SHOE REBUILDING**  
124 E. 26th St. Dept. PS-8 Chicago 16, Ill.



## S Success Plan! Make Big Money S Flocks, Sandblasts, Smalts, Beads

All Purpose Spray Gun! Uses only 25 lbs Air Pressure!  
NEW Rich Field! New miracle Spray Gun & Accessories make Auto Interiors Clean & New. Lines drawers, marproofs, refinishes any object with miracle finish. Etch & Frost windows, removes paint, rust, from Autos, Tools, Machinery etc. Thousands profitable uses for Shop, Industry, Farm, Home. Act Now! Get the facts Free!

**BLASTO SPRAY GUN MFG.**  
Dept. 23, 7007 Haas Ave. Los Angeles 44, Calif.

## HANDY SEWING AWL



Patented lock-stitch awl, complete with 2 needles and reel of waxed thread at this special price! Satisfaction guaranteed, or money back. HUNDREDS OF USES—sewing and repairing leather goods, tents, belting, awnings, saddles, sporting goods and others. Complete instructions. Send currency, check or money order. Postpaid.

**RADEN SALES COMPANY**  
Dept. B, Box 625, Ft. Worth, Tex.

BE A **GOVERNMENT LICENSED AIRPLANE AND ENGINE MECHANIC** Train Now **at LINCOLN**

EARN BIG PAY IN **AVIATION**  
 Start your aviation career by enrolling in our **MASTER AVIATION MECHANICS**, CAA Approved 1 Year Course, a complete course in both airplanes and airplane engines. Our **REFRESHER AIRPLANE & ENGINE MECHANICS COURSE** is designed for veterans or others with aviation mechanics experience. Either course is available to veterans under the **G.I. Bill of Rights**. Write today for complete information.

**LINCOLN AVIATION INSTITUTE**  
 UNION AIR TERMINAL DEPT. A-8 LINCOLN, NEBRASKA

**PLYWOOD BOAT KITS**

**\$67.50**  
 (Freight Included)

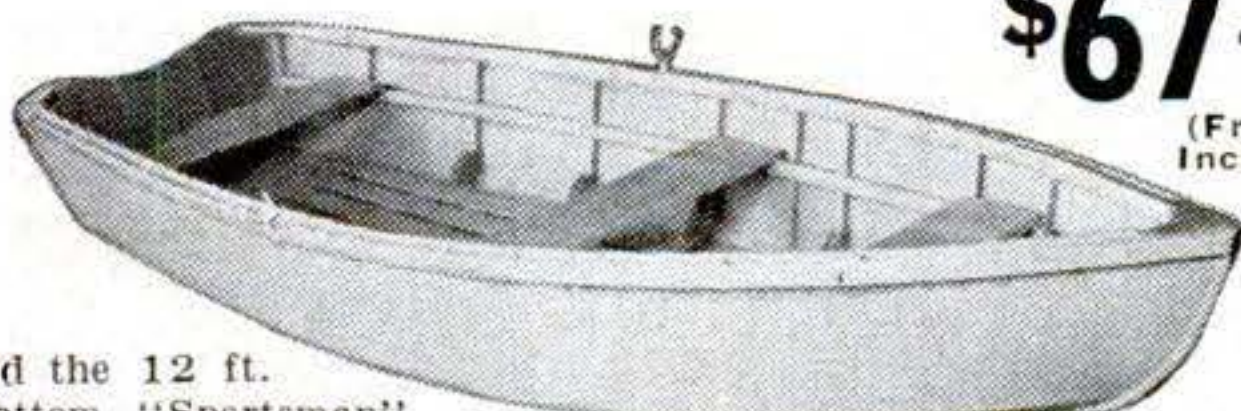

Build the 12 ft. V-Bottom "Sportsman" as shown. Ready-cut kits include all hardware, paint, etc. Send for free folder on all models as low as \$29.95, freight included.

**TAFT MARINE WOODCRAFT**  
 Dept. "R," 636 39th Ave. N.E. Minneapolis 21, Minn.

AMAZING NEW CHEMICAL MAKES **OLD BUMPERS LIKE NEW!**

**NOT A PAINT! NOT A POLISH!** Looks like expensive chrome plating! Wonderful new chemical puts chrome-like finish on car bumpers, door handles, trim, etc. No electricity—no plating tanks—no acids needed. Just smooth it on and watch it gleam! Takes a brilliant polish **JUST LIKE CHROME**—so simple a child can do it. **REFINISH BUMPER IN 10 MINUTES!** WORKS LIKE MAGIC—finish lasts for years. Increases resale value of your car and adds NEW beauty to other chrome plated or metal items. **TRY AT OUR RISK! SEND NO MONEY!** Just send name and address. Pay postman amazing low price of \$1.00 plus few cents postage for each kit ordered, or send cash and we pay postage. Try kit 10 days. If not delighted return for instant refund! **JACK T. ERMAN, Box 147, Hamtramck, Mich.**

**\$100**

**MASTER COURSE IN HYPNOTISM**

SECRETS REVEALED! Actual methods, techniques of master hypnotists . . . how to hypnotize suitable subjects at a glance—a command—by phone! How to control subjects after they awaken—help break tobacco, other habits. Self-hypnosis. Group hypnosis. Entertain with amazing hypnotic stunts for fun or profit. Get this easy-to-understand, how-to-do-it course now! **Money-back guarantee.** Fully photo-illustrated . . . **\$2 (complete).** EXTRA! Unique "ALARM-CLOCK MIND" instruction folio and catalog of unusual Power Books included. Order "Hypnotism Course" today!

**POWER PUBLISHERS, Dept. M2, 790 Broad St., Newark, N. J.**

**NEW SELF-DRIVE B-M POWER MOWER!**

**For Modern Lawn Care**

End grass-cutting drudgery with B-M's newest model self-drive, three-wheel, rotary blade mower. Equipped with 1½-2 h.p. Clinton Engine. Smooth, positive clutch. Handlebar controls. Light. Sturdy. Puncture-proof rubber tires. Shipped completely assembled. Other models available, including 3 h.p. 22-inch mower. Prompt shipment. Order direct if not supplied by dealer.

**LOW FACTORY PRICE**

LOW PRICED • FULLY GUARANTEED

Write For FREE Literature

**B-M MOWER CO., Box 66-PS, Blue Mound, Kansas**

**NEW "SURPRISE of the MONTH"**



It's new! A surprise package delivered to you each month—for only \$1.00 including postage.

The excitement alone is worth a dollar as you open your package with a beautiful useful, tasty or interesting ??? in it. If you happen not to like one of your surprises, just return it and your dollar will be refunded.

It's too much fun to miss. Give a subscription to your friends—and subscribe yourself. \$6.00 for six months, \$12.00 for 12 months. Clip the coupon below.



● ● ● ● ● ● ● ● ● ● ● ● ● ● ● ●

**Surprise-of-the-Month, Dept. 1-H-8**  
**303 Guardian Life Bldg., Dallas, Texas**  
 OK! Surprise me! Enclosed is cash, check or money order for ..... months' subscription  
 NAME.....  
 ADDRESS.....  
 CITY.....

● ● ● ● ● ● ● ● ● ● ● ● ● ● ● ●

**Learn MECHANICAL DENTISTRY**

To make Crowns, Plates, Bridgework, etc., for Dentists. Easy practical way to learn mechanical dentistry at home in spare time. **FULL EQUIPMENT OF TOOLS AND MATERIALS INCLUDED WITH COURSE.** Low tuition. Easy terms. Write for **FREE BOOK** about this money making profession that is not affected by the machine age.

**McCARRIE SCHOOL of Mechanical Dentistry**  
 207 N. Broad St. Dept. 889 Philadelphia, Pa.

**LEARN TO WRITE**

The Magazine Institute, a private school owned, operated, and staffed by successful writers and editors, offers an up-to-the-minute course in writing for magazines which makes it easy for beginners to get started in this rich field. You work in spare time at home. You may concentrate on either fiction or non-fiction. Send today for the **FREE CATALOG** describing the Magazine Institute method. **VETERANS: THIS COURSE APPROVED FOR VETERANS' TRAINING.**

The Magazine Institute, Inc.  
 Dept. 468-A, 50 Rockefeller Plaza,  
 Rockefeller Center, New York 20, N. Y.  
 Please send free catalog, without obligation, to:

Name.....  
 Address.....  
 Check here if eligible under G. I. Bill (Inquiries confidential. No salesman will call)



**HIGH PAY • SECURITY**  
When You  
**LEARN A TRADE**



Get ready for a well-paid, lifetime job or a business of your own in one of these **FIVE ESSENTIAL TRADES**. Complete training under expert instructors with practical experience prepares you to step into a good paying job with a future and security.



**ELECTRICITY:** Basic electricity, Residential and Industrial Wiring and Appliance Repair



**PLUMBING:** Every phase — pipe cutting and threading to complete installations, blue print reading.



**AUTOMOTIVE & TRACTOR:** Engine overhaul, Transmissions, Carburetion, Generator-Ignition Systems, Tune Up

**DRAFTING:** College level training in general Machine and Architectural Drafting.

**SHOE REPAIRING:** Complete practical training includes reconditioning and rebuilding.

Approved For Veteran's Training

**NATIONAL TRADE SCHOOL**  
DEPT. C • 2610 Grand • Kansas City 8, Mo.

Without obligation to me please send full information on the course checked.

.....Automotive and Tractor Technician ..... Drafting  
.....Plumbing .....Electricity .....Shoe Repairing

Name.....Age.....

Address.....

City.....State.....

Veteran?.....

**WALKIE TALKIES**

**ELECTRONIC Sound Powered Phones**

- 2 complete units
- Guaranteed to work
- Absolutely complete—ready to use
- Nothing extra to buy
- Works anywhere
- Ideal for: outdoors, indoors, anywhere

**TELEVISION MEN ATTENTION:**

Ideal for Television Installations  
Complete two way Communication System  
C.O.D.'s, send \$1.00 deposit, pay \$2.95 post  
postman balance plus postage. paid

**NORTH EAST SALES CO.**

366 Madison Ave., Dept. PS-2, New York, N. Y.



**USE YOUR BOAT ANYTIME—**  
for Fishing & Fun!

ONE MAN PUTS IT ON TOP

Employing the principles of counter balance and leverage the Superior One Man Boat Loader virtually loads a boat onto your car.

Rack has one moving part and is constructed of all steel channel bar mounted on oversize suction cups to carry a boat up to 54" outside, weight 150 lbs.

INQUIRE AT YOUR SPORTING GOODS DEALER

If he doesn't stock our Loader, write us giving his name and we will be glad to send both of you more detailed information.

RETAIL \$28.75\*

**Superior SPORTS EQUIPMENT, INC.**  
87-95 STATE STREET, LYNN, MASS.

\*Prices may vary slightly according to your locality.

**Ball-Bearing SPEED WHEELS**



**Juvenile Wheels** (No bearing, solid tires)  
5" .....45c 6" .....65c  
7" .....75c

(Semi-pneumatic tire, ball bearing)  
8 x 1.25.....1.85 10 x 1.25.....2.20  
8 x 1.75.....1.95 10 x 1.75.....2.30  
8 x 2.....2.20 12 x 1.75.....3.45

**Industrial Wheels for Heavy Loads**

5 x 1.75 Bolted...3.65 10 x 2.75 Pneu. 6.80  
6 x 2 Welded.... 3.45 10 x 3.50 2-ply 10.55  
6 x 2 Bolted .....4.00 12 x 2.00  
8 x 1 Alum .....5.25 Bolted .....6.90  
8 x 2.00 Bolted...5.20 12 x 3.00  
8 x 2.50 Bolted...5.40 Bolted .....9.20  
8 x 3.00 2-ply 11.00 4.00 x 8 2-ply..13.10  
10 x 2.00 Bolted 6.10 4.00 x 8 4-ply..13.90  
10 x 2.75 H.C. ..5.15 16 x 4.00 .....15.15

Dealers, Jobbers, and Manufacturers! Our new prices will interest you.

Available Now—CASTERS  
Write for circulars on all wheels.  
No. c.o.d. orders. Prices F.O.B. our plant.

**JIM BROWN TOY COMPANY**  
1093 Home Ave. Akron 10, Ohio

**LOTS \$300 LOW TERMS**

In California's loveliest Garden Spot, on scenic shores of beautiful Morro Bay. Enjoy future independence with excellent soil, soft water, wonderful fishing, hunting, boating, bathing, etc. Grow fruits, vegetables, poultry. Perfect temperate climate. Congenial community. Finest investment. Free literature.

RICHARD S. OTTO

Dept. PS

San Luis Obispo, California



**Free Sample!**

Big profits showing amazing GLOW-IN-THE-DARK SPECIALTIES. House numbers, pictures, plastic novelties, religious and nursery objects, etc. Large manufacturer. Enormous demand. Sell on sight. Write at once for FREE SAMPLES.  
**MADISON MILLS, Dept. X-5**  
303 Fourth Ave. NEW YORK 10, N. Y.

**LAW**

STUDY AT HOME for Business Success and LARGER PERSONAL EARNINGS. 39 years expert instruction—over 114,000 students enrolled. LL.B. Degree awarded. All text material furnished. Easy payment plan. Send for FREE BOOK NOW—"Law and Executive Guidance."  
[G.I. Approved]

**AMERICAN EXTENSION SCHOOL OF LAW**  
Dept. 17-PS, 646 N. Michigan Ave., Chicago 11, Ill.

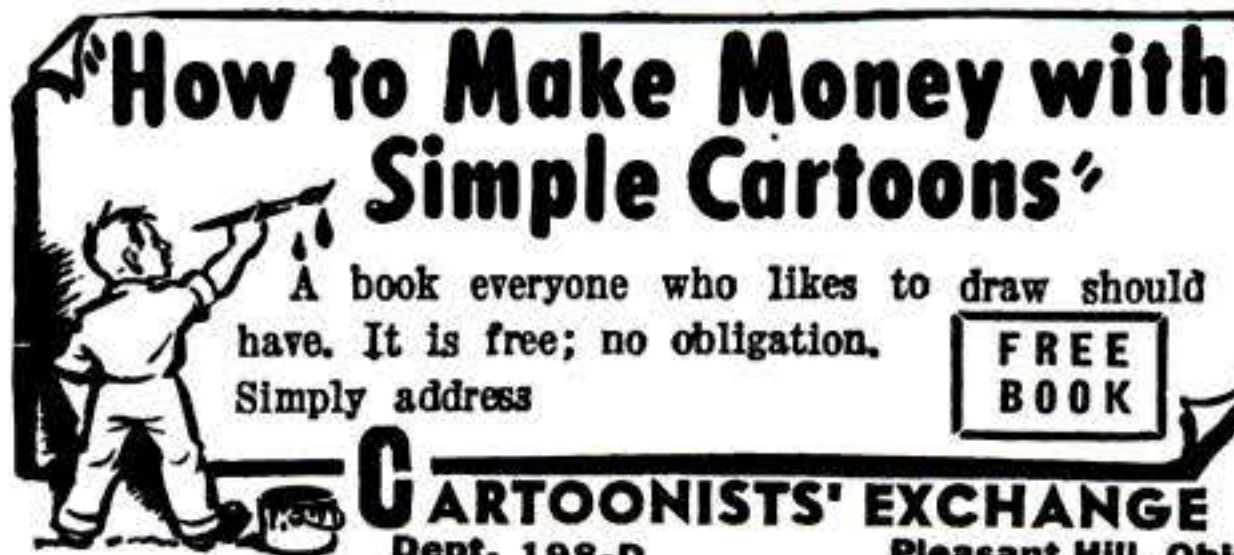

**How to Make Money with Simple Cartoons**

A book everyone who likes to draw should have. It is free; no obligation. Simply address

FREE BOOK

**CARTOONISTS' EXCHANGE**  
Dept. 198-D Pleasant Hill, Ohio

☆ **GIANT** ☆  
**ASTRONOMICAL TELESCOPE**

Ready for use. 6 ft. tripod. 100 diameters magnification. (10,000 area magnification). Extra eyepiece especially suited to observing Milky Way, Nebulae, Comets, Double Stars and Star Clusters. Sun projector lens for watching sun spots. Full power and clear vision guaranteed. \$15.00. 25% deposit on C.O.D. orders.

Shipped via Express F.O.B. Manorville

**SUFFOLK SCIENCE SERVICE**  
DEPT. CT. MANORVILLE, N. Y.



# SURPLUS BARGAINS

**SPECIAL !! SPECIAL !! SPECIAL !!**

## SEALED BEAM SPOTLIGHT ELEMENTS

Here is an outstanding buy . . . Brand new G. E. or Westinghouse sealed beam elements. Perfect for outdoor lighting, display spots, window illumination, etc. 110-115V—300 watts—5 3/4" dia. Ordinarily retails for \$5.25 each. Send full amount with order.

**\$2.00**  
ea.  
**3 for \$5.00 Postpaid**



## C & H WAR SURPLUS CATALOG

—that is jam-packed with values galore for the factory, home, workshop, farm and outdoors! New, used and reconditioned items priced amazingly low!

Send  
**10c**  
Today!

**C & H SALES CO.**

1850-58 East Colorado St. Pasadena 8, Calif.



## Bar Bells

Buy Direct From Factory

Write for free booklet  
and price list

**\$8.95**  
up

INDEPENDENT IRON WORKS  
2416 East 23rd Street, Dept. C  
Los Angeles 11, Calif.

## FOAM RUBBER

For CHAIRS, BENCHES, Etc.

Send just 10c for a generous sample and price list of this luxurious padding. Available in all sizes in thicknesses from 1/4 to 1". Set of 4 Foam Rubber Bridge Chair Pads 12 3/4 x 13 1/2 x 1/4" or set of 2 Kitchen or Dinette Chair Pads 15 x 15 x 1/2" each \$2.00 complete. Set of 2 large Dining Room Chair Pads 15 1/2 x 17 x 3/4" just \$3.50—all Postpaid. Quotations Submitted. Write!



**SANI-SPEED MFG. CO.** 323 FERGUSON BLDG.  
CLEVELAND 14, OHIO

## LEARN PLASTICS AT HOME

Get 7 Big Kits with course—make useful attractive articles.

Write for free catalog.

**PLASTICS INDUSTRIES TECHNICAL INSTITUTE**

1601 South Western Avenue, Dept. PS-89 Los Angeles 6, California

## ASSEMBLE YOUR OWN TRAILER

**SAVE UP TO 50%**

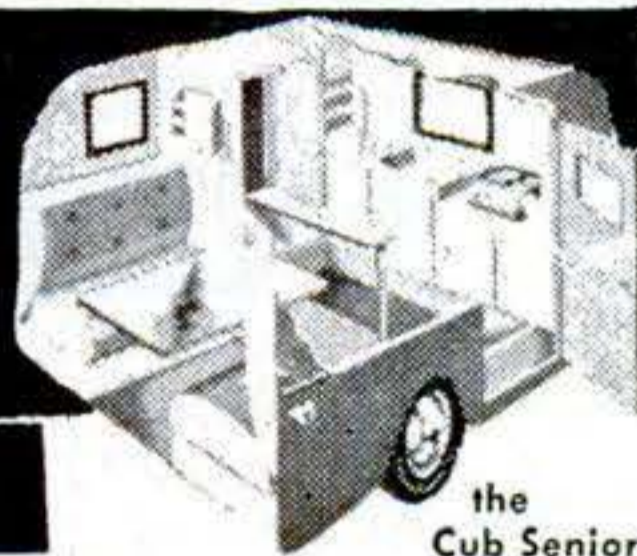

For less than cost of materials alone, we ship complete trailer kit . . . everything fits perfectly. Factory finished panels & sub assemblies easily assembled in a few hours with only a hammer, wrench, and screwdriver "CUB" SENIOR (shown above) A walk-in trailer with everything shown complete. 10' long, 6'4" wide and 6'9" high. ONLY \$395. F.O.B. Los Angeles

"CUB" SPORTSMAN (Teardrop camper model) Aluminum body, steel frame. 12'7" long, 6' wide, 5' high ONLY \$279.50 F.O.B. Los Angeles.

**WRITE FOR FREE BROCHURE**

Includes complete detailed information on both trailer models.

**DEALER INQUIRIES INVITED**

**NATIONAL TRAILER STORES**

BOX 2353, DEPT. S-89  
Terminal Annex,  
Los Angeles, Calif.



**YOU**  
can  
acquire

## LAW NIGHTS AT HOME! L L.B. DEGREE

LaSalle's famous Law Library—used as reference in many Law libraries and Law offices—has enabled thousands to master Law surprisingly fast, in spare hours at home, for business and professional advancement.

These 14 remarkable volumes, compiled by leading professors and lawyers, cover the whole basic field of Law in condensed, orderly, simplified manner.

You advance rapidly with this great library, plus special lectures furnished. We guide you step-by-step with personalized Problem Method of instruction . . . you learn by doing—handling legal problems—not by memorizing rules.

Send for two FREE 48-page booklets, "Law Training for Leadership," and "Evidence," answering questions about Law and its value to you, and telling how LaSalle Law graduates are winning rapid advancement in business and public life. Mail coupon below. No obligation.

## LA SALLE EXTENSION UNIVERSITY

A Correspondence Institution

417 S. Dearborn St. Dept. 883-L Chicago 5, ILL.

Send me your two FREE booklets described above, without obligation.

Name \_\_\_\_\_ Age \_\_\_\_\_

Street \_\_\_\_\_

City, Zone & State \_\_\_\_\_

## MAKE MONEY IN LANDSCAPING

Thorough training by Internationally known Landscape Architect to start your own business, improve your home or advance in this well paid field. Many Opportunities. Approved for Veterans. Send for FREE BOOK.



**NATIONAL LANDSCAPE INSTITUTE**

310 So. Robertson Dept. PS-8 Los Angeles 36, Calif.

## Hydraulic SPEED REDUCER OF MANY USES Variable Speeds and INSTANT REVERSE

From ZERO to 700 R.P.M.

For LATHES, REAMERS, TRANSMISSION, MIDGET CARS, MILLING MACHINE TABLE, SHAPER, THREAD MILLING FIXTURES, HOME MADE WOOD WORKING LATHE, EXHAUST FAN, PUMP, HOIST, GENERATOR, OVERHEAD TROLLEY, PRODUCTION BELT, OPENING and CLOSING DOORS, and MANY OTHER USES. Industrial or Home Use. Cost Government \$300.00. High Quality Precision Workmanship. Case measures 7 1/2" Long, 7" High, 6 1/2" Wide. Input and Output Shafts 5/8" diameter. Beautiful Red Crackle Finish Case.

FINGER TIP CONTROL

Output  
Torque  
Adjustment  
Zero  
to 100  
Inch  
Pounds

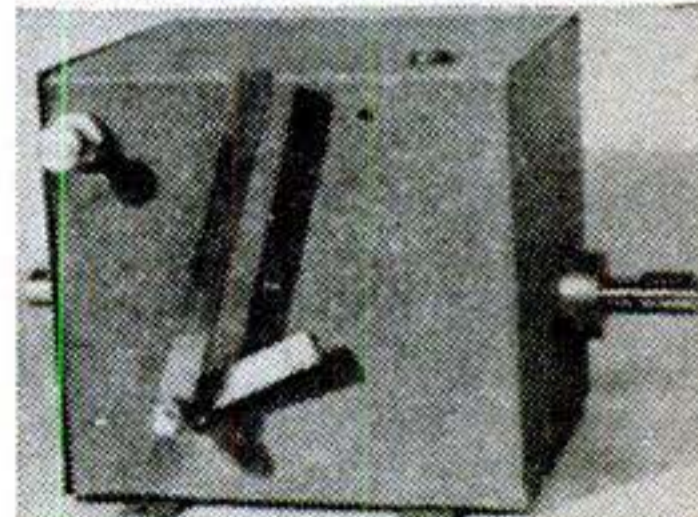

Shipping Wght. **Only \$54.50**  
25 pounds.

If C.O.D. is requested a 10% Deposit must accompany order and we ship F.O.B. Chicago.

1 1/2"—8 thread Lathe Chuck Adapter \$3 ext.

Prepaid 2 quarts oil included FREE

DIRZIUS MACHINE SHOP "L." 1423-25 So. 52nd Ave., Cicero 50, Ill.

# SALESMEN!

WRITE  
THREE  
WORDS  
COLLECT  
\$9<sup>95</sup>

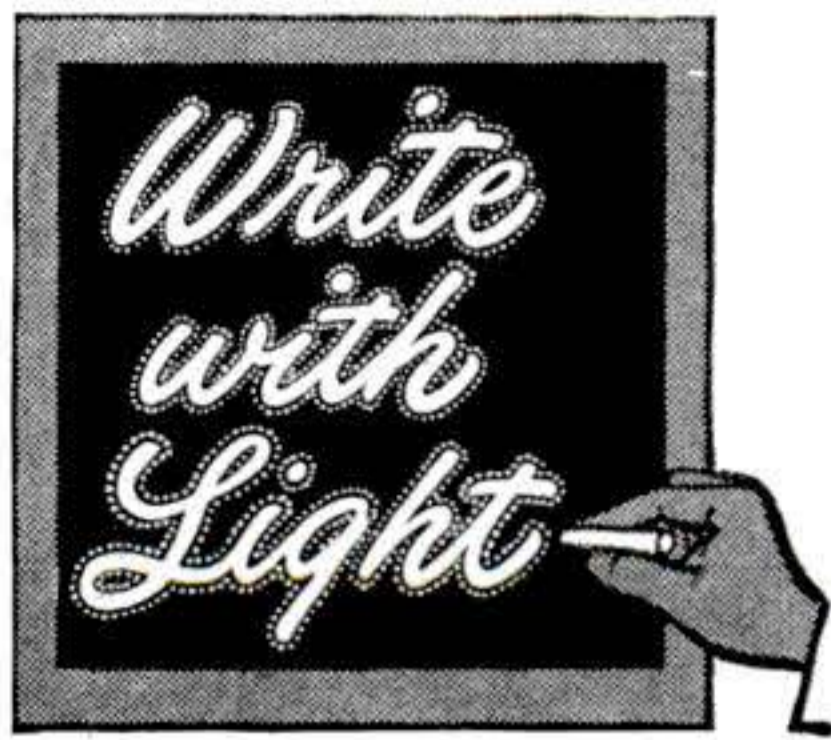

## SENSATIONAL NEW ADVERTISING SIGN

YES, MAKE \$9.95 on 10-second demonstration to merchants. Write on glass with amazing magic crayon and presto—a 5-color advertising message takes fire and glows like a brilliant neon sign! Three sales a day and \$29.85 profit is for "lazy" men. Workers can double to triple that amount. FREE SALES KIT. Don't wait. Rush your name and address on a penny postcard for full details and complete sales kit—ALL FREE.

**MAXILUME CO., 125 W. Hubbard  
DEPT. L-98 CHICAGO 10, ILLINOIS**

## Do you want

- .. to go to College?
- .. or to enter a Profession?
- .. or get an Office Position?

*(Such as Accounting, Architecture, Nursing, Dentistry, Teaching, Social Work, Osteopathy, Beauty Culture, Optometry, Embalming, Chiropody, Law, Medicine, etc.)*

To get anywhere, you practically MUST finish High School FIRST. You can complete our simplified High School Course in SPARE time at home, as FAST as your time and abilities permit. Equivalent to resident school work—prepares you for college, pre-professional examinations, business, industry. Standard texts furnished. Diploma. Credit for H.S. subjects already completed. Single subjects if desired. Low tuition, easy terms. American School, Chicago, est. 1897—endorsed by educators. Finish your high school education NOW. Write TODAY!

## High School Course at Home Many Finish in 2 Years

American School, Dept. HC-46, Drexel Ave. at 58th St., Chicago 37

Gentlemen: Send me FREE information covering special training in subjects checked below. No obligation on my part.

- |                                                      |                                                                |
|------------------------------------------------------|----------------------------------------------------------------|
| <input type="checkbox"/> High School Course          | <input type="checkbox"/> Diesel Engineering                    |
| <input type="checkbox"/> Electronics, Industrial     | <input type="checkbox"/> Drafting and Design for Men and Women |
| <input type="checkbox"/> Architecture and Building   | <input type="checkbox"/> Plastics                              |
| <input type="checkbox"/> Automotive Engineering      | <input type="checkbox"/> Private Secretary                     |
| <input type="checkbox"/> Business Management         | <input type="checkbox"/> Mechanical Engineering                |
| <input type="checkbox"/> Electrical Engineering      | <input type="checkbox"/> Aviation                              |
| <input type="checkbox"/> Elec. and Gas Refrigeration | <input type="checkbox"/> Salesmanship                          |
| <input type="checkbox"/> Air Conditioning            | <input type="checkbox"/> Radio                                 |
| <input type="checkbox"/> Railway Training            |                                                                |

Name .....

Address .....

## DARK ROOM VENTILATORS

13 1/2"  
D  
I  
A  
M  
E  
T  
E  
R

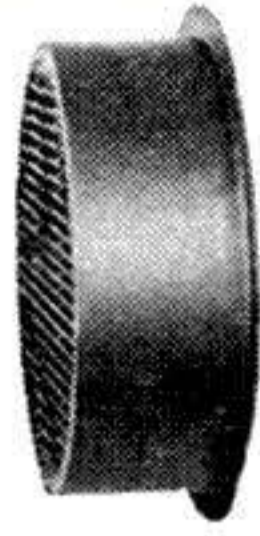
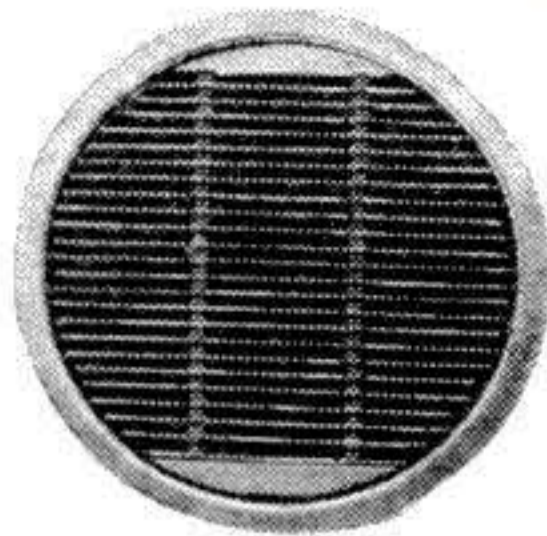

4 1/2"  
T  
H  
I  
C  
K  
•  
S  
T  
E  
E  
L

### VENTILATE YOUR DARKROOM

\$25.00 Value—PRICE \$7.50 set or \$4.00 Each

New government surplus. Air flows through these steel louvers freely due to the arrangement of baffle plates. Light does not show through these ventilators. Hundreds of these vents have been installed in darkrooms. You will need two for your darkroom. Install one in or near the ceiling and one near the floor. \$7.50 for set of two, or \$4.00 each.

Pay by Money Order or Check, 25% dep. on C.O.D.'s. Prices are F.O.B. Fresno. Shipping weight 29 lbs. for set of two.

### ARMY SURPLUS SALES

OF FRESNO  
Dept. PS-8 1820 Tulare Street Fresno, Calif.

## MANUFACTURE BUILDING BLOCKS

Easy to start your own profitable business. General high speed, low cost Concrete Vibrator Block Machine produces 1000 blocks in 8-hour day. All sizes and shapes. Complete details FREE. Mail \$1 for wonderful book, "How to Build Your Own Concrete Block Home."

Only  
\$199

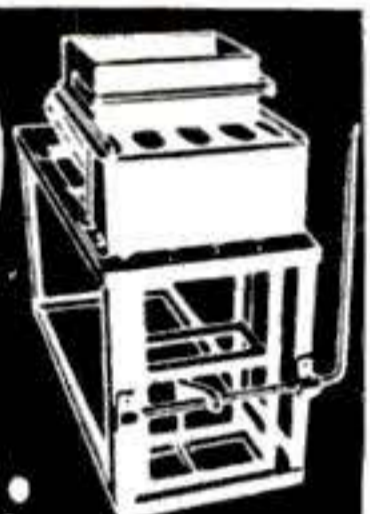

**GENERAL ENGINES CO.**  
(EASTERN DIVISION) DEPT. H - DREXEL BLDG., PHILA. 6, PA.

## —SLUM (GIVE-AWAYS)—

FOR SALE

Novelties—Brooches—Pins—Necklaces—Rings, Etc. 10 pound—Sample Shipment.....\$10.00

SEND REMITTANCE WITH ORDER

B. LOWE Holland Bldg., St. Louis, Mo.

## Build your own JET ENGINE!

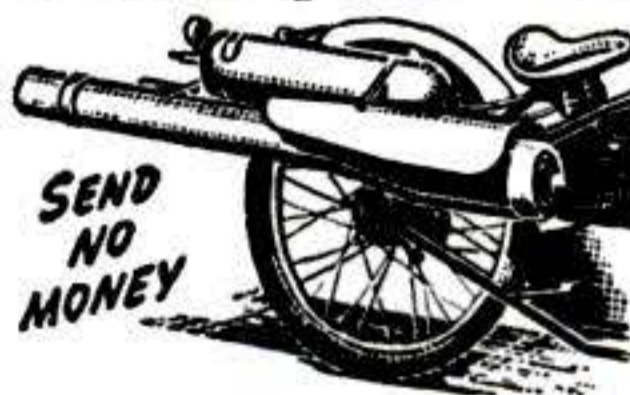

SEND NO MONEY

Order these plans today

1. JET PROPELLED BICYCLE. Assemble your own. Photo and instructions \$1.00.
2. HOW TO MAKE EXPERIMENTAL JET ENGINES. Seven sheets drawings with information and instructions \$2.95.
3. BOTH OF ABOVE in one order \$3.75. SEND NO MONEY. Order both at once \$3.75 C.O.D. in USA plus c.o.d. postage. Send check or Money Order and we pay postage. Get other information too. Rush Order.

J. HOUSTON MAUPIN, Dept. 66, Tipp City, Ohio

## SHARPEN CIRCULAR SAWS LIKE AN EXPERT



\$6<sup>95</sup>

No experience needed. Two simple adjustments. Gets hollow-ground, cross-cut or combination saw blades true and sharp. Fits 6" to 12" blades with 1/2" to 13/16" centers. Includes file and complete instructions. \$6.95 postpaid. (Check or money order) C.O.D.s postage extra. Guaranteed—Money back if not satisfied after 10 day trial. A money maker for fix-it shops. Soon pays for itself. Order today.

SURE SHARP MFG. CO., Dept. S-89, P. O. Box 24 Santa Ana, Calif.

## BUILD OR BUY A LAWN SWEEPER

No tiresome raking. The quick and easy way for cleaning your lawn. Picks up leaves, grass, acorns, sticks, and combs the grass. Easily built from available parts. Mail 35c for complete plan telling you how. Catalog listing parts, and factory built sweeper, sent free with plan. LEJAY MFG. CO., 123 LeJay Buldg., Minneapolis 8, Minn.



PLAN 35c

Get Your  
**SAV-A-CHORE**  
The Utility Carrier  
With a 100 Uses!

Only  
**\$17.95** complete  
Originally \$27.50

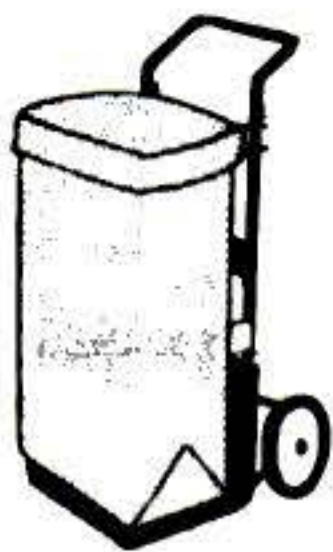

Bag Attached

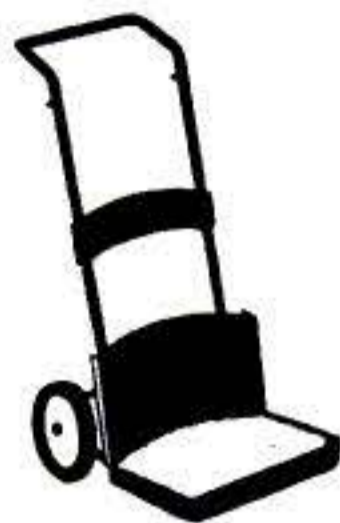

Bag Removed

"Sav-A-Chore" handles loads up to 200 pounds. With bag attached it's ideal for laundry, waste paper, rubbish, leaves, etc. Remove bag and you have a sturdy hand truck for hauling ash barrels, cordwood, beer cases, milk cans, bales of hay, steel drums and other bulky objects. It's balanced... rolls easy... up or down stairs.

"Sav-A-Chore" has a strong, green crinkle enamel steel body and semi-pneumatic, rubber tired 10" yellow wheels. Height, 46", base width 22". Tough, detachable canvas bag is 24" in diameter, 36" deep.

Order your "Sav-A-Chore" today at this special price. Send check, or specify C.O.D., or Sight Draft B/L.

**SALES REPRESENTATIVES WANTED**

**AMERICAN PRODUCTS CO.**

1106 S. Kirkwood Rd., St. Louis County 22, Mo.



**OPPORTUNITIES AHEAD!**  
TRAIN FOR A FUTURE IN  
**DIESEL**

Prepare for the big earning power of **Diesel Trained Men**. Start learning at home, in spare time. UEI's easy, practical training covers all phases of DIESEL engine operation, fuel systems, auxiliary equipment, repairs and maintenance. When home course is completed, you come to Chicago for actual shop practice on DIESEL MOTORS under expert instructors, at UEI's fine, modern school. **BEGIN AT ONCE—GET ALL THE FACTS FREE. WRITE TODAY!**

**DIESEL UTILITIES ENGINEERING INSTITUTE**  
2521 Sheffield Avenue Dept. DM-3, Chicago 14, Ill.



**BUILD YOUR OWN ENLARGER**

Enjoy Photography's most fascinating hobby at a fraction of usual cost. With simple step-by-step instructions and diagrams plus a screwdriver and pliers you assemble your own Enlarger and Save! Get all features of more expensive Enlargers: precision machined aluminum alloy castings, 90° tilt for wall projection of prints, spherical aluminum lamp-house, helical rack and pinion focusing with extra large knobs, unconditional guarantee. For 35mm to 2 1/4 x 3 1/4 negatives. Time payment plan.

Write Today for Free Illustrated Folder

**CALIFORNIA TECHNICAL PRODUCTS CO.**  
448 So. Hill, Dept. K-8, Los Angeles 13, Calif.

LEARN **Radio** TELEVISION **ELECTRONICS**



**Get a Good Pay Job - or Start Your Own Business**

Want to make *more* money? Want to be your *own* boss—have your own money-making business—with your future *assured*? Then learn Radio and Television with my proven two-way method (lesson instruction plus actual practice) that can help you get into this great and growing business *quicker*. You learn by doing, right in your home in spare time. During your training you get 10 big kits of radio parts with which you perform hundreds of tests and experiments, build scores of circuits and testers to help you learn faster, more thoroughly.

Since 1929 I have been training men all over the world for success in radio, television and electronics. To learn how I can help *you too*, take the first step *now* by sending for my big 56-page illustrated book that tells how you may cash in on radio and television's *big opportunities*. My book is Free but it may mean your future success. Send coupon for it today.

**C. H. MANSFIELD, President**  
Hollywood Radio and Television Institute  
810 West 6th Street, Los Angeles 14, Calif.

**FREE**

**APPROVED FOR VETERANS**  
Check coupon

**SEND for THIS BOOK**

**C. H. MANSFIELD, Pres., Dept. D-21**  
Hollywood Radio and Television Institute  
810 West Sixth Street, Los Angeles 14, California, U. S. A.

Send me your FREE book "Your Opportunities in Radio, Television and Electronics" which explains your 2-way home study training method. No salesman will call.

NAME \_\_\_\_\_  
Please print or write plainly  
ADDRESS \_\_\_\_\_  
CITY \_\_\_\_\_ ZONE \_\_\_\_\_ STATE \_\_\_\_\_  
If a veteran of World War II, check here

**BELT SANDER EASY SPEEDY**



Save time and effort... use American Portable Sanderplane! Handles more work and is many times faster than a hand plane—well balanced, powerful, efficient. Write for details.

**AMERICAN FLOOR SURFACING MACHINE COMPANY**  
532 So. St. Clair St. Toledo 3, Ohio



Start a **profitable welding business** of your own

**Earn \$350 to \$550 extra profit monthly**

**Earn extra money from the BIG PAY WELDING JOBS**

..easy pay out of profits-terms. **FREE**

New AC Welder lets you do hundreds of jobs easily and quickly. No special training necessary—no secret to getting established in the welding business. Start now. Let Hobart give you helpful hints.

**Hobart Brothers Co., Box P-89, Troy, Ohio**  
One of the world's largest builders of arc welders

Write for booklet "How to Start a Profitable Welding Business"



**NEW! COMPLETE HOT ROD MANUAL**

NEW! 128 page manual, chock full of cutaway construction drawings, photographs and valuable, easy to read and understandable technical data. A neatly bound manual with colorful eye-catching cover. Includes complete data on how to install V-8 engine in Model A chassis.

**SENT POSTPAID FOR \$2.00**

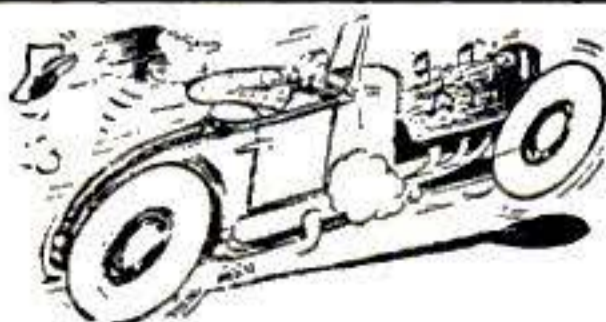

How to rework the following engines for speed and power: V-8, Merc, Ford 6, Zephyr, and Model A & B. Also includes data on column shifts, Zephyr gears, and how to install hydraulic brakes in any year Ford. California Bill's manual is guaranteed to be the finest.

**CALIFORNIA BILL**  
BOX L-3, EAGLEROCK, LOS ANGELES 41, CALIFORNIA

# BRAND NEW! UP-TO-THE-MINUTE REFRIGERATION

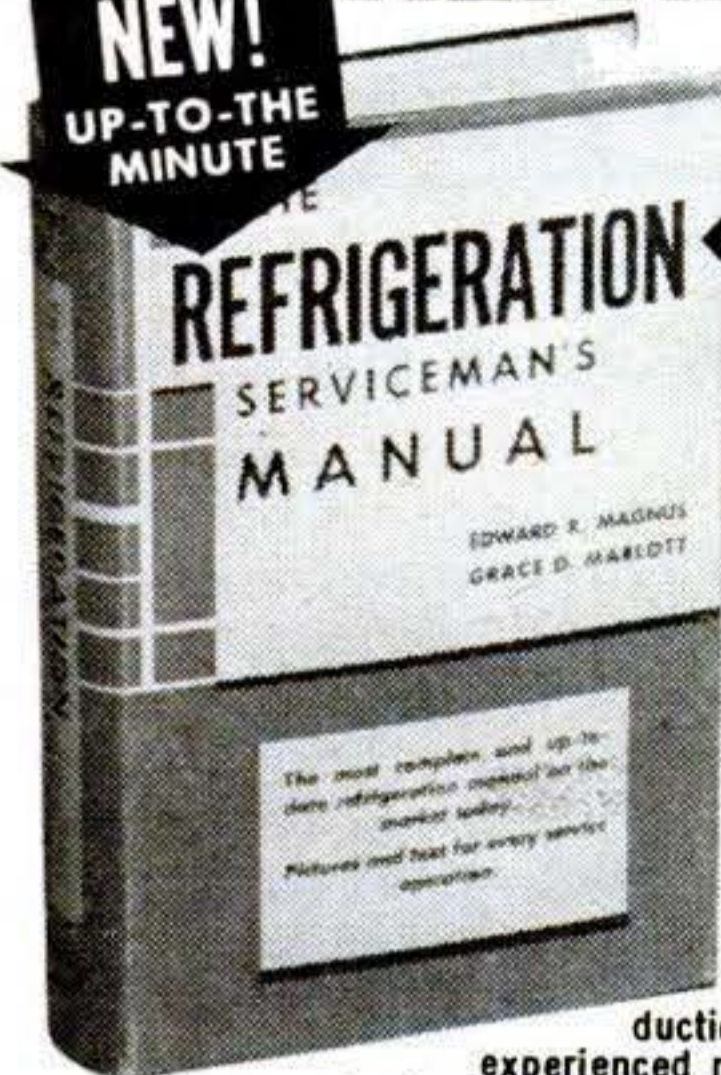

Amazingly Complete Manual—Based on Today's Research and Field Testing!

not revised—NEW!

No. 1 on school and training programs—today's and tomorrow's recognized authority

For student and experienced—this book has the detailed basic information for maintaining service, repair electrical absorption system refrigerators—complete instructions on how to develop the mechanical skills required for this big, money-making trade.

All material based on principles of every post-war manufacturer of refrigeration equipment—today's on-the-job practical problems—all drawings made especially for this book—enable you to understand all makes. Designed for manufacturers as basic text—for production workers, service and sales personnel—

experienced men's only modern refresher and students' invaluable foundation course. This is your stepping stone to a growing, big money career.

"Refrigerator Engineering," published by American Soc. of Refrigerating Engineers, says, "We recommend RSM to the practical engineer and technician without reservation... well written..."

**5-DAY FREE TRIAL—MONEY-BACK GUARANTEE**—if you're not 100% delighted return it within 5 days for full refund. But don't delay, use coupon today.

## SEND NO MONEY

Wilcox & Follett, 1255 S. Wabash Ave., Chicago 5, Dept. AA  
Rush me THE REFRIGERATOR SERVICEMAN'S MANUAL. On delivery I will pay postman \$5.00 plus C.O.D. postage.

Name.....

Address.....

City..... Zone..... State.....

( ) To save postage charges I enclose full amount. Same money back guarantee.

**"LEARN-BY-DOING"**

## ELECTRICITY

**PRACTICAL TRAINING NOT "HOME STUDY"**

**G.I. APPROVED** Get actual experience in great shops of M.T.I. Learn all phases Practical Electricity; Housewiring, Motors, Const., Maintenance, etc. Living arrangements, Part-time jobs, etc

Send coupon TODAY.

**MICHIGAN TECHNICAL INSTITUTE**  Veteran  
2281 W. Fort St., Detroit 16, Mich., Dept. PS-8

Name.....

Street.....

City..... State.....

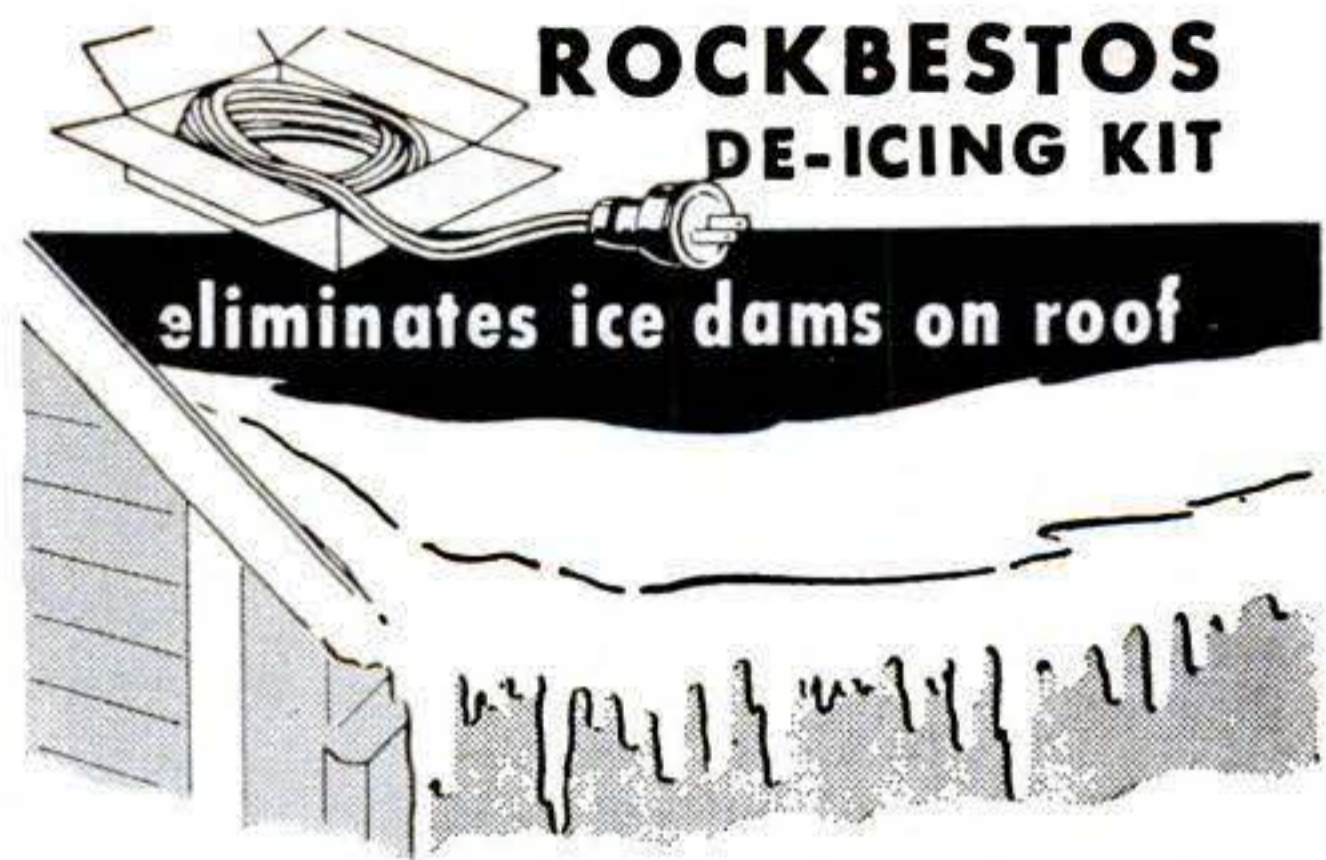

## ROCKBESTOS DE-ICING KIT

eliminates ice dams on roof

...saves costly repair of walls and ceilings

This complete heating kit—ready to use—protects 18' of roof by melting ice on roof edge and gutter. Eliminates winter water damage... costly replastering and repapering. Easy to install... will not damage roof. Kit contains 60' durable, lead-covered heating cable with plug, roof clamps, instructions. 120 Volt AC-DC.

**ROCKBESTOS PRODUCTS CORP.**  
New Haven, Connecticut

See your  
**ELECTRICAL  
DEALER**

One of the Biggest Buys of the Year.

## WAR SURPLUS



**SAFEGUARD YOUR TOOLS & EQUIPMENT**  
**10,000 ALL STEEL MECHANICS TOOL BOXES**  
Used—but in perfect condition. Galv. Steel 16 gauge with Handles on each end and Hasp for Padlock Quality Heavy Construction. Used in Navy Yards. Good for a lifetime. Special price while they last.  
18" Long x 8" x 8" \$2.00 Ea. 24" Long x 8" x 8" \$2.50 Ea.  
10" x 10" \$2.50 Ea.  
Our Replacement Cost \$10.00 Ea. Practically fireproof. Ideal for Plumbers, Welders, Electricians, Fishing Tackle, Gardening Tools, etc.. Radio Mechanics, Garages, Home, Auto-mobile, Workshops, etc. Add 50c each for shipping charges.

**METROPOLITAN, 313 East 31 Street, Dept. PS, N.Y. C. 16, N.Y.**

## SURPLUS SALE!



### ARMY FIELD PHONES

Genuine Army EE-8 phones. 17 mile reception with 2 flashlight batteries. As simple to operate as a house telephone. Perfect condition. Complete with leather case. **\$18.95**  
Wt. approx. 10 lbs.....

1/2 mile reel wire..... **\$9.95**

- **ARMY PACK BOARDS**, unused, hdwood frames, heavy durable canvas cover..... **\$4.95**
- **MAE WEST LIFE JACKETS**, navy, unused, pre-tested..... **\$1.95**
- **MACHETTE KNIVES**, new, army. 18". With canvas sheath that fastens to belt..... **\$1.95**
- **RECOIL PADS**, army, rubber. Fits most guns..... **95c**

**MONEY BACK GUARANTEE!** Send check or money order. 25% deposit with C.O.D.'s. Freight collect on Field Phones & Wire. All other items postpaid. Write for free catalog!

**GRAND-HAWTHORNE SURPLUS, 1439 SE Grand, Dept. S, Portland, Ore.**



## LIGHTWEIGHT

3 speeds • FOOT GEAR SHIFT • Handlebar clutch control • Telescopic front fork • Weight only 230 lbs. • 9.5 horsepower at 5000 rpm • 70 miles per gallon • Over 60 miles per hour • Low center of gravity • Rugged • Safe • Compare Mustang performance with that of popular imported lightweights costing \$200 to \$400 more. Ask your dealer for full details and demonstration or write for free literature.

**MUSTANG MOTORCYCLE CORP.**

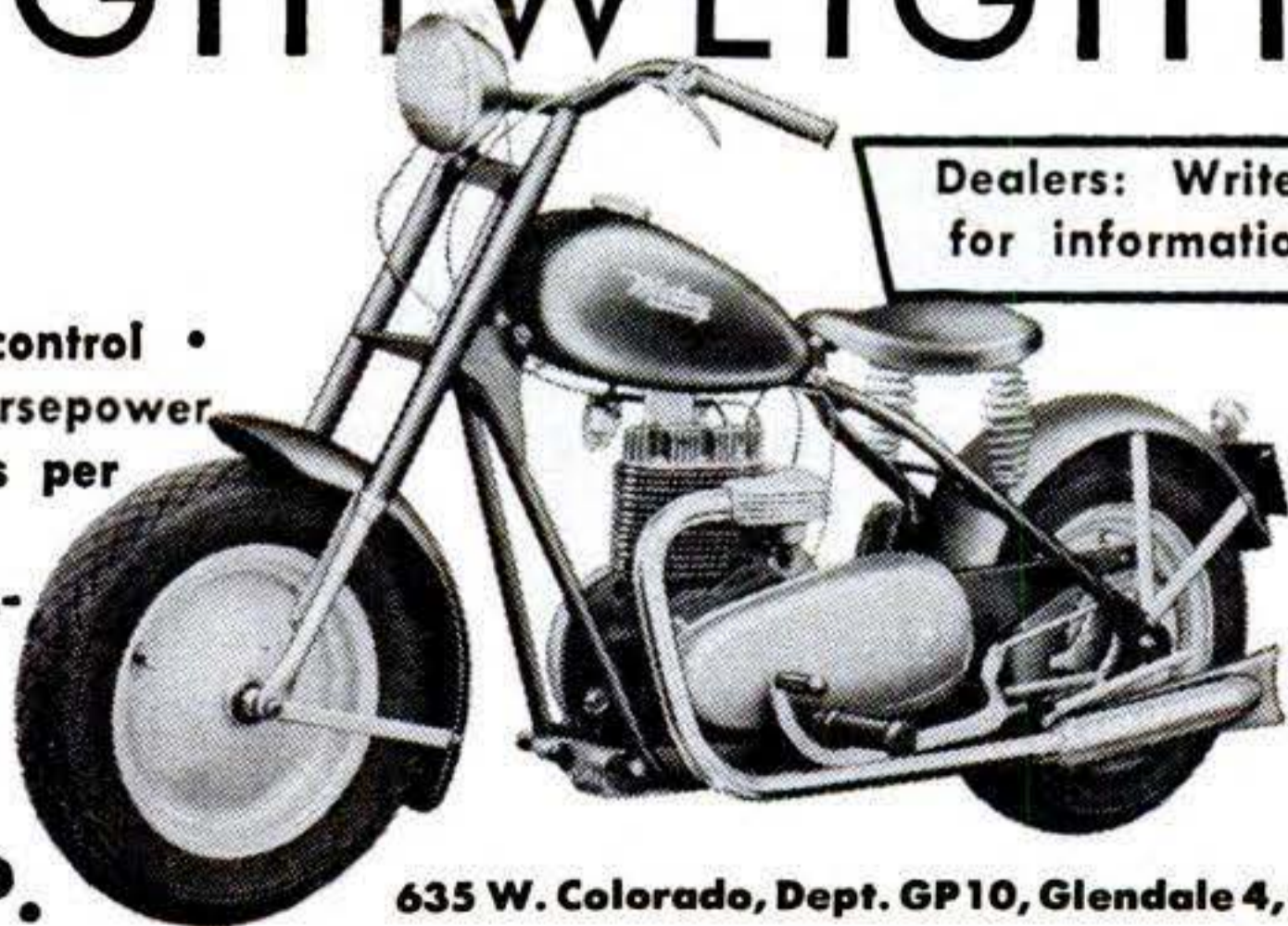

Dealers: Write for information

635 W. Colorado, Dept. GP10, Glendale 4, Calif.

**WAR SURPLUS BARGAINS**

**WAR SURPLUS BARGAINS**

**\$500,000.00 INVENTORY for QUICK LIQUIDATION**

Surplus items—hundreds of them for home, shop, factory, farm and outdoor use. New items, used items, reconditioned items—all at tremendous savings—all priced for quick sale.

**PAGE AFTER PAGE OF VALUES**

This big catalog shows page after page of amazing money saving values. Write for your copy today. Send 10c to cover postage, mailing, etc. Write today!

**SEND TODAY FOR YOUR COPY**

**10c**

**STARK'S** 509 So. State St. Dept. PS-8 CHICAGO 5, ILL.

**FREE PLANS POWER MOWER KITS FREE PLANS**

Have one of the finest mowers money can buy. Write for **FREE PLANS** and **PARTS LIST** showing you how to **SAVE up to 75%** by assembling Triangle's **POWER MOWERS**.

**SPECIAL FACTORY PRICES**

Kits, Parts, Engines, Wheels. Etc. Also complete **TRIANGLE MOWERS** ready to mow, at Low Factory Prices. 3 and 4 wheel Models.

**3 WHEEL MODEL** **4 WHEEL MODEL**

SAVE your back. Assemble or build your own 3 or 4 wheel power mower with our precision made kits and parts. Write today for full facts, Free Plans, Parts List, Low Factory Prices. **DEALERS INVITED.**

**TRIANGLE MANUFACTURING CO., Dept. S-6, Box 185, Fort Scott, Kansas**

**SEE THE WONDERS OF THE HEAVENS!**

Amazing value! Wonderful 192-page cloth-bound book, *Astronomy for Amateurs*, now yours for only \$1.00! Contains star charts, tables, telescope-making instructions, how-to-do-it ideas for astronomical equipment you can build, etc. *Supply limited!* Order today! Write:

**POPULAR SCIENCE**

Dept. 89, 353 4th Ave. New York 10, N. Y.

**MAKE! FOLDING TABLES - BENCHES - HORSES - IN A JIFFY**

**FOLD-A-WAY CHANNEL STEEL LEGS**

Shipped complete, ready to fasten to your top in a minute. Rubber tipped. Used on the job, in homes, workshops, ping pong tables, trailers, camps, boats, churches, lodges, banquet halls.

Send for free circular

**\$4.98 Pr. 24" Legs**  
**\$5.98 Pr. 30" Legs**  
Postpaid in U.S.A.

**THE DIAMOND MFG. COMPANY**

Dept. PS. 1100 Altamont Ave. Schenectady 7, N. Y.

**I SHOW YOU HOW TO**

**1 MAKE MONEY AT ONCE**

**2 START YOUR OWN BUSINESS**

**IN 2 WEEKS - AT HOME IN SPARE TIME**



**METALIZE BABY SHOES**

**FREE! MONEY MAKING PLAN**

Full Details Without Obligation

**MAIL COUPON TODAY!**

IF YOU ACT NOW, I will show you how to start earning extra money immediately—in spare or full time. **AND I SHOW YOU HOW** to start your own profitable business. With my complete course and easy-to-understand illustrated instructions containing trade secrets of ALL metalizing processes PLUS 2 beautifully processed sample metalized baby shoes AND all my tested and proved methods of operating a successful metalizing business, I show you how to start **YOUR OWN** profitable, fascinating business right in **YOUR OWN HOME**. Up to \$5 per hour possible. Absolutely no experience needed. For **PROOF** send coupon today for **FREE** details of my **MONEY MAKING PLAN** for you and be convinced.

**John Kiktavi, KIKTAVI CO.**  
Dept. PS-8, 2111 W. Manchester, Los Angeles 44  
Send me **FREE** details of your **MONEY MAKING PLAN**, without obligation.

NAME \_\_\_\_\_

STREET \_\_\_\_\_

CITY \_\_\_\_\_ ZONE \_\_\_\_\_ STATE \_\_\_\_\_

**The Modern PLASTIC for lasting Home Repairs**



**DURHAM'S Rock Hard WATER PUTTY**

WILL NOT SHRINK STICKS AND STAYS PUT

**PERMANENTLY** mends cracks or holes in wood, tile, stone or plaster. Sticks and stays put—Does not chip, shrink or fall out. Easy to use. Economical. Mold it, chisel it, polish or paint it. If unobtainable from your lumber, paint or hardware dealer, the big 4-lb. can will be sent you postpaid (in U.S.) for only \$1. Full money-back guarantee, order now.

**DONALD DURHAM CO.**  
Box 804-G, Des Moines, Iowa

**BUILD A BETTER BOAT**

*With Industrial Molded Hulls*



**H**ERE are the hulls which proved a sensation at this year's New York and Toronto Boat Shows. Molded in **ONE SEAMLESS PIECE** of selected birch and mahogany veneers they're lighter—stronger—faster—leakproof and take a beautiful piano-like finish. For dinghies, outboards, runabouts, 8 to 18 feet; also in ready-cut Boat Kits. All at **BIG SAVINGS**. Send for **FREE** illustrated folder.

**INDUSTRIAL SHIPPING CO., LTD.** 158 Hollis Street, Halifax, Nova Scotia

## OVER 250 SURPLUS BARGAINS

### GENUINE G. E. 2 H.P. 4-CYCLE GASOLINE ENGINES

Brand new! In original factory cartons. Complete with oil air filter, dustproof magneto, gas tank, shaft pulley, throttle control, etc. Excellent for mowers, boats, saws, etc. Ship. wt., 37 lbs. Shipped express collect. \$69.50 value.

**\$39.95**



### NYLON JUNGLE HAMMOCKS—NEW

Only **\$4.98**



Never before at these low prices. They're insect proof, rot proof, and bug free. Fine mesh, genuine Nylon net sides. Waterproof, rubberized top and bottom. Complete with ropes, hanging rings, etc. Govt. cost \$14.00. Wt. 9 lbs.

Pup Tents—Two halves . . . 5 x 9 ft. with poles and pins. Waterproof, used. Good condition. 8 lbs. . . . \$3.79  
 Water Bag—2 1/2-gal. U. S. Desert type. New . . . \$1.98  
 Officers' Tents . . . 9 x 9 ft. Wt. 60 lbs. New . . . \$29.50  
 U.S.A. folding cots, heavy cover and frame—wt. 25 lbs. New \$4.98  
 U. S. Navy Oxfords, finest leather, black. New . . . \$6.44  
 Sleeping Bag O.D. wool, poplin cover—like new . . . \$4.70

### 2 in 1 MAT RAFT

For Water or Beach



Easily inflated by mouth or cartridge. Separate air cells for safety. Folds compact when deflated. 2 sizes—6 cell, 55" x 24"; wt. 12 lbs. 8 cell, 55" x 30"; wt. 16 lbs. Complete.

6 Cell **\$4.98** 8 Cell **\$5.98**  
 Extra dual tubes, \$1.19 ea. Inflating Cartridges, 10 for 79c

Mail orders add sufficient postage unless stated otherwise  
 Write for BIG FREE CATALOG TODAY

**FISLER SALES CO.** 723 Walnut St. Kansas City 6, Mo.

Always Mention Popular Science when writing



ONLY 2 SHINES A YEAR AND SHE GLEAMS LIKE NEW!

Yes, sir—give your car the glow that rests your elbow! Use LACQUERWAX—the peerless auto finish protector. It's 5 times faster and easier to apply than ordinary paste waxes—and one treatment lasts 4 to 6 months!

LACQUERWAX contains no lacquer, but this hard, liquid wax is CLIMATE-PROOF! Its brilliant luster shines right through hot sun and driving rain. You can't wash it off... it won't spot! It brings out and preserves the full beauty of your car's finish. Only \$1.00 for a pint can. Mail coupon NOW!

LACQUERWAX CO. Dept. P. S. HARTFORD 3, CONN.

Gentlemen: My check, cash or money order for \$..... is enclosed, covering cost of..... can(s) of LACQUERWAX. Please send my order to:

Name .....

Address .....

City..... Zone..... State.....

**LACQUERWAX**

LACQUERWAX CO. HARTFORD 3, CONN.

## SURPLUS HIGH SPEED DRILLS MICROMETERS

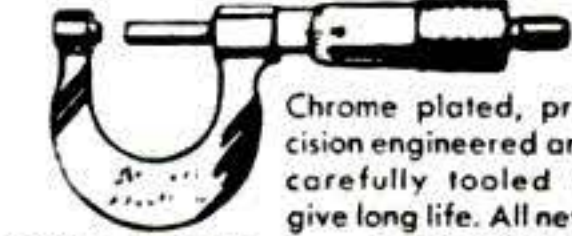

Chrome plated, precision engineered and carefully tooled to give long life. All new.  
 0-1" capacity . . . each **\$2.25**  
 1-2" capacity . . . each **3.50**  
 2-3" capacity . . . each **5.50**  
 3-4" capacity . . . each **6.50**

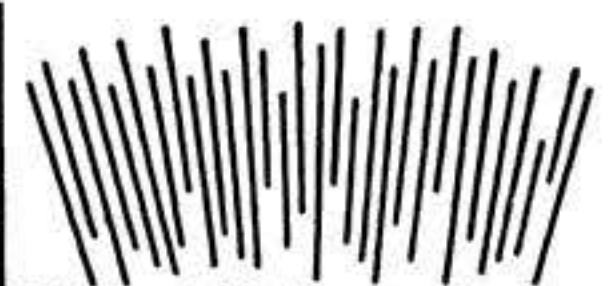

All New Drills! Fractional and numbered. Original value \$15.00. Thirty assorted sizes and lengths . . . **\$3.50**

### EXPANSION REAMERS



Spiral Flute. Mfd. by Alvord Polk Tool Co. All New, original pack. 1/4"-3/8"-7/16" Recommended expansion limit, .006". Original value \$12. Set of 3 . . . **\$4.95**

SEND 10c FOR ILLUSTRATED CATALOG

Send check, money order or cash. 25% deposit required on C. O. D. orders. All prices F. O. B. Culver City, Calif.

**AIRBORNE SALES CO., INC.** DEPT. PSM CULVER CITY, CALIF.

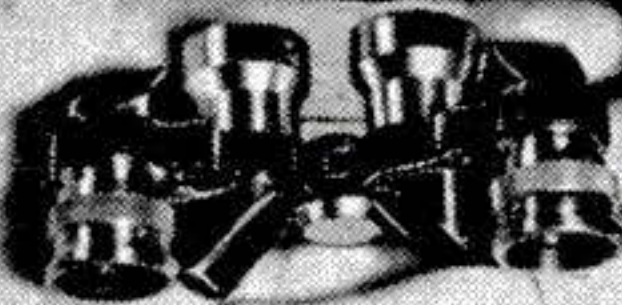

**6 POWER PRISM BINOCULARS**

VEST POCKET IN SIZE

Dynamic in power and range. At 1,000 yards has sharp, clear field of 370 feet! Made to military specifications. Moisture-proofed—Dust proofed! All metal construction. Individual eye focussing. Adjustable for all eye widths! A compact, durable, all-purpose, prism binocular. NOT a field glass. Economy priced at fraction of what similar glasses sell at retail! Complete with quality leather, plush-lined case and straps only \$19.95 plus 20% Federal tax. Cash orders sent postpaid. On C.O.D.'s include \$2.00 deposit. **GUARANTEED.** Try for 20 days at our risk and expense.

**UNITED PRODUCTS CO.**

7941 S. Halsted, Dept. ARF-1616, Chicago 20  
 Reference Dun & Bradstreet.

### Decorative

## METAL WORK

A new manual for the amateur. Tells in easy to understand language how to make useful metal articles in your home workshop. You'll be surprised how easy and interesting metal work really is. Fully illustrated with diagrams and step-by-step instructions. Sturdy cloth binding. 253 pages. Send only \$2.00 and your copy will be sent postpaid. Popular Science Monthly—Dept. 89, 353 4th Ave., New York 10, N. Y.

## WESTINGHOUSE

### Air Compressor

WITH 20 FT. AIR HOSE AND DETACHABLE TIRE CHUCK **\$22.95**

### 2-CYLINDER PISTON TYPE

Spray paint your buildings, cars, trucks, machinery, etc. Inflate tires, grease machinery, spray insecticides.

Built to sell for 3 times our low price. Operates from 1/2 h.p. motor or equivalent gas engine. Or may be run from truck, tractor, jeep power take-off or fan belt; designed for easy mounting. Capacity up to 6 1/2 cu. ft. 100 lb. pressure. Delivers filtered "Oil free air". Air output double that of similar compressors. Rugged, super-efficient, portable.

Special \$22.95 price F.O.B. Chicago area includes compressor, 20 ft. double braid heavy duty air hose, Schrader Air Chuck. You save over 1/2. Act now! Money back guarantee. Send check or money order to:

### MAIL COUPON TODAY

A & K Equipment & Supply Company, Dept. 27, Burlington, Wis.

Enclosed find remittance for \$22.95. Send brand new Westinghouse Compressor, 20 ft. of heavy duty air hose and tire chuck.

Name .....

Address .....

City..... State.....

# FISTULA

**FREE BOOK—Explains Dangers of Associated Ailments**

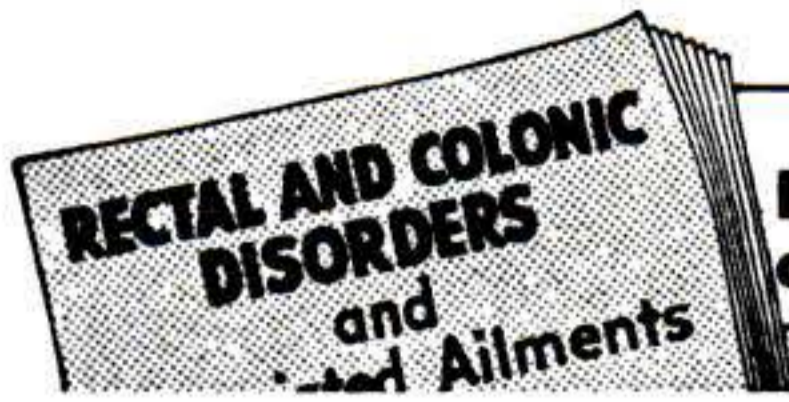

**Avoid Dangers of Delay**

Piles, Fissures and Rectal Abscess are common ailments that may also be associated with neglected Fistula. Our new 160-page illustrated book sent FREE. Write today—McCleary Clinic & Hospital, 871 Elms Blvd., Excelsior Springs, Mo.

## FOR MORE MONEY LEARN FINANCE

**Multiply your earnings and profits.**

Write for your FREE copy of:

**"THE SOURCE OF WEALTH AND INDIVIDUAL FORTUNES"**

**WALL STREET BUSINESS INSTITUTE**

79 Wall St.

New York 5, N. Y.

## TALK ANYWHERE-INSTANTLY-TO ANYONE!



Just push a button and talk to or from **WITH INTERTALKIE** 1 to 36 different places up to 1/2 mile away. No buzzers or bells—can be heard up to 50 ft. away from unit. No troublesome tubes or electric "plug-ins" needed. Set or hang it—Quick easy hookup—For any business, Doctor, Lawyers, stores, Farms—Cabin as low as Camps, etc. Satisfaction guaranteed. A real money maker for Sales Agents. Write for details today. **\$9.97 each**

**MIDWAY CO. PS-8 Kearney, Nebr.**

**TRAIN**

# Your VOICE!

**Results GUARANTEED**

STRENGTHEN your voice this tested, scientific way. Yes—you can now build yourself a POWERFUL speaking or singing voice in the privacy of your own room. Silent self-training lessons; no music or piano required. Just send your name for sensational details of this amazing course. I'll send you FREE a vocal mechanism chart. State your age.

Perfect Voice Institute, 1141 S. Wabash Ave., Studio H-1, Chicago 5, Ill.

**BUILDERS BUY THE Cushman "HUSKY" POWER UNIT**

Fulfills basic power requirement for home-built vehicles.

Build your own vehicle around this balanced power unit.

**\$167**

- 4 1/2 H.P. Gas Engine
- Manual Disc Clutch
- Transmission with 2 Speeds forward and a reverse.

Send your order and payment direct. Immediate Shipment **DEPT. PS-79 CUSHMAN MOTOR WORKS INCORPORATED LINCOLN, NEBR., U. S. A.**

## LOCKSMITHING & Key Making

### PRACTICAL UP-TO-DATE COURSE

Easy-to-learn modern information for self-instruction. How to work on locks, pick locks, de-code, make master-keys, repair, install, service, etc. For every handyman, home owner, carpenter, mechanic, service station operator, fix-it shop, hardware dealer, gunsmith, 53 plain illustrated lessons. Full price only \$3.95. SEND NO MONEY. Just pay postman plus C.O.D. postage. Or send \$3.95 with order, we'll ship postpaid. Satisfaction guaranteed or refund. Address below.

### WATCH & CLOCK REPAIRING

Learn at Home in Your Spare Time! . . . Prepare for a happy future, with security—and qualify for a good job NOW. A fascinating and thorough self-instruction training in American and Swiss watches and clocks, special section on alarm clock repairs. Fast-growing field. Satisfaction is guaranteed. Full price only \$1.95, postpaid—or COD plus postage.

**Nelson-Hall Co., 1139 S. Wabash Ave., Dept. H-1, Chicago 5, Ill.**

# TRAVEL for "UNCLE SAM"



**START as high as \$3,351 Year**

Prepare NOW For Next Examinations

20,000 appointments each month

**VETERANS GET SPECIAL PREFERENCE**  
 Many examinations expected soon  
 City Mail Carriers  
 City Postoffice Clerks  
 Stenographers-Typists  
 Messengers,  
 Liquor Inspectors—and many others.  
**40-Page Book on Civil Service FREE**

Mail Coupon today—SURE



**FRANKLIN INSTITUTE**  
 (Not Government Controlled)  
 Dept. 581  
 Rochester 4, N. Y.

Rush to me, entirely free of charge, 40-page book with:  
 (1) A full description of U. S. Government jobs; (2) A list of U. S. Government jobs; (3) Tell me how to qualify for a job.

Name.....

Address.....

..... Vet?.....

## Learn A Trade NOW! PRACTICAL SHOP TRAINING!

### In Our Chicago Shops

- AUTO MECHANICS
- DIESEL MECHANICS
- REFRIGERATION
- BODY-FENDER
- WELDING—ARC and GAS
- MACHINIST
- PIANO TUNING

Above Approved For G. I.'s and Civilians  
 One of America's Leading Practical Schools  
 7 Floors of Fully Equipped Shops  
 Over 48,000 Successful Graduates  
 Expert Individual Instruction  
 Learn by Doing—Low Living Expense  
 Established 1902—Day and Evening Classes

### Also the following Home Study Courses

- PLASTIC
  - REFRIGERATION
  - DIESEL
- CALL IN PERSON OR MAIL THIS AD TO

## GREER SHOP TRAINING

(Desk 12) 460 South State St., Chicago 5, Ill.

Please send without obligation free information regarding trade checked above. (Specify whether you are a Veteran  or Civilian )

Name.....Age.....

Address.....

City.....State.....

# REPAIR *Electrical Appliances and Utilities with the aid of* The New AMSTERDAM Model 100 **ELECTRIC TESTER**

A new kind of instrument for testing ALL Electrical circuits and appliances such as

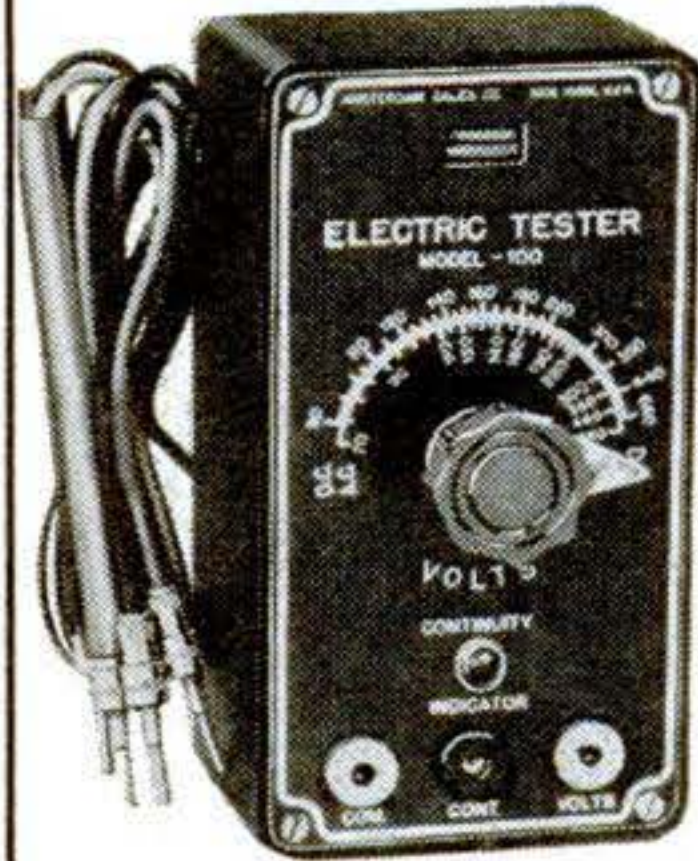

- |         |                        |
|---------|------------------------|
| Ranges  | Vacuum Cleaners        |
| Shavers | Air Conditioners       |
| Heaters | Refrigerators          |
| Ironers | Sun Lamps              |
| Washers | Circuit Breakers       |
| Fans    | Lighting Systems, etc. |

- Ideal trouble-shooter — instantly locates opens, shorts and grounds.
- Accurately measures all A.C. and D.C. Voltages between 70 volts and 660 volts.
- Indicates whether current is A.C. or D.C. and if frequency is 25 cycles or 60 cycles.
- Accurate checks on all circuit factors such as condensers, field coils, motors, etc.

The Electric Tester comes housed in a round cornered molded bakelite case. Complete with all test leads and operating instructions — only.....

**\$7.50**

20% deposit on C.O.D. orders  
Money Back Guarantee if not satisfied.

**AMSTERDAM SALES CO.**

Dept. PS8

98 Park Place, New York 7, N. Y.

## SANDEE

Mufflers—All Ford, Chev., Ply.....\$4.45  
All Buick, Pont., Olds., Chrys.,  
Dodge, Hudson, K.F., Pack., etc.....\$5.45

V-8 and Merc. Duals  
(32-49 incl.)

**\$15.95**



**SPORTONE MUFFLERS**  
(Pats. Pend.)

DEALERS WANTED

Beautiful  
SANDEE  
Fender Skirts  
**\$16.95**

A SANDEE Sportone will outlast two ordinary mufflers and give More Power! More Speed! More Mileage!—plus a tone quality unsurpassed.

Please ship (item): \_\_\_\_\_ Price \_\_\_\_\_

Car and Year \_\_\_\_\_ Name \_\_\_\_\_

Address \_\_\_\_\_

**SANDEE MUFFLER CO. 5643 Corryne Pl. Culver City, Calif.**

## JEWELER'S SCREW DRIVERS

8 Jeweler's Screw Drivers. A must for every hobbyist and model builder.

Ideal for precision work, camera and fine instrument repairs. In 8 sizes—from the smallest size 9 up to size 2. Finest tempered steel blades. Lowest price!

**MONEY BACK GUARANTEE IF NOT SATISFIED**  
C.O.D. \$2 plus postage, or send \$2 and we pay postage.

SET  
OF  
**8**

**PINE WATCH CO.** 29 ELDRIDGE STREET  
Room 40 N. Y. 2, N. Y.

## NEW GAS ENGINES

### 6.5 HP BRIGGS & STRATTON GAS ENGINES

Model ZZR-6. 4 cycle, single cylinder air cooled. Develops 6.5 HP at 533 RPM. Adjustable governor and built in 6 to 1 reduction gear. New in original crate. List price \$165.00

OUR PRICE **\$97.50**  
f.o.b. Milwaukee

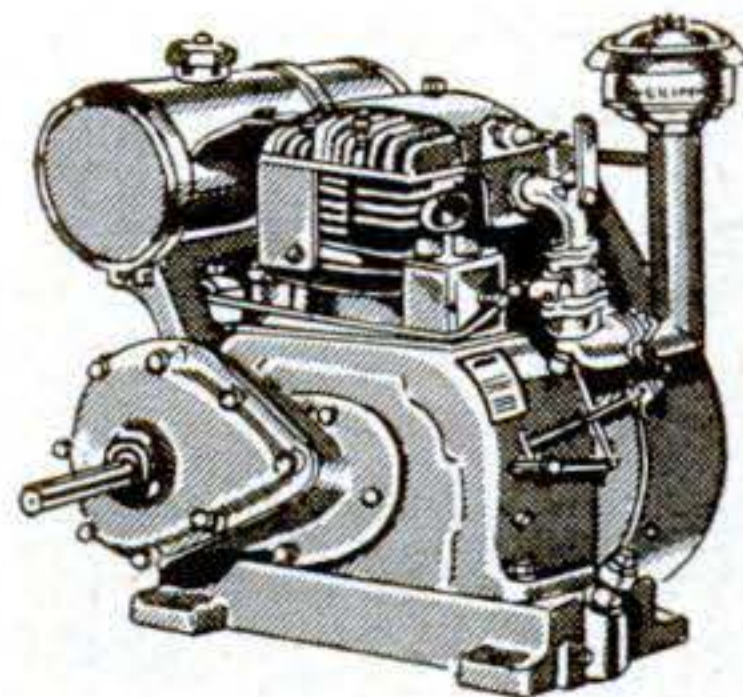

**ORDER TODAY—LIMITED QUANTITY AVAILABLE**  
SEND MONEY ORDER OR CERTIFIED CHECK

**J. J. TRUNDE**

1937 N. Hubbard

Milwaukee 12, Wisconsin

## BE STRONG USE BARBELLS



**95 POUND SET**  
Only \$10.80  
Extra Plates 10c. pound

We have been selling the finest barbell equipment since 1928. We operate our own foundry and sell direct to you at a very low profit. No other company can match our low prices.

Send for our  
**FREE Barbell Catalog.**

**BUR BARBELL CO.**

LYNDHURST 8,  
NEW JERSEY

## Wheels Wheels



## Wheels Wheels

5" Disc Wheel	5/8" Tire	5/16" or 3/8" Sleeve	30c ea.
6" " "	3/8" " "	5/16" or 3/8" Sleeve	35c ea.
7" " "	3/4" " "	3/8" sleeve	45c ea.
8" " "	1 1/8" " "	1/2" sleeve	70c ea.
7" " "	1" " "	1/2" ball bearing	80c ea.
8" " "	1 1/8" " "	1/2" ball bearing	1.00 ea.
8" " "	2" semi-pneum. T.	1/2" B.B.	1.35 ea.
10" " "	1.75 " "	1/2" B.B.	1.50 ea.

Above wheel prices includes hub cap.  
10" Aluminum Wheel 2 3/4" semi-pneum. T. 1/2" B.B. \$4.50 ea.  
Plus Postage. 20% C.O.D.'s accepted.

**UNITED WHEEL STAMPING CO.**  
2756 W. 115th STREET PS-8 CHICAGO 43, ILLINOIS

## SPEED & MILEAGE MANUAL

125 ILLUSTRATIONS EASILY OBTAIN GREATER SPEED, MILEAGE, RACING PERFORMANCE FROM ANY AUTOMOBILE!

Famous new book shows simplified soup up methods—Speed Tuning—Mileage Secrets—Economy Tips! Tells how to build your own speed equipment! Fast Conversions! "Hot Rods"! Sports Cars! Complete instructions on building inexpensive superchargers. Hi-Speed Heads, Dual Mufflers, Manifolds. "Water Injectors!" All about engines, "Economy Tuning," Restyling, "Racing Tricks"—Fuels! Reveals Track Proven Methods that will give your car thrilling new getaway—with up to 40% more speed and mileage!

Also shows latest "Hollywood Custom Styling" methods! Streamlining! Sport Changes! Money-Saving Speed Conversions! California Roadsters Plans! Racer Diagrams! Working Drawings! Speed Catalogues! Photographs! Complete Data—Plus "Beautiful Custom Car and Hot Rod Pictorial Supplement!"

**SATISFACTION GUARANTEED—ONLY COMPLETE BOOK OF ITS KIND..... ONLY \$1.98 Post-paid**

**ALMQUIST ENGINEERING** Milford 9, Pennsylvania



**Remember This** You can't Buy A \$20 Goldpiece for \$10. So it's Dangerous to Pay Less—If You Want Safe, Balanced, Matched Tires. A Full Page Ad couldn't offer more value. We Repeat: Consider Your Family's Safety—Not Just Price! You See Our Reliable Adv. Month After Month After Month!



Vets take 10%. We Owe Our Prosperity to You! **GOODYEAR** Original High Tread, Slightly Worn, Not Recaps—Not Remolded—Not Retreads. Pass. & Truck 30,000 Miles Golden Rule Guar. Genuine Factory Adjusted "All-Purpose" "AAA" Tires Read That Top Line Again! You'll Save More than \$

600-16	\$5.50	650-16	\$5.75	700-15	\$6.00
600-16 (6)	6.50	650-16 (6)	6.75	650-15	5.75
700-16	6.50	750-16	7.75	550-17	7.75
700-16 (6)	7.50	475-19	5.50	525-18	6.75

**WE ARE TRUCK-TIRE EXPERTS.** Matched Tires  
 600-20 \$9.00 32x6 (8) \$ 9.95 900-20 \$15.95  
 650-20 9.50 32x6 (10) 10.95 1000-20 16.95  
 700-20 10.50 825-20 14.95 1100-20 17.95

750-20(8) \$9.50 34x7(10) \$13.50 1000-22\$17.95 1100-22\$18.95  
**Military:** 750-16 "AAA" Guar. 14,000 Miles \$9. Premium, 30,000 Miles, \$11. 900-16 "AAA" Guar. 14,000 Miles \$8. Premium, Guar. 30,000 Miles, \$11. 750-20 (Fits 32x6) Super Guar. 14,000 Miles, \$10. All Purpose Guar. 30,000 Miles, \$13.  
**GOOD USED TIRES** Any Car \$3.25. 12,000 Miles Guarantee  
 Send ck, or money order for rush shipment. Save this ad. We won't ship a tire we wouldn't use ourselves. Instant shipment down South, Far West, and the world over. The Name to trust in Rubber.  
**BLATT GIRARD & LANCASTER AVE.** DEPT. PS  
**BLATT BLDG., PHILADELPHIA 31. PA.**

**ELECTRIC SHEAR SHARPENER**  
**Over 55,000 Sold—It Must Be Good!**



Genuine Carborundum Motor driven wheel ideal for shop or home use. Send remittance with order and shipment will be made at once, prepaid to your door, complete with electrical goods catalogue.  
**\$9.75** complete with vise

**WILLIAM MARVY COMPANY, Dept. 7**  
 479 St. Peter Street St. Paul 2, Minn.

**USE YOUR BENCH SAW**  
**FOR JOINTING & CUTTING MOULDINGS**

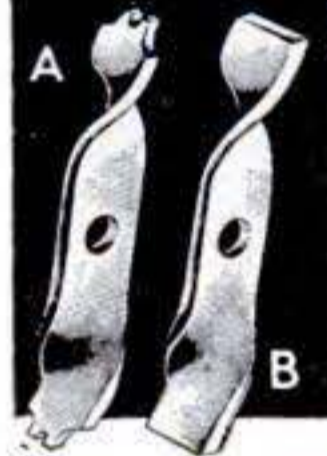

With our six inch tool steel cutters make mouldings, casings, drop-leaf tables, grooves beading and jointing. Moulding cutters, A 1 in. wide \$1.75. 1 1/2 in. \$2.25. Jointing cutters, B 1 in. \$1.75. 1 1/2 in. \$2.25. E 1 in. for drop-leaf tables. \$1.75. E 1 1/2 in. Makes 3/4 in. cove & Quarter. \$2.25. Postpaid. Guaranteed. State size hole. List & Folder free.  
**JOHN A. SANDSTROM**  
 Rt. 2-P. Clearwater, Fla.



**Build it — Fix it with AMBROID**



The Universal Liquid Waterproof Cement  
**"It Stays Stuck"**

At your dealers— or send 25c for generous 2 oz. tube. Postpaid.

**AMBROID CO., 306 Franklin Street, Boston 10, Mass.**

**COMPOUND ANGLE VISE**  
**for GRINDING MILLING DRILLING AT ALL ANGLES**  
 Base 4" x 6"—Vise 1 1/2" x 2 1/4"—Vise Detachable  
 Shipped postpaid cash with order or C.O.D. plus charges. WRITE FOR FREE CIRCULAR.  
**EN FAB, INC. 338 PARSONS ST., KALAMAZOO, MICH.**

**New Hose Attachment**  
**BLASTS DIRT with SOAP and WATER**  
**NO RUBBING, NO SCRUBBING, NO MUSS!**

Your car, basement, house, screens, rugs, porch, garden furniture, etc. come clean in a jiffy when you use the amazing new SUDS-O-MATIC nozzle that fits any standard hose. Press the plunger—out shoots a stream of suds that removes dirt quickly and thoroughly! Release the other nozzle—on comes rinse water! Easy to load with "cigarette-like" pellets of concentrated detergent; works by water pressure alone. Made of non-corrosive alloys, chrome-plated finish, and guaranteed. Order today—you'll leave SUDS-O-MATIC on your hose permanently when you see how useful this nozzle-washer-sprayer is around your house and garden! Complete, with generous supply of detergent pellets, only

Load Suds-O-Matic with our fertilizer pellets and spray on lawn or garden. Bottle of 75 pellets, \$1.50

**\$4.95**  
**WINKITTY PRODUCTS, INC.**  
 818 Wyandotte Kansas City, Mo.

**WHICH ONE IS YOU?**

 <b>HARD WORK—SMALL PAY</b>	 <b>YEARS OF SERVICE—NO ADVANCEMENT</b>
 <b>CONSCIENTIOUS—NO THANKS</b>	 <b>GOOD TRADE—TOP WAGE</b>

**Learn a trade thru C.T.I.!**

Does your job "gripe" you? Then learn a trade! Skilled men enjoy their work, receive more pay, get frequent promotions. Select one of the opportunities listed in coupon. Train thru C.T.I.'s Home Study methods, or in our Chicago shops. G. I. approved. Finance plan for non-vets. Important—Mail coupon today!



R. C. Anderson President

R. C. Anderson, President  
**COMMERCIAL TRADES INSTITUTE, Dept. EI-8**  
 1400 W. Greenleaf, Chicago 26, Ill.  
 Send free illustrated Brochures and other information about the field I have checked below:  Veteran  Non-veteran  
 Refrigeration-Air Conditioning  Automotive Mechanics  
 Electricity  Body & Fender Rebuilding  
 Radio Servicing-Television  Building Construction  
 Diesel Mechanics  Drafting  
 Name \_\_\_\_\_ Age \_\_\_\_\_  
 Address \_\_\_\_\_  
 City \_\_\_\_\_ State \_\_\_\_\_

**OWN YOUR BUSINESS**

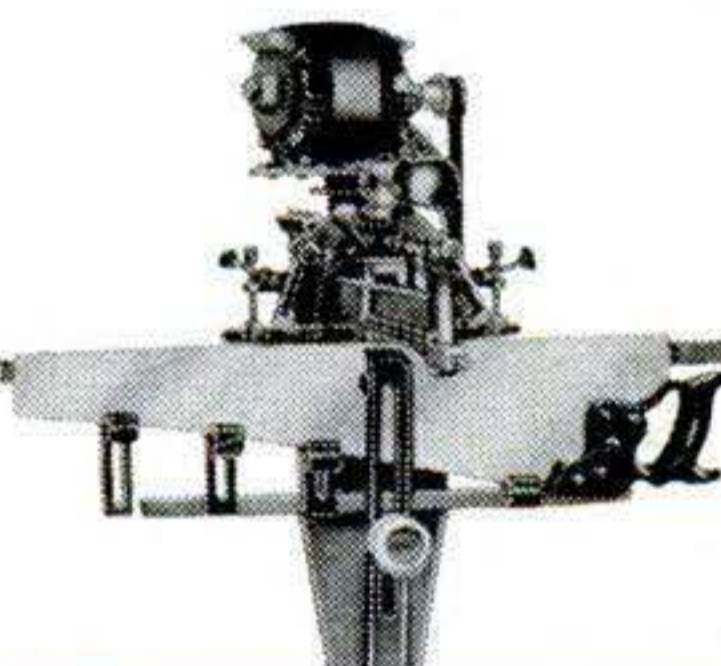
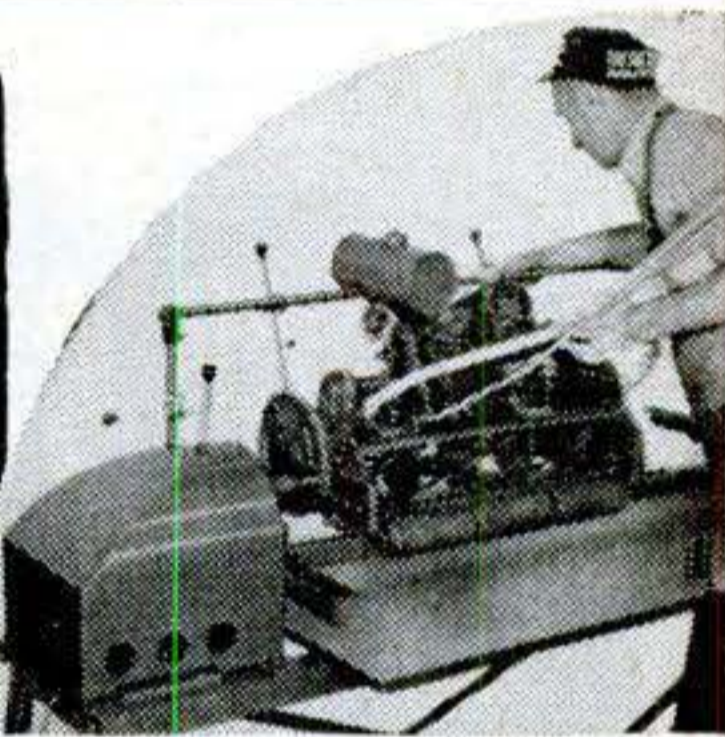

You can start a steady, CASH business at home in spare time, with small investment. The Foley Lawn Mower Sharpener sharpens mowers in 15 or 20 minutes, and 99c out of every dollar is profit. With the Foley Saw Filer you can make up to \$2 or \$3 an hour, filing hand, band and circular saws. Make \$20 to \$30 a week extra money as a starter.

**Send Coupon for FREE PLAN**

**FREE PLAN** shows you how to get work without canvassing, and build up your own business. Start with one machine—let it pay for itself and help you buy the other. Send coupon today.

**FOLEY MFG. CO., 808-9 Foley Bldg., Minneapolis 18, Minn.**  
 Send **FREE PLAN** and information (check one) on  
 Foley Lawn Mower Sharpener  
 Foley Automatic Saw Filer  
 Name \_\_\_\_\_  
 Address \_\_\_\_\_

# SURPLUS BARGAINS ASSEMBLE YOUR OWN BINOCULARS!

Complete Optics! Complete Metal Parts!

WE SUPPLY FULL INSTRUCTIONS



## GOVERNMENT'S 7x50 BINOCULARS

Save More Than 1/2 Regular Cost

**METAL PARTS**—Set includes all Metal Parts—completely finished—for assembly of 7 X 50 Binoculars. No machining required. A sturdy Binocular Carrying Case is optional with each set of Metal Parts.

Stock #842-N .....\$39.40  
Postpaid, plus \$4.80 for Case.  
Total .....\$44.20

**OPTICS**—Set includes all Lenses and Prisms you need for assembling 7 X 50 Binoculars. These are in excellent condition—perfect or near-perfect—and have new low reflection coating.

Stock #5102-N .....\$25.00 Postpaid  
(These are standard American-made parts . . . not Japanese, French or German.)

**NOTICE!** If you buy both Binocular Optics and Binocular Metal Parts, add 20% Federal Excise Tax to above prices.

**ARMY'S 6x30 BINOCULARS**—We have complete Optics and Metal Parts. Write for Catalog N.

**SLIDE PROJECTOR SETS**—Consist of all unmounted lenses you need to make the following size projectors:

Stock #4038-N—2 1/4" x 2 1/4" .....\$3.35 Postpaid  
Stock #4039-N—2 1/2" x 3 1/2" .....\$3.35 Postpaid  
Stock #4035-N—35 mm. ....\$4.85 Postpaid

**SIMPLE LENS KITS!—THE LENS CRAFTERS DELIGHT!** Fun for adults! Fun for children! Kits include plainly written, illustrated booklet showing how you can build lots of optical items. Use these lenses in photography for copying, ULTRA CLOSE-UP SHOTS, Microphotography, for "Dummy Camera", Kodachrome Viewer, Detachable Reflex View Finder for 35 mm. cameras, Stereoscopic Viewer, ground glass and enlarging focusing aids. And for dozens of other uses in experimental optics, building TELESCOPES, low power Microscopes, etc.

Stock #2-N—10 lenses .....\$1.00 Postpaid  
Stock #5-N—45 lenses .....\$5.00 Postpaid  
Stock #10-N—80 lenses .....\$10.00 Postpaid

Order by Stock No. Satisfaction Guaranteed

Edmund Salvage Company P. O. AUDUBON, NEW JERSEY

NEW  
Edition

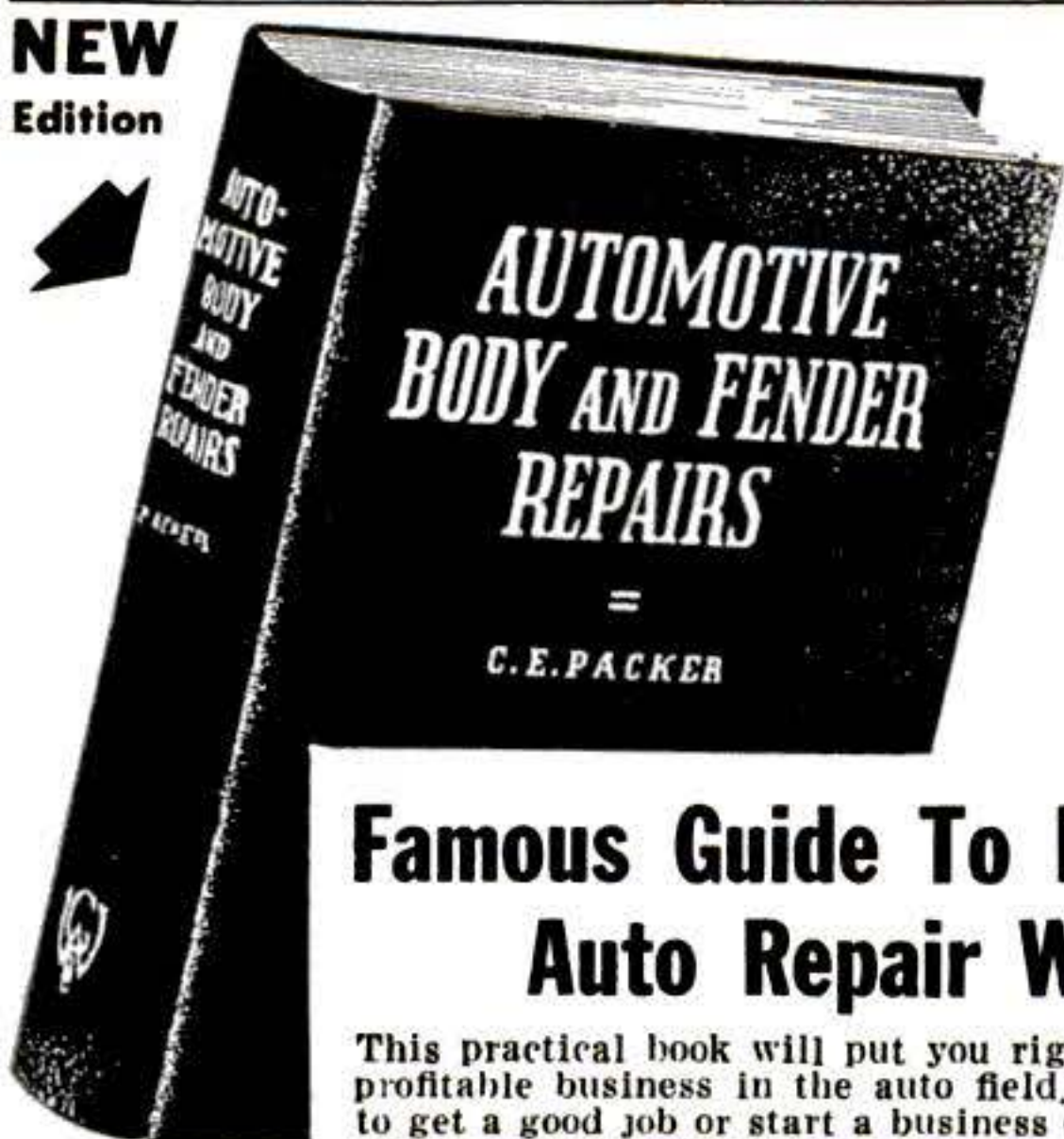

NOW  
HAS  
325  
PAGES  
232  
ILLUS.  
\$3.50  
Total Cost

## Famous Guide To Best Pay Auto Repair Work

This practical book will put you right into the most profitable business in the auto field. Shows you how to get a good job or start a business of your own with little or no capital. Easy to use and understand. Covers use of tools and equipment, gives approved methods, describes materials and shows you how to actually do a professional job, operate a shop, etc. The very latest information and pictures on all interior and exterior body work and fender repairs—the kind of work people everywhere want and will pay big for when you can do it. Mail coupon now. Use book 5 days and if not O.K. return it and we will refund your money.

Most  
Complete  
Information  
Ever  
Published.

Goodheart-Willcox Co., Dept 3B  
1321 S. Michigan Avenue, Chicago 5

MAIL ORDER  
COUPON

Send Auto Body and Fender Repairs ( ) C.O.D., I will pay postman plus charges. (C.O.D. in U.S. only.)  
( ) Remittance for \$3.50 enclosed, send postage paid.  
If not O.K. I will return in 5 days and you will refund purchase price.

Name.....  
Address.....  
City.....State.....

POPULAR SCIENCE



## HOW TO BUILD YOUR OWN LOG CABIN LODGE OR BUNGALOW!

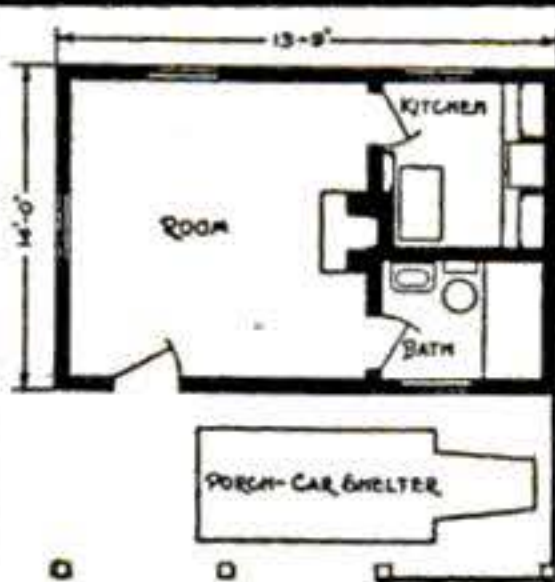

## COMPLETE INSTRUCTIONS IN ONE GREAT BOOK!

Countless thousands say this great volume brings them *complete detailed plans* for building their own log cabins and bungalows!

180 PICTURES - 250 PAGES - ONLY \$1.98!

Just take your pick from the scores of cabins, lodges, tourist homes, wayside stands and bungalows jam-packed into this big book, "How to Build Cabins"! You'll learn how to lay a foundation . . . how to build walls . . . how to lay floor boards and roofs. Yes, you'll discover step-by-step details for building porches and garages . . . for cutting doors, windows, and attaching shutters . . . for building fireplaces and chimneys . . . and even for installing plumbing and lighting!

### SAVES YOU HUNDREDS OF DOLLARS!

Now you can have a vacation spot of your own—a place where you won't be gouged by sky-high summer rentals—one that you can build yourself and *save hundreds of dollars* on the construction costs! And don't imagine that it's hard for you to build—for you'll find this great how-to-do-it book makes it as easy as pie—shows you every move!

### SEND NO MONEY - 7-DAY FREE TRIAL!

Imagine! This big book with 180 pictures and 250 pages costs *only* \$1.98! So fill out the order form below right now! When book arrives pay postman only \$1.98 plus a few cents mailing charge as payment in full. If after 7 days' free trial you aren't delighted, return it for a full refund!



## MAIL COUPON TODAY!

POPULAR SCIENCE Publishing Co., Dept. 89  
353 Fourth Avenue, New York 10, N.Y.

Send me "How to Build Cabins" in edition checked below. I will pay postman price plus postage. If not delighted I may return it within 7 days for full refund.

- DeLuxe Edition in handsome Buckram binding, only \$2.48
- Regular cloth-bound Edition, only \$1.98

Name.....

Address.....

City.....Zone.....State.....

Check here if you send payment with order, and we will pay shipping costs. Same return privilege.

# POWELL AGAIN SETS THE PACE

\* Luggage rack extra

ONLY \$247.34  
F.O.B. COMPTON, CALIF.  
Excise Tax Included



Only POWELL brings you all these BIG cycle features . . . at so low a price

- Cruises at 45 MPH—with faster pickup than car
- 39" high, 71" long overall, wt., 190 lbs.
- 8 HP motorcycle engine—Bore 3-1/16"—Stroke 3-1/4"—24 cu. in. displacement
- 50 miles to the gallon
- Automatic clutch
- Internal expanding brakes (42 sq. in. braking surface) handle-grip controls
- Finished in rich black baked enamel with chrome trim

**DEALERS:**  
There are still a few dealer franchises available. Write today for complete information.

## RIDE IT! IT'S YOURS IT'S THE POWELL P-81!

The husky, lightweight (190 lbs.) low cost motorcycle you've dreamed about is here! It's the powerful Powell P-81, with a 24 cu. inch engine; rugged, lightweight, tubular, all steel frame; and BIG motorcycle features throughout and at an unbelievably low price! Send in coupon and get full details.

**POWELL**

**MANUFACTURING COMPANY**  
Since 1927

Compton

California

### Send for Free Folder and Name of Nearest Dealer

Your Name.....  
Address.....  
City.....County.....  
State.....Age.....  
PS 8

## ZIRCONS

Loose. Genuine Siam Imports. Pure white. Special: 3 Genuine Zircons, from 1/2 kt. to 1 1/2 kts. 3 gleaming gems \$6.00 tax included. We can supply Zircons in all sizes and mountings of all types. Send order or write for details today.

B. Lowe, Dept. PS, Holland Bldg., St. Louis, Mo.

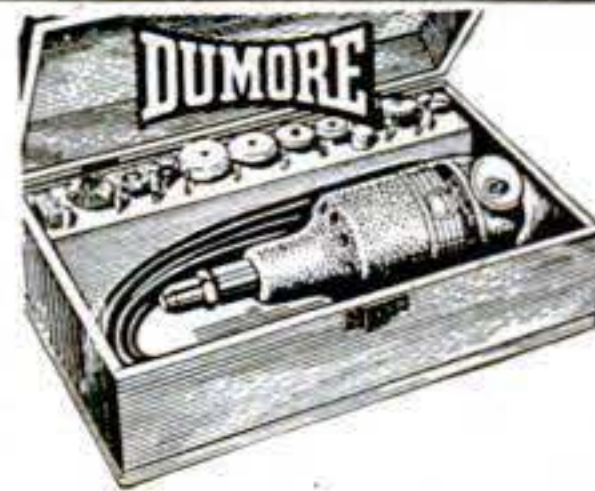

### DUMORE Duplex Grinder Makes work faster, easier, twice the fun!

Do more in metal, wood, and plastics! A Duplex gives you extra power, chucks three different tool sizes, converts for flexible-shaft, bench, or lathe work. It's a honey.

Write for Free folder.

The Dumore Company, Dept. H-52, Racine, Wis.



### LAWN ORNAMENT-NOVELTY PATTERNS

28 Lawn Ornament Patterns, 25c. Other patterns: 15-20" high; Dutch Girl, Dutch Boy, Pirate, Bull Terrier, Mexican Girl, Mexican Boy, Dwarf, Penguin, Flower Girl, 10c each. 25 Novelty Patterns, 30c. All 62 Full-Size Patterns, \$1.00 Postpaid.

### FLYING DUCK

Wind revolves wings. Realistic appearance. Pattern, Instructions and wing Pinion Kit; brass bearing, steel shaft, wing lugs, bolts, nuts and washers. 50c. Pattern and Instructions without kit, 25c. Postpaid.



STROTHER PATTERN SERVICE  
Dept. 7-AW Box 128 Belington, W. Va.

### WALL MODEL TELEPHONES



We can meet any inter-communication telephone requirement. Telephone set, 2 \$17.95 of either model Complete with batteries, wire, etc. Telephone supplies and parts of every description. 25% deposit with order, balance C.O.D., F.O.B. Brooklyn.

### DESK MODEL



INQUIRIES WELCOMED  
EASTERN TELEPHONE CO. Dept. PS-6 320 18th St. Brooklyn, 15, N. Y. S0uth 8-6161

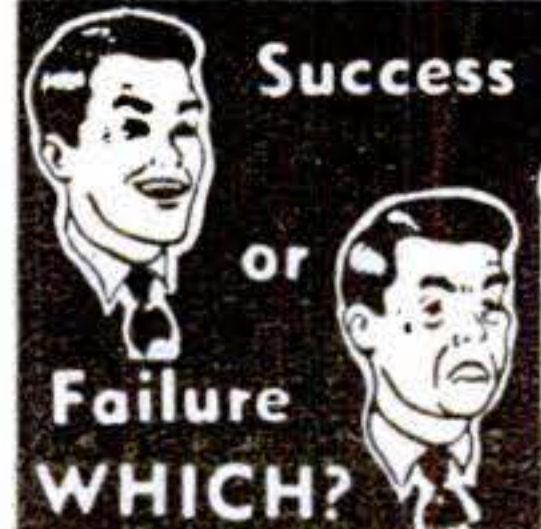

## UNLEASH THE POWER OF YOUR MIND

Are YOU successful? YOU have what it takes. Many have fulfilled their desires by understanding the POWER OF THE MIND, a power many possess, but few make use of. YOUR mind can be TRAINED

to work for YOU day and night. Many others have been helped by our Plan. Write for our FREE PERSONALITY CHART. Send no money—just your name and address on a post card—Do it NOW.

SELF-HELP FOUNDATION, Dept. PS-8

746 So. Lake St. Los Angeles 5, Calif.



FOR ALL MAKES AND MODELS

### DOUGLASS Steel-Pack MUFFLERS

Performance that excels • Stamina that endures  
Rugged construction. Steel tubing. Straight-thru-design. Solid tube with steel packing. "Throbbing Deep Tone." Complete for Easy Installation Satisfaction Guaranteed

32-40 FORD V-8	\$5.96	29-48 CHEVROLET	\$5.96
41-49 FORD V-8	6.85	31-41 PLYMOUTH	5.96
39-49 MERCURY	6.85	42-48 PLYMOUTH	6.85
35-49 FORD & MERCURY DUAL SETS			\$23.00
49 FORD & MERCURY DUAL SETS			25.00

Specify Year and model • Enclose Money Order or Check with Order.



ORDER NOW!



1949 COMPLETE RACING EQUIPMENT CATALOG 25c

WRITE RACING EQUIPMENT DIVISION

DOUGLASS MUFFLER MANUFACTURING CO. Dept. S-8 1916 W. VALLEY BLVD. - ALHAMBRA, CALIF.

# NOW EASY TO START A Big Business ON A SMALL INVESTMENT



## WARNER SUCCESS PLAN Gives exact instructions showing you

- How to start in spare time
- How to use home as headquarters
- How to bring in the business
- How to do real METALIZING in genuine GOLD, SILVER, or BRONZE, by the easy Warner Method
- How to start without risking your job
- How to pyramid your profits
- How to be sure of steady, big income.

Don't turn this page until you've given serious thought to your future. In the uncertain years ahead, the men who own their businesses are the ones who will be happiest. A small start now easily can lead you to complete independence, freedom from time clocks, freedom from fear of lay-offs, freedom from the limits of a pay check.

Now, while you can do it without risk—now is the time to investigate the exceptional opportunity offered you by the Warner Success Plan. Looking into the market, checking up on the possibilities for big sales and big profits will not cost you anything. Isn't this the time to lay the foundation for a future of complete independence—a life of happiness—a steady, dependable income?

## METALIZING BABY SHOES AND OTHER KEEPSAKES

offers an exciting new opportunity to men or couples who want personal independence

If you'd like the feeling of being boss instead of being bossed—the Baby Shoe business is made to order for you. Just think of the appeal. A mother's love for her child—her desire to preserve forever the tiny shoes in which her baby took its first toddling steps. No wonder orders come easy and fast. No wonder profits are big. Then think of the Future. Fifteen Million babies in the last five years—three million last year—millions more next year. As long as babies are born, this business will prosper—in good times or bad. Think of the fun. Every job is different, interesting. And when you deliver a job and collect the money, you get a tremendous glow of satisfaction out of the mother's happy exclamations over your work. There's not another business I know of that offers you such big rewards in cash, in security, in a future, in independence that can be started on such a shoestring. You'll be glad you saw this ad—IF YOU SEND THE FREE COUPON.



## READ THE ENTIRE PLAN

7 DAYS AT MY RISK

### DON'T SEND A PENNY NOW — Just Send Your Name

This is one of the most fascinating businesses you can imagine. There are 15 MILLION pair of baby shoes waiting right now to be METALIZED. The opportunities are unlimited. The future is very big. And it's a business in which the whole family can have fun helping. A perfect business for man and wife to start—or for two partners. And I want you to read the whole Plan at my risk. Don't spend a cent unless you go ahead.

I want every serious minded man to let me show what I've done in our own shops here in Chicago—reveal the exact facts about the profits to be made and the way to make them. I don't want you to spend a cent for supplies until you've studied the facts, talked them over with the family and satisfied yourself that this is the ONE BIG OPPURTUNITY FOR YOU. That's why I allow you to read all trade secrets contained in the Warner Success Plan at My Risk. If you don't go ahead, you don't pay a cent.



## You Have Nothing to Lose

### ALL FACTS FREE! MAIL!

Raymond E. Brandell, Mgr., Warner Electric Co.,  
1512 Jarvis Ave., Dept. 28, Chicago 26, Ill.

As long as it doesn't cost me a cent, I am willing to read the facts, investigate, then give you my decision. Send the facts by next mail. Everything you send now is FREE!

NAME \_\_\_\_\_

ADDRESS \_\_\_\_\_

CITY \_\_\_\_\_ Zone \_\_\_\_\_ STATE \_\_\_\_\_



## \$5.00 AN HOUR

Yes, it's possible for one man to turn out enough work to make \$5.00 an hour for his time. Think of how that pyramids when a partner or the whole family works.

### Old Established Firm Backs You Up

The Warner Electric Company just celebrated its 26th year of success. You get a Real Start when you "join up with Warner"—you get real Guidance to Success.

Warner Electric Co., Dept. 28,  
1512 Jarvis Ave., CHICAGO 26, ILL.

## WE SUPPLY EVERYTHING

You don't have to go "hunting" when Warner is behind you. We supply all materials, all mounts, chemicals, and metals. And you get the low prices made possible by our big quantity purchases and our own manufacture. You send for just what you need—and never have any big investment tied up in stock.

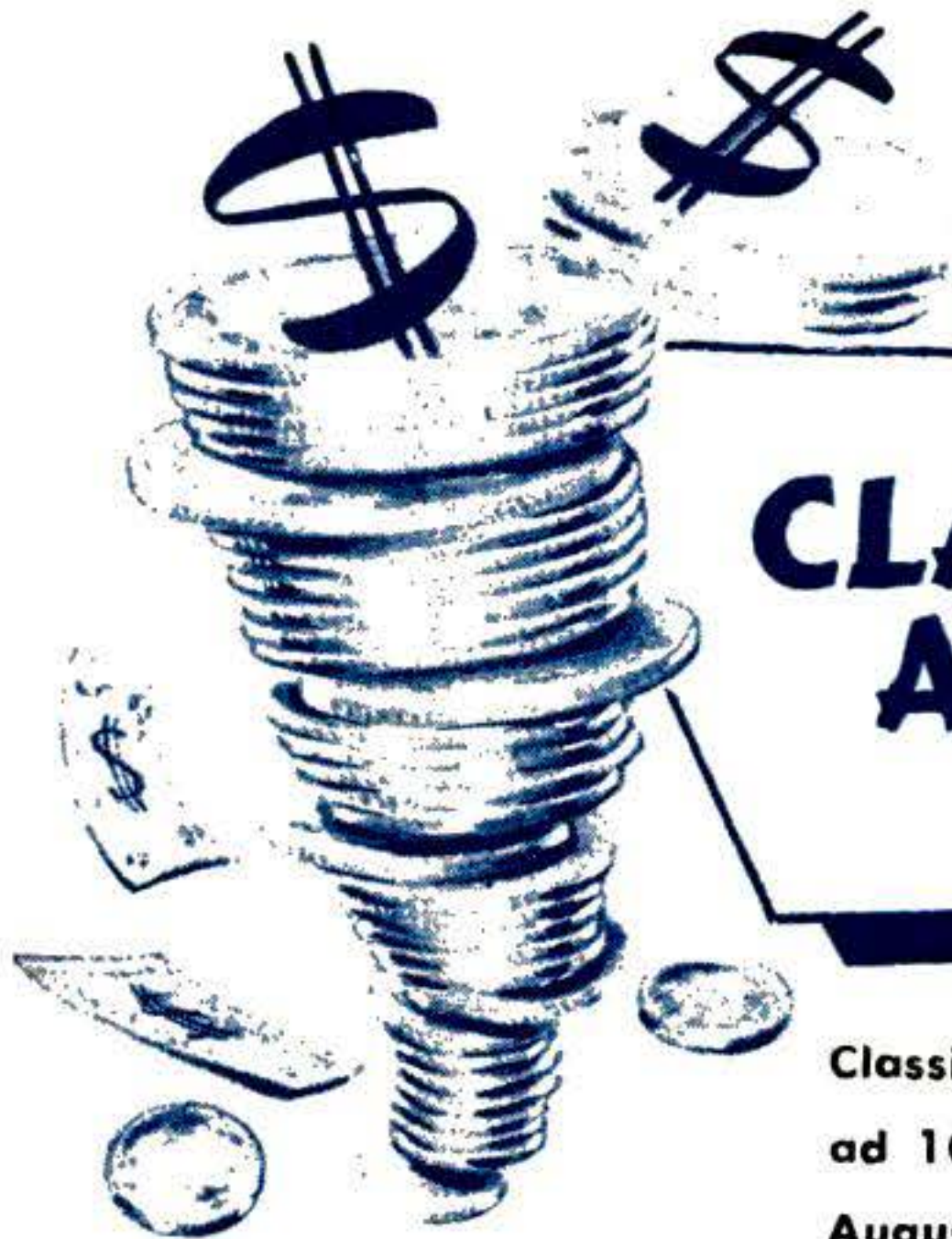

# CLASSIFIED ADVERTISING DEPT.

Popular Science Monthly • 353 Fourth Avenue, New York 10, N. Y.

Classified Ads only 80c per word per insertion, payable in advance. Minimum ad 10 words. To be included in October issue, copy should be in our office by August 24. October issue on sale October 1st.

## 1 AUTOMOBILES

**RACING** Car Equipment for all cars. Engines, Racing Heads, Manifolds, Carburetors, Mufflers, etc. Speed instructions and literature \$1.00—refunded first order. Lee Motorcraft Co., 1412-B Great Northern Bldg., Chicago 4, Ill.

**FROM** Speedway to Roadway! Track-proved Hi-speed Heads and Manifolds now available for your passenger car! No special tools needed! Increase horsepower 25%! Astounding getaway! Free illustrated catalog. Speedsport, 6215AB Diversey, Chicago 39.

**BUICK** Parts. Enjoy new-car pep and power in your old Buick. Same day service from World's largest stock of new (not rebuilt) Buick parts and engines. Ship anywhere. Write today. Robertson Buick Co., 1002 S. Wabash Ave. Chicago 5, Ill.

**"SPEED & Power"** Handbook—50 chapter Library Edition! Breathtaking methods—Authentic—Direct from California! Covers Fords to Cadillacs—all makes! Build your own Dual Manifolds! Superchargers! Hot Cams! Water Injectors! Hi-Compression Heads! Mileage Devices! Save many dollars! Get racing speed, lightning acceleration, dynamic power increases from any make automobile! Build fast Stock Cars! California Roadsters! 150 MPH Rods! Get construction drawings! Tuning Techniques! Speed Tricks! Picture Catalogues! Ingenious formulas! Economy secrets! Including—"Racing Frames"—"Reciprocating Masses"—"Jet Engines"—"Braking Characteristics"—"Dynamometers." Also—Dual Pipes—Gears—Fuels—Porting—Relieving—Lowering—Balancing! Includes "California Automobile Customizing"—Glossy photographs! Diagrams! Very newest ideas! Conversions! Re-styling all makes! Streamlining! Chopping! Channeling! Customizing! Complete—\$1.98 postpaid Newhouse Automotive Industries, 5805-A2 East Beverly, Los Angeles 22.

**"VAPO-Steamic"** Water Injector. Easily built! Finest automatic "Moist-Humidity" system! Engineering triumph—Gets up to ten extra miles per gallon! Tremendously increases horsepower! Eliminates ping, carbon, overheating! Reduces wear—Lengthens engine life! Copyrighted "Water Injection Handbook"—with working drawings covering automobiles, motorcycles, airplanes, tractors! Includes Plans, Catalogues, Diagrams, Instructions—\$1.00 complete. Newhouse Automotive Industries, 5805-A1 East Beverly, Los Angeles 22.

**AUTOMOBILE** Racing. Sixth Edition. 100 illustrations. Working drawings with building instructions for Ford-60 midget, California roadster, Offenhauser racer. Details on racer parts. Sample entrance blank. World's record 158.5 M.P.H. rear engine four-wheel drive car. Interesting information for fans, drivers, mechanics. \$2.00 postpaid; \$2.40 C.O.D. Ray Kuns, Department 62, Cincinnati 27, Ohio.

**PHOTOS:** Latest American, foreign sports cars. Large assortment \$1.00. Box 101, 2317 Fruitvale, Oakland 1, Calif.

**AUTOMOBILE** Racing Book. Fifth edition-revised. Tells how to build dirt tracks bodies, frames, engines. Records, superchargers, rules, formulas, plans, stock conversions, roadster racing, fast Fords. \$1.00 postpaid, \$1.40 C.O.D. Ray Kuns, Department 274, Madisonville, Cincinnati, Ohio.

**CALIFORNIA** Custom accessory headquarters. Buy direct from original designers and save. Solid hood sides, grille panels, lowering kits, fender skirts, dual pipes, chrome motor accessories, speed equipment. 32 page illustrated catalog. 200 custom accessories—25c. 3319-D South Grand, Los Angeles 7, Calif.

**NEW** Clymer Books. Catalog of 1949 Automobiles, 120 photos every American car with complete specifications, compares all cars in one book. \$2.00. Ford Owner's Handbook gives complete servicing information all Fords 1932-1949. \$1.50. Complete Service Manual Model "A" Ford \$1.00, Model "T" \$1.50. Life of Ted Horn, three-time American Automobile Racing Champion, \$2.00. Complete Outboard Service Manual covers all makes, \$3.50. Revised Hot Rod Book 1946, 1947, 1948 records, \$1.50. Steam Traction Engine Album, 160 pages describes, illustrates 105 Historical Steam Vehicles, \$2.50. How to Build Racing Automobile, \$2.00. All postpaid. Specify books wanted. Floyd Clymer, Dept. B-FC, 1268 So. Alvarado, Los Angeles 6, California.

**"SPEED** Equipment" Bargains! "California" Mufflers \$4.50. V-8 Duals \$16.95. Famous Racing Heads \$45.00. Chrome Carb Stacks 98c. Echo Cans \$1.65. Dual Manifolds \$9.95. Octa-Gane Water Injectors \$17.50. Gas Savers \$1.50. Lowering Kits \$2.95. Many Others! Illustrated "Speed Catalog" 25c. Dealers Wanted. Almquist Engineering, Milford 8, Penna.

**"HOLLYWOOD"** Deeptone Mufflers! Powerful "straight-thru" design increases efficiency, speed, acceleration, mileage! Singles, all cars \$4.85. V-8 Duals \$16.95—(Satisfaction Guaranteed). Speed equipment catalog 25c. Dealers wanted. Almquist Engineering, Milford 8, Pennsylvania.

**"SPEED & Mileage"** Manual!—140 Illustrations! Most authoritative and widely read book of its kind! Easily gain up to 40% more speed, power, mileage, from any automobile! Complete instructions on building inexpensive speed equipment! Fast Sports Cars! "California Hot Rods"! 155 m.p.h. conversions! Superchargers! Dual Manifolds! Twin Mufflers! "Water Injectors"! Heads! Economizers! All about fast engines—Speed Tuning—Restyling—"Customizing"—Gas saving—"Racing Tricks"—Fuels—Lowering—Ratios! Latest California methods! "Custom Styling Information"! Streamlining! Sport Changes! Racing Conversions! Working Diagrams! "Hollywood Roadster Plans"! Parts Lists! Drawings! Charts! Photographs! All Cars! Manual plus "Hot Rod Handbook" and Equipment Catalog—All three \$1.98 (Satisfaction Guaranteed). Almquist Engineering, Milford 8, Pennsylvania.

**MOTOR** Manual Monthly, the magazine reviewing cars from all countries, servicing, etc. \$3.00 year. 1-7 Knox Place, Melbourne, Australia.

**"WATER** Injection." Free descriptive illustrative information. Neher Industries, La Verne 6, Calif.

SEE our ad under motorscooters for Midget Car Bargains. Midget Motors Directory, Athens, Ohio.

**"HOT** Rod" Handbook plus "California Speed Manual" and "Racing Equipment" Catalog—All three only \$2.00. Speed Publications, Port Jervis 14, N.Y.

**IT'S** Here. The last thing in customizing. Front Fender Skirts. Unbelievable beauty. Easily made at home. Full plans only 50c. Customcraft Auto Works, Box 1002, Springfield, Mass.

## 2 AUTO SUPPLIES & EQUIPMENT

**AUTO** parts for all autos and trucks. Trans, motors, differentials, fenders, carburetors. Also Body Parts, Security Auto and Truck Parts, 1923-PS Grace, Chicago 13.

**AUTO** parts. Buy direct. Get dealers' prices. Represent us in your territory. Write requirements. Specify car make. Mechanics Auto Parts, Factory Warehouse, 3807-PS N. Ashland, Chicago 13.

**BRUSH** Plating Outfits connect to a battery. No tanks or shop required. Free particulars. Gunmetal Co., Avenue K, Decatur, Illinois.

**AUTOMOTIVE** Surplus Tool Specials! Pullers, wrenches, socket sets, reamers, other bargains. Nationally advertised merchandise. Free catalogue. Glenco Supply Co., 7519 Myrtle Avenue, Glendale 27, New York.

**"SMITHY** Mufflers" for all cars. Free list. Buck's Auto Parts, 1629T, Merced 3, California.

**GANE** Aero Jets Save Gas. Send postpaid for free trial with directions for installing your car. Pay postman nothing. If not delighted after ten days return them and you owe nothing. Send make car and carburetor today. Advanced Automotive Products Co., 563 Lake Road, Webster 4, New York.

**BUILDING** Construction. All kinds. 100 ways to save. 100 illustrations. 52 page book. \$1.00. Home Industries, Omaha 5, Nebraska.

**FREE** Details: Auto bells for your Car. Two loud musical chimes. \$8.50. Bermuda Auto Bells, D-18, 16 Concord St., West Hartford 7, Conn.

**WELDING** bodies, blocks, repairing fenders adds profits. Easy with Hobart Welders. Low Cost. Terms. Free Catalog. Write Hobartweld, Box P-892, Troy, Ohio.

**NATIONALLY** known parts at wholesale prices. Give year, make and model. Ship C.O.D. Parts, P. O. Box 325, Willimantic, Conn.

**PARTS.** New, Used, for all cars—trucks. Auto Parts Service, 111 Sunset Ave., Fairfield, Conn.

# POPULAR SCIENCE OPPORTUNITIES

**CONVERTIBLE Top Covers** Plastic fabric. Protects-Insulates. Clipon snap fasteners. All convertibles \$19.50. Satisfaction guaranteed. Vassar, Cleveland 5, Ohio.

**SAVE Gasoline!** Quick Starting! "Air-flow Needles." Free Trial! Specify Car, Carburetor. Neher Industries, La Verne, California.

**SAVE Gas!** Instant starting. "Lektron" atomic coil booster. Only \$2.00. Money-back guarantee. Specify car. Electronic Industries, Cleveland 11, Ohio.

**CHEVROLET Parts.** Scarce motor, body, sheet metal parts. Grossman Chevrolet, Minneapolis, Minnesota.

**SKIRTS**—big hubcaps—mufflers, and all accessories, best prices. C.O.D. Latest catalogue 25c. Mello-Tone Muffler Shop, 1220 So. Robinson, Oklahoma City, Okla.

**VAPOJET** gives car jet performance. Saves gas. See Page 34.

**NEW Grilles for All Cars.** 1940 Plymouth Shells \$12.75. Wagner Grille Co., Route 2, Bernville, Pa.

**AMERICAN Hammered Flexible Power re-ring Piston Ring Sets.** For cylinders with less than .015 taper, will fit Dodge & Plymouth 1942 to 1949. Our price \$3.00 a set postpaid. Arrow Sales Co., Billings, Montana.

## 3 AUTO TRAILERS

**BUILD Your own trailer!** Save money! Have every feature you want! Plans for house, sport, camp and utility trailers. Catalog describing 9 models 10c. 15c in Canada and overseas. Jim Dandy, Box 125-B, Wausau, Wisconsin.

**TRAILER plans**—house, utility, boat, etc. Axles, chassis, hitches, windows, etc. Catalog with booklet, "Trailer Hints," \$1.00. Catalog only, 50c. Marine Mart, Buffalo 7-A, N. Y.

**FREE Trailer Plan.** Write Penny Card Today. Dept. A1, Airplane Tire Co., Tulare, California.

**LIGHTWEIGHT Trailer Plans.** 100-page Caravan Book \$1.00. Motor Manual, 1-7 Knox Place, Melbourne, Australia.

## 4 MOTORCYCLES BICYCLES, SUPPLIES

**MOTORSCOOTERS.** New Design, 6 big features. Literature 10c. Rollaway Motors, Lancaster, N. H.

**WHEELS!** Build wagons, scooters, mowers, trailers, wheelbarrows, grocery carts, baby carts, play pens, baby carriages. 4" to 16". Free list. Trulsen Mfg. Co., 811 E. 31, Kansas City, Mo.

**RECONDITIONED motorcycles and motors.** Chromium accessories. Complete stock Indian parts. Expert rebuilding. Fast service. Indian Motorcycle Sales, Kansas City 1, Mo.

**MOTORCYCLE pistons and parts,** new, used. Harley, Indian, Henderson, Super-X. List 10c. Ballak, 811 N. 9th, St. Louis 1, Missouri.

**CUSHMAN motorscooter** (4 H.P. motor) \$19.98 complete; Midget car (leather seat) \$25.00; Motoscoot \$15.00; 1946 Whizzer \$35.00; Motorbike outfit \$5.00; Indian motorcycle \$30.00. Other motorscooters \$8.00 up, motors \$3.00 up. Send 25c for new Summer catalog listing many other sensational bargains in used motors, motorscooters, motorcycles, parts, etc. Associated, Box 1764-CS, Toledo, Ohio.

**WHIZZER Bike-motor** \$25.00; Cushman motorscooter \$15.00; Midget Racer \$40.00; Shaw Bicycle-motor \$15.00; Harley-Davidson Motorcycle \$15.00; Smith Motor-wheel \$25.00; Good motorscooter (twist grip) \$22.50. Rush 25c for new catalog #14 listing many other amazing bargains in motorscooters, used motors, midget cars, parts, wheels, etc. Gall, 538 Erie, Toledo, Ohio.

**POWERCYCLES**—New—Factory overstock—Latest Models—\$98.50 up plus tax and freight—Regular \$179.50 to \$267.50 values—Amazing Buy—Regular Factory Warranty—Send For Free Catalog. R. C. Cheney Co. Mfg. Division, La Crosse, Wis.

**WORLD'S Leading motorcycles** shown in 100-page "Motor Cycle Guide" \$1.00. Motor Manual, 1-7 Knox Place, Melbourne, Australia.

**SCOOTER Parts** for all American Moto-Scoots from 1940 available. State Model, Serial. Also Tires, Chain, Generators and Motor Parts for Briggs & Stratton and Lauson Engines. Moto-Scoot, Inc., 1323 W. Carroll, Chicago 7, Ill.

**MIDGET car** \$5, motorbike conversions \$5 brand new Regal motorscooters \$37.50 less motors, Indian motorcycle \$25, midget car \$20, Custer motorscooter \$25, all complete. Gasoline engines \$2 up. Super-cycles, Cushmans, Salsburys. Plenty new motorscooters, midget cars, homebuilders parts, automatic clutches, transmissions, engines, tires, etc. at factory prices. Special sale: Four balloon tires for \$3. Over 5500 tires in stock. Mailorder only. Send 25c for Big War-Bargain Catalogue just out listing these and hundreds of other bargains. (35c by First Class Mail.) Midget Motors Directory, Athens, Ohio.

## 5 AVIATION

**JET Engine** \$3.00; Plans \$1.00; Literature 10c; M.E.W., 387 University, St. Paul, Minn.

**PROPELLERS**—2-3 Blade, for sleds, air-drive boats. Catalog. Standard Aero Craft, Box 387, Ft. Worth, Texas.

**PROPELLERS,** plans for snow sleighs & air boats. Catalog 10c. Banks-Maxwell, R.F.D. 12, Ft. Worth.

## 6 AVIATION INSTRUCTION

**GUARANTEED:** "Ross Questionnaires" cover all C.A.A. Ratings. Free Folder. Ross Aero Publishers, Tulsa, Oklahoma.

## 7 ELECTRICAL SUPPLIES & EQUIPMENT

**BUY Lamp Parts Wholesale.** Parts you need for building, repairing, or assembling. Save money on large or small orders. New catalog for 10c. Gearon Company, Dept. 300-A8, 27 South Desplaines, Chicago, Illinois.

**LAMPS**—If you build or repair and had trouble getting parts—your search is ended! 24 hour service from the most complete stock in country. Illustrated catalog 10c. Dealers, send business card for quantity discount. Gyro Lamps, 5402B Clark, Chicago 40.

**ELECTRIC Pencil:** Engraves all Metals \$1.25. Beyer Mfg., 10511-C Springfield, Chicago 43.

**ELECTRONIC door lock!** Sensational! Invisible! Positive protection! Inexpensive! Ends losing keys. Distributorship available. Send only \$2 for thoroughly engineered drawings—Complete simplified instructions. Satisfaction guaranteed. Amesworth, 17544 Raymer, Northridge, California.

**LAMPS**—Build own Originals. Parts Wholesale, any amounts. Catalogue 10c. Brown Lamp Co., No. 501, Wellston, St. Louis 12, Mo.

**LAMP Parts**—Build-Repair-Details 10c. Wrona Lamp Co., 2012PS-Cortland St., Chicago 47.

## 8 WELDING, SOLDERING, PLATING

**"BUILD-Ur-Own"** portable Arc Welder. Save \$350. Easy with Hobart Welder plus Auto Engine. Send 10c for valuable instruction book. Free Catalog. Write Hobartweld, Box P-893, Troy, Ohio.

**WELDERS!** New Portable Champion Special Transformer Welder: 110/120 volts. AC 9 heat stages up to 75 amps; Welds, brazes, solders, cuts all metals. Easy to use. Simple instructions. Special Flame Weld Torch Free. Splendid for Shop, Farm, Home repairs. Saves hundreds of dollars yearly. Only \$27.50. Also heavier models. 10 Day Free Trial. Magic Welder Co., 239 PS Canal St., New York, N. Y.

**RADIATOR Repairing**—Cleaning—recoring. How to equip small shop at low cost. Supply sources, trade secrets. Instructions only \$3.50 postpaid. Radiator Service, McBain, Mich.

**WELDERS 110 V.** Welds 1/2" Steel \$32.50. Unassembled \$22.50. Morris Welding Service, 1850B State, Schenectady 4, N. Y.

**WAR Surplus 200 Ampere generators** \$33.00 each. Free literature. Lewis Short, Burrton, Kansas.

**ELECTROPLATING Units**—Complete \$2.00 and up. Free Literature. Regency Sales, 5316 S. Justine, Chicago 9, Illinois.

**WELDERS** for all requirements. Free Catalog. Write Hobartweld, Box P-894, Troy, Ohio.

**RADIATOR Repairing Books, Supplies, Equipment.** Gasoline Torch. Write for circular. Curfman Mfg. Co., Maryville, Mo.

**BANDSAW Owners**—repair broken blades 2c each. Special silver solder, flux, instructions—50c. Sample 10c. Products Supply Service, 24310-A Mary, Inkster, Michigan.

## 10 MACHINERY, TOOLS, SUPPLIES

**WONDER Drill Sharpener.** Guaranteed. \$2.45. Circular. Ellery Thompson, Wonder, Oregon.

**SHAPERS, Knives, Swing Saws, Sanders, Lawnmowers, Trailers.** J-M Machine Works, Sylacauga 3, Alabama.

**WELDERS** for all requirements. Free Catalog. Write Hobartweld, Box P-895, Troy, Ohio.

**POWER tools, equipment** wholesale prices. Free Bulletin. Homecrafters Cooperative, Grand Rapids 6, Michigan.

**BUILDERS:**—Make concrete blocks. \$39.50 machines average 400 daily, standard sizes. Free Catalog. Concrete Equipment Co., 5129-S Compton, St. Louis 11, Missouri.

**SNAP Center Finder.** \$1.00 Postpaid. Earl Engineering Co., P. O. Box 52, Fresno, Calif.

## 13 BATTERIES, GENERATORS, ETC.

**EDISON Non-Acid lifetime storage batteries** for home lighting, motors, industrial uses, radio, etc. Free interesting literature. Hawley Smith Co., Croton Falls 2, N. Y.

## 14 BOATS, OUTBOARD MOTORS, ETC.

**NEW, used, rebuilt marine motors.** Marine conversions, fittings. Free Catalog. Stokes Marine Supply, Dept. 23, Coldwater, Mich.

**STEERING Wheels, windshield brackets,** from \$6.95. Modern fittings at lowest prices. Complete pre-cut plywood boats. Bargains galore. Folder 10c. Marine, Box 681, Mendota, Minnesota.

**FULL size, cut to shape boat patterns, blueprints,** 7 1/2-38 feet. Illustrated "Build a Boat" catalog, 25c (coin). "How to Build Boats" book, \$1.00. PolyWog Houseboat Plans \$10. Marine Catalog \$1.00. Cleveland Boat Blueprint Co., Dept. A-77, Cleveland 13, Ohio.

**PACKAGED Lumber**—Marine plywood, seasoned oak and cedar, sized, selected. Send \$1.00 for booklet, "Plywood Boats," with quotation form and literature. Forms and literature, 25c. Marine Mart, Buffalo 7-A, N. Y.

**MARINE Specialties and motor conversions catalog.** Sixty pages of struts, finishes, hardware, plexiglass windshield kits, electric tachometers, inboard and outboard air cooled motors, etc. Immediate delivery. Catalog with booklet, "Conversion Hints," \$1.00. Catalog only, 50c. Marine Mart, Buffalo 7-A, N. Y.

**BOAT Builders' guide**—250 pages—15,000 items pictured, priced, deliverable. Send \$1.00. Marine Mart, Buffalo 7-A, N. Y.

**MARINE conversions for Ford and Jeep engines.** Catalog 10c. Lehman Manufacturing Company, Department A, Newark 2, New Jersey.

**SAVE 2/3 cost.** Assemble your own boat. Complete plans and boat parts machined ready for assembly. No experience necessary. Rowboats to cruisers. Illustrated catalog 25c. Midwest Boat Company, Menomonee Falls, Wisconsin.

**BOATS Unpainted.** 12' Long V Bottom. \$69.50. Wilson Boat Co., Rice Lake, Wisconsin.

## 15 ENGINES, MOTORS, ETC.

**WELDER 150 ampere** \$47.50. Water pumps 400 gallon \$12.75. Fans 32 volt 2 speeds \$3.75. Butler, 1885 Milwaukee, Chicago.

# POPULAR SCIENCE OPPORTUNITIES

WINDING Data, listing 225 motors, single and three phase, \$1.00. Motor Data, Box 7631, Kansas City 3, Mo.

**MOTORS!** 1/2 HP DC converted to AC. All new, High speed 110 volt, 25 or 60 cycle, ball bearing motors. Actual value about \$75.00. Now \$15.00 each or 3 for \$40.00 With forward and reverse switch \$19.50, 3 for \$50.00. Countless uses for home mechanics. Can be used in any position. Order today! Immediate delivery! No C.O.D. order. "Amazing Bachman's," 27 Herman Street, Rochester 5, New York, Dept. PS.

**HOTTEST** surplus list in the country. Electronics, Hydraulics, Aircraft, Gadgets. Dick Rose, Everett, Washington.

**MOTORS** 1/2 hp 1750 RPM \$18.50, 1/2 hp 3450 RPM \$16, 3/4 hp \$3450 RPM \$26, Roberts, 7232 Madison, Forest Park 1, Illinois.

**WATER Motors**—All Sizes for any Purpose—Rotary and Semi-Rotary—Duplex Motors, Burlington, Iowa.

**MARINE & Industrial Engines**, Diesel & gasoline, bought, sold, exchanged, J. Helwege Co., 1 Woodcleft Ave., Freeport, N. Y.

**NEW Midget Steam Engines**, Single or V-Type, Literature Free, R. Looker, Box 105, Michigan City, Indiana.

## 16 AMERICAN POLICE JIU JITSU

**DEADLY Judo**—Fiercest fighting technique, Trick knockouts, (200 photographs—plus illustrations.) Expert instructions—Three volumes, Complete \$2.25, Variety House, Box 46-A, Wall Station, N.Y.C. 5.

## 18 BODY-BUILDING COURSES

**BARBELLS**—finest quality \$8.98 up. Catalog Free, Lurie Barbell Co., 1729-S8 Rockaway Parkway, Brooklyn, New York.

**BECOME** a big Strong Muscleman. Instructions only \$2.00. (News and Pictures 10c.) Write Sid's System, Dept. P.S.M., 8421 1/2 Evergreen, Southgate, California.

**BARBELLS, Dumbbells**, Exercise equipment, Courses, Free booklet, Good Barbell Co., Reading, Penna.

## 19 SPORTING GOODS, GUNS, FISHING TACKLE, ARCHERY

**"SHOTGUNS"**—"Rifles"—"Handarms"—"Ammunition"—"Rods"—"Reels"—List 10c. PS-Rudolph's, Atchison, Kansas.

**BOWS**—Arrows—Quality Archery Equipment, Popular prices, Catalog 10c. Illustrated Archery Instruction Book 50c. Archery, 617-J So. State, Chicago 5

**190 PROFUSELY** illustrated pages antique and modern pistol, sword, etc. values, 50c. Robert Abels, PS860 Lexington Ave., New York 21.

**SEND 10c** for list 100 used guns, Frayseths, Willmar, Minn.

**5,000 BARGAINS**, firearms, binoculars, war relics, catalog 40c. Smith Museum, Runnede, N. J.

**ANTIQUE and Modern Guns**, Bargain List 10c. Rywell, Harriman, Tennessee.

**SHOTGUNS, Rifles, Revolvers**, Over 500 Modern, Obsolete, Also Cartridges, List 10 coin, Ed Howe, 26 Main Street, Coopers Mills, Maine.

**FISHING**—Barometer; Know best Fishing Time, Homemade, Details \$1.00, John Habiger, Wichita, Kansas.

**GOOD used Army leather rifle scabbards** complete \$2.95, .45 shoulder holsters \$1.50. Send for complete sportsman's catalog, Glendale Industries, 368 W. 50th St., New York.

## 20 FIELD GLASSES, TELESCOPES, ETC.

**TELESCOPES**, Binoculars, Microscopes, —big bargain catalog free, Brownscope Company, 24 West 45th Street, New York.

**WAR Surplus Bargains**, Binoculars, Telescopes, Sextants, Millions of Lenses, Prisms, Reticles, Eyepieces, Objectives, etc. Request Free Catalog CN, Edmund Salvage Co., Audubon, N. J.

**HOW to make telescope**, astronomical equipment, etc., told in handy book "Everybody's Astronomy", Send \$1.00 to Popular Science, Dept. 88C, 353 4th Ave., New York 10, N. Y.

**BINOCULAR Sun Filters**, U. S. Navy snap-on type, Eliminates Glare! \$1.00 pair, Satisfaction guaranteed, Bushnell, 678-8 South Lafayette, Los Angeles 5.

**"TERRIFIC" Bargains**—Government Surplus Telescopes, Binoculars, Send \$1.00 for 10 piece Hobbyist Lens Set, Contains magnifying and reducing lenses, Send stamp for "Bargain" list, H. Jaegers, 93-08 95th Ave., Ozone Park 16, N. Y.

**TELESCOPES**—17 power; extends 36 inches, precision ground lenses, Ideal for studying stars, plane spotting, etc. Satisfaction guaranteed or money refunded, \$2.95 postpaid, Dept. PSC2, Criterion Co., 438 Asylum St., Hartford 3, Conn.

**REFLECTING Telescopes**, completely assembled, 60X, \$25.00, Guaranteed Observatory clearness, Free information, Skyscope, 475 Fifth Avenue, New York 17.

**ASTRONOMICAL telescopes**, binoculars, microscopes; Bought, sold, repaired, Books, Lists 10c, Rasmussen-Reece, Amsterdam, New York.

**POWERFUL astronomical telescope** easily made, Perfect lenses and instructions; 100X \$3.00; 100X and 200X \$4.00; 100X, 200X and 400X \$6.00, Full power, clear vision guaranteed, Instructions alone 10c, Suffolk Science Service, Manorville, N. Y.

**4" ACROMATIC lenses** for astronomical telescopes, \$45.00, James Bray, 860 Walnut Avenue, Burlingame, California.

**"How to Select Binoculars"** Free Booklet, Write Today! Bushnell Importers, 678-8 South Lafayette, Los Angeles 5.

## 21 OPTICAL

**PRISMS**, Government surplus, Ideal for experimenters, Silvered for making photo-stats on enlargers, Unsilvered for showing spectrum, reflecting telescopes, etc. 1 1/4" size \$1.00, 1 1/2" \$1.50, Wolf, 1261 Union Street, Brooklyn 25, New York.

## 24 DOGS, BIRDS, PETS, RABBITS

**SEE Gulf Hamstery** ad page 29, Shows picture of Hamster.

**RAISE Chinchilla rabbits**, Year-round money-makers from furs, meat, breeders, Experience unnecessary, Write today, Willow Farm, Sellersville 16, Pa.

**RAISE Guinea Pigs**, Make money at home, Booklet free, Taylor, Box 426B, Hapeville, Georgia.

**HAMSTERS** \$2.75 pair, Mice \$3.50 dozen, Alligator \$2.50, Chameleon 35c, Turtle 35c, Mealworms 50c hundred, Hobby Catalog 10c, Reptile List 5c, Quivira Specialties, Topeka, Kansas.

**\$50 WEEKLY Raising Angoras**, Free Illustrated Booklet tells How, Wilson's, Stanton, Calif.

**KENTUCKY Foxhounds**—kind to catch and kill fox with—\$30.00—\$60.00 each, Harvey Satterfield, Princeton, Kentucky.

## 25 FROG RAISING

**"RAISE Frogs!"**—Pleasure and profit, New book explains everything, Marlboro-B, Box 7002, New Orleans 19, Louisiana.

## 30 FARMS, OTHER REAL ESTATE

**SOLD For Taxes!** California, Oregon, Washington, timber, grazing, ranch & mining lands 25c to \$3.00 acre minimum bid, 10c (coin) brings circulars and maps, Pacific Lands, Box 2350-PS, Hollywood, California.

**GOOD FARMS**—Ranches, Washington, Minnesota, Montana, Idaho, Oregon, North Dakota, Dependable crops, favorable climate, Write for literature, lists describing typical farm opportunities, Specify which state, J. W. Haw, 120 Northern Pacific Ry., St. Paul 1, Minn.

**FREE Fall Catalog**, farm bargains, many states, some equipped, many illustrated! United Farm Agency, 428-PS BMA Bldg., Kansas City 2, Mo.

**COME To The Beautiful, Healthful, Pleasant Ozarks** for cheap homes and free stock range, Free literature, Ozone Land Co., Ozone, Ark.

**80 ACRES** So. Missouri, Oklahoma, Sacrifice \$37.00 acre, National Petrol, 6126 Michigan Ave., Chicago, Ill.

**STROUT'S Farm Catalog!** Time and Money-Saver—Free! Describes 2790 Bargain Properties—35 States Coast-to-Coast, Write today for your Free copy! Strout Realty, 255-ZB—4th Ave., New York 10, N. Y., 20 W. 9th St., Kansas City 6, Mo., 453 S Spring, Los Angeles 13, Calif.

## 32 PROFITABLE OCCUPATIONS

**\$40.00 WEEKLY**, Made growing mushrooms, Fresh, Dried, Dominion Patent 331.583, free spawn, North American, 169Y Yonge, Toronto, Canada.

**NO selling**, operate coin machines, amazing profits, details Free, Parkway Corporation, Dept. 12, 623 W. North Avenue, Baltimore 17, Maryland.

**\$5000 FROM** half acre growing Ginseng, crop bought, Particulars 10c, Associated Growers, 1169 Corydon, Winnipeg, Canada.

**SENSATIONAL!** It's easy to earn big money with your own profitable business, Earn \$10.00 to \$50.00 a day, Make lamps at home, General illustrated course teaches you quickly, Course and wholesale supply catalog only \$2.00, Gearon Company, Dept. 200-A8, 27 South Desplaines, Chicago, Ill.

**TYPISTS**, Profitable business at home, Complete copyrighted information 50c, Rosdahl Industries, 72-B W. Washington St., Chicago 2, Ill.

**MAKE Beautiful Holiday Flowers**, Novelties, Wonderful home business pays excellent profits, Literature free, Velva Art-crafts, 324-X East 14, New York 3, N. Y.

**RAISE Fishworms**, Easy, Profitable, Send 25c in coin for complete instructions, Huffman's Worm Ranch, Rives Junction, Michigan.

**LOCKSMITHING secrets!** Key fitting, lock repairing, opening; prices, sources, Illustrated book \$1.00, Wechsler, 7 West 36, New York City.

**BIG money** decorating Dresden Figurines, Gifts, etc. to rival expensive China-ware, No experience necessary, Royal Dresden Statuary, 186 No. Syndicate, St. Paul 4, Minn.

**MAKE money** with hamsters, New Tiny animal, Easily raised at home, Write for details, Hudson Hamstery, Newfoundland 2, N. J.

**PUT your classified ad** to work in Popular Science Monthly, You'll get profitable results from this low cost advertising, Write for order form to C. K. Kelly, Classified Advertising Manager, 351 Fourth Avenue, N. Y. C. 10.

## 33 BOOKS, PERIODICALS, ETC.

**MAGAZINES** (back dated)—foreign, domestic, arts, Books, booklets, subscriptions, pin-ups, etc. Catalog 10c. (refunded), Cicerone's, 363 First Ave., New York 17, New York.

**USED Correspondence Courses** and Books bought, sold, rented and exchanged, Catalog Free, Lee Mountain, Pisgah, Alabama.

**ADULT Stories**, 25c, Eight—\$1.00! Free catalogs! Hirsch, Spring Valley 3, N. Y.

**CARTOON Booklet** 10c, Laughs! Fun! Harris, Box 1567, Portland 7, Oregon.

**QUICK profits** taking magazine subscriptions, handing greeting cards, Cas-sell Publishers Service, Westfield, N. J.

**OPERATE** book rental service by mail, Information free, J. W. Stenger, 500-20th St., Rock Island, Illinois.

**BOOKHUNTERS!** All Subjects, Send Wants! Jaher Book Service, 620-K East 178 Street, New York 57.

**HYPNOTISM**, Mental Phenomena students—adults only, Send 10c for unique Hypnotic Catalog, Power Publishers (Un-usual-Book Specialists), 790-X Broad, Newark 2, New Jersey.

**ADULT Books**—Unusual—Revealing—il-lustrated, Five \$1.00, Catalogs 10c, Kogan, 1032-DP, Church Annex, New York 8.

**8 PAGERS** The vestpocket comic book-lets that men like, 15 for \$1 cash no re-fund or c.o.d., sent in plain wrapper, T. W. T. Books, Box 5033, Chicago, Ill.

**LITTLE** books of comic characters, Adult humor illustrated as you like it, 10 for one dollar, Stellar Sales, Box 3353 Mdse. Mart, Chicago 54, Ill.

# POPULAR SCIENCE OPPORTUNITIES

**NATIONAL Geographic Magazines 1888-1949.** any issue. Periodical Service. Box 327-PS. Swarthmore, Pa.

**ADULTS Only "Daring Books."** Free literature. Home Pix, 1674 Broadway. New York 19.

**BACK-date Magazines.** Specific issues; years. Arkell's, Tarzana 2. Calif.

**PHOTOGRAPHS—Books—Unusual Interest lists—dime.** What-Knot Shop, 2331 Market St., San Francisco 14. Calif.

**SANCTILEAN University.** Florence 9. Arizona. "Impending Golden Age." \$2.50. Best seller.

**SELF-Hypnosis.** Amazing new book—guaranteed!! \$2.00. Psyche, 542-BH 5th Ave., N. Y. 19.

**"HOW To Make Money Out of Classified Advertising."** To get this free booklet send a postal card to O. K. Kelly, Classified Advertising Manager, Popular Science Monthly, 351 Fourth Avenue, New York City, 10.

## 35 MAGIC TRICKS, PUZZLES, ETC.

**MAGICIANS' Gamblers' secrets exposed.** Cards, Dice, Punchboards, Slot Machine. Catalog 10c. Book Co., Box 671. St. Louis 1. Mo.

**FREE Dollar Magic Set with Professional Catalog 25c!** "Mysto." 4462-PS Germantown, Philadelphia.

**ITCHING.** Sneezing Powders. Eighteen Other Tricks and Joker's Catalog 25c. 2404N15. Philadelphia.

**WE supply every noted magician.** Large professional catalog 50c. Holden's. P220 West 42nd Street, New York.

**BE a Magician.** Large professional magic catalog of latest tricks. 35c. Ireland, F-109 North Dearborn, Chicago.

**500 TRICKS Catalog and book "84 Card Tricks".** Both only 50c. Robbins Co., 152-P West 42nd St., New York.

**500 TRICKS you can do!** Send 10c for Douglas famous Catalog, best in magic at lowest prices. Unequaled service to magicians for 30 years. Douglas Magicland, Dept. 2. Dallas, Texas.

**200 ELECTRIC stunts.** 110 volts. \$1.00. Cutting Sons, Los Altos 2. Calif.

**LEARN magic.** Ventriloquism, Mind-reading. Write for particulars. Quackenbush, Big Flats, N. Y.

**VENTRILLOQUISM Taught.** 3c stamp brings particulars. Smith, 801 Bigelow, Peoria 5. Ill.

**400-PAGE Catalogue of 2000 Tricks,** pocket, parlor, stage. World's Finest Magic. Send \$1.00 for Catalogue (refunded first \$5.00 order). Kanter's, S-1311 Walnut, Philadelphia 7.

**VANISHING Quarter trick and catalog 25c.** Sterling Magic Co., Royal Oak, Mich.

**AMAZING Ghost Quarter Trick Free If 25c is sent for Big Illustrated Catalog listing 500 Wonderful Magic Tricks.** Rush 25c Now. The Magician, 2463-S Kensington Ave., Phila 25. Pa.

**LARGE 160 Page Magic Catalog 35c for Beginners and Professionals.** Chicago Magic Company, 2300-X No. Mason Avenue, Chicago 39.

**LEARN the tricks of the card and dice shark by reading our expose book and catalog mailed prepaid for 25c.** Vine, Hill & Co., Box 35P, Swanton, O.

**LEARN Ventriloquism.** Free Information. State Age, Maher, Box 36-S89 Kensington Station, Detroit 24. Michigan.

## 37 COIN COLLECTING

**FREE! Foreign coin, banknote and Coin Collectors' Illustrated Catalog to approval service applicants.** Send 3c postage. Tatham Coin Co., Springfield-D50, Mass.

**OLD Money Wanted.** Do you know that Coin Collectors pay up to \$100.00 for certain U. S. Cents? And high premiums for all rare coins? We buy all kinds. Send 4c for Large Coin Folder. May mean much profit to you. Nuismatic Co., Dept. 30, Fort Worth, Texas.

**GET profit and pleasure in collecting old coins.** Send 10c for 56 page illustrated coin catalog. You'll be delighted with it. Send for it now. B. Max Mehl, 374 Mehl Bldg., Ft. Worth, Texas. Largest rare coin establishment in U. S. Established 48 years.

**FREE Appraisal on your coins.** If you wish to Buy coins, send 5c for selling list. Twin City Coin Exchange, Room 301, Nissen Bldg., Winston-Salem, N. C.

**\$10.00 EACH for certain Lincoln pennies; Indianheads \$50.00.** Send dime for catalogue of prices paid. Lincoln Coin Company, Elkhart 4. Indiana.

**LARGE \$1.00 Bill \$1.60. Large \$2.00 Bill \$3.40. 10 Wooden Nickels \$1.00. 100 different Foreign coins \$3.95. 255 Page Guidebook \$1.50; Handbook 75c; Giant Bargain Catalogue 15c.** Bebee Coin Co., 1180 East 63rd, Chicago 37. Illinois.

**U. S. coins lowest prices.** Send stamp for lists. Hutchinson, 3463 I Street, Philadelphia 34. Penna.

**BUYING—Selling—Lists 10c. Catalogs 50c.** Bason, 24 Maple Drive, New Hyde Park, N. Y.

**MAGNIFICENT stock of U. S. coins.** All series. Catalogue listing 2500 coins 15c. \$50,000.00 Stock of gold coins Worldwide selection. Catalogue 15c. James Randall, 116 South Michigan Avenue, Chicago 3. Illinois.

**COMMEMORATIVE \$1½ — Columbus.** Washington, Cleveland, Stone Mountain, \$1.50 ea. Illustrated Catalogue 25c. Norman Schultz, Salt Lake 9. Utah.

**43 MIXED Indian Pennies \$1.00. 33 Different Foreign Coins \$1.00.** Chelsea, 40 West 18. N. Y. C. 11.

## 40 STAMP COLLECTING

**ZOWIE-E-E! A Barrel of Fun for only a Dime!** 500 United States Stamps—Absolutely unpicked and unsorted, just as received from church missions. Many varieties, including large commemoratives, airmails, high denominations up to \$5.00! Stampdom's biggest package of fun, and you might find something really valuable!! Price only 10c to serious approval service applicants. Money back if not delighted. Illustrated bargain lists with each order. Mystic Stamp Co., Dept. 55, Camden, New York.

**FREE! Crystal-Mount Sample.** Harrisco, 204 Transit Bldg., Boston, Mass.

**DEALER'S Wholesale Catalog.** Postage 3c. Franksco, 5031 Queensbury, Baltimore, Maryland.

**NICARAGUA "Tin Pan Alley" Diamond.** Ecuador showing George Washington, and American Flag in natural colors. Fezzan, Trieste. "American Army" stamp First U. S. Commemorative. \$100.00 Shanghai, Corsica, Anzac, Antique, others all 5c approvals. Capital Stamp Co., Dept. 10, Little Rock, Ark.

**128-PAGE United States Catalog.** 1,000 illustrations. 25c. Harris & Co., 204 Transit Bldg., Boston.

**WORLD'S Largest Stamp (7½ x 14 inches).** A real curiosity! Retail for 50c, only 3c to approval applicants. Tatham Stamp Co., Springfield 50, Mass.

**200 DIFFERENT,** including Roosevelt triangle, 5c to approval applicants. S. Avalon Stamp Co., Springfield, Mass.

**POUND stamps containing thousands \$1.00.** Longacre Shop, 100c West 42nd, New York City 18.

**WOW! \$10.00 Worth Of Fun 10c!** What a treasure hunt! Big package 500 Foreign Stamps, including airmails, pictorials and others from the world over; stamps worth up to 25c each. This offer sent for 10c to Approval Applicants Only. Jamestown Stamp Co., Dept. 5, Jamestown, New York.

**FREE! Unusual Illustrated Lists.** Littleton Stampco, Box 66, Littleton, New Hampshire.

**FREE! Illustrated United States Catalog.** Low Prices! Americo, Bristol, Conn.

**UNITED STATES approvals complete coverage fine quality, attractive prices.** Seminole Stamps, Box 1138-S, Coral Gables, Florida.

**FREE—Illustrated Catalog.** Kenmore Stamp Co., Dept. 39, Arlington 74, Mass.

**CASH For Your Duplicates.** Particulars free. Goliath, Bethlehem 8. N. H.

**FREE—Famous Americans Set, Flag Set, National Parks Set, and Presidential Set to \$5.00.** A total of 90 Stamps Free to Customers for our unsurpassed U. S. and foreign selections. Send 3c for 15 of the above Stamps and full particulars. Triboro Stamp Co., 145 Nassau St., Dept. 208, N. Y.

**COLD-Blooded M-u-r-d-e-r!** 200 British Empire Stamps; Contains new colonies of Norfolk and Tokelaw Islands; Grahamsland (Britain's only colony at the South Pole); Pakistan; Nepal; big stamp commemorating murdered Mahatma Gandhi; many other fascinating varieties, including stamps cataloging up to 20c each! Amazingly Low Price (with approvals) Only 10c. Kenmore Stamp Co., Section 16, Arlington 74, Mass.

**POSITIVELY Greatest Free Offer!** Latest Scott's International \$6.00 stamp album—covering entire world, contains 36,000 illustrated descriptive spaces; Scott's 1949 Standard \$7.00 catalogues "Philately's Encyclopedia"—absolutely Free to applicants for foreign approvals becoming customers. Approval Service, P. O. Box 1700, San Francisco.

**YOU Need These! All six for 10c!** To introduce our Exceptional Approval Service, we'll send you: 1. Pocket Stock Book. 2. Watermark Detector. 3. Stamp Tongs. 4. Perforation Gauge. 5. Book for Duplicates. 6. Package of Stamp Hinges. All only 10c to approval applicants! Free! Big list other bargains. Jamestown Stamp Co., Dept. D, Jamestown, New York.

**FREE! Asia, Africa, Europe Packet.** Approvals. Desk B, Standard Stamp Co., Barneveld, N. Y.

**UNITED States Commemorative Collection.** Thirty-three different unused. Columbians to 1943 issues only. Price \$1. Request approvals. "Stamps," Albany 5, New York.

**FREE—Canadian Sets Royal Visit, George VI, George V, Coronation, Jubilee, others,** to approval applicants. Ensign, Box 118-P, So. Orange, N. J.

**FREE! Porto Rico Airmail Triangle (World's Only American Colonial Triangle!) Cook Islands, Syria, Ivory Coast, Damascus, Elephant Land, Cambodia, Harem, Philippine "Slave," others.** All Free for 3c postage. Approvals, Belmont Stampco, Washington 10, D. C.

**FREE. Military Govt. Set.** Approvals. Raymax, 123-X William St., N. Y. C. 7.

**FREE—Bulgaria, Congo, Algeria, Sudan.** Foreign Approvals, Colonial, Box 326B, Passaic, N. J.

**1862 PRINCE Edward Islands—Just 3c with approvals.** Viking, 130-P Clinton St., Brooklyn, New York.

**UNITED States stamps nearly 100 years old.** Roosevelt set, others, 40c value—only 5c to applicants United States approvals. Wakonda, 140F Nassau, New York 7.

**\$1—\$2—\$5 UNITED States, commemoratives, airmail, high values in large collection United States stamps only 5c to applicants United States approvals.** Metropolitan, 140A Nassau, New York 7.

**FINE Approvals.** Fast, personal service. What countries do you prefer? I'll send their stamps. Milton Skinner, 438 Locust, Long Beach 12, Calif.

**FREE! United States Mint Block.** Russia Airmails Packet, Approvals, Greenwood, 263 Meridian, Miami Beach, Florida.

**FREE! Powerful magnifying Glass—to approval buyers; also big bargain lists.** Jamestown Stamp Co., Dept. 202, Jamestown, New York.

**OLD, scarce U. S. seconds on approval.** Slightly defective, bargain prices. Hearnfeld, Clintonhill Station, Newark 8. N. J.

**25 DIFFERENT stamps 10c.** F. Tunis, Wakeman Ave., Newark 4, N. J.

**WORLDWIDE Different: 200—25c; 500—50c; 1000—\$1.25; 2000—\$3.00; 5000—\$15.00.** Beacon Sales, Maynard 3, Mass.

**U. S. PRICE List.** Send Postage, State Stamp Studio, 1225 Park Building, Pittsburgh 22, Pa.



# POPULAR SCIENCE OPPORTUNITIES

FREE "Stamp Finder." Tells instantly country to which any stamp belongs. 32 pages profusely illustrated. Approvals. Garcelon, Calais 18, Maine.

EXOTIC Pictorial Collection:—Sakalava Chieftain, Fezzan Ghadames, Djibouti, Togoland, Reunion, Andorra, Algeria, Miquelon, Tunisia, Monaco, Guadeloupe, Martinique. Many others. Everything 5c. Imperial Stampco, Tampa, Florida.

50 DIFFERENT U. S. 10c. No approvals. Price list free. Seidenberg, Cassopolis, Michigan.

50,000 STAMP Grabbags 25c each. Anderson, 630 Bingaman, Reading 2, Pa.

307 ALL Different 10c. Commemoratives, Triangles, Bicolored beauties. High Values! Strange Countries! New varieties galore. Only 10c with approvals. Garcelon, Box 418, Calais, Maine.

FREE! 25 Diff. Stamps from 25 Diff. Countries. Approvals included. Ciula, P. O. Box 2511, Paterson, New Jersey.

LIBERIAN Triangulars, 10c with approvals. Vargo Stamps, 6044 South Fairfield, Chicago 29, Ill.

U. S. 797 SPA Sheet only 5c to applicants for U. S. approvals. M. Haycock, 333-86th St., Brooklyn, N. Y.

AIRMAILS—worldwide variety. Bargain. With approvals 5c. Arthur Wirth, Norwichtown 2, Conn.

FLAG Stamp Free with U. S. Approvals. E. Wenigman, 1933 Patterson, Chicago.

WORTHWHILE New Zealand Semipostals (1943 Princesses Triangulars) only 10c with approvals. George Richie, 840 Oak, Alameda, California.

10 U. S. Over 40 years Old 5c Approvals. Scott, Middle St., Lexington, Mass., 73.

75 STAMPS from 75 countries 10c to approval applicants only. Bjorn Nielsen, Monmouth 1, Maine.

PENNY Approvals by Country. M. H. Hoerning, 102 Farmington, Arkansas.

25 EGYPT 5c plus big price list (packets). Chase, 1026 Walker Avenue, Oakland 10, Calif.

GENUINE "Goya Nude" set 15c (Catalogs 55c). Approvals. Royal Stamp Company, Tamaqua 2, Pa.

NEWFOUNDLAND, most popular country now a province of Canada. Many Newfoundland stamps becoming scarce. 25 different, 50c; 50 different, \$1.50. Russell, 224 West 17th St., New York City.

ALL-Aboard! The Philatelic Special, 12 Train Stamps and packet of 100 different stamps for 10c with approvals. Reich Stamp Co., 4647 Kenmore, Dept. S19, Chicago 40, Ill.

1c EACH and Less! Thousands of Bargains! Cole, 43-G Rinewalt, Buffalo 21, N. Y.

750 FRANCE and Colonies Stamps only 10c with Approvals. Littleton Stamp Co., Littleton 26, N. H.

FREE 500 hinges and 15 different Canada with approvals. Jaydee, 218 W. Dickenson, Grand Rapids 7, Michigan.

TOPS! Our booklet "How to Collect Stamps." Send for your free copy today! Littleton Stampco, Littleton 29, N. H.

UNPICKED: 5000 U. S. \$2.00; 5000 Foreign \$3.00. Kuhn, 81-10 Broadway, Elmhurst, N. Y.

FREE! 25 different U. S. Approvals accompany. Village Stamps, 90-39A 214 St., Queens Village 8, New York.

## 42 HOBBIES, COLLECTIONS

INVENTING can be an interesting and profitable hobby. Write for complete particulars. Institute of American Inventors, Dept. 30-E, 2926-Eye St., N. W., Washington 6, D. C.

UNUSED matchbook covers—100 different \$1.00—Catalog 10c—Charles Edelman, 1311P East 84, Cleveland 3, Ohio.

10 ANCIENT Indian Arrowheads \$1.00. Tomahawk \$1.00. List Free. Lear's, Kirby, Arkansas.

UNPAINTED plaster ornaments. Loxite for moulds. Free literature. Midwest Novelty Manufacturers, Box 788-B, Anaconda, Montana.

## 44 ANTIQUES, RELICS, INDIAN GOODS

AM selling my huge collection of Authentic Indian relics. M. F. Selleck, Box 1342, Denver, Colo.

## 46 MINERALS & PRECIOUS STONES

SCINTILLATING Australian Opals 5 Dollars, specimens 50 Cents. Woodrow Oldfield, 22 Russell Street, Drummoyne, Sydney, Australia.

ZIRCONS, diamond-like white, blue, or golden, carat size plus 2 crystal clear sparkling zircon side stones \$3.85. Others Catalog 10c. Imhusex, Box 232, White Plains, New York.

GEMSTONES, Mineral specimens. Every variety. Lowest prices. Postcard brings free list. Plummer's, 2177D Bacon, San Diego 7, Calif.

GEMS, precious and semi-precious, all genuine from world wide sources. Deal direct, no overhead, save money. Catalog 10c. Hill Co., Route 7-K, Salem, Oregon.

## 47 CAMERAS, PHOTO SUPPLIES

BARBEAU Buys, Sells, Exchanges Cameras, Enlargers, Projectors—Leica with 3.5 Elmar and case \$90.00. Barbeau's, Oswego, New York.

BASS Says: Bargaingram 257 ready and waiting for you. The book which tells all . . . the finest in new and used camera equipment, a veritable encyclopedia. Write, phone or call the sign of the old "Horse Trader". 39th year of satisfaction or your money back dealing. Bass buys, sells and trades. Bass Camera Company, Dept. AG, 179 W. Madison St., Chicago 2.

PHOTOGRAPHY for pleasure or profit. Learn at home. Practical basic training. Long established school. Write for free booklet. American School of Photography, 1315 Michigan, Dept. 174C, Chicago 5.

AMATEUR Photographers—send for free copy of new, outstanding photographic publication. Photomarketeer, 542 5th Ave., New York 19, N. Y.

USED 2 1/4 x 3 1/4 Speed Graphic with Coated Ektar Lens, Supermatic shutter, King Sol Flash, Kalart Rangefinder Three holders case, \$190.00. Barbeau's, Oswego, New York.

BUILD Contact Printer described July issue Popular Science Page 202. Write for Parts Price List. Dick Rose, Everett, Washington.

## 48 PHOTO FINISHING

THREE prints each 8 exposure roll 40c. Two each 35c. One each 25c. Reprints 3c. L. A. Eastman, Bode, Iowa.

8 PRINTS all enlarged to nearly postcard size from your roll or negative 25c; 16-50c. (Trial offer) Willard Studios, Box 3535G, Cleveland, Ohio.

16 ENLARGED, Jumbo, oversize deckled prints from any 6-8-12-16-20 or 36 exposure roll film developed only 35c and this ad. Electronically exposed. Enlargement coupon free. Skrudland, 6444-W Diversey, Chicago.

WALLET photos and cards sealed in plastic are moistureproof and soilproof. Three for \$1. Mankato Plastic Seal, Mankato, Minnesota.

OIL coloring photographs can be a fascinating hobby or profitable sideline for those with artistic talent. Learn at home. Easy simplified method. Send for free booklet. National Photo Coloring School, 1315 Michigan, Dept. 1726, Chicago 5, Ill.

8 BEAUTIFUL Double Size pictures and roll developed 30c. 8 hour service. Free Mailers. Pacific Photo Service, Box 666, San Francisco, Calif.

35MM ROLLS Developed—Enlarged 3 1/2x5 Prints, 36 exposures \$1.25. 20 exposures 75c. 8 exposure rolls developed, printed oversize 30c. 12 exposures 45c. 16 exposures 55c. MacDonald's Photos, Box 228-C, Congress Park, Illinois.

NO Negative? Send picture and \$1.00 for new negative and two enlargements. Negative and enlargements from each additional picture, 50c. Individual attention. No mass production. Atlantic Photocraft, P. O. Box 27, Boston 26, Mass.

SENSATIONAL! 8" x 10" enlargement, beautifully oil-colored 50c. Surgals, 3300 Beach, Chicago.

GREAT News! Price reduction on our famous Century Jumbo Oversize finishing. Our new Chicago plant makes these reductions possible, and new improved equipment, exclusive with Century, produces sensationally magnificent quality work. Any 8-exposure roll finished deluxe style only 30c. 12 exp. 45c. 16 exp. 55c. 36 exp. \$1.25. All oversize reprints 4c each. Free Mailers. Send us your next order, you will be delighted with results. Century Photo Service, Box 5208, Chicago 80, Illinois.

ROLL developed, 8 prints and two enlargements 25c. Trial offer. Young Photo Service, 406-C, Albany 2, New York.

2 BEAUTIFUL Hi-Gloss prints each good negative and enlarging coupon with each 6 or 8 exposure roll developed 28c. Owlphoto Co., Weatherford, Oklahoma.

FILMS Developed. Quality work. Enlarged Fanfold prints, 35c 8 exposures, 45c 12 exposures. Pittsburgh Photo Lab., Box 9665, Pittsburgh 26, Pa.

## 50 PHOTOPRINTS, PHOTOCOPIES

HOLLYWOOD Model Directory. "Photophone 400 pin-ups." Artists-Photogs' Casting Guide. (sample copy—\$1 and this Adv.) 1117 1/2 W. Olympic, Los Angeles (15), California. VA-8793.

PHOTOCOPY anything yourself. Papers, books. No darkroom. 8 1/2 x 11" complete, \$6.95. Fotoflek, 4801 Yarmouth Place, Cincinnati 29, Ohio.

## 51 MOTION PICTURES, SOUND EQUIPMENT

GUARANTEED fresh anti-halo outdoor movie film! Weston 12! Daylight loading! Processing free! Three spools double 8mm, \$3.45! Six single 8mm for Univex, \$4.60! Postpaid! Catalog. Filmcraft, 47th Holly, Kansas City 2, Missouri.

BASS Says: 39 years of leadership guarantees satisfaction. Finest Cine equipment, 8mm., 16mm., and 35mm., silent and sound. Write the old "Horse Trader". Satisfaction or your money back always! Bass Camera Company, Dept. A., 179 W. Madison St., Chicago 2.

85 KODACHROME movies! War, Atom Bomb, Travel, Air, National Parks, Beautiful Models. Catalog, 3c stamp, 2 scene "Waikiki" sample, \$1.00. Specify 8mm, or 16mm. World In Color Productions, Elmira, N. Y.

BETTER 8mm and 16mm Movie Camera Film. Lower prices. Better Films, 742 New Lots, Brooklyn 7, N. Y.

397 FREE Rental Film Sources. Latest Compilation \$1.00. Waverlynn Company, Dept. 2, 436 W. 42nd St., N. Y. 18, N. Y.

UNUSUAL Film Subjects, 8-16mm Kodachrome projection length sample "Allure", \$1.00 (Refunded). Art slides, sample 50c, five for \$2.00. "Strip Polka" 16mm sound, \$6.50. Exchanges! Bargains! Big catalog with sample film, 25c; refunded first order. Write today. National Film Supply, Broadway Sta. (E), Toledo 9, Ohio.

35MM ANSCO Color Reloads—fresh stock guaranteed! 20 exposures \$2.50 includes color processing, unmounted, 3 for \$5.50. Indoor, outdoor—specify type. Photo Surplus Sales, Box E, 12 Duane St., New York City.

8-16MM. Silent-sound films. Complete rental library. All latest subjects. Free catalogue. (sample film 10c). Garden Film, 317 West 50th, New York 19.

ORIGINAL Party Films and Records. Adult Entertainment. Details, interesting offers dime. Alberts, Dept. P, 6369 De Longpre Ave., Hollywood 28, Calif.

SEND 10c for 1949 photographic catalogue. Bargain list included. Sterling's, 679 Northampton, Easton, Pa.

LEARN movie projection, management. Free Catalog. Theatre School, Elmira, N. Y.

FREE Processed Film Weston 10 100 ft. 16mm \$3.25. 25 ft. double 8mm \$1.50 without processing. 100 ft. double 8mm \$2.35. 16mm \$2.25. Free Circulars. Fromaders, Davenport 5, Iowa.

# POPULAR SCIENCE OPPORTUNITIES

**\$4.00 RENTS** 16mm sound 1½ hr. programs. Free lists. Valuable premiums with film rental contracts. Community Movie Circuit, 1285 Bailey, Buffalo 6, New York.

**WANTED.** We'll pay hard cash for silent or sound 8mm or 16mm, new or used movie film. Write and tell us what films you have, and how much you want for them. Camera Shop, 760 Broad St., Providence, R. I.

**FREE** movies. Thousands of subjects. Interesting. Entertaining. Fascinating. New directory—only 50c. International Cine Society, Dept. 102-D, 1300 Taylor, N.W., Washington 11, D. C.

**"LADY Eve"** Glamour Movies. Equipment. Free catalog. Home Pix, 1674 Broadway, New York 19.

**ART** model films 16mm rentals exclusively, adults list. Enclose stamp. Revere Films, Box 1051, Detroit 31, Mich.

**DYNACOLOR**—New 8MM—at last you can afford color film. Send \$3.00 cash, check or MO or inquire today. Guaranteed. Dynacolor, Dept. S2, Rochester 3, New York.

**EXCITING** Films, 8 or 16mm. Send 25c for sample strip and giant list. Art-Photo, Dept. S, 628 Nostrand Ave., Brooklyn, N. Y.

**COLOR** Film 50' 8MM \$3.95, F-a-s-t Panchromatic \$1.65. MK Photo, 451 Continental, Detroit 14, Mich.

## 52 MUSIC, MUSICAL INSTRUMENTS

**SWISS** Musical Units \$2.75. Music Boxes, 131 West 42nd, New York 18.

**FRASER** Violins lead all! Folder. Fraser, 2025 Stark, Saginaw, Michigan.

**GUARANTEED** Band Instruments. Accordions, Guitars, Pianos, Drums, Equipment. Lower Prices by Mail. Send 10c for catalog. Harden's Music, Marion P, Ohio.

**HAWAIIAN** Guitar System \$1.00. Morgan, 222½ West Third, Tulsa, Oklahoma.

**SWISS** Music Box Movements suitable for novelties. 400 Tune Selection, \$1.00 to \$3.50. Send for Catalog. Bell Music Box Company, Box 49, Planetarium Station, New York 24, New York.

**SWISS** Music Movements Assorted Tunes \$1.90 Direct From Manufacturers Agent. Helax Company, 233 West 72 Street, New York.

## 53 SONG WRITERS

**POEMS** Wanted to be set to music. Free examination. Send poems. McNeil, Master of Music, 510-PS, S. Alexandria, Los Angeles, California.

**SONGWRITERS.** Songs Published Monthly. Advance Royalty. Send your songs or poems today for our exciting offer. Hollywood Tunesmiths, Dept. 10F-C, 1537 N. Vine, Hollywood 28, Calif.

**POEMS** Wanted For Musical Setting. Send poem for free examination. Five Star Music Masters, 646 Beacon Bldg., Boston.

**YOUR** poems set to music, recorded. Free booklet, attractive offer. Write, Songland, 331 West 46th, New York.

**POEMS** Wanted. Splendid offer! Rush! Radio Composers, WPSJ, Clinton, N. C.

**SONGWRITERS!** Outstanding, ethical offer. Hibbeler, C15, 2157 N. Avers, Chicago 47.

**RECORDS** outsell sheet music 5 to 1. Juke Box demand increasing writers opportunities. Music furnished usable poems on percentage. Recola Records, Hollywood 28, Calif.

**POEMS** Wanted. Percentage basis collaboration. Terry Tune Master, 709½ PS North Broadway, Oklahoma City 2.

## 54 RADIOS, SUPPLIES & EQUIPMENT

**FIX** any radio. Amazing new instrument locates radio troubles double quick. Simple instructions show you how. Thousands now in use. Free—Write today for 28-page illustrated technical manual. "The Inside Story". Feller Engineering Co., Dept. 8PS9, 945 George Street, Chicago, Ill.

**BEGINNERS.** Valuable experimental data free. Catalog. Laboratories, 578-T, San Carlos, Calif.

**FREE**—Money Saving Bargain Bulletins in radio and television sets, record changers, tubes, parts, amplifiers, speakers, etc. Write today. Radionic Equip't Co., Dept. 1508, 170 Nassau St., New York 7, N. Y.

**HEADPHONES.** Guaranteed U. S. Signal Corps used headsets with adjustable leather headbands and Black Bakelite Earphones. Special now \$1.99. Allen Radio, Dept. HPS, Clinton, Missouri.

**PHOTOFLASH** unit. Outlasts 10,000 flashbulbs. \$49.50. Very limited quantity. Precise Measurements, 942 Kings Highway, Brooklyn 23, New York.

**BARGAIN** Kits! Build electric eye, voltmeter, oscillator, \$2.95 complete. Snooper-scope supplies. Infra red filters 15c. Precise. 942 Kings Highway, Brooklyn 23, New York.

**NOT** selling radio courses! But if planning to study radio, don't fail to write for free information. Valley Radio Service, Pharr, Texas.

**BUILD** AC Operated B Supply for your Portable Radio Described July issue Popular Science Page 194. Write for Parts Price List. Dick Rose, Everett, Washington.

**MAKE** Simple, Tubeless, Batteryless, Distance-Getting Crystal Radios. Crystal and illustrated instructions 25c postpaid. Allen, 427-S, Clinton, Mo.

## 55 TELEVISION

**ENHANCE** TV and FM Reception, triple antenna life. Maintain peak performance with "Tele-Cote" a liquid application of stainless steel applied to antenna dipoles and reflectors. 16 oz. can \$2.25, to "Tele-Cote," 385 East 18th Street, Brooklyn 26, New York.

## 56 BUSINESS OPPORTUNITIES

**\$25 WEEKLY** working two hours daily. No canvassing. No Manufacturing. Lycke, Box 2471, Cleveland 12, Ohio.

**ENVELOPES** addressed accurately, reasonably. Fast Service. We have capable addressers in your city. Glenway System, 5713-Z Euclid, Cleveland 3, Ohio.

**137 PLANS** to make money local, mail order. Particulars free. Elite Co., 220-A Grand St., N. Y.

**GOOD** Paying Business Silvering mirrors, plating autoparts, reflectors, bicycles, bathroom fixtures, etc., by late methods. No tanks or shop required, outfit furnished. Free Booklet. Gunmetal Co., Ave. E, Decatur, Illinois.

**A FACTORY** in your home garage! Mfg. and sales rights, mechanics' waterless hand cleaner, \$500-\$800 monthly. No special equipment necessary. Formula free. Western Aircraft Mfg., Dept. G, Los Angeles 6, Calif.

**OPERATE** profitable mail order business. Write Walter Service, 4159-B East 112th, Cleveland 5, Ohio.

**PLASTIC** Tablecloth Covers, Curtains, Drapes, Baby Pants, Bowl Cover and other Plastic Articles selling like wildfire! Make big money now! Free Details. Write L & M Co., Dept. 59-N, 510 St. Charles, St. Louis, Missouri.

**TRAVEL** Anywhere: Anytime. Earn \$85.00 week up. No experience necessary. Literature free. Travel, LaGrange 2, Ind.

**MAKE** money addressing envelopes. Our instructions reveal how. Glen Glenway, 5713 Euclid, Cleveland 3, Ohio.

**VENDING** machines earn big money! An investment as low as \$10.50 will start you in this fascinating, profitable business that can lead you to the road of success and independence. Routes can be established and operated in either full or spare time with no experience needed. Write for full details and our Free catalog illustrating our nut, candy, gum and stamp vendors; also pin ball machines, music boxes, etc. Write immediately to Parkway Machine Corporation, Dept. 9, 623 W. North Avenue, Baltimore 17, Maryland.

**POPCORN** Machines, Potato Chip outfits. Long Eakins Co., 4963 Hi St., Springfield, Ohio.

**I MAKE** big money in the mail-order business. You can do the same at home with copyrighted system. Write me. I'll tell you how. F. Little, RD # 1, Glenshaw, Pa.

**RECAST** old batteries into new. Latest achievements. Battery Laboratories, Minneapolis.

**MAIL** Order Offers Increases Income, Independence, Unlimited Possibilities; free literature. Manhattan House, 126 Lexington, New York 16.

**START** Mailorder Bookshop—Everything furnished. 25c brings booklet, samples, exciting ideas. General Publications, Ossining 1, New York.

**PEANUT** roasters; popcorn machines, vendors, copper kettles, heating equipment. Northside Co., Indianola, Iowa.

**CASH** For your idea. 280 manufacturers need inventions, patented or unpatented. List free. Invention Bureau, 208-S Clinton, Oak Park, Illinois.

**EARN** \$50.00 or more weekly operating vending machine route in your spare time. As small an investment as \$13.95 will get you started. Details free. Danco Coin Machine Co., Dept. PS., 1302 E. Baltimore St., Baltimore 31, Md.

**"ELECTROPLATING-Know-How"** includes baby shoe metallizing and other lucrative fields for you. Write for my free illustrated booklet! Joseph B. Kushner, Electroplating Consultant, Stroudsburg, 33, Pa.

**"SPECIALTY** Manufacturing". Big money business. Start on small capital with dependable formulas. Send for Free interesting booklet. Howard Robinson, Ph. G., 1300-B South Ohio Street, Sedalia, Mo.

**UNPAINTED** figurines—Wholesale—Retail. Illustrated list free! Oman, 642M Broadway, St. Paul 1, Minnesota.

**METALLIZE** Baby Shoes. Excellent profits. New system assures success. Free details. Treasures Forever, 89 Henry Ave., Lynn, Mass.

**BIG** Money—Spare or full time. Hand painting fabrics, ties, blouses, leathers, etc. is big business. New easy method. Help us fill demand. Free samples and complete plan. Hollywood Artlabs, 333-A E. 2nd, Los Angeles 12.

**START** a Christmas Card imprinting business. Write Dunbar, Middlebush, N. J.

**FOR** an extremely profitable lifetime business, operate a Collection Agency—Credit Bureau. Easily learned. Free folder. Cole & Associates, Syracuse 2, New York.

**BRONZECRAFT** Baby Shoe Mountings. Beautiful Designs, Ashtrays, Bookends, Picture Frames. Special Price \$12.00 Dozen Sets. Sample \$1.00 Prepaid. Bronzecraft, 774 Newark Ave., Jersey City, New Jersey.

**DEPRESSION** Insurance. Own money-making business. Information Free. Pru-Bx, Kingsport, Tennessee.

**"METALLIZING** Techniques"—Manual for plating baby shoes, etc. \$1 per copy. Plastics Research, Box 346, Alhambra, Calif.

**HOW** To Set Up and Run a Mirror Shop! Resilver Mirrors. Make chipped glass nameplates. Electroplating Salts and Rectifiers. John Sprinkle, V 90, Marion, Indiana.

**MAKE** money making new greaseless doughnuts at home on electric machine. Wholesale to grocers, drug stores, cafes, hamburger shops. Send for free recipes and plans. Ray Do-Nut Company, 3605 South 15 Ave., Minneapolis 7, Minnesota.

**MAKE** Rubber Stamps, Feather Pictures. Metallize Baby Shoes. Repair Dolls. Make plaster Novelties. Catalogue of "30 Ideas" Free. Universal, Box 1076-B, Peoria, Ill.

**GET** Into the Paint Business! Help fill increasing demand for top quality guaranteed house paints, roof coatings, interior finishes, specialties. Sell direct from long-established manufacturer, full or part time, permanent; advance commissions, no investment. Particulars free, or send 50c for Sales Kit and start next week. Standard Industrial Products, Inc., Dept. PS-8, Evansville 4, Indiana.

**MAKE** strange plastic—1c pound. Makes attractive floors, walls, build-ins, roofs. Build charming house \$150.00 room. Bays Laboratory, Oklahoma City 9.

**NATURAL** molding latex. Extra thick. Free Sample. W. Wooley, 115-B Donald, Peoria, Illinois.

# POPULAR SCIENCE OPPORTUNITIES

**MAKE** Money spare or full time, casting Metal Toys and Novelties. Big wholesale and chain store demand for cast Metal Autos, Soldiers, Ashtrays, Banks, etc. keeps manufacturers busy. Production moulds furnished for up to 100 and more castings per hour. No experience or special place necessary. "Cash-in" on holiday orders now being placed. Write for full information and illustrations of patterns needed. Mast Cast Products Co., Dept. E. 1696 Boston Road, New York 60, N. Y.

**400% PROFIT Making—Distributing Postwar Hand Cleaner.** (Not Ammonia—Kerosene!) Free literature. Rythmo-H-Ex. Kingsport, Tennessee.

**TRADE** Magazines help you get ahead. Latest single copies. Over 1000 covering every trade, business and interest. List with prices. Free. Commercial Engraving Publishing Co., 348 North Ritter, Indianapolis 19, Indiana.

**"EVERYBODY Likes Candy"**—Learn to make professionally. (Our 39th year.) Ragsdale Candies, D7, East Orange, New Jersey.

**LIQUID Rubber,** make flexible molds. Free Sample. Chaney, 1130 E. 16th St., Jacksonville 6, Fla.

**YOUR** own profitable home business. Preserve live flowers to last forever. Spare or full time. New discovery—simple—fascinating. No experience necessary. Send \$2.00 for working equipment, instructions and valuable sales plans. Satisfaction guaranteed or money refunded. Hermanesen, 210 Fifth Ave., Suite 1102, New York 10, N. Y.

**PLANNING** a small mail order business? Booklet shows How. 36 pages full of opportunities. Copy only 10c. Special. Clarence Woodfall, Publ., Route 3, Charleston, Illinois.

**ELECTROPLATE** on non-metals. Instructions \$1.00. Four ampere plater \$19.95. Eight ampere \$29.95. 30 ampere \$85.00. Kissel Electric Products, 431 Sherman, Galion, Ohio.

**MAKE—Perfume—Profitable mail order business.** Information free. "International," 6347 Parnell-PS-8, Chicago, Ill.

**QUICK** Fortunes from this Fabulous New Oil Boom Colorado-Wyoming-New Mexico-Idaho. Shoot \$100 or so for 40 acre lease with possibilities to \$20,000 or more. I'll watch everything for you. Money Back 30 days if not pleased. Free particulars quick. Dyer-PS, 1835 Champa, Denver, Colorado.

**FOR Penny-Ball Gum Venders Factory To You** Write Coastal Photo-Supply Co., Export-Division, Wallace, N. C.

**"LIFETIME Repeat Orders!"** Sell our Business Cards by mail, your territory. Small "Starter" Plan. Lynn Products, 5710-12 Bankfield, Culver City, California.

**UNPAINTED** Plaques, novelties, figurines. Instructions dime. Perry Novelty Company, Perry, N. Y.

**BABY** shoe business For Sale with or without manufacturing equipment, bookends, ash trays, photopanel, 400 satisfied retail distributors with samples, 25000 Advertising Folders. A going business that will stand closest investigation. Priced for quick cash sale—Provo Statuized Shoes, Escanaba, Michigan.

**ASSEMBLE** Swiss Musical Churches. Complete Kit \$3.50. Sells on sight. Piltzcker Swiss Imports, Wood-Ridge, New Jersey.

**WOULD** you pay 3%—first \$350 made? Illustrated book "505 Odd, Successful Enterprises" free! Work home. Expect something odd! Pacific, Oceanside, Calif.

**100 BUSINESS** Ideas—Formulas—Also 209 Plans for Heavy Duty Machines for Shop-Home-Farm, Flasco Sales, 2505PC 150 St., Flushing, New York.

**COIN** machine that dispenses America's most popular and fastest moving candy bar. Terrific profit returns on investment as low as \$37.50. Unlimited opportunities. Saratoga-National Enterprises, 101, 2317 Fruitvale Avenue, Oakland 1, California.

**FREE** Folio, Wholesale Supply Sources, Business deals, Plans, Ideas, Formulas. Kolamite Co., Box 572 C, Dayton, Ohio.

**HOW** and where to obtain Capital? Free details. Star Service, Wapakoneta, Ohio.

**BABY** Shoe metallizing. Everything you need to know. Schoettle, Friendship 4, Ohio.

**FIGURINES** and all Supplies for Dresden painting. Gift ornaments. Unpainted, many to choose from. Start a profitable business—hobby. Send 25c for Catalog. Will refund on first order. Suiter Art Industries, 314 Westport, Kansas City, Mo.

**REAL** money making opportunity making Interlocking Concrete building blocks. Rex Products Co., Dept. 21, Piqua, Ohio.

**NEW** Industrial Hand Cleaner. Free manufacturing-distributing plans. Unusual money-making proposition. "Acro-Sol-Ex," 623-D West 14th Ave., Denver 4, Colorado.

**SAWDUST.** Turn it into cash. Six methods. Instructions 25c. Charles, 12-FG, Norwood, Ohio.

**COLORGLAZED** Concrete Pottery made without molds. Patented method. Cemetery products, novelties, tiles. Basement leak-sealing. Money-making projects. Booklet, details free. Men only. National Potteries, Grand Rapids, Minnesota.

**MAILING** postcards selling repeat merchandise is profitable. Everything supplied. Details free. Gordon Publishers, Box 23, Pawtucket, R. I.

**GLASY-Cast.** The Liquid Plastic that works the quick and easy way. Cold-Set. 15 to 30 minutes for finished product. Free Samples and Instructions. Make embedments, novelties, plastic frames, machine parts, etc. for real profits. Two lbs. for \$2.95. Elasto-Mold: Flexible production molds made in 20 minutes. Also finest quality Rubber Latex. Wholesale Prices. Plastic Service, 294 Washington Street, Dept. K-2, Boston 8, Mass.

**SPARE** minutes bring dollars selling this new burn ointment. Free details. Clover Products, 11860 Mississippi, Los Angeles 25.

**BRONZING** shows profits. Literature concerning equipment and process free. Luther Jones, Box 7283, Ft. Worth, Texas.

**BIG** Money Regraining-Refinishing Automobile Dashboards-Garnish Mouldings for Automobile Owners, Dealers, Body Shops. Profitable-Fascinating-Undeveloped Field. Full details. Write Outman, 4323 So. 38th, St. Louis 16.

**LEARN** Piano Tuning, repairing at home. Tremendous field! Piano parts, tools furnished. Established 1935. Empire School of Piano Tuning, 606-A East University Ave., Champaign, Illinois.

**EARN** At home, casting novelties. Free course using latex molds. Major Chemical Co., 164 Portland St., Cambridge, Mass.

**MAKE** Big Money in Home Mail Business! Few dollars starts you—interesting, profitable! Write: Smith, Box 2592-B, Hines, Illinois.

**\$46 FROM** Square Foot Plywood; Jigsaw necessary. Write: Woodart, Bridgewater, Massachusetts.

**BIG** money. Spare or full time in your home. No Selling! Spray New Miracle Finishes, Plush and Suede, on signs, radios, automobiles, figurines, lamps, toys, etc. Our business is booming. Help us fill huge demand. New easy Flok-Kraft methods. Material costs few pennies. You get dollars. Free samples, complete powerful money making plan free. Write now! Coast, 1008 S. Los Angeles St., Los Angeles 15.

**WOULD** You Like to earn \$2 to \$5 an hour reupholstering friend's or your car. Post card for details. First Upholstery Service, 727A West Congress St., Brookhaven, Mississippi.

**HOME** Business! "Learn How To Fix Cracked Batteries!" Money-maker! Instructions \$1.00. Batteryman, Grand Junction, Colorado.

**FREE** Book "372 Unusual Worldwide Businesses." Australia, South America. \$800.00 month reported (exceptional). Work delightful enterprises home. Prepare for surprise! Publishers—C8, Carlsbad, Calif.

**HIGH** readership—over four million; Low cost—only 80c a word. That's what you get when you place your classified ad in Popular Science Monthly. You also get profitable results. Write for order form to O. K. Kelly, Classified Advertising Manager, 351 Fourth Ave., N. Y. C. 10.

## 57 MONEY MAKING OPPORTUNITIES

**NO** selling, operate coin machines, amazing profits, details Free. Parkway Corporation, Dept. 18, 623 W. North Avenue, Baltimore 17, Maryland.

**PROFIT** with Larson Leathercraft. Belts, purses, 100 other ideas. Largest supply in U. S. Catalog 10c. Larson, Dept. C, 826 S. Tripp, Chicago 24.

**LEARN** Sewing Machine Repairing at home. Install our wholesale motor kits. Make \$125 to \$300 a week. Free particulars. Taylor Service Co., Hamilton PS, Ohio.

**DETECTIVES** Earn Big Money. Experience unnecessary. Particulars free. Waggoner, P-125, West 86th, N. Y., N. Y.

**SHELLCRAFT!** Make beautiful sea shell jewelry. Income or Hobby. Pace's, Box 279SP, Bradenton, Florida.

**200 SELECTED** Money Making plans 50c. Special offer. New York Publishing Co., 86-44 121 St., Richmond Hill 18, New York.

**DOLLARFUL** Ideas for you Every Month in Advance—Voice Of Mail Order. Details Free. Advance Publishing Company, 313 East 21st Street, Suite 800, New York 10.

**OPPORTUNITY** Copy Fair Monthly. 25c. Distributors wanted. Brewster, Eastport, Maine.

**WOULD** You pay 3%—first \$350 made? Illustrated book "505 Odd, Successful Enterprises" free. Expect something odd! Pacific, Oceanside, Calif.

**173 WAYS** to Make Money at Home"—Big book yours as gift! Tells how to play for pay. Given with special trial subscription to Profitable Hobbies—read by 100,000 ambitious folks. Four big monthly issues only \$1.00. Money back guarantee. Write Profitable Hobbies, 4041 Hobbies Building, Kansas City 16, Missouri.

**MAKE** extra money at home in spare time. Raise Golden Hamsters. Small investment. Literature free. Golden Gate Hamstery, 631-G Richmond St., El Cerrito, Calif.

**INTERESTING** money makers 25c. Satisfaction guaranteed. Dawson, 1308F, The Dalles, Oregon.

**GLAZED** Donuts! \$500 Monthly Positively Easy. Comprehensive Instructions. Goldenrich Course Complete. \$15.00. Goldenrich Bakeries, Hastings, Nebraska.

**NO** work. No cost. Fabulous money paid for Dwarf trees, grown in your room. Details for stamp. American, 385 La Tijera Station, Los Angeles 43, California.

**\$100 WEEKLY.** Own boss. Sell mothers. Leads spare or full time. Details \$1.00. Hamlin, 6215 1/4 Heliotrope, Bell, California.

**OPPORTUNITY** for your classified ad to be seen by over four million readers in Popular Science Monthly. Write for order form to O. K. Kelly, Classified Advertising Manager, 351 Fourth Ave., New York City 10.

## 58 FORMULAS, PLANS, ETC.

**FORMULAS—All** kinds. Latest products. Literature free. Kemico, Park Ridge 15, Illinois.

**10,000 FORMULAS** and Trade Secrets Free Literature. Stillmans, 555 Kingston Ave., Brooklyn 3, N. Y.

**PRODUCTS** analyzed. Duplicated. Improved. Formulas. Consulting Scientific Company, Swarthmore, Pennsylvania.

**GROW** plants without soil. Formula and instructions \$1.00. Young, 219 Strathmeade St., Falls Church, Va.

**LABORATORY** tested formulas. Lists free. Pont, Box 635-PS, Terre Haute, Ind.

**FORMULAS.** Secret Laboratory Tested. Big Profits—Small Investment. 15—\$1.00. Edmunds, 317 E. 157th St., Bronx, New York.

**FREE** Formula Catalog. Anything Analyzed \$20.00. Western Chemical, Salem, Oregon.

## 59 PLASTICS

**PLEXIGLAS—Write** for Free Price List The Unique Glass Shop, 309 Cowar Ave., Richmond, Virginia.

# POPULAR SCIENCE OPPORTUNITIES

PLASTIC supplies, materials, instructions for hobby or business. Send for free catalog. Tells about internal carving. Hays Plastics, 2333 Lincoln Avenue, Alameda, California.

NEW Liquid plastic. Clear, colors. Cast without heat. Embed flowers, insects, coins. Saw, drill, carve. Complete kit only \$3.95 postpaid, or send 25c for exciting new home project manual showing how to get started. Castolite, Dept. J-104, Woodstock, Illinois.

LUCITE, Plexiglas. Any size sheets, masked. Square foot (12 x 12) cost. 1/16" 95c; 1/8", \$1.25; 3/16", \$1.50; 1/4", \$1.80. Colors add 10%. Include 10% postage. Almac Plastics, 230 Fifth Avenue, New York 1, N. Y.

PLASTIC, Sheets, Rods, Tubes, etc. Free List, Plastic Supply Co., 2901 N. Grand Blvd., St. Louis 7, Mo.

FLEXIBLE Mold Making Handbook. Be an expert. Send only \$1.00 for your post-paid copy today. Multi-Mold Products, 265 West 30 Street, New York 1.

## 60 CHEMICALS AND APPARATUS

NEW Idea Chemical and Apparatus Outfits for Home Experimenting. Photo-Scales, Microscopes, Chemicals, Biological and Laboratory Supplies in Small Quantities. Catalog 15c. Established 1931. John H. Winn, 124-B West 23rd Street, New York, N. Y.

MAKE Chemistry Your Hobby. Fascinating. Educational. Recreational. Vocational. Large general catalogue Chemicals and Apparatus 15c. Microscopic Stain Catalogue 20c. Both for 25c. National Scientific Company, (Est. 1916), 2204 W. North Ave., Chicago 47, Illinois.

HANDBOOK for Chemical Experimenters, illustrated, hundreds of experiments, 50c. Experiment booklet, 15c. Reading Scientific Co., Reading, Pa.

NEW catalog: Chemistry, mineralogy, biology, physics 10c. Tracey Laboratories, Evanston, Ill.

CHEMICALS and apparatus for industrial, analytical, and private laboratories. Catalog 15c. Dept. M-26, Biological Supply Co., 1176 Mt. Hope Ave., Rochester 7, N. Y.

COMPLETE supply catalog, 10c. Pilgrim Chemical, 348-UU Edith, Salt Lake City 4, Utah.

## 61 HELP WANTED

BOYS Wanted. Over \$2.00 hour! Sell name plates for front doors. Free Sample. Write Dept. 69, National Engravers, 214 Summer, Boston, Mass.

ALASKA. The Last Frontier offers unlimited opportunities. \$1 brings government map and Directory listing firms in Fishing, Construction, Mining, Aviation, Fish & Game rules, Homestead data, Alaska Opportunist, Box 883-S, Hollywood 28, Calif.

FOREIGN Construction Work. Construction men, building trades mechanics, helpers, office men. Good workers needed for oil projects, mining, pipe lines, dams, power plants, roadways, shipping, etc. Transportation and quarters furnished; high wages. Listings of firms actively working and hiring on projects in South America, Arabia, Asia, Africa, Alaska, Central America, etc. Send \$1.00 for foreign construction compendium and application form. Foreign Service Bureau, Dept. PS-8 (Employment), P. O. Box 295, Metuchen, New Jersey.

APPLIANCE Designer. Well established company in mid-west has permanent salary position for a man 35 years of age or over to design, develop and follow through on mechanical and electrical household applying and dispensing equipment. Write fully stating experience, salary requirements, and give references. Replies will be held confidential. Leve, Room 1158, Merchandise Mart, Chicago 54, Illinois.

1,000,000 CONSTRUCTION Job Project List. \$1.00 brings Monthly News Bulletin "giving authentic projects starting all over the world." U.S.A., Alaska, Canada, Mex., Arabia, Latin America, India, Africa, Europe. Tells How-When-Where to apply. Global Reports, P. O. Box 883-P, Hollywood 28, Calif.

BIG-Pay Jobs available. Particulars free. George Lenhoff, Lincoln 8, Nebraska.

FOREIGN Employment?? List of Overseas projects with application form. \$1.00 Cash (C.O.D. \$1.32). Foreign Service Institute, Box 3980, Miami 24-A, Florida.

INTERESTED In Latin American And Foreign Employment?? \$1.00 brings copyrighted "Foreign Service Directory" with complete listing of firms in Oil, Mining, Aviation, Construction, Steamship, Manufacturers, Importers and Exporters with Hot Tips for immediate application. Published since 1944. Global Reports, P. O. Box 883-S, Hollywood 28, Calif.

## 62 AGENTS WANTED

GOOD Paying Business Silvering mirrors, plating autoparts, reflectors, bicycles, bathroom fixtures, etc. by late method. No tanks or shop required, outfit furnished. Free Booklet, Gunmetal Co., Ave. G, Decatur, Illinois.

EXCELLENT Sideline for printing and advertising salesmen. Decalomania name plates in small quantities. Great demand. Also, make money with our line of Automobile Initials and Sign Letters. Free Samples. "Ralco", XL-Roxbury, Boston 19, Mass.

AGENTS—300% profit selling genuine gold window letters; stores and offices. Free samples. Metallic Letter Co., 437 N. Clark, Chicago.

FREE water and our concentrates make flavors, lotions, shampoos, 125 products. Labels, bottles supplied. Qualco, F-20030 Russell, Detroit.

STOP! Want To Make Money All Year Round Selling a complete line. Wool Uniforms, Shirts, Caps, Ties, Badges, 2000 Emblems, Personal Initialed Buckles, Belts, and hundreds of other easy-to-sell items. Sales Kit furnished. Please write today. Hook-Fast Company, Box 480-PS, Roanoke, Va.

ADVERTISING book matches—Cash in on big demand—sell Union Label matches. Cuts for all businesses and political parties—Free powerhouse selling kit—low prices—protection guaranteed on repeat orders—Cash commissions. Superior Match Co., Dept. P-89, 7530 Greenwood, Chicago.

PHOTO-Salesmen-Agents. Sell beautiful hand-colored plastic enlargements. Collect deposit, we deliver. Profitable sideline. Send card for free sample kit. Novel Portrait Co., 3343-A North Ave., Chicago, Ill.

SEWING Machine electrification kit. Nationally advertised. Has Good Housekeeping Guaranty Seal. Can be demonstrated and sold in 5 minutes. Make at least \$5 per sale. For complete details write today to Brownell Distributors, Inc., Dept. PS, 308 Canal St., New York 13, N. Y.

START Your Own Business On Credit. Always your own boss. 1554 Dealers, sold \$5,000 to \$26,500 in 1948; their average \$6,742. We supply stocks, equipment on credit, 200 home necessities. Sales experience not needed to start. Wonderful opportunity to own pleasant, profitable business backed by world-wide industry. Write Rawleigh Co., Dept. H-U-PSC, Freeport, Ill.

LOOK! Make money all year round selling personal initialed individualized belts, buckles, cap badges, western buckles, tie holders, name plates, 2000 emblems to choose. Big profits, whole or part time. Please write today special outfit offer. Hook-Fast Specialties, Box 1425, Dept. 7, Providence, R. I. Established 1926.

BE renewal headquarters for all magazines. Handle everything at home. Big profits. No experience. No capital needed. Free Catalog tells how. Write McGregor Magazine Agency, Dept. 139, Mount Morris, Ill.

BE first! Clean up selling brilliant new, metal Christmas cards featured in America's greatest box assortment line. Special metal, plastic, foil and novelty assortments. Five portfolios of personal cards. Fast imprint service. Free samples. Elmercraft Chicago, 5930 South Western, Chicago 36, Ill.

ABSOLUTELY Free! Big package actual sample fabrics and style presentation of dresses, lingerie, hosiery, etc. Take orders. Commissions big. Send money. Melville Co., Dept. 5104, Cincinnati 3, Ohio.

GOLD lacquered Window Sign Letters. Large Sizes Penny Each. New Foils. Absolutely Beautiful. Free Samples. Atlas, 544 W. 79th, Chicago 20.

AMAZING offer—\$40 is yours for selling only 50 boxes Christmas cards. Also 50 and 25 for \$1.00 with or without name. Free samples. Other boxes on approval, including entirely new, different deluxe assortment with feature television card. Cute plastic assortments. Write today. It costs nothing to try. Cheerful Card Co., 844 White Plains, New York.

A DRESS Yours with every 3 you order for yourself and family. Amazing new bonus plan. Everything Free. Harford Frocks, Dept. A-335, Cincinnati, Ohio.

PROFITS. Big demand and repeat orders selling rubber mats for home or auto. Free sales plan. Mitchell, Dept. PS8, 2140 San Fernando Road, Los Angeles 41.

SHINE Shoes Without "Polish". New Invention. Lightning seller. Shoes gleam like mirror. Samples sent on trial. Kristee 132, Akron, Ohio.

EXTRA Money! Sell friends Christmas Cards—including fascinating Plastics, 100% profit. Request free samples Exclusive Name-Imprinted Christmas Cards, Stationery unobtainable elsewhere with Christmas and Everyday Assortments on approval. Regal Greetings, Dept. PS-8, Hazel Park, Mich.

CALL On Friends with sensational Christmas Cards in handy assortments. Sell for \$1.00. Profit up to 50c. Also popular-priced Personal Christmas Cards, Everyday assortments, Stationery, Imported Napkins. Samples on approval. Wallace Brown, Dept. B-4, New York 10, New York.

QUICK, easy, cash for you! Sell amazing variety new Christmas cards. Profits to 100%. Novel Plastic, 3-dimension "Stage Set", Metallic, Christmas Carol cards, Gift Wraps, Animated Books, Table Settings, 8 special offers. Bonus. Write for Feature samples on approval and free samples 4 different Name imprinted Christmas Card lines. Floral and Personal Stationery, Elmira Greeting Card Co., MB-110 Elmira, New York.

AT last! Something new and sensational in Christmas Cards. Show Gorgeous Satins, Velours and Plastics never before offered. Gets Easy orders Fast! Pays Big Profits. Free Samples of Christmas Cards With Name 50 for \$1. Imprinted Stationery, Floral Charquettes, Napkins, 50 other assortments 60c to \$1.25. Samples on approval. Write, Puro Co., 2801 Locust, Dept. 941-K, St. Louis, Mo.

BIG Money Taking Orders: Shirts, Ties, Sox, Pants, Jackets, Sweaters, Shoes, Uniforms, etc. Sales equipment free. Experience unnecessary. Nimrod, 4922-AV Lincoln, Chicago.

NEW Sensational money maker. "2-in-1" scissors and knife sharpener. Nothing like it before. Proven success. 100% profit. 30 second demonstration gets order. Special Trial Offer. Barberdier, 916 Eleventh, Sacramento, Calif.

FREE Samples. Big profits showing amazing Glow-In-The-Dark specialties. House numbers, pictures, plastic novelties, religious and nursery objects, etc. Large manufacturer. Madison Plastics, 303 Fourth Ave., New York 10, N. Y.

SELL Calendars Now. Be the first in your district. Good sideline or full time. Every business wants them. Few calendar salesmen are on the road now which means more sales for you. Fleming Calendar Co., 6539 Cottage Grove, Chicago 37.

MAKE money easily. New spare time plan. Up to 100% profit. No experience. Show unusual Christmas, Everyday card assortments, Plastics, Gleam and Glo, Kiddies Cards, Wrappings, Attractive Gift items. Bonus. Special offers. Send today for free samples 30 different Christmas cards with name, 50 for \$1.00 up. Stationery, Coasters, Thomas Terry Studios, 100 Union Ave., Westfield, Mass.

SALESMEN-Sideline. Earn \$3,000 next 5 months selling calendars, advertising specialties. Buyers everywhere. Big Comm. advanced. Samples Free. Continental Calendar, 542-B South Dearborn, Chicago.

# POPULAR SCIENCE OPPORTUNITIES

**MAKE \$50** selling only 100 boxes America's leading 21 card Christmas assortments. Samples on approval. Complete line plastics, wrappings. Free samples 50 for \$1.00 Name Imprinted Christmas cards. Write Lorain Art Studios, Dept. AP, Vermilion, Ohio.

**EXTRA money quick!** Take easy orders low cost—high profit Christmas cards. Wonderful new type Plastic, Metallic assortments. Send at once for free 48-page catalog. Feature samples on approval and free Name Imprinted Christmas Card sample portfolios. Special offers. New England Art Publishers, North Abington 51, Mass.

**PROFITS Galore!** Make \$100 weekly easy by offering valuable gift premiums with subscriptions to leading magazines everybody buys. Write for details. Progressive Sales Company, 1611-P Walnut St., Philadelphia, Pennsylvania.

**OWN Your Own Business.** Sell Men's Neckwear full or spare-time. Low investment, big profits. Send \$1.00, receive two Sample ties plus free catalogue, color portfolio, selling plan. Radio City Neckwear, Dept. P.S. 1, 112 W. 50th, N. Y. C.

**GET Into the Paint Business!** See our ad in Business Opportunities. Standard Industrial Products, Inc., Dept. PS-8, Evansville 4, Indiana.

**EARN Extra Money easily,** sell new Christmas cards and Gifts-n-Things. 21 folder Ass't sells for \$1.00, sent on approval; no investment. Get \$50 or more selling only 100 boxes. Amazing Sample Offers. Headquarters for new 3-dimension Christmas Cards. Plastics, genuine engraved etchings. We send Free Samples of easy-to-sell personal Christmas cards and stationery. Pen-n-Brush Studios, Dept. PS-8, 139 Duane St., N. Y. 13, N. Y.

**SELL Big Money-Maker** to men and Women. Easy handwork makes fast-selling useful articles. Sample free. Sunmade Company, Brockton, Mass.

**SELL ultra-blue stock signs** to stores. 1000 slogans, comedy, general, religious. "7x11" cost 6c—Sells 35c—Make money. 15 samples Ultra-blue signs "7x11"—\$1.00 postpaid. L. Lowy, 8 West Broadway, Dept. 487, New York City 7.

**SELL Large Profit Merchandise.** Write Adams, 15 Park Row, Room 1216, New York 7, N. Y.

**1949 CHRISTMAS Card Catalog** Now Ready! Earn more Money! Be a wholesale Jobber! A large selection of Box Assortments, Imprint Lines, Religious, Personalized Cards and Christmas Novelties. Three sample boxes, retailing for \$2.60, only \$1.00 postpaid. Catalog Free! Elfko, 440 North Wells, Chicago 10.

**DON'T sell junk!** The Frawley Chairside Coin Radio is in America's finest hotels. Proven and accepted! Your local hotels, courts, hospitals, resorts, coin operators, investors, radio men, etc. are all prospects. Splendid commissions! Time payment plan and complete sales helps for easy selling. Write today! Hotel Radio Corporation, 3000 E. Jefferson Ave., Detroit 7, Michigan.

**BUY thousands of nationally advertised products** direct from manufacturers and distributors. Write for "Buy Direct and Save". Service Publishing, 218-B Investment Bldg., Pittsburgh 22, Pa.

**WOULD you pay 3%—first \$350 made?** Illustrated book "505 Odd, Successful Enterprises" free! Expect something odd! Pacific, Oceanside, Calif.

**PAINTS—Enamels, Roofing 65c Gal. up.** Your name on label. Certified Products, 812F 38th, Louisville, Ky.

**WHERE To Buy 800,000 articles** direct from manufacturers. Send for "Your Profits Under the Spotlight." Glass Publishing Company, Ellwood City 3, Pa.

**BRAND New!** Amazingly different and smart Christmas Cards bring you big money! Take easy orders for sensational new Christmas Cards. Amazing values. Pays up to 100% cash profit. Big line of Christmas, Everyday Assortments from 60c up. Christmas Cards With Name 50 for \$1. up. Imprinted Stationery, Floral Charmettes, Napkins. Get samples on approval, imprints Free. Write North Star, 31 Glenwood, Dept. A-19, Minneapolis, Minn.

**FREE Nylons** given if Kendex hosiery runs or snags! World's only women's hosiery sold with written guarantee amazing everybody. Mere words could not express unbelievable money making opportunity. Fantastic earnings become reality. Armstrong earned \$202 in 9 days. Watkins sent 92 orders in one day. Imagine replacing hosiery free regardless of cause—whether use or abuse! Truly sales dynamite for terrific profits. Even if you never sold before, three magic words: "Guaranteed Against Everything" will open doors for you—make women listen and pour money in your pocket. Complete line from sheerest to service (15-20-30-40-60 denier) all lengths 28 to 35 inches—latest colors—seamed full fashioned and seamless. No competition because Kendex guaranteed nylons not sold in stores. Also complete line men's hosiery actually guaranteed for one full year! Nothing like this anywhere. Includes rayon, nylon, lisle, wool, cotton, mixtures, etc. All styles, patterns, colors, prices to please everybody. Thousands shipped daily. 100,000 pairs constantly in stock for fast delivery. Over 30 years in business. You need no money or experience. Nothing to pay now or later. Show free outfits. Write orders. We deliver and collect. Big advance cash plus huge bonus. Earn money spare or full time—exclusively or side line. No restrictions. Become manager—appoint others to sell for you—earn steady income on their sales. Complete money-making outfits including salesbooks in color, samples of hosiery materials, etc. furnished free and prepaid. Simply mail name and address to: Kendex Company, Babylon 84, New York.

**TRACTORADIO (Tractors-Trucks).** Sensation. Earn yours—Free. Smith Agency, T-2017, Excelsior Springs, Missouri.

**HOTTEST 39c Item** on the market. National Sales & Service, Greenville, Pa.

**SELL!! Balloons, Combs, Specialty Merchandise.** Carleton House Distributors, Texas City, Texas.

**NEW Jobs open in selling!** Send name, address for five free issues of Opportunity Magazine's money-making guide, listing hundreds of companies who'll pay you well, full or part-time. No experience needed. Opportunity, 28 E. Jackson, Dept. 18, Chicago 4, Ill.

**MAKE Money** selling Christmas decorations. Details from Wales Christmas Company, Cold Spring, New York.

**NYLON, Poplin, Rayon Uniforms,** white and colors. Immediate Delivery, Immediate Profits. Sell to Doctors, Dentists, Nurses, Waitresses, Beauticians, Housewives. Free Sales Kit. Superior Fabrics, Dept. A8, 3936 Market St., Phila. 4, Pa.

**PROFITS Big, Repeat Orders** Selling Rug and Upholstery Cleaner. Send \$1 for Sales Plan and sample to Clean your Rug. Micro, 161 E. Utica, Buffalo 8, N. Y.

**BIG Bargains** for Big profits. Over 100 sensational values. Men's used suits \$2. pants 35c, topcoats \$1.25, overcoats \$2, shoes 20c. Experience unnecessary. Free wholesale catalog. Superior, 1250-B Jefferson, Chicago 7.

**SELL Amazing non-electric fluorescent signs.** Extraordinary brilliance. Huge profits—Patented process. Send \$1.00 for fast-selling samples. Hatt Industries, 1412-B Great Northern Bldg., Chicago 4.

**UP to 442% profits** selling "Quick Determing Atomic Metal Plates." Instantly cleans silverware, jewelry, metals. Wholesale, retail, sideline. Manufacturers, 508-PS9 New York St., Aurora, Illinois.

**BIG Profits** selling Guaranteed Sport Shirts, Pajamas, Nylons, Dresses, Lingerie. Free Outfit. Jarod Manufacturing, Rockville Centre 76, N.Y.

## 63 HIGHGRADE SALESMEN

**LOOK Here!** Wanted—Men and women to start in business on credit. Sell some 200 farm-home Products. Thousands our Dealers now make quick sales, big profits. For particulars write Rawleigh's, Dept. H-192-PSC, Freeport, Ill.

**SALESMEN—Put yourself in line** for big money, real future. Keep stores supplied with 5c-10c to \$1 counter goods. Nationally advertised merchandise. Top profits for you, merchants. Liberal deals boost sales. Sideline or full time. World's Products, Dept. 83-W, Spencer, Indiana.

**GET Into the Paint Business!** See our ad in Business Opportunities. Standard Industrial Products, Inc., Dept. PS-8, Evansville 4, Indiana.

**SALESMEN.** Earn \$100.00 weekly, selling only six pair shoes daily. Commission and bonus. Wide variety for men, women, children. No investment. Experience unnecessary. Free catalog. Tanners Shoes, 515 Boston, Mass.

**UP to \$50.00 in a week** and tailored suit for yourself without paying one cent. Write for plan. Progress Tailoring Co., Dept. V-221, Congress & Throop, Chicago 7, Ill.

## 67 EDUCATIONAL AND INSTRUCTION

**BOOKKEEPERS!** Increase your earnings! Operate your own simplified "Dollar-A-Week" Bookkeeping and Tax Service. Full or Spare time. Details Free. No obligation. Ellis, Box 203, Cedar Grove, North Carolina.

**BE a piano tuner.** 13,000 needed in U. S. A. Make \$3,000 to \$5,000 each year, full or spare time in this intensely interesting and fascinating work. Experience unnecessary. Easy course qualifies you. Knowledge of music helpful, but not necessary. Approved by Veterans Administration. Penny post card brings free details. Free placement service. Harmony School of Piano Tuning, 147-A N. Cameron, Harrisburg, Pa.

**EXPORT!** Learn at home from established World Trader. Big paying positions. Your own profitable world-wide business by mail order without capital; or travel abroad. Experience unnecessary. Free booklet. Mellinger, 208W, Los Angeles 24, California.

**LEARN Piano Tuning** at home with sound recordings in thirty days. Electric record player, recordings, tools, and instructions furnished. An uncrowded profession with unlimited income. Write today for detailed information. Capitol City Tuning School, Dept. K, 211 East Michigan, Lansing, Michigan.

**PIANO Tuning Pays.** Learn this profitable profession at home. Our Tonometer and mechanical aids make learning easy. No knowledge music necessary. Diploma granted. Largest and oldest school—51st year. G. I. Approved. Write for booklet. Niles Bryant School, 77 Bryant Bldg., Washington 16, D. C.

**SECRETS of musical instrument repairing** revealed in 200 page fully illustrated book only \$5.00. Erick Brand, Elkhart 21, Indiana.

**BECOME a Doctor of Psychology or Metaphysics.** Teach secret of contentment, happiness. Win degree of PsD, or MsD. Solve mental worries. Free book. College of Universal Truth 5153-K N. Clark, Chicago.

**MAKE Up To \$35-\$45 Week** as a Trained Practical Nurse! Learn quickly at home. Booklet free. Chicago School of Nursing, Dept. M-8, Chicago.

**GET A Dependable U. S. Gov't Job!** Start high as \$3,351.00 year. Qualify Now. Many openings expected. Free 40-page book, details. Write: Franklin Institute, Dept. T22, Rochester, N. Y.

**FALL Classes in Air Conditioning, Refrigeration Heating and Heat Pump Engineering** are forming Now. Write for free information. Detroit Air Conditioning Institute, Dept. A, 4125 Grand River, Detroit, Michigan.

**U. S. GOV'T Jobs!** Start high as \$3,351.00. Men-Women. Qualify Now for secure positions. Free 40-page book, sample tests. Write today: Franklin Institute, Dept. T-22, Rochester, New York.

**MEDICAL Laboratory Technicians** in great demand. We train you in your own home. Catalogue free. Imperial Technical Institute, Box 973-B, Austin, Texas.

**HOME Study Courses.** Chiro-Deo-Therapy, Drugless Healing Certificates, Diplomas, Degrees. Western University, 911-13 West University Ave. San Diego 3, Calif.

**PREPARE Now** for a professional career in industry or a business of your own. You can learn Safety Engineering at home, quickly and easily. Accident Prevention Institute, Box 1796, Dallas, Texas.

# POPULAR SCIENCE OPPORTUNITIES

USED Correspondence Courses and Educational Books Bought, Sold, Rented; Catalog Free. Educational Exchange, Summerville, Ga.

HOW to get ahead in your job, win social success. Free information. Cedo, P. O. Box 4, New York 51, N. Y.

PHOTOGRAPHIC mind with Super-memory, write Thor Books, S-8 Box 1210, Chicago.

MASTER A Trade With A Future—Register Now!!! Thorough courses in: Automobile mechanics, Diesel mechanics, motor tune-up, auto body and fender, welding, refrigeration, radio, etc. Modern equipment and buildings, room and board accommodations. Write for free literature. Fully Accredited to Train Veterans. Thirty Years' Experience Training Men. Nashville Technical College, Dept. No. 245, Y.M.C.A. Bldg., Nashville 3, Tennessee.

## 69 CONTESTS

HITCH Your Wagon to a ConteStar! Send 3c stamp. National Contest Bulletin, Box 2685-C, Miami 31, Fla.

## 70 LANGUAGE OUTFITS

LINGUAPHONE Makes Languages Easy. At home learn to speak Spanish, Portuguese, Italian, French, German, Russian, by quick, easy Linguaphone conversational method. Save time, work, money. Linguaphone Correspondence Courses are available to veterans under G.I. Bill of Rights. Send for free book. State if G.I. Linguaphone Institute, 54 RCA Bldg., New York 20, N. Y.

## 72 AUTHORS SERVICE

I WANT New Writers to cash checks of \$1 to \$100 offered daily. The easiest way to write for pay. No previous experience necessary. Free Details. Saunders M. Cummings, 468-15 Independence Bldg., Colorado Springs, Colo.

## 73 BUSINESS SERVICE

SUCCESSFUL letters developed which pull results. P.O. Box 1067, San Francisco.

COLLECTING Letters. Set one dollar. General Adjustment Co., Waco, Texas.

## 74 CARTOONING, SIGN PAINTING, DRAWING AIDS

"HOW to make money with simple cartoons". A book everyone who likes to draw should have. It is free; no obligation. Simply address Cartoonists' Exchange, Dept. 198-C, Pleasant Hill, Ohio.

PROFESSIONAL showcard, letter patterns. Samples, Dime, Refundable. Demonstrators, 1743S Harrison, Chicago 12.

CARTOONING and Life Figure Drawing. Learn our modern system and make money doing advertising art. Amazing set of 5 easy lessons. Send only \$2. Waller Art Studios, Dept. 1, 1000 N. Charles Street, Baltimore 1, Maryland.

SIGN painting taught at home. Test lesson free. Ben Kerns, Box 812-PS, Greenville, S. C.

EARN Money Evenings, copying and duplicating comic cartoons for advertisers. Adservice, Argyle (2), Wisconsin.

## 75 CHALK TALK-STUNTS

CHALK Talks. Laugh Producing Program. \$1.00. Illustrated Catalog 10c. Cartoonist Balda, Oshkosh, Wisconsin.

## 76 TYPEWRITERS AND OFFICE MACHINES

ADVERTISE. Increase business. "Printomatic" selffeeding "Mimeograph" Post Card Duplicator prints, reproduces, thousands anything typewritten, handwritten, \$13.50. Literature. Pittsburgh Typewriter Company, 336-2 Fourth Avenue, Pittsburgh 22, Pennsylvania.

RECONDITIONED Typewriters. Printing Devices. Office Appliances, Supplies. Dixigraph, King, N. C.

## 77 OFFICE SUPPLIES & EQUIPMENT

STANDARD Typewriters \$17.50; Duplicators \$12.50; Adders \$12.50. Ship all States. Typewriters, 118 Spruce, Wichita 7, Kansas.

MAILERS, Shippers Labels, Packet useable samples, 10c. Riteway, Sanford 5, Michigan.

## 78 RUBBER STAMPS

3 LINES 45c. Pads 35c. Signature \$1.95. Printright, Wauwatosa, Wisconsin.

## 79 PRINTING OUTFITS, SUPPLIES

PRINTING Presses, Type Supplies, Lists 3c. Turnbaugh Service, Loysville, Penna.

INEXPENSIVE home-make printing press. Details free. Novelty Shop, Downsville, Louisiana.

MAKE Your Own rubber printing cuts. Self-molding process. Plexirubber, Argyle 2, Wisconsin.

PRINTING Presses, type, supplies. Send stamp for details or dime for complete illustrated printer's supply book and samples. Kelsey Corp., J-8, Meriden, Conn.

## 80 PRINTING, MULTIGRAPHING, ETC.

MIMEOGRAPHING—Drawings, Script, Any Copy; Best Prices! Free Sample. Topical Emprise, 1527 Highland, Box 42, Louisville 4, Ky.

MIMEOGRAPHING, anything, lowest prices, quality work. Rapid Service, 317A W. 26 St., N. Y.

1000 BUSINESS Cards \$2.50 Prepaid. Samples free. Reliable Print Shop, 907 East Jefferson, Louisville 6, Ky.

LETTERHEADS—Envelopes—Statements—Billheads. Mango, 555-B South 20th, Newark 3, N. J.

## 82 PATENT ATTORNEYS

INVENTORS. For "Record of Invention" form, contact Carl Miller, Registered Patent Attorney, Woolworth Building, New York.

INVENTORS: Write for free brochure "Evidence of Invention." Labiner, World Building, New York 7.

PATENT practice before U. S. Patent Office. Validity and infringement investigations and opinions. Booklet and form "Evidence of Conception" forwarded upon request. Lancaster, Allwine & Rommel, Registered Patent Attorneys, Suite 413, 815-15th St. N.W., Washington 5, D. C.

INVENTORS: Without obligation, write for information explaining the steps you should take to secure a Patent. John N. Randolph, Registered Patent Attorney, 207 Columbian Bldg., Washington 1, D. C.

INVENTORS: When you are satisfied that you have invented something of value write me, without obligation, for information as to what steps you should take to secure a Patent. Write Patrick D. Beavers (Formerly Randolph & Beavers) Registered Patent Atty., 938 Columbian Bldg., Washington 1, D. C.

INVENTORS: Learn how to protect your invention. "Patent Guide" containing detailed information concerning patent protection and procedure together with "Record of Invention" form will be forwarded upon request—without obligation. We are registered to practice before the U. S. Patent Office and prepared to serve you in handling your patent matters. Clarence A. O'Brien & Harvey Jacobson, Registered Patent Attorneys, 92B-G District National Building, Washington, D. C.

IF An Inventor believes he has an invention, a search of the most pertinent prior U.S. Patents should be made and a report obtained relative to its patentability. Write for further particulars as to patent protection and procedure and "Invention Record" form at once. No obligation. McMorrow, Berman & Davidson, Registered Patent Attorneys, 1439 Victor Building, Washington 1, D. C.

PATENTS—If you have a valuable invention, the usual procedure is to authorize a preliminary search through appropriate classes of U. S. patents. This firm is registered to practice before the Patent Office. —is available to make such a search and report to you concerning the probable patentability of your invention. Booklet and convenient "Evidence of Invention" form sent upon request. Victor J. Evans & Co., 441-J Merlin Building, Washington 6, D. C.

INVENTOR'S Guide free on request. Frank Ledermann, Registered Patent Attorney, 154 Nassau St., New York 7.

PATENTS—Trade Marks. Patent Lawyer, Gustave Miller, 89-B Warner Building, Washington 4, D. C.

C. A. Snow & Co.—S-427, Snow Building, Washington 1, D. C. Registered Patent Attorneys. Write for information.

PATENTS—Trade marks. Irving L. McCathran, 316 McLachlen Bldg., Washington 1, D. C. Registered Patent Attorney.

## 83 FOR INVENTORS

INVENTORS: Without obligation, write for information explaining the steps you should take to secure a Patent on your invention. John N. Randolph, Registered Patent Attorney, 206 Columbian Bldg., Washington 1, D. C.

INVENTORS: If you have an invention for sale, patented or unpatented, write Institute of American Inventors, Dept. 30A, 1926 Eye St. N.W., Washington 6, D. C.

INVENTORS. For "Record of Invention" form, contact Carl Miller, Registered Patent Attorney, Woolworth Building, New York.

"INVENTOR'S Guide" free on request. Frank Ledermann, Registered Patent Attorney, 154 Nassau St., New York 7.

INVENTORS: The usual First Step is to have a search of the U.S. Patents conducted, so I can report on Patentability. Write, without obligation. Patrick D. Beavers (Formerly Randolph & Beavers) Registered Patent Atty., 939 Columbian Bldg., Washington (1), D. C.

INVENTORS: Learn how to protect your invention. "Patent Guide" containing detailed information concerning patent protection and procedure together with "Record of Invention" form will be forwarded upon request—without obligation. We are registered to practice before the U. S. Patent Office and prepared to serve you in handling your patent matters. Clarence A. O'Brien & Harvey Jacobson, Registered Patent Attorneys, 92A-G, District National Building, Washington, D. C.

IF An Inventor believes he has an invention, a search of the most pertinent prior U. S. Patents should be made and a report obtained relative to its patentability. Write for further particulars as to patent protection and procedure and "Invention Record" form at once. No obligation. McMorrow, Berman & Davidson, Registered Patent Attorneys, 1438 Victor Building, Washington 1, D. C.

CASH For your idea, 280 manufacturers need inventions, patented or unpatented. List free. Invention Bureau, 208-S Clinton, Oak Park, Illinois.

PATENT Protection—Unless an inventor is thoroughly familiar with such matters, he is advised to employ a competent registered Patent Attorney as the value of a patent depends largely upon the skillful preparation of the specifications and claims. Send for booklet, "Patent Protection for Inventors," outlining preliminary steps to take to obtain patent protection. Victor J. Evans & Co., 442-J Merlin Building, Washington 6, D. C.

INVENTORS! Have you good, patentable ideas? Write Patent Agent Metzler, 11 West 42nd, New York.

LIST your invention with Qualified Brokers. Write Elo Development Co., Long Island City 1, New York.

CONFUSED? "Conception to Marketing" reveals our experiences. Our mistakes guaranteed to save you time, money and headaches! \$1 copy. Turner Mail-Teller Co., Lima, Ohio.

YOUR idea engineered, drawn and model made. Years of experience, inquiries no obligation. Stevens and Grow, Engineers, 746 South Alvarado St., Los Angeles 5, Calif.

PATENT Searches \$5.00. Includes nearest patent copies, 48 hour service. Free protection forms. Patent Research Engineering, 318 Evans Building, Washington 5, D. C.

PATENT Searches \$5.00. Includes patent copies, 48 hour service. Free protection forms. Patent Service Institute, 945-B Pennsylvania Ave., Washington 4, D. C.

# POPULAR SCIENCE OPPORTUNITIES

**PATENTED.** Unpatented inventions promoted. M. Joyce Humpries, 1424 Land-tite, Philadelphia 10, Pa.

**LIST** Of 25 manufacturers seeking new inventions. Guaranteed authentic only \$1. Bruce, Box 341-CT, Palo Alto, California.

## 84 INVENTIONS WANTED

**INVENTORS:** Hundreds of manufacturers have requested our assistance in locating marketable new products. Complete information, free. Institute of American Inventors, Dept. 30C, 1926 Eye St., N.W., Washington 6, D. C.

**INVENTIONS** Promoted. Patented or Unpatented. Write Adam Fisher Company, 183-A Enright, St. Louis, Mo.

**CASH** For your idea. 280 manufacturers need inventions, patented or unpatented. List free. Invention Bureau, 208-S Clinton, Oak Park, Illinois.

**INVENTIONS** Wanted. Patented or Pending only. Inventors Exchange-D, Hartford 1, Conn.

**HIGHEST** Royalties—Cash. Official U.S.I.R.C. certification. Request free Booklet "C". Universal Marketing Co., 354 South Spring St., Los Angeles 13, Calif.

**SMALL** Inventions wanted by manufacturers. I'll help you sell your invention. Write for circular. Stanley Hull, 7829 Euclid, Cleveland 3, Ohio.

**INVENTORS**—What have you, patented, patent pending to offer manufacturers? Request free copyrighted booklet. Market Contacts, 11106-B2 Longwood, Chicago 43.

**INVENTORS**—Charges from royalties only. Inventors-Manufacturers Associates, 5 Beekman St., New York.

## 85 PATENTS

**INVENTORS:** Test the commercial value of your patented or unpatented inventions, quickly and inexpensively. Write for free information. Institute of American Inventors, Dept. 30-B, 1926 Eye St., N. W., Washington 6, D. C.

## 89 MODELS, MODEL SUPPLIES

**MODEL** Ship Builders! Are you looking for authentic, precision ship models? Send for richly illustrated fully descriptive catalogue in full color of famous ships of all kinds. Only 25c. Halesite Yacht Service Inc., Dept. C-49, Halesite, Long Island, N. Y.

**MOST** complete Illustrated Catalog—"O-HO OO" Model Railroad Parts ever published. Send 5c for mailing. Selley, 1377 Gates Ave., Dept. 836, Brooklyn, N. Y.

**SHIP** and Yacht model fittings; blueprints. Send 25c for illustrated catalog No. 24—Listing hundreds of items. A. J. Fisher, 1002-2 Etowah Ave., Royal Oak, Mich.

**SHIP** Models—most complete line in New England. Kits, parts, plans, books. Steam and electric power plants. Illustrated catalog 25c. James Bliss & Co., Inc., 220 State St., Boston, Mass.

**CATALOG** Illustrating Largest Assortment Ship Model Parts Send 5c. Selley Boats, 1373 Gates Ave., PS, Brooklyn, N. Y.

**BUILD** Historic Ship Models, complete kits 39c to \$9.00. Catalog 10c. Ideal Models, 21 West 18th, New York 11, N. Y.

**SHIP** Model and yacht supplies, complete large 64 page catalogue, 30c. Wm. Wild, 510 E. 11th St., New York City.

**STEAM** Marine Engines, Boilers, Casting Kits. Box 326, Evanston, Illinois.

**STEAM** engines, boilers, castings. Catalog 25c. Anton Bohaboy, 2297 Price, Rahway, New Jersey.

## 91 HOME CRAFTSMEN

**PROFIT** with Larson Leathercraft. Belts, purses, 100 other ideas. Largest supply in U. S. Catalog 10c. Larson, Dept. C, 826 S. Tripp, Chicago 24.

**TURN** your workshop into cash. Send postcard for catalog for modern salable projects. Craftplans, 7241-S Madison, Kansas City 5, Missouri.

**LEATHERCRAFTERS!** Complete stocks of leathers, tools, supplies. Metal tooling supplies. Immediate shipment. Free catalog. Kit Kraft, 7377 Melrose, Los Angeles 46, Calif.

**90** ALL new, full size lawn ornament and novelty patterns up to 20" high. Only \$1.00. Mastercraft 8S2, 7041 Olcott, Chicago 31, Illinois.

**METALLIZING** service. Plastics, non-metallics professionally plated. Philip Stein, Oswego, Illinois.

**16** NEW lawn chairs, 22 tables, benches, trellises, etc. All 38 plans, with full size patterns. \$1.00. Mastercraft 8S3, 7041 Olcott, Chicago 31, Illinois.

**LEATHERCRAFT** Bargain List. F. Byrd, 3406 Montrose Avenue, Richmond, Va.

**KNOCKDOWN** Cedar Chest, Lumber and Veneers. Free Price List. Giles Co., Brownsboro, Alabama.

**CRAFT** Supplies—Leather, Metal, Plastic, Tools, Free Catalog—Kale Crafts, 2252 Milwaukee, Chicago 47.

**MAKE** money by mail with your jig saw. Unusual plan. 25c (Refundable). Gard, 106 W. 3rd, Los Angeles.

## 93 BUILD IT YOURSELF

**BUILD** Your Own garden tractor. Plans, easy instructions. Light or heavy duty. Send postcard for free information. Ellsworth Tractor Co., Dept. E, Camptonville, Calif.

**"CONCRETE** Block Homes." 32 page booklet on how to build. \$1.00. Other Home Building booklets. \$1.00. H. C. Lightfoot, Civil Engineer, Richboro, Penna.

**KITCHEN** Cabinets, Modern streamlined construction described in illustrated manual. Includes individual designing service and factory prices on knockdown parts. All for \$1.00. Thombert Company, Newton 9, Iowa.

**WALK** Under Water. Build a home made diving outfit described July issue Popular Science page 168. Write for parts price list. Dick Rose, Everett, Washington.

## 94 WATCH REPAIRING

**WATCHMAKERS'** Journal contains helpful hints on watch repairing. New, enlarged August issue 20c. Dean Co., 116-B Nassau St., New York 7, N. Y.

**WATCHMAKERS** Tools, Supplies. Sold—Bought. Catalogue! Bengale Company, Culver City, Calif.

**EXPERT** Watch Repairing Established 25 years. Further information International Watch Service, Box 229 Grand Central, New York.

## 95 OLD GOLD, WATCHES, ETC.

**HIGHEST** Cash for Old, Broken Jewelry, Gold Teeth, Watches, Silverware, Diamonds, Spectacles. Free Information. Satisfaction Guaranteed. Government Licensed. Rose Smelting Company, 29-Y East Madison, Chicago.

**GOLD** \$35.00 Ounce—Mail old gold teeth, jewelry, watches, diamonds—receive cash by return mail. Satisfaction guaranteed. Free information. Dr. Weisberg's Gold Refining Company, 1500V Hennepin, Minneapolis, Minn.

## 96 JEWELRY

**JEWELRY** Making. Illustrated catalog 10c. George Sassen, 154 Nassau Street, N. Y. C. 7.

**BROKEN** Jewelry Bought—Everything. Best cash prices paid for gold teeth, rings, jewelry, spectacles, diamonds, bracelets, watches, etc. Cash mailed promptly. Send for Free shipping container today. Lewis', Dept. SP, International Building, St. Louis, Missouri.

**MAKE** Your Own Jewelry! All types of findings, plastic and metal; cameos, beads, shellkits, illustr. catalog, 20c. Hobby Art, Dept. 6, POB 276, New York 18, N. Y.

## 97 TOBACCO & PIPES

**CIGARETTES**—Popular brands \$1.51 per carton postpaid. West of Mississippi add 7c per carton. Min. order 3 cartons. Send check or money order. King Co., Box 1713-E, Baltimore, Maryland.

## 100 MISCELLANEOUS

**BUILD** own mailorder business. Beginners booklet 25c, or get details. Wayne Berger, Baltic, Ohio.

**BOOKFINDERS!** (Scarce, out-of-print, unusual books) Quickly supplied. Send wants. Clifton, Box 1377-PSM, Beverly Hills, Calif.

**GEIGER** Counters! New, lightweight, super sensitive uranium detectors. Sensational low price. Write today. The Detec-tron Co., 5637 Cahuenga Avenue, North Hollywood, California.

**TROUSERS** for Big Men—Rochester-tailored to measure. From \$11.00. Send for catalog. The Large Sizes Company, 118 Shepard Street, Rochester 7, New York.

**AIRFOAM** Rubber. 1"x16"x18", \$1.95; 4"x21"x22", \$3.95; 6"x21"x22", \$5.95; 4"x22"x37", \$5.95; 1"x24"x62", \$7.95; 6"x24"x38", \$9.95. Other sizes cut or fabricated to order. Write for prices. All shipments prepaid. In Calif. add 2½% sales tax. United Foam Rubber, Dept. B, 233 Broadway, Oakland, Calif.

**GRAVITY.** If you are interested in Gravity—Write us. No expense to you. Gravity Research Foundation, New Boston, N. H.

**BIG** Mails Three Months. Name Listed Directory 25c. Harvey Teeple, Decatur, Indiana.

**"INTERESTING** Mails." 25c will keep your mail box full for three months. Bentz, Jr., Chatawa 89, Mississippi.

**URANIUM!** Exploration, detection, recognition methods understandably explained. Particulars free. Woodwid Industries, 5217-B Hollywood Boulevard, Hollywood 27, Calif.

**GEIGER** counters. Make your own and cash in on \$10,000 Uranium bonus or resell profitably. Send \$1.00 for detailed plans for simple, sensitive unit any home mechanic can build. We can supply any or all parts. Box 486, Main P. O., Detroit 31, Michigan.

**WE** purchase Indianhead pennies. Complete alloy catalogue 10c. Winslow Fairview, 277 Broadway, New York 7.

**RECEIVE** mails, magazines, samples. Your name in numerous mailing lists 10c. Ulysses Greenwood, 273 Broadway, New York 7.

**FEET** Hurt? Valuable outstanding offer. Corssan, 2638 Geyer, St. Louis 4, Mo.

**USED** Vending Machines All types. Satisfaction guaranteed. Vassar, Cleveland 5, Ohio.

**PANNING** Gold—Free instructions. Catalogue mining books—supplies. Old Prospector, B-256, Dutch Flat, Calif.

**GEIGER** counter, miniature. Under one pound, \$48.50 complete with phones, directions, and radioactive sample. Guaranteed. Western Radiation Laboratory, 1107 West 24th Street, Los Angeles 7, Calif.

**LETTERS** mailed 25c each. Cash. Geo. Costello, Box 81, Newport, Arkansas.

**BE** Cool This summer—Warm Next Winter—Inexpensively. Send for free circular. Macon Distributors, 111 Broome St., New York 2.

**TREASURE** Locators, Mineral Detectors. Geiger Counters for Uranium ores. Free literature. Fisher Research Laboratory, Inc., Palo Alto, California.

**NEW** steel letters and figures 1/16 characters complete set \$4.95 postpaid. Reconditioned Victor 100 lb. oxygen line regulators \$4.95 postpaid. Arrow Sales Co., Billings, Montana.

**ULTRASONICS.** New Handbook Describes Theory, startling Experiments \$2.00. Box 882, Providence, Rhode Island.

**BEAUTIFUL** Gift Hand Blown Perfume Bottle. Use as bud vase when empty. Glas-tube Products, Hawthorne, California.

## 101 FOR SALE—MISCELLANEOUS

**WAR** Surplus. Aircraft items. Shop Equipment, Machinery and a million other items. Free Catalog. Atlas Equipment, 229 Southwest Blvd., PS., Kansas City 8, Mo.

**BEAUTIFUL** Gift—Baseball player figure hand finished metal ashtray. Valued many times special introductory price of \$1.00. Park City Crafts, P. O. Box 132, Bridgeport 1, Conn.

**KNAPP** Shoes. Re-order? Free pamphlet? 1808 South Broadway, Pittsburg, Kansas.

# POPULAR SCIENCE OPPORTUNITIES

**FREE** catalog! War surplus clothing. Men's, women's. Amazing bargains. N. Y. Clothing Co., 2079B Second Avenue, New York 29.

**HOSIERY**. Handkerchiefs. Shirts. Sheets! Wholesalers write for prices. Spartan Hosiery Company, Spartanburg, S. C.

**STEEL** Shelving. Work Benches. Parts Bins. Legs. Angles. Etc. Catalog Free. Vimar Co., 211 Loeb Arcade, Minneapolis 2, Minn.

**WRITE** us for prices. Give us Make and Model Number. Bargains. Fortunes. Box B. Sperry, Okla.

## 102 WANTED MISCELLANEOUS

**MERCURY**—Highest prices. Free Containers. Write Mercury Terminal, Norwood, Mass.

## 104 PERSONAL

**RUPTURED?** Positive comfort, no understraps, no steel, no elastic. Write Smith Manufacturing Co., Preston, Ontario.

**PSORIASIS** Sufferers: Has everything failed to bring even temporary relief from scales, lesions and itching? Then write today for Free important information. You needn't invest one cent! Pixacol Company, Dept. S. Box 3583, Cleveland, Ohio.

**MEDICAL** Prescriptions filled at guaranteed lowest cost. Ask for prices on all your drug, hormone, and vitamin requirements. Ace Mail Order Co., E. East Orange, N. J.

**HEMORRHOIDS:** Don't suffer from painful, itching piles. Send \$1.00 for simple formula, which can be prepared in own kitchen. E. B. Marshall, 48A Marian Court, Upper Darby, Pennsylvania.

**"HOW** Can I Find Out?" You Can! Information discreetly developed. Any matter, personal, problem, anywhere, worldwide. Officially licensed, bonded service. Established 1922. Reasonable. Confidential. William Herman, 170 Broadway, New York.

**HANG** it all!!! Why should your hair fall or scalp itch? Enjoy thicker, healthier hair. Others do. Write Michael's, 849CPS, 3027 Atlantic Ave., Atlantic City, N. J.

**"HAIR-Saver** Plan." Wonderfully simple, non-medicinal exercise plan which has helped me. Why not you? For complete plan send only \$2.00 today to Hair-Saver Plan, P. O. Box 901, Phila. 5, Pa.

**WORRIED?** Problems? Confused? Let us solve what's bothering you, objectively, through scientific deduction. Write details enclosing one dollar to Adjustment, Box 811, Richmond 7, Virginia.

**MEXICAN** Law. General Practice Attorney. 1203 Arizona Street, El Paso, Texas.

**FORGET** Sinusitis, colds. Safe, sane new way quickly helps relieve. Medically recommended. Write today Free information. Pinolator Inc., 1809 Minnehaha Avenue, Minneapolis 4, Minn.

**INFORMATION** for single people by Human Relations Consultant. University Graduate. Dr. B. Long, Box 375, Los Angeles 53, Calif.

**LEARN** how the Chinese tune in on Nature and find real happiness and emotional adjustment. Send \$1.00 for my account of "The Secret of the Chinese Way of Life," result of two years of personal research in China. Weekley, Box 444, Dept. C, Upper Darby, Pennsylvania.

**MONTREAL** Remailing, Forwarding. 25c. F. Fenwick, 255 Lafleur, Montreal 32.

**SAVE** On Vitamins—Complete line. List free. Levitt Drugs, Box 718, Woodmere, New York.

**SUCCESS** can be yours! You may discover the golden key to happiness. Learn to apply the principles which have helped men to gain success and prosperity. Send only \$1.00. Institute of Applied Philosophy, Box 1429, St. Louis, Mo.

**NEW** book, "How To Live Without Money," ends your money worries. Howard, 1778-S Hamburg St., Schenectady 4, New York.

**ELEMINE** Minerals and Multiple Vitamins. Used successfully by those suffering from deficiency diseases. Money back guarantee. Six months supply \$21.00. Box 262, Provo, Utah.

## 106 ADVERTISING

**ADVERTISE:** 24 words, 40 Newspapers. \$3.50. Lists free. Advertising Bureau, 10511-P Springfield, Chicago 43.

**24 WORDS** in 50 Weeklies. \$4.96. J. Darnell, 730 Hays, Jackson, Tennessee.

**LISTS:** 24 words, 40 weeklies. \$3.50. M. Pennebaker, San Marcos, Texas.

**ADVERTISEMENTS,** mailorder letters, literature, campaigns, worded to sell anything worthwhile. Investigate! Finkle Advertising, 257P South Spring, Los Angeles 12, Calif.

## 109 HANDWRITING ANALYSIS

**HANDWRITING** Reveals Character:—For Free Information Bulletin On This Most Interesting Science Send Name And Address To: Analyst, Box 6124, Station B, Albuquerque, N. M.

## 114 DRAFTING INSTRUMENTS

**SPRING** Dividers 8-inch hrd-pts. \$.60. Calipers w/mike adjustment \$.85. Goggles green polarized lens leather trim ventilated \$.65. postpaid. Tri-State Mercantile, Lewiston, Idaho.

## 115 DRAWING & ART SUPPLIES

**DRAFTING** and artists' materials catalog—thousands of items—25c (deductible first \$2 order). Gordon's, 187 Madison, Chicago.

## 117 TATTOOING SUPPLIES

**TATTOOING** Outfits, Supplies. Illustrated List Free. Zeiss, 728 Lesley, Rockford, Illinois.

## 119 SCIENTIFIC SUPPLIES

**NEUROTIC.** Write about yourself, offering gracious. Artisan Psychiatrist, 281 E.M., Watertown, N. Y.

## 125 WOODS

**WOOD** cards. Business, Christmas. Announcement. Cards of Wood, Manlius 2, N. Y.

## 126 CAMPING

**TENTS,** war surplus, all sizes; cots, hammocks, camping equipment, canvas covers, fishing & sporting goods, rope. Morsan, 10-19D 50th Avenue, Long Island City 1, New York.

## 131 TREASURE FINDERS

**METAL** Detectors. The very latest circuit. Send 25c for literature. Hedden Metal Detectors, 3329 Liberty Ave., Pittsburgh 1, Pa.

**TREASURE**—Mineral Locators. M-Scope. Low Priced, lightweight, unsurpassed in efficiency. Revolutionizes locating of minerals and precious metals. Geiger Counters for Uranium ores. Time payment plan. Factory guaranteed. Free 16-page booklet upon request. Fisher Research Laboratory, Inc., Palo Alto, California.

## 137 DETECTIVES

**DETECTIVE** Training. Phillips Secret Service System, 1917C North Kenneth, Chicago 39, Illinois.

**DETECTIVES**—Work home—Travel. Experience unnecessary. Write Wagoner P-125 West 86th, N. Y., N. Y.

## 143 NAME LISTS

**1,000 NAMES** Opportunity Seekers \$1.00. Siegel, Box 183, New York 2.

**MAILING** lists; most classes, 1000 \$5.00. Free Prospectus, Dixie Service, King, N. C.

## 145 SOUVENIRS

**THREE** Military Emblems and price list 10c. Hobbyguild, 57X Sumner Ave., Brooklyn, N. Y.

## 146 REFRIGERATION

**SAVE** Electricity, install own rubber refrigerator door gaskets. Replacements: ice cube and glass defrosting trays. Free Catalog. Rues Trading, 6017C 13th, Brooklyn 19, N. Y.

## USE THIS ORDER FORM TO INCREASE YOUR MAIL ORDER BUSINESS

### LOOK AT THESE LOW RATES

**80c** Per Word, Per Insertion      **WHITE SPACE**—\$4.50 Per Line.  
Minimum Ad—10 Words—\$8.00      **CASH WITH ORDER**

IF YOU SELL A PRODUCT OR SERVICE TO MEN, USE THIS EASY MEANS TO GET MORE SALES

### CLASSIFIED ADVERTISING ORDER

POPULAR SCIENCE MONTHLY • 353 FOURTH AVENUE • NEW YORK

Please insert the ad below in your.....issue.

Heading .....

Enclosed is \$..... Word Count.....

.....

.....

EACH WORD IN NAME AND ADDRESS MUST BE COUNTED AS A WORD

Name .....

Address.....City & State.....

TO BE INSERTED IN THE OCTOBER ISSUE, THIS ORDER MUST REACH US BY AUGUST 24TH



# SAVE UP TO 85% in WAR SURPLUS & BANKRUPT STOCKS

at "GADGETEER'S HEAVEN" IN MANY ITEMS WE HAVE THE WORLD'S LARGEST SUPPLY

NEW 1949 CATALOG 92 PAGES-ILLUSTRATED SEND 25c TODAY!

**Sportsman's Tent**  
Sturdy, lightweight, easy to erect. Will pack into a 12" roll 36" long. Made of 8 oz. forest green, WATERPROOF DRILL. Full floor cover, with mosquito netting on window & door. Reinforced throughout—Hardwood jointed center pole & 12 stakes included. A LIFETIME VALUE

9' x 9' size \$34.50  
11' x 9' size \$39.50

**Aviation Emergency Vests**  
Sturdy, Yet Light Weight. Satin Lined with Tie Straps. 14 Outside Pockets. Plus Knife, Gun, or Tool Leather Holder. 2 large 11" x 8" Pockets Inside. Wonderful Hunting, Fishing, or Mechanic Cost the Government \$30. A Steal at

**\$3.49**

**HUNTING KNIFE #307**  
6" chrome vanadium blade, handle, leather grip In leather sheath

\$5.98 Value for ONLY **\$1.89**

(Like Above) 5 in. polished blade \$1.69  
With Parkerized black Finish **\$1.49**

**BOLO KNIFE**  
10" x 2" Parkerized blade. 5" Gripped Handle. Weight 1 1/4 lbs. Ideal for Hunting, Clearing Brush or Trails. With Case **\$1.19 ea.**

**FOAM RUBBER CUSHIONS**  
Genuine **GOODYEAR AIRFOAM** Molded and pre-shaped. Cement or cut to fit. Variety of sizes and shapes. For chair pads, auto & truck seats, trailer & boat seats outdoor furniture and nooks.

18" x 18" x 6" \$4.89 ea.  
17" x 22" x 4" \$4.89 ea.  
36" x 18" x 4" \$5.39 ea.

**LEATHERETTE**  
Genuine Leatherette to cover Chairs, Patio Furniture, Nooks, Auto Seats, etc. 10 colors at a BARGAIN PRICE.

WIDTH COLORS PRICE (per run. yd.)  
36" Grey, Brown, Black \$1.19  
36" Lt. Green, Dark Green, Blue 1.65  
54" Red, Grey, Lt. Blue, Ivory, Yellow 1.89

**MESS TRAY** 6 compartments, rustless, stainless steel. Barbecue, outdoor cooking, save dish-washing. Hospital, Restaurant, Home, or roughing. **83c**

#311 New **83c** ea.  
#311A Used but in Fine Serviceable Condition **59c** ea.

**SLEEPING BAG**

**KAPOK BAG** Heavy duty, water repellent with wind breaker hood and cover. 1/2 zipper Has air mattress pocket. Size 32" x 77". 7 lbs. **\$14.95**  
Like above with wool filler **\$14.95**

**DOUBLE BAG** Like above. Wool filler. Full zipper. Size 34" x 77". 8 lbs. **\$15.95**  
2 of these bags may be zipped together to hold two people.

**LARGE SIZE BAG** Wool filled. Full zipper. Air mattress pocket. 36" x 80". 11 lbs. **\$25.95**

**MUMMY TYPE BAG** Feather and Down filled. 1/4 length zipper. Water repellent cover. 6 1/2 lbs. **\$14.95**

**FOLDING STEEL** With Tubular Headstands and sturdy double heavy wire twist springs. A Life time buy. **SC-1 \$2.95 ea.**

**NAVY BUNK BED** With steel angle headstands, steel frame spring made of twisted heavy gauge wire reinforced with lateral stringers. Can be used as single bed or joined two-high to serve as double bunk bed. Specially suited to hard wear active children dormitory camps, etc. Single, SB 1. Ea. **\$3.95**  
In sets of two Ea. **\$7.75**

**PILLOWS, Curled Chicken Feathers 99c Each**  
26" x 17" blue & white Ticking

The cots or bed each weigh approximately 62 lbs. Consult your local motor freight for shipping cost due to 100lb. mm. mattress shown below can be included at no extra shipp. cost.

**MATTRESS** for above cot or bed, cotton filled 3 1/4" thick spec. built not to flatten out. Tuffed edges, quilt tied, blue & white heavy ticking. **MT 1 \$6.95 Each**

**CLAMP-ON ANYWHERE LAMP** With adjustable ball and socket swivel head, long rubber covered cord and wall plug.

The All Purpose Lamp. Wonderful for Indoor Photography, Floodlights, Baby Spot or Large Spot, Personal Bed Reading, Workbench, Garage, etc. Lamp Alone **99c**  
Highly Polished 9" diameter Parabolic Reflector or 5" diameter Spot Reflector at Only **85c** ea.

**PROTECT YOUR EYES!!**

**Genuine ARMY AIR FORCES SUNGLASSES** HERE'S THE REAL McCOY!

ARMY AIR FORCE 6 base Precision Polished and Ground. Glare Free lens with leather case that can be attached to belt. Gold plated adjustable frame. Pearloid sweat bar and pads. A real Palley \$17.50 Value for Only **\$3.95**

ARMY AIR FORCE TYPE SUNGLASSES 4 base polished and ground lens 93% Ultra Violet Ray free gold plated frame pearlloid bar & pads, leatherette case. Our price **\$2.39** ea.

**SAVE A LIFE! IT MAY BE YOUR OWN!**

**KLEER-VUE NIGHT DRIVING GLASSES**  
With 57 mm yellow amber lenses. These lenses are 6 base especially PRECISION GRND. and Polished to reduce Glare of headlights from on-coming cars, also to focus objects sharply and more clearly during night driving.

INTRODUCTORY OFFER  
In Men's size or Ladies Harlequin style. ND-1 \$16 VALUE **\$5.89**  
SAME GLASSES but clip-ons. Fit-over style without temple bars **\$4.59**

**GOGGLES**  
New One Pc. Type Shatterproof Sponge Rubber Frame. Flexible Lens. Colored and Polaroid. **59c** ea.

LENS IN INFRA RED, GREEN, OR CLEAR

**GENUINE GOGGLES**  
Aviators (AN-6530) Windproof & Dustproof  
Sponge and leather protected frame with ground lens in clear, amber, or green. Clear set in replaceable metal frame with hinged nose bar. Ideal for Motorcycling, etc. **Go-65 \$1.69** ea.

**HERE ARE PLASTIC KITS**  
UNSURPASSED VALUES for ARTISTICALLY INCLINED HOME HOBBYIST!

Start Planning Novel Xmas Gifts Now!  
Kit #1 contains 2 lbs. plexiglass & Lucite sheet in various shapes, 1 oz. bottle of clearset cement and 5 bottles of colors in  
Orchid, Red, Yellow, Peach, etc. Also a Plastic Handbook of uses and instructions. This set easily worth \$5.50. Our Price **\$2.19**

Kit #2 contains 1 1/2 lbs. of plastic sheet, a 1 oz. bottle of clearset cement, and the Plastic Handbook. A \$2.50 Value for ONLY **99c**

**Plexiglass & Nascolite clear plastic shts.** at Tremendous Savings to You!

NASCOLITE—Full sheets opp 1/2 x 37 1/2 x 49 1/2, opp. 10 1/2 lbs. Per Sheet **\$12.50**  
PLEXIGLASS—Full Sheet  
5/16" x 36" x 24" Per Sheet **\$13.00**  
5/16" x 36" x 48" Per Sheet **\$25.00**

Fabricators write in for our special quantity prices, all above are new & masked. Also inquire about our other large stocks of Plastics.

**NEW SUN VISOR**  
Adjustable arm. Swivel lead. Can be swung in any direction. Made of clear green plastic. Mid. for Air Corp by Fulton Co. A very useful accessory for your Car, Truck, Tractor or Boat. **SPECIAL \$1.29**

**NEW TARPES - HEAVY CANVAS**  
Mildew & Flame 9' x 16' **\$11.95** ea.  
Resistant. Cheap Outside Storage. They are Really Moving at These Prices.

5' x 7' **\$3.95** 16' x 32' **\$29.95**  
8 1/2' x 10' **\$8.50** 16' x 22' **\$20.95**

Rubberized Linen  
7' x 11' NEW **\$5.95**

Only 3 lb. light weight yet waterproof Ideal for outside car storage.

**THE Air Forces' BEST Loose Leaf BINDER**  
3 metal post. Cylindrical locking, heavy duty 3/16" fabricated hinged cover. End identification window. Ideal for price books, salesman catalogues, photo albums, students, publications. Reference books, artist sketch books, etc. Will hold 500 sheets. 8" x 11". A \$5.00 Value for Only **59c**

**NAVY BATTLE LANTERN**  
This powerful battle tested lantern complete with 2 standard 1 1/2 volt dry cell batteries. Size 8" x 7" x 4" with a 4" dia. reflector. Comp. Only **\$3.29**

**FOOT LOCKER** Pine wood. Store clothes, bed covers, books, tools, and handy in moving. Removable tray 3" deep, rounded metal corners, single hasp hinged. Length 30", width 17 1/2", height 13". Used, but in good condition. Sturdy & well built. Limiting value. **ONLY \$4.95**

**Sperry Aircraft Directional GYRO COMPASS**  
Precision made for Positive direction. 360° swing calibrated in 1/10 degree (six min.) luminous dial. Built-in bank indicator. Case is 4 1/2" square with 3" dia. face. Operates on vacuum. Ideal for autos, light planes and boats. Can be used in autos and boats by attaching one tube to intake manifold. Complete with caging and reset knob. Re-issue—good condition. **ONLY \$4.49**

**New Navigators Magnetic Compass**  
Type D-12 size 7" dia x 4 1/4" deep Rubber lined - rotating verge range ring calibrated in 1 degree from 0-360° with 2 parallel grid wires for alignment with N.S. line. Boats. **\$14.95**

**COMPASSES #151** Marching. lensite, with luminous dial **\$1.59**  
#152 Matchbox, both jewel & liquid floating dial **39c**  
#154 Wrist Strap Compass **69c**

NEW!! Jeweled Watch Pocket Compass #153 **\$1.59**

**Hand Mike** Highly Sensitive with thumb control button on handle. Ideal for home recorders, public address systems, etc. Comp. with 2 ft. rub. cd. & telephone plg. **Only \$1.19**

**HS 33 NEW LOW IMPEDENCE RADIO HEADSET**  
The latest and most improved style, currently in use in aircraft. New. Packed in original boxes. Leather head band, sponge rubber ear pads. Includes CORD and JACK **\$3.25**

High to Low Impedance Adapter **35c** ea.

**HEADSET HS-30-U** Two Magnetic Type receivers in watertight brass case. Soft rubber inserts in each receiver to fit late wearers' ears. Pliable steel head band. Ideal for communications, divers, workers in noisy compartments, etc. NEW! **\$1.59**

**Radio ANTENNA Reel**  
Just the thing for tuning beam antenna. Powered by 1/4 h. p. 24v G. E. Motor. Removable 8" Reel-limit Switch - Cam Worm gears. Bevel gear. Solenoid clutch. Motor engaged to gear reduction only when electrical contact made. Operates in either direction. Ideal for auxiliary power take-off, opening and closing doors, etc. **\$4.29**

**NYLON FISHLINE Special**  
Strong - Lightweight - 2 ply NYLON FISHING LINE. ROT-PROOF and WATERPROOF... Especially treated for strength and long life. ON SPOOLS.

a. 10 LB. TEST. 2500 FT. BLACK OR WHITE **\$1.69**  
b. 45 LB. TEST, 750 FT. GREEN **\$3.19**  
c. 50 LB. TEST, 400 FT. Green **\$1.19**  
d. 75 LB. TEST, BRAIDED BLACK AND GREY 300 ft. **\$3.49**  
e. 100 LB. TEST, 300 FT. WHITE **\$3.79**

**AT REAL VALUES!**  
1/4" Cotton Clothesline .01 ft.  
1/4" dia., 3 strand, treated jute .02 ft.  
5/8" dia., 3 strand, jute .06 ft.  
1" dia., 3 strand, sisal .12 ft.  
3/4" dia., 3 strand Manila .08 ft.

**PALLEY THE LARGEST FIRM OF ITS TYPE SUPPLY CO. IN THE WORLD** DEPT. P.S. 8 6321 SAN FERNANDO RD GLENDALE 1, CALIF.

Order from this Ad. All sales final. All Prices F. O. B. Los Angeles. Pay by M. O. or Check. P. O.'s. Acct'd. from D & B firms. 1/2 deposit with C.O.D's

# Weeds — or CROPS, America ?

The farmer looked at his untilled acre.  
"Nope," he said, "Won't stick a plow in there. Don't care if it is fertile—I just don't like the color of the soil."

So the weeds grew rank and spread their seeds to his other acres, fouling his cotton and stunting his corn. And his harvest was poor.

There are some who would do the same for America. They would neglect the cultivation of the minds of young growing Americans. They would set them apart, deny them equal advantages . . .

. . . because of their race, their name or their religion.

Stupid, isn't it, that anyone should want a weedy harvest?

For our own sake—for America's sake, we can all do three things to help the cause of unity:

1. Accept—or reject—people on their individual worth.
2. Don't listen to, or spread, rumors against a race, or a religion.
3. Speak up wherever we are, against prejudice, and work for understanding.

**Remember—  
THAT'S BEING AN AMERICAN**

Post this message in a public place.  
Extra copies free.  
Write Advertising Council, Dept. T-35,  
25 West 45th Street, New York 19, N. Y.



## Popular Science

Plastic Coasters  
and Tiles

## EMBED REAL FLOWERS in NEW Magic PLASTIC



Now create many lovely and unusual things like the distinctive pansy coaster shown—made by embedding real pansies in Castolite—the "magic" liquid casting plastic. Comes crystal clear, or may be dyed to produce gorgeous color effects. Make really different jewelry, book ends, picture frames, candle sticks, figurines. Embed butterflies, coins.

medals, photos, for novel plaques, paper weights, tiles, other art objects. Use only home utensils. Follow simple step by step method. New pleasure, fine profits are possible. Send 25c for exciting new Home Project Manual showing how to get started. Write today! The Castolite Company, Dept. J-4, Woodstock, Ill.

MANUAL  
25¢

Protect Your **O-V-E-R-D-R-I-V-E!!** Save Money



**FITS ALL CARS FROM '46 THRU '49\***

"SIG-NA-LITE" flashes green light the instant car is ready for Overdrive! No guessing or forgetting! Permits effortless "CLUTCHLESS SHIFTING" in conventional gear! Saves gas! Reduces wear! Beautifies dash! Install in 5 min. Money-back guarantee. Only \$2.00 complete, postpaid, including "Overdrive Hints" folder. (COD's small fee). \*Also includes—DeSoto, Chrysler, and '49 Dodge "Gyro-Matic."

C. D. HILL PRODUCTS 5227 Parker Ave., Dept., PS-8 Chicago 39, Ill.

## DEPENDABLE CRAFT SUPPLIES

LEATHER CRAFT • PLASTICS • POTTERY CRAFT  
BLOCK PRINTING • BELT CRAFT  
TEXTILE COLORS • POWER TOOLS • WOOD BURNING  
INSTRUCTION BOOKS • WRITE FOR CATALOG

**DWINNELL CRAFT SHOP**

Dept. PS-98 • Elm Grove, Wheeling, W. Va.

**JUMBO Heavy Duty**  
DEALERS WANTED

Cuts Nails  
Without Injury

15 5/8" OPEN  
14 Ozs.



QUALITY GUARANTEED

Handy around  
• ORCHARDS  
• SHOPS  
• SHIPPING ROOMS

Great for HUNTERS, TRAPPERS,  
SCOUTS, CAMPERS, etc.

Check | Gun Metal \$2.95  
or M.O. | Chrome Plated \$3.95

JUMBO JACK KNIFE CO.  
2452 W. 28th ST., GRAND RAPIDS, MICH.

## Poc-Kit Pal Radio

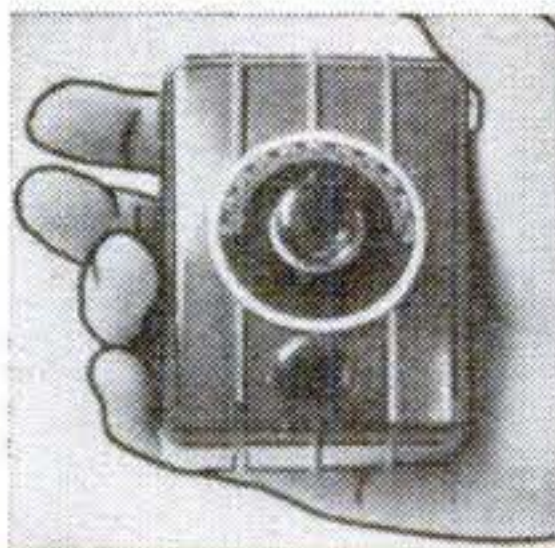

A power packed, super-sensitive one tube beginners kit includes miniature tube, factory wound loop antenna, plastic case and all parts with simple instructions. Works on pen-lite or hearing-aid cells. All parts, tube and batteries protected inside case. Astounding results. Poc-Kit Pal less phones and batteries only \$3.98 post paid. SEND \$1.00 balance COD plus fee. (FOREIGN \$5.00 U. S. Cash). Lee Electronics Laboratory, Dept. 1-S, 17 E. 48th St., New York 17, New York

# You'll be Glad

## YOU BOUGHT A SCHULT"

Engineered for cool comfort in summer; cozy warmth in winter. Attractive, livable interiors. Outstanding Schult quality and value, backed by the 3-year written warranty of the most famous name in trailering.



Write  
FOR FREE BOOK

Describes sparkling new models designed and equipped to meet every demand for luxury and economy, in living or travel. See exclusive Schult "Heat-Saver"—greatest contribution to trailer comfort in years.



SCHULT CORP., Dept. 3108 Elkhart, Ind.

In Canada: John Inglis Co., Ltd., Toronto

**SCHULT** Trailer Coaches  
Member T.C.M.A.

## NOW! More Shooting Fun

with  
Crosman's New \$14.95  
"Town & Country Jr." RIFLE

Expert or beginner—you'll like this rifle for year 'round shooting indoors and out. Accurate, hard hitting, yet safe to use anywhere thanks to Crosman's "controllable power" feature. Has rifled barrel; standard sights. Weighs only 4 lbs. 7 ozs. Available in .177 and .22 cal. single shot models at your dealer. Write for literature.

Crosman Arms Co., Inc. 9 HENRIETTA STREET  
ROCHESTER 7, N. Y.

**EARN \$3800.00 A YEAR!** ADVANCE TO \$7000.00

A CRITICAL SHORTAGE OF STATION AGENTS and TELEGRAPHERS EXISTS!  
ATTEND THE WORLD'S LARGEST RAILROAD SCHOOL

VETERANS! NON-VETERANS! THIS IS IT! Thousands of trained men are needed by all U.S. Railroads because of new 40 hour week provision, and men reaching retirement age. Assure yourself of immediate employment after graduation... attend the school endorsed by the ORDER OF RAILROAD TELEGRAPHERS. Gale Institute has placed over 1,000 men in the past 18 months. YOU MUST ACT NOW—CLASSES ARE LIMITED. WRITE TODAY!

IN RAILROAD WORK YOU GET:

- Free travel passes
- Vacation with pay
- Low cost insurance
- Advancement opportunity
- Retirement fund

GALE INSTITUTE, 2932 Hennepin Ave., Minneapolis 8, Minn.



NOT A SEASONAL JOB—  
A LIFETIME OPPORTUNITY

G. I. APPROVED

THE GREATEST  
THING

IN  
PLASTICS!

# PLASTICAST



## A NEW HOME INDUSTRY AND HOBBY!

**PLASTICAST** is a transparent liquid plastic; can be poured into ANY kind of mold or container. Hardens in a few minutes into a transparent solid, clear-as-glass, tough as steel plastic! No tools, machinery or skill required. IDEAL for imbedding pretty flowers, butterflies, photos, medals, souvenirs, biological specimens, etc. Makes a PERMANENT and ATTRACTIVE display. Make attractive jewelry, gems, lenses, knick-knacks, novelties. Easily cast into sheets, rods, blocks, ANY color, ANY shape! EVERYTHING furnished including molds, for making about \$50.00 worth of unusual novelties! **PLASTICAST OUTFIT, Complete with \$3.50 3 molds.** Illustrated Instruction Manual included.

Our Casting Plastics are as easy to use as pouring water out of a glass! **PLASTIDUR . . . (LIQUID IVORY).** Ideal for casting all OPAQUE articles. Hardens in a few minutes into an extremely hard IVORY-like plastic! May be dyed any color or cast into any shape. Works in EVERY type of mold! Non-inflammable, waterproof. Durable. Ideal for statuary, novelties, figurines, toys, gadgets, tools, knobs, bases . . . a million useful applications! Outfit comes complete with molds, dyes, accessories, instructions, etc. for making about \$100.00 worth of attractive jewelry, etc! **\$5.00 PLASTIDUR OUTFIT, Complete with 3 molds.**

**TERMS:** We pay the postage (U.S.A.) if full cash accompanies your order. C.O.D. accepted (U.S.A. only) if \$1.00 deposit is included for each item ordered. C.O.D. orders not postpaid.

A very attractive novelty made with one of above plastics FREE with our BIG catalog! Catalog lists largest selection of **MOLD MAKING and CASTING** materials in the WORLD! Liquid Plastics, Liquid Ivory, Liquid Marble, Liquid Glass, Ceramics, Liquid Porcelain, Moulage, Latex, Multiplex, Etc.

Also Shellcraft, Internal Carving, Plastics, Glazes, Jewelry Accessories, etc. Price of catalog only 10c U.S.A. (25c Canada).

**DEALERS: WRITE FOR ATTRACTIVE WHOLESALE PRICE LISTS**

**PLASTICAST CO. (Dept. A)**  
4637 N. Kedzie Ave. Write to Nearest Address P. O. Box 987  
Chicago 25, Illinois Palo Alto, Calif.  
Canadian Customers, please order directly from: Canadian  
Industrial Plastics, Ltd., 1056 1/2 Pender West, Vancouver, B. C.

Pioneers **BENJAMIN** Leaders  
**AIR RIFLES WITH SAFETY LOCK AIR PISTOLS**

SEND FOR FREE FOLDER OF LATEST MODELS TODAY

If you want a REAL GUN for PRACTICAL USE inside or outdoors, get a SAFE—CLEAN—ECONOMICAL—BENJAMIN with Adjustable Power and Amazing Accuracy. Use BENJAMIN H-C PELLETS for BEST RESULTS in all rifled models. WRITE AT ONCE.

BENJAMIN AIR RIFLE CO., 811 MARION ST., ST. LOUIS 4, MO.

THOUSANDS BUILD AT 1/2 THE PRICE  
**3 NEW ATOMIC RACERS**  
**U-MAK-IT BOATS**  
START NOW!  
EASY TO ASSEMBLE KITS

NO EXPERIENCE NECESSARY Everything Complete in Kit. Quality Material. Simple as ABC instructions. Immediate Delivery. Save Money, Big Value. Sturdy ROWBOATS, KAYAKS, DINGHIES, INBOARDS, OUTBOARDS, RUNABOUTS, CABIN CRUISERS

SEND 25¢ Colorful Illustrations show all '49 Models, 8 to 23 Ft., and (COIN) FOR CATALOGS Construction Details.

**U-MAK-IT PRODUCTS MARINE DIVISION**  
Formerly Kayak Boat Co. 703R-WHITTIER ST., N. Y. 59, N. Y.

## 5 YEAR WRITTEN GUARANTEE 17 JEWEL CHRONOGRAPH

2 PUSH BUTTON

ORIGINALLY \$71.50

- WRISTWATCH
- STOPWATCH
- TELEMETER
- TACHOMETER

Our Price  
Now Only

**\$21.95** Plus  
\$2.20  
Tax



Precision 4 in 1 Time-piece. Incablock shock resistant feature. Sweep Second hand. Anti-magnetic. Radium Dial. Stainless steel back. Unbreakable crystal. Perfect for physicians, scientists, technicians, engineers, aviators, photographers, broadcasters, navigators, sportsmen, servicemen, etc. Thousands sold at \$71.50. Order now while they last at this record breaking low price. Send only \$1 down payment with order. Pay balance to postman on arrival plus postage. Or we pay postage if you include full payment plus tax with your order. **FREE!** Handsome Expansion Band Included. Money back in 5 days if not delighted. Order now!

**MARYLAND DISTRIBUTORS, Dept. 69**  
501 E. Baltimore St. Baltimore 2, Md.

## Now She Shops "Cash And Carry"

Without Painful Backache

When disorder of kidney function permits poisonous matter to remain in your blood, it may cause nagging backache, rheumatic pains, leg pains, loss of pep and energy, getting up nights, swelling, puffiness under the eyes, headaches and dizziness. Frequent or scanty passages with smarting and burning sometimes shows there is something wrong with your kidneys or bladder.

Don't wait! Ask your druggist for Doan's Pills, a stimulant diuretic, used successfully by millions for over 50 years. Doan's give happy relief and will help the 15 miles of kidney tubes flush out poisonous waste from your blood. Get Doan's Pills.



Helps you s-t-r-e-t-c-h your dollars on TV, electronics, radio and tools.

Write today for the 1949 Lafayette-Concord catalog. A penny postcard will do the trick. You'll find pages and pages of the finest equipment at new low prices. Use the catalog to order everything you need and save. It's free. Write to Lafayette-Concord, Dept. KH9, 100 Sixth Ave., New York 13, 901 West Jackson Blvd., Chicago 7.

## LEARN MOVIE PROJECTION THEATRE MANAGEMENT

The Motion Picture Theatre Business offers big opportunities for trained men. Get into a fascinating field with a promising future. Train at home in spare time. Free Catalog. Established 22 years.

THEATRE INSTITUTE, 385 Washington St., Elmira, New York

## IMPORTED ZEISS TYPE BINOCULARS

BRAND NEW 7x50 Leather Case included. Add 20% Fed. Tax. Selection of other sizes equally low priced. SUPERB QUALITY—LIFE-TIME CONSTRUCTION—MONEY-BACK GUARANTEE. DEAL DIRECT WITH THE IMPORTER AND SAVE UP TO 50%! Know the EXTRA PLEASURE OF OWNING a pair of FINE BINOCULARS. Enjoy the thrill and satisfaction of clear, vivid close-ups at sporting events, theatricals, week-end trips, vacations, cruises, etc. Send NOW for Booklet "How to Select Binoculars for Your Personal Needs." It's FREE! Write for it TODAY!

**BINOC FILTERS**  
Brand new, U. S. Navy Snap-on Type. Eliminate strong sun-glare—\$5 value. Our special price: ONLY \$1.00 set, postpaid. Complete satisfaction or money refunded.

BUSHNELL IMPORTERS, 672-P8-So. Lafayette, Los Angeles 5, Cal.

# King Midget

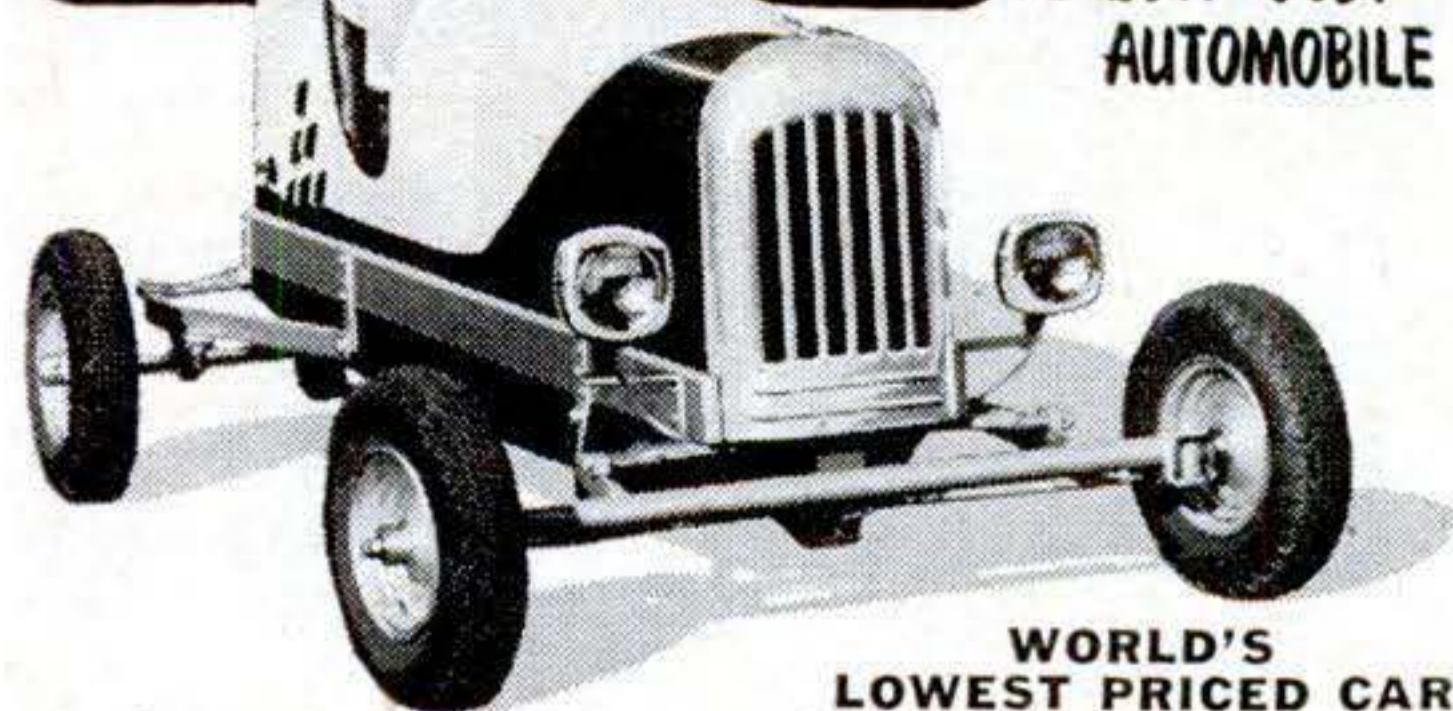

- HOME ASSEMBLED
- MASS PRODUCED
- LOW-COST AUTOMOBILE

## WORLD'S LOWEST PRICED CAR

Drive this car for as low as 50c per week. Up to 90 miles per gallon. 45 to 50 m.p.h. Large enough for a husky six footer. A pleasure to assemble. Just bolt together our precision built parts. Get the facts. Send 25c for detailed circular with large photo, 4 view drawings, price of all parts. Better still, send \$1 (refunded first order) for this plus actual assembly book with 42 photos, drawings, blueprints of snow and ice conversions, etc.

**MIDGET MOTORS MFG. CO., Athens 2, Ohio**

## BE A NOTARY PUBLIC

Get paid for life for signing your name. Old legal-supply house, 22 cities, guarantees your appointment by governor if you qualify. No training needed, no course to study. As a public notary your signature is important; you certify legal papers by signing, get paid. Money intake grows as you become known. Like compound interest. Income steady, for life. We equip you completely. Pay us after you are appointed—2 payments \$12.50 each. That's all. Details free.

**STATIONERS EXCHANGE Boerne 28, Texas**

## HUNDREDS OF ITEMS AND IDEAS FOR THE WOODWORKER

**Big New 144 Page Catalog No. 16** of hard to find woodwork items, hardware and supplies; the finest craftsman catalog Harold Hunt ever published—32 rare and fancy woods in natural colors—also in color, 43 matched veneer designs, multi-colored bandings, inlays, overlays, shows over 275 scroll patterns to choose from. Only 15c rebated on first order.

**CRAFTSMAN WOOD SERVICE CO.**  
2729 S. Mary St. Dept. B-8

## HARD TO FIND LUMBER

Top Grade Kiln Dried A Board or a Carload

### UNEQUALED BARGAINS

WALNUT  
MAHOG.  
CHERRY  
MAPLE  
WH. HARD  
AND SOFT  
POPLAR  
PL-QTR.  
OAK  
AROMATIC  
RED CEDAR

Chicago 8, Ill.

## SPEED AND POWER HANDBOOK



Build fast Stock Cars! California Roadsters! 150 MPH Rods! Covers Fords to Cadillacs—all makes! Breathtaking methods—Authentic—Direct from California!

### SAVE MANY DOLLARS

Build your own Dual Manifolds! Superchargers! Hot Cams! Water Injectors! Hi-Compression Heads! Mileage Devices! Get racing speed, lightning acceleration, dynamic power increases from any make passenger automobile! Get construction drawings! Tuning techniques! Speed tricks! Picture catalogues! Ingenious formulas! Economy secrets! Including—"Racing Frames"—"Reciprocating Masses"—"Jet Engines"—"Braking Characteristics"—"Dynamometers." Dual Pipes, Gears, Fuels, Manifolds, Porting, Relieving, Balancing, Lowering!

Includes "CALIFORNIA AUTOMOBILE CUSTOMIZING"—Glossy photographs! Diagrams! Newest Ideas! Conversions! Re-Styling all makes! Streamlining! Chopping! Channeling! Customizing!

50 CHAPTER LIBRARY EDITION—complete—\$1.98 Postpaid.

### NEWHOUSE AUTOMOTIVE INDUSTRIES

5805-A4 EAST BEVERLY

LOS ANGELES 22, CALIF.

## New Advertising Machine



## PRINTS and ILLUSTRATES

### 1¢ Post Cards

**FREE** Learn how thousands of business men, in every line, are boosting sales in spite of conditions—with 1¢ messages—printed and illustrated in a few minutes on gov't post cards—with amazing new patented **CARDMASTER**. Your "today's" ideas, read by your prospects next morning. Not a toy, but a sturdy advertising machine, built to last for years. Low price, sold direct. Guaranteed for five years. Send name today.

**SEND NAME** We'll send **FREE** illustrated book of money-making IDEAS for your business and complete, unique advertising plans. **RUSH YOUR NAME TODAY.**

## CARDMASTER COMPANY

1920 SUNNYSIDE, Dept. 168, CHICAGO 40, ILL.

## SHINE WITHOUT 'POLISH'



### New Invention! • Sells Like Wild

Replaces messy pastes, liquids. Simply glide over shoes—and **PRESTO!**—you have a lustrous, long-lasting shine. No mess. No muss. No soiled hands. Clean. Handy. **WORKS LIKE MAGIC!** For Men's, Women's and Children's Shoes. Low priced. Lightning seller!

**SAMPLES FOR AGENTS** Sample offer sent immediately to all who send name at once. A penny postal will do. **SEND NO MONEY—just your name.** KRISTEE CO., 727 Bar Street, AKRON, OHIO

# Sensational New Electric ① WELDER ② CUTTER!

FOR 110-115 AC or DC • WELD—BRAZE—CUT—SOLDER—HEAT TREAT INSTRUCTIONS INCLUDED • LOWEST PRICE IN HISTORY!

The **WELDRITE** Combination—tested and proved by countless commercial and amateur users, is now offered direct to you at the amazingly low price of only **\$12.00**. No Gas—No Gauges—No Spark Lighter needed. Always ready for immediate use—Just plug **WELDRITE** into 110-115 AC or DC outlet. Uses standard welding and brazing materials. **WELDRITE** furnished complete with Converter Unit, #1 Single Holder for welding metal to 3/16" thickness, using up to 3/32" rod, and #2 Double Holder with Copper Coated Carbon Electrodes for Brazing, Cutting, Heat Treating, etc. Starting welding

materials and instructions included. Ideal for home workshop. Invaluable for garages, repair shops, farms, etc. **SEND NO MONEY! 10 DAY TRIAL.** Order your **WELDRITE** Electric **WELDER-BRAZER-CUTTER C.O.D.** today. Pay postman **\$12** plus postage charges (wt. 4 lbs.) or send **\$12** and we pay postage. Either way, if not satisfied, return **WELDRITE** in 10 days for refund, less postage charges. **WELDER HOOD**—Approved Arc Welding lens—only **\$3.95**. Calif. orders add 2 1/2% tax.

**BOTH only \$12**



## CALIFORNIA TECHNICAL PRODUCTS CO.

Dept. B-8 448 So. Hill St., Los Angeles 13, Calif.

TUBE GIVEN WITH EVERY TIRE



NEEDLESS TO PAY MORE  
—RISKY TO PAY LESS  
EVERYONE

TAKE 10% DISCOUNT  
ON ALL TIRES

OUR GUARANTEE  
OUR TIRES must make good or WE WILL  
If You Want SAFE TIRES  
Be Wise—See Us Before You Buy  
Our Experience Insures Your Safety  
You get what we advertise  
Highest Quality Lowest Prices  
HIGH ORIGINAL TRENDS Slightly Used  
BUY IN CONFIDENCE safe dependable  
selected POPULAR BRANDS—Guaranteed  
to give A-1 SERVICE. These tires are  
absolutely NOT Re-caps or Re-molds.

REMEMBER: Tube SENT with EVERY tire regardless of QUALITY—PRICE or GRADE  
SELECTED for TOUGHEST JOBS Not just good... THE BEST  
These are genuine Values! One Trial will CONVINCE YOU

TOPS IN VALUE—TOPS IN SAFETY  
6.00-16 .. \$5.02 | 6.50-16 ..... \$4.72 | 7.00-16 ..... \$6.02  
6.50-15 .. 4.72 | 7.00-15 ..... 5.02 | 7.50-16 ..... 7.62

World's Best Truck Tire Values, Top Service, Minimum Prices  
6.00-20(6) \$9.22 | 7.50-20(10) \$13.92 | 11.00-20(12) \$16.42  
6.50-20(6) 9.22 | 8.25-20(10) 15.52 | 11.00-22(12) 18.42  
7.00-20(8) 10.52 | 9.00-20(10) 15.52 | 32x6 (8) 10.02  
7.50-20(8) 10.52 | 10.00-20(12) 16.22 | 32x6 (10) 12.82

7.50-20 MILITARY 8 PLY REGULAR \$9.62—SUPER \$12.92  
9.00-16 MILITARY 8 PLY REGULAR \$8.72—SUPER \$10.92  
ONE QUALITY THE BEST AVAILABLE

HERE'S MAXIMUM QUALITY IN THESE O. K. SAFE TIRES

6.00-16 .. \$3.42 | 6.50-16 ..... \$3.62 | 7.00-16 ..... \$4.42  
6.50-15 .. 3.62 | 7.00-15 ..... 3.72 | 7.50-16 ..... 5.62

6.00-20(6) \$7.72 | 7.50-20(10) \$ 9.02 | 11.00-20(12) \$13.42  
6.50-20(6) 7.52 | 8.25-20(10) 11.02 | 11.00-22(12) 15.92  
7.00-20(8) 9.02 | 9.00-20(10) 11.62 | 32x6 (8) 9.02  
7.50-20(8) 8.02 | 10.00-20(12) 12.22 | 32x6 (10) 10.92

OUR SPECIALTY—TIRES FOR SCHOOL BUSES AND  
AMBULANCES

Thousands of Tires Shipped to Satisfied Customers Through-  
out United States and Many Distant Points. Please Note:  
We've made Thousands of Friends by giving a Tube with  
Passenger and Truck Tires. MAIL ORDERS given Personal  
Attention—Send This Ad with Check or Money Order. Dep't. 5

STANDARD 834 N. Broad St., Phila. 30, Pa.

## Stucco Spraying Earns High Incomes

It's today's biggest business oppor-  
tunity in the building field. High  
returns from a low investment. Easy,  
fascinating work. Large waiting  
market because Colorcrete is applied  
over all kinds of old and new masonry  
surfaces — exterior and interior.



### Beautifies and Protects All Types of Buildings

Pneumatic pressure sprays plastic-like  
Colorcrete to give enduring beauty  
and water-resistant values. Range of 30  
gleaming colors; many textures. Easy  
to wash. Smartly modern. Write or  
wire today for Opportunity Portfolio.

**COLORCRETE** COLORCRETE INDUSTRIES, INC.  
572 OTTAWA AVE., HOLLAND, MICH.

## FOR BIG MEN ONLY!



"10 to 16—AAA to EEE"

We specialize in large sizes only—sizes  
10 to 16; Widths AAA to EEE. Wing  
Tips, Loafers, Moccasins. Hand  
Woven Oxfords, Dress Oxfords,  
Work Shoes, Sox. Styling specially  
designed for large sizes. Satis-  
faction guaranteed. Sold by mail  
only. Write now for FREE catalog.  
\$9.95 UP

Write  
For  
FREE  
CATALOG

KING-SIZE, Inc., 136, Brockton, Mass.

## The Signal that Softly Whistles "TAKE OFF THE BRAKE"

195

Send \$2.00  
and we  
prepay  
postage.

You'll never again drive  
with the hand brake on,  
because when you start  
the engine you hear a  
melodious whistle unless  
the brake is OFF. Put on  
with screwdriver. Oper-  
ates off hose to wind-  
shield wiper.



Guaranteed for life of  
car—Saves you cost of  
new hand-brake lining.

No letter necessary—just print name, address, year and  
make of car. Enclose check, M.O. or cash. Gladly sent  
C.O.D. plus charges. Money back in 10 days if not satisfied.

**MONARCH GOVERNOR COMPANY**  
DEPT. A 1 • 1832 WEST BETHUNE • DETROIT 6, MICH.

### OUT OF PAWN

GENUINE  
DIAMONDS

SAVE UP  
TO 50%

AND MORE  
Money-Back  
Guarantee



Approx. 1/2 Ct.  
Incl. Tax  
\$95  
\$200 VALUE

All diamonds reset in new mountings.

**BERMAN'S DIAMOND LOAN BANK**

DEPT. PS  
BERMAN BLDG., BALTO. 1, MD.  
Reference: Your Own Bank or Any Mercantile Agency

SEND FOR

FREE  
Diamond Catalog

**BERMAN'S  
Illustrated  
Catalog**

Diamonds  
from estates,  
banks, unredeemed  
pledges offered  
at substantial  
savings

VALUES FROM \$10  
TO \$10,000

### WHAM-O SPORTSMAN\*

HITS LIKE A.22 RIFLE—  
KILLS RABBITS, SQUIRRELS.  
For Hunting, Target,  
Routing Pests.

\$1.00  
postpaid



Dealers  
Write

HEAVY  
DUTY  
STOCK

A man's sport!  
Powerful, silent, accurate.  
Complete with 40 pellets and extra  
rubber straps. Send \$1.00 today to—  
Wham-O Mfg. Co., Box 13H, South Pasadena, Calif.  
\*PROFESSIONAL MODEL USED BY MEMBERS OF NAT'L SLINGSHOT ASSQ

## WILL YOU WEAR THIS SUIT



AND MAKE UP TO \$12.00 IN A DAY!

YOU CAN GET this fine, tailored-to-measure suit as a  
bonus, without paying one penny cash, by taking a few  
orders from friends. My plan also helps you make up  
to \$12.00 in a day without experience or house-to-  
house canvassing. Big opportunity—full or spare time.

Send for Samples—FREE! Write today for FREE CLOTH  
SAMPLES and "Sure-Fire"

money-making plans. For quick action write fully giving age, etc.  
SEND NO MONEY. H. J. Collin, PROGRESS TAILORING COMPANY,  
500 South Throop Street, Dept. V-220, Chicago 7, Illinois

## EXPORT PAYS BIG

World Trade firm offers men and  
women quick preparation for big  
pay positions or unlimited-profit  
businesses of their own. Mail  
order World-wide without capi-  
tal, from home; or travel abroad.  
Represent manufacturers. Past ex-  
perience not needed. Write today for  
FREE BOOK. State if veteran. Airmail reaches us over night.  
Mellinger Co., 1422-HG Westwood Blvd., Los Angeles 24, California

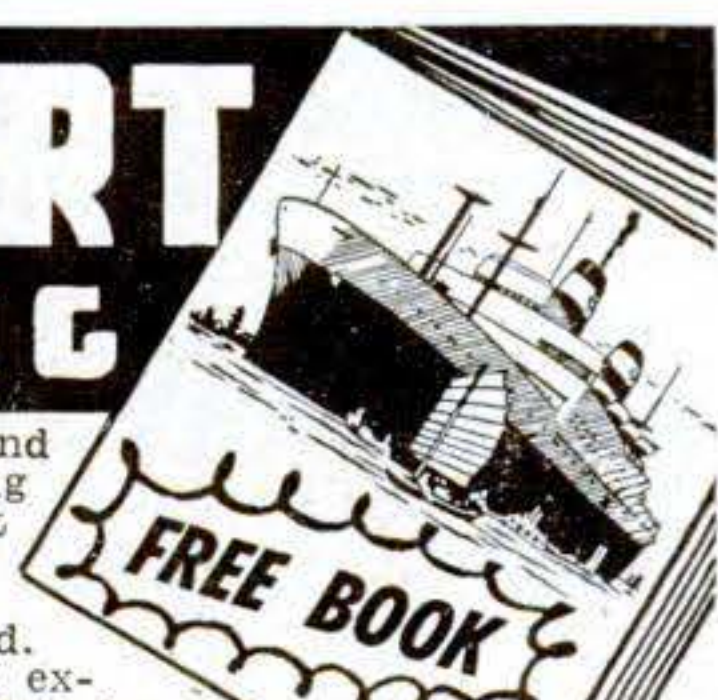

## PRINT YOUR OWN POST CARDS

COMPLETE  
OUTFIT  
only  
**\$7.50**

Amazing results in sales, inquiries and contacts . . . saves time and money . . . very easy to use GEM STENCIL DUPLICATOR is ideal for Advertising, Announcements, Notices, Labels, Forms, Price Lists—hundreds of uses for every type of business and organization. Comes complete with all supplies, instructions and 60-page Book of Ideas.

**FREE TRIAL OFFER:** Try it before you buy it! Write and a GEM OUTFIT will be sent you postpaid After 10 days, send only \$7.50 or return the GEM, no questions asked. The GEM must sell itself; you be the judge.

**BOND EQUIPMENT CO. • Dept. 151**  
6633 Enright • St. Louis 5, Mo.

**SEND NO MONEY • FREE TRIAL OFFER**



# HOW BLACK

should a black cat be?



Not an "ink-spot," without the sheen of silky fur and bristling whiskers. A WESTON Exposure Meter insures getting clear, brilliant pictures with every tone perfect, every time you use your still or movie camera. Correct color pictures, too. See the WESTON at your photo dealers today.

## WESTON *Exposure Meters*



*Master II*

The meter most photographers use!



### LEARN MEAT CUTTING

through actual practice. Profitable Meat Cutting and Self Service Meats taught easily, quickly. LEARN BY DOING at Toledo in just eight short weeks under actual market conditions. For beginners or men with experience. All subjects taught thoroughly and completely. Diploma. Job help. Get store of own. People must eat. School in operation over 25 years. Approved for GI training. Send today for FREE illustrated catalog. No obligation.

**NATIONAL SCHOOL OF MEAT CUTTING, Dept. 51-L, Toledo 4, Ohio**



### WOOD CARVING

9" TALL FIGURINE Postpaid in U.S.A. **\$1.85**

This beauty is easily carved in white pine with a mahogany and velvet base. Complete kit includes Material, Tru-Form templates and instructions. For more new and unusual projects send 10c for latest catalog.

**BRAUN-CRAFT** 1232 ETOWAH, DEPT. PS-21  
ROYAL OAK, MICHIGAN

**BURIED TREASURE, MINERALS  
AMAZING NEW GOLDAK LOCATORS**

**SENSATIONAL NEW MODEL!**  
ONLY 11 pounds weight! One hand operation! Money-Back Guarantee of Superiority. Write for full details.

**THE GOLDAK CO.**  
1544 WEST GLENOAKS BLVD.  
GLENDALE 1, CALIFORNIA



World's largest maker of fine locators.

### REAL DIESEL ENGINE

# \$2.95



**WE'RE CRAZY,** they tell us, giving away a real diesel engine, complete with cylinder and piston, carburetor, crankshaft and connecting rod. All parts completely machined, ready for easy assembly. **ONLY \$2.95.** How do we do it? We're selling thousands of DEEZILS. So production's up; costs tumble down. **DEEZIL** is a precision engine. Actually runs at 7500 RPM. Produces 1/7 HP. Ideal for planes, boats, midget cars. Send \$2.95 plus 25c postage today.

**GOTHAM HOBBY CORP.**  
107 East 126th Street New York 35, N. Y. Dept. "S"

# FREE

## parts catalog

**Build Better Trailers  
with Safety-Engineered**

- ★ Torq-less Axles
- ★ Bull Dog Hitches
- ★ Parking Jacks

... Send for your copy **TODAY!**



**HAMMER BLOW TOOL CO.**

Dept. D-35 Wausau, Wisconsin

## GOOD WEAR FOR WORK GOOD LOOKS FOR PLAY



REEVES Army Twill is a double duty fabric that's right for work and play. It's highly resistant to wear and tear, and its wide variety of vat dyed colors are fast to sun, water and perspiration. Being Sanforized\*, it can take repeated washings and still come up fresh and new. For better looks and longer wear—demand Reeves Army Twill.

\*Residual shrinkage less than 1%

**REEVES BROTHERS, INC.**  
54 Worth Street, New York 13, N. Y.



## E-Z CAR WASHER

SOAPS  
and  
WASHES

Can also be used to wash  
Windows, Walls, Boats,  
Porches, Cellars,  
Garage Floors and  
many other uses.

*in one operation*

Easily attached to garden hose  
—46" aluminum handle  
Built-in soap pouch, Replaceable mop  
Cars can be washed easily  
without getting yourself wet

### ORDER NOW!

Send \$3.50 check  
or money order.  
We deliver post-  
paid. Money back  
if not entirely sat-  
isfied.



## E-Z CAR WASHER

401 West 48th St., Dept. P.S. 5, New York 19

**\$3.50**  
POSTPAID

# Free for Asthma

If you suffer with attacks of Asthma and choke and gasp for breath, if restful sleep is difficult because of the struggle to breathe, don't fail to send at once to the Frontier Asthma Company for a FREE trial of the FRONTIER ASTHMA MEDICINE, a preparation for temporary symptomatic relief of paroxysms of Bronchial Asthma. No matter where you live or whether you have faith in any medicine under the sun, send today for this free trial. It will cost you nothing.

FRONTIER ASTHMA Co.  
462 NIAGARA ST.

890-C FRONTIER BLDG.  
BUFFALO 1, N. Y.

# Midget Camera 99c

## TAKE SECRET PICTURES



Midget camera only 2x3 inches! Actually conceal in palm of hand! Easy to carry, easy to use. Black & white or color pictures. Standard Eastman 828 film. Bakelite case, good quality lens and shutter. 8 pictures 1 3/4 x 1 1/2-in. on each roll. Beautiful enlargements. **99c**  
SPECIAL CASH PRICE .....  
Carrying Case, 50c; Black & White Film 35c Roll, 3 for \$1.00

JOHNSON SMITH & CO., Dept. 130, Detroit 7, Michigan

she's some **SMOOTHIE!**  
(YOUR CAR, THAT IS)

when equipped with

**ADVANCE "ULTRA DEEP-TONE" MUFFLERS**  
DUAL OR SINGLE STRAIGHT-THRU

Rich, low, mellow tone. Also greater power, speed, and economy result from reduced back pressure. Rugged steel tube, blow-out proof. Simple to install. No welding. Dual set comes complete with rubber mounted clamps, fittings.

**ADVANCE FENDER SKIRTS**

These heavy duty steel skirts will beautify and streamline your car. Tight fit, no rattle, easy to install, prime painted. Real top quality, not to be confused with cheaper, light weight makes.

**ADVANCE KI-YI AND RAZZ HORNS**

Get these novelty horns for laughs.

MAIL COUPON BELOW      DEALER INQUIRIES INVITED

**ADVANCE MUFFLER CO.** of Los Angeles, Dept. PS89  
1458 EAST COMPTON BLVD., COMPTON 3, CALIF.

- Send check, money order, or we will mail C.O.D. You pay postage upon receipt.
- |                                                                           |                                                                      |                                                     |
|---------------------------------------------------------------------------|----------------------------------------------------------------------|-----------------------------------------------------|
| <input type="checkbox"/> Dual Muffler Set (Ford Mercury only) ... \$19.95 | <input type="checkbox"/> Single Muffler (other makes) ..... \$5.50   | <input type="checkbox"/> Fender skirts, pr. \$12.95 |
| <input type="checkbox"/> Single Muffler (Ford, Chev., Plym.) ... 4.86     | <input type="checkbox"/> 2 1/2" Chrome tail pipe tips . ea. ... 1.75 | <input type="checkbox"/> Ki-Yi Horn, each 3.25      |
| <input type="checkbox"/> Razz Horn, each 3.25                             |                                                                      |                                                     |
- Send free catalog showing complete line.

Car make \_\_\_\_\_ Year \_\_\_\_\_ Model \_\_\_\_\_  
Name \_\_\_\_\_  
Address \_\_\_\_\_ City \_\_\_\_\_ State \_\_\_\_\_

## One Swipe of NEW PLASTIC Makes these LEATHER and LEATHERETTE Items LIKE NEW

### Get Into A Money Making Business

Make like new, worn, scuffed or faded leather and artificial leather equipment. Either your own to renew, recolor and beautify, or cafe, restaurant and hotel equipment as a business. Single stroke with a brush renews. Does not crack, peel or scuff. Resists acid, alcohol, caustics and weather. All colors. Mail coupon for free sample.

## FREE Sample SHOWS EFFECT

### \$50 to \$500 Profit On One Job Possible

Let me show you how, as I have shown others. Get your own exclusive territory while available. Mail coupon today, I'll do the rest. — Jack Edwards, Sales Mgr.

**LEATHER-NEW PRODUCTS,**  
6082 Suney Slope, Kansas City, Mo.  
Send me without obligation a sample of Leather-New coated material so I can inspect it.

Name \_\_\_\_\_  
Address \_\_\_\_\_  
City \_\_\_\_\_ State \_\_\_\_\_



# MAKE YOUR OWN!

WITH

## Griffin READCUT LEATHER PROJECTS

Over 100 KITS in every kind of Tooling and Carving Leather, accurately cut, all parts included. Only Top Grade Leathers used. You do the choosing. You do the tooling, carving, stamping, the punching and assembling.



SEND FOR COMPLETE CATALOG Please send 10c to cover mailing.

SINCE 1924

OUT OF THE WEST, THE HOME OF LEATHER CARVING

**Griffin Craft Supplies**

5515-B GROVE STREET  
OAKLAND 9, CALIFORNIA

### EVERYTHING FOR THE LEATHER WORKER

Largest, most complete stock of *Leathercraft Tools and Accessories* in U.S.A.



HIDES AND SKINS of Craft Leathers of every kind if you prefer to cut your own.

# "EVEREADY"

BRAND

The Flashlight Battery With "Nine Lives"

*Recovers Power Between Uses—  
Bounces Back for Extra Life!*



FOR GREATER ACCURACY • DEPENDABILITY YOU WILL WANT THIS PRECISION MADE **17 JEWEL SWISS WATCH**

CHECK ALL THESE FEATURES:

- Waterproof
- Shockproof
- Anti-Magnetic
- Radium Dial
- Sweep Second Hand
- Chrome Case with Stainless Steel Back

SPECIAL! A sturdy stainless steel expansion band furnished with every watch. Order this smart, dependable watch today! **One year guarantee.** Send no money. Pay postman or save C.O.D. charges—send check or money order. Satisfaction guaranteed or your money promptly refunded!

Registered Jewelers, Dept. 1214,  
545 Fifth Ave. New York 17, N. Y.

ONLY \$23.75

(Includes Fed. Tax)

# MAKE EXTRA MONEY

*Selling Christmas Card Box Assortments*

Also 25 and 50 cards for \$1.00 with name imprinted. Personalized stationery. Rush name.

Samples on approval.

GENERAL ART CO., 225-4th Ave., N. Y. 3, N. Y.

## LAWNMOWER SHARPENER OPERATORS

Increase your output...  
Year 'round business!

**NEW BED KNIFE GRINDER**  
sharpens all  
**STRAIGHT EDGE TOOLS**

**Model 50 Ideal Bench Grinder**  
doubles your output of sharpening jobs, speedily grinds straight blade knives. Sharpens all kinds of straight edge tools and ice skates. Write for FREE, fact-filled folder.

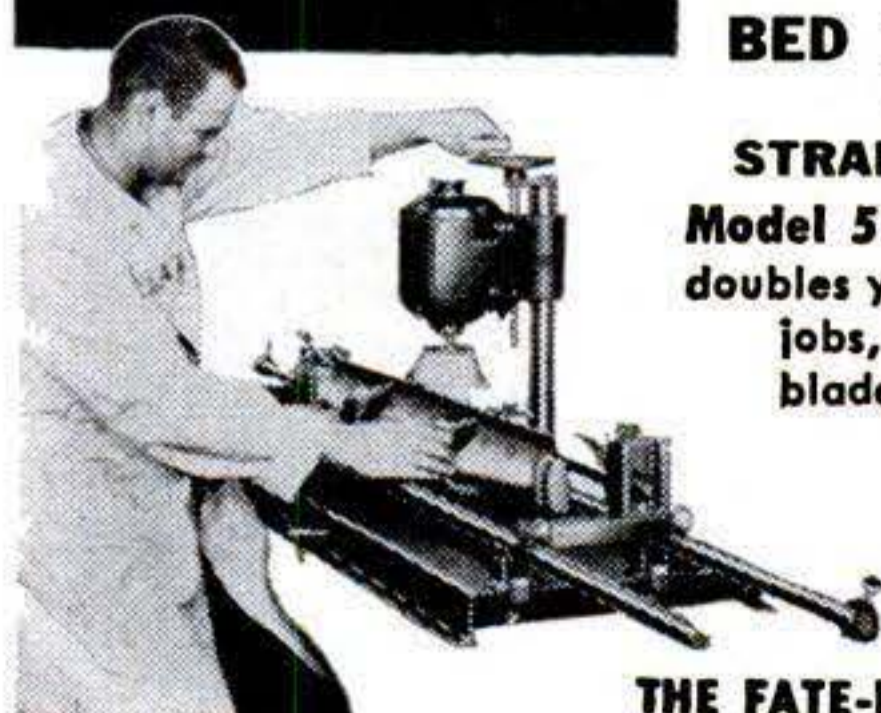

THE FATE-ROOT-HEATH COMPANY  
Dept. D-4, Plymouth, Ohio

"Just bought my third **CROSLEY**"



"I am over six feet tall. I bought the second Crosley ever sold in Baltimore by the Freedom Motor Company," writes Mr. George Kachaylo of Baltimore, Md. "I have since purchased another Crosley for myself and also one for my mother. I have previously owned seven cars but from now on it's Crosley for me!"

Take a tip from over 60,000 Crosley owners. Get a Crosley, the smart, new American car everyone can afford. Hundreds of improvements including amazing Hydradisc brakes, ultra-modern hydraulic brakes of the type used on the biggest planes. New CIBA (Cast Iron Block) engine—larger, longer body lines—luxury interior appointments! Real economy! Up to 50 miles a gallon, and prices that range downward from the Station Wagon at \$929 F.O.B. Marion, Ind. Free—New Catalog of all 5 new passenger and commercial models. Write name and address in margin of this ad, tear off and mail to Crosley Motors, Inc., 2530-JH Spring Grove Ave., Cincinnati 14, Ohio.



a FINE car

Can You Equal This Home for \$2475

Shipped Direct from Our Mill



Save 30% to 40% on Your New Home..



Don't pay several hundred dollars more than necessary when you build a home! Buy it direct from our mill at our low factory price. We ship you the materials—lumber cut-to-fit, ready to erect. Paint, glass, hardware, nails, etc., all included in the price—no extra charges. Plans furnished—also complete building instructions. No wonder our customers write us that we saved them 30% to 40%. Prices subject to change without notice.

Handsome Big CATALOGUE

Pictures wonderful homes in colors at money-saving prices. Designs to suit everyone. Send 25c for catalogue today.

**LEWIS MANUFACTURING CO.**  
1398 Lafayette Ave., Bay City, Mich.

BIG BOOK of House Plans in Colors 25¢

# FREE ALLIED'S LATEST RADIO CATALOG!

Radio's Biggest Values  
SEND FOR IT TODAY

## Everything in Radio At Lowest Prices!

See the latest ALLIED Catalog for greatest values in Television receivers, latest radios and radiophones, high-fidelity custom sound components, recorders, sound systems, Amateur receivers and station equipment. Everything for Builders and Experimenters—thousands of parts, tubes, test instruments, tools, books, diagrams and kits. World's largest stocks—all at really low-money-saving prices. Get your Free ALLIED Catalog now!



The **DEPENDABLE** Radio Buying Guide

**FREE CATALOG**  
Send for it

## ALLIED RADIO

833 W. Jackson Blvd., Chicago 7, Ill. Dept. 7-H-9

Rush FREE ALLIED Catalog.

Name .....

Address .....

City ..... State .....



### WHOLESALE SLIGHTLY USED TIRES DIRECT TO YOU

(10% discount on 4 or more tires if you send this ad with order)

TUBE DELIVERED WITH TIRE AT NO EXTRA COST

Safe—Our tires used on school buses and ambulances  
All good tires with a

#### GOLD BOND GUARANTEE FOR 12 MONTHS

550-16 \$3.54	600-20 .....\$7.98	825-20.....\$11.19	1000-22.....\$17.70
600-16.... 3.59	30-5 ..... 7.98	900-20.... 11.89	1100-22.... 16.89
650-16.... 3.89	650-20..... 7.69	1000-20.... 12.89	900-24
700-16.... 4.59	700-20 (8).. 9.29	1100-20.... 13.89	(40-8).... 21.60
550-15.... 3.79	700-20	1200-20.... 18.78	900-16..... 8.98
650-15.... 3.89	(10) .....12.48	750-24	825-15
700-15.... 3.98	750-20 (8).. 8.19	(36-6).... 12.21	(14 ply) 14.10
550-17.... 5.69	750-20	38-7	750-15
750-16.... 8.40	(10) ..... 9.19	(825-24).. 13.75	(12 ply) 11.30

#### Exceptionally good tread—No recaps—With a GOLD BOND GUARANTEE FOR 24 MONTHS

550-16 .....\$5.19	450-21 .....\$6.25	825-20 ..\$15.98	600-20 ....\$ 9.75
600-16 ..... 5.29	475-19 ..... 6.35	900-20 .. 15.98	650-20 .... 9.75
650-16 ..... 5.29	525-18 ..... 6.69	1000-20 .. 16.89	700-20 .... 10.98
700-16 ..... 6.29	550-17 ..... 7.99		32-6(8).... 10.49
550-15 ..... 4.81	650-15 ..... 4.98	700-15 .. 5.29	32-6(10).. 13.75

<b>GOLD BOND SPECIAL—750-20 MILITARY TIRES</b>			
Will fit 650 x 20	700 x 20 (8 & 10 ply)	34 x 7 (8 & 10 ply)	
Special.....	\$10.49	Guaranteed 12 months	
Superior Quality.....	12.98	Guaranteed 18 months	
Gold Bond Finest.....	14.98	Guaranteed 24 months	
900 x 16 Special.....	9.03	900 x 16 extra	\$11.19

Send check or money order with this ad

**GOLD BOND TIRE CO., Dept. PS 24**  
512 NORTH 1ST ST., RICHMOND, VA.

"A gold bond written guarantee with every tire"

## World Famous EASY TO ASSEMBLE PACKAGED BOAT KITS



18 models—8 to 18 Ft.

1949 line—many new models—increased performance—simplified assembly. All parts pre-cut, frames pre-assembled. Send 25c (coin) for literature. Literature plus booklet "Plywood Boats," \$1.00.



### BOAT PATTERNS-BLUE PRINTS

100 designs by Deed, Lord, Crandall, etc., plank, steel, and plywood types 6-35 ft. Detailed blueprints, full-size paper patterns. Catalog 35c (coin). Catalog and booklet "Boat Building" \$1.00.

MARINE MART-DEPT. 23-BUFFALO 7, N. Y.

## BROKEN JEWELRY WANTED

All kinds, Highest cash prices paid for rings, jewelry, spectacles, gold teeth, diamonds, broken and usable watches, etc. Cash mailed promptly. Write for FREE shipping container.

**LOWE'S**

Dept. PS, Holland Bldg., St. Louis, Mo.



## WORLD'S LOWEST PRICED ADDING MACHINE

IDEAL FOR BUSINESS AND PERSONAL USE—GUARANTEED ACCURATE. Not a toy. Operates with only a finger flick. Adds, subtracts, multiplies, divides. Counts up to one billion. Pays for itself over and over. Ideal Gift—for Business, Income Tax and School use. MONEY BACK GUARANTEE. Send name and address. Pay postman only \$2.95 plus postage. (Send full cash if outside U.S.) Beautiful rich-looking Leatherette Case included at no extra cost. MONEY back in 10 days if not delighted. AGENTS WANTED.

CALCULATOR MACHINE CO., (Mfrs.)  
Dept. 515, P. O. Box 248 Glenview, Illinois

Army 16 Jewel waterproof wristwatch, Elgin or Bulova. \$42.50 value.....	<b>\$19.50</b>
New Canvas Roll Carry-All for sportsmen and general use. Gov. surplus. \$12.50 value.	<b>2.25</b>
Binocular Cases, all leather, 6 x 30, \$5.00 and \$7.50. 7 x 50.....	<b>7.50</b>
Engineers Metal Army Type SIGHTING LEVELS, new.....	<b>2.00</b>
TELESCOPES, U. S. Navy, 16 power, wood cabinet, length 31 in., focusing eyepiece, 2 3/4 in. objective lens.....	<b>29.50</b>
	<b>35.00</b>

**PUBLIC SPORTS SHOPS**  
11 SOUTH 16th ST., PHILA. 2, PA. (No COD's)

## Thompson BEATS the World on BOATS



**Better Built Lower Prices**



Canoes

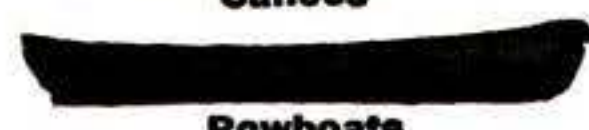

Rowboats



Outboards

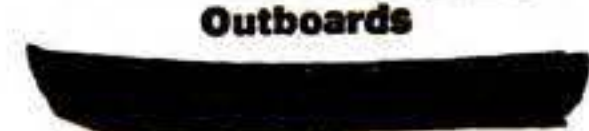

Light Boat for Auto

**Safe Boats With Full Length Spray Rails**  
Keep passengers perfectly dry—even at high speeds. Catalog also shows two new models of "Take-Along" Boats. Two big factories—save you freight.

**CATALOG FREE**  
Write for your copy. State kind of boat in which you are interested.

**THOMPSON BROS. BOAT MFG. CO. (151)**  
219 Ann St. (Write to either place)  
PESHIGO, WIS. 119 Elm St. CORTLAND, N.Y.

# MARVEL INVERSE OILER

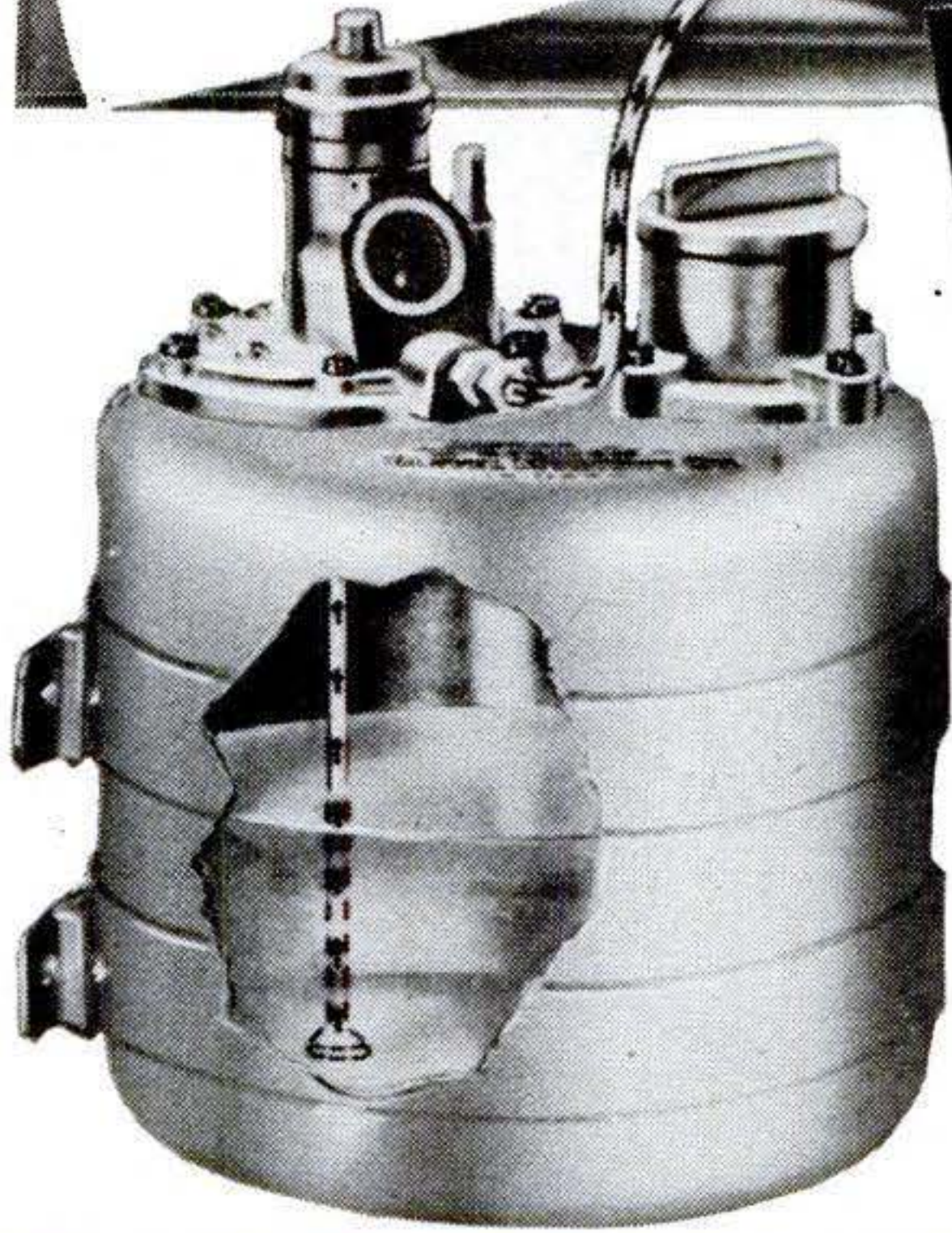

**Protected Power  
FOR YOUR CAR!**



The power and performance of your car, truck or tractor depend on lubricant protection for *every* engine part. Yet vital valves, pistons and cylinder walls operate so HOT that ordinary lubricants can't do their job. Guard these essential parts! Install a compact Marvel Inverse Oiler . . . it meters Marvel Mystery Oil *directly* to the top cylinder zone. And Marvel resists heat . . . it's expertly compounded to hold up where ordinary lubricants fold up! Enjoy surging *protected power* with the Marvel Inverse Oiler and Marvel Mystery Oil.

**Easily Installed**

**EMEROL MANUFACTURING CO., INC.**  
242 W. 69th Street, New York 23, N. Y.

**WRITE  
FOR THE  
FACTS—  
NOW!**

**"TOOK IN \$217  
FIRST 10 DAYS"**

Some Make More,  
Some Less . . .

**We Help You  
to Start Your Own  
All-Year Business,  
Make Big Money!**

With our easily operated, highly efficient wall washer, Chas. Stelle took in \$217 gross in first ten days. E. L. Goss took in more than \$10,000 in one year. E. C. Taber wrote, "I made \$400 gross in two weeks." And no wonder—this machine washes walls 6 times faster and better than by hand.

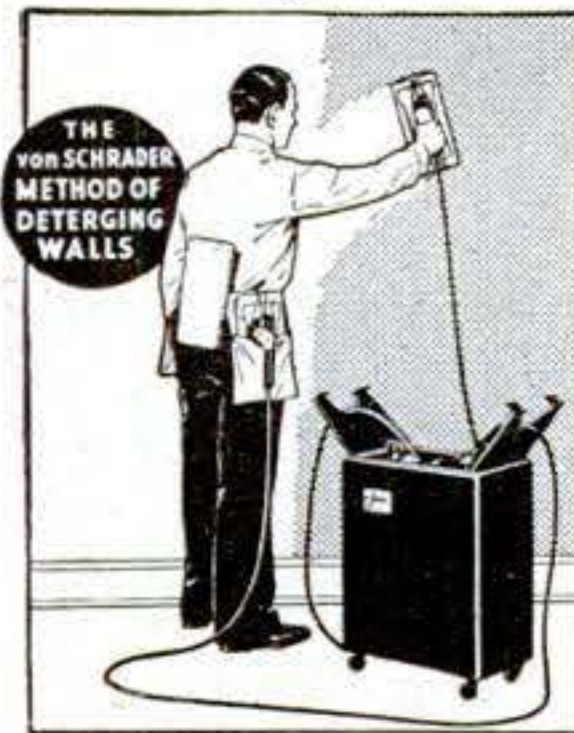

**YOUR MONEY-MAKING OPPORTUNITY**

We want more men to go into this profitable business for themselves and enjoy independence. There are customers everywhere—homes, offices, schools, churches, hotels, stores, etc. What you take in is mostly profit, for material costs are low. And there's no need to rent a shop or office. Operate your business from your home.

Lose no time. Get all facts without obligation. **WRITE FOR FREE INFORMATION.** Ask for Wall Washer Details at once.

**VON SCHRADER MFG. CO., CC-93, Racine, Wis.**

# BUILD YOUR OWN DARKROOM



—gamerom, laundry, or any extra room. You can do it easily, quickly and at low cost with Gold Bond Gypsum Wallboard. Big lightweight panels are fire-proof, moisture resistant and easy to nail. Then paint with Gold Bond Sunflex, the low cost wallpaint . . . dries in one hour. Get both at your local Gold Bond Lumber and Building Material Dealer's.

*Free Book of suggestions*



**NATIONAL GYPSUM COMPANY,**  
Dept. J-2, Buffalo 2, N. Y.

Gentlemen: Send free copy of new Book-let, "Modernizing Magic" showing remodeling ideas and methods:

Name .....

Street .....

City ..... State .....

*(Please print name and address.)*

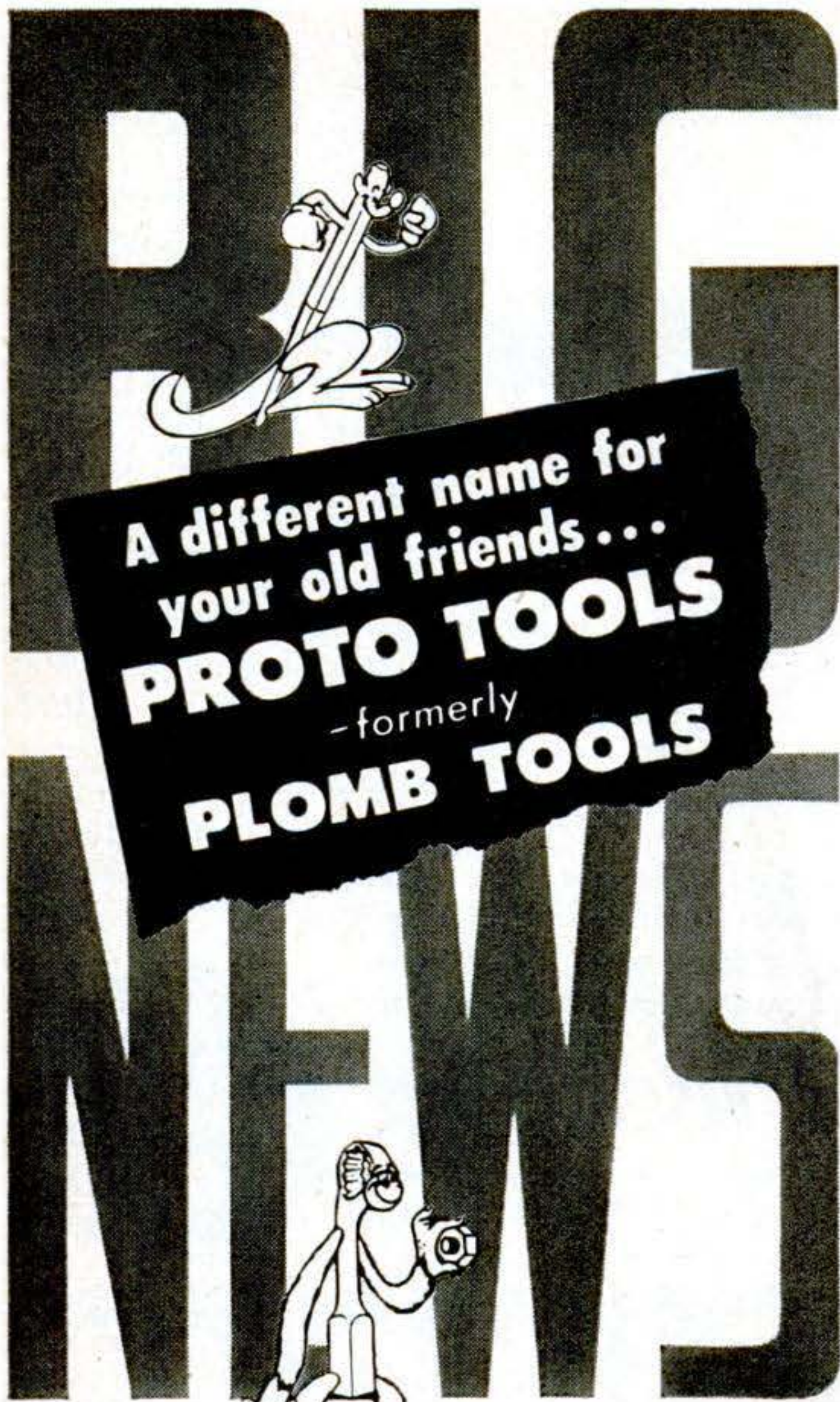

A different name for  
your old friends...  
**PROTO TOOLS**  
-formerly  
**PLOMB TOOLS**

In your work, you deserve the best. And that means you deserve PROTO tools —formerly Plomb tools. They've been the favorites of professionals for 42 years because of their superior designs and extra long life. Buy them today from your dealer.

Write for catalog to  
**PLOMB TOOL COMPANY**  
2257L Santa Fe Ave., Los Angeles 54, Calif.

4984



*I'd like  
to see them  
make...*

Everybody has his own pet idea of some gadget he would like to see in general use. What is YOURS? Popular Science will pay \$5.00 for each one published. Use government postcards only. Contributions cannot be acknowledged or returned.

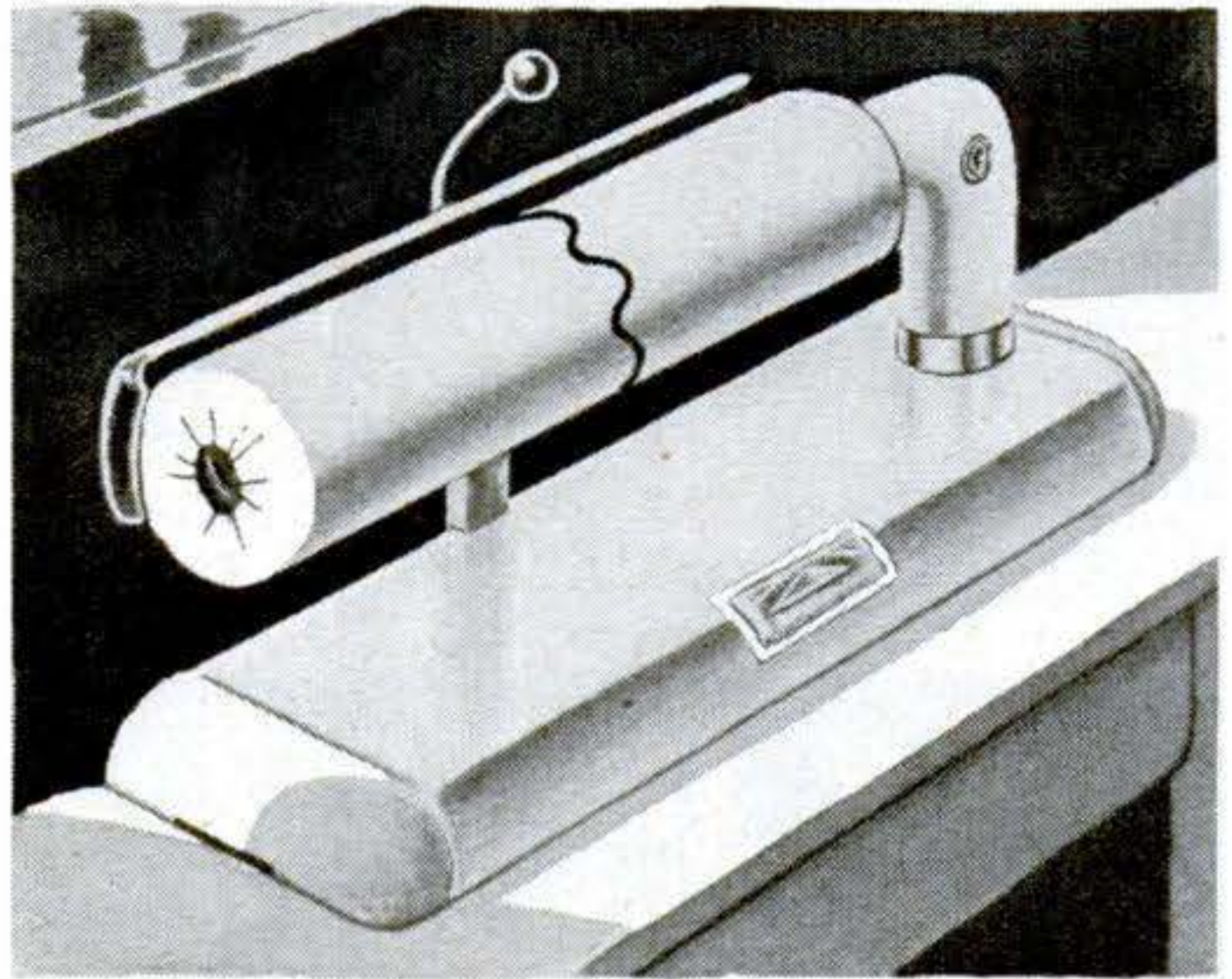

**Safety markings on home ironers.** It's often difficult to see when the roller is revolving. A wavy line on the roller cover would show at a glance when the machine was operating.—*Herbert E. Fey, New Braunfels, Tex.*

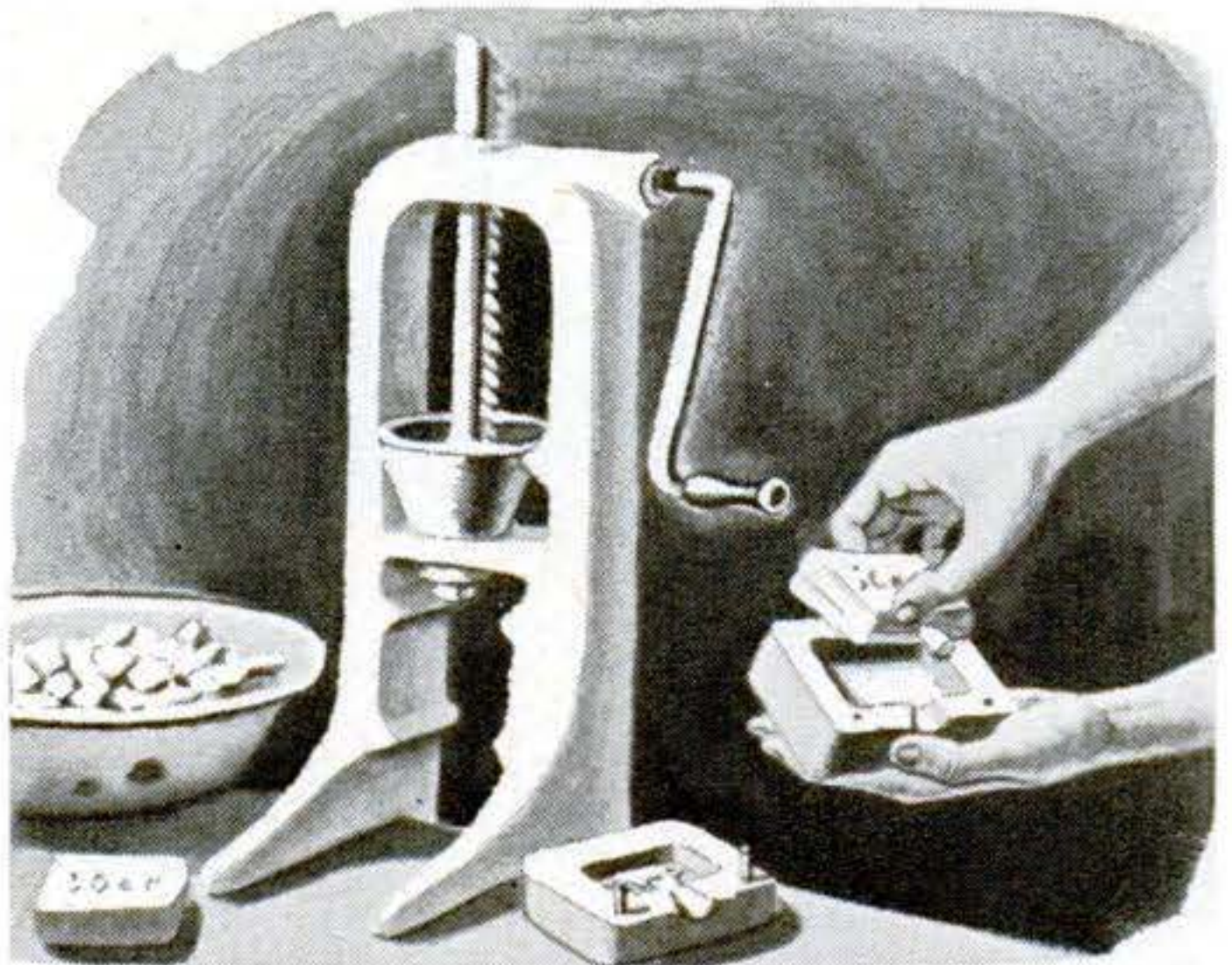

**A home soap press.** Working on the principle of an injection molder, this gadget would take accumulated small slivers of soap and squeeze them into one cake. Unless dry, they'd pack solidly.—*Eric St. Clair, Richmond, Calif.*

IF YOUR ARCHERY TURNS  
OUT LIKE THIS...IT'S TIME  
FOR NEW ARROWS...

and

IF YOUR CAR FEELS LIKE THIS  
IT'S TIME FOR MARFAK  
CHASSIS LUBRICATION

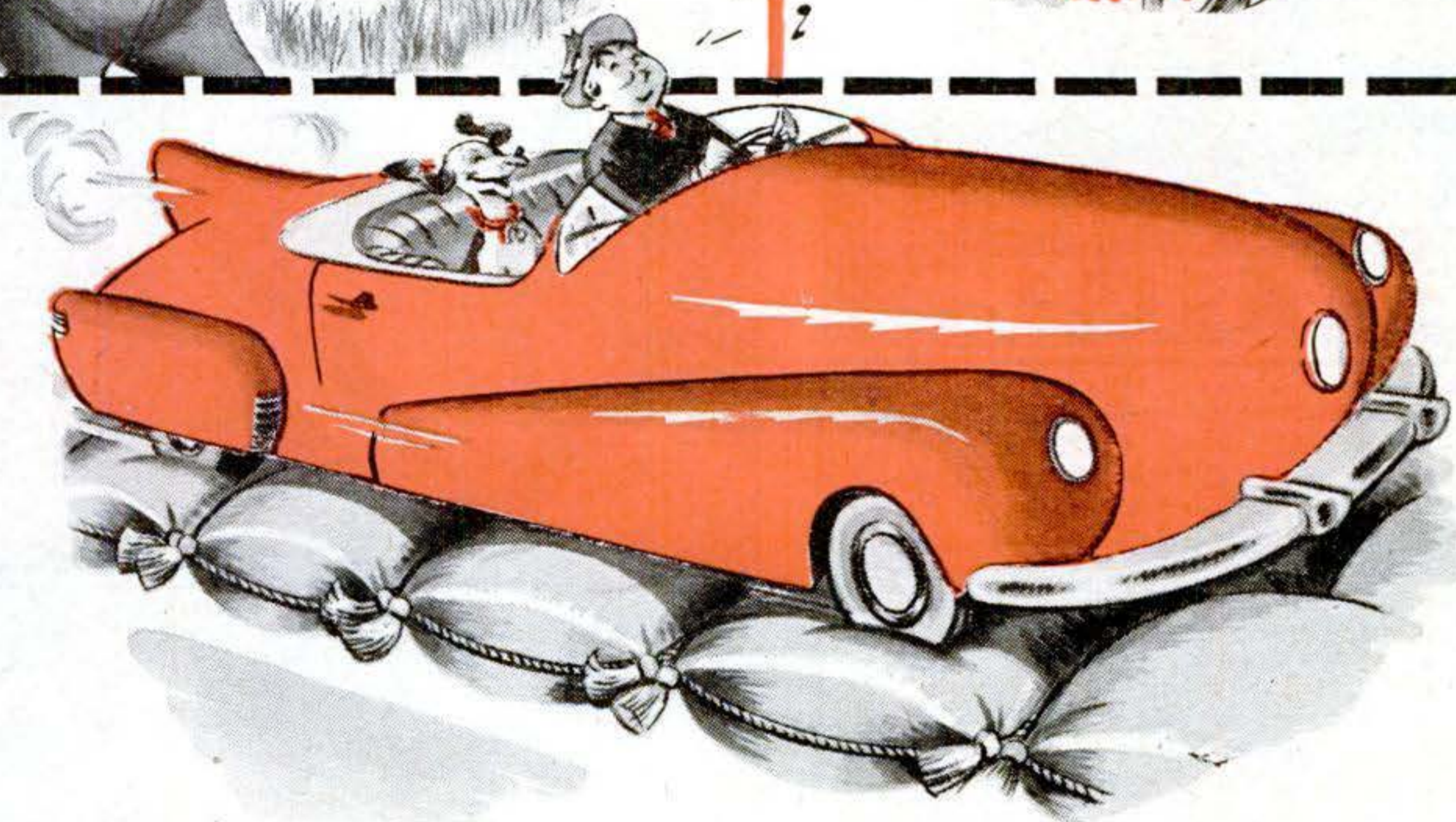

THAT CUSHIONY FEELING LASTS LONGER WITH MARFAK!

You can't beat *Marfak* lubrication for *longer-lasting* chassis protection. *Marfak* is specially compounded for extra toughness. Protects bearings and wear points against costly friction for 1,000 miles and more. *Marfak* resists wash-out, squeeze-out, shock. That's why you get that grand "cushiony" driving that lasts. Get *Marfak* lubrication today at your friendly neighborhood Texaco Dealer, *the best friend your car ever had.*



**THE TEXAS COMPANY**  
**TEXACO DEALERS IN ALL 48 STATES**

*Texaco Products are also distributed in Canada*

# Last Year's Profit \$3,000!

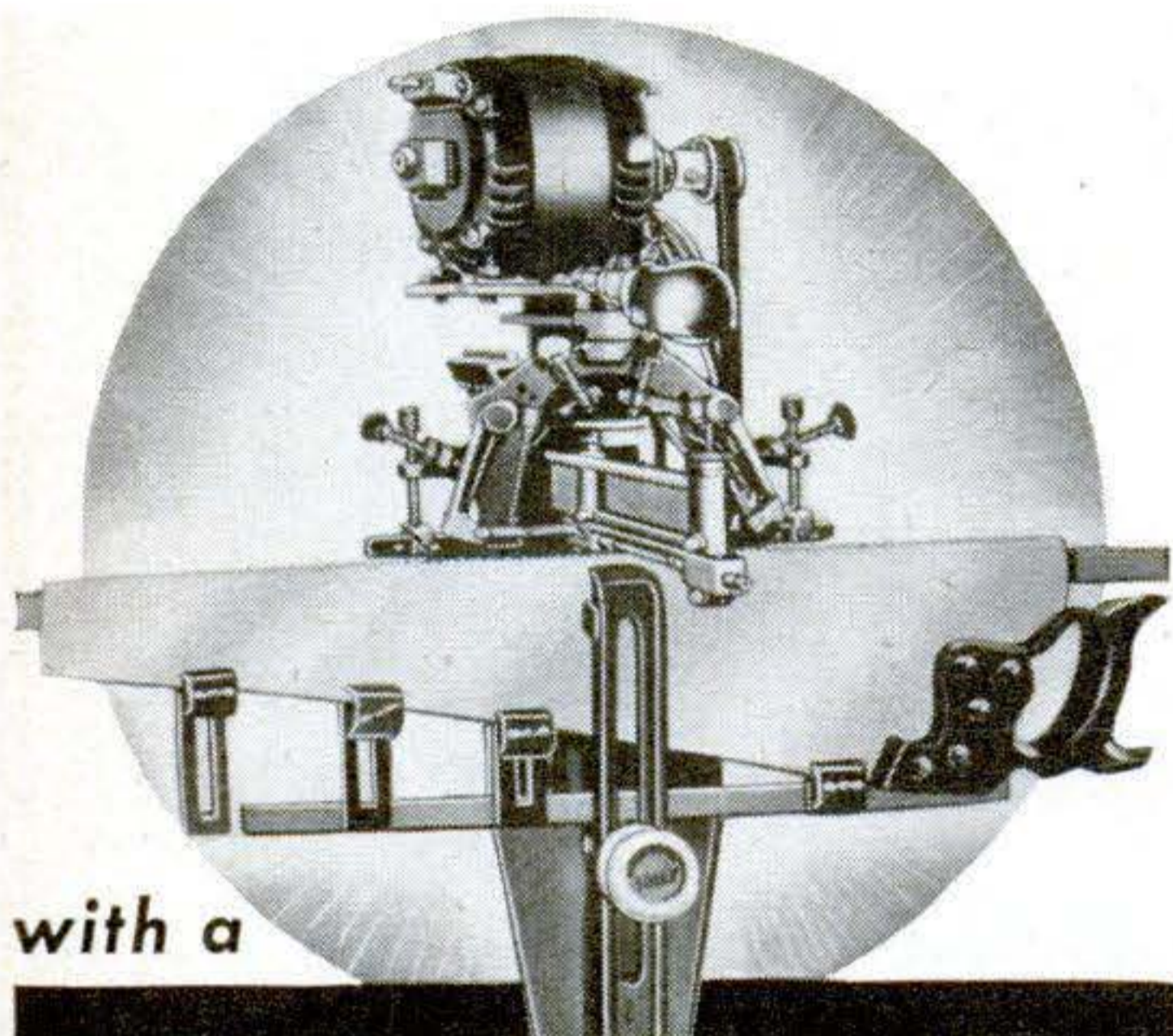

with a

## FOLEY automatic SAW FILER

"Last year's profit amounted to \$3,000. Not so bad for a one-man outfit"—from Chas. C. Hough.

From Ohio James B. Williams wrote us—"I made \$765 last year filing saws, and it sure comes in handy. I do this work in my spare time". Men in communities of all sizes make up to \$2 or \$3 an hour with the Foley Saw Filer working full time or part time. That extra money comes in mighty handy.

It's no trick to take care of the saw filing for your neighborhood hardware or lumber dealer—plus looking after the saws for farmers, townspeople, manual training departments and factories. The Foley files all hand saws, also band and cross-cut circular saws. It's a cash business, no canvassing, no eyestrain and no experience needed.

### FREE BOOK SHOWS HOW TO START

INDEPENDENCE AFTER 40 shows just how you can start at home in your spare time working in your basement or garage. It's an immediate cash business that can develop into a full-time repair shop.



### Send For FREE BOOK

FOLEY MFG. CO., 819-9 Foley Bldg.  
Minneapolis 18, Minn.

Send me free book "INDEPENDENCE AFTER 40".

Name.....

Address.....

I'd like to see them make . . .



**Childproof sections in medicine cabinets.** If a small compartment—built into one of the shelves—could be locked, dangerous drugs could be kept from kids. It'd also help stop mistakes caused by sleepiness.—W. Beglen, Pittsburgh.

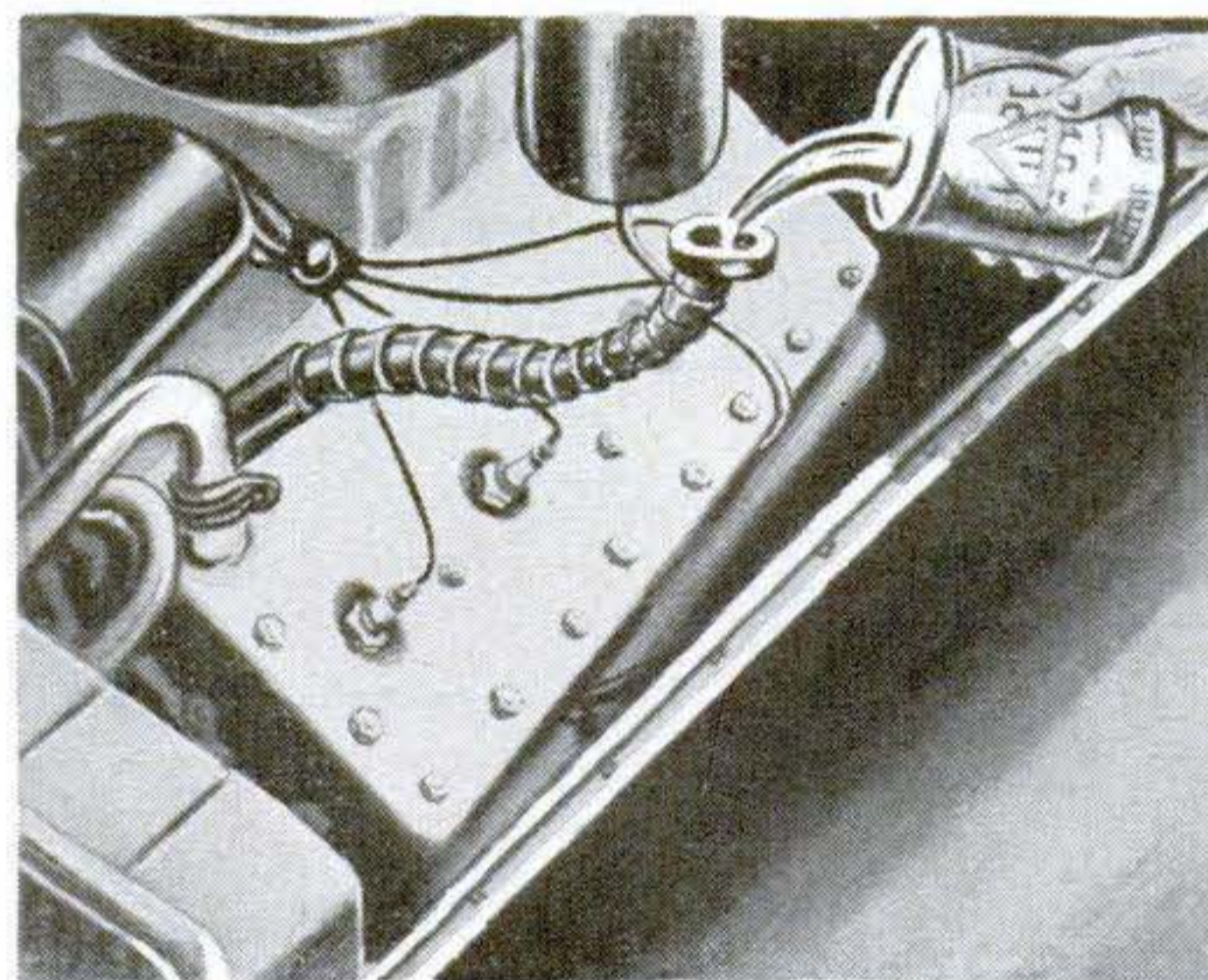

**Telescoping oil filler pipes.** They could be pulled out and turned to the most convenient angle for pouring oil into the crankcase from ordinary containers. Less oil would be spilled on the engine.—Noble Peeler, St. Paul, Minn.

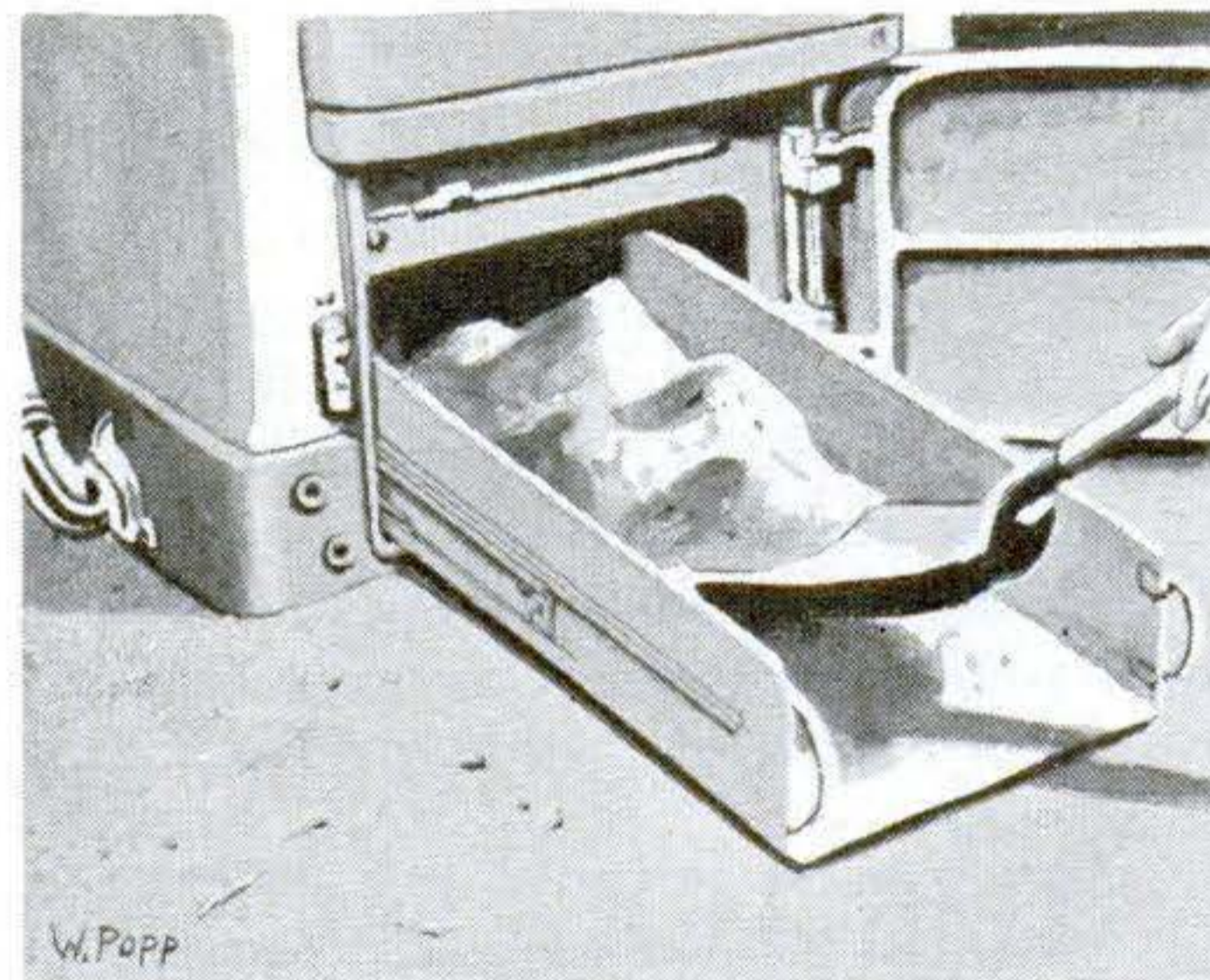

**Rolling ashpans.** Tracks and rollers similar to those on the drawers of filing cabinets would let you roll the ashpan out of the furnace for easy removal of the ashes.—Douglas Verduin, Hawthorne, N. J.

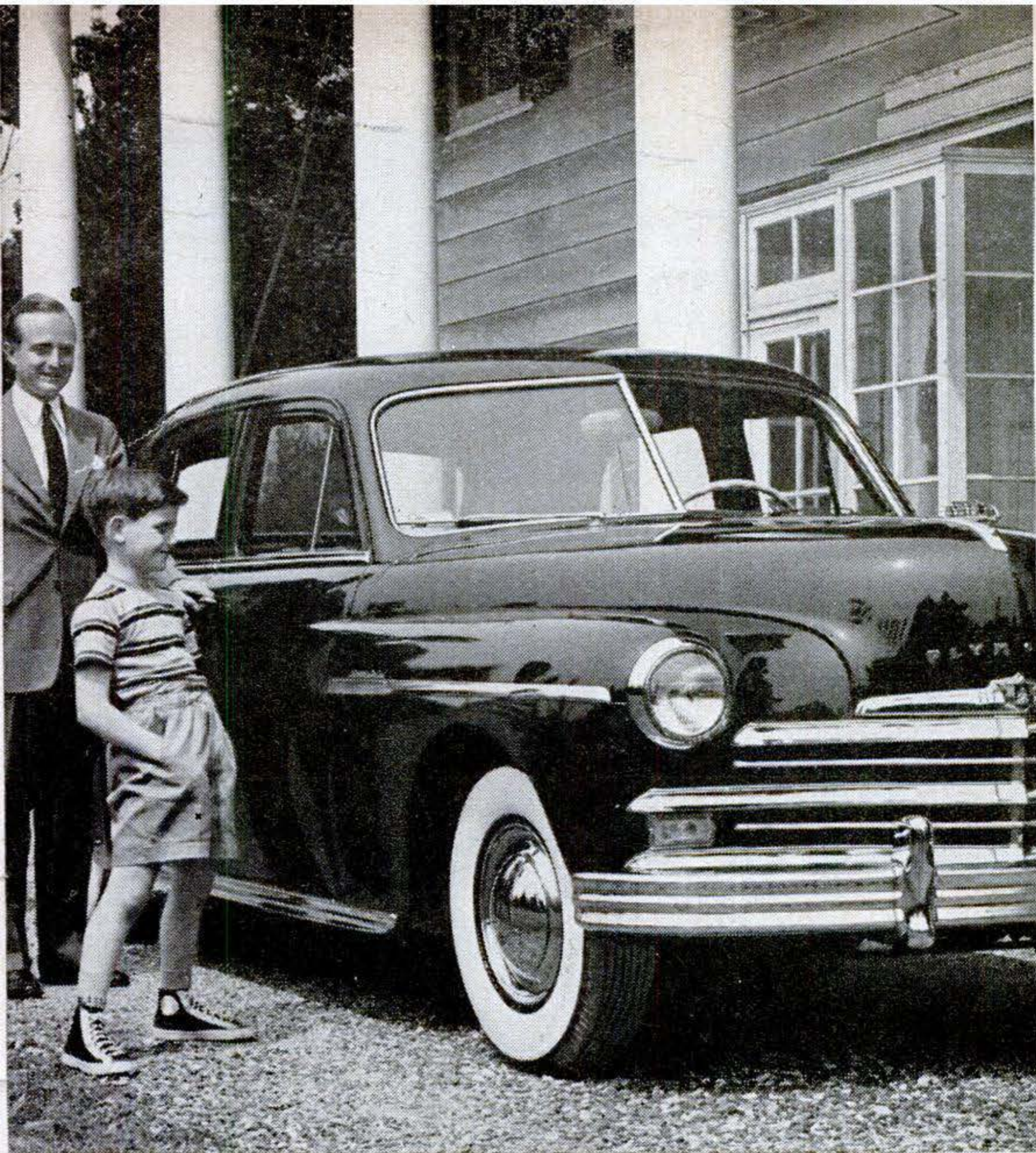

*White sidewall tires and chrome wheel covers optional at extra cost.*

The car that  
likes to be  
compared

NEW

# PLYMOUTH

Yes, it likes to be  
compared for **SAFETY**, too!

**Hear** the soft click, solid-sounding as a bank vault, when you slam a door. Box-type construction of important steel members, and many other engineering improvements give the body and frame 23% greater rigidity.



**See** ahead through a windshield now 37% larger. See back through a 35% bigger rear window. See the road with clear, control-tower visibility.



**Hold** the road easily in case of tire failure. Safety-Rim Wheel keeps the tire straight on the rim — and, as always, Safe-Guard Hydraulic Brakes slow you to a safe, sure stop.

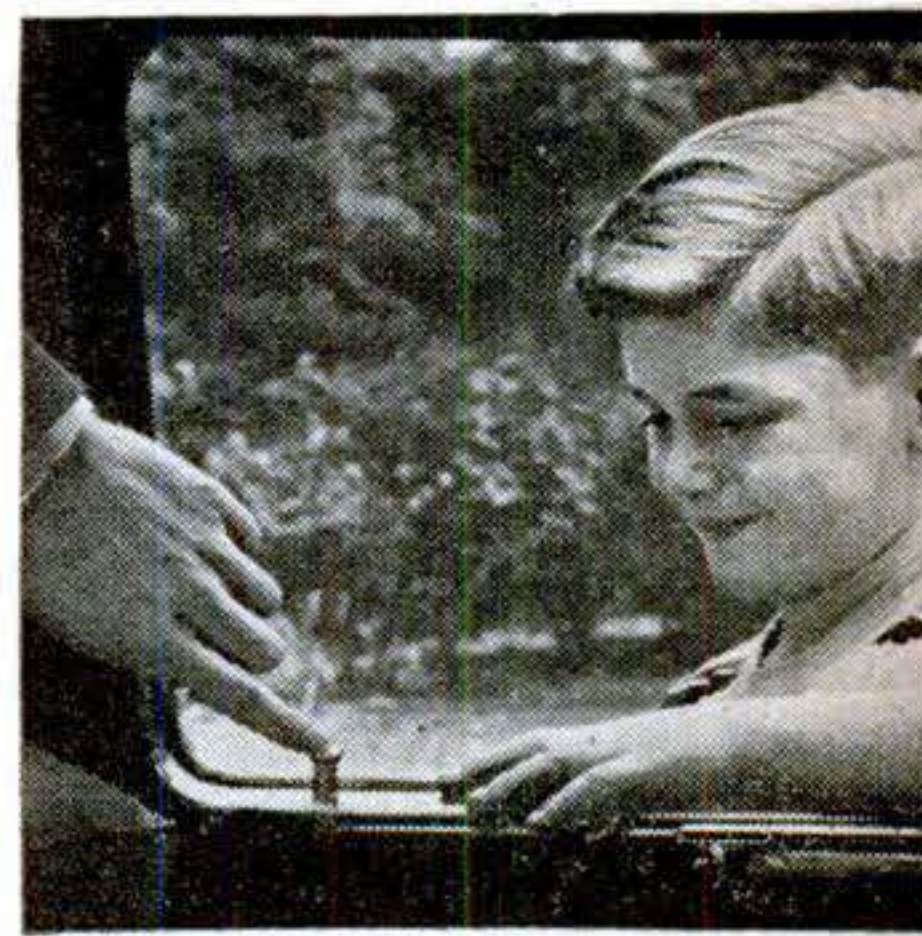

**Press** the safety lock and rear doors can't be opened from the outside or accidentally from the inside. And all doors are hinged in front.

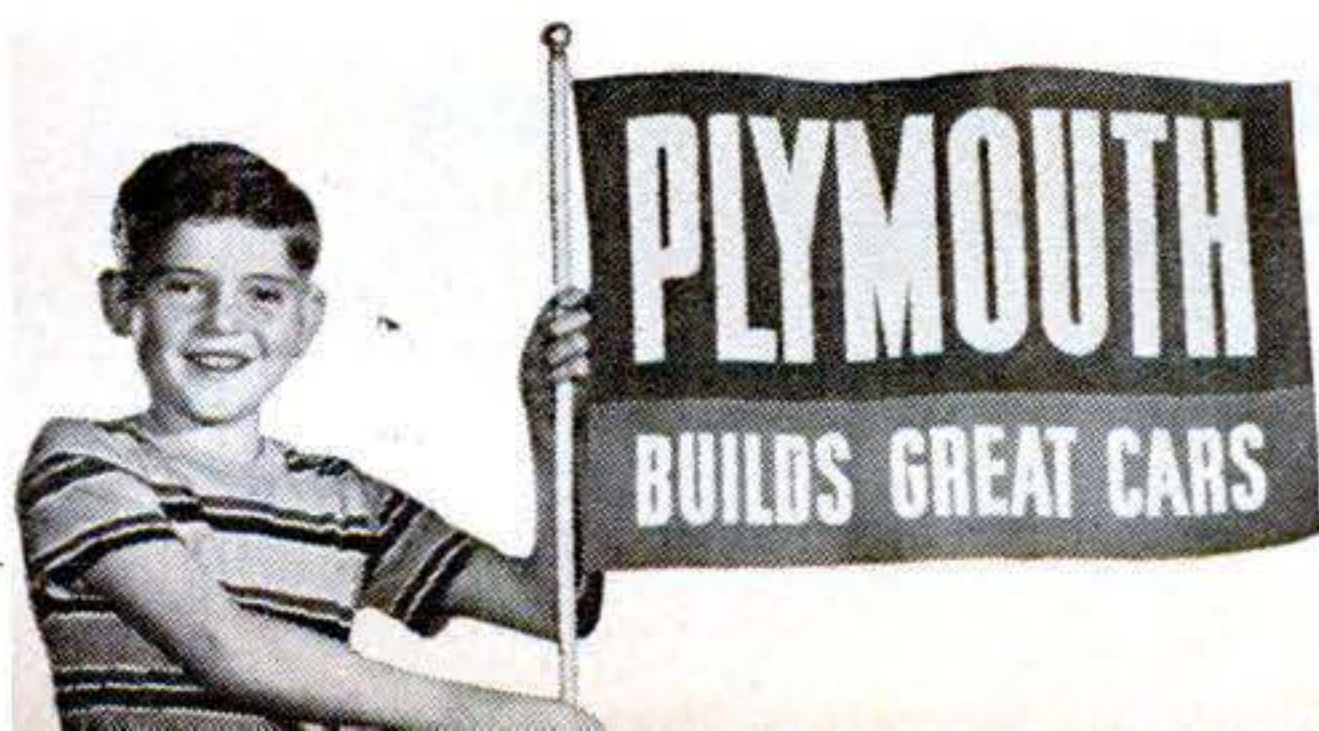

**Check** the new Quality Chart at your nearby Plymouth dealer's. Of 22 Quality Features found in most high-priced cars, you'll see that low-priced Plymouth has 21, low-priced car "A" has 13, and low-priced car "B" has 4. Then as a final clincher, take the wheel. Drive the Plymouth—let the ride decide!

PLYMOUTH Division of CHRYSLER CORPORATION, Detroit 31, Michigan

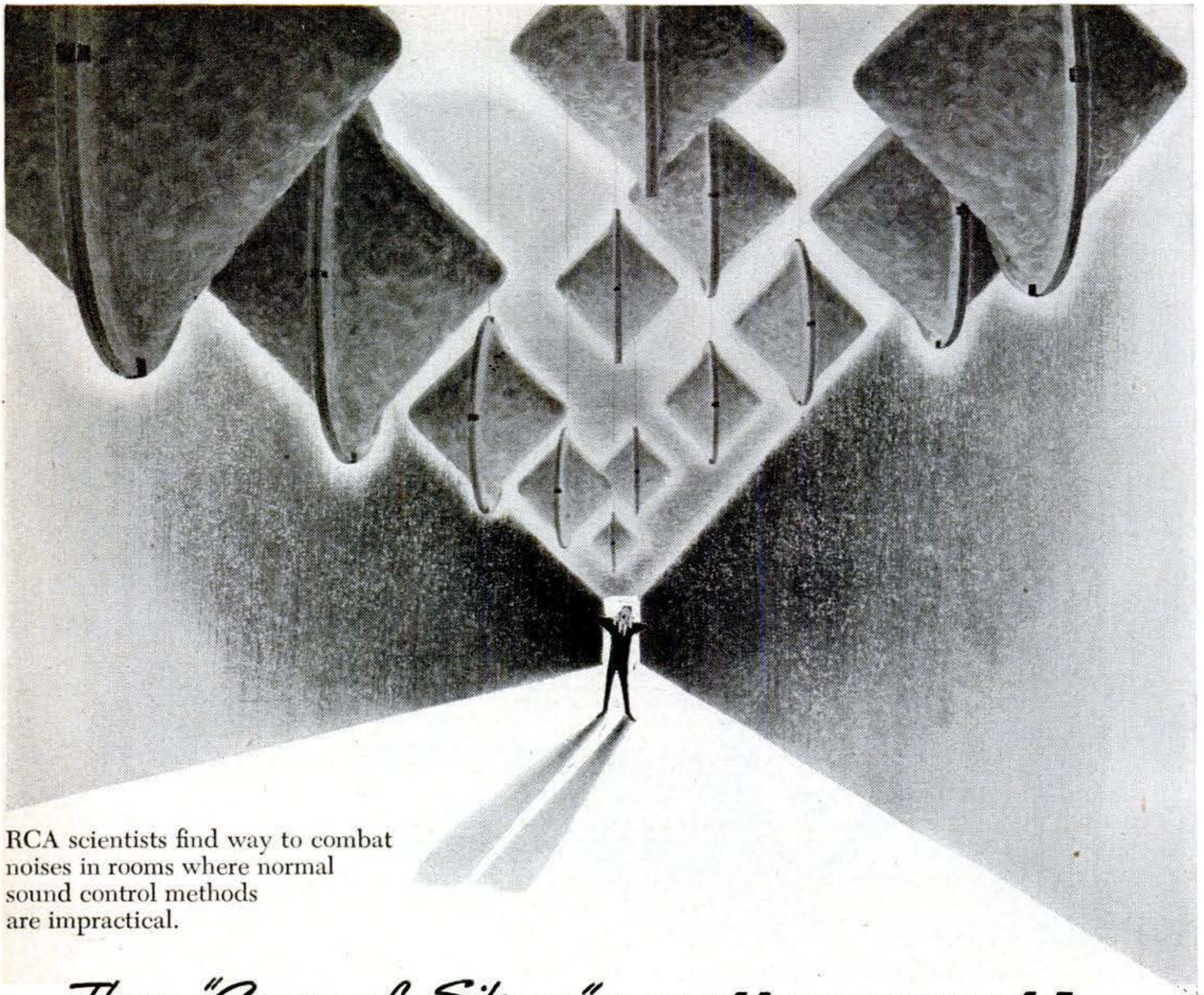

RCA scientists find way to combat noises in rooms where normal sound control methods are impractical.

## *These "Cones of Silence" smother sound!*

You think of RCA Laboratories—in part—as a place where scientists work with *sound*, for radio, television, phonographs. This is true, but they are also concerned with *silence*.

One example is a recent RCA development, a way of killing clatter in places where conventional sound-conditioning—with walls or ceilings of absorbent materials—would get in your way. Overhead pipes,

ducts or other fixtures might prevent the installation of a sound absorbent ceiling—and you wouldn't want to blanket a skylight.

RCA's invention solves the problem in this way: Cones of sound-absorbent substances are clamped together base-to-base... then hung in rows where not in the way. Light, inexpensive, easy to install, these "Cones of Silence" convert sound waves into heat energy, absorb from 60% to 75% of the clatter in a noisy room.

### **How you benefit:**

The development of this new functional sound absorber indicates the type of progressive research conducted at RCA Laboratories. Such leadership in science and engineering adds *value beyond price* to any product or service of RCA and RCA Victor.

*The newest developments in radio, television and electronics can be seen in action at RCA Exhibition Hall, 36 West 49th St., N. Y. Admission is free. Radio Corporation of America, Radio City, New York 20.*



**RADIO CORPORATION of AMERICA**

*World Leader in Radio — First in Television*



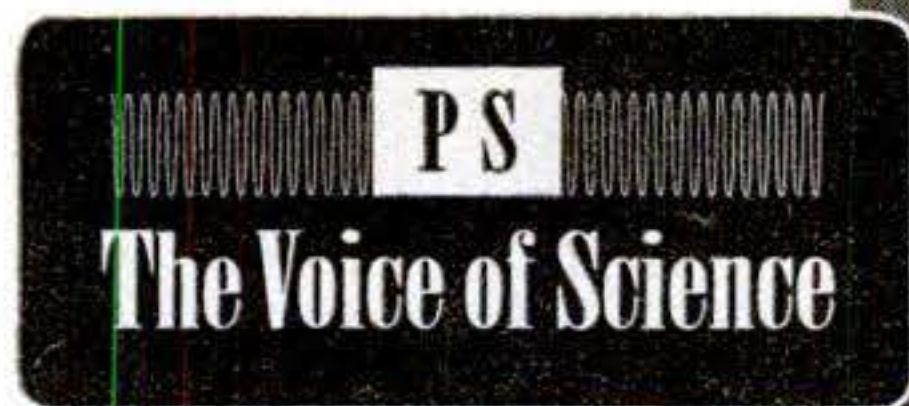

## ***Will You Gamble a Buck For Brain Food?***

**M**ORE than a million men like you buy this magazine every month. Between three and four million more see it and read it, one way or another. That makes POPULAR SCIENCE probably the most widely read science magazine in the world.

But the special emphasis of this magazine on the science of life and the mechanics of living has been such that the editors have refrained from supporting any and all causes. It has been our feeling that factual and tangible editorial content such as ours was not the proper background for any drive for funds, however worthy. It has been my own belief that as readers of your own local newspapers and of magazines with more emotional impact, you have probably paid your dues to the deserving charities that make a community and a nation decently human.

Now comes a cause for which I can ask your support. CARE—that's short for the Cooperative for American Remittances to Europe, the non-profit agency that has sent eats to the hungry overseas—has just announced a new campaign to provide "food for the mind." A drive to send American technical and scientific books to the shot-up countries where books have been scarcer than gold since Hitler started burning them.

This is not a plea for your old shoes, but for fresh cash to buy the latest textbooks

from American publishers for use in institutions training students like you yourself, your kid brother, or your son.

These books, handy packages of American ideas, will go to Austria, Belgium, Czechoslovakia, Finland, Italy, France, Greece, Korea, Japan, the Netherlands, Norway, Poland, Great Britain, western Germany zones, and all Berlin. So unless you are one of those rare Americans named Powhatan or Massasoit, these books will go back where some old man of yours probably came from.

The people at CARE say that for \$10 you can name your country, or even the kind of books or institution. If you've got that kind of money, send it direct to CARE, 20 Broad St., New York. But if a buck is a buck to you, too, or if you think a lone dollar is little, just remember there are a lot of us between the pages of POPULAR SCIENCE. A buck apiece would feed a lot of libraries—and minds. *If you will print your name and address under mine on this page, and send it with your dollar to CARE, 20 Broad St., New York, I will personally pick one name out of the hat to receive the original painting for the cover of this issue, suitably inscribed by the staff and the artist.*

*Perry Githens*

AUGUST 1949 87

*Piston Rings  
need  
replacing, too!*



**WHEN OIL-PUMPING** flashes its warning that your piston rings are worn out, don't delay. The sooner you replace worn-out piston rings the longer your engine will last.

Fortunately, rings are *easily replaced*. And when you replace

with Hastings piston rings, you *stop* oil-pumping, *check* cylinder wear and *restore* performance. It's the best money you can spend on your car.

HASTINGS MANUFACTURING COMPANY  
HASTINGS, MICHIGAN  
Hastings Ltd., Toronto

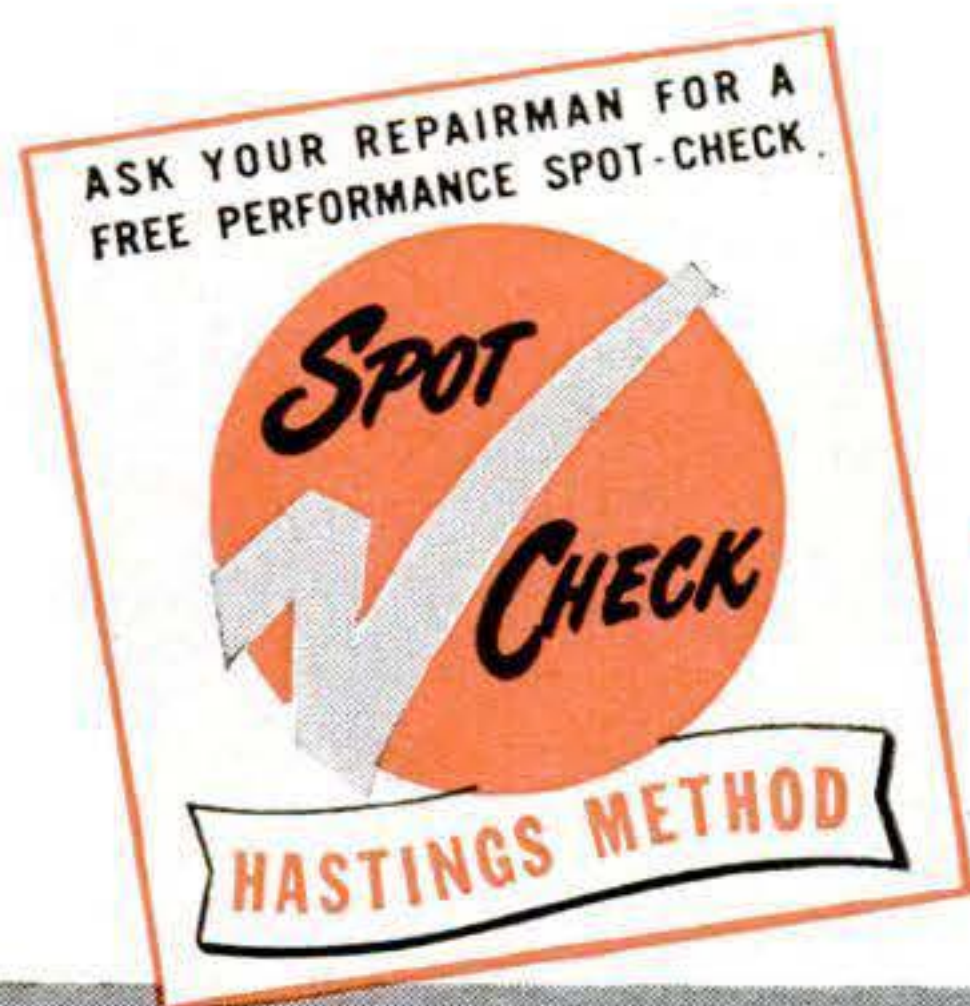

**HASTINGS**  
*Steel-Vent Piston Rings*

"TOUGH... BUT OH SO GENTLE"

**TOUGH** on oil-pumping — **GENTLE** on cylinder walls



***Nerves of Steel...*** These sweeping, intertwining ribbons of steel are part of the thousands of miles of pipes that are the "nerves" of a large oil refinery. Just as human nerve fibers transmit sensations of heat, cold, pain, and pressure to the brain, these pipes transmit vital data about the cracking process from the refining plant to the control station. Here the small pipes are pneumatic lines that transmit pressure, rate of flow, and level of a liquid by minute pressure variations in tiny streams of air. The larger pipes carry samples of liquids and gases produced by the process, tapped off for direct measurement of pressure. The installation above is part of the Humble Oil & Refining Company's butyl plant at Baytown, Texas.

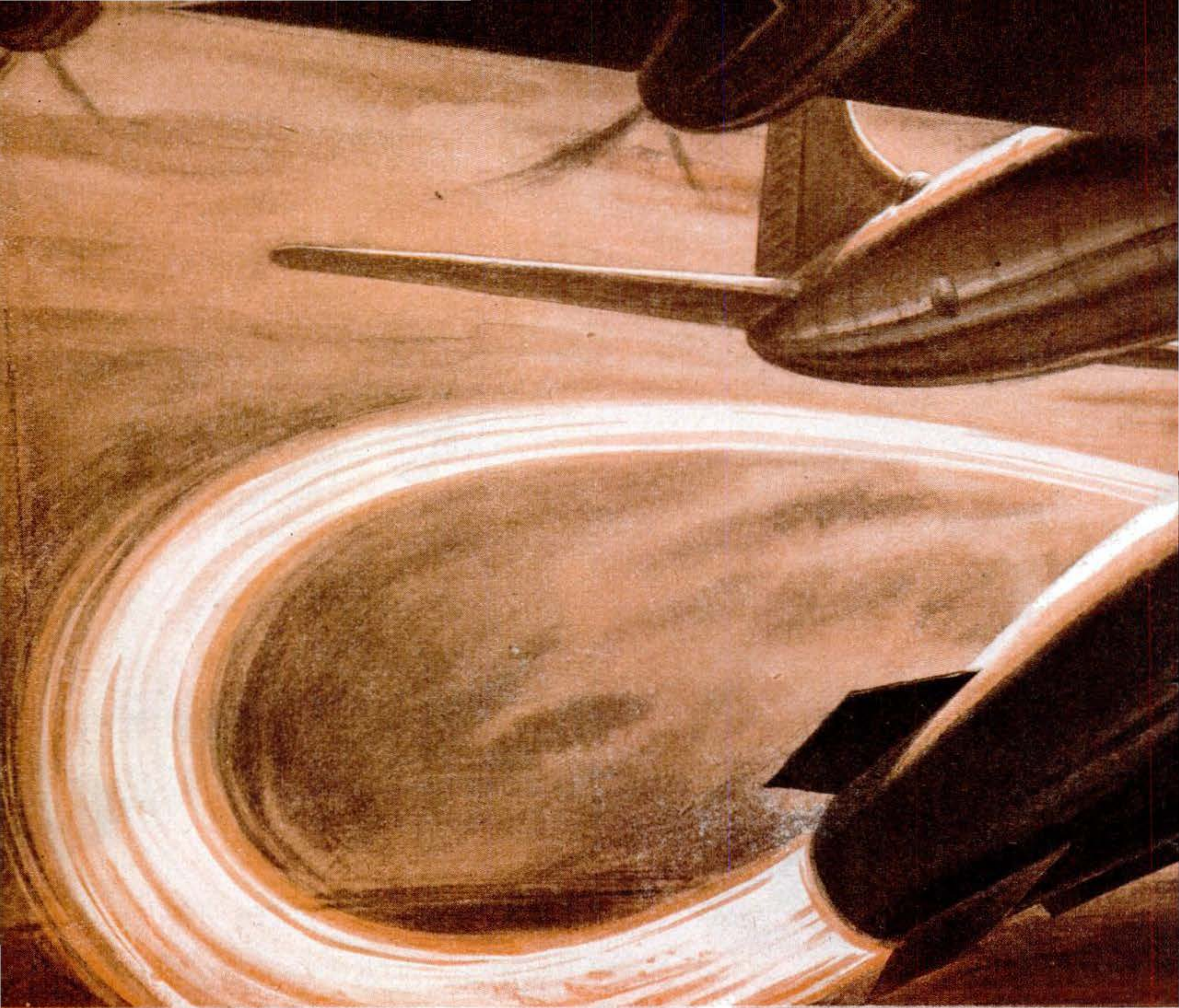

Guided missiles, fired from heavyweight fighter and designed to "home" on their target,

# Can Superfighters Stop

**Are the huge new bombers invincible? Have they made fighters obsolete? Or will big, new "fighter-bombers" be the answer to air defense? POPULAR SCIENCE assigned a tough-minded reporter, with no previous military experience, connections, or prejudices, to interview the experts—military, civilian, and scientific. Here is his evaluation of the hottest argument in the history of air power.**

**THE EDITORS**

**T**HE whispered words, "Bee Thirty-Six," will start an argument anywhere in aviation. And there are no neutrals in the war of words that has burst about this most controversial of all airplanes.

The Air Force says the B-36 can get out of town, do a job, and get back. The claims that these warplanes can take off from continental U. S., fly through enemy defenses, hit any major industrial area in the world, and come home nonstop, have been made the subject of a Congressional investigation.



would be most logical weapon against elusive new bombers. They could be ready to use soon.

# the Bombers?

**By Herbert Yahraes**

*Drawings by Ray Pioch*

They have also challenged the whole history, theory, and practice of air defense.

Bombers, historically, have always been vulnerable to fighter planes. Big warships have been sunk by torpedoes (the original guided missiles) fired by little warships and aircraft.

Why has moving the battlefield a mere two miles (straight up) from where it was in World War II seemingly changed all the rules? What happens at 40,000 feet to enable big planes to escape little planes?

These were some of the questions tossed at me. I was told I had been chosen for this chore because all the regular aviation writers and military writers affiliated with POPULAR SCIENCE either had served with the Air Force or the Navy, or had worked so closely with bombers or fighters that they might have unconscious prejudice.

So I talked to airmen in Washington and elsewhere. To salty fighter pilots now bright with brass, and peppery bomber boys now baldly gleeful. To scientists con- ▶

AUGUST 1949 91

LOW SPEED  
AND  
ALTITUDE



MORE  
HITS

WORLD WAR II BOMBER  
WAS SLOW ENOUGH TO BE  
RIDDLED WITH BULLETS  
WHILE PASSING THROUGH  
FIGHTER'S "CONE OF FIRE"



HIGH SPEED  
AND  
ALTITUDE

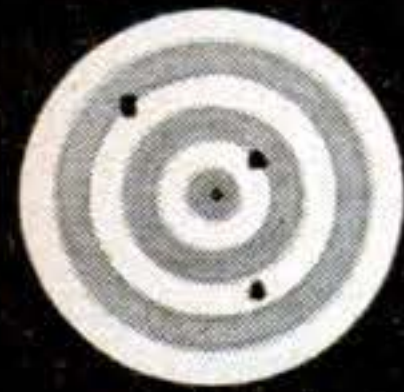

FEWER  
HITS

MODERN BOMBER IS FAST  
ENOUGH TO FLASH THROUGH  
"CONE OF FIRE" COMPAR-  
ATIVELY UNSCATHED



WORLD WAR II  
FIGHTER HAD  
ENOUGH MARGIN  
OF SPEED TO GET  
TWO CHANCES  
AT BOMBER

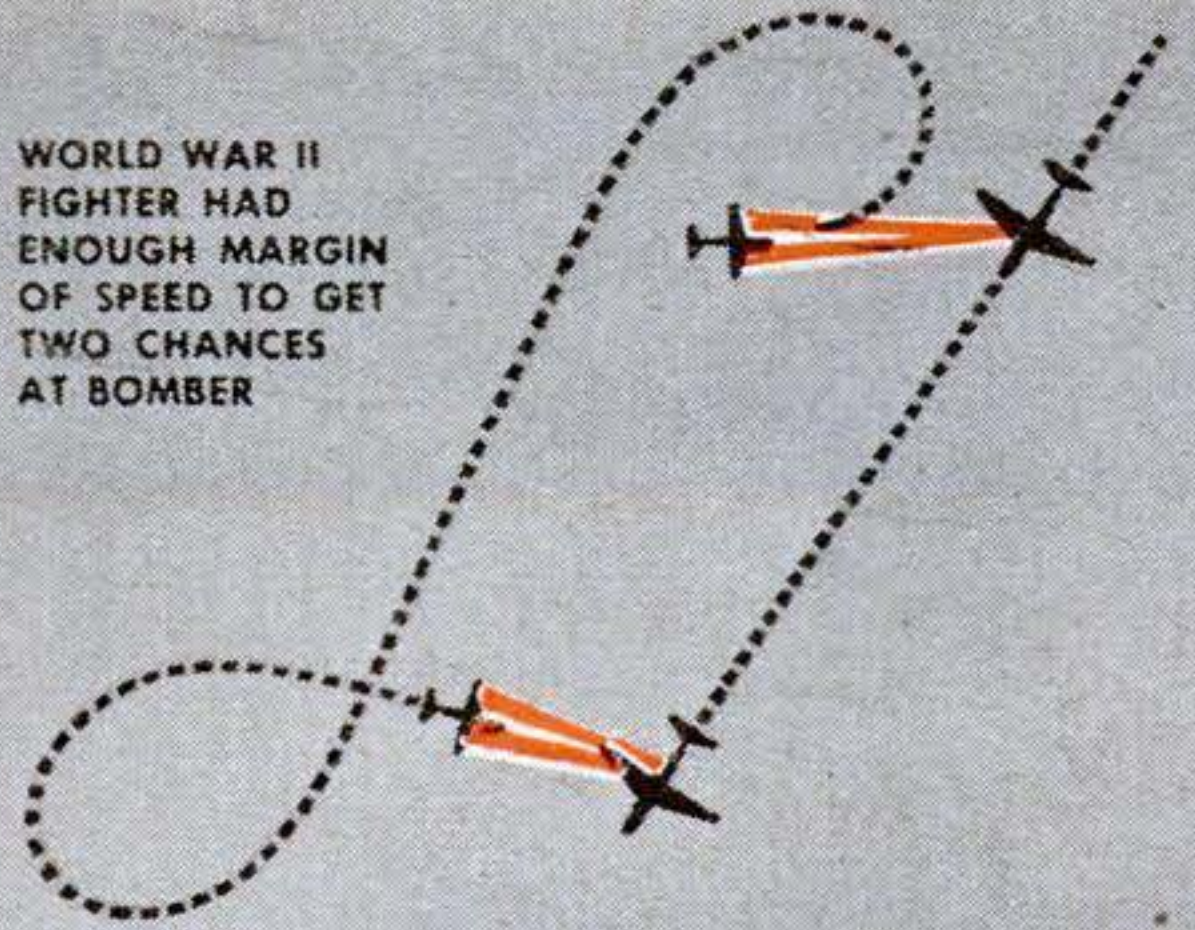

PRESENT SPEED RATIO GIVES  
FIGHTER ONLY ONE CHANCE AT  
BOMBER BEFORE LOSING CONTACT

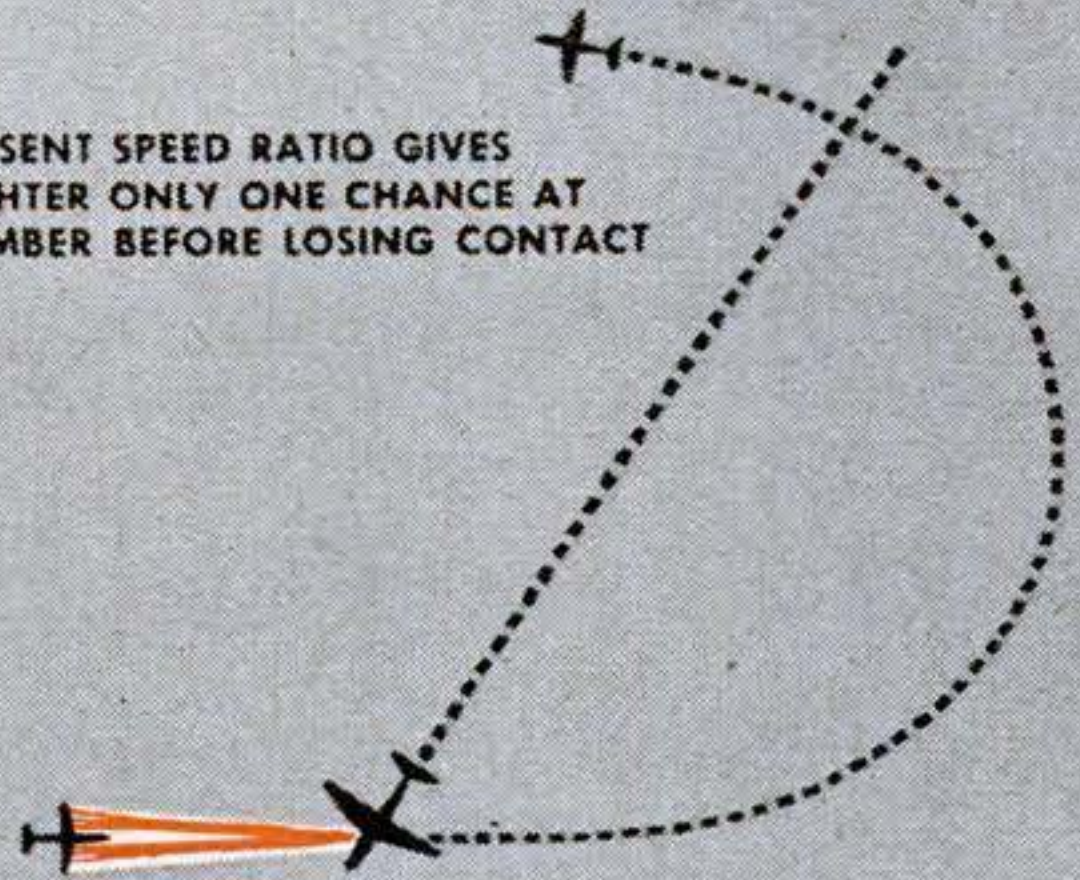

**Drawings** show reasons for bombers' decreasing vulnerability. Above, the bomber's greater speed lessens exposure to fire from fighter.

**Fighter plane** gets fewer opportunities for "passes" at bomber because of its shrinking speed advantage and loss of maneuverability.

cerned with the mathematics of the higher altitudes. To civilians now in laboratory and airline work who were pressing trigger buttons or dodging flak only a few years back. All of them tried to convert me to their very real faith.

The tough truth seems to be that big airplanes, flying very high and very fast, cannot easily be downed by little airplanes flying no matter how fast.

Imagine that you are an Air Force fighter pilot. What they call "early-warning radar" has spotted bombers a scant 200 miles away. That's about as early as radar can get right now. And that's about half an hour horizontally, plus whatever time it takes to get upstairs. How long it takes to get upstairs is another argument. But let's suppose you are up—and at 'em.

You are jockeying a jet job, screaming something over 500 m.p.h. You can even see your target. You start your gunnery run.

If you attack head on, your closing speed is 15 miles a minute. If the effective range of your guns is 400 yards, that means you have slightly less than one, single-second in

which to do business. And, at such speeds, one "brrp" can put only a handful of slugs into one, single bomber.

If you try what pilots call the pursuit curve, you head for your special victim at right angles and turn in with him. This worked beautifully in the old days—five years ago. Even with today's jets it's all right at 35,000 feet. But try it at 40,000 plus and a small plane stalls in the thin air. That's because a sharp turn means slowing down. And when you slow down, your jet doesn't suck enough air—so you drop.

If you try creeping up on your target from behind, your superior speed lets you move right up. Forgetting his tail guns (as if you could), you wait for the range. Then he swerves sharply—but you can't. By the time, seconds later, you have come about, he is out of range—or even out of sight.

At upwards of 40,000 feet, I am told by those who have been there, seeing is not necessarily believing. Things look different. At this altitude, bombers have been sighted 70 miles away by their vapor trails—in clear weather, of course.

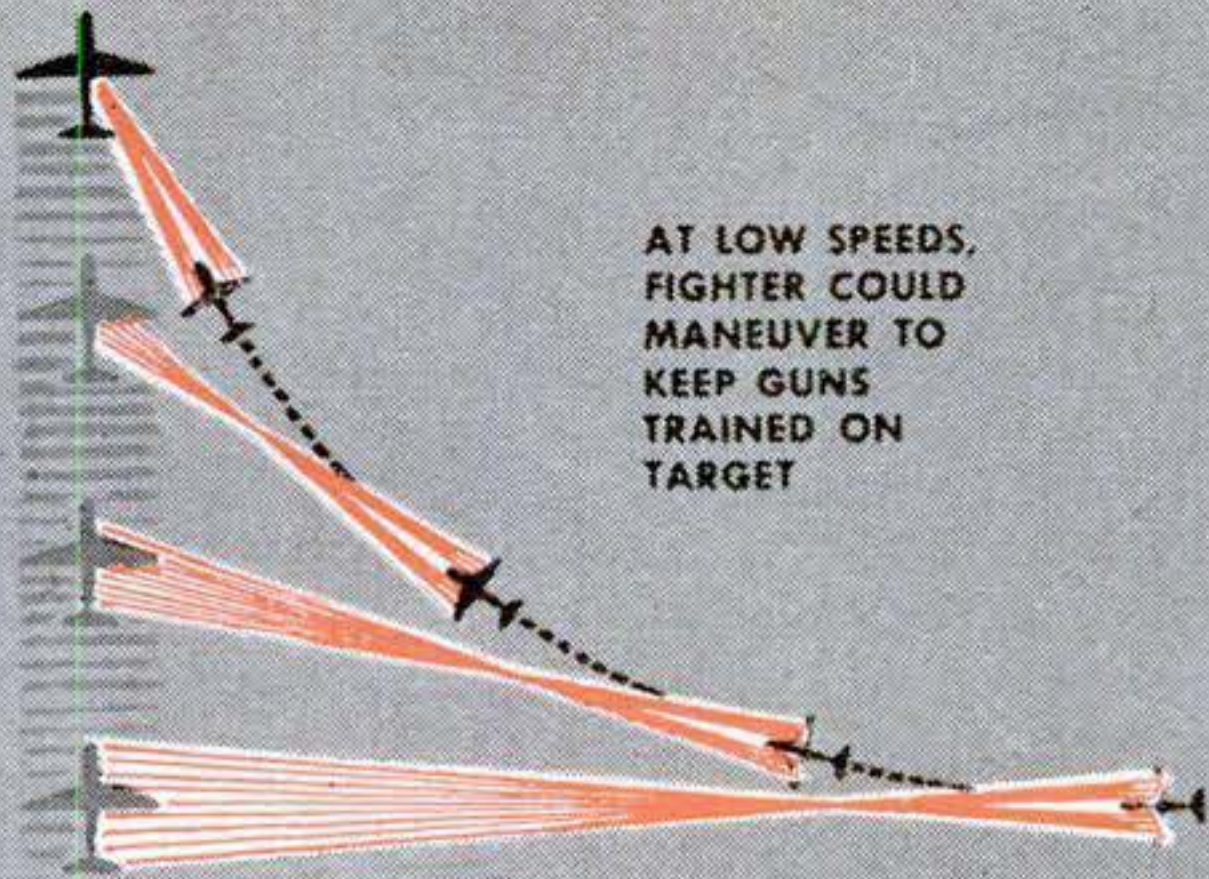

AT LOW SPEEDS, FIGHTER COULD MANEUVER TO KEEP GUNS TRAINED ON TARGET

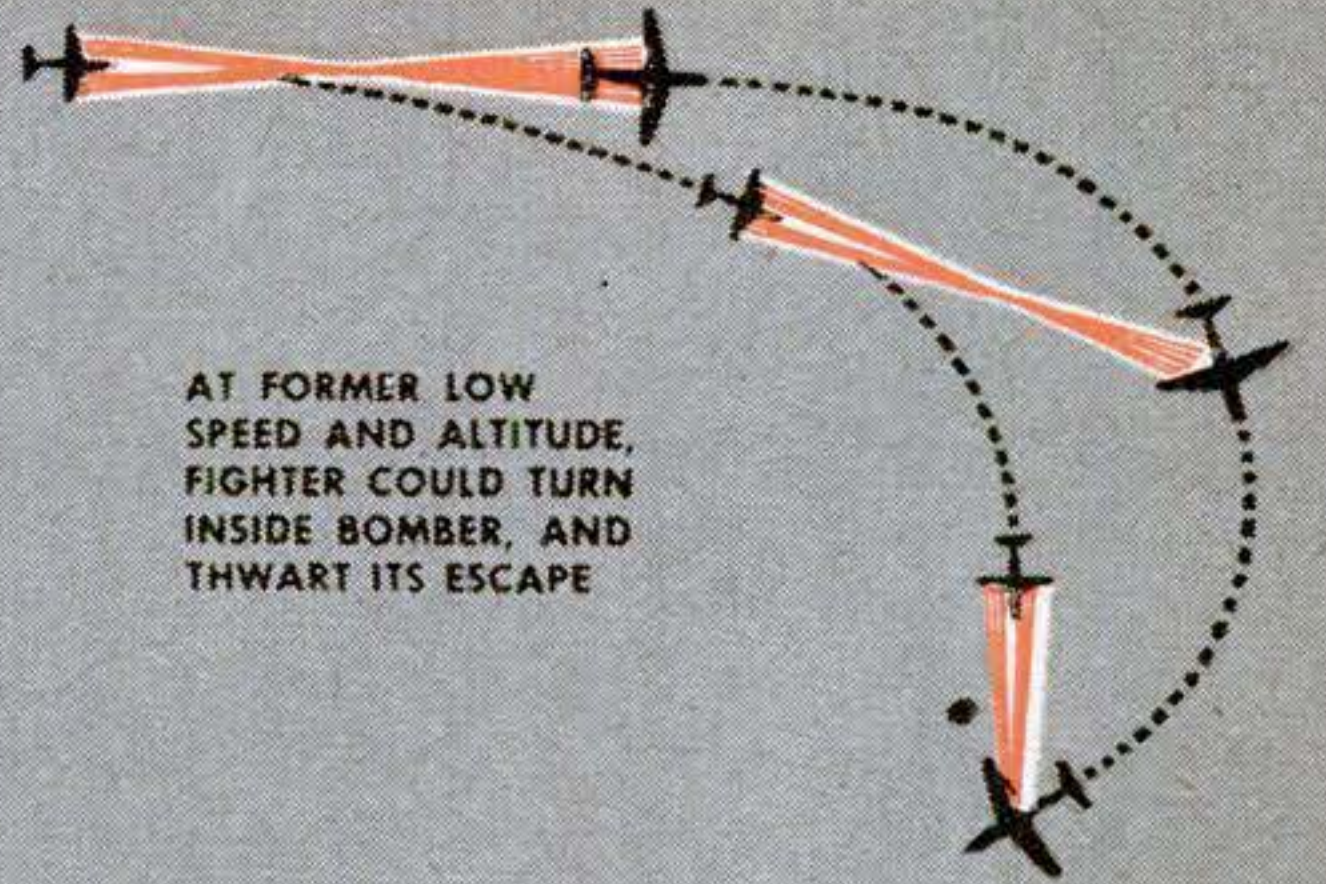

AT FORMER LOW SPEED AND ALTITUDE, FIGHTER COULD TURN INSIDE BOMBER, AND THWART ITS ESCAPE

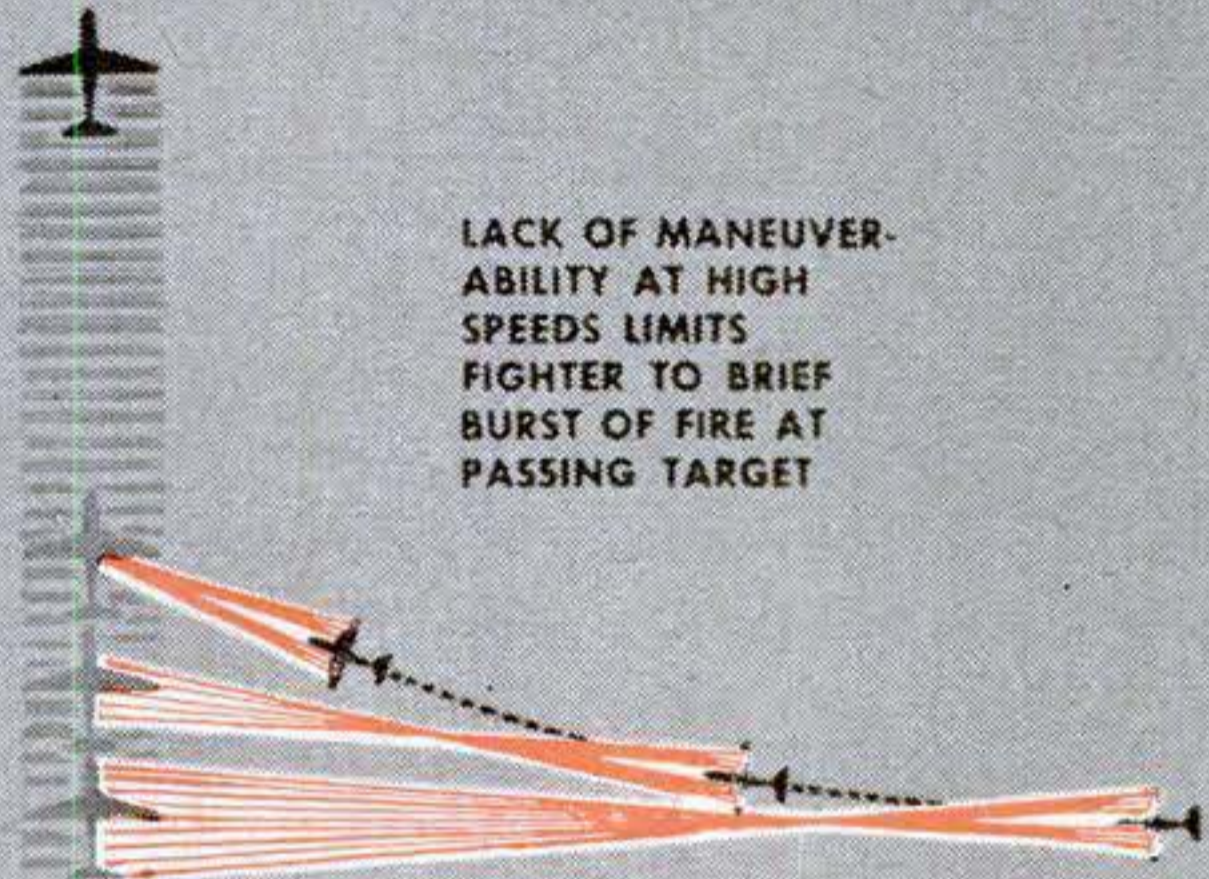

LACK OF MANEUVERABILITY AT HIGH SPEEDS LIMITS FIGHTER TO BRIEF BURST OF FIRE AT PASSING TARGET

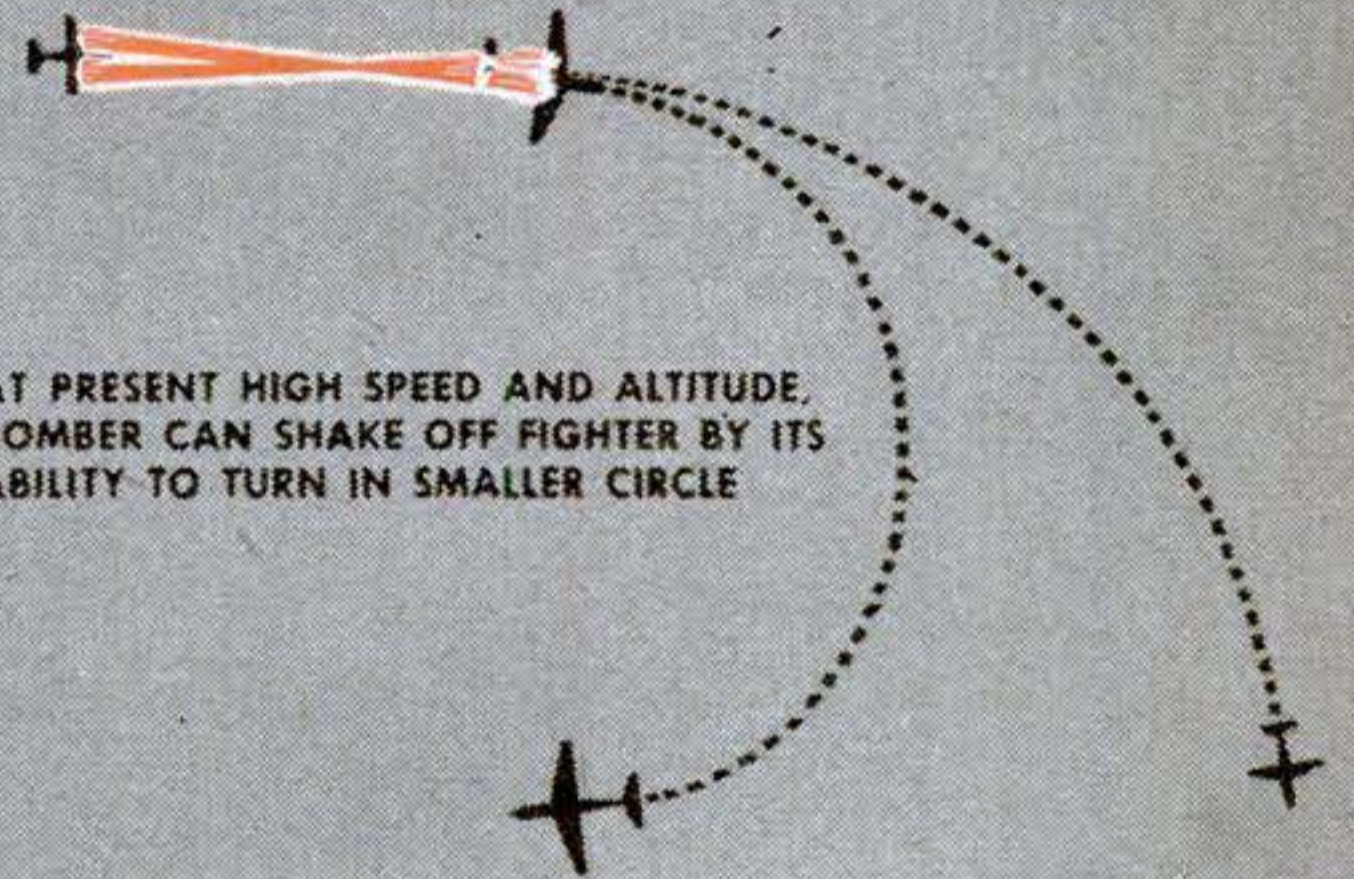

AT PRESENT HIGH SPEED AND ALTITUDE, BOMBER CAN SHAKE OFF FIGHTER BY ITS ABILITY TO TURN IN SMALLER CIRCLE

With increasing speed and altitude, keeping fixed guns of fighter trained on target by maneuvering the plane becomes more difficult.

Comparative maneuverability of fighter and bomber has been reversed. Now the bomber, instead of the fighter, has the advantage. ➔

## TODAY'S FAST, HIGH-FLYING BOMBERS ARE HARD TO INTERCEPT

Bomber speeds on toward target while radar warning is relayed and fighter pilots scramble for take-off.

Still unmolested, bomber continues nearing target while fighter planes climb to its altitude of 40,000 feet.

Fighters have only brief chance to intercept bomber, and may miss it by even slight navigating error.

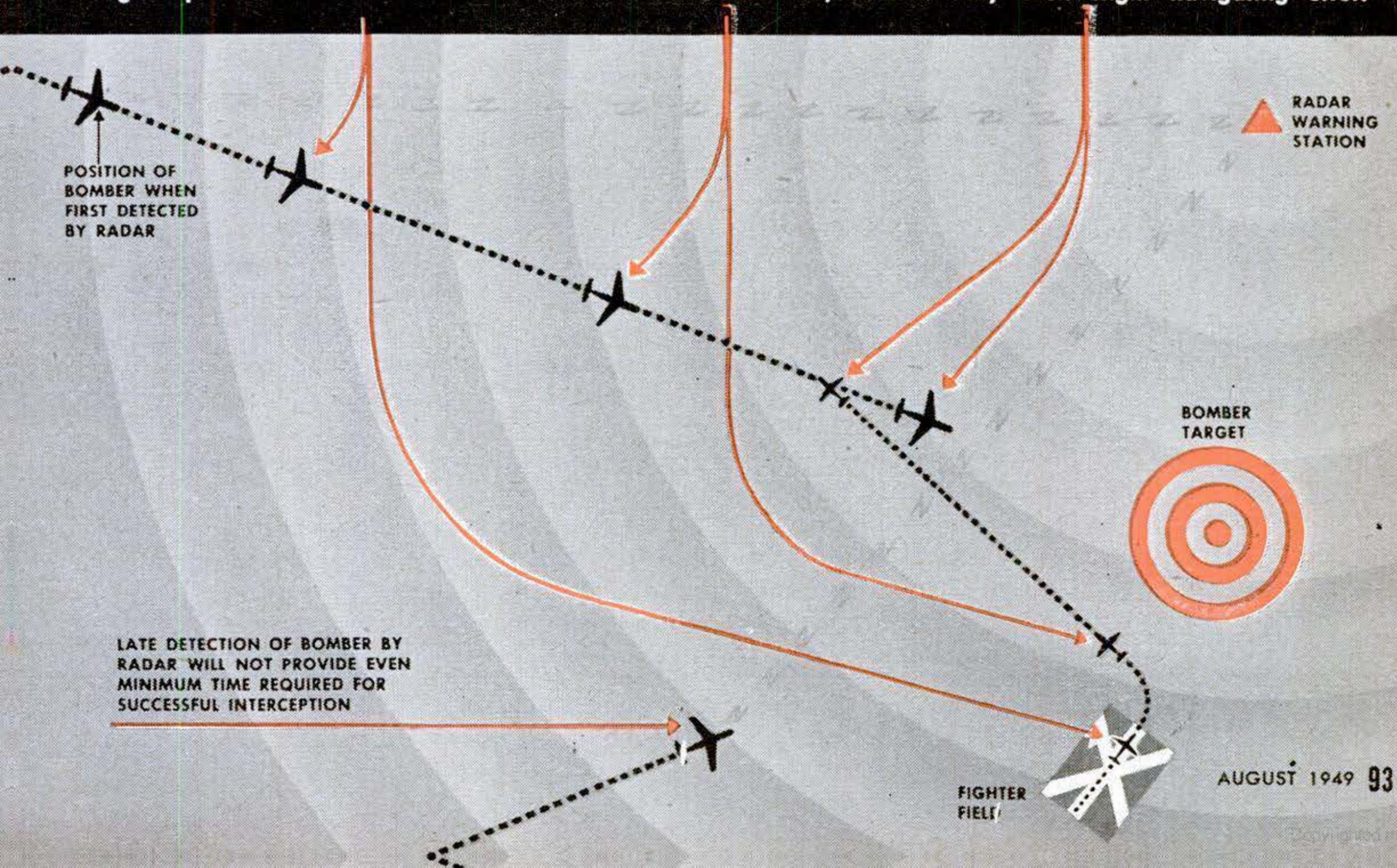

The problem of stopping the bombers, I learned, shakes down into phases. First, catch your bombers. That means getting the pips, like glimmering apple seeds, on a radar scope. Second, intercept the attackers with defensive aircraft at the attackers' altitude. Third, knock them down.

For the purposes of this article, I was told not to concern myself with detection or interception—no mean feats at the altitudes and speeds of our own best bombers. I was told to confine myself to the ultimate solution of that final phase: knocking down the bombers once discovered and confronted.

When I had talked to the last expert, I could not answer flatly that fighters were finished, that bombers had become invincible.

But I can say, as a reporter with no pretense to being a military or aviation expert, that *the best existing fighters have an awfully bad time trying to cope with the best existing bombers—based on available statistics of performance.*

It is a fact that a good big airplane now can get away from a good little airplane. But it is not a fact that the best big airplane cannot be stopped. And there simply are no facts whatever concerning a conflict between large numbers of airplanes.

#### ***New Fighters Sure to be Bigger***

We do know that visual shooting is almost obsolete. High altitudes and high speeds make airborne pistols seem silly.

We do know that some of the newest fighters are as big and heavy as some not-so-old bombers.

We can suspect that normal evolution will bring forth a defensive airplane big enough to carry detection equipment, fire-control equipment, long-range weapons, and the crew to man such a plane and such gear.

What kind of airplane will it be? The name isn't important. Call it a fighter-bomber. Or call it a superfighter. It won't be as big as a bomber like the B-36, but it will almost certainly be bigger than the fighters now operating, and it will have to cut the corners closer, climb fast, and catch up quick. And then what?

You can be sure that mere machine guns, or even fast-firing cannon like the 20-mm. artillery on the B-36, won't be up to the job. Even unarmed bombers could fly through such short-range fire with small chance of a vital hit. The best airborne boom-boom is about as effective as a



**Newest U. S. fighter** to challenge bombers is one above—the needle-pointed, twin-jet F-90.

drunken cowboy's six-shooter on woodcock.

Rockets? They have the punch, all right. But they have to be fired within a visual distance—dangerously close—and by aiming the airplane.

The guided missile seems to be the only probable weapon against the big bombers.

Eventually, its proponents claim, the guided missile will make even airplanes obsolete. There will be no need for bombers when whole coveys of these deadly quail can be flicked from one continent to another. There will be no chance for fighters, either, when ground-to-ground missiles take over.

But in the next few years, there will be ground-to-air missiles hurtling toward their targets without pilots. And air-to-air missiles that need no human hand once set.

It is these air-to-air guided missiles that will most likely make the biggest bombers gone geese. The superfighters of the fairly near future will be submarines of the air.

Early-warning radar will alert these jumbo jets. Once upstairs, their own airborne radar will track them to intercept the big bombers long before they come into visual range. They will fire their missiles, as submarines fire their torpedoes, in calculated spreads.

Once out of the tubes, the missiles will speed toward their targets. When they get within range of the homing devices in their noses, they will change course to close with the moving enemy. Finally, the proximity fuses will take over.

In this interim period between the big fast bombers and the nation-to-nation missiles that need no pilots, bombardiers, or navigators, the main problem of the defensive air force will be to provide a lot of flying killers—of types more dangerous to their flying prey.

Designers are working to meet these specifications. One hope is a jet engine to operate more efficiently at high altitudes. Another is adjustable wings. You can get more speed with either a small, conventional wing or a



(OUTLINES SHOW COMPARATIVE SIZE.  
RULED SQUARES ARE 10 x 10 FT.)

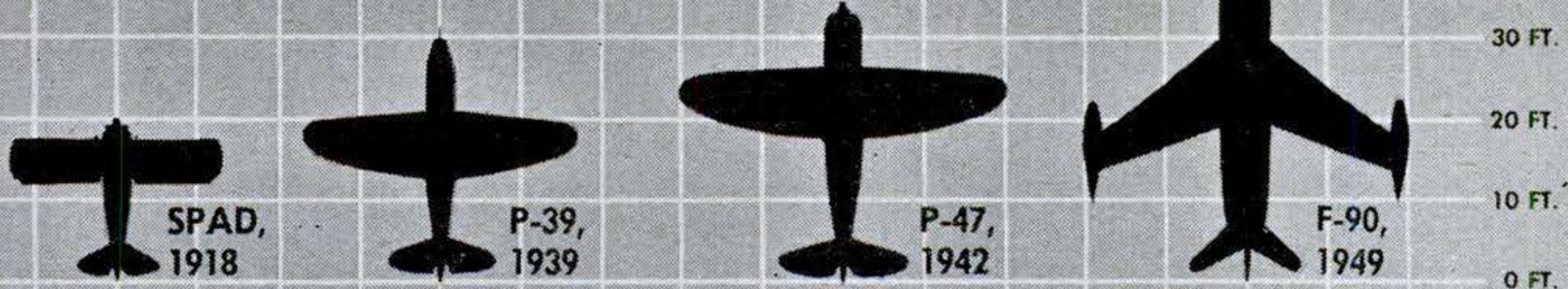

**Evolution** of fighter plane from 1918 to 1949 is shown in these silhouettes. F-90 measures

55 feet long, has 40-foot span, and is designed to fly at approximately the speed of sound.

swept-back wing that looks like the head of an arrow, but when you slow down to maneuver, you may stall out. So why not build a wing whose area or sweep can be altered while in flight? Can do, say experts of the National Advisory Committee for Aeronautics.

Then there is a gadget designed to give a jet a swift kick in the tail. It's called an after-burner (PS, Oct. '47, p. 82). It shoots a mixture of alcohol and water into the engine's tailpipe, thereby speeding up the gases that rush out of the end and shove the plane ahead. The AF's F-88 has one of these; also the Navy's F7U, the Cutlass, now in production and designed to do at least 650 m.p.h. even above 40,000 feet.

But all the climb, speed, and maneuverability in the world won't help the fighter unless it can find the target in any sort of weather. So a lot of research work is going into improving airborne radar.

We'll still need early-warning ground radar, too; but, as a Pentagon officer put it, "A bomber crossing a radar-guarded frontier is like a fly zipping through the front door of a big hotel. Anybody can see the darn thing enter, but how are you going to tell what room he's headed for?"

Then—most important of all—that quick knockout punch. For even with all the climbing ability and speed he'll be packing, the pilot will have precious little time for sparing around.

Tomorrow's superfighters will have to be flying *weapons*. Primarily they'll have to be thought of, not as planes, but as platforms to carry the biggest possible punch to the place where it will do the most good.

That's one of the reasons the Air Force is setting up a center at Eglin Air Base to test air-to-air and air-to-ground weapons—and the instruments needed to guide them. Aeronautics research people expect the effectiveness of existing weapons to be perked up considerably by an automatic

aiming mechanism. This will be a combination of radar, to track down the bomber, and a computer to figure such factors as relative speed and course.

But, the planners say, the only sure answer to a fighter's need for a quick, lethal blow is the guided missile. Eventually it will be the job of radar ground crews not only to detect approaching bombers but also to send pilotless missiles against them. First, though, long-range accuracy must be perfected.

Short-range accuracy, on the other hand, is relatively simple to achieve. Once we've got it, all we need is a suitably placed launching platform. The earth won't serve because it's too far away from the bomber, but a fast-climbing fighter will do nicely.

#### **Radio Could Guide Missile**

The simplest guided missile is controlled by radio, which means that the operator must be able to see both it and the target either with his own eyes or through radar. For the job at hand, however—knocking out a bomber that may be shooting at almost sonic speed through black or murky weather—the fighter's best bet is a missile that, once launched, needs no human control. Carrying its own gray matter, it seeks out the target with the instinct of a homing pigeon.

Such a bloodhound of the air has a sensing mechanism—commonly called a scanner—built into its nose. One type is sensitive to light; it locks onto and follows a source of light the way moths follow a lamp moved around a room. It can be made to sniff out an opaque object moving against a background of different density.

Another type can track down anything that makes noise. A third responds to heat: enter a huge hangar where a heat-scanning head is stored, and the warmth of your body is enough to make it follow you no matter how fast you turn or side-step. Still another—perhaps the most useful in this case—navigates like a bat, sending out

silent sound waves that obstructions reflect.

No matter what the type, the missile follows its sensitive nose to within lethal distance of the target, where a proximity fuse sets off the explosive-packed body.

By the end of World War II we were already producing such homing weapons (PS, Feb. '46, p. 84). Most of them were designed for use against ground targets and ships, but it takes no miracle of ingenuity to fit them for work against bombers, as well. Says General Joseph T. McNarney, chief of the Air Materiel Command: Their development into operational missiles "will take only a relatively short period of time."

You can't put radar, and somebody to run it, or an auto-pilot to take over the controls while you run it, and mechanism to control adjustable wings, and automatic sighting devices into a fighter the size of those operating today. Planes carrying guided missiles will change some of the specifications: they won't have to get so close to the target and they won't have to be so maneuverable, but they will need something else—stability. Unless they are to be one-shot weapons, they will have to be pretty sizable.

The trend has already set in. The Navy's Banshee weighs only 14,000 pounds and the

Air Force's F-84, 15,000. But the Cutlass, now being turned out, weighs 22,000, and the XF-90, now being tested, 3,000 pounds more. *The last-named "fighter" is both heavier and longer than the "bomber" Jimmy Doolittle used against Tokyo.*

The end is not yet in sight. Conceivably the fighter plane of the future could be much like a plane we already have, the B-47, a jet-powered bomber that recently whizzed from Seattle to Washington, D. C., in three hours, 36 minutes. Its weight is 125,000 pounds; speed, 600 m.p.h.; climb, 5,000 feet a minute; ceiling, 38,000 feet. It's big enough to carry plenty of radar and a covey of guided missiles.

Eventually, scientific and engineering developments will make both the bomber and the fighter obsolete—maybe civilization, too. But first they seem destined to produce better and costlier fighters than ever.

To keep ahead of the fighter, the bomber will have to do some terrific humping. But don't pin your hopes for safety on defensive armament. From the last war came this clear lesson: when a bombing attack has once been launched, no human force can stop *all* the planes. Some, at least, will carry out their mission. END

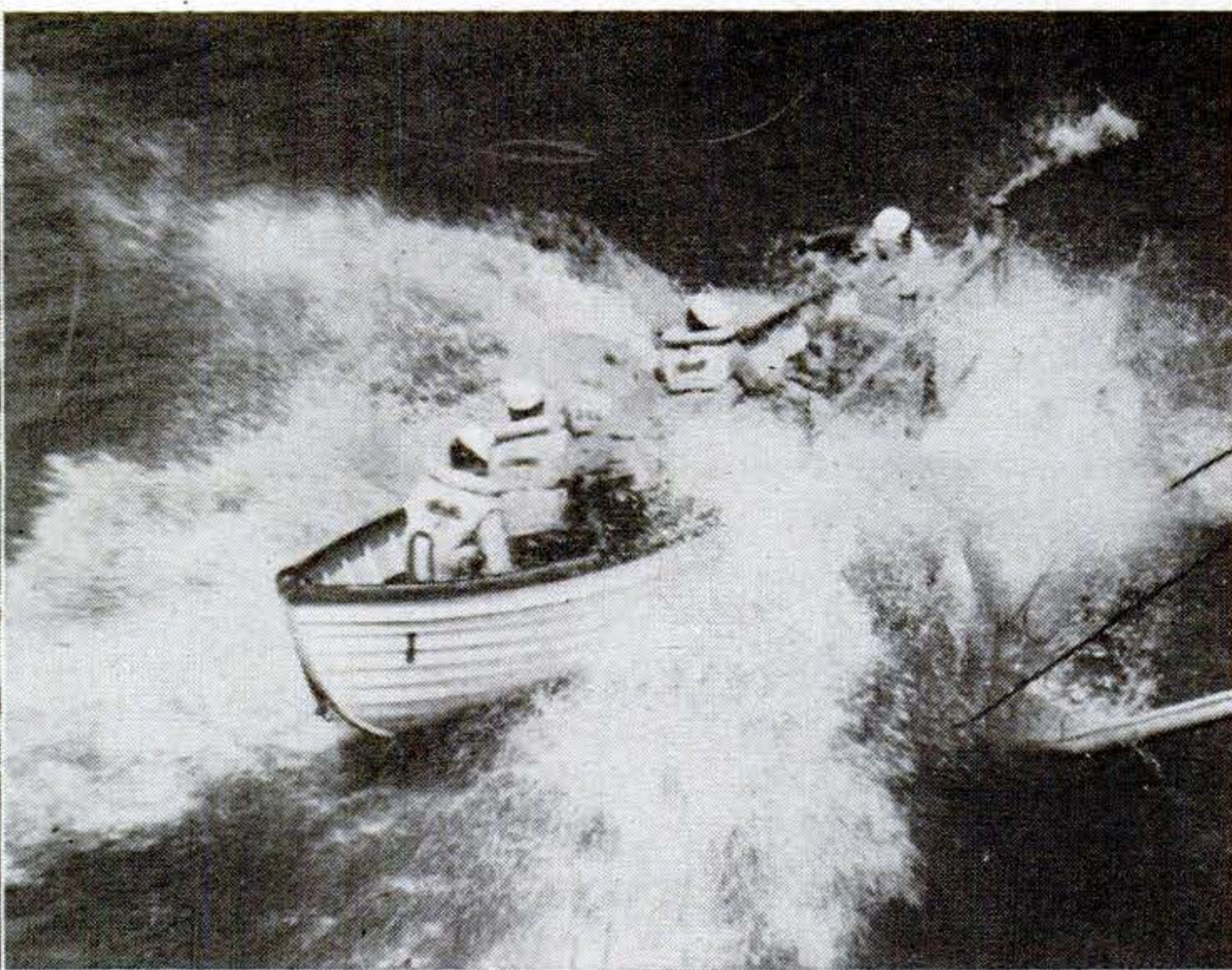
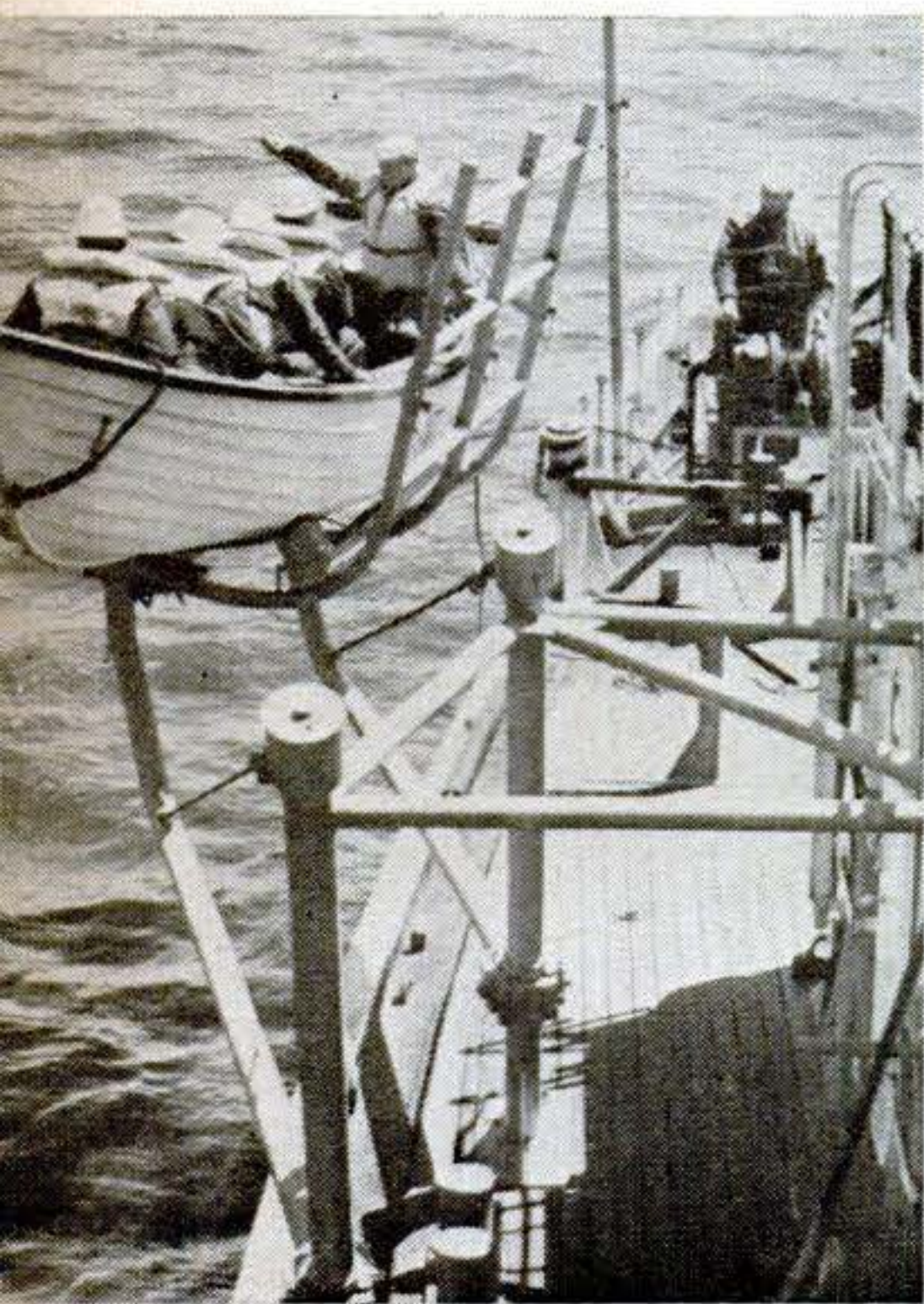

## New Lifeboat Launcher Speeds Sea Rescues

SWINGING down like a drawbridge, this new Coast Guard lifeboat launcher (left, above) gets a fully manned boat off the deck and into the water in five seconds—from 25 seconds to two minutes faster than

old-type launchers. Designed to speed rescues at sea, it supports the boat in a cradle on two booms that can be lowered by one man. As the boat strikes the water (right), the cradle drops lower to clear it.

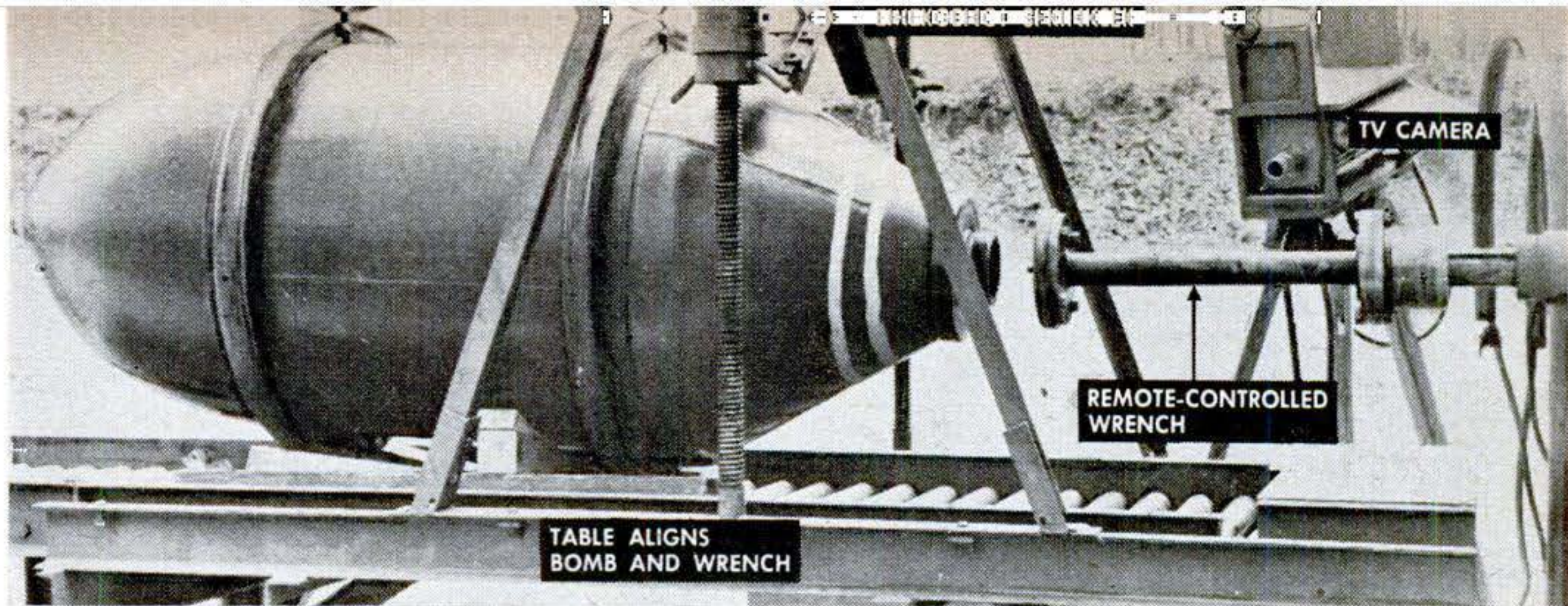

## TV Helps Pull Bomb's Fangs

IF THIS 4,000-lb. bomb blows up while its booster is being removed, the only casualty will be the Remington Rand Vericon® tele-

vision camera. It is transmitting the scene to a screen in an explosion-proof barricade a safe distance away, where an Army Ordnance technician operates remote-controlled electric motors that do the job.

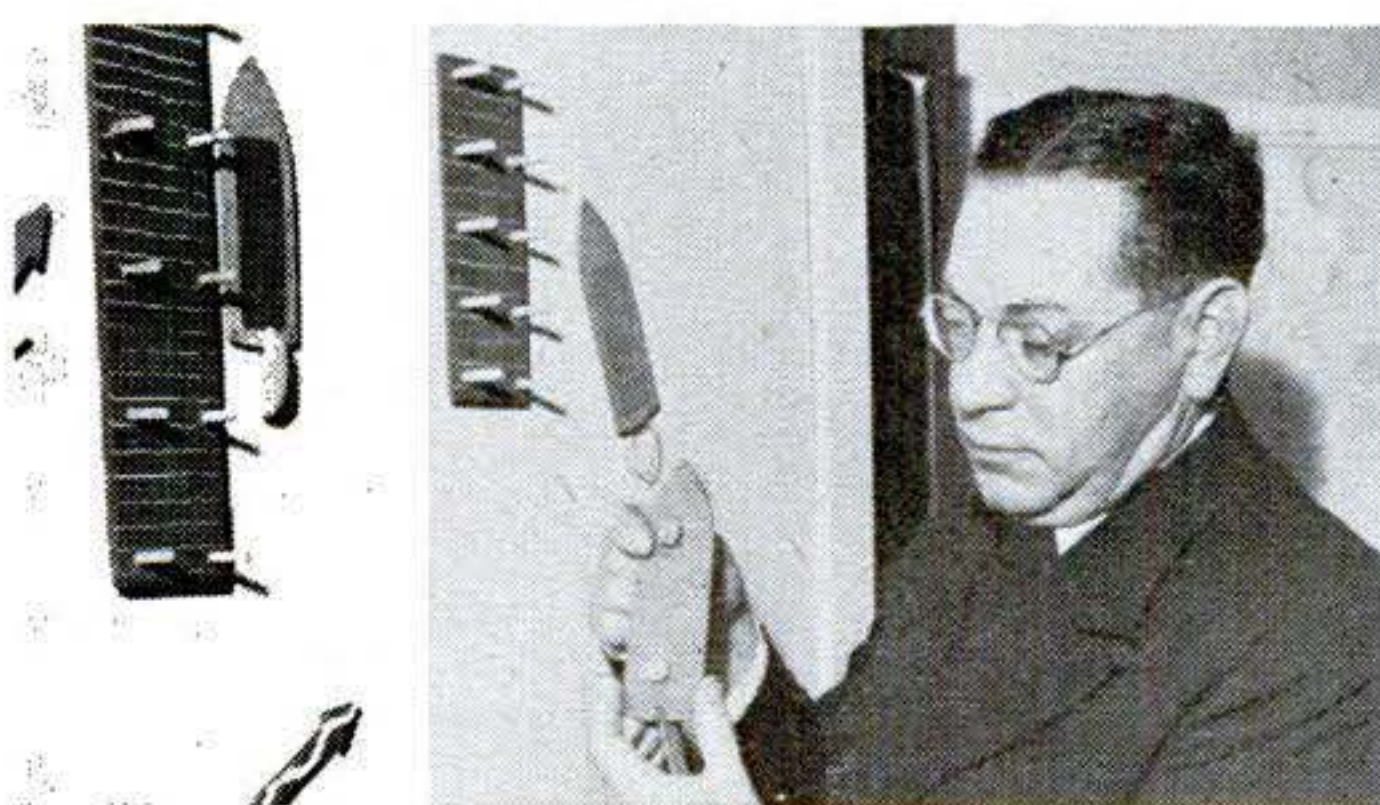

## Magnets Aid Yachtsmen

YACHTSMEN can visualize a boat-handling problem easily with the aid of this special demonstration board. It is simply a piece of sheet steel on which cutouts representing ships, docks, wind-direction arrows, etc., are held in any desired position by tiny Alnico® magnets fastened to their undersides. The Cleveland Power Squadron built this one.

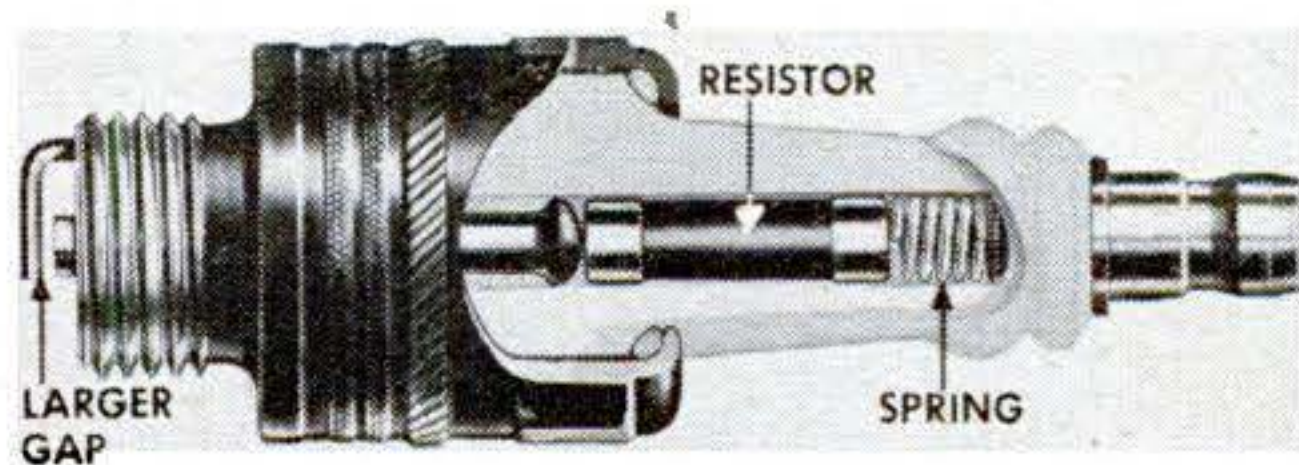

## Spark Plug Reduces Static

POWER-CRUISER owners won't be bothered by engine interference with radio-telephone, radio, and television operation if they use this new spark plug, reports the Electric Auto-Lite Co. It has a built-in, 10,000-ohm, carbon resistor, shown above, that cuts down the high-voltage variations causing the static. Similar plugs are available for cars.

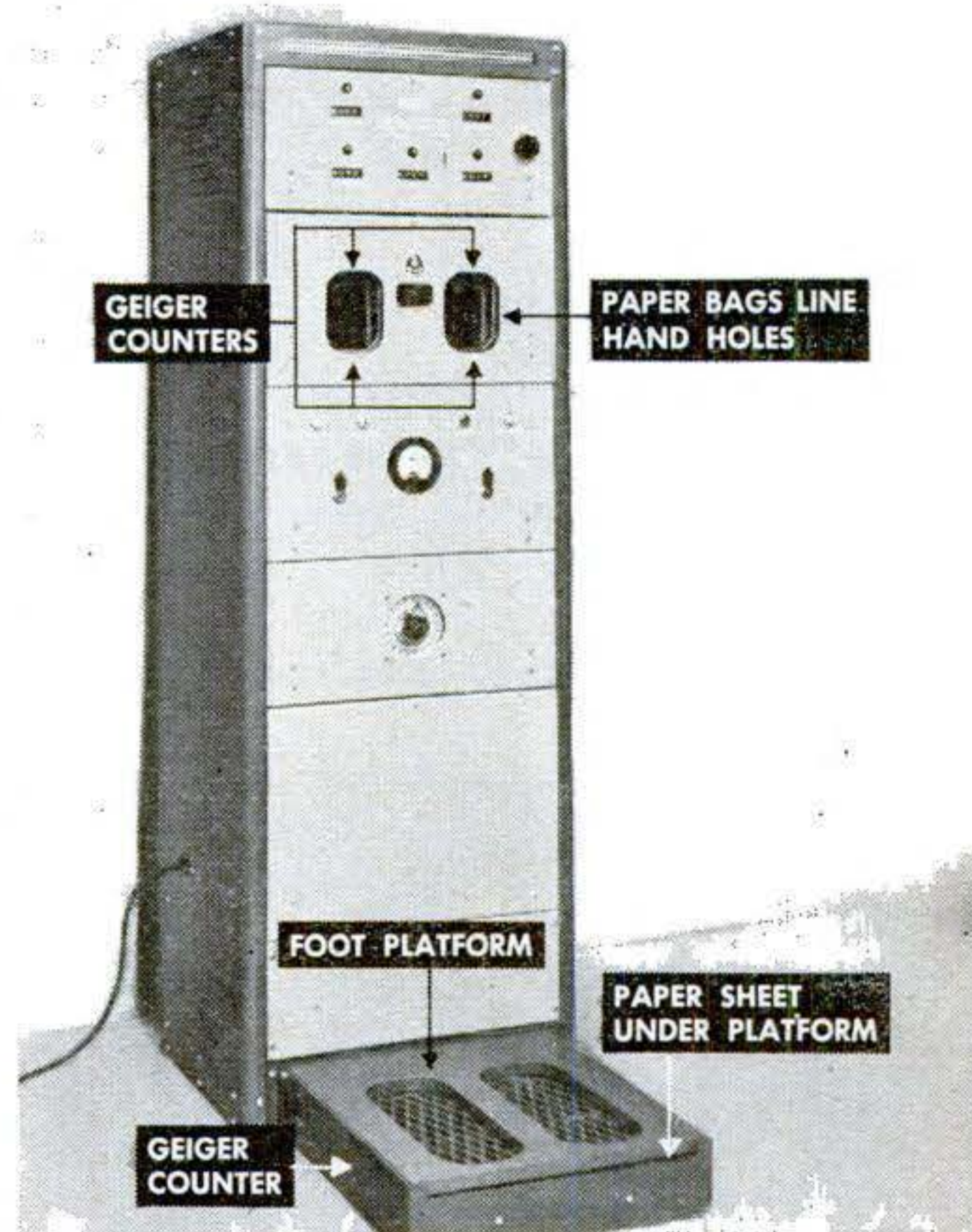

## Monitor Guards Atom Workers

THIS machine, which looks like a penny-in-the-slot scale, checks on the "cleanliness" of atom workers' hands and feet. The worker merely sets dials, steps on the platform, and sticks his hands in the holes. Geiger counters measure the radioactivity while a pen records the amount. Paper bags lining the hand holes and a paper sheet under the foot platform are thrown away after each use to keep "hot" dust out of the works. The device was designed at the Hanford plutonium plant and is made by Kelley-Koett Manufacturing Co., Covington, Ky.

## New Ideas from the Inventors

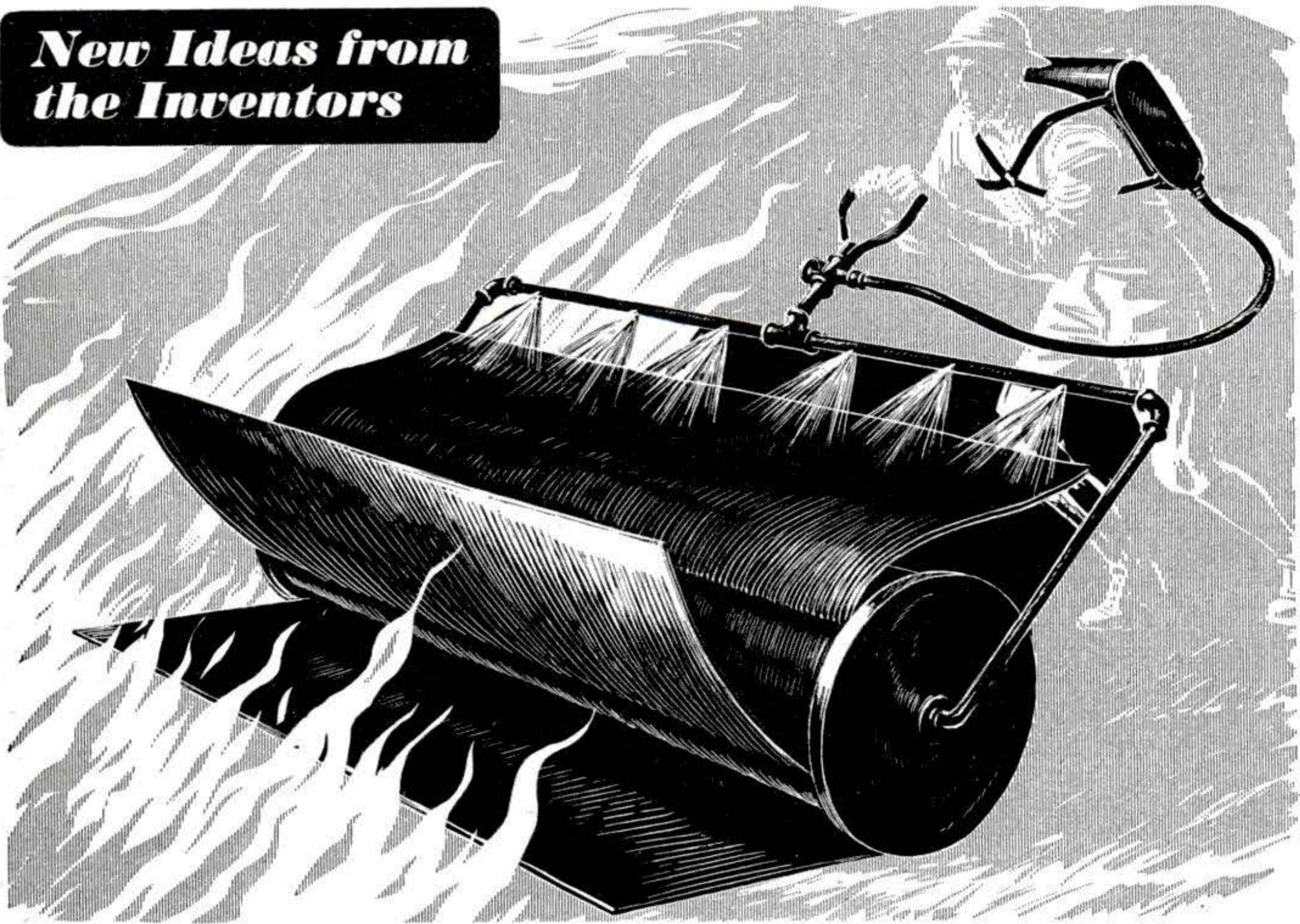

### **"Paddle Wheel" Puts Out Fires.**

This novel fire-fighting apparatus is designed to extinguish brush fires by beating them out, as in the old broom method. As the big roller is pushed forward, flexible

mats slap the ground one after another, smothering the fire. Spray jets along the top keep the mats wetted down with water or chemicals from a back-pack tank. The inventor is P. H. Murphy, of Helena, Mont.

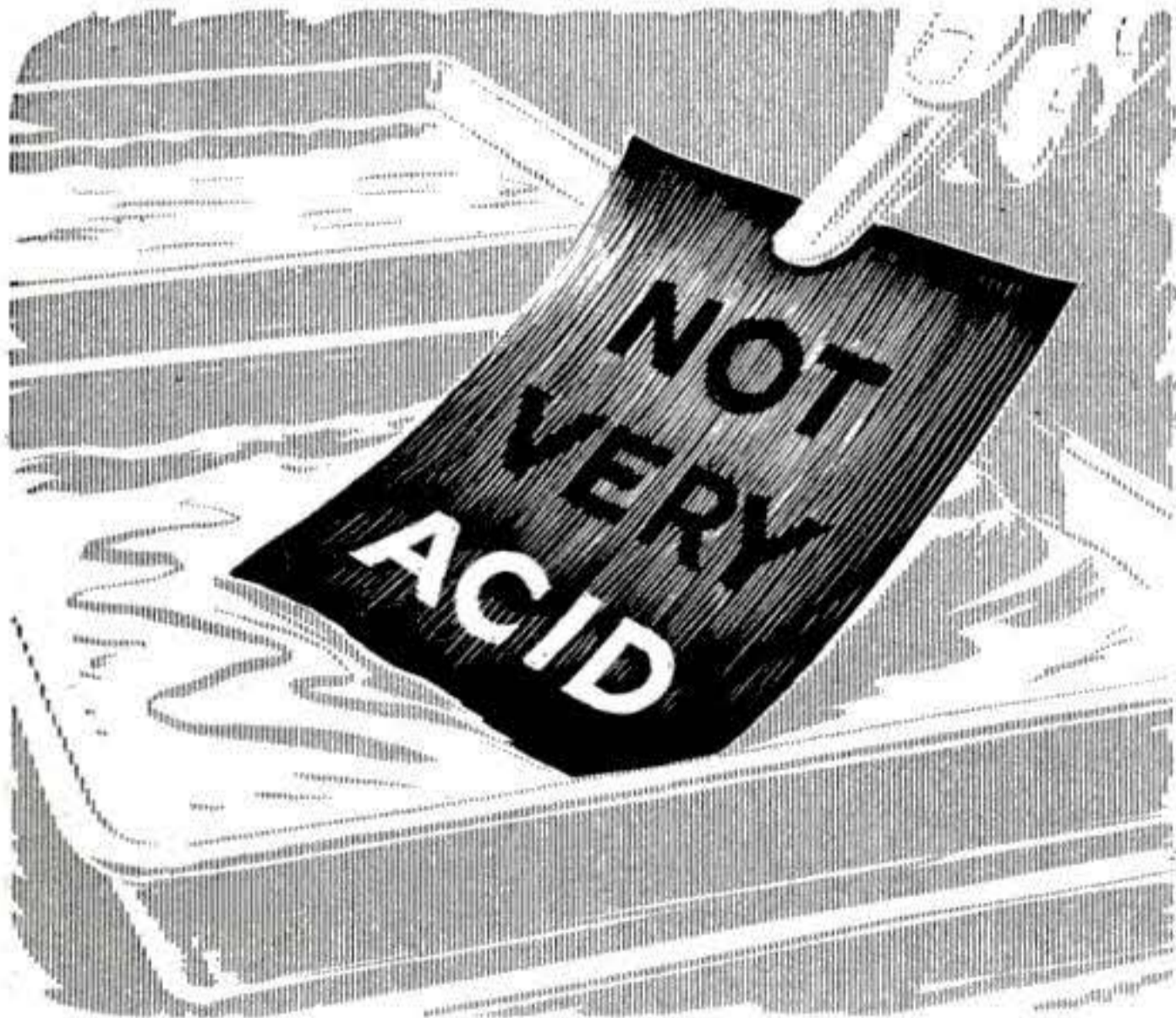

**Photo Aid Tests Stop Bath.** If a photographic stop bath is acid, this red-dyed paper indicator blackens, and the word "not," printed in black, disappears. As the acidity dwindles, the paper returns to red, the "very," in red, vanishes, and the black "not" reappears. The inventors are J. Crabtree and H. Russell, of Rochester, N. Y.

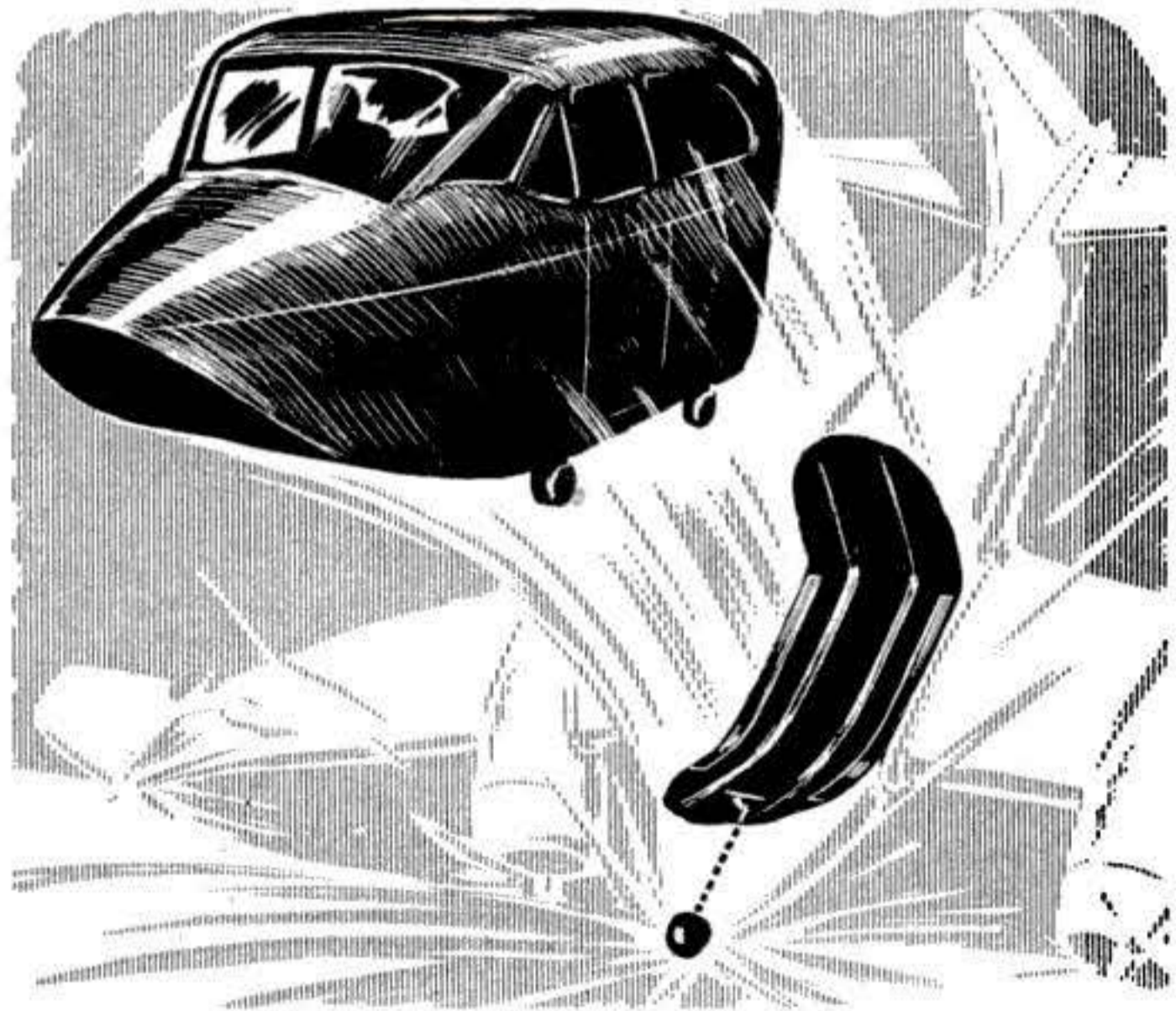

**Crash Releases Plane Cabin.** If this airplane crashes, a plunger in the nose releases the detachable cabin so it will be thrown clear of possible fire or explosion. Two curving tracks in the fuselage guide the wheeled cabin and give it an upward toss to make sure it lands well ahead of the plane. Inventor is F. Reed, of St. Paul, Ind.

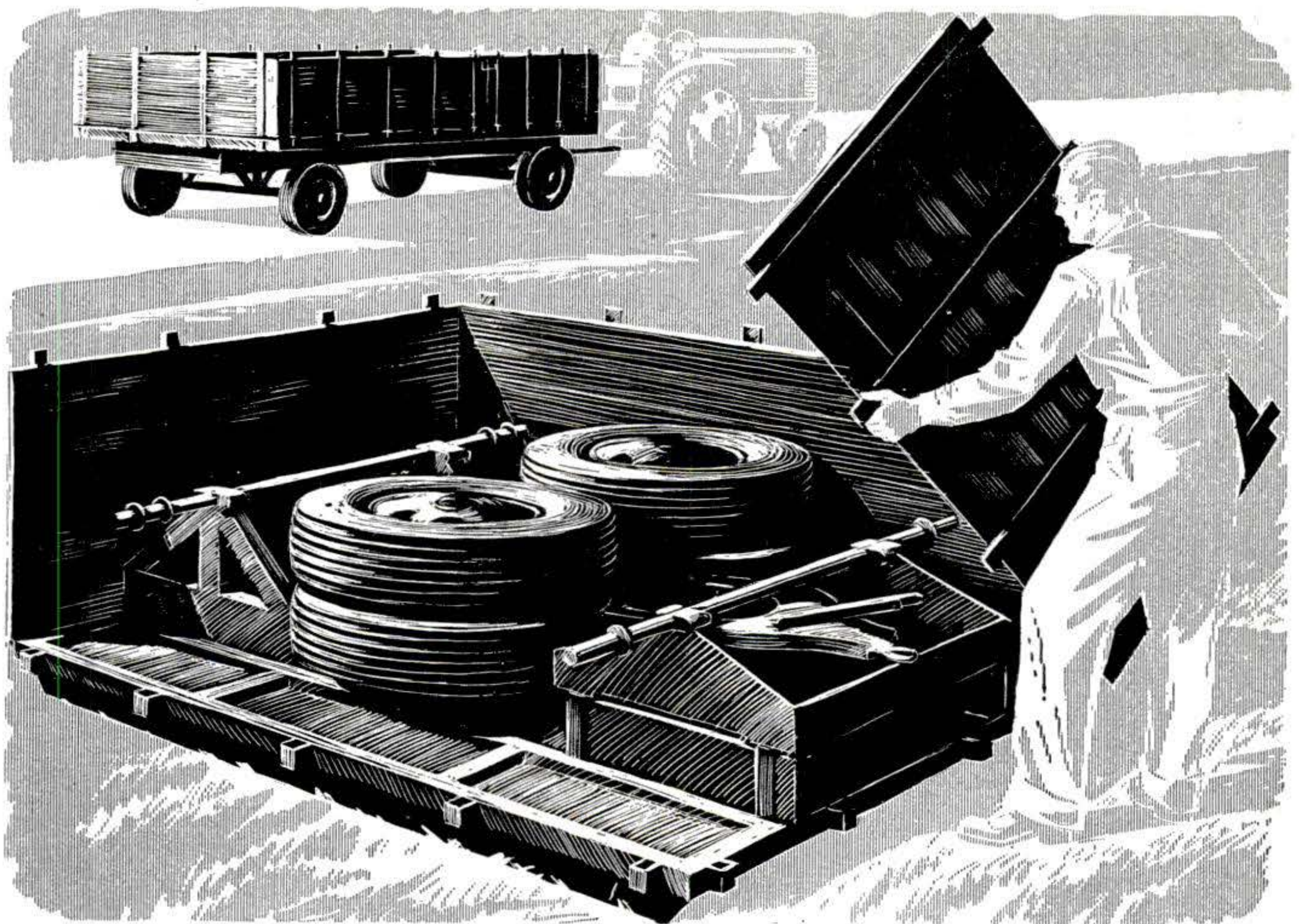

### Trailer Packs into Own Crate.

This trailer can not only be taken apart and packed up in a crate, but it even supplies its own crate. Its floor folds up to form one end and the bottom of the crate, while

its sectional walls fit together to make the sides and top. The underframe telescopes together, fitting inside the crate along with the wheels and axles. J. H. Stark, Jr., of Springfield, O., invented the trailer.



**Golf Balls Lift Out of Cup.** You wouldn't have to fumble in this golf cup to retrieve balls. Just pull up the lifter in the bottom, and its sloping sides roll the balls right out onto the green. A hole in the handle holds the marker staff, while others let rain water drain through. The inventor is D. Matheny, of New Brighton, Pa.

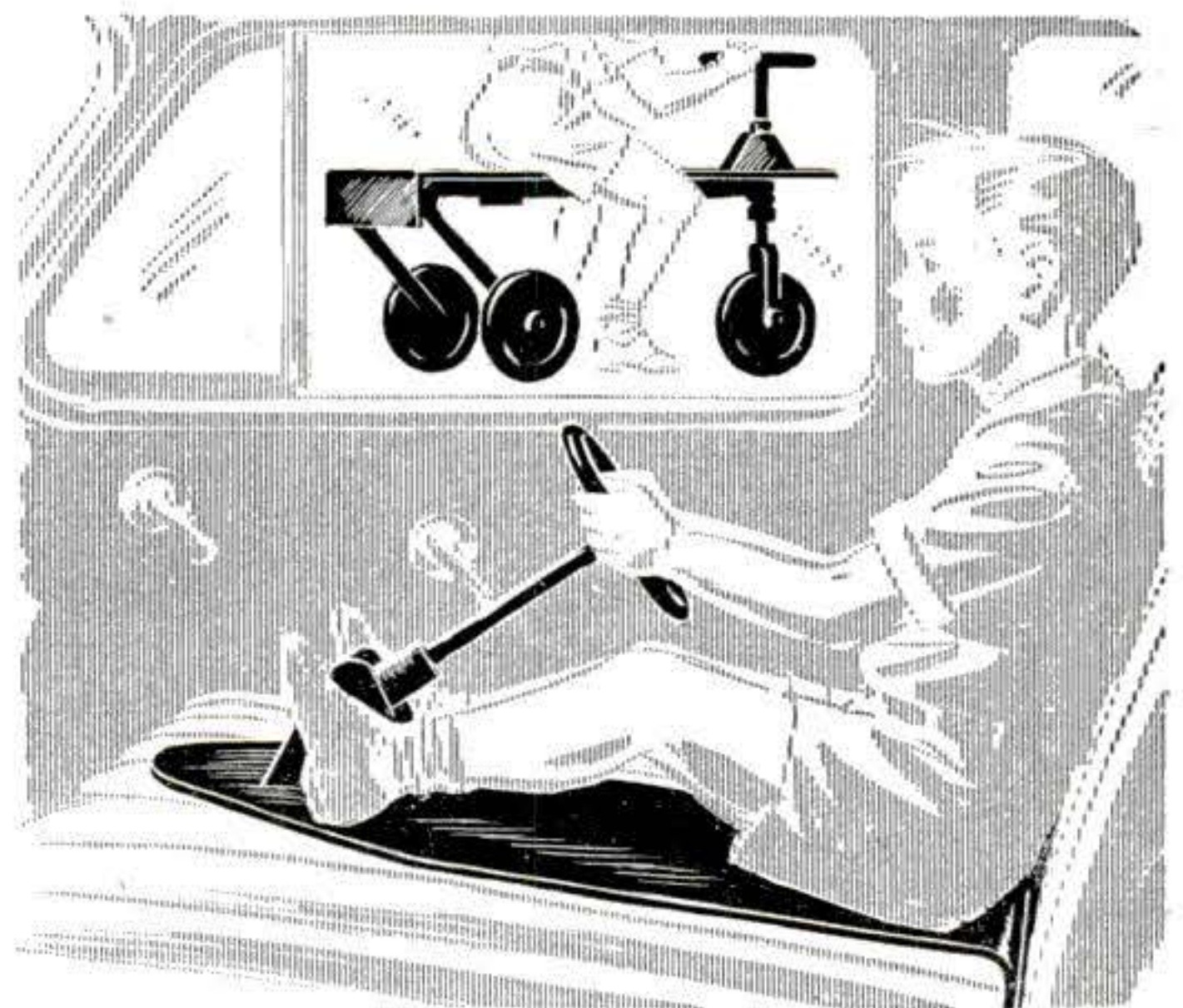

### Kiddy Car Makes Car Seat.

Junior could ride this kiddy car even on auto trips. The underframe comes off and folds up for easy storage, while the steering wheel tilts back so he can hold it. The turned-down flange on the rear hooks over the car seat to keep him from sliding. Inventor is F. White, of Bound Brook, N. J.

# New TV Sets Project Pictures

A PACKAGED projection unit made by North American Philips Co. is being incorporated in current models by more than a dozen manufacturers of home television receivers. Some of these new models will throw the video picture on a screen outside the unit, just like home movies. Main components of the Protelgram® are shown in the photo at right. The optical system is diagrammed below.

A 2½-in. picture tube, whose face is a lens as well as a fluorescent screen, forms the heart of the unit. A 25,000-volt power supply produces a picture of high brilliance on the tube face. The image is reflected by a concave mirror and another tilted at 45 degrees. Spherical distortion is removed as the image passes through a correcting lens.

The projector is a modification of the Schmidt-type optical system. Most of the receivers in which it will be used will employ 12- by 16-inch viewing screens in the cabinet; a few will use the projector to throw a three- by four-foot image onto an external screen.

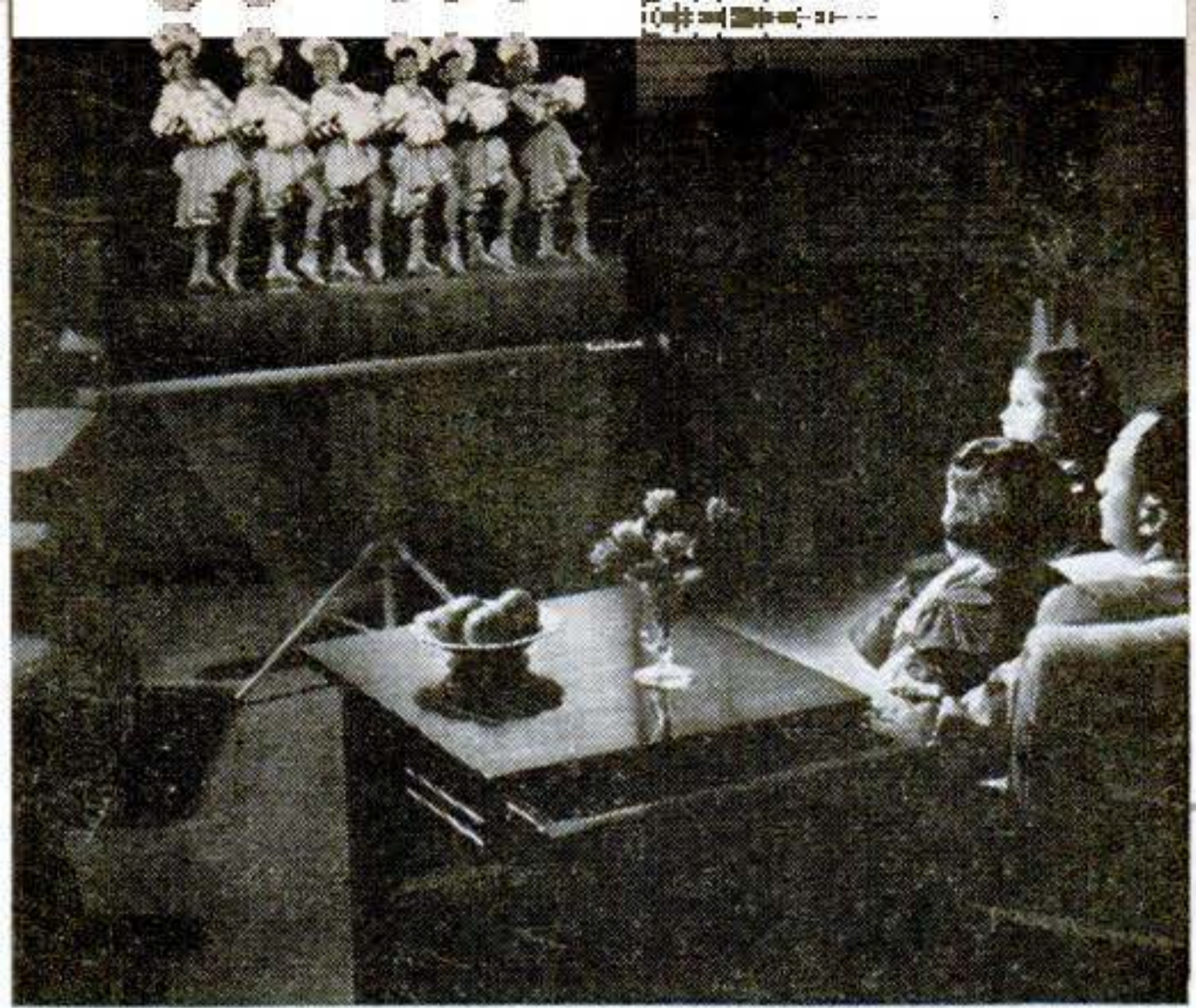
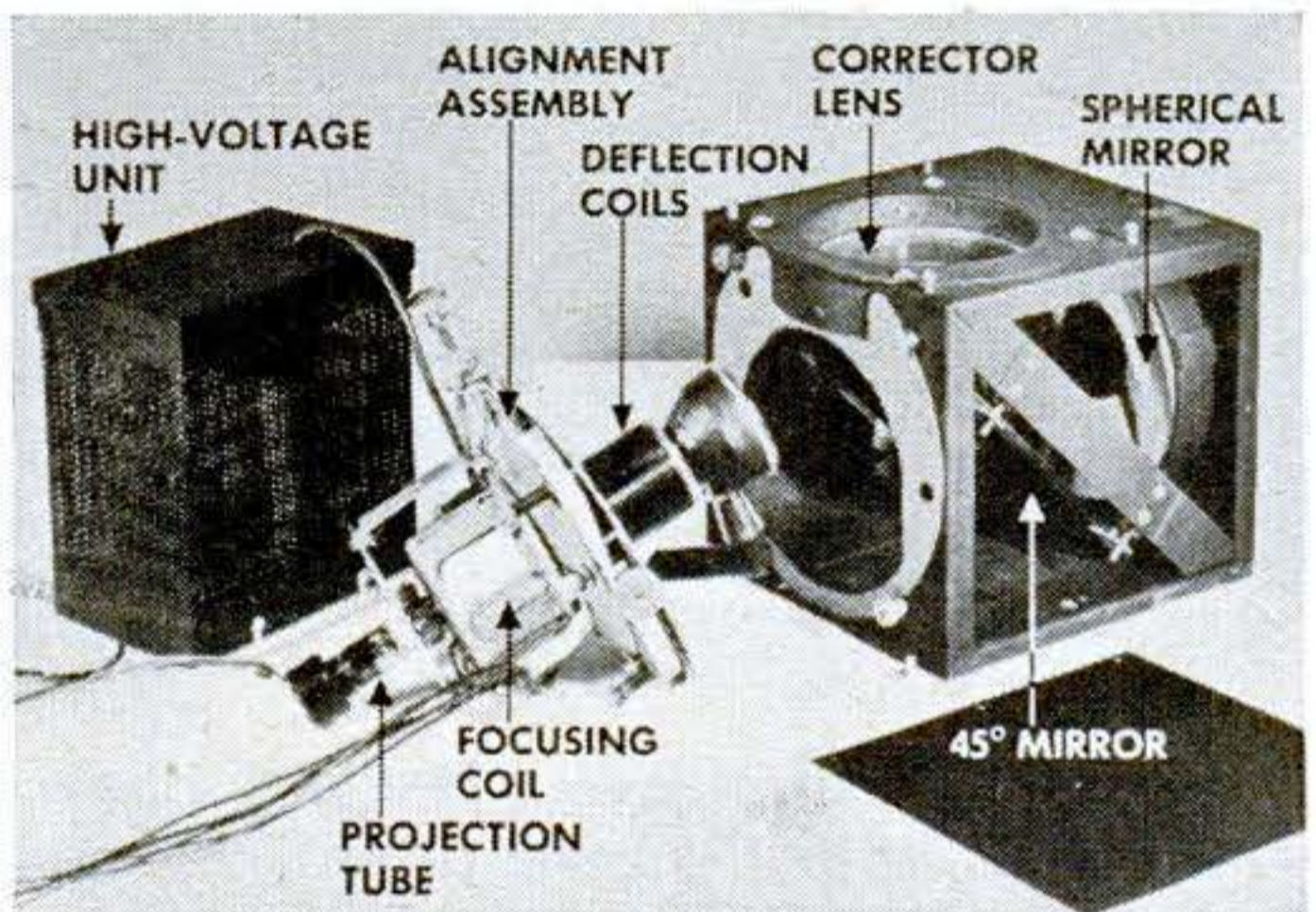
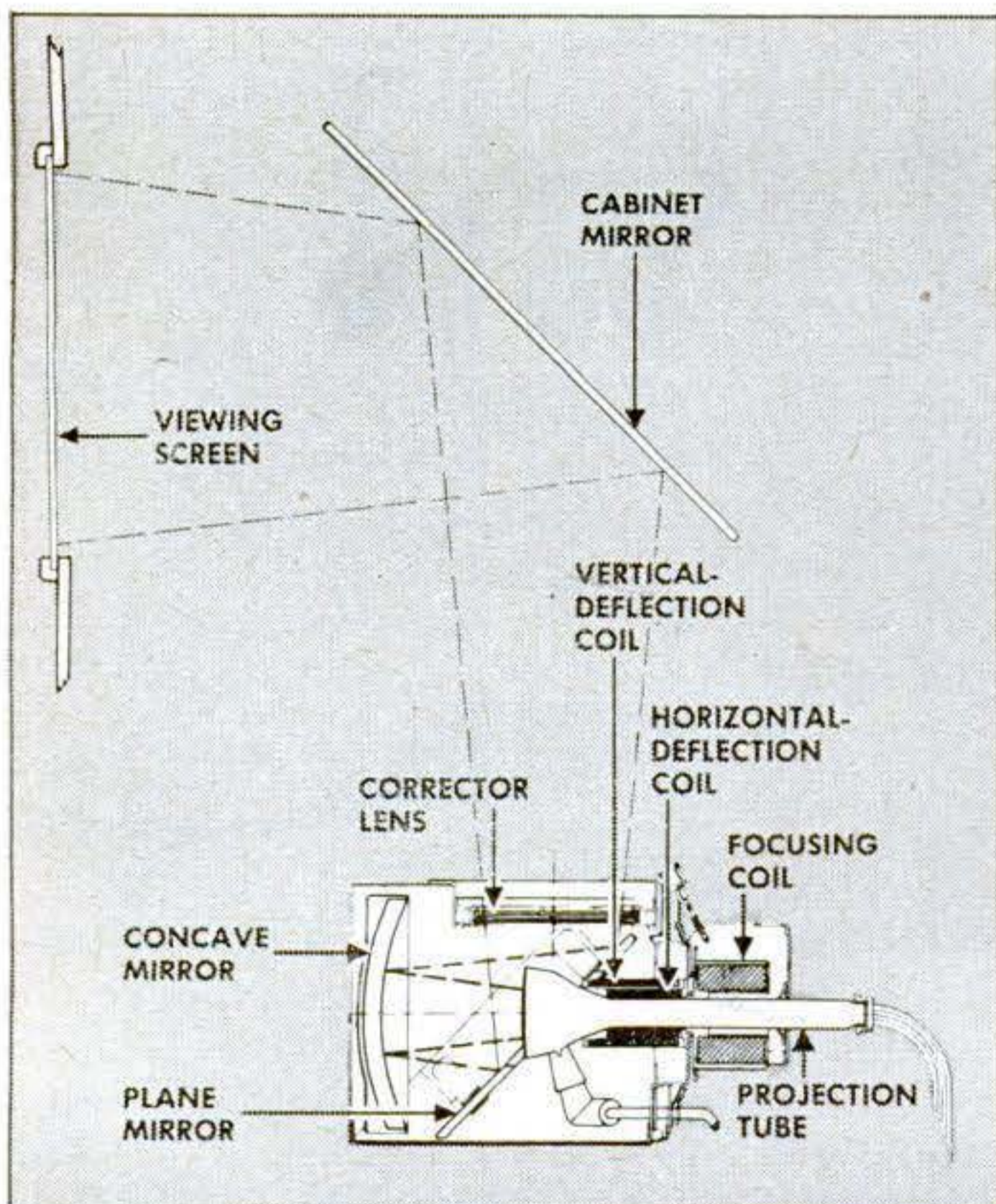

Image is thrown onto an external screen by the Ansley Tele-Movie®. Optical system is similar to unit shown below. Set costs \$795.



Protelgram® consists of power supply, left, and projector employing 2½-in. tube. Each set maker designs his own receiver chassis.



"Folded" Schmidt optical system beams picture onto concave mirror. Corrector lens and two angled mirrors put it onto viewing screen.

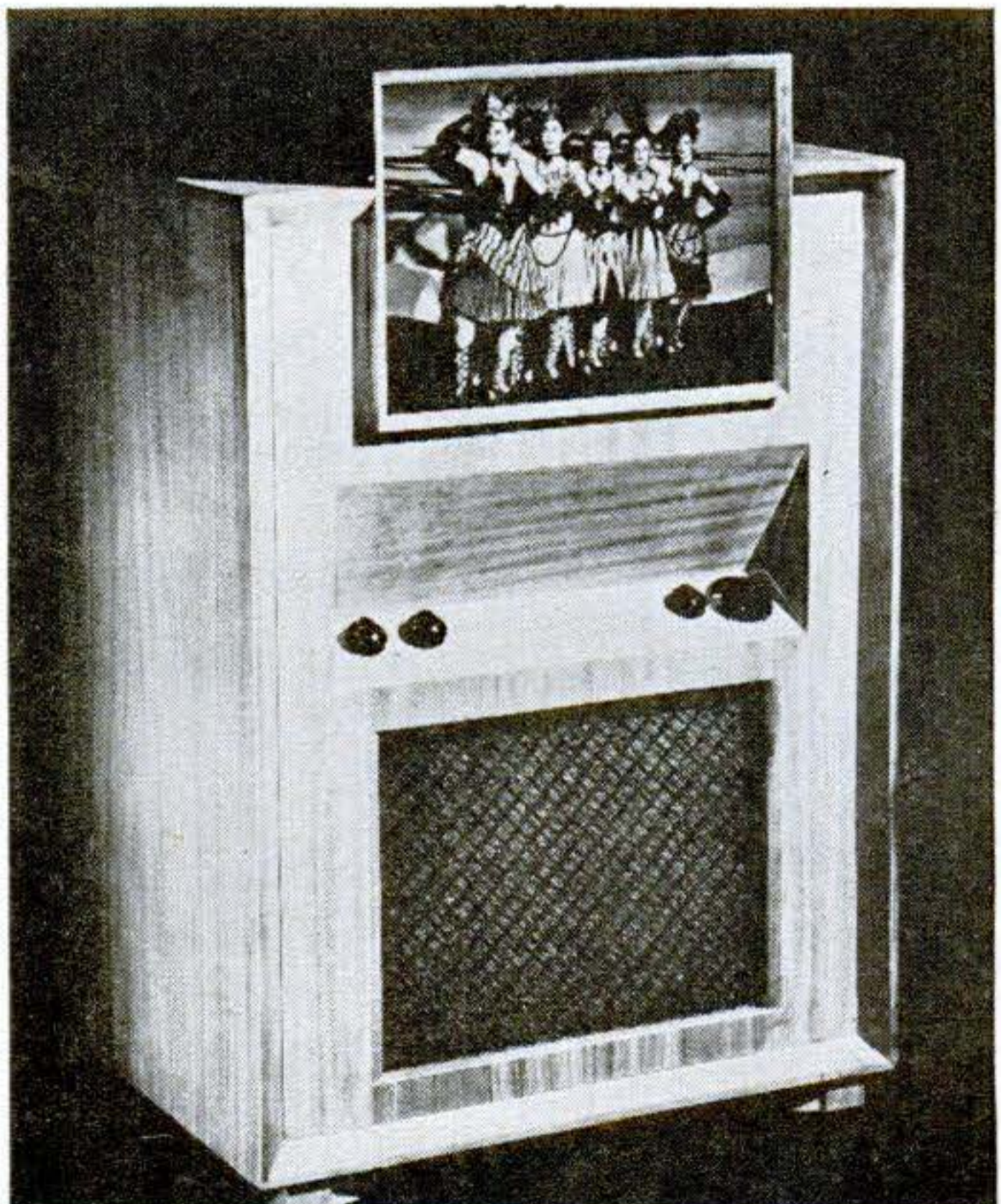

Cabinet type of projection set will be most common. In some the viewing screen folds into the cabinet. This Fisher model sells for \$795.

# How to Spend \$200,000 on One Automobile

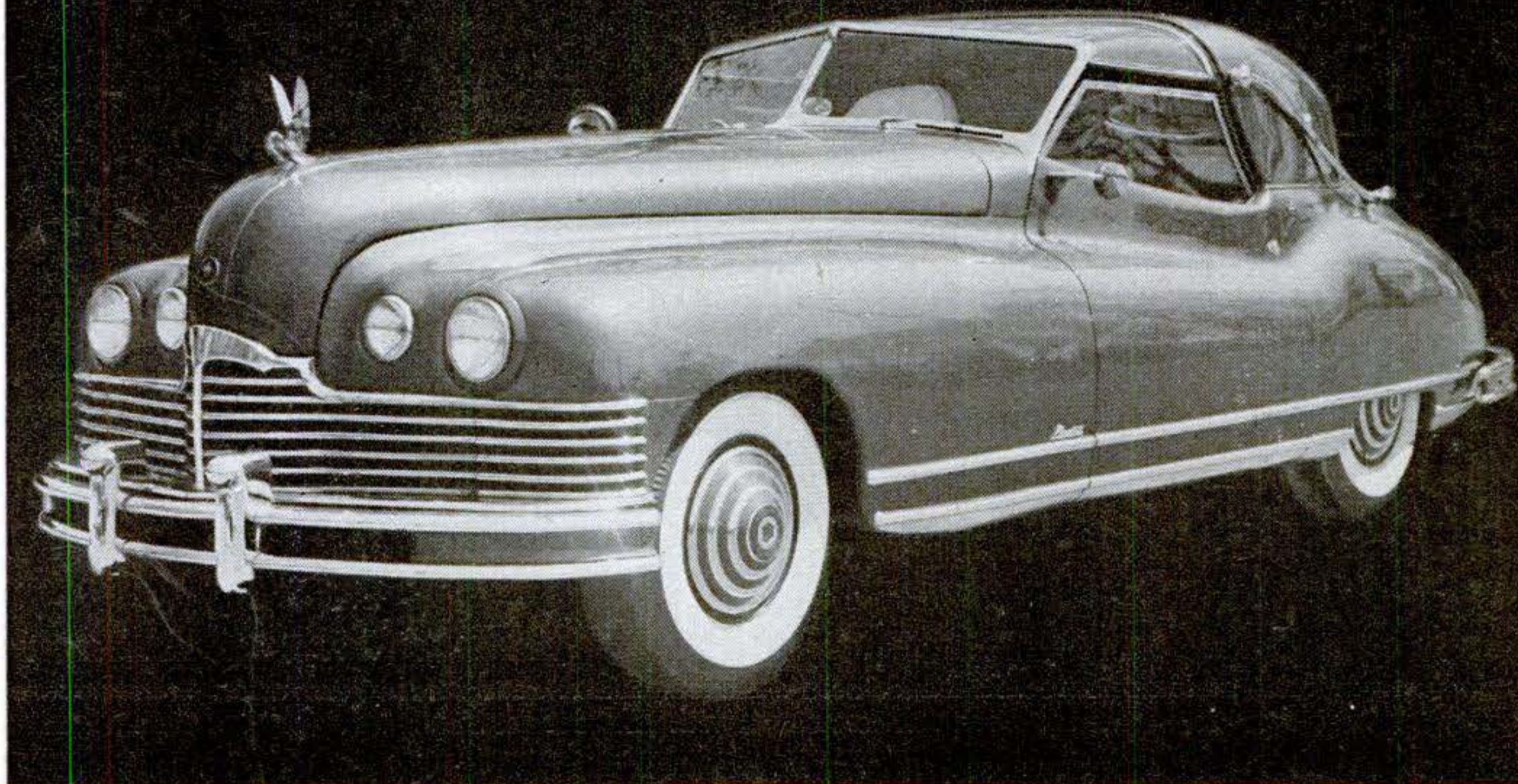

Money spent up to now on this designer's dream would purchase 100 medium-priced cars.

**Restyled and re-equipped countless times, Packard's "dog" car is a changing parade of automotive progress.**

**By Devon Francis**

*PS photos by W. W. Morris*

**P**ICTURED on this and the following two pages is the most expensive car in the United States. Up to now it has cost around \$200,000. The man who drives it is Edward Macauley, chief stylist of the Packard Motor Car Co. He has been offered \$50,000 for it.

When Packard thinks up something new in equipment or styling to put on its automobiles, it first tries it out on a "dog"—and the "dog" is Macauley's machine.

The car has been restyled, rebuilt, and re-equipped so many times that Macauley, son of Alvan Macauley, former president and board chairman at Packard, has to refresh his memory from photographs to recall what it looked like years ago. That's what makes it so expensive.

The grillwork that the company has put on its production cars for the last two years was first tried out on the Macauley car in 1940. The bumper on the 1948 Packard was first used by Macauley. He has tested scores of other items, including liner springs, that were adopted for production.

At one time, the dog car actually contained a 500-lb. refrigerating unit, to cool its occupants on hot summer days. 

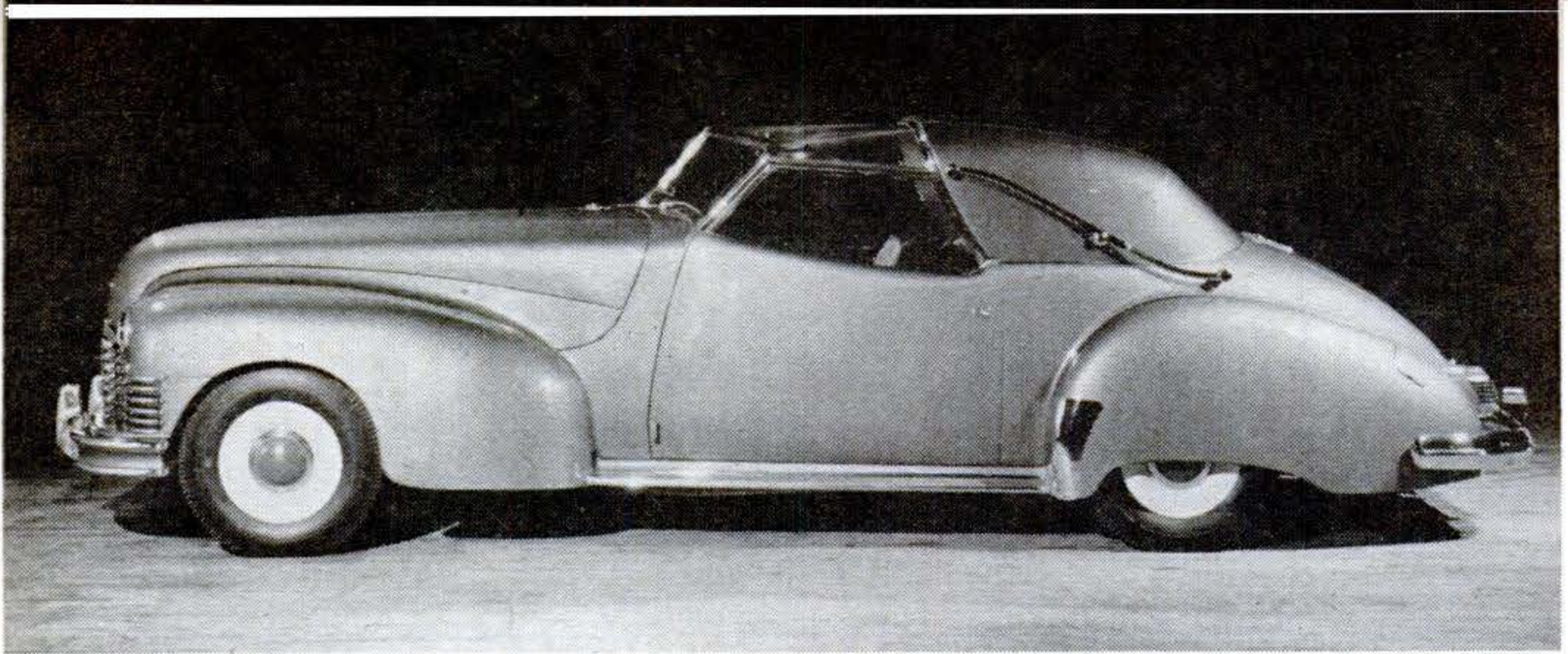

**1944 version** of Macauley's "dog" car had separate, well-defined fenders instead of long, continuous ones on present version shown on previous page. The hood, grillwork, and bumpers,

however, were similar. Note one-piece, nearly closed rear fenders. Special hood is 13 inches longer than standard Packard design, creating racy appearance but cutting down visibility.

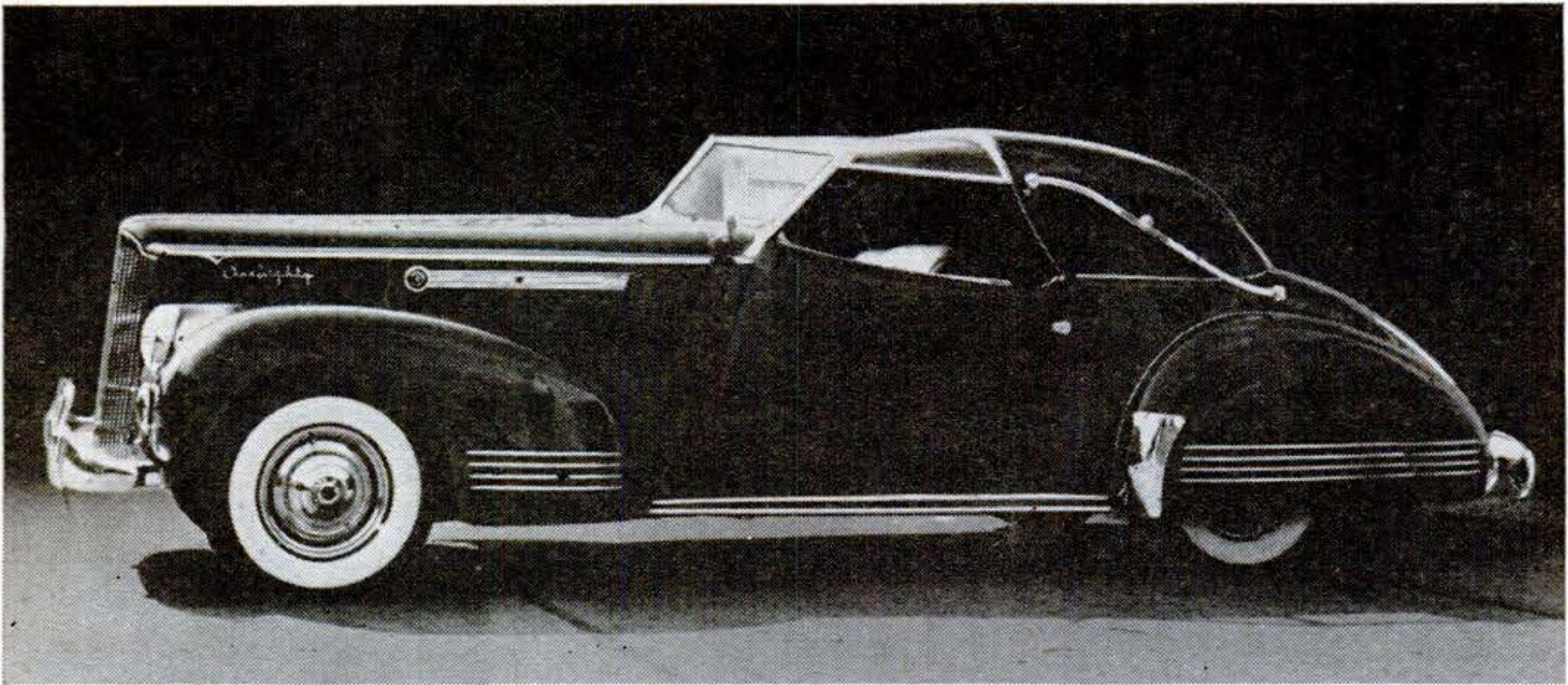

**Original version**, as it appeared in 1940, combined sleek, rakish lines with traditional Packard hood and grille design. Individual fenders were similar to those on later, 1944 version (at top),

except that rear ones were open type covered with fender skirts. The car, called "Brown Bomber" because of its present golden-brown finish, is known officially as "The Phantom."

Macauley likes to drive something snappy, so he ordered the car's general configuration when the machine was first built nine years ago. It has a standard chassis and engine. Once, it contained a 12-cylinder engine and on one test clocked 128 m.p.h.

Some of the things Macauley has added to the car are merely for his personal comfort and that of his wife. The right front seat reclines, for instance, so Mrs. Macauley can take a nap on long trips. Vanity compartments in the side walls accommodate mirrors, lipsticks, and powder puffs.

The car invariably draws crowds. When it was driven to Detroit's Belle Isle to have its portrait made by POPULAR SCIENCE, passers-by collected in such numbers that the PS photographer had to spend half his time shooing people away.

Its owner can't park it on the street. It stops traffic. He always has to put it in a commercial parking establishment—preferably a dark corner of a garage.

Macauley has arrived at some firm conclusions as a result of driving his dog car. One of them is that plastic tops, regardless of their color, are just too hot in the summer. Another is that fog lights, at anything above the bumper level, are useless, and that the color of the glass in them has nothing to do with their penetrating qualities.

He also concludes: "This car proves that all styling in the automobile business is evolutionary."

Take a good gander at the machine as it looks today. It's always undergoing changes, and it probably won't look this way by the time the snow flies.



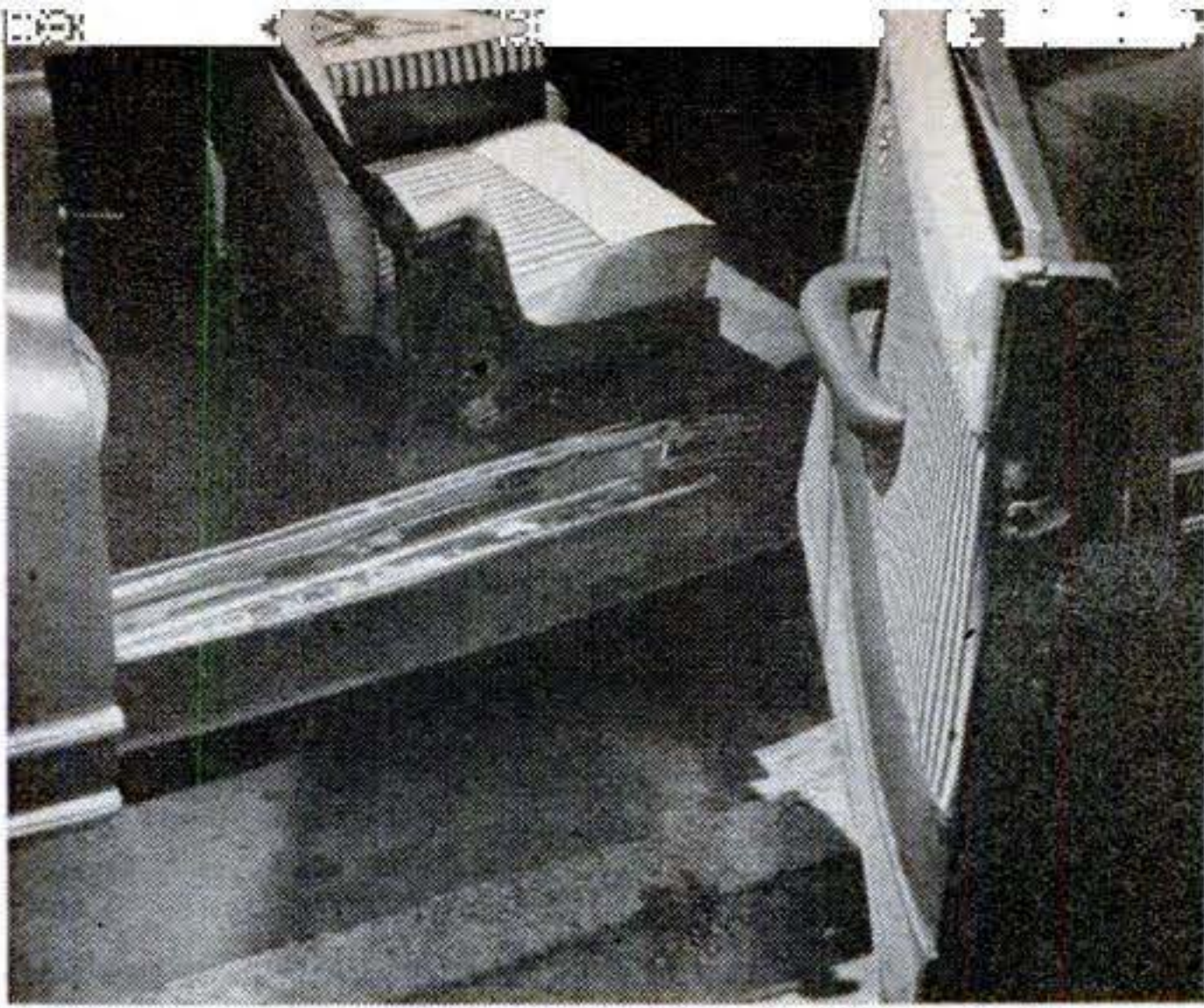

**Long, sloping doors** are push-button operated and extremely heavy. Hydraulic windows are remote-controlled. Other refinements include air brakes, reclining front seat, and center armrest.



**Transparent sun roof** over front seat has been retained throughout all versions for experiments in filtering sunlight with different-colored plastics. Rear part of the car's top is solid steel.

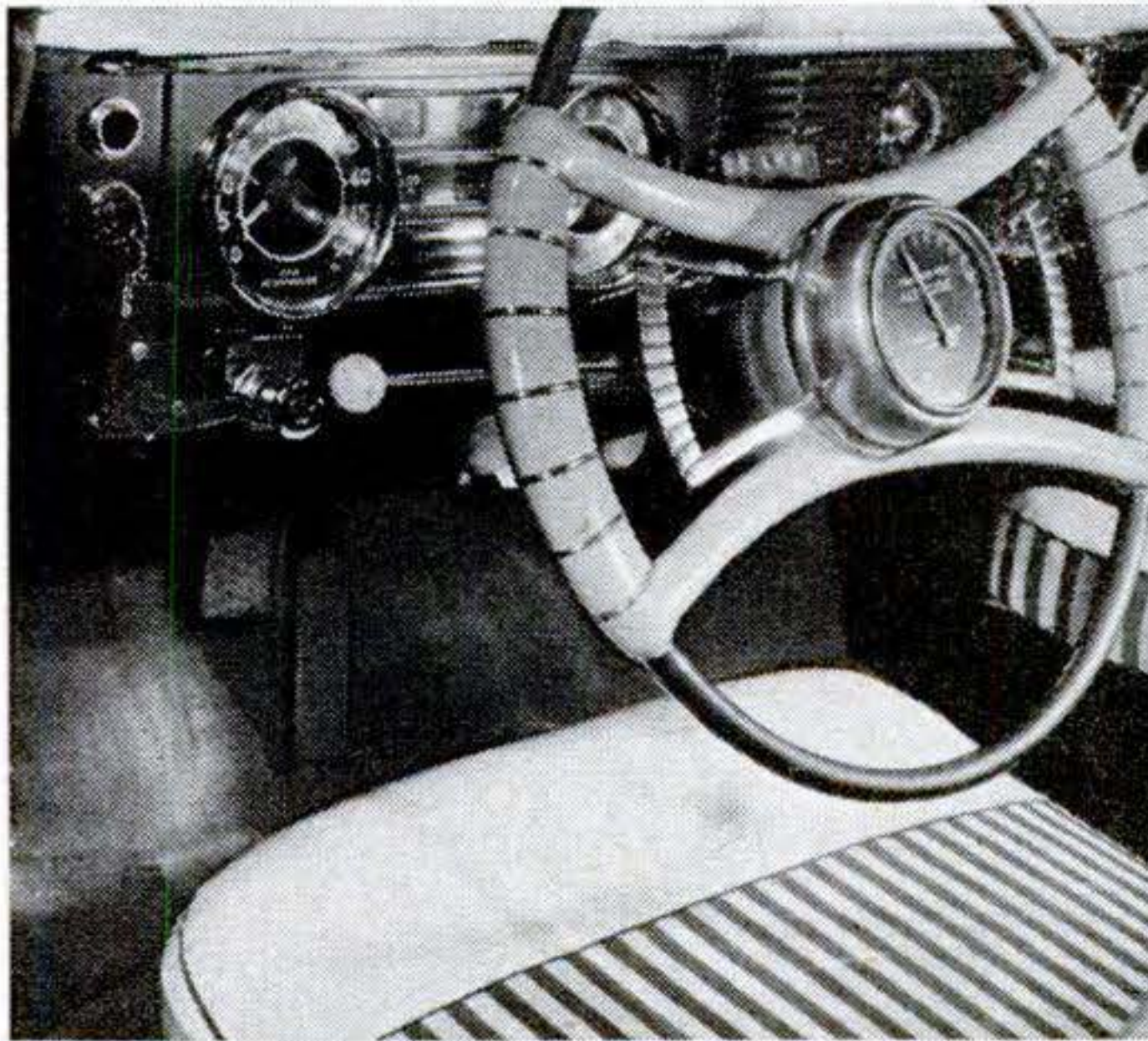

**Special equipment** includes extra-loud highway horn (white knob), tachometer, barometer, altimeter (on steering-wheel hub), light that glows red when oil pressure drops or water overheats.

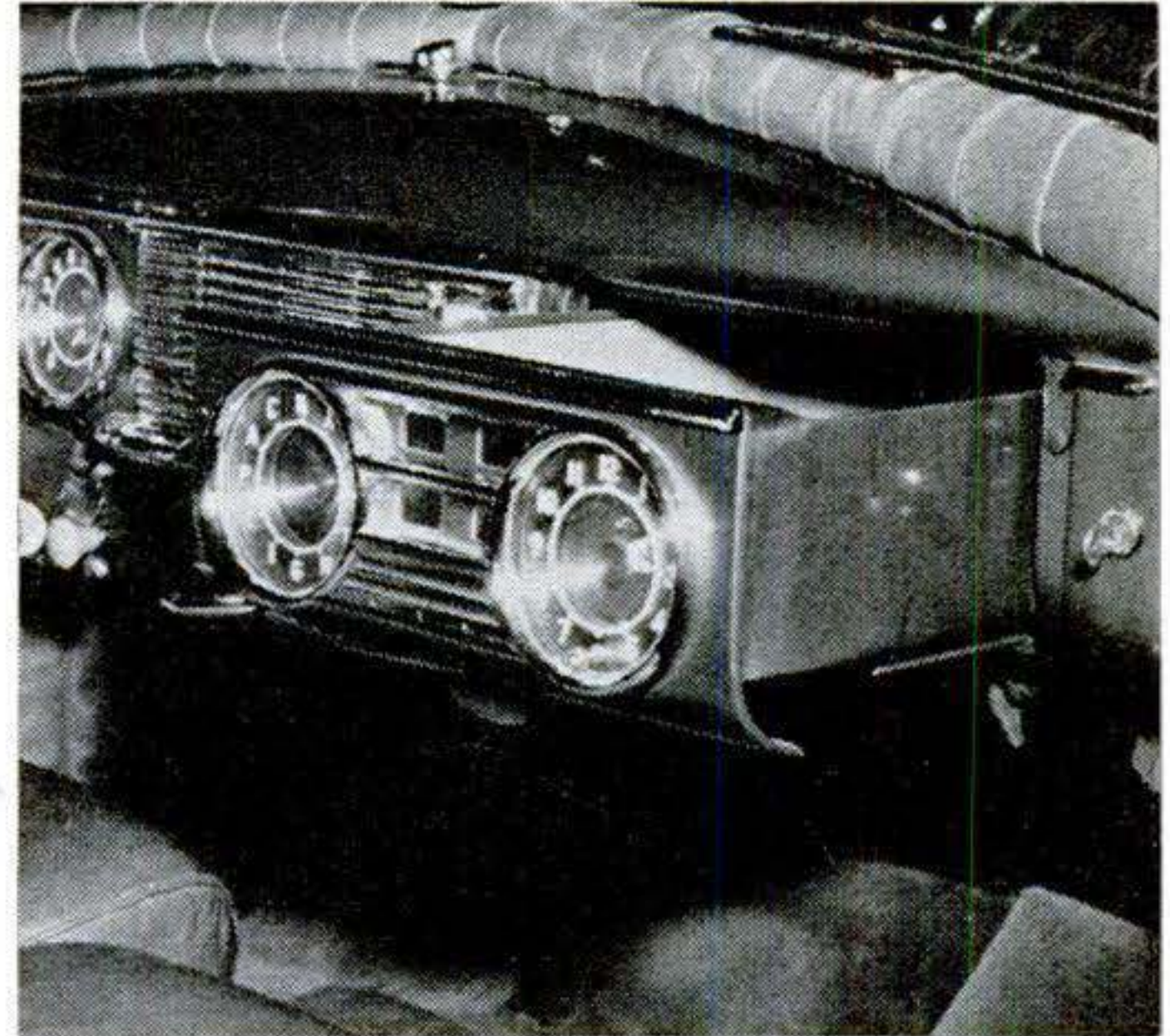

**Large, roomy drawer** was substituted for conventional glove compartment. Cowl shoulder is covered with pale-yellow plastic. Dash controls include transmission lockout and engine blower.

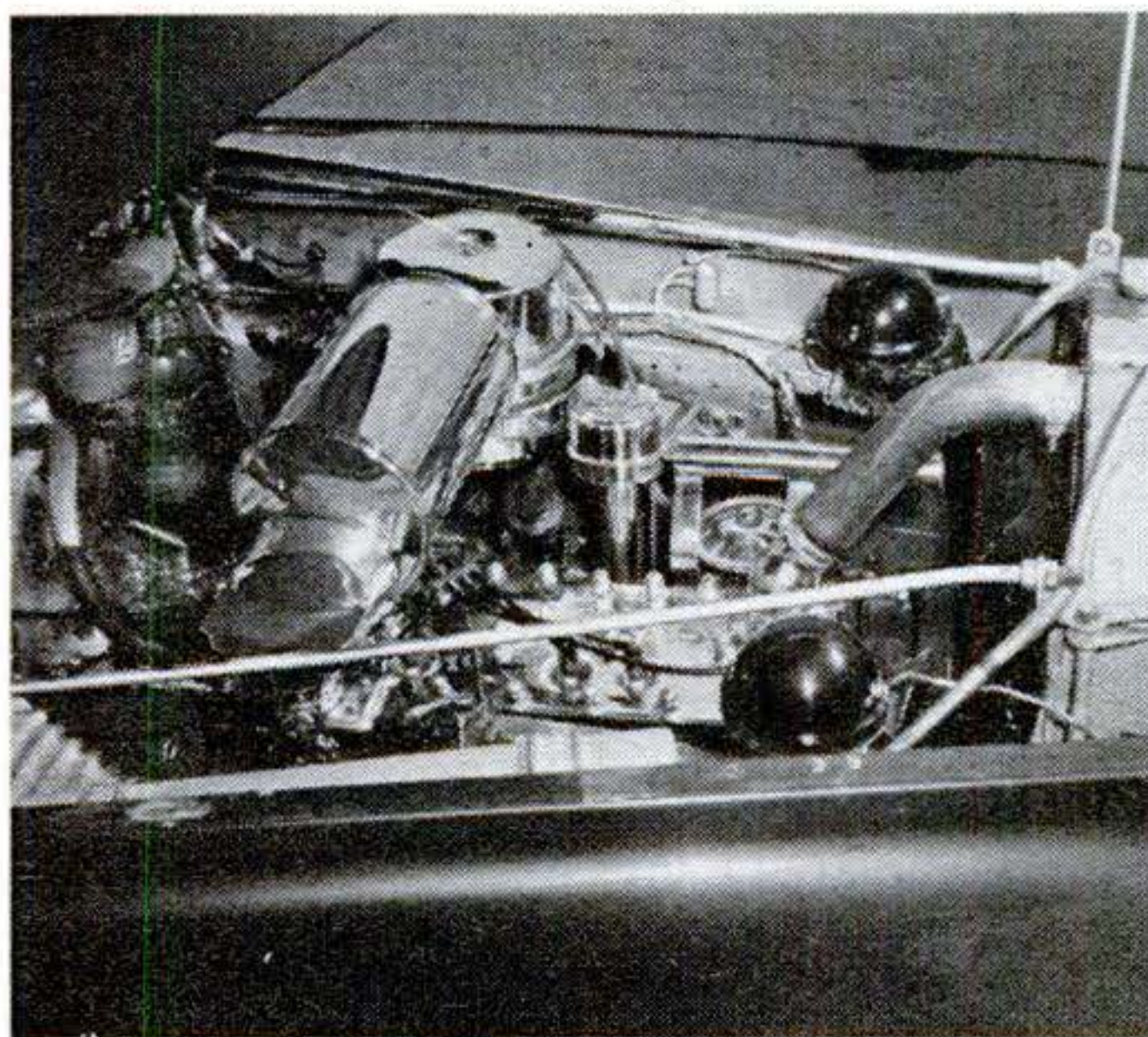

**Snazzy, chromed engine** is standard Packard eight. Car weighs 5,800 lb., averages 15 miles per gallon, is now equipped with Packard's new Ultramatic Drive® (PS, June '49, p. 139).



**Trunk lid** raises hydraulically; so does radio aerial to its right. Inside are fire extinguisher and compressed-air cylinder for filling flat tires. The eight-stack exhaust pipe is just for looks.

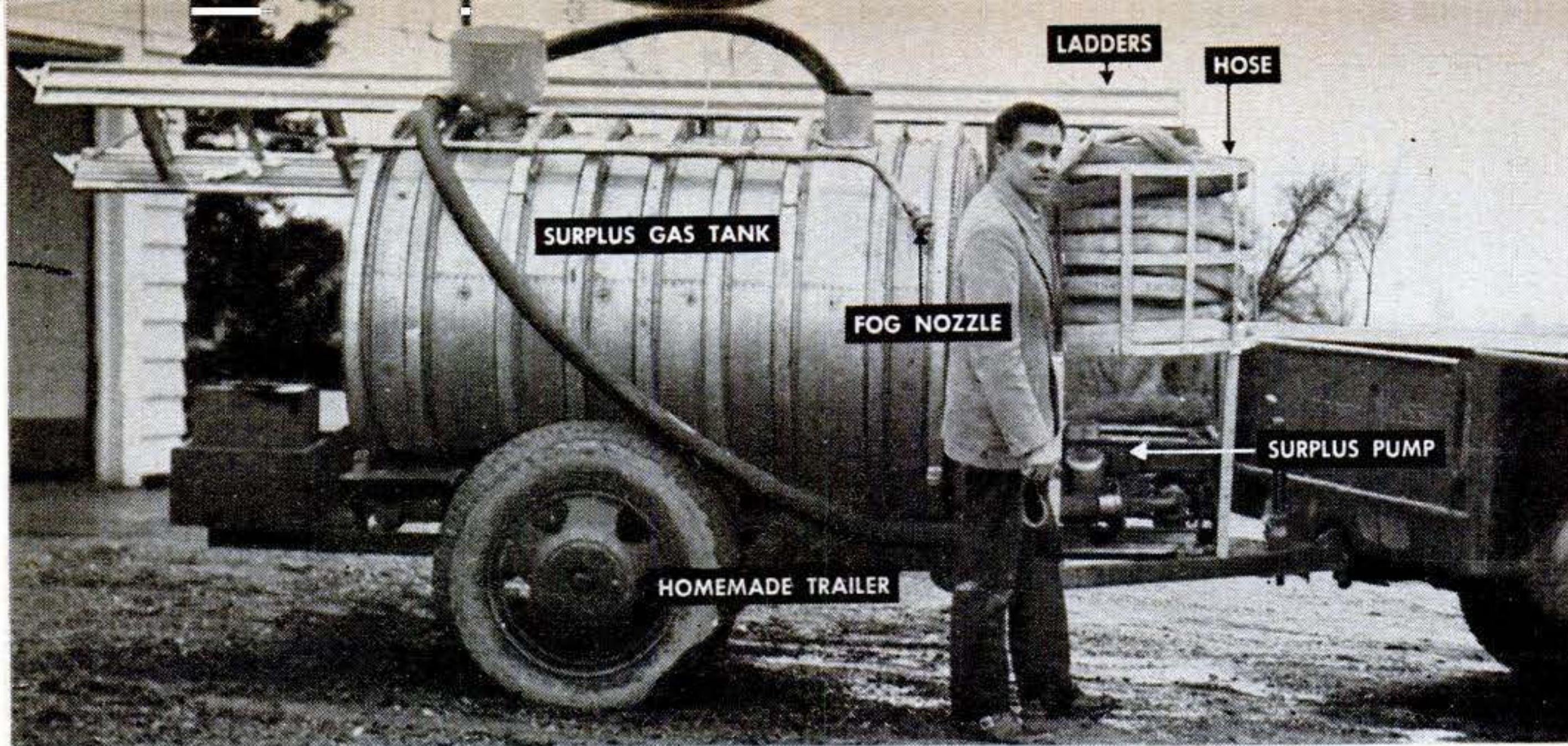

## Salvaged Fuel Tank Makes Rural Fire Fighter

A SURPLUS aircraft fuel tank mounted on a homemade trailer now provides extra fire protection for the rural areas around Lapeer, Mich. Towed by a light truck, it can fight blazes all alone—it carries 470 gallons of water, a motor-driven pump, hoses, ladders,

and other equipment. Or it can assist other fire apparatus, pumping water to trucks from its tank or from a stream. The unit, built from used parts, cost under \$1,000, reports designer Bob Myers, and carries as much water as a \$10,000 fire truck.



## Hoe Does Day's Work in Hour

THIS new British rotary hoe, which has a four-stroke, single-cylinder motor and self-sharpening blades, can prepare seed beds in a single operation—a day's hand work in one hour. The blades not only lift, break up, and aerate the soil, but mix it with cover crops, fertilizers, and manures. The hoe is manufactured by Rotary Hoes Ltd., of Essex, England, and is now being tried out in California.

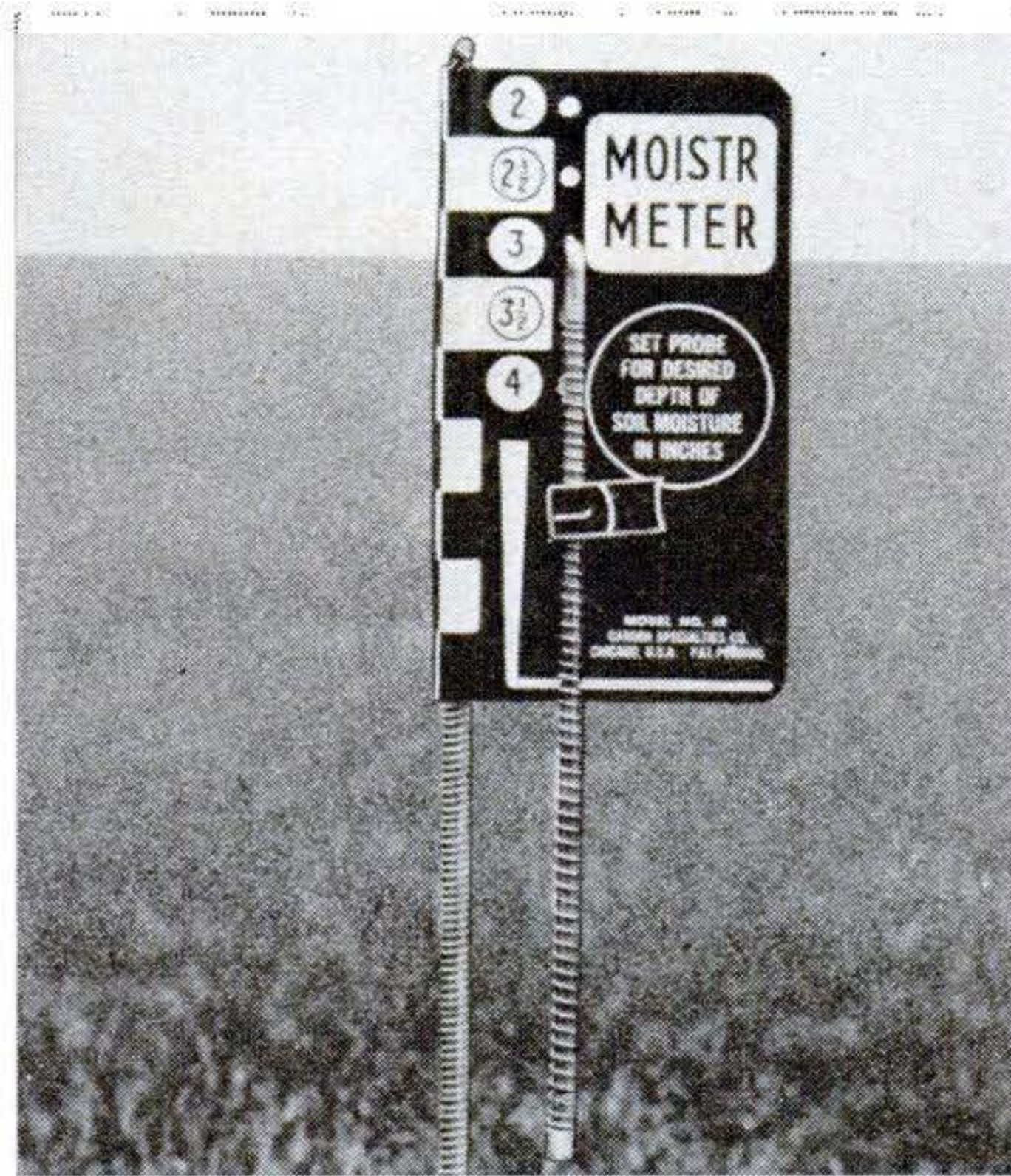

## Flag Says Stop the Water

THIS device waves a flag at you when the lawn has had enough sprinkling. The flag is held down by a metal probe sticking into the ground. When moisture soaks down to the probe tip, it loosens the soil enough to release the probe, which in turn lets a spring push the flag up. The depth you push in the probe, which measures water depth, can be varied. Garden Specialties Co., Chicago, makes the Moistr-Meter®, priced at \$1.50.

# The Best Seat in the Ball Park

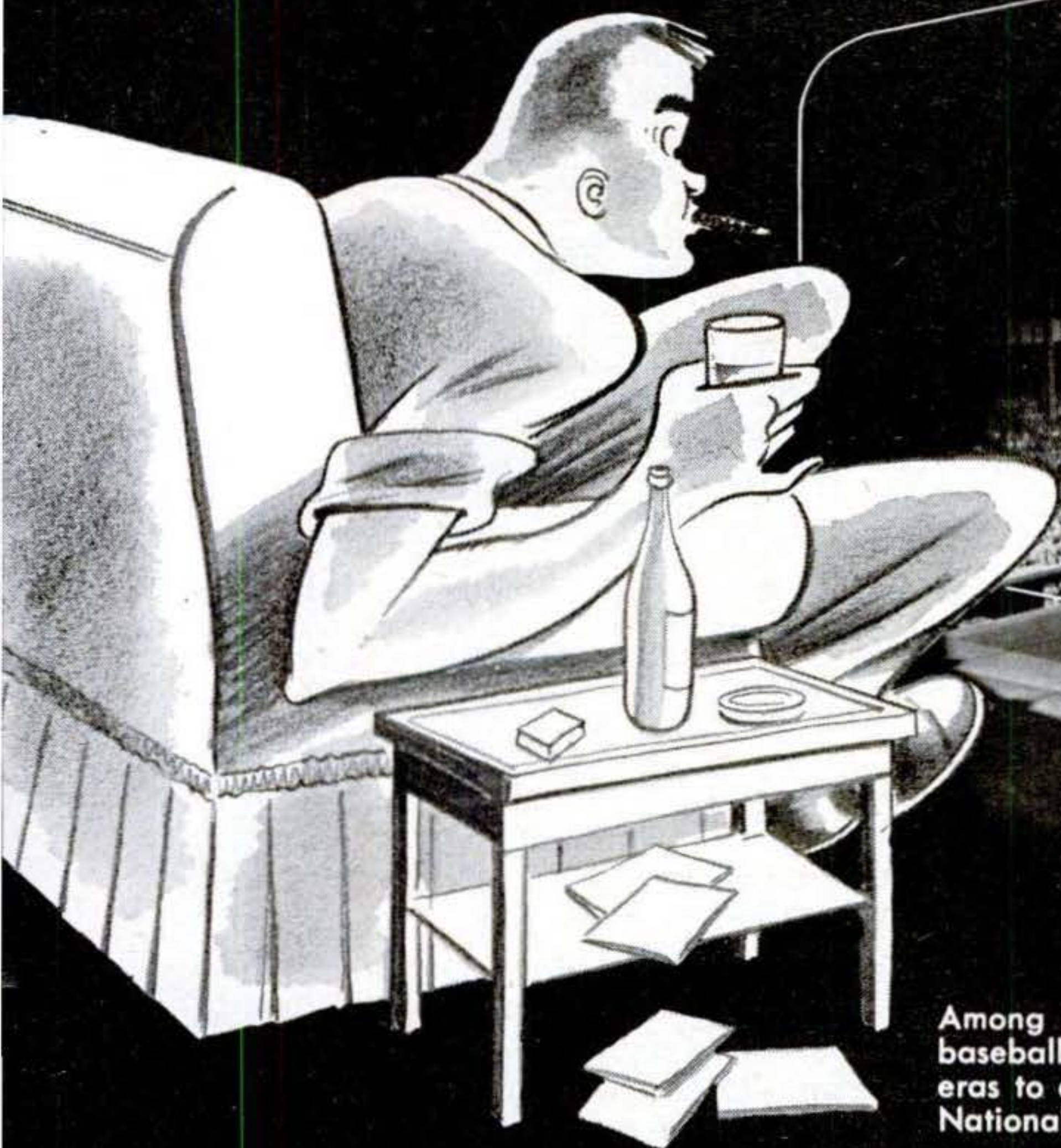

Among those who know, it is generally agreed that baseball is the toughest sport for the television cameras to cover. Here is the story of how they bring the National Sport right into your home.

Television's baseball team puts your easy chair right up behind home plate for a bird's-eye close-up of the game.

**By Herbert Johansen**

*PS photos by Hubert Lockett*

**P**LAY ball!

Johnny Pesky, up for the Boston Red Sox, steps into the batter's box.

Lefty Joe Page, on the mound for the New York Yankees, goes into his windup for the first pitch.

Cameraman #2, up in the press box behind home plate for the television "team," trains his wide-angle lens on the scene below.

There is a sharp crack of bat against ball. All three teams go into action.

While #2 camera follows the spinning

ball, its #3 twin in the press box picks up the running Pesky, ready for a close-up at first base if he makes it. But it's a long hit to the outfield! That's the job of #1 camera from its vantage point in an upper-tier "basket." Its telephoto lens picks up the fielder as he runs back—nails him as he makes a sensational catch right in the stands.

Meanwhile, #3 camera sweeps the cheering crowd in the stands, then "pans" to pick up the next batter as he walks out swinging a couple of bats. And #2 camera has shifted back to its main job of covering the pitcher-batter for the play coming up.

What you see on the screen of your television set at home is a rapid-fire selection of the best of these three images, resulting in a smooth continuity of action. And as you will notice from the diagrams on the following pages, the three cameras that play television baseball bring you the game's

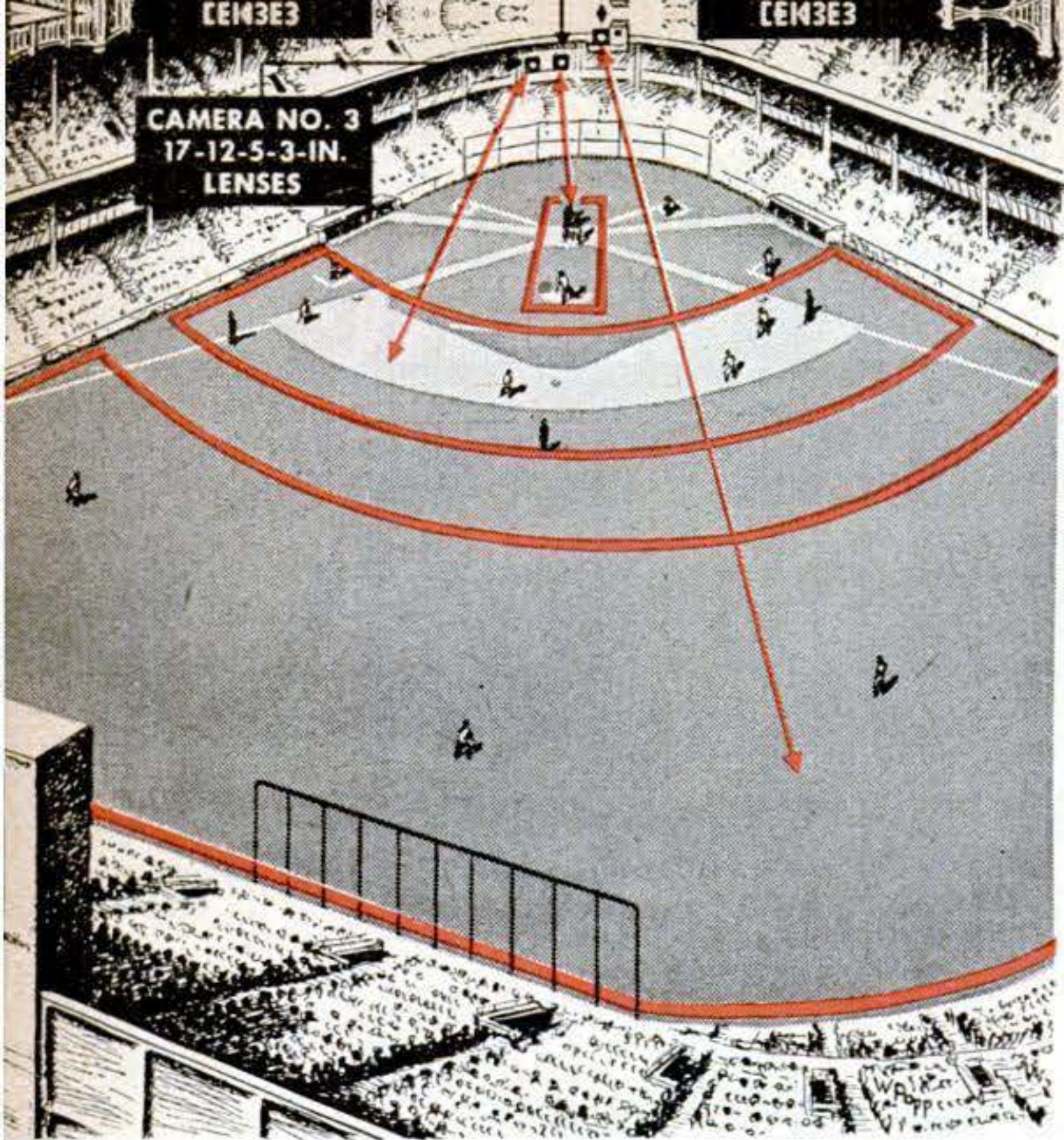

The main job of each of the three television cameras is shown in drawing above. Outfield is covered by #1 camera's telephoto lens; the pitcher-batter by #2, and the infield by #3.

action from one viewpoint. The effect of their coordinated "play" is to project your easy chair into space behind and above the home plate—giving you the park's best seat.

If you watched television baseball in the past years, you may have noticed a jumping around that gave you the jitters. You would be looking at a play from behind home plate. Suddenly you were shifted around to behind third base. Before you could orient yourself, the same play came on the screen as if you had been sitting in still another part of the stands. It was something like watch-

The upper-tier television "basket" during a scene of activity. This is the location of camera #1. At far right is the sound-catching "parab" reflector. Man at top is radio broadcaster.

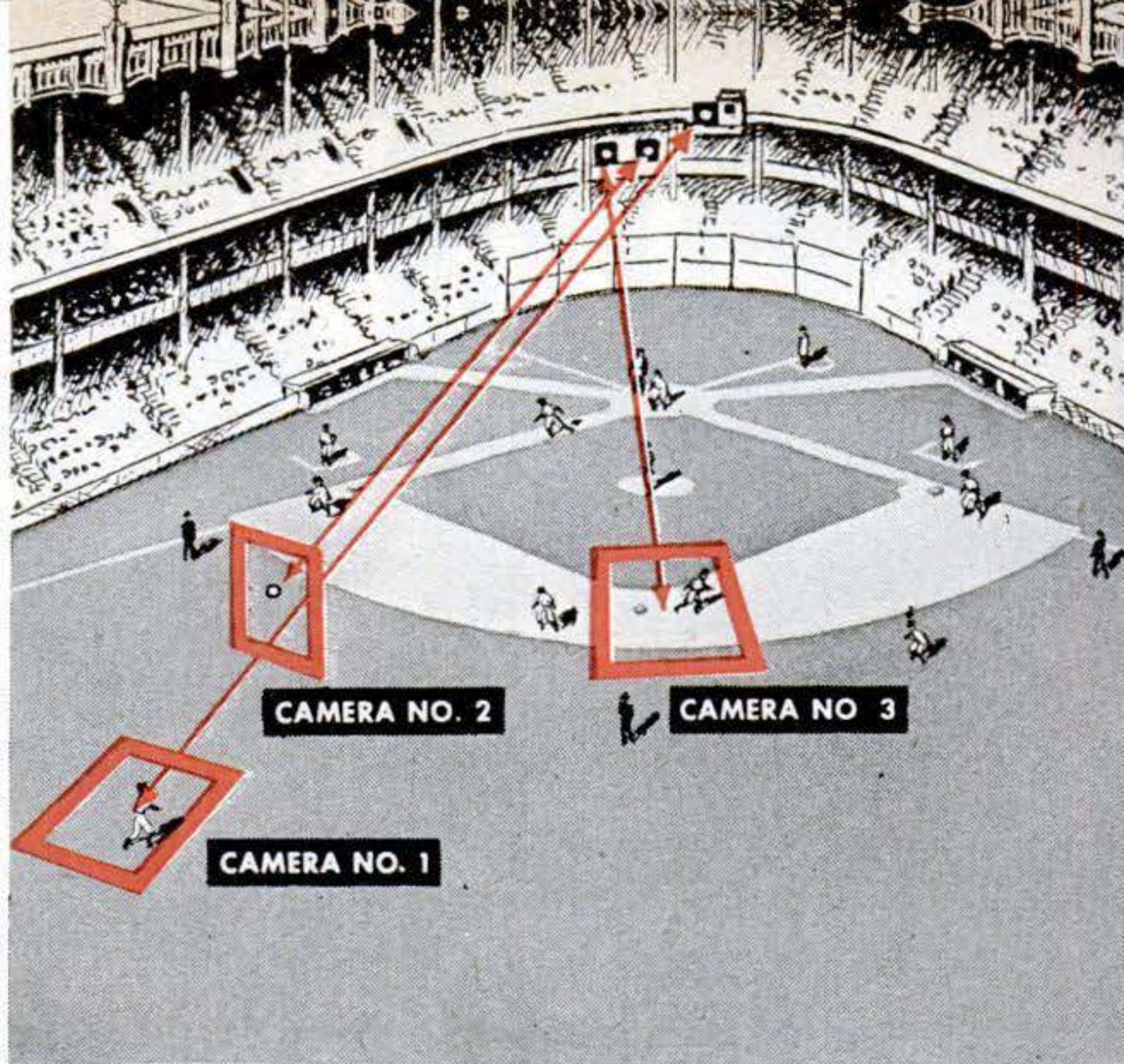
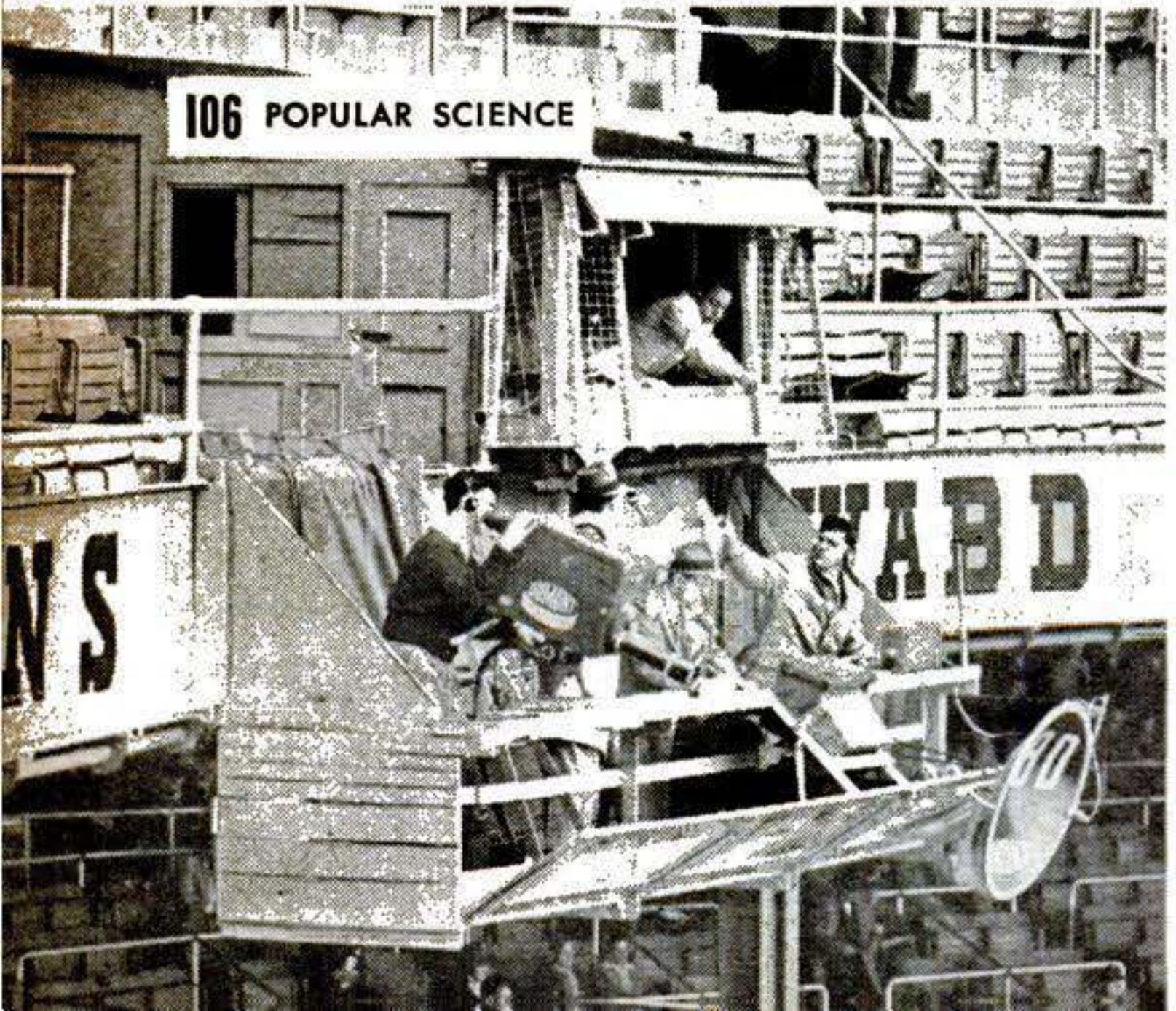

Here the #2 TV camera follows a ball hit to the outfield, while #1 camera is trained on outfielder running in for the catch. Camera #3 was on man at 2d base and follows him as he runs to 3rd. Camera #2 will then shift to pick up runner at 1st base, ready for close-up.

ing the game through a big kaleidoscope.

That, decided Harry Coyle, young director of mobile operations for Du Mont's WABD and manager of its television "team," isn't the way a fan at the park watches a ball game—or would want to.

"He may jump up and down in his seat as his blood pressure rises," says Coyle. "But he doesn't dash madly from one side of the stands to the other as the action shifts on the field. He stays put—more or less. So why shouldn't television do the same?"

That's why Coyle eliminated his camera

Other two "eyes" of the triple television seat are located in front row of the press box, behind home plate. The cameras are electronically controlled from booth shown on the next page.



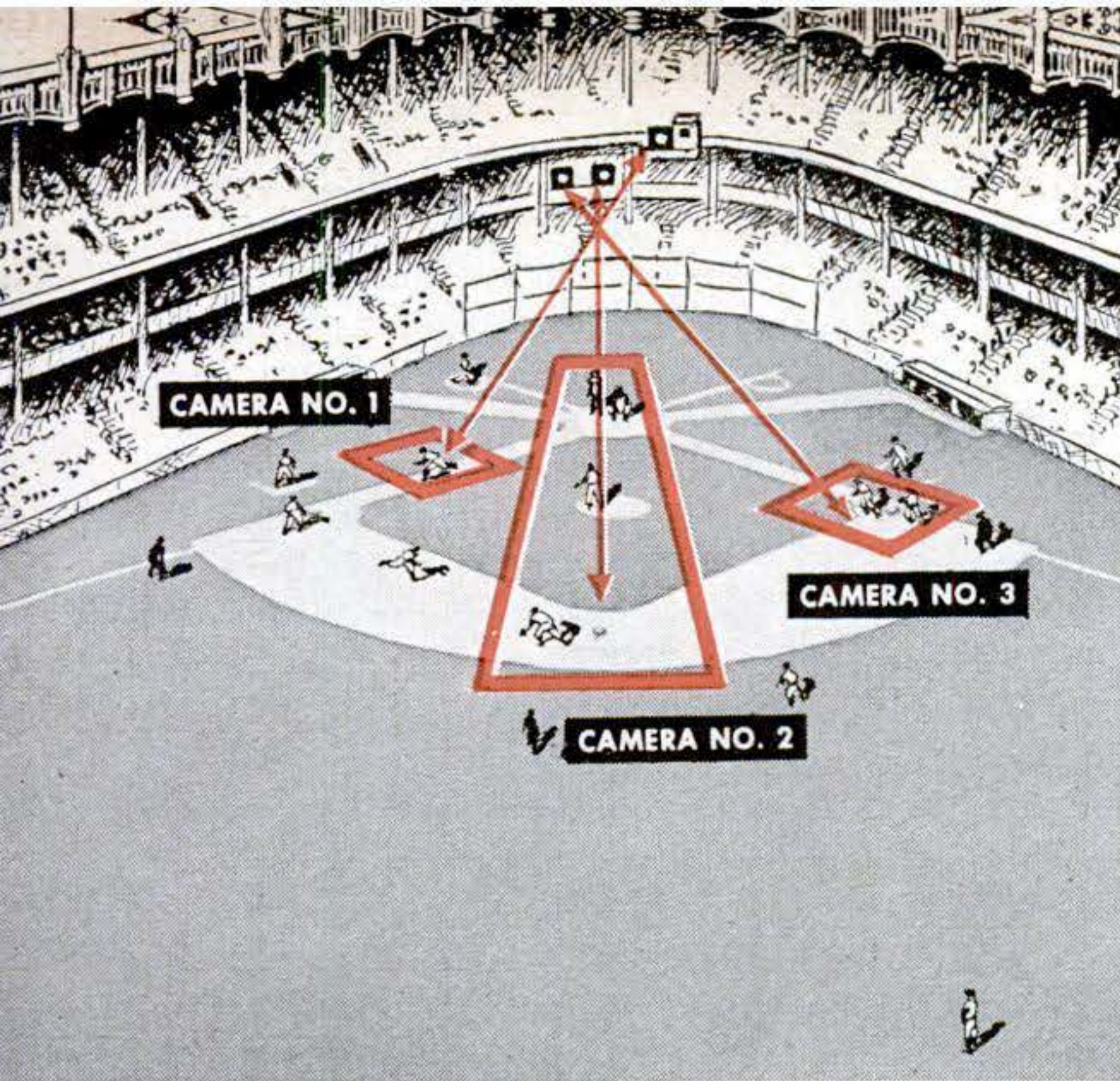

In this situation batter has hit a blistering grounder to 2d base. Camera #2 has followed the ball, while #3 camera covers man at 3rd base in case he tries to score. Meanwhile #1 camera has swung from the outfield, ready to catch a possible close play at 1st base.

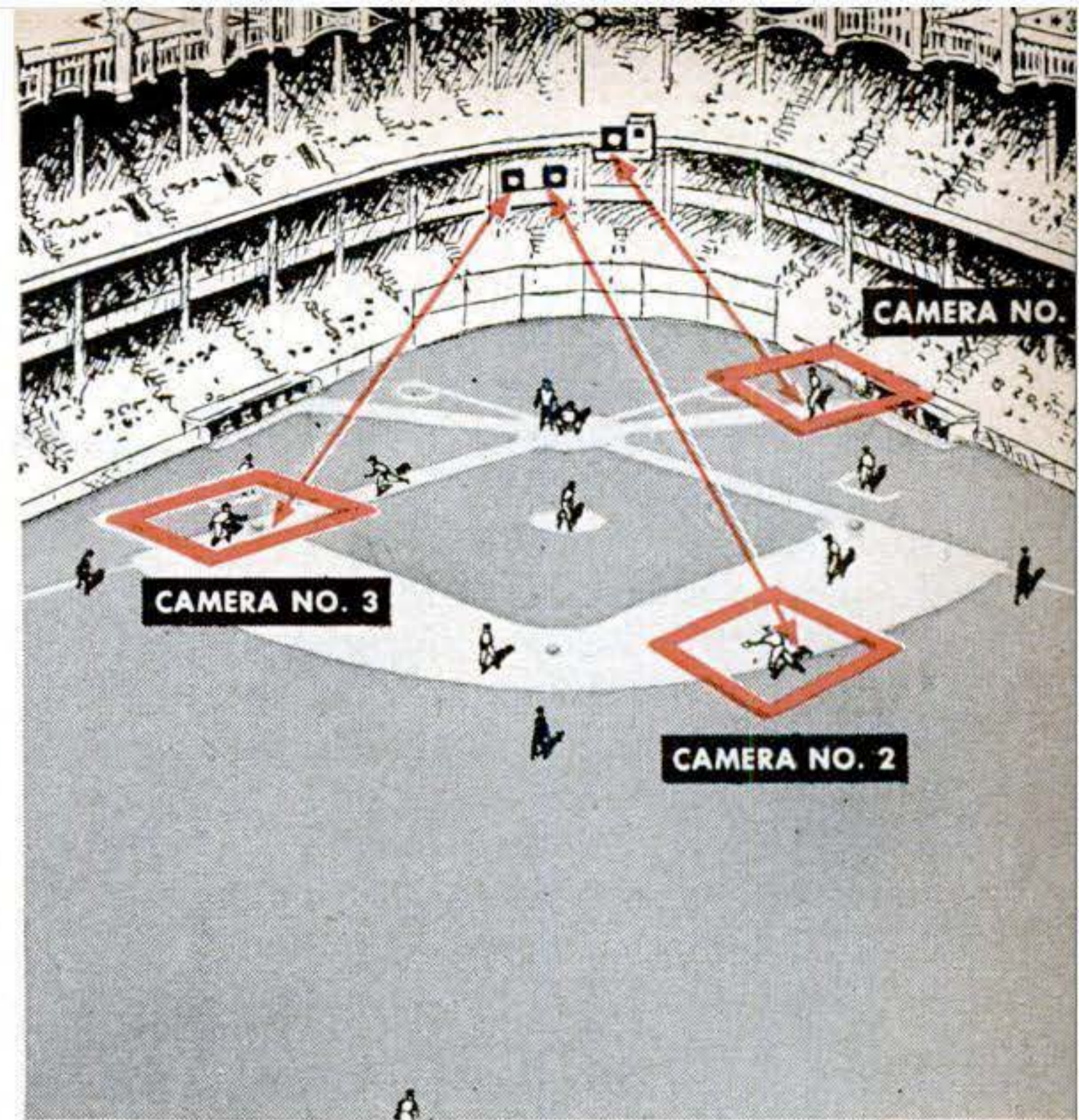

A hit to shortstop is picked up by camera #2, which then follows a throw to 1st base. Camera #3 already has followed runner and gets close-up on the put-out. Camera #1 picks up next batter coming out of the dugout, and holds him until #2 camera comes in with wide-angle lens.

behind third base and grouped them all together behind and above home plate for this year's telecasts of the Yankees' home games. But that doesn't mean the new technique limits the field of coverage. It lets the viewer see just as much, but without the confusion.

Each swivel-mounted camera has a turret of four versatile lenses that can be instantly shifted by a push button from a wide-angle sweep of the entire field to an intimate close-up of hot arguments among umpires, players, and managers. While each cam-

era has one main job, all double in brass.

Behind this camera battery is the rest of the television baseball team. Squeezed in with camera #1 in the upper-tier basket is the announcer, the man who adds rapid-fire words to the pictures. He not only must watch the action of the field, but he must keep part of one eye fixed on the screen of a small television set in front of him so that he knows what scenes are going out over the air. If he didn't, there would be times when he excitedly described one scene but your TV set showed something else. ➡

**Control booth** is the nerve center of a baseball telecast. The director, far right, watches monitor viewing scopes and selects the image that will be transmitted to the television audience.

**Here one press-box cameraman** aims lens at a commercial trade-mark. The ring image will be superimposed on image of the playing field provided by another camera.

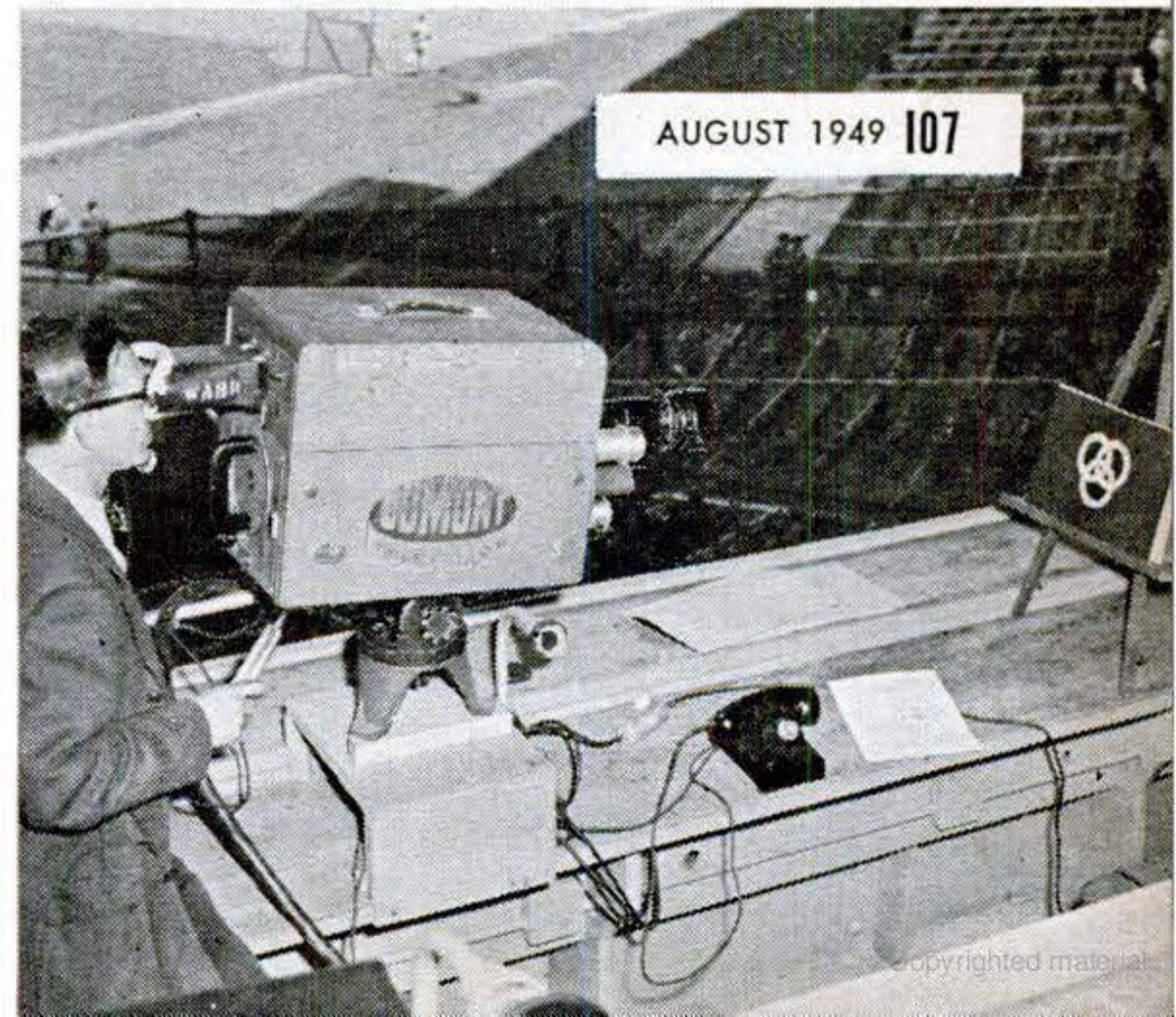
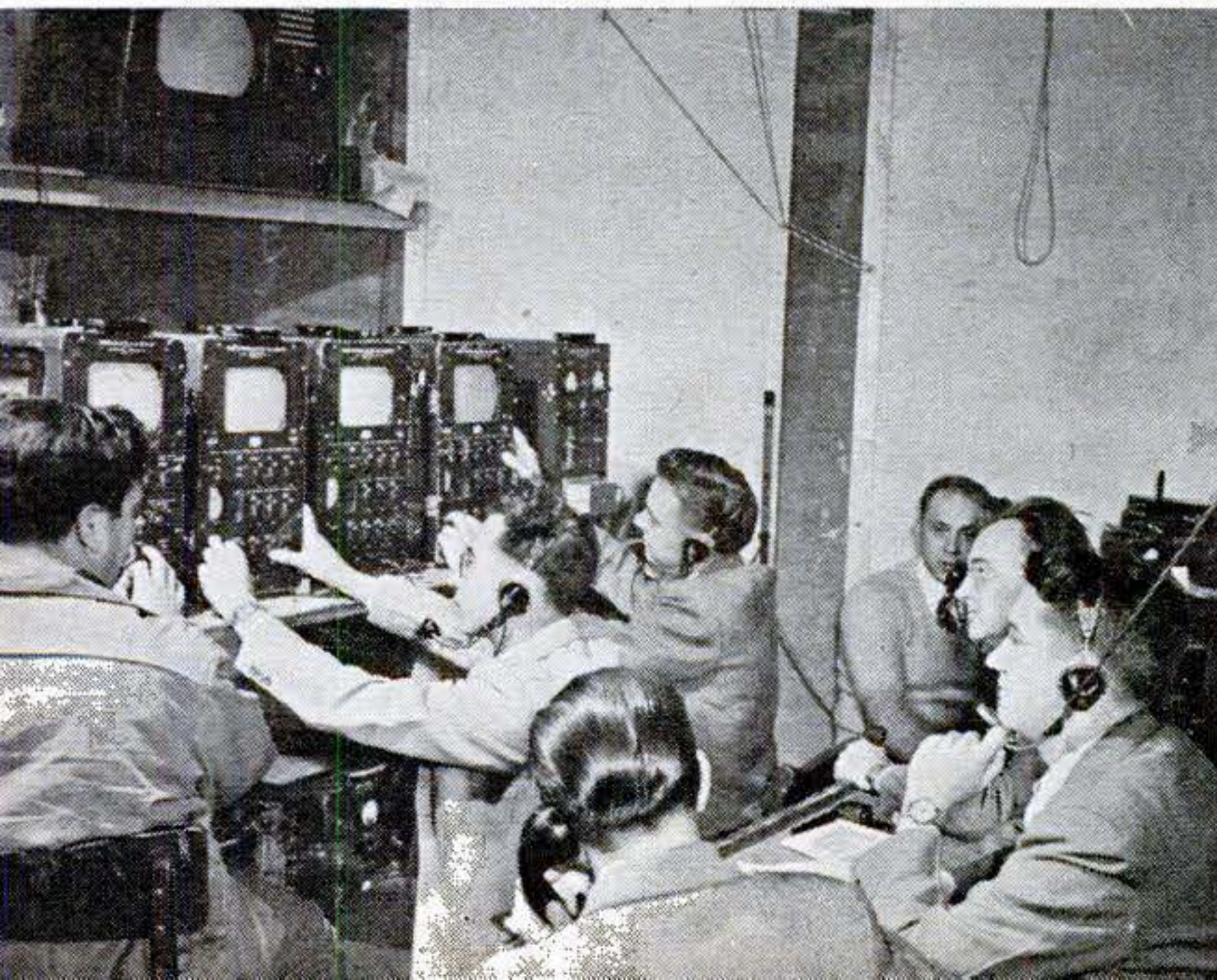

This works both ways, and mostly the other way. You may be sure that the man at the television mike knows his baseball and is describing the action and color the man on the receiving end wants to see and hear. So the director, who selects the image that is going out over the air, keeps his ears tuned to a loudspeaker in the control booth. In many cases he will order a camera pick-up switched to illustrate the commentary.

Recently a telecast announcer describing a fly ball going into the "teeth of the wind" remarked, "it's too bad there's no way of showing you folks the whale of a wind we're having here at the Yankee Stadium today."

That was the director's cue. He got his #3 cameraman on the interphone and told him to shoot to the flags on top of the stands with a telephoto lens. Then he ordered the resulting #3 image on the air. The viewing audience saw the pennants standing straight out and practically felt the wind the announcer had described. The announcer, not aware of what was being done until he saw the flag image on his television set, fell into line and said, "You see what I mean about the wind?"

It was only an instant flash, a few words, then back to playing baseball. But it's that kind of local color that makes the guy at the screen end of television 50 or 100 miles away feel that he's right in there with the fans, missing nothing.

### *Sound Is Important, Too*

Elbowing the announcer in the basket is the audio man. His job is to see that you get the announcer's running account of the game, the crowd's roars, the between-inning interviews, at just the right sound level. In his charge is the "parab" sound-catching reflector that brought in that crack of bat against ball. At times it also picks up certain brickbat language that he must muffle before it hits the air waves and the tender ears of young baseball telenthusiasts.

Now we go into the television team's "dugout"—the control room behind the upper tiers. That's where our umpire sits, the director who decides what picture is sent out to your screen.

In front of him are three viewing scopes, one for each camera, and their electronic control panels. At the far left is a fourth unit and scope that shows the picture he has selected and carries it to the transmitter.

At the same time the director is listening to the announcer's commentary on the loud-

speaker and analyzing it instantaneously picturewise; keeping tabs of the viewing scopes, judging them for clarity and continuity of action, and from time to time phoning instructions to the cameraman to "open that iris" for a better image or "get back there in the right outfield" for a play he has a hunch is coming up; eyeing a television screen up in one corner to see whether his pictures are going out over the air or if a film commercial has been cut in from the studios downtown.

After one WABD telecast, Du Mont's Harry Coyle mopped his brow and agreed heartily that baseball is tough to cover.

"Why?" we asked.

"Well," he explained, "mainly because the action is not concentrated, and there is so much of it. And to make it tougher, you can't anticipate what will happen as in football and basketball.

"It's the unexpected that keeps you on your toes. A guy who hits out to right field nine times out of ten suddenly fouls you up by smacking one way out to left field. The bases may be loaded with two down and you get set for a routine third out. Then up come a couple of errors, and the ball and everybody are all over the place. Double steals are dynamite if you're napping—which you aren't. And," he sighed, "if only they played baseball with a basketball or football instead of with a pill."

On guard at the three monitor panels are two video men on the alert for electronic errors. Their main interest is not so much in the viewing screens as in the small, jumping oscilloscope patterns. Just as the audio man adjusts sound levels, the video experts adjust light levels. By twisting dials and turning knobs they also control the electronic insides of the cameras. The fourth monitor is the switcher, tended by an engineer who flips levers to pick up the image selected in running order by the director. He also has final control over light levels before the picture goes to the transmitter.

This year the rooting roars of armchair and tavern television fans are louder than ever. All major-league home games are being televised except those of Pittsburgh—and those not for the lack of television facilities but for the lack of a sponsor.

Come the World Series, the bet is that it will be on the television screens—the bet being that sponsor money will be paid out to reach the "best-seat-in-the-ball-park" audience. The TV team will be ready. **END**

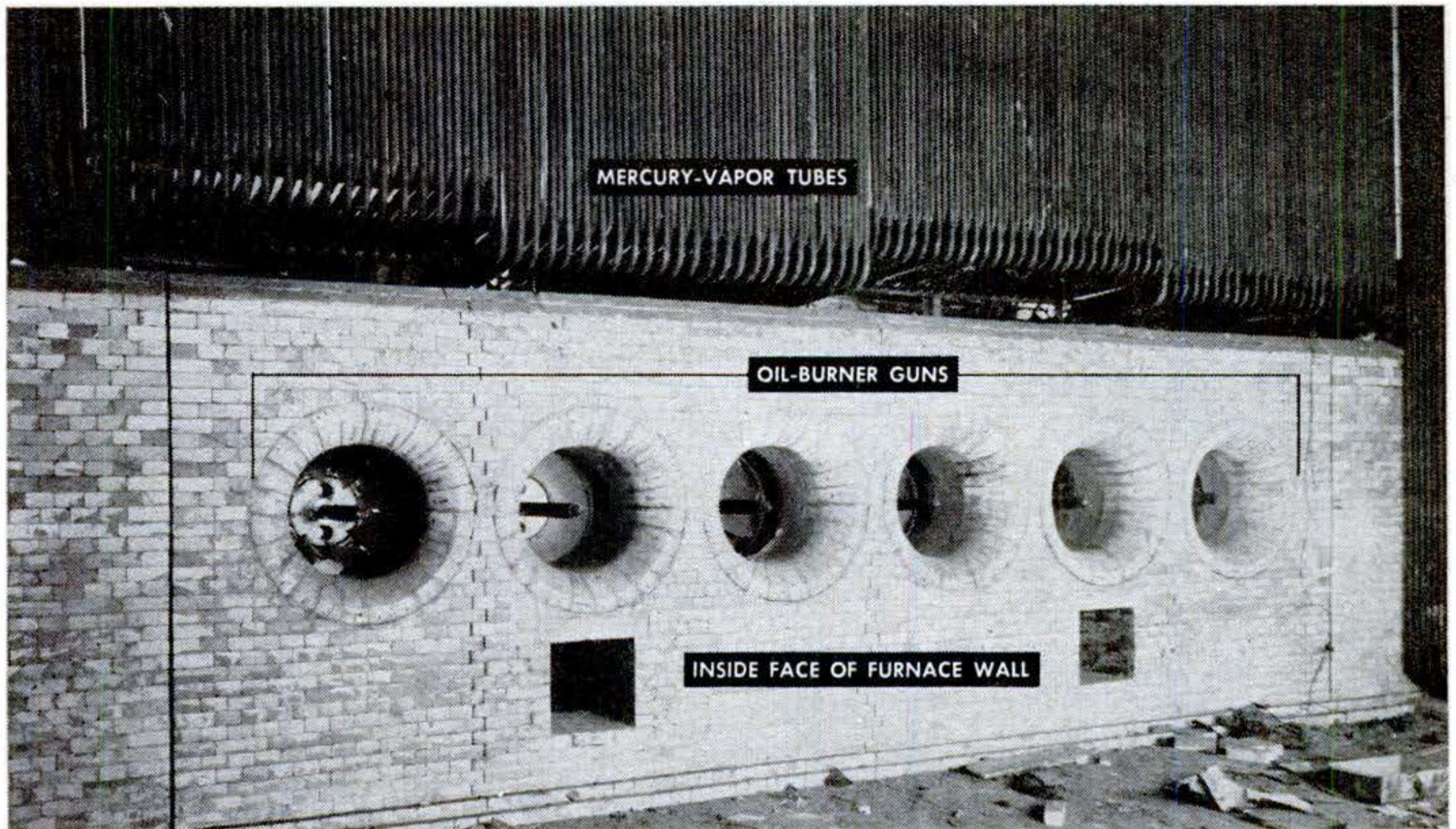

Flame's-eye view shows inside of mercury power plant replacing pioneer Connecticut set-up.

### Inside View of Mercury Boiler

You see a rare view of a rare piece of equipment in the photo above. It shows the oil burners and tubes of a boiler that uses mercury—the silvery liquid metal found in good thermometers—instead of water. The mercury is vaporized in the tubes and

then turns special turbines. When it condenses to a liquid again, it gives up heat to make steam to drive other turbines.

The occasion for this inside peek was the erection of a new, 15,000-kilowatt GE mercury plant at the Hartford Electric Light Co. It replaces a smaller installation—one of the first ever built—that had run 19 years.

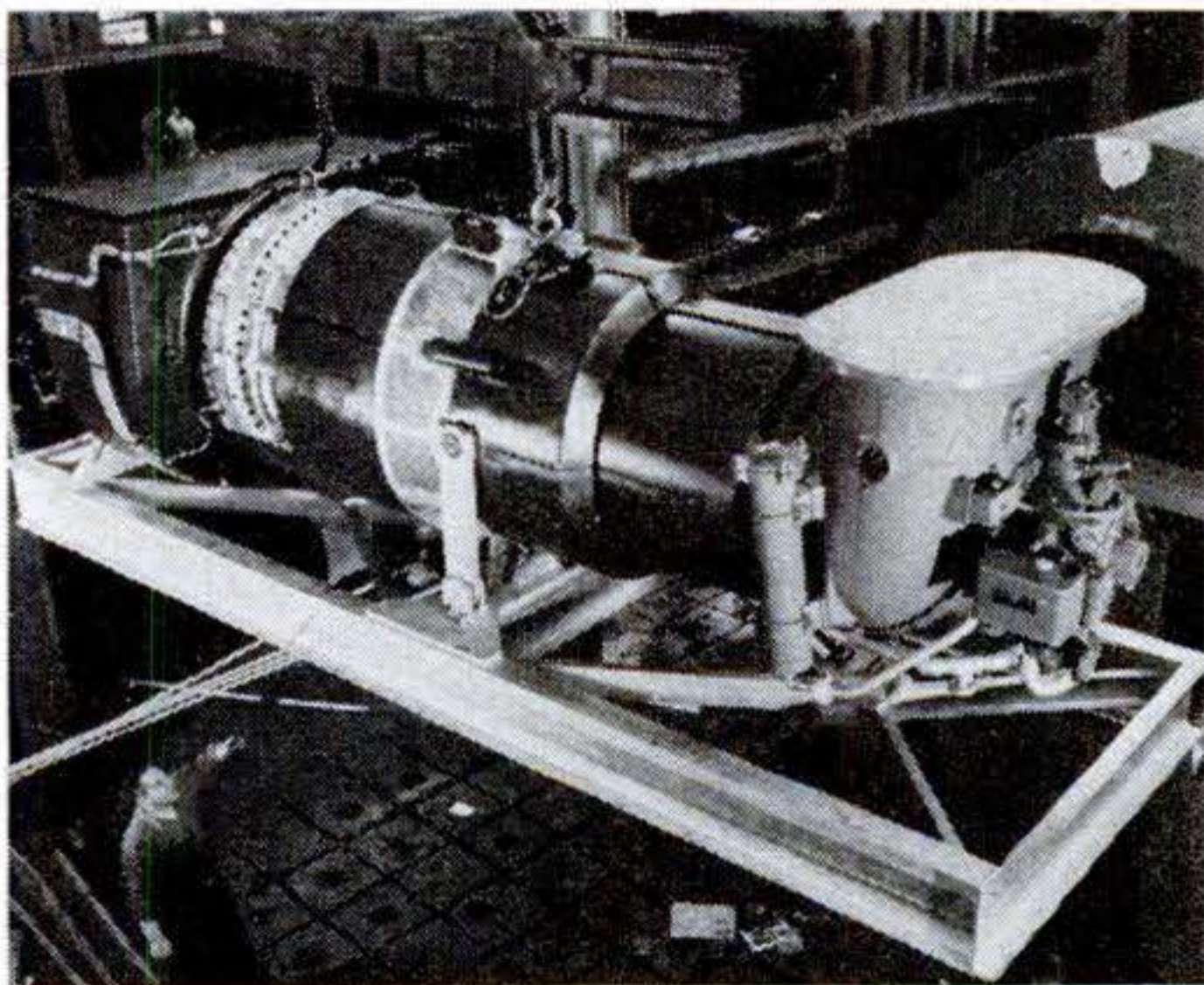

### Gas Turbine to Make Power

HOMES around Oklahoma City will soon be lighted by electricity generated by gas turbines—the first such installation in the U. S. The 3,500-kilowatt GE turbine (above), similar to the power plants now used in some experimental locomotives, is to supplement steam generators at a station of the Oklahoma Gas and Electric Co.

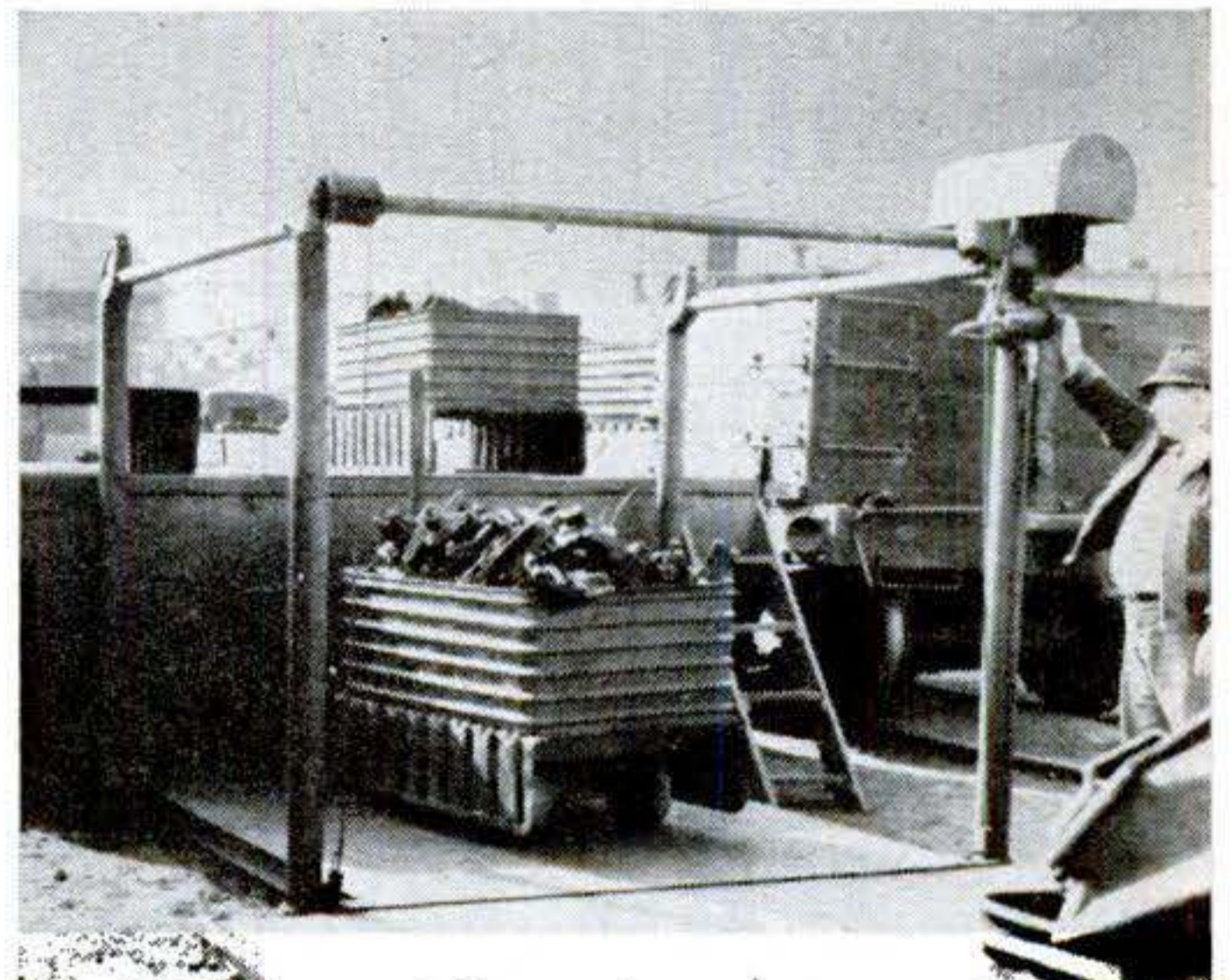

### Elevator Loads Freight Car

ONE man can now load heavy material into freight cars with a small elevator to do the lifting for him. Able to operate in spaces too cramped for a crane truck, it raises a three-ton load with a one-hp. motor. It has a platform 8 ft. long and 6½ ft. wide. Service Caster and Truck Corp., of Albion, Mich., makes the Leveler®.

## HOW TO TAKE MILK APART

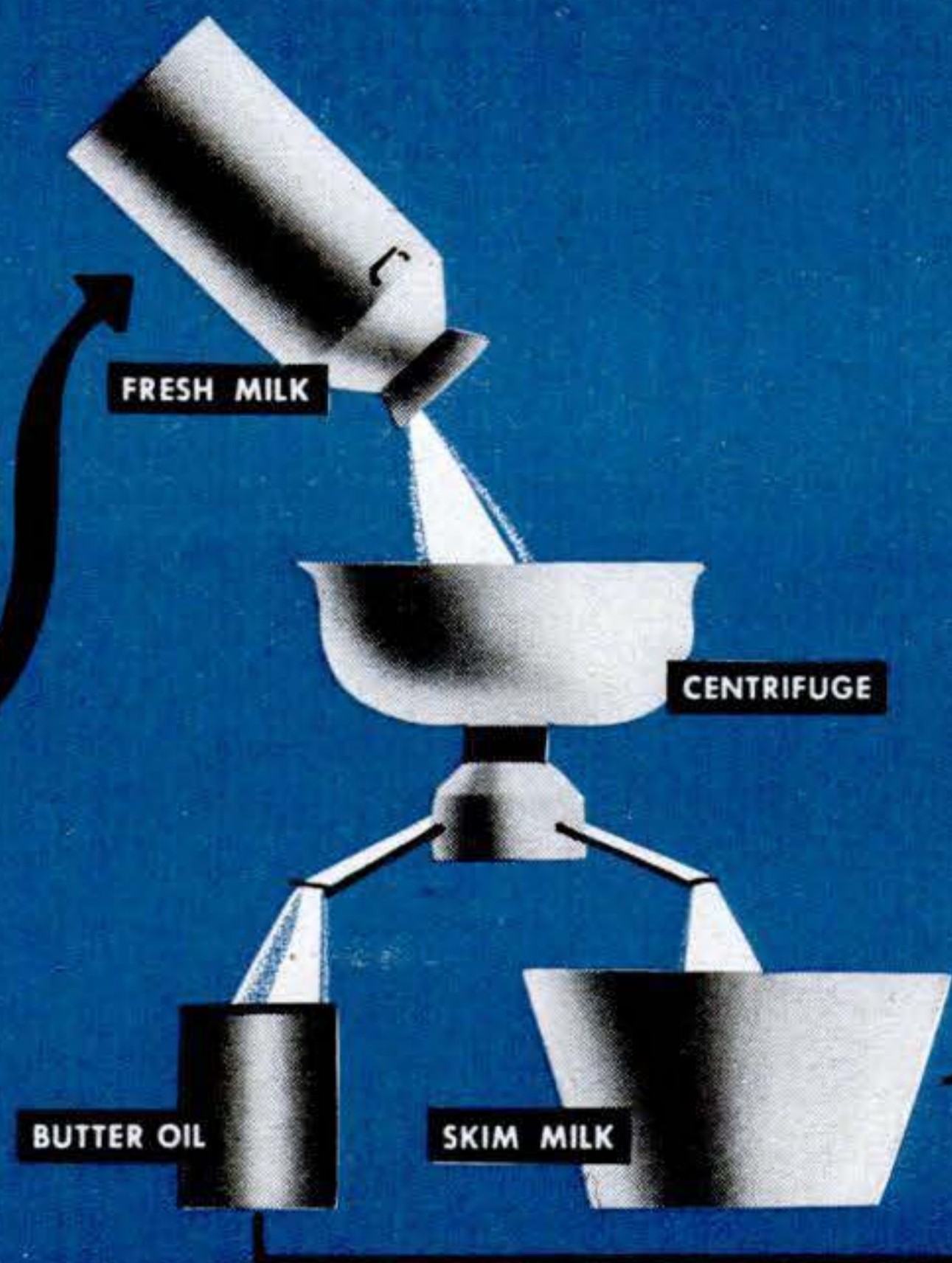
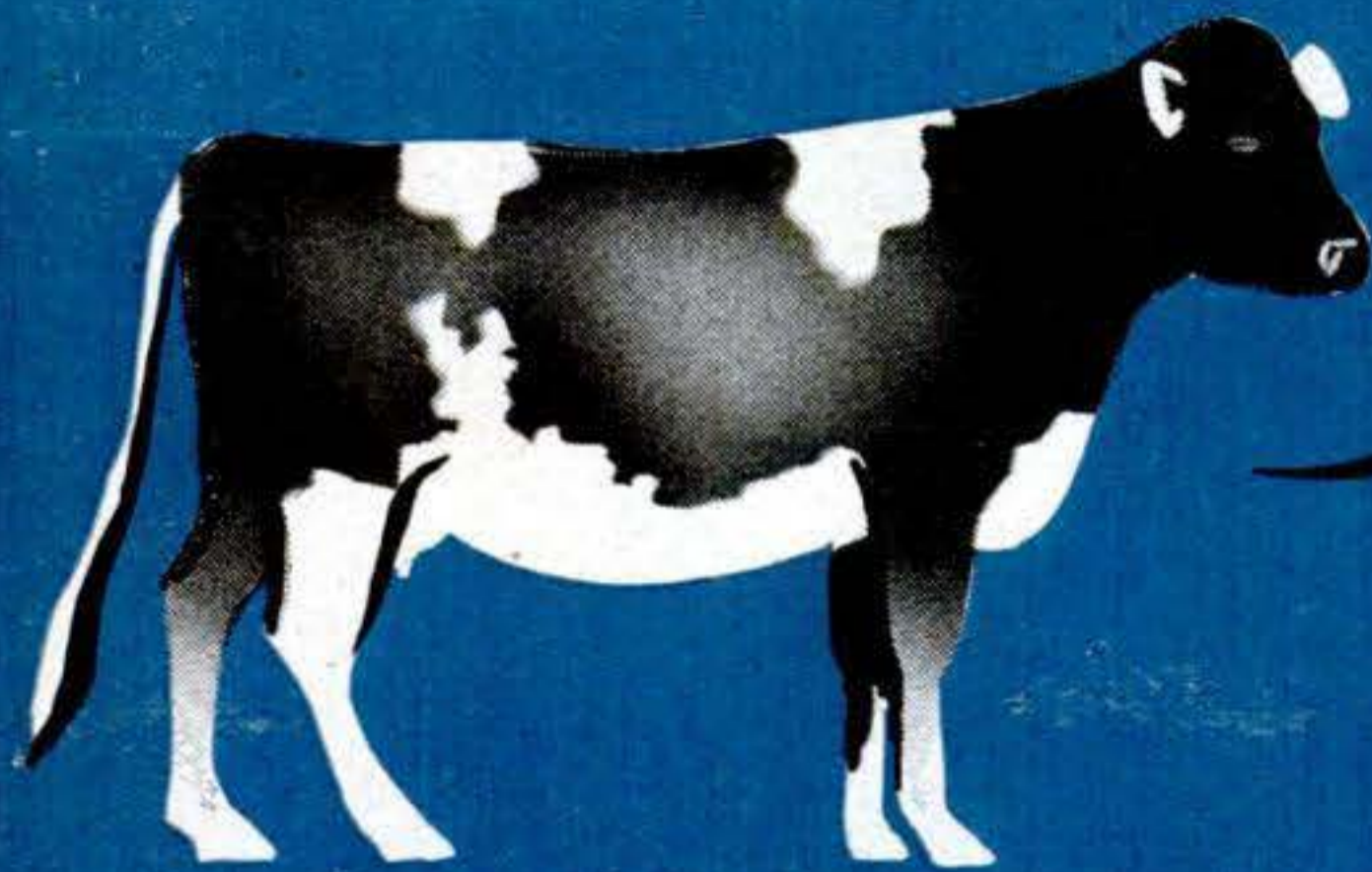

Way to retain flavor of fresh milk while drying it has eluded researchers until development of present processes and equipment. First of the steps, indicated in drawings above, is removal

and purification of butterfat with high-speed centrifuge and settling tank. This gives yellow, honey-like butter oil, which is sealed in cans with nitrogen gas. The remainder is skim milk.

# Mechanical Cow Serves Global Milk Route

Splitting milk solids into fat and skim powder permits later recombining with water without harming taste.

**By Martin Mann**  
*Drawings by Jere Donovan*

GIS in the Pacific are now drinking milk from cows that don't moo—they clank. These new mechanical cows produce pasteurized, homogenized, grade-A milk that only a calf can tell from the original. And a quart costs no more, maybe less, than the ones you buy from the corner grocer.

The postwar-model mechanical cows are providing pure, tasty milk in places with little or no local supply. In the Far East, the American soldier's thirst for milk is being slaked by seven machines making 22,700 gallons daily—equivalent to a herd of 7,500 live cows. Any surplus goes to native kids. One strictly civilian plant is now running in Haiti (unlike the GI plants, it uses coconut oil instead of butterfat, to cut costs). And others will shortly be supplying the milk-thirsty citizens of the Philippines, Venezuela, Trinidad, Curacao, and Aruba.

All this is possible because a way has finally been found to take the water out of milk before shipment and put it back again at its destination—without affecting the taste. Until recently, no one had been able to do that trick. There was lots of powdered milk—the Army shipped tons of it to troops



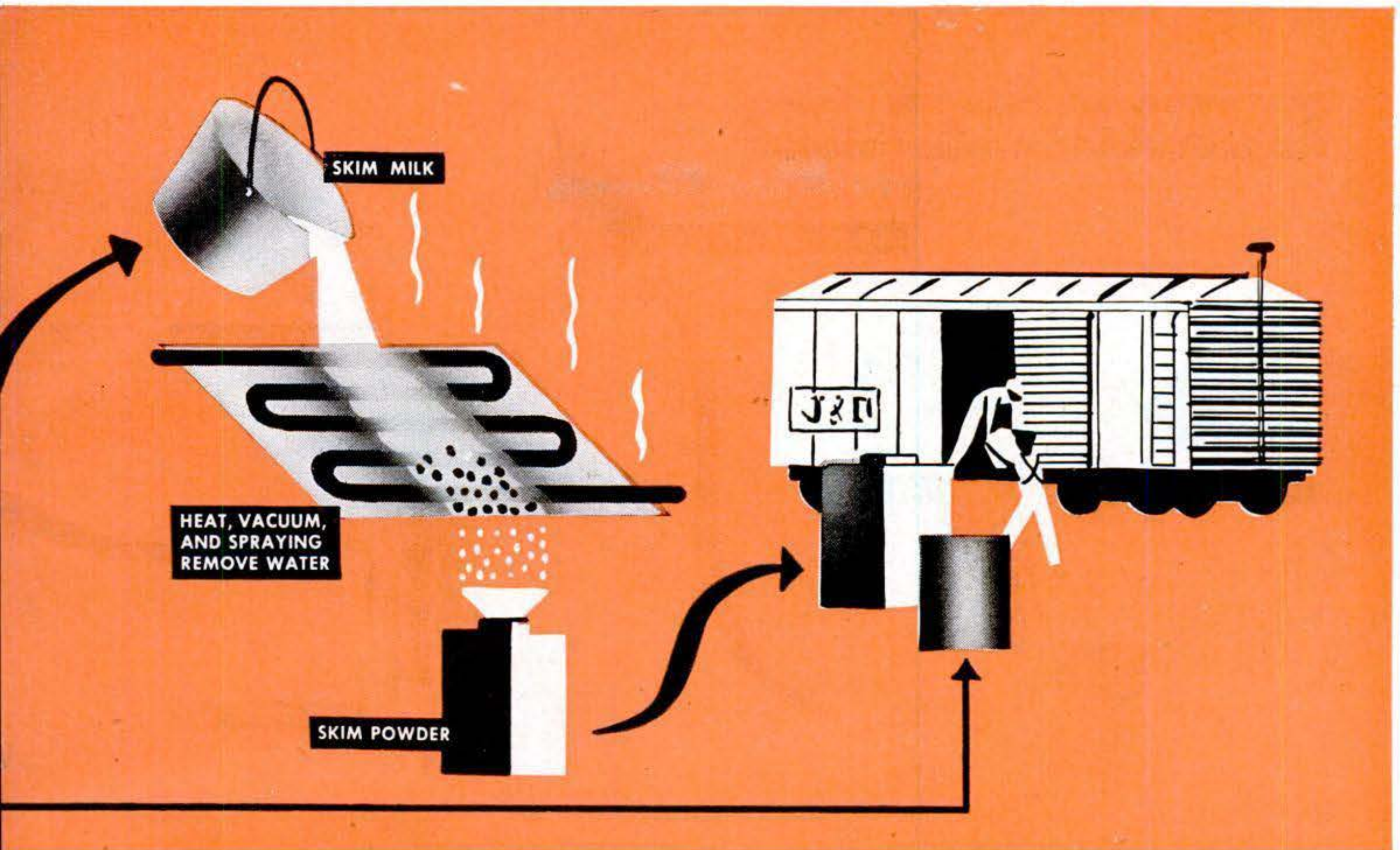

**Dehydration of skim milk** is second step (above, left). To avoid "cooked" taste when ingredients are recombined, water must be removed very carefully. Milk is heated very

quickly in a vacuum, evaporating biggest percentage of water. Then it is forced through tiny holes to complete the drying operation. The resulting skim powder keeps without ice.

overseas during the war. But chances are that anyone who tasted it will wrinkle up his nose at the memory. The new stuff, its makers report, tastes just like milk straight from the cow.

There are several tricks to protecting the flavor. First, it's not enough just to evaporate water from milk, giving whole-milk powder; you must separate the butterfat from the milk and then evaporate the water from the remaining milk solids. Next, the evaporation itself must be done with extreme care, quickly, under vacuum, with little heat, to avoid the "cooked" taste typical of the older powders.

Many of the details of the process that gets milk from a Stateside cow to a Japanese glass are trade secrets. However, Dr. Charles E. North, who himself has invented many of the methods and machines used, outlined for *POPULAR SCIENCE* the general procedure followed at his pilot plant in New Paltz, N. Y.

There the first step is removal of the butterfat. This is done in machines like souped-up cream separators—huge high-speed centrifuges that spin the milk at

18,000 r.p.m. The butterfat is then put in special tanks, where curd and other impurities settle out. The result is a clear-yellow, honey-like material that is as close to 100-percent butterfat as laboratory analysis can determine. This "butter oil" is sealed under pressure of nitrogen gas in metal cans. Packed that way, it stays fresh indefinitely without refrigeration.

The skim milk left after removal of the butterfat is next dried. It is evaporated to one-fourth its original volume in a vacuum with as little heat as possible. Then pressure of 2,500 pounds per square inch forces it through a nozzle, creating a spray that causes the rest of the water to evaporate.

The dry skim milk and butter oil can then be shipped any place milk is needed. There—unlike Humpty Dumpty—they are put back together again with pure water.

In a typical recombining plant, such as the one the International Dairy Supply Co. operates for the Army in Yokohama, workers feed the skim powder into an agitator tank, where it is mixed at great speed with the correct amount of water. (Since the water previously removed was H<sub>2</sub>O

## HOW TO PUT MILK TOGETHER



**Recombining process** reverses dehydrating operation, but uses, for most part, standard dairy equipment. In first step (left), skim powder is mixed with correct proportion of dechlorinated,

demineralized water to recreate original skim milk. This mixture is piped to pasteurizing vat (right), and melted butter oil is added. Vat revolves while contents are heated to 143°F.



**Milk powder from the States** begins its way to a glass of milk for a GI in Japan as technician pours it from shipping tin into tank in which it will be mixed with pure water.

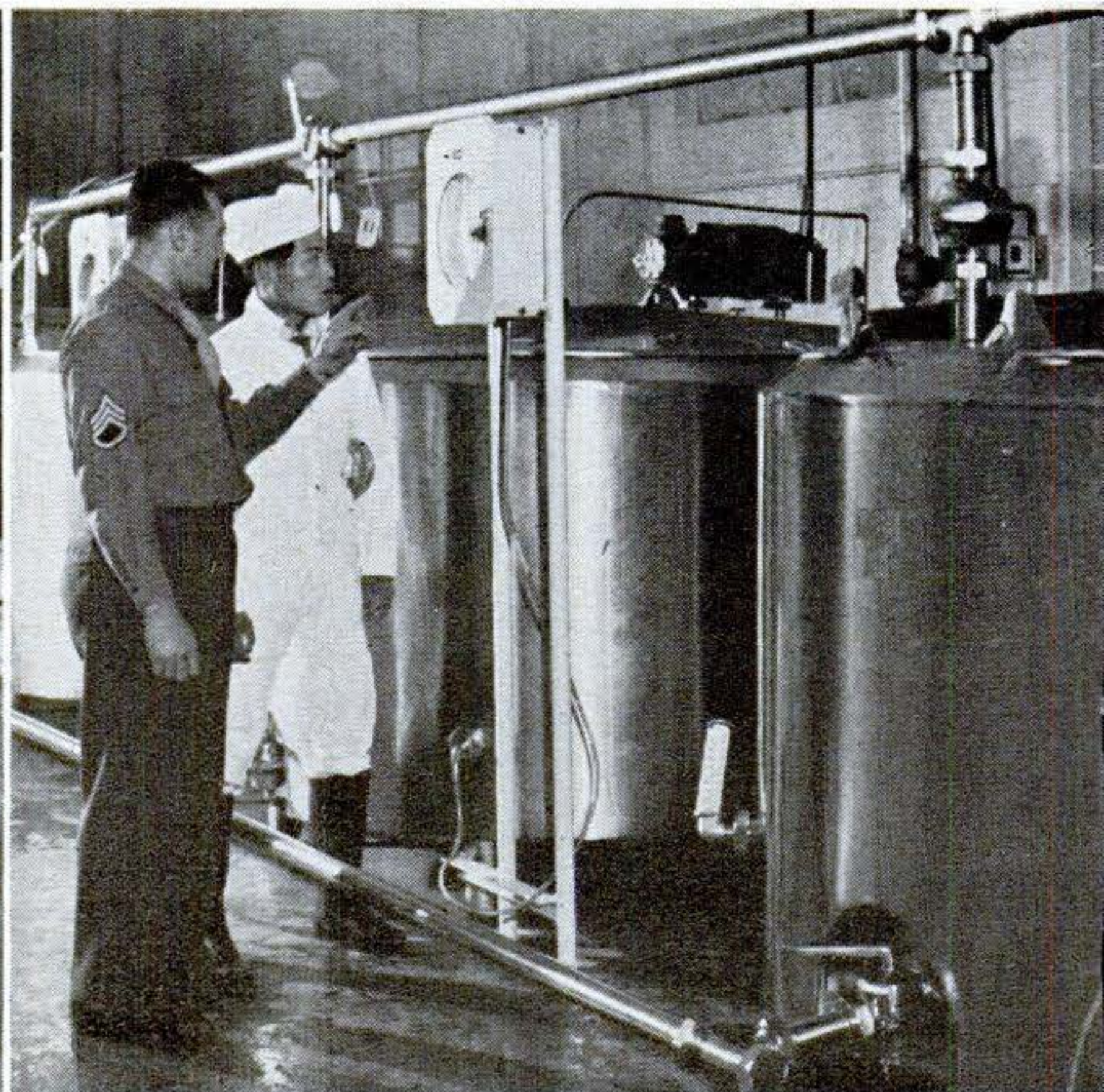

**Modern pasteurizing equipment** in Yokohama recombining plant has automatic recorders to keep track of process. These vats now contain mixture of skim powder and water plus the oil.

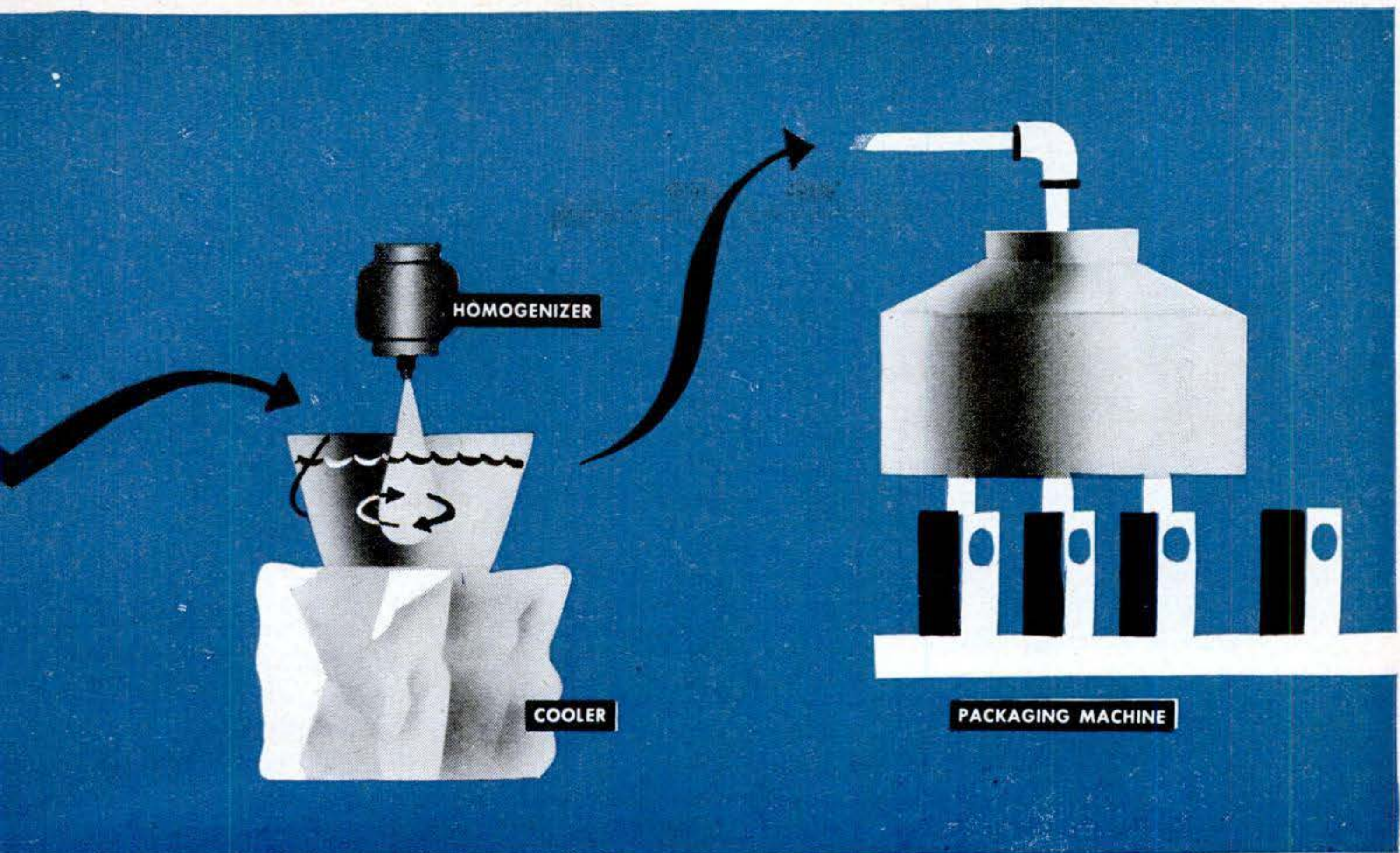

**Standard homogenizer** (above, left) insures that pasteurized milk is completely mixed, with all particles broken up, eliminating any danger of separation. During homogenization, temper-

ature of milk is reduced from 143° to 36° in 10 seconds. Milk is then bottled (right). Its looks, taste, and food value are now almost identical to those of the stuff that came from the cow.

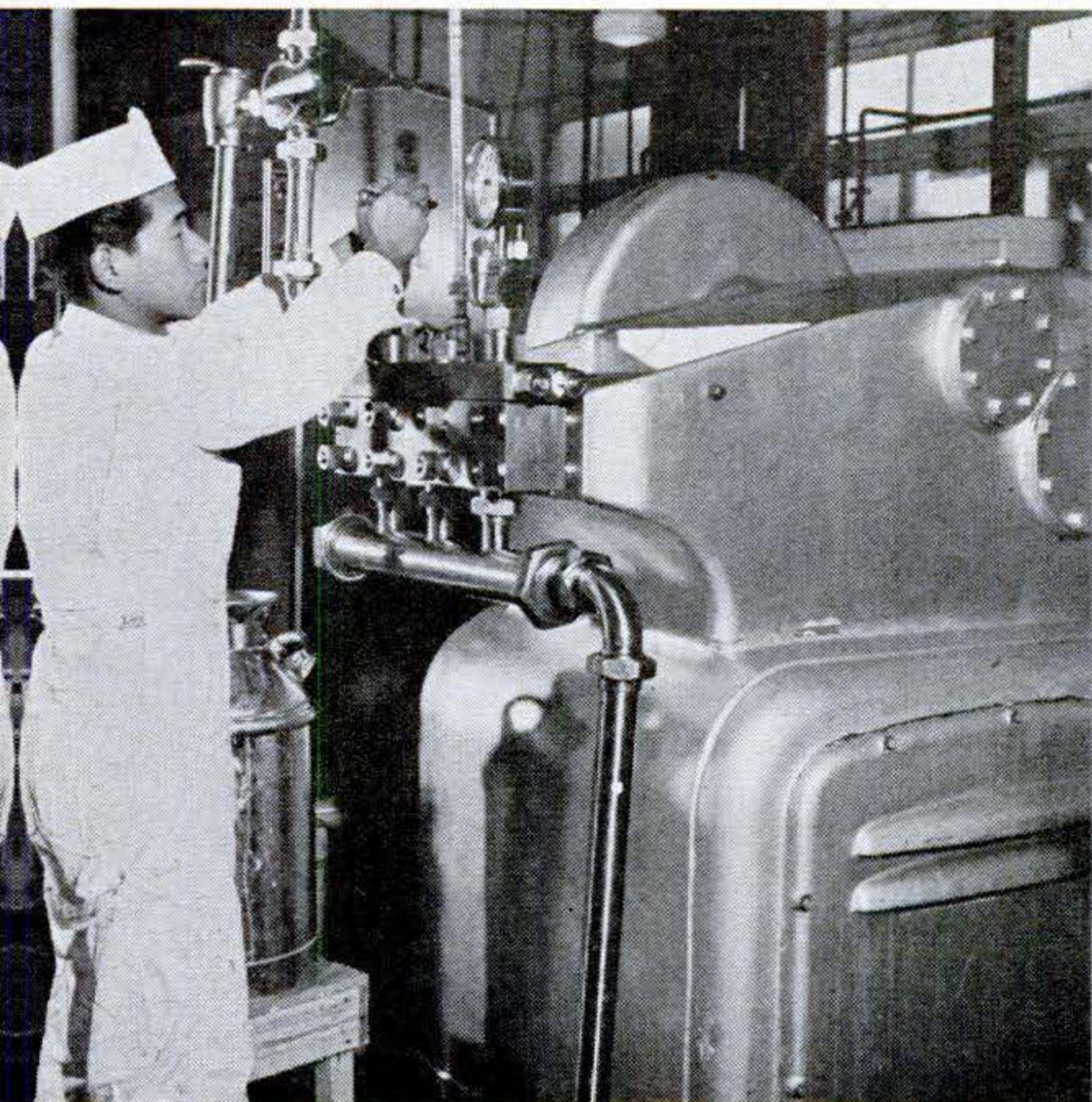

**With his eye on pressure gauge** of homogenizing machine, Japanese technician adjusts process. These machines break up butterfat globules by forcing milk, under pressure, through tiny holes.

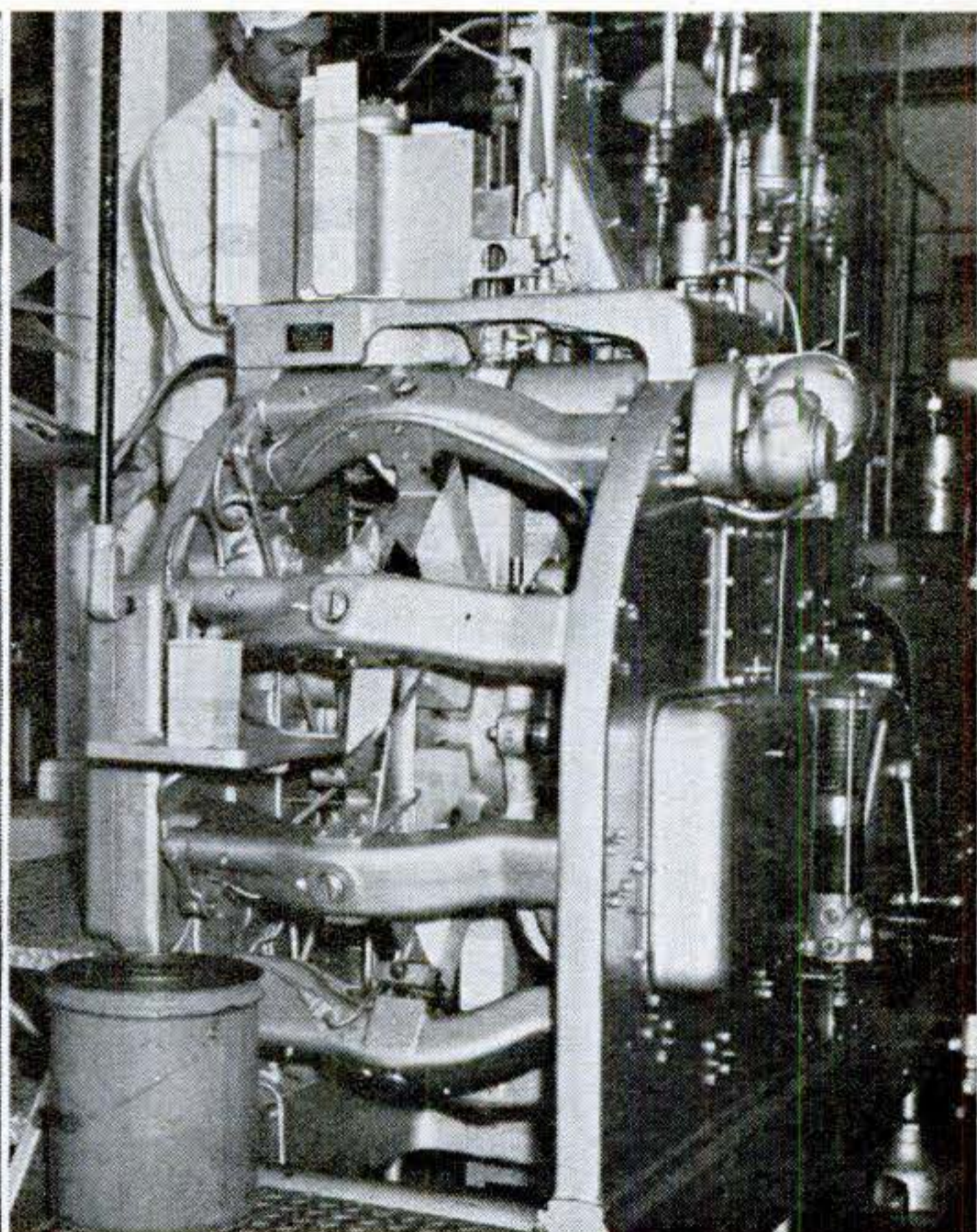

**Packager** puts American milk into American waxed containers in Japan. Machine can handle 65 quarts a minute. Plant is one of seven run for Army by International Dairy Supply Co. ▶



**Regular tests** of the recombined milk's purity, stability, and butterfat content are made by Japanese chemist. Civilian-operated, plants have Army personnel as resident inspectors.

and nothing else, the water put back must be just as pure, free of minerals, chlorine, etc.) A 500-gallon pasteurizing vat receives this mixture, plus melted butter oil, and holds it for 30 minutes at 143°F.

Next a homogenizer breaks up the butterfat particles, making smooth milk that cannot separate on standing. At the same time, the milk is chilled to 36° in 10 seconds.

To finish the job, standard packaging machines open up flattened cartons, seal the bottoms, dip them in paraffin, cool them, fill them with the milk, and close and staple them. Each machine turns out 65 quarts a minute. The entire process—mixing, pasteurizing, homogenizing, cooling, and packaging—takes less than two hours.

How does the "new" milk stack up against the genuine article? Most experts admit that nothing yet available exactly duplicates milk fresh from a cow. Yet, in a series of tests, 20 non-expert men couldn't tell the difference. And food values are identical: both have equal amounts of vitamins, calories, mineral salts, amino acids, and proteins.

Recombined milk is first being introduced on an extensive scale in places where local milk is poor or nonexistent—and that means much of the world. Dairy cattle can't take the climate of the tropics. Other sections, like Japan, are so overcrowded that good land is not available for grazing. A plentiful supply of wholesome milk in these areas

should help improve health, particularly among children. And American business men are not blind to the potential profits in a global milk route.

Here at home, plenty of good milk is available. Recombined milk will have to win a U. S. market the hard way—by furnishing a product that is as good or better at a lower price. Men like Dr. North, Grover T. Turnbow of International Dairy Supply Co., and Paul Jones of International Dairy Products Corp. think it can.

If this fresh-tasting milk were available in the U. S., they say, you might save as much as 25 percent on your milk bill. They estimate that recombined milk could be sold in New York City for 15 cents a quart. Fresh milk costs about 20 cents.

They point out that fresh milk is mostly water. In a gallon weighing nearly nine pounds, all but about one pound is just plain water. And since transportation expenses make up much of milk's cost, you must pay a lot of money to haul water.

Other factors add to the cost of fresh milk. Even under refrigeration it stays fresh only a few days. Hence it must be produced close to big cities—on comparatively expensive real estate—and rushed to the creamery in express trains of expensive, glass-lined, refrigerated tank cars.

#### *Could Save Water Haulage*

Recombined milk could reduce many of these expenses. There is no water to haul. Butter oil and skim powder stay fresh indefinitely—one sample of Dr. North's oil was stored by the U. S. Quartermaster Corps for nine months in a 100°F. test chamber without spoilage. It can be shipped in ordinary boxcars on ordinary freight trains. The dairy farms could be located wherever convenient, perhaps as far away as Australia or New Zealand, where production costs are about half those in the U. S.

The economies of the recombining process have already found it some uses in this country. Many restaurants and institutions make ice cream, cooking cream, and other milk products by this method.

If recombined milk gains wider use, the dairy industry may concentrate far from population centers. Then children almost everywhere, like city kids now, would know live cows only from picture books. But that would be a small price to pay for the better health more and cheaper milk promises people all over the world. END

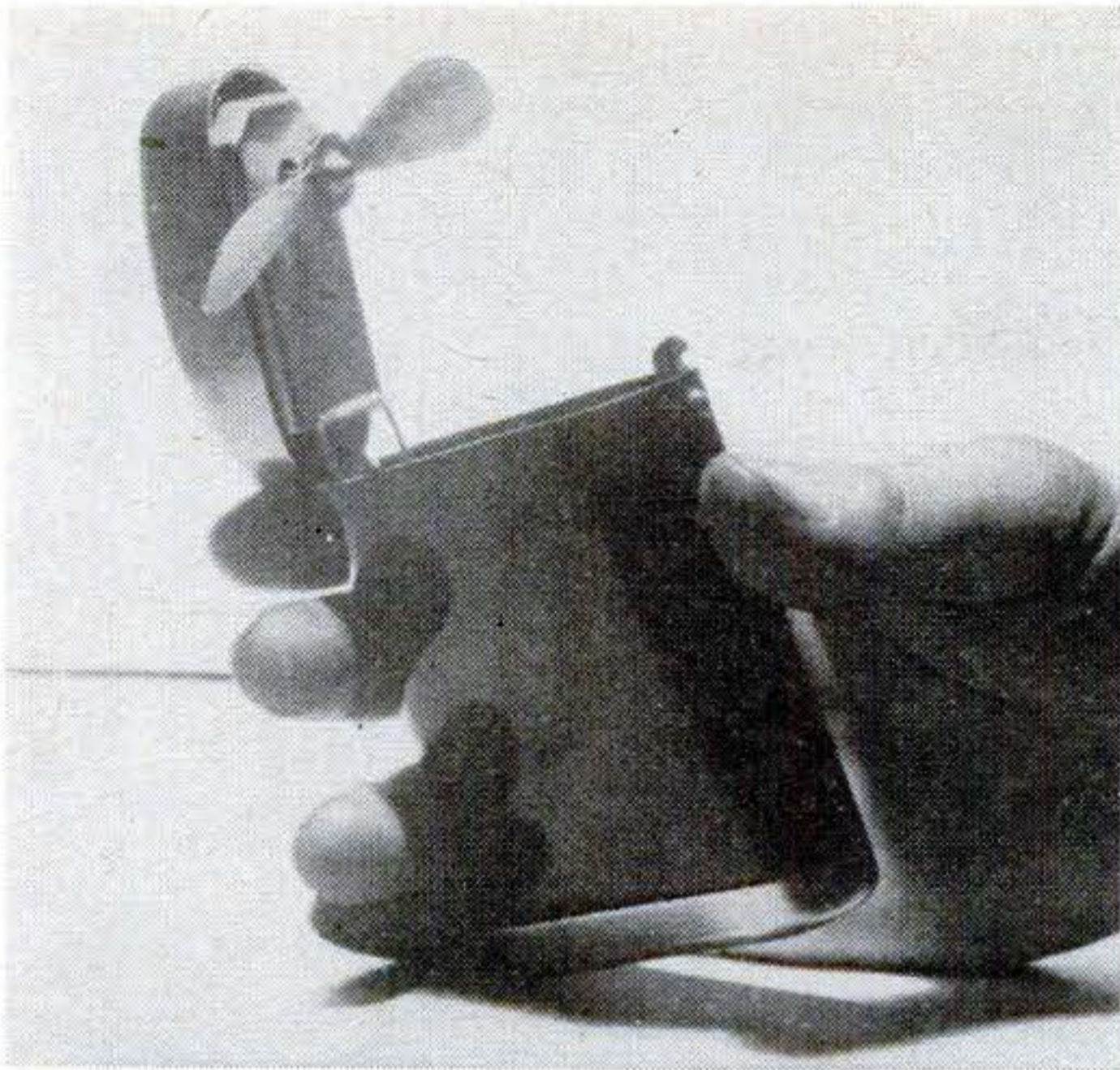

### Electric Fan Fits Pocket

BRITISHERS have thought up a new gimmick to help them stay cool—a battery-operated fan hardly bigger than a cigarette lighter. It has a tiny permanent-magnet motor inside the hinged cover, and a fan with two blades that fold together when the device is closed. Power is supplied by a standard, 4½-volt dry cell contained in the base. The pocket fan, called Don Quixote®, is made by the Arran Electrical Manufacturing Co., of London.

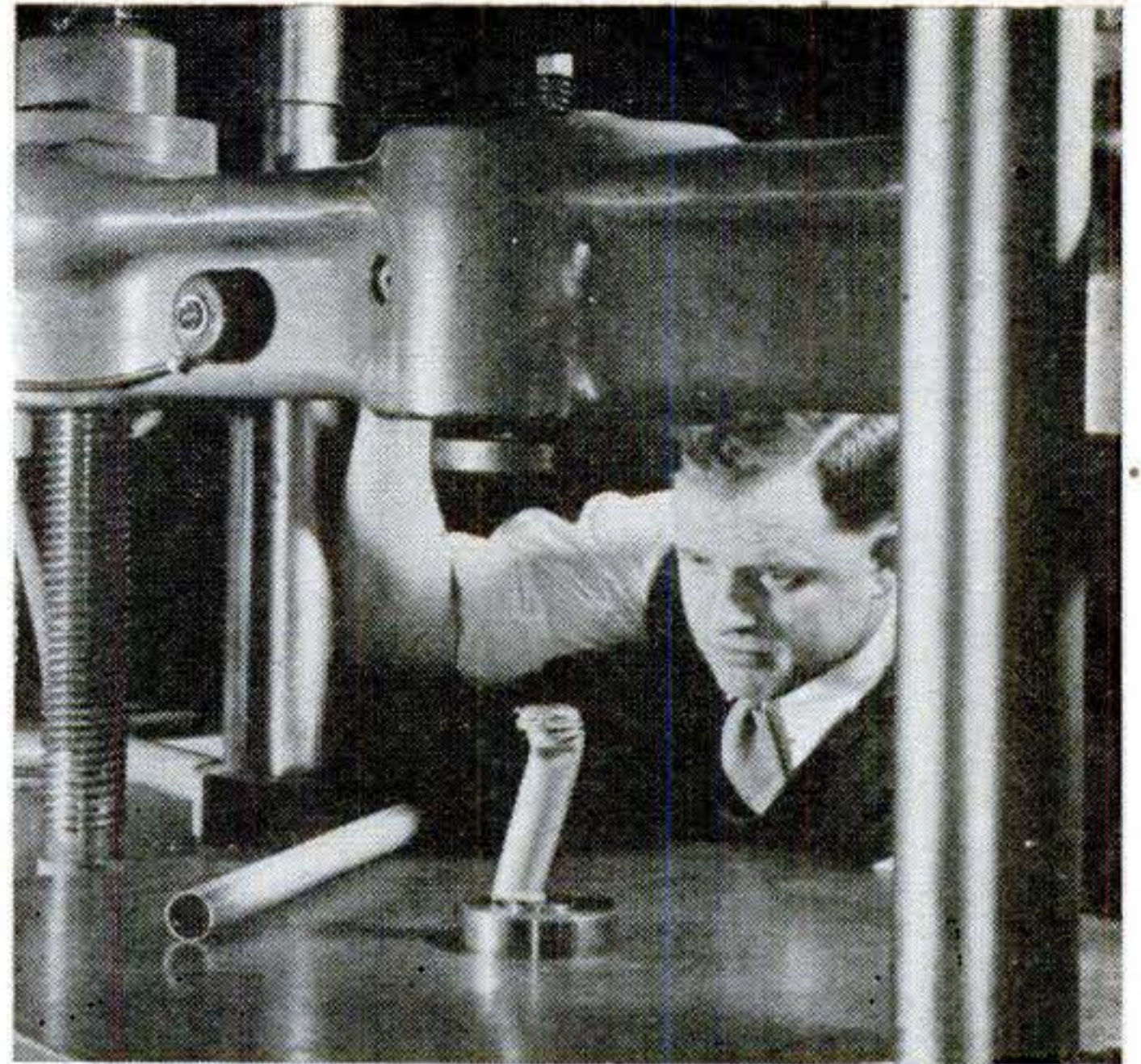

### Plastic Coat Rustproofs Steel

A PLASTIC coat less than .002 in. thick protects steel tubing against rust better than galvanizing, reports the Jones & Laughlin Steel Corp., Pittsburgh. Their Perma-Tubing® withstood more than 2,000 hours of exposure to salt spray, compared to 24 hours for galvanized tubing. And as shown in photo above, it can be bent, expanded, flanged, fluted, or flattened without harm to the protective covering. The vinyl plastic is applied in two coats.



### Car Heater Warms, Amuses

MORE than one kind of hot air comes out of this gadget. A car heater, it also contains a loudspeaker for reproducing the sound from movie film in drive-in theaters. Designed to hang inside car windows, it lets outdoor theaters operate when it's cool. Both sound volume and heat are adjustable, and the heat can be turned off in warm weather. Theatrecraft Mfg. Corp., Cleveland, makes the Mobiltone® heater-speaker.

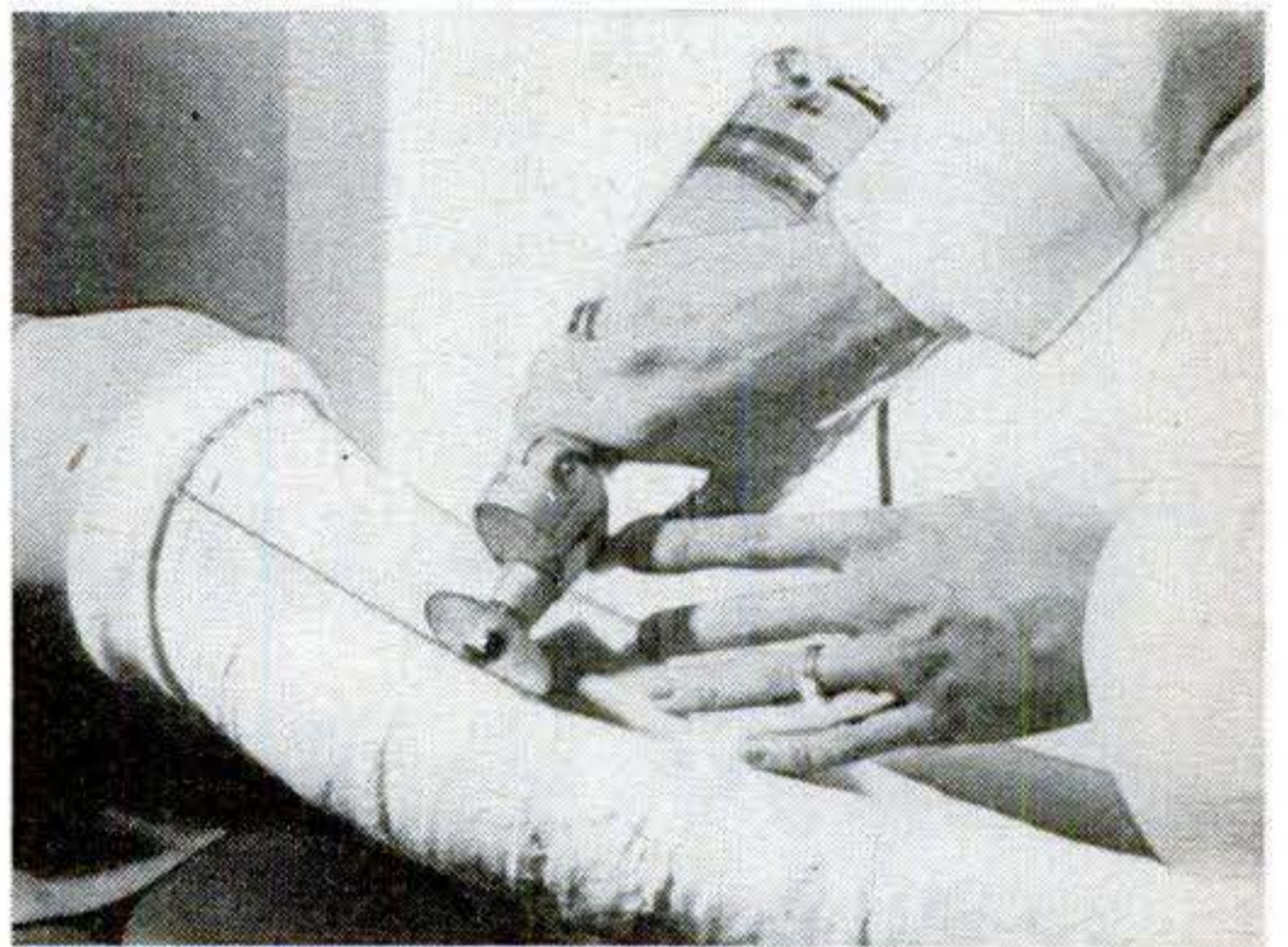

### Saw Cuts Casts, but Not Flesh

PLASTER casts are cut like butter—yet flesh can't be harmed—by a new kind of electric saw that eliminates the discomfort involved in removing casts with old-fashioned large shears. The blade in the Stryker Cast Cutter® makes short back-and-forth strokes 28,000 times a minute. These easily cut hard, unyielding materials like plaster, but do not affect soft materials, like flesh and cloth, which vibrate with the blade.

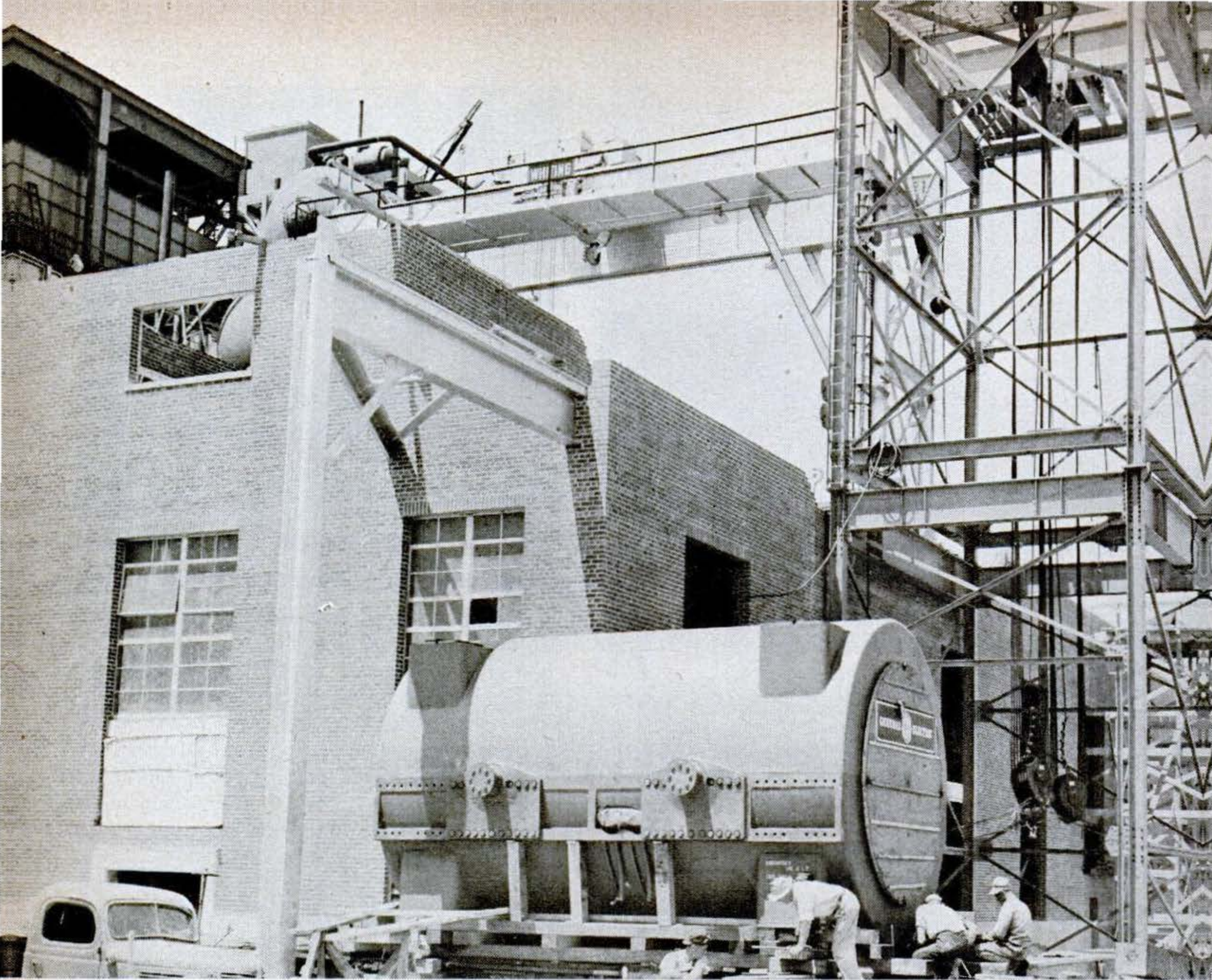

**1** Destination of this 130-ton electric generator (tank in foreground) is the roof of the powerhouse at left. Workmen are getting ready to skid it into the special hoisting tower (right)

that will do the job. Upper and lower sections of the two-part, 65-foot tower can be seen bolted together at level of the roof. The hoist has a maximum capacity of 165 tons.

**4** View looking down on top of the powerhouse shows the steel skids in place, ready for the big side-slide of upper section of the hoisting tower, which still holds the generator.

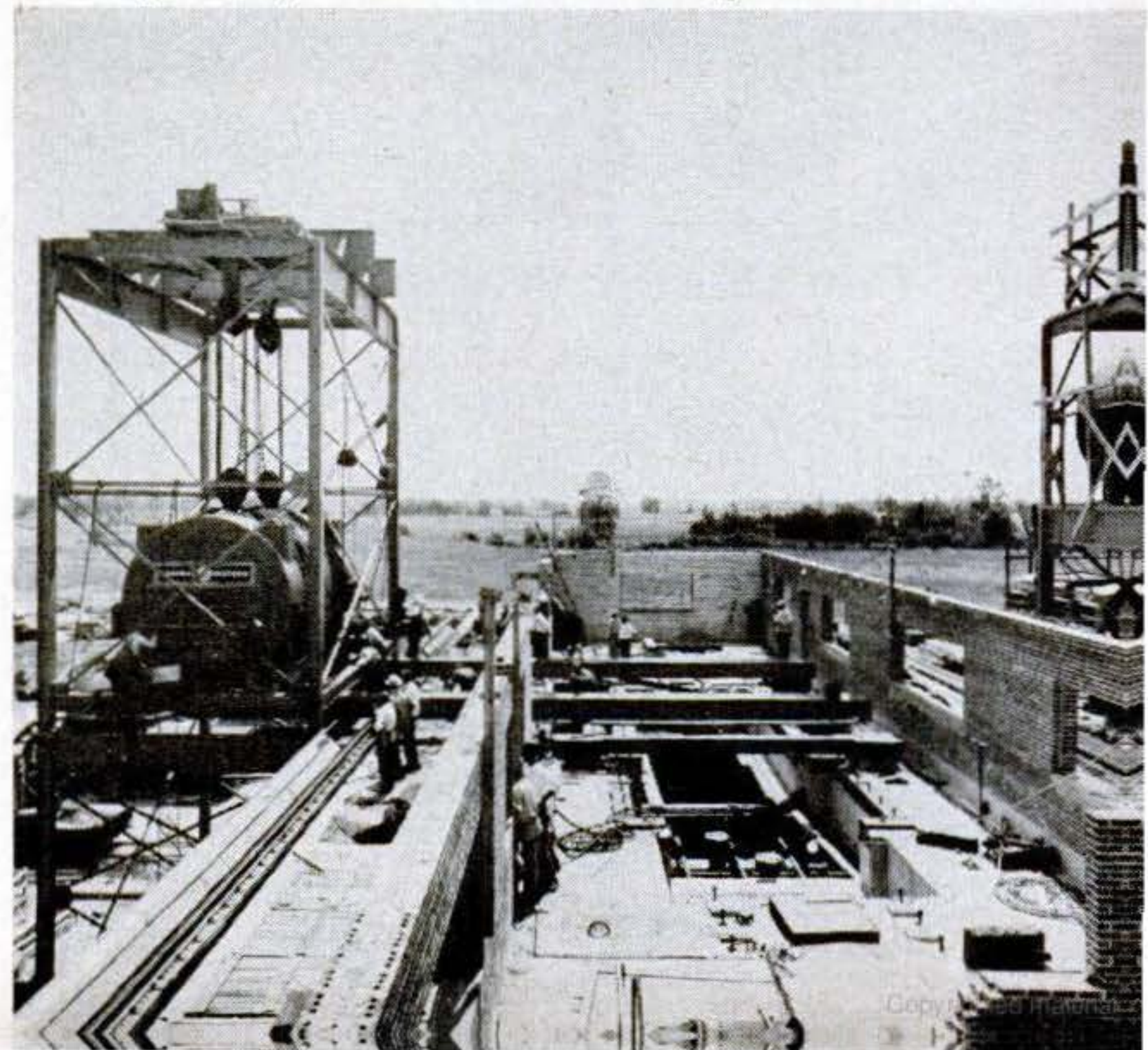

## ***Tower Splits for Trick Lift***

**T**HE problem: How to get a 130-ton electric generator from a flatcar on the ground to its foundation atop a 30-foot powerhouse—and do it quickly. The Arkansas Power and Light Co., of Little Rock, solved it with a special two-part hoisting tower. Lifted to the top of the first 32½-foot tower section, the huge generator was at roof level. Then the upper tower section was unbolted, skidded laterally 30 feet to the rooftop bed, and the generator was lowered into place—all in seven hours.

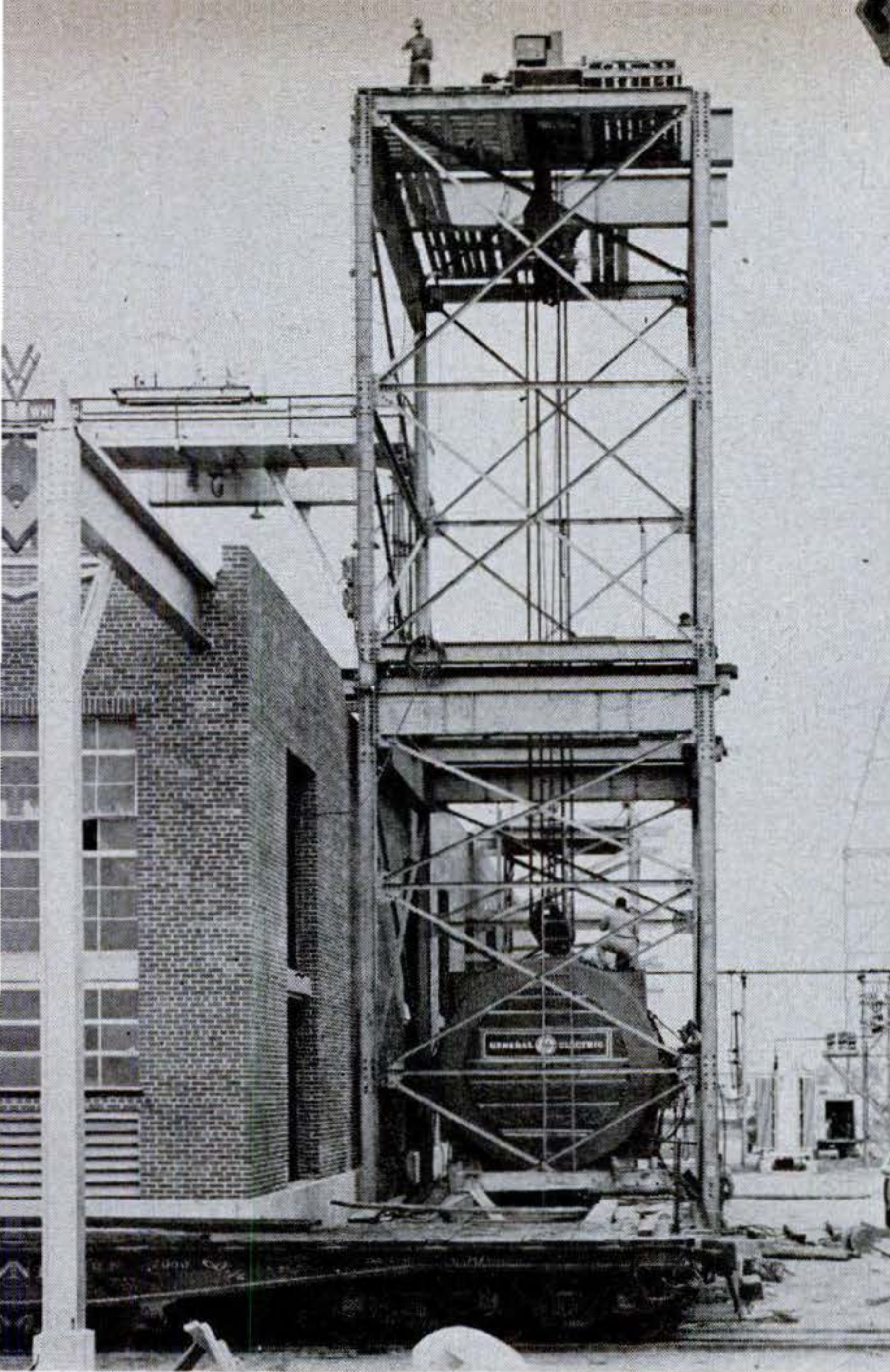

**2** Here the generator is shown in place in the hoisting tower, with lifting blocks attached. The workman on top of the tower operates two 20-hp. motors that do the lifting.

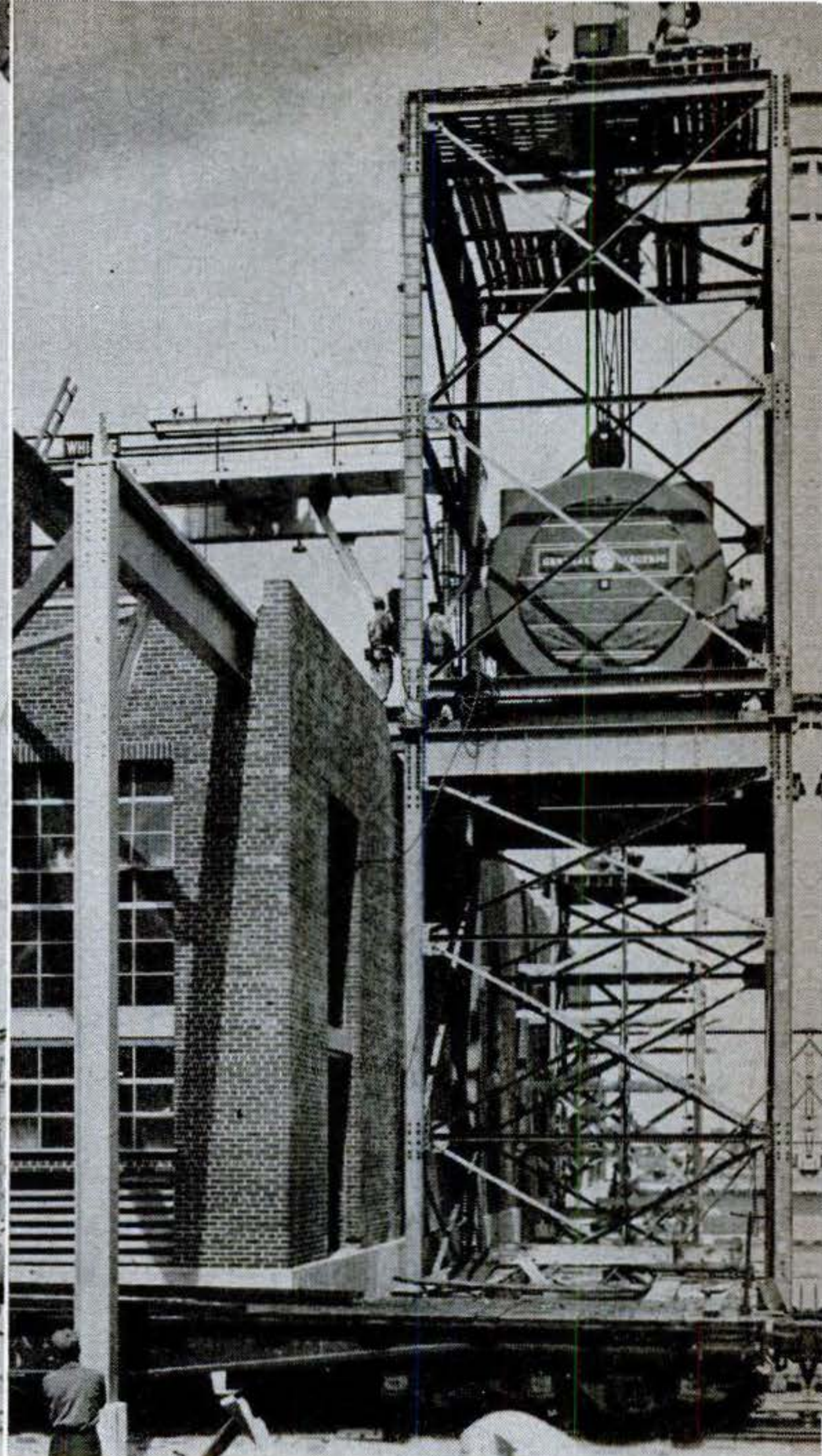

**3** The generator is up in the air, even with the roof. Workmen are placing steel beams under top section of the tower, which will be unbolted and then skidded left across the roof.

**5** After a 30-foot slide across the roof, the top section of the tower is ready to lower the generator to its rooftop foundation. A gantry crane pulled the tower across the roof.

**6** With the big generator in its resting place, workmen are preparing to skid the tower top back to its original position. The tower then will be dismantled and shipped to another job.

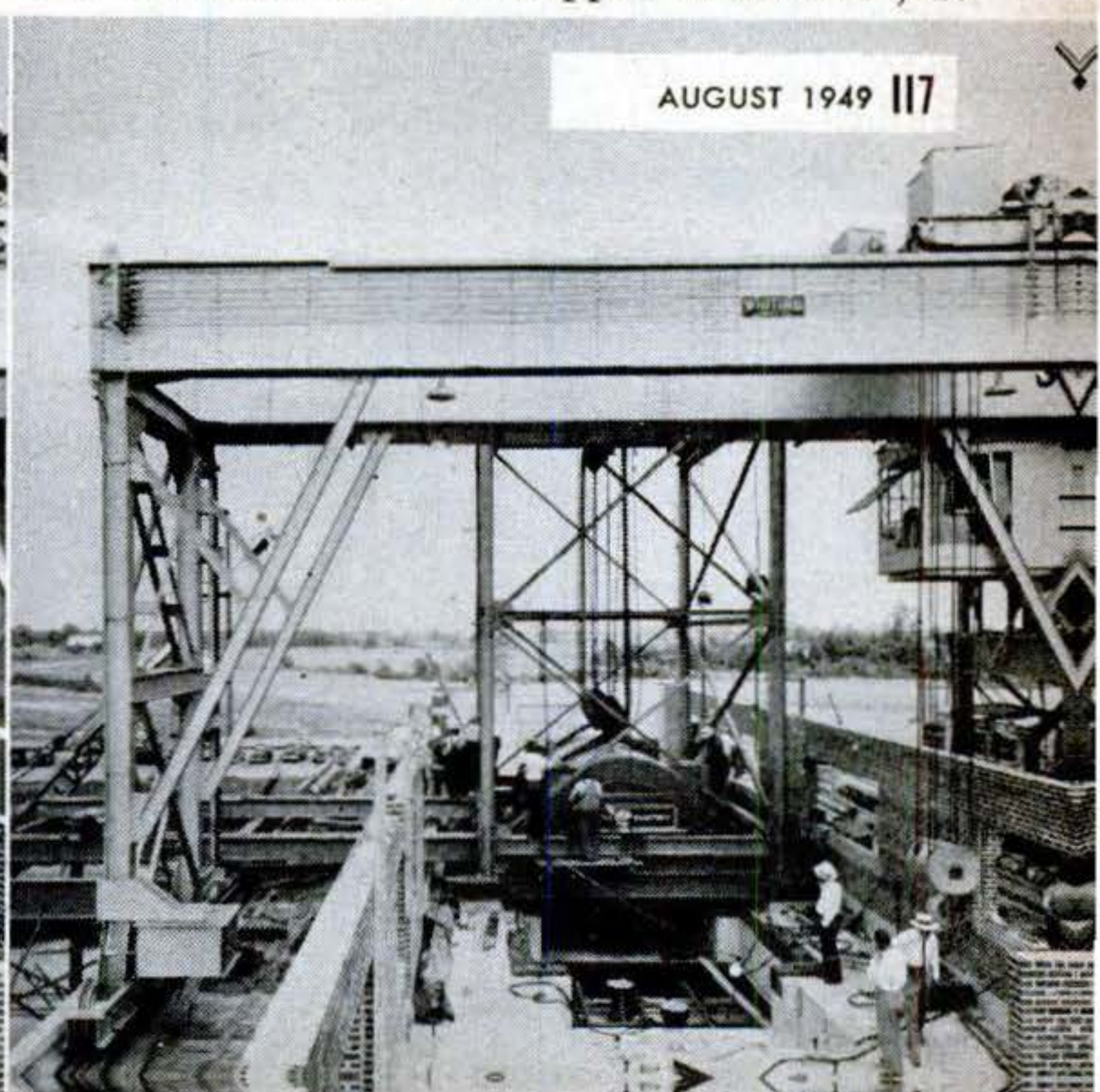
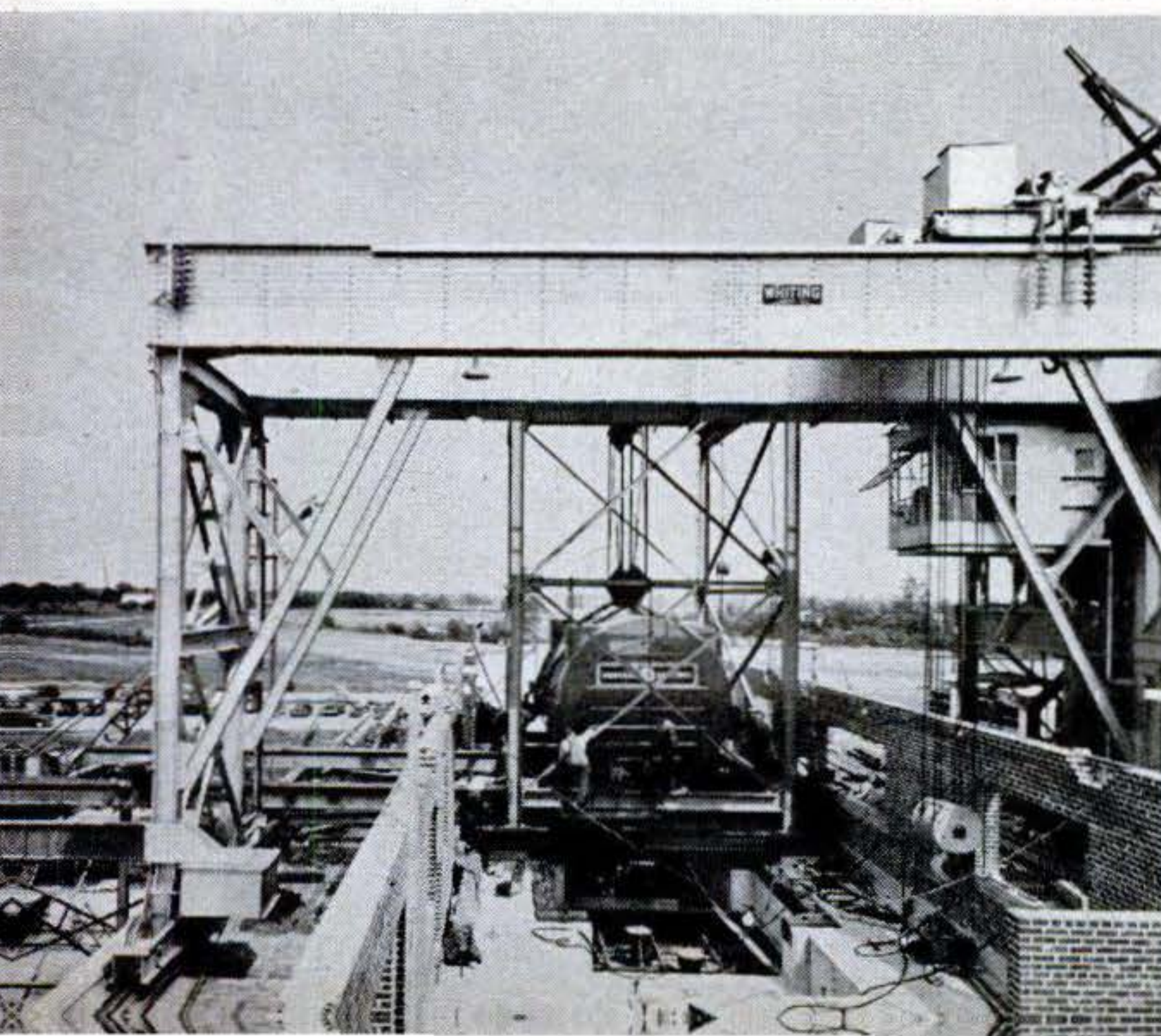

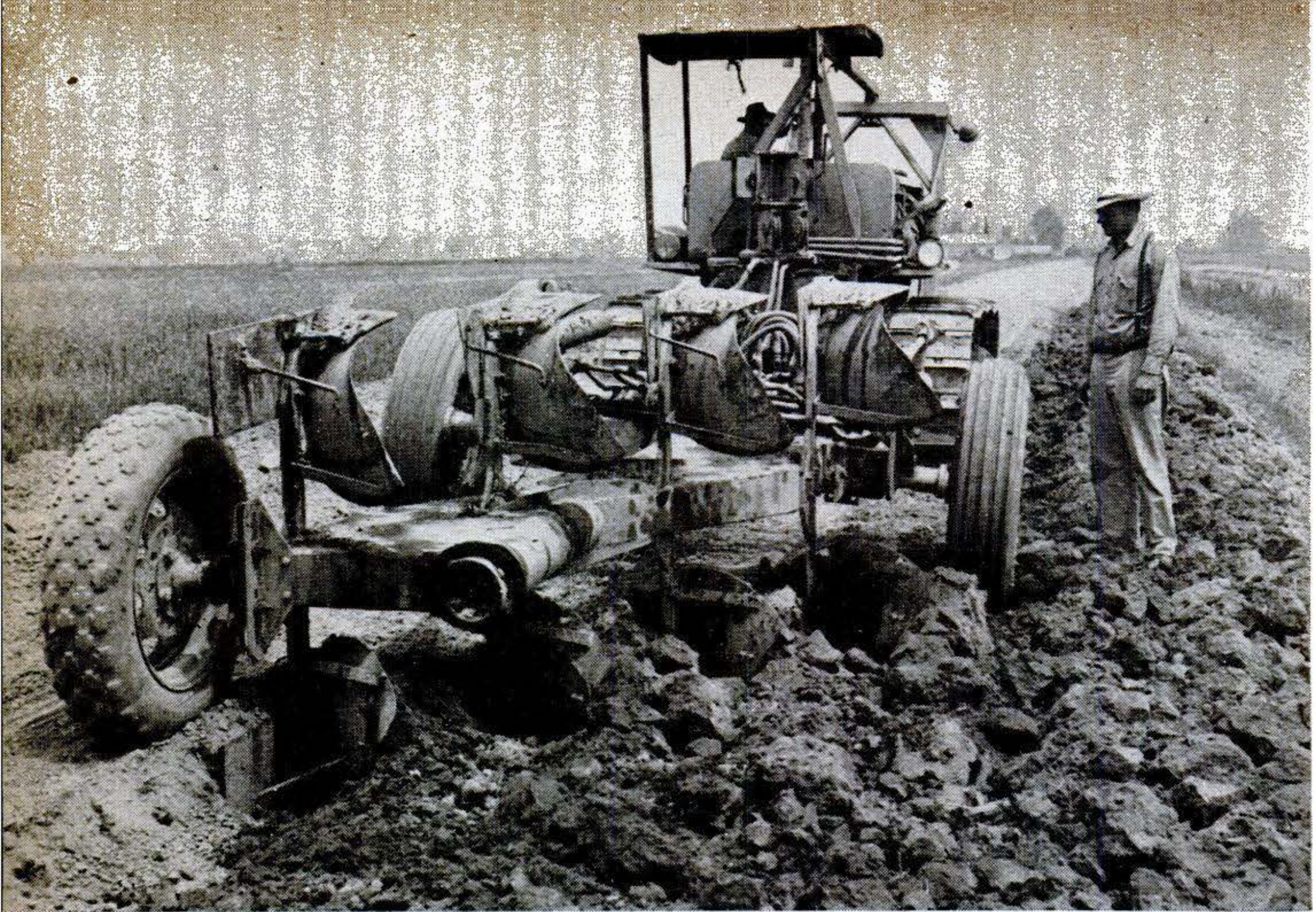

### Flip-Flop Plow Aids Farmers

FARMERS can plow back and forth across their fields with a plow (above) that has two sets of shares and can turn itself over. An ordinary plow with one set of shares can go only one way because the shares turn furrows just one way—say to the right

—and would make a ditch or ridge between each strip. With the reversible plow one set of shares turns a furrow to the right, the other to the left. Thus it avoids plowing circles and then driving the heavy equipment out from the center over the plowed land. Made by Atlas Scraper and Engineering Co., Bell, Calif., it is flipped hydraulically.

### Digs Holes to Catch Rain

PUNCHING holes in the ground is the latest method proposed to stop erosion. The Land Saver® below digs “pores”—28,000 per acre—as it is pulled by a tractor. These pores, claims inventor Homer K. Shonts, a Washington State wheat farmer, make rain soak into the ground instead of running into gullies and washing away priceless topsoil.

### Hoist Gives Driver Free Ride

THE truckman gets a free ride on the new hydraulic lifter shown below. He’s lifted right up with the load so that he can handle the whole job by himself. The Hydro-Loader®, made by Stratton Equipment Co., Cleveland, lifts weights as great as 1,500 pounds up to seven feet off the ground. It folds against the truck when not in use.

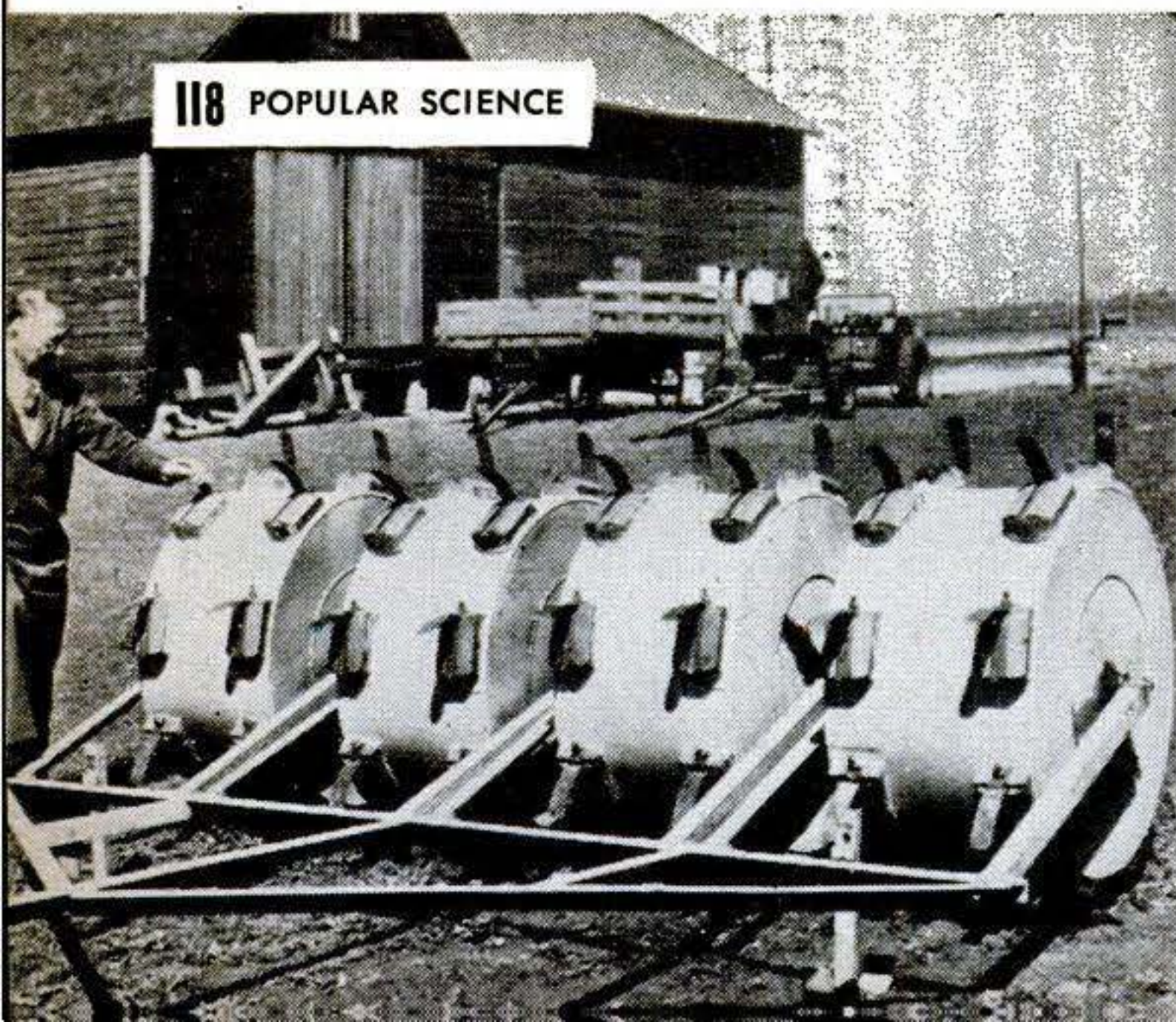



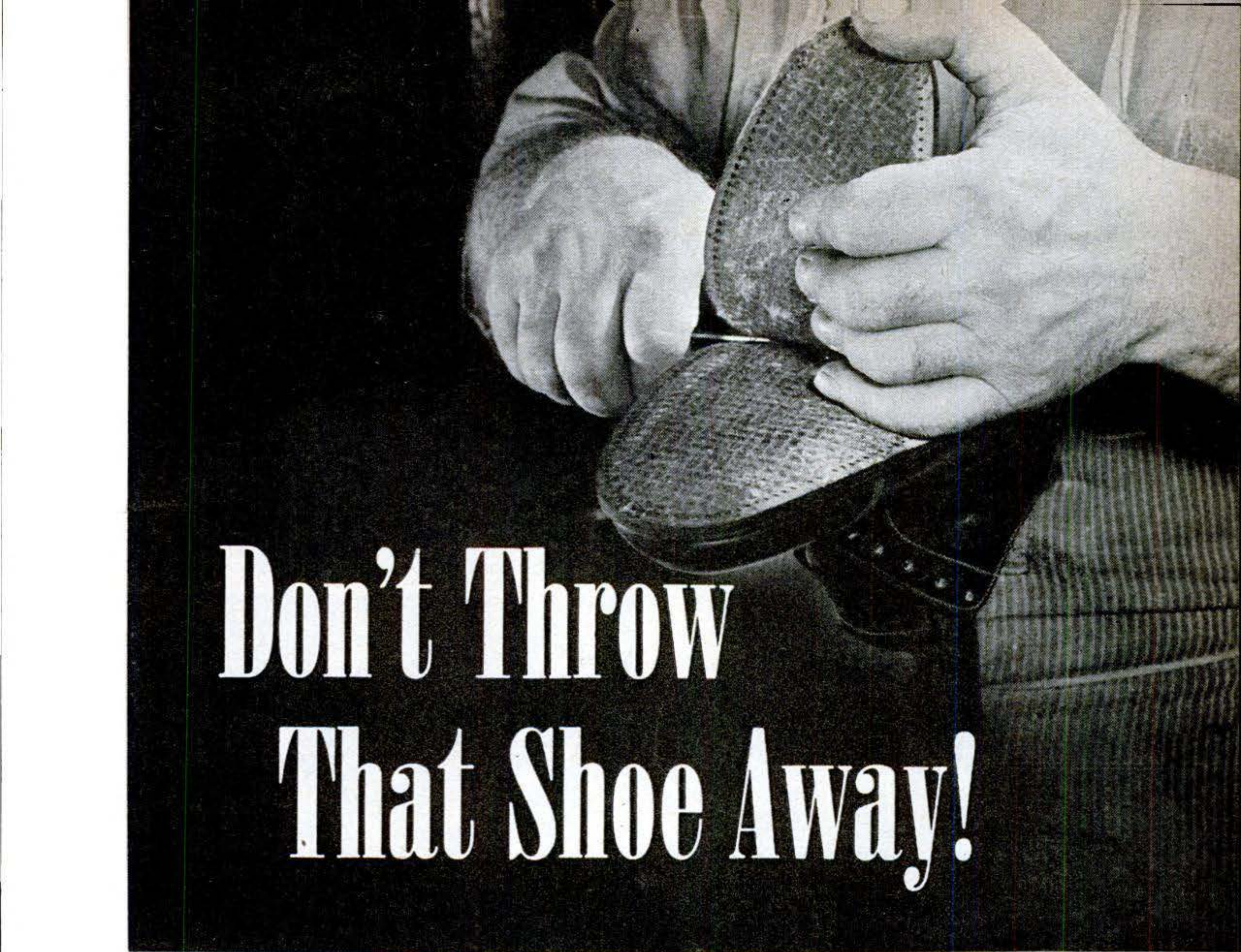

# Don't Throw That Shoe Away!

Workman tears off shoe's double sole to get at lining and insert a lengthening strip.

**Shoes don't fit? This 70-year-old rebuilding process can make them longer or wider, even change style.**

**By C. Ennis**

*PS photos by W. W. Morris*

**B**BETTER not throw away those tight shoes that pinch your feet every time you wear them. They might be worth fixing. This story tells how one shoe rebuilder solves the tight-shoe problem.

Using a 70-year-old method, the B. Nelson Co., of New York, can take a pair of ill-fitting shoes and make them one full size longer or wider than they were originally. The extra room is gained by ripping off the shoe sole and attaching a leather strip to the lining. Before this insert is added, a last of the proper style is fitted into the shoe so that it keeps its shape during the reconstruction process.

The Nelsonizing® technique can also be

used to restyle women's footwear. Toes and backs can be removed or put in, heel height changed, platform soles added or taken off, and the gaping sides of shoes corrected. If the leather on a shoe upper needs to be matched in the restyling process, skins in all types and colors are available. The strip of photographs at the bottom of pages 120 and 121 shows how style changes were made on four pairs of women's shoes.

Shoe-repair orders, covering a variety of requests, come from all over the world. Customers often ask to have slipper straps or other shoe parts replaced because pet dogs have chewed them. Sally Rand, the dancer, has the toes of all her shoes rebuilt because years of toe dancing have broadened her toes beyond the width of ordinary shoes. Turn the page and you'll see how the experts lengthen a pair of men's shoes. So don't discard those last year's shoes—to these shoemakers the "last" is just the beginning. ▶



**1** Tape measure shows that size-11 shoe above, which is to be lengthened half a size to 11½, measures 12 inches from tip to tip before the rebuilding process begins.



**2** A crosswise slit is cut in the canvas lining and insole of shoe above to attach insert. Note shoe's rearward shank, made of steel and cardboard, that supports the wearer's arch.

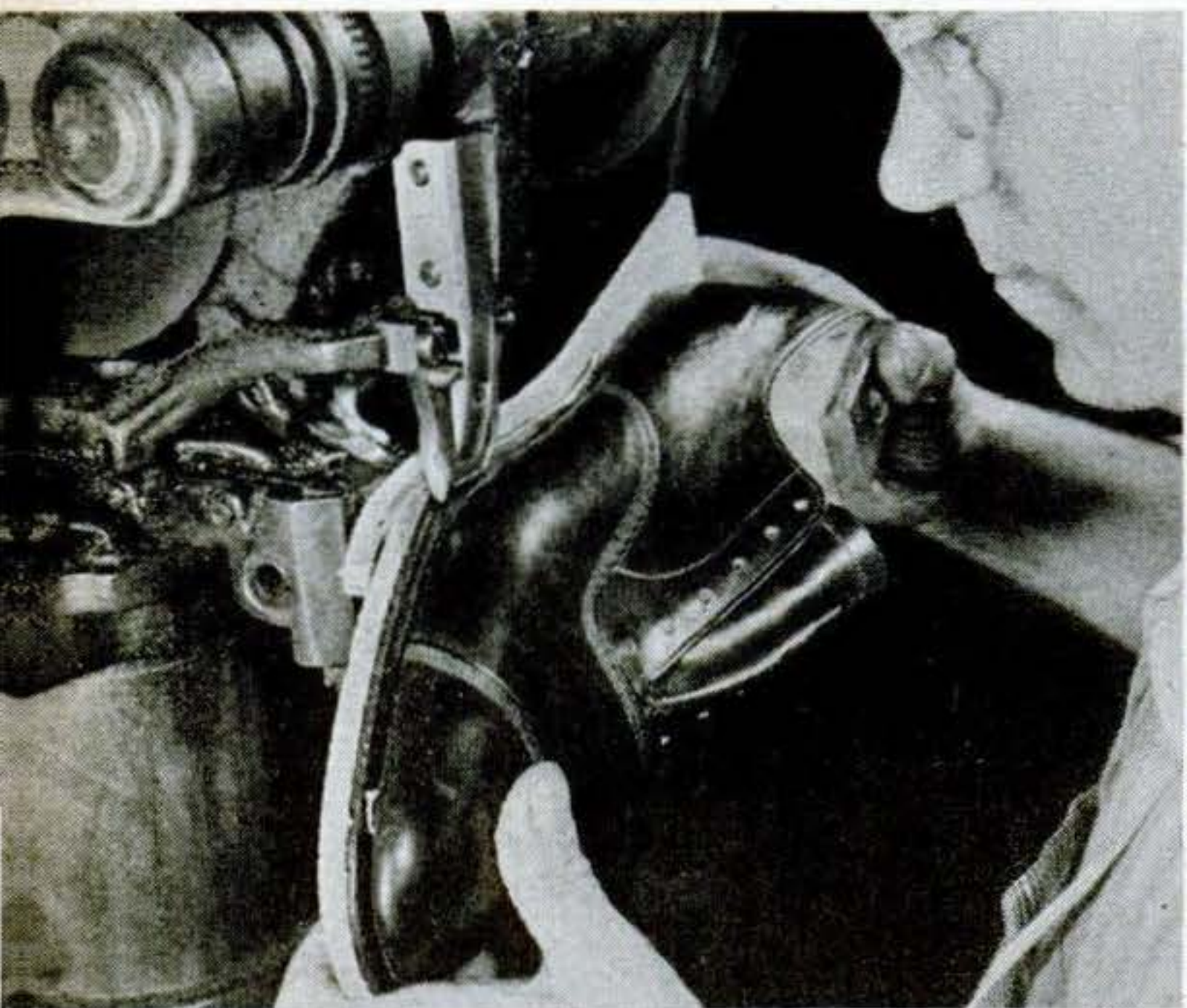

**5** Operator evens shoe's edge on a trimming machine (above) before stitching on sole. A vertically moving feed bar jogs shoe past a knife-edged pick that chews off excess leather.

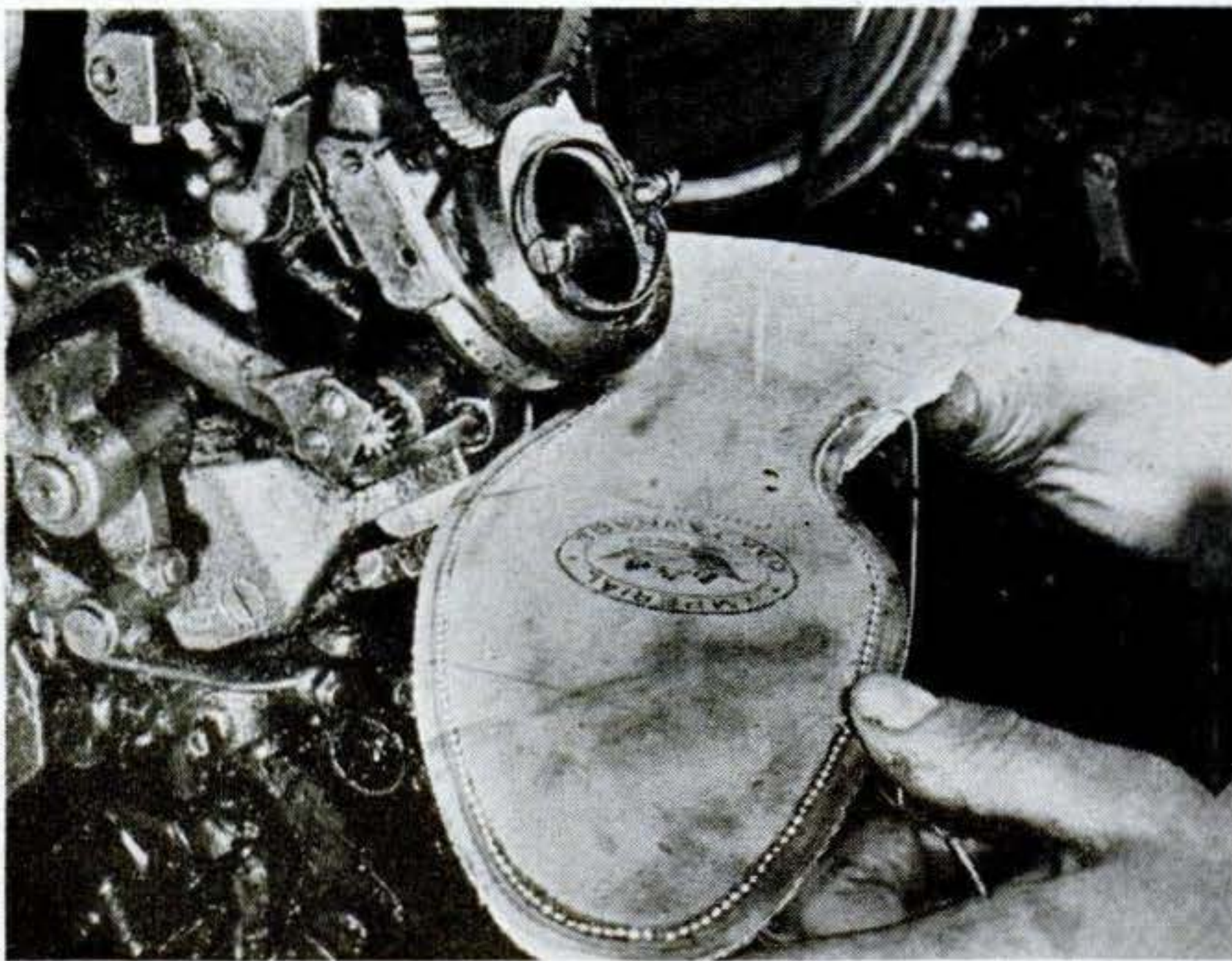

**6** Sole is sewed to shoe with waxed linen thread, softened for stitching by a heating unit in the machine. Well hole above the sole in photo is a bobbin case that holds thread.

The shoe at right below shows how this pair looked before remodeling. To achieve the "D'Orsay" style (left), leather was cut away from the shoe vamp, making it lower.

The customer who owns these shoes wants to have the open-toe style. After the toe section is removed, a ribbon binding is sewed around the edge of the opening to give a neat finish.



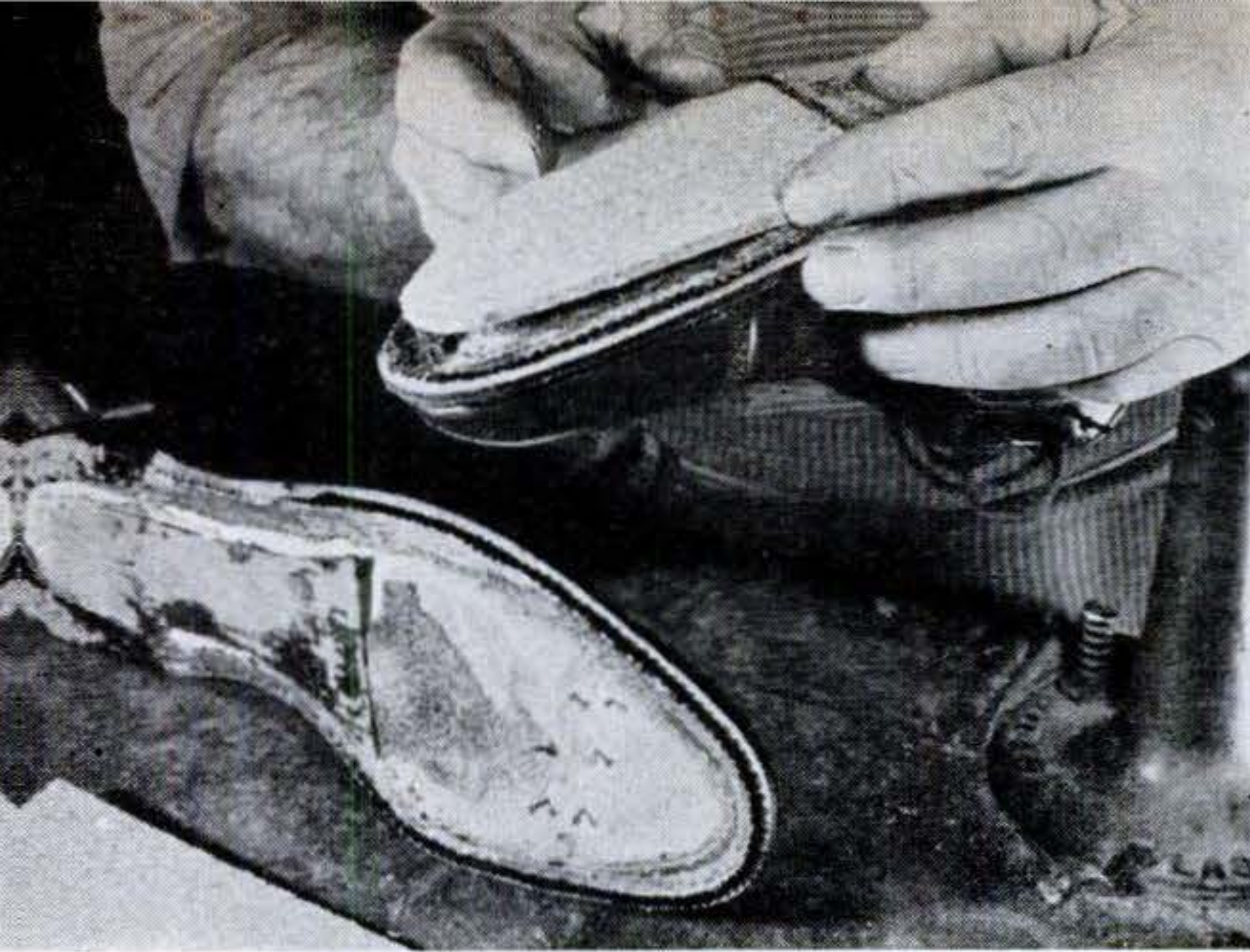

**3** Having glued and tacked insert into slit of the shoe in foreground, worker cements a new cork sole cushion on shoe mate at right to give an even surface for attaching the sole.



**4** After sandpapering the cork cushion (shoe in foreground) to give it a smooth finish, a leather sole is temporarily attached (shoe on the stand) with some rubber cement.

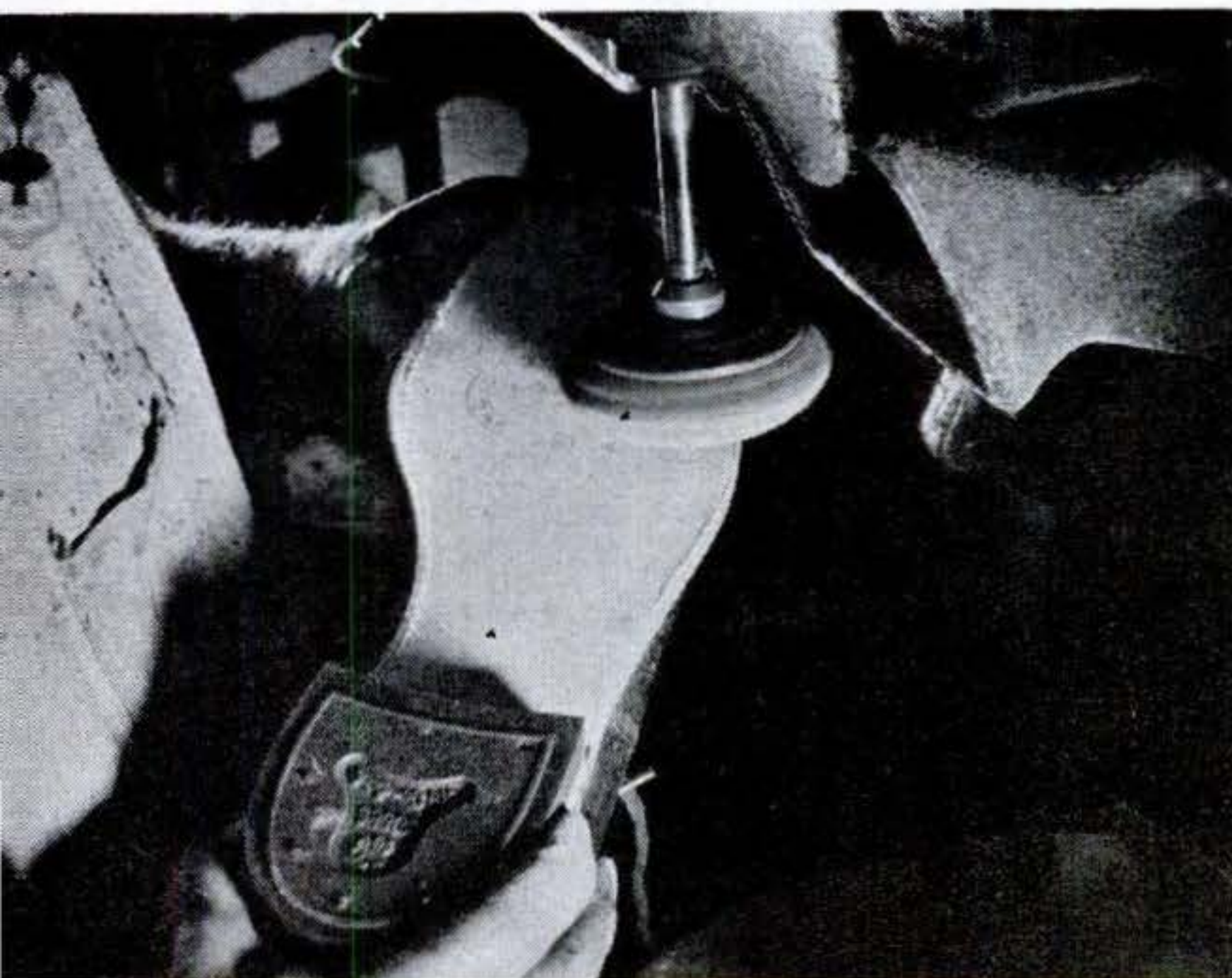

**7** Before final polishing, sole is smoothed by holding it up to rotating rubber buffer. Smaller wheel is used to buff narrow part of sole. Funnel (upper right) draws off dust.

**Black suede shoes** with backs are remodeled to the backless style. When rear section is removed—as on shoe in foreground below—a strap and buckle matching rest of shoe are added.

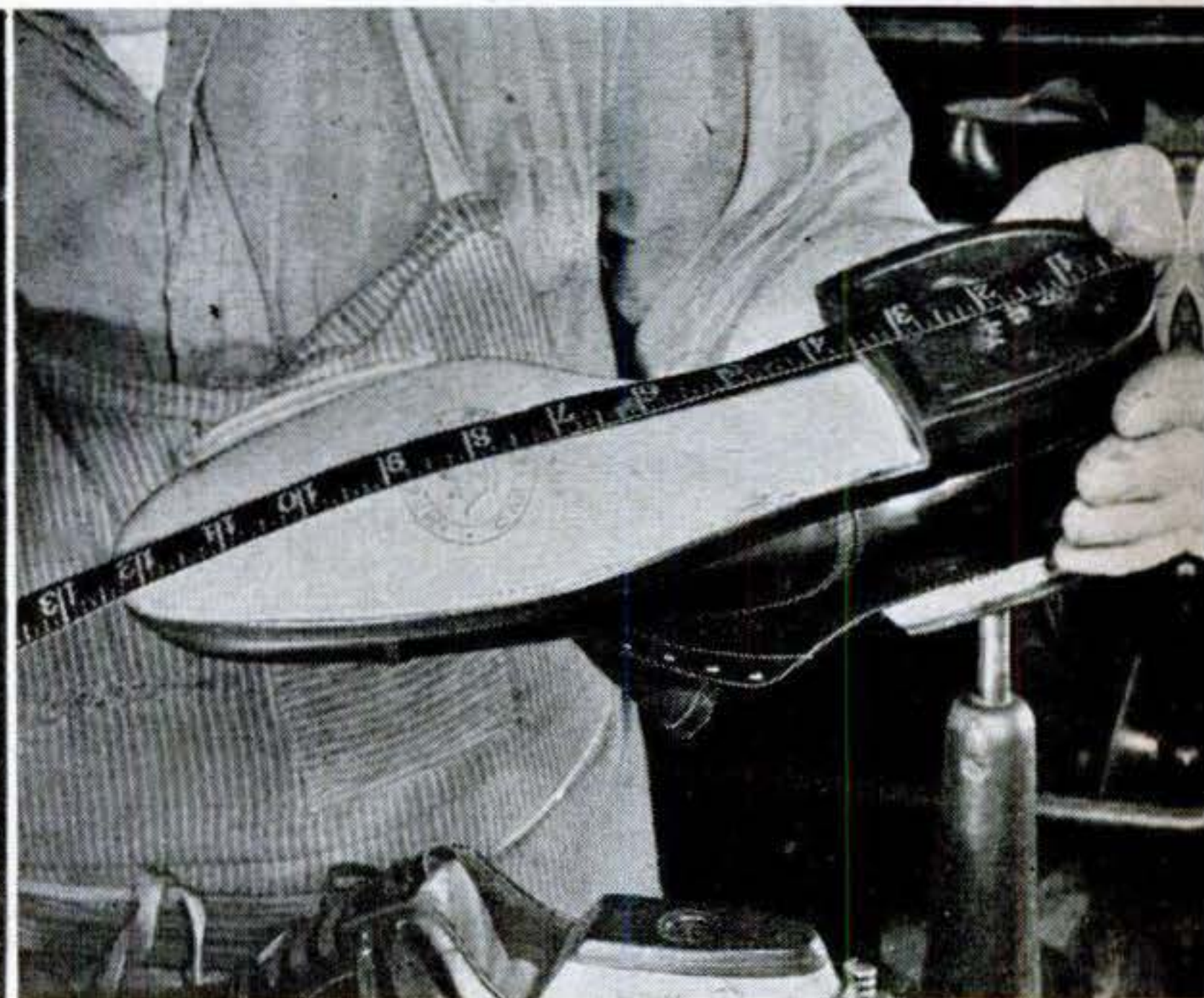

**8** After the rebuilding process is finished, worker measures the right-foot shoe to show how its length has been increased. Now it's about an eighth of an inch longer than before.

**These shoes are getting a new pair of heels**, the "French" heel at right being replaced by the "military" heel at left. Leather to match shoe upper is used on the new heel.



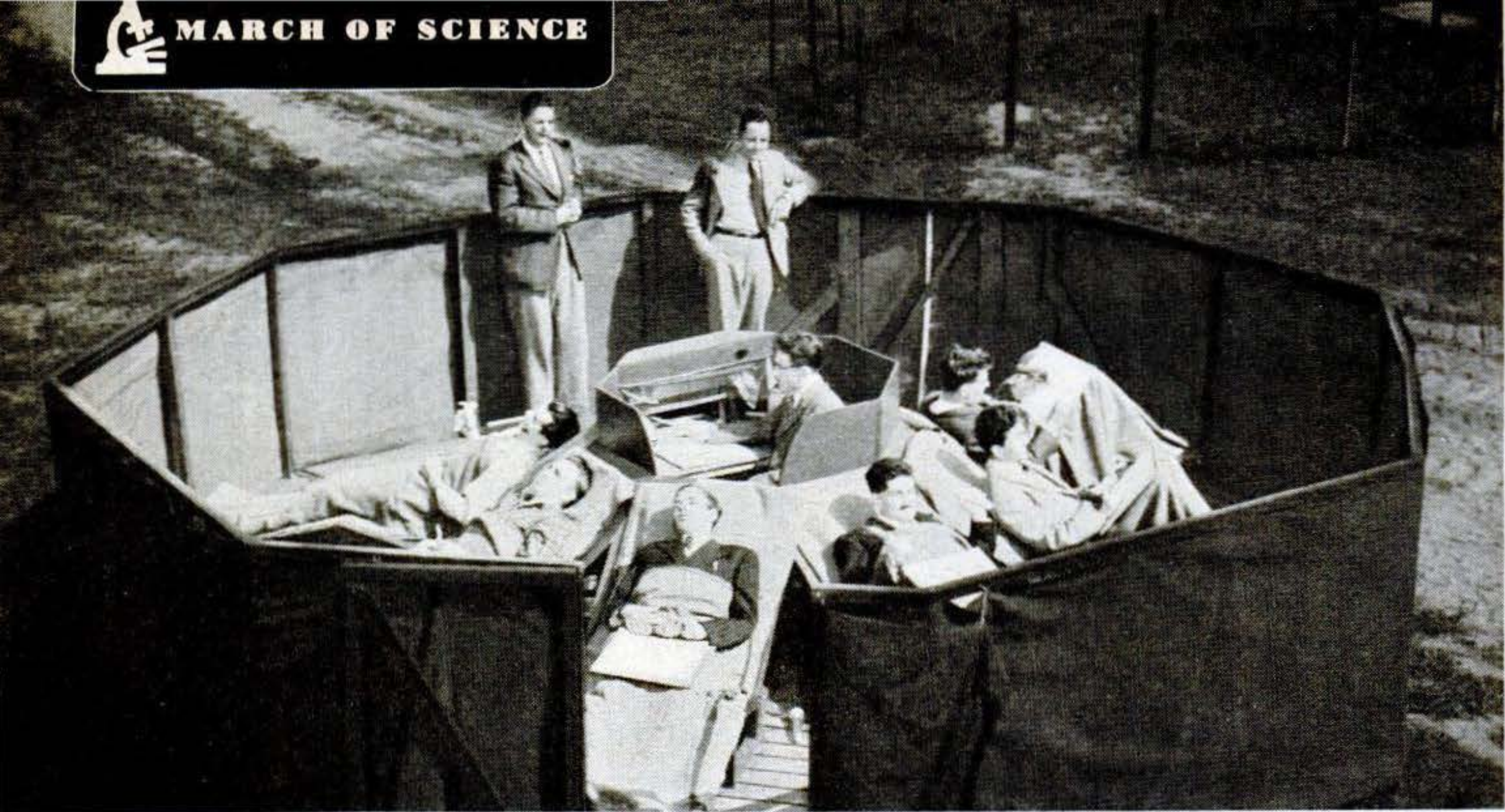

**Clocking Meteors.** Reclining comfortably in this shelter near Ottawa, Canada, stargazers for the Dominion Observatory time the flight of shooting stars. When one is seen, an observer presses a button that

registers the time on photo film. The same film clocks radar echoes when a meteor is about 60 miles above the earth. Echoes from Perseid meteors usually appear on a scope just as the meteors fade from sight.

**Heat Makes Photos.** Pictures made with heat rays, instead of light rays, now record objects' temperature patterns for Eastman Kodak technicians. Focused on a phosphor screen by a curved mirror, the heat rays produce a glowing image whose brightness varies with the object's temperature. This is photographed by a camera at a hole in the mirror (below). The inset shows a heat photo of a man's hand.

**Map Reveals Wear.** Placed in an instrument that measures electrical capacity of fibers, below, worn clothing yields odd patterns resembling contour maps. The capacity falls as wear increases, so that while only a hole may be visible (lower left), the map (lower right) reveals wear over the surrounding area. This permits more accurate measurements of a fabric's durability by National Bureau of Standards experts.

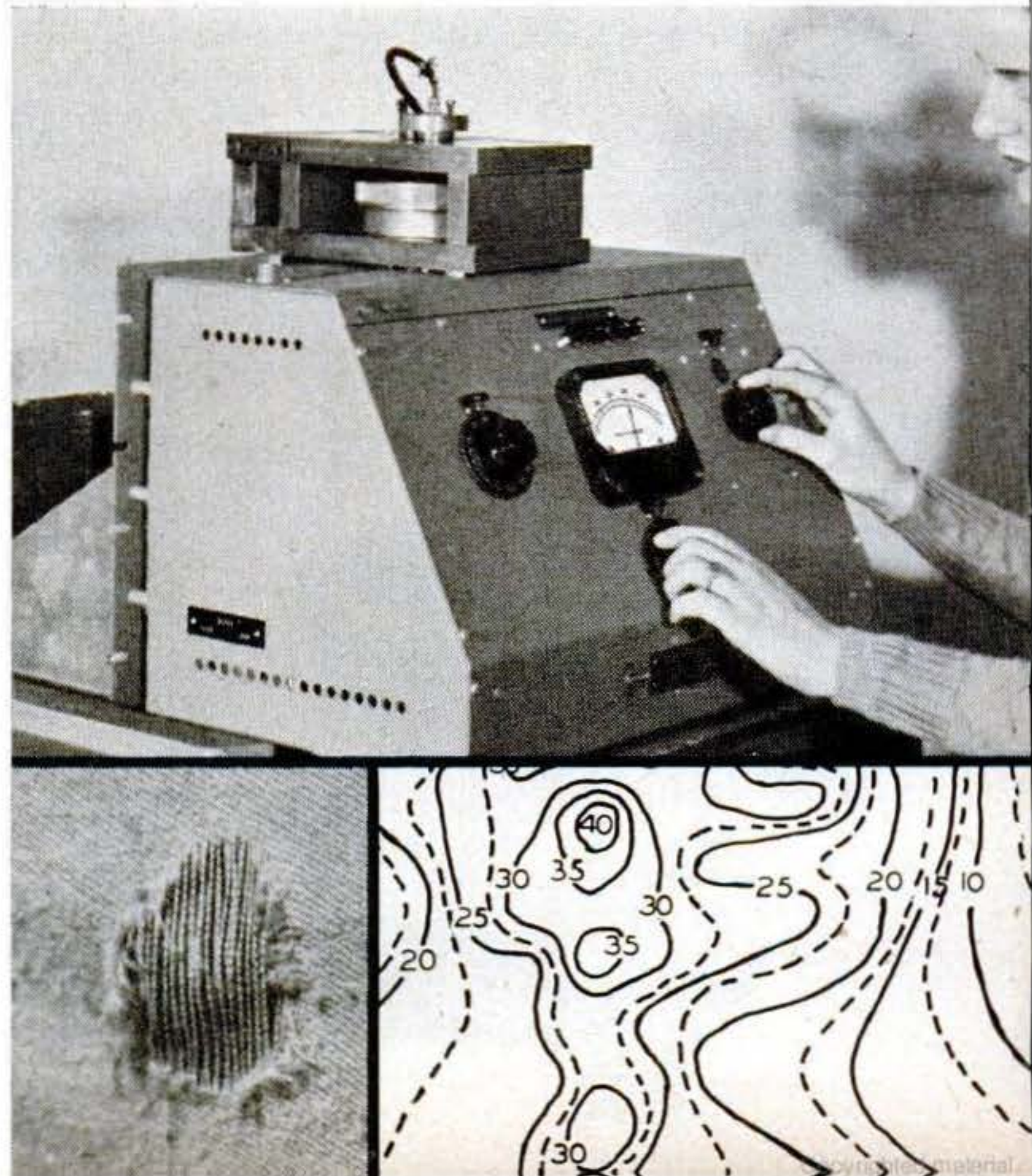
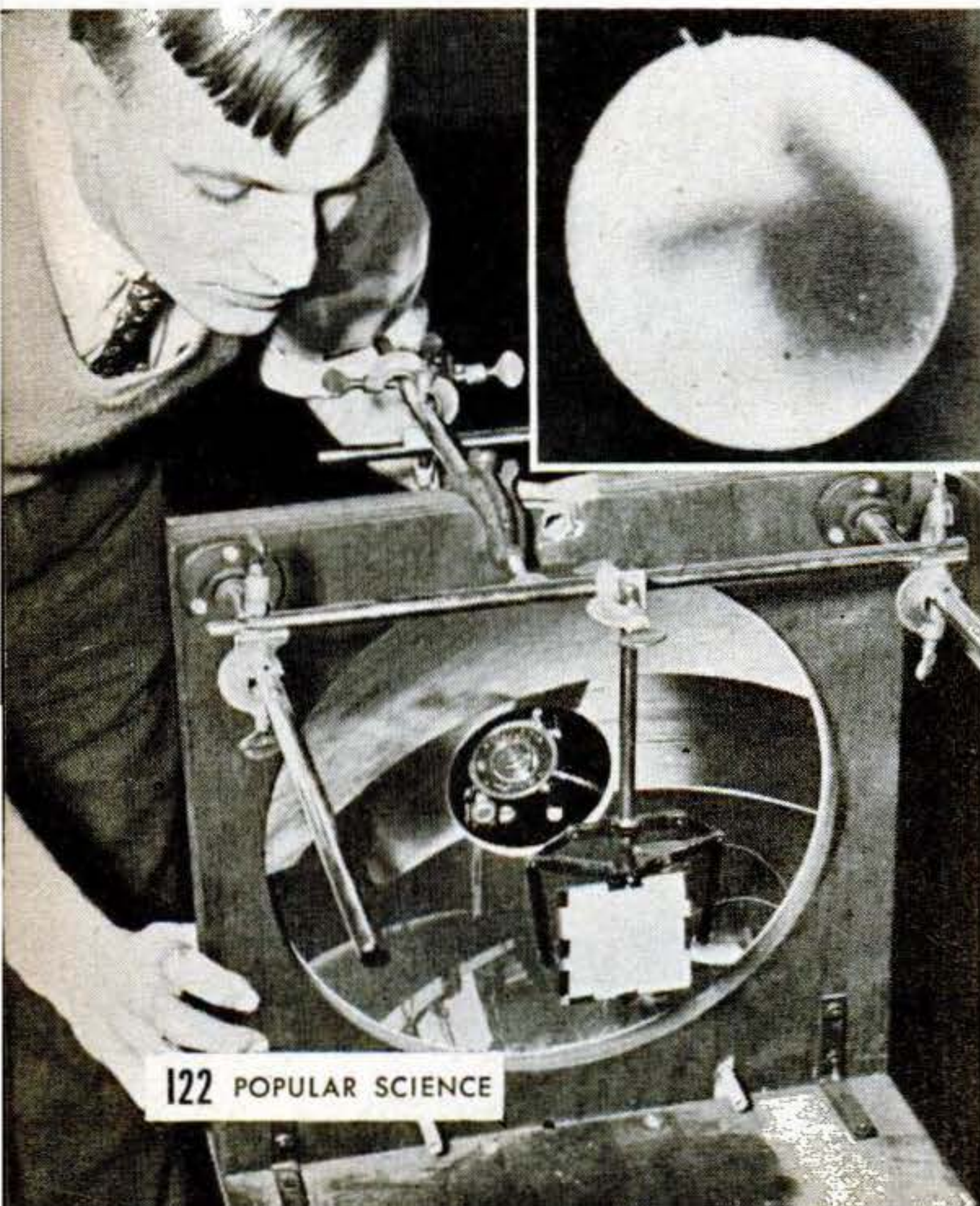

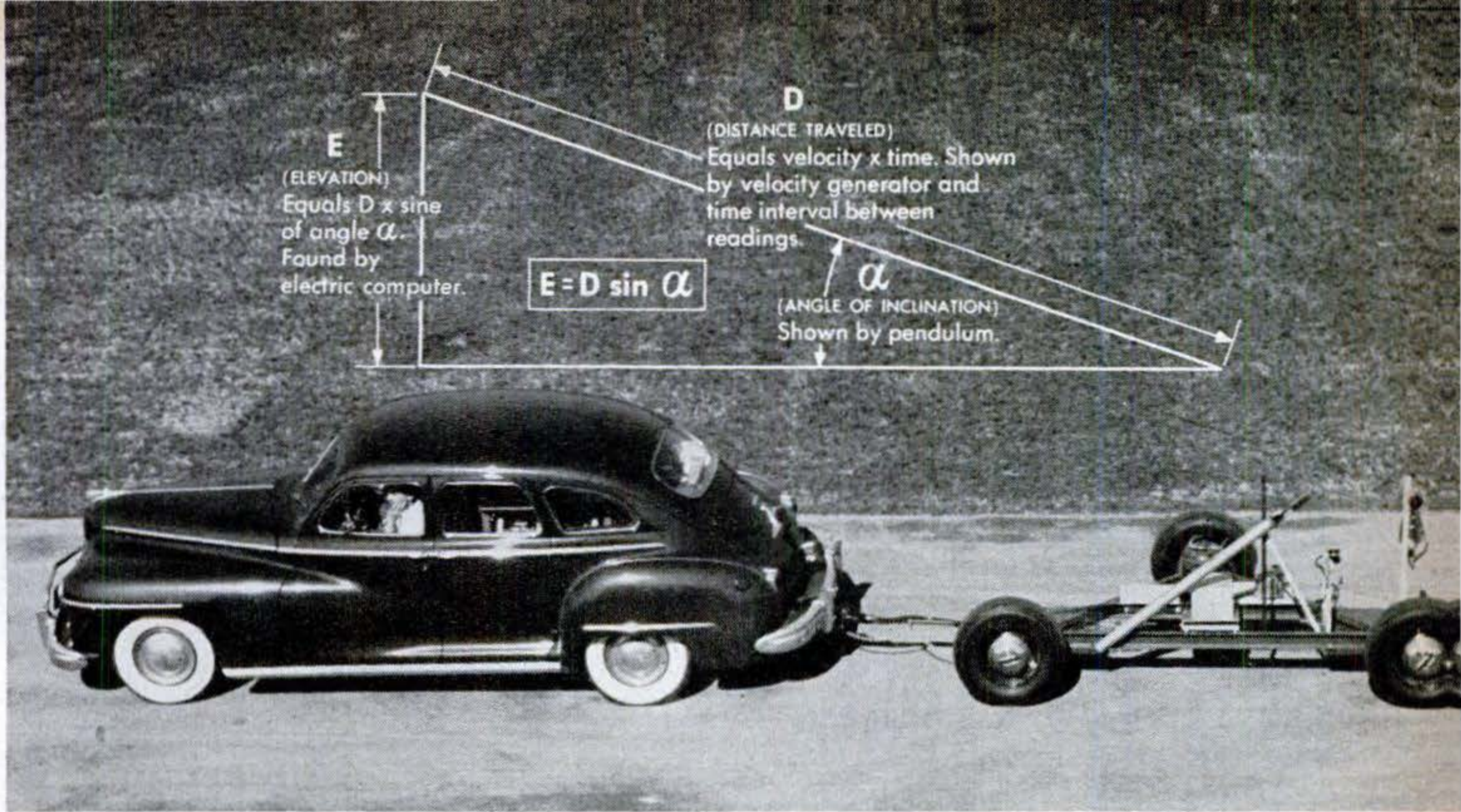

**Up-and-Down Meter.** Towed from one point to another, this Sun Oil trailer measures the difference in their heights above sea level, eliminating elaborate surveys. Distance is figured from a speedom-

eter, while a pendulum measures the angle up or down hill at which the car moves. An electric brain solves the illustrated problem in trigonometry thousands of times a second, totaling the results and final answer.

**Flying Teakettle.** Because water boils at lower temperatures with increasing height above the earth, the instrument below serves to measure altitude. Carried aloft by Army Signal Corps balloons, it brings water to a boil in a small vacuum bottle with the tiny doughnut-shaped electric heating element shown in the foreground. Called a hypsometer, it has another electric element that takes the water's temperature.

**Bounce Tester.** Dropping three-ounce ball bearings down glass tubes in the scientific "pinball machine" below, Firestone experts learn how new kinds of rubber will behave in extreme cold. At the bottom of the tubes, the ball bearings strike refrigerated samples of rubber. How high they bounce is noted against a scale. This is a test of the rubber's resiliency, which commonly decreases as temperature falls.

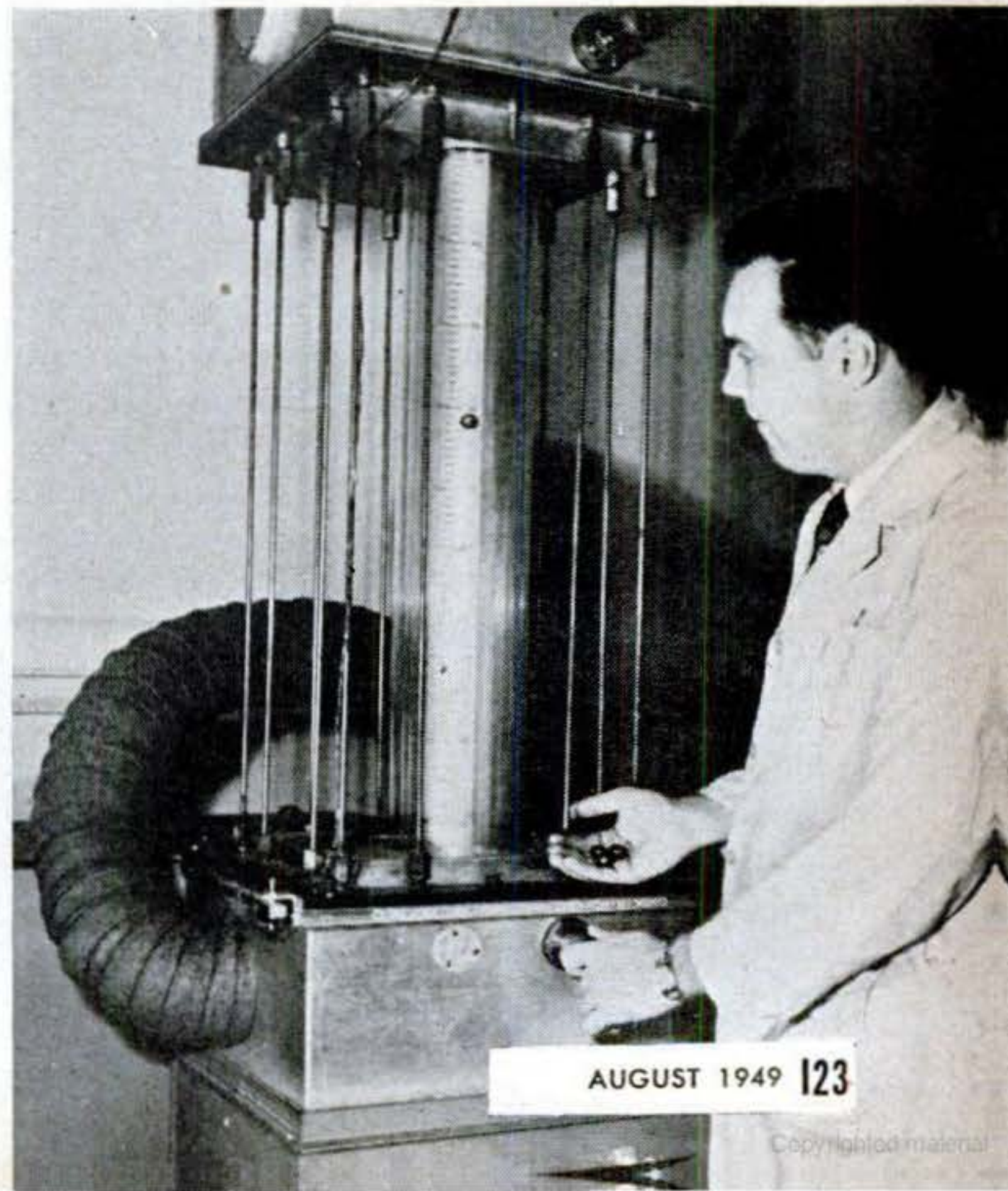

# Jersey "Jungle"

## Is Hottest and Wettest

Air conditioning in reverse creates man-made "rain forest" that outdoes Nature at her hot and humid worst.

**By Herbert Johansen**

*PS photos by W. W. Morris*

**N**OW the Army Signal Corps can enjoy all the discomforts of a steaming jungle right in northern New Jersey. The tropical chambers at Fort Monmouth provide everything from torrential rains to torrid humidity—and make them even worse than the originals.

Lock yourself inside one of these rooms and you'll get prickly heat, and fungus will sprout between your toes. The only things lacking are mosquitoes, palm trees, and pythons.

"And we could have those, too," says A. W. Rogers, of the supervising laboratory, "if they would serve any useful purpose. What we have is a fine piece of scientific machinery. A miniature jungle thicket might be exciting and colorful, but it wouldn't help us in our job of speeding up the effects of corrosion and tropical rot on the equipment we test—in getting answers in 10 days that would take 10 months to get in the field."

So the heavily insulated walls of the chambers, lined with corrosion-resistant Monel® metal, have a cold, clinical look. But there is nothing cold about these laboratories when a test is on to simulate a piece of equipment rotting deep in the New



Mobile radar tracking set is rolled into the main tropical test chamber. Door behind the cone can be closed to make two test rooms. Note observation windows in the rear wall.

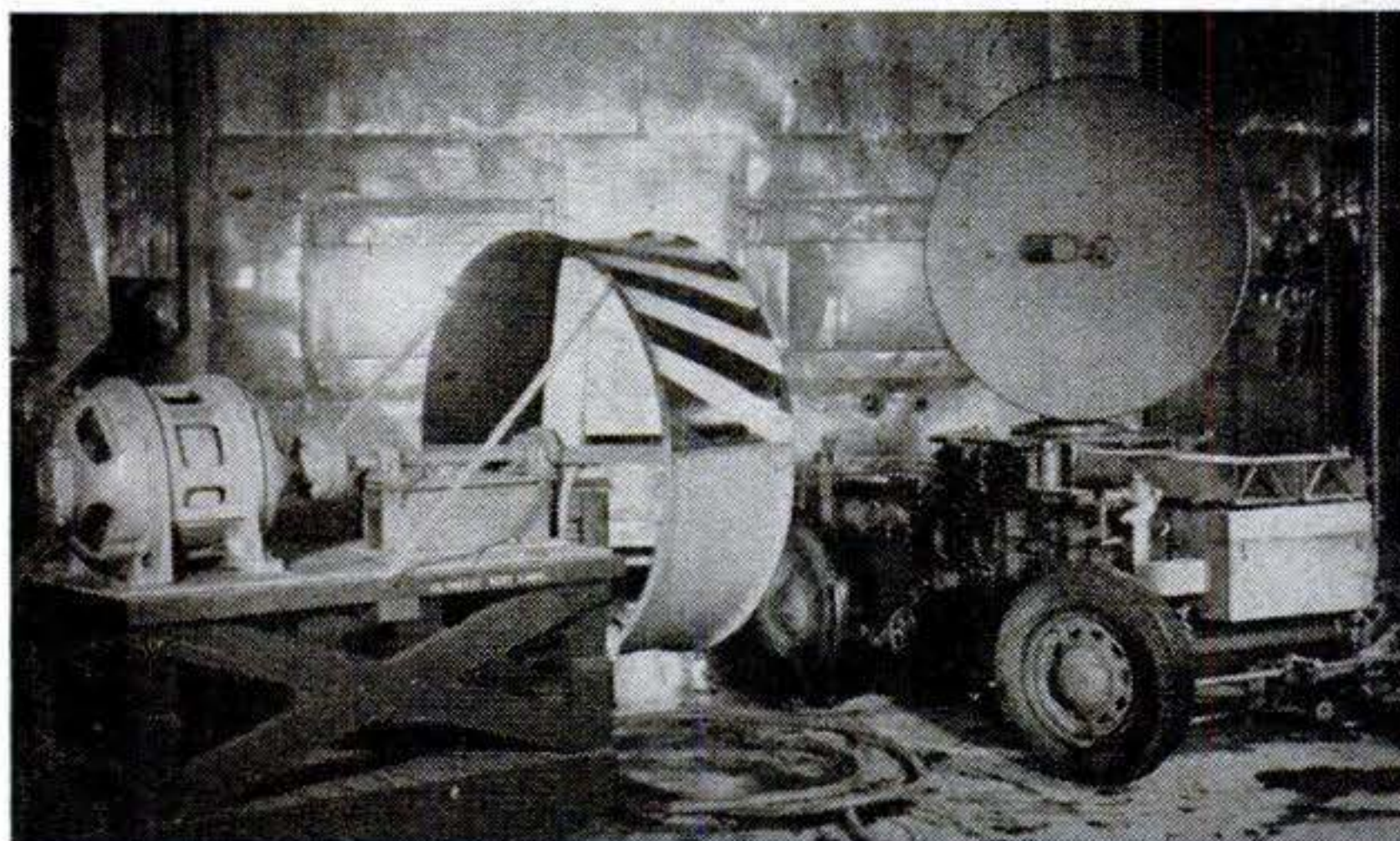

Inside, field radar set is ready for tropical test. Unit at left is electrically driven, stub airplane propeller that whips up a 40-m.p.h. wind. The room can hold a General Sherman tank.

Guinea jungle. With the controls set for maximum conditions, the heat climbs to an intolerable 190° F., with humidity at 100 percent, a soaking saturation. That's hotter and wetter than anything man is likely to find in jungle or desert.

"But," points out Thomas M. Child, head of the test section, "lots of our equipment got that kind of heat treatment during the war. Take a radio set inside a tank on the desert. You start with an air temperature of 125°. Desert absorption raises it to a ground temperature of 150°. Add another 10° and you get the thermometer reading inside the tank. And with the radio set itself generating heat, its parts might be operating at a sizzling 200° or more. In these chambers we not only duplicate that condition, but go it one better by adding humidity—and that's like boiling a radio set in water.

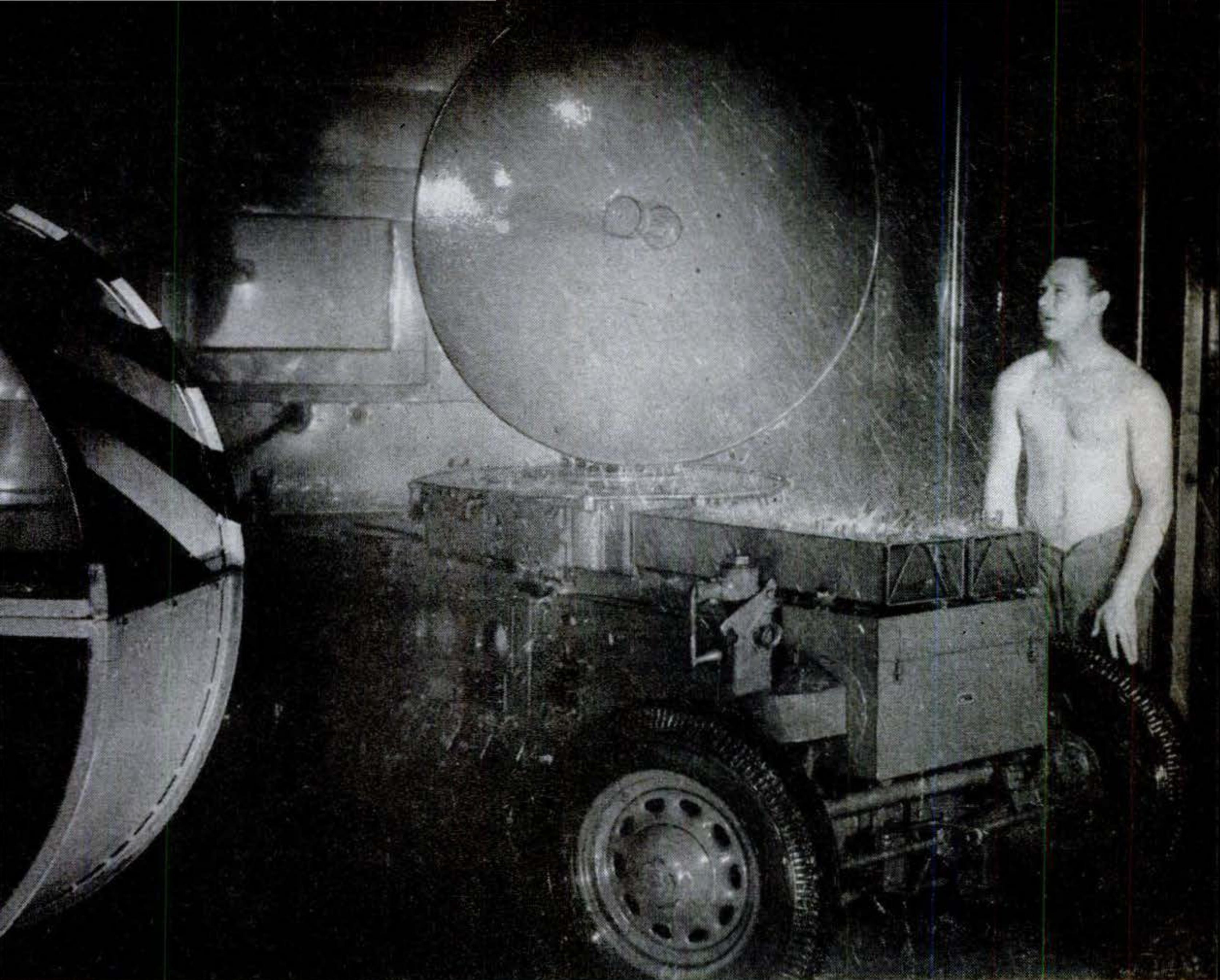

**Here a tropical hurricane** breaks loose in all its fury. Heat is on at about 180° F.; humidity is at saturation—with a torrential downpour thrown in. The technician at right can't take

it for more than 15 minutes, but the radar set must stand up under the grueling attack for many days to prove its mettle. Temperature-controlled rainfall comes from ceiling sprays.

If it comes through that treatment, we know it really will stand up.”

Mr. Child has been in one of the chambers with the temperature at 185° and the humidity high. Fifteen minutes is the most a man can take it, and he has to handle the equipment with asbestos gloves to prevent searing his hands. So real are these jungle conditions that working inside the chambers would be dangerous for technicians having any history of malaria or heart disease.

Another way of speeding things up is to accelerate the tropical cycle by setting the controls to operate twice a day from a low of 77° to a high of 150°, with high humidity. The effect of the increased condensation, producing greater absorption, is 10 times that experienced in an actual tropical day. Anything that comes through this corrosion test for 10 days and still works should be

good for at least a year of use under ordinary tropical conditions.

The tropical testing wing consists of six insulated rooms. The main chamber, more than 30 feet long and with a 14-foot ceiling, is big enough for a General Sherman tank or a mobile field radar set to be driven in and out. The machinery to produce the heat and humidity is located on top of the test rooms. Each room has its own unit, consisting of a circulating air blower, an air washer or humidifier, and radiator-like heating coils for temperature control.

When a room is in operation, there is an endless circulation of conditioned air. Coming up from the chamber, it is blown into the humidifier, consisting of two banks of water sprays. These sprays bring the air to the desired dew-point (humidity) temperature. The air then passes through an elimi- ➤

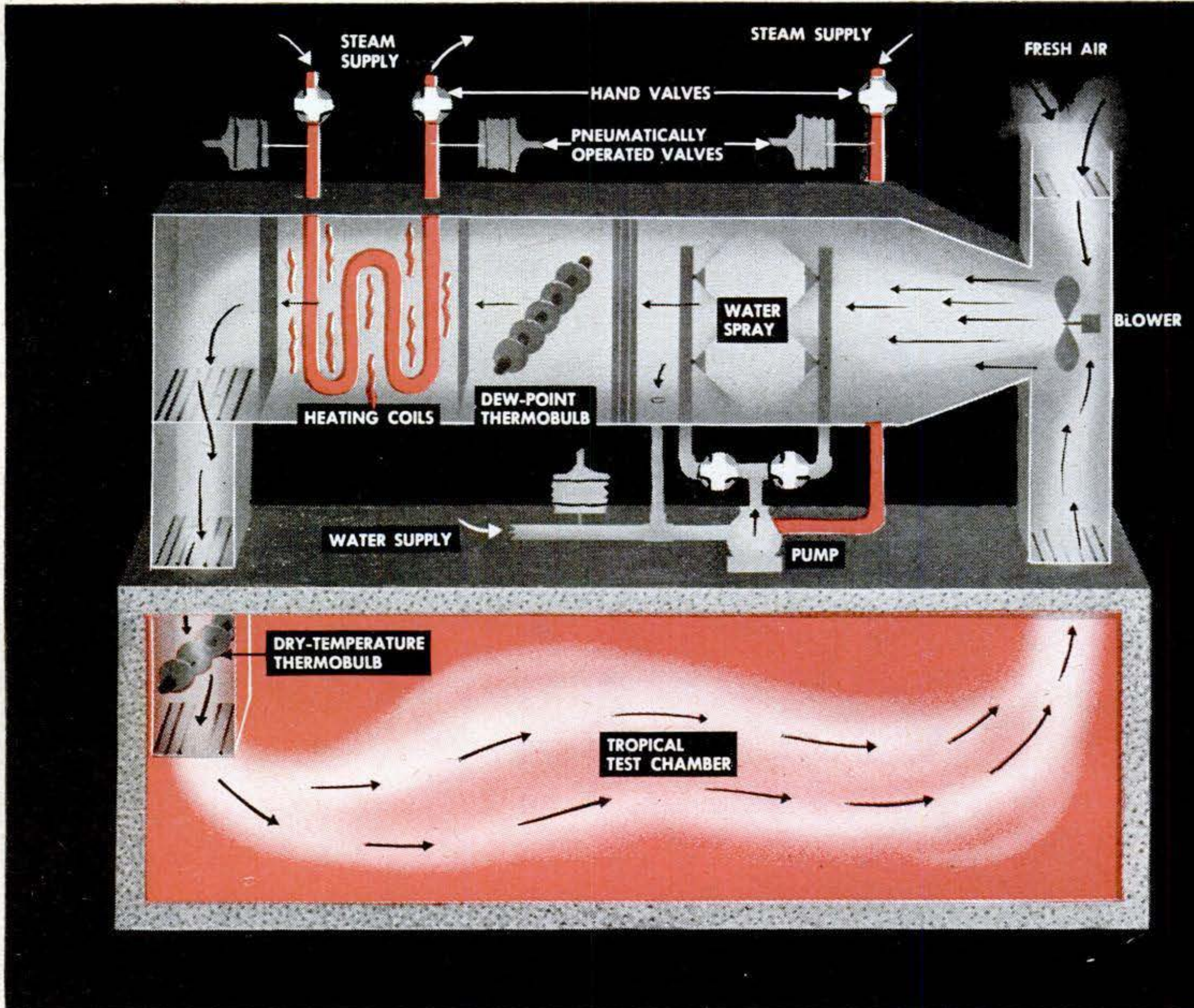

Schematic drawing above shows how heat and humidity are made to produce conditions worse

than those of any jungle. Each of the tropical rooms has its own climate-making machinery.

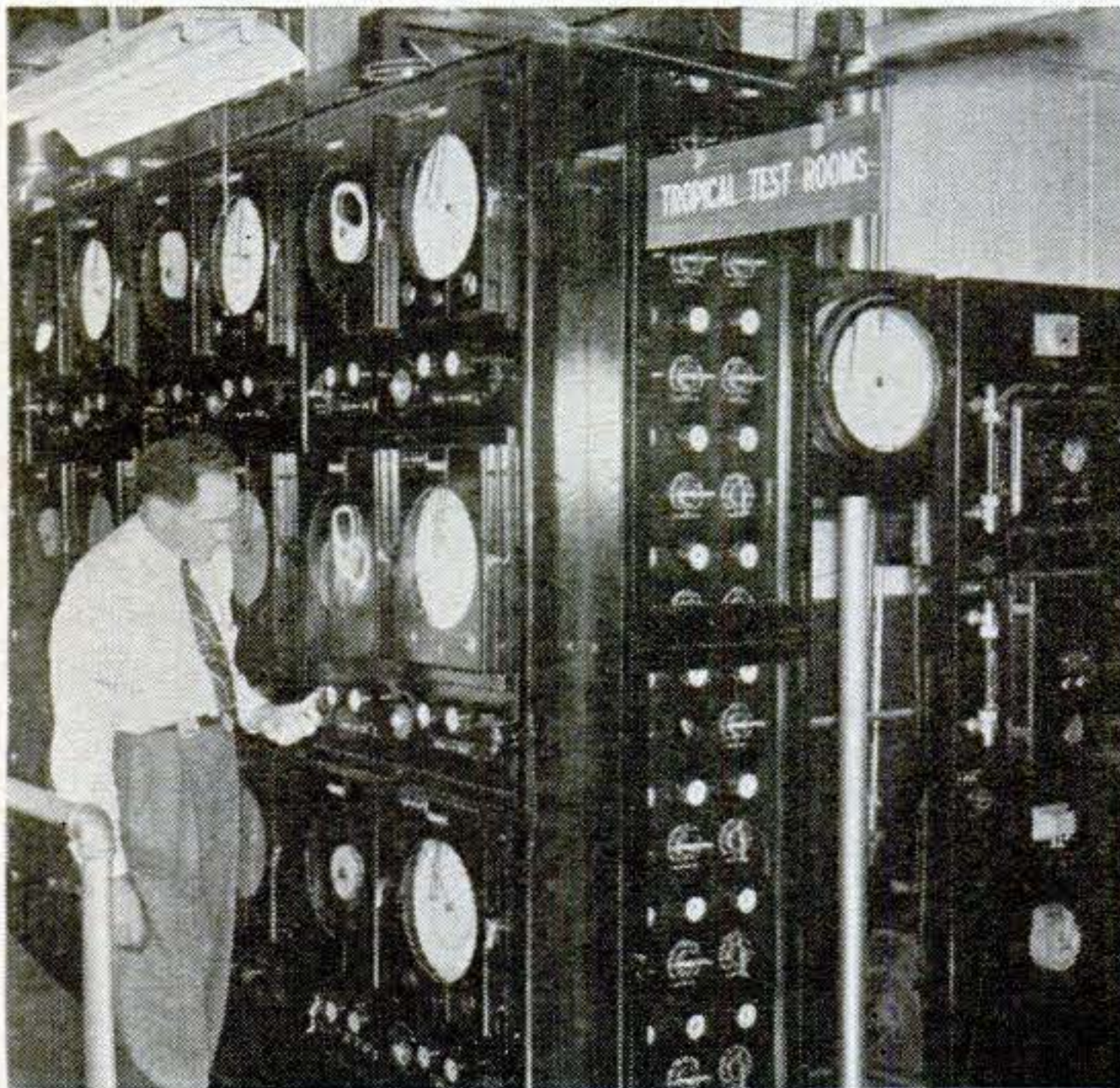

Each test room has its own controls on this panel located outside tropical wing. The system is pneumatically operated for smoother adjustment than that given by electrical controls.

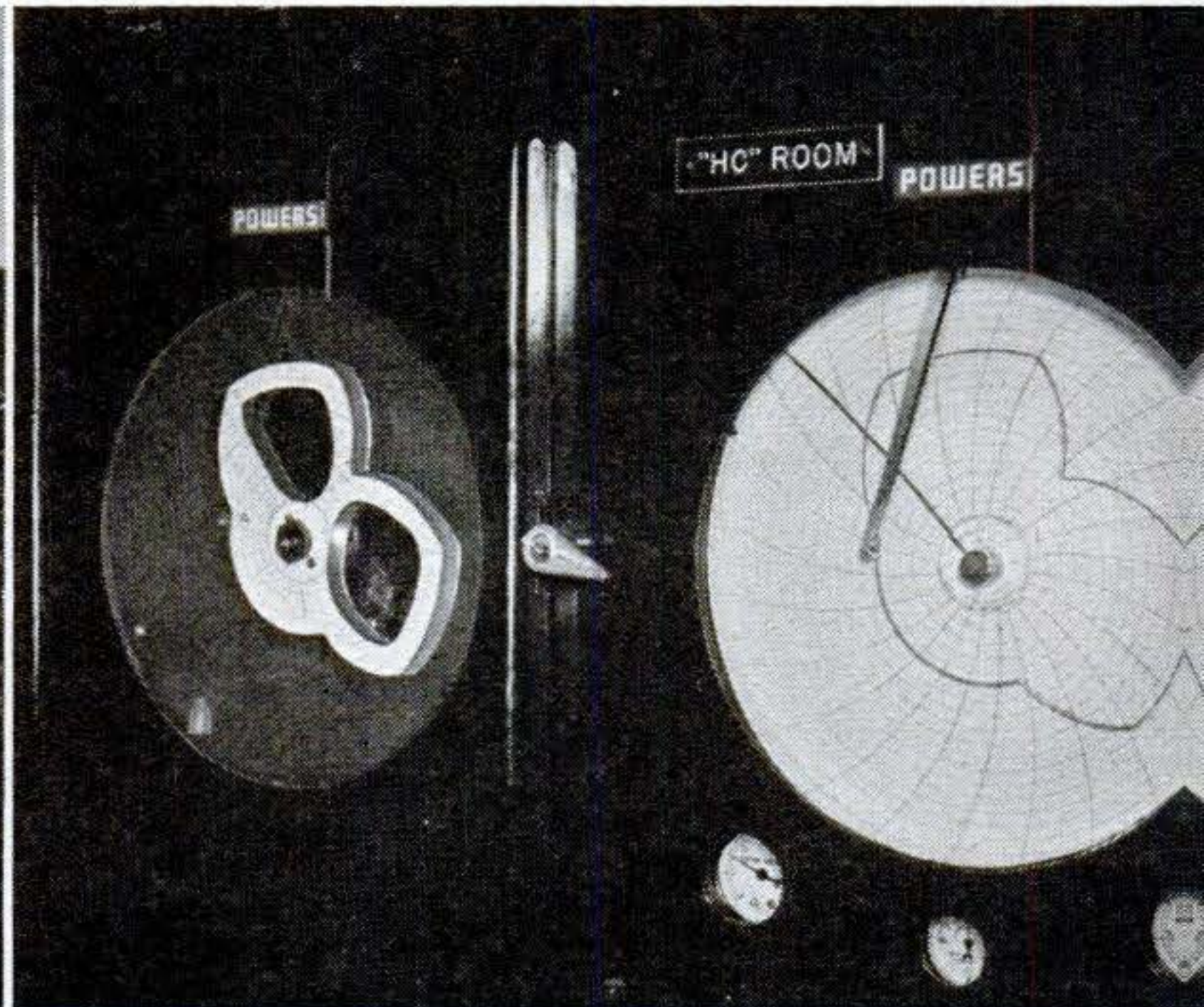

Cams at left above are rotated by an electric clock, actuating control pointers that regulate heat and humidity. Circular graph at right records actual conditions in the test room.



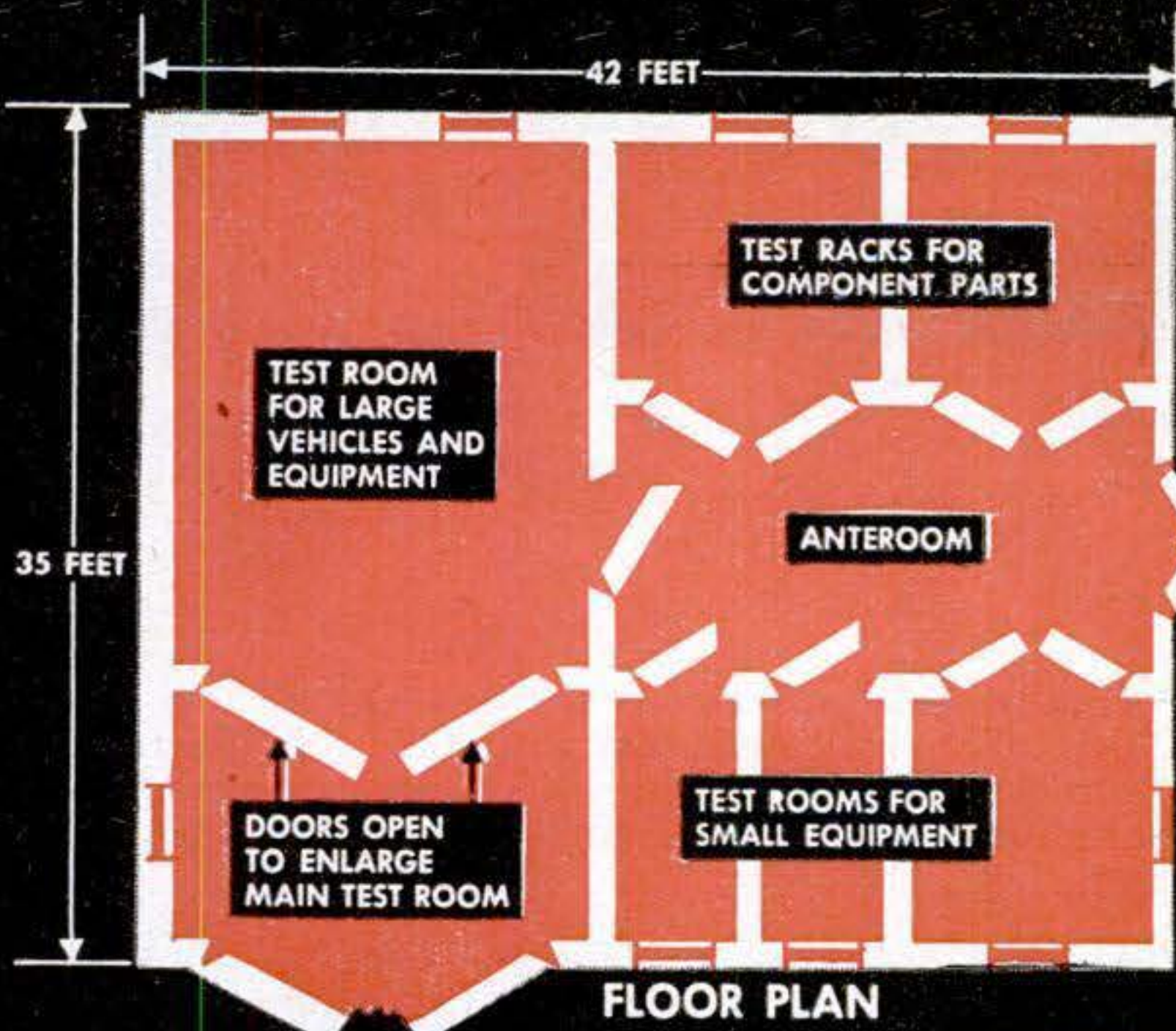

FLOOR PLAN

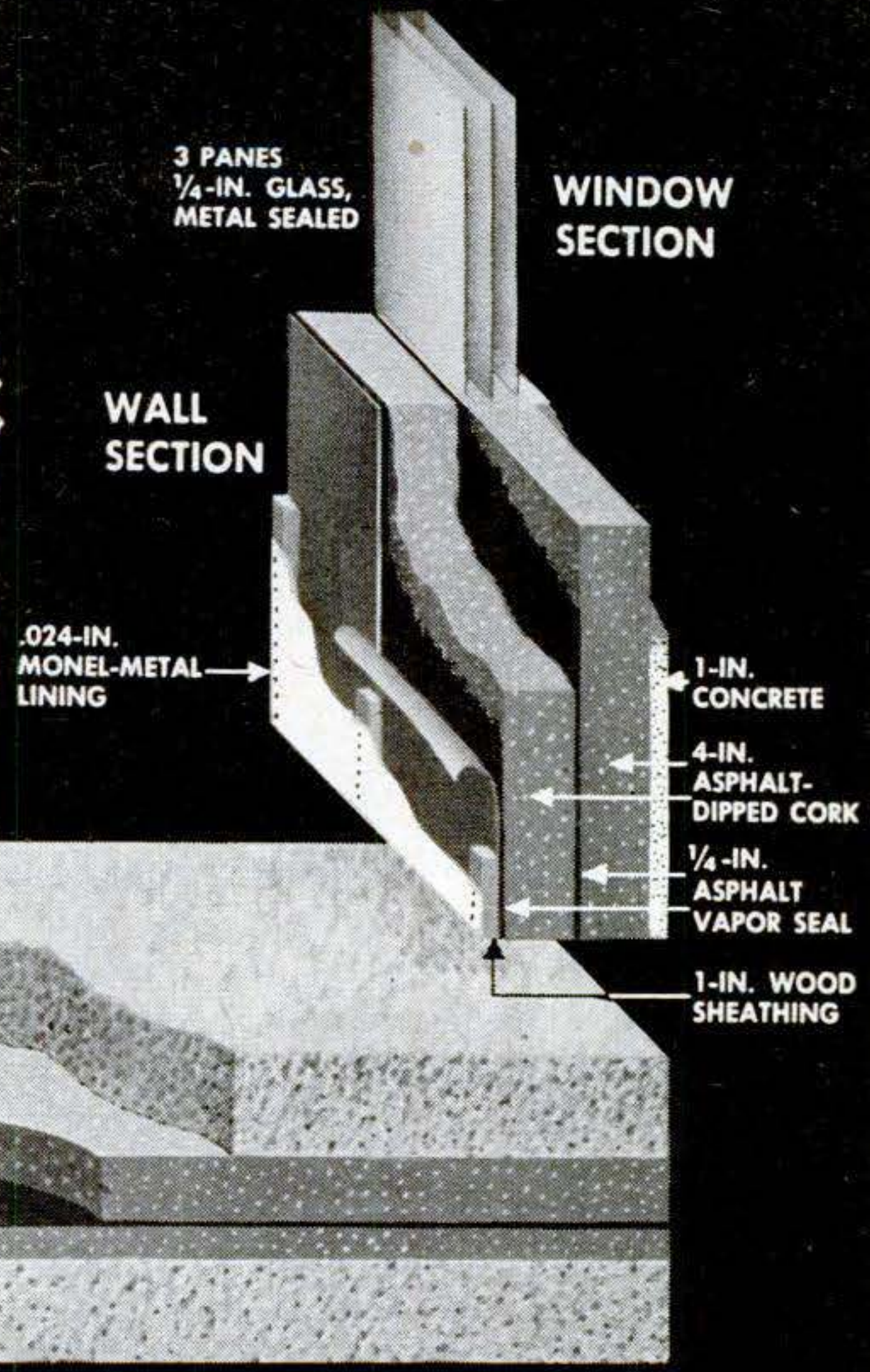

FLOOR SECTION

The six tropical chambers are arranged in a U around an anteroom that also has heat and

humidity control. Sectional views above show how walls, floor, and windows are insulated.

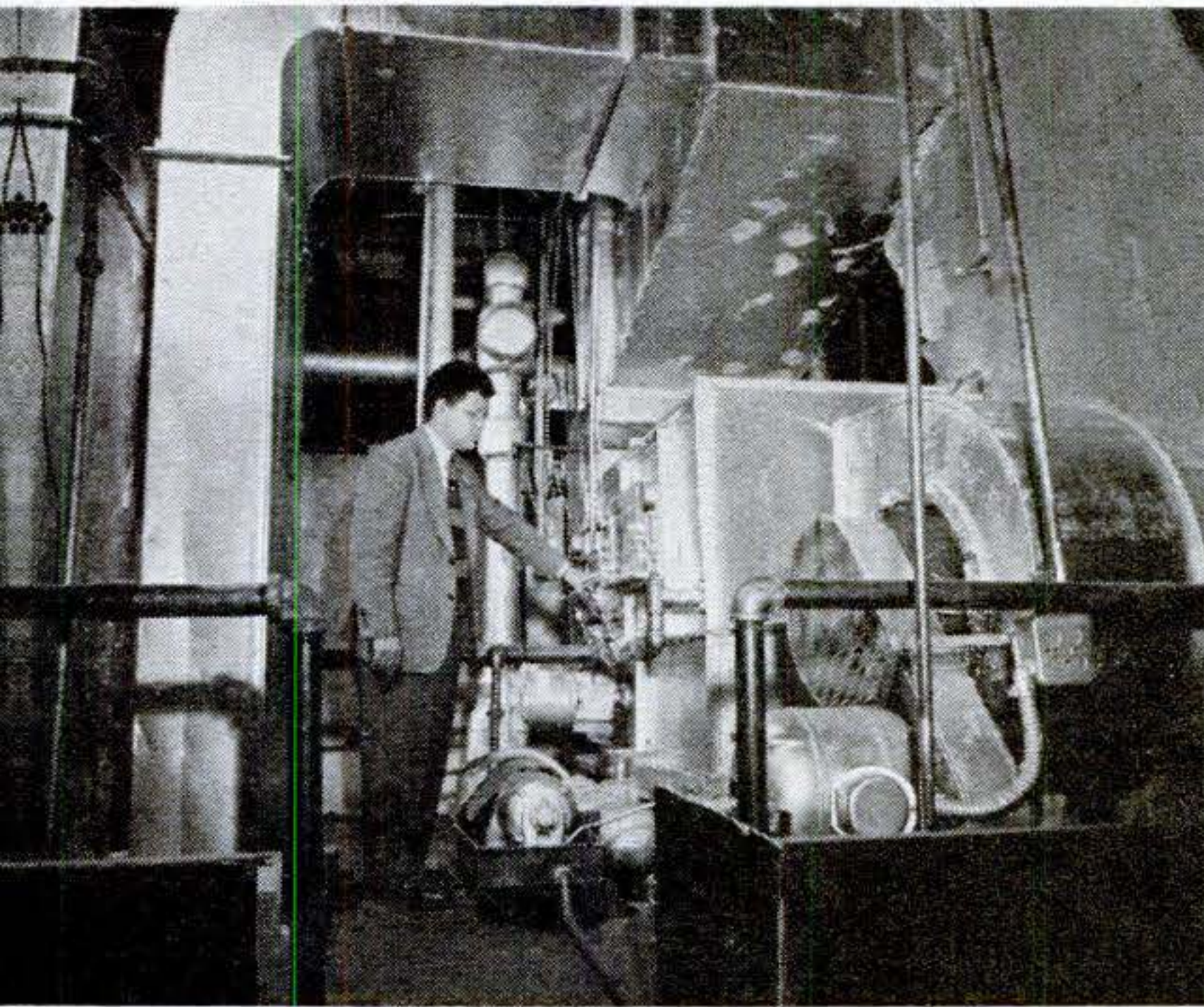

This view shows part of the heat- and humidity-making machinery located on top of the test rooms. Technician is pointing to water-spray humidifier. It is air conditioning in reverse.

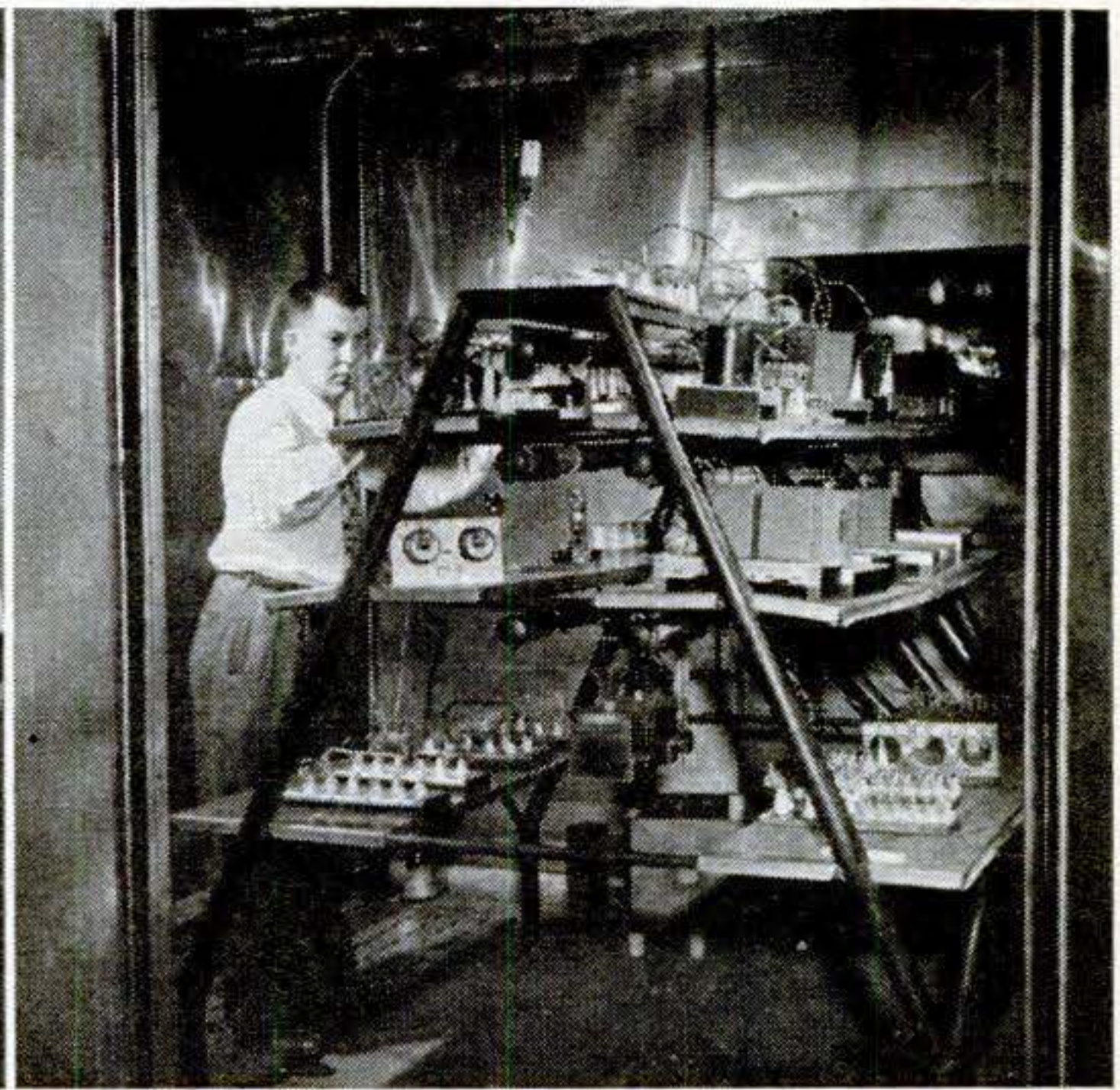

Small room above is used for testing component parts of communications equipment. Like all other rooms, it is lined with corrosion-resistant Monel® metal 25/1,000 inch thick. ▶

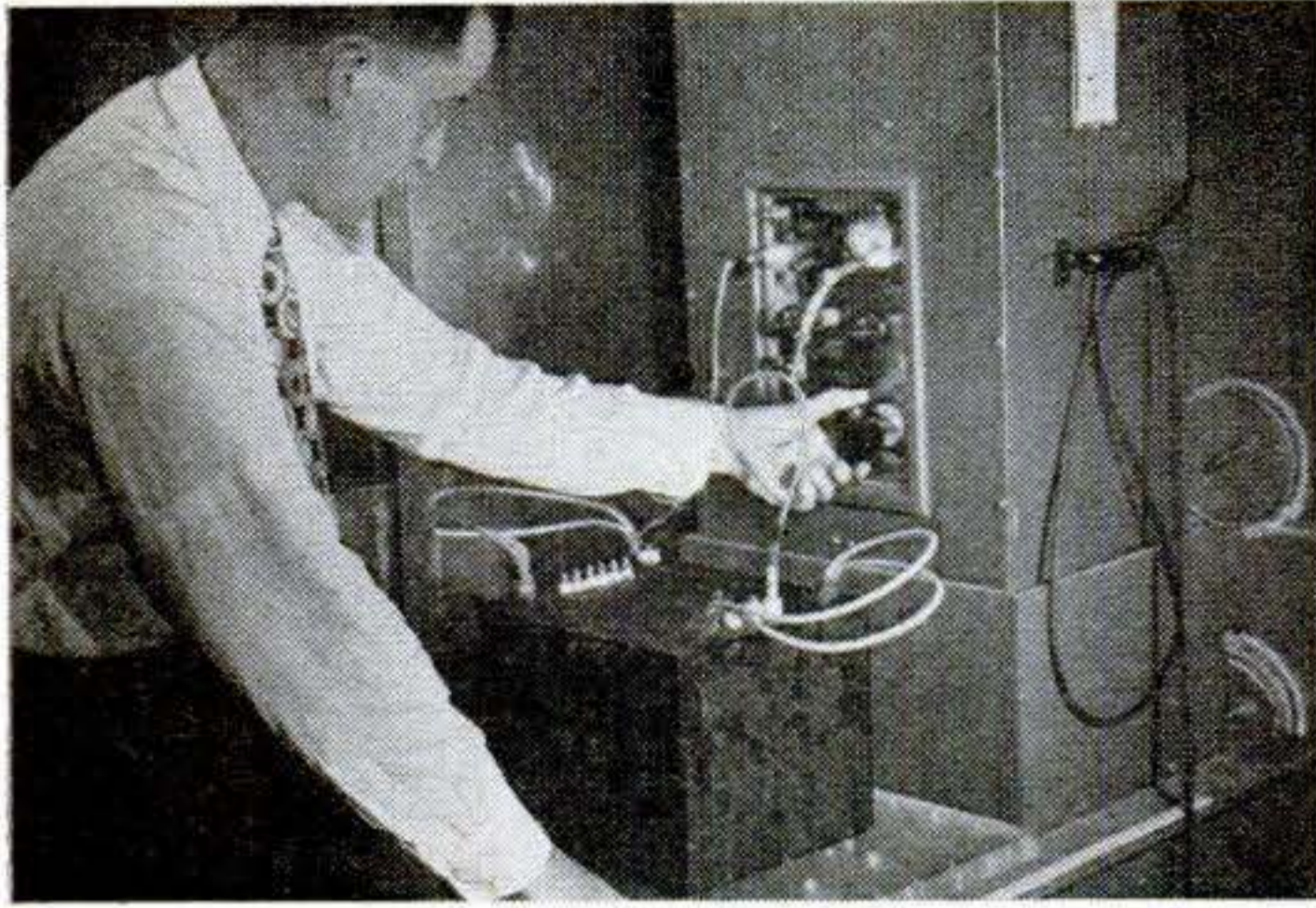

**Transformer above** has been removed to check-up room for testing after two days of tropical treatment. This one is already ruined by corrosive action. It should have lasted 10 days.

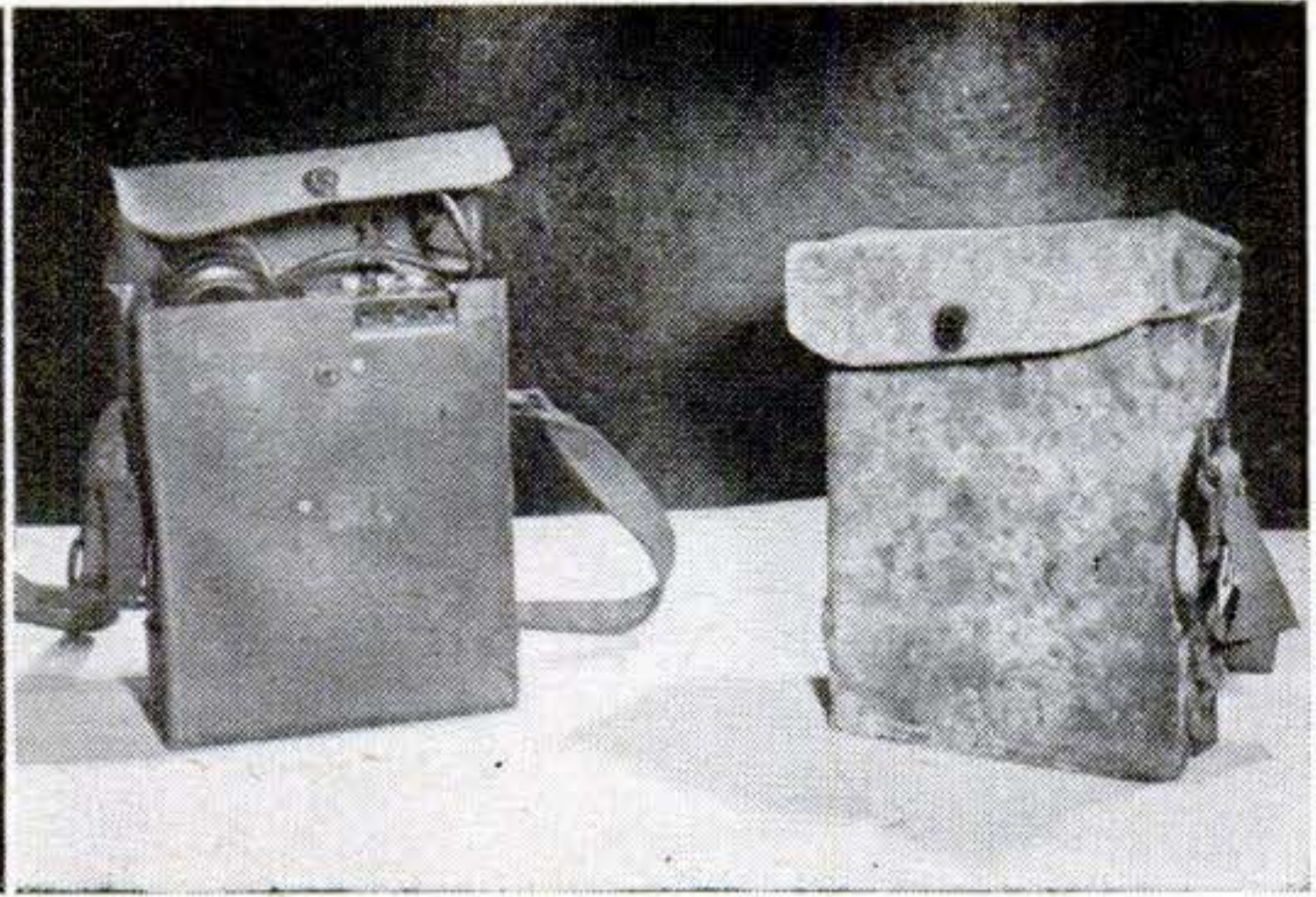

**Leather case at left** was sprayed with a fungicide; the one at right was not. Both were given identical tropical treatment. Lessons learned from such tests are passed on to manufacturers.

nator screen that catches and retains any solid moisture (drops of water). From there the saturated air is blown across steam coils that raise it to the selected dry temperature, and then sent down into the test chamber.

Outside the wing is a panel with separate controls for each room that automatically determine the rate of change from one condition to another. The desired cycle is cut on two cams, one for dew-point and the other for dry temperature. Control pointers, or followers, ride the cams as they are rotated by an electric clock. If these pointers do not match the actual temperatures as registered by special thermometers, called thermobulbs, regulating valves are pneumatically adjusted on the humidifier and steam coils to bring about the control-set conditions. The cams illustrated in the picture at the bottom of page 126 have been cut to produce a minimum temperature of 77° and a maximum of 140° twice every 24 hours, with corresponding minimum humidity of 90% and a maximum of 98%.

Each room also has its own rain-making apparatus, a network of nozzle sprays suspended from the ceiling that will produce anything from a fine mist to a torrid down-pour of two inches an hour. Added effect of a tropical hurricane is whipped up by the whirling of an electrically operated airplane propeller mounted on a mobile stand.

The Signal Corps has learned many lessons from its tropical roughhouse. Wherever possible, parts are enclosed and hermetically sealed. Molded plastics have replaced laminated plastics. The use of cotton and linen is avoided, and ceramic insulating surfaces are glazed for greater protection. An increasing number of parts are being

ordered from manufacturers with lacquer or varnish coatings. In the laboratory battle against fungus, ways have been found of effectively treating leather cases and insulating materials with fungicides that greatly prolong their life. Results of research along these lines, possibly of great value to industry, are made available to the public through the U. S. Department of Commerce.

But the jungle treatment is only half the story of climatic testing at Fort Monmouth. Across the hall are the companion arctic rooms (PS, March '48, p. 158) where man-made blizzards blow at 40° below zero. The Signal Corps is a firm believer that it pays to blow both hot and cold. **END**



**Three Popular Science explorers**, Herbert Johansen, W. W. Morris, and Robert Beals, cool off at 20° below zero in an arctic room after a safari through the Fort Monmouth jungle.

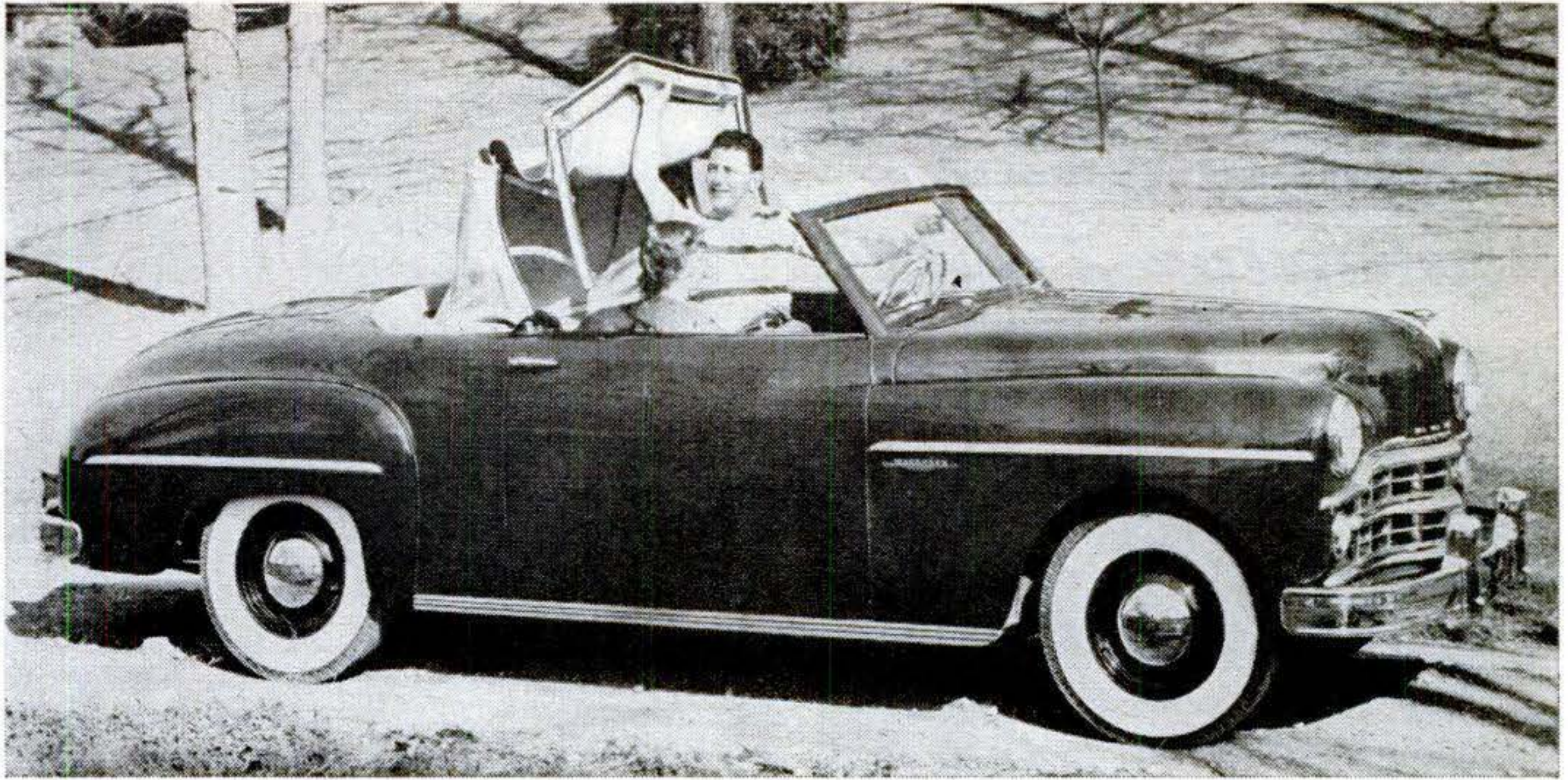

### Dodge Revives the Roadster

REMEMBER that snappy little roadster of a decade ago with its single seat, buggy top, and buttoned curtains? Well, it's back—in modern style.

Roadster is the type designation Dodge gives its new Wayfarer® above. The 58-inch seat carries three persons comfortably. You can change from an open to a closed car in a matter of seconds. Just reach back, pull

the lightweight top forward, and slip one-piece plastic side windows, framed in aluminum, into sockets in the doors. While not in use, these are stored in a compartment behind the seat.

Built on a 115-inch wheelbase, the Wayfarer is powered by the standard Dodge L-head engine, but has a 3.73-1 axle gear ratio. It has Fluid Drive®, low-pressure tires, and bonded brakes. The factory price is \$1,635, plus taxes.



### New Plymouth Hauls Big Load

PLYMOUTH'S new all-metal Suburban® combines comfortable passenger accommodation and the cargo capacity of a small truck in one smart vehicle.

Its two seats take five persons. With both seats in use, an enclosed cargo space measuring 3½ feet long and a little over 4½ feet

wide remains at the rear. This carrying space can be lengthened to nearly 7½ feet by pivoting the rear seat into a floor well and opening the tailgate. Interior body height is 39¼ inches.

The Suburban is built on a 111-inch wheelbase and has the same 97-hp. engine found in conventional Plymouths. The retail price at the factory is \$1,740.

# **Physicist-M.D. Engineers New Radiation Tools**

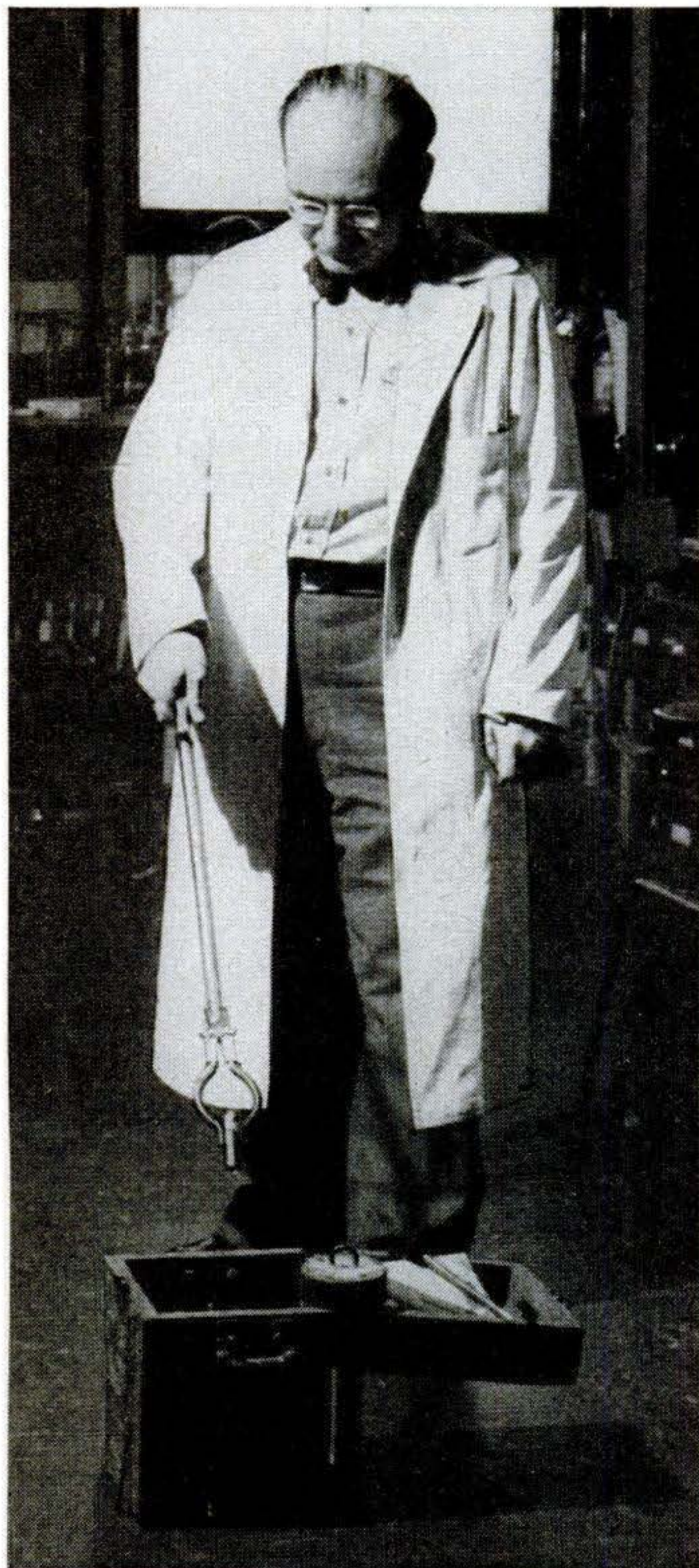

**Shipment from Oak Ridge.** Mt. Sinai Hospital receives Radioiodine 131 every week and Radiophosphorus 32 every fortnight. The iodine's half-life is only eight days, that of the phosphorus is 14 days. Iodine is used in treating thyroid cancer, phosphorus in treating leukemia, skin cancer, and other diseases. Dr. Sergei Feitelberg is seen here removing radioactive material with tongs from its lead container inside a sturdy shipping box.

**A** CANCER patient may someday be treated with a glass of water. This water will contain no more iodine than is in ordinary tap water. But this iodine, when it proceeds to his thyroid gland, may emit radiation that will attack cancerous tissue.

The patient will be the beneficiary of a new kind of workshop—one in which radioactive materials and instruments needed to use them are prepared for the doctors. Dr. Sergei Feitelberg now has such a workshop at Mt. Sinai Hospital in New York, and these pictures will give you an idea of his work.

Brig. Gen. David Sarnoff has suggested that a new word, "radionetics," be used to describe this kind of work. It involves the application of the physicists' knowledge to the problems of physicians. More and more such work is being done in hospitals throughout the country. The number of patients benefiting from it is increasing so rapidly that David Lilienthal of the Atomic Energy Commission believes "every human being in the United States may become a beneficiary of radiation."

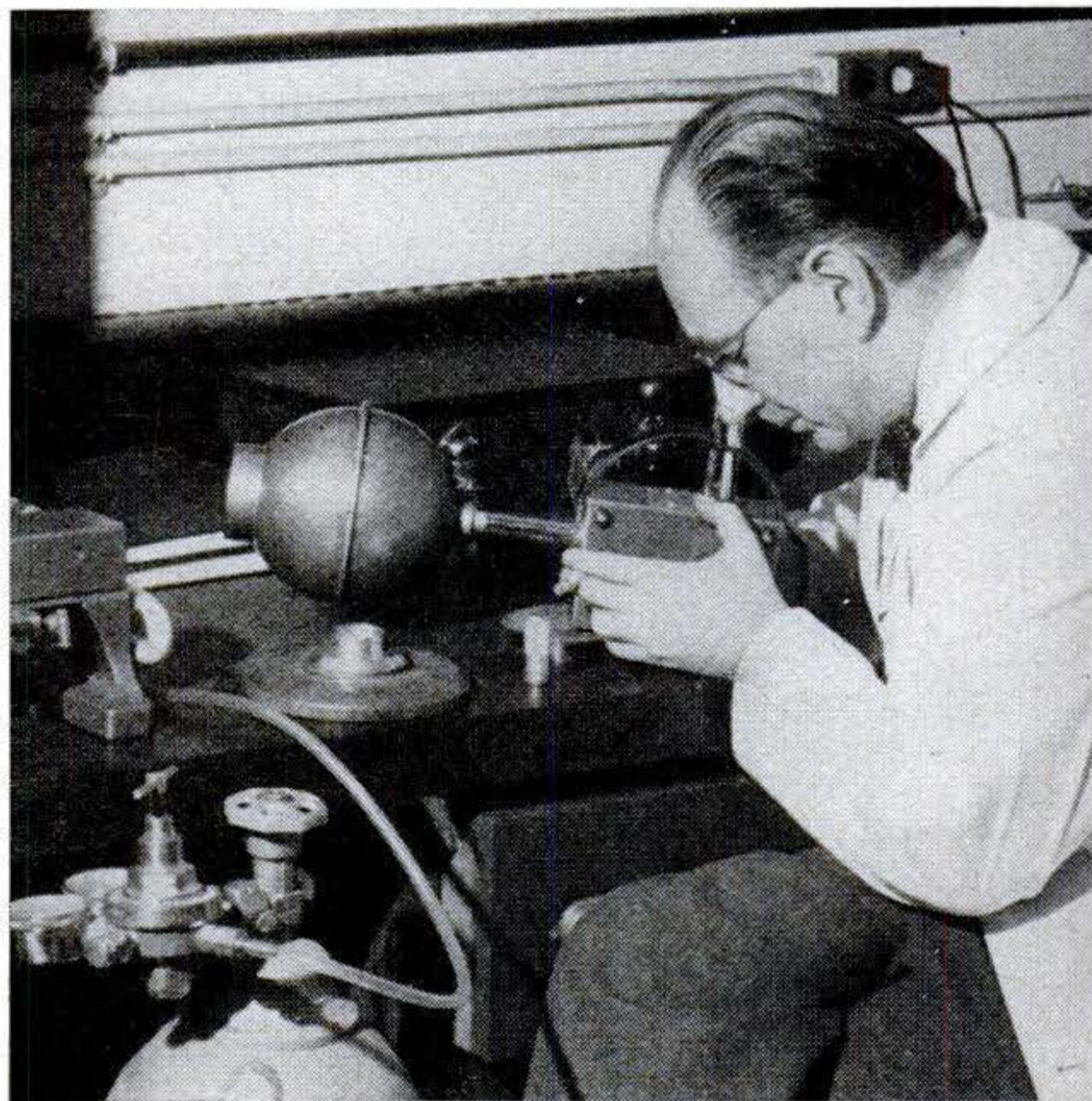

**Ionization chamber** that Dr. Feitelberg made himself is used to measure radioactivity of a few hundred-millionths of a gram of material. This part of his work might be likened to that of a pharmacist, but he often deals with quantities too small to be weighed. Lead blocks must be kept between him and some of the "prescriptions," and his supplies are kept in a locked closet. But accurate measurements make use of such materials perfectly safe.

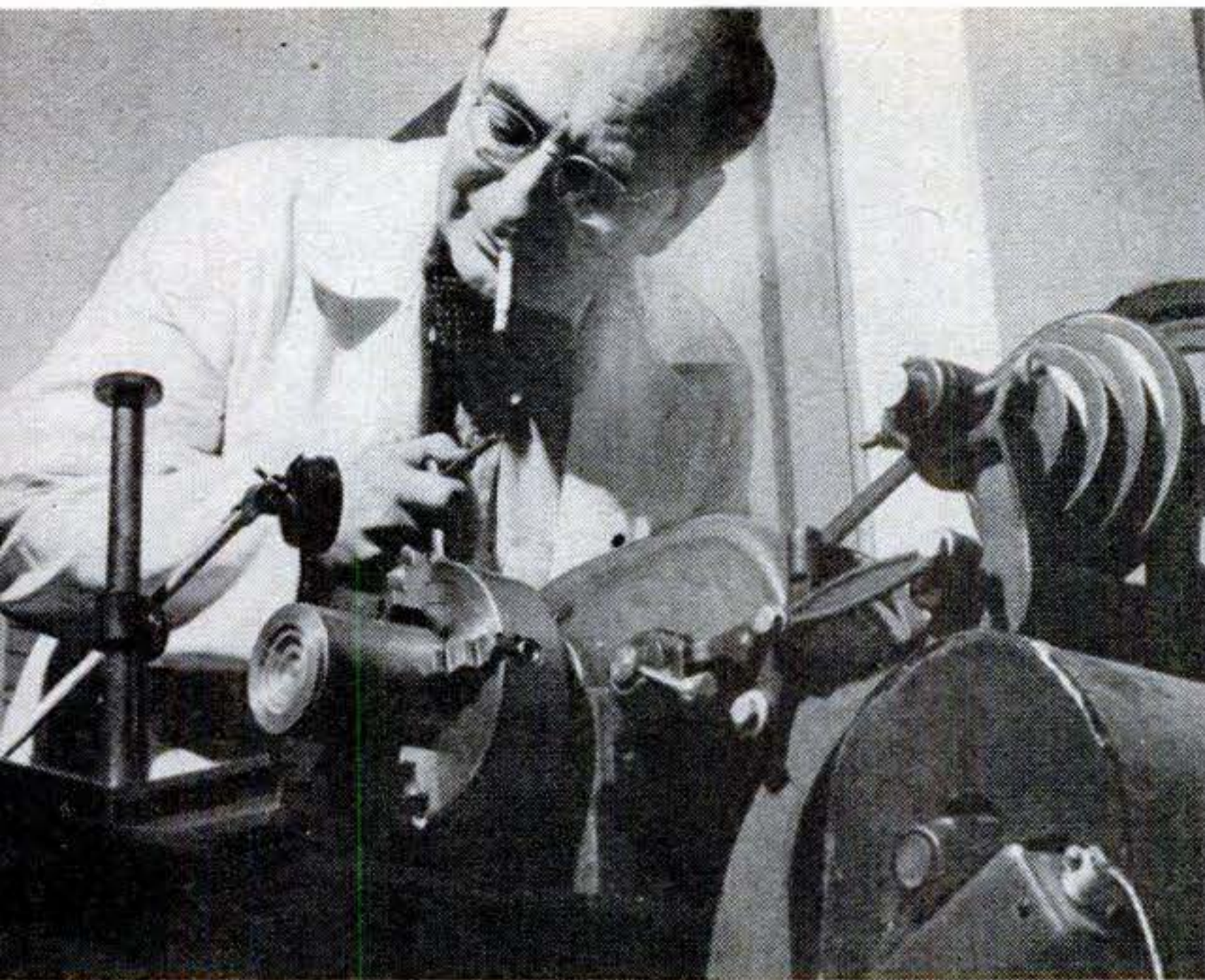

At his lathe in his workshop, Dr. Feitelberg makes much of his own apparatus. He first studied engineering in Germany and England, then studied medicine in Austria, Germany, and Switzerland. During the war, he was in U. S. Signal Corps. Although he has not practiced medicine himself, he has found it helpful to have studied both engineering and medicine. His workshop in the hospital enables its doctors to make extensive use of atomic treatments.



X-ray diffraction patterns obtained with this instrument enable physicians to investigate molecular details of human tissues that are beyond the reach of their most powerful microscopes. This apparatus is used now to analyze kidney stones for data on which special diets can be prescribed for patients from whom the stones have been removed. It is also being used in the study of rheumatic skin nodules and in many other medical research programs.

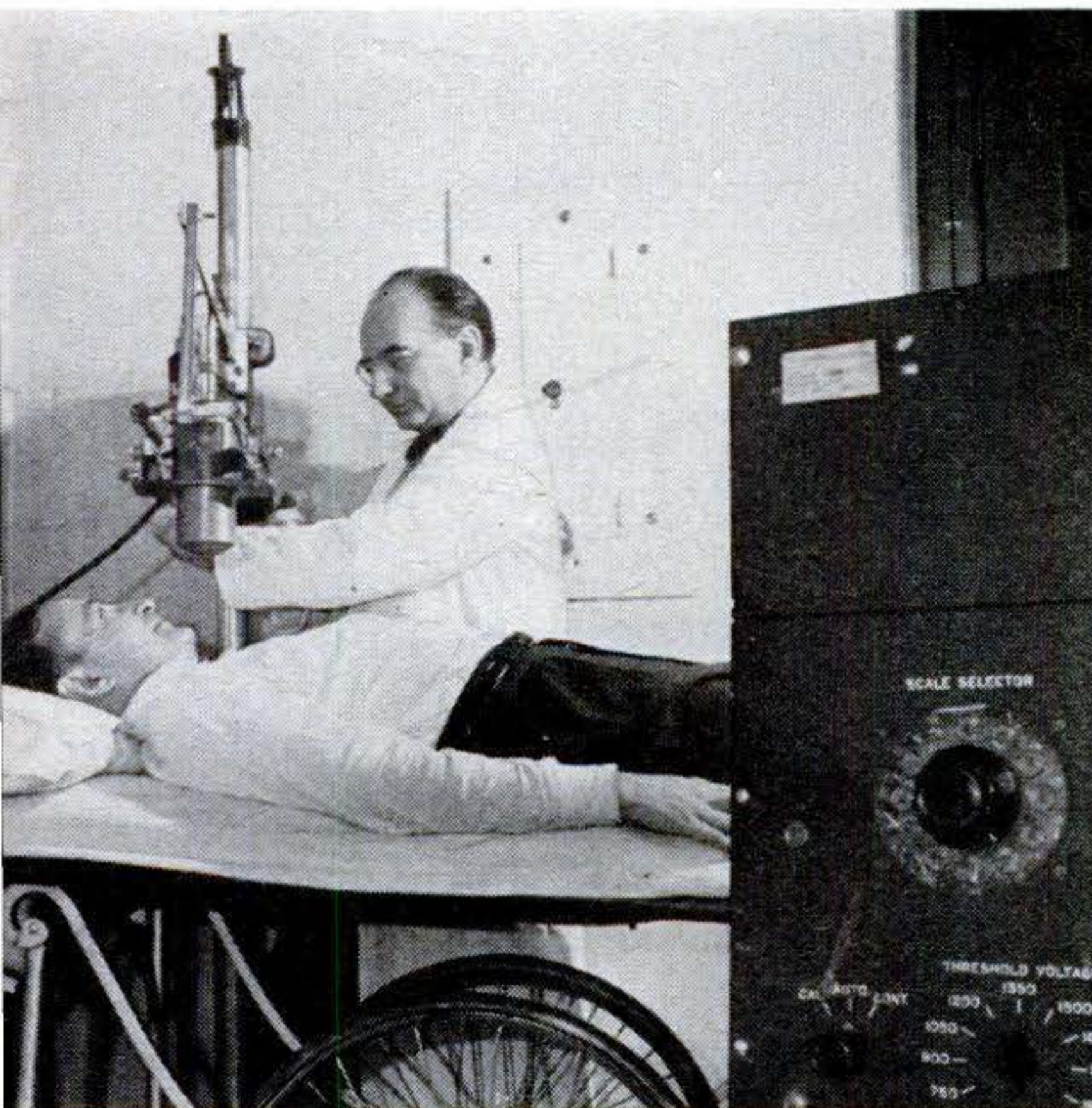

Using a Geiger-Mueller counter, the doctor can trace his medicine after patient has taken it. Counter is mounted so that radioactive material can be located anywhere in body. This enables the doctor to tell exactly how much of the medicine that the patient has taken has reached those parts of the body in which it is needed. Scale selector at the right can be set so that nuclear disintegrations can be counted in groups of different sizes.



Impulses from the Geiger counter that detects radioactive tracers in the human body can be fed to a cathode-ray oscilloscope to aid record-keeping. This is another piece of apparatus constructed by Dr. Feitelberg and his collaborators in his hospital workshop. With such devices, he can solve problems that previously stumped doctors. Many instruments used in this work can now be purchased, but Dr. Feitelberg finds it helpful to be able to build his own.

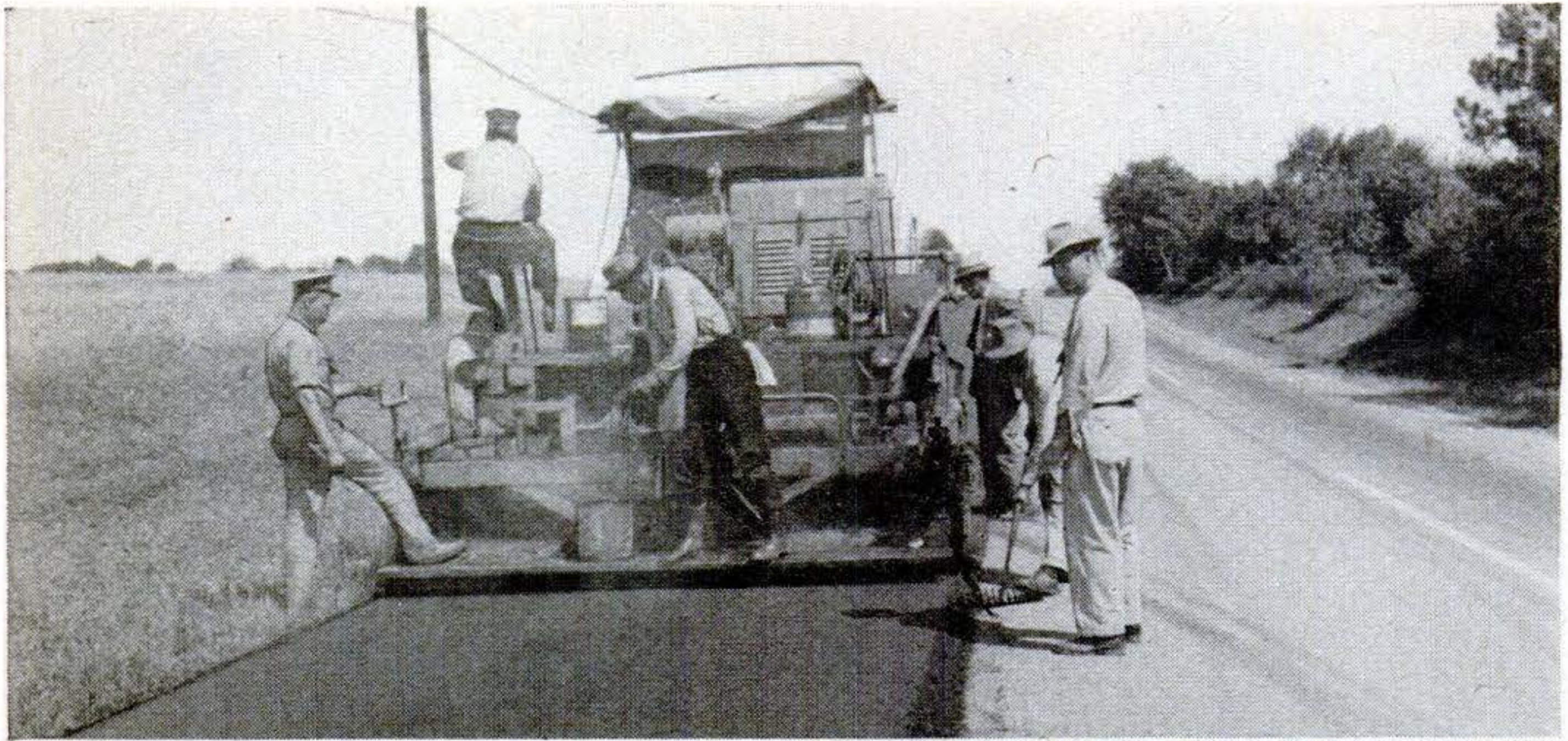

### Cars Roll on Rubber Roads

FIRST state in the country to have a rubber road, Virginia has laid a 1,000-foot test strip on Route 250 outside Richmond. A small amount of powdered rubber, right, mixed with asphalt forms the resilient, long-wearing surface being applied above. Ohio, Texas, and Minnesota are also trying out the novel pavement. Originally developed in Holland, it requires from 600 pounds to a ton of rubber per mile. It is said to reduce car skidding, dust, and expensive and traffic-blocking road repairs.

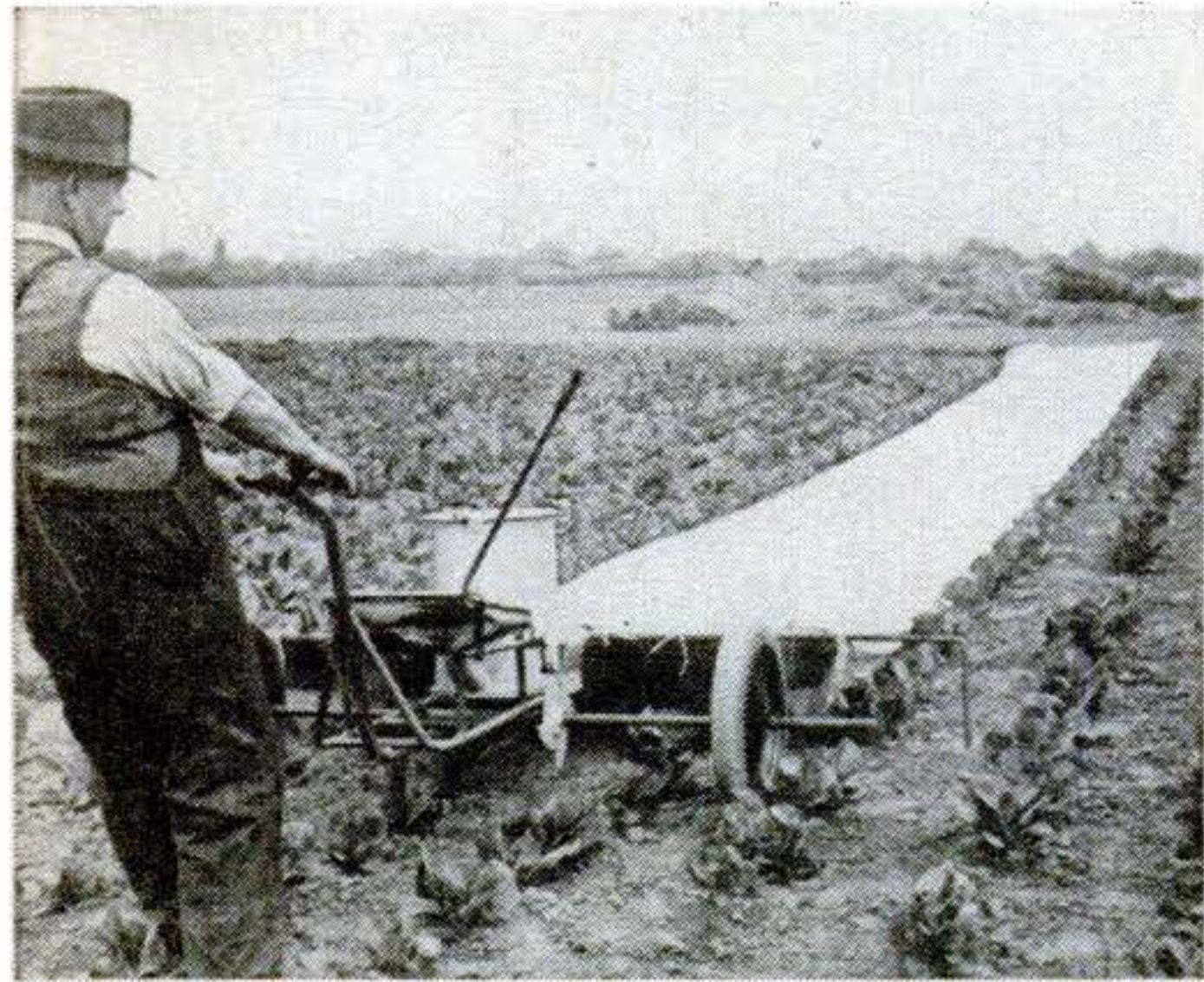

### Tool Rids Crop of Pests

PLACED in a chamber of the hand-drawn British fumigator above, a nicotine smoke cartridge is ignited and vaporized to destroy insects attacking crops. A bellows geared to the axle varies the amount of generated smoke to suit the operator's pace, and a trailing canvas cover helps to hold the fumes in contact with the plants.

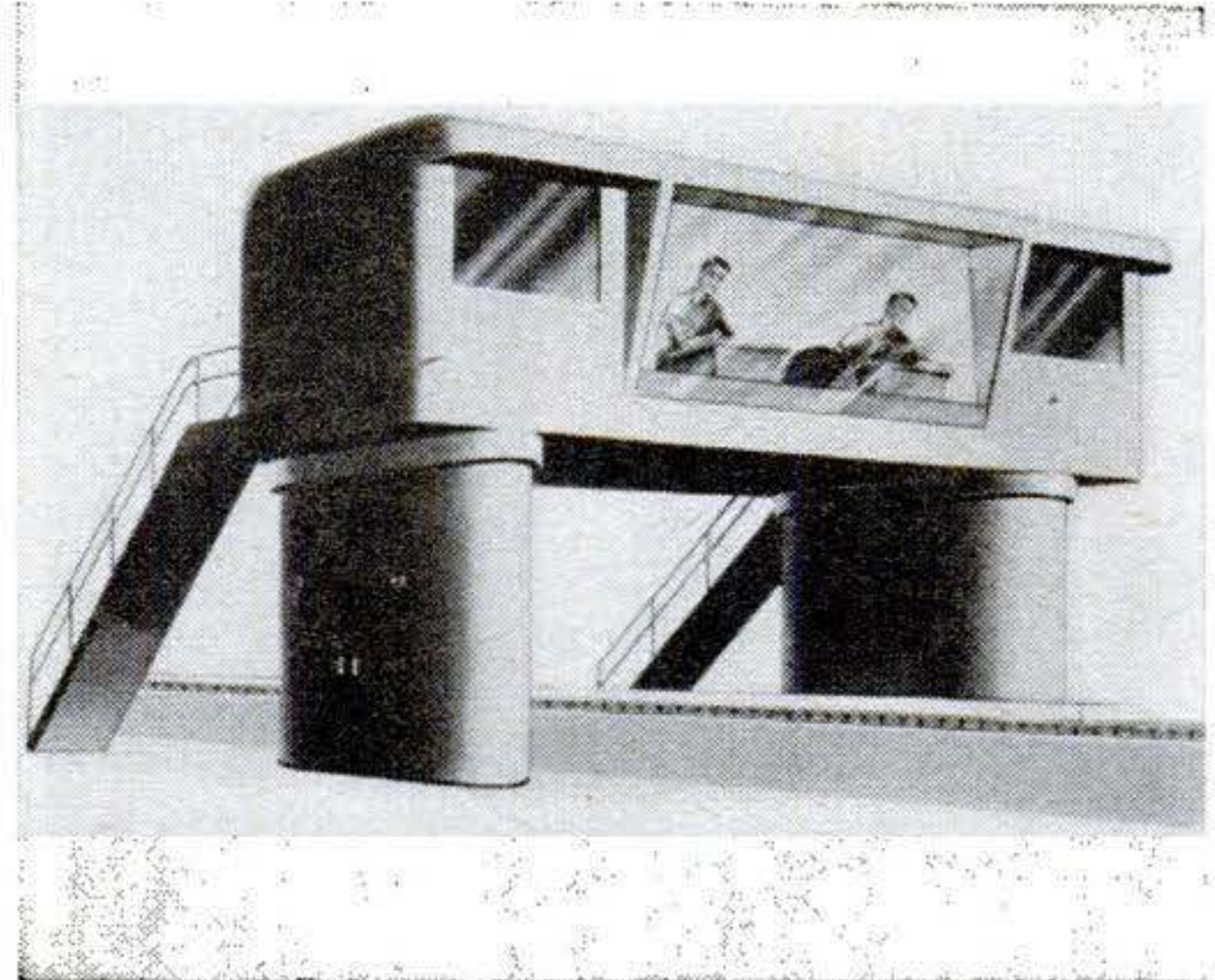

### Steel Men Work in Comfort

STEEL men who once worked in the open are now protected against heat, noise, and flying metal inside this modern steel-mill "pulpit" where operators control the rolling of red-hot billets. Designed by the Lee Wilson Construction Co., of Cleveland, it has air conditioning, an acoustical ceiling, and a heavy, shock-resistant glass shield.

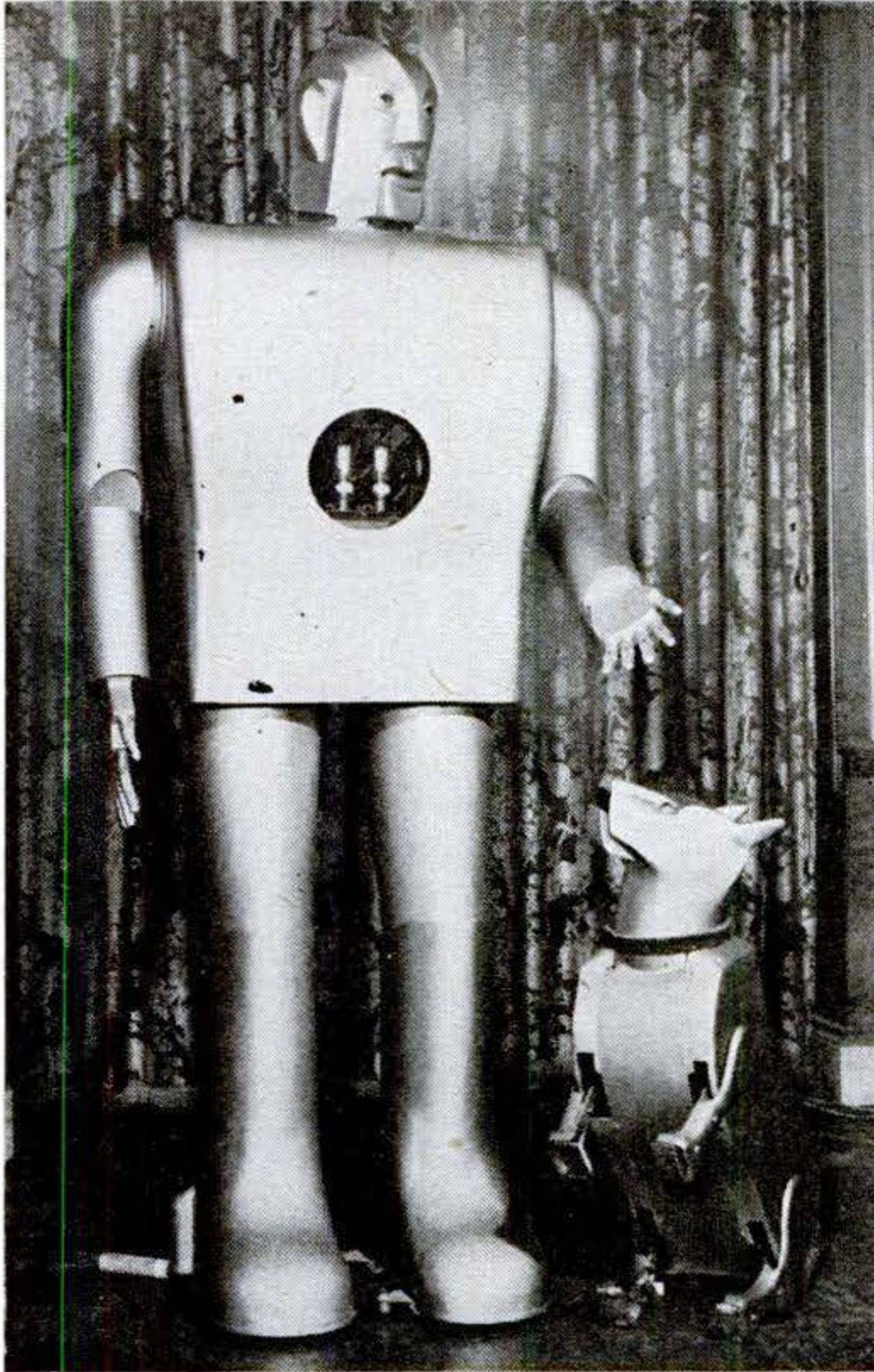

**Elektro** walks, talks, and gestures, and his dog Sparko does tricks, at command of an attendant offstage. Four motor-driven rubber rollers under each foot enable Elektro to walk.

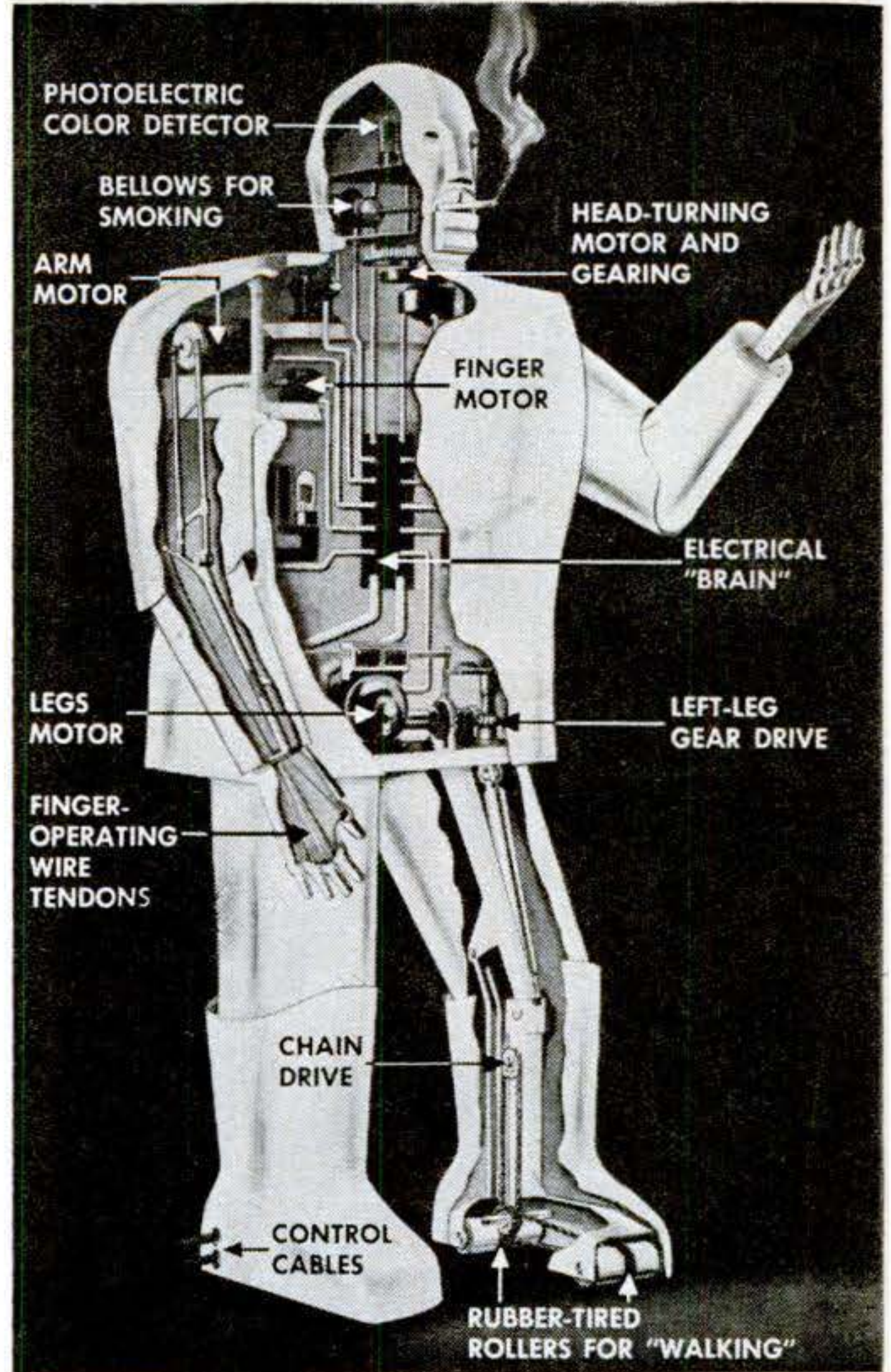

This hidden mechanism gives Elektro 26 life-like motions. He smokes cigarettes with motor-driven bellows, tells colors apart with electric "eyes" behind red and green filters.

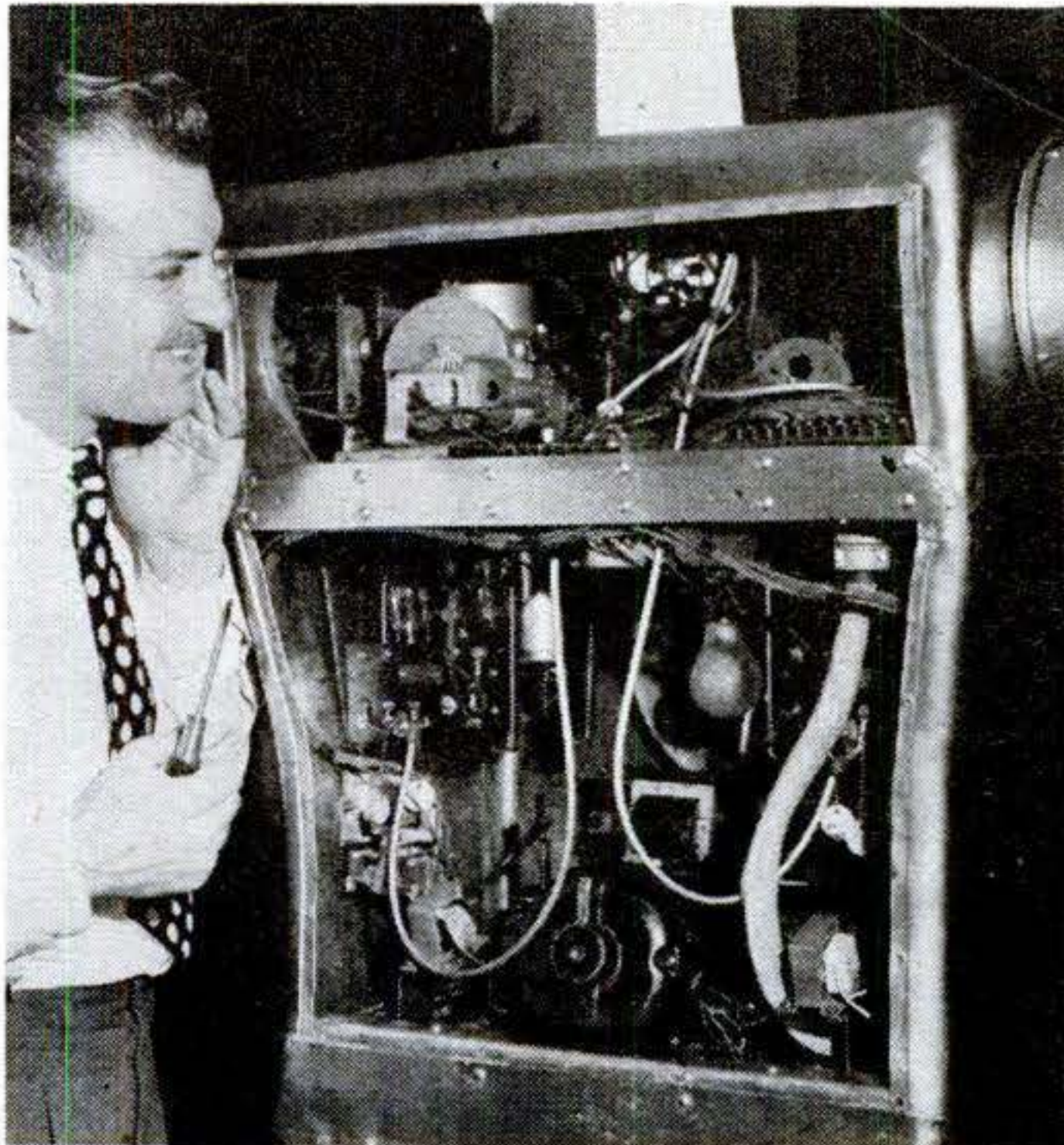

Secret of Elektro's "brain," above, is response to number and spacing of words in command. What the words are doesn't matter provided phrase gives right number of electric impulses. Two-word commands start action; one word stops it; four words return relays to normal.

## ***You Say It, Robot Does It***

**E**LEKTRO may be dumb by human standards—but among mechanical men, he's a mental giant. He walks, smokes, counts to 10 on his fingers, speaks 77 words, and even distinguishes colors.

A star performer at the New York World's Fair 10 years ago, the seven-foot-tall, 260-pound aluminum robot has come back to the stage. Now he dramatizes the possibilities of Westinghouse controls for automatic machines at a Pittsburgh, Pa., industrial exposition. Elektro responds to an attendant's commands, spoken into a microphone or given by flashing a light.

Through 82 relays in his electrical "brain," these commands trigger 11 electric motors that work his mechanical "muscles" and turntables containing his vocabulary. An aluminum dog performs with him. **END**

## What's New in Aviation

**British Unveil Jet Bomber.** Very secretive about their first jet bomber to fly, shown at right, the British say only that the plane was built by the English Electric Co., and that it is powered by two Rolls-Royce Avon® jet engines. It is of conventional design, with a straight wing. The bubble canopy cockpit is placed far forward for unobstructed vision. The engines, Britain's most powerful, are mounted in the wings.

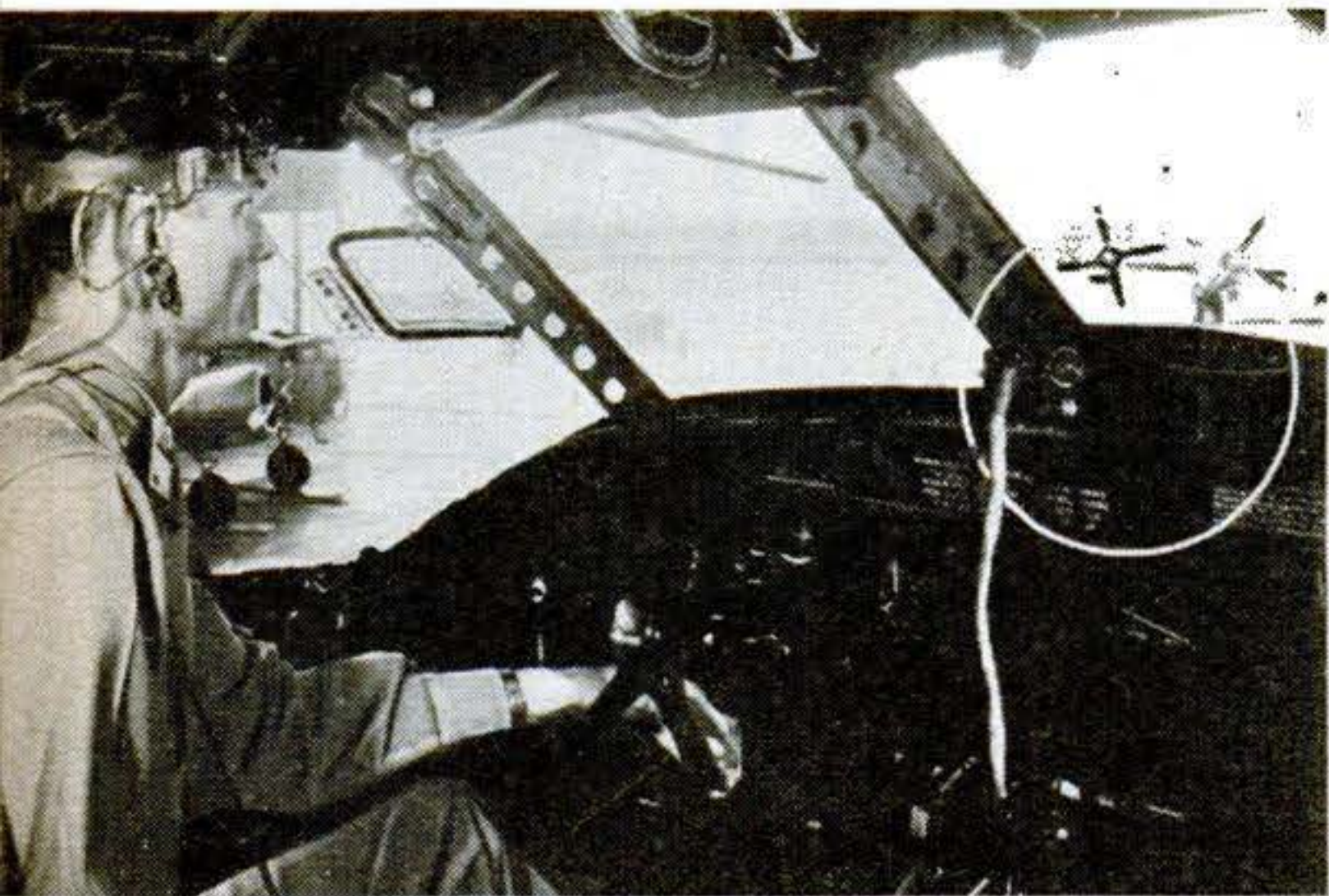
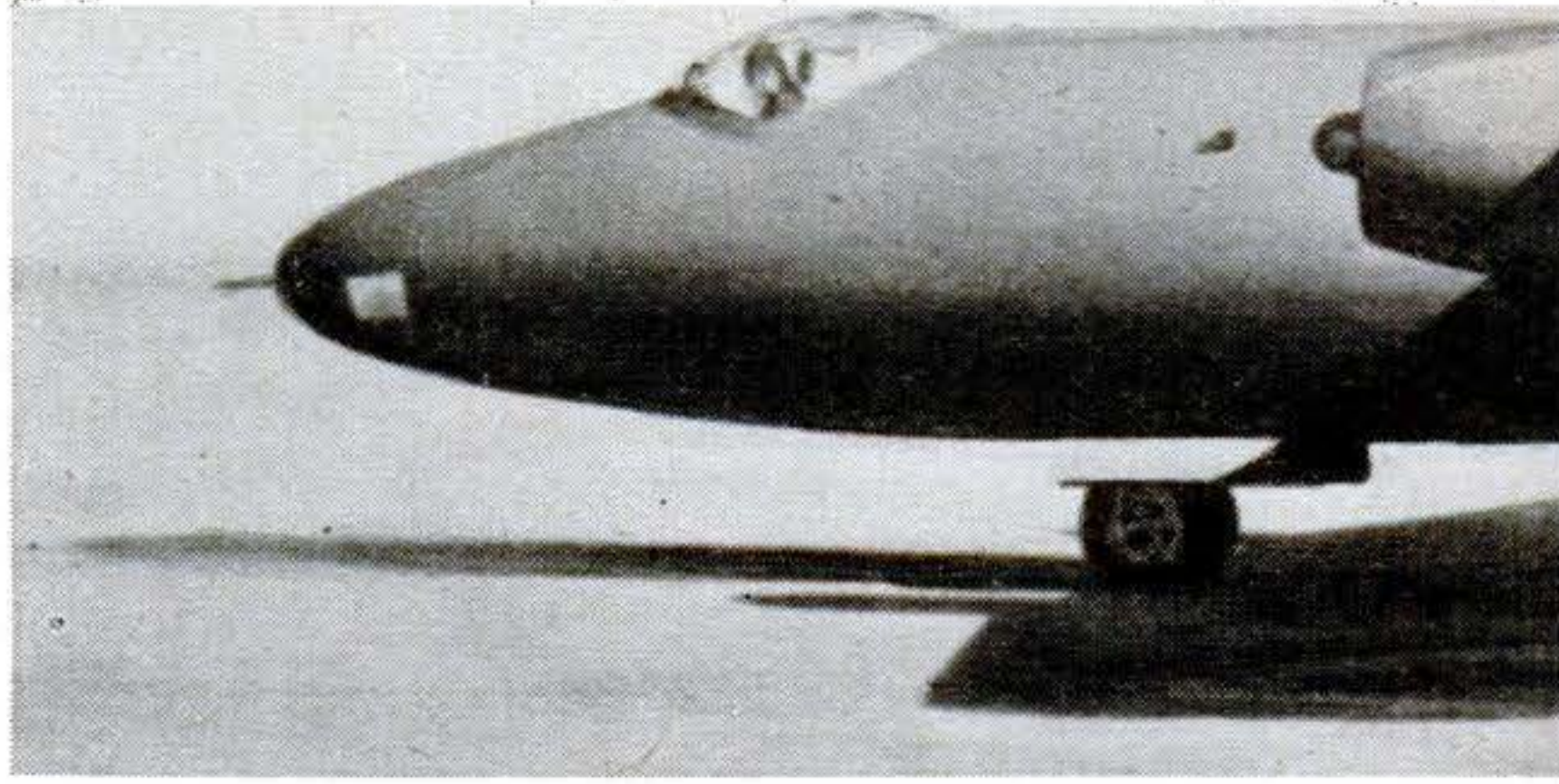

**Brain Waves Check Oxygen.** Lack of oxygen can knock a pilot out before he knows anything is wrong—with fatal results. But now the Air Force has a gadget that warns a pilot to adjust his oxygen supply. A modified electroencephalograph—brain-wave recorder—picks up electrical waves in the brain from electrodes on the pilot's head and triggers an alarm (circle) when the waves forecast a blackout.

**Plane Sprays, 'Copter Dusts.** Piper's new PA-11 sprayer, left below, carries 47 gallons of liquid chemicals for killing weeds or bugs. The streamlined tank is under the fuselage and the 24 nozzles, fed

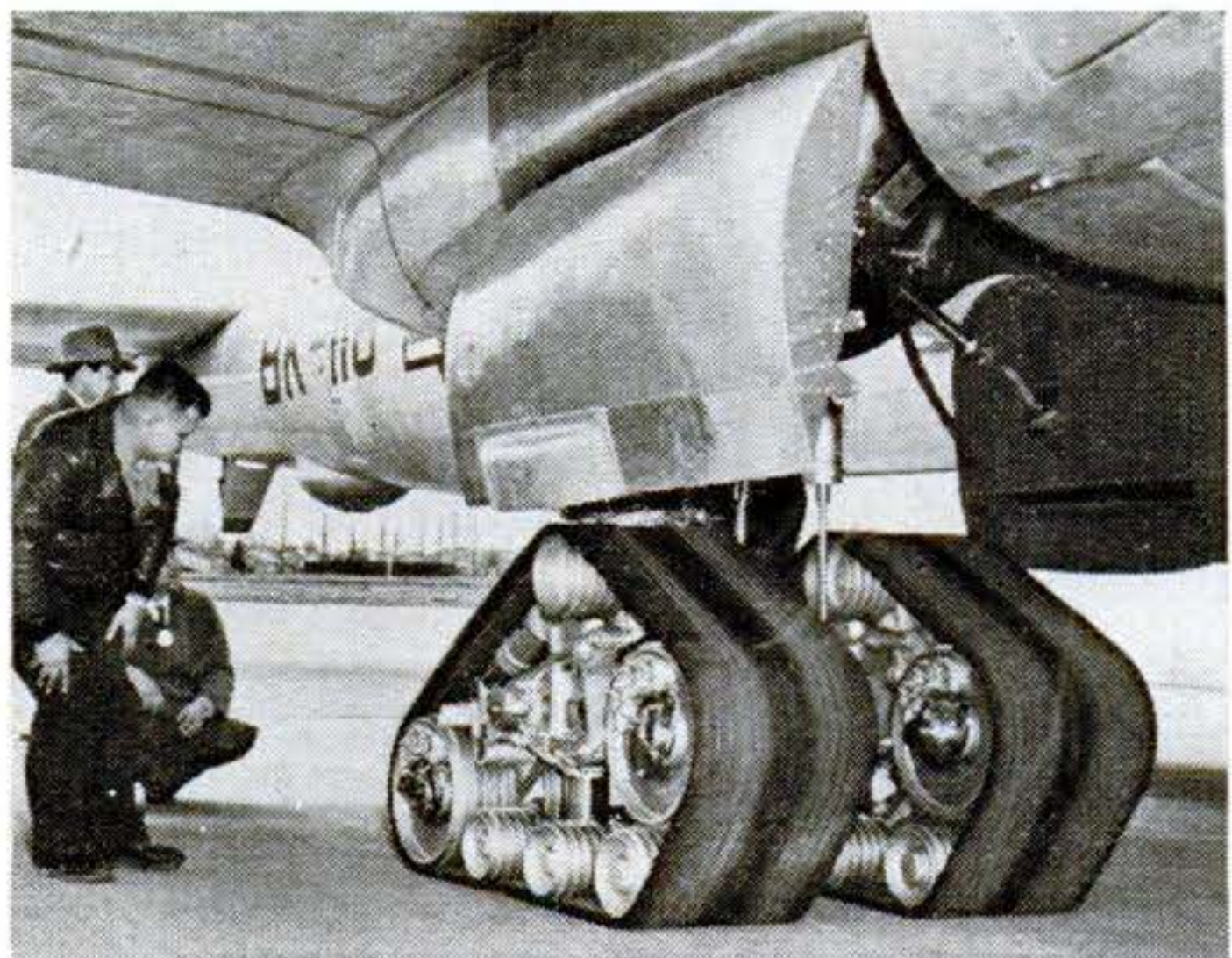

**Big Bomber Gets Tractor Gear.** The Air Force's B-50 is trying out track-tread landing gear that will let it land on unimproved runways—or almost anywhere. The new "feet," with three times the "footprint" area of the usual landing gear, retract completely in flight; do not affect the 164,000-lb. bomber's 400-m.p.h. speed. Boeing designed, the main gear, above, was made by Goodyear; the nose unit, by Firestone.

by a pump run by a wind-driven propeller, are under the wings, so they take no cabin space. The Kaman K-190 utility helicopter, at right, uses the down wash of its twin rotors to spread dust evenly over crops.





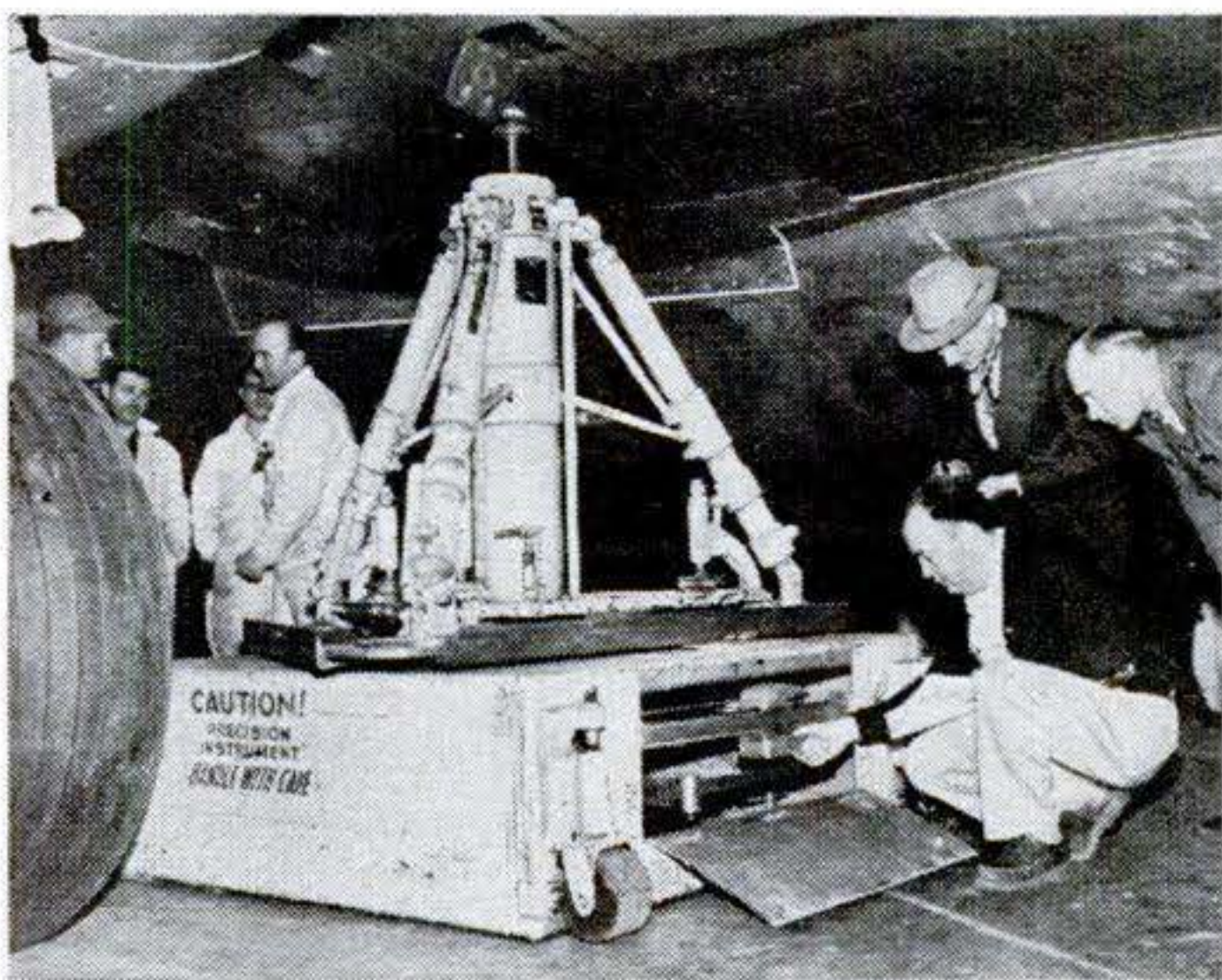

**How to Weigh a Skyliner.** If you are buying 80,000 pounds of Stratocruiser®, each extra pound means that much less payload. That is why Boeing guarantees the poundage of its double-deckers by weighing them before delivery. The Stratocruiser is so big it needs three 20-ton-capacity scales—one under each wing root and a third under the nose. Jacks on each scale then lift the plane off the ground.

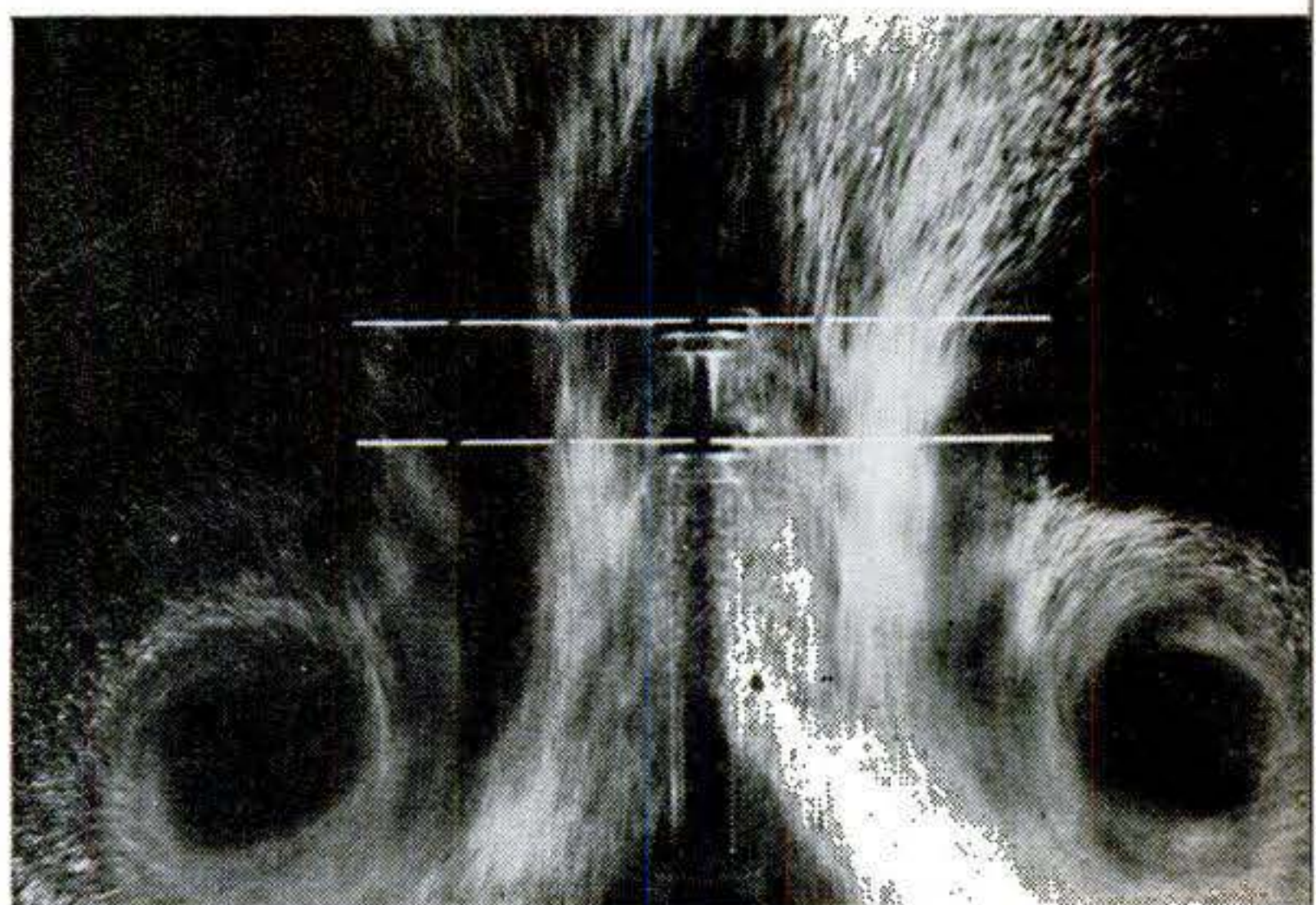

**’Copter Blades Churn Air.** This pretty pattern shows how air flows past a pair of coaxial helicopter blades when they’re increasing thrust quickly. It is an actual photograph, snapped against a black background, of balsa-wood dust being whipped around by the air stream of a laboratory model. The National Advisory Committee for Aeronautics made it as part of a study of the air flow of rotor systems.

**Small Plane Copies ’Copter.** The Helioplane®, below, looks like an ordinary plane. It can take off and land, however, in little more space than a helicopter. A tennis court can serve as an airfield and the little

plane can clear a five-story building 100 yards from its starting point. It can fly as slowly as 27 m.p.h. without stalling. Otto Koppen, of MIT, and Dr. Lynn Bollinger, of Harvard, designed the plane.



# Steam Now Cools, Too

THE steam that warms buildings in the wintertime can now be used to cool them in the summer. In a new kind of air-conditioning plant, steam, instead of electricity, does most of the work. The steam may come from the building's heating plant, from a city central-steam system, or may even be waste steam from industrial processes.

The new system cools by evaporation—just as nature does—making use of the fact that heat is absorbed when a liquid turns to vapor. Heart of the machine is a chamber where water at room temperature is sprayed from nozzles, chilling itself by evaporation. The chilled water, piped as a refrigerant to individual room-cooling units, cools the air they circulate.

Up to this point, its principle is similar to that of other refrigerating systems. But it has no compressor to turn the vapor formed in the evaporation chamber back into liquid. Instead, the vapor is removed by a chemical solution—a solution of an inorganic salt—that has the property of absorbing water vapor. The steam is used to re-

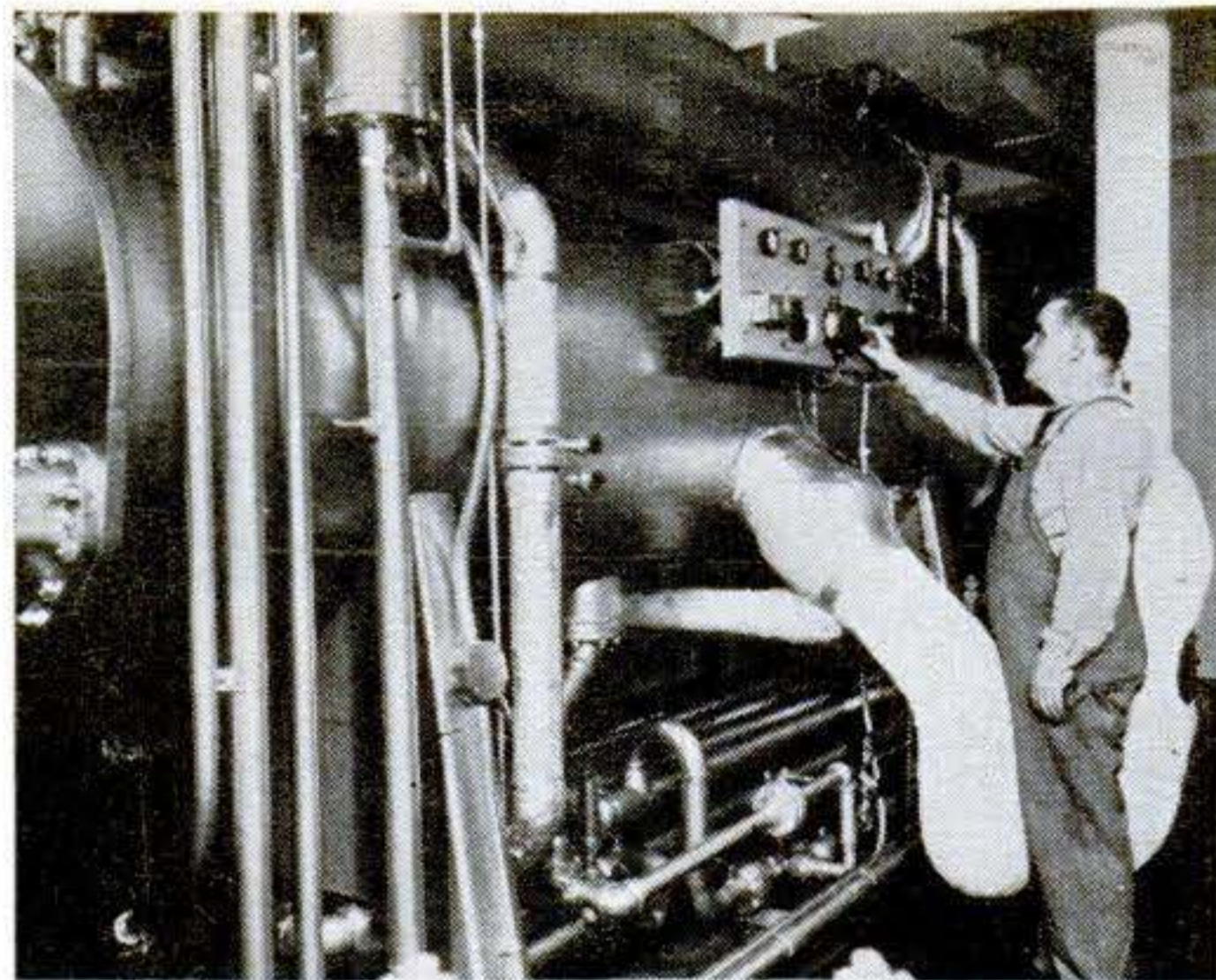

Compact new air conditioner, powered by steam, supplies chilled water to room-cooling units through large insulated pipe beside operator.

concentrate the resulting diluted solution, for use again, by boiling off the water. This boiled-off water is then condensed and put back in circulation.

The new air-conditioning system was developed by the Carrier Corp. for use in office buildings, factories, and department stores. It has few moving parts—mainly pumps for circulating the liquid. Virtually noiseless and vibration-free, it may be installed on a building's roof or on any floor, as well as in the basement. A single unit is able to air-condition areas of from 34,500 to 60,000 square feet. END

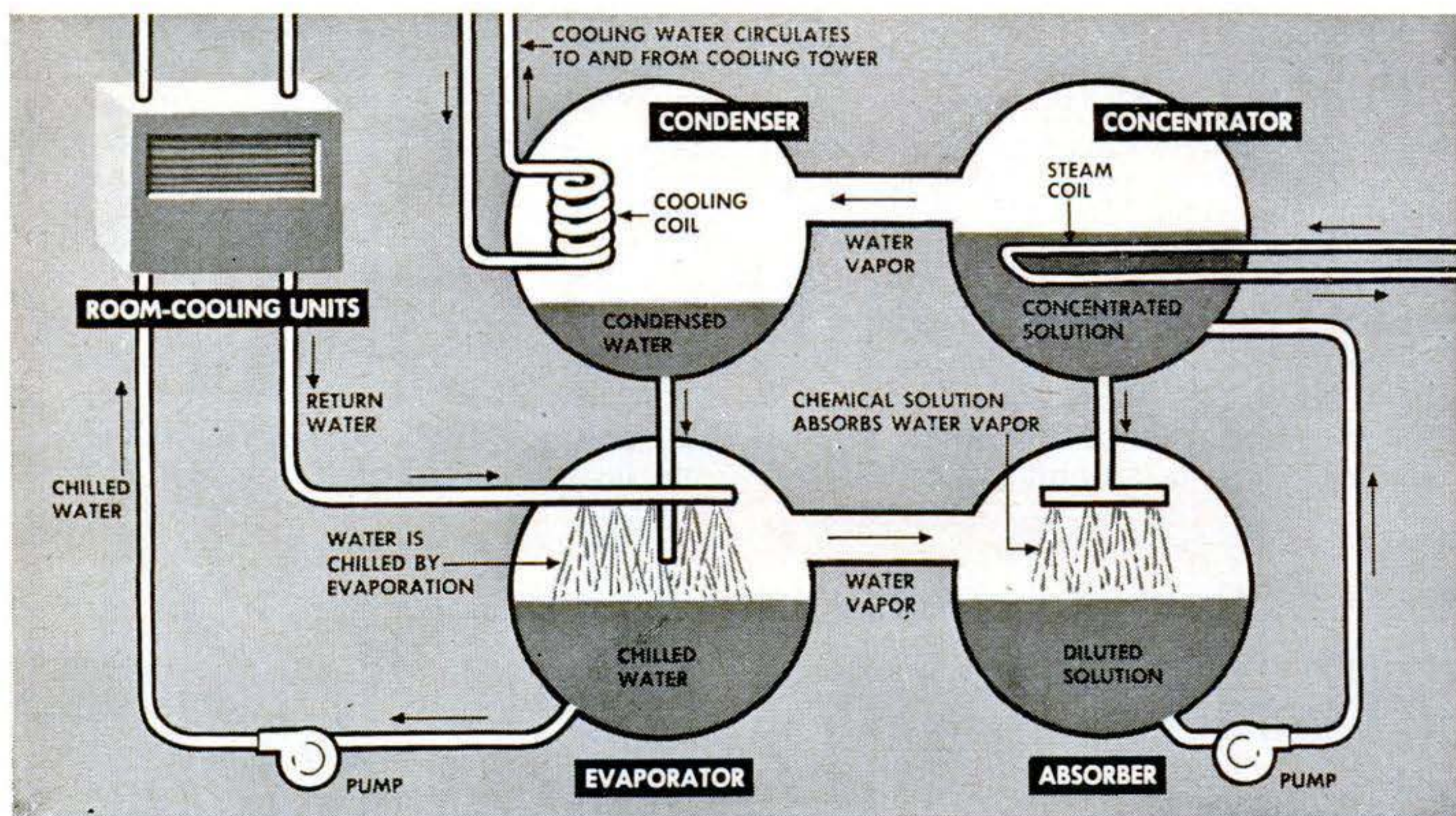
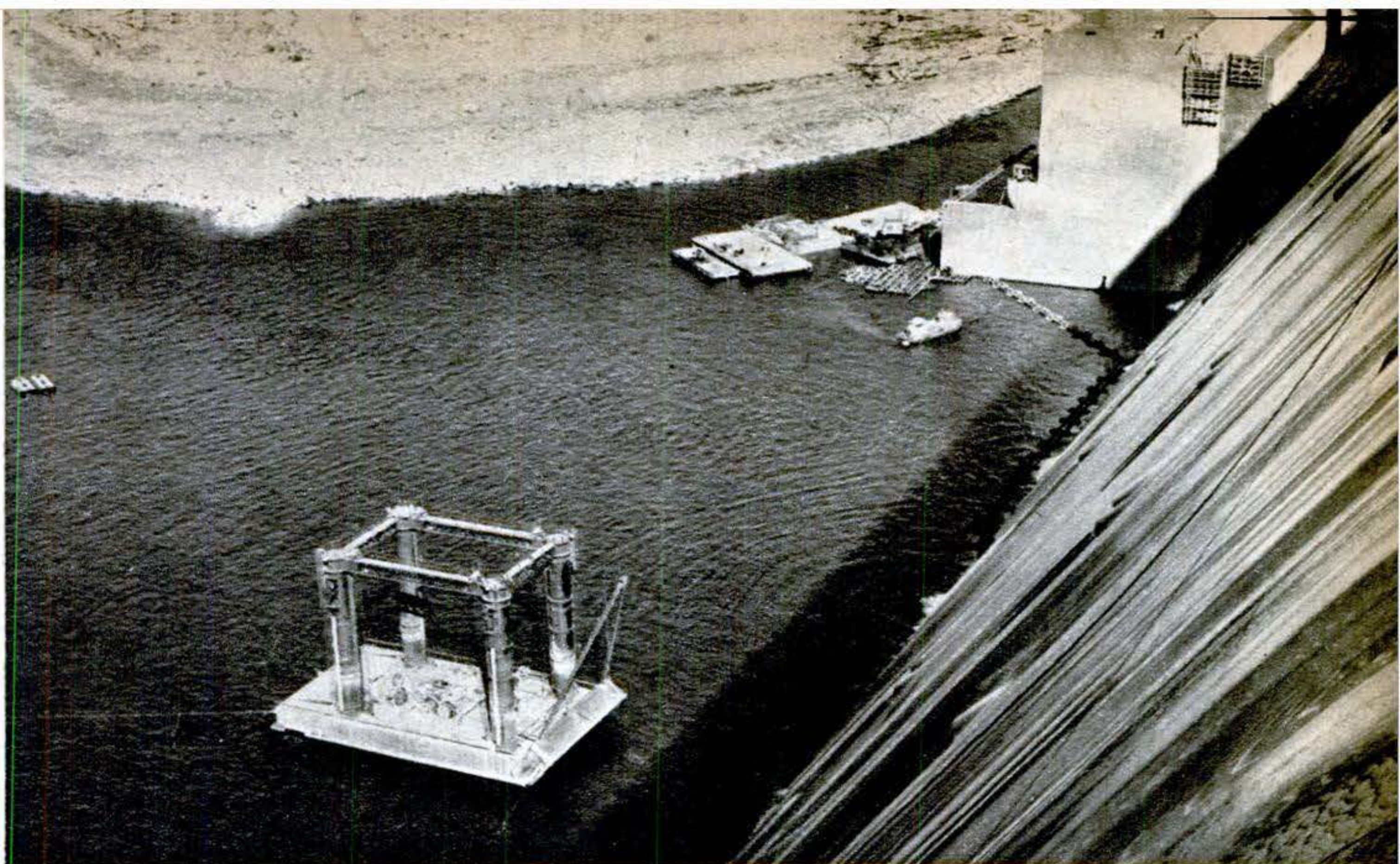

Diagram shows features of new air-conditioning system separately, for simplicity. In actual

machine, one chamber contains evaporator and absorber; another, concentrator and condenser.



The floating repair dock is shown above moored to Grand Coulee's spillway, seen at right. Still

undergoing tests, it won't start to work on underwater repairs until autumn, when flow slackens.

## Barge to Fix Coulee's Toe

WHEN Washington State's giant Grand Coulee Dam was being built across the path of the Columbia river, powerful currents tossed boulders and gravel into the curved toe or "bucket" at the bottom of the spillway. They wore away the massive underwater masonry just as a grinding wheel wears away metal.

To get at eroded areas 70 feet under the swirling waters, Coulee Dam engineers have built a huge, 1,500-ton floating caisson that

will give workmen direct and dry access to the concrete shelf. It consists of a barge from which is lowered a steel working chamber. The chamber fits snugly against the curved bucket, making a water-tight seal. Its open bottom covers 6,750 square feet.

When the water has been removed by pumping machinery contained in two chimney-like shafts, workmen descend on an electric elevator through a third shaft. A fourth shaft is a hoistway for building supplies. END

Cutaway below shows the caisson's working chamber fitting tightly into the curved shelf of the dam's spillway "bucket," giving workmen free access to repair the eroded concrete surface.

Exact in every detail, working model of the floating caisson, shown below, went through many trials in a water-filled test tank before Grand Coulee Dam engineers gave it their okay.

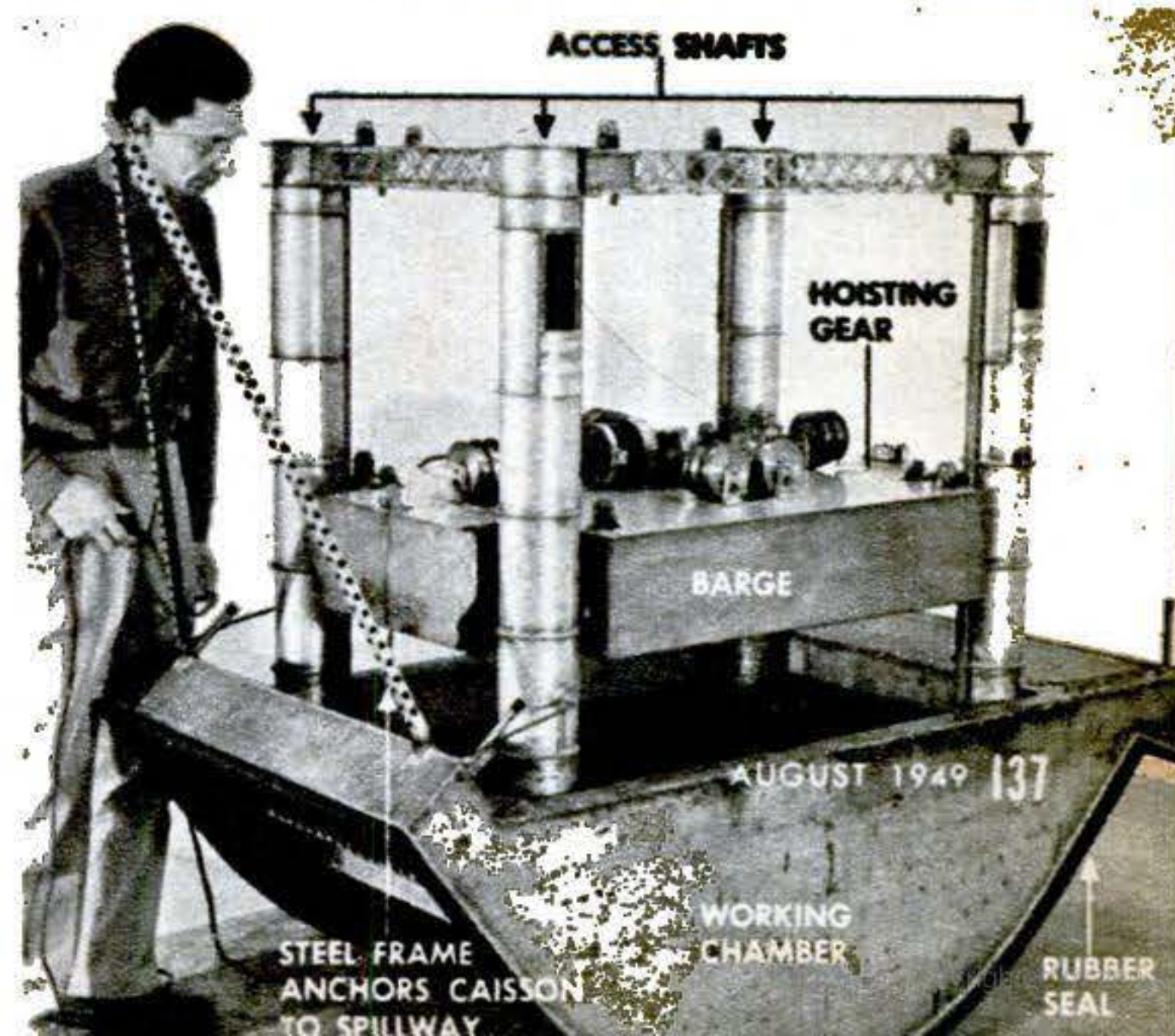
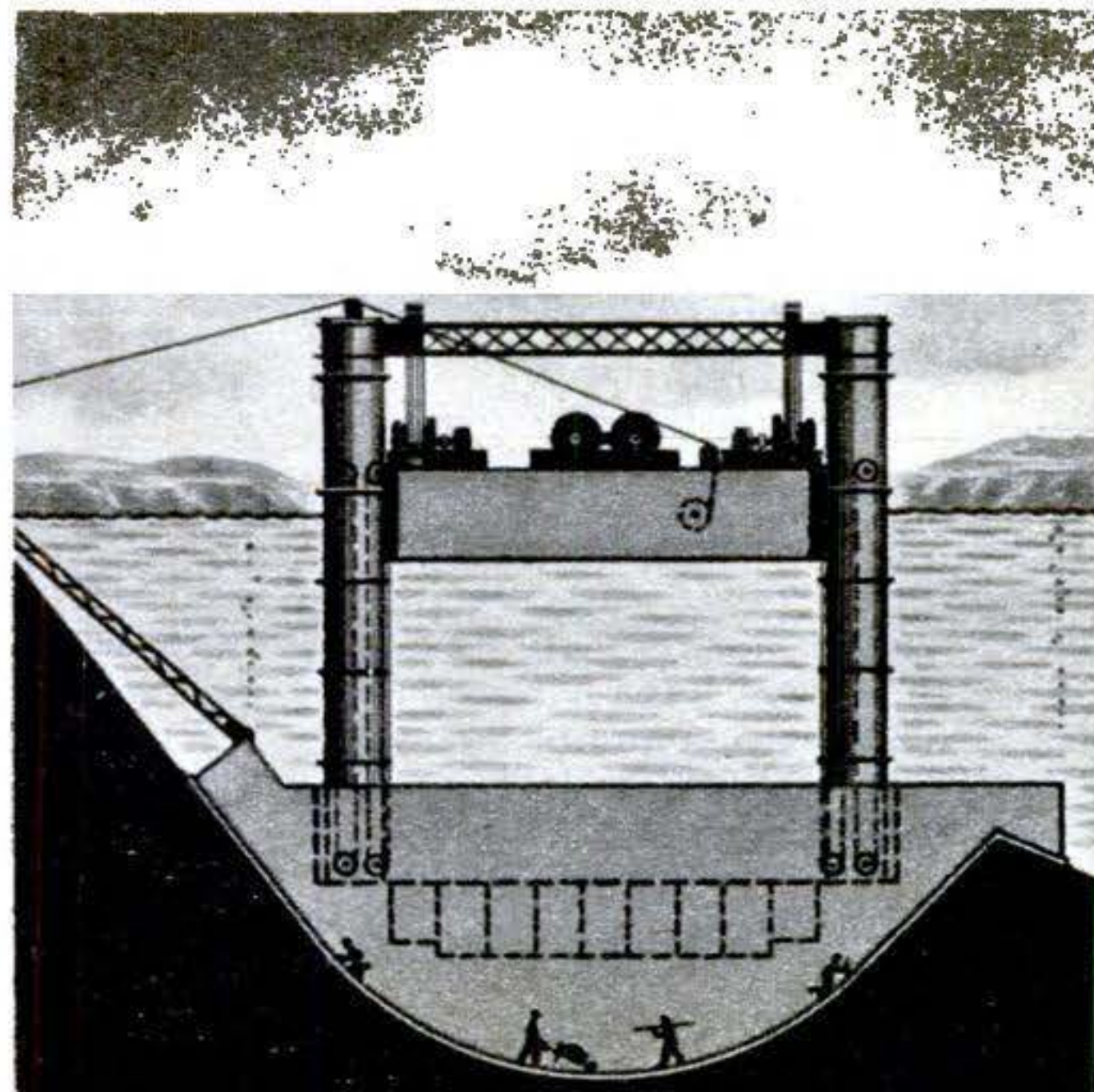

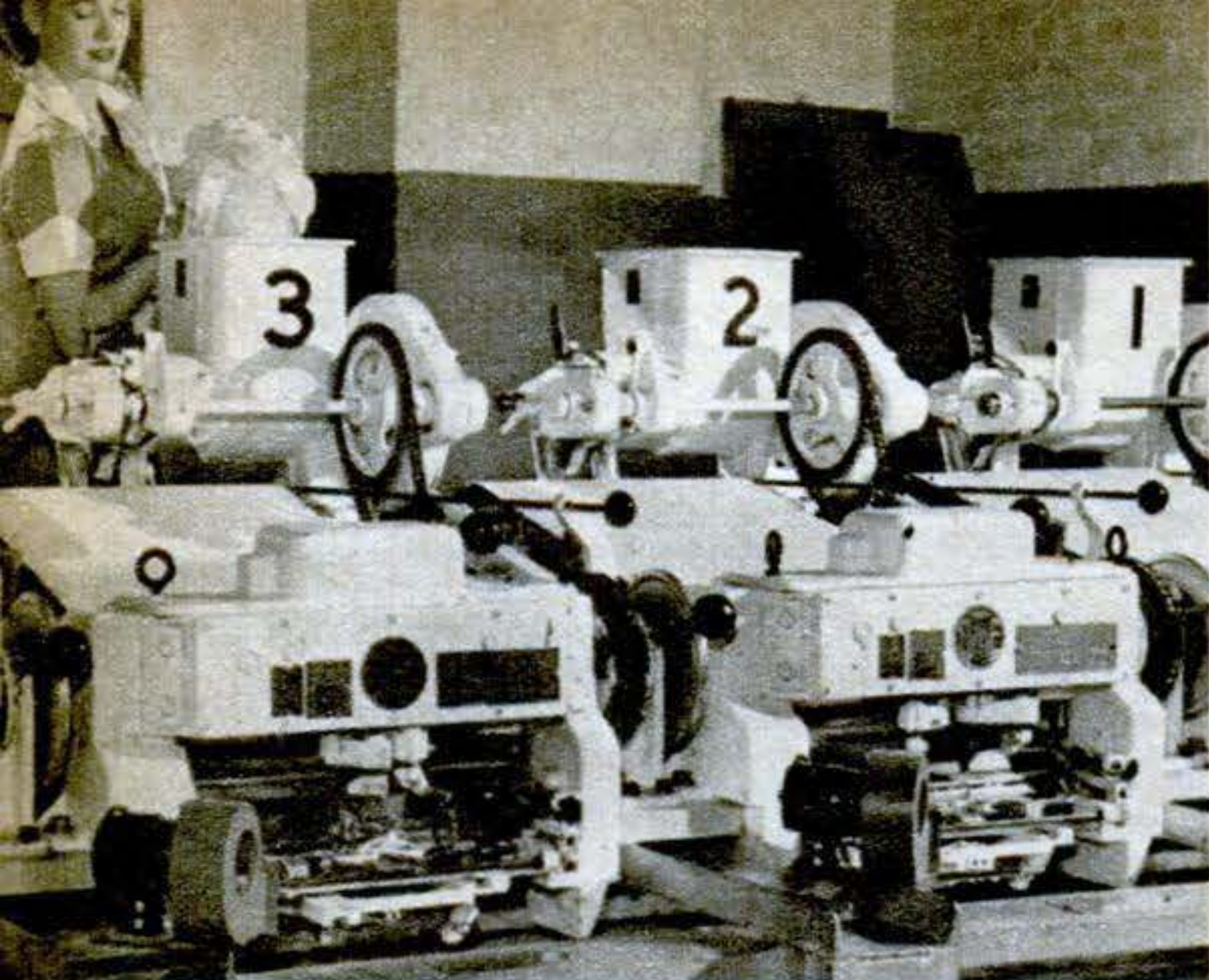

**1** Fed into the hopper of the pretzel-making machine, dough is extruded through an opening at the hopper's side, and cut into proper lengths by a revolving knife blade.

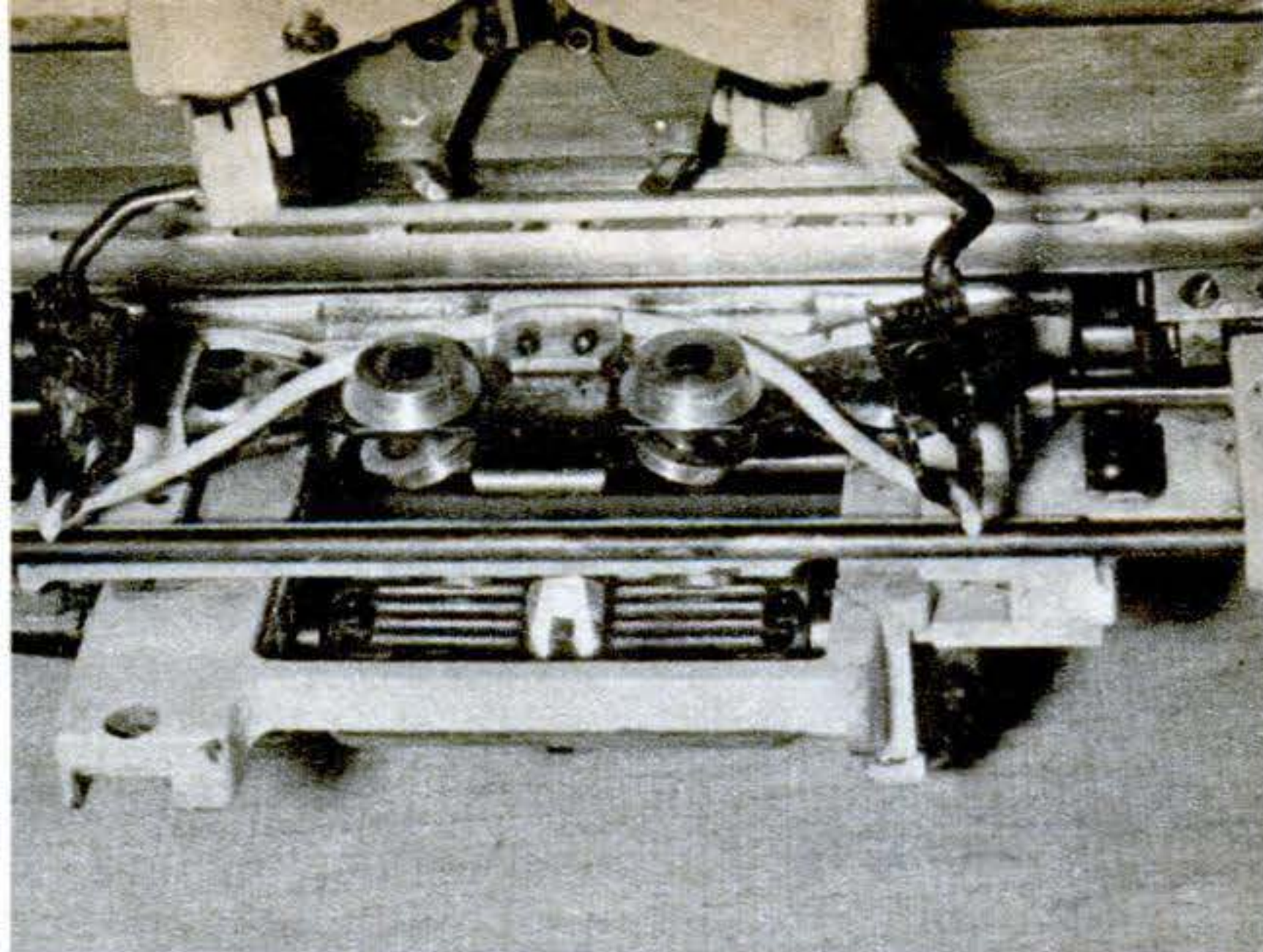

**2** Rolled into a "snake" by belts moving in opposite directions, dough drops to front of machine and is picked up by gripper fingers. They wrap it around a pair of shaping wheels.

# Machine Speeds Pretzel Bending

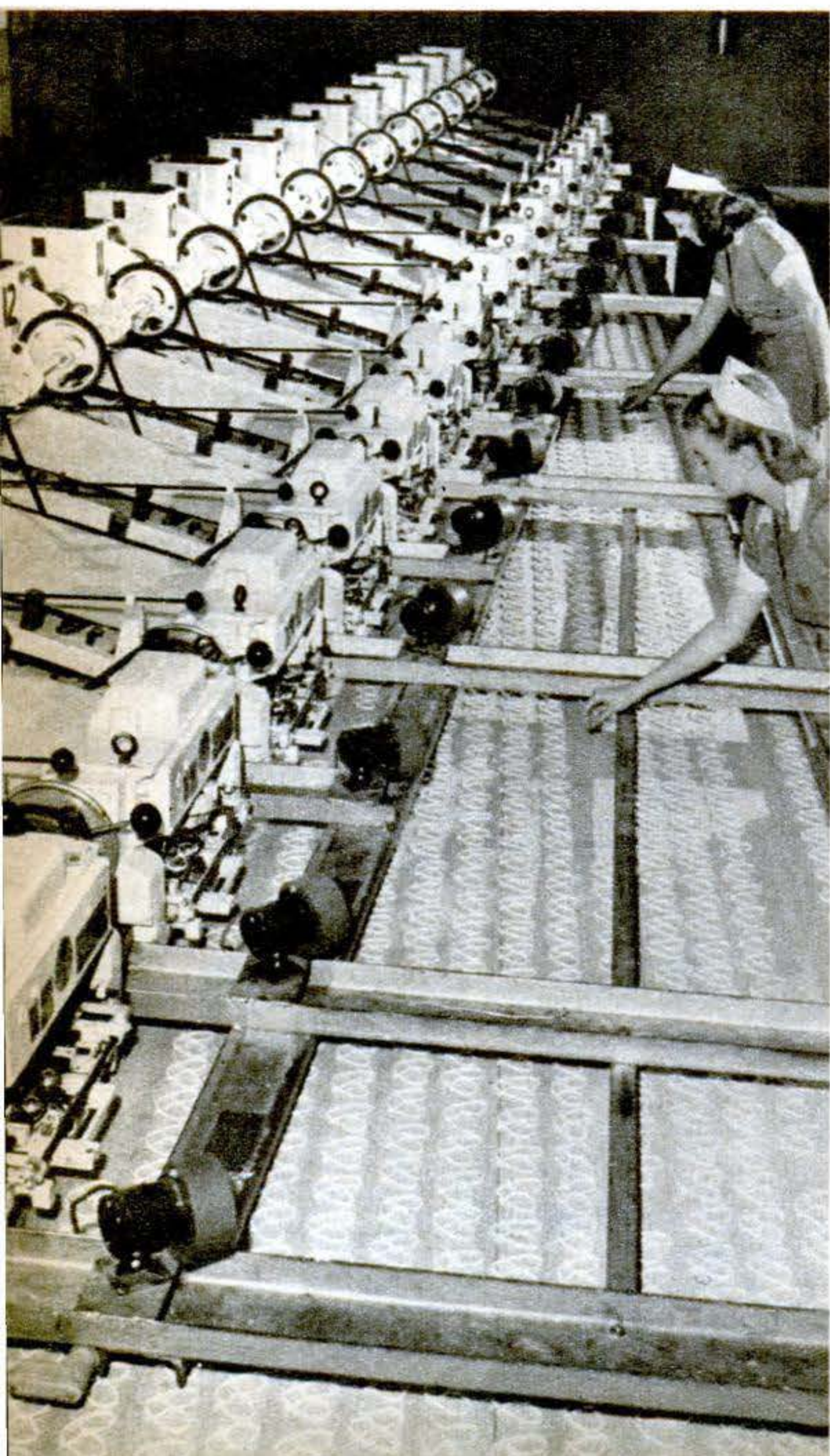

**T**HERE are more crunchy pretzels to munch when you sip long, cold drinks this summer, thanks to a new automatic pretzel-twisting machine that rolls and ties them at the rate of 50 a minute—more than twice as fast as skilled hand twisters can make them. Developed by the American Machine & Foundry Co., of New York City, the pretzel bender is helping to meet the increased demand of pretzel lovers, who eat millions of pounds each year. On this and the following page is the story of how pretzels march from raw dough to baked twist.

After the machine's mechanical hands have bent the pretzels into shape, they ride on a conveyer belt past a battery of infrared lamps that make the dough rise quickly. (Ordinarily, fresh dough has to set for a long period before rising.) Following the infrared-lamp treatment, pretzels are boiled in a salt solution at 225° F. to expand the dough and give it a toasty color. Then they pass underneath a hopper that lets fall a shower of rock salt. Finally the pretzels ride into a gas-fired oven, 90 feet long, for baking.

← **This bank of 15 machines, set up in a Baltimore bakery, twists 750 pretzels a minute. Diagonally mounted over a broad endless belt, each machine makes a row of the biscuits.**

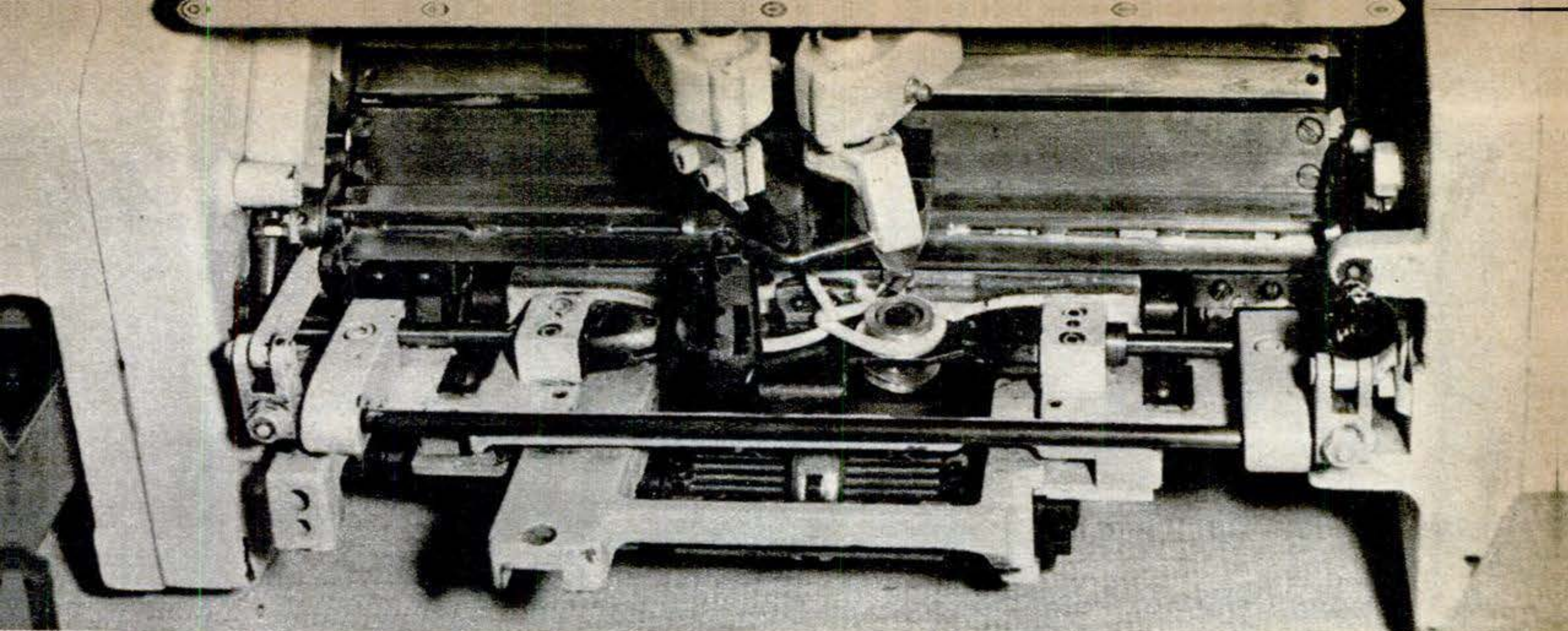

**3** Imitating the tying motion of human hands, the gripper fingers cross over, looping the pretzel to give it the twist. Having completed its tying action, one gripper (above) swings

back to its original position while the other gripper finishes knotting the pretzel. The pretzel-forming wheels then pivot downward, dropping the tied pretzel onto a metal plate.

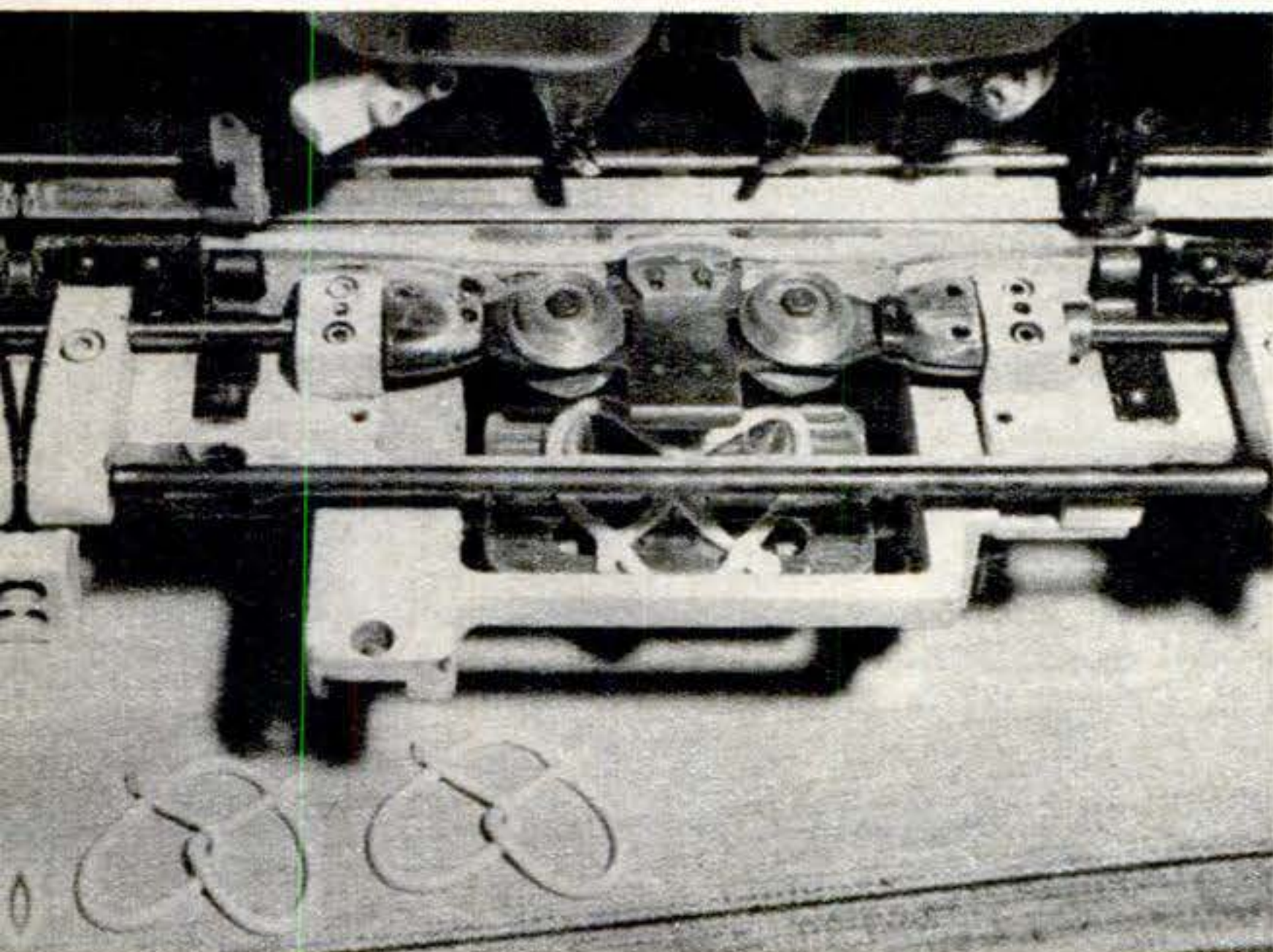

**4** While fingers grasp another dough snake, plate holding knotted pretzel revolves, dropping it onto a conveyer belt that carries it through boiling and baking processes.

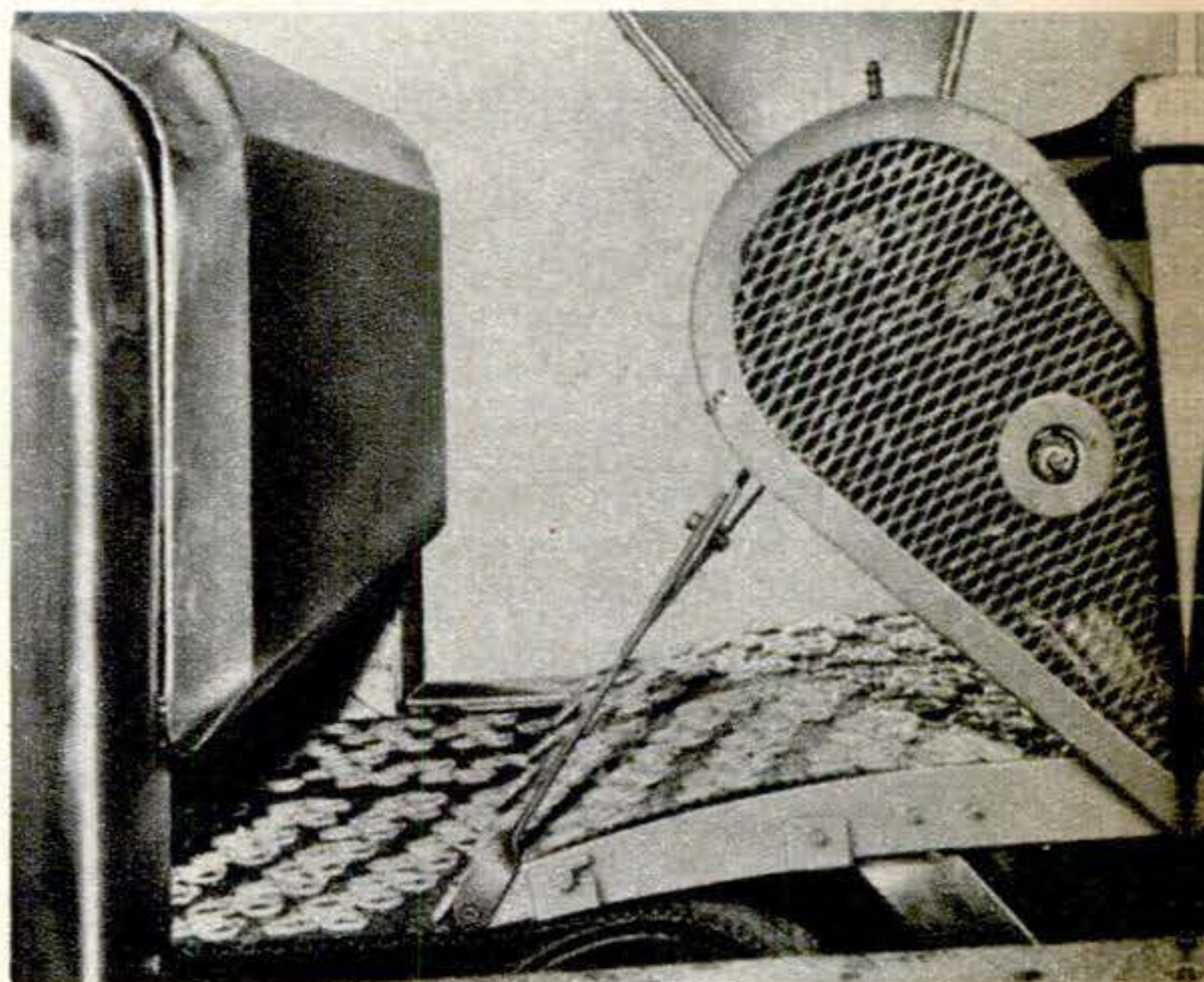

**5** Traveling on a wire-mesh conveyer belt, the pretzels, which have been boiled in a saline bath, now receive a shower of rock salt from overhead hopper before moving into oven.

**6** Through an observation door (below) in the lower part of a gas-fired oven 90 feet long, inspectors can check baking of the pretzels as conveyer belt moves through the oven.

**7** Worker catches baked pretzels in a carton as they fall down a chute to a weighing mechanism that measures them in 12-oz. lots. Box is then closed and wrapped in cellophane.

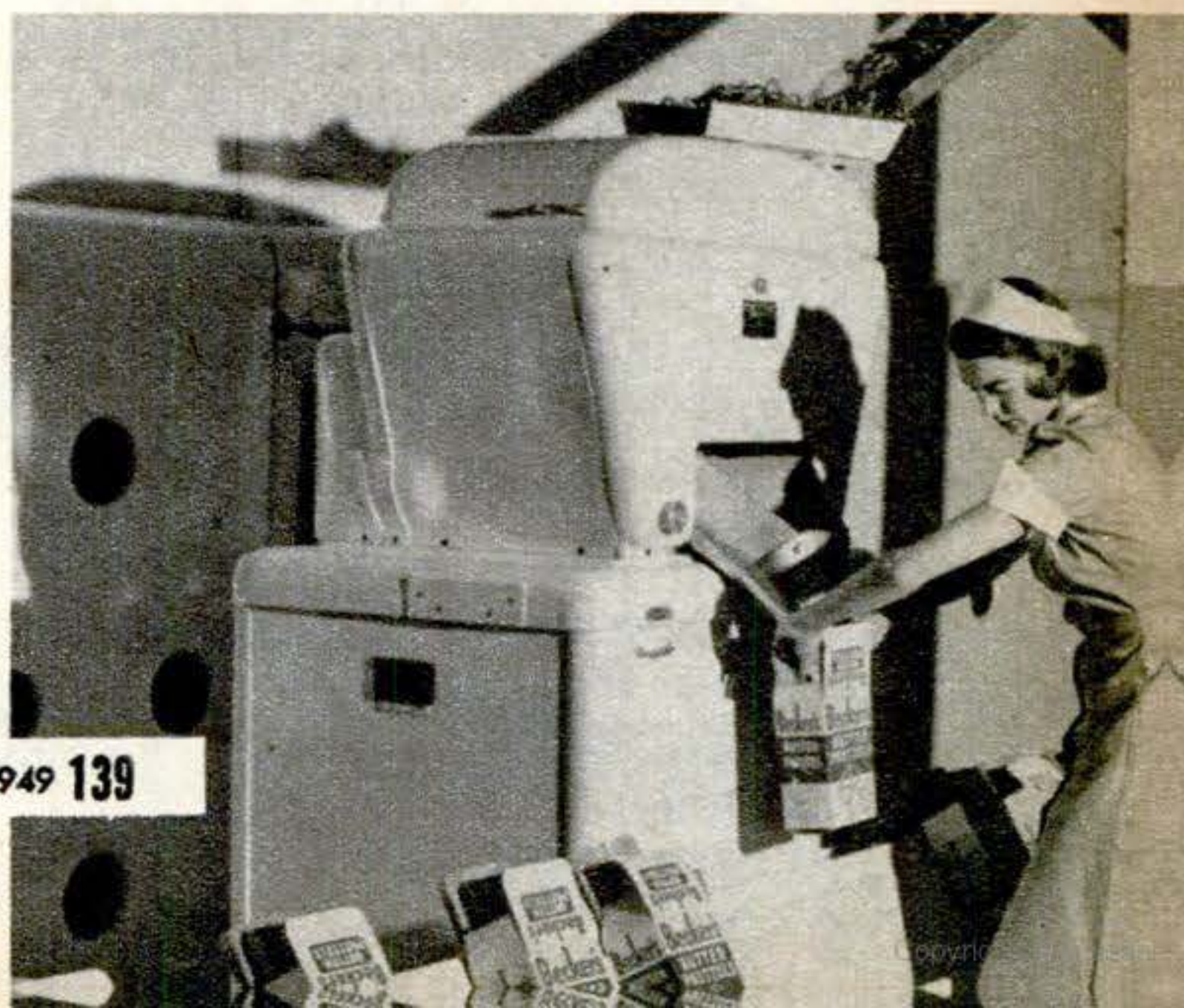
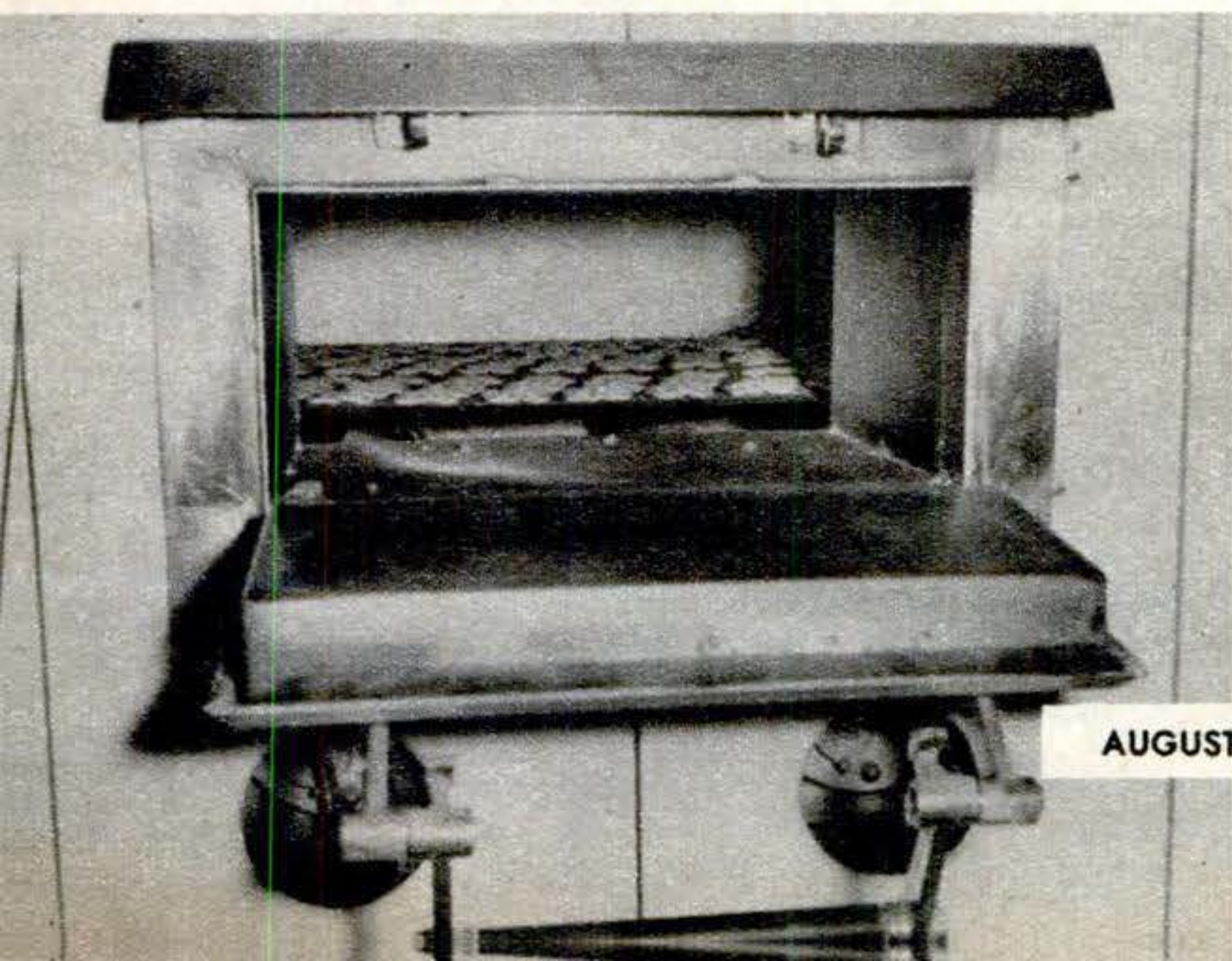

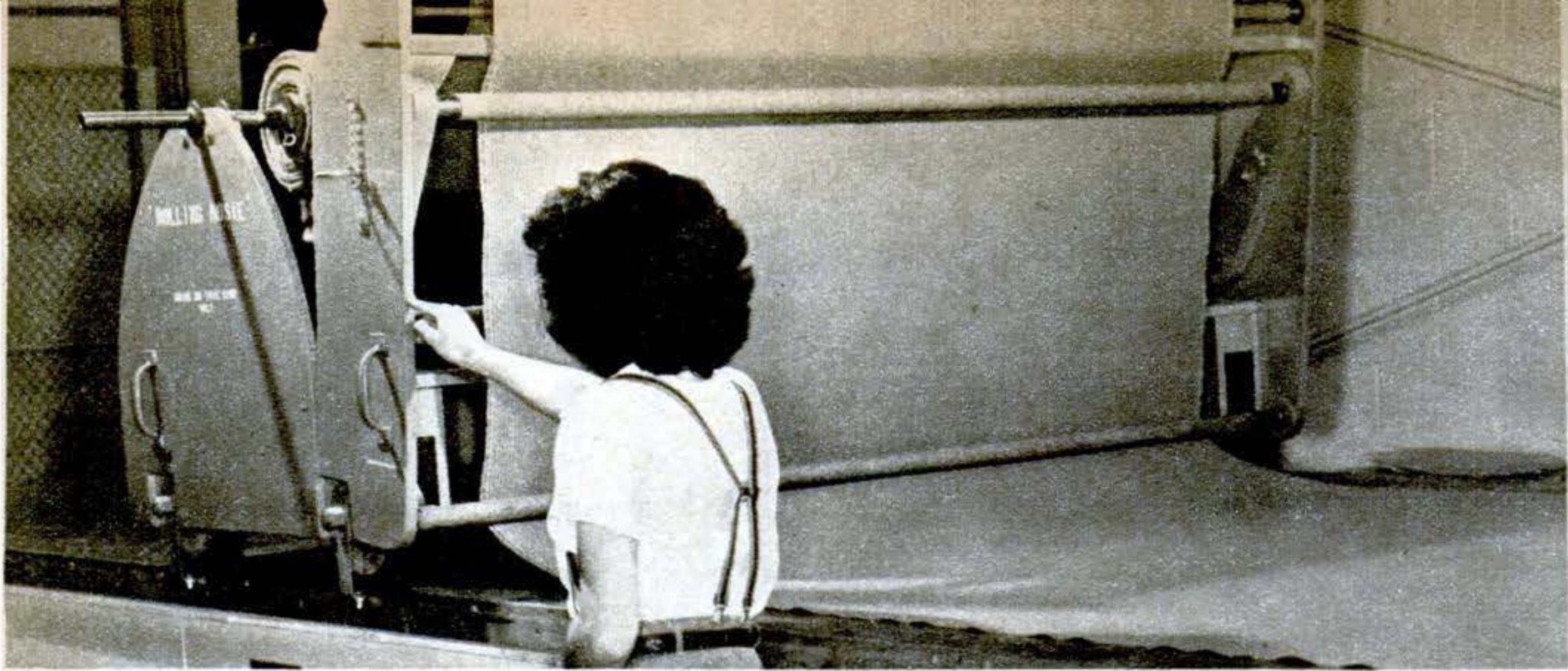

### Fabric Reel Spreads Cloth

It's mighty hard to unroll a big bolt of cloth by hand. But this large machine does it at the touch of a finger. Gliding along an 84-foot-long pattern-cutting table, it spreads a heavy,

60-inch-wide roll of fabric in even layers. The bolt is threaded through rollers and aligned by guide bearings that roll against the table edge. The spreader was developed by United Air Lines' employees at the maintenance base in San Francisco.

### Watch Is Always Fully Wound

THE merest motion of the wearer's wrist keeps a new, lady's wrist watch fully wound—thanks to the unique mechanism at the right. It is difficult to design a woman's self-winding watch, both because of its small size and because most women carry their handbags on the left—wrist-watch—arm, reducing the motion that keeps the mechanism going. Now Eterna claims to have solved the problem with a weight, attached to a matchhead-size mount having five tiny ball bearings, that swings in either a clockwise or counterclockwise circle to wind the mainspring. If taken off the wrist, the watch will run for 40 hours before needing rewinding.

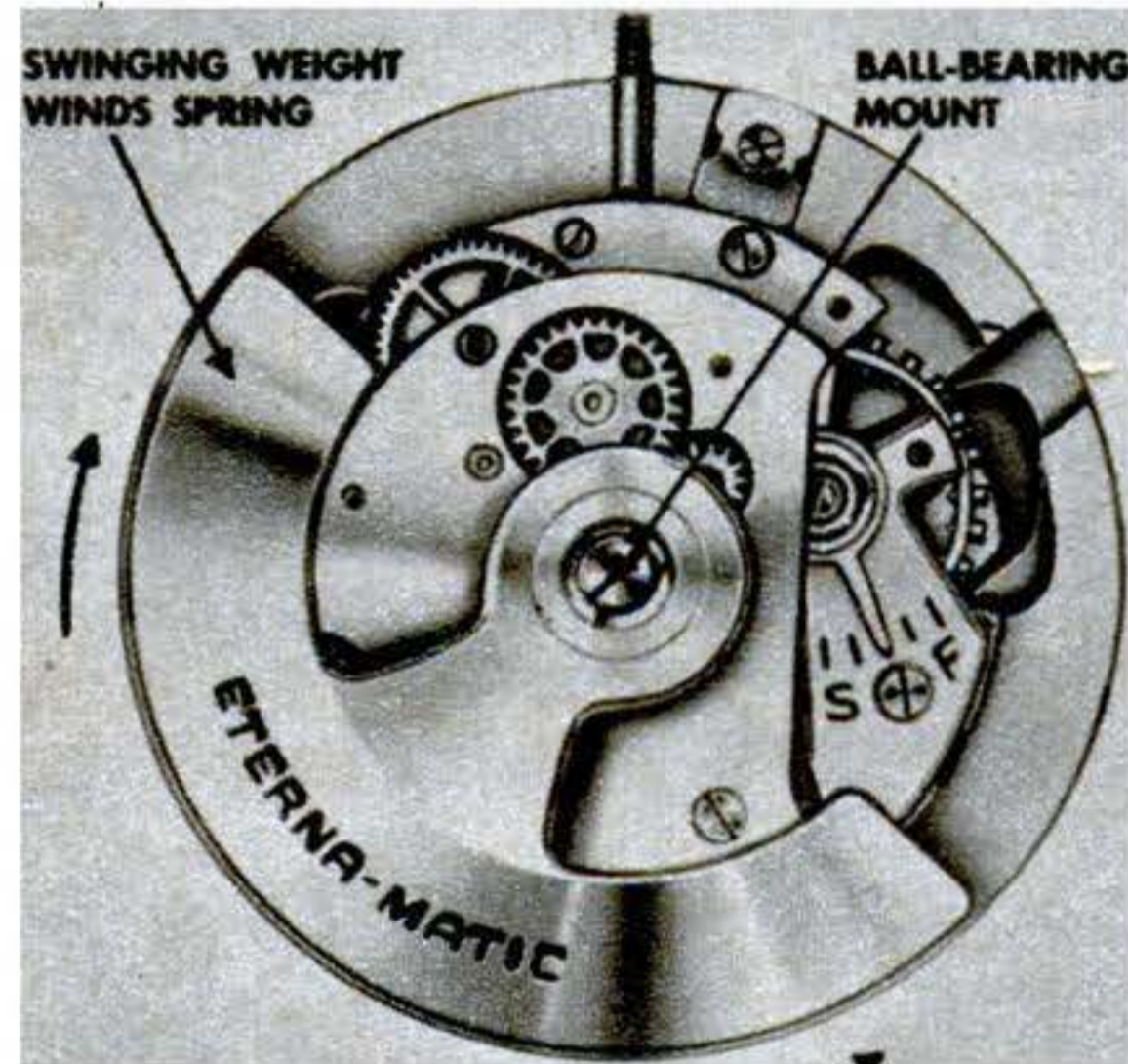

### Jacket Floats Victim Face Up

THIS British self-righting life jacket keeps you afloat face upward even if you're unconscious, lessening risk of drowning. You slip the collar over your head after strapping on the jacket. The hose seen at left on the jacket lets it be blown up by mouth should the inflating device—a small, gas-filled cylinder—fail to operate properly.

### New Liquid Dulls Pants Shine

HERE'S one way to get that mirror look off the seat of your blue-serge pants. Killshine® is said to soften the fibers temporarily so that they can be brushed back to their original unflattened shape. This restores the nap and dulls the shine. Made by Vitatex Products Corp., of New York City, the nonflammable liquid comes with a special applicator.

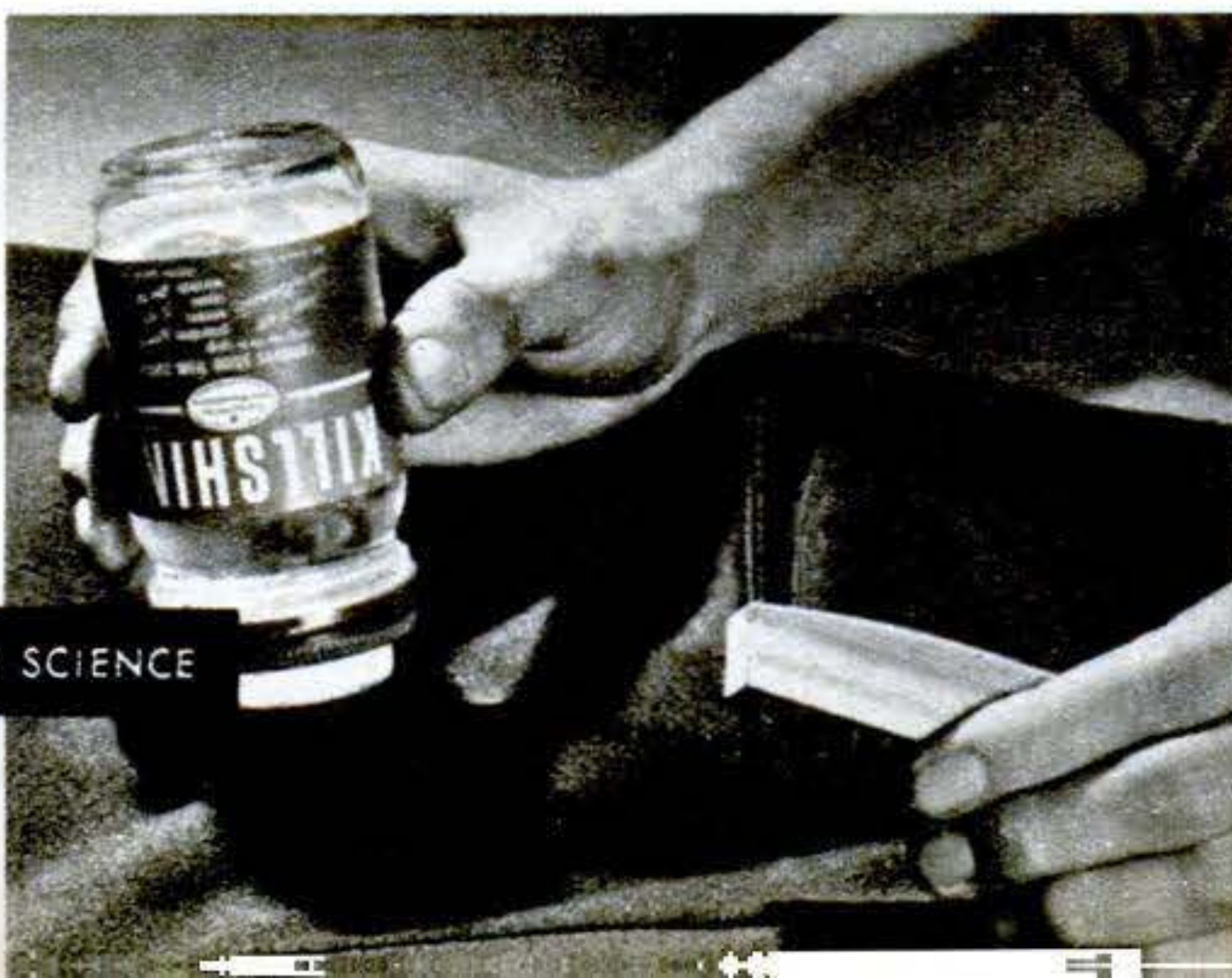



An ultrasonic radar flight simulator in operation at Naval Air Station, Los Alamitos, Calif.

## *Copycat Radar Scans 20 Miles in 8 Inches*

**Sound waves bouncing in water tank give blind-bomber trainees realistic scope pictures from plastic maps.**

**By Andrew R. Boone**

**B**y bouncing "silent" sound waves off a plastic map at the bottom of a small tank of water, U. S. bomber crews can spot on their radar scopes a target halfway around the world—without leaving their classroom.

What happens is this:

The sound waves in water act much like real radar pulses, except that they travel only 1/200,000 as fast. The result is a kind of slow-motion radar that is scaled down in both speed and range to operate within the confines of a classroom. By placing different map sections in the water tank, bomber

trainees can make simulated flights over any spot in the world.

Since the sound waves travel 1/200,000 as fast as radar, the relief maps are built on a scale of 1 to 200,000. Thus the maps are in the same ratio to real terrain as the sound waves are to real radar. Cities, seacoasts, and other landmarks are represented by Carborundum® crystals and glass beads, both excellent for reflecting sound waves.

Heart of the device is a quartz-crystal "airplane" from which the sound waves are radiated. Suspended in the water from a carriage sliding on tracks, the crystal can be moved anywhere around the tank to simulate the course of an airplane. Its "pilot," standing at a control panel, can direct its path and feed in all types of flight conditions by means of motor controls. Thus, the instructor can

not only set up problems, but can also feed in their solutions as the mission progresses.

Operation of the device is simple: a pulse from regular radar equipment is directed at the quartz-crystal "airplane." The crystal vibrates at 15 megacycles for one microsecond, or millionth of a second. This creates ultrasonic waves (sound waves above the audible range) directed at the underwater map. The echoes that bounce back are received by the crystal vibrator, transformed again into electrical impulses, amplified, and fed into ordinary radar scopes. The scopes then show the students exactly the same radar pictures that would unfold before them if they were speeding along on a real mission.

In addition to the underwater map, a second, flat map, duplicating it, has been drawn on a sheet of glass that covers the top of the tank. Small lamps on the moving carriage below shine up through this map and show the precise position of the "airplane" at all times. And underneath the glass map is a large piece of paper on which a pen traces a continuous course of the flight.

#### *Tempest in Teapot*

You can also play tricks with the Ultrasonic Trainer. A ragged-edged square of cotton dropped into the tank of water produces a realistic "storm front." A sprinkling of table salt creates the effect of radar "window jamming," achieved during the war by spreading aluminum foil from other aircraft. Airplanes in flight, singly or in formation, are simulated by dangling single Carborundum crystals by human hairs from tiny corks. A small metal strip,  $\frac{1}{8}$  inch wide and one inch long, looks like a bridge when placed across a river; a longer strip would be taken for an air strip. Grains of sand, placed on the non-reflecting map areas that represent water, come out on the scope as ships or convoys.

The simulator aids training in many ways. It saves money by cutting instructional flying. It saves time. By hooking up a number of scopes to the amplifier, dozens of students can be trained at one time and kept proficient in the interpretation of radar pictures and the maintenance of constantly changing and improved radar equipment.

Lt. Ben G. Lewis, electronics officer at California's Los Alamitos Naval Air Station, where scores of reservists watch the radar "pips" move across the scopes, says: "When radar first reached us, we learned only by flying. Now we can sit in armchairs and watch the world go by." END

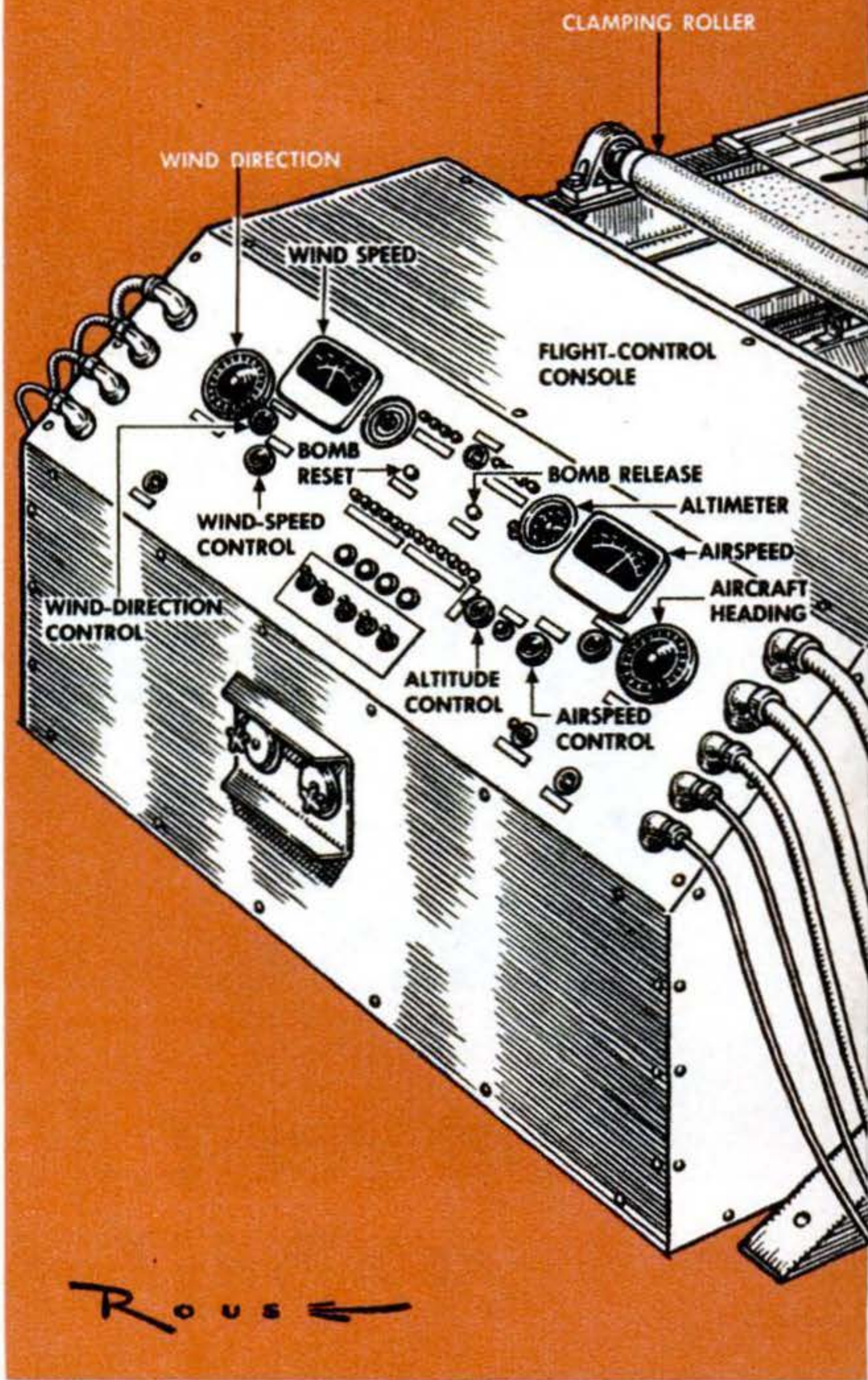

**Ultrasonic map** is a plastic sheet built up with sand and varnish where "radar" reflections are desired. Below, blobs of Carborundum crystals are glued on to represent cities and other targets.

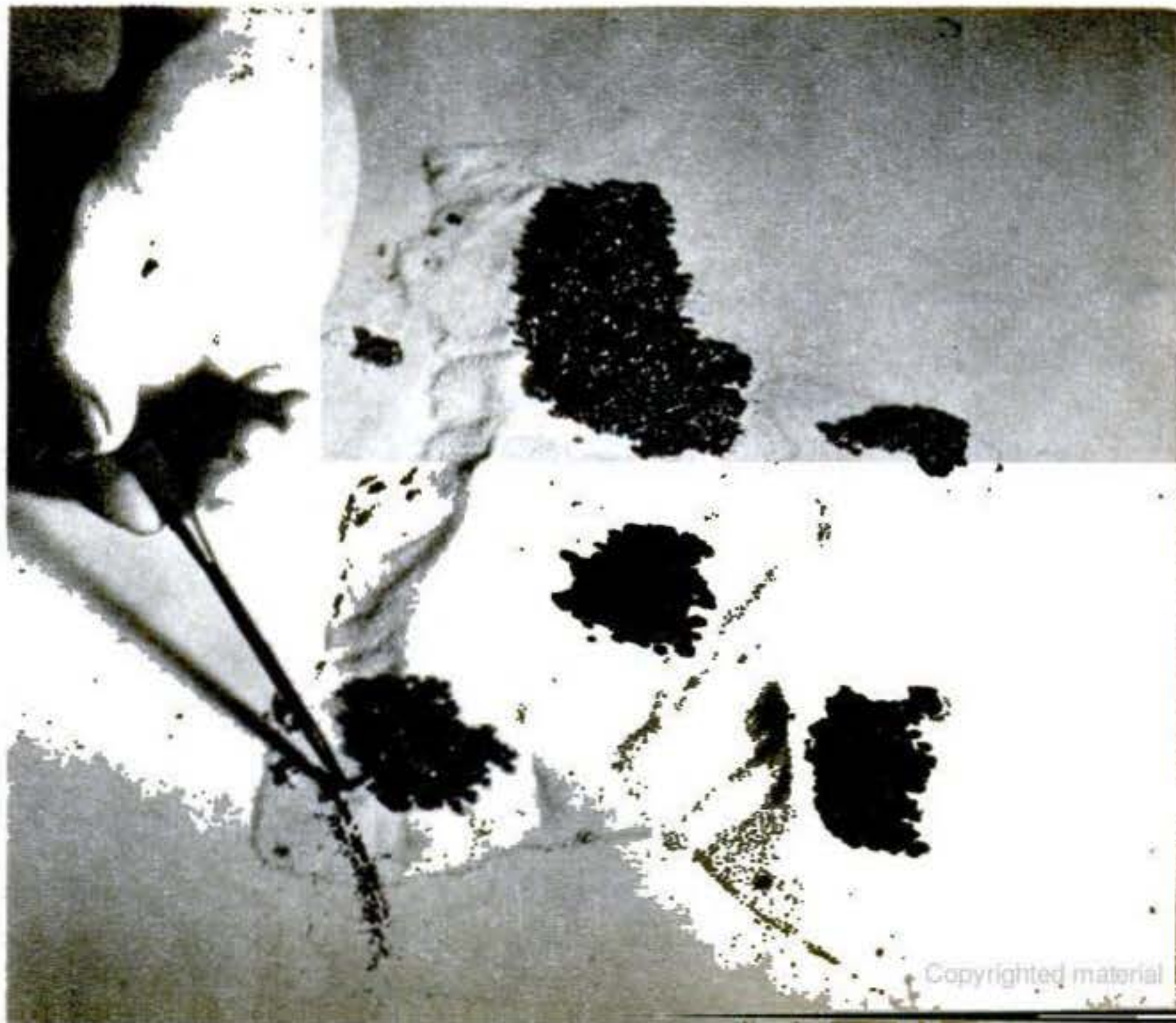



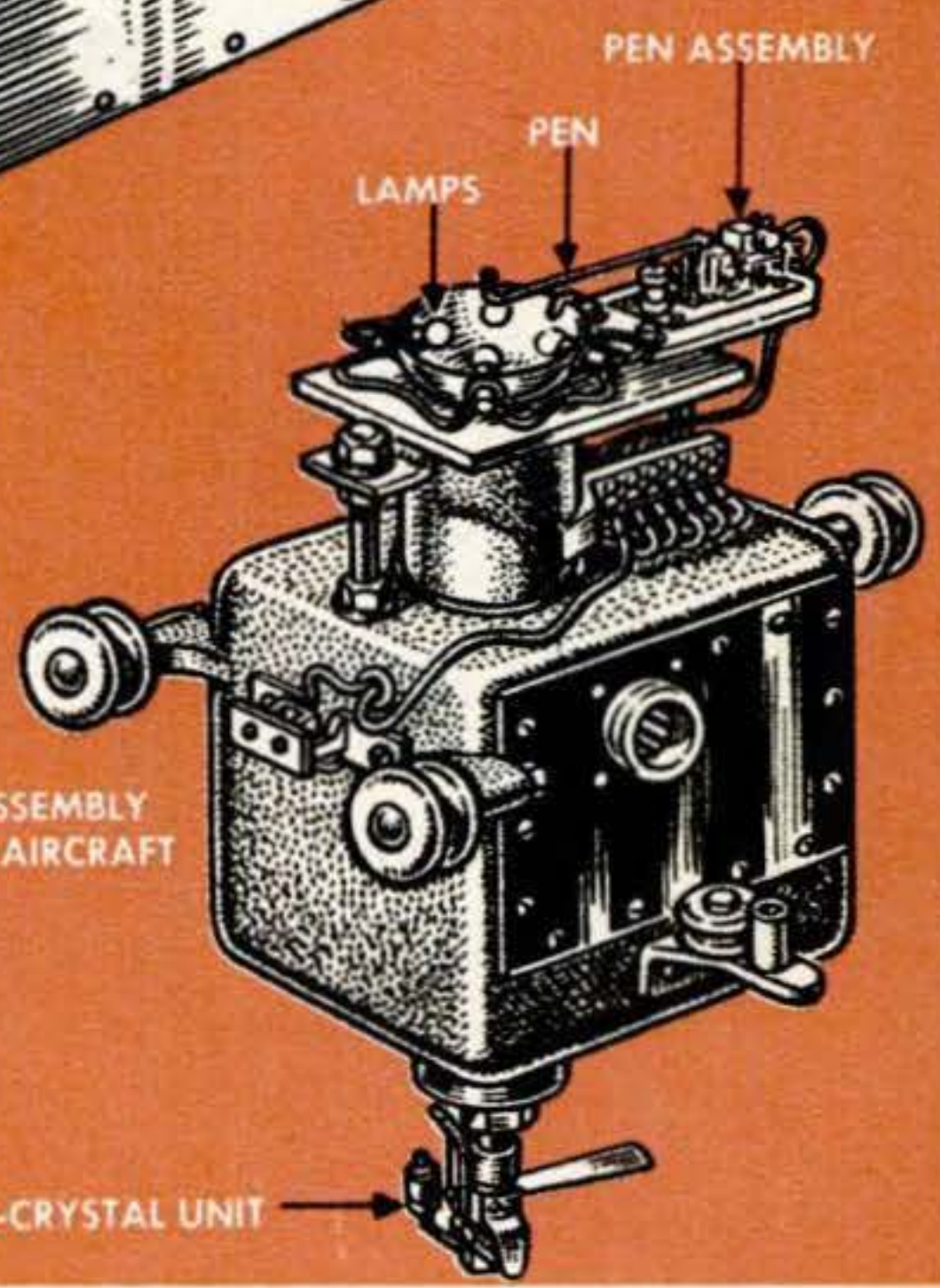
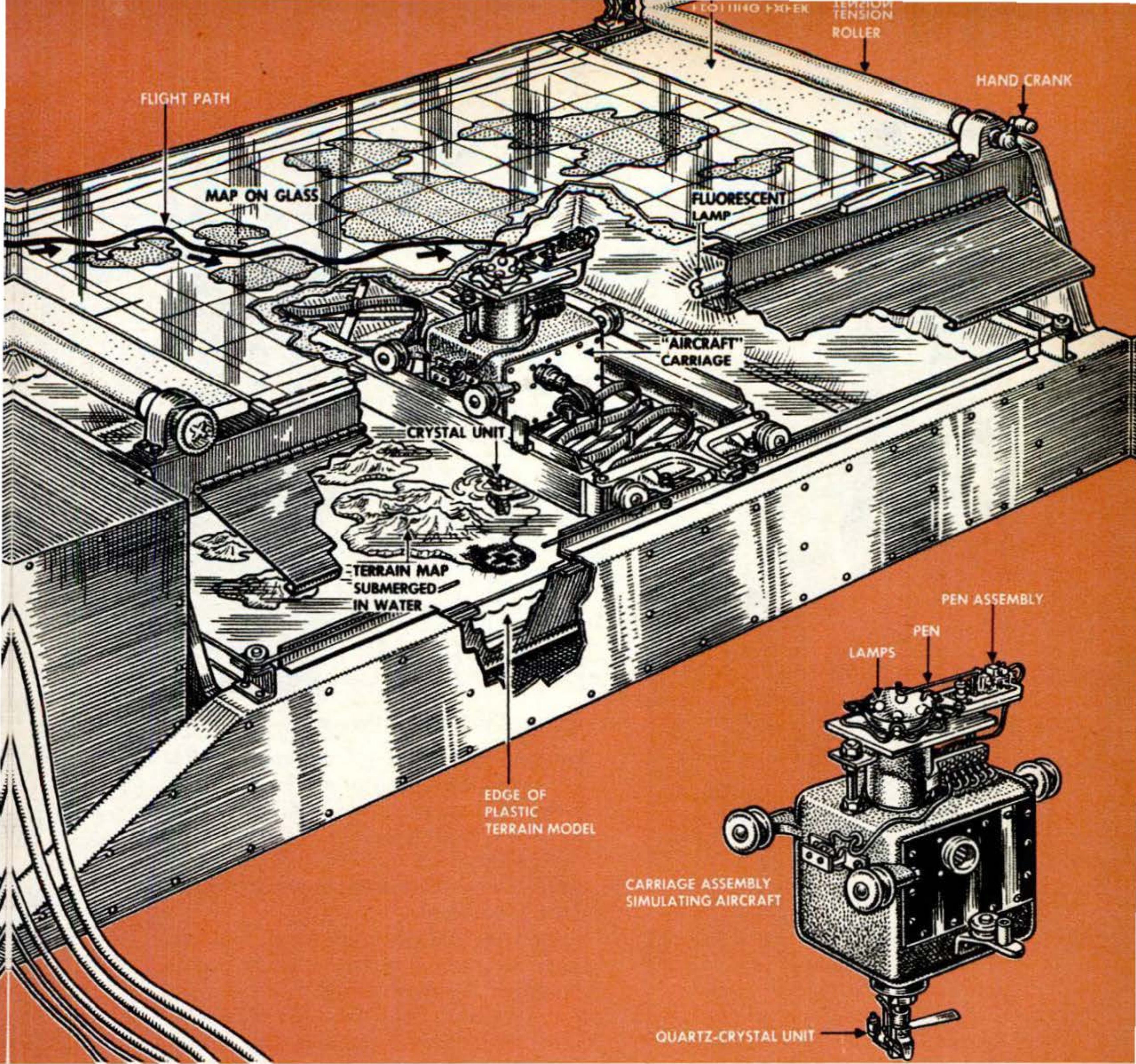

Naval officer below is making adjustment to the airplane simulator, or carriage, that moves in any direction over the tank. Suspended from it and submerged in water is the quartz crystal.

Peering into repeater scopes, students learn to interpret various radar patterns. They soon are able to identify the "pips" made by small crystals representing a large variety of targets.

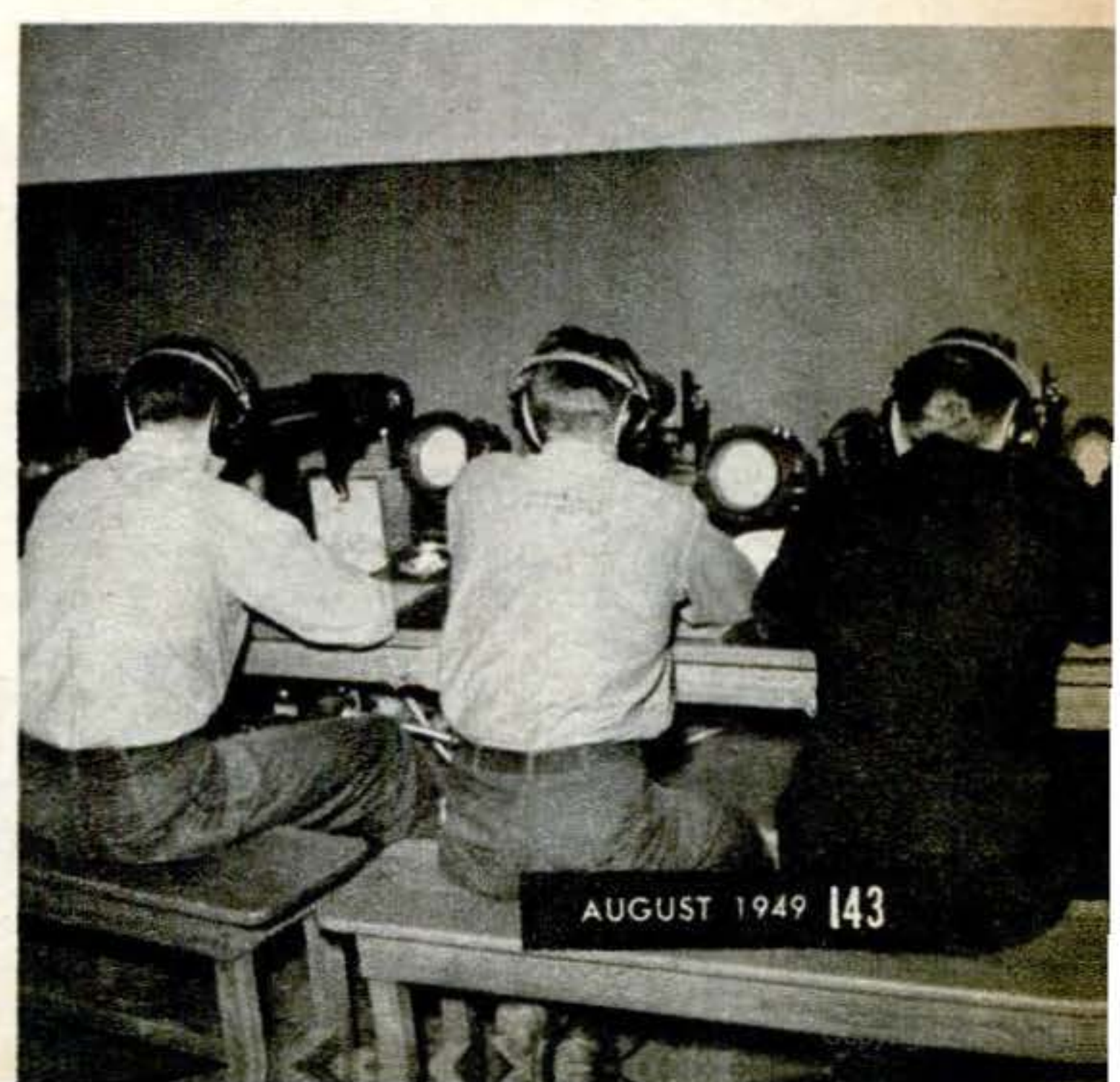

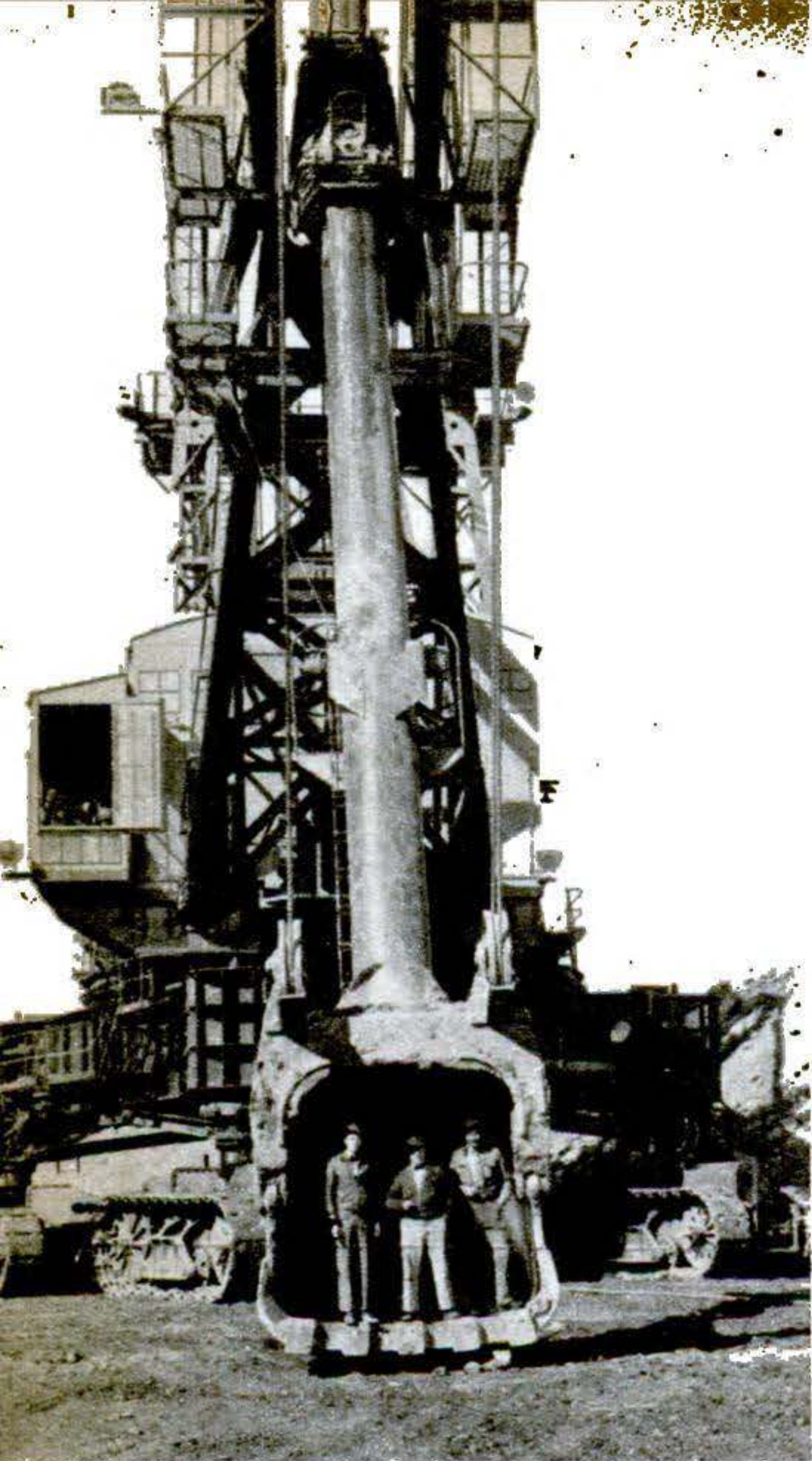

### **“Dipper Stick” Made of Pipe**

HUGE power shovels now have “dipper sticks”—the long arms—made of pipe instead of the usual braced girders. The cylindrical sticks are just as strong and much lighter.

The stick for this giant shovel, made of several cylinders welded together, was rolled by National Annealing Box Co. on a machine developed by Baldwin Locomotive Co.

### **Truck Tests Army Tanks’ Pull**

A 60-TON self-propelled dynamometer—biggest in the world—tells Army Ordnance engineers how powerful their trucks and

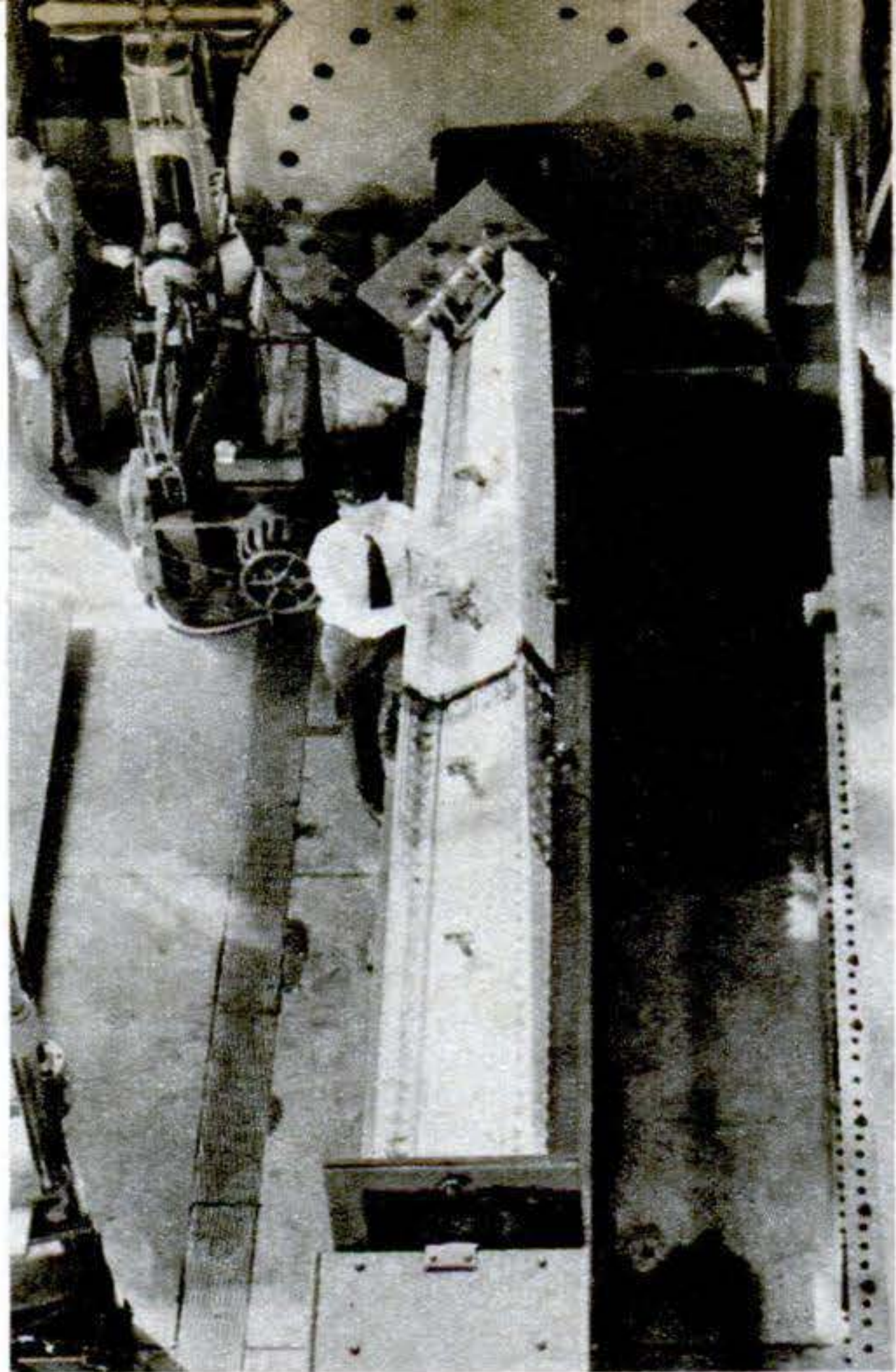

### **Tester Twists Girders**

THIS machine twists heavy steel girders the way you wring out a wet bathing suit. The world’s largest torsion tester, it is now being used at Lehigh University to learn more about the torsional, or twisting, strength of structural units. This is important in railway bridges, for example.

In Lehigh’s giant twister, the test piece is clamped at one end to the stationary part of the machine. A drum, turned by an electric-powered press, twists it from the other end. Electric strain gauges measure the torque. The machine, which takes specimens as big as 16 feet long and four feet in diameter, can exert 2,000,000 pound-inches of twist.

tanks are. It exerts a 60,000-lb. pull at speeds up to 45 m.p.h. Test vehicles pull against the dynamometer, whose 19 electric generators create accurate resistances. Cameras in the huge cab record test data.

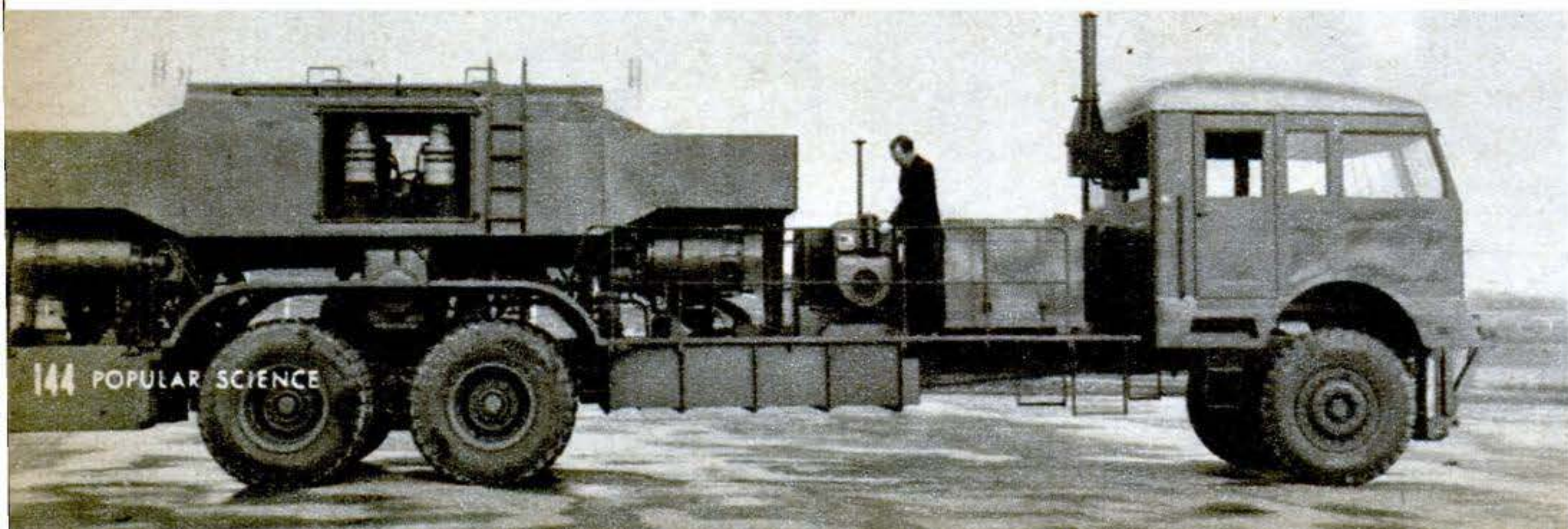

## New Blocks Make Walls Fast

CEMENT blocks have been crossed with pouring forms to produce a new building material. Called Klee-blocks®, the units consist of two 8- by 16-inch pieces of concrete held rigidly apart by steel connecting rods (right, above). The rods are adjustable so that the thickness can be varied.

The Klee-blocks essentially make a permanent form for various types of concrete walls. The blocks are laid without mortar, and the hollow centers can then be filled solid with poured concrete, creating a strong, steel-reinforced wall of the monolithic type.

Another Klee-block wall has a sandwich core—two layers of insulating cardboard with poured concrete between. This core leaves the corrugations in the inner faces of the block empty, for use as raceways for wires and pipes or as ducts for hot or cold air. Lower photo at right shows these two types of “filling” and an unfilled block.

Klee-blocks, which can be shipped unassembled or assembled, are made by the Klee-block Corp., Belfast, Me.

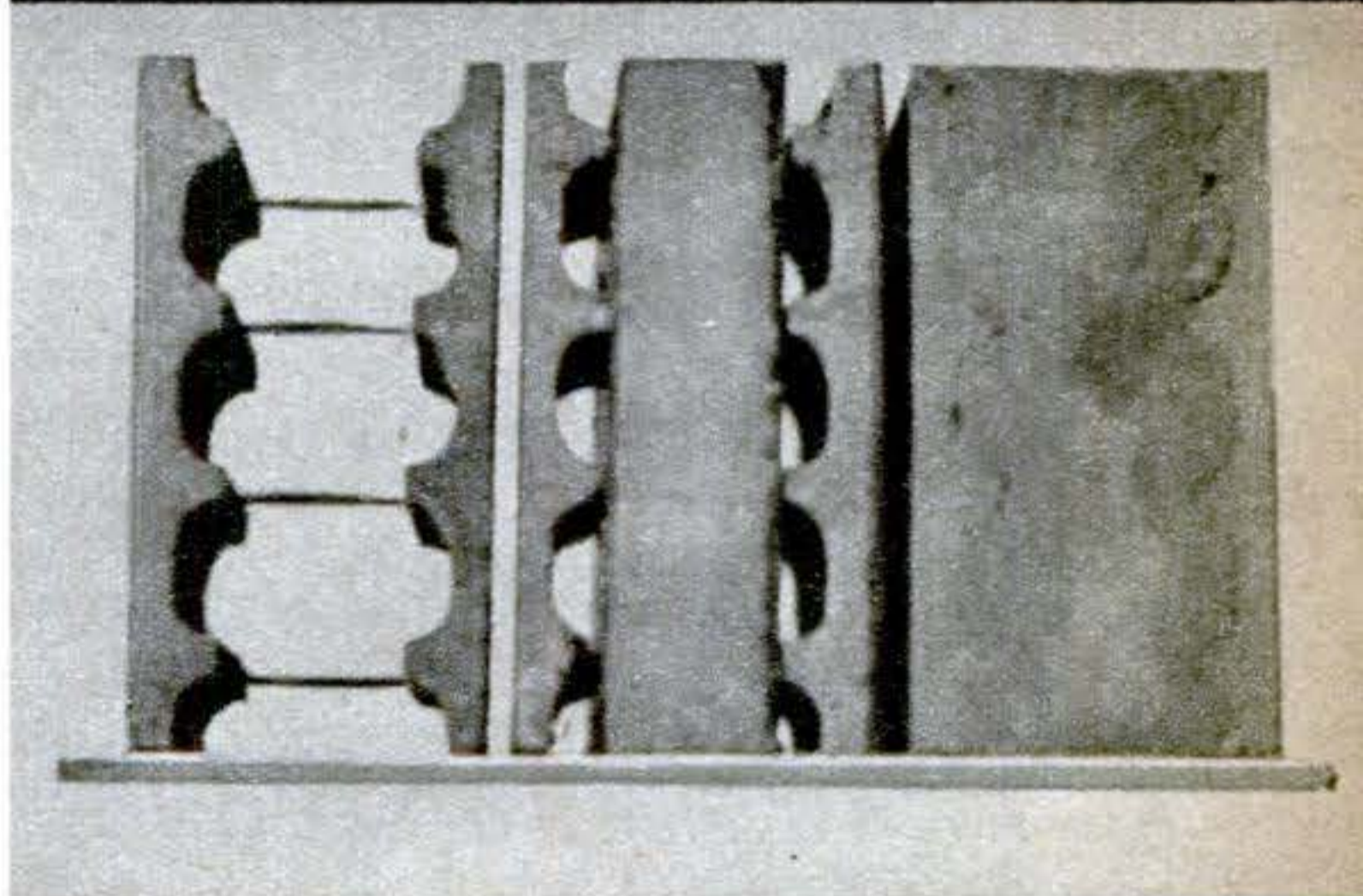
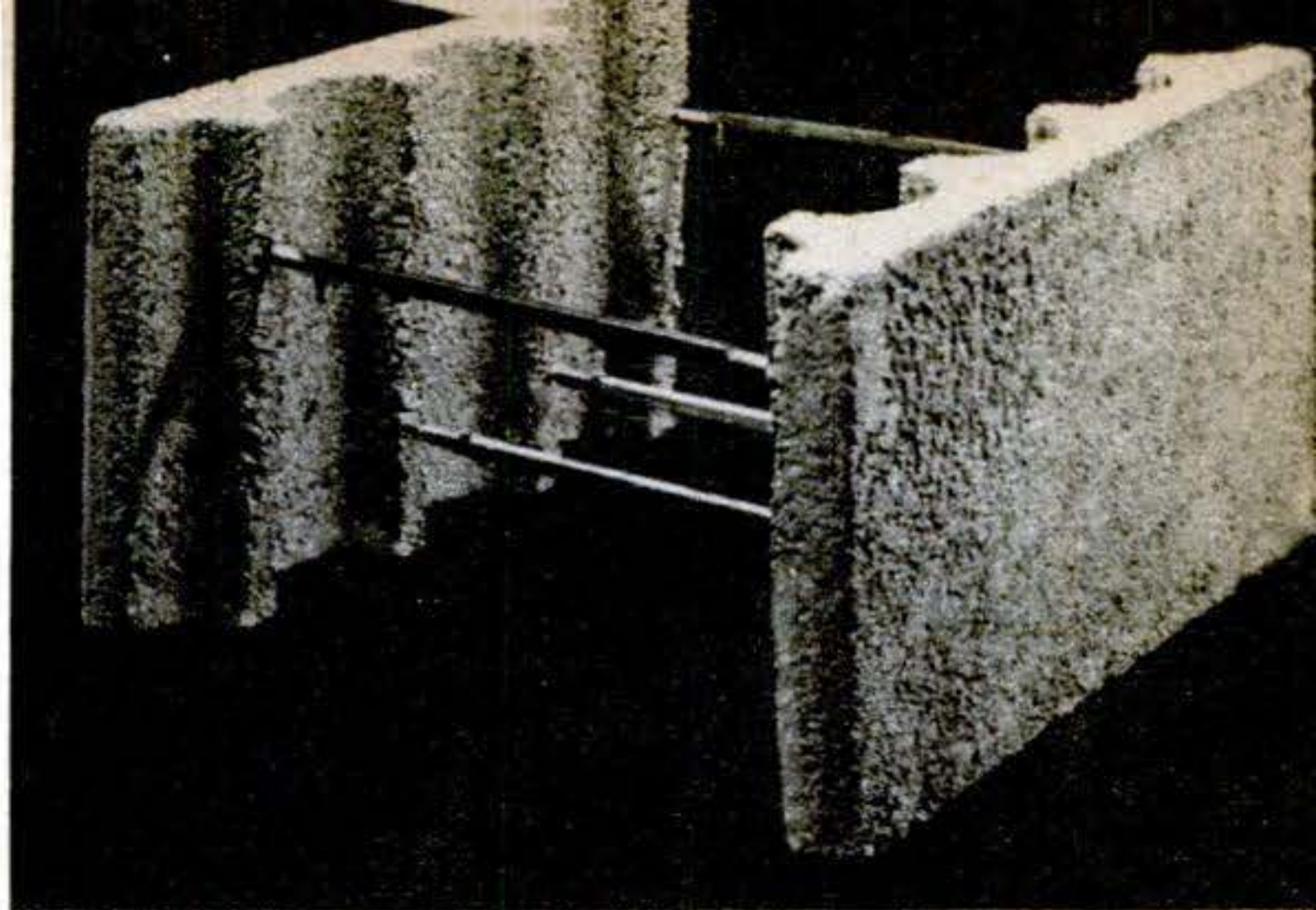

## Machine Scrubs Sidewalks

SHOPPERS will walk across extra-clean sidewalks to enter the snooty shops on New York's upper Fifth Avenue. The walks are to be scrubbed by an adaptation of the standard street-cleaning machine. It sprays chemicals and water on the walk, then two brushes scour the pavement. One is a five-foot cylinder brush; the other (visible at left) is a circular brush that gets into the angle between building wall and street.

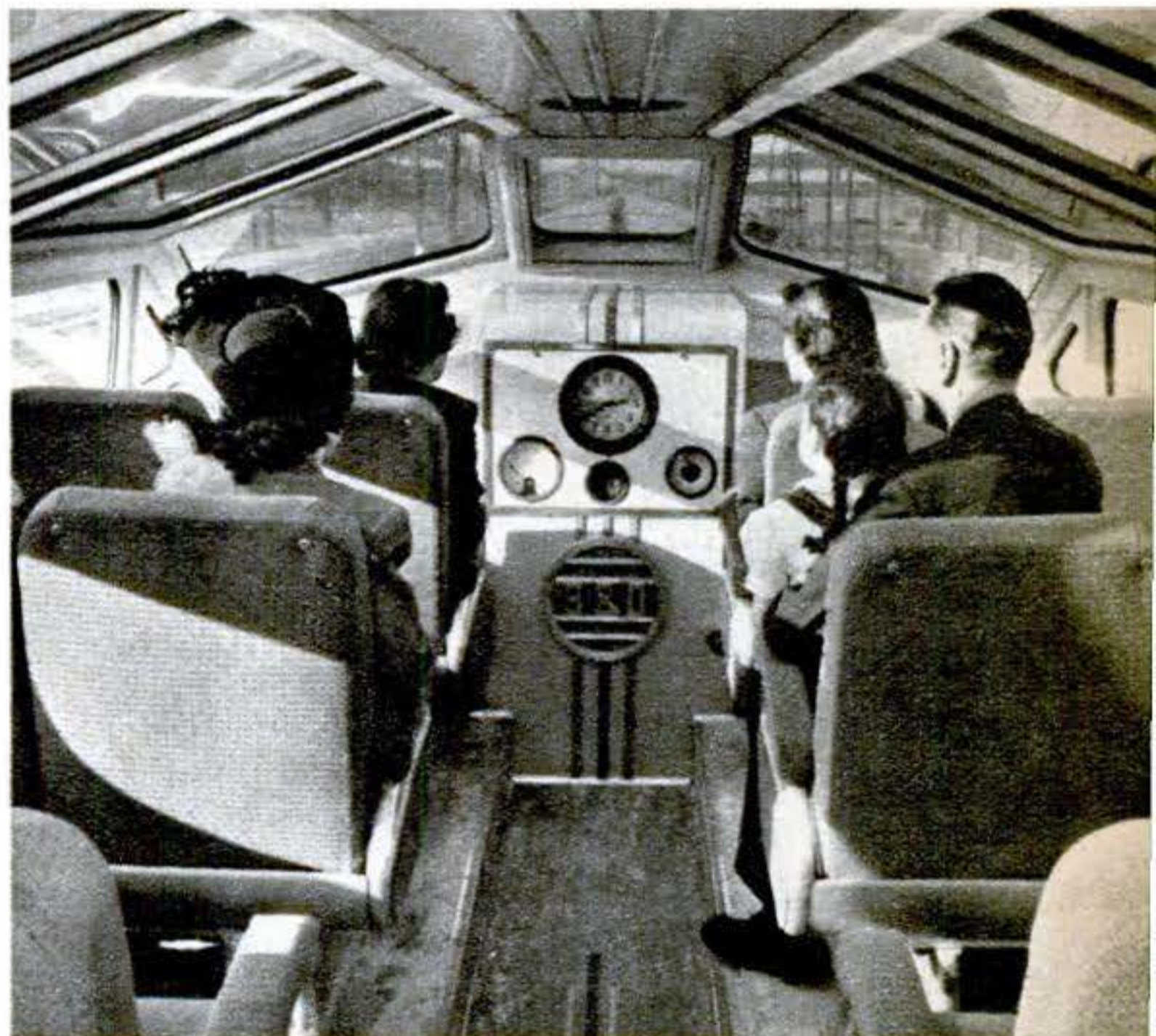

## Train Travelers Can See Speed

TRAVELERS between Washington and Chicago will be able to keep tab on the engineer if they ride the Baltimore & Ohio's New Columbian trains. The Strata-Dome® car, which gives passengers a bird's-eye view of the scenery, also has an instrument panel with a speedometer. The other dials (center in above photo) are a clock, an altimeter (so you can tell how high you are when you cross the Alleghenies), and a barometer.

# Ice Grows Out of Fast Freezer

By **Walter F. Oakes**

**A** NEW ice-making machine freezes ice so fast you can see it grow.

Invented by Prof. John R. Watt, of the University of Texas, it can squirt out a ton of ice a day—like toothpaste from a tube—50 percent cheaper than standard equipment makes ice.

The secret of its speed lies in freezing the water from the inside out, where old methods freeze it from the outside in. Just as nature forms hailstones, the Watt machine wraps successive thin layers of ice around a core, building big blocks at 30 times the usual rate.

Today most ice is made by suspending large cans, each containing 300 pounds of water, in pools of very cold salt water. It takes 40 hours for a can to freeze solid because the ice first forms around the edge, creating an insulating layer that slows freezing of the inner water. This low production rate, plus the labor involved in emptying the cans, adds to the cost of ice.

Prof. Watt's machine both speeds the process and eliminates most of the handling. To start, pre-chilled water fills a freezing cylinder shaped like an upside-down pyramid. Refrigerant in the cylinder's hollow walls freezes this water solid. Then a ram in the bottom of the cylinder lifts the ice block a quarter-inch, shearing it away from the sides of the cylinder. Because of the tapered shape, this lifting creates a thin space between the raised block of ice and the steel walls. Water flows into the space and quickly freezes to the ice block, forming a new layer—called the "incremental film"—on the lower sides and bottom. Then the ram lifts the ice block again, and the process is repeated. Automatic blades slice off blocks as they rise out of the cylinder.

Other continuous ice-making machines have been built, but they turn out flakes, cubes, and other small forms that are not as suitable for refrigerating railroad food cars and other of the most common ice uses as the big blocks frozen by this machine.

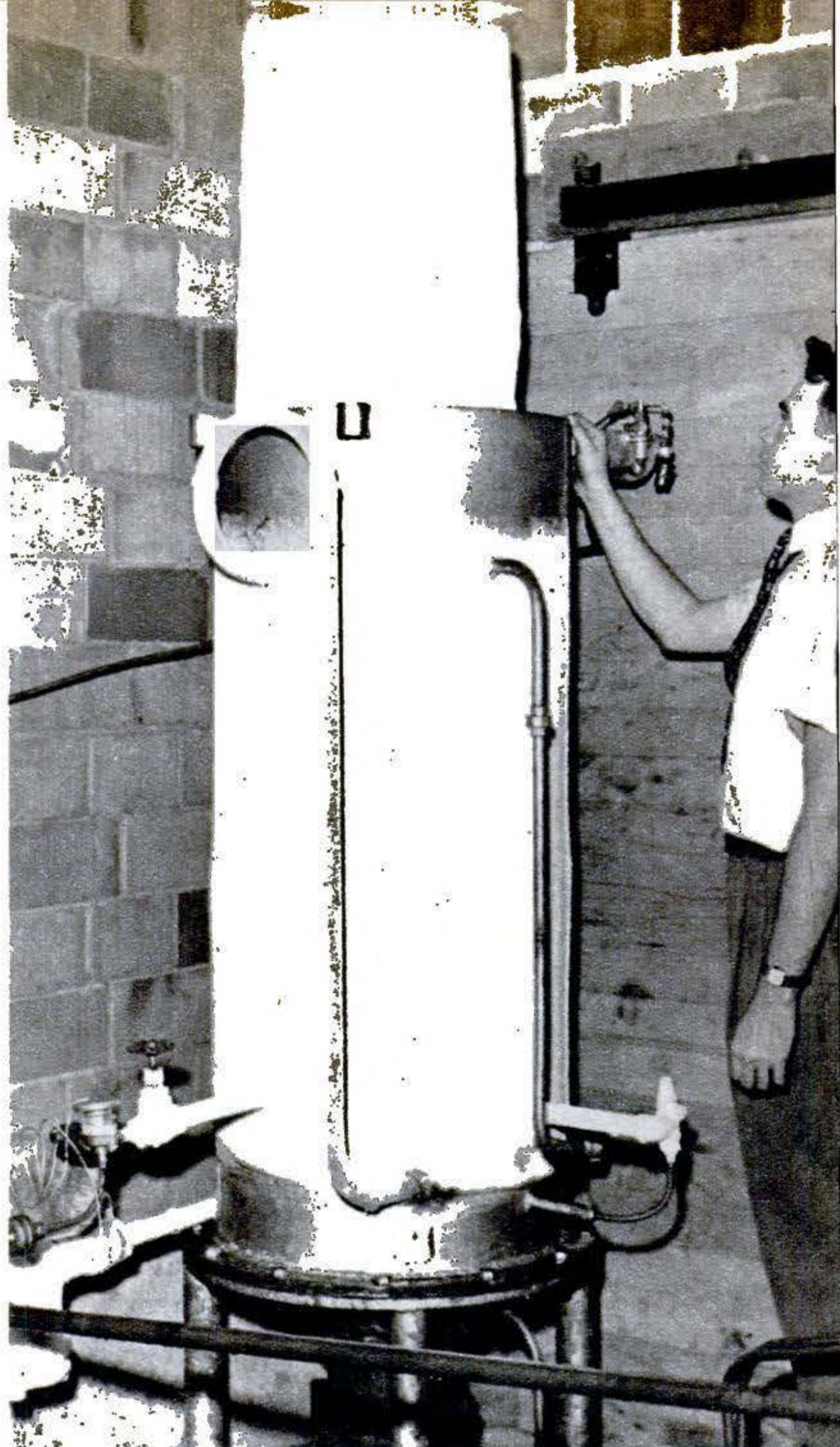

**Ice grows** right out of the top of this new machine. This model, the first one of commercial size, can make 80 lb. an hour. A device to chop off blocks of the right size can be added.

**Looking down on freezing cylinder,** you can see its pyramid-like form (below). Ram operates through small square hole at bottom. Space around the cylinder holds the pre-chilled water.

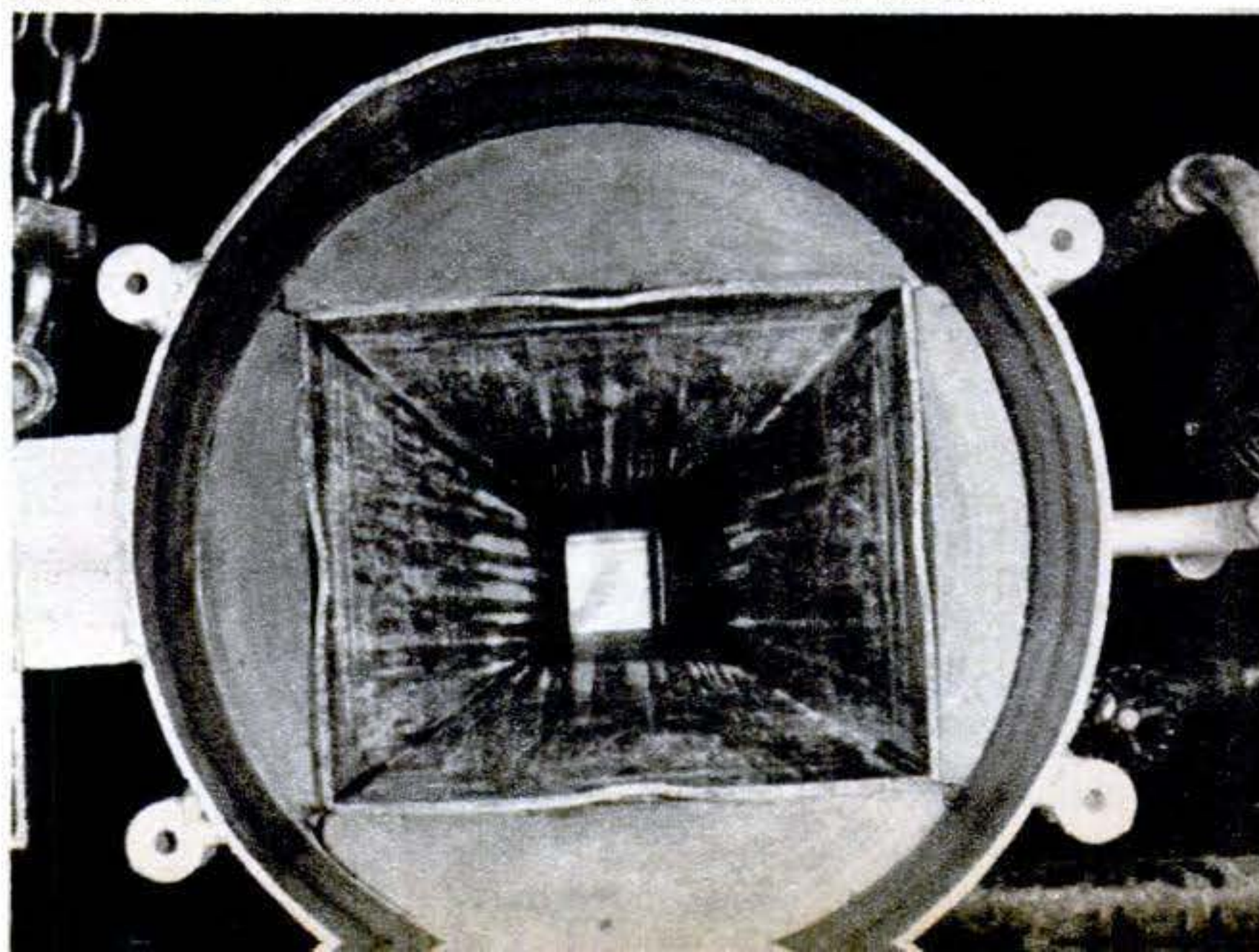

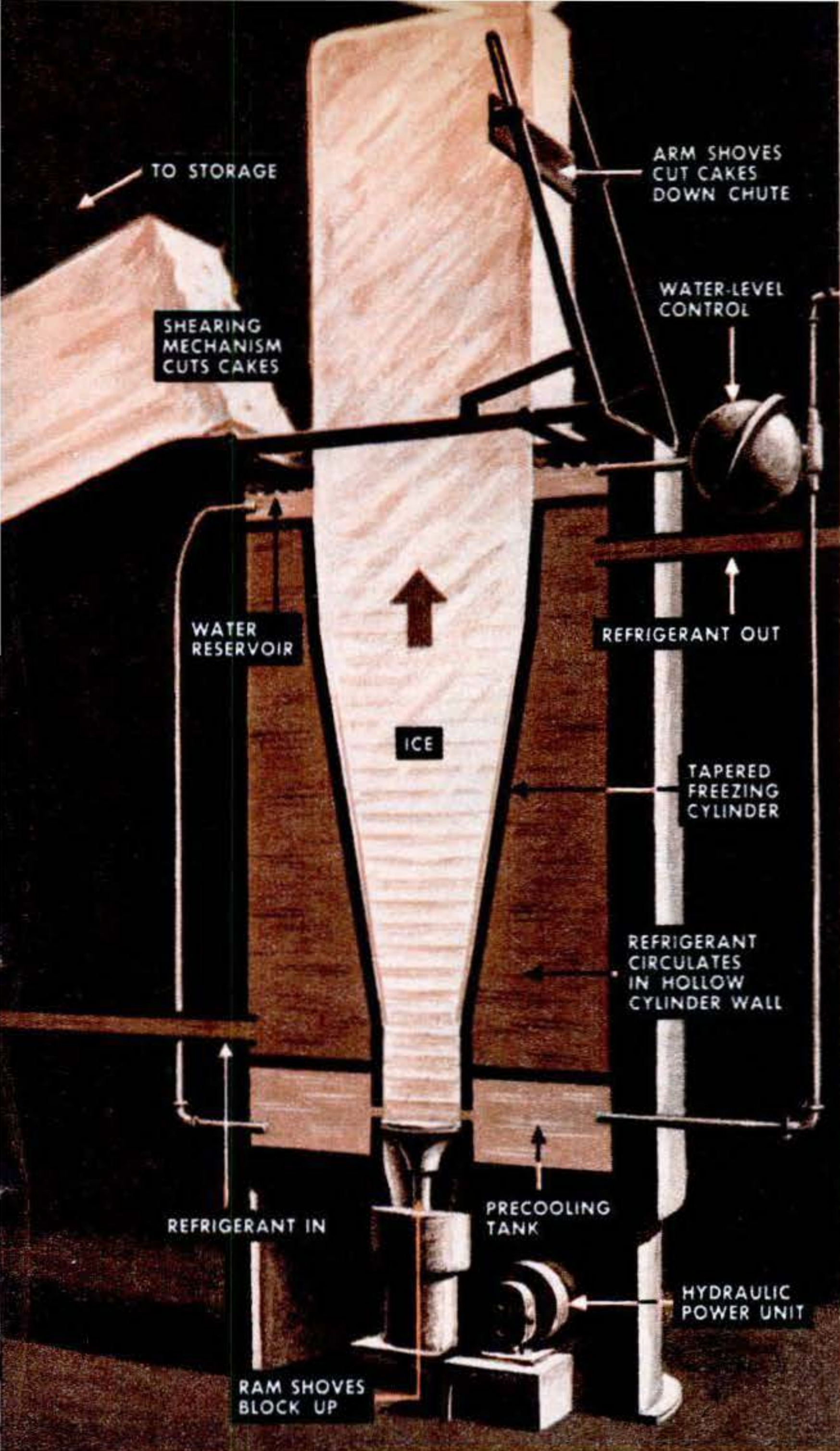

**Fast, continuous operation** depends on tapered shape of freezing cylinder. Ram at bottom lifts block, leaving space around it that fills with water from reservoir. Water freezes new layer on block.

**Water enters machine** at the bottom through the small curved pipe. It is chilled by passing over refrigerating coils before flowing into the reservoir that feeds it to the freezing cylinder.

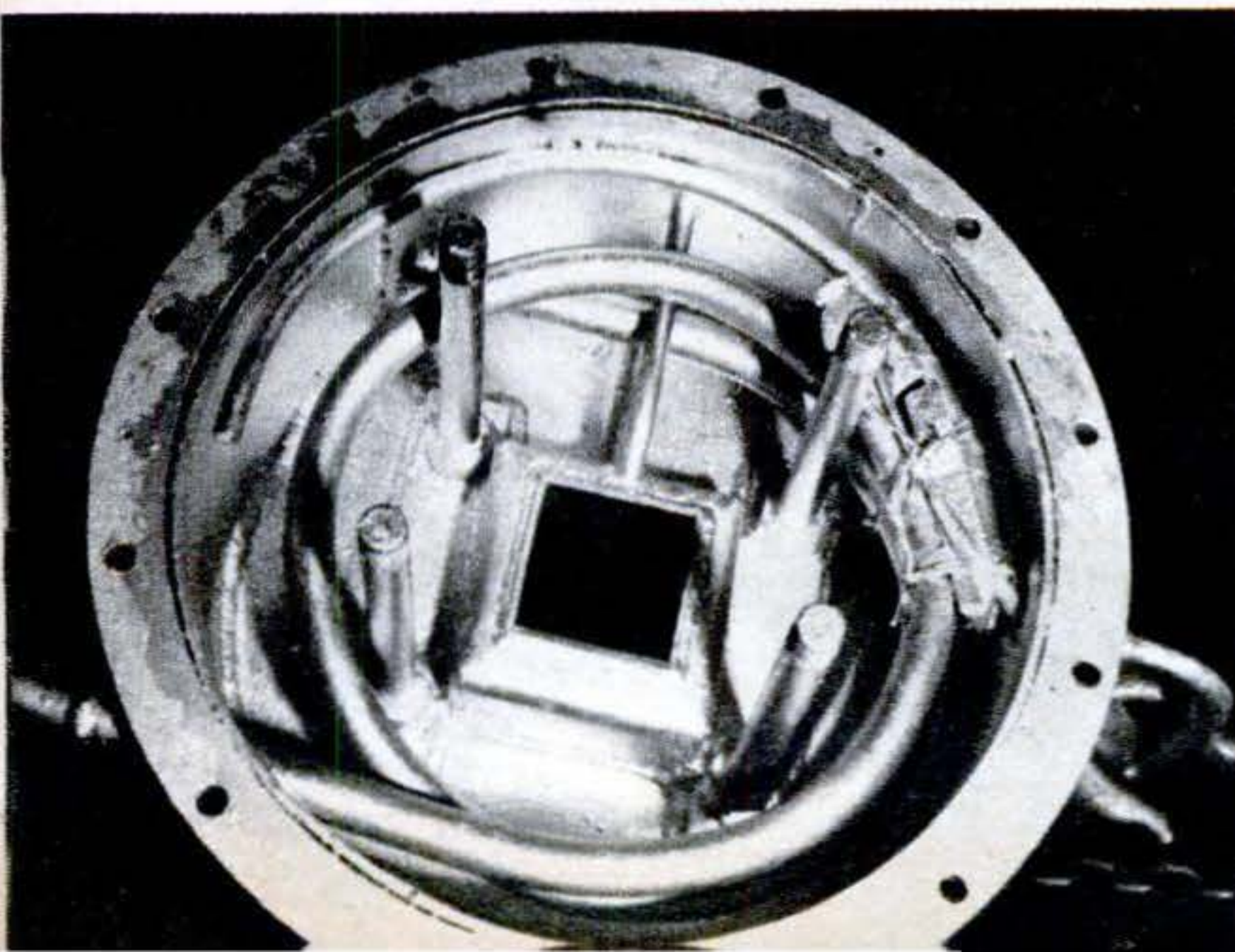

## Measures Out Just One Dram

**T**his automatic pipette transfers exactly one dram of perfume—to the drop—from a large bottle to a small one. Designed for use at a sales counter, its ingenious principle might also be used in laboratory measuring devices. Squeeze and release its bulb, while holding a finger over a discharge pipe, and its chamber fills with liquid from a bulk container. Take your finger off the pipe, and excess liquid drains back until the level falls below the top of the central drain pipe—leaving a precisely measured quantity to be poured out. It is made by Schindler Stamping and Toy Co., of Cleveland, O.

Place center tube in liquid, cover discharge tube with finger, and measuring chamber will fill when bulb is pressed (1) and released (2). Lifting finger (3) breaks suction and excess liquid drains back into container.

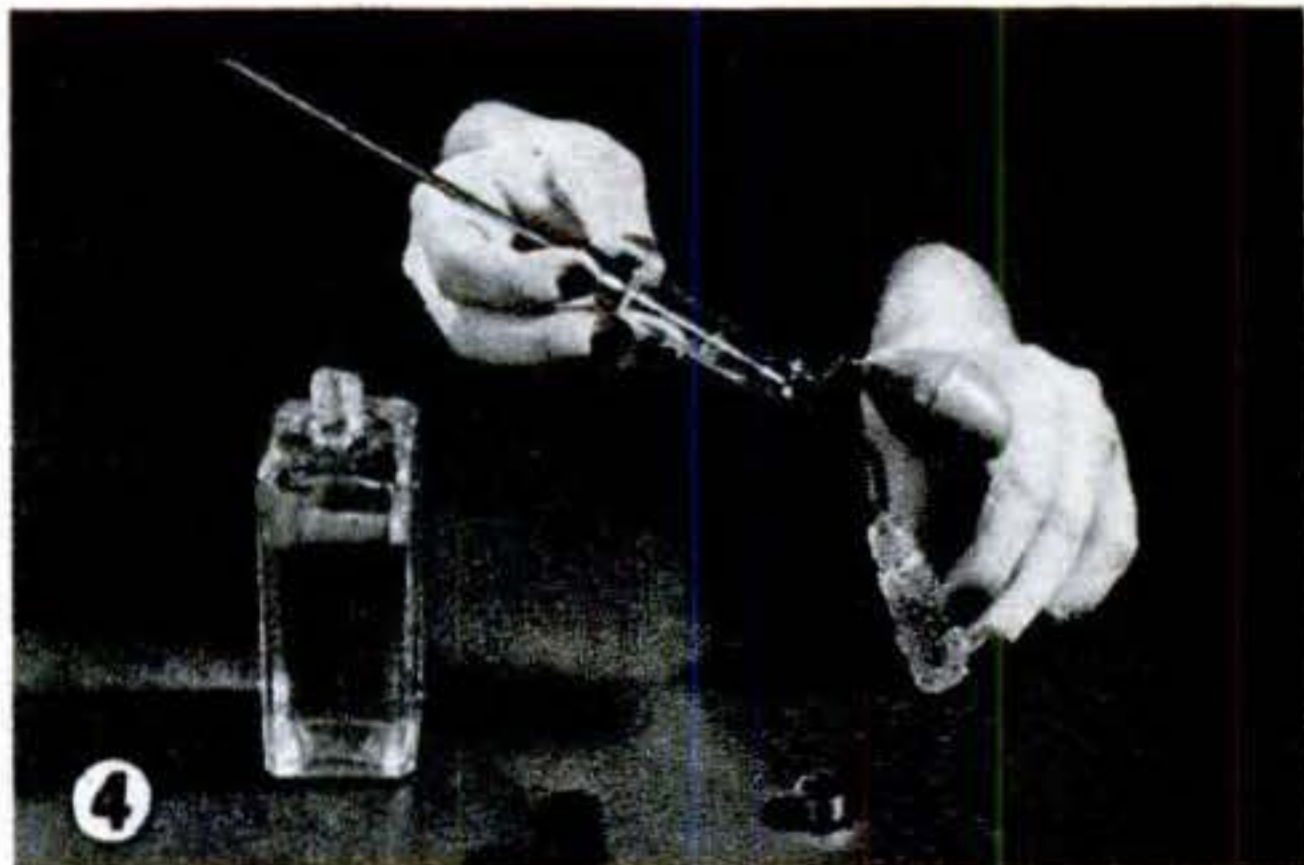
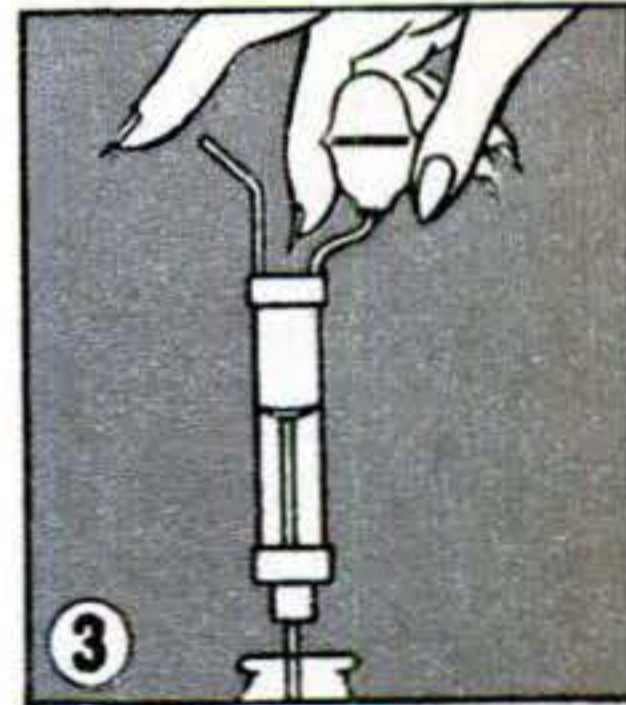
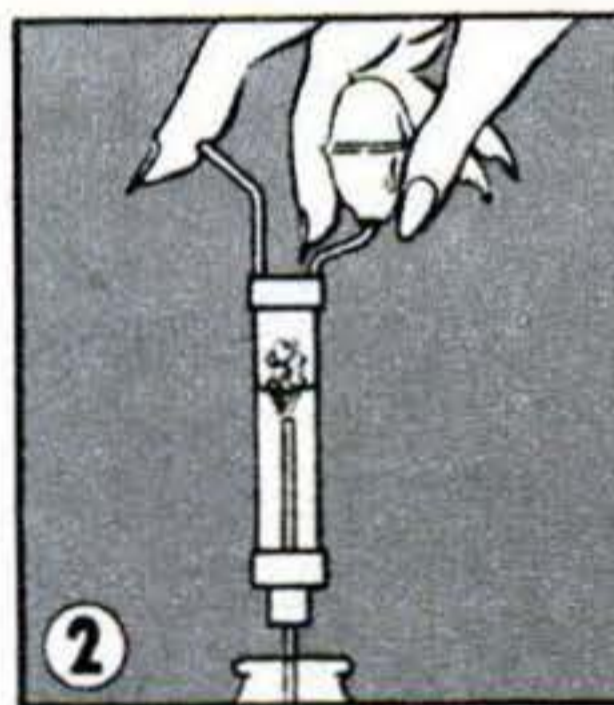
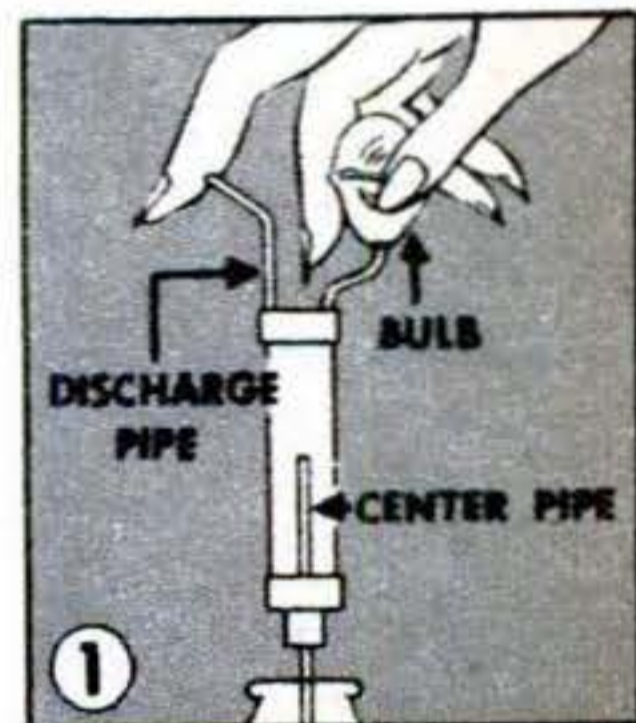

**Exactly one dram** of liquid remains in measure, which is inverted (4) to pour it out. Here, the measure is shown in use for transferring perfume from flask to small bottle.

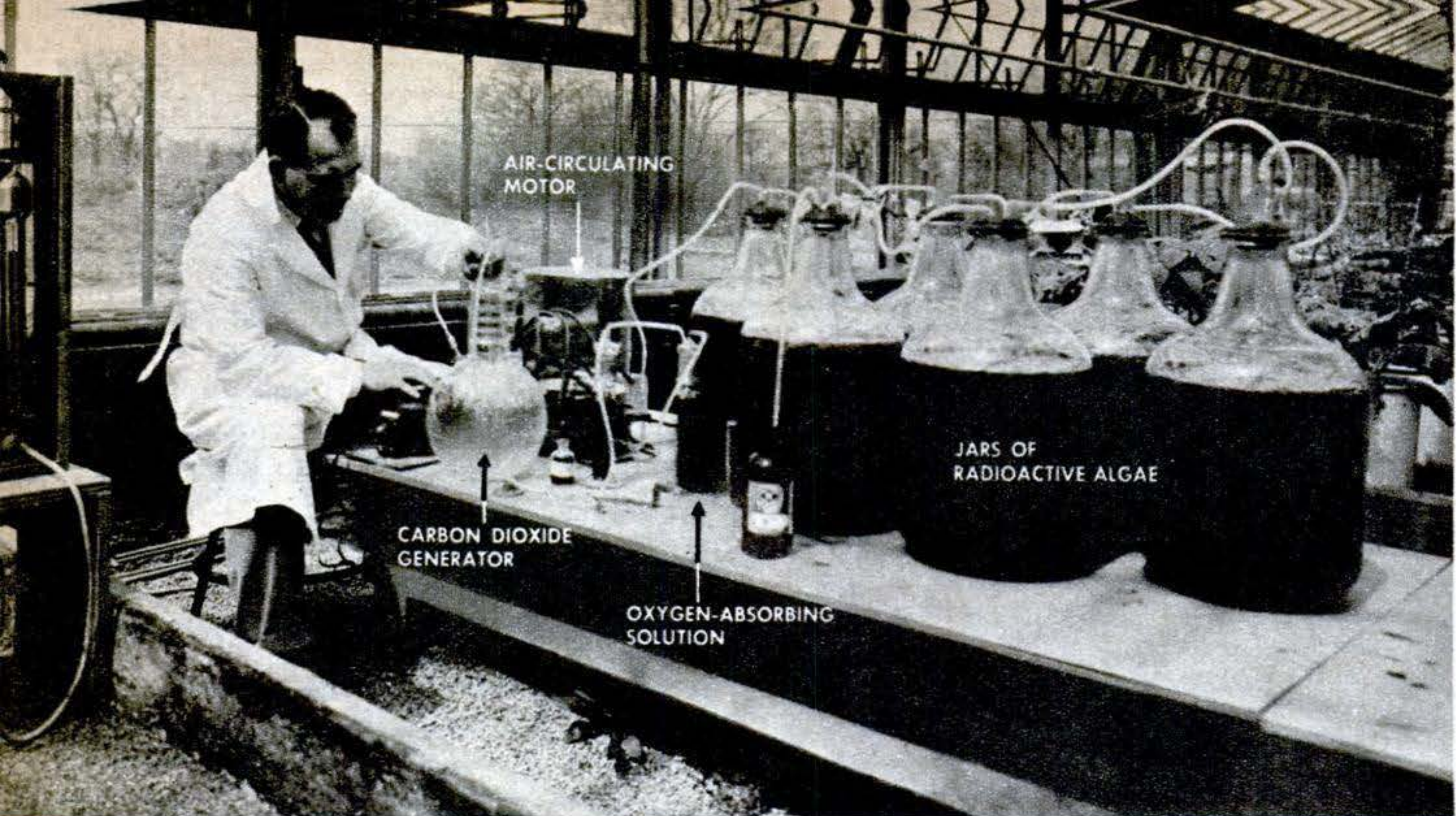

## Algae Work for Science

ONE of the simplest forms of plant life, made radioactive, will give scientists a new tool for probing the secrets of life processes. Algae are being "tagged," then fed to research animals. It is hoped that they will reveal details of animal metabolism. In the

photo above a researcher at the "isotope farm" of the Argonne National Laboratory in Chicago is preparing a mixture that creates radioactive carbon dioxide. Pumped into a culture medium of algae, this makes them radioactive. A limited quantity of these algae is being made ready for use by qualified scientists and research institutions.

## Photo Eye Starts Runners

TRACK-MEET events are guaranteed a fair start by the photoelectric-cell device shown below. It not only automatically fires the starting pistol, but blows a foul horn on any contestant who tries to beat the gun. The photo-eye light barrier is beamed along the starting line in front of the runners to a reflector placed on the opposite side of the track. Also used successfully in swimming meets, the portable, battery-operated unit is made by the Electric Eye Equipment Co., of Danville, Ill.

## A Big Tankful of Volts

FUTURE billion-volt X-ray machines may be foreshadowed by a new type of General Electric synchrotron of 300,000,000 electron volts. Called a "nonferromagnetic synchrotron," it dispenses with the usual massive electromagnet of many tons' weight. Instead, it employs the magnetic field of comparatively lightweight, solenoid-type, current-carrying coils within the compact cylindrical vacuum tank below. The same tank serves as an accelerating chamber for electrons, eliminating a separate "doughnut" tube.

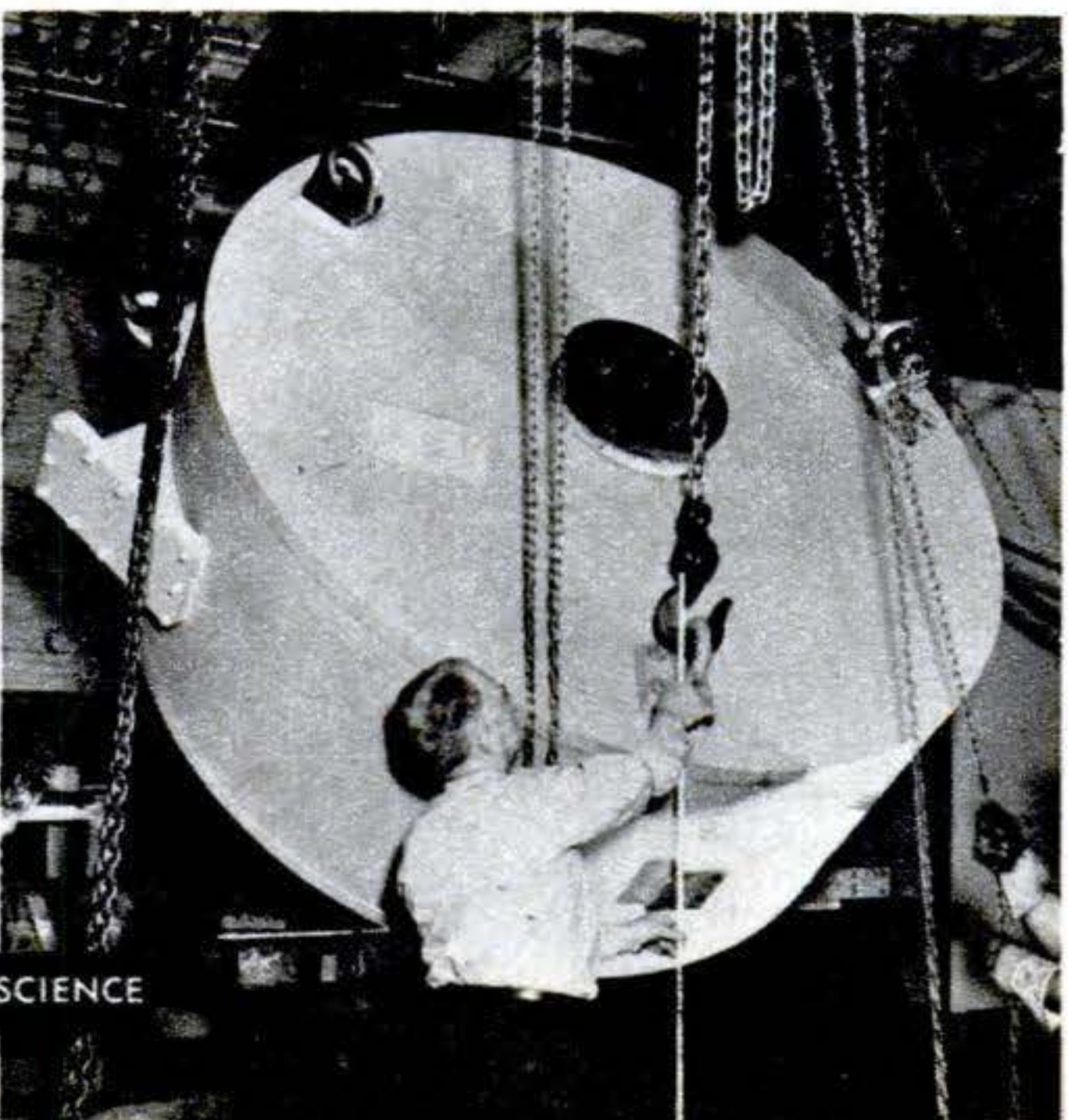
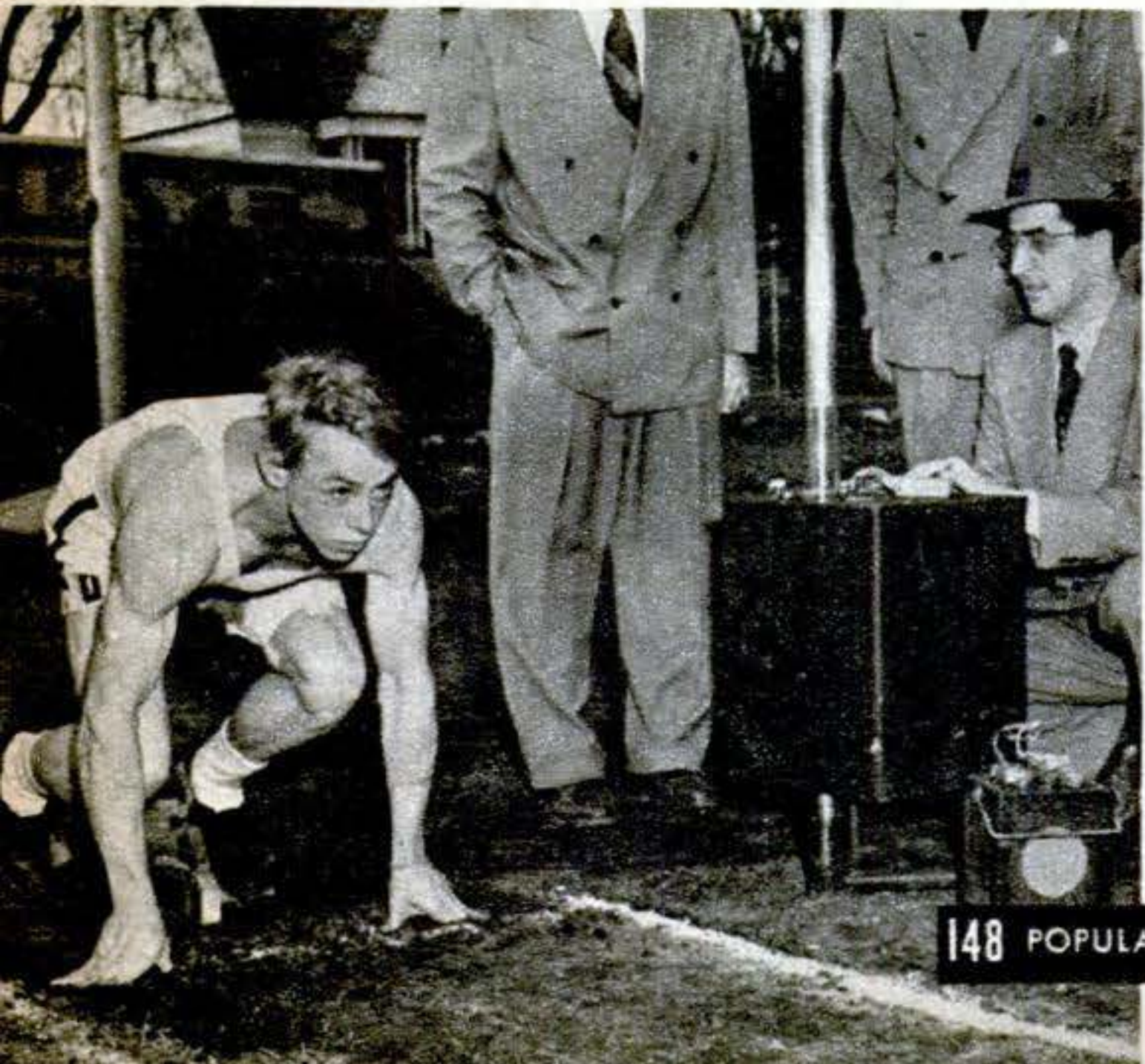

# Firemen Take Train to Fires

**T**HESE firemen go to a fire on a railroad train—one that's painted bright red, naturally. They are part of the fire-fighting force of the British Railways, which includes 7,700 men in one region alone.

Recently re-equipped with the latest types of fire-fighting apparatus, the red trains can be on their way at a 60-m.p.h. clip within five minutes after an alarm. Each carries 8,500 gallons of water, miles of hose, foam units for oil fires, and mobile pumps that can deliver 350 gallons a minute.

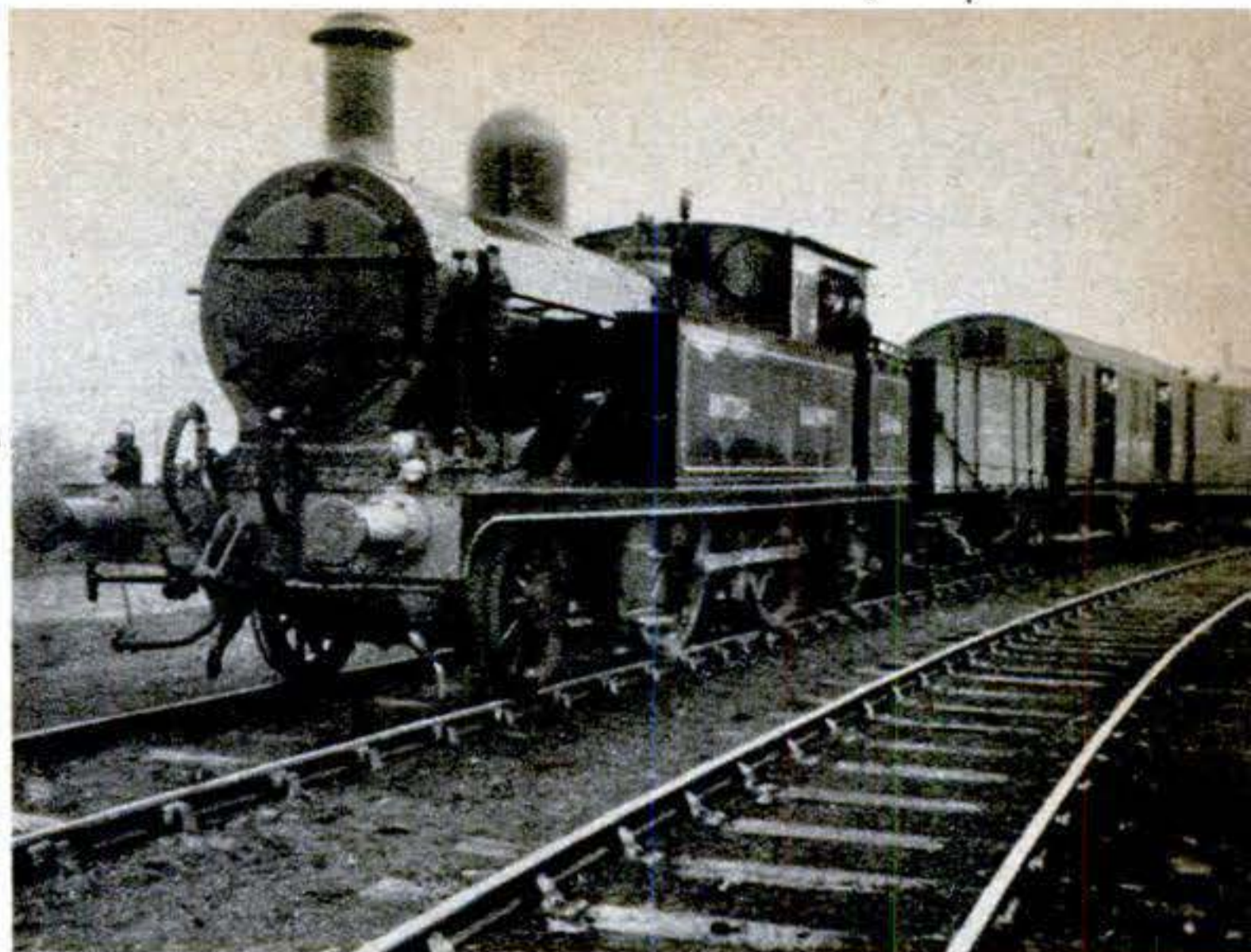

Bright red fire trains of the British Railways are kept ready to fight fires on railroad property. Car behind engine carries the 8,500-gallon water supply; others hold crew and equipment.

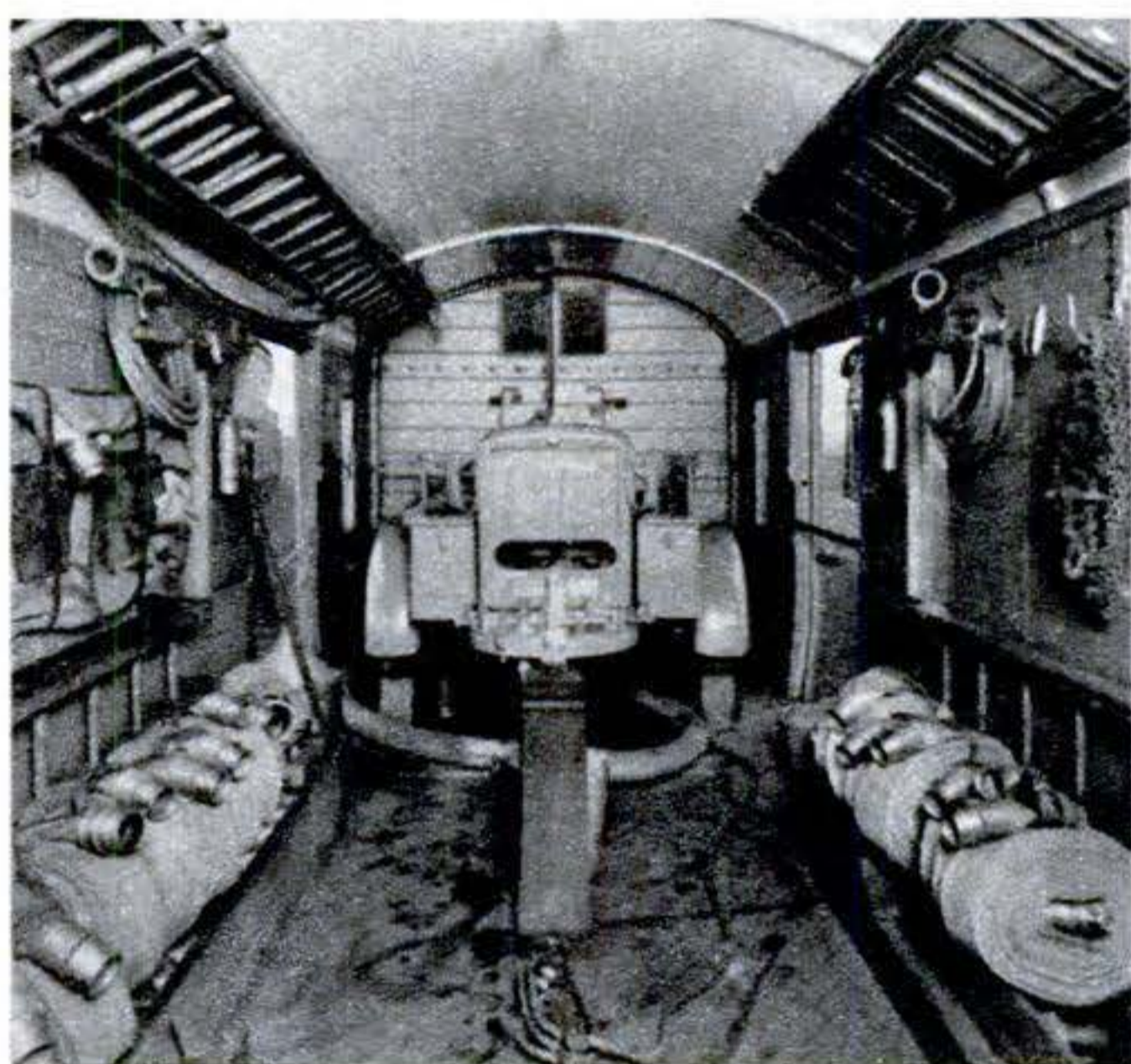

Special equipment car has hose, ladders, foam units, floodlights, hand pumps, and 350-gallon-per-minute motor pump. Note big doors behind mobile pump that open up entire end of car.

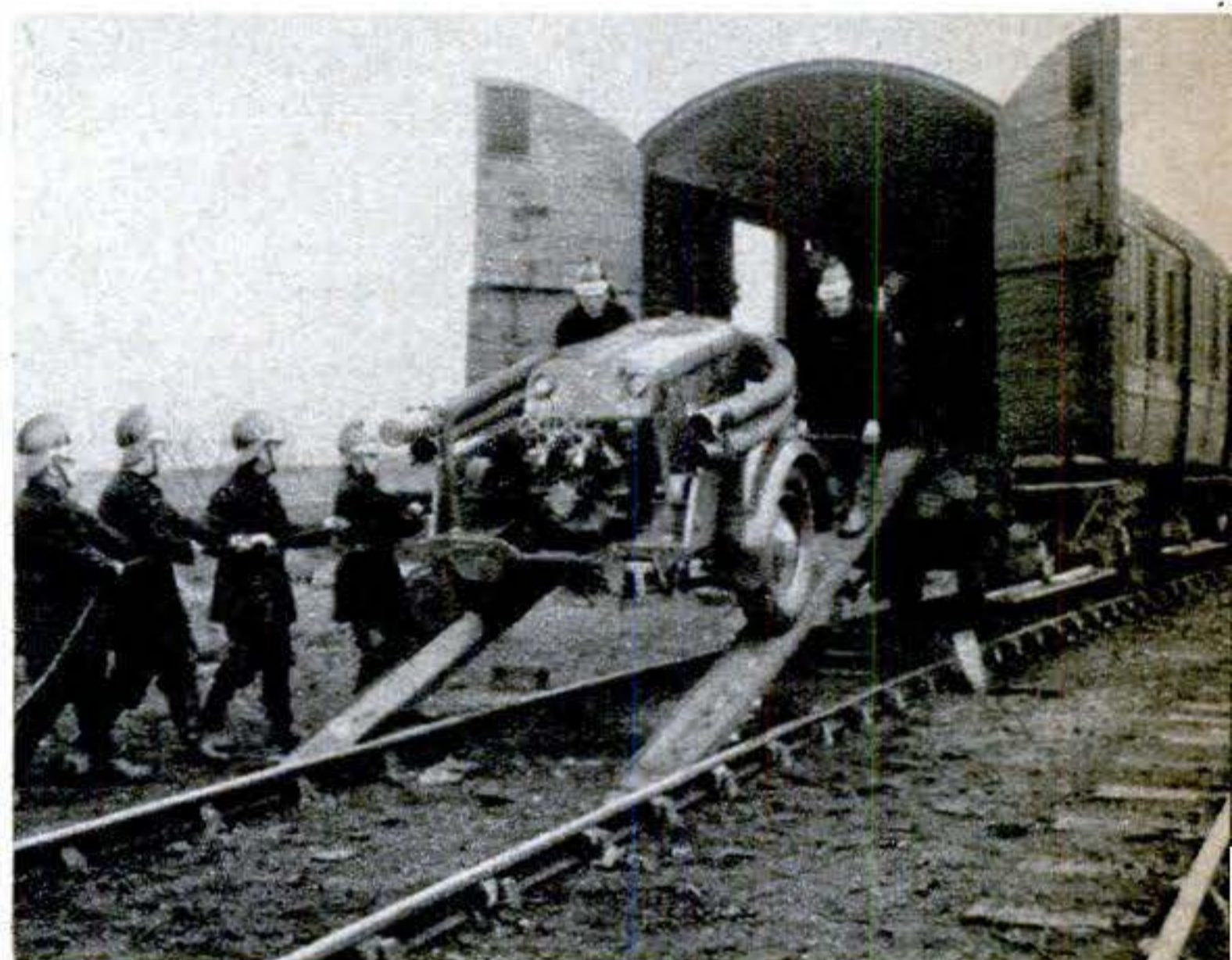

A ramp lets the powerful mobile pump down from the equipment car. Men at left lower it slowly with the help of a block and tackle, while others behind the pump guide it into place.

Helmeted fire fighters of the railroad stage a demonstration in the yards. This protection force,

numbering many thousand men, is kept on stand-by duty for quick response to emergency calls.

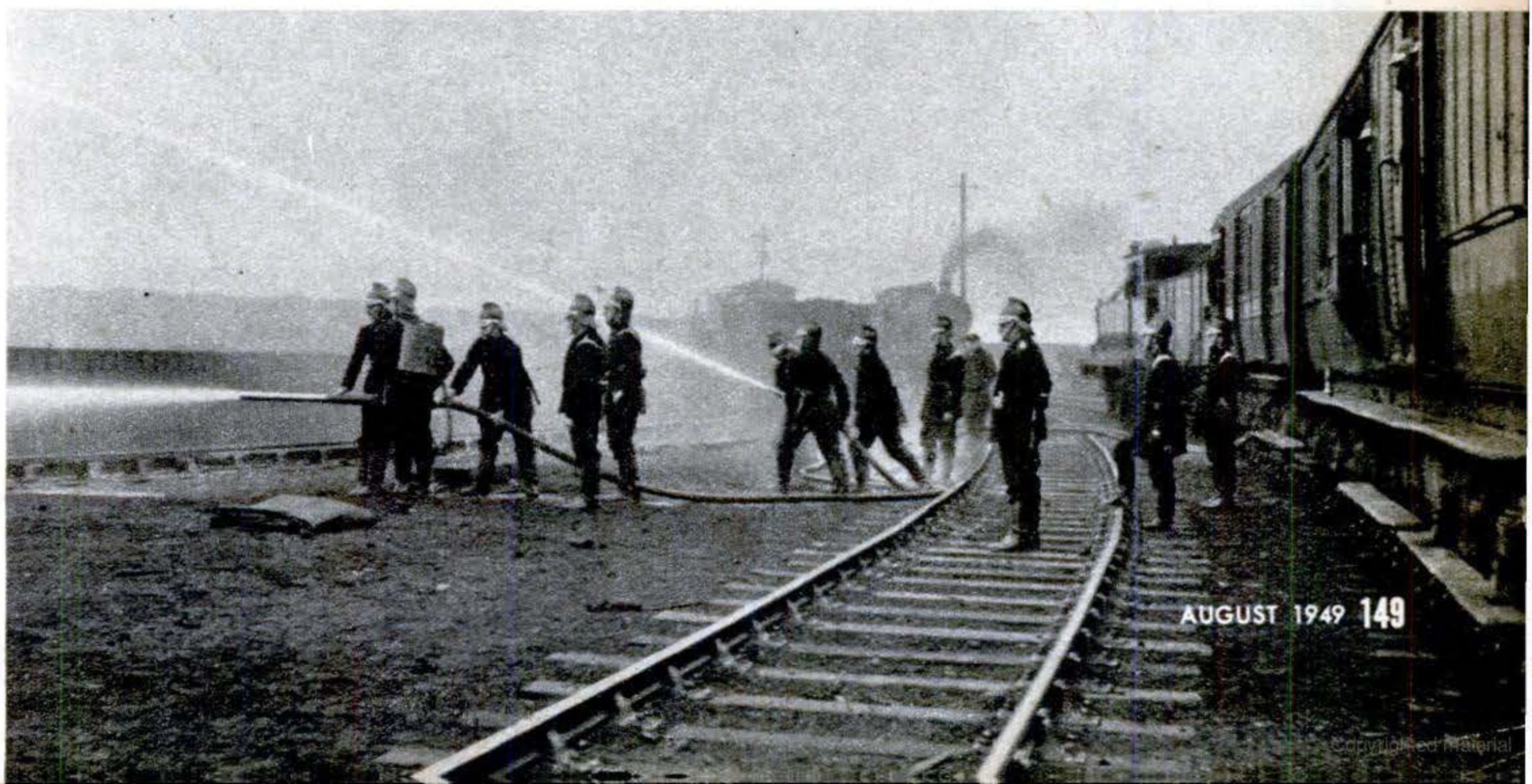

## MECHANICS OF LIVING

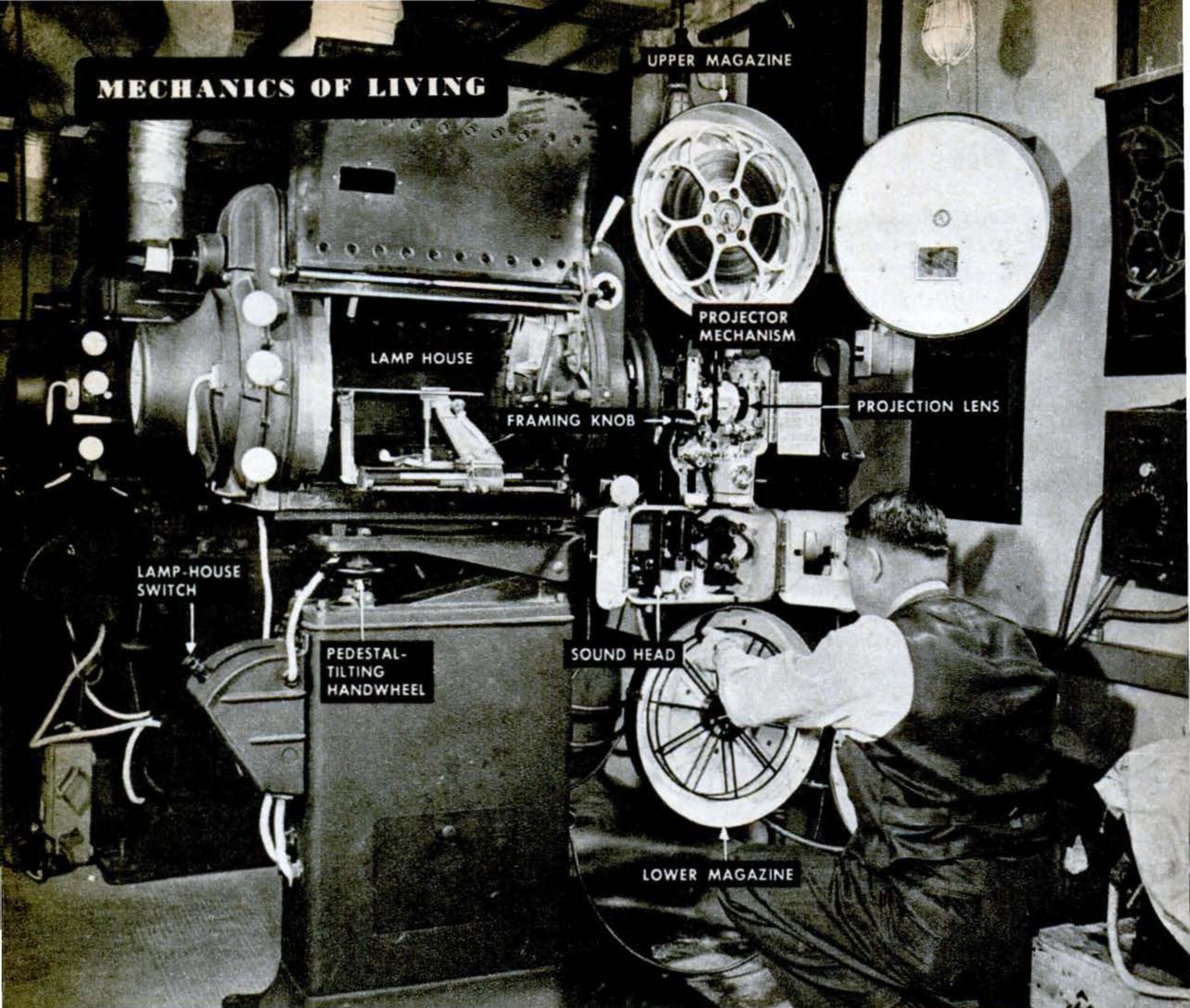

A theater movie projector, like this 775-lb. Simplex®, produces its pictures-and-sound show with a light source, an intermittent mechanism that throws a fast succession of still pictures on the screen, and a system for converting light

variations into sound. Here an operator is finishing the threading procedure, taking the film leader as it comes down from the sound head and attaching it to the take-up reel. Note the ducts that lead heated air from the lamp house.

# How Motion Pictures

By **Devon Francis**

PS photos by *Hubert Lockett*

**T**HE next time you go to a movie, begin watching the upper right-hand corner of the screen about 19 minutes after the feature goes on. If your eye is sharp, you will presently see a dot — white if the background is dark, or black if the background is light. It will last for only about 1/6 of a second, and eight seconds later another dot will flash by.

These dots are cues used by that past master in the art of legerdemain, the projectionist.

The first dot warns that it is almost time to switch reels. The second one signals the instant to do it. As it appears, the operator neatly chops off the image being thrown on the screen by one machine, together with its sound, and cuts in the image and sound from a second machine. He does it so deftly that the audience, preoccupied with heroine or hero, is unaware of the transition.



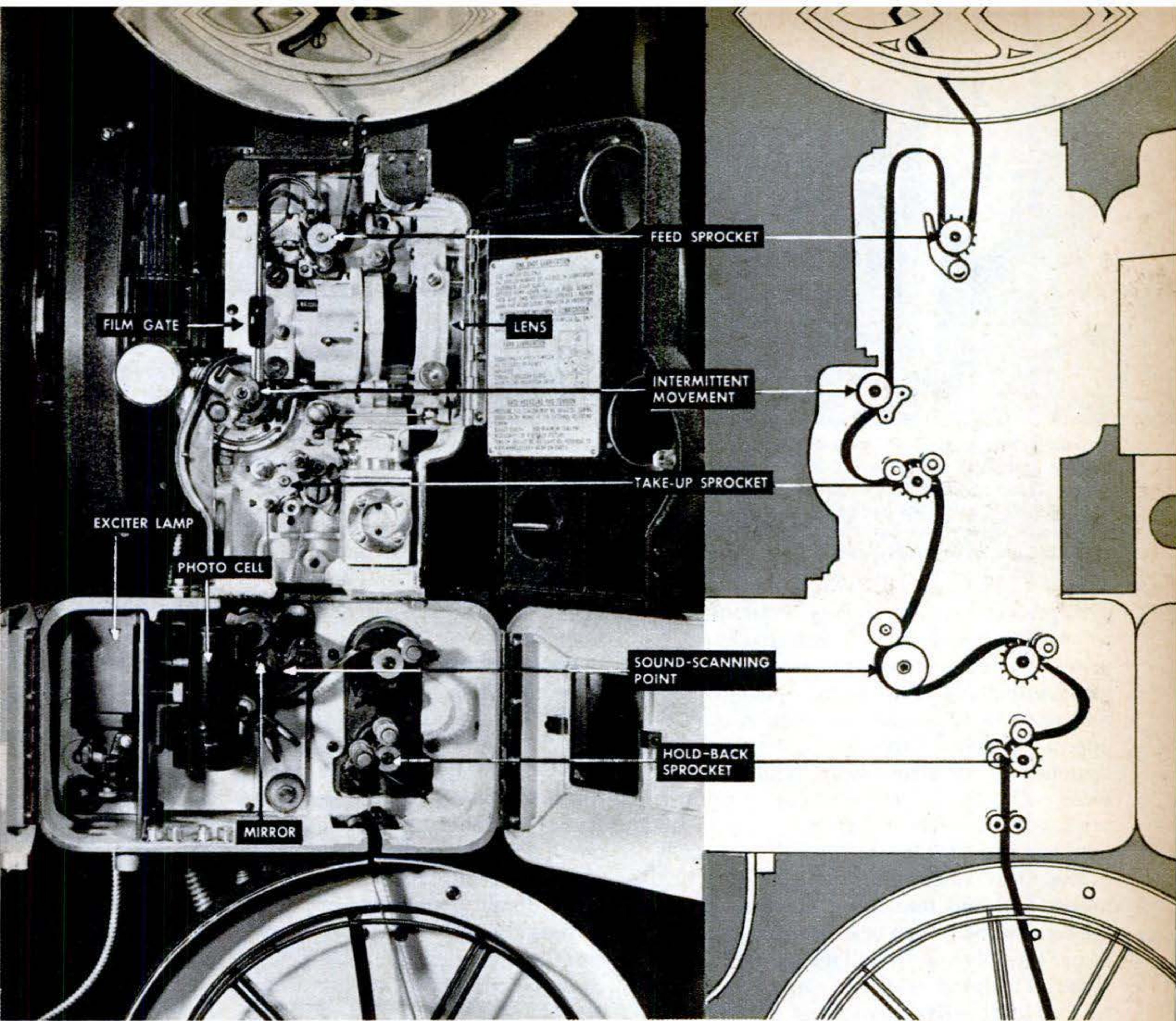

**Film path** through the "mechanism"—trade lingo for the intermittent film-transport device—and the sound head is shown here. Each frame of film is projected for about 1/45 second; illusion of movement comes from eye's persistence of vision.

In sound head, light beamed through sound track on film strikes photoelectric cell, giving fluctuating currents that are amplified and fed to speakers. Sound track may be either bands of varying transparency or a jagged opaque pattern.

## *Are Projected*

The projectionist is a magician. His main prop is an elaborate, costly machine designed to kid our senses with an illusion of reality. To throw the shadows from a film strip on a screen, and to make an eye "see" them move, costs even a small, two-machine theater, with sound equipment, about \$8,000.

Modern theater projectors have come a long way since the invention of the zoetrope in 1853. They have come a long way, in fact, since the kinoscope and cinematograph be-

fore the turn of the century (PS, Dec. 1897, pp. 177-188).

A projector consists of three essentials—a lamp house, a film-and-shutter mechanism, and a sound head. The first provides the intensely bright light required. The second shoots 24 separate still pictures a second onto the screen. And the third converts the squiggle of the sound track into minute electric currents that, greatly amplified, produce the sound. ➤

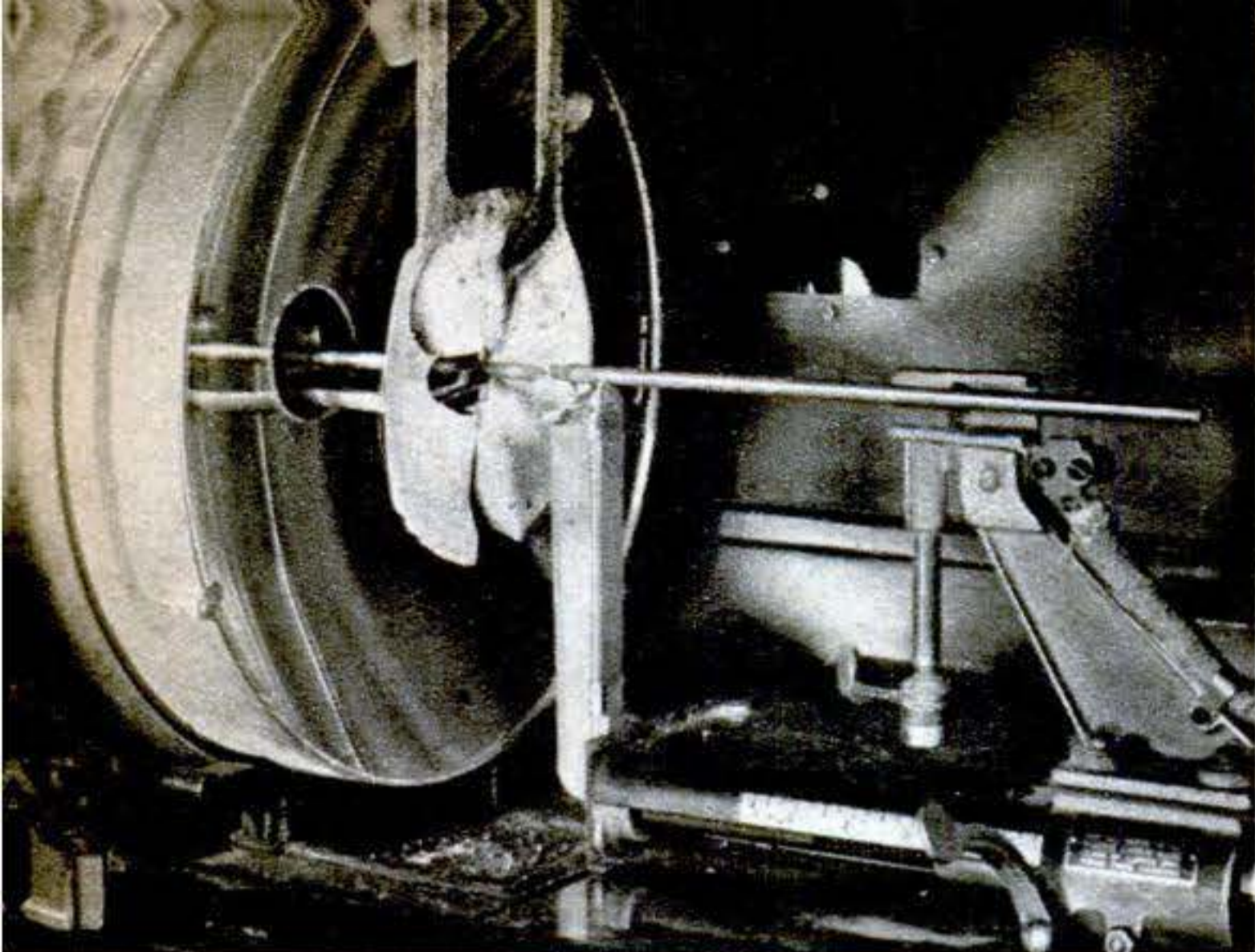

**Inside lamp house** are two carbons in front of highly polished reflector. A shield protects reflector from splatter when 65-amp. arc is struck. Motor keeps carbons properly spaced as they burn back; pair lasts for about three reels. This two-kw. arc gets really hot — about 5,500° F.



**Two shutters clip the light** while new frame of film moves into place. Although both shutters actually turn in the same direction, the rear one is behind the lens so its motion on the screen is reversed. Together they "scissor" off the light. Rear shutter also helps protect film from heat.

A projector is a complex, semi-automatic robot. The switch in reels and machines, for instance, occurs when the operator steps on a foot switch and triggers the "change-over." Solenoids in the machine being shut down operate a "douser" that cuts off the light and switches off the sound head, while other devices cut in the second machine at the same precise instant. The entire change-over may take less than 1/20 of a second.

Even the notification that the reel is nearing its end and that the synchronizing dots are due on the screen is automatic. When the upper (supply) reel is full it turns at 22 r.p.m. When it's almost empty it turns at about 85 r.p.m. The effective diameter of the film whirling on the reel has shrunk; the mechanism still takes the same amount of film per second, but it now takes many more turns to supply it. When the reel builds up to about 75 r.p.m. a bell or buzzer, set off by a centrifugal speed trip, tells the projectionist to stand by for the change-over.

He is prepared. He has threaded the second machine. He strikes and adjusts the arc in the second lamp house. In a moment he switches on the current to start the second machine rolling and bring it up to speed. Practice tells him when his 20 feet of "leader" — the part of the film the audience never sees — will have run past the film gate and through the sound head. The leader has three parts — a protective leader that can dangle on the floor and get dirty in the threading process, an identification leader that shows if the reel is in sequence; and a synchronizing leader that overlaps the action of the reel running

out. When the second dot appears he trips the change-over switch and the job is done.

Projectors use both AC and DC. A constant-speed AC motor drives the film-transporting mechanism and the take-up reel, and AC is also the power supply for the sound system. The DC supply, usually provided from a rectifier or motor-generator set, is used for the lamp-house arc. An ingenious variable-speed motor feeds the positive carbon into the arc at just the rate that the carbon is burned, maintaining a constant level of illumination. Variations in the amount of current in the arc, which depends on the distance between carbons, cause this motor to change speed.

#### *Projectors Still Require Supervision*

The projectionist isn't idle between reel changes. Like everything mechanical, projectors require supervision. Despite its automatic feed, the arc may need occasional attention. Or the sound level in the theater may grow too high or low. This may be due to an increase in the size of the audience; an almost empty house needs less sound than a full one, because human bodies and clothing absorb sound waves. Or the audience may be one that knocks itself out laughing at a comedian, drowning out the sound from the big speakers by the screen. In most theaters the projectionist has a sound-monitoring speaker in his booth, but often the actual level is fixed by ear from the auditorium, the operator being phoned to lower it or boost it.

Another of his jobs is to check the focus of the picture. Even though the lens-to-screen distance is constant, minute variations in

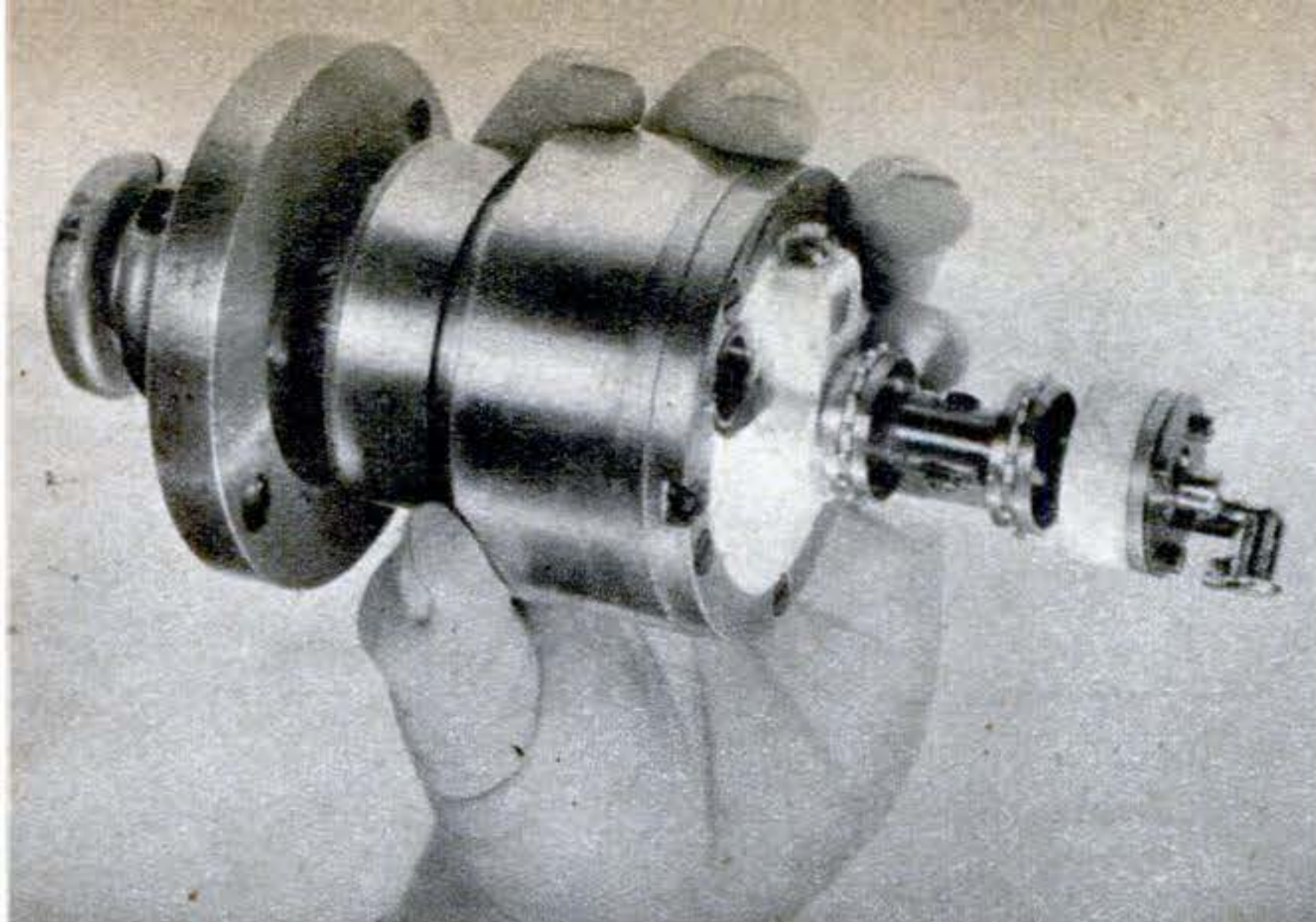

**Intermittent movement**, which is removable as a unit, is the heart of a projector's film-transporting mechanism. Its job is to pull a frame of film down, halt it briefly, and then pull down another—and do this 24 times a second. A ¼-hp. AC motor powers this mechanism and the take-up reel.

thickness of the film stock may destroy sharpness of the image. He takes care of that with a micrometer focusing screw.

Improvements in both projectors and projecting techniques have largely eliminated the film breaks or misframings that, in days gone by, caused audiences to stamp their feet or clap in impatience. With a well-maintained projector, these troubles are almost always attributable to faulty splices, and today no operator worth his salt will let a defective splice leave his hands.

Film fires are also almost unknown these days. The film races past its scorching hot light source at 90 feet a minute. An automatic fire shutter, also triggered by a centrifugal governor, drops down between light and film if for any reason the speed falls to 50 or 60 feet a minute. Even if the film should catch fire, it can burn only in the projection mechanism and sound head. Fire rollers at the exit from the top magazine and the entrance to the lower one keep any fire from spreading. As an added precaution, there are magazine doors that deny the spooled film an adequate oxygen supply.

The fact that shows in big theaters or little neighborhood houses alike are almost always run off these days without breaking the illusion of reality is a testimonial to both the machines and their operators. Only in the case of major breakdowns or current failure does a show have to close down, and these contingencies are rare. The magic machine that creates mass illusion for millions of Americans each week does its intricate job with high precision. **END**

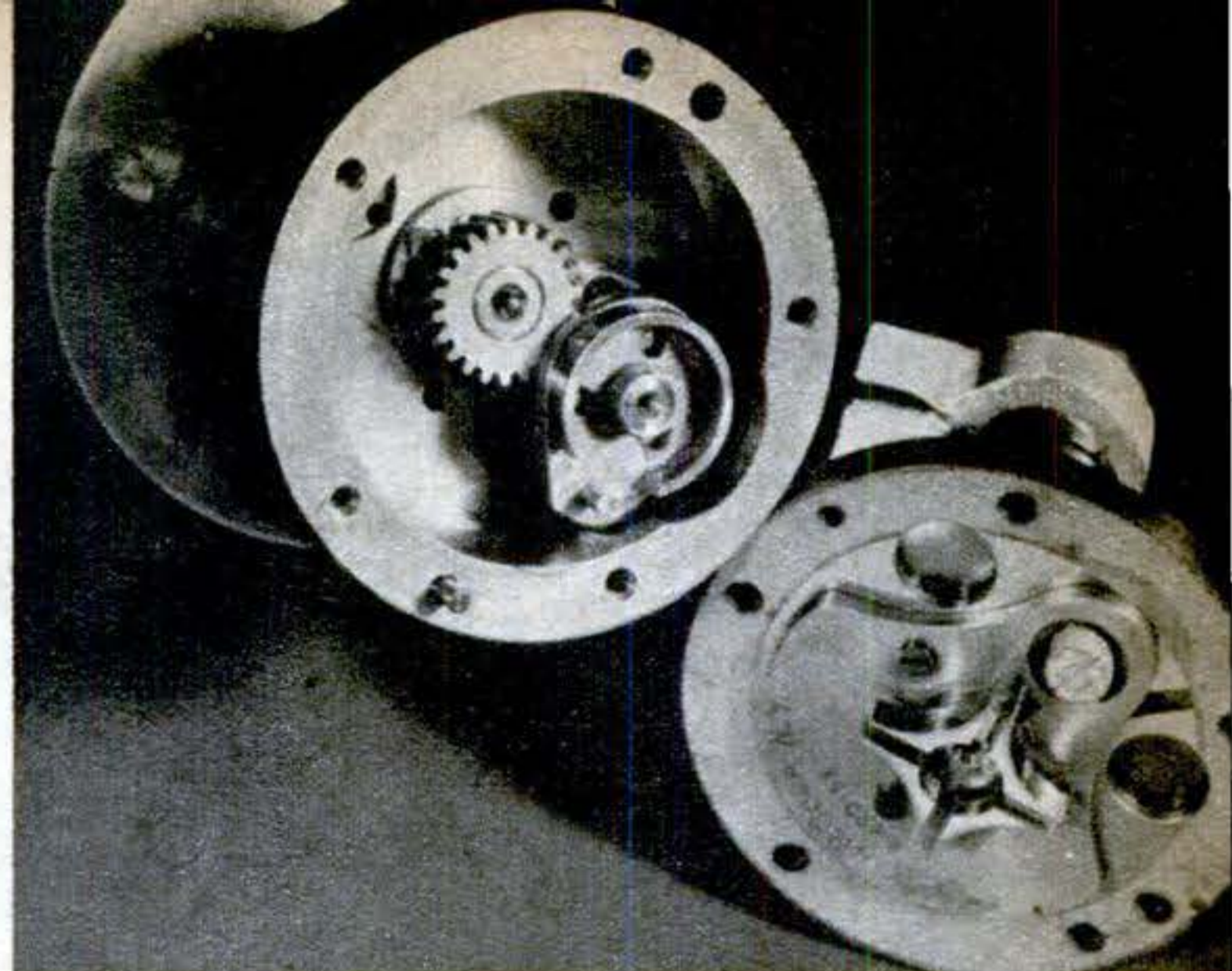

**Taken apart**, the intermittent movement looks like this. A gear-driven eccentric pin in the left-hand section flips over the slotted star or Geneva wheel in the right-hand part. The pin turns constantly; the Geneva wheel turns only as the pin engages it, moving the film ahead one frame.

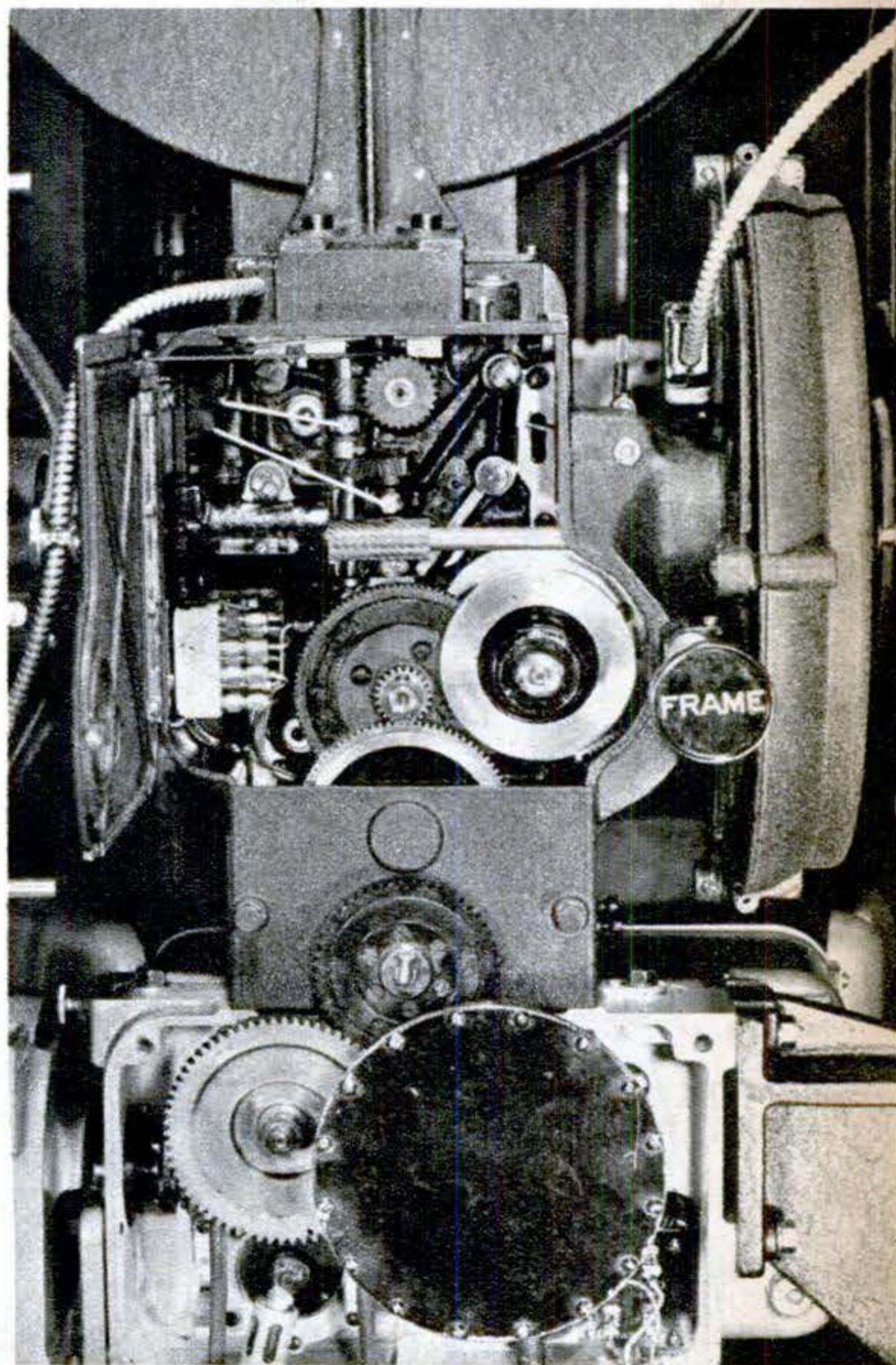

**A complex gear train** is used in modern projectors, as this view of left side of the mechanism shows. Many parts run bathed in oil, and elaborate seals are needed to keep oil from film passages. An oil-damped flywheel aids the constant-speed motor in maintaining correct sound pitch.

# Plant Chops Old Bottles for New

**S**MASHING old bottles can be a bigger job than you'd think. Breaking and washing half a million every day requires a \$250,000 plant especially designed for this important industrial process.

A South Gate, Calif., scrap-glass dealer, M. I. Sessler, has built a new, almost completely automatic plant that does just that. At one end it takes in used glass; at the other end it pours into railroad cars smooth, clean, reclaimed glass, called cullet. (The name comes from "collar," the piece remaining on an old-time glass blower's pipe after he had finished blowing a bottle.) Cullet is added to the batches of raw materials in making glass—



**From mountain of discarded glass, bulldozer starts material on its way to becoming cullet by shoving it into pair of 500-ton-capacity concrete hoppers that feed the crushing plant.**

a new bottle may contain up to 40 percent.

In the Sessler plant, old glass passes through a series of washers, a crusher, and under an electromagnet (to pick out stray metal), as shown in the drawing and photos. Human hands touch the broken glass only to pick out the last bits of foreign material.

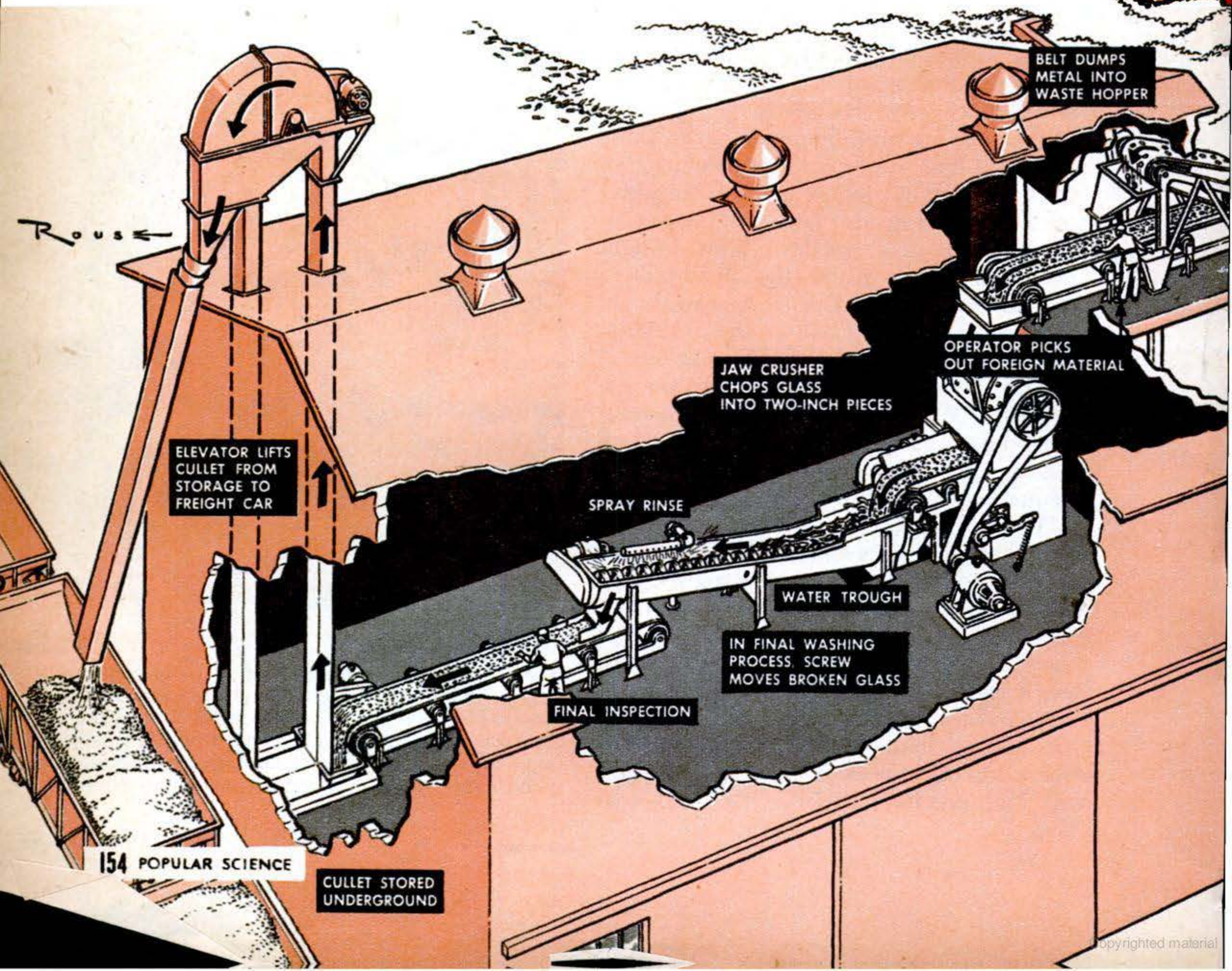

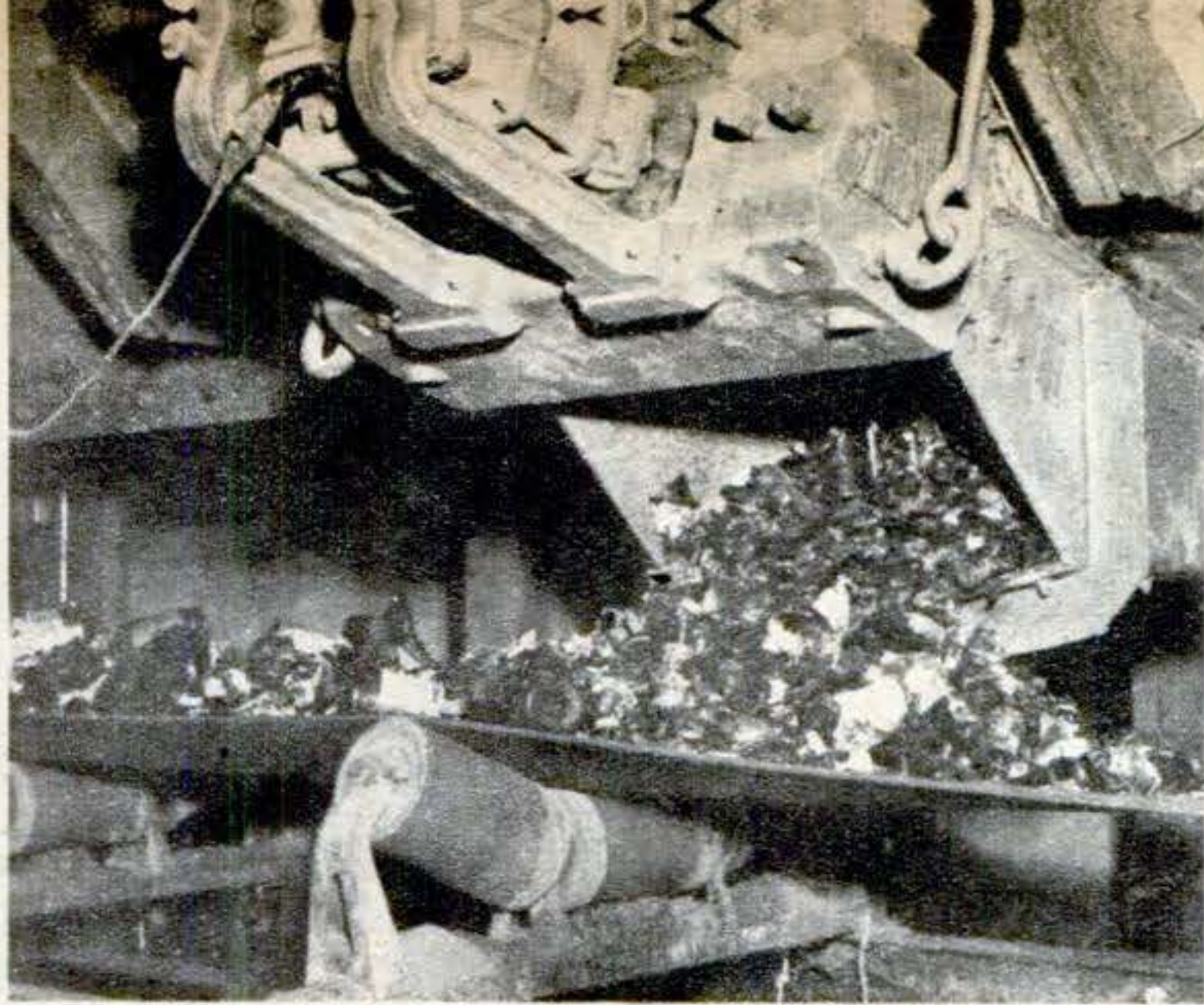

**Under the hoppers,** electric vibrators shake the glass out of these openings onto 30-in. conveyer belts. Each of these vibrators can shake about three tons of glass out of its hopper every hour.

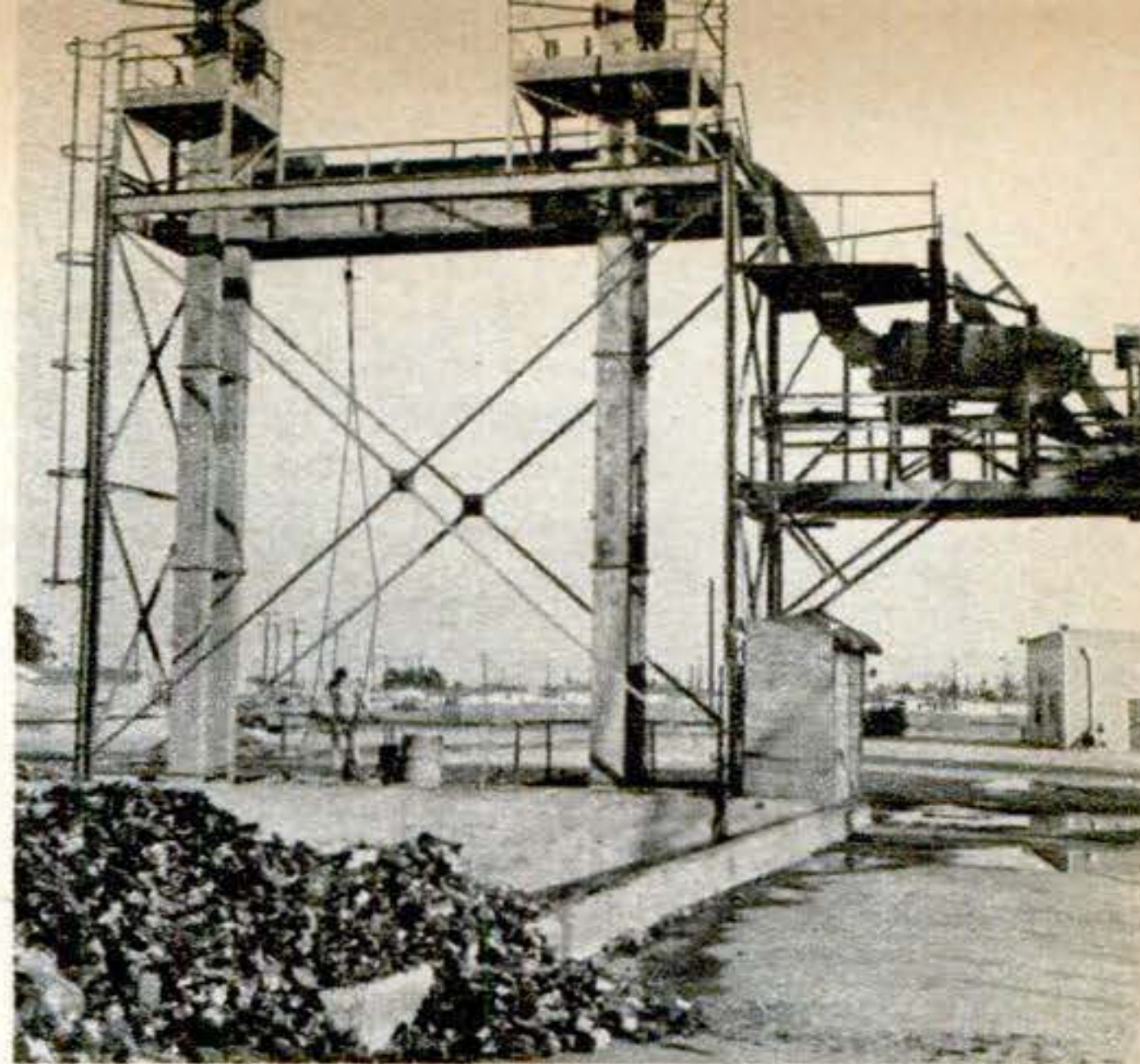

**The belts** carry their loads to elevators 60 feet high (above) that lift the glass onto a second conveyer. Conveyer feeds glass to the first washer, a tumbling drum (center right edge of photo).

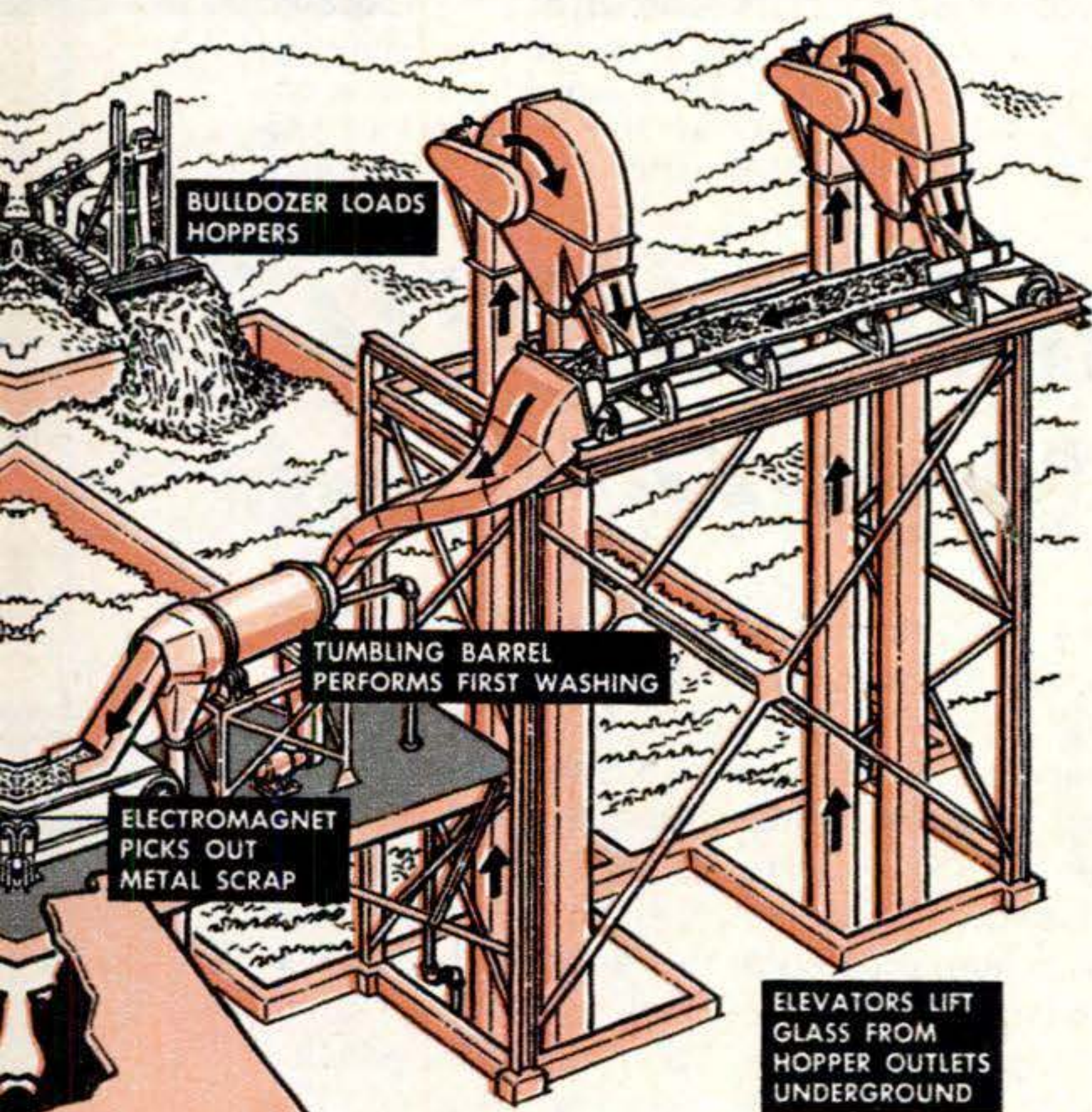

**The glass next falls** into this crusher, whose jaws snap raw material into two-inch pieces. A second magnet then picks out metal knocked loose in crusher.

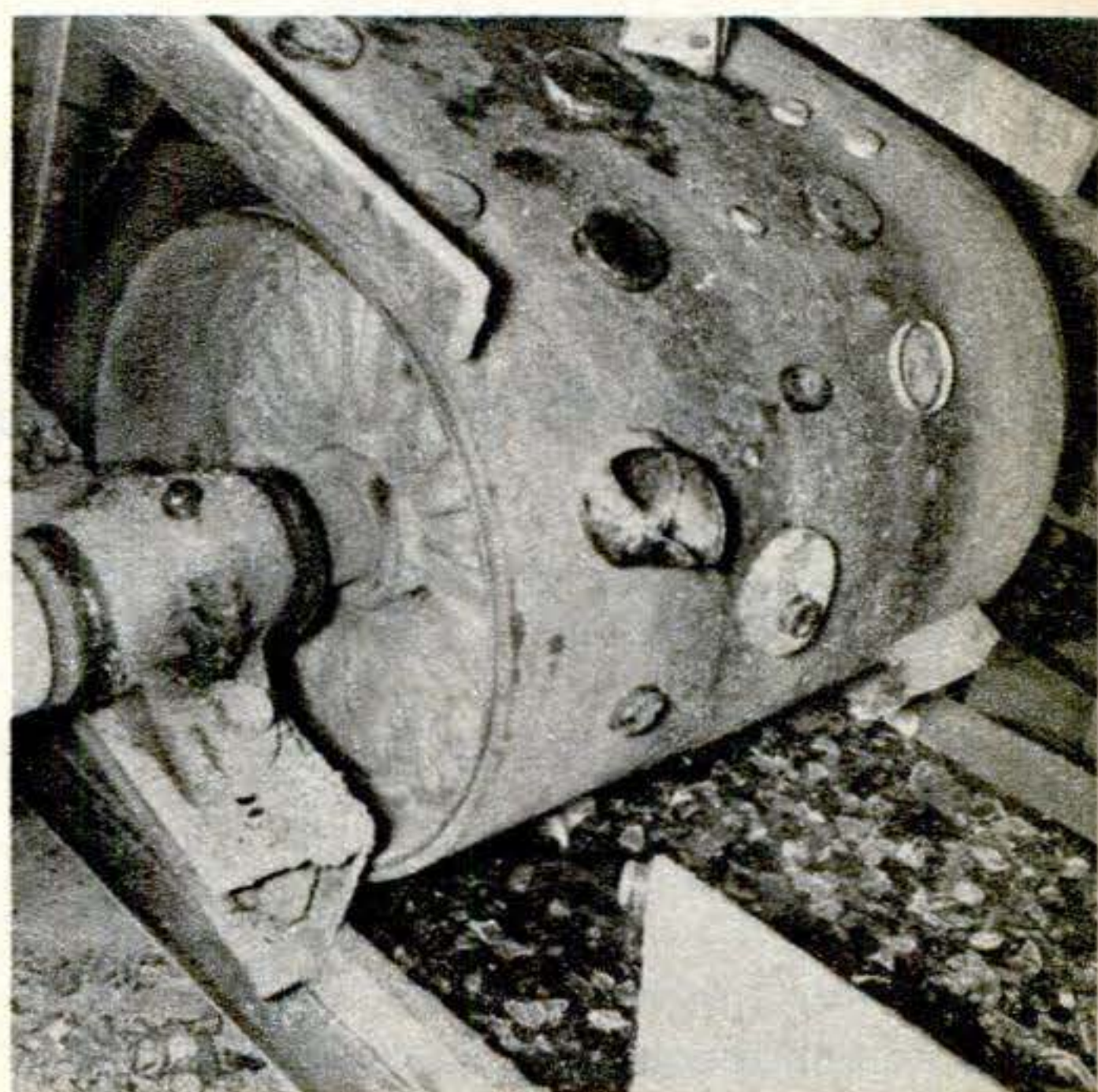

**After washing,** the scrap material passes under an electromagnet that pulls out bottle caps, cans, and other metal and makes them stick to the belt. The belt then delivers them to a waste hopper.

**This is cullet** after final, two-step washing, and inspection, ready for shipment to bottle maker. The cleaning process rubs off sharp edges so that it can be handled without danger of cuts.

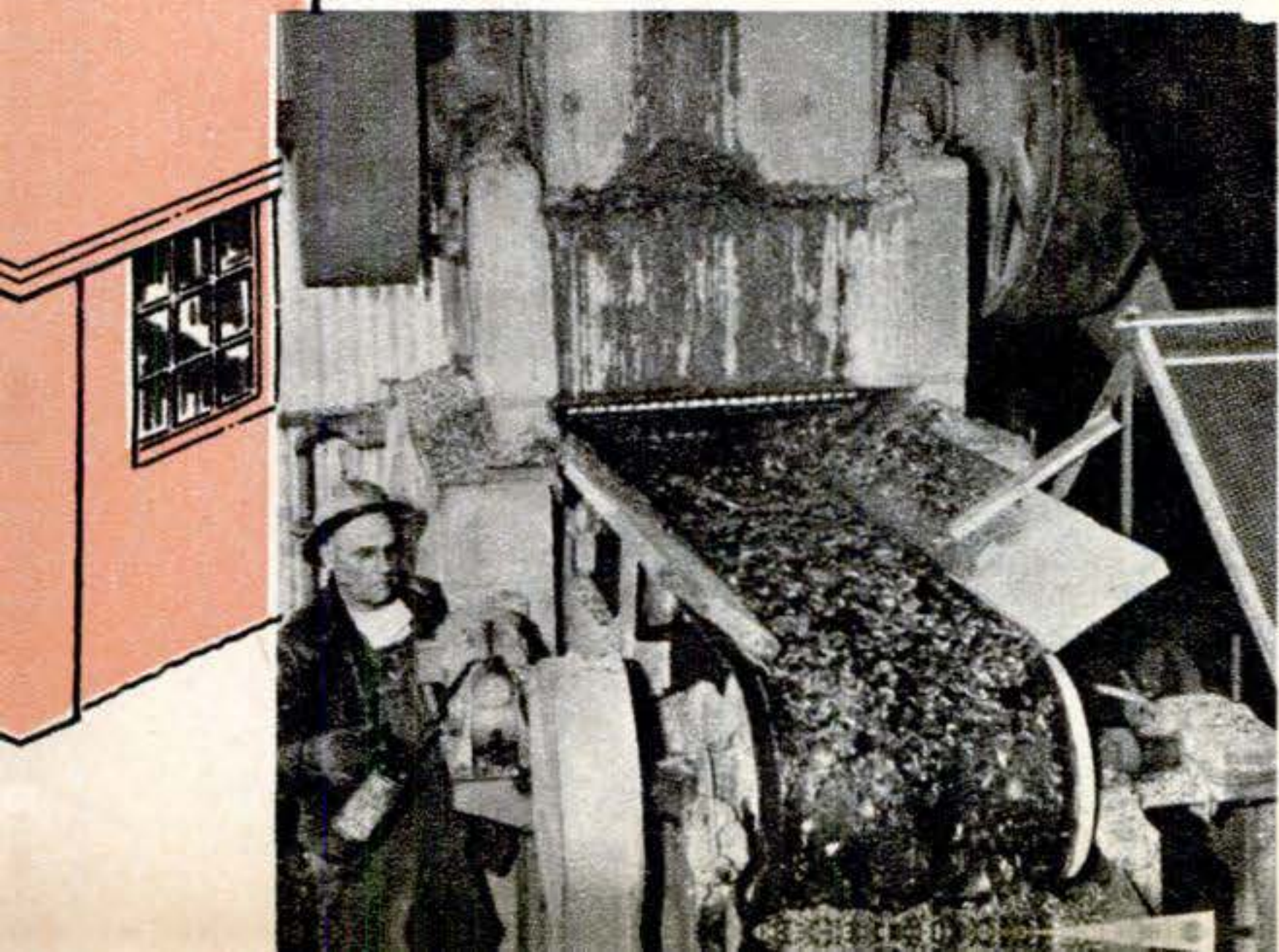

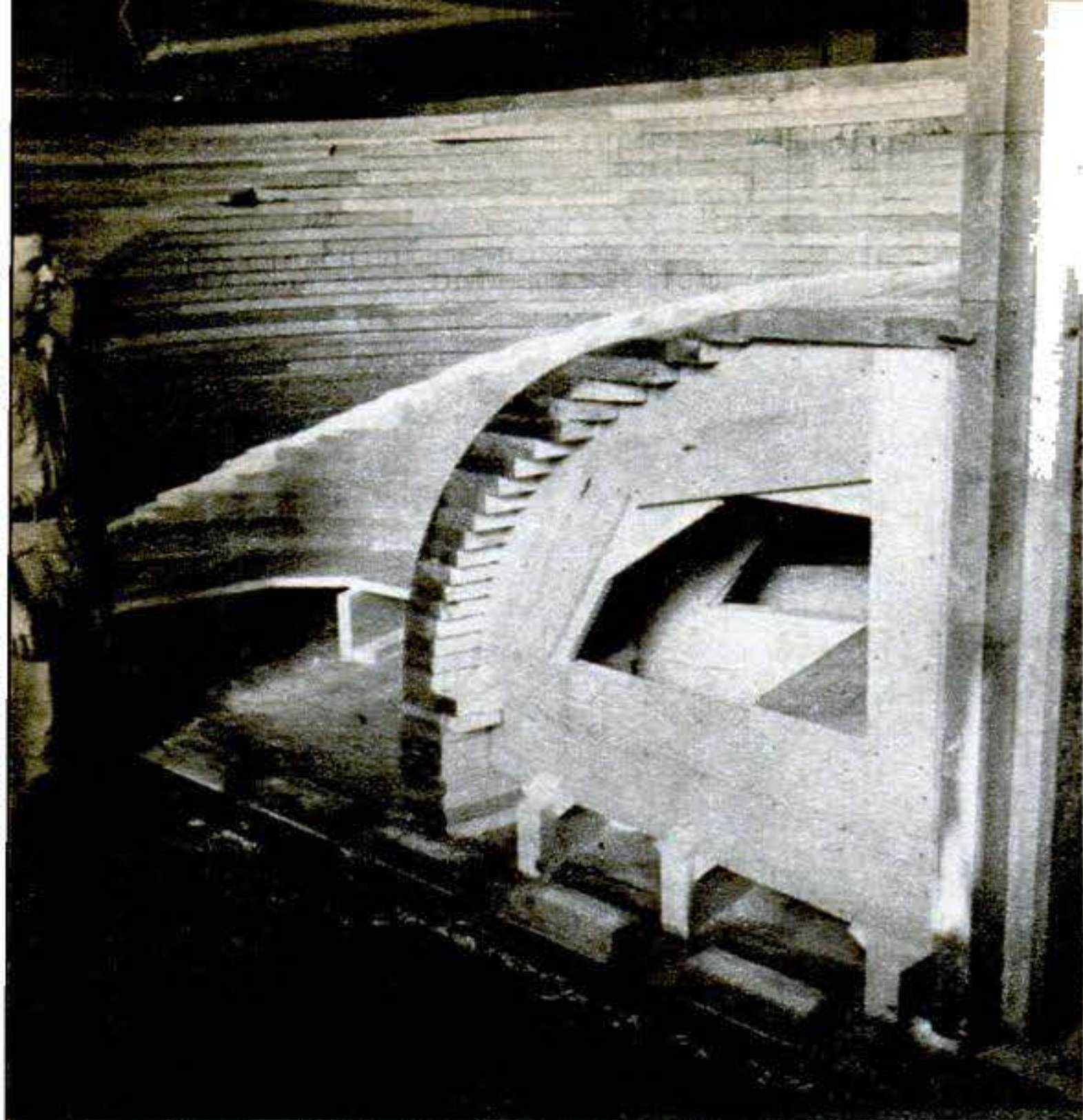

Construction of the world's largest pumps starts with this wooden core box. Made of Honduran mahogany, it forms the sand core of the mold in which the impeller wheel of the pump is cast.

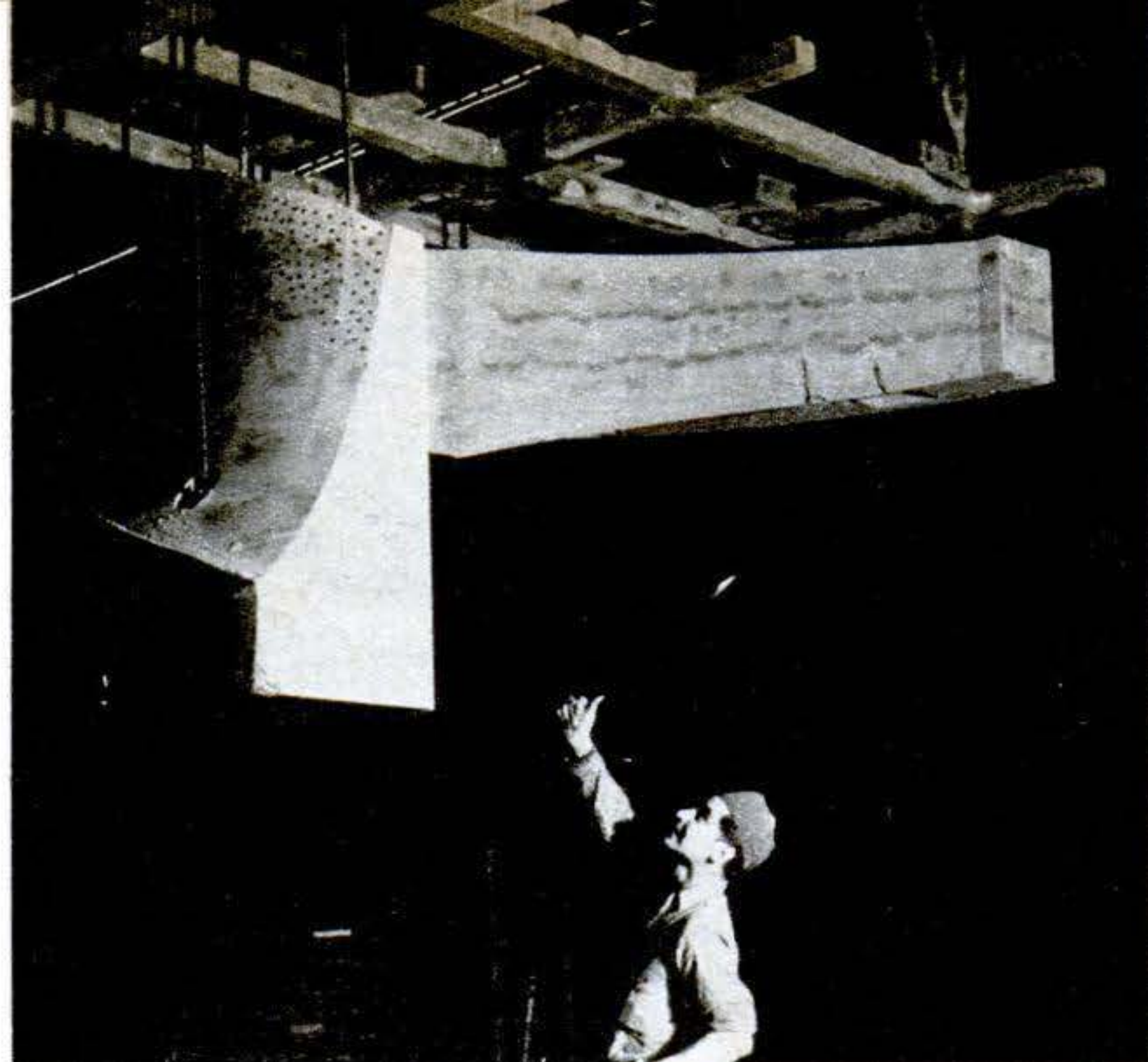

The cores are carried by an overhead conveyer into an oven to be baked hard. This core is one of seven that will create the seven water passages in the 14-foot-diameter impeller wheel.

# *Biggest Pumps to Lift River into Wasteland*

**By Andrew R. Boone**

**T**HE biggest pumps in the world will soon be turning the clock back to the ice ages, making water from the Columbia River flow in a channel unused for at least 300,000 years. They will lift water from Lake Roosevelt—formed by Grand Coulee Dam (PS, Feb. '36, p. 11)—about 270 feet over a hill to an irrigation reservoir. This water will turn more than 1,000,000 acres of near-desert into some of the world's best farm land.

The last time Columbia River water flowed through this area—a plateau called the Big Bend, around which the river now circles—was in the Pleistocene epoch, when huge glaciers covered most of North America. One glacier grew across the river, right where the man-made dam is now. The water piled up behind this ice block until it finally overflowed the surrounding hills and cut a new channel. The Columbia ran there a long time, wearing the hill passage down to a sharp gorge a sixth of a mile deep called the Grand Coulee. But eventually the glacier melted, the Columbia went back to the channel it had used before—and uses today—

and the Grand Coulee was left high and dry.

When the giant pumps are running, water will again fill the Coulee. It will serve as the reservoir, feeding canals that are to carry the irrigation water to the farms. Experts of the U. S. Bureau of Reclamation, which planned the project, estimate that the new farm land created in this way will be equivalent to adding a whole new state to the Union.

Almost everything about the Grand Coulee undertaking is the world's biggest. The pumps are at least eight times larger than any similar ones. Each can handle more than enough water to supply all New York City. Grand Coulee Dam is the biggest ever built, and the biggest masonry structure of any kind ever built—more than five times the size of a huge Egyptian pyramid. It will produce more electric power than any other.

The first of Grand Coulee's 12 pumps is expected to be installed next year. Made by the Byron Jackson Co. and the Pelton Water Wheel Co., each pump will have a 14-foot impeller wheel driven by an individual, 65,000-hp. electric motor. Power will come from the dam's own generators—making the Columbia lift itself by its bootstraps.

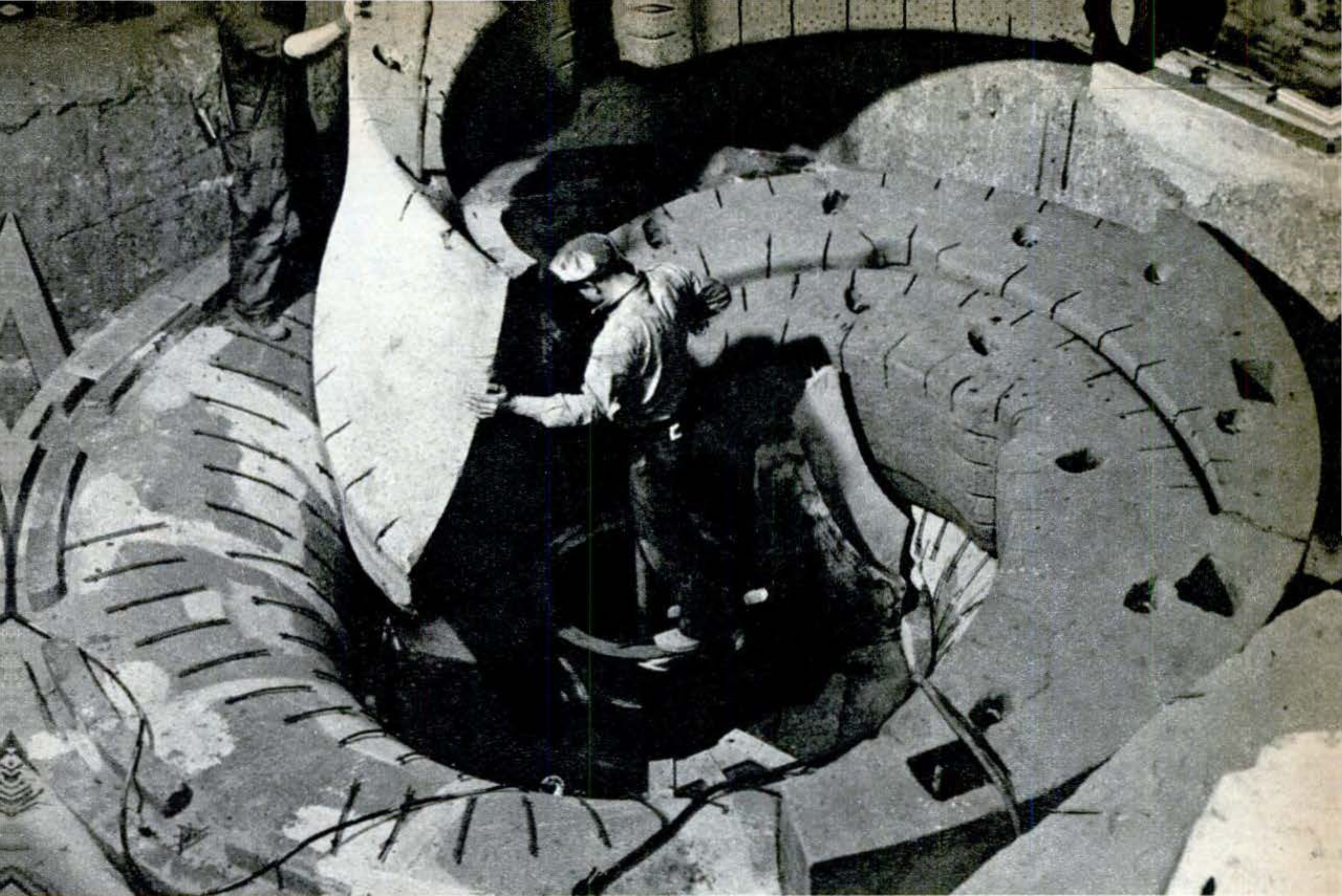

**Inside a nine-foot-deep pit,** workmen guide third of the seven core sections into place in the

mold. Steel from two 25-ton open-hearth furnaces at Columbia Steel Co. filled the mold.

**The impeller wheel** looks like this when the mold is first broken away. Stumplike projections

are "risers"—extra steel left in filling holes of mold. All excess like this is later machined away.



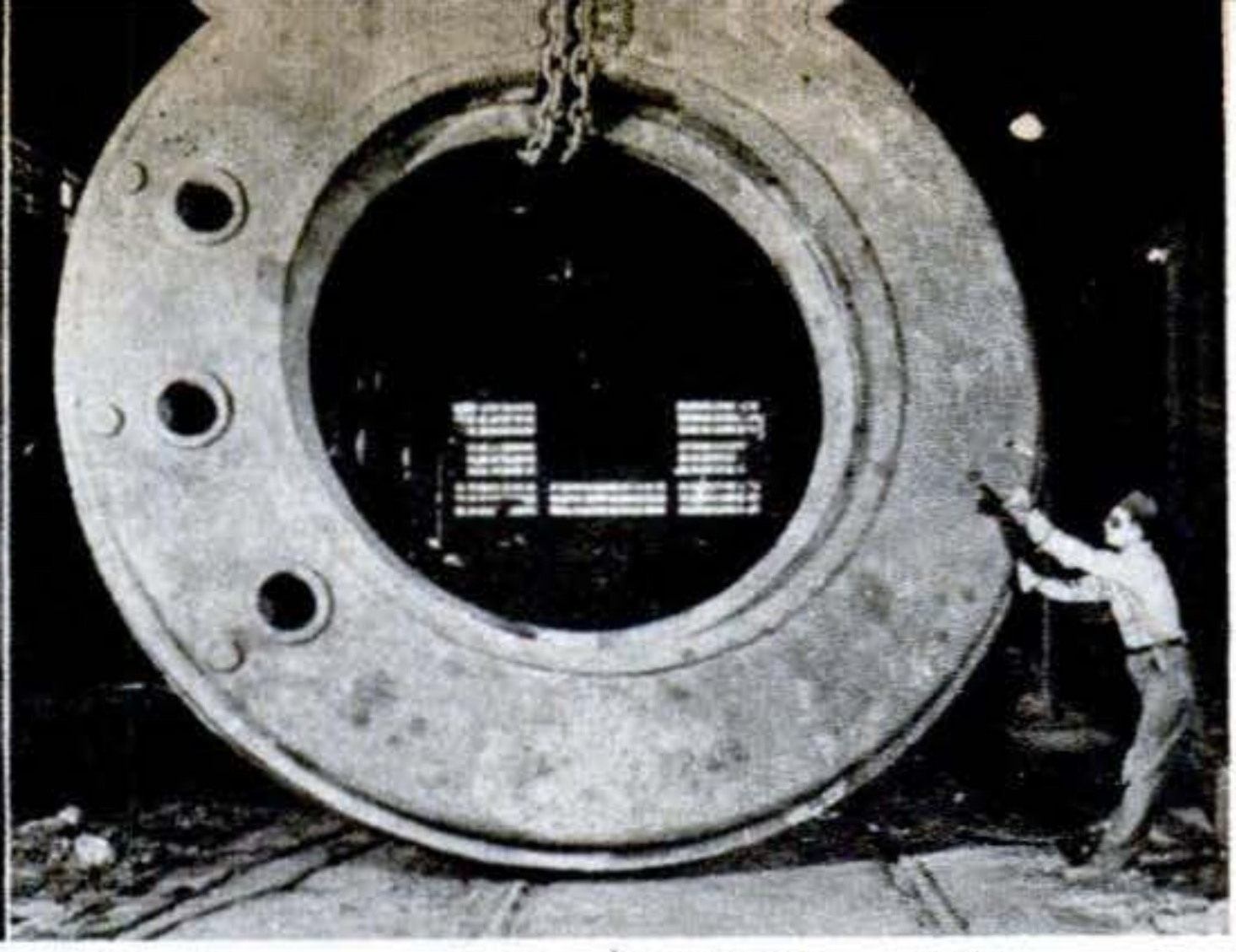
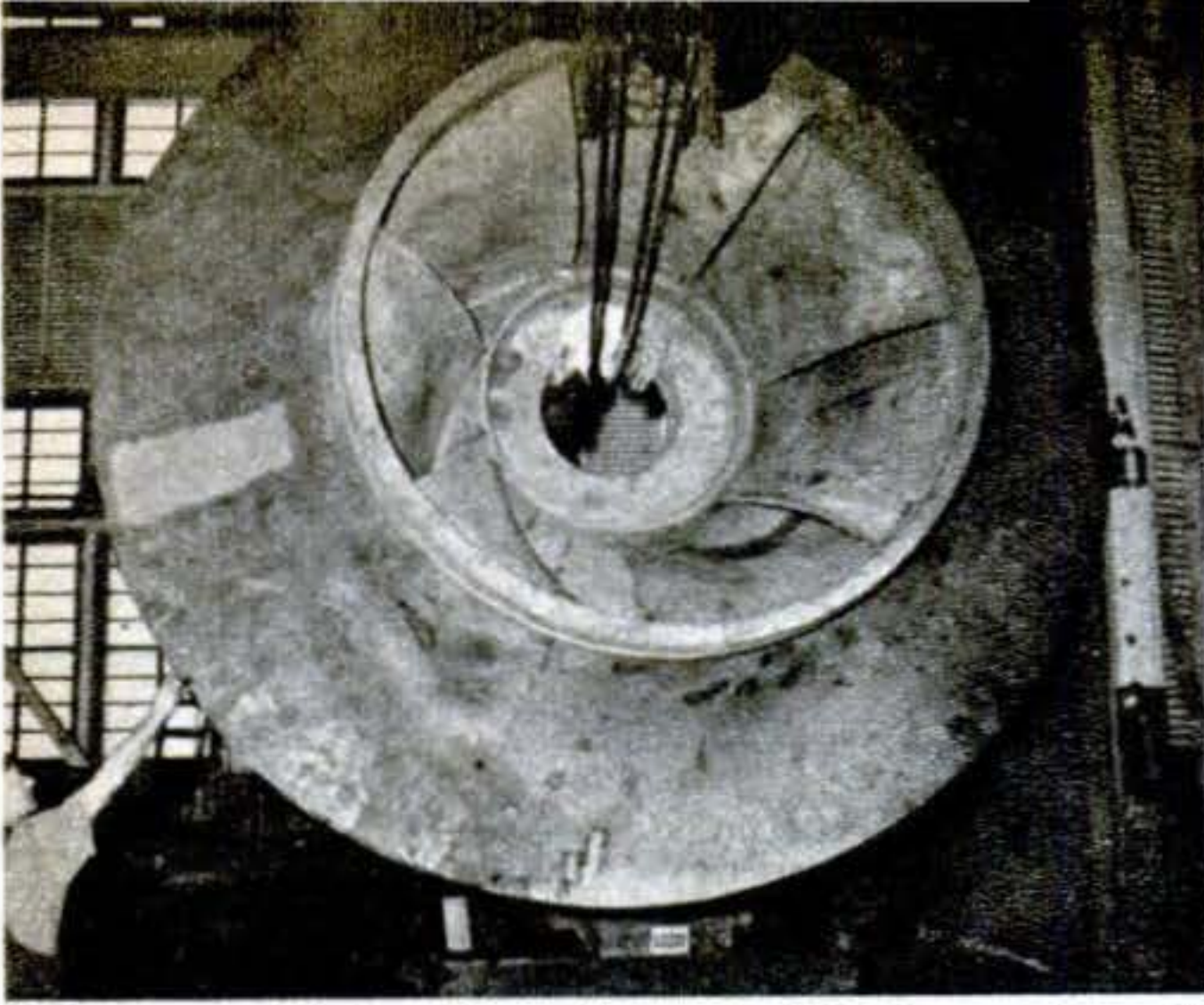

After machining has cleaned off 20 tons, impeller still weighs nearly 30 tons. It is one of 12 that will divert part of Columbia River over 270-ft. hill into ice-age channel in Grand Coulee.

Head cover, weighing 38,000 lb., will keep water in pump from rising into motor room. The drive shaft passes through center hole; three small holes provide access to oil reservoir in pump.

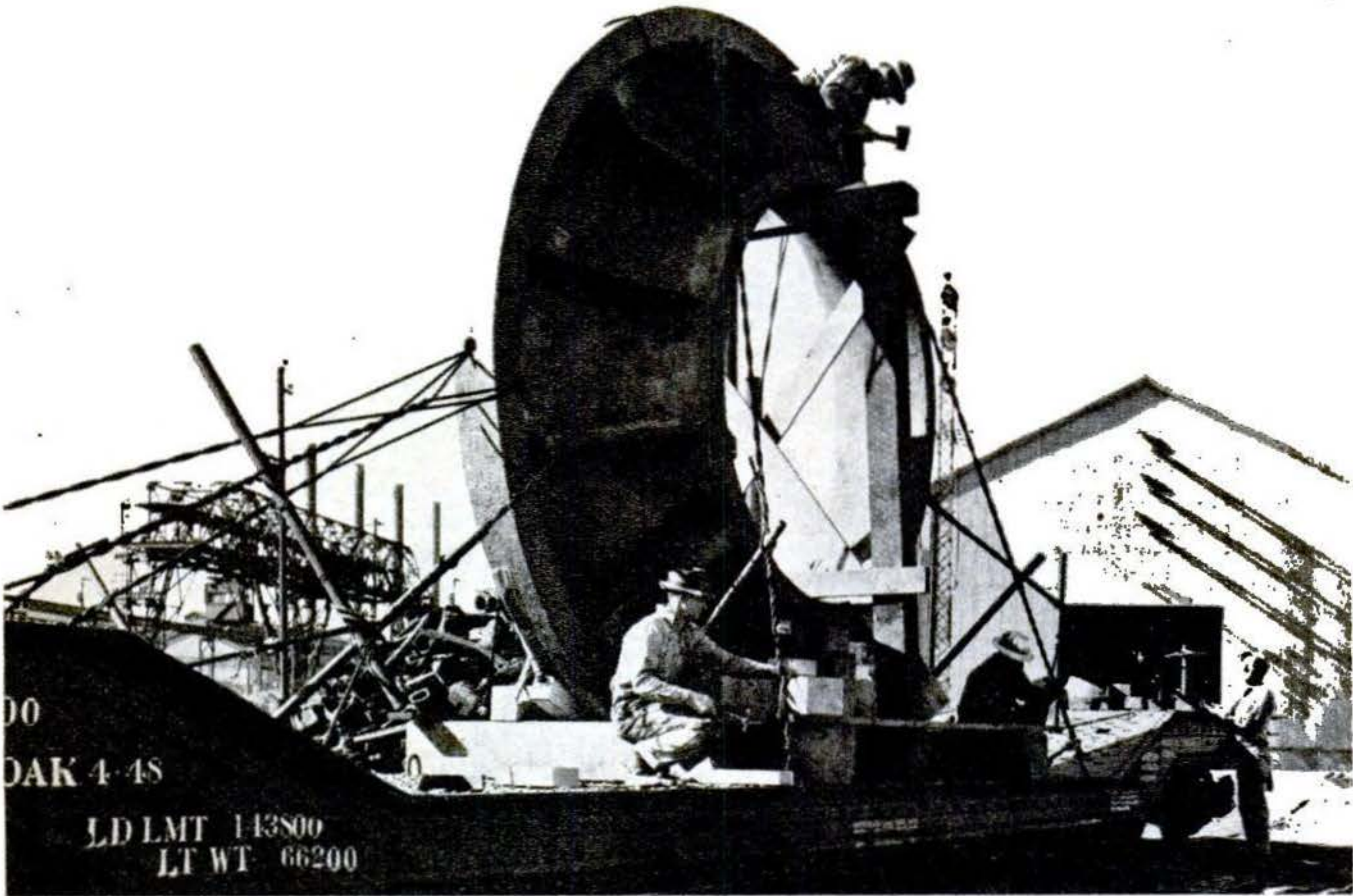

Railroad flat car is needed to move lower cover to shop for final machining. When finally in-

stalled, it will be attached to suction elbow bringing water from Lake Roosevelt to the pump.

How Columbia River will lift itself by its bootstraps is shown in drawing. Water impounded by dam will drive generators (far left). Electricity thus made will power pumps (center and inset).

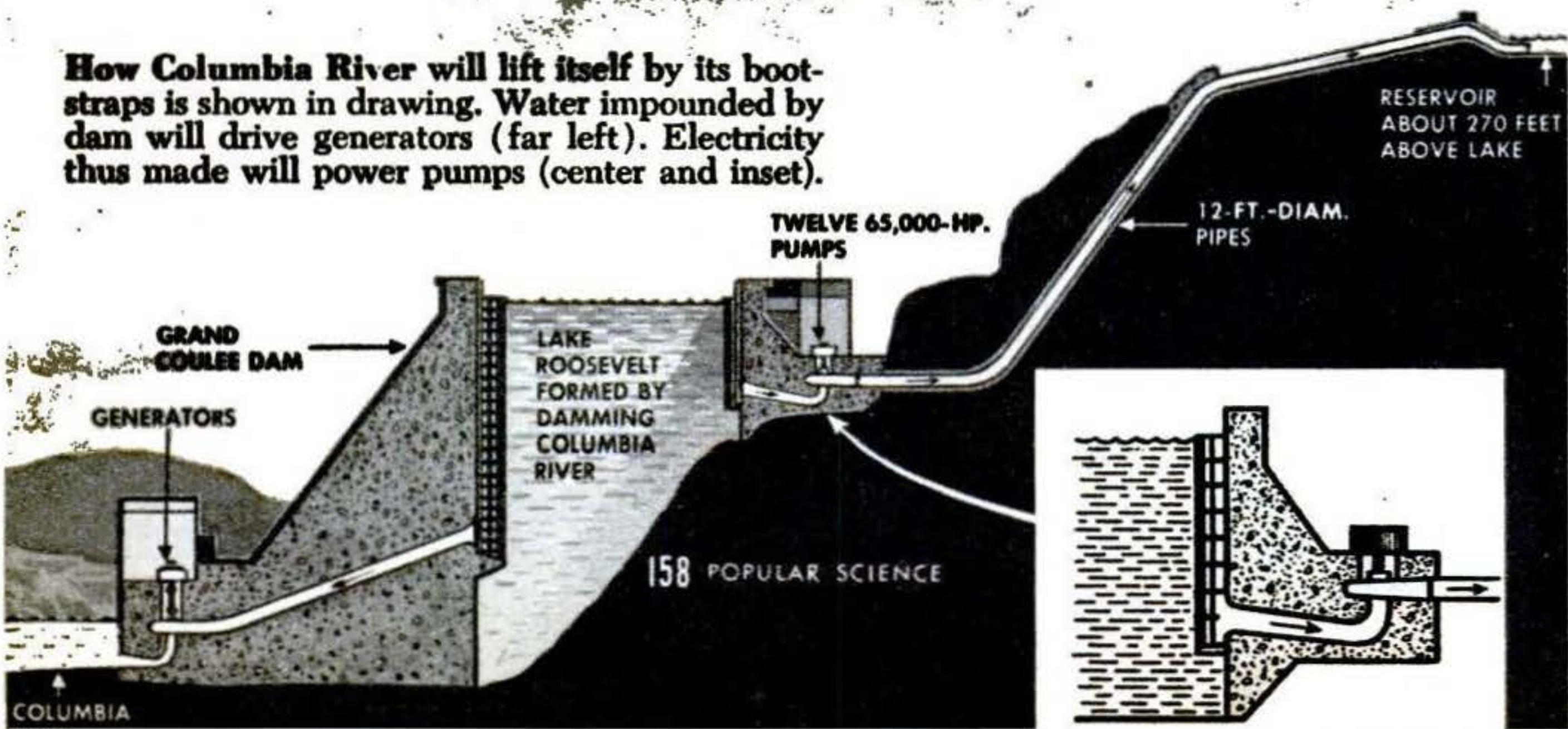



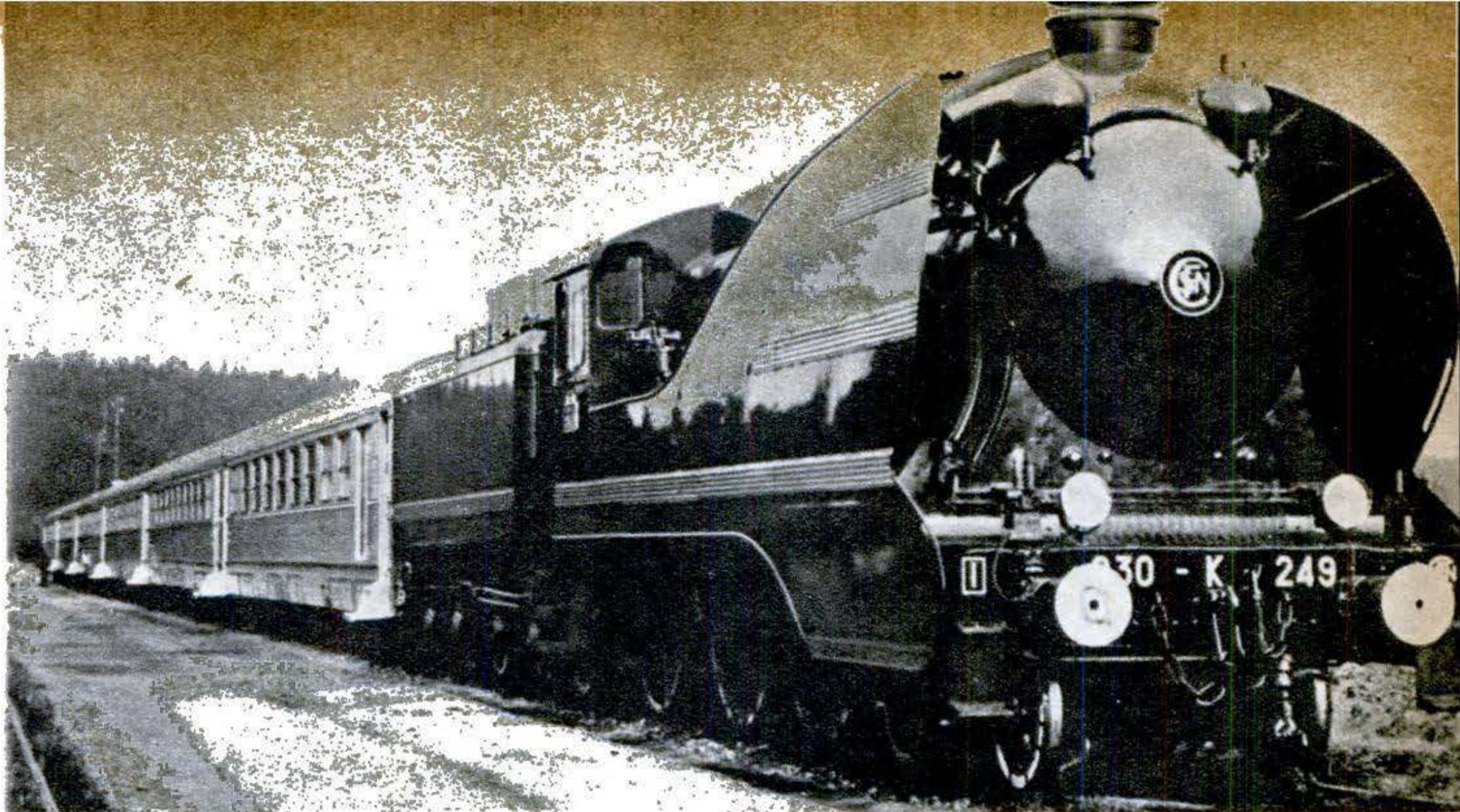

**New train, one of three built, has six pneumatic-tired coaches and standard-wheeled engine.**

## ***Fast New Train Runs on Tires***

**R**OLLING on pneumatic tires, a French six-coach train of new design makes high-speed travel luxuriously joltless and quiet. Cars have 20 wheels apiece, each with a tire riding on top of the rail with an inner metal flange to guide it. Tires have tubes and are rim mounted. A flat need be changed only at the end of the run, the other tires easily taking the load meanwhile. Separate electric rail-contact shoes and axles close track signal circuits. Tires are inflated to between 120 and 140 lb. per sq. in. Each carries a load of more than 2,600 lb. and has a life of about 21,000 miles. Going at 50 m.p.h., the train can stop in 390 ft., thanks to its light weight and the way the tires grip the track, three times as well as steel.



**Speeding at 75 m.p.h.,** passengers can converse without raising their voices. Pneumatic tires and rubber vestibules between coaches get credit for quiet and comfort. Easy riding qualities permit lighter car structure. Elimination of noise insulation also saves weight. Thus load reduction required by pneumatic tires is partially made possible by the tires themselves.

**Pneumatic tires roll over the rail joints without a jolt. Shoe, between tires, works signals.**



# Gus Clears



*While Harcourt stood by and watched, Gus first checked the gas line and fuel pump.*

*ZAY QUIGLEY*

# an F.B.I. Suspect

Even as you and I, a G-man can run into a snag. But a fast bit of headwork by Gus gets this agent off the hook.

**By Martin Bunn**

GUS WILSON slipped the socket wrench into a pocket of his coveralls, wiped his hands on a wad of waste, and took the identification card the young man offered him.

"F.B.I.," Gus said.

"That's right," the man answered, pocketing the card.

"Okay, Mr. Harcourt," Gus said. "What can I do for you?"

"I'd appreciate your help in a matter I'm looking into. Know the Acme plant?"

Gus nodded.

"Know what they're doing there?"

"Heard it was something hush-hush."

"That's putting it mildly," Harcourt grinned. "Anyway, here's my problem. A little after midnight last night, someone tried to break into the department of the plant where top-secret work is done. If he'd succeeded . . . well, it wouldn't have been so good."

"But where do I come in?" Gus asked.

"I'm getting to that," Harcourt went on. "There was a slip-up last night when the late shift of plant guards came on duty at midnight. Man named Joseph Swinton, a retired cop, was late. By the time he got there in a taxi—at 12:30—the excitement was over. The break had failed and whoever tried it had made a getaway."

"I still don't see where I fit in," Gus said.

"Swinton lives in a tourist court near here," the agent said. "His story is that he couldn't start his car and had to call a taxi to take him to the plant. I'd like you to check over his car and see what's wrong."

"I'll take a look," Gus said.

"The whole problem hinges on that car," Harcourt explained. "Did the person who tried to break in know that Swinton wouldn't be on the job? If so, how did he know? And, most important, was it true that Swinton couldn't get his car started?"

"Maybe I can tell you and maybe I can't," Gus said. "Lots of things could have been done to that car between midnight and now."

"I think we've got that pretty well covered," Harcourt remarked quietly. "I got to the plant just about the time Swinton did. The first thing I did was send a man to the auto court to keep an eye on the car. No one's touched it since then."

"That'll help," Gus said.

"Got time to take a ride out there and look at it?"

Gus glanced at the clock. "Let's go," he said.

### *The Wrong Cottage*

As Harcourt and Gus drove up to the Hill-top Tourist Court, a maid was walking across the crescent of lawn in front of the office. Harcourt asked for the Swinton cottage.

"That one." She pointed vaguely.

Harcourt stopped at the first cabin that had a car parked near by. They got out and stepped up on the tiny porch. Harcourt rapped on the screen door. The wooden door was open. While they waited, they stood looking into the room. A wrinkled suit and shirt lay where they had been tossed into an open suitcase. On a bureau top were the contents of a man's pockets: a wallet, notebook, about a dollar in change, pocketknife, pliers, and a handkerchief.

"Sounds like he's taking a shower," Harcourt said.

Just then a man called from the porch of the next cottage. "Over here, Mr. Harcourt."

The G-man laughed. "That's Smith, my assistant. He must think he's working with a hot-shot cop. Can't even find the right house."

"And in broad daylight, too," Gus laughed, as they walked across the lawn.

Inside the second cottage they found a heavy-set, elderly man slouched on the edge of the bed. Smith held the door open for them. As they entered, the man got up.

"This is rough on me, Mr. Harcourt," he said. "I've got a good record and I don't want any bad marks on it now."

"Routine investigation," Harcourt told him. "Got to go through with it. You know that, Swinton. . . . This is Mr. Wilson. He's an auto expert. Mind if he looks over your car?"

"It's all right with me," Swinton answered.

Smith handed the car keys to Gus. As Harcourt and Gus walked outside, the agent told Swinton and Smith to wait.

The car was a postwar coupe. Gus slid behind the wheel. When he pressed the but-

ton, the starter motor turned over but the engine didn't fire. After several tries, Gus cut the switch, first noting that the ammeter registered when the ignition was on. While Harcourt stood by and watched, Gus raised the hood and looked over the engine. It was spotlessly clean and evidently well cared for.

"Got any ideas?" Harcourt asked.

"Not yet," Gus told him. "Could be any one of several things."

At the carburetor end, Gus disconnected the gas line leading from the pump. He pushed the manual button on the starter solenoid and a little gas squirted out as the engine kicked over.

"Getting gas to the carburetor," he commented as he reconnected the line.

Next Gus turned to the ignition system. With the switch on and the solenoid button pressed, he used a screwdriver to check for a spark at a plug. There wasn't any. Gus flipped down the distributor-cap springs and removed the distributor cap.

### *Where's the Spring?*

"There's the trouble," he pointed. "The rotor spring's broken off. The distributor just isn't getting any high-voltage juice to distribute." He pulled off the rotor and showed it to the G-man. The little blue-steel spring leaf designed to make contact with the central cap lead was snapped off short.

"That happen by itself?" Harcourt asked.

"Every now and then," Gus answered. "It sometimes happens that a spring will just snap. But it's not very likely, especially on a fairly new car."

"Could someone have done it deliberately?" the G-man asked.

"Sure," Gus said. "Say, wait a minute. Someone *must* have broken it."

"What do you mean?" Harcourt asked.

"Take a good look at the broken end. See how it curls up a bit just at the break? That shows it was bent upward until it snapped."

"We figured something like this might have happened," Harcourt remarked quietly.

"Maybe we can check on it further. Just a minute." Gus bent close over the open distributor and fingered the points cautiously. Then he straightened up, nodding his head.

"If it just broke, the broken leaf would have to be in the distributor. That little piece of spring isn't here."

Harcourt frowned. "So Swinton could have disabled his car to have a good excuse not to show up at the plant on time. Let's go see him."

Harcourt led the way back to the room. Swinton was sitting on the bed looking worried. Smith was reading a crime comic book.

"Do any work on your car yesterday?" Harcourt asked.

"Work?" Swinton repeated. "Same as I do every day—shined it up a little. I like to keep a car looking good."

"Mechanical work, I mean," the G-man said.

Swinton shook his head. "Haven't had the hood up in a week until she wouldn't start last night."

"Keep your car locked?"

"No, I don't," Swinton replied. "I'm always around when the car is."

"What did you do last evening?" Harcourt asked.

### **Found: One Broken Spring**

"Read the paper and listened to the radio until about nine-thirty. Then I played three games of pinochle with Jackson. He owns this court."

"Did you play here?"

"No, we played in his room back of the office."

"Check that," Harcourt told Smith.

Smith hurried out and Harcourt led Gus out of the cottage.

"You're sure it couldn't have been an accident?" he asked Gus in a lowered voice.

"That's right," Gus said. "If that spring had snapped of its own accord, the broken part would still have been in the distributor."

Harcourt rubbed his chin and looked thoughtful. He glanced back into the room at Swinton, who had resumed his seat on the bed.

"I guess I'm going to have to hold Swinton."

"Wait a minute," Gus said. "Remember the wrong cottage?"

Harcourt nodded.

"There was a lot of stuff scattered on the bureau," Gus went on.

"I didn't pay particular attention," Harcourt said. "A wallet and some change and . . ."

"And pliers," Gus finished. "That stuck in my mind because most people don't carry pliers around. Let's go take a look."

They hurried to the cottage to find the occupant—a broad-shouldered blond man—packing his suitcase. The articles still were on the bureau. Harcourt rapped and showed his card.

"Just a routine check. Mind identifying yourself?" he asked mildly.

The man admitted them. Then he handed his wallet to the agent. Gus idly picked up the pliers and opened them.

"Good tool you have here," he remarked. "Used it lately?"

"Yeah. I pulled out a nail some dope'd driven into the wall. Pretty near ripped my hide on it," was the answer.

Gus moved toward the door, casually holding a bit of blue steel before Harcourt's eyes.

The big man wheeled and slammed into Gus, who, ready for him, blocked a wild swing. Harcourt grabbed him from behind and expertly pinioned him against a wall.

The door nudged open behind Gus's back. "Swinton's story checks," reported Smith, entering. "From the noise, I thought maybe business was good in here."

The big man, all fight gone, didn't resist the handcuffs.

"Looks like I was lucky when I bumped in here, and you were smart," the G-man said after Smith had hustled the prisoner away. "How did you know where to find that bit of broken spring?"

"That's where I was lucky," Gus grinned. "It was just a long shot that paid off. When plier jaws are greasy, they may hang on to any small, light thing they've gripped. Guess I just didn't want to believe Swinton had done it. I'd hate to think a guy who keeps an engine that clean could be a crook." **END**



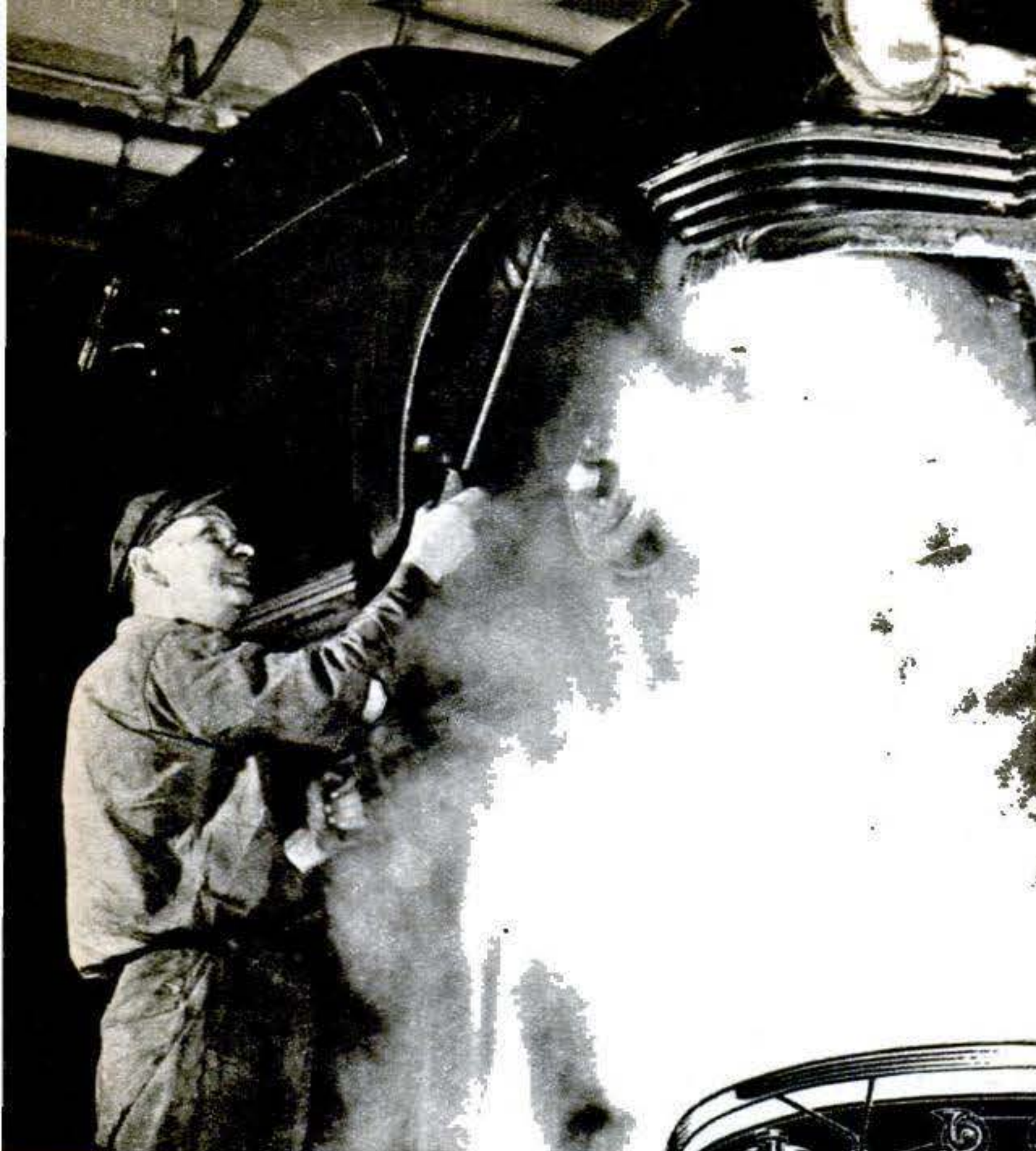

# What About

Sound deadening and rust prevention are its major advantages. Here are points to look for if you are planning to have the job done.

Steam cleaning, at the left, removes dirt, grease, and rust scale before undercoating is applied. When the car is new, this may not be required. Car must dry thoroughly.

**THESE PARTS SHOULD BE COATED**

**THESE PARTS SHOULD NOT BE COATED**

FENDERS

SPLASH PANS

FLOORING

ROCKER PANELS

GAS TANK

FENDER SKIRTS

GRAVEL DEFLECTORS

INSIDE BACK BUMPER

GREASE FITTINGS

OIL PAN

TRANSMISSION

MUFFLER

DRIVE SHAFT

BRAKE SYSTEM

REAR-AXLE HOUSING

TAILPIPE

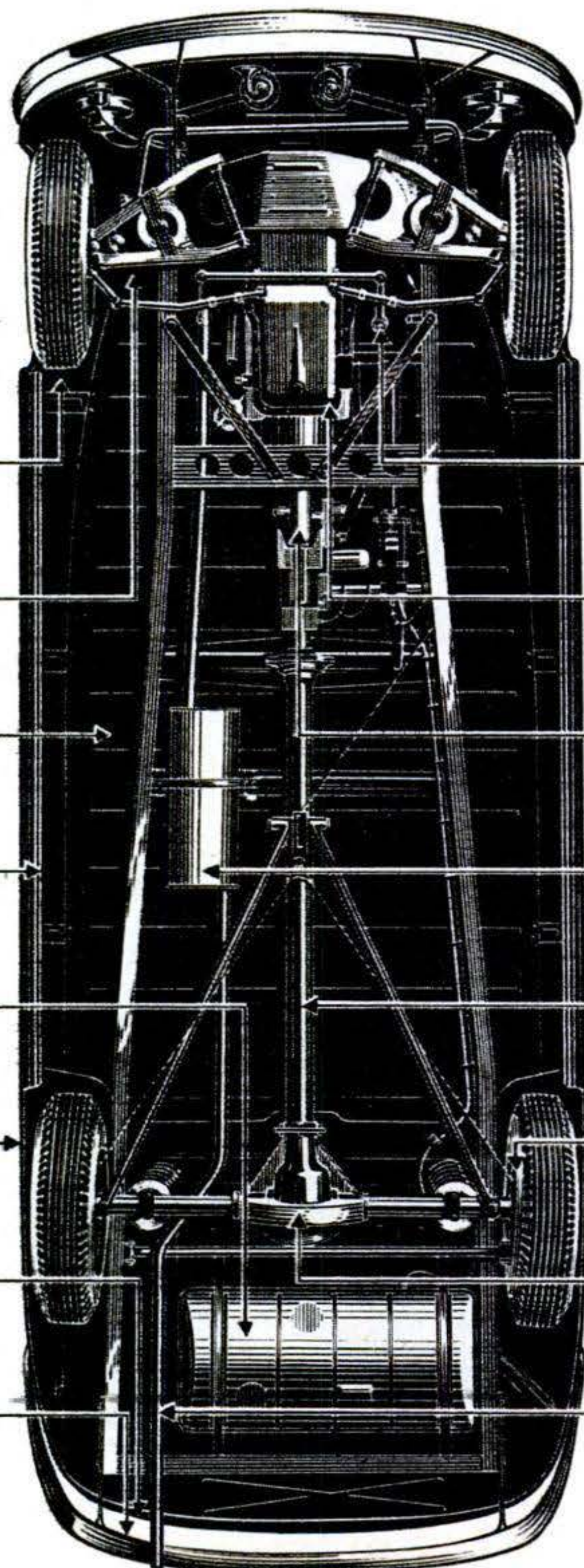

# Undercoating?

**By R. P. Stevenson**

*PS photos by Hubert Luckett*

**W**HAT can you expect from undercoating? Does the job pay on an older car? How can you tell whether the material has been properly applied?

Sooner or later, you'll probably wonder about such points. Undercoating, the practice of spraying the belly of a car with an asphalt material, popped up just before the war. It has now become big business.

Drop into almost any large garage these days and you are likely to get a sales talk about it. If you buy a new car, the dealer probably will suggest undercoating, often with considerable enthusiasm.

This enthusiasm is understandable. At \$35 to \$50—the price you pay—the garage can do a good job and turn a neat profit.

Undercoating fills a real need. There's no doubt of that. Think back a bit over the years. Chances are you have given little attention to the grimy expanse of metal underneath your car. Rust prevention in this neglected region is one big point on which undercoating is sold.

Sound deadening is another. Sprayed into cracks and crevices under the car, the material hardens and keeps metal from rubbing against metal. Sealed in, the body bolts and nuts aren't likely to loosen. Many squeaks and rattles disappear. Road and motor noises are muffled.

On a lighter car, the noise-killing effect of undercoating helps give a big-car feel. Drumming sounds lessen or stop. And by sealing cracks in the flooring, it keeps dust from swirling into the car.

Spectacular reports are sometimes heard about the way undercoating prevents rust. For instance, there's a story about a group of factory workers who parked their cars on a lot where chemicals had been dumped. Fenders rotted out in a matter of weeks. Undercoated cars parked in the same lot showed no sign of corrosion.

Generally speaking, undercoating has greatest value as a rust preventive in coastal regions. Salt-laden sea air always lends a hand to corrosion. Undercoating also gives

protection when chemicals are used to clear ice and snow from streets. The same is true in areas with corrosive soil conditions—in desert regions, for instance.

Materials used for undercoating vary considerably in their makeup. Almost without exception, all the 20 or so commercial brands of undercoating now on the market have an asphalt base. Other ingredients, however, vary with the brand.

Recommendations offered by the manufacturers for applying their materials all follow the same general pattern. But you will note a difference of opinion about the question of thickness.

Some specify a 1/8" coating. This, they contend, is necessary to provide adequate sound deadening and protection against the abrasive action of flying gravel, sand, road-top dirt, and other debris.

Others argue that 1/16" is enough if their particular product is used. To buttress this claim, they offer reports on controlled abrasive tests showing their product equalled or surpassed that of a competitor.

Keep this debate in mind when you order an undercoating job. If the manufacturer of the product being used stipulates 1/8", let the garage know you expect that thickness. Some operators in the past have tried to get too many coatings out of a single barrel of material.

Two general kinds of undercoating are available. In one, the asphalt and other ingredients are carried in a water solution. After application, this type must stand overnight or longer before the material will have hardened enough so that the car can be driven away.

The most common type, however, has an inflammable solvent that evaporates quickly. Undercoatings of this kind set in a few hours, although it may take several days for thick areas to harden thoroughly.

In a wet state, all solvent-vehicle undercoatings are inflammable. Smoking, an open flame, and welding are taboo in the vicinity of a spray operation. When the solvent has

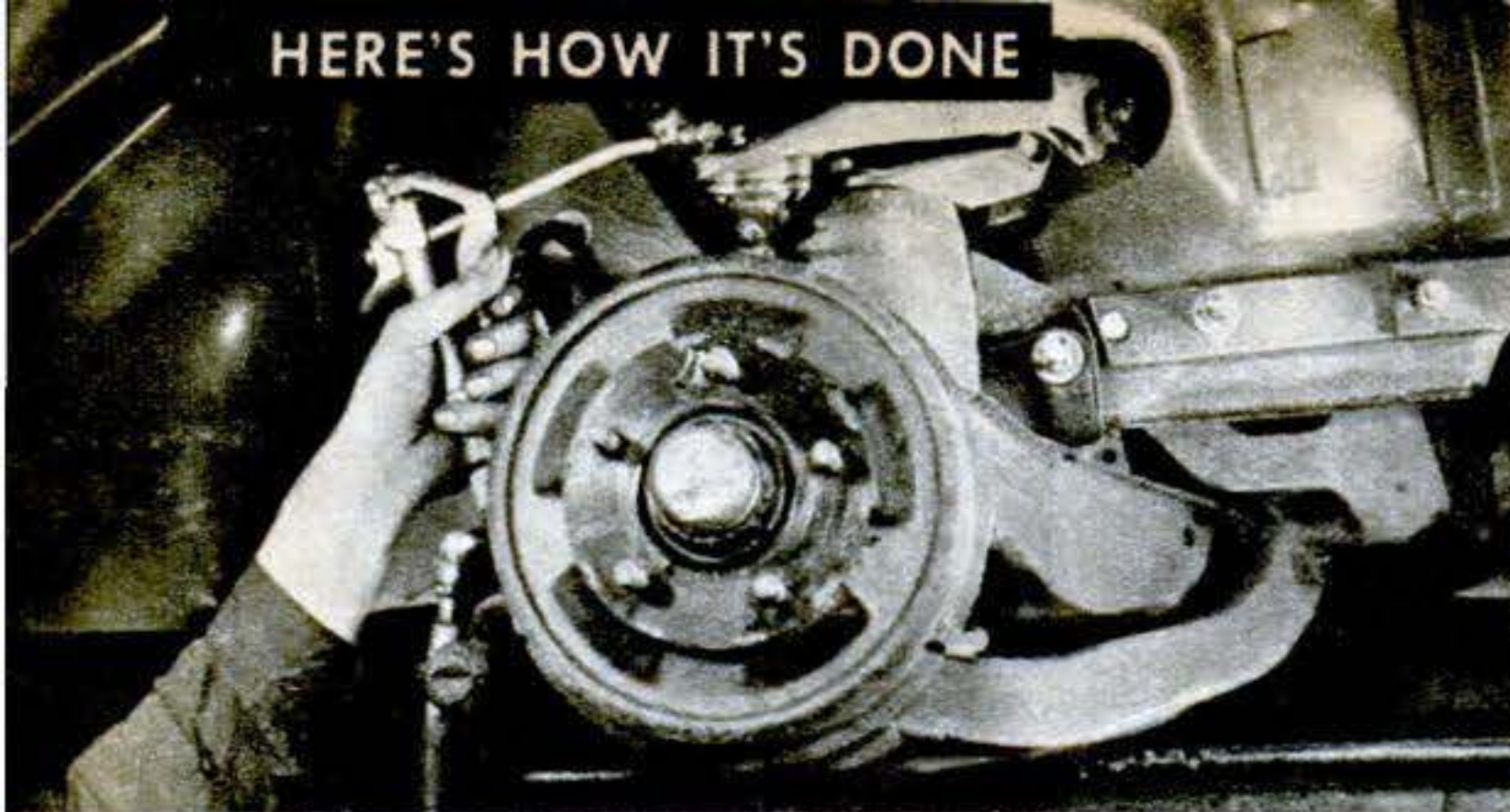

**1. The grease fittings** are gone over with a gun if the car has been steam cleaned. Steam always knocks out part of the grease. In some cases, greasing might be left as the final step.



**2. Body bolts** must be tight, for undercoating material will cover them up. Sealed in, bolts are less likely to loosen. Note that wheels have been taken off to give more working space.

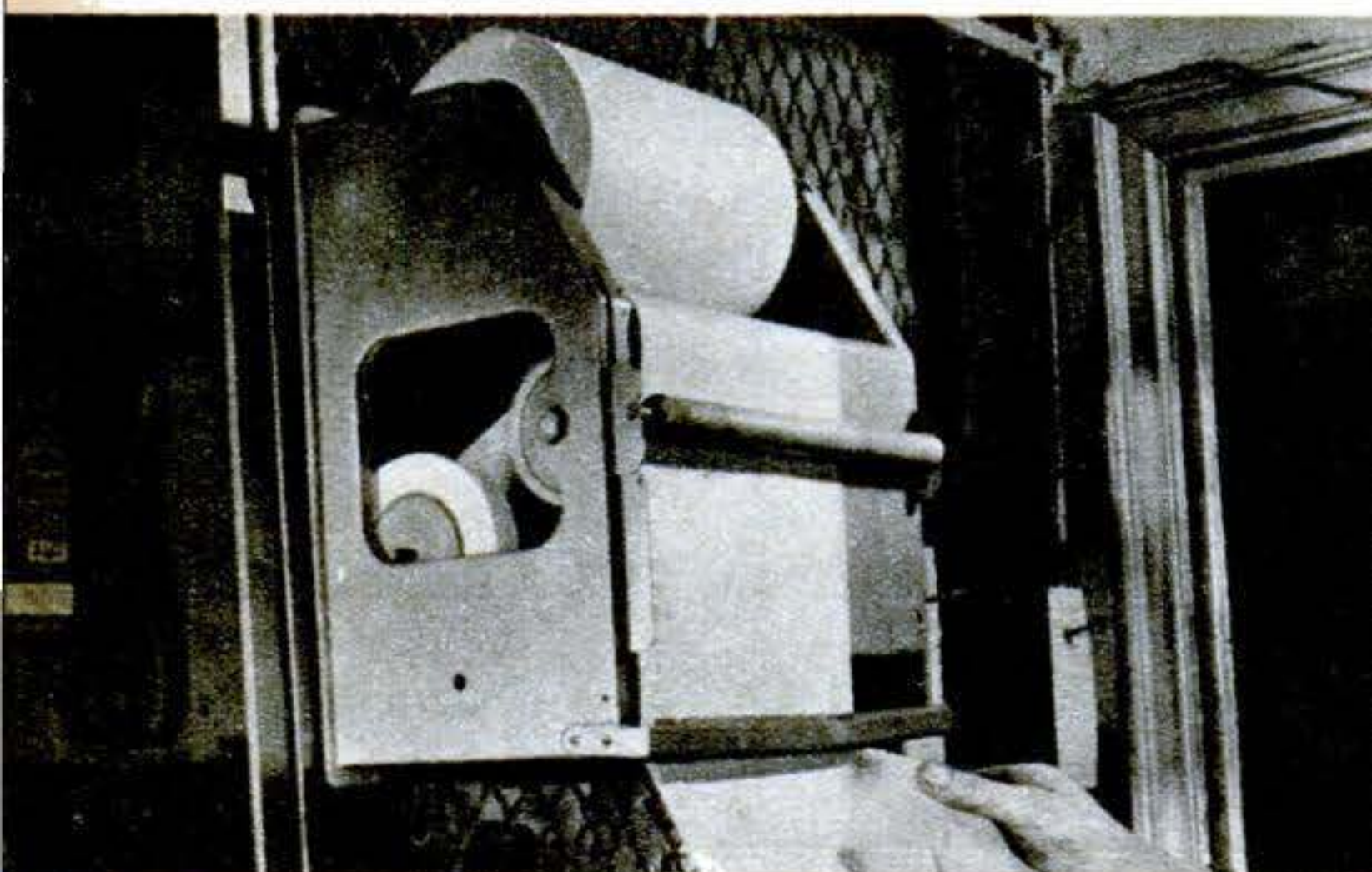

**5. Paper dispenser** speeds up the masking job in shop where these photos were taken. Gummed tape from small roll automatically attaches to edge of masking paper as latter is pulled.

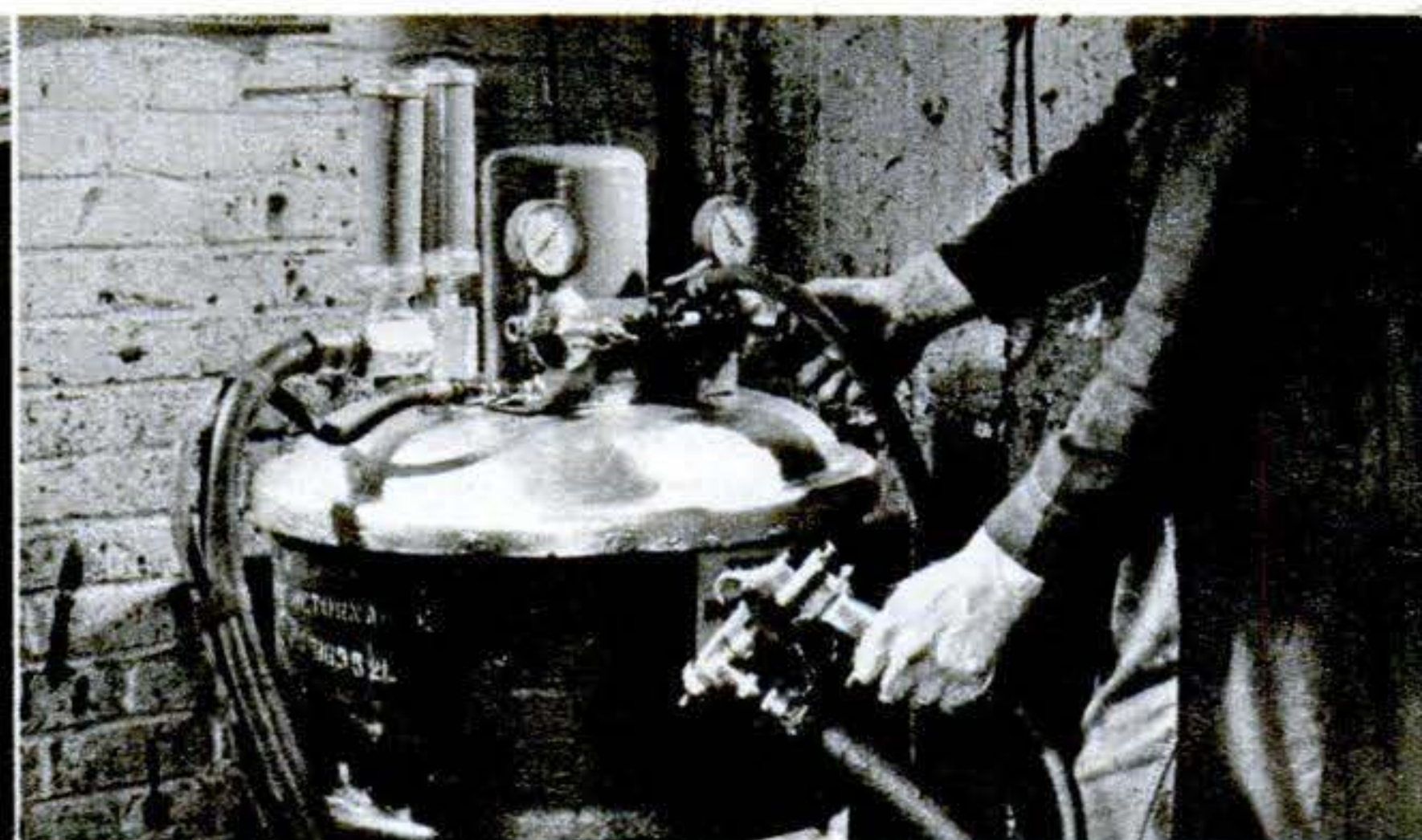

**6. Adjusting equipment,** operator is now ready for the actual spraying. Fairly high pressure is necessary to get a good flow from the gun. Guns are now made specifically for the job.

completely evaporated, the undercoating material is perfectly safe.

Before any undercoating is applied, the metal areas must be clean and dry. Even a thin film of grease or dust will prevent good adhesion. In time the undercoating material will drop away.

If the car has been on the road for some time, steam cleaning should be the first step. Some dealers, charge extra for this. Such cleaning normally will remove all dirt, grease, and rust scale. But it's advisable for the workman to check over the car, especially the fenders, and scour away any remaining rust with a wire brush or steel wool.

Steam cleaning will knock some of the grease out of the fittings. Consequently, the garage should go over these with a gun before turning the car back to you. Overnight is not too long for the car to dry after steam cleaning.

While the car is drying, the workman can take care of an important preparatory step—body tightening. All bolts and nuts should be turned up fully. You can be virtually certain

the dealer will do this on his own hook. It will save the traditional headache of detecting the elusive squeaks and rattles that frequently crop up a few months after a new car has been delivered.

On some cars, especially those made by Chrysler, you will find a coating of chassis black on certain parts under the car. This is a protective paint made from a residual asphalt. This must all be washed off to let the undercoating adhere properly. A cloth dampened with gasoline or kerosene does the job.

Masking paper applied around the lower edges of the fenders and body in skirt fashion serves two purposes. It prevents overspray from hitting your car or another standing alongside. It also enables the operator to apply the material right out to the paint line along the edges without infringing upon the paint itself.

Undercoating should be applied only to certain parts. The ones to be skipped are as important as those to be covered. Do not let the garage coat the drive shaft, transmission, oil pan, rear-axle housing, muffler, tailpipe,





**3. Chassis black**, a thin asphalt paint, must be washed from gas tank and other parts with solvent so undercoating material will adhere. Not all cars have this protective paint.

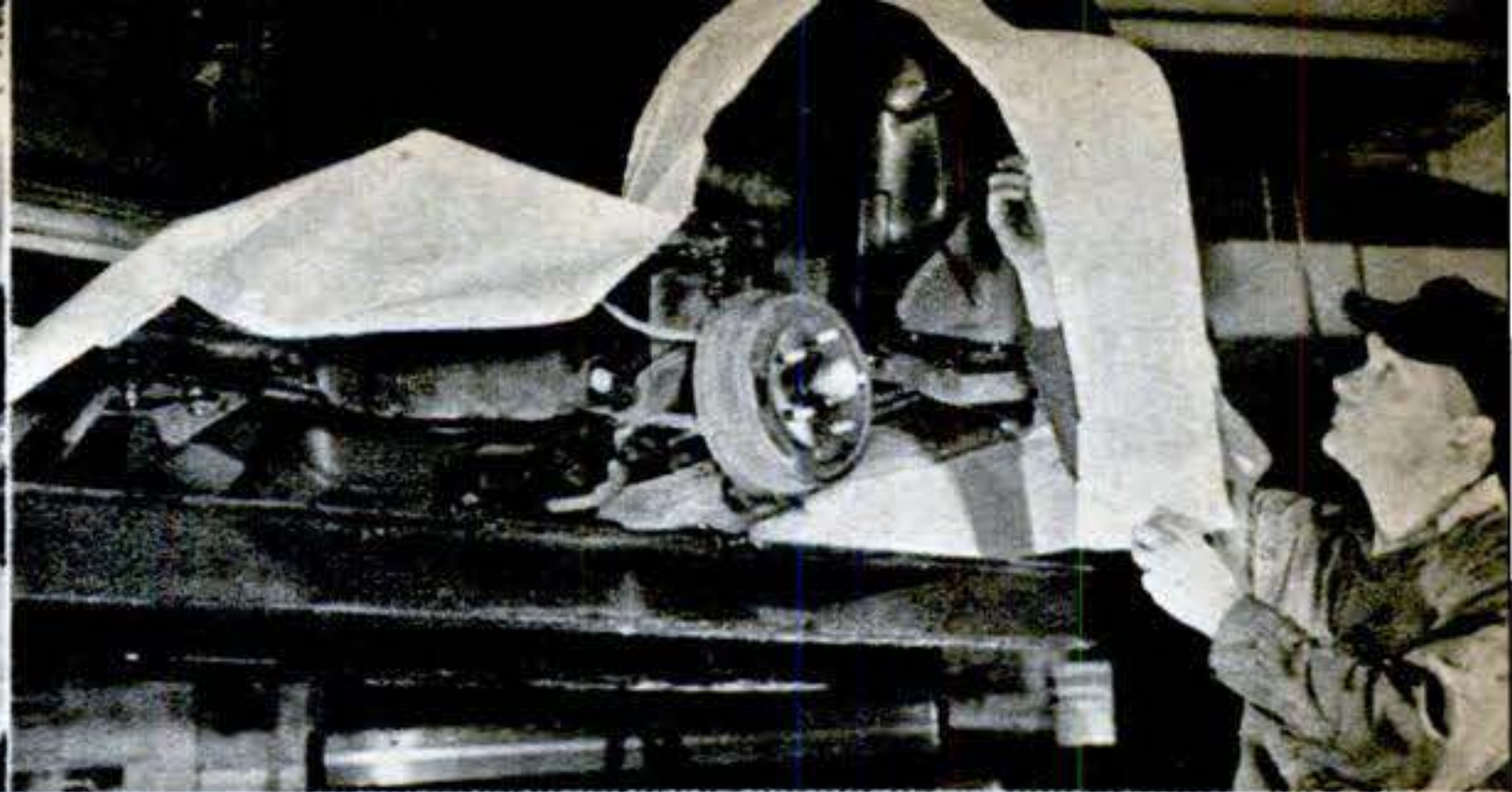

**4. Masking paper** is attached in skirt fashion around the edges of the fenders and body. This enables operator to spray undercoating out to the paint line without splattering the finish.

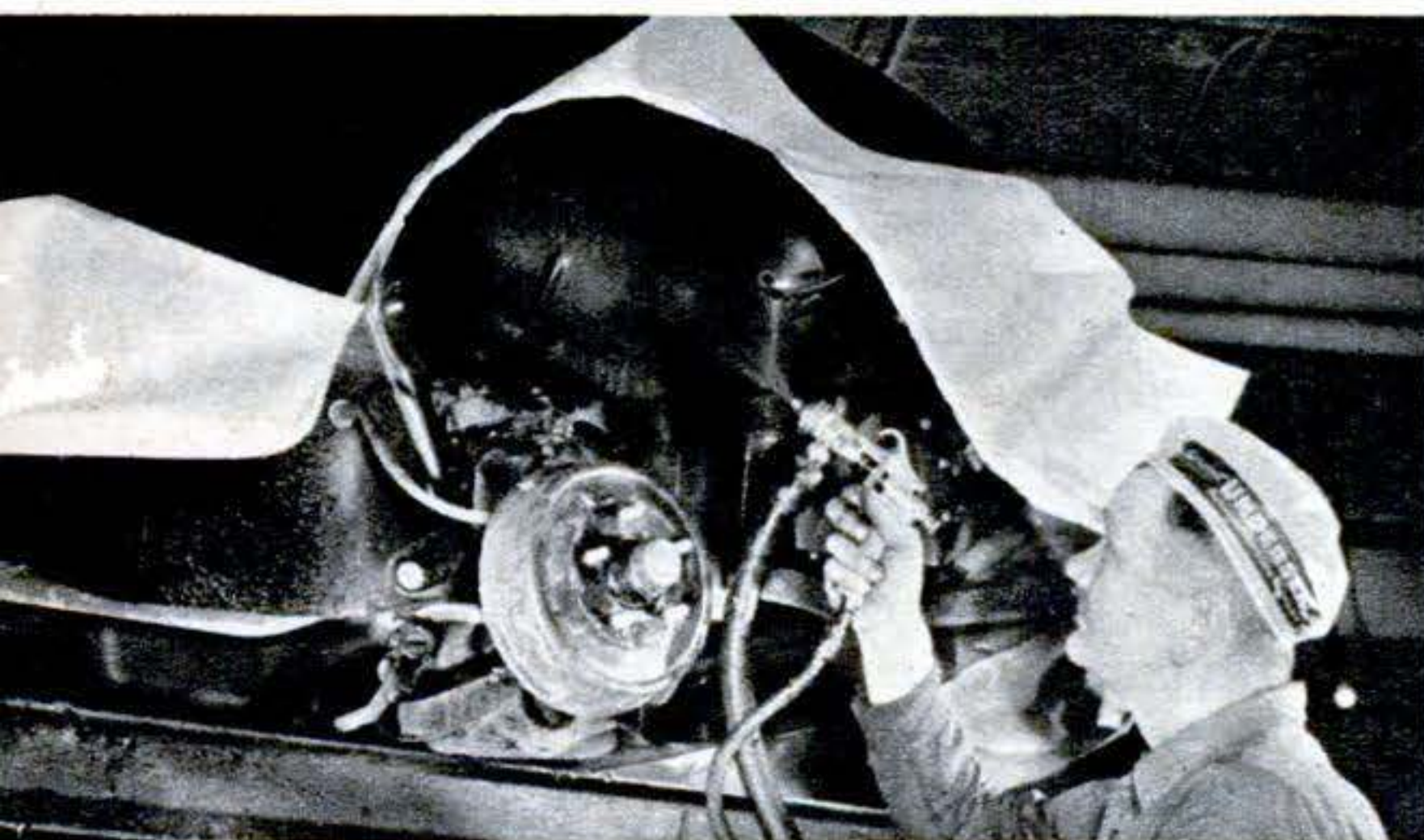

**7. Undercoating** is sprayed with slow, steady strokes to assure even coating. The workman sometimes uses a plastic face shield while doing the job. Spraying takes about an hour.

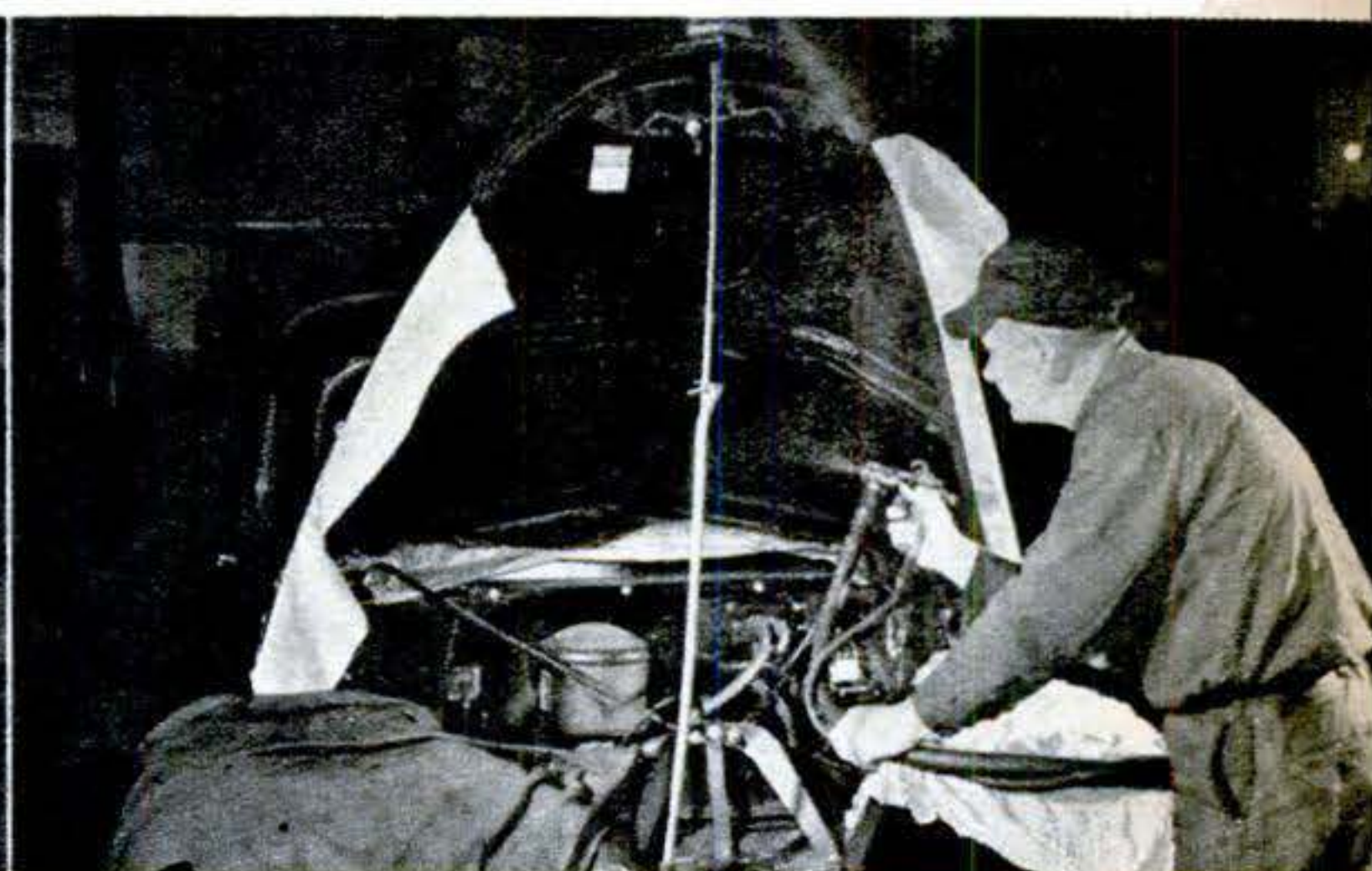

**8. Inside of hood** is coated to deaden engine noise. The coating also adds desirable rigidity to the thinner sheet metal found on some new cars. Car can be driven in a few hours.

the brake mechanism, or any of the lubrication points. On most of these parts, the coating would lock in too much heat.

You should be sure, however, that an even, continuous coating is applied to the fenders, fender skirts, gravel deflectors, gas tank, rocker panels, flooring, splash pans, and the inner face of the back bumper. The material should be sprayed extra thick on the joints where a fender meets the body.

The underside of the hood is usually included in the job, but this is up to you. Here, the objective is sound deadening only.

You may have heard that some fleet operators apply undercoating to the oil pan to prevent low-temperature sludge. This is true, and the idea has proved its value on stop-and-go vehicles. But this type of application is not advisable for passenger cars, since the engine would overheat on long runs. In some cases, too, the fire wall is coated. But this demands a lot of finicky masking.

As a rule, a good undercoating job should last the life of a car. But this rule, like others, has its exceptions. Constant driving over

loose-gravel highways may wear through the coating, especially if it has been applied too thin in the first place.

Temperature extremes have no appreciable effect on the better undercoating materials. These usually will not soften to the point of dripping unless heated to at least 300° F. At the other end of the thermometer scale, the materials will not crack unless the temperature drops to around 30° below zero.

Like seat covers, undercoating adds to the resale value of a car. Not only will the prospective purchaser be more apt to like the sound and feel of the car, but the lack of rusted-out spots will be a point in your favor.

You probably have wondered what happens if you dent an undercoated fender and must have it bumped out. Will the undercoating present a problem?

The answer is no. The material is quickly softened by applying a torch to the painted side of the fender. It then can be scraped off the area where the work is to be done. If necessary, body bolts can also be uncovered by torch softening.

END

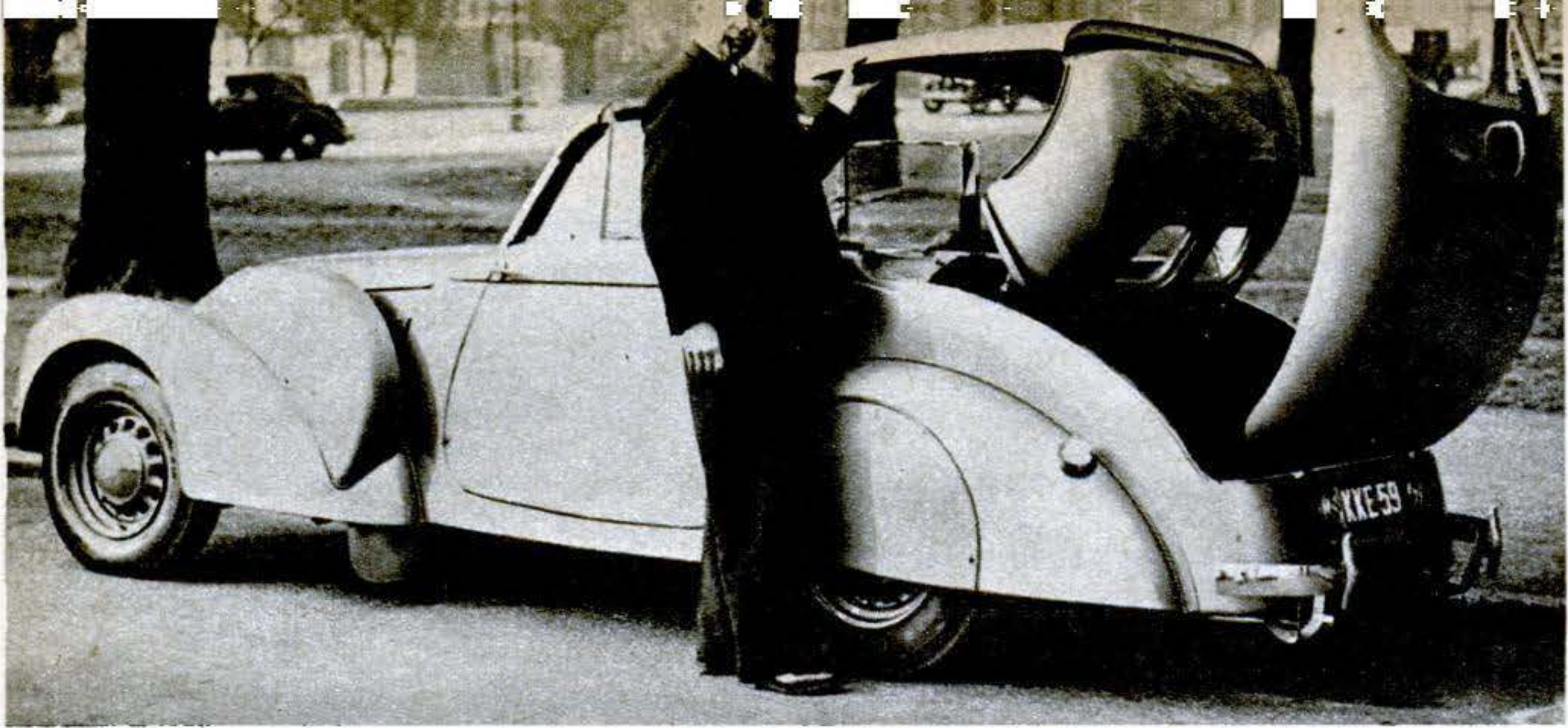

## Open Car Becomes Closed Sedan in One Minute Flat

THIS all-metal convertible, built in England by Col. John Dolphin, can be converted from a smart open tourer to a completely enclosed sedan in exactly 60 seconds.

As a convertible, the roof lies snugly out of sight in the hinged boot. You don't have to be a professional strong man, either, to lift the steel roof into position. It just takes a little nudging, since the weight is neutralized by counterbalances. Two locks on the windshield secure the roof, while rubber sealing makes all joints watertight. Dolphin, who contrib-

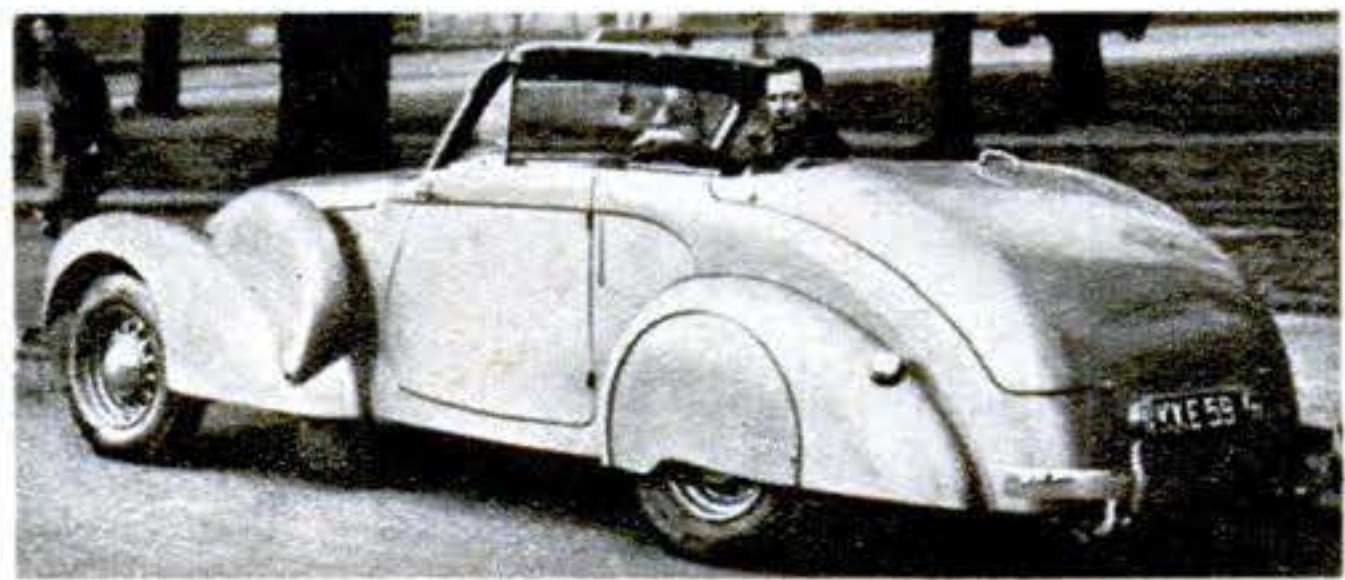

uted two important inventions to World War II—a one-man submarine and a folding motorcycle used by paratroopers—built his unusual car around the chassis of an Allard, a standard British automobile powered by a V-8 engine of 221 cu. in. displacement.

## Old Motorcycles Race in Great Britain



Two entries in England's 13th annual race of historic motorcycles are shown here. Only machines built before 1915 were eligible. At left is a Beeston Tricycle that was built in 1899, one of the oldest entries. Its engine has a displacement of 10.675 cu. in. Below, an early American-built motorcycle—a 1911 Pierce Arrow—gets away to a flying start with the aid of a couple of willing helpers. The engine, four cylinders in line, displaces 48.19 cu. in.



# New Pinch Brakes

## Stop the Crosley

**C**ROSLEY has pulled something new out of the air—a type of brake previously used only on planes. Actuated hydraulically, the brakes consist of small pads of a hard braking material that pinch together on a revolving cast-iron disk when you step on the pedal.

This gives a soft but positive braking action. The brakes were tested for a year before being adopted. The friction surfaces are said to wear very slowly.

Besides the brakes, the latest Crosleys introduce a new engine called the Ciba®. Instead of using brazed steel stampings as in the old 59-lb. Cobra®, the new engine has a cast-iron block. This ups the weight to about 85 lb. In design, the engine is the same, but power is slightly increased. **END**



**Hand-brake lever** in the newer Crosleys is located just under the dash. It sets the new disk brakes on the rear wheels by mechanical linkage. Hand brake was previously on the floor.

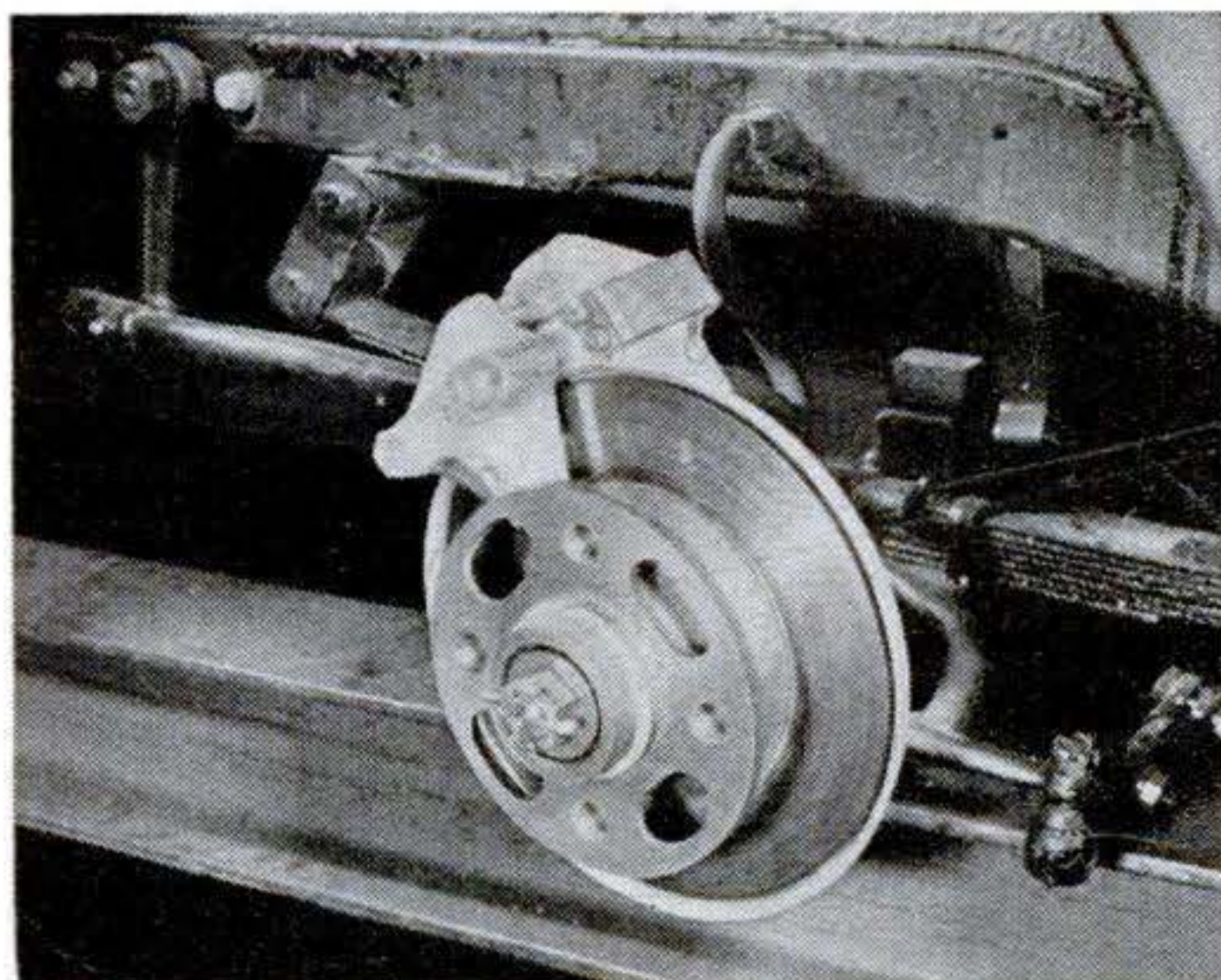

**New disk brake** is operated by a conventional hydraulic system. Above is what you see when you take off wheel. Disk revolves with wheel.

**Dust cover** protects inner face of the disk but allows cooling air to circulate. Water and oil are said not to impair the action of the brake.

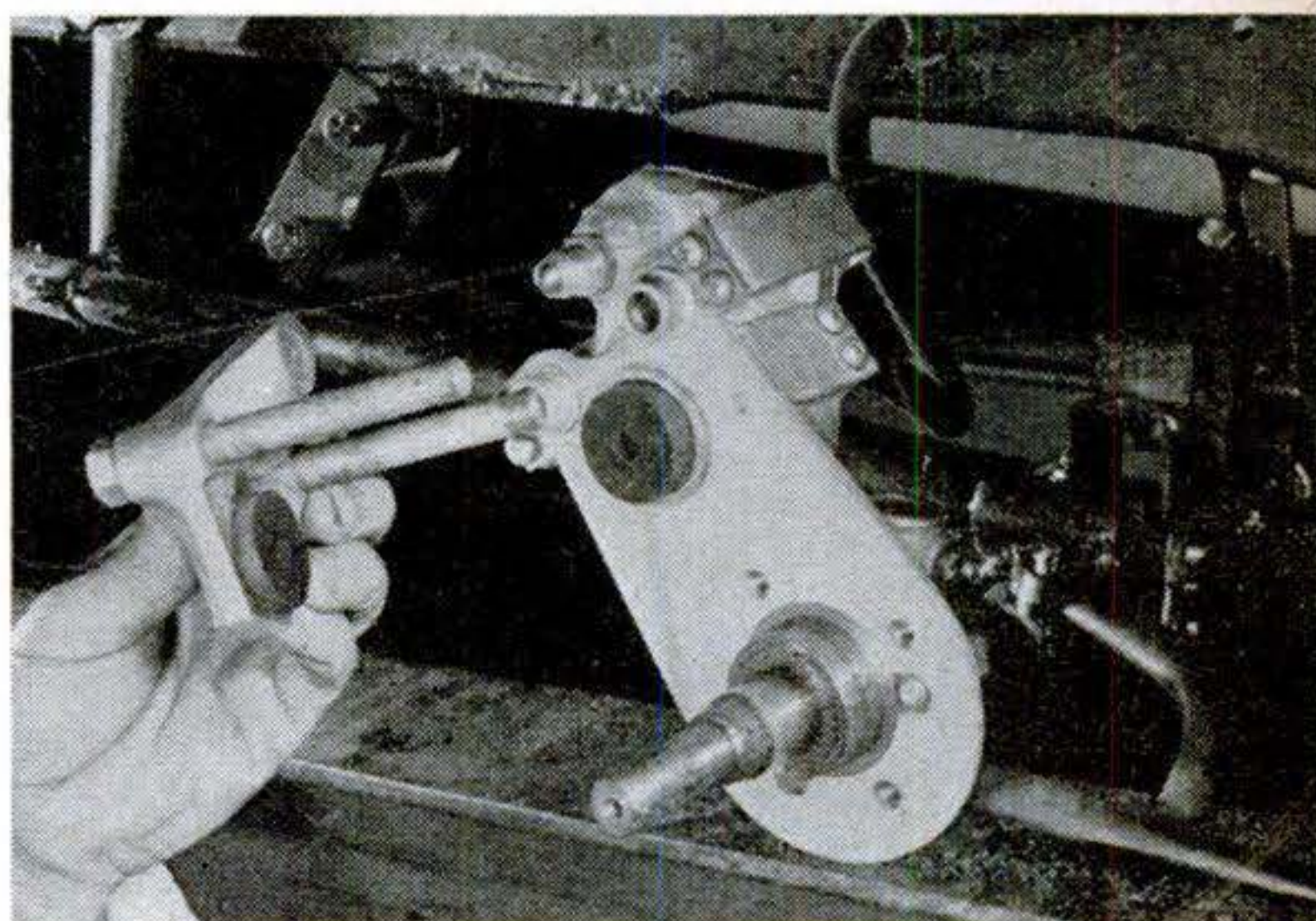

**Two pads** of braking material about size of half dollar pinch against sides of disk. A spring separates the pads when you release the pedal.

**Turning this nut** on back of cylinder assembly adjusts the braking pads to proper clearance. Previously, the Crosley used mechanical brakes.

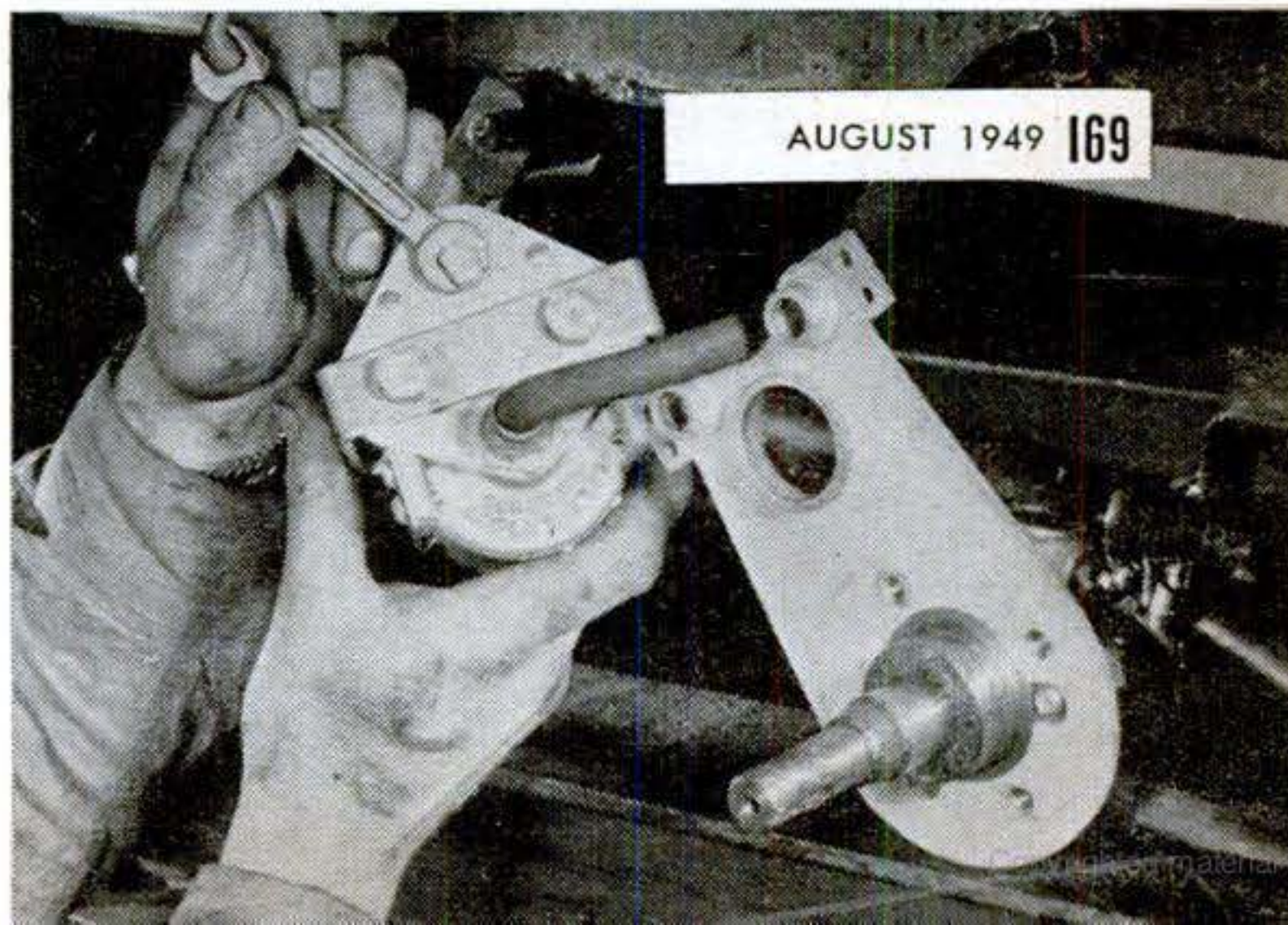
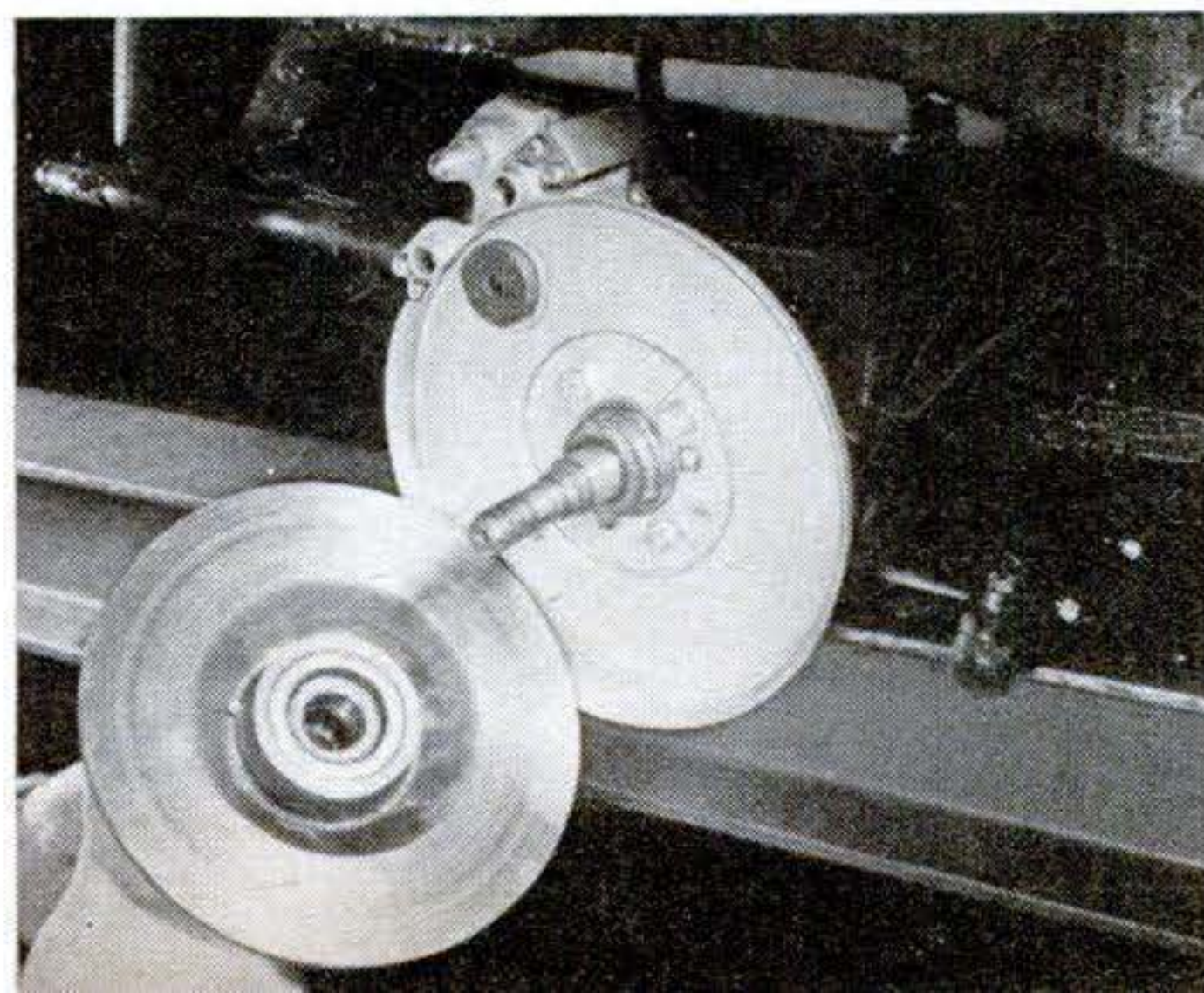



Big one or little, take your choice. Both trailers are sold knocked down for home assembly.

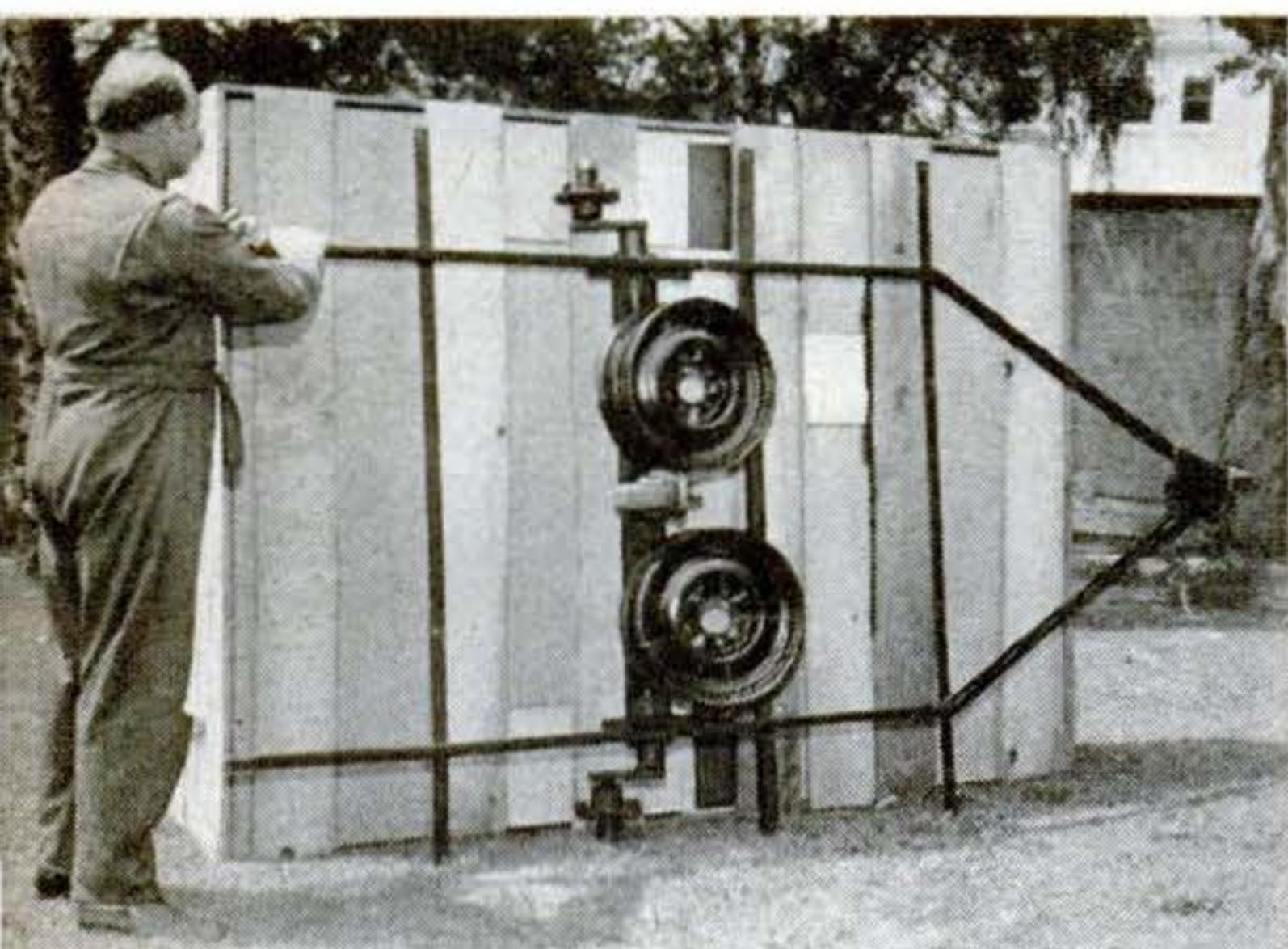

# Trailer Comes in a Package

Here's what you get. Crated for freight shipment, big trailer, at left, weighs 1,000 lb. Here, 16" Ford wheels are simply wired to the underframe. Tires and tubes are not furnished.

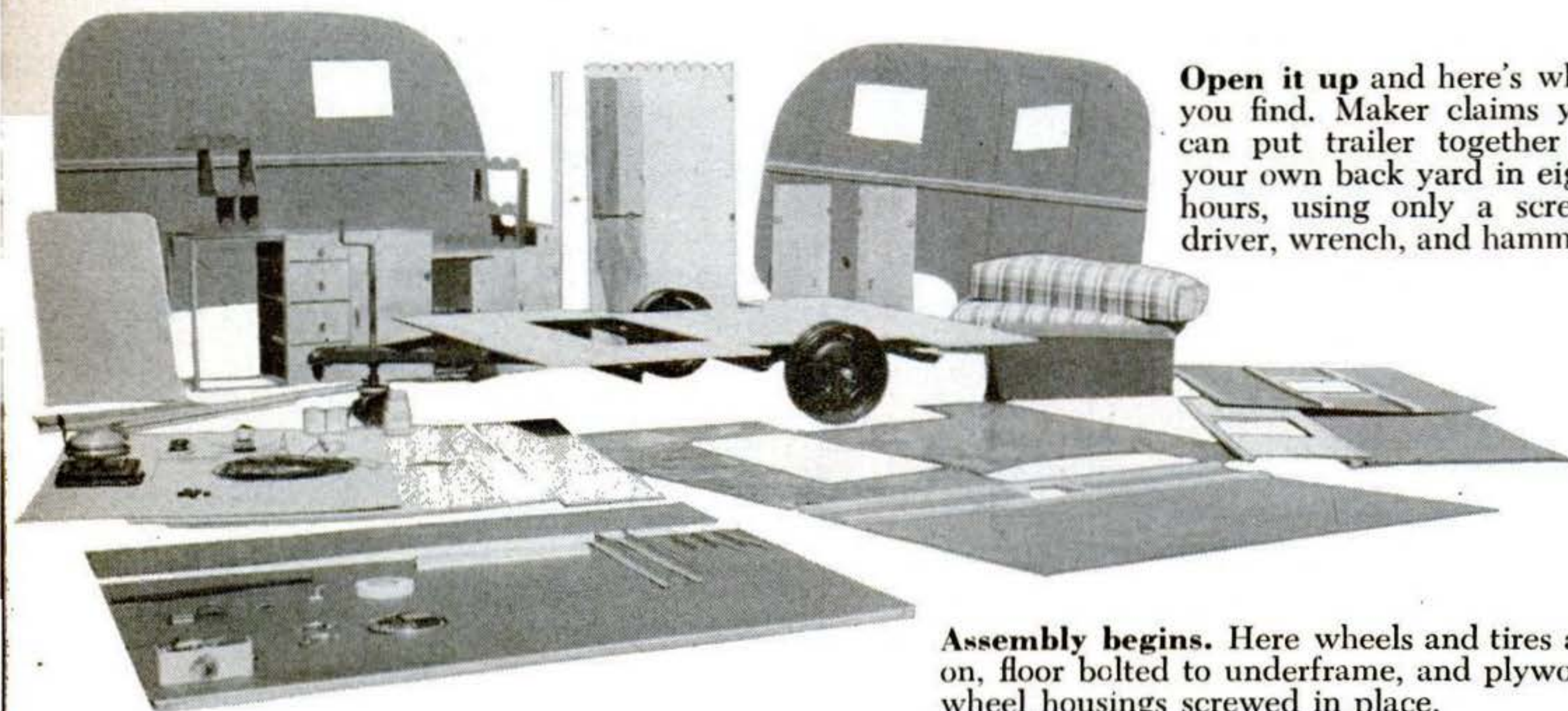

Open it up and here's what you find. Maker claims you can put trailer together in your own back yard in eight hours, using only a screwdriver, wrench, and hammer.

Assembly begins. Here wheels and tires are on, floor bolted to underframe, and plywood wheel housings screwed in place.

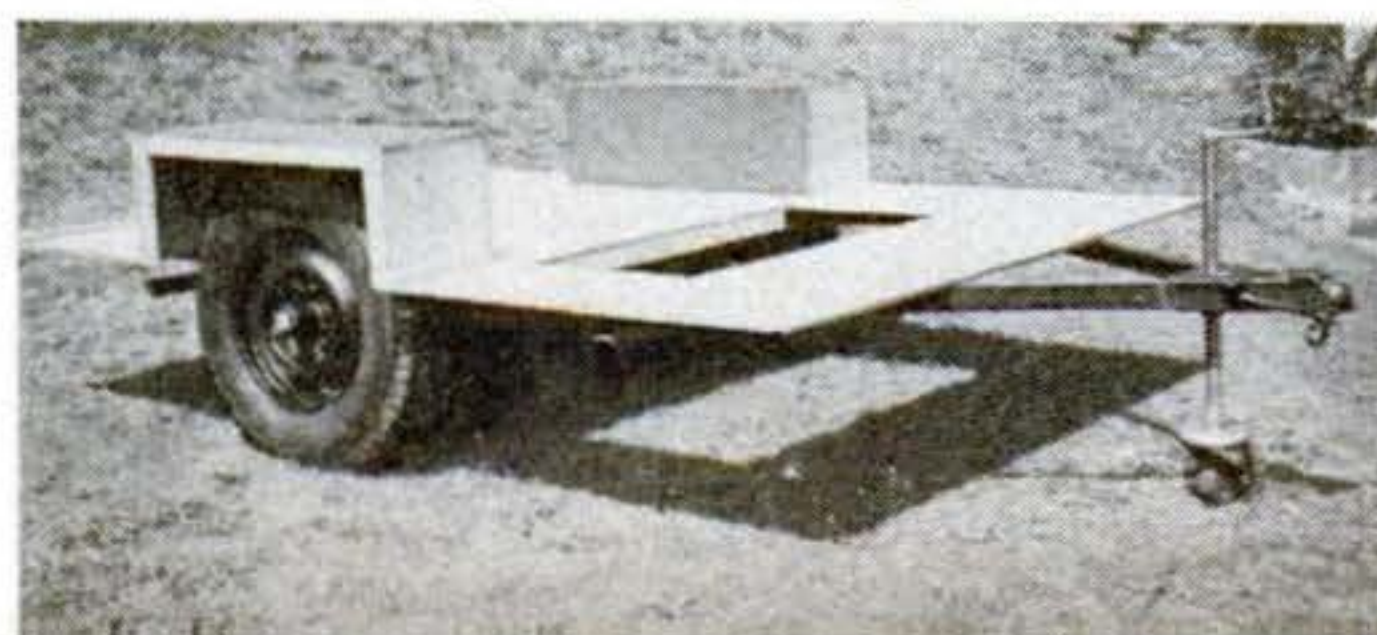

**E**VENTUALLY, it had to come—a trailer a man handy with hammer, wrench, and screwdriver could assemble in the back yard. Now, Prefab, Inc., of Los Angeles, offers you a choice of two—the Cub Senior® and the Cub Sportsman®.

All you must do is unwire the crate and follow detailed instructions. The parts are all pre-cut and everything is furnished except tires, tubes, and paint.

Senior boards the train in Los Angeles at \$395, Sportsman at \$279.50. You pay the freight, but shipping knocked down saves more than half on delivery charges.

The house trailer includes all conveniences for living on the road. The less de-luxe Sportman, designed chiefly for hunting and fishing trips, has an aluminum body and weighs about 450 lb. A mattress on the floor provides comfortable sleeping.



**Top curves into place** after side walls and front bulkhead have been attached. All seams are caulked to keep out water. Sides and top are composition board, reinforced with wood.

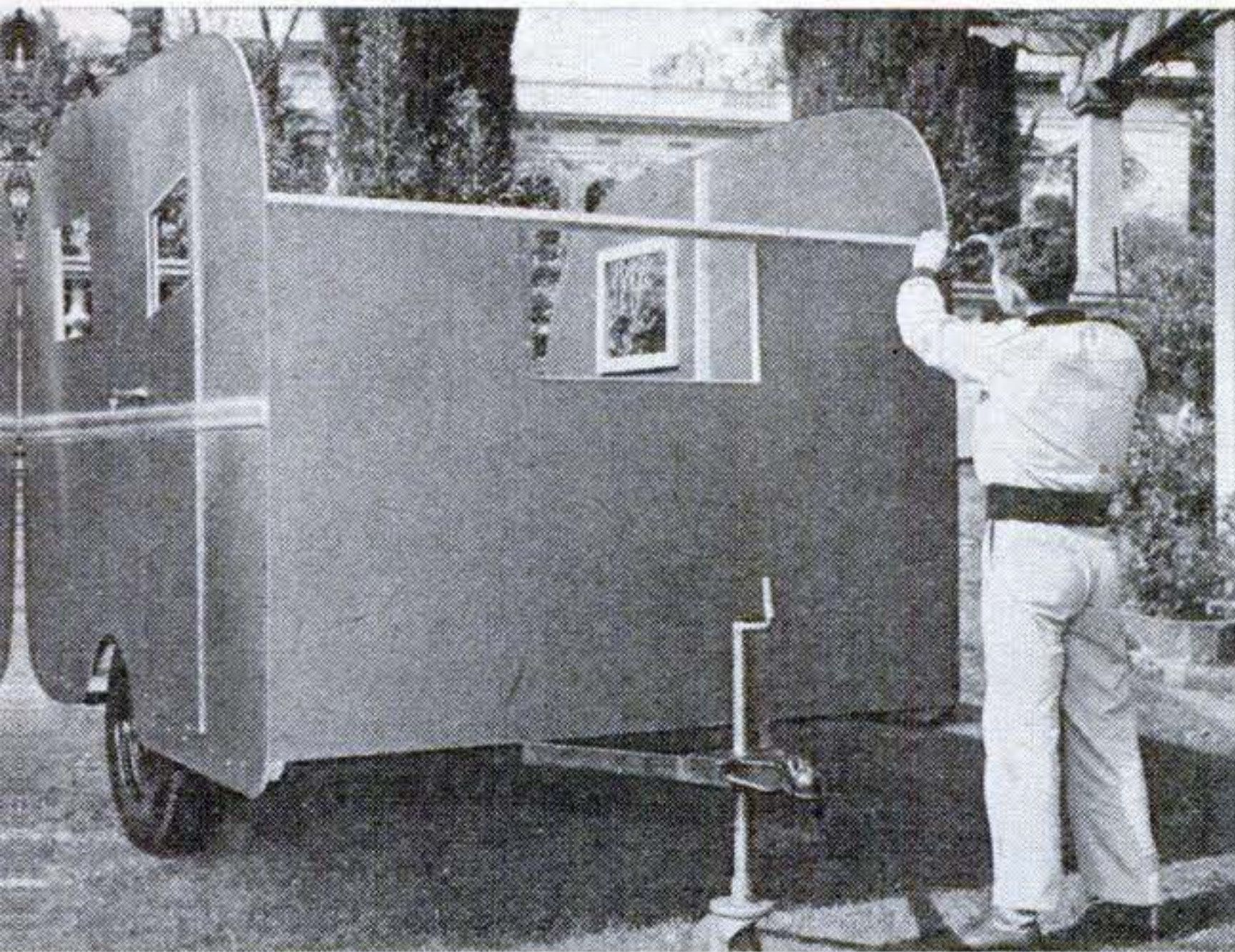

**Walls are nailed temporarily**, then permanently secured with screws. All units are predrilled for screws and bolts. Tape is applied over the seams to hide nails and any irregularities.

**Four persons can sit** comfortably on the seats. Inside, the bigger trailer is 8' long and 6' wide and high. Equipment includes a pull-down ironing board and hinged and screened windows.

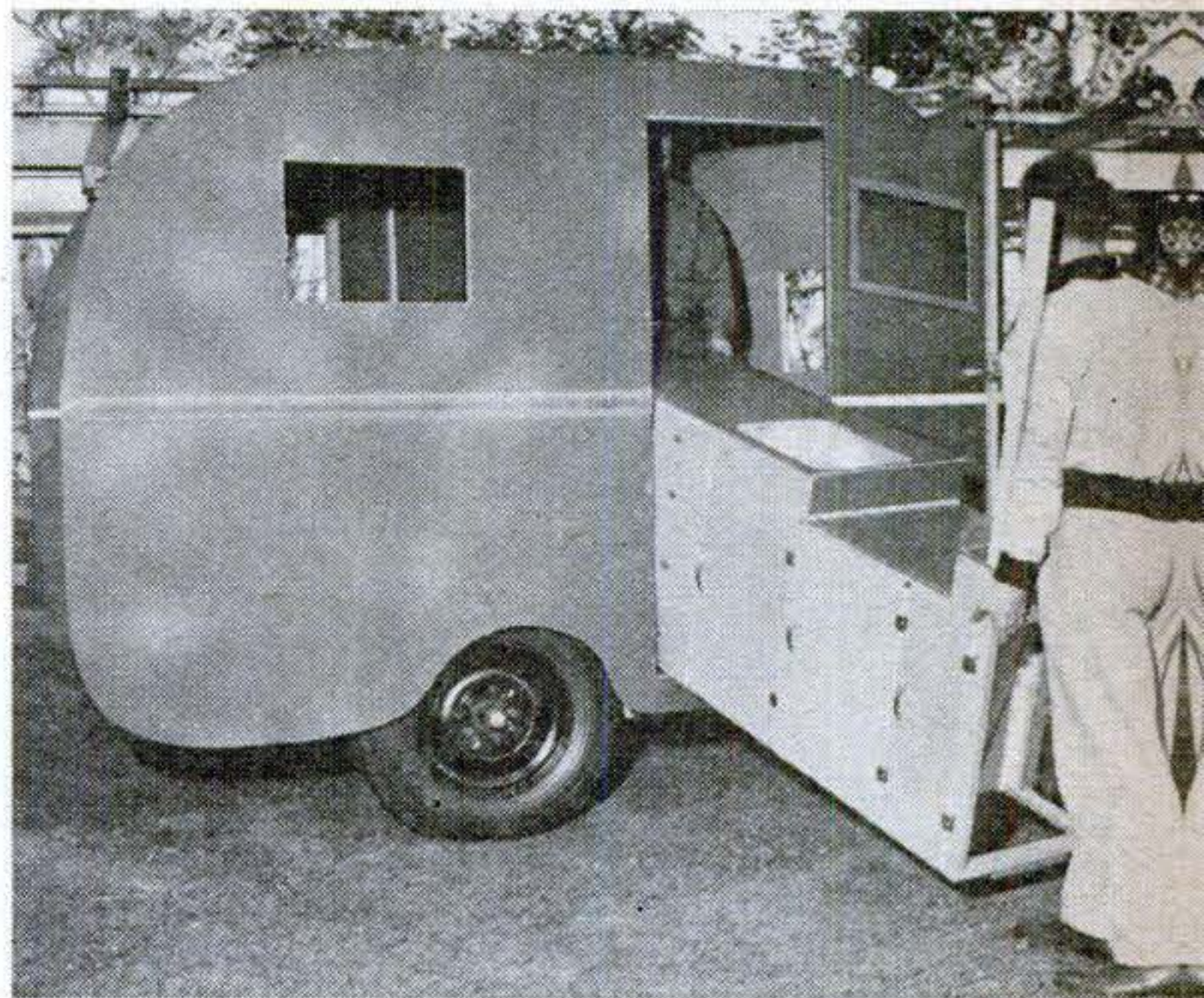

**In goes the sink assembly.** This includes ice box, aluminum basin, and four drawers. Four other assemblies come with the kit—shelves, table, clothes closet, underseat cabinets.

**Pulled out**, the seats make a double bed. The closet comes already wired for either 6-volt or 115-volt electricity. Detailed instructions make it easy to assemble the trailer.

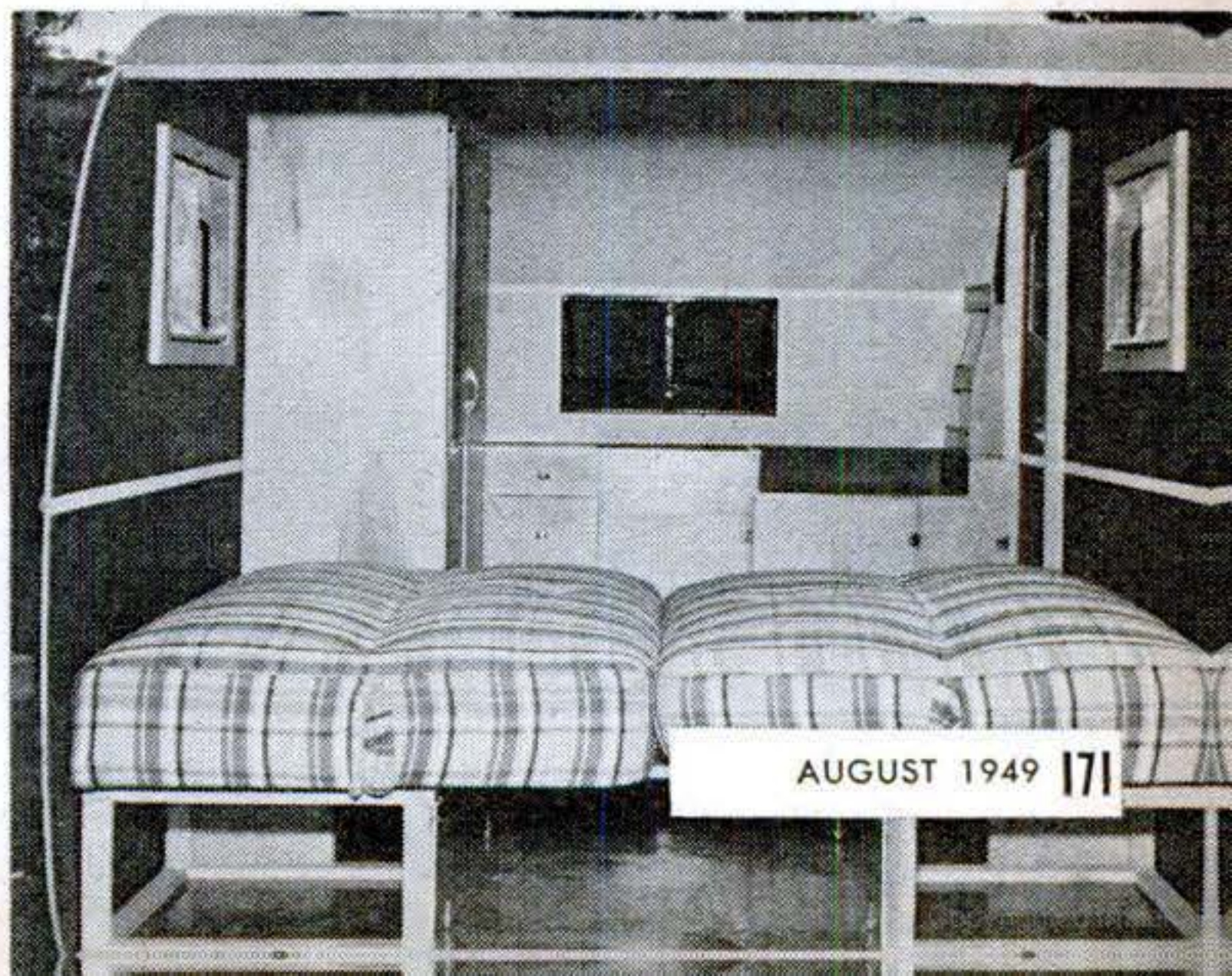
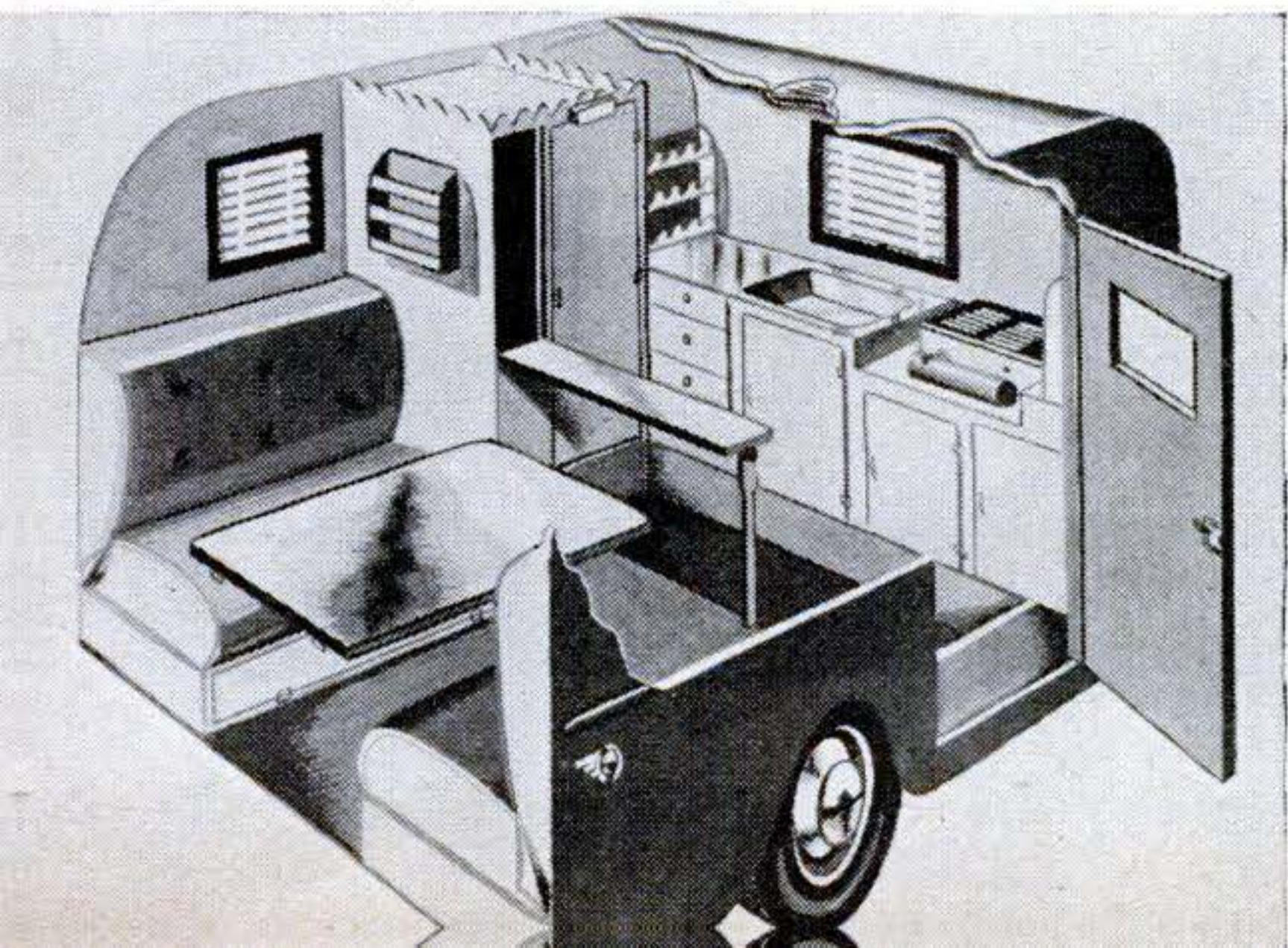

## Low-Cost Convertible Does 30 Miles per Gallon

EXPECTED to sell for about \$1,170 at the factory, this little car is now being tooled up for production in a wartime aircraft plant at San Diego, Calif. The maker is Del Mar Motors, Inc.

Powered by a 4-cyl., 63-hp. Continental engine, the pilot model is said to give around 30 miles per gal. In tests, it has been clocked at 100 m.p.h. Fifty is an easy cruising speed.

Built on a conventional chassis, the Del Mar has a 100" wheelbase and 58" tread. Three models are planned—a convertible, accommodating three persons on the single seat; a two-door, five-passenger sedan, and a three-passenger business coupe.



As designed, the car is to be largely assembled from standard parts obtained from automotive-industry suppliers. The car will use 6.00 by 12 tires.

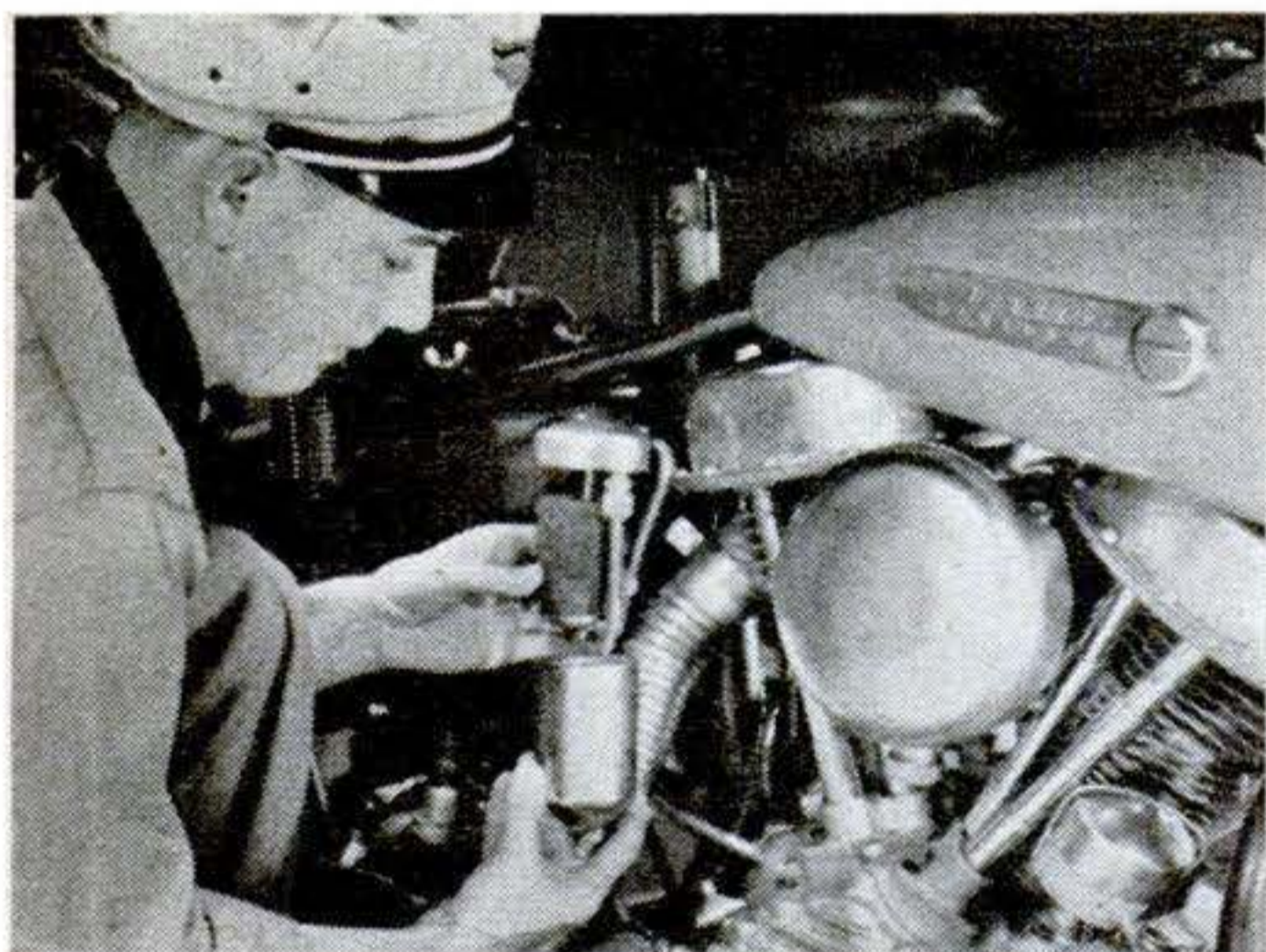

### Oil Filter Has Safety By-Pass

A NEW motorcycle oil filter announced by the Harley-Davidson Motor Co., Milwaukee, Wis., forces the lubricant to pass through a  $\frac{1}{2}$ " cylindrical felt filter element. The unit has a ball check valve to by-pass the oil if the element becomes clogged.

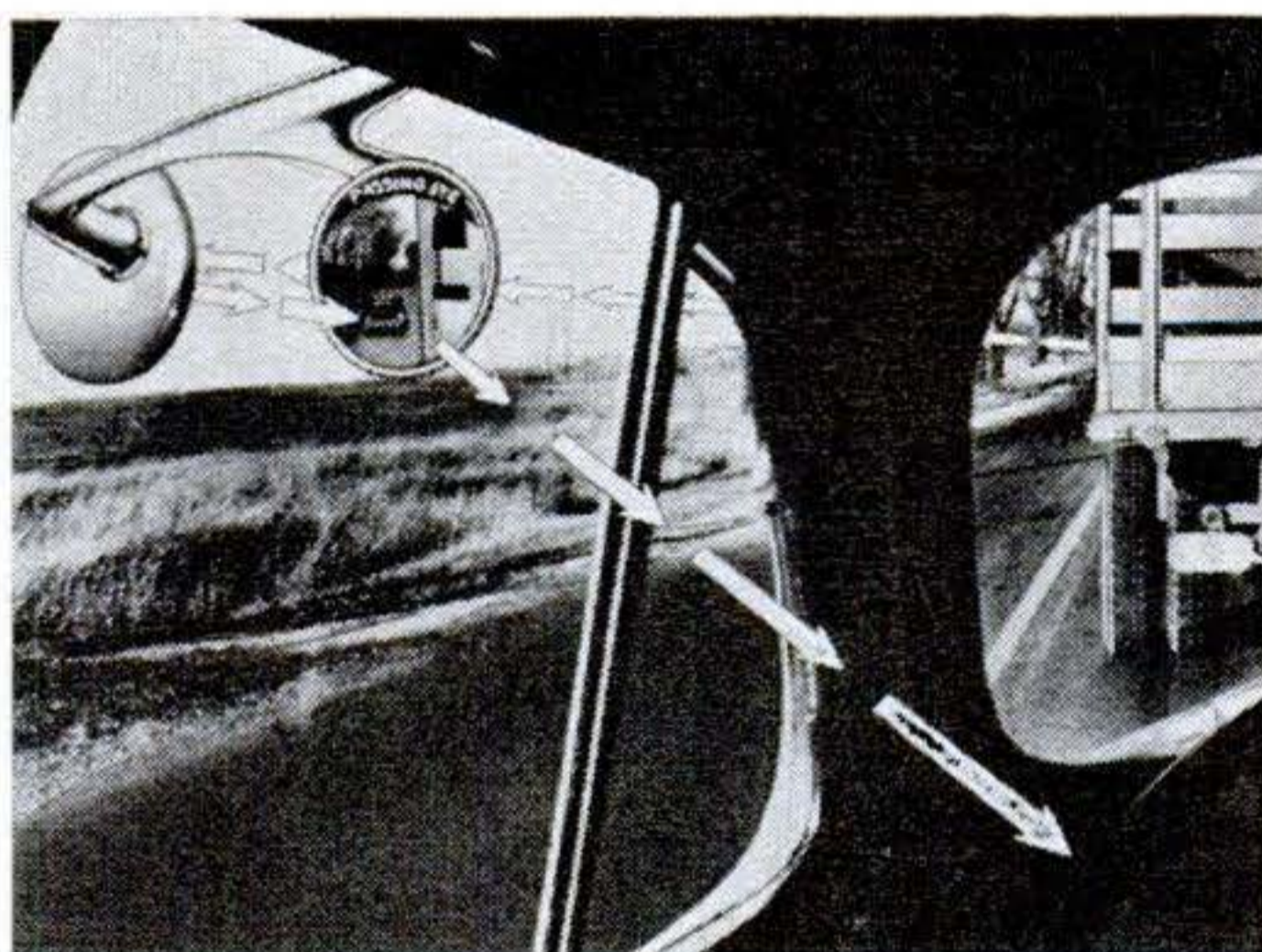

### Double Mirror Looks Ahead

WHILE you are driving behind a truck or other large vehicle, this device is said to give you a view of the oncoming traffic. Made by Passing Eye, Inc., Kenosha, Wis., it consists of two mirrors on a chrome-plated double arm that clamps to the door.



### Reflecting Sign Protects You

NIGHT repairs along the highway can be made in greater safety if you use this new reflecting danger signal. Made of steel, it folds for storage in the luggage compartment. It's painted red, and glass reflecting beads form the lettering. The Veecliff Corp., New York, makes it. Called Steer Klear®, the sign retails for about \$3.50.

# Mechanics and Handicraft

REG. U. S. PAT. OFF.

*Five Power Tools in a Box*

PAGE 174

*Outrigger Boat Is Week-End Job*

PAGE 182

*Making Draw-in Lathe Collets*

PAGE 200

*Vacuum-Tube Voltmeters*

PAGE 210

*Air-Conditioning a Car*

PAGE 222

Workshopping comes easy with this power-tool rig. Everything fits into a box. See next page.

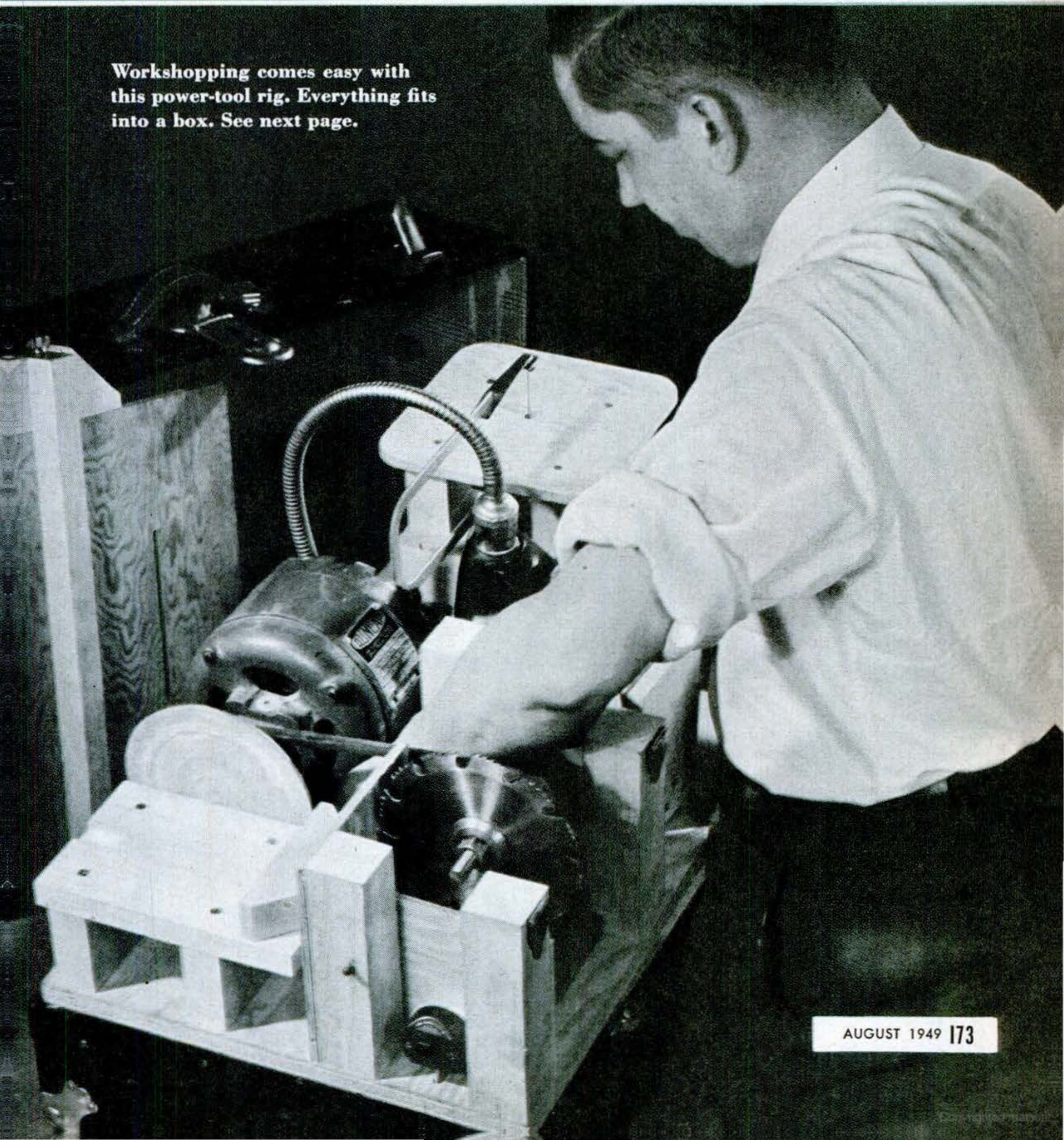

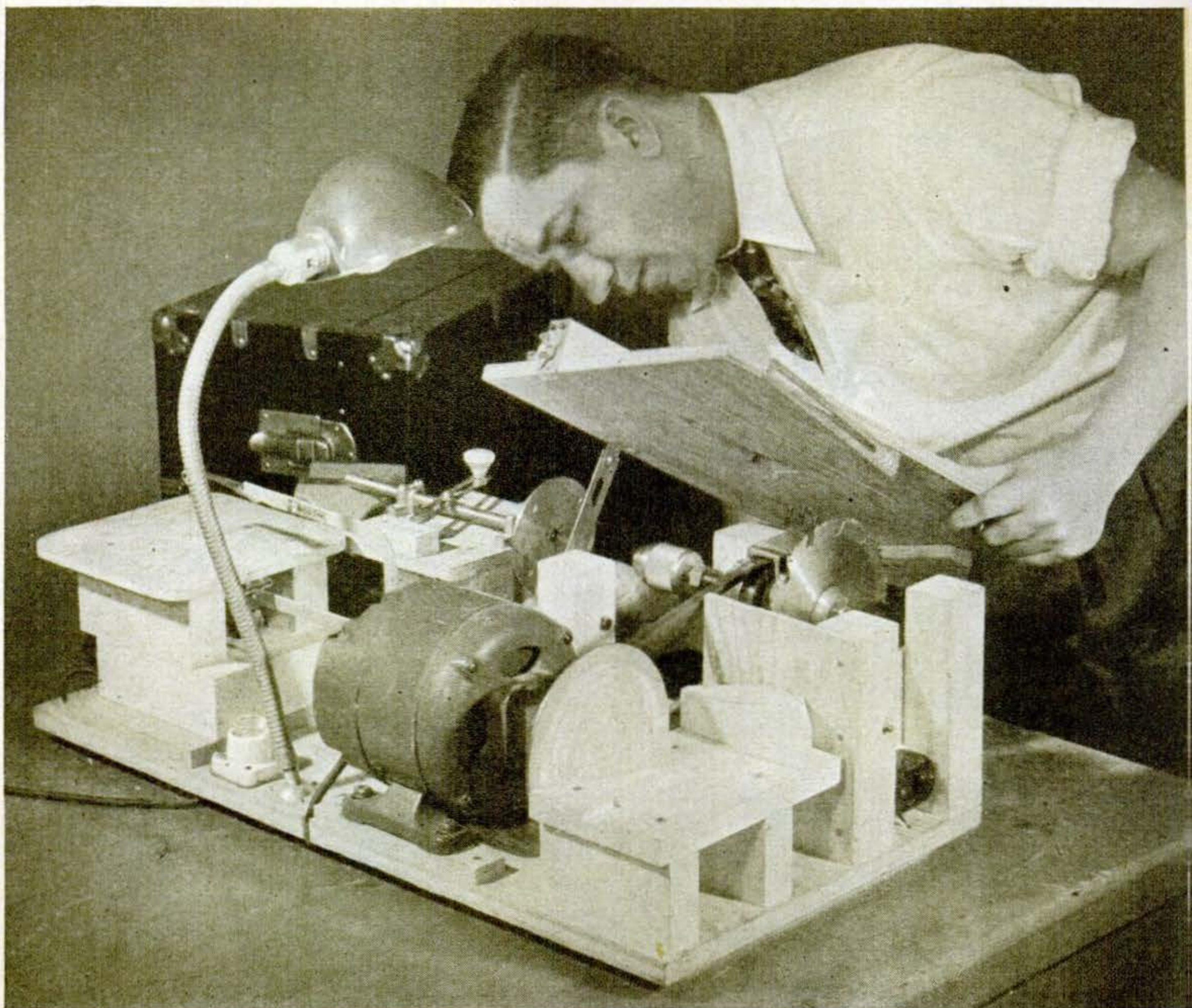

**Popular Science  
Practical Solution**

# Power-Tool Shop

**Motor and spindle arbor are heart of five power tools in a trunk**

1. You start with this—a plywood panel to fit inside trunk, a ¼-hp. motor mounted on blocks to let 6" sanding disk clear the base, and a polishing head. Note lifting handles.

2. Mount table posts with angle brackets and long wood screws. Low plywood wall supports switch; other pieces guard the saw blade. Pulleys take sanding disk and drill pad.

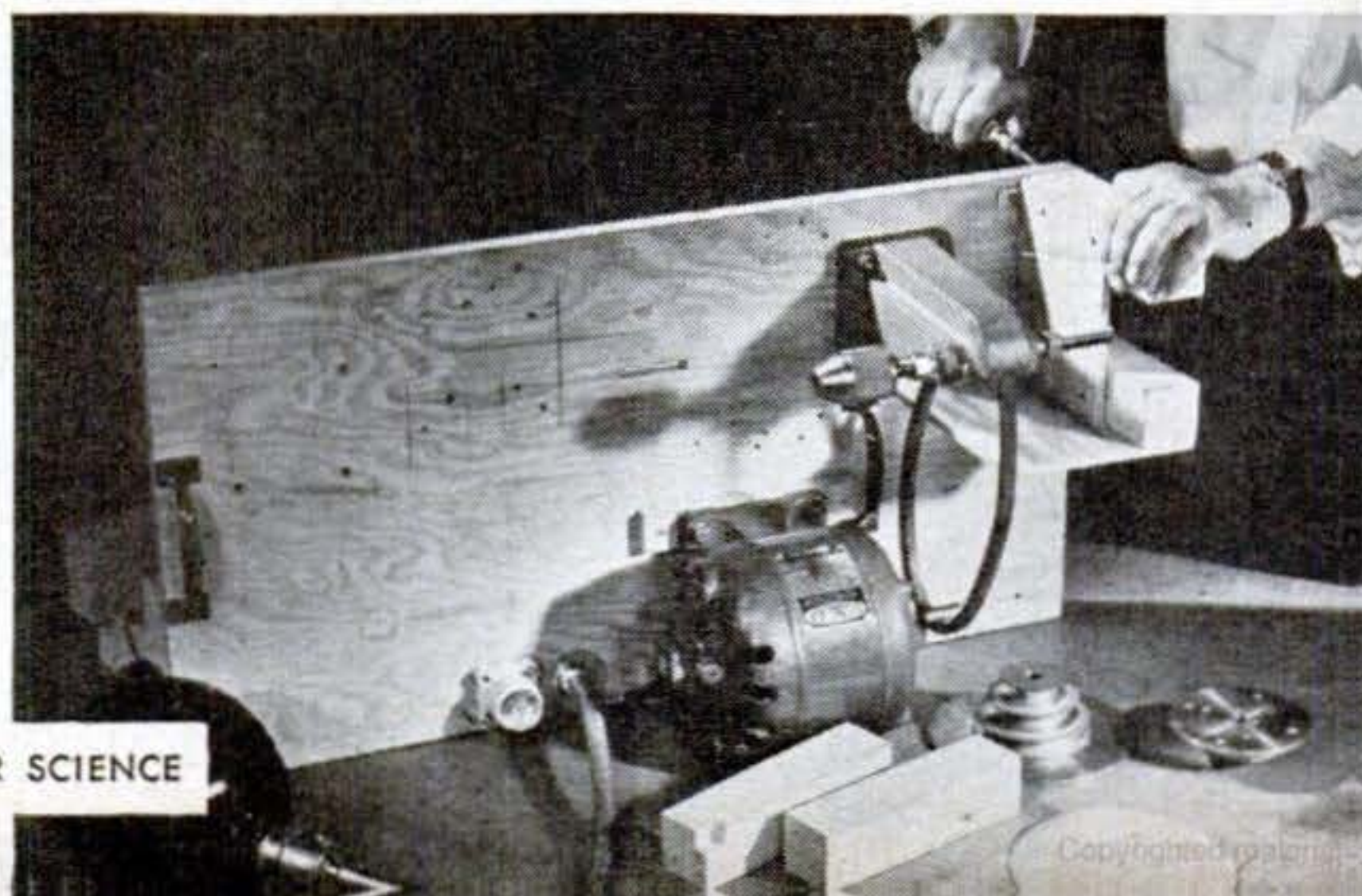
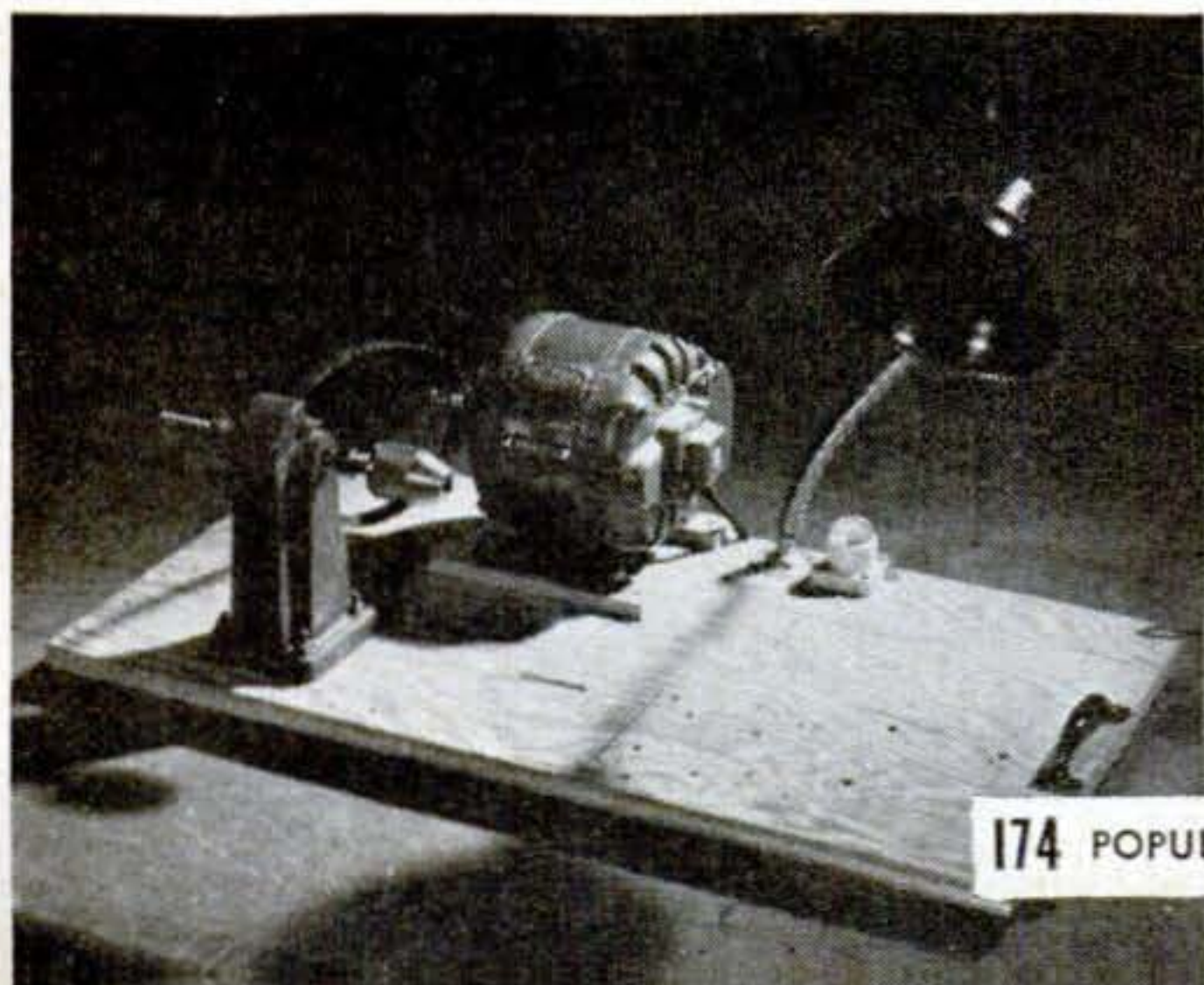



**With saw blade removed, this rig does turning, jigsawing, disk and drum sanding, drilling, buffing, wire brushing.**

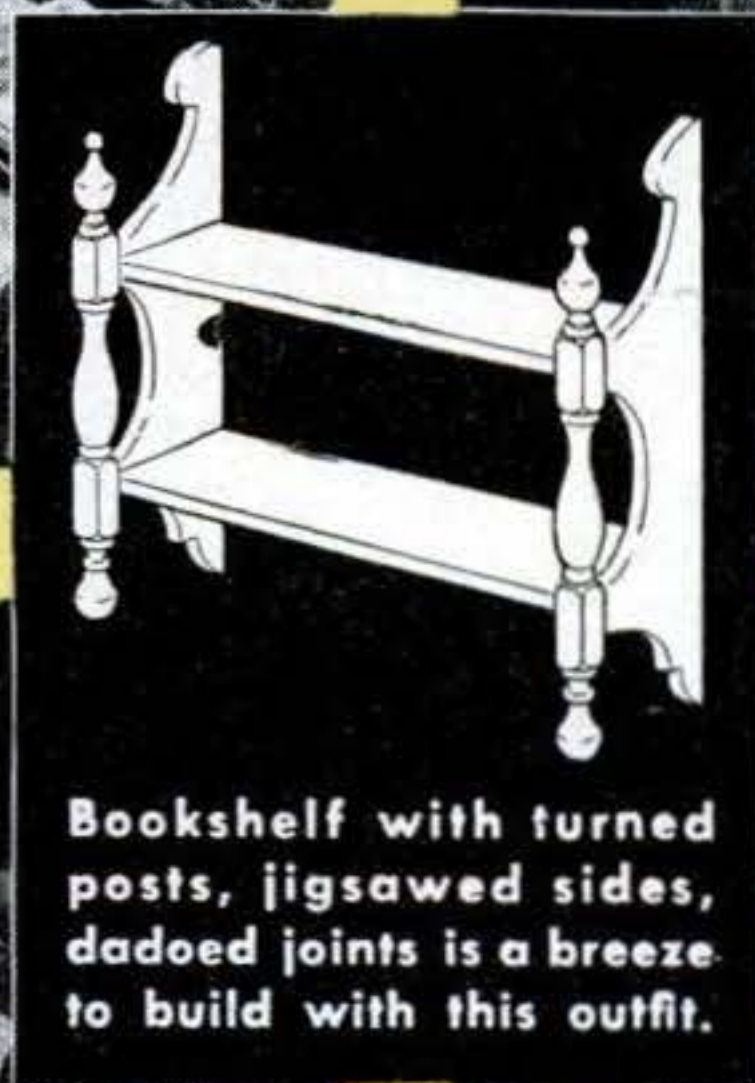
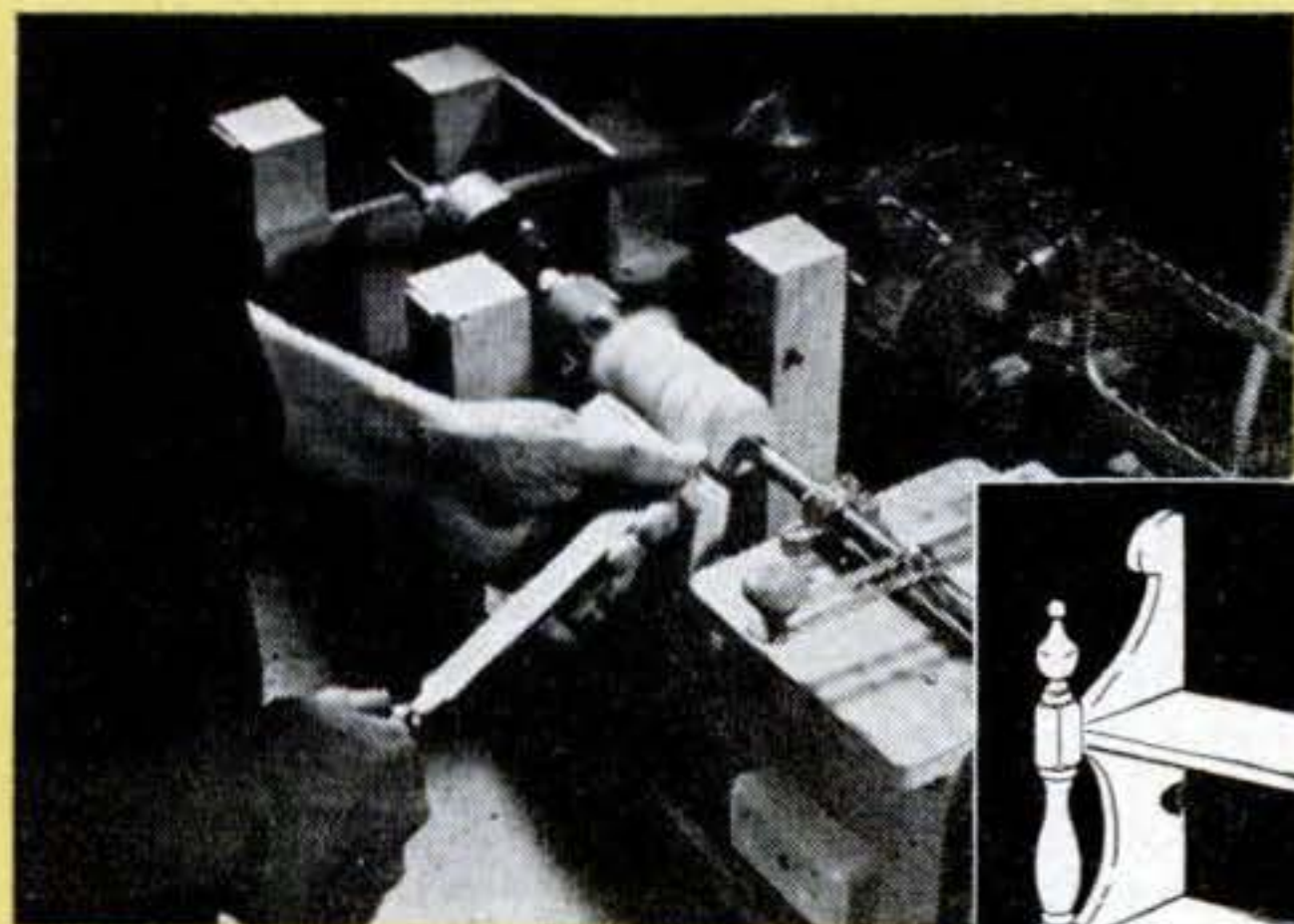

# Builds Itself

**that make real work real fun.**

3. Attach leaves of hinges to forward posts. Screw matching leaves to  $\frac{1}{2}$ " plywood table with countersunk bolts. Insert removable hinge pins and mark recess for head housing.

"COULDN'T a practical set of power tools be built around a motor and a polishing head?" asked our Editor. "Something a fellow living in an apartment, or even a furnished room, could put to use?"

The only answer to that was to try. The result is an eye opener. With electricity

4. Chisel recess and remount 12" by 15" table after putting saw blade on. Lower table slowly to cut saw slot. Widen it to  $\frac{1}{4}$ " by filing or reclamping saw to cut a second kerf.

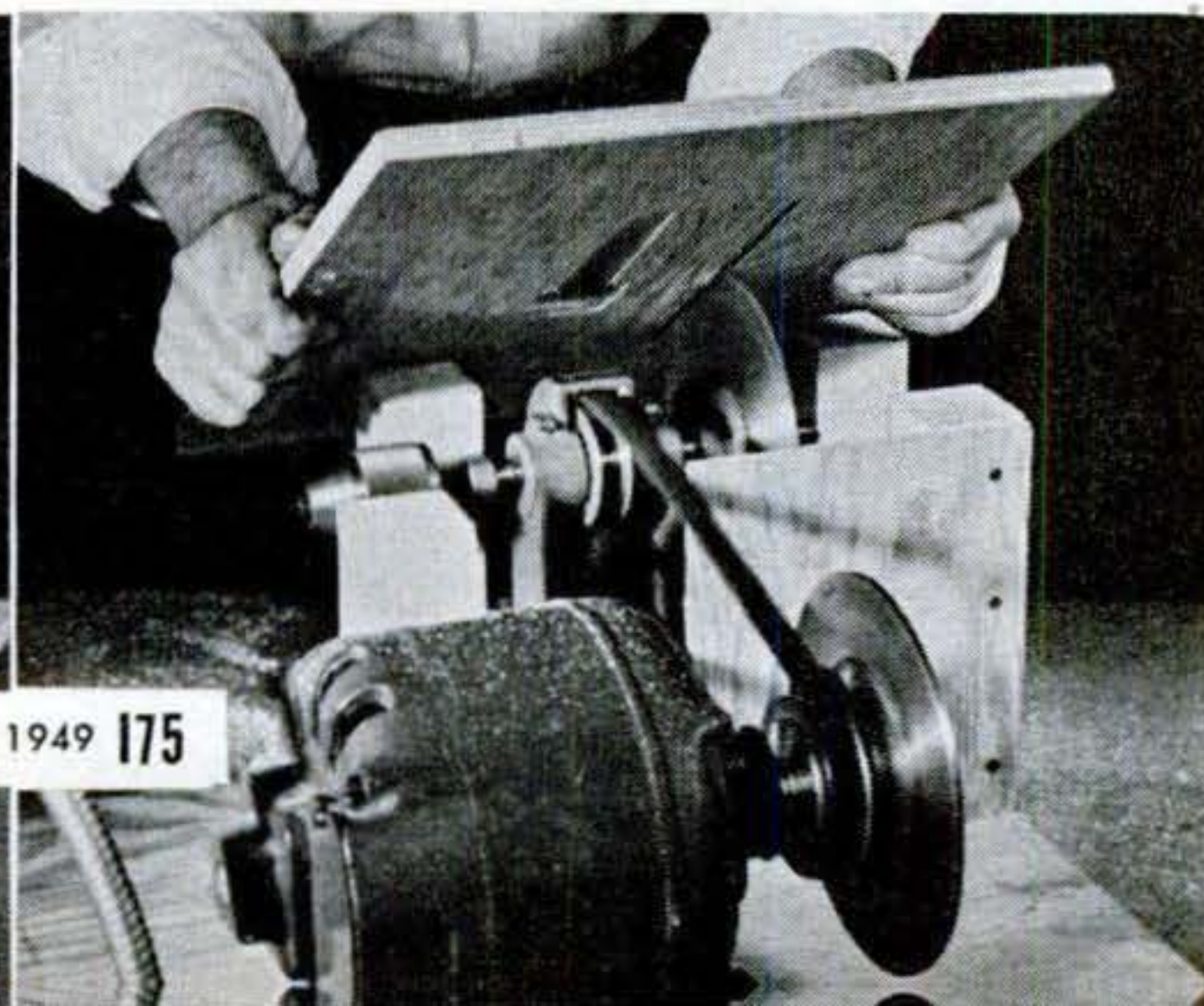
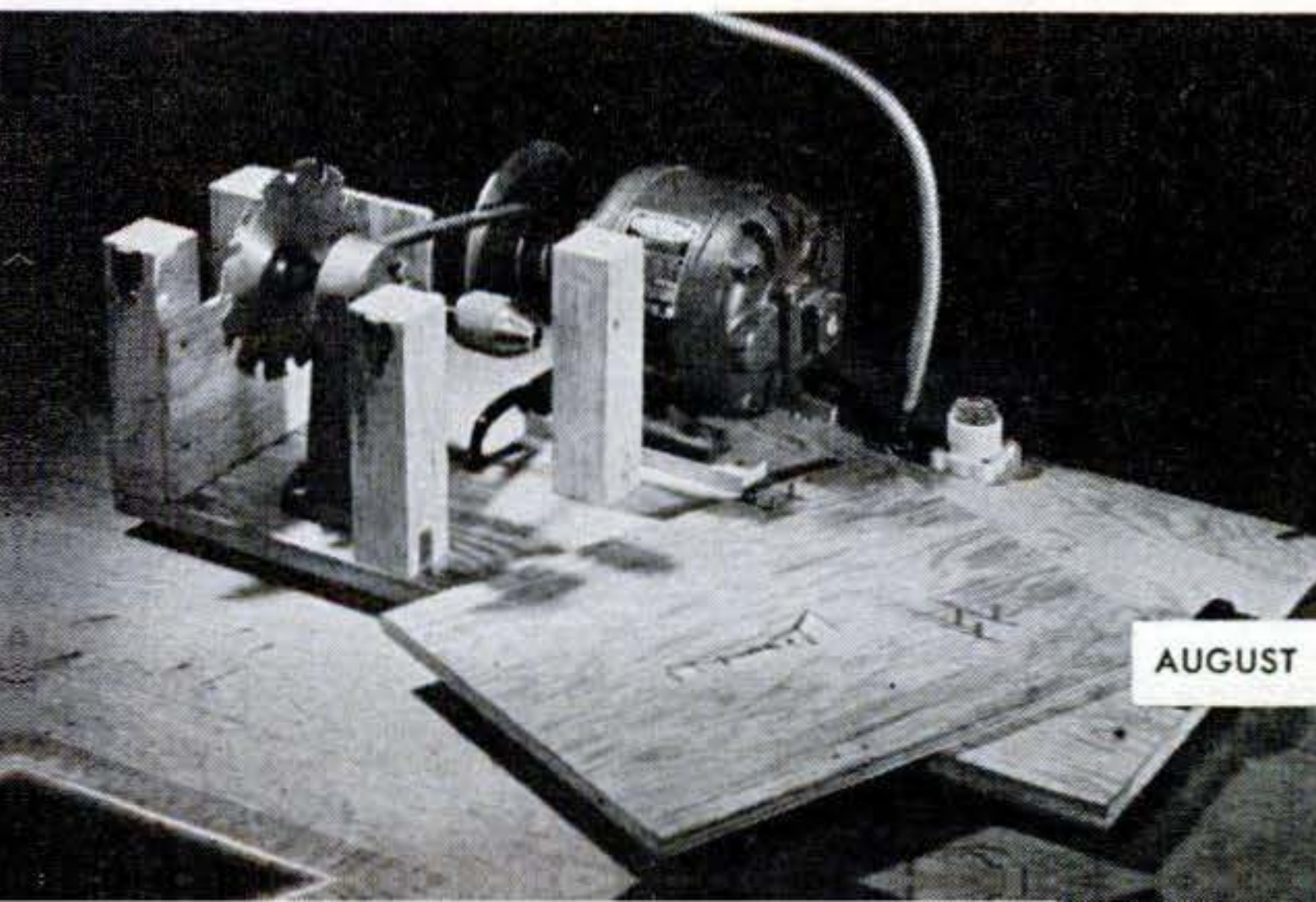

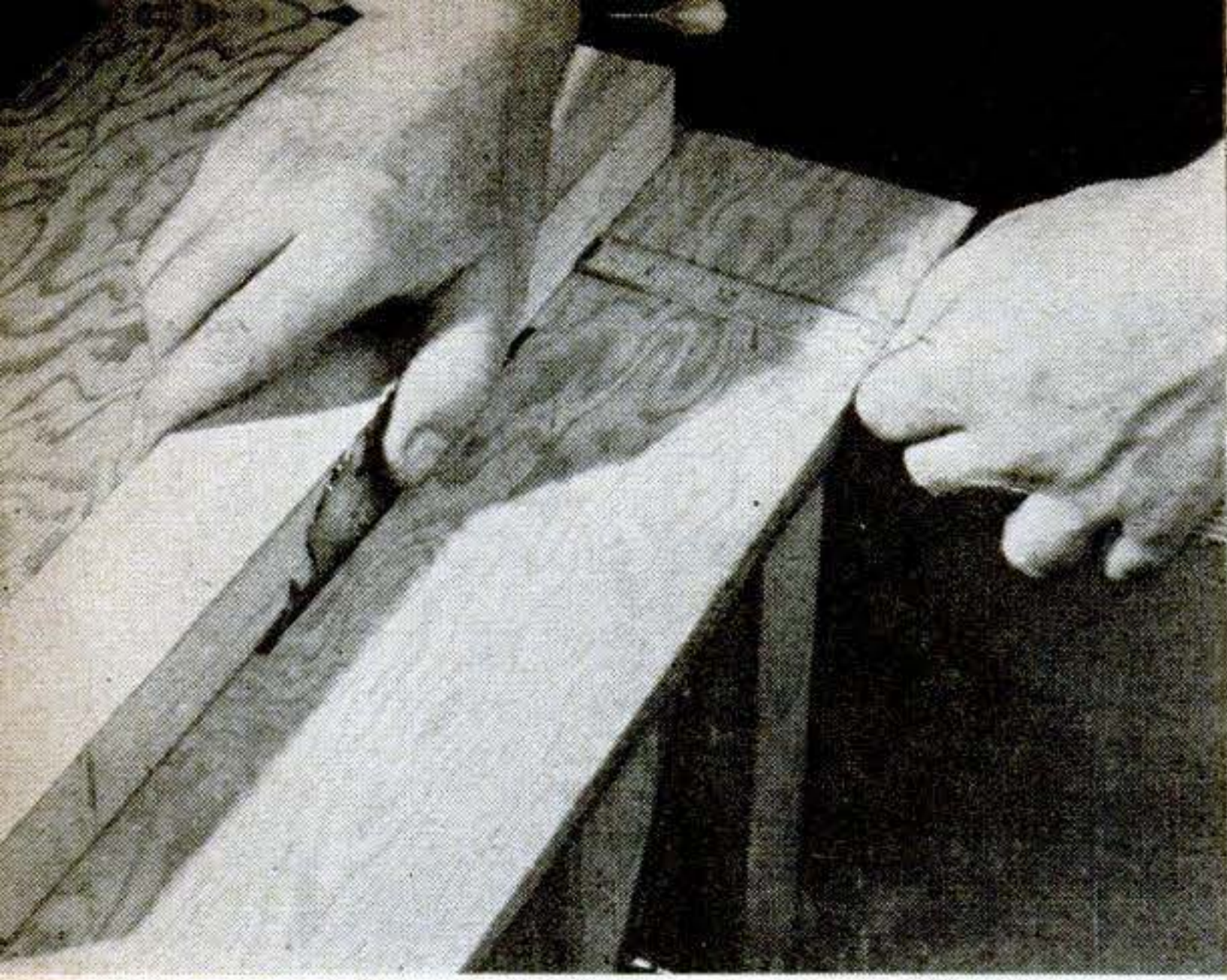

**5. Hold straightedge** against blade. Measure to table edge at both ends. If edge isn't parallel to blade, plane true. Fit cabinet lid supports and wing nuts as below.

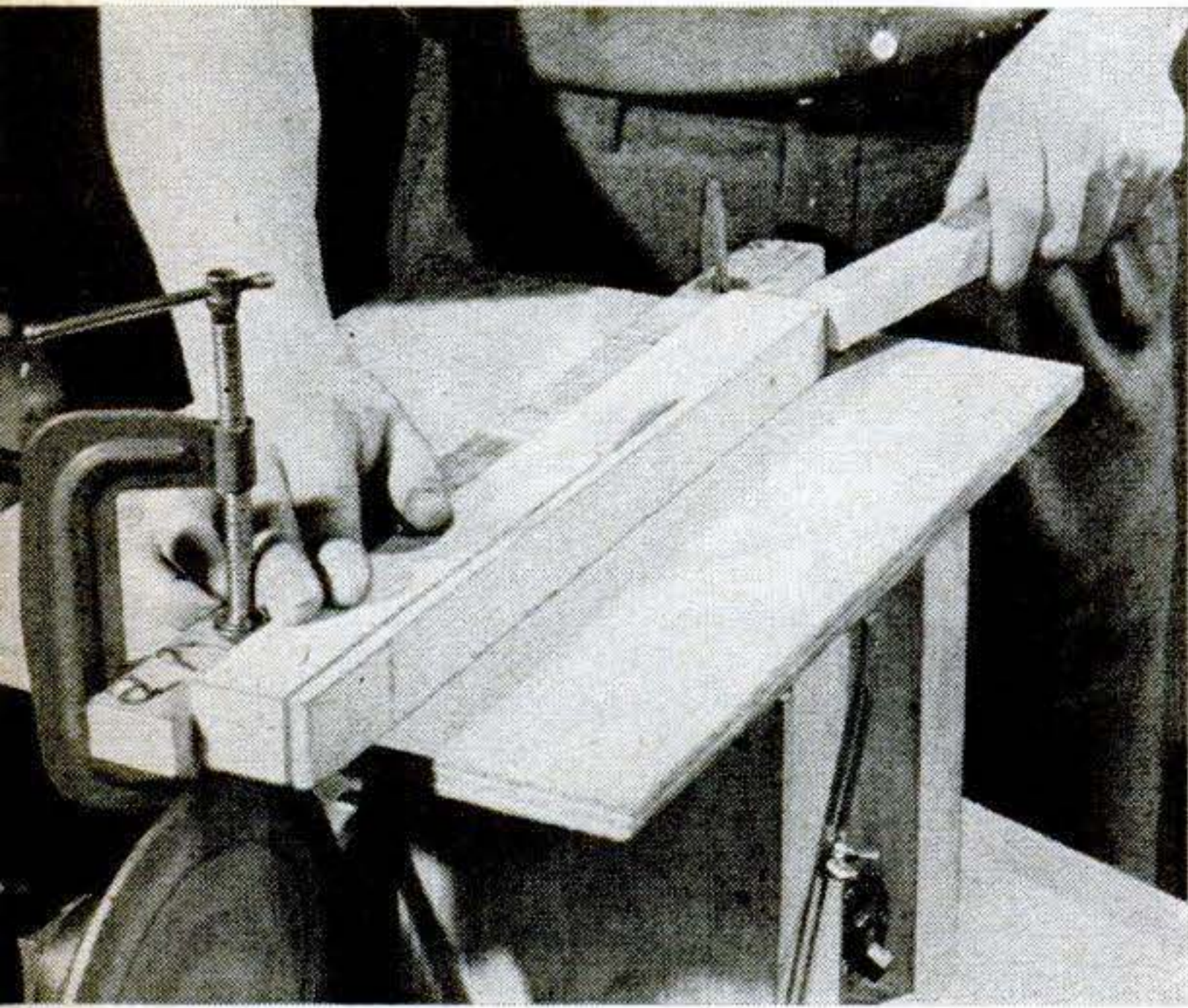

**6. Rip fence is ripped** to size against temporary fence, a straightedge clamped to table. Raise and lock table to rip groove  $\frac{3}{4}$ " deep for clamp rod, as shown in drawing opposite.

**7. With finished fence,** you can groove  $\frac{3}{4}$ " sanding table  $\frac{1}{4}$ " deep. Reset fence to widen groove each cut. Note bolt and wing nut that clamp table support on each side.

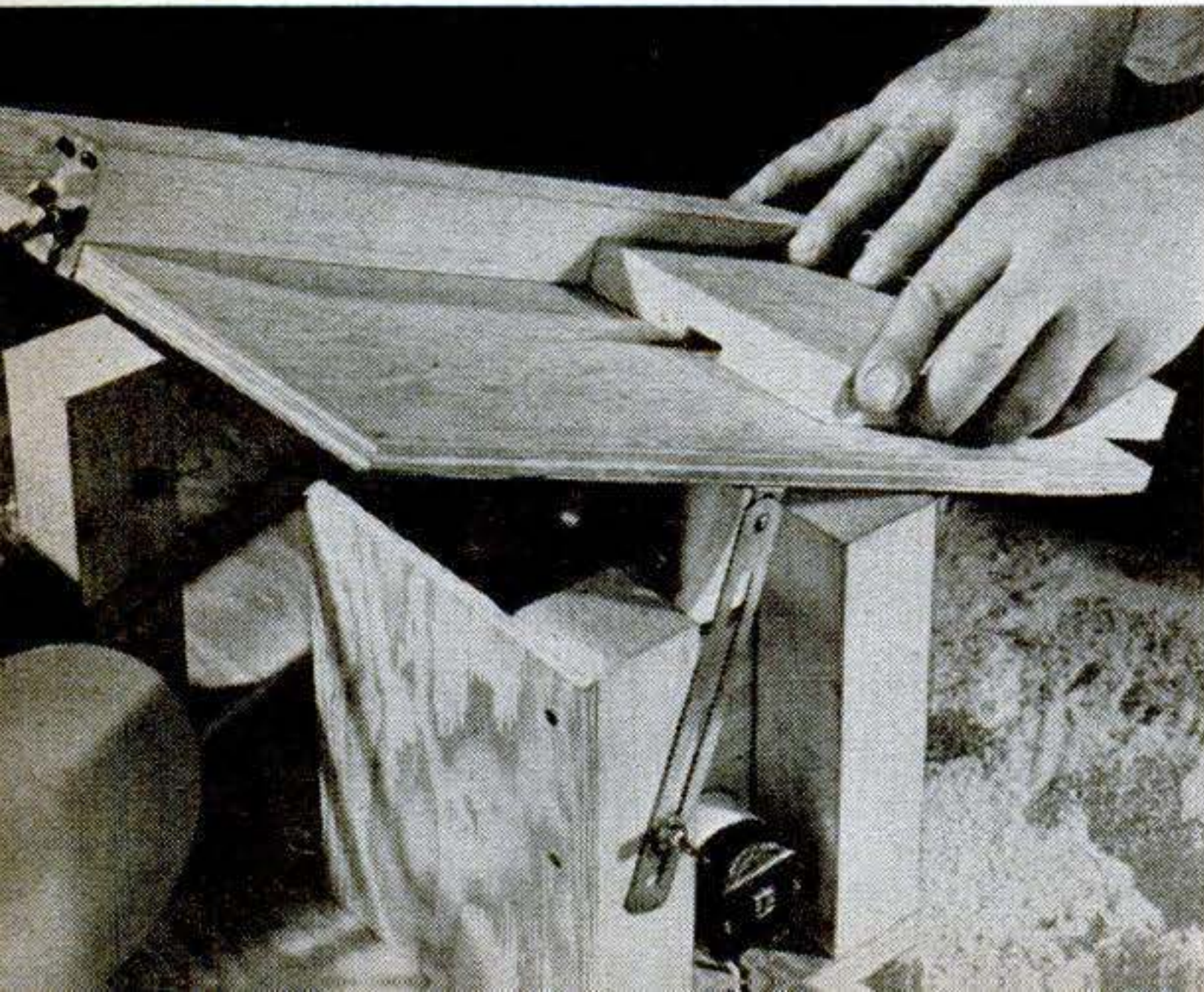

doing the work, you're free to enjoy the sheer fun of craftsmanship. Difficult dados, recalcitrant rip cuts, and finicky fits become swift routine. You're no longer "too tired to make things" after supper.

Best of all, you needn't turn your pockets inside out. The setup is tailored to slim budgets. And the rig literally makes itself: it's designed to cut and sand its own parts.

Its capacity is necessarily limited. It won't take the place of a 10" tilt-arbor saw, nor handle a bedpost turning, compound miters, or the oak stem of a cabin cruiser. But these are the rare jobs. What it will do is make the many cuts, grooves, dados, holes, and short turnings that are 90 percent of most jobs. It's a natural for modelmaking.

You'll need a 1,750-rpm,  $\frac{1}{4}$ - or  $\frac{1}{8}$ -hp. motor, costing new from \$10 to \$15. With luck you may find a used one for less, but don't buy any rated less than  $\frac{1}{4}$  hp.

As the polishing head is the heart of the setup, it pays to get the best you can within size limitations. The one shown is 6" from mounting surface to shaft center, and has bronze bearings and a single pulley. Needle bearings would be better, of course, and a two-step pulley would give a speed choice for drilling and turning.

Check the shaft for up-and-down play in the bearings (there should be none). All end play should be removed by adding thin shim washers as needed next to the pulley.

You'll need a drill chuck, preferably of  $\frac{1}{2}$ " capacity, that will thread on the right-hand end of the shaft, a three-step pulley, and a single small pulley. Brass facings bolted to the pulleys turn them into a sanding disk and drill pad. Instead of brass, you can use  $\frac{1}{2}$ " plywood disks, turned true as they spin on the motor shaft.

If you intend to put the outfit into a small trunk, buy a very short V-belt. Should you have more room, spacing the motor and polishing head farther apart will allow more swing over the sanding disk.

The combination saw blade shown does both ripping and cross cutting. Be sure to use regular recessed arbor washers both sides of it, and clamp it securely (the left-hand end of the shaft will have left-hand threads). Always play safe by removing the blade when you do work that requires removal of the saw table. And use  $\frac{1}{4}$ " plywood to box in the blade below the table.

The table shown wasn't grooved. Small stock is cross-cut by holding it against the miter gauge and sliding this along the table

edge. Larger work is handled by clamping a straight strip on crosswise and guiding this on the edge. The same dodge, with the strip clamped lengthwise, enables one to rip stock at settings the fence won't permit.

If you want a grooved table, mount a temporary one and clamp on an improvised fence. With this setup, groove the table.

The tailstock bar must be turned or filed to a point, and tapped for a screw that slides in the slotted feed lever. File a sharp cross on the end of a short rod, which you can chuck as a live spindle. Small turnings can be gripped right in the chuck.

Besides the sponge-rubber pad under the jigsaw, there are two under the base panel. A double outlet mounted in front is for a hand grinder and an engraving tool. The 10-amp fuse protects house fuses. You can unscrew this to prevent children from hurting themselves. All wiring is underneath. END

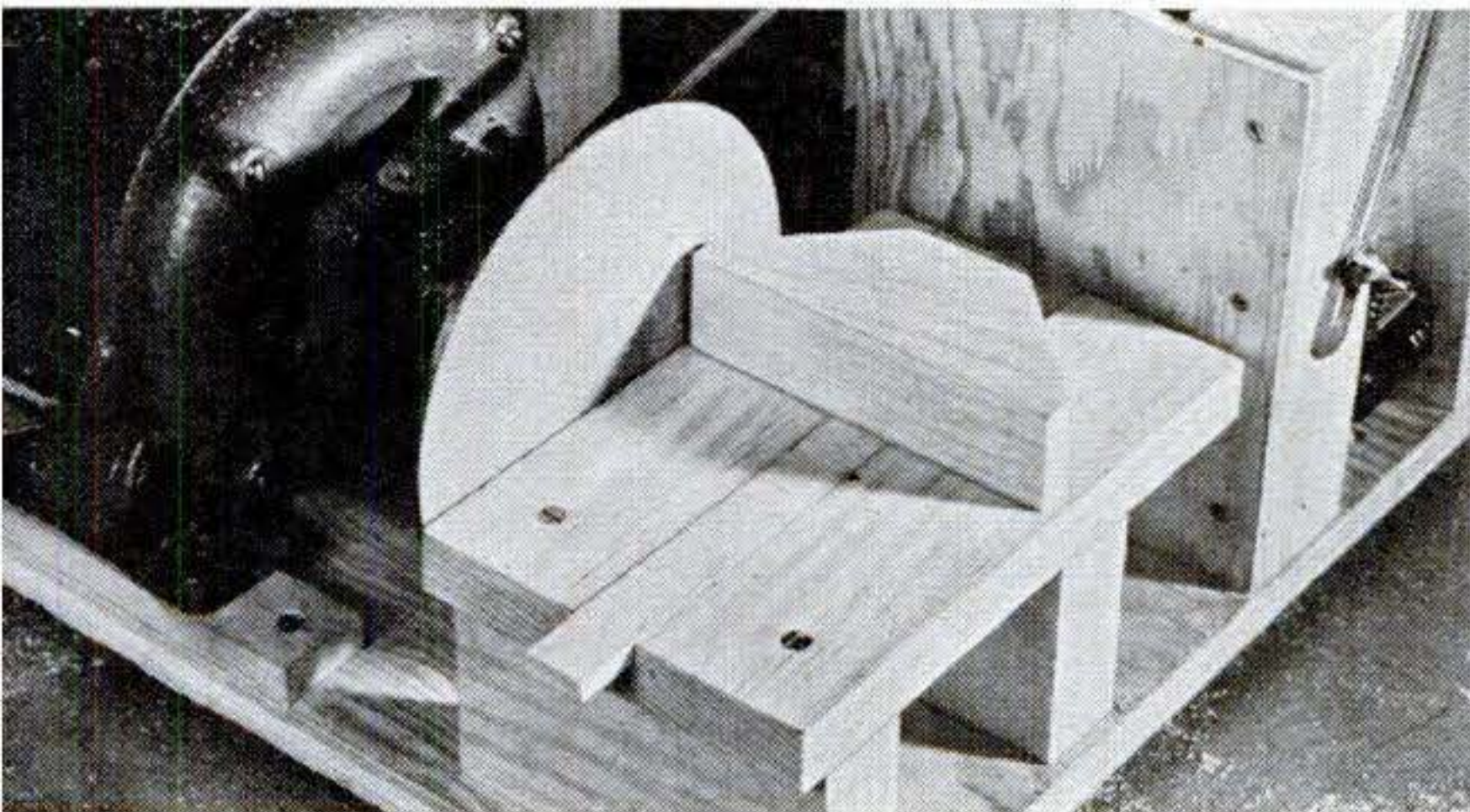
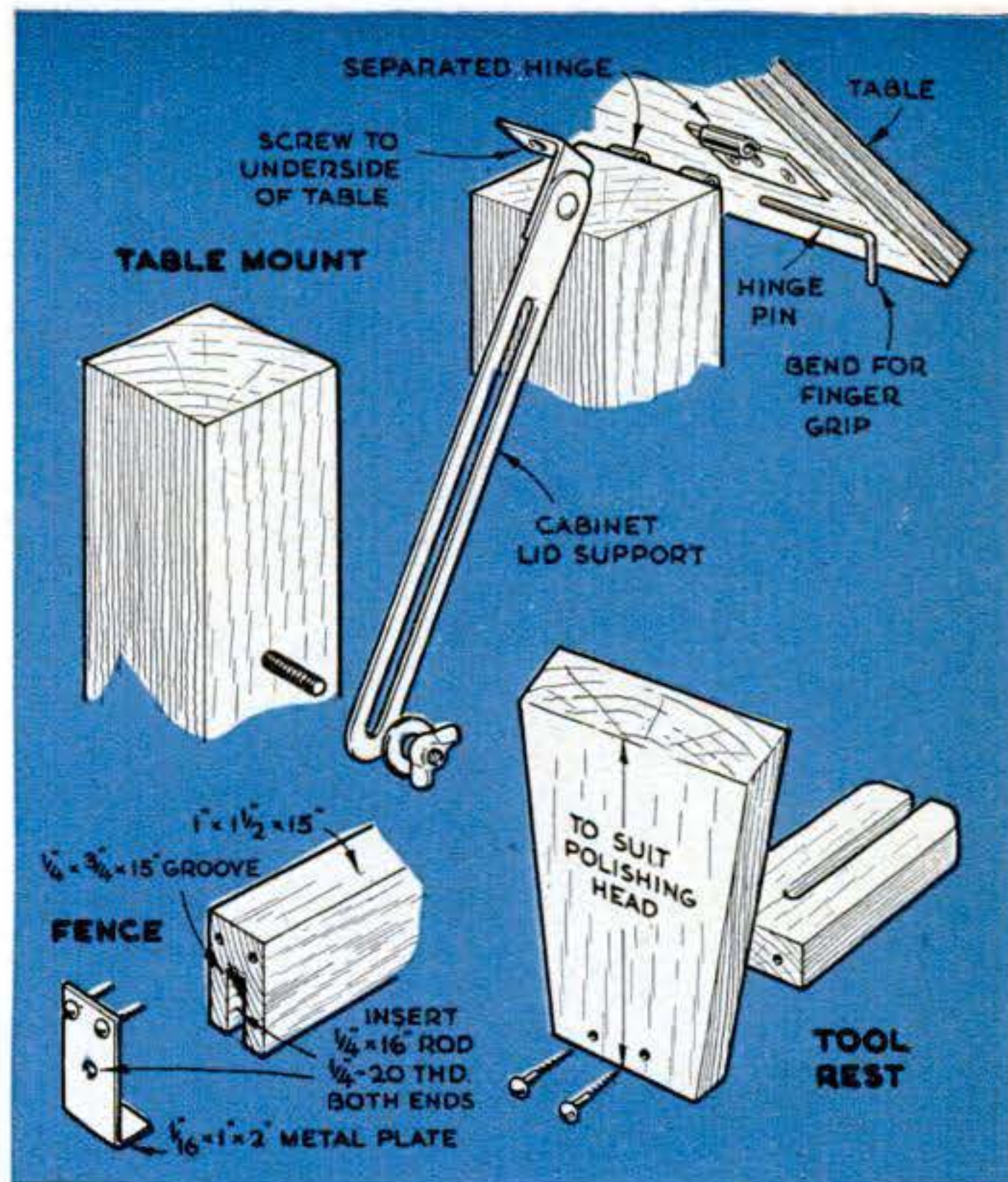

**8. Attach sanding table** to blocks that raise it to center of disk. Finish table and gauge with wax only. Reversing switch makes motor run backward for sanding on near side of disk.

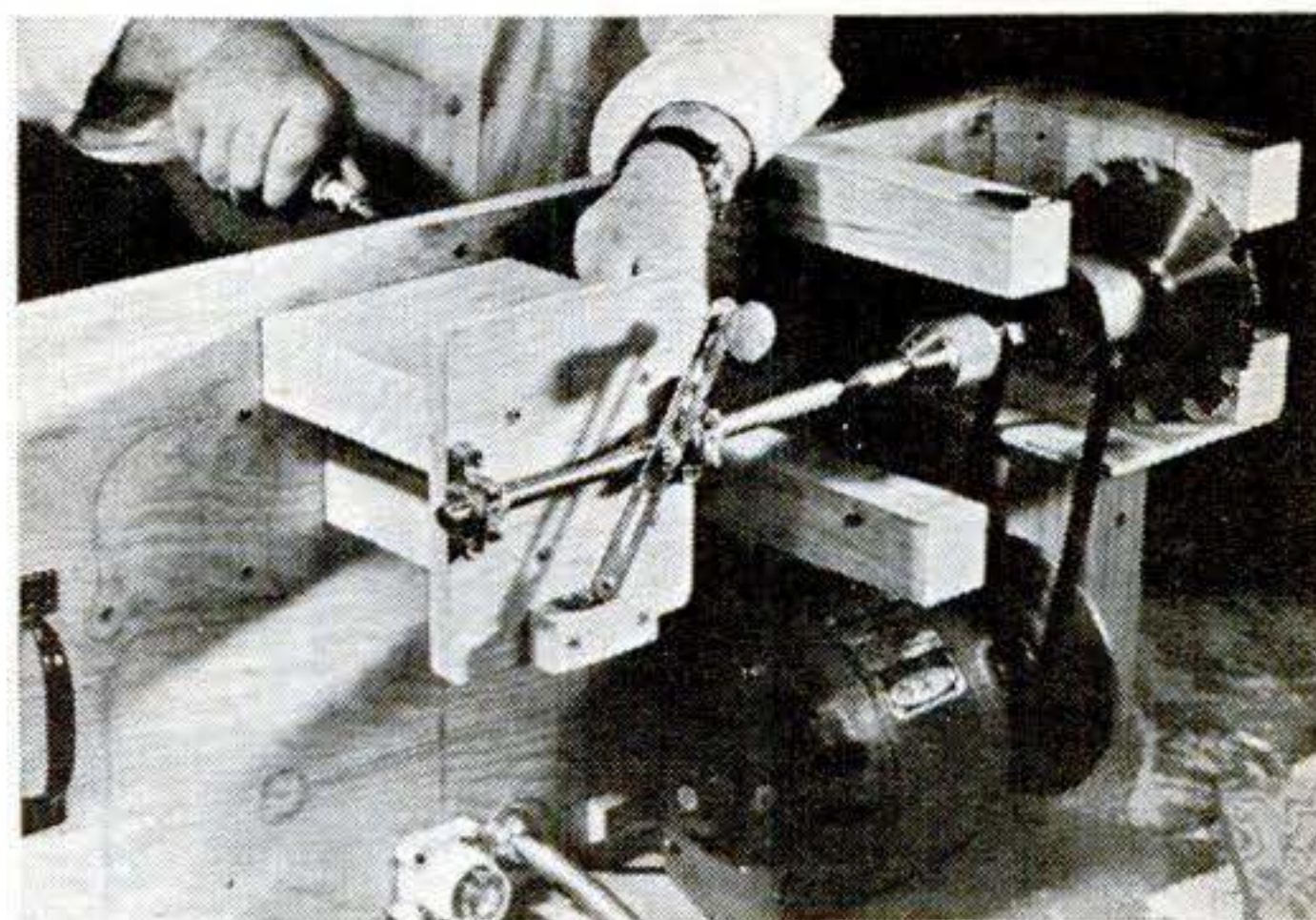

**9. Mount tailstock table** on blocks. Put  $\frac{1}{2}$ " rod in chuck through pillow blocks to align them. File cap of one block so it clamps spindle when tightened. Pivoted lid support is feed lever.

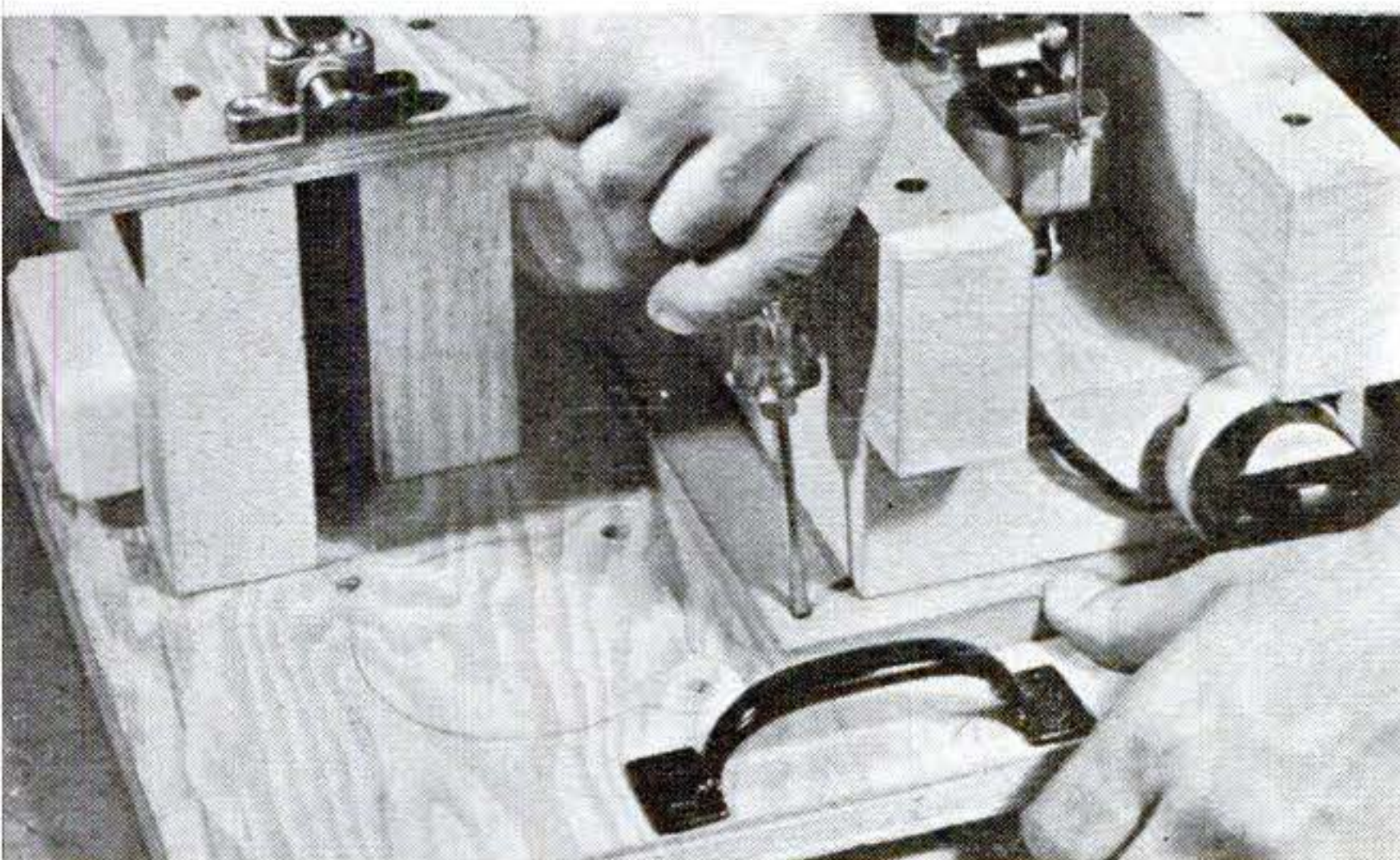

**10. Magnetic jigsaw** is hand type mounted on blocks atop sponge-rubber pad. It has plywood table 8" square. Switch is on base. A double outlet is mounted on tailstock at left.

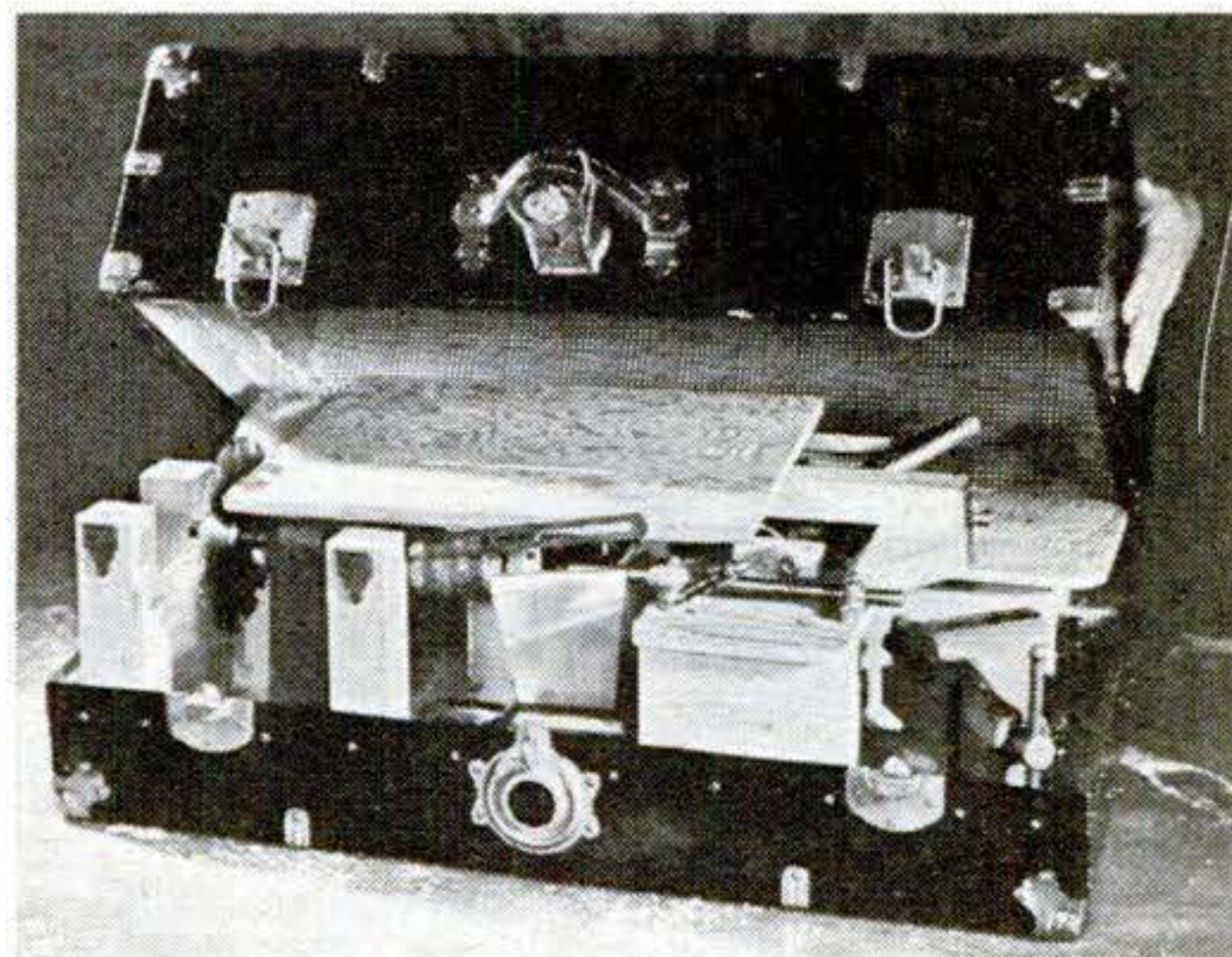

**11. Everything fits**, including vise at corner. Gooseneck lamp is bent down, saw table detached and laid lengthwise. Trunk base becomes lid, removed like table by pulling hinge pins.

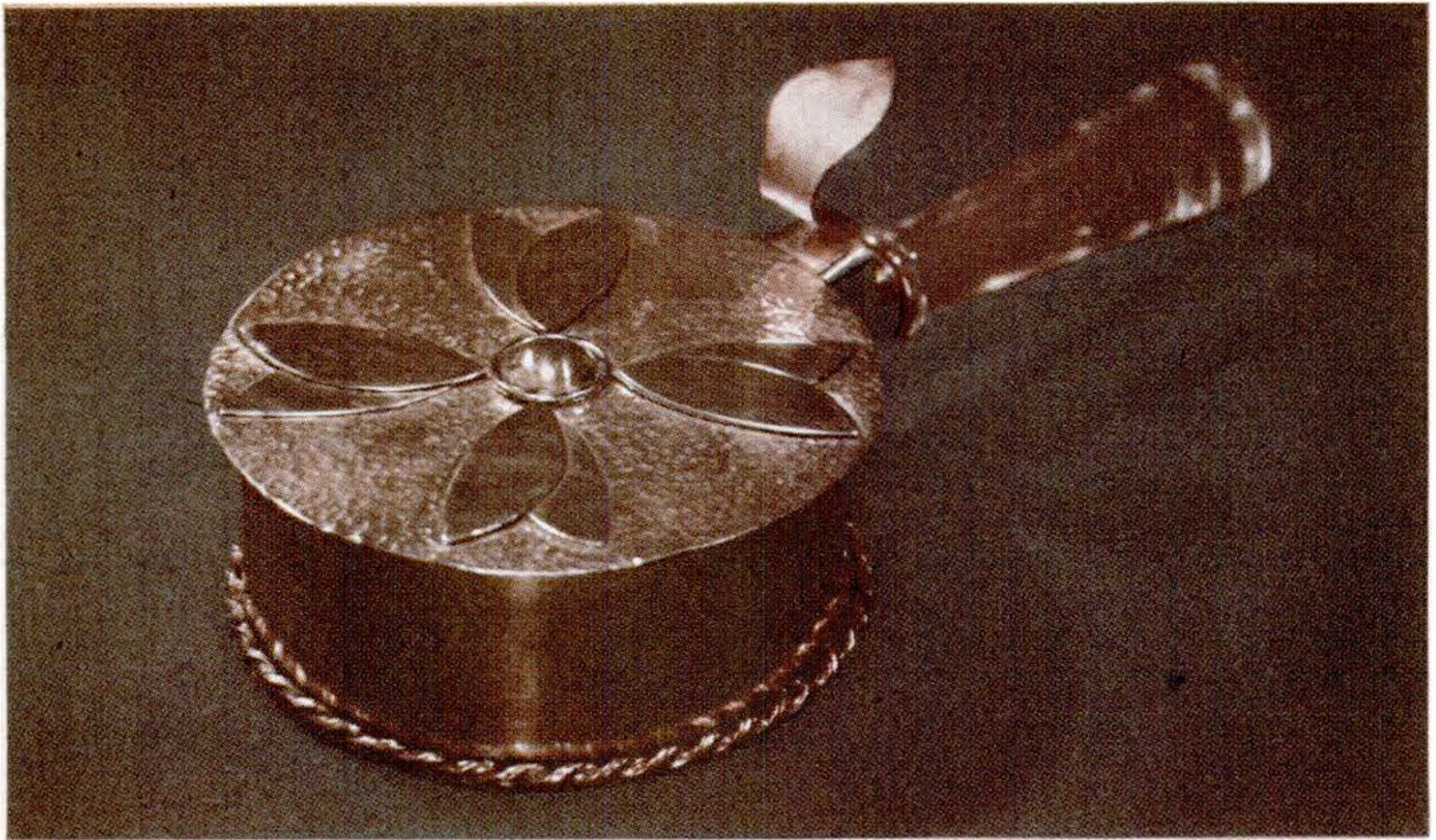

Touches of brass and a clear-plastic handle set off copper. The peened areas add contrast.

# Silent Butler in Two-Toned Metal

By Bill Luther

**D**URING a party, you *could* empty the over-flowing ash trays into a bucket, but a silent butler makes a better impression. This one presents a handsome appearance but isn't very difficult to make.

Four brass petals and a center brass ring on the cover stand out against peened and burnished copper. Round brass wire, soldered in place, creates a clean dividing line between the plastic handle and its copper socket.

All other parts are copper. Get soft cop-

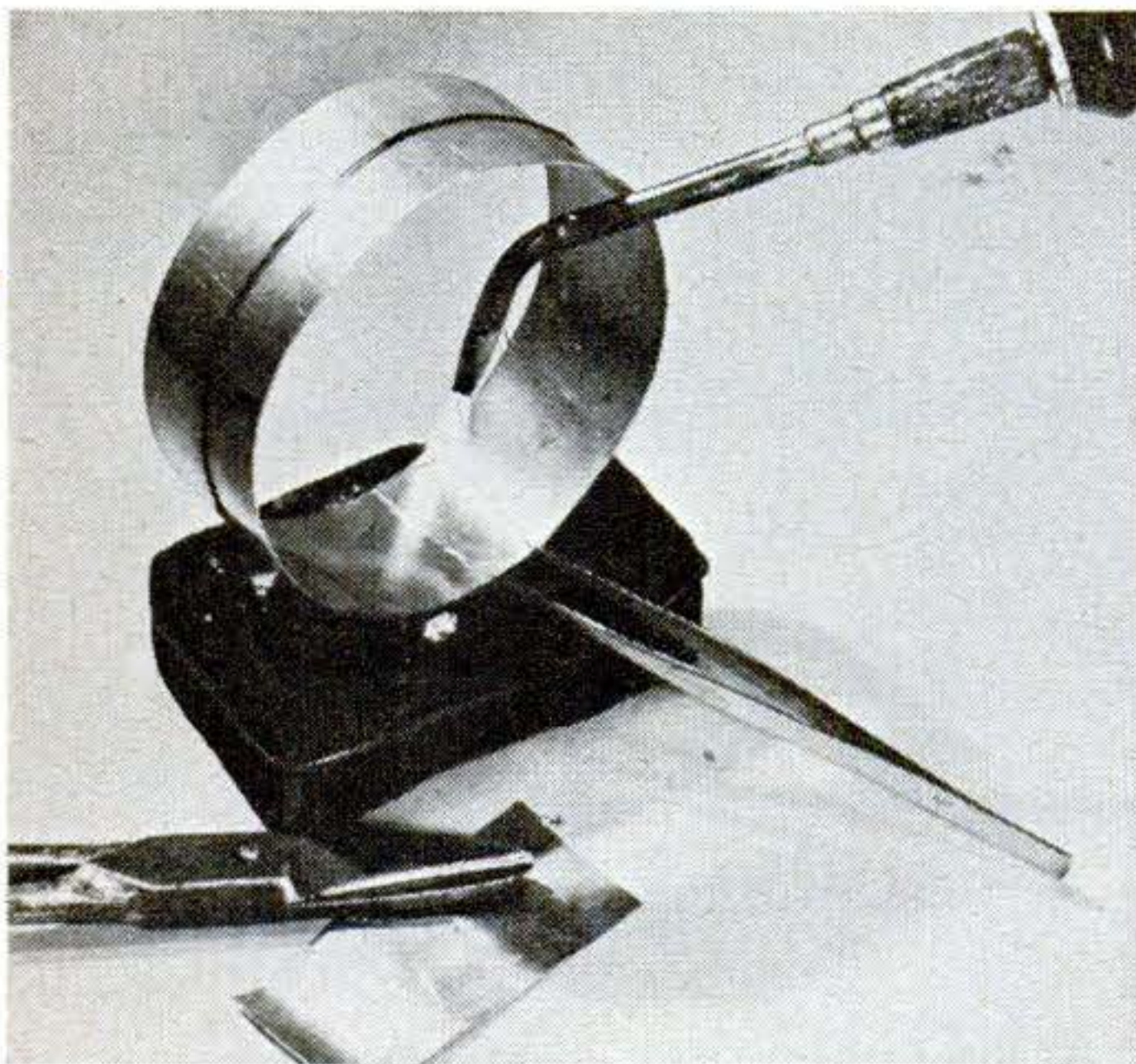

Form body from 1½" by 12" strip of 20-gauge copper. File the ends square, bind band temporarily with wire, and silver-solder together.

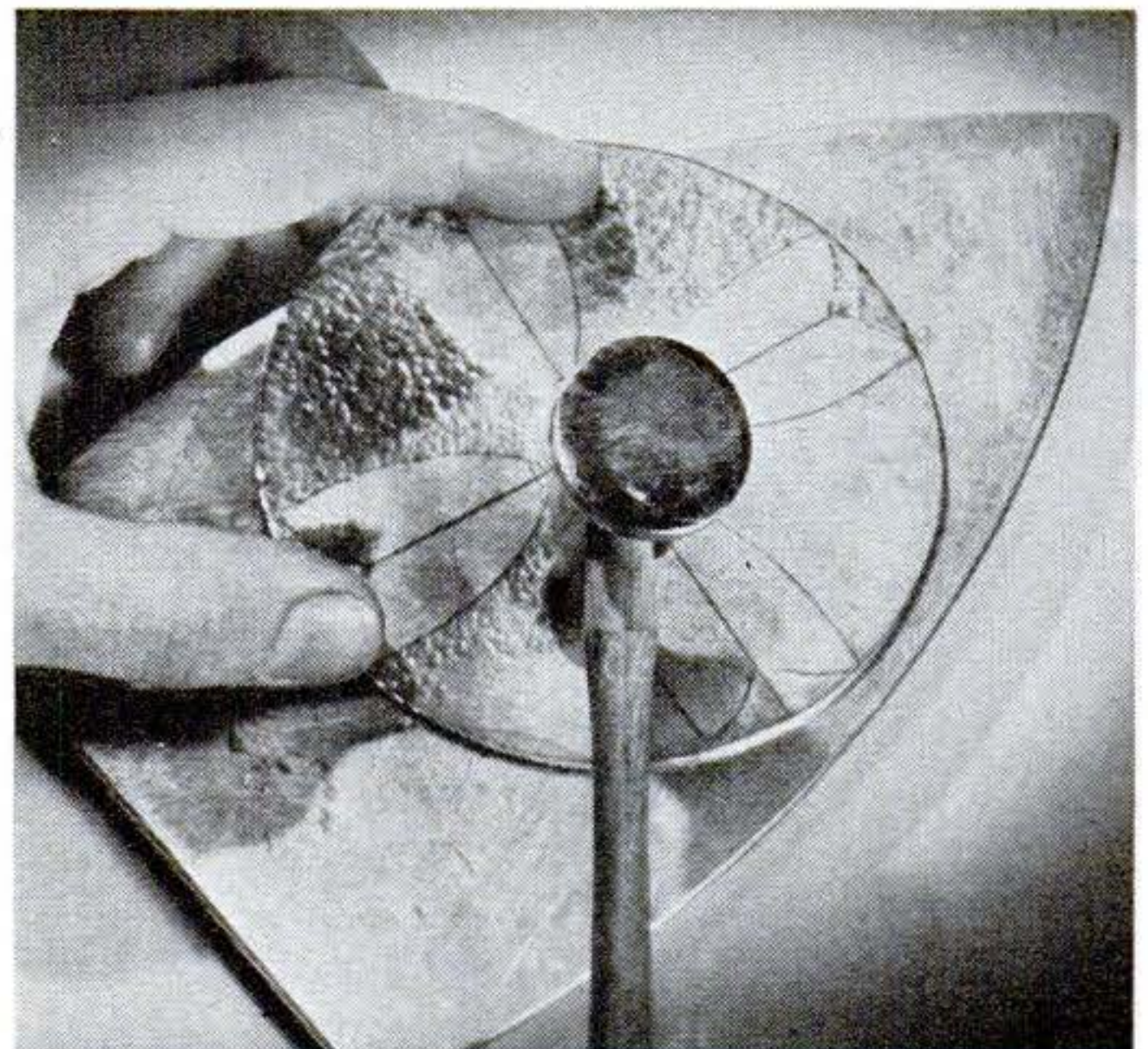

Peen the copper top outside the spaces to be occupied by petals. This rough texture makes a pleasing contrast to the burnished petals.

per if you can. Otherwise, anneal the stock before working. Form the circular body from a 1½" by 12" strip of 20 gauge sheet, flattening the metal well before bending. Silver-solder the joint.

The spiral decoration around the bottom consists of two pieces of 1/16" square copper radio bus bar twisted together. Before twisting, roll up the pieces, heat red hot, and plunge into dilute sulphuric acid. This removes the tinning coat.

Clamp the ends of the wires in a vise and twist into a tight spiral. Wrap around the body and saw to the correct length, matching the twists to make an invisible joint. File the ends square and join with silver solder. Cut and solder together a ring of this square wire to finish off the top edge of the pan.

After cleaning the outside surface of the body band, tin the edges lightly with soft solder. Also lightly tin the inner faces of the decorative rings. Slide on the band and sweat-solder in place.

Cut a 3¾" disk from 20-gauge copper for the bottom. Flatten, tin the edge, and sweat into place. The handle socket is a 1" length of ⅝" o.d. copper tubing. After soft-soldering a ring of 1/16" brass wire around one end, sweat the socket to the body.

The top is a 4" disk of 16-gauge sheet copper. After tracing off the outline of the top decorations, peen all areas outside these lines. At the center, form a ⅝" dome, using a round-ended punch on a lead block. Around the dome solder a ring made from 1/16" brass wire.

Tin the backs of the brass petals and half the tops of the copper ones. Sweat these units together. Then sweat to the cover.

After cutting and bending the hinge to shape, file a shallow notch in the edge of the body just above the handle socket. Use the hinge itself as a guide. Sweat the hinge to the underside of the lid.

Turn the handle from 1" clear plastic rod. Polish with soft rag buffing wheels, using a light pressure and white buffing compound. Finish with a clean wheel and no compound. The handle should fit snugly in the socket. It is secured by the hinge pin, made from heavy copper wire.

Polish all the metal parts to a mirror finish, using tripoli followed by rouge. Clean off the polishing compound with solvent and hot soapy water. Then apply a coat of clear lacquer. When dry, push in the handle and peen the pin. **END**

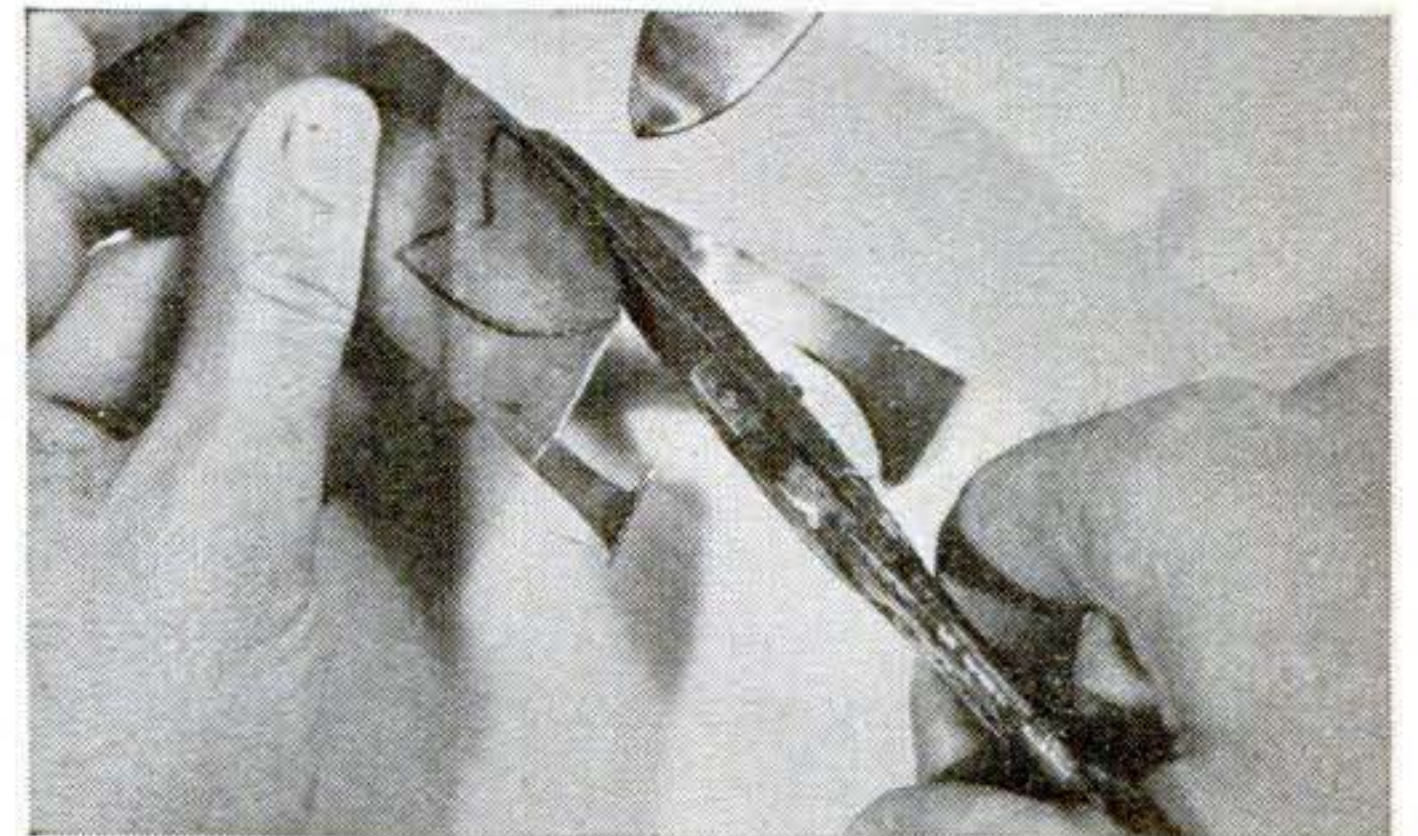
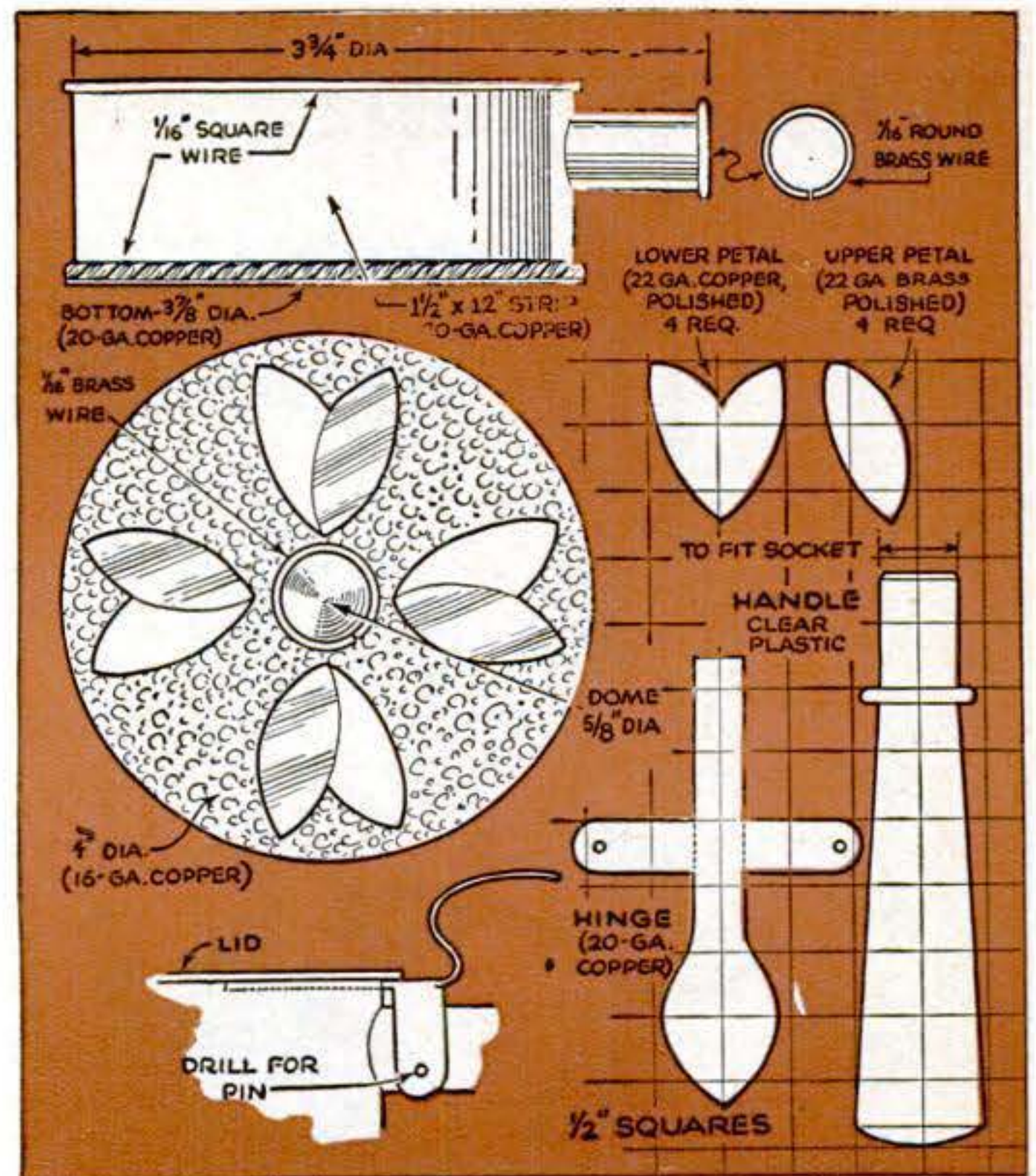

Snip the bottom petals from thin copper, top ones from brass. Thoroughly flatten all petals before sweat-soldering them in place.

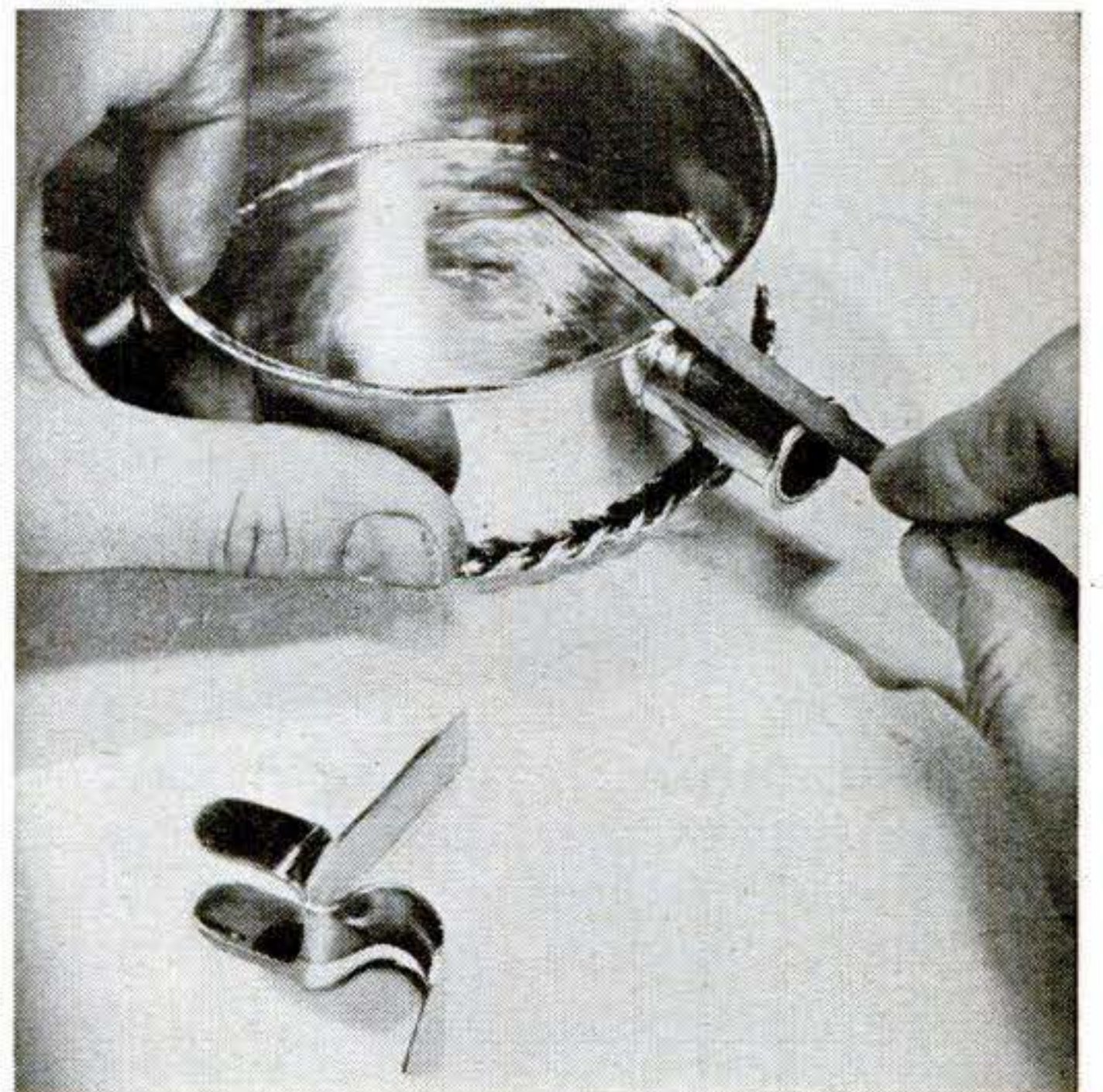

File a slot in the top edge of body above the handle socket to admit the hinge shank. This permits the lid to fit down flush on the pan.

# What's Your Ingenuity Quotient?



**My personal snorkel**, the hose and extension on a tank-type vacuum cleaner, is wonderful for retrieving small objects dropped into inaccessible places. Tie a piece of gauze over the nozzle to keep the article from going into the tank when the suction picks it up. Don't use this for picking up something from an aquarium (you may lose the guppies), or for cleaning a canary cage (you may get the bird).—*Pat Fey, Columbus, O.*

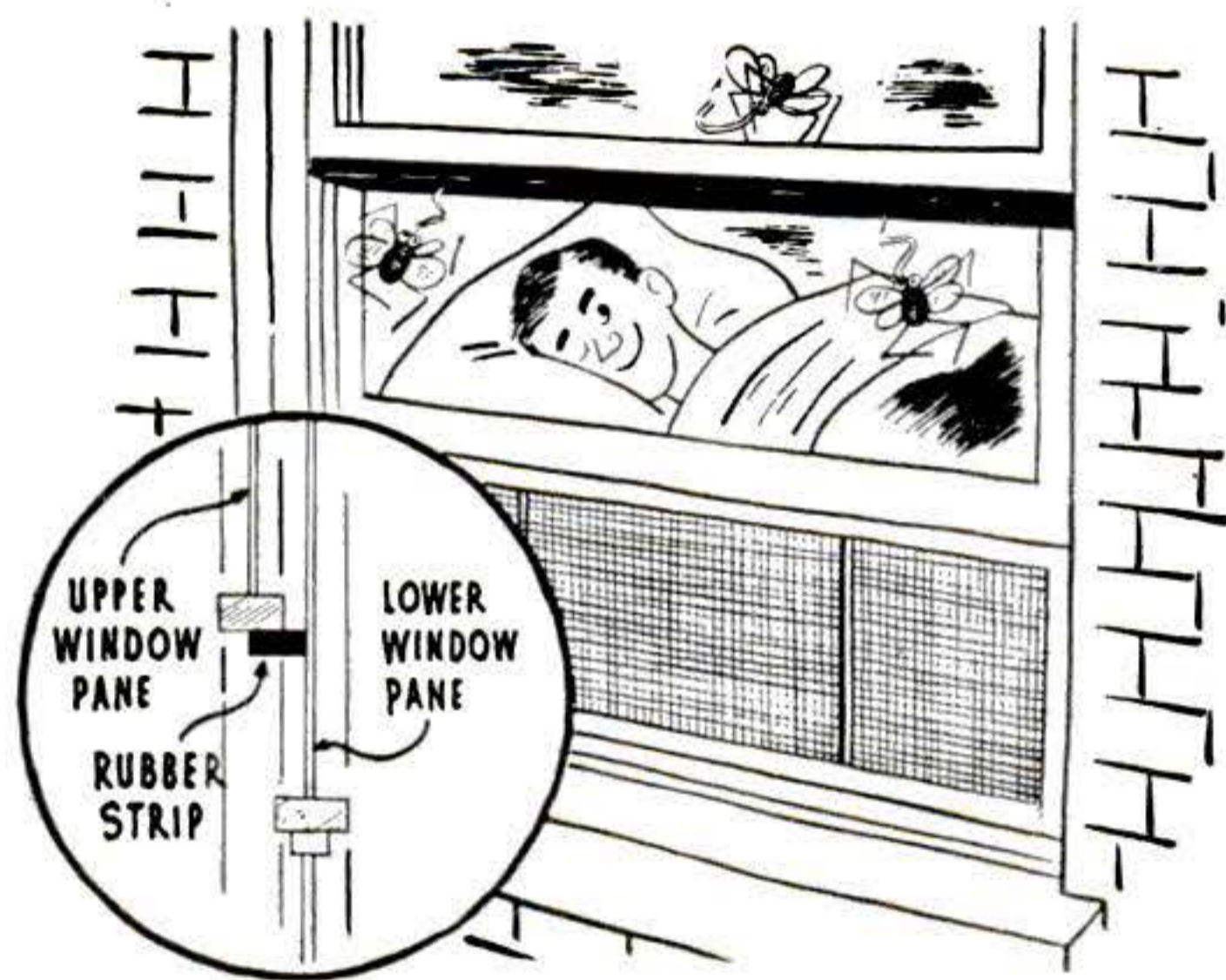

**My bedroom** seemed like an air base for three fighter squadrons of mosquitoes. Once landed, they took me for a blood bank. I had fit-in screens on the windows but the bugs flew in the gap between the upper sash and lower pane. Then I tacked a rubber strip along the lower edge of the upper sash to block the opening. Now I sleep without swatting or spraying insect dope.—*Joseph Shulman, Brooklyn, N. Y.*

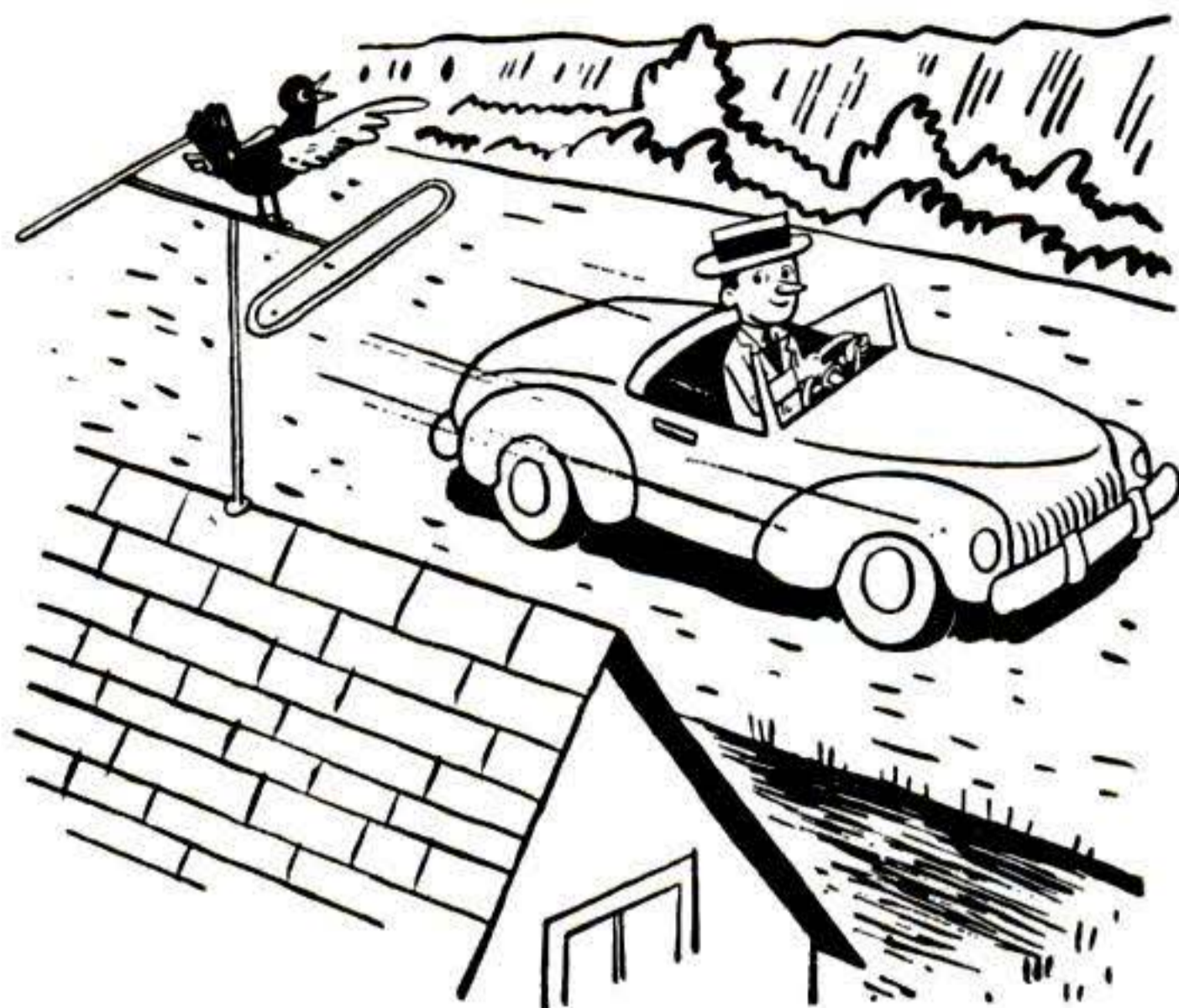

**Show me the video home.** I was driving in to the city and ducked off the main highway to escape heavy traffic. Soon I was hopelessly lost. After driving around side roads and lanes for awhile, I suddenly thought of the TV aerials. The dipoles are set up facing toward the stations, which in my area are in the city. By following the dipoles, I soon was on my way home.—*Walter Katig, Manhattan, N. Y.*



**Paddling your own kayak** is fun—but not when dripping water from the blades runs down your sleeves. After an hour of paddling, you get sort of soggy. I solved the problem for about a tenth of what regular drip cups would have cost. Cutting the centers out of 1 1/4" sink stoppers, I forced the rims over the takedown ferrules and up to the blades.—*J. B. Ehrhardt, Madison, N. J.*

Have you pulled off a smart one lately? We will pay for acceptable contributions showing ingenious solutions of problems in the home, shop, garage, or camp. It doesn't matter if it's wacky—if it works. Use government postcards only. Contributions cannot be acknowledged or returned.

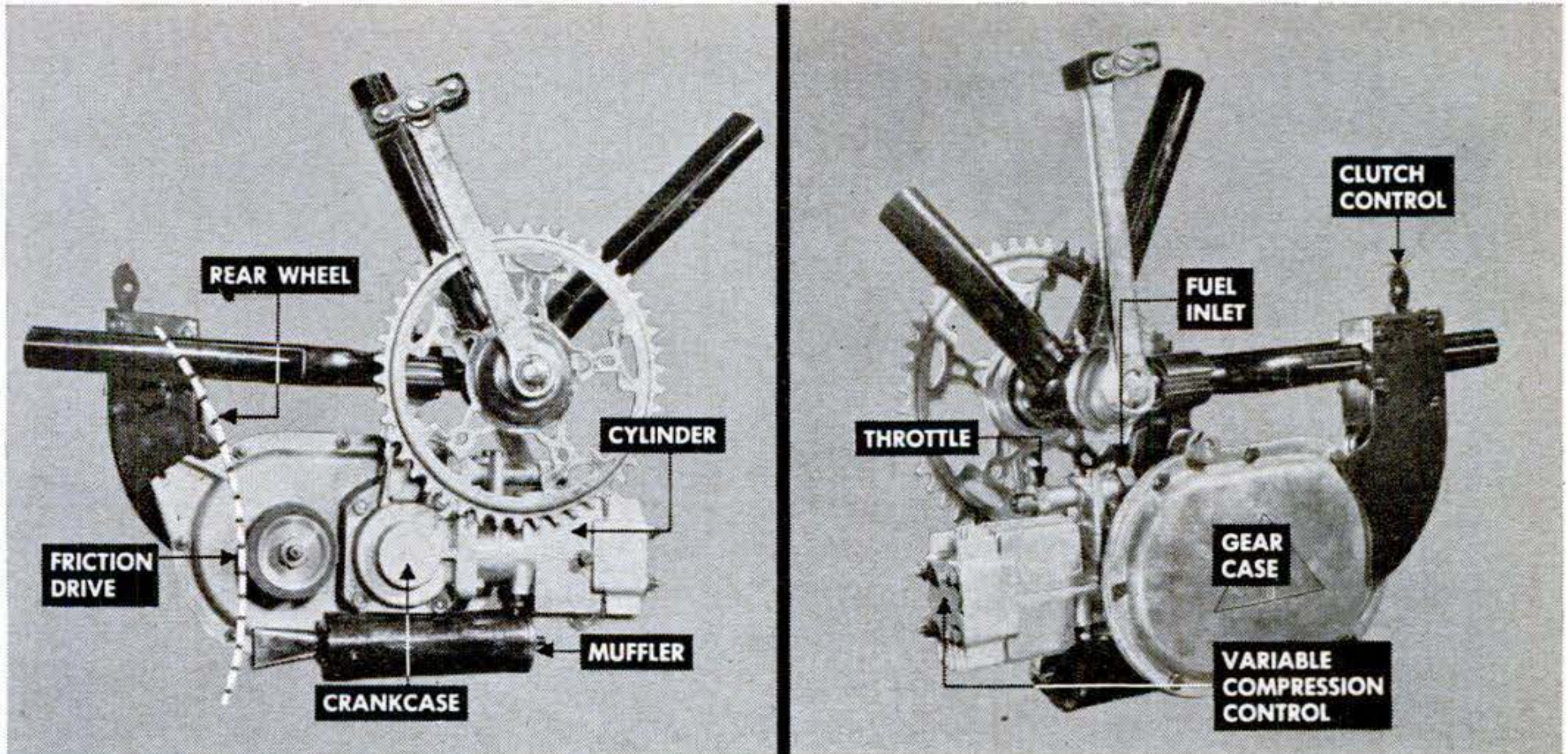

## Midget German Diesel Motorizes Bicycles

A LIGHTWEIGHT bicycle motor that will run on almost any fuel from heavy bunker oil to kerosene is being manufactured by the Lohmann Company, Bielefeld, Germany. Main feature of the 11-lb., two-cycle engine is its economy of operation; fuel-tank capacity is  $\frac{1}{4}$  gal., said to be good for 100 miles. A Diesel, it has no electrical system, ignition being effected by compression heat. A handle-bar control allows compression to

be varied from 1-to-70 for starting to 1-to-50 for running. Bore is 27 mm., about  $1\frac{1}{8}$ ".

Made for bikes weighing 22 to 28 lb., the motor is simply clamped on, leaving the pedal drive unaltered. A friction roller transfers power to the rear wheel. On a level the 0.6-hp. motor gives speeds from 1 to 12 m.p.h., and it's said to take a 7-percent grade with ease. Arrangements have not been completed for its distribution here.

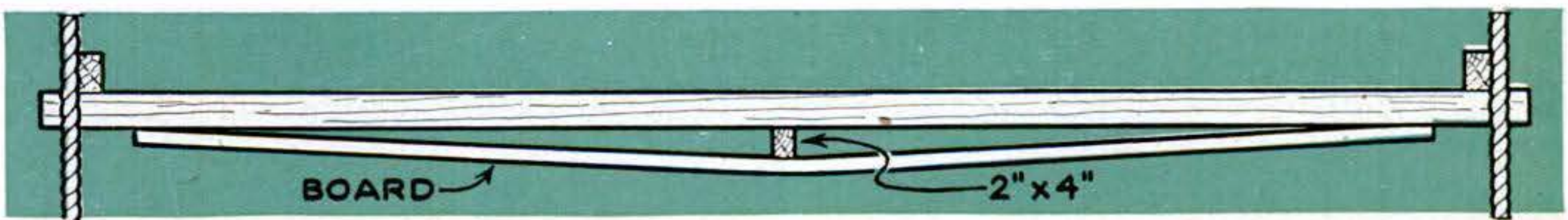

## Cantilever Reinforcement Makes Scaffold Safer

DON'T take chances with weak or springy scaffolds. One carpenter makes his hanging platforms safer by the method shown above.

For a single-plank scaffold he nails a two-by-four cleat across the center of the plank. A long board is bent over the cleat and nailed at both ends. Two-plank scaffolds require only two cleats across the double width.—Victor H. Lamoy, Upper Jay, N. Y.

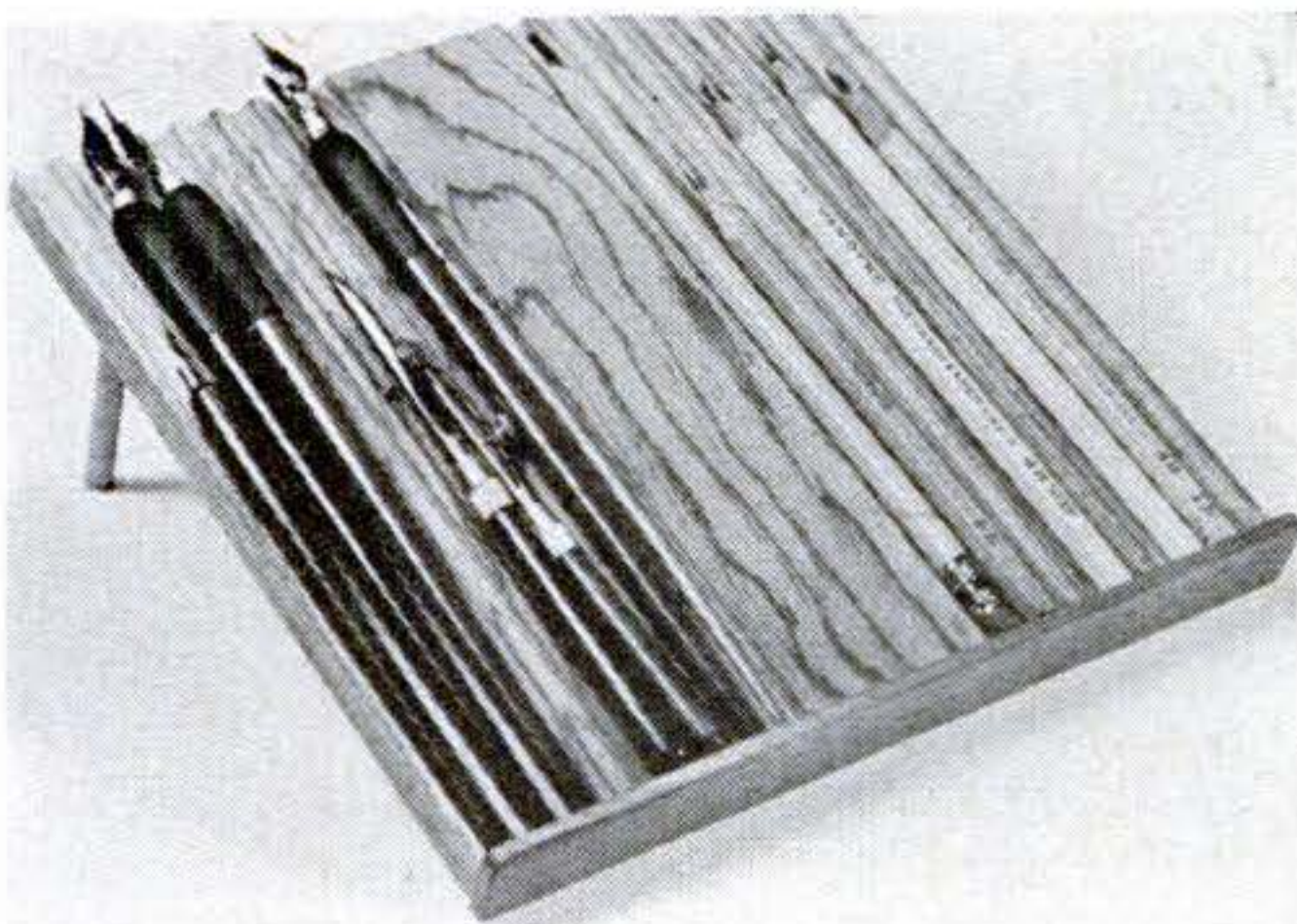

## Rack Keeps Pens and Pencils from Rolling off Table

YOUR drawing table won't be as cluttered if you keep pencils and other drafting tools arranged in this wooden rack. The board is  $7\frac{1}{2}$ " by  $7\frac{1}{2}$ " with  $\frac{1}{4}$ " grooves routed as shown. A  $\frac{1}{8}$ " by  $\frac{3}{4}$ " strip in front acts as a stop, and the slant is provided by two  $\frac{1}{4}$ " by  $2\frac{3}{4}$ " dowels in back. The rack lines the pencils up for easy selection and prevents them from rolling off the desk or under the work.—Glenn A. Wagner, Delmar, N. Y.

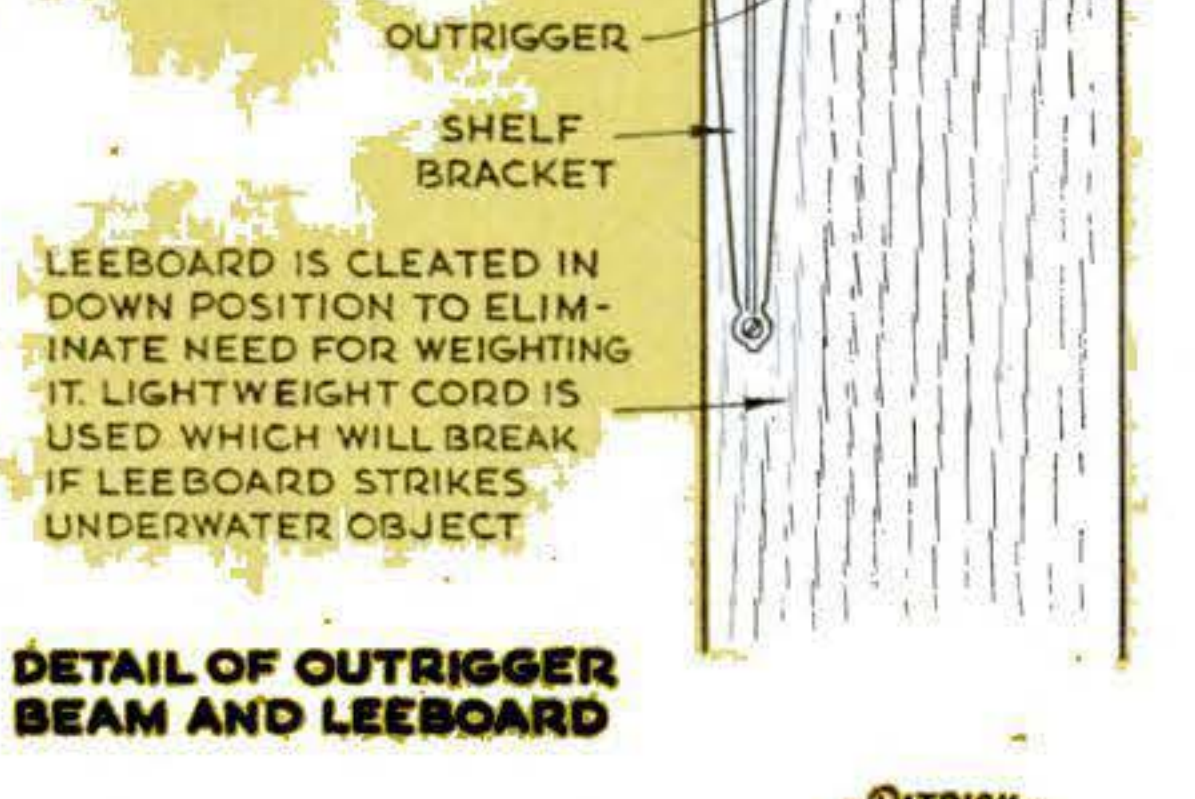
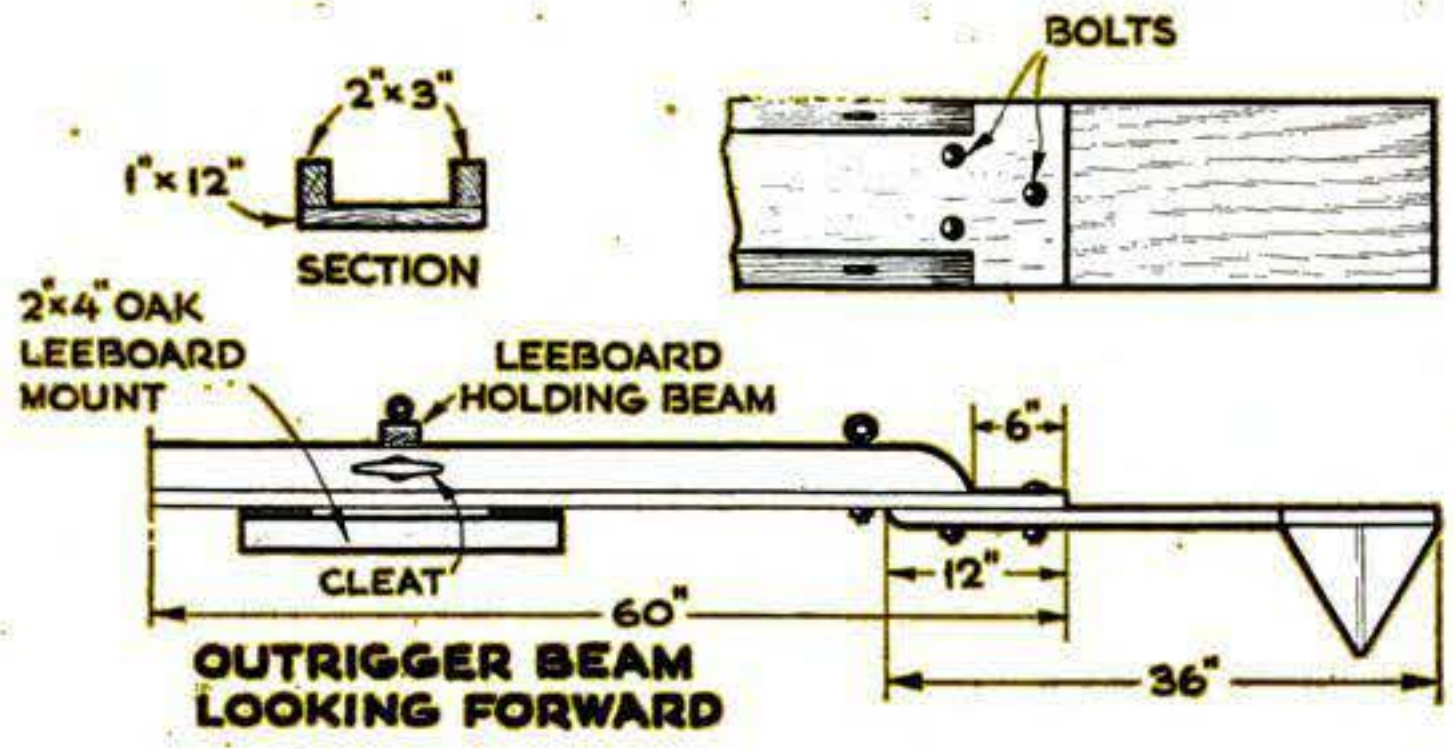
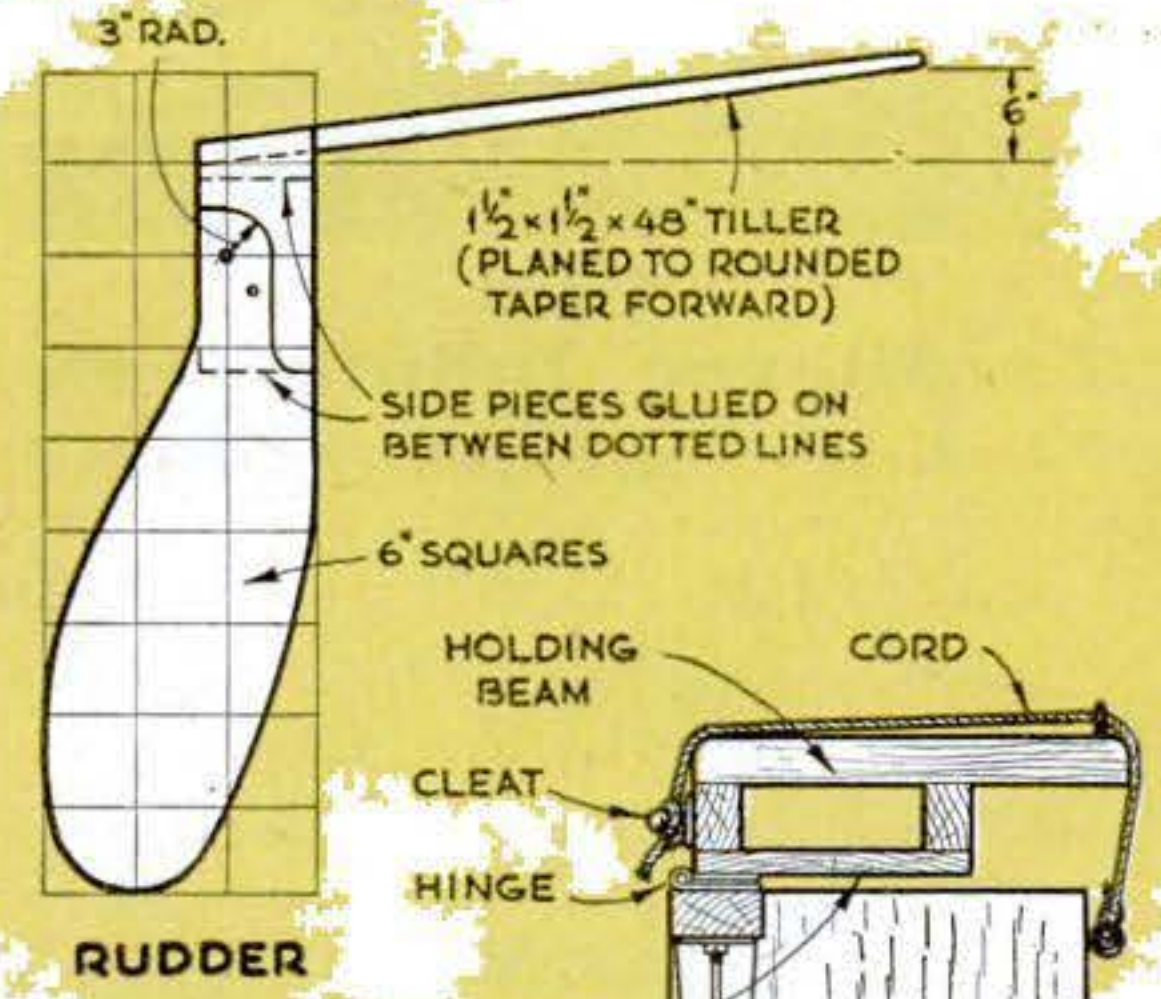
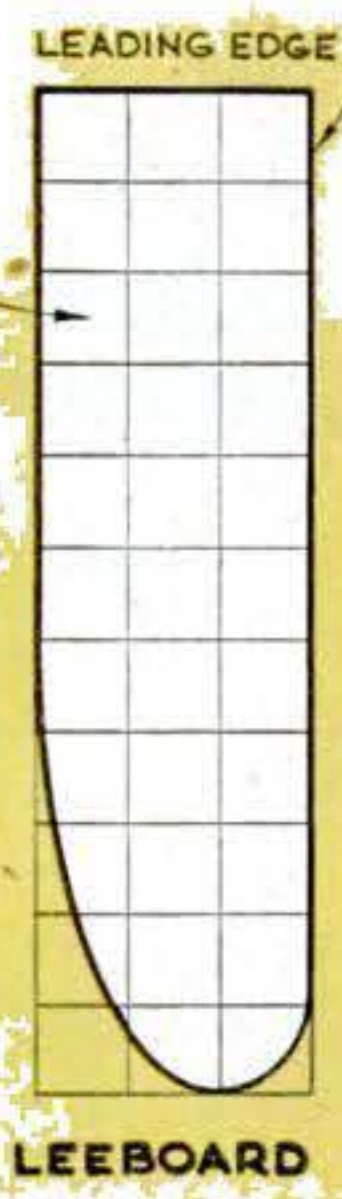
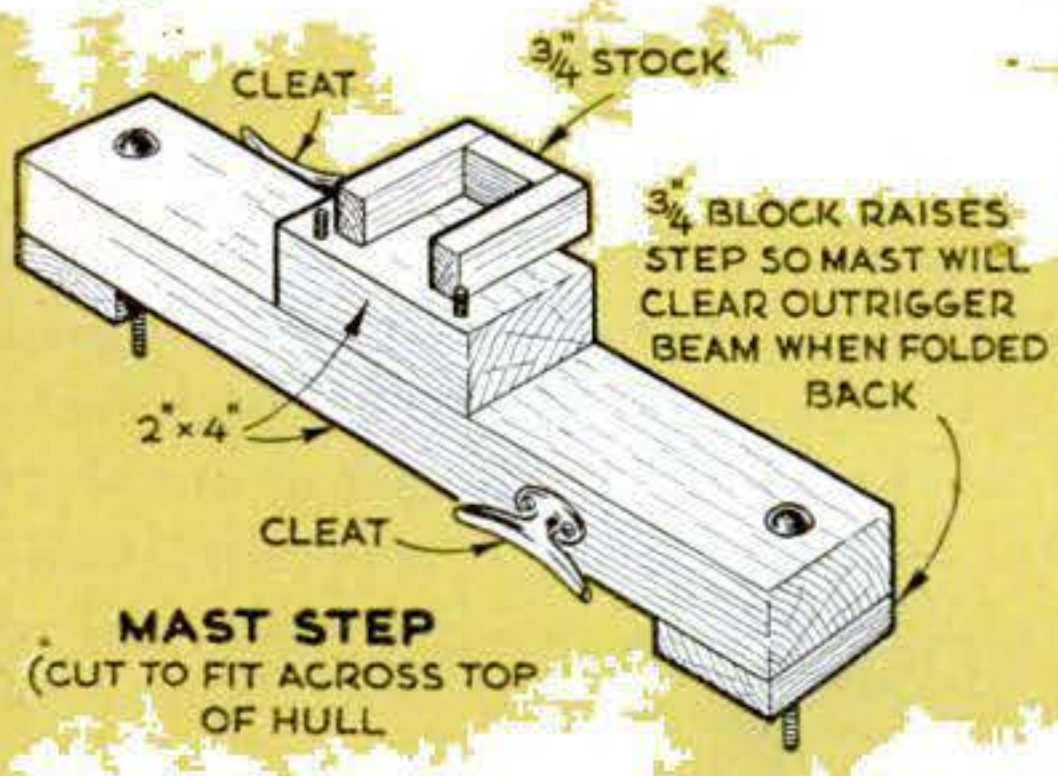
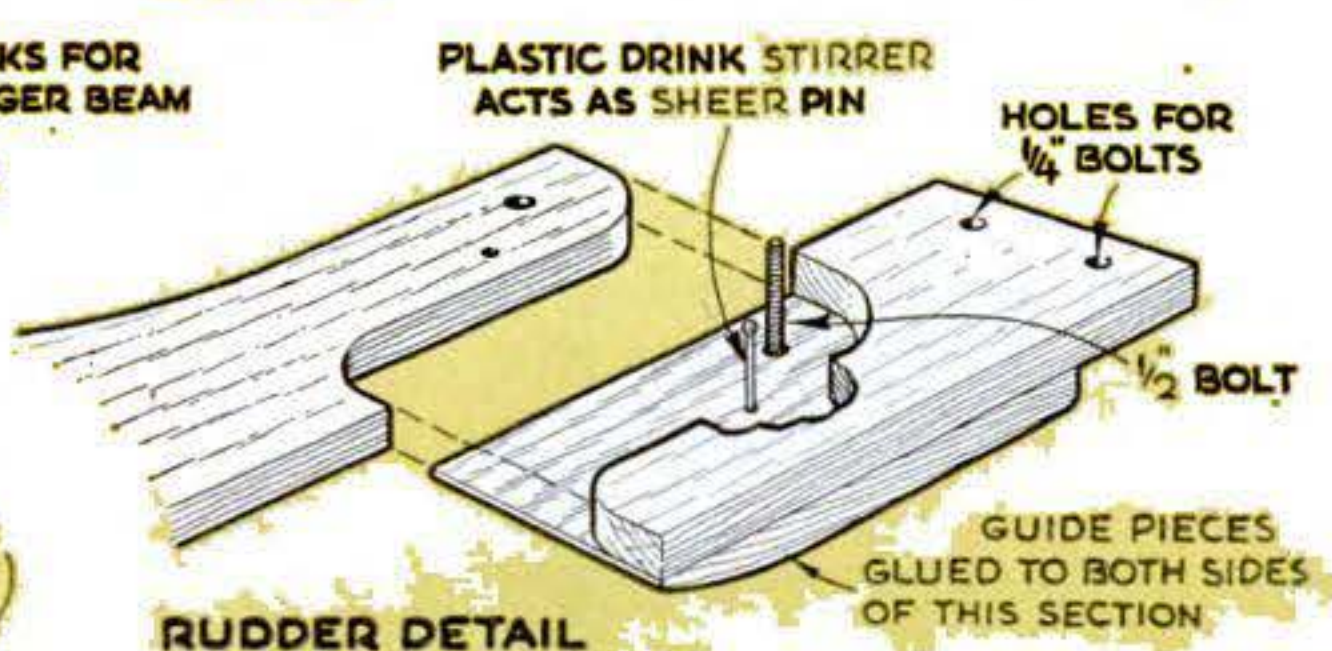
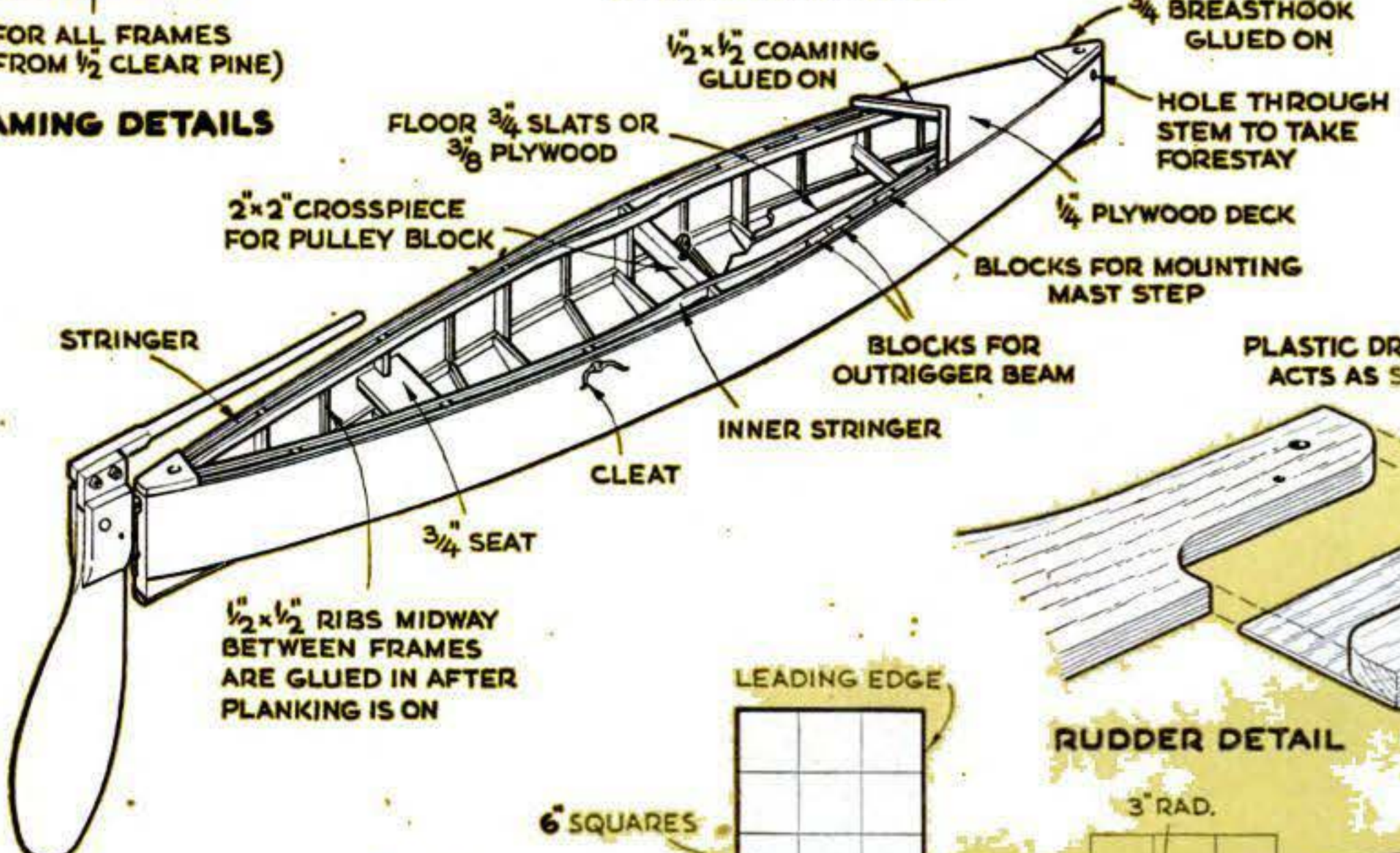
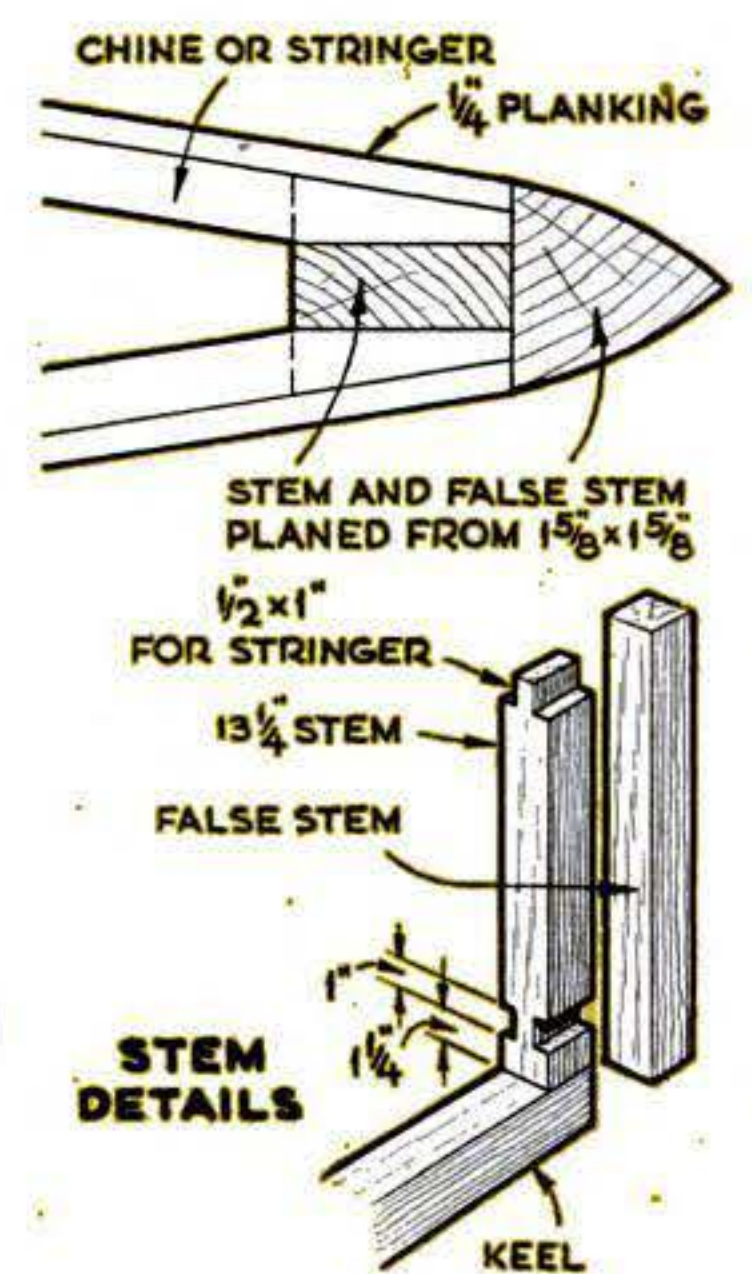
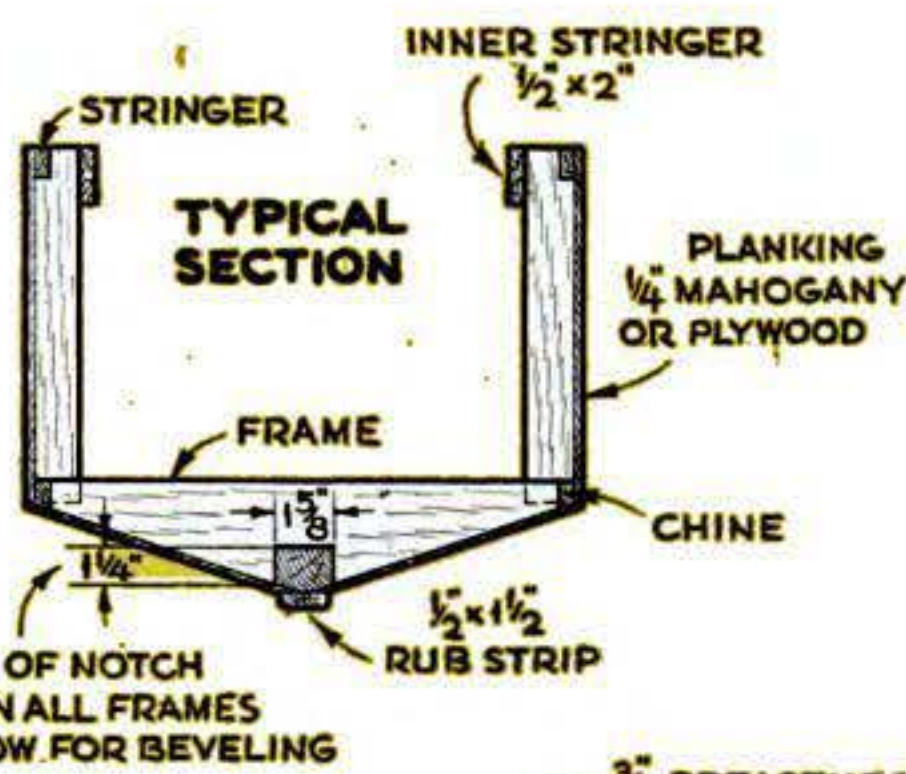
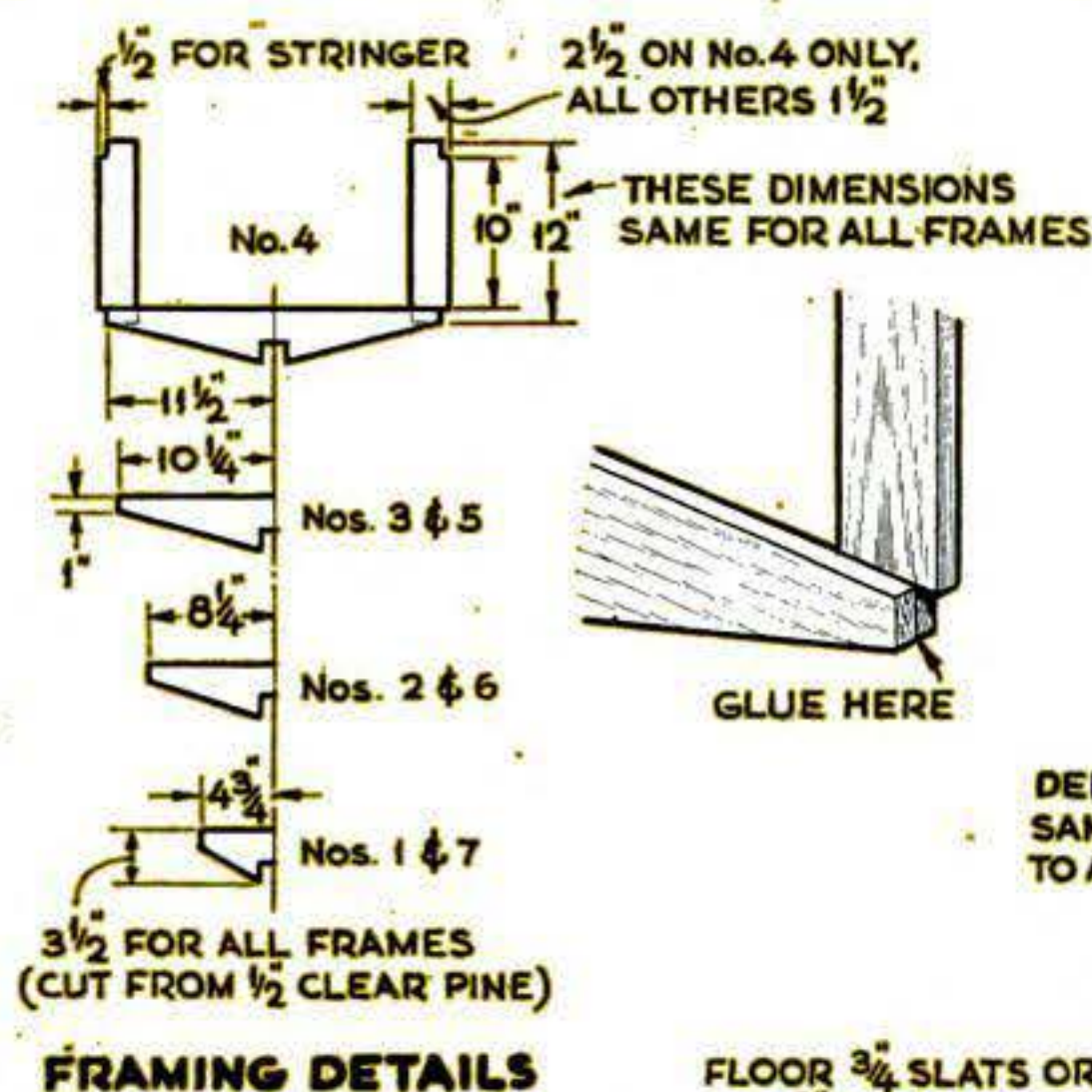
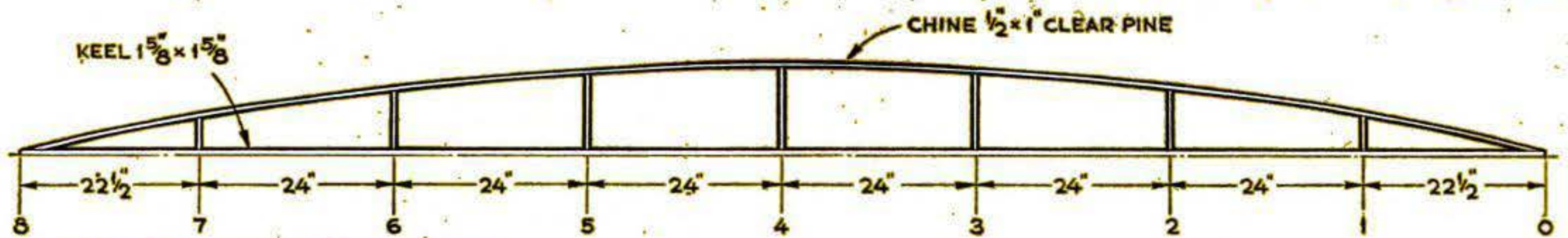

-PATRICK-



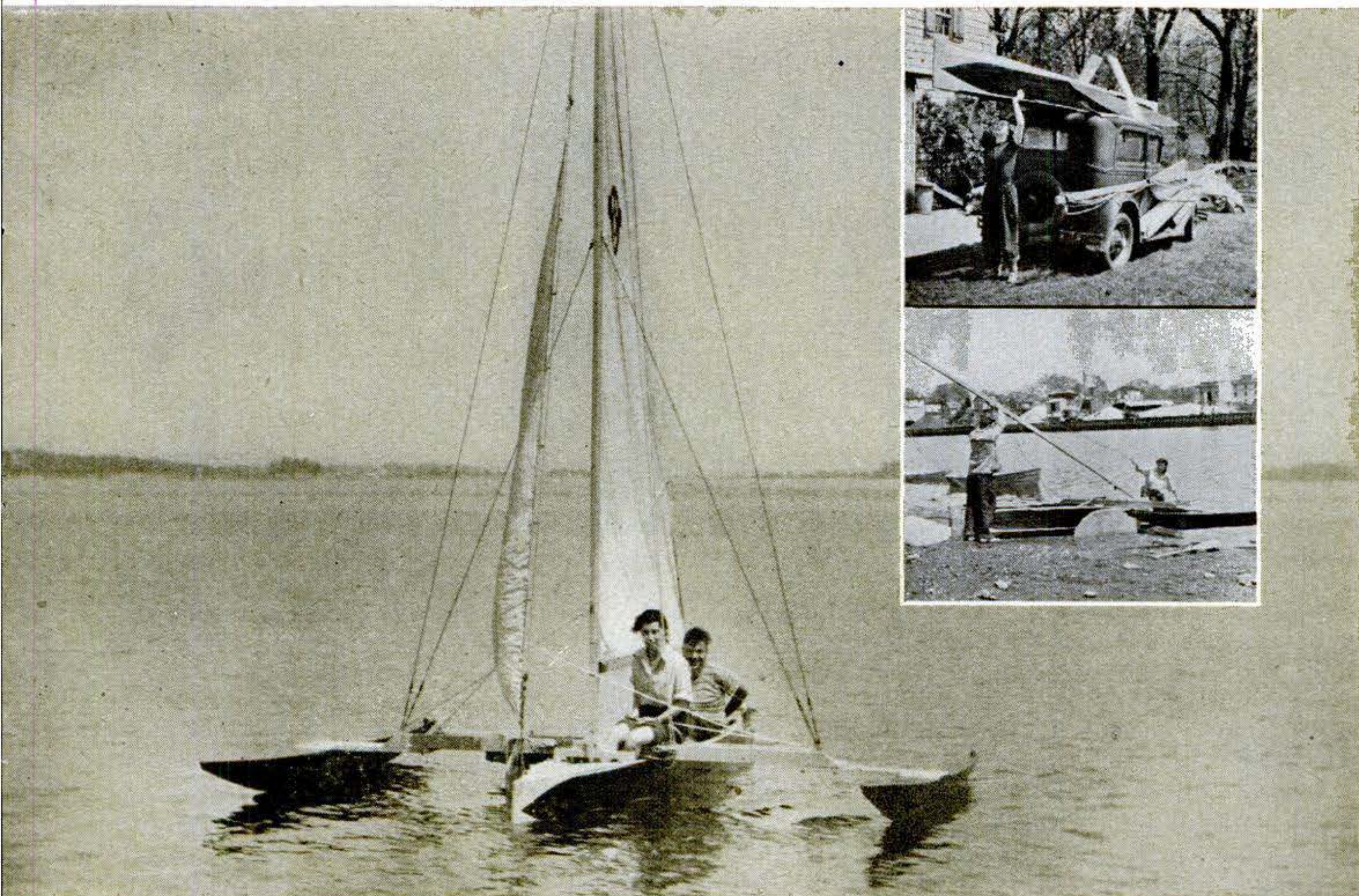

**Light and fast,** this three-hulled craft will quickly put you under sail, whether you live near salt water or fresh. Built for easy dismantling, she can be carried for miles on a car.

# *Outrigger Sailboat Built in Week End*

**By George Daniels**

**H**ERE'S a fast little boat you can stick together in a couple of days. The secret of the speedy job is a synthetic-resin adhesive. This provides a bond stronger than the wood itself and so waterproof that you could boil the joints all day without causing them to weaken.

The boat belongs to the class of fast sailing craft sometimes dubbed trimarans. She's so light a mere whisper of a breeze is often enough to move her. In a really good breeze, you'll streak along like a speedboat—without heeling more than a few degrees. If becalmed, the boat's light enough to paddle.

Little work space is needed. The hulls are so narrow you can build them in the house, upstairs or down, and slide them out the window. I worked in our living room,

winding up the entire job in one week end.

Several waterproof adhesives suitable for boat work are on the market. Mix just before use and apply with an inexpensive paint brush, coating both of the surfaces that are to be joined. When you are through, wash the brush in cold water.

At ordinary temperatures, the glue will set hard overnight. But you can speed up the job by putting the glued parts in a room heated to 85° or 90°. For instance, the main hull frames for this boat were cut and glued in the morning, hardened in a hot kitchen during the day, and fastened to the lengthwise pieces—the keel, chines, and stringers—in the evening.

Cut the hull frames as the first construction step. You'll note from the drawing on the facing page that two frames of each size are required, except in the case of the middle

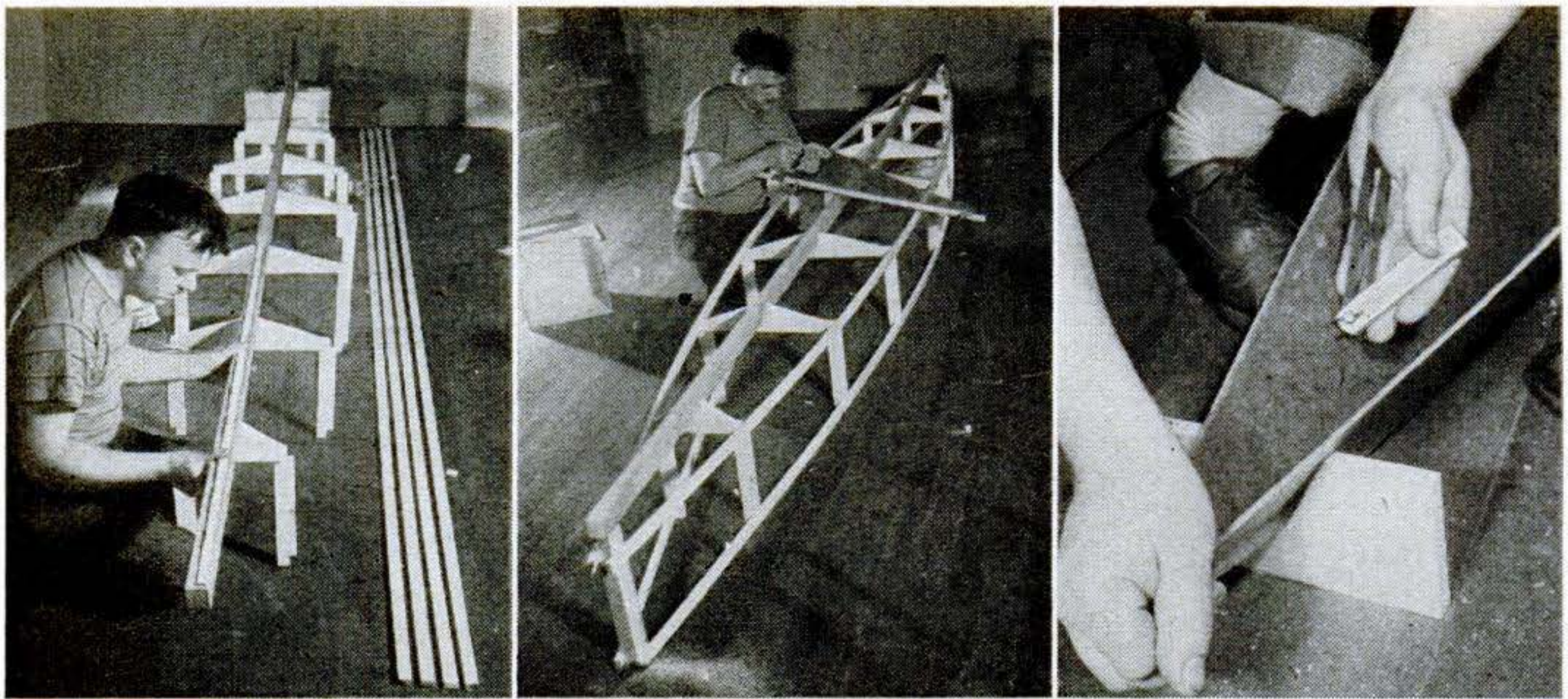

**Glued frames** for the main hull are spaced at 24" intervals along keel (above left). Guide cuts for beveling the keel and chines are made with a saw (center). Battens are clamped to

the sides of the saw to keep it from cutting too deep. V notches cut at a 60° angle in several pieces of scrap stock (right) keep the pontoon planks aligned while glue is setting.

one. For the latter only, use side members 2½" wide.

Clamp the parts together until the glue has set. If you haven't enough clamps, drive a brad or two through the pieces. You can pull these out later if you wish.

In assembling the hull frames, align the upright members and the bottom piece carefully with a try square. This is important, for after the glue has hardened it won't be possible to make changes. Use newspapers to keep the glued parts from sticking to the floor or workbench.

When the frames have set, glue them and the two stems to the pine keel. For added strength, join the stems to the keel with ¼" dowels, or perhaps simply a nail driven through the keel into the base of each stem. Also glue the chines and stringers in place, tying them and the frames with heavy cord until the glue has set. Be sure all elements are properly aligned before setting the hull frame aside to dry.

Then turn to the pontoons. Use battens to lay out the side and top planking to the dimensions given on page 186. In the origi-

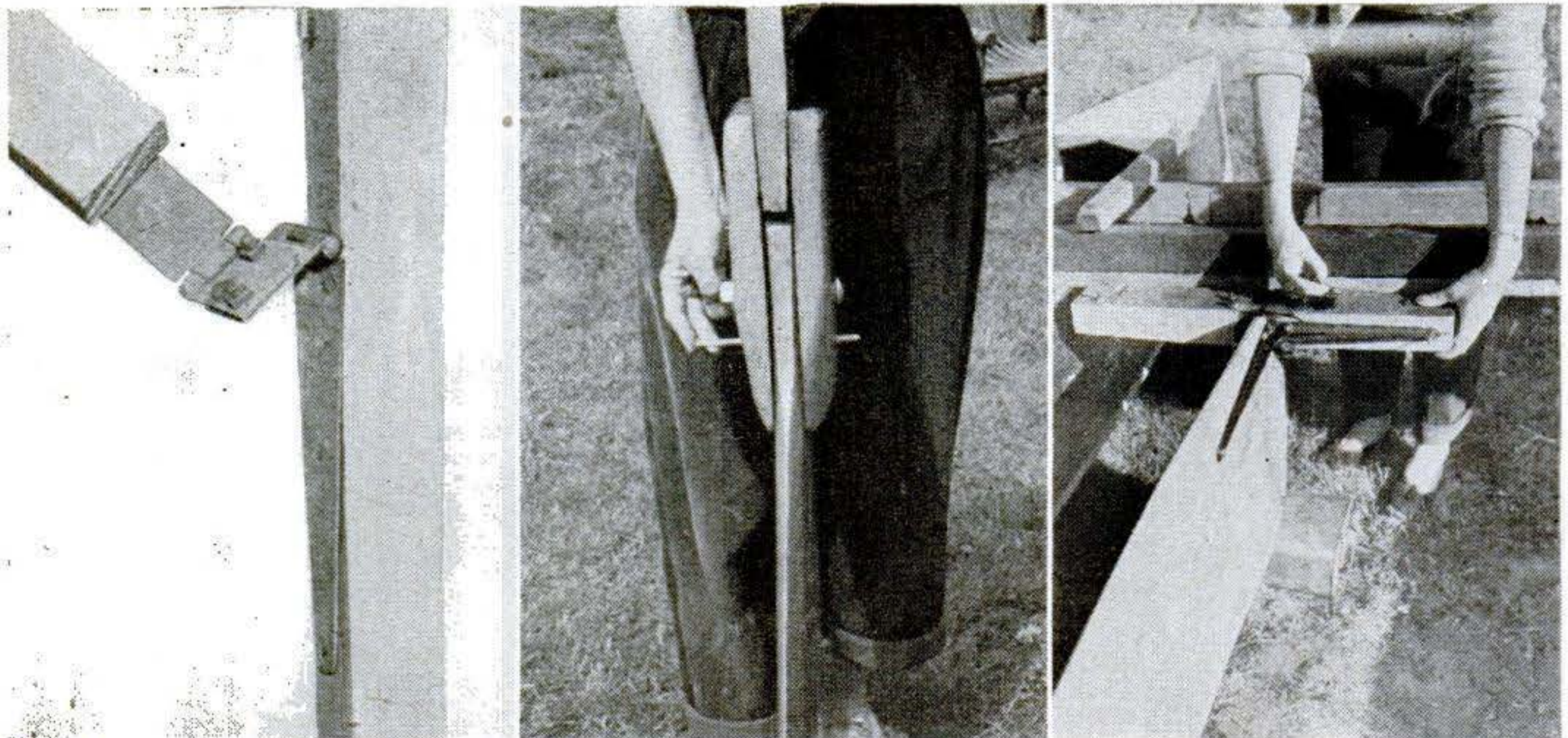

**Two hinges** bolted together join the boom and mast (left), allowing the boom vertical and horizontal movement. A plastic drink stirrer (center) serves as shear pin for the rudder.

Leeboard cross arm, a length of two-by-four, is marked (right) for two brass door hinges that hold it to the outrigger beam. Here the leeboard is seen in the up position.

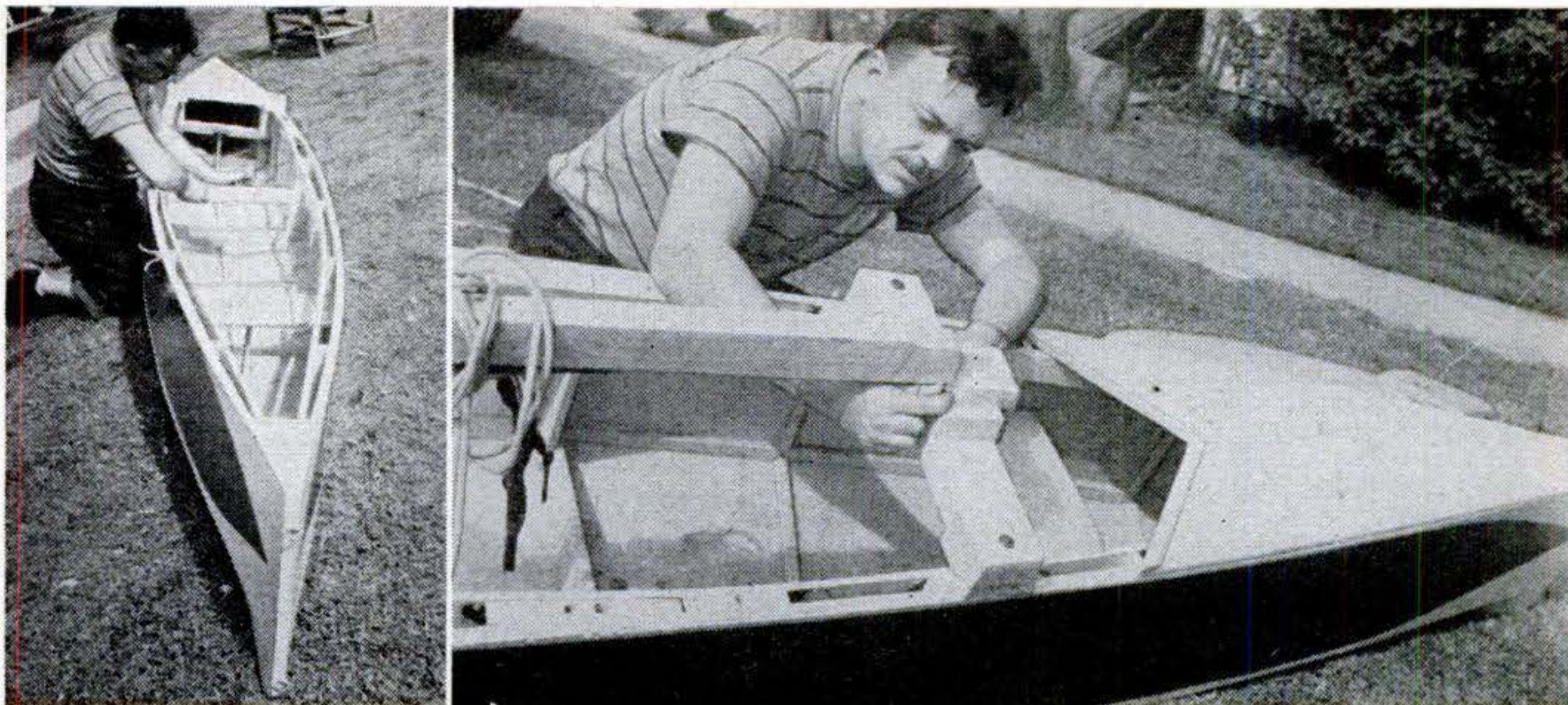

**Main hull** presents trim appearance as it nears completion (left). Note the large screw eyes in stern. A pin dropped through these and two mating eyes in the rudder hold rudder-tiller

assembly in place while boat is in use. Mast is mounted on its step with a hinge (right), permitting mast to be walked up. Two bolts in the step allow removal of hinge and mast.

nal boat, these parts were cut from  $\frac{1}{4}$ " mahogany veneer, but  $\frac{1}{4}$ " waterproof plywood could be used just as well.

With a block plane, bevel the bottom edges of the sides to about  $60^\circ$ . You don't need to worry about the bevel being exact since the glue will fill in small gaps. Also cut the nose blocks and the two  $60^\circ$  bulkheads on which the outrigger beam is to be mounted.

Coat the beveled surfaces of the sides with glue and join them by driving in a few brads. Cut  $60^\circ$  V notches about 3" deep in several blocks of scrap wood and rest the glued sides in these. Glue in the nose blocks and two center bulkheads.

Other frames for the pontoons are simply cut to length and stuck in place with glue. It's not necessary to notch or fit them. The gap-filling qualities of the adhesive will take care of this.

When the sides have set, plane off the upper edges so the top panels will lie flat for gluing. You will notice at this point that the top edges have a definite upward curve near the ends. The top planks will easily conform to this curve if drawn down at the center with cord.

Before gluing on the top panels, apply a good boat paint to the inner surfaces of the top and sides, leaving unpainted strips where glue must be spread. Glue on the 1" by 12" by 36" tongue for the outrigger beam at the same time you are attaching the top panels.

By now the main hull frame should be fully dry. The side planks go on first. These

are straight lengths of  $\frac{1}{4}$ " mahogany 12" wide in my boat, but  $\frac{1}{4}$ " waterproof plywood could be used. Since the curve of the sides is so slight, very little beveling is necessary on the edges of the frames. Here again, the glue saves you time by making an exact fit unnecessary.

Tie the side planks in position temporarily and mark on them the position of stems, side frames, stringers, and chines. Then remove the planks and apply glue both to the framework and planking. At this point, it's best to have a helper in applying the glue so it won't begin to dry on any part before the plank is set in place.

If you use partly driven brads to hold the planks to the chines, you will find it possible to apply the bottom planking before the sides have set. Bevel the lower edges of the side planks and the keel so the bottom planks will fit flat. Try these in place before applying the glue, and be prepared with enough clamps to hold the twisted portions at each end of the boat.

If your bottom planking is not plywood, the stresses may cause it to develop a split or two. But don't let minor splits worry you. A little glue will seal them. As the final step in the planking job, glue on a rub strip, holding it in place with partly driven brads. When the glue has set, pull these out and plane down the strip.

Then turn the hull over and glue in  $\frac{1}{2}$ " by  $\frac{1}{2}$ " reinforcing ribs midway between the frames. Floor the boat with slats or plywood, glue in a seat cut from  $\frac{3}{4}$ " stock, and

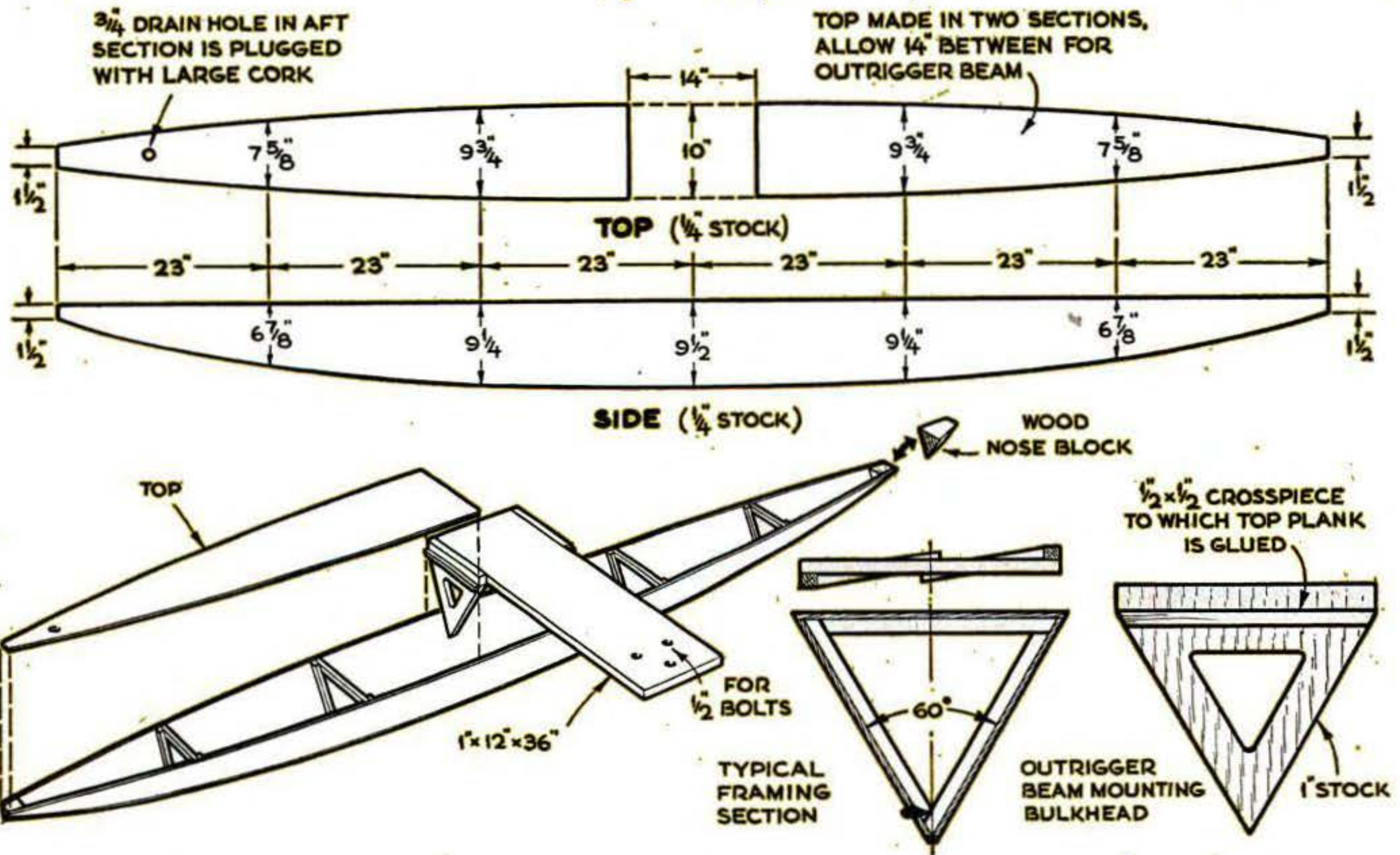

Pontoons are bolted to the outrigger beam. This allows dismantling boat into smaller units.

follow with blocks for mounting the mast step and outrigger beam. Install a 2" by 2" crosspiece at No. 4 frame for the pulley block, and add the inner stringers. The forward deck can be glued on, but you may prefer screws to give access for seasonal painting.

Glue up the outrigger beam, using two lengths of 2" by 3" fir for the side members.

This beam allows some flexing, preventing any excessive twisting on the lightweight hulls. Like the mast step, the beam is attached with bolts for easy removal. Removing these parts allows the hull to rest flat on the car top.

Shape the leeboard and rudder from 1" white pine. Only one leeboard is used, since this kind of boat doesn't heel enough to lift out of the water to any appreciable extent. In the original boat, the leeboard was mounted on its oak crosspiece with heavy shelf brackets. If the boat is to be left in the water, however, it would be advisable to use straps of 1/4" bronze bent to a right angle instead of steel brackets.

If you find it necessary to splice a mast, take special pains with the joint. Cut the two pieces at an angle and clamp firmly while the glue is drying.

The finish consists of clear varnish on the main hull sides and on the pontoons, yellow enamel on the bottom, trim, and the spars. A secondhand Comet sail will serve very nicely if you are not prepared to buy a new one this season.

One advantage of the boat is its portability, allowing you to pick and choose sailing locations. The main hull weighs only 75 lb., the pontoons less than 30 lb. each. Dismantled, the boat has often been carried 50 miles atop a car. END

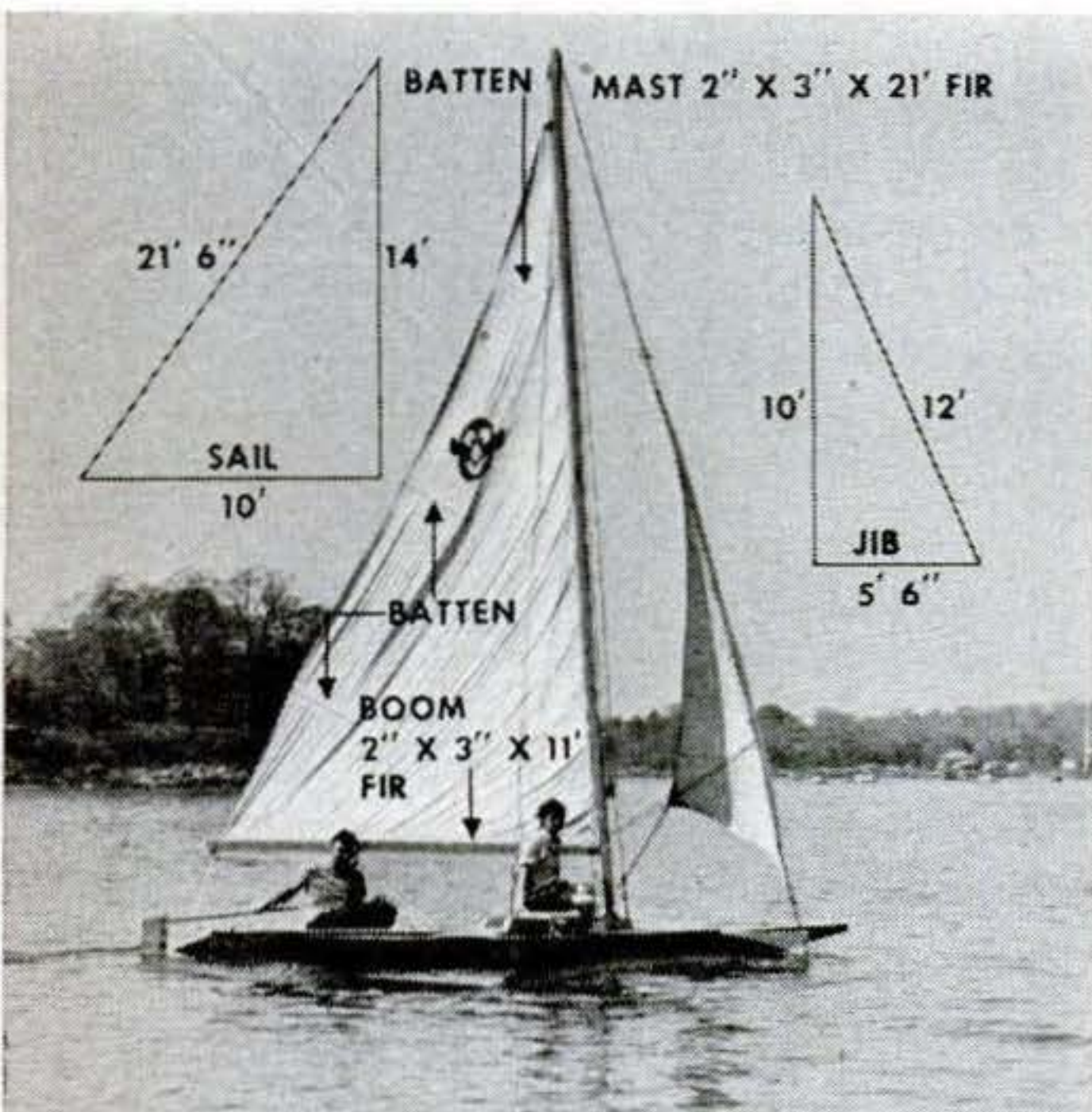

Boat is rigged like this. The jib is run up on the forestay. Stays are stainless steel sash cable. Three battens are used in the sail.

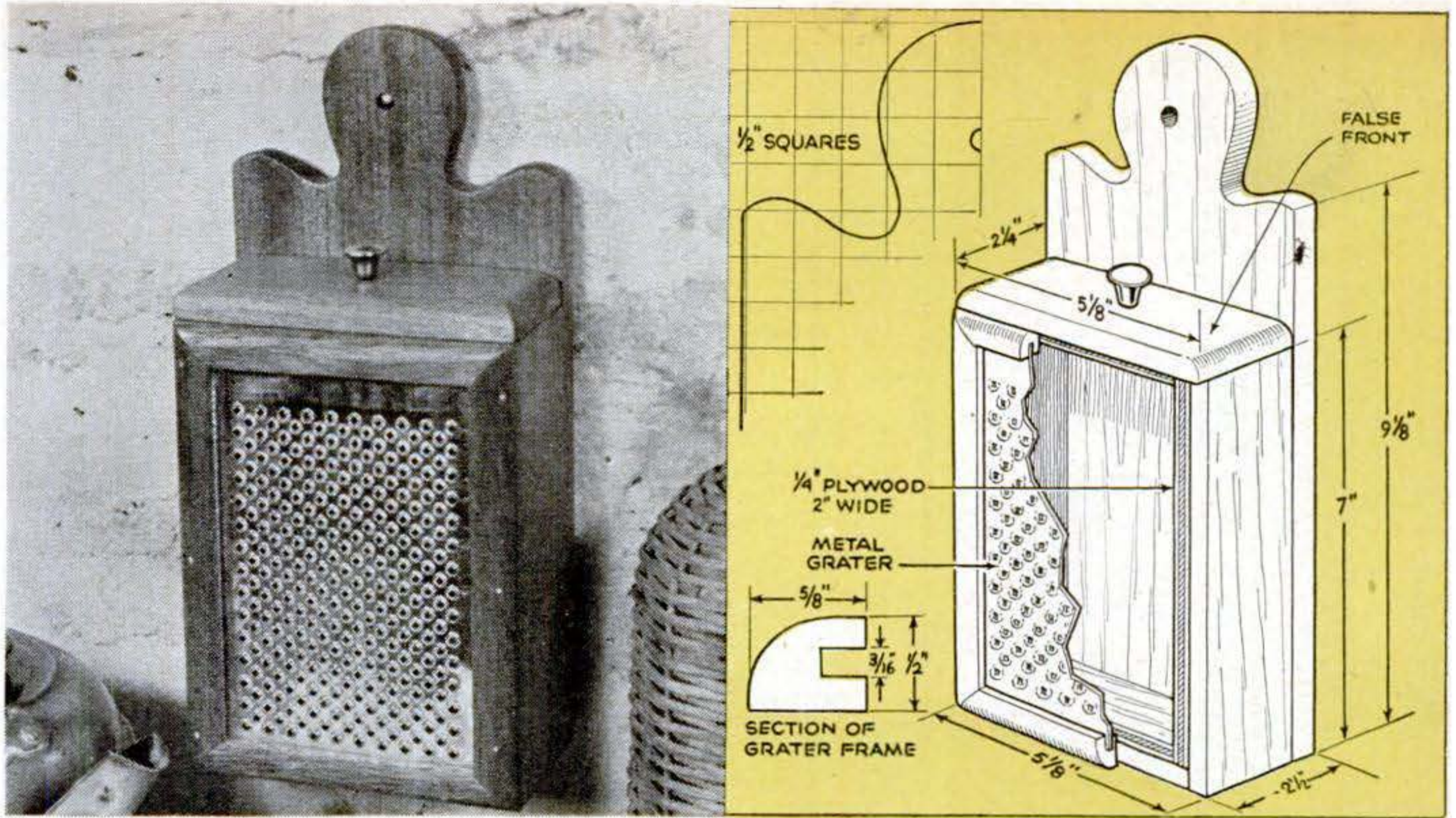

## Cheese Grater Catches the Crumbs

**I**F SPAGHETTI is a specialty in your home, you'll want this attractive grater for the dry Italian cheese that tops it off. The grater does a fine job, too, on bread crumbs and other dry foodstuffs. The gratings fall into a drawer, ready for use.

First obtain a suitable grater. Its size determines dimensions of the box and drawer. I used the common half-round type, snipping off the ends and then flattening it. Dimensions in the drawing are suited to the grater that I had.

All wood parts were cut from  $\frac{1}{2}$ " stock with the exception of the body of the drawer. This is  $\frac{1}{4}$ " plywood. The drawer pull is a small five-cent knob.

Begin by making the grooved molding

that frames the grater, modifying the dimensions given if necessary. Lay out a pattern for the back and cut to shape. Drill a hole for hanging up the grater. After cutting other parts, assemble with glue and small brads. First join the sides to the back. Then butt the bottom between the sides. After tacking the molding to the sides and bottom, slide in the grater, and put the top part of the molding in place.

Butt joints also are used for the drawer. Glue on a false front and strengthen it with brads driven from the inside.

Round all edges with a rasp or coarse sandpaper, finishing with fine sandpaper. The wood parts may be stained or left natural.—Doris Aller, San Francisco, Calif.

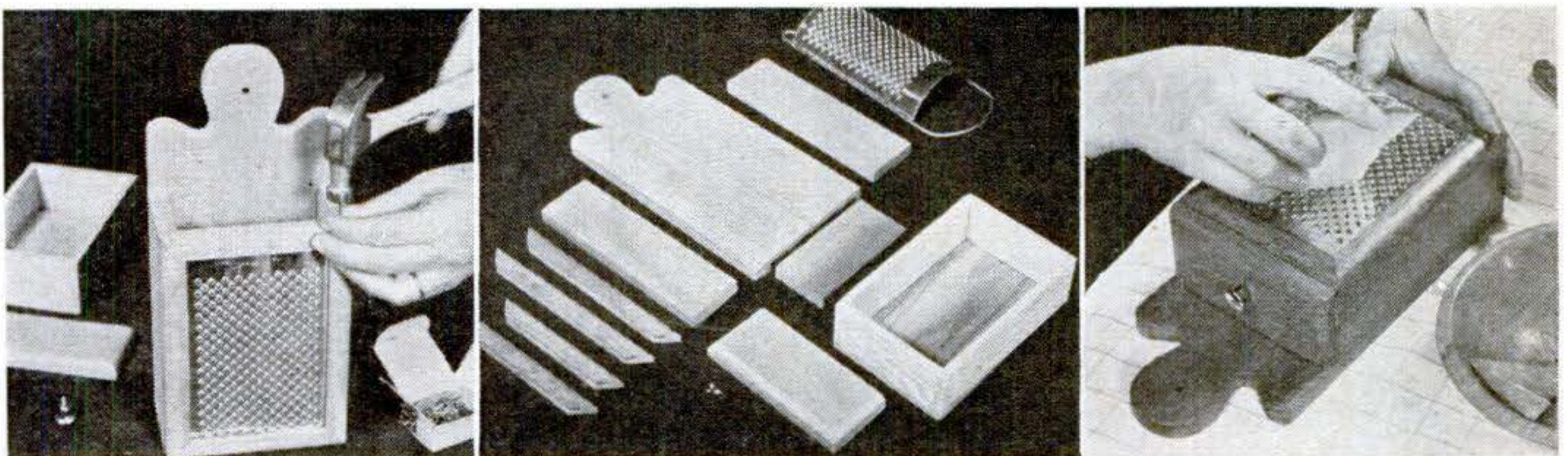

**Metal grater** fits into a  $\frac{3}{16}$ " groove cut in the frame molding. If cutting this presents any difficulty, you may be able to buy suitable molding already grooved. The molding is

mitered, but other parts are assembled with butt joints. The finished grater is used as above. Protect the box with spar varnish or lacquer, rubbed down and waxed.

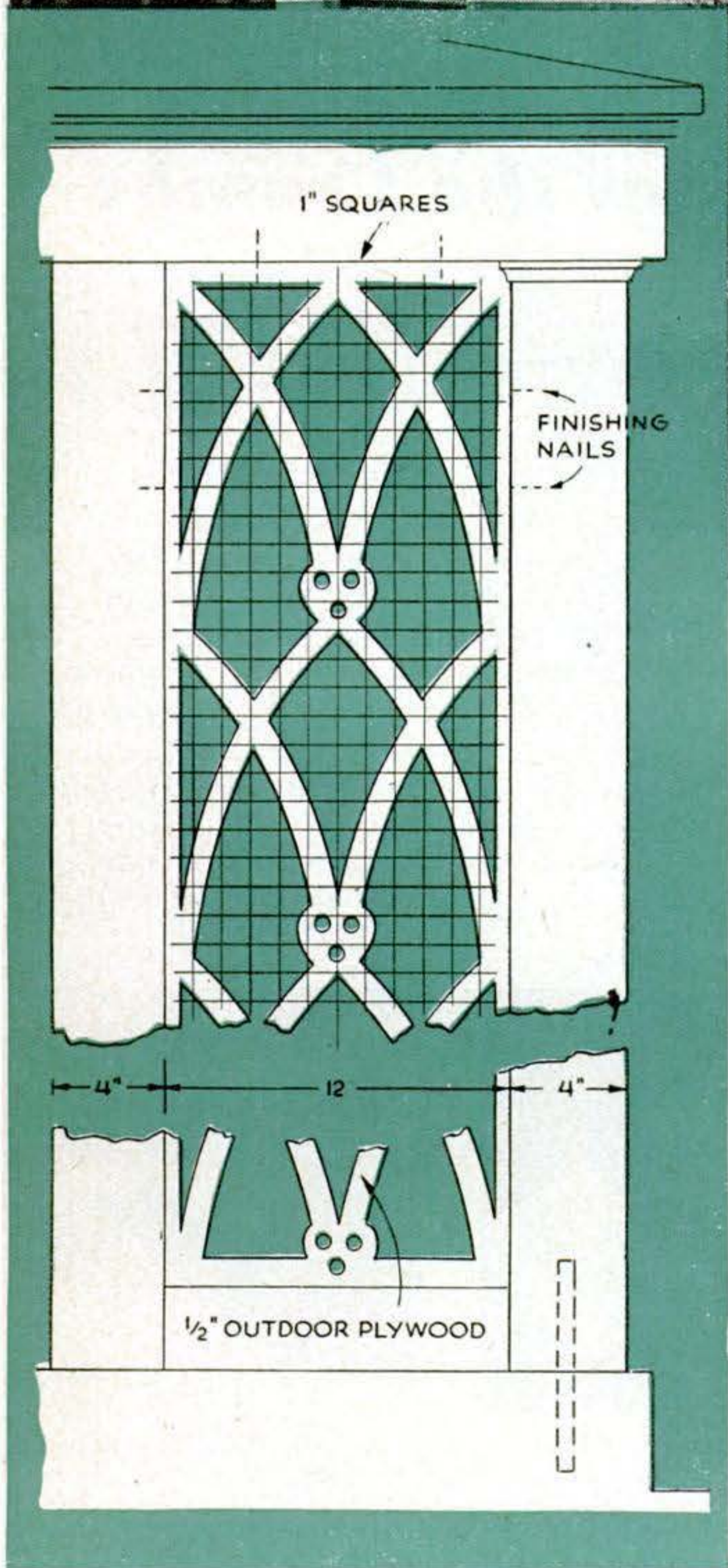
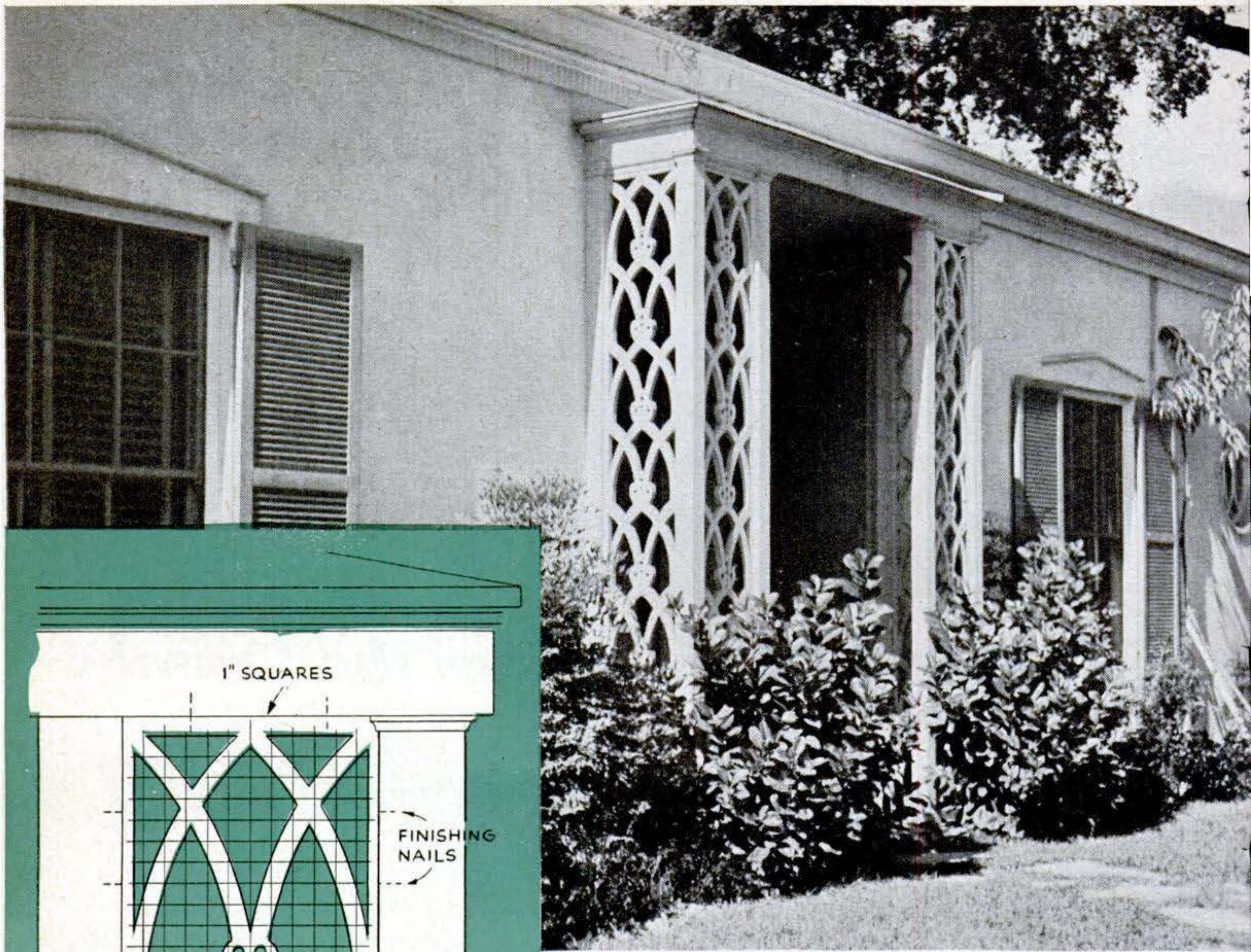

This filigreed latticework was jigsawed from  $\frac{1}{2}$ " waterproof plywood. The drawing at left gives you the pattern on 1" squares.

## Trellises Add Glamour at Low Cost

*By Hi Sibley*

**N**OTHING you can do with a hammer and saw will add more to a plain arch or entrance than latticework. Most of designs shown here can be straight hand-tool jobs. Even the filigreed trellis shown on this page was cut out by hand. If you have

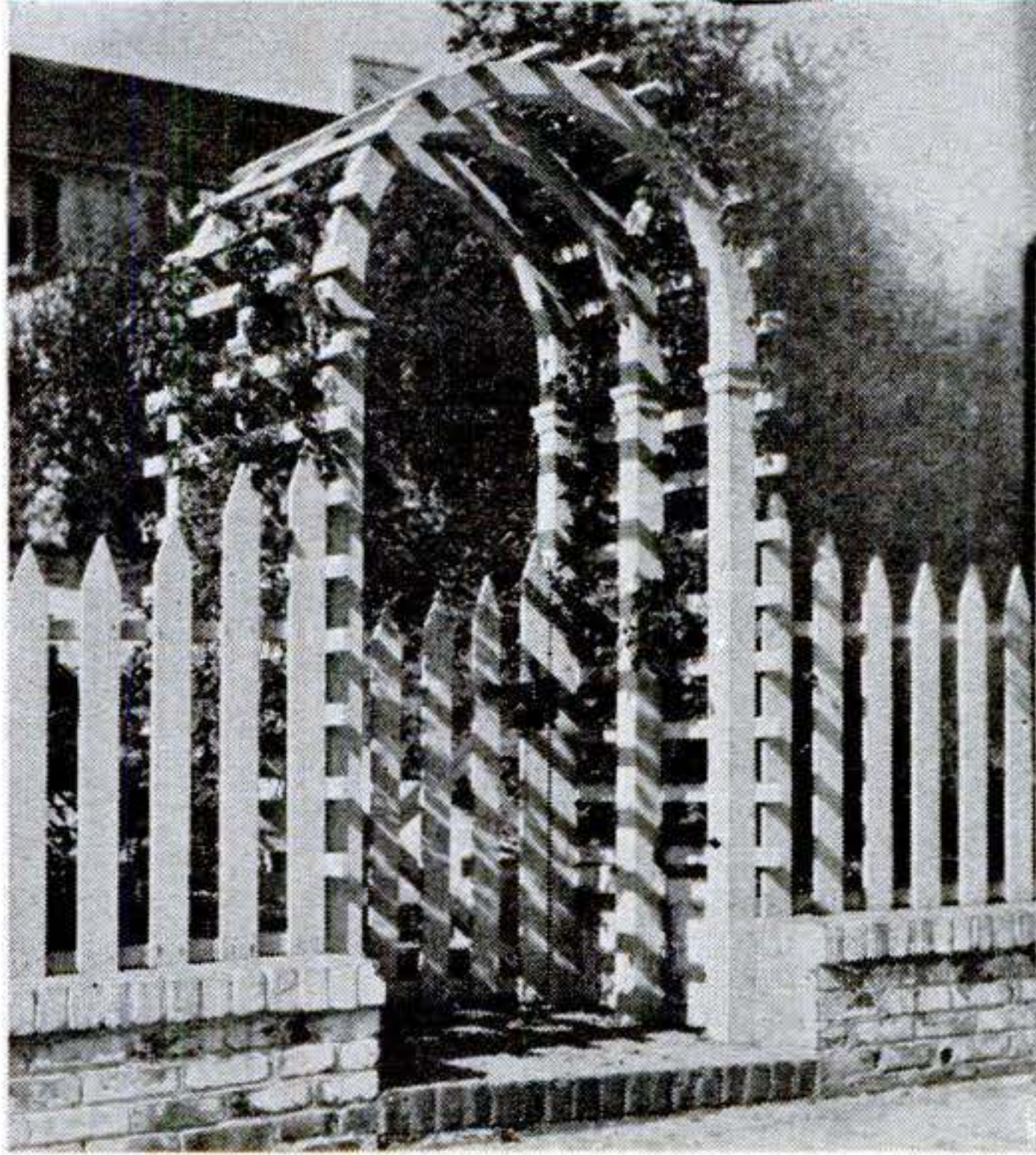
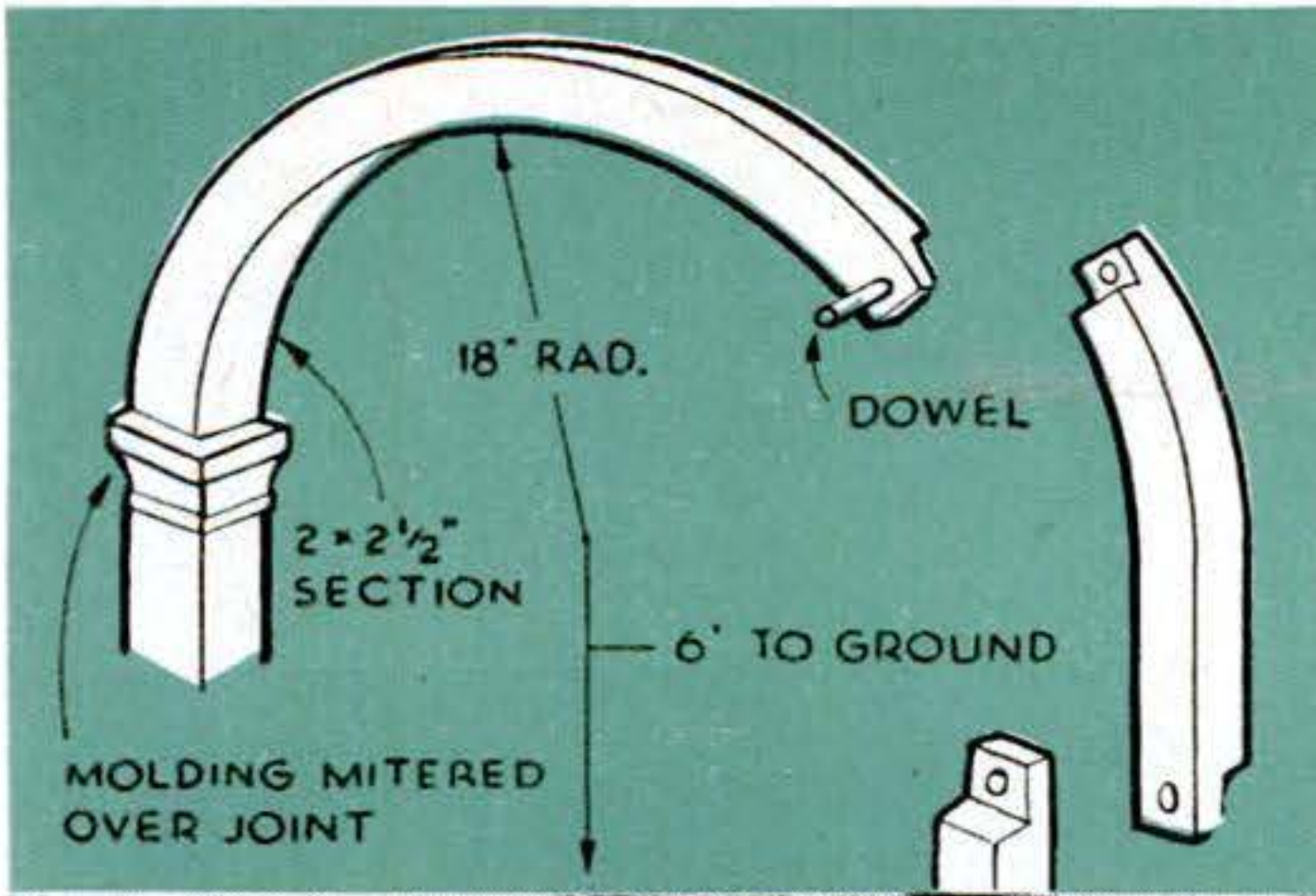

**Arched gateway** is a universal favorite. Bandsaw was used to cut out arch members. They are joined with dowels and waterproof glue.

a power jigsaw but find that the panel is too long to be handled conveniently with your equipment, you can cut it out in sections. Then assemble it in its location with glued and splined or doweled joints. In all such outdoor work, use a waterproof glue such as a resorcinol or urea type.

A simpler installation is shown at the top right of this page. Here the lattice is nailed to strips on the posts and porch roof. You'll find that one lattice strip at top and bottom needs a short filler piece between it and the nailing strip.

One of the most popular types of gateway is the arch pictured above. The arch members are bandsawed in three sections and joined with dowels and waterproof glue. Note that the horizontal strips project beyond the frame members both ways.

At right is an effective design for an archway of not less than 4' radius. The

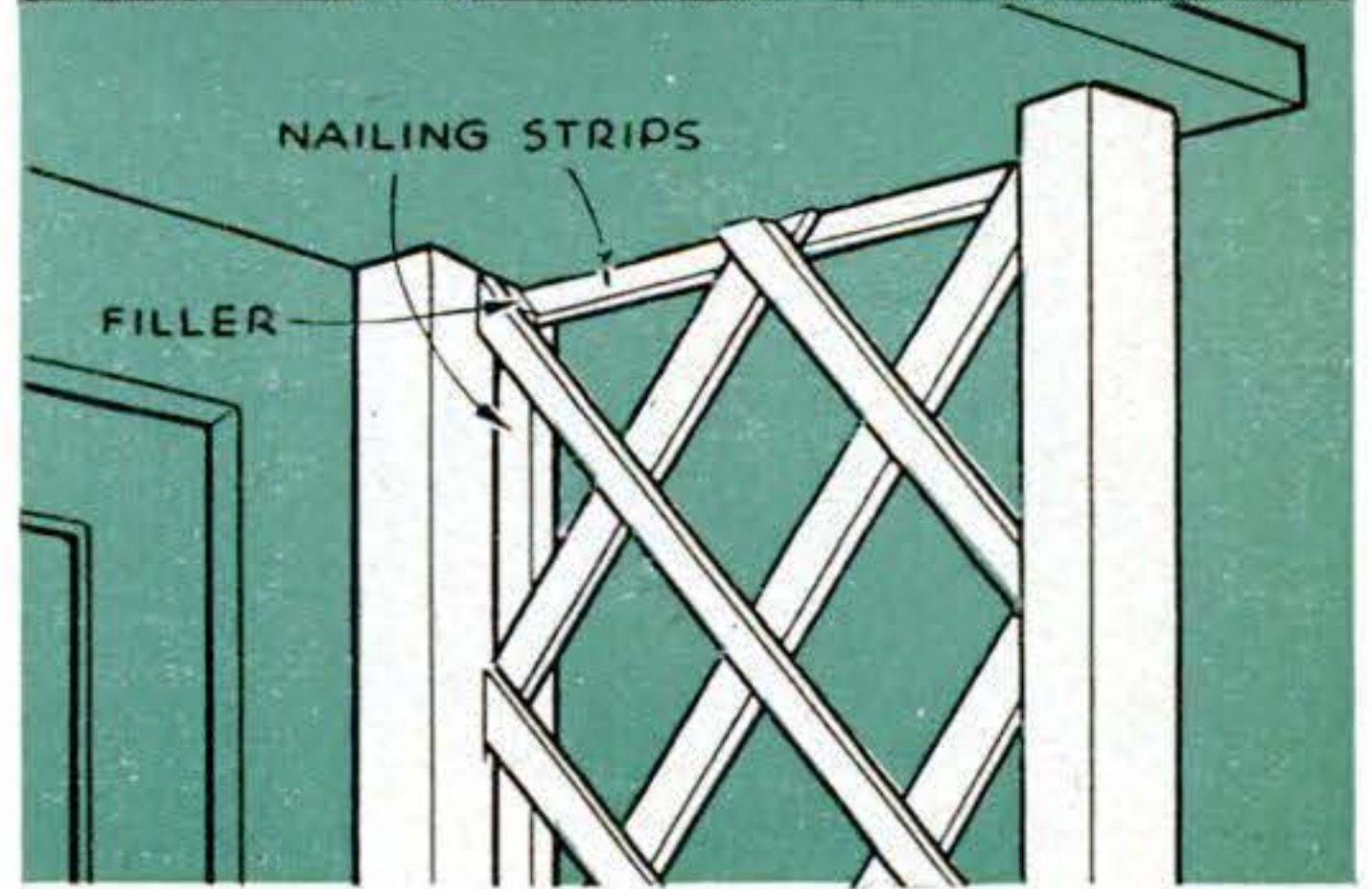
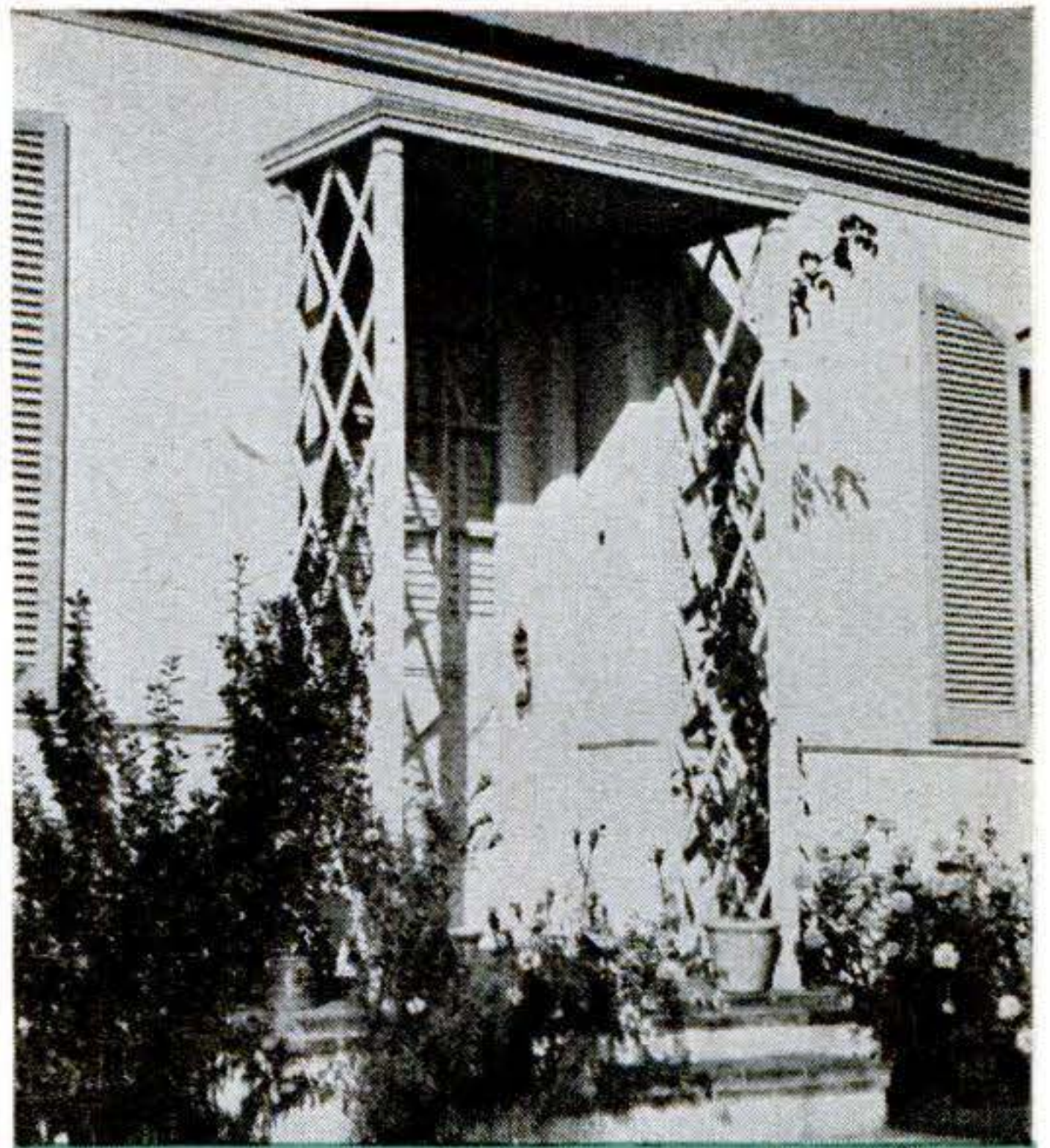

**Simpler design** above is a hammer-and-saw job. Middle slat overlying others should be shimmed up at top left-hand corner.

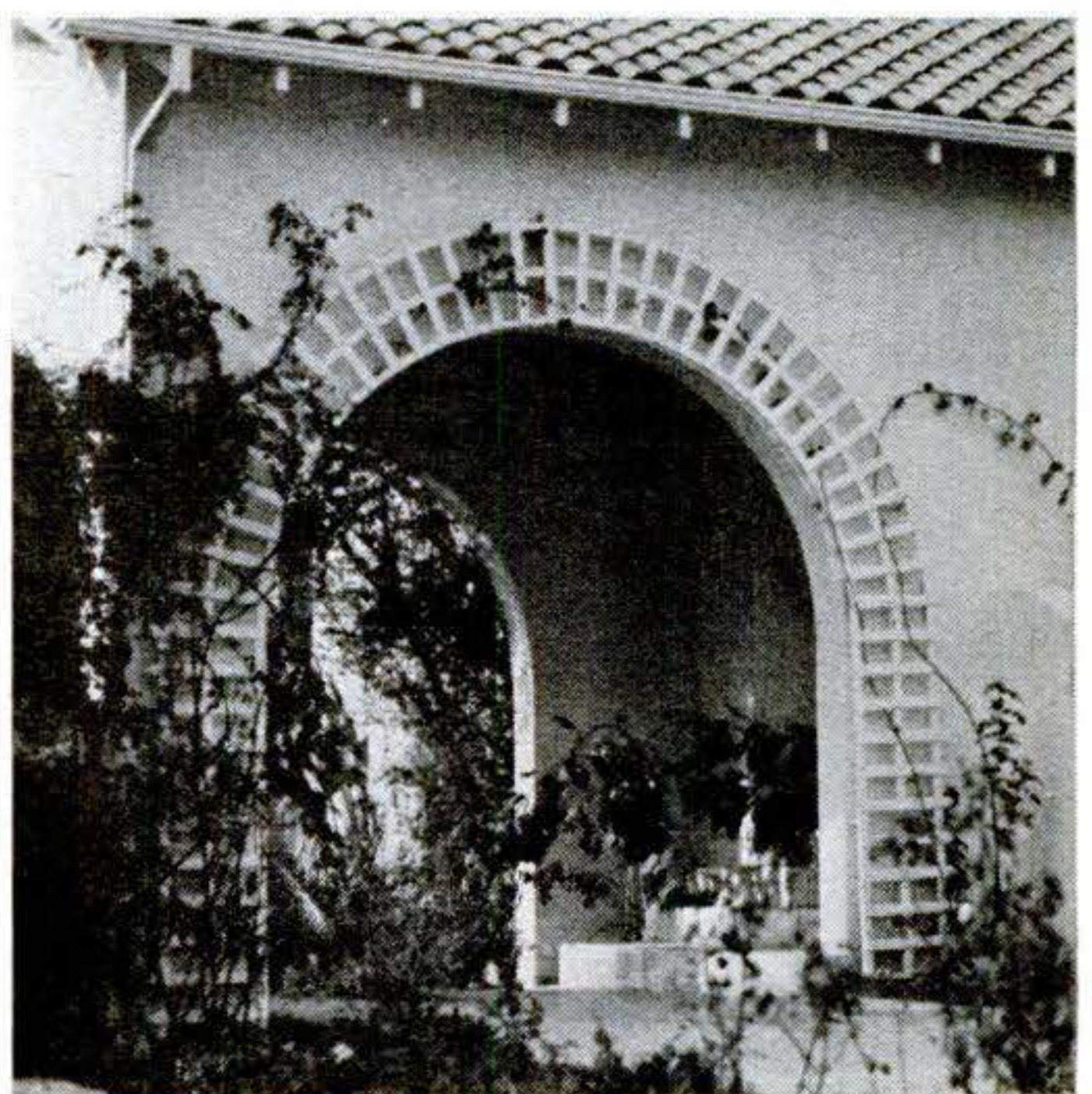

**This style is adaptable** to an arch with an opening large enough to permit bending the frame. Spruce was bent and screwed to wall.

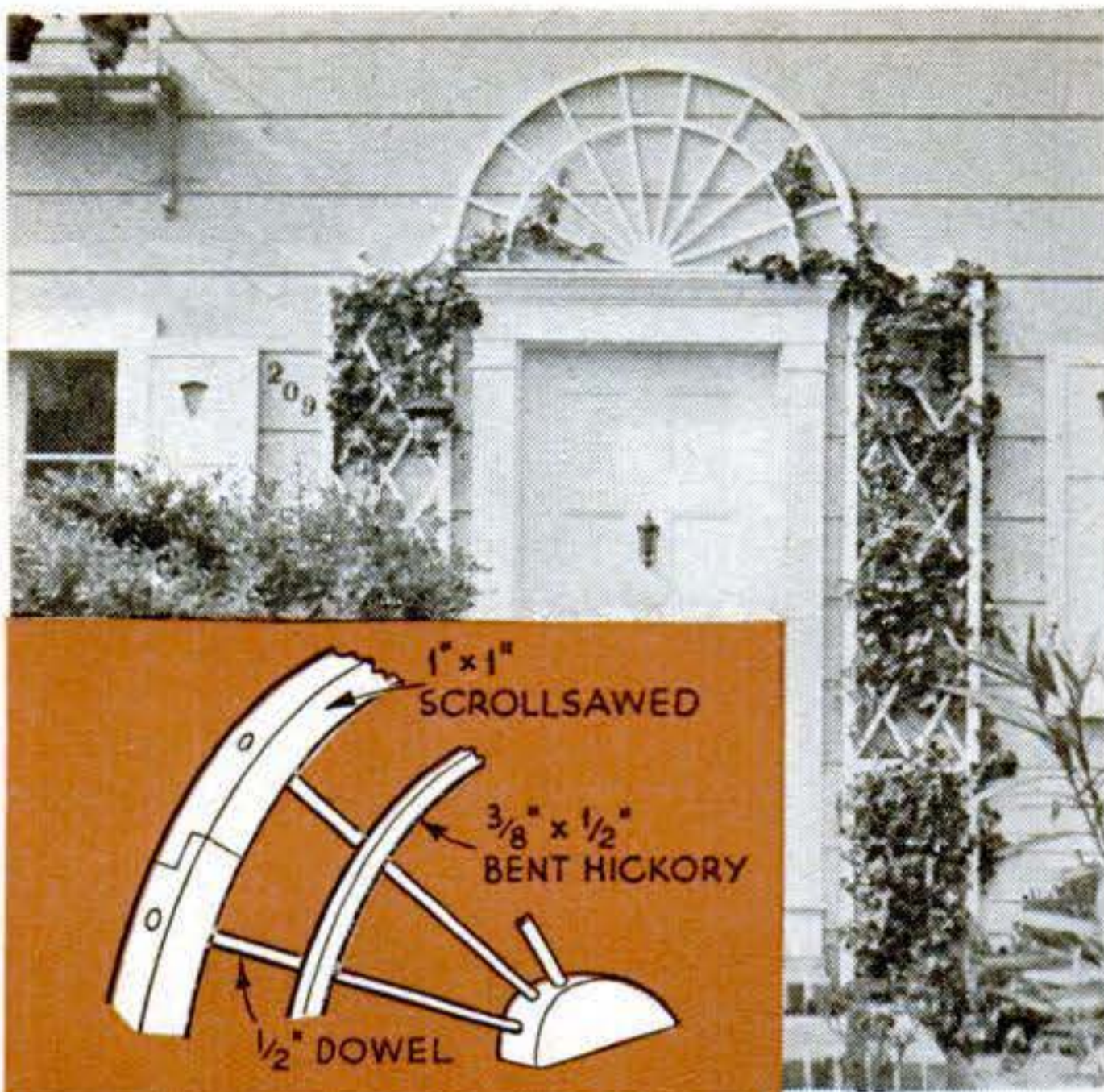

curved pieces are spruce, soaked and bent and then fastened to the wall with masonry anchors. The slats were nailed on radially.

The half-wheel pattern at left has a rim scrollsawed in three pieces. The inner ring was bent and nailed to the spokes. Hickory or spruce, soaked overnight or steamed, is suitable for this part of the design. END

Rim of this half-wheel pattern was scrollsawed in three sections and joined with glue and dowels. Inner curved piece was nailed.

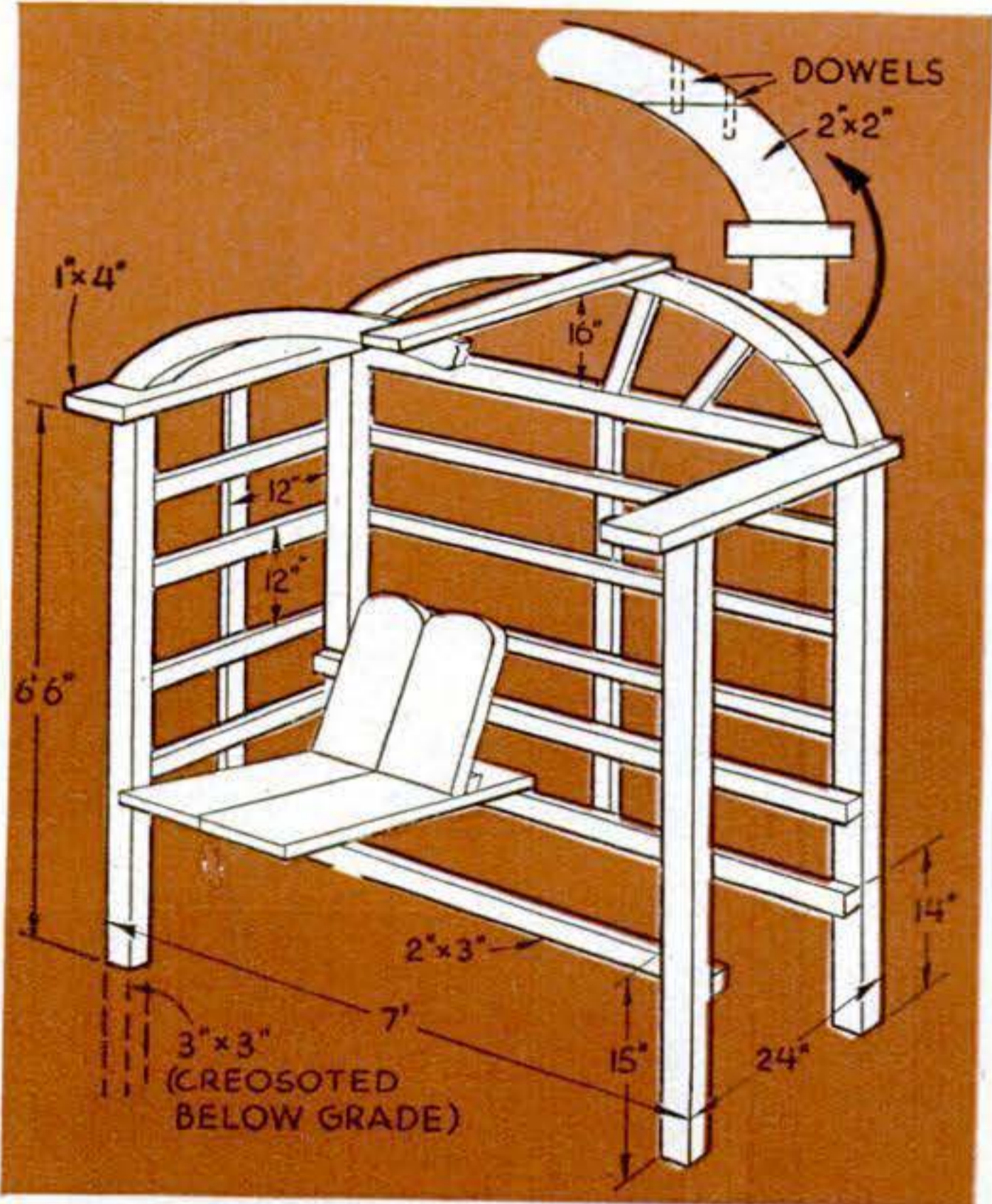

Seat with trellis has bandsawed top beams built up with doweled lap joints. Note that posts are creosoted below grade as rot protection.

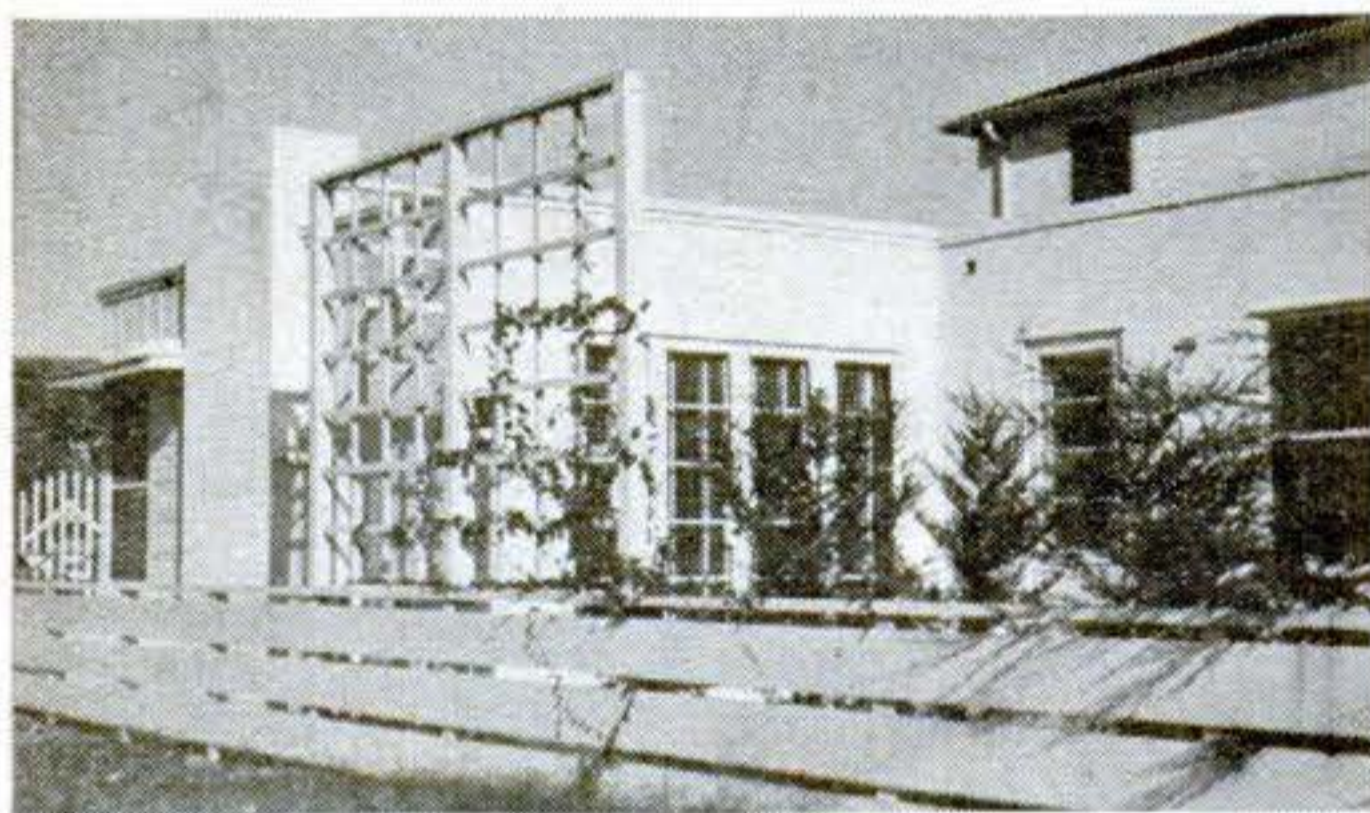

Attractive trellis arrangement alongside chimney breaks up the straight lines of the fence and provides support for climbing vines.

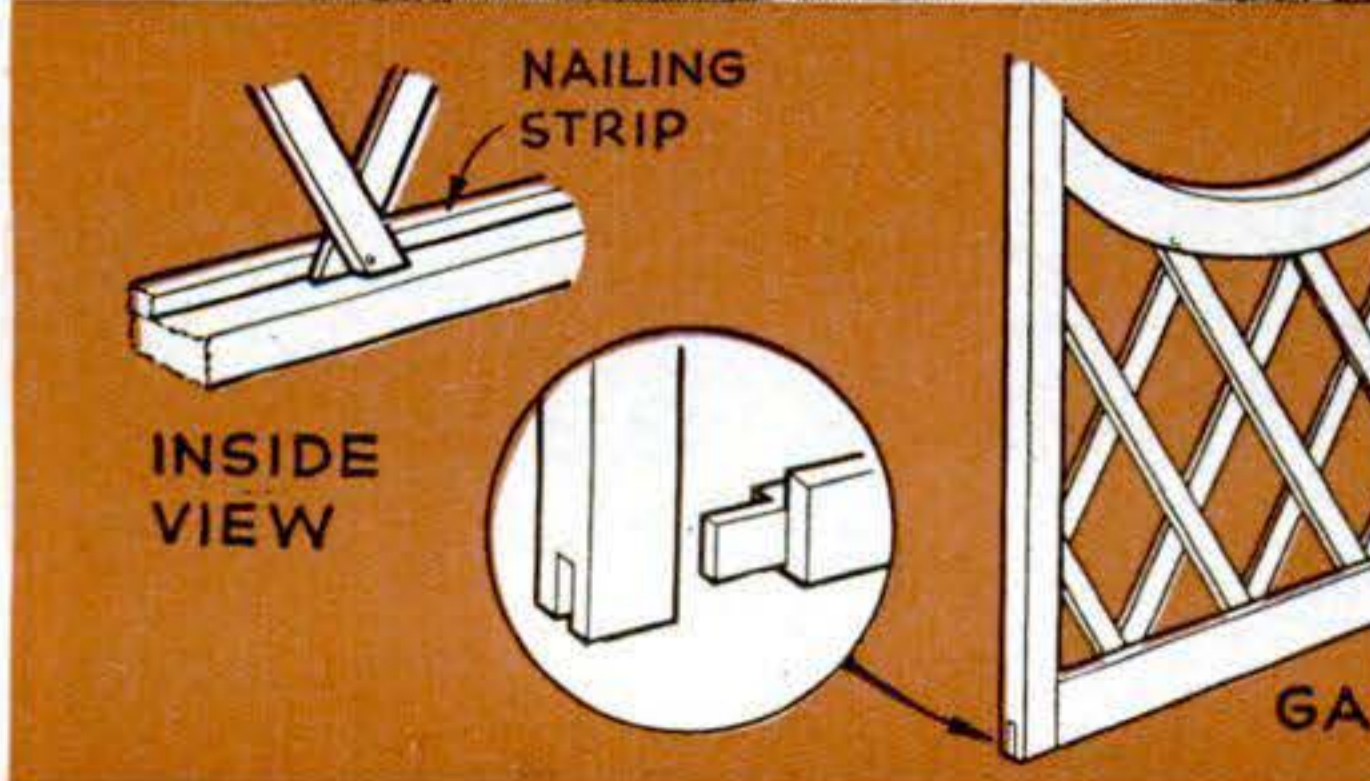
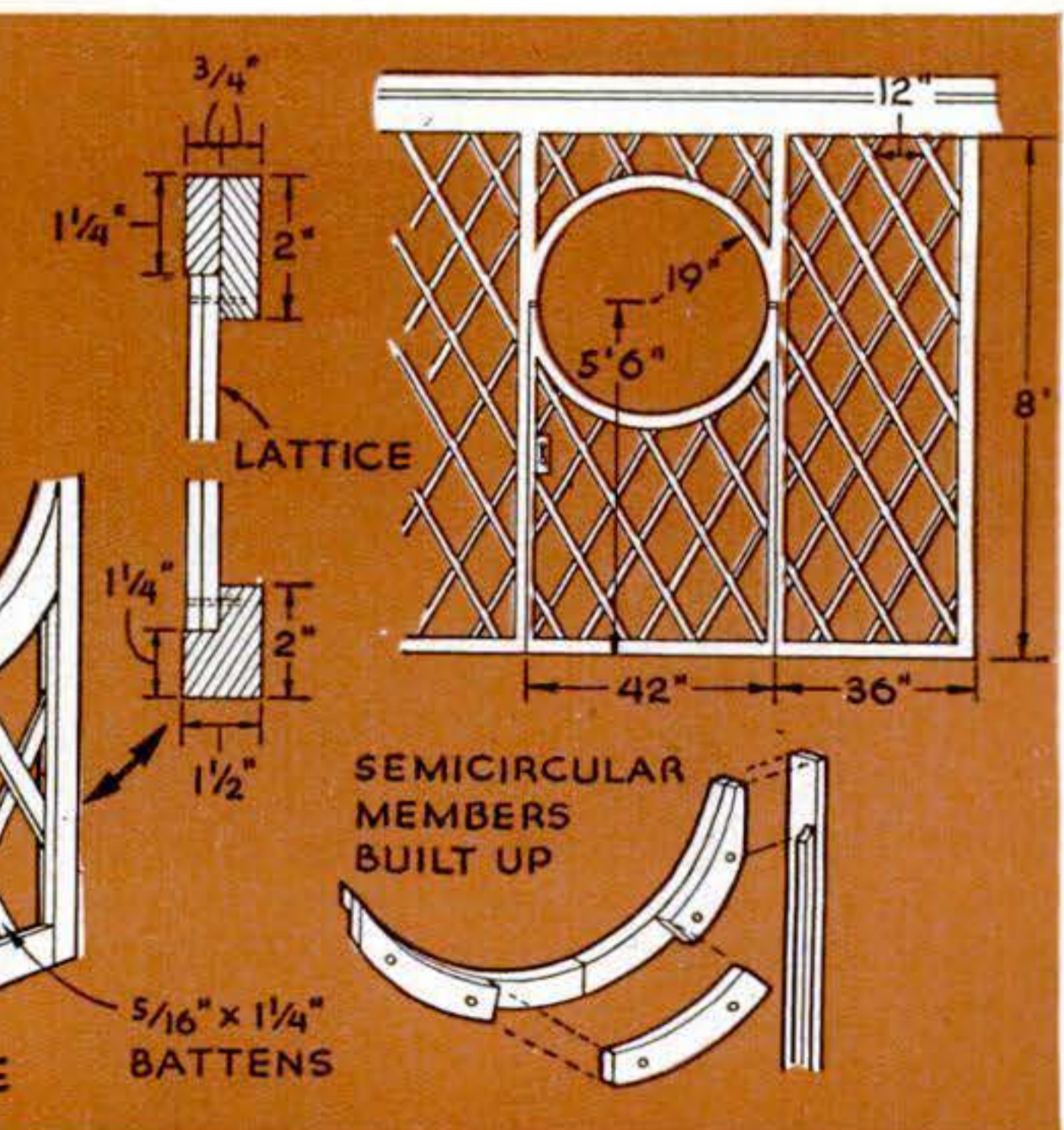

Open latticework encloses this long porch. Circular opening at the gate was built up of

several pieces glued and doweled together. Careful sandpapering and filling conceals joints.



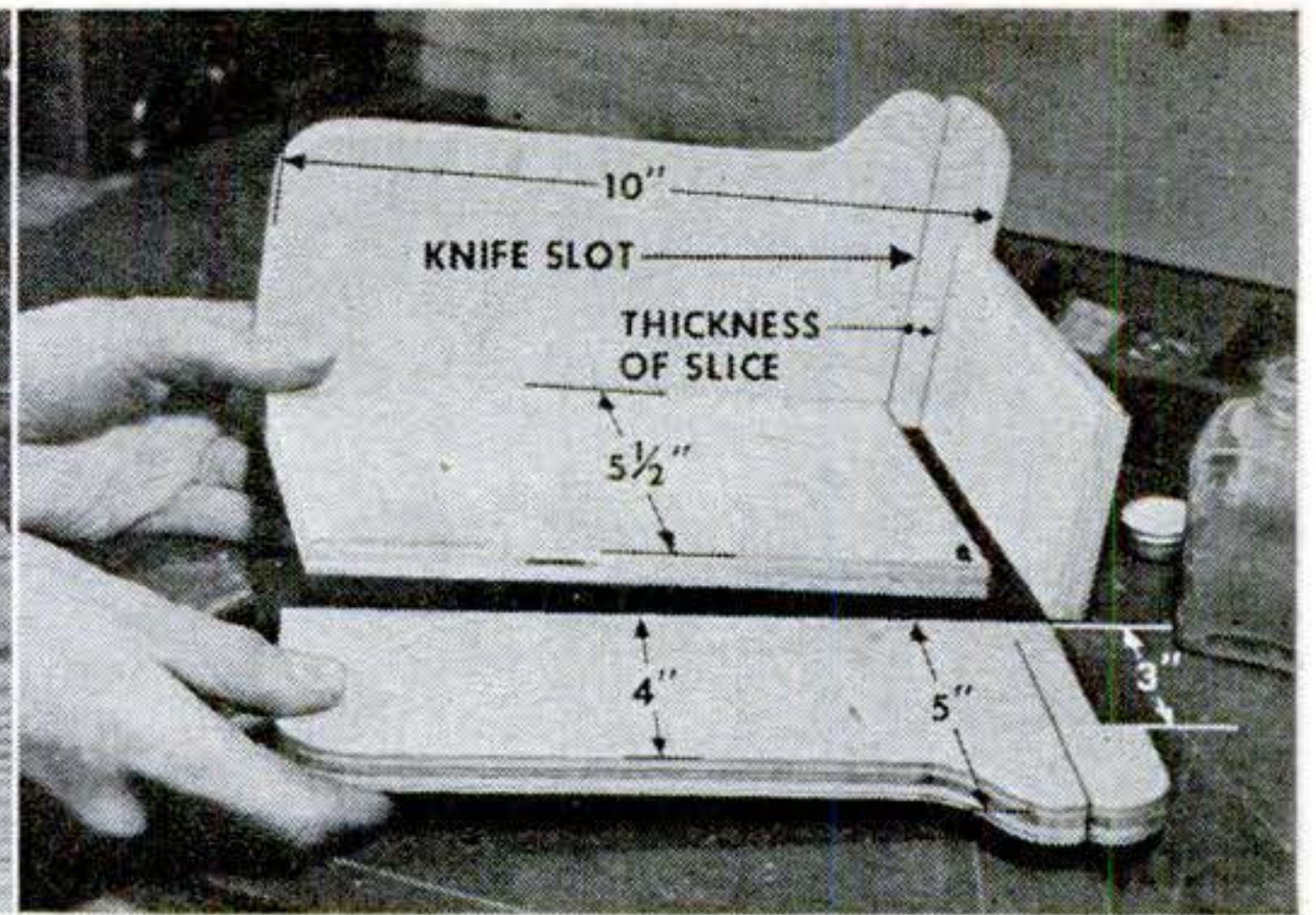
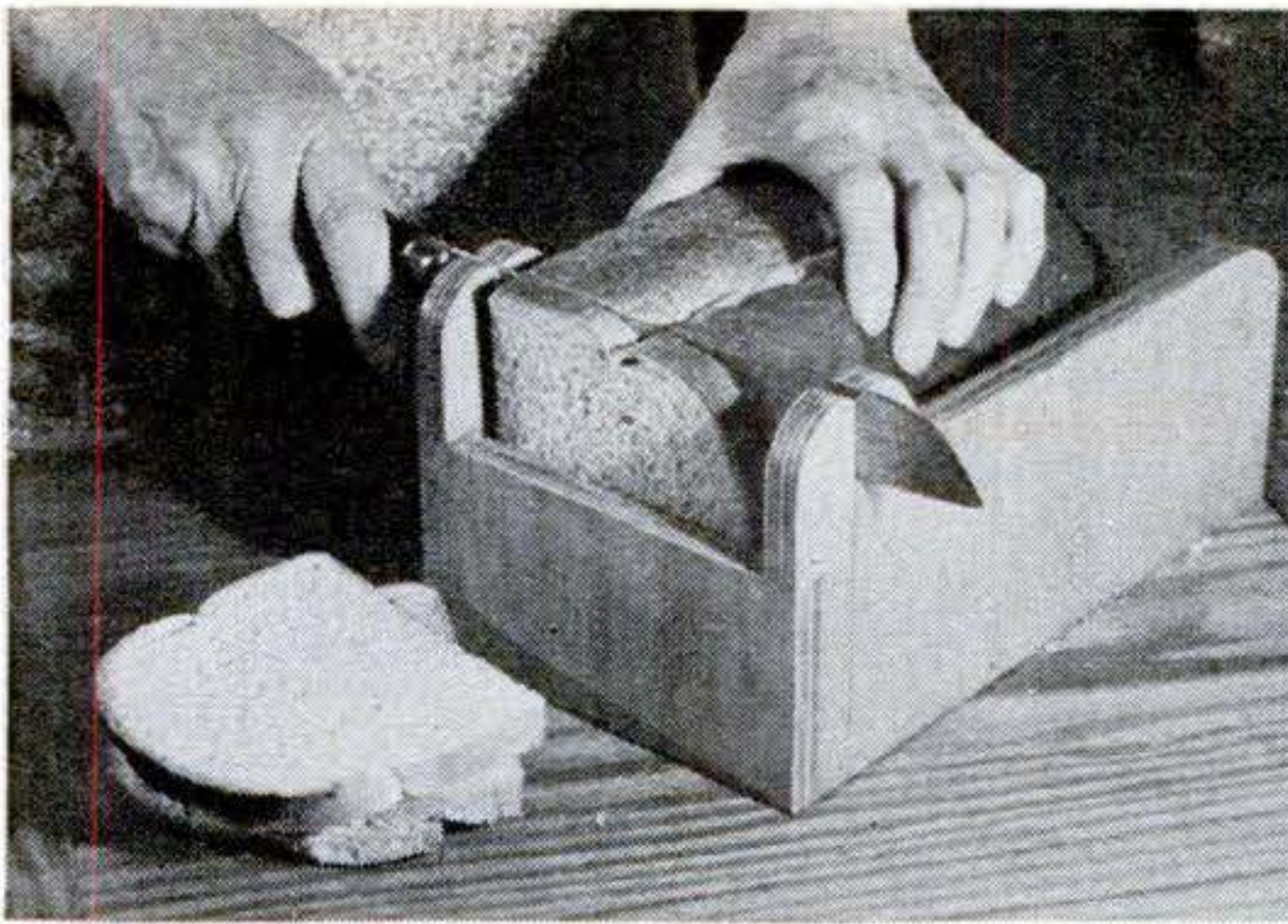

## Bread Slicer Works like a Miter Box

UNIFORM slices of bread drop out a slot into a basket or pan when the end of this cutter is allowed to overhang the work surface. A sawing action with the knife cuts the slices evenly as fast as you can feed the loaf into the box.

The slicer was made from  $\frac{1}{2}$ " plywood. For some home-style loaves it may be necessary to vary the dimensions slightly. In laying out the parts, note that the sidepieces

are notched to receive the 3" by 6 $\frac{1}{2}$ " end. The lowered sides make it easier to grasp the loaf and box.

Continue the knife slots  $\frac{1}{32}$ " below the top surface of the bottom so the knife will separate the slice cleanly. If the slots are cut with a power saw, widen the kerf with a second pass. Smooth the slots by drawing sandpaper through them. Varnish or lacquer the finished box.

## Quick-Adjusting Clamp Jaw Locks with a Twist

WITH these C clamps, you don't have to waste time making adjustments. To suit the clamp to the work, you slide the pressure rod in or out. A clockwise twist of the handle then locks the rod to the threaded member, a roller jamming in an internal cam when the rod is turned in one direction.

A further twist of the handle causes the foot to exert pressure on the work. A counterclockwise turn unlocks the bar and allows it to be withdrawn.

Richards' Industries, Inc., Grand Rapids, Mich., makes the clamp in 2" to 6" sizes. A ball bearing between the foot and rod end prevents torsion on the work.

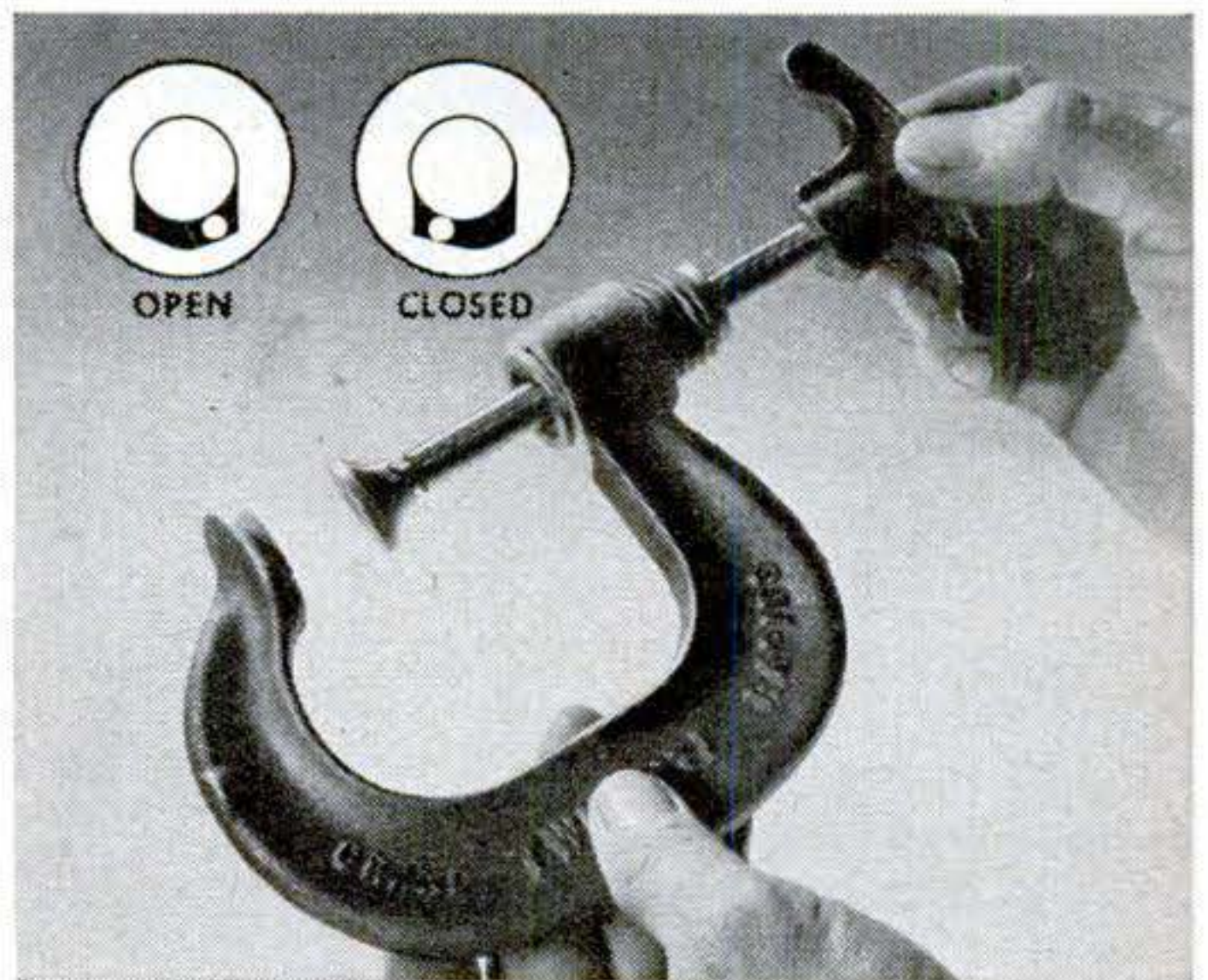

## Plastic Cemented for Turning

RUBBER cement provides an easy mounting method when you want to turn a plastic disk. Attach a piece of wood to the lathe faceplate or mount the wood on a screw center. Apply cement to the wood and to the masking paper on the plastic, let it dry, and then press the plastic and wood firmly together. Push a smaller block of wood against the plastic with the tail center.—*Joseph F. Gréce, Bronx, N. Y.*

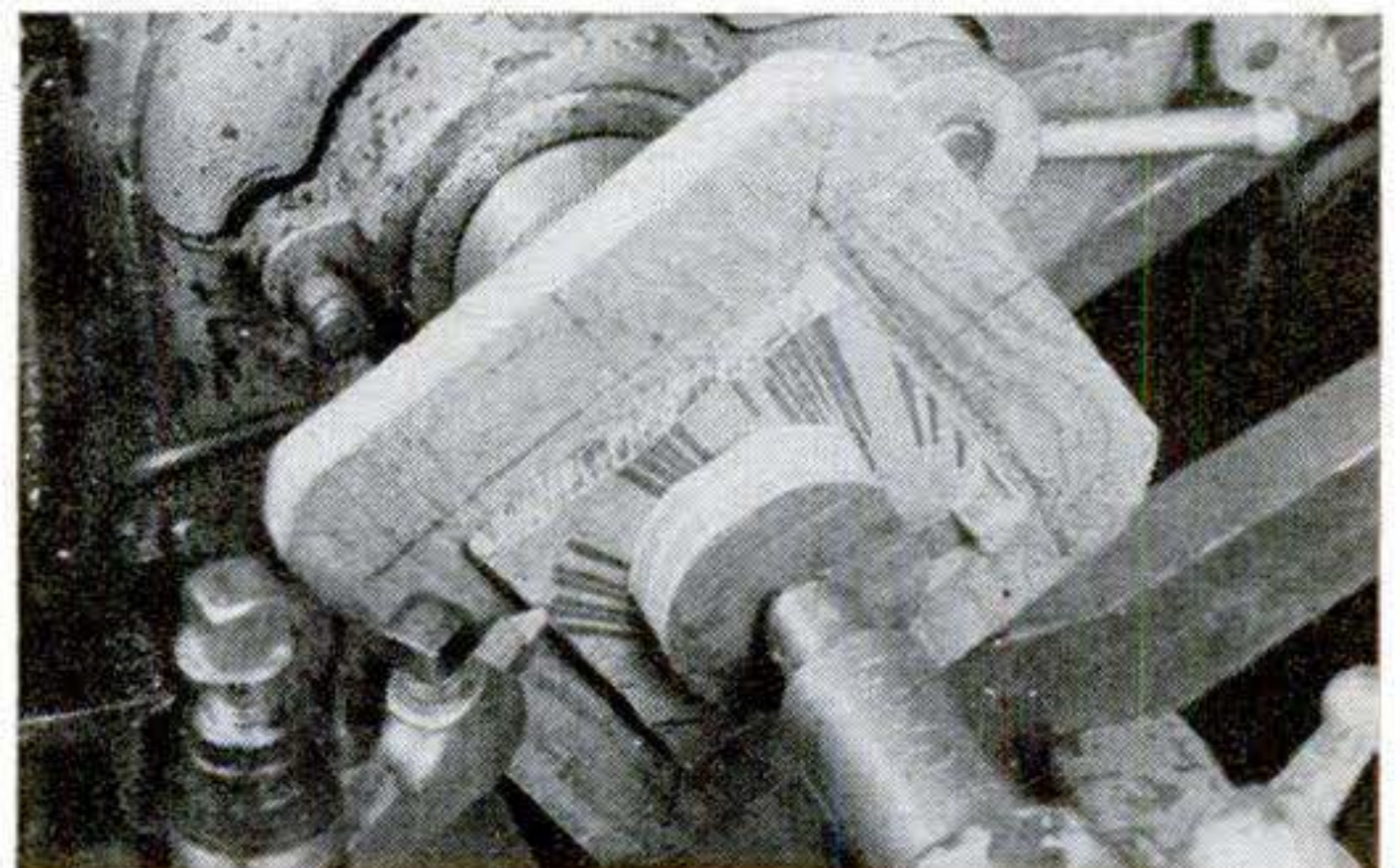

# Making Hopper Joints by Hand

By Edwin M. Love



**Though they look like straight-cut tapers, hopper joints can be tricky because compound angles deceive the eye.**

**T**APERED boards are those that are cut on a slant. In most cases that's all they are—which is fortunate for the amateur workshopper. Calculating angles and cutting them accurately with hand tools can sometimes be a tough job.

But when you are tapering table legs the exact angle makes precious little difference.

All that matters is that the mating pieces have the same taper—or appear to have it. The same is true for bench ends, door stops, and clamp wedges.

In this form tapers are easy, for even where precision is required, the measurements are usually given in lengths rather than angle of slope. All you have to do is

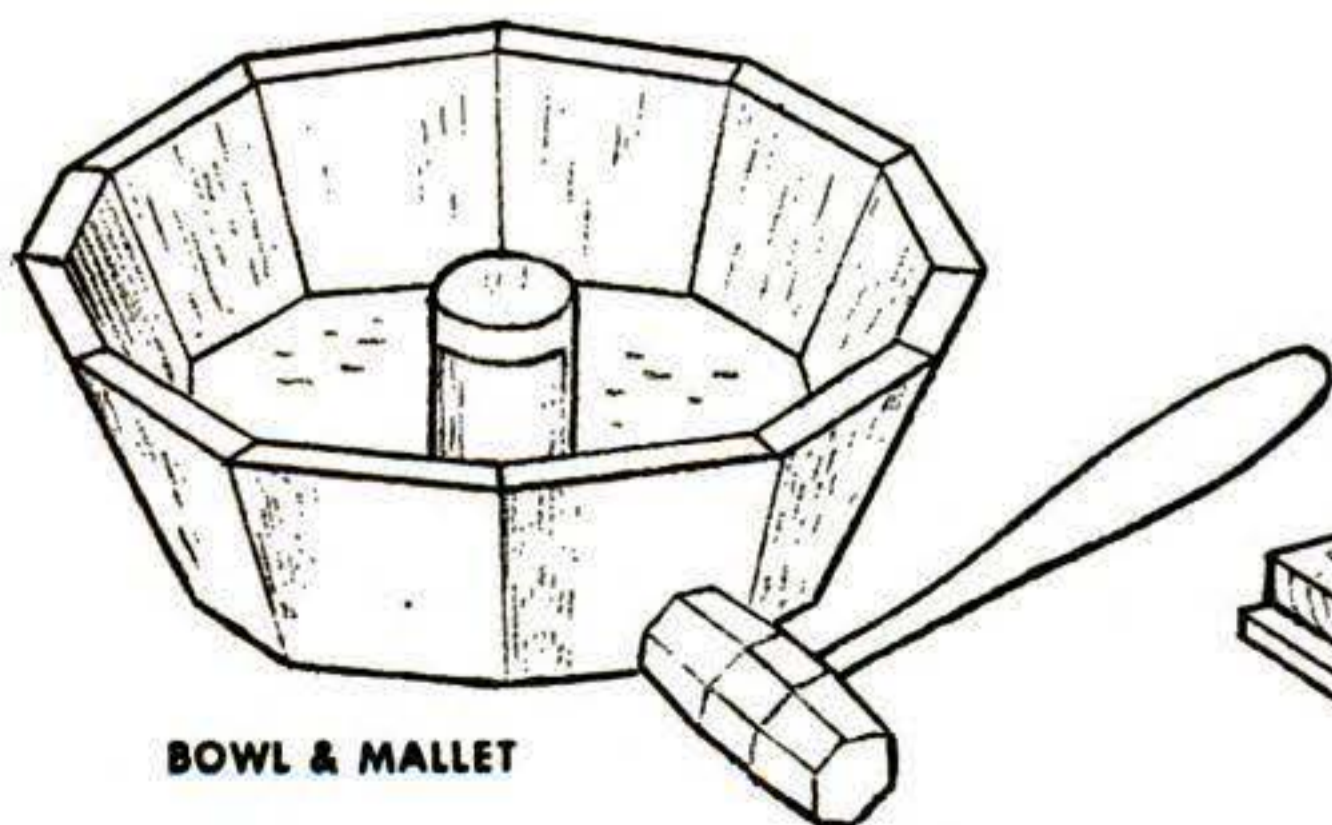

BOWL & MALLET

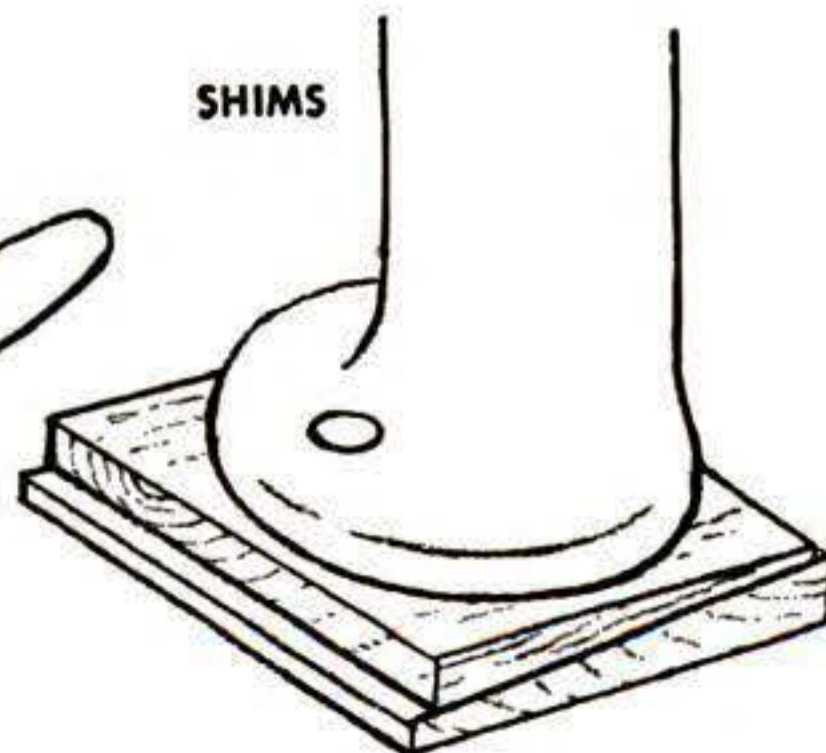

SHIMS

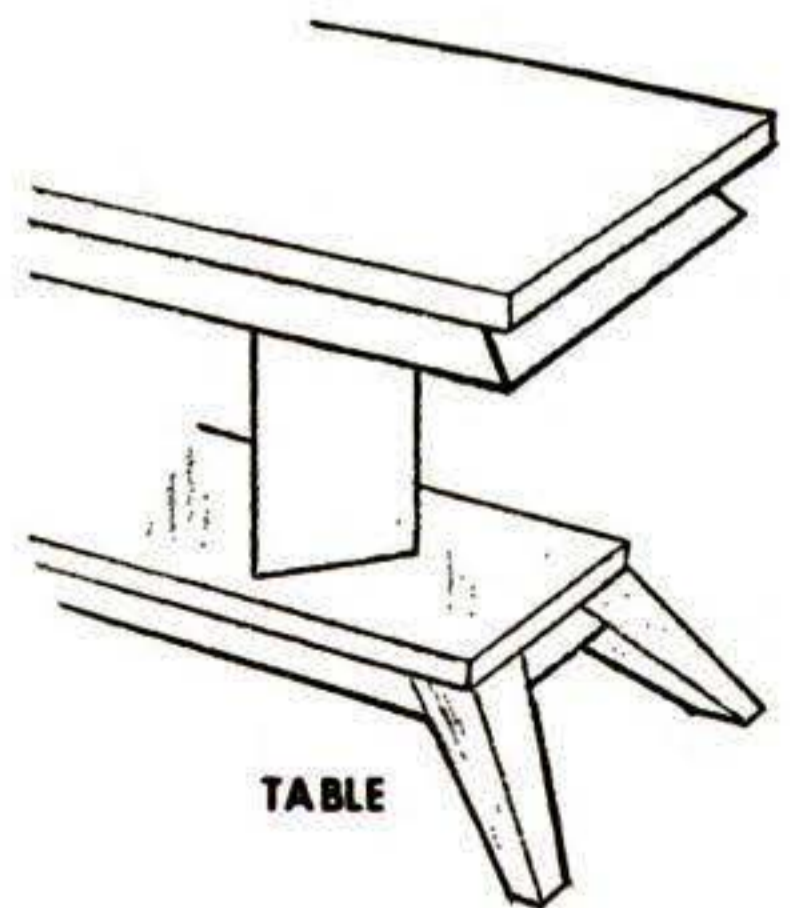

TABLE

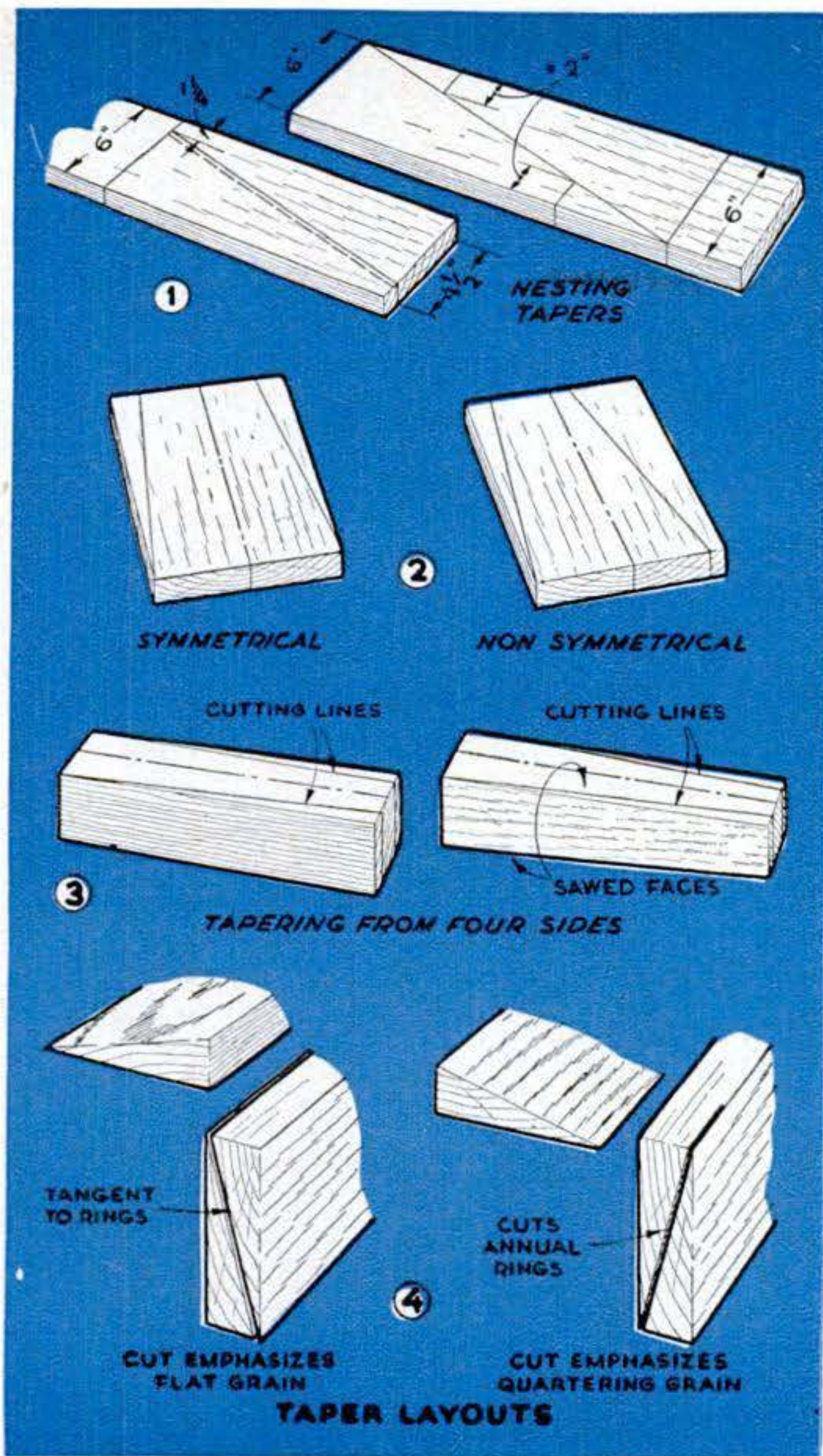

Saw tapers as you would any straight edge. Pencil center lines; cutting lines may be scored. When nesting tapers, allow for saw waste.

measure the given dimensions—say the width at top and bottom—and connect the lines with a straightedge.

Let's say you need a board of given length with one edge tapering from  $4\frac{1}{2}$ " at one end to  $1\frac{1}{4}$ " at the other. All you have to do is mark these dimensions and saw to the line, letting the angle fall where it may.

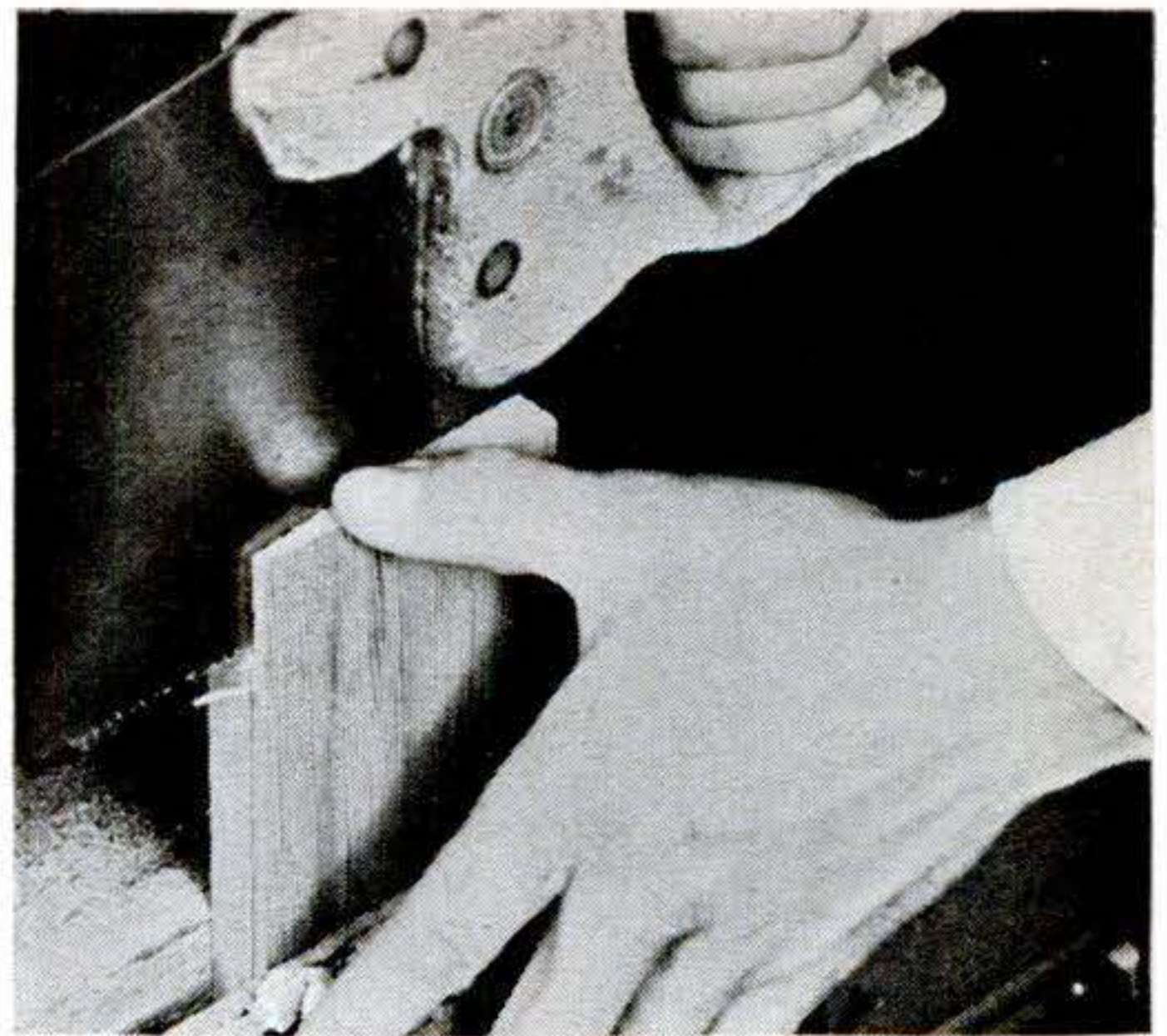

5. Rip short sections by holding the work in a vise. Saw half through; then cut from the other end. Support long pieces on sawhorses.

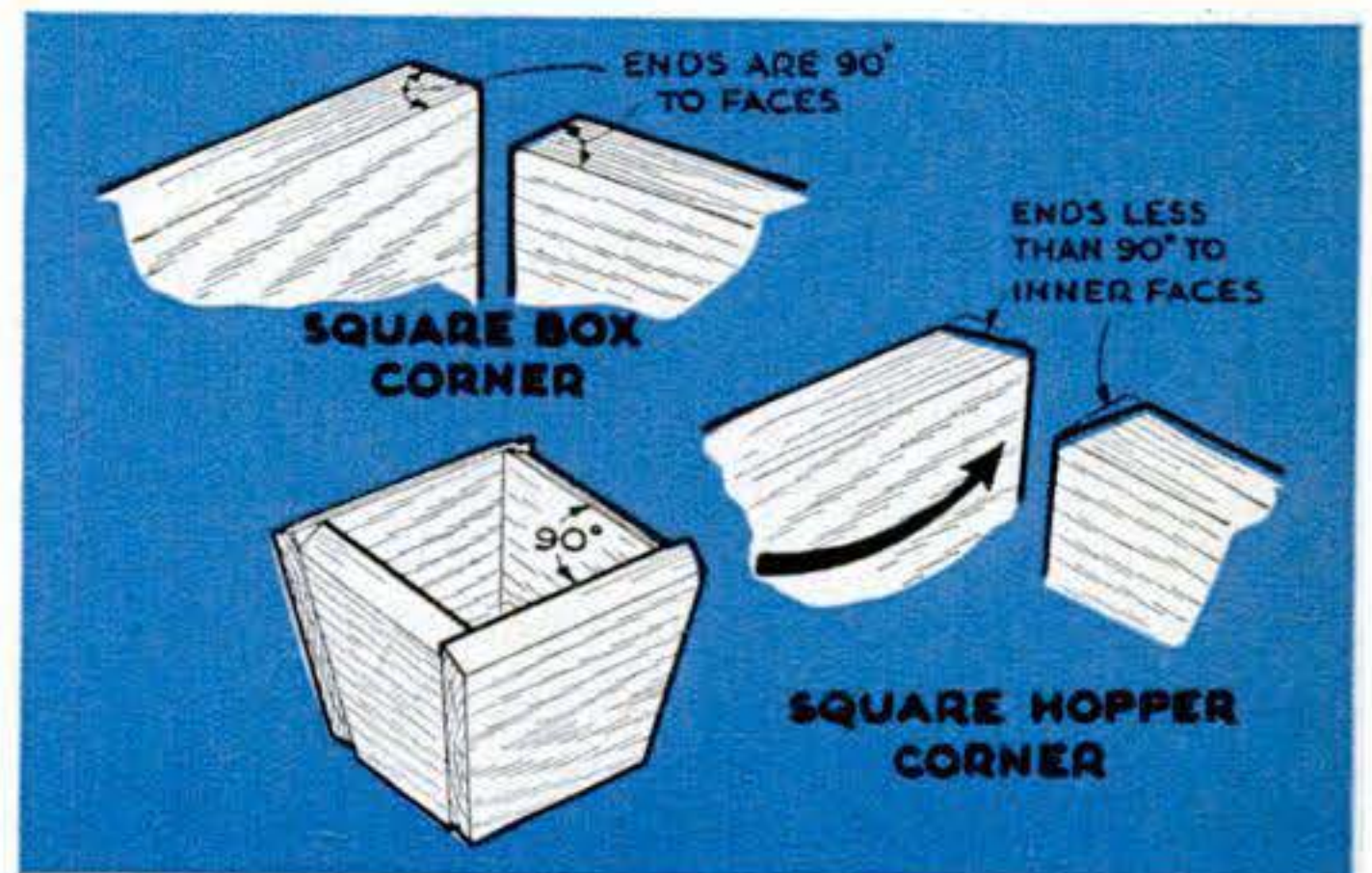

6. Ends are at right angles to the faces in square box. But to make hopper come out square ends must be at a less than  $90^\circ$  angle.

Often you'll need two such pieces, and you can save material by nesting them in a single board of sufficient width (Fig. 1). Remember that some stock is lost in sawing, so allow  $\frac{1}{8}$ " or more between the pieces. If the board isn't wide enough to make two such pieces in the same length (as would be the case if the measurements were upped to

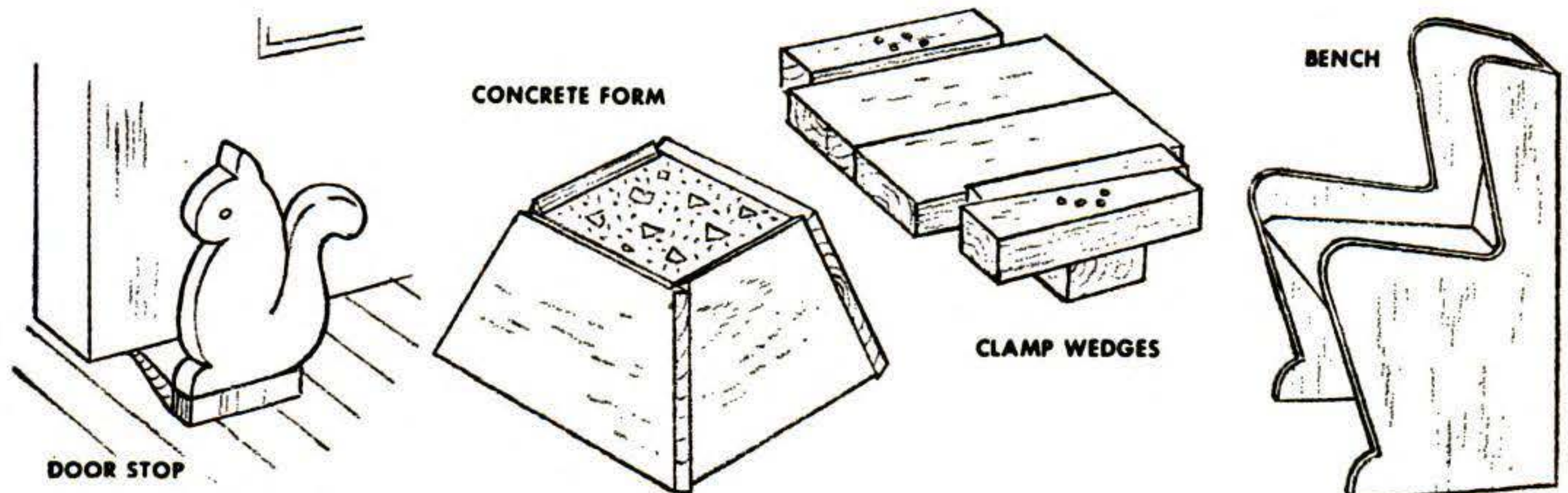

2" and 6") you can still save some stock by nesting them for part of the length. This is shown in the upper sketch of Fig. 1.

Bench ends and the like are often tapered about a vertical center line (Fig. 2), especially when hardwood chosen for its grain is used. To lay out such a piece, pencil a center line and measure to both sides. Incidentally, it's easier to erase a pencil line from wood than to sand it off.

To taper legs symmetrically from four sides, square the ends and draw the taper lines on opposite faces (Fig. 3). This will give you guide lines to follow and enable you to correct the saw by cutting alternately from one side and then the opposite. Begin ripping at the thick end of the waste where it is easy to start and there is enough support to establish the direction of the cut. As the waste strip gets thinner, hold it against the saw with the left hand. Smooth the sawed faces and draw cutting lines on them to guide you in sawing the remaining sides.

If the taper is slight, hold the work in a vise or against a bench stop and rough down with a jack plane. More taper can be negotiated with a draw knife. When a leg tapers only from two adjacent sides, half the work is called for but the layout is approximately the same as in Fig. 3. Draw the taper for one edge on opposite faces, and work to the line. Lay out the second taper on the finished side and the one opposite to it.

Section tapering, illustrated in Fig. 4, is accomplished by ripping a strip from opposite corners—or points near these corners. Give thought to the direction of the diagonal, for one way it emphasizes the flat grain while from the opposite corner it gives a quarter-sawed effect. Rip short pieces in a vise, as in Fig. 5.

Up to this point tapering is a cinch. But sloping sides appear also in that mathe-

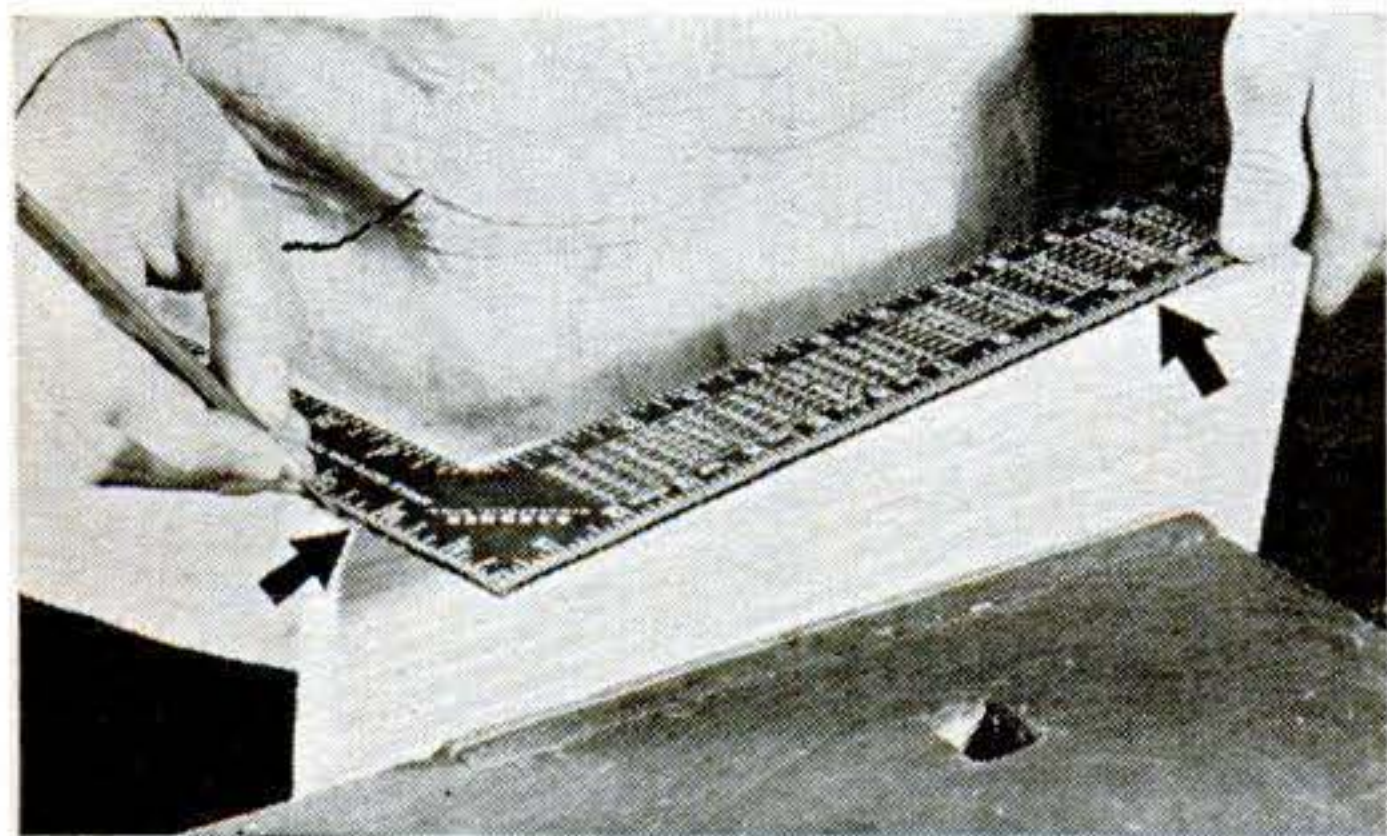

7. Measure column length on the blade of a square and slope on the tongue. A line drawn along the tongue gives the end angle.

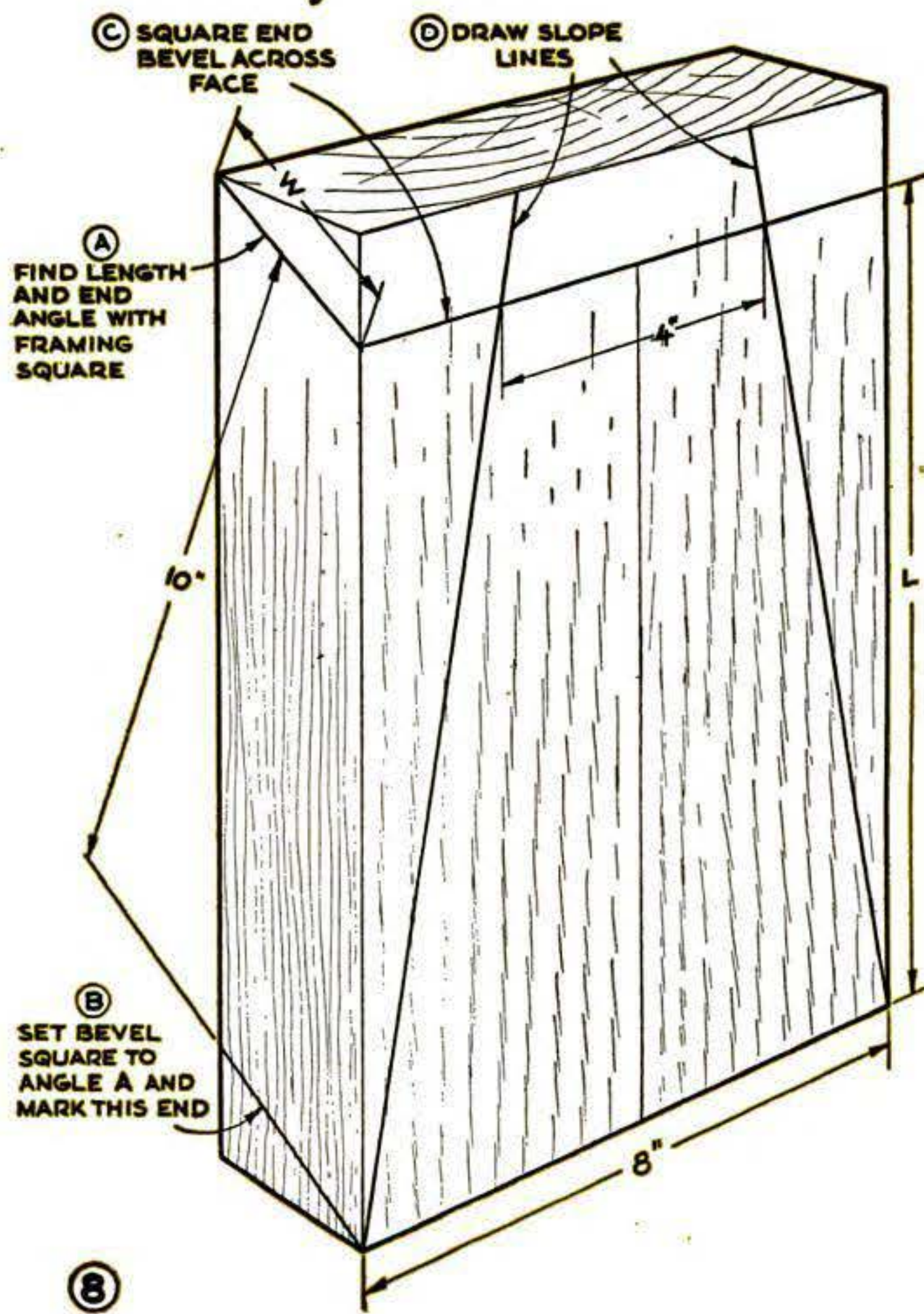

These are the first steps for practically any kind of hopper side. Bevel A is obtained as in Fig. 7; for B, set a bevel square to A.

matical headache, the hopper. Sometimes you see this construction as a flared bowl or flower-pot holder, sometimes as a tapered column or a form for a concrete pier. The chief difficulty with hoppers is that their angles are never quite what they seem to be. In Fig. 6 the butted corners of a hopper are compared to those of a square-sided box. In the box the butting ends are square with the faces of the stock and also with the top and bottom edges. In the hopper the ends are square with the edges, but since these are beveled, neither end nor edge is square with the face.

To locate cutting lines for the sides of a hopper or tapered column it is necessary to proceed systematically. Some information is usually given in advance. Or, if you are drawing up your own designs, you will pick dimensions to fit your requirements. Let's say you need a column 10" high having a slope of 2". The height is measured along a plumb line dropped perpendicular to the base. Since the sides lean off the vertical,

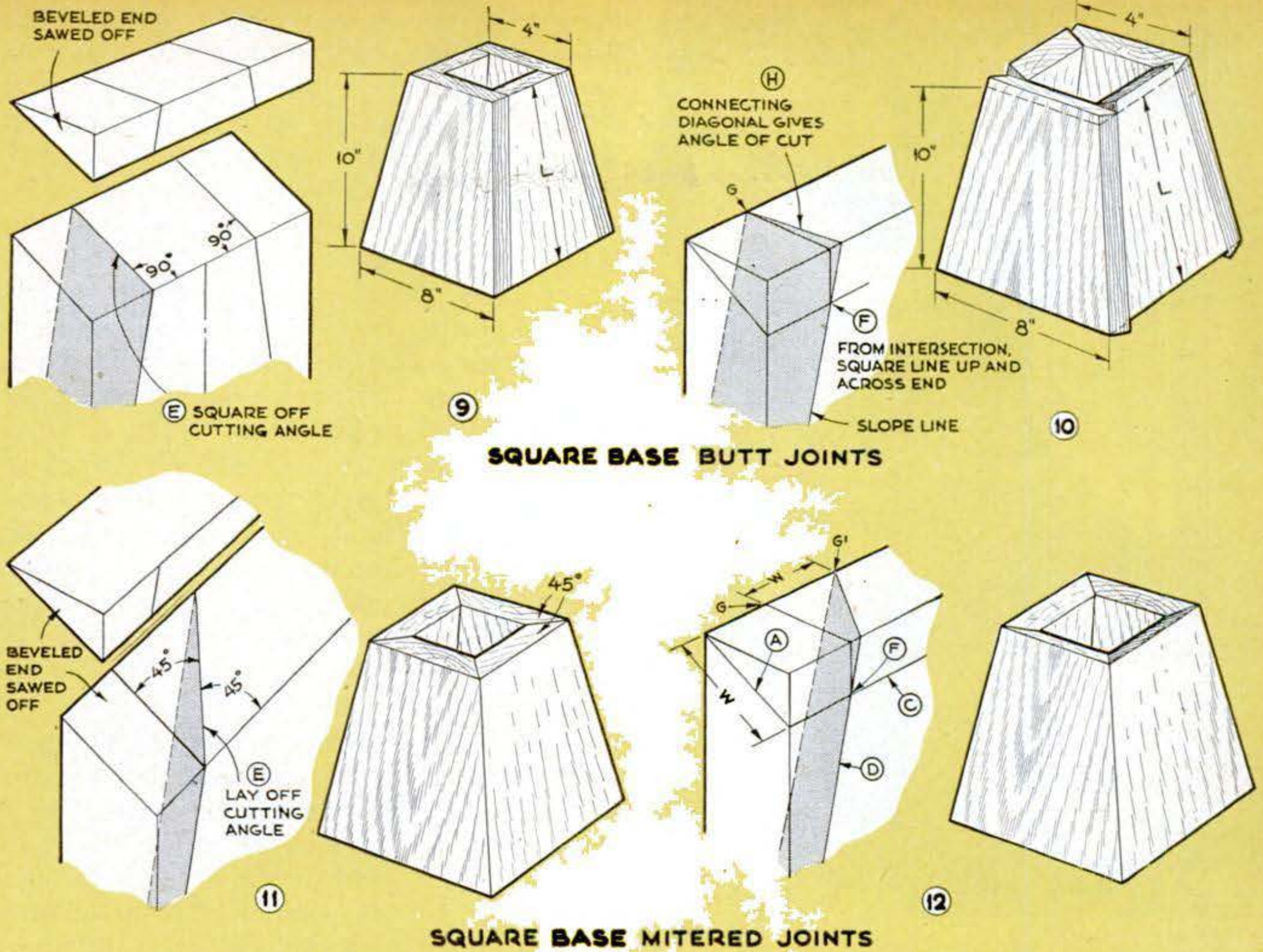

The edge angle for square-base hoppers may be found by any of these methods. On a beveled end, mark the angle with square or pro-

tractor as in Figs. 9 and 11. To mark the cutting line on a square end, follow Figs. 10 and 12. The first four steps are same as in Fig. 8.

they will actually have to be more than 10" long. Knowing the height and slope, you can determine the length by using a framing square as in Fig. 7. Lay the square on the edge of the piece with these figures coinciding with an arris. A pencil drawn along the tongue marks the angle of the end. Set an adjustable bevel square on this angle and use it to mark the same angle at the opposite end. These are indicated as steps A and B in Fig. 8.

From the point where the end-bevel line meets the face of the stock, square a line across the face (step C, Fig. 8). Draw a center line and measure each way from it to determine the slope of the sides (step D, Fig. 8). The slope here is given as 2" in 10". That is, each edge slopes 2", making the hopper 4" narrower at the top than at the bottom. Since the joints are butted, these dimensions apply only to the overlapping members; the inner pair must be narrower by twice the width of the end bevel, W.

Getting back to the out-of-square joints

shown in Fig. 6, if you saw off the ends on the bevel line, all you have to do is square across the bevel to get the cutting angle. This is shown in Fig. 9. When the sides are put together, the beveled ends will be horizontal. Therefore cuts that are 90° to the bevels will square up.

This is a fairly easy solution, but it won't hold in all cases. There are times when it

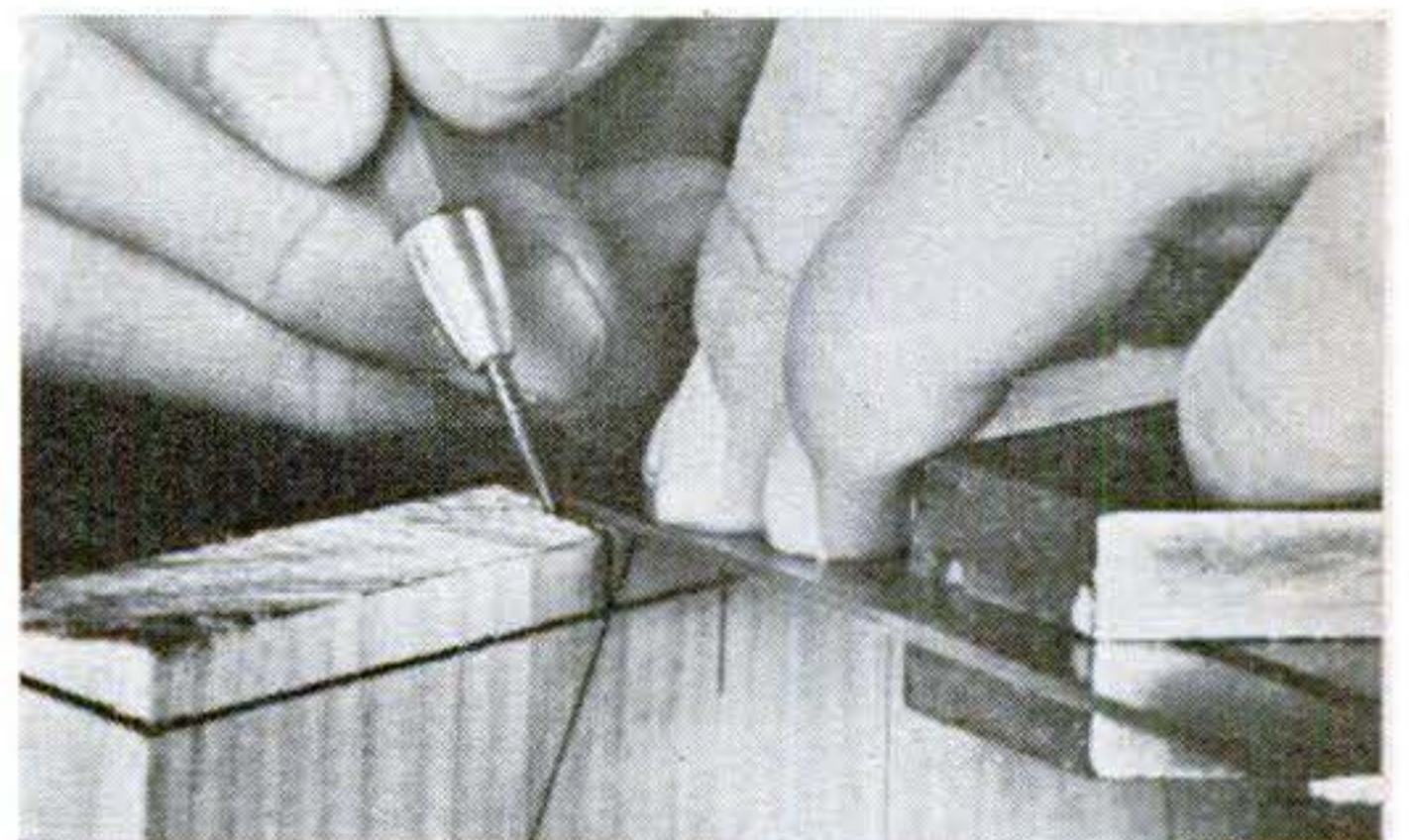

13. Lay a straightedge from the end of the slope line to point G or G' and mark the cutting line. Use a sharp point or knife blade.

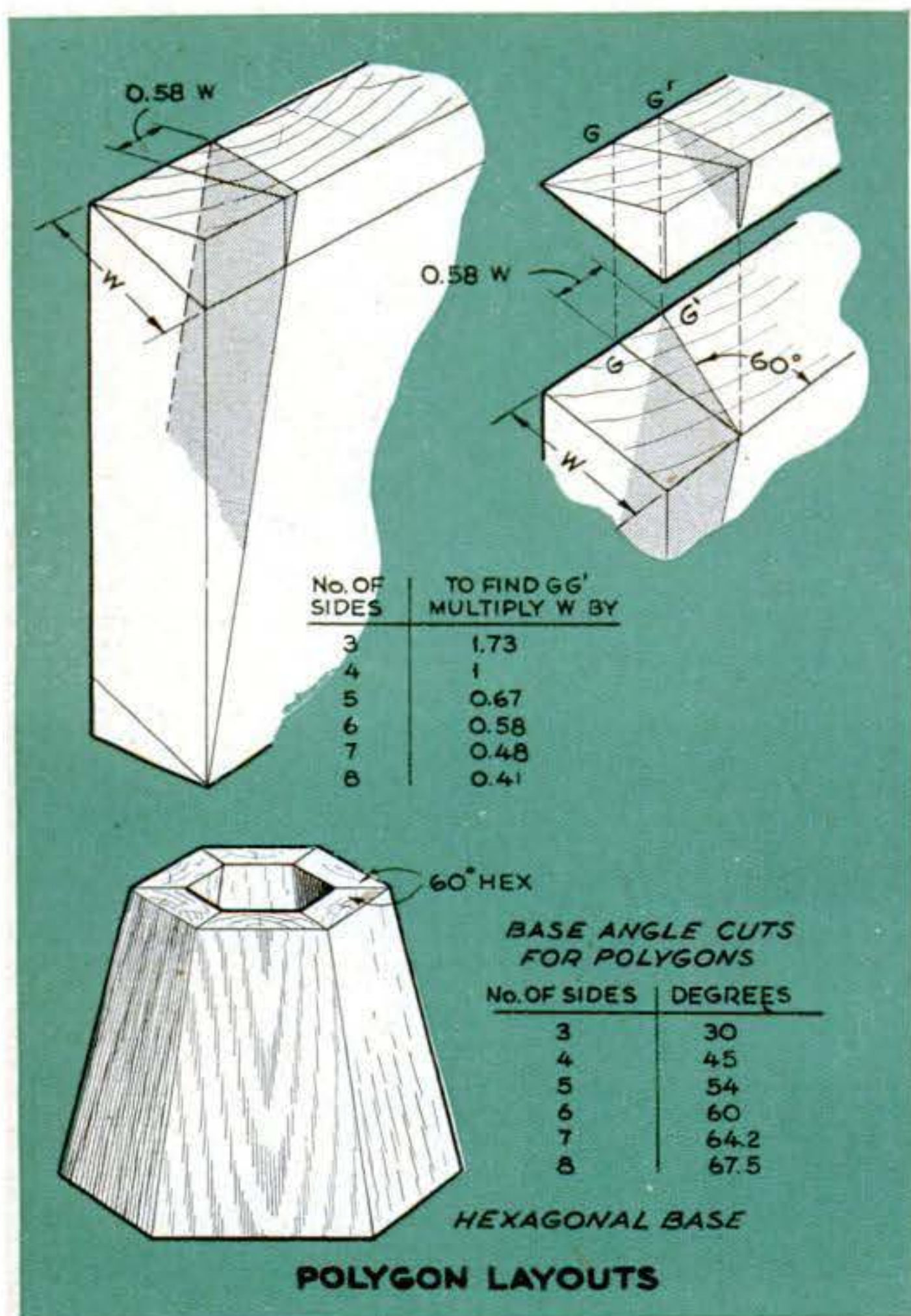

14. Layouts for polygons follow the same procedures as for squares except that the angle or distance G-G<sup>1</sup> varies with number of sides.

finding the cutting angle are shown in Figs. 9 and 10. For other applications it is only necessary to extend these methods or substitute the appropriate angle. Thus, Fig. 11 shows how to mark the side of a four-sided, square-base hopper using miter joints. As is usual with miter-joined structures, all four sides are the same width. Find the end bevel as in Fig. 8 and cut off the waste. Draw a cutting line on the beveled end 45° to the face. The only difference between a mitered and a butted edge is that the angle is 45° instead of 90°.

To find the angle without beveling first, proceed as in Fig. 12. Steps A to D again follow Fig. 8. Step F, is the same as in Fig. 10. Now measure the length of the bevel line, W, and lay off an equal distance from point G. This measurement gives you G<sup>1</sup>. Connect G<sup>1</sup> with the end of the slope line to get the cutting angle.

This is typical procedure for any polygon. Referring to Fig. 14, you can see that the layout of any hopper having from 3 to 8 sides is exactly the same as in Fig. 11 or 12 except for the base angle or the distance from G to G<sup>1</sup>. If you cut the bevel first, mark the edge angle 30°, 54°, 60°, or whatever is required for the given number of sides. Note that the angle is measured from the face. Mark the desired angle with a protractor and extend the diagonal to the opposite arris (G<sup>1</sup>).

Laying out the angle on square-end stock exactly follows the procedure described for four-sided miters except that the length of the line G-G<sup>1</sup> is determined by multiplying the bevel length, W, by the factor given in the upper table of Fig. 14. In a six-sided polygon, for example, the multiplier is .58. Thus, if W measures 1½", the length G-G<sup>1</sup> will be 1.5" multiplied by .58 or .870". The distance to lay off would be ⅞". It isn't exact (⅞" would be .875") but it's as close as a saw and pencil will come in any case.

After sawing the edge you'll usually have to true it up with plane and sandpaper. You can correct for slight irregularities in this smoothing operation.

Hoppers can be assembled with plain or reinforced joints, using slip tongues or dowels. Clamping is a little more difficult than with straight columns, but if the taper is so steep that the clamps fall off, they can be restrained with wires fastened to nails inside the column. A square tapered column is easily clamped by driving over it two or three square frames built to fit. END

is better to lay out the cutting line on the square end before sawing the bevel. The process then becomes slightly more complex.

Repeat steps A to D of Fig. 8. You will notice that the lines called for in steps C and D intersect. From the intersection, square a line straight up and across the end, as in step F, Fig. 10. For convenience, let's call the place where this squared line terminates point G. Connecting G with the end of the slope line gives the cutting line (step H, Fig. 10). Though it's arrived at differently, the angle is precisely the same as that obtained in Fig. 9. Set the bevel square on this angle and use it for marking the remaining edge or edges.

If you are still in doubt as to why a cutting angle drawn on a square end differs from that drawn on a bevel, study Figs. 9 and 10. Whereas the line drawn on the bevel is square with the face, the diagonal, H, swings to the right because the slope line moves toward the center as it extends from the intersection, F, to the end of the stock.

Though there are many variations in hopper joints—miters, polygons, and the like—the two basic approaches to the problem of



## NEW TOOLS

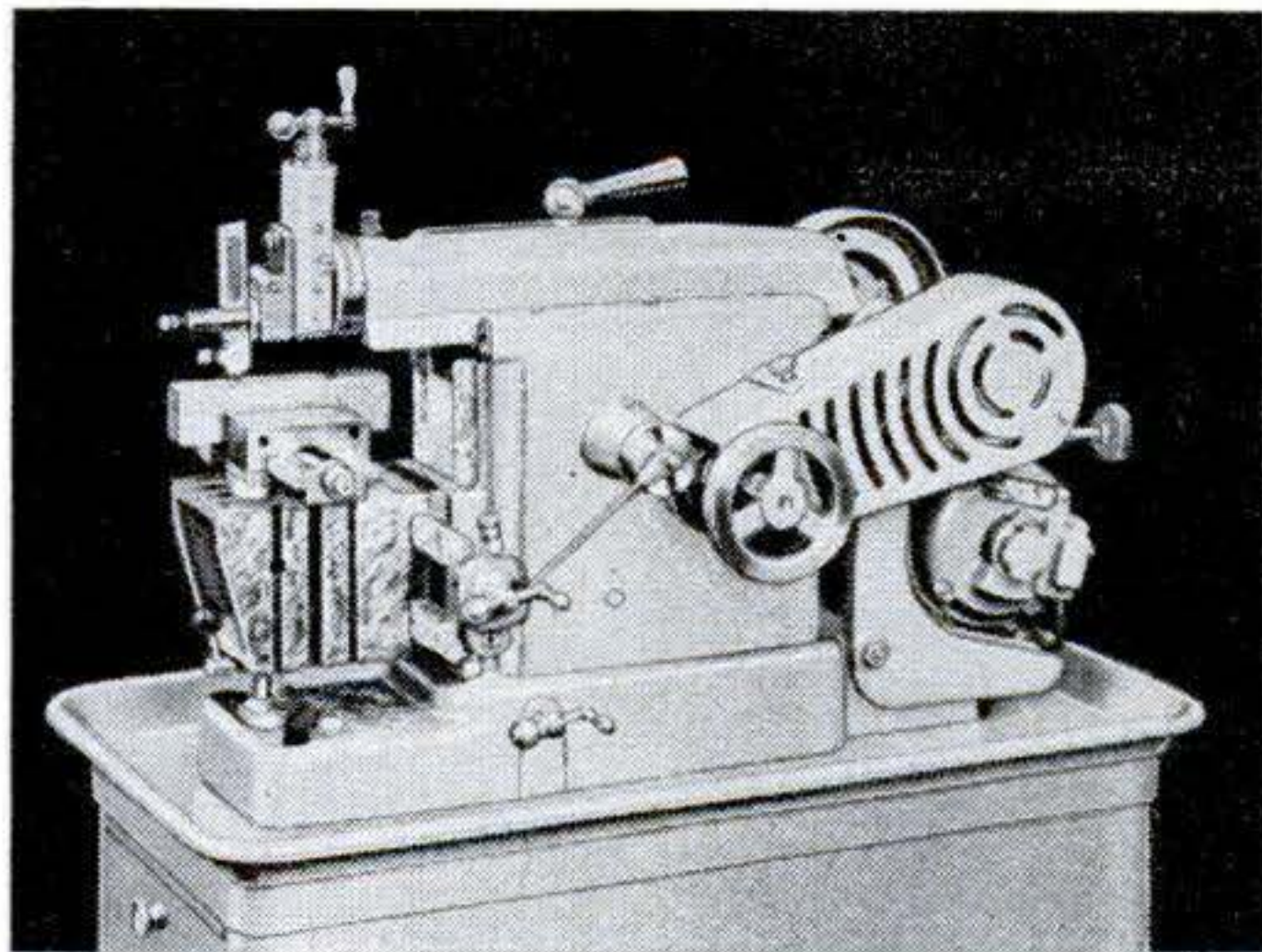

### **New Precision Bench Shaper.**

A 7" bench shaper is now being manufactured by the South Bend Lathe Works, South Bend, Ind. Table slides and the 18" ram are milled and hand-scraped for precision fit. Cutting speed is variable from 3' to 118' per minute. Stroke rates from 42 to 195 are available in four steps. The swiveling tool head has 3" feed. A 1/3-hp. motor drives the shaper.



### **Torch Burns Tank Gas.**

A new series of torches introduced by Weldit, Inc., Detroit, is designed to use atmospheric air and propane or acetylene, carried in small portable tanks. Shown in use above is a light torch with needle-valve adjustment. In the inset is a larger type that has Weldimatic® trigger control. When released, this cuts the flame to a pilot light. Pressed, the trigger again gives the original work flame.

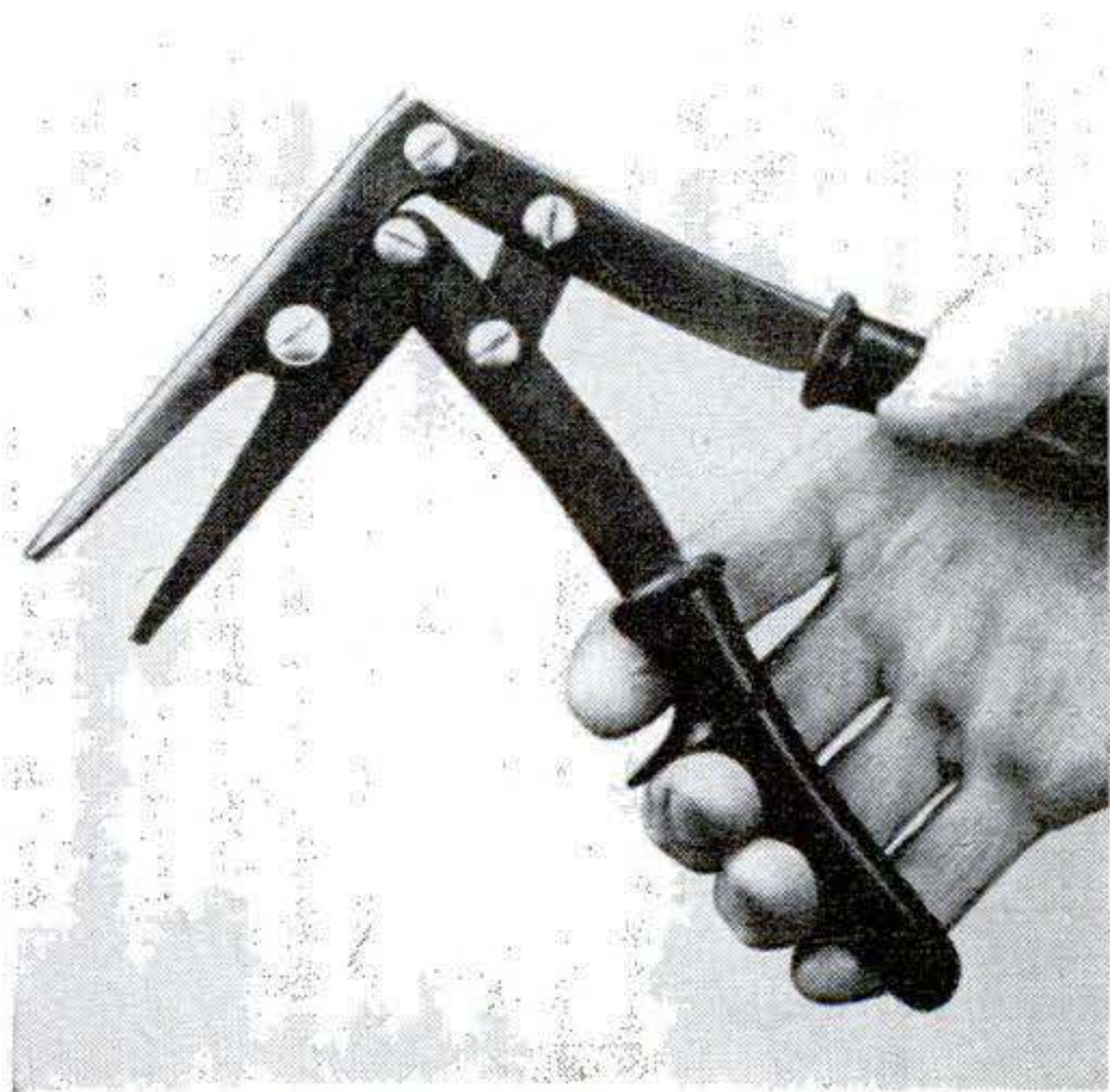

**Pliers Turn Corners.** Designed for work in tight and inaccessible places, these new pliers are quickly set to various angles to suit the job at hand. They are said to provide plenty of holding power at any angle. The jaws release automatically by spring action. Manufactured by Industrial Products Company, Philadelphia, the pliers are 10 3/4" long, weigh 8 1/2 oz., and sell for about \$3.25.

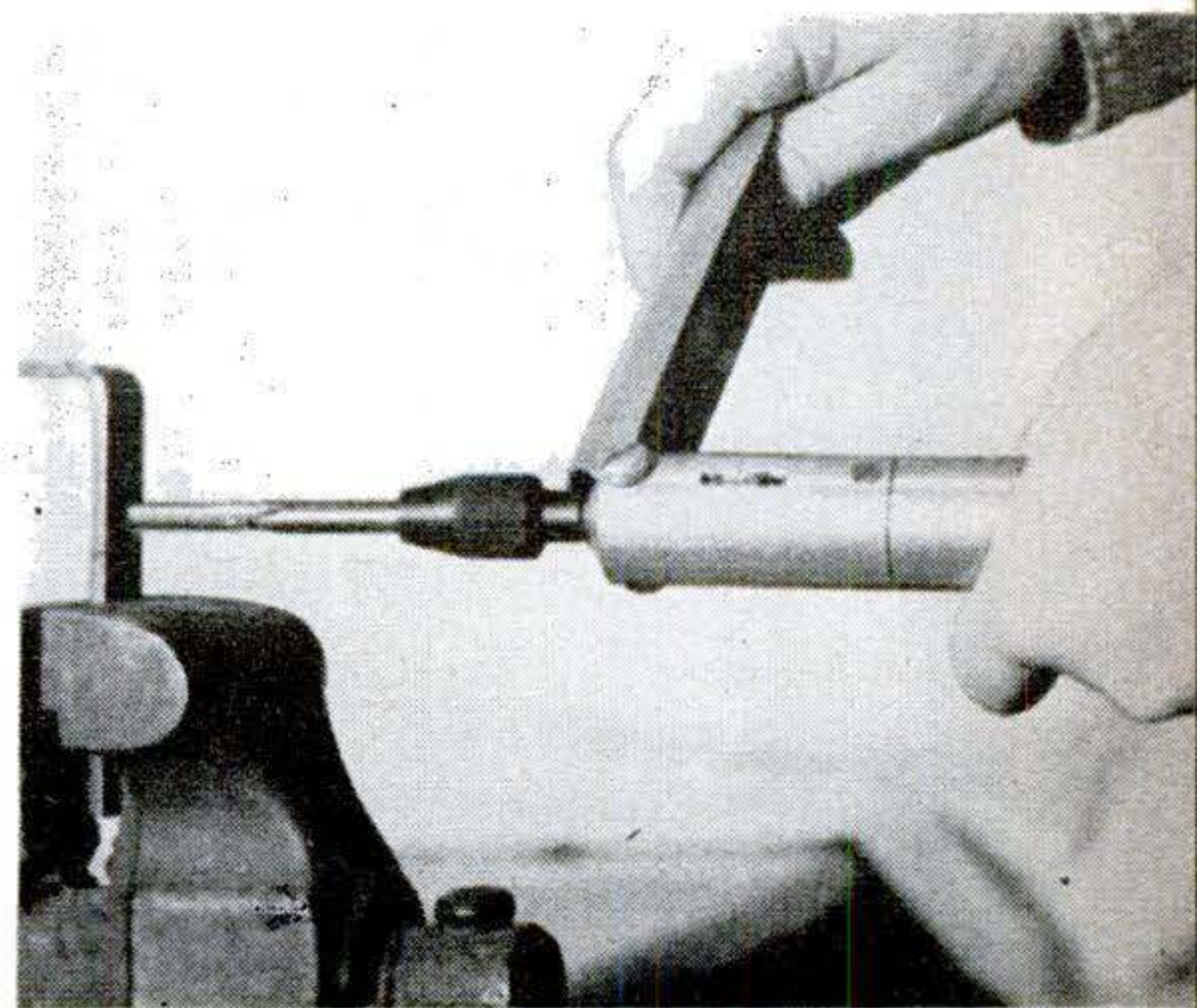

### **Tool Drives Screws and Taps.**

A folding lever on the Tooldriver® gives leverage for driving big screws and taps. A ratchet mechanism makes the action similar to a brace and bit when the lever is out. With the lever folded down, the tool becomes a ratchet screwdriver. The chuck takes taps up to 1/4". Westport Tool Co., Portland, Ore., prices it at \$3.75. Screwdriver bits of different size can be used.



## NEW SHOP IDEAS

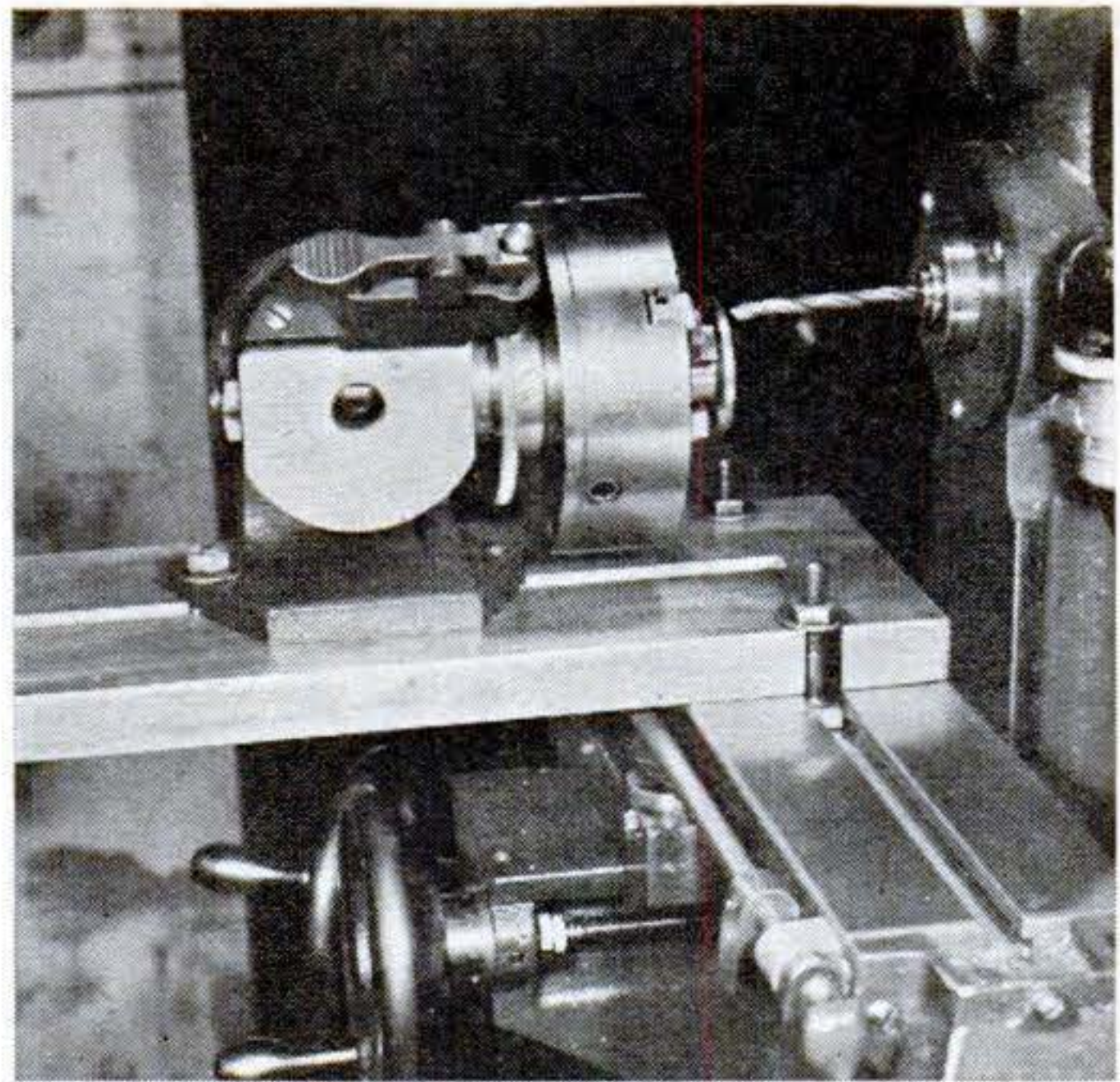
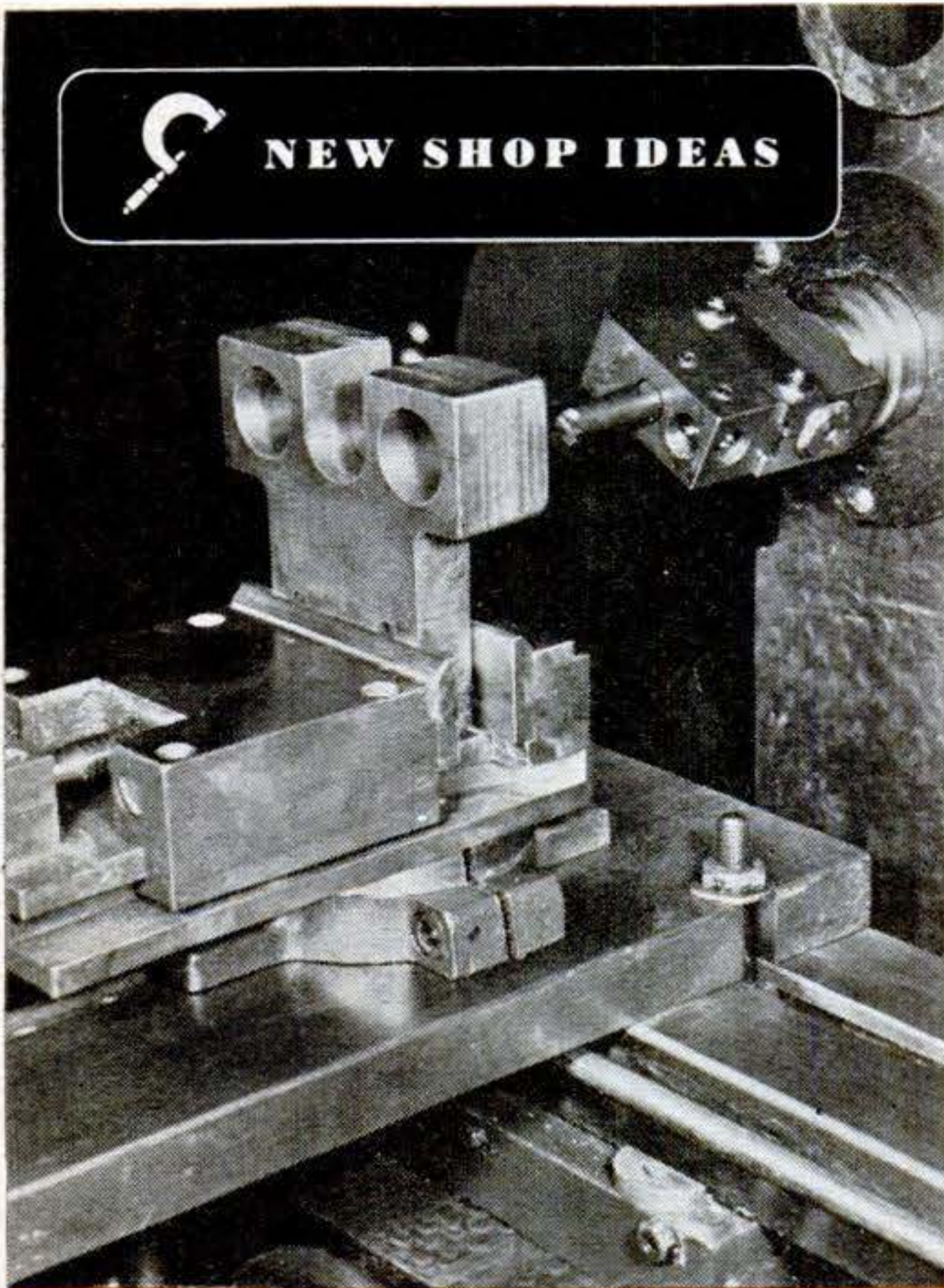

**Milling Capacity Increased.** The short transverse travel of small milling machines limits their usefulness. An adapter plate overcomes this difficulty by allowing the vise or work to be mounted at a greater distance from the spindle. This permits the use of boring heads and standard-length drills and reamers.

The plate can be made from aluminum alloy, brass, or steel, but cast iron probably is best. The plate dimensioned in the drawing is for milling machines that use  $\frac{1}{2}$ " square T-slot keys.

The plate opens up a big new field of possibilities. An index head usually is mounted with its axis perpendicular to the spindle, but with the plate you can mount it to face the spindle for such jobs as rotary milling or making simple drill jigs.—*J. C. Magee, Schenectady, N. Y.*

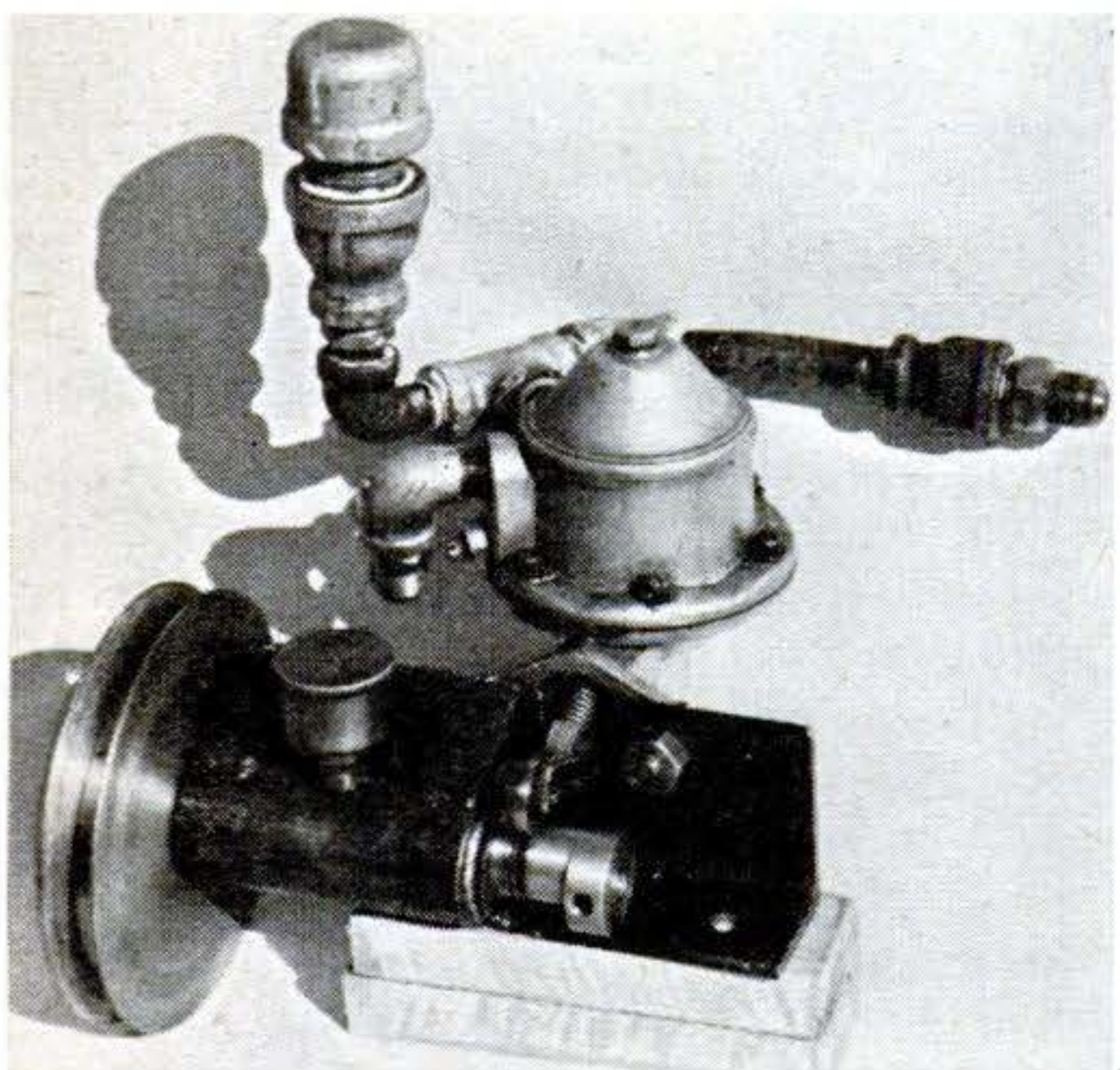
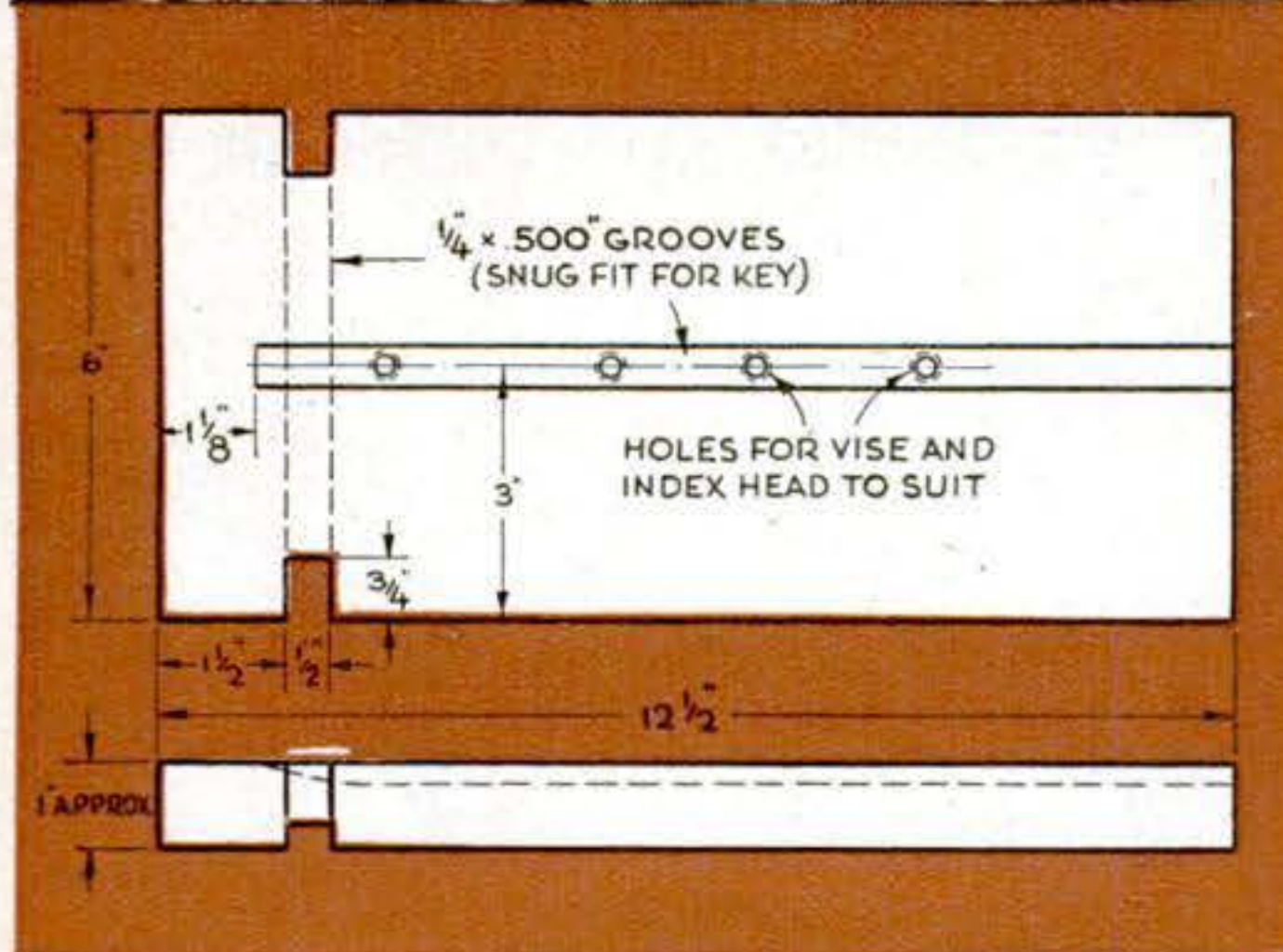

## Fuel Pump Circulates Coolant.

A Ford fuel pump can be adapted for use as a small coolant or circulating pump. As set up in the accompanying photo, the pump lifts liquid about 24" and delivers about two quarts a minute at 700 r.p.m.

The socket that receives the push rod was removed and a pair of side arms, enclosing a brass roller, riveted on in its place. An eccentric installed on the end of the pulley shaft provides movement of  $\frac{5}{32}$ ". A bearing was made by welding a piece of  $\frac{3}{4}$ " pipe to the edge of a piece of  $\frac{1}{8}$ " by  $1\frac{1}{2}$ " by  $1\frac{1}{2}$ " angle. The pipe was poured solid with babbitt metal and then bored on a lathe. The upright  $\frac{3}{4}$ " fittings act as an air chamber and help deliver an even flow.—*G. R. Enevoldsen, Lovell, Wyo.*



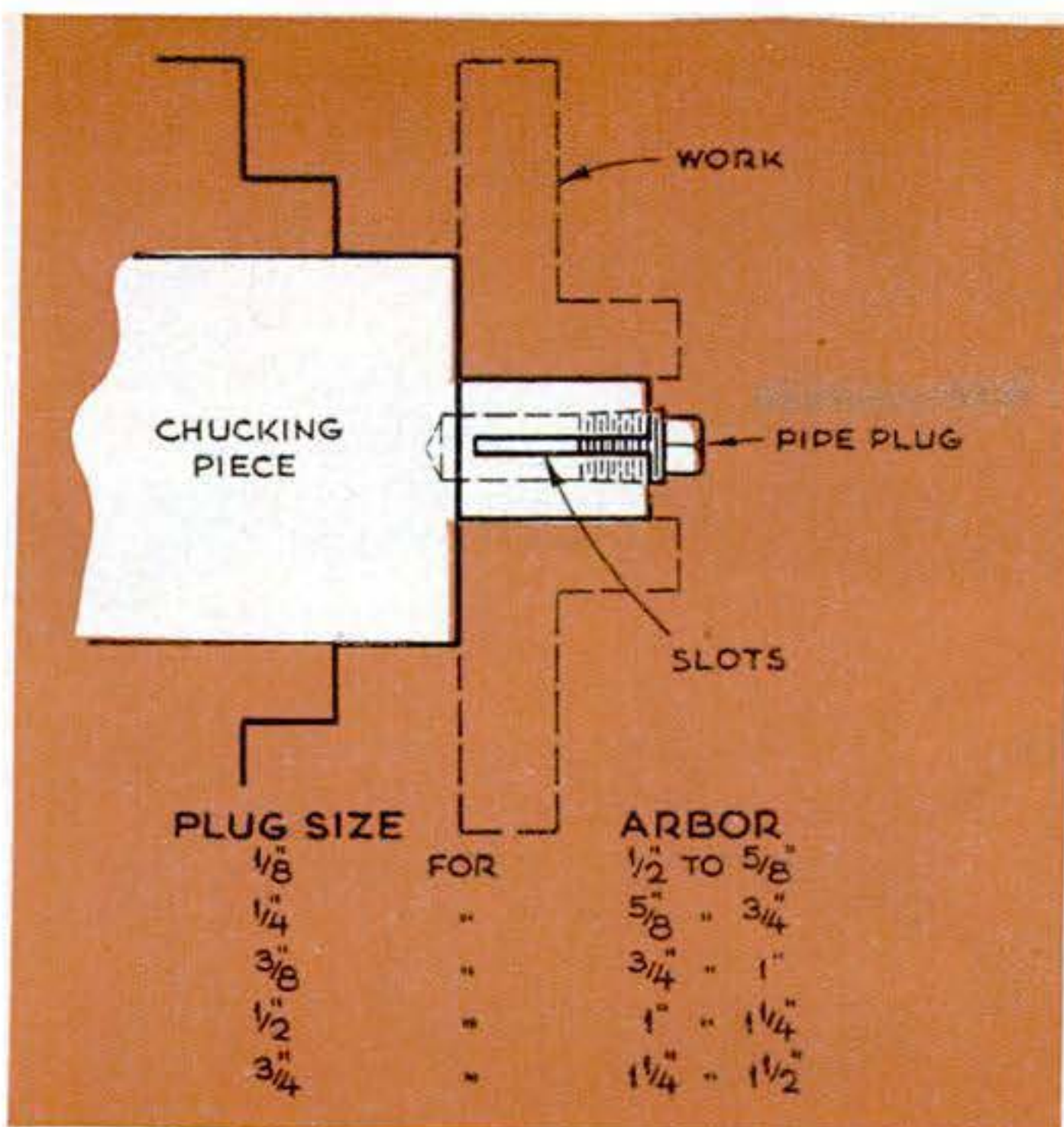

### Stub Arbor Uses Pipe Plug.

There are several ways of mounting a piece of work to turn it down concentric with an existing hole. The method above holds the work tightly but doesn't mar the bore.

Rough-turn the stub to about 1/32" greater than the desired diameter. Then drill and tap it for a suitable tapered pipe plug and mill or hacksaw a slot 1/16" wide across it. Rechuck the arbor, screw the pipe plug lightly in place, finish-turn to exact size to fit the bore, and face the locating shoulder. Tightening the plug expands the arbor, holding the work securely for either turning or facing.

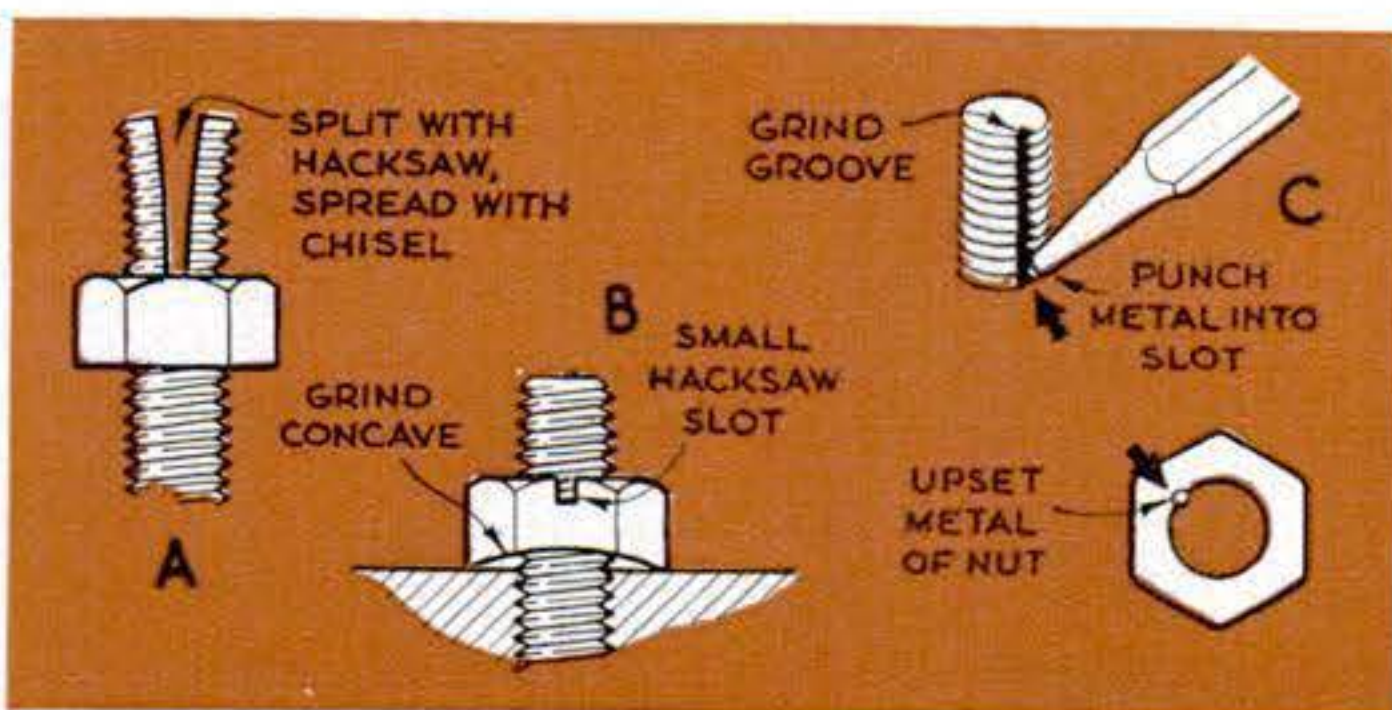

**Locking Studs or Nuts.** If lock washers aren't available or won't do for the job at hand, here are some other dodges. When a nut is used, you can resort to the solutions illustrated in A or B. To lock a stud in a metal block, grind a groove lengthwise, turn the stud into the block, and jam it by punching metal into the slot from the edge of the block, as in C. Alternatively, metal from a nut can also be upset to lock it on a stud.—George Burnley, Oakland, Calif.

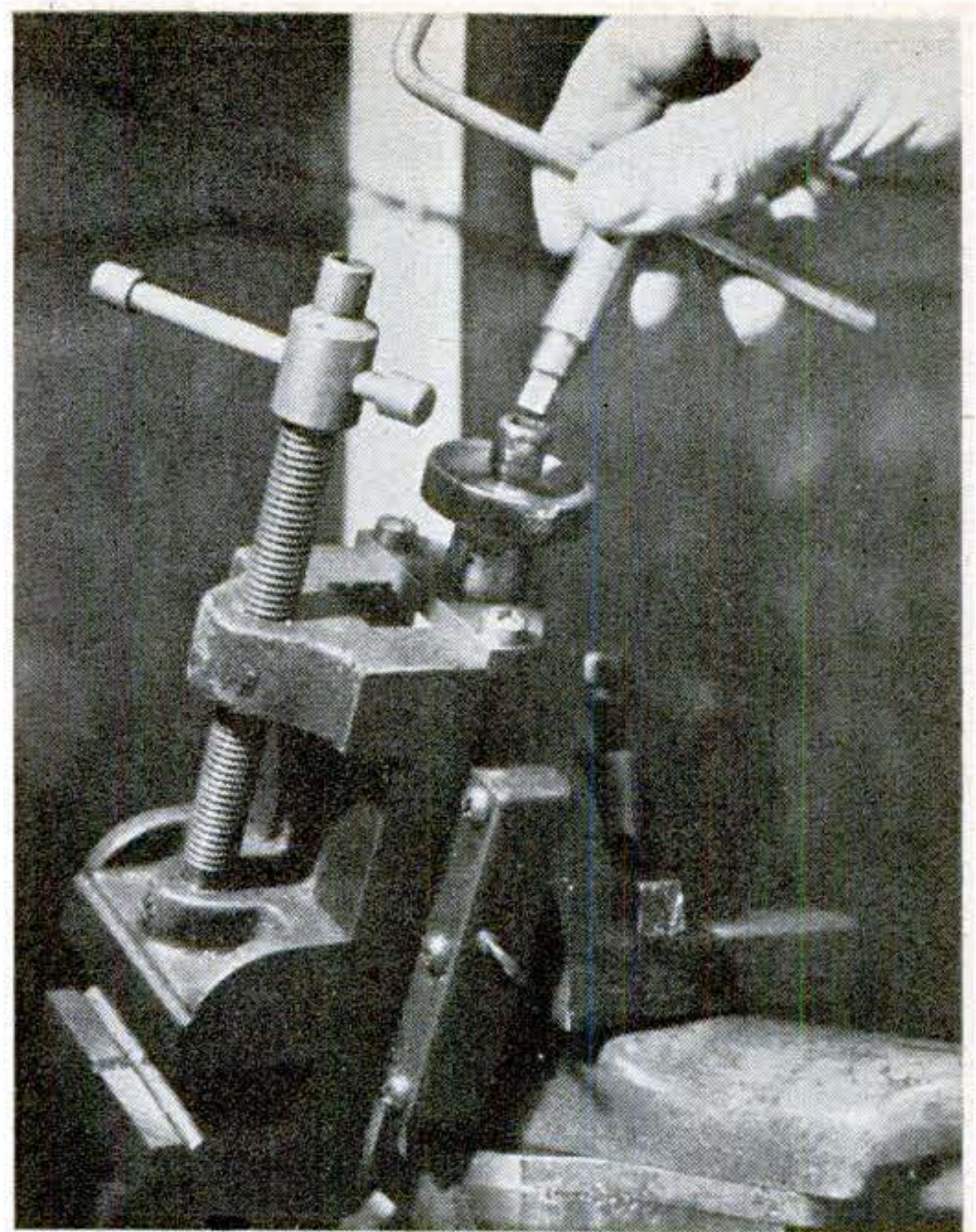

**Sockets Speed Adjustment.** Two 1/4" wrench sockets pressed or brazed on the vertical feed knob and vise screw of the milling attachment above provide quick adjustments and a more even feed.

The 3/16" size hex or 12-point sockets are well suited to the job. Adjustments are made by inserting a chuck wrench into the square holes. In my case the wrench is fitted with a hooked pin to give crank action. When the feed slide is near the upper limit of its travel, the chuck wrench may foul the vise screw. Then, instead of the chuck wrench, I use a standard 1/4" speed wrench.—H. Landauer, Tampa, Fla.

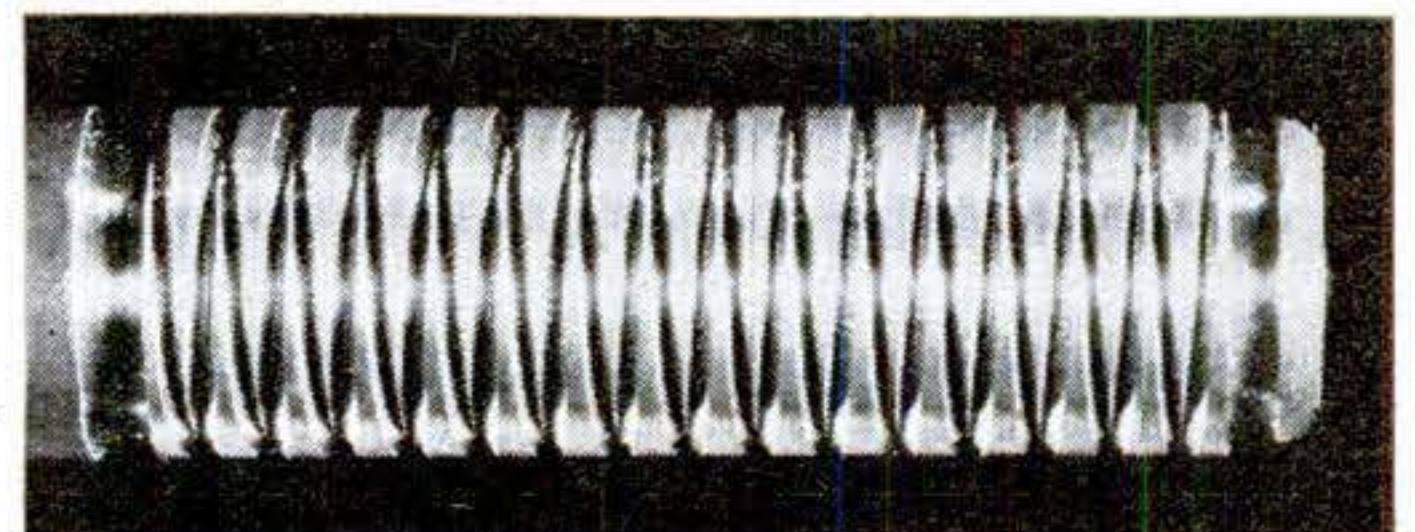

**Opposite Threads Make Knurl.** Lathe owners who lack a knurling tool can accomplish the same result by first cutting right-hand threads and then left-hand threads on the knob or other metal part where knurling is desired. The finer the thread, the finer the knurl, but eight threads per inch give a good pull grip. Multiple threads provide a better twist grip.—Fred F. Davis, Edmonton, Alberta.

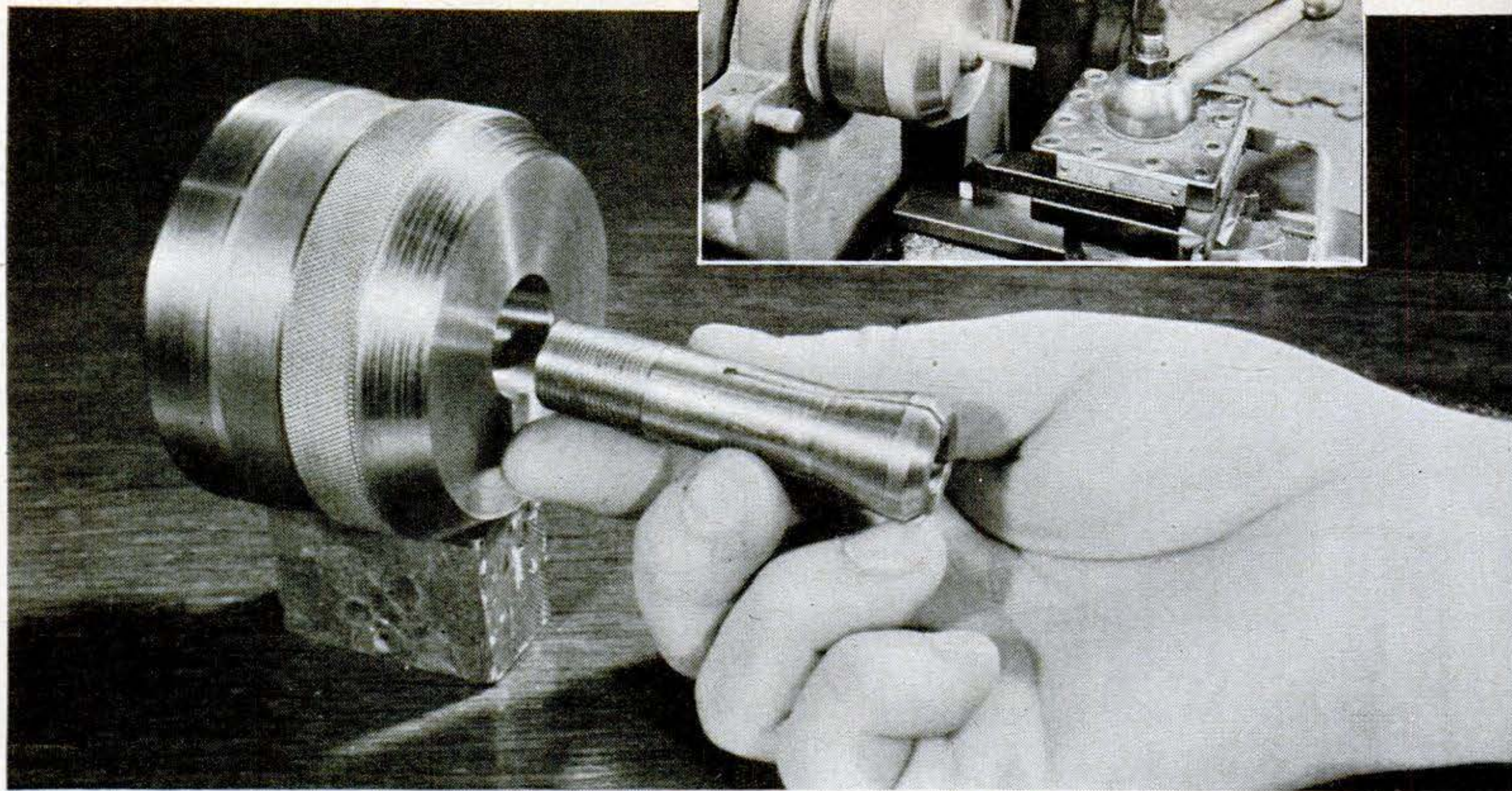

Husky and rigid, this spindle-nose chuck and its collets are capable of really precise work.

# Making Draw-In Collets

By Ken Murray

**E**XTREME accuracy, the principal merit of draw-in lathe collets, is sometimes lacking in ordinary collet sets that use a fairly thin sleeve for the spindle-nose chuck. This one is big enough to give great rigidity and strength, and is capable of high precision. In the dimensions given it fits a popular 10" lathe, but the simple design can readily be modified for others.

With the collet chuck shown, a standard draw-in spindle was used, being already at hand. If you don't have one, you can make it from a length of seamless steel tubing. One end is threaded internally to take the collets and a hand wheel is fitted to the other. Dimensions will depend on the lathe.

To make the nose, cut a piece of 3" cold-rolled round stock to approximate length, chuck in the three-jaw, and face off. Reverse in the chuck and face to length. Run a  $\frac{1}{2}$ " hole through the center and counter-bore to a depth and diameter suitable for threading to match your lathe spindle. After threading (in my case  $1\frac{1}{2}$ "-8), remove the work from the chuck and screw it on the spindle. Bore out the through hole to  $.652$ " with a  $12^\circ$  taper opening out to  $.840$ " at the face. Knock off the edge of the nose at  $45^\circ$  and knurl part of the nose barrel. Run a  $\frac{3}{8}$ " drill into the side to make a blind hole for a spanner wrench for unscrewing the nose.

Time can be saved if you make the collets in pairs, using  $\frac{7}{8}$ " by  $6\frac{1}{2}$ " drill rod mounted between centers. Turn the outside diameter to  $.850$ " and then turn a length of 2" from each end down to  $.650$ ". Thread each

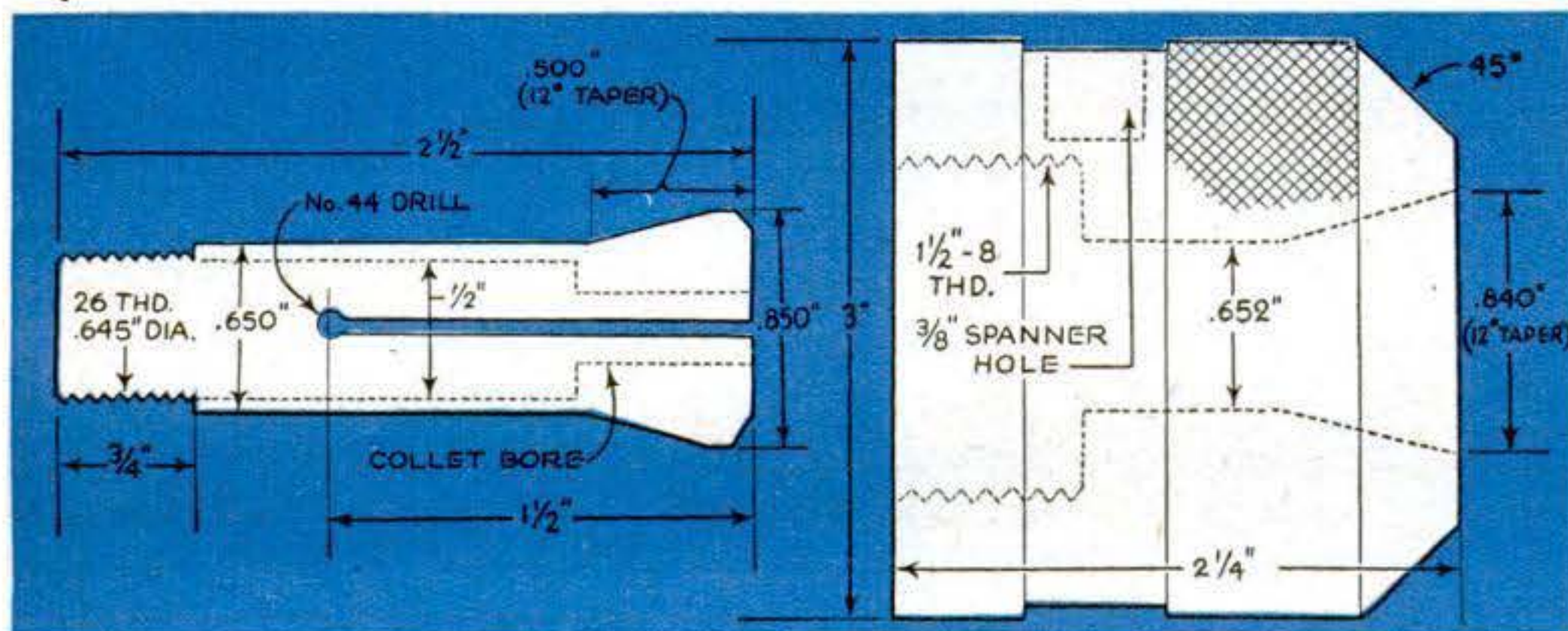

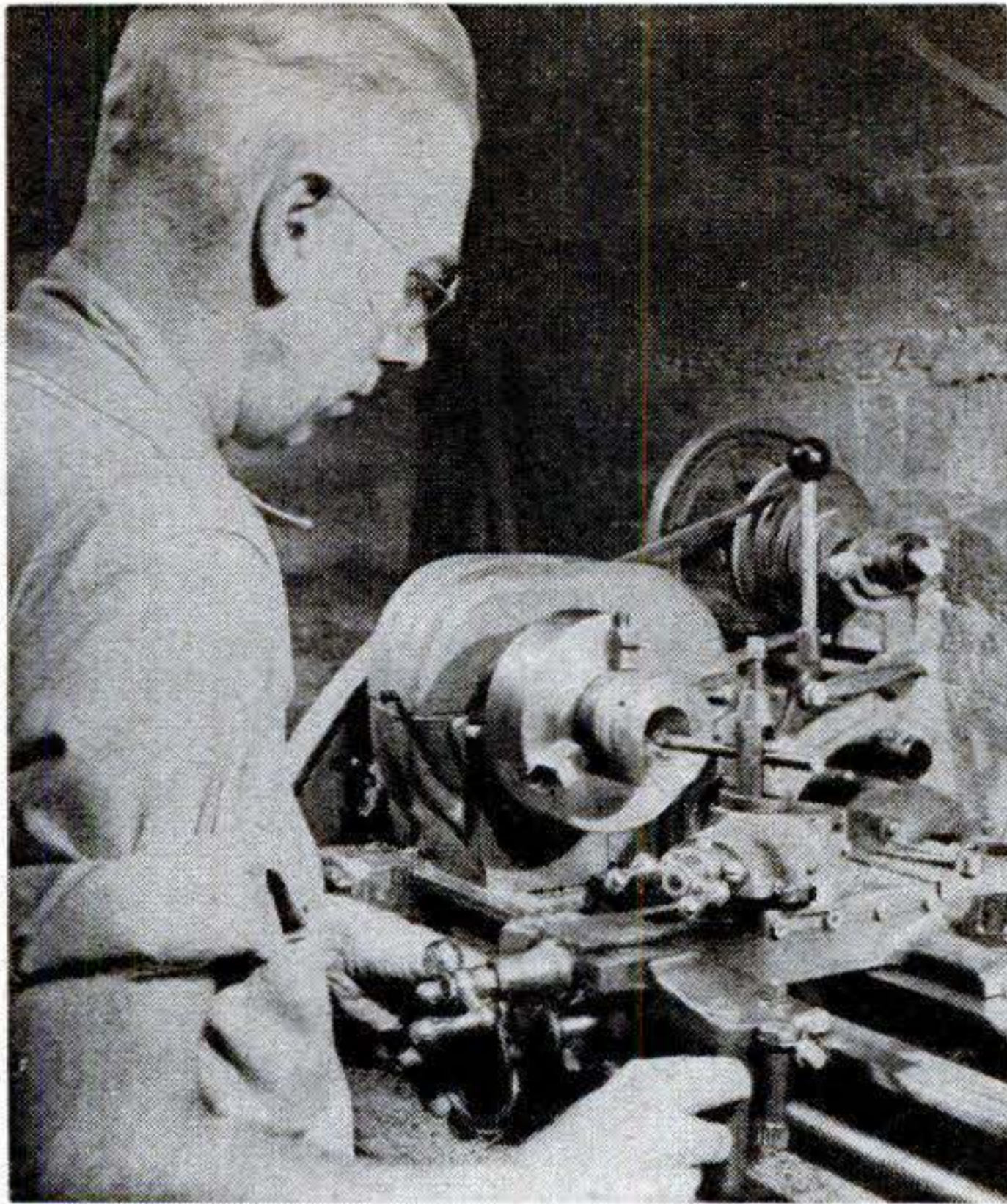

After the bar stock is faced on both ends, it is bored out and threaded to fit the headstock spindle. The threads should be cut carefully.

end for  $\frac{3}{4}$ " to suit the draw-in spindle—.645"-26 for standard ones. At the middle of the piece, take  $12^\circ$  taper cuts down to the .650" diameter, forming the collet heads. Remove the work from between centers, chuck near the middle, and separate the two blanks with a parting tool. Put the collet nose on the spindle and use it to hold the collets, one at a time, as you face and chamfer them.

The collet holes to receive the work—a full set might range from  $\frac{1}{2}$ " down to  $\frac{1}{32}$ " in 32nds—should be made with care. Use a drill  $\frac{1}{64}$ " under the desired finished

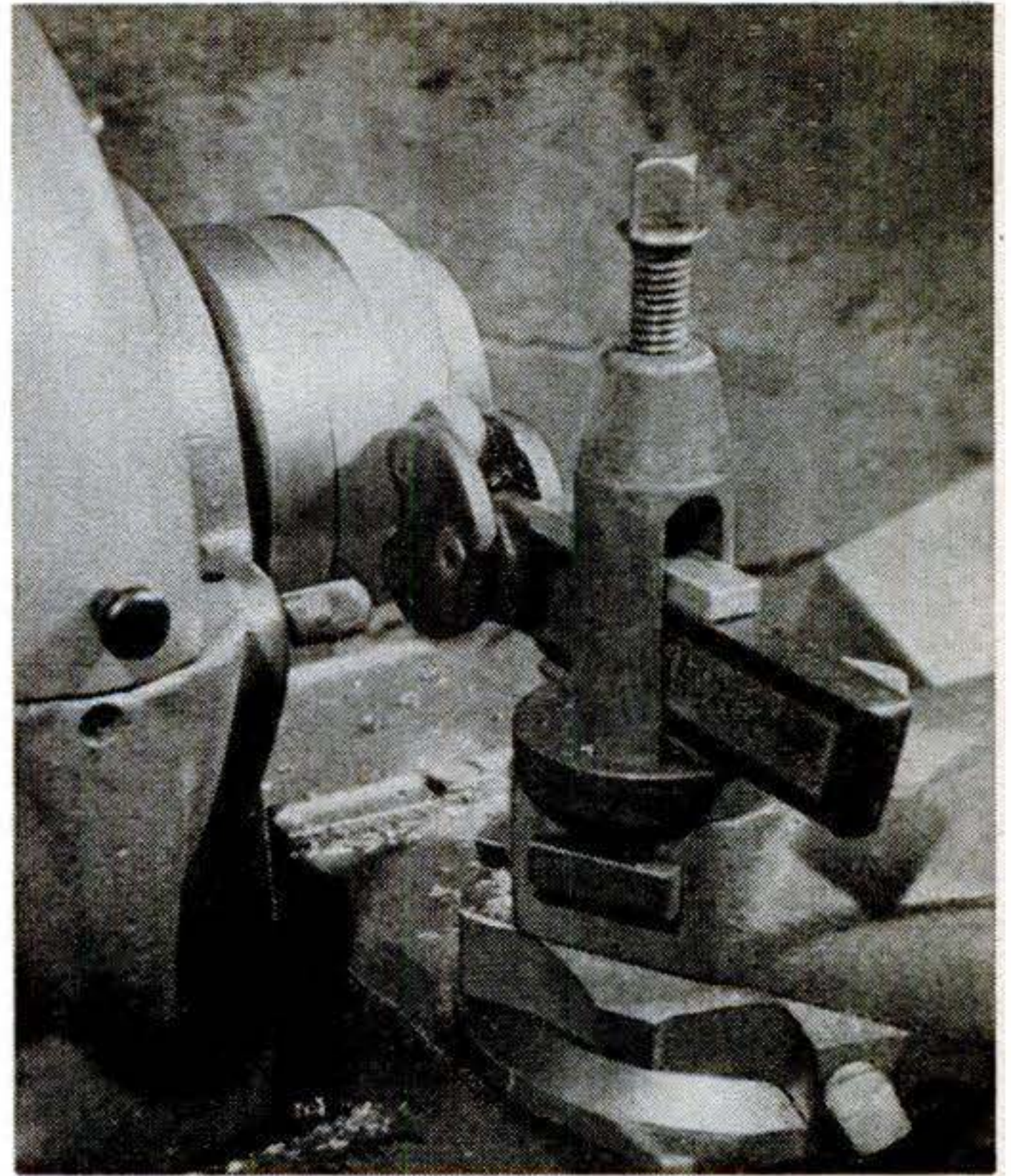

Medium diamond knurl is made with the collet chuck on the spindle. A transverse blind hole for a spanner goes in relieved center section.

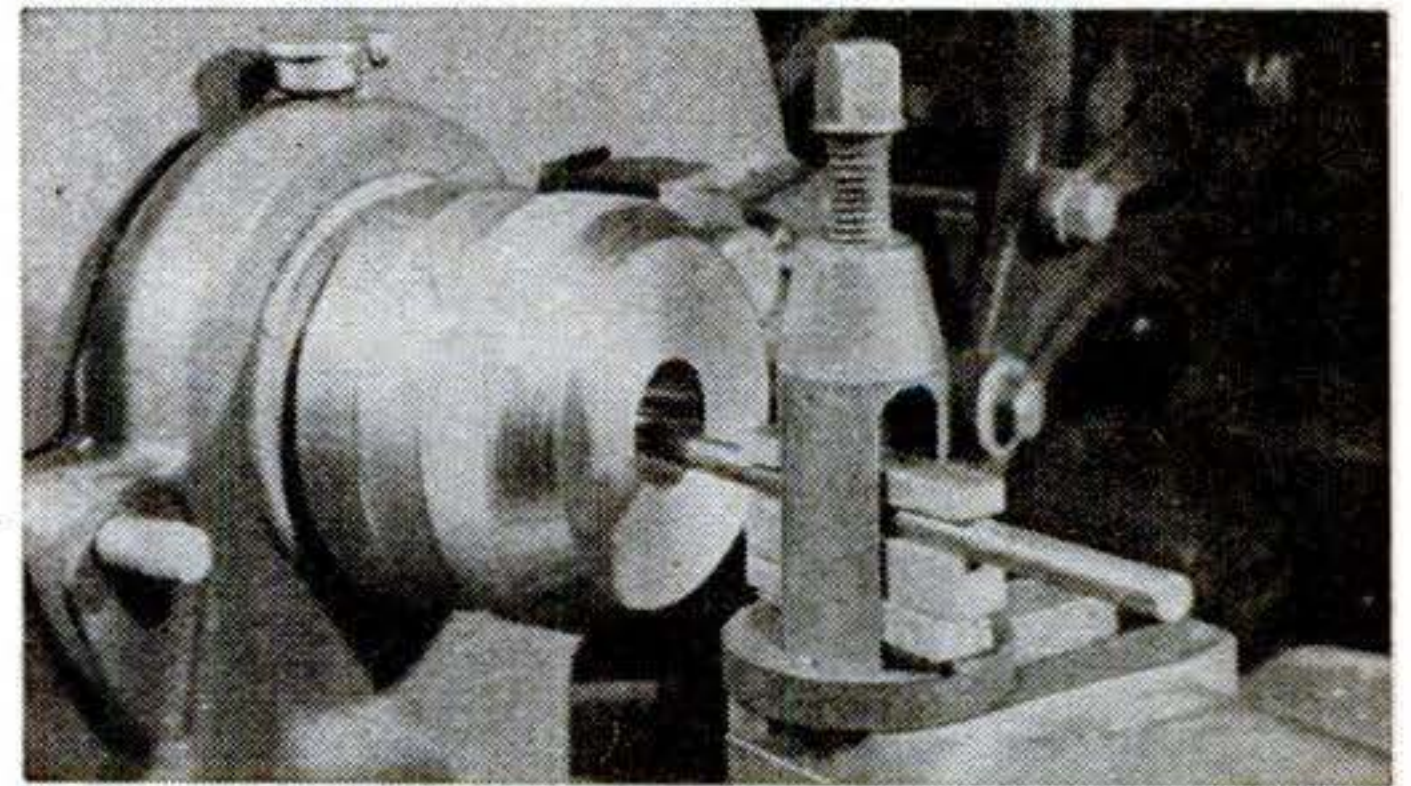

The taper in the collet chuck is made with the compound set over  $12^\circ$ . For best finish, use a newly honed round-nose tool and very fine feed.

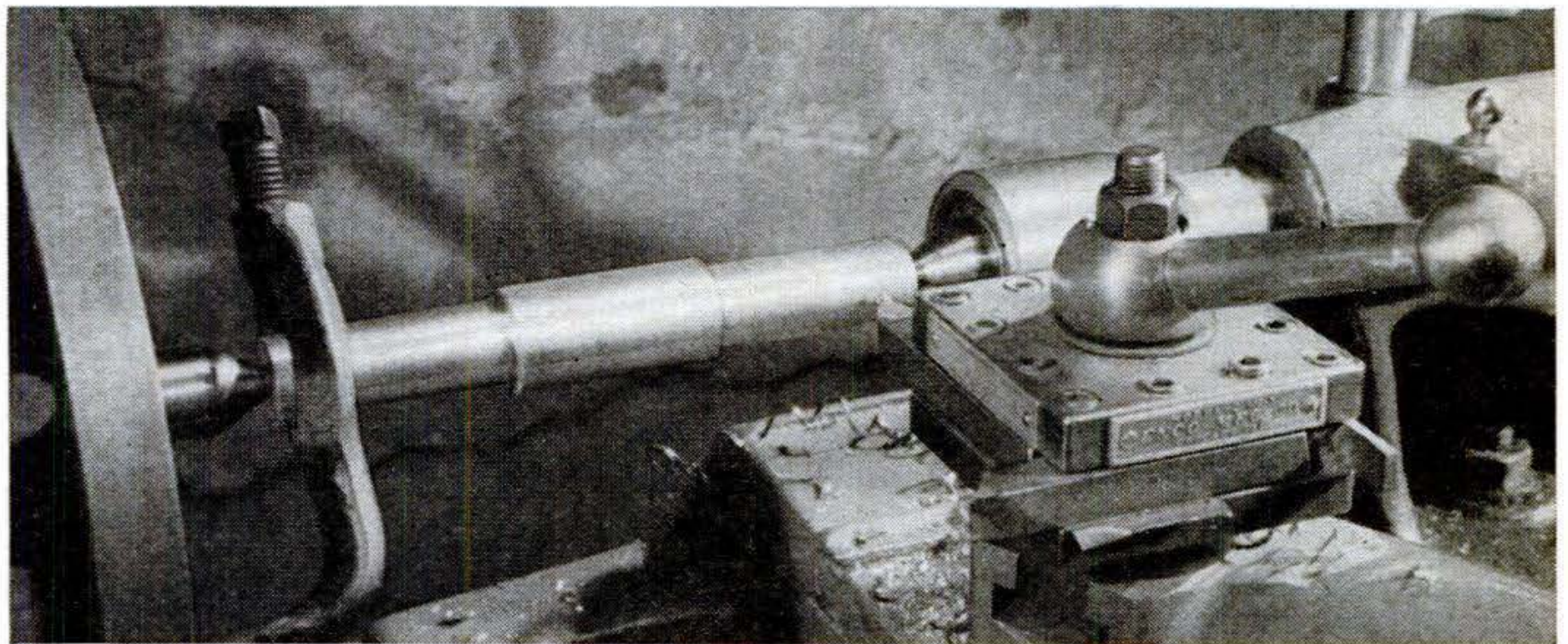

Collets are turned in pairs, nose to nose. The blank is chucked to cut them apart. A finished

collet should never be used to hold stock that's more than .005" over or under its nominal size.

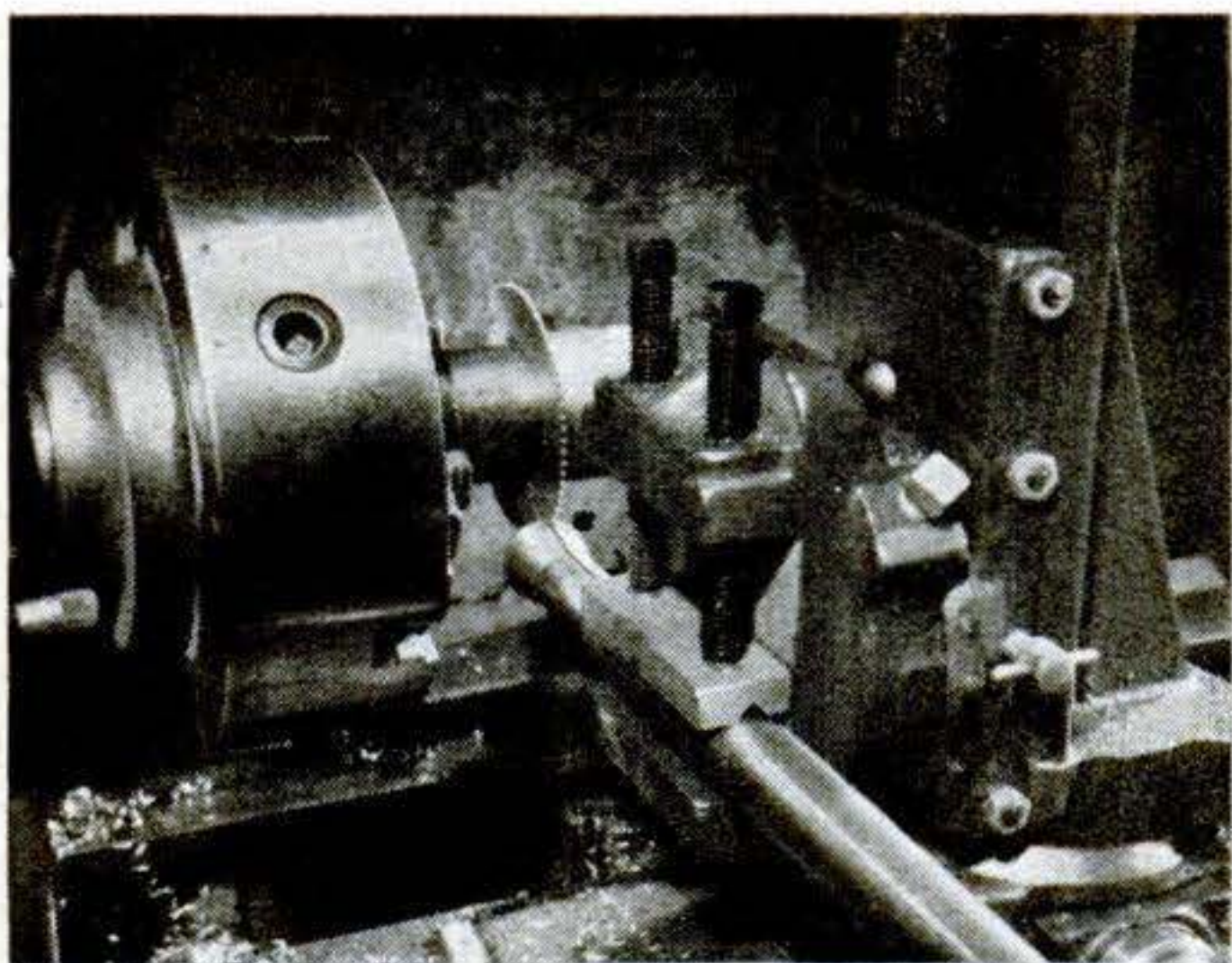

**Setup for slotting.** Here saw is reversed and lathe run backward to avoid inside burr. With work over saw, a conventional setup would do.

size and then a drill of the exact size. Chuck them in the tailstock and run in the drills to a depth of about  $\frac{3}{4}$ ". When all collets have been drilled, put on the three-jaw and chuck each collet backward, with the threaded end toward the tailstock. Then feed in a  $\frac{1}{2}$ " drill to the base of the head, leaving a collet bore about  $\frac{3}{8}$ " long.

Use a milling attachment, if you have one, to make the three slots  $120^\circ$  apart. (Lacking it, you can devise some clamping arrangement on the carriage.) Use the draw-in spindle to protect the collet threads from the milling vise, and mount a .040" slitting saw. If you set up the cut under the saw, reverse the tooth direction and lathe rotation to avoid an inside burr. END

## Small Drills Chucked with Cored Wire Solder

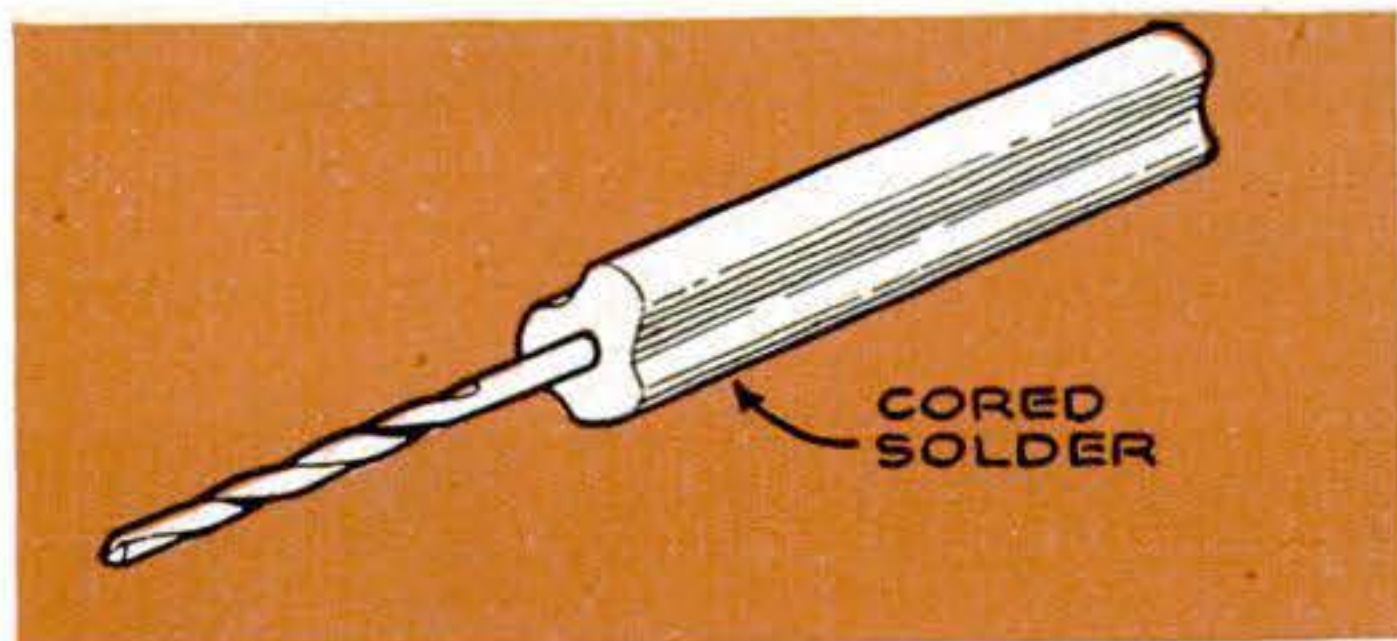

IF YOUR drill chuck won't close down on a very fine drill, cut a short length of rosin-core solder, roll it on a flat surface until it's straight, and force it on the drill shank. If necessary, ream the solder core out with the drill itself. The chuck jaws will form the ridges shown at left.—E. H. Godfrey, Highland Park, Ill.

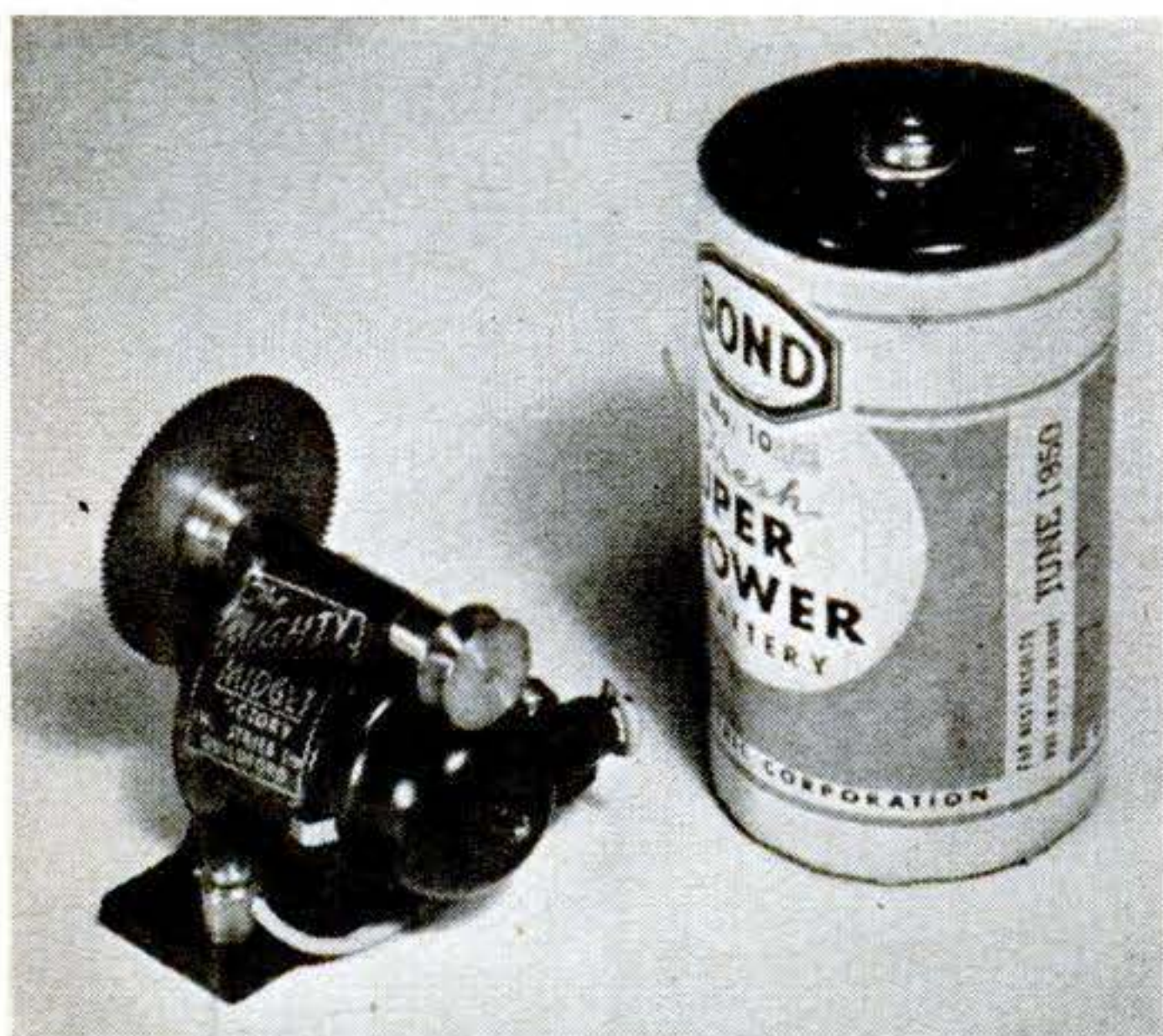

## Tiny Motor Has Reducing Gear

PROVIDED with a 12-to-1 reduction gear and a pulley, this British electric motor is designed for use in models and small control devices. The Mighty Midget® operates on a single flashlight cell, and its armature turns up to 10,000 r.p.m. on two cells. The permanent-magnet DC motor is reversible by a change of polarity. Distributed by Modelcraft, Ltd., London, it is made by Victory Industries, Guildford, England.

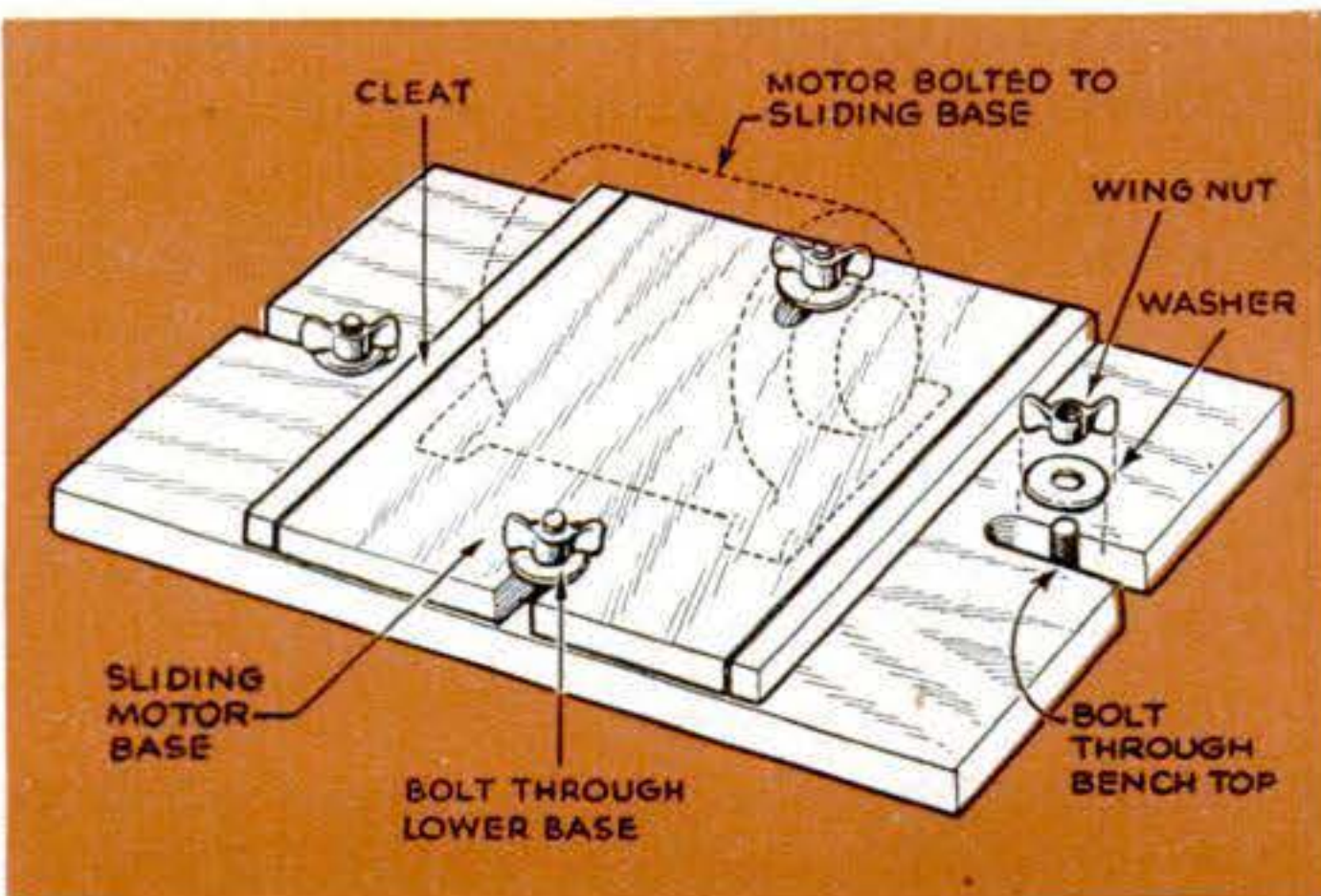

## Motor Mount Set Two Ways

AMONG the advantages of this motor mount are easy adjustment of belt tension, easy speed changes by means of step pulleys, and easy transferal of the motor to operate separate power tools. Make as many of the lower bases as there are locations where you'll want to use the motor, and leave each such base permanently there. The upper base is permanently mounted to the motor, and the cleats on each of the lower bases are spaced to make a sliding fit for it. Plywood,  $\frac{3}{8}$ " or  $\frac{1}{4}$ " thick, is preferred material for both of the pieces.—W. Teeboon, Masterson, New Zealand.

# Rugged Boring-Bar Mount

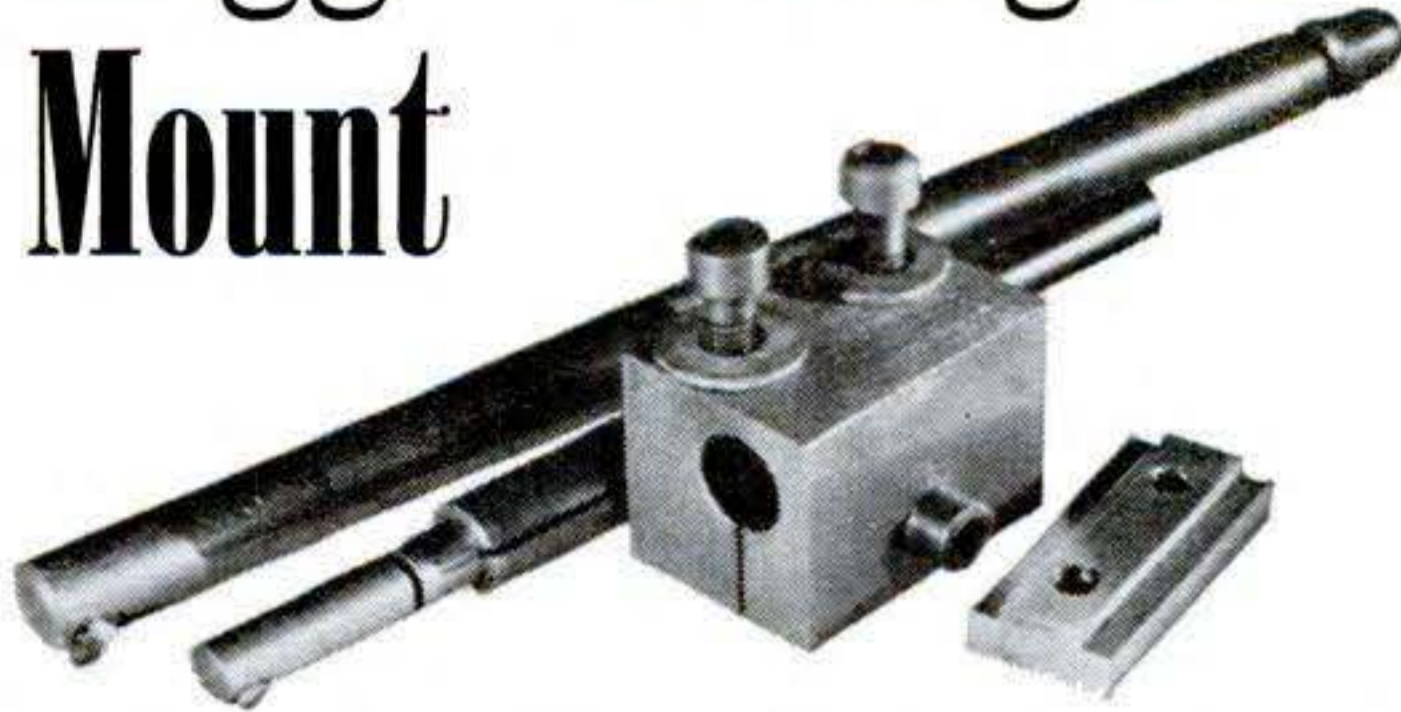

Both small and large boring bars fit this holder. Note split sleeve on small one above.

**SO HUSKY** it will handle the toughest boring jobs your lathe is capable of, this boring-bar mount merits a permanent place on your tool shelf. With the addition of simple split sleeves or bushings, it will hold bars of various sizes.

For the body, use a block of cold-rolled steel approximately the size shown in the drawings, which will fit a 9" or 10" lathe. Face the bottom in the four-jaw chuck, if you haven't a shaper. Then reclamp it with the trued face flush against one jaw as shown below, and drill and ream, or bore to size, the hole for the bar. In use this must lie at lathe center height. Spot the hole as far from the bottom face as the distance from the lathe center to the top of the compound rest on your lathe.

Drill two  $\frac{3}{8}$ " holes through from top to bottom of the block for the clamping bolts. Then cut the slot up from the bottom to the boring-bar hole, using a hacksaw or, if you have a milling attachment, a slitting saw as shown at the right below.

Drill the transverse hole for the bar clamp screw  $\frac{5}{16}$ " past the slot with a  $\frac{5}{16}$ " bit; then open it just to the slot with a  $\frac{3}{8}$ " drill. Tap the smaller part  $\frac{3}{8}$ "-16. Finally, chamfer all edges of the block and draw-file smooth all over.

Make the clamp shoe from a piece of  $\frac{1}{2}$ "

With trued face flat against one chuck jaw, the  $\frac{3}{8}$ " hole is started with a smaller drill, eventually reamed or bored to specified size.

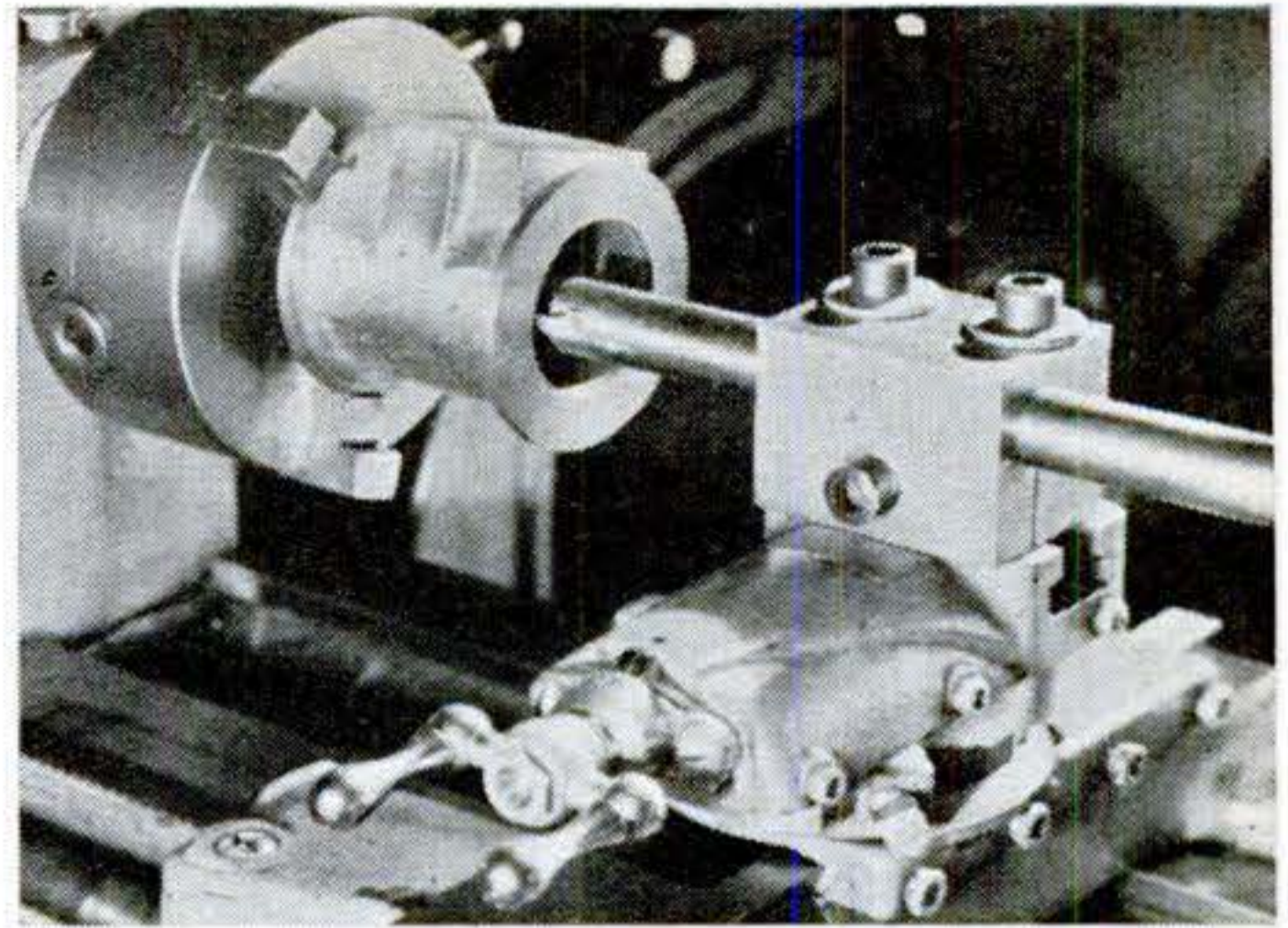
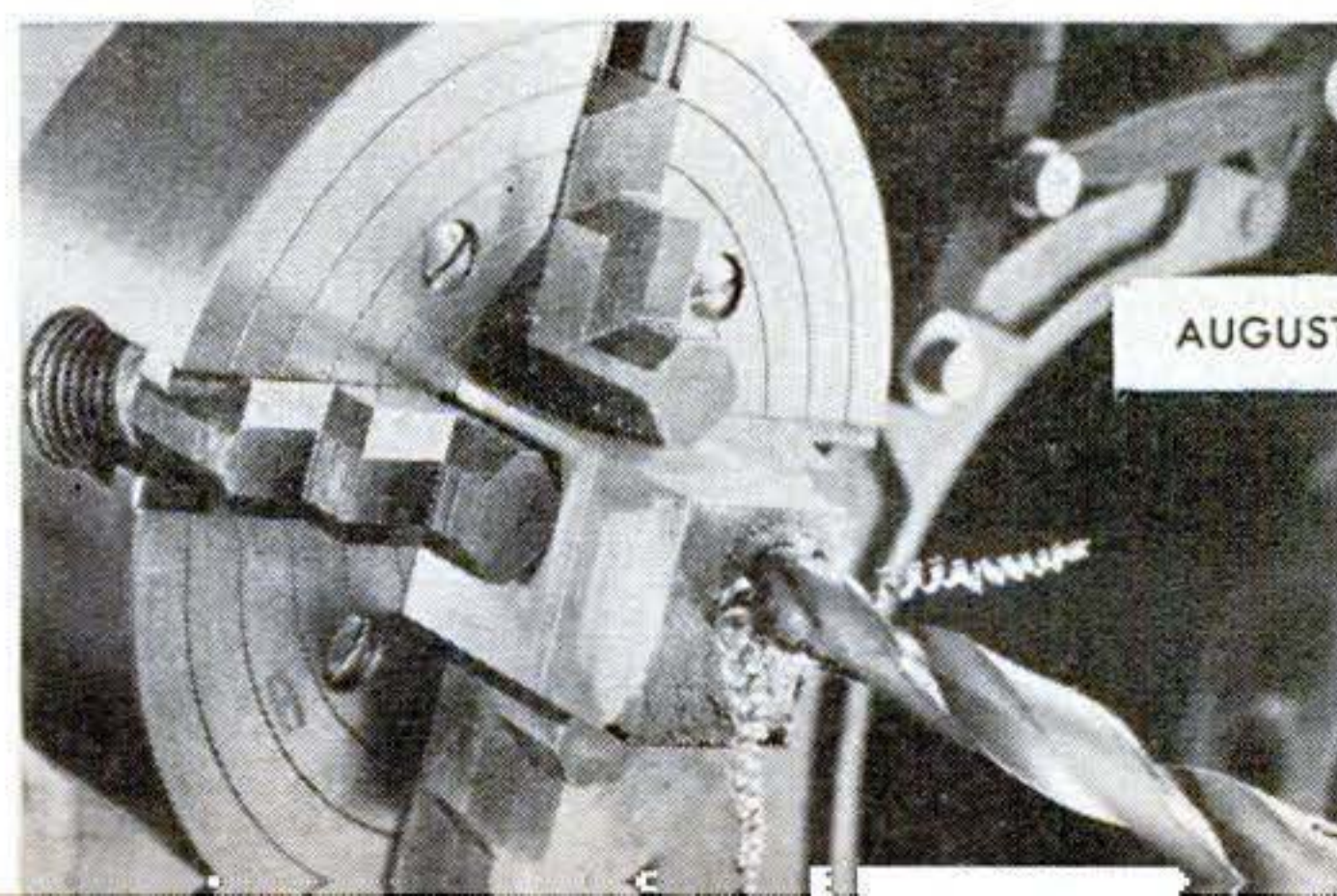

Straddling full width of compound rest, the holder gives sturdy support for heavy cuts.

by 1" bar stock to fit the tool-post slot. The steps for the T shape can be hacksawed and filed, but are a simple milling job. The shoe can also be built up of two pieces. Space the  $\frac{3}{8}$ "-16 holes to match the bolt holes in the block. With hollow-head cap screws and washers, the mount is ready for use.—C. W. Woodson, East Aurora, N. Y.

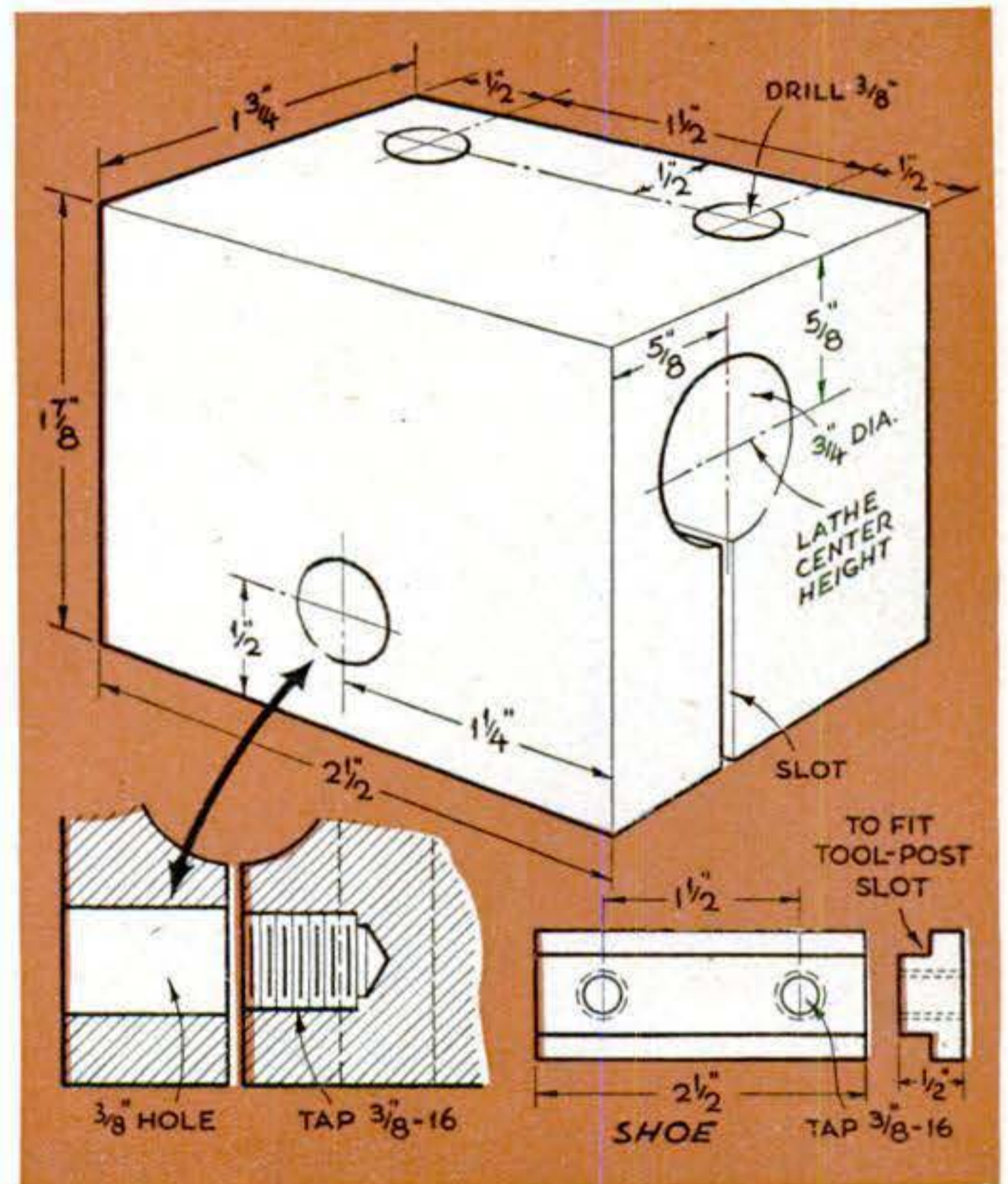

Mounting holes are drilled through from top face (left below). Slotting the block is a job for the milling attachment and a slitting saw.

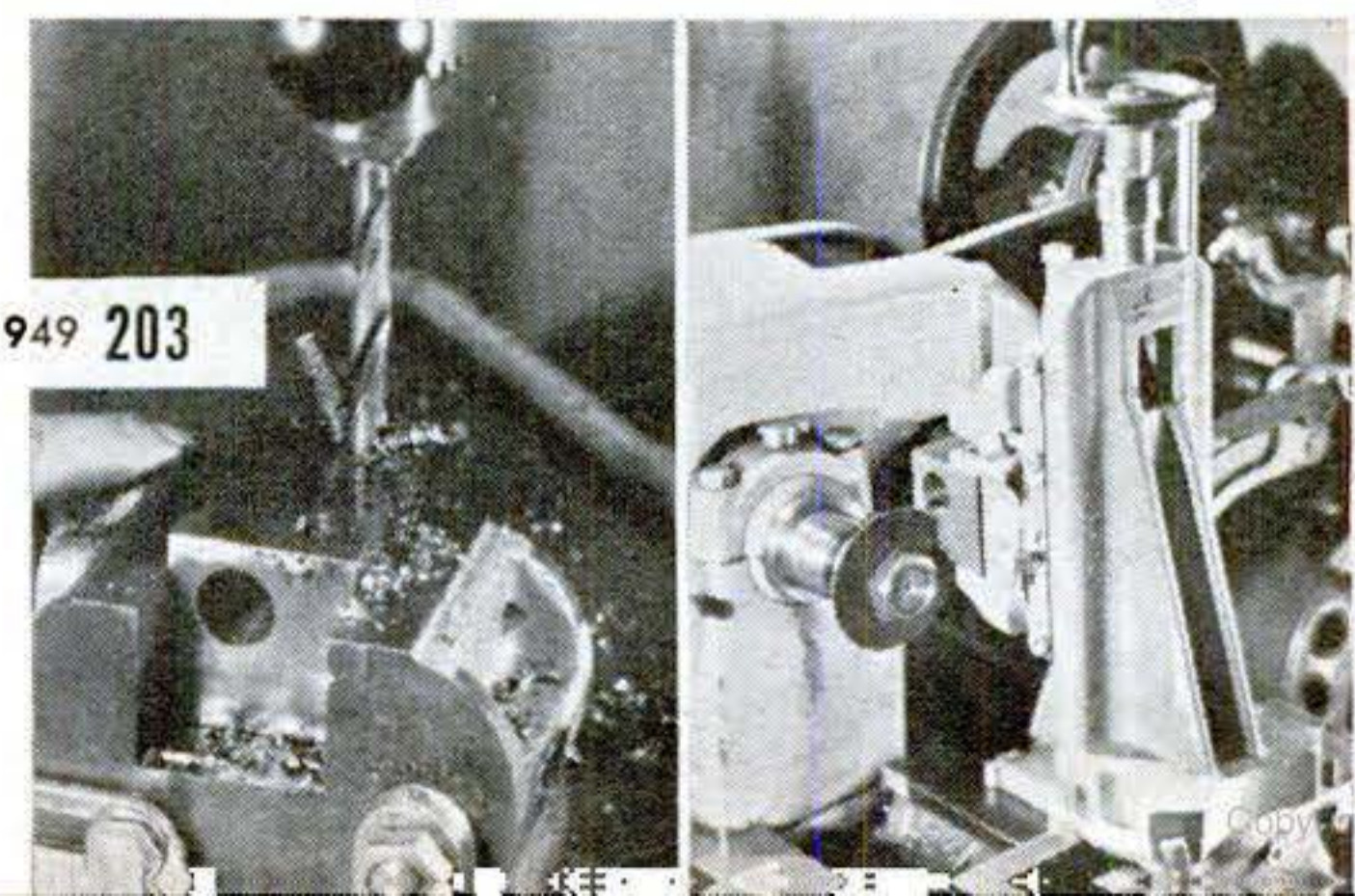

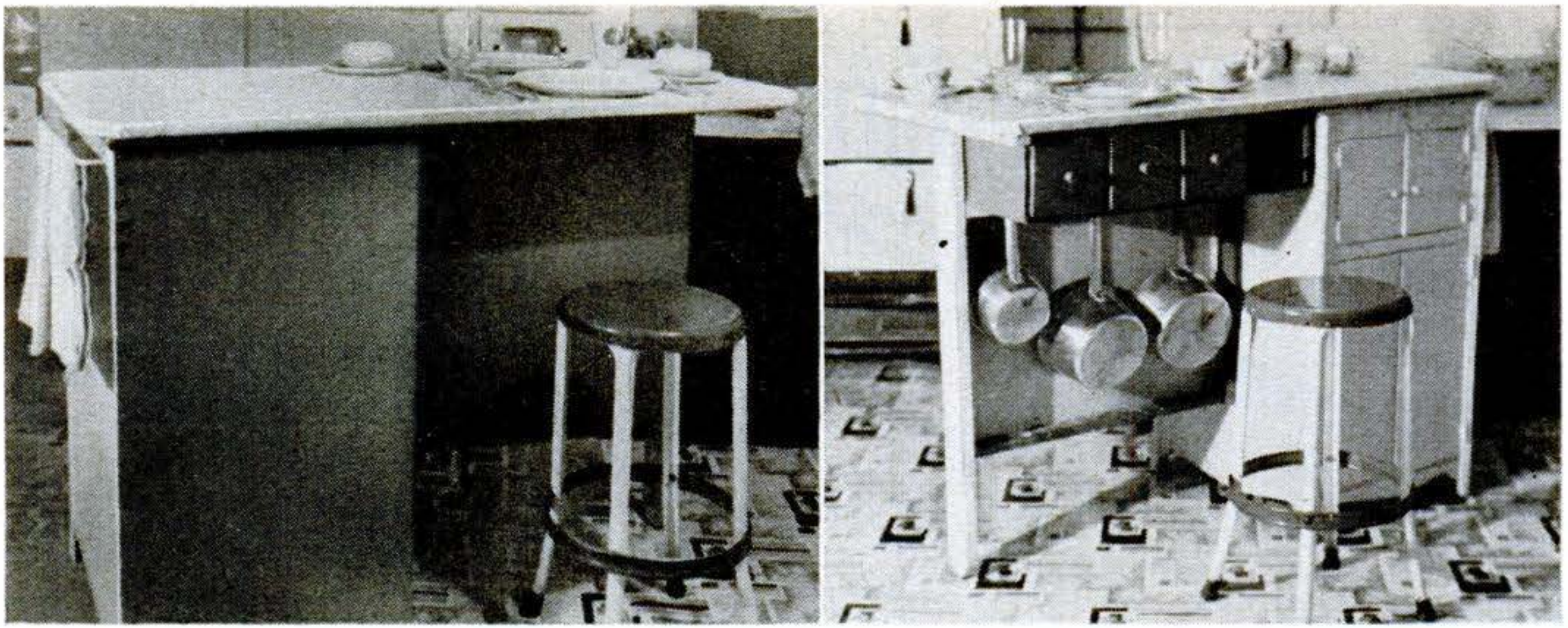

## Kitchen Bar Built Around Old Phonograph

AN OLD phonograph cabinet forms the principal part of this kitchen combination. The built-on top serves as a snack bar while the drawers and cabinet provide storage space.

First, remove the cabinet trim and cut down the legs. (Save the lid; it can be used as a shadow-box picture frame.) Next take out the works and the turntable, as well as album partitions that may be in the lower section. Using  $\frac{1}{2}$ " or  $\frac{3}{8}$ " plywood, lay out the top to suit your needs. The apron between

the single leg and the phono cabinet provides all the bracing needed. The drawers beneath the top are from a fiberboard shoe wardrobe. Hooks for the pots are screwed into a strip of wood under the drawers.

Cover the top of the bar with imitation leather or sheet plastic—the kind used on table and counter tops in lunchrooms. Enamel the leg, cabinet, and apron to suit the color scheme of your kitchen. The addition of gliders and door handles completes the job.—*Phil Swanson, Los Angeles.*

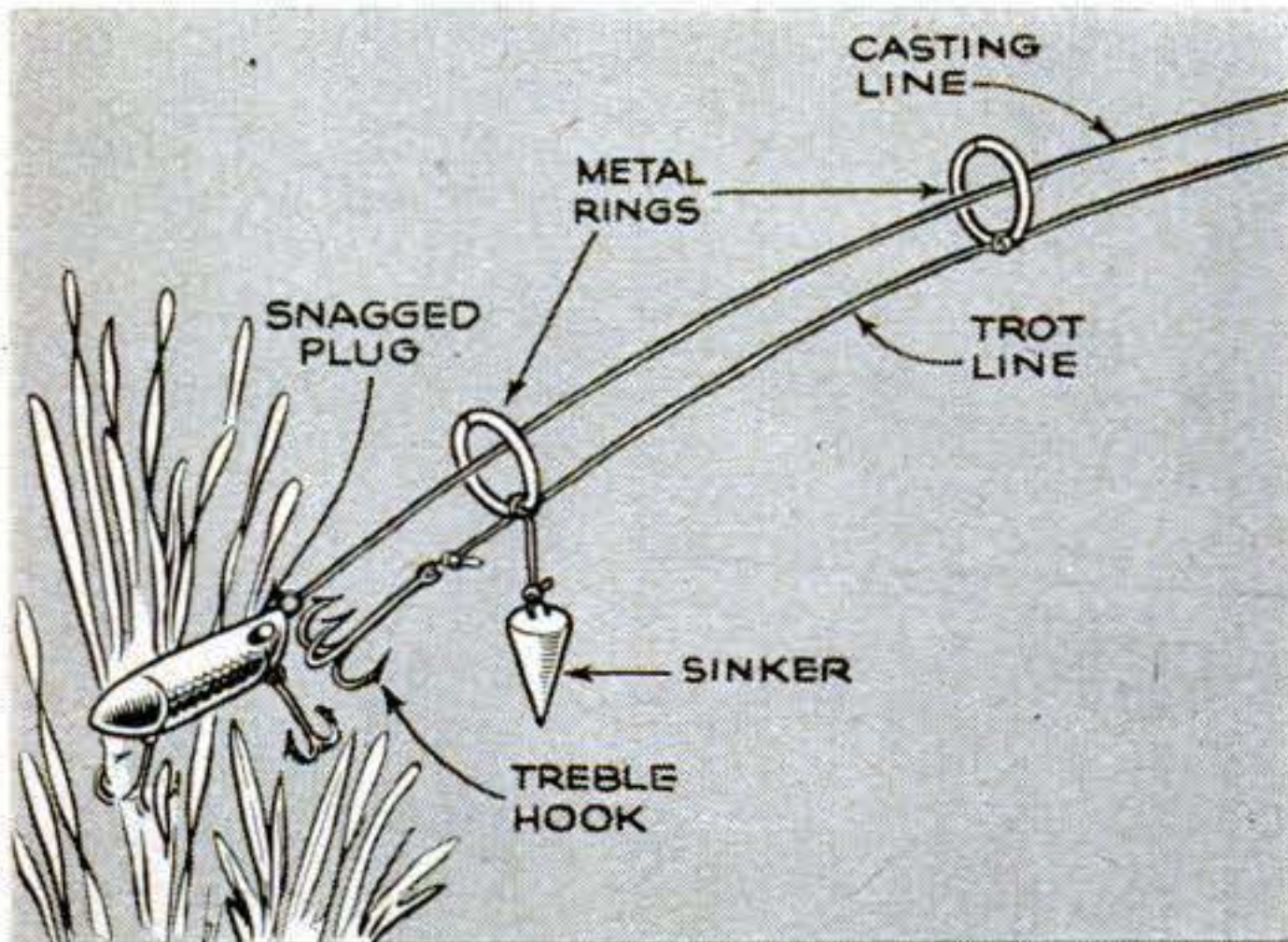

## Rig Frees Snagged Plug

FOR retrieving fouled fishing plugs, I've found this rig to be the answer. On the end of a length of trotline, I fastened a large treble hook. An inch up from the hook, a metal snap ring—the kind used in notebooks—was knotted in the trotline. About 3' up a second ring was tied on. A large sinker was tied to the lower ring. I snap the rings around the casting line and slide the rig down the line. With a little manipulation the hook catches in the fouled plug.—*C. H. King, Chattanooga.*

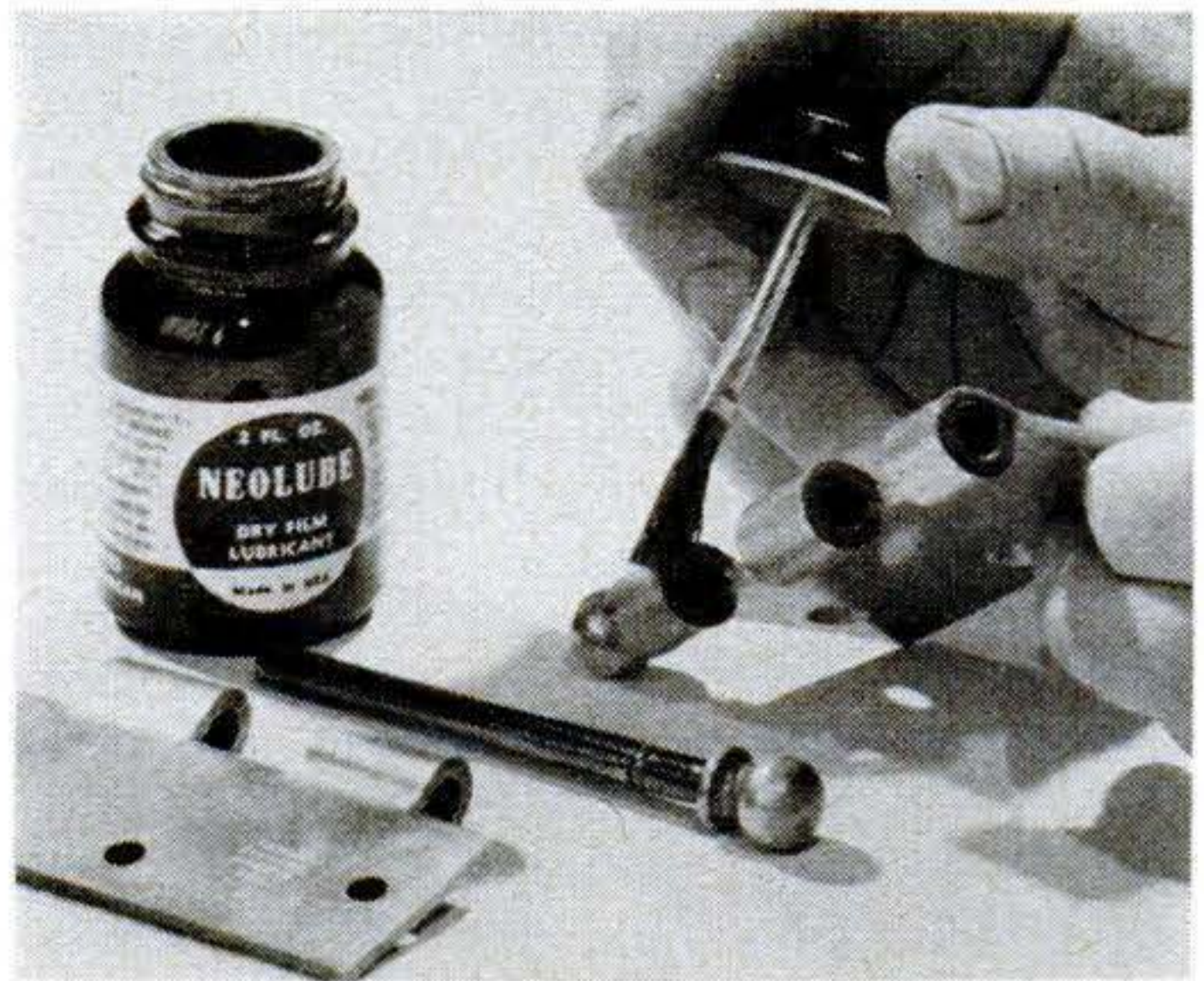

## Liquid Forms Dry Lubricant

APPLIED like paint, Neolube® dries quickly, leaving a corrosion-resisting coating of graphite. The maker, Huron Industries, Port Huron, Mich., says that, unlike oil, this compound will lubricate at both high and low temperatures and is electrically conductive. Among suggested uses are guns, sticking drawers and windows, locks and latches, model railroads, and piano mechanisms. Price is \$1 for 2 oz.

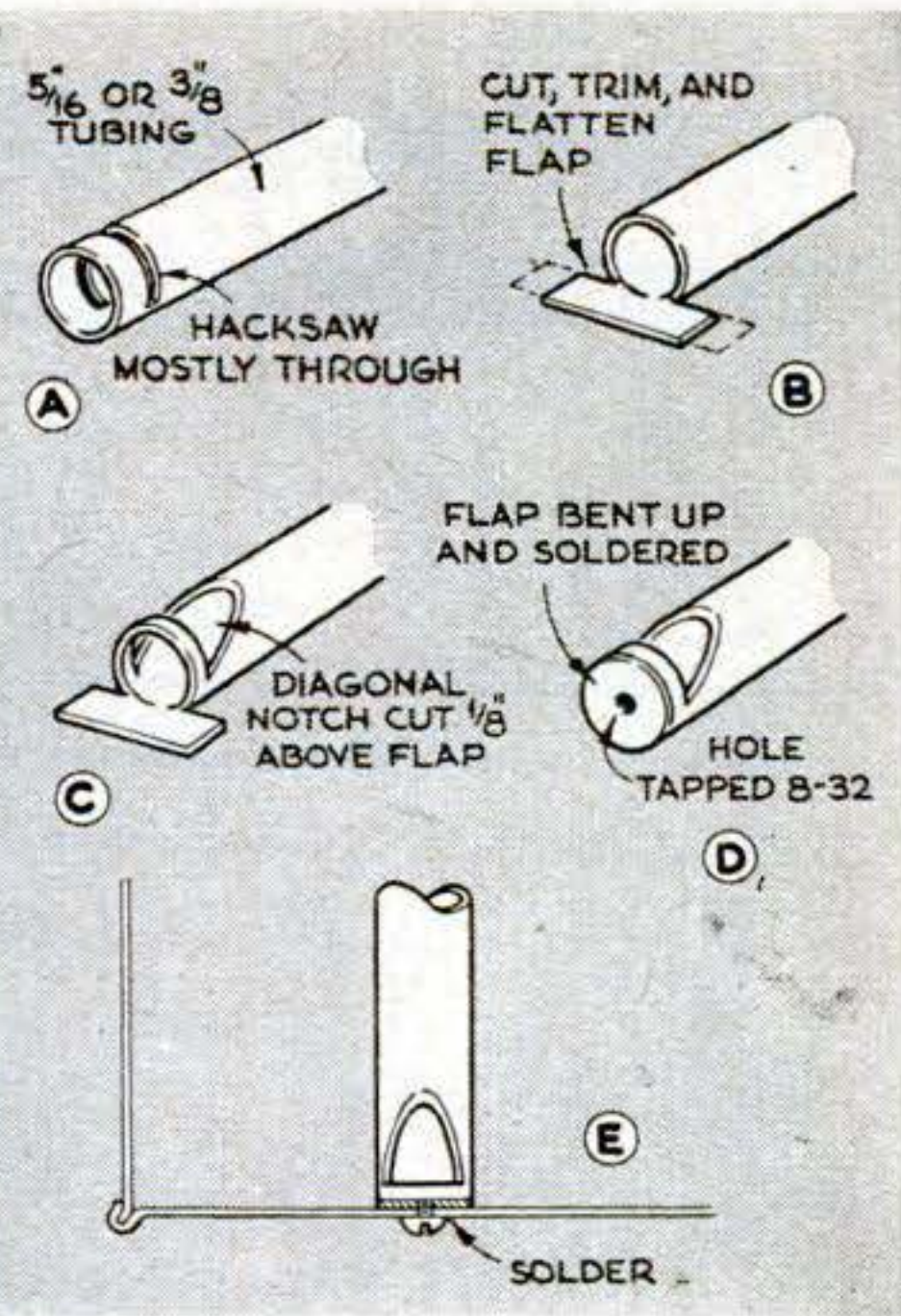
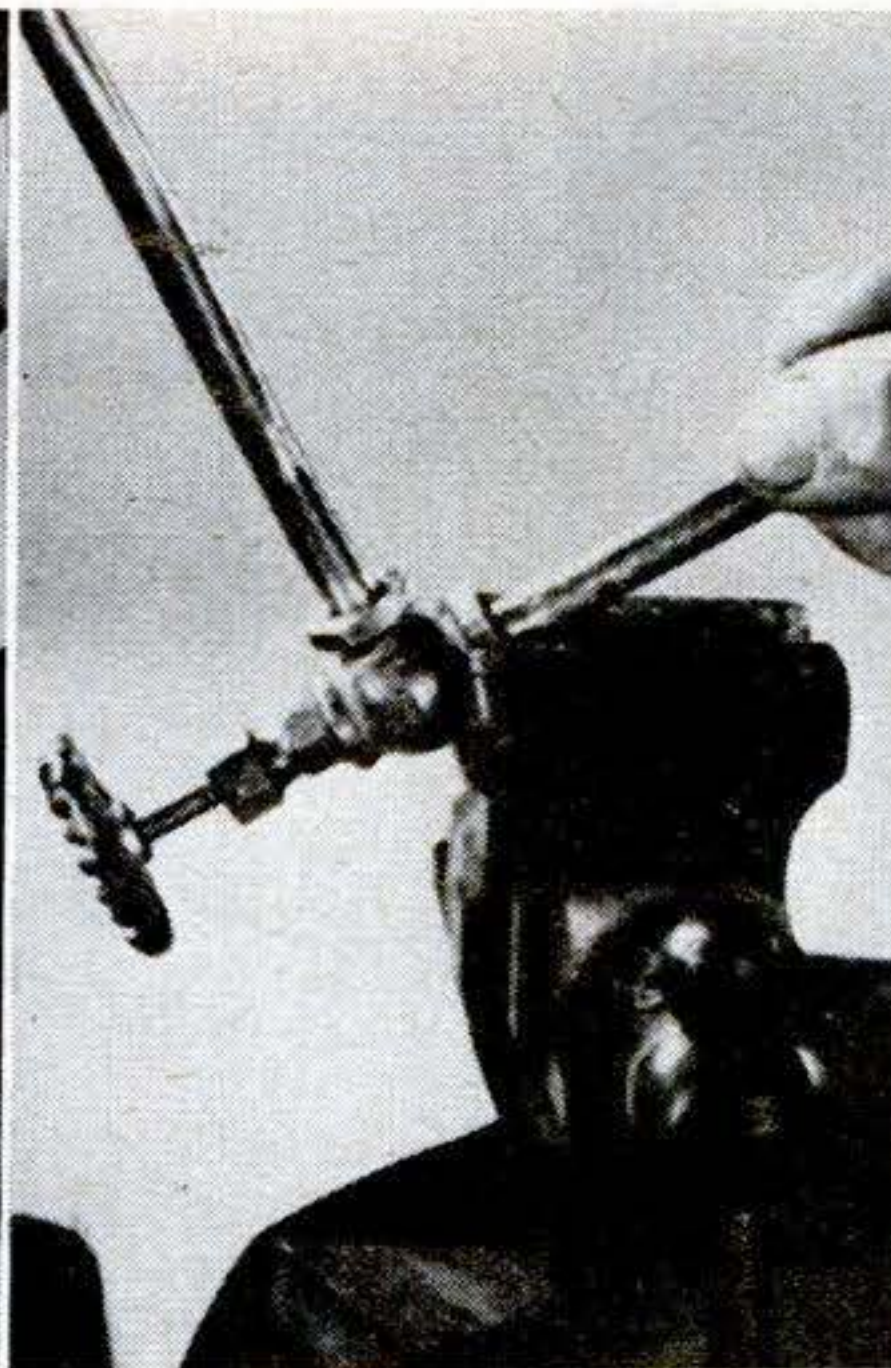
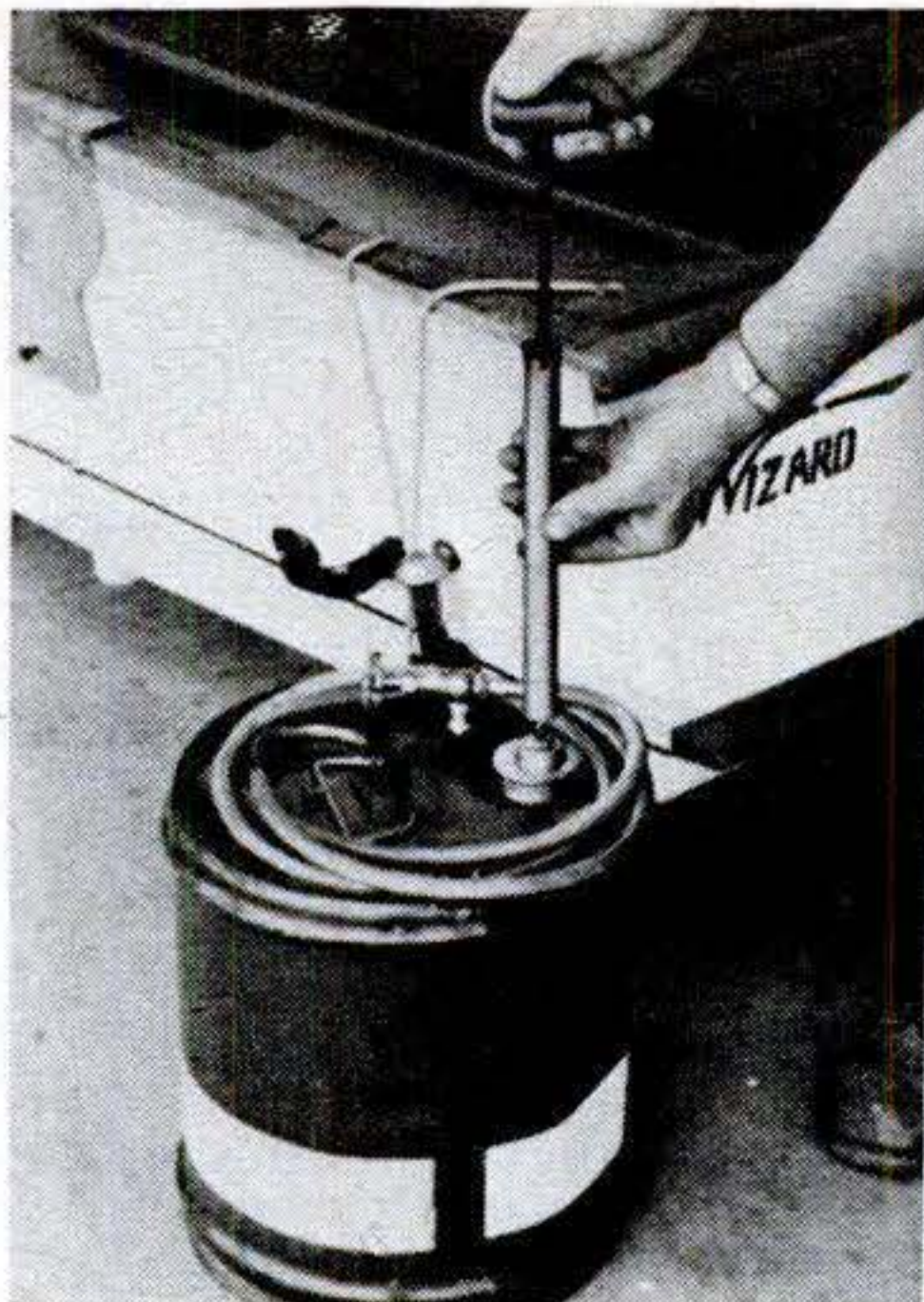

Completed outfit is shown at left. Working the hand pump forces air into the can. Air shoves fuel through hose to outboard's tank. Tubing may be screwed directly into brass globe valve,

center; brass cuts its own threads in copper tubing. Seal joints by soldering. Drawing at right shows how tubing is secured to bottom of can. Cover 8-32 screw with solder.

# Pressure Tank Fuels Running Outboard

**I**F YOU'VE ever filled an outboard's tank in a choppy sea, you'll appreciate this pressurized can. Without stopping the motor or lifting the can, you can refuel. Working a hand pump builds up a small air pressure that forces fuel from the auxiliary tank through a Neoprene® hose to the motor.

Drill a hole in the top of a sturdy 5-gal. can to take a length of copper tubing. Saw and bend the lower end of the tubing as shown. Screw a small globe valve on the

other end. Thread a short piece of tubing in the other valve opening and force the hose over it. Fit the other end of the hose with a U-shaped copper tube to hang in the motor's tank when fueling. Locate the valve so the wheel and nipple are protected by the rim of the can. Keep the valve closed when the tank is not in use. For maximum safety, use no valve inside the inner-tube stem, so that pressure cannot be maintained. —Clinton R. Hull, Costa Mesa, Calif.

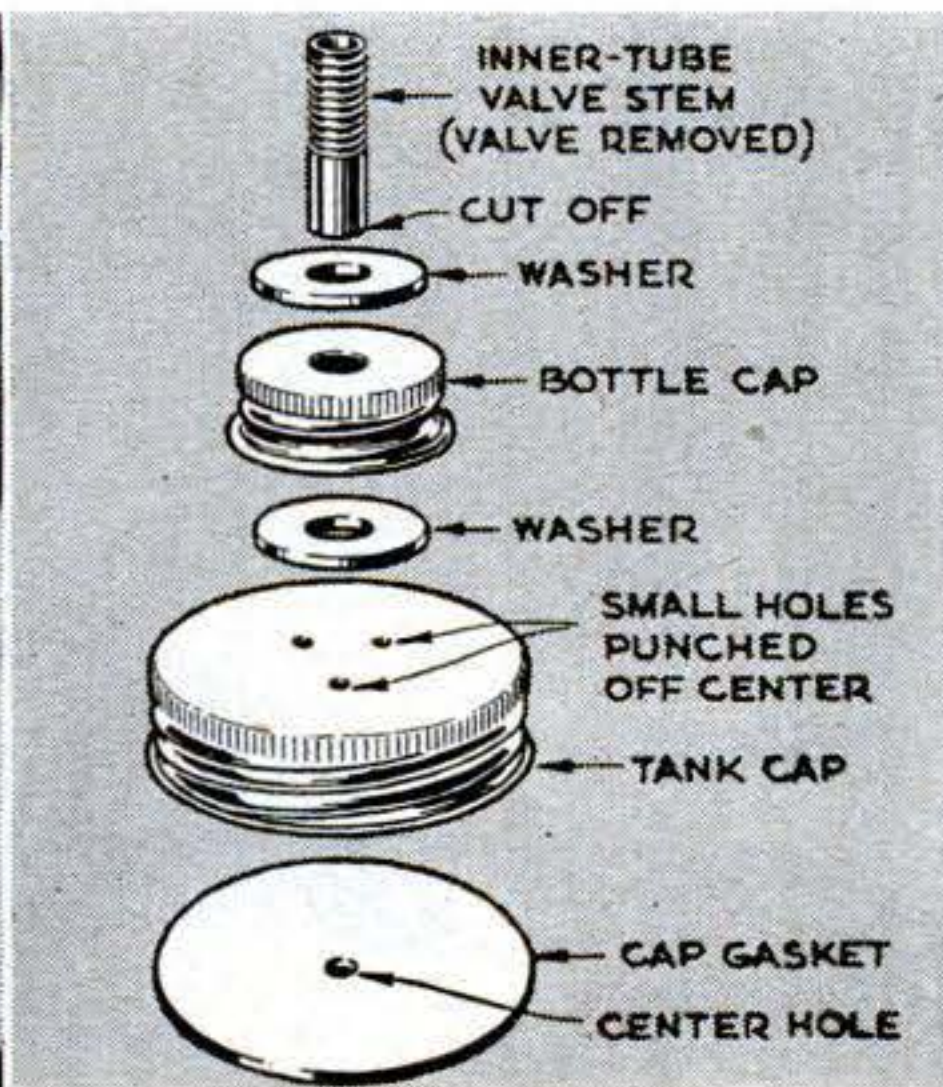

Where copper tubing protrudes through top of can, solder around it (left) to make tight seal. Center shows tank-cap assembly. Altered valve stem, with valve removed, is soldered in bottle

cap. This is soldered to tank cap, right. Small holes, punched off center, let air into tank through 1/8" hole in gasket but keep fuel from splashing out. Valve cap closes stem.

## Keeping the Home Shipshape



A **low-vision mirror** makes a handy dressing aid. Use any wood-framed mirror of reasonable size. Mounted in a corner as shown, it takes up little space. Fit a wood shelf on top.

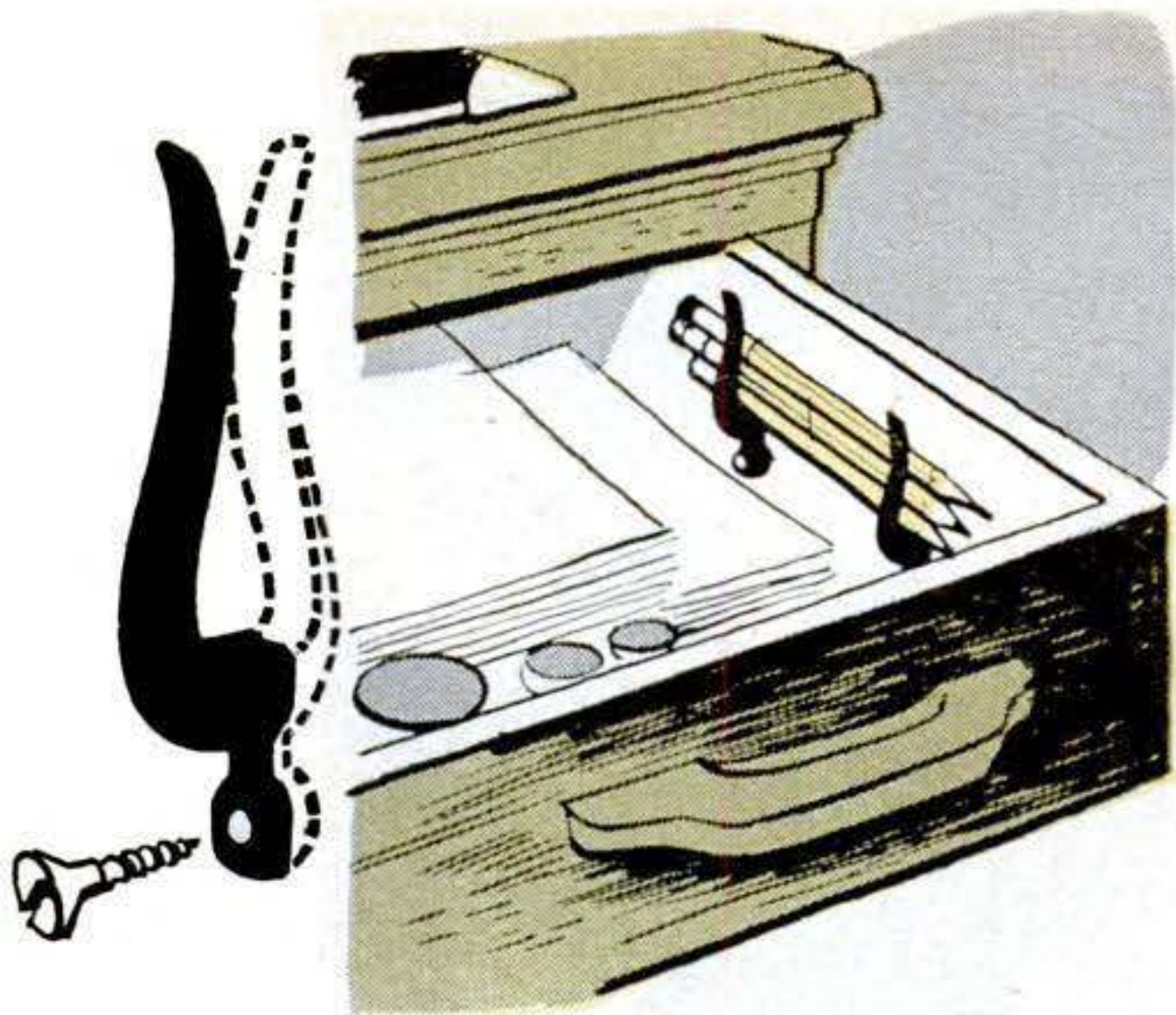

**Pencils** don't have to roll around in a desk drawer. Keep them in order by cutting down two plastic clothespins. Attach the one-prong pins to the drawer side with short wood screws.



**Tweezers** of any kind can be made from hacksaw blades. Grind the teeth off and shape the desired point. Heat and bend the tips. Bolt the ends together, spacing them with nuts.

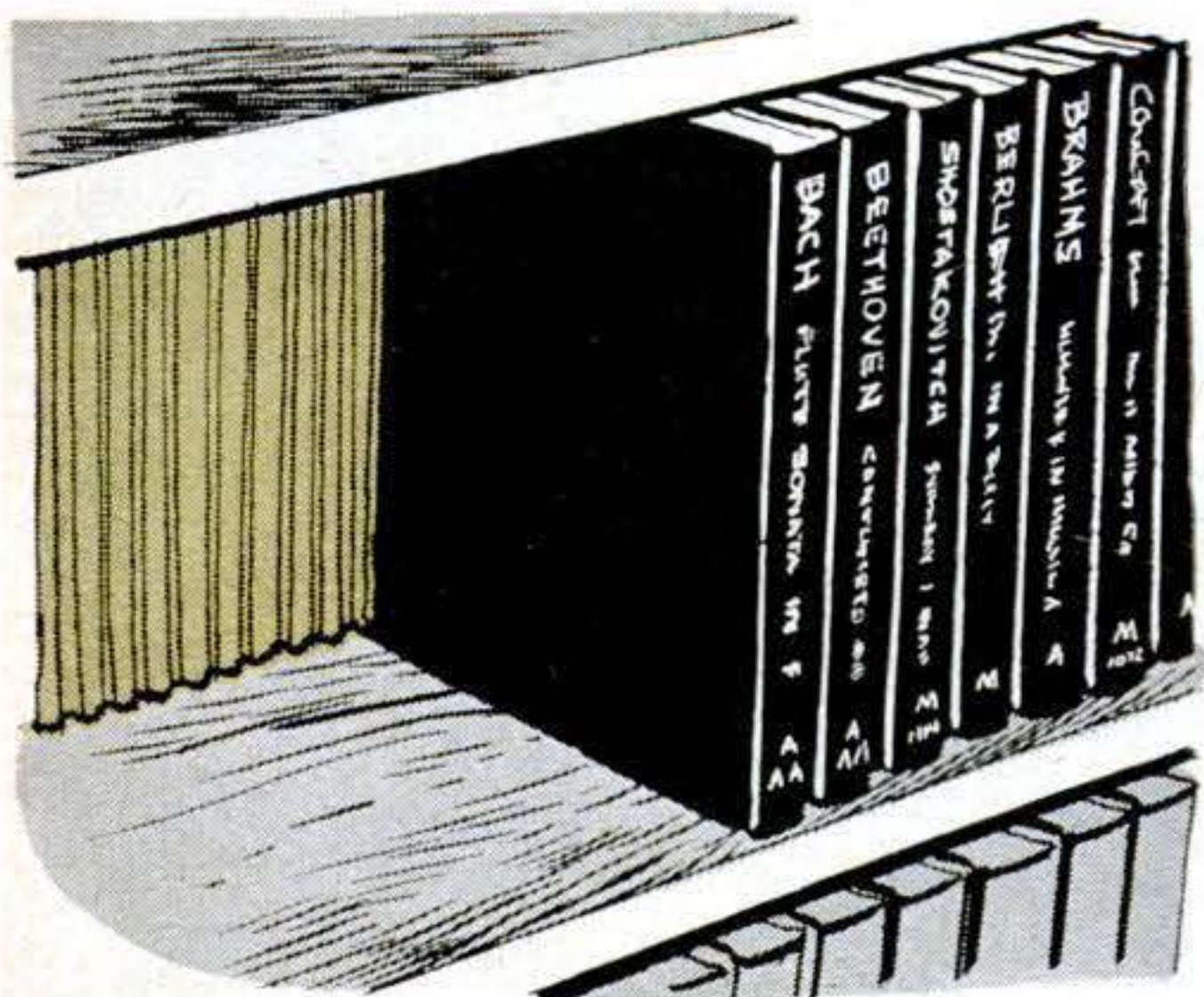

**Record albums** won't topple over when some are removed if you glue a sheet of corrugated cardboard inside the back of the cabinet. The cardboard ridges will keep the albums upright.

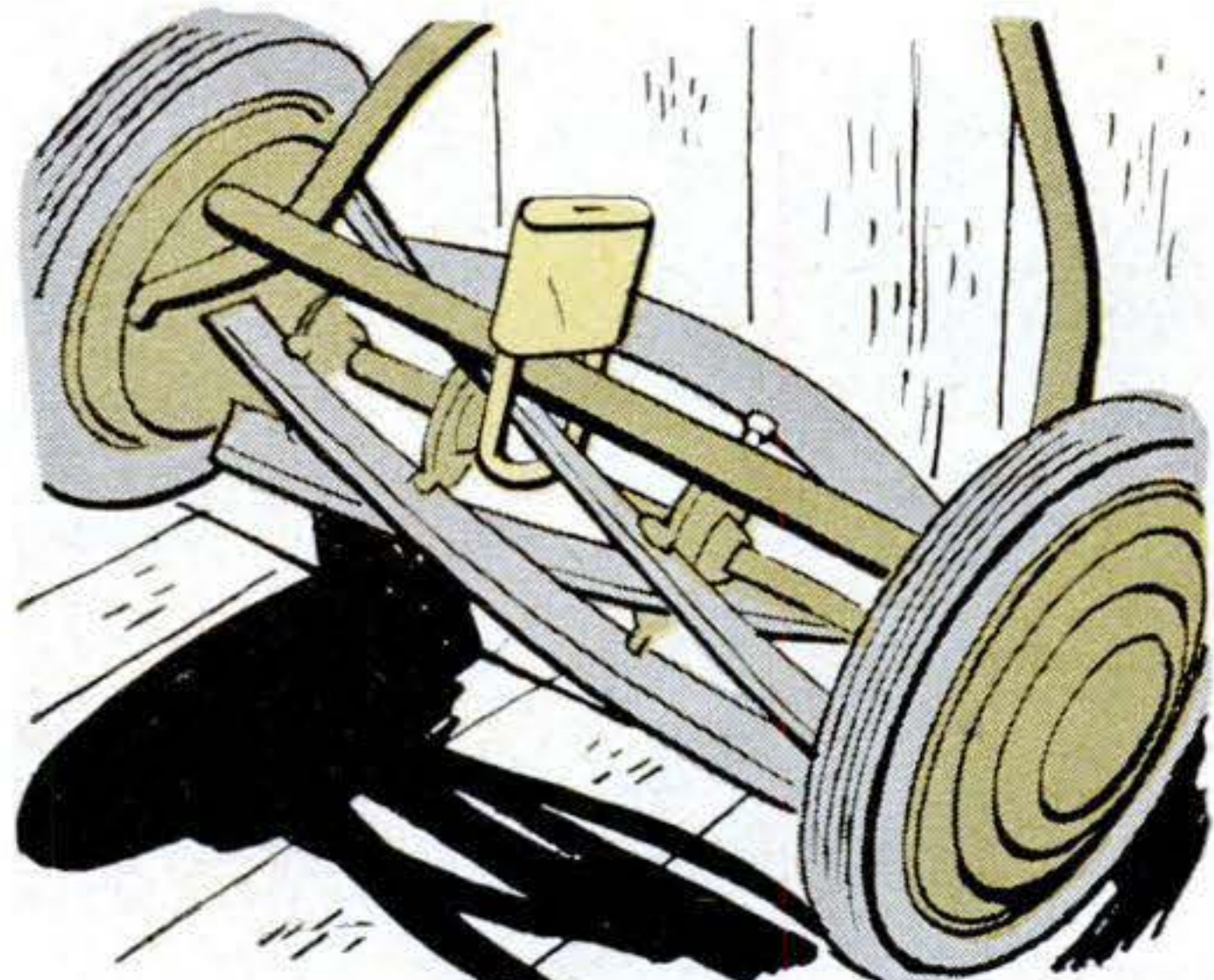

A **safety lock** for lawn mowers will discourage unauthorized borrowing and eliminate danger to children's fingers. One cutter blade is fastened to the crossbar by a bicycle lock.



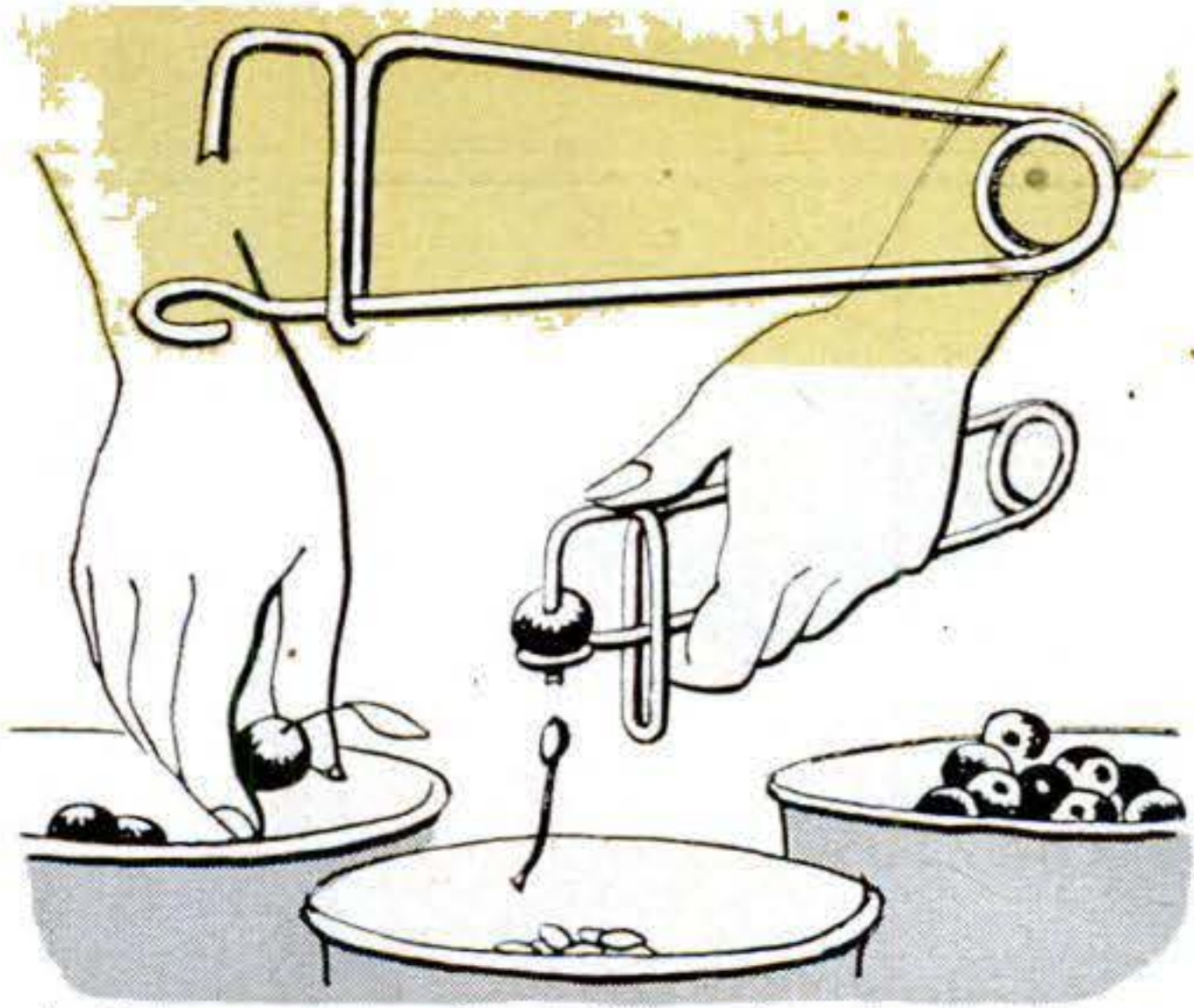

A **cherry pitter**, bent from about 20" of coat-hanger wire, will be a help at canning time. The wire is shaped and used as shown. Hammer out the plunger end and file cross notches.



When you wash walls or woodwork, fold a washcloth and fasten it around your wrist with a rubber band. The folded cloth will keep water from running down your arm.

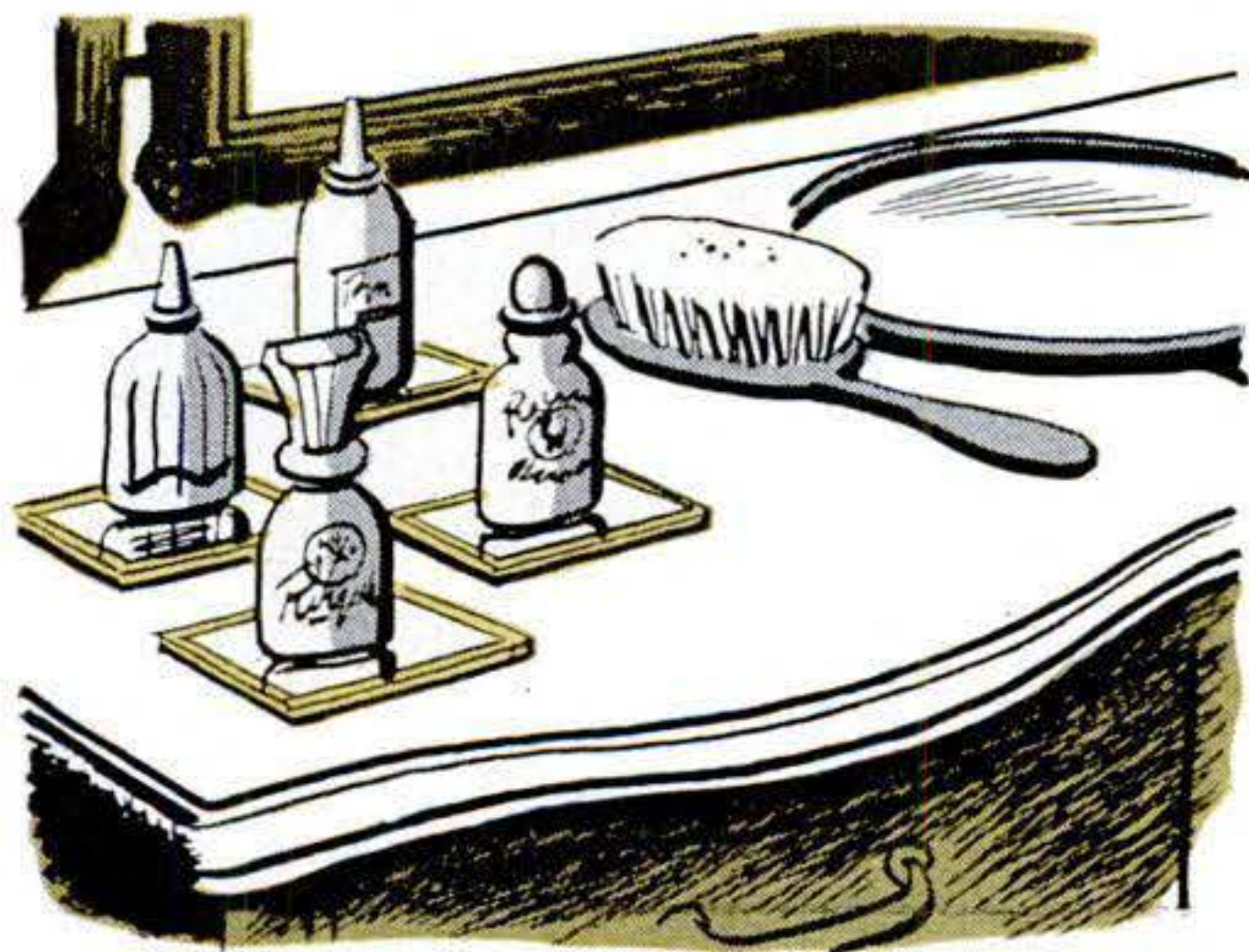

**Purse mirrors** make decorative coasters for the dressing table. Use them under polish, perfume, and similar bottles. They're easily cleaned and protect the table surface.

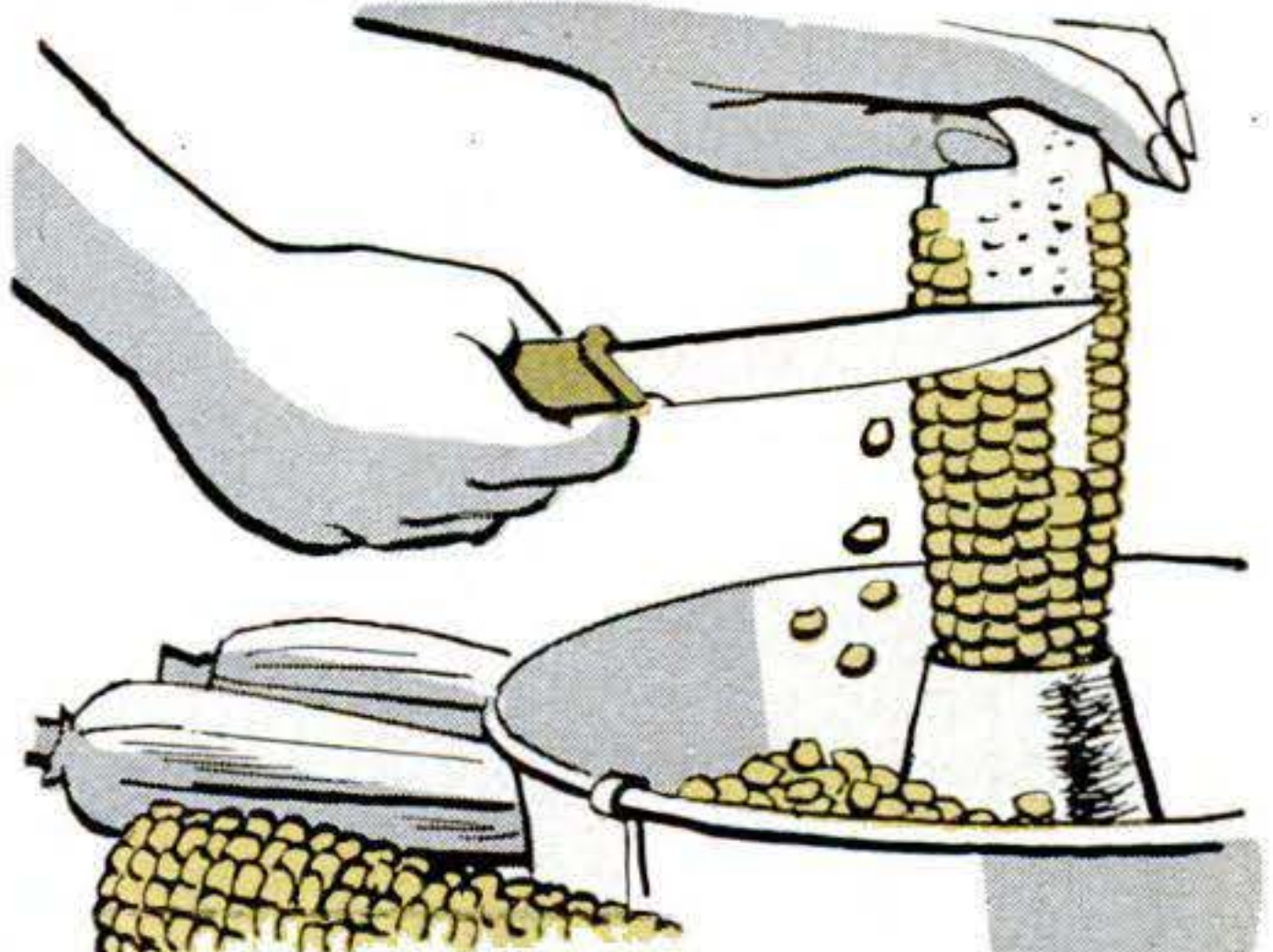

To cut corn from the cob, set one end of the ear into the center of an angel-food cake pan. It will hold the ear steady as you cut, and the kernels will be collected in the pan.

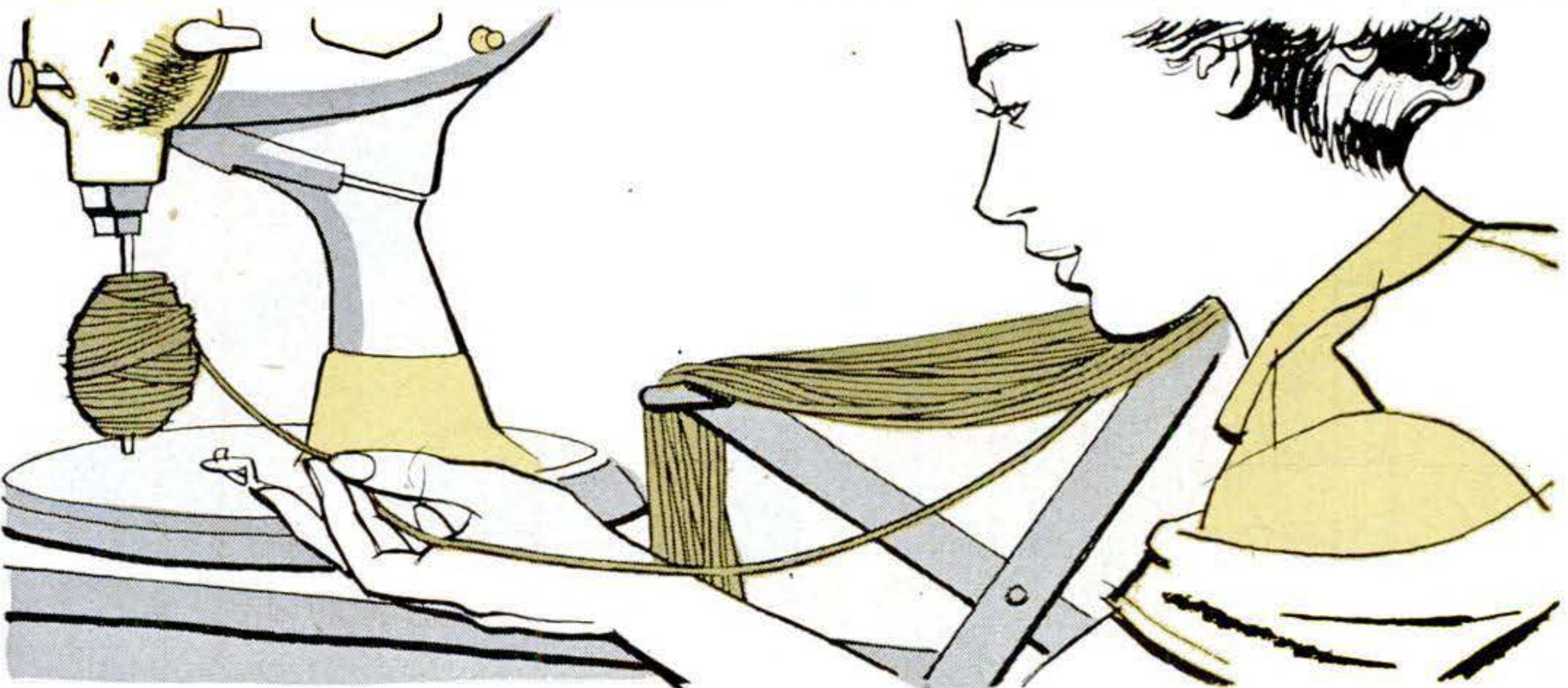

Tired of winding yarn by hand? Put your electric mixer to work. Remove the beater and

insert a small dowel. Running the mixer at lowest speed, guide the yarn lightly as it winds.



### Camp Cooking with Metal Foil

AVAILABLE as a kitchen food wrapping and dish liner, aluminum foil simplifies outdoor cooking. With a roll of the foil in your pack, you can leave at home many of the usual camp utensils. Just wrap the food securely in the foil and place the package in a bed of medium hot coals until cooked. In experimenting with cooking times for various foods, the package may be opened, inspected, and replaced in the coals. We've cooked steak, fish, chops, hamburger, chicken, sliced potatoes, and even apple pie this way. Build the fire large enough so the bed of coals will remain hot for at least 30 minutes.—Paul F. Runge, Atlanta, Ga.

### Cord Does Double Duty

A VERSATILE extension cord can be made from the cord used with some tank-type vacuum cleaners. Simply splice in a cube tap or socket by the end. The cord still can be used on the cleaner.—Henry E. Van Apeldoorn, Rochester, N. Y.

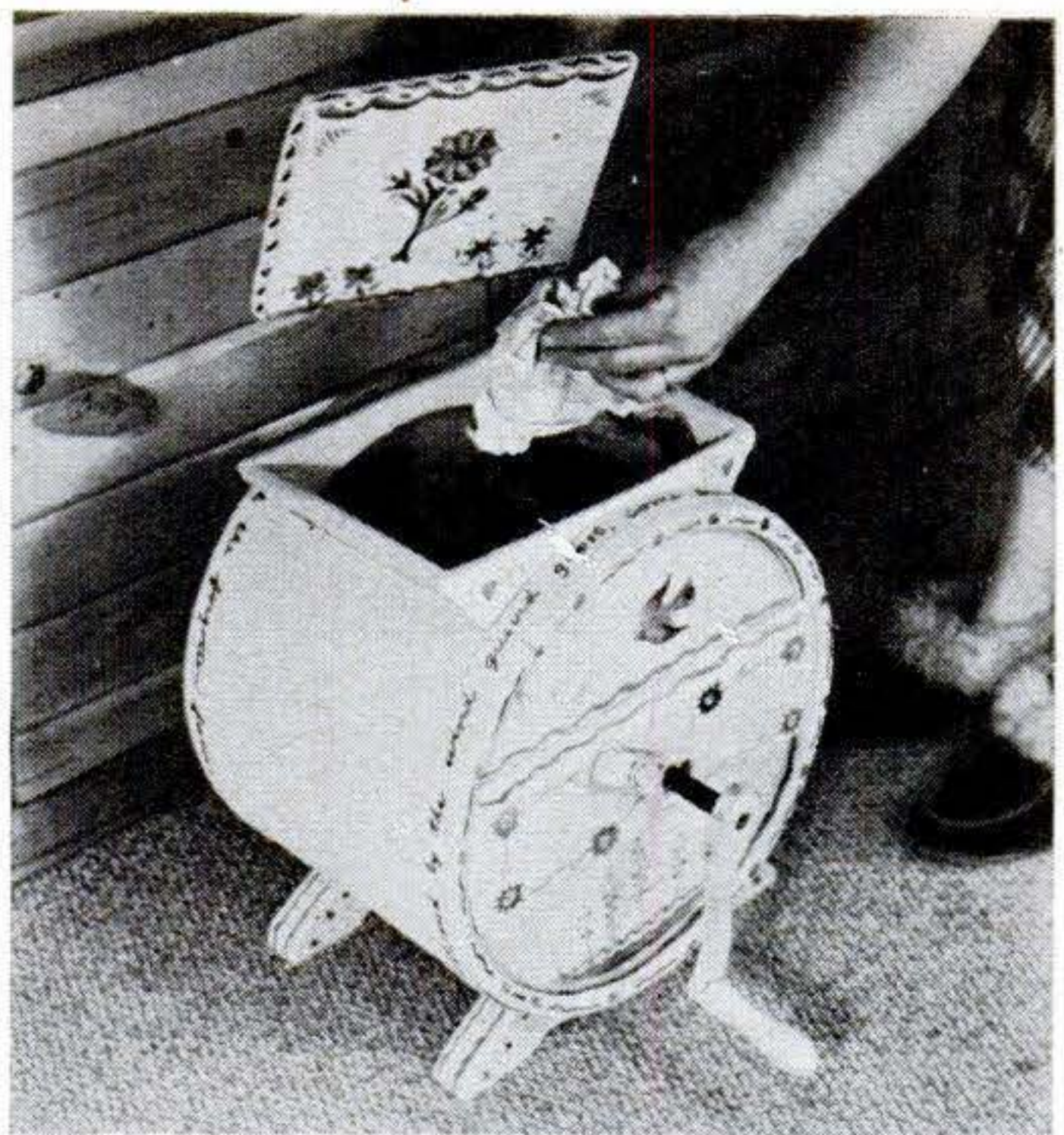
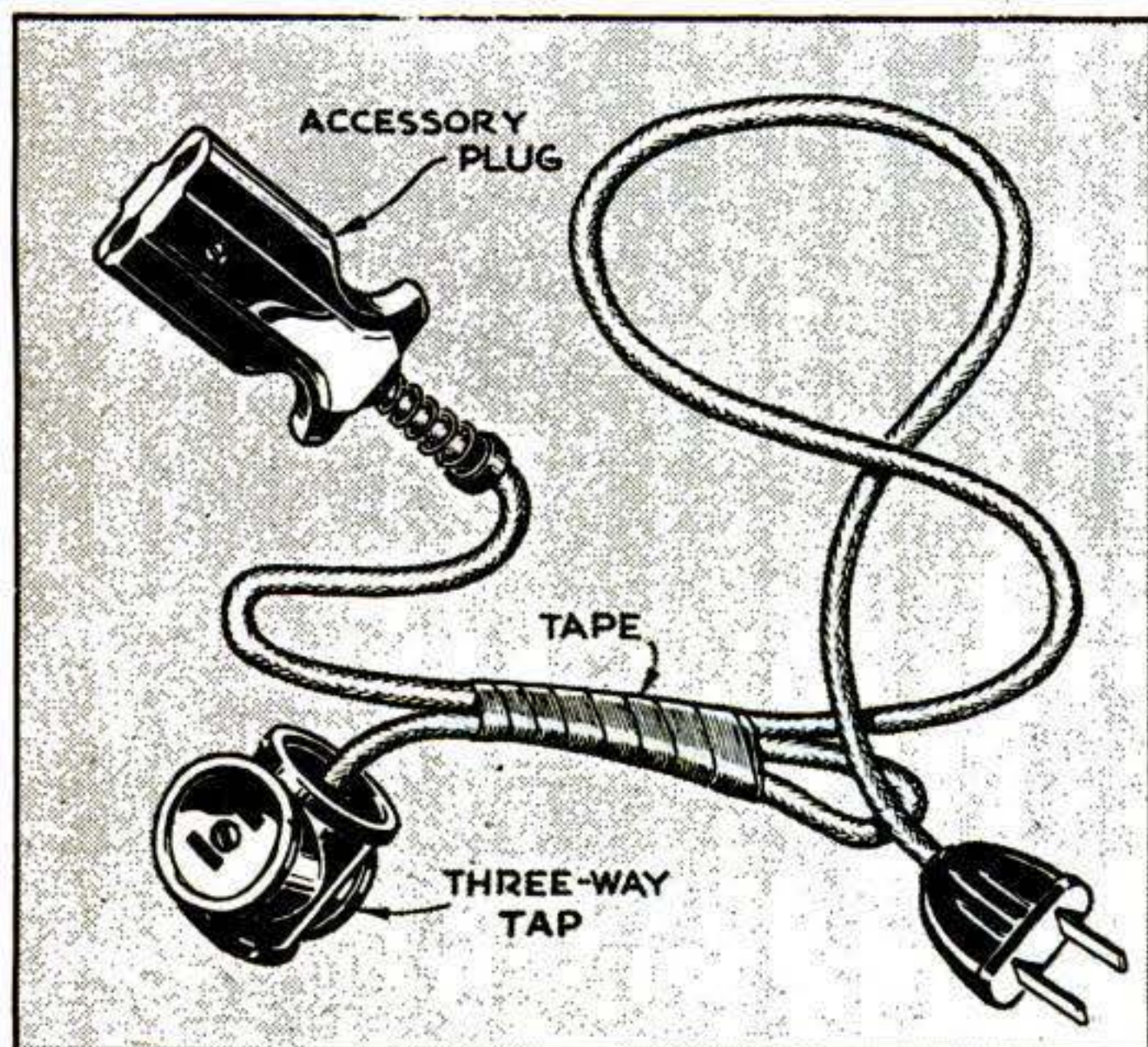

### Old Churn Holds Wastepaper

THE UNUSUAL wastebasket pictured above is an old butter churn that I picked up in a secondhand store for 50 cents. I replaced the cracked lid and mended a split foot. Then the churn was sanded and given a coat of flat white followed by pale cream paint. I used a small brush to paint on the decorations. If you're not handy at designing decorations, find some to copy or use decals.—Roland Cueva, Heyburn, Id.

### Gadget Dispenses Bread

TURNING the knob raises the loaf to bring to the top a slice at a time. When not in use, the lid is kept closed. The maker, Ward Philips Co., of Chicago, says the Bread Butler® keeps bread fresh for at least two weeks. It's priced at about \$3.



# Carving Houses Inside Out

**T**URNING a hobby into a career, nice work if you can do it, put one PS reader right into business. It started when Karl J. Burg, of Clinton, Iowa, reached for some plastic scraps after reading an article on internal carving (PS, August, '47, p. 160). His skill made a quick hit with friends and co-workers.

Spare-time orders kept him so busy that in June, 1948, he started a full-time plastics specialty business. He now makes carvings ranging from tiny flowers in jewelry to public buildings in good-sized blocks, besides doing more conventional sign and display work. The architectural models are made to scale from photos or blueprints of actual buildings and bring from \$20 to \$200.

The photos below show a ranch-style house of Burg's own design, which he hopes to build as his home. The plastic block is about 3½" by 4" by 6". In such work, a vertical milling machine is used to form the main cavity, corners being squared up with tiny chisels and scrapers made to suit the job. Breezeways and overhanging roofs must be done largely by chip chiseling. All parts are dyed in natural colors.

Burg's workshop includes a circular saw, jigsaw, small lathe, and other tools he has made himself. In spare time he still makes models as a hobby.

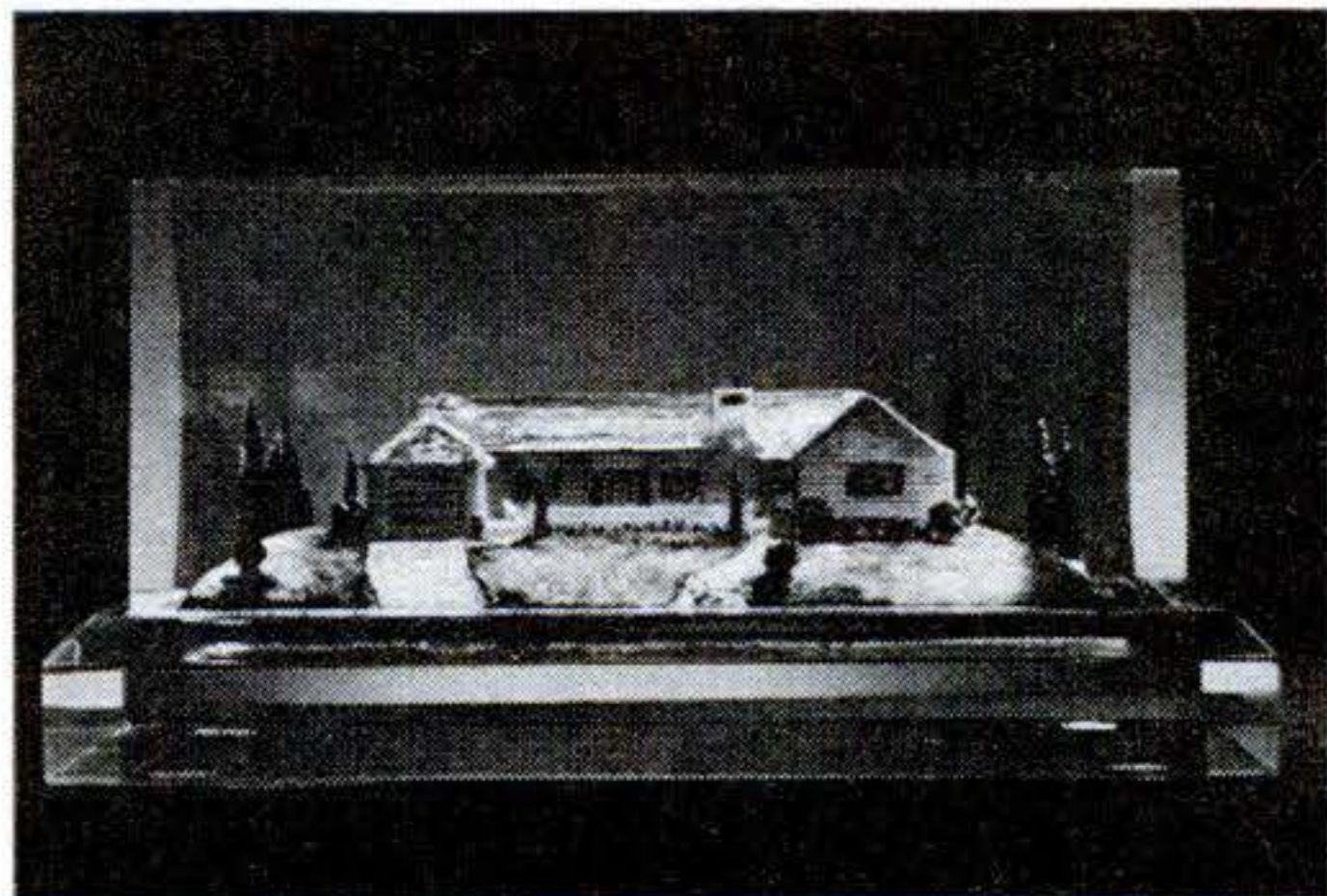

**Three-dimensional carving** lets you see house from ground level, moderate height, or bird's-eye view at will. A model this big is \$80.

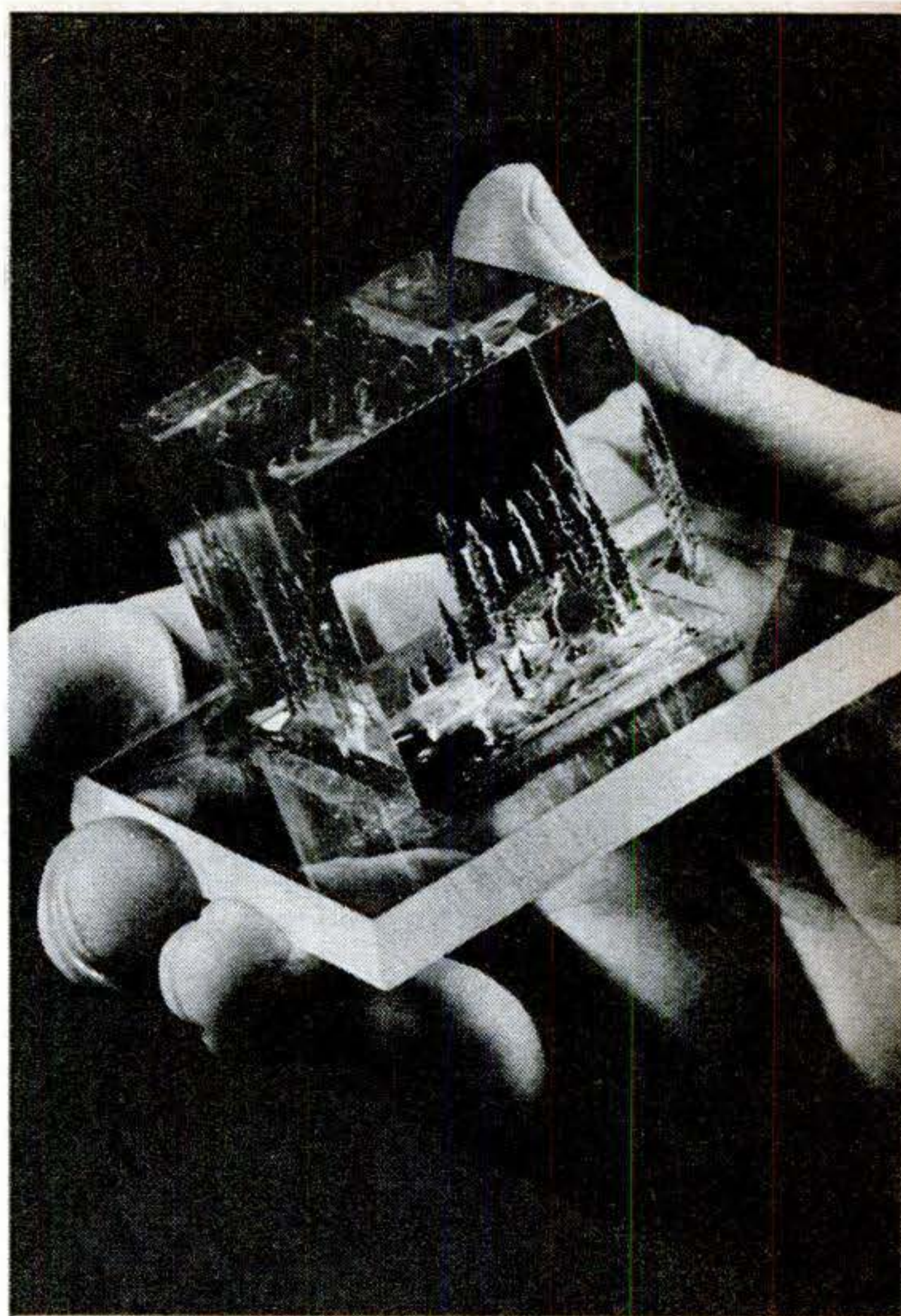

**Cabin in the pines** desk piece displays trees, a lake shore, boat at dock, a path, and cabin with a stone chimney. The carving sells for \$5.

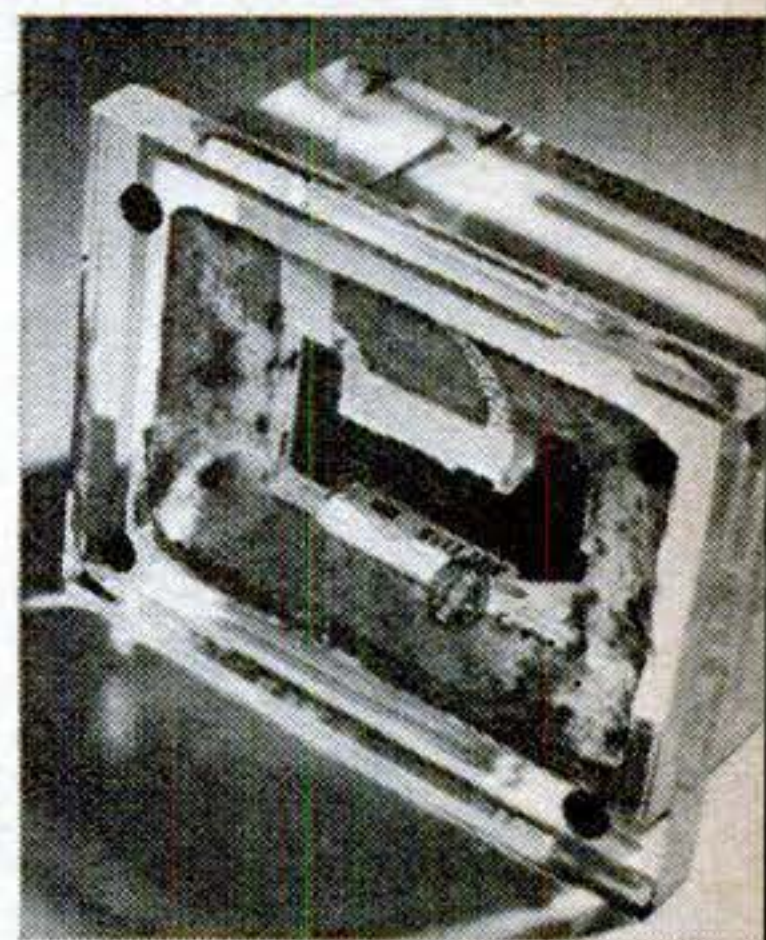

**Ranch-style home** shown below is turned up at right to reveal bottom cavity, made with both burrs and chisels. Carved parts are dyed.

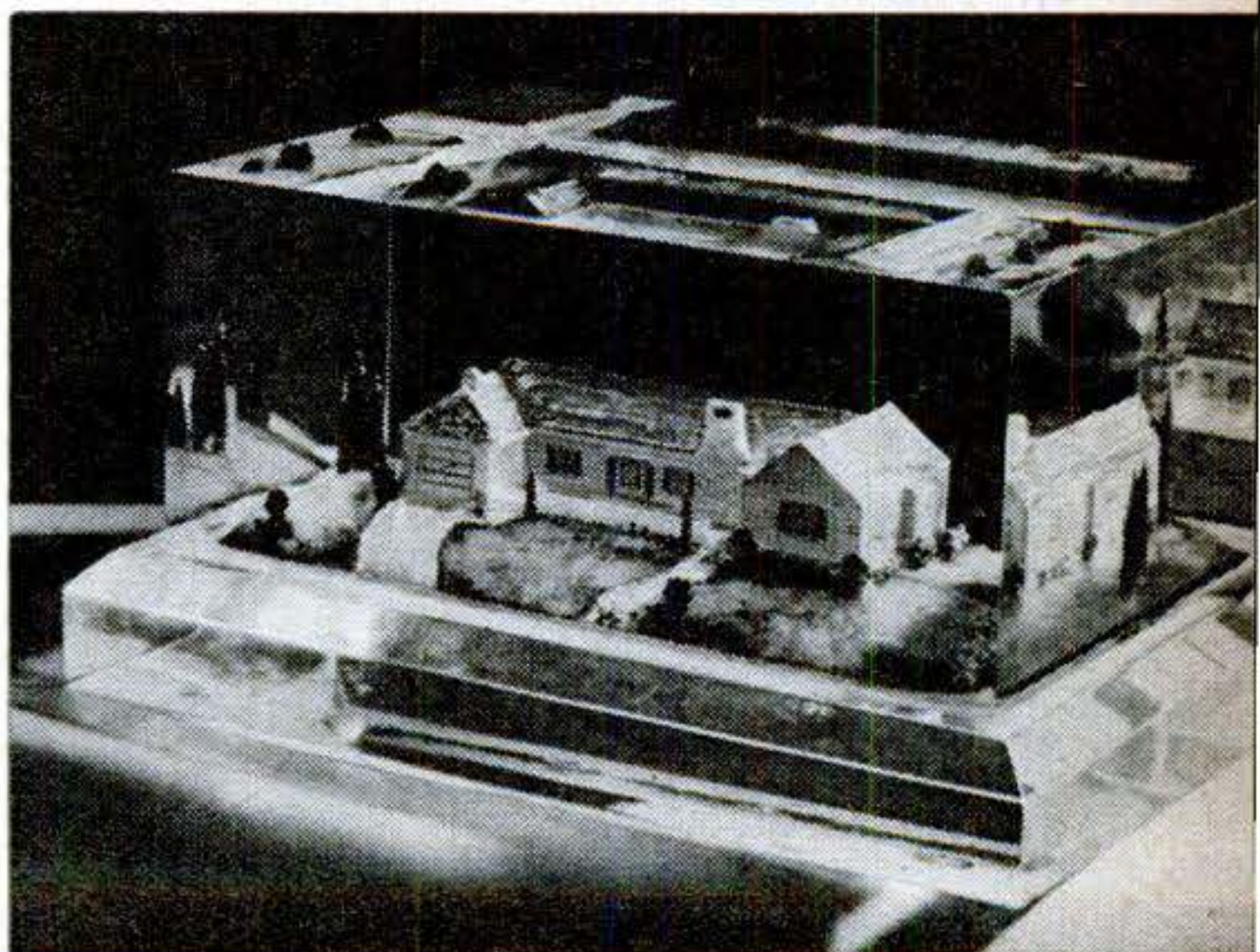

# Vacuum-Tube Meters Read Voltage Right

Does a VTVM draw current from the circuit under test? The milliammeter gives the answer.

**I**F YOU'VE ever tried servicing a radio, you don't have to be told that a voltmeter is like an extra right arm. It's the tool that often tells you what the trouble is, and when it can't do that, tells you where to look for it.

Voltmeters can be roughly divided into three classes. Low-resistance meters are the commonest. They are usually rated for sensitivity in the neighborhood of 1,000-ohms-per-volt and require 1 ma. of current to deflect the pointer full scale. High-resistance meters of the 20,000-ohms-per-volt class are distinctly better and will give accurate results under most conditions. They need only .05 ma. to drive the needle across the dial. The third type is the vacuum-tube voltmeter, or VTVM. It has almost infinite resistance and takes practically no current for its operation. If you bear in mind that any current required by the meter must be

taken from the circuit being tested—which tends to "load" the circuit—you can see why it is often important to keep drain to a minimum.

None of this should be read as a criticism of the first two types of meter. Both have numerous applications if you understand their limits. But take the situation diagrammed in Fig. 1. The tube is receiving its plate current through  $R_1$  and  $R_2$ . Now if you try to measure the voltage at the plate with a 1,000-ohms-per-volt meter, you introduce another current-drawing element into the circuit, the meter itself. The extra drain may be very little (say a half or quarter milliampere); but since it must also flow through  $R_1$  and  $R_2$ , it introduces an extra voltage drop. Thus the very presence of the meter changes the circuit you are trying to measure.

Another way of viewing the same problem

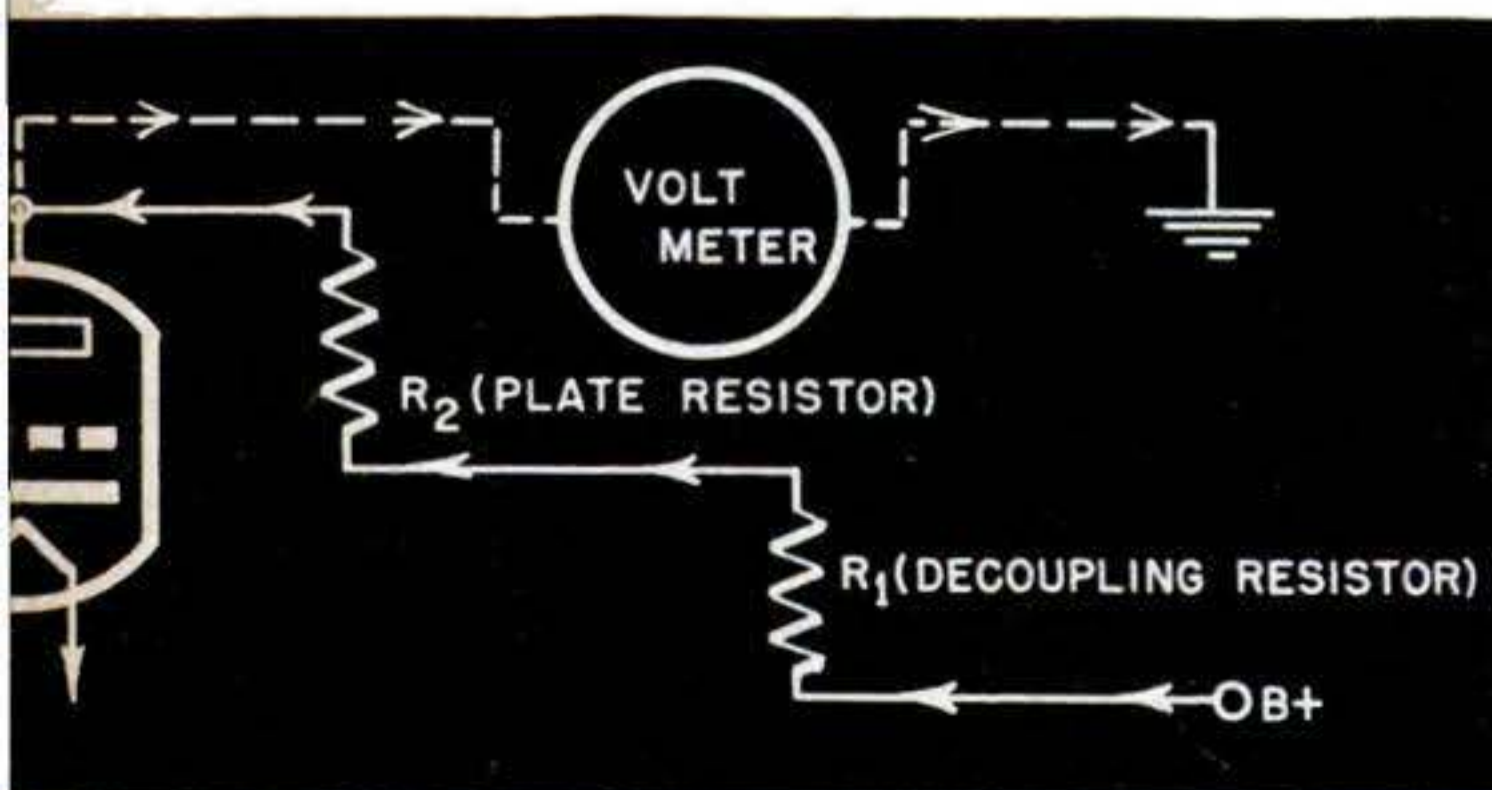

1. Here's where the current goes. The meter "loads" the circuit by drawing extra current.

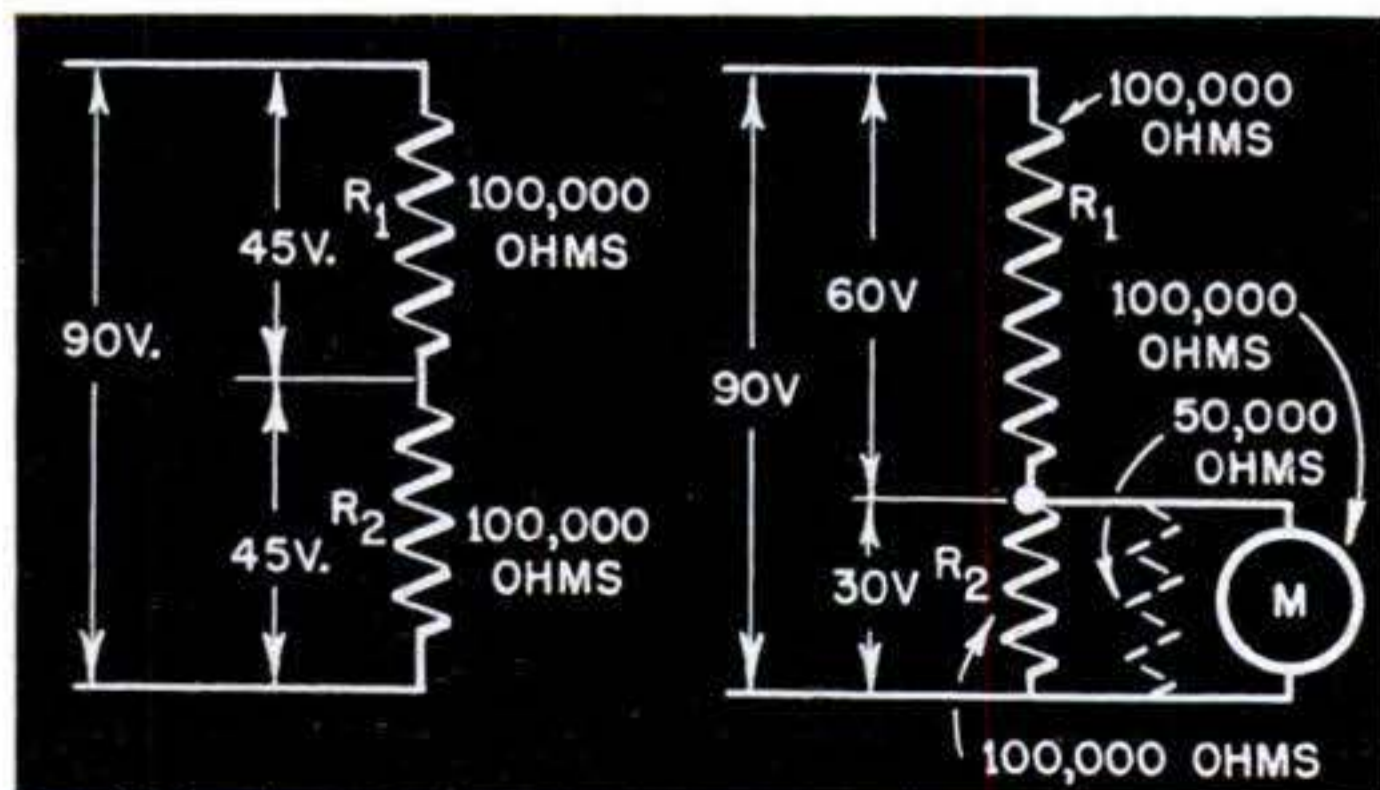

2. There should be 45 volts across  $R_2$ , but an ordinary meter will give a reading of only 30.

is illustrated in Fig. 2. The left-hand sketch shows a 90-volt source across which two identical resistors have been connected in series. Basic electrical theory tells you that the voltage will divide equally across the resistors. Now connect a low-resistance meter across R2. A 1,000-ohms-per-volt meter used on the 100-volt scale would have a resistance of 100,000 ohms. This gives you the effective circuit shown in the right-hand sketch. The net resistance of the meter and R2 is only 50,000 ohms. Voltage drop across this part of the circuit, therefore, is no longer 45 volts but 30.

The more we increase the resistance of the meter and the less current is needed to drive it, the more accurate will the reading become. That's a job for vacuum tubes. Tubes are able to amplify because a small change in current at the grid produces a much larger change at the plate. Thus if you feed an unknown voltage to the grid and place a reasonably accurate milliammeter in the plate circuit, you can obtain a meter in which the minutest amount of current will be sufficient to operate the meter movement.

The photos and drawings on the following pages show two vacuum-tube voltmeters. The larger one, diagramed in Fig. 6, was built by Tracy Diers, of Richmond Hill, N. Y. The smaller one (Fig. 14) made by Albert Rowley, Manhattan, N. Y., is a less versatile unit but easier to build.

Mr. Diers' unit will measure both alternating and direct voltages and has four ranges from 0 to 1, 10, 100, and 500 volts. A 6SQ7 was selected for the meter tube because in addition to the triode it contains diodes for rectifying AC. The grid of the triode is given a fixed bias of  $1\frac{1}{4}$  volts by a bias cell of the type used in some amplifiers.

For the meter itself you may use any surplus or standard unit provided it has a basic movement of 0-1 ma.—that is, 1 milli-

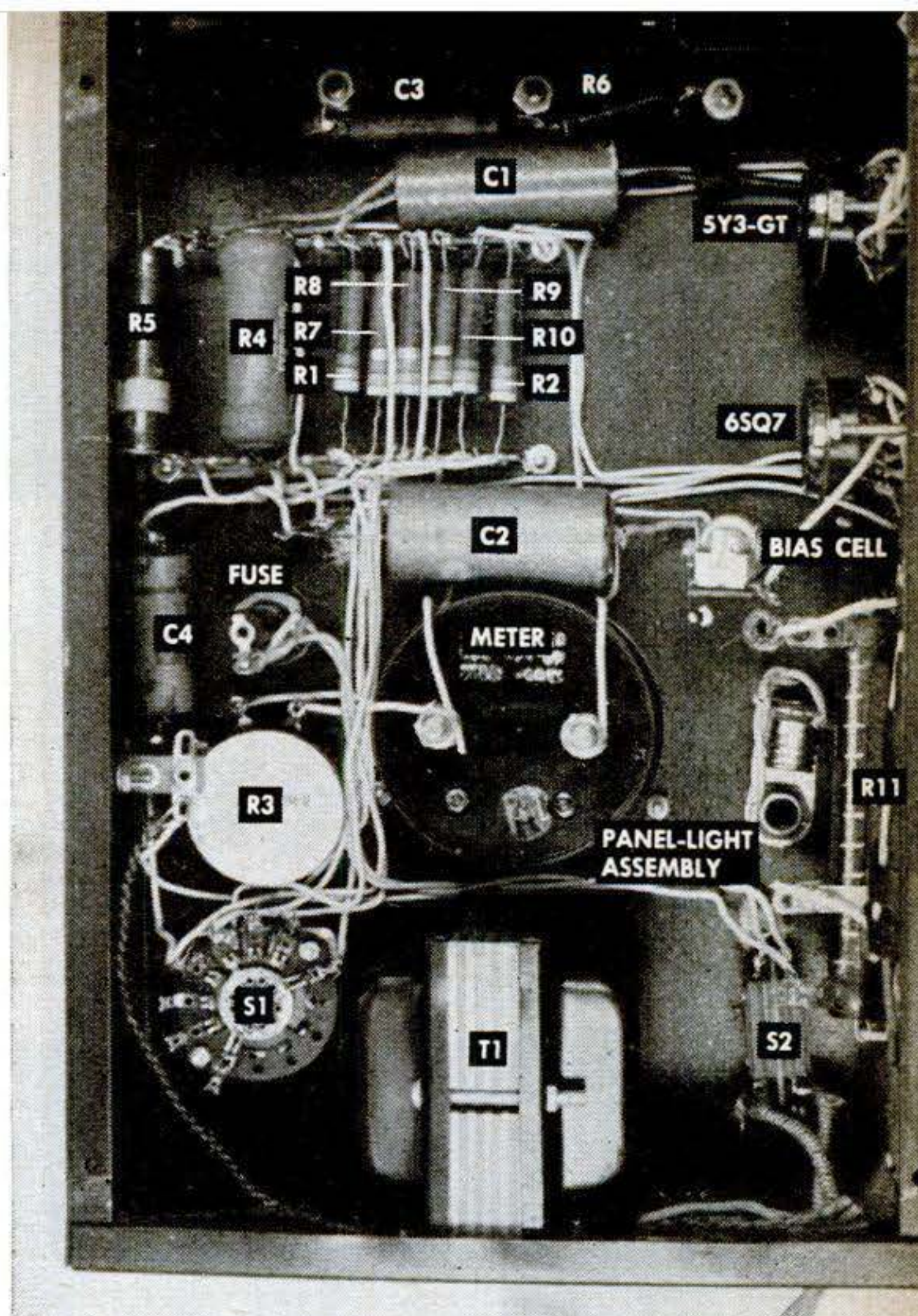

3. A combined chassis and cabinet is used for assembling the parts. Layout isn't very critical.

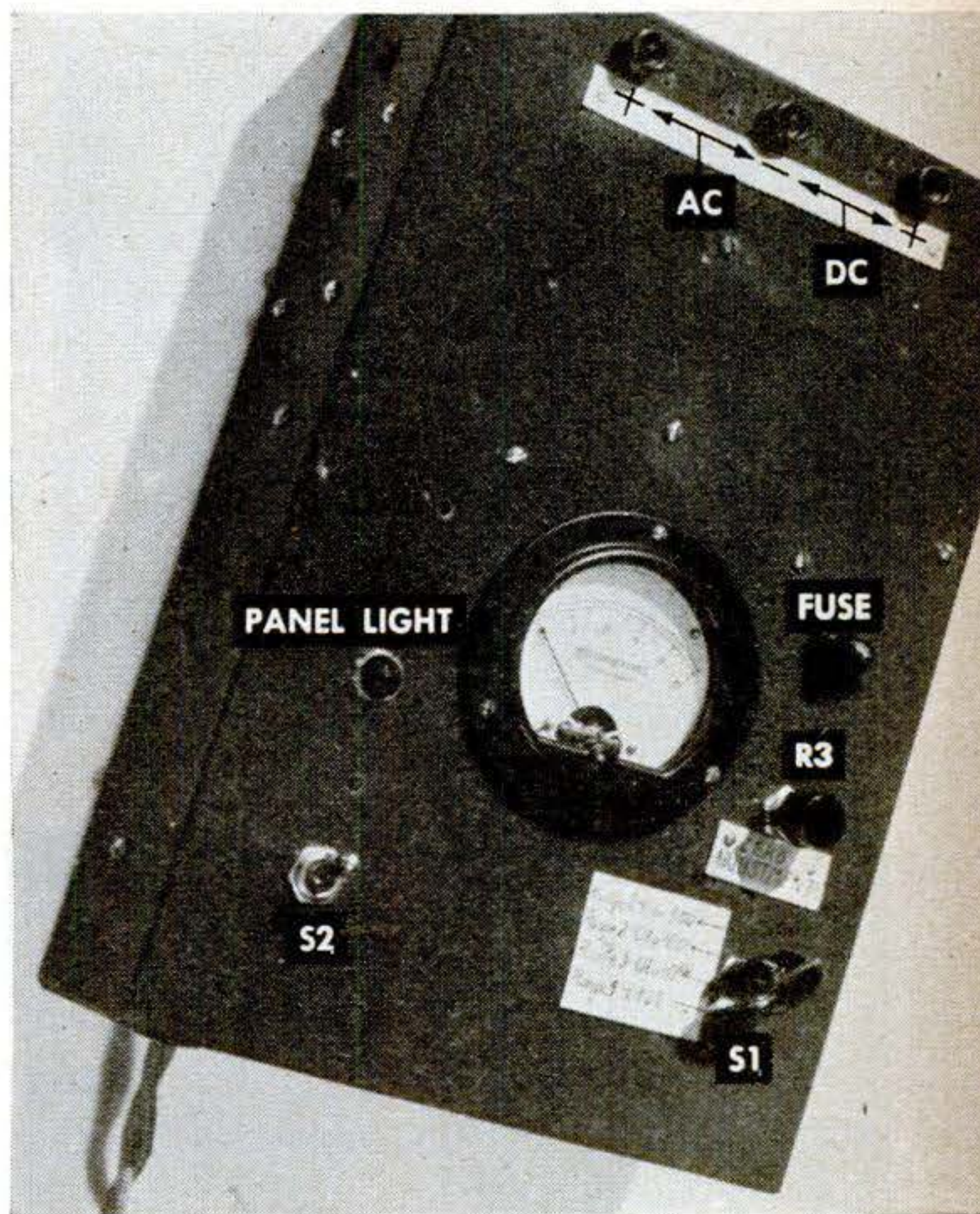

5. Range switch, test-prod jacks, and zero adjustment must be located on top of the panel.



4. If a meter is altered to read 0-1 ma. by removing a shunt, the scale must be re-marked.

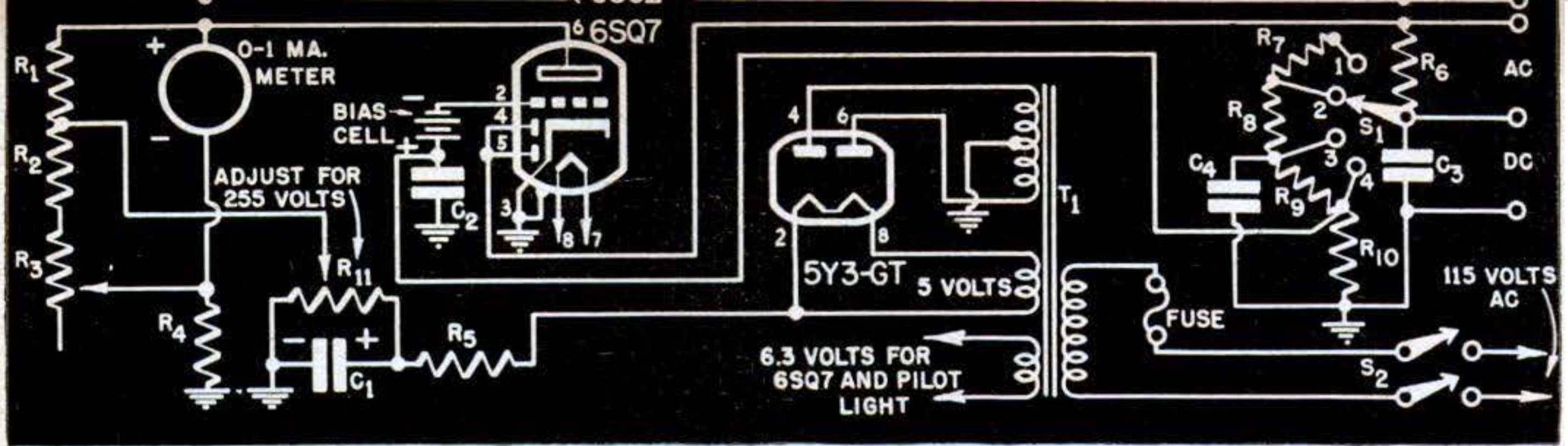

6. Parts used in building the VTVM must be of close tolerance, but the wiring is simple.

### LIST OF PARTS

R1: 10,000-ohm, 1-watt carbon.  
 R2: 1,500-ohm, 2-watt carbon.  
 R3: 2,000-ohm wire-wound potentiometer.  
 R4: 40,000-ohm, 20-watt adjustable wire-wound. Set slide for 36,000 ohms. See text.  
 R5: 2,500-ohm, 5-watt wire-wound.  
 R6: 1-meg., 1-watt carbon.

R7: 40-meg., 1-watt carbon (2% tolerance).  
 R8: 9-meg., 1-watt carbon (2% tolerance).  
 R9: 900,000-ohm, 1-watt carbon (2% tolerance).  
 R10: 100,000-ohm, 1-watt carbon.  
 R11: 15,000-ohm, 50-watt, adjustable wire-wound.  
 C1: 8-mfd., 450-volt electrolytic.

C2: .5-mfd., 450-volt paper.  
 C3: .05-mfd., 600-volt paper.  
 C4: .1-mfd., 600-volt paper.  
 S1: 4-contact rotary switch.  
 S2: DPST toggle.  
 T1: 600 to 650-volt power trans.  
 Meter (0-1 ma. DC), 1¼-volt bias cell and holder, panel-light assembly, tubes and sockets, misc. hardware.

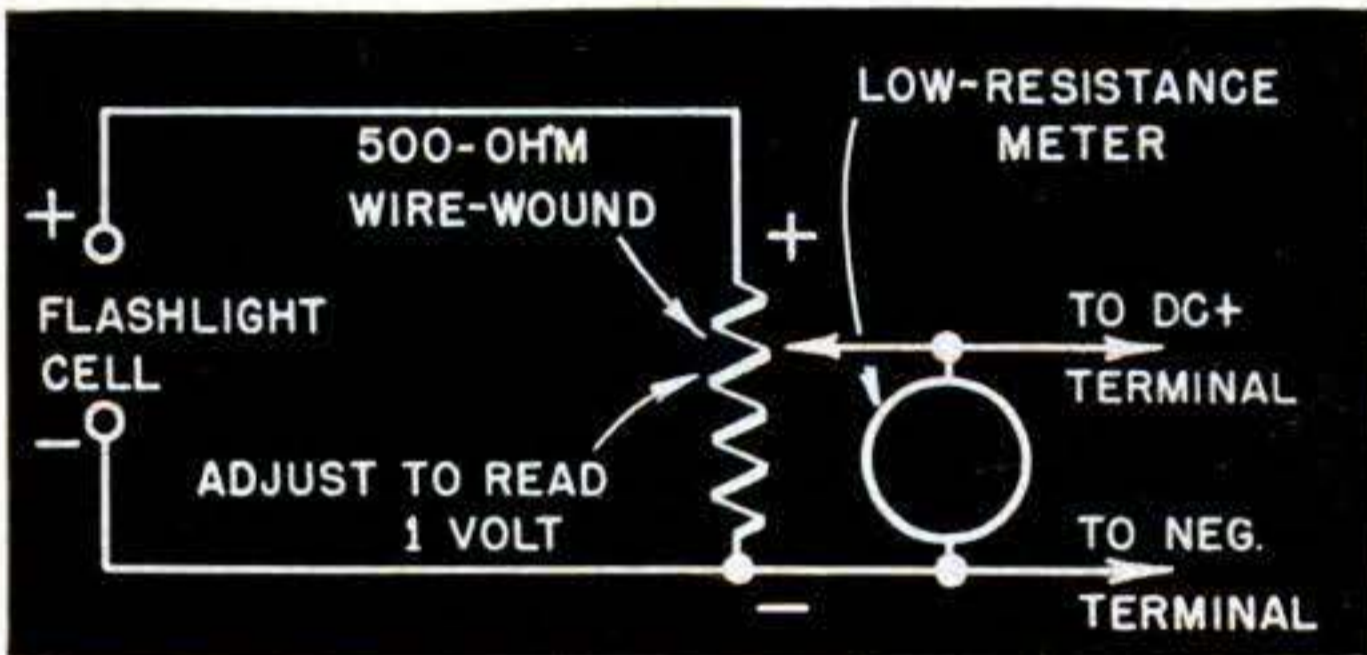

7. Calibrate the meter with this setup. Leave the low-resistance meter connected throughout.

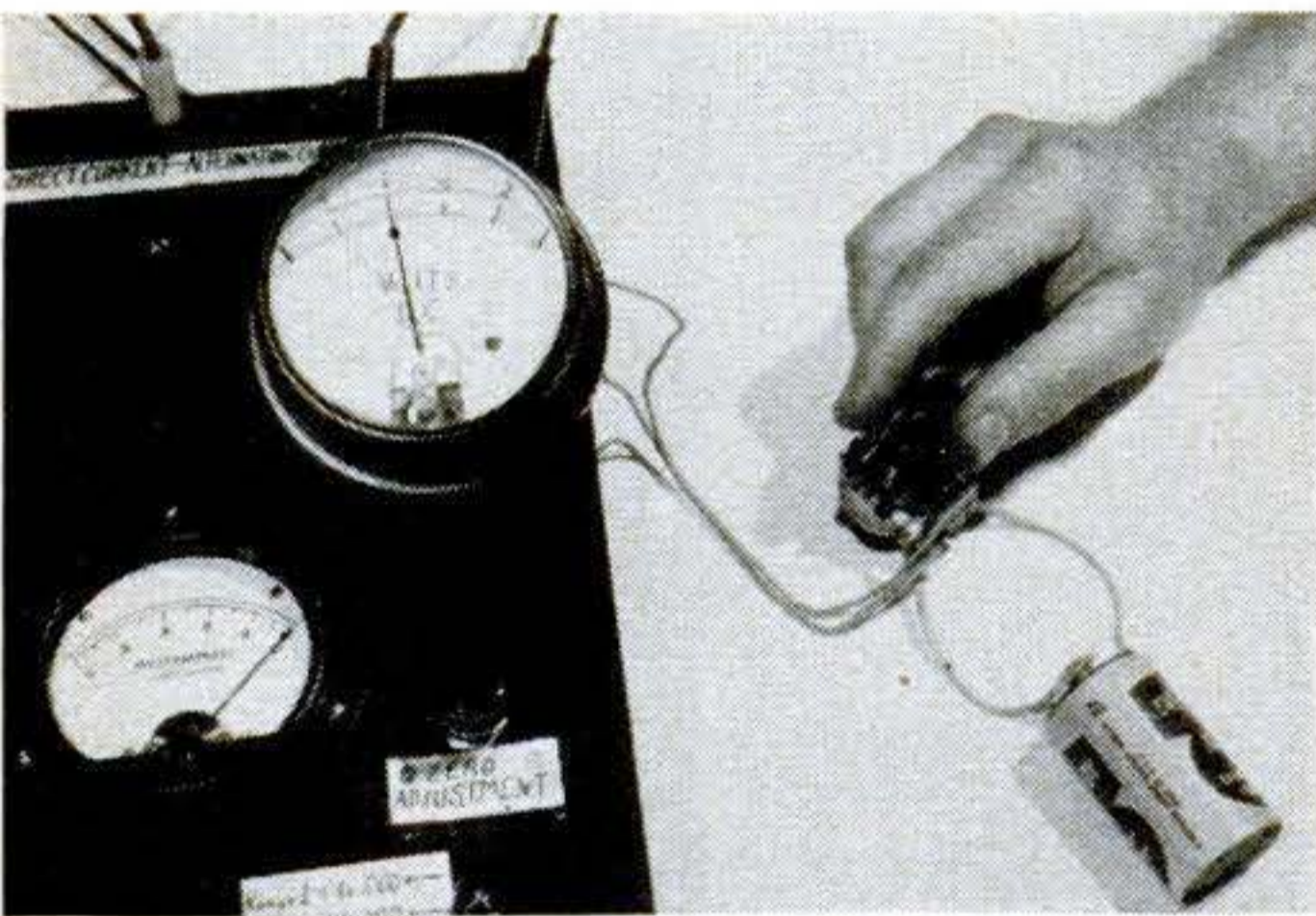

8. The VTVM should give the same reading as the calibration meter. Zero the VTVM first.

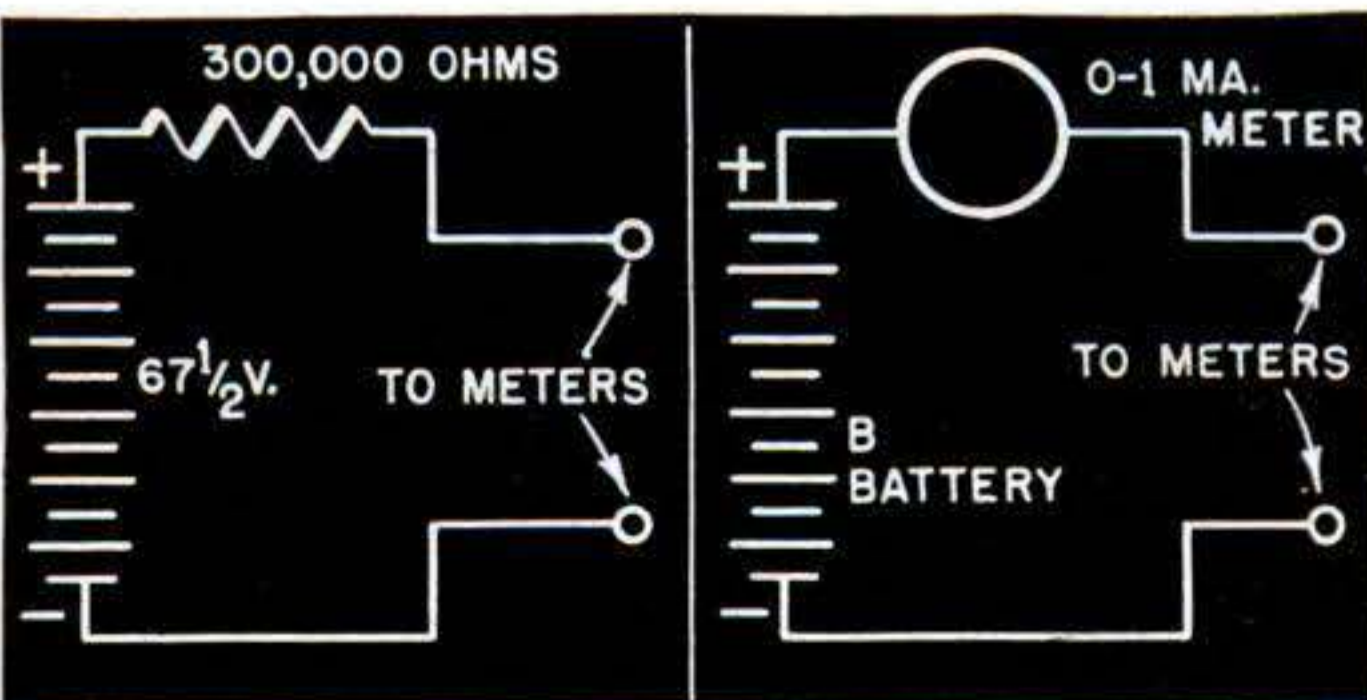

9. In each of these circuits try first a low-resistance meter and a VTVM; compare results.

ampere causes full-scale deflection. It may be necessary to remove shunts or multipliers that are used to give the meter a different scale. If you do, re-mark the dial as in Fig. 4. Figures 3, 5, and 6 show the location of the parts and the method of connection. Scrape every contact and tin those that need it before soldering. This is important if you want clean, firm joints.

The unit is built into a chassis measuring 3" by 10" by 12". Tube sockets are mounted along an inner chassis edge by means of bolts and spacers. Some of the resistors called for may be hard to come by. If you have trouble finding any, remember you can always make up the right resistance by adding two or more smaller units in series. A higher wattage than specified will do no harm.

To obtain the proper operating voltage, a power transformer, T1, and a 5Y3 rectifier are used. The sliding arm on R11 has to be adjusted to 255 volts from slide to ground.

Scale selection is accomplished by means of a single-pole four-position rotary switch. With the slider on contact 1, the meter reads from 0 to 500 volts full scale (which means that you multiply the meter scale by 500). Contact 2 gives the 0-to-100 range (multiply by 100). Contacts 3 and 4 are for the 10- and 1-volt scales.

The meter is calibrated for DC. Note, however, that a separate terminal is provided for measuring alternating voltages. These are rectified in the diode portion of the 6SQ7. The meter registers *peak* voltage. Alternating current or voltage changes its value every instant, ranging from zero to

peak. The thing you usually want to know about it is the *effective value*, which is known also as *root mean square*, or *r.m.s.* To convert the voltage indicated on the meter dial to r.m.s., multiply the peak value by .707. In most cases multiplying by .7 gives a sufficiently close answer.

When you have completed the wiring, check the VTVM for accuracy of calibration. Turn it on and allow it to warm up. The meter needle will swing off scale, and then gradually fall toward zero. Insert one test lead in the common terminal and another in the DC jack. After about five minutes, short the prods by touching them together. Adjust R3 until you obtain a zero reading. These adjustments should be made with the selector switch on the 1-volt scale. When the prods are not touching the needle may swing away from zero, but the important thing is to have the pointer at zero when the prods are shorted.

If the meter fails to zero properly, you may have to readjust R4 slightly. The initial value of this resistor was figured as 36,000 ohms, but it may be necessary to raise or lower it a little by shifting the sliding contact. A 40,000-ohm adjustable resistor is suggested for R4. Note however, that it is shown in the diagram as a fixed resistor because once the proper value is found no further adjustment should be needed.

Hook up a flashlight cell and a 500-ohm potentiometer as shown in Fig. 7. An ordinary but accurate voltmeter may be used for the calibration. Vary the resistor until the meter reads exactly 1 volt. Connect the terminals of the VTVM to the points shown. The meter should read 1 milliamperes—or, if you have re-marked the scale—1 volt.

If R7, R8, and R9 are known to be within 2-percent tolerance, it should not be necessary to calibrate for the higher ranges. However you may do so by adapting the setup of Fig. 7, using a higher voltage source, a 1-meg. potentiometer, and a multi-range voltmeter. Check full- and half-scale deflection on each range.

To demonstrate the superiority of a VTVM over ordinary meters, duplicate the circuit shown at the left in Fig. 9. With a low-resistance meter the probable reading will be about 25 volts; the VTVM will indicate very close to 67½ volts.

As a second step, check the current needed by each of the meters by inserting a 0-1 ma. meter in place of the 300,000-ohm resistor. Make a voltage reading across the



10. This simplified VTVM uses one tube. Scale divisions, from 0 to 25, are marked on glass.

terminals with a low-resistance meter and the VTVM. The milliammeter in series shows how much current is taken by each of the voltmeters. It will probably be something like .6 ma. for the low-resistance unit. How much does the VTVM draw? You can read the answer yourself at the top of page 210.

#### Compact One-Tuber

Everything that has been said about vacuum-tube voltmeters applies equally to the simplified model shown above and on the following page. Mr. Rowley's meter uses one tube and reads DC voltages only. It has three ranges, from 0 to 2.5, 25, and 250 volts. Selector switch and bias cell have been omitted, and one half of the 7N7 dual triode is used as a power rectifier by tying the grid and plate together.

Again, any good 0-1 ma. meter may be used; one with a fairly large scale is desirable since this hookup causes the meter to zero at midscale. A small meter would make the divisions hard to read.

The power transformer has a high-voltage secondary of 240 volts on either side of the centertap. One of the outer leads is cut off and taped, as are both leads of the 5-volt secondary, which is not used.

Tube, calibration control, and most of the small parts are mounted on a 2½" by 4½" aluminum chassis. This unit, in turn, is installed in a larger cabinet on which are placed the meter, zero control, selector terminals, and switch.

Like the other meter, this one has to be calibrated before it can be used. After completing the wiring, turn on the switch and let the tube warm up. After a few seconds

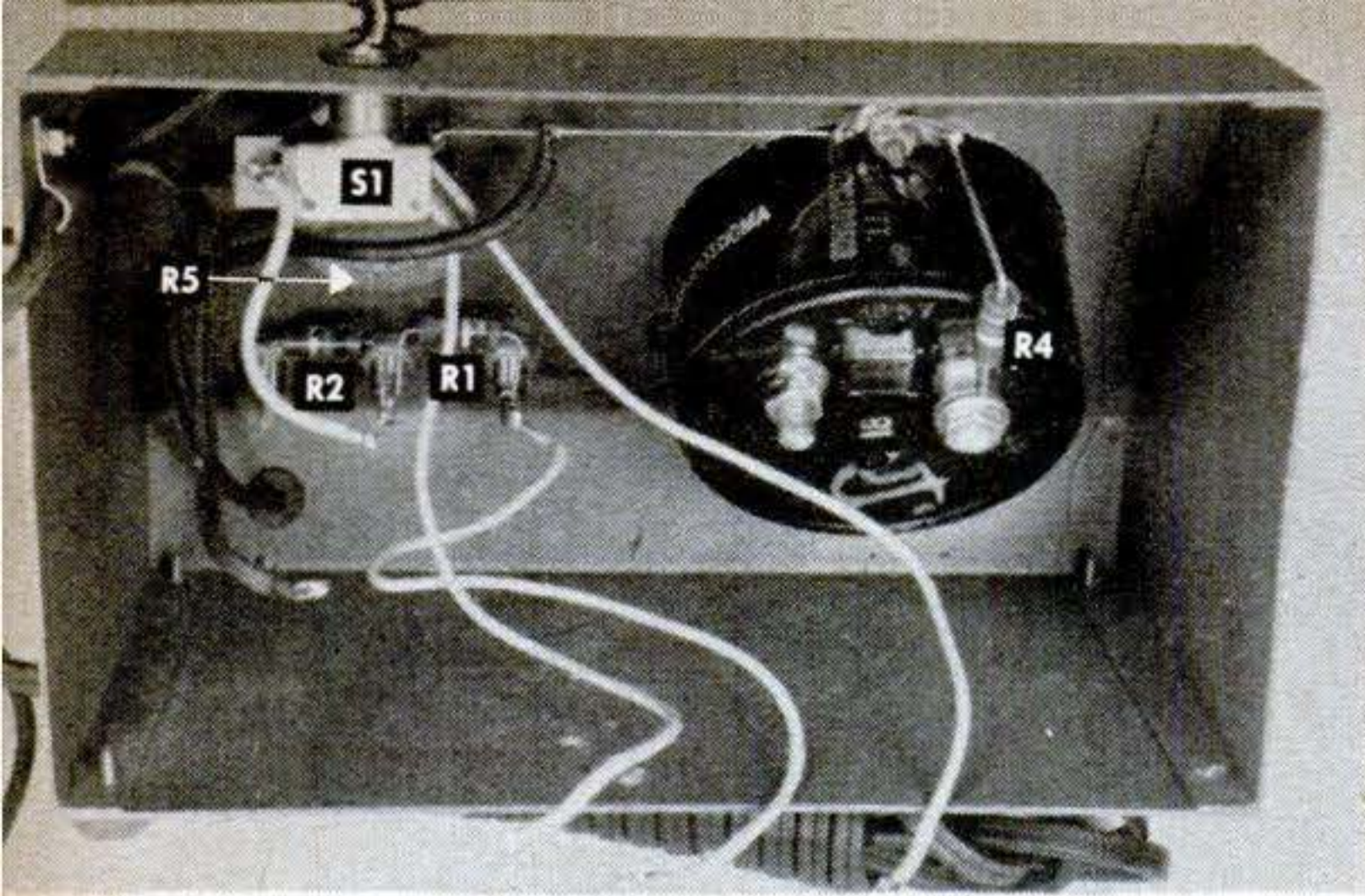

11. A few of the parts are attached directly to the front and top of a small metal cabinet.

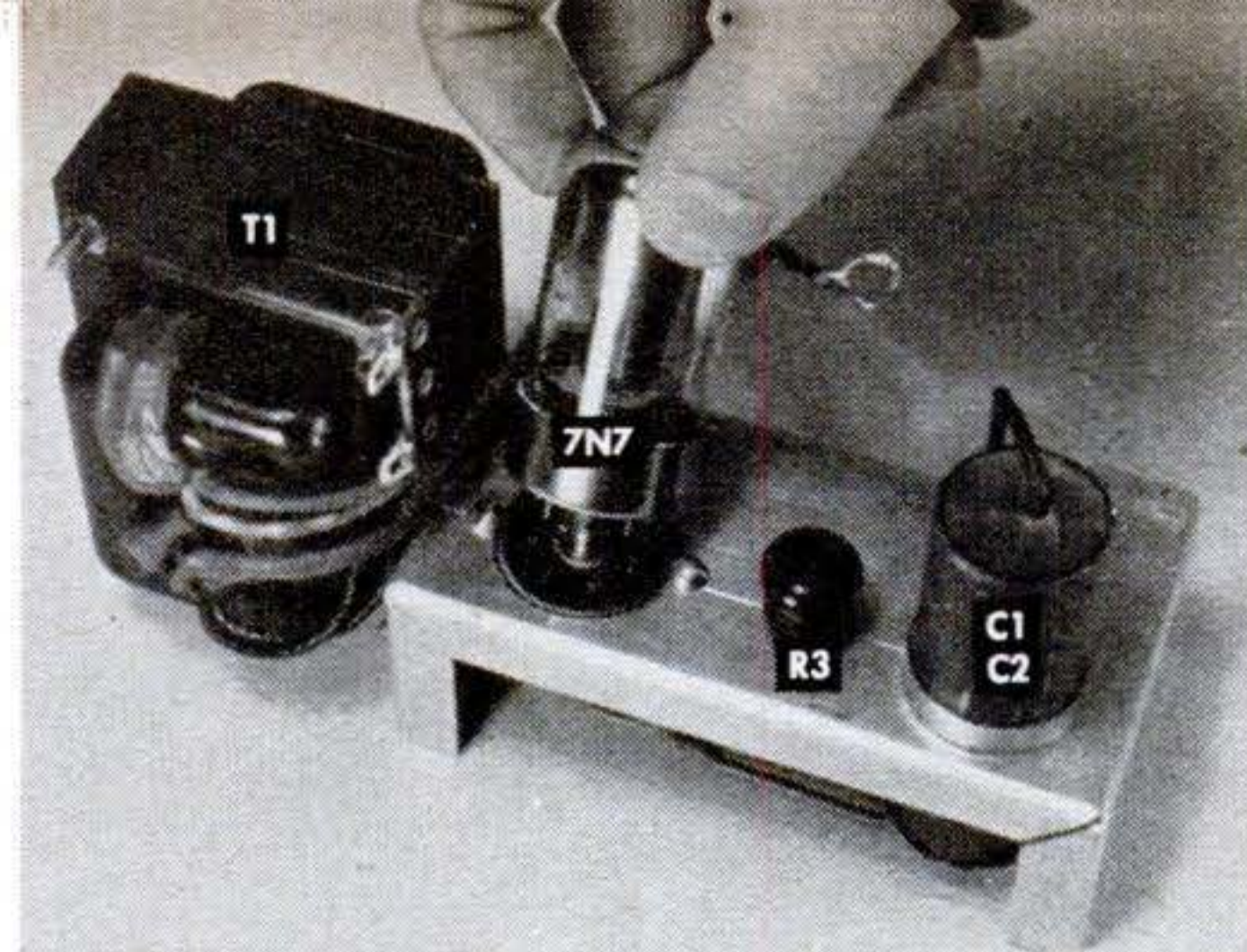

12. The transformer is bolted to the chassis. Calibration control and the tube go on top.

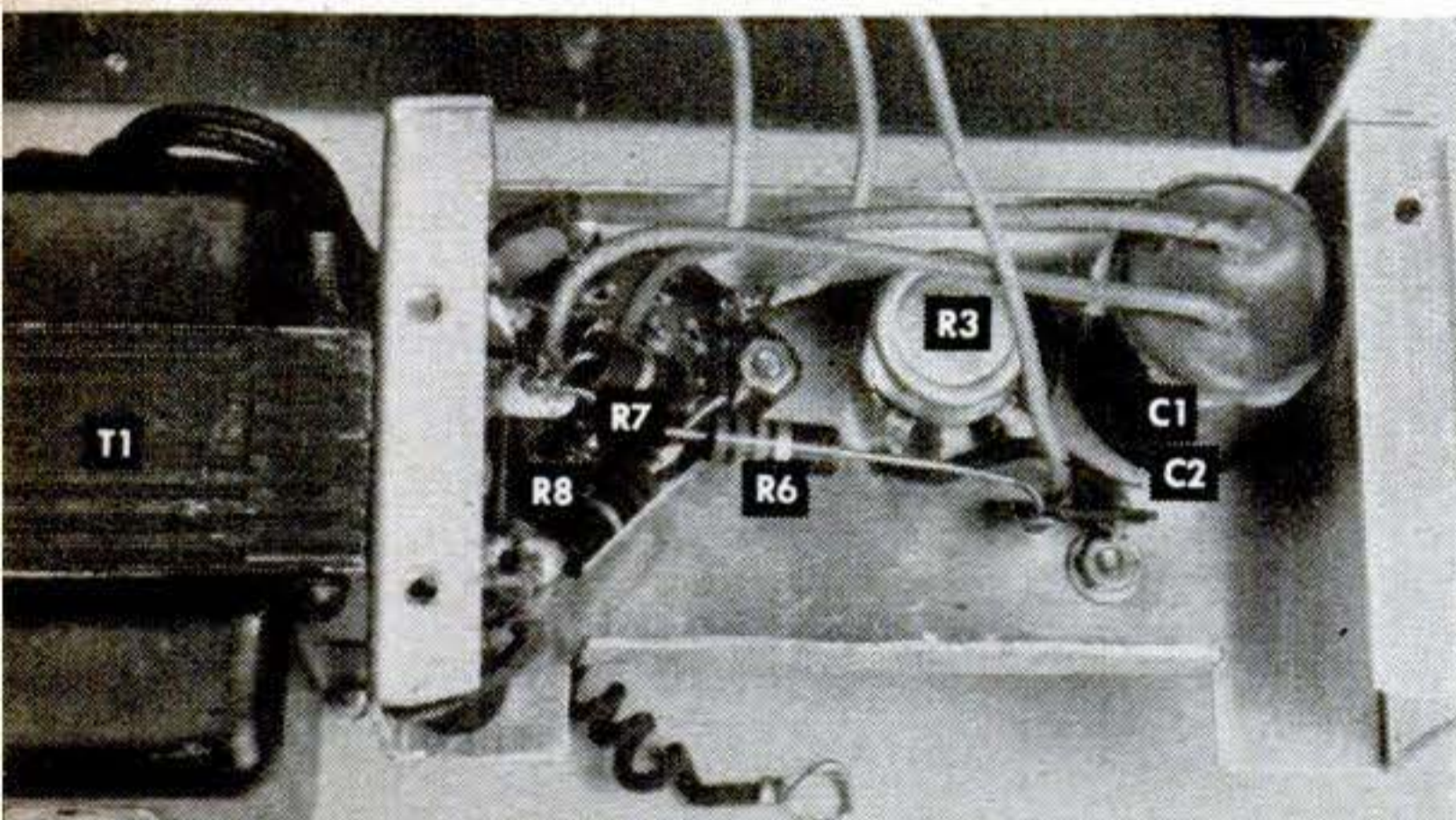

13. Remaining parts are wired underneath the chassis, which is then placed in the cabinet.

the needle will start climbing to the center of the scale. Use the zero control to bring the needle to exact center. Repeat the setup shown in Fig. 7. Plug a positive test lead into the 2.5-volt jack and connect the leads to

take a reading. Adjust the calibration control so that the needle swings exactly one division when the low-resistance meter shows 1 volt. Reverse the polarity of the test prods and check the swing in the opposite direction.

Should the reading be inaccurate, readjust the zero control until the swing is exactly one division either way. Disconnect the test prods and make a sharp mark on the glass dial face at the point where the needle rests. Re-mark—on the glass—this new zero position and use it whenever you are testing on the 2.5-volt scale. Use the normal zero—i.e., dead center—on the 25 and 250-volt ranges. The meter reads both ways from center, so you don't have to worry about polarizing the test prods. This is handy in checking bias voltages where you'd usually have to reverse the prods. END

#### LIST OF PARTS

All fixed resistors 1-watt carbon.  
 R1: 10 meg.  
 R2: 820,000 ohms.  
 R3: 250,000-ohm potentiometer.  
 R4: 2,700 ohms.

R5: 25,000-ohm potentiometer.  
 R6: 68,000 ohms.  
 R7: 1,000 ohms.  
 R8: 2,200 ohms.  
 C1, C2: 8-8-mfd., 450-volt dual electrolytic.

S1: SPST toggle.  
 T1: 480-volt power transformer.  
 Meter (0-1 ma. DC), 7N7 tube and lock-in socket, test prods.

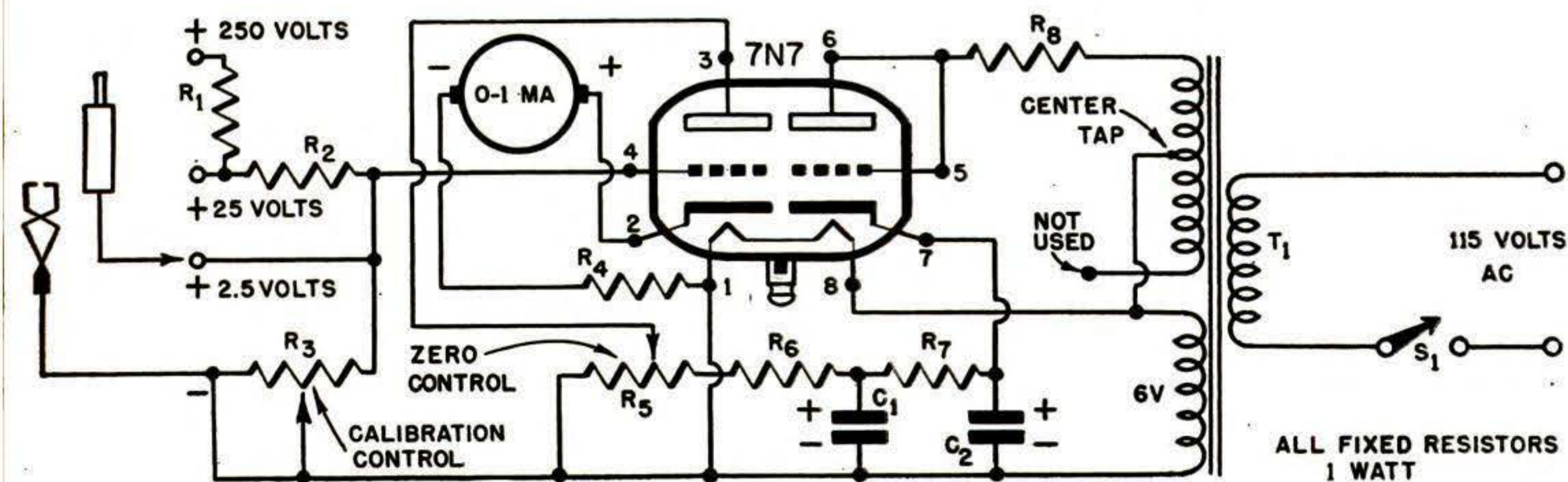

14. Half of the dual triode serves as a power rectifier, the other half as the meter tube.



RECEIVED  
FEDERAL BUREAU OF INVESTIGATION  
U. S. DEPARTMENT OF JUSTICE  
COMMUNICATIONS SECTION  
AUG 11 1949

**California amateur sends voice and picture over transmitter made from \$500 worth of war-surplus parts.**

**By Andrew R. Boone**

**P**ULSING through the California skies from a weather-beaten back-yard shack, the image of a beautiful brunette flows into television receivers around San Francisco Bay. The boys who have seen her call the vision Gwendolyn.

Reproduced by a collection of second-hand tubes and war-surplus video equipment, Gwendolyn represents the first standard TV image broadcast successfully and repeatedly by an amateur. Soon, from the same station, W6JDI-TV, radio ham Clarence Wolfe, Jr. hopes to televise live images.

For over a year the 35-year-old amateur has been broadcasting Gwendolyn's picture from Burlingame, Calif., to demonstrate that

**Gwendolyn**, a picture of a beautiful brunette, is Clarence Wolfe's TV trade-mark. It's the only image he can now send over his homemade transmitter. Later he hopes to send live images and movies. At right, W6JDI's three rotating antennas.

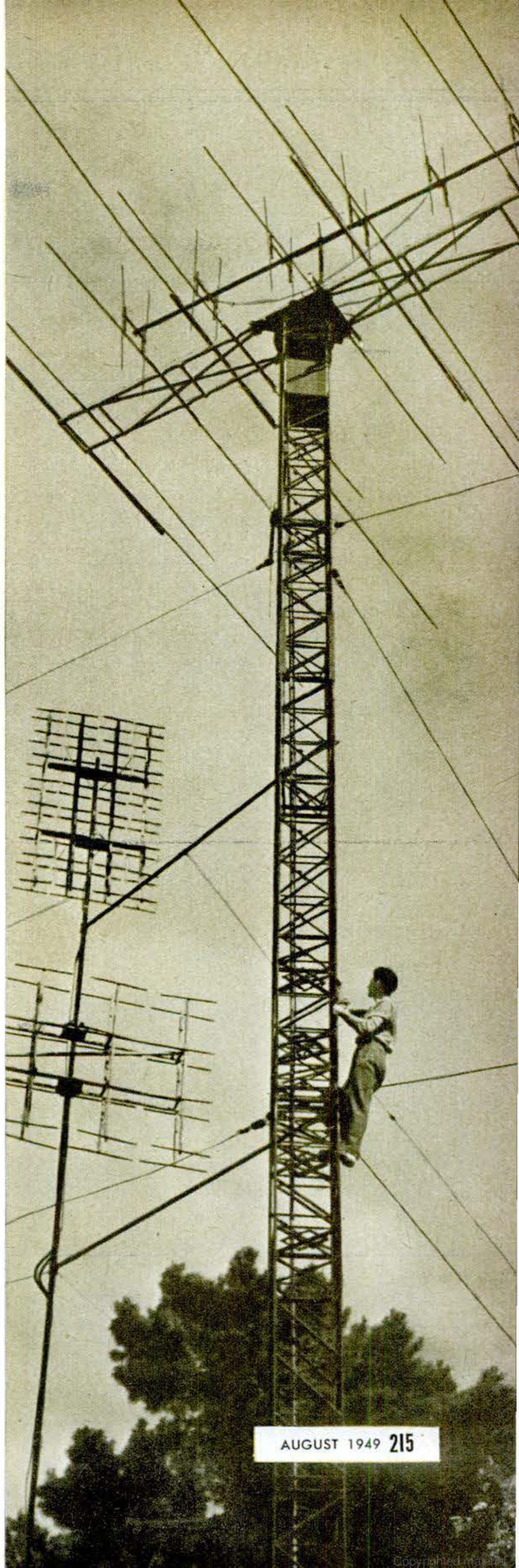

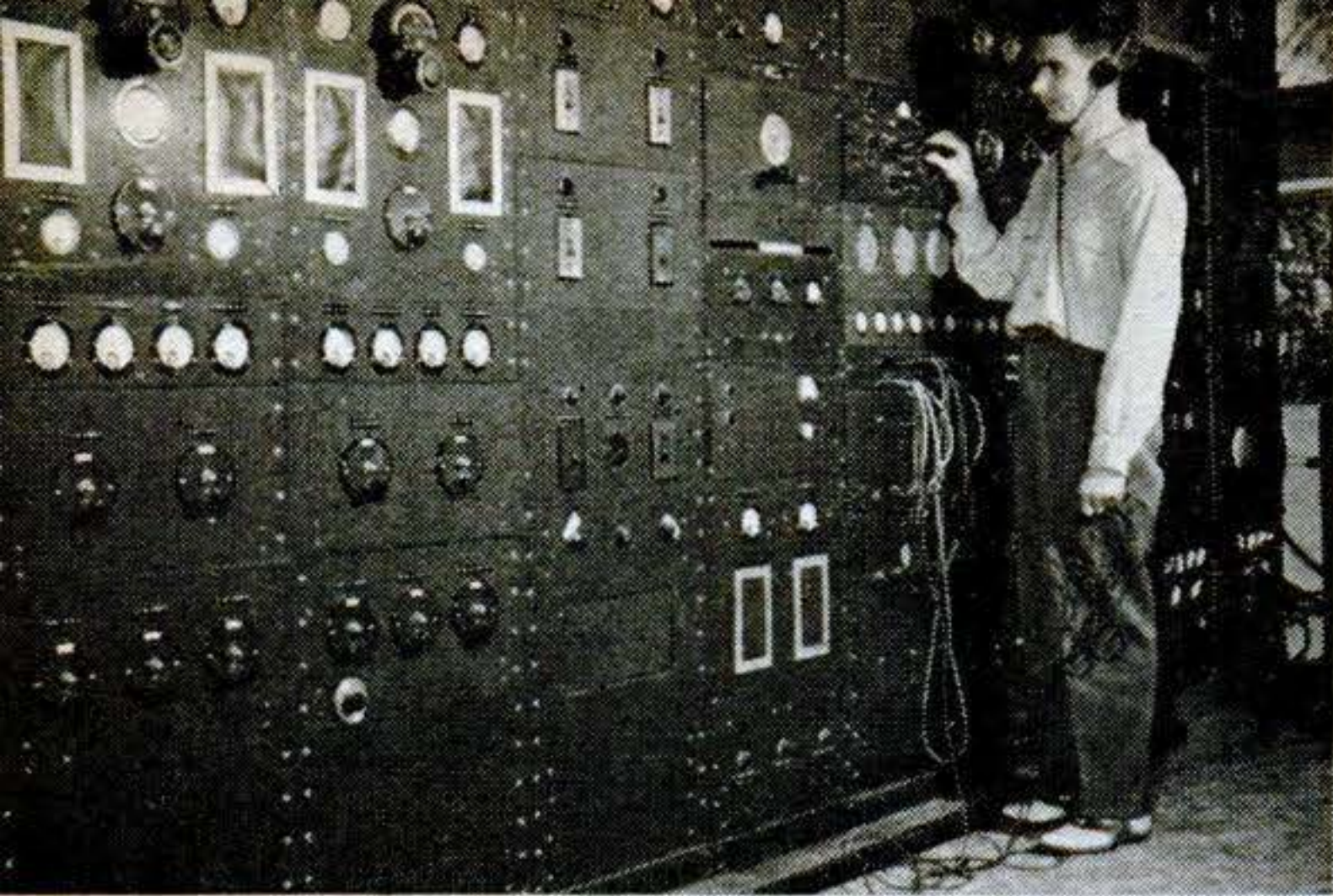

**Control panels** for radio and TV fill one room of radio shack in Wolfe's back yard. Most of his equipment was built from scratch.

his homemade \$500 TV outfit can compete with commercial stations. His R.M.A. signal—meaning a standard TV image that meets rigid standards laid down by the Radio Manufacturers Association—was flying into the winds six months before the first commercial telecaster went on the air in nearby San Francisco.

Not many have seen Gwendolyn yet. She is an image of 525 interlaced lines per picture and 30 pictures a second. The thing that keeps her audience down to a select few is that she travels around in the 429-mc. band, reserved by the Federal Communications Commission for amateur experimental work. Standard home receivers, tuned for the commercial bands between 50 and 200 mc., must use converters to receive ham TV. To hams that's only a minor problem. There

**From 14 tubes** and a wartime chassis, Wolfe built this 50-watt, crystal-controlled transmitter. It is the final link to the antenna.

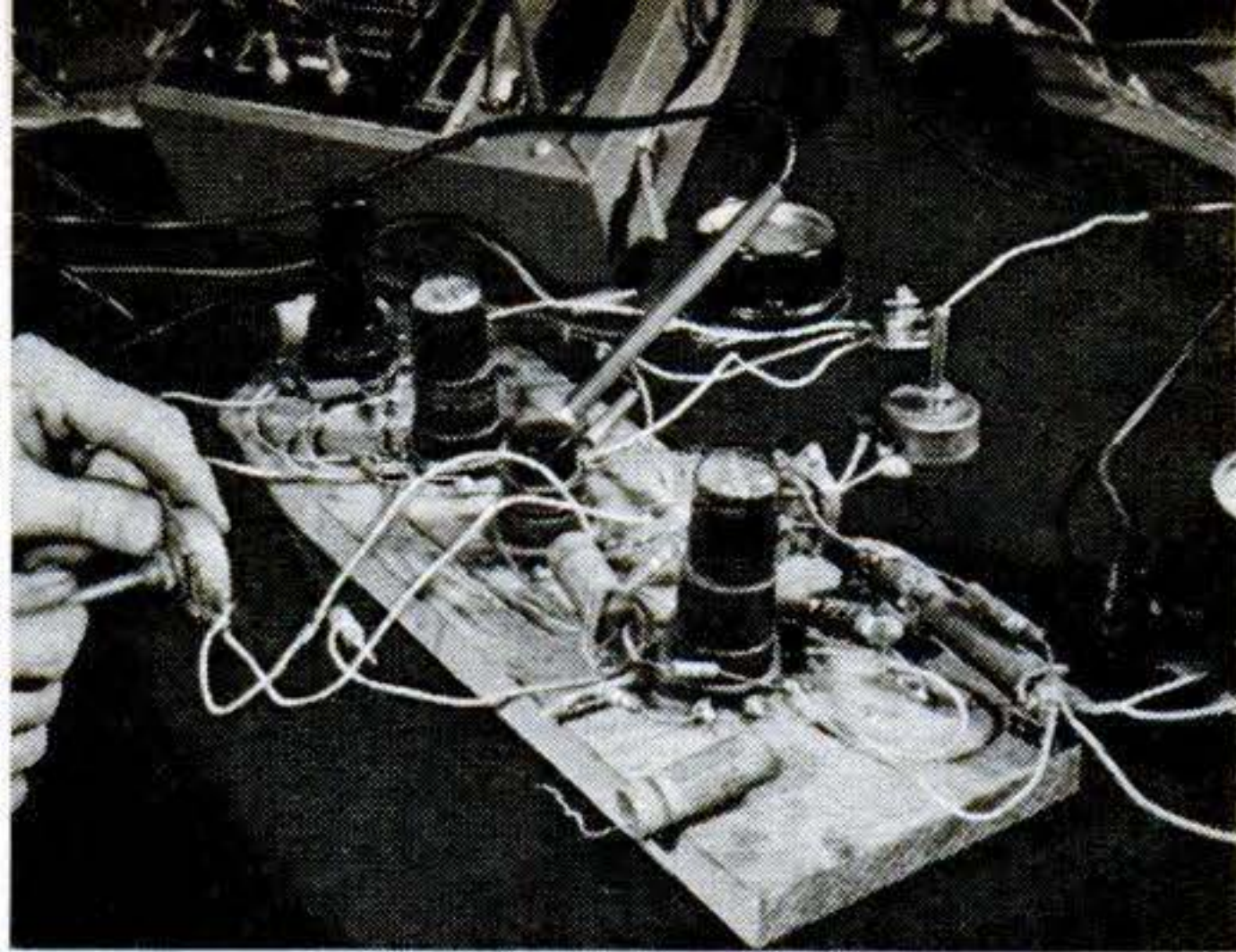
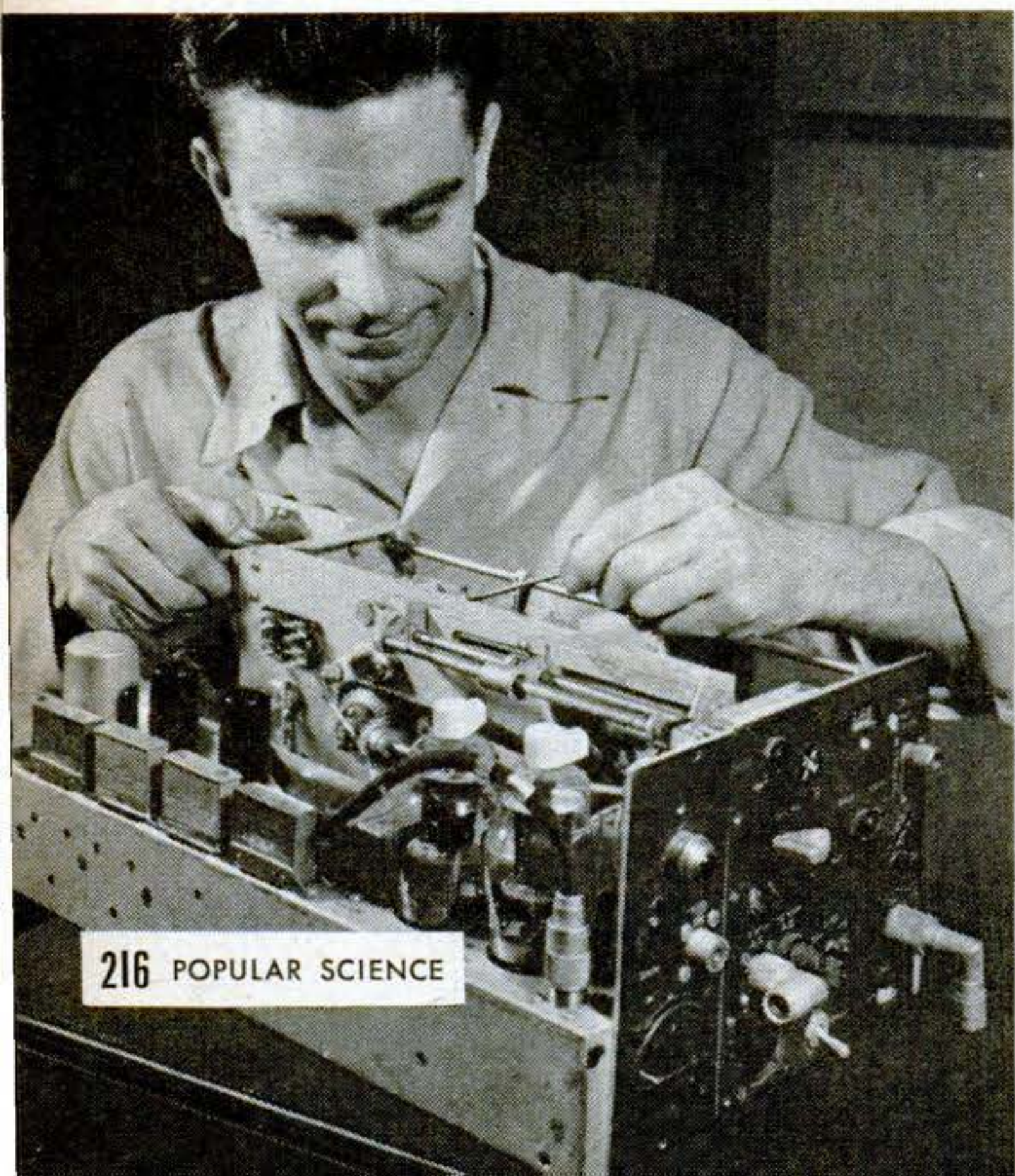

**Real laboratory** of W6JDI-TV is this board. On it each circuit was set up and tested. The best were later incorporated in the TV system.

are a number of war-surplus radio altimeters that will step down the frequency properly.

Gwendolyn is the chief store-bought item in Wolfe's setup. She is a photograph of an unknown girl pasted inside a monoscope—a tube built to send a single image. Unlike the iconoscope or camera tube which scans any picture or scene, a monoscope sees only the photo bottled within it.

Two years were spent building the transmitter, but before that Wolfe spent 22 years building the experience that went into it. He became a radio bug in 1925 when he was 11 years old. In the following years he started a one-man radio service and repair shop in his home town, won his ham license (1932), and began seriously to study radio. Soon after he built the Burlingame police department's first two-way radio system.

**Experimental camera** for live broadcasts and movies consists of an iconoscope or picture tube, three coffee cans, and a lens.

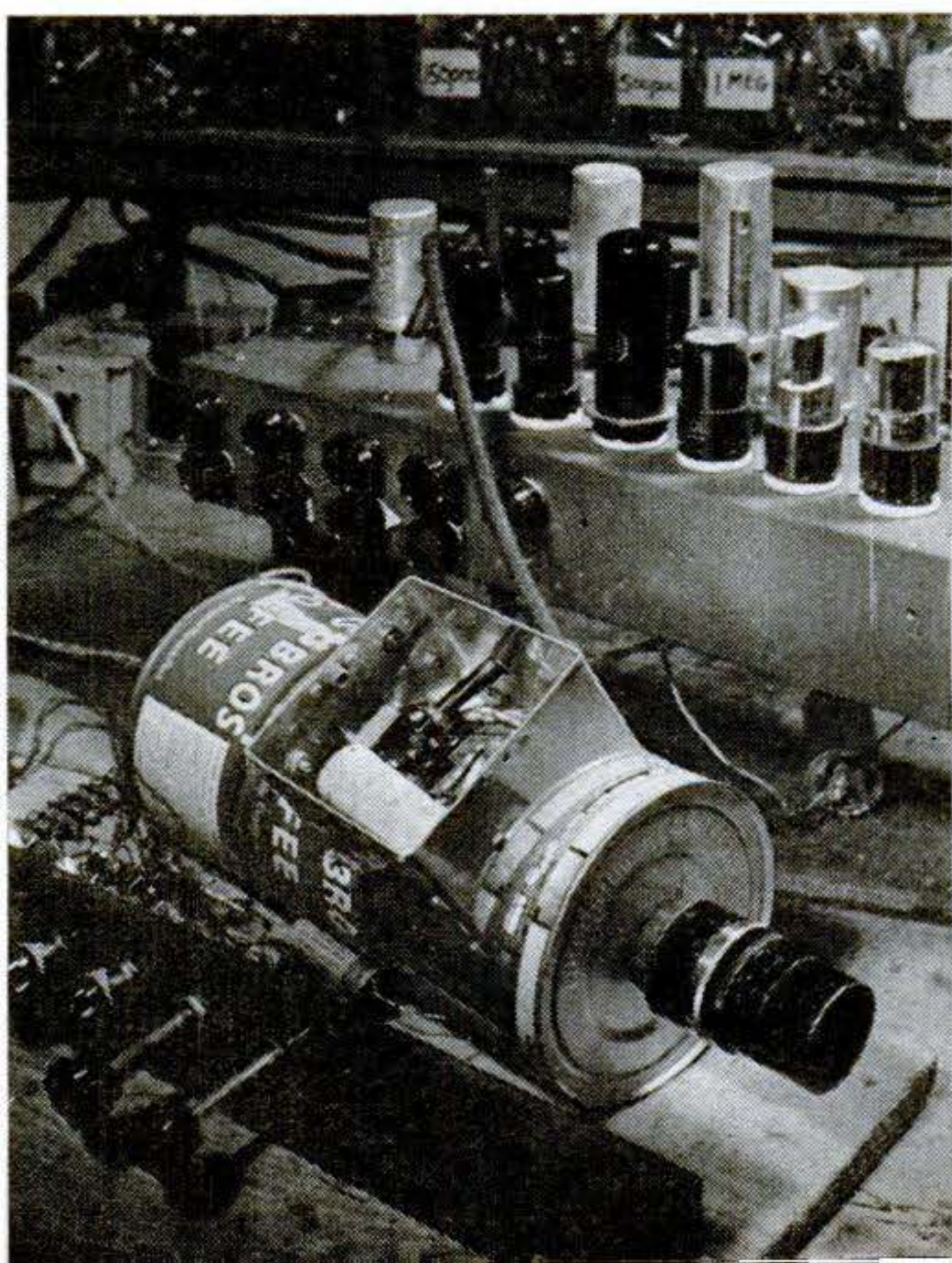

During the war he taught radio and radar, and later installed delicate fire-control apparatus. On returning to his store after the war he started learning the ways of television, and decided to become the first ham on the air with a standard TV picture. Unable to buy expensive commercial equipment, he set about building and adapting what he had or what he could get cheaply. For help he turned to a ham friend, Leslie Seabold, an airline radio engineer.

No well-equipped laboratory awaited his experiments. He had a few pieces of test equipment and a shop-full of odd and spare parts. To make a test panel, he screwed a few sockets to a board. With Seabold, Wolfe worked out the circuits on paper. Then he tried them out in practice. Literally hundreds were tested; only the efficient survived, and these were incorporated in the final sending apparatus.

He tackled the timer first. Twenty modifications came and went before he was satisfied with the neat unit that does the job today. After that came the control assembly, an intricate array of 120 tubes.

To get Gwendolyn's picture out with a big push, Wolfe settled on the antenna array shown in these pages—64 short lengths of aluminum tubing 1" in diameter. Half carry power, the other half serve as reflectors. In the favored direction, field strength is equivalent to 5,000 watts from a dipole. What's surprising about this figure is that the signal comes from the transmitter with only 50 watts of muscle behind it.

When field tests showed that he had what he wanted, Wolfe started his transmitter humming. "This is W6JDI-TV, broadcasting image of a girl on 429 mc.," he said into the microphone suspended above his battered desk. "Do you see her?" For several months he received no response. Except for the hams who picked up the pictureless voice, no one knew an amateur was putting out a TV picture. Then a few, eager to share in the adventure, hooked up radio altimeters to their television receivers. Six months after Wolfe went on the air, Bob Melvin, of Berkeley, answered: "Gwendolyn coming in clear and beautiful."

The name stuck. Confirmations came from Oakland, Vallejo, San Francisco, San Jose.

Incidentally, Melvin caught the bug shortly afterward and built a transmitter of his own in the family garage.

Wolfe now is trying to perfect a camera to replace his single-image monoscope. His



**Lovely Gwendolyn** reposes in lightproof tube made from candy container. On top is a monitor scope; in the foreground is the timing unit.



**Control assembly** started as a single oscillator. It develops three sets of synchronized signals that form the composite signal or picture.

**Voice accompanies the picture.** This is the control console of W6JDI-TV; it serves also for regular transmissions on other ham bands.

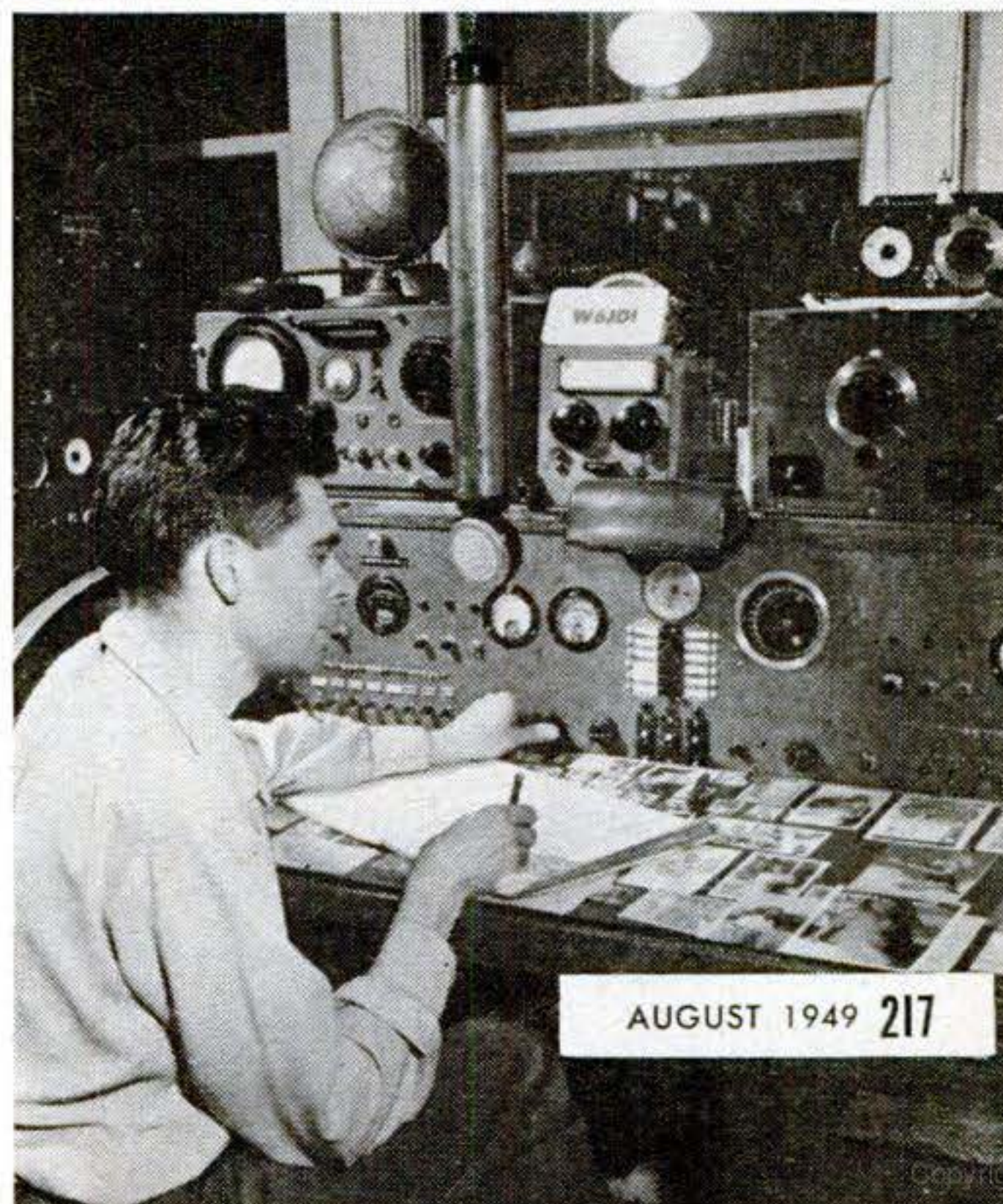

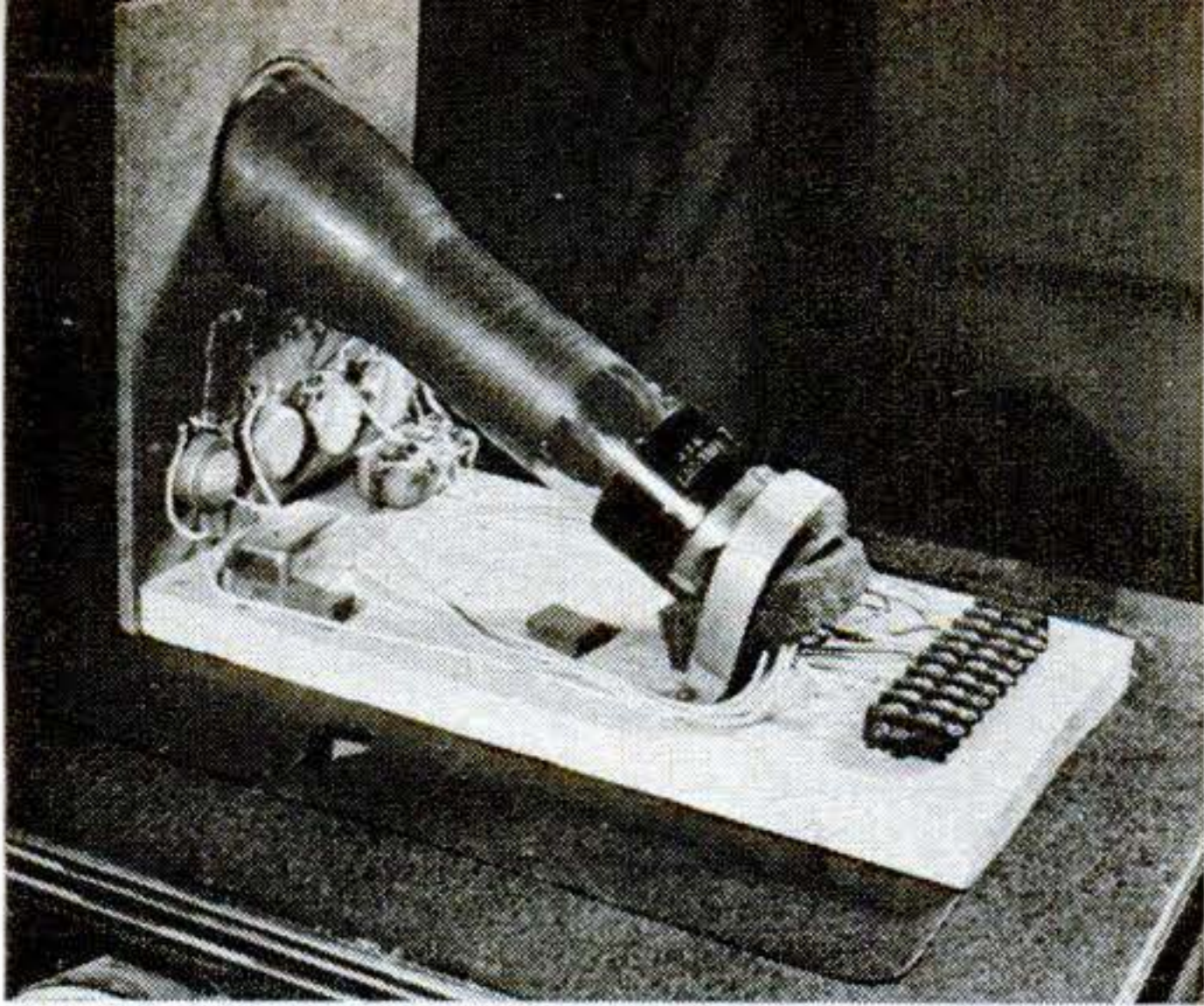

**Experimental monitor tube** in this portable viewer permits Wolfe to see from anywhere in his shop the quality of the outgoing signal.

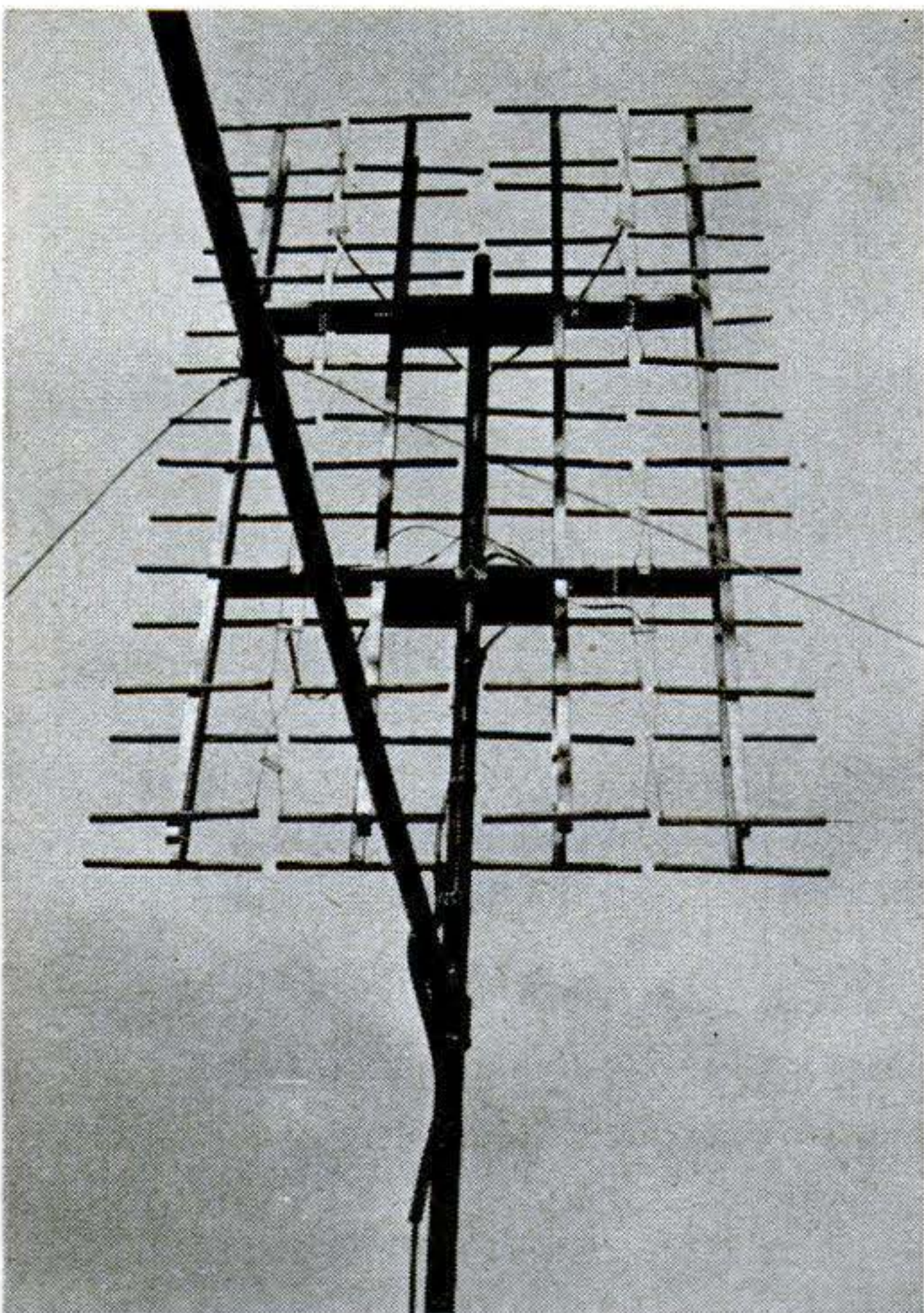

**Broad-band TV antenna** consists of 64 elements; half are driven, the rest reflectors. Antenna covers a band 4.5 mc. wide.

**Radio altimeter** is used to convert a standard receiver to pick up the 429-mc. experimental band on which the broadcasts go out.



fifth model is a simple device—three 1-lb. coffee cans enclosing an iconoscope that receives images through a 2" f/1.5 lens taken from an old 16-mm. movie camera. With it he hopes to transmit live images and also motion pictures. But broadcasting movies will require a projector. That's in the works, too. From a standard projector he plans to remove the intermittent mechanism and run the film through continuously. By pulsing a light source 30 times a second and projecting the illuminated images onto the iconoscope he will change the frame speed from the 24 per second used in films to the 30 needed in video.

Movies present a special problem for the ham televiser since one of the FCC rules governing ham operation is a restriction on broadcasting entertainment. Wolfe thinks that a good deal of the movie fare used on commercial TV stations runs no risk of entertaining anybody, but a legal definition of what a ham can televise is still to come.

What does the future hold for amateur TV? Wolfe doesn't expect many hams to follow his lead, at least for the present. Cost won't be the big factor. The \$500 that this rig cost is a lot less than many hams put into voice equipment, but a lot of know-how and work is needed too.

Then, too, there are a lot of technical limitations that have to be overcome before TV can be reshaped into the ham tradition. First step will be simplification of the circuits and some method of getting more stations into the limited space in the airwaves. Perhaps ham ingenuity will also conquer the distance barrier that now makes television a short-range affair.

These are questions for the future. Radio once posed similar problems, and hams played a big part in solving them. Will they do the same for television? Wolfe has proved that video has a place for hams. He's given the wheel the first spin, and you never know where it will stop. END

**This standard image** of Gwendolyn has been picked up at points 35 miles away. She's proof that \$500 and ingenuity can put TV on the air.

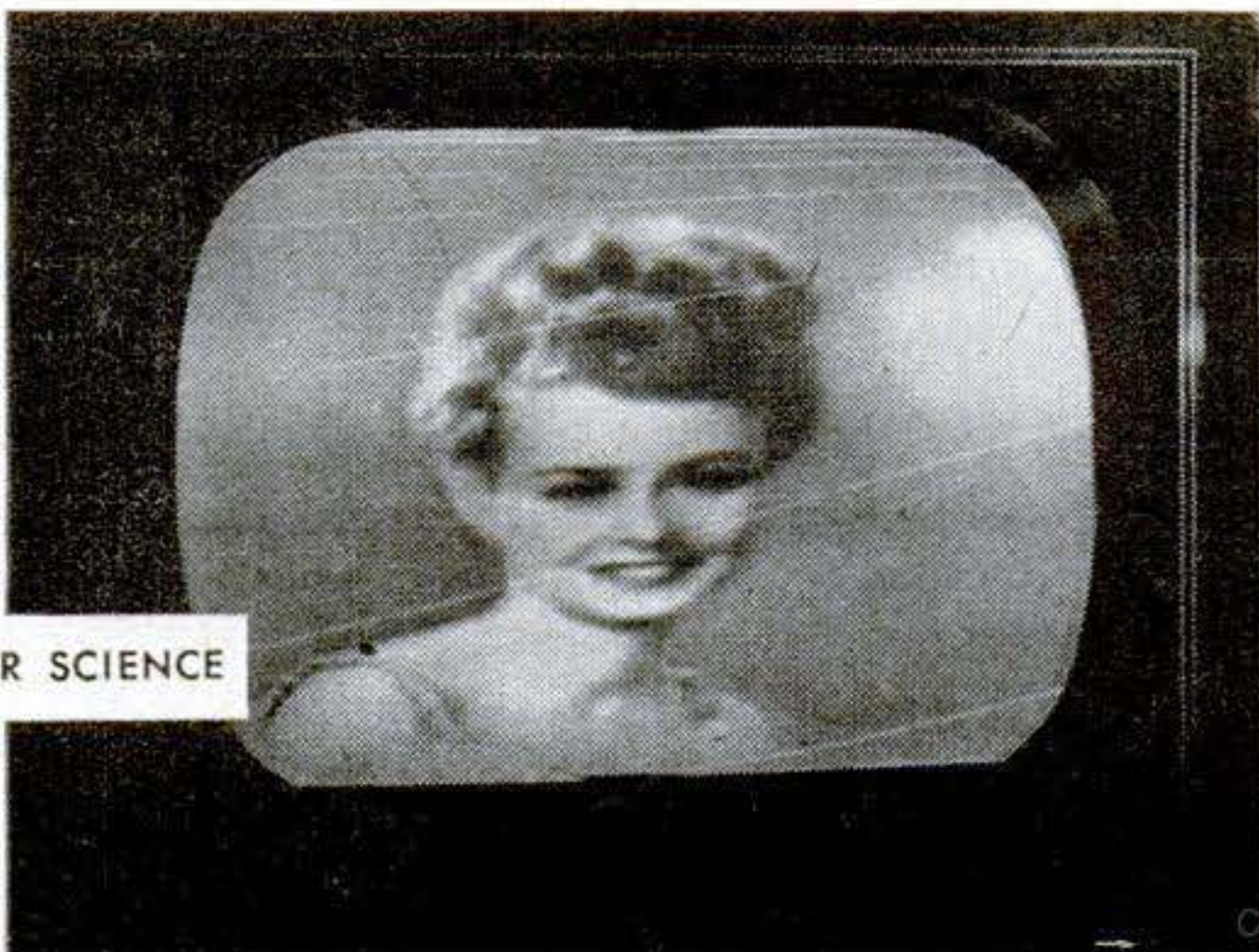

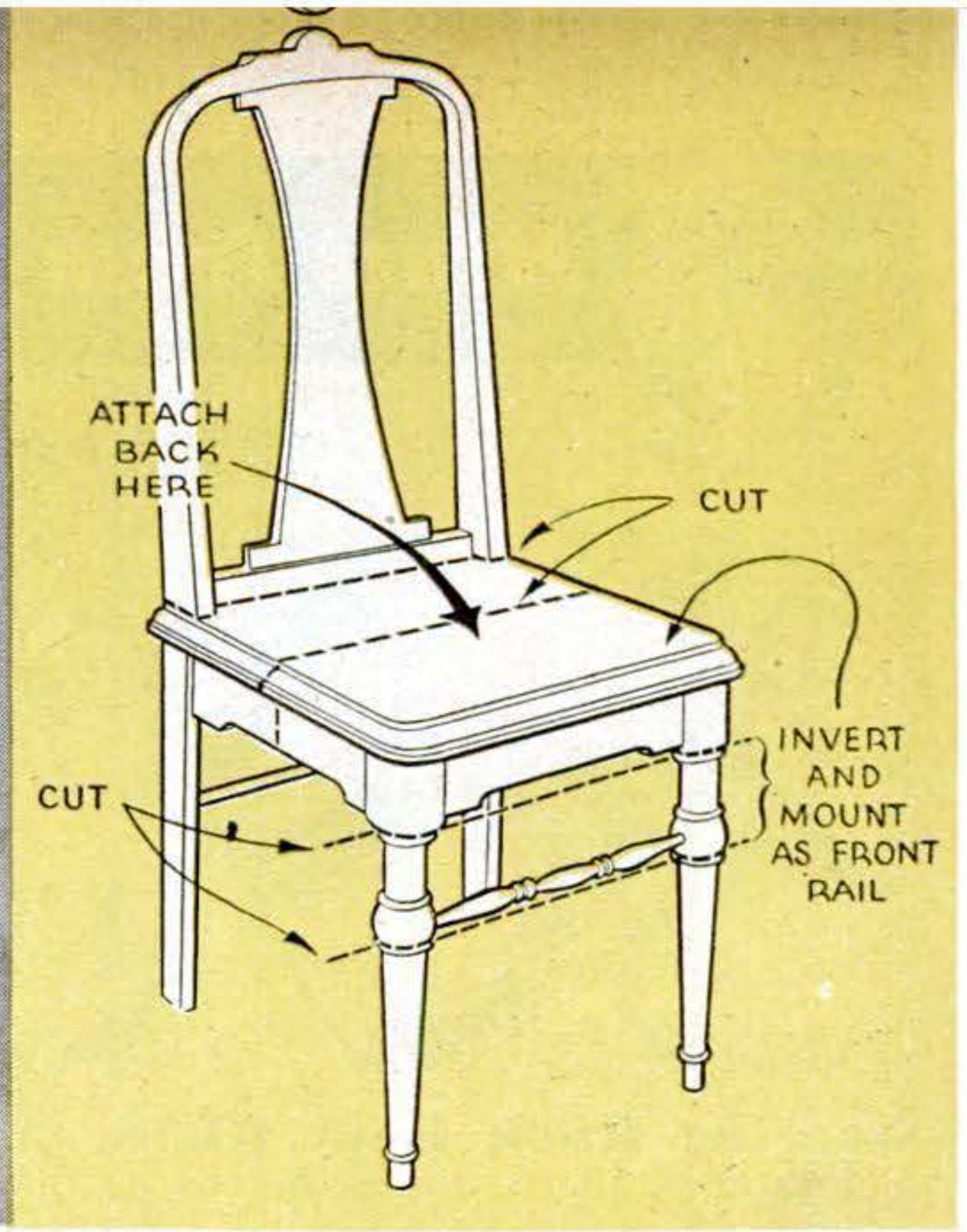

## Parts of Chair Shuffled to Create Wall Shelf

MAKING something new out of something old often gives as much pleasure as starting from scratch. This hanging novelty shelf was an example.

The front legs of a side chair were cut off just below the apron. A section including the rung also was cut from each front leg. Inverted, this assembly serves as a rail at the front of the shelf.

As the drawing shows, the seat was cut crosswise and the front section used as the shelf. The chair back and rear leg stumps were fitted to this.

After chips, cracks, and dents had been filled in, the entire job was sanded down to a fine surface. A priming coat, then enamel, and application of decals wound up the job.—*Simon S. Palestrant, Bronx, N. Y.*

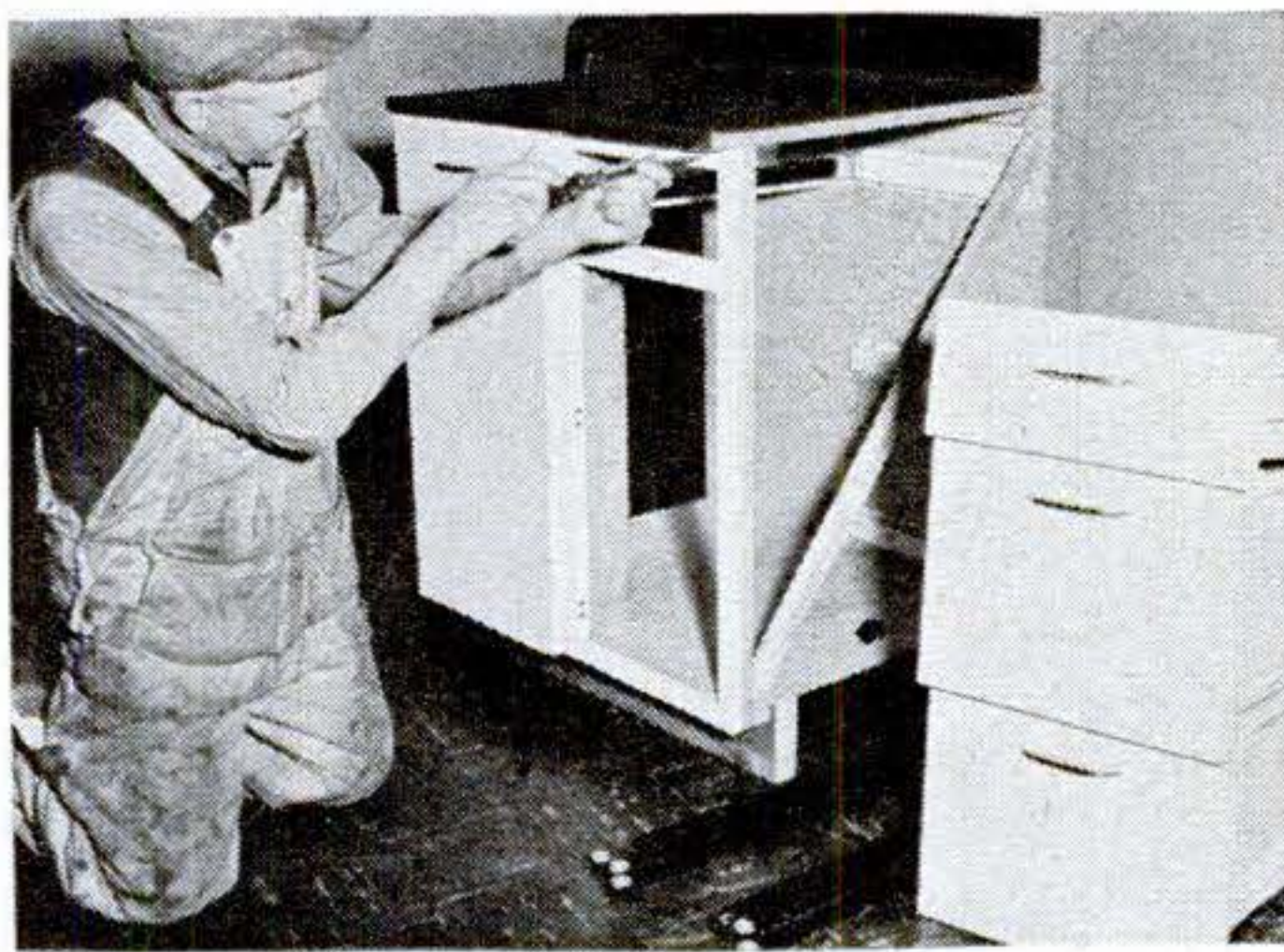

## Cabinet Fronts Now Available

IF YOU want to build cabinets in the kitchen, bathroom, or shop, these steel fronts introduced by Western Metalcraft, Inc., Olympia, Wash., may make your job easier. They consist of a metal frame and door or drawers—depending on the type of cabinet desired. The fronts are designed for use with simple plywood framing.

## Suction Holds Handle on Glass

A SLIDING glass panel that partitions off the nursery in a local church had no handle. It could be opened or closed only by pressing a palm firmly against the glass. As a result, the glass always showed fingermarks.

The problem was solved by attaching a couple of suction cups to a plastic drawer handle, wetting the cups, and sticking them to the glass. The screws in the suction cups were the same size as those for which the handle was threaded, making it a simple matter to install the cups.—*Arthur Trauffer, Council Bluffs, Iowa.*

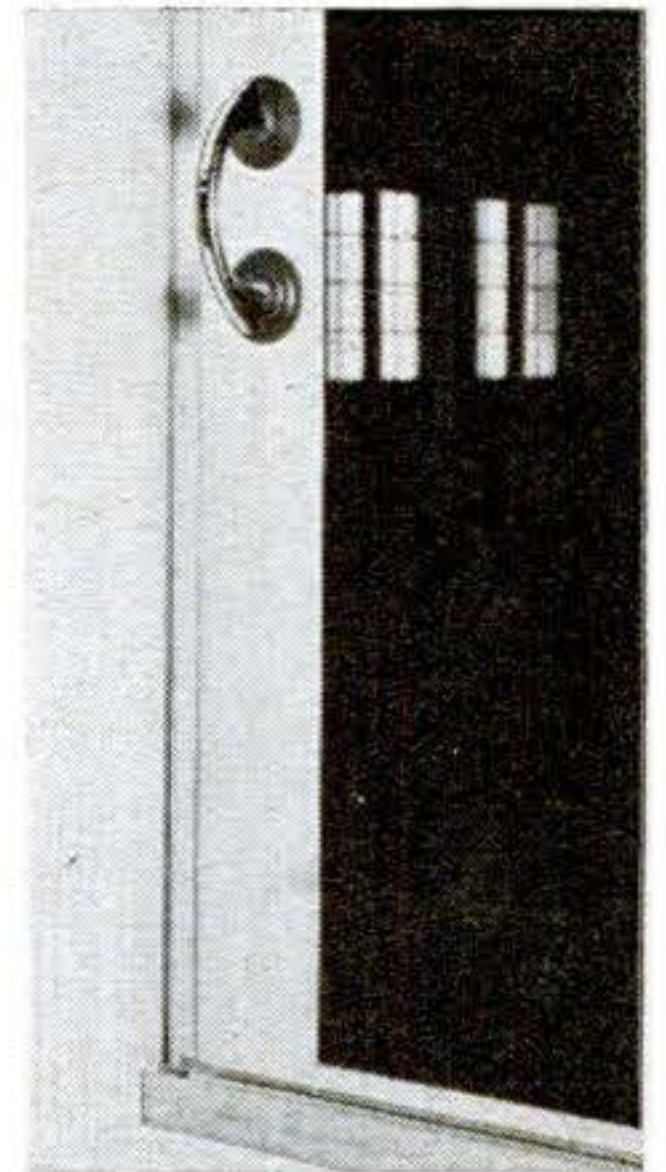



# Hints from the Model Garage

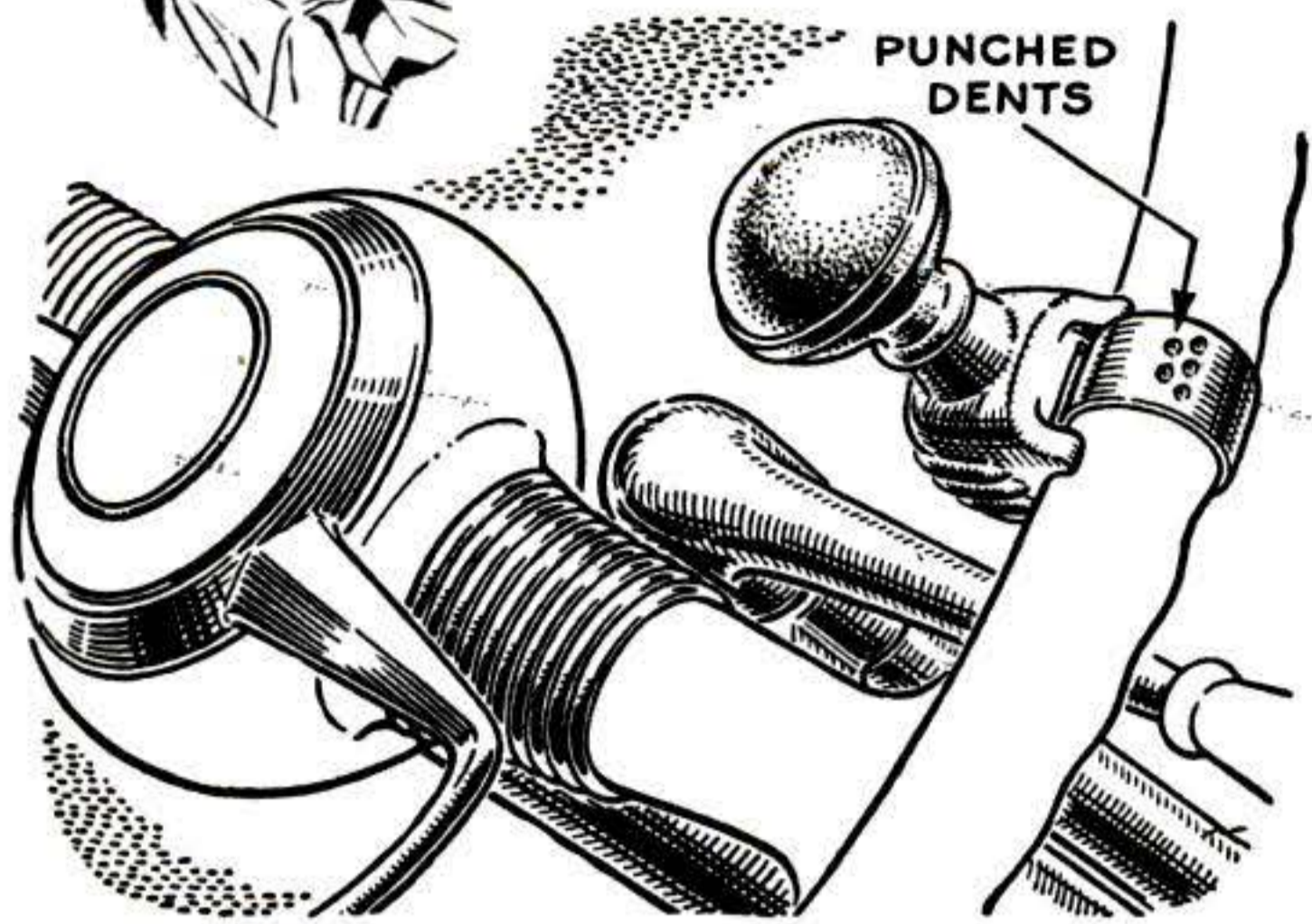

**Steering Knob Kept Rigid.** A spinner knob that twists in or out on the steering wheel can be cured by putting a few punch dots in the clamp. To avoid the possibility of cracking a plastic wheel, it's best to remove the spinner and clamp it on a broom handle or similar object. With a prick punch, make four or five dimples on opposite sides of the strap. When clamped, the spinner will remain in position permanently.—*Jim Sisley, Seattle, Wash.*



**Light Does Double Duty.** An accessory back-up light—the kind controlled by a separate switch—can be put to extra use as a direction indicator. Using red paint, I painted on the lens a big arrow pointing to the left. Now, when I'm making a left turn or pulling away from the curb, I flick the light on and off a few times. I've used the light for some time now and find it does its new job very nicely. It still gives ample light for backing.—*Ray Smiley, Detroit, Mich.*

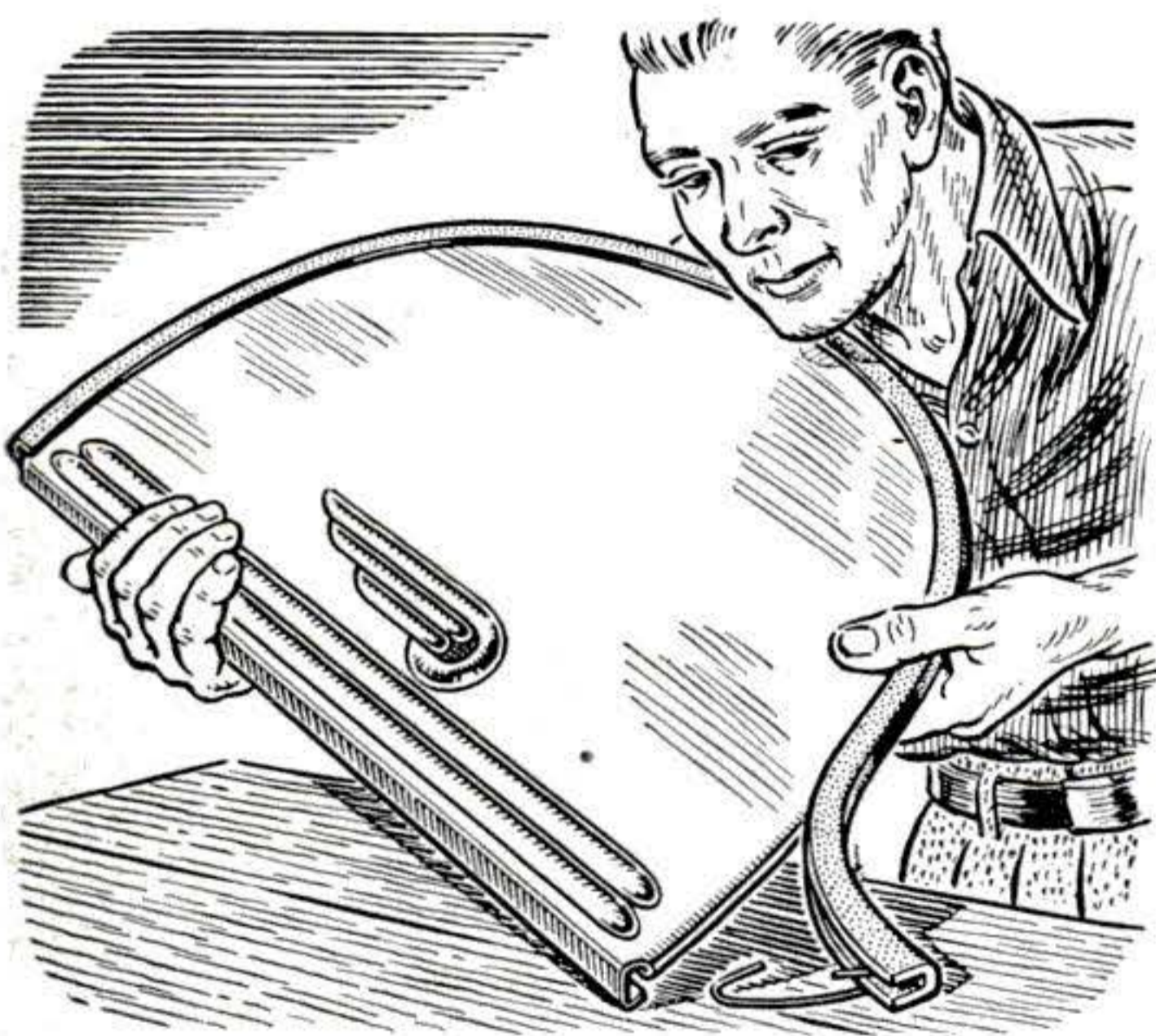

**Replacing a Skirt Gasket.** You can use a wide washing-machine cover gasket to replace a worn one on the fender skirts of some cars. Cut the rubber to length and stretch it around. Run a small wire hook through the inner side of each end. Fasten the hooks to the projections on the back of the skirt to hold the gasket.

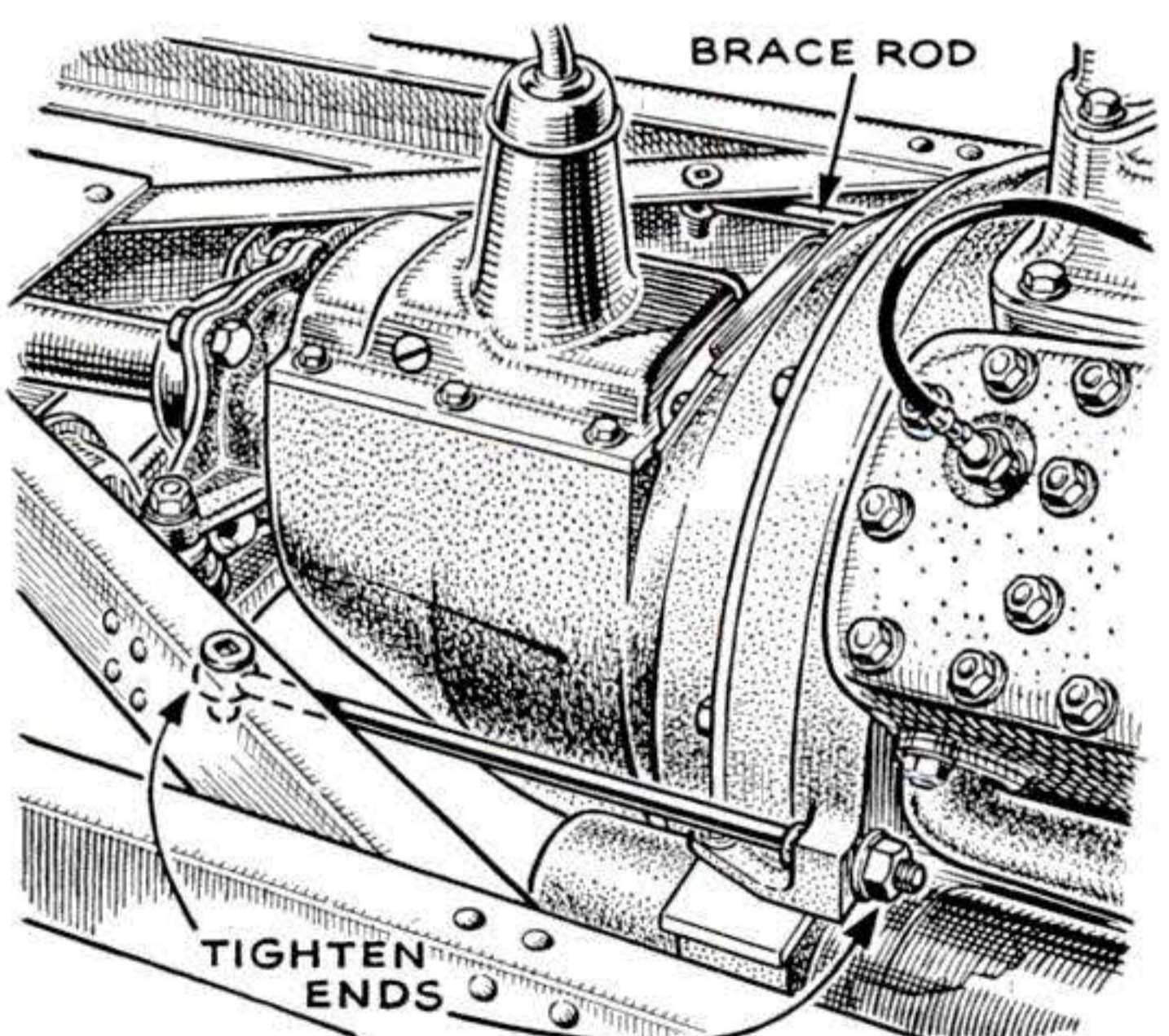

**Keep Support Rods Tight.** On prewar Ford V-8s, the two support rods that help anchor the engine at the rear have sometimes led to a false diagnosis of clutch trouble. If the rods loosen up, the result is similar to clutch chatter. The remedy is simple: either tighten the rods or replace them.—*A. Zanelli, Clifton, N. J.*

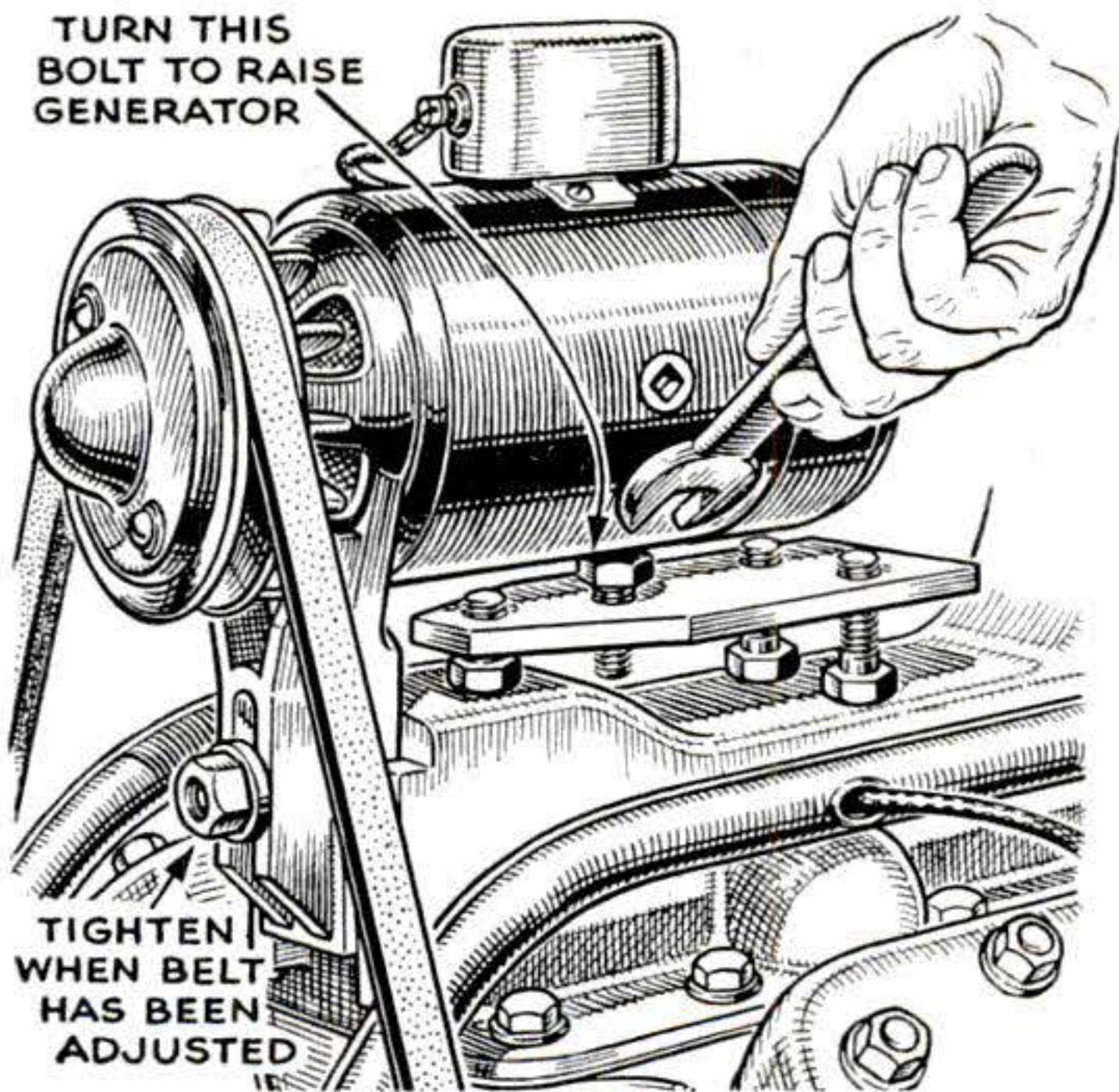

**Tool Supports Generator.** On some cars it's very tough to hold the loosened generator up in position while adjusting belt tension. The tool illustrated takes care of this. It consists of a piece of  $\frac{1}{2}$ " steel plate tapped for four  $\frac{1}{2}$ " bolts. Turning the one at the center with a wrench gives a powerful upward thrust, holding the generator at the desired level until the belt-adjustment nut can be tightened. Adjust the length of the leg bolts as required.

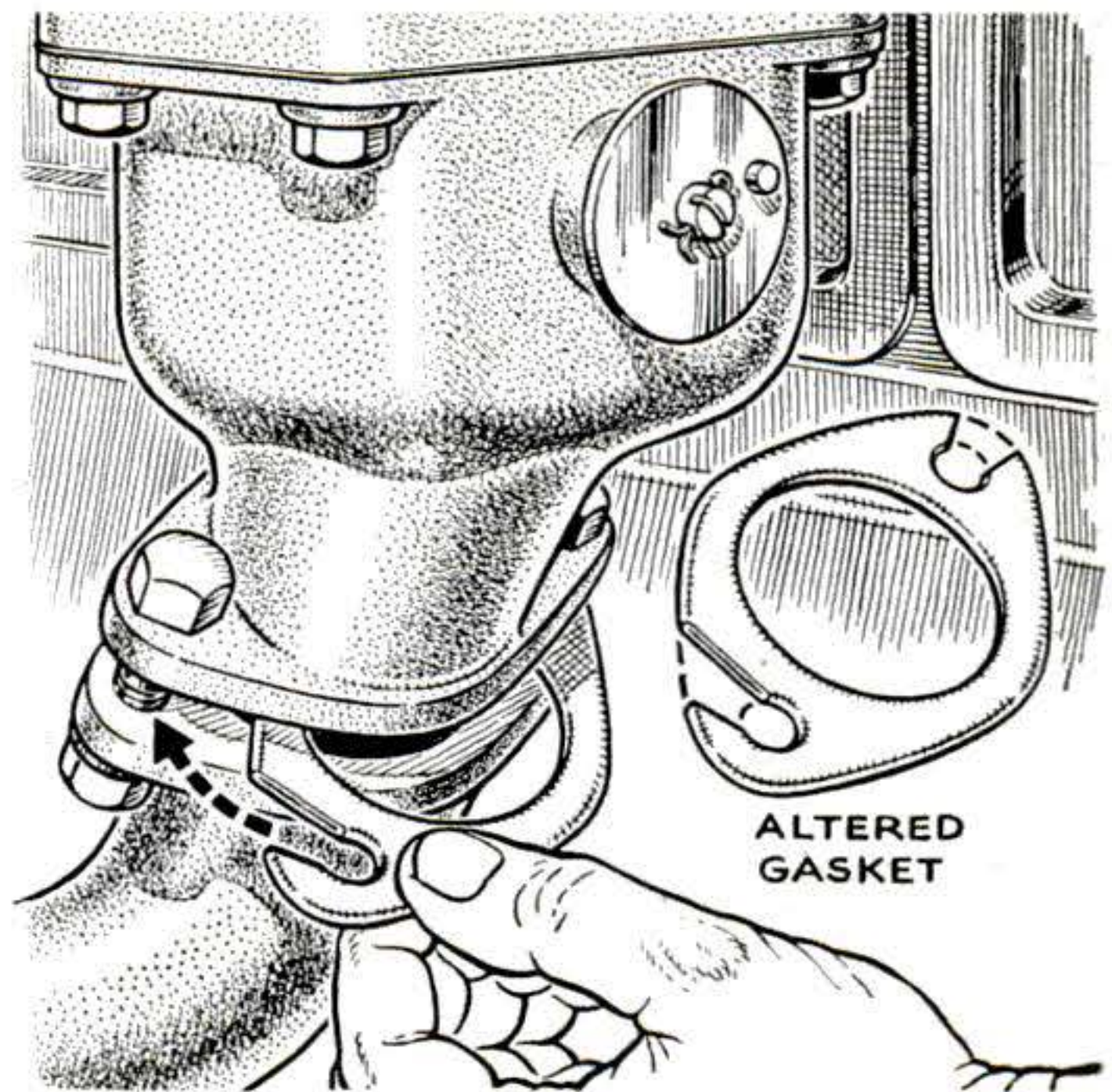

**Gasket Slots Ease the Job.** Narrow slots cut from the edge of a gasket to the bolt holes allow you to install a new one without taking out the bolts. This may be specially helpful on exhaust manifolds or other parts where bolthead clearance is scant, or where threads are so rusty that complete removal would be a time-consuming job. Just loosen the bolts enough to separate the flanges. The slots do not impair the efficiency of the gasket.

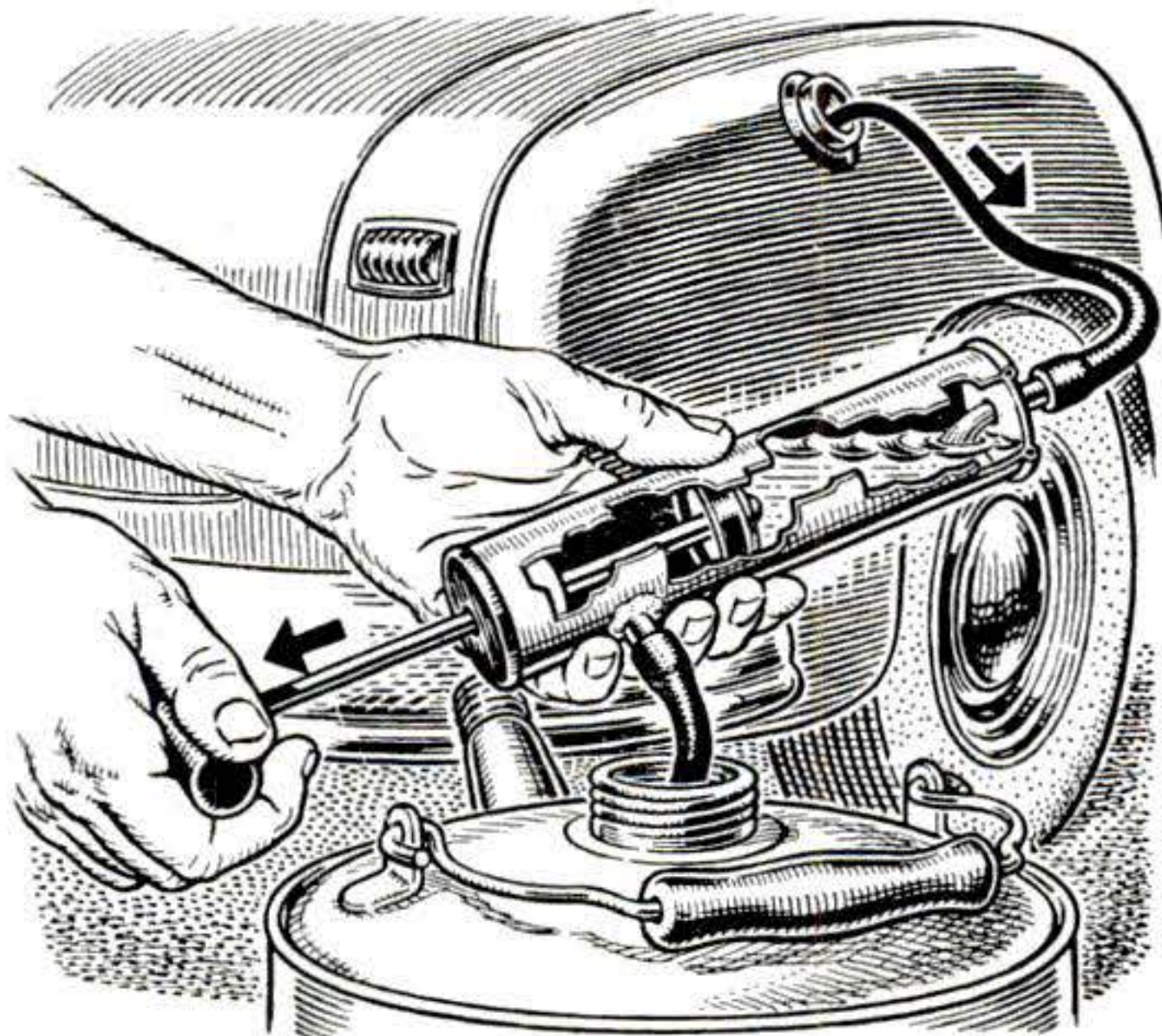

**Spray Gun Siphons Gas.** A siphon for drawing gas from a tank can be made out of an insect spray gun. Take out the plunger and reverse the cup leather. Cut off the spray container, enlarge the hole in the end of the cylinder, and solder in a piece of  $\frac{1}{4}$ " copper tubing. Solder a delivery tube near the other end.

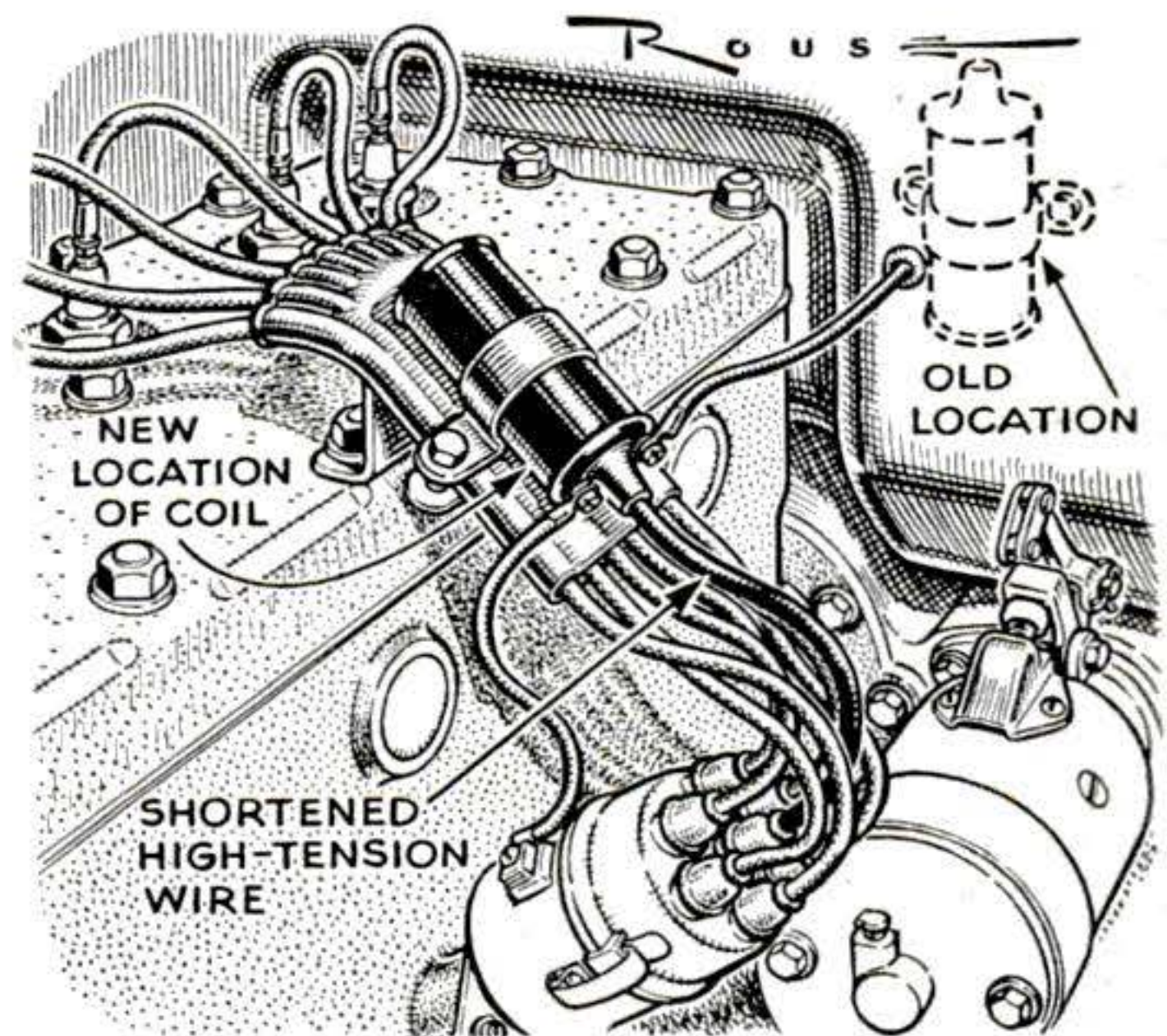

**Short Lead Improves Starting.** On an older-model Plymouth, I have found that moving the coil from the firewall to the spark-plug cable support makes the engine easier to start. In the new position, the high-voltage wire from the coil to the distributor cap is shortened considerably.—*Ralph Wyant, Indianapolis, Ind.*

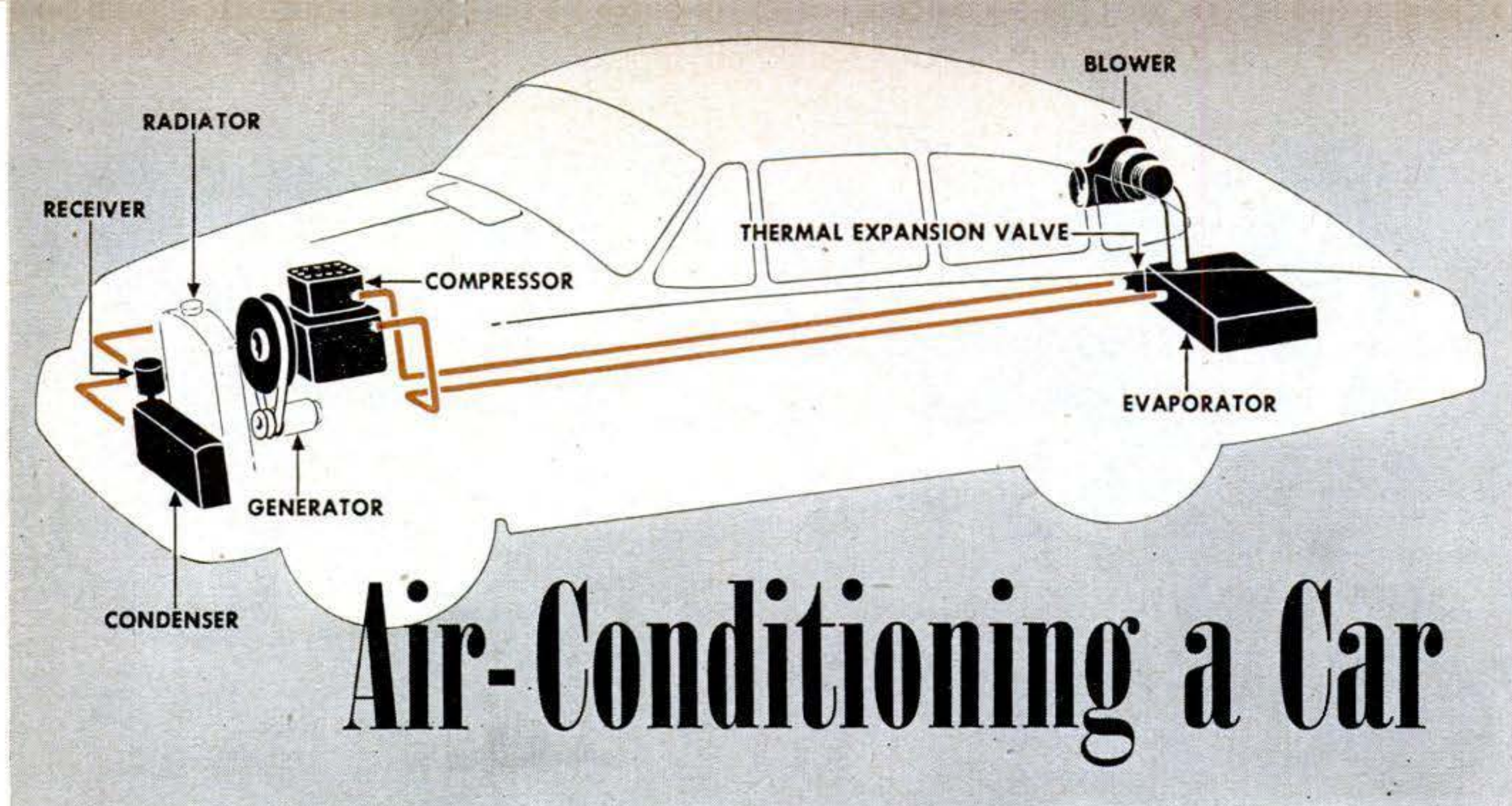

# Air-Conditioning a Car

A home-installed mechanical cooling system keeps passengers in this 1948 Oldsmobile comfortably cool, even in the hottest midsummer weather.

*By Walter B. Moses, Jr.*

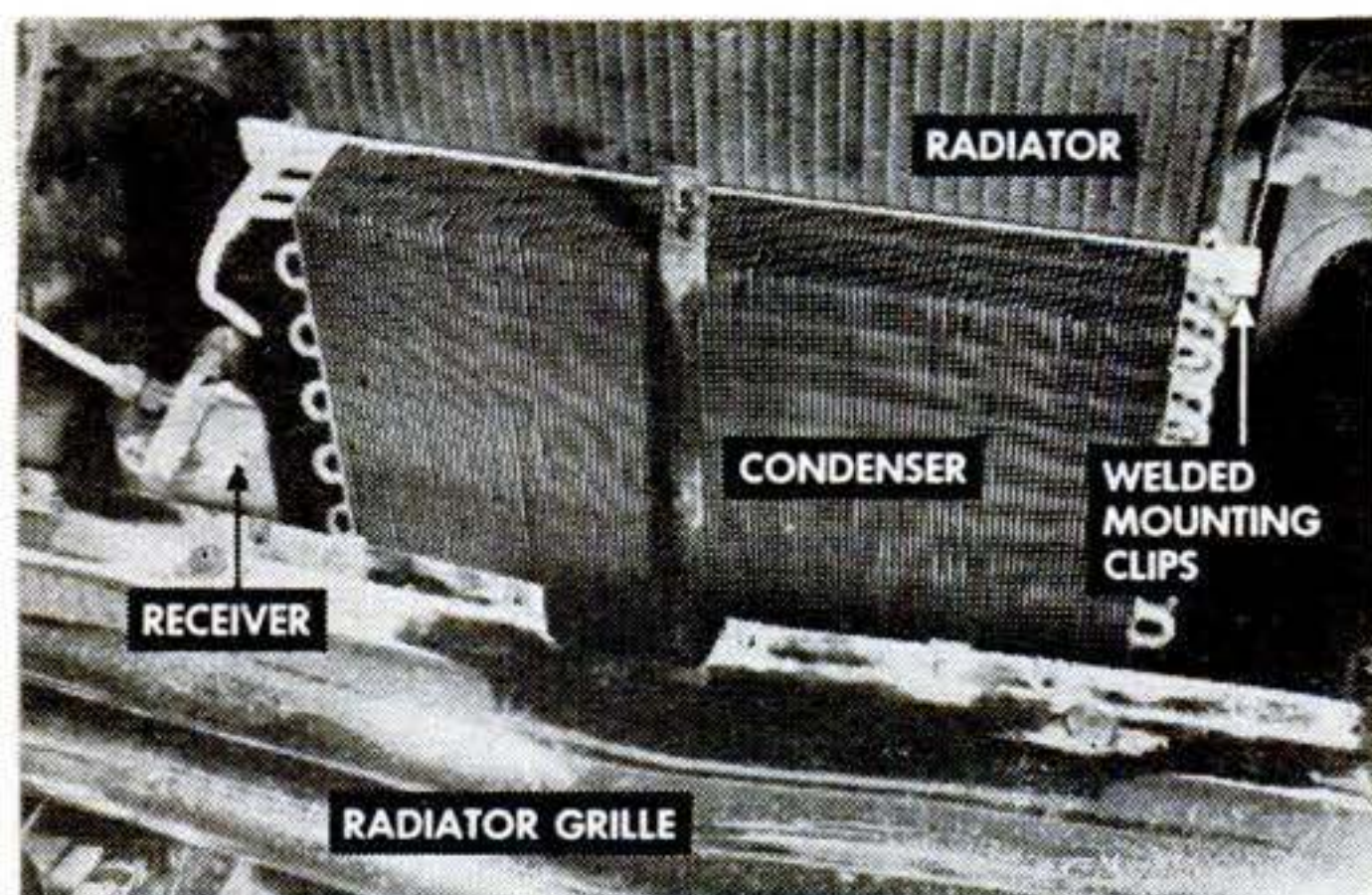

Though bolted directly in front of lower part of the radiator, the condenser has been found not to interfere with cooling of the engine.

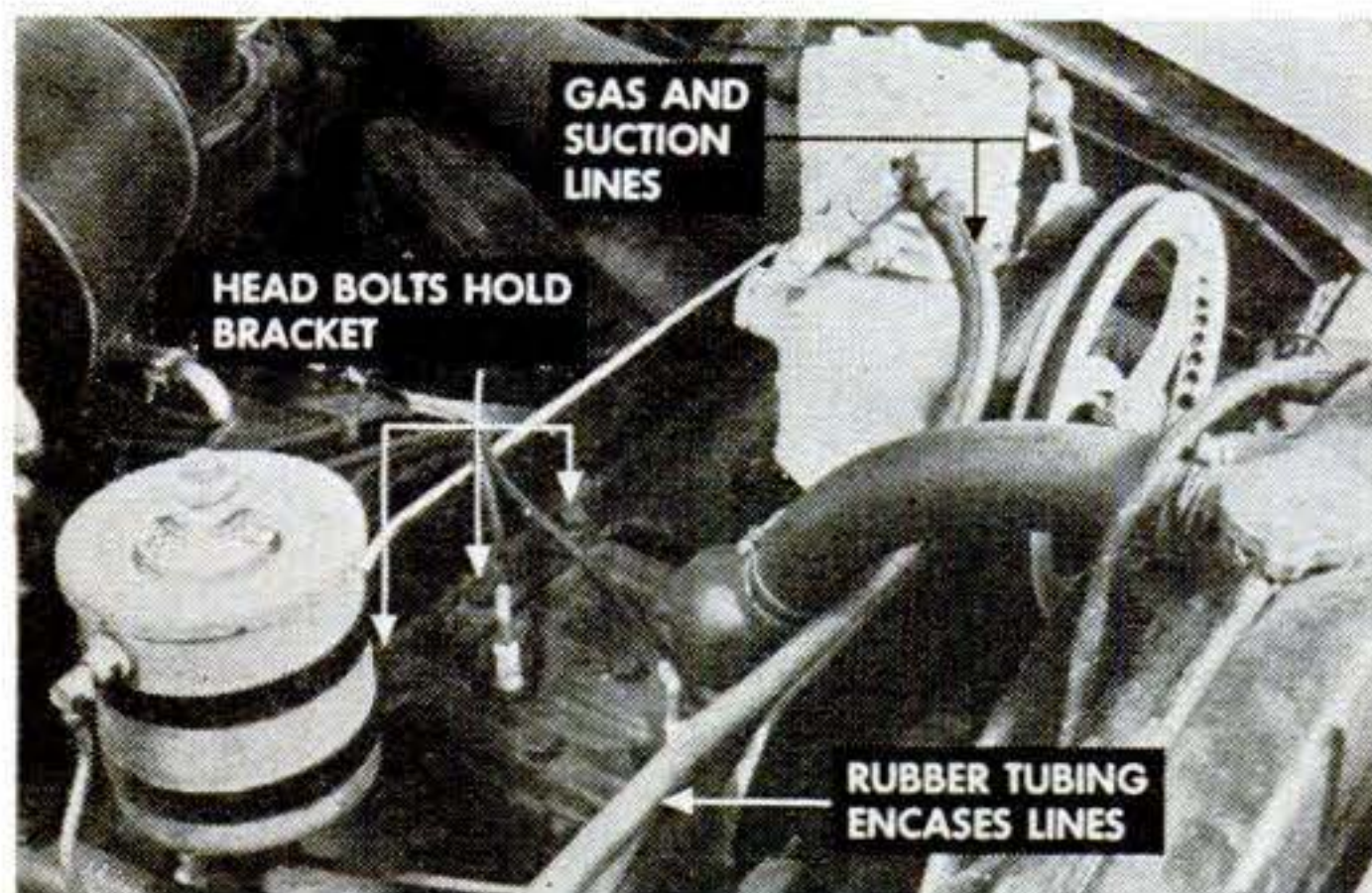

Cylinder-head bolts hold the cut-away piece of channel on which compressor is mounted. Note sponge-rubber insulation on the tubing.

**P**ITY the poor motorist who must drive on a heat-soaked highway under a broiling sun, cooped up in an upholstered steel box, and propelled by a gasoline-fired heat engine. It's about time we did something to cool him as well as his engine.

Of course you can buy an evaporative-type window cooler, good on long, fast trips in dry country, but it won't help much where heat is accompanied by high humidity—which it is in most of the country. Here mechanical refrigeration, the kind that's custom-installed in high-priced cars, must be used. I've put it in my 1948 Oldsmobile and it keeps the car comfortably cool on the hottest midsummer days in Louisiana.

The actual heat load on a car is tough to calculate, depending as it does on many variables, including window area, speed, outside temperature and humidity, tightness of windows and doors, and insulation in the roof, firewall, and floor. However, it seems

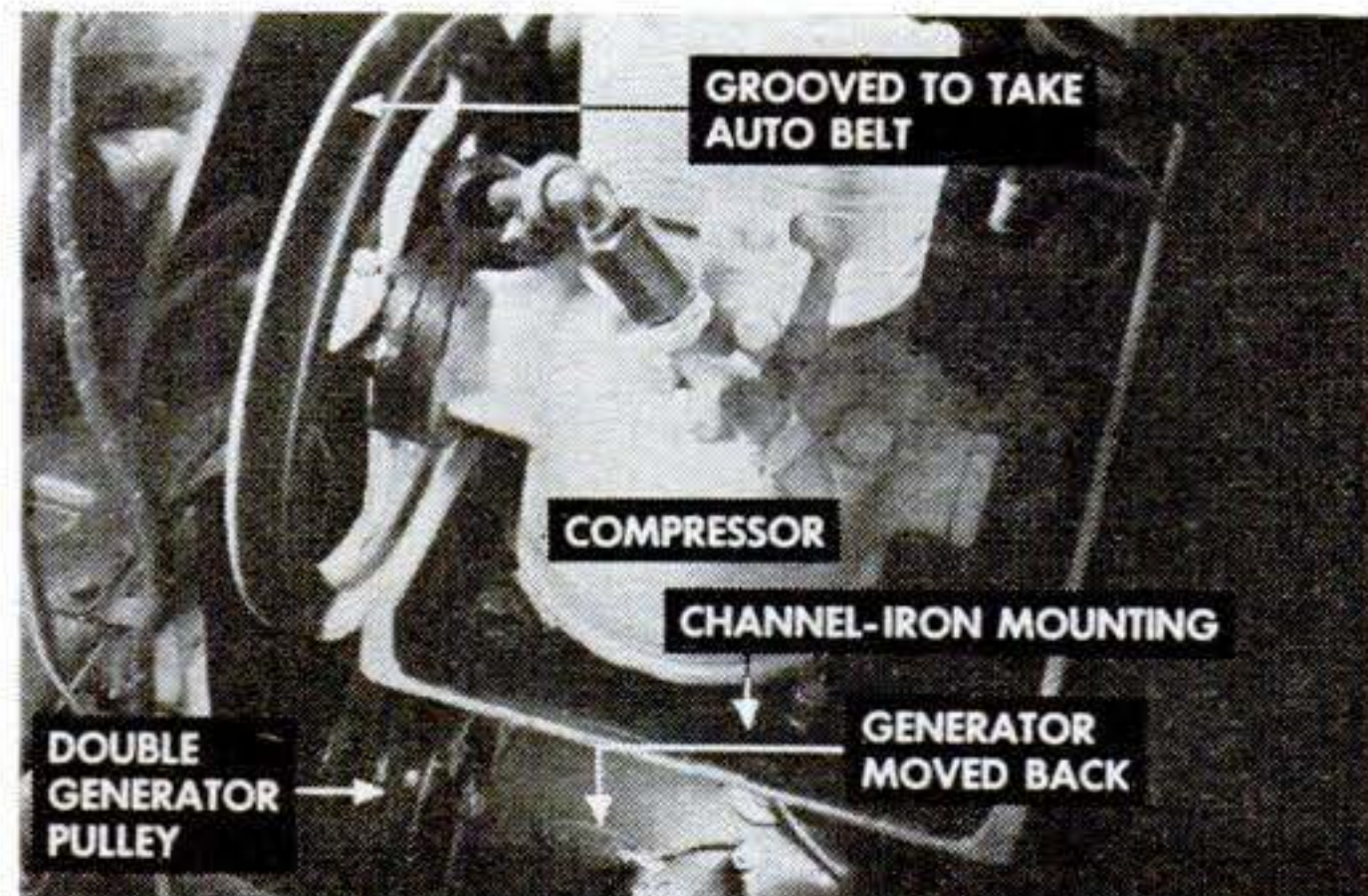

Compressor is aligned with the rear one of two pulleys on the generator shaft. Front channel flange is trimmed to clear boss on compressor.



safe to say that the average car generally requires from one to two tons of mechanical refrigeration. (This means that it needs provision for removing as much heat as would melt from one to two tons of ice every 24 hours.)

A cooling system this size is several times larger than the ordinary room air-conditioning unit for home use. The compressor and condenser in my car are both nominally rated at ½-ton capacity, but they work fine. This is because the compressor runs faster than before when the car is driven at normal highway speeds, and because the volume of air passing through the condenser is much greater than in fixed applications. I keep the belt on the compressor at all times during the cooling season, handling day-to-day variations with the blower fan.

Three major pieces of equipment comprise the system: (1) the compressor, which changes the Freon® refrigerant from a gas to a liquid and which needs belt power; (2) the evaporator, which absorbs heat from the air inside and which has an electric blower; and (3) the condenser, which discards the heat extracted and which needs a flow of outside air. These parts might be taken from old commercial refrigerators.

Other parts include a receiver to hold the condensed Freon, a thermal expansion valve by the evaporator, and a drain to discharge water removed from the air into a fender well. Installing this equipment isn't too easy, since it involves numerous problems of support and clearance. Most of the work has to be planned on the car itself rather than at the drawing board.

I mounted the compressor on a cut-down piece of 10" channel iron bolted to the head with the existing bolts. Rather than use a single belt on the engine, water pump,

generator, and compressor, I drive the compressor from a special double pulley attached to the generator. This permits removal of the extra belt when cooling isn't needed. The generator was moved back 1½", the width of the pulley, and a second pulley was silver-soldered to the first while both were aligned on a mandrel. The pulley on the compressor was grooved out on the lathe to take a standard auto V belt.

The condenser is mounted in front of the bottom half of the radiator by angle clips welded to the radiator frame, to which are bolted matching clips welded to the condenser. Brass bolts hold the assembly in place. Even in extremely hot weather I have been able to detect no increase in engine operating temperature due to air obstruction from the condenser. The receiver is secured by a bolt running up through the dust pan in front of the radiator.

Located to minimize obstruction of trunk space, the evaporator is bolted under the deck behind the rear seat. Air entering the trunk around the seat and through the center arm rest is drawn through the evaporator to be cooled and dehumidified. The moisture it gives up is piped out the left fender well. The air is then drawn up through an aluminum duct and discharged toward the front of the car by the 6-volt fan.

Normal infiltration of outside air is more than adequate to handle ventilation. The blower, connected through a SPDT switch to the regular heater switch, effects a one-minute recirculation of air inside.

The refrigerant lines are mainly ½" soft copper and are fitted at several points with necessary flexible connections. I covered them with "spaghetti" insulation of sponge rubber and ran them back inside the right frame channel. END

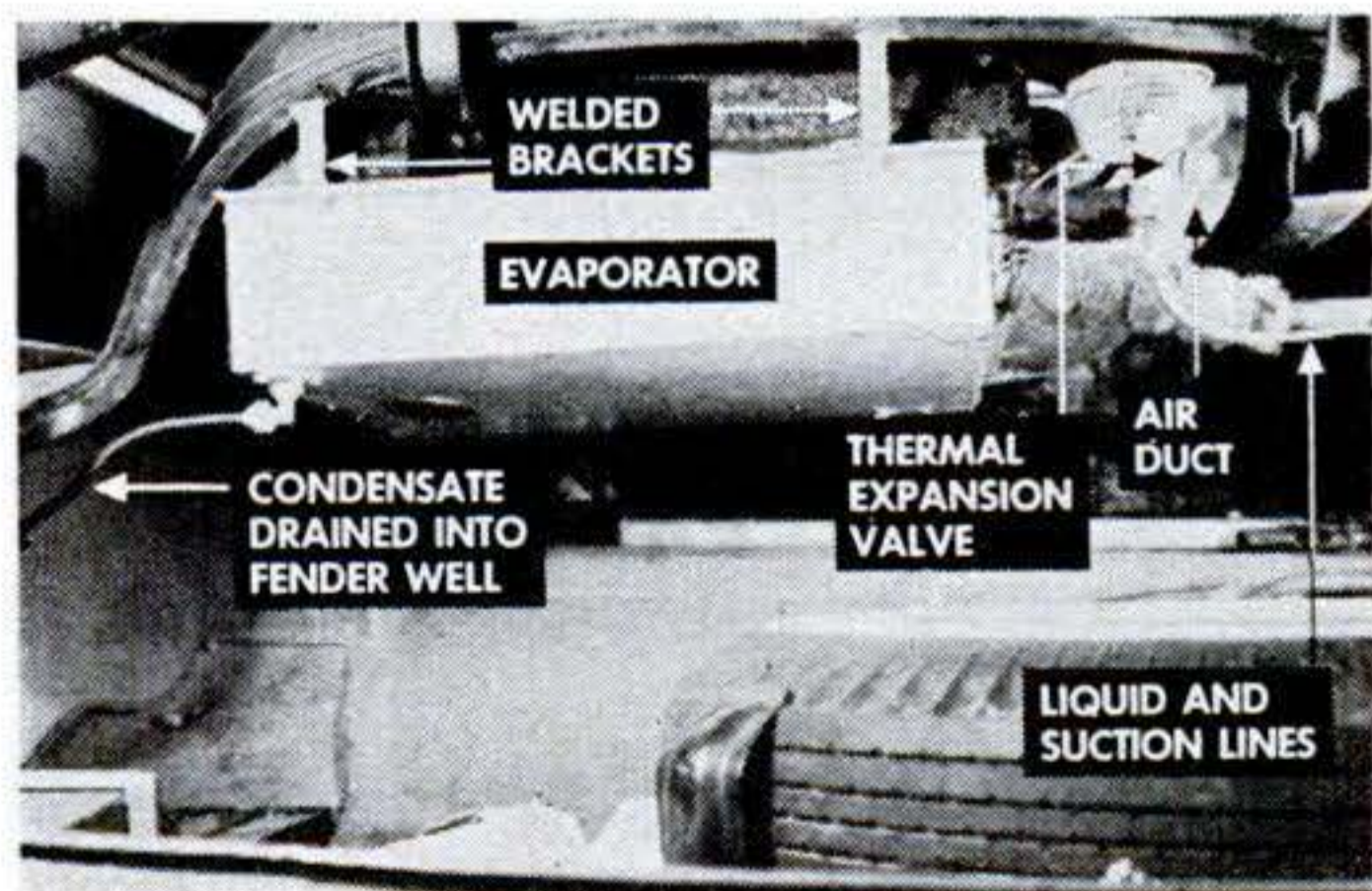

**Where the coolth is produced.** Air entering the trunk around rear seat is drawn through the evaporator and ducted upward and forward.

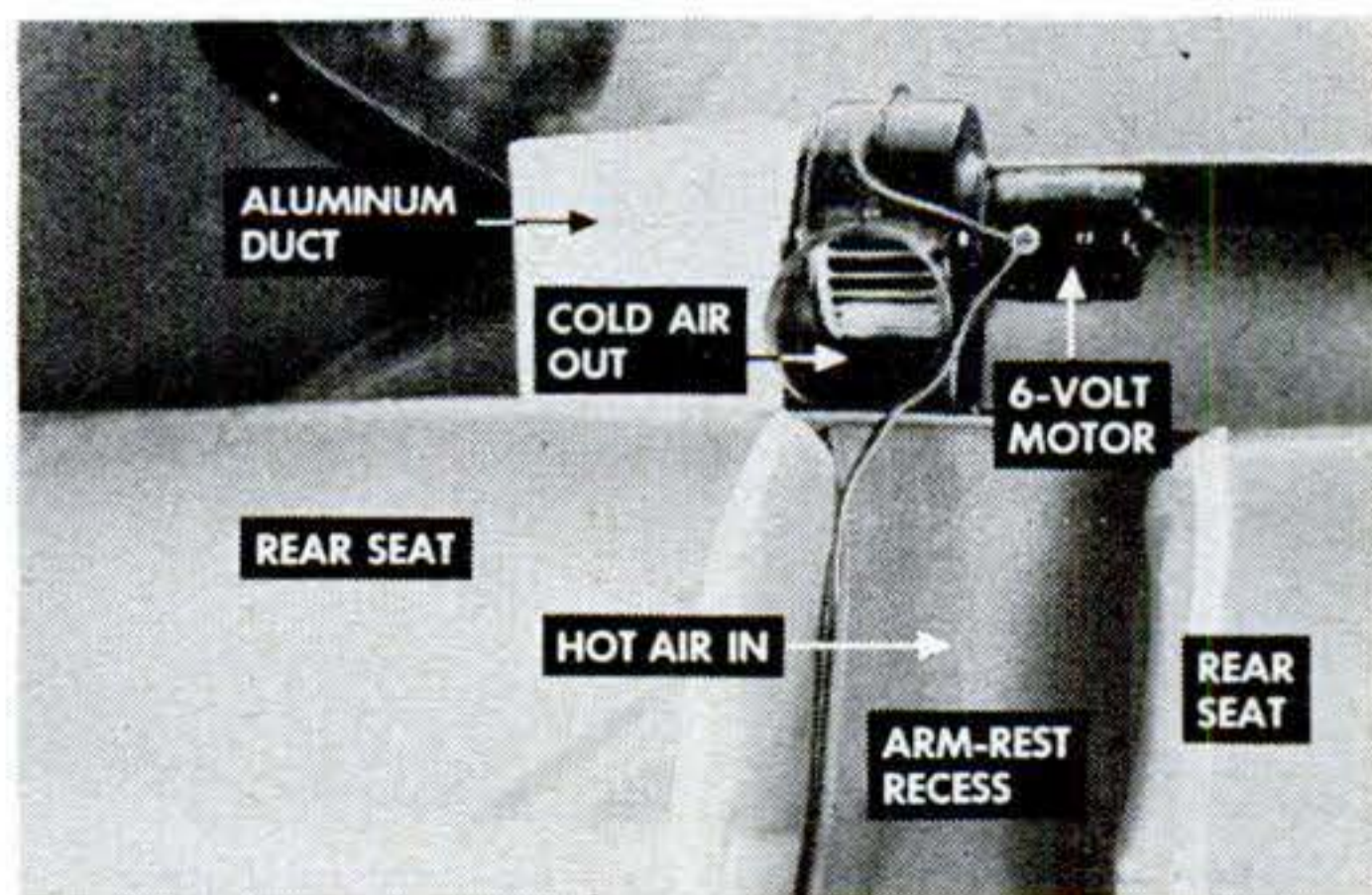

**Blower on rear deck** directs air toward front of car. All windows and ventilators are kept shut when air-conditioning system is working.



**Tap cork sharply** and this water-filled bottle shatters into a hundred pieces. Being incompressible, the water transmits the full force of the blow to the sides of the bottle. . . .

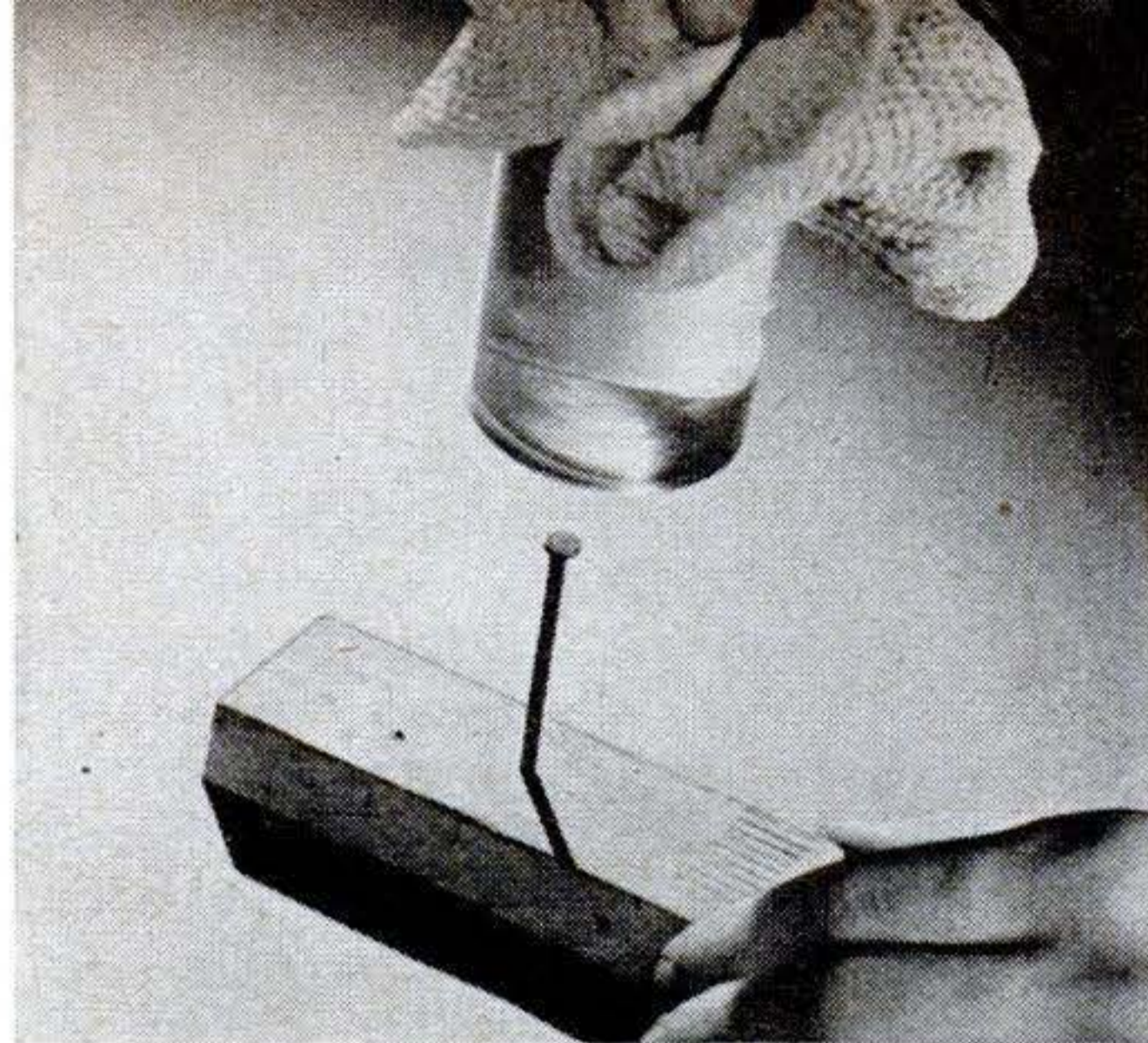

**But look at this.** You can drive a nail into a piece of soft wood with a water-filled bottle. The bottle doesn't break in this case because the water won't allow the glass to give.

## Water Wizardry

**Y**OU can squeeze a gas into smaller space, but liquids can hardly be compressed at all. The water experiments on this page demonstrate that natural law.

For the two stunts above, boil the water first to drive out dissolved air. Allow it to cool to room temperature. Then fill the

bottles to the brim and stopper snugly without introducing air.

Holding the hammer at arm's length, lightly tap the cork in the flat-sided bottle. The cork won't go in because the water isn't compressible. Tap a little harder and the bottle will shatter.

For the nail-driving experiment, use a round bottle and glass stopper. Turn the bottle on its side to be sure no bubble is trapped. As a safety measure, hold it with a cloth.—*Kenneth M. Swezey, Brooklyn, N.Y.*

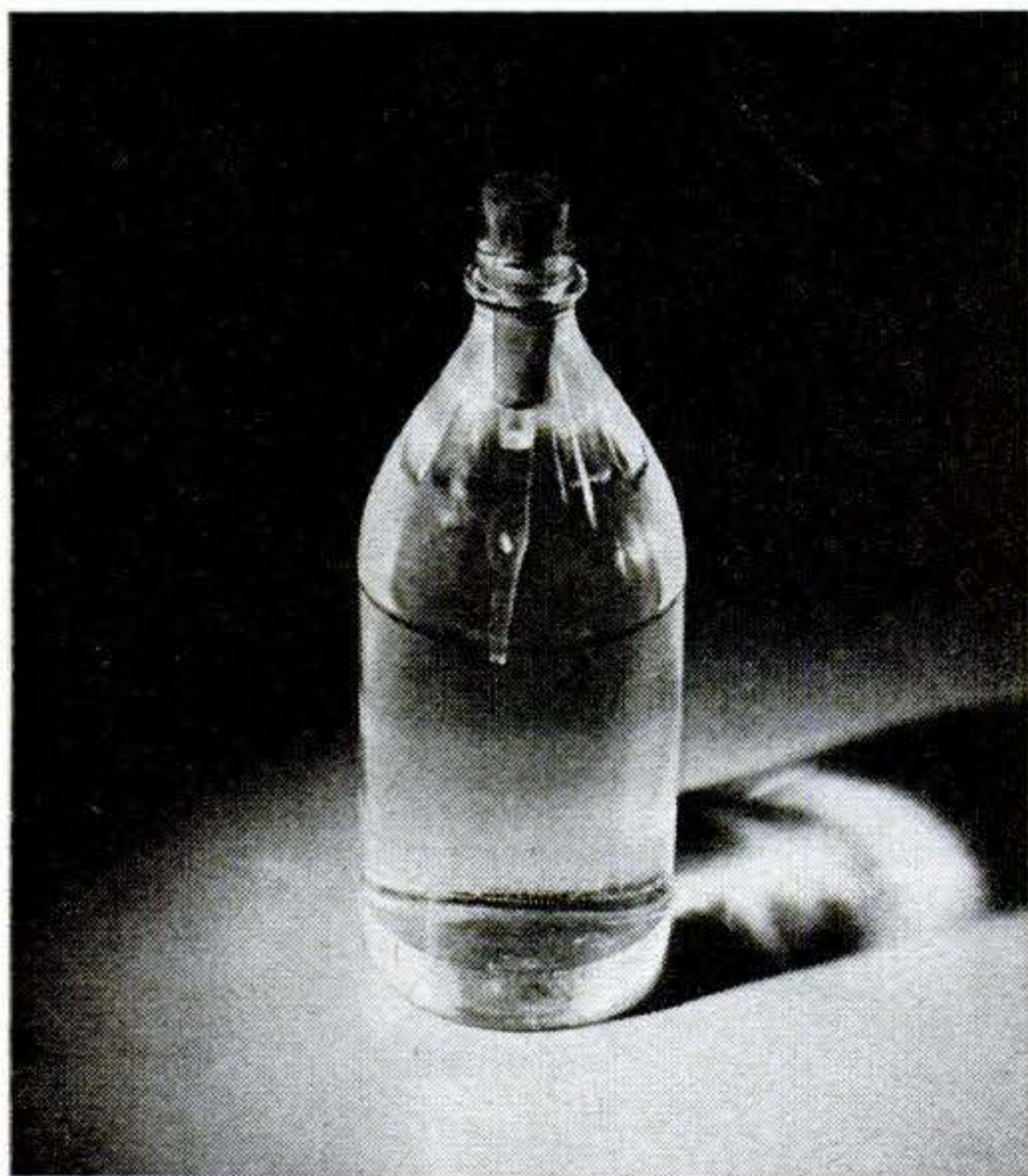

**Water compresses air** in the famous Cartesian diver. You can make one by putting water into medicine dropper until it just barely floats. Fill bottle to brim and insert cork. Pressing



cork causes "diver" to sink. Here, the incompressible water compresses the air in bulb to a smaller volume. Because of this, the dropper loses its buoyancy and drops toward bottom.

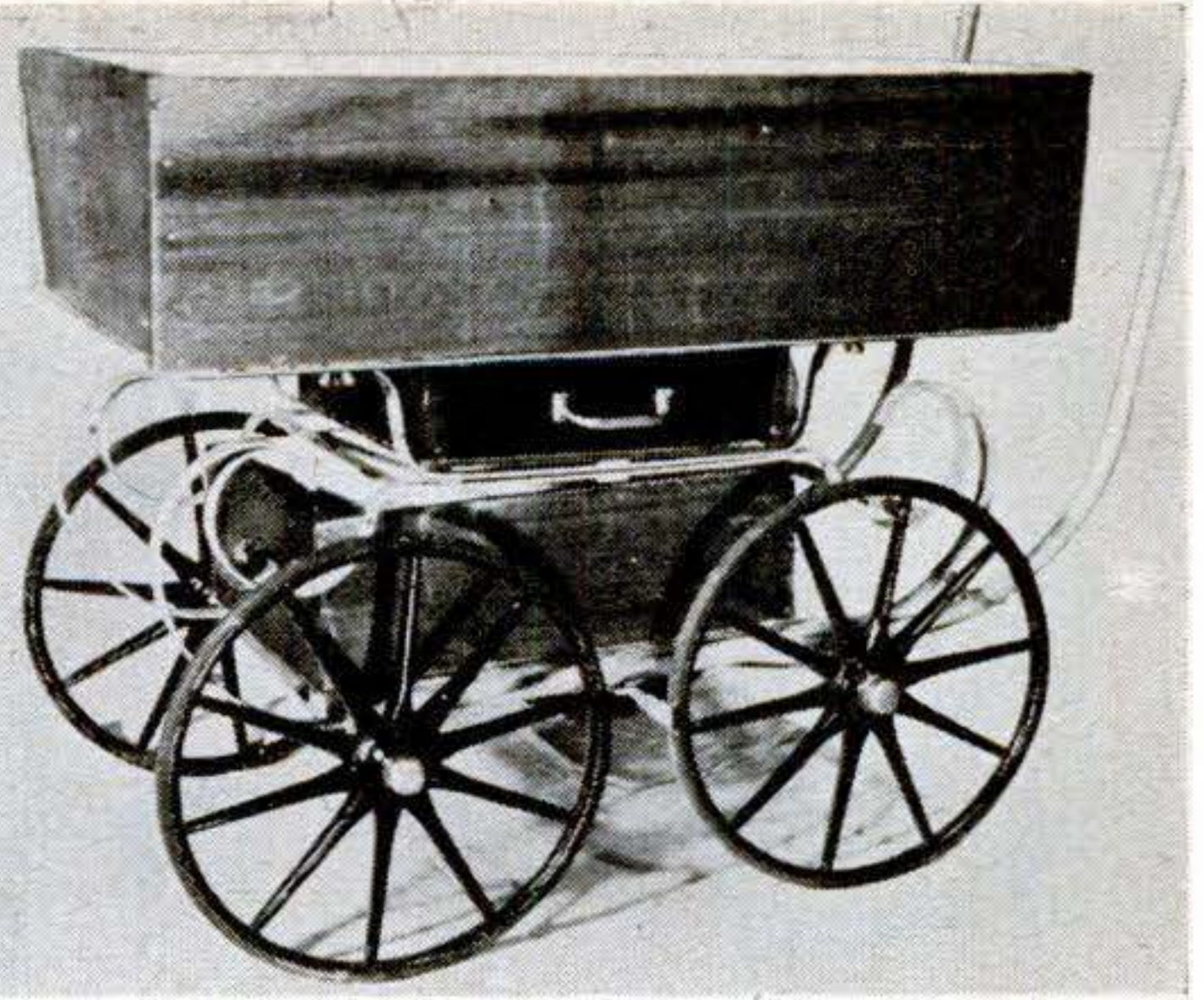
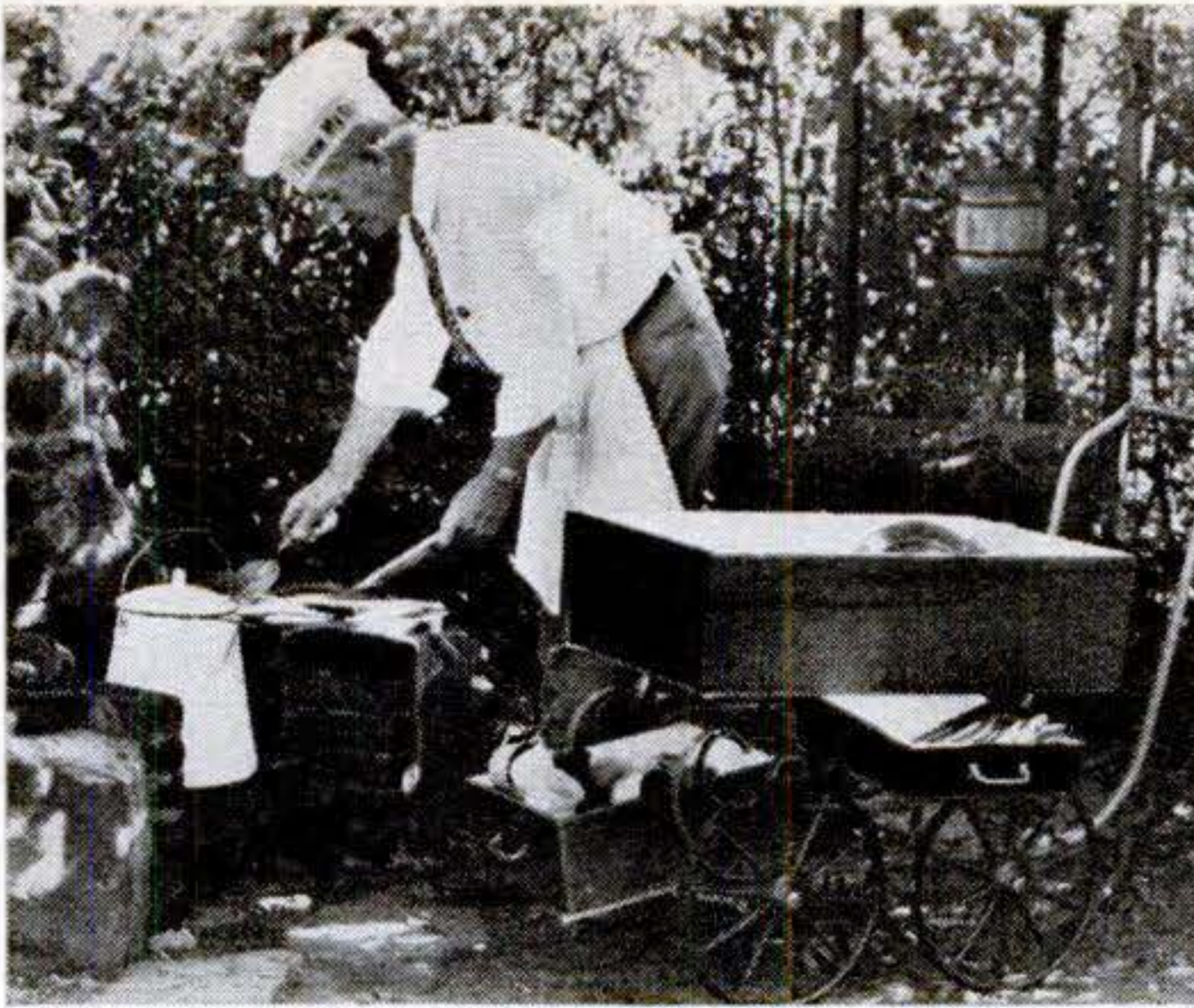

### Carriage Becomes Carryall

LUGGING the makings of an outdoor meal from house to fireplace is quite a chore if you have to make several trips. An old baby carriage, retrieved from the attic, was converted to carry dishes, food, linen, and silver

in one haul. The frame is a natural for two drawers and a general utility box on top. Drawers and box are made of redwood. Clear varnish covers the outside and white enamel the inside. The framework is painted jade green and the wheels a bright red.—*F. W. Essex, Maplewood, N. J.*

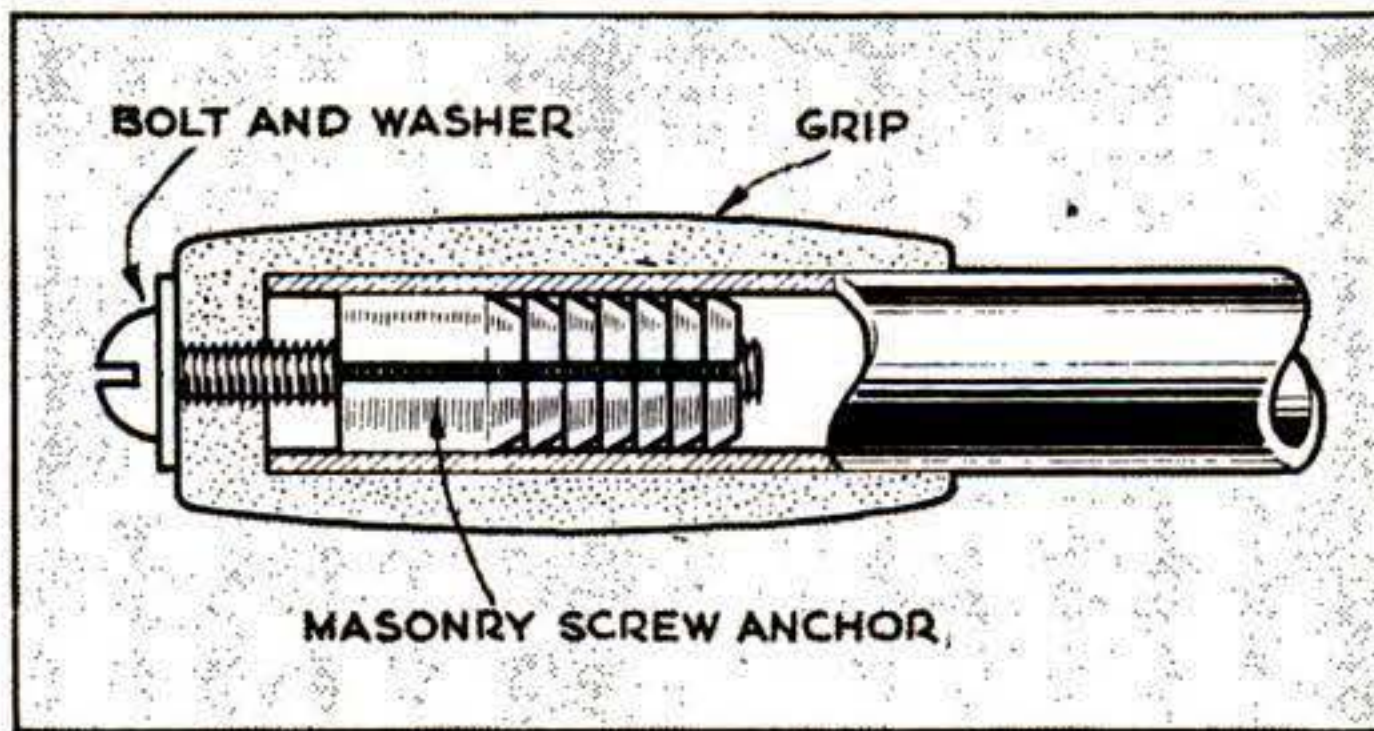

### Plug Anchors Bike Grips

TO PREVENT children from removing—and probably losing—the handle-bar grips of their bikes, use this improvised lock. Drill the end of the grip  $\frac{1}{4}$ ". Wrap a strip of rubber cut from an old inner tube around an expansion plug and insert it in the handle bar. Replace grip and tighten the  $\frac{1}{4}$ "-20 screw.—*W. Quisenberry, Baltimore, Md.*



### Plastic Pool Is Family Size

MEASURING 6' in diameter, this inflatable plastic pool holds up to 170 gal. of water and is deep enough for youngsters to float in as well as wade. It's made of marine blue Vinylite® by the Bilnor Corporation, of New York City, and is priced at \$25.

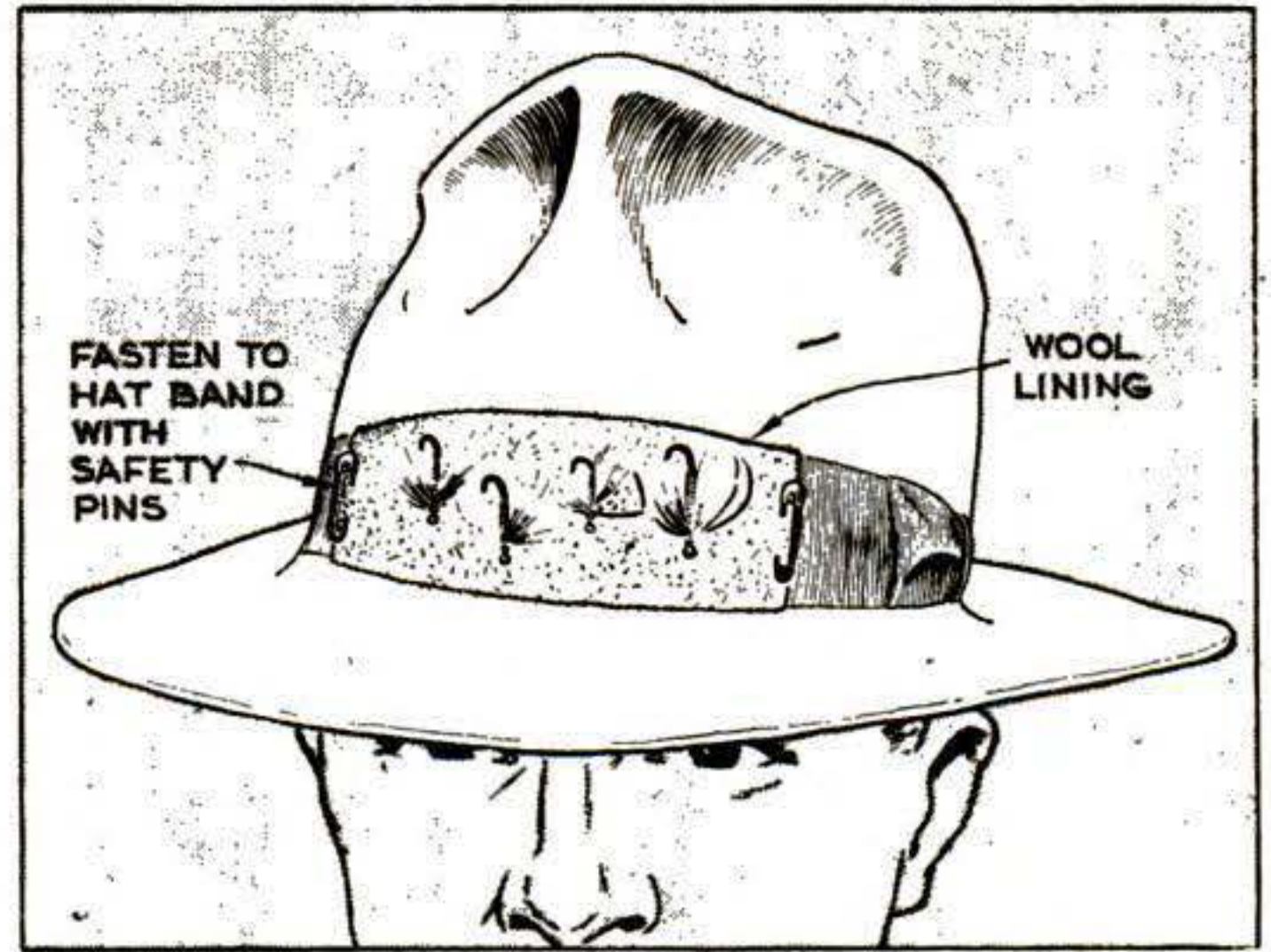

### Sheepskin Is Fly Carrier

PIN a strip of sheepskin clipped from an old jacket lining to a hatband and you have a ready-made carrier for fishing flies. The flies hook into the wool more easily than into the hatband and they can quickly be removed.—*R. A. Jenkins, St. Louis, Mo.*

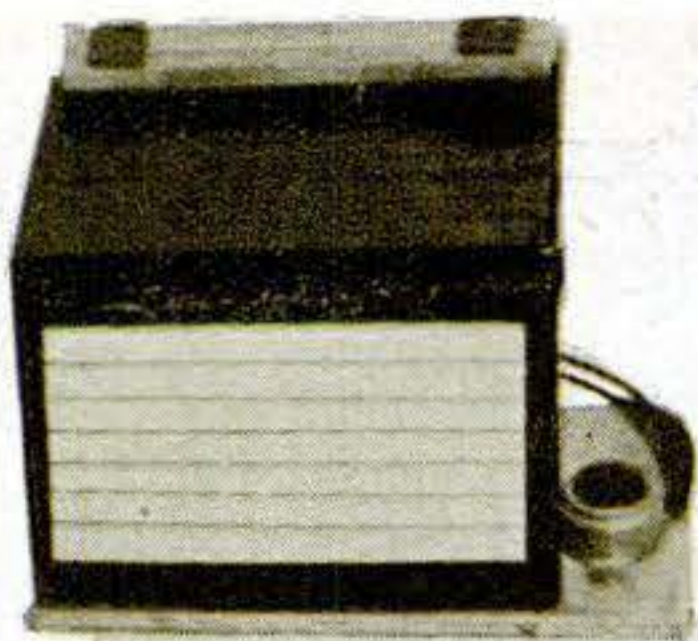
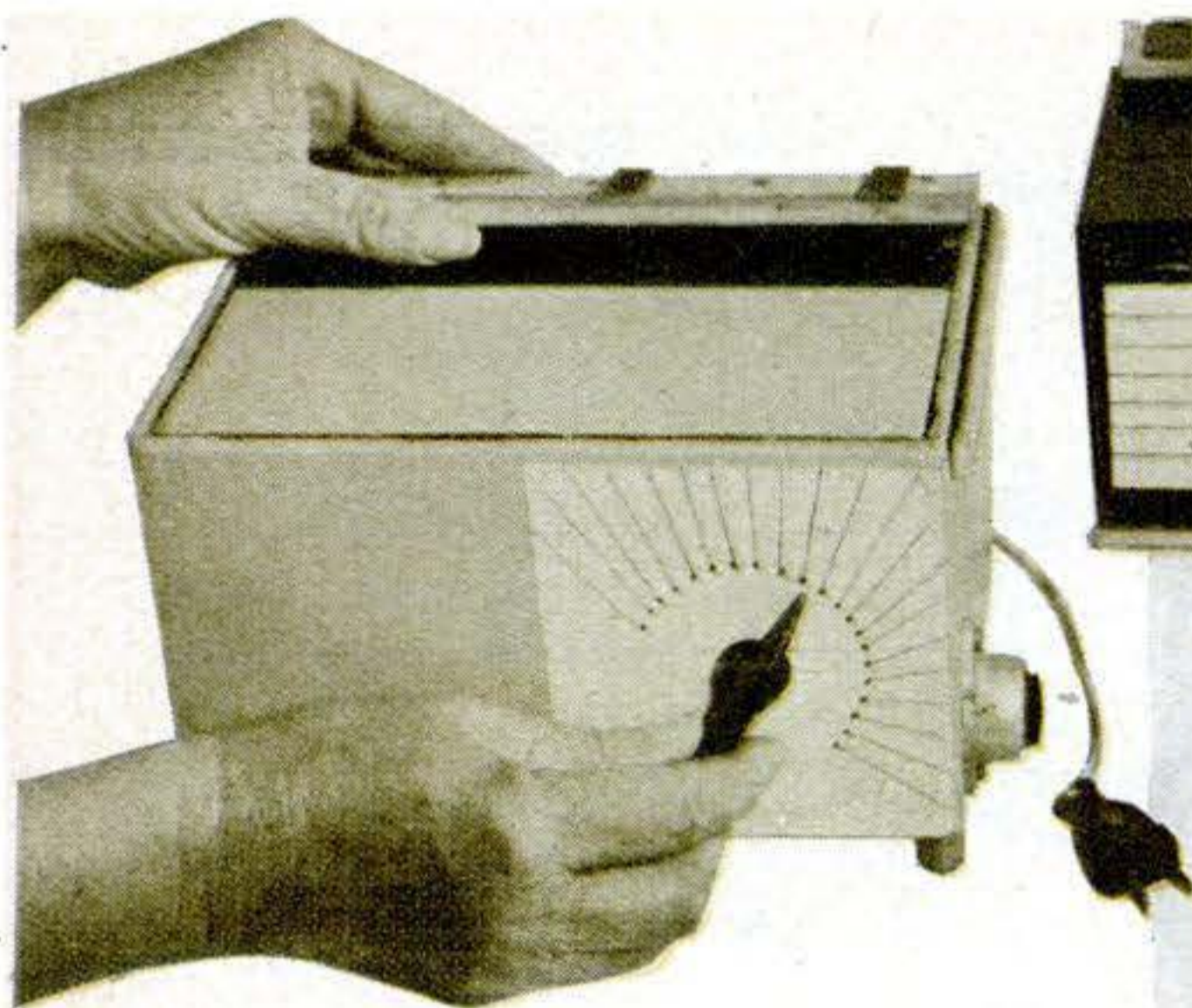

Your name can be placed on the border of a photo with either of the two printers at left. They work in the same way as a contact printer. The panels on front are for jotting down exposure data that give best results on different papers.

# Border Printer Brands Photos

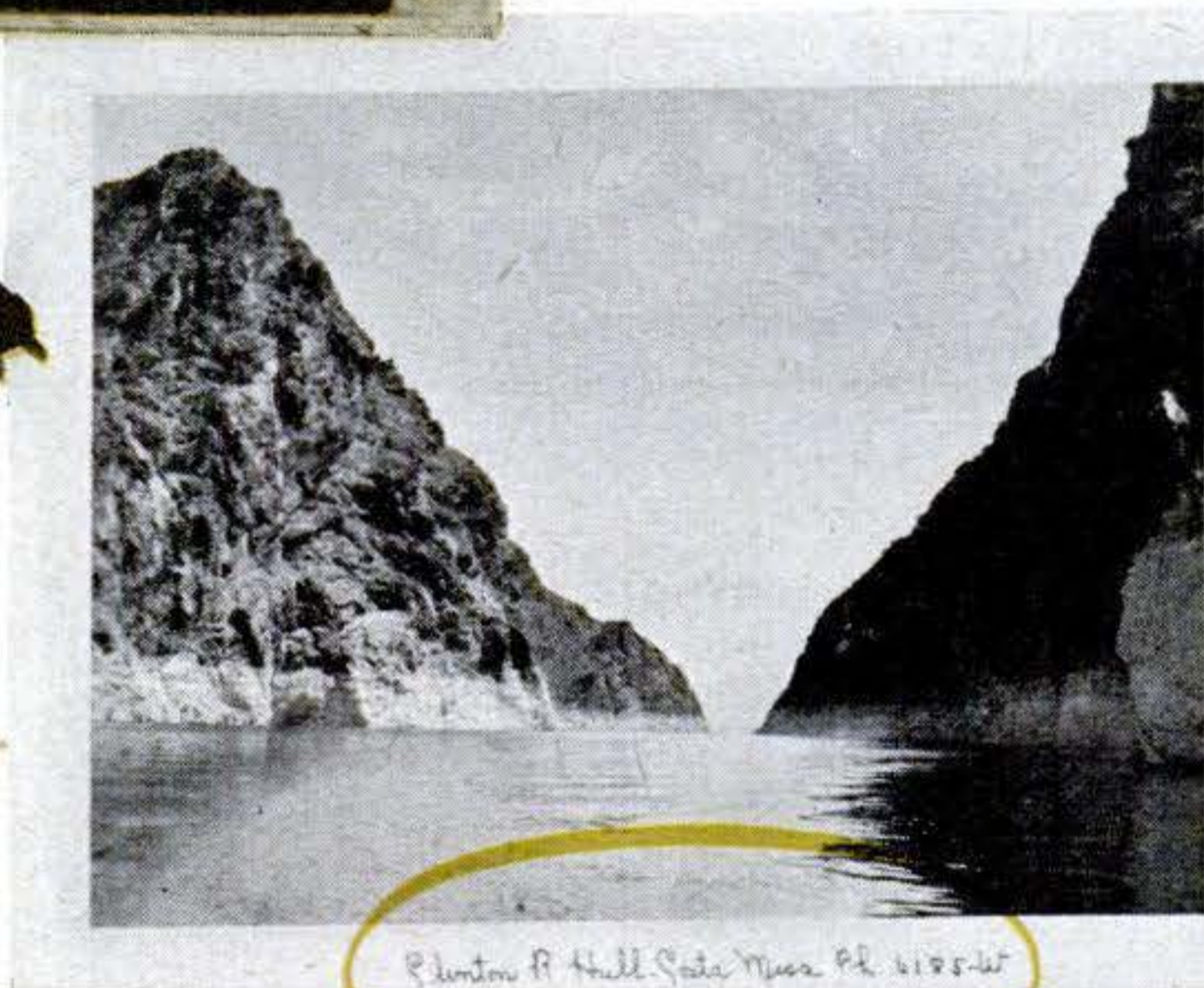

WITH either of these homemade printers, you can put your name and address on photos during the normal developing process.

Both work on the same principle. You make a negative of the desired wording on contrast film and mount this permanently over a slit in the printing box. After taking the paper from the enlarger or contact printer, you slip the edge under the border-printer pressure plate and expose.

The large printer, housed in a plywood box, has a 6-volt transformer, a rheostat, tail-light bulb, and switch wired in series. The rheostat varies the light for contact or enlarging papers. Glass set flush in the cover supports the taped negative.

In the small one, two flashlight batteries provide the power. Leather hinges join the plywood pressure plate to the alignment stop.—Clinton R. Hull, Costa Mesa, Calif.

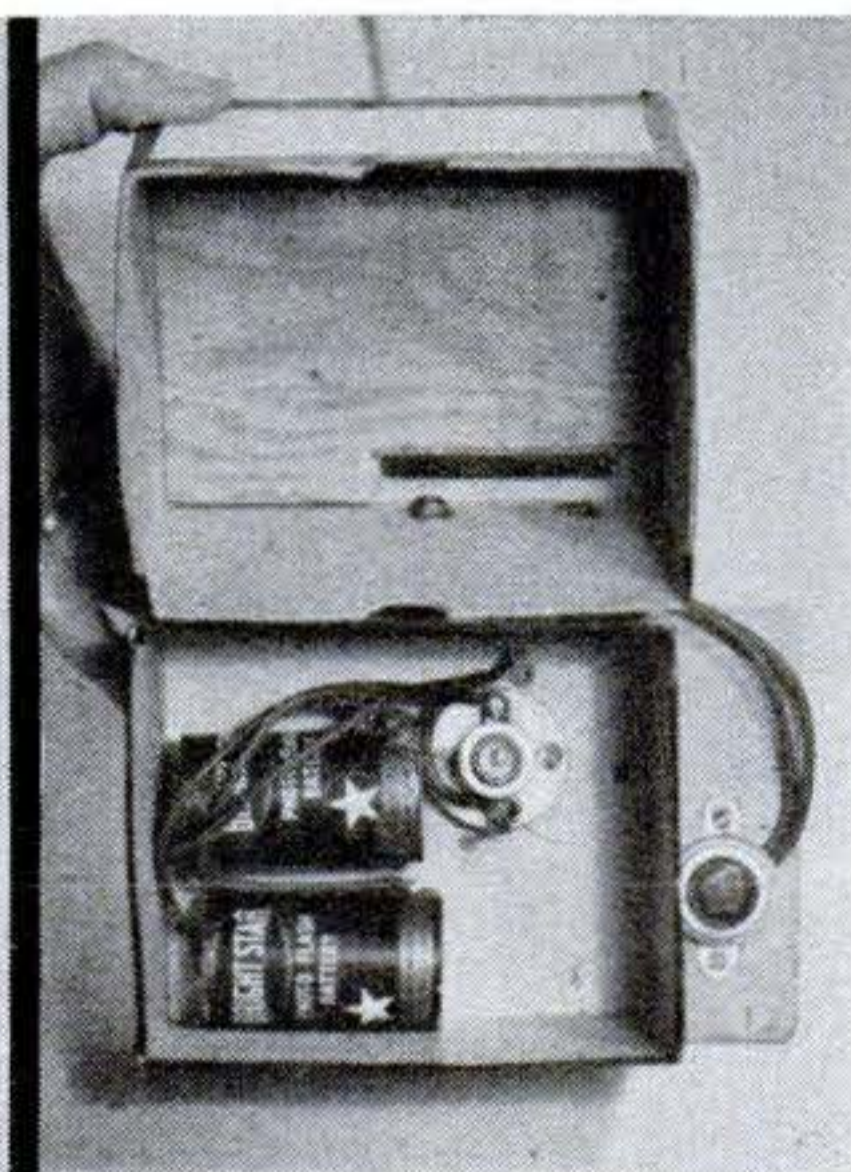
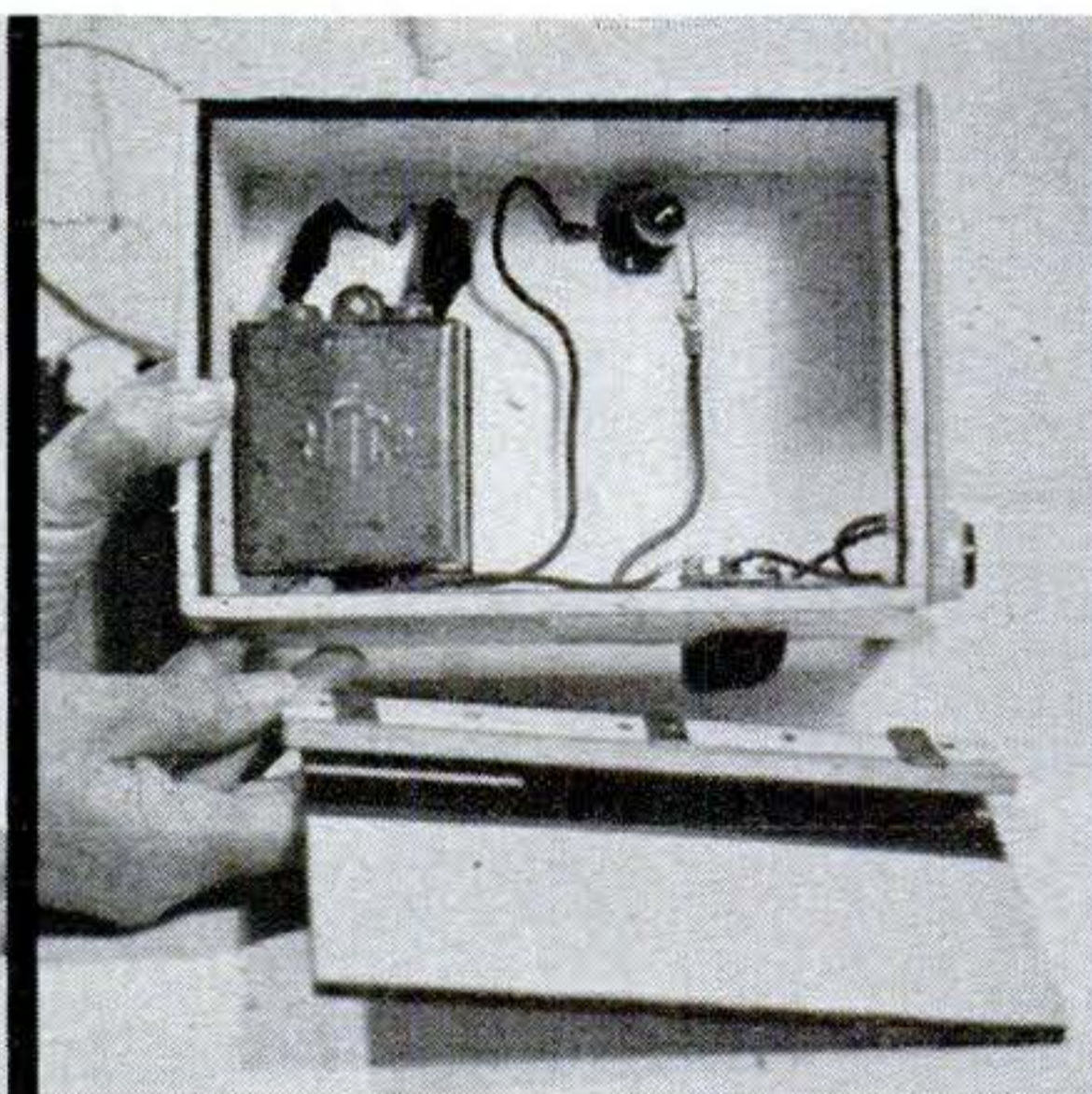
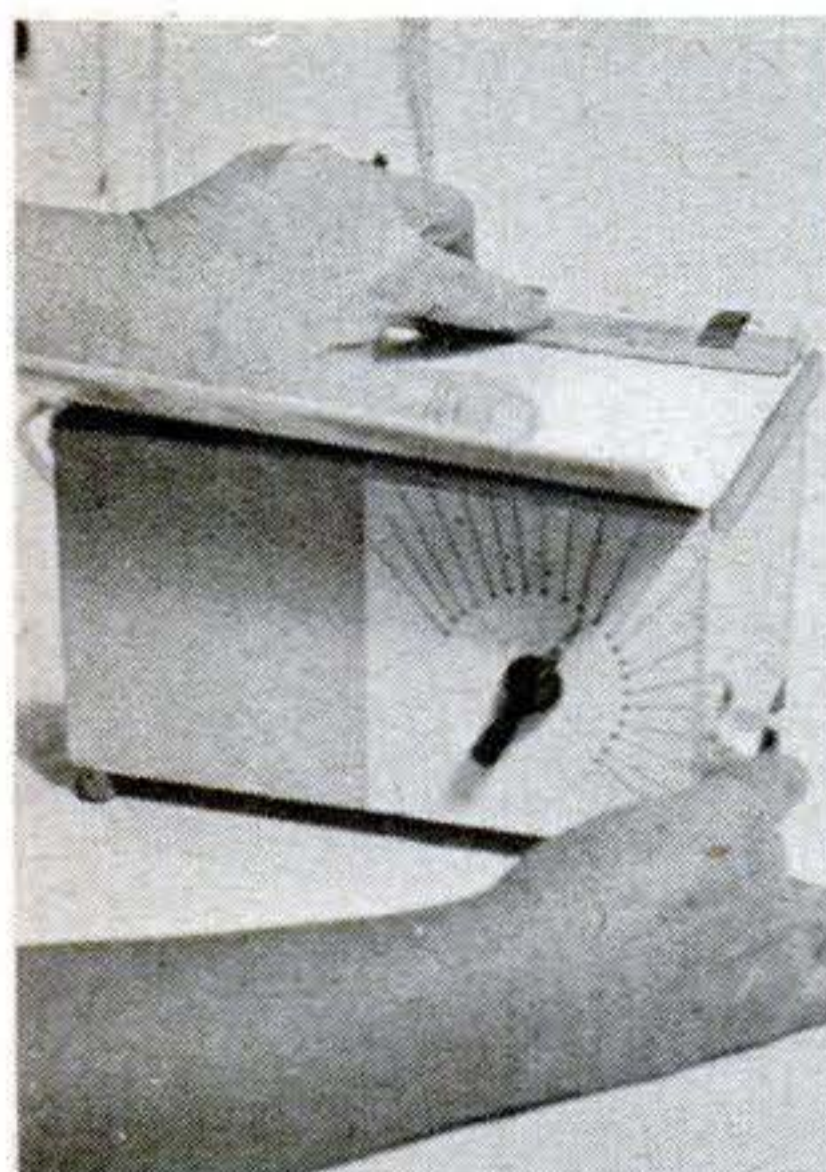

Exposure is made by slipping edge of the paper under pressure plate, left, and holding it in contact with signature negative while pressing switch. Lines radiating from rheostat pointer

enable you to reset the bulb to any illumination that you've found gives proper exposure on a certain paper. Center, an inside view of the larger printer; at right, the smaller one.

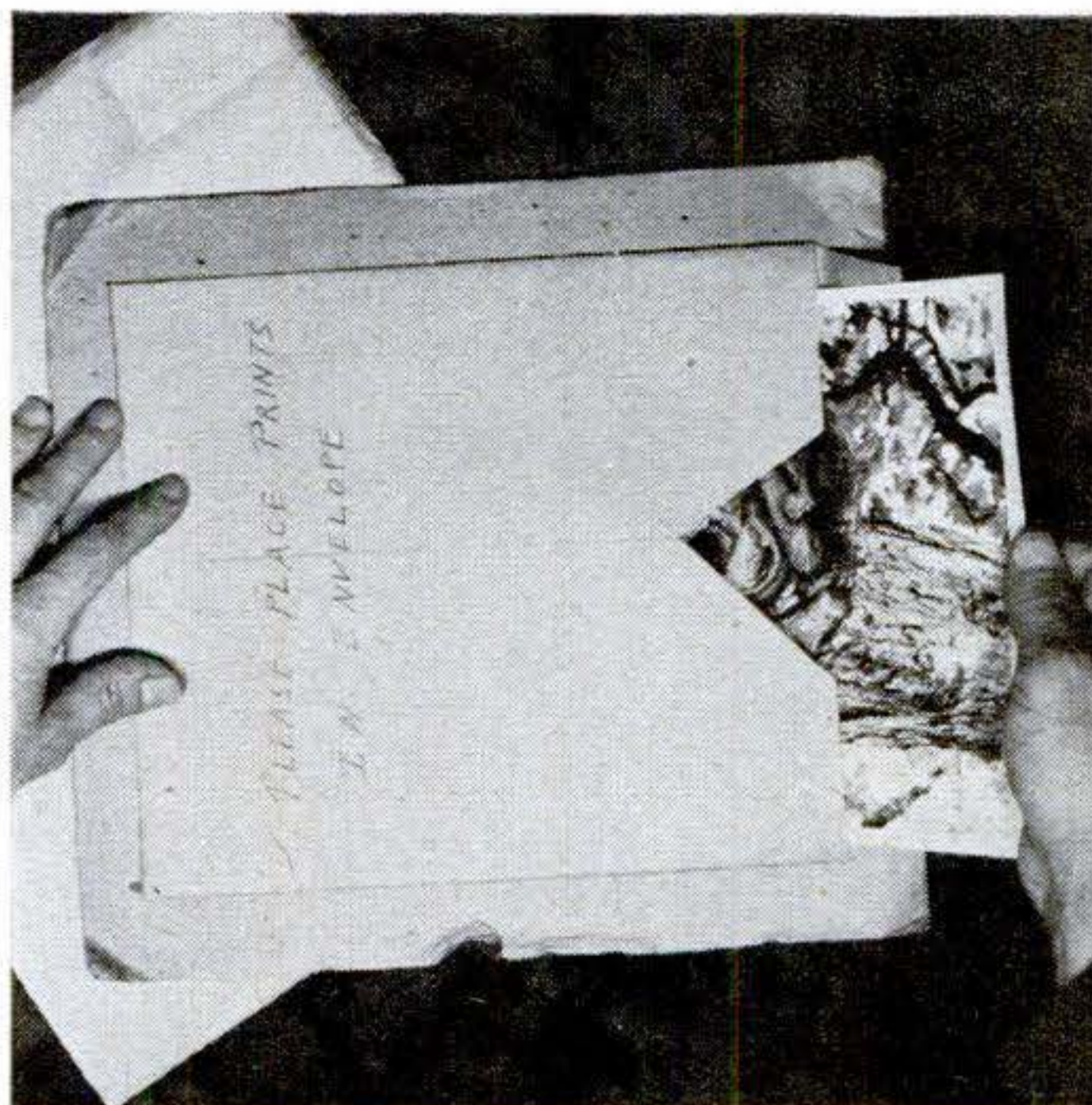

**Mailer Protects Photos.** Here's a packaging method that helps mailed prints reach their destination in good condition. Select two corrugated cardboards an inch or more larger all around than the prints. On one, center and glue an envelope that just fits the prints. Even though the cardboard corners become dented, the prints are less likely to be damaged.—A. C. Porter, South Bend, Ind.

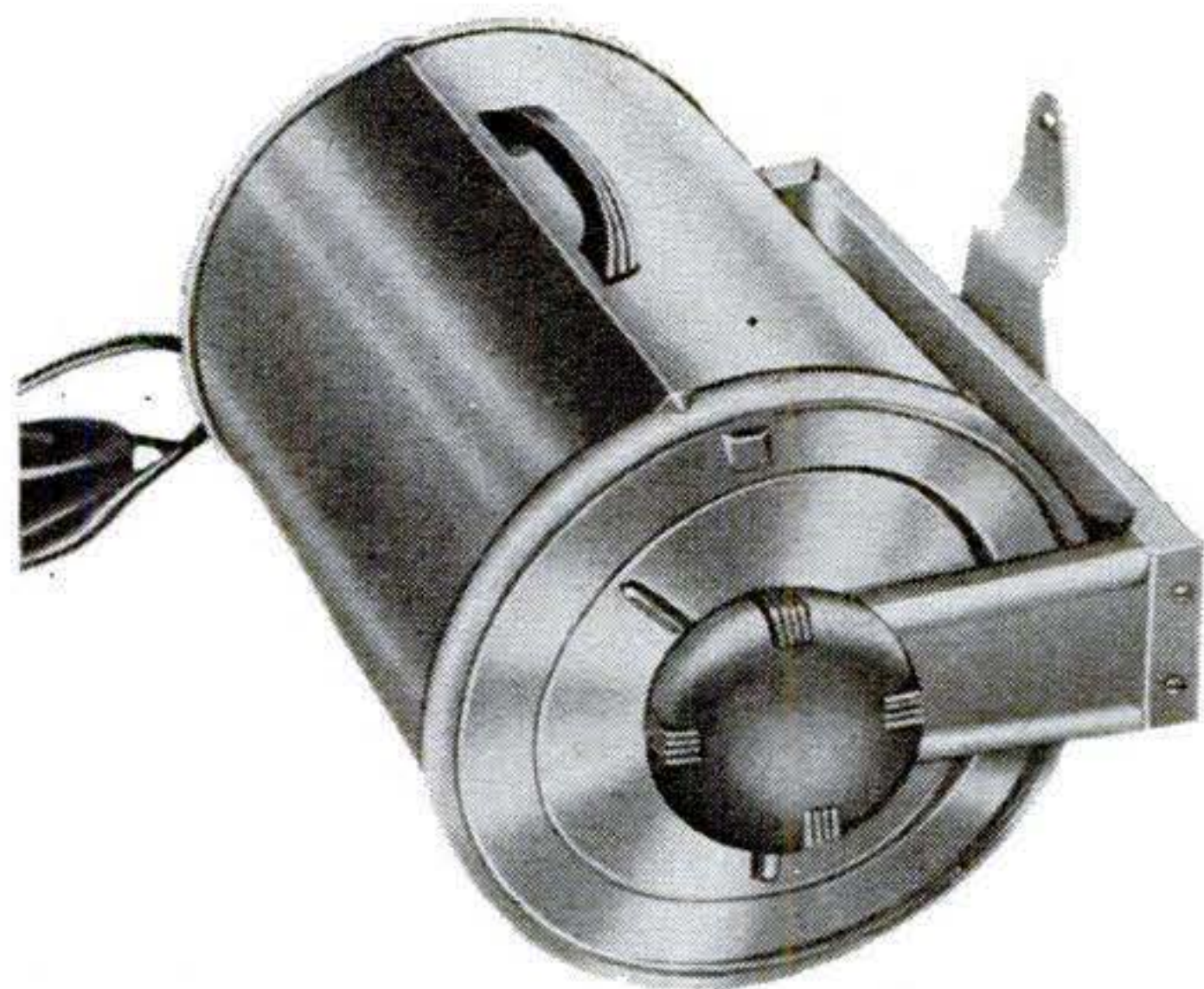

**Safelight Has Three Filters.** A rotary safelight announced by the Golden 'B' Manufacturing Company, Cleveland, gives you a choice of three filters—red, green, or yellow—simply by turning the housing. This allows you to suit the filter quickly to the work being done. The light retails for approximately \$11.

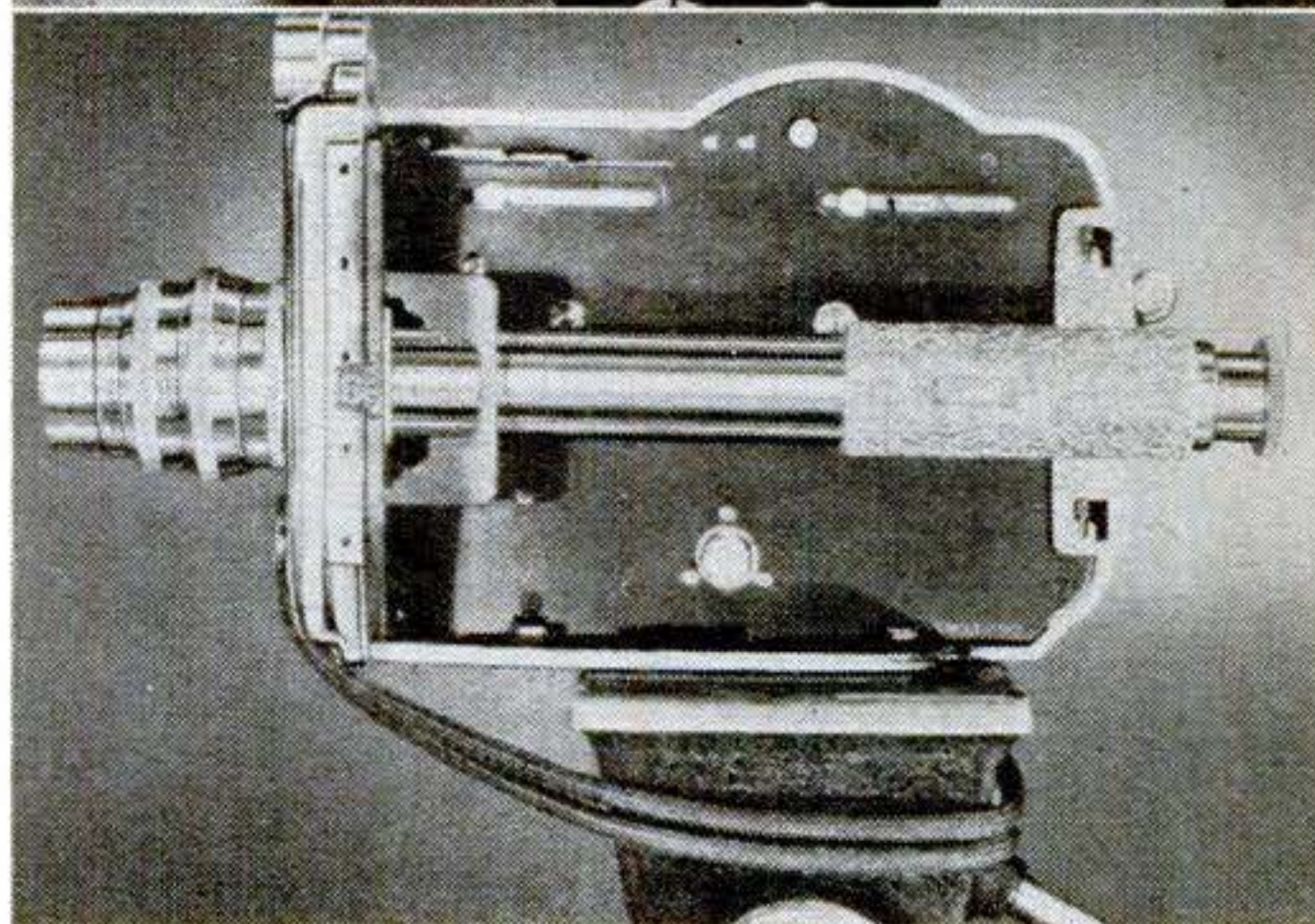
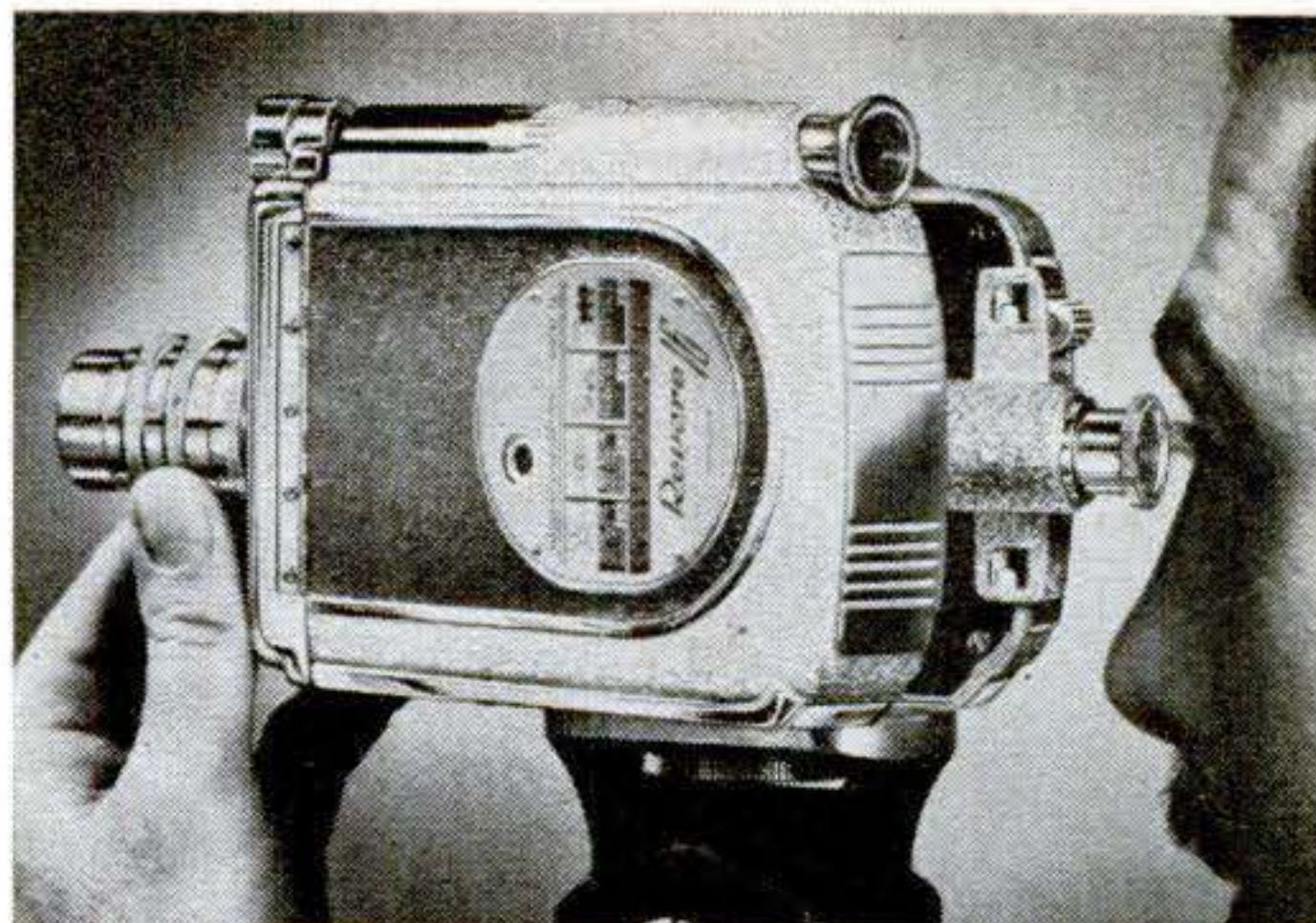

**New Finder Centers Close-Ups.** For critical focusing and centering of subjects at distances of less than 6', the Revere Camera Company, Chicago, offers a Thru-Lens Finder<sup>®</sup> as an accessory for its 16-mm. camera. With the camera on a tripod, you remove the film magazine and insert the finder. When the camera is aimed and focused properly, you remove the finder and replace the magazine.

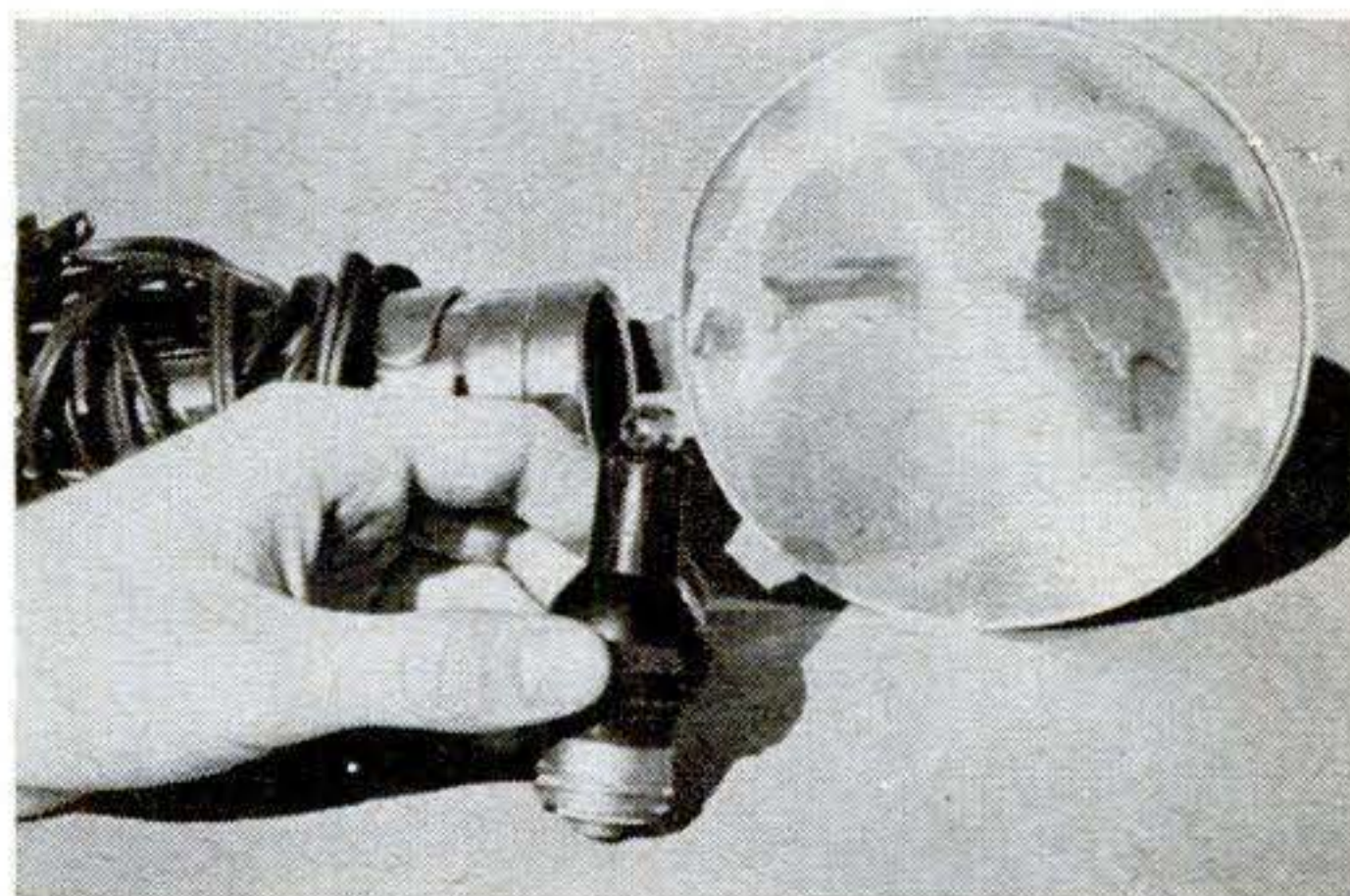

**Bulb Tests Flash Outfit.** A flash tester can be made by soldering wires to a flashlight bulb, pushing the bulb into a cord long-shank plug, and connecting the wires to the prong screws. Plug directly into the gun or, for extension sockets, insert the plug in a screw-in receptacle.—Don Pittwood, Moscow, Idaho.

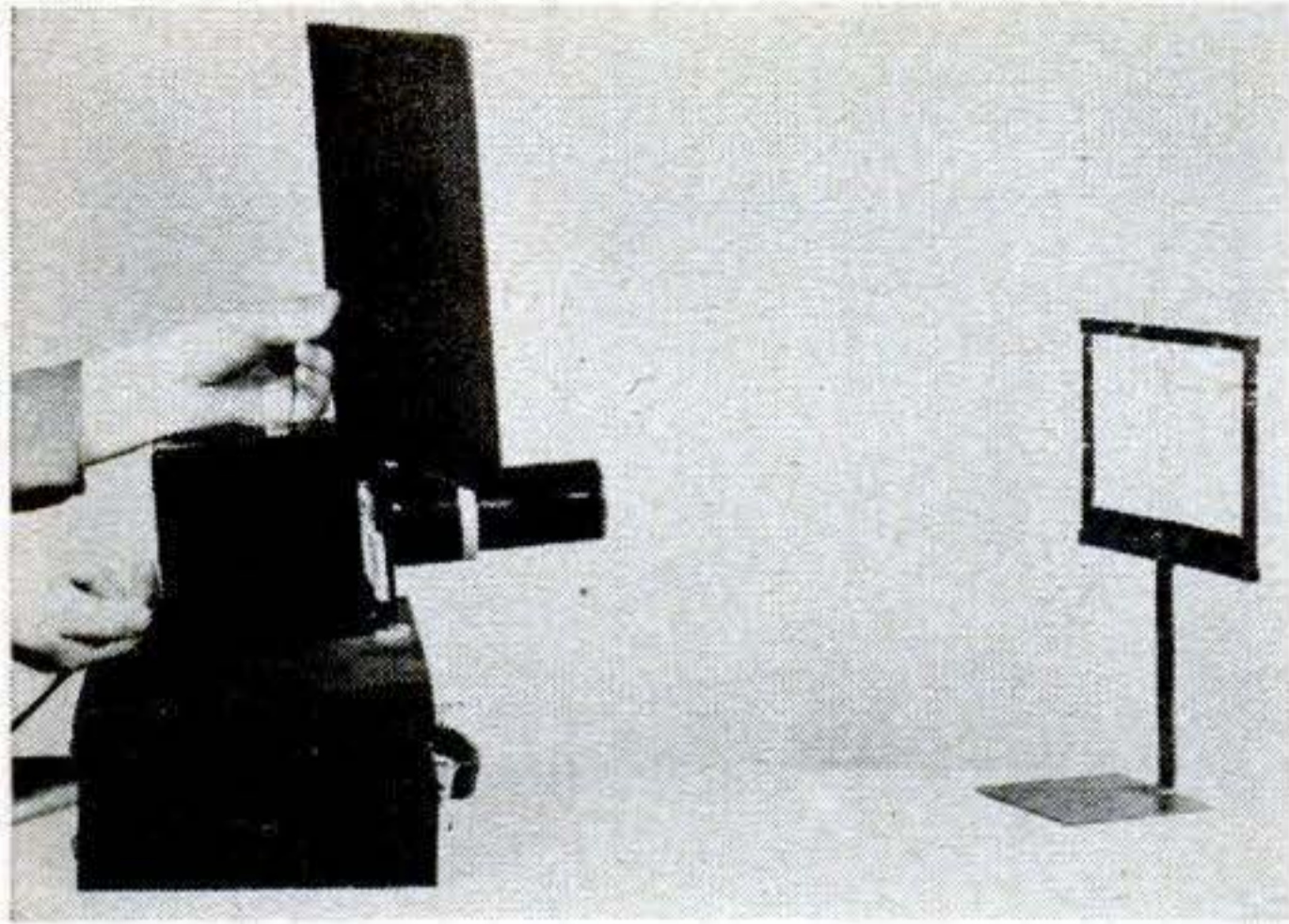

During exposure, stray light is kept off easel with a shield. It could be held in place by cutting a hole and sliding it onto the lens barrel.

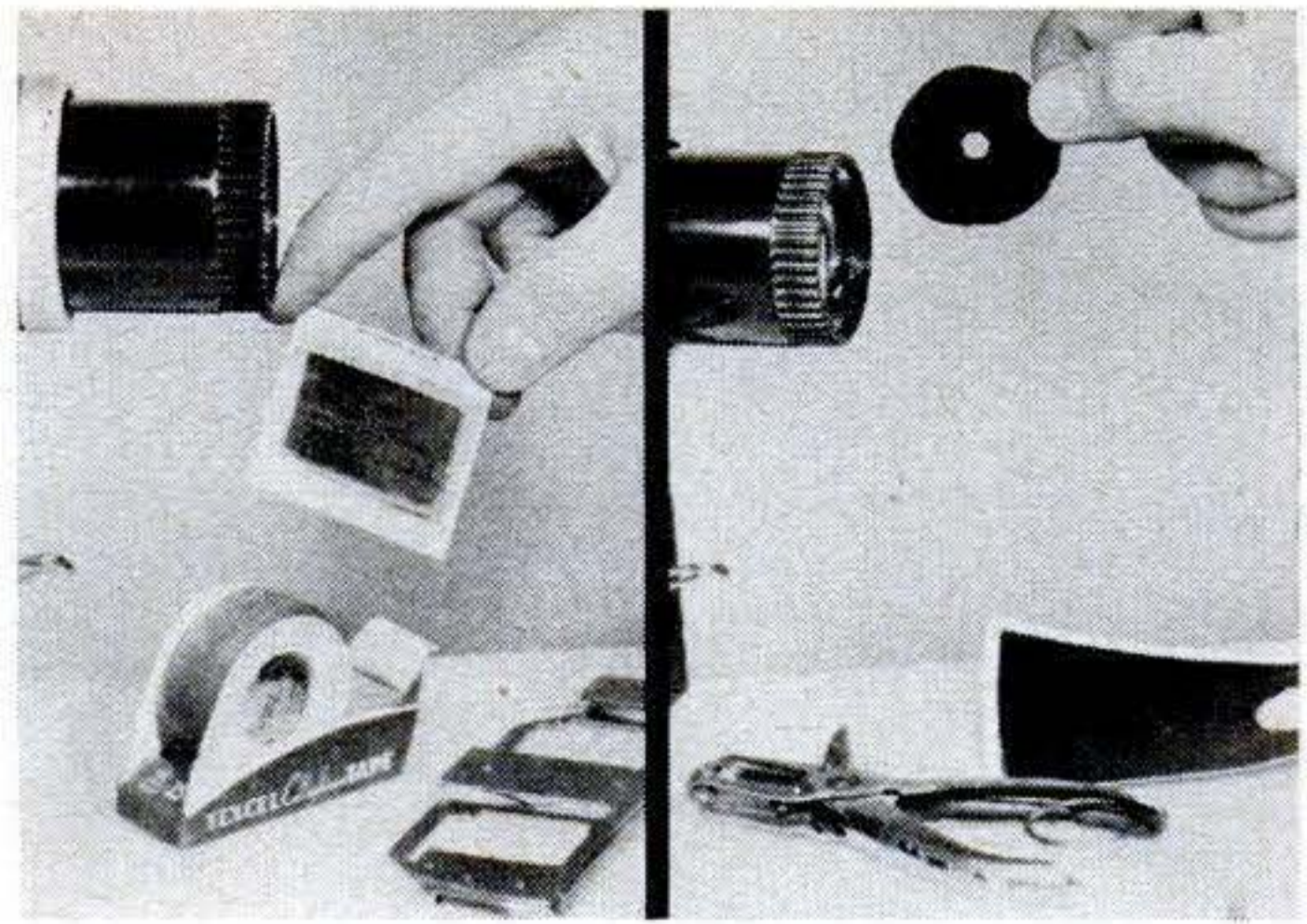

Negatives are taped over a blank slide mount and then inserted in the slide holder. Cardboard disk with  $\frac{1}{4}$ " hole serves as lens stop.

## Color Slide Projector Doubles as Enlarger

SOME photographers operate 35-mm. cameras chiefly for color, only occasionally exposing a roll of black-and-white film. In such cases, they can make fairly satisfactory enlargements from their negatives by using a slide projector as an enlarger.

The photos above show how it's done. Adequate enlargements up to 5" by 7" have been made in this way.

A cardboard disk was cut to fit over the

lens and a  $\frac{1}{4}$ " hole punched in the center. This permits exposures of about 1 sec. with the 100-watt lamp in the projector. To lengthen the time, the hole could be made smaller or a smaller bulb used.

A display-card holder serves as an upright easel. A weight should be placed on the foot of the holder to prevent movement while inserting the enlarging paper after focusing.—H. Leeper, Canton, Ohio.

## Oscillating Fan Agitates Two Film Tanks at Once

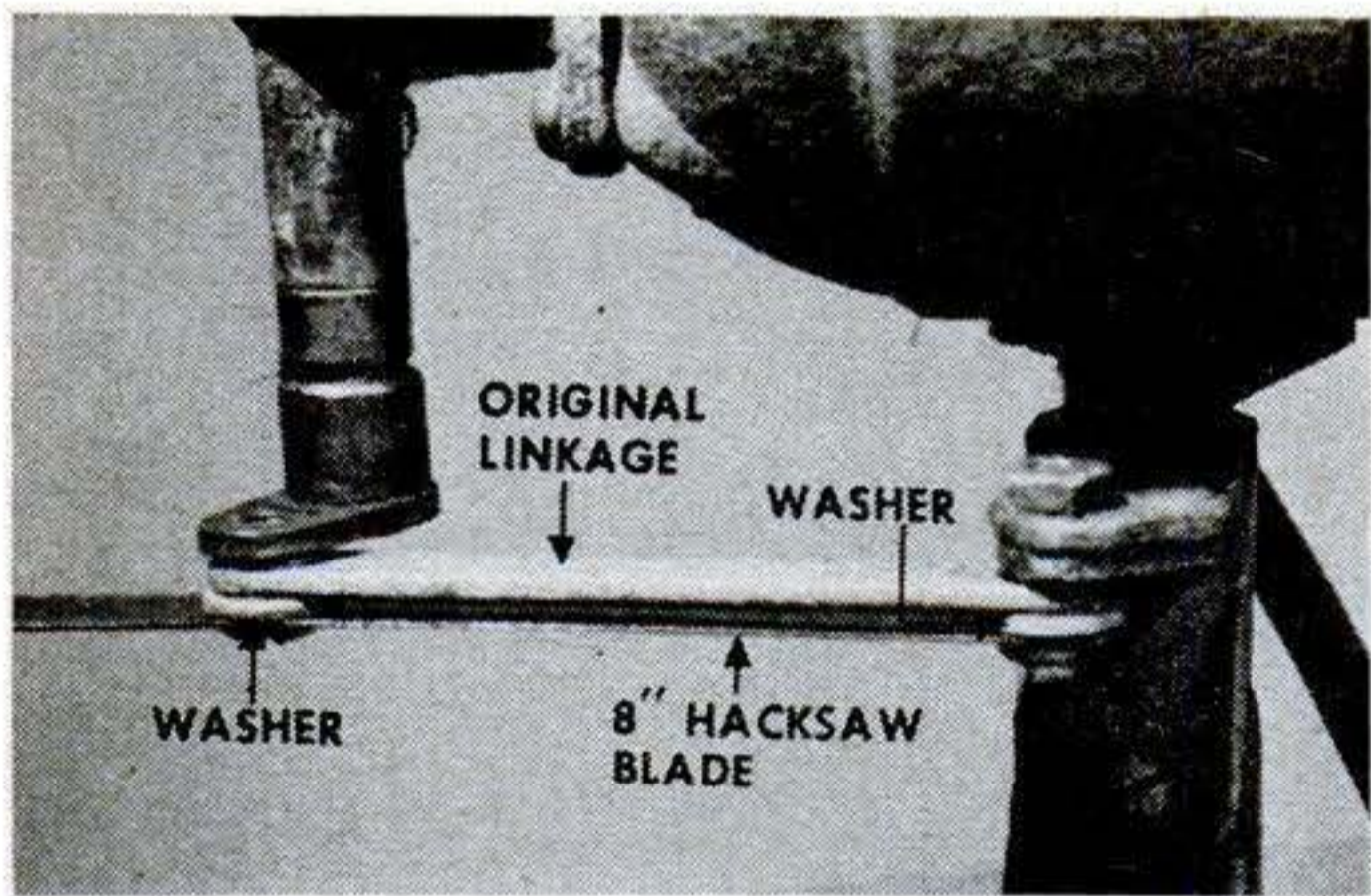

UNIFORM agitation of one or two film tanks is possible with this device. Snap two 8" hacksaw blades at the center to provide the four parts of the linkage nearest the tanks. Anneal the metal by holding the ends in a flame and drill for  $\frac{1}{8}$ " bolts. Take off the regular drive link from an oscillating fan, (see above), use it as a guide to drill corresponding holes in an unbroken 8" hacksaw blade, and reassemble the link and blade with washers.

Remove the metal rings from two sink stoppers, punch holes to make the stoppers

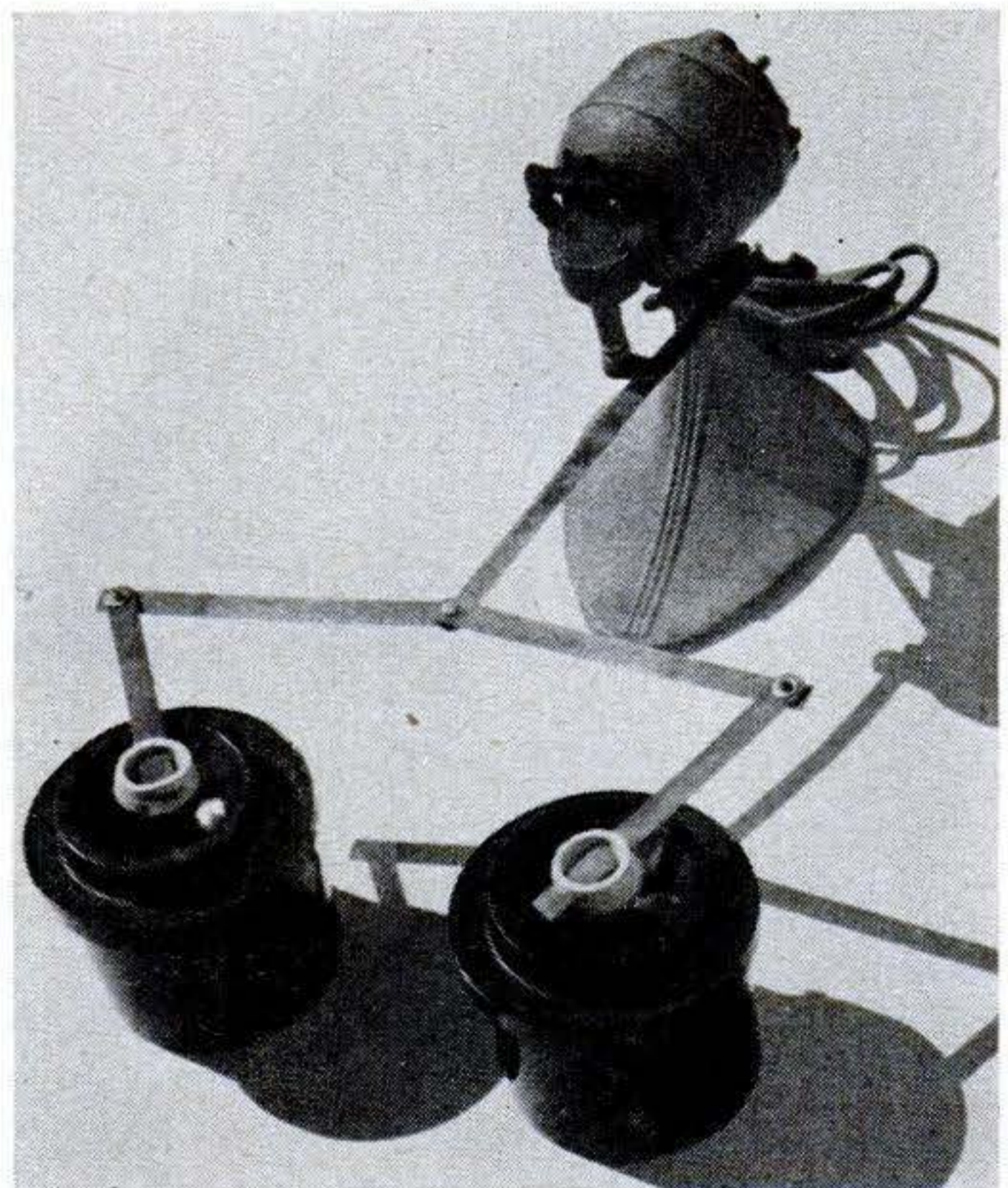

a tight fit on the reel knobs, and cut slits on opposite sides for insertion of the blades.—H. D. Smith, Los Angeles.

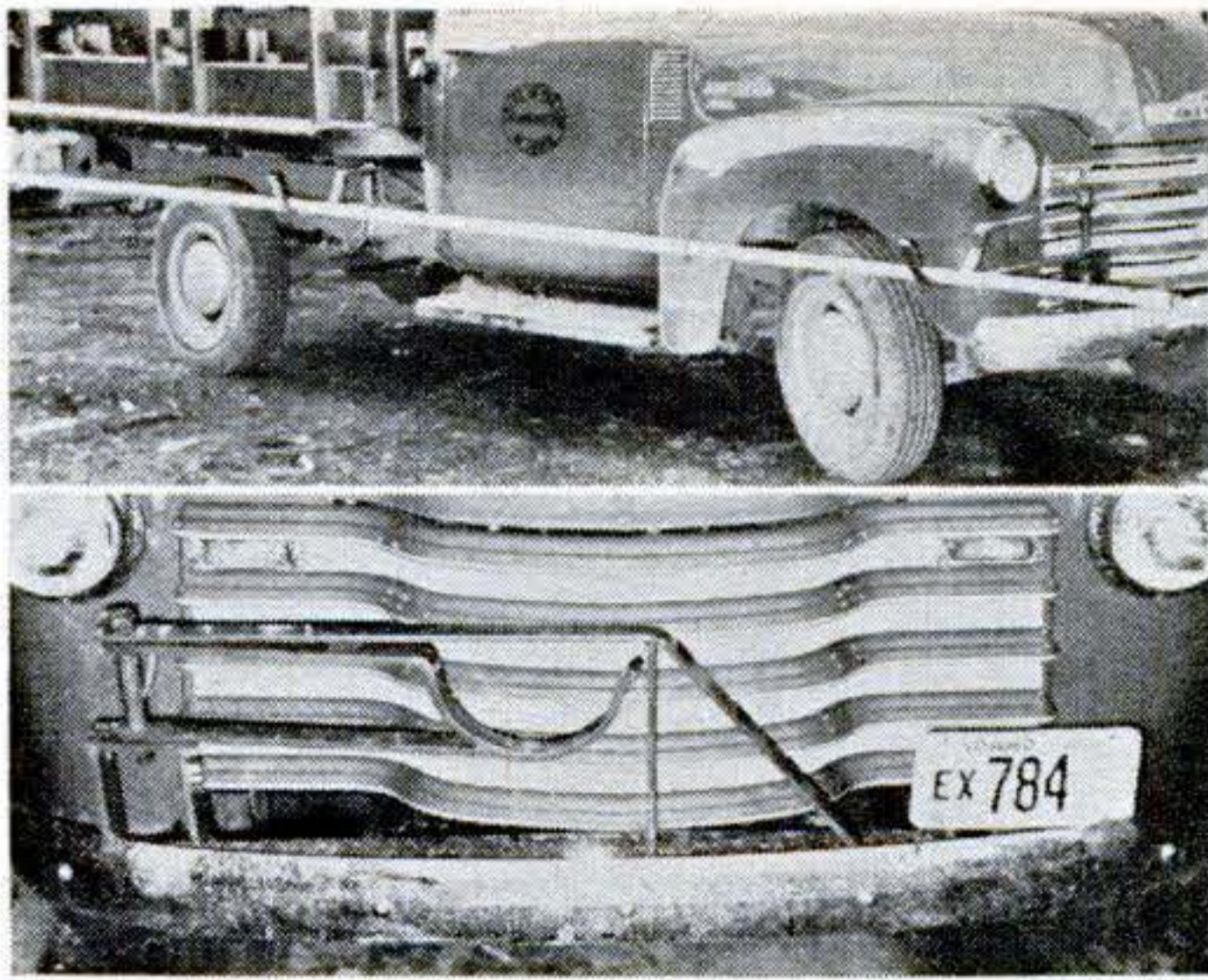

Three folding pipe racks are fitted on truck pictured at top above. Photo just above shows the front rack folded out of the way. Same  $\frac{3}{4}$ "

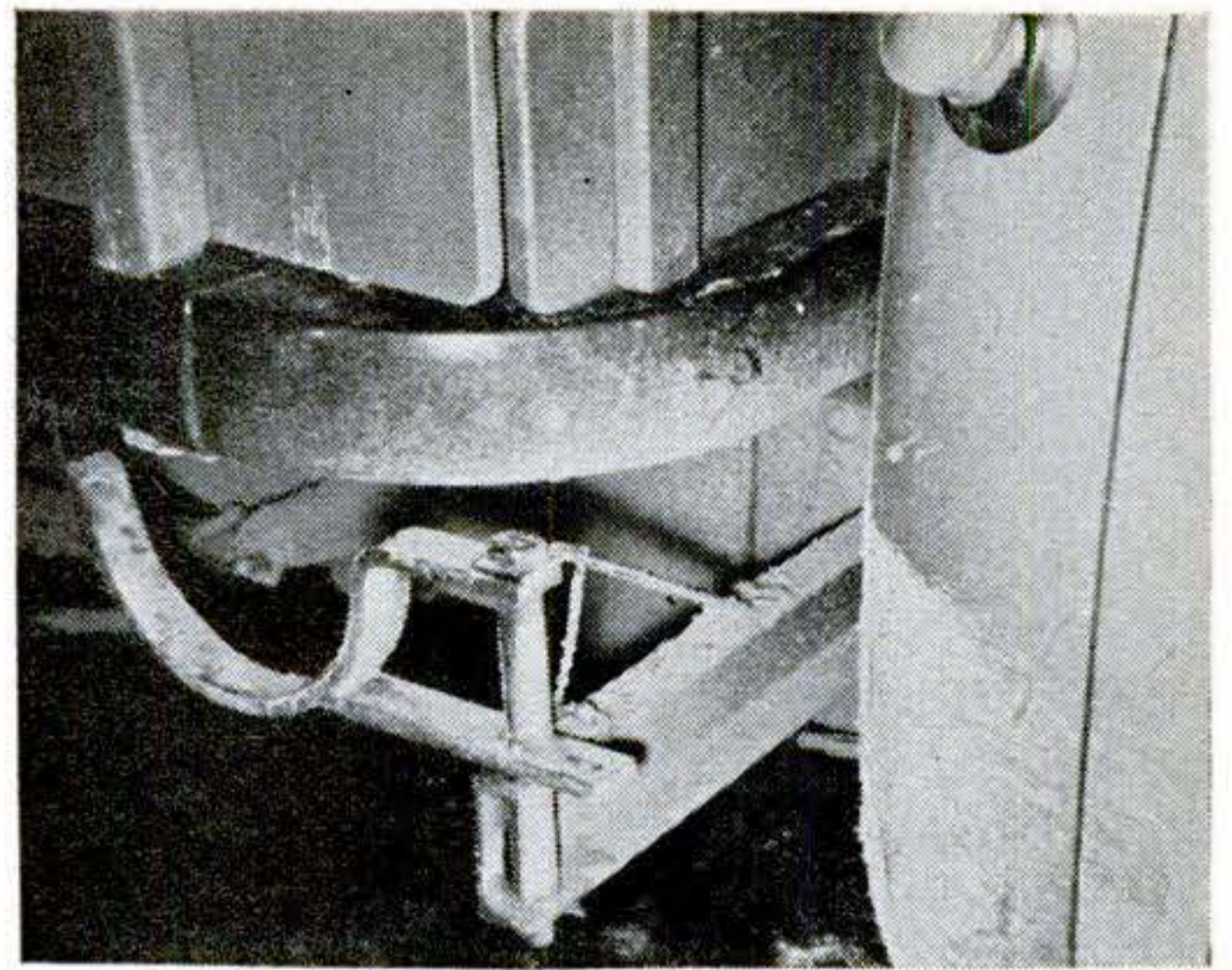

bolt that holds it in open position also locks it when folded. The center rack is swung back parallel to the truck chassis when not in use.

## Pipe Carrier Swings Out of Way

THESE folding pipe racks will increase the capacity of a truck or pickup. Built by Roy Kayler, superintendent of the University of Idaho maintenance shop, each carrier is held in position by a single  $\frac{3}{4}$ " iron bolt. A short piece of chain, welded to the bolt head and to the rack, keeps the bolt from being lost. Details are shown in the drawing below. The front rack is mounted on a heavy piece

of iron that was cut out to fit the inner contour of the front bumper. It is welded to the bumper braces. A section of 3" channel iron supports the rear rack. The channel iron runs the full width of the chassis and is welded to the frame. Bolts could be used instead of welding. Make sure the racks don't violate highway regulations in your state.—Don Pittwood, Moscow, Id.

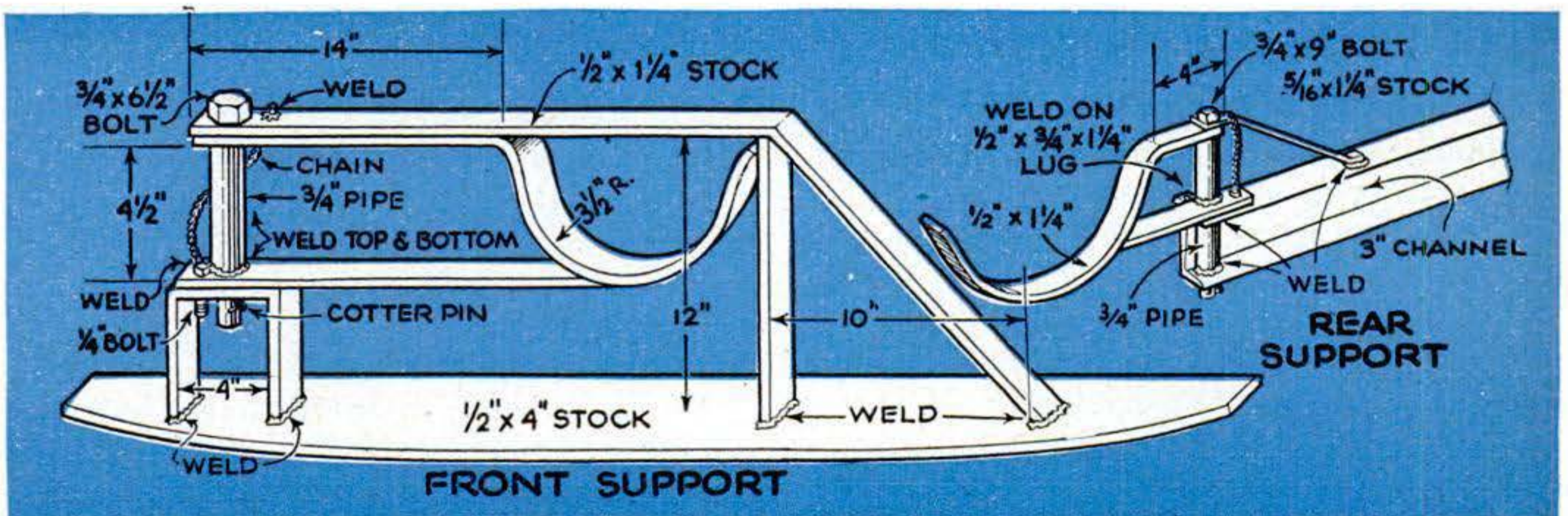

## Automatic Defroster

THIS timing mechanism will automatically defrost your refrigerator, eliminating all manual de-icing. To connect it, the unit is plugged into an outlet and the refrigerator cord plugged into the timer. The pointer is set to the nearest hour of the day to synchronize the clock mechanism with the correct time. Then at 1 a.m. each day, the unit shuts down the refrigerator just long enough to defrost it. Priced about \$13 by Automatic Controls Corp., Ann Arbor, Mich.



## Apple Crates Frame Cabinet

HALF a dozen apple crates, stacked as seen in the inset photo, form the basis of this dining-room cabinet. The cabinet was built by Mrs. O. B. Woods, of Bigfork, Mont., to house her dishes, glassware, silver, and the like.

Besides the boxes, you need about one full 4' by 8' panel of  $\frac{1}{4}$ " plywood to duplicate the cabinet. The plywood is used for facings and doors. Hinges and catches from the dime store, a handful of nails, and varnish or paint to suit your taste complete the list of requirements.

Four boxes placed on their sides, two high, form the bottom of the cabinet. A 4" space is left between for the facing to which doors are latched. A fifth box is placed upright at the end of the double tier. Nail the end from another box in the middle of this one as a shelf.

Place the sixth box across the space separating the bottom four. After all the boxes have been nailed in position, face the ends, top, and front with plywood. The cabinet shown rests on the baseboard in a corner, the facing of the right side extending to the floor for support. If not built into a corner, the cabinet should have extensions at both ends to serve as legs.—*Mildred Kelso, Bigfork, Mont.*



## Jar Increases Dust Capacity

TIRED of constantly refilling my garden duster, I cut an opening in it and soldered on a standard metal jar lid through which I had cut a hole. This fitting accepts a standard fruit jar, increasing the capacity of the gun several times. The cloth seen in the photos keeps dust from backfiring.—*Clinton R. Hull, Costa Mesa, Calif.*

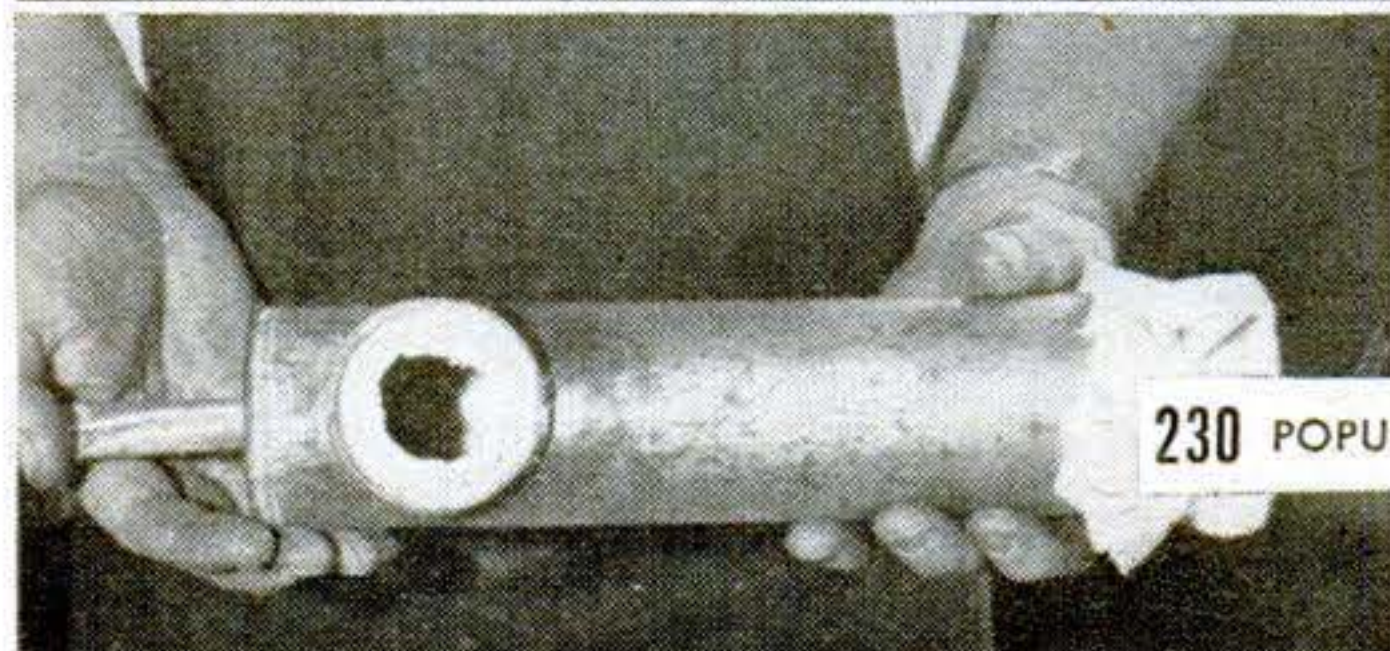
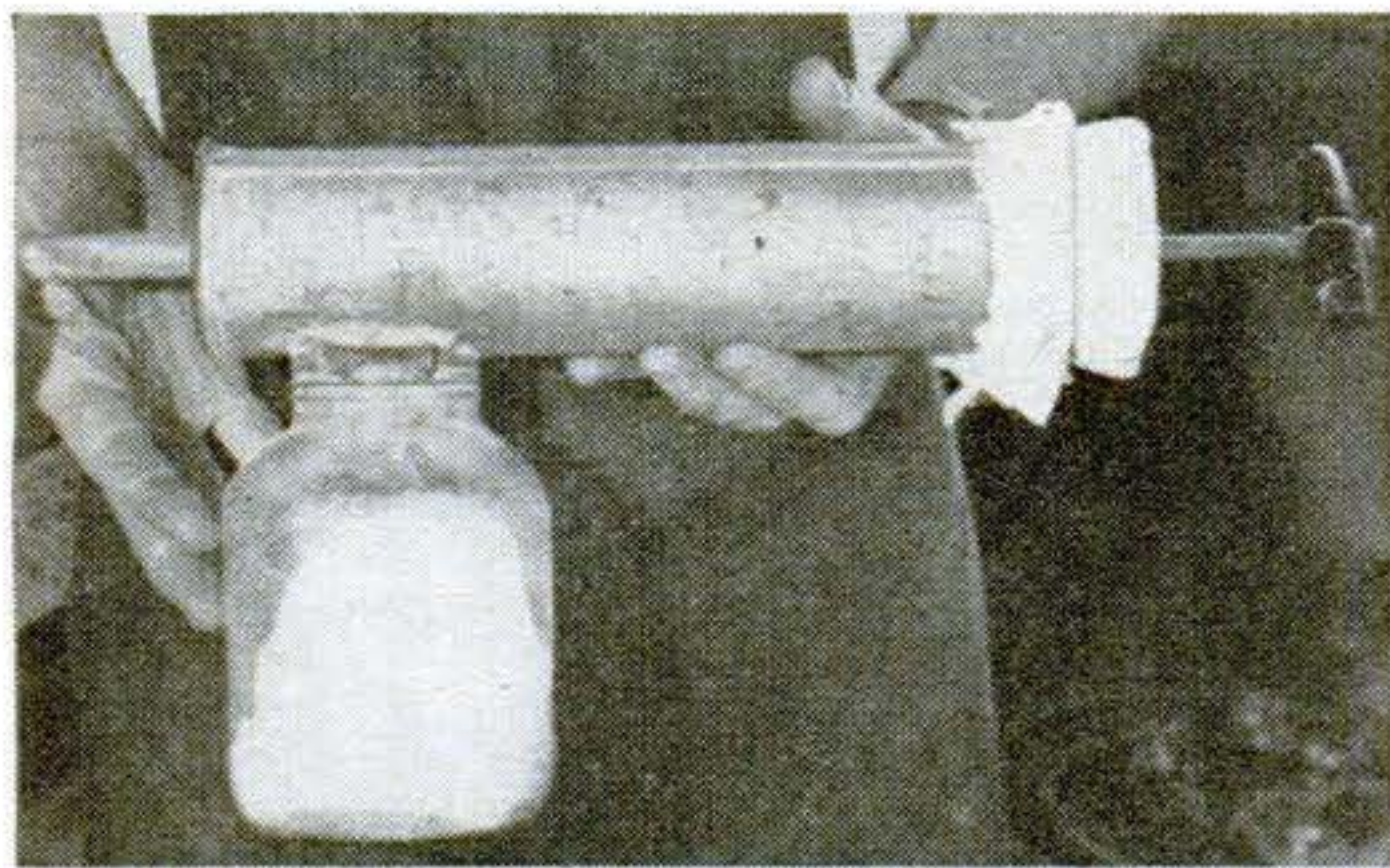

## New Loader Picks Up Bales

HITCHED alongside a truck or wagon, a new bale loader takes the back-breaking labor out of a familiar farm job. Guides 3' long direct the bale into the elevator as the loader moves across the field picking up hay deposited by the baler.

Made by the International Harvester Company, Chicago, the loader is driven by a chain connected to a sprocket on the axle of two wheels, which are fitted with 6.00 by 16 tires. The loader is 7' high, 12' long, and weighs about 688 lb.

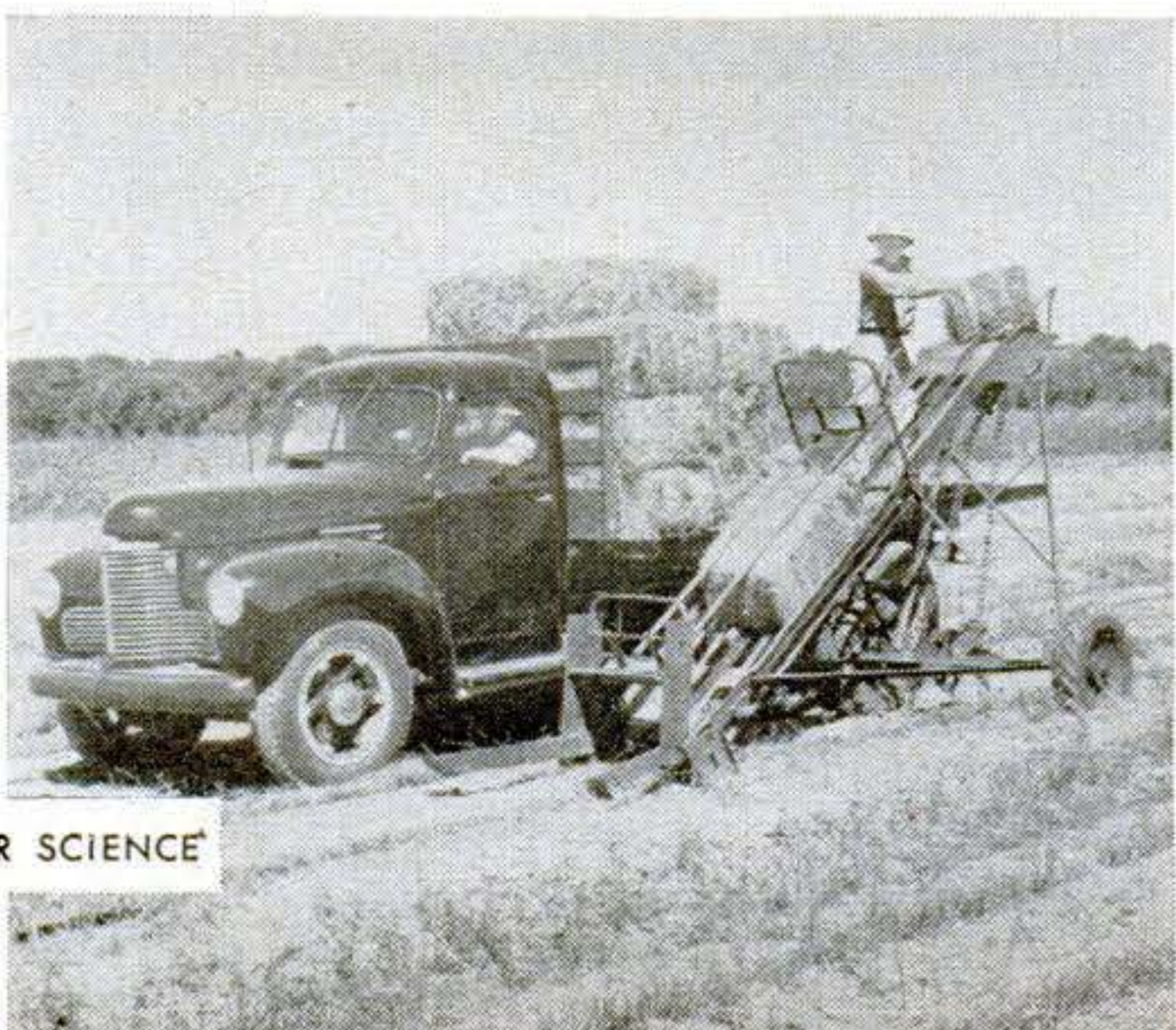



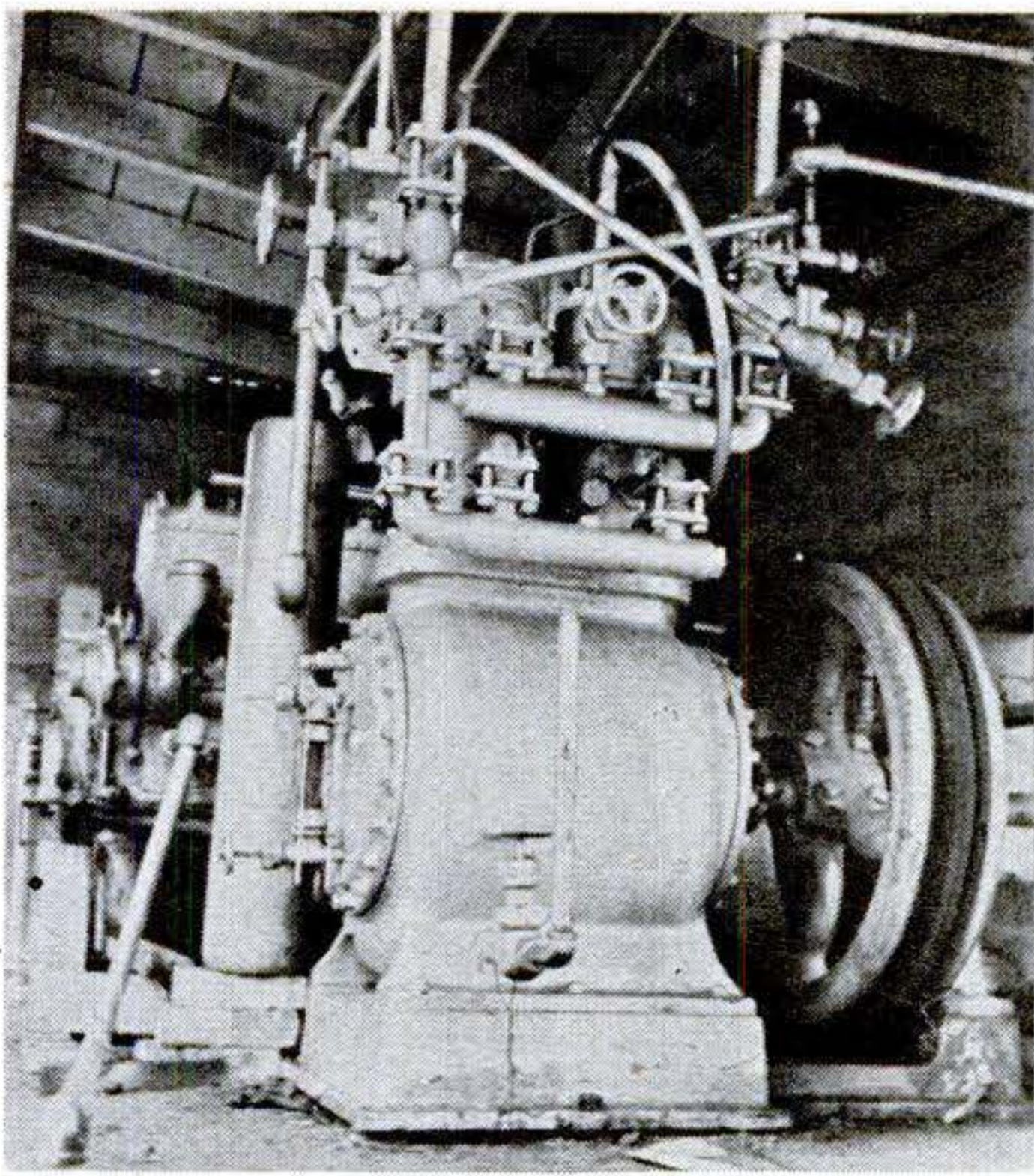

**Ammonia compressor**, bought secondhand, is backbone of air-conditioning system that cools and dehumidifies an eight-room house.

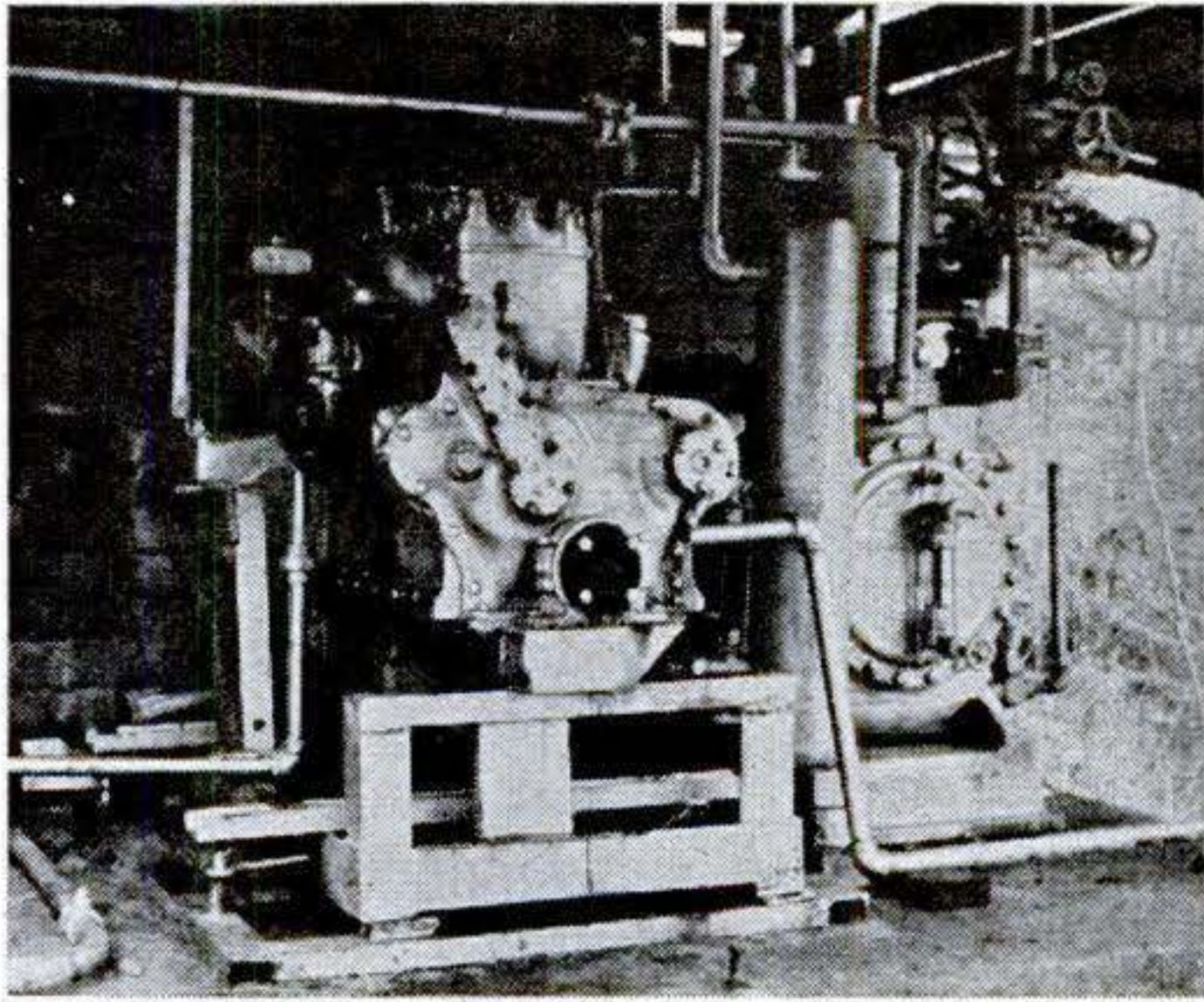

**Gasoline motor**, run on natural gas, furnishes the power for the compressor and a centrifugal pump that recirculates water from the pool.

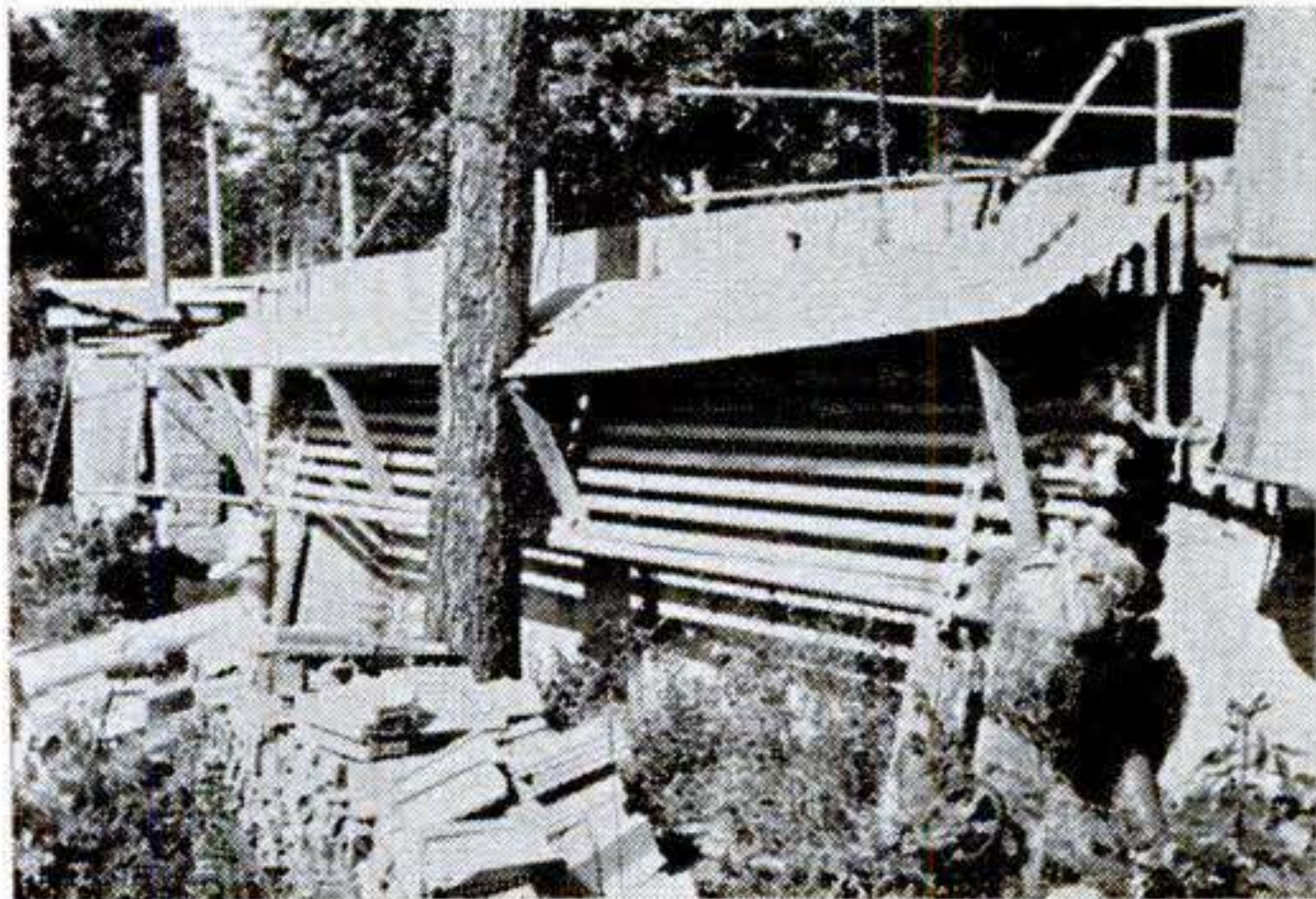

**Condenser coils** are located behind back-yard swimming pool. Water from pool absorbs heat taken from house. Compressor is at far left.

## Ammonia Plant Cools Home Air

**A**N AMMONIA refrigeration plant cools the Little Rock, Ark., home of Don Leveck. The used ammonia compressor and auxiliary equipment cost \$500. Energy for the pumps is furnished by a gasoline engine, which is run on natural gas.

Mr. Leveck's forced-air heating plant and back-yard swimming pool are used in the cooling system. House air, ammonia-cooled in the air chamber near the furnace, is filtered and washed by water sprays and forced back into the rooms by the furnace fan. The compressor sucks ammonia gas from the house cooling unit and forces it through condensing pipes which surround smaller pipes carrying water from the pool. In a liquid state, the ammonia is sent back to the house to absorb more heat. —*Ruth D. Arnold, Little Rock, Ark.*

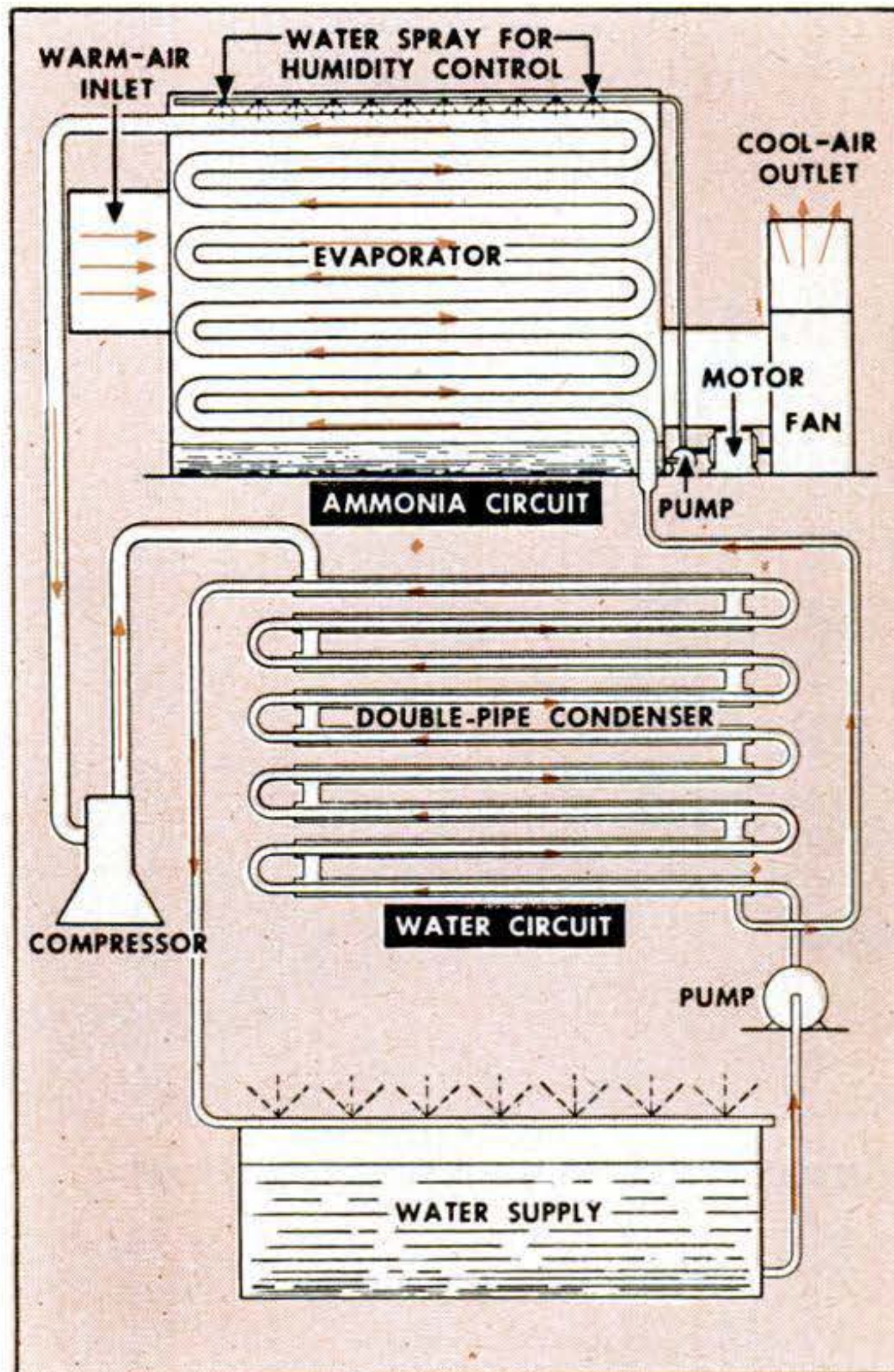

**Schematic view** of three-element cooling system shows house's heating plant, double-pipe condenser, and swimming-pool water supply.

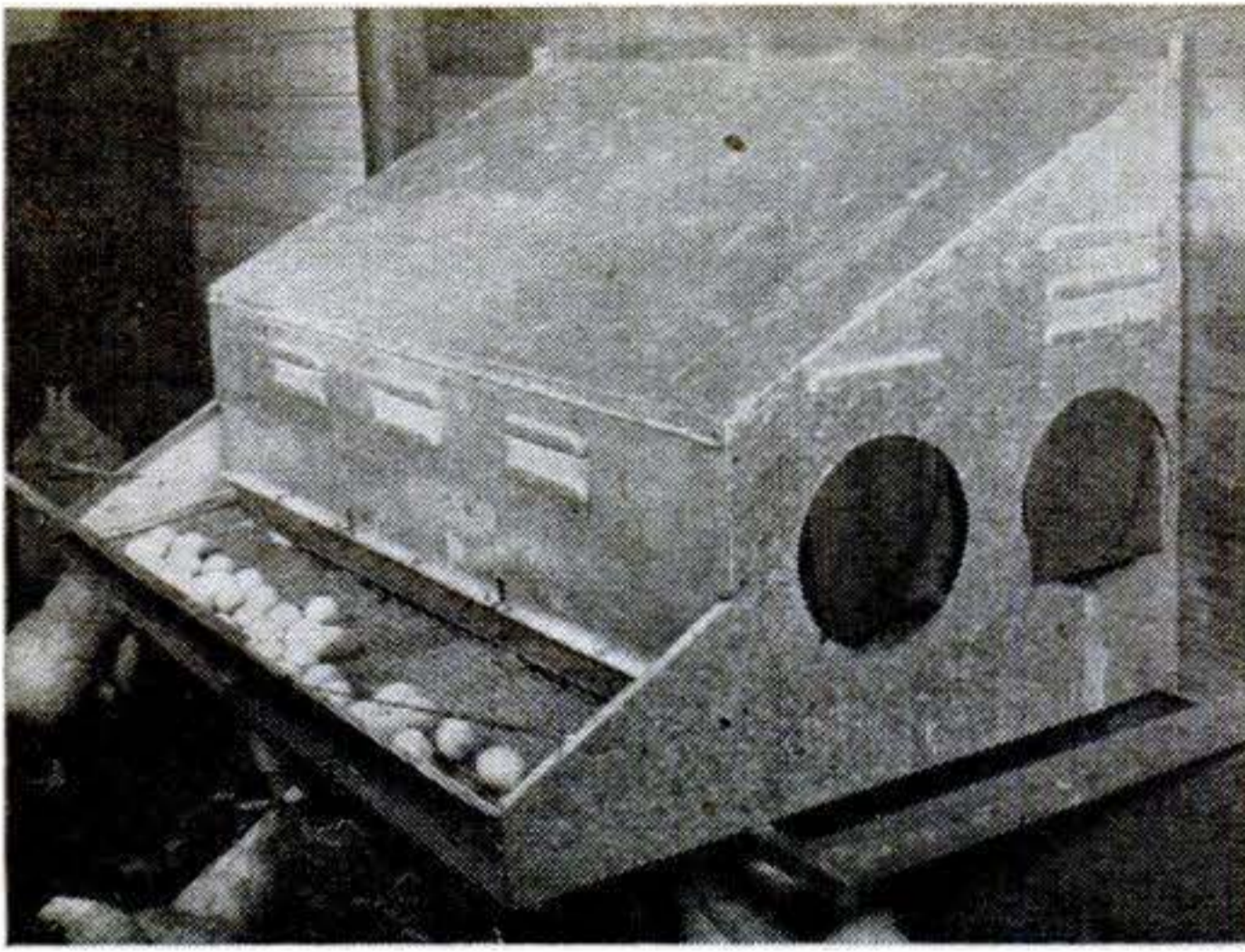

### Eggs Roll into Collecting Pan

COMMUNITY laying nests for poultry made by the Russel Manufacturing Co., Caro, Mich., are said to do away with the necessity of washing and buffing the eggs.

The nest floor is a sloping wire screen. When laid, the eggs roll down the screen into a collecting compartment outside the nest itself. A hinged top swings back, as above, to give access to the eggs.

Each nest, made of aluminum and steel, has four entrances for the hens. The interior is divided by curtains. The front of the laying compartment is hinged for easy cleaning. Shallow trays under the screen floor catch dirt that falls through.

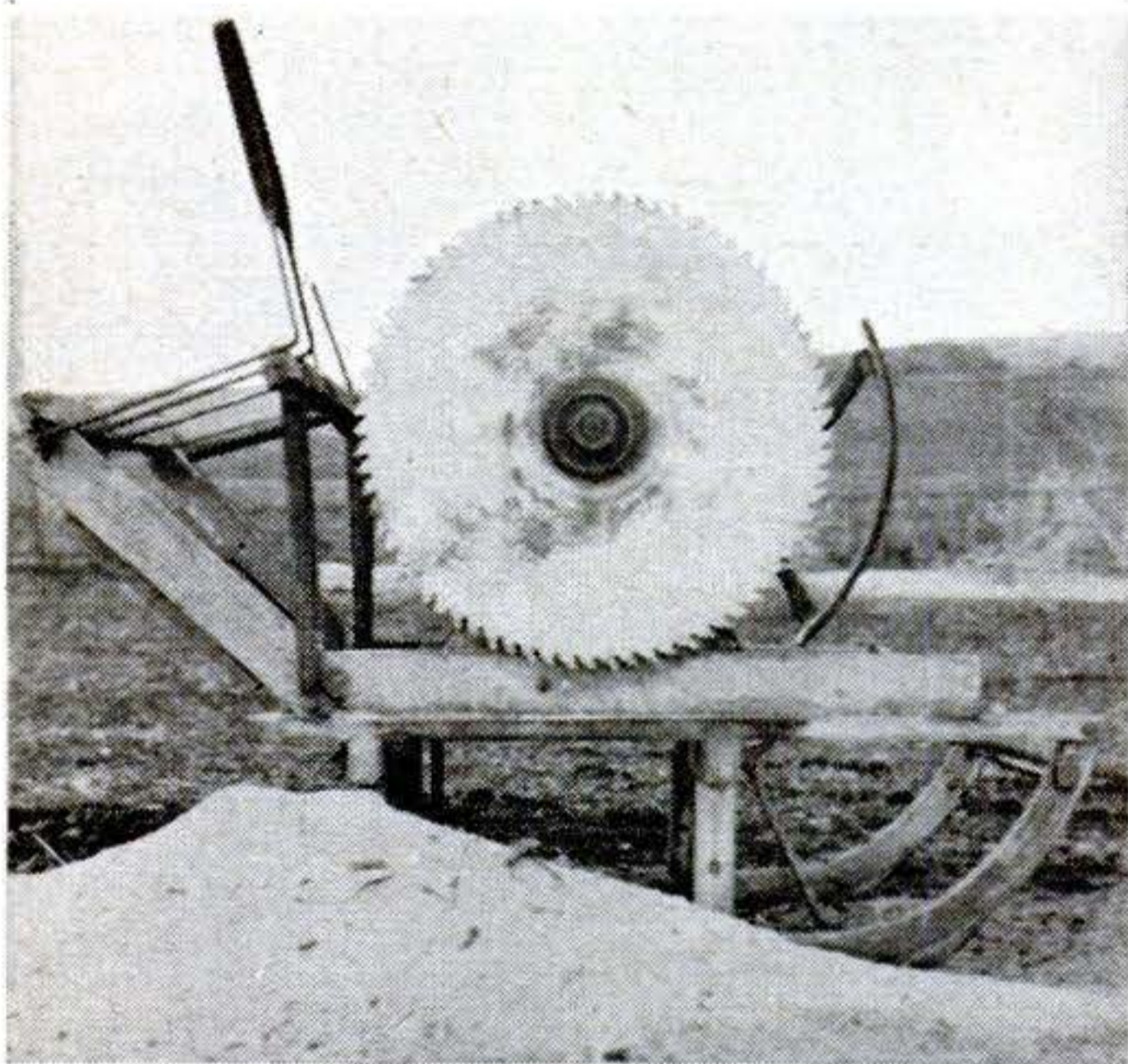

### Farm Saw Mounted on Sled

WE USE an old sled as the base for the farm buzz saw. Mounted on the sled, the saw can be easily skidded to a new location when the need arises. While the saw is in use, the sled is staked to give a firm base.—*Leonard O. Timm, Bennington, Neb.*

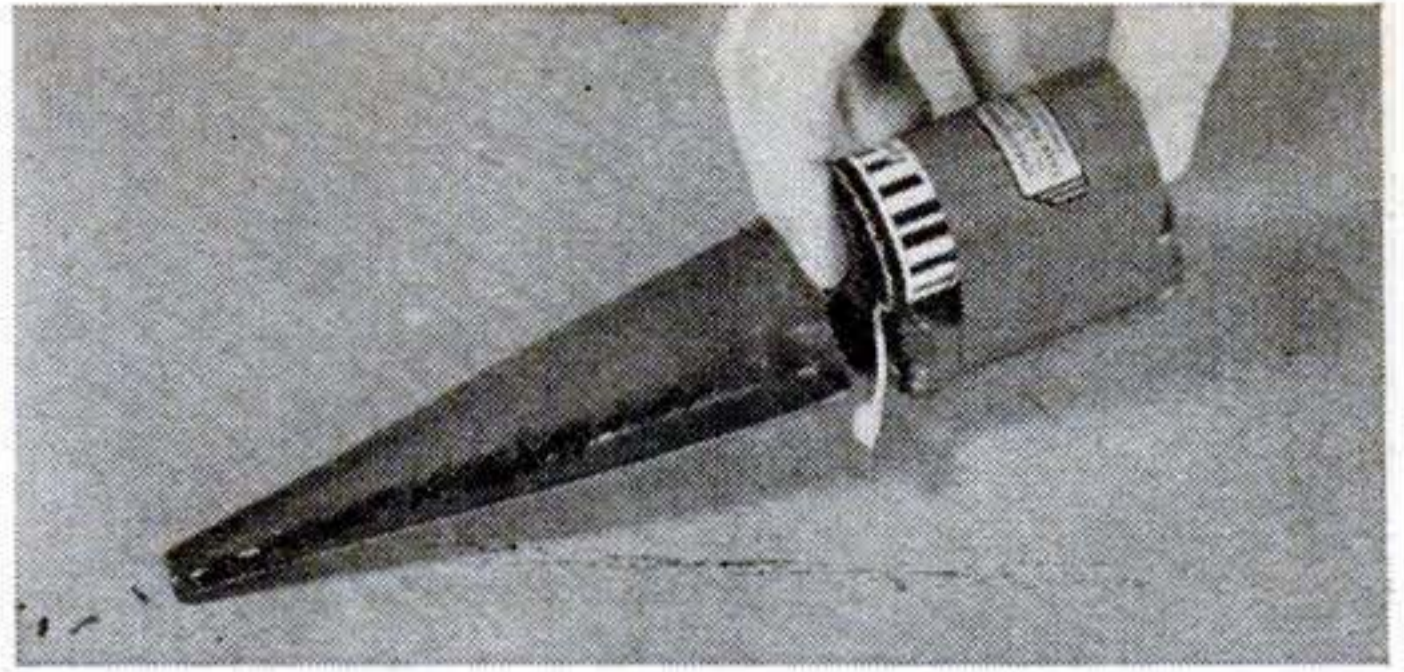

### Electric Vibrator Drops Seeds

ACTUATED by a single flashlight cell, a vibrating planter made by the Park Products Co., Lombard, Ill., is said to ease the job of row-planting small flower and other seeds. When held as above, the vibrator goes into action. Placed in the trowel-shaped hopper, hard-to-handle seeds will drop into the furrow one by one.

### Engine Moves from Job to Job

HERE'S a two-cycle gas engine that's designed as a jack-of-all-jobs. Made by the Gresengine Corp., Antioch, Ill., it is intended for various light-duty applications about the farm and elsewhere. One feature is that the base is separate from the engine proper. After a base has been mounted and aligned at each location where you need occasional power, you can quickly move the engine from job to job. The engine shown has a 1.7-hp. rating; more powerful ones are planned.

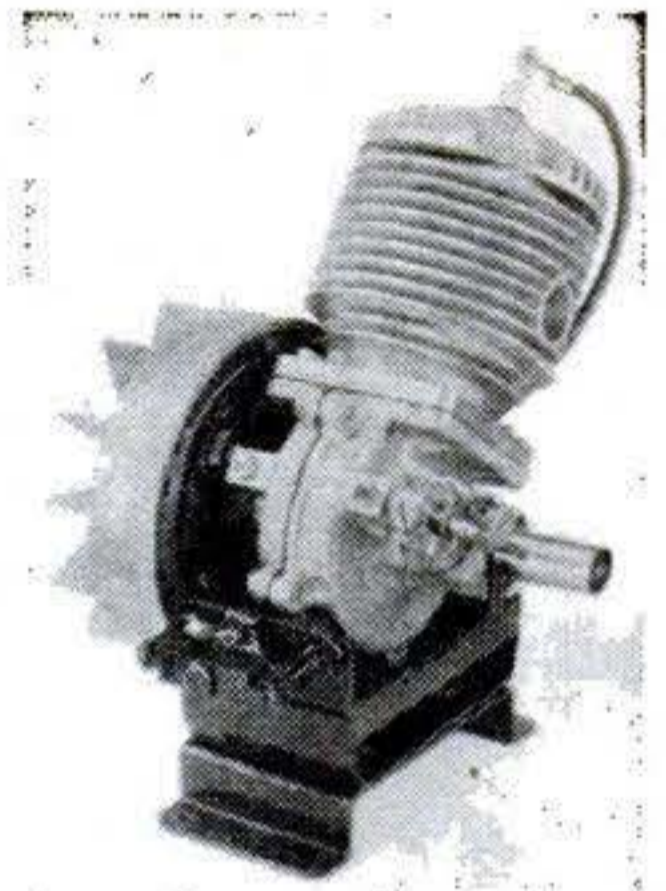

### Seals Frozen-Food Packages

A LIGHTWEIGHT electric sealer for closing plastic bags prior to home freezing of foods is now offered by Sears, Roebuck and Co. Plugged into a 115-volt outlet, it seals a bag in two to five sec. When you release the normally separated handles, a spring clamps heated jaws on the mouth of the bag. Price, about \$4.

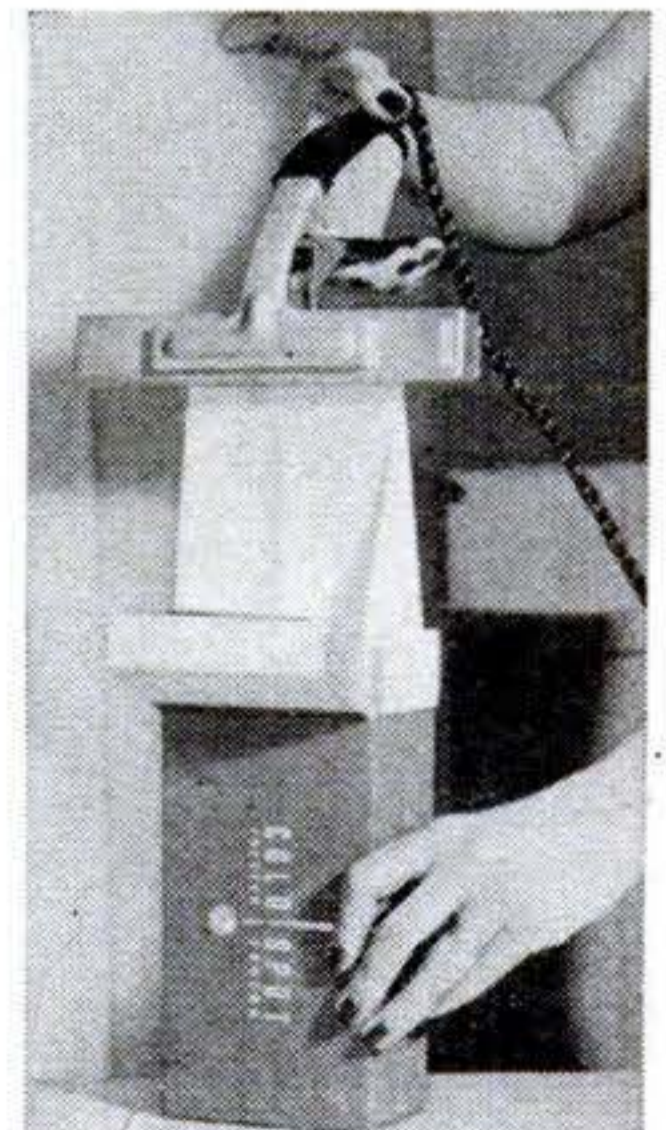

# harmony...

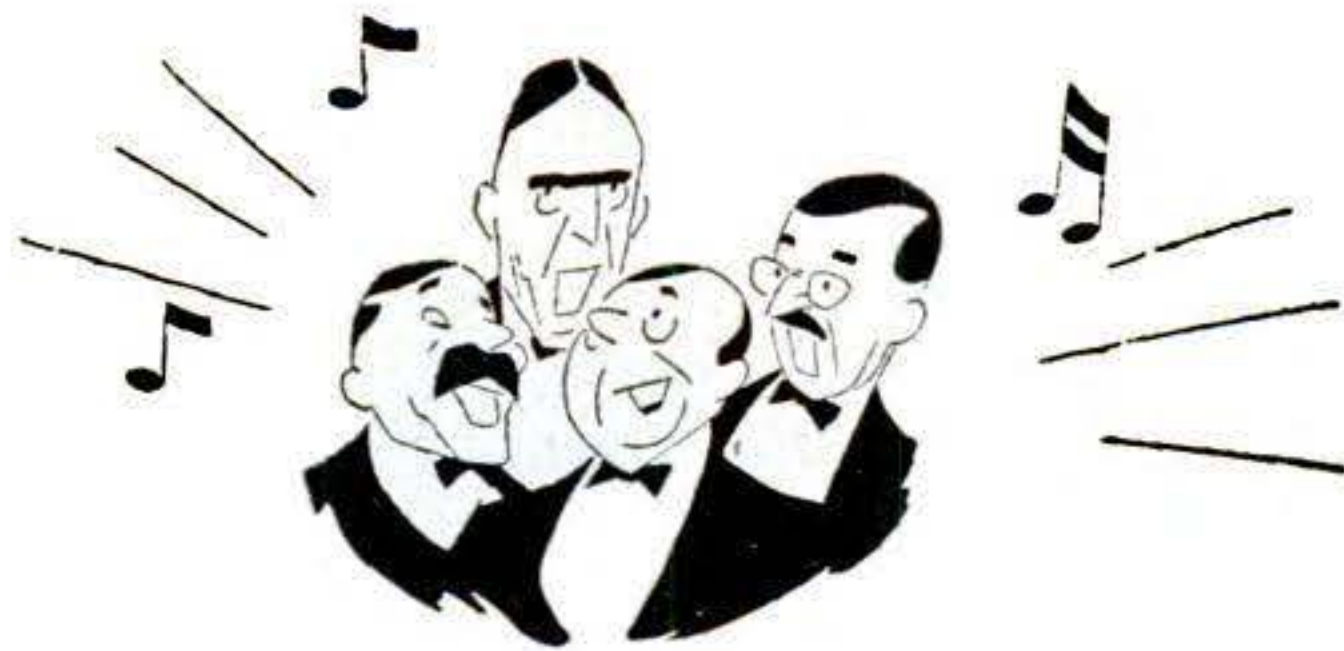

● **Harmony under the hood.** Today's AC Spark Plugs, with patented Coralox Insulator,\* are always in tune with your engine . . . whether it's cold or hot . . . loafing or under heavy load.

They surpass all previous spark plugs in their ability to fire steadily under a wider range of operating conditions.

They remain efficient through substantially longer life.

If you want your engine to sing a sweet song of smoothness and power, get a set of new AC's today.



## SPARK PLUGS

BUY WHERE YOU



SEE THIS SIGN

\* AC's patented processes make this the finest insulator in spark plug history. Improved electrical insulation, no matter how high the temperature. Better heat conduction. Maximum resistance to heat shock. Less fouling, harder, stronger, longer-lived.

AC SPARK PLUG DIVISION • GENERAL MOTORS CORPORATION

AUGUST 1949 233

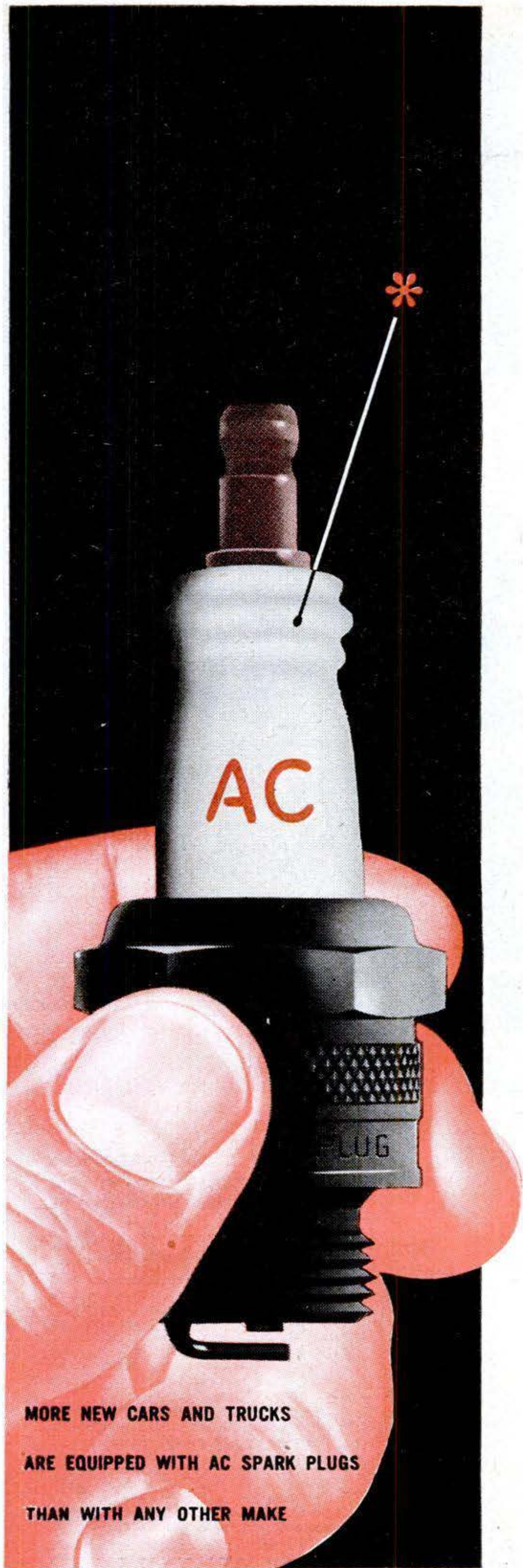

MORE NEW CARS AND TRUCKS  
ARE EQUIPPED WITH AC SPARK PLUGS  
THAN WITH ANY OTHER MAKE

# THIS IS IT!

## THE LOWEST-PRICED BALL BEARING, TILT/ARBOR SAW IN AMERICA!

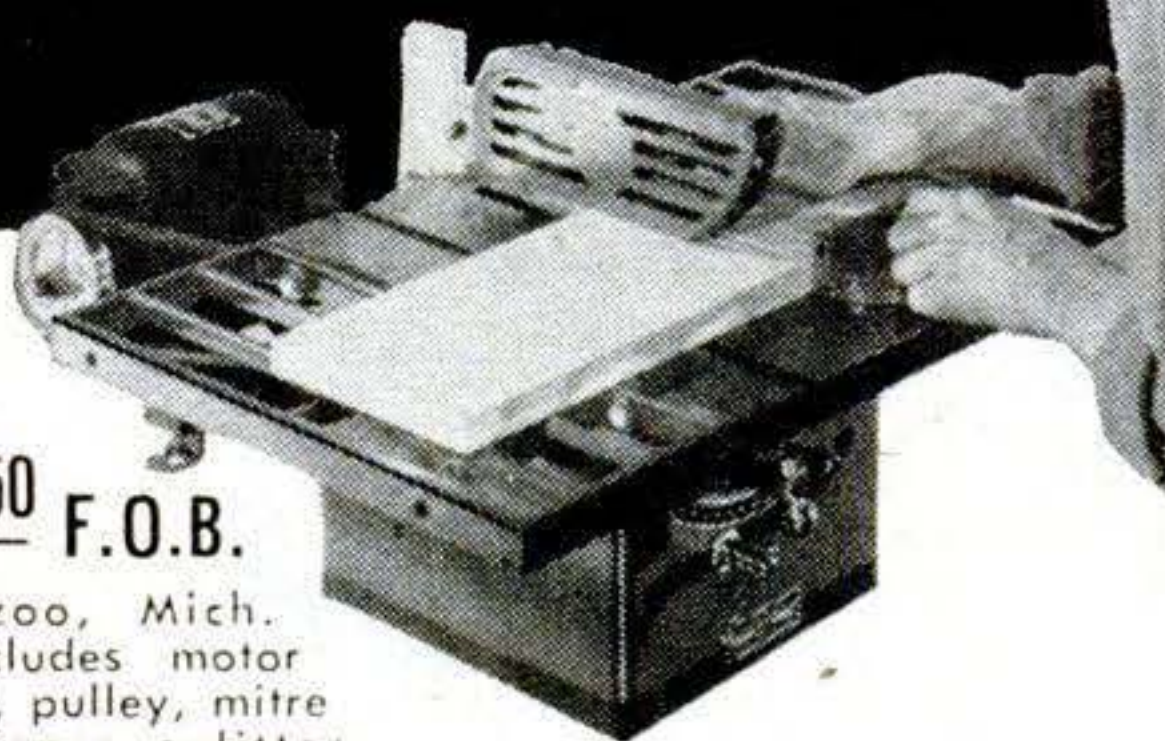

**\$39<sup>50</sup> F.O.B.**

Kalamazoo, Mich.  
Price includes motor  
rail, belt, pulley, mitre  
gauge, fence, splitter,  
guard — less motor. Extensions \$3.50 each.

## THE NEW *Atlas*

# POWER KING 3001

Yes, this is it! The saw thousands of shop owners have been asking for. The new 3001 ball bearing tilt/arboreal Power King. A big-capacity saw with big saw features, yet priced so low it pays for itself quickly with the money you save on a few projects alone.

Compare these features and we think you'll agree the new 3001 is today's outstanding circular saw value!

### BIG SAW FEATURES!

- ★ **TILT/ARBOR CONSTRUCTION** — table and work are always flat for safe angle sawing.
- ★ **BALL BEARINGS** — sealed from dirt and dust, assure smooth running and lasting accuracy.
- ★ **BIG CAPACITY.** With a 2 1/4" depth of cut, and a 12" x 16" table that has 7 1/8" area ahead of blade, the 3001 handles a broad range of work.
- ★ **PRECISION-GROUND GREY-IRON TABLE.** Heavy cast iron table is rib-braced and reinforced for absolute rigidity. Precision ground top assures smooth easy sliding surface.
- ★ **RIGID RIP FENCE** — full table width, locks at both ends, releases instantly.
- ★ **TABLE EXTENSIONS AVAILABLE.** Exclusive, grey-iron grill type extensions, measuring 6 3/4" x 16"; can be added to the 3001 at low cost. Add one to right side and you can rip to the center of a 24" panel. Add one to each side, and table area is increased to 25 1/2" x 16". Tops are precision ground.

Please send circular on the new Power King 3001 tilt/arboreal saw.

Name \_\_\_\_\_

Address \_\_\_\_\_

City, State \_\_\_\_\_

**ATLAS PRESS CO.**

855 N. Pitcher St., Kalamazoo, Mich.



**MATCHED PRECISION TOOLS FOR  
WOODWORKING AND METALWORKING**



**1-minute angle set-ups!**  
Tilt it for the angle and lock it. You're set up for any operation, machine or bench. Two sizes, 2" and 2 3/4" jaws, with or without swivel base. Write for Vise

Folder and "Yankee" Tool Book.

YANKEE TOOLS NOW PART OF

**STANLEY**

Reg. U.S. Pat. Off.

THE TOOL BOX OF THE WORLD  
NORTH BROS. MFG. CO.  
Philadelphia 33, Pa.

← YOUR MOTOR

## Foredom PRESTO-FLEX

with PENCIL-SIZE Handpiece \$5.95

WITH MARVELOUS EASE, you can grind, polish, drill, rout, mill, saw, sharpen, clean, carve, engrave, etch, etc.—on metal, wood, glass, plastic or linoleum. Simply attach to your electric drill, drill press or motor. Presto—a flexible shaft machine! Off again in a jiffy! Pencil-sized handpiece gives finger-tip control. Gets into tight places. Handy 35" overall length. And—only \$5.95 complete! ORDER NOW. If you order Presto-Flex for use on motor, specify motor shaft diameter. Add 50c for motor coupling. (Available for 1/4", 5/16", 3/8" and 1/2" shafts.) No. 50 Accessory Set available \$1.50 extra.

Finger-Tip Control

Foredom also makes a complete line of motor driven models at low prices. Write for Catalog E-2020 and see the many Foredoms now available.

FOREDOM ELECTRIC CO., Dept. E-2020  
27 Park Place New York 7, N. Y.

## Drive by HULL

### AUTOMOBILE COMPASS

AVOID DIRECTION WORRIES  
ON STRANGE VACATION ROADS

Beaconlite Illuminated \$5.95  
Streamline Standard \$3.95

At your dealer's. Write for literature.

HULL MFG. CO., P. O. Box 246-E8, Warren, Ohio

Easy and Cheap to Operate

SAVE TIME, WORK, MONEY!

## SHAW DU-ALL

and "PEPPY PAL" TRACTORS

**PLOW**

These rugged walking or riding tractors are ideal for farm, truck garden, orchard, poultry farm. Operate on a few cents an hour. A child can handle them.

**CULTIVATE**

**DO DOZENS OF JOBS** Both riding and walking tractors quickly and easily plow, cultivate, harrow, disk, bulldoze, spray, haul, grind, saw wood, etc.

**LOW FACTORY PRICES** Buy direct or thru your dealer. Year's guarantee.

**RIDING TRACTORS** Four models from 5 to 12 1/4 H.P., 58 in. wheelbase, 36 to 52 in. wide, 24 in. plant clearance, Hand or electric starter. Walking Tractors 1 1/2 to 5 H.P.

**FREE** Illustrated folders giving complete details, pricelist — write today.

**SHAW MFG. CO.**

5708 Front Street, Galesburg, Kans.  
668PS North 4th Street, Columbus, O.

**YOU'RE  
"ADVENTURE BOUND"**

**ON A  
HARLEY-DAVIDSON  
WITH THE NEW  
HYDRA-GLIDE FORK**

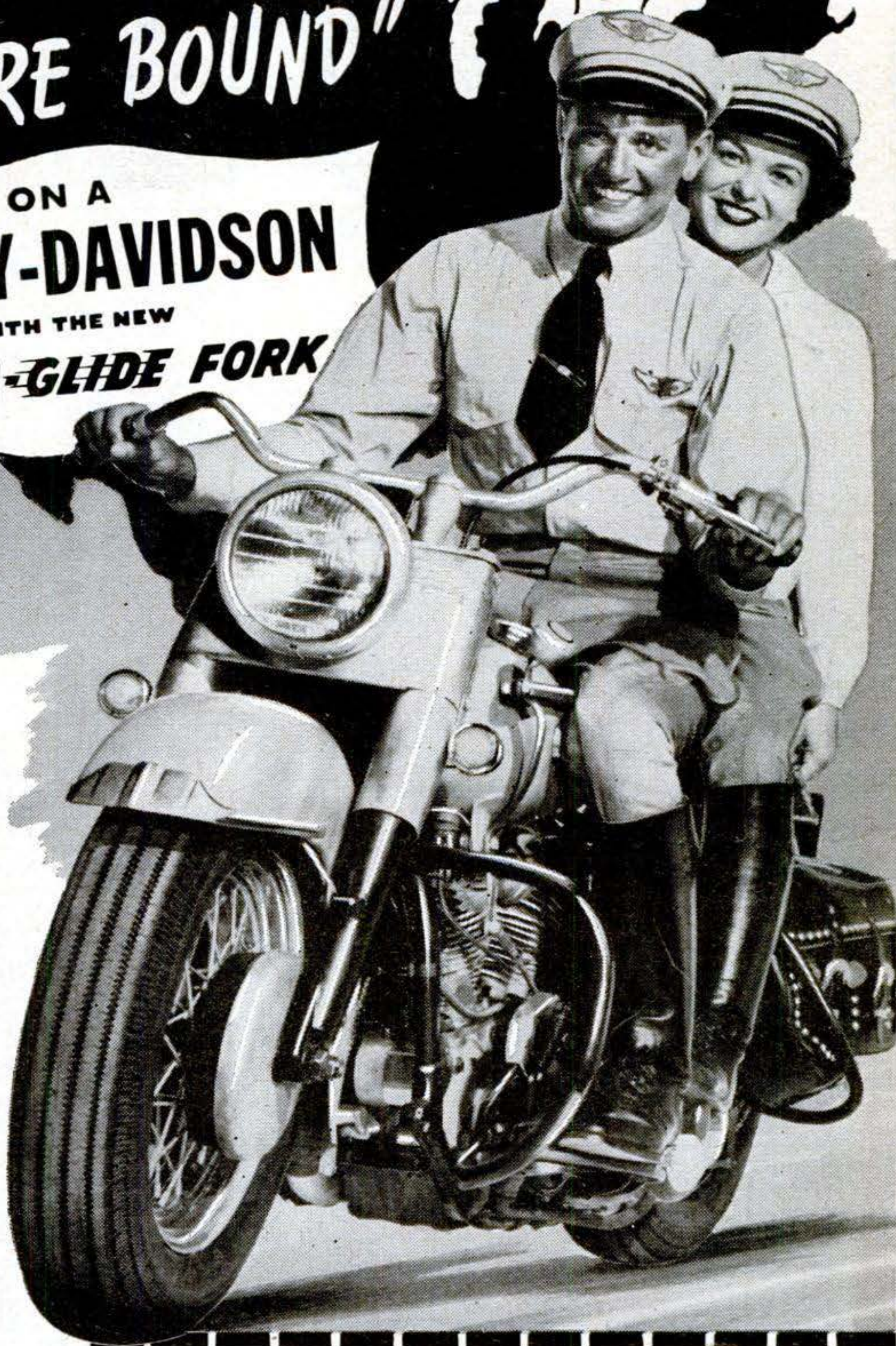

**G**ET away from hum-drum living and hit the adventure trail on a Harley-Davidson Hydra-Glide! Explore back country roads that lead to rare scenic splendors, hidden valleys, little known hamlets and historic places, out-of-way lake and mountain areas — so hard to reach by other transportation. See great cities, fascinating rural regions, glamorous resorts and vacation spots. New thrills, new friends, new pleasures await you at every turn . . . at gypsy tours, exciting race meets, endurance runs, hill climbs, club gatherings of every kind. There's no sport like motorcycling; no fun like riding a sleek, swift, "comfort-cruising" Harley-Davidson! See your dealer today. Mail the coupon now.



HARLEY-DAVIDSON MOTOR CO., Dept. P5, Milwaukee 1, Wis.

Send *free* copy of ENTHUSIAST Magazine filled with motorcycle action pictures and stories; also literature on latest models.

Name.....

Street or R.F.D.....

City.....Zone..... State.....

**2 Pages of GROBAN'S WAR SURPLUS Specials!**

**MINIATURE HIGH SPEED Electric Motor**

Ideal for Model Builders, Model Railroaders, Experimenters, Hobbyists

AC or DC. Reversible, speed may be regulated by varying voltage. Has miniature Klaxon thermo-static switch. All connections are external and accessible. Has 3 mounting feet for easy installation. Double-end ball bearing supported shaft with small gear on one end. Die-cast housing with laminated field. Overall Dimen.: 3 1/4" long x 2 3/8" wide x 1 3/8" high. Net wt. 12 oz. A \$22.00 VALUE.

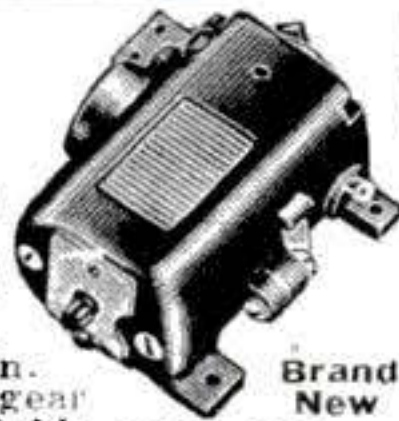

Brand New \$2.95 postpaid (Item #5)

**SPECIAL! Brand New HANNA AIR CYLINDER**

Used for heavy duty industrial applications on shop air lines or with low pressure systems. With 100 lbs. of air pressure, will deliver 1900 lbs. pressure at the ram shaft. All steel construction. Adjustable cushions at both ends of cylinder. Shaft dia. 1 1/2". Foot mounting with clevis on ram shaft. 2 6 1/2" double-acting stroke; 5" bore, 40 1/2" overall length closed, 7" overall width, 89 1/2 lbs. net wt. Gov't acq. cost \$101.85. AN EXCELLENT VALUE for

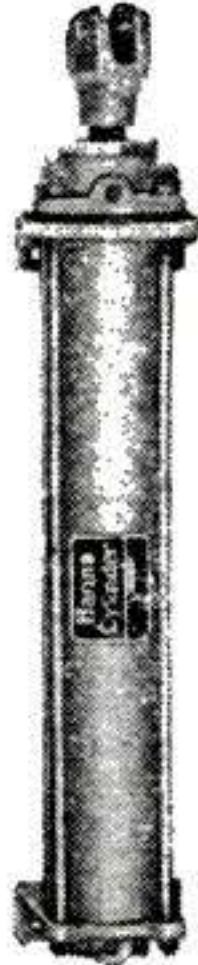

\$39.50 F.O.B. Chicago (Item #61)

**Brand New Pneumatic Riveter**

MADE BY CHICAGO PNEUMATIC TOOL CO.

Equipped with built-in control valves for use with cable operated remote control. Has 6" dia. actuating cylinder with right angle head. Base is 27 1/2" x 4". Height 40". Ram assembly adjustable for height. Approx. wt. 1300 lbs. A \$1200.00 value

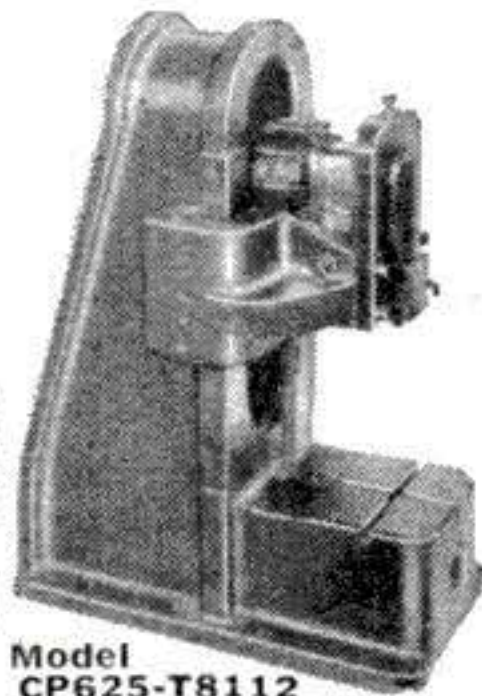

\$169.50 F.O.B. Chicago (Item #62)

**ROSS 4-Way Foot Operated AIR VALVE**

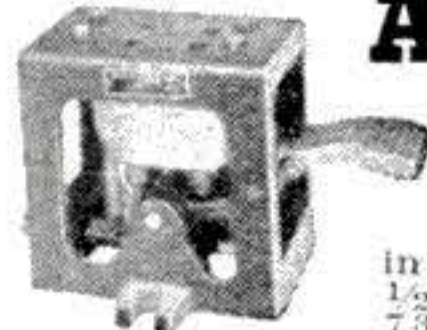

BRAND NEW. For double-acting pneumatic devices. Fine for operating presses, air vises, air machinery of many types. Heavy duty cast construction. No neutral position. Maintains pressure against the piston when the foot control is in the "Up" position. Threaded for 1/2" pipe. Dimensions of valve body: 7 3/4" L x 4 1/4" W x 7 1/2" H. Net wt. 28 lbs. A \$64.00 value for only

MODEL 398 \$19.50 F.O.B. Chicago (Item #60)

**LOGAN 4-Way Foot Operated AIR VALVE—Model 6520**



BRAND NEW. For double acting pneumatic devices. Fine for operating air vises, presses, air machinery of many types. Heavy cast construction. Threaded for 1/2" pipe. Dimensions of valve body: 8 1/2" L x 5 3/4" W x 7 1/2" H. Net Wt. 28 lbs. Gov't acquisition cost \$42.00. AN OUTSTANDING BUY AT

\$15.00 F.O.B. Chicago (Item #59)

**CENTRIFUGAL PUMP BELT DRIVEN READY FOR USE ON ANY LIQUID PUMPING NEED**

A super value for all types of intermittent service in pumping large volumes of liquid in home, farm and industrial service. Ideal for home water systems, draining basements, fire protection, etc. On the farm for watering stock, draining ponds, sprinkling, etc. In shops and factories for all types of pumping service.



Brand New

Use it for Draining Basements, Home Water Systems, Irrigation, Stock Watering, Fire Protection, Draining Ponds, Tanks, etc., Industrial Pumping

MOVE LARGE VOLUME QUICKLY. When operated at 1750 RPM, will pump 42 gallons per minute on a 23 foot head; at 3600 RPM on 52 foot head will pump 88 gallons per minute. May be run with electric motor, gas engine or power take-off on tractor.

COMPLETE ENGINEERING REPORTS AND OPERATING INSTRUCTIONS FREE WITH PUMP. Pump has cast aluminum housing—accurately machined bronze impeller vanes. Complete with mounting bracket and 3 1/4" V belt pulley. Shaft rotates on sealed ball bearings with grease gun fitting. Has 1 1/2" threaded intake flange, two 1 inch outlets. Use one or both, as necessary. Made for Packard Motor Car Co. for use in Rolls-Royce Merlin Aircraft engines.

Greatest Pump Value in Years. Shipping weight 23 lbs. You can't beat this value at anywhere near this price. Satisfaction guaranteed.

Original Cost Approx. \$147.00. \$29.75 F.O.B. Chicago (Item #64)

**SPECIAL AUGUST BUYS!**

**BRAND NEW 3-IN-ONE GEAR PUMP.** Three independent gear pump section running off of one shaft; for single or multiple pumping. Has pipe thread connections. Shipping wt. 10 lbs. (Item #14) F.O.B. Chicago \$9.95

**AIR FORCE WOOD PROPELLER. BRAND NEW—**Made of polished laminated hard wood, 90 inches long, shipping weight 75 lbs. (Item #30) F.O.B. Chicago \$9.75

**BRAND NEW GENERAL ELECTRIC 8" SEALED BEAM FLOODLIGHTS**

300 Watts, 110 Volts, A.C. - D.C. Has countless uses for: Homes, Garages, Workshops, Driveways, Outdoor advertising, Displays, Beach lighting, Private air ports, Photography. Wherever you need flood-lighting! Bought by the U. S. Army for signal use. This is the greatest surplus bargain ever offered. Lens, reflector and electrode vacuum sealed in one dustproof, air tight unit. 300 Watts, 110 Volts. Weights only 2 1/2 lbs. List price \$10.50. A TREMENDOUS VALUE for 12 or more \$2.50 ea. postpaid (Item #8)



\$2.75 ea. postpaid

**HALE FIRE AND IRRIGATION**

**HIGH VOLUME CENTRIFUGAL PUMP**

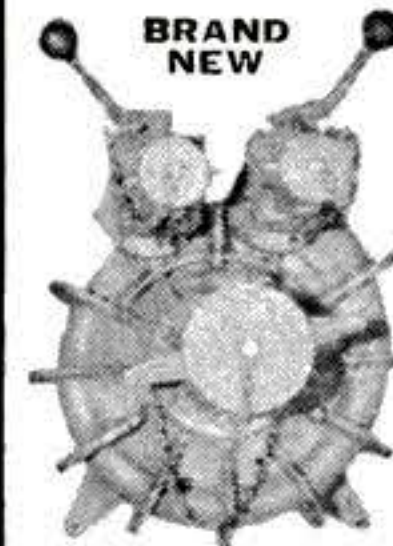

For Fire Protection, Irrigation, De-Watering, Industrial Uses, Farm Uses, Etc. PUMPS RATED 500 GALLONS PER MINUTE AT 275 FT. HEAD PRESSURE. Equipped with 1 1/2" diameter straight splined shaft for direct coupling drive; 4 1/2" threaded suction intake; two—2 1/2" threaded discharge outlets: Hale Pump Co. Model CF volute type; use any 4 or 6 cylinder gas engine or couple directly to front of truck or auto; or use 25 H.P. electric motor; dimension 21" x 24" x 28". Complete with full accessory kit including suction and pressure gauges, priming equipment, and instruction book. Ship. wt. 415 lbs. Gov't acquisition (Item #48) cost \$425.00. NOW \$149.50 F.O.B. Chicago

**SCREW JACK**

Ideal for raising, lowering, leveling and adjusting. Use on tables, machine tools, toys, etc. Overall length closed 9 inches, open 14 inches. Worm gear box with 54 to 1 reduction, with double end drive shaft. Use either end or both. Extension screw shaft 30 to 1 reduction. \$35.00 value. (Item #45) AN OUTSTANDING BUY



BRAND NEW \$3.95 POSTPAID

**SHOCK ABSORBERS**

Use them to spring suspend vehicles, hoists, pumps, heavy and light machinery, compressors, etc. 1 1/2" x 2" dia. Welded steel construction for extra strength—U. S. Air Force bought them for bomber gas tank shock absorbers. Rated 2500 lb. Ship. wt. of 4—11 lbs. Each \$1.50 F.O.B. CHICAGO 4 for \$5.00 (Item #21) F.O.B. Chicago

**Self-Priming ELECTRIC PUMP**

APPLICATIONS: oil burners, aquariums, fluid metering, fuel pump, tool post grinder, coolant pump, pressure lubricating pump, general industrial, etc. MOTOR MFD. BY BLACK & DECKER; double ball bearing series wound, continuous duty, 1/30 H.P. electric motor, rated 12,000 R.P.M. Transformer included for use on 110 V AC current. Also applicable for 24-32 V DC. PUMP MFD BY WELDON TOOL CO. with standard 1/4" tubing ports; rated 2 G.P.H.; remove pump and use motor as high speed grinder. OVERALL DIMENSIONS: 7 3/4" long x 3 1/4" wide x 3 1/4" high. Approx. wt. 5 lbs. \$51.00 value (Item #1) postpaid \$12.95

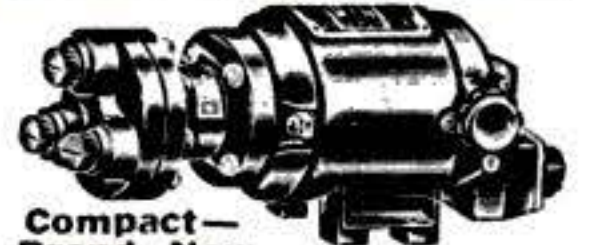

Compact—Brand New

**BRAND NEW GEAR TYPE INSECTICIDE PUMP**



All Manganese Bronze for spraying D.D.T., 2-4D, Sulphur Compounds, Etc. Pressures up to 150 lbs. to 14 gallons per minute—1500 RPM. Will not rust, pit, foul or freeze up. Use rubber hose inlet, pipe or tubing outlet. Equipped with 1/2" standard pipe thread port. Wt. 10 lbs. Dimen.: 8" x 5" x 6 1/2". Standard 1" manganese bronze shaft with keyway. U. S. Gov't. Acquisition Cost \$62.00. NOW ONLY \$15.00 (Item #50) F.O.B. Chicago

**GENERAL ELECTRIC DC GENERATOR**

BRAND NEW For Farm—Home—Factory Welding—Light Plants. Delivers 30 volts, 267 amps. at 4000 RPM. Rated 8 Kilowatts, ball-bearing supported. Fan cooled armature. Drive it off of farm tractor, gas engine of 10 H.P. or more. Ship. wt. 65 lbs. U.S. Government acquisition cost -- \$277.00. (Item #51) Now Only \$28.50 F.O.B. Chicago



ORDER DIRECT FROM AD. Send payment or purchase order today. SATISFACTION GUARANTEED

## BRAND NEW AIR OR OIL HYDRAULICS



Use hydraulics on arbor presses, hydraulic presses, hay lifts, manure loaders, lift trucks—push or pull, tilt or turn, press or squeeze, open or close, lift or lower—and other hydraulic and industrial applications. Use with either air or oil . . . of finest precision workmanship.

- Item #4. Double action, 1" bore, 3" stroke, will lift 770 lbs. in 1/10 of a second using Logan Pump. All steel barrel. Ideal for controls, door openers, positioning, etc. An \$18.00 value. . . . **postpaid \$4.95**
- Item #33. Double action, 1 1/2" bore, 5" stroke, will lift 1760 lbs. in one second with Logan Pump. Wt. 3 lbs. A \$35.00 value. . . . **postpaid \$8.95**
- Item #32. Double action, 1 1/2" bore, 9" stroke, will lift 1760 lbs. in one second with Logan Pump. Wt. 4 lbs. A \$45.00 value. . . . **postpaid \$10.95**
- Item #16. Use these cylinders on farm trucks, bulldozers, hay lifts, manure loaders, etc. Double action, 1 1/2" bore, 27" stroke. (Will lift 1760 lbs. in 2 seconds with Logan Pump). Wt. 8 lbs. A \$55.00 hydraulic cylinder value for only. . . . **postpaid \$12.95**
- Item #17. Double action, 2 3/8" bore, 8" stroke. (Will lift 4400 lbs. in one second with Logan Pump). Will withstand 1500 P.S.I. against wall. Wt. 7 lbs. A \$65.00 value. . . . **postpaid \$14.50**
- Item #20. Double action, 2 3/8" bore, 4" stroke, two-way solid 5/8" alloy steel shaft (will lift 4400 lbs. in one second with Logan Pump). A \$73.00 value. . . . **postpaid \$16.50**
- Item #15. Double action, 3" bore, 8 1/2" stroke. All steel hydraulic cylinder, will lift up to 12,000 lbs. (7000 lbs. in 3 seconds with Logan Pump). Complete with fittings. Wt. 12 lbs. A \$78.00 value. . . . **postpaid \$19.50**
- Item #31. Double action, 3 1/2" bore, 11" stroke. (Will lift 9600 lbs. in 7 seconds using Logan Pump.) Complete with fittings. Wt. 15 lbs. A \$92.00 value. . . . **postpaid \$22.50**
- Item #6. Double action, 3" bore, 23" stroke, hydraulic cylinder will lift 7070 lbs. in 5 1/2 seconds using Logan Hydraulic Pump. Especially suited for farm and construction machinery. Clevis mounting for easy use. Wt. 22 lbs. A \$145.00 value. **\$27.50**

F.O.B. Chicago  
HI-PRESSURE FITTINGS for cylinders and valves available at 35c ea. for 3/8" pipe and 50c ea. for 1/2" pipe.



## Hydraulic Control Valves BRAND NEW

- Item #24. Four-way control valve for use with double action hydraulic cylinder, may be used with 1500 P.S.I. hydraulic system to open and close hydraulic cylinders. Brand new. Ship. Wt. 4 lbs. A \$38.00 value. . . . **postpaid \$7.95**
- Item #26. Four-way control valve for use with two hydraulic double action cylinders. Each cylinder may be operated independently of the other or in conjunction with the other. Oil may be locked in any of the cylinders to hold the piston at any required position. Brand New. Ship. Wt. 6 lbs. A \$60.00 value. . . . **postpaid \$10.95**
- Item #28. A two cylinder double action valve with a unique arrangement, allowing the operator to raise both cylinders simultaneously, to lower them simultaneously or to raise one and lower the other at any predetermined rate and speed. Brand New. Ship. Wt. 8 lbs. A \$75.00 value. **\$14.95**

## LOGAN Double-Action Pneumatic—Hydraulic PRESS

Using air or oil, this device is ideal as a punch press, vise, arbor press, etc. An excellent tool for industrial and shop use.

Use 150 lbs. of air pressure or 250 lbs. of oil pressure. Cushioned double action "Logan" Model AC ram. 6" bore and 6" stroke. Capable of up to 4200 lbs. of pressure using air.

Has 3" throat. Lubricated gibs provide perfect alignment. Has adjustable work space. Hardened alloy steel piston rod 1" diameter. Frame constructed of cast steel with 3/4" base plate. Manufactured by Sipp-Eastwood Co. Unit is 49" high. Base is 9 1/2" wide by 18" deep. Wt. approx. 300 lbs. AN OUT-LET. (Item #7) STANDING BUY at **\$79.50** F.O.B. Chicago



BRAND NEW

## 18" Wire Spoke Wheel

BRAND NEW. For use on motorcycle or adaptable for midget cars, trailers, small trucks, any wheeled vehicle. With bearing races and gear. Takes 18" tire. Wt. 19 lbs. **\$3.95** each F.O.B. Chicago (Item #57) A REAL VALUE at

## BRAND NEW FIN-COOLED HIGH PRESSURE AIR COMPRESSOR

For pneumatic tools, filling hi-pressure vessels, paint spraying, insecticide vaporizing and other uses.

Rated 450 P.S.I. at 1200 R.P.M. Used on Packard Merlin Engine, this aluminum air pump with air filter intake weighs only 4 1/2 lbs. 9" x 5" x 3 1/2". Gov't. Acq. Cost \$185.00. **\$15.00** NOW ONLY (Item #56) **postpaid**



SHOP BY MAIL and SAVE at GROBAN'S Buy direct from ad!

## LOGAN HEAVY DUTY OIL HYDRAULIC PUMP

BRAND NEW . . . for operating hydraulic cylinders and hydraulic motors on tractors, bulldozers, construction machinery, lift trucks, industrial applications, etc. Delivers 8 GPM at 1200 RPM at 1000 P.S.I. using 5 H.P. Has 1/2" pipe thread inlet, 3/8" pipe thread outlet. 3/4" shaft with flat and keyway for direct or pulley drive. Has flange with 4 bolt holes for convenient mounting. Ship. wt. 22 lbs. Overall dimen.: 7" L x 5 1/2" H x 5 1/2" W. A \$105.00 value. FOR ONLY. . . . **\$22.50**



F.O.B. Chicago (Item #29)



(Item #37)

## LOGAN HEAVY DUTY OIL Hydraulic Control Valve

BRAND NEW control valve with built-in adjustable relief valve, will operate one double-acting hydraulic cylinder or two cylinders as one or a reversible hydraulic motor. Valve handle latches in neutral position. Made of rugged cast aluminum alloy. Open center unloads the pump in neutral position. Throttling control allows operator to regulate the speed of movement of the hydraulic cylinder or motor. Has removable mounting brackets with 4 bolt holes. 3/8" pipe thread connections. Overall dimen.: 12 1/2" H x 8 1/2" D x 8" W. Ship. wt. 17 lbs. Gov't. Acquisition. Cost over \$100.00. An Excellent Buy. F.O.B. Chicago **\$21.95**

## G-1 Stainless Tank

Use these tanks on compressors, for tire inflators, pulsation chambers, floats, buoys, hydraulic reservoirs, fluid and milk containers, fuel containers, etc. Tough, light. 450 lbs. P.S.I. Aviators Breathing Oxygen bottles, type G1. 2100 cu. in. (approx. 9 gallons) int. vol. 24" x 12". 1/4" threaded openings at each end. Wt. 19 lbs. .051" thick. (Item #63) Price. . . . F.O.B. Chicago **\$4.95**



## HYDRAULIC PRESSURE GAUGE

BRAND NEW Ideal for high pressure hydraulic systems, adjusting pressure, relief valves, etc. Range 0 to 2000 P.S.I. Black plastic case 2 3/8" square, 1 3/4" deep. Black instrument face with white pointer and numerals. Worth many times this low price of. . . . **\$2.95** **postpaid** (Item #36)



## HAND HYDRAULIC PUMP Brand New

Used for hydraulic jacks, presses, hoists and other hydraulic applications. For operating hydraulic cylinders to pump oil or hydraulic fluid under pressure. Hand pump has built-in check valve and is capable of delivering 1000 lbs. of pressure. Has alloy aluminum housing. Dimen.: 8" long x 3 1/2" high x 2 3/4" wide. Ship. wt. 3 lbs. A \$45.00 value. . . . (Item #11) . . . Now **\$8.95** **postpaid**



## Vickers MF9 Hydraulic PUMP or MOTOR

complete with mounting kit ready to install **\$19.90** **postpaid** **\$75.00** value

Pump is compact, powerful, rated 1,000 P.S.I., .507 cu. in. per revolution, 8 gal. per min. at 3750 RPM. Change rotation by reversing flow. Delivers up to 6 H.P. Requires 1/3 to 6 H.P. to drive directly or by pulley. BRAND NEW.

Mounting kit has been especially designed to provide maximum utility and ease of mounting MF Series Vickers Pumps. Brackets are constructed of heavy steel plate; shaft is made of 1/2" steel with one end splined to fit pump; other end of shaft has machined flat for mounting a standard pulley with 1/2" hole. Shaft runs in oilite bronze bearings.

(Item #18) Pump only . . . . . \$14.95 **postpaid**  
(Item #38) Mounting kit only . . . . . \$ 4.95 **postpaid**  
(Item #39) Both as complete unit . . . . . \$19.90 **postpaid**

ADJUSTABLE RELIEF VALVE. (Item #34) . . . . . \$2.95 **postpaid**

HYDRAULIC FLUID. (Item #53) Per gallon. F.O.B. Chicago \$1.75

10 ft. length of Hi-Pressure HYDRAULIC HOSE, with 1/4" female pipe thread fittings. (Item #27) . . . . . F.O.B. Chicago \$3.95

Brand New HYDRAULIC TANK. 3 gallon capacity with oil-indicator cap. 4" x 12" x 13 1/2". Ship. wt. 13 lbs. NOW AT THIS LOWEST PRICE. (Item #58) . . . . . F.O.B. Chicago \$4.95

**FREE:** Write for free copy of our 40 page catalog including Hydraulic Manual featuring diagrams, photographs and instructions. Catalog lists excellent war surplus values: pumps, valves, hydraulics, lights, motors, etc.

GROBAN SUPPLY CO.

1507 SOUTH MICHIGAN AVE.

Chicago 5, Ill. Dept. PS-7

# AMAZINGLY LOW PRICED CASCO Power Tool KITS

With a Casco Power Tool Kit, every job is a *better* job! For the finest equipment at *any* price is right at your fingertips. And the cost is so *very* low, it quickly pays for itself. A "must" for every craftsman, hobbyist, builder and repairman!



for WOOD, METAL, PLASTICS,  
FIBRE, GLASS, LEATHER...

It drills!	It polishes!
It saws!	It etches!
It carves!	It grinds!
It sands!	It buffs!
It sharpens!	It cuts!

## CASCO ELECTROMATIC (What a Gift!)

50-pc. set  
ONLY \$19<sup>95</sup>



## CASCO TOOL 'N' RAK hangs up where you work!

40 pieces, ONLY \$17<sup>95</sup>

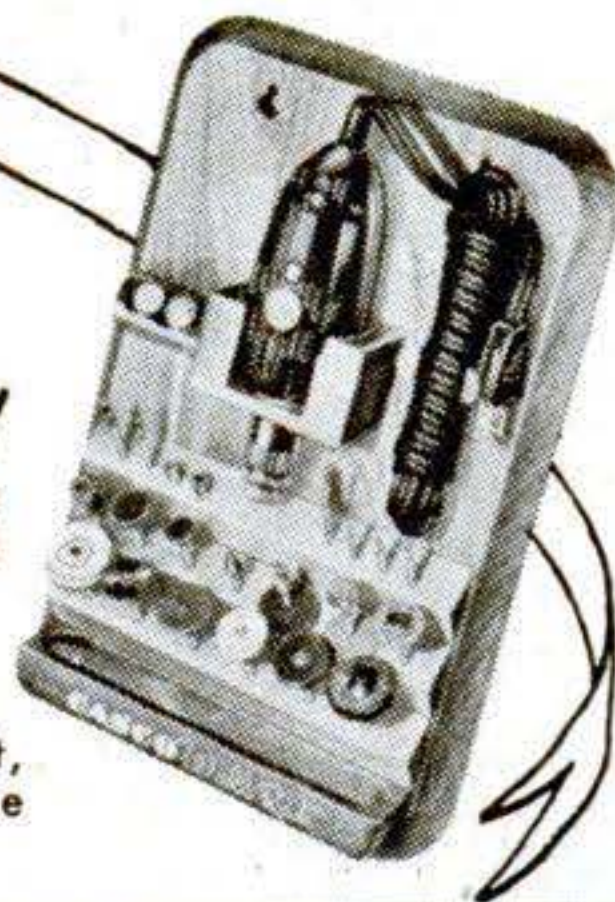

GET YOURS NOW at Department, Hardware, Auto Supply, Appliance and Jewelry stores.

## DRIVE AND KEEP COOL!

A year-'round asset—silent, safe, sure! Cools car in summer . . . defrosts in winter . . . keeps windshield clear always. 6-in., rubber blades, 2-speed switch, universal mounting bracket fits all steering columns.

\$9<sup>45</sup>

CASCO AUTO FAN ONLY

Now at Car Dealers, Auto Supply Stores, Garages, Service Stations.

# CASCO

CASCO Products Corp.  
Bridgeport 2, Conn.

## SAVE UP TO 20% on QUALITY BALL BEARING POWER MOWER ATTACHMENTS

Build your own power mower with our spindle and blade attachment. Pully for easy connection with engine. Sealed in New Departure Ball-Bearing for lifetime service. 20 or 18 inch blade of tempered steel with razor sharp cutting edge. Read guarantee — you'll order now and enjoy an easy power mower

SEALED-IN BEARINGS PULLEY



REPLACEABLE CUTTING BLADE

Attachment for gasoline power mower, complete (designate 20 or 18 inch blade)...\$14.95

Replacement blade (designate 20 or 18 inch blade) .....\$1.25

**GUARANTEE:** No better products are made regardless of price; 10-day return privilege

## SAVE UP TO 25% ON BALL-BEARING WHEELS

### Ball-Bearing Replacement Wheels (For 1/2 Inch Axles)

6 x 1.00 in....	\$1.30
8 x 1.75 in....	\$1.80
10 x 1.75 in...	\$2.15
10 x 2.00 in...	\$2.45
Industrial Wheel for Heavy Loads (For 3/8 in. axle)	
10 x 2.75 in. ....	\$4.65



For REPAIRING or BUILDING Lawn Mowers, Garden or Laundry Carts, Kiddie Tricycles and Wagons, Wheelbarrows—anything that rolls on rubber! Semi-pneumatic, Puncture-proof Tires. Compare for QUALITY and PRICE—and you'll order TODAY. If the size you need isn't listed, write for Folio A  
**ORDER TODAY—Send Cash, Check, or M. O.—Pay postage on arrival.**

## BILT-RITE PRODUCTS CO.

Dept. 63, 520 East Missouri Ave., Kansas City 6, Mo.

## Sensational New MOTOR Offering

### John Oster Heavy Duty Fractional H.P.

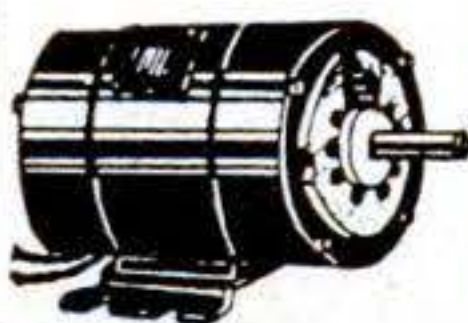

1/40 HP Induction Type, single phase, 110 V. AC, 60 cycle, bronze bushings, 5/16" shaft, 1725 RPM, Standard Base. Ideal for Hobbyists for many uses. Window and regular fans, grinders, etc. Shpg. \$4.95 wgt. 6 lbs.....

Add 35c handling and mailing

## Make Your Own POWER LAWN MOWER

with this DRIVE CUTTER ASSEMBLY.

Constructed for those who desire to build their own mower or to replace your old cutter assembly. Complete with 18" only blade and double ball bearing drive. Add 50c to cover handling & shipping. No COD's.



**ATLAS EQUIPMENT CO., Dept. PS8A**  
229 S W BLVD. KANSAS CITY, MO.



Unbreakable Fire-Safe Amber Hammer Proof Shock Proof  
TOOL STEEL PRICED FROM 5c TO \$1.00 EACH

## Ask Your Hardware Store for FULLER'S Unbreakable Amber Handle SCREW DRIVERS

America's most popular line of moderately-priced screw drivers! Wide range of sizes. FULLER TOOL CO., Inc., 911 Faile St., New York 59  
World's largest maker of Amber-Handle Tools

## CHAMPION V-GLOW PLUGS

for model engines only

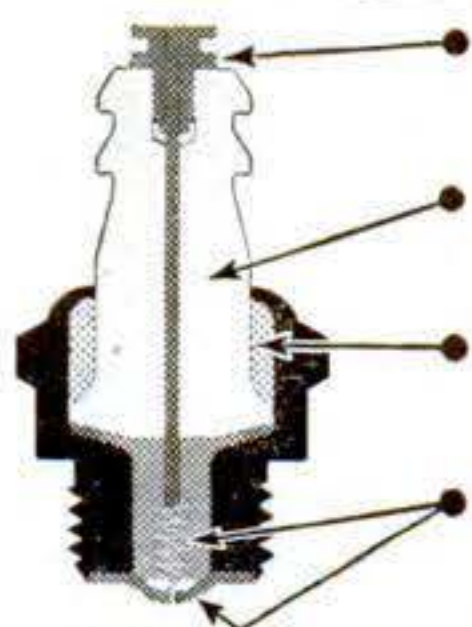

- CHAMPION TERMINAL—assures better center electrode seal and provides sturdier electrical connection.
- CHAMPION-CERAMIC INSULATORS—proved dependable in millions of Champion Spark Plugs.
- CHAMPION SILLMENT SEAL—prevents excessive compression leakage between insulator and shell.
- CHAMPION "THERM-O-FLEX" CONSTRUCTION—longer element life, more dependable performance.

Follow recommendations of plug types and fuels approved by engine manufacturer.

**CHAMPION SPARK PLUG COMPANY, TOLEDO 1, O.**



DEPENDABLE

# CHAMPION

SPARK PLUGS

← America's Favorite!



The modern farmer will tell you that car, truck, tractor, stationary engines and other power farming equipment are the key to increased farm production. That's why *dependable* spark plugs are of paramount importance to him—why he uses *dependable* Champion Spark Plugs in vast majority. This preference is unquestionably based upon better performance in every type of engine, so whether you are farm, town or city folk, insist on Champion Spark Plugs—the leader in public preference for more than a quarter century.



**FOLLOW THE EXPERTS**

**USE THE SPARK PLUGS CHAMPIONS USE!**

Listen to the CHAMPION ROLL CALL . . . Harry Wismer's fast sportscast every Friday night, over the ABC network

AUGUST 1949 239

# BULL BUFFER

announces a sensational new

## HOME KIT

FOR THE FIRST TIME, YOU CAN POLISH,  
SAND AND DRILL "THE RIGHT-ANGLE WAY"  
—AND PICK THE RIGHT SPEED FOR THE JOB!

all for only \$29.95!



### KIT INCLUDES

- BULL DRILL — new streamlined, power packed, 1600 r.p.m. electric drill, with JACOBS GEARED CHUCK.
- BULL BUFFER — right-angle polisher-sander with gear reduction.
- ADAPTER SET — for sanding at twice drill speed.
- Sheepskin bonnet and 2 sanding discs.

## You Asked for It— Here It Is!

A streamlined, powerful electric drill . . . PLUS one of the finest geared chucks money can buy . . . PLUS the famous Bull Buffer, now in use in more than 100,000 homes . . . PLUS an adapter that enables you to sand at twice drill speed . . . a kit that comes to you complete, ready-to-use with no "extras" to buy . . . a kit you'll use day in, day out, for drilling, waxing, removing paint, and polishing and sanding your car, boat, floors, woodwork, furniture . . . all these quality tools of a thousand uses at one low price—and your Bull Buffer Kit carries a 90-day guarantee! Order today, at your dealer, or send cash, check or money order.

**IF YOU ALREADY HAVE A DRILL** order your Bull Buffer today! It's the only right-angle polisher-sander with gear reduction, and it fits any drill. Comes complete, including 5-inch rubber disc, sheepskin bonnet and 2 sanding discs, only **\$9.95**



POLISH at 800 r.p.m.



SAND at 3200 r.p.m.



DRILL at 1600 r.p.m.

### ORDER THESE KIT ITEMS SEPARATELY, IF YOU WISH

- Bull Drill—new streamlined, power-packed 1600 r.p.m. electric drill with Jacobs geared chuck. . . . . \$19.95
- Adapter B set (for sanding at twice drill speed—can ONLY be used with Bull Buffer). . . . . 2.00
- Extra sheepskin-bonnets, each. . . . . 1.25
- Extra sanding discs, (000-00-0-1-2 1/2-3-4), each. . . . . .10

AT YOUR DEALER OR ORDER DIRECT TODAY — WE PAY POSTAGE

**BERTRUM S. ENGINEERING CO.**

3121 MAIN ST.

KANSAS CITY, MO.

## AUTOMATIC RETOOTHING

MAKES NEW PROFITS

for **HAND SAWS**

Cuts new teeth in 50 seconds — any size 4 to 16 points. Old teeth fall off as chips. Easy to operate. A perfect job.

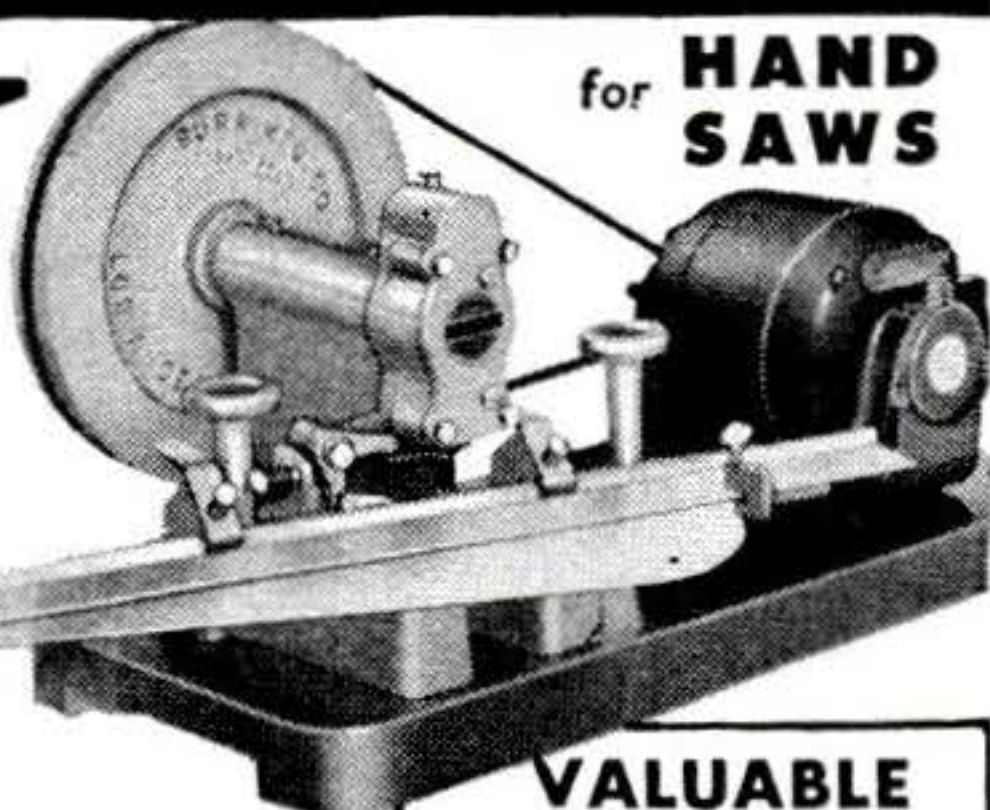

IMMEDIATE DELIVERY

**BURR MFG. CO.**  
8943 VENICE BLVD.  
LOS ANGELES 34, CALIFORNIA

VALUABLE BOOK

Order Burr's Blue Book of Coast to Coast prices for saw shop services.

25c



## WELDS • BRAZES • SOLDERS • CUTS

**ANYONE CAN OPERATE** the newly invented Four-Way Portable Electric Welder—does brazing, soldering, welding, cutting on iron, steel, brass and other metals. **WORKS INSTANTLY** off any properly wired **110 VOLT AC or DC line.** The time and money you save on auto, home appliance, farm and shop repairs will quickly pay for this machine. Comes COMPLETE with Power Unit and ALL SUPPLIES ready-to-operate, including simplified instructions. Write for Free particulars or order one today for **10 Day Trial.** **FOUR-WAY WELDER CO., Dept. PSF-89, 2326 So. Michigan Ave., Chicago 16, Illinois**

## BUILD YOUR OWN FAN

One-piece cast aluminum propellers for cooling and ventilating.



Size Inches	2 Blade	3 Blade	Unpolished 2 Blade	Unpolished 3 Blade	Bore Inches
15	\$3.00	\$4.00	\$2.50	\$3.00	1/2, 5/8, 3/4
18	3.75	4.50	3.00	3.50	1/2, 5/8, 3/4
20	4.00	5.00	3.25	4.00	1/2, 5/8, 3/4
24	4.50	5.50	4.00	4.50	1/2, 5/8, 3/4

Let us give you our prices on your aluminum castings.

Write for pamphlet on larger fan blades, wire guards, fan bases, shutters, pillow blocks, exhaust fan frames, etc., shipped prepaid if money accompanies order. Dealers write for discount.

**KLOPPENBORG ALUMINUM FDY., Dept. PS-89, Davenport, Iowa**

## KODACHROME PRINTS and ENLARGEMENTS

up to 11x14 . . . from your color transparencies

Order through your Kodak dealer

**EASTMAN KODAK CO., Rochester 4, N. Y.**

## CARTWRIGHT'S TRU-CUT TIN SNIPS

Easiest cutting tin snip. Handy tool for 1,001 jobs. No pinch feature. Cuts perfect circle, right or left. Also square points, both ways. Special "Cup Tension Washer" retains tight fit. Cuts well with either hand. Will last lifetime.

Write for Free Catalog

Patented



See Your Local Dealer  
**J. CARTWRIGHT & SON,**

Dealer Inquiries Invited  
Dept. PS8, Malaga, Calif.

## HIGH POWER TELESCOPE

60 POWER-ALUMINUM TUBES-OPENS TO 33"

Variable Power Eyepiece Adjustable to 15X, 30X and 60X.

4.50

Leather Case Included

5 Sections. 4 Ground & Polished Lenses. Also used as 50X Microscope. Ready to use, only \$4.50 POSTPAID.

**BROWNSCOPE CO.** Dept. 8P, 24 W. 45th St., NEW YORK 19, N. Y.

# SAVE MONEY WITH SHOPMASTER TOOLS

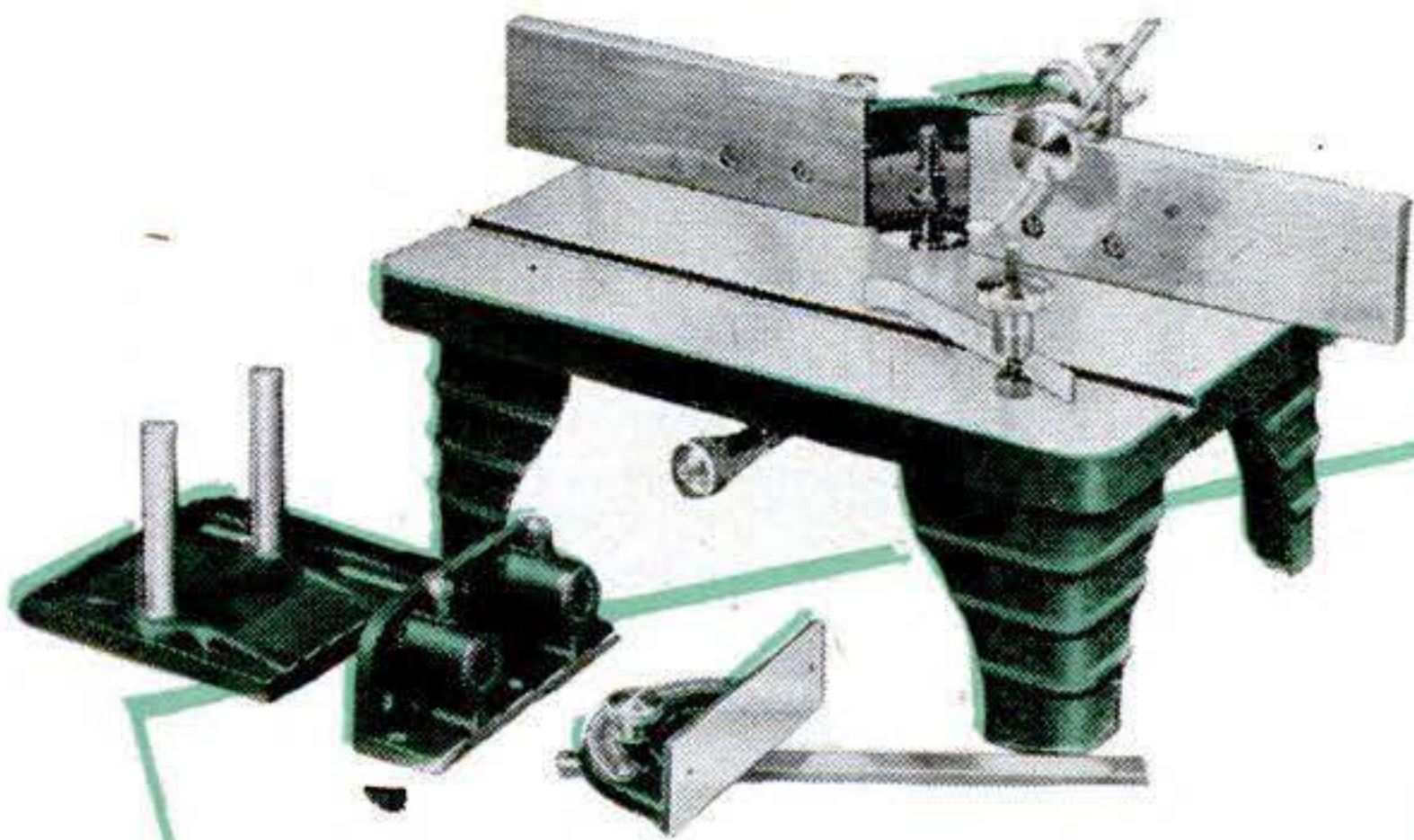

## The Tool of a Thousand Uses

The Shopmaster Shaper will make moldings, edge table tops, finish off odd shaped pieces, add fluting, and do many other jobs that give a professional touch to your work.

*"Dad, I'm really proud of this table!"*



Less than \$16.00 starts your Shopmaster Shop with the Shopmaster Saber Saw. The Shopmaster Saber Saw crosscuts, rips, cuts circles, bevels, and is ideal for making internal cuts on large stock. It cuts material up to 1½ inch thick.

Each Shopmaster Tool, with accessories that are available, will do many tasks. Only a few are required for a complete shop, and the total cost is surprisingly low.

It's easy to do skilled work with Shopmaster Tools. They will return their cost many times in what you save when you build it yourself.



Millions of Americans find fun and profit with power tools.



WRITE FOR THIS FREE CATALOG, DESCRIBING THE COMPLETE LINE OF SHOPMASTER TOOLS.



SHOPMASTER, INC.  
1214 THIRD ST. S.  
MINNEAPOLIS 15, MINN.

Send me your free catalog.

Name \_\_\_\_\_

Address \_\_\_\_\_

City \_\_\_\_\_ State \_\_\_\_\_



## If you like fine tools

... then you'll certainly like to work with the new GREENLEE Socket Chisels. Perfectly balanced... handsome, transparent green plastic handles... fine bevel-edged GREENLEE blades, so long the choice of true craftsmen. Ask your hardware dealer about them.



**SPECIAL OFFER... WOODWORKING CALCULATOR... 10¢.** Quick solutions to countless problems... converting linear to board feet, nail and bit sizes, etc. Send 10¢ to Greenlee Tool Co., 2128 Columbia Ave., Rockford, Ill.

## NEW WAR SURPLUS

### SOCKET WRENCH KIT

"Snap-On" Brand 1/4" drive, complete with 8 sockets - 3/16" to 7/16", extension, handles, steel box. Wt. 22 oz. Mfg. list price \$8.10. Surplus price, brand new. **3.95**



### "OLIVER" WOOD-TRIMMER

Woodworker's dream. For accurate mitre and angle cuts in all types of wood, moulding, casing, etc. Cuts from either end. Capacity 4 3/4" vert., 29" long, 9" high, 11" wide. Bench mount, portable. Demanded by finest craftsmen. Wt. 65 lbs. Manufacturer's list \$120. New, only. **67.50**

**PIANO HINGES**  
ALUMINUM Lt. Wt. AN251-2-72, 1 1/2" wide, 72" long, .040 thickness. Wt. 11 oz. Each **95¢**  
STAINLESS STEEL, heavy wt., AN251-C2-48, 1 1/2" wide, 48" long, .062 thick. Corrosion resistant. Ideal for general use on drop tables, cabinets, etc. Wt. 31 oz. Each only. **1.05**

**B. F. GOODRICH REPAIR KIT**  
1 qt. acetone, 1 qt. Ethylene Dichloride, 8 oz. accelerator, 1 qt. 3M Thiokol cement, 1 pc. heavy rubber patch 18 x 48". Worth \$21. Hundreds of uses for each item. Only. **6.95**

**PLIER CLAMPS**  
"Knu-vise" #140, an extra pair of hands on any work bench. Adjustable clamp works just like pliers. 400 lb. pressure. Wt. 17 oz. Gov't. cost \$7.50, now only **2.95**

Write for list of thousands of other new surplus bargains! Prices F.O.B. El Cajon, California. 25% deposit on C.O.D. orders. Send check, money order, or cash. All items guaranteed to be new and as represented.

**TUTTLE BROS. 300 No. Second St. El Cajon, California**

### WORK APRONS

Durable canvas, heavy stitching, many pockets for tools, nails, etc. Terrific handy-man's apron. Surplus bargain. **39¢**

### MARINE LIGHTS

Use outside. Light driveways, gardens, barns, outbuildings. Weather and moisture proof, explosionproof. Screw-down top on rubber gasket, solid brass lamp base. Operates on 12, 24, 32, 110, 115 or 220 volts AC by simply changing bulbs. Wt. 6 lbs. Specify red, blue or white. Cost Navy \$30. Surplus price. **4.95**

### Explosion-proof Motors

DC and AC (please specify). Famous Leland make, 32 V 1/4 h.p. Wt. 27 lbs. Terrific bargain. Retail for \$30. Surplus price. **17.95**



## BUILD YOUR OWN TILTING ARBOR SAW!

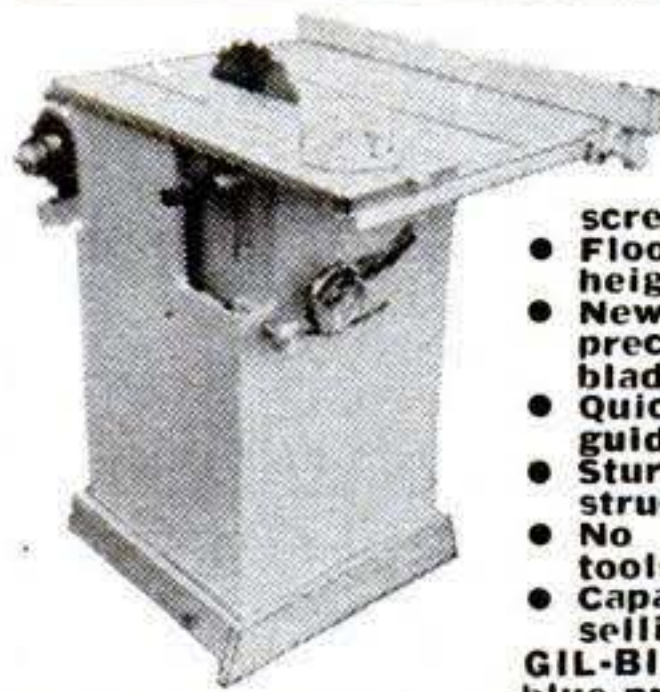

**SAVE \$50 OR MORE**

- 27x28 in. table stays level. Blade tilts full 45 degrees.
- 10 in. blade cuts 3 1/4 in. deep, jack-screw depth adjustment.
- Floor model, 34 in. table height.
- New Departure ball bearing arbor, 3/4 in. precision shaft, ready to run, 5/8 in. bore blades.
- Quick-positioning, self-aligning rip fence guide.
- Sturdy wood, steel and aluminum construction.
- No machining—build easily with hand tools only.
- Capacity and performance of floor saws selling for \$150.00 and up!!

GIL-BILT Step-by-Step pictorial plans (No blue-print reading required), full scale patterns, 11 actual photographs. **\$1.00**  
GIL-BILT Metal Parts Kit includes Plans, ball-bearing arbor, cast aluminum miter gauge and bar, rip fence guide, machined lock knobs, jackscrew mechanism with 4 1/2 in. handwheel, and all other metal parts including every screw, bolt, nut and washer (less blade) **\$20.95**  
Same Kit with 10" combination blade. **25.90**  
Same Kit with 8" combination blade. **24.90**

Return in 10 days for full refund if not satisfied. (Prices include postage up to 600 miles)  
Also available—Plans and Metal Parts Kits for 8" Tilt/Table Saw and 12" Band Saw. Order Plans at \$1.00 each—sent postpaid anywhere in the world, or write for FREE descriptive Catalog.  
**GILLIOM POWER TOOLS P. O. Box 1-VH, Lambert Field St. Louis 21, Missouri**

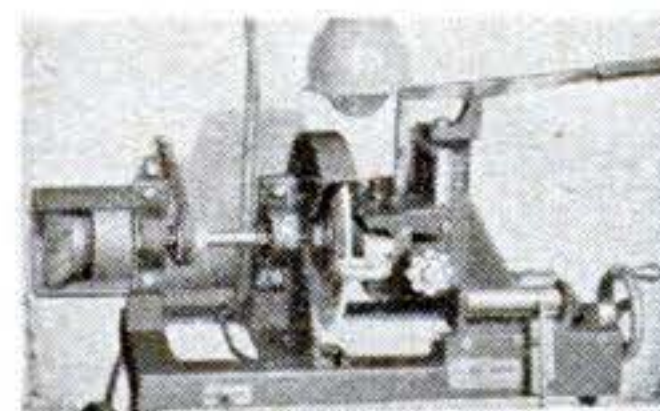

Pat. applied for

**Start a NEW BUSINESS Or Add to Your Present Repair Business**  
Sharpen Dull Pipe Wrenches  
Pipe Taps & Dies  
"Gum" Circular Saws  
Write for information.

**J. C. MOORE INDUSTRIES P.O. Drawer 276 FREDONIA, PA.**



## GEIGER COUNTERS for locating Valuable RADIOACTIVE MINERALS

There is a model to exactly fit YOUR requirements.....

Write today for details and prices

**OMAHA SCIENTIFIC SUPPLY CO. Dept. 8, 3601 N. 24th, Omaha 10, Nebraska**

## 10<sup>H</sup> PORTABLE POWER PLANT from any CAR or TRUCK

**NEW, EASY, ECONOMICAL METHOD!**  
ASPEN DRIVE-ALL gives power when you want it—where you want it! Just line up with rear wheel (of any car or truck) drive onto unit, and you're set for work! No jacking up, or demounting! Use rugged DRIVE-ALL for ALL belt-driven operations requiring up to 10 h.p.

**FREE Illustrated Circular**  
**ASPEGREN MANUFACTURING CO. 1612-P Webster Ave., NYC 57**

## UTICA TOOLS For More Tool Mileage

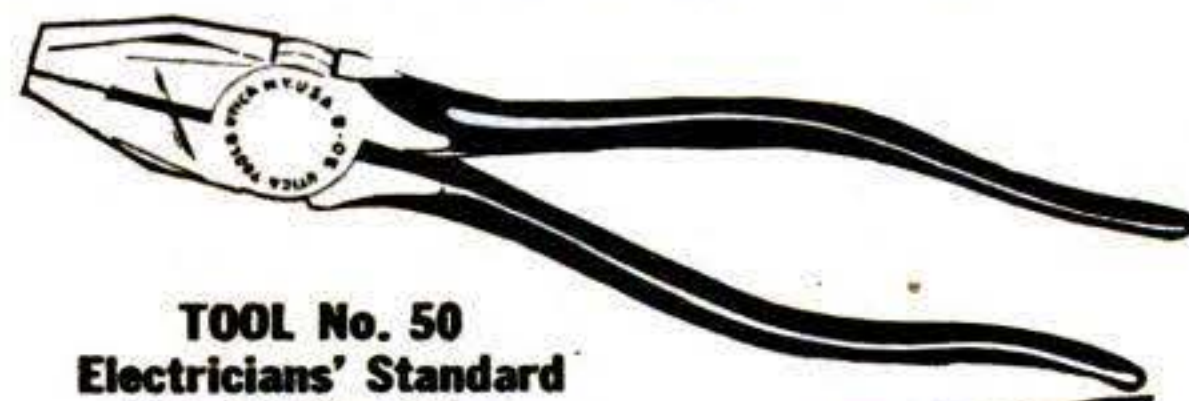

**TOOL No. 50 Electricians' Standard Side Cutting Pliers 5", 6", 7", 8"**

SEE YOUR DEALER

**UTICA DROP FORGE & TOOL CORP. UTICA 4, NEW YORK**

# WAR SURPLUS BIGGEST BARGAINS

These bargains were chosen from over 4,000 items in stock



## CLUTCH

For motor scooters, Motor bikes, lawnmowers, etc. Mercury centrifugal clutch for use with any small gas engine. (a) Belt pulley, 5/8" bore, brand new. Stock #400. only.

Stock #400. only. \$9.95  
In lots of 12 ..... \$8.00 each.



## All Bronze GEAR PUMP

All bronze corrosion resistant gear pump. Lifts water 25'. Delivers 1020 gal. per min., at 1200 RPM. Develops 110 lbs. pressure or 250' head. Self locking packing nuts, drain cock, reversible head. Will pump brine, salt water, oil, vinegar, gasoline, etc. Dimensions: 10" L x 7" H x 5 1/2" W. Base holes 1 3/4" x 3". Shaft 1 1/16". 1" x 1" inlet & outlet. Wt. 24 lbs., Mfg. by Sherwood Brass Works. All pumps belt driven. All bronze gear pump with 8" V pulley. Pump only. Stock #314. . . . \$80 value. . . . \$24.00

Same pump as above, with motors, (electric) Stock #549

1/2 HP ..... \$67.00    1 HP ..... \$87.00  
3/4 HP ..... \$74.00  
Same pump with Briggs-Stratton gas engine. Stock #550

1 1/2 HP .. \$89.50    2 1/2 HP .. \$135.00  
3 1/2 HP .. \$165.00    6 HP ..... \$195.00  
The MORE HP the more PRESSURE.

## HOSE 20' LENGTHS

Gas, oil or water resistant. Neoprene treated 1 1/4". Male & female brass connectors. Standard filling station size. Value \$20.00. Stock #528. Our price. . . \$7.50  
Foot valve. . . . . \$3.00

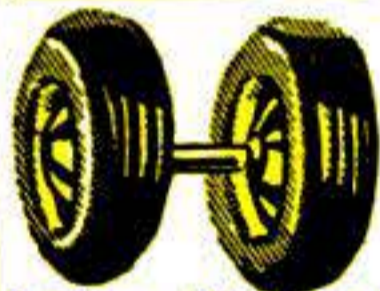

## RUBBER WHEELS

Good for boats, scooters, wheelbarrows, etc. Stock #536.

2.75 x 10 5/8" bore. . . . . \$4.50  
4.00 x 8 5/8" . . . . . \$10.95  
10 1/2 x 4, 6 ply 5/8" . . . . . \$8.95  
14 1/2 x 5, 6 ply 1" . . . . . \$10.95  
NEW airplane tires, tubes and wheels with high speed Timken Hyatt ball bearings. 800 x 5, 6 ply 1". Stock #544. . . . \$14.50  
1700 x 20" 12 ply tubes for earthmovers, trucks. \$83.00 value—Stock #545— price. . . . . \$44.50  
56" 16 ply Bomber tires and tubes. \$600 value. Stock #546. price. . . . . \$59.50  
AIRPLANE TIRES with landing gear hydraulic strut. Firestone & Goodyear standard tires, 8 ply 27, 29" high. Hydraulic strut is 44" long, 3 1/2" dia. Can be made into Heavy duty trailer. Stock #551. . . . . \$22.50  
PRICE each. . . . .

## Briggs-Stratton GAS ENGINES

SAVE \$25 ON LIST PRICE

All are NEW in original crate. Rope start. 1700 RPM all brand new and guaranteed. 1 3/4 to 2 1/2 HP Model AP. List price \$102.10. Stock #307. Our price. . . . \$77.00

3 1/2 HP Model BP. List price \$111.50. Stock #308. Our price. . . . . \$86.00  
5 to 7 HP Model ZP. List price \$137.00. Stock #309. Our price. . . . . \$102.00



## CHIMES OR CALL SYSTEM

Navy type. Good for schools, hospitals, office, homes etc. 110 Volt AC or DC. Weather proof. LIST PRICE \$15.00  
Stock #552. Super value at only \$1.95

## A REAL BUY BULL BUFFER

Fits any 1/4" drill. Polishes, sands & grinds. Sheepskin, 4 3/4" rubber disc. COMPLETE. Stock #553. . . . . \$1.95  
Imagine it's only. . . . .  
Extra sanding discs \$1.20 a Doz.

## STAINLESS STEEL TABLE TOPS

Polished top, dull bottom, hardwood veneer center 3/4" thick. Ideal for: work table, laundry tubs, shelves, back bar work board, etc. Stock #411.

22 x 19 1/2" . . . . . 11 lb. . . . . \$1.95  
22 x 21 1/2" . . . . . 12 lb. . . . . \$1.95  
23 1/2 x 27" . . . . . 15 lb. . . . . \$2.45  
22 x 29 1/2" . . . . . 16 lb. . . . . \$2.95  
22 x 34" . . . . . 20 lb. . . . . \$3.45  
22 x 37" . . . . . 22 lb. . . . . \$3.95

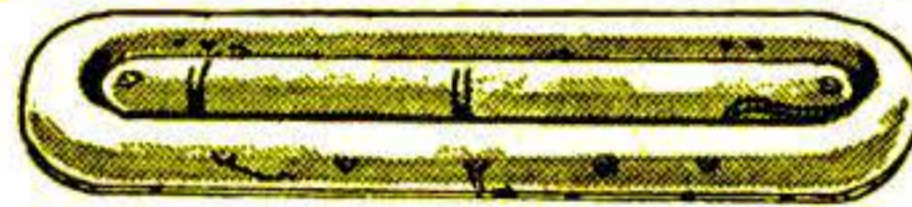

## MARINE FLOAT

Heavy rubberized fabric. 1/2" rope encircles raft passing through dee rings as handles. Can be used as wading pool, dock, raft, etc. Will support 4 ton and cannot tip. Used but like new. 6' W x 20' L    6' W x 25' L  
\$49.50    \$59.50

50% deposit to handle shipping.

## HALES FIRE PUMP

For fire depts., factories, forest fire prevention, etc. 600 gal. per min. Can be operated with a four or six cylinder gas engine. 4 1/2" intake . . . . . 2-2" outlets . . . . . 265' head at 120 lbs. pressure. Passed by national board of fire underwriters. NEW. Stock #407. Price . . . . . \$149.50

## BALL BEARING ARBORS



Grinding and saw arbor, has 1/2" double end shaft, 1 1/2" long with 2" center pulley. New Departure double roll ball bearings. Right and left hand thread. Self aligning Dodge pillow block 10,000 RPM. Bearings alone list at \$10. Complete arbor. NEW. Stock #305. . . . . \$4.95  
HI-SPEED GRINDER (not pictured) has two step pulley driven thru rear or base. Stock #328. . . . . Only \$10.95

## PLASTIC TUBING

Good for water, oil, air, electrical installations & radio work. Available in 100' lengths Min order 50'.  
1/8", 3/16", 1/4",    1/2", 7/16" per ft. 4c  
(your choice)    1" 3 ft lengths only . . . . . 6c  
per ft. . . . . 2c    per ft. . . . . 6c  
5/16", 3/8" per ft. 3c    1 3/8" per ft. . . . . 8c

## HALF TON WAGON

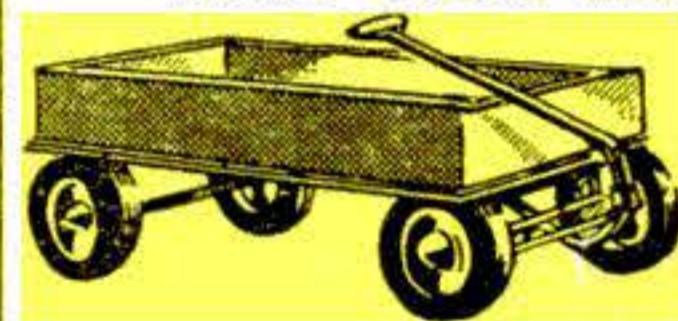

Half ton wagon with plate aluminum body 24" x 42" 5/8" steel axle. Stock #332. Write for details.

## Swimming or Bathing Pool

Made of heavy glass cloth with rubber impregnated on both sides 12' diameter, 5' high, 3000 gal. cap. Ideal for: small irrigation project, swimming pool, animal watering. Complete with cover & guide lines. Gov. price appx. \$350. Our price. . . . . \$69.50  
Due to handling remit full amount.



## WESTINGHOUSE

3 phase motors. All models 1/2 HP to 1 1/2 HP. 220 volts. Motors totally enclosed—ball bearing. Stock #541 40% off list prices.

## AIR COMPRESSORS

All ratings from 1/3 HP to 10 HP—new and rebuilt. Write for free details.

## GENERATORS & AC ARMY LIGHT PLANTS

All new unless specified. All 110 volt 60 cycle unless specified.

300 watt, 110-220 volt AC, 60 cycle light plant powered by 1 HP gas engine, direct drive. Mounted on base weighs 40 lbs. Stock #409. . . . . \$99.50

500 watt. Onan direct connected. Stock #414. NEW. . . . . \$149.50

NEW 1000 watt Briggs & Stratton belt driven Leland generator. Stock #351 . . . . . \$189.50

NEW 1500 watt with Briggs & Stratton belt driven Leland generator. Stock #352 . . . . . \$209.50

2500 watt. Briggs & Stratton Model Z and Leland generator. Stock #317. Used but like new. . . . . \$225.00

NEW tools and spare parts included \$295.00

5000 watt, automatic remote control. Powered by 4 cyl. Jeep gas engine. Used like new. Stock #318. . . . . \$575.00

7500 watt, powered by a VE 4 Wisconsin 4 cyl. gas engine. Continental or Hollingsworth generator. Remote control starting. Complete with switchboard. Used but like new. Stock #347. . . . . \$675.00

Add \$65.00 for transformer to make this plant 3 phase 220 volt.

10,000 watt, 110-220 volt AC, 60 cycle. Remote control. Powered by a Jeep 4 cyl. gas engine. Used like new. Stock #319 . . . . . \$900.00

NEW job original crate only \$1100.00

25,000 watt 220 volt AC, 3 phase. Spare parts. NEW packed for export. Stock #415. . . . . \$1995.00

## GENERATORS

300 watt, 12 volt DC, 2000 RPM. Heavy duty with current cut out relay. High and low switch. 30 amp. meter. Can be bought less shaft and base to be used directly mounted to a Briggs & Stratton 1 HP engine. Stock #323. . . . . \$7.00

NEW only . . . . . \$15.95  
Complete with shaft base and bearing. Stock #324. . . . . \$15.95

300 watt, 110-220 volt AC, generator. Mfg. by Electric Specialties Co. Weighs 20 lbs. Stock #416. . . . . \$34.50

NEW only. . . . . \$89.50

1000 watt, 110 volt AC, 60 cycle generator with built in radio filter. Leland ball bearing 1800 RPM. Stock #526. . . . . \$89.50

1500 watt. Same as above. Stock #527. . . . . \$99.50

2500 to 3000 watt. Leland generator 110 volt 60 cycle. Self excitor, radio filter, junction box for plug in. Stock #525. NEW. . . . . \$145.00

3000 watt, Delco. 110 volt DC. Plug in, ball bearing 2800 RPM. List price \$343.00. Used but like new. Stock #321 . . . . . \$99.50

## HEAVY DUTY RUBBER CABLE

3 wire #10 Super cable. Stock #351. 65' with lugs. Value \$26.00. Our price. . . . . \$13.00

3 wire #10 government submarine type. Used underground, underwater, overhead. Cost U. S. 90c ft. Stock #542. Our price 100 ft. . . . . \$24.00

" " 250 ft. . . . . \$55.00  
" " 500 ft. . . . . \$100.00  
" " 2900 ft. reel. . . . . \$530.00

2 conductor rubber cable #4—stranded—75 ft. length with connectors. List price \$177. Stock #543. . . . . \$90.00

Our price . . . . . \$30.00  
4 wire #6 stranded heavy duty. List price \$2.36 per ft. Stock #548. . . . . \$35.00

Our price 50 ft. . . . . \$30.00  
" " 100 ft. . . . . \$55.00  
" " 250 ft. . . . . \$125.00  
" " 500 ft. . . . . \$225.00  
" " 1000 ft. reel. . . . . \$400.00

3 wire #10 rubber cable two male connectors. Value \$109.50  
Stock #554. Price. . . . . \$35.00

## WESTINGHOUSE TRANSFORMERS

Dry type—insulated—440 volt, 220 volt to 110 volt—single phase.

75 K.V.A. List price \$1009.00. Our price . . . . . \$504.00

37 1/2 K.V.A. List price \$717.00. Our price . . . . . \$358.00

30 K.V.A. List price \$626.00. Our price . . . . . \$310.00

25 K.V.A. List price \$558.00. Our price . . . . . \$279.00

20 K.V.A. List price \$460.00. Our price . . . . . \$230.00  
All like new and guaranteed.

ALL ITEMS GUARANTEED C & H ELECTRIC Co.  
AS REPRESENTED 438 W. JUNEAU AVE.  
MILWAUKEE 3, WISCONSIN

All prices F.O.B. Milwaukee. 25% deposit required on all C.O.D. orders. No C.O.D.'s under \$10.00. Use stock number when ordering. Many other bargain items not listed—write for our free circulars.

60 Cycle  
110-120  
Volt AC

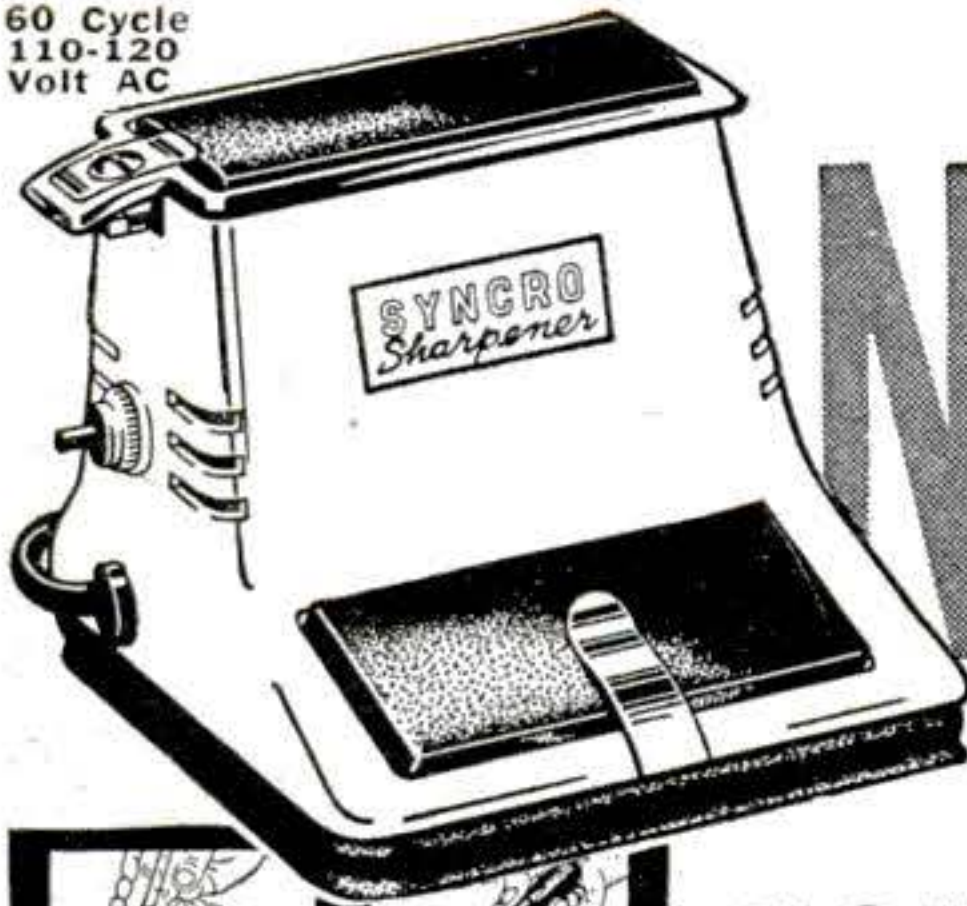

# NEW

## BETTER WAY TO HONESHARP

Almost ANYTHING!

Pictures SHOW YOU how brand-new SYNCRON Electric HONE SHARPENER STARTS sharpening where ordinary electric sharpeners STOP! The ONLY Electric HONE with 14,400 strokes a minute! Invaluable for workshops, homes, kitchens, cafes, industry! A novel Gift. No belts, gears, wheels. HONING is best, safest way. SYNCRON comes with 3 Honing Stones, cord, plug, switch.

**\$10.50**



## NEW and BETTER Electric SANDER-POLISHER Ready!

SYNCRON presents a new, superior electric sander-polisher! For light sanding, refinishing, finishing, etc. Polishes furniture, autos, shoes. 14,400 "POWER" MOTION strokes a minute sand or polish better, faster! With 9 sheets Aluminum Oxide sandpaper, felt and virgin lambs-wool pads, 8 ft. cord, plug



**\$14.50**



## WORLD'S SAFEST Electric JIG SAW!

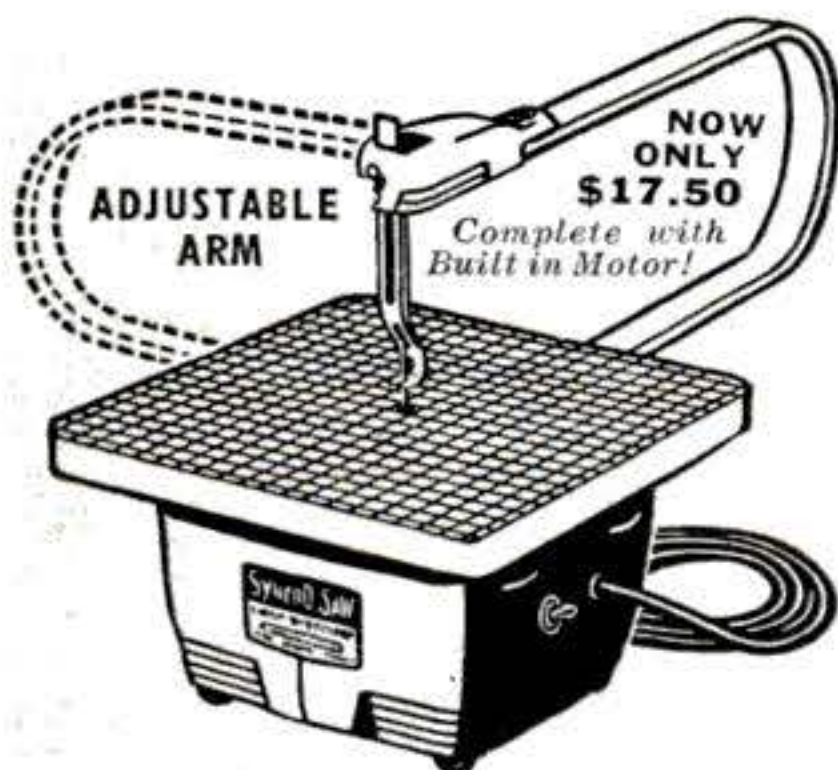

Safe for children, powerful enough for any workshop! Portable. THOUSANDS OF SAFE SYNCROS SOLD! Arm adjusts to permit cutting ANY length material. For delicate work on cardboard, wood, plywood, thin metal, plastic. No belts, no gears. NO OILING. Self-contained motor included. Just plug in any 60 cycle, 110-120 volt AC—and saw SAFELY. Fun and profit making scroll-work, what-nots, photo silhouettes, etc. With cord, plug, 3 blades, only

**\$17.50**

YOU CAN DO IT BETTER WITH

# SYNCRON

QUALITY PRODUCTS FOR

• HOMES • WORKSHOPS • COMMERCE • INDUSTRY

### HOW TO GET YOUR SYNCRON:

At your dealers. If dealer hasn't the brand new Sharpener, new Sander-Polisher or Saw, order direct from factory. Send full amount, we'll ship PREPAID.

DEALERS! Write for SYNCRON'S "BIG 3" Profit Facts.

SYNCRON CORP., DEPT. M-89, ROCHESTER, MICHIGAN

244 POPULAR SCIENCE

## STEERING WHEEL SPINNERS



FOR EASY PARKING  
—SAFE DRIVING!

Top of spinner shows Hollywood glamour girl attractively posed in full color. Base is chrome plated and fits any steering wheel. Choice of red, blue or green. Send no money. Pay postman \$1.69 plus postage. If remittance is made with order WE pay postage.



Dealer Inquiries Invited

WELDON PRODUCTS—Dept. 8A

1213 N. La Brea, Hollywood 38, Calif.

## NEW QUICK-CLAMP 30" BRAKE

Forms angles, channels, vees, flanges, locks, etc. Handles 24 gage sheet steel, heavier gages of aluminum. Cam hold-down. No unscrewing. Held in vise, bolted down, or clamped to truck. All steel. Wt. 45 lbs. Shipped express collect.

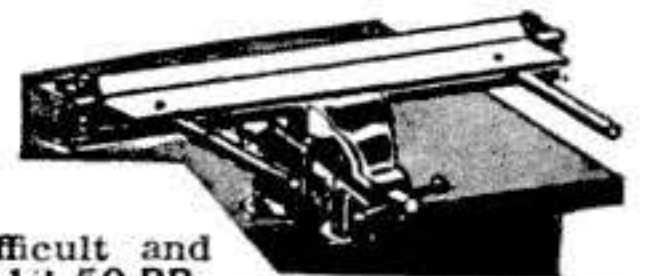

12" BRAKE. Fits in vise to form difficult and compound bends, up to 20 gage steel. \$12.50 PP. SHEAR. Cuts 16 gage steel any length and width. \$12.50 PP. SHEET METAL PLIERS. 2 1/2" wide, \$2.00; 5", \$3.00. NEW SHAPING MACHINE. Does work of metal and wood cut-off, planer, lathe, etc. Notching and grooving up to 30", \$36.50 IRON BENDER. Forms hooks, braces, eyelets. Bends 1/4x2, \$10.00 Immediate delivery. Order direct, cash or C.O.D., or send for folder. 1116 So. 27th St. VISE BRAKE MFG. CO. Omaha 5, Nebr.

## DRAINS CELLARS, WASH TRAYS CIRCULATES OIL



Pumps 1800 GPH 300 gal. 30' high, uses 1/8 to 1/3 HP motor. Will not clog. **\$6.50**

Postpaid if cash with order. (Add 50c for west of the Mississippi.)

Thousands in use since 1936

LABAWCO PUMPS, BELLE MEAD 3, N. J.

## Genuine Snap-on Tools

Available Only Through Snap-on's Direct-To-User Tool Service

WRITE FOR INFORMATION

SNAP-ON TOOLS CORP. • Kenosha, Wisconsin



## NOW! FILE YOUR OWN SAWS

Do expert saw filing at home. Precision filing easy without experience. Two simple adjustments. Keeps any hand saw extra sharp and true-cutting. Complete with file. Money back guarantee. Cash with order, prepaid. (COD postage extra.) Order today.

THE SPEED CORP., Dept. PS  
512 N.E. 73 Portland 16, Oregon

## BUILD YOUR POWER TOOLS

WITH OUR GUARANTEED INDUSTRIAL

POLY BALL BEARING ARBORS  
(No extra charge for left hand threads) ORDER NOW

C4-1/2x12 1/2 spindle, housing 2x8 \$7.95 pp.  
C5-5/8x12 1/2 spindle, housing 2x8 \$8.45 pp.  
C6-3/4x12 1/2 spindle, housing 2 1/4x8 \$9.45 pp.  
D8-1x17 1/2 spindle, housing 2 5/8x11 \$18.75 pp.

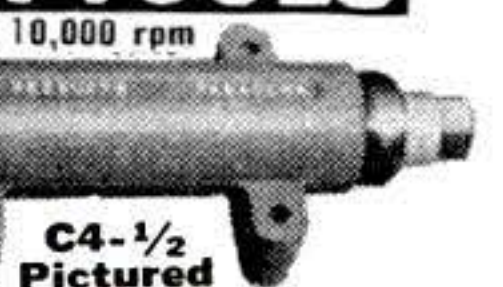

C4-1/2 Pictured  
New Departure Self Lubricating Bearings

POLY PRODUCTS, 2032-B E. Walnut, Pasadena 8, Calif.



**AMERICA'S LARGEST STOCKS OF JEEP PARTS AT THE LOWEST PRICES**

**BIG, FREE CATALOG  
YOURS FOR THE ASK-  
ING . . . WRITE FOR  
YOUR COPY TODAY!**

**THOUSANDS  
OF OTHER PARTS  
AND ACCESSORIES  
AVAILABLE.**

**SHOP BY MAIL  
ORDER DIRECT  
FROM THIS AD  
Send Payment or  
Purchase Order  
Today**

**We Guarantee All  
Merchandise to be  
as Represented. You  
must be Satisfied or  
Your Money Will Be  
Promptly Returned.**

All Prices are F.O.B. Our Yards, Chicago, Illinois. Be sure to include sufficient postage on Parcel Post Orders. Any overage will be promptly returned. All Exchanges Must be Shipped to us Prepaid. **TERMS:** Net cash with order. C.O.D. Shipments should have 25% deposit with order. Open account to rated firms only.

All Items Subject to Prior Sale. All Prices Subject to Change Without Notice. We sell exclusively wholesale and operate on a small margin of profit . . . the savings are passed right on to you.

**Let us know  
your special  
requirements  
. . . if Berg  
doesn't have it  
. . . no one has.**



**RADIATOR ASSEMBLY**  
A1214—  
GPW8005 **\$27.50**

Rebuilt . . . . . \$22.50  
Also interchangeable with Civilian Jeep #640145-640146.

**CYLINDER HEAD**  
NEW A1534—  
GPW6050 **\$8.40**  
Reprocessed . . . . . \$6.95

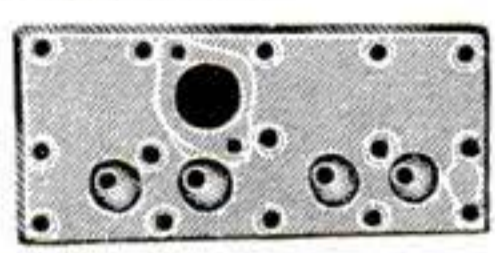

**CARBURETOR  
REPAIR KIT**  
A6840—  
GPW18357B **\$4.35**

**COMPLETE DIFFERENTIAL  
ASSEMBLY**  
A788—  
GPW4207 **\$22.50**  
Complete with pinion



**HUB AND DRUM  
ASSEMBLY**  
A1690—  
GP1102 **\$9.35**  
Reprocessed . . . . . \$6.50

**8 PIECE BRAKE  
LINING SET**  
116600—  
GPW18367 **\$3.50**



**CLUTCH PRESSURE PLATE  
ASSEMBLY (Outright)**  
638992—  
GPW7563 **\$7.60**  
Exchange . . . . . \$6.50

**CLUTCH DISK 636755—GPW7550 . . . . . \$5.50**  
Exchange . . . . . \$4.75

**UNIVERSAL JOINT  
JOURNAL SERVICE PACKAGE**  
A1433—  
GPW18397 **\$3.50**

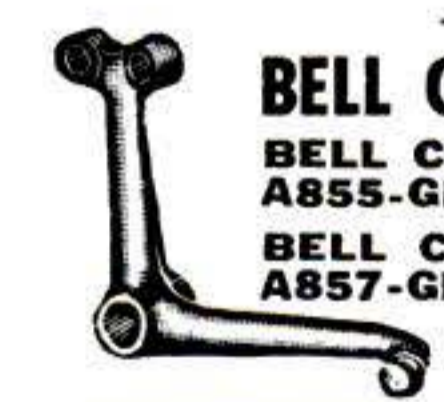

**BELL CRANK** A1211—  
GPW3131 **\$4.65**  
**BELL CRANK SHAFT**  
A855-GPW3165 . . . . . \$0.80  
**BELL CRANK BEARING**  
A857-GPW3171 . . . . . \$0.40

**SPEEDOMETER HEADS**  
A8180—  
GPW17255A **\$7.50**  
Inner Speedometer Shaft  
1344-GPW17262 . . . . . \$0.90  
Outer Speedometer Shaft  
1343-GPW17261 . . . . . \$1.20



**TRAILER LIGHTING CABLES  
WITH ONE SOCKET**  
A6019—  
GPW14407 **\$4.00**

**COMPLETE TRANSMISSION**

REBUILT NEW  
Outright . . . \$55.50 \$67.50  
Exchange . . . 49.50 60.00

A1145— GPW7000

Large stocks of parts for complete transmission assemblies. Also available are Transmission Parts for CJ2A Willys. Write for prices and special needs.



**REAR POWER TAKE OFF**  
GPW7257 (AMPHIBIOUS TYPE)  
Mounts directly behind transmission. Provides a quick and ready means for auxiliary power use of the jeep engine. **\$34.50**

**COMPLETE TRANSFER CASE**  
A1195—  
GPW7700 **\$120.00**  
Exchange . . . . . \$95.00



**BRAKE SHIELDS AND SHOE**  
A1496 . . . . . **\$6.95**

**OIL PAN GASKET**  
639980—  
GPW6710 **12c**



**VALVE REGRIND GASKET SET**  
A1537-GPW18387 . . . . . \$0.75



**STARTER-AUTO LITE NO. MZ4113**  
NEW A1245—  
GPW11001 **\$26.50**  
Replacement Type . . . . . \$18.50

**WATER PUMPS**

639992—GPW8501  
REPROCESSED NEW  
Outright **\$5.50 \$6.75**  
Exchange **4.50 5.75**



**MASTER CYLINDER—COMPLETE**  
A556—  
GPW2140 **\$5.95**

**FRONT AXLE SHAFT—LONG**

A6030—  
GPW3207 **\$27.00**



**FRONT AXLE SHAFT (Short)**  
A6031-GPW3206A . . . . . \$27.00  
Interchangeable with Civilian Jeep CJ2A

**SEAT CUSHIONS**

A2986—  
GPW1162900B New **\$3.50**  
Used . . . . . \$2.50

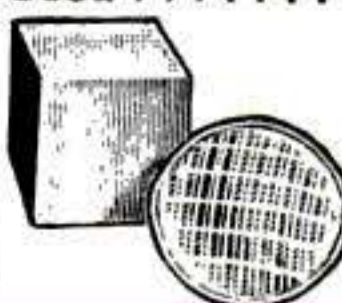

**SEAL BEAM UNIT**  
A1033—  
GPW13007 **\$1.65**

**BERG TRUCK & PARTS CO., INC., 1610 South Wabash Avenue, Chicago 16, Illinois**

**SAVE \$\$ LATEST STYLE LINE AUTO ACCESSORIES • BUY RETAIL AT WHOLESALE PRICES SATISFACTION GUARANTEED**

<p><b>STEEL FENDER SKIRTS*</b></p>  <p>Fit snugly. Secure locking levers. Lots of quality rubber. Won't rattle. Permanent. Tear drop styles, most cars, 36 to 41. special—pair <b>\$10.95</b>. Other types for most cars. See catalog.</p>	<p><b>EXHAUST EXTENSIONS</b></p>  <p>Heavy steel, chrome plated. Hollywood design. Custom built for your car. <b>\$1.29</b> ea. Universal models same as above <b>\$1.50</b>.</p>	<p><b>ORIGINAL SMITHY'S MUFFLERS*</b></p>  <p>The original Smithy's mufflers. Deep mellow tone. Dual custom-built muffler sets for Ford V-8 and Mercury. As low as <b>\$23.00</b>. Singles from <b>\$5.50</b>.</p>	<p><b>GRAVEL GUARDS</b></p>  <p>Highly polished, chrome plated steel for 42-48 Chev. only. Set of two <b>\$4.50</b>.</p> <p><b>HOOD LOUVRE ORNAMENTS</b></p> <p>For that '49 Buick Dynaflo look... Set of six <b>\$3.75</b>.</p>	<p><b>POLISHED CHROME PLATED WHEEL RINGS</b></p>  <p>Snap instantly in place. Enhance beauty of your car. Fit all cars, models. Set of four. . . . <b>\$9.50</b>.</p>
-----------------------------------------------------------------------------------------------------------------------------------------------------------------------------------------------------------------------------------------------------------------------------------------------------------------------------	--------------------------------------------------------------------------------------------------------------------------------------------------------------------------------------------------------------------------------------------------------------------	------------------------------------------------------------------------------------------------------------------------------------------------------------------------------------------------------------------------------------------------------------------------------------------------------	---------------------------------------------------------------------------------------------------------------------------------------------------------------------------------------------------------------------------------------------------------------------------------------------------------------------	----------------------------------------------------------------------------------------------------------------------------------------------------------------------------------------------------------------------------------------------------------

**STATE YEAR, MAKE AND MODEL WITH YOUR ORDER — SEND CHECK OR MONEY ORDER — 25% DEPOSIT C.O.D.**  
**SEND 10c for big, illustrated catalog. AUTOMOTIVE MILLINERY OF HOLLYWOOD P. O. Box 2452 Terminal Annex Los Angeles 54, California**  
 Postage free on all prepaid orders except mufflers and fender skirts

**New LABOR SAVER for the HOME**



**Patented Electric**

**"MOTO-SANDER-POLISHER" ONLY \$14.85 Postpaid**

Say "Good-bye" to Hand Sanding & Polishing! Let speedy "Moto-Sander" do the work while you just guide it. Use for light sanding jobs—finishing, re-finishing, redecorating. **Moto-Sander** quickly and smoothly sands furniture, walls, woodwork, wall board, plaster joints; boats, workshop projects, etc. **Straight-line action (non-rotary)** will not burn or scratch surface. Also ideal for fast, effortless polishing of furniture, refrigerator cabinets, automobiles, other waxed surfaces. There are dozens of time and money-saving uses in every shop and home for this inexpensive machine. **Moto-Sander** is the lightest, most practical electric sander & polisher. Gets into tight corners . . . 7,200 strokes a minute . . . weighs only 21½ lbs. Furnished complete with 6 sheets assorted grade Garnet Paper for sanding, plus felt pad and sheepskin for wax polishing. Operates on 110-120 V., 60 cycle A.C. Thousands of users.

**WHERE TO BUY IT:** Buy **Moto-Sander** from your dealer. If he cannot supply you, send only **\$14.85** (check or M. O.) and we will ship **postpaid**. Or, send only **\$2** now, and pay postman balance plus postage. **MONEY BACK** if not delighted after 5 days' trial.

**DREMEL MFG. CO., Dept. SP129-H, Racine, Wis.**

**How TIP-TOP Liquid Solder Caught a 12 lb. Northern Pike**



"The tip of my bait casting rod broke loose on my first day of Minnesota fishing. I went back to camp and put Tip-Top Liquid Solder on it. The next morning that rod took a fighting 12 lb. Northern! Best catch of the day, thanks to Tip-Top."  
**Mr. D.B.A.—Nebraska**

Sportsmen, keep a tube of Tip-Top handy in your kit. It's perfect for emergency repairs on all kinds of sports equipment. This amazing Liquid Solder forms a perfect joint in metal, wood, glass and fabric. Tip-Top is water and gasoline proof . . . sticks where others fail.

Keep Tip-Top handy at home, too. It licks hundreds of home mending problems. Buy Tip-Top at your hardware dealer's today, or write Tip-Top Products, Omaha, Nebraska. Insist on Tip-Top, the original and superior Liquid Solder.



**7x50 PRISM BINOCULARS**  
**PRECISION OPTICS-BRAND NEW \$36\***

**6x50 Achromatic Field Glasses \$16\***  
 \*20% Federal Tax

Send for Free Catalog of Binoculars, Telescopes & Microscopes

**BROWNSCOPE CO.**  
 Dept. 8P, 24 W. 45th St., New York 19, N. Y.



Money Back Guar. **7x50 \$36** Illustrated

**SURPLUS BRAND NEW AIR COMPRESSORS**  
**for Garage - Shop - Factory - Farm or Home. Height 9" - Weight 7½ lbs. Uses ¼ HP Motor**



A sturdy, well built air compressor of steel and die cast metal constructed to give satisfactory and lasting service. 20-30 lbs. continuous pressure. Higher pressure for intermittent service. Formerly sold for \$14.50. Synthetic rubber hose with fitting, 12½ feet \$1.70, 23½ feet \$3.00.

**While They Last \$8.50**

Orders with remittance shipped prepaid



**\$4.90**  
**Syphon Type Spray Gun**

**COMPRESSOR CORPORATION OF AMERICA**  
**WAYNE STREET, ST. JOSEPH, MICH.**





Remember Weldwood Glue when you need dependable wood-to-wood bonds. Quick and easy to mix with cold water . . . tremendously strong . . . stain-free . . . rot-proof . . . and *permanent*. At paint, hardware, variety stores and lumber yards. 15¢, 35¢, 65¢, 95¢ and larger sizes.

**WELDWOOD PLASTIC RESIN GLUE**  
*United States Plywood Corporation, New York 18, N. Y.*

**ALSO HANDY FOR WOOD HOBBYISTS!**



**Firzite**  
 — to give you smooth finishes on fir plywood and other soft woods.

A pre-finishing material that seals the wood pores . . . tames the wild grain . . . virtually eliminates checking and grain raising. An excellent base for stain, paint or enamel. White or clear. White Firzite provides an easy, low-cost way to achieve "blond," "bleached" or "wiped" finishes.



**Satinlac**  
 — to preserve the beauty of all woods.

An inexpensive coating for the proper finishing of Weldwood Hardwood Plywood and similar woods. Clear. No brush marks. Brings out all the natural beauty of wood. Does not yellow or darken with age.

FIRZITE and SATINLAC are available from paint, hardware and lumber dealers. Write us for leaflet on finishing plywood.

**FIND RADIOACTIVE MINERALS WITH A SNIFFER GEIGER COUNTER**

\$10,000.00 U. S. Govt. Reward offered. NOW, you can prospect for uranium and other precious minerals at low cost. No technical knowledge needed. SNIFFER is supersensitive. Weighs only 2 pounds. Operates from coat pocket. Uses only 2 ordinary flashlite batteries—less than 1c per hour. Loud noise-free audible signal eliminates meters and calculations. Liberal factory guarantee.

- FEATURES**
- Extremely Sensitive
  - Lowest price
  - Economical
  - Lightest weight
  - Smallest size
  - Liberal guarantee

**RUGGEDLY BUILT — EASY TO CARRY & USE — ORDER TODAY.**  
 (All orders shipped same day received). We ship C.O.D. on \$5.00 deposit. **complete post paid**  
**ONLY \$54.50**  
**TROUP ENGINEERING CO.**  
 2223 Grand Ave., Long Beach 4, Calif.

**4 SPEED MOTORS**

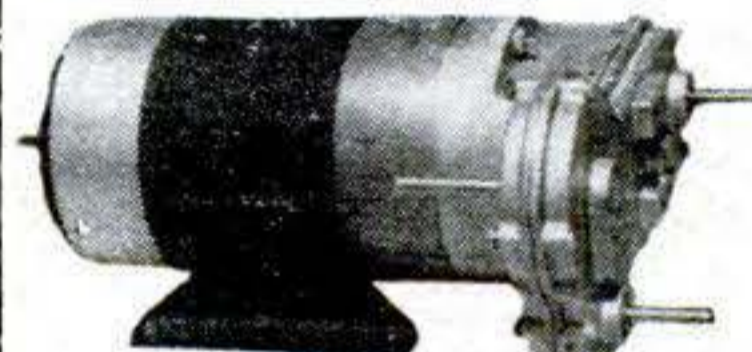

ONLY **\$9.95** Prepaid

Californians Please Add 23c For Sales Tax

Approximately 11 inches Long  
**1/20th HORSEPOWER 115 VOLT 50/60 CYCLE AC MOTORS** with integral gear box having four 1/4 inch drive shafts turning simultaneously at the following speeds!  
**4000RPM**—For grinders, buffers, small drills, etc.  
**150 RPM**—For wrapping fishing rods, slow speed tools.  
**25 RPM**—For developing tray rocker for photographic darkroom.  
**5 RPM**—For turning barbecue spits, advertising displays.  
**A THOUSAND OTHER USES AROUND THE WORKSHOP**  
 Money Back Guarantee. Pulleys, Mandrels, Belts, etc. Available.  
**TROUP ENGINEERING CO.**  
 2223-D S. GRAND AVE. LONG BEACH 4. CALIF.

**2 TERRIFIC BUYS FOR YOUR CAR**



**ACE AUTO VISOR** makes driving safer, more restful. Keeps rain, sun, and snow off of windshield. Streamlined design and heavy chrome trim beautifies your car. Adjustable to any angle. Tested at 100 miles per hour for no rattles. **INSTALL WITH ONLY A SCREWDRIVER—NO HOLES TO DRILL.** Specify.  Prime finish for painting.  Hi-Polish finish requires no paint

**ACE FENDER PANTS** give your car that "NEW LOOK!" Hooks on in a jiffy to any 1935 to 1949 model car—all makes. Made of heavy gauge body steel, prime finished, with rubber stripping to prevent rattles and scratching. Specify car, make, year and model. Order by mail now!



Enclose check or money order . . . or \$5.00 deposit, pay balance on delivery

**ACE AUTO PRODUCTS • DEPT. PS-89 • Box 366, Huntington Park, California**

**Build Your Own Portable Welder save up to \$300**

Pay for it out of profits . . . **Easy Terms**

**\$300 to \$500 extra profit monthly**

Write for this booklet on how to build your own Arc Welder

**BUILD YOUR OWN** portable ARC WELDER and have a profitable business of your own. It's easy. No experience required. Go after big pay welding jobs.  Send catalog on Arc Welders.

**HOBART Bros. Co., Box P-891, Troy, O.**

**FREE** "One of the world's largest builders of arc welders"

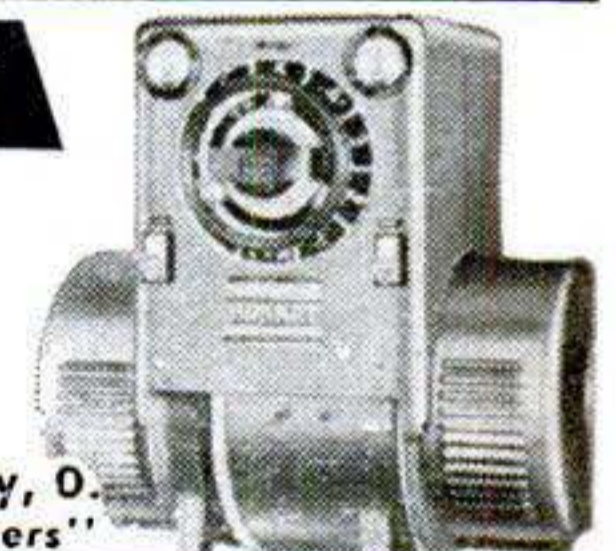

# FOR YOUR SHOP... The DU-FAST<sup>®</sup> OSCILLATING SANDER and POLISHER... tool of a thousand uses!



Especially designed as a versatile attachment for the well-known HOME UTILITY, 1/4" Electric Drill, and HOME UTILITY 5" Disc Sander-Polisher (products of Black & Decker). It brings quick, easy, fine finishes within the reach of every craftsman!

**\$14<sup>95</sup>**  
DU-FAST  
ATTACHMENT  
ONLY

Regardless of what your specialty... if you work with wood, metal, plaster, wallboard, plastics or other project materials... DU-FAST saves you money, time and work on every job... in your home, in your shop, in your hobby and wherever you want professional type finishing and polishing. Working surface a full 3 3/8" x 7".

IDEAL FOR... SHOP PROJECTS • FURNITURE • AUTO BODY WORK • MARINE USE • FLOORS • AROUND MOLDINGS • IN CORNERS • WOOD, PLASTIC, METAL FINISHING • and hundreds of other applications!

SAFE, QUICK, EASY, FOOL-PROOF AND ECONOMICAL TO USE... DU-FAST IS PERFECT FOR YOUR SHOP... \*Pat. Applied For ASK YOUR HARDWARE DEALER TODAY!

MANUFACTURED BY  
**DU-FAST, Inc.**  
32 EAST FOURTH STREET, NEW YORK 3, N. Y.

Available only at hardware dealers carrying Black & Decker Home Utility Tools. Stop at one today!

## ELECTRIC MOTOR BARGAIN

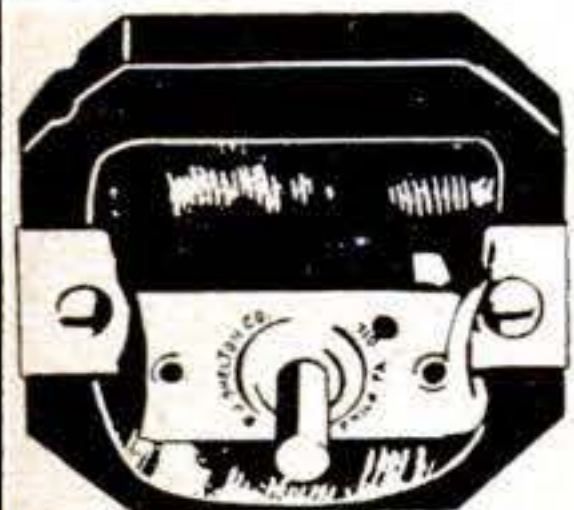

We have a surplus of 1/150 HP motors. Original cost \$2.00 each. 110 volts, A.C., induction type. Self-aligning bearings.

FINE FOR FANS, HEATERS, BLOWERS, TOYS, DISPLAYS.

Special, each... **95¢**

STANDARD ELECTRIC MFG. CO.  
WEST BERLIN, N. J.

Postpaid if \$1.00 is sent with order. Otherwise, C.O.D.

## PAINTERS' STRIPING TOOL

NEW, IMPROVED

Modern—streamlined—fits the hand like a fountain pen! Easy to use as a pencil. Draws parallel lines—straight, curve or circular. Does expert job on autos, furniture, toys, bikes, model planes, signs, bulletins, linoleum. (Makes wall board look like tile.) Every painter and craftsman needs one! Type "M" MASTER Painters' Striping Tool complete with tip for 1/16" stripe, \$1.00. Tool with choice of 1/64", 1/32", 3/64", 5/64", 3/32", 1/8" tip—\$1.50... all tips 75c ea. Tool with complete set of 7 tips \$5.00. (COD's postage collect) Paint dealers, write!

EASY AS USING A PENCIL!

**\$1.00**  
POST PAID

A TOOL... NOT A BRUSH

WENDELL MFG. CO.

4234-A Lincoln Ave., Chicago 18, Illinois

## POWER TOOL COSTS **Reduced 75%**

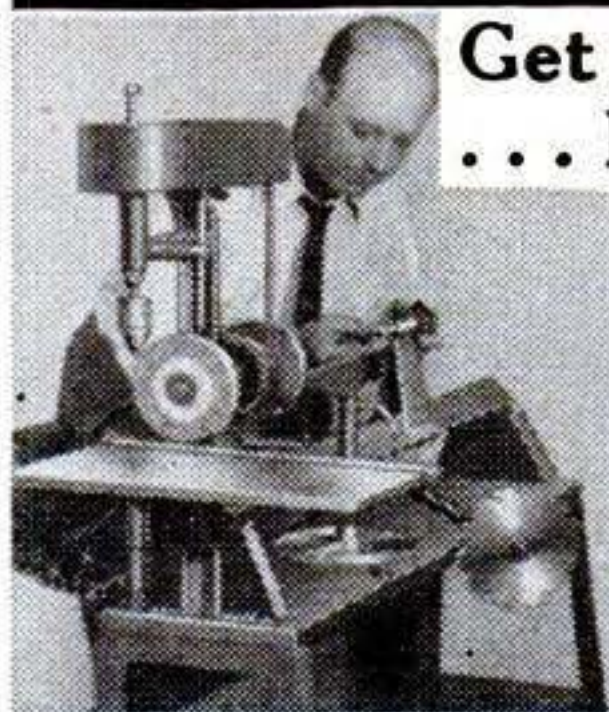

Get This 5-in-1 Machine... Do the Work Yourself

Save money; have fun! Make your own furniture—handle hundreds of home repair jobs. Emrick 5-in-one Workshop includes big capacity Lathe, Drill Press, Saw Arbor, Grinder and Sander. Only \$39.95 cash, or Time Payments. (Separately such power tools often cost up to \$160.) Send for FREE Catalog and Free Trial plan.

EMRICK, INC., 1693 Clinton, Kalamazoo, Mich.

## SURPLUS HYDRAULIC PUMP

Genuine Vickers constant displacement high pressure pump. Use it for any type of liquid pumping job. Will pump 400 gal. per hour at 3750 R.P.M. Precision piston type design provides 1000 lbs. per square inch pressure. Self priming. Standard thread 3/4 inch intake and discharge ports. With 3/8 inch splined shaft—just add pulley and power and you're ready to go. These pumps are brand new. Original acquisition cost approx. \$100.00. Can also be used as hydraulic motor; for rams, opening doors, hydraulic lifts, etc. also for any liquid transporting job. War surplus, but brand new. Shp. **\$9.95** wgt. 7 lbs.

F.O.B. HOUSTON. SEND CHECK OR MONEY ORDER  
SOUTHWEST AERO SUPPLY Dept. P58, Drawer 488  
South Houston, Texas

## A \$50 A DAY BUSINESS IN YOUR SPARE TIME

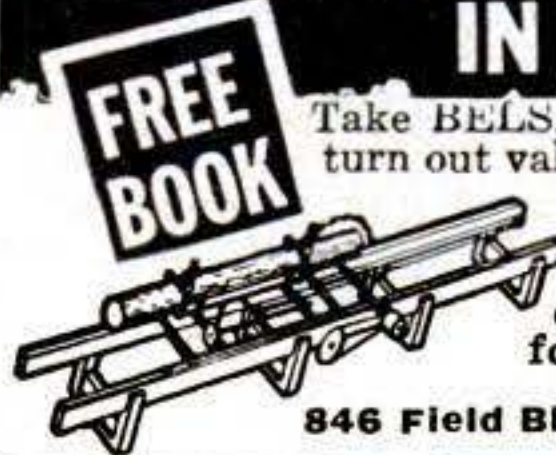

Take BELSAW Portable Sawmill right to the trees—turn out valuable lumber for local yards—do "custom sawing" for neighbors. BELSAW lasts a lifetime. No crew needed. Power with old auto engine or tractor. Beginners get excellent results. \$62.50 down Send postcard for FREE BOOK, "How To Make Lumber."

BELSAW MACHINERY CO  
846 Field Bldg., 315 Westport Rd., Kansas City 2, Mo.

We'll Pay You  
**\$1000.**

for 3 gallons of "worn out" motor oil from your own auto, truck or tractor engine. Details, page 30, in our FREE BOOK "Oil Facts."

RECLAIMO MFG. CO., 5083 Elston Ave., Dept. 98, Chicago 30, Ill.

## FREE! SOUTH BEND CATALOGS

Cat. 100—9" to 16" SWING LATHES  
Cat. 400—14" DRILL PRESSES  
Cat. 500—7" BENCH SHAPER  
Cat. 77—ATTACHMENTS

Write today—state catalog wanted



SOUTH BEND LATHE WORKS  
456H E. Madison St., South Bend 22, Ind.

## INCREASE SAW SHARPENING PROFITS!

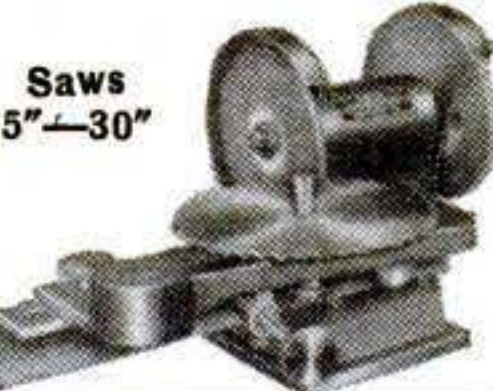

Saws 5"—30"

REYNOLDS CIRCULAR SAW GRINDER produces top quality results in fraction of time usually necessary for reshaping, jointing, gumming and tooth forming. Any hook or pitch of tooth and depth of cut is quickly adjusted. Both hands are free to control position of saw while grinding. Write now for free circular!

PROVIDENCE SAW & KNIFE COMPANY  
Eddy & Ship Sts. Providence 3, R. I.

Only \$498



## OTTAWA Mule Team Tractor

Finest of all low cost tractors. Costs too little to do without. Has the toughness and strength of a team of mules. Over 4,000 in use. With ease and low operating cost, it plows, discs, harrows, mows, plants, cultivates, etc. Weighs nearly 1,000 lbs. and has Bull-Dog traction. Sold only direct to user. Write quick for FREE details.

OTTAWA MFG. CO., 2-901 Garden St., Ottawa, Kansas

**"Wellworth" Sensational Offer! Reg. \$60.50**  
**WESTINGHOUSE AIR COMPRESSOR**

**Model T-1  
Brand  
New!**

**2-Cylinder Piston Type**  
**Operates with 1/2 H.P. motor**  
**or equivalent gas engine.**

Automatic clutch makes it suitable for mounting and operating from truck, tractor, etc. Instructions furnished. Replacement parts available. Price of compressor only. (Wt. 26 lbs.)

**\$21<sup>50</sup>**

Complete outfit consisting of compressor, pressure tank, air gauge, air chuck, 20-ft. hose, pop valve, copper tubing with 4 brass flared fittings for connecting compressor to tank, 4-way cross and 3 nipples—complete outfit, only. . . . (Wt. 40 lbs.)

**\$31<sup>25</sup>**

Equipment less compressor **\$11<sup>50</sup>**  
 Wt. 15 lbs.

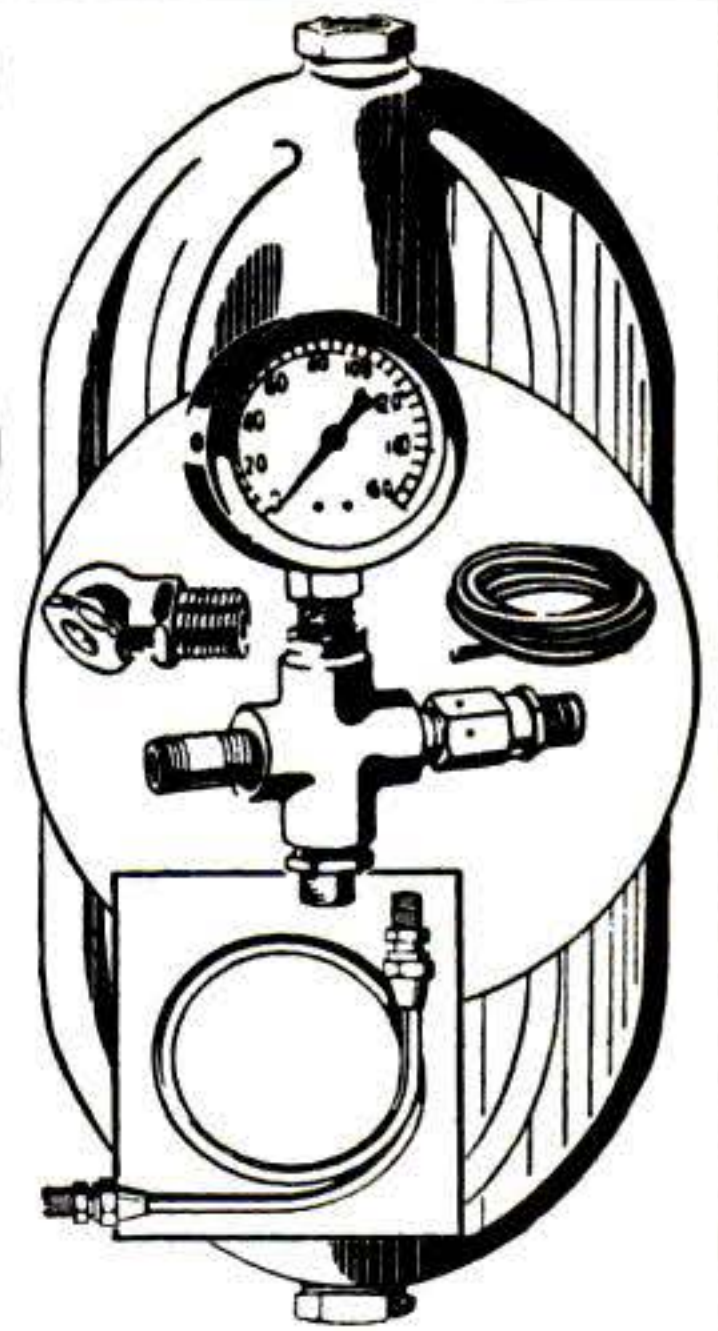
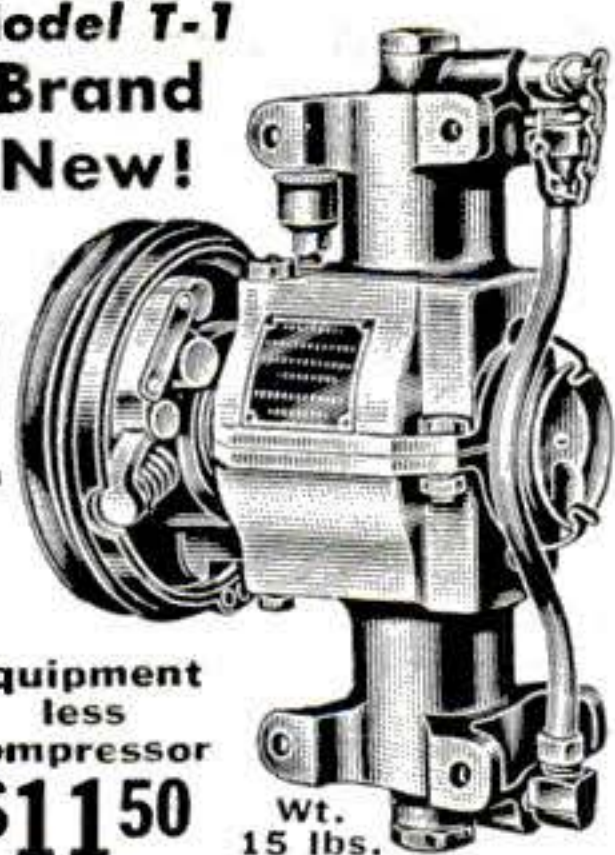

**THE COMPRESSOR**

Piston Type, 2-cylinder, 2 inch bore, 1 1/2" stroke Ball Bearing **AUTOMATIC CLUTCH**. OIL FREE AIR. 3.27 C.F.M. at 600 R.P.M. Capacity up to 6.54. Suggested operating pressure 75 P.S.I. DIMENSIONS: 9" wide, 11 7/8" high, 6 3/8" deep. Wt. 26 lbs.  
**TANK and ACCESSORIES**  
 6" x 24" stainless steel tank. Suitable for 150 lb. pressure. Two 1/4" openings. Air gauge, pop valve, air chuck, 20 ft. hose, copper tubing and fittings as described.

**IDEAL for HOME • FARM • FACTORY**

*Wherever Compressed Air Is Needed*

A fortunate purchase from the Government enables us to offer you this amazing buy. This low price is but a fraction of the price of manufacturer and of leading mail order houses. All Brand New Equipment. **ORDER NOW!**

**PORTABLE SPRAY OUTFIT**

**1/4 H. P. HEAVY DUTY**

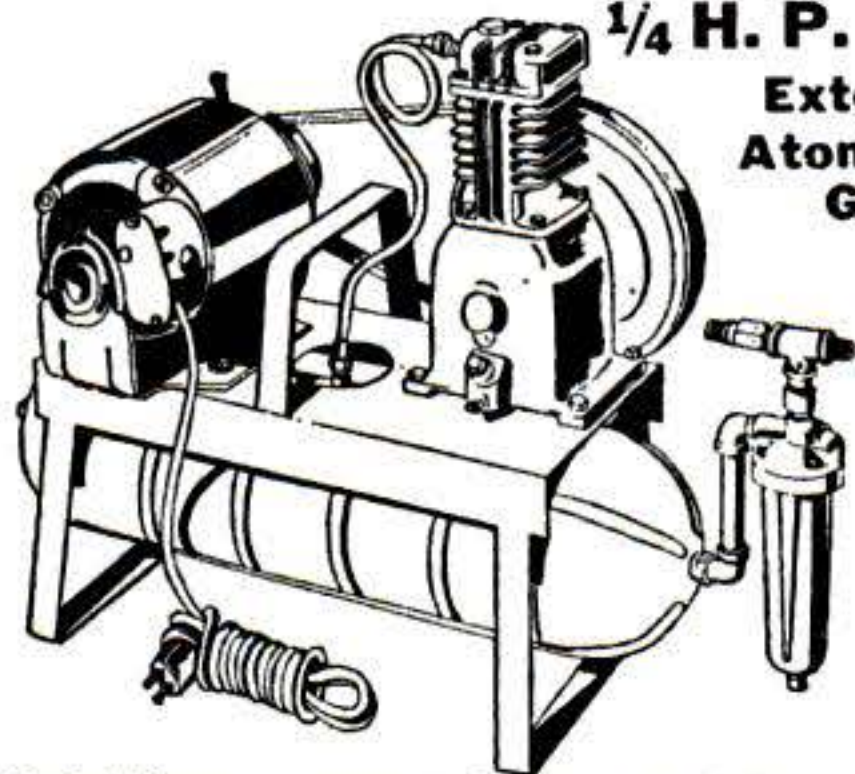

**External  
Atomizing  
Gun**



**None Better  
at Double  
This Price**

Paint Sprayer mounted on 6 x 24 inch tank, 1/4 H.P. 110 V. 60 cy. Heavy duty motor with overload relay, 10 ft. cord and plug, V Belt drive. Piston-type Compressor with 2 Compression rings, 1 oil ring, 2 inch Bore, 1 1/4 inch stroke, displacement 2.86 C.F.M. at 60 lbs. pressure, Safety Valve. Gun external atomizing. Flat and round spray, quart cup; maintains 35 to 40 lbs. working pressure. Oil and water extractor, 1 air gauge, 20 ft. heavy duty 2-braid air hose with leak proof fittings, complete with carrying handle. Net weight 54 lbs., ship. wt. 60 lbs.

**\$57.50**

Outfit less motor ..... \$47.50  
 Compressor only ..... 17.50  
 Spray gun and 20 ft. hose .... 12.95

**PNEUMATIC AIR TOOLS**

**CHICAGO PNEUMATIC RIVETER & CHIPPING HAMMER**

CP4X Pistol grip handle. Takes up to 3/16" rivet. Weight 6 lbs. List price \$73.00.



Special Price... \$14.50  
 Same as above, brand new ..... \$22.50  
 Size CP3. Takes 5/32" Rivet ..... \$10.95

**Chicago Pneumatic Lever Type AIR DRILL**



With 1/4" Jacob Chuck. Wt. 2 lbs. List price \$55.00. Only ..... \$17.50

**Ingersoll Rand AIR DRILL**

With 1/4" Jacob Chuck. Wt. 2 lbs. List price \$55.00. Only ..... \$17.50

**AUTOMATIC COMPRESSOR UNIT**

1 3/4 H.P. heavy duty capacitor motor AC 110/220 volt 60 cycle, 2 x 1 3/4 inch piston type compressor, splash feed lubrication, 12 x 24 inch tank, automatic pressure switch, pressure range 100 to 125 lbs., CFM 2.2, check valve, safety valve, air regulator with gauge and filter, 20-ft. air hose with air chuck for inflating tires. V. belt drive. Shipping wt. 90 lbs.

Special **\$79.50**  
Price

Same unit as above with 1/2 H.P. motor, furnished with 13" x 24" tank. CFM 2.8 at 125 lb. pressure. Shipping **\$98.50**  
 wt. 125 lbs....

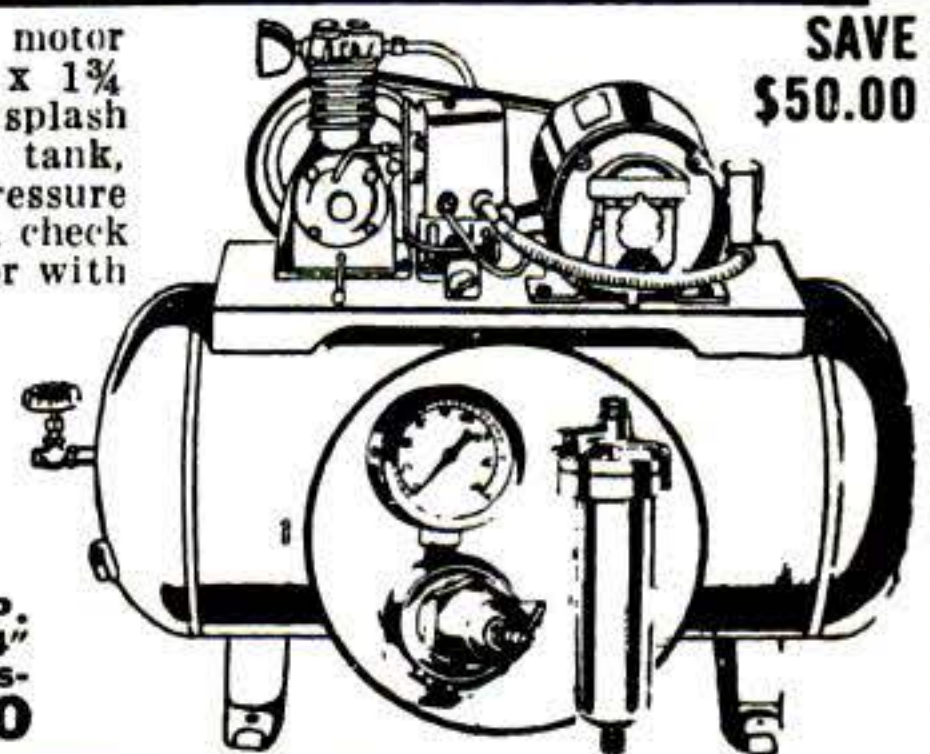

**SAVE \$50.00**

**"Wellworth" Two Stage COMPRESSOR UNIT**

Ideal for paint spraying and general use. Compressor: Size 3 1/2 & 2 x 2 1/2 with unloader for continuous pressure service; displacement 10 C.F.M. at 200 lbs. pressure. Unloader set at 150 to 165 lbs. Compressor idles when 165 lbs. is reached, starts pumping again when pressure is down to 150 lbs. Wisconsin Gasoline air cooled, easy starting engine 3 1/2 H.P. at 1800 R.P.M. 4.1 H.P. at 2400. Air Tank; A.S.M.E. 200 lbs. working pressure; size 16" x 20" with safety valve, drain, two 3/8" globe valves and pressure gauge, 2 "V" belts and pulley, 10 ft. air hose and fittings. Wt. 350 lbs. Reg. price \$400, less base..... **\$225.00**

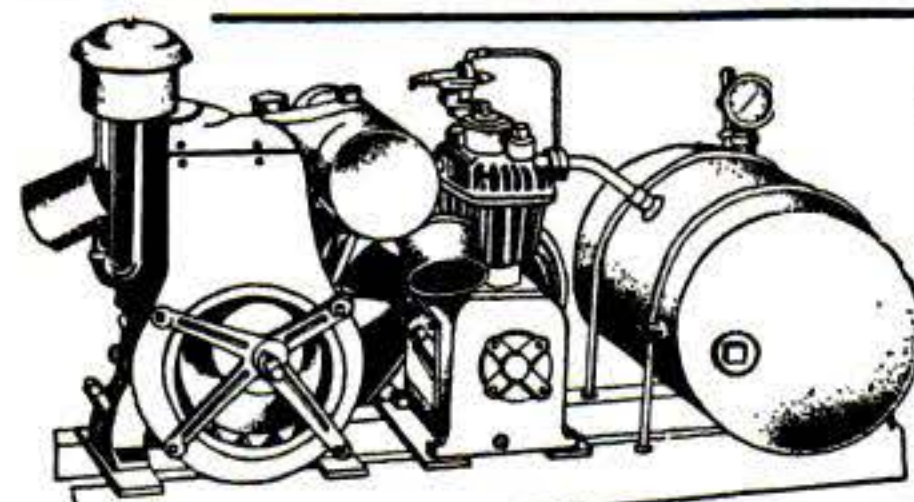

Price of compressor with unloader, wt. 160 lbs. **\$128.00**  
 Price of engine only, wt. 90 lbs. .... **87.50**  
 Price of tank and accessories, wt. 110 lbs. .... **62.50**

Prices f.o.b. Chicago. Immediate delivery.  
 All items sold on money back guarantee.  
 Send check or money order today.

**WRITE FOR FREE CATALOG WELLWORTH TRADING CO.**

Merged with C & M Equipment Co.

1831 S. STATE ST. DEPT. B-8 CHICAGO 16, ILL.

**OVER 50,000 SATISFIED USERS!  
DYNAMIC HEAVY DUTY WELDER**

**MAKE OR SAVE TIME & MONEY!**

Now You Can Repair Auto, Home Appliance, Farm & Shop Equipment for yourself & others with this Genuine Transformer Type Welder—75 Amp. Capacity. Does Welding, Brazing, Soldering and Cutting on iron, steel, brass and other metals. Portable. Easy to operate from any properly wired 110 Volt Line (other voltages at slight extra cost). Has 8 metallic and carbon arc welding heat stages. Comes **COMPLETE** ready-to-weld with helmet, rods, cable, etc. and Simplified Instructions which are actually a short course in welding. A few repair jobs will more than pay for it. **SPECIAL GIFT \$6.80 ARC TORCH** yours at **NO EXTRA COST**. Write today for **FREE** details and **10-DAY TRIAL OFFER**. **DYNAMIC WELDER CO., 15 E. 23rd St., Dept. ATD-89, Chicago 16, Ill.**

**ONLY \$28<sup>50</sup>**  
**COMPLETE**



**15 ESSENTIAL WORKSHOP OPERATIONS ON YOUR DRILL PRESS**

Barron Precision Drill Press Tools and Accessories—Planers, Rotary and Drum Sanders, Auxiliary Tables, Hi-Speed Router Bits, Shaper Fences, Molding Cutters, Dovetail Cutters—a host of other useful drill press items give complete workshop facilities at 1/4 the cost. Over 200,000 Barron owners. Get the facts on these popular, versatile drill press tools today. Sold on 10 day money back guarantee.

**BARRON TOOL CO. Inc.**  
 770 ARCHITECTS BLDG.  
 DETROIT 1, MICHIGAN

**FREE Workshop Guide & Catalog**

**SO HANDY FOR  
SO MANY USES  
AT HOME  
OFFICE AND SHOP**

**32 DRAWER  
MODEL PICTURED  
ONLY  
\$5.95  
POST PAID**

**THE  
JIFFY  
METAL  
CABINET**

**NOW you can keep  
nuts, bolts, screws,  
nails, parts, wash-  
ers, stamps, hobby-  
ist needs, etc., at your fingertips.**



Just think, 32 or 64 drawer cabinet to keep those small items that usually get mislaid. Spot welded steel cabinet, enamel finish, metal drawer guides. Looks good anywhere. Send check or money order please—no C.O.D.'s. Prices below. Your money refunded if not satisfied.

SPECIFICATIONS	WITH ALUMINUM DRAWERS	WITH CARDBOARD DRAWERS
<b>32 Drawer Unit</b> 6" Deep 12 3/4" Wide 15 1/4" High	One piece rustproof aluminum drawers for heavy service—good for work bench and industry use.	Suitable for most home uses. Heavy board kraft covered. Metal drawer pulls.
<b>64 Drawer Unit</b> 6" Deep 25 1/2" Wide 15 1/4" High	<b>32 drw. \$8.95</b>	<b>32 drw. \$5.95</b>
<b>Drawer Size</b> 1 1/4" Deep 2 3/4" Wide 6" Long	<b>64 drw. \$15.95</b>	<b>64 drw. \$9.95</b>
	POSTAGE PAID	POSTAGE PAID

**KAYTEE PRODUCTS DEPT. S BOX 588. CANTON, O.**

**HOLD-E-ZEE**  
The Original  
**AUTOMATIC GRIP  
SCREWDRIVERS**

Hold, start and set up screws in unhandy places. Gripper instantly released by SPRING ACTION, sliding up out of way when not in use. Highest quality throughout.

*New Models FOR RECESSED  
HEAD SCREWS* 

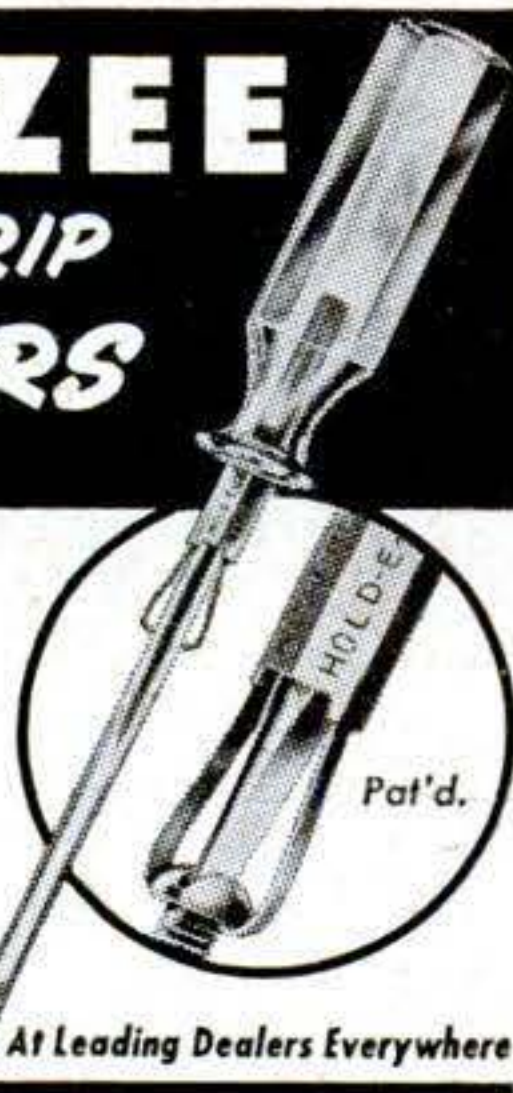

**UPSON BROS., INC., ROCHESTER 4, N. Y.** At Leading Dealers Everywhere



**Plans... Projects...**

**How-To-Do-It Information  
for woodworking hobby fun**

**Yours — in every issue of  
THE DELTAGRAM®**

A whole year's supply of easy-to-work drawings and step-by-step project instructions. New ideas on beautifying your home. Inspiration for projects that win admiration. Tips on using tools efficiently and safely. Leaves nothing to guesswork. Everything detailed and specific. Read by thousands. Get your subscription in now for The Delta-gram. Send name and address today—with coin, U. S. postal note, or money order.

**DELTA MANUFACTURING DIV.  
Rockwell Manufacturing Company**

**6 Big  
Issues  
75¢**

HM-75 682H E. Vienna Ave., Milwaukee 1, Wis.



**Aids to**

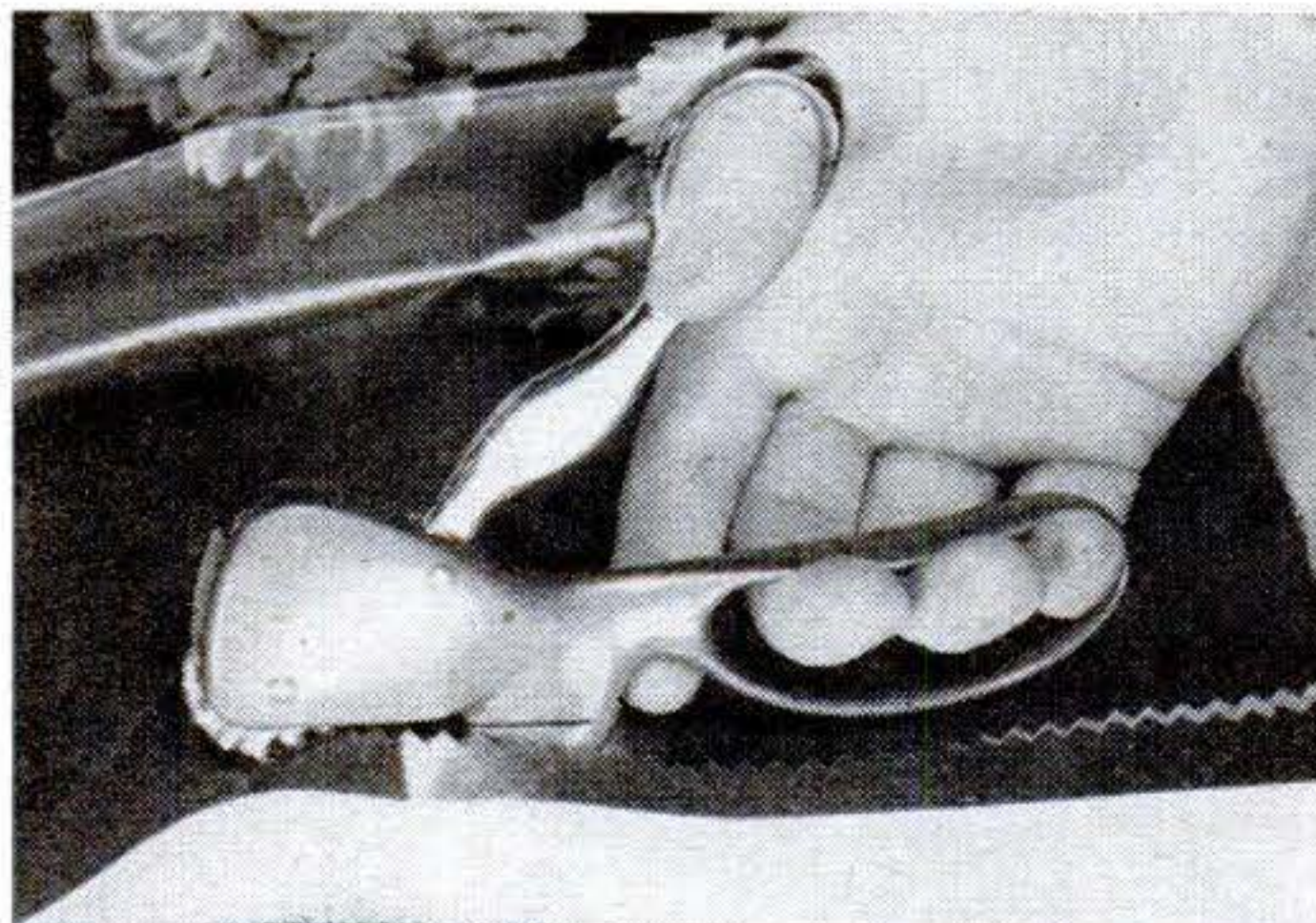

**Rolling Pinker.** Although the handles of this sewing tool resemble those of the conventional pinking shears, that's as far as the similarity goes. The lower handle remains stationary. Moved with a pumping motion, the upper handle operates the pinking wheel through gears. It's priced at \$7.50 by Florian Mfg. Co., Plantsville, Conn.



**Grease-Draining Frying Pan.** Pushing the plastic lever in the handle of this frying pan opens the valve and lets you drain off excess fat. A slight tilt lets the grease drain out with no chance of tumbling out the food. The 9 1/2" pan is made of cast aluminum by the Hollis Company, of Newark, N. J. It sells for about \$5.

# Modern Living

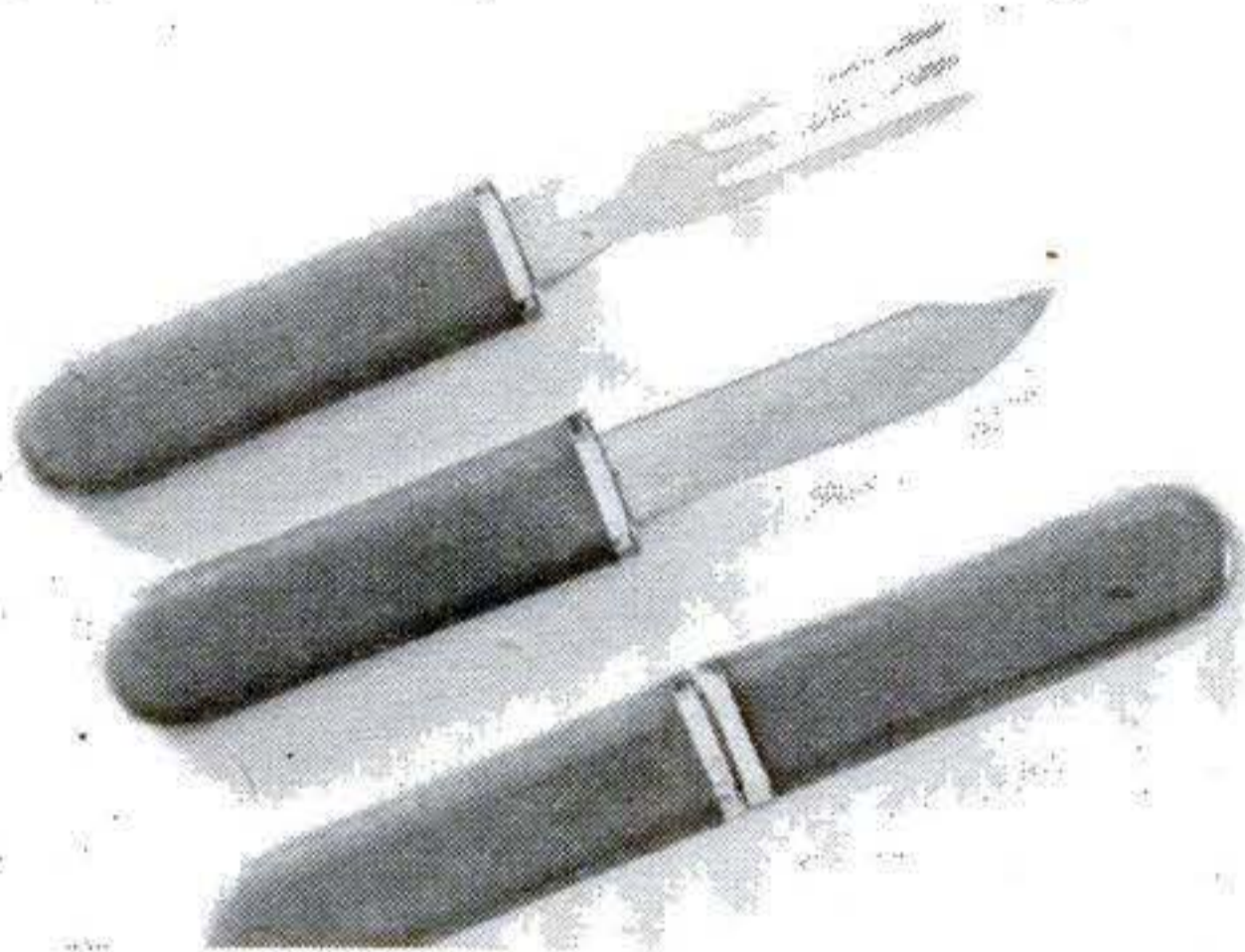

**Combination Knife-Fork.** This combined knife, fork, and bottle opener fits snugly into a self-contained case. Closed, the outfit is 7½" long and fits easily in a pocket or in the glove compartment of a car. Knife blades and fork tines are offset to permit sheathing. It's distributed for \$1 by California Brands, Los Angeles.

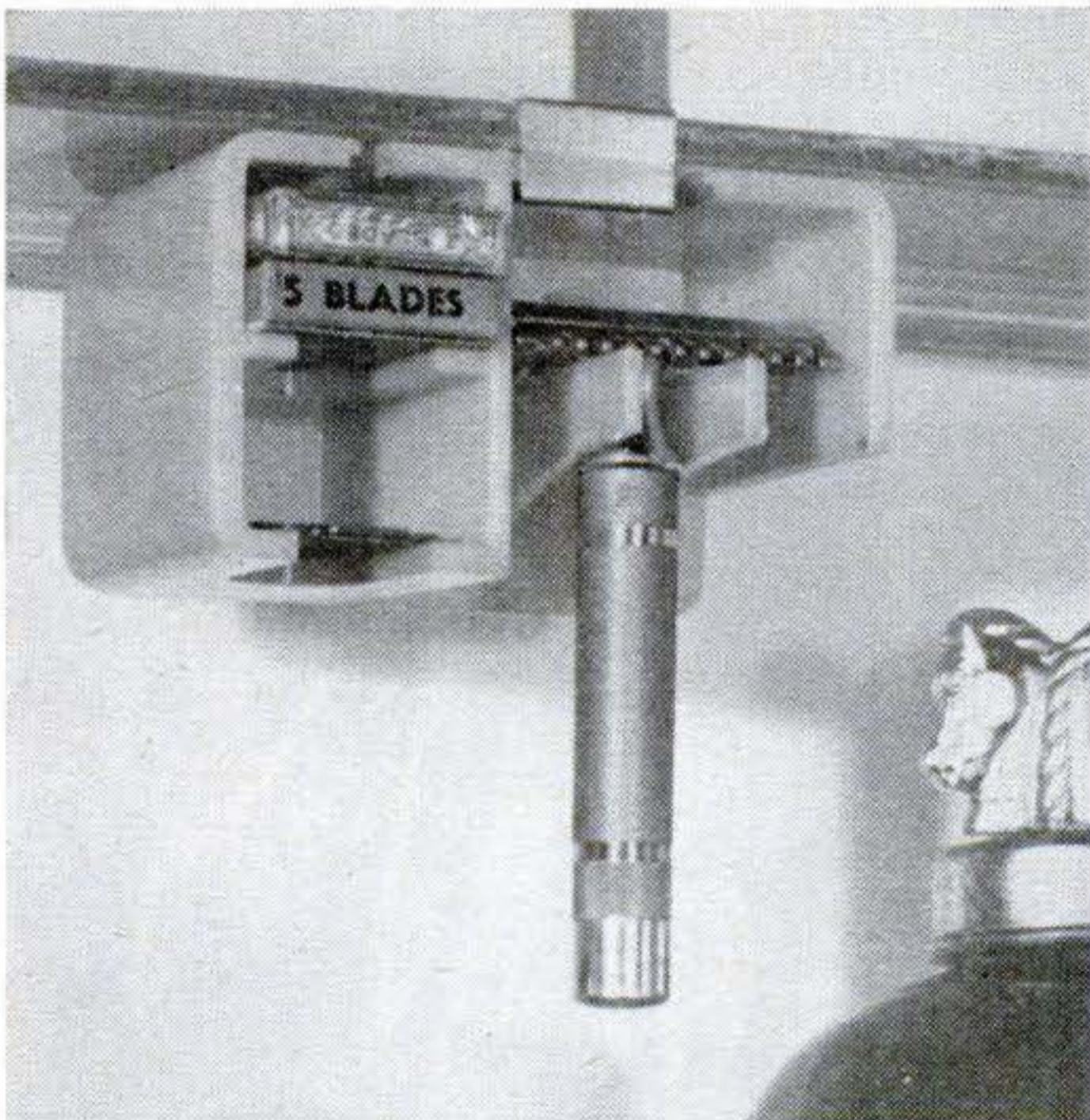

**Razor Holder Clips on Shelf.** Clipped to the underside of a shelf in the bathroom cabinet, this plastic holder keeps both razor and blades up out of the way. It has compartments for new and used blades. Screws are furnished for mounting beneath wooden shelves. Carvanite Products, Los Angeles, prices the holder at about 30 cents.

## WANT A BASEMENT WORKSHOP?



BUILD a handy workshop easily with Gold Bond Gypsum Wallboard, at low cost. Big, lightweight panels are fireproof, moisture resistant, and easy to nail. Decorate with Gold Bond Sunflex, the low-cost, one-hour wallpaint. Get both at your local Gold Bond Lumber and Building Material Dealer's.

Free Book of suggestions



NATIONAL GYPSUM COMPANY,  
Dept. J-1, Buffalo 2, N. Y.

Gentlemen: Send free copy of new Book-let, "Modernizing Magic" showing remodeling ideas and methods!

Name .....

Street .....

City.....State.....

(Please print name and address)

## Build your own SMITH Compressor

Operates spray guns, rock drills, tampers, paving breakers, sandblasting . . . Uses only 1 gallon of gas an hour!



Save Money—build your own Smith Air Compressor! Famous the world over! Capacity 60 cu. ft.; pressure up to 100 lbs. per sq. inch. Just order the Smith Compressor Head and Accessories with complete instructions for assembling. All you need is a Ford Motor and shop facilities. Head equipped with high speed compressor valves; automatic unloading and idling.

Write for complete information!

GORDON SMITH & COMPANY, Inc.  
405 College Street • Bowling Green, Ky.



## ONAN Portable ELECTRIC PLANTS

FOR CABINS, TRAILERS, CONTRACTORS, BOATS

Light weight, compact, air-cooled engine-driven. Furnish regular city-type A.C. electricity for lights, appliances, radios, etc. Can be carried by hand. Fit trunk of car. Plug-in receptacles on plant. Larger models for farms, homes, businesses beyond highlines. Catalog shows over hundred models. 350 to 55,000 watts.

Gasoline or Diesel Powered

WRITE FOR CATALOG

D. W. ONAN & SONS INC.  
2798 Royalston Ave., Minneapolis 5, Minn.



## Cracked Water Jacket SEALED TIGHT

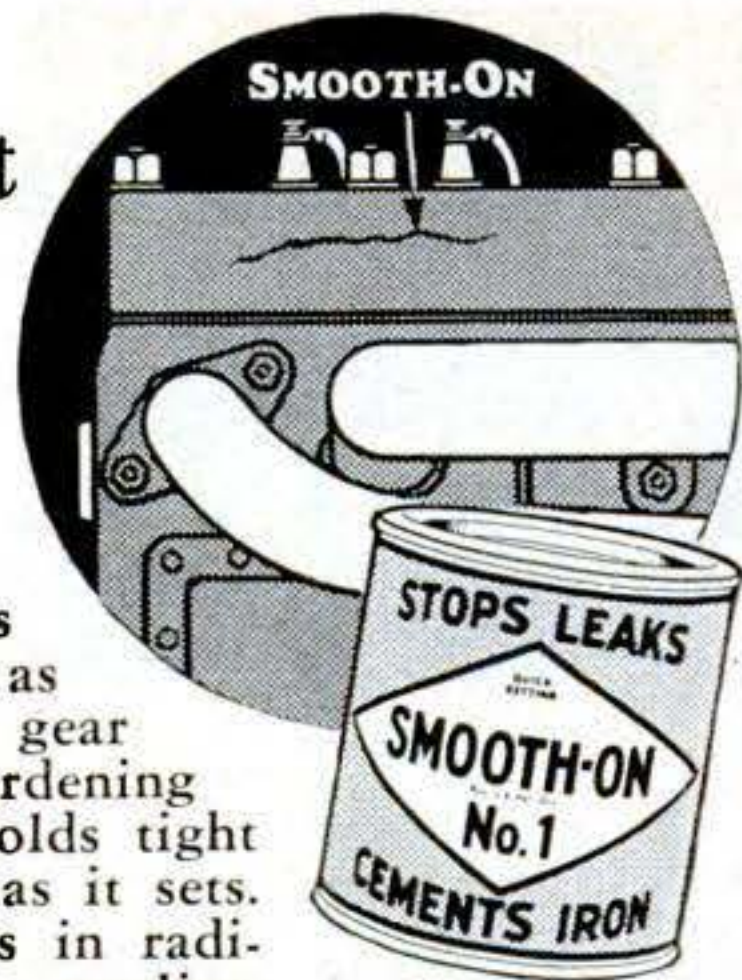

Use Smooth-On No. 1 Iron Cement to seal cracks in cast metal parts such as water jackets, crank cases, gear cases, etc. This quick-hardening cement stops leaks and holds tight—for it expands slightly as it sets. Use it, too, to stop leaks in radiators, gas tanks, heating, cooling and exhaust systems. Keep Smooth-On No. 1 handy for many auto and household repairs. Buy it in 1-, 5- or 20-lb. size at your hardware store. If they haven't it, write us.

## FREE 40-Page Repair Handbook

Shows, besides above repairs, many time-saving, money-saving household uses. Heating and plumbing system leaks stopped. Loose hinges, handles, parts tightened. 170 illustrations. Write for your free copy TODAY.

SMOOTH-ON MFG. CO., Dept. 58-H,  
570 Communipaw Ave., Jersey City 4, N. J.

*Do it with*

# SMOOTH-ON

THE IRON CEMENT OF 1000 USES



Guaranteed to cut clean grooves—12 widths—no sanding. No fuss—no trick assembly. 5 sizes— $\frac{1}{2}$ ",  $\frac{5}{8}$ ",  $\frac{3}{4}$ ", 1", 1 $\frac{1}{2}$ ". SEE WARREN DADO SAWING WASHERS AT YOUR DEALERS, OR WRITE. **\$4.95** Set

WARREN WASHERS CO., 70 MEDBURY—DETROIT



## NEW! Trash Disposal Unit Burns Refuse Safely

● A new type outdoor dispose-all unit safely and quickly burns garbage and trash in any weather. All refuse, damp, green or dry is fully consumed. Scientific draft design completely eliminates fire hazard of flying ash, sparks, burning, blowing bits of paper. Intense combustion removes neighbor-annoying nuisance of flying scraps, smoke, smell.

Sturdily built to last for years. Nothing to get out of order. Needs no watching. Will not blow over. Will not destroy grass or shrubs. Ends refuse hauling and fire hazards to quickly pay for itself. Measures 23" square at base by 40" high. Weighs 19 lbs. Over 2 bu. capacity. Recommended by Bureaus of Fire Prevention. Full price \$9.95—nothing else to buy. Sent F.O.B. Cleveland. Money back guarantee. Send check, cash, or money order to:

ALSTO COMPANY, Dept. PS8, Engineers Bldg., Cleveland, Ohio

## Aids to Modern Living



**Lifting Pencil Lights Lamp.** Remove the pencil to jot down a note and the light goes on. Replace the pencil and the light turns off. The Mem-O-Lite®, designed for use on night tables and telephone stands, is manufactured by the Bollman Industries, of Kansas City, Mo. It's made mainly of plastic and comes in black, walnut, or ivory.

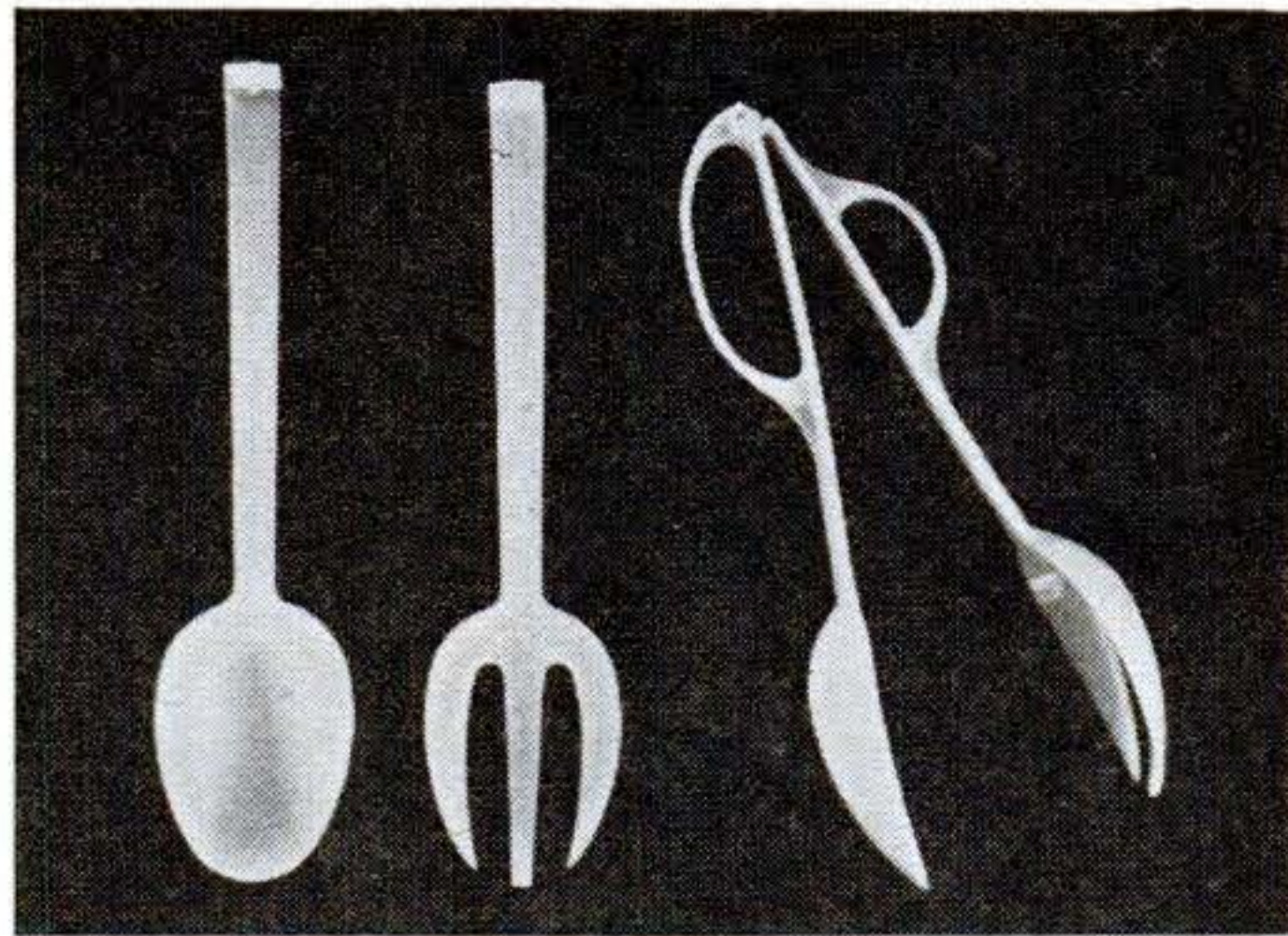

**Serving Tongs Unhinge.** Made of Lucite® by Amos Molded Plastics, Edinburg, Ind., this salad server can be used as a one- or two-piece unit. The hinge has no pin. To assemble, the end of the fork handle is inserted in the grooved end of the spoon handle and the two brought together. Reversing the operation separates the pieces.

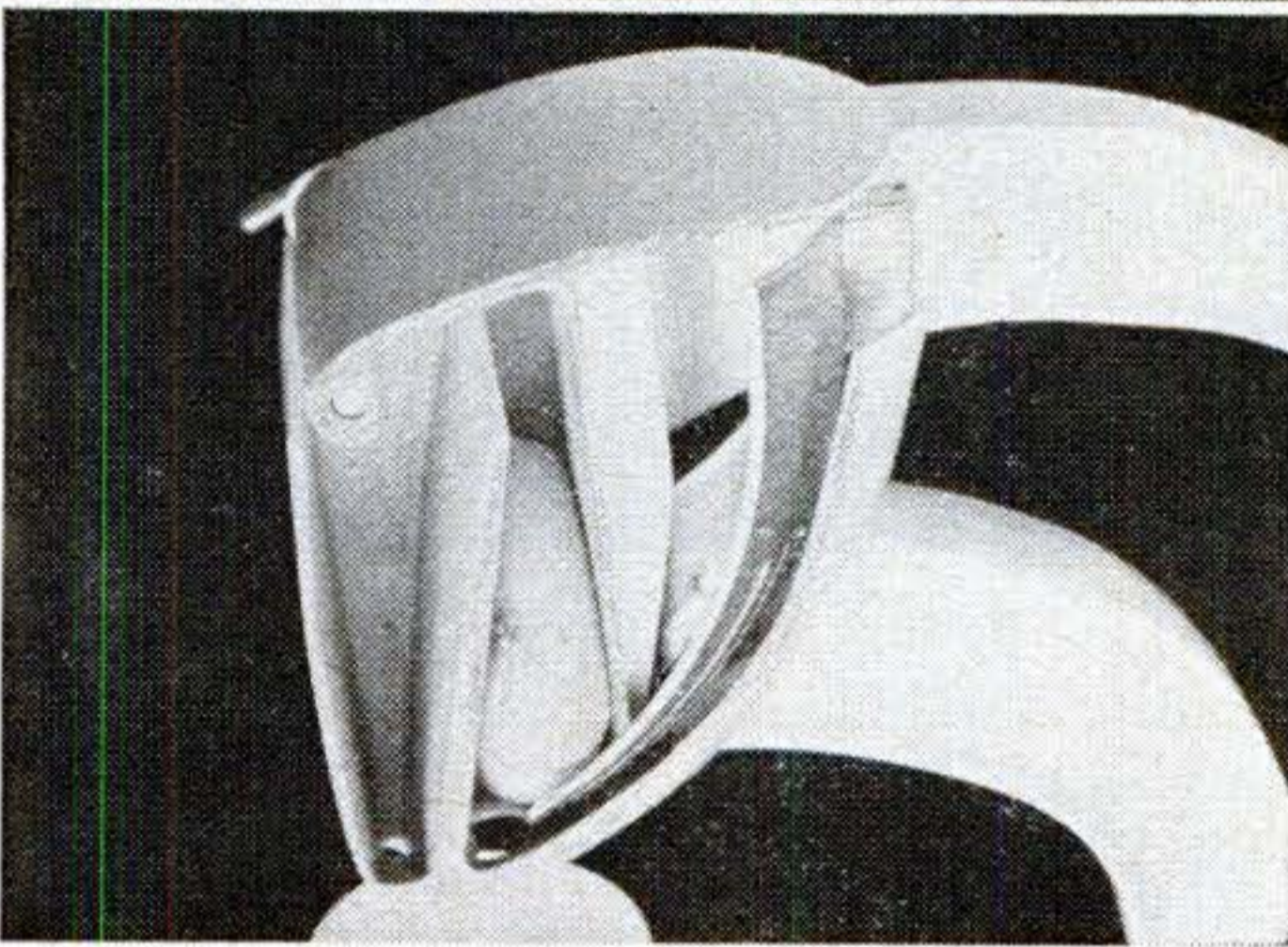

### Juicer Squeezes Whole Fruit.

You can skip a knife and cutting board with this juicer. Press down on the arm and it cuts and squeezes a whole orange or lemon at a time. Knives in the bowl cut the fruit as it is compressed. It's made by the Van Dusen Engineering Co., Escondido, Calif., and priced at about \$9.

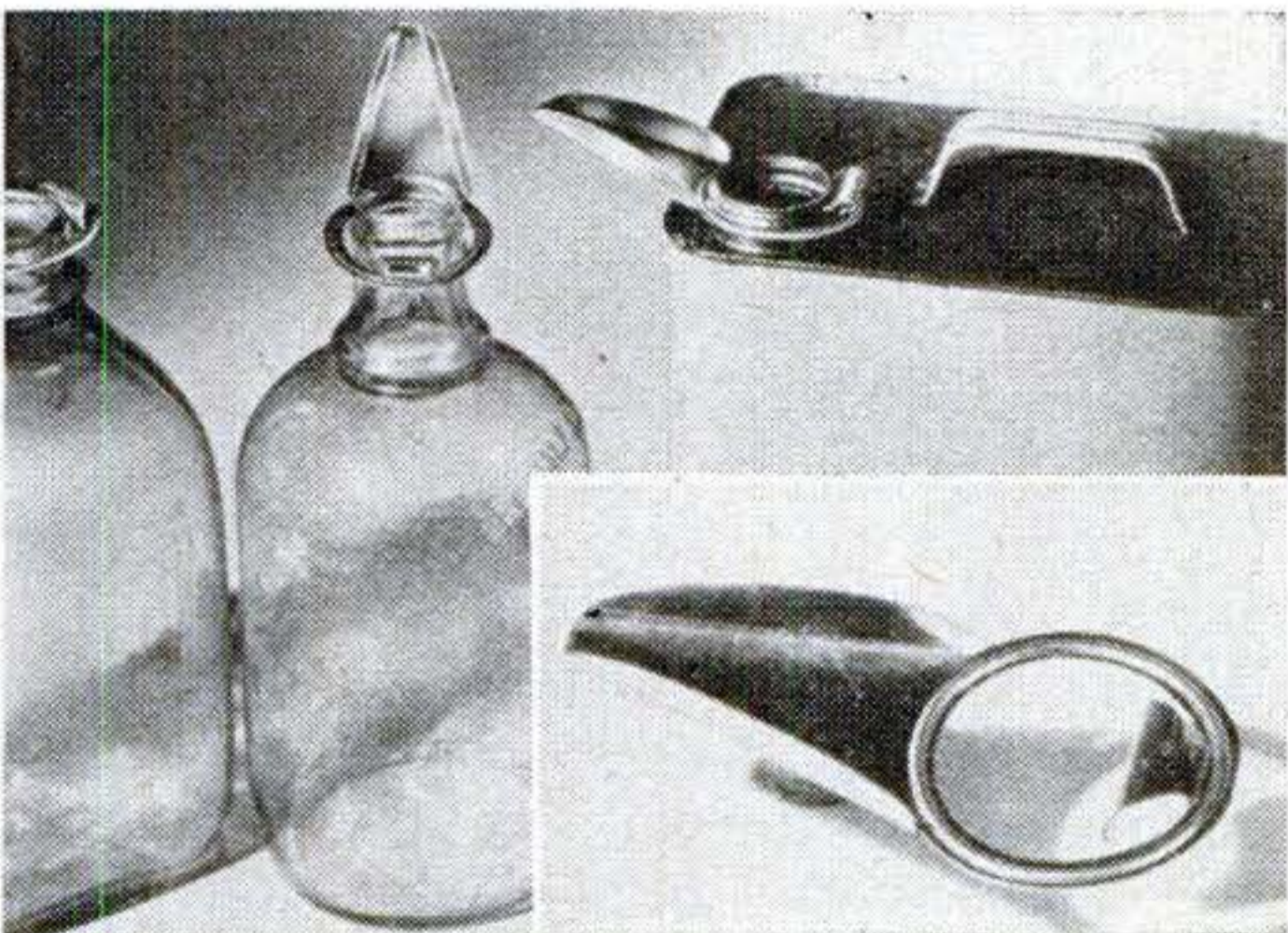

**Pouring Spout Snaps On.** Adjustable to openings from 1" to 1 1/4" in diameter, this metal pouring spout fits most glass and metal containers, including many milk bottles. When used on bottles, the spout is tilted upwards at a sharp angle. It also may be used on faucets. The maker is Abbott Industries Co., New York City.

## PROTECT SCREEN DOORS

... beautify them too!

### FITS-ALL Adjustable Screen Door Grille

This handsome grille dresses up your door and braces it, too! Strong and sturdy; silvery satin finish will not rust or tarnish. Completely adjustable for windows or doors. Comes complete with screws. Can be installed by anyone in minutes. Also makes perfect window guard.

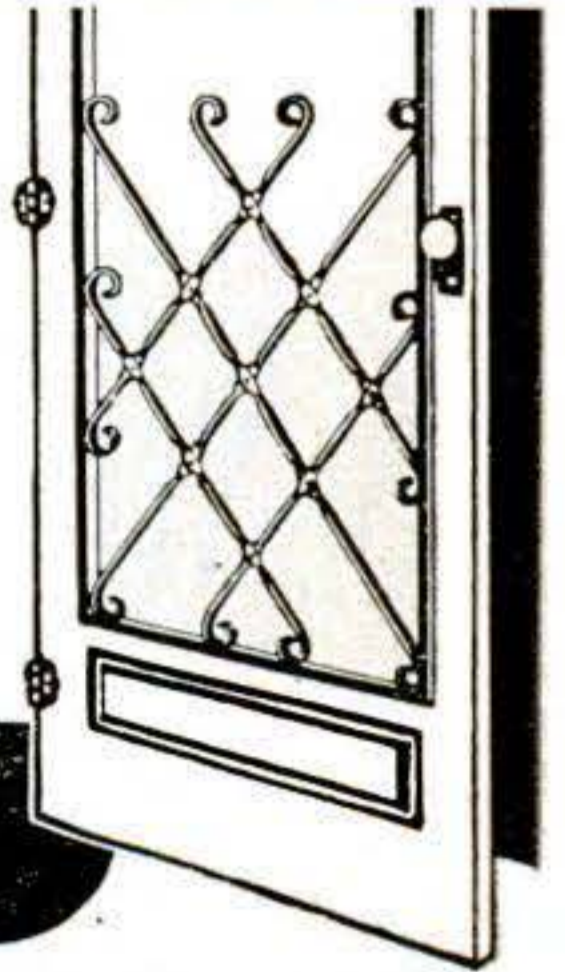

NO CUTTING OR FITTING  
Easily Installed

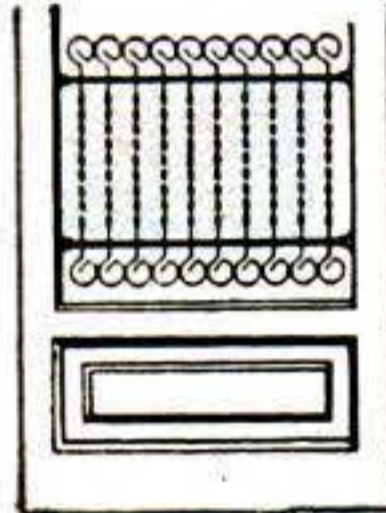

### Nu-WAY Screen Door Grille

This equally sturdy, attractive style comes in black, flexible enamel finish. Adjustable to nearly all doors and windows. Makes perfect window guard, too! Furnished fully assembled, ready to install.

MACKLANBURG-DUNCAN CO.  
OKLAHOMA CITY 1, OKLA.



BUY AT YOUR LOCAL HARDWARE STORE, BUILDING SUPPLY DEALER OR LUMBER YARD.

## NEW BOOK FOR OUTBOARD SKIPPERS

• 64 picture-packed pages • ONLY 10¢  
Written by experts • Tells how to have more fun with your outboard!



**EVERYTHING** you need to know to get the most out of your outboard is told in this compact handbook. Neat Nautical Tricks, How To Buy And Care For a Boat And Motor, Trouble Shooting Made Easy, Navigation, Safety Afloat, Nautical Law, many other topics! Write for your copy now. Send name, address, and 10¢ to: Dept. PS-7, Scott-Atwater Mfg. Co., Inc., Minneapolis 13, Minn.

## ARC WELDING FOR PROFIT OR PLEASURE

60 LBS. OF READY MADE PARTS

Only \$24.95

### BUILD YOUR OWN HEAVY DUTY WELDER

SAVE BUY ONLY NECESSARY PARTS

All parts Ready-Made and easy to assemble. You can do all around welding on steel, cast iron and other metals after only a few hours practice. Illustrated instruction manual included. Sold on 30 Day Money-Back Guarantee!

FREE: Write today for fully illustrated Pamphlet S-6.

ATOMIC ARC WELDER CO.  
S-8-1039 So. 39th St., OMAHA, NEBR.

Gives 100% penetration. Welds are stronger than original metal. Operates on 110 or 220 AC

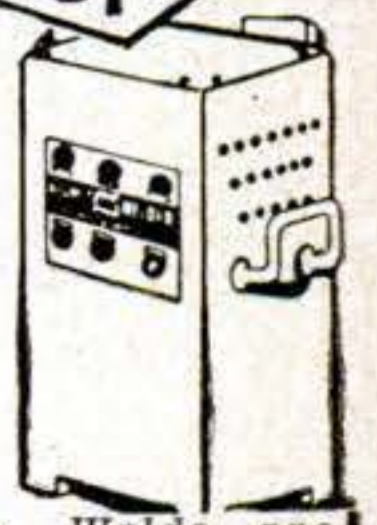

TO: Reader  
FROM: Editor

## PS Story Grows Into Book



FOR more than 20 years, Dr. Donald H. Menzel, professor of astrophysics at Harvard, has been a friend and occasional contributor to POPULAR SCIENCE. One of his articles, which PS published under the title "Celestial Yardstick" in January 1943, told how the distance from the earth to the sun was measured.

That same year, Dr. Menzel was called to active duty as a Commander in the U. S. Navy. Censorship then prevented him from reporting many further advances in men's knowledge of the sun. But now, secrecy about solar research is no longer necessary; Dr. Menzel has resumed his research, teaching, and avocation of popular-science writing; and that 1943 article has grown into a book.

It is called *Our Sun* and has been published by Doubleday & Co. as another volume in a series of "Harvard Books on Astronomy." The first chapter is a revised and expanded version of the article PS published. The book is full of facts which you may enjoy pondering while basking in the sun's rays this summer. For example:

- Every square inch of the sun's surface shines with the intensity of 300,000 candles.
- Every second, the sun converts about 4,000,000 tons of matter—the equivalent of 60 ships as big as the *Queen Mary*—into energy enough to supply the world with power for 2,000,000 years.
- The sun's equator revolves faster than other regions, completing the circuit in

about two days less time than a point at a latitude of 40 degrees.

- A single sunspot, in April 1947, was so big it could have contained 100 earths.

Gee-whizzy facts like these, however, are merely the spice in Dr. Menzel's book. He is mainly interested in telling how such information about a body 93,005,000 miles away was acquired, and how solar research is contributing to knowledge of radio, weather, and even atomic phenomena.

Harvard professors of mathematics, chemistry, and other subjects frequently refer reporters who pester them with questions about what they are doing to Drs. Menzel, Shapley, or Bok over at the observatory, and POPULAR SCIENCE writers often have been amazed how much the astronomers could help them when they were writing about other sciences. This book shows why. The men studying the sun and stars have to know a great deal about many sciences.

Hence, they are, in a sense, "general scientists," who often can explain new developments better than specialists in narrower fields. Dr. Menzel is one of the best of these "explainers," and we're seizing this opportunity to congratulate him on having written a book about the sun which should interest almost everybody. That he has done so comes as no surprise to PS editors.

*Volta Torrey*



What's **NEW**  
in Batteries?

# AUTO-LITE **Sta-ful** BATTERY...needs water only 3 times a year\*

A revolutionary new development, the Auto-Lite "Sta-ful" Battery, protects you against a major cause of battery failure . . . damage to plates due to liquid loss. This new "Sta-ful" Battery design permits a liquid reservoir with 3 times the capacity of ordinary batteries . . . keeps plates fully covered and active months longer in normal car use.

In addition, "Sta-ful" has Fibre-glass mats to hold the power-producing material in the plates for longer battery life. To get more for your battery dollars, replace with an Auto-Lite "Sta-ful". Money cannot buy a better battery.

AUTO-LITE BATTERY CORPORATION  
Toledo 1 Ohio

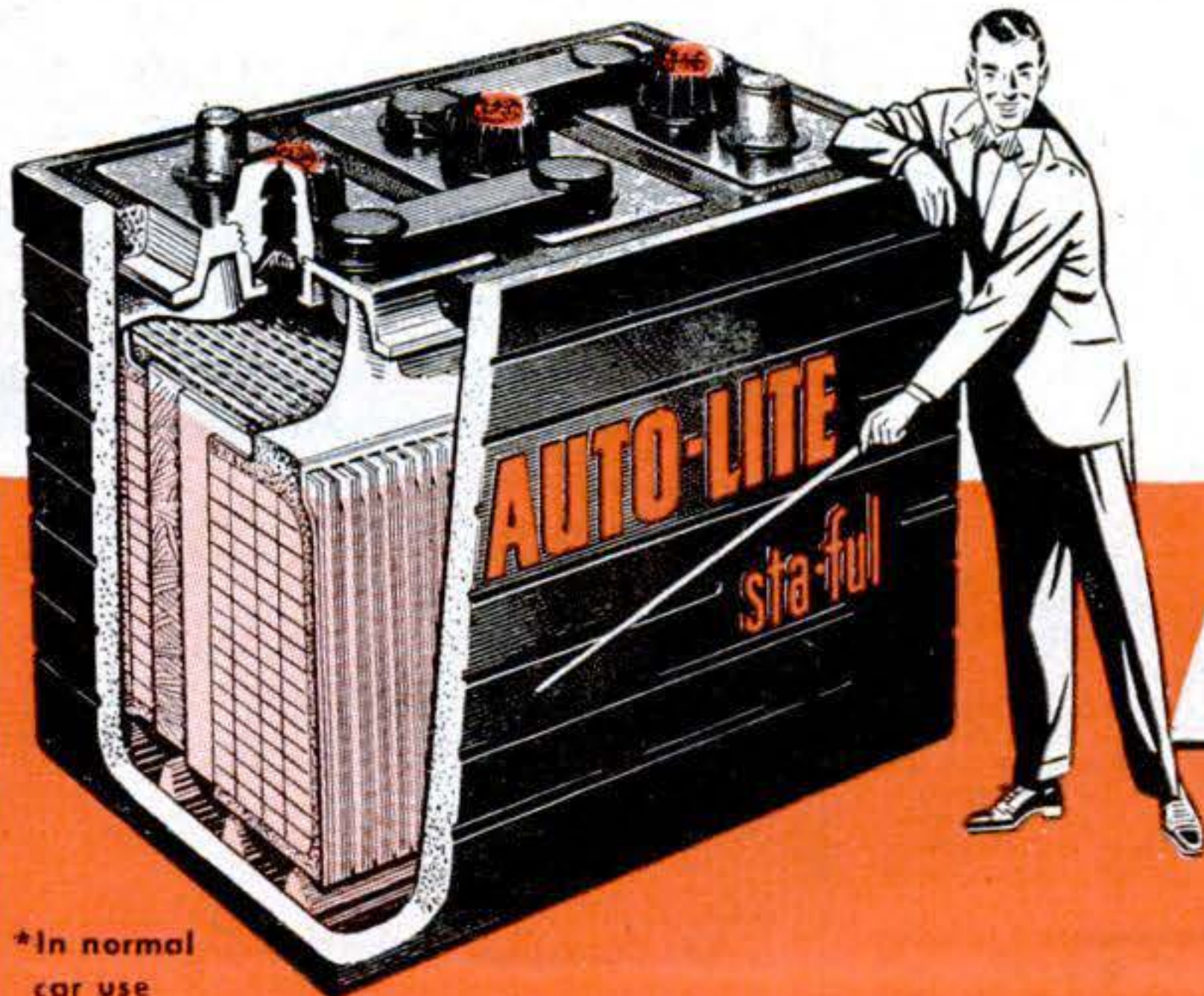

\*In normal car use

Because of a unique construction, the new Auto-Lite "Sta-ful" Battery holds more than 3 times the liquid reserve of ordinary batteries.

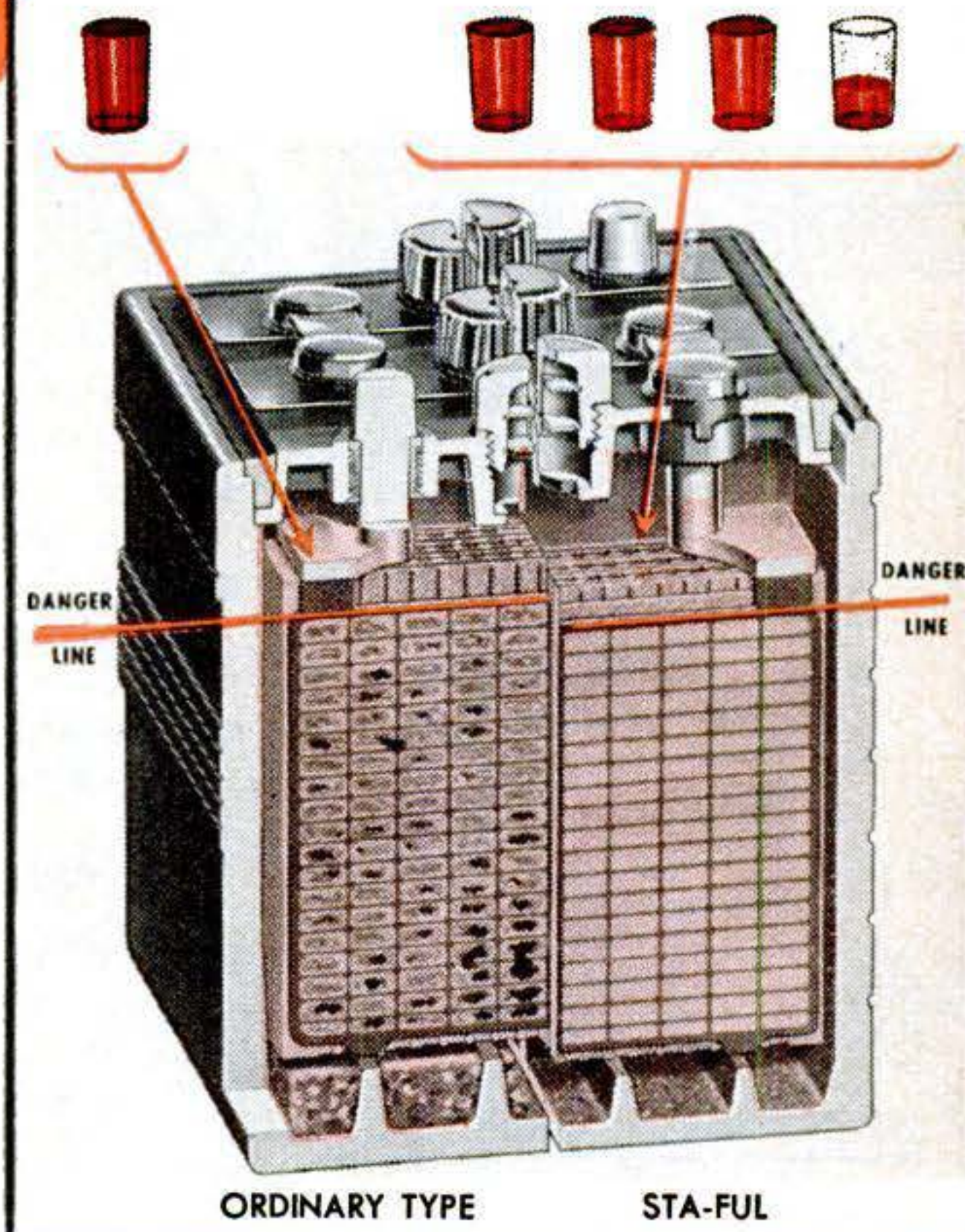

Note how the protective Fibre-glass mat retains the power-producing material in the positive plate while ordinary battery plates shed the active material until it fills the sediment well.

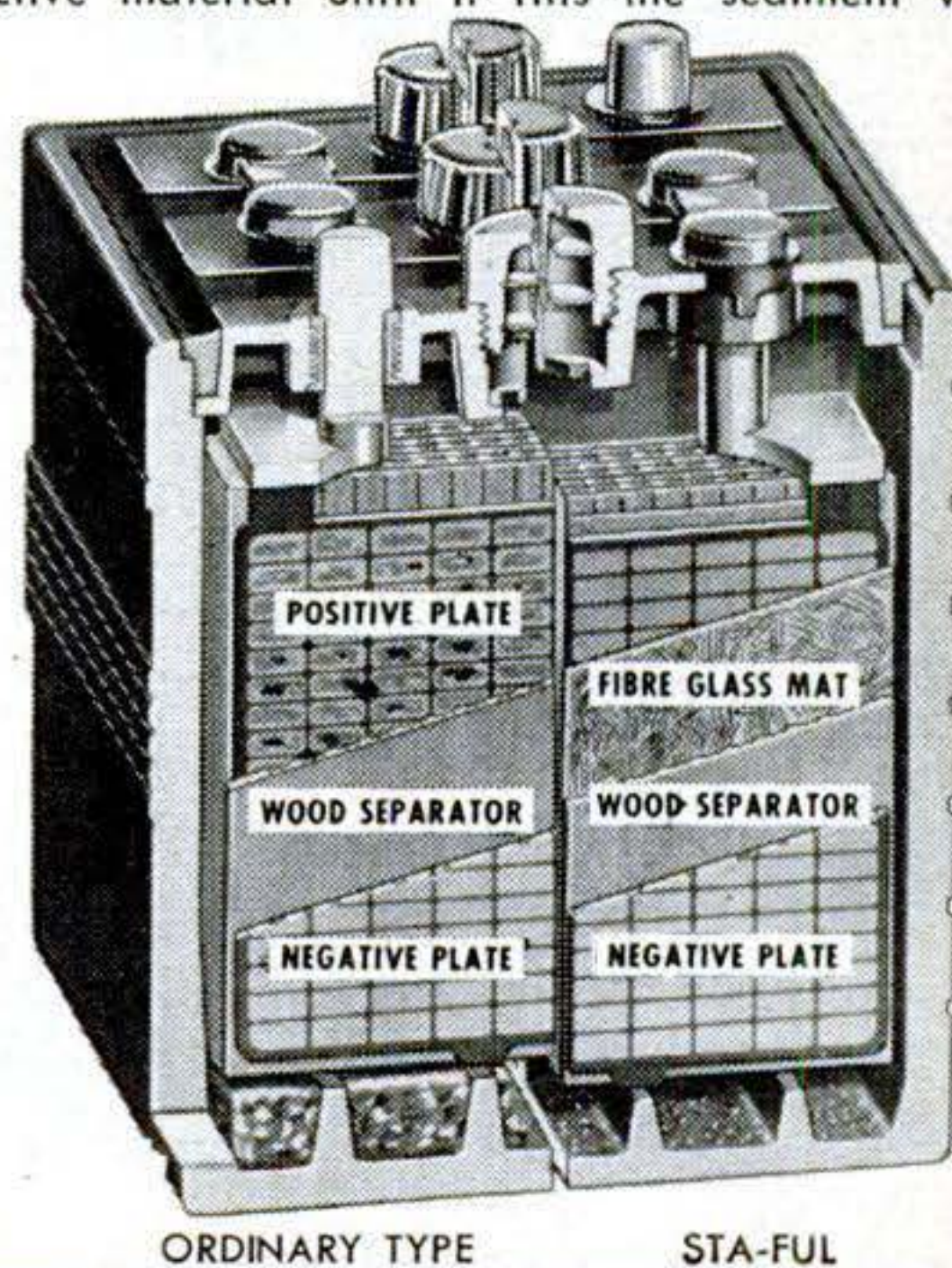

# AUTO-LITE Sta-ful BATTERIES

# Amazing New **LOW PRICED** Electric Sprayer For Home Use **Makes Painting Easy!**

**SAVE MONEY, TIME, WORK! GET PROFESSIONAL SPRAYING RESULTS!**

- Paint Floors, Ceilings, Walls, Woodwork, Furniture, Toys
- Enamel Auto Bodies and Fenders, Storm Windows, Screens
- Varnish Table Tops, Linoleum
- Spray Moth-Proofing Liquids in Closets and Attics
- Spray Flit or Other Insect and Pest Solutions
- Spray Insecticides on Flowers, Plants, Shrubs
- USE VIBRO SPRAYER for EVERY Job of Painting and Spraying in and Around the Home
- Self-Contained Unit—No Motor, No Compressor, Produces Equivalent of 40 lbs. Pressure!



**HOUSEHOLD ITEMS**—It's easy to paint clothes hampers, kitchen chairs, shelving, partitions, slat fences, metal trash drums, etc., with Vibro-Sprayer!



**OUTDOOR FURNITURE**—Just the thing for painting rustic chairs, reed furniture, brickwork, boats, wagons, and other equipment!



**ROUGH SURFACES**—Makes quick work of painting concrete, rough wood or window screening!



**INSECT CONTROL**—Efficiently aids extermination of roaches, waterbugs, flies, mosquitoes and other pests. Fine for mothproofing clothes!



**AUTOMOBILE MAINTENANCE**—Provides the answer to quick, smooth touch-up work on fenders and body. Sprays light oils for under-chassis lubrication.



**GARDEN PEST CONTROL**—Ideal for spraying insecticides and fungicides on flowers, plants and shrubs.

**JUST PLUG IN—  
PULL THE TRIGGER  
& PAINT OR SPRAY!**

## TRY IT 10 DAYS FREE IN YOUR OWN HOME!

Yes, now you can do a professional painting job on everything in and around your house with this amazing, brand new, self-contained electric paint sprayer. Just fill the big, 25-ounce capacity, interchangeable mason jar with any kind of ordinary oil-base liquid—lacquer, glossy paint, enamel, varnish, shellac, residual type insecticides, light oils, moth sprays, disinfectants, etc. Then plug the 8-ft. insulated cord into any 110-volt A.C. household outlet—pull the trigger—and get satin-smooth, professional results every time!

### SAVE MONEY, TIME AND WORK

VIBRO-SPRAYER paints twice as fast as a brush, saves strain, fatigue, backache and sore muscles. Paint goes on **FASTER, SMOOTHER** and far more **EASILY** than with a brush. Adjustable spray control allows wide or narrow spray, thick or fine, as the job requires. Spray radius is always under complete control. VIBRO-SPRAYER cannot clog or drip—and is amazingly simple to clean. What's more, VIBRO-SPRAYER is **SAFE!** Will never break in use as there is **NO** pressure in the jar.

### COSTS LESS THAN A GOOD BRUSH

Not only does VIBRO-SPRAYER paint faster, smoother, more easily than a good brush, but it actually costs less! And because VIBRO-SPRAYER applies paint more evenly and uniformly, you use **LESS PAINT**—save the cost of the sprayer in just a few months! In addition, VIBRO-SPRAYER shoots a fine, even spray into deep crevices where ordinary paint brushes can't reach, makes short work of rough or pebbled surfaces that are so difficult to brush.

### MADE BY A FAMOUS COMPANY

VIBRO-SPRAYER is manufactured by the world-famous Burgess Battery Company, makers of popular auto and flashlight batteries. Every VIBRO-SPRAYER is guaranteed by the manufacturer to be free of mechanical defects. In addition, we guarantee that VIBRO-SPRAYER will give you exactly the professional, fast, labor and money saving results you desire, or you may return your sprayer within 10 days for full purchase price refund. You get **FULL PROTECTION** under this **DOUBLE GUARANTEE!**

### SEND NO MONEY

Send only the coupon, now. When your VIBRO-SPRAYER arrives, pay the postman only \$12.95 plus small delivery charge—or enclose full payment now and we pay all delivery charges. In either case you are fully protected by the manufacturer's guarantee of mechanical perfection, and our guarantee of complete satisfaction, or return your VIBRO-SPRAYER within 10 days for full purchase price refund. Send the coupon **AT ONCE!**

**FOSTER PRODUCTS, INC.**  
179 Wooster St., New York 12, N.Y.

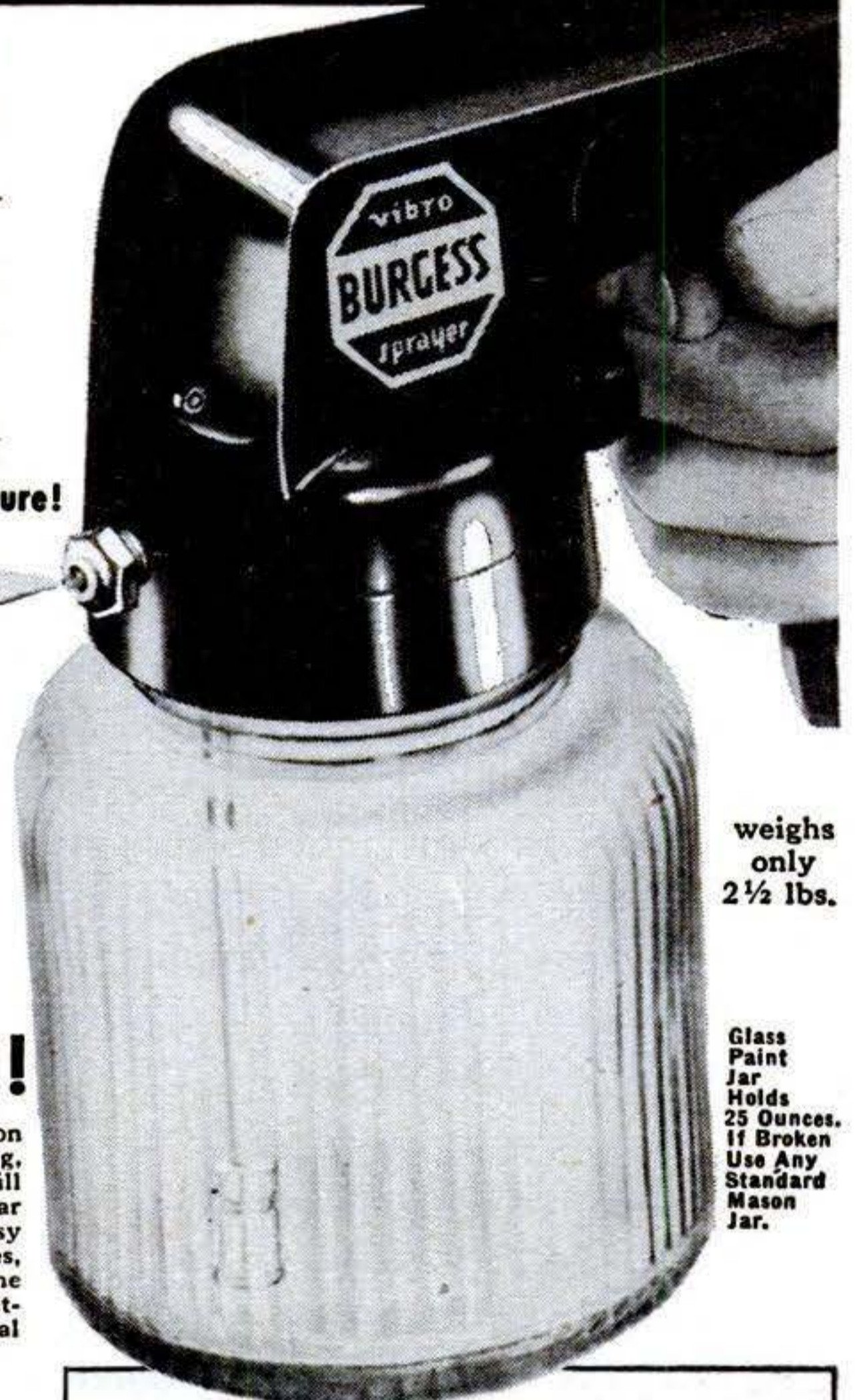

weighs only 2 1/2 lbs.

Glass Paint Jar Holds 25 Ounces. If Broken Use Any Standard Mason Jar.

**Comes Complete—All Ready to Use—No Extras to Buy!**

VIBRO-SPRAYER is completely self-contained—the **ONLY** unit of its kind on the market. Nothing else to buy, no hose, compressor, motor, tank, etc. Just pour liquid into paint jar, (25 ounce capacity) plug in and press the trigger! Size 8 3/4" high, 6 1/2" deep, 4" wide. Works on activated piston and suction principle. Built like professional equipment—does the work of a \$100.00 unit producing 40 lbs. pressure!

**ONLY \$12.95**

**FREE TRIAL COUPON—MAIL NOW!**

**FOSTER PRODUCTS, INC., Dept. SG-169**  
179 Wooster St., New York 12, N. Y.

Please send a VIBRO-SPRAYER for 10 days no-risk examination. On arrival I will pay the postman only \$12.95 plus small delivery and handling charge.

Check here if you enclose \$12.95 now. We pay all delivery and handling charges.

Name .....

Address .....

City..... Zone..... State.....

**NOTE:** Whether you order C.O.D., or prepaid, you receive the full protection of our **GUARANTEE** of satisfaction or money back!

**NEW for  
1950**

# MIDWEST

Celebrates its 30th YEAR of FACTORY-TO-YOU Selling with a Sensationally NEW 1950 LINE of

# TELEVISION

CONSOLES and Complete CHASSIS

**New GIANT 16" PICTURE TUBE**

Here is Television at its finest! . . . brought to you by Midwest, for 30 years a leader in the field of radio and electronics. Immense 151-square-inch screen on new 16" metal-glass tube . . . clear, steady, bright pictures . . . Synchronized sound and picture that a child can tune in perfectly . . . Highest quality FM sound . . . Big 12" Electro-Dynamic Panasonic Speaker. Available in beautiful Consoles or in complete chassis as illustrated (not a kit, but a complete Television receiver ready to plug in and play) to place in your own cabinet. And you can buy Midwest Television at Low Factory Prices, with Low Down Payment and Long Easy Terms — and on 30 Days Trial!

**NEW LOW**  
Down Payment  
**Long EASY TERMS**

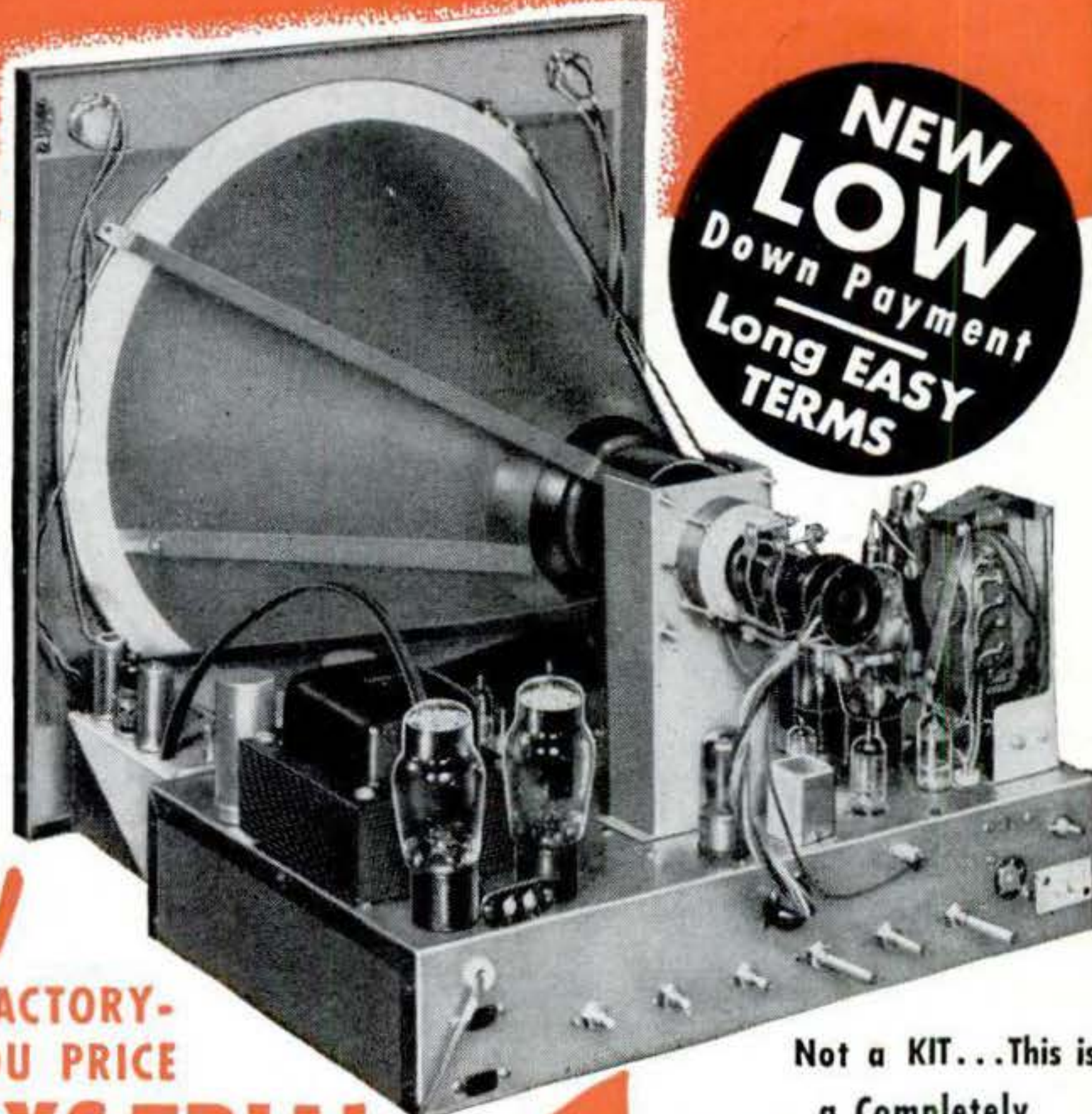

**LOW**  
FACTORY-TO-YOU PRICE

**30 DAYS TRIAL**

Not a KIT... This is a Completely assembled Receiver

... also a Magnificent Line of NEW 1950 **MIDWEST RADIOS** featuring the latest Improved FM Circuit and the New 3-SPEED RECORD PLAYER

SEND FOR **FREE** 32-Page Full Color CATALOG



Powerful new 1950 Series 16 and Series 12 AM-FM Radio in complete chassis. Also beautiful new Console models including the magnificent Symphony Grand Radio-Phonograph with latest FM circuit and new 3-Speed Automatic Record Player. New portable and Table Models also available.



**BUY DIRECT FROM THE MIDWEST FACTORY and SAVE!**

**MIDWEST RADIO & TELEVISION CORP.**

Dept. X241, 909 Broadway, Cincinnati 2, Ohio

Write in Name and Address (Please Print) on Coupon or 1c Postcard.

**MIDWEST RADIO & TELEVISION CORP.**  
Dept. X241, 909 Broadway, Cincinnati 2, Ohio  
Please send me your new FREE 1950 Catalog.

NAME \_\_\_\_\_  
ADDRESS \_\_\_\_\_  
CITY \_\_\_\_\_ ZONE \_\_\_\_\_ STATE \_\_\_\_\_



R. J. Reynolds  
Tobacco Co.,  
Winston-Salem,  
N. C.

# 30-Day Mildness Test wins thousands of smokers to Camels!



**PATRICIA MORISON**, musical comedy star: "I made the test. I smoked Camels for 30 days. Camels for me!"



**FOREMAN Merritt C. Humeston**: "30 days? I've given Camels a 10-year test. I *know* how mild they are!"



**HOUSEWIFE Mrs. D. Reilly**: "I've tried many brands. There's nothing like Camels for taste and mildness!"



**JOHNNY VANDER MEER**, pitcher: "I've smoked Camels since I was a rookie. Camel flavor bats 1,000 with me!"



**"THE 30-DAY TEST** was fun! I learned how truly mild a cigarette can be."—**Cecelia Garland**, bank teller.



**R. M. ELLIOT**, merchandiser: "Camels are a year 'round hit with me. That rich Camel flavor suits me to a 'T'."



**"I ENJOYED** the test! It led me to the mildest, best-tasting cigarette I have ever smoked."—**Marylee Hahn**, student.



**VETERAN** diver, Pete Desjardins: "I'd *swim* a mile for a Camel! Their full flavor doesn't tire my taste!"



**COLORATURA Virginia MacWatters**: "I'm glad I made the test! I found the answer to mildness — Camel!"



**"I SMOKE** up to 2 packs a day. Camels are mild and don't tire my taste."—**Lew Worsham**, professional golfer.



**PHOTO. ASS'T., Michael Pop**: "It's great to find a mild cigarette with so much flavor. The test won me to Camels!"

In a recent test of hundreds of people who smoked only Camels for 30 Days, noted throat specialists, making weekly examinations, reported

**Not one single case of throat irritation due to smoking CAMELS!**

*Make the Camel 30-day test in your "T-Zone"*

**TASTE**

**THROAT**

● The doctors' findings (left) speak for themselves. But test Camels in your "T-Zone." See if you don't agree... Camels are the mildest, best-tasting cigarette you've ever smoked.