

POPULAR SCIENCE

MONTHLY
MECHANICS AND HANDICRAFT



America's Fastest Liner
PAGE 10

May 25¢



**How
Belanger
Builds
Winners** PAGE 88

1872 · 80th Anniversary · 1952

Here's the MONTA MOWER Story



**TRIMS
AS IT CUTS**

The MontaMower story is about the thousands upon thousands of people who are mowing their lawns in less time than they ever did before . . . with scarcely half the effort.

With a MontaMower you can mow and trim your lawn in one easy operation . . . mow right up to walls, trees, fences . . . under foliage, around close quarter borders . . . with practically no grass left to trim by hand.

Smoothly cut through grass, dandelions, spike grass and tall lawn weeds (including those that always popped back up).

Mow up, down, or across your terraces without scalping the crown . . . anyone can operate it easily and efficiently.

Unsolicited testimonials from thousands of satisfied owners everywhere have convinced us that, in your own hands — on your own lawn, under most conditions, the fine low priced MontaMower will prove itself far superior to any other hand operated mower. **TRY IT on your own lawn . . . ON APPROVAL** with our **WRITTEN GUARANTEE!** Write today!

HERE'S HOW IT WORKS FOR YOU

Eight pairs of self sharpening, precision made and fitted, tool-steel cutting disks revolving toward each other gather the grass and cut it cleanly at the intersection of the disks. Easily and quickly adjustable to cutting height!

TRY it on YOUR OWN LAWN . . . ON APPROVAL!

Use Coupon Below

TRIMS CLOSE
TO WALLS - TREES
SHRUBS - FENCES

Weights Only 8 1/4 Lb.
CUTS A FULL STANDARD 16" SWATH

SO DESIGNED,
IT CANNOT SCALP
TERRACE CROWN

CUTS TALL
LAWN WEEDS
WITH GRASS

SOLD DIRECT ONLY NO AGENTS
NO DEALERS

MontaMower Distributing Co. Sales and General Offices
P.S. 25 KEELER BLDG., GRAND RAPIDS 2, MICHIGAN

Gentlemen: Without obligation, kindly send me completely illustrated, descriptive literature, price, guarantee information, and full details of your amazing "Try it on your lawn" Approval Offer.

NAME _____

ADDRESS _____

MAIL THIS COUPON TODAY —
PASTE ON A POST CARD
(if possible, for quickest reply.)

FREE

More FUN with a Camera

There's no thrill like seeing your pictures
60 seconds after you shoot them

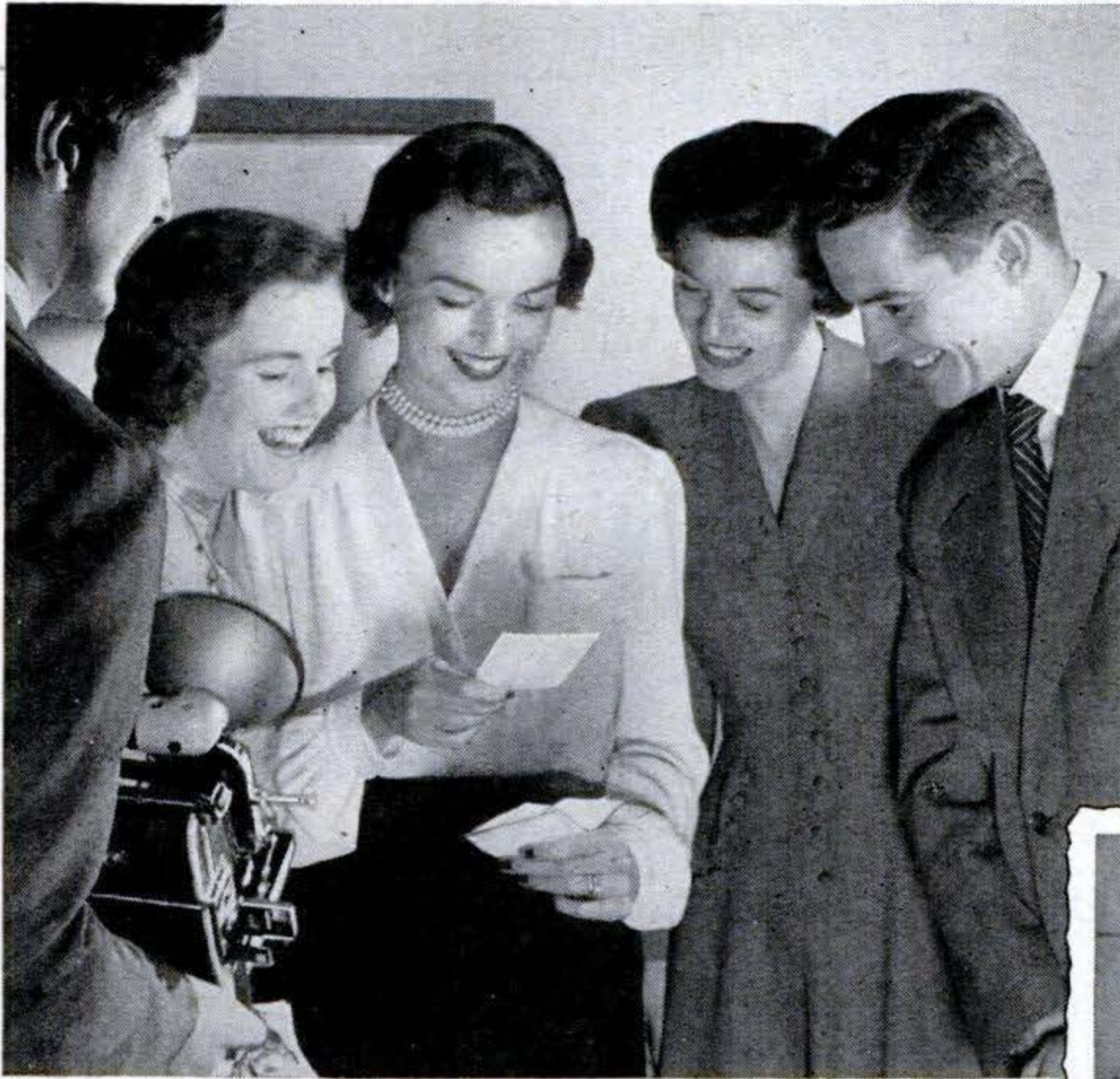

You're the life of the party with a Polaroid Land* Camera. You snap the shutter . . . a minute later get the finished picture for all to enjoy then and there! Big, clear, lasting prints (3¼ x 4¼).

Just drop the film in your Polaroid picture-in-a-minute camera and you're ready for a great new experience in photography. Almost everything is automatic. No tanks . . . no liquids . . . no delays. The whole photographic process is at your fingertips.

Picture-in-a-minute photography gives you an entirely new opportunity to use your ingenuity. You can make better pictures because you see your results at once and vary lighting, pose and composition as you go along.

Think of the fun! You can enclose in your letters snapshots that are still news.



*Named for its inventor, Dr. Edwin H. Land Polaroid ®

POLAROID Land CAMERA
"60 seconds from snap to print"

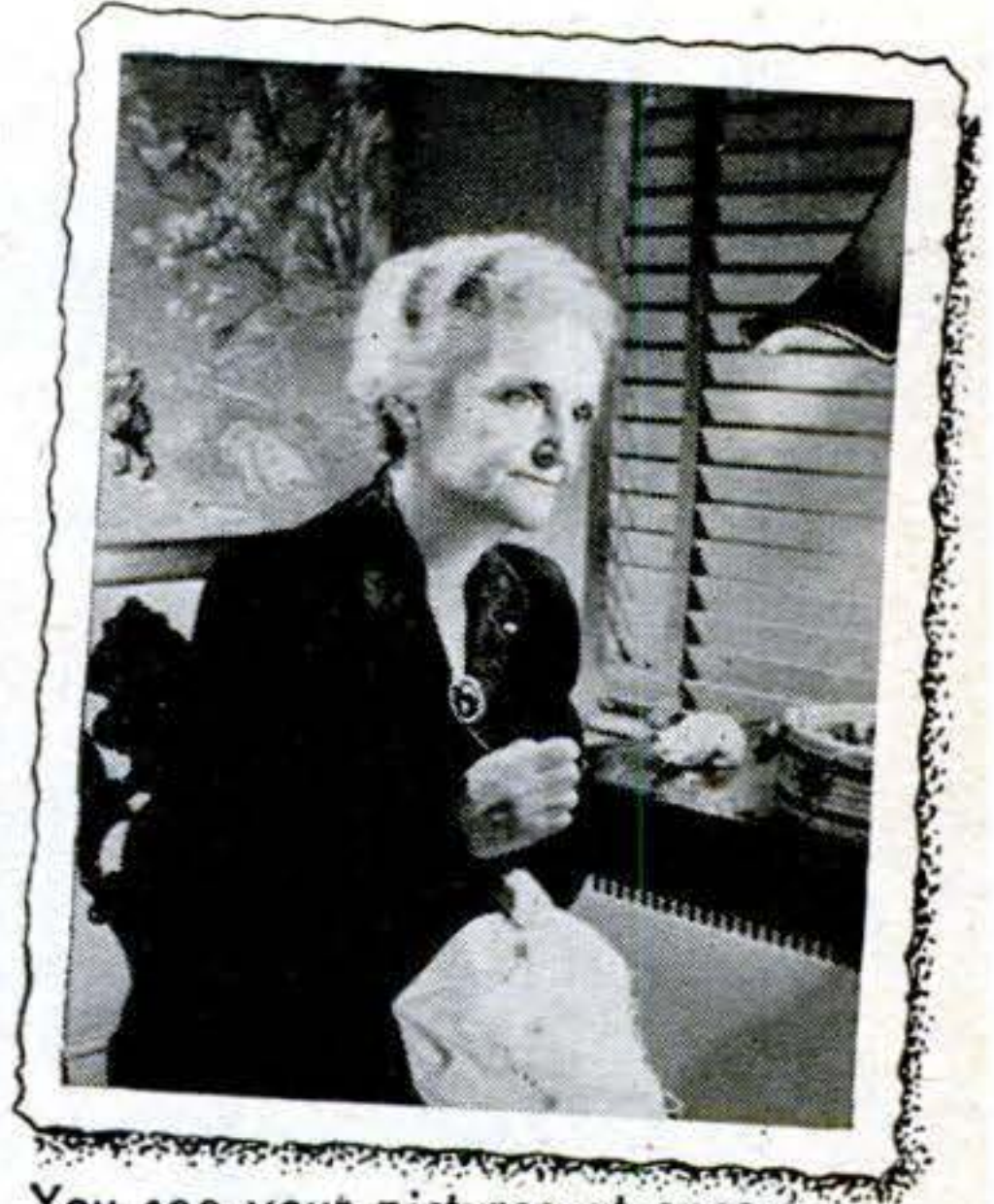

You see your pictures at once,
can improve pose and lighting.



You are always sure of
once-in-a-lifetime shots.



Weekend or vacation pictures
ready to show immediately.

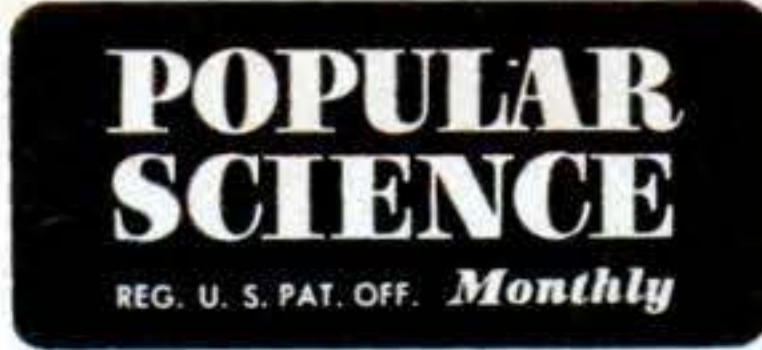

VOLTA TORREY, EDITOR • Howard Allaway, MANAGING EDITOR
Howard C. Jensen, ART EDITOR • Frank Rowsome Jr., ASSISTANT MANAGING EDITOR

SENIOR EDITORS: Harry Walton (Mechanics & Handicraft), Hartley E. Howe (Features), Martin Mann (Copy).

ART: Harry Samuels (Director), Herbert Anthony, Rolf O. Erickson, Eric Karminski Jr., Richard Meyer, Frances Cooper Daniels.

ASSOCIATE EDITORS: Alden P. Armagnac, Devon Francis, Sheldon M. Gallager, Kendall W. Goodwyn, Robert Gorman, Wesley S. Griswold, Herbert O. Johansen, Herbert R. Pfister, Denis Sneigr, Robert P. Stevenson, Ruth Westphal, Andrew R. Boone (Los Angeles).

PHOTOGRAPHY: W. W. Morris (Director), Hubert Luckett, Orlando Guerra.

EDITORIAL ASSISTANTS: Julia C. Bove, Carol Ennis, Rita K. Gilbert, Georgette Sparks, Harriet Trowbridge.

*This Month's
Big Features:*



His face deeply creased from tight-fitting headgear, this frogman is ready to risk his life on an Underwater Demolition Team in daring shoreline raids. For a vivid account of a frogman's toughening-up process, see page 135.

What Will They Think of Next?..... 81

How Belanger Builds Winners..... 88

DC Battles AC to Pull the Heavy Loads..... 96

Soapbox Racers Hit the Big Time.....102

America's New Liner Challenges Queens....108

Your Shape Shapes Your Life.....116

Down the Alaska Highway on a Scooter.....122

Shaw Drives the New Kaiser.....140

Flying Saucers Are Old Stuff.....145

How We Fight with Words.....148

Are Your Gutters Doing Their Job?.....161

More Put-Puts Take Over Yard Chores.....168

Plastic Sports-Car Bodies in Kits.....172

Gus Diagnoses the Flat-Tire Case.....178

How You Can Use Chalkboard Paints.....184

Installing Inboard Power in a Rowboat.....196

Putting in an Electric Outlet Yourself.....210

How I Drilled a Well: Part 2.....214

(More features and departments are listed on page 4.)

Godfrey Hammond, PUBLISHER • Stephen P. Glennon, ADVERTISING DIRECTOR

ADVERTISING OFFICES: NEW YORK — 353 Fourth Ave.; CHICAGO—360 North Michigan Ave.; DETROIT—820 Book Bldg.; SAN FRANCISCO—681 Market St.; CLEVELAND—328 Citizens Bldg.; LOS ANGELES—1052 West 6th St.
EDITORIAL OFFICES: 353 Fourth Avenue, New York 10, N. Y.

Published monthly at 353 Fourth Avenue, New York 10, N. Y., by Popular Science Publishing Co., Inc., Godfrey Hammond, President and Treasurer; R. C. Wilson, Stephen P. Glennon, Vice-Presidents; F. W. Briggs, Secretary. Entered as second-class matter Dec. 28, 1918, re-entered as second-class matter July 26, 1948, at the Post Office in New York, N. Y., under the act of March 3, 1879; additional entry as second-class matter at Dayton, Ohio. Entered as second-class matter at the Post Office Department, Canada. Printed in U.S.A. Copyright, 1952, by Popular Science Publishing Co., Inc. All rights reserved in the United States, Great Britain, and in all countries participating in the International Copyright Convention and Pan-American Copyright Convention. Yearly subscriptions to United States, its possessions and Canada, \$3.00 (2 years, \$5.50; 3 years, \$7.50); foreign countries \$1 per year extra. Four weeks' notice is needed to change a subscriber's address. Please give both old and new addresses, including postal zone numbers.

New oil economy... lasting power

for
thousands
of **EXTRA**
miles!



SOLID CHROME PROTECTS THESE WEARING SURFACES

Two interchangeable expander springs with each oil ring—NORMAL PRESSURE spring for rebored and slightly worn cylinders, HiPRESSURE spring for badly worn engines and known oil pumpers.

Perfect Circle's 2 in 1 chrome piston ring set



Your car and your money . . . both will go farther with a set of 2-in-1 Chrome Piston Rings. For the 2-in-1 Chrome Set *more than doubles the life* of cylinders, pistons and rings!

Positive oil control is assured because *only* the 2-in-1 Set provides two interchangeable expander springs with each oil ring. For the first time, mechanics can select the spring pressure that's *right* for your engine. And with 2-in-1 you'll enjoy smooth, instantly responsive power, right from the start with no tedious break-in period.

If your car has lost its pep . . . if it's wasting gas and oil . . . give it a whole new life of sustained power and oil economy with Perfect Circle's 2-in-1 Chrome Set! Ask your Doctor of Motors, your reliable mechanic, to install it in your engine. He'll respect your judgment!

Perfect Circle
PISTON RINGS
The Standard of Comparison

Operate YOUR OWN Business

**EASY TO LEARN
QUICKLY ESTABLISHED**



Gross \$5 Hourly!

If now employed
you can profitably operate
part time while building a
full time business with serv-
icemen.

Clean and Mothproof Rugs and Upholstery

Increase your income . . . with a business of YOUR OWN. We'll help finance your dealership with this world-wide 22 YEAR OLD organization.

Alert dealers can average \$5 hourly gross profit on service they render and \$3 on EACH serviceman at National Price Guide charges.

If you are honest, dependable and willing to work, we can help you establish a business of your own. You use **proven** successful methods of long established **Duraclean** Dealers. Your services are recommended by America's foremost furniture and department stores.

DURACLEAN safely cleans by absorption! Aerated foam absorbs the dirt holding it in suspension above the surface until removed. No harsh, machine scrubbing. No soaking or shrinkage. Dirt, grease and many unsightly spots vanish as if by magic. Wool fibers come to life . . . matted pile rises . . . colors revive. Upholstery and floor covering look newer, last longer. Service rendered right in the home. No inconvenience to customers.

DURAPROOF is another year 'round service rendered right in the home. Not only kills moths and carpet beetles, but makes materials resistant to both. **Duraproof** is the only mothproof service backed by an International Money Back, 4 YEAR WARRANTY.

Upholstery and floor coverings are serviced "in the home," office or public buildings. No experience needed. Almost every building houses a potential customer needing one or both these modern services. Even auto dealers buy your service to revive upholstery in used cars.

Duraclean dealers sales increased during last war due to calls from customers of other cleaners who were unable to give service because short of help. This is a year-round "war-proof" business.

NATIONALLY ADVERTISED in McCall's, House Beautiful, Ladies' Home Journal, Better Homes & Gardens, etc. See Duraclean Dealers of America 1/4 page ad in the May issue of Living Magazine.

Portable equipment . . . no shop needed. However, some dealers establish a shop or an office after their business has grown. Start full or part time. It's easy to learn . . . quickly established. We'll supply Easy Terms to help finance you.

FREE Booklet Open territories are limited! Send coupon for FREE booklet describing these unusual services and how you can become independent in a business of YOUR OWN built upon satisfied customers. No obligation! Mail coupon TODAY!

"OWN a Business" Coupon

Duraclean Co. 2-185 Duraclean Bldg., Deerfield, Ill.
Without obligation to me, send FREE booklet and letter giving full details. Tell me how I may OWN a growing business of my own built upon satisfied customers.

Name.....
Address.....
City..... Zone..... State.....

Picture Features

Escape Pod Fired from Jet..... 86
Commuters May Use Helicopters Soon....120
How a Garbage Disposer Works.....128
His Cadillac Has a Kitchen and Bath....130
Slicked-Up Nash Rambler.....153
How an Expert Thwarts Lightning.....155
Twin-Huller Built for Speed.....159

Mechanics & Handicraft

How Push-Button Car Antennas Work....170
Cars Without Carburetors?.....174
Tips on Care of Convertible-Car Tops....175
Auto-Top Carrier Loads at Side.....177
Spreader Sifts Lawn Fertilizer.....183
A Kitchen Stool for Your Wife.....188
Making Your Black-Top Driveway.....192
Building an Insulated Picnic Box.....202
Vacation-Time Camera Check.....206
Tailor-Made Storage for Your Kitchen....222

Departments

Letters 10
New Ideas from the Inventors.....113
Aids to Modern Living.....132
I'd Like to See Them Make.....139
P.S. Last Minute News and Notes.....160
Craftsmen in Uniform.....166
Hints from the Model Garage181
Keeping the Home Shipshape.....190
New Shop Ideas.....204
New Tools.....220

NEXT MONTH . . .

What to Do About Shocks

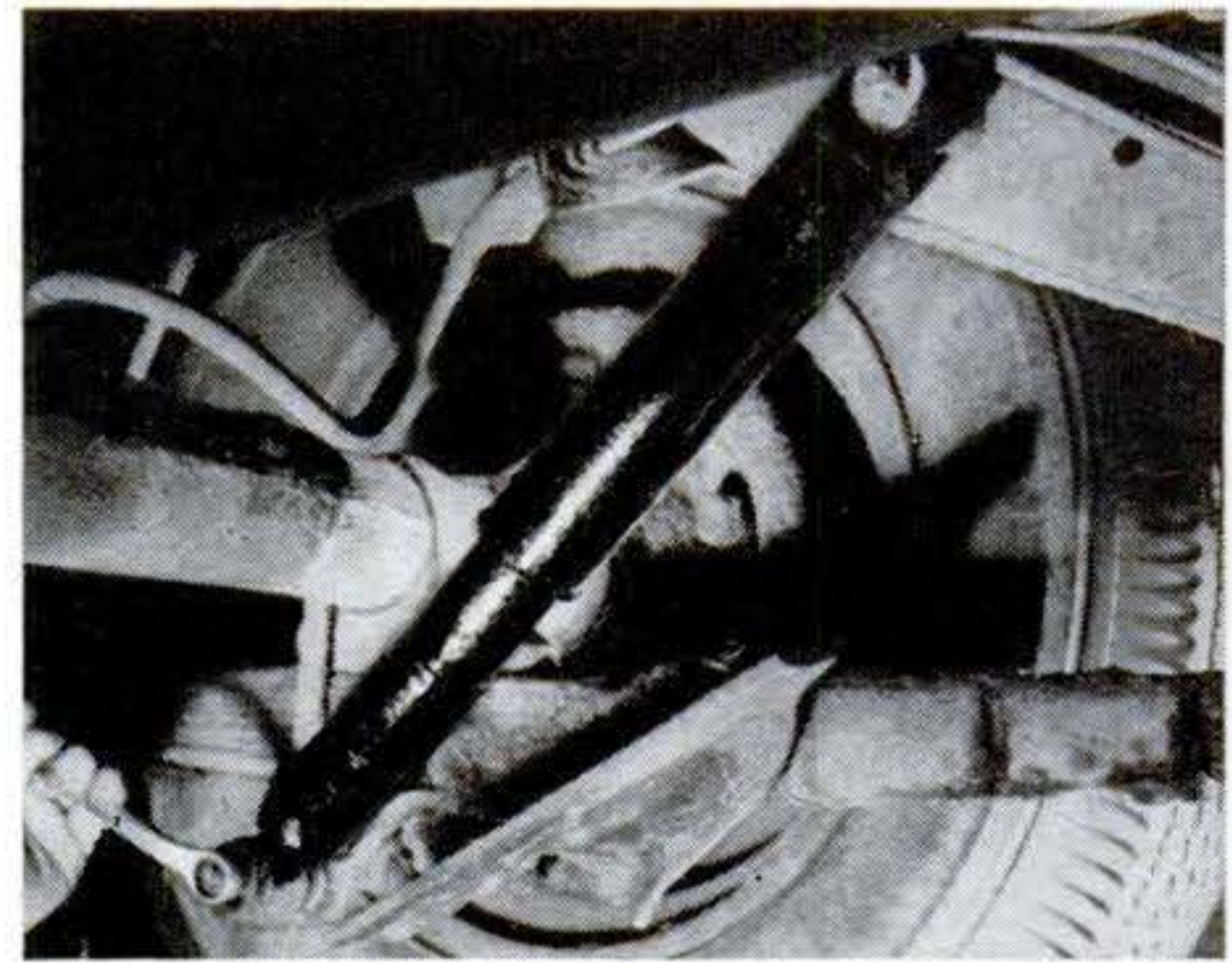

If your car bounds off the high spots like a five-year-old on a Pogo stick, those mud-encrusted gadgets commonly called shocks are probably to blame. Next month a fact-packed article will explain how they work and what you can do about it when they don't.



Up to the top . . . together



If you've ever asked yourself "What can I do to get ahead?" you'll find the story of Ernest and Janet Jarvis interesting and inspiring

They married young. Neither had finished grammar school. Both worked—and studied.

Ernest was enrolled with the International Correspondence Schools. Janet helped him with his lessons. Together they mastered Chemistry, Metallurgy and other I. C. S. subjects.

Slowly, surely, their training bore fruit. Ernest was made plant manager of a marine pump and valve factory. Mrs. Jarvis worked as a chemist in the laboratory.

Then, with \$3500 savings, they started their own business, the Niagara Falls Smelting & Refining Co. Inside twenty years, it became the nation's largest producer of nonferrous alloys.

In 1944 they sold the company and retired as millionaires. But they couldn't stop. Before the year was out, the Jarvises were working again.

Today, Ernest Jarvis is President of the Continental Copper & Steel Industries, Inc. And Janet Jarvis, a chemist and metallurgist famed throughout the industry, is Vice-President.

Says Mr. Jarvis: "I have always felt that the training we obtained by studying I. C. S. courses at night was responsible for our success in life."

It takes courage and co-operation, hard work and sound training to do what the Jarvises did. The first three are up to you. Sound training starts with the coupon below. Mail it *today*.

INTERNATIONAL CORRESPONDENCE SCHOOLS

BOX 7602-N, SCRANTON 9, PENNA.

Without cost or obligation, please send me full particulars about the course BEFORE which I have marked X:

- | | | | |
|--|---|--|--|
| <input type="checkbox"/> Accounting and Management | <input type="checkbox"/> Air Conditioning and Plumbing Courses | <input type="checkbox"/> Structural Drafting | <input type="checkbox"/> Radio Courses |
| <input type="checkbox"/> Architecture | <input type="checkbox"/> Air Conditioning <input type="checkbox"/> Heating | <input type="checkbox"/> Structural Engineering | <input type="checkbox"/> Electronics |
| <input type="checkbox"/> Automobiles | <input type="checkbox"/> Refrigeration <input type="checkbox"/> Steam Fitting | <input type="checkbox"/> Surveying and Mapping | <input type="checkbox"/> FM and Television Servicing |
| <input type="checkbox"/> Chemical Engineering | <input type="checkbox"/> Aeronautics Courses | <input type="checkbox"/> Communications Courses | <input type="checkbox"/> Radio, General <input type="checkbox"/> Radio Operating |
| <input type="checkbox"/> Civil Engineering | <input type="checkbox"/> Aircraft Drafting, Design | <input type="checkbox"/> Telegraphy <input type="checkbox"/> Telephony | <input type="checkbox"/> Radio Servicing |
| <input type="checkbox"/> Commercial Art | <input type="checkbox"/> Aeronautical Engineer's, Jr. | <input type="checkbox"/> Electrical Courses | <input type="checkbox"/> Textile Courses |
| <input type="checkbox"/> Drafting | <input type="checkbox"/> Engine Mechanic | <input type="checkbox"/> Electrical Drafting | <input type="checkbox"/> Cotton Manufacturing |
| <input type="checkbox"/> Electrical Engineering | <input type="checkbox"/> Architecture & Building Trades Courses | <input type="checkbox"/> Electric Light and Power | <input type="checkbox"/> Loom Fixing <input type="checkbox"/> Rayon Manufacturing |
| <input type="checkbox"/> High School | <input type="checkbox"/> Architecture | <input type="checkbox"/> Lighting Technician | <input type="checkbox"/> Textile Eng'g <input type="checkbox"/> Woolen Manuf'g |
| <input type="checkbox"/> Industrial Engineering | <input type="checkbox"/> Architectural Drafting | <input type="checkbox"/> Practical Electrician | <input type="checkbox"/> Stationary Engineering Courses |
| <input type="checkbox"/> Mechanical Engineering | <input type="checkbox"/> Building Estimating | <input type="checkbox"/> Diesel Engine Courses | <input type="checkbox"/> Power Plant Engineering |
| <input type="checkbox"/> Plumbing | <input type="checkbox"/> Contractor's Building | <input type="checkbox"/> Diesel Engines | <input type="checkbox"/> Stationary Fireman |
| <input type="checkbox"/> Radio & Television | <input type="checkbox"/> House Planning | <input type="checkbox"/> Internal Combustion Engines | <input type="checkbox"/> Stationary Steam Engineering |
| <input type="checkbox"/> Salesmanship | <input type="checkbox"/> Art Courses | <input type="checkbox"/> Mechanical Courses | <input type="checkbox"/> Business Courses |
| <input type="checkbox"/> Shop Practice | <input type="checkbox"/> Commercial Art | <input type="checkbox"/> Forging <input type="checkbox"/> Foundry Work | <input type="checkbox"/> Advertising <input type="checkbox"/> Bookkeeping |
| <input type="checkbox"/> Steam Engineering | <input type="checkbox"/> Magazine Illustrating | <input type="checkbox"/> Heat Treatment of Metals | <input type="checkbox"/> Business Administration |
| <input type="checkbox"/> Textiles | <input type="checkbox"/> Show Card and Sign Lettering | <input type="checkbox"/> Industrial Engineering | <input type="checkbox"/> Bus. Correspondence <input type="checkbox"/> Bus. Law |
| | <input type="checkbox"/> Chemical Courses | <input type="checkbox"/> Industrial Instrumentation | <input type="checkbox"/> Certified Public Accounting |
| | <input type="checkbox"/> Chemical Engineering | <input type="checkbox"/> Industrial Metallurgy | <input type="checkbox"/> Commercial <input type="checkbox"/> Federal Tax |
| | <input type="checkbox"/> Chemistry, Analytical & Industrial | <input type="checkbox"/> Machine Shop <input type="checkbox"/> Millwrighting | <input type="checkbox"/> Fore'ship <input type="checkbox"/> High School and College |
| | <input type="checkbox"/> Petroleum Production & Refining | <input type="checkbox"/> Mold-Loft Work | <input type="checkbox"/> Industrial Supervision |
| | <input type="checkbox"/> Plastics <input type="checkbox"/> Pulp & Paper Making | <input type="checkbox"/> Patternmaking—Wood, Metal | <input type="checkbox"/> Motor Traffic <input type="checkbox"/> Postal Civil Service |
| | <input type="checkbox"/> Civil Engineering Courses | <input type="checkbox"/> Reading Shop Blueprints | <input type="checkbox"/> Personnel—Labor Relations |
| | <input type="checkbox"/> Civil Eng'ring <input type="checkbox"/> Highway Eng'ring | <input type="checkbox"/> Sheet Metal Worker | <input type="checkbox"/> Retailing <input type="checkbox"/> Retail Bus. Management |
| | <input type="checkbox"/> Sanitary Engineering | <input type="checkbox"/> Ship Drafting <input type="checkbox"/> Ship Fitting | <input type="checkbox"/> Secretarial <input type="checkbox"/> Stenography |
| | | <input type="checkbox"/> Tool Designing <input type="checkbox"/> Toolmaking | <input type="checkbox"/> Traffic Management |
| | | <input type="checkbox"/> Welding—Gas and Electric | |

Name _____ Age _____ Home Address _____

City _____ State _____ Working Hours _____ A.M. to _____ P.M.

Present Position _____ Employed by _____

Special tuition rates to members of the Armed Forces. Canadian residents send coupon to International Correspondence Schools Canadian, Ltd., Montreal, Canada.

Now . . . an easy way to wash your car

DU PONT CAR WASH

Floats away grime . . . saves you time

**JUST
SPONGE
IT ON**

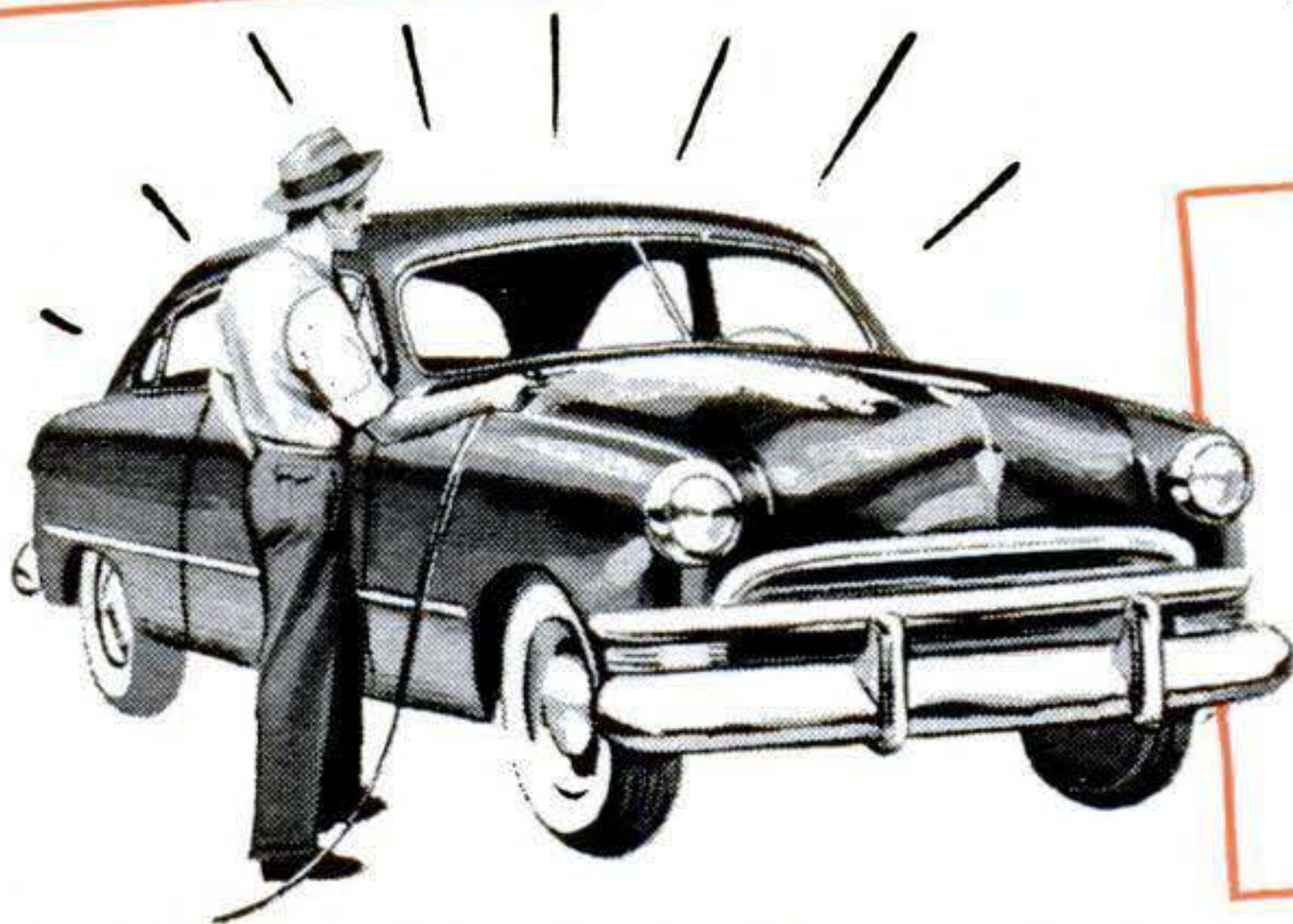

**THEN
RINSE
IT OFF**
(AND LET IT DRAIN)

It's a wonderful new detergent . . . gets your car spotlessly clean

You'll never know how fast and easy it is to wash a car until you've used remarkable new **Du Pont Car Wash**. Just a tablespoonful in a pail of water produces a bucketful of fluffy foam. Then this ideal solution goes to work . . . makes the most stubborn dirt, grease and oil disappear in a wink. Simply rinse it away, let it drain, and your car will dry—with no streaks or spots! Next time, let Du Pont Car Wash make the job a cinch for you.

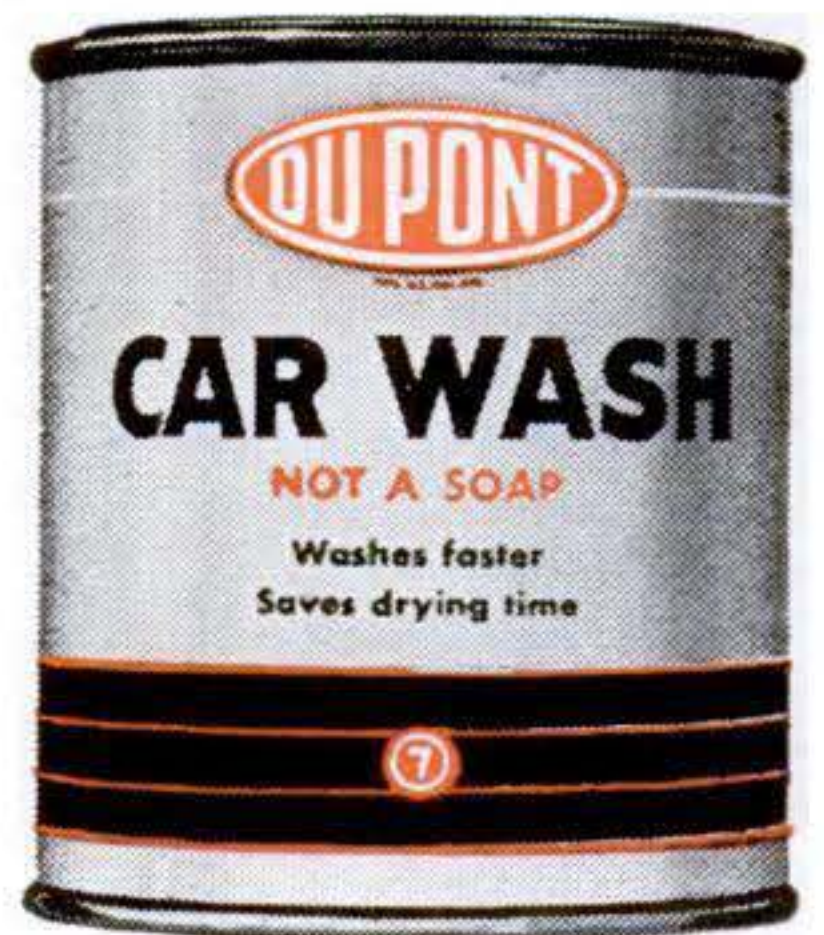

DU PONT No 7 PRODUCTS

BETTER THINGS FOR BETTER LIVING . . . THROUGH CHEMISTRY

This **FREE SAMPLE LESSON** will prove you can become an expert **BOOKKEEPER... ACCOUNTANT** OR **C.P.A.**

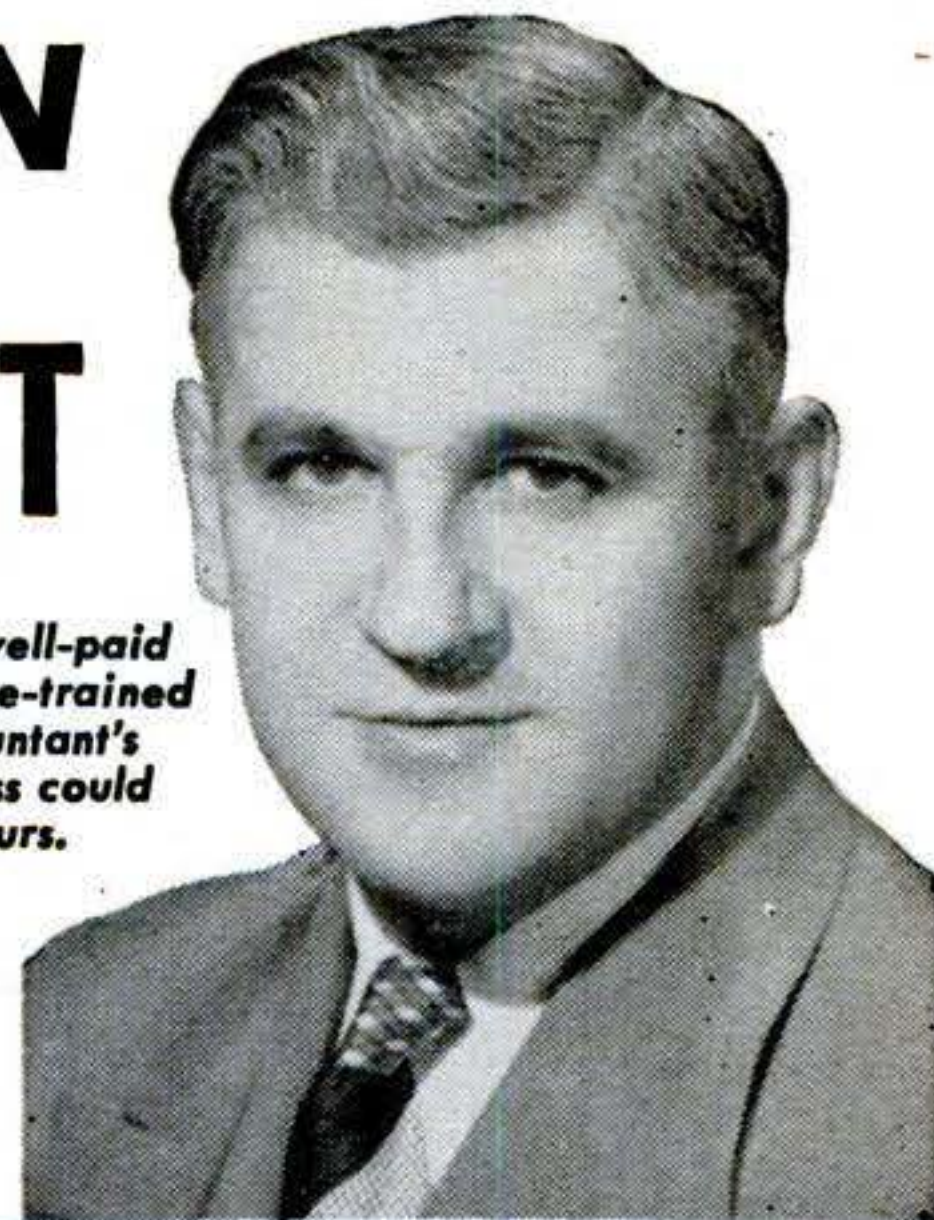

This well-paid LaSalle-trained Accountant's success could be yours.

FREE SAMPLE LESSON

We offer you this free sample lesson so that you can prove to yourself that you CAN master Accountancy—quickly, thoroughly—in spare time at home.

You will see exactly how LaSalle's famous "Problem Method" works . . . how you are led step-by-step through actual accounting work—learning by doing and not by study of theory alone. First you tackle easy problems, then more difficult ones—until soon you master them all. And at every step you have the close personal guidance of LaSalle's large staff of C.P.A. instructors.

HIGHER ACCOUNTANCY

By the LaSalle Problem Method..

• Practical Accounting

Assignment 1

THE BALANCE SHEET



QUOTING from the "Journal of Accountancy," the authoritative organ of the professional accountants of the United States:
"...the accounting profession is probably the best paid in the world. If there be a profession in which the average compensation is higher, it is not known to us."
"There is need for accountants. There is ample compensation for accountants. There is no prospect that the supply will overtake the demand within the lifetime of even the youngest of us."

LaSalle Extension University
A Correspondence Institution
CHICAGO

THIS SAME LESSON HAS STARTED HUNDREDS OF THOUSANDS toward well-paid accounting careers—in business, government, and as C.P.A.'s. Even without previous knowledge, progress is rapid—earning power climbs fast. This sample lesson shows why.

If you have been envying the high incomes and good jobs enjoyed by thousands of men and women Accountants today... incomes ranging from \$4,000 to \$10,000 and more per year... why not launch such a career for yourself?

Do you doubt that you can?

Then let us send you—without cost or obligation—the same Lesson Number One with which LaSalle has started several hundred thousand

men and women toward successful accounting careers. We want you to see for yourself how this remarkable method, originated by LaSalle, makes Accountancy simple, interesting, practical, and certain . . . how it leads you step-by-step to a complete mastery of Accounting—and on up to the coveted degree of Certified Public Accountant if you so aspire.

It doesn't matter whether you've had previous bookkeeping experience, or whether you don't know a debit from a credit. Whether you wish to qualify as an expert bookkeeper, advanced accountant, cost accountant, auditor, government accountant, income tax specialist, or public accountant . . . you'll find in LaSalle's Problem Method the exact plan to prepare you rapidly and inexpensively—in spare hours at home—without losing a day from your present job.

So right now, today . . . if you are an adult, employed, and earnestly ambitious for rapid advancement in this highest-paying of all professions . . . send your name and address on the coupon below. We'll send the free sample lesson—plus our 48-page book outlining today's career opportunities and how you can qualify for them. A coupon like this has started many thousands toward greater success. It can do the same for you. Mail it today!

**Nearly 10%
of all C.P.A.'s
in the U.S. have
been trained by the
LaSalle Problem
Method**

GOOD-PAY JOBS IN 5 BIG FIELDS

If you were an expert accountant right now, chances are you would find yourself among the highest-paid of all professional men and women. Surveys show that accountants earn more than those in other major professions.

There are five big fields of opportunity open to Accountancy-trained men and women . . . opportunities that are wide open and highly inviting, offering maximum income and job security in good times or bad. And under LaSalle's "Problem Method" you can start earning while still learning—either in spare-time or full-time employment . . . or in business for yourself with no capital required.

Get the latest information by sending for our 48-page book, "Accountancy, the Profession That Pays" . . . plus free sample lesson. The coupon at right will bring both to you without cost or obligation. LaSalle Extension, 417 S. Dearborn St., Chicago 5, Ill.

Clip Coupon... Mail TODAY!

LaSalle Extension University . . . A Correspondence Institution
Dept. 583H, 417 S. Dearborn Street, Chicago 5, Illinois

YES, I want to see how LaSalle's "Problem Method" works.. how I can qualify for high-pay Accountancy positions. Send Free Sample Lesson — also your 48-page book, "Accountancy, the Profession That Pays"
...all without cost or obligation.

Name Age

Street Address

City, Zone & State

Present Position



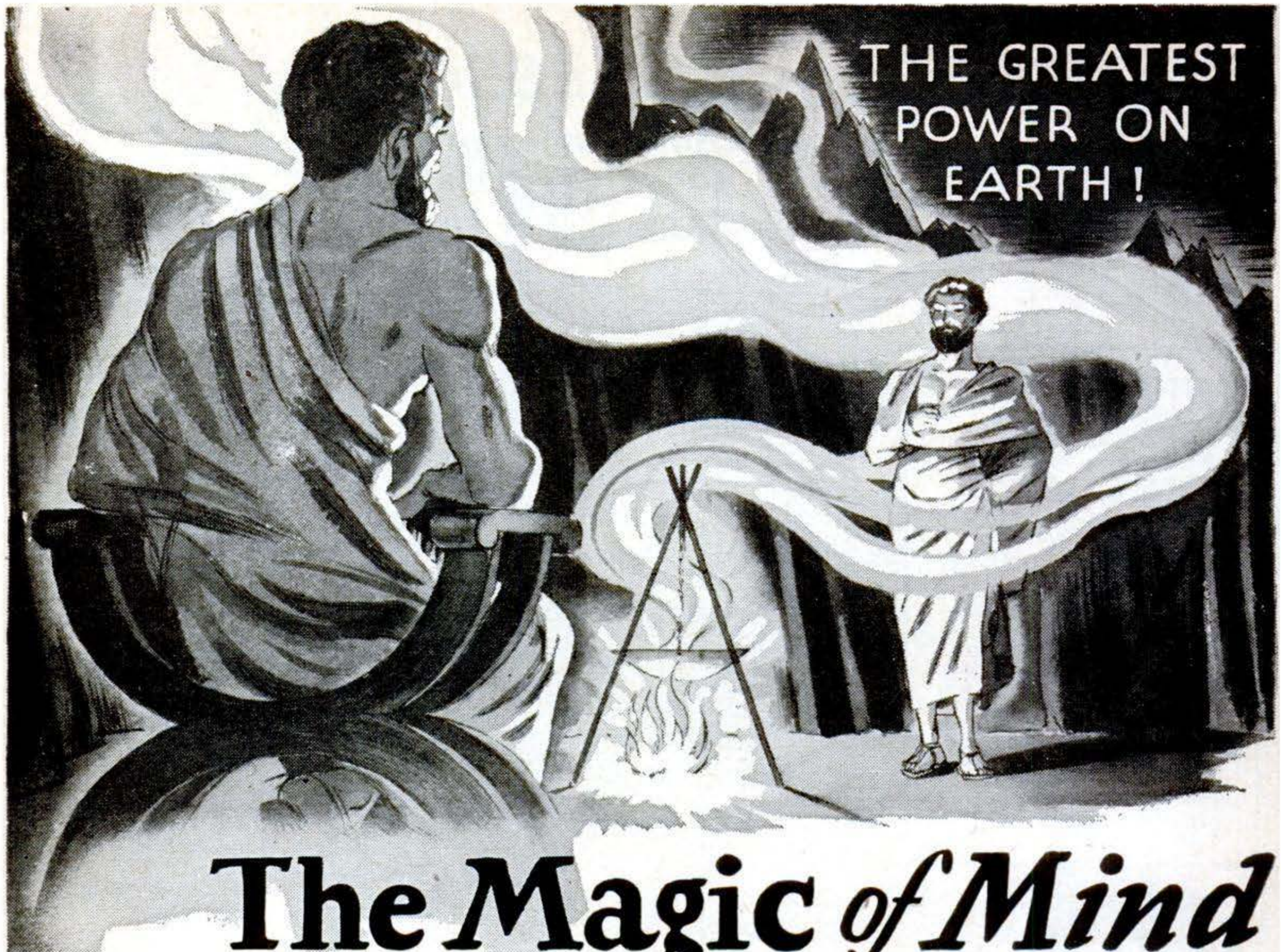

The Magic of Mind

WERE the great personages of the past victims of a stupendous hoax? Could such eminent men of the ancient world as Socrates, Pericles and Alexander the Great have been deluded and cast under the spell of witchcraft—or did the oracles whom they consulted actually possess a mysterious faculty of foresight? That the human mind can truly exert an influence over things and conditions was not a credulous belief of the ancients, but a known and demonstrable fact to them. That there exists a wealth of infinite knowledge just beyond the border of our daily thoughts, which can be aroused and commanded at will, was not a fantasy of these sages of antiquity, but a dependable aid to which they turned in time of need.

It is time you realized that the rites, rituals and practices of the ancients were not superstitions, but superfluges to conceal the marvelous workings of natural law from those who would have misused them. Telepathy, projection of thought, the materializing of ideas into helpful realities, are no longer thought by intelligent persons to be impossible practices, but instead, *demonstrable sciences*, by which a greater life of happiness may be had.

One of America's foremost psychologists and university instructors, says of his experiments with thought transference and the powers of mind—"The successes were much too numerous to be merely lucky hits and one can see no way for guessing to have accounted for the results." *Have you* that open-minded attitude of today which warrants a clear, positive revelation of the

facts of mind which intolerance and bigotry have suppressed for years? *Advance with the times*; learn the truth about your inherited powers.

Let this free book explain

The Rosicrucians (NOT a religious organization) have been leaders in introducing the ancient wisdom of mental phenomena. Established throughout the world for centuries, they have for ages expounded these truths to those thinking men and women who sought to make the utmost of their natural faculties. Use the coupon below—avail yourself of a pleasing book of interesting information which explains how you may acquire this most *unusual* and *helpful knowledge*.

The ROSICRUCIANS (AMORC)

USE THIS COUPON

Scribe: E. W. A.
The Rosicrucians, AMORC
San Jose, California

I am sincerely interested in knowing more about this unseen, vital power which can be used in acquiring the fullness and happiness of life. Please send me, without cost, the book, "THE MASTERY OF LIFE," which tells me how to receive this information.

Name _____

Address _____ State _____

STOP WASTING GAS!

"Amazing New Auto Guard"
MOTOR TUNE-UP GAUGE
SOLVES ENGINE PROBLEMS!



Special Offer...
\$3.95

DRIVE UP TO 3,000 MILES A YEAR. GAS FREE!

Get Up to 35 Miles per Gal.
Get Faster Starts
Get Greater Power:

Unique and revolutionary gauge has no delicate needles... no complicated dial. Guaranteed to be as sensitive as expensive vacuum gauges used by leading mechanics! Auto-Guard's life-like movements show over 30 necessary motor adjustments. Eliminates costly major repairs! Mounts on car dash in a few minutes. NO HOLES TO DRILL! Operates so simply a child can understand it. Recommended by leading motor authorities.

BUY BY MAIL
Save UP TO 50%

FREE 10 DAY TRIAL

New WRIST WATCH... with Amazing MECHANICAL BRAIN!

- It Remembers
- It Tells Time
- It Tells Date

Measures Speed. Measures Distance. Records up to 12 Hours. OVER 40 QUALITY FEATURES. Precision Jeweled. Independent Swiss Movement. Accurate.

Push-Button Stop & Start. Red Sweep-Second Hand. Unbreakable Crystal. Triple Chrome Plated Case. Shock Resistant. NITE-VUE RADIUM GLOW DIAL. Anti-Magnetic. Times Shop work. Times Photography. Times Sports. Times Races. Times Lab. work. Times Planes. Smart Expansion Band Included.

Includes 1 year guarantee and Lifetime Service Certificate.

You'd expect to pay over \$50...
Special Offer **\$8.95**
Plus 10% Fed. Tax

AUTO SEAT COVER Bargains

What A Buy!

Special Offer!

Now at last you can have smart seat covers that will protect your upholstery and add distinction to your car at amazingly low cost. These remarkable seat covers are tailored of miracle plastic in rich, lustrous colors. New snap-on action holds them tight. FITS ALL CARS. Colorfast. Will not fade or shrink. WATERPROOF, STAINPROOF, GREASEPROOF. Resists burns. Cleans easily with damp cloth.

Give year and make of car, 2-door, 4-door or coupe.

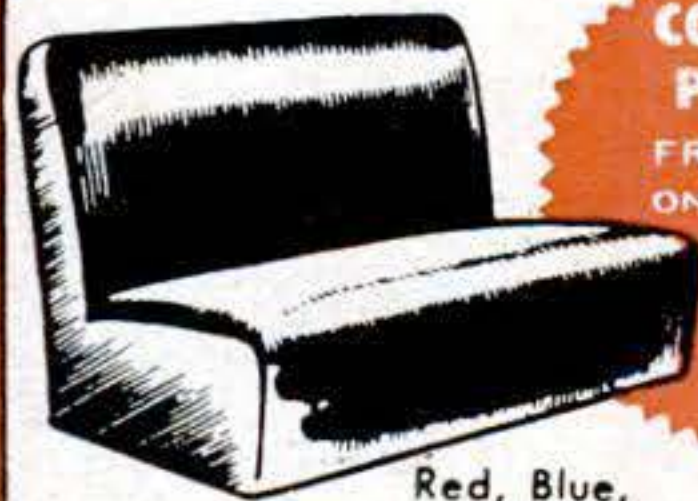

Red, Blue, or Green

COLORFUL PLASTIC
FRONT ONLY **\$1.98**

FRONT AND REAR **\$3.89**



"SCOTCH" PLAIDS
FRONT ONLY **\$2.98**

FRONT AND REAR **\$5**

Simulated LEOPARD

FRONT ONLY **\$2.98**

FRONT AND REAR **\$5**



Lifelike ZEBRA

FRONT ONLY **\$3.69**

FRONT AND REAR **\$6**



New Miracle AUTOMATIC AUTO WASHER

3 ft. Long

Special Offer

\$3.95

De Luxe Model, 4 foot long with shut-off valve, 4.95.

Soft Morlon Bristles can't mat or tangle

Luster-tone plastic head can't break

Attach this miracle washer to your garden hose and watch it float dirt and grime off your car. In less than 10 minutes your car will be shiny as the day it left the showroom. A FEW WASHINGS WILL RE-PAY ITS SMALL COST. New model has features never before incorporated in one washer: Luster-tone plastic head defies breakage... RUST-PROOF ALUMINUM HANDLE gives you reach without weight... all brass couplings last a lifetime. Extra large brush of soft Morlon bristles will never mat, shed, or tangle. Gently soaks, scrubs, washes and rinses automatically.

R. V. REED, noted Cadillac Sales Manager, says: "It's like magic. Cars practically wash themselves."

New

New



Introductory Offer **\$1.69**

New WINDSHIELD WASHER

- SIMPLER TO OPERATE
- LOWER IN COST
- EASIER TO INSTALL

Guaranteed trouble free operation... outperforms \$8.95 custom models. Can't clog... easy to refill. Visible fluid supply. One filling cleans windshield 35 times. TRY 10 DAYS ON YOUR CAR AT OUR RISK. Act now... this low price can't last.

SEND NO MONEY

Just send name, address, items wanted. We ship C.O.D. Pay postman plus postage. Or send cash, check, money order... we pay postage. ORDER AT OUR RISK. Money back if not delighted.

YOUNG PRODUCTS, Dept. 247
2605 Elmhurst • Detroit 6, Mich.

Letters



A General Says "Well Done"

Many thanks to POPULAR SCIENCE MONTHLY for publishing the fine article by Joseph Stocker on Civil Air Patrol's search and rescue work, "Trouble Is Their Pastime" [Jan. '52, p. 96]. I consider this story exceptionally well written.

GEN. CARL A. SPAATZ, USAF Ret.
Civil Air Patrol

Bolling Air Force Base, Washington, D. C.

Planes Take to the Road

In your January issue [p. 106] I saw a picture of a truck 91 feet long moving the tail section of a B-36 bomber in Texas.

I would like you to take a look at this picture [below] showing three trailer trucks



each carrying the fuselage section of a B-29 bomber 105 feet long, 17 feet high and 12 feet wide.

As the driver of one of the trucks, I think this was much more of a load than the tail of the B-36. The planes were moved from Pyote Air Force Base in Texas to Denver—some 800 miles. We had to make the trip under special permits that prohibited traveling at night, on Saturdays after noon, and on Sundays and holidays.

FRED L. BORN, Oklahoma City.

Burning Up the Road Burns Car

In your October and January issues there were accounts of drivers filling their tires with straw and then running on them [Oct. '51, p. 103; Jan. '52, p. 14]. This may be so, but I would like to tell you about a similar case that had different results.

Returning late one night from a motor trip, we had a flat tire traveling at high speed that ruined the tube. Since there was no chance of getting another tube at that

time of night, we stopped at a farm house, bought several gunny sacks, rolled them up as tight as we could and stuffed them in the tire.

Everything was fine until a highway motor cop stopped us and said our brakes were burning. It wasn't the brakes, but the sacks were a glowing mass of charcoal and the



tire was a melted mass of rubber. The friction had set the sacks on fire, so we had to ride home on the rims.

C. M. HUNTLEY, Seattle.

You'd Get Plenty Cold Out There

In your article "How the World Is Shrinking" [Jan. '52, p. 137], Mr. Ley stated that something placed in the shadow of a space station would be cooled nearly to absolute zero.

But if an object were placed outside the space station it would be surrounded by a vacuum. Although a perfect vacuum has a temperature of absolute zero, it won't absorb heat like a chunk of ice. The object would not be cooled, but would be insulated against temperature change because a vacuum won't conduct heat.

LEE MORSE, West Union, Iowa.

A vacuum won't absorb heat or conduct heat, but neither will it block the transmission of radiated heat. Otherwise, how would we receive heat from the sun? So an object placed in the shadow of a space station, where it could not be warmed by the sun, would quickly radiate all its heat away and approach absolute zero.

Ready for Anything

In your January issue [p. 81] you had an article "Death Designed This Fire Truck" about the East Orange, N. J., rescue truck.

Allow me to inform you that Rescue No. 1 of the Providence Fire Department has the same equipment with the exception of the chainsaw. Also we have a portable iron lung, shallow- and deep-diving equipment, experienced divers, and a 14-foot unsinkable

You Practice COMMUNICATIONS

I send you parts to build this transmitter

As part of my Communications Course you build this low power broadcasting transmitter, learn how to put a station "on the air," perform procedures demanded of Broadcast Station operators, make many tests.

This is just part of the equipment my students build. You keep all parts I send.

You Practice Radio SERVICING

on this modern radio you build with parts I send

As part of my Servicing Course, I send you the speaker, tubes, chassis, transformer, loop antenna, EVERYTHING you need to build this modern, powerful Radio Receiver! I also send parts to build many other Radio circuits. You use equipment for practical experience and to earn EXTRA money in spare time.

BE A RADIO-TELEVISION TECHNICIAN

NOW! Advanced Television Practice

New, special TV kits furnished to build high-definition SCOPE . . . RF OSCILLATOR with flyback power supply . . . complete TV set . . . many other units. You see pulse, trapezoidal, saw-tooth wave forms. Get valuable PRACTICAL EXPERIENCE locating and correcting TV troubles. Mail coupon for facts, pictures and prices!

Learn Servicing or Communications Practice at Home in Spare Time



Do you want good pay, a job with a bright future and security? Would you like to have a profitable shop or store of your own? If so, find out how you can realize your ambition in the fast growing, prosperous RADIO-TELEVISION industry. Even without Television, the industry is bigger than ever before. 90 million home and auto Radios, 3100 Broadcasting Stations, expanding use of Aviation and Police Radio, Micro-wave Relay, Two-way Radio for buses, taxis, etc., are making opportunities for Servicing and Communications Technicians and FCC-Licensed Operators.

Television is TODAY'S Good Job Maker

In 1950, over 5,000,000 TV sets sold. By 1954, 25,000,000 TV sets estimated. Over 100 TV Stations now operating. Authorities predict 1,000 TV Stations. This means more jobs, good pay for qualified men all over the United States and Canada.

Many Make \$10 Extra a Week in Spare Time

Keep your job while training. Hundreds of successful RADIO-TELEVISION TECHNICIANS I trained had no previous experience, some only a grammar school education. Learn Radio-Television principles from illustrated lessons. Get PRACTICAL EXPERIENCE—build valuable multimeter—experiment with circuits common to Radio and Television. Keep all equipment. Many students make \$5, \$10 extra a week fixing neighbors' Radios in spare time. SPECIAL BOOKLETS start teaching you the day you enroll.

Send Now For 2 Books FREE—Mail Coupon

Send now for my FREE DOUBLE OFFER. You get actual Servicing lesson to show you how you learn at home. Also my 64-page book, "How to Be a Success in Radio-Television." Read what my graduates are doing, earning; see equipment you practice with at home. Send coupon in envelope or paste on postal. J. E. SMITH, President, Dept. 2EB, National Radio Institute, Washington 9, D. C. Our 38th Year.

Good for Both—FREE

MR. J. E. SMITH, President, Dept. 2EB, National Radio Institute, Washington 9, D. C.

Mail me Sample Lesson and 64-page Book about How to Win Success in Radio-Television. Both FREE. (No Salesman will call. Please write plainly.)

Name.....Age.....
 Address.....
 City.....Zone.....State.....

Approved for training under G. I. Bill

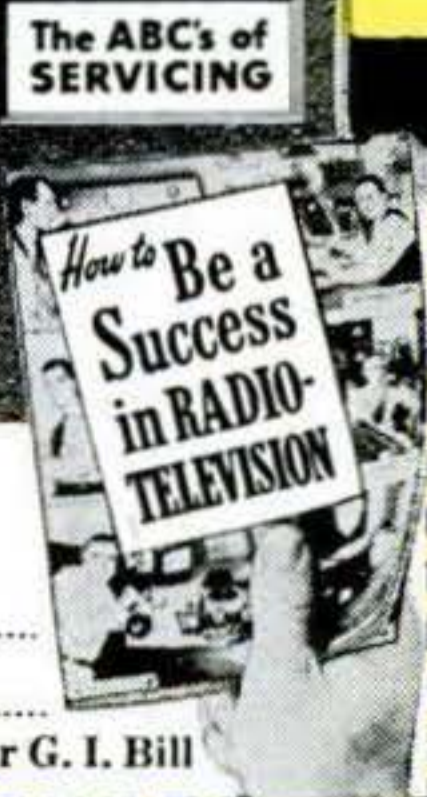

I TRAINED THESE MEN

"I have been operating my own Servicing business. In two years I did \$14,000 worth of business; net profit \$6,850. Have one full time employee, an NRI student."—PHILLIP G. BROGAN, Louisville, Ky.

"Four years ago, I was a bookkeeper, with a hand-to-mouth salary. Now I am a Radio Engineer with a key station of the American Broadcasting Company network."—NORMAN H. WARD, Ridgefield Park, New Jersey.

"When halfway through the NRI course, I made \$5 to \$8 a week fixing sets in my spare time. Am now selling and installing Television sets and antennas."—E. J. STREITENBERGER, New Boston, O.

"My first job was operator with KDLR, obtained for me by your Graduate Service Dept. I am now Chief Engineer of Police Radio Station WQOX. I never hesitate to endorse NRI."—T. S. NORTON, Hamilton, Ohio.



EXTRA PAY IN ARMY, NAVY, AIR FORCE

Knowing Radio, TV, Electronics can help you get extra rank, extra prestige, more interesting duty at pay up to several times a private's base pay. You are also prepared for good Radio-TV jobs upon leaving service. Mail Coupon TODAY.

Have Your Own Business

Many N.R.I. trained men start their own Radio-Television sales and service business without capital. Let me show you how you, too, can be your own boss, have a good income from your own shop. Send coupon for FREE book now!

Tested Way to Better Pay

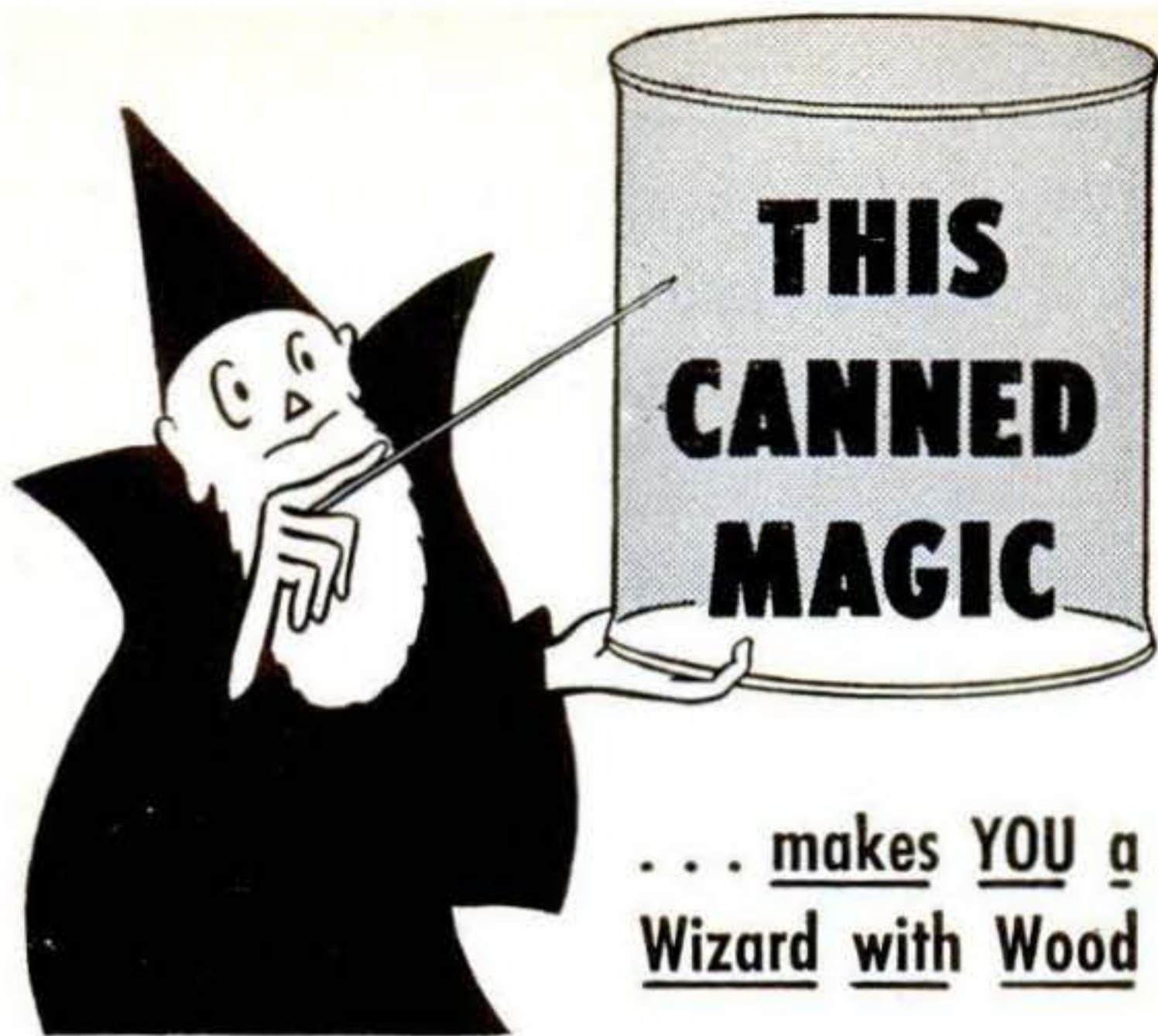

... makes YOU a
Wizard with Wood

Handy with your hands? Is making things your hobby? Like to do odd jobs? You'll bless the day you discovered the magical results you can obtain with Weldwood Glue, Firzite and Satinlac. At hardware, paint and lumber dealers. Mail coupon for free leaflets.

Gets that blond or pickled effect—



Produces those magical "woody" effects—on hard wood or soft, plywood or solid lumber. For light pastel tones, tint White Firzite with Colors-in-Oil. (On fir plywood stain jobs, tame that wild grain with Clear Firzite.)

WHITE FIRZITE*

Gets that Natural-Wood Finish



—without shellac or varnish. On furniture, panelling or woodwork, there's nothing like Satinlac. Brings out natural grain and color beauty of any plywood or solid wood. Avoids that "built-up look; will not turn yellow or darken with age. "Water-clear," easy to brush or spray, dries ready for next coat in 2 or 3 hours.

SATINLAC*

The Wood Glue you can rely on!



To make things or fix things, use Weldwood Glue for all wood-to-wood bonds. Makes joints stronger than the wood itself. Mixes easily with water. Stain-free, rot-proof...highly water-resistant!

WELDWOOD®
PLASTIC RESIN GLUE

Pints, Quarts,
Gallons

*Trade Marks

United States Plywood Corporation,
Dept. 53, 55 West 44th St., New York 36, N. Y.

Send me free leaflets on Weldwood Glue, Firzite
and Satinlac.

NAME _____

ADDRESS _____

aluminum boat with an outboard motor. In other words, we carry everything for any emergency from a one-inch compress to a five-ton derrick.

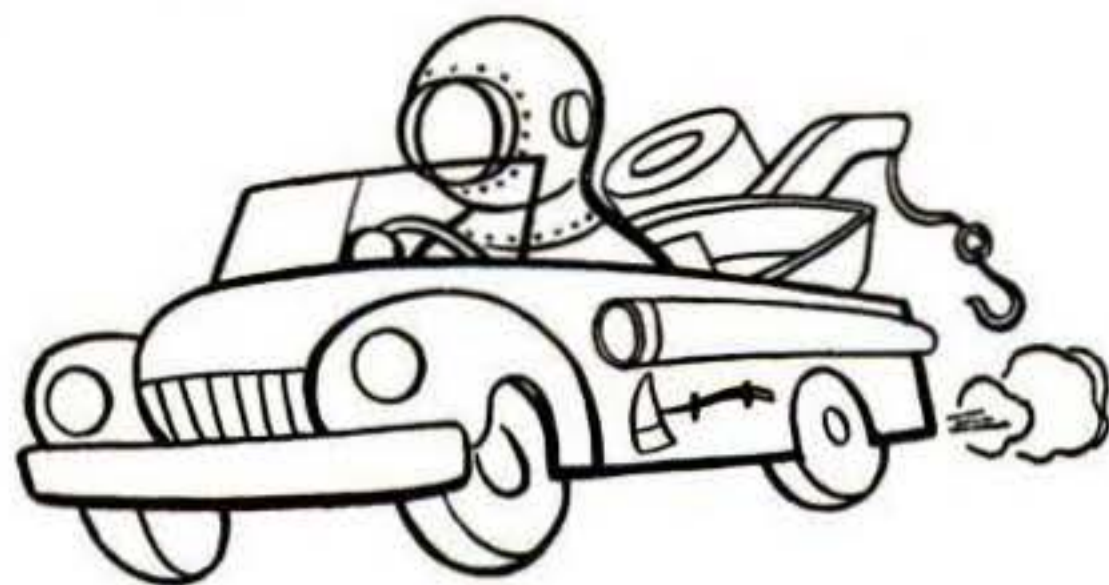

Rescue No. 1 made 689 runs in 1951. An additional rescue truck will be in service in the near future.

EDWIN A. FAY, Providence Fire Department
Providence, Rhode Island.

In Defense of Wrenches

Your "Hints from the Model Garage" in March [p. 200] showed how a pair of wrenches for working on a car's fuel and brake lines can be made by cutting a box wrench in two and filing in each box a slot slightly larger than the tubing.

It would be rather silly to spoil a perfectly good box wrench, which is needed for so many other purposes, when the slotted-flare, nut-type wrenches are available through any automotive distributor. They are also available through refrigerator distributors who have far more tubing work than the average automotive mechanic encounters.

E. S. SENSENDERFER

Bonney Forge & Tool Works, Allentown, Pa.

Anyhow, You Shouldn't Do It

In the February Letters column, John W. Nestler asks for a coined word to describe crossing the street against a red light, just as "jay-walking" describes crossing at other than an intersection.

I'd like to suggest "light-crashing."

E. P. ERNEST, Washington, D.C.

How about "red-erring"?

GEORGE BELLAMY, Cooperstown, N.Y.

Bats are color blind, so "bat-walking."

FRANK M. BROWN, Fayetteville, Ark.

"Red-beating."

HARRY WYMAN, Brooklyn.

Pirates used to make their prisoners walk the plank. Why not "plank-walking"? The result is the same.

CHESTER L. KINSCH, Palacios, Tex.

THESE MEN ARE GETTING PRACTICAL TRAINING IN **ELECTRICITY**

On Real:

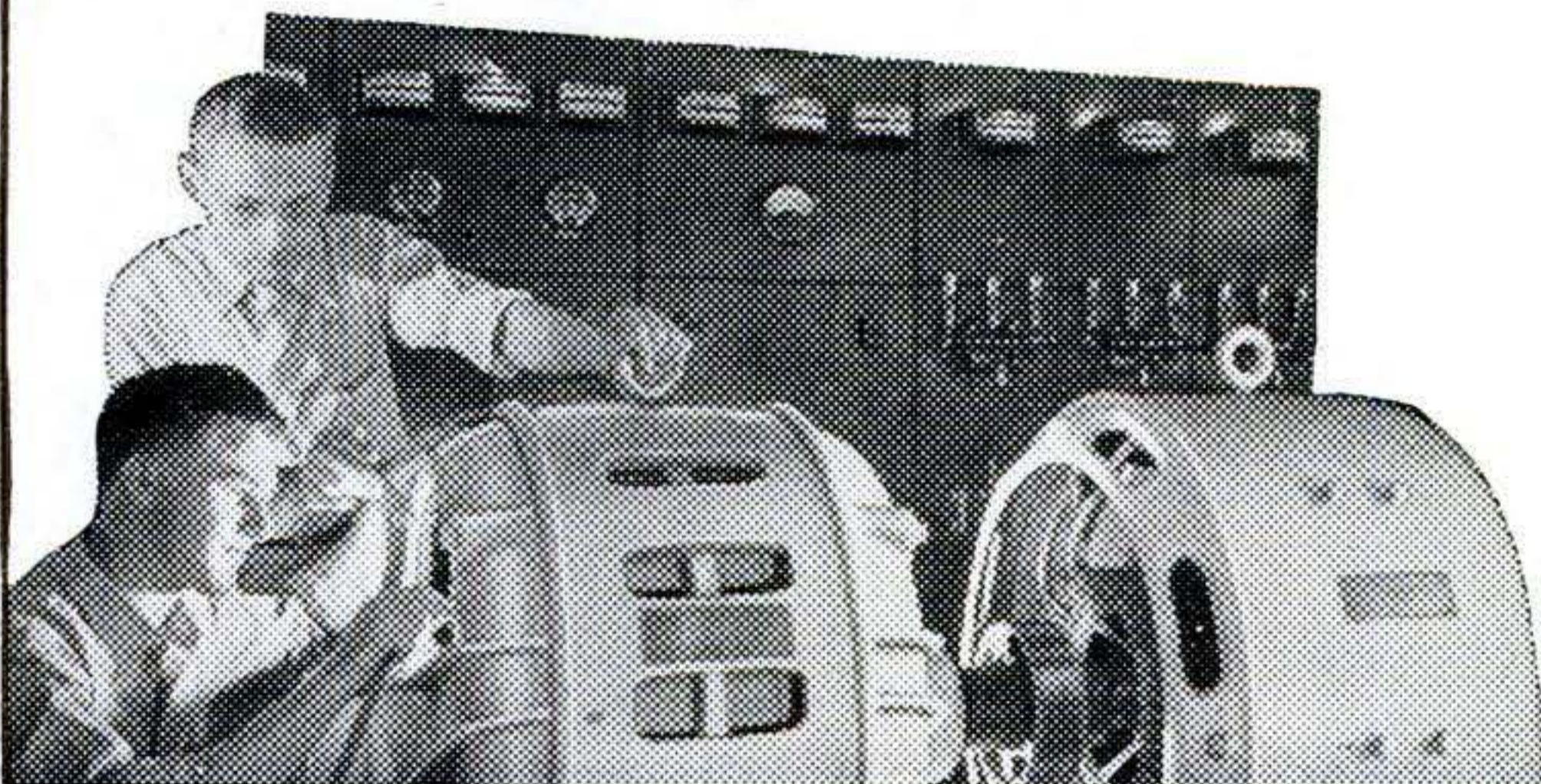

**A.C. and D.C. MOTORS
GENERATORS
SWITCHBOARDS
CONTROLLERS
WIRING JOBS
APPLIANCES
ELECTRONIC UNITS**

(Shown at left - Instructor explaining operation and testing of a large Motor Generator in our A.C. Department.)

AND **TELEVISION-RADIO**

On Real:

**TELEVISION SETS
RADIO RECEIVERS
F.M.
(Frequency Modulation)
RECORD CHANGERS
AUTO RADIOS
PUBLIC ADDRESS Systems**

(Right - Instructor helping students check the wiring and trace circuits of television receivers.)



Trained Men Needed for Defense and Military Programs

ELECTRICITY—RADIO—TELEVISION—ELECTRONICS—VITAL in defense program. Trained men whether 16 or up to 50 needed. **TRAIN QUICKLY** for better rating if drafted—Vital job in industry if not.

FINANCE PLAN for non-veterans. G. I. Approved. Special plan for men of draft age.

NOT "HOME-STUDY" COURSES! At Coyne you learn on real, full-size equipment. Trained instructors show you how, then you do typical jobs yourself. We don't teach by mail.

CLIP COUPON NOW for big new illustrated Coyne book. Check whether interested in **ELECTRICITY** or **TELEVISION-RADIO** or both. No obligation; no salesman will call. Get vital facts now!

B. W. COOKE, President



**Mail Coupon for
BIG FREE BOOK!**

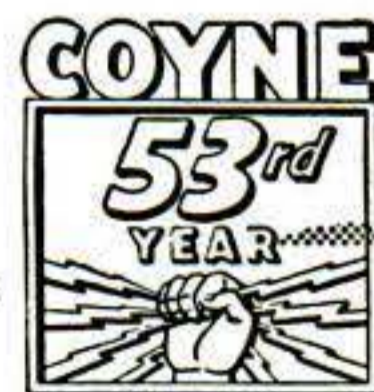

B. W. COOKE, President
COYNE SCHOOL
500 S. Paulina St., Chicago 12, Ill. Dept. 52-73H

Send **BIG FREE** books and details of your training offer. This does not obligate me and no salesman will call. I am interested in:

ELECTRICITY **TELEVISION-RADIO**

NAME

ADDRESS.....

CITY.....STATE.....

COYNE
SCHOOL

**A TECHNICAL TRADE INSTITUTE
CHARTERED NOT FOR PROFIT
Established 1899
500 S. Paulina Dept. 52-73H
Chicago 12, Illinois**

ELECTRICITY ★ TELEVISION ★ RADIO ★ REFRIGERATION ★ ELECTRONICS

Will her **caress test**
tell tales
about your hair?



**Grooms hair,
never
greases it**



 The proof is in
the palm of your hand!

20% more
Cream Hair Oil
for your money!

When she runs her fingers lightly through your hair, will you pass the test? Try your present hair tonic now, and see! Rub your palm across your hair, as she might do. Find a film of sticky oil? Think of her reaction and switch to Mennen Cream Hair Oil—lightly blended to keep each hair in place, yet never leave a trace. Contains lanolin. Helps remove dandruff scales and relieves dry scalp. Get a bottle today, and pass that caress test tonight!

MENNEN
Cream Hair Oil **FOR MEN**



Do it with the
DO-ALL-KIT
for only **\$9.75**

Is your chair or sofa sagging... are springs showing? Repair it yourself—right at home. Do a really professional job and save on upholstery repair bills. All you need is the wonderful new DO-ALL-KIT with complete step by step easy to follow Illustrated Instruction manual... over 32 photos! The kit contains enough ma-

terials to repair 2 chairs or 1 couch. This type of work is in great demand. Start your own profitable business in your spare time. No risk... No overhead... No capital needed. Order your kit at once. Send check or money order for \$9.75 plus 35¢ for postage. No. C.O.D. please. Money back Guarantee.



EASTERN
SCHOOL OF UPHOLSTERY
555 BROADWAY
New York City Dept. S.

\$2.98 SPATZ PISTOL INVENTION!



Complete with
50 bullets
GUARANTEED
Mahogany Grip

Nickel
Finish

All
Metal



SEND THIS
COUPON
For FREE
MIDWEST
1952 Catalog

30 DAYS TRIAL — FACTORY-TO-YOU
MIDWEST RADIO & TELEVISION CORP.
Dept. 24M, 909 Broadway, Cincinnati 2, Ohio
NAME _____
ADDRESS _____
CITY _____ ZONE _____ STATE _____



INVENTORS

Learn how to protect your invention. The U. S. Patent Laws provide that any new and useful art, machine, article of manufacture, or composition of matter, or any new and useful improvement thereof, may be patented if the act of invention is involved. Therefore, every inventor with a valuable invention should take advantage of the Patent Laws and proceed for patent protection in order to safeguard his rights.

A patent gives the inventor the exclusive right to prevent others from making, using, or selling the invention claimed in the patent for a period of seventeen years.

The Patent Laws were enacted for the benefit of the inventor to give him protection for the features of his invention which are patentable. These features must be properly and concisely set forth and claimed in a formal application for patent, in order to comply with the requirements of the Patent Laws. For that reason, unless the inventor is familiar with patent matters, he should engage a competent registered patent attorney or agent to represent him. We are registered to practice before the U. S. Patent Office and are prepared to serve you in the handling of your patent matters.

A specially prepared booklet entitled "Patent Guide for the Inventor", containing detailed information with respect to patent protection and procedure, together with a "Record of Invention" form will be promptly forwarded to you without obligation upon request.

CLARENCE A. O'BRIEN & HARVEY JACOBSON

Registered Patent Attorneys

22 - E DISTRICT NATIONAL BUILDING

WASHINGTON 5, D. C.

MAY 1952 15

AUTOMOTIVE MAINTENANCE AND Trouble Shooting

For
 ✓ SHOP INSTRUCTION
 ✓ GARAGE
 ✓ SERVICE STATION OPERATOR
 ✓ FLEET OWNER
 ✓ HANDYMAN

10 Day Free Trial Examination

Partial list of contents:

Engine Tune-Up; Generator Output Low; Starting Motor Spins; Cranks, but does not start; Misfires at High Speed; Fuel Mixture Too Lean; Spark at Some but not all Spark Plug Wires; Test Coil Output; How the Magneto Works; Engine Overheats; Diagnosis of Steering Control; Wheel Alignment; Low Pedal Reserve, etc.

Shows you:

- How to forestall trouble
- How to locate sources of trouble
- How to restore vehicle to satisfactory operation
- How to do a complete tune-up job

A brand new, complete, step-by-step manual—unsurpassed in its field—that shows you HOW and tells you WHY!

This big abundantly-illustrated volume is as much for the expert who needs an up-to-date shop reference at hand, as it is for the beginner who is looking for the perfect guide and tool.

No previous work in the field of automotive mechanics can compare to AUTOMOTIVE MAINTENANCE AND TROUBLE SHOOTING. For in its over 400 pages you will find trouble shooting procedure, tests and adjustments arranged in an unusually simple and easy to follow order—one that quickly directs you to the specific solution.

An important part of this useful volume is the jacket itself which unfolds into a valuable 17 x 20 tune-up wall chart. By following this chart and the step-by-step tune-up procedures described in the book, you can quickly isolate the seat of the trouble.

You will marvel at the way this book helps you understand WHY certain things are done through its down-to-earth explanation and clear-cut illustrations. And it won't be long before you will find yourself developing the ability and know-how to apply similar logic to any unusual situation!

Over 400 Pages

Over 200 Illustrations

\$4.75

THIS COUPON IS GOOD FOR 10 DAYS TRIAL!

American Technical Society (Publishers Since 1898)
 Dept. AM-20, 848 East 58th St., Chicago 37, Illinois
 Please ship me at once AUTOMOTIVE MAINTENANCE AND TROUBLE SHOOTING for free 10 day examination. If I keep the book, I will pay \$4.75 plus a few cents postage, otherwise I will return books and owe nothing.

- | | | | |
|------------|--------------------------|--|--------|
| Examine | <input type="checkbox"/> | Automotive Maintenance and Trouble Shooting | \$4.75 |
| Free | <input type="checkbox"/> | Automotive Fundamentals | 4.90 |
| at Home | <input type="checkbox"/> | Automotive Engines, Maintenance and Repair | 4.50 |
| No | <input type="checkbox"/> | Automotive Suspensions, Steering, and Wheel Alignment..... | 4.50 |
| Obligation | <input type="checkbox"/> | Machine Shop Work..... | 3.75 |
| | <input type="checkbox"/> | Practical Mathematics..... | 2.75 |

Print Name _____

Street or RFD _____

City _____ Zone _____ State _____

To save postage, I am enclosing payment.

The NEW Model 50 UTILITY TESTER FOR REPAIRING ALL ELECTRICAL APPLIANCES-MOTORS an all-around electrical trouble shooter



- Measures A.C. and D.C. Voltages, A.C. and D.C. Current, Resistances, etc.
- Will measure the current consumption while the appliance under test is in operation. The appliance or utility may be plugged directly into the front panel receptacle. A special pair of insulated clip-end leads is included for motors, etc.
- Incorporates a sensitive direct-reading resistance range which will accurately measure all resistances commonly used in electrical appliances, motors, etc. This range will enable continuity checks and tests for shorts and opens.
- Will test thermostats, radio tube filaments, bulbs, fuses, fluorescents, condensers, switches, field coils, circuit breakers, lighting systems, etc.

Handsome round cornered molded bakelite case 3 1/8" x 5 7/8" x 2 1/4". Complete with all test leads and instructions.

\$13.90

SOLD ON EASY PAYMENTS AT THE NET CASH PRICE

No interest or carrying charges added. Simply remit \$3.90 with order, pay balance, \$2.00 per month for 5 months.

SUPERIOR ELECTRONIC CO., INC.

Dept. B-65 • 227 FULTON STREET • NEW YORK 7, N. Y.

Free for Asthma

If you suffer with attacks of Asthma and choke and gasp for breath, if restful sleep is difficult because of the struggle to breathe, don't fail to send at once to the Frontier Asthma Company for a FREE trial of the FRONTIER ASTHMA MEDICINE, a preparation for temporary symptomatic relief of paroxysms of Bronchial Asthma. No matter where you live or whether you have faith in any medicine under the sun, send today for this free trial. It will cost you nothing.

FRONTIER ASTHMA Co.
 462 NIAGARA ST.

792-J FRONTIER BLDG.
 BUFFALO 1, N. Y.

FREE BOOKLET TELLS YOU HOW

ART

Offers You a Profitable Career —a wonderful hobby!



New Trial Plan proves that you can learn how to draw at home the easy WSA way. Commercial Art, Illustrating, Designing, Cartooning all in one course. Write for free book; read the interesting stories of opportunities for you in many Art fields. See how we prepare you in this well paid field.

MAIL COUPON FOR FREE BOOK

WASHINGTON SCHOOL OF ART
 Studio 135F, Washington 5, D. C.
 Send Free Book, "Art for Pleasure & Profit."
 No Salesmen will call.

PLEASE PRINT

Name.....Age.....

Street.....

City.....Zone.....State.....

I am interested in your new Trial Plan

INVENTORS

If you believe that you have an invention, you should find out how to protect it. The first step is to have a search made of the prior pertinent U. S. patents. If a report on this search indicates that the invention appears patentable you can apply for a patent, and the specifications and claims should be prepared.

The firm of McMorrow, Berman & Davidson, with offices in Washington, D. C., is qualified to take the necessary steps for you. We can make a preliminary search on your invention, advise you whether we think it can be patented, and prepare your application for patent.

Unless you are fully familiar with the U. S. Patent Laws, we recommend that you engage the services of a Registered Patent Attorney to protect your interests. The patent laws are *your* laws. A patent gives you the right to prevent others from making, using or selling the invention claimed in your patent for a period of 17 years.

Use these patent laws for your protection. Investigate whether your invention can be patented. If you have what you believe to be an invention, we suggest that you have this firm make a search for you.

Send for a copy of our Patent Booklet entitled "How To Protect Your Invention," containing information about patent protection and patent procedure. Along with this we will also send you an "Invention Record" form, for your use in writing down and sketching details of your invention. We will mail them promptly. No obligation. They are yours for the asking.

McMORROW, BERMAN & DAVIDSON

Registered Patent Attorneys

PATENTS • COPYRIGHTS • PATENTS

1426 VICTOR BUILDING, WASHINGTON 1, D. C.

MODERNIZE YOUR WALLS
WITH BEAUTIFUL, THRIFTY

CONGOWALL

TRADE-MARK ®



Looks—cleans—feels like tile!

Easy as A-B-C to apply!

Why waste your time on wall treatments that will soon need refinishing? Gold Seal Congowall is not only easy to apply and inexpensive, but durable, too.

Congowall's baked enamel surface simulates ceramic tile, even to the mortar lines! . . . costs only about 15¢ a square foot . . . yet rivals the performance of wall materials costing several times as much!

Be sure you get the genuine—with the patented duplex backing that's proved successful in over 3,000,000 home installations! The Gold Seal *guarantees* you satisfaction or your money back!



Look for the back-marking that identifies the genuine Gold Seal Congowall!



Half the depth of the backing is moisture resistant—half *will absorb the paste*. Paste becomes part of Congowall, *locks it to the wall!*

MAIL THIS COUPON!

Congoleum-Nairn Inc.
Kearny 8, New Jersey

Please send me the free Congowall color guide and instruction folder.

Name

Address

City Zone State

© 1952, Congoleum-Nairn Inc.

DESIGN ENGINEERS!

Lockheed Aircraft Service, Inc.
offers

Diversified work on Commercial and Military projects to Engineers experienced in aircraft modification.

Top salaries, retirement plan, group insurance plus many other outstanding benefits.

Skill and ability count here. Age is no barrier.

Address qualifications to:

Employment Dept. S

Lockheed Aircraft Service, Inc.

BOX 48, BURBANK, CALIF.



MARVEL

Mystery Oil

- Frees Sticky Valves
- Stops Hydraulic Valve Clatter

Buy it at your favorite gas station

READING-MAGNIFYING
EYE
GLASSES
BY MAIL
30 Days Trial



Write Today for Free Catalog. Send no Money
ADVANCE SPECTACLE CO., Inc.
537 South Dearborn Street, Dept. SP-5, Chicago, Illinois

Start Your OWN ELECTRICAL APPLIANCE REPAIR BUSINESS

Repair electrical appliances of friends and neighbors. Service electrical equipment in factories, stores, etc. Work full or part time! New Shop Method home-training system. Rush name today for **FREE BOOK** and special form for getting Electronic Kit, Valuable Heating Element Kits, Advisory Service and Illustrated Instructions on new easy-payment plan. Pay later from **EARNINGS WHILE LEARNING**. Rush name today.

CHRISTY TRADES SCHOOL

4432 N. Kedzie Dept. D-1501 Chicago 25



This story actually happened. The man's name has been changed and this is not his photograph, but the facts are true.

"How do I feel about being Superintendent?"

Well, that story begins in Scotland . . ."

"I was an apprentice lad in a big machine shop. Just one among many. But I was ambitious and I was studying with I. C. S. Well, one day the shop started buzzing . . . *the Superintendent had come in!* I should explain that this was very unusual. To even an expert machinist, the Superintendent was as distant as the Deity. But I saw him walk in, with his derby hat and high collar and cravat. And as he came he asked, 'Where is Tom McDermott?' Well, that was me. And he walked right up to me and said, 'Are you the lad who's studying with the I. C. S.?' I just nodded — for I couldn't say a word. Then he laid his hand on my shoulder and said, 'Lad, stay with it . . . for if you do I prophesy that some day *you* will be Superintendent!' Well, today here in America I am Superintendent of a big machine shop . . . and maybe that story will give you some idea of how I feel about it."

In the files of I. C. S., stories like this are fairly common. Some day *your* story may be there. If you start *today* by filling out the coupon.

INTERNATIONAL CORRESPONDENCE SCHOOLS



BOX 7603-N, SCRANTON 9, PENNA.

Without cost or obligation, please send me full particulars about the course BEFORE which I have marked X:

- | | | | |
|---|---|--|--|
| <p>Business Courses</p> <ul style="list-style-type: none"> <input type="checkbox"/> Accounting <input type="checkbox"/> Bookkeeping <input type="checkbox"/> Business Administration <input type="checkbox"/> Business Correspondence <input type="checkbox"/> Business Law <input type="checkbox"/> Certified Public Accounting <input type="checkbox"/> Commercial <input type="checkbox"/> Federal Tax <input type="checkbox"/> High School and College <input type="checkbox"/> Industrial Supervision <input type="checkbox"/> Motor Traffic <input type="checkbox"/> Personnel—Labor Relations <input type="checkbox"/> Postal Civil Service <input type="checkbox"/> Retail Business Management <input type="checkbox"/> Sales Management <input type="checkbox"/> Salesmanship <input type="checkbox"/> Stenography <input type="checkbox"/> Aeronautics Courses <input type="checkbox"/> Aeronautical Engineer's, Jr. <input type="checkbox"/> Aircraft Drafting and Design <input type="checkbox"/> Aircraft Mechanic <input type="checkbox"/> Engine Mechanic <input type="checkbox"/> Air Conditioning <input type="checkbox"/> Heating <input type="checkbox"/> Plumbing | <ul style="list-style-type: none"> <input type="checkbox"/> Advertising <input type="checkbox"/> Cost Accounting <input type="checkbox"/> Foremanship <input type="checkbox"/> Refrigeration, Domestic <input type="checkbox"/> Refrigeration & Air Conditioning <input type="checkbox"/> Steam Fitting <input type="checkbox"/> Architecture <input type="checkbox"/> Architectural Drafting <input type="checkbox"/> Building Estimating <input type="checkbox"/> Contractor's Building <input type="checkbox"/> House Planning <input type="checkbox"/> Art Courses <input type="checkbox"/> Commercial Art <input type="checkbox"/> Magazine Illustrating <input type="checkbox"/> Show Card and Sign Lettering <input type="checkbox"/> Chemical Courses <input type="checkbox"/> Chemical Engineering <input type="checkbox"/> Chemistry, Analytical <input type="checkbox"/> Chemistry, Industrial <input type="checkbox"/> Food-Plant Sanitation <input type="checkbox"/> Petroleum Production & Refining <input type="checkbox"/> Plastics <input type="checkbox"/> Pulp and Paper Making <input type="checkbox"/> Civil Engineering <input type="checkbox"/> Highway Engineering <input type="checkbox"/> Reading Structural Blueprints <input type="checkbox"/> Sanitary Engineering <input type="checkbox"/> Structural Drafting <input type="checkbox"/> Structural Engineering <input type="checkbox"/> Surveying and Mapping | <p>Communications Courses</p> <ul style="list-style-type: none"> <input type="checkbox"/> Telegraphy <input type="checkbox"/> Telephony <input type="checkbox"/> Electrical Courses <input type="checkbox"/> Electrical Drafting <input type="checkbox"/> Electrical Engineering <input type="checkbox"/> Electric Light and Power <input type="checkbox"/> Lighting Technician <input type="checkbox"/> Power House Electric <input type="checkbox"/> Practical Electrician <input type="checkbox"/> Diesel Engines <input type="checkbox"/> Internal Combustion Engines <input type="checkbox"/> Mechanical Courses <input type="checkbox"/> Forging <input type="checkbox"/> Heat Treatment of Metals <input type="checkbox"/> Industrial Engineering <input type="checkbox"/> Industrial Instrumentation <input type="checkbox"/> Industrial Metallurgy <input type="checkbox"/> Machine Shop Inspection <input type="checkbox"/> Mechanical Drafting <input type="checkbox"/> Mechanical Engineering <input type="checkbox"/> Millwrighting <input type="checkbox"/> Patternmaking—Wood, Metal <input type="checkbox"/> Reading Shop Blueprints <input type="checkbox"/> Sheet-Metal Drafting <input type="checkbox"/> Sheet-Metal Worker | <ul style="list-style-type: none"> <input type="checkbox"/> Ship Drafting <input type="checkbox"/> Tool Designing <input type="checkbox"/> Welding—Gas and Electric <input type="checkbox"/> Radio Courses <input type="checkbox"/> Electronics <input type="checkbox"/> FM and Television Servicing <input type="checkbox"/> Radio, General <input type="checkbox"/> Radio Servicing <input type="checkbox"/> Railroad Courses <input type="checkbox"/> Car Inspector and Air Brake <input type="checkbox"/> Diesel Locomotive <input type="checkbox"/> Locomotive Engineer <input type="checkbox"/> Locomotive Machinist <input type="checkbox"/> Railroad Section Foreman <input type="checkbox"/> Stationary Engineering Courses <input type="checkbox"/> Power Plant Engineering <input type="checkbox"/> Stationary Fireman <input type="checkbox"/> Stationary Steam Engineering <input type="checkbox"/> Textile Courses <input type="checkbox"/> Cotton Manufacturing <input type="checkbox"/> Designing, Finishing <input type="checkbox"/> Loom Fixing <input type="checkbox"/> Rayon Manufacturing <input type="checkbox"/> Textile Engineering <input type="checkbox"/> Woolen Manufacturing |
|---|---|--|--|

Name _____ Age _____ Home Address _____

City _____ State _____ Working Hours _____ A.M. to _____ P.M.

Present Position _____ Employed by _____

Representatives in all principal cities. Canadian residents send coupon to International Correspondence Schools Canadian, Ltd., Montreal, Canada.

Pointers for home painters Windows:

For a lasting job, remove *all* old or cracked putty. Hold tip of an electric soldering iron against putty until it is softened. Scrape out with putty knife.

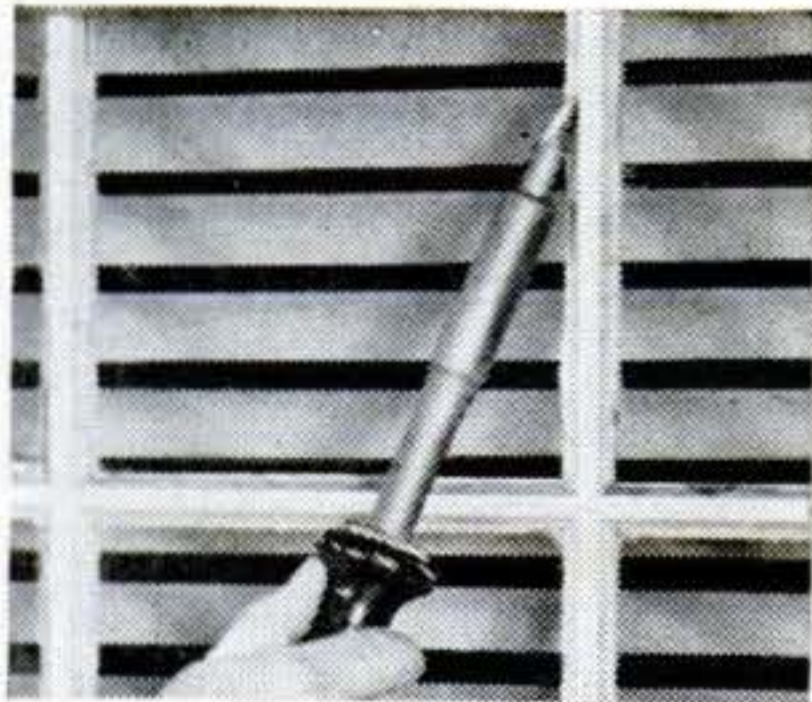

Don't let your brush "fishtail" (see insert) by painting window frame with oversized brush. Use small nylon-bristled brush—one designed for the job.



Use a protecting strip of cardboard or sheet metal when painting near glass. Leave window slightly opened during drying, so it won't stick shut later.



Clean brushes with thinner after daily use. Suspend brush in thinner overnight. Bristle tips should not touch bottom of can. Work out thinner before repainting.

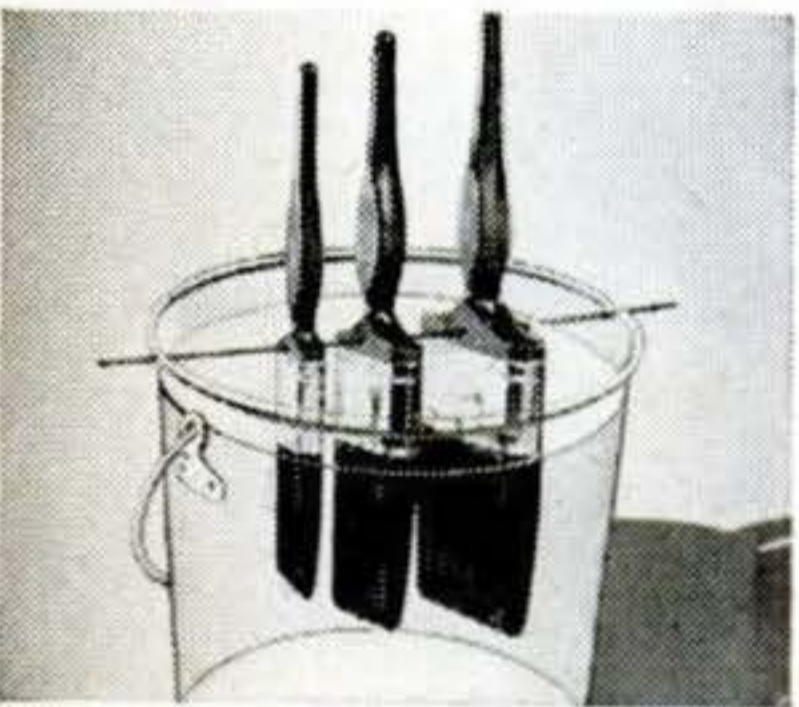

JOB AFTER JOB you'll get best results with a well-tipped nylon paint brush. Durable Du Pont nylon bristles paint smoother . . . are clean and sanitary . . . never get brittle . . . don't break off even under the roughest treatment. And nylon bristles last from 3 to 5 times longer than ordinary bristles. Leading manufacturers make nylon paint brushes in all types and sizes. Look for the name **NYLON** on the handle. Be sure to pick the size brush designed for the job . . . and demand Du Pont nylon bristles.

150th Anniversary



Better Things for Better Living
... through Chemistry

The best brushes have
**DU PONT NYLON
BRISTLES**

BLACK EBONY SEAT COVERS SWEEP TO SENSATIONAL NATIONAL POPULARITY



Salesmen jamming pockets with \$1000 bills TAKING ORDERS FOR KEY EXPERTLY TAILORED AUTO SEAT COVERS

BIG SEASON NOW STARTING

You've seen the huge color advertisements in Saturday Evening Post on the new seat cover sensation—miracle SARAN in the beautiful new *Black Ebony* pattern. SARAN—the plastic, woven like cloth, that has the color permanently "locked" right into each thread! Car owners everywhere are demanding Black Ebony Saran Seat Covers. Now you can serve that eager demand at a fraction of the cost the customers expect to pay! No wonder salesmen are making money hand over fist with this sensational new Key line. **Make big money daily.** Take orders from car owners everywhere. Beat all competition with covers cut to accurate patterns like the finest suit of clothes...Slick, smooth, wrinkle-free fit adds an accent of elegance to any car...just like the original upholstery job!

Rush Name for FREE Outfit

Give **MAKE, YEAR and MODEL of YOUR CAR**

Anyone working full or spare time can realize big money in this business. No need to search for prospects. Every car owner is one. Be the first to cash in . . . Make year around **STEADY PROFITS.** Don't put it off—get your Free Selling Kit at once for some real money. *Actual seat covers given FREE to producers for OWN USE!* Write for full details!

KEY PRODUCTS CORP., Dept. 65
800 N. CLARK ST., CHICAGO 10, ILLINOIS

TRAIN AT HOME FOR TOP PAY JOBS IN BUILDING CONSTRUCTION

Nearly a million dwellings will be erected this year. Thousands of jobs at top pay waiting. Learn Building Construction in months thru easy home study. Course can save thousands if you plan to buy or build. Write for booklet.

COMMERCIAL TRADES INSTITUTE, Dept. BCI-5
1400 Greenleaf Ave. Chicago 26, Illinois

MASTER MIND!

Learn Short-Cut Mathematics

Juggle figures, do baffling number tricks. Make people gasp at your marvelous lightning-quick mind. Multiply 4 figures by 4 figures without using old-fashioned multiplication! Big cloth-bound volume; fully illustrated course.

Sharpen up Your Brain Power

Includes worked-out problems, answers, etc. Sensational bargain, only \$1.95, postpaid or COD plus postage. Satisfaction guaranteed or refund. Order this amazing "Short-Cut Mathematics" today!

NELSON-HALL CO., 210 S. Clinton St.
Dept. 4EY-1 Chicago 6, Ill.

\$1.95
Complete

Illustrated

BOOKLETS

HERE THEY ARE, illustrated comic booklets just off the press. Good clear illustrations. Send \$1 for 12 booklets and receive FREE two of the larger size 32 page books. Rush a buck for all 14 books to,

AL'S PRINT SHOP
DAYTON 10, OHIO

118-D EAGLE ST.

**NOW... GET EVERYTHING YOU
NEED TO LEARN AND MASTER**

TELEVISION

**RADIO-ELECTRONICS
...AT HOME!**

Use REAL commercial-type equip-
ment to get practical experience

Your future deserves and needs every advantage you can give it! That's why you owe it to yourself to find out about one of the most COMPLETE, practical and effective ways now available to prepare AT HOME for America's billion dollar opportunity field of TELEVISION-RADIO-ELECTRONICS. See how you may get and keep the same type of basic training equipment used in one of the nation's finest training laboratories... how you may get real STARTING HELP toward a good job or your own business in Television-Radio-Electronics. Mail the coupon today for complete facts — including 89 ways to earn money in this thrilling, newer field.

D.T.I., ALONE, INCLUDES BOTH MOVIES and HOME LABORATORY

In addition to easy-to-read lessons, you get the use of HOME MOVIES — an outstanding training advantage — plus 16 big shipments of Electronic parts. Perform over 300 fascinating experiments for

practical experience. Build and keep real commercial-type test equipment shown at right

**Get BOTH of these
information packed
publications FREE!**

MODERN LABORATORIES

If you prefer, get all your preparation in our new Chicago Training Laboratories—one of the finest of its kind. Ample instructors, modern equipment. Write for details!

MILITARY SERVICE!

If you're subject to military service, the information we have for you should prove very helpful. Mail coupon today.

**89 WAYS
TO
EARN
MONEY
IN TELEVISION
RADIO ELECTRONICS**

**YOU GET
ALL 6**

ACT NOW! MAIL COUPON TODAY!

DE FOREST'S TRAINING, INC. DEPT. PS-5-1
2533 N. Ashland Ave., Chicago 14, Ill.

Without obligation, I would like your Opportunity News Bulletin showing "89 Ways to Earn Money in Television-Radio-Electronics"; also, the folder showing how I may prepare to get started in this thrilling field.

Name.....Age.....
Address.....Apt.....
City.....Zone.....State.....



ABOVE: Build and keep a real 17 INCH commercial TV receiver. Optional after completing regular training at moderate added cost.

**Here's the
REAL THING!**

**SET UP YOUR OWN
HOME LABORATORY**



R-F Signal Generator



Oscilloscope



**6-Tube
Radio**



Multimeter

**Home
Movies**

**"ONE OF AMERICA'S FOREMOST
TELEVISION TRAINING CENTERS"**

DeFOREST'S TRAINING, INC.
CHICAGO 14, ILLINOIS
A DeVRY INSTITUTION

MAKE MONEY

• ON THE FARM • AT HOME with a
LINCWELDER

J. W. Jarboe
Pratt, Kansas,
Says:

"My Lincoln welder saves me more money than any other piece of farm equipment. It makes quick repairs on broken machinery. It builds hay loaders, post hole diggers, spray rigs, cattle chutes, and many other things by welding together scrap pipe and angle iron. Next to my tractor, my "Lincwelder" is the most important piece of equipment I have."



"LINCWELDER" AC-180-C
... costs only \$170.00, including accessories. (Varies to \$176.00 on West Coast.)



For the Home Workshop

"LINCWELDER" 60 ... costs only \$45.00, including accessories. (Varies to \$48.00 on West Coast.)

Earn spare cash in your spare time. Handle repairs and small welding jobs for neighbors with your handy "Lincwelder" 60. It welds, cuts, solders, brazes, even charges batteries with the optional rectifier. Operates from 115-volt circuit (12 gauge wire, fused for 20 amps).

THE LINCOLN ELECTRIC CO.
The World's Largest Manufacturer of
Arc Welding Equipment
Cleveland 1, Ohio

ORDER NOW

Fill out and mail to
Dept. 202
THE LINCOLN ELECTRIC COMPANY
Cleveland 1, Ohio

- Ship me the "Lincwelder" AC-180-C and accessories \$176.00.
- Ship me the "Lincwelder" 60 with accessories \$48.00.
- Enclosed is check money order
- Send me free bulletin on the new "Lincwelder" 60.
- Send me free bulletin on the "Lincwelder" AC-180-C.

Name _____

Address _____

City _____ State _____

202

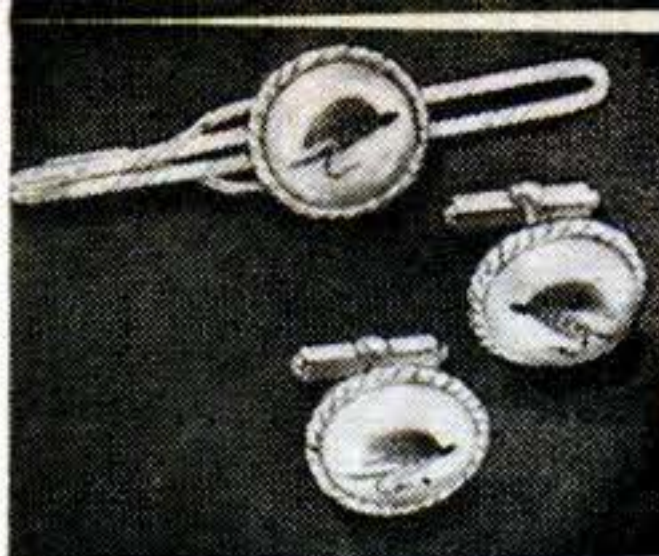

Snappy Fish Fly Tie Clasp, Matching Cuff Links and Key Tag

Brand New Book Tells You How:
HOW to make these Yourself
HOW to sell at Big Profits
HOW to embed Real Flowers
HOW to create Smart Jewelry
HOW to buy at Wholesale
HOW to Make Money—At Home
HOW to Have Your Own Business
HOW to Use "The 3-Step Plan"



Hundreds of truly different articles which you can make profitably are described and illustrated in the new Castolite Creations Manual.

FREE—with this valuable book, our inspiring booklet "A Success Plan for You." Shows you how to earn and save more money and have a lot of fun doing it. Send 25c today to:

The CASTOLITE Co., Dept. E-2, Woodstock, Ill.

BE A FROGMAN!



Join the new national **FROGMAN CLUB** today. All you have to do is send \$1.00—be sure to include your name and address—and here's what you get:

- 1) A miniature pair of Frog Feet. Can be worn on key chain, lapel or hung on windshield as lucky charm.
- 2) An attractive membership card.
- 3) A Frogman decal to be used on your windshield, bicycle or notebook.
- 4) A booklet on "How To Swim Underwater" and "The Supreme Sport of Spearfishing."
- 5) Periodic bulletins on the latest developments in Frogman equipment and news.
- 6) Complete catalog of Frogman equipment available for purchase.
- 7) A free coupon for \$1.00, which can be used toward the purchase of a pair of regular size Frog Feet, \$6.95 or equivalent in value. This is redeemable at your local sporting goods dealer, drug store, auto supply store or toy departments. If no such dealer available in your area, we will handle direct.

BE A FROGMAN — Send your dollar today!

National Frogman Club

1428 Maple Avenue, Dept. PS-5, Los Angeles 15, Calif.

Learn to HYPNOTIZE!

Command others with hypnotic power! Amaze everyone with your new spellbinding technique. New easy to master course teaches you this mystic art, quickly, expertly, professionally. Have subjects at your mercy. Make them obey your every desire. Send for this Valuable Book Now! Just pin \$1 to this ad and "25 lessons in Hypnotism" will be mailed to you postpaid. Satisfaction guaranteed or your money back.



Books Publishing Co., 56 W. 24th St., New York 10, N. Y.

Want A Gov't Job?

START HIGH AS \$3,795.00 YEAR

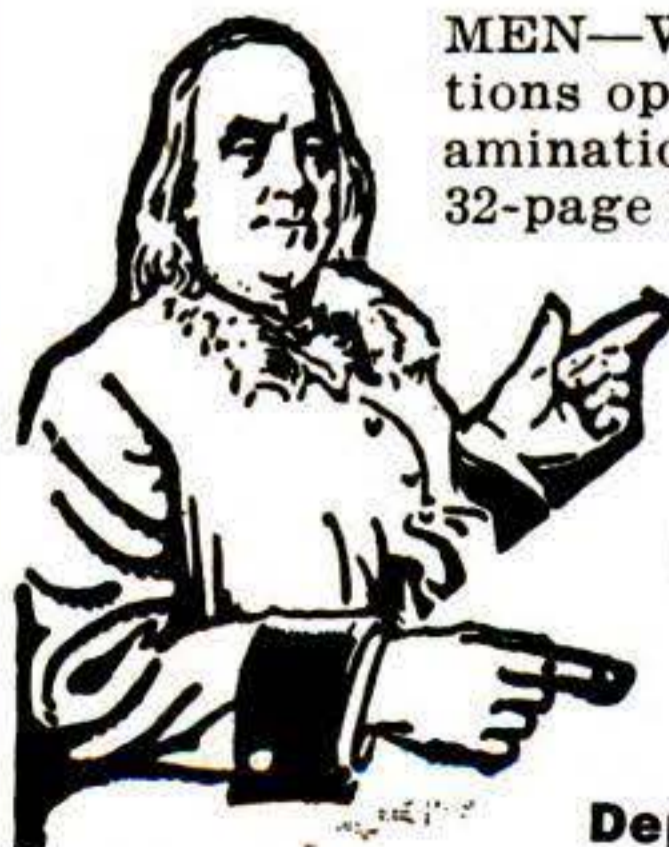

MEN—WOMEN. Thousands of positions open. Prepare NOW for next examinations. Write immediately for free 32-page book, with list of positions and particulars telling how to prepare. Experience usually not required. Veterans get preference.

FRANKLIN INSTITUTE

(Not Government
Controlled)

Dept. H-80 Rochester 4, N. Y.

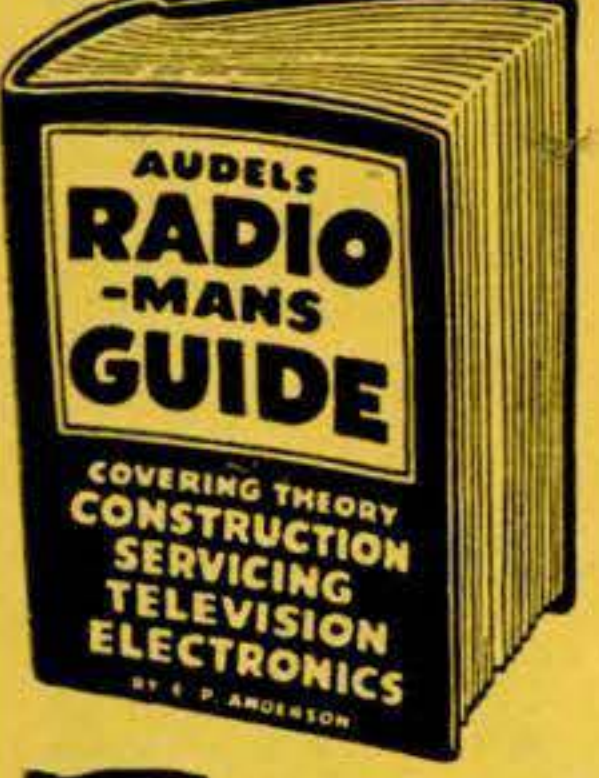

AUDELS TV-RADIO SERVICE LIBRARY

2 VOLS. \$6 COMPLETE \$1 A MONTHLY PAY ONLY

HERE IS LATE INFORMATION IN A HANDY FORM FOR RADIO & TELEVISION REPAIRMEN, SERVICEMEN AND STUDENTS **IT PAYS TO KNOW!**

AUDELS T.V.-RADIO SERVICE LIBRARY presents the important subjects of Modern Radio, Television, Industrial Electronics, F.M. Public Address Systems, Auto, Marine & Aircraft Radio, Phonograph Pick-Ups, etc. Covers Basic Principles—Construction—Installation—Operation—Repairs—Trouble Shooting. Shows How to get Sharp, Clear T.V. Pictures, Install Aerials—How to Test. Explains Color Systems & Methods of Conversion. 1001 Facts—Over 1260 Pages—625 Illustrations of Parts & Diagrams—Valuable for Quick Ready Reference & Home Study. Tells How to Solve T.V. & Radio Troubles—Answers T.V. & Radio Questions.

Get this information for Yourself, **7 DAY TEST—ASK TO SEE IT!**

MAIL ORDER

AUDEL, Publishers, 49 W. 23rd St., New York 10, N. Y. Mail AUDEL'S T.V. RADIO SERVICE LIBRARY 2 Vols. \$6 on 7 days free trial. If O.K. I will remit \$1 in 7 days and \$1 monthly until \$6 is paid. Otherwise I will return them.

Name _____

Address _____

Occupation _____

Employed by _____

AUDELS Carpenters and Builders Guides 4 vols. \$6

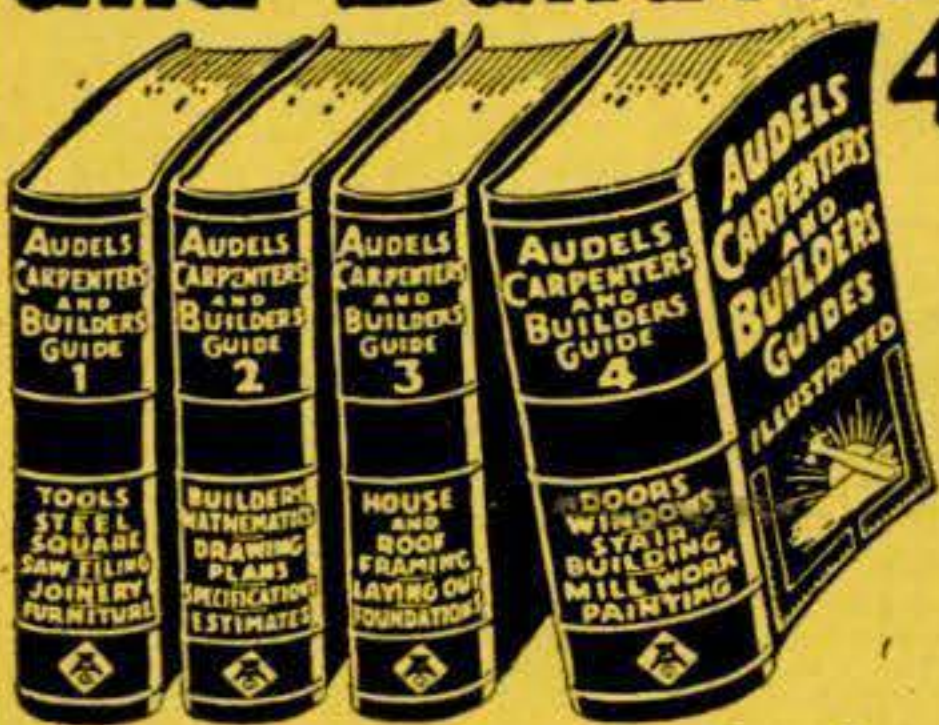

Inside Trade Information for Carpenters, Builders, Joiners, Building Mechanics and all Woodworkers. These Guides give you the short-cut instructions that you want—including new methods, ideas, solutions, plans, systems and money saving suggestions. An easy progressive course for the apprentice and student. A practical daily helper and Quick Reference for the master worker. Carpenters everywhere are using these Guides as a Helping Hand to Easier Work, Better Work and Better Pay. To get this assistance for yourself, simply fill in and mail the FREE COUPON below.



Inside Trade Information On:
 How to use the steel square—How to file and set saws—How to build furniture—How to use a mitre box—How to use the chalk line—How to use rules and scales—How to make joints—Carpenters arithmetic—Solving mensuration problems—Estimating strength of timbers—How to set girders and sills—How to frame houses and roofs—How to estimate costs—How to build houses, barns, garages, bungalows, etc.—How to read and draw plans—Drawing up specifications—How to excavate—How to use settings 12, 13 and 17 on the steel square—How to build hoists and scaffolds—skylights—How to build stairs—How to put on interior trim—How to hang doors—How to lath—lay floors—How to paint

AUDEL, Publishers, 49 W. 23rd St., New York 10, N. Y. Mail Audels Carpenters and Builders Guides, 4 vols., on 7 days free trial. If OK I will remit \$1 in 7 days and \$1 monthly until \$6 is paid. Otherwise I will return them. No obligation unless I am satisfied.

Name _____

Address _____

Occupation _____

Employed by _____

WHAT ALL AUTO MECHANICS WANT TO KNOW

1800 PAGES

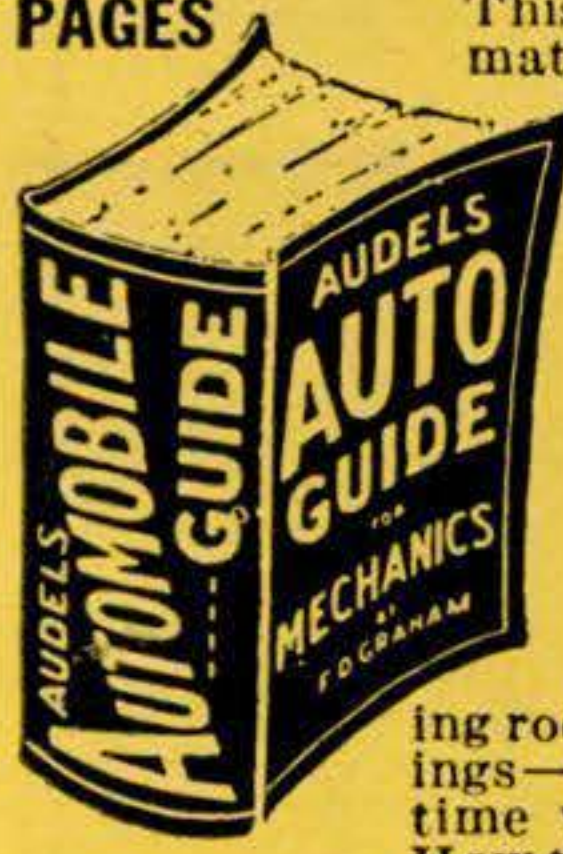

This Big Practical Book gives full information with working diagrams covering the principles, construction, ignition, service and repair of modern cars, trucks and buses.

Diesel Engines, Hydramatic & Fluid Drives Fully Explained.

A complete Guide of 1800 pages, with over 1500 illustrations showing inside views of working parts, with instructions for service jobs.

IT PAYS TO KNOW

How to fit pistons—How to locate engine knocks, How to fit connecting rod bearings—How to service main bearings—How to recondition valves—How to time valves—How to adjust fan belts—How to adjust carburetors and chokes, How to rebuild a clutch—How to service automatic transmissions—How to service brakes—How to adjust steering gear—How to cope with ignition troubles—How to service distributors—How to time ignition—How to "tune up" an engine.



\$4 COMPLETE • PAY \$1 A MO. TO GET THIS ASSISTANCE FOR YOURSELF SIMPLY FILL IN AND MAIL COUPON TODAY.

Step up your own skill with the facts and figures of your trade. Audels Mechanics Guides contain Practical Inside Trade Information in a Handy Form. Fully illustrated and Easy to Understand. Highly Endorsed. Check the book you want for 7 DAYS FREE EXAMINATION. Send No Money. Nothing to pay postman.

MAIL ORDER



AUDEL, Publishers, 49 W. 23 St., NEW YORK 10, N. Y.

Please send me postpaid for FREE EXAMINATION books marked (x) below. If I decide to keep them I agree to mail \$1 in 7 Days on each book or set ordered and further mail \$1 monthly on each book or set until I have paid price, otherwise I will return them.

- AUTOMOBILE MECHANICS GUIDE, 1800 Pages \$4
- TRUCK & TRACTOR GUIDE, 1299 Pages . . . 4
- DIESEL ENGINE MANUAL, 575 Pages . . . 2
- MACHINISTS HANDY BOOK, 1650 Pages . . . 4
- WELDERS GUIDE, 400 Pages . . . 1
- BLUE PRINT READING, 416 Pages . . . 2
- MATHEMATICS & CALCULATIONS, 700 Pages. . . 2
- SHEET METAL PATTERN LAYOUTS, 1100 Pages . . . 4
- SHEET METAL WORKERS HANDY BOOK, 388 Pgs. . . 1
- MECHANICAL DRAWING GUIDE, 160 Pages . . . 1
- MECHANICAL DRAWING & DESIGN, 480 Pages . . . 2
- AIRCRAFT WORKER, 240 Pages . . . 1
- TELEVISION SERVICE MANUAL, 384 Pages . . . 2
- RADIOMANS GUIDE, 914 Pages . . . 4
- ELECTRONIC DEVICES, 216 Pages . . . 2
- ELECTRIC MOTOR GUIDE, 1000 Pages . . . 4
- ELECTRIC WIRING DIAGRAMS, 272 Pages . . . 1
- ELECTRICIANS EXAMINATIONS, 250 Pages. . . 1
- ELECTRIC POWER CALCULATIONS, 425 Pages. . . 2
- HANDY BOOK OF ELECTRICITY, 1440 Pages. . . 4
- ELECTRIC DICTIONARY, 9000 Terms . . . 2
- ELECTRIC LIBRARY, 7000 Pages (12 Book Set) 18
- MARINE ENGINEERS HANDY BOOK, 1258 Pgs. . . 4
- SHIPFITTERS HANDY BOOK, 250 Pages . . . 1
- REFRIGERATION & Air Conditioning, 1280 Pgs. . . 4
- MILLWRIGHTS & MECHANICS GUIDE, 1200 Pgs. . . 4
- POWER PLANT ENGINEERS GUIDE, 1500 Pages . . . 4
- ENGINEERS & FIREMANS EXAMS, 525 Pages . . . 1
- PUMPS, Hydraulics & Air Compressors, 1658 Pgs. . . 4
- ENGINEERS LIBRARY (3 Book Set) . . . 9
- MECHANICAL DICTIONARY, 950 Pages . . . 4
- GARDENERS & GROWERS GUIDES (4 Book Set) . . . 6
- CARPENTERS & BUILDERS GUIDES (4 Book Set) . . . 6
- PLUMBERS & Steamfitters Guides (4 Book Set) . . . 6
- MASONS AND BUILDERS GUIDES (4 Book Set) . . . 6
- PAINTERS & DECORATORS MANUAL, 450 Pgs. . . 2
- HOUSE HEATING GUIDE, 1000 Pages . . . 4
- OIL BURNER GUIDE, 384 Pages . . . 1

Check NOW!

You Can Look Over Any Guide In Your Own Home — Start the Easy Payments If Satisfied

MAIL THIS TODAY



Name _____

Address _____

Occupation _____

Employed by _____

Yep...sure is easy

to give your car long-lasting wax protection!



"Ain't it wonderful what that stuff'll do fer a car in 20 minutes! Reckon Puny-Mae will be tryin' Car-Plate on herself next!"

Johnson's Car-Plate Waxes any car in 20 minutes!



Spread it on—no rubbing—let it dry!
Wipe it off—no rubbing—that's all!

Johnson's Car-Plate is the no-rubbing auto wax described in Reader's Digest. It gives a brighter, longer lasting shine than even hard-rub professional wax jobs costing \$15 or more! Don't delay. Wax your car the easy way. Pick up a can of Johnson's Car-Plate today.



Clean first with Johnson's CARNU

The easy way to prepare the finish on your car for a Car-Plate waxing is to clean it super-clean with Johnson's Carnu. For exceptionally dirty cars, ask your dealer for Johnson's Heavy-Duty Cleaner.

Protect your car's chrome trim. Clean with Johnson's Chrome Cleaner—protect with Johnson's Car-Plate.

© S. C. Johnson & Son, Inc., Racine, Wis., 1952
"Johnson's", "Car-Plate" and "Carnu" are trademarks.



C2

COLORCRETE

Lifetime beauty comes out of a gun! Colorcrete is a cementitious plastic, applied by pneumatic pressure to new or old concrete, stucco, etc. Tough, tenacious, enduring. Can be washed or scrubbed. Dirty, drab surfaces become sparkling white or tinted from a range of 30 colors.

"Building-Beautifying" —Your Big Opportunity

Colorcreting is a fascinating and profitable opportunity for men who want to build a substantial, long-term business. Colorcreting is exclusive. Rich in sales appeal to building owners. Income potentials are high; investment is low. We supply complete equipment, full instructions and liberal cooperation. Requires no previous experience or special ability. Write or wire for the Opportunity Book today. Be the first in your community.



COLORCRETE INDUSTRIES, INC.
572 Ottawa Ave., Holland, Mich.



**TUBE GIVEN WITH EACH
PASS. & TRUCK TIRE**

28 MONTHS WRITTEN GUARANTEE
Sent with Every Tire You Buy

SEND THIS AD IF YOU WANT
discount on every tire.

10% SAVE TIME
SAVE MONEY

GOOD USED TIRES "Not recapped."

18 YEARS AT THIS ADDRESS

600x16 \$5.42	670x15 \$5.82	710x15 \$6.42	760x16 \$7.32
650x15 5.42	700x15 5.42	750x16 10.92	820x15 7.32
650x16 5.62	700x16 7.22	760x15 6.62	670x16 6.42
640x15 5.62	550x17 5.62	475x19 5.62	550x18 5.62

600x20 \$9.92	32x6 (10) \$12.22	1000x20 \$19.92
650x20 11.52	750x16 (8) 12.02	1100x20 22.92
700x20 12.32	825x20 20.52	1000x22 22.92
750x20 14.22	900x20 19.32	1100x22 23.92

Thousands of tires shipped all over U. S. A. All tires shipped F.O.B. Phila. Send Check or M.O. with this ad. Dept. 5.
STANDARD, 834 N. Broad St., Philadelphia 30, Pa.



Learn Profitable Profession in 90 days at Home

MEN AND WOMEN, 18 to 60

Swedish Massage graduates make big money working full or spare time with doctors or in hospitals, health resorts, sanatoriums, clubs, private practice. A dignified, interesting career! Qualify for your graduation certificate. Thorough instruction at home as in class rooms. Write now for Illustrated Book—FREE.

The College of Swedish Massage
Dept. 270E, 41 E. Pearson, Chicago 11

Tells How You Can Learn to



FREE BOOK

Yes, FREE. Beautiful strange, valuable Book, telling all about Taxidermy. Contains over 100 beautiful game-pictures. And it's yours FREE, if you rush your request. You can mount all kinds of wild-game, and common specimens too. We can positively TEACH YOU. So GRASP this opportunity. RUSH letter or postal for this amazing FREE BOOK. Don't delay. State your AGE. N. W. SCHOOL OF TAXIDERMY, 2605 Elwood Bldg., Omaha 2, Neb.

GET THIS FREE BOOK!

NOW AT HOME IN SPARE TIME!
Get the "BASICS" you've missed!



LEARN RADIO *plus* TELEVISION AND ELECTRONICS

LEARN IT THOROUGHLY! FROM AMERICA'S MOST COMPLETE HOME TRAINING SCHOOL!

You Get All The Parts - Even Tubes - for this modern Superheterodyne Receiver - and lots of other equipment. And you get to keep it!

Let **NATIONAL SCHOOLS**—the famous resident-training school founded in 1905—train you as you want to be trained. One of the largest schools of its kind, National is located in Los Angeles—center of Radio-Television world! You learn from lessons prepared by men who are successful Radio and Television technicians.



ONLY NATIONAL SCHOOLS GIVES YOU THIS PROFESSIONAL MULTI-TESTER!
 You get this amazing new testing instrument! Ready to use! Simple to operate. Accurate and dependable. And—it's light enough to carry around—so you can use it at home or on service calls.



BIG FREE BOOK TELLS YOU HOW
 Page after page—in **COLOR**—tells you everything you want to know! Mail the coupon. Get yours—today!
PLUS A FREE SAMPLE LESSON!

You Train at Home—In Your Spare Time!
 National Schools Shop-Method Home Training gives you basic and advanced instruction in all the phases of Radio-Television-Electronics. You learn *fast* from hundreds of diagrams and pictures. All instructions are written by experienced technicians who work in Radio and TV every day. All instructions have been developed and tested in National Schools' own big labs and studios, which are equipped with the latest RCA equipment. No wonder this National Schools course is so up-to-date, practical, easy!

We Teach You How To Make Welcome Extra Money—While You Learn!
 Many National Schools students—men like you—make plenty of extra dollars in spare time! Fixing neighbors' radios and appliances—and other ways we teach you. You can earn while you learn!

LOOK! WE SEND YOU ALL THESE PARTS!



With famous National Schools Shop-Method Home Training, you learn *by doing*—the easy, practical, interesting way. The way *you* want to learn. We send you many parts — all of modern professional quality. You do lots of practical experiments. You advance day by day, step by step. The free book tells you all about it. Answers all your questions. Use the coupon. And do it now—while you're thinking of it.

HERE ARE ONLY A FEW OF THE GOOD-PAYING JOBS YOU CAN CHOOSE!

- Radio Station Engineer
- District Service Manager
- Aircraft Radio Inspector
- Own Your Own Repair Shop
- Inspector Technician
- Service Specialist
- Special Gov't Positions
- Sound Truck Operator

Today's Shortage of Trained Technicians Creates Chance of a Lifetime For You!
 Think of it! With guided missiles, radar, and other electronic devices so important to defense! And with over 90,000,000 radios, over 12,000,000 TV sets. With more than 3100 radio stations...over 100 TV stations — and more building every day. Men are wanted in Radio-Television-Electronics—America's fastest-growing field—act quickly!

Job Security! Big Money! For YOU! in Today's Expanding Industries!
 National Schools graduates—men just like you—are earning good money all over the country. Why not you? *Enjoy* your work—rather than having to drag along in just any old job. Mail coupon today—find out how easy it is.

National Schools Has Trained 1000's of Successful Men! Why Not YOU?
 In almost every state — and many foreign countries—National Schools graduates are filling big jobs with national companies. Or running their own successful businesses. National Schools Shop-Method Home Training is *complete* training. You can take advantage of today's great opportunities in Radio-Television-Electronics—fast.

DON'T PUT IT OFF! GET THE BIG SALARY YOU HAVE ALWAYS WANTED!

Attention! Men Going into the Service Soon!
 With this training you can get into *special* service classifications—with higher pay and grade—fast!

FREE SERVICE FOR GRADUATES!
 National Schools helps you find your place in the field of your choice. We help you start toward the good pay you've dreamed of. Get the training you should have. Mail the coupon for the facts—today.

NATIONAL SCHOOLS
 LOS ANGELES 37, CALIFORNIA • ESTABLISHED 1905
 In Canada: 193 E. Hastings St., Vancouver, B.C.

MAIL THIS COUPON TODAY—WITHOUT FAIL!

NATIONAL SCHOOLS, Dept. CR-52
4000 South Figueroa Street
Los Angeles 37, California

Mail me **FREE** the book mentioned in this ad. Also a free sample lesson. I understand no salesman will call on me and that there is no obligation.

NAME _____ AGE _____

ADDRESS _____

CITY _____ ZONE _____ STATE _____

Vets! Check here if released from service less than 4 years ago.

Mail in envelope or paste on postal card

VOTE TODAY FOR THE FUTURE YOU WANT!

AMERICAN SCHOOL, Dept. G546, Drexel at 58th, Chicago 37, Ill.
Without obligation, please send FREE and postpaid, full particulars about the subject checked below.

- | | | |
|--|---|---|
| <input type="checkbox"/> Accounting | <input type="checkbox"/> Drafting—Building Trades | <input type="checkbox"/> Plastics Engineering |
| <input type="checkbox"/> Air Conditioning | <input type="checkbox"/> Drafting—Machine Trades | <input type="checkbox"/> Plumbing—Practical |
| <input type="checkbox"/> Architecture & Building | <input type="checkbox"/> Electrical Engineering | <input type="checkbox"/> Private Secretary |
| <input type="checkbox"/> Automotive Technician | <input type="checkbox"/> Electricity—Practical | <input type="checkbox"/> Refrigeration |
| <input type="checkbox"/> Better Foremanship | <input type="checkbox"/> Electronics—Industrial | <input type="checkbox"/> Retail Merchandising |
| <input type="checkbox"/> Bookkeeping | <input type="checkbox"/> High School Courses | <input type="checkbox"/> Salesmanship—Outside |
| <input type="checkbox"/> Business Management | <input type="checkbox"/> Machine Shop Operations | <input type="checkbox"/> Sheet Metal Work |
| <input type="checkbox"/> Contracting | <input type="checkbox"/> Mathematics & Slide Rule | <input type="checkbox"/> Tool Making |
| <input type="checkbox"/> Diesel Technician | <input type="checkbox"/> Mechanical Engineering | |

NAME OCCUPATION
HOME ADDRESS AGE
CITY STATE

THIS IS YOUR BALLOT
Find the subject that interests you most and then... Check, Sign and Mail Today

• Today, choose the job you want — and prepare for it in spare time at home. Or if you are already engaged in the work you like best, start training now for quicker promotion. In hours you might otherwise waste, gain the knowledge and skill that can help you to get ahead faster, make more money, and have greater security.

Training Backed by 55 Years of Experience

For over half a century American School has helped ambitious men and women toward success by providing specialized training for commercial and technical advancement. Its study program for you has been planned by experts with years of experience in the subject you select and they will give you needed guidance every step of the way.

Don't Delay Your Start

Give serious thought to the list of training courses listed above. Pick the opportunity that interests you, check it and add your name and address. (Check more than one if you are undecided as to which appeals most.) Finally clip out and mail the "ballot" and full information will be supplied, without cost or obligation.

AMERICAN SCHOOL
DEPT. G546, DREXEL AT 58th, CHICAGO 37, ILL.

THE SOONER YOU START, THE SOONER YOUR GOAL CAN BE REACHED

WESTINGHOUSE HYDRAULIC TRANSMISSION

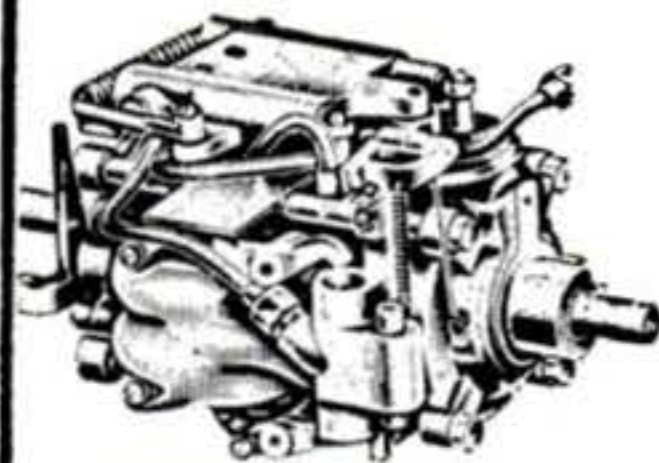

ALTIMETERS



Ideal for lathes, drills, chain saws, power machinery, chucking machines, farm machinery, tractors, trucks, or hydraulic torque converters, etc. Contains hydraulic pump and hydraulic mtr.; reversible controls. Designed for 2-ton 40 mm AA guns; high quality precision workmanship. Overall size: 12" long x 5 1/2" wide x 6 1/2" high. Shipping wt. 20 lbs. Govt. cost more than \$300.00

BRAND NEW... \$29.95

Pioneer sensitive altimeters. Range 0-35,000 ft., calibrated in 100's of feet. Barometric setting adjustment. No hook-up required... for auto or aircraft installation.

Used, Good \$12.95

U. S. Navy surplus altimeters. Range 0-10,000 ft. Adjusts to sea level setting of terrain. Requires no hook-up for auto or aircraft installation.

NEW \$7.95

All Equipment F.O.B. Pasadena • Enclose Full Amount With Order

C and H Sales Company

Box 356-T 5 • East Pasadena Sta. • Pasadena 8, California

BOOST YOUR EARNING POWER WITH

DIESEL

Train Now For This Big Pay Trade!

Are you mechanically inclined? Then you'll like DIESEL! You'll like working on these modern engines... pulling down the big pay of DIESEL-TRAINED men. Train at home for Diesel opportunities with simple, practical UEI Training. Learn DIESEL engine operation, fuel systems, repairs, maintenance PLUS Scientific Motor Tune-up. Course includes shop training in our big, well-equipped shops, working on Diesel engines. Write now for FREE booklet!

UTILITIES ENGINEERING INSTITUTE (Founded 1927)
2521 Sheffield Avenue, Dept. DM-14, Chicago 14, Illinois



HYPNOTIZE

Yes. Anyone. Modern speed hypnotism taught. Methods revealed. You are shown exactly what to say and do. Photo illustrated. Many interesting experiments. Self-hypnosis is fully explained. Amazing results. Detailed hypnotic tests given. Learn this exciting fascinating art. Hold your friends absolutely spellbound. Entertain.

A professional hypnotist tells you his secrets.

Free catalog of new hypnotism books sent on request.

Send for the startling book "HYPNOTISM REVEALED" → \$1

78 RPM Phonograph Record Inducing Self-Hypnosis & Group-Hypnotism → \$5

Thought of using sleep for learning, self-development? Send for new intriguing book, "Mental Power Through Sleep Suggestion." → \$1

MELVIN POWERS, Master Hypnotist, 1324 Wilshire, Dept. 89, Hollywood 17, Calif

A BIG MONEY-MAKER

IDEAL Lawnmower Sharpener

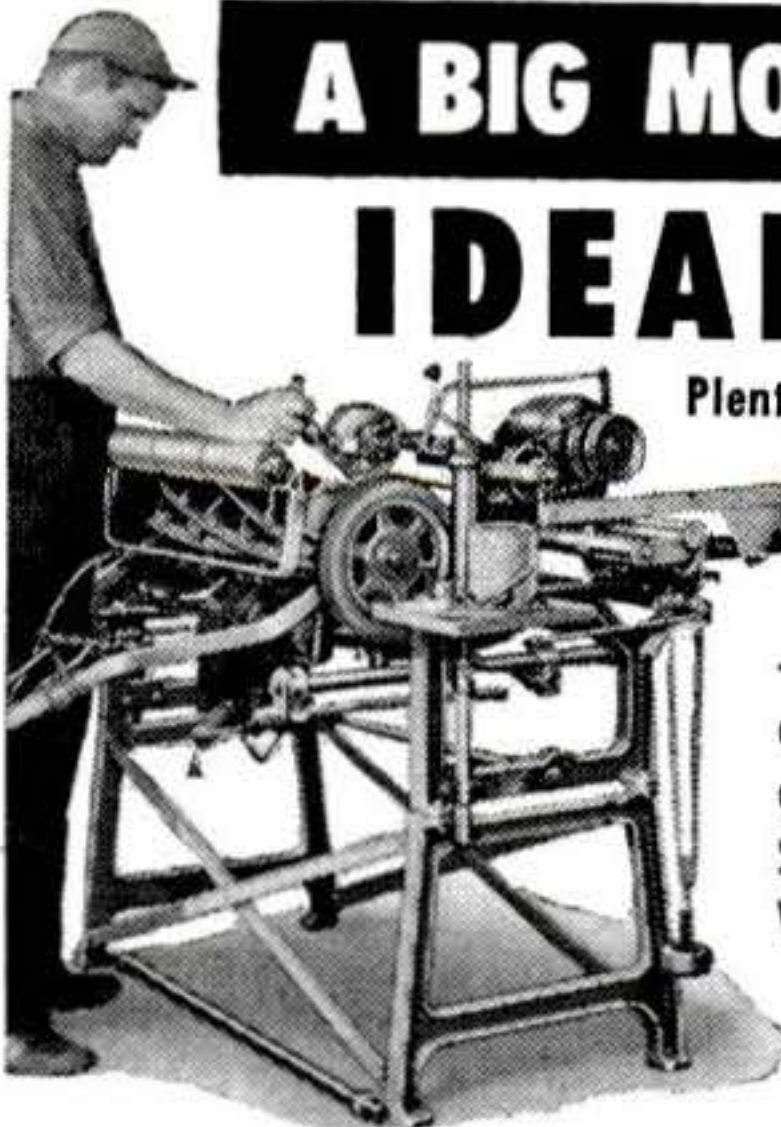

Plenty of business in your community— for a big, steady income! Cash in with the IDEAL Model 300 —a rugged, precision sharpener, easy to use, backed by 50 years of experience. Sharpens all mowers. Start now, full time or spare time. Write for free catalog today.

THE FATE-ROOT-HEATH COMPANY
Dept. R-4, Plymouth, Ohio

NOW! LET INDIANAPOLIS SPEEDWAY CHAMPIONS SHOW YOU

106 EASY WAYS TO GET MORE SPEED & POWER!

Get 42-47 Miles

PER GALLON FROM YOUR CAR!

**BURN WATER
SAVE GAS!**
(U. S. Agricultural Dept. Scientist say new water alcohol combination can save you money!)

**DRIVE 8,000 MILES
WITHOUT OIL CHANGE!
Zoom From 0 to 60 M.P.H.
in 12 Seconds! Add 30 M.P.H.
to Top Speed Of Your Car!
(Many results proved in official testing labs.)
ANY CAR! ANY MAKE! ANY YEAR!**



NEWEST SPEED & POWER MANUAL!
No Experience Needed—Easy A-B-C
Picture Instructions Show How To Mix,
Burn Water & Gas For Amazing Speed
& Economy—Resurface Cylinder Walls,
Stretch Car Life Without Taking Engine
Apart—Do Speed & Power Tuning With
Crewdriver—Restyle '37-'47 Models to
Expensive "Foreign" Look—Get Flash
Starts, Top Performance, Hi Resale —
Beat High Cost of Minor Repairs —
SAVE HUNDREDS OF DOLLARS A YEAR!

INDIANAPOLIS: Years ahead of the industry!
Ballon Tires: Introduced in Indianapolis . . . 1917! Industry adopted in 1923!
Self-Starter: Introduced in Indianapolis . . . 1916! Industry adopted in 1928!
Ethyl Gas: Introduced in Indianapolis . . . 1916! 1st sold Nationally — 1925!
Other Indianapolis Firsts: Rear view mirror — front wheel drive—super charge—4 wheel brakes — foolproof spark plugs — demountable wheels—better springs—etc.

SPEED and

\$1.98 ONLY

7 Day FREE Proof Money Back Guarantee

HERE'S PROOF! Ever notice how your car runs better on damp days? Engineers and Govt. testing bureaus now tell us what is actually taking place is moderate water injection, mixing with gas to give tremendous explosive power! (And test after test proves less engine wear and corrosion!) Now, easy picture directions show you how to take an ordinary Mason jar and a few inches of rubber hose, attach this simple, powerful "supercharger" to your carburetor, and suddenly discover sensational new power! . . . and gas savings up to 33 1/2%! This is only 1 of the 106 new motor miracles any car owner can do with new SPEED & POWER MANUAL!



No Guesswork — Everything You Have To Know!



Here for the first time is the only book of its kind ever published—a show-how, do-it-yourself SPEED & POWER MANUAL that shows you how to save 33 1/2% on gas bills—80% on oil bills—90% on repair bills—add \$300 to the resale value of your car! With sensational new discoveries of Automotive Engineers, Research Scientists and Indianapolis Mechanics, now it's easy to add new surging Power, Life, Mileage, Economy to your car! . . . whether it's a 5 year old jalopy or a shiny new '52 model — and SAVE \$75 to \$300 THIS YEAR!

Clear — Simple — Complete — Easy as A-B-C with "Show-How" Pictures



This new SPEED & POWER MANUAL is so complete, so easy to follow, so FOOL-PROOF, it's like having a master Indianapolis mechanic right at your elbow! Written in plain language with simple show-how drawings and cutaway diagrams anyone can understand! You not only read what to do, YOU SEE HOW IT'S DONE! It's so easy when you do it the SPEED & POWER way, and right from the start you'll learn the 30 to 40 quick tricks to get flash starts, lightning pickup, 15 more horsepower, amazing fuel economy; plus hundreds of tips like using simple gas and oil mixtures to add instant power and years of driving life to your car, even if you've never looked under a hood before!

Not A Step Overlooked — For Beginner Or Expert



Learn Speed and Power Tuning! Simple adjustments for new pep.

1001 MONEY SAVING TRICKS of the master mechanics crammed into 1 great book! How to resurface cylinder walls in 10 minutes without removing 1 part from your engine! Stop power waste with 25¢ worth of graphite in your crankcase. How to double explosive power of your engine. How to fix-it-yourself; spot trouble, make emergency repairs with the tools in your car. Cut engine wear; stop summer overheating. Amazing jiffy-car-polish tricks. So complete it even has step-by-step sections showing how to rebuild, repower even junkyard Fords, Hudsons, etc., into sleek, 180 horsepower, 126 mph speedcars, with push-button doors, plastic tops, custom grillwork, exclusive redesigning with "pickup" parts, for foreign car features! It's the biggest, most complete, up-to-the-minute volume of automotive information ever published for the average car owner, yours FREE FOR A WEEK if you send TODAY!

WHAT EVERY CAR OWNER WANTS TO KNOW!

Partial Contents:

- Water-alcohol injection systems. How they work and why. How to make and install a Mason-jar water injector. 10 ways to save on gas. 8 ways to save on oil. Special fuels, carburetion. Better carburetor action. Hi-test vs. regular gas. Treated gas and oil. Air-fuel mixture adjustment. New type carburetors. Building your own dual manifold —dual carburetor. Using adjustable jet screws and air-flow needles. Supercharging your car. Speed and power tuning. Increasing top car speed. Increasing pickup on hills. Flash starts in icy weather. Re-working engine, ignition. Dual ignition systems. Easy ways to higher horsepower. Eliminating tappet noise.
- Eliminating carburetor flooding, fuel pump surge, motor cut-out, fuel waste. How to eliminate overheating. Engine lubrication magic: lifetime oil filters. 1 minute spark plug checkup. Hi-compression conversions. Sport and model changes. Building your own roadster. Hard chroming tricks. Customizing, restyling ideas. 10,000 extra tire miles. Touching up nicks, dents, for perfect blend and finish. Mounting tires on rear. Calif. style convertible tops. How to preserve car finish. 20 ways to increase resale \$. How to have automatic hill holder—6 forward speeds—no clutch shift, in present car. Emergency repairs made easy. Building a practical jet engine. 12 tips to A-1 car condition.

PLUS: Latest Information on Care, Replacement, Repair of:

- Fuel pumps—ignition, electrical systems—starter—battery—generator—body, chassis care—new silicone polishes—tires, brakes, cooling system—lubrication—oil filters—directional signals—accessories—performance boosters — lights, switches — shocks — ventilating system — transmission—rear end—engine—bearings—carburetor—speedometer cable—windshield wipers—steering wheel—etc.

. . . and much, much more!

SEND NO MONEY Mail Free Gift Coupon NOW

all 3 FREE

- (even if you return book)
1. Speed and Special Equip. Catalog. 36 pages, reg. 25c value. PLUS: Free membership National Discount Club saves you up to 45% on auto supplies and products.
 2. How To Obtain 150 Miles Per Gallon. Amazing economy secrets! Thousands of copies sold at \$1.
 3. Economy In Driving. Can cut your bills in half! 48 pages, reg. 50c value.

ACT NOW

Special Offer Gives You 3 Valuable Handbooks FREE!

Send TODAY and get 3 extra handbooks described here (reg. \$1.75 value) yours FREE with SPEED & POWER MANUAL. Examine for 7 days. If not convinced book will pay for itself 10 times over in 1 week, save you \$75-\$300 in 1 year, return for money back, but keep 3 extra handbooks as FREE GIFT!

NEWHOUSE AUTOMOTIVE INDUSTRIES, DEPT. PWR 699 Madison Ave., New York 21, N. Y.

Gentlemen: Without obligation please rush me new SPEED & POWER MANUAL for NO RISK examination and trial. I agree to pay postman on arrival \$1.98 plus postage. If I am not satisfied, I may return in 7 days for full money back.

Also send me ABSOLUTELY FREE, the 3 handbooks described here (reg. \$1.75 value), plus my FREE MEMBERSHIP in National Discount Club. I understand these are mine FREE, whether or not I keep SPEED & POWER MANUAL.

NAME _____
ADDRESS _____
CITY _____ ZONE _____ STATE _____

SAVE MORE! If you send \$1.98 with coupon, we pay all postage charges. Same money back guarantee.

NEWHOUSE AUTOMOTIVE INDUSTRIES
Dept. PWR 699 Madison Ave., New York 21, N. Y.

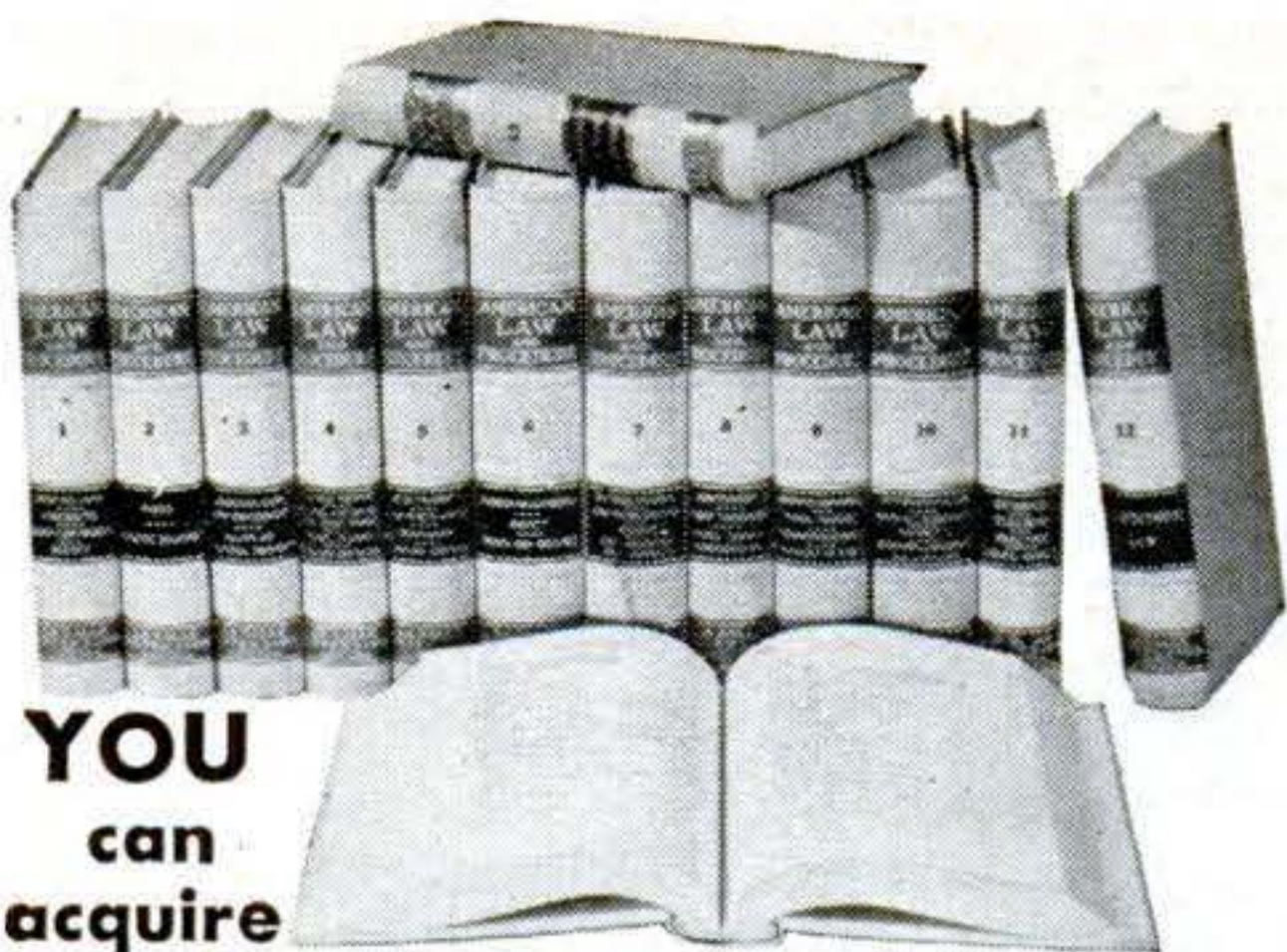

**YOU
can
acquire**

**LAW NIGHTS AT HOME!
L. B. DEGREE**

LaSalle's famous Law Library—used as reference in many Law libraries and Law offices—has enabled thousands to master Law surprisingly fast, in spare hours at home, for business and professional advancement.

These 14 remarkable volumes, compiled by leading professors and lawyers, cover the whole basic field of Law in condensed, orderly, simplified manner.

You advance rapidly with this great library, plus special lectures furnished. We guide you step-by-step with personalized Problem Method of instruction . . . you *learn by doing*—handling legal problems—not by memorizing rules.

Send for two FREE 48-page booklets, "Law Training for Leadership," and "Evidence," answering questions about Law and its value to you, and telling how LaSalle Law graduates are winning rapid advancement in business and public life. Mail coupon below. No obligation.

**LA SALLE EXTENSION UNIVERSITY
A Correspondence Institution**

417 S. Dearborn St. Dept. 583L Chicago 5, Ill.

Send me your two FREE booklets described above, without obligation.

Name..... Age.....

Street.....

City, Zone & State.....

INVENTORS

Your first step—if you consider your invention to be something of importance—is to have a search made of pertinent, prior U. S. patents. If our search report indicates probable patentability of your invention, you may apply for a patent which gives you the right to exclude others from making, using or selling your invention as claimed for a term of 17 years.

This firm is registered to practice before the U. S. Patent Office and is available to assist in the preparation of the necessary drawings, specification and claims.

Ask for a copy of our instructive booklet, "Patent Protection for Inventors" and our convenient "Evidence of Invention" form. No obligation.

VICTOR J. EVANS & Co. *Merlin M. Evans*
REGISTERED PATENT ATTORNEY
740-E MERLIN BUILDING, WASHINGTON 6, D. C.

INVENTORS

Before you make any effort to market your invention, you should take the first steps toward proceeding for patent protection.

I shall be pleased to furnish you with information relative to patent procedure upon request from you, and this will be without any obligation on your part.

PATRICK D. BEAVERS
Registered Patent Attorney
937 Columbian Building, Washington 1, D. C.

INVENTORS

IF YOU WISH TO PROTECT YOUR INVENTION, You should take steps to protect it by a U. S. Patent. Write me for "INVENTION RECORD" FORM

CARL MILLER
REGISTERED PATENT ATTORNEY
WOOLWORTH BLDG., 35th FLOOR, 52C
NEW YORK CITY

PATENTS
C. A. SNOW & CO.
REGISTERED PATENT ATTORNEYS
WRITE FOR INFORMATION TO
426 SNOW BUILDING, WASHINGTON 1, D. C.

INVENTORS

Whether an invention is patentable can be substantially determined by a search of the U. S. Patent records. Without obligation, write for information explaining the steps you should take to secure a patent.

JOHN N. RANDOLPH
Registered Patent Attorney
205 Columbian Building Washington 1, D. C.

INVENTORS

Send for PATENT INFORMATION Book and INVENTOR'S RECORD without obligation GUSTAVE MILLER 52PS Warner Building Washington 4, D. C.	REGISTERED PATENT ATTORNEY PATENT ATTORNEY & ADVISOR U. S. NAVY DEPT. 1930-1947 ASSOCIATE EXAMINER U. S. PAT. OFF. 1922-1929 PATENT LAWYER
---	---

FREE SAMPLE LESSON **WATCHMAKING**

CHICAGO SCHOOL OF WATCHMAKING
1608 Milwaukee, Dep. 452, Chicago 47, Illinois

Show me without obligation how I can learn watch repairing at home. Rush free sample.

Name.....
Address.....
City..... Zone..... State.....



CRESCENT SCHOOL

"One of the largest schools of its kind"

I WILL START YOU
on a **HIGH PAYING CAREER**
in **RADIO-TV SERVICING**
FREE!



Dr. Alexander Schure
B.S., M.A., Ph.D.

LEARN AT HOME
in your spare time!

"Now you can prove to yourself that you can have a profitable career in RADIO and TELEVISION—at no cost to you! The free booklet I send you is actually an illustrated, simplified CRESCENT SCHOOL lesson on how to make basic TV adjustments. With it you can start earning extra cash in your spare time—immediately! Don't wait...send for this valuable FREE offer today!"



INCREASED EARNINGS



INTERESTING WORK



AN UNLIMITED FUTURE

COMPLETE TV-RADIO SERVICING COURSE

The famous CRESCENT SCHOOL course is available to you complete for home study! New simplified, illustrated lessons show you the latest techniques—no previous training needed! Carefully selected parts-kit included with the course: you learn by doing! Complete the course as quickly as you can learn; CRESCENT SCHOOL certificate — recognized by industry — awarded upon completion.

PAY AS LITTLE AS
\$5 MONTHLY

Total cost for complete course
as little as **\$100**

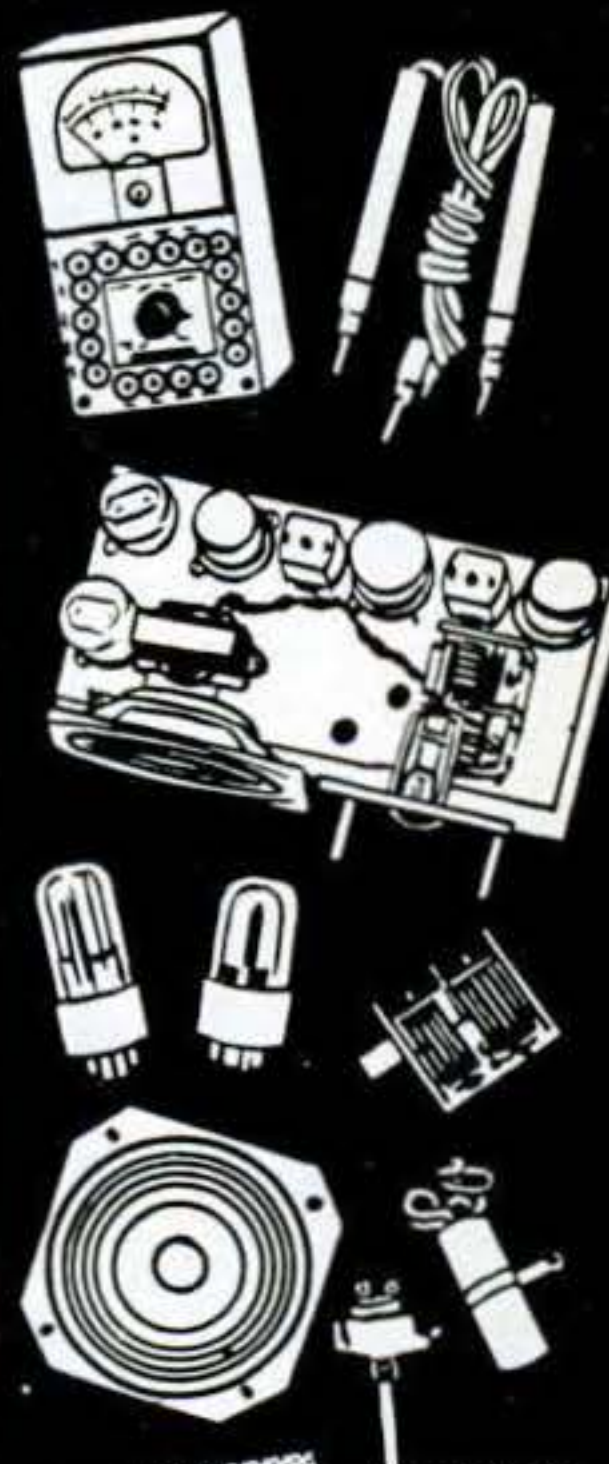
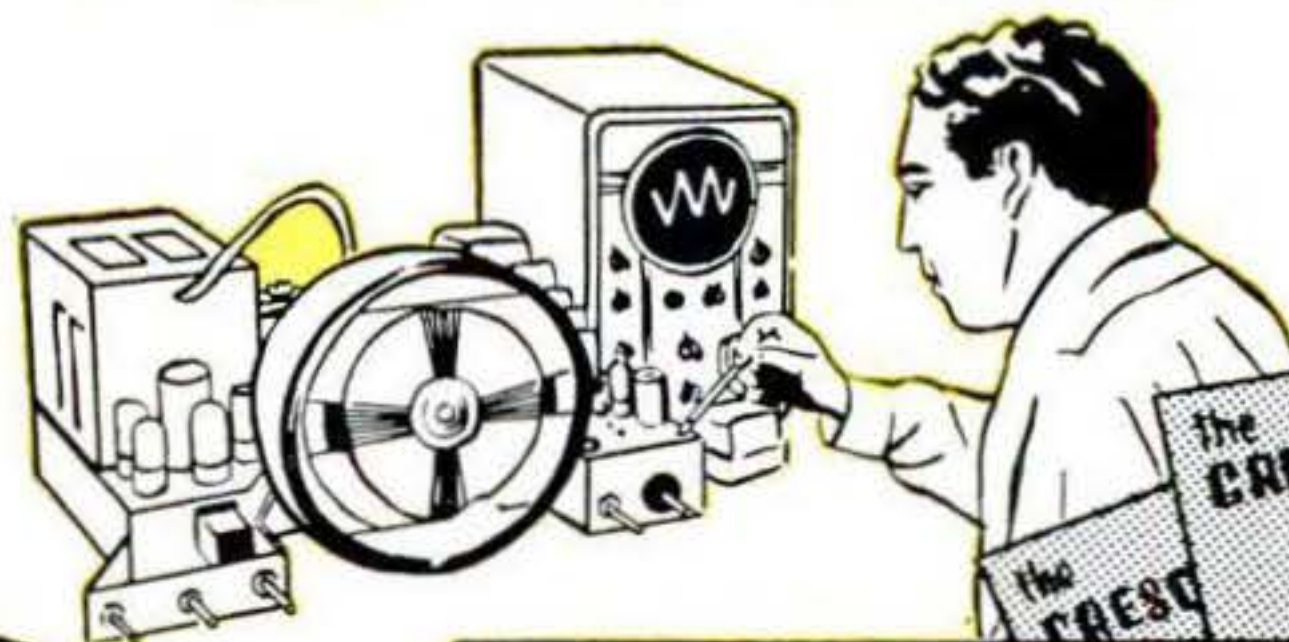

BIG DEMAND FOR TRAINED MEN

All of the advantages of higher earnings, an interesting job with prestige and a truly unlimited future in a fast-growing field await men trained in RADIO and TV! This training can help earn extra pay and rank in the ARMY, NAVY and AIR FORCE!

SEND COUPON TODAY
for sensational
FREE OFFER!

CRESCENT SCHOOL Dept. A-5
500 Pacific St., B'klyn 17, N. Y.

Dr. A. Schure: Rush FREE booklet illustrating basic TV adjustments, and full details about the CRESCENT SCHOOL Home Study Course—all at no obligation to me!

NAME
ADDRESS
CITY..... ZONE..... STATE.....

C. T. C. TRAINING IN DRAFTING

PREPARES FOR PROMOTION
MORE MONEY
SUCCESS

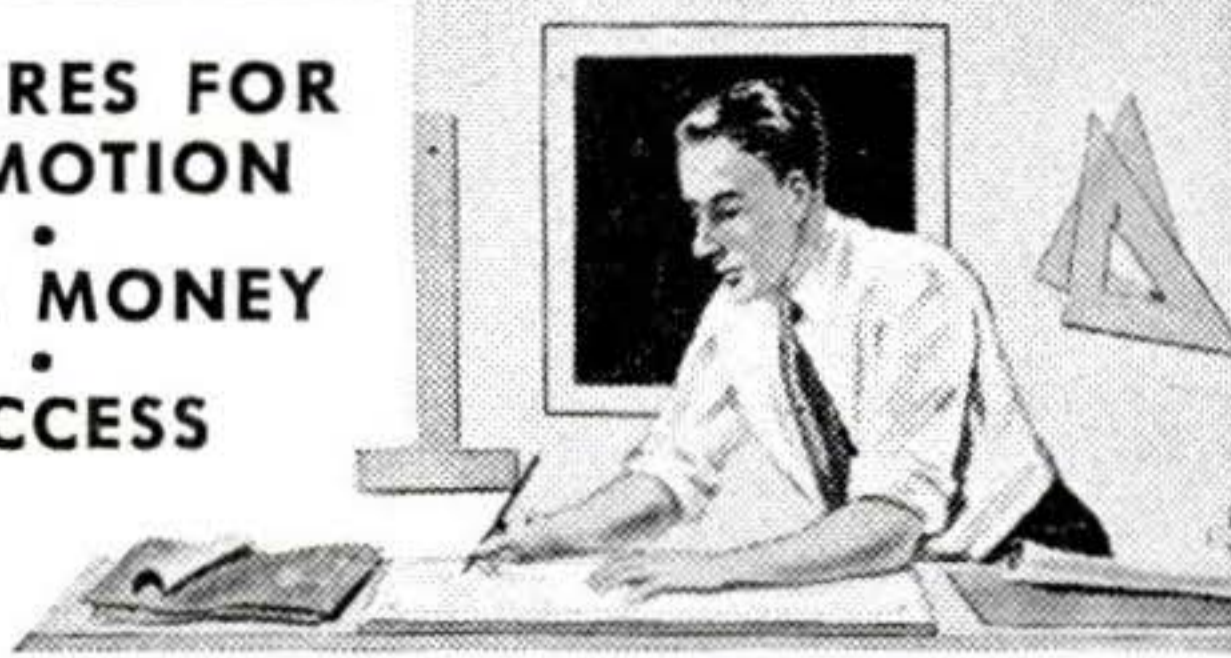

"Here I am at work making good money as a draftsman. I'm glad I sent the coupon to Chicago Tech for that Free Trial Lesson and found out how easy it is to learn Drafting in spare time at home. Today, I feel secure in my job. What's more, I feel I'm slated for promotion and more pay."

LEARN IN SPARE TIME—AT HOME!

(or at the College in Chicago)

A few hours of pleasant home study every week—that's all. All the tools you need; drawing outfit included. This tested method—developed over 48 years of C.T.C. progress—prepares men quickly for good positions in industry.



FREE INFORMATION — SEND COUPON

To prove to you how easy it is to learn Drafting at home by the Chicago Tech method, we will send you this FREE TRIAL LESSON. No charge for this lesson, now or later. Fill out and mail coupon, or send post card today.

CHICAGO TECHNICAL COLLEGE

E-220 Tech Bldg., 2000 So. Michigan Ave., Chicago 16, Illinois

Mail me FREE Lesson with information about big opportunities in DRAFTING.

Name.....Age.....

Address.....

City.....Zone...State.....

I GAINED 53 LBS. OF SHAPELY POWER-PACKED MUSCLES

OF SHAPELY POWER-PACKED MUSCLES

say's Roger Hirsch, N. Y.

NOW BEFORE

2 Which of these? ME'S is YOU?

"That 112 lb.—6 ft. spindle-armed Sissy at right was ME a few short weeks ago", says Roger Hirsch. Look at him NOW! I gave him 53 lbs. of MIGHTY MUSCLES, added 6½ inches to his CHEST, 3 inches to each ARM! They don't call him SKINNY any more!

NO! I don't care how skinny or flabby you are. All I want is 10 minutes a day in your home to make you over by the same method I turned myself from a wreck into a Champion of Champions. You'll become an ALL-ROUND, ALL-AMERICAN, HE-MAN, A WINNER in everything you tackle—or my training won't cost you one cent.

ROGER HIRSCH was a 112 lb. 6 ft. WEAKLING. Look at him NOW!

SEND ME ONLY 10¢ for all 5 PICTURE-PACKED HE-MAN BUILDING Courses and also get Both FREE 1. PHOTO BOOK OF STRONG MEN 2. A MUSCLE METER

JOWETT INSTITUTE, Dept. PS-25
230 Fifth Ave., New York 1, N. Y.

Dear George: I enclose 10c for which please send me on trial all 5 picture-packed HE-MAN Building Courses, FREE Photo Book, and Muscle Meter.

NAME.....AGE.....
(Please print plainly. Include Zone Number)

ADDRESS.....No C.O.D.'s

CITY.....ZONE...STATE.....



"Win This 15" Silver Trophy as I did." *Roger Hirsch*

Be your own boss... operate your own

Jetmatic VENETIAN BLIND LAUNDRY



The world's largest manufacturer of Venetian Blind Cleaning Equipment, and inventor of the Jet Spray method can show you

THE WAY TO BIG PROFITS

Your Jetmatic is easy to install and operate. Start in a basement or garage — Expand as your business grows. We operate the world's largest Venetian Blind Laundry, and can give you

The Know How You Need For Success

Don't be misled by imitations. Jetmatics are sturdily built for professional use.—Used the world over. No other method known today will guarantee to clean the dirtiest, greasiest Venetian Blind without hand rubbing. Jetmatic re-uses detergent—Wide fan spray cleans entire Blind without taking apart. Thousands of homes, factories, offices, institutions want this quick, efficient service. If you are sincerely ambitious, and want to start a profitable business of your own with small capital, write or wire for the facts.

L. C. ROBINSON MFG. CO.

522 N. Rural St. Indianapolis 1, Indiana
In Canada — 24 Jahnke St., Chatham, Ontario

PUMP WATER FAST!



DRAIN WASH TUBS, CELLARS, CISTERNS IRRIGATE—FILL TANKS—DRAW WELL WATER

Pumps 2800 GPH. 420 GPH at 75' High or 1600 GPH from 25' well. Sturdy, Rustproof Alloy Metal. Six Blade Impeller. Uses any 1/8 to 1/2 H.P. Motor Will not leak or clog. Fits any garden hose. Immediate Money Back Guarantee. Send Check, M.O. or C.O.D. **895** IN U.S.

MOORE MANUFACTURING CO.
SWEDESBORO 2 NEW JERSEY

PHOTOGRAPHY



EARN BIG MONEY! PERSONAL ATTENDANCE TRAINING in News-Magazine-Fashion-Portrait-Advertising-Natural Color Photography. Splendid equipment, glamorous models. Or — our COMPLETE HOME STUDY COURSE provides you with a spare time short-cut to success.

Our 42nd year. Write immediately for BIG FREE BOOK!

NEW YORK INSTITUTE OF PHOTOGRAPHY
Dept. 5, 10 West 33 St., New York 1, N. Y.

ENORMOUS PROFITS CASTING AT HOME

Write today for NEW FREE CATALOG

Learn to cast thousands of perfect figurines, plaques, book ends, ash trays, etc. Start NOW—NO EXPERIENCE LITTLE CAPITAL needed. Earn GREAT PROFITS with X.L. RUBBER MOLDS. X.L. Rubber. Pts. \$2.50, Qts. \$4.00 (postage extra); Models and enough rubber for 3 molds... \$1.50 postpaid.

PLASTIC ARTS STUDIO

3403 S. Madison St. Dept. 3
MUNCIE, IND.



FREE FACTS SENT

CHEVROLET CAR & TRUCK OWNERS

(1938 thru 1951)

Get Smo-o-oth Clutch Action

with CLUTCH-EZE

Clutch-eze takes grab and groan out of any Chevrolet clutch, either passenger car or truck. Gives smooth-as-silk starting in traffic. More pleasure in driving. Increases clutch life. Saves expensive repairs. Patented steel fingers. Easily installed in a few minutes by anyone. Only a screwdriver needed. SATISFACTION GUARANTEED or money back. **\$3.45** Postpaid

Send Cash, Check or M. O. with order. \$1.00 deposit on C. O. D.'s, with C. O. D. charges extra.

AUTOMOTIVE AIDS CO. Dept. 34
201 East Fifth Street Plainfield, New Jersey

GET INTO **AUTO-DIESEL** & **ALLIED MECHANICS** *Master All Phases*

JOBS LIKE THESE ARE AVAILABLE TO TRAINED MECHANICS. CHOOSE THE FIELD YOU LIKE BEST

GET COMPLETE TRAINING FOR:

Automotive Motor Tune-Up • General Garage Mechanic • Agricultural Implements Mechanic • Diesel Engine Rebuilding • Diesel Fuel Injection • Auto Engine Rebuilding • Auto Electrical Service • Parts Dealers • Bus & Truck Lines • Industrial Maintenance • Contracting and Excavating • Business of Your Own • AND MANY OTHERS!

SHOP-METHOD HOME TRAINING BY AN ESTABLISHED RESIDENT SCHOOL TRAINS YOU FOR ALL OPPORTUNITIES IN AUTO & DIESEL INDUSTRIES!

Opportunity is everywhere for the trained Auto-Diesel Mechanic. Highways throng with cars, buses, trucks, tractors. Garages and service stations are busy. Farm machinery is "going Diesel." Factories, ships, farms, railroads, general industry, are dependent on engine power. Here's a dynamic, fast-growing field that needs trained men who know *all* phases: installation, operation, maintenance and repair. Now—National Schools offers you a practical, all embracing Auto-Diesel Mechanic's Course, including all these advantages:

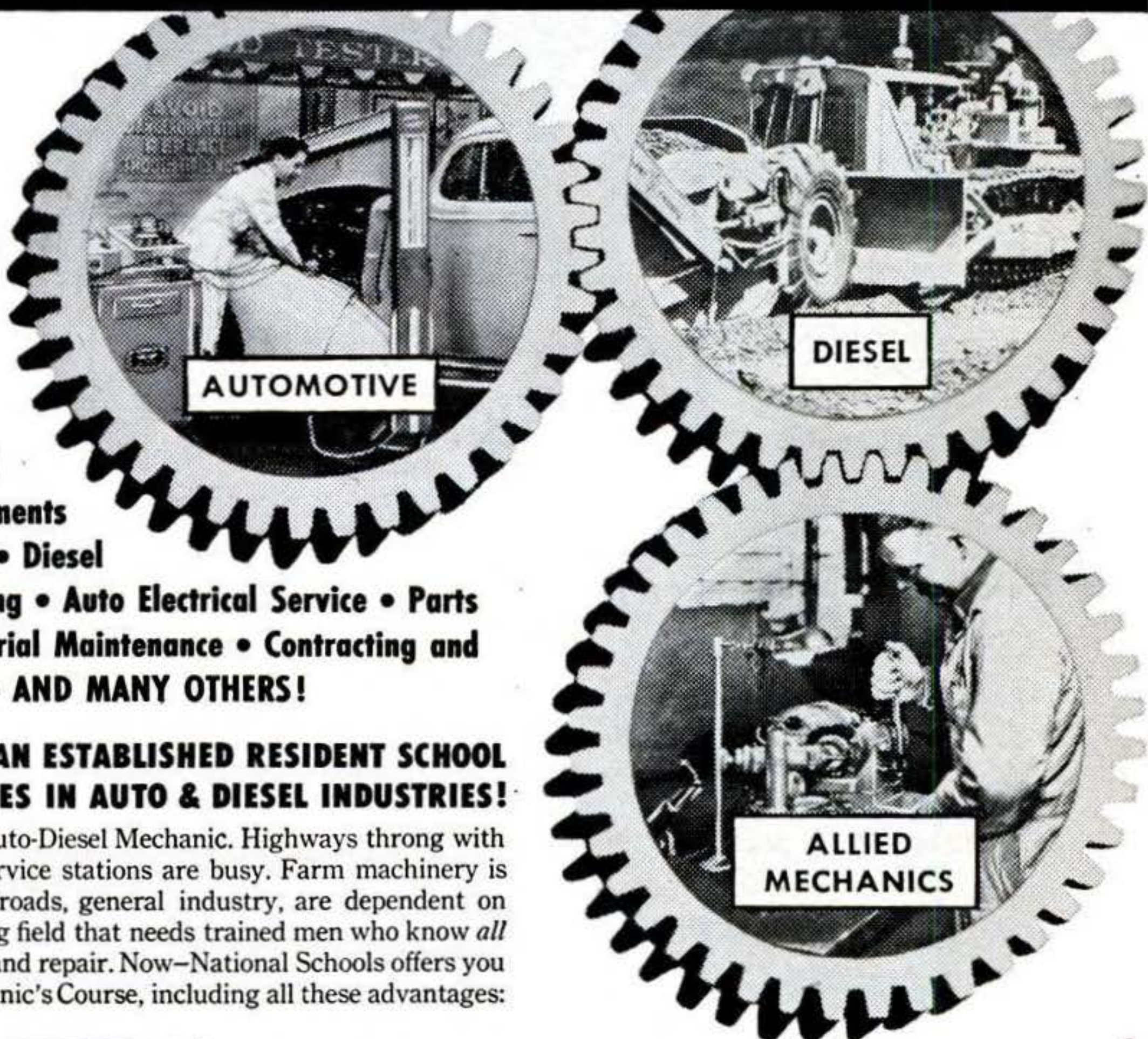

COMPLETE SHOP-METHOD HOME TRAINING COVERS

DIESELS—High Speed and Heavy Duty SEMI-DIESELS—Gasoline and Special Fuel Engines AND ALLIED MECHANICS!

- | | |
|-----------------------|------------------------|
| Basic Lesson Texts | Engine Service Manuals |
| Diesel Installations | Engine Repair |
| Operation-Maintenance | Drive Systems |
| Diesel Chart Manual | Diesel Electric Power |
| Spare Time Lessons | Thermodynamics |

AND YOU CAN EARN WHILE YOU LEARN!

With our practical Master Shop-Method Home Training, you study at home in your spare time. You get Spare Time Work Lessons showing you how to earn while you learn, for extra money and experience. You learn by **DOING**.

DRAFT AGE? Services offer better ratings, more pay to men with training. Start now—if called while training, we'll make satisfactory adjustment for you.



FREE BOOK and SAMPLE LESSON show how we train you! SEND FOR THEM TODAY!

WE GIVE YOU TOOLS OF YOUR TRADE

TO MAKE YOUR TRAINING COMPLETE, WE GIVE YOU PROFESSIONAL QUALITY TOOLS AND EQUIPMENT, INCLUDING ALL-METAL TOOL BOX! THEY ARE PART OF YOUR INSTRUCTION, YOURS TO KEEP! DON'T MISS THIS OPPORTUNITY OF A LIFETIME! GET THE FACTS—MAIL THE COUPON NOW!

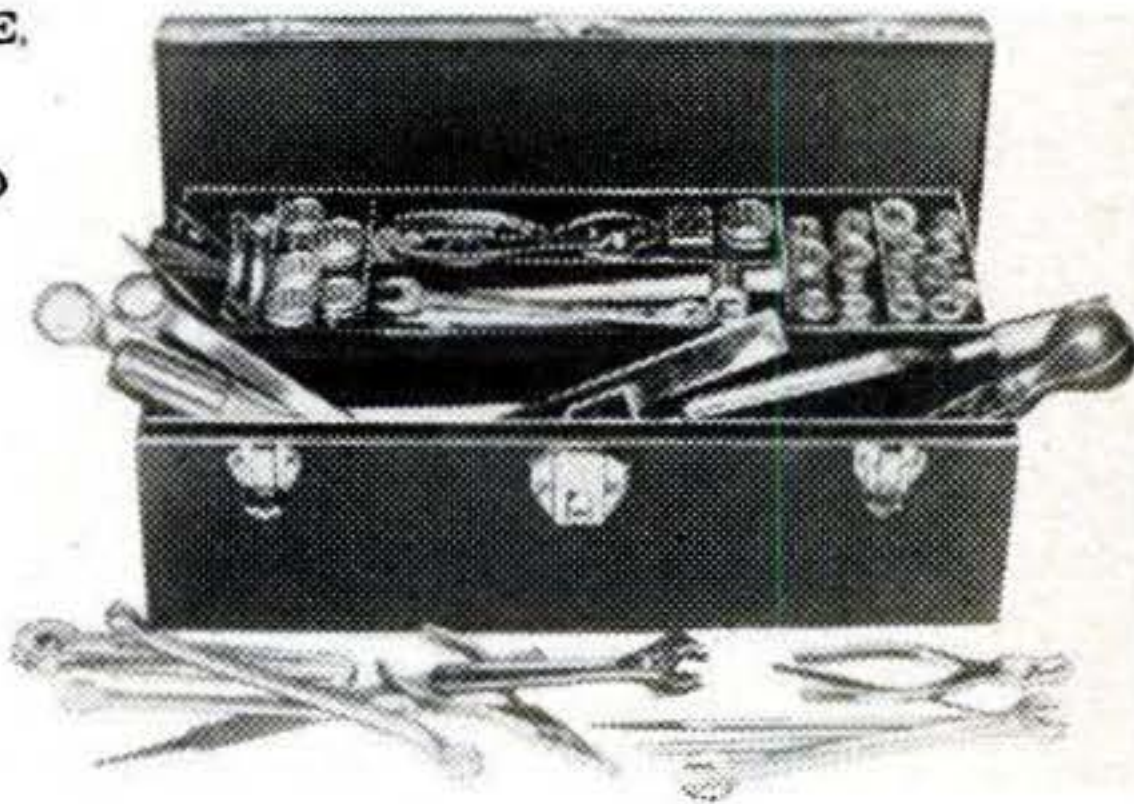

NATIONAL SCHOOLS

LOS ANGELES 37, CALIFORNIA • ESTABLISHED 1905
In Canada: 192 E. Hastings St., Vancouver, B. C.



FIND OUT NOW...MAIL COUPON TODAY

**NATIONAL SCHOOLS, Dept. CD-52
4000 South Figueroa Street
Los Angeles 37, California**

Mail in envelope or paste on postal card

Mail me FREE the book "My Future in Automotive-Diesel & Allied Mechanics" and the Sample Lesson. I understand no salesman will call on me.

NAME _____ AGE _____
ADDRESS _____
CITY _____ ZONE _____ STATE _____

I'LL **PAY** YOU
to "GIVE AWAY"
NYLONS AT 49¢!



Did you ever hear of first quality, full fashioned nylon stockings at 49c a pair? Would you make money writing orders? Would any woman refuse to order? Would you have the sensation of the century? Sounds impossible, of course, but that's all they cost if they run or snag within guarantee period up to THREE WHOLE MONTHS!

This isn't selling. It's giving something away. Every day, women buy over two million pairs of nylon stockings. Imagine how eagerly they will order when you show them these fantastic savings on nationally advertised Kendex nylons.

There's nothing for you to buy or deliver. Just write orders. We'll deliver and collect. You get advance cash on every order and, in addition, can easily qualify for my huge cash bonus which increases your earnings by 40%!

FREE SAMPLE STOCKING!

I'm so positive you can make money that I'm willing to give you a sample stocking, color card and all sales materials absolutely free! I'll even pay the postage. What's more, you need promise nothing. The whole outfit is yours and if you don't make enough money, just throw it away!

I don't care if you are 18 or 80—whether you can spare one hour or fifty hours a week. Man or woman—young or old—spare or full time—experienced or not, this can be the opportunity you have been hoping for.

If you write me quick, I'll also include complete money-making outfit of a wonderful line of men's hosiery actually guaranteed ONE FULL YEAR or replaced free without question!

MAIL THIS COUPON NOW!

Michael H. Kent, President
Kendex Corporation
Babylon 749, N. Y.

Send me, absolutely free and postage prepaid, your complete money-making outfits including free sample stocking. It is understood I am under no obligation and if I am not satisfied with the money I make, I will throw away the outfits.

Name.....

Address.....

City..... Zone..... State.....

Date.....

MONTH AFTER MONTH, YEAR AFTER YEAR, YOU SEE OUR AD. REMEMBER IT'S DANGEROUS to pay less if you want the finest nonskid USED tires.

GOOD YEAR Firestone

GOODRICH, UNITED STATES, GENERAL, & OTHERS, NOT RECAPS

Our policy is to select your tires so carefully, as if our very future depended on the service given by that particular tire.

FREE TUBE WITH ANY GRADE TRUCK OR PASS. TIRE (EXCEPT MILITARY TREAD TIRES)

GOOD GRADE TIRES 16 MONTHS GOLDEN RULE GUARANTEE	
600-16 \$4.14	820-15 \$5.44
650-16 5.42	700-15 4.54
700-16 5.04	670-15 4.74
650-15 4.44	710-15 4.94
760-15 5.04	550-17 4.64
600-20 \$7.14	32x6 (8) \$8.64
650-20 7.94	32x6 (10) 9.94
700-20 8.54	900-20 13.94
750-20 8.64	1000-20 13.94
825-20 15.92	1100-20 14.94

FINEST GRADE, 29 MONTHS GOLDEN RULE GUARANTEE BOND

THIS GRADE MADE THE BLATT NAME "WORLD FAMOUS"	
600-16 \$5.29	LO-PRESSURE TRUCK TIRES (8-10-12-14 PLY
600-16(6) 6.80	550-15 \$5.60
650-16 6.12	640-15 5.65
650-16(6) 7.75	670-15 5.95
700-16 6.42	710-15 6.17
750-16 7.75	760-15 6.27
525-18 4.92	800-15 6.84
550-17 5.64	820-15 6.80
650-15 5.60	670-16 6.42
700-15 6.05	760-16 6.94
700-15 6.05	760-16 6.94
32x6(10) 12.02	1100-20 19.95

Buy THE "Right" TRUCK TIRES For "Your" Job 8-10-12-14-Ply DEPEND ON US

Std. Guar. 16 Mos. Rugged Guar. 30 Mos. MILITARY MUD-SNO TREAD	750-20 \$10.	750-20 Rg. \$16.64
	600-16 Std. 6.75	600-16 Rg. 9.95
	900-16 Std. 10.	900-16 Rg. 16.00



BLATT BLATT BLDG., GIRARD & LANCASTER AVES. DEPT. PS, PHILADELPHIA 31, PA. Send check or money order. Save this ad to re-order. We won't ship a tire we wouldn't use. The name to trust in rubber. Shipments RUSHED Down South, Up North and Far West

TASOPE PHOTO-ENGRAVING PLANTS



MATERIAL COST OF THIS CUT 3/4c SELLING PRICE \$1.00 AND UP

Establish your own profitable PHOTO-ENGRAVING business. Make cuts for newspapers, printers, and advertisers. Make etched name plates, plaques etc. Instructions furnished, no experience necessary. Sold direct from factory since 1931. First five hundred cuts sold locally or by mail will pay for plant and pay you well for your time. Write for FREE catalog. TASOPE DEPT. PS-5, AURORA, MO.

SHORTHAND IN

Famous Speedwriting Shorthand system. No symbols; no machines. Uses ABC's. Easiest to learn, write, transcribe. Low cost. 100,000 taught by mail. Also typing. 29th year. Write for FREE booklet to:

Speedwriting
Dept. 2605-2
55 W. 42nd Street, N. Y. 18

6
WEEKS
AT HOME

MECHANICAL DENTISTRY

To make Crowns, Plates, Bridgework, etc., for Dentists. Easy practical way to learn mechanical dentistry at home in spare time. FULL EQUIPMENT OF TOOLS AND MATERIALS INCLUDED WITH COURSE. Low tuition. Easy terms. Write for FREE BOOK about this money making profession that is not affected by the machine age.

McCARRIE SCHOOL of Mechanical Dentistry
207 N. Broad Street Dept. 423 Philadelphia, Pa.

MAKE CRIME YOUR BUSINESS

ON THE SIDE OF THE LAW!

Help fight crime! . . . Earn steady good pay as a Finger Print Expert or Investigator. I.A.S. trains you—by easy, low-cost home study lessons. Learn this exciting work in spare time. Write for full details now!

OVER 800 POLICE BUREAUS...

Employ I.A.S.-trained men . . . proof of what I.A.S. can do. Write today (state age) for details. No obligation. No salesmen will call.

INSTITUTE OF APPLIED SCIENCE

Dept. 1365, 1920 Sunnyside Avenue
Chicago 40, Illinois



Yes,
I'm an engineer...but
how can I become
an AIRCRAFT
engineer?

Lockheed in California can train you – at full pay!

The step up to Aircraft Engineering isn't as steep as you might expect.

Aircraft experience isn't necessary. Lockheed takes your knowledge of engineering principles, your experience in other engineering fields, your aptitude, and adapts them to aircraft work. You learn to work with closer tolerances, you become more weight conscious.

What's more, Lockheed trains you at full pay. You learn by doing—in Lockheed's on-the-job training program. When necessary, you attend Lockheed classes. It depends on your background and the job you are assigned. But, always, you learn at full pay.

These opportunities for engineers in all fields have been created by Lockheed's long-range production program—building planes for defense, planes for the world's airlines.

And remember this: When you join Lockheed, your way of life improves as well as your work.

Living conditions are better in Southern California. The climate is beyond compare: Golf, fishing, motoring, patio life at home can be yours the year 'round. And your high Lockheed salary enables you to enjoy life to the full.

Send today for illustrated brochure describing life and work at Lockheed in Southern California. Use handy coupon at right.

ENGINEER TRAINING PROGRAM

Mr. M. V. Mattson, Employment Mgr., Dept. PS-5



Dear Sir: Please send me your brochure describing life and work at Lockheed.

My Name _____

My Field of Engineering _____

My Street Address _____

My City and State _____

POWERFUL

Only \$2.98

DRIVES MODEL PLANES, BOATS, CONSTRUCTION SETS, Etc. WITH AMAZING SPEED! RUNS ON FLASHLIGHT BATTERIES!

MOTOR

BOYS! MODEL-MAKERS! Get this new MIGHTY MIDGET D. C. Electric motor. It's a honey! Looks and runs just like a big one. Motor is powerful yet measures only 1 x 1 x 1 1/4 inches; weighs one ounce! Turns up 6,800 r.p.m.'s. REVERSES INSTANTLY. Motor is in durable black plastic housing. Comes complete with two 1 1/2 volt batteries in clip holder, transparent plastic gear-box—PLUS ten extra gears and pulleys for working out your own ratios. No shocks, sparks or shorts. Endless hours of fun. Educational, too! 10 Day Money back guarantee! Send no money. Order today. Pay postman only \$2.98 plus postage when delivered. Or send \$2.98 with order and we will pay postage.

IMPERIAL SALES CO., Dept. 376
480 Lexington Ave. New York 17, N. Y.

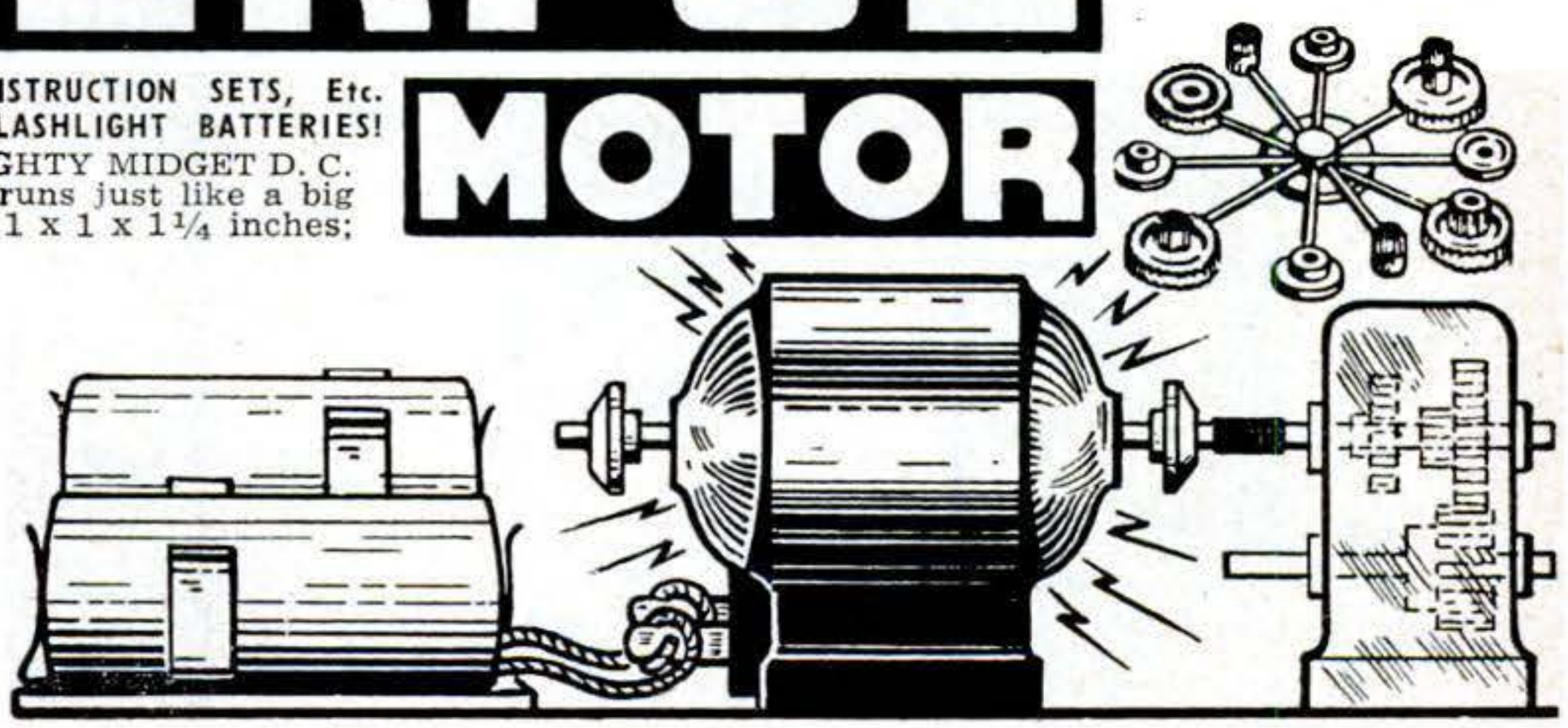

Northrop Students BUILD MINIATURE — PULSE JETS —

**Train Now at NORTHROP
for an Exciting
AVIATION CAREER**



Men training today at Northrop Aeronautical Institute as Aeronautical Engineers or Aircraft & Engine Mechanics, will design, build, and maintain the jet and rocket aircraft of tomorrow! You can begin NOW to prepare yourself for this exciting, profitable future!

Train at NORTHROP! At Northrop Aeronautical Institute, a division of the famed Northrop Aircraft Inc., you study in an atmosphere of aeronautical achievement! You put your mechanical skills to work helping design, layout, draw, mock-up, fabricate, test and assemble experimental aircraft!

Extra Advantages for You! It's the trained man who gets the best jobs—advances the fastest in important work, either civilian or military. For example, Northrop Engineering graduates are educationally qualified for Naval Aviation Cadet, Air Force Cadet, or Officer Candidate training.

FREE Northrop Catalog. Send today for the big 34-page Northrop catalog that describes the career opportunities in aviation, outlines the courses offered, and shows pictures of the training facilities you will use.

Northrop Aeronautical Institute

APPROVED FOR VETERANS

1525 E. Broadway, Hawthorne, Los Angeles County, Calif.

NORTHROP AERONAUTICAL INSTITUTE
1525 E. Broadway, Hawthorne, Los Angeles County, Calif.

Please send me immediately the Northrop catalog, special military information and employment data, and schedule of starting dates of classes. I am interested in:

Aeronautical Engineering ★ Aircraft & Engine Mechanics

Name _____ Age _____

Address _____

City _____ Zone _____ State _____

VETERANS—Check here if you are entitled to training benefits under the G. I. Bill.

SN7-A



Start a Business in Your Backyard



Earn BIG MONEY MAKING BUILDING BLOCKS

**General Concrete Vibrator
BLOCK MACHINE**
CAPACITY 1000 BLOCKS A DAY

only \$218 LESS MOTOR
F.O.B. PLANT

SHIPPING WEIGHT 400 LBS.

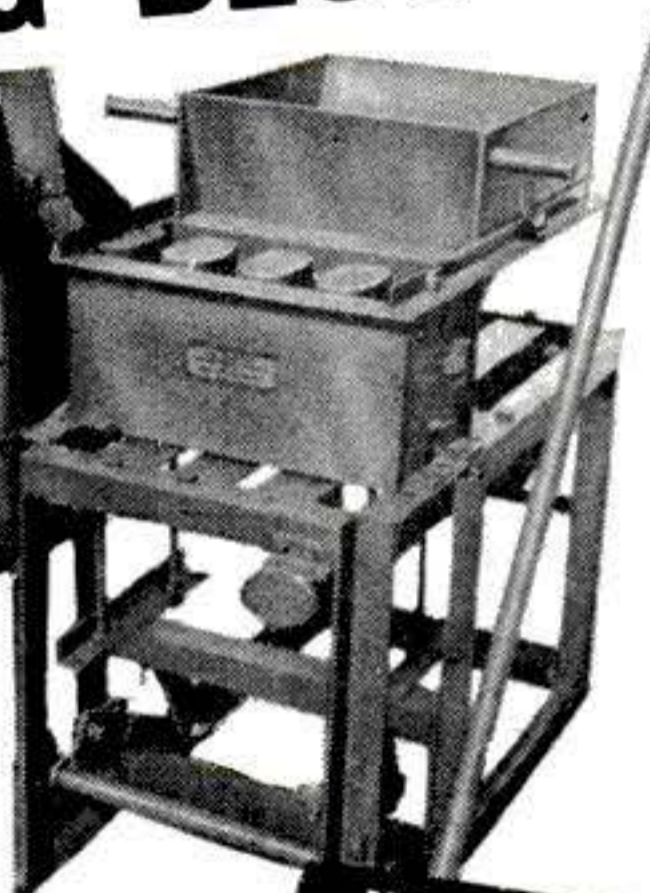

Here is a business you can start on small capital—in your own backyard—that earns 100 to 150% profit, with unlimited opportunities. Make concrete or cinder blocks. Millions used for homes, factories, public buildings, garages. Sell all you make to building trade. Do it with a General—and you're headed for success.

1000 BLOCKS A DAY

The General is a high speed, power-driven block machine at amazingly low cost. Rugged all-steel construction. Simple to operate indoors or outdoors. Makes superior 3 core type block meeting all code requirements. Produces up to 1000 blocks per day. Full operating instructions and mixing formulas supplied. Write for FREE details.

Dealer Inquiries Invited

Wonderful
Book Written
& Illustrated
by Experts



GENERAL ENGINES CO.

DEPT. S-52 • 307 HUNTER ST. • GLOUCESTER, N. J.

Includes floor plans for 6 beautiful, easy to build concrete block bungalows. Shows ways to save money. How to lay blocks, lay out building lines, mix concrete, build steps, porches and concrete floors. Mail coupon at once with \$1.

Name.....
Address.....
City.....Zone...State.....

No Experience Needed To PRINT YOUR OWN POST CARDS

The GEM STENCIL DUPLICATOR saves money... gets results quickly! Hundreds of uses for every type of business and organization. We ship the GEM complete with all supplies, Guide Board for accurate printing and 60-page Book of Ideas at the special low price of only \$8.50 (a \$15 value).

FREE TRIAL OFFER

Our
21st Year

Use the GEM FREE at our expense! SEND NO MONEY. Write and complete GEM outfit will be sent you postpaid. After ten days, send us only \$8.50 or return the GEM. You must be satisfied!

BOND EQUIPMENT CO. Dept. 49
6633 Enright • St. Louis 5, Mo.



LEARN AT HOME UPHOLSTERING

EARN MONEY SPARE TIME—OR OPEN A SHOP!

Earn excellent profits spare time—open a shop—or get a top-pay job: Learn upholstery at home in months. Easy picture lessons show how. Valuable tools and materials to build ottoman included. Write for free booklet.

COMMERCIAL TRADES INSTITUTE, Dept. U1-5
1400 Greenleaf Ave. • Chicago 26, Illinois



Cut and polish beautiful GEMS!

Big GEMMASTER LAPIDARY MACHINE

Does Everything! saws-grinds-sands-polishes

FASCINATING! PROFITABLE! Everything you need to cut and polish genuine gem stones for business or hobby. Write at once for FREE illustrated "How-to-do-it" folder or send 25c for complete instruction booklet and catalog.

LAPIDARY EQUIP. CO. Dept. B 1545 W. 49
SEATTLE 7, WASH

FOR FUN OR PROFIT
LEATHERCRAFT,
TEXTILE PAINTING,
COPPER TOOLING,
KITS, PROJECTS,
TOOLS, SUPPLIES

**REMEMBER RUSSO for ALL
LEATHER & CRAFT
SUPPLIES!**

SEND 25c FOR OUR **BIGGEST CATALOG YET** 25c REFUNDED WITH 1st ORDER

RUSSO HANDICRAFT SUPPLIES Dept. G, 245 S. Spring, Los Angeles 12, Calif

OIL FILTER REFILLS... 10c

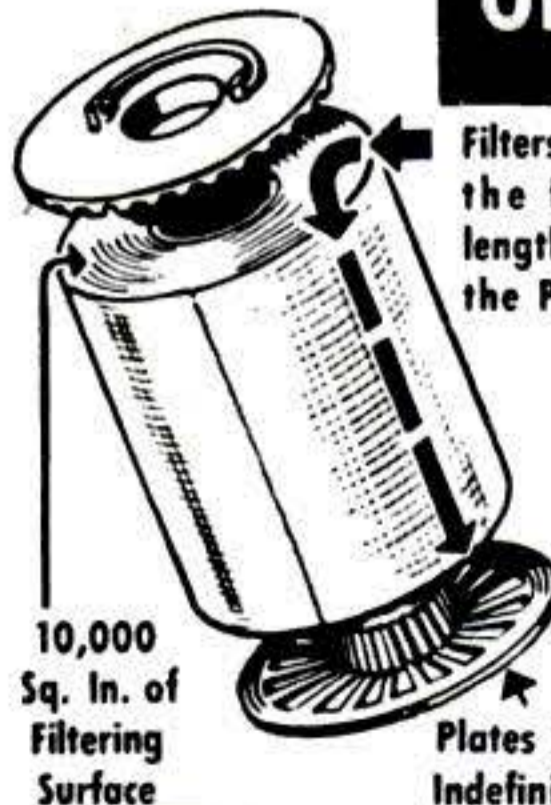

10,000
Sq. In. of
Filtering
Surface

Filters Oil
the full
length of
the Pack

Plates Last
Indefinitely

Here's News! Ordinary toilet paper makes an ideal oil filter. Laboratory tests prove it cleans oil faster and better than popular makes of filter elements. All you need is a simple set of RETLIF ADAPTER PLATES... and you can start using ordinary toilet paper rolls in your present oil filter. For proof and descriptive literature, send name and address to:

RETLIF CORPORATION, Dept. 101
1239 No. Highland Ave., Los Angeles 38, Calif.

DYNA-MITE POCKET RADIO

POWERFUL! PERSONAL! PORTABLE!

- Covers Full Broadcast Band 550-1600 K.C.
- Selective Dyna-Coil Tuning
- Batteries and All Parts Fit Within Case
- Hearing-Aid Battery Powered, Long Life
- Tiny Acorn Low Drain Tube
- Loud Clear Tone
- Over 1,000 Mile Range
- No Antenna Used for Local Reception
- No Ground Connections Ever Needed
- Picture Diagram for Radio Beginners



\$5.99 Postpaid

This neatly engineered little kit was designed to give you a real personal, portable radio that you can enjoy anywhere without disturbing others. Use it at the ball games, camping trips, in bed, in your office or just anywhere. Remember this is not a weak crystal set but a powerful tube receiver that will give you good local and long distance reception. Set, less batteries, ONLY \$5.99 postpaid. On C.O.D. orders please remit deposit of \$1.00. If batteries are desired we will supply at only \$1.50 per set or you may obtain from your local hearing-aid concern.

Order Today at this Unbelievable Low Price!

PRECISION ELECTRONICS LABORATORY

MILLER WAY

PLACERVILLE, CALIF.

MAKE EXTRA MONEY

PLASTICS

LEARN AT HOME

LEARN HOW TO MAKE fast selling PLASTIC NOVELTIES FURNITURE JEWELRY SIGNS TOYS LAMPS

There are RICH OPPORTUNITIES for MEN and WOMEN with "know-how" in Plastics. Interstate's amazing new Plastics course tells and shows how to make hundreds of fast selling items out of Plastics. Gives complete training in fabrication, casting, lamination, molding, etc., in simple, easy, step-by-step language and pictures.

START A PLASTICS BUSINESS OF YOUR OWN. No other industry holds such promise for the future. You can make big money manufacturing novelties, toys, signs, etc., in your own home in spare or full time. Don't wait! Learn NOW how Interstate's Plastics Training qualifies you for success in the plastics field.

Write for FREE Information Today!

INTERSTATE TRAINING SERVICE

School of Plastics, Dept. C2E
PORTLAND 13, OREGON

High School at Home

Many Finish in 2 Years

No classes. No time wasted going to and from school. Progress as fast as your time and abilities permit. Standard H. S. texts supplied. Thousands enroll each year in this 55-year-old school. Send for FREE descriptive booklet.

AMERICAN SCHOOL, Dept. H-546
Drexel at 58th St., Chicago 37, Ill.

Without obligation, please send FREE descriptive booklet.

Name.....

Address.....

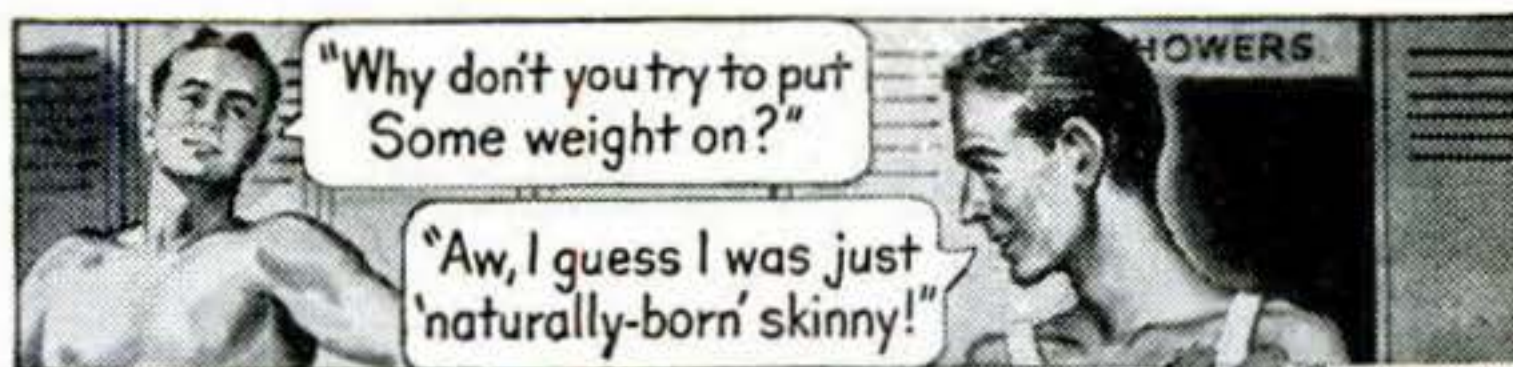

BUNK!

NOBODY IS JUST "Naturally"

SKINNY!

Give Me 15 Minutes A Day And I'll Give YOU A New Body

WOULD you believe it? I was once a skinny 97-pound weakling. I was ashamed to strip for sports or for a swim. Girls snickered at me behind my back. Folks said I was just "naturally-born skinny!"

Then I discovered my marvelous new muscle-building system—"Dynamic Tension." And it turned me into such a complete specimen of manhood that today I hold the title, "The World's Most Perfectly Developed Man."

WHAT'S MY SECRET?

When you look in the mirror and see a healthy, husky fellow smiling back at you—then you'll be astonished at how fast "Dynamic Tension" gets results! And you'll be using the method which many great athletes use for keeping in condition—prize fighters, wrestlers, baseball and football players, etc.

"Dynamic Tension" is the easy, natural method that you can practice in the privacy of your own room—just 15 minutes each day—while your scrawny chest and shoulder muscles begin to swell . . . those spindly arms and legs bulge . . . and your whole body starts to feel full of zip, self-confidence, new energy!

FREE My 32-Page Illustrated Book is Yours —Not for \$1.00 or 10c—But FREE

Send NOW for my famous book, "Everlasting Health and Strength." 32 pages, packed from cover to cover with actual photographs, valuable advice, answers to many vital questions. Page by page it shows what I can do for YOU. This



book is a real prize for any fellow who wants a better build. Yet I'll send you a copy absolutely FREE. Just glancing through it may mean the turning point in your whole life! Rush the coupon to me personally: **Charles Atlas, Dept. 1S, 115 East 23rd St., New York 10, N. Y.**

Charles Atlas

Awarded the title of "The World's Most Perfectly Developed Man."

CHARLES ATLAS, Dept. 1S,
115 East 23rd St., New York 10, N. Y.

Send me—absolutely FREE—a copy of your famous book, "Everlasting Health and Strength"—32 pages, crammed with actual photographs, answers to vital health questions, and valuable advice to every man who wants a better build. I understand this book is mine to keep, and sending for it does not obligate me in any way.

Name..... Age.....
(Please print or write plainly)

Address.....

City..... State.....

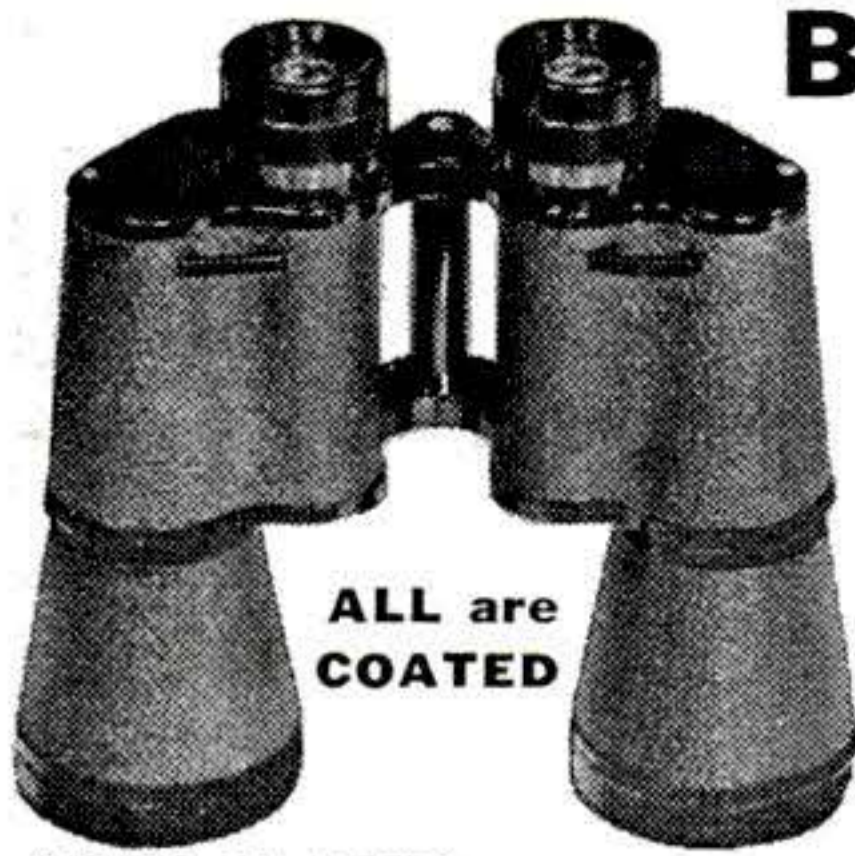

BARGAINS

Brand New, top quality glasses. All have precision ground optics, durable light-weight bodies. Moisture and dust proofed. Bear the **UNITED "Seal of Quality"**, your guarantee of satisfaction. Achromatic!

Coated! Featherweight
16x50 \$69.50
COATED

The ultimate in a fine binocular. Tremendous power. Featherweight (weighs only 25 ounces!). Precision made in every detail. **COATED** providing sharper, brighter images. Individual focus. Objective lens is 50mm (2 inches) across!



- ALL are COATED**
- 6x15 4 oz. Pocket \$16.95
 - 7x18 Pocket **ALL CHROME** 19.95
 - 6x30 16 oz. Economy 27.95
 - 7x50 3 1/2 oz. Sharp, bright, Bargain 36.00
 - 7x50 Center Focus, Sale priced 39.50
 - 8x30 17 oz. Clear, crisp 32.50
 - 8x30 Center Focus 37.50
 - 10x30 18 1/2 oz. 39.50
 - 10x50 35 oz. More Power 62.00
 - 12x50 35 oz. Reaches out 65.00
 - 12x50 Center Focus, 25 ozs. 67.50

GERMAN WORLD'S LIGHTEST

- 8x30 4"x5 1/4" 11 Oz. \$39.50
- 7x35 5"x6" 14 Oz! 57.50
- 20x56 8 1/2"x6 3/4" 27 Oz! 99.50

Made in GERMANY, optical center of the world! **COATED. Whisper Weight!** Center focus, prismatic binoculars with individually focussing right eye piece. Follow moving objects faster, easier. Enjoy clearer, sharper, brighter images.



SIX TELESCOPES IN ONE!

15 to 40 POWER



American made Wollensak telescope. Instant focusing at 15x, 20x, 30 and 40x, etc. Turn power tube to click—no guess work. Telescope measures 9" closed, 27" when extended. Weighs only 18 oz! Has rust proof chrome tubes, large 40mm objective lens. All 12 optic surfaces are **COATED**. See .22 bullet holes clearly at 300 feet. Use also for astronomical observation. \$30.75 price includes tax and fine leather case. **UNCONDITIONALLY GUARANTEED.** Try for 30 days at our risk! If not fully satisfied return for full refund! Cash orders rushed postpaid. On C.O.D.'s include \$2.00 deposit. Add Federal Tax. Prices on all of above include handsome genuine leather case and straps. **DEALERS—WRITE FOR 24 PAGE WHOLESALE CATALOG.**

UNITED BINOCULAR CO.
9043 S. Western, United Bldg., Dept. ARF-6416, Chicago 20
Display Sales Rooms open 9:00-3:30 Mon. thru Fri.

IS \$210⁰⁰ A WEEK

Worth a Post Card to You?

Then **rush** post card with name and address. Get **FREE** details of amazing full- and spare-time **PROFITS** made by ambitious men handling new Automatic Defroster for refrigerators on **FREE TRIAL** basis. Learn how the housewives hand you **BIG PROFITS** when you just plug in the D-Frost-O-Matic to end defrosting mess, forever. Send post card for **SPECIAL OFFER TODAY!**

D-FROST-O-MATIC

173 W. Madison St., Dept. H-14, Chicago 2, Ill.

Paint it with Suede!

FLOK KRAFT A SENSATIONAL NEW HOME BUSINESS
A NEW INDUSTRY... A NEW MIRACLE FINISH!
MAKE \$5 to \$10 PER HOUR and more!
YOU CAN LEARN IN A FEW DAYS!
Make to \$5.00 — yes! even \$10.00 and more hourly. Complete, easy-to-understand Flok-Kraft instructions show you how to start on the road to big money, full or spare time.

PROFESSIONAL SECRETS CAN BE YOURS
At last, secrets of amazing miracle finish can be yours! Huge profits waiting in tremendous new field. Flok-Kraft gives a velvety, luxurious surface to radios, lamps, toys, signs, store displays, figurines, auto dashboards—a 1001 items on every hand easily — quickly beautified, increased in value with Flok-Kraft. Make old objects beautiful—saleable, make new ones worth much more. This soft, rich covering can be applied to any surface, even if old or worn.

WE FURNISH EVERYTHING YOU NEED TO START
Complete Flok-Kraft kit and equipment enables you to start at once. Add to your income from your regular job or begin to build your own successful business in corner of your basement, garage, service porch or kitchen.

PROTECTIVE COATING FOR BOTTOM OF 101 ITEMS

FULLY GUARANTEED TIRES COST LESS!

Nationally famous **FIRESTONE, GOOD-RICH, U.S. ROYAL, GOODYEAR**, and other makes. Every tire selected and inspected for your safety.

NEW TREAD TIRES GUAR. 24 MOS. (WHITE WALLS \$2.00 EXTRA)	S 550x16 8.98	600x16 (6) 10.98	650x20 (8) 20.95	700x16 (6) 15.48
	A 550x17 8.98	650x15 10.98	640x15 9.98	710x15 11.48
	L 600x15 8.98	650x16 11.48	670x15 10.98	760x15 12.48
	E 600x16 8.98	650x16 (6) 13.48	700x15 12.48	820x15 13.98
GOOD TIRES GUARANTEED 12 MONTHS	STOCK 600x16 4.14	700x16 5.14	32x6 (8) 8.84	825x20 14.24
	650x16 4.54	670x15 4.74	32x6 (10) 10.84	900x20 13.34
	650x15 4.34	650x20 7.84	750x20 (8) 8.54	1000x20 14.14
	700x15 4.64	700x20 (8) 8.94	750x20 (10) 9.94	1100x20 16.14
AAA PREMIUM GRADE GUARANTEED 18 MONTHS	LARGEST STOCK 600x16 5.58	700x16 (6) 7.98	600x20 9.78	825x20 18.68
	650x16 5.98	750x16 (6) 8.98	650x20 10.88	900x20 18.98
	650x15 5.98	820x15 7.48	700x20 12.88	1000x20 19.98
	670x15 5.88	710x15 6.48	32x6 (8) 10.48	1000x22 21.98
PENNA'S LARGEST STOCK	670x16 5.98	550x18 5.98	32x6 (10) 12.48	1100x20 20.98
	700x15 6.68	760x15 6.78	750x20 (8) 12.98	1100x22 21.98
	700x16 6.78	550x17 5.88	750x20 (10) 14.98	1100x24 23.98
	MILITARY SPECIAL			
AA Guaranteed 12 Months—				
900x16 11.98		900x20 19.98		
750x20 12.89		1100x20 21.98		
AAAGUARANTEED 18 MONTHS				
900x16 14.98		750x20 16.48		
New Tread Guar. 24 Mos. Wears Like New				
600x16 10.98		700x15 (6) 16.95		
750x20 (8) 25.98				
Passenger Tubes—Water Tested—All Sizes... \$.95				
Truck Tubes—Water Tested—All Sizes... \$2.45				

Largest stock of used tires in the East. Thousands of satisfied customers. Write for sizes not listed.

MONEY ORDER OR CHECK WITH ORDER. NO C.O.D.'s

PENNA'S

PYRAMID TIRE CO.
1333-35 North 5th St. Dept. S., Phila. 22, Pa.

GET TOP PAY JOBS IN TELEVISION-ELECTRONICS

Our **TWO FREE BOOKS** show you **HOW!** Earn extra money or start your own business. Ask for **FREE** television books. Write Dept. R-15

RADIO TELEVISION TRAINING ASSOCIATION
(State age) 1629 Broadway, New York 19, N.Y.

INVENTORS

If you have working models, blue prints, or patents, covering "special use" parts or assemblies for Chevrolet, Ford, or Plymouth Cars, it will be to your advantage to get in touch with us. Write us at the factory. Dept. PS

NATIONAL MACHINE WORKS, INC.
P. O. BOX 4305 AUTOMOTIVE PARTS MANUFACTURERS OKLAHOMA CITY 9, OKLA.

Locksmithing AND KEY MAKING

Now Made Easy! Practical up-to-date course teaches you how to pick locks, de-code, make master keys, repair, install, service, etc. New self-instruction lessons for every handyman, homeowner, carpenter, mechanic, service station operator, fix-it shop, hardware dealer, gunsmith. 53 easy illustrated lessons. Full price only \$4.95, post-paid; or C.O.D. plus postage. Satisfaction or refund guaranteed.

Complete course \$4.95 now only \$4.95

Nelson-Hall Co., Dept. EY-1
210 S. Clinton St., Chicago 6, Ill.

SPRAY ON RAINBOW COLORS... for PROFIT and PLEASURE!

FLOK-KRAFT COVERS...

- PLASTER
- FABRICS
- METAL
- PLASTIC
- RUBBER
- WOOD—ANY SURFACE

PROFESSIONAL SECRETS CAN BE YOURS
At last, secrets of amazing miracle finish can be yours! Huge profits waiting in tremendous new field. Flok-Kraft gives a velvety, luxurious surface to radios, lamps, toys, signs, store displays, figurines, auto dashboards—a 1001 items on every hand easily — quickly beautified, increased in value with Flok-Kraft. Make old objects beautiful—saleable, make new ones worth much more. This soft, rich covering can be applied to any surface, even if old or worn.

WE FURNISH EVERYTHING YOU NEED TO START
Complete Flok-Kraft kit and equipment enables you to start at once. Add to your income from your regular job or begin to build your own successful business in corner of your basement, garage, service porch or kitchen.

FLOK-KRAFT and DEFENSE
Flok-Kraft offers a way to big, extra money, assisting defense manufacturers in many lines as well as filling a big demand on the home front.

GRASP THIS LIFETIME OPPORTUNITY TODAY
I'll arrange to send you everything you need to start—for leisurely, no-risk examination in your home. You owe it to yourself to investigate. Write today for **FREE** details. Everything I send you now is **FREE** of charge and postpaid. Airmail is faster.

COAST INDUSTRIES.
Dept. 15, 1006 S. Los Angeles St., Los Angeles 15, Calif.

FREE SAMPLE, Booklet, Plan!

No More Flies!

**AMAZING NEW "MYSTERY SCENT" TRAP
LURES FLIES TO SURE DEATH...
KILLS THEM BY THOUSANDS!**

YOUR WHOLE PLACE can be free from annoying, disease-carrying flies! New outdoor trap draws them from house, barn, grounds—destroys them wholesale. Works wonders in backyards, on farms, outside food markets, restaurants, factories, hospitals, motels, etc. Send check or money order for "Big Stinky" Fly Trap (named for its fly-scent principle). Complete with full season's Control Fluid, only \$4.49 postpaid. Money back if not satisfied. Order No. HR495.

Home and Garden Gifts
BRECK'S
RELIABLE SINCE 1818

663 Breck Building, BOSTON 10, Mass.

**10,000
FLIES
CAUGHT
HERE!**

All kinds of flies—houseflies, green bottles, blue bottles, horse flies, midges, etc. Not harmful to pollinating insects.

**SEND FOR
FREE CATALOG**

Always something new at Breck's! Write for latest catalog



1/2
GAL.
SIZE



Put trap in garden and be free from flies as you work.



Place trap in yard to rid house and grounds of flies.



Flies are lured to trap from barns, poultry runs, etc.



Flies leave porch and house to follow scent to trap.

**IT'S HERE . . .
IT'S DIFFERENT . . .
IT'S DYNAMITE . . .**

DYNATONE Deep, Mellow Tone MUFFLER

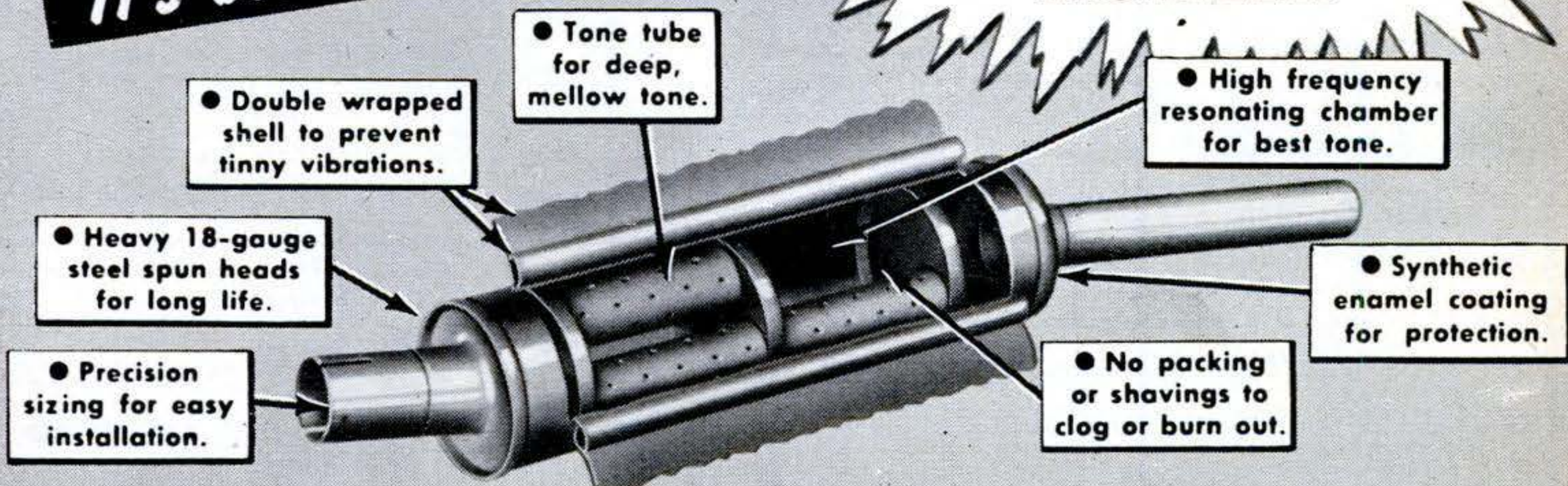

ENGINEERED — Not Packed

YET COSTS LESS THAN MOST HOLLYWOOD MUFFLERS!

The Dynatone has guts! It's the only special muffler engineered for your car. You'll go for its deep, mellow tone—and you'll go for these features, too: • Lower back pressure • More power • More gas mileage • Longer Life • No tinny vibrations

Listen to a phonograph recording of the Dynatone at your automotive dealer. Or write us for the name of your nearest dealer.

GOERLICH'S 811 Smith Street • Toledo 1, Ohio

Ask
About the
Completely New
**DUAL
EXHAUST
SYSTEMS**
for
Popular Priced
Cars



Illustrated
book sent
FREE

WORK IN COOL SAN DIEGO

San Diego offers you California living at its best — and Convair gives you the top working conditions. Employee Retirement Plan. Group Insurance. Two weeks vacation. Eight holidays annually. Free Housing Office and much more — plus that wonderful San Diego climate. These classifications now open for you:

- | | |
|-----------------------------|-------------------------------|
| 1. TOOL DESIGNERS | 8. FIELD & SERVICE MECHANICS |
| 2. TOOL PLANNERS | 9. AIRCRAFT MECHANICS |
| 3. PATTERN MAKERS | 10. AIRCRAFT ELECTRICIANS |
| 4. TOOL & DIE MAKERS | 11. IBM TAB MACHINE OPERATORS |
| 5. JIG AND FIXTURE BUILDERS | 12. INSPECTORS |
| 6. MACHINISTS | |
| 7. LOFTSMEN | |

CONVAIR

Send this coupon for FREE book and details:

Employment Office 600
Consolidated Vultee Aircraft Corporation
3302 Pacific Hiway
San Diego, California

NAME _____

OCCUPATION _____

ADDRESS _____

CITY _____ STATE _____

ENGINEERING DEGREE IN 27 MONTHS

Big Demand for Graduates

AERONAUTICAL, CHEMICAL, CIVIL, ELECTRICAL, MECHANICAL and RADIO ENGINEERING (inc. TV and Electronics).

Hundreds of young men are earning B.S. ENGINEERING DEGREES annually in this recognized institution—year around operation. New terms start quarterly. Many students earn a major part of their college expenses in this large industrial center.

Low tuition. Competent instruction. Thorough, intense, practical program. Modern, well-equipped laboratories including new physics laboratory and modern wind tunnel. Individualized instruction emphasized.

Gov't approved for G.I.'s. Engineering preparatory courses. Students from 48 states and 21 foreign countries. Enter June, September, December, March. Send coupon for free catalog and full information. Enroll now.

SEND COUPON TODAY

INDIANA TECHNICAL COLLEGE

652 E. Washington Boulevard
Fort Wayne 2, Indiana

Please send me free information on B. S. Engineering degree in 27 months as checked.

- Aeronautical, Chemical, Civil,
 Electrical, Mechanical, Radio-Television.

Name.....

Address.....

SENSATIONAL OPTICAL BARGAINS

IMPORTED MICROSCOPE ONLY \$12.50
200 POWER

Performance equals that of \$50 to \$75 instrument! Amazing optical qualities, fine focusing, superb definition and clarity. 1 ocular, 1 objective lens, micrometric type adjustment, revolving disc-light adjustable mirror. Case incl. Greatest bargain on the market! 10-day refund priv. if not fully sat. STOCK # 70.000-N. \$12.50 Postpaid



SLIDE PROJECTOR SETS. Consists of all unmounted lenses you need to make the following size projectors:
Stock # 4029-N—35 mm. \$2.85 Postpaid
Stock # 4038-N—2 1/4" x 2 1/4" \$3.35 Postpaid
Stock # 4039-N—2 1/2" x 3 1/2" \$3.35 Postpaid
SIMPLE LENS KITS—Include plainly written, illustrated booklet showing how you can build lots of optical items. Use these lenses in photography and for dozens of other uses in experimental optics, building TELESCOPES, low power Microscopes, etc.
Stock # 2-N—10 lenses \$ 1.00 Postpaid
Stock # 5-N—45 lenses 5.00 Postpaid
Stock # 10-N—80 lenses 10.00 Postpaid

We Have Literally Millions of War Surplus Lenses and Prisms for Sale at Bargain Prices. Numerous Types of Instruments. Too! Write for FREE CATALOG-N.
EDMUND SCIENTIFIC CORP. BARRINGTON, N. J.

WHAM-O SPORTSMAN

\$1.50 POSTPAID

35-LB. PULL!

HITS LIKE A .22 RIFLE—KILLS RABBITS, SQUIRRELS. Powerful, silent, accurate. For hunting, target, routing pests. Sportsman's choice sold world over!



HUNTING SLINGSHOT

Heavy duty 7" ash stock. 40 steel balls, extra rubber, target. GUARANTEED. At dealers, or send \$1.50 to Wham-O Mfg. Co. Box 8B, South Pasadena, Calif. * Professional model of Nat'l Slingshot Assn.



Want GOOD LUCK?

Love, wealth, happiness may be yours. Carry the alleged Lucky Talisman of the Orient. Try this amazing charm for one week. Satisfaction guaranteed or money refunded. Send only \$1.00 today.

DEL MONTE

21-72 21st St., Suite 28-A, Long Island City 5, N. Y.



ANYBODY HANDY WITH TOOLS CAN BUILD LEATHER LOUNGES FOR KITCHENS AND RESTAURANTS

Frames, springs, filling, construction simplified.

Send \$5.00 for complete plans and instructions, or 10¢ for brochure.

STEFAN GALENSKI
Designer & Manufacturer

2221 BROADWAY Dept. P-1 BUFFALO 12, NEW YORK

For Prospectors, Miners, Oil Companies, Plumbers, Treasure hunters, etc.

SCR 625 FAMOUS ARMY MINE-DETECTOR

This unit is being offered now at a considerable reduction in price. Recently advertised at \$79.50 it is now available in the same brand new wrappings in suitcase carrying case (less batteries) at

\$59.50 WHILE THEY LAST! Used, like new, **\$39.50**

F.O.B. Chicago — 20% Dep. with order; Bal. C.O.D.

ARROW SALES, INC. DEPT. PS-3, 1712 SO. MICHIGAN AVE. CHICAGO 16, ILLINOIS

Do FALSE TEETH Rock, Slide or Slip?

FASTEETH, an improved powder to be sprinkled on upper or lower plates, holds false teeth more firmly in place. Do not slide, slip or rock. No gummy, gooey, pasty taste or feeling. FASTEETH is alkaline (non-acid). Does not sour. Checks "plate odor" (denture breath). Get FASTEETH at any drug store.

I tried 'em all—
then I **BOUGHT** a **SAVAGE!**

That 'gunsmith' craftsmanship
really sold me!



Extra-
dependable
1.6 h.p.,
4-cycle Briggs
& Stratton
engine.

COMPARE the Savage Yard Chief with *any* other power mower on the market. You'll see instantly what a big difference genuine precision-manufacturing can make. Fine machining to closer tolerances gives you clean cutting and smooth, easy operation. Higher quality materials and extra-rugged construction assure you years

and years of service. Notice the tougher "Sta-Temp" blades. Totally enclosed chain and sprocket. Convenient finger-tip controls. External oil cups. The famous Timken bearings. Big traction-grip tires. It's a mower you'll be proud to own! Write today for free illustrated folder. Savage Arms Corporation, Lawn Mower Division, 103 Broadway, Chicopee Falls, Mass.



SAVAGE

21-INCH Yard Chief

SAVAGE Makes a Complete Line of Lawn Mowers for the Home. Ask your dealer to help you select the Savage hand or power mower best suited to your needs.

TRUE SAVAGE CRAFTSMANSHIP

Savage lawn mowers are produced with the same care and skill that have made Savage rifles and shot-guns world-famous.

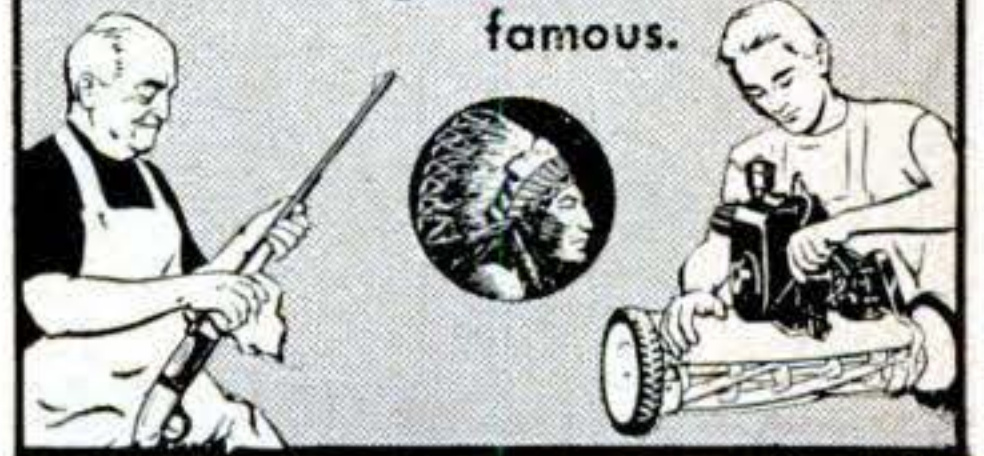

YOUR DREAM HOME—

HOW TO BUILD IT FOR LESS THAN \$3500

SAVE up to \$8,000 with help of this practical how-to-do-it book! Prepared by "Handyman" Hubbard Cobb and other experts. Plans and instructions for eight modern homes! Book also shows how to make every type of improvement—Foundations, Frame and Sheathe, Roof, Set in Windows, Doors, Inside Partitions; install Plumbing, Heating, Wiring; and more! 576 big 6 1/4" x 9 1/4" pages, 650 illustrations, 2 colors throughout! 750,000 copies sold! Only \$3.95. Mail postal card for 7 days FREE Trial today! Write Dept. 805

Wm. H. Wise & Co., Inc., 50 W. 47th St., N. Y. 36, N. Y.

LAW FREE BOOK



Your FREE copy of "The Law-Trained Man" shows how to gain prestige and greater earnings through Blackstone home law study. All instruction material furnished including 17-volume Law Library written by 65 well-known law authorities. Lawyers, judges among our graduates. LL.B. degree. Low cost; easy terms. Write today.

BLACKSTONE COLLEGE OF LAW Dept. 125, Chicago 1, ILL.
225 N. Michigan Ave.

A Correspondence Institution Founded in 1890

SO BADLY NEEDED—

that Our Men are NOW SELLING—

5 to 10 in One Home—

10 to 80 in One Office—

50 to 432 in a Factory.

Men Actually Making \$40 to \$60 A DAY! Right NOW!

Read the facts in the panel at the right. Then you'll understand how Riggs could make \$187.26 in three hours—how Jackman got an order for 432 with a five minute demonstration—why an office girl in spare time could sell 87 in just two calls in one building.

No more tangled phone cords, appliance cords, extension cords on power tools. No more danger of fires from short circuits in broken, twisted wires. No more knocking papers all over the desk every time the phone is used. So badly needed that there are millions and millions waiting for just one demonstration to give orders for five, fifty, or a hundred.

There's never been anything like it for fast

MAXILUME CO., 125 W. Hubbard Street, Dept. T-9-E, Chicago 10, Ill.

money for any kind of salesman. Companies like Std. Oil, Pure Oil, Bank of America buy in large quantities. Cities buy, States buy, Hospitals buy. Everyone buys. And our salesmen are coining cash, hand over fist.

GET TWO SAMPLES QUICK.

Two models fit all needs. Retail at 95c each. You make as high as 120% profit markup on your cost. Rush name and a dollar bill. We'll send two Coillettes—one of each model, as samples. Money back if you return them in ten days.

The stampede is on. Salesmen and crew managers are throwing other lines overboard. Get in now on the biggest "pay-off" in years.

PAT. NO.
1,790,666



A simple little piece of coiled piano wire takes the kinks out of all electric cords—Re-coils the wire in a neat stack each time it is used—on phones, fans, irons, vacuums, adding machines, power tools. Two minute demonstration sells 8 out of 10 prospects—and almost every prospect buys from 3 to 100. Re-orders will swamp you. You have to see it to understand. Send for two samples today.

**WHICH
DO YOU
WANT?**

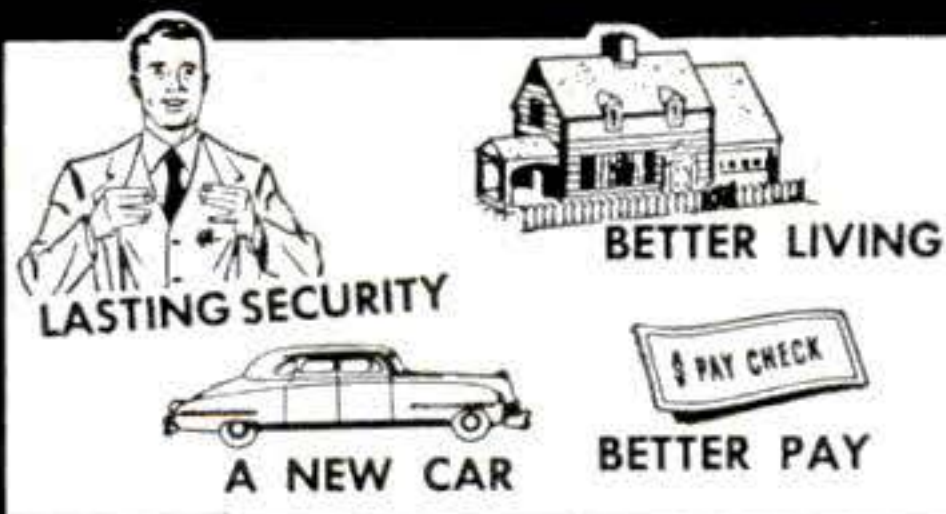

LASTING SECURITY

BETTER LIVING

A NEW CAR

BETTER PAY

GET THEM ALL! LEARN . . .

DRAFTING

EASILY AND QUICKLY AT HOME
IN YOUR SPARE TIME

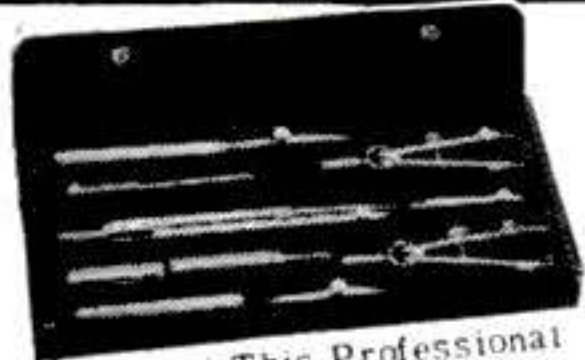

You Get This Professional Set of Instruments at no Extra Cost

You can be free of money troubles when you enjoy the unlimited opportunities open to skilled draftsmen. CEI training, under licensed professional engineers, quickly gives you the necessary technical background to fill the growing, desperate need for draftsmen. Thousands have succeeded; you can too, with a CEI diploma. We guarantee to train you until you qualify. Get full information today.

Cleveland Engineering Institute
Extension Division P55B
6300 Euclid Avenue, Cleveland 3, Ohio
Rush your *FREE* book showing how I can learn drafting easily and quickly at home.

NAME
ADDRESS
CITY STATE

No Obligation—No Salesmen

**FREE 1952
SUCCESS
BOOK**

EVEN IF YOU DON'T KNOW A NOTE OF MUSIC NOW...

YOU CAN LEARN YOUR FAVORITE
INSTRUMENT THIS EASY A-B-C WAY

• No special talent, no previous training needed. This U. S. School home-study method is so successful because you learn to play by playing real tunes by note, right from the start. And just think, you can learn your favorite instrument for only a few cents a day!

If interested, mail coupon for *FREE* Booklet and Print and Picture Sample. See for yourself how easy it is to learn any instrument, right at home, in spare time, without a private teacher. U. S. SCHOOL OF MUSIC, Studio B155, Port Washington, N. Y. (54th Successful Year.)



Send For Free Book

FREE! Print and Picture Sample

U. S. SCHOOL OF MUSIC,
Studio B155, Port Washington, N. Y.
Please send me Free Booklet and Print and Picture Sample. I would like to play (Name Instrument).

Instrument Have you Instrument?

Name (Please Print)

Address

BROOKS can make a career for YOU

LEARN INVESTIGATIVE PHOTOGRAPHY
LEGAL - CRIMINAL

Securing evidence through ballistic photos, fingerprints, scenes of accidents and crimes is INTERESTING • EXCITING • PROFITABLE

At Brooks Institute, you learn by doing. You use the finest up-to-date equipment and you're trained by instructors, each an expert in his field. Brooks is the only recognized photographic school offering this opportunity to learn legal and criminal photography.

Opportunity knocks — with the click of a shutter. Start your Investigative Career by investigating today . . .

Write for our *FREE* booklet and full information. . . . Dept. 6

BROOKS
INSTITUTE OF
PHOTOGRAPHY

2190 Alston Road
SANTA BARBARA • CALIFORNIA

"PHOTOGRAPHER'S PARADISE . . .
Where the mountains meet the sea."



MONEY for MEN ALL DATA FREE

THE PLASTEX Industry needs manufacturers on small scale and for big production of Lamp and Clock Stands, Art Goods and Novelties in Plastex and Marble imitation. Experience unnecessary. 1/2c material makes regular 10c store sellers. Rubber moulds furnished for speed production. Small investment brings good returns. We are now placing big chain store orders with manufacturers. Ambitious men have chance for real prosperity. Our Free booklet will interest and benefit you.

PLASTEX INDUSTRIES, Dept. 2, 3400 Third Ave., New York 56, N. Y.



LEARN MEAT CUTTING

through actual practice. Profitable Meat Cutting and Self Service Meats taught easily, quickly. LEARN BY DOING at Toledo in just eight short weeks under actual market conditions. For beginners or men with experience. All subjects taught thoroughly and completely. Diploma, Job help. Get store of own. People must eat. School in operation over 25 years. Approved for GI training. Send today for *FREE* illustrated catalog. No obligation. NATIONAL SCHOOL OF MEAT CUTTING, Dept. 51-E, Toledo 4, Ohio

COMPLETE HIGH SCHOOL

in less than a year
STUDY AT HOME

Better yourself. Learn more, earn more. Get ahead socially. Complete high school courses leading to college entrance if desired. WRITE FOR *FREE* BULLETIN. No salesman will call.

ACADEMY FOR ADULTS

Dept. 5 30 W. Washington, Chicago, Ill.

LATEST MODELS HISTORY-MAKING TANKS by

Authenticast
Precision built tank miniatures
. . . 75 models of 5 nations . . .
Cast in metal and hand assembled
. . . Moveable turrets . . . In-
cluded are styles used in Korea.
SEE THEM IN VOL. III - 35c
COMET METAL PRODUCTS CO., INC.
Richmond Hill 18, N. Y.



5180 WALKER BULLDOG \$1.75

RUPTURED?

Get Relief This Proven Way

Why try to worry along with trusses that gouge your flesh—press heavily on hips and spine—enlarge opening—fail to hold rupture? You need the Cluthe. No leg-straps or cutting belts. Automatic adjustable pad holds at real opening—follows every body movement with instant increased support in case of strain. Cannot slip whether at work or play. Light. Waterproof. Can be worn in bath. Send for amazing *FREE* book, "Advice To Ruptured" and details of liberal truthful 60-day trial offer. Also endorsements from grateful users in your neighborhood. Write:

CLUTHE SONS, Dept. 14, Bloomfield, New Jersey.

It's a cinch to Install!



**Combustioneer®
AUTOMATIC
HUMIDIFIER**

A few dollars, your own tools, a couple of hours will give your home all the benefits of healthful, protective *automatically humidified air!* Yes, in your *present* warm-air furnace—coal, gas or oil! No plumbing necessary!

Exclusive Combustioneer features... Twin-Valves of stainless steel, can't rust, corrode or leak... "Noverflow", prevents water dripping *inside* furnace... big "Thirsty-Thick" ceramic plates for larger water evaporation area... Selector Dial for positive humidity control... Water pan of heavy non-corroding metal.

Low Prices! Model CH-300, 4 plates for 13" to 20" plenum (width or length), \$20. CH-200, 6 plates for 22" to 25" plenum, \$22, F.O.B. Springfield, Ohio. Prices include 10 feet of tubing, saddle valve and adjustable hinge face plate. Immediate shipment. Check or Money Order. **Combustioneer DIV.**

THE STEEL PRODUCTS ENGINEERING CO.
1213 W. COLUMBIA STREET, SPRINGFIELD, OHIO

**U.S. OIL LEASES PAY OFF
FIND WHAT YOU CAN DO FOR ~ \$200.**

Congress has given any U. S. citizen the right to file for oil leases on certain public lands. Some U. S. oil leases have lately paid \$150,000 for under \$200; \$250,000 for \$250; \$137,000 yearly for \$200. We locate you a lease in a possible oil area. Scores of our clients have sold U. S. leases we obtained for them to major oil companies, keeping part of the oil for themselves. In California the estimated oil under 40 acres of OIL LAND is 2 million barrels. That is why you have a chance at enormous returns by risking \$200. Write for free booklet.

CALIFORNIA LEASE CO.
7075 HOLLYWOOD BLVD. LOS ANGELES 28, CALIF.

**Jet Power... for your CAR
with the ECON-O-MISER**



U. S. Agriculture's Exhaustive Tests (Bulletin AIC-240) show:

**Up to 30% mileage increase
More of engine's power utilized
Less Ping or Detonation**

By Water Alcohol Injection in high compression engines.

ECON-O-MISER is a scientific instrument of the diaphragm type, operating automatically by use of vacuum, injecting water and alcohol into the fuel system. Designed to help your motor attain its full power, speed and mileage.

By Reducing—CARBON, ENGINE WEAR, PING OR DETONATION. In all cases the results obtained might not prove consistent, therefore we urge you to take advantage of our 30 day money back guarantee.

ONLY
\$14.95

Send cash, check or money order—\$2.00 deposit required on C.O.D.'s.

Complete with tank, bronze injector, Carburetor Flange, hose and all fittings for easy installation.

ECON-O-MISER MFG. CO.

3019 Pico Boulevard, Santa Monica 2, California



**NOW ANY
AUTO REPAIR JOB**

**CAN BE A
"Push-Over" for You!**

**IN LESS TIME —
WITH LESS WORK —
AND MORE PROFITS!**

Used by
U. S. Army
and Navy



NOW, tackle anything from carburetor to rear end on ANY car built from 1935 thru 1952. Fix it quick, easy, right the FIRST time! Just look up make, model, and job in quick index of MOTOR'S brand-new 1952 Edition AUTO REPAIR MANUAL. Clear, illustrated instructions—you just can't go wrong! 7-DAY FREE TRIAL!

Earn More Money! Win Prestige!

Boiled down in one BIG book, over 780 pages — the complete "dope" from 170 Official Factory Manuals. 225,000 service, repair, tune-up facts, 38,000 essential dimensions!

Covers 851 car models. Includes ALL automatic transmissions, ALL new engines. 2400 cut-away photos, diagrams, charts show what the clear text tells. Used by Army, Navy, Tech Schools, thousands of auto-repairmen. Makes every operation so easy, you'll tackle jobs you wouldn't think of doing before. You'll win added prestige, more money!

SEND NO MONEY

Mail coupon—without money! When book arrives—make it show you what it's got! Unless you agree it's the greatest time and work saver you've ever seen—return it in 7 days, pay nothing. Mail coupon NOW! MOTOR Book Department, Desk 2E, 250 West 55th Street, New York 19, N. Y.

**Covers 851 Models
—All These Makes**

- | | |
|-----------|--------------|
| Buick | La Salle |
| Cadillac | Lincoln |
| Chevrolet | Mercury |
| Chrysler | Nash |
| Crosley | Nash Rambler |
| De Soto | Oldsmobile |
| Dodge | Packard |
| Ford | Plymouth |
| Frazer | Pontiac |
| Henry J. | Studebaker |
| Hudson | Terraplane |
| Kaiser | Willys |
| Lafayette | |

Also complete tune-up adjustments on Auburn, Cord, Reo, others.

**Same FREE Offer On
MOTOR'S Truck and
Tractor Manual**

Covers EVERY job on EVERY popular make gasoline truck, tractor made from 1936 thru 1951. FREE 7-day Trial. Check proper box in coupon



MAIL COUPON NOW FOR 7-DAY FREE TRIAL

MOTOR BOOK DEPT.

Desk 2E, 250 W. 55th St., New York 19, N. Y.

Rush to me at once (check box opposite book you want):

MOTOR'S New AUTO REPAIR MANUAL. If O.K., I will remit \$1 in 7 days (plus 35c delivery charges), \$2 monthly for 2 months and a final payment of 95c one month after that. Otherwise I will return the book postpaid in 7 days. (Foreign price, remit \$8 cash with order.)

MOTOR'S New TRUCK & TRACTOR REPAIR MANUAL. If O.K., I will remit \$2 in 7 days, and \$2 monthly for 3 months, plus 35c delivery charges with final payment. Otherwise I will return book postpaid in 7 days. (Foreign price, remit \$10 cash with order.)

Print Name.....Age

Address

CityState

Check box and save 35c delivery charge by enclosing WITH coupon entire payment of \$5.95 for Auto Repair Manual (or \$8 for Truck and Tractor Repair Manual.) Same 7-day return-refund privilege applies.

Choose as Your College Career Electrical Engineering

- Major in Electronics or Power
- B. S. Degree in 36 months
- Television Technician: 18 mo.



By 1954 there will be at least two positions for every engineering graduate. Enter these opportunities early... earn your B.S. degree in 36 months through optional year 'round study.

FOLLOW THIS PLAN — Become a Radio Technician in 12 months. In 6 additional months become a Radio-Television Technician. These Technician Courses are complete in themselves and can be applied as one-third of the B. S. degree program.

MILWAUKEE SCHOOL OF ENGINEERING FOUNDED 1903. MILWAUKEE

MILWAUKEE SCHOOL OF ENGINEERING
Dept. PS-552, 1025 N. Milwaukee,
Milwaukee, Wisconsin

Without obligation send Catalog for Electrical Engineering, B. S. Degree, major in Electronics; Power; "Your Career"; Occupational Guidance Bulletin on: Radio-TV Electrical Power Welding Heating, Refrigeration, Air Conditioning.



Name.....Age.....

Address.....

City.....Zone.....State.....

If veteran, indicate date of discharge.....

EAVESDROP...

behind the "IRON CURTAIN"!
hear Aircraft! Ships! Amateurs!

Sensational

**TABLE
RADIO
SW-54
\$49.95**



**GUARANTEED RECEPTION
ON 3 SHORTWAVE BANDS
PLUS STANDARD BROADCAST**

Turn the knob and — presto! — Radio Moscow is pouring propaganda into your ears! Turn it again and hear music from Paris, or amateurs chatting, or an aircraft control operator! Thousands have discovered a whole new world of listening pleasure with the "Mighty Midget," by the makers of radio equipment for the famed Kon-Tiki Expedition. Write for details and name of nearest supplier.

NATIONAL COMPANY, INC.
61 Sherman St., Malden, Mass.

PARTS FOR MILITARY TRUCKS

At A Savings. New FREE Catalog
For Jeep, Dodge, Chevrolet, G.M.C., Studebaker

Brand New—Not War Surplus—Complete
JEEP TOPS and SIDE CURTAINS

Fits all Military Jeeps. Also adaptable to some Civilian Jeeps. Waterproof O.D. **\$59.50**

AXLES FOR TRAILERS

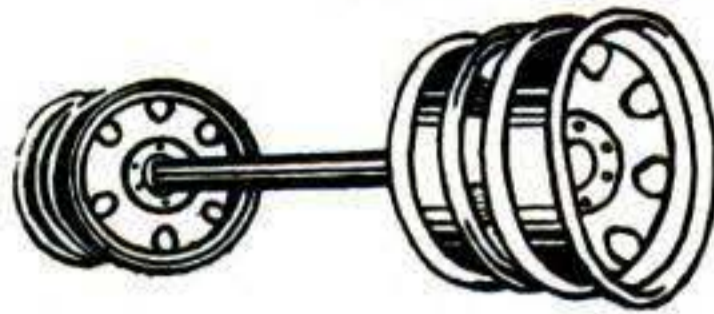

(Surplus) Heavy Duty axles suitable for building of many types of trailers, farm wagons, etc. Standard width straight axle, 2 inch square and is complete with Hubs, Timken bearings, 6 Hole 750x20 or 825x20 wheels, with- **\$69.50** out brakes, only.....

Dual Wheels . . . add \$15.00 extra

Hundreds of Other Truck & Jeep Parts and Supplies
All prices quoted good 30 days FOB, Kansas City
25% deposit required on COD orders.



UNITED AUTO PARTS CO., INC.
1901 TROOST-GR.1800-KANSAS CITY, MO.

A "GOOD HAND" HELPS YOU SUCCEED!

LEARN TO WRITE WELL

Your Name

beautifully written, plus special pen-point for shaded writing.

Only 10¢

Handwriting quickly improves with our easy-to-understand picture lessons! Put your spare time to good use; send today for **FREE BOOKLET**, "How to Become a Good Penman," or check volumes wanted below at \$1 each: Business Writing Artistic Writing Card Writing Bird & Design Flourishing Engrossing Alphabets. COMPLETE SET \$4.50. Ask for price list of penman's supplies.

TAMBLYN SCHOOL of PENMANSHIP
S. A. Ziller, Pres. 438 Ridge Bldg., Kansas City, Mo., USA

WALKIE TALKIES! — \$4.99 Set of 2

POCKET SIZE

—ELECTRONIC VOICE POWERED



No tubes, batteries, adjustments, license or permit needed! Guaranteed to work anywhere up to 1/4 mile with extra wire. Swell for room to room—garage to house, etc! Your own private, talk-listen phone. Not war surplus. Brand new. Guaranteed. Two complete units with wire —READY TO USE!

SEND \$1.00 deposit and pay postman \$3.99 plus postage charges or send \$4.99 for postpaid delivery. Limited Supply.

THE MIDWAY COMPANY, Dept. WPS-5, Kearney Nebraska

CONVERT-A-MOWER YOURSELF

You can convert your present lawnmower to an electric power mower

You may already have some of the parts necessary to do this. Let the same power (electricity) that washes and irons your clothes, vacuums your rugs, and refrigerates your food mow your lawn. Satisfaction Guaranteed.

Send \$1.00 for complete plans and instructions.

CONVERT-a-MOWER, P.O. Box #109, Syracuse 1, N. Y.

Personal To Women With Nagging Backache

Nagging backache, loss of pep and energy, headaches and dizziness may be due to slowdown of kidney function. Doctors say good kidney function is very important to good health. When some everyday condition, such as stress and strain, causes this important function to slow down, many folks suffer nagging backache—feel miserable. Minor bladder irritations due to cold or wrong diet may cause getting up nights or frequent passages.

Don't neglect your kidneys if these conditions bother you. Try Doan's Pills—a mild diuretic. Used successfully by millions for over 50 years. It's amazing how many times Doan's give happy relief from these discomforts—help the 15 miles of kidney tubes and filters flush out waste. Get Doan's Pills today!



DIVING GEAR

The very same as used by Uncle Sam's Underwater Commandos, as you saw them in the exciting movie, "THE FROGMEN".

- AQUA-LUNG Jr.**, self-contained diving unit, for free swimming down to 300 ft., up to 30 min. **99.95**
- STANDARD Model**, good for one hour's diving. **150.00**
- NAVY type**, 2-tank block, for 2 hours' diving. **275.00**
- FROGMAN SUITS**—to keep diver warm and dry to 55° temp. Short arms and legs **29.95**. Same with hood, illustrated above **\$47.50**. Frogman suits for colder water—long arms and legs **39.95**. Same with hood and boots **60.00** (When ordering give height and weight).
- ARBALETE**, powerful, economical, accurate, rubber powered, silent spear-gun which won all internatl. competitions during last 4 yrs. Free spear range: 35 ft. **25.00**
- Arbalete DeLUXE**, four slings, double power, range 50 ft. **35.00**
- FRENCH CHAMPION DIVE MASK**, 100% watertight seal on any face, free of synthetic rubber, extra wide vision. . . . **4.95**
- SQUALE**, the only shatterproof glass mask, Navy standard. . . **6.95**
- FLOATING DAGGER**—cork handle, sharp stainless blade. . . . **4.95**
- SNORKLE tube** allowing breathing with face under water, without disturbing vision (see drawing). **1.95**
Same with automatic water-seal ball attachment. **2.95**
- DEPTH GAUGE**, indicates depth of dive down to 160 feet, easy reading. **3.50**
- UNDERWATER FLASHLIGHT**, pressure-proof. **2.95**
- "SHALLOW WATER DIVING"**, most comprehensive book on the subject, shows all eqpmt. . . **2.50**
- "I LIKE DIVING"**, a book by a Navy diver. **3.00**
- "THE SEA AROUND US"**, by Carson. **3.50**
- "DIVING TO ADVENTURE"**, by Haas. **3.75**
- TREASURE MAPS**, authenticated. **3.00**
- "SELF-CONTAINED DIVING"** digest. **95c**
- "I DIVE FOR TREASURE"**, by Rielseberg. **3.00**
- "TREASURE BELOW"**, by Ellsberg. **2.75**

U. S. DIVERS CO.
Dept. PS-5
1045 BROXTON AVENUE
W. LOS ANGELES 24, CAL.

Order from this ad. Prices
F.O.B. Los Angeles. In Calif.,
add 3 1/2% tax. All sales final.

How to get more mileage out of your motoring dollar

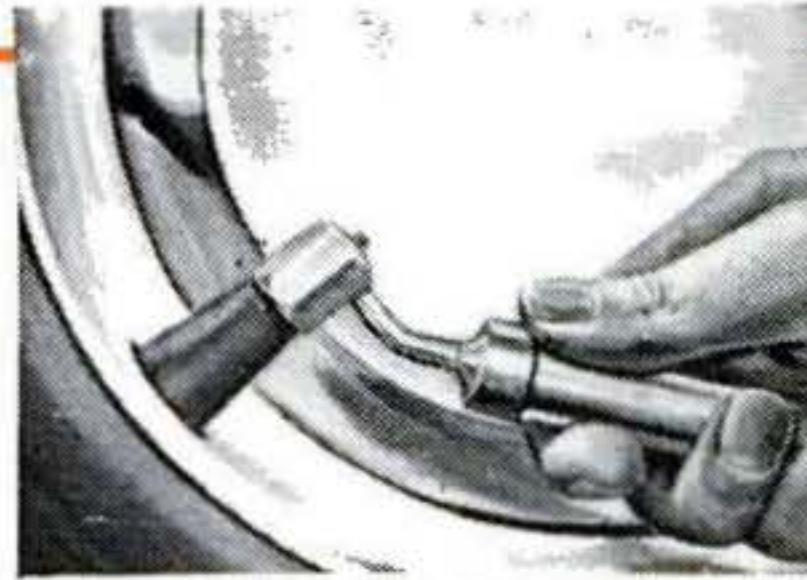

WATCH TIRE PRESSURE

Check your tires while they are cool. Recommended tire pressure is based on ordinary outdoor temperature . . .

takes into account heat generated in running. For correct pressure—check tires *before* long drives.

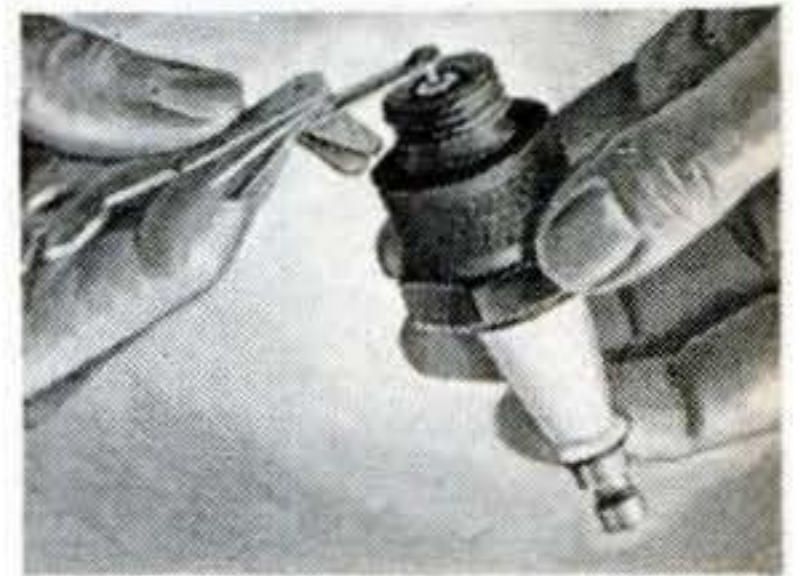

KEEP SPARK "HOT"

Re-gap spark plugs regularly. No engine performs efficiently if plugs fail to deliver a consistently full, hot spark. Worn plugs may increase gas consumption as much as 10%. Good, economical practice is to check gap every 5,000 miles . . . install new plugs every 10,000.



MAKE THIS SIMPLE TEST

Check your oil filter this quick and easy way. When the engine is warm—feel the outside of the filter housing. If it's cool, filter is probably clogged . . . can't trap any more abrasives and sludge. Next step is to get in a new

Purolator Micronic* Refill. Purolator's accordion-pleated plastic-impregnated element provides up to 10 times more filtering area . . . removes abrasive particles as tiny as .000039" in diameter from your engine's oil stream. Yet a Purolator* Refill costs as little as \$1.60. Takes just a few minutes to install.

*Reg. U. S. Pat. Off.

Check your oil filter every time you change your oil

PurOlator
(ENGINEERED FOR EVERY MAKE OF CAR)
Micronic OIL FILTER



BUILD A \$15,000 A YEAR FUTURE!

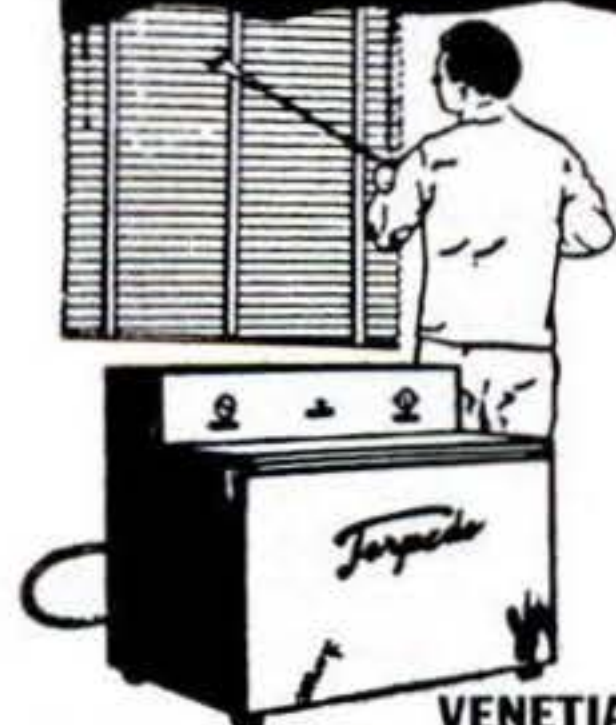

In the exciting new business of LAUNDERING VENETIAN BLINDS

Send name, get pictures, profits, prices, facts—all Free—showing how to start on small investment in basement or garage. Big demand—high profits—spare or full time. Others NOW MAKING \$15,000 a year. **FREE!** Learn all about machine and easy time-pay plan. Get names of successful men near you so you can investigate. Rush name now.

VENETIAN BLIND LAUNDRY EQUIPMENT CO., Inc.
442 North Seneca Street, Dept. 125, Wichita 12, Kansas

STOP HEADLIGHT GLARE



AMAZING BLACK LIGHT REDUCES EYE-STRAIN

Why drive blind . . . risk accident? Metallic-bearing glass lens produces invisible Black Light Rays that screen out dangerous glare. Clips to sun visor or direct to car. Easy to install. Truckers love it. **ORDER NOW!**

* TRADE MARK

COMPLETE \$6.85 Postpaid

BLACKFORD MFG. CO. • UPLAND, INDIANA

WAR SURPLUS INSTRUMENTS—WATCHES—SUN GLASSES

AIR FORCE type SUN GLASSES



Precision polished sage green optical lens. Shell-type nose pads and sweat bar, designed for extra comfort. Frame is gold-plated, will last for years. Made to specifications established by the Bureau of Standards. Ideal for Summer driving, beach, all-round wear. For men and ladies. Includes case. Limited quantity. A real bargain at **\$1.69 ea.**

SPECIAL: Regular \$15.00 world-famous Bausch & Lomb Ray-Ban optically ground sun glasses, ONLY \$6.95. Built for rugged wear. See everything in true colors. Save your eyes. Order today!



PRECISION ELGIN Stop WATCH

Hundreds of uses in sports, industry, photography, etc. 17 jewels, nickel case. 60-second dial—long hand shows fifth seconds. Small hand measures 30-minutes total time. One easy control, starts, stops, fly-back.

Made to Bureau of Ordnance specifications for U.S. Army. An unusual bargain at... **\$22.50**

PESCO HYDRAULIC PUMP

A precision-built, versatile type pump. Can be used for unlimited applications. At 1500 RPM, 1500 pounds PSI, 1 1/4 GPM continuous operation. At 2300 RPM 1000 pounds PSI, 2 GPM. Continuous maximum operating speed 3750 RPM. Intermittent maximum 4500 RPM. Equipped with 24V 200 Amp. 2300 RPM 3 HP motor. Complete unit

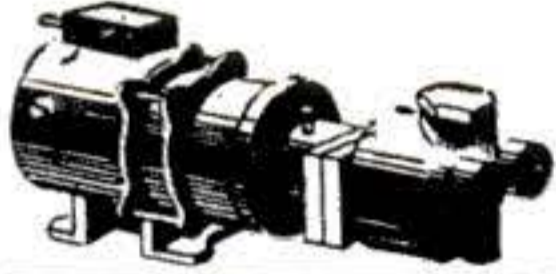

\$18.95

Either pump or motor separately **\$9.75**

THROAT MICROPHONE



For clear, distinct voice reproduction. Ideal for ham radio broadcasting, aircraft work, consists of twin mikes, rubber neck-piece, elastic neck band. NOW

only **\$1.39**

SIGNAL LAMP

Controlled directional beam. All metal lamp housing. Crackle finish. Two triggers—one is off-on switch, other controls 4" parabolic Pyrex mirror reflector. Complete with interchangeable red & violet filters, two bulbs. 25' cord—all in wooden case.



SPECIAL at \$5.95

PHOTO FLOOD LAMP



All-purpose lamp for photography, illumination, night work, etc. Adjustable ball & socket swivel head, clamp-on fixture, rubber cord and plug. With 9" parabolic reflector.

ONLY... **\$2.25**



HEAD PHONES

Govt. specification Head Sets. Used but guaranteed. ONLY... **\$1.89**

16 M.M. MOVIE FANS !!

Save 50% on motion picture film reels and cans in 400', 800', 1200', 1600' sizes. Send today for FREE PRICE LIST!



MAGNESYN INDICATOR

For remote indicating compass. Automatic direction finder. Calibrated from 0 to 360°.

Govt. Cost \$90.00.....NOW **\$3.75**

All merchandise guaranteed. Order these Surplus Bargains Today. 20% Deposit on C.O.D.'s.

Semlers' ASSOCIATED SURPLUS Dept. P-118 5730 WILSHIRE BLVD., LOS ANGELES 36, CALIF.

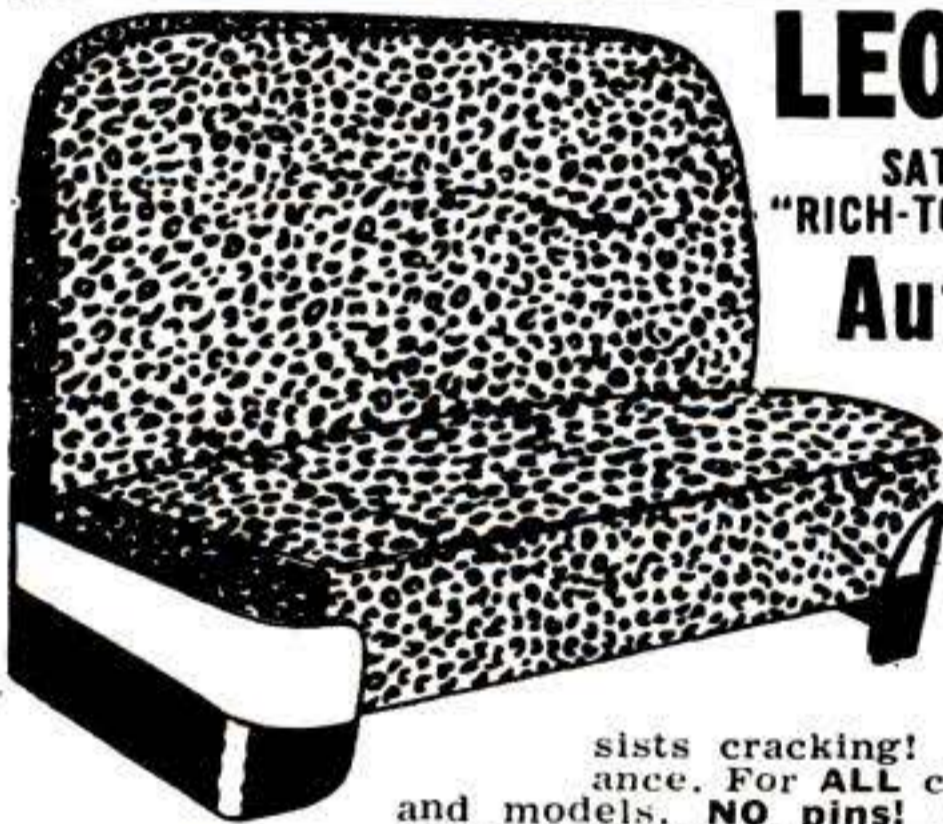

LEOPARD 295 EACH

SATIN-LIKE "RICH-TONE" DESIGN

Auto Seat Covers

TERRIFIC VALUE! New, deluxe RICH-TONE material looks like LEOPARD FUR, gives beauty and distinction to your car. Adds new life to old, worn interiors. Protects new car upholstery against wear, dust, grime, stains, grease, bad weather. Tough, durable, resists cracking! Handsome tailored appearance. For ALL cars, ALL years, ALL makes and models. NO pins! No tacks! No sewing! Ingenious SNAP-TITE feature. Just SNAP on or off

in a JIFFY! Best of all: they're only 2.95 for front or rear seat. **SPECIAL!** Pair for front and rear, only 4.95. Send no money. Pay price plus postage on delivery or send check or money order for free delivery and SAVE! Mention car make, model & year; also if front seat is full front or SPLIT coupe front. Try 10 days at our risk! Guaranteed to satisfy or money back! RUSH!

CONSUMERS MART, Dept. 7-E-150
131 West 33rd St., New York 1, N. Y.

Sensational Device Tests Eyes

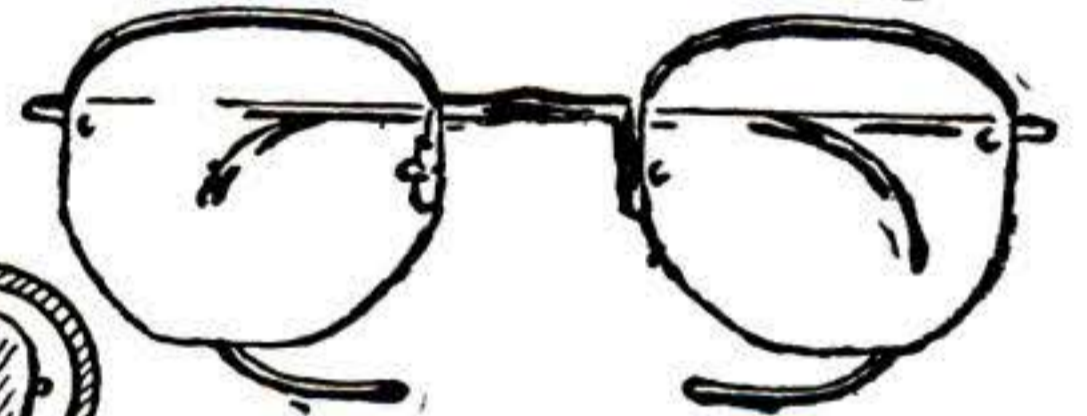

SAVE up to \$15.00 on Glasses! Big news to the millions of Spectacle Wearers and Prospects. Means Freedom from Outrageous Prices. Sold on Money-back Guarantee.

MAKE BIG MONEY QUICK—FREE SAMPLE KIT! Show it to friends and others. Let them use it Free and watch their amazement over this Self Testing system. Here is a great new opportunity in a tremendous new field of unlimited possibilities. Spare or full time. No experience needed. Write for Free sample kit.

C. G. Optical Co., Dept. A-132, 20 E. Delaware Pl., Chicago 11, Ill.

UNLIMITED OPPORTUNITIES IN ENGINEERING DEGREE IN 27 MONTHS

Study Engineering in this world-famed school, established 1884. Demand for our graduates exceeds supply. Growing shortage of engineers. No field offers greater opportunities for responsible, lucrative positions.

Bachelor of Science Degree in Mechanical, Civil, Electrical, Chemical, Aeronautical, Radio (Television) Engineering; Business Administration and Accounting. Also 36-weeks certificate courses in Surveying and Drafting.

Personalized Instruction. Accelerated courses. Non-essentials eliminated. For ambitious, earnest students. Earn your degree in the shortest possible time. Preparatory courses. Placement service.

Extensive Campus. Well equipped, new and modernized buildings; up-to-date labs. Low cost. New terms start quarterly. Enter September, January, March, June.

Mail Coupon Today

TRI-STATE COLLEGE

552 College Avenue, Angola, Indiana

Please send me free catalog and special information. I am particularly interested in courses as checked:

- Mechanical Civil Electrical Chemical Aeronautical
 Radio (Television) Business Administration Accounting
 Short Diploma Courses

NAME.....

ADDRESS.....

Any mowing job made easier!
TOMY-WESS POWER MOWER
Big New Feature—Spinning saucer carries 18" blade—mows grass low and even like a reel type mower. Cuts the toughest weeds and trims close. Briggs Engine—large 10 inch wheels.
15% Off for Schools and Churches—WRITE FOR DETAILS. CASH ORDERS PREPAID.
Mower complete \$123.50—Less engine \$63.50.
TOUHY MOTOR CO.
Dept. S Touhy, Nebraska

FLORIDA OPPORTUNITY BULLETIN

The Florida Opportunity Bulletin is an exciting new publication, issued on the 1st & 15th each month and listing hundreds of job openings, business opportunities, farms, groves, city lots, homes, etc. All important areas of the "Sunshine" State covered—Jacksonville, Tampa, Miami. Detailed reports in each issue on employment, trade, real estate. New business & industries are reported, giving names, locations, etc. No other publication like it. Of vital importance in helping you find the right job... buy the right business, farm, grove or home. Let the BULLETIN be your gateway to opportunity, health & happiness. Send only \$1.00 cash, check or money order today for trial subscription next 5 big issues.
FLORIDA OPPORTUNITY BULLETIN
Box 539-PS, MIAMI BEACH, FLA.

Trial Subscription
5 Issues **\$1.00**

Satisfaction guaranteed. If not delighted on receipt of first issue your \$1 will be promptly refunded. Act now!

"A FASCINATING...MONEY-MAKING

art career can be yours

America's 12 Most Famous Artists Show You How!"

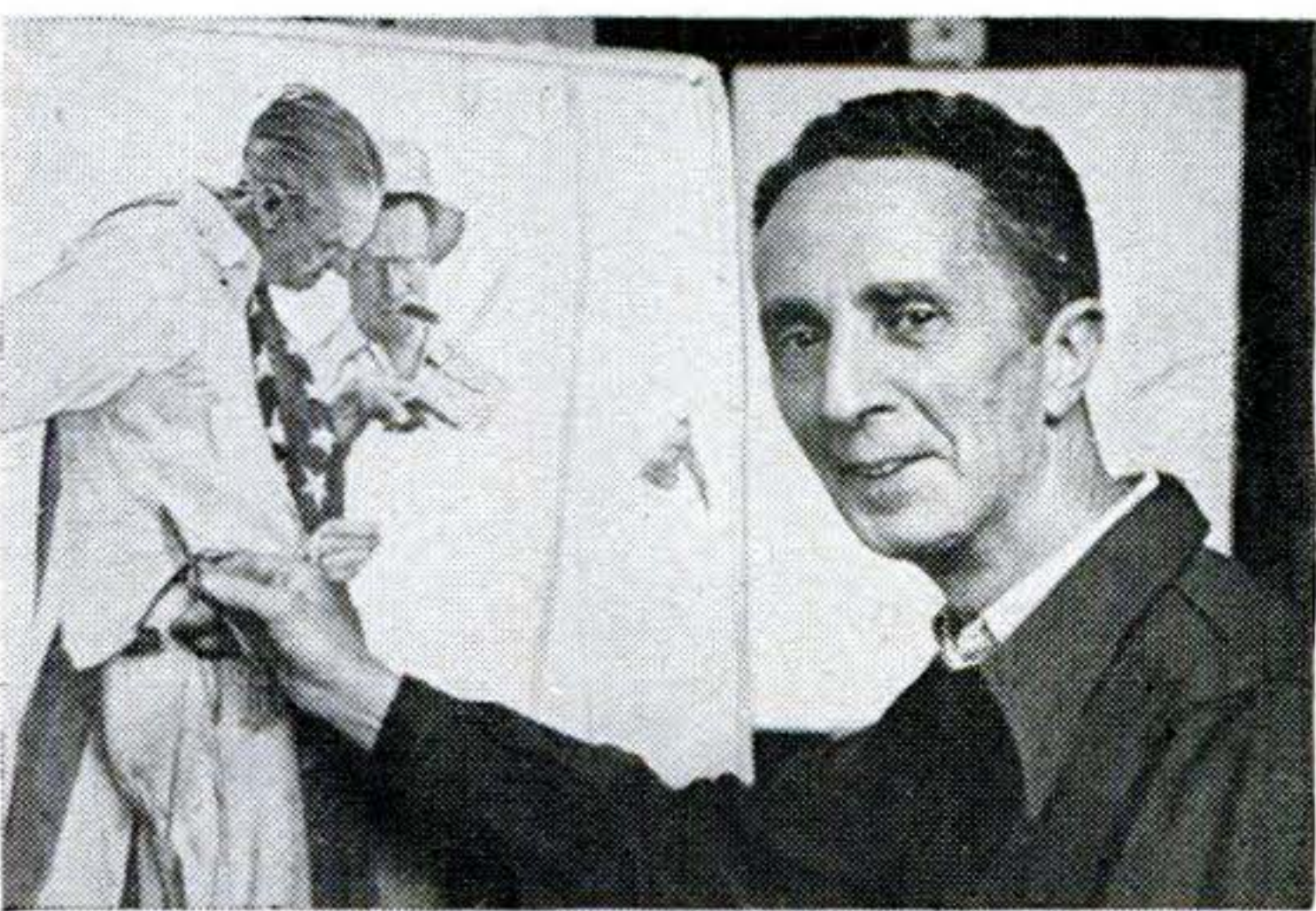

says **NORMAN ROCKWELL**
WORLD'S MOST FAMOUS COVER ARTIST

We show you our successful methods and art secrets...you learn them at home, in your spare time. Write for our big, handsomely illustrated free booklet that tells how you can have a great new art career! **WRITE TODAY!**

FACULTY

- | | |
|--------------------|----------------|
| Norman Rockwell | Al Parker |
| Jon Whitcomb | Ben Stahl |
| Stevan Dohanos | Robert Fawcett |
| Harold Von Schmidt | Austin Briggs |
| Peter Helck | John Atherton |
| Fred Ludekens | Albert Dorne |

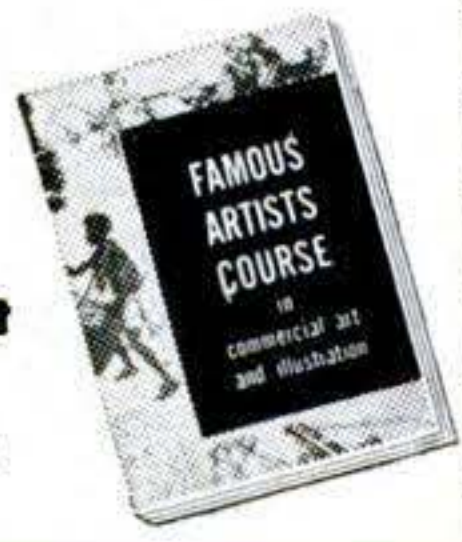

FAMOUS ARTISTS COURSE

Studio 11-E, Westport, Conn.

FREE

Please send big illustrated booklet about my art career,

Mr. Mrs. Miss Age

(please print)

Street

City, Zone, State

RADIO-TV SERVICING!
Easy To Learn At Home



Prepare now for big pay opportunities with learn-by-doing course. Completely covers every phase of Radio-TV, including set conversion, master antenna installation, U.H.F.-TV, others. You work on a large screen, modern TV receiver furnished with course and yours to keep. Age is no barrier. For FREE illustrated booklet and valuable lesson, **WRITE NOW!**
MILTON S. KIVER, Pres.
TV COMMUNICATIONS INST., 205 W. Wacker Dr., Dept. PS-2, CHICAGO 6, ILL.

BRAND NEW **30 DAY FREE TRIAL**
High Power BINOCULARS
Finest Precision Optics
Featherlight
Money Back Guarantee
Easy Pay Plan
Leather Case Incl'd.
Free! Catalog & Book
"How to Select Binoculars"
Dealer Inquiries Invited
Bushnell Bldg., Dept. P45
Pasadena 1, Calif.

33 MODELS
\$14⁹⁵ up
BUSHNELL Binoculars

Make \$20 to \$30 a Day with this new ONE MAN MAIL ORDER BUSINESS



DO PLASTIC LAMINATING AT HOME!

Would you like to get orders and cash from your mail-man—then in space of hours make and ship the things people ordered from you? If you have spare time and a little spare room in kitchen, garage, or basement, get the facts about the newest and most fascinating of all home operated businesses. For the first time a simplified machine brings the fabulous profit of **Plastic Sealing and Plastic Laminating** within the reach of the small operator. Any one can learn to operate the machine with a few minutes practice—then

with our **Magic Mail Plan** can get mail orders pouring in daily with cash in every envelope. No canvassing—no selling. We even supply the circulars you mail to bring back cash and orders. Don't waste a minute. Rush your name. We'll send you, **FREE** and postpaid, pictures, prices, details, all the facts you need to start. Mail coupon or send name on postcard. No charge.

Make Thousands of Beautiful Art Creations
COSTUME JEWELRY • CIGARETTE BOXES
TRAYS • CANDLESTICKS • COASTERS
LAMP BASES • BOOK ENDS...ALL IN
SPARKLING COLORED PLASTIC



THIS MAN . . .
... is taking out of the machine a Plastic Sealing Job—ordered by mail—only 11c in material cost brings back \$2.58 in cash by mail. Capacity of machine: \$25.00 profit per hour of operation.

WARNER ELECTRIC CO., 1512 Jarvis Av. DEPT. L-9-E - CHICAGO 26, ILLINOIS

WARNER ELECTRIC CO., 1512 Jarvis Av. Dept. L-9-E, Chicago 26, Ill.
At no cost to me, please rush complete details postage prepaid. I am under no obligation.

Name

Address

City.....Zone.....State.....

FAMOUS 15 & 17 JEWEL BULOVA WRIST WATCH \$16⁹⁵ PLUS TAX

UNLIMITED WRITTEN GUARANTEE

SAVE \$44 ON THIS 17 JEWEL WRIST WATCH \$14⁹⁵ PLUS TAX



WERE UP TO \$59.50
SAVE \$42.55

Also Choice of
● BENRUS
● GRUEN
● WALTHAM
● or ELGIN WATCHES

You get these unredeemed LIFETIME GUARANTEED famous Bulova and other movements in latest style Yellow Gold Cases at this sensationally low price because we bought out SURPLUS STOCKS of leading New York and Md. jewelers. Order now while they last. Specify make preferred and whether men's or ladies! Only \$16.95, plus \$1.70 tax. Order right now!

WEAR AT OUR RISK! Money Back guarantee in 10 days if not delighted.

FREE 10 DAY TRIAL

FREE EXPANSION BAND WITH EACH ORDER

FORMERLY SOLD FOR \$59.00
INCABLOC SHOCK PROTECTED WATER & DUST PROOF
Worn By ARMY, NAVY & MARINES

Luminous dial, sweep second hand. Super Accurate. Imported Swiss precision movement and case. You get these brand new LIFETIME GUARANTEED watches now for a small fraction of the original price. You save \$44, because we bought out surplus stocks. Order men's style \$14.95 plus \$1.50 tax or ladies' and nurses' style, \$16.95, plus \$1.70 tax. Order now at this low price.



Nurses Model \$16.95 Plus tax

SEND ONLY \$1 DOWN PAYMENT with order. Pay balance to postman on arrival plus postage. Or we pay postage if you enclose full payment plus tax.

MARYLAND DISTRIBUTORS, Dept. 377 501 E. BALTIMORE ST. BALTIMORE 2, MARYLAND

FREE! Watch and Jewelry Catalog at almost Wholesale Prices.

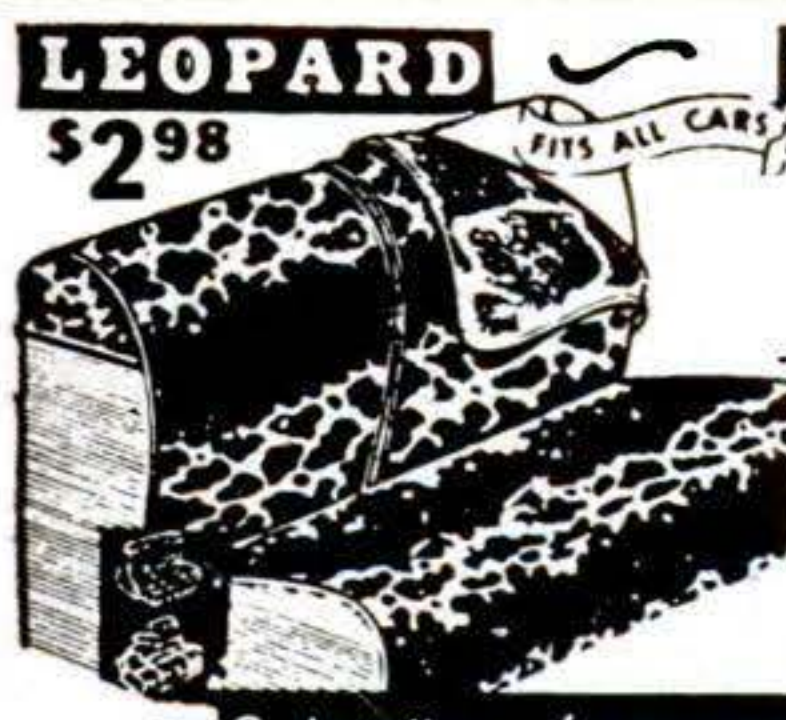

LEOPARD \$298 **COWHIDE**
REVERSIBLE AUTO SEAT COVERS
Made of FLEXTON
Approved by Good Housekeeping

Order direct from manufacturer and save! LEOPARD SKIN on one side COWHIDE on the other. Made of Heavy Gauge plastic for long wear. WATERPROOF and STAINPROOF. Simple to attach—with REINFORCED OVERLAP side grip elastics that hold securely. PERFECT FIT COVERS are made roomy and dress up your car's interior. PATENTED SHIRRING holds seat and back neatly. Sewn with NYLON THREAD for long wear. LONG WEARING-DOUBLE DUTY

5 DAY MONEY-BACK GUARANTEE!

CHOICE OF SPLIT OR FULL FRONT SEAT STYLES only \$2.98. Complete set for front and rear seats only \$5.00. When ordering specify make of car and style of seat. Order NOW. Enclose payment and save shipping charges. C.O.D. orders sent collect plus postage.

MARDO SALES CORP., Dept. 630
480 Lexington Avenue New York 17, N. Y.

Piles May Lead to Chronic Ailments

FREE BOOK—Explains the Causes and Effects

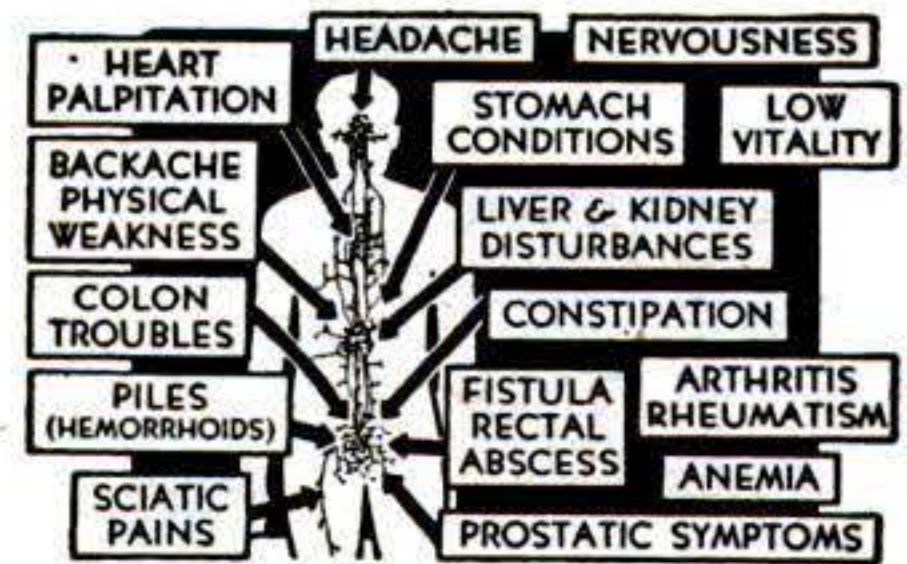

No obligation. Write to Thornton & Minor Clinic, Suite 549, 911 E. Linwood, Kansas City 3, Mo.

BENJAMIN SUPER CO₂ GAS PISTOL

NEW! Different

SAFE • NON-TOXIC • HI-POWER ACCURATE • ECONOMICAL CONVENIENT • PRACTICAL

Easy to operate—Uses low cost Soda Cartridges. Shoots Cal. .177 Benjamin H-C Pellets & Darts or BB. Write Today for Illustrated Folder of All Models Benjamin Air Rifles and Benjamin Air Pistols.

\$15⁰⁰

Benjamin Air Rifle Co., 852 Marion St., St. Louis 4, Mo., U.S.A.

BECOME AN EXPERT IN TRAFFIC

Traffic men earn \$4,000 to \$10,000 and up. Thousands of firms need experts on rates, tariffs, regulations. We train you thoroly in spare time at home for executive traffic jobs. Personal training under traffic authorities. Placement counsel and help. Write for free 48-page book "Traffic Management—the Fast Growing Profession."

LASALLE Extension University, 417 So. Dearborn St. A Correspondence Institution Dept. 583T Chicago 5, Ill.

Build the Best! EASY TO ASSEMBLE BOAT KITS

NEW CATALOG
OVER 40 PAGES, INCLUDES ALL YOU NEED TO BUILD YOUR OWN

- 1-BOAT KITS—30 MODELS
- 2-MARINE HARDWARE
- 3-MARINE ENGINES
- 4-MARINE CONVERSIONS
- 5-PAINTS & COLOR CHARTS

All For Only 35c. SEND COIN TODAY

ROWBOATS 8-10-12-14 FT. \$39 up

OUTBOARDS 8 Models 12 to 18 FT.

INBOARDS & CABIN CRUISERS 16 TO 23 FT.

NEW 18 FT. OUTBOARD CABIN CRUISER

FAST VEE BOTTOM HULL SPEEDS UP TO 25 M.P.H. — ROOMY CABIN, WITH TOILET, SLEEPS TWO —

U-MAK-IT PRODUCTS
703R-WHITTIER ST., Bronx 59, N. Y. City

ARE YOU IN THE RIGHT JOB?

Let us test you to find the field for which you are best adapted.

Let us give you confidence in the knowledge that you are headed in the right direction. Those who take our tests also take the worry and guesswork out of their future.

We are equipped to guide you, both from the standpoint of educational qualifications and from years of experience.

When you have answered and returned the tests which we will send you, we will analyze them and advise you as to your job possibilities.

Our service is strictly confidential. Send \$10 for the complete battery of tests, or write for further information.

CAREER COUNSELLING SERVICE
408 Heard Building Phoenix 1, Arizona

One Sweep — Destroys Static Electricity

...and Removes Dust and Lint

with **STATIC master** — The most useful Photographic Tool ever invented

- For cleaning slides before mounting
- For cleaning negatives before printing

Staticmaster removes static, dust and lint with one simultaneous brushing action. By this neutralizing action, dust is eliminated on negatives, film holders, enlargers, printers, slides and slide mounts. Print spotting and negative opaquing are reduced to a minimum.

Buy Staticmaster at your local photographic store or sent postpaid if cash with order.

Amateur 1" Model \$4.95
Professional 3" Model \$12.50

NUCLEAR PRODUCTS COMPANY

2164 Newport Boulevard

Costa Mesa, California

ELECTRIFY your SEWING MACHINE

NEW LOW PRICE! \$10.50 1 YEAR GUARANTEE

Buy direct from manufacturer and save! Kit comes fully wired, installed in a jiffy. Fits all machines! You get **ALL-NEW PARTS**

- Motor & Bracket
- AC-DC 115v 60c
- Multi-speed foot control
- Cord set & block
- Easy instructions
- Steel pulley & belt

FREE . . . reg. \$2.95 chrome SEWLITE given with every kit.

10 DAY FREE TRIAL—ORDER NOW!

Send no money, pay COD or send money order and we'll pay postage. Please state whether wheel on your machine turns toward you or away from you. Shipping wt. 6 lbs.

SENIOR SEWING MACHINE CO.

197 Clifton Place

Dept. PS-37

Bklyn., N. Y.

DON'T LET ADDED QUARTS BREAK YOUR BANKROLL...



Sound your **Z**
SWITCH TO

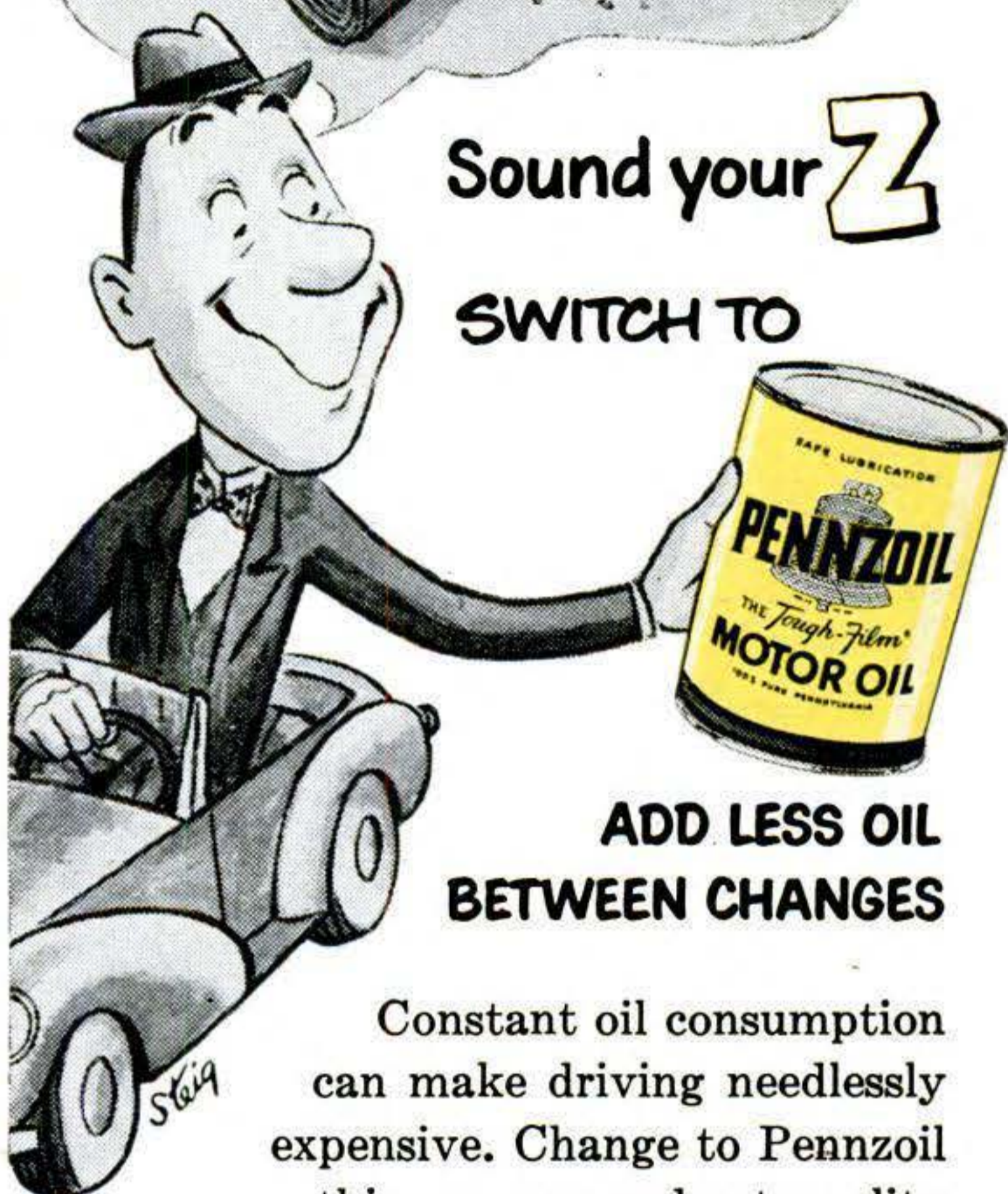

ADD LESS OIL
BETWEEN CHANGES

Constant oil consumption can make driving needlessly expensive. Change to Pennzoil this summer and get quality motor oil that lasts longer. Pennzoil is specially refined from 100% Pennsylvania crude oil, with a tough-film that safeguards your engine from sludge, varnish and carbon. By keeping pistons, rings and valves clean and smooth-running you use less oil with Pennzoil. Change over now! Switch to Pennzoil...

at this sign...



GIVES ALL ENGINES AN EXTRA MARGIN OF SAFETY

Member Penn. Grade Crude Oil Assn., Permit No. 2

PENNZOIL® MOTOR OIL AND LUBRICANTS AT BETTER DEALERS . . . COAST TO COAST

Watch for these
DANGER SIGNS
of Worn-Out Shock Absorbers



Guaranteed
for one year
or 15,000
miles



Play Safe—Replace With New
MONRO-MATIC
SHOCK ABSORBERS

The Only Shocks with Automatic Adjustment

Don't take chances. Check your shock absorbers now and install new MONRO-MATICS if replacements are needed. They give a smoother, safer ride over any road.

EASY TO INSTALL

It takes only a few minutes to install MONRO-MATICS on the average car. Clip this ad and send with your name and address for installation and service manual.

MONROE AUTO EQUIPMENT CO., Dept. B MONROE, MICH.



SEND
NO MONEY
•
MORE THAN
4000 PAGES
•
2750
PICTURES

9 BIG COMPLETE BOOKS
BUILDING, ESTIMATING, CONTRACTING

Examine this Up-to-Date Edition for 10 days. See how these nine books supply easily understood training that will help you to get a better job and make more money, or start a profitable business for yourself. Think what a BIG help it will be to have them handy for use in solving all sorts of building problems.

Learn to draw plans, estimate, do all-new construction and modern remodeling to meet fast growing demand. More than 4000 pages of practical, pay-raising information with 2750 helpful illustrations, on such subjects as blueprint reading, concrete forms, masonry, carpentry, steel square, electrical wiring, plumbing, heating, painting, and hundreds more.

In our more than 50 years we have never offered more complete building information. Send the coupon TODAY.

(A year's consulting privileges with our engineers now given with these books without extra cost.)

AMERICAN TECHNICAL SOCIETY—Publishers Since 1898
Dept. G520, Drexel Ave. at 58th St., Chicago 37, Ill.

I would like to examine your 9-Volume Set of Building, Estimating, Contracting Books. I will pay the delivery charges only, but if I choose I may return them express collect. If after 10 days' use I prefer to keep them, I will send you \$3 and pay the balance at the rate of only \$4 a month until \$34.80 has been paid. Include consulting service as offered above.

Name _____
Address _____
City _____ State _____

Please attach letter giving employer's name and address (if self-employed give business man reference). Men in service please give home address.

BE YOUR OWN WEATHER FORECASTER
WITH THIS FINE, IMPORTED

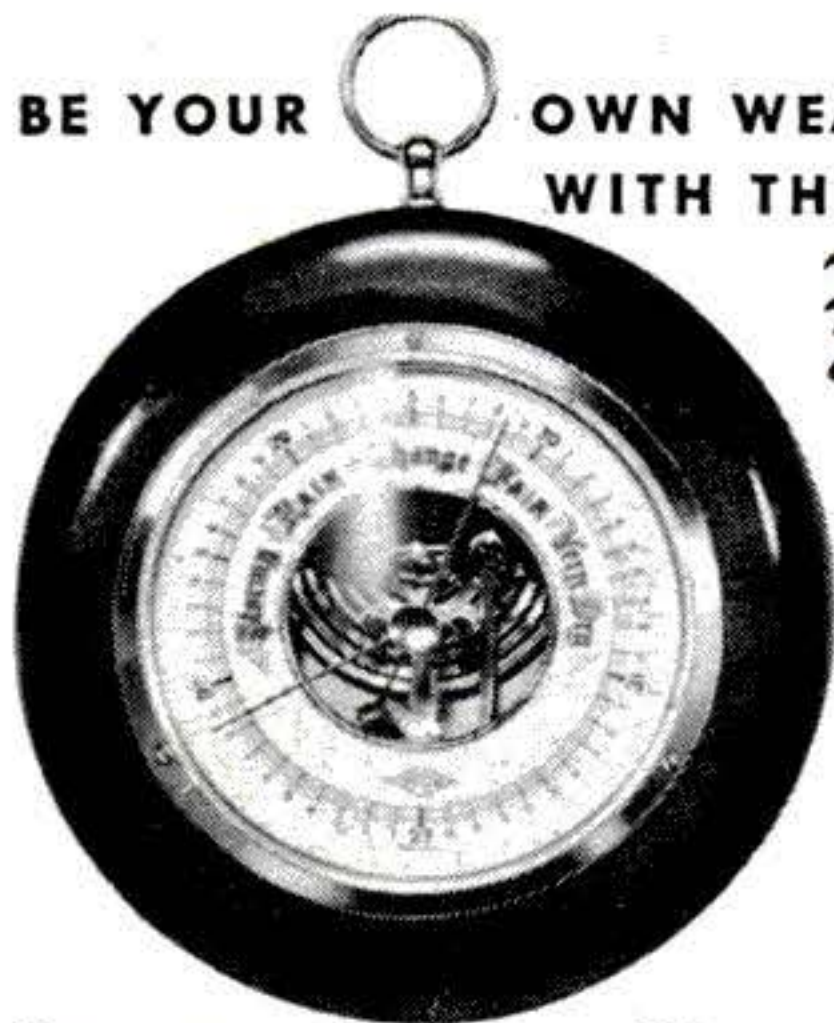

Barometer

Precision-made by German craftsmen, this scientific ANEROID BAROMETER is something every man has always wanted. Useful, decorative, accurate. In cherry-finished hardwood case, its intriguing mechanism in gleaming brass and clear glass reflects its excellence. A gift to OWN or give. 5 1/4" diam. Forecasting chart with each Barometer.

\$6.95 POSTPAID
(No C.O.D.'s please)

Campus Camera Shop, 1083-A Broxton Ave.
Westwood Village, Los Angeles 24, Calif.

make your own **Gems** **29.50**
F.O.B.

All necessary lapidary equipment is furnished, including a super-charged diamond blade for sawing, and all wheels for grinding, shaping and polishing; also complete instructions. The complete equipment as shown, less motor and belt, for only \$29.50, f.o.b., Burlington, Wisconsin. Write today for information and literature.

B&I MANUFACTURING CO.
Dept. M Burlington, Wis.

ILLUSTRATED COMIC BOOKLETS
FOR MEN ONLY! POCKET SIZE!



THEY'RE TERRIFIC! PACKED WITH RARE CARTOONS and GOOD CLEAR ILLUSTRATIONS AS YOU LIKE IT. RICH IN FUN and HUMOR. **20 BOOKLETS** ALL DIFFERENT, SENT PREPAID FOR \$1 IN PLAIN SEALED WRAPPER. NO C.O.D.s.

NATIONAL, Dept. 478, BOX 5-STA. E, TOLEDO 9, OHIO

Secrets of VENTRILOQUISM
Now Revealed!

Easy to learn in 60 to 90 days with our Home Study Course. **RESULTS GUARANTEED.** Make Money! Be Popular! Have Fun! Big Opportunity! Radio, Television, Stage Appearances! For Free Information regarding price and terms, WRITE. You must state your age. Dummy Catalog 25c.

FRED MAHER SCHOOL OF VENTRILOQUISM
Box 36, Studio 5 Kensington Station
Detroit 24, Michigan

**Free Book on Arthritis
And Rheumatism**

HOW TO AVOID CRIPPLING DEFORMITIES

Explains why drugs and medicines give only temporary relief and fail to remove the causes; tells all about a specialized non-surgical, non-medical treatment which has proven successful for the past 33 years. Write for this 44-page FREE BOOK today.

Ball Clinic Dept. 36 Excelsior Springs, Mo.

Salesmen CHECK (✓) HERE
HOW MUCH YOU WANT TO MAKE THIS YEAR
\$1,000? \$4,000? \$8,000?
\$15,000? More?

Will you reach your financial goal with the product or service you are now selling? If you aren't satisfied with your present income... what you need is just one hour alone with the SALESMAN'S PRODUCT RATING GUIDE. Not a "course"—but a book of knowledge—FACTS for men who sell. Over 2,000 deals and offerings by most every company in the nation that sells through direct salesmen—every deal—every product is rated in this big 200 page Guide that you as a salesman can't do without—rated as to selling power—profits to you. ARE YOU GETTING THE BIGGEST COMMISSION POSSIBLE? The SALESMAN'S PRODUCT RATING GUIDE tells you. How about a better side-line? What is the hottest selling deal today? Get the answer to these and a thousand more questions every salesman asks—SEND NO MONEY, just your name and address. GUIDE sent for no-risk examination. FREE, full details. Write NOW!
SALESMAN'S PRODUCT RATING BUREAU, Palm Desert 15, California.

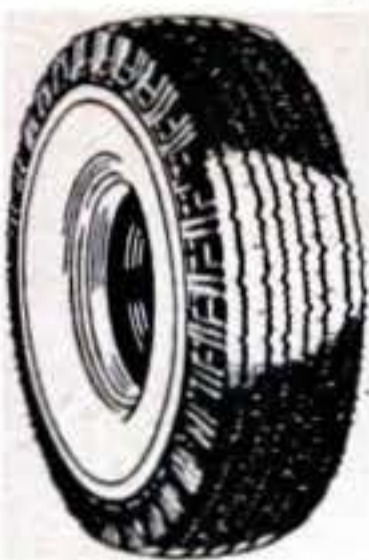

THE MOST AMAZING OFFER IN USED TIRE HISTORY. EVERY PASSENGER TIRE UNCONDITIONALLY GUARANTEED plus TIRE INSURANCE FREE

Here's DOUBLE proof that we bear the loss if your passenger tire wears out within the guarantee period or is damaged in any way (except willfully). Don't take risks: we send FREE insurance certificate PLUS written unconditional guarantee with your order.

10% OFF ON TWO OR MORE TIRES

TRIPLE INSPECTED PASSENGER TIRES							
UNCONDITIONAL ONE YEAR GUARANTEE plus TIRE INSURANCE FREE							
600-16	\$5.59	700-16	\$7.59	700-15	\$5.59	550-16	\$5.95
600-16(6)	6.50	600-15	5.59	750-16	12.25	550-17	5.75
650-16	5.79	650-15	5.59	550-15	5.59	475-19	5.75
640-15	5.95	710-15	6.50	820-15	7.50	760-16	7.75
670-15	5.95	760-15	6.75	670-16	6.95		

MUD AND SNOW TIRES			
2 YEAR WRITTEN GUARANTEE			
600-16	\$6.95	900-16	\$12.95
650-16	7.50	650-16(6)	9.50
		750-20 Reg.	\$12.50
		650-15	6.50
			Spec. \$15.95

EXTRA VALUE TRUCK TIRES							
ONE YEAR WRITTEN GUARANTEE							
600-20	\$10.75	750-20	\$14.50	825-20	\$21.50	1100-20	\$26.95
650-20	11.75	32x6(8)	11.75	900-20	19.50	1100-22	24.50
700-20	12.50	32x6(10)	12.50	1000-20	20.00	750-20(10)	18.00

Complete line of High Mileage Tires in stock. Write for price list for sizes not listed. Take off 10% on orders for two or more tires. Remember—every passenger tire unconditionally guaranteed PLUS TIRE INSURANCE FREE.

MAIL ORDERS PROMPTLY FILLED. Send check or money order with this ad. **THE SAFTYRE CO.** "FOR THAT SAFE TIRE" Dept. PS, 920 W. CARY ST., PO Box 2254, RICHMOND, VA.

Learn TELEVISION RADIO—ELECTRONICS

Prepare in spare hours for good pay in Television, Radio and Electronics. Train at home with Frank L. Sprayberry, America's outstanding Radio instructor. Big Kits of equipment furnished. Build testers, sets, etc. VETERANS: Approved for Training under GI Bill. Rush name and address for details and 2 BIG RADIO BOOKS—ALL FREE! No salesman will call. Write today! Sprayberry Academy of Radio, Dept. 55-J 111 N. Canal Chicago 6, Illinois

Find HIDDEN TREASURES

GEIGER COUNTERS for Uranium Detection (see at left). **TREASURE DETECTORS** for gold, silver, etc. Lightweight, ultra sensitive. None finer at ANY PRICE. INFORMATION FREE. *Detection co.* 5631 Cahuenga, No. Hollywood, Calif.

REAL ESTATE BE A BROKER

PAYS BIG! SEND FOR FREE, BIG, ILLUSTRATED CATALOG NOW! No obligation. Graduates report making substantial incomes. Start and run your own business quickly. Men, women of all ages, learn easily. Course covers Sales, Property Management, Appraising, Loans, Mortgages, and related subjects. **STUDY AT HOME** or in our classrooms in big cities. Diploma awarded. Nationally known. G. I. Approved. **WEAVER SCHOOL OF REAL ESTATE (Est. 1936)** Suite 300 Law Bldg., Dept. PS, Kansas City, Mo.

\$5000.00 in PRIZES DRAW MY HEAD

YOUR DRAWING JUDGED & ANSWERED 1st & 2nd Prizes Complete \$130.00 Art Courses **80 OTHER VALUABLE PRIZES** Take this test and try for a thrilling prize. Discover if you have profitable Art talent. You may gain a lifetime of happiness and high earnings if you mail your drawing today. Amateurs only. Our present students not eligible. Copy this girl 4" to 6" high in pen or pencil and mail to us. None returned. Winners notified. New \$5,000 contest each month. Your drawing will be entered in Contest for the month in which we receive it. Send your drawing now and include your name, address, age and occupation. Enter today. **WALLER ART EXCHANGE** Studio 95, 1000 N. Charles St. Baltimore 1, Md.



BE AN ARTIST WRITE FOR FREE BOOK

Money-Making Jobs... ALL AROUND YOU!

BE YOUR OWN BOSS! Big Money waiting for you today in floor surfacing! Hundreds of prospects near you! The floor next door may be your first job—and business mushrooms as folks tell others. Earn as high as \$50 and more a day sanding floors with an easy-to-run American Machine. Pleasant indoor work—steady the year round. A sound opportunity to get in something for yourself and be your own boss! No schooling—no experience needed. Only small investment in sander gets you started to success! Send coupon for "money-making booklet" entitled "Opportunities in Floor Surfacing"—enclose 25c in coin or stamps to cover handling.

AMERICAN FLOOR MACHINES

SEND!

The American Floor Surfacing Machine Co.
532 So. St. Clair St.
Toledo 3, Ohio

Enclosed find 25c in stamps or coin for booklet "Opportunities in Floor Surfacing", telling me how I can start my own floor sanding business.

Name.....
Street.....
City..... State.....

Copyrighted material

FREE BOOK AND ACTUAL SAMPLE

Screen Print, Dept. 15
1010 So. Los Angeles St.
Los Angeles 15, California
Dear Mr. Nowak: Please rush me FREE BOOK, ACTUAL SAMPLES, and your amazing new PRINTING PLAN

Name _____
Address _____
City _____ State _____



C. J. NOWAK
General Manager
AT HOME
SPARE
TIME

IT'S AMAZING! I'll show you
how to make up to \$12.50 per hour

PRINTING WITHOUT A PRINTING PRESS

Print paper
of all kinds



PRINT
BANNERS

PRINT
FABRICS

PRINT
INSTRUMENTS



PRINT
SIGNS

FOR SALE

YOU
CAN PRINT
ANYTHING
WITH



AMAZING NEW COLOR PRINTING METHOD
A fascinating new miracle-way to print—a secret method that lets you print colorful signs, posters, banners, drapes, wallpaper, flags, glass, fabrics—ANYTHING without an expensive printing press or costly equipment. This new process is revolutionizing the entire printing industry—it's one of America's fastest-growing businesses—it's your "chance of a lifetime" to make Big Money Now! Be the FIRST in your area to profit. The secret can be yours—just mail the coupon above today!

EASY TO LEARN! NO EXPERIENCE NECESSARY! Simple fascinating method! No artistic ability needed. It's possible for anyone (young or old) to make up to \$50 PER WEEK printing in SPARE TIME alone—AT HOME!

START YOUR OWN BUSINESS—BE YOUR OWN BOSS Wouldn't you be happy if you could take only one hour of your time and \$1.00 worth of materials—and sell your printing for \$15 or more. It's that easy! It's amazing! Your home can be your office—No selling because there's a huge demand everywhere. **GOVERNMENT CONTRACTS AVAILABLE TO BID.** Biggest opportunity in America—costs you nothing to receive all CONFIDENTIAL FACTS—Mail coupon today!

SCREEN-PRINT

1010 S. Los Angeles St., Los Angeles 15, California

Watch Repairing Pays Big Money Learn at home

Free Literature Tells How

Watch repairers in big demand. You train step-by-step in 10 easy lessons. You learn to take a watch apart—repair and put in perfect working order. We furnish all tools, and a 15 jeweled watch. Practice movement with first lesson.



Turn spare time into cash—perhaps a business of your own. A licensed school. Students 18 to 65 have profited by our training. Low cost.

Write Today for All the Facts—No Obligation

ILLINOIS SCHOOL OF WATCH REPAIRING

2870 Elston Ave., Dept. PS-52, Chicago 18, Ill.

TREASURE -- \$10,000

New locator detects metals, valuable minerals and buried treasure. Money-back guarantee of superiority.



Also geiger counters. Govt. reward of \$10,000 for uranium discovery. Write for FREE information.



THE GOLDAK COMPANY

1544 W. GLENOAKS BLVD., GLENDALE 1, CALIF.



Bar Bells

BUY DIRECT FROM FACTORY
Write for free booklet
and price list

\$8.95
up

INDEPENDENT IRON WORKS
2416 East 23rd Street, Dept. "C"
Los Angeles 11, Calif.

PROPANE GAS ON YOUR CAR

with normal operation on gasoline. Switch to either instantly—Save up to 1/2 on fuel. SEND \$2.00 for "How-to-do-it" booklet, photos, drawings and low prices on complete outfits. (Refunded on parts order.) Rush order today—NOW!



LPG PRODUCTS
Dept. PS-5 Kearney, Nebraska

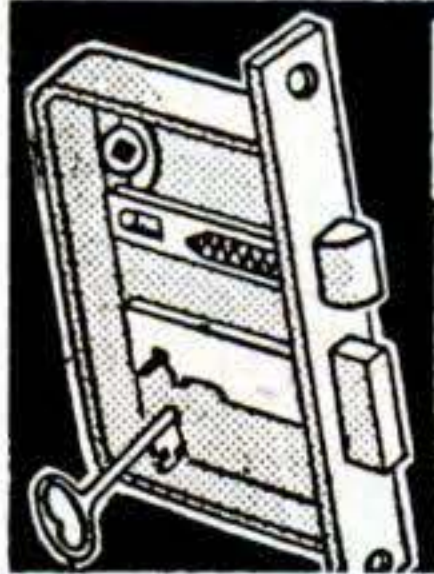

FIX LOCKS

Learn Locksmithing and Keymaking from Experts in Your Spare Time at Home! Age or physical handicap no disadvantage. Year-round, steady income in this permanent, respected field. Full or part time. Practical, illustrated lessons show you how to make money even while learning! All materials and special tools supplied. Send for FREE BOOKLET. LOCKSMITHING INSTITUTE, Dept. PS-29 15 Park Ave. Rutherford, N. J. Lic. by State of N. J. V.A. Approved

NO CAR TROUBLE IS HARD TO FIND...

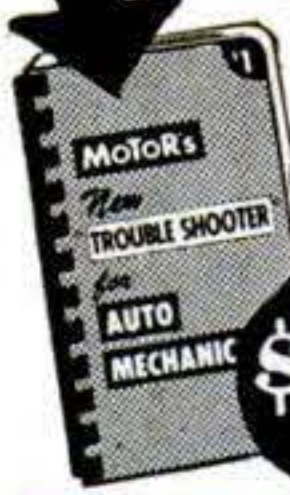

when you have MOTOR'S new "Trouble Shooter" Handy, pocket-size indexed manual lists 2000 CAUSES of car troubles and tells WHERE to look for them. For instance, suppose Fan Belt is noisy; index leads you instantly to 7 things that can be wrong. In same way, "Trouble Shooter" covers engines, clutches, brakes, ignition, rear axles, overdrives, etc. Section on automatic transmissions alone is worth more than price of book! Spiral binding; book stays open while you work.

SEND NO MONEY. Try book at our risk. Just mail your name and address to: MOTOR Book Dept., Box CW, 250 West 55th St., New York 19, N. Y. Pay postman \$1 plus C.O.D. chg. Use 7 days. If not delighted, your \$1 back. (Or save C.O.D. cost by sending \$1 now.)

BUY NATIONALLY KNOWN, NATIONALLY ADVERTISED FILM DIRECT FROM MANUFACTURER—SAVE!

ROLL FILM



FINE GRAIN FILM
WESTON 40 RATING
LATE 1953 DATING
Shipping Weight (10 rolls) 1 lb.

AVAILABLE IN THESE POPULAR SIZES:

#120, #620, #116,
#616, #127

SAVE OVER 50%
WITH QUANTITY
PURCHASES!

\$1.95 20 rolls....\$3.75
30 rolls.... 5.50
FOR 50 rolls.... 8.75
10 100 rolls....16.50
ROLLS

MOVIE FILM

Black & White
and Color

price includes
FREE processing
and return postage.
LATE 1953 DATING



COLOR FILM NOW AT
THE PRICE OF
BLACK & WHITE

FREE!

one roll of black
and white film with
every order of 6 rolls

	COLOR	B&W Weston 50
8mm roll, 25 ft., double Ship. wt. (6 rolls) 2 lbs.	\$2.75	\$1.25
16mm roll, 100 ft. Ship. wt. (6 rolls) 4 lbs.	7.50	3.00
16mm mag., 50 ft. Ship. wt. (6 rolls) 5 lbs.	4.95	2.75

Mailing Instructions
Remit by cash,
check, M.O. 20%
deposit on C.O.D.'s.
Include postage.
Excess postage re-
turned. Orders
without postage
sent collect.

EIGHT-SIXTEEN FILMS, Dept. PS, 243 W. 55th St., N. Y. 19, N. Y.

PAINT SPRAYER



Powerful Professional Type:

\$7.95

Complete

Use on any hard to brush surface... Chairs, wicker furniture, screens, autos, boats, in fact anything that needs painting. MOTHPROOF clothes, rugs, drapes, storage closets, etc.

NO EXTRAS TO BUY

- Just plug in and spray... glossy paints, enamel, varnish, lacquers, stain, oils, disinfection, insecticides, mothproofers, etc.
- A lifelong useful tool. • Simple, easy to use. • Complete with instruction. • Guaranteed for life.

Send your name and address. Enclose check or money order for \$7.95. Or sent C.O.D. Plus Postage.

IMPERIAL SALES CO., Dept. B-347
480 Lexington Ave. New York 17, N. Y.

LEATHERCRAFT and many other crafts

SHELLCRAFT • easy to do
TEXTILE PAINTING • profitable too

Send for **FREE** **BIG CATALOG TODAY**

• complete supplies • everything you need

KIT KRAFT • 7373 Melrose Ave., Dept. 39, Hollywood 46, Calif.

BOYS! MAKE YOUR OWN RADIO

Make your own simple, tubeless, batteryless Crystal Radio. SEND 25c for a GENUINE MELOMITE CRYSTAL with complete illustrated instructions for making your own set. Crystal sent postpaid with instructions and our own publication, "THE MAGIC CRYSTAL" which is full of news, diagrams, questions and answers of interest.

SEND 25c FOR YOUR CRYSTAL TODAY!
ALVA ALLEN RADIO Dept. PS-5 Clinton, Mo.

HYPNOTISM

Learn to apply this tremendous POWER. Develop will-power, self-confidence, self-control. ANYONE can master this exciting, profitable profession in short time by training at home, with GUARANTEED RESULTS. DON'T DELAY... Write to America's oldest Hypnotic school for free information now—today!

INSTITUTE OF APPLIED HYPNOLOGY
120 Central Park So., N. Y. 19, Dept. 78

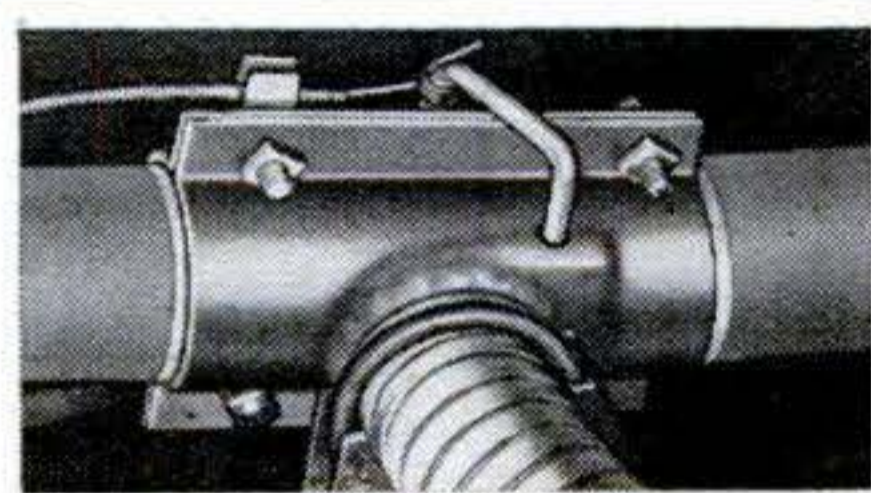

HURRICANE EXHAUST CUT-OUT

This specially engineered cut-out enables you to install special pipes and mufflers without removing the original muffler. Now control your exhaust tone from a dash control button. Cut back into your original muffler in restricted areas at will. This cut-out is well constructed; actually strengthens exhaust pipe; made of heavy plate steel, designed for easy installation—no special tools required. Fits all exhaust pipes from 1 3/4" to 2 1/4" size. Sent postpaid for only \$6.95 check or money order. Satisfaction guaranteed or your money back.

ST. LOUIS PRODUCTS CO., Box 24-B5, Normandy 21, Mo.

Immediate Comfort And Relief for You with RUPTURE-EASER

Trade Mark (A Piper Brace Product) For MEN, WOMEN and CHILDREN

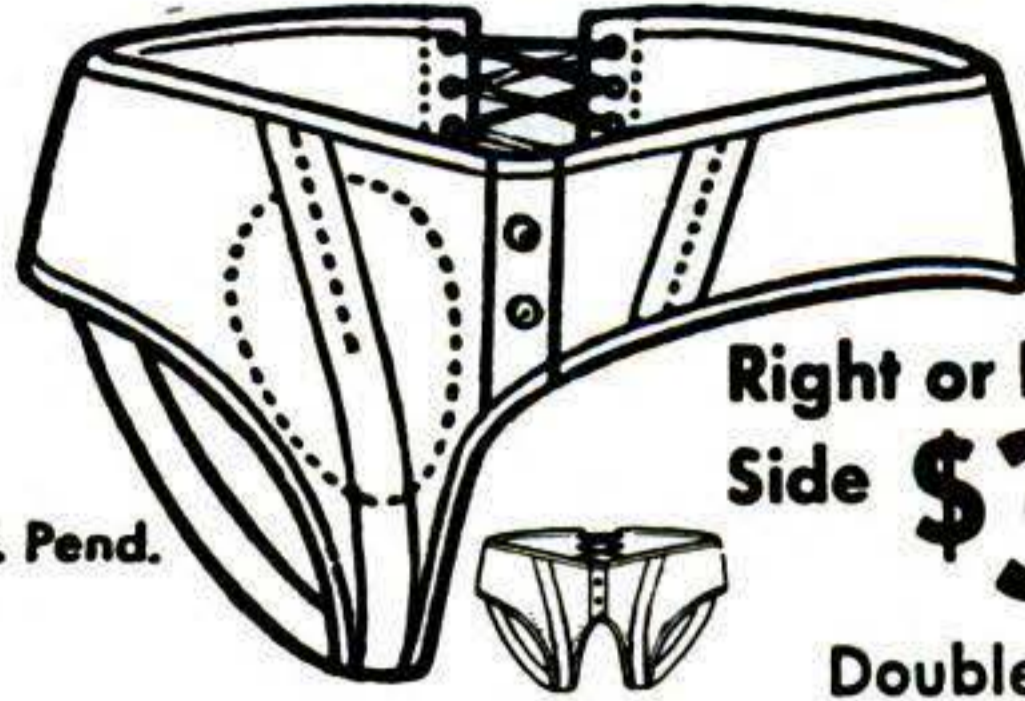

Right or Left Side **\$3.95**
Double **\$4.95**

A strong, form fitting washable support designed to give you relief and comfort. Adjustable back-lacing and adjustable leg straps. Snaps up in front. Soft flat groin pad—**NO STEEL OR LEATHER BANDS.** Unexcelled for comfort, **INVISIBLE UNDER LIGHT CLOTHING.** Washable. Also used as after operation support.

- **THE MOST EFFECTIVE HERNIA SUPPORT.**
Thousands of people who have tried old-fashioned, expensive devices turn to Rupture-Easer for new comfort.
- **RUPTURE-EASER IS SANITARY.**
Can be washed without harm to fabric—you never offend when you wear Rupture-Easer.
- **NO FITTING REQUIRED.**
Just measure around the lowest part of the abdomen and specify right or left side or double.

Over 300,000 Grateful Users

Harley Decoteau, Montpelier, Vt. writes: "The last brace you sent me was wonderful. I have been ruptured for 30 years. I am now 36, and in 30 years, I have never been more pleased."
Minnie LaJeunesse, Minneapolis, Minn. says: "... the Rupture-Easer is very comfortable and almost a miracle as to the way it holds one in place, and am very much pleased and satisfied with the belt."
Frank H. Lewis, Adrian, Michigan writes: "Thanks to your Rupture-Easer I am able to continue my work."

BLESSED RELIEF DAY AND NIGHT—You can sleep in it—work in it—bathe in it!
10 DAY TRIAL OFFER
Money-back guarantee if you don't get relief.
PIPER BRACE CO., DEPT. PS-52
811 Wyandotte, Kansas City 6, Mo.



Piper Brace Company, Dept. PS-52
811 Wyandotte, Kansas City 6, Mo.
Please send my RUPTURE-EASER by return mail.

Right Side \$3.95 Measure around lowest part of
Left Side \$3.95 my abdomen
Double \$4.95 is INCHES.

(Note: Be sure to give Size and Side when ordering.)
We Prepay Postage except on C.O.D.'s.
Enclosed is: Money Order Check for \$_____ Send C.O.D.

Name.....
Address.....
City and State.....

RUSH THIS COUPON NOW!

We teach you FREE!



We put you in Business!

HERE'S THE BIG OPPORTUNITY FOR YOU! Learn a new and fascinating occupation... a wonderful hobby... and MAKE MONEY AT THE SAME TIME! OPERATE AT HOME OR IN A SMALL SHOP! AND... the complete Instructions... books, lessons and personal guidance COST YOU NOTHING! We teach you FREE how to make the most beautiful jewelry you have ever seen: door-knobs imbedded with interesting objects, nite-lites, book-ends, coasters, name-plates, ash trays, paper weights, statues, figurines, souvenirs, novelties, gadgets, etc. . . . an endless variety of high-quality, highly saleable products out of LIQUID MARBLE, TRANSPARENT GEM-LIKE LIQUID PLASTIC, CERAMICS, PLASTER, COMPOSITIONS, STONE, ETC! All without tools or machinery! The manufacture of these lovely objects is as easy as pouring water out of a glass! And—you learn how ABSOLUTELY FREE! The only limitation is your own IMAGINATION! No special talents or experience are required!

You get more than the FREE INSTRUCTIONS! We also show you methods of selling your finished work... even selling part of it to us! Start on a shoestring! And overnight, become established in one of the most fascinating and profitable occupations in existence.

Just send 25c for our big catalog, "CASTING MATERIALS, MOLDS, ETC."—and you're on your way! Along with the catalog we will include the book, "THE ART and BUSINESS OF CASTING" absolutely FREE! And—surprising details on an amazing, exclusive Plasticast offer guaranteeing your success! DON'T DELAY! This could be the most important step of your lifetime! WRITE TODAY!

PLASTICAST CO. (Dept. A)

P.O. Box 6737 (Write to) P.O. Box 987
Chicago 80, Ill. nearest address Palo Alto, Calif.

CANADIAN CUSTOMERS: Send 35c for catalog to Canadian Ind. PLASTICS, 1056 1/2 W. Pender St., Vancouver, B.C.

Make Dad Happy On Father's Day!

OLD-TIME AUTOS in MINIATURE
\$1.95 to \$3.95
THEY'RE SUCH FUN TO BUILD!



Check "OLD TIMERS" You Want To Give:

- 1904 Olds \$1.95
- 1911 Maxwell \$2.50
- 1910 Model "T" Ford \$2.50
- 1909 Stanley Steamer \$2.95
- 1909 Model "T" Ford \$2.95
- 1903 Rambler \$2.50
- 1911 Buick "Bug" \$2.50
- 1903 Model "A" Ford \$2.50
- 1902 Air-Cooled Franklin \$2.50
- 1906 Columbia Electric \$2.50
- 1910 International Harvester \$2.95
- 1900 Packard \$2.50
- 1903 Cadillac \$2.50
- 1914 Stutz Bearcat \$3.95
- 1913 Mercer Raceabout \$3.95
- 1906 "Old 16" Locomobile \$3.95

FATHER'S DAY— Sunday, June 15th, and what gift is more nostalgic than an "Old Timer" he can build in his leisure hours? These miniature 3/4" scale models are so authentic they are on display in famous museums. 6" to 10 1/2" in length when completed. Set includes history of car; also step-by-step instructions make it easy to assemble set! All completely pre-fabricated, with ready-shaped parts, die-cut die-cast plastic wheels, radiator, horn, lamps, etc. Nationally-known; satisfaction guaranteed. At toy, hobby and dept. stores. Perfect gift for fathers, young or old. Order a complete set today!

Write to us — Add 25c for postage and handling. No. C. O. D.'s please

hudson miniatures OLD TIMERS

"Originators of Antique Autos in Miniature"

SCRANTON HOBBY CENTER, Dept. 28, Scranton 10, Pa.

\$9⁰⁰ DOWN DELIVERS Brand New 29 Pc. ARGUS C-3 OUTFIT

Balance as little as \$6¹² per month!



ONLY THE GENERAL could give you so much: Argus C-3 Camera, Flashgun, Carrying Case, 35mm. Projector, 4 Filters, Filter Holder, Sun Shade, 10 Flash Bulbs, 6 rolls Ansco or Kodak reloads, 1 roll Color Film, 1 - 30"x40" screen, copy of "This is Photography".

ALL BRAND-NEW \$9950 FOR ONLY

Use the General's famous "Pay as You Shoot" Plan

\$9⁰⁰ DOWN - BALANCE \$6¹² MONTHLY

Mail order with down payment and short note about yourself, your occupation, age, employer for last two years, and two references. Write today!

The GENERAL CAMERA CO.

Mail Order Div., Dept. P-25 Chicago 45, Ill.

COLT FRONTIER REVOLVERS

"LOW" PRICES

ALL NEW CATALOG #2

Over ONE HUNDRED COLT FRONTIER Model Revolvers in Stock. Complete line of Holsters, Parts, Ammo., etc.

SEND 50c FOR BEAUTIFUL ALL NEW UP-TO-DATE CATALOG. Price of Catalog applied on first purchase

HY HUNTER, 5666 W. 3rd St., Dept. 9, Los Angeles 36, Calif.

BOYS-IT'S FREE!

"THE WONDERS OF CHEMISTRY"

This exciting new book shows how to amaze your friends with chemical magic, describes many fascinating home experiments, tells of fun, thrills and big future opportunities for boys who know chemistry. Special atomic energy feature. Send today!

THE PORTER CHEMICAL COMPANY
189 Prospect Avenue Hagerstown, Maryland



DO OWN MODERNIZING ^{save 50%}

Do your own home repairing, modernizing. Don't be robbed by sky-high labor costs. Giant new book shows how to save hundreds of dollars. Make space-saving cabinets, install picture windows, add new porch, convert attic into modern rooms, put on new roof, siding, insulate and save on fuel. How to do concrete work, build own garage, even complete new home. Reduces jobs to simple, easy steps. Over 1100 illustrations. SEND NO MONEY. Simply clip this ad and mail with name, address (U. S. Only). If not pleased return in 5 days, pay nothing. If you keep book send only \$5 plus 35c for shipping. NOTE. Save 35c by sending remittance with order. Same return privilege?

GOODHEART-WILCOX CO., Dept. 179, 1321 S. Michigan Ave. Chicago 5, Ill.



LEARN FASCINATING

Leathercraft

Make your own bags, belts, wallets, etc. Learn fascinating, profitable leathercraft in spare time. Send 25c for valuable Catalog, has over 200 photographs. (refunded first purchase).

BURTONS LEATHERCRAFT

Dept. PS-5, 1755 1/2 Glendale Boulevard, Los Angeles 26, Calif.

WEBSTER-VM-G. I.

3-SPEED RECORD CHANGERS

General Instrument. Brand new. Fully automatic. Plays all size records—7", 10", 12". 12" x 12 3/4". Long Life needle included.

OUR PRICE \$15.95
\$47.50 List Immed. Deliv.



ORDER YOURS TODAY. Comes with RCA plug to attach to your radio or T.V. set. Full guarantee. Original factory cartons.

REPLACE YOUR OLD CHANGER NOW!

3 tube amplifier, 5" speaker, volume and tone controls with tubes. Ready to operate. Same as used in portable units.....\$8.95
VM #950 Flip Cart. \$22.95 Webster #100 Flip Crystal Cart. \$23.95
WEBSTER 100 With G.E. Triple-Play Reluctance Cart.....\$29.95
Pre-Amp with tube for G.E. Cart. \$4.95 Metal Base for above changers \$3.50 HIGH FIDELITY FM-AM CHASSIS COMPLETE, READY TO OPERATE \$69.50
(Send for descriptive literature.)

Please enclose shipping charges. Order direct from this ad.
JAN ELECTRONIC DIST. CO. 218 Fulton St., N.Y.C. 7, Dept. S, WO.4-0632

NEW "PAINT PEN"

PAINT STRIPING TOOL
Works like a Fountain Pen
Stripes with Paint instead of Ink!

This amazing new "PAINT PEN" is a Paint Striping Tool that makes it easy to do expert striping on furniture, bikes, model planes, autos, signs, toys, linoleum, wall board, etc. Makes plain, painted walls look like tile. Paint straight, curved, circular or evenly spaced parallel lines the same way a professional painter does. Simply fill Tubular Glass Paint Fountain with any color paint and wheel tip feeds paint evenly. Tips interchangeable — jaws split apart for easy cleaning. Tool complete with tip for 1-16 inch stripe only \$1.00 postpaid. Other complete tools with 1-64, 1-32, 3-64, 1-16, 5-64, 3-32, 1-8 inch tips, \$1.50 ea. Extra tips, 75c each. Complete KIT with 7 tips, \$5.00. C.O.D.'s postage collect. Here's the handiest tool in your whole painter's kit. Get yours today.

Paint STRAIGHT, CURVED OR PARALLEL LINES

Home Craftsmen
 Just the tool you've been waiting for! New Paint Striping Tool gives "professional" results every time, yet simple and easy to use as a fountain pen. Adjustable guide keeps lines straight as an arrow. Just as easy to make curves or free hand designs. Adds new beauty and finished look to everything you paint. Send \$1 now!

DEALERS
 PAINT STRIPING TOOL packed in display cartons of 1 doz. Fast, profitable seller. Write for illustrated circular, discounts

Only **\$1.00**

WENDELL MFG. CO., Dept. 2-E.
 4234 LINCOLN AVENUE, CHICAGO 18, ILL.

DAN LURIE
 "America's Most Muscular Man"
 —on television's "Big Top."



FAMOUS DAN LURIE BARBELLS

with 4 courses—low factory prices

50 lb. set....\$ 8.48	150 lb. set....\$20.48
100 lb. set.... 13.98	200 lb. set.... 25.98

Write for Free Catalog Order by Mail; 50% with order, bal. C.O.D. Extra wts. 13c per lb., F.O.B. plant

DAN LURIE BARBELL CO.
 1701-55 Pitkin Ave., Dept. 270-E, Brooklyn, N. Y.

'How to MAKE MONEY with Simple CARTOONS'

A book everyone who likes to draw should have. It is free; no obligation. Simply address **FREE BOOK**

CARTOONISTS' EXCHANGE
 Dept. 195-D Pleasant Hill, Ohio

HIGH POWER TELESCOPE
 60 POWER—ALUMINUM TUBES—OPENS TO 33"
 Variable Power Adjustable to 15X, 30X, and 60X.

\$5.95 Leather Case Included

5 Sections, 4 Ground & Polished Lenses. Also used as 50X Microscope. Ready to use, only \$5.95. POSTPAID.

CRITERION CO. 438 ASYLUM ST.
 DEPT. SA5 HARTFORD 3, CONN.

1949—'50—'51—'52
AUTOMATIC CUSTOM-BUILT AUTO RADIOS



FORD, CHEVROLET, PLYMOUTH, DODGE, HENRY J., HUDSON, STUDEBAKER. Each radio a six tube superheterodyne, three gang tuning condenser PM speaker Alnico No. 5. Rugged and dependable. Powerful, clear reception. INSTALL IT YOURSELF EASILY. QUICKLY. **ONLY \$59.95**
 Shipping charges prepaid in U.S.A.

UNIVERSAL MOUNT AUTO RADIO
 Fits all cars and trucks. Simple, quick installation. **ONLY.... \$49.95**
 Shlp. chgs. prepd. in U.S.A.

FREE ANTENNA
 with every radio, 62" top cowl. Send check or M.O., 20% deposit on C.O.D.'s. We pay all shipping in U.S.A.

COMET ELECTRONIC SALES CO.,
 Dept. P, 22 Washington St.
 BRIGHTON 35, MASS.

FREE ANTENNA WITH EVERY RADIO



AC OIL FILTERS

WITH

ALUVAC ELEMENTS

ESPECIALLY ENGINEERED FOR CHEVROLET



TRAP ENGINE OIL DIRT AS SMALL AS 1/100,000 OF AN INCH

AC Oil Filters with *Aluvac* Elements are designed to help preserve and protect engine power and lengthen the life of moving parts. They provide the finest filtration money can buy, removing particles as fine as 1/100,000 of an inch. Whenever you need a new oil filter element—regardless of the make of car you drive, or the make of filter you are using—install an AC *Aluvac* Element.

AC SPARK PLUG DIVISION  GENERAL MOTORS CORPORATION

**MANUFACTURE THIS BEAUTIFUL
CONCRETE OUTDOOR FIREPLACE**
Right In Your Own Back Yard

**\$4.00 Worth of
Sand & Cement
produces this
Attractive
Fireplace.**

**Sells on Sight
from \$60. to
\$80. Easy to
start your own
Profitable Bus-
iness.**

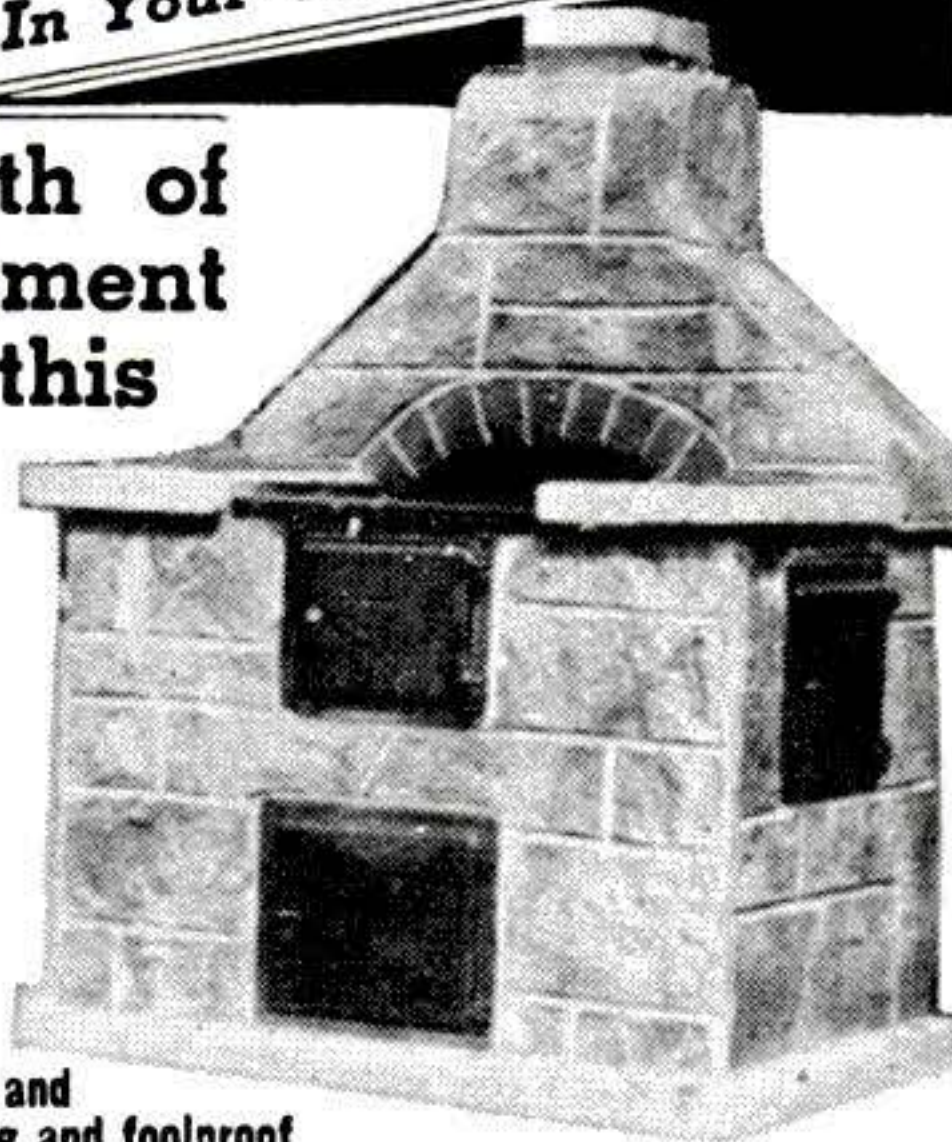

The General Fireplace Molds and Process are the most amazing and foolproof ever invented. Simple to operate, two men can produce five fireplaces a day.

BIG DEMAND!!

Sell all you produce to Department Stores, Homeowners, Parks, Nurseries and Picnic Groves. Fireplaces sell on sight. No experience necessary, we supply full operating instructions and equipment plus the know how that spells **BIG PROFITS**. This is an outstanding opportunity for men of vision and small capital to get into a busy rich paying field. Don't delay, be the only exclusive manufacturer in your own home town. Mail coupon at once for full details as to how you can reserve your territory.

Molds sold only on exclusive franchise.

GENERAL ENGINES CO., Inc., Dept. SF-52
307 HUNTER ST. • GLOUCESTER CITY, N. J.

Mr. Tor of Phila. writes:
Sold 250 in first 4 months. Selling to
Sears Roebuck, John Wanamaker &
Gimbel Bros. in Phila. area.

Name
Address
City Zone State

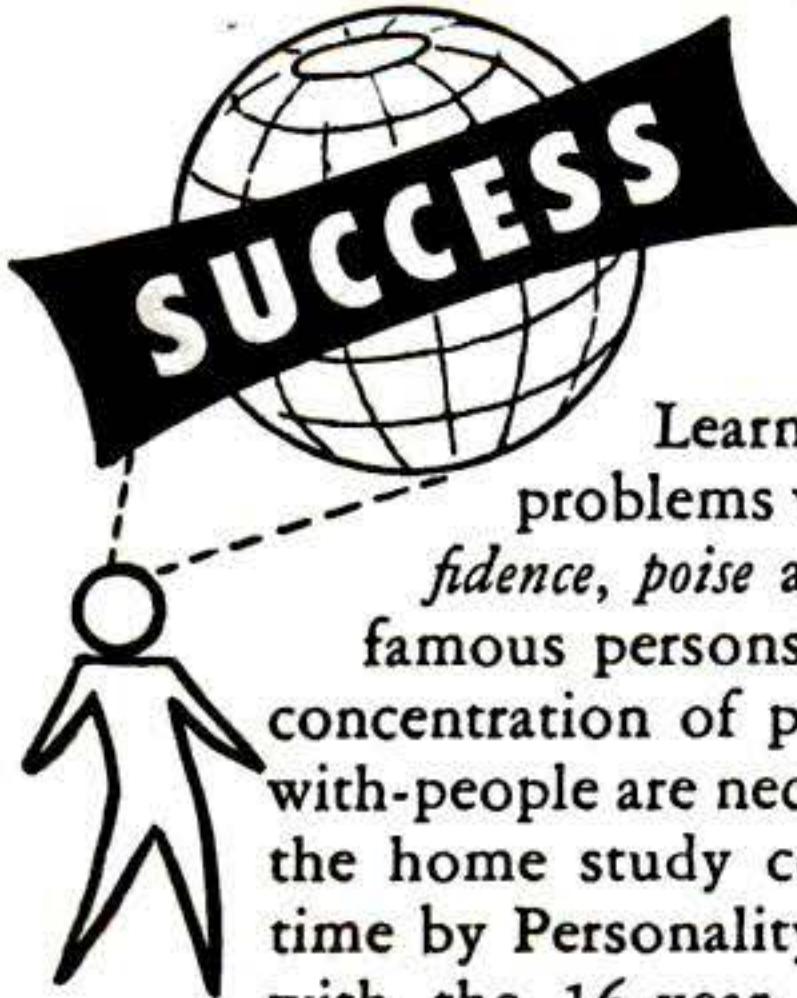

**through
RE-EDUCATION**

Learn to take care of your daily problems with *ease, assurance, self-confidence, poise and follow-through*. Lives of famous persons illustrate that confidence, concentration of purpose and getting-along-with-people are necessary to success. Through the home study course, offered for the first time by Personality Re-Education, associated with the 16-year old Personal Adjustment Bureau, you can acquire *the personality traits* that will make your life happier and more rewarding. Send for full information TODAY.

SPECIAL OFFER!

You can take a Personality Evaluation test by sending \$1.00 to Personality Re-Education. "Know yourself" NOW!

Department 85-S 16th Successful Year
Personality Re-Education, Associated with
Personal Adjustment Bureau, Room 208
416 N. Bedford Drive
Beverly Hills, California

Name _____
Address _____
City _____ Zone _____ State _____

**DYNAMIC POWER TOOL
COMBINATION**



INCLUDES: Cummins 1/4" Electric Drill; Cummins Saw Attachment; Combination Saw Blade; Set of Drills; Lambs Wool Bonnet; 6 Sanding Disks; Steel Arbor and Attachments; Cloth Buffing Wheels; Grinding Wheel; Wire Wheel Brush; Steel Paint Mixer; Steel Bench Stand; Portable Steel Carrying Case.

Price of Dynamic Power Tool Combination complete is \$26.95

**SHIPPED ON APPROVAL
NO MONEY WITH ORDER - NO C.O.D.**

Try it ten days before you buy. If completely satisfied then send \$2.95 and pay balance at rate of \$4.00 per month for 6 months—No Interest or Carrying Charges Added. If not completely satisfied, return to us, no explanation necessary.

KAPNER HARDWARE, INC.

Dept. A-32, 2248 Second Ave., N. Y. 29, N. Y.



**MAKE YOUR OWN!
WITH**

GRIFFIN LEATHERCRAFT KITS
Best assortment of tools, materials in U.S.A.! Send 25¢ for 116-page catalog. (money refunded first order)

GRIFFIN CRAFT SUPPLIES
SINCE 1924

5626-B Telegraph Ave., Oakland 9, Calif.

**100 POWER...
Telescope Lens Kit COMPLETE ONLY \$3.00**

See The Wonders Of The Sky.—Explore planets, island universes, new stars and million other phenomena. Lens kit consists of a 47 M.M. dia. 52 in. focal length ground and polished objective lens and a 100 power astronomical eyepiece lens. Simple to follow directions for assembling in one or two evenings. Mounting and tripod not included but easy to make from directions. Money back guarantee.

LE MAR SCIENTIFIC CORP., Dept. E5, 3412 W. Jackson Blvd., Chicago 24.



Study HYPNOTISM!

FASCINATING! Almost Unbelievable

This unusual course reveals the fundamentals of PRACTICAL hypnotism. It discloses how an expert operator performs—how he has developed his PERSONAL POWER and uses it to bring others under his domination and control. Illustrated instructions. Startling low price. Full satisfaction or refund guaranteed. Only \$2.95 postpaid... or C.O.D., plus postage. Send for "Hypnotism Course" today!

COMPLETE PRICE \$2.95
NELSON-HALL CO., 210 S. Clinton St. Chicago 6, Ill. only



**ILLUSTRATED
CARTOON BOOKLETS!**

SAY FELLOWS! BE THE LIFE OF THE PARTY WITH THESE SMALL ILLUSTRATED CARTOON BOOKLETS OF COMIC CHARACTERS! 10, ALL DIFFERENT, \$1 POSTPAID SORRY NO POSTAL C.O.D.'S!

REGINALD SALES

210 L Fifth Ave., New York, N. Y.

New CHRONOGRAPH Wrist Watch



**A "Once In A Blue Moon" Value—
with a Lifetime GUARANTEE!**
(Exclusive of Parts)

Fine Timekeeper PLUS precision stop-watch with sweep second hand to time races, operations, moving objects, etc. Perfect for time-study work. Rugged movement in handsome, non-magnetic, shock-resistant stainless steel case. "SOLD EVERYWHERE AS HIGH AS \$17.00" Our Price \$7.75 plus 10% tax (Total \$8.63). Send check or money order now and we will pay postage. Or we will send C.O.D., plus charges. Act Quickly.

\$7.75

Plus Tax MARDO SALES CORP., Dept. 631 480 Lexington Ave., New York 17, N. Y.

New FALSE PLATE for OLD IN 24 HOURS

Low As Only
\$15.95



Wonderful New Scientific Method Transforms OLD, LOOSE, Cracked or Chipped Plates into LUSTROUS BEAUTY-PINK DUPONT PLASTIC PLATES

MONEY BACK GUARANTEE

Why envy beautiful false teeth of others? We will transform your old, loose, cracked or chipped plate into a beautiful new, lightweight DuPont Beauty-Pink Plastic Plate, using your own teeth. All missing and broken teeth matched and replaced. Your cost amazingly low; actually save many dollars. No impression needed under our new scientific False Plate Method. 24-Hour Service.

SEND NO MONEY Enjoy life again, and save money on beautiful, new, natural-looking plastic plate. Rush name, address for full details sent FREE. If your plate is loose, we show you how to make it comfortable, tight-fitting before duplication. West Dental Laboratory, 127 N. Dearborn St., Dept. E-34, Chicago 2, Ill.

CARBURETOR TOO RICH MAKES MOTORIST TOO POOR



Car owners who are wasting money and not getting proper gas mileage due to over-rich mixtures will be pleased to learn how to save gasoline by VACU-MATING over-rich mixtures. VACU-MATIC fits all cars, trucks and tractors. It is automatic and operates on the supercharge principle. Easily installed in a few minutes.

SALESMEN WANTED! Big Profits!

Send name, address on a postcard for free particulars and how to get yours for introducing.

VACU-MATIC CO., 7617-1895 W. State St., WAUWATOSA, WIS.

GOLD - SILVER - COINS

Easily located with new Light-weight M-Scope Detector. Superior performance, lowest price, monthly payment plan.

FREE LITERATURE

FISHER RESEARCH LAB., INC.
PALO ALTO CALIF.

WRITE 3 WORDS MAKE \$6.00 PROFIT—

—on 10-Second Demonstration to merchants. Write on glass with amazing Magic Crayon—Presto!—5 color advertising message takes fire, glows like brilliant Neon. Three sales daily bring \$18 profit. Rush name for FREE Sales Kit! MAXILUME CO., 125 W. Hubbard, Dept. L-9-E, Chicago 10, Ill.



FREE CATALOG!

GENUINE Diamonds

SAVE 50% and more! Genuine diamonds from N.Y.'s leading pawnbroker at fabulous savings. Re-set in brand new, distinctive settings. Every diamond graded and bonded. 10 DAY MONEY BACK GUARANTEE. Our references:—your own bank or any Mercantile Agency. SEND FOR FREE CATALOG

KASKEL'S Kaskel Bldg., 9 Columbus Ave.
(Est. 1882) New York 23, N. Y. Dept. E-8



ONLY 2 SHINES A YEAR
AND SHE GLEAMS
LIKE NEW!

\$1.00 BRINGS YOU BOTH CANS!

Yes sir—give your car the glow that rests your elbow! Use LACQUER CLEANER, the amazing pre-wax cleaner, and LACQUERWAX, the famous car finish protector. It's 5 times faster and easier to apply than ordinary paste waxes. One treatment lasts 6 months or longer.

LACQUERWAX contains no lacquer, but this hard, liquid wax is CLIMATEPROOF! Its brilliant luster shines right thru hot sun and driving rain. You can't wash it off—it won't spot! It brings out and preserves the full beauty of your car's finish. Use the LACQUER CLEANER first to remove dead paste wax and dirt, then LACQUERWAX for the beauty treatment. BOTH 10 oz. cans—ample to do your complete car—for ONLY \$1. Mail coupon NOW!

LACQUERWAX CO. Dept. PS-5
31 SPRUCE ST., HARTFORD 3, CONN.

Gentlemen: My dollar bill, check or money order is enclosed for the 2 ten oz. cans—LACQUERWAX & CLEANER.

Name

Address

City..... Zone..... State.....

LACQUERWAX

GROW Living MIDGET TREES!

EARN \$10.00
PER HOUR!

- AT HOME
- IN SPARE TIME
- NO EXPERIENCE NEEDED



It's new! Amazing! At last, the secret of growing miniature (MING) trees can be yours. FULL GROWN, dwarf trees—only a few inches high. Beautiful miniature fir, orange, oak, Chinese elm, peach, pine, cypress—any kind! ALL BLOOM and even BEAR FRUIT. All perfect healthy specimens—but miniature in size! Make costly home decorations and expensive centerpieces. (SOLD FOR OVER \$1,500 EACH) Big demand. Costs only pennies—takes only minutes per week. IT'S EASY! Fun! A new fascinating hobby—a new fabulous \$\$\$\$ business. Send for free secret plan details and real seed.

HELP US FILL HUGE DEMAND!

These trees are being demanded by STORES CLUBS • HOTELS • FLORISTS • HOUSEWIVES • INTERIOR DECORATORS • COLLECTORS • HOBBYISTS—A Big Money Opportunity FOR YOU.

FREE! GENUINE SEED AND PLAN!

NATIONAL NURSERY SUPPLY CO., Dept. N5
8463 South Van Ness
Inglewood 4, Calif.
Rush me FREE plan and seed IMMEDIATELY!

Name

Address

City..... State.....





STOP
BURNING OIL
IN YOUR CAR

GET A TUBE OF
Piston Seal

The Original
Overhaul Compound

Accept no substitute for this time-tested product endorsed by automotive experts the world over. Stops piston slap, improves engine performance, restores compression, and pays for itself many times over in oil saving. Anyone can install in a few minutes. Just remove spark plug, insert rubber tube and squeeze 10,000 miles of motor oil economy in every tube.

GUARANTEED NOT TO HARM
ANY INTERNAL COMBUSTION
ENGINE

SEND NO MONEY

Write today for FREE details on Piston Seal, stating make and model of your car, truck or tractor. We'll rush you details at no obligation to you.

AUTOMOTIVE AIDS CO.
201 E. Fifth Street, Plainfield, N. J.
DEPT. 11-S

**FIX SAGGING
FLOORS YOURSELF**
with
TEL-O-POST

Save big repair bills for fixing sagging floors — which cause cracking plaster, sticking doors, open joints. Install Tel-O-Post yourself for only \$10.

Tel-O-Post is the original adjustable steel post with a built-in jack. Used in cellars, under porches, in garages, barns, etc. Only 20 minutes to make installation... patented locking pin assures safety.

Ask for Tel-O-Post at your building supply, lumber or hardware dealer... or send coupon and \$10 check.



BRAINARD STEEL DIVISION, Dept. Y-5
Griswold Street, Warren, Ohio



- Send illustrated booklet on Tel-O-Post installation.
- My dealer does not stock. Enclosed is check for \$10 (\$15 West of Kansas City). Ship via express prepaid one No. 1 Tel-O-Post, adjustable from 5' to 8'4".

Name _____

Address _____

City _____ State _____

MONEY-BACK GUARANTEE IF NOT SATISFIED



**WAR
SURPLUS
BARGAINS**

**WAR
SURPLUS
BARGAINS**

**\$500,000.00 INVENTORY for
QUICK LIQUIDATION**

Surplus items—hundreds of them for home, shop, factory, farm and outdoor use. New items, used items, reconditioned items—all at tremendous savings—all priced for quick sale.

PAGE AFTER PAGE OF VALUES

This big catalog shows page after page of amazing money saving values. Write for your copy today. Send 10c to cover postage, mailing, etc. Write today!

SEND TODAY FOR YOUR COPY

10c

STARK'S

509 So. State St.
Dept. PS-E
CHICAGO 5, ILL.



**TALK—SING—PLAY
OVER YOUR RADIO**

with the real Radio Mike! Attaches in a jiffy—full instructions given! Swell for "parties"—"cut in" on or "kid" regular network programs or put on your own broadcasts! Amaze your friends—real fun. Beautiful Metallic Plastic 6 in. high! 12 RADIO BROADCAST LESSONS GIVEN with each mike

SEND NO MONEY Just pay postman \$3.99 COD plus postage or send \$3.99 and we pay postage! Radio Mike is available only from us by mail—guaranteed.

Midway Co., Dept. MPS-5, Kearney, Nebr.

**STUDY TO BE A DOCTOR
of Psychology or Metaphysics**

Obtain a Ps.D., Ms.D., D.D., or Ph.D. degree. Be a Teacher, Lecturer or Accredited Practitioner. Teach others how to achieve Health, Happiness and Contentment. Chartered by State. Write for FREE book telling how.

THE NEOTARIAN COLLEGE OF PHILOSOPHY
Desk 5, Pickwick Building Kansas City 6, Missouri



**ZIRCONS
LOOK SO MUCH LIKE REAL
DIAMONDS**

Your friends won't know, if you don't tell 'em! Inexpensive, too! Write now for free catalog of jewelry—set with this remarkable gem.

NATIONAL JEWELRY CO.
DEPT. 9, WHEELING, W. VA.

**Catalog
FREE!**



HE-MAN VOICE!

STRENGTHEN your voice this tested scientific way. Yes—you may now be able to improve the POWER of your speaking and singing voice... in the privacy of your own room! Self-training lessons, mostly silent. No music required.

FREE BOOK Write TODAY for Eugene Feuchtinger's great booklet "How to Develop a Successful Voice." It's absolutely FREE! You must state your age. Booklet mailed postpaid in plain wrapper. No salesman will call. Send your name and age RIGHT NOW! Prefect Voice Institute, 210 S. Clinton St., Studio EY-1, Chicago 6, Ill.

If Ruptured



TRY THIS!...

If you can obtain relief by holding back your rupture or ruptures in this manner—**I CAN HELP YOU!** Write today for my valuable FREE information which is based on 23 years of practical experience.

FRED B. MILLER, Mfr.
Dept. P, Hagerstown, Maryland.

BUY photographic supplies wholesale. Films. Cameras. Projectors. Expert camera repairing. Free catalog. Capitol Photo Supplies, 2428 Guadalupe, Austin, Texas.

SKYHOOKS, aerial pictures with your kite and camera. Dollar postpaid. Burns, Box 84E, Manhasset, New York.

35 MUSIC, INSTRUMENTS & SONG WRITERS

POEMS Wanted. Broadcast consideration. Sooner Song Co., 22 Northwest 8th, Oklahoma City 2.

POEMS Wanted for musical setting. Send poems for free examination. Five Star Music Masters, 646 Beacon Bldg., Boston, Mass.

POEMS Wanted to be set to music. Free examination. Send poems, McNeil, Master of Music, 510-PS, S. Alexandria, Los Angeles, California.

SONGWRITERS: Hillbilly. Western Honest Outstanding Offer. Dick Reynolds, Leonard 7, Texas.

WANTED! Poems for musical settings. Write Songwriters' Service, Clifton, N. J.

POPULAR Songs. How to write and sell them. Write for free booklet Successful Songwriting. Gateway Songs, Box 2470, Hollywood 28, California.

SONGPOEMS And Lyrics Wanted with new and clever ideas to be set to music. Tin Pan Alley Inc., 1650 Broadway, New York 19, New York.

SONGS Arranged. Poems set to music. E. Cole Ingle, 555 West Third, Mansfield, O.

SONGWRITERS! Send poems, songs. Music Service, 243 West 72nd St., PS, New York 23.

YOUR Words and our music—a winning combination! Send poems. Free examination. Song Promotion Guild, 350 Broadway, New York 13.

ELECTRIC guitars, amplifiers, wholesale. Free catalog. Carvin, PS, Baldwin Park, Calif.

HOW a Songwriting Service Operates. Inside Secrets, Home-Study, 408 North High, Salem, Indiana.

RECORD Your Songs! Valuable information free. "Recording Society", New Boston, Ohio.

SONG Writers—Send for our proposition. Gurley Music Co., Utica 2, N. Y.

GUITAR. Play a song a day. With my simple system. Contains chord charts, tuning, picking, fingering. Songs included. Send only \$1 today. Moneyback guarantee. Dept. 1, Bennett, 629 N. St. Andrews Place, Hollywood 4, Calif.

RECORDS New Latest Hits. Cheap. Catalog Dime, Burnell, 710-B Thomas Road, Lynchburg, Virginia.

36 RADIO, TELEVISION, SUPPLIES & EQUIPMENT

MAKE simple, tubeless, batteryless, distance-getting crystal radios. Crystal and illustrated instructions 25c postpaid. Allen, 427-S, Clinton, Mo.

FREE! 212 Page Radio-Television-Electronic Catalog! World's largest stocks, lowest prices. Complete supplies for builders, experimenters, amateurs, servicemen. Latest radios, phonos, television, recorders, sound equipment. Thousands of parts, tubes, test instruments, books, diagrams. Top quality money saving values. Get yours now! Allied Radio Corp., 833 W. Jackson Blvd., Dept. 31-E-2, Chicago 7, Ill.

BUILD 15 Radios—Only \$1.30 Each. Experience Unnecessary. Home Radio & T.V. Course, includes Trouble-Shooting and Servicing Lessons, Radio Principles, Code Instructions, Practical Radio Building and Repairs. You build and keep Receivers, Transmitters, Amplifiers, Test Equipment, Code Oscillator. All parts, tools, instructions supplied including Radio Tester and Electric Soldering Iron. Write for full particulars and receive absolutely Free your copy of "Radio & TV Repair Guide". No obligation. Progressive Electronics Co., 497 Union Ave., Dept. PS-18, Brooklyn 11, New York.

HIGH Fidelity Sound For Your T.V. Set. This 3 tube Push-Pull Sound Amplifier, when plugged into your TV Set or Radio will produce remarkable improvement in tone quality. \$14.95 C.O.D. Send check with order, save shipping charges. Vidair Television Company, 576D W. Merrick Road, Lynbrook, New York.

LITTLE Wonder Crystal Radio. Little but Loud. All complete. Sent prepaid only \$2.00. Bill Cotter, Washington 18, D. C.

FREE Electric Soldering Iron, every serviceman needs one! Get full information: Rose Co., 985 Park Place, New York 7, New York.

ANY Information \$1.00. Tubes 1/2 Price. Would you pay \$1.00 to stop expensive Repairs? Television, 25N Sarah, St. Louis, Missouri.

BUILDER'S "Pictorial Construction Plans". Free List. Alena, Box 24, Astoria 6, New York.

MINIATURE radio with short wave band, weight 8 oz. with batteries. Write for prices. Ekeradio, 10 East Orange Grove, Pasadena, Calif.

15 TESTED One-tube circuits 25c, including "Radiobuilder," catalog. Laboratories, 1131-T Valota, Redwood City, Calif.

37 BUSINESS OPPORTUNITIES

SAWDUST. Turn it into cash. Twenty methods, instructions 50c. Charles Company, 12-EAB, Norwood, Ohio.

GOOD Paying Business Silvering mirrors, plating autoparts, reflectors, bicycles, bathroom fixtures, etc., by late methods. No tanks or shop required, outfit furnished. Free Booklet. Gunmetal Co., Ave. E, Decatur, Illinois.

ENVELOPES addressed accurately, reasonably. Fast Service. We have capable addressers in your city. Glenway System, 5713-X Euclid, Cleveland 3, Ohio.

OPERATE profitable mail order business. Write Walter Service, 4159-B East 112th, Cleveland 5, Ohio.

FABULOUS Earnings—Fascinating part-time. Growing Genuine, living miniature (Ming) Trees. New sensational Business or Hobby. Astounding information free. Dwarf Gardens, Box 355H, Briggs Station, Los Angeles 48, Calif.

TRAVEL Anywhere, Anytime. Earn \$50 up a week. Free details. Travel, La Grange 22, Indiana.

MAKE money addressing envelopes. Our instructions reveal how. Glen Glenway, 5713 Euclid, Cleveland 3, Ohio.

BIG Money and fun growing Live Miniature Ming Trees on your window sill. Write for Free rare tree seed and plan. National Nurseries, 8620B Ruthelen, Los Angeles 47, Calif.

VENDING Machines earn big money! An investment as low as \$10.50 will start you in this fascinating, profitable business that can lead you to the road of success and independence. Routes can be established and operated in either full or spare time with no experience needed. Write for full details and our Free catalog illustrating our nut, candy, gum and stamp vendors; also pin ball machines, music boxes, etc. Write immediately to: Parkway Machine Corporation, Dept. 9, 715 Ensor Street, Baltimore 2, Maryland.

EXTRA Money—No Selling—operate vendors. Amazing profits, details Free. Silver King, Suite 221, 622 Diversey, Chicago 14.

INVISIBLE Reweaving. Men-Women. Instructions shipped for no-risk examination. \$5.00 hour possible spare-full time. Reweave burns, tears, moth-holes like new at home. Free details. Skilweave, 1717-FJ Westwood, Los Angeles 24.

SELL by mail; free details; instructive booklet 25c. Manhattan House, Box 51-L, St. Albans 12, New York.

IMPORT-Export! Men-Women. Instructions from established World Trader shipped for no-risk examination. Opportunity profitable world-wide mail-order business from home without capital; or travel abroad. Experience unnecessary. Free details, Melinger, 1715-AN, Los Angeles 24.

\$25 WEEKLY Working two hours daily. No canvassing. No manufacturing. Lycke, Box 2471-B, Cleveland 12, Ohio.

MAKE Money At Home as renewal headquarters for all magazines. Liberal commissions. No experience—No capital needed. Supplies furnished. Write for Free Catalog. McGregor Magazine Agency, Dept. 510B, Mount Morris, Ill.

INVISIBLE Reweaving—big profits, big demand, easy-to-learn with low-cost complete course—nothing else to buy, ever. Details free, write today; Fabricon, Dept. K-4, 8342 Prairie Ave., Chicago 19, Ill.

A Practical Beginning To Successful Rabbit Raising, 48 Page Illustrated Booklet, Dime. American Rabbit Breeders Association, 44 ARCBA Bldg., Pittsburgh, Pa.

START Mail Order Bookshop—Profits to 70%. Profitable future. 25c brings booklet, samples, exciting ideas. General Publications, Ossining 1, New York.

RECAST old batteries into new. Latest achievements. Battery Laboratories, Minneapolis.

SELL your products by Radio! No risk! Pay commission, 400 nationwide broadcasters! Simon-C5, 48 Fifth Avenue, Pelham 65, New York.

LIQUID Molding rubber, \$2.95 quart, \$9.95 gallon prepaid! Plastercraft Supply Company, 3051 St. Clair Ave., Cleveland 14, Ohio.

MAKE Money spare or full time, casting Metal Toys and Novelties. Big wholesale and chain store demand for cast Metal Autos, Soldiers, Ashtrays, Banks, etc. keep manufacturers busy. Production moulds furnished for up to 100 and more castings per hour. No experience or special place necessary. Write for information and illustrations of patterns needed. Metal Cast Products Co., Dept. E, 1696 Boston Road, New York 60, New York.

EARN Extra Money weekly mailing circulars for advertisers. Complete instructions—25c. Siwaslian, 4317-B Gleane Street, Elmhurst 73, New York.

MAKE \$3.00 Hour At Home—I do—making sandals. George Youngs, 1308 South First, Arcadia, California.

LIQUID Rubber, make flexible molds. Free Sample. Chaney, 1130 E. 16th St., Jacksonville 6, Fla.

COLORGLAZED Concrete Pottery made without molds. Patented method Cemetery products, novelties, tiles. Basement leak-sealing. Money-making projects, Booklet, details free. Men only. National Potteries, Grand Rapids, "Minnesota."

TO \$35.00 Weekly. Spare Time. Home Operated Mail Order Business. Successful small "beginner's" plan. Everything Supplied. Lynn, 10420-C National, Los Angeles 34, California.

POPCORN and Potato Chips make respectable business. Long Eakins Company, 5263 High, Springfield 99, Ohio.

A \$5000-\$6000 in a year business. Keeps growing. Sewing Machine repairs, trade, sell new machines, motors, etc. Necessity business every community. Free details. Taylor Service, Hamilton PS-5, Ohio.

WOULD you like to make extra money in your spare time! For free information write. Grable Enterprises, 26314 Normandy, Roseville, Michigan.

AMAZING new patented labor-saving, precision screw-holding screw drivers! Removes, inserts screws hard-to-get at places! Fast sales, large profits. Stores, factories buy quantities. Exclusive distributors appointed. Toolco, 90-K Summit, Brookline, Mass.

\$5.00 PER hour spare time. Make Art-kote Stone Facing. Information free. Dividend Company, Liverpool, N. Y.

EARN \$15,000-\$30,000 per year. \$12,500 minimum or money back. Protected by Franchise. Live at home. No merchandise to buy. One of the most exclusive and non-competitive businesses in United States. Send 50c for explanatory book. Money refunded when book returned. Harrell & Company, Box A-2, Louisville, Illinois.

BIG profit. Cast brilliant plastic fish lures. Information and \$1.00 sample lure for 50c. Fish-Allure, Box 392, American Fork, Utah.

SILVERING mirrors, complete procedure highest quality results only 15 years experience. Silvering and resilvering \$5.00. Copper (Rose) mirrors \$10.00. Both gold and gun metal mirrors \$5.00. Silver spray process \$20.00. Questions answered 1 year free. Chemicals available if needed. S. Pavenick, Box # 181, South Orange, N. J.

WATERLESS Hand Cleaners. Highly profitable home mfg. & route business. Simply add water to concentrates, or ready-packed under your label. Dispensers at cost. Western G Aircraft, Los Angeles 19.

EARN \$3 to \$5 an Hour Easy Pleasant Research Work at Home. No selling. Alliance Sales, 568-A, Alliance, Nebraska.

LOOKING for a business or position? Then investigate My proposition. Particulars free. Ornstee, 1609 South Adams, Peoria, Illinois.

YOU Can Sell brand new Adding Machines for only \$14.95! Yes! You can sell 'em and make \$6.73 on every sale. They're executive model Portables, precision built, fully guaranteed. For life size color photo and all details, write to Lightning Adding Machine Co., Inc., Dept. PS-1, 1260 West Second Street, Los Angeles, California.

\$5.00 HOUR! Possible! Invisible Simplicity Reweaving Instructions. Automatic latch steel tool assembly that makes moth holes, burns, cuts, tears in clothing disappear like magic, 28 samples, 81 explanatory details. Material for life. Complete Kit \$4.00. Satisfaction guaranteed, details free. Walsh, 894 Main, Buffalo 2, N.Y.

OPERATE Profitable Mailorder Business. Particulars Free. George Lenhoff, Lincoln 1, Nebraska

MAIL literature offering fast selling Books Merchandise, details furnished. Maxted Book Agency, Western Springs, 10r-S, Illinois.

PROFITABLE—Plastic lamination service, complete information, Universal, 2851-A Southwest Blvd., Kansas City 8, Mo.

BUY Wholesale thousands nationally advertised products at big discount. Sent free "The Wholesale Plan." American Buyers' Service, 629-S Linden, Buffalo, N. Y.

IS \$210, a week worth a postcard to you? Then rush card with name and address for special Free Trial Plan that sells amazing new Automatic Refrigerator Defroster "like hot cakes!" Write to Mr. Lewis, D-Frost-O-Matic Corp., Dept. H-103, 173 W. Madison, Chicago 2, Illinois.

\$100 WEEKLY. Power mowers. Wholesale deal. Guaranteed sales. Rotacut-52, Excelsior Springs, Missouri.

NAMEPLATES for homes, desks. Free sample. Whitney Co., West Springfield 22, Mass.

HOUSE Paint—Wholesale price \$2.85 Gallon. Private label. Big profits. Certified Products, Louisville, Kentucky.

MEXICAN Feather Pictures. Sell on sight; 200% profit! Free details. Sample 20c stamps. (No Coins). Sylvias, Apartado 9036, Mexico City.

SALESMAN Wanted in different parts of your state to call on restaurants, cigar stands, drug, grocery stores. Variety carded merchandise. Unusual profits for salesman and merchant. Request territory wanted. Old firm, AA-1 rating. Contact P. M. Laymon, Sales Manager, World's Products Co., 1002 West St., Spencer, Ind.

BIG profits! Sell new, factory guaranteed watches—Benrus, Bulova, Elgin, Gruen, Hamilton, Longines. Write: Standard, 1541-S North Fuller, Hollywood, Cal.

CALIFORNIA sweet smelling beads, sensational sellers. Particulars free. Mission, 2328P West Pico, Los Angeles 6, Calif.

WHOLESALE—Hottest novelty cards on the market today. Sample and catalog 10c. Ray Daum, 204 Hiddeson, Greenville, Ohio.

NICKEL Silver key checks—Key check stamping outfits. Catalog free. General Products, 11PS, No. Pearl, Albany, N. Y.

SCOTS Guard Automatic Fire Alarm requires no batteries, no wiring. Retail \$3.95. Sample, \$2.50. Royal Scot, Waterbury, Connecticut.

STOP oil pumping! Restore compression! 200,000 mile guarantee! Only \$3.00. Nerlind, Box 7, Inglewood, Calif.

FIRST time offered! New! 75 amazing, fast selling inventions. Huge profits. Repeat orders. Free door openers, catalog. Write Durever, 2781T Atlantic Ave., Bklyn, 7, New York.

ANYONE can sell Hoover DuPont Nylon Uniforms for beauty shops, waitresses, doctors, nurses, others. In white and colors. Exclusive styles. Top quality. Low priced. Exceptional income. Real future. Equipment free. Write fully. Hoover, Dept. E-101, New York 11, N. Y.

SELL \$2. Fire Extinguishers. Locally, mailorder. Lorrac Products, Albany 1, N.Y.

FREE book "505 Odd, Successful Businesses." Work Home! Expect something Odd! Pacific-38C, Oceanside, Calif.

44 HIGH-GRADE SALESMEN

REPRESENT America's largest factory selling advertising pencils. High commissions. Attractive line. Send \$1.00 for pencil kit (refundable). Union Pencil Company, 389 Broadway, New York City.

ADVERTISING book matches—Cash in on big demand—sell Union Label matches. Cuts for all businesses and political parties—Free powerhouse selling kit—low prices—protection guaranteed on repeat orders—Cash commissions. Superior Match Co., Dept. P-552, 7530 Greenwood, Chicago.

AD Matches! Sell Amazing Designs—20, 30, 40 and 240-light book matches. Biggest spot cash commissions; every business a prospect. Low prices for high quality. Repeats. Start without experience; men, women; full, part time. Buy Nothing! Sales kit furnished. Match Corp., Dept. PS-29, Chicago 32, Illinois.

WRITE 3 Words—Collect \$7.65 on 10-second Demonstration to merchants—write on glass with Amazing Magic Crayon—Presto!—5-color advertising message takes fire—glows like brilliant Neon. Three sales daily bring \$22.95 profit. Rush postcard for details.—Complete Sales Kit. Free! Maxilume Co., 125 W. Hubbard, Dept. CL-9-E, Chicago 10, Illinois.

45 EDUCATIONAL & INSTRUCTION

BOOKKEEPERS! Increase your earnings! Operate your own simplified "Dollar-A-Week" Bookkeeping and Tax Service. Full or spare time. Details Free. No obligation. Ellis, Box 203-E, Cedar Grove, N.C.

PIANO Tuning Pays. Learn this profitable profession at home. Our Tonometer and mechanical aids make learning easy. No knowledge music necessary. Diploma granted. Largest and oldest school—51st year. G. I. Approved. Write for booklet. Niles Bryant School, 77 Bryant Bldg., Washington 16, D. C.

LEARN Piano Tuning. Repairing—at home in 30 days. Unlimited income. Phonograph recordings, tools and instructions furnished. Write Capitol City Tuning School, Department C-533, 129 East Michigan, Lansing 16, Michigan.

USED Correspondence Courses and Books sold and rented. Money back guarantee. Catalog free. (Courses Bought.) Lee Mountain, Pisgah, Alabama.

MEDICAL Laboratory Technicians in great demand. We train you in your own home. Catalogue free. Imperial Technical Institute, Box 973-B, Austin, Texas.

HIGH School—No Classes. Study at home. Spare time. Diploma awarded. Write for Free catalog. HBA-12 Wayne School, 2527 N. Sheffield, Chicago 14, Ill.

WANT A Diesel Job? New Opportunities to increase income. Higher Pay. More Money. We can help you Qualify. Tools. Shop method home training. Write today! Diesel. Tractor. Heavy Equipment Division. Interstate Training Service, Dept. 2-E, Portland 13, Oregon.

BECOME a Doctor of Psychology or Metaphysics. Teach secret of contentment, happiness. Win degree of PsD, or MsD. Solve mental worries. Free book. College of Universal Truth, 5153-K N. Clark, Chicago.

WELDING training pays at Hobart Welding School, Box P-522, Troy, Ohio. VA Contract. Best equipment. Catalog Free.

OWN profitable Collection Agency. Quickly learned by home study. Franklin Credit School, Roanoke 7, Virginia.

MIDLAND Linotype School. Charles City, Iowa. Civilian, Veteran courses. Free placement.

USED Correspondence courses bought and sold. List free. Walsh, 894 Main, Buffalo 2, New York.

PRACTICAL Nursing—Learn Easily at Home. Spare Time. Big demand, good earnings. High School not necessary. Write for free facts. Wayne School, Dept. FH-8, 2525 Sheffield, Chicago 14, Ill.

INVESTIGATE the collection agency business. Highly profitable. Easily learned. Free folder. Cole Associates, Syracuse 2, New York.

DENTAL Technician's Experimental Kits. Comprehensive Instructions. World Wide. Inquire Grant Laboratory, 219 W. 7th, Los Angeles 14, Calif.

SAVE algebra worry. New, analytic method teaches instantly. Rush \$1. Guaranteed. Zieman, 6123 Orchard, Dearborn, Michigan.

CURE yourself of stammering at home. Complete Instructions \$1.00. John E. Thompson, Gastonville, Pennsylvania.

BARTENDING—School or Home Training. American Bartending School, P-334 S. Wabash, Chicago 4, Illinois.

46 CONTESTS

TIE-Breakers for DAV. American puzzle contests exposed. Manual, \$5.00. Satisfaction Guaranteed. F. Werograd, Box 1495, Phila 5, Pa.

\$1000 WON by client. Contest Service, United 13 Earl, Red Bank, N. J.

FORTUNES Won by contest fans! Here's How and Where! Enclose stamp for lifetime opportunities. National Contest Bulletin, Box 2685-S, Miami 16, Florida.

47 DETECTIVES

DETECTIVE Training. Phillips Secret Service System, 1917-C North Kenneth, Chicago 39, Ill.

DETECTIVES—Work home—Travel. Experience unnecessary. Detective Particulars free. Write. Wagoner, P-125 West 86th, New York 24.

DETECTIVES needed in every town. Hanna, 8118 Fielding, Tampa, Florida.

48 LANGUAGE OUTFITS

LISTEN—Learn A Language by Linguaphone. At home, quickly, easily, correctly master Spanish, French, German, Russian, Chinese—any of 29 languages through Linguaphone Conversational Method. Add to Armed Services job, travel opportunities. Save time, work, money. Send for Free book, Linguaphone Institute, 5405 Radio City, N. Y. C.

49 PLAYS, STORIES, ETC.

MUSICAL comedy plays. Dorby Publications, Box 131, Brier Hill, New York.

50 BUSINESS SERVICE, INFORMATION, NAME LISTS

MAILING Lists. All kinds 1000 \$5.00. Dixie Service, King, N. Carolina.

NEED capital? Raise it under the Ideal system. Details write Tucker, 3633 Warder St., N.W., Washington 10, D. C.

REMAIL. Forwarding Service from New Orleans. Commercial, Private, 25c each. \$4.00 monthly. Sinclair, Box 762, New Orleans 2, Louisiana.

START Business without Capital! Reliance, 15-B Park Row, New York 38, N. Y.

RADIO—and—electrical—research. Henry Twillmann, R. #1, Chesterfield, Missouri.

51 SPECIAL SERVICES

INFORMATION on any matter. Ferguson Research Specialists, 116-14 141st St., South Ozone Park 36, New York.

WYOMING Remail Service 20c. Zotti, Box 170, Rock Springs, Wyoming.

52 AUTHORS SERVICE

LOOKING For A Publisher? Write for free booklet PS-5. Vantage Press, 230 West 41st, New York.

I Want New Writers to cash checks of \$1 to \$100 offered daily. The easiest way to write for pay. No previous experience necessary. Free Details. Saunders M. Cummings, 468-15 Independence Bldg., Colorado Springs, Colorado.

AUTHORS' typing service! Expert, reliable. 50c 1,000 words. L. Wingerter, Waynesburg, Ohio.

BEGINNING Writers: Let us show you How to get \$1 to \$20 checks in your daily mail doing simple spare time writing. Experience unnecessary. Details Free. W. Herwell, 7016 Euclid, Cleveland 3, Ohio.

53 ADVERTISING

ADVERTISE: 24 words, 100 Canadian Newspapers, \$5.50. Lists Free. Advertising Bureau, 10511-P Springfield, Chicago 43.

MAILING lists—New Orleans area. Thousand \$4.00, others \$3.00, \$1.00. Sinclair, Box 762, New Orleans 2, Louisiana.

54 CARTOONING, SIGN PAINTING, CHALK TALKS

"HOW To Make Money With Simple Cartoons"—A book everyone who likes to draw should have. It is free; no obligation. Simply address Cartoonists' Exchange, Dept. 195-C, Pleasant Hill, Ohio.

LEARN Cartooning, Commercial Art, Showcard Writing, etc., quickly. Literature free. National Artists, 801 North Marsalis, C-3, Dallas 3, Texas.

LEARN Sign Painting at Home. Test Lesson Free. Ben Kerns, Box 812-PS, Greenville, South Carolina.

55 TYPEWRITERS & OFFICE MACHINES

RIBBONS. Pads Typewriters, Adding Machines, 10c bargain catalog. G & T Typewriter Supplies, 131 Chatterton, White Plains, New York.

TYPEWRITERS. Printing Devices. Office Machines supplies appliances. Dixie Graph, King, N. Carolina.

SAVE 10%—new portable typewriters. Anywhere. Write Brackley, Farmington, Me.

TYPEWRITERS \$22.50. Duplicator, adders \$12.95; Meier's, 118 Spruce, Wichita, Kansas.

VARI-Typers, reconditioned electric typewriters \$100—Sachs, 119 West 23rd, New York 11.

56 RUBBER STAMPS & OFFICE SUPPLIES

3-LINE: Self-inking pocket stamp \$1. Deluxe 3-line desk set, enclosed case \$2. Bauer-Lee, Sierra Madre 7, California.

BETTER Quality! 3 lines, \$1.00; one, 40c. Fast service. Printing, etc. Catalogue. Johnson Press, Box 6-B, New York City 26.

3 LINES 50c; Pads 35c; Signatures \$2.35. Printright, Wauwatosa, Wisconsin.

57 PRINTING, MULTIGRAPHING, ETC.

1000 BUSINESS Cards \$2.50 Prepaid samples Free. Reliable Print Shop, 905 East Jefferson, Louisville 6 Kv.

QUALITY Printing. Stationery, circulars, booklets, publications. Free catalog. Adams, 30 West Washington, Chicago 2, Ill.

INTRODUCTORY offer: 100 8 1/2 x 11 Letterheads \$1.00 prepaid. Albert Weeks, 342 Woodycrest, Nashville 11, Tennessee.

PRINT Without A Printing Press. Big Money! See page 50.

200 LETTERS mimeographed on printed letterheads 8½x11 only \$2.00; 500 \$4.25; 1,000 \$6.10. Ross S. Weygandt, Box 313P, Wooster, Ohio.

MIMEOGRAPHING, Screen printing, Posters (any copy), Mailing. Lowest prices. Sinclair, Box 762, New Orleans 2, La.

PROFESSIONAL, personal stationery. Wholesale, Free Samples, Lynn Peltcher, 4804 Voltaire, San Diego 7, Calif.

1000 **BEAUTIFUL**, perfectly embossed business cards \$3.25. Samples, Aveco, 112-S Elizabeth, Wichita 12, Kansas.

FREE Samples, prices. Quality work postpaid. Fast service. Sutton Printing, Box 853-S, Waycross, Georgia.

MILITARY Stationery Name, insignia, processed gold, large box \$1.95 cash. Wainwright, Dolgeville, New York.

SALESBOOKS—\$3 dozen, 1200 sheets. Business or personal stationery, 50 envelopes, 50 paper, \$1.00. Broadbrook, Newtown, Conn.

58 PRINTING OUTFITS, SUPPLIES

PRINT your own cards, stationery, circulars, advertising. Save money. Simple rules. Print for others, nice profit. Raised printing like engraving too. Have home shop. Details free. Kelsey Presses, L-8, Meriden, Connecticut.

PRESSES, Supplies. Paper, catalog 10c. Custom, Box 211-S, Springfield, Missouri.

MAKE your own, self-molding, rubber printing cuts. Plexirubber, Argyle 2, Wisc.

59 PATENT ATTORNEYS

INVENTORS: Without obligation, write for information explaining the steps you should take to secure a Patent. John N. Randolph, Registered Patent Attorney, 207 Columbian Bldg., Washington 1, D. C.

C. A. Snow & Co.—S-427, Snow Building, Washington 1, D. C. Registered Patent Attorneys. Write for information.

INVENTORS: When you are satisfied that you have invented something of value write me, without obligation, for information as to what steps you should take to secure a Patent. Write Patrick D. Beavers, Registered Patent Atty., 938 Columbian Bldg., Washington 1, D. C.

INVENTORS: Write for free brochure "Evidence of Invention." Labiner, World Building, New York 7.

"**INVENTOR'S** Guide" free, Frank B. Ledermann, Registered Patent Attorney, 154 Nassau Street, New York.

INVENTORS: Learn how to protect your invention. "Patent Guide" containing detailed information concerning patent protection and procedure together with "Record of Invention" form will be promptly forwarded to you upon request—without obligation. We are registered to practice before the U. S. Patent Office and prepared to serve you in the handling of your patent matters. Clarence A. O'Brien & Harvey Jacobson, Registered Patent Attorneys, 22B-D District National Building, Washington, D. C.

INVENTORS, For "Invention Record" form, contact Carl Miller, Registered Patent Attorney, Woolworth Building, New York.

INVENTORS—If you believe you have an invention, we can make a preliminary search on your invention and advise you whether we think it can be patented. Send for copy of our Patent Booklet "How to Protect Your Invention" and "Invention Record" form. No obligation. Mc Morrow, Berman & Davidson, Registered Patent Attorneys, 143-H Victor Building, Washington 1, D. C.

PATENT Protection — This well-known organization will send you promptly upon request and without obligation a booklet containing detailed information concerning steps to take to protect your invention by a United States Patent. Victor J. Evans & Co., Merlin M. Evans, Registered Patent Attorney, 741-E, Merlin Building, Washington 6, D. C.

PATENTS—Irving L. McCathran, 316 McLachlen Bldg., Washington 1, D. C. Registered Patent Attorney.

60 FOR INVENTORS

SEARCHES—Put your patent searches in the hands of a Registered Patent Attorney or Agent, as he qualifies to give a worthwhile patentability report. Record of Invention form upon request and information on patent protection. Patrick D. Beavers, Registered Patent Attorney, 939 Columbian Bldg., Washington 1, D. C.

INVENTORS: If you have an invention for sale, patented or unpatented, write Institute of American Inventors, Dept. 30A, 631-E St., N.W., Washington 6, D. C.

INVENTORS: Without obligation, write for information explaining the steps you should take to secure a Patent on your invention. John N. Randolph, Registered Patent Attorney, 206 Columbian Bldg., Washington 1, D. C.

CASH For your idea, 280 manufacturers need inventions, patented or unpatented. List free. Invention Bureau, 208-S Clinton, Oak Park, Illinois.

INVENTIONS Promoted, Patented or Unpatented, Established 1911. Write Adam Fisher Company, 183 Enright, St. Louis, Mo.

INVENTORS: Learn how to protect your invention. "Patent Guide" containing detailed information concerning patent protection and procedure together with "Record of Invention" form will be promptly forwarded to you upon request—without obligation. We are registered to practice before the U. S. Patent Office and prepared to serve you in the handling of your patent matters. Clarence A. O'Brien & Harvey Jacobson, Registered Patent Attorneys, 22A-D District National Building, Washington, D. C.

PATENT Searches \$5.00, including copies of closest patents. Same reliable searches we conduct for Patent Attorneys. 48 hour Airmail Service. "Record of Invention" free. Capitol Patent Service, Box 664-S, Washington 4, D. C.

INVENTORS, For "Invention Record" form, contact Carl Miller, Registered Patent Attorney, Woolworth Building, N. Y.

HAVE a working model made of your idea or invention. Astoria Products, 67 Fulton Street, New York City 38.

PATENT Searches, \$5.00 including patent copies. Same reliable search as conducted for patent attorneys. Free Protection Forms, 48 hour service. Patent Service Institute, 945-B Pennsylvania Avenue, Washington 4, D. C.

INVENTORS—If you consider your invention to be something of importance, take steps to protect it with a United States Patent which gives you the right to exclude others from making, using and selling your invention as claimed. "Patent Protection for Inventors" outlines steps to take to secure patent protection. Mailed promptly without obligation. Victor J. Evans & Co., Merlin M. Evans, Registered Patent Attorney, 742-E Merlin Building, Washington 6, D. C.

INVENTORS! For "Copyright, Design & Patent Guide" contact Mr. Metzler, 11 West 42nd, New York 18.

INVENTORS—If you believe you have an invention, we can make a preliminary search on your invention and advise you whether we think it can be patented. Send for copy of our Patent Booklet "How to Protect Your Invention" and "Invention Record" form. No obligation. Mc Morrow, Berman & Davidson, Registered Patent Attorneys, 143-G Victor Building, Washington 1, D. C.

ADVANCE your invention through the facilities of Helgeson & Company, Box 842-A, St. Louis, Mo.

PATENT Searches \$5.00, 48-hour service. Patent Applications and Drawings prepared. Protection forms free. Write Miss Ann Hastings, P. O. Box 176, Washington 4, D. C.

PROMOTE your own inventions! Keep all profits! Inventors' Correspondence Kit tells who, what, where, how. Supplies stationery, forms, manufacturers' addresses. Only \$2. Inventor's Supply House, Box 1118S, Newark 1, New Jersey.

PATENT Office drawing paper for inventions, 25c sheet, postpaid. Minimum order, \$1.00. Patent Drawing, Dandridge, Tennessee.

PATENT Searches, \$5.00 including closest patent copies. Protection forms free. 48 hour service. Inventors' intermediaries. Applications and drawings prepared. American Inventors Service, 431 Kennedy Street N.W., Washington 11, D. C.

61 INVENTIONS WANTED

INVENTIONS Promoted, Patented or Unpatented, Established 1911. Write Adam Fisher Company, 183 Enright, St. Louis, Mo.

INVENTIONS Wanted by Manufacturers. Patented-Pending only. Free Details. Inventors Exchange, Dept. D, Hartford 1, Conn.

INVENTORS—Good patented, patent pending inventions wanted by manufacturers. Booklet free. Market Contacts, 719-B2 Magnolia, Tupelo, Miss.

INVENTORS: Hundreds of manufacturers have requested our assistance in locating marketable new products. Complete information, free. Institute of American Inventors, Dept. 30C, 631-E Street, N.W., Washington 4, D. C.

SCHAULAT Associates, Agents, purchasing and marketing inventions, 1110 Brentwood Blvd., St. Louis, Missouri.

INVENTIONS Wanted, Patented or Patent Pending, 21 years experience Promoting Inventions, National Service Bureau, 3122 Meramec, St. Louis 18, Mo.

HIGHEST cash and royalties. Inventors having unpatented gadgets, patents. Request free booklet. Inventors Creative Service, 354 South Spring Street, Los Angeles 13 Calif.

64 MODELS, MODEL SUPPLIES

SHIP and Yacht model fittings: blueprints. Send 25c for illustrated catalog No. 27—Listing hundreds of items. A. J. Fisher, 1002-2 Etowah, Royal Oak, Mich.

SHIP Model and yacht supplies, complete large 64 page catalogue, 30c. Wm. Wild, 510 E. 11th St., New York City.

BUILD Historic ships, Vehicles, 50c to \$9.00 kits. Illustrated catalog 10c. Ideal Models, 21 West 18th Street, New York 11.

BUILD your dream house in miniature with our realistic model makers' materials. It's easy and exciting with our plywood panels of brick, siding, shingles—and plastic doors, windows, etc.—accurately scaled, economical, time saving. For booklet, "How You Can Build Model Homes," samples; and handsome 1952 book containing 65 plans of popular homes, illustrated in full color; send \$1.00 to Architectural Model Materials, Inc., Dept. S52, 4208 Armitage Avenue, Chicago 39, Illinois.

MINIATURE electric motor, precision built, not a toy. Operates 1½, 6V. Self starting, reversible. Only \$1.95 check. M. O. Catalog 10c. Sid's Hobby Center, 1701 Boston Road, New York 60, N. Y.

STEAM engines, boilers, castings. Catalog 25c. Anton Bohaboy, 2297 Price, Rahway, New Jersey.

JET powered model airplanes \$1.98. Circ. 3c. L. Pauly, 9025 West Colfax Avenue, Denver 15, Colorado.

FREE, Examine without cost leading model railroad reference book—"Manual and Catalog of All Gauges." 144 big pages—valuable data. Beautifully printed. Lots of pix. How-to-do-it articles. After ten days either remit \$2.00 or return book. Model Railroad Equipment Corp., Dept. S, 23 W. 45th St., New York 19, N. Y.

65 HOME CRAFTSMAN

LEATHER, tools, lacing, supplies. Free Catalog, National Handicraft, 199 William St., New York 7.

OUR biggest Leather and Craft Catalog yet! 1000's of items. Send 25c (refunded with 1st order). Russo Handicraft Supplies, Dept. 40, 245 S. Spring, Los Angeles, California.

LEATHERCRAFT, Copper, textile painting, beadcraft, shellcraft, many other crafts. Big free catalog shows everything you need. Kit Kraft, 7377 Melrose, Hollywood 46, Calif.

ABUNDANT low priced leathers. Make leather belts, billfolds, purses. Big Catalog Free. Tandy Leather, Box 397-D, Tulsa, Okla.

90 ALL new, full size lawn ornament and novelty patterns, up to 20" high. Only \$1.00. Mastercraft 52S, 7041 Olcott, Chicago 31, Illinois.

LEATHERCRAFT supplies catalog. Pleasure and profit. New style handbag patterns, belts. Leathercraft school G.I. approved. 25c for catalog (Refund 1st order). Dept. PS, Apache Leather Co., 2804 E. Washington St., Phoenix, Arizona.

89 FULL size Jig Saw patterns of beautiful shelves, ornaments, toys, novelties. Plus "How, Where to Sell." Only \$1.00. Mastercraft 54S, 7041 Olcott, Chicago 31, Ill.

LEATHERCRAFT Tools, Leather Embossing Plates, Craft Accessories, Dies. Catalogue 10c. Louis Jones Engineering Company, 1613 Main, Fort Worth, Texas.

LEATHERCRAFT, Everything needed by beginners, advanced hobbyists and professional leatherworkers. Largest stock of supplies in U. S. Moderate-priced tooling leathers, top quality calfskins, tools, supplies, kits. Send 10c for Big Catalog. J. C. Larson Co., 820 S. Tripp, Dept. 2054, Chicago 24, Illinois.

"**PRACTICAL** Painting, Wood Finishing" shows how to get professional results. Furniture finishing, workshop projects, home decorating. Complete Modern brush and spray methods. Tricks you've never seen. Write Home Craftsman, 115-F Worth St., N. Y. 13.

60 PATTERNS—furniture—shelves—toys—garden cut-outs and 80 Page Hobby Book. Send \$1.00. Crafters of Pine Dunes, 225 Bird Street, Oostburg, Wisc.

HOW to make Forty useful articles from wood, Lawn furniture etc. 50c coin. Peterson's, 1368 Grand, St. Paul 5, Minnesota.

PANNING Gold lesson—Catalogue Beginners supplies, Mining Books, Maps, "Where To Go", Free. Old Prospector, Box 729D2, Lodi, Calif.

BIMETALLIC specimens for experimenting development and fabrication. \$1.00. Innumerable rewarding Applications. Illinois Alloys, Box 1527, Chicago 90, Illinois.

"**COMMODORE'S**" commission in "Confederate Navy," your name inserted. Beautifully printed. Send \$1, or \$2 for framed copy. Southern Documents, Box 4607, Jacksonville, Florida.

BIG interesting mails three months 25c, year \$1.00. Harvey Teeple, Decatur, Ind.

ADULT novelties asst. \$5.00 express. Tupler, 1305 W. Wilson Ave., Chicago, Ill.

WE purchase Indianhead pennies. Complete allcoin catalogue 20c. Vincent Fairview, 277 Broadway, New York 7.

RECEIVE mails, magazines, samples. Your name in numerous mailing lists 20c. Walter Greenwood, 273 Broadway, New York 7.

INDISPENSABLE Pocket Kits. Tool. Fishing. Outdoor. Knife. Free catalog. Trader Lewis, 105A East Delaguerra, Santa Barbara, Calif.

LEARN sharpening and adjusting power and hand lawn mowers \$1.00. Wirt's, 2419 Gnahn, Burlington, Iowa.

YOUR Leather Jacket renovated expertly. Free circular. Berlew Mfg. Co., Dept. 7, Freeport, N. Y.

SOURCES of supply of anything 50c. Satisfaction guaranteed. Gene, 415 Gregory St., Rochester 20, New York.

300 BIG Mails Guaranteed. Samples, plans, propositions, offers, eight months listing. \$1.00. (refundable). Wright Publications, 2276-M Hubbard, Memphis 8, Tenn.

POST-Rite letter Scales, \$1.50 per display card of 8; retails for 50c each, samples 25c each. Post-Rite, Box 802, Sioux Falls, South Dakota.

80 PERSONAL

"**HOW** Can I Find Out?" You Can! Information discreetly developed. Any matter, person, problem, anywhere. Worldwide. Officially licensed, bonded service. Established 1922. Reasonable. Confidential. William Herman, 170 Broadway, N. Y.

CONFIDENTIAL information for single persons. Copyrighted literature explains future happiness. Mailed Free upon request. Strone, 2488 PS Grand Concourse, New York 11.

DETECTIVE'S Opportunities. Detective Particulars free. Write, Wagoner, P-125 West 86th, New York 24.

PSORIASIS Victims: Hopeless? New Discovery! Free Trial offer. Write Pixacol, Box 7097-S, Cleveland, Ohio.

BORROW by mail. Loans \$50 to \$600 to employed men and women. Easy, quick. Completely confidential. No endorsers. Repay in convenient monthly payments. Details free in plain envelope. Give occupation. State Finance Co., 323 Securities Bldg., Dept. L-14, Omaha 2, Nebraska.

MEXICAN Legal Practice Reliably Conducted, Box 1736, El Paso, Texas.

SHOPPING, Remailing, Printing, Mimeographing, Mfg. Rep., Sightseeing. Waterson, 25 Third Street, San Francisco 3, Cal.

HOW to get what you want. Proven system. Book and personal chart \$2.00. Satisfaction guaranteed. Your inquiries invited. Frank Marney, Box 878, Wichita Falls, Texas.

CONFIDENTIAL information for single people, leading to happiness—romance. Write today! Karl Miles, Ph.D., Director. Personal Acquaintance Service, Inc., 601-G South Vermont, Los Angeles 5, Calif.

PERFUME: Wholesale Only! World's finest French-type perfumes: Distributors Wanted: Catalog, details, generous sample 25c: Elliott-Stuart Limited, 4616-F Hollywood Blvd., Hollywood 27, Calif.

HELPFUL care of scalp and hair. Literature 20c. Richard Giacom, Corry, Pa.

HAIRSAVERS Booklet. Avoid Baldness. Send \$1 to Woods, 6823 Ridge Boulevard, Brooklyn 20, New York.

OUR Nation's Capitol-Letters remailed 25c. Mailco, P. O. Box 476, Washington, D. C.

INFORMATION for single people by Human Relations Consultant, Dr. B. Long, Box 375, Los Angeles 53, Calif.

THE Secrets to Avoid Heart Trouble and Keep Young. Positive formula \$1.00. Science Publications, Box 402, Canton 1, O.

EARN more money. Make more friends. Learn how to remember names and faces. Quick, easy method sent on approval postpaid, or send \$1. Edward Mehren, Box 31-B, Beverly Hills, California.

PSORIASIS Sufferers: Free trial "How To Combat Psoriasis." Dermoco Company, 355-A Imperial, Youngstown 9, Ohio.

LETTERS remailed Miami, 25c. Tropical souvenirs, candies. Information, P. O. Box 599, Allapattah Sta, 42, Miami, Fla.

JOIN National Guild Hypnotists. Details, Hypnodiscs etc, 10c. Guild 48B Harlem, Dorchester 21, Massachusetts.

KEFAUVER Crime Comm. Report racketeering—crime, etc. Send dollar for book. And, Snyder, 169 Norfolk Street, New York 2, N. Y.

BEAUTIFUL view cards 10/\$1.00. Letters remailed \$1.00. Grayson, #3 Campbell Block, Honolulu, Hawaii.

LOSING your hair? Dandruff? Itch? Important information. Write Today! S. Viggiano, 6556 Ladson, Pittsburgh 6, Penna.

LETTERS—Remailed—Louisiana postmarked, 25c. Bruha Esteven, Box 11, Amite, Louisiana.

"**INTERESTING** Mails"—25c keeps your mail box full three months. Bentz, Desk-E/87, Chatawa, Mississippi.

MECHANICAL "Brain" (Vestpocket!) "Teaches Logical Reasoning!!" (Settles "Arguments!!") "Answers" Questions!! ("Intellectually Stimulating!!") Guildcrafters, Gloversville 2, New York.

CLEVELAND Remails 25c:—Also Private or Commercial Receiving and Forwarding. Prompt, Reliable. Conway, 1380 West 58th Street, Cleveland 2, Ohio.

LETTERS remailed 50c. cash. Munger, 923 Johnson St., Victoria, British Columbia.

INCREDIBLE! Unprecedented! Become a mental superman overnight! Floor everybody! No studying! 'Memoprop' does all your thinking! It's uncanny! Revolutionary! Write: Bijou, Box 1727-VR, Hollywood 28, Calif.

PILES! Tormented with the irritation and discomfort due to piles? Write for free important information. Mutal Products, Box 836-P, Cleveland 22, Ohio.

DEVILISH cartoons from your snapshot—\$1. Volynnskey, 1411 Stebbins, New York 59.



COLT SINGLE ACTION "PEACEMAKER"
AUTHENTIC REPRODUCTION ONLY \$195
Looks And Feels Just Like
REAL SINGLE ACTION ARMY PEACEMAKER IS FULL GUN SIZE AND HAS STEER HEAD GRIPS. IS COMPOSED OF PLASTIC AND METAL PARTS.
MONEY BACK GUARANTEE!
Send 50c for Picture Catalog of One Hundred & Fifty Genuine COLT PEACEMAKERS
MY HUNTER, Dept 24 5666 W 3RD STREET, LOS ANGELES 36, CALIFORNIA



Our 500th Advertisement
REAL DIESEL ENGINE
\$2.95 • for planes, boats, midget cars
• 7500 RPM; 1/7 HP; ht. 3 1/2"; wt. 5 oz.
• precision machined for smooth operation
You just can't beat this price for a precision diesel engine! Streamlined, compact, easy to install. Thousands of satisfied users all over the world. Fast delivery if you ORDER TODAY! Send \$2.95 plus 25c postage.
Gotham Hobby Corp. Dept. S, 107 E. 126th St. New York 35, N.Y.

GARDEN TRACTORS
SPEEDEX
Two Types
8 H.P. RIDING
2 1/2 H.P. WALKING



Exceptionally Low Prices Still In Effect. New catalog gives you full details on the famous Speedex. Illustrates many labor-saving uses. Complete descriptions.
SEND POSTCARD FOR YOUR FREE COPY OF NEW CATALOG TODAY.
SPEEDEX GARDEN TRACTOR CO.
Box 216-E12D, RAVENNA, OHIO P-251-32

New Lightning Seller! 47 Million Prospects!
Up to \$4.97 PROFIT on Every Order!

An invention like the new "Magic Defroster" comes along only once or twice in a man's entire lifetime. **GRAB IT QUICK!** Everybody in the United States who owns an electric refrigerator is a prospect for the "MAGIC DEFROSTER" because it ends FOREVER the need of manual defrosting. Just plug in any outlet and the refrigerator defrosts AUTOMATICALLY overnight. Saves electric current... saves time, work, and money. And the "MAGIC DEFROSTER" is **NATIONALLY ADVERTISED — outsells all similar devices.**
FREE! "MAGIC" SALES PLAN
NOTHING ELSE LIKE IT. Roosts cash earnings to new all-time high. Sent FREE with complete money-making facts about the "MAGIC DEFROSTER" — fastest seller to hit Direct Selling Field in years. Salesmen, Crew Managers, Distributors are flabbergasted by Sales. Rush your name on a postcard today. Everything is FREE.
MAXILUME COMPANY, 125 West Hubbard Street, Dept. D-9-E, Chicago 10, Illinois

AMAZING
"Magic Defroster"
RETAILS FOR
Only \$9.95





ROOM FOR EVERYBODY in Old Town Oceanboat

TAKE the whole family for a spin in your fast, big (16-foot) outboard boat! Well-braced for the heaviest motors, planes beautifully. Safe and seaworthy. Bows flare to keep your passengers dry. Planking's painted gleaming white. Built for years of service.

FREE CATALOG illustrates boats for sport, for the family, and all kinds of canoes, outboard boats, rowboats and dinghies.

OLD TOWN BOATS

Old Town Canoe Co., 845 Wood St., Old Town, Maine
PLEASE SEND ME FREE CATALOG

Name _____

Address _____

City _____ State _____

PFLUEGER TRUMP REEL

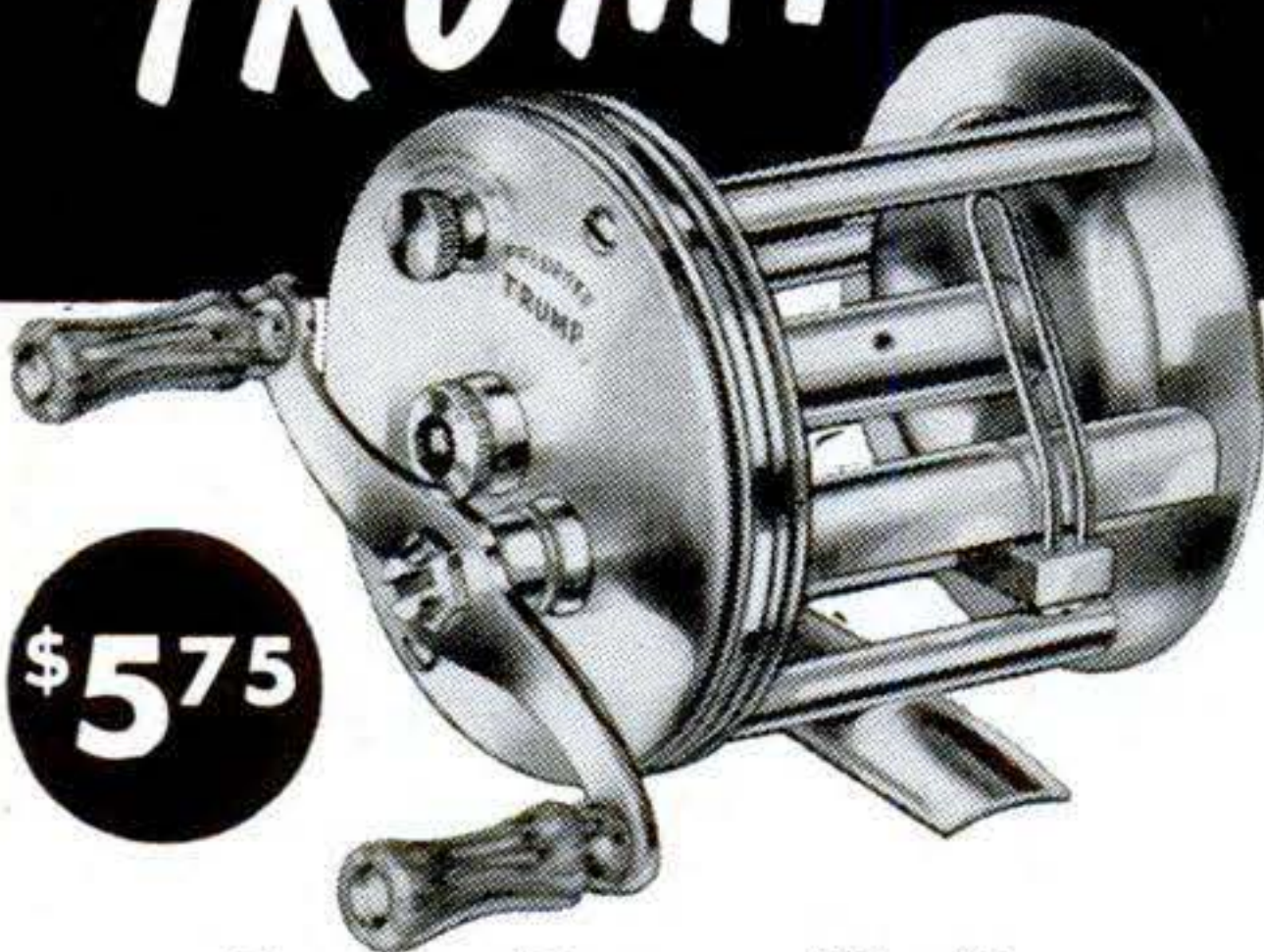

\$5.75

Casts Beautifully

You'll be surprised at how well the Pfluegers make this smart looking reel. Its dependable gears and level-wind mechanism work smoothly—its anti-back lash has graduated tension to assure positive action. Its extra heavy chromium of finest quality resists corrosion. Here's the ideal reel as an extra in your tackle box or for regular fishing. Ask your dealer.

THE ENTERPRISE MFG. CO., AKRON, OHIO
88 years making fishing tackle
Everything for fresh or salt water fishing

PFLUEGER

(Pronounced FLEW-GER)

A GREAT NAME IN TACKLE

.455 WEBLEY

\$29.50 "Very Good"



Made by WEBLEY of England, supplier to the British Government, War Dept., Air Force, Navy and major Police Depts. Recently proof tested. W. H. B. Smith in the NRA's book "Small Arms of The World" states, "One of the finest heavy duty hand weapons ever made, permits opening and extracting cartridges with one movement of the hand." These revolvers TRIPLE lock cylinder during firing. "Very Good." Truly a fine value at \$29.50. Same model "Excellent Condition" \$34.50. Immediate delivery. Ammunition plentiful. Use any .450 or .455 Revolver ammunition suitable for Colt or S & W Revolver (not automatic). Or we can supply Smokeless, Non-Corrosive 265 Grain Box of 50 for \$5.35.

SPECIAL Converted to .38 Caliber, Refinished and Reblued

We have converted the Webley by adding a brand new .38 Special barrel lining, had the cylinders bushed and chambered, so added to its normal advantages this double action revolver will fire the most popular pistol cartridge in America, the .38 S & W Special. Standard with all law enforcement agencies. Price complete only \$49.50! UNCONDITIONALLY GUARANTEED. If not satisfied return within 5 days for a full refund. In ordering you must state that you are not a minor, alien, fugitive from justice, under indictment, or been convicted of a crime of violence. No C.O.D.'s please. Prices F.O.B. Chicago. Mail Orders Only.

UNITED ARMS CO., 9043 S. Western, Dept. FA-1155, Chicago 20



SENTINEL GALVANIC ANODE KEEPS RADIATORS CLEAN

Stops Engine Rust, Reduces Cooling System Repairs, Lengthens Engine Life!

Engine block corrosion from electrolytic action causes clogged radiators! Sentinel Anodes stop corrosion, keep cooling system clean. Block stays clean, cooler, so improves cylinder lubrication, retards ring wear and sludge formation, lowers oil consumption. Keeps anti-freeze clear. Anyone can install. Guaranteed. Rush check, M.O. or C.O.D. or write.

SENTINEL MFG. CO., P. O. Box 6097A, Seattle 88, Wash.



WARN HUB CAP MAKES 2 JEEPS OUT OF 1

Ends front wheel drag on 4-wheel drive Willys Station Wagons, Pick-ups and Jeeps

Saves gas up to 5 miles per gallon, tire wear, front axles, increases speed and power. Stops shimmy—front wheels coast out of gear! 4-wheel drive handles, performs, climbs like 2-wheel. Install or remove WARN HUB CAPS in 10 minutes. Polished aluminum, guaranteed. Rush check, M.O., or C.O.D. Write for circular.

WARN MFG. CO. P. O. Box 6064B Seattle 88, Wash.

NEW SENSATIONAL LOCKING ELECTRIC CORD PLUG

- KEEPS PLUG AND CORD IN PLACE
- PREVENTS CHILDREN FROM PULLING PLUGS FROM RECEPTACLES
- WILL SAVE MANY EXPENSIVE SERVICE CALLS CAUSED BY LOOSE OR PULLED PLUGS

3 Plugs... Only \$1.00 POSTPAID

JERO SALES CO. 871 PAYNE AVE., DEPT. A
ST. PAUL 1, MINN.



GROW MINIATURE TREES

FOR PROFIT & PLEASURE



Fabulous Money—Real Fun! Grow genuine live dwarf (Ming) trees. A terrific new business and hobby. Astounding details Free. Write—

DWARF TREES, Dept. 12
P. O. Box 355 • Briggs Station
Los Angeles 48, California



100% PROTECTION

TEAR GAS

**A REAL SURE-FIRE SELLER!
THUGS AND THIEVES BEWARE!**

Here is a tear gas pencil gun which discharges smothering clouds of tear gas to instantly stop, stun and incapacitate the most vicious man or beast. A safe and effective substitute for dangerous firearms. No permanent injury. Needed in Stores, Banks, Autos and Homes, everywhere to protect Life and Property. No skill required. Handle our tear gas as a side line and you'll soon give it full time. For a quick start send \$4.25 for complete demonstrator outfit consisting of an Automatic Pencil Gun with 10 demonstrators and 3 powerful Tear Gas cartridges fully guaranteed. Many thousands now in use. Order your outfit today. Not sold to minors. Hagen Supply Corp. Dept. A505 St. Paul 4, Minn.

BOWLERS! GOLFERS!

To keep hands from slipping, for

- BETTER GRIP
- BETTER SCORES
- BETTER CONTROL

use

"Claro Non Slip"



50c at bowling alleys, sport shops, golf clubs, or send \$1.00 direct for two jars postpaid.

CLARO LABORATORIES, S. M.
1032 W. Indiana Ave., South Bend 14, Ind.



the sportsman's CROSSBOW

tremendous power, accuracy for hunting and target 45-65 lb. pull



Old Weapon—New Sport. Superbly crafted, 1-1/2" x 29" hardwood stock, precision steel trigger mechanism, highly tempered steel bow—arrows. Aims and hits like rifle. Not a toy. Will kill deer. Real thrill and excitement.

\$14.95 postpaid

KENRON PRODUCTS • Room 150
840 E. Washington St., Pasadena, Calif.

FAMOUS Battle Saber

\$2.45

A TREASURE FOR COLLECTORS

Ideal for mounting or wall decoration. Two sabers can be attractively crossed. Made in Solingen from finest German steel. Length 27 1/2".

Carried in battles of the past. Used also as bayonet on famous 1867 Rolling Block Rifles.

FREE . . . if you order now! Handsome black-leather scabbard trimmed in shining steel.

Add 35¢ for postage and handling. Money back guarantee. No C. O. D.'s please.

WINFIELD ARMS CORPORATION

409 East Pico Blvd., Dept. F-5, Los Angeles 15, Calif.

BOAT KITS

- Use simple tools to assemble
- Step-by-step instructions
- Precision pre-shaped parts
- One-piece plywood planking
- Screws, paint included



12 ft. model pictured

Marine hardware & complete accessories

Complete Catalog of all models 10c

MINNESOTA MARINE 3207 FREMONT AVE. SO. MINNEAPOLIS 8, MINN.

IF YOU OWN A CAMERA YOU NEED THESE AIDS FOR BETTER PICTURES!



"IDEAL" EXPOSURE METER

\$9.95

WITH LEATHER CASE! Accurate photo-electric meter — for perfectly exposed pictures. Quick, easiest-to-use. For movies or "snaps" — regular or color film.

3 Year Guarantee

"IDEAL" RANGEFINDER

Shows exact distance for clear, sharp focus. Just look thru finder, turn knob until images come together. Specify feet or metric.

\$2.95

3 Year Guarantee

AT YOUR DEALER, OR SEND TO:

FEDERAL INSTRUMENT CORP. Dept. PS-5
1402 Broadway, Long Island City 6, N. Y.

Please RUSH: _____ I Enclose \$ _____

Name _____

Address _____

City _____

State _____



Model 413D

Your

"OUTING PALS"

for Good Food

Good Light

Wherever You Go!



Model 200

You always have good food with a Coleman Camp Stove along. You're sure of plenty of light in camp at night with a Coleman Lantern. Unsurpassed for emergency uses in floods, disasters, power failures.

Coleman

CAMP STOVE • LANTERN

Easy Meals—The Coleman Camp Stove cooks like a city gas range. Instant lighting. Two and three-burner models. Make and burn their own gas from gasoline. Safe—help prevent forest fires. Fold up and carry like a suitcase.

More Fun with the powerful Coleman All-Purpose Lantern. Floodlights 100-ft. area. Compact; light weight; sturdier built. 8 to 10 hours lighting service from one filling. Safe; can't spill fuel. Stormproof. Coleman REFLECTOR makes it a high-power spotlight. See it lighted—ask your dealer.



THE COLEMAN COMPANY, INC., WICHITA, KANS.

MAIL COUPON TO

The Coleman Co., Inc.
Dept. 207-PS, Wichita 1, Kansas

Please send me free literature about Coleman Camp Stoves, Lanterns and other Coleman Appliances.

NAME _____

ADDRESS _____

CITY _____

STATE _____

EXPAND YOUR HOME!

**USE
YOUR
ATTIC**

Install the
**PRECISION
Folding Stairway**
at a cost of
\$60 to \$75

Equipped with *Roller Bearings*

Makes your home more livable by providing extra rooms and storage space in the most economical way. Fits all ceilings—Just saw a 26x54 inch hole in your ceiling, frame the hole with 2x8's, nail the stairway in place and cut off at the calibrated ceiling height.

SIMPLE AND EASY TO OPERATE—A slight pull of the cord and the counter weights that operate on factory packed roller bearings silently ease the stairway into down position. The same counter weights return the stairway to its up position with equal ease. **RUGGED AND STRONG**—Construction of No. 1 kiln dried poplar. Brackets, rocker arms and hinges of heavy cast aluminum alloy. All parts numbered and interchangeable. Panel insulated and protected with tough chip board. Steps covered with safety treads. **FITS ANY CEILING**—from 7 feet to 10 feet 3 inches high. Runners graduated to facilitate cutting off for different ceiling heights. **REQUIRES NO ATTIC SPACE**—Full height above attic floor only 36". Folds completely into opening in ceiling. **SHIPPED IN ONE PACKAGE**—Each stairway thoroughly inspected, assembled and ready to install. Shipping weight 130 pounds. Sold by more than 12,000 dealers in U.S.A. and Canada. **APPROVED BY F.H.A. EVERYWHERE.** Mail coupon **TODAY** for descriptive folder and complete information concerning delivery, prices and installation.

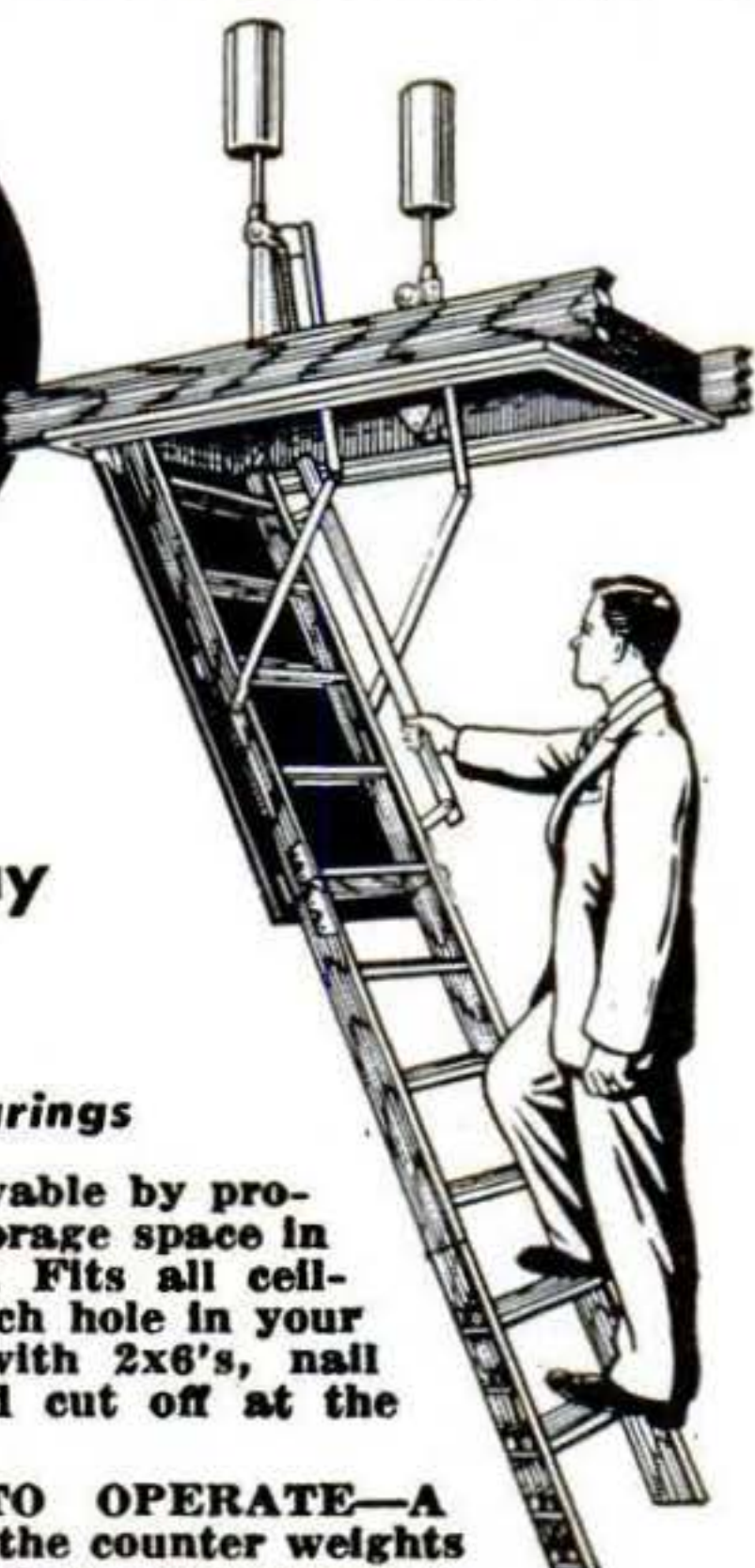

TO MAKE YOUR HOME MORE LIVABLE,
Mail This Coupon today!



PRECISION PARTS CORPORATION

402 North First Street, Nashville 7, Tenn. PS

Please send me **FREE** folder and complete information on **PRECISION** folding stairways.

Name _____

Address _____

Free Catalog

Just off the press! Fully illustrated, 104 pages, showing special fishing tackle, footwear, clothing and forty-eight other leather and canvas specialties of our own manufacture.

L. L. Bean, Inc.
70 Main St.
Freeport, Maine

Mfrs. Fishing and Camping Specialties



FUN FOR EVERYONE!



The Easy Way to Build Your Own OUTDOOR FIREPLACE

Food Cooked Outdoors Tastes Better... offers real enjoyment for the entire family... perfect for entertaining guests! It's easy and economical to build your own Cook Nook. Just add the masonry (any design you prefer) around the Majestic all-metal unit and start cooking! See your dealer today or send check or M. O.

Model OF-28 only
21" x 26" x 13 1/2" \$20⁹⁵



The Majestic Co.
401 Erie St., Huntington, Ind.

SEND FOR
free DESIGN
BULLETIN!
Big Selection
of easy-to-
follow designs

Build your own JET ENGINE!



Order these plans today

1. JET PROPELLED BICYCLE. Assemble your own. Photo and instructions \$1.00.
2. HOW TO MAKE EXPERIMENTAL JET ENGINES. Seven sheets drawings with information and instructions \$2.95.
3. BOTH OF ABOVE in one order \$3.75. SEND NO MONEY. Order both at once \$3.75 C.O.D. in USA plus c.o.d. postage. Send check or Money Order and we pay postage. Get other information too. Rush Order.

J. HOUSTON MAUPIN, Dept. 66, Tipp City, Ohio

\$750 BUILDS 4 ROOMS & BATH!

WHY PAY RENT? For Seven Hundred Fifty Dollars and 30 days of your spare time, you can build yourself this Beautiful Home.



Living room 11x15. Front bedroom 9x11. Back bedroom 10x12. Kitchen 9x11. Bath 5x8. Hall 3x4. Wind out steel Casement windows. Concrete block, stuccoed. \$1.00 brings you Step-by-Step Instructions, Blueprint & Material List. L. H. FARROW, Dept. D Box 645 Columbus 16, Ohio

Reduce RADIO NOISES

SIMPLY PLUG Radio or Appliance cord



into Noise Eliminator and plug into wall socket. Enjoy reception **FREE** from many distracting noises. Send No Money, pay postman \$1.25 each (2 for \$2.00) plus postage or send cash and we'll mail postpaid. Try 5 days, money back if not delighted. Many hundreds of satisfied users. Send for yours today.

MERIT SALES, Dept. E-27 \$2.00
4225 Eldone Dr. Baltimore 29, Md.



AXLE ASSEMBLIES

Ideal axles for farm implements, carts and trailers of all kinds

\$65.29 Less Tires
F.O.B. Factory

Solid steel construction with springs and saddles—U-bolts and shackles—spring bolts and brackets—hubs and bearings and 15" or 16" Wheels—shipped complete, ready for use. Dept. 14E

HAMMER BLOW TOOL COMPANY

Wausau
Wisconsin

REAL SHOOTING FOR YOU!

MARKSMAN Air Pistol For Sports
And Target Practice



LOOKS & FEELS LIKE A REAL .45 AUTOMATIC

PLENTY OF POWER—amazingly accurate: Has Front & Rear Sights! All metal with man's size grip! Looks, feels & handles like the real thing! Ideal for sports, target-work, chasing animal-varmints, etc.

\$5.95
No Permit
Needed!

FREE LIBERAL AMMUNITION SUPPLY!
Incl. BB's, Darts, Pellets. Remit \$5.95, we pay del. chgs. NO C.O.D.

CAROL CO. (Dept. GG-33) 114 E. 32nd St. NYC16, N.Y.

For fishing at its best... get the motor with the **best-for-fishing** features!

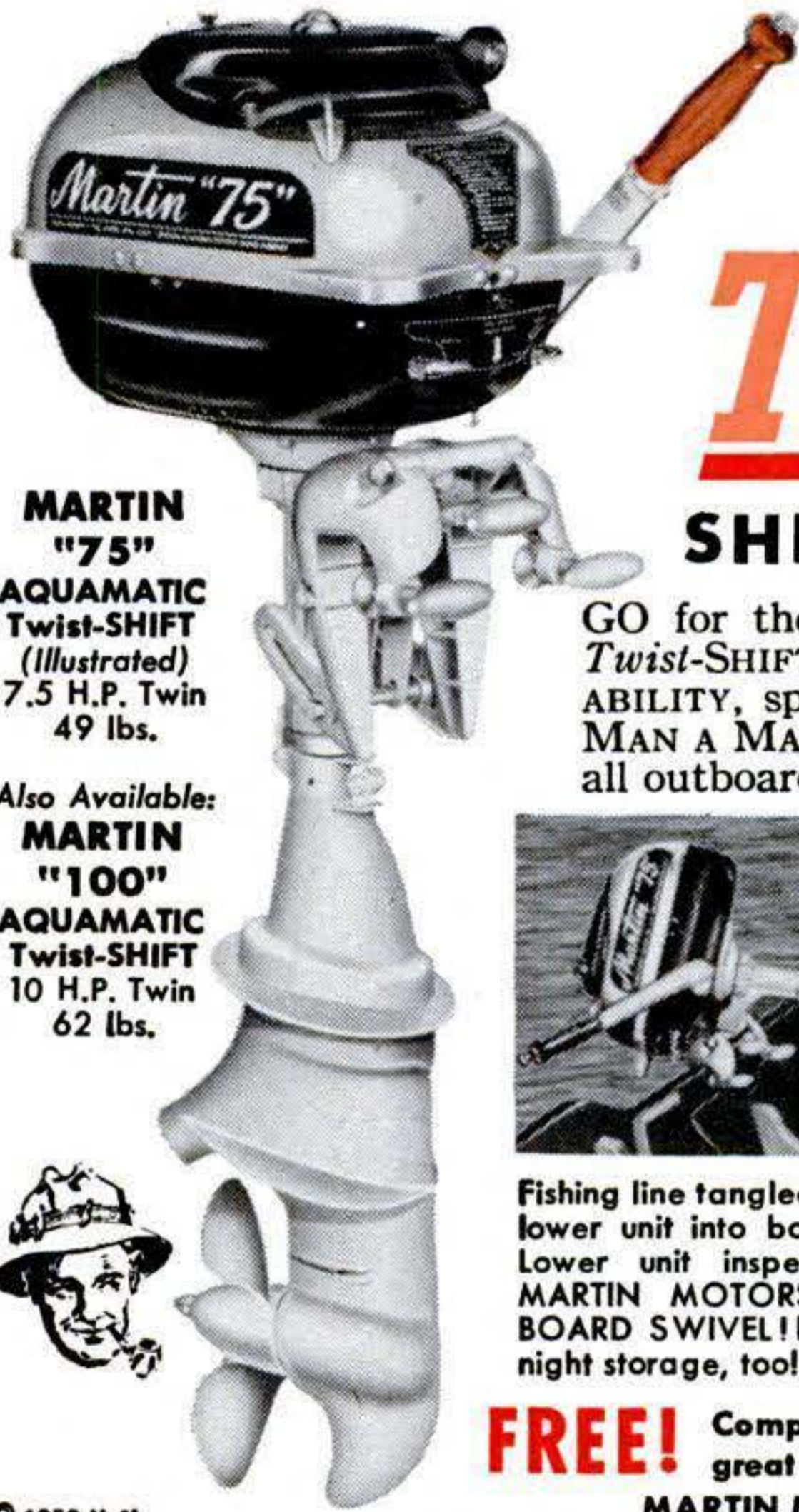

**MARTIN
"75"
AQUAMATIC
Twist-SHIFT
(Illustrated)
7.5 H.P. Twin
49 lbs.**

Also Available:
**MARTIN
"100"
AQUAMATIC
Twist-SHIFT
10 H.P. Twin
62 lbs.**

Martin

AQUAMATIC

Twist-Shift



SHIFT-SPEED-STEER... with One-Hand Control!

GO for the big ones with a MARTIN AQUAMATIC Twist-SHIFT OUTBOARD MOTOR! Built-in CON-troll-ABILITY, speed, endurance for more fun in fishing! MAN A MARTIN... "Best Outboards Ever Built" for all outboarding fun and the most fishing fun!



Fishing line tangled? Just swivel entire lower unit into boat, free your line! Lower unit inspection's easy, with MARTIN MOTORS' EXCLUSIVE IN-BOARD SWIVEL! It's great for over-night storage, too!

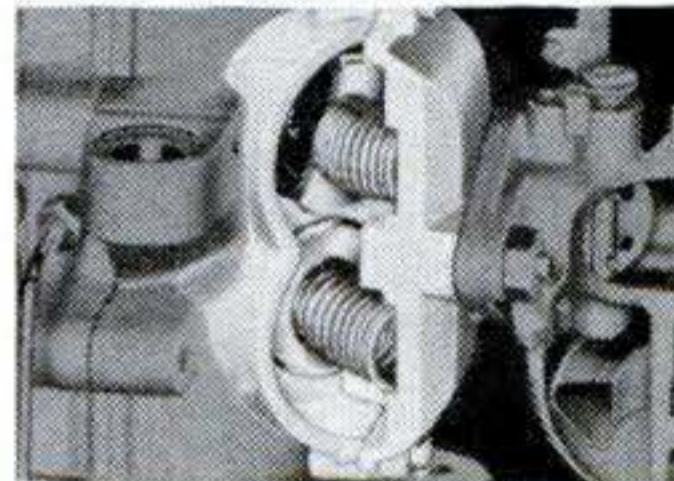

Want smoother, better, turtle-pace trolling, or blazing speed, in seconds? Get it with... MARTIN MOTORS' EXCLUSIVE MECHANICALLY-CONTROLLED INTAKE POPPET VALVES!

Backed by a History-Making
**FULL-YEAR
GUARANTEE**
With Nationwide Service

Martin
AQUAMATIC
Twist-Shift
TRADE MARK

OUTBOARD MOTORS
MARTIN MOTORS
Division: National Pressure
Cooker Company, Eau Claire, Wis.
Canadian Sales by:
MARTIN MOTORS
Division: National Pressure Cooker Co.
(Canada) Ltd., Wallaceburg, Ontario

FREE! Complete, colorfully illustrated literature on all the great new MARTIN MOTORS for 1952. Write:
MARTIN MOTORS, Dept. 5236, Eau Claire, Wis.

© 1952 M.M.

FROGMEN!

Get in the swim with a complete underwater outfit. All tested and approved by the world famous Sparling School of Deep Sea Diving.

SAVE \$15.90—ORDER THE COMPLETE OUTFIT

SPORT DIVER GEAR...\$55.00



(Underwater Breathing Unit as Illustrated) Includes I.C.C. approved tank filled with 1800 PSI Air, Harness (standard fittings), Pressure Reducer, Demand Regulator, Connecting Hose and Clamps. Complete instructions for quick, easy assembling.



FROGMAN TYPE SUIT (specify size)	50.00
QUICK RELEASE BELT.....	6.00
FACE MASK.....	5.95
SWIM FLIPPERS.....	8.95
TOTAL (singly)	\$125.90
LESS:	15.90
COMPLETE KIT ONLY	\$110.00

Items may be purchased singly at above prices. **SATISFACTION GUARANTEED**

Cash Orders Shipped Prepaid... C.O.D.'s 25% Deposit. In Calif. add 3% Sales Tax. Write for FREE Catalog of other deep sea, shallow and sport diving equipment.

**DIVERS' SUPPLY, Dept. PS5
1150 Wilmington Blvd. Wilmington, Calif.**

FAST, SMART & SNAPPY

FOLBOT

FOLDS IN TWO LIGHT BAGS

Paddles • Outboards • Sails

Versatile, streamlined craft; wide beam, large decks, low center of gravity for sturdy performance with greatest safety record. Weighs only 65 lbs.—loads 750 lbs.—3 people and gear. One person can handle it. Easily packed and stored, fits inside car trunk. Wonderful for cruising, hunting, fishing in open seas, surf, rapids, or rocky waters. Rock resistant and leak-proof. Noup-keep or fees.



Set up in a jiffy. No tools required.

**BIG CRAFT
NOW ONLY
\$134
and up**

Since 1933, thousands of enthusiastic Folbot users.

FREE giant illustrated catalogue. Write today: **FOLBOT**
42-09 PS Hunter St.
Long Island City 1, N. Y.

30

SHOTS

30 Shorts or 20 Long Rifle cartridges—world's largest magazine capacity. Greatest number of sighting combinations available on any rifle. Just two of many reasons for the tremendous popularity of the 146B.

No sales at factory

Model
146B

22 cal.

\$2895

(\$29.95 West of Rockies)

YOUR MOSSBERG DEALER WANTS TO SHOW YOU THIS ONE

And when you see it, note the fine quality, the beautiful finish. Compare it with the finest!

Send for **FREE** catalog

YOUR FRIEND, THE GAME WARDEN

The game laws conserve wild life in order to preserve for you the sport you love. Cooperate with your friend, the game warden.



O.F. Mossberg
E. SONS, INC.

26505 St. John St., New Haven 5, Conn.

Put smiles in your miles



Get a WHIZZER motor!

- 3 horsepower
- 138 c.c., 4-cycle
- Up to 100 miles per gallon of gas

Here's the new 700 Series Whizzer motor! *Everything* to make any man's standard bike a complete motorbike! Look what you get when

you buy this 1952 Whizzer motor: 3 h.p. motor with built-in generator, lights, controls, gas tank, all mountings in a single, low-cost package. Put it on your bike and go anywhere. 5 to 35 m.p.h., comfortably, safely, dependably. For real fun and riding pleasure, get a Whizzer NOW! See your dealer or write today.

WHIZZER MOTOR CO., 314 S. Sanford, Pontiac, Mich.

72 POPULAR SCIENCE

Aim HIGH-Aim LOW!

You don't need a third hand with a Delta Reddy-lite. Hang it up. Set it down. Aim the 800-ft. beam anywhere! Uses 6-volt battery. See your dealer. Yours, less battery, for **\$350** only



Delta ELECTRIC CO.
Marion, Ind.

REDDYLITE 360° Swivel
ELECTRIC LANTERN



SPORTONE MUFFLERS

Ford & Chevrolet.....\$ 4.45
All other popular cars..... 5.45
V-8 Dual Sets..... 15.95
Chromed Silentips..... 2.95
(Please state make & year of car on all orders.)

SANDEE MUFFLER CO.
5643 Corryne Place • Culver City, California

ONE MAN BUSINESS



Surprise yourself with the amazing number of uses for these Swiss Music Movements. Make music boxes and musical toys. CHRISTMAS, NURSERY, WALTZES, POPULAR TUNES. Full size patterns for Christmas Church, Musical Fireplace, Christmas Manger, Cake Plate, Doll Cradle 15c ea. SPECIAL—one free pattern with first purchase. Send \$2.50 for sample unit. Results guaranteed to delight you. Further information upon request. Here's a profitable hobby. GET STARTED NOW!

MARITIME—13 East 60—New York 22, N. Y.

140 POWER

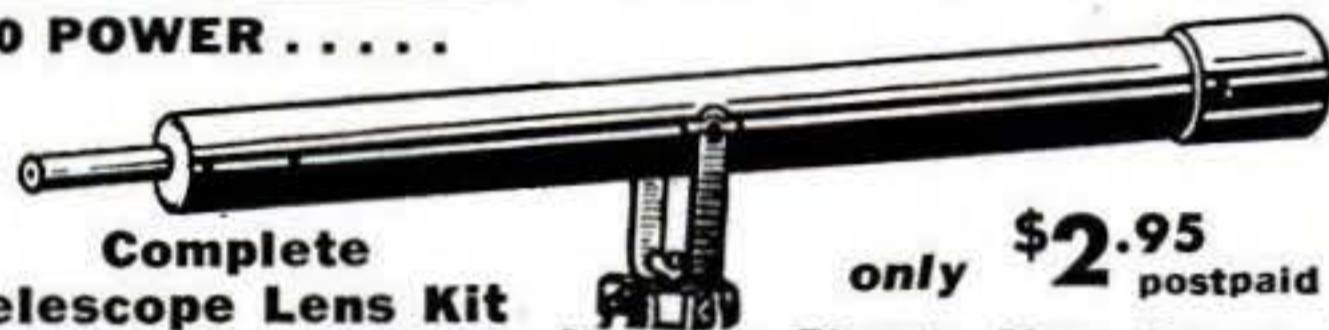

Complete Telescope Lens Kit only **\$2.95** postpaid

Conquer Space, Explore the Universe, Planets, Moon Craters, New Stars, etc. Complete Lens kit consists of 54 inch focal length ground and polished objective lens, 140 Power Astronomical Eyepiece lenses, 100 Power Eyepiece Lens, 20x lens and all necessary lens fittings. Simple step by step directions for assembling in one evening. Tripod and mounting, not included, easy to make from instructions. Money back guarantee.

BUSSE SALES COMPANY, Hartford 3, Conn.

Dept. P.S. 2

NEW 1½ H. P. MOTORS \$59.50

REGULAR PRICE \$110.00. Small surplus stock due to material curtailment. 115-230 volt, single phase, heavy duty, 3450 R.P.M., ball bearing, capacitor motor with thermal overload. Suitable for vertical or horizontal mounting. Ideal for workshops, power tools, pumps, compressors, elevators, etc. Made and guaranteed by leading Mfr. Send check or money order and we pay shipping charges.

E. G. OLSON, MFRS. REPRESENTATIVE
325 S. Cedar Lake Road Minneapolis, Minn.



SENSATIONAL NEW "NO-SNAG BOBBER"

Amazing Invention—Saves Hooks, Sinkers . . . Pays for Itself . . . Makes Wonderful Gift.

Use as ordinary casting or slip float. Cast bobber way out over sunken brush, weeds, snags, roots. Line slides through tube in bobber allowing hook to sink to desired depth. Automatically, bobber partly fills with water—stays in one spot—no drifting. To bring in—pull on line—hook rises straight up to bobber and comes in close to surface—no snagging—no lost hooks, weights or line. All plastic unbreakable. Send cash, check or M.O. **\$1.00** Post Paid (NO C.O.D.) Fully Guaranteed.

Air Light Products, Dept. (P.S.) Box 649 Omaha, Nebr.

Wagemaker WOLVERINE BOATS

You can't buy a finer boat than a "Wolverine." Large variety of models and sizes to fit every boating need. Send for free literature today!



WAGEMAKER CO. DEPT. 36 GRAND RAPIDS, MICH.



Malayan THROWING DAGGER

BALANCED TO STICK! \$1.98 postpaid

This MALAYAN FIGHTING KNIFE is used for self-defense, killing game, target skill. Powerful, silent, accurate weapon. Splits 1" board at 30 ft.



Fun, Thrills, Excitement!

Indoors—outdoors. Learn this Sport! Easy to throw accurately with our clear instructions Beautiful, heavy-duty 10" knife. Tempered steel. Tough, rawhide-bound handle Rare souvenir, unusual bargain. Limited quantity. At dealers or send \$1.98

WHOLESALE IMPORT CO. Dept. B, 604 Marengo, Alhambra, Calif.

LAWN ORNAMENT-NOVELTY PATTERNS

28 Lawn Ornament Patterns, 25c. Other patterns: 15-20" high: Dutch Girl, Dutch Boy, Pirate, Bull Terrier, Mexican Girl, Mexican Boy, Dwarf, Penguin, Flower Girl, 10c each. 25 Novelty Patterns, 30c. All 62 Full Size Patterns, \$1.00 Postpaid.

FLYING DUCK

Wind revolves wings. Realistic appearance. Pattern, instructions and wing Pinion Kit: brass bearing, steel shaft, wing lugs, bolts, nuts and washers, 50c. Pattern and instructions without kit, 25c. Postpaid.



STROTHER PATTERN SERVICE
Dept. 7-CO Box 128 Bellington, W. Va.

AMAZING NEW TINY RADIO

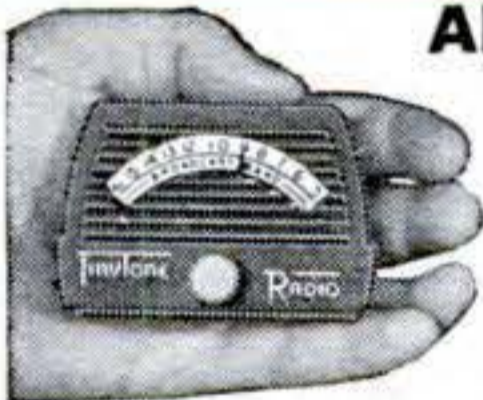

Fits in Your Pocket—Really Works. No tubes, batteries or electric AC hookup needed! Has V.H.F. crystal diode—EZ tuning dial—Red plastic cabinet—Clear tone phone. Guaranteed to work most anywhere you go on local stations. Should last for years! SEND \$1.00 (bill, ck, mo) and pay postman \$3.99 COD postage or send \$4.99 for p.p. delivery. Limited Time Offer—includes DX

Aerial kit. Real fun—Wonderful gifts. Sold only by mail from MIDWAY CO. DEPT. BPS-5 KEARNEY, NEBR.

NEW! For Sports — Thrills — Marksmanship!

"Diana" ENGLISH AIR PISTOL

- Contour Grip
- Satin-Finish Barrel
- Shoots Pellets, Darts, BB's

A world-famous pistol—for adults only! A fine example of British craftsmanship! Precision constructed to last a lifetime! Favorite of sportsmen, hobbyists, campers. Handsome appearance... smooth action, like a fine "real" pistol. Accurately adjusted sights. A world of fun and training in marksmanship! Order by Mail! Enclose Check or M.O. No C.O.D.'s

ONLY \$5.98 ppd.

FREE!
Targets—
Pellets—
Instructions

GODFREY IMPORT CORP., Dept. L-11, 277 Broadway, N.Y.C. 7

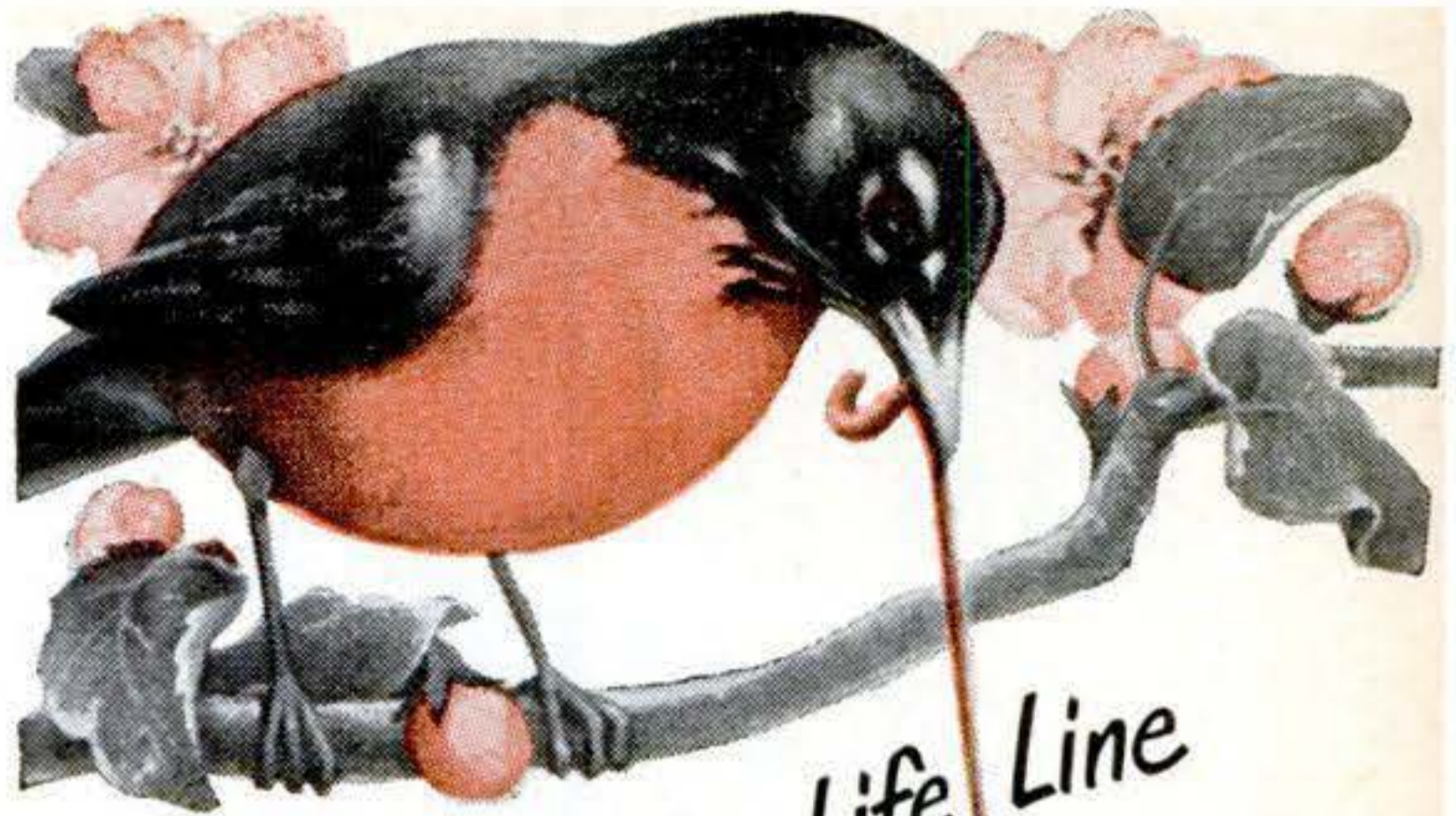

In the Spring this Life Line is important...



and so is the LIFE-LINE of your car engine's fuel system



It's more fun to take that spring motor trip with a smooth running engine... more economical too!

CARTER



PRODUCTS

The LIFE-LINE of your Car Engine's Fuel System

THE PUMP
to insure fuel supply



THE FILTER
to clean the fuel



THE CARBURETOR
to vaporize and deliver the fuel into the cylinder



Look under CARTER in the classified pages of your phone book for the authorized dealer nearest you and have your Life-Line checked now.

You get a liberal trade-in allowance on your old carburetor or fuel pump



CARTER CARBURETOR CORPORATION

St. Louis 7, Missouri

Division of American Car and Foundry Company

They're DYNAMITE

FOR SPINNING OR CASTING



New FIN-DINGO®

FIN-DINGO®—Sensational, slow-sinking, fish-like action. Wt. ½ oz.—\$1.25

WEE-NIPPEE®—Famous Nip-I-Diddee® action. Semi-weedless. Wt. ¾ oz. \$1.35

SPIN-I-DIDDEE®¼ oz. size Nip-I-Diddee®. Real fish-getter. \$1.25



New WEE-NIPPEE®

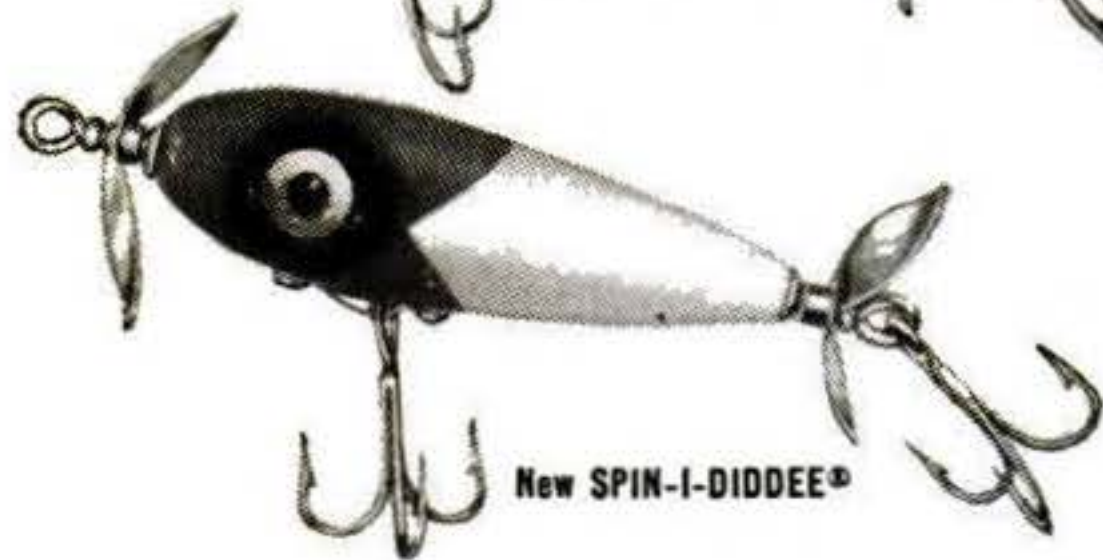

New SPIN-I-DIDDEE®



FREE BOOK. 116 pages of helpful hints, new tackle, etc. Write for it now. SOUTH BEND BAIT CO., 892 High St., South Bend 23, Ind.

SOUTH BEND
A Name Famous in Fishing

SAVE 50% - THOUSANDS HAVE ASSEMBLED

\$42^{UP} **PACKAGED BOAT KITS**



27 MODELS

Dinghies, skiffs, racers, inboards, outboards and cruisers. Assemble your own boat, it's easy, it's fun! All parts pre-cut or pre-fabricated from finest materials. Get all the facts from our big 24 page catalog. See how Packaged Boats are built, how they perform, how exclusive construction features make assembly easy. Includes specifications, performance data plus hardware and paints.

SEND 25¢ for NEW 24 PAGE CATALOG
CUSTOM-CRAFT - DEPT. 5 - BUFFALO 7, N. Y.

BOAT PLANS PATTERNS ▶ Over 50 modern plans and full size patterns. Racing classes, cruisers, inboards, outboards, sail boats. By famous designers. 6' to 30'. DESIGN CATALOG 35¢. Design Catalog and boat building handbook, \$1.00

MARINE MART - DEPT 5 - BUFFALO 7, N. Y.

ELECTRICITY *Anywhere*

FOR PORTABLE, EMERGENCY OR HOME USE

ONAN Electric Plants generate 110-volt, 60-cycle current for homes, farms, cabins and resorts beyond the highline. Lightweight, portable plants cut costs, speed work for contractors. Standby plants protect hospitals, homes, civil defense units against power failure. 400 to 55,000 watts. Gasoline or Diesel-powered. Priced from \$219.00.

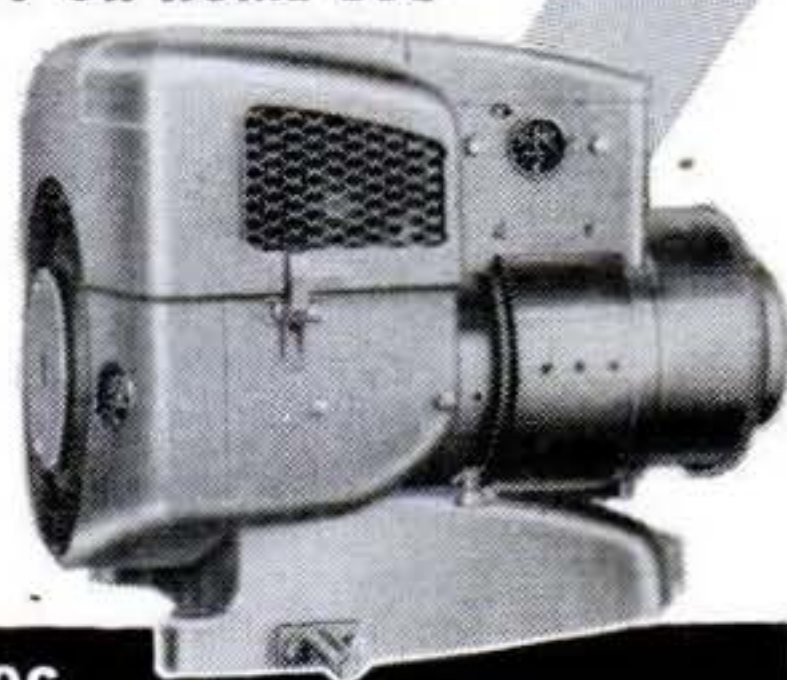

WRITE FOR CATALOG

D. W. ONAN & SONS INC.
6739 ROYALSTON AVE. • MINNEAPOLIS 5, MINN.



INSIST ON A
HULL AUTO COMPASS

BECAUSE... there are more Hull Auto Compasses in use than all other makes combined... simple comparison reveals the accurate, scientific instrument quality that creates this preference. Write for local dealer's name, free literature.

Beaconlite® illuminated \$6.95

STREAMLINE® standard \$4.95



HULL MFG. CO. P. O. Box 246-E5, Warren, Ohio

SHIP MODEL KITS



Largest supply in New England. Fittings — Blueprints — Books. All prices. Write Dept. PS52. BIG ILLUSTRATED CATALOG 25c
JAMES BLISS & CO., INC.
220 State St., Boston 9, Mass.

120 Years in Business



HOT RUNNING WATER!

Attaches easily, quickly to any standard faucet. Regulates temperature by turning faucet. Operates AC or DC. Comes with 8-ft. rubber cable and plug. Our DELUX heater has delighted many thousands of users. Send \$4.95 cash, check, or M. O. We will ship prepaid or, if you wish, we will ship C. O. D.—you pay postman \$4.95 plus few cents postage. Order 3 for \$12—save \$2.85.
METROPOLITAN ELECTRONICS CO.
Dept. 374, 106 5th Ave., New York 11, N. Y.

Catalog of 3000 Novelties 10c

Send 10c for amazing catalog of novelties, live animals, scientific supplies, hobbies, funmakers, planes & boats, looms, magic tricks, joke articles, unusual seeds, gadget timesavers, cameras, optical goods, projectors, movies, lucky jewelry, religious novelties, disguises, musical instruments, stamps, coins, puzzles, fortune tellers, radios, auto & bike accessories, telescopes, magnifiers, compasses, banks, smokers' gadgets, artists' supplies, printing sets, engines, motors, shockers, knives, billfolds, fireworks, guns, rifles, sports, books, games, plants, etc. Send name, address & 10c to:
JOHNSON SMITH & CO., Dept. 495 Detroit 7, Michigan

WESTERN GUNS



WINCHESTER 73 \$24.95 UP

COLT FRONTIER \$59.95 UP

COLT ARMY (CAP & BALL) \$29.95 UP

LARGE SELECTION - LOW PRICES
Complete Stock of Western Weapons and Accessories
Send 50c for Big Illustrated Collectors Catalog
Gives Complete Details & Prices on all Items • Catalog Price Deducted from First Purchase
WESTERN GUNS 7517 MELROSE AVE. Dept. 1
HOLLYWOOD 46, CALIF.

Get more **KICK** out of life!

Power riders get more ZING out of life — have barrels of fun. Never a dull moment — always something exciting to do — when you own a Harley-Davidson 125! Now's the time to get into this fast-growing sport and treat yourself to an endless round of thrilling good times with other throttle-twisters. See your Harley-Davidson dealer — or send us 25¢ for literature on the 1952 models and a copy of the ENTHUSIAST Magazine filled with power-riding action pictures and stories.

HARLEY-DAVIDSON MOTOR CO.
Dept. PS-5, Milwaukee 1, Wis.

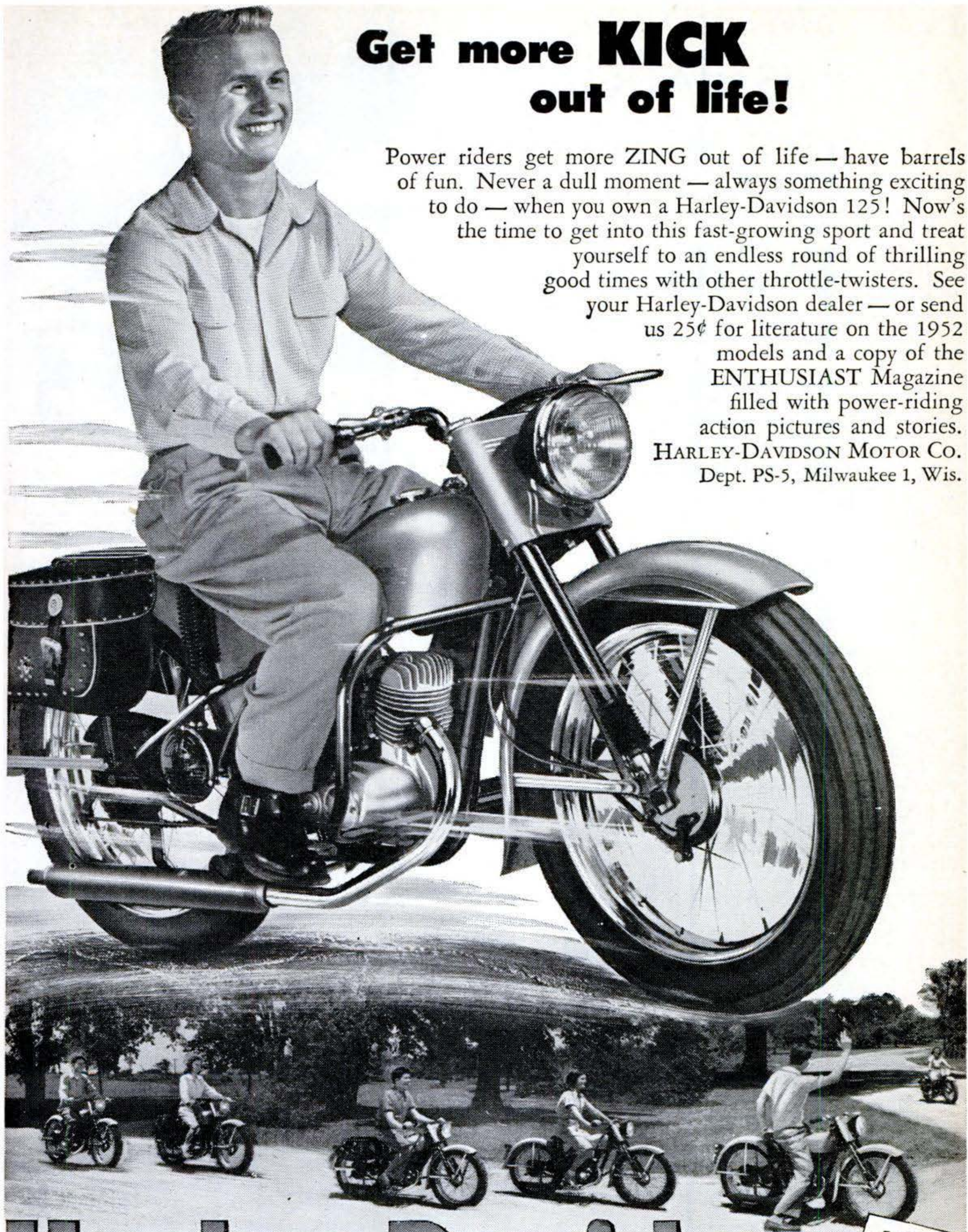

Harley-Davidson **125**

WITH *Tele-Glide*® FORK

MAY 1952 75

FOR SMOOTHER ADMINISTRATION OF YOUR CAR . . .

vote for

PYROIL

Here's the Pyroil platform—with a promise to bring you greater driving satisfaction for years.

- Eliminate "high taxation" on your motor, caused by exposure and condensation.
- Assurance of "grime prevention." Pyroil cleans your motor, and keeps it clean.
- Prevent friction of piston rings and cylinder walls.
- Reduce the high cost of repair bills.
- Improve lubrication.

Pyroil contains the special property of making ordinary oil cling to exposed metal surfaces. It keeps your motor lubricated at all times.

For smoother administration of your car—add Pyroil—add miles to your car.

Pyroil for Aircraft Engines

Use Aircraft Pyroil B for lubricating oil, Aircraft Pyroil A for gasoline.

GIVEN! An attractive Pyroil metal savings bank—takes coins up to 50c pieces. **MOTORISTS**, it's yours for the asking—sent postage paid.

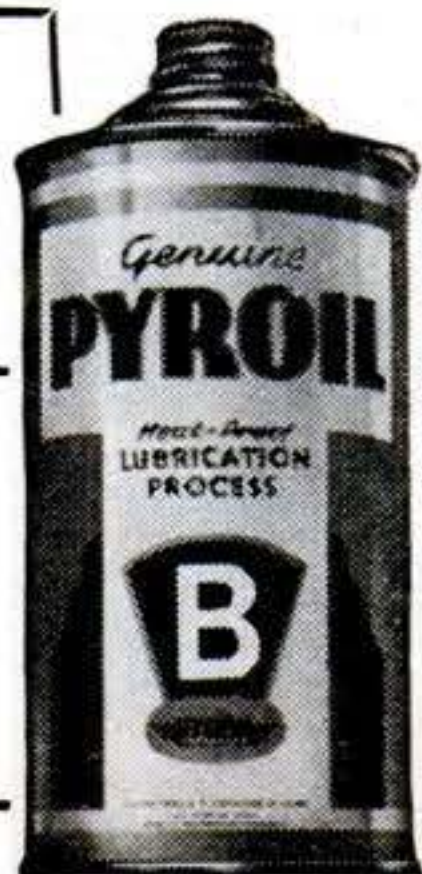

Manufactured and Guaranteed by Pyroil Company, 130 Pyroil Bldg., La Crosse, Wisconsin.

Canadian Distributors: Central Purchasing Agencies, Ltd., Toronto, Ontario

PYROIL COMPANY

130 Pyroil Bldg., La Crosse, Wisconsin

I want my car to last and run properly. Please tell me more about Pyroil and how it can accomplish this for me.

Name _____

Address _____

City or Town _____ State _____



For Brilliant
Light
Anywhere
Any Time

IT'S THE NEW *Big Beam* HERMETICALLY SEALED BEAM

only
\$750

less standard
6-volt
lantern battery

Hand Lamp

Model
166



HAS UNLIMITED
SPORTS, UTILITY,
EMERGENCY USES

See your dealer or write for folder

U-C LITE MFG. CO., 1071 W. Hubbard St., Chicago 22, Ill.

FISHERMEN! BACKLASH IMPOSSIBLE with the New KANT-Lash Reel Adapter

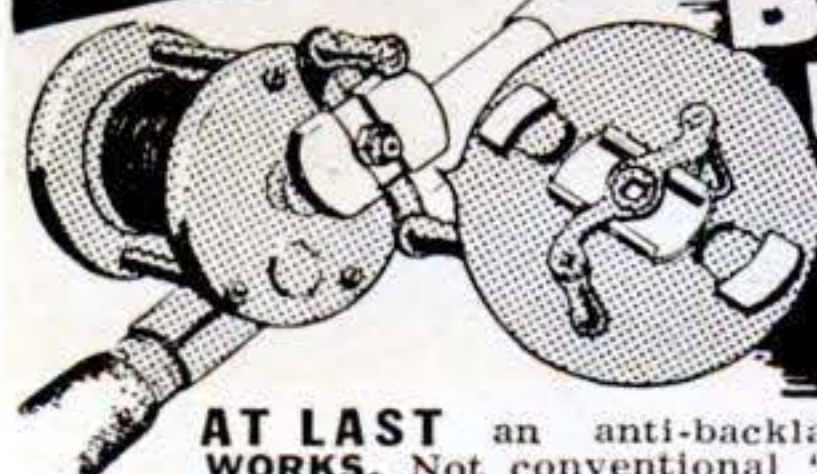

AT LAST an anti-backlash device that WORKS. Not conventional "brake" but precision "Governor" that ends all backlash . . . gives greater casting distance & accuracy. Fits old or new bait casting reels. "On" in 30 seconds. KANT-LASH must work for you or money refunded. Send \$2.95 to:

ONLY
\$2.95
POSTAGE
PAID

RENE-CRAFT PRODUCTS

220 OWENS BUILDING
WILMETTE, ILLINOIS

Crosman... does it!

Powered by CO₂ GAS

At dealers
everywhere



QUIET
ACCURATE
POWERFUL
ECONOMICAL

WRITE FOR
CATALOG

CROSMAN ARMS CO. Dept. 8 ROCHESTER 20, N.Y.

SEA SHELL only \$35

formerly built by
HAGERTY



FUN TO ASSEMBLE FROM KIT

More than 22,000 in use. Kit includes pre-cut marine plywood and wood parts, brass screws, oarlocks, seam compound, full instructions. Easy to assemble. Free booklet.

Sea Shells of Branford
5570 N. Main St., Branford, Conn.

GOIN' FISHIN'?

JOHNSON IS THE MOTOR!

More fishermen by far—76% more—own Johnson outboard motors than own any other make! You just can't beat Johnson's wonderfully smooth performance, extraordinary compactness, unbelievable stamina and world-famed **DEPENDABILITY**. See your Johnson Dealer. Look for his name under "Outboard Motors" in your classified phone book.

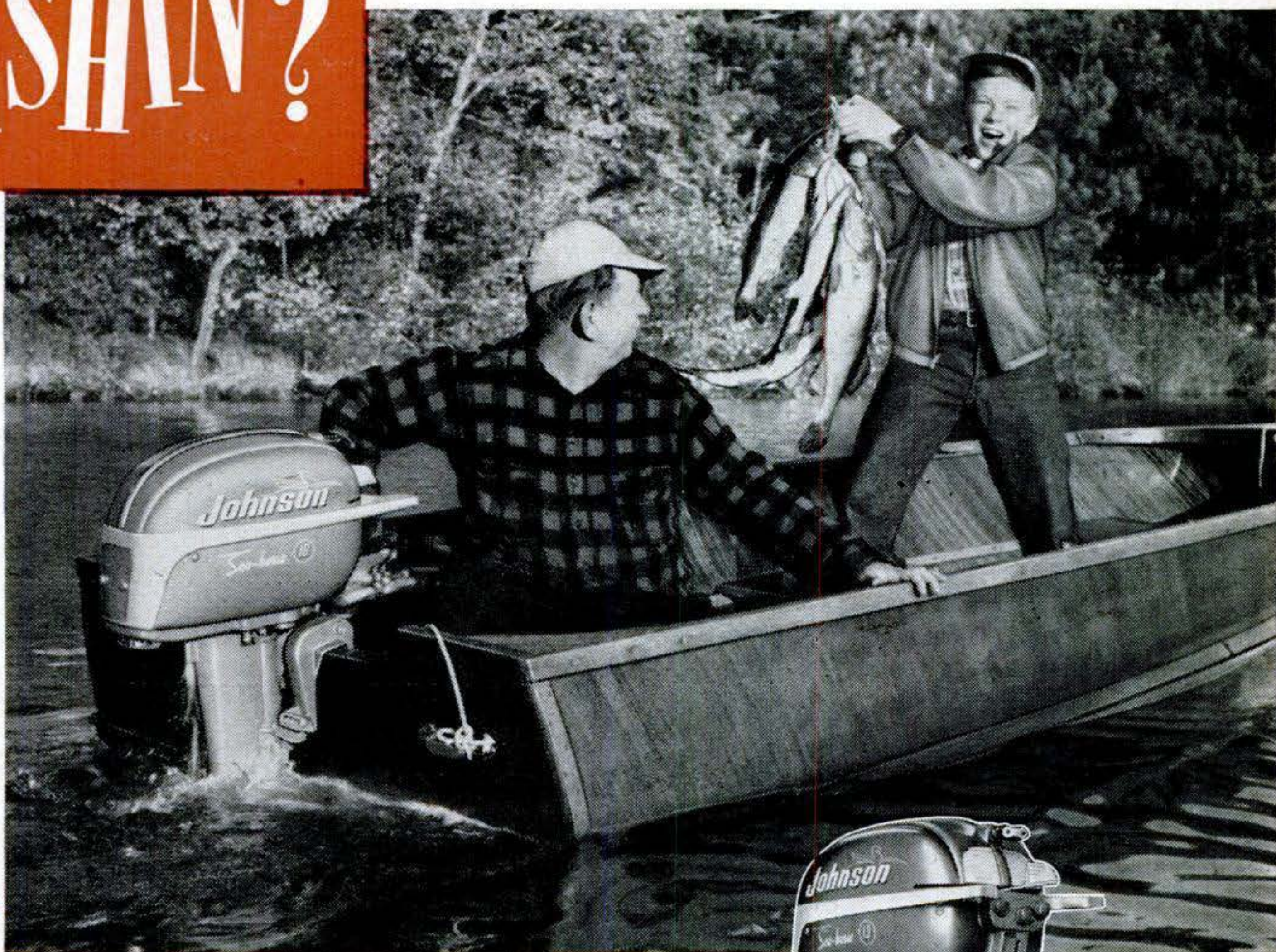

*It's a
Fact!*

YOUR DOLLAR BUYS MORE IN A JOHNSON

Compare and see! No other manufacturer has created so many important, patented outboard developments. When you own a Sea-Horse you have the latest and finest features. It's a fact . . . your dollar buys more in a Johnson.

FOR 1952 — 4 GREAT ALTERNATE FIRING TWINS

- SEA-HORSE 3:** 3 hp. Less than 30 lbs.! Patented Angle-matic Drive \$145.00*
- SEA-HORSE 5:** 5 hp. Neutral Clutch. No shear pin. America's largest selling outboard motor \$187.50*
- SEA-HORSE 10:** 10 hp. Gear Shift. Mile-Master Fuel Tank (6 gal.). Brilliant acceleration and performance \$295.00*
- SEA-HORSE 25:** 25 hp. Gear Shift. Mile-Master Fuel Tank (6 gal.). Synchro Twist-Grip Speed Control. Sensational performance and value \$390.00*

FREE! New Sea-Horse Handy Chart. Motors fully described. Write!
JOHNSON MOTORS
 500 Pershing Road,
 Waukegan, Illinois
*Johnson Motors of
 Canada, Peterborough*



OBC certified brake hp at 4000 rpm. *All prices f.o.b. factory, subject to change without notice.

Johnson

SEA-HORSES

FOR DEPENDABILITY



SEA-HORSE
10



How to take the guess out of picture-taking



GRAFLEX

Ciro-flex

One look at the brilliant focusing ground glass and you know the picture is the way you want it . . . no cut off heads, no tilting. A twist of a knob and you're in focus . . . no more fuzzy, blurred results. *Ciro-flex* is ideal for all-round picture-taking . . . indoors or out . . . comes in five models (three with built-in flash). Each has fast, coated f/3.2 or f/3.5 lens and a host of features to take the guesswork out of picture-taking. Yet most *Ciro-flex* models cost under \$100! No wonder it's America's most popular twin-lens camera.

GRAFLEX® *Prize-Winning Cameras*



Graflex, Inc., Dept. 92
Rochester 8, New York

Please send me details on *Ciro-flex*

Name _____

Street _____

City _____

County or Zone _____

State _____

BRAND NEW 4-DRAWER METAL UTILITY CABINET

Handsome 2-tone grey metal cabinet, baked enamel finish, with 4 countersunk drawers. 5½" high, 9" long, 6¼" wide. Complete with 6 short and 2 long dividers, to form inner drawer compartments. Safe storage for small parts, screws, dies, precision tools, coins, stamps, files, hooks, leaders, spinners, and precious jewels. You'll use it constantly.

Buy now at this amazingly low price **\$2.50**

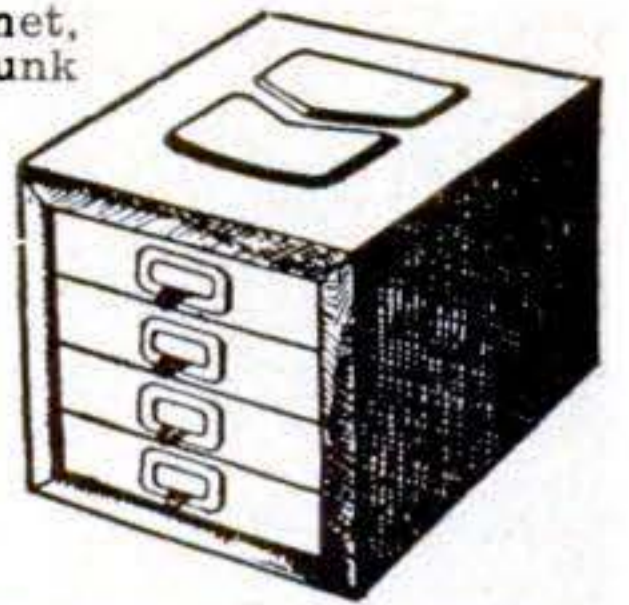

Add 50c for Parcel Post and Handling
Calif. Res. Add Sales Tax

GIANT BALLOONS



Neoprene, Surplus Gov't Weather and Target Balloons. Terrific attention getters for Lodges, Civic Events, School Functions, Conventions, Exhibitions, Trade Shows. Advertise your special events in the Hollywood manner.

Make any occasion a success. Great back-yard fun. Marvellous for parties, dances, fairs, picnics.

3 Ft. Dia. 39c 6 Ft. Dia. 79c 13 Ft. Dia. \$1.39

Add 10% For Postage and Handling. Calif. Res. add sales tax.

PITH HELMETS

SPECIAL PURCHASE The Original Genuine British Army Pith Helmet. Finest heat-protective helmet made. Same helmet as worn by British Army in Africa. Khaki covered pith cork, foil lined, leather sweatband, ventilated. Easily a \$12.50 Value. Sizes: 6⅞, **\$3.95**
7, 7⅞

(Add 35c for Postage and Handling)

WAR ASSETS DIV. VOLUME SALES CO.

Dept. S-5-52, 3930 Sunset Blvd., Los Angeles 29, Calif.

World's Fastest Boats!



Be a champion! Drive a high speed **Champion Boat!** Build one yourself from easy-to-follow plans — or we'll build for you. Send 25c for catalogue with pictures, descriptions, low prices of hydroplanes, 3 points, utilities, other models. **Champion Boats**, 1524 W. 15th St., Long Beach 13, Calif. Dept. 18-R.

Mustang

LIGHTWEIGHT
\$370.00

9.5 hp. 4-cycle. 3-speed. Foot-shift.
Over 70 miles per gal. Over 60
m.p.h. Write for free circular.

MUSTANG, Dept. PS
635 W. Colorado, Glendale 4, Calif.



(Fed. tax paid,
at factory)

JITTERBUG GETS MORE FISH

The old standby of anglers everywhere. Famous gurgling, paddling surface action makes the big ones strike viciously. Casting size (5/8 oz.) or spinning and light tackle size (3/8 oz.)—\$1.25 each. Musky size (1-1/4 oz.)—\$2.00 each.

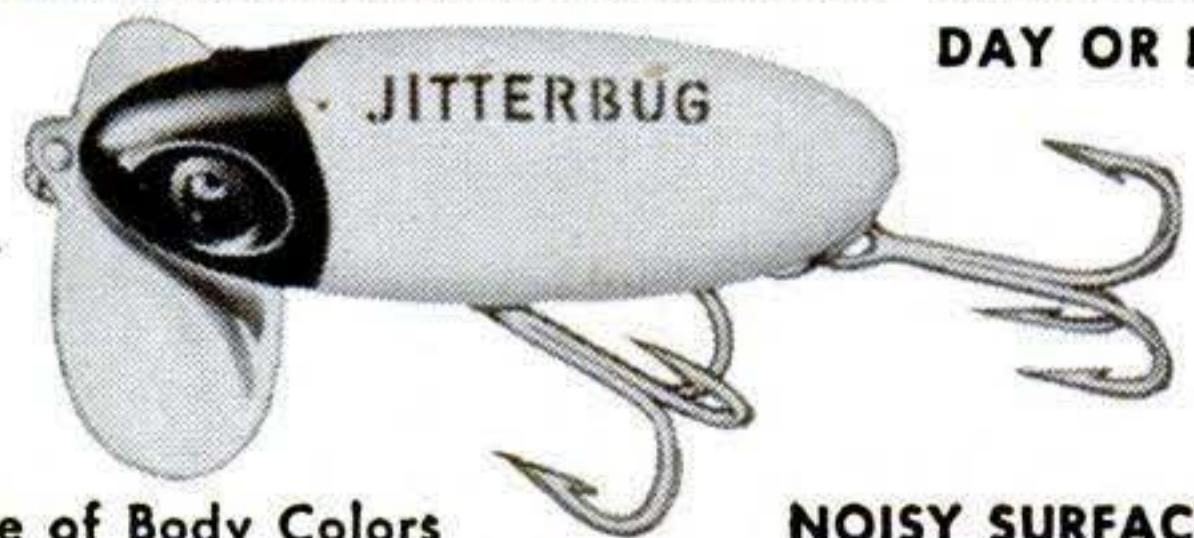

DAY OR NIGHT

Choice of Body Colors

NOISY SURFACE BAIT

FRED ARBOGAST & CO., INC., 2345 W. NORTH ST., AKRON 3, OHIO

FREE WRITE TODAY FOR BIG FREE COLOR CATALOG OF BAITS — FULL OF PICTURES OF CATCHES

SPEED



STEVENS 87 AUTO-LOADER
.22 CAL. RIFLE

15 SHOTS AS FAST AS YOU CAN PULL THE TRIGGER

How fast is your trigger finger? That's how fast you can get off 15 shots with your Stevens Model 87 .22 cal. "auto-loader." This accurate, moderately priced .22 cal. tubular magazine rifle (also Model 85, clip magazine) opens up a new and exciting field of small bore sport. Try speed shooting at small running game or plinking at "bustible" targets with a Stevens auto-loader. You'll agree that *both* the sport and the rifle are *tops*. See it and other popular Savage, Stevens and Fox Shotguns and Rifles at your dealer's.

SAVAGE ARMS CORPORATION
Firearms Division Chicopee Falls, Mass.



SAVAGE

SAVAGE • STEVENS • FOX Rifles and Shotguns

SAVAGE • WORCESTER Power and Hand Lawn Mowers



First in the Field

Three Rifles in One

Stevens Models 87 (tubular magazine) and 85 (clip magazine) are instantly adjustable as auto-loaders, bolt action repeaters or single shot rifles. This *exclusive* "3-in-1" feature allows a ready choice of *either* rapid fire, or more deliberate, precise, bolt action shooting.

Simple, Sturdy ACTION



Stevens "auto-loading" actions are a marvel of simplicity and efficiency with only a few large, sturdy parts. They are quickly disassembled, *without tools*, for cleaning.

Install an **AUTHORIZED** Reconditioned Ford Engine..

for about half the price of a new one!

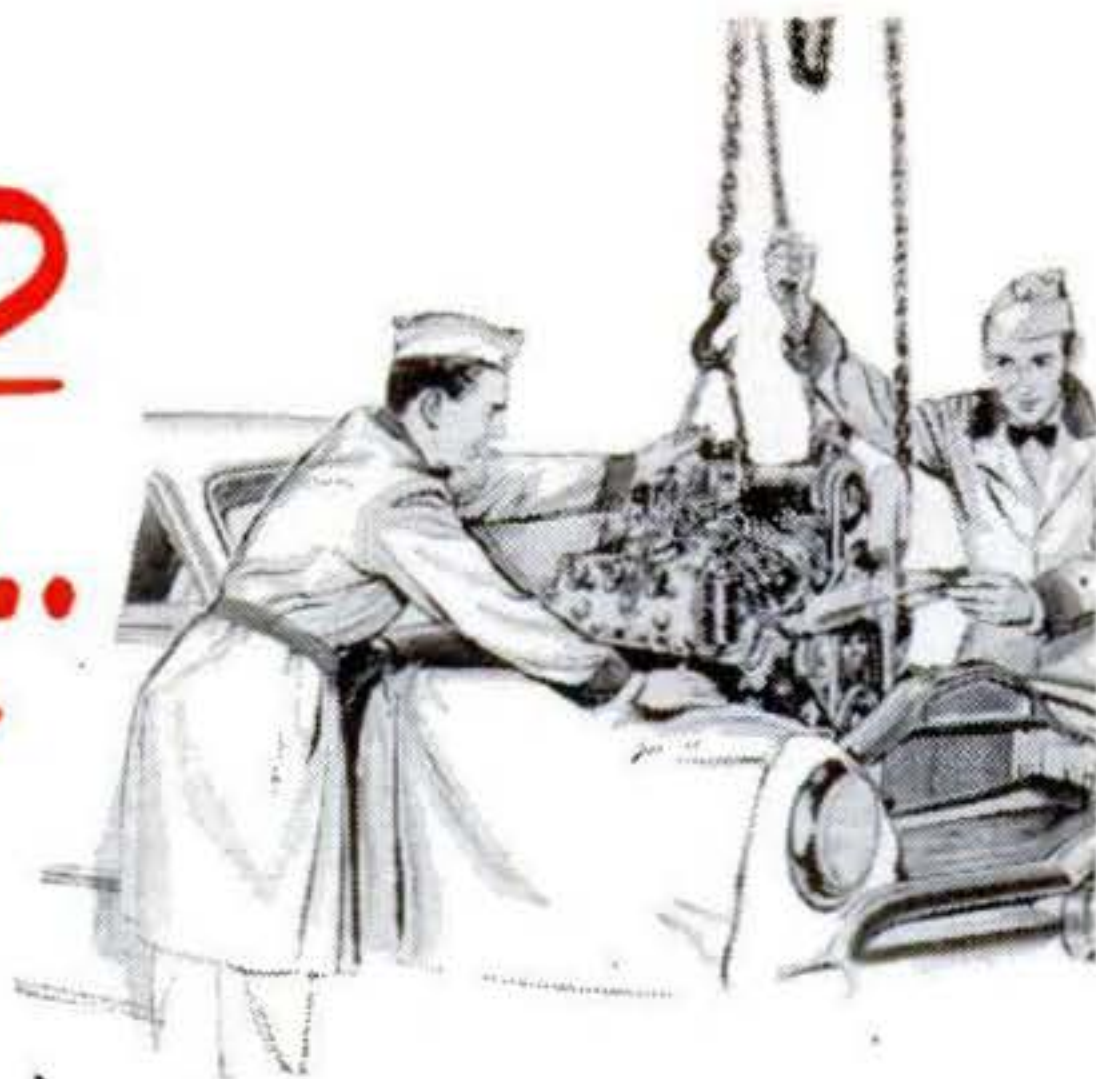

Owners report 50,000 miles or more added to the life of their faithful Ford!



Over 150 new Genuine Ford Parts or Reconditioned Parts in every rebuilt engine!

New genuine Ford Controlled Expansion pistons, *new rings, new pins, new main and rod bearings, new valves, new timing gear, new valve springs* . . . all help to give you new-engine power and economy with an Authorized Reconditioned Ford engine.

Also major reconditioning operations in Ford-inspected Plants assure you of high-quality performance in every engine. Up to 50,000 extra miles of day-in, day-out service for about half the price of a new engine is a bargain you shouldn't miss. See your Ford Dealer today—one-day installation by appointment.

Supplied by Ford Authorized Reconditioners through Ford Dealers

*Look for this
Authorized emblem...*

on the engine and parts you buy. It's backed by the Authorized Reconditioner's Warranty. Any defect in material or workmanship appearing in 90 days or 4,000 miles . . . whichever occurs first . . . will be remedied at no extra charge by the dealer from whom it was purchased.



Save money, too, with these AUTHORIZED Reconditioned Ford Parts

. . . carburetors, clutch discs, voltage regulators, fuel pumps, distributors, generators, starting motors, brake shoes.

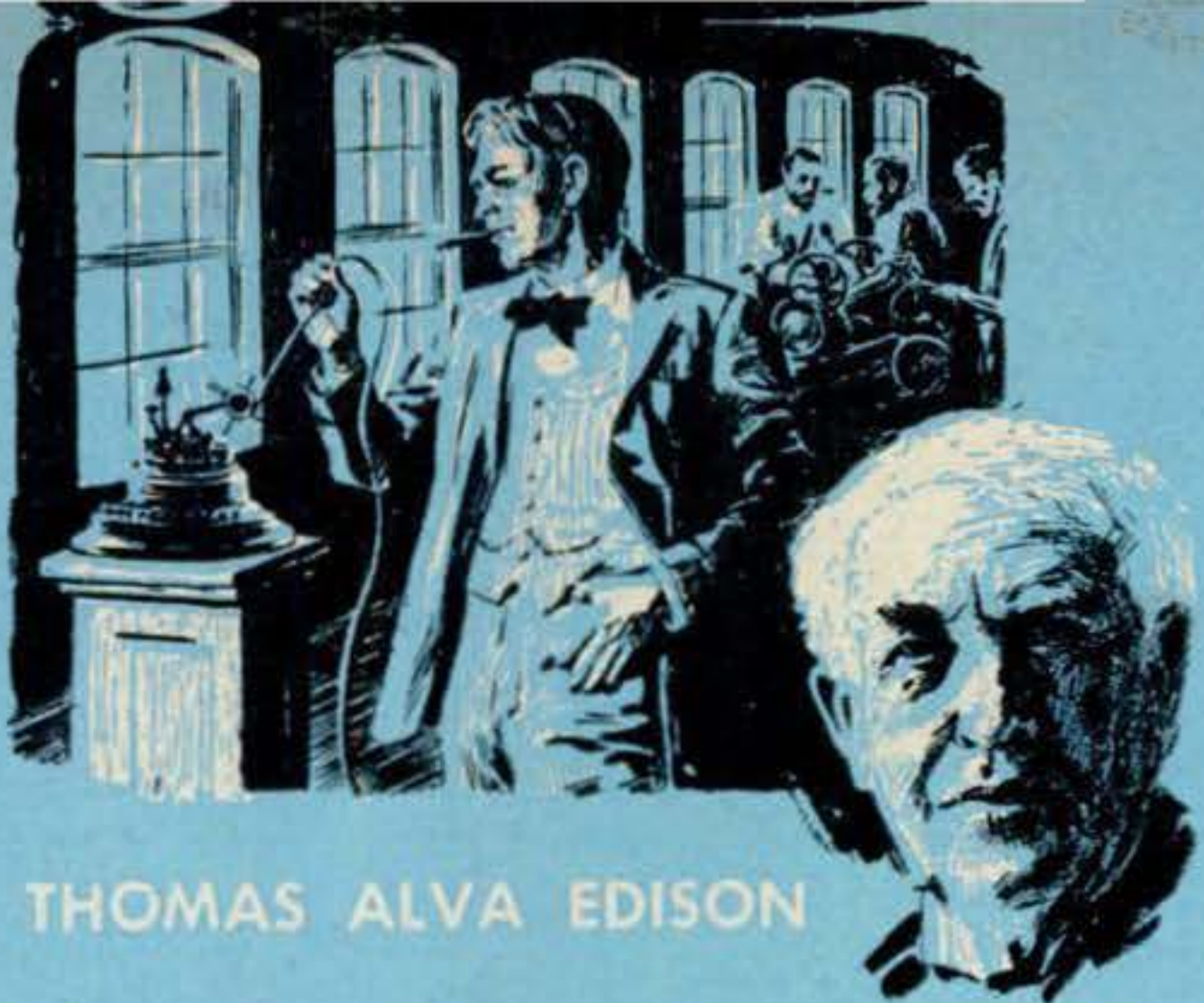

THOMAS ALVA EDISON

80 years ago...

POPULAR SCIENCE MONTHLY began its distinguished career in May, 1872. In that same year, Thomas Edison, 25, perfected the stock ticker and still found time to work on 45 other inventions. His incandescent electric light lay six years ahead. Alexander Graham Bell, also 25, was making experiments with tuning forks and piano strings that led to his creation of the telephone four years later. Henry Ford was a farm boy of nine, forever building things with his treasured small stock of tools. Louis Pasteur, 50, was proving that pasteurization, a process that got its name that summer, helped purify and preserve beer. This was nine years before he demonstrated the effectiveness of his method of vaccination. Between then and now, the inspirations of these men and others have changed the way of life of all civilized peoples.

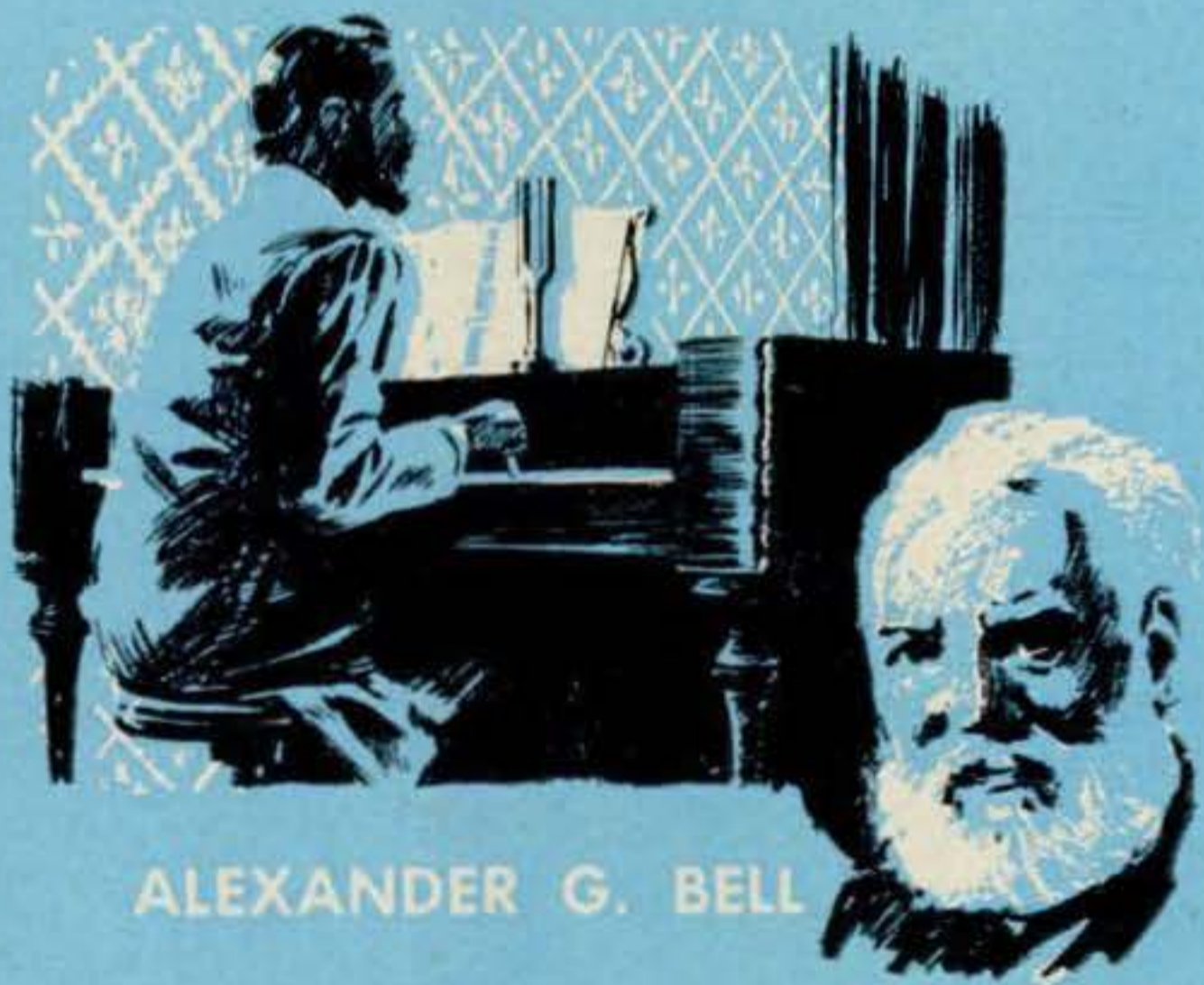

ALEXANDER G. BELL

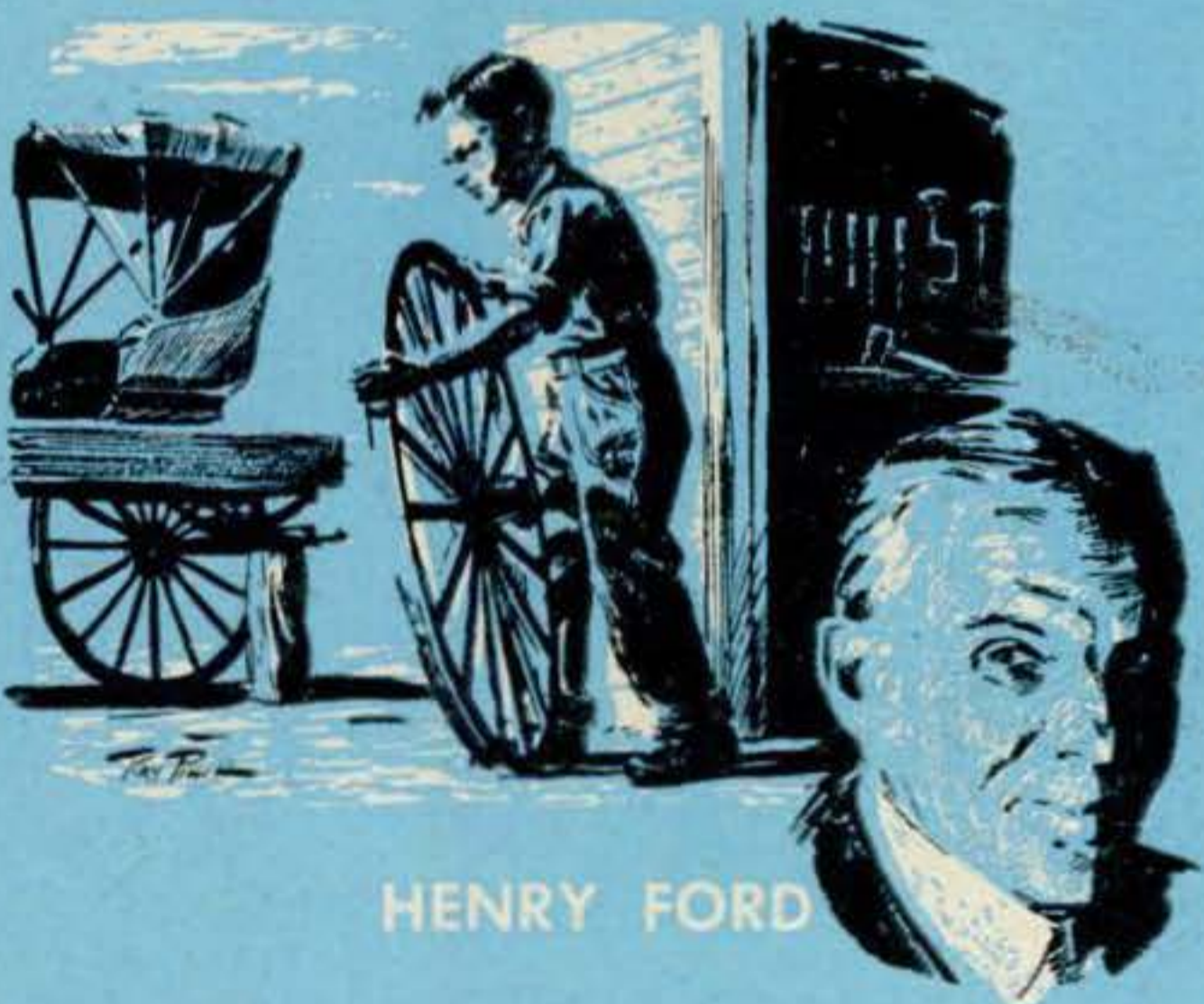

HENRY FORD

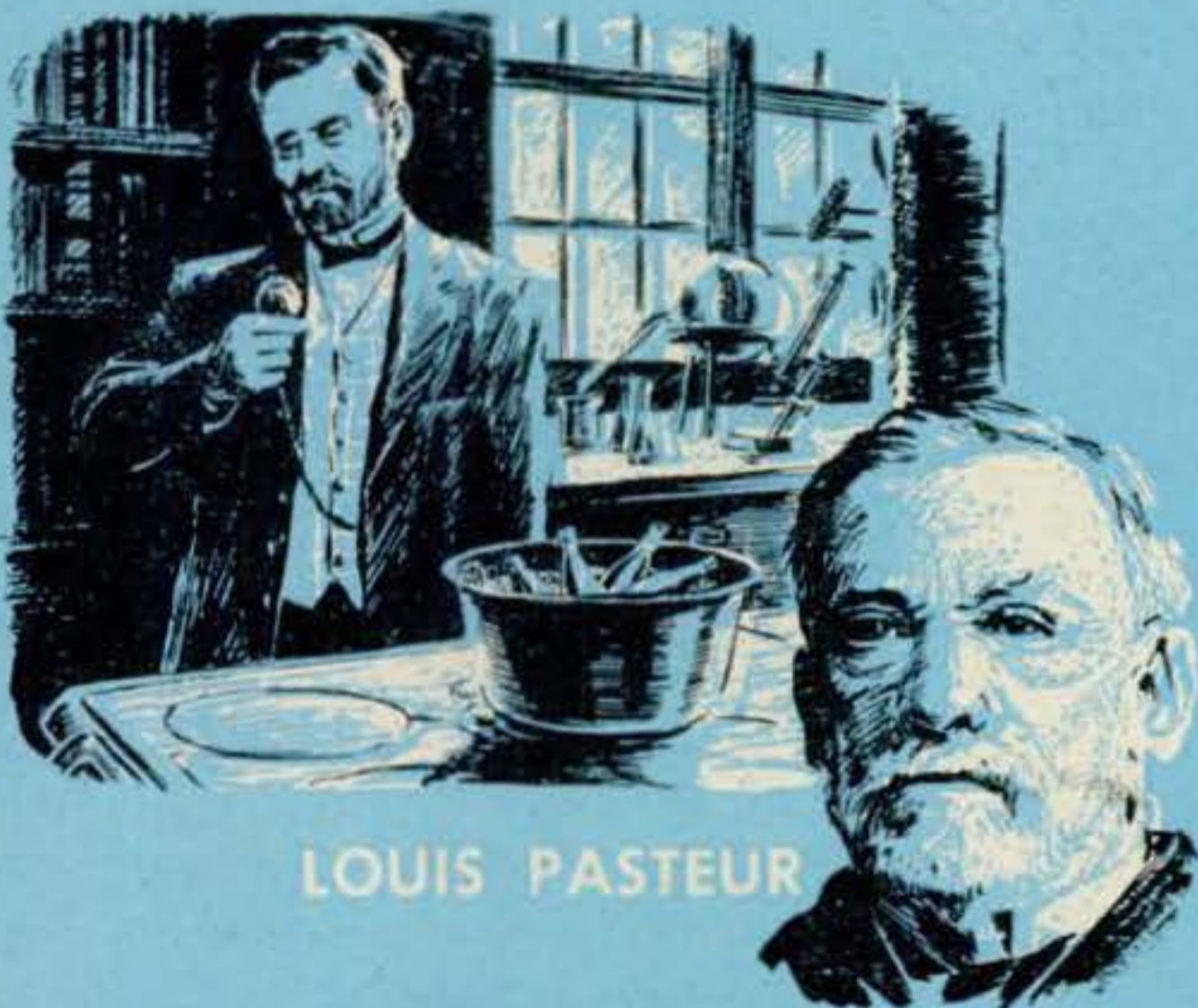

LOUIS PASTEUR

What will they think of next?



EDITOR'S NOTE: *The London Daily Express (circ. 4,240,200) once called Hugo Gernsback, 67-year-old editor and publisher of Radio-Electronics, "the world's greatest prophet." He predicted radio loudspeakers and chain broadcasting back in 1909, radar and television in 1911, atomic artillery in 1915 and radio contact with the moon in 1927. His earlier prophecies were made in installments of a pioneering science-fiction story called "Ralph 124C 41+." His current prophecies—what the world will be like in 2032—are presented here.*

such as Gernsback foresees will function something like this. In case a crash is imminent, radar waves (D) and the effect of the electrical field of one

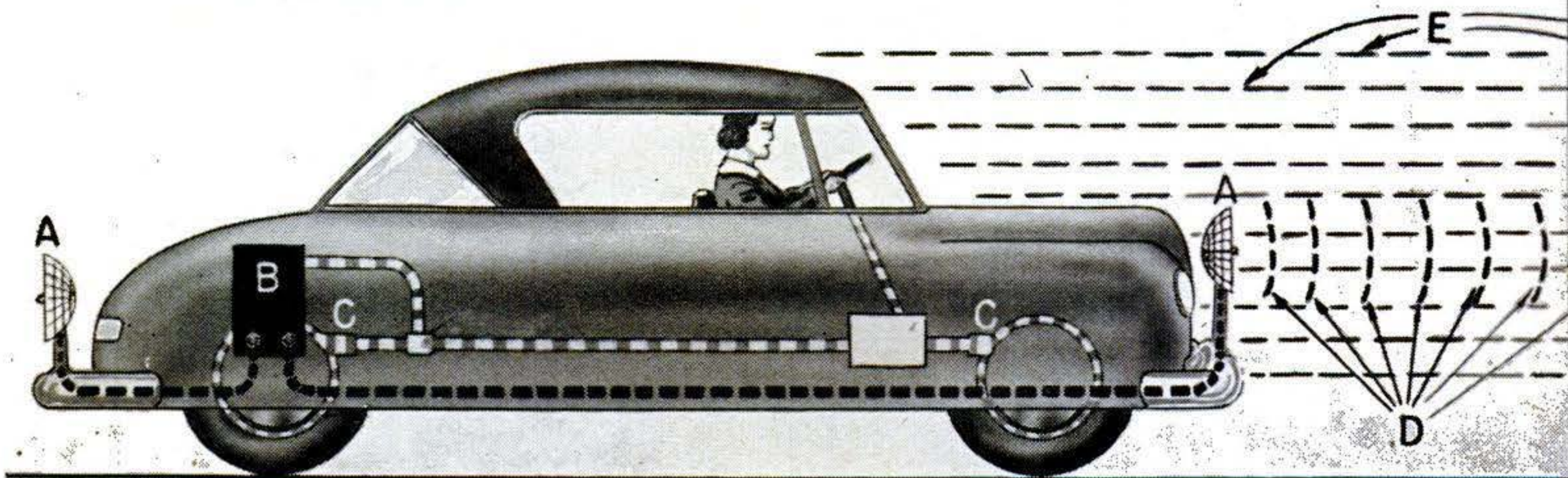

as the author imagines it, will be of metal, laced with electric heating and cooling circuits. The sitter can set the thermostats for any temperature he likes.

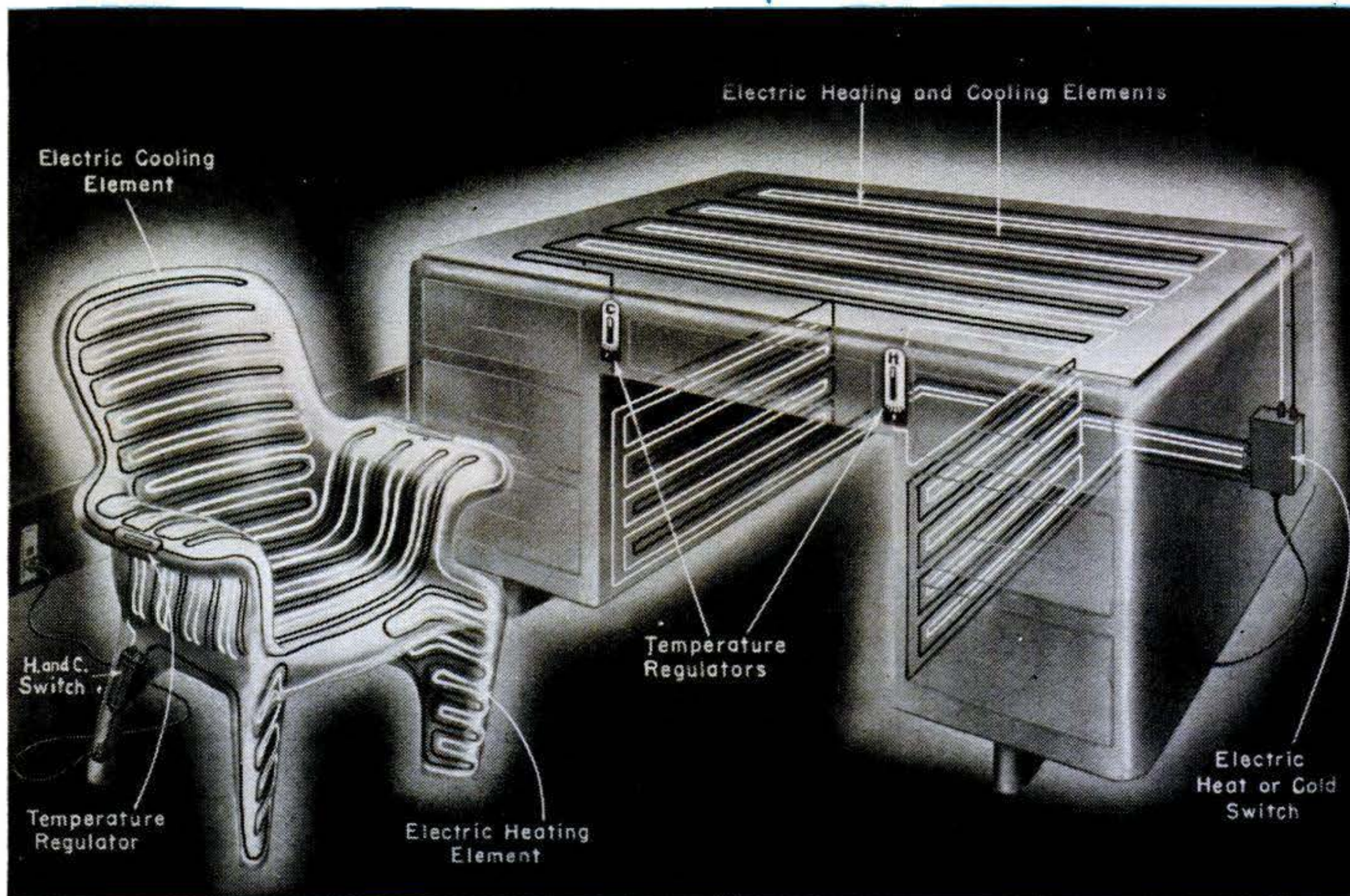

A noted prophet with a high batting average takes a crack at predicting some of the wonders the future will bring.

By Hugo Gernsback

SCIENCE moves at so swift a pace that what seems too fantastic to take seriously today has a good chance of coming true tomorrow. Accordingly, there is no telling what wonders are in store for us 80 years from now.

I predict, however, that by then we will have cars that avoid collisions by themselves, with no help from the driver. I predict that electronic brains will be deciding who is to marry whom, and that therefore there will be many more happy marriages than there are now. I predict that we will be able to heat or cool our furniture, and that

car upon that of another (E) will cause a radar-wave collector (A) to signal an electronic brain (B), which will apply brakes (C). Similar setup will avoid sideswipes.

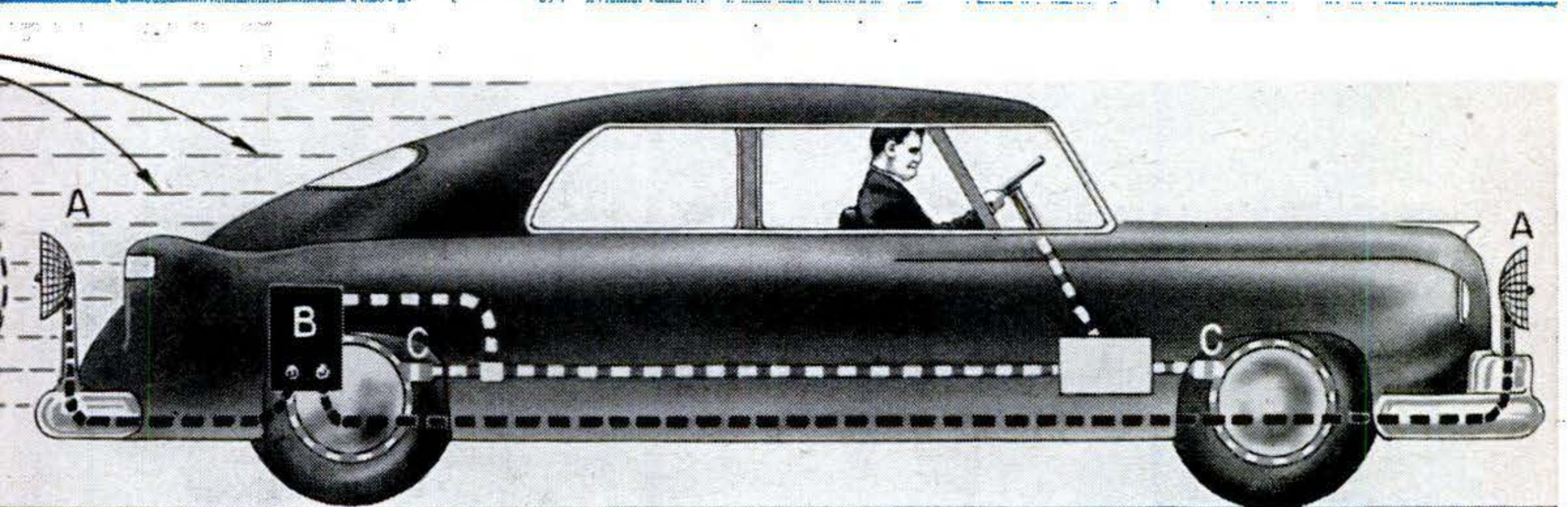

will let a calculator choose ideal couples, bring about happier marriages.

can be produced with three screens or, as below, mirrors.

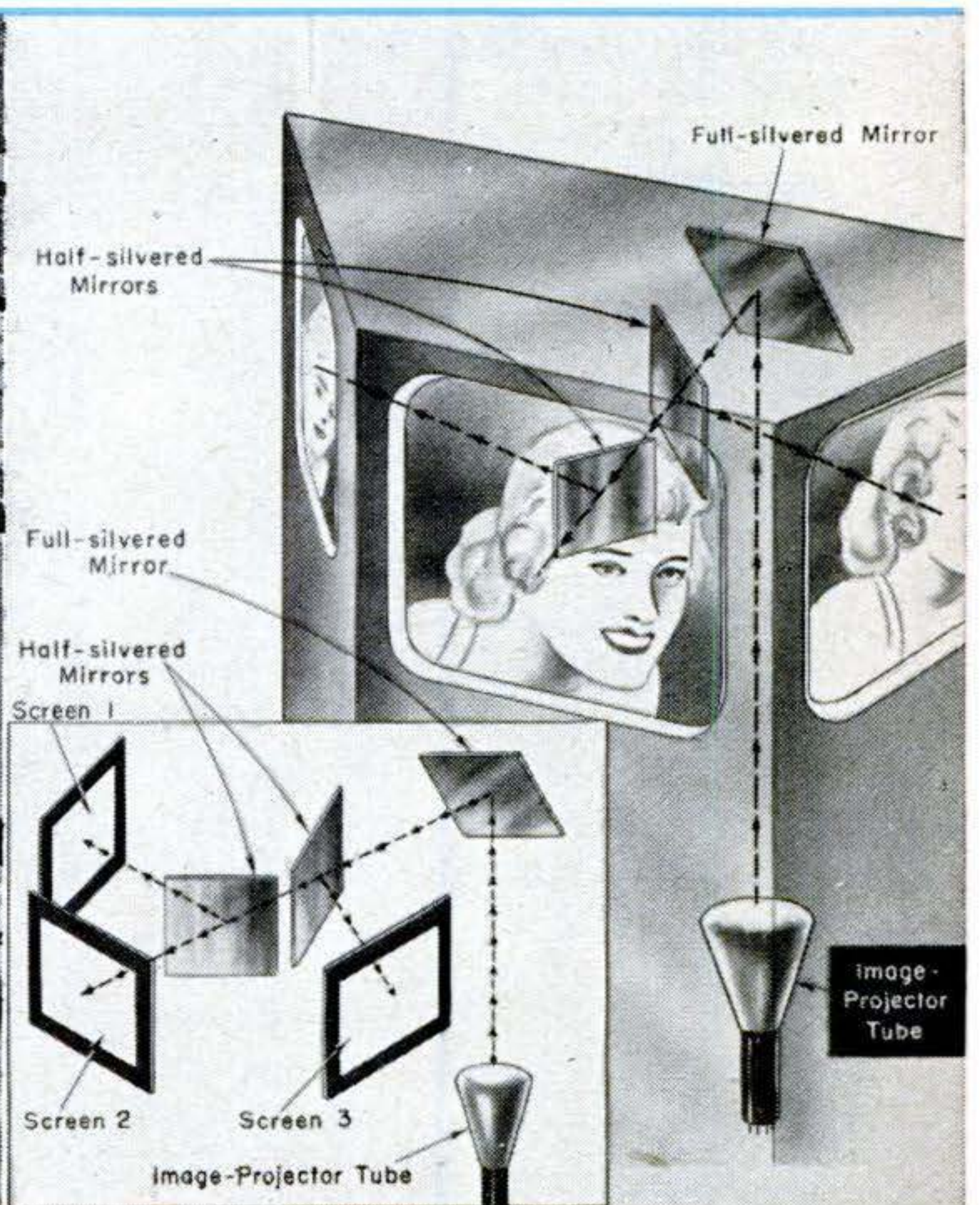
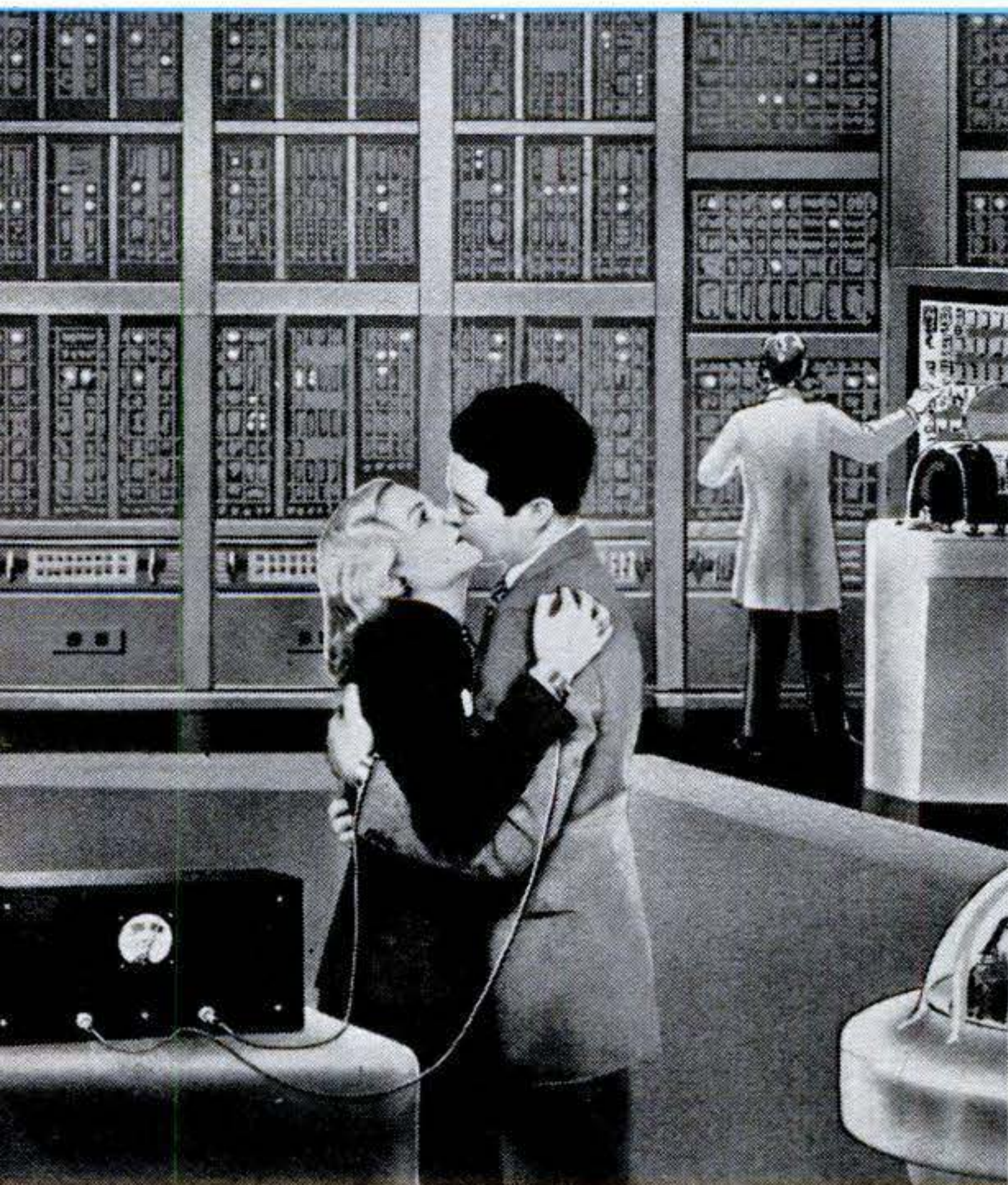

three-screen TV sets will be commonplace.

There is no valid reason for not equipping cars with anti-collision electronic devices. I can visualize an electronic system which embodies a combination of a simplified, special radar plus a capacitance-effect device—both acting together. Such a system should give us a greater margin of safety to prevent or minimize collisions.

True, such improved cars will be more expensive than present-day ones, but it is a certainty that the public will want them—at almost any price.

With constantly increasing car speeds, no human can be trusted always to stop a car quickly enough to avoid accident. Human reactions are too slow. With a car moving at 60 miles an hour, let us picture a common situation. From a shrubbery-obscured side street another car moves across the main road. The driver of the first car sees the

other car 75 feet away. But it takes about three-quarters of a second for him to apply the brakes. In that time his car has traveled 66 feet. Then the car's momentum will cause it to cover, say, 185 feet before it can be brought to a dead stop. Thus the first car will have traveled 251 feet from the moment its driver sighted the second car until it was stopped. Result—unless both cars manage to swerve—a bad crash.

Electronics Will Slam on Brakes

Why will an electronic control be better in such a situation than the driver? The answer is that human reactions are not instantaneous; in an emergency a driver rarely has sufficient time to put on his brakes—but electronics can do it *instantly* when the car gets in the danger zone. True, not all collisions will be prevented, but the force of the impact will be greatly reduced. It will make the difference between death and injury.

The electronic anti-collision device need not be very large or cumbersome, perhaps not much larger than a medium table radio. It will have a rudimentary radio brain that will also make certain decisions as to when and where *not* to put on the brakes.

I would use electronics, also, to help reform our customs and our approach to marriage, which still remains man's greatest gamble.

Science May Choose Your Marriage Partner

Let us begin with a workable plan. A group of bright young research scientist-psychologists should be organized under the tutelage of a brilliant and able leader, such as Dr. Alfred C. Kinsey, author of *Sexual Behavior in the Human Male*.

The group of researchers then will interview 25,000 or more married couples. They will be armed with lengthy questionnaires as well as special test equipment. After a few years they will have ascertained which of the 25,000 marriages were successful and which were not. Like the original coded and self-proving Kinsey questionnaire, these marriage questionnaires, by eliminating any possible false answers, will be as perfect as modern science and ingenuity can make them.

The questionnaire and tests will go exhaustively into heredity, individual taste, sex habits, education, race, color and texture of skin, IQ, general health, past illnesses, texture of hair, Rh blood factor, odor prefer-

[Continued on page 242]



75 years ago this month

Popular Science Monthly reported:

“THE two islands of New Britain and New Ireland, lying east of New Guinea, have been visited by a Wesleyan missionary, Rev. George Brown, who has explored 150 miles of the coast of the former, and 100 miles of the latter. Mr. Brown also crossed the latter island and made large natural-history collections. Abundant evidences of cannibalism were found, but the natives live chiefly on bananas, cocoanuts and pork. No white man had ever been seen inland before, but no opposition was offered to the explorer.”



Which End Is Which?

It's hard to tell whether this German car is coming at you or just leaving. The windshield-like rear window and large center tail light (above) look like the real front (right). A supercharged 40-horse engine gives a top speed better than 125 m.p.h. Note the four exhaust pipes and transparent roof. Designed by Rudolf Haller, a speedboat and airplane builder, the car cost \$5,000.

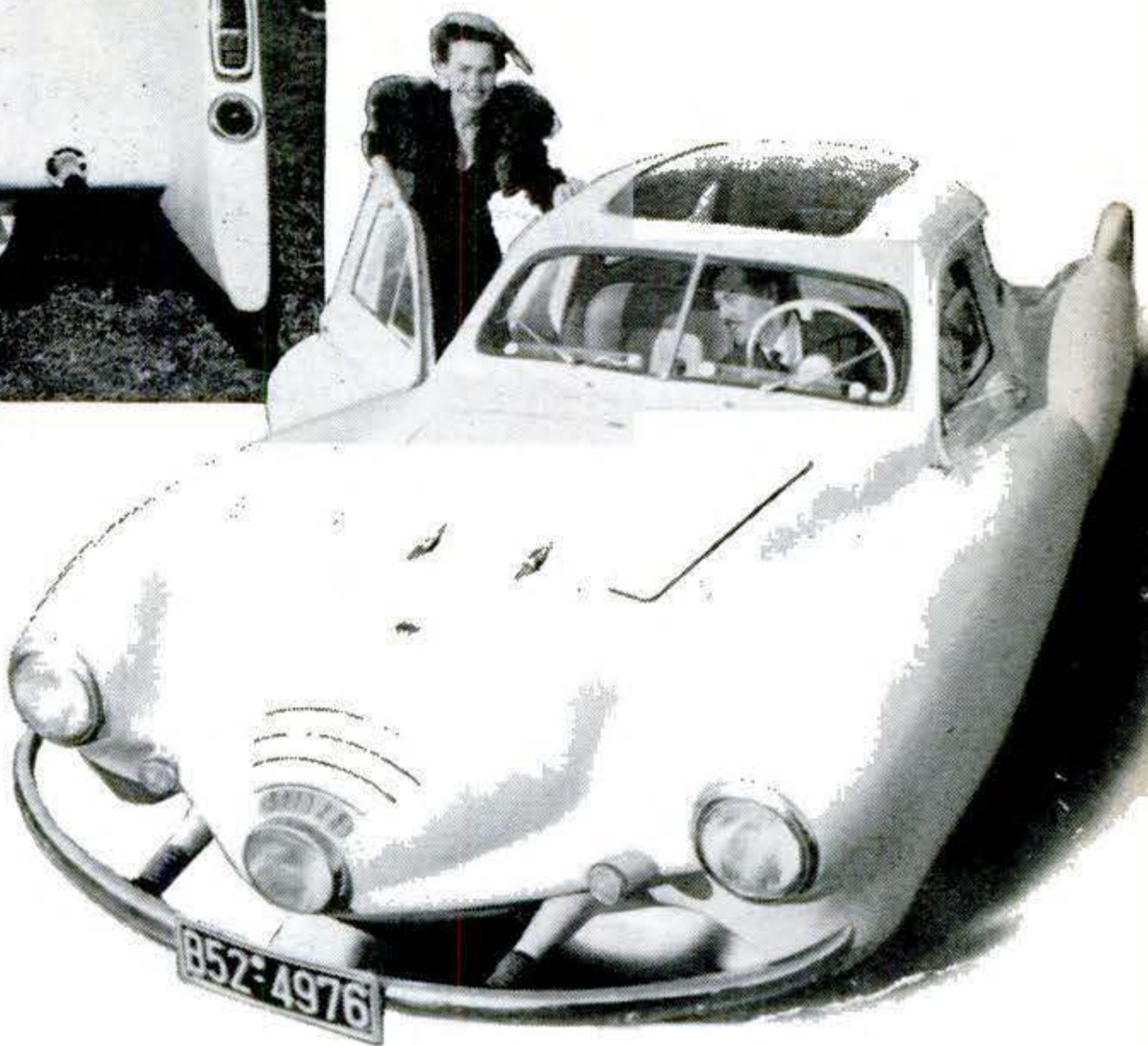

Track Officials Get Lift

AN ELECTRIC lift truck is speeding up pole-vault events at track meets. Officials riding the lift can quickly take measurements or replace the crossbar. Previously they had to use tall, rickety ladders and long forked poles. The truck is a standard Yale & Towne model like those used in industrial plants.



Cabana Folds for Travel

THIS plastic cabana can be folded into an underarm package when you leave the beach. Set up, six anchoring points in the inflatable base prevent tipping. A rustproof plastic slide fastener on the entrance flap can be worked from either inside or out. The Bilnor Corp., Maspeth, N.Y., makes the cabana.

Exit Pod Fired from Jet



FLIERS of tomorrow's supersonic planes will catapult to safety enclosed in armor plate like a seed in a pod. The Navy capsule below, developed by Goodyear, will protect them from the sledge-hammer blows of supersonic slipstreams and the 65-below cold of the stratosphere.

1 Pilot sits in armor-plated capsule during a flight, set for quick getaway.

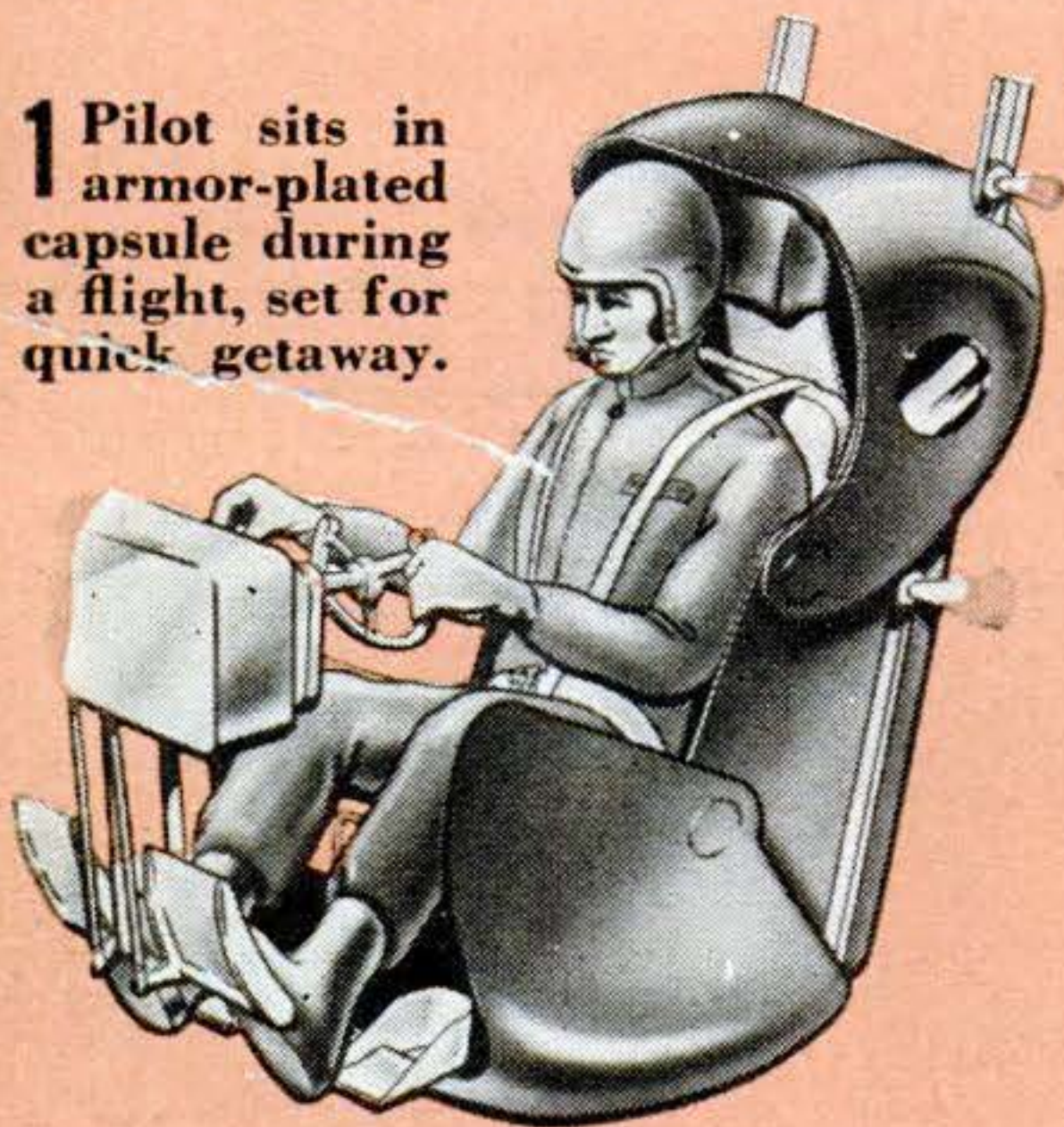

2 To catapult, flier places his feet on footrests, pulls pre-drop handle.

3 Seat retracts into capsule and is locked in place. Doors begin to close.

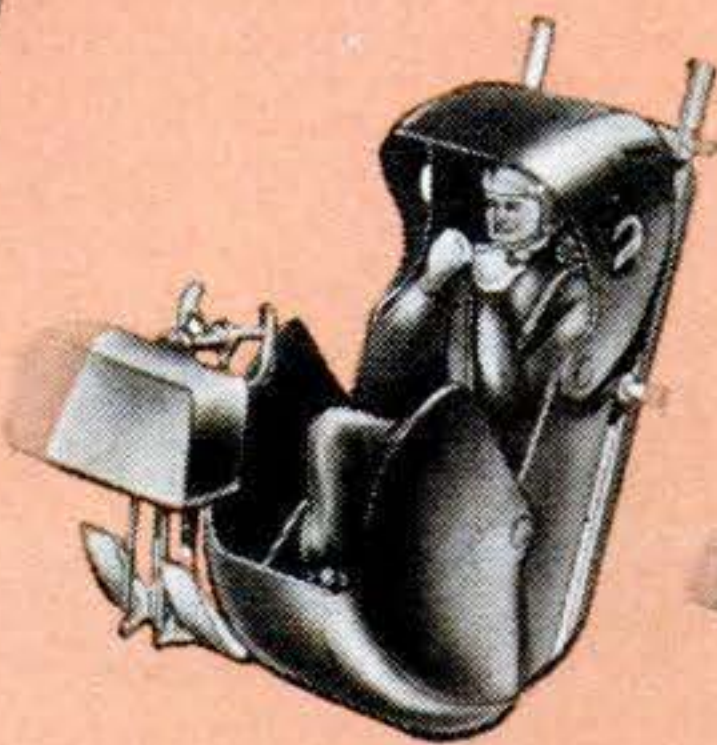

4 Doors lock, after closing clamshell fashion. Escape hatch is then jettisoned, arming the catapult.

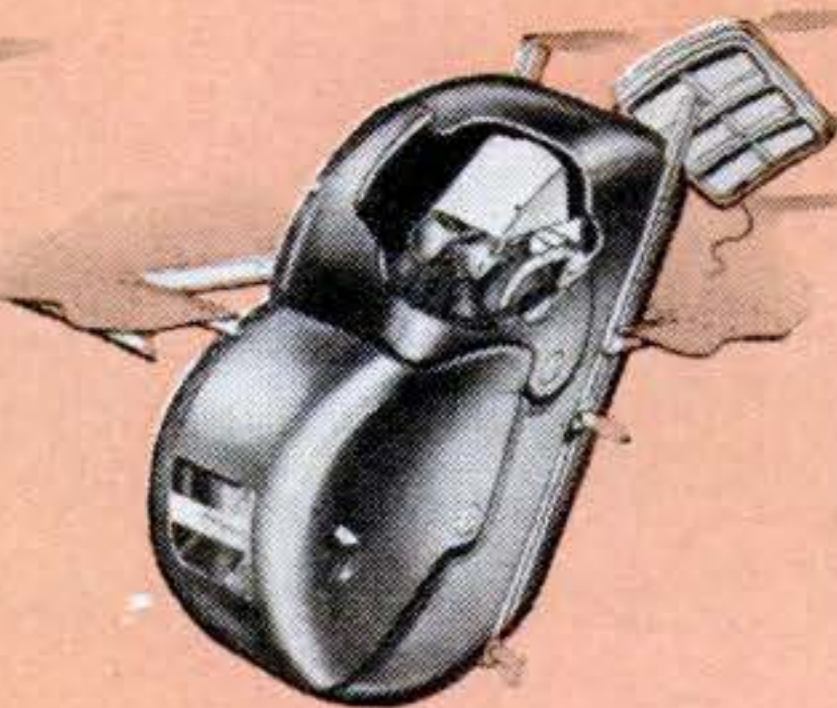
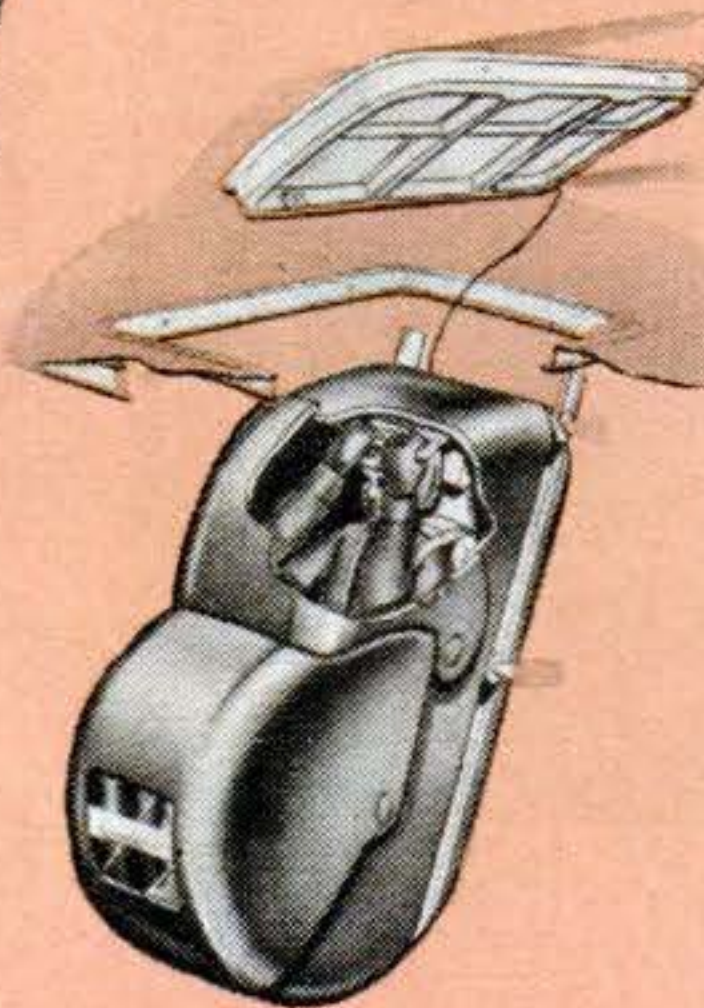

5 Catapult is fired as flier pulls head-retention curtain over his face. Unit is pressurized and contains oxygen equipment.

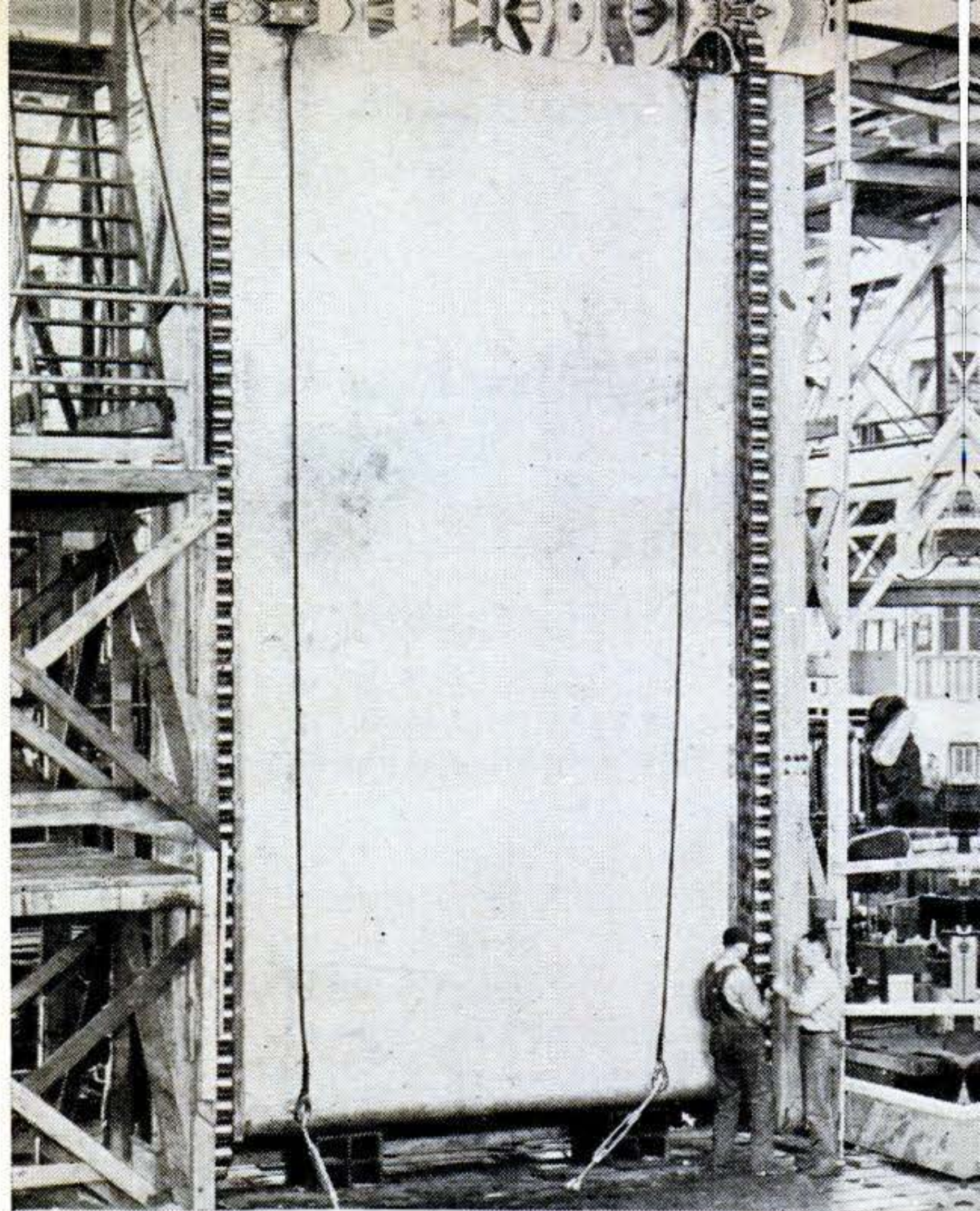

55-Ton Gate to Harness River

THIS huge intake gate will harness the rush of water at Garrison Dam on the Missouri River, 75 miles upstream from Bismarck, N. D. The 55-ton steel giant is 27 feet high, 14½ feet wide, 3½ feet thick. When the frame is embedded in the concrete face of the dam, a cable hoist will lift and lower the gate on stainless-steel bearings riding on a track. It is one of 10 gates being built by Westinghouse for the Army Engineers' Missouri River Basin project.



Truck Tests Rotors

THE rotor goes 'round and 'round, but what looks like a hybrid helicopter-truck above won't take off. It's just an old White truck fitted with special rigging to test parts and prove new designs for the Piasecki Helicopter Corp., Morton, Pa. The truck dates back to World War I days.

Toys Train Firemen

Toy engines squirting water on fires set in this miniature building teach firemen of West Hartford, Conn., the right and wrong ways of directing water on a blaze. A sprinkler system drawing water from a tank on the roof is also used. Smoke bombs teach ventilation methods.

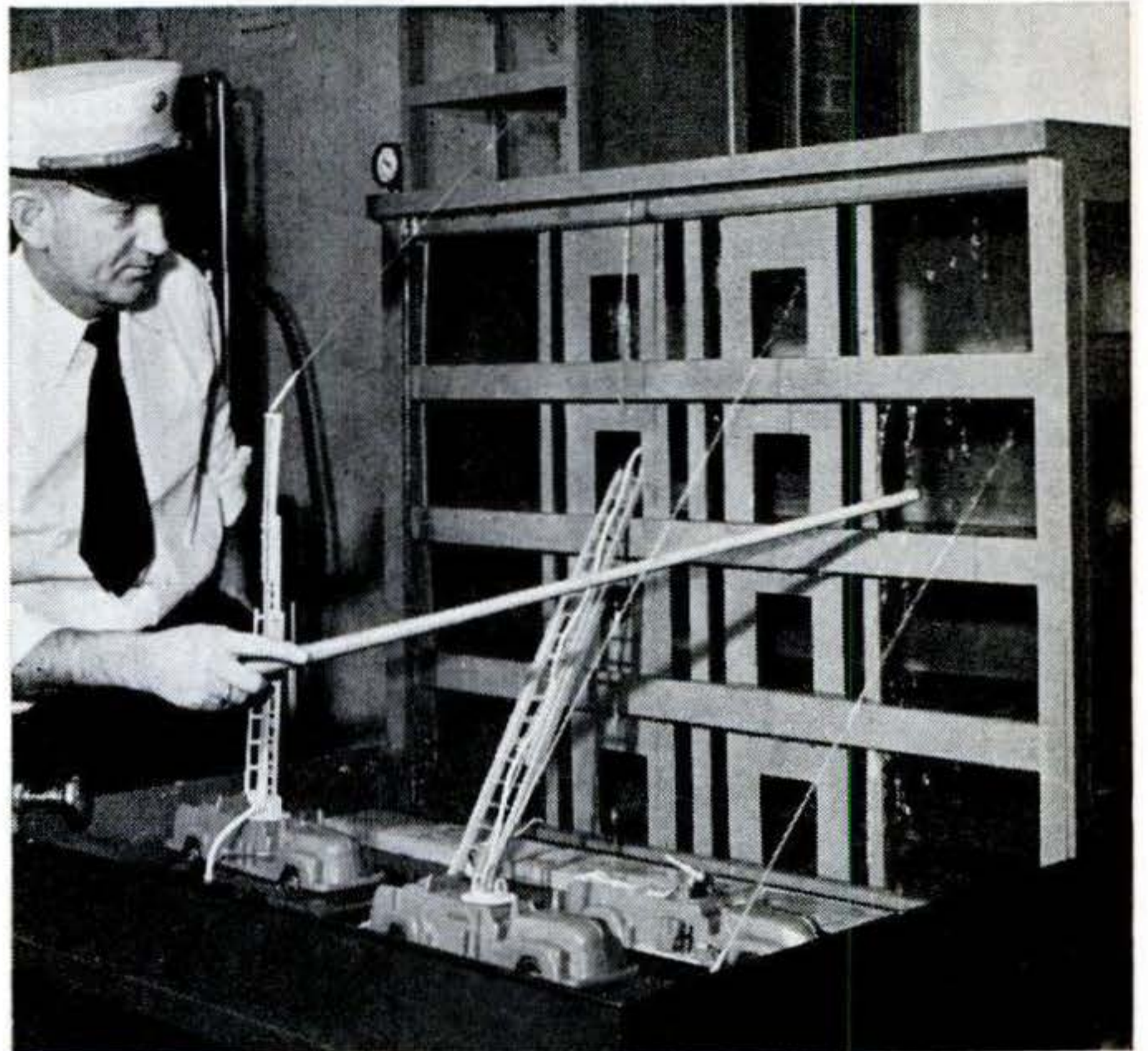

6 Zooming out into space, unit safely clears tail of plane. Fins stabilize pod, slow fall.

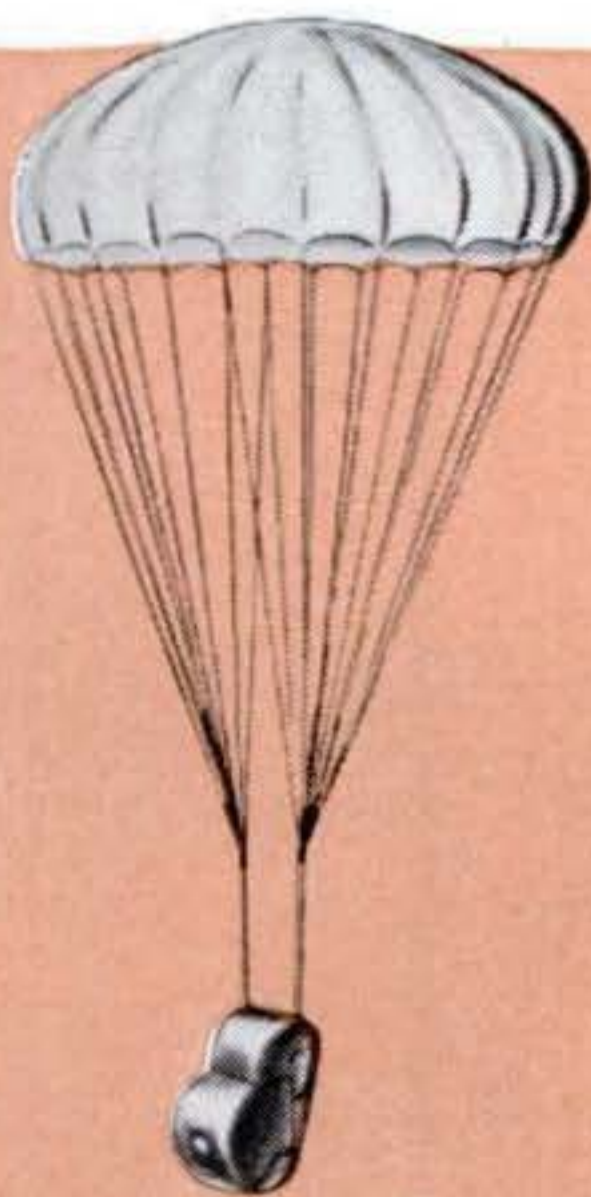

8 Capsule strikes ground—parachute is automatically released. Unit will float if it lands in the sea.



9 Flier jettisons doors and walks away, or remains inside until rescued. Heater warms men in Arctic.



7 Parachute, controlled by barometer, opens to cushion last part of descent.



How Belanger Builds

He has what it takes to keep his racing cars out in front—

BELANGER'S championship racing car, shown with skin off, is a purely functional machine. Its qualifying speed last year was 135 m.p.h.—which meant about 165 on the straightaways. Tires shown here are used only on dirt tracks.

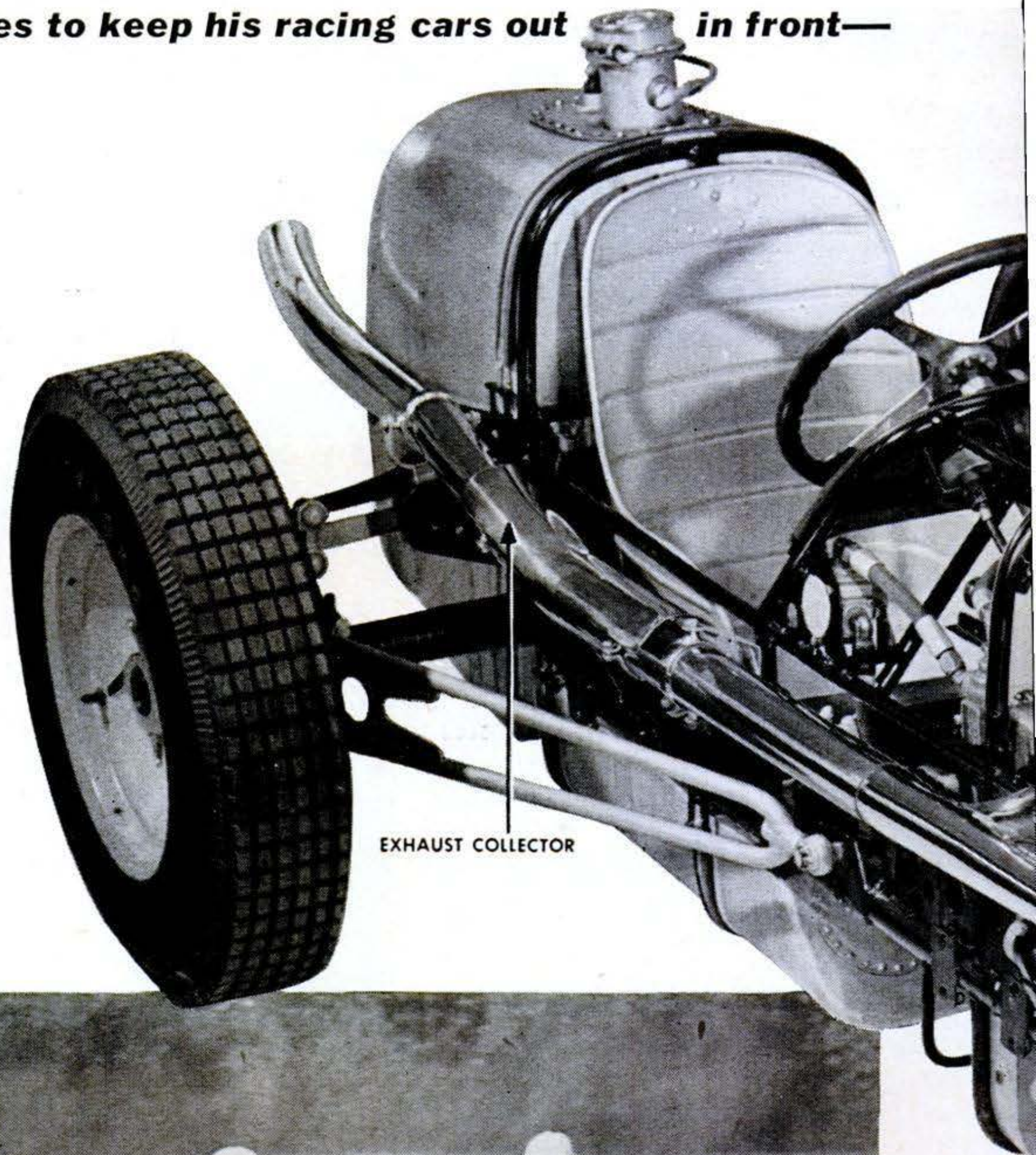

EXHAUST COLLECTOR

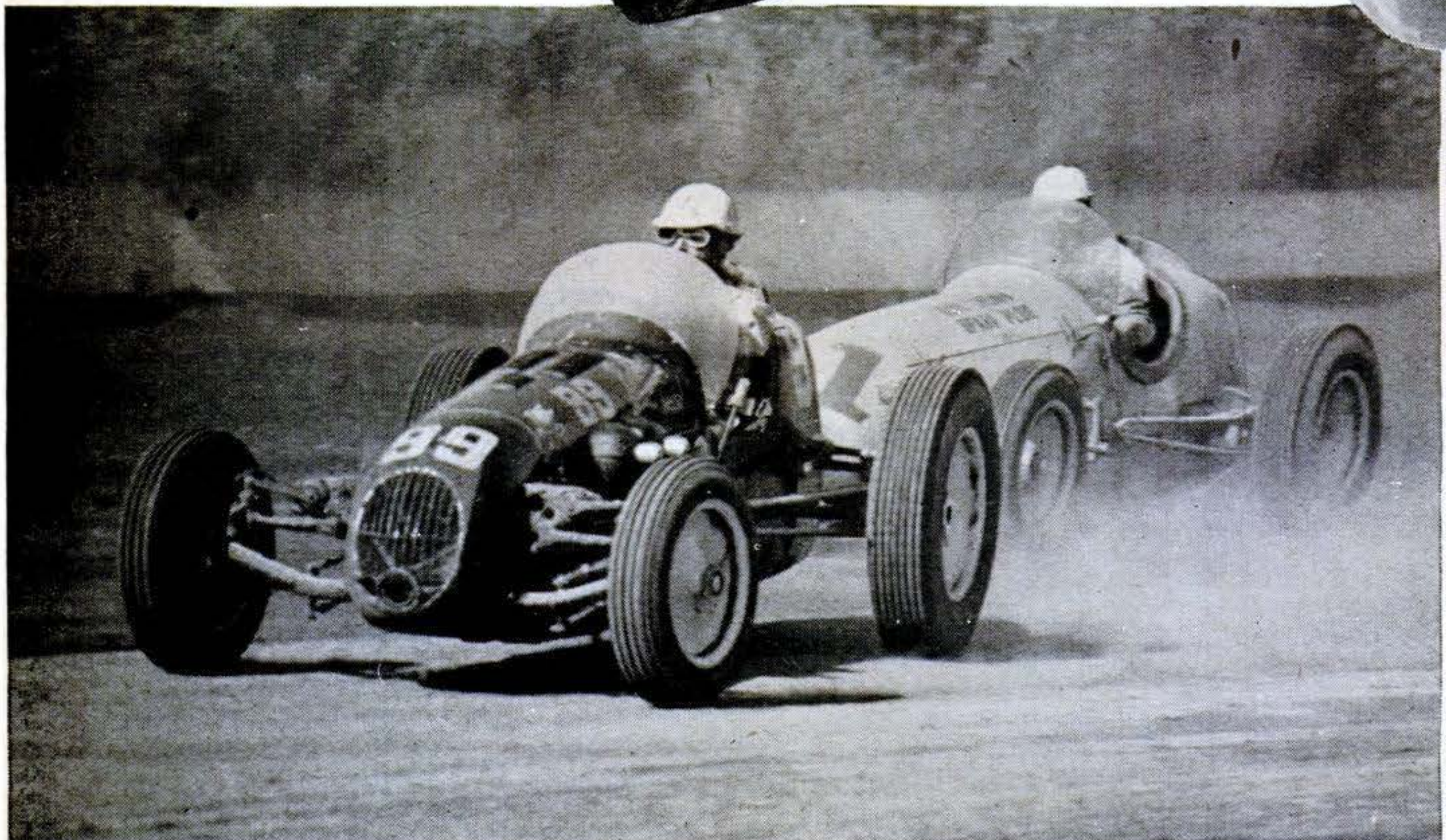

No. 99 rounding a turn on dirt last year. Front wheels are pointed in direction of skid.

Winners



money, yes, but mechanical genius, top drivers and the breaks, too.

By Devon Francis

ONE day last summer Tony Bettenhausen, racing driver, shoehorned himself into the cockpit of a tiny mount at Langhorne, Pa., and fired up his engine for 100 circuits of a one-mile dirt track. Then he wagged an admonitory finger at his pit crew.

"Don't let me be more than 23 seconds behind at the 75th lap," he ordered.

Other drivers, tense at their wheels, crept up and passed him. But Bettenhausen, past master of all the tricks of his trade, took it easy, tailing the field for most of the race.

As he flashed by on the 75th lap his pit crew held up a blackboard with "L75" chalked on it. Below was "23" with an arrow pointing down the track.

Bettenhausen straightened up and hit the accelerator. For the next 25 laps he improved his time exactly one second a lap. That was enough to beat the man who had been leading

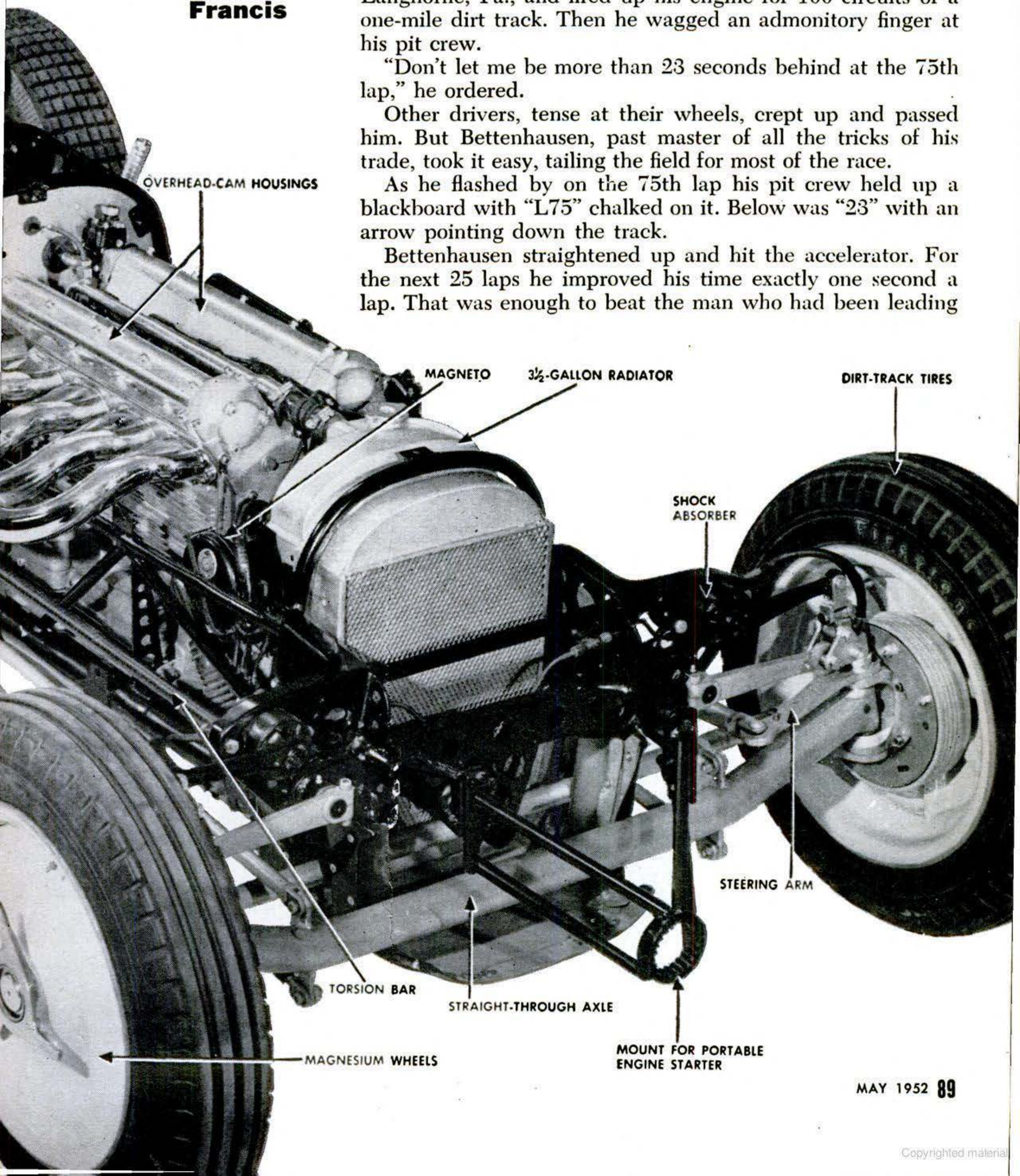

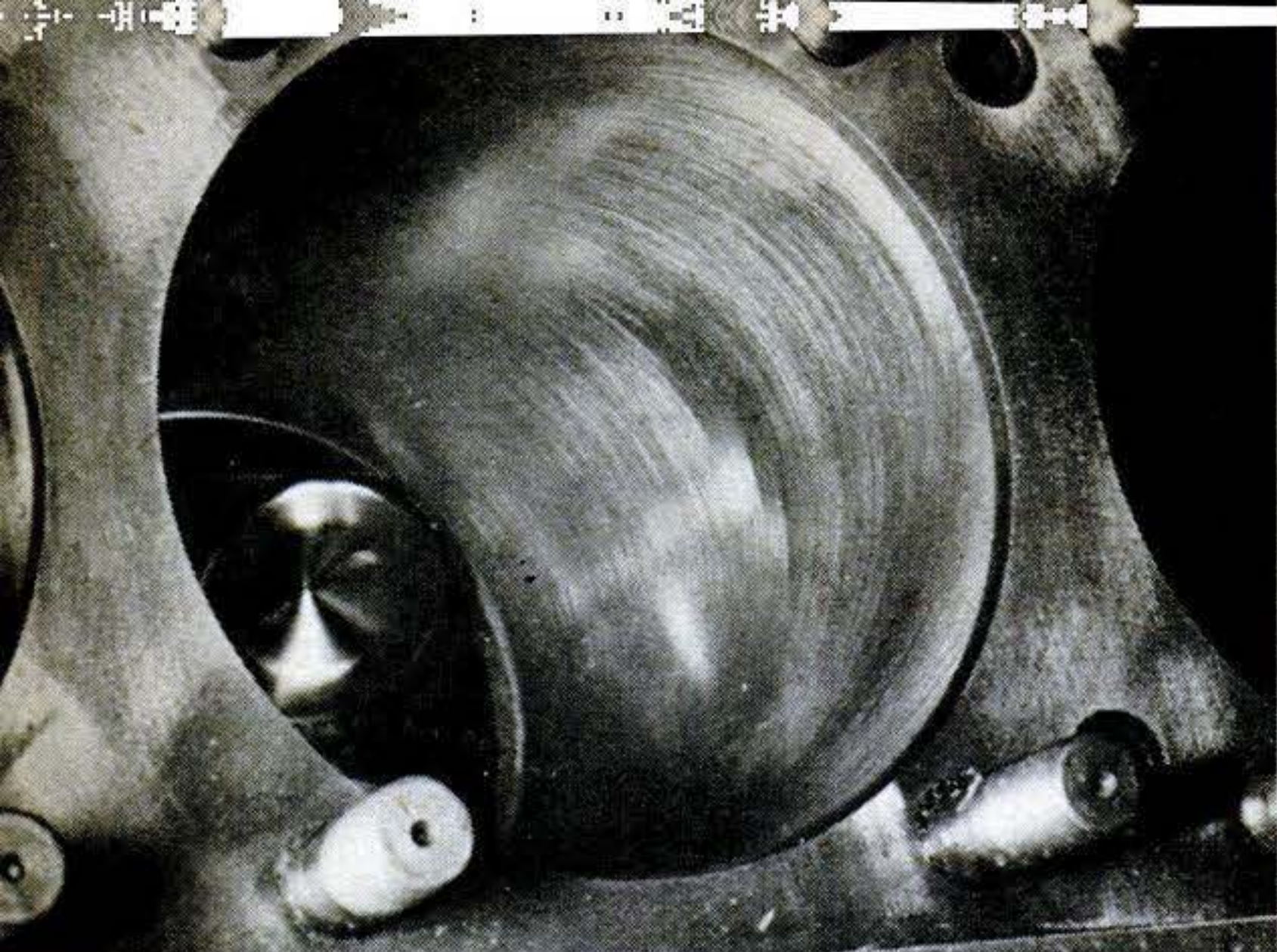

CYLINDERS are deliberately scratched. This is bottom of car No. 1's block. Unlike conventional cars, racing-car cylinder heads are not removable. Bore is 4 5/16 inches, stroke 4 1/2.

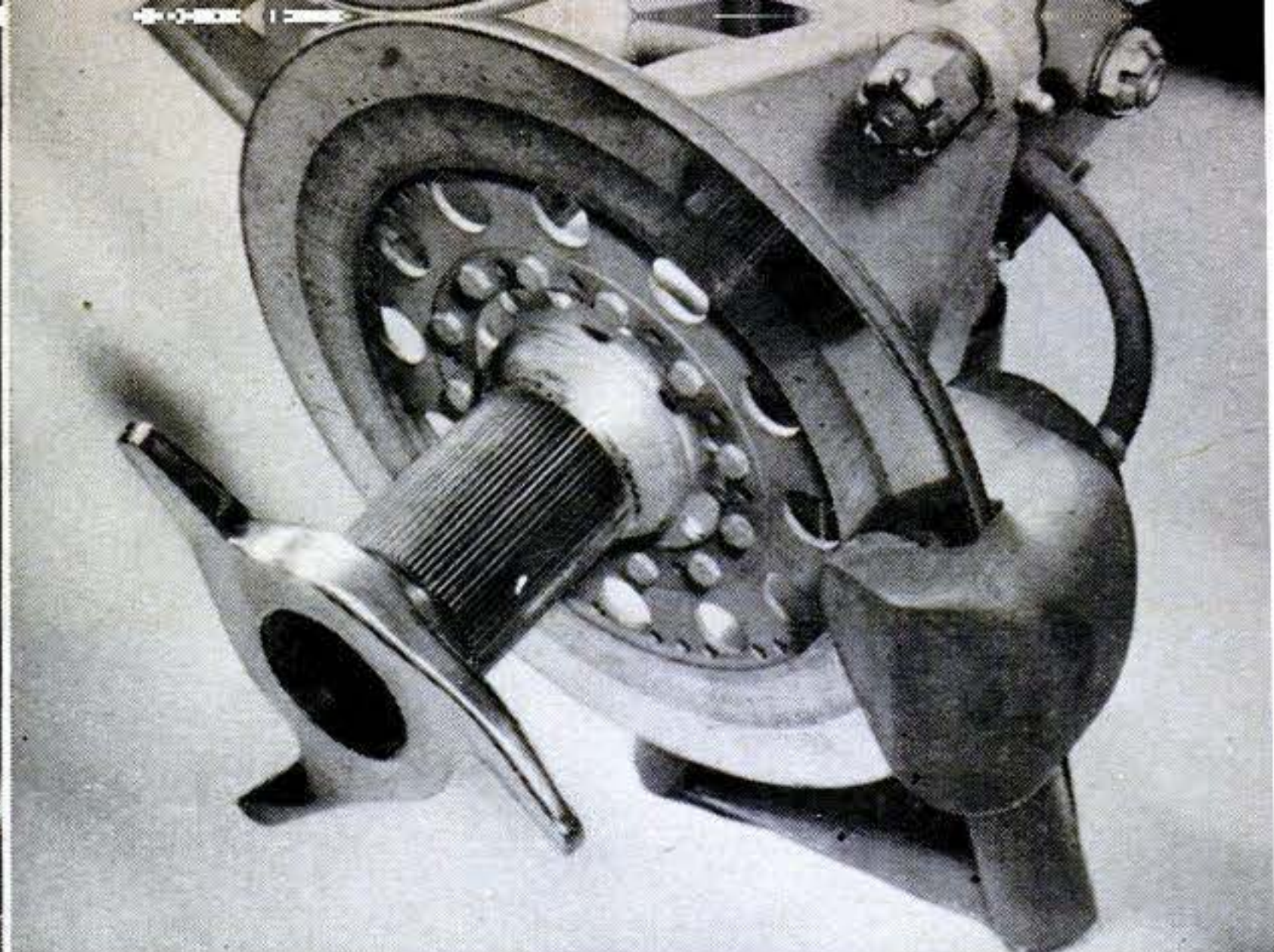

SPOT BRAKES consist of two hydraulic pinchers with linings of two-inch pads that clamp down on iron disk. Brakes are hand-operated. Cockpit has no room for foot brake.

the race—by a comfortable two seconds.

Bettenhausen had confidence in his car—because it was from the most successful stable of racing cars in the United States. This stable, in the drowsy little town of Lowell, Ind., is to professional gasoline racing what Kentucky's Calumet Farms is to horse racing.

Husky, handsome Murrell Belanger, its owner, has spent \$400,000 in the last 10 years on four mechanical blue bloods. His newest car, just arrived, bore a price tag of \$30,000. What Bettenhausen's mount, No. 99, is worth is problematical. Belanger has turned down \$60,000 for it.

No. 99 is the stable's star performer. It won the Memorial Day 500-mile race in Indianapolis last year. Then it carried Bettenhausen to the American Automobile Association national championship on dirt tracks speckled here and there across the country from Langhorne to San Jose, Calif.

With any kind of a fair break, Belanger believes that No. 99 will win again at Indianapolis this month. His newest car, No. 1,

FUEL TANK'S three-inch filler neck, with quick-lock secondary cover, takes 50-odd gallons in 45 seconds. This opening is on left side to avoid spillage on exhaust pipe.



is almost a duplicate of 99. It too has been entered in the 500. One of his other cars, No. 18, holds the world's record for 100 miles on a one-mile dirt track—an average speed of 95.5 miles an hour. And his fourth car, No. 34, holds the world's record for one lap of a mile dirt track, 106.38 miles per hour.

To the unpracticed eye, 99 looks like most other racing cars. It has a Meyer-and-Drake four-cylinder engine, made in Los Angeles, like most of the other cars which compete annually for the AAA championship.

It has a tubular-steel frame and, like the others, a stiff front axle, a one-piece rear axle without a differential, and a three-speed transmission. Its weight is suspended on torsion bars, which is customary, and its brakes are the disk type mounted inboard of the wheel anchorage, which is nothing unusual. Like other racing cars, it has no fan to cool the engine. At track speeds, a fan is superfluous.

Something Extra Added

But the similarities between 99 and competitive cars, like the similarities among horses, are superficial. It has something extra that makes it a championship mount.

It is smaller and lighter than most other racing cars. It weighs less than 1,600 pounds "dry"—without oil, fuel and water. That's half the weight of a Ford, Chevrolet or Plymouth. It's squattier. Its center of gravity is four to five inches lower than ordinary because of the unusual height of the suspension—18 inches in front, 20 in the rear. This is one reason that, while 99 has an unusually narrow tread and has been in four bad

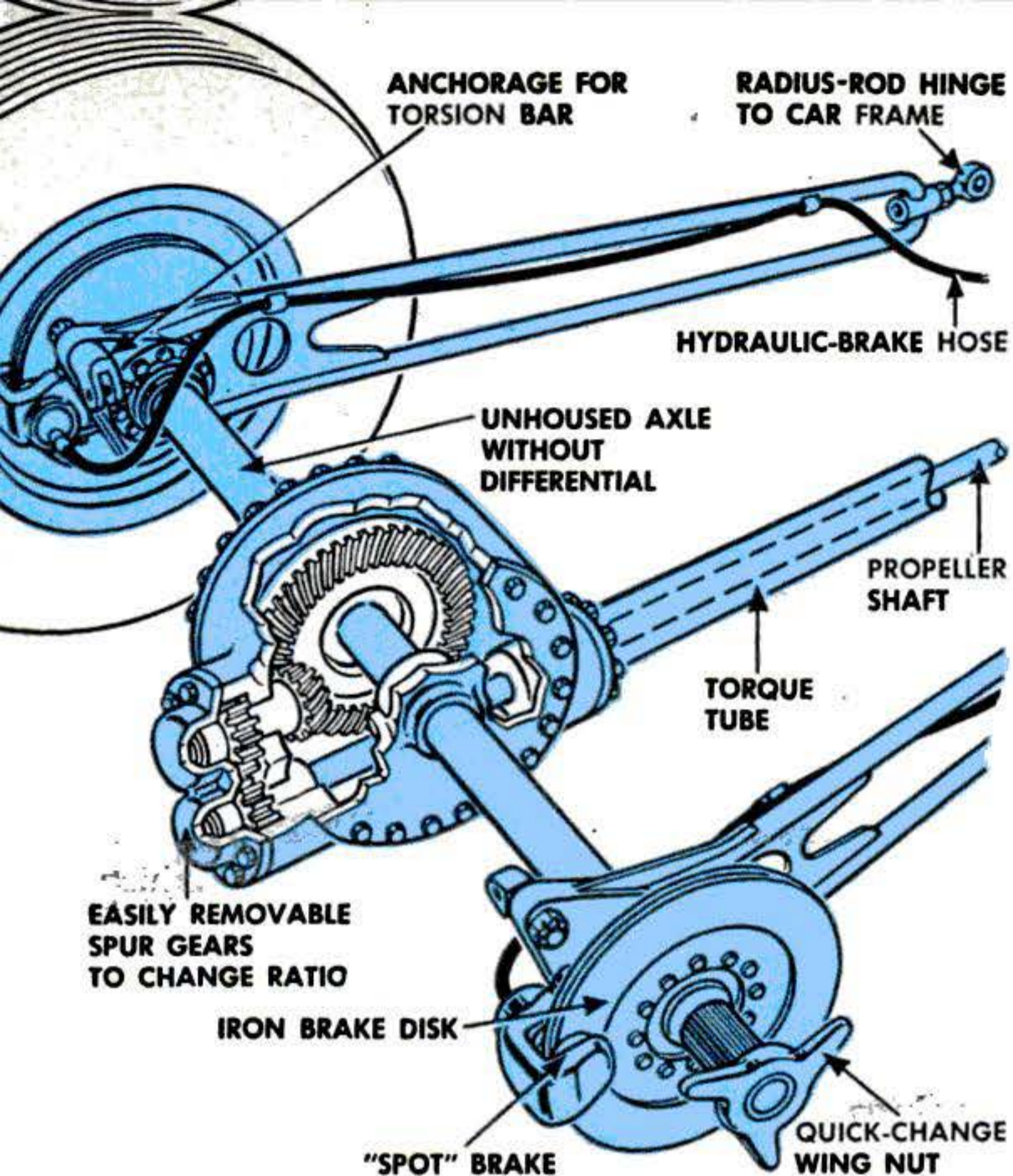

TWENTY DIFFERENT GEAR RATIOS can be mounted on rear axle, which has no differential. To fit track conditions, two spur gears allow variations from 6.41 to 1 up to 3.17 to 1. Two men can make gear change in 15 minutes.

Indianapolis Speedway). For comparison, the Cadillac, the most powerful production passenger car today, develops 190 horsepower.

The exhaust pipe of 99 has a particular diameter and length. Just what they are is strictly Belanger's business. The stable arrived at the dimensions by cut-and-try methods. Diameter and length affect horsepower output.

To own a championship gasoline-racing stable like Belanger's you need an exquisite knowledge of mechanics, a good deal of shrewdness, the breaks of the game, and money. A barrel-chested man of French descent, Belanger has these requisites.

Special Fuel Mixture Used

Last year they all added up to hit the jackpot. Before the 500-mile race on the 2½-mile Indianapolis track, Belanger ran exhaustive fuel-consumption tests on 99. With the mixture determined upon, he figured he would put Lee Wallard, his driver, or "chauffeur," well out in front for a safe lead during the first 200 miles by giving him a light fuel tank—just 30 gallons to start. The car holds 54.

Wallard was instructed to make just one stop, at 200 miles to refuel. With gas consumption of eight miles to the gallon at a speed of 130 miles an hour, he would have a cushion of 16½ gallons for the remaining 300 miles when he filled up at his stop.

But things went haywire. Instead of 130

crack-ups in its four seasons of racing, it has never been on its back.

"This car," remarks Bettenhausen, "is peculiar. You can't gain time with it by coming out of the chute (the straightaway) fast and throwing it sideways in a corner. You have to drive it differently."

No. 99 has a smaller engine than most racing cars, displacing only 262.9 cubic inches. That's a measurement of its cylinder size. It develops 340 horsepower at a 14-to-1 compression ratio with alcohol (used on dirt because it burns cool when crud from the track plugs up the radiator), and 310 horsepower at a ratio of 11.5 to 1 using Belanger's particular gasoline-alcohol mixture (used on the bricks and asphalt of the

MAIN TANK, with baffles to prevent sloshing, holds 48 gallons, feeder tank six. Floatless carburetors have fixed fuel levels to prevent engine starvation in hard maneuvering.

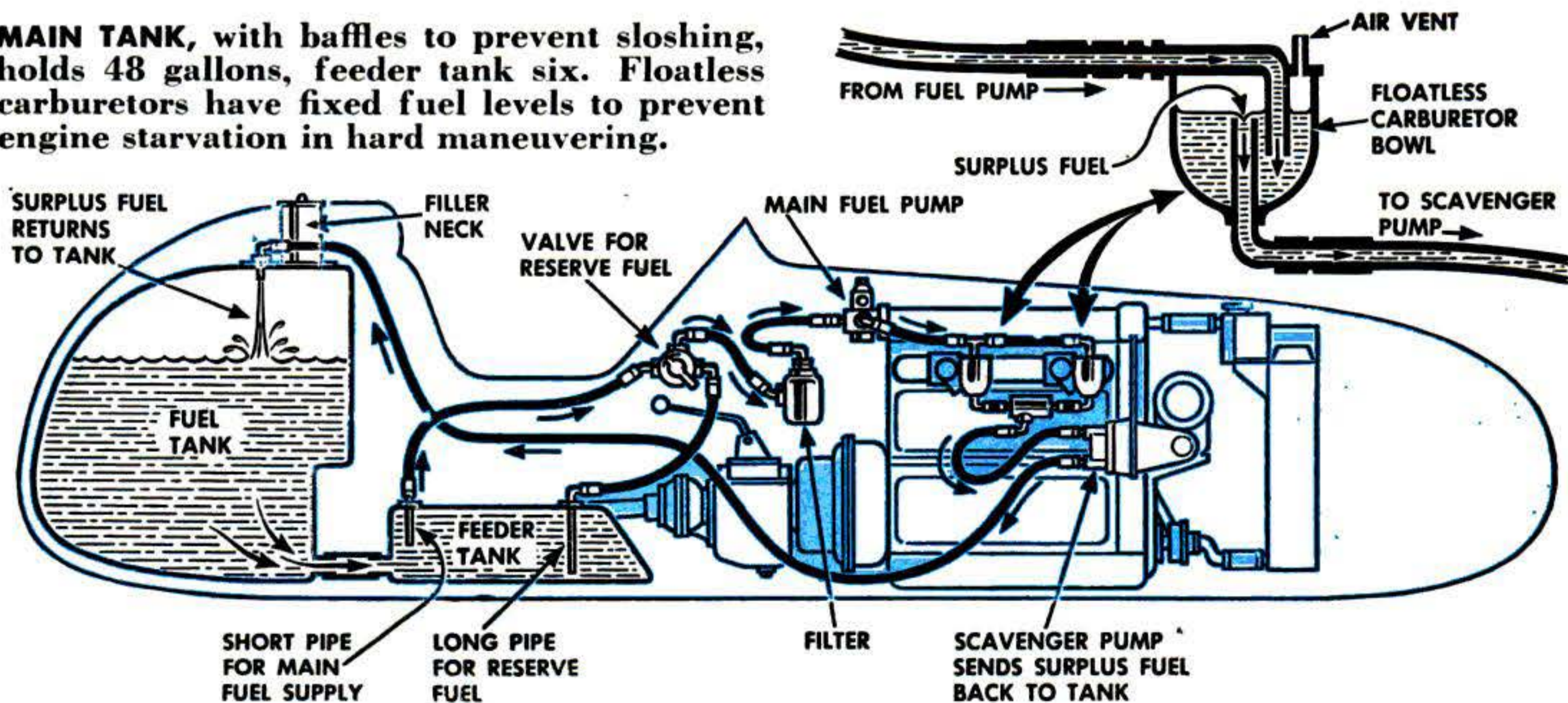

m.p.h., Wallard drove many laps better than 133. That, Belanger was sure, was going to throw his calculations off. Then, at the 125-mile mark, the blow came. Wallard braked to a stop in the Belanger pit. Two of his tires were going. Belanger groaned.

A quick check of the tank, however, showed that consumption still was only a gallon every eight miles. Mathematically, Wallard could still complete the race without another costly pit stop. As the driver, refueled and re-tired in 75 seconds, threw his car into gear, Belanger slapped him on the back.

A Winner After 17 Tries

"You've got 375 miles to go and 422 miles of gas," he said over the roar of the cars.

"See you in the bull pen, boss," the chauffeur called back, using a driver's term for the fenced-in victor's circle.

He did. But Belanger was not exactly surprised. He figured from the start that he held the cards—even though he had been unsuccessful in trying to win this race for 17 years.

Merchant and sportsman, Belanger has his own way of doing things. Up to an hour before a race, there's not a drop of fuel put in the tanks of his cars. If he runs up his

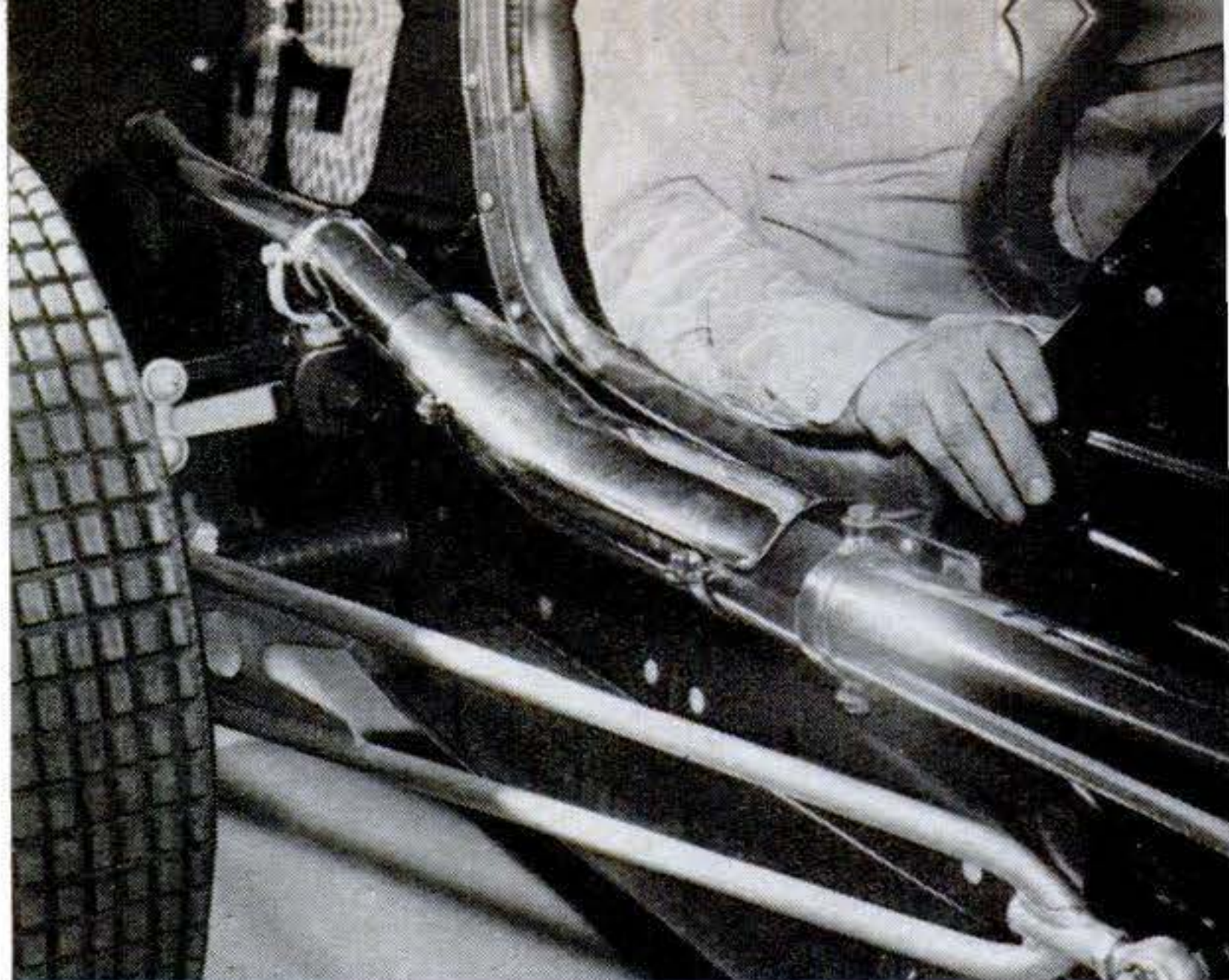

SLEEVE over big exhaust pipe keeps driver from accidentally burning hand. Tread of both No. 99 and No. 1 is 52 inches. Steering ratio is 8 to 1 on dirt, 12 to 1 on asphalt.

engines, he draws fuel from milk cans piped to the carburetors. He says alcohol, one of the fuels used in racing, congeals and dirties his filter screens.

After a race he siphons off every drop of fuel left in the tanks. The nearest his crew ever came to getting fired outright was after a race last year when they failed to empty the tanks.

Belanger has his eye on everything.

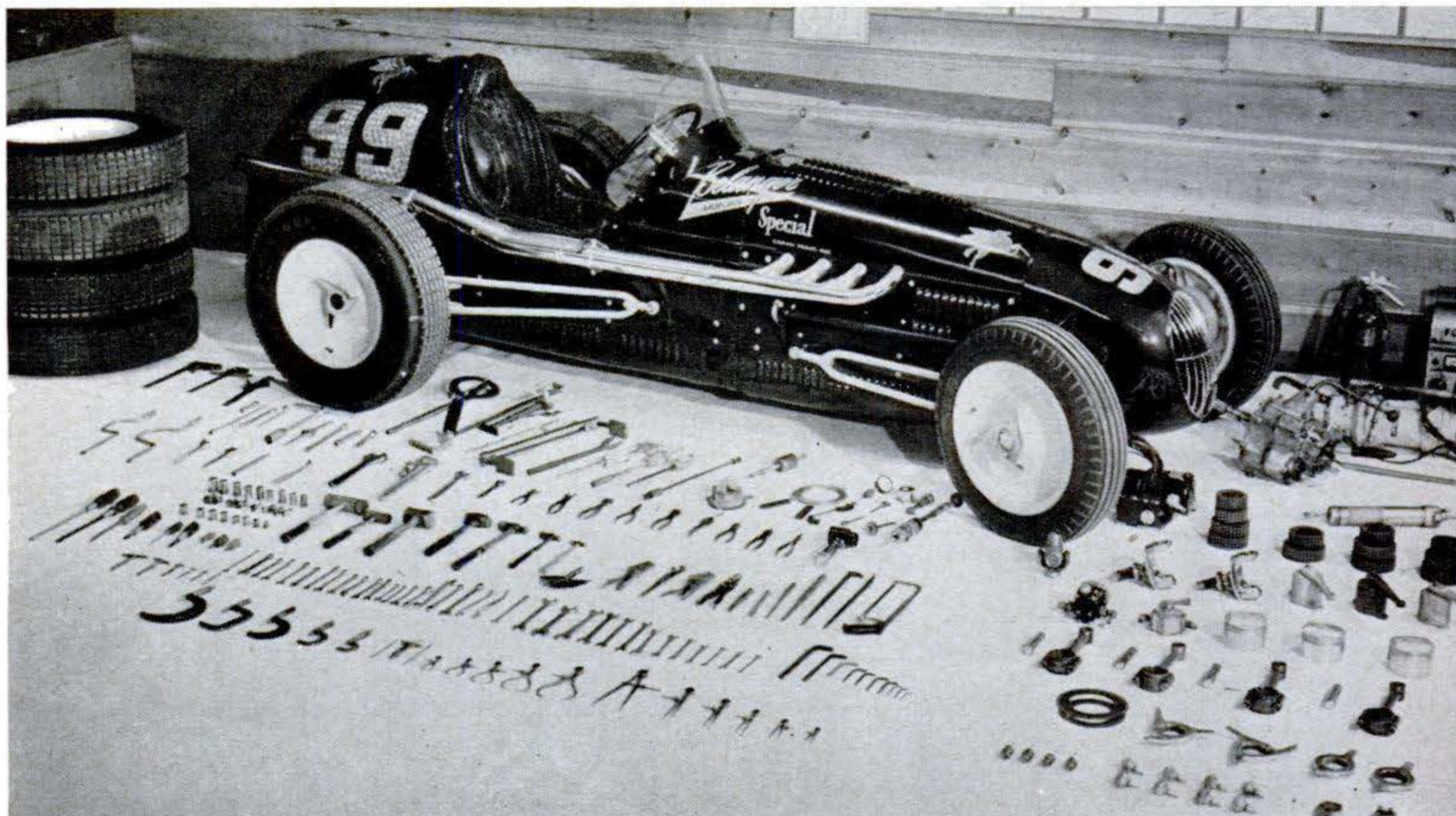

THESE TOOLS AND PARTS, plus others not shown, accompany a Belanger car to every meet. Tools include bearing pullers, ring filers and expanders, removers for valve springs

and guides, battery charger, weighing scales, electric cranks. Spare parts include tires, rear-axle gears, magnetos, pistons, spindle arms, clutch plates, universal joints.

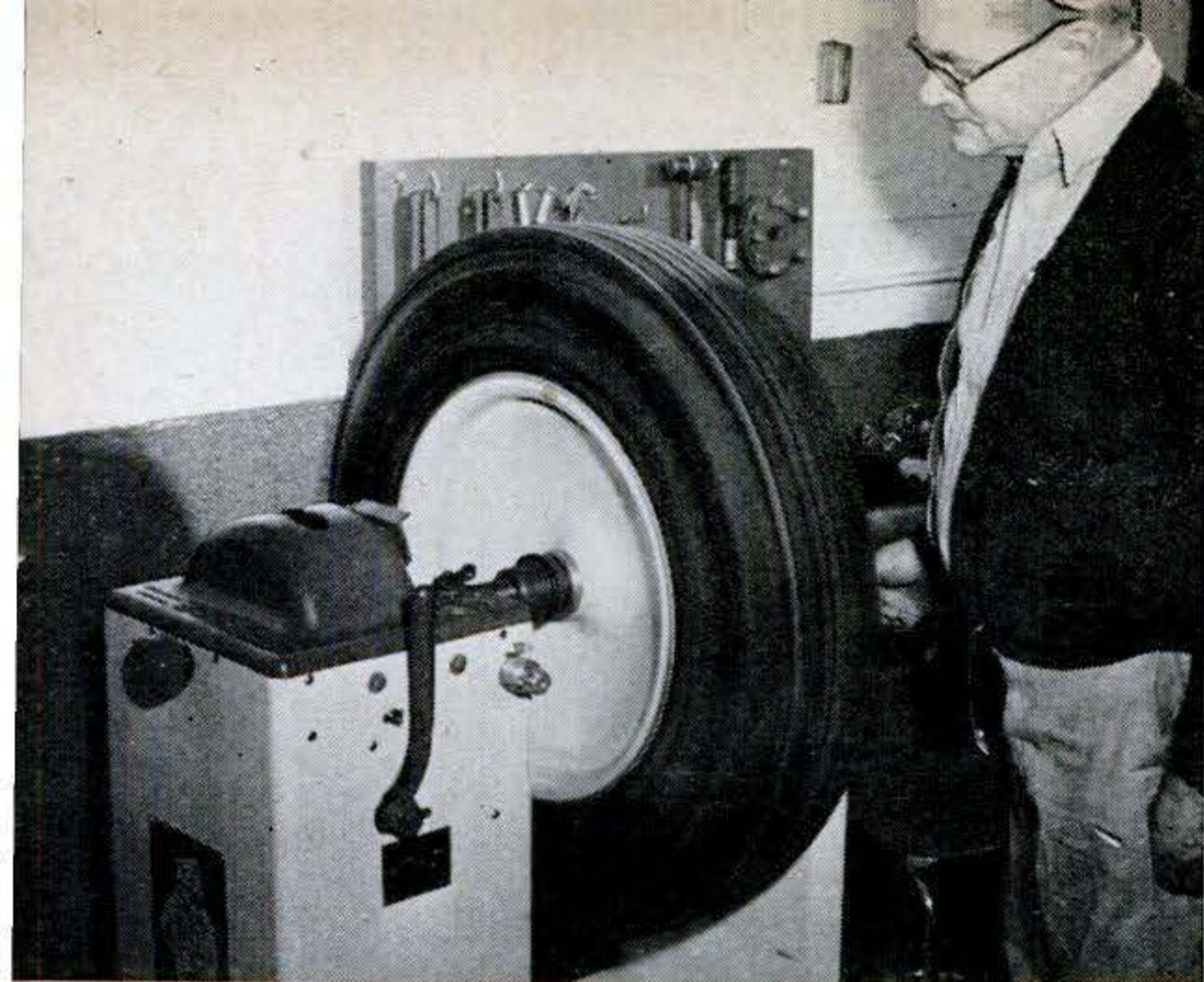

BUSS BROWNELL balances wheel in Belanger shop. Championship car's rear wheels are 30 inches in diameter, with 7.00 by 16 tires; front wheels, 26 inches with 5.00 by 16 tires.

"Remember your extra weight in the corners," he will say to a driver at a fuel stop. All racing cars skid the turns—the "corners"—but they skid differently after a refueling because the rear wheels are carrying more. Sometimes a chauffeur momentarily forgets.

Belanger lets his drivers look at the fuel pressure, oil pressure and temperature gauges on their instrument panels when they are "cutting one" around the track for

practice. But before a major race he disconnects all the dials. A faulty instrument reading might worry them. He wants them to concentrate on winning.

Most of the between-seasons work on 99 and its sister cars is done at Lowell in a shop that is a mechanic's paradise. It is on the second floor of its owner's farm-equipment store, and a special elevator hauls the cars up and down. One side of the shop is paneled in knotty pine.

Stable a Community Project

Like a small-town baseball team, the stable is a sort of community project. Arrive in Lowell to see Belanger, and within an hour the barber, chief of police and local agent for the Monon railroad know your name and business connection. Earl "Frenchy" Sirois, a competitor of Belanger in the farm-equipment business, will get wind of you, too, because he's one of Belanger's mechanics during the racing season. Lowell's fire chief for the last 16 years, Harold "Buss" Brownell, most certainly will know about you because he's also a Belanger mechanic.

The traffic of Lowell citizens through the Belanger shop starts the day after the racing season closes. That's when the active mounts in the stable are torn down and rebuilt. The

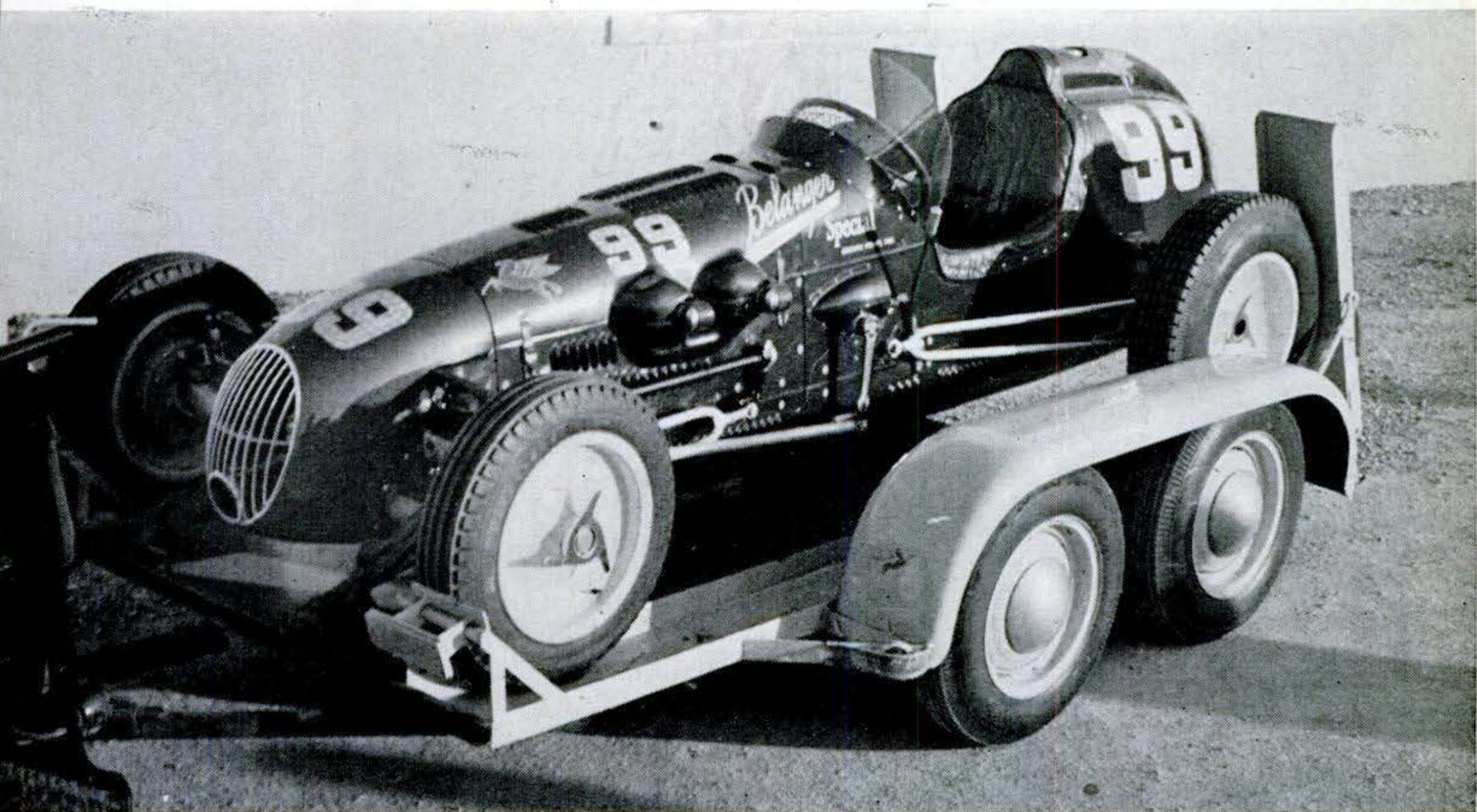

STABLE'S CARS are hauled to races on special trailer. Body and wheel locks prevent movement. Its cargo, No. 99, has a wheelbase of 99 inches, over-all length of 153. Height to top

of headrest is 42 inches. Steering wheel is one piece of chrome-moly steel with rubber cover. Belanger estimates his prize money from 10 years' racing at \$200,000—half his outlay.

1951 season ended on November 11. By December 23, No. 99 had been taken apart and put together again.

When the crew got through, half the car's parts were new. But you couldn't tell them from the used parts. All were spotless and shiny. That's the Belanger touch.

So is the sign on the outside of the shop's

big sliding door. It reads: "Stop—Please Wipe Feet On Mat." You'd better, too.

Belanger has three expert mechanics on his payroll the year 'round. One, Buss Brownell, studied mechanical engineering at Purdue.

"No use looking for a chair," Buss will

[Continued on page 226]

New Diesel Entered at Indianapolis

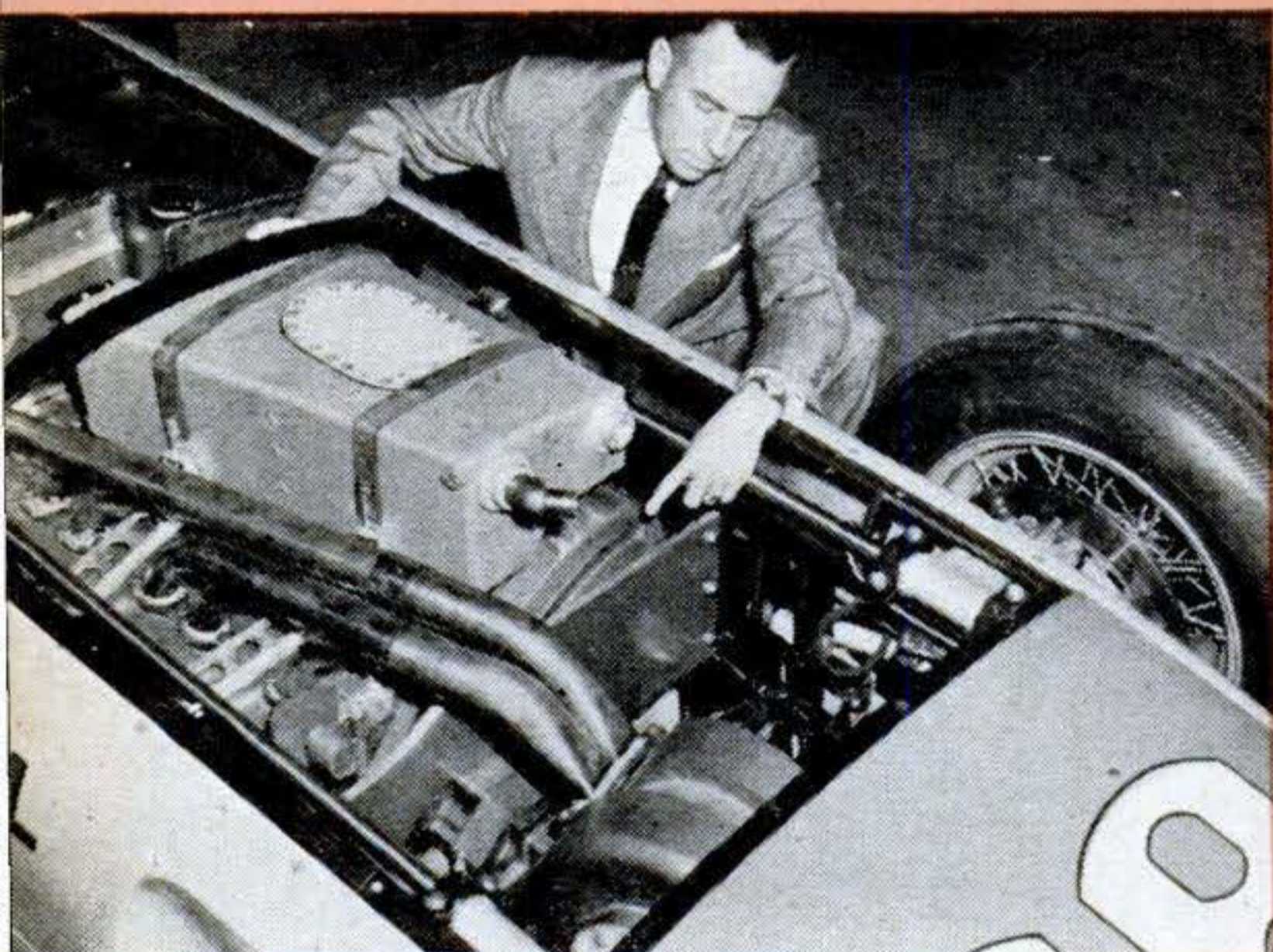
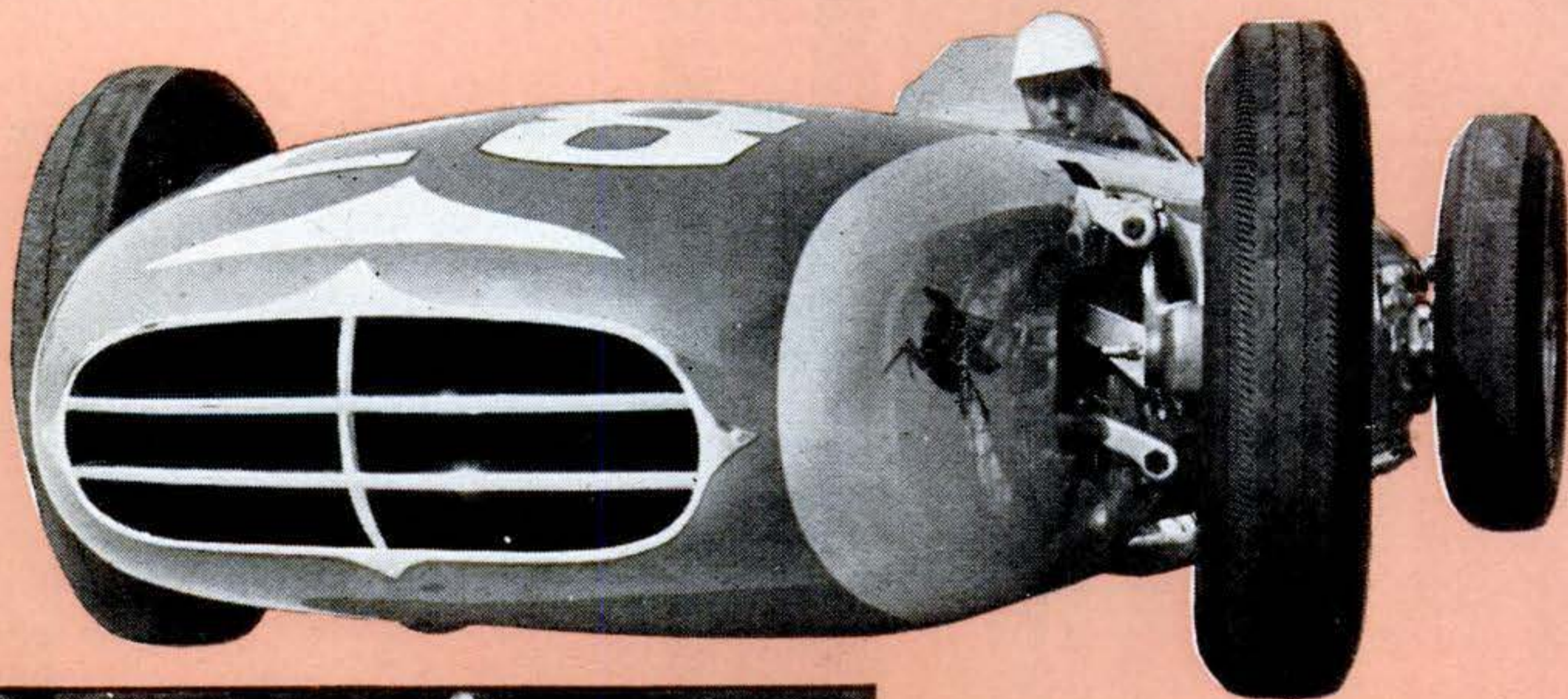

FOUR-CYCLE ENGINE, with two intake, two exhaust valves for each of six cylinders, develops 345 horsepower. It weighs 800 pounds—300 more than a four-cylinder gasoline racing engine, but 700 pounds less than a standard Diesel of like horsepower.

DIESEL RACING CAR is only 29 inches high at cowl, several inches lower than usual. This is third car produced by Cummins Engine Co.,

A DIESEL-DRIVEN car, with its drive shaft running down the left side, will be seen this year on the Indianapolis Motor Speedway. It is the newest version of the ignitionless Cummins race car.

The engine, which burns standard Diesel fuel, is "pancaked"—it lies on its side and the pistons work horizontally. Because of the position of the drive shaft, the driver sits in a well on the right side of the car.

The Cummins is several hundred pounds heavier on the left side than on the right. Since races are run counterclockwise, the right side is on the outside of the turns. The Cummins' odd weight distribution is supposed to equalize the pressures on the tires—imposed by centrifugal force—in the turns and make them wear evenly. Racing cars normally wear out their right tires faster.

Columbus, Ind., to be entered in 500-mile race on competitive basis. Last year's entry qualified at 135 miles an hour.



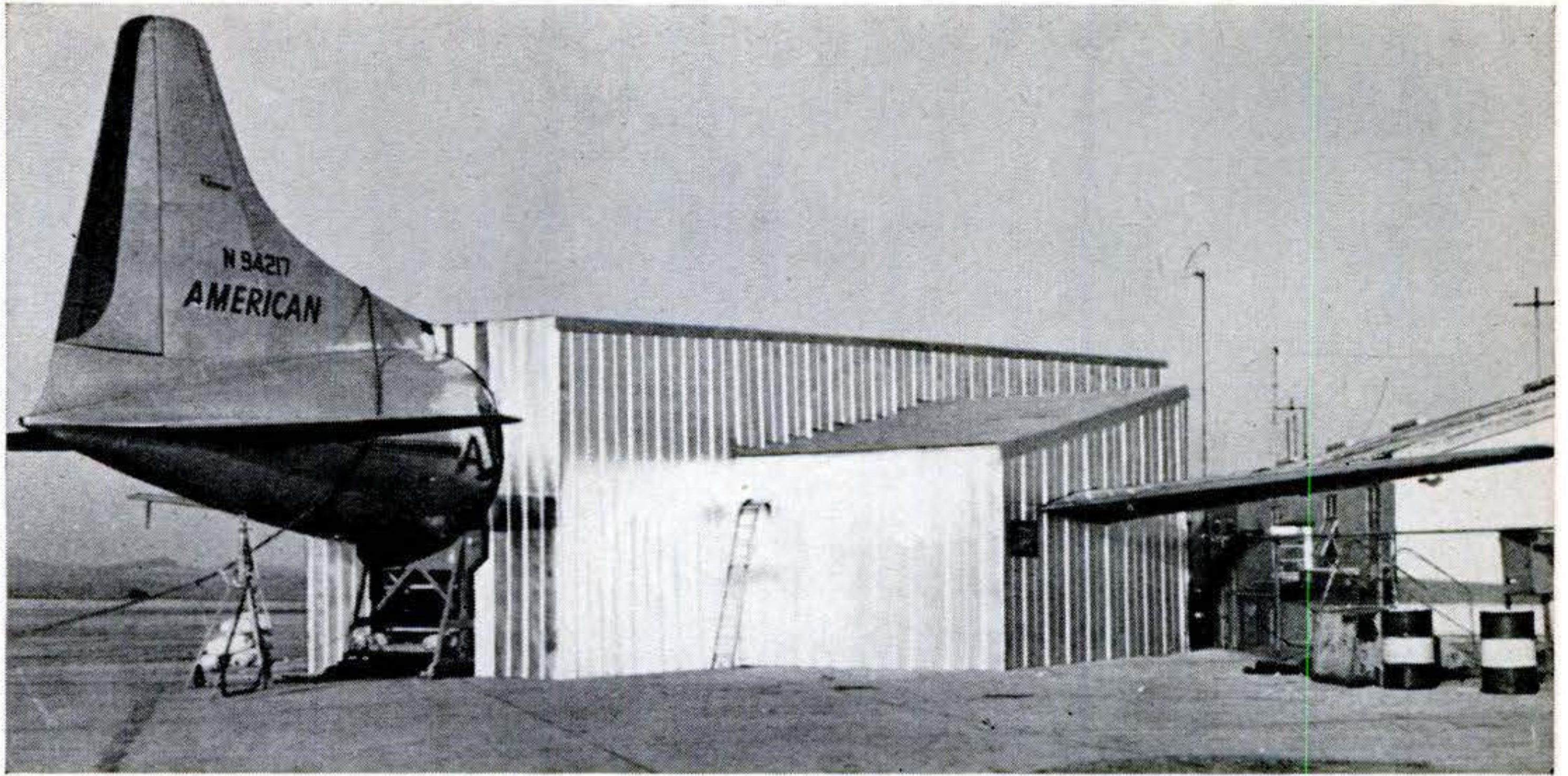

It Has Wings, But Can't Fly

WHAT looks like a flying garage in the photograph above was the answer to a repair problem worked out by an American Airlines maintenance crew. The aluminum

structure was built around the plane to permit repair work in midwinter at an airport that had no hangar facilities. The Convair suffered damage to its nose gear during a landing at Charleston, W. Va.

Tire Grippers Brake Truck

"ATTENTION! Emergency Brake. Stops in 5 meters." So reads the sign on the German truck at right—a warning that its newly developed friction brakes will stop a heavy truck, going 30 miles an hour, in a little more than five yards. Braking, according to the Frankfurt inventor, is accomplished by four curved metal shoes slamming against the rear tires. They are hydraulically operated by the driver.

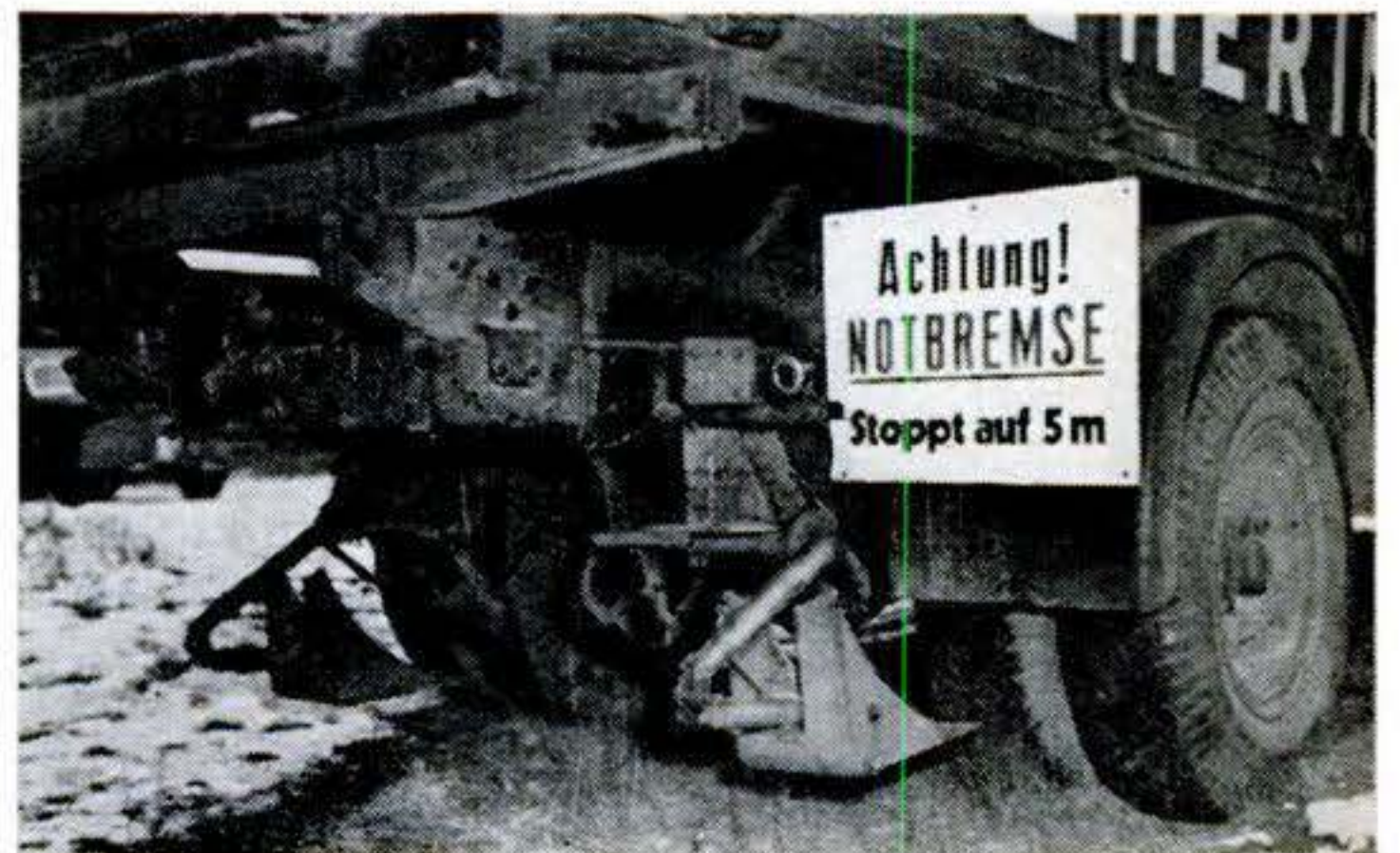

Supersonic "Wind" Cuts Its Way Through Samples of Metal



A "CUTTING WIND" in the microtome at left really slices thin. Used to produce sections of metals and minerals—invisible to the naked eye—for laboratory study under an electron microscope, it has cut a shaving less than two-millionths of an inch thick, or 1,000 times thinner than a human hair.

Dr. E. F. Fullam, GE scientist who designed the instrument, believes that the cutting is done when the material is torn by a pocket of compressed air produced just ahead of a knife blade spinning at more than 818 miles an hour.

DC Battles AC to Pull the Heavy Loads



DC

TROLLEY WIRE
(HIGH-VOLTAGE AC)

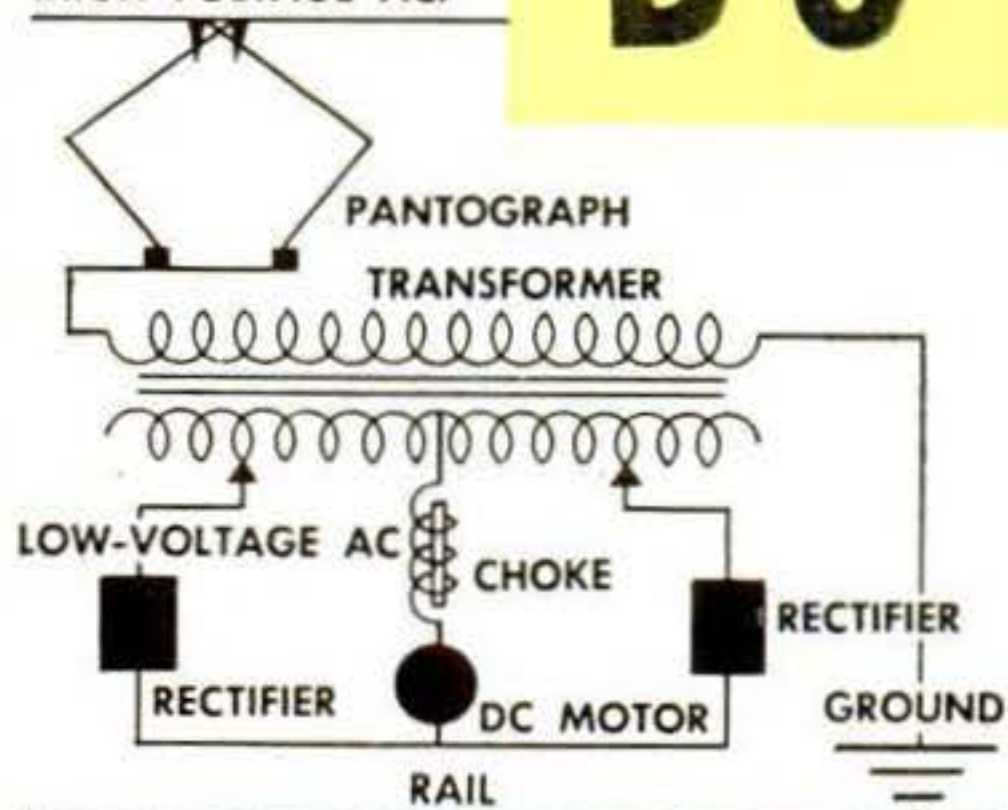

RECTIFIERS convert low-voltage AC to run DC motor.

Two new electric locomotives —one radical in design, one conventional but souped-up— are trying their muscles on the world's busiest high iron.

By Henry B. Comstock

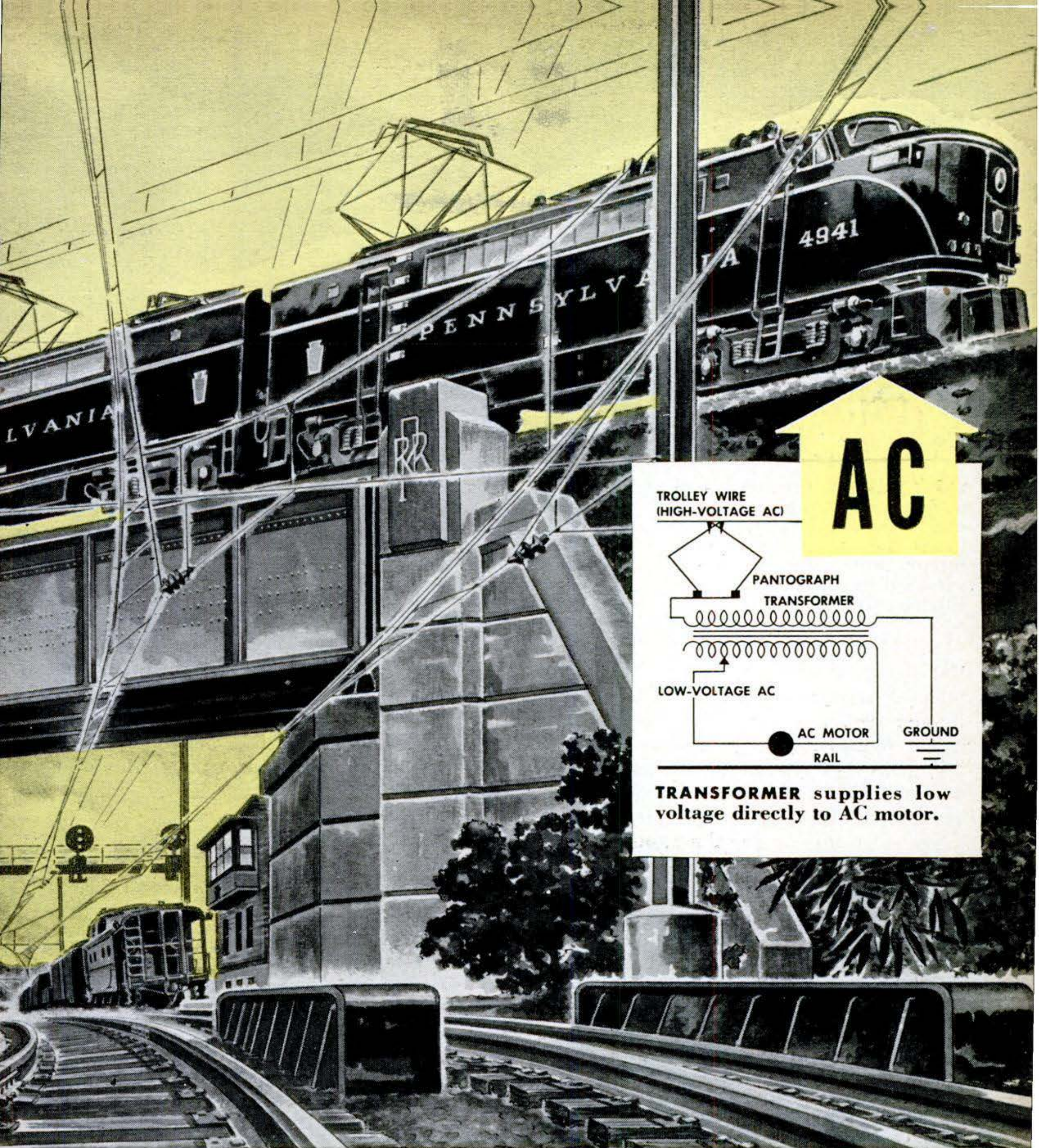

AC

TROLLEY WIRE
(HIGH-VOLTAGE AC)

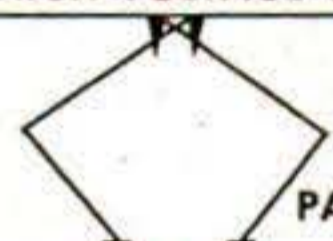

PANTOGRAPH

TRANSFORMER

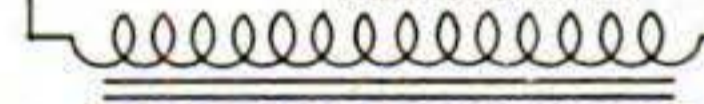

LOW-VOLTAGE AC

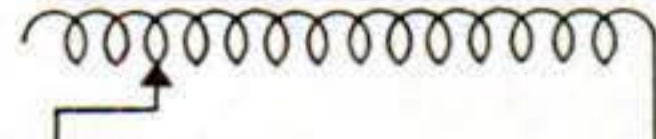

AC MOTOR

GROUND

RAIL

TRANSFORMER supplies low voltage directly to AC motor.

I HAVE just hit the cinders in Waverly Yard, near Newark, N.J., after 16 hours spent high in the cabs of two giant electric locomotives now undergoing tests on the Pennsylvania Railroad. The trip was about as cozy as a slow slide down a staircase in a vacuum cleaner. But I wouldn't have traded my head-end rides on these big freighters for all of the comforts of the Super Chief.

This was more than an engine ride. It was a ringside seat at a million-dollar scrap be-

tween the topflight engineering talent of the two greatest names in electric traction—Westinghouse and General Electric. Out of it may well come a super-performance, low-cost-per-horsepower engine which will give electric railways a powerful shot in the armatures. It may even lead to new electrification projects, a development that the experts have considered as unlikely as a return of the cowcatcher.

There has been no "me too" approach to

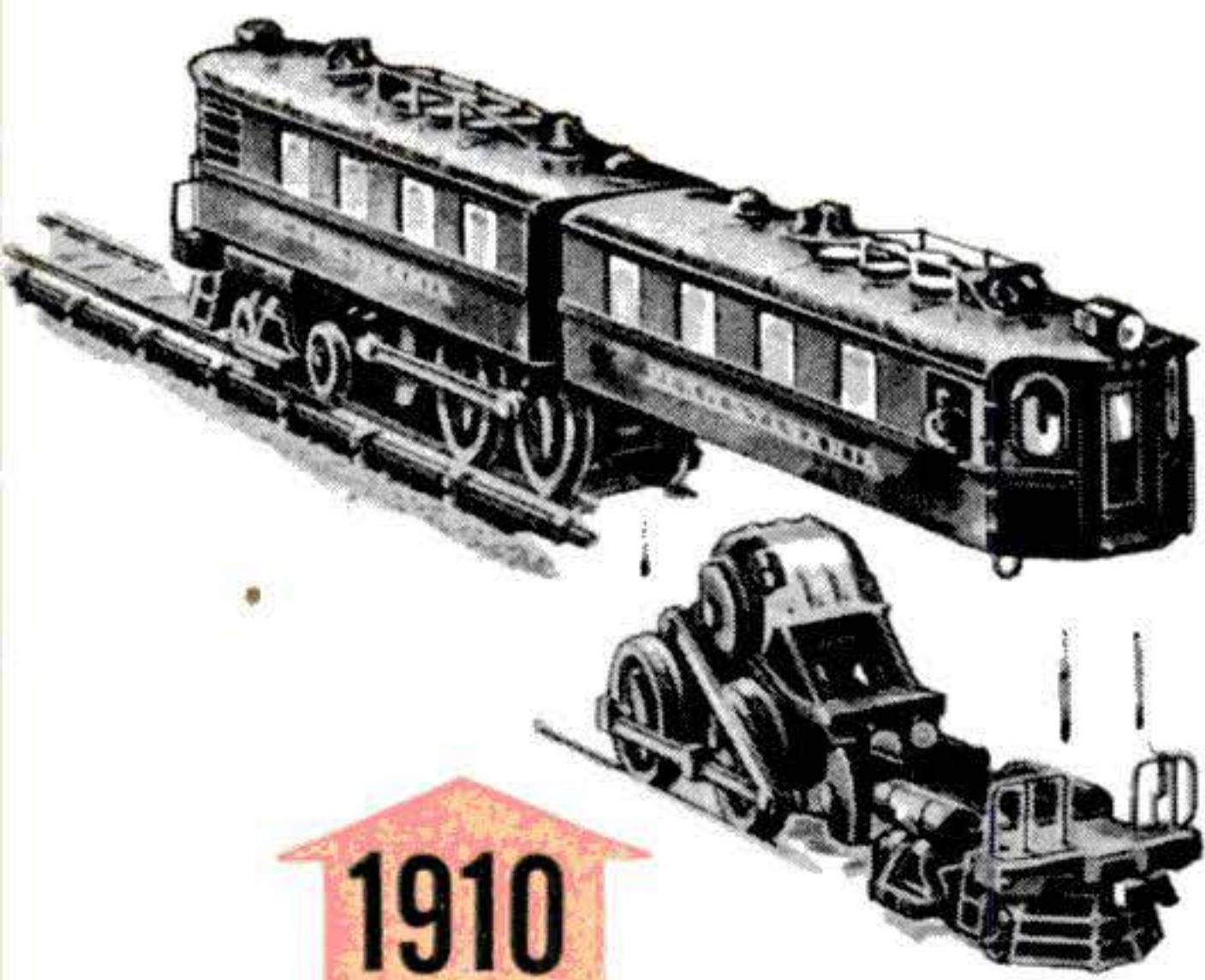

1910

EARLY ELECTRIC, the DD-1, had a single 2,000-hp. motor in each cab. Too large to fit between the engine frames, the motors were coupled to the wheels through jackshafts and side-rod rigging.

the design of the experimental machines which I have just seen slugging it out on the busiest section of high iron in the world.

The Westinghouse product is revolutionary. It leeches alternating current from the overhead wires, shoots it through king-size versions of the rectifier tubes in your own radio set, and delivers the resulting direct current to its traction motors. The theory is simple. AC is superior to DC for power transmission. Today it times the heartbeat of 269 locomotives bearing the Pennsylvania's keystone insigne. But direct-current driving motors are inherently more powerful than AC motors in the low-speed ranges. So, in its new freight engine, Westinghouse has combined the advantages of both AC transmission and DC motors.

Seeking the Perfect Power Plant

The General Electric engine, on the other hand, is evolutionary. Here there has been no radical departure from tried and proved alternating-current design. Instead, the accent is on improvements to existing apparatus and the engineering of a husky AC traction motor intended for low-speed operation. No attempt has been made to pack spectacular horsepower into a single cab. Rather, General Electric intends its engines to be coupled together in multiples of two, three and four, to meet the demands of individual trains.

Each locomotive, in the opinion of its

IMPROVED P-5 came when New York-Philadelphia route was electrified. Through gearing, two 625-hp. motors turn a hollow shaft or "quill" in which a driving axle floats. Springs on quill transmit power to spokes of the driving wheels.

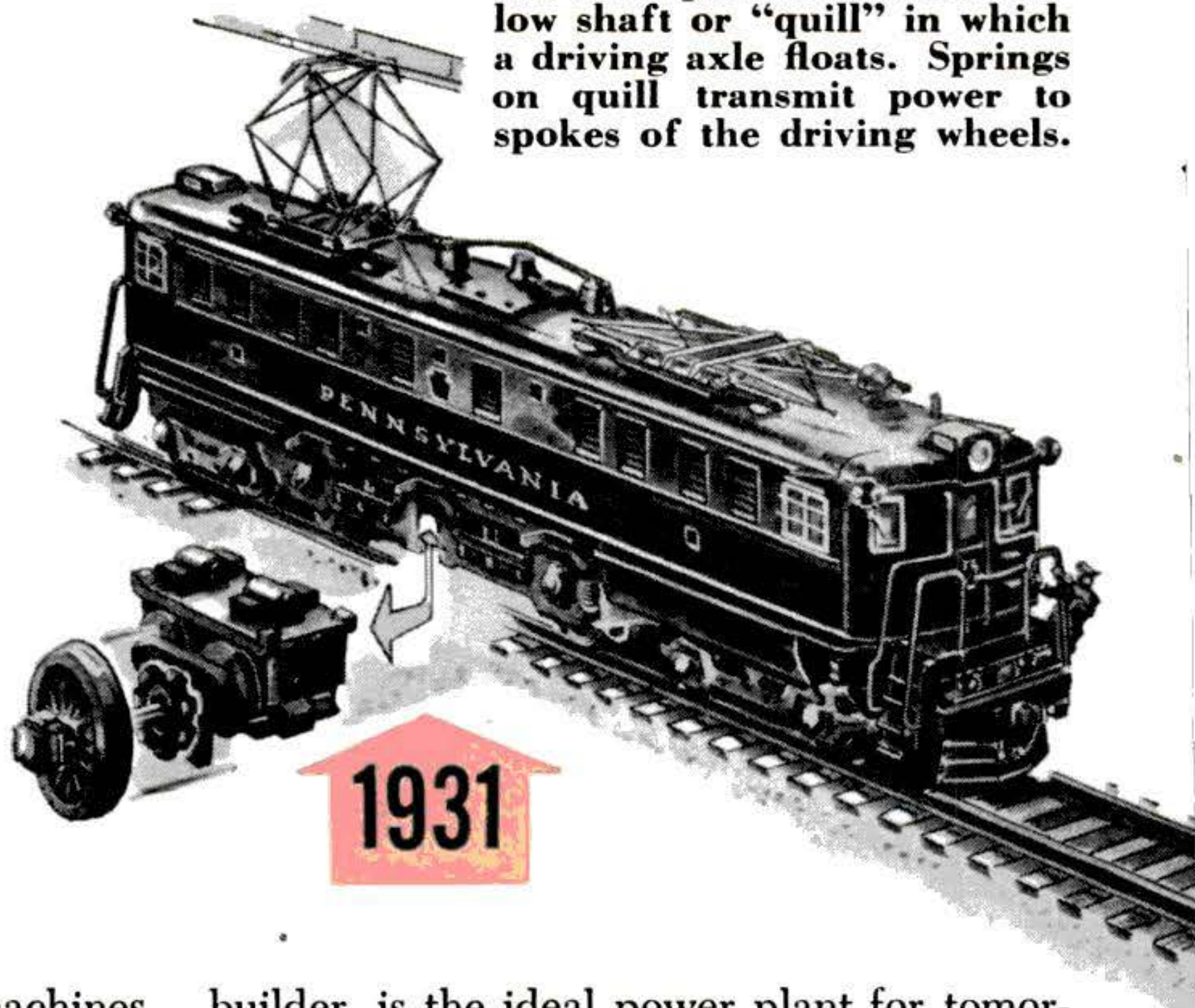

1931

builder, is the ideal power plant for tomorrow's freight train. As to which of them is right, your guess, at the moment, is almost as good as the Pennsy's. If you would like to size up the situation, come along with me to Harrisburg, Pa., and make the test run for yourself.

There, in the Enola Yard, you will find Westinghouse locomotive No. 4995-4996 waiting for you—124 feet of green-black powerhouse, grumbling softly to herself. But for the diamond-shaped pantographs which have already stretched to lazy contact with the trolley wire overhead, you'd mistake this big white-coaler for a Diesel.

Special Crew Takes Over

In spite of the bright 11 a.m. sunlight, it is a bit chilly down on the ground and you welcome a blast of electrically heated air as you climb into the cab.

There is as much official brass in that operating compartment as there is copper in the control cabinets behind it. Assistant Electrical Engineer S. V. Smith is stowing his grip in the crew locker. Once out on the road, he will check every click of the massive throttle against a battery of gauges under the big safety-glass windshield. Sprawled comfortably in a bucket chair in front of Smith, Road Foreman of Engines D. E. Schlegel explains the operation of the dynamic brake to Engineer H. C. Williamson and W. J. Fletcher, special duty engineman,

Maryland Division. Fireman J. H. Hall is downing black coffee from a Thermos. Beside him a stocky young fellow in a checkered hunting cap is doing his multiplication tables on a slide rule.

"Meet Sandy Ames of Westinghouse," Smith shouts into your ear. "This is Sandy's baby. Don't let him sell you a bill of goods."

Sandy grins at the Pennsy engineer. "It's your locomotive now."

the yard office. One hundred and thirty-nine cars; 14,980 tons!

Ebaugh takes your ticket (you need one even to ride a freight engine) and drops back to the ground. The road foreman of engines flips the reverse lever, and his left hand closes over the throttle. There is a sharp click and a couple of hundred feet of rail slide noiselessly away from the snout of the engine. You make an unseen coupling with your train and wait for the compressor to pump up the air brakes.

DC Locomotive Goes To Work

At 11:40 you are ready to roll. Signals at the crossover ahead show a clear lane down-track. Schlegel pulls the controller lever back. One, two, three, four, five—six notches. You count them by the snapping of the ratchet. There is hardly a tremor as the big girl pulls out the long black ribbon of cars behind you.

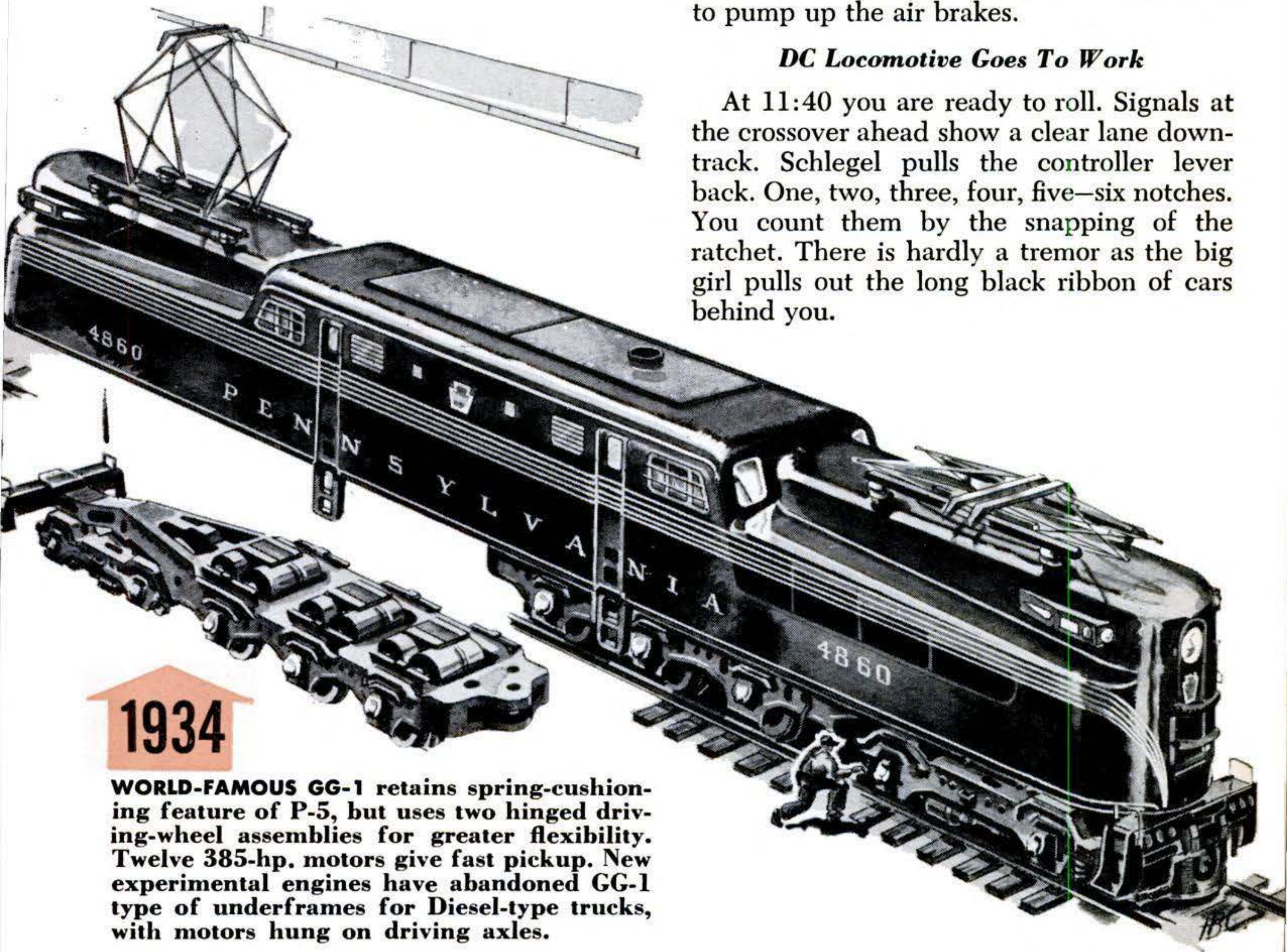

1934

WORLD-FAMOUS GG-1 retains spring-cushioning feature of P-5, but uses two hinged driving-wheel assemblies for greater flexibility. Twelve 385-hp. motors give fast pickup. New experimental engines have abandoned GG-1 type of underframes for Diesel-type trucks, with motors hung on driving axles.

"And your reputation," Smith cracks back.

Between them, they brief you on the run: "Two units. Six power trucks; 12 driving axles; 44-inch wheels. One 600-volt DC motor geared to each axle. Same motors used on Baldwin and Fairbanks-Morse road Diesels. Total horsepower: 6,000. Combined weight of the two locomotive units: 755,000 pounds. Explain rectifier tubes later.

"Our train, today—a solid coal job: Altoona to Baltimore. Don't know tonnage or number of cars yet. But she ought to be a lulu."

It turns out that she is. Conductor J. E. Ebaugh brings the glad news forward from

All eyes are fixed on the instrument panel as you weave past the tower that marks the end of the yard and the beginning of a two-by-two march of massive trolley poles to the east. There are more than 27,000 of these steel H beams along the electrified route linking New York, Harrisburg and Washington, D.C. You will follow a comparatively level line skirting one of the most scenic reaches of the gray-green Susquehanna.

Ames calls attention to another kind of beauty; the effortless starting characteristics of these DC traction motors. He says that it would have taken five 2,000-horsepower



HEART OF DC ENGINE is bank of rectifying tubes called ignitrons (cylinders at bottom of cabinet above), which convert AC from power lines into DC for motors. Previous DC engines carried AC motors to run DC generators which powered DC driving motors. Ignitrons weigh one-fourth as much as such equipment, have no rotating parts to be serviced.

Diesel units to do the same job. This seems a bit out of line with the 6,000-horsepower rating of No. 4995-4996.

"Horsepower" Is a Deceptive Term

Horsepower, however, is not the complete yardstick in freight-locomotive performance. Tractive effort, or the actual pulling power developed at the wheels is equally important. And that is where the trolley-fed DC motor shines. In the case of the Diesel, the horsepower rating refers to the output of the internal-combustion engine which turns the generator—not to the train-hauling power. Actually a 6,000-horsepower Diesel provides only 4,800 horsepower to pull its train. The rest is lost in electrical conversion and in the demands of auxiliary apparatus. The rectifier, or *ignitron* locomotive, as Westinghouse calls it, suffers no such losses and therefore shows a substantially higher tractive effort through its entire speed range. Also, it can draw upon an almost limitless supply of trolley-fed electrical energy for temporary overloads that the Diesel, which must generate its own power, cannot.

Beyond the Pennsylvania Turnpike overpass, the roadway spreads to four tracks and the big gray controller lever beats a fast tattoo as Schlegel pours on the kilowatts. Smith taps you on the shoulder and points

to a large hydroelectric plant down-river. "Safe Harbor," he shouts. "They've got 25-cycle water wheels. Feed us direct."

Ames isn't missing a trick.

"That doesn't mean a thing with these motors," he points out. "We can use 60-cycle just as well. That's another ignitron advantage—AC traction motors need 25-cycle, so 60-cycle commercial current has to be converted before they can use it. Discourages railroad electrifications."

In This Corner—the Ignitron Tube

Ames is now ready to exhibit the pint-sized wonder that makes a traveling substation of 4995-4996. He opens a steel door at the rear of the operating compartment and you find yourself in a long corridor full of the roar of giant blowers. Talk is impossible, so you fall back on sign language. Passing up all of the conventional equipment, Ames takes you to the feature attraction, a cupboard-like cubicle with six steel containers, arranged like jars of jam, on a well-protected shelf. These are the ignitrons, mercury-filled vacuum tubes which change the AC from the wires into DC for the motors. A handful of raised fingers indicates that there are four such groups aboard this two-unit locomotive. Each motor, then, uses two tubes; one to shoot power into it when the alternating current is traveling in one direction, the other to carry on the good work when the current reverses itself. The result of this "two-cylinder" pump action is a nearly smooth flow of DC which is leveled off still more through husky chokes cut into the circuits.

AC Challenger Enters the Ring

You have just seen one bid for the rubber-insulated Golden Gloves. Now it is time for some road work with General Electric's AC contender. It doesn't have quite the breadth of shoulder of the Westinghouse DC job. The combined weight of its two units is 491,000 pounds; their over-all length, 108 feet six inches; the horsepower rating, 5,000.

The unlimited supply of power from the trolley wires—which lets you overload the motors—combined with 48-inch wheels, makes for fast acceleration. So does Engineer W. N. Gillespie of Perryville, Md., who has running rights over four divisions, and intends to make use of them. He gets out of Baltimore at 9:31 shoveling in the white coal so fast you'd never guess that you had

[Continued on page 270]



ELECTRIC WATCH on man's wrist (left) is prototype of model that will later appear on market. Near-microscopic size of motor is illus-



trated by experimental field coil for it (right), wound with 3,000 turns of insulated copper wire only 1/6 as thick as human hair.

You Won't Need to Wind This Battery-Powered Wrist Watch

ONE of these days you'll tell time by an electric wrist watch, according to a leading maker who plans to put one on the market. It will never need winding and will keep even better time, it is said, than the finest spring-driven counterpart.

A laboratory-built prototype, first of its kind, has been assembled and is illustrated here. Inside it, a battery smaller in bulk than a penny runs it for more than a year and may then be replaced. The motor, a masterpiece of engineering in miniature, is built to comparable scale.

No conventional electric-clock movement could possibly be scaled down to such small size, so research by the maker, the Elgin Na-

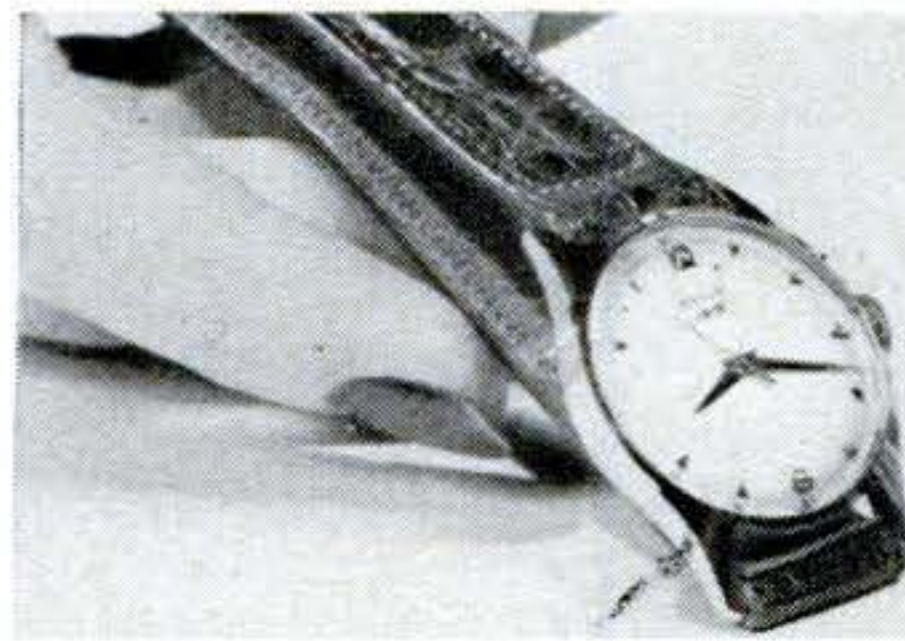

TINY BATTERY, represented at right above, takes up less space than a penny. Battery runs electric watch for more than a year.

tional Watch Co., had to start from scratch. The resulting "watch of tomorrow" is called "probably the greatest single advance in the science of watchmaking" since the 15th Century invention of the mainspring, with which it dispenses.

German Sports Car Looks Like Airplane, Hits 125 M.P.H.



You don't step into this new German sports car—you climb in through the roof. Instead of doors, it has two airplane-like cockpit hatches that are hinged at the top to swing up. Intended primarily for racing, the two-seater Daimler-Benz 300 SL is expected to reach a top speed of nearly 125 miles per hour. Its relatively small six-cylinder engine, with a displacement of only 183 cubic inches, puts out 175 horsepower.

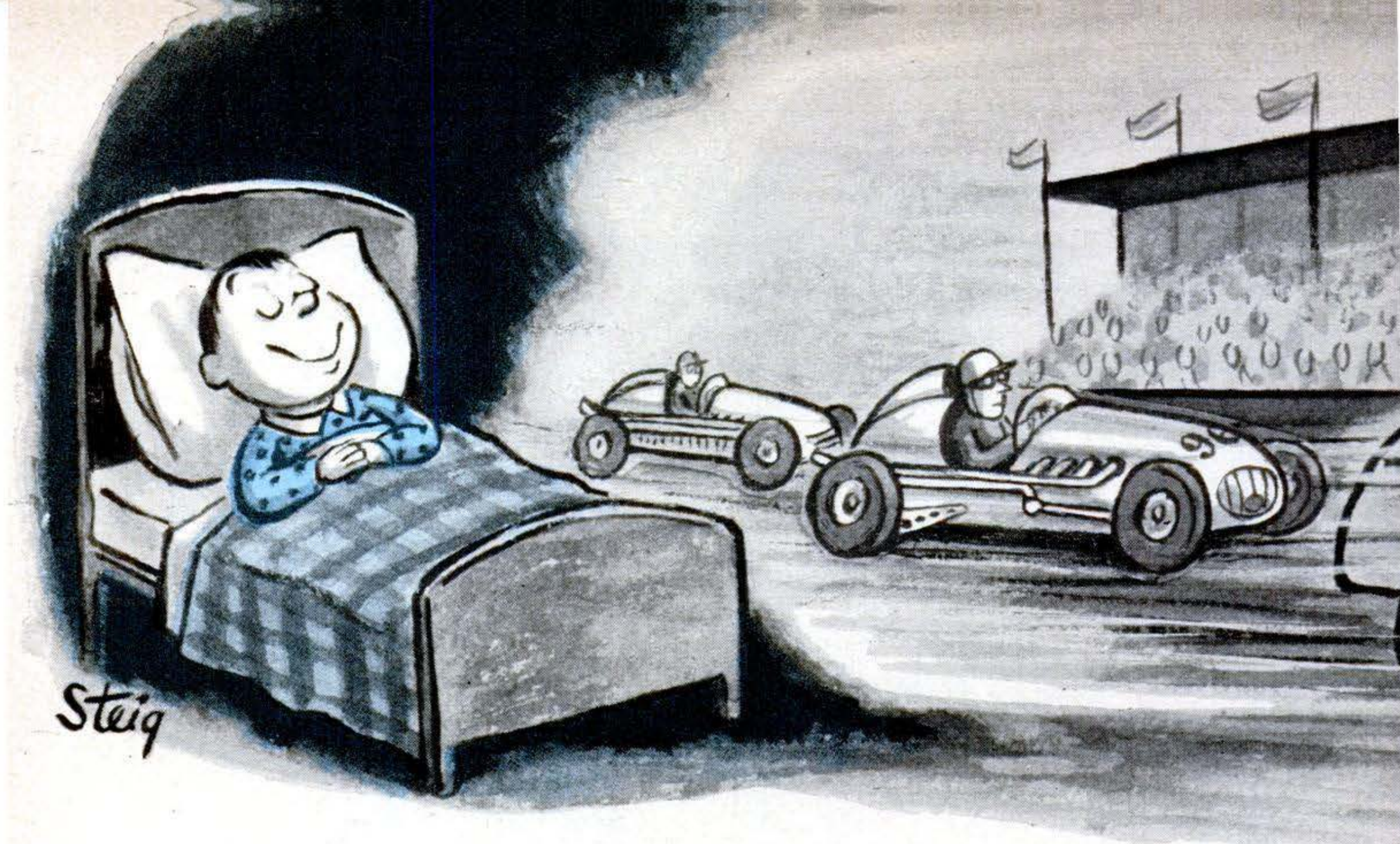

The boy speed demons are battling it out for a crack at the All-American Derby title at Akron. But today's streamlined

By Carl Konzelman

REMEMBER those wonderful automobiles you used to make as a kid—a soapbox nailed to an old plank, rolling on wheels swiped from a broken-down baby buggy? If you haven't looked one over lately you're in for a surprise. The cars are still called soapbox racers, but the 1952 model looks as much like a soapbox as a Jag resembles a piano case. They are long, low, streamlined, polished. And the kids work over them with the anxious care of Briggs Cunningham tuning up his latest.

The way the kids race is just as different. No more bumping down a hilly street, dodging traffic and hollering at the cops. The boys have special tracks of their own these days, complete with grandstands, electric timers and photofinish cameras. When they gather in Akron this August for the All-American Soap Box Derby, there will be all the crowds, ceremony and excitement of the Memorial Day classic in Indianapolis.

In fact, the excitement is already starting.

In 150-odd communities all over the country, some 50,000 kids are hitting the big time in elimination races sponsored by local newspapers. By the time the final winner has received his gold cup before 70,000 roaring fans at Akron's Derby Downs, between three and four million people will have taken part in the racing program as competitors, officials or spectators.

Boys Build Cars Themselves

The kids love it. If they had their way, their racing cars would be even fancier than they are now. But officials of the Derby struggle to keep the entries simple, cheap and safe. All boys must build their cars without help; the over-all cost, excluding wheels and axles, must not exceed \$10; and designs are limited to those that are stable and easy to control.

Despite strict rules, the ingenuity of American boys is hard to stifle. Metal springs, for instance, are barred as too difficult to make and too expensive to buy. Yet springs still show up on Derby entries—tennis

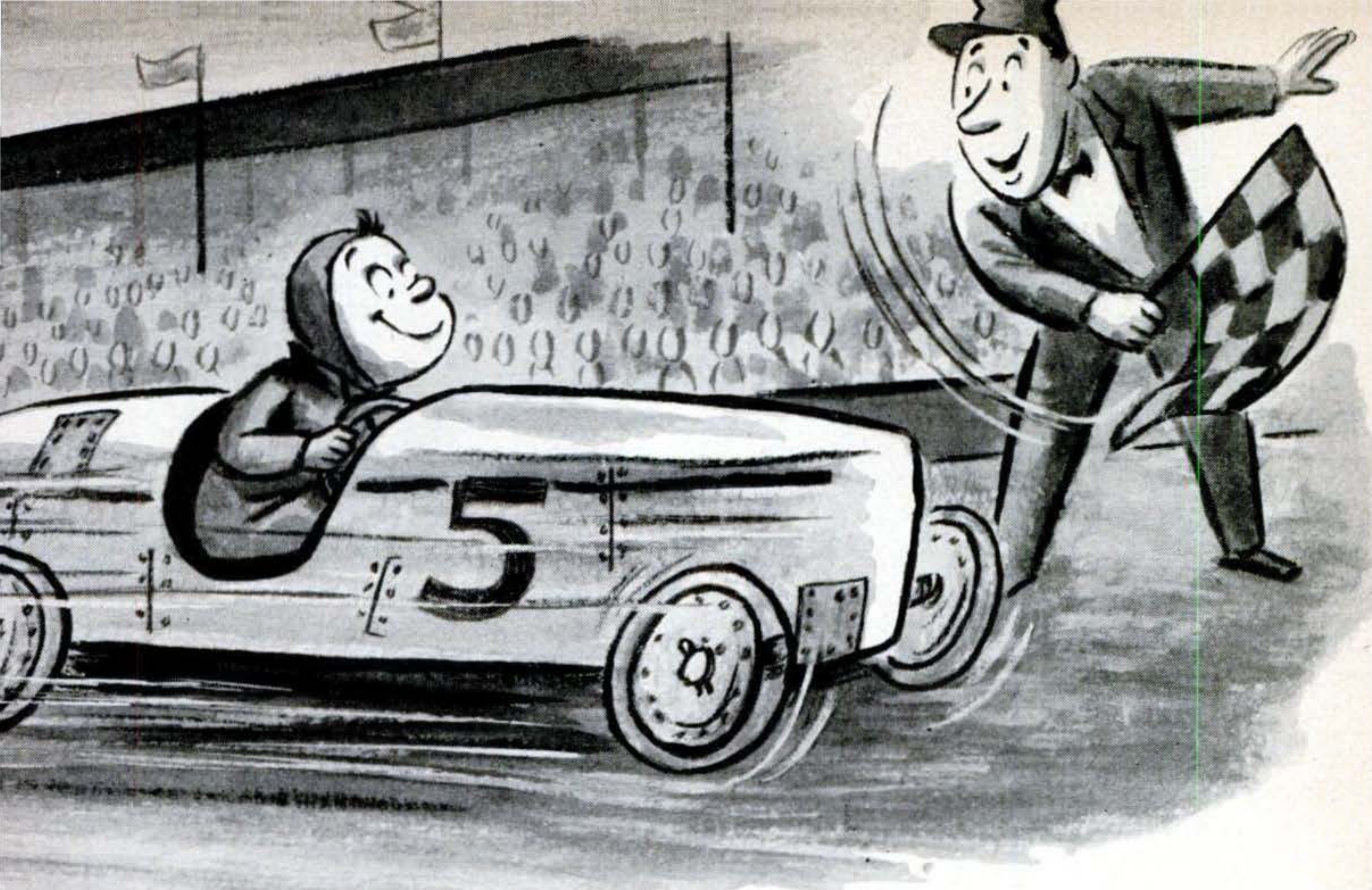

racing cars have come a long way from that old soapbox.

balls or sponge rubber floating in pairs of jar tops, or hickory boards sprung against each other.

Or take brakes. The rule book is pretty specific. Only a foot brake can be used, because cars weave when drivers let go the wheel to grab a hand brake. The brake must stop the car in a straight line, and its single grab must be faced with tire treads or the equivalent and have at least nine square inches of contact area. But strict as these limits are, improvements creep in. One Detroit entry last year had a hydraulic gizmo to give surer, more even braking.

It met specifications and got by. A lot of other bright ideas have been outlawed, however. One year a boy from Indiana built a body that he could shift forward over the wheels as he approached the finish line, figuring that it might gain a few valuable inches in a close race. Today this wouldn't be allowed.

A lot of streamlining has been barred, too. The boys used to build special windshields, fins, enclosed cockpits. All of these, together



DRAWING NUMBERED CUBES determines lanes in which these heat winners will race in next round of All-American Soap Box Derby. Three cars run in each heat up to semi-final round.

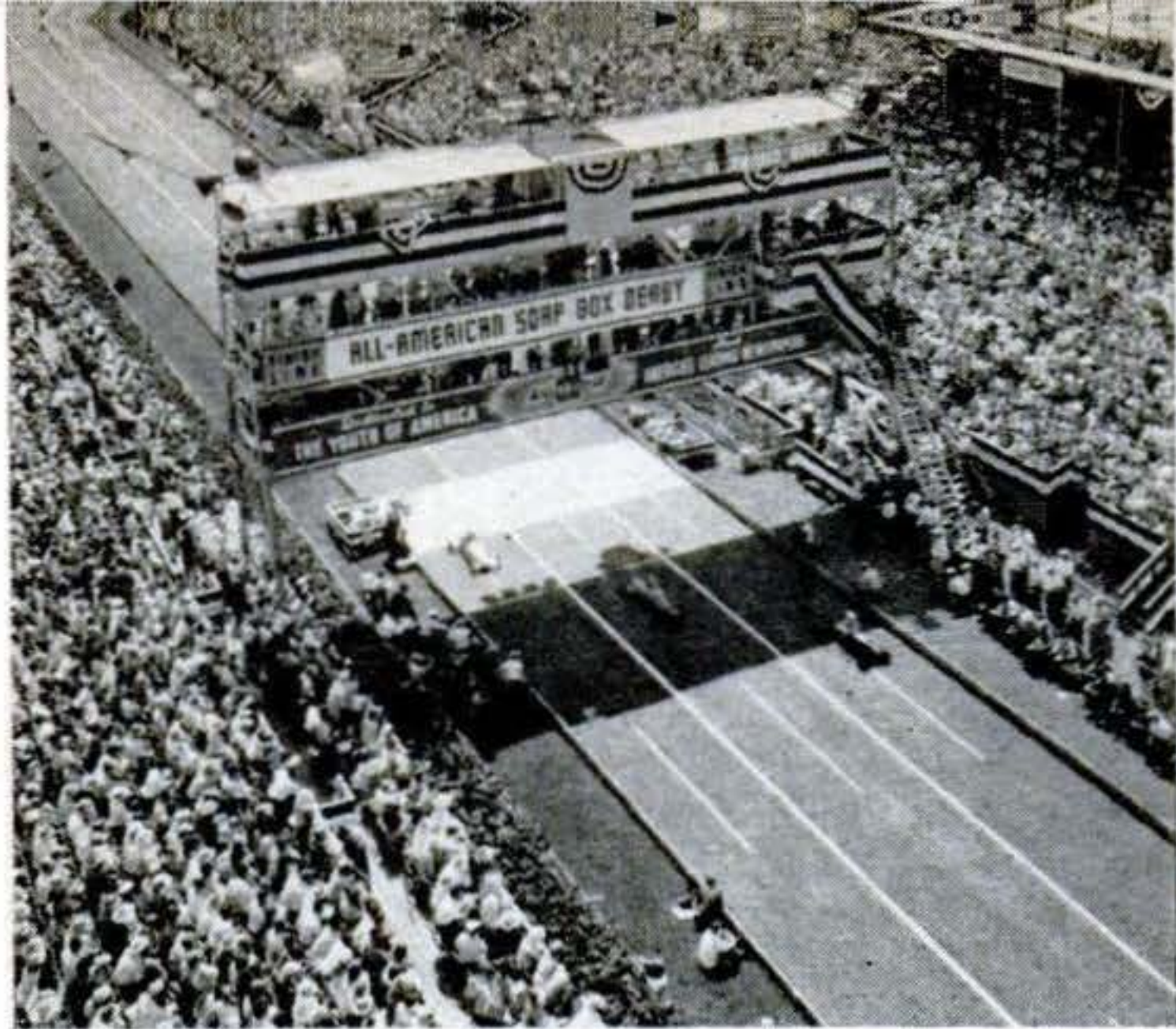

THREE-DECKER BRIDGE straddling finish line carries photofinish camera, officials, newspapermen, cameramen, radio and TV reporters. Above, three cars have just crossed line.

AT STARTING LINE, each car is rolled gently against a baffle plate, held on head of heavy shaft beneath track. At signal, baffles drop together, releasing cars, and timer starts.

with prone driving positions, are now out.

The kids have developed a lot of theories on streamlining, but one fact stands out. Slim and simple silhouettes, looking like a canoe from above, beat all other designs in the Akron finals. This has confounded some auto experts who claim that streamlining has little or no effect at speeds under 35 m.p.h. Today's Derby racers run at 30 or under. (At one time speeds climbed to around 50, but officials clamped down.)

Dry Ice Cools Tires.

Streamlining is only one factor considered by the young builder-drivers. A favorite theory is that the heavier the car and its driver, the faster it will go. But John Valenti, a 12-year-old competitor in 1950 finals, challenged this by racing at 190 pounds against much heavier competition. He copped his local championships and lost by a short nose in the All-American finals.

During the 1939 finals, one small entry asked for dry ice. General Motor's Charles F. Kettering followed the ice to the boy and watched him rub it on the rubber tires.

"Think that will help, son?" asked Boss Ket.

"Maybe," replied the lad. "One of the cars in my next heat has the same time as mine. I figure that if I can cool these tires they'll go faster and I might pick up enough to win." He led the heat, too—by the smallest fraction of a second.

There's plenty of variety in advice on how to win. Tommy Fisher, Detroit's only national champion (1940), credited his victory largely to use of a lapping compound for running in the wheel bearings. He rigged

all four to a motor and ran them simultaneously for the equivalent of 500 miles.

Darwin Cooper of Danville, Pa., who raced from Williamsport, Pa., and went on to take the Akron crown last year, feels that the wheels and "steering as straight as you possibly can steer" are a major part of the winning combination. Darwin worked for months running in his wheels. When the time came to go to Akron, he shipped the racer ahead but packed its wheels in his father's car. Then, to make sure they got to Akron on time, he had his cousin follow along in another car in case of a mishap.

Robert L. Ballard, who entered from White Plains, N.Y., to win the 1937 title at the age of 12, attributes his speed to good wheels, springs and streamlining—in that order. He believes that lubrication is rela-

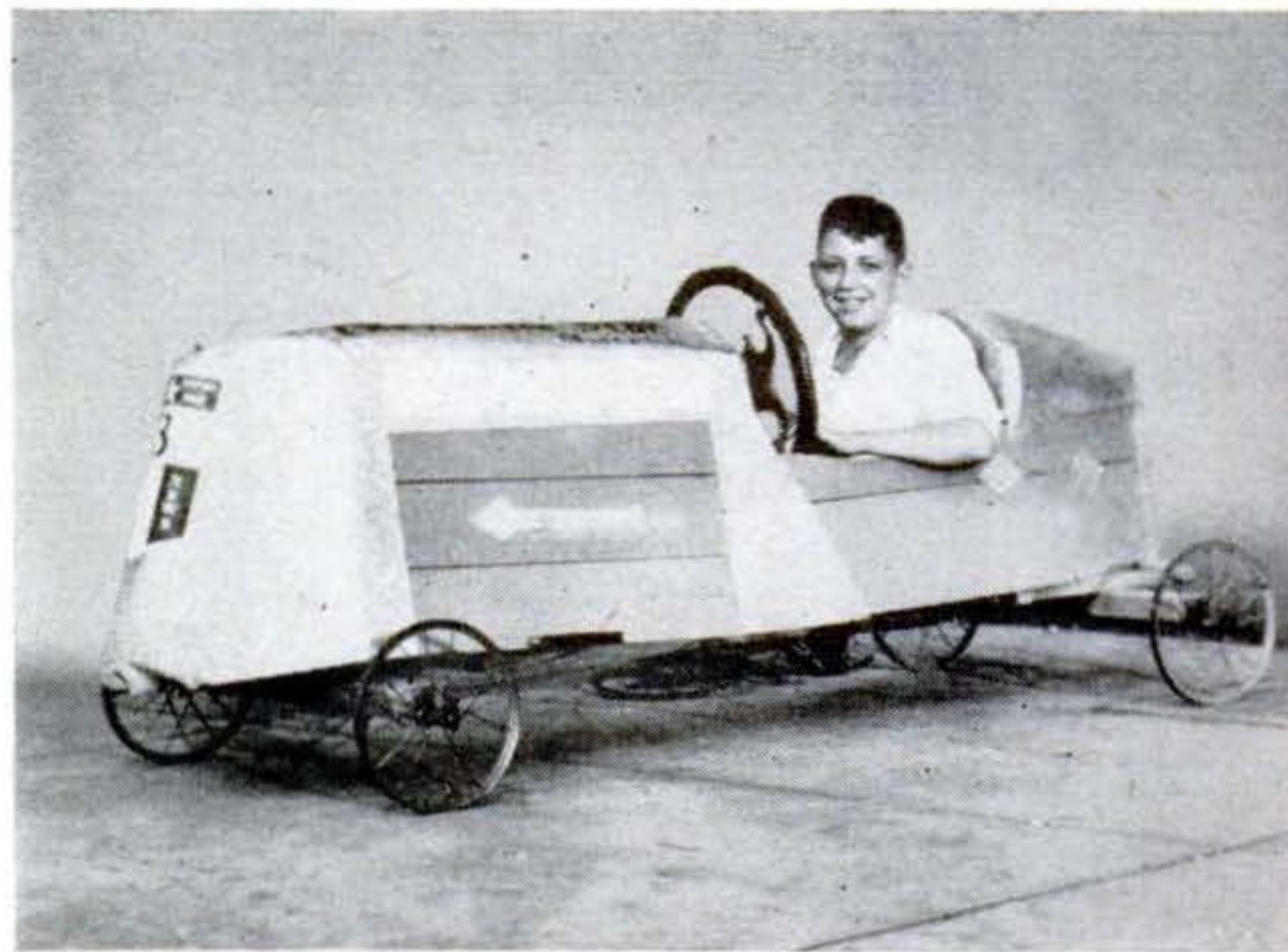

WINNING CAR IN 1934, built by 11-year-old Robert Turner of Muncie, Ind., shows simple soapbox build of entries in first race.



PHOTOFINISH CAMERA, triggered by electric eye, catches winner of 1951 Derby crossing the finish line. Picture makes permanent record of spacing, times, order of finish.



DARWIN COOPER of Danville, Pa., receives the 1951 first-place trophy from T. H. Keating, general manager of Chevrolet, which sponsors Derby. Mother greets victor with hug.

tively unimportant; a single drop of very light oil on each wheel, he says, is best, although some winners have raced dry.

Even the car color enters the speed picture. In 1949, Fred Derks of Akron figured it all out with a complicated system of calculating heat, pressure and resistance, and raced a black car. He won handily.

Gilbert Klecan of San Diego had a somewhat similar theory in 1946, but the black was graphite, rubbed liberally over both car and driver. He emerged the national champ—but graphite is on the black list now. Too many black sheets, too many black pillow cases, too many black boys.

Klecan has some other ideas about winning cars. "The wheels must be balanced by drilling holes and covering them with tape," he says. "Bulges on the rubber must be

sanded off . . . bearings must be polished by running them slowly for many hours in light oil and powdered graphite . . . the steering must be sound, no slack, all inside . . . the lower the head and back in the car, the better . . . a slender, flexible boy is ideal . . . I built the car around my body . . . a knife-blade nose, tapering lines, every bolt and screw flush."

Growing Owners Must "Stretch" Cars

Growing boys being just that, his advice about a "slender, flexible boy" isn't always easy to follow. Tom Kurz, a competitor from Mt. Clemens, Mich., grew four inches taller between the '50 and '51 races. He ended up a tidy six foot one, and his car had to be made roomier for him.

Once a driver not only tailored his car

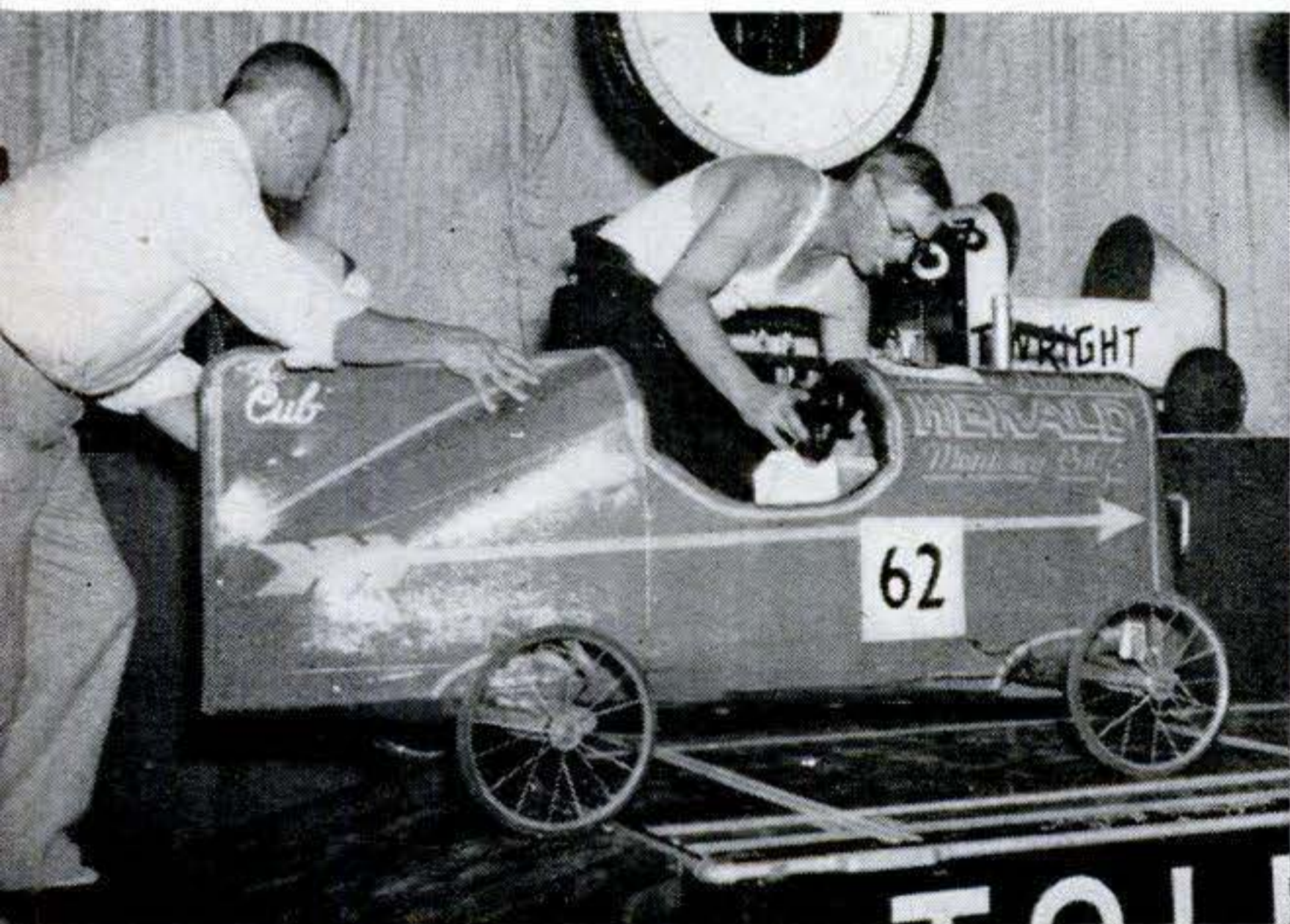

BY 1938 streamlining began to appear, as shown on this entry weighing in at Akron. Today, tail fins would not be allowed.

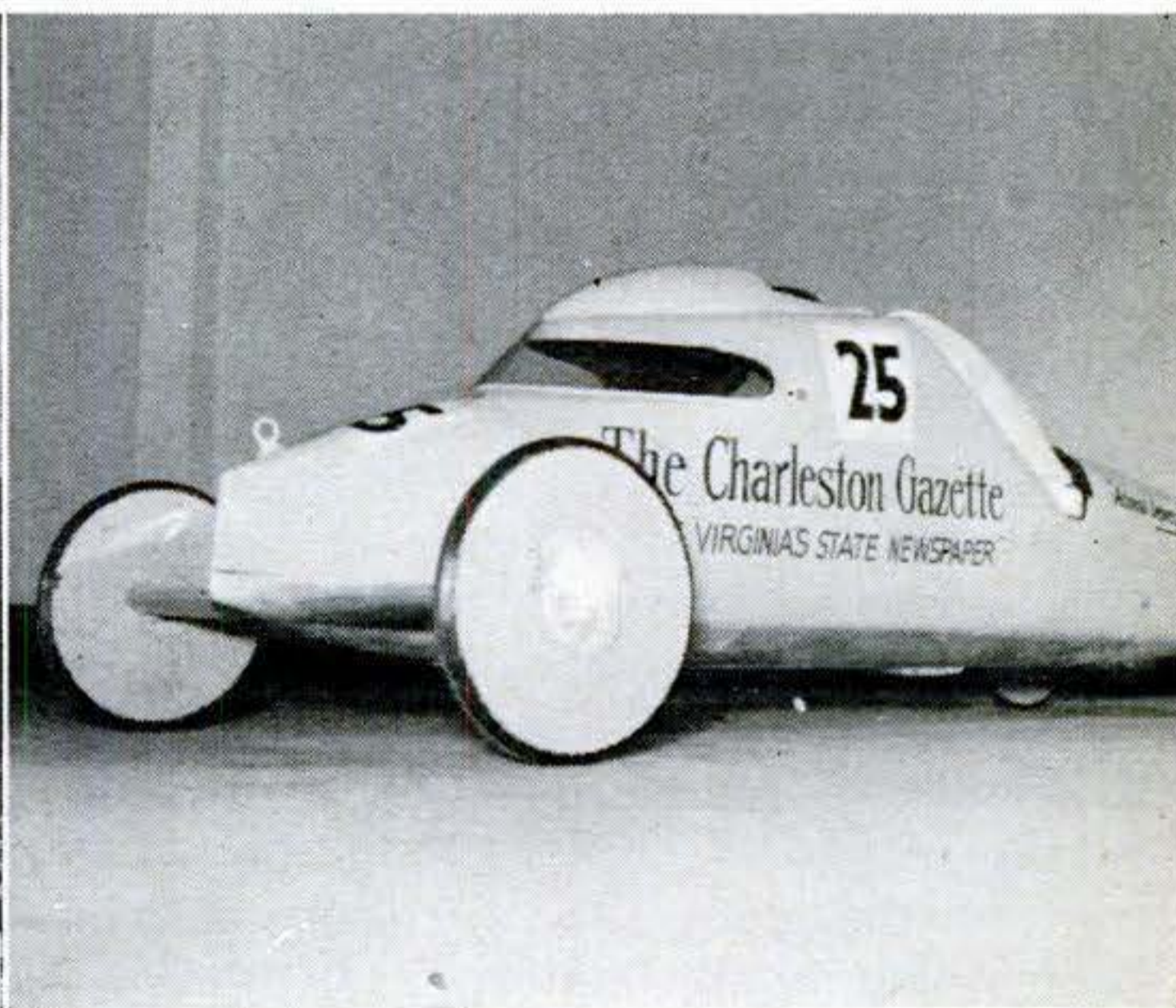

SUPER-STREAMLINED JOB raced in 1940. No partial enclosures or windshields are allowed today, as shown by 1951 racers at top of page.

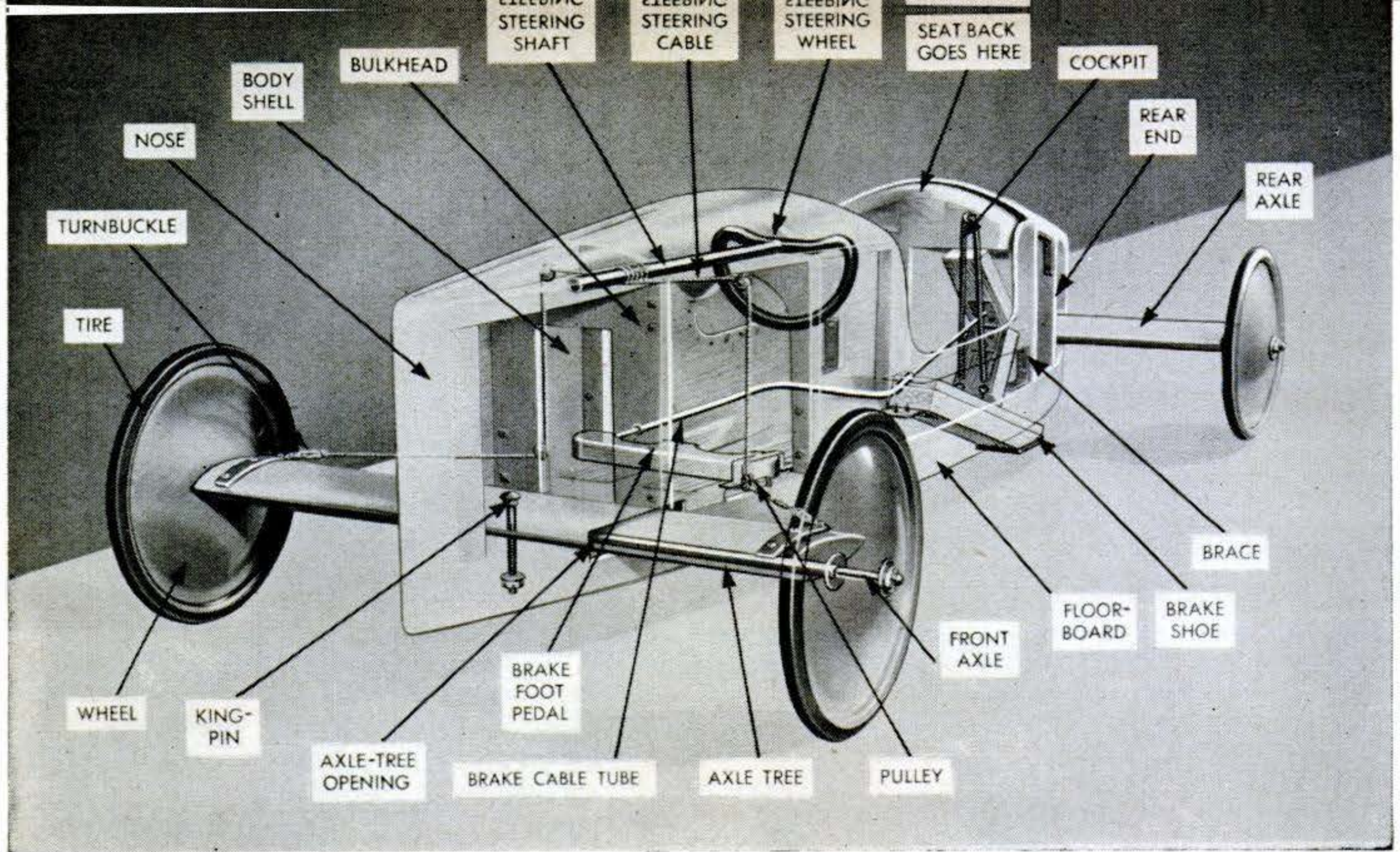

THIS IS RECOMMENDED CONSTRUCTION for current Derby entries. The rules aim at sim-

licity in order to keep cars inexpensive, easy to build and—above all—safe to race.

to fit himself, but to fit the track it was to race on. Detroit has what is believed to be the only curved course, 620 feet of black-top roadway descending through River Rouge park. Because winds can be an important factor in speed, one lad in the Thirties built his car to swing above the wheels, so that his body presented a sail-like surface to the quartering breeze. Today, this would be outlawed as unsafe.

Well Equipped Speedway

The Derby tracks, scattered across the country, are alike only in having a hill to roll down. Hilly Boston had no natural hill available and had to build one from scratch. Owensboro, Ky., made the track a community project, with land, materials and labor donated. But the heart of the soapbox program is Akron's Derby Downs, the championship track.

The Downs is a 30-foot concrete speedway, 975.4 feet from start to finish line and 1,265 over all. From the starting line it drops sharply with a 16-percent grade, then eases off to six percent. Dotted lines divide the track into three lanes.

Behind the rubber-surfaced guard rails that edge the track are stands for spectators. At the top of the hill, behind the starting line, are the garage and service pits. These are manned by mechanics who help the boys tune up their entries. A hospital is nearby.

The Downs will really come to life next

August, when some 150 local champions gather for the fifteenth annual All-American Soap Box Derby. The boys are assorted sizes between 11 and 15 years old. Their cars are assorted sizes within the limits of the rule book—no more than 28 inches high or 42 inches wide; wheelbase at least 40 inches; over-all length not over 80. The eight-inch steering wheel must clear the driver's body by at least two inches, be no farther forward than his knees, and be set so he can look over the top of the car. No transparent materials can be used anywhere in the car—which eliminates windshields. The driver must sit in an open cockpit in a "position permitting easy operation of steering and brakes and a clear view to the front and both sides."

All cars must have four wheels, running on two axles. Weight can be added to the car to bring it up to the 250-pound limit, but—again for safety—must be firmly attached to the car.

Entries Get Thorough Examination

The racers must be built so that they can be easily examined, for inspectors give them a careful going over before local and national events. Dangerous cars are weeded out. Bearings are examined to make sure that precision units have not been used. Any work that looks as if the boy might not have done it himself gets hard scrutiny. Should

[Continued on page 246]

Deadly Napalm Tank Becomes Mercy Bomb

MAJ. ROBERT L. HOLSOMBACK and Sgt. Walter C. Monize noticed an obsolete napalm tank at their air base in Korea and figured it would be a natural for dropping survival equipment. Now the tanks are saving the lives of downed airmen. Painted for better visibility, they are dropped at low altitude packed with heavy clothing, food for three days, water-purifying tablets, a carbine, ammunition, a first-aid kit, a portable stove and a radio.

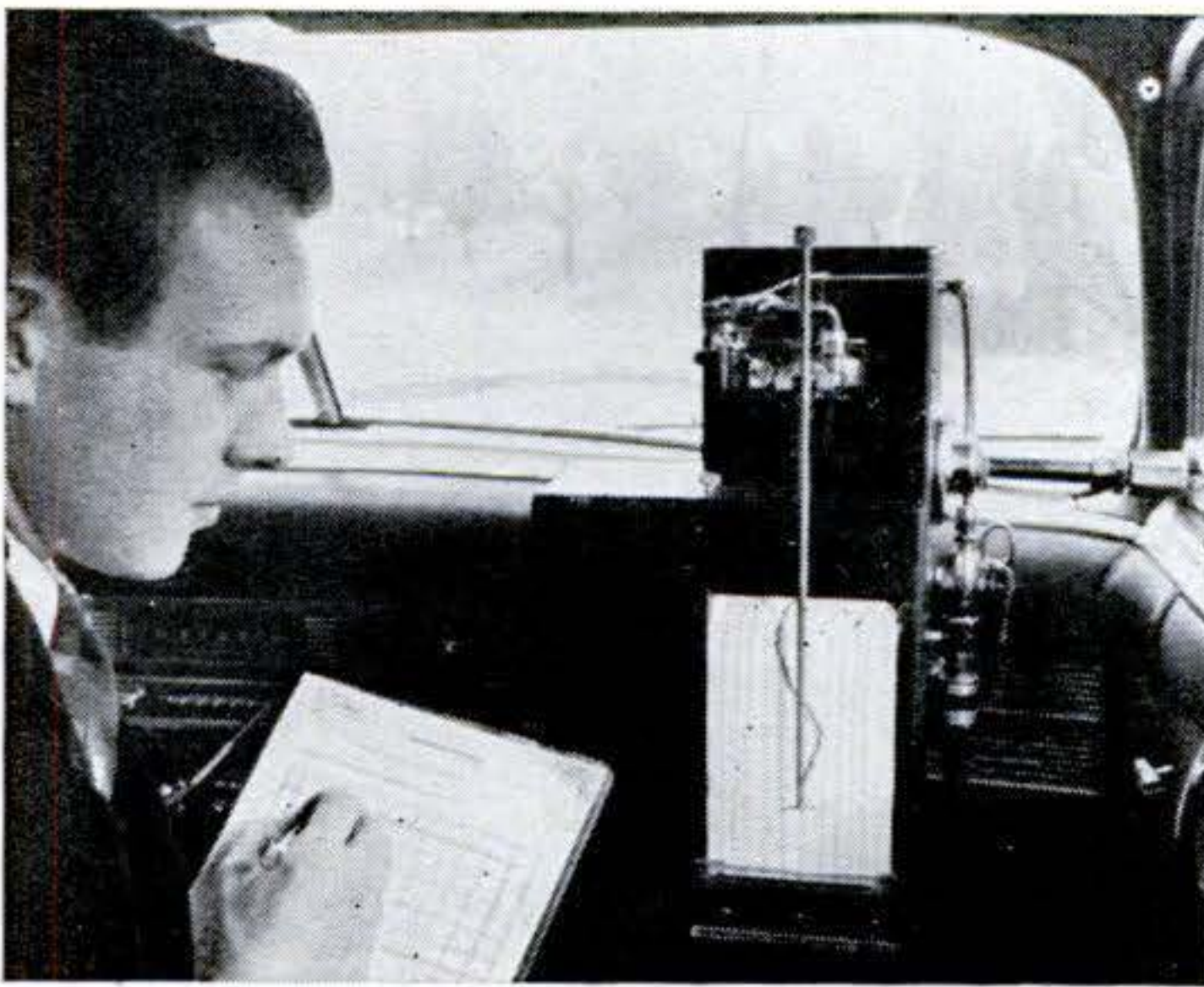
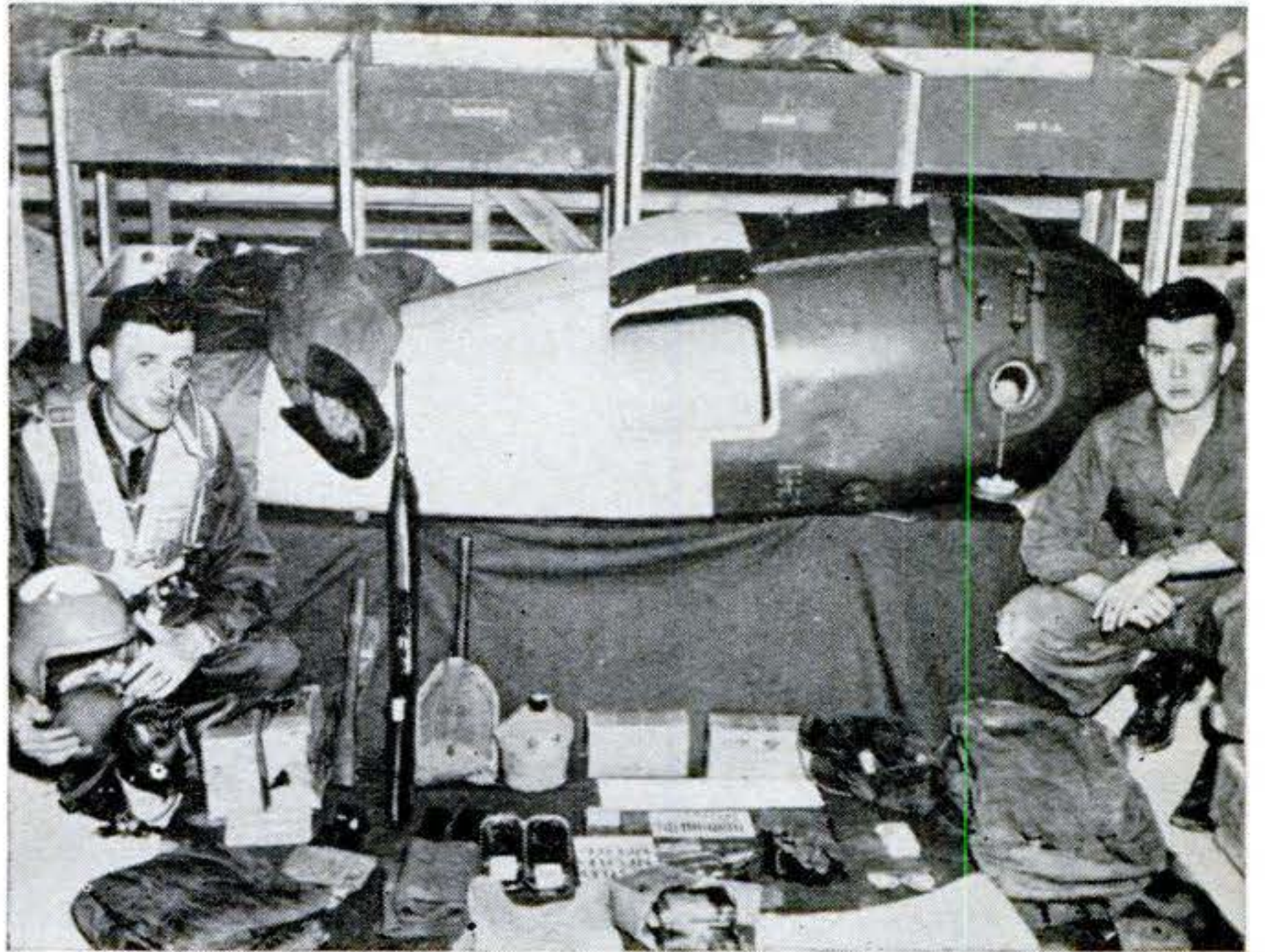

Robot Records Road Bumps

NEWEST tool for designing more comfort and safety into passenger cars is the ride recorder above. The device "feels" with the aid of a small gyroscope, a gas-driven turbine and a spark coil. A metal pointer makes a wavy-line record on tape of the slightest rolling, pitching or zigzag motion of a car under test. Chrysler engineers developed it to compare the smooth-riding qualities of various car suspension systems.

Shot in Roots Kills Weeds

You can rid your lawn of dandelions without even bending over—just poke the tip of this plastic tube into the ground near the roots of the weed. A spring-operated rubber valve then releases four streams of weed killer. It can be filled with any standard formula, and holds enough for 125 shots. The 30-inch tool, called Dispensaweed, is distributed by the Ceca Corp. of Glendale, Calif.

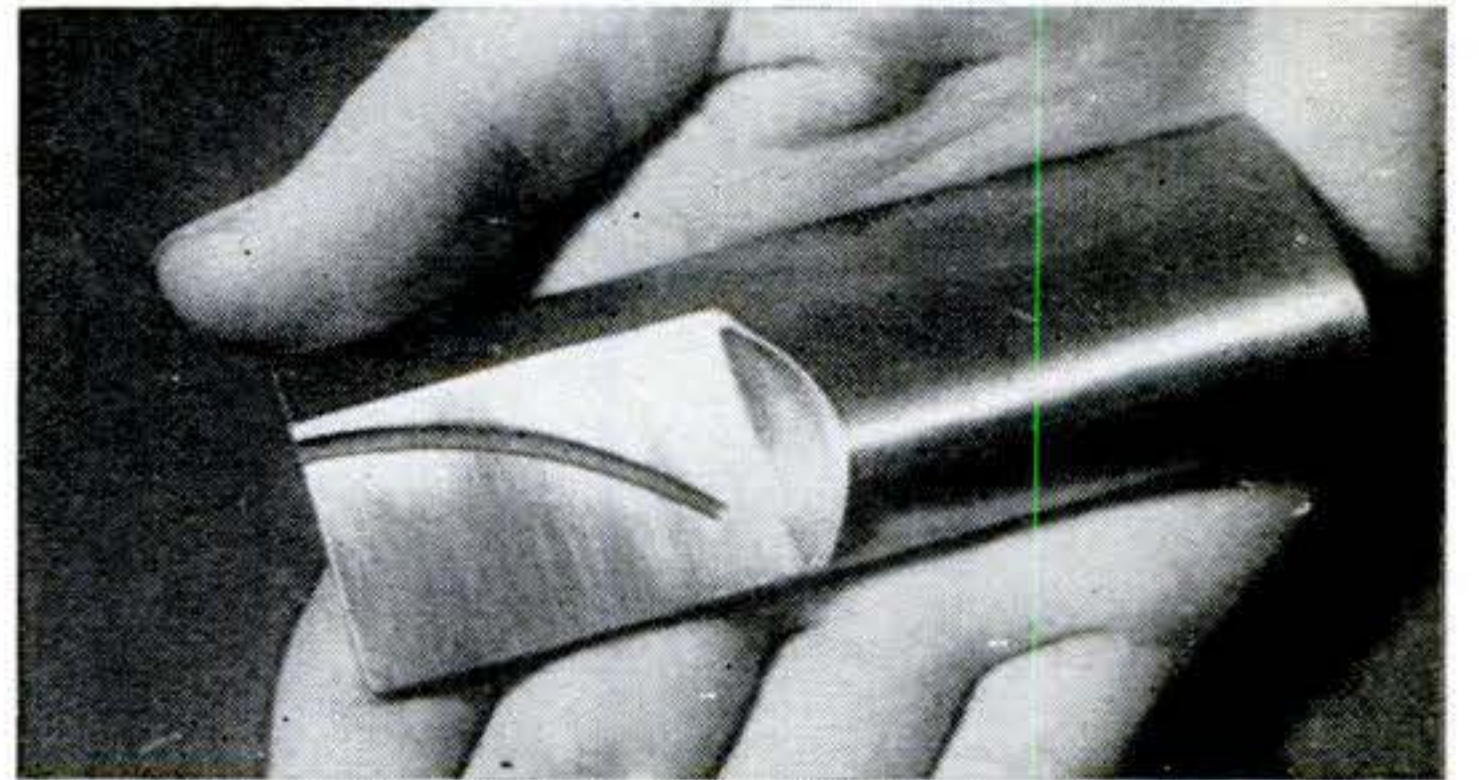

Electricity Drills Crooked Holes

IT SOUNDS like a left-handed screwdriver, but a drill for crooked holes is no joke. There now is such a thing. It drilled the curved hole shown in the sliced-open sample above, and may lead to simpler lubricating systems for engines.

George Kemeny of Westinghouse invented it because he wanted to measure temperatures inside steel castings and couldn't reach the right spots with a single straight hole. So he attached a curved, hollow electrode to an electric disintegrating machine. The arc eats a path of the same shape as the electrode. Water flowing inside the electrode washes out molten metal.





BRITANNIA 1840
14 DAYS

**SS United States is out to win
Atlantic speed supremacy from
Britain's Mary and Elizabeth**



MAURETANIA 1910
4 DAYS 10 HOURS



NORMANDIE 1937
3 DAYS 23 HOURS



QUEEN MARY 1938
3 DAYS 20 HOURS



UNITED STATES 1952 ?????

By C. B. Palmer

THIS month the waters of the Atlantic Ocean will feel for the first time the smooth rush of something very special in the way of superliners. The S.S. *United States* will be taking her builder's trials and acceptance trials preparatory to entering the de luxe transatlantic trade on July 3.

For the first time in 75 years this country has built a competitor in the top-speed bracket. The entirely mythical "blue riband," denoting the holder of the record for the fastest passenger-ship crossings of the Atlantic, has been in European hands for a century. In a sense this has been a matter of default; American ship operators in recent years have not chosen to enter the competition for many reasons. We have built many

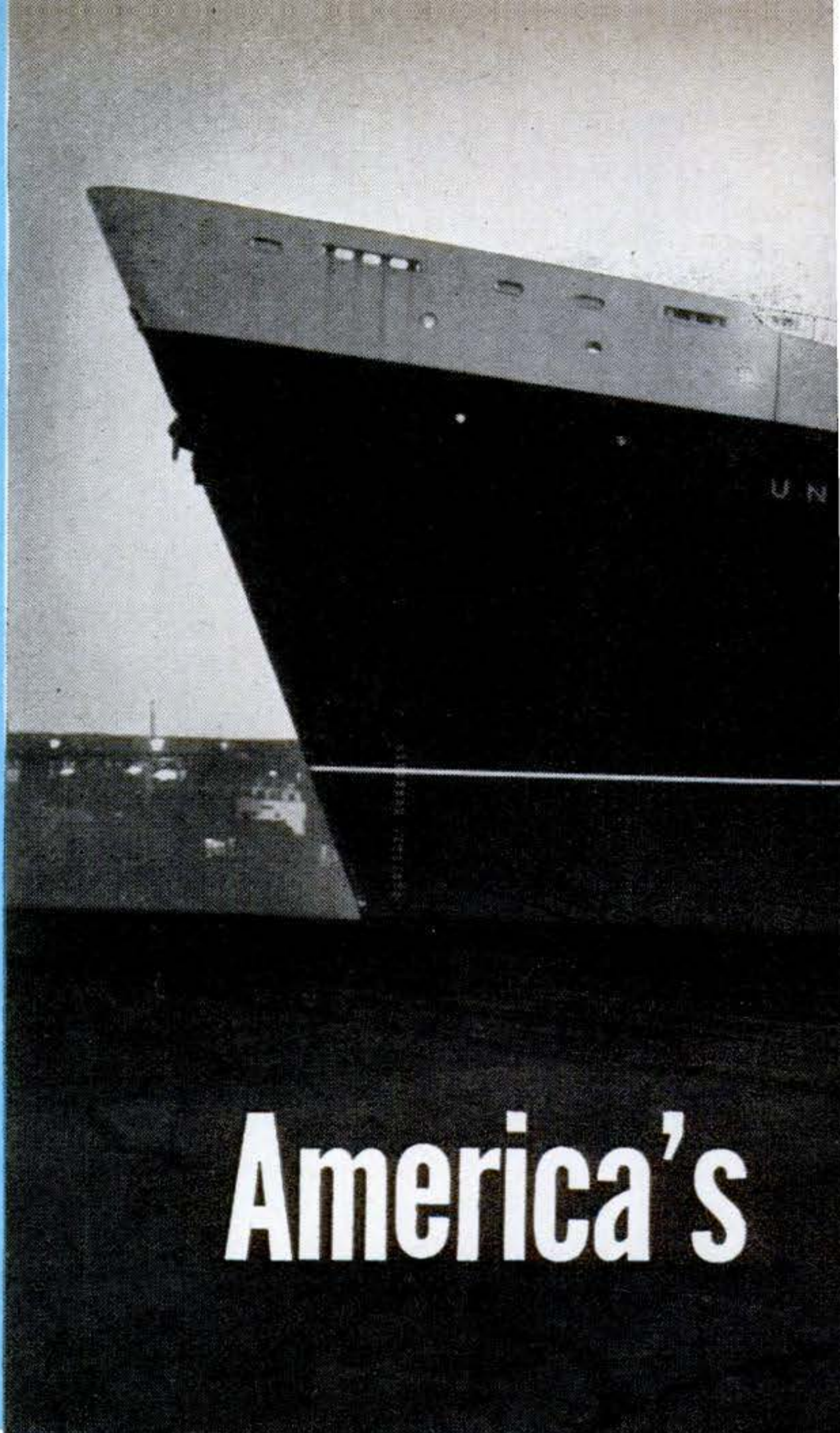

America's

Racing lines of 990-foot *United States* stand

fine and popular ships—highly comfortable and of good speed—but not ships designed to travel at the 30-knots-and-above necessary to make record passages and headlines. The *United States* is definitely in this field.

Beyond that there are other toppers about this ship. She is the largest passenger vessel this country has ever built—51,500 gross tons. Operated by a 1,000-man crew, she will carry more passengers than any other American-built ship—nearly 2,000. She is fireproof beyond any standard ever set by any commercial vessel under any flag. She is air-conditioned throughout—all public rooms, cabins, crew quarters. She uses more aluminum than any other single structure ever built, land or sea. It is used structurally and for decoration and furnishings.

Usually, such technical matters do not strike the eye of the beholder or customer. But those who board the *United States* for her maiden voyage and for trips thereafter

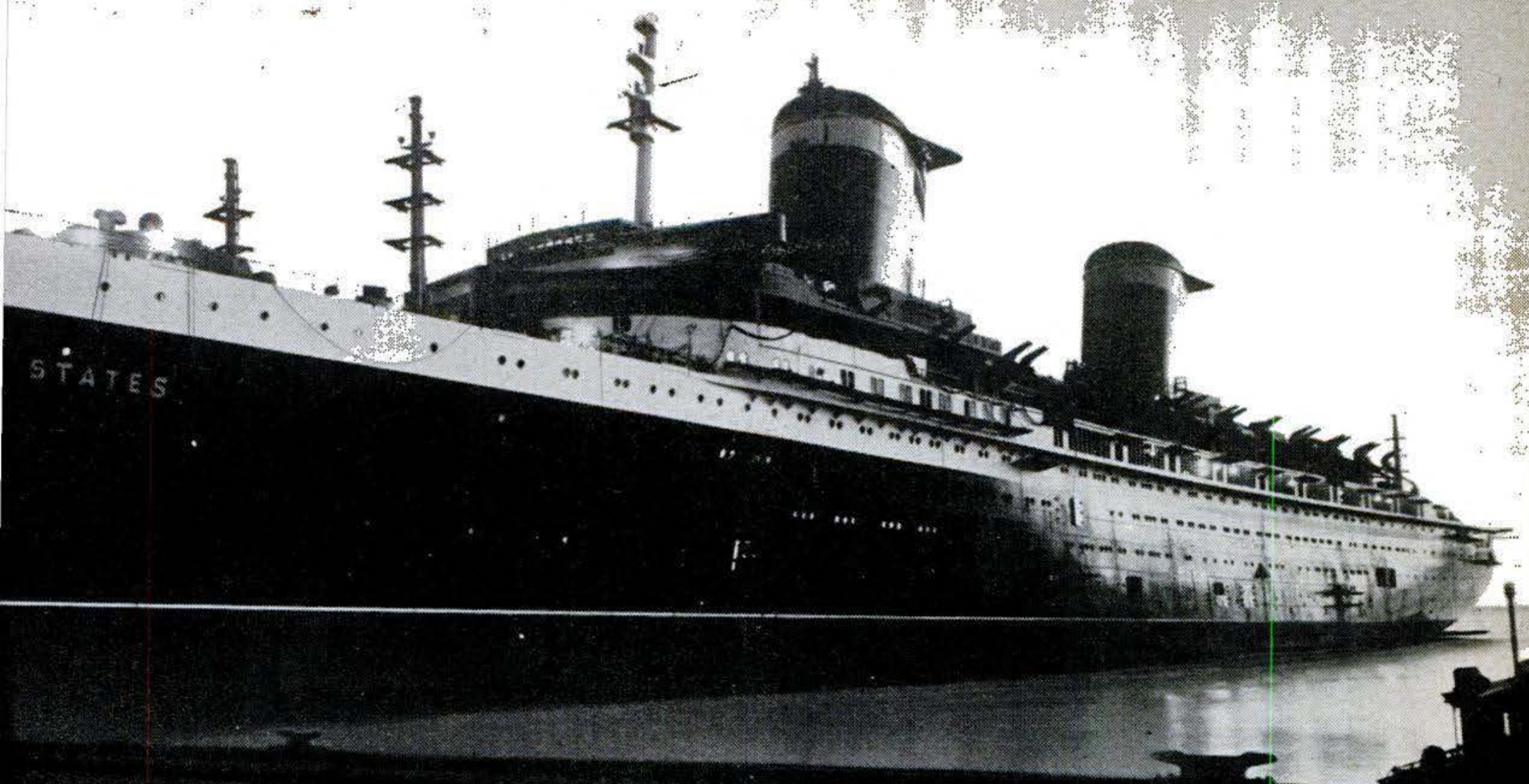

New Liner Challenges Queens

out as she lies at Newport News dock. Note radar tower, which replaces the usual foremast.

will sense the new qualities. At dockside she shows all the bigness of her 990-foot length, her 101½-foot beam and her 13-story height above the waterline. Yet there is a lightness and easiness about her lines. The bow springs forward not sharply but cleanly and in harmony with the bulk behind it. The white superstructure and the great stacks lie easily on the sleek black hull.

Step aboard this ship and both your eyes and your feet tell you there's something different about her. On the open decks you expect the "plock" of teak decks underfoot and the feel of teak rails under your hands. But there's no teak. The decks are a brand-new mastic composition spread over aluminum or steel. The rails are long sections of extruded aluminum, glossy under a special finish. And the decks are remarkably open, swept free of all possible protrusions and fittings, with few ups and downs. The overhead is sheeted smoothly in metal to conceal

FOUR OF THE THOUSANDS of men who built the *United States*. At times as many as 3,000 men—skilled in more than 150 individual trades—were working on the ship at once.



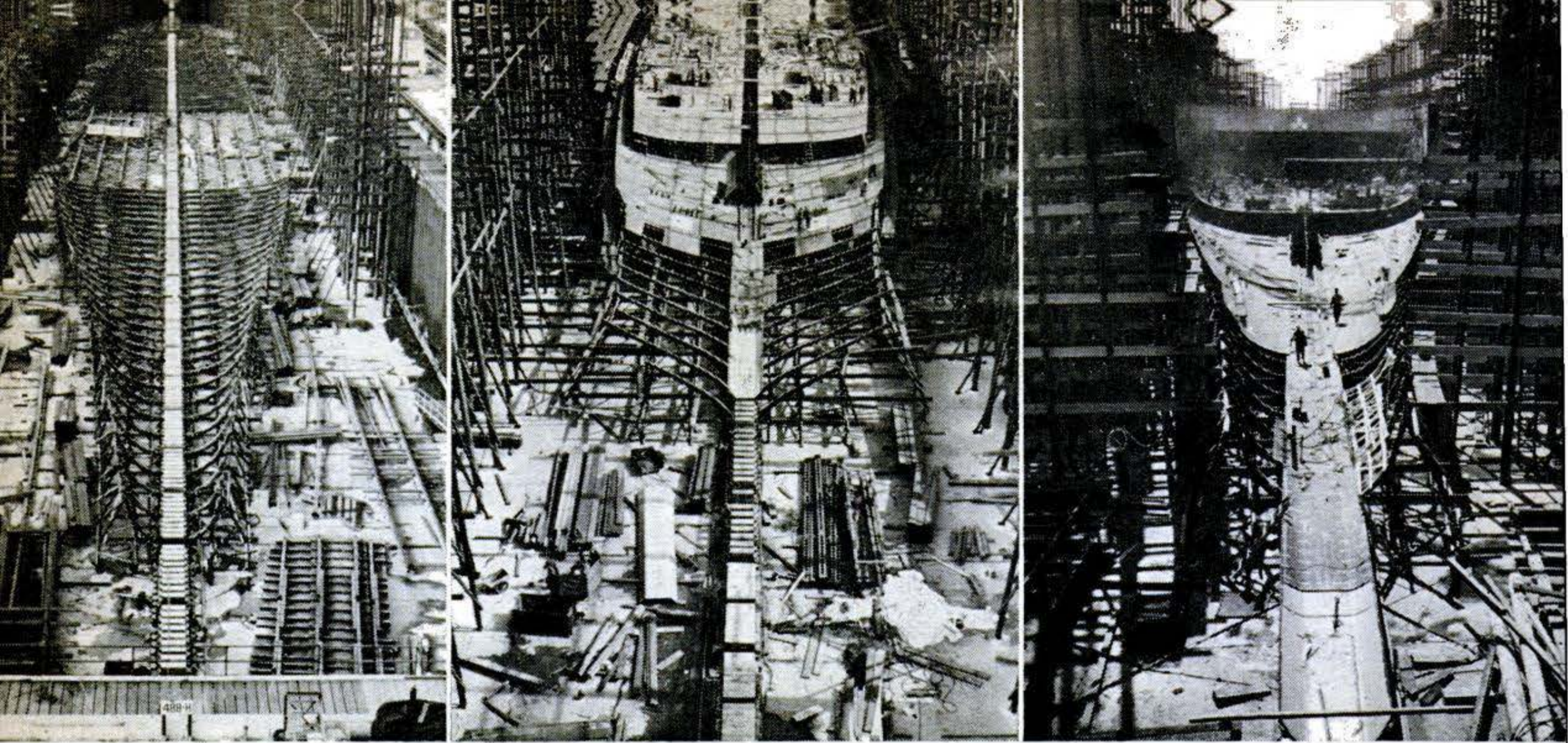

How a Ship Grows

SUCCESSIVE STAGES in the growth of the *United States* are shown in the graving dock where

beams and pipes that would be eyesores.

The same inside. The corridors are long straightaways, with few jogs and turnings and with the usual plumber's nightmare all out of sight. Many of the public rooms extend the full width of the ship. There are many pieces of art on American themes, some in metal or glass—no wood is used in the ship itself. There are screens of glass sculpted by sandblasting. There is a plaster relief map of the North Atlantic. There are aluminum panels anodized to give them soft colors. There are four-foot sculptures carved out of foam glass.

Furnishings Retard Fire

Fabrics and wall finishes run the whole spectrum, but both fabrics and paints are fire-retardant. Furniture is aluminum; upholstery and cushions are springy and soft but they are filled with a new material that will not flame.

For those who must take their shoreside fun to sea with them there are all the facilities. There are two smart theaters for movies and other entertainment. There are swimming pools, lounges, restaurants, night clubs, libraries, barber shops, beauty parlors, gift shops—all the things that go into a modern luxury liner. There is even a special refrigerated room for the storage of those bon-voyage baskets!

For the athletic-minded, there are sports decks—topside, forward and aft—plus a gym

she was built. She was too big for the usual ways. Instead of being launched, ship was "floated" by flooding dock. First piece in place was 55-ton keel section. As ship grew,

and indoor pool. Enclosed promenade decks sweep along the sides. Cabins range from four-in-a-room for tourists to suites up to five rooms in first class. Cabin class—524 passengers—and first class—888 passengers—have private baths; in tourist class—554 passengers—the baths are shared. The cabins have a wide range of color schemes—soft tones and bright, worked out in contrasts, a far cry indeed from the dead whites and "institutional" colors familiar not so long ago.

Can Be Converted into Troop Transport

Despite the ship's charms for pleasure travelers, she was built with very different auxiliary purposes in mind. In time of war the *United States* would become a troop transport, capable of carrying a full Army division. Accordingly, Uncle Sam, who has provided part of the financing, is keeping some of the secrets about her. Her compartmentation—the number and location of watertight bulkheads with their automatic doors—is not being told.

Details of the power plant also are shielded by security. Certain things, however, are evident about the punch in the *United States*. Here is a ship of 51,500 gross tons, as against the 80,000 or so of the *Queen Elizabeth* and the *Queen Mary*. Yet this ship will carry almost as many passengers as the Queens and will carry them as fast. This means that important space has been gained somewhere, and it's

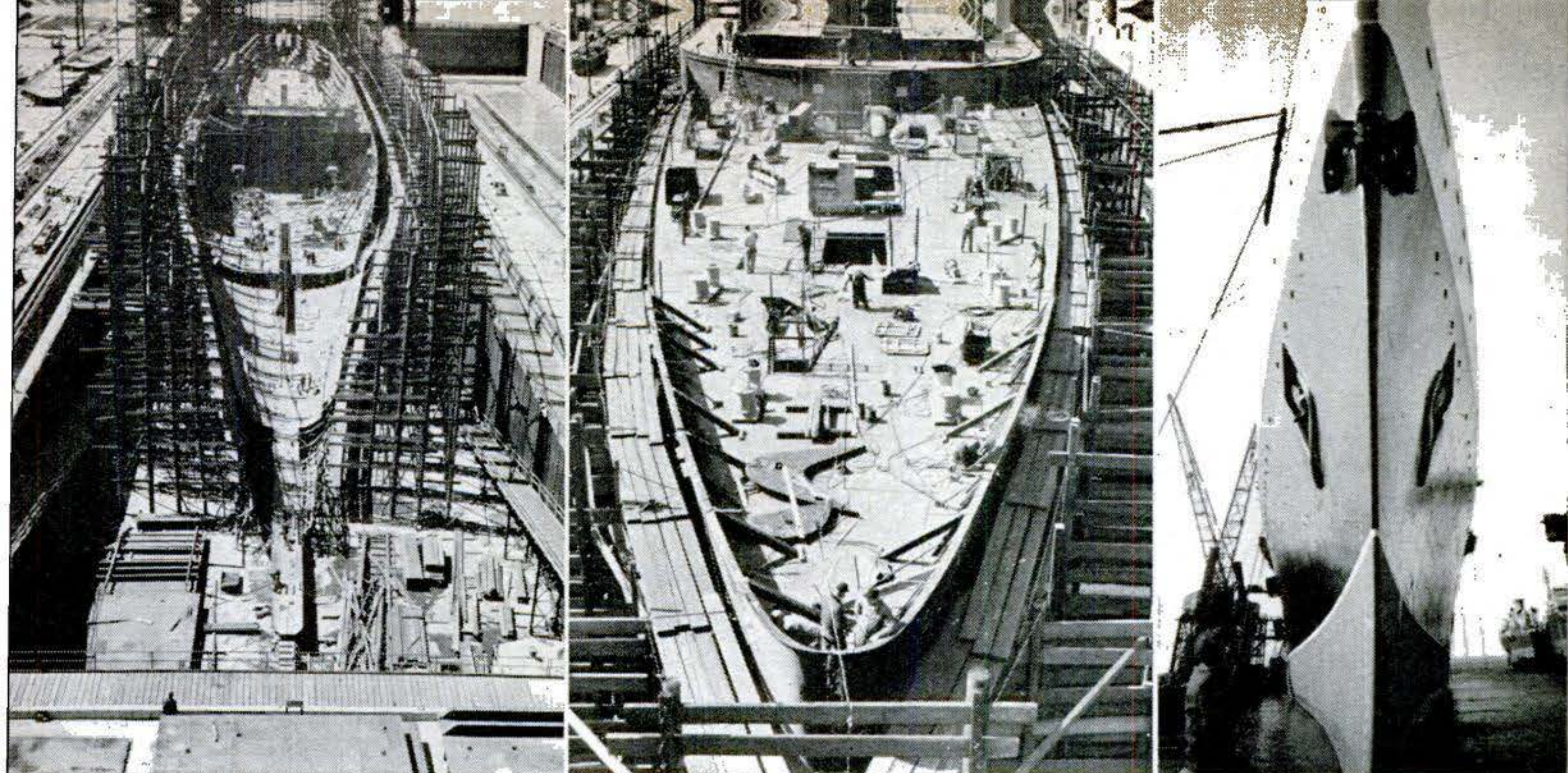

huge subassemblies were built ashore and lifted into place. More than 1,500,000 steel and aluminum rivets and 1,500 miles of welding were required. Steel plating would make a

6½-foot walk 4¾ miles long. More than 8,400 master drawings and nearly 1,500,000 blueprints had to be made. Final picture shows *United States* in the outfitting dock.

a good guess that it has been gained in boiler room, engine room and fuel storage.

The boilers and turbines operate at very high temperatures and high pressures. To handle these in the small space and weight called for new tricks by the metallurgists who worked out the alloys and by the fabricators who designed and built the machinery. In the laboratories and shops of the Newport News Shipbuilding and Dry Dock Co., which built the vessel, and of Westinghouse and Babcock & Wilcox, which built the engines and machinery, technicians took all that was known about marine propulsion and added a few new items.

Air Conditioning a Problem

The air conditioning was a highly desirable feature but its headaches were many. Finding space for the pumps, fans, ducts and controls was one of them. There are really 50 independent air-conditioning systems, and their ducts range in size from three inches to some that are big enough to drive a truck through. And once fitted in—on paper—there still remained the problems of building them and making them work.

The space problem was one for the designers. As fast as they cleared a blueprint it went to the sheet-metal shops at Newport News and the men began cutting out and assembling the fantastic shapes that had to carry the air around corners and up and

down in the ship. Subassemblies were made as large as possible and stacked up on the dock. There they looked like the principal ingredient of alphabet soup—and in a foreign language at that. But they were fitted in place and hooked up.

Making the air-conditioning systems work

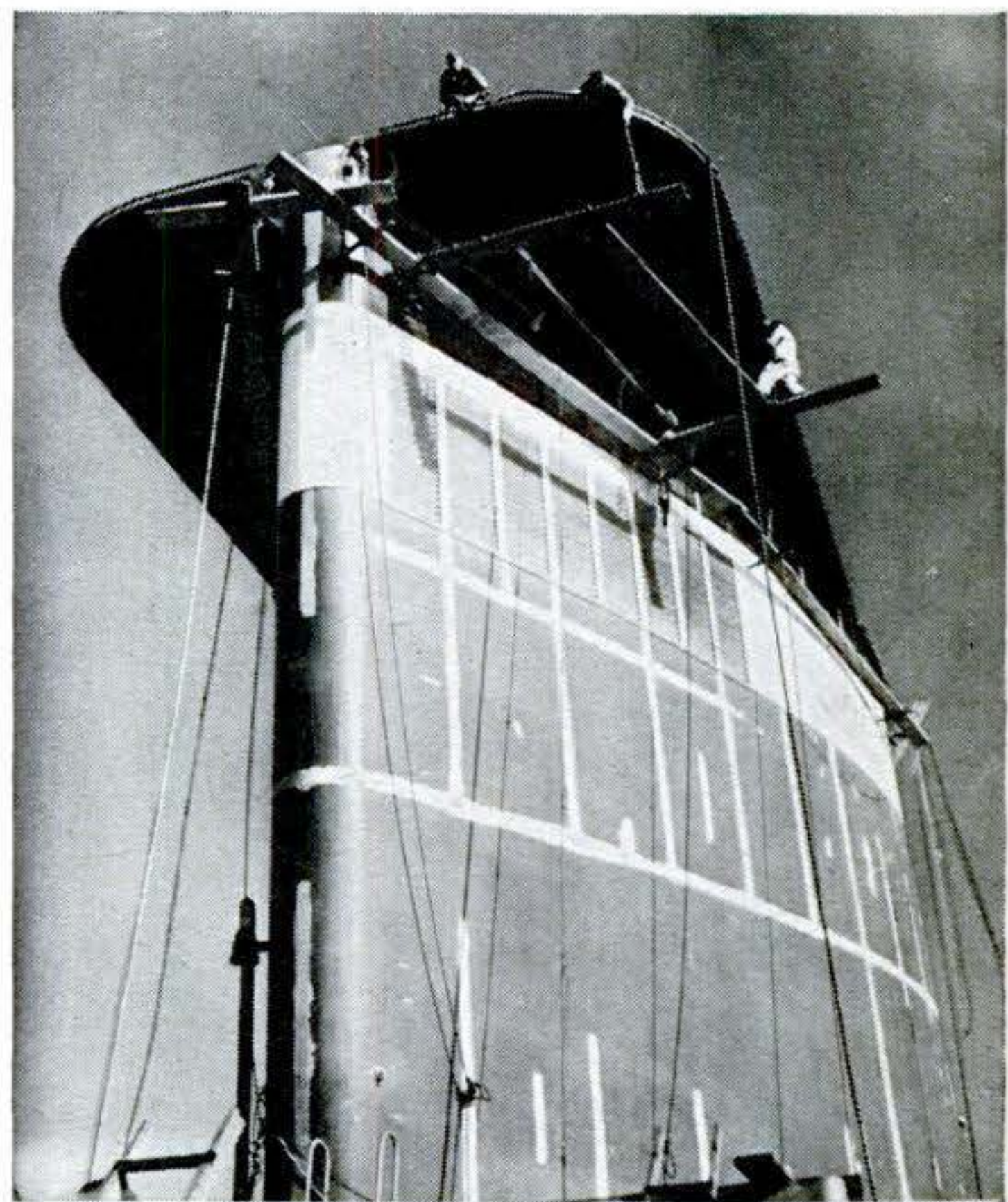

HUGE "SAMPAN" STACK, one of two, gets final touches. Wind tunnel tests of many stack models showed this design would keep fumes clear of decks under all speeds.

was a special problem. Air conditioning at sea offers different problems than on land. There is more moisture in the air most of the time; there are greater contrasts of temperature inside and out. The problem of condensation was severe. It was solved by insulation and by using filter traps at intervals all along the ducts. These collect the moisture in a few spots rather than let it accumulate anywhere on the surface of the ducts. Another feature of the system is the thermostatic control in each cabin. All the air, filtered from the outside, is circulated in the ship at 50°. When it reaches a cabin it passes through an electric heating unit controlled by the thermostat; the passenger in an outside cabin may want more heat, one in an inside may want more cooling. Each will get what he wants.

Aluminum Was Tricky

The use of so much aluminum, in so many ways, called for new tricks. Plain sheet was no problem, and some shapes could be stamped, molded or extruded. But when it came to the stacks it was economic folly to think of shaping them with dies and presses. The heavy sheets could not be worked like steel, with rollers or torches and hand hammers, because aluminum just won't shape that way. It had to be worked slowly and carefully by hands and clamps and

special jigs. And when the stacks were done they were so big they had to be cut in half to be lifted into place.

The aluminum rails were turned out to approximate dimensions, including all the curves and fittings, in the shops of the Aluminum Co. of America. Then they were put in place, with precise machining, on the ship. Next they were marked, removed and shipped back to Alcoa for "alumilite" coating, the final finishing process. And then they were sent back to the ship for permanent installation.

Aluminum panels and decorations had to go through much the same laborious process. Aluminum rivets were handled like trick confectionery. Received from the factory, they were first heated to 1,040°, to "smooth out" the alloys, then quenched in water and rinsed in alcohol. To prevent the rapid aging which takes place at ordinary temperatures, the rivets were sunk in freezer cabinets at 40° below zero. Thereafter they were stored in insulated containers (including standard ice-cream cabinets) until they were driven. Once in place the aging, which results in greater strength, could take place.

The virtue of all this aluminum topside is of course its lightness. Averaging one-third the weight of steel, it lowers the ship's center of gravity, in turn reducing her tendency to roll. [\[Continued on page 270\]](#)

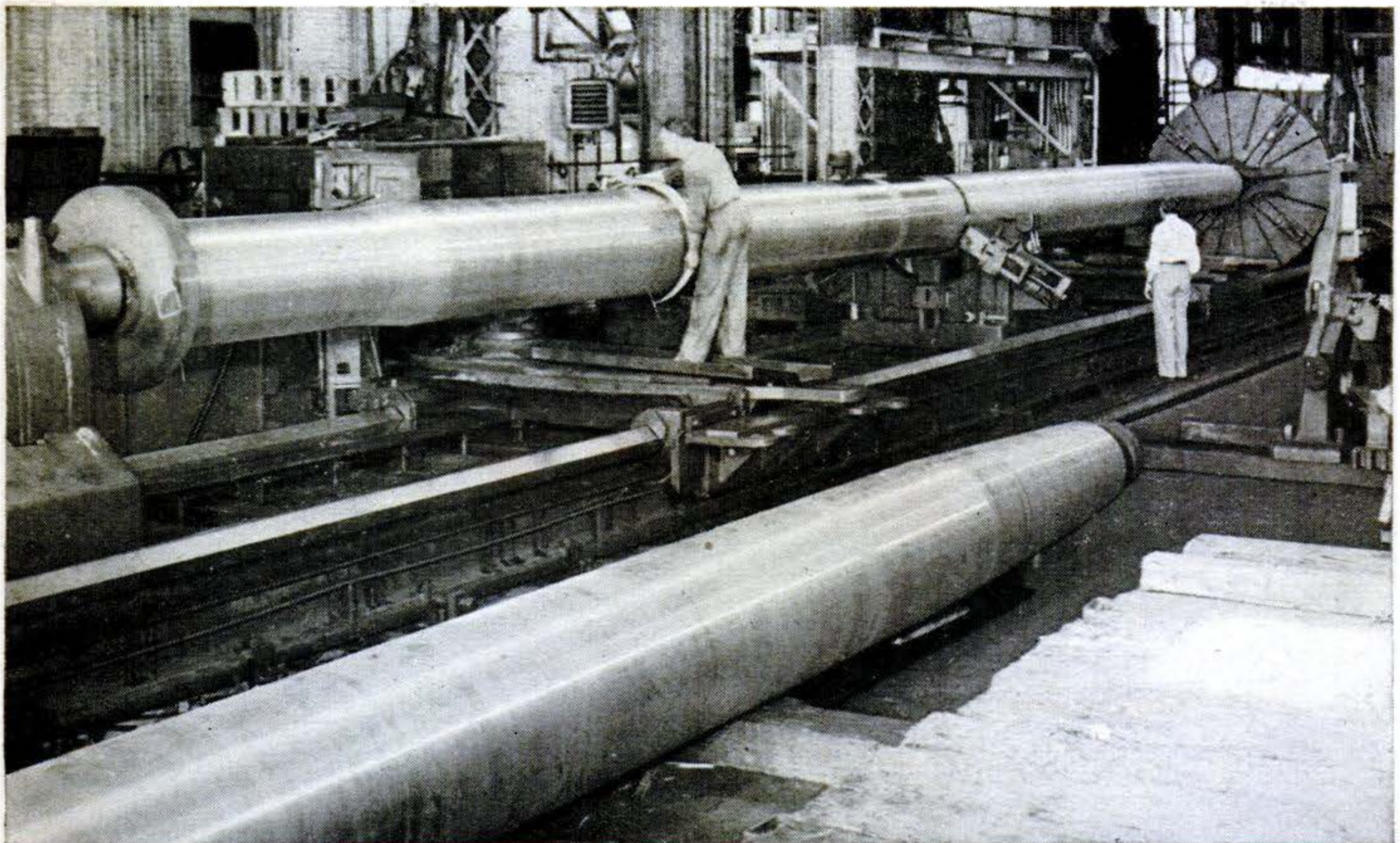

GIANT PROPELLER SHAFTS of the *United States* are made of special alloy steel. Steam tur-

bines of secret design turn four screws fast enough—designers hope—to break record.

New Ideas from the Inventors

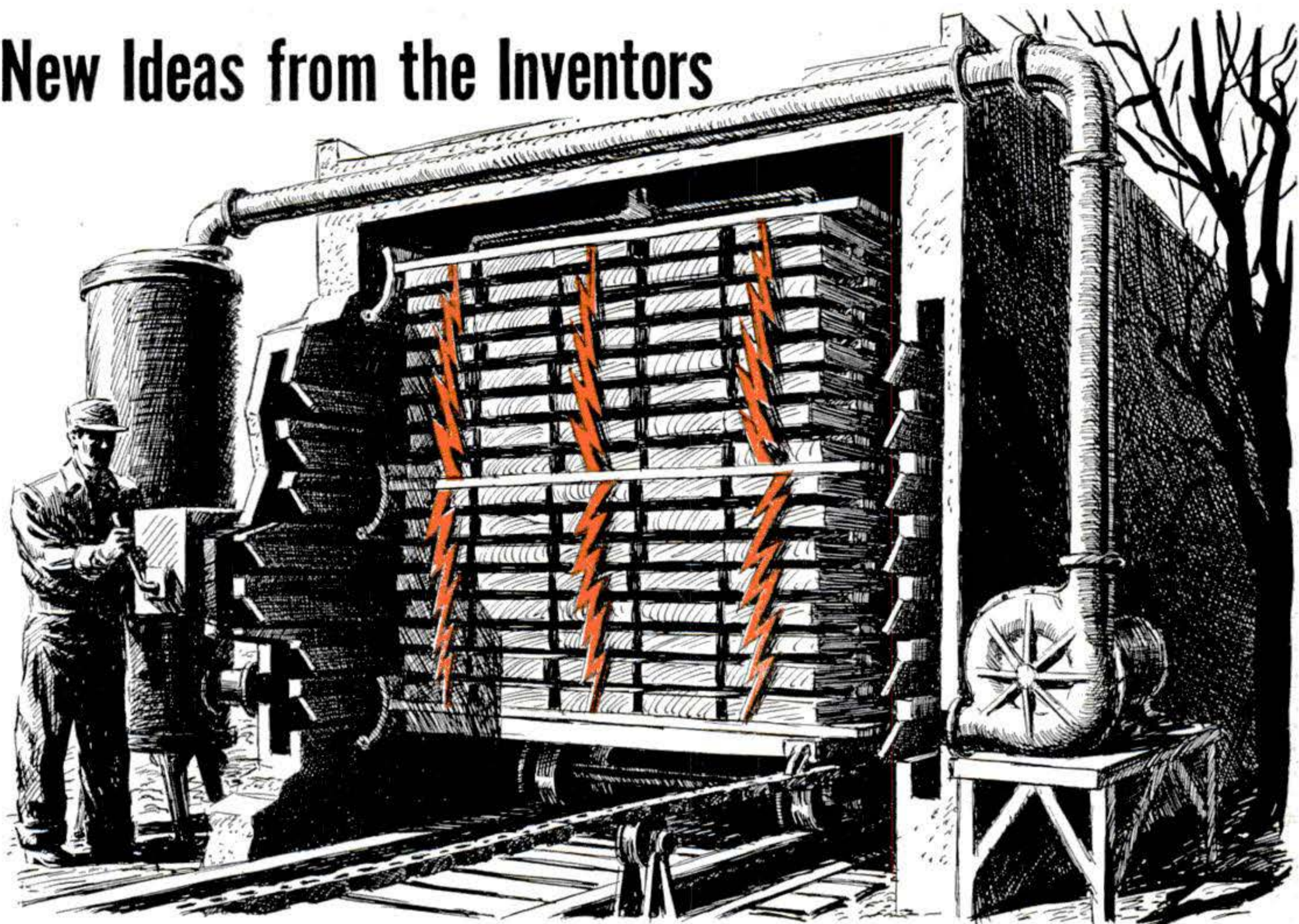

1 Heat Plus Radio to Dry Lumber. Although it has been known that high-frequency radio waves will dry green lumber much quicker than conventional hot-air methods, their use has proved too expensive.

A proposed process would combine both methods to cut costs. Lumber would progress through three compartments, being dried by hot air in the first two, and by hot air plus radio waves in the third.



2 Seesaw to Trap Mice. No mouse could steal the bait from this rocking trap. If one so much as stepped on it, the baited end would tilt down and trip a trigger underneath, releasing the spring jaw to snap shut on his neck. The trap could even be used without bait if placed in a path mice had to use to reach food.



3 Shoe Lights to Blink In Dark. Clipped onto a child's shoes, these novelty lights would blink on and off as the youngster walked. Each light would have a bulb, a flashlight cell, and a switch consisting of a metal ball that would open and close the circuit as it rolled back and forth with the motion of the foot.

Please turn the page for more new ideas.

MAY 1952 113

MORE New Ideas from the Inventors

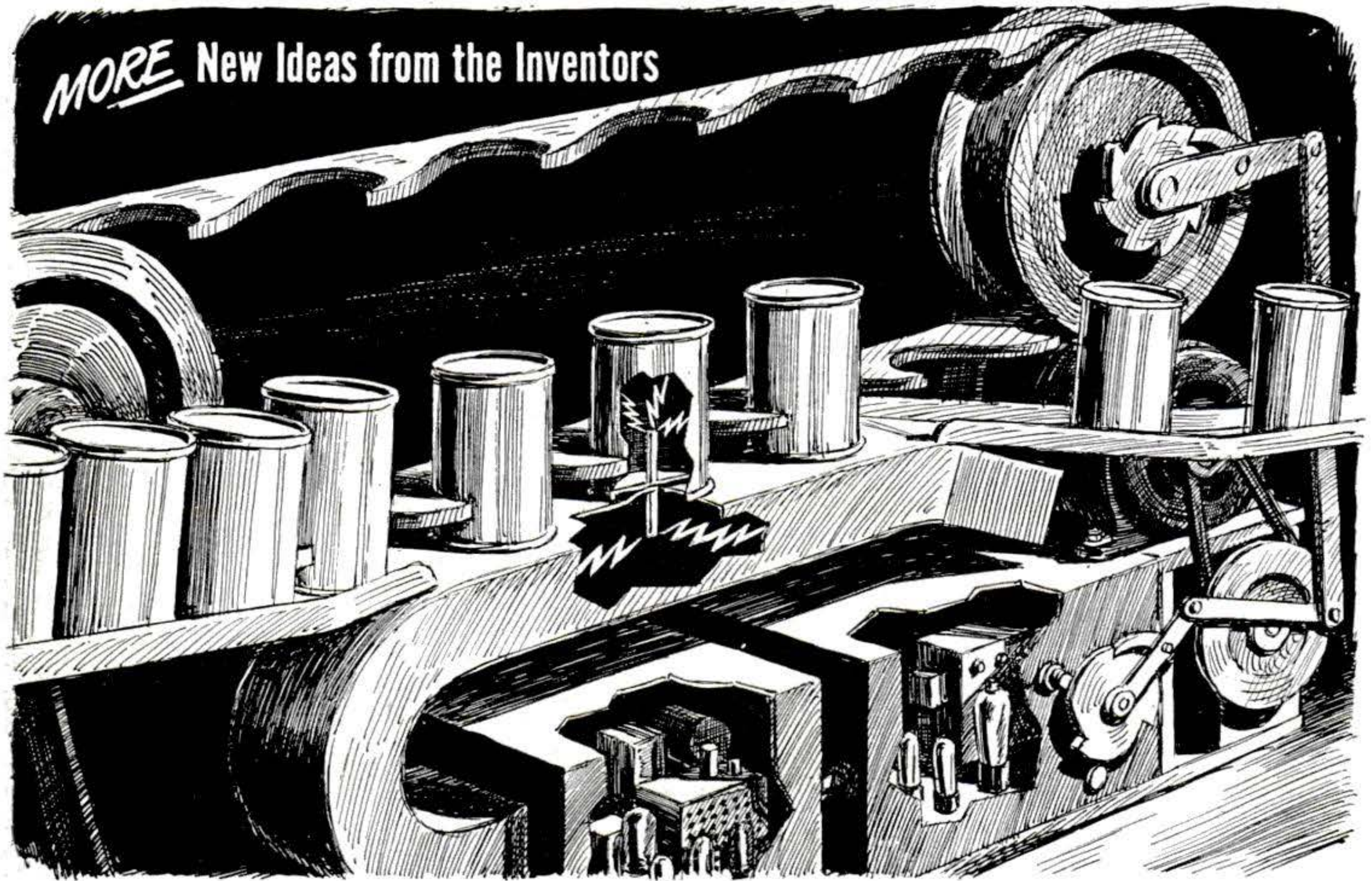

4 Radar to Preserve Food. Tests of radio waves for sterilizing food could not use sealed cans because the metal acted as a shield. This invention may be the answer. It proposes a can fitted with a rod inside its

bottom to act as half of a dipole antenna. The second half would be in the wave guide of a high-frequency generator. Bringing the two together would transmit the waves to the canned food.



5 Lamps to Have No Cords. Wiring a large restaurant for table lamps should be no problem according to the designer of this system. It uses no wires. The fluorescent lamps would be powered by radio energy radiated from a ceiling antenna. The circular support on each lamp would serve as a loop antenna to pick up the power.



6 Tester to Spot Live Circuits. Held against a bus bar, this tester would spot a live line. The indicator would be a glass-windowed cell containing two electrodes and two non-mixing liquids of different conductivities. If current flows, change in distribution of the fluids would show in the window.

Patents on these inventions have been granted to: 1. H. Wood, North Berwick, Me.; 2. E. Brust, Norwood, N. J.; 3. N. Rikelman, The Bronx, N. Y.; 4. K. Smith and A. Grinnell, Los Angeles; 5. N. Wales, New York City; 6. H. Petch, Edgware, England.

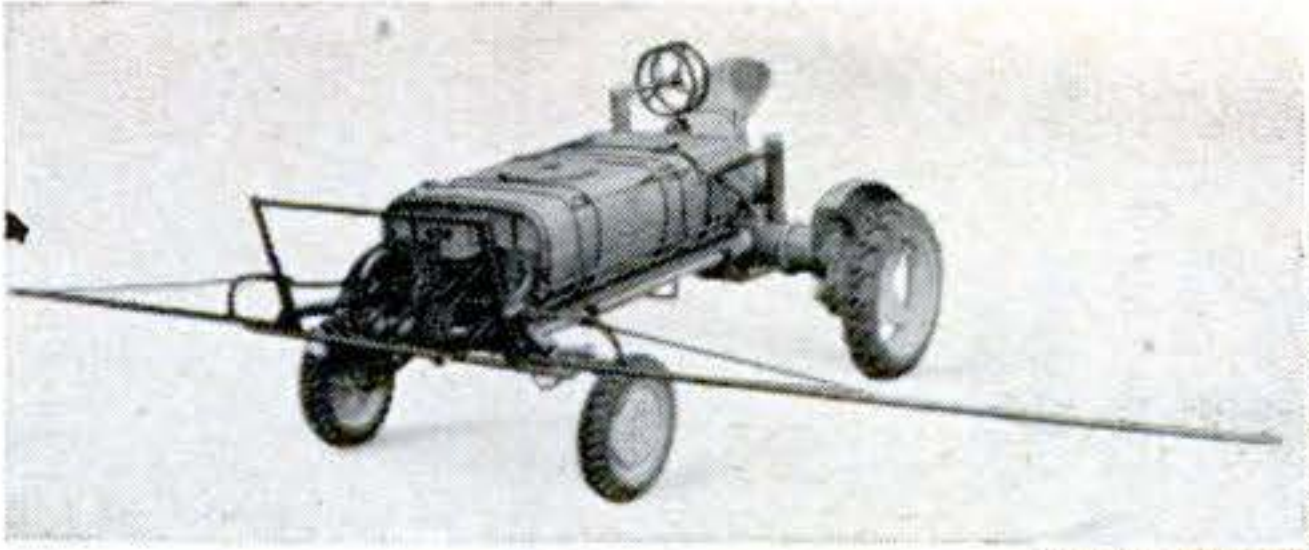

Tractor Steers Like Hook & Ladder

THIS new lightweight German tractor has two steering wheels, one for each axle, so that it can turn in its own length. Instead of pulling farm implements behind, it carries them in front on a frame, enabling the driver to see how the work progresses. For spraying insecticides, the tractor carries a 200-gallon tank (inset above). It can cover a 25-foot-

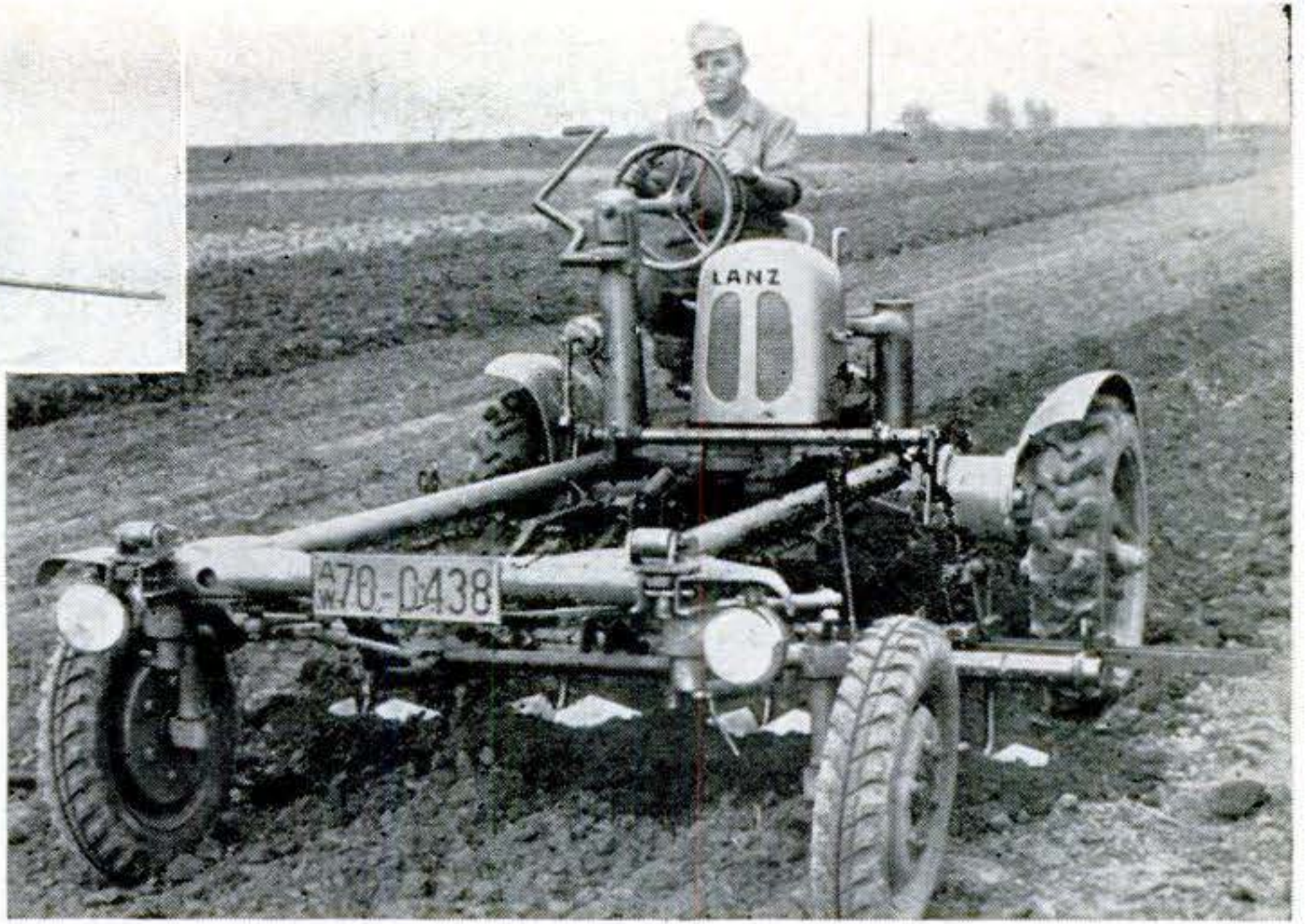

wide strip while moving five miles an hour. Made by H. Lanz Co., of Mannheim, it is powered by a Gemo engine.



You Can Wash This Air Filter

A NEW filter for hot-air furnaces and air-conditioning systems need not be replaced when dirty—you just wash it and reuse it. The filtering material, a plastic film shredded into a porous mass, picks up an electrostatic charge when exposed in a current of air. This charge attracts and retains pollen, dust, soot and even fine cigarette-smoke particles suspended in the air. Simply rinsing in cold water cleans the filter, and it can be put back in place while still damp. Goodyear Tire & Rubber Co., Akron, makes it.

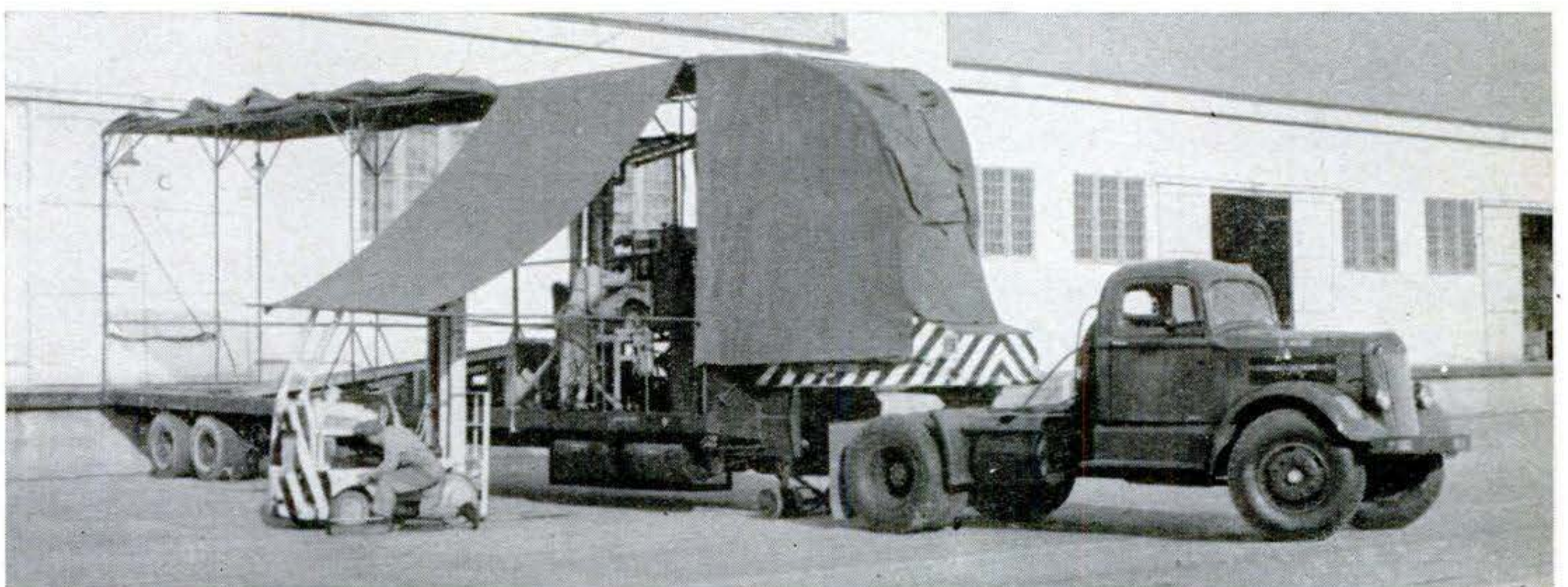

Service Station Goes to Trucks

THE service-station-on-wheels above goes to the aid of fork-lift trucks and tractors whenever they need repairs at Cheli Air Force Depot, Maywood, Calif. Towed by a heavy truck, the 40-foot flat-bed trailer is

equipped to change a wheel or elevate the little vehicles on a grease rack. Electric lines and hoses permit work to be done on three trucks at once. A gas-powered compressor supplies air pressure for greasing apparatus.



ENDOMORPH

How Your Shape Shapes Your Life

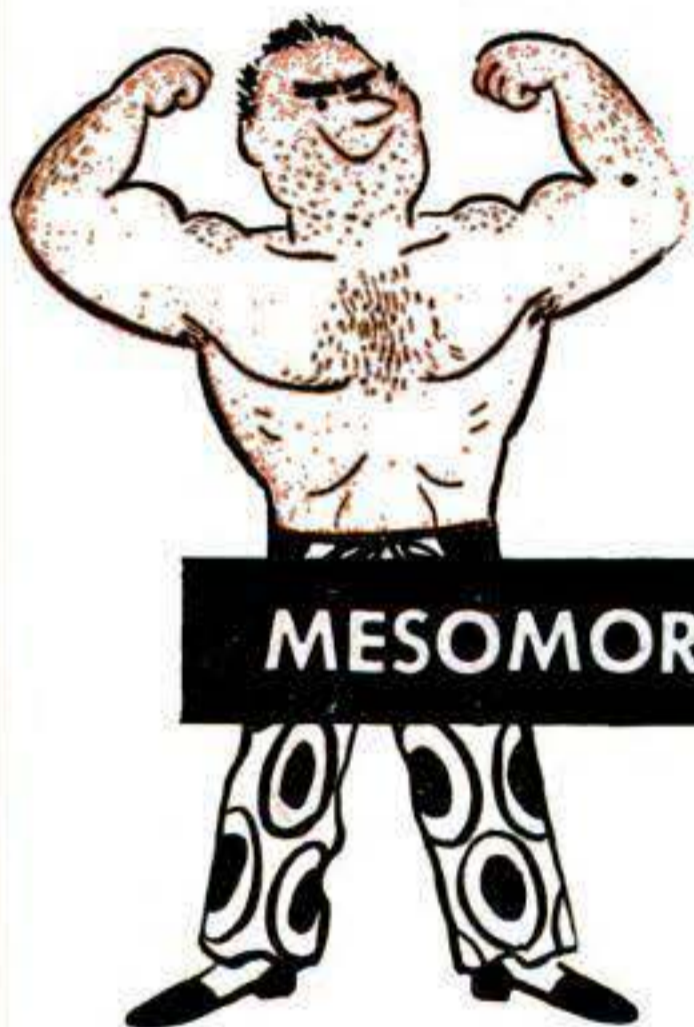

MESOMORPH



ECTOMORPH

The muscle men wield power, size 46s enjoy themselves, but it's the skinny, nervous guys who have the drive to get the girls.

By Liam O'Connor

A JUNIOR executive I know has a pet method for hiring men. "I tell the job applicant to look me straight in the eye," he says. "If the fellow blinks before I've finished counting ten, I don't take him on. I know right away he's sneaky. He'll probably lie. He may steal."

This procedure is simple and quick. But scientific research has revealed that confirmed criminals often can hold an unblinking stare longer than many an honest citizen.

From earliest times, men have tried to get clues to human personality by casting horoscopes, or by reading the palm, or by studying some other part of the anatomy—

THE THREE EXTREME BODY TYPES are shown above—the fat, lazy endomorph; the strong, energetic mesomorph; the skinny, nervous ectomorph. Most people are not extreme types—but every type, extreme or not, can be accurately measured.

The Nervous Ectomorph Worries All Day Long

Mr. Ecto awakes harried and unrefreshed. On the way to the office, he gulps down a quick cup of coffee, then dashes for his bus. He has difficulty cultivating good living hab-

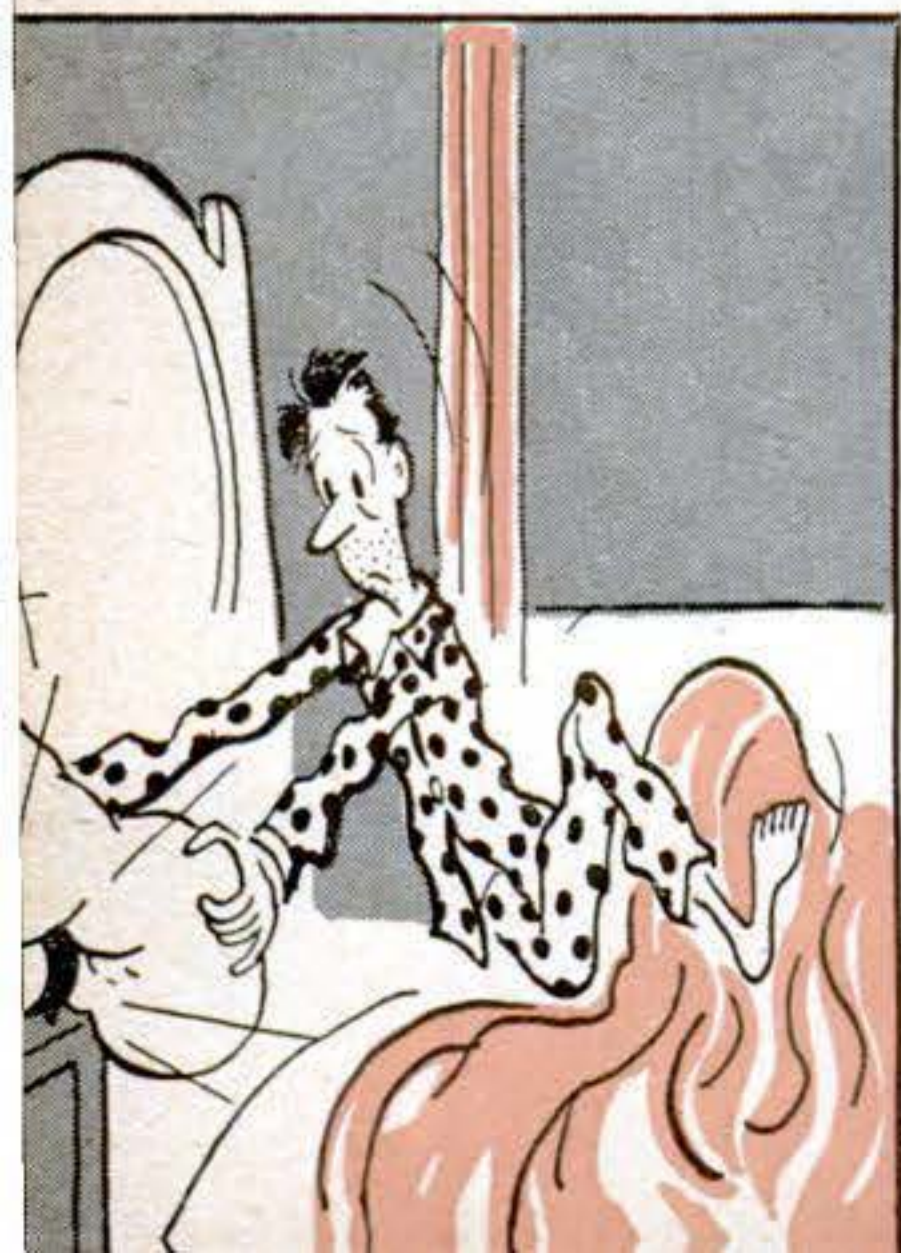



Careful measurements of 100,000 people show close relationship of body build to personality.

the skull, the forehead, the eyes, the fingernails, the feet. When subjected to analysis, however, all these magical systems have failed to live up to their claims.

100,000 Bodies Can't Be Wrong

Yet common sense stubbornly insists that people *can* be sized up—to some extent—from physical appearance and behavior. Aren't most fat men placid and easy to get on with? Aren't thin men liable to be jittery and rather difficult customers? Can't scientists, then, systematize such items of information, discover more of the same, and give us a comprehensive and practical classification of human beings?

Answer: It now looks as if they *can*.

The man who has come closest to doing

its, is frequently late, often untidy. At work, he prefers to be off by himself. After hours, he struggles to relax, seldom can. But his

it is Dr. William H. Sheldon, director of the Constitution Laboratory at Columbia University. Dr. Sheldon has been investigating body build and temperament for about 25 years. Thus far, he and his associates have produced three monumental volumes: *The Varieties of Human Physique*, *The Varieties of Temperament* and *Varieties of Delinquent Youth* (published by Harper & Brothers).

Four more books are now in preparation. About 30 medical schools, hospitals and other institutions are cooperating with Dr. Sheldon. The Rockefeller Foundation recently made a grant of \$100,000 for further research. He and his co-workers already have photographed and studied more than 100,000 individuals.

Dr. Sheldon classifies people into three

evening is likely to be the pleasantest time of day—for the nervous little guy is the lady-killer. Honest!

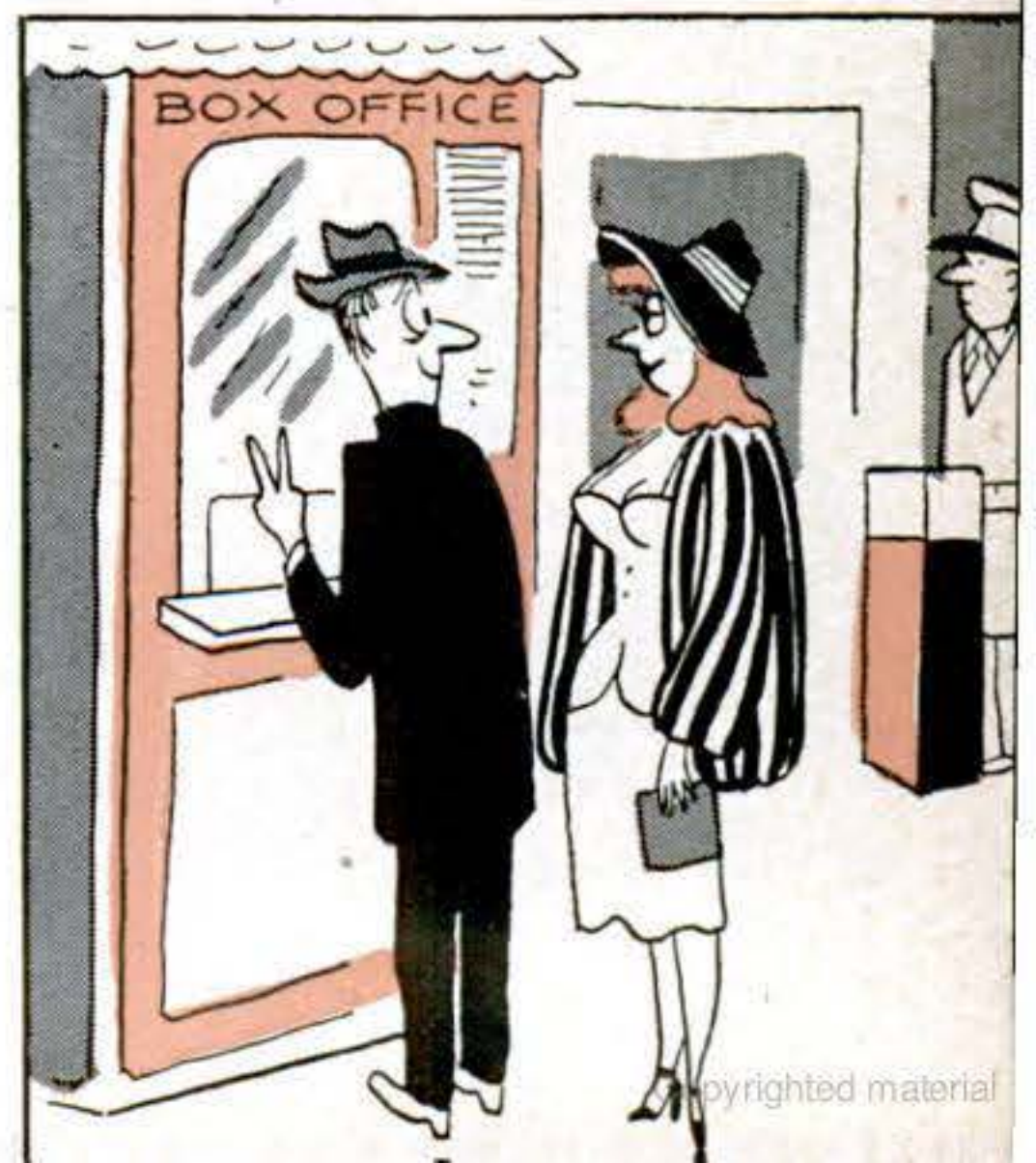
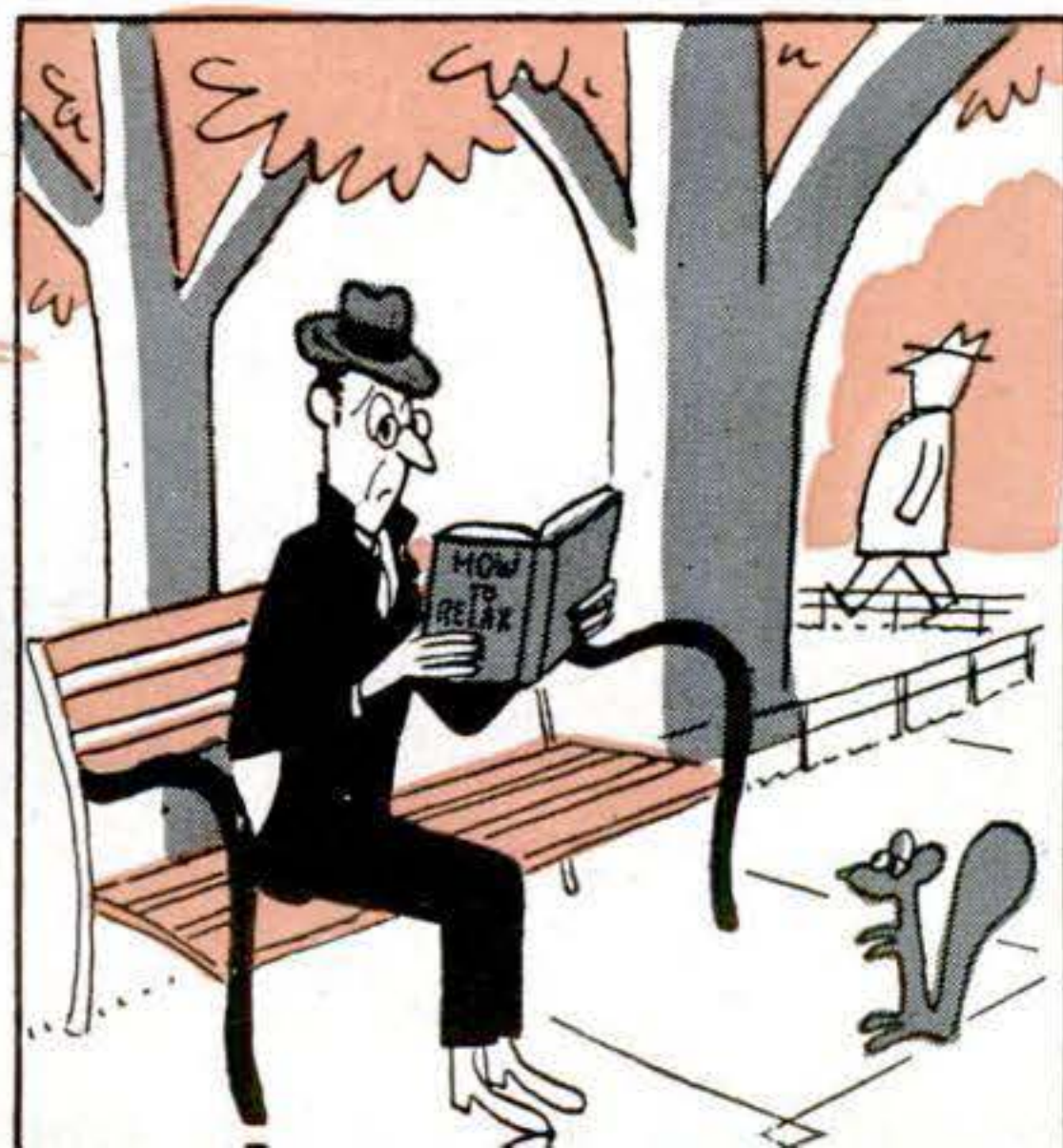

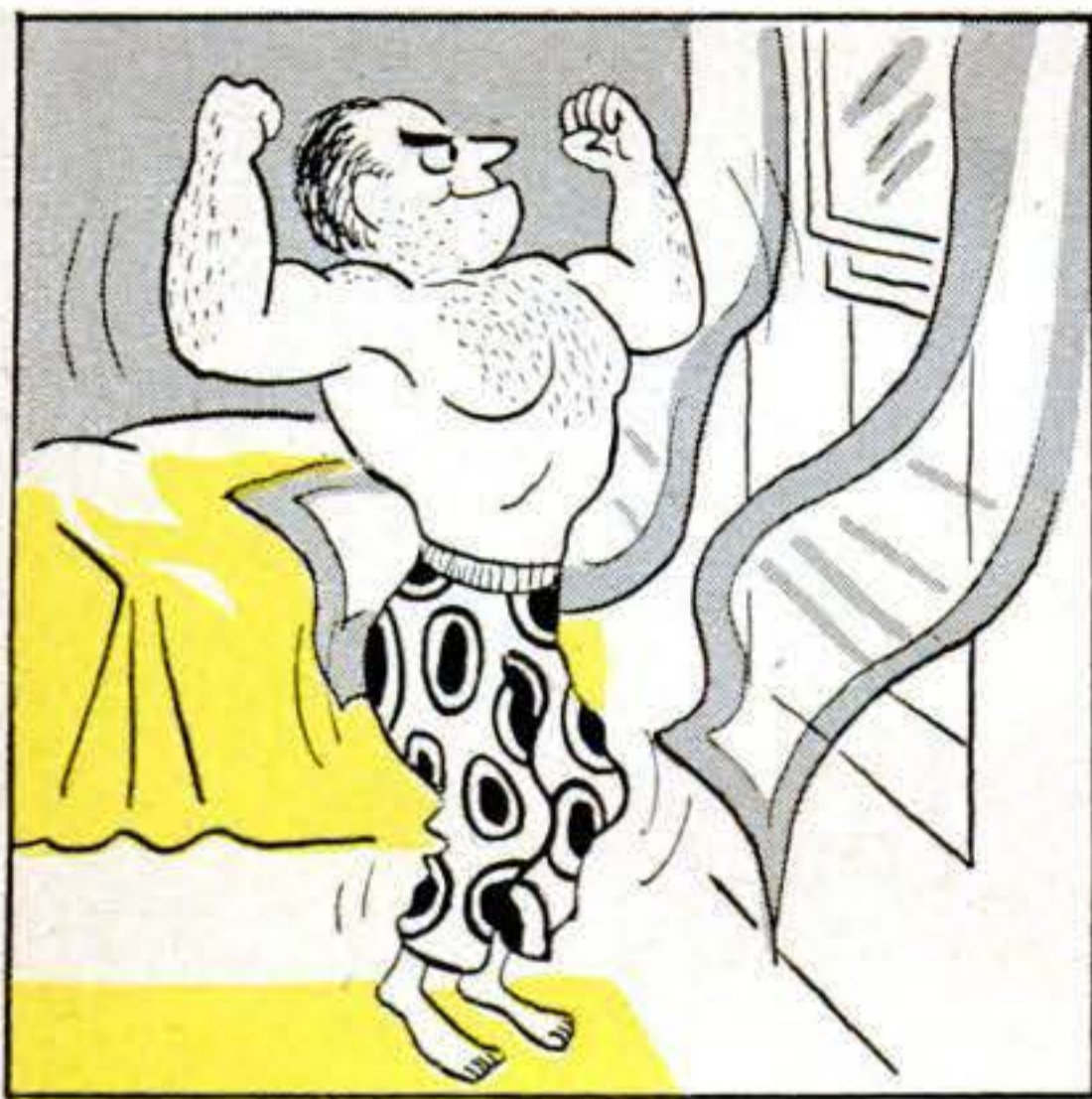

The Rugged Mesomorph Puts in a Bustling Day

Mr. Meso arises briskly, plunges into vigorous setting-up exercises, then wolfs down a moderate breakfast while he concentrates on the sports page. Later, he swings aboard

basic constitutional types according to the three different layers of cells that make up the human embryo. The inner layer, the endoderm, has most to do with the development of the digestive machinery. The middle layer, the mesoderm, has most to do with the formation of muscles, the skeleton and the circulatory system. The outer layer, the ectoderm, has most to do with the development of skin, nails, hair and nerves.

Three Basic Body Types

Now these three layers don't have exactly the same amount of influence in every person's history. Some individuals have particularly large stomachs, livers and intestines. They put on fat easily. These are called *endomorphs* or fatties.

Those who have big muscles, heavy bones, powerful hearts and large blood vessels are called *mesomorphs* or muscle men.

Those who are thin, with relatively great surface area compared with bodily mass and with highly developed nervous systems, are called *ectomorphs* or nervous types. These people, incidentally, are not necessarily more intelligent than other types.

To classify a person, Dr. Sheldon rates the nude body for fat, muscles and nerves—always in that order—on a seven-point scale. On this scale, 1 represents the minimum, 7 the maximum and 4 the average.

The extreme endomorph or fatty therefore has 7-1-1 as his *somatotype* (body-build) number. If he were less fat, more muscular and more nervous, his somatotype might be 6-2-2 or 5-3-3. In the same way the extreme mesomorph or muscle man is rated 1-7-1, and the extreme ectomorph or nervous type is rated 1-1-7. A man who is average in all three components—fat, muscle and nerves—is 4-4-4.

The Happy Endomorph Enjoys the Whole Day

Mr. Endo sleeps soundly, arises to a huge, unhurried breakfast attended by a large and devoted family. Later, he ambles off to the office, where he is a constant source



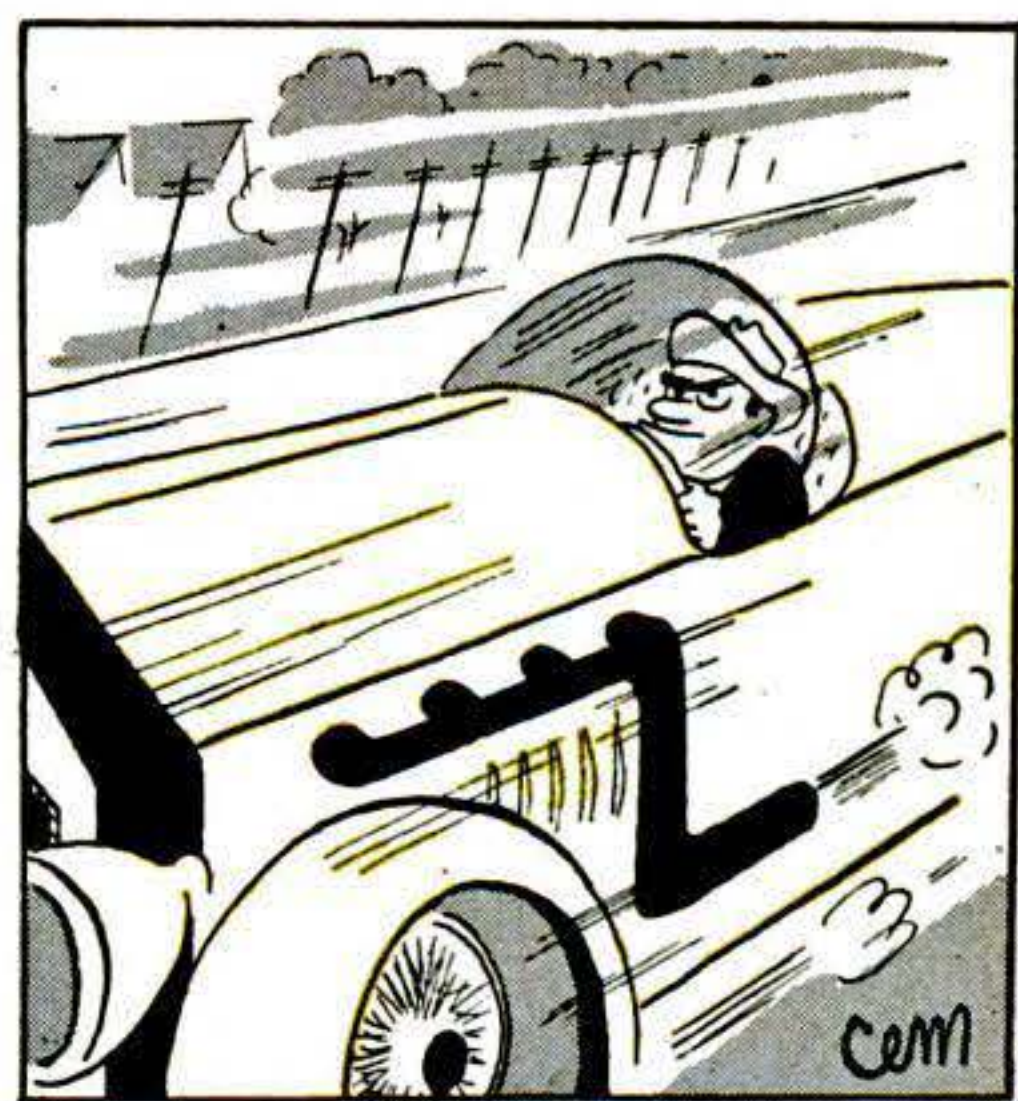
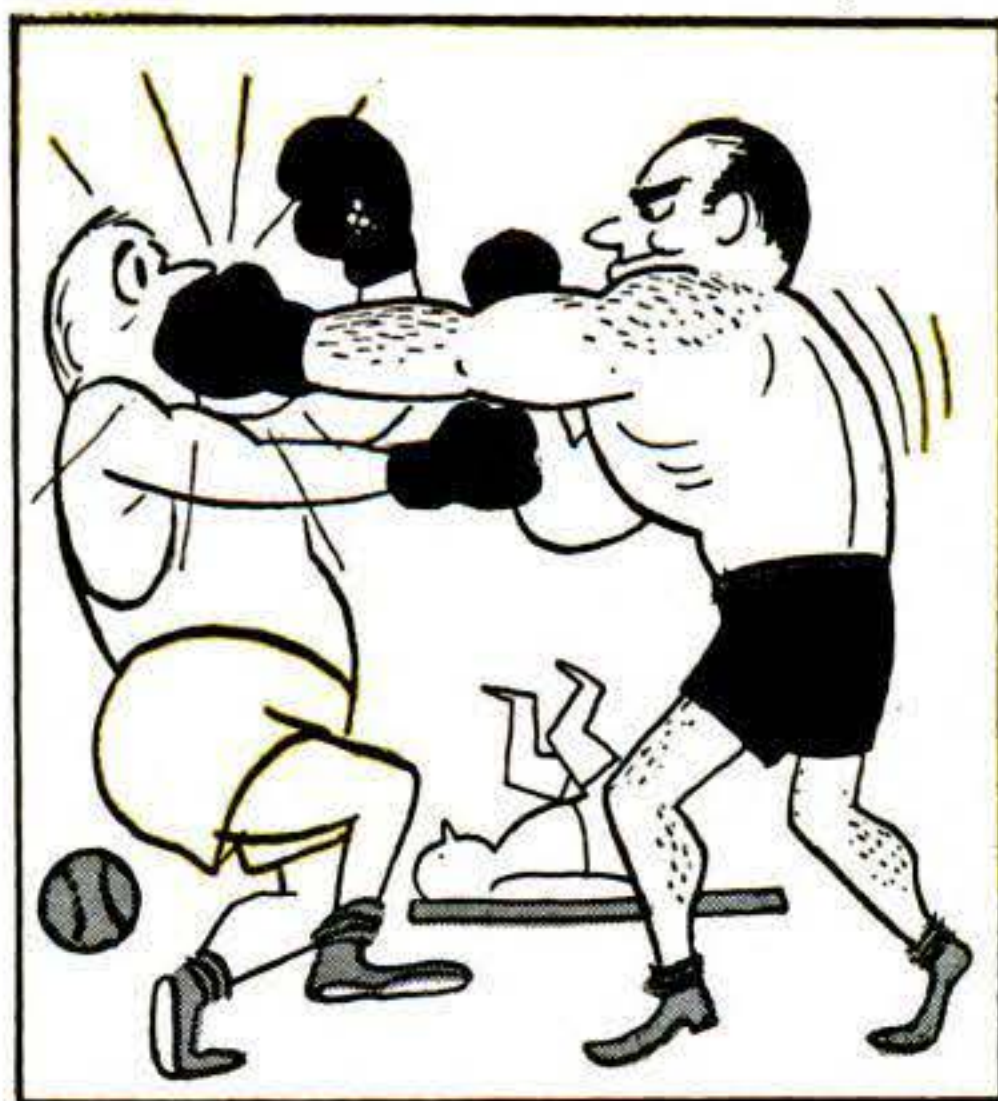

a speeding commuter train with daredevil abandon. A forceful, aggressive businessman, he drives home a point at the office while his

subordinates cower, then knocks off for a work-out at the gym. His idea of an evening's relaxation is a fast ride in a powerful car.

Dr. Sheldon's next step is to measure how each type of body chassis behaves. For this he has developed a scale of temperament: a list of 60 personality traits, boiled down during five years of testing from an original total of 650.

Different Bodies Act Differently

When you run over the items on this scale for each body type, you can see that they ring true with your own observations:

- **The extreme fatty** is a very relaxed fellow; he likes to sink limply into an easy chair as overstuffed as himself; he walks like the elephant in a slow, smooth amble. He loves eating and being with people and is therefore a great one for parties. He expresses his feelings easily.

Alcohol makes him even more relaxed, more sociable, more radiant with emotional warmth. When in trouble he seeks out

of entertainment for himself and his fellow workers. After work, he joins the boys for a drink and a few verses of "Mother Machree."

people—particularly other fatties—and talks it out of his system. He thinks childhood is the best time of life and idealizes the family and mother-love. His sexual drive is low.

- **The extreme muscle man** holds himself erect without effort and walks vigorously with brisk arm and leg movements. He has a tendency to use marked gestures of the head and hands in conversation. He loves physical exercise and physical adventure—in war, exploration, competitive athletics, mountain climbing, wherever he can find it.

Usually he is crazy about speed. If you want to see him really happy, watch him at the controls of a car, a boat or an airplane, eating up time and distance. He also loves to have power over others, and to take unnecessary chances. He likes large, open spaces. Free of doubts, he makes decisions quickly. He is a born executive.

[Continued on page 228]

He spends the evening enthroned in his easy chair, absorbing chocolates and television, flanked by family and half the neighborhood.



Commuters May Take a

They'll Whistle Into Ports Like This One in London If Progress Continues.

COMMUTING by helicopter may be coming for suburbanites here and abroad. Cheered by the windmills' military success in Korea, 'copter enthusiasts are busy planning ways to use them in cities.

In England, which probably has more regular passenger-helicopter routes already than any other country, a heliport is proposed for the heart of London. It would be built partly over the busy Charing Cross railway station and extend over the River Thames, as shown in the drawing at right.

Complete with Radar

Plans call for an installation as complete as any large airport, including radar aids for landings in London's pea-soup fogs. Elevators would lower helicopters to a hangar deck for servicing. The location was chosen because it provides unobstructed approaches over the river as well as excellent connections to every part of the city by bus, subway and railway (inset, upper right).

The helicopters seen in the drawing represent two types now flying in England. One leading rotary-aircraft builder, Westland Aircraft Limited, also has several advanced models on the drawing boards: the W.80, a 24-passenger helicopter designed for intercity travel and a larger 35-passenger W.81 powered by a twin Mamba gas-turbine unit. Still another, designed for the military at present, would carry 100 troops. With jet power in the tips of a three-bladed rotor, the craft could be redesigned for civilian use.

New York to Get 'Copter Service

New York also is preparing for hovering helicopters. For some time there has been local air-mail 'copter service out of Los Angeles and Chicago. Recently the Civil Aeronautics Board authorized a shuttle service between New York's big airports.

Looking for a mid-Manhattan landing site, engineers hit on a Hudson River pier that was being reconstructed. By adding a substructure of watertight concrete boxes, it could serve as heliport and ship dock.



Helicopter to Work Soon

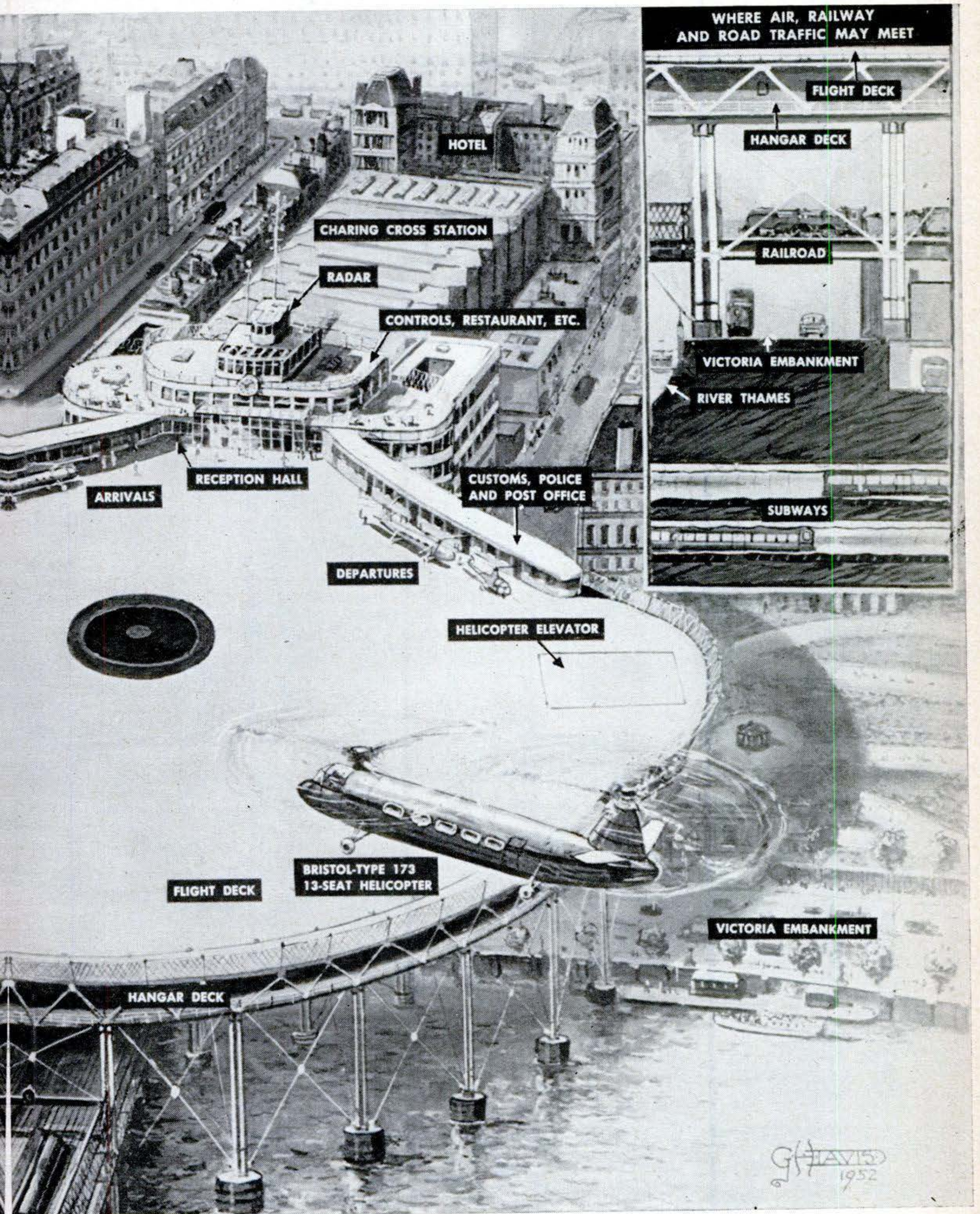

Down the Alaska Highway



on a One-Lung Scooter

When one man and his "tiny vehicle" challenged the world's toughest road, adventure hitchhiked a ride.

By Gardner Soule

IN FAIRBANKS, Alaska, Ronald C. Bulstrode pondered how to get back to his home on Long Island, N. Y. "This," he says today, holding up his broad right thumb, "is a man's ticket to anywhere." Bulstrode has used that ticket often. But under his bed, he decided, was a better way.

Under that bed was a dismantled Cushman scooter. He had bought it for \$100 at an Air Force base in Alaska. He wanted to be the first man to ride a scooter—he calls it a "tiny vehicle"—down the toughest, roughest road in the world: the Alaska Highway, from Fairbanks to Dawson Creek, Canada. He would then, he decided, ride on all the way to Long Island.

When Bulstrode announced he would return home by scooter, the sourdoughs announced they didn't think he would. "The road's too slippery," said one. "It's too rough, too steep and too muddy. I don't think that little thing will get over even one mountain and there are hundreds of mountains. Man, I just wouldn't try."

Bulstrode said he'd try. He pulled his

ROAD SIGNS at Fort St. John, Canada (photo at left), show distances to almost everywhere. Below, scooter is parked at border marker between Alaska and Yukon Territory.



BACK IN THE STATES, Bulstrode got rid of his beard, added windshield to his scooter.

transportation out from under his bed, put it together and tuned it up. It was the first scooter he'd ever owned, so first he had to learn how to ride it. (This took five minutes.) An oil-furnace repairman at home, he is mechanically inclined.

The scooter's one-cylinder, four-horsepower engine, he had learned, drove the rear wheel by means of a chain. The engine was started by a kick of the right foot on the kicker—an arm with a flat piece at its end. There was no transmission to vary the ratio of engine speed to load. (The automatic

THE ALASKA HIGHWAY lives up to its reputation as the world's toughest road. Ice makes it slippery in winter, loose gravel almost as treacherous in summer.



transmission shown on the facing page has been added to later-model Cushman scooters.) The accelerator, on the handle bars, sped up the engine to the point where the clutch would engage as the scooter started out, and slowed down the engine till the clutch disengaged when the scooter slowed to a stop. The total weight of this scooter was 250 pounds.

The engine was under the seat. The rider sat in the seat as in a kitchen chair; he did not straddle as on a motorcycle. This makes it easy to jump off when the scooter slides out from under.

Bulstrode, then 25, went ahead with his plans and packed his gear on the scooter. He knew he shouldn't overload it and he left behind what he could. He carried no water and no food except snacks because he knew general stores were located every 100 miles or so along the road. He took no extra gasoline because the scooter's tank held two gallons—enough, he estimated, for 140 miles—and there would be a filling station near each store.

There were some things that he wanted to get aboard. With methodical care, he managed to squirrel away aboard the scooter: two spare tires, a goose-down sleeping bag, a camera and its flash equipment, two changes of clothing, two pairs of boots, a set of tools (wrench, pliers, screwdriver, etc.), tire-repair kits, tire pump, penknife, can of oil, pair of goggles, three pairs of Indian moosehide slippers, a segment of the toe bone of a mastodon (a prehistoric woolly elephant), eight pieces of teeth of saber-tooth tigers, a desk penholder of mastodon ivory, a package of 12-by-14-inch drawings of the Calgary Stampede (a rodeo) and a moosehide large enough to cover a double bed.

He also tucked in plenty of folding money. Hamburgers were 75 cents on the Alaska Highway, Cokes 25 cents, and gasoline 69 cents an imperial gallon. On August 1, 1950, Bulstrode's brother Eddie left Fairbanks by car for New York. The next day Bulstrode

set out. He was at last alone with his scooter, his equipment, his souvenirs—and his problems.

The chuckholes were among his problems. They were terrible. To avoid them, he had to pilot the scooter on a path like a corkscrew, even on those stretches where the highway is straight from horizon to horizon.

Day after day there was the gravel. There was gravel of large stones. There was gravel of small stones. There was dirt. "The Alaska Highway," says Bulstrode, "is all dirt and gravel."

There was wind. Because he had no windshield on the scooter, the dirt and wind wore away his face despite a beard he had grown for warmth. "The skin on my nose came off first. Then my face went—right down to the meat."

Every mountain was, as the sourdoughs had predicted, a challenge. "They seemed to shout defiance," he says. "When I came upon a mountain, I'd wonder how a one-lunger like

the scooter would ever make it. But I'd get around the mountain, or over it. Somehow." He went over Steamboat Mountain, which requires a steady 14-mile climb, as he went over the others, without having to push once.

Silence Ruled the Nights

The silence was among his problems. It was worse at night. "When I shut off the engine," he says, "I had to cough or make some noise myself to know I wasn't deaf. That's how deep the silence was."

He would go off the road to try to find a level spot for his sleeping bag. Not very far off. "You have to stay close to the road. Either thick forests, swamps, underbrush or something keeps you close to the road.

"When I did lie down to go to sleep, I never heard anything except one noise—something in the distance, like a bump on the ground. It probably was a moose stomping or knocking its antlers against a tree. I never found out. There was nothing else to hear. No cries of animals. No bird calls. Nothing. Nothing. Only silence."

[Continued on page 236]



AUGUST SNOWSTORM overtook the scooter rider at Dawson Creek, Canada, terminal of the road, which is marked "Mile 0, Alaska Hi-way." Bulstrode says he looks fatter here because of bulky woolen clothes.

How Automatic Shift Works in New Scooter

TO ALTER RATIO to suit load, Cushman's Varimatic Drive uses two V pulleys, each having a fixed and a sliding flange. Springs normally hold sliding flange of driven pulley in, forcing belt to ride high. At low engine speeds, belt pull holds driving pulley open, so drive is from small to large diameter.

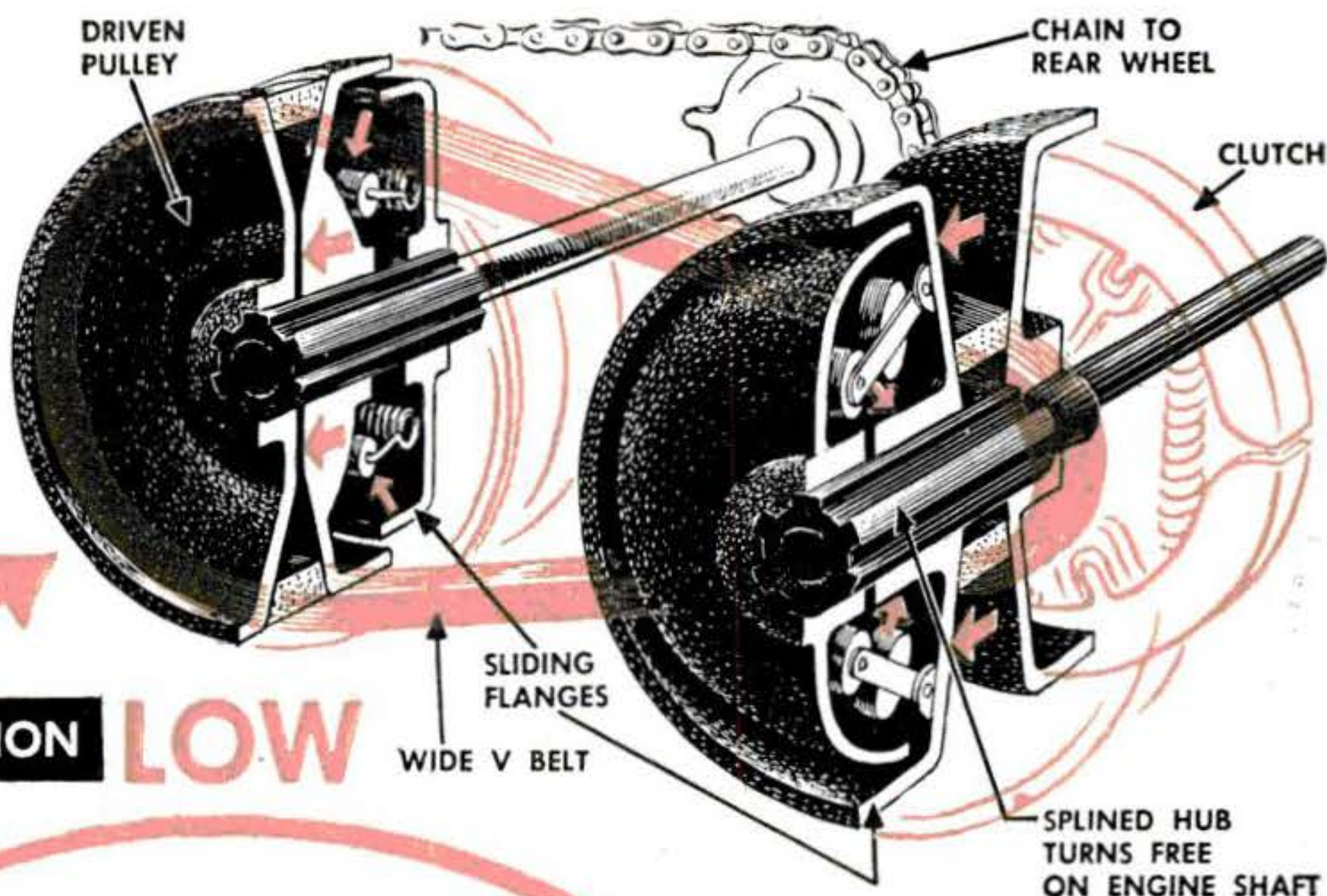

TRANSMISSION LOW

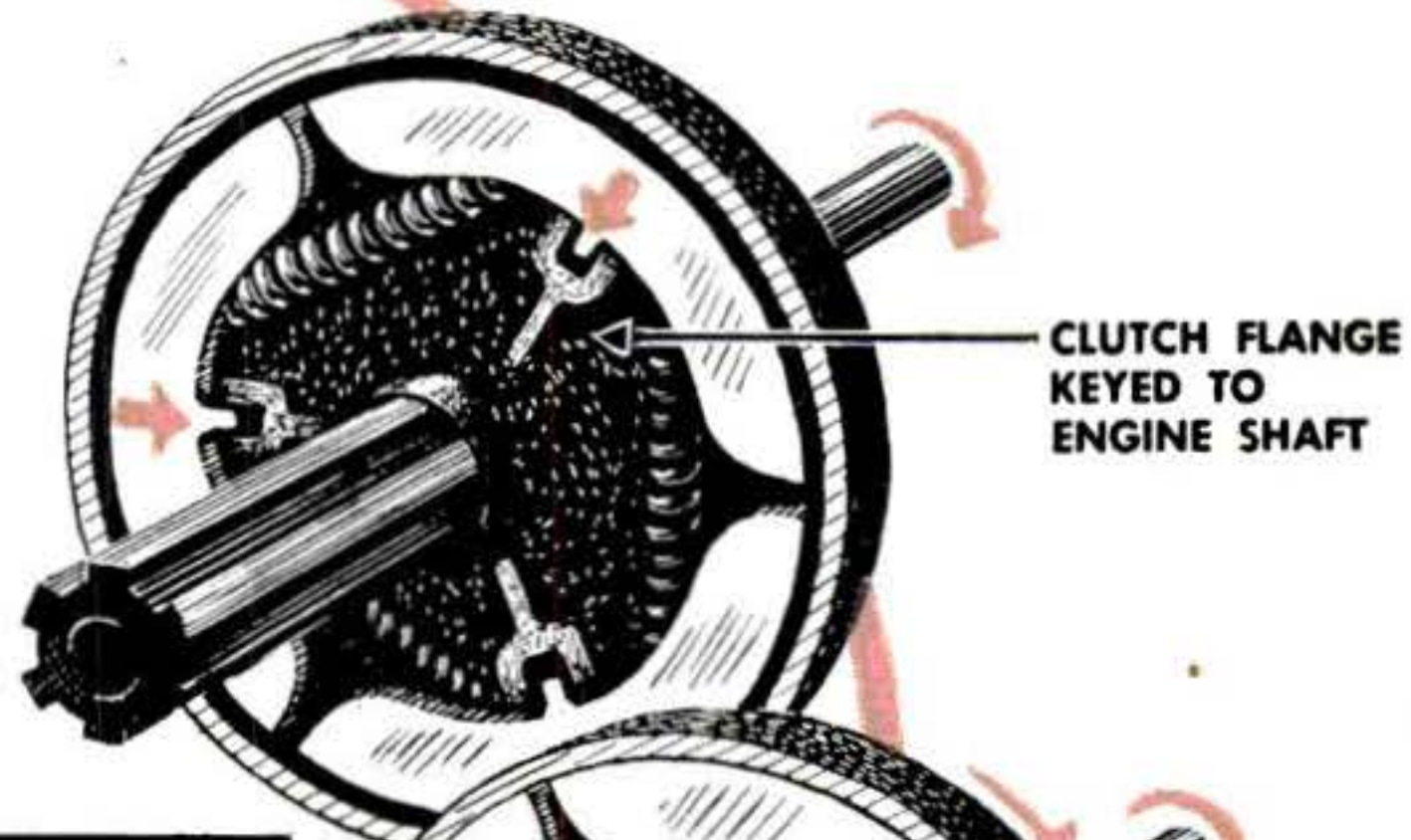
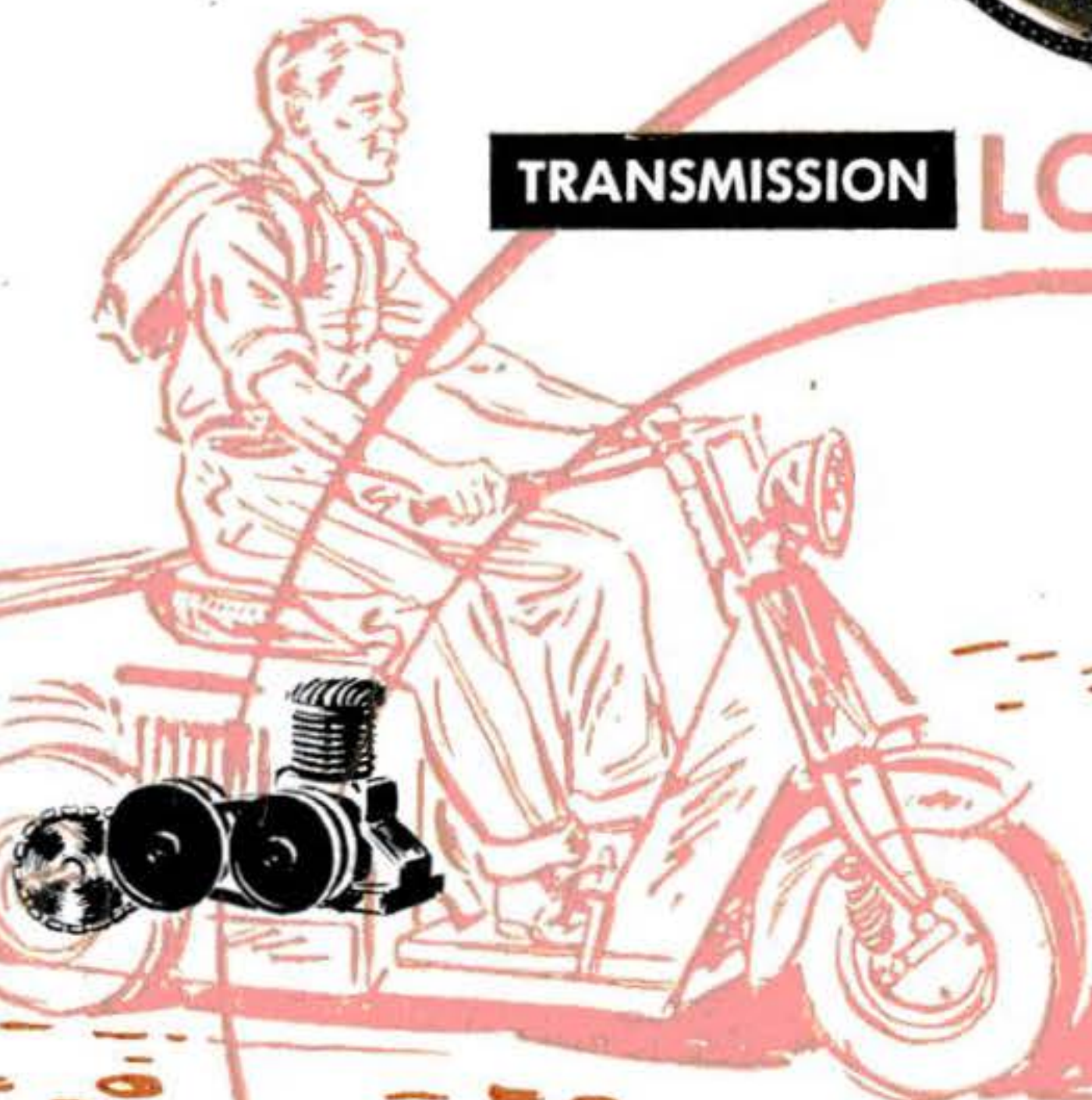

CLUTCH

CENTRIFUGAL CLUTCH frees idling engine from drive pulley. Shoes turn freely inside fixed pulley flange until revs go up. Then centrifugal force overcomes springs, and shoes grip rim. Clutch itself does not shift belt.

TRANSMISSION HIGH



AS SHOES EXPAND, HUB AND PULLEY TURN

AS SPEED CLIMBS, weights pivoted on movable driving flange ride up bell curve, push flange in. Forced high on driving pulley, belt overcomes springs in driven pulley, opens it to ride low. Thus drive is from large to small diameter. If engine speed drops, driving flange will open, and driven pulley close to take up belt slack, shifting back to "low."

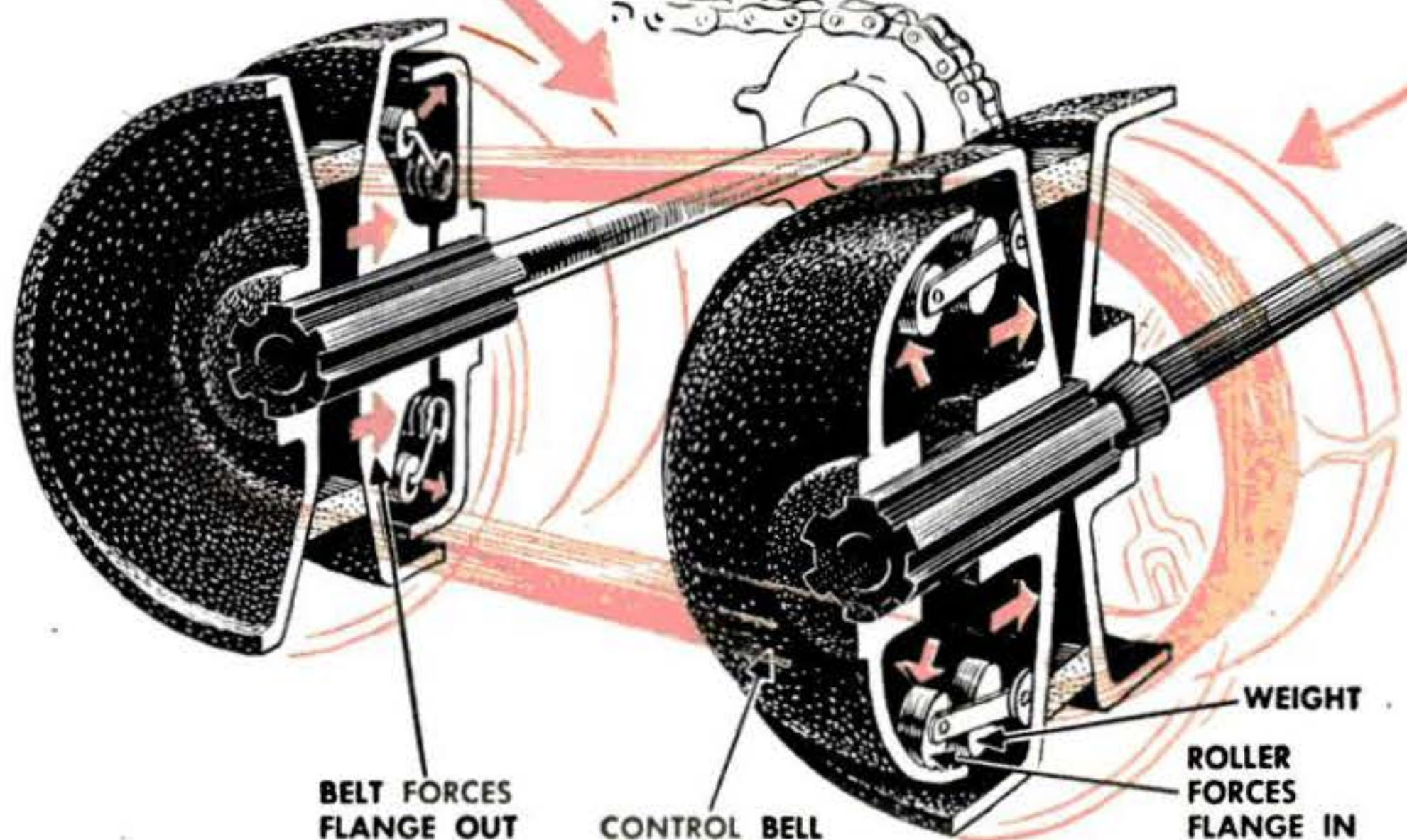

BELT FORCES FLANGE OUT CONTROL BELL WEIGHT ROLLER FORCES FLANGE IN

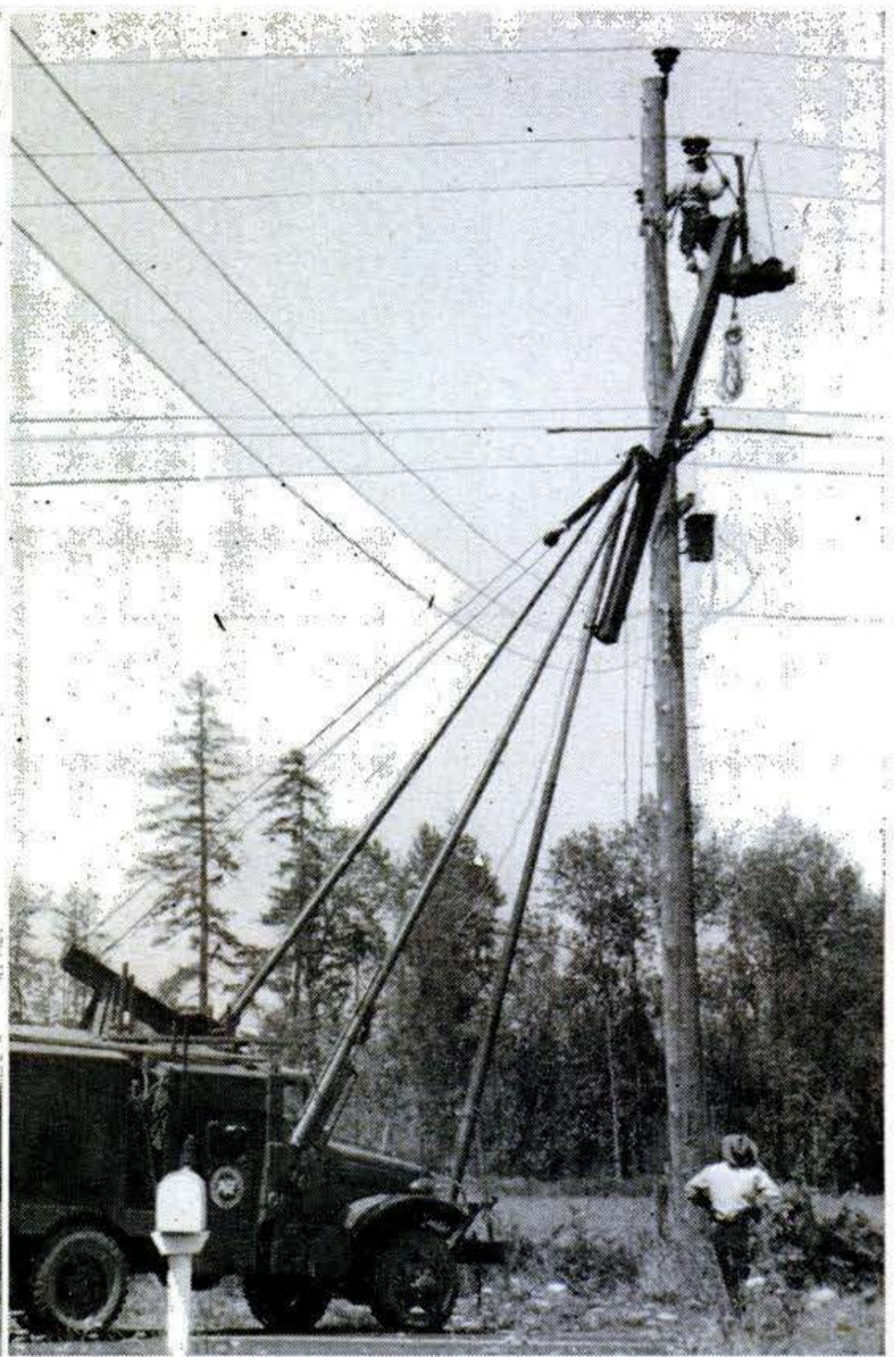
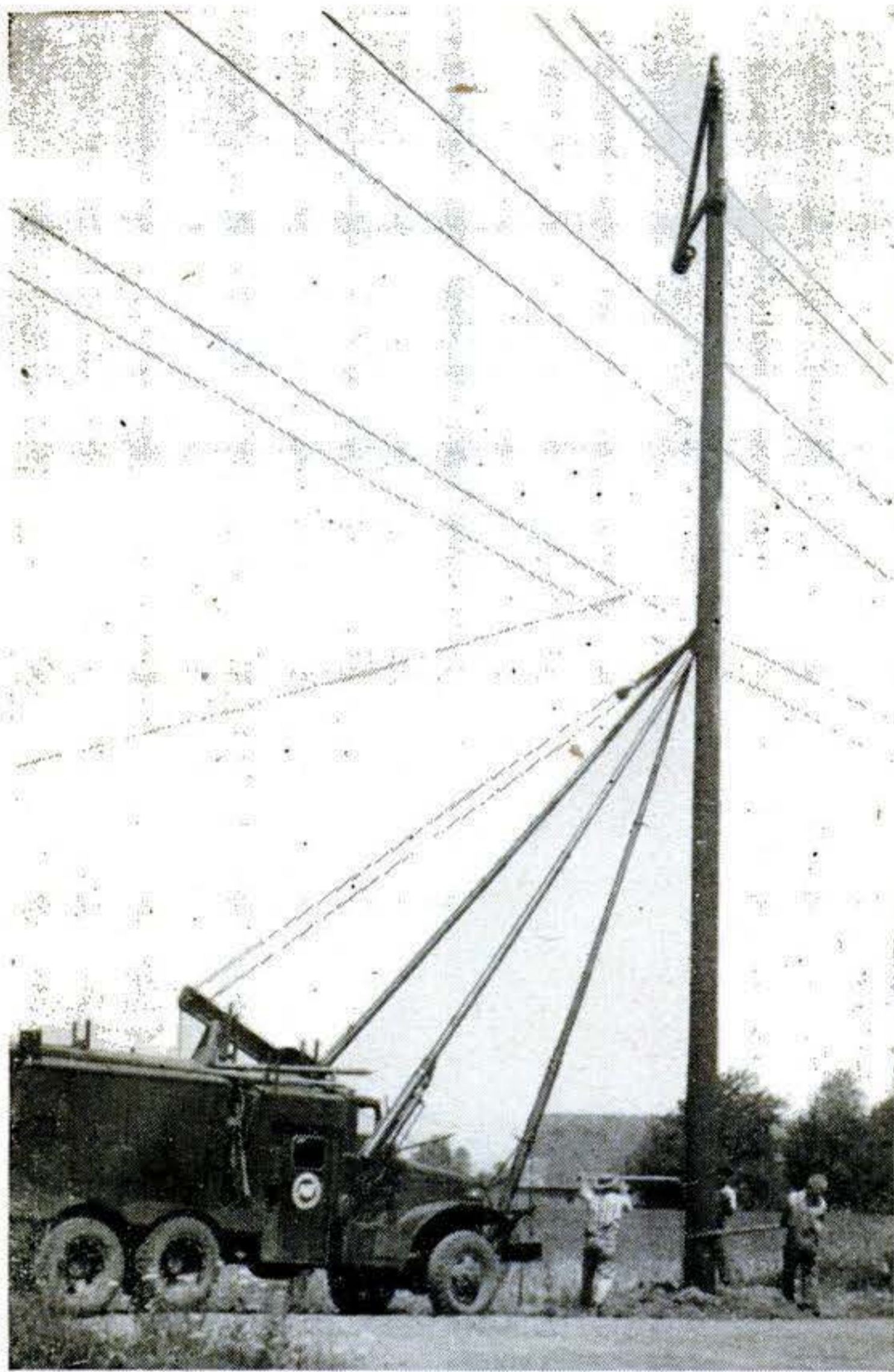

Long-Legged A Frame Sets Pole

POWER linemen in Oregon swing heavy poles around like sticks with this three-legged A frame mounted on the front of a truck. Two men can put it into action in two minutes. Able to swing 10 feet to either side, it will handle loads as heavy as three tons. The telescoping legs are made of steel tubing. Rising only 11 feet above the ground when traveling, the legs can be extended

hydraulically to 32 feet for hoisting jobs. When a wooden mast is added, as shown in the photo at right, a workman can ride 52 feet up in a bosun's chair.

The frame was built by the Portland General Electric Co. for a wide variety of jobs including pole setting, installing insulators when stringing wires, installing transformers and trimming trees. The truck mounting it carries six linemen in its oversized cab.

Pads Banish Housemaid's Knee

You won't feel the hard, hard ground when you kneel down for garden digging if you're wearing these knee cushions padded with sponge rubber. Straps hold them in place as you move from spot to spot.

They'll also take some of the discomfort out of other knee-banging chores, such as laying floors or doing a thorough scrub-and-wax job in the kitchen. The Sponge-Eze Co., Portland, Ore., makes them.



What's New on Radio Row

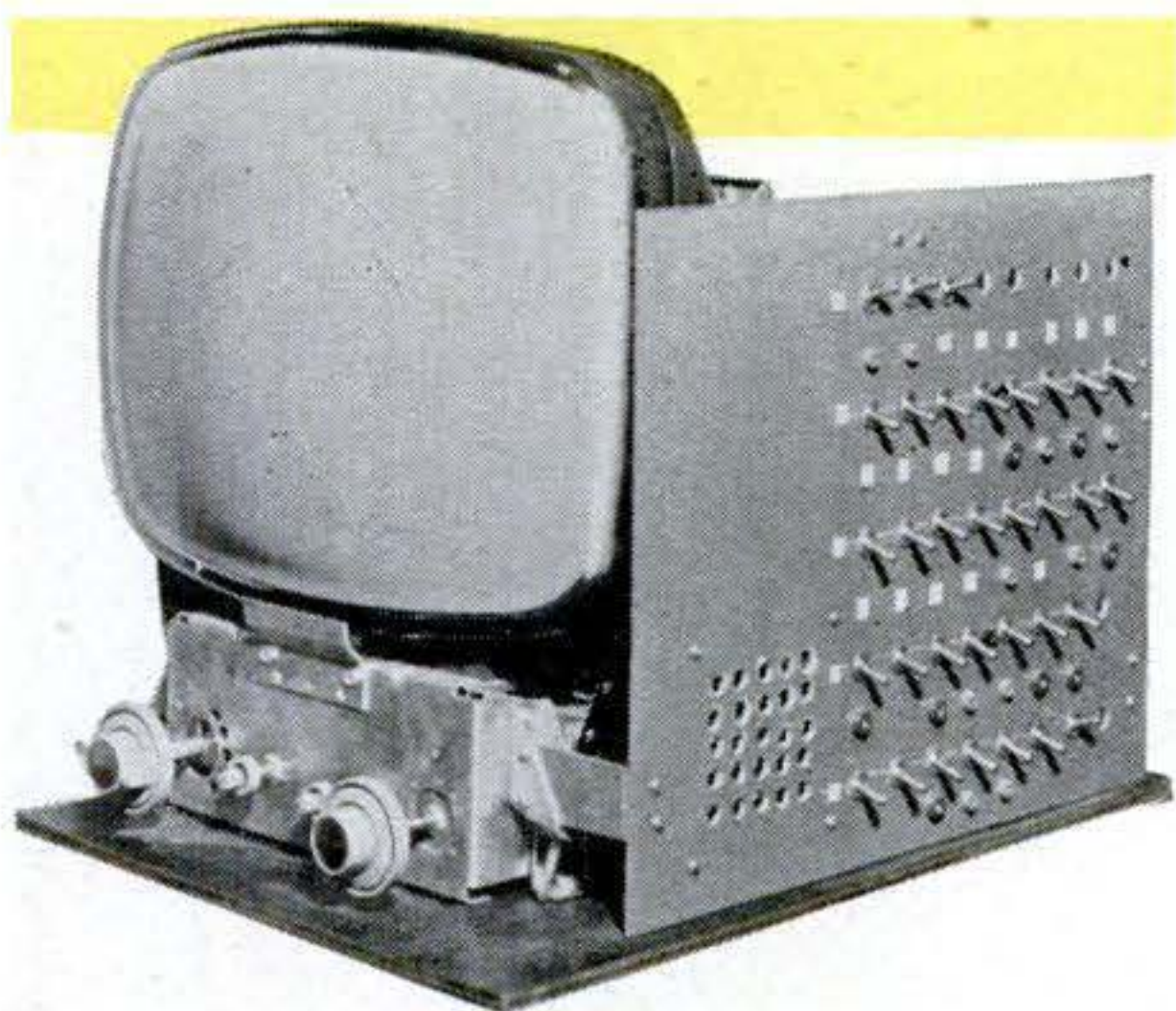

TV Troubles Made to Order

SERVICEMEN can learn to diagnose TV troubles by watching this GE demonstrator show what common set faults look like. Switches and plug jacks connected to the circuits of a standard chassis short out condensers and resistors and cause other circuit changes. The screen pattern below, one of 33 that can be produced, shows horizontal tearing produced by an off-value resistor.

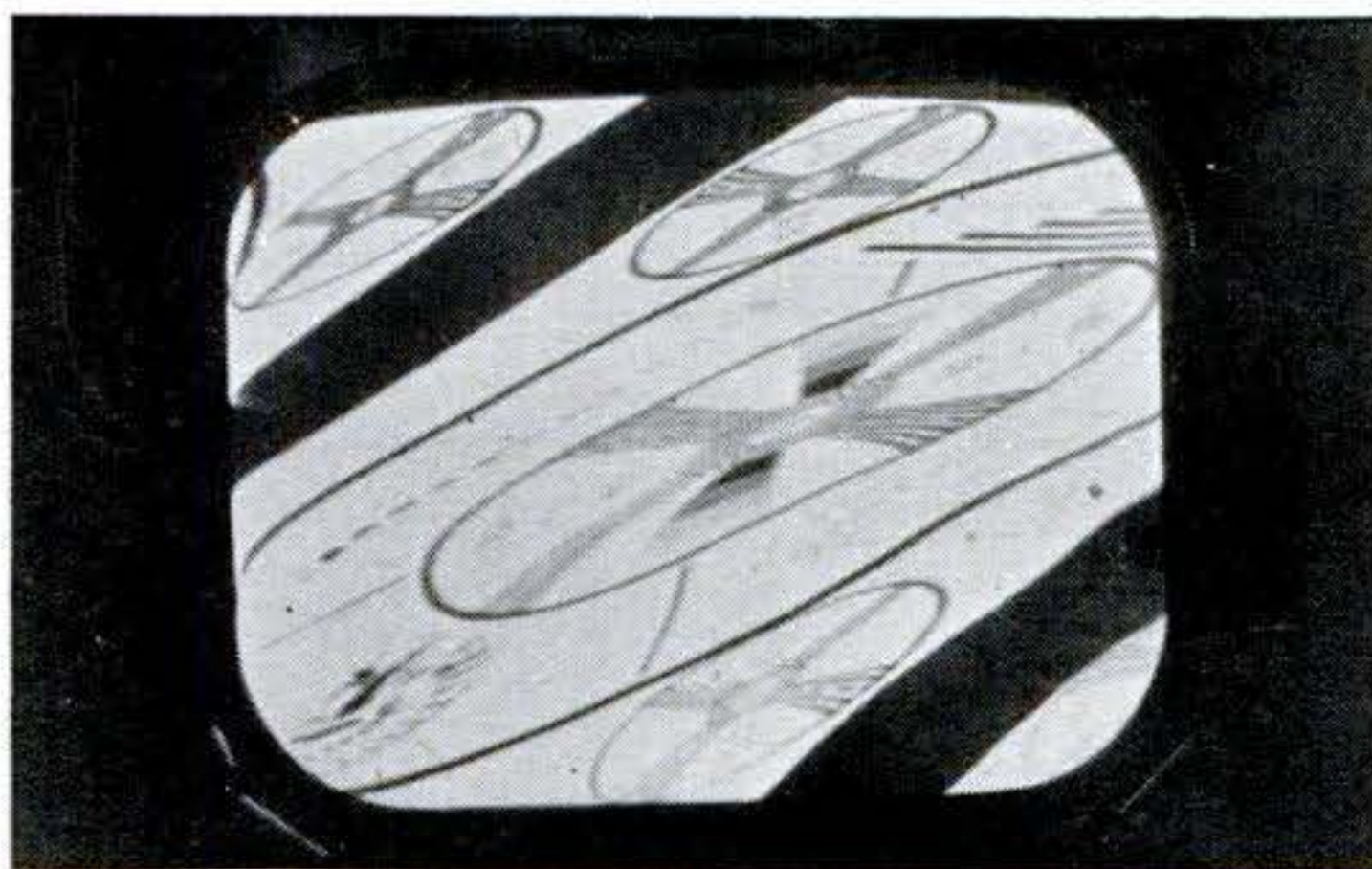

Tube Shatters Television Set

You see at right what can happen when a picture tube implodes. An implosion is like an explosion but force is exerted inwards by air rushing to fill a vacuum. In this case it shoved in the 3/16" safety glass and bounced tube fragments around with enough force to bend some metal parts. Luckily tubes don't implode often, but this photo shows why servicemen are warned to handle them with gloves, goggles—and care.

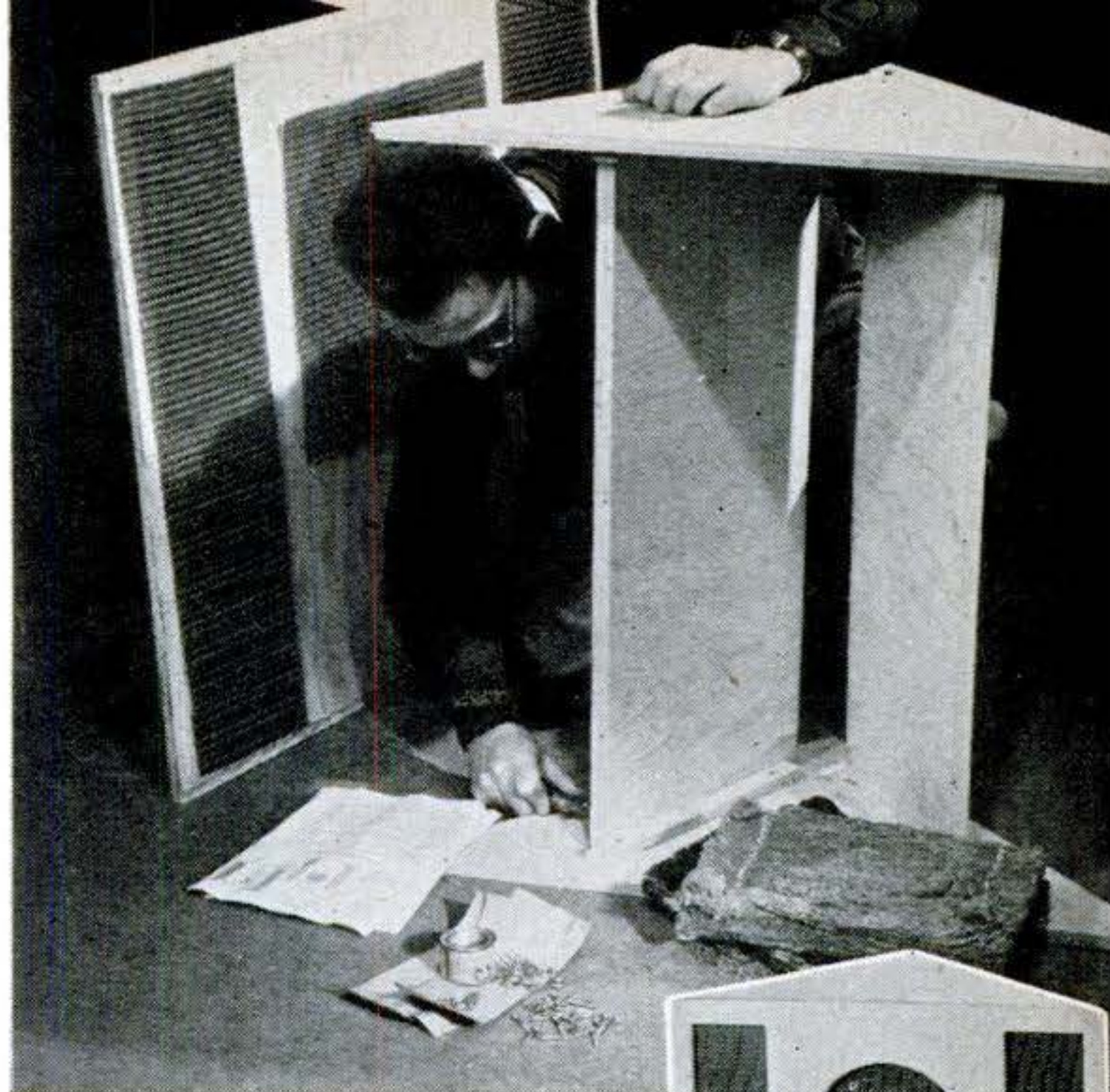

Speaker Cabinet Built from Kit

You can make a good loudspeaker cabinet without knowing anything about acoustic theory just by putting together the pieces in this kit. They are cut and drilled and arranged for easy assembly into a "folded-horn" speaker box. It fits a corner and uses the walls as acoustic extensions of the speaker. The kit costs less than half as much as a finished cabinet. G & H Wood Products Co., Brooklyn.

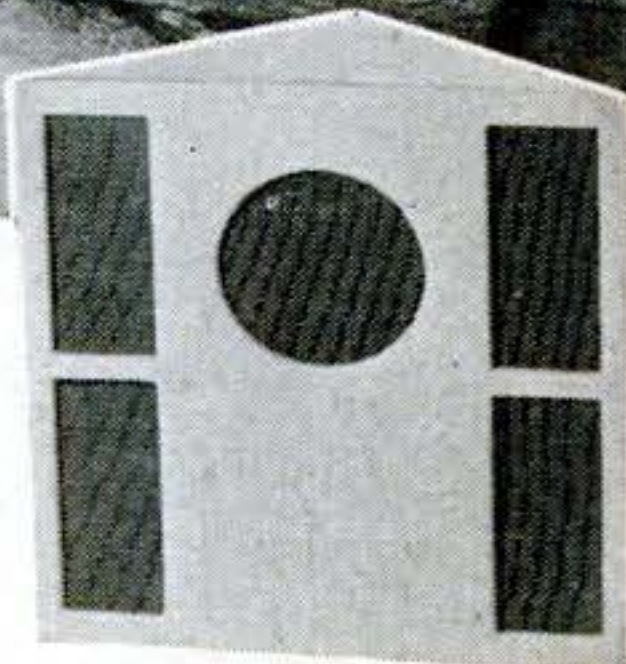

Mike Broadcasts Through Radio

THE microphone at right broadcasts through a radio, turning the set into a public-address amplifier or intercom. The Micro-Vox, sold by Johnson Smith & Co., Detroit, needs no connection to radio or power line.

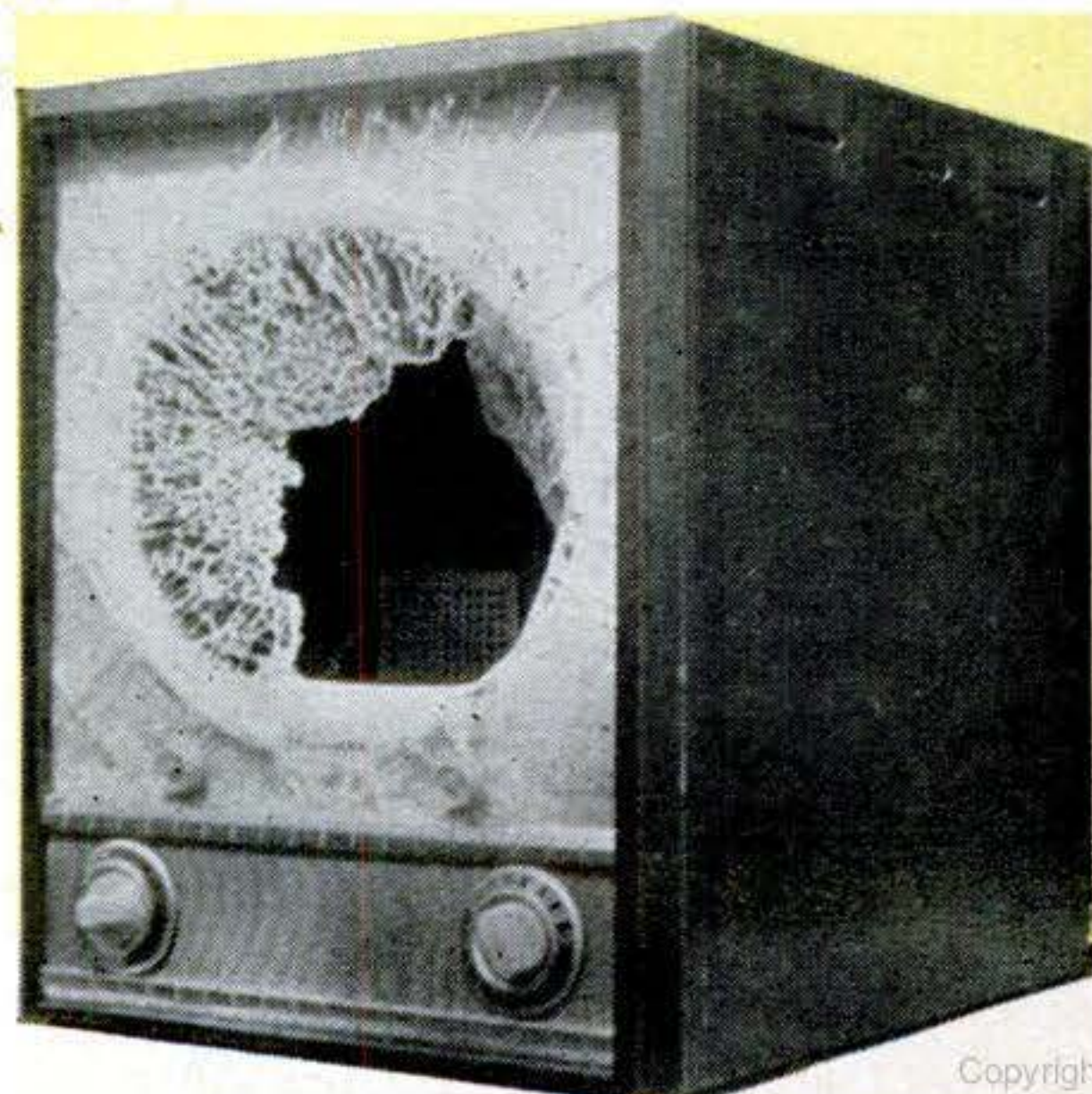
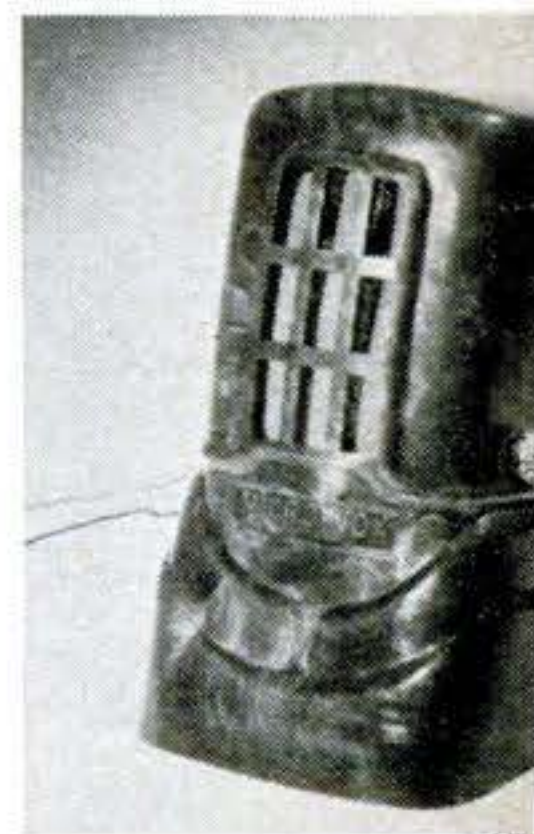

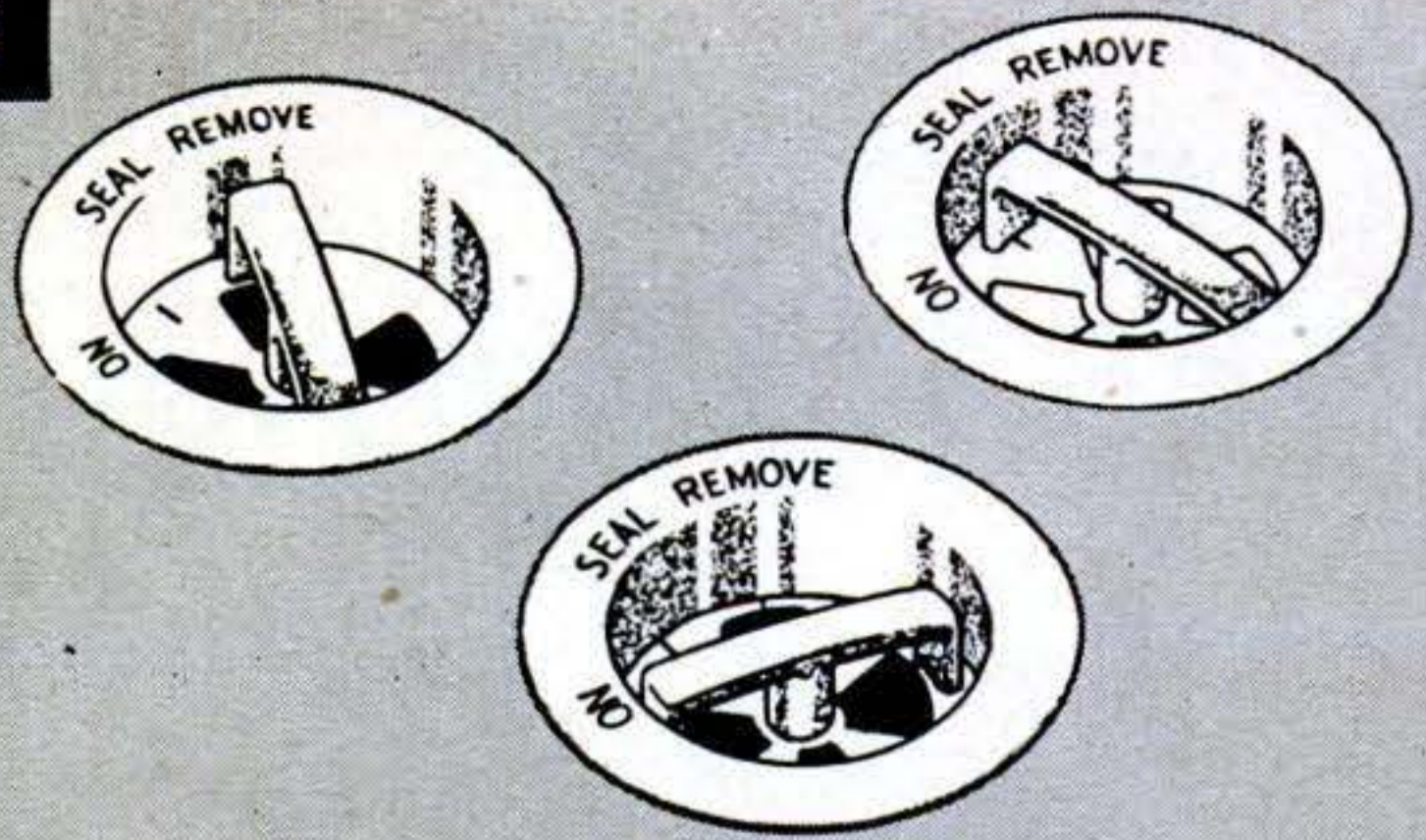

A THREE-PURPOSE CONTROL at the sink-drain opening is common among garbage disposers. Control shown is GE's Twistop. At Remove the top is a strainer, which is lifted off when the housewife is ready to load the grinder. At Seal it is a stopper. At On it is locked in place, awaiting a sufficient flow of water to start the disposer grinding up waste.

How a Garbage Disposer Works

ANY man who has known the dismay of having a bottom-soaked bag of garbage give way in his hands and shower him and the floor with coffee grounds, wilted lettuce and eggshells is inclined to regard the electric garbage disposer with warm gratitude. This emotion runs highest in Los Angeles, which leads all other U.S. cities in the number of waste-disposal units installed in its homes—more than 200,000. But the feeling is sufficiently widespread to have caused manufacturers to turn out between 300,000 and 400,000 garbage disposers during 1951.

There are several makes, but they are fun-

damentally alike. Each one fits under a kitchen sink, receives food scraps through the drain opening, grinds them fine and sluices them into the sewer or septic tank. (Septic tanks must be large or cleaned often.) Each makes a certain amount of noise at work, but most householders who use one find this easier to take than the old-fashioned process of filling, emptying and cleaning a garbage pail.

Most electric garbage disposers are designed for sinks with a drain opening three and a half to four inches wide, which is standard. The two best known makes have a

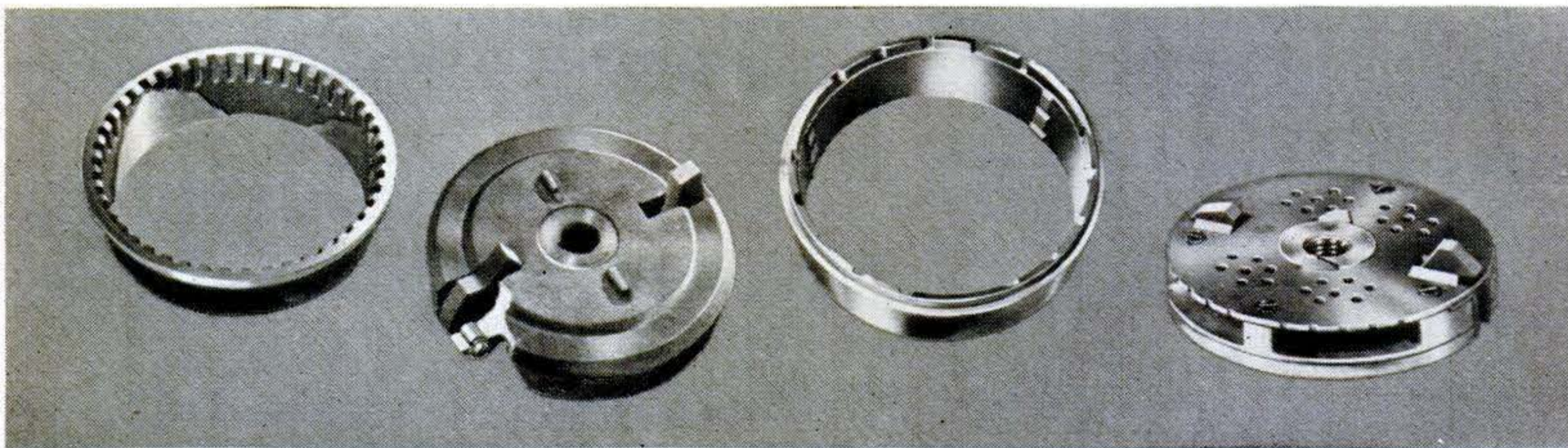

WORK HORSES of any electric garbage disposer are the flywheels, with their impellers, and the shredders. Shown here disassembled

are the shredding rings and the flywheels of Westinghouse's Waste-Away (left) and General Electric's Disposall (right).

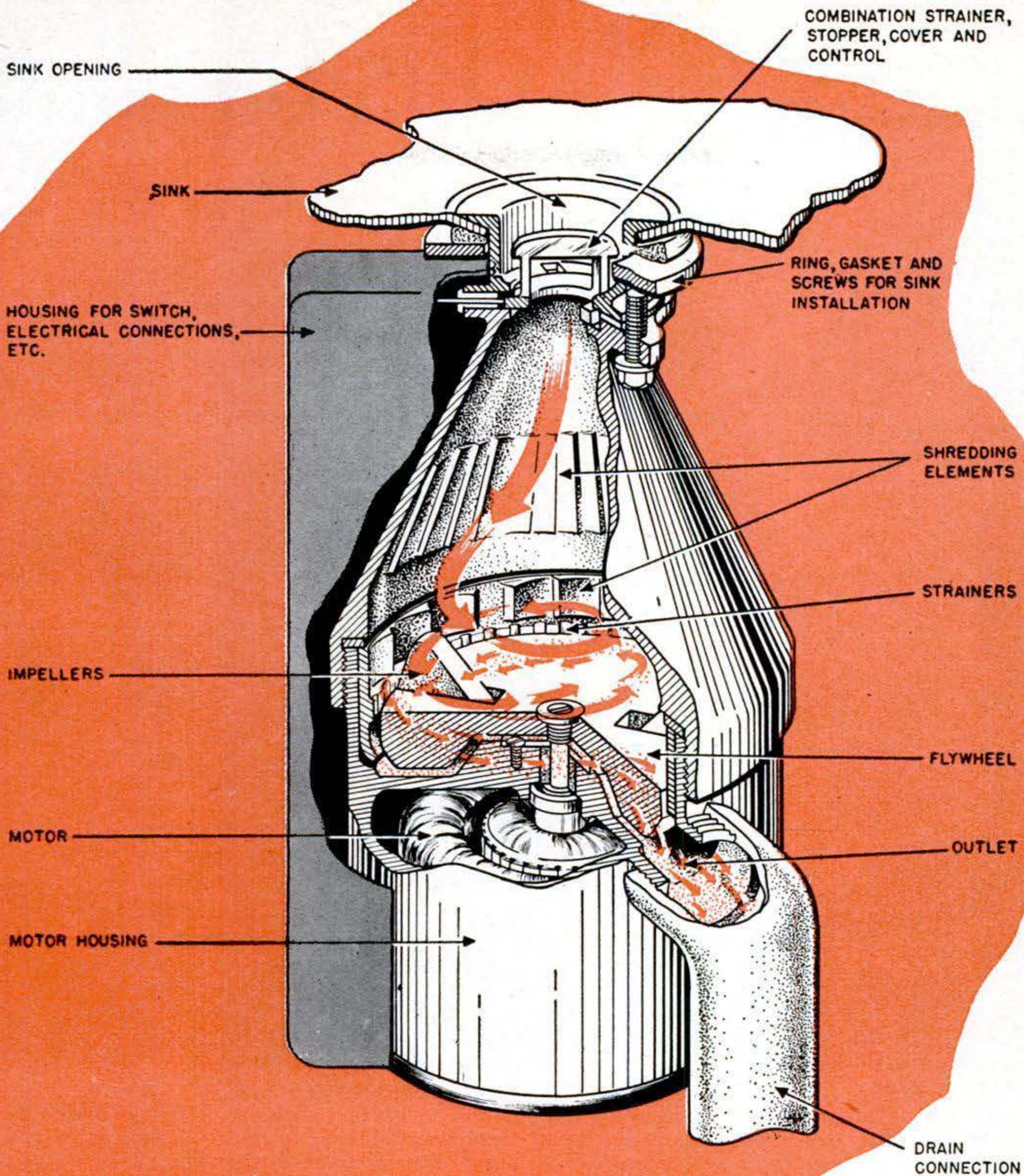

flow switch, connected with the cold-water line to the sink. The flow switch won't let the grinder operate until cold water from the faucet is flowing into it at the rate of one and a half to two gallons a minute.

The diagram above combines features of these two popular makes. It shows how the flow of water pushes the garbage down against the flywheel, which, with its impellers, hurls the waste at the shredding elements until it is small enough to go through the strainers and into the drain.

Some cities and towns won't permit garbage disposers, claiming they overtax the sewers. On the other hand, Jasper, Ind., has practically forced residents to buy them—but at a discount.

The average garbage disposer will calmly dispose of peelings and pits, eggshells, coffee grounds, small bones and corncobs. It will balk at shells, string, fish skins, cans, jars, broken glass and crockery, and large bones. Large bones, quite properly, still go to the family dog.

END

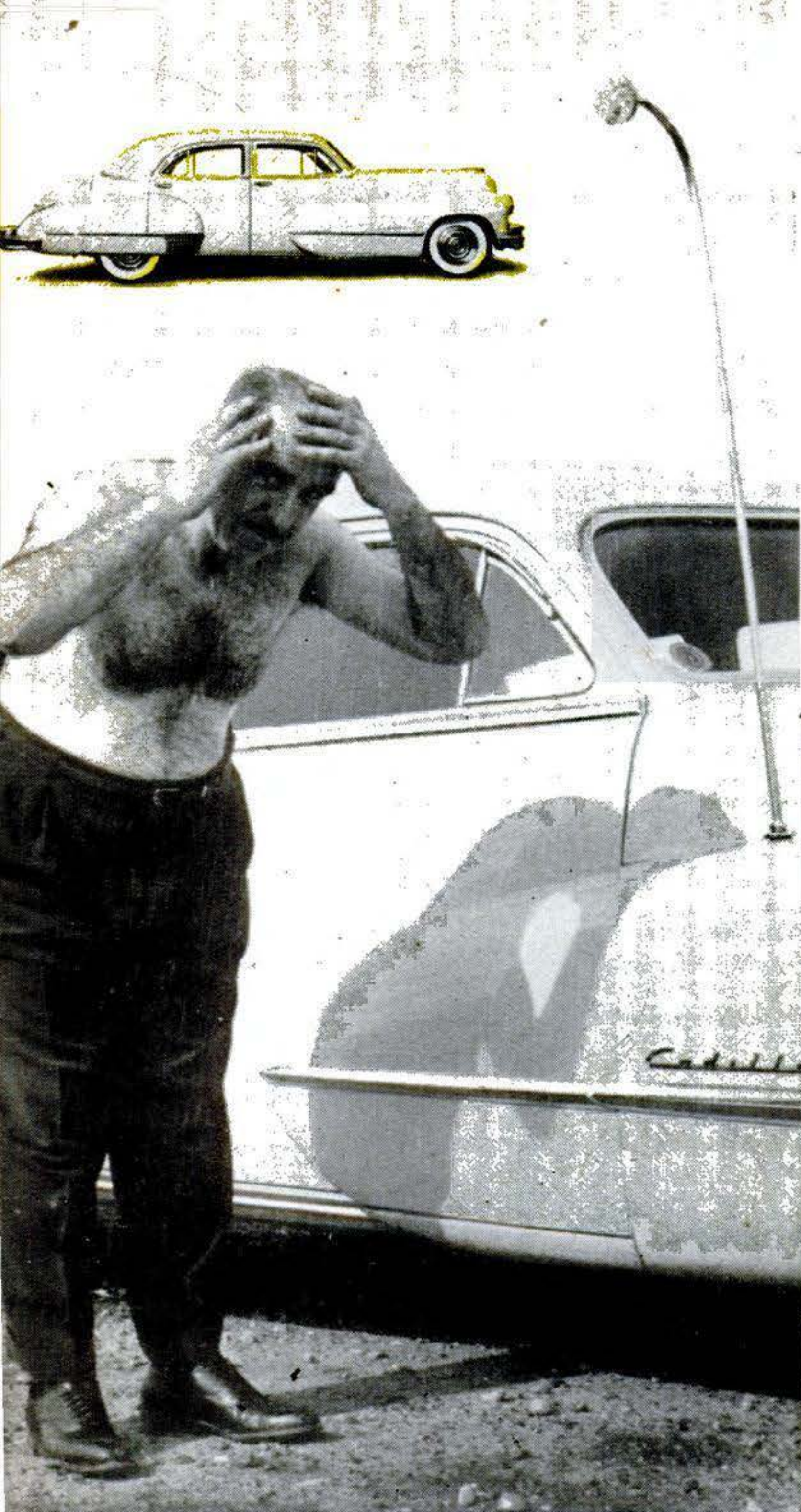

SHOWER, one of homelike conveniences of made-over '47 Cadillac (inset), screws into front fender. Electric pump supplies hot water from coils around exhaust manifold.

TURKISH WATER PIPE is installed on dash for owner to puff on whenever he wants. Miniature bar, also on dash, has separate faucets for dispensing whisky, soda and water.

His Cadillac

ROLLING along California's highways, Louie Mattar's light gray Cadillac looks strictly stock—but when you peer inside, your eyes pop.

Its owner dines on meat grilled in a built-in electric barbecue and quenches his thirst from a drinking fountain in the right rear fender. He washes dinner dishes in a kitchen sink and does laundry with a pow-



KITCHEN SINK big enough to do dinner dishes has running hot water and is surrounded by linoleum tile. It's hidden away beneath right-hand side of rear-seat cushion.

MEDICINE CABINET, with mirror and electric shaver, hides behind back cushion on right-hand side of rear seat. Cabinet is over sink shown in photo directly above.

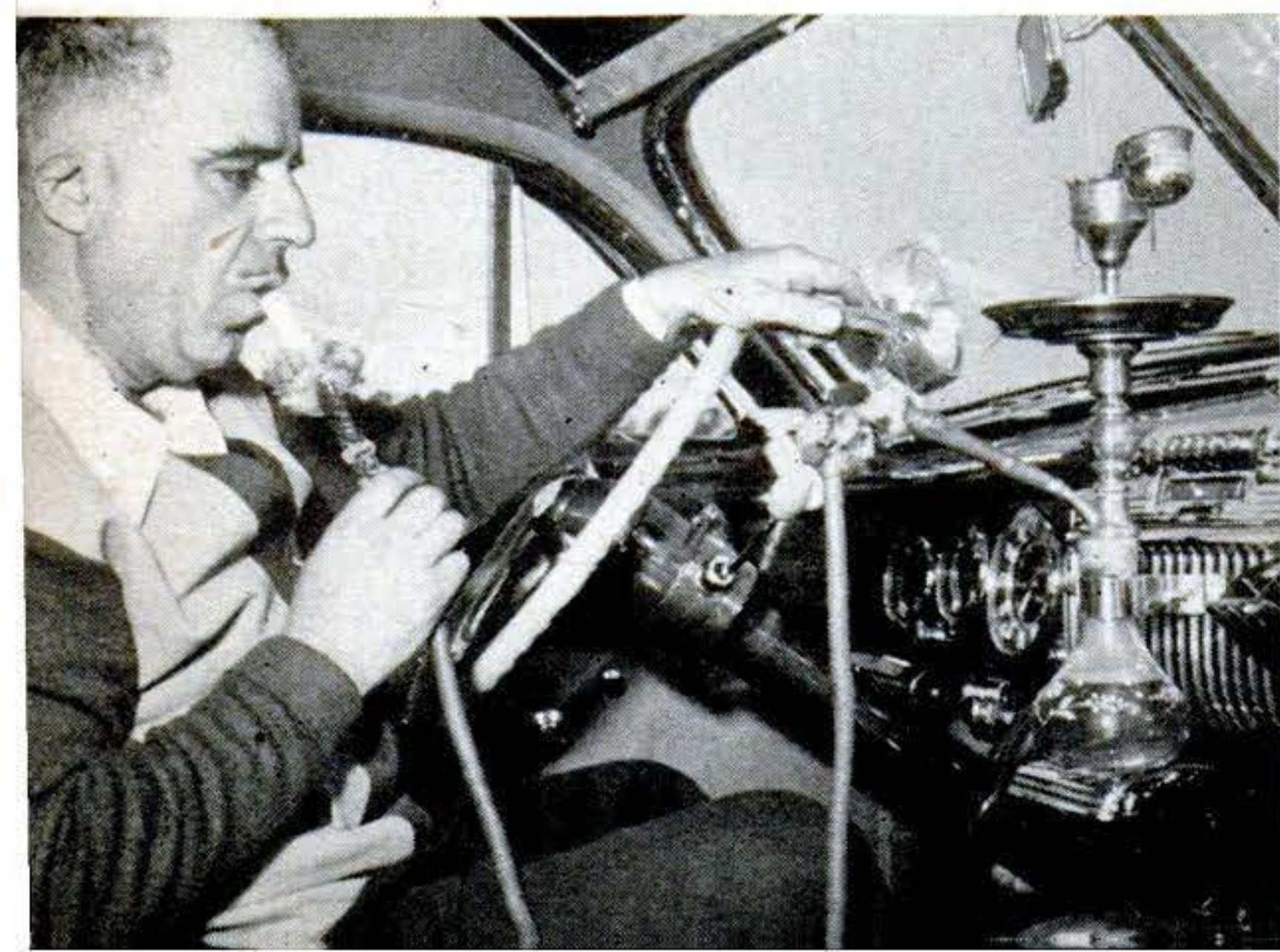

Has a Kitchen and Bath

ered washing machine. He bathes beneath a hot shower. For relaxation he may smoke his favorite Turkish water pipe, enjoy a highball from a miniature bar and listen to wire-recorded music of his native Lebanon from a pair of speakers. He uses a microphone connected to the speakers to call his three children. Secret of his supply of power for all these conveniences is a pair of

submarine-type storage batteries, which delivers ample six-volt current.

To date, Mattar, proprietor of a service station in San Diego, has spent \$7,000 on extras, and he's still thinking up new ones. Coming next, he says, will be a bathtub beneath the front seat.

Mattar won't install a bed though. For sleeping, he still prefers hotels.

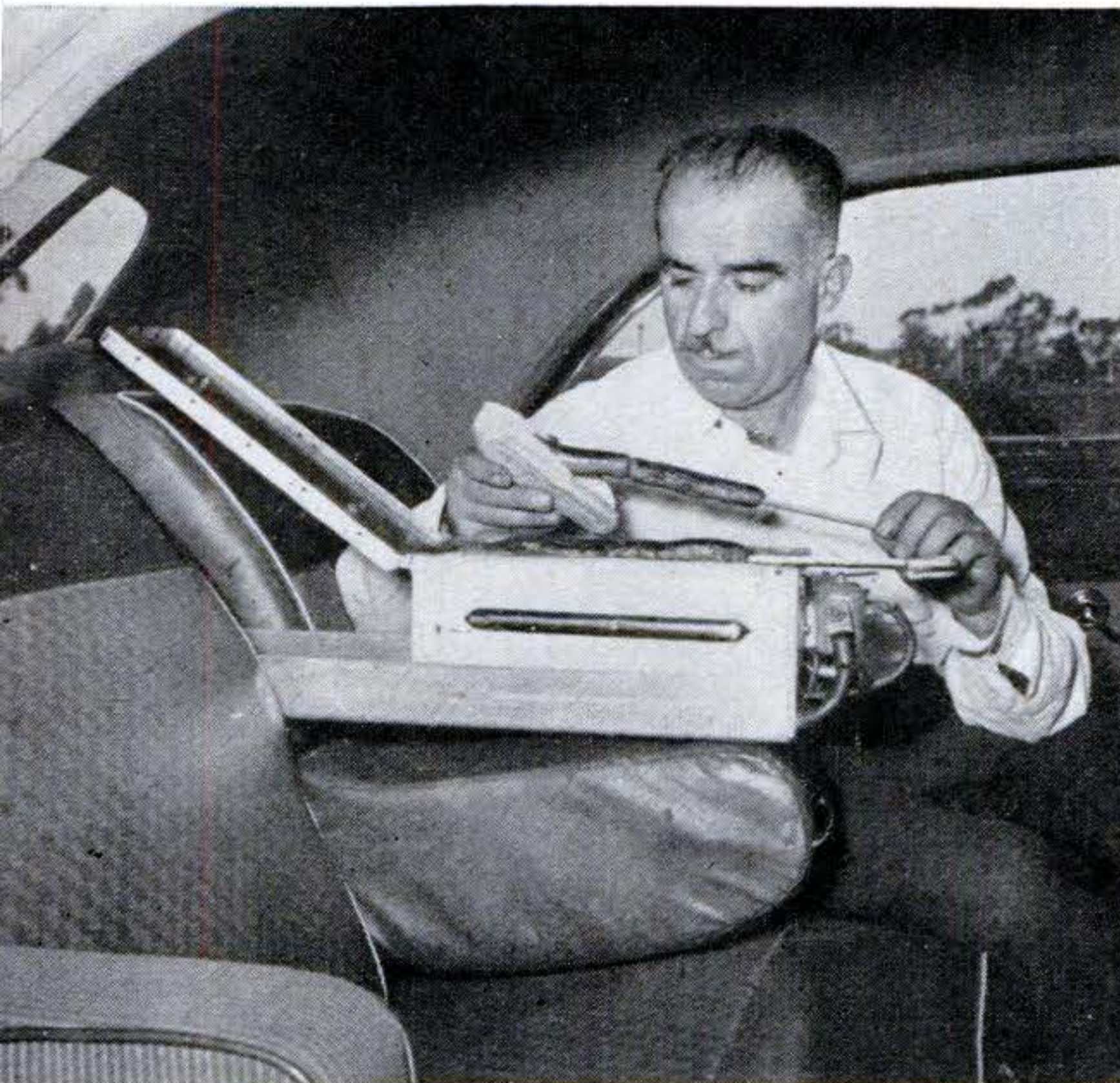

BARBECUE PIT large enough to cook six wieners slides out when armrest at center of rear seat has been lowered. Insulation keeps food warm after current is turned off.



WASHING MACHINE, beneath left-hand side of rear-seat cushion, has tiny homemade wringer cut down from a standard model. Lid of "home laundry" contains electric power unit.

WATER comes from four tanks holding total of 50 gallons. This airplane tank in trunk contains 20 gallons. Other cold-water tanks are beneath car, hot-water supply under hood.

DRINKING FOUNTAIN, operated by pressing button, is under metal cover on right rear fender. Enough water is stored in car's tanks for several baths and plenty of drinks.

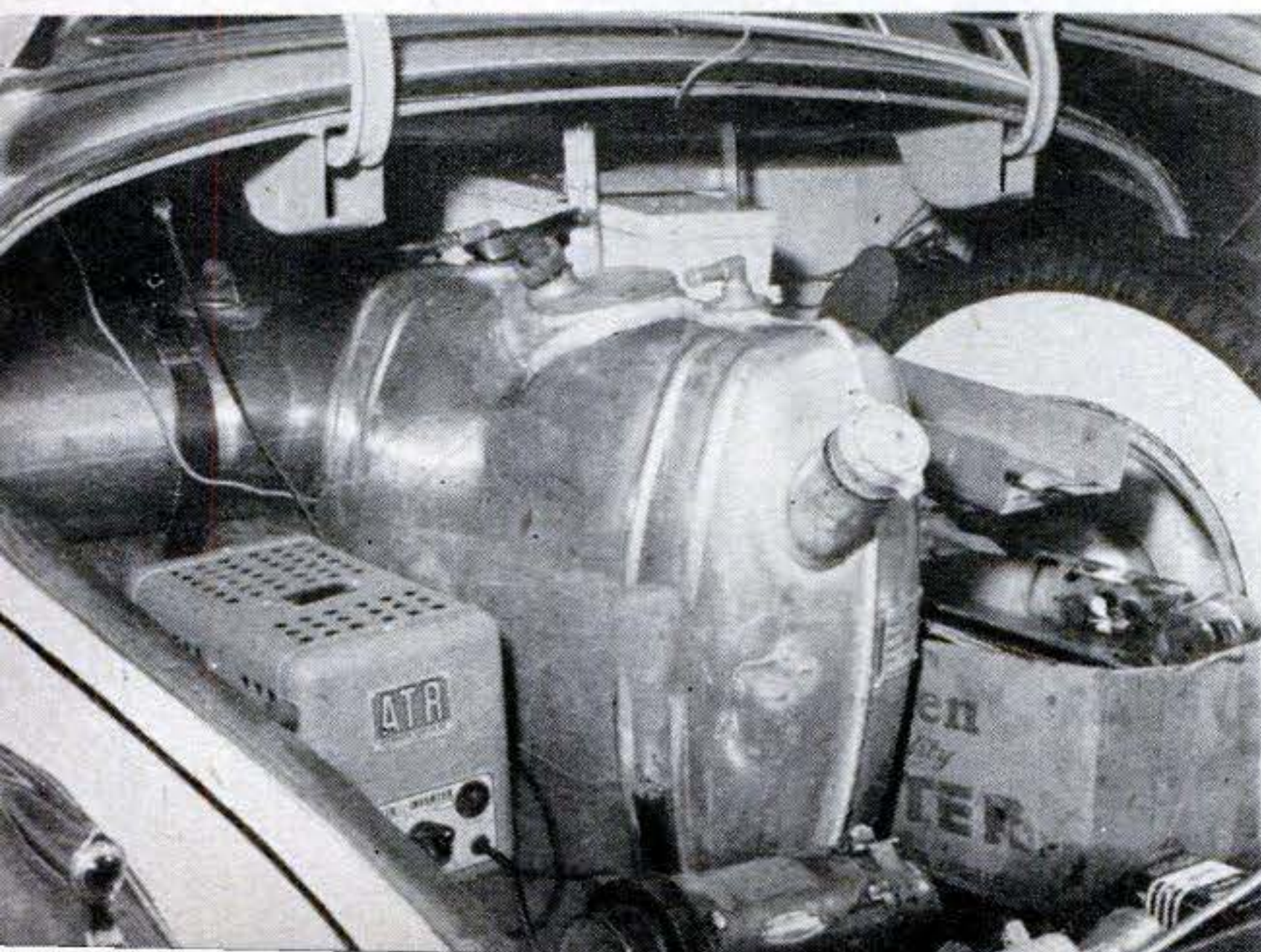

Aids to Modern Living



TV-Stove. A housewife can follow telecast cooking instructions step-by-step on the TV set built into this electric oven. A clock and an oven timer flank the screen. *Western-Holly Co., Culver City, Calif.*



Baby Shower. Attached to the walls of a stall shower, this removable hammock lets mother bathe baby without crouching over a tub. A hose attachment gives a gentle spray. *Henry Weis Mfg. Co., Elkhart, Ind.*

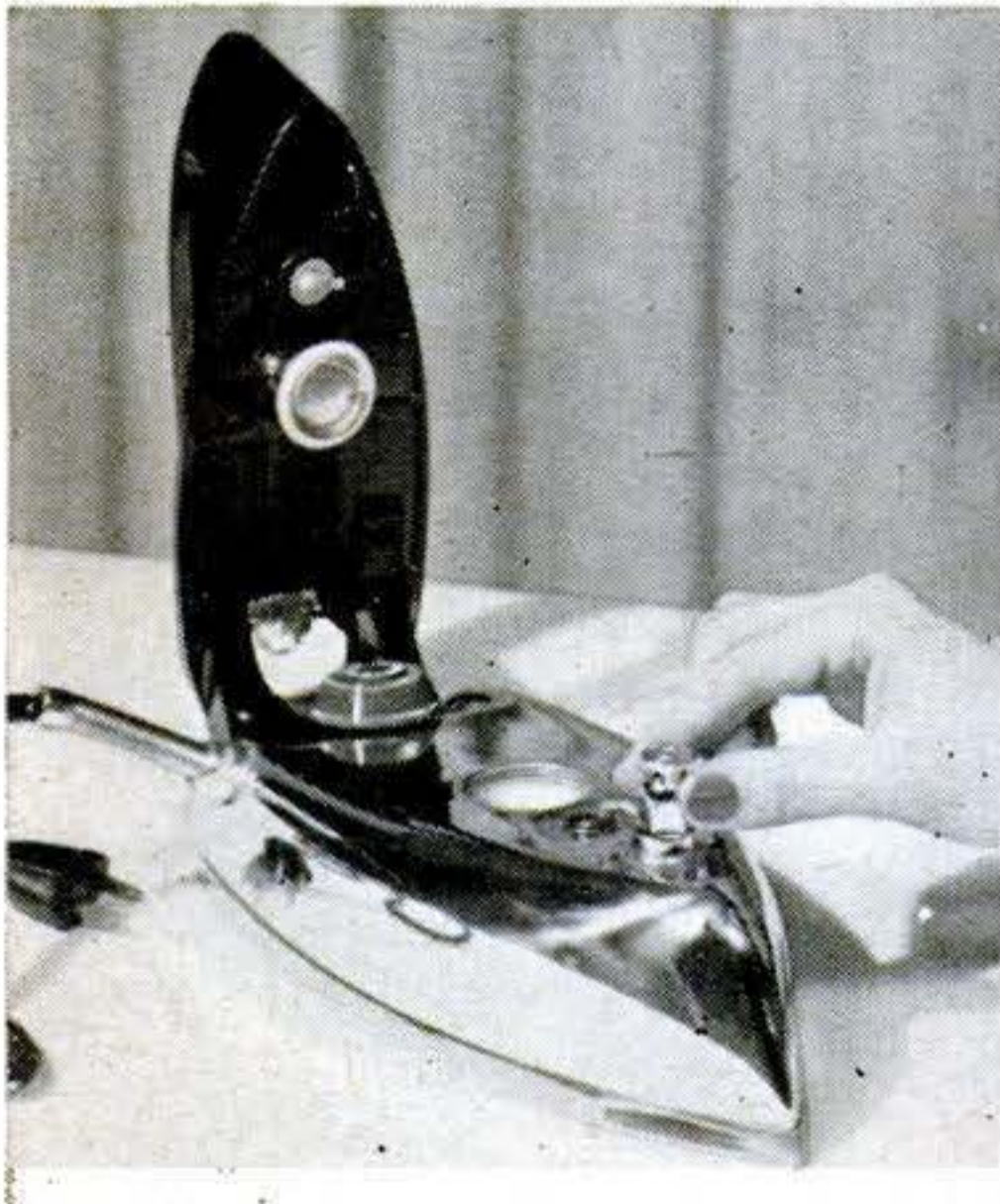

Iron Empties Easily. You can leave the water in until this steam iron cools, then empty it like a tea kettle. Water pours off through a spout at the nose. *Casco Products Corp., Bridgeport, Conn.*



Plastic Bag. Two pleats running across the bottom and up the sides of this bag are said to make it strong enough to tote 50 pounds of groceries. *Danae Creations, Minneapolis.*



Arm-Power Cultivator. The garden tool above gets your whole arm into the act, not just your wrist. A nylon band fastens upper handle to arm; sponge-rubber pad eases pressure. *Dreer's, Philadelphia.*

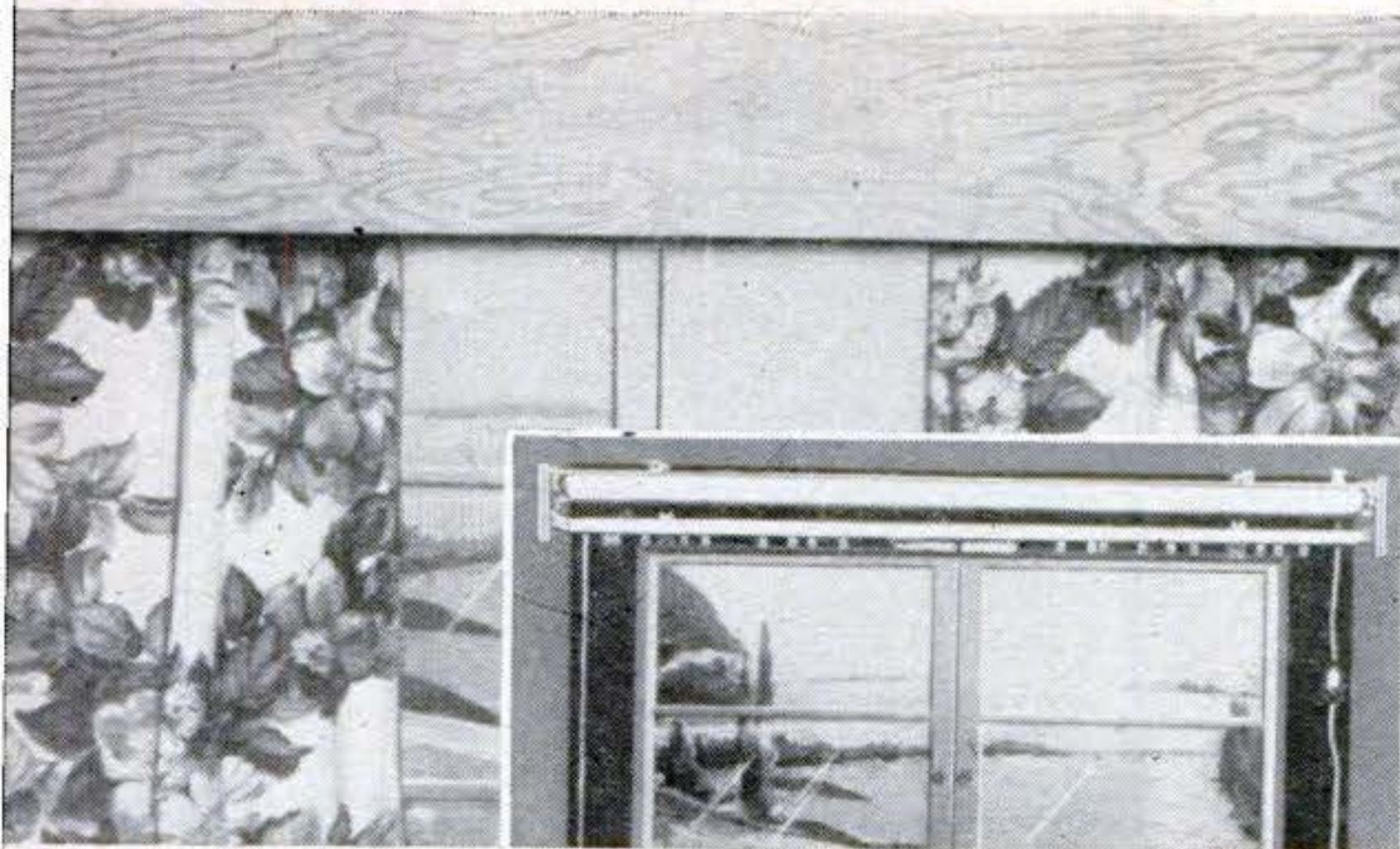

Illuminated Valance. With a fluorescent-lighted valance hung over windows you get indirect lighting without expensive installation costs. *Joleco Corp., St. Louis, Mo.*



Air-Powered Polisher. This appliance for polishing, waxing or scrubbing floors runs on air from any tank-type vacuum cleaner. *Beal Speed Polisher, Portland, Ore.*

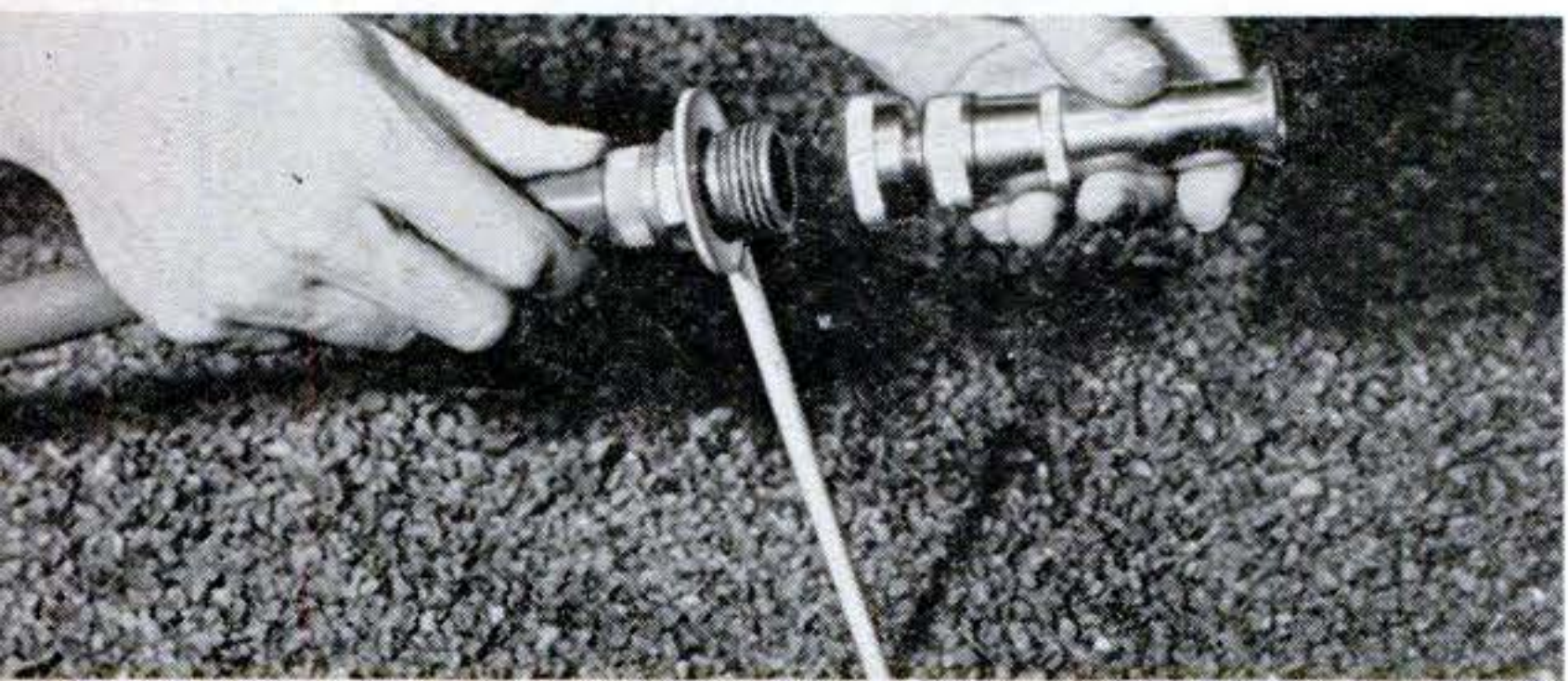

Hose Holder. Where deep soaking of soil is necessary, a spike hose support will release you from a tedious job. It fits any garden hose having a 3/4-inch thread coupling. *Sunset House, Hollywood.*



Rare Jewelry. Cuff links and earrings are now being made from ancient coins. Aurei of Nero, mounted, sell for \$475. For \$1,000 you can have rare, gold Greek staters. *Numismatic Gallery, Beverly Hills, Calif.*

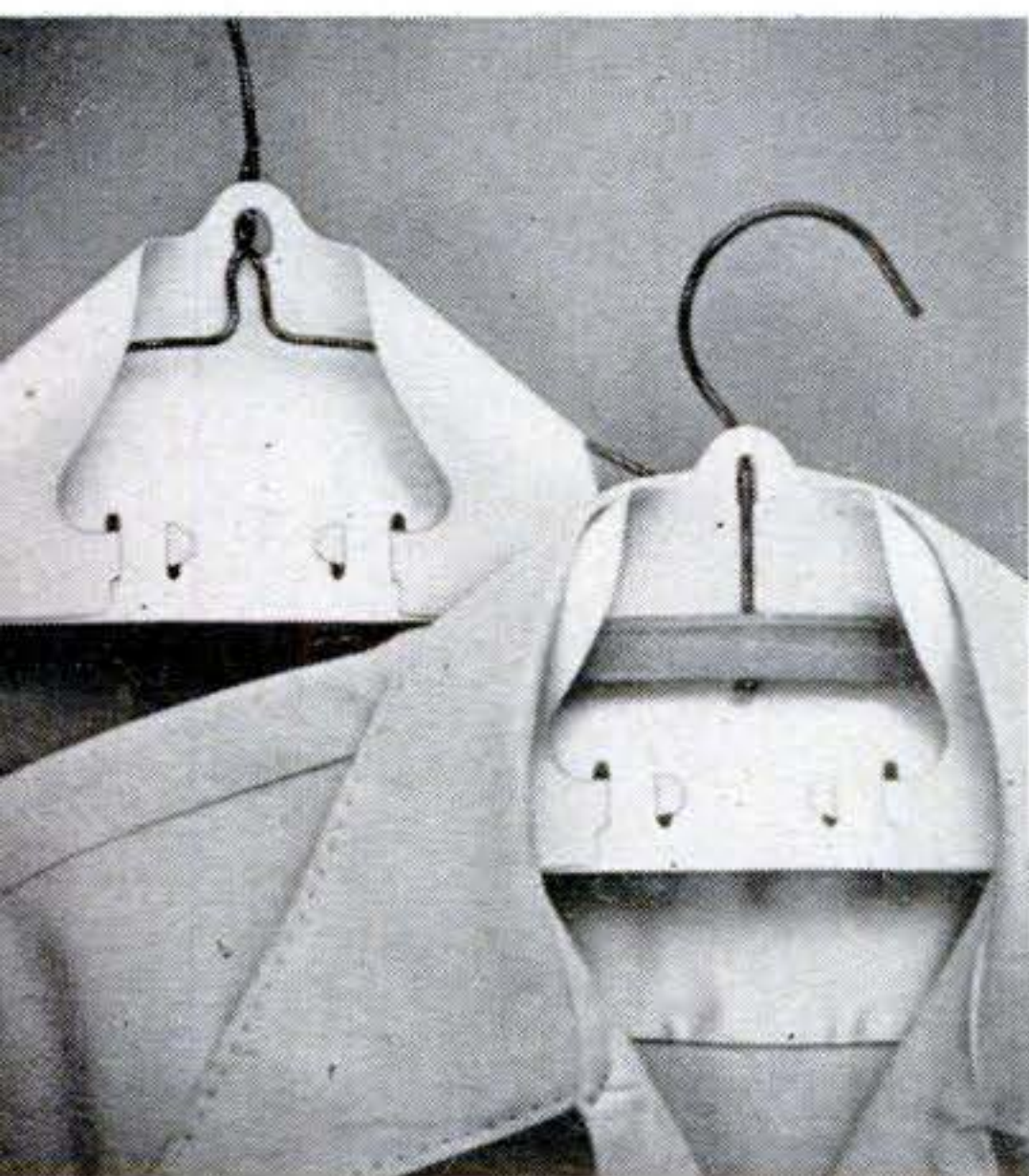

Collar Guard. Clipped around wooden or wire hangers, these plastic guards keep collars gently rolled and prevent wrinkles. *Kempfert-Bowman Mfg. Co., El Monte, Calif.*



Convertible Cart. Just replace the collapsible basket with a tray and this laundry cart serves as a tea wagon or a portable bar. Base folds for storage, too. *Dennis Mitchell Industries, Philadelphia.*

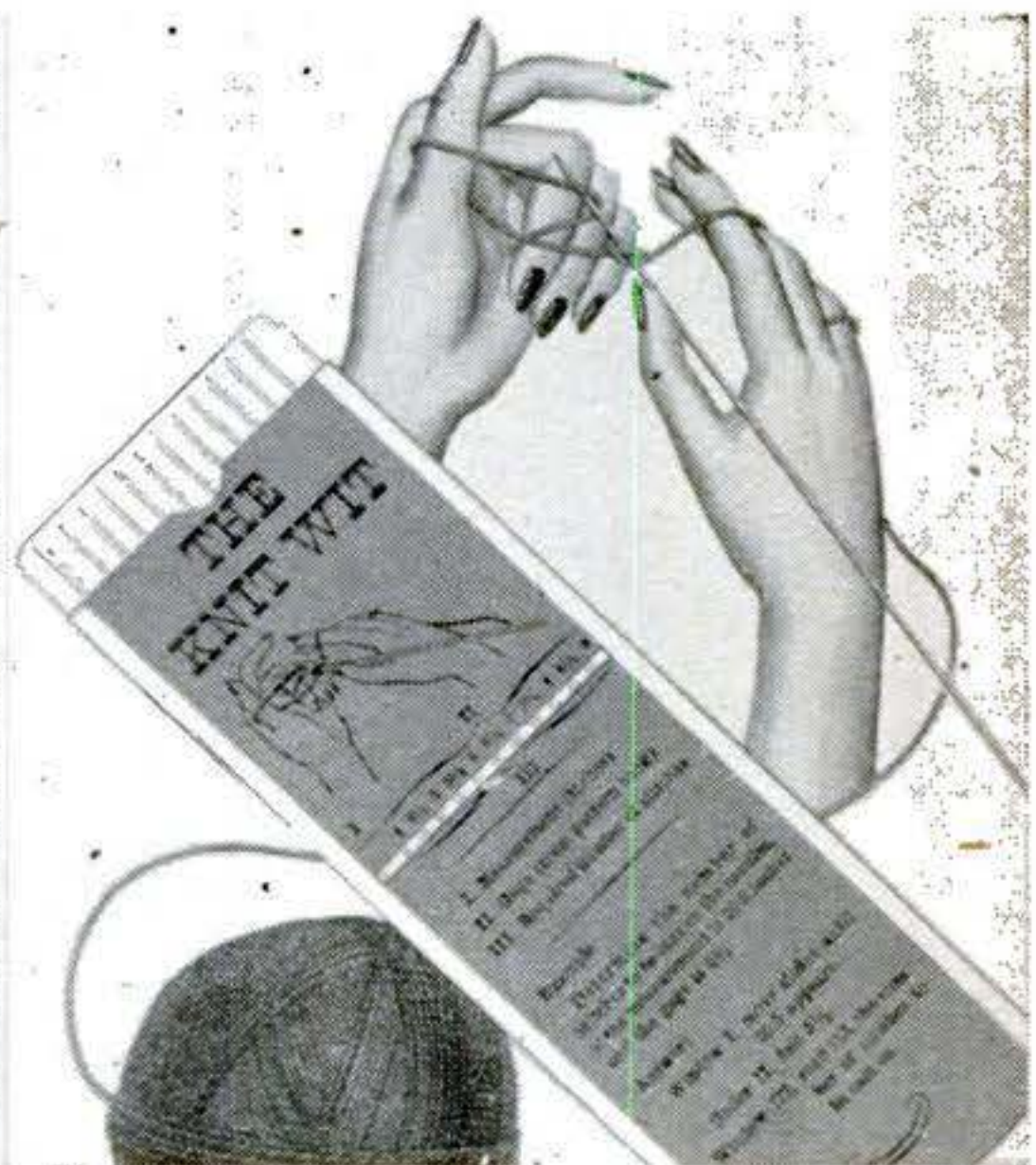

Knitters' Slide Rule. This computer tells how many stitches to cast on for any number of inches up to 100, using any yarn from four to nine gauge. *Progressive Enterprises, Los Angeles.*

Please turn the page for more aids to modern living.

MAY 1952 133

MORE Aids to Modern Living



Kitchen Ventilator. Cooking odors are removed at the source when the fan is built into a cabinet hung directly over the stove. Lifting the hood starts the motor. *Lyon Metal Products, Aurora, Ill.*



Rain Pants. These plastic protectors will keep trouser legs dry and in press on rainy days. *Sta-Dri Products Co., N. Y. C.*

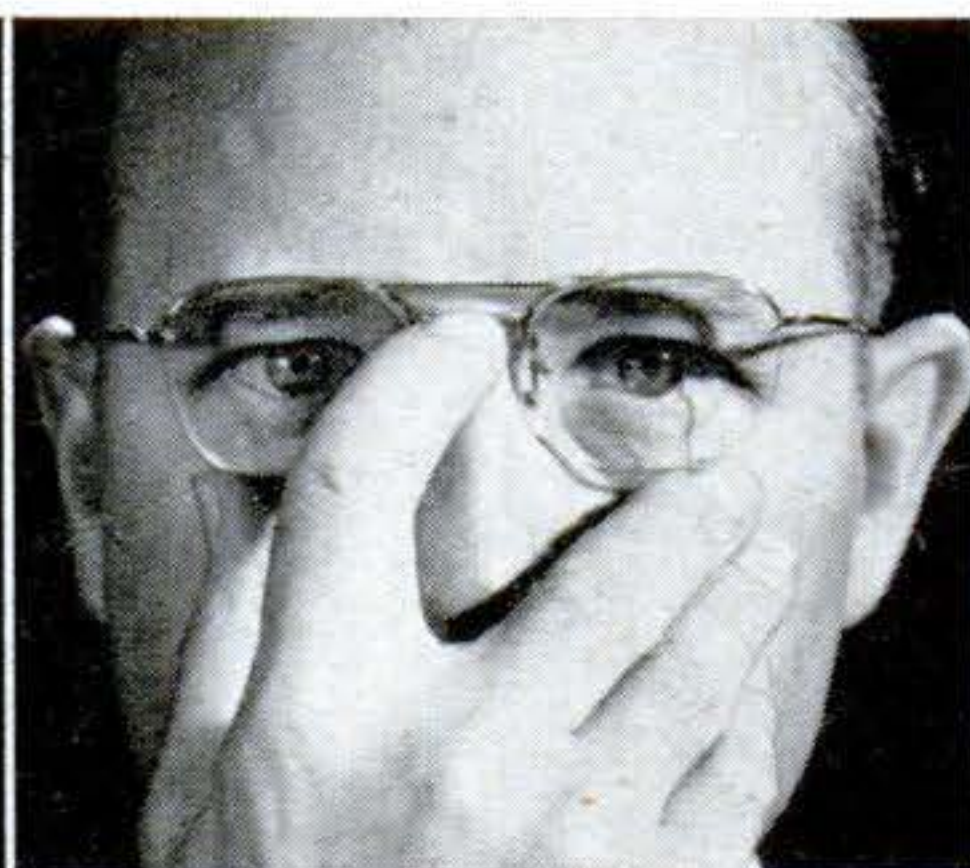
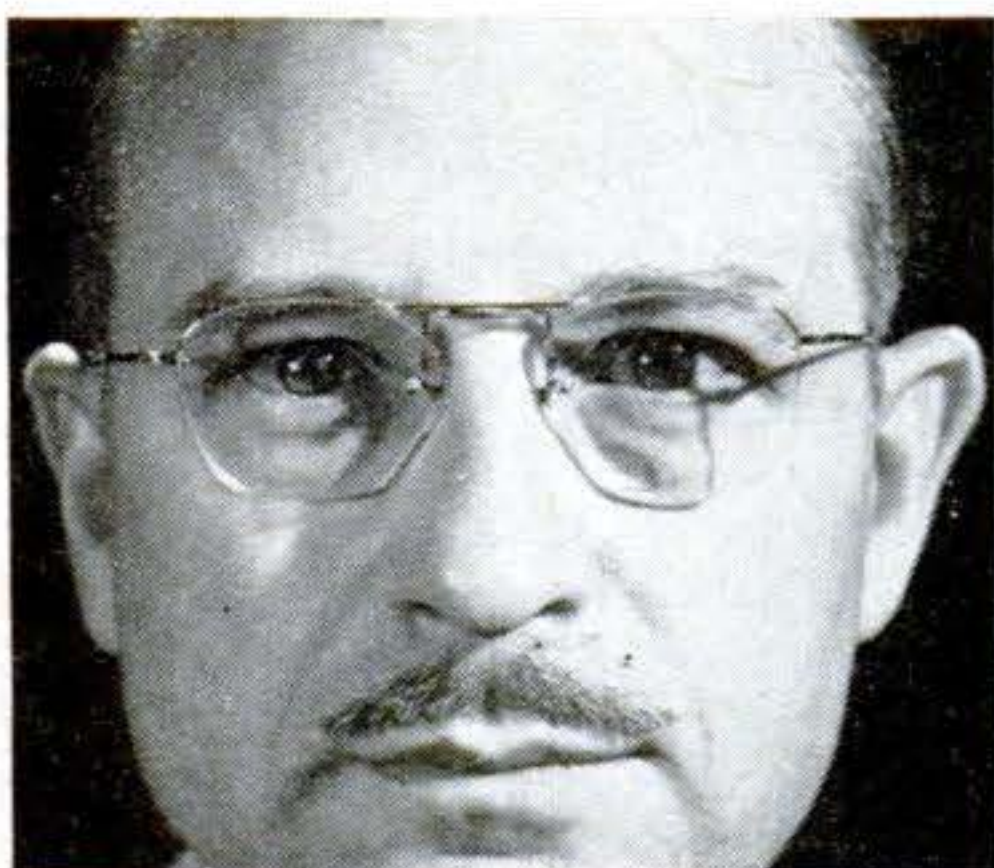

Adjustable Glasses. The wearer of bifocals won't have to squint down his nose or peer over the glasses if lenses are set in this frame. An extra bridge on the nosepiece allows lenses to be lowered for distant vision (left above), raised for close work (right). Finger push (center) adjusts them. *Page Optical Specialties, Hollis, N.Y.*

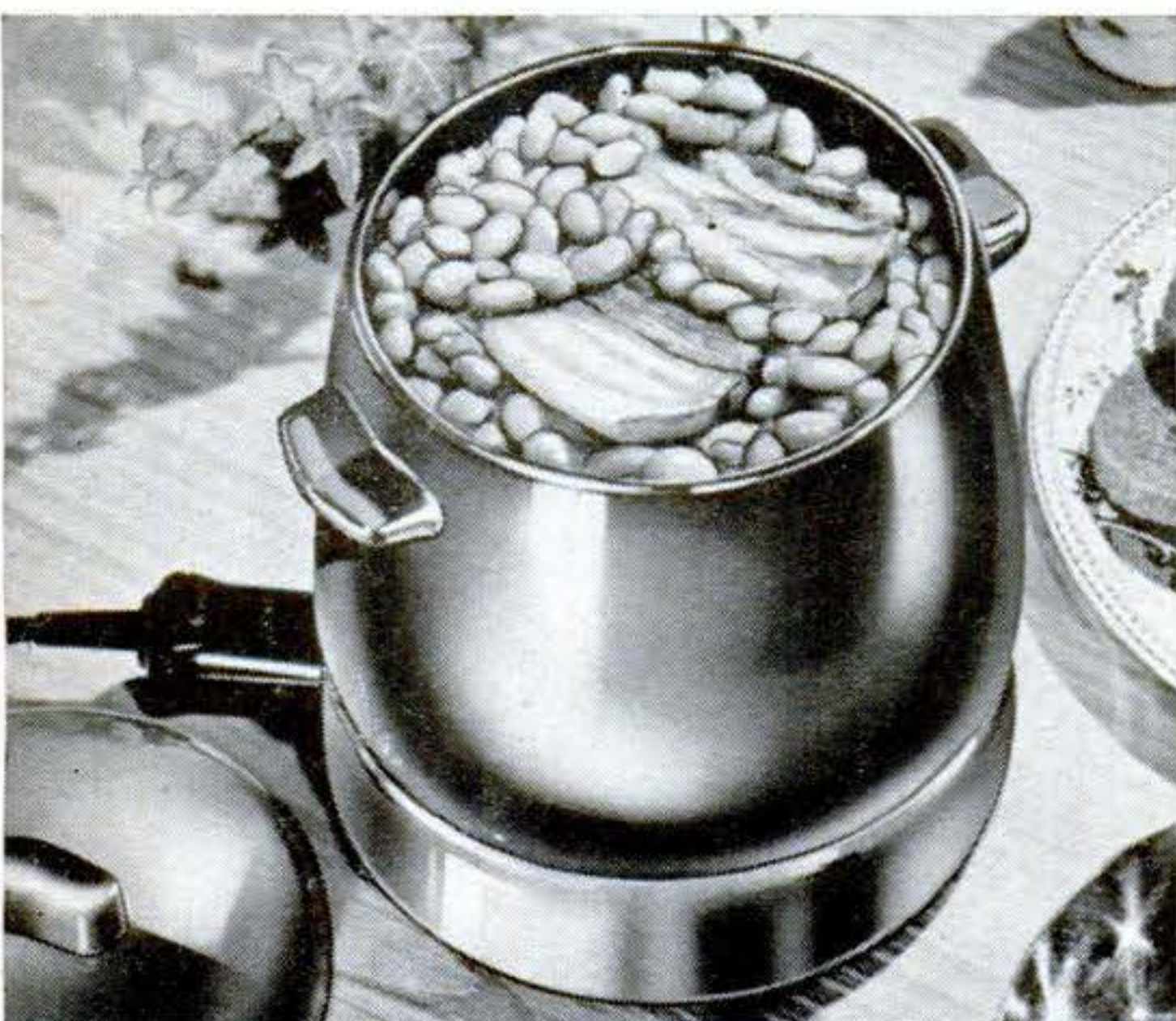

Bean Pot Electrified. Here's an electric cooker that slow-bakes beans or simmers stews, soups and casserole dishes. The ceramic pot lifts off the heating unit for washing; the unit doubles as a hot plate to keep any food piping hot for serving. *West Bend Aluminum Co., West Bend, Wis.*

How You Become

a Frogman

You have to be rough, tough and ready to risk your life either under the sea or on enemy beaches.

By Andrew R. Boone

CHILLED to the bone, seven young sailors with oxygen bottles strapped to their backs walk slowly along the bottom of the Pacific Ocean, 100 miles behind Communist lines. One scoops up a fistful of sand, noting its texture on a slate fastened to his right leg. Another almost bumps into a mine. Consulting his compass and watch, he writes down its location. Others chart reefs and sharp-edged obstacles that would rip into the bottom of landing craft.

After an hour, the seven surface at their appointed offshore rendezvous. They climb into a waiting rubber boat and paddle silently out to their mother ship, lurking in the

A FROGMAN'S most important job is demolishing enemy installations either underwater or on land. Trainee below sets off TNT practice charge on beach at Coronado, Calif.



darkness off the Korean shore. Following a brief report to their skipper, the men move shoreward again. This time they carry sacks of TNT and necessary detonating equipment. Soon their buoyant boat bounces over the breakers smack into enemy territory. Silently they crawl ashore to stack explosives under the timbers of a railroad bridge and at the entrance to a tunnel. Minutes later several blasts disrupt that line for weeks to come. By now, the daring sailors are shrouded in the sea's blackness, paddling like mad toward the mother ship.

The Sneak-and-Wham Boys

The Navy speaks of them as a UDT—Underwater Demolition Team—better known as frogmen. Theirs is the Navy's toughest job, to sneak and peek, then wham and scam. They get the first close-up of enemy beaches and shore installations. Often, since paddle-footed commandos preceded D-day assault troops onto Normandy, frogmen have cleared the way for army troops and marines to hit enemy shores. They get their name from their water green exposure suits. From a distance they resemble bullfrogs.

For his hazardous and daring performances, the frogman draws 50 bucks a month extra pay. How does he get that way?

Let's say you are an enlisted Navy man with at least two more years to serve. You meet a frogman or hear through the grapevine of his exploits. You write the Bureau of Personnel in Washington, volunteering for UDT training. If you are between 18 and 35, the bureau may give you a tentative go-ahead. You must be the type who wants to stick his neck out.

Qualifications Are Rigid

Are you qualified? That depends upon several things. If you're an almost perfect physical specimen, require no medical attention, are not afflicted by claustrophobia—fear of being confined in small space—and have no fear of water and explosives, you may get a chance. If tapped for the opportunity, you will have to take about 15 weeks of the toughest training imaginable at one of two Naval Amphibious Bases—Coronado, Calif., or Little Creek, Va. If you finish the course successfully, you win your fins. Chances are about even you won't make it. You may lack adaptability, a strong will—or plain guts.

You start as a polliwog. UDT commanders don't care too much whether you're a quali-

fied swimmer at the outset. In a few weeks, however, you will be swimming two miles through surf and rollers, and varying distances under water. You must swim noiselessly without telltale splashes that would reveal your position to the enemy.

For the first two weeks you swim in a pool. Endlessly you practice three strokes: side, breast and back. "Stop splashing," shouts a hard-bitten instructor, "want white water to draw fire?" Silence and invisibility will be your best defense.

The third week you are assigned to a boat crew, one of seven men. Holding overhead a 250-pound inflated rubber craft, you walk into the crackling surf and launch the boat. Then—on purpose—you capsize it, and right it again in the swells. You swim short distances, distances that will lengthen day by day. By night you practice infiltrating "enemy" camps, then you paddle out to sea to place explosives around shallow-water obstacles that duplicate those you'd encounter on some foreign shore.

Worst Tests Come in Hell Week

Five weeks pass. The sixth is Hell Week. Each morning you roll out at 5:45, gobble a light breakfast, set out on a one-mile run through the sand. Next comes a two-mile swim; an hour of judo training, sentry stalk-



INFLATABLE rubber boat is used by Underwater Demolition Team to sneak ashore at night. Frogmen must learn to right boat if it capsizes, handle it in heavy seas.



AFTER "EXPLODING" beach defenses, frogman returns to his sea-going boat. Hooking onto

a line looped around a wooden block, he is hauled aboard craft by another frogman.

ing and infiltration; and another one-mile run. You top off these wearying activities—after lunch—with another hour of calisthenics, a round of some competitive sport and a run through an obstacle course.

You end each day's round so weary you can barely walk from dinner to your bunk. You're dreaming of a soft berth when—wham!—a whistle blasts in your ear. It's 10 o'clock and time for a forced march of 15 miles, half of it through knee-deep water. You hit the sack again at four, making the 5:45 reveille a hollow joke. Well rested, beef-fed instructors have another go at you after you breakfast on K rations.

One of your buddies is cut by barnacles, another struck by a sting ray—a sea creature that inflicts painful wounds. Some fall by the wayside, but none gives up voluntarily.

These problems are but a warm-up for Hell Week's last evening—a fine way for a sailor to spend Saturday night.

Promptly at nine your class lines up on the beach near headquarters. On signal, you shoulder your boats and run one-half mile to the ocean. Launching them, you stage a swift 7½-mile race to Fort Emory, portage across the narrow sandy strand and race back through San Diego Bay, checking at seven stations enroute. Arriving at "Pickle Island," a weed-swathed stretch of rocky beach, you portage to a jetty, launch the boat once more, then paddle to the original take-off beach. You polliwogs cover 19 miles this night.

Windup Is Demolition Study

You've had a taste of combat operations. Comes now cold-water swimming. For 10 weeks you plunge into the sea repeatedly. The fins feel awkward at first, but soon you get the feel of these appendages. They help propel you faster. You tackle the surf, outbound and inbound, plunging outward

10 Swimming Tips from the Frogmen

- ▶ Learn to swim from an instructor, preferably in a pool.
- ▶ Never swim until weary, for your muscles may give out.
- ▶ Do not swim within one hour after a hearty meal.
- ▶ Never swim alone. Cramps are dangerous.
- ▶ Do not splash others, especially beginners, for they may choke or become panicky.
- ▶ Swim out from shore line only half the

- distance that you think yourself capable of.
- ▶ Swim in the sea only under the eyes of a lifeguard.
- ▶ To enter the sea, go out under the breakers. This takes less effort than fighting their incoming crests.
- ▶ To land from the sea, ride the breakers. Make like a surfboard.
- ▶ Use the stroke you like best. It's less wearying.

under the breakers, riding them in like a surfboard. The cold penetrates to your bones, but gradually you accustom yourself to the near-freezing temperatures. You lengthen your swims, until at last you surpass considerably the two-mile requirement. Explosives lose their mysteries. During the final week you practice demolition techniques so secret not even the rest of the Navy knows about them.

You manage to survive the killing routine, purposely so rough that only the toughest

can take it and come back for more. You win your mythical fins, but get no badge identifying your service. There are fewer than 250 frogmen qualified to wham an enemy shore and scam to safety, and the Navy doesn't want them easily identified. You will serve with one of five UDT outfits. But who's lucky, you or the guy who flunked? That depends upon the point of view. Some freezing black night when you ease from a rubber boat and start swimming toward an almost invisible enemy shore, you will find out. **END**



STUDENT FROGMEN set TNT charges in ocean to destroy hedgehog obstacles—sharp-edged

angle irons, arranged in the shape of a triple X, that cut into the hulls of landing craft.

I'd like to see them make...

Everyone has his own pet idea of some gadget he would like to see in general use. What is YOURS? *Popular Science Monthly* will pay \$5.00 for each one published. Use government postcards only. Contributions cannot be acknowledged or returned.

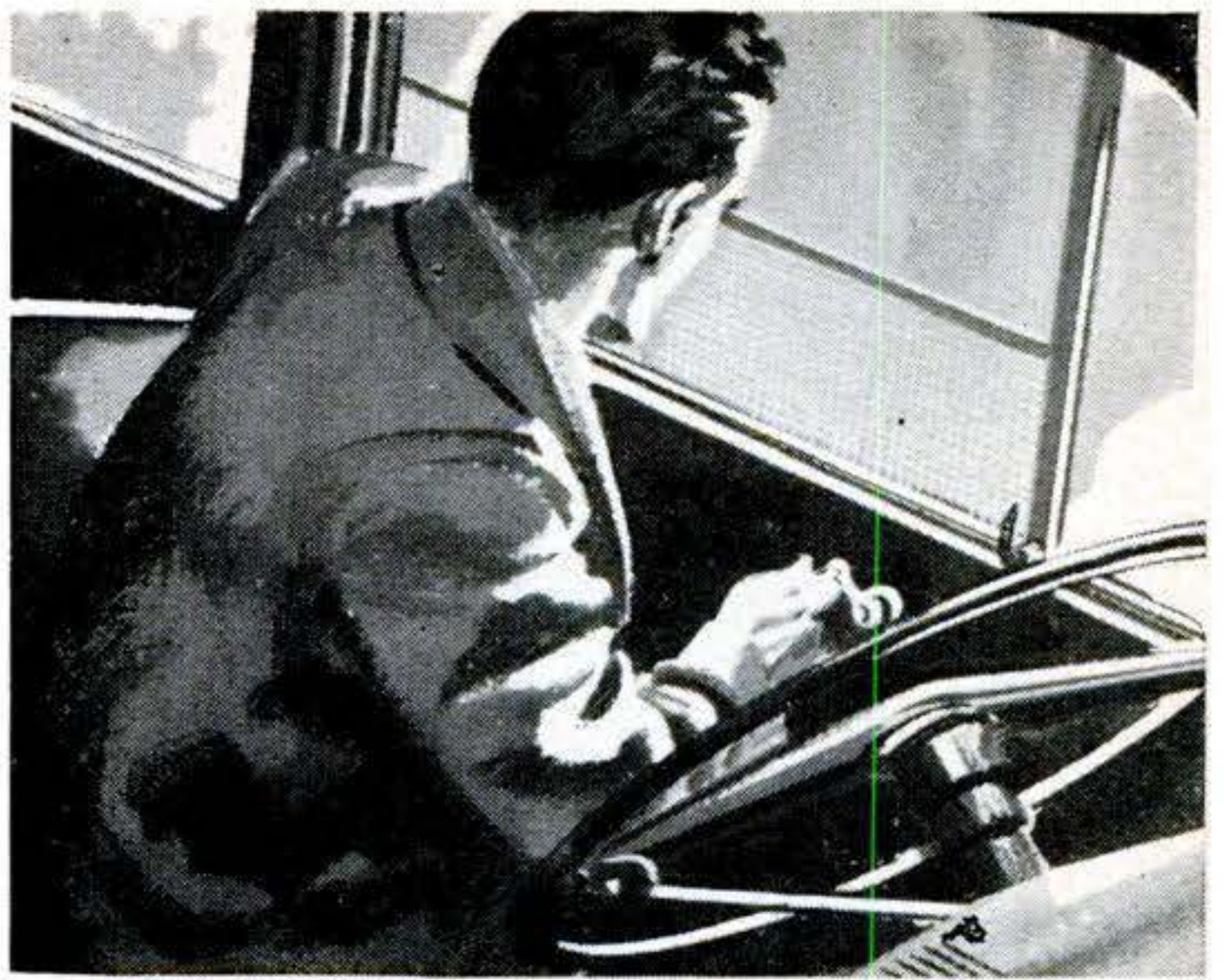

ROLL-DOWN SCREENS FOR CARS so salesmen and shoppers wouldn't have to leave their cars all buttoned up during hot summer months.—*S. P. Wiener, So. Norwalk, Conn.*

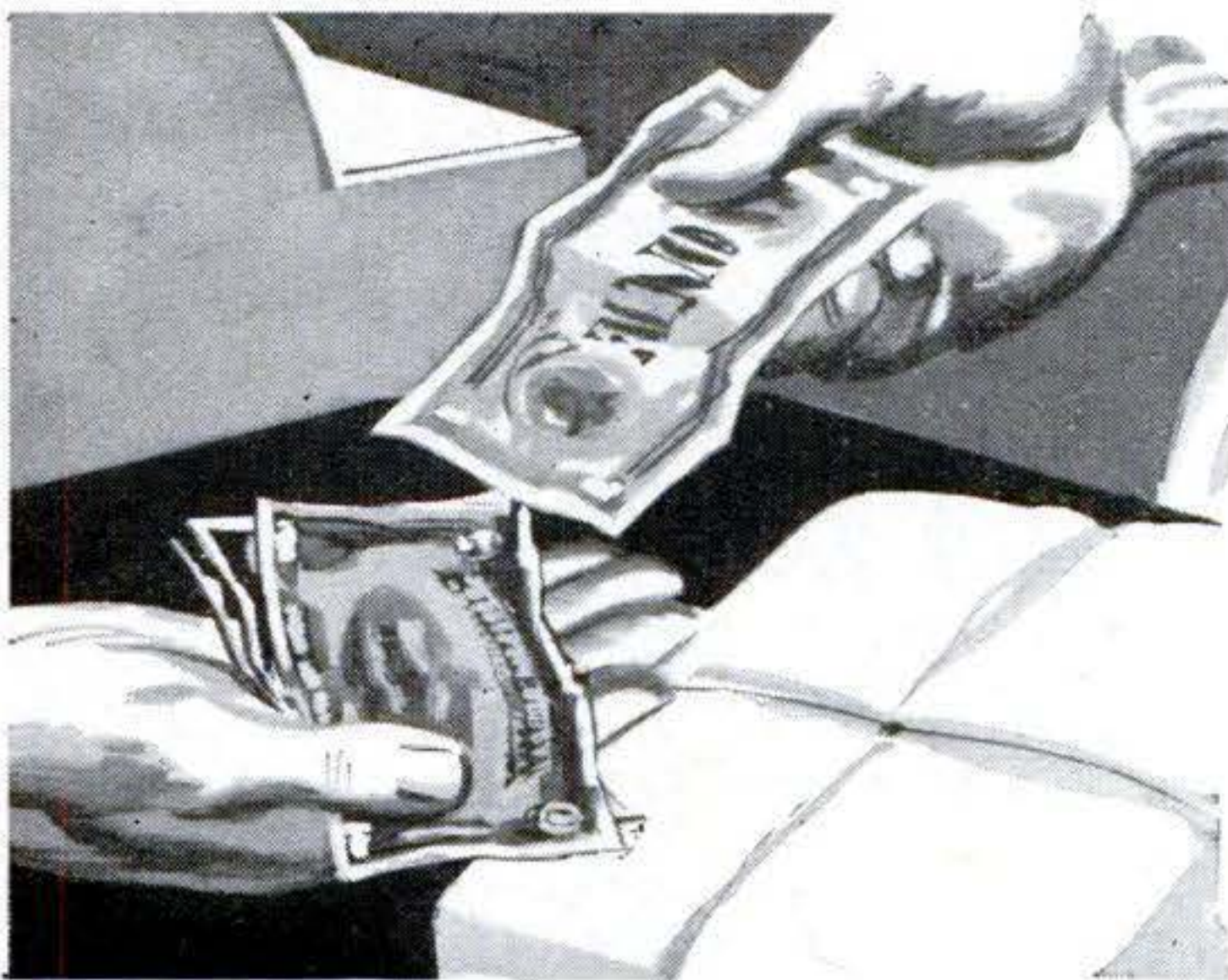

PAPER MONEY IN DIFFERENT COLORS, one for each denomination, for quick identification and prevention of costly mistakes.—*Herbert E. Fey, New Braunfels, Tex.*

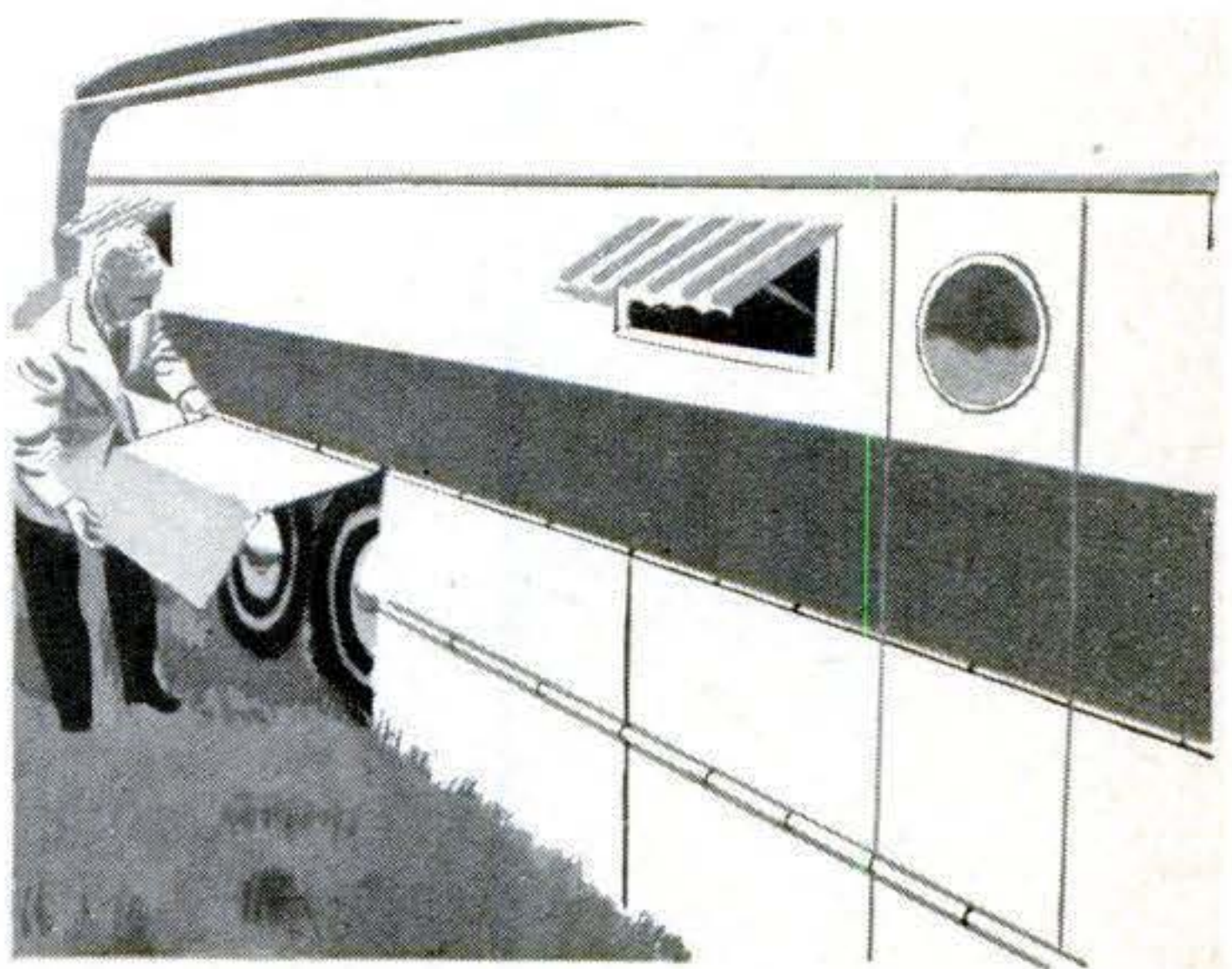

SIDE PANELS FOR TRAILERS. You could pull them down when you parked vehicle, making the base more attractive and shutting off drafts.—*Mrs. R. C. Armstrong, Lafayette, Ind.*



A FOOT-OF-THE-BED ROLLER like a window shade. You could pull up the quilt when cold, let it rewind automatically when you didn't want it.—*W. Scheel, Bloomington, Ill.*

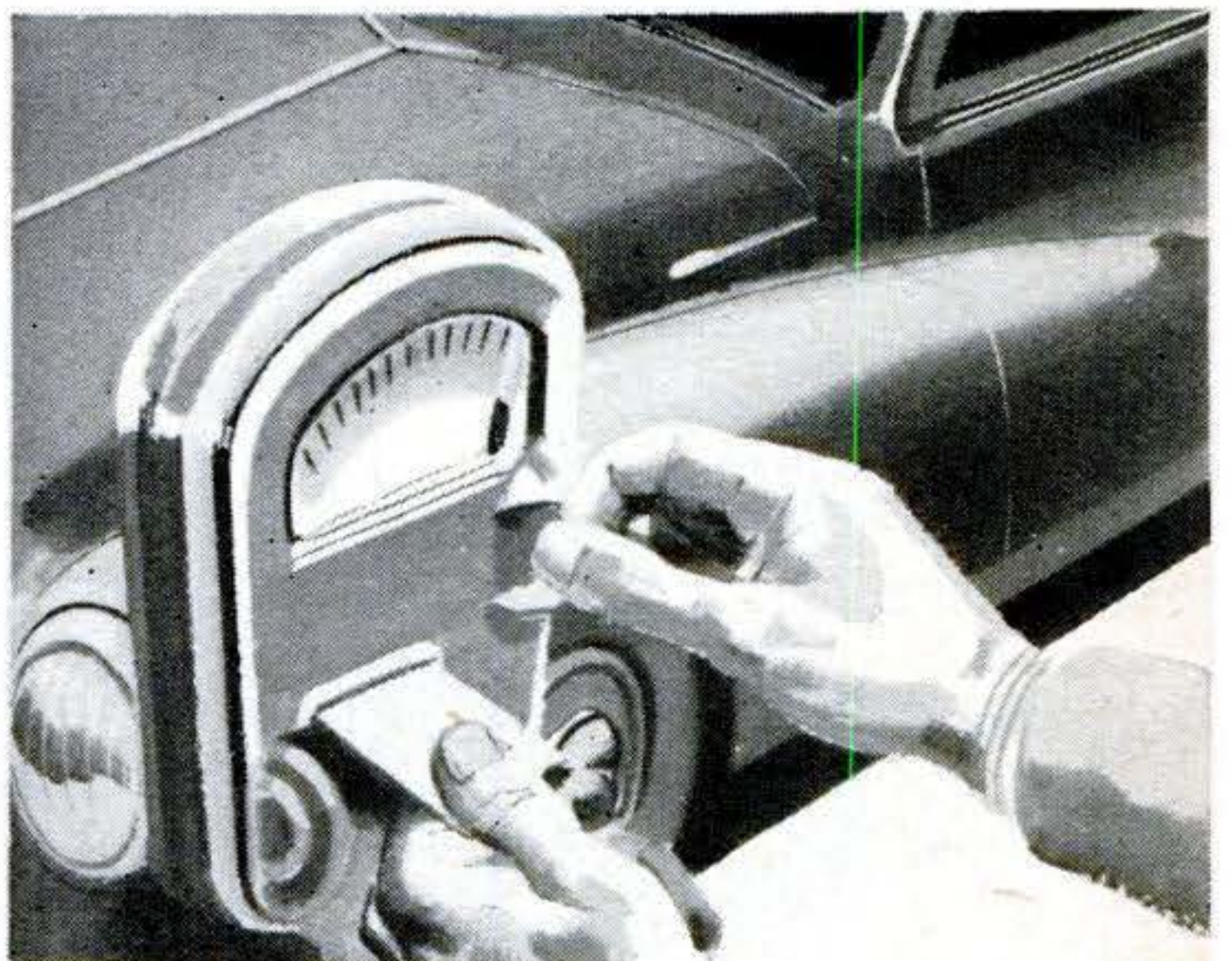

A DEVICE ON PARKING METERS which, when a coin was inserted, would eject a card showing when your parking time would run out.—*John D. Sterringer, Lancaster, Pa.*

You Can Really See Out of a Kaiser

The '52 Kaiser combines classy lines with sassy performance in a car that's as easy to look at as it is to look out of.

By Wilbur Shaw

WHEN Henry J. Kaiser decided to break into the automobile-manufacturing business after World War II, he bit himself off quite a chunk to chew. No major effort like this, in competition with long-established companies, had been made since Walter P. Chrysler barged into the business in the early 1920s.

I've just had a chance to see how Henry is doing after six years. I've driven the 1952 Kaiser.

The Kaiser is a conventional car. I remarked on that on my recording set as I slid behind the wheel of a four-door sedan, equipped with a Hydra-Matic transmission, at the Kaiser-Frazer factory in Willow Run.

There were all sorts of stories . . . right after the war . . . about what this new

brand of car was going to be like. For one thing, we heard that it would be a front-drive affair. Well, Henry didn't desert the beaten path when the Kaiser and the Frazer finally came out . . . he was wise . . . the public doesn't cotton to the unusual. Anyone who gets too revolutionary sticks his neck out a mile.

I liked the car, even before I fired up. The visibility was superb. I want to emphasize that. A British automobile critic has written that the Kaiser windshield is a broad bay window. And the hood is low.

You See Where You're Going

With a measuring tape I counted off how close a driver could see in front of the car. Over the top of the hood a medium-sized man can see the road as close as 15 feet seven inches ahead of the front bumper.

REPORT FROM THE



DRIVER'S SEAT . . .

Visibility from the Kaiser is eloquently illustrated by this picture. The camera could see right into the driving compartment and identify me as I made a speed run on the Detroit Expressway. Chrome for dressing up doesn't seem lacking, but I suspect defense needs have thinned it out.

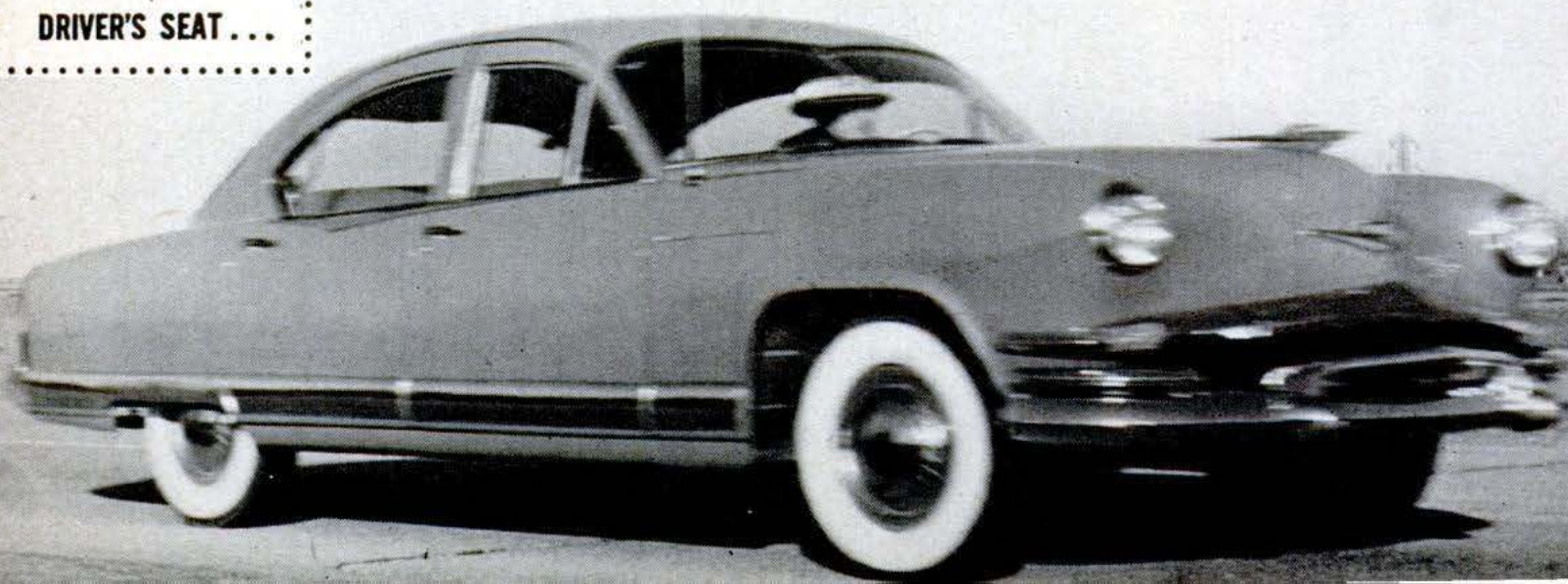



Looks just like I'm sitting out in the open, doesn't it?—except for that low mirror, of course.

Looking through the crease between the left fender and the hood, he can see it to within 11 feet three inches ahead. That is a commendable safety feature.

I started the engine with the ignition key. That's new. No starter button on the dash.

There are some other new items—a one-

piece curved windshield, a refurbished front end and hood ornament, and a restyled rear bumper, rear-deck handle, rub rail and interior trim combinations. Rear springs have been softened, a wider brake pedal goes with the Hydra-Matic transmission, and both the front suspension and the front

The spare is sunk in a well in the trunk. I found the luggage space a little skimpy. Outside rear-deck hinges enhance the car's appearance. K-F has discontinued the Frazer.

For an L-head, the engine has a lot of sass. The upper piston rings are chromed. This prevents scuffing and permits greater tension on the cylinder walls without added friction.



shocks have been re-engineered this year.

The engine is quiet . . . there's the slightest tendency toward vibration at idle . . . but I've never driven a six-cylinder car that didn't have that. The Hydra-Matic quadrant is conventional and—as she starts off now—the gear engagement is smooth and soft.

My proving ground was the high-speed Expressway between Willow Run and Detroit. The cops pay no attention to your

speedometer readings on this divided highway unless you drive just plain dangerously.

This seat is exceptionally comfortable . . . and the sill behind the windshield is so low that a person getting into trouble with this car had better see his oculist. The windshield slants back until you feel as though you were sitting out in the open . . . you can see a traffic light almost directly overhead without bending forward . . . that does cut down the headroom, but it's not objectionable . . .

This car had enough miles on it to let it out. So I picked a traffic-free stretch of the Expressway and let my accelerator foot get heavy.

60 M.P.H. in 15 Seconds

The acceleration is good . . . I hadn't expected it to be so good with a 3.31 rear-axle ratio . . . that ratio with the automatic transmission obviously was adopted for better gas mileage . . . which amounts to 16 to 17 miles to the gallon . . .

She marches right up through 50 miles an hour . . . 60 . . . 65 . . . 70 . . . 75 . . . and 80 . . . The top speed—we'll have that in a moment—doesn't come too easily as the engine begins reaching its power peak . . . there we are—an indicated 90 miles an hour.



Jumbo-size tail lights (above) and redesigned rear springs (right) are new features on '52 Kaiser line of cars.

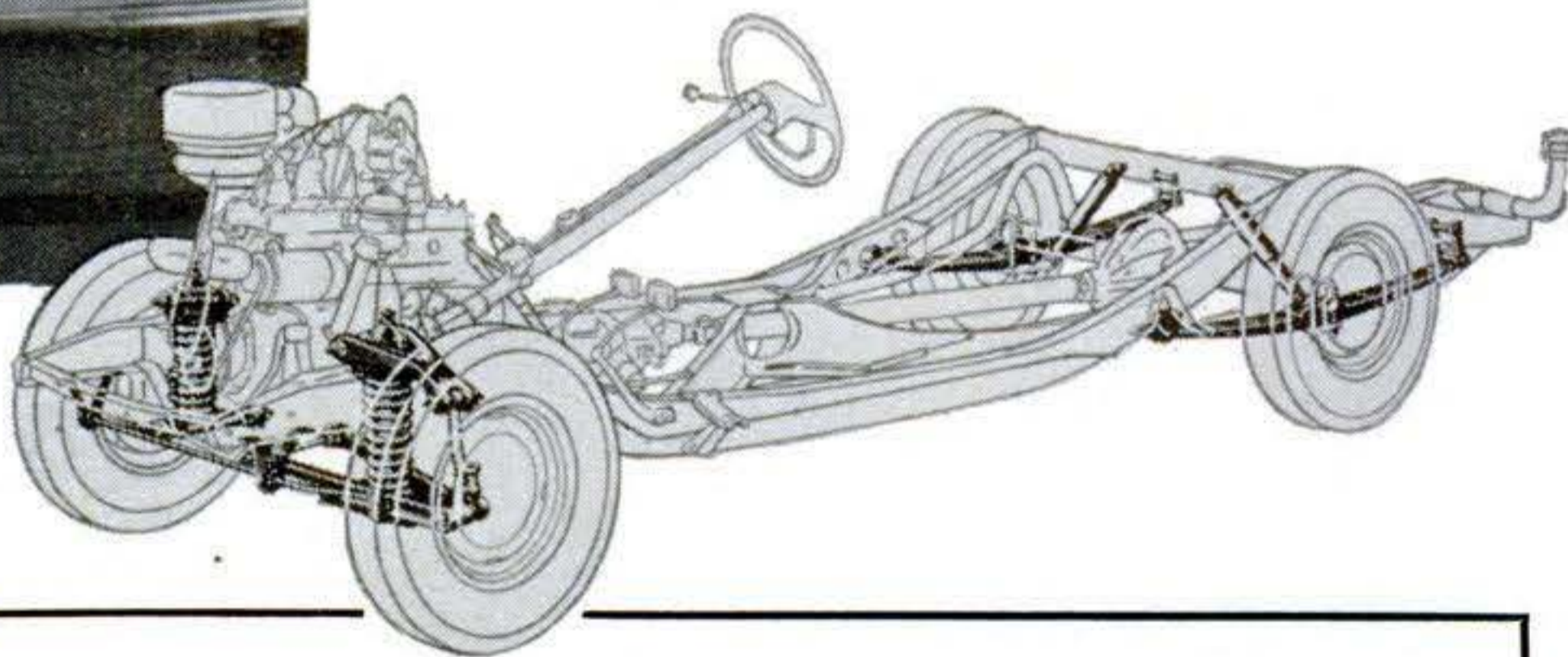

FACTS ON '52 KAISER

Model: Manhattan four-door sedan.

Engine: 6-cyl. L-head; 115 hp. at 3,650 r.p.m.; car weight per hp., 28 lb.; bore and stroke, 3 5/16" by 4 3/8"; compression ratio, 7.3:1; piston displacement, 226.2 cu. in.

Piston travel: (in feet per car mile at 20 m.p.h.) 1,915.

Crankshaft bearing surface: 44.6 sq. in.

Torque: 190 lb.-ft. at 1,800 r.p.m.

Transmission: Dual-Range Hydra-Matic.

Rear-axle ratio: 3.31:1; with standard transmission, 3.91; optional, 4.55.

Steering ratio: 18.2:1.

Radius of turning circle: 19'.

Effective brake-lining area: 175.7 sq. in.

Springs: front, coil; rear, semi-elliptic.

Weight and outside dimensions: 3,220 lb.; height, 60"; over-all length with bumpers and guards, 212"; width, 74"; wheelbase, 118 1/2"; overhang, front 38 3/4", rear 54 3/4"; tread, front 58", rear 58 3/4".

Inside dimensions: seat-cushion width, front 64", rear 63"; leg room, front 43", rear 40"; headroom, front 37 1/4", rear 36"; seat height, front 10 3/4", rear 12 3/4"; vertical distance, steering wheel to seat cushion, with seat in mid-position, 6"; front-seat adjustment, horizontal 7", vertical 5/16".

Tire size: 6.70 by 15.

New Henry Js Offer Sports and Family Versions

The Henry J's changes include new bumpers and tail lights. A 4.27-to-1 rear-axle ratio gives better fuel economy.

And now there's a glove compartment (below). Trunk lid has no handle. Unlocked, it pops up.

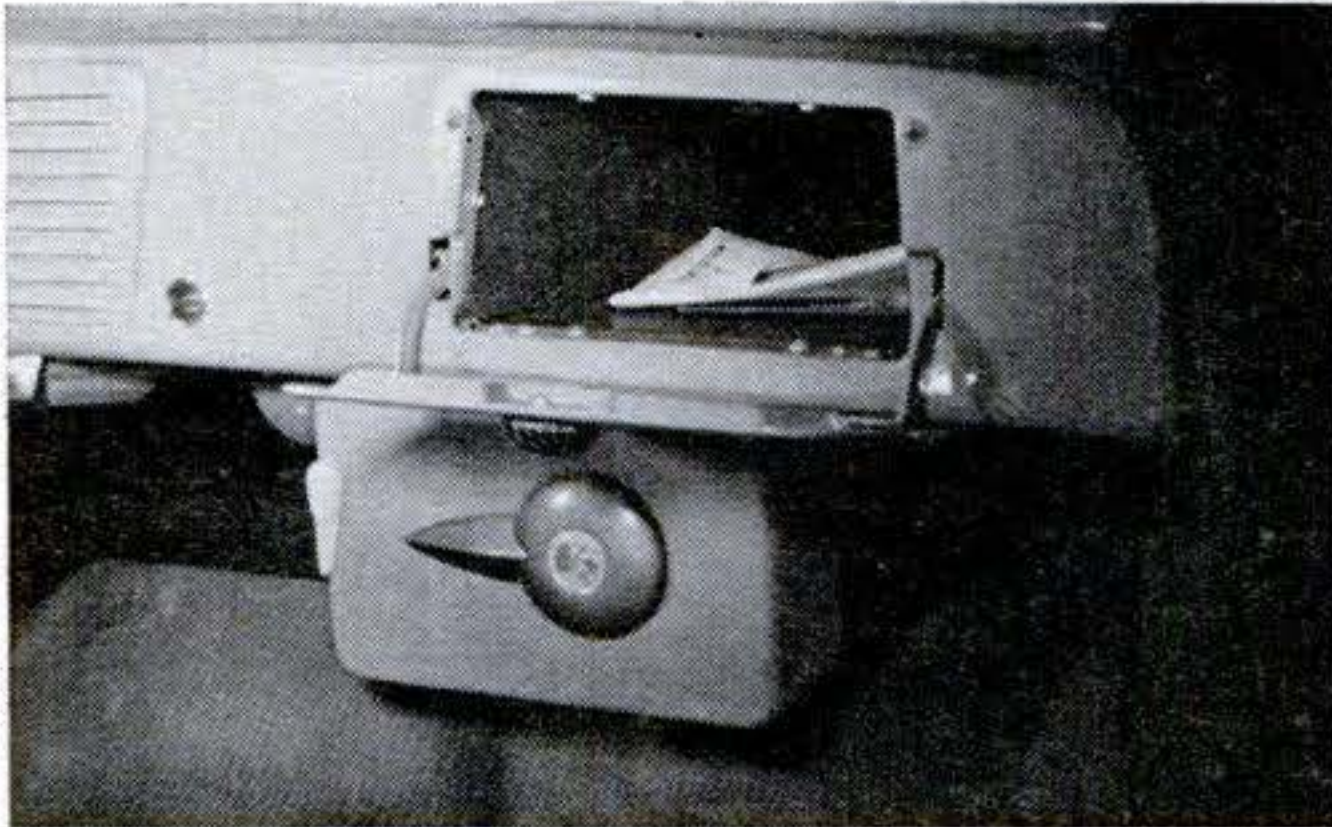
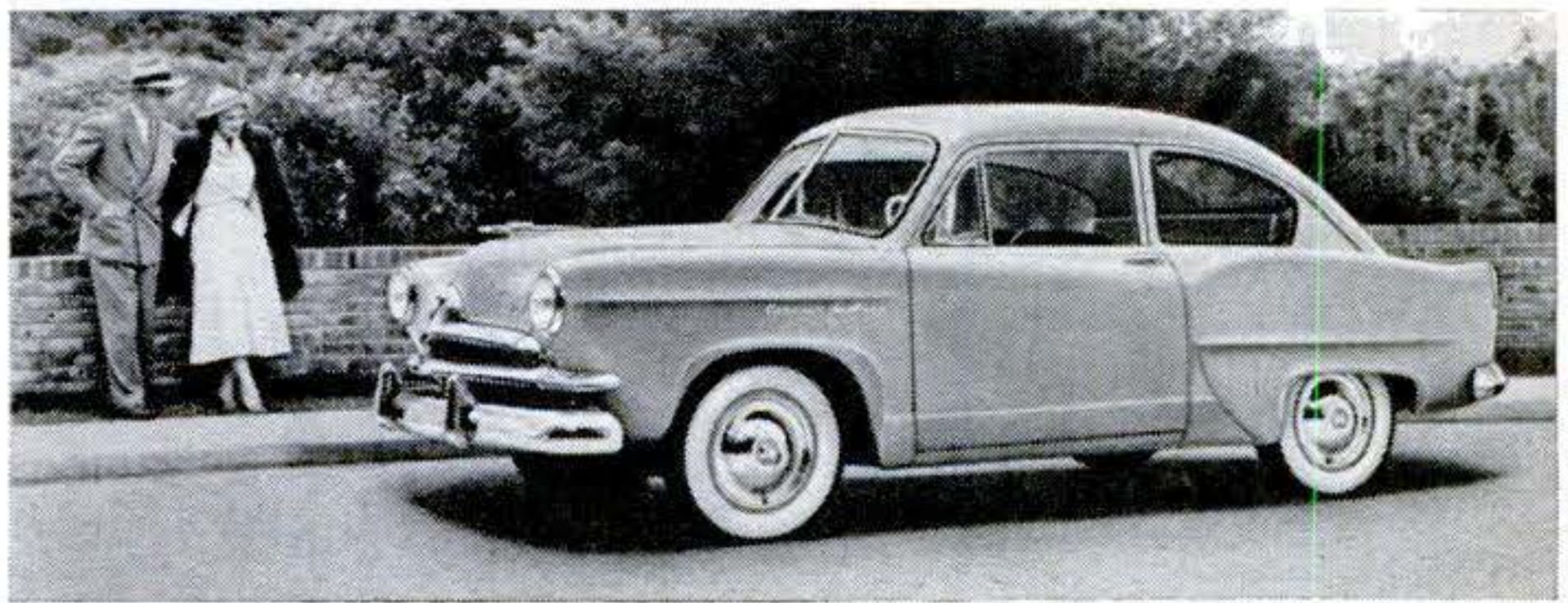

KAISER'S little Henry J, introduced in the fall of 1950, is getting sophisticated. For '52, it comes in two models—a Vagabond sports sedan with an outside-mounted spare wheel, and the Corsair. Other new features: shock absorbers that dampen spring action better, a starting motor that stays glued to the flywheel until the engine starts, revamped interiors.

I slacked off and let the car coast to a stop. I wanted to put a timer on the acceleration. The speedometer had calibrated to an error of three miles, registering 60 at an actual speed of 57. That's about normal for car speedometers these days—in the higher speed registers the manufacturers keep widening the gap between indicated and actual speeds. It represents an effort to reduce deaths on the highway.

First, I stop-watched the Kaiser from a standing start to an indicated 60 miles an hour by starting in Low range and shifting to Drive at 30 miles an hour. The first try took 15.9 seconds. A second try took 15.1. Then I timed the acceleration using Drive range from the start.

I've got one passenger aboard and a full gas tank . . . and unless I'm mistaken . . . I'll beat the acceleration time I got when I shifted. Here we go . . . the take-off is fast . . . it always is with these Hydra-Matics . . . 30 miles an hour . . . 40 . . . 50 . . .

Again . . . there's 40 . . . 50 . . . 60, in . . . let's see here . . . 14.5 seconds. That's only about one second slower than the fastest big-production Hydra-Matic car I've ever driven . . . and it had more horsepower. This L-head engine's got what it takes.

Now I tried the braking power. The Kaiser stopped dead with hard braking from an indicated 60 (which was 57 miles an

hour) in an even 117 feet. That's 68 feet better than the figure given by the National Safety Council for stopping from 60.

It *was* hard braking. The car dived severely. It also weaved. The left rear brake grabbed. The brakes needed adjustment.

Nothing Else Like It

I made my final comments on the Kaiser as I steered back toward the factory abutting the vast Willow Run airport.

I can find little faults . . . this rear-vision mirror is too low, for instance . . . it cuts off part of my view of the road . . .

But Henry Kaiser has a good car here . . . make no mistake about that . . . these safety features in the front seat . . . he deserves a pat on the back for them. The windshield that pops outward if it breaks . . . control knobs recessed in the dash so you can't get caught on them . . . padding on the dash . . . all help protect anybody riding that danger spot beside the driver . . . And in styling he could teach a thing or two to other manufacturers . . . its lines are as graceful as a woman's. There's really nothing like it in the industry.

As if in corroboration, my eye fell on a two-tone green job in the company garage as I parked. Anyone who wouldn't give it a double-take probably wouldn't look at a pretty girl either.

END

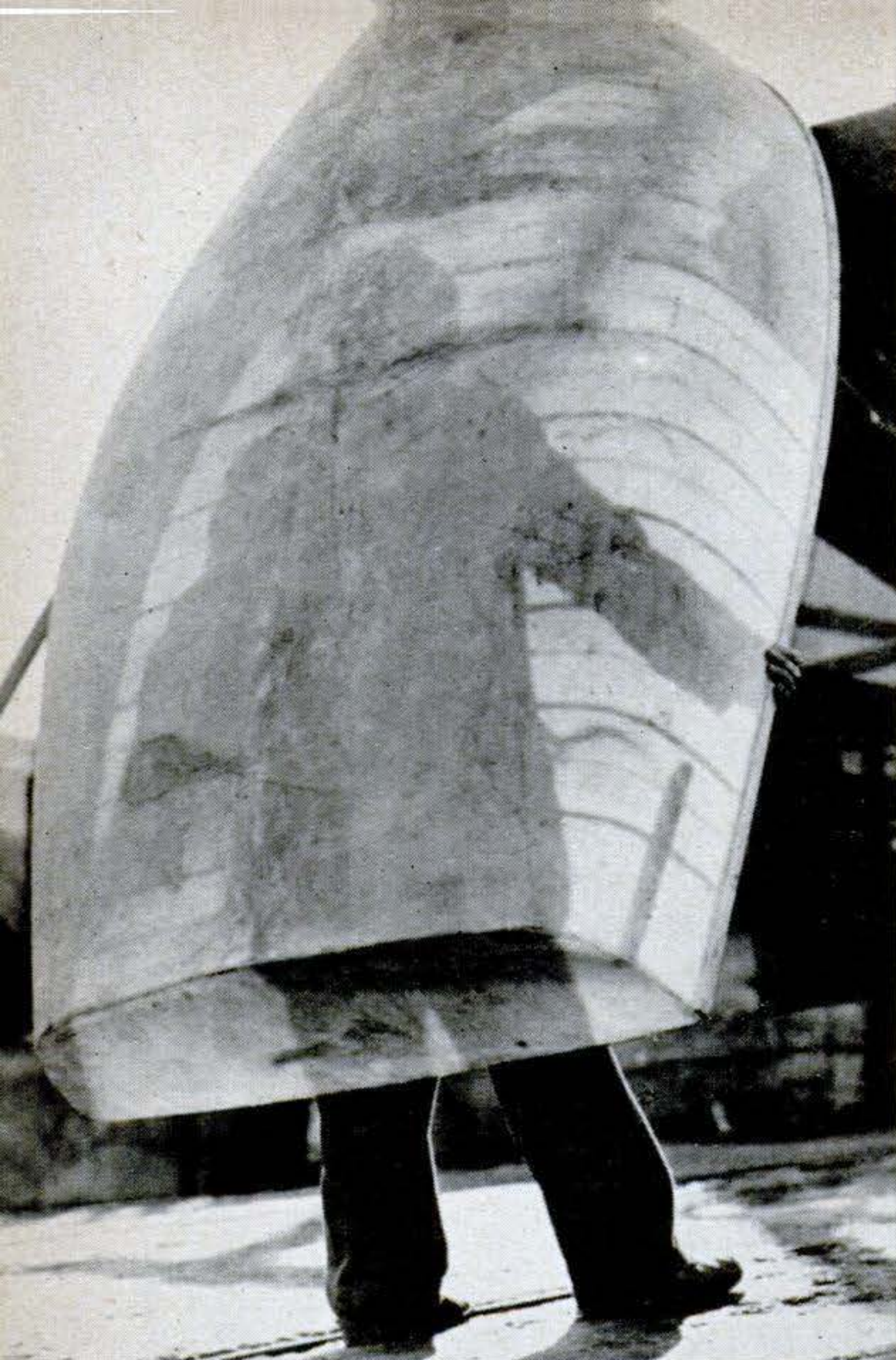

Boat You Can See Through

THIS lightweight, glass-hulled dinghy is less than an eighth of an inch thick but is said to be extremely tough. Molded of resin-bonded glass fiber at the Medina Yard on the Isle of Wight, in England, the translucent boat requires no attention apart from cleaning. It cannot rot or decay and is safe from attack by insect borers.

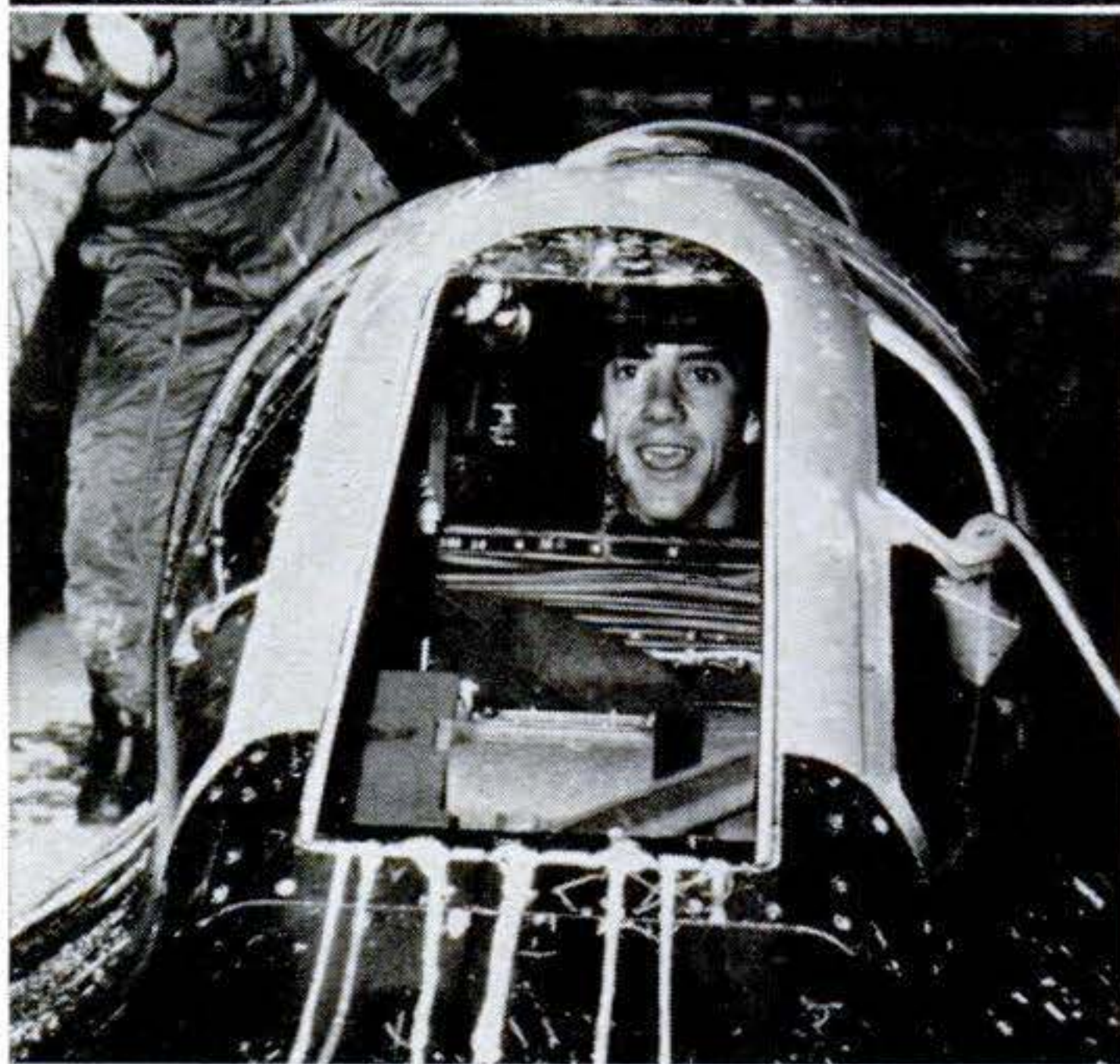

Jet Pilots Get Quickie Deicer

WINDSHIELD icing holds no terrors for F-89 pilots. An electrical-resistance coating on the outside of the windshield heats when the deicer is turned on. Lower picture above was taken only a few minutes after upper one was snapped. The cold-weather test was made to check the Scorpion's ability to operate in the Arctic.

Baby Jet Engine May Speed Small Planes at 300 Miles an Hour

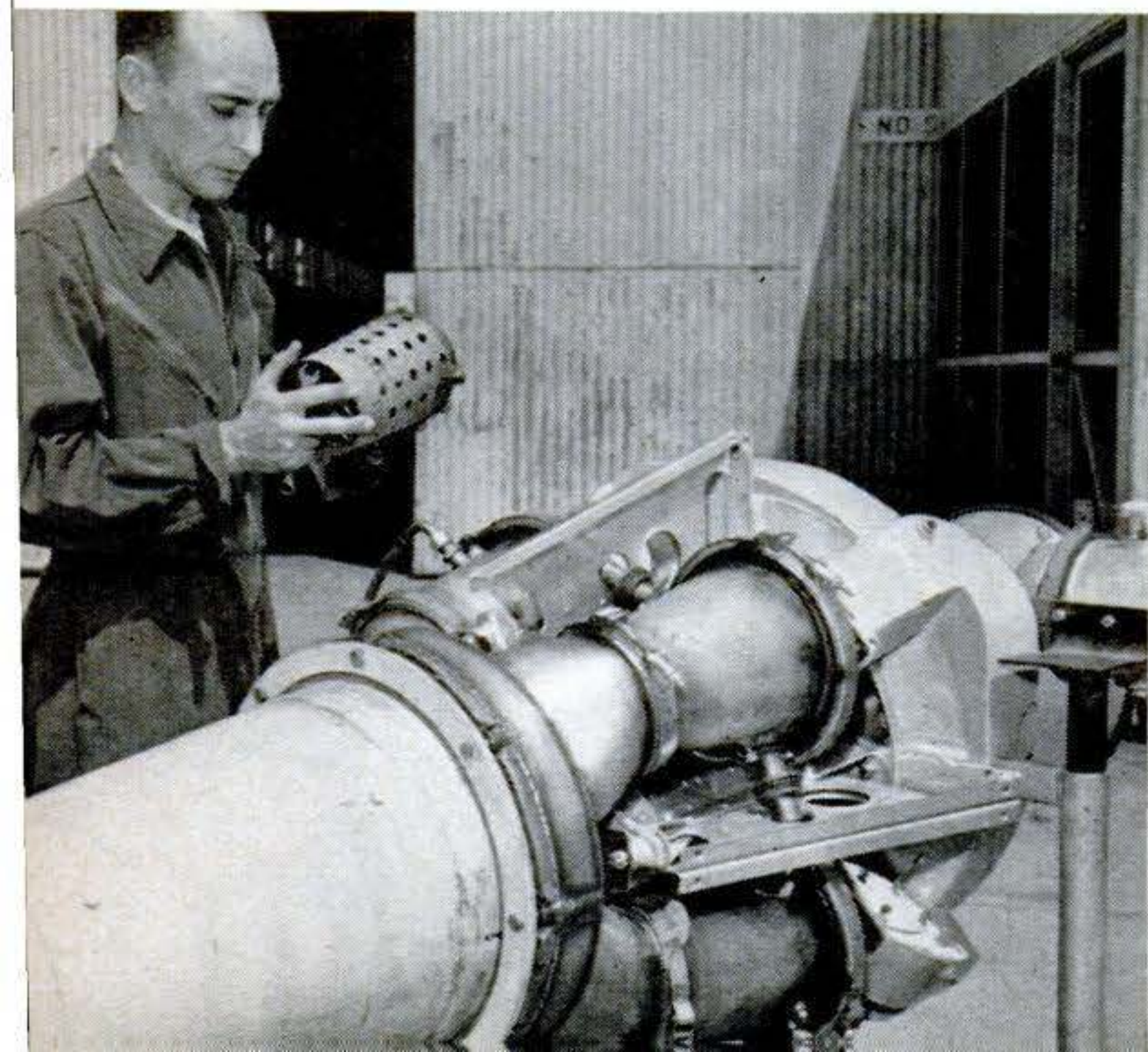

PRIVATE fliers, too, may soon become jet jockeys. A baby jet engine (left) weighing only 172 pounds has been designed by students at the Northrop Aeronautical Institute, Hawthorne, Calif. It develops 340 pounds of thrust, has twin air intakes and a single exhaust. The student shown is holding one of four burners. First installation is planned for a Ryan Navion.

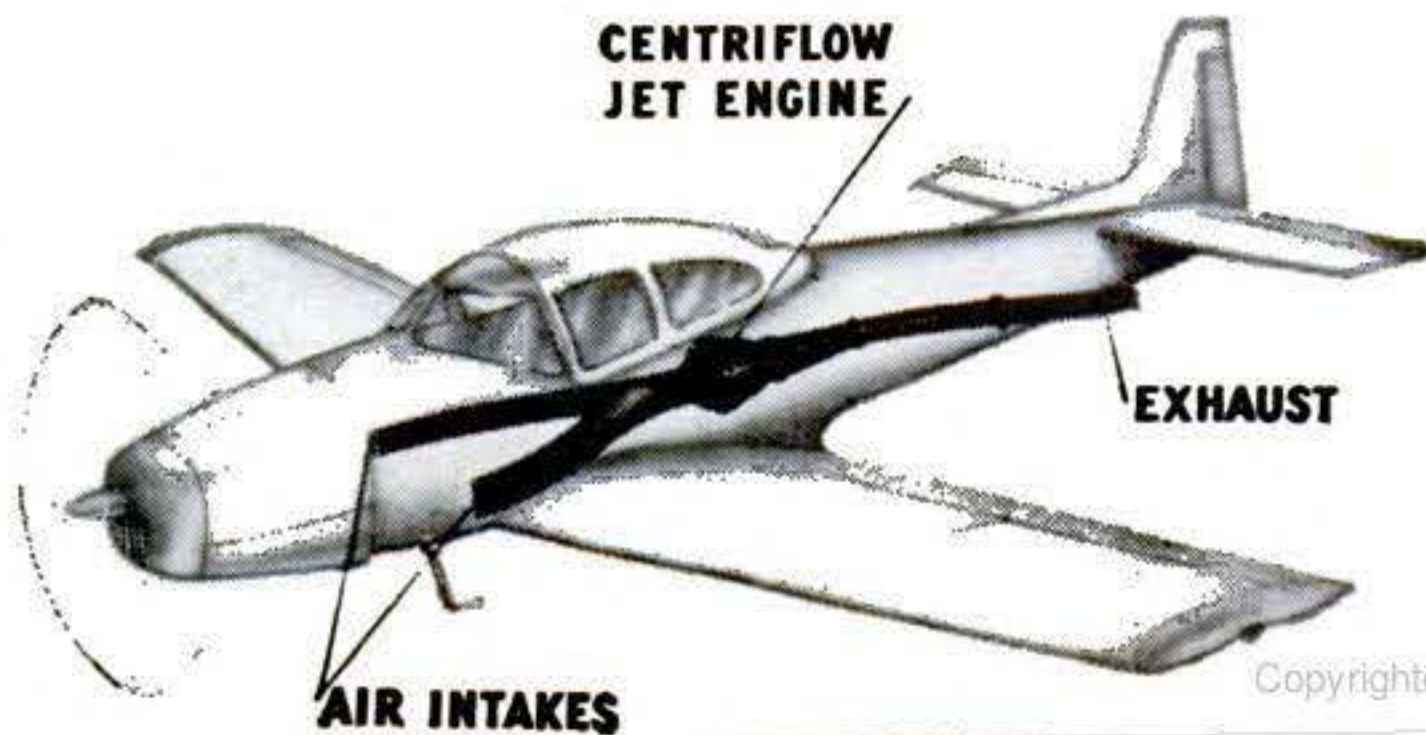

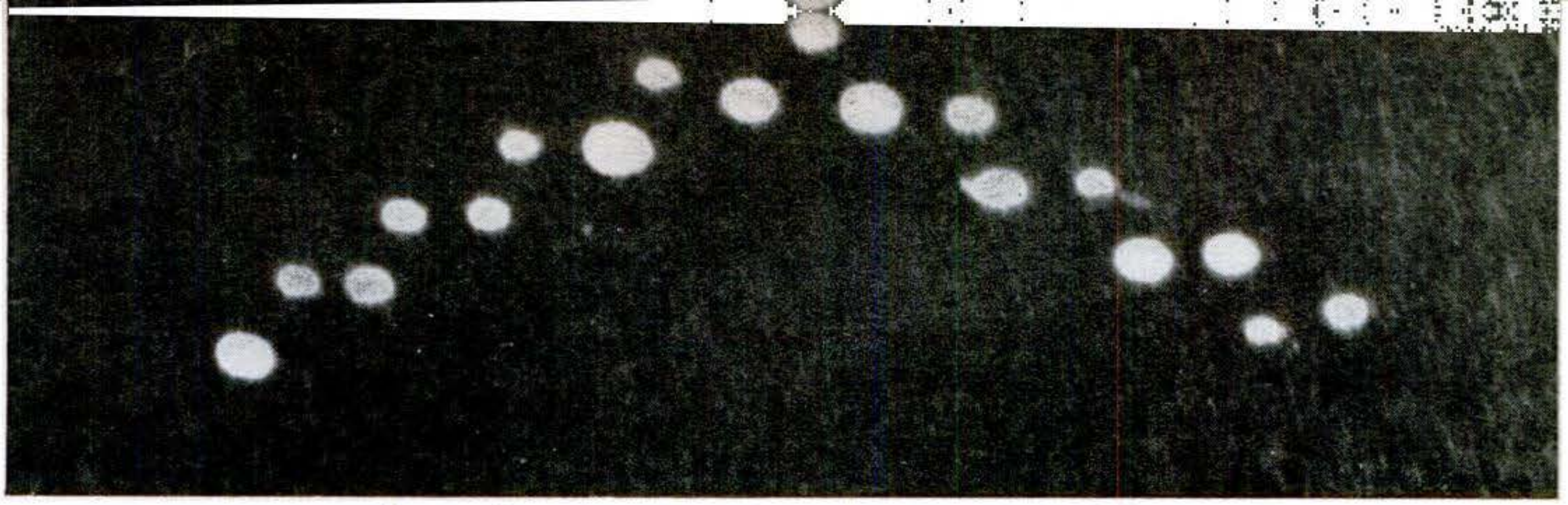

THE LUBBOCK LIGHTS, shown here in one of five photographs taken in 1951 by Carl Hart, 18, of Lubbock, Tex., mystify our foremost

scientists. In 1886, a young man in Wales reported a similar, smaller group of what he called meteors that traveled together.

Flying Saucers Are Old Stuff



Robert L. Unger

They've been sighted and reported in pretty much the same terms for centuries, says writer who has found 300 ancient accounts.

IN 1872, long before there were any airplanes or plastic weather balloons, the Royal Meteorological Society of Britain received a strange report from the captain of the sailing ship *Lady of the Lake*.

While homeward bound for England from tropic ports, the vessel's crewmen had called Capt. Frederick William Banner's attention to an amazing sight in the sunset-stained sky.

Captain Banner later described it in his log as "a most curious-shaped cloud." It was circular, light gray, and luminous. It looked, he wrote, "like the sun or moon with a halo around it." Furthermore, it was behaving most unlike a cloud. It was moving against the wind, rising from a point in the southeast where no other clouds were at the time until it was nearly overhead. There it briefly hovered, and the astonished sailors saw that it had strange markings and a dis-

tinct tail, like a comet's. Captain Banner noted that "patches of cirro-cumulus seemed to squirt from the back." Then the frightening object headed downward toward the horizon, still against the wind, and disappeared into the northeast as darkness shut in.

Captain Banner sent a copy of his log to the Royal Meteorological Society. At the society's next meeting, January 15, 1873, the report was read, discussed, and dismissed as unexplainable.

Similar sights still baffle scientists. Many of the flying saucers seen in recent years have turned out to be weather balloons. But, an Air Force spokesman admitted this spring, "a number of reported sightings cannot be thus explained, and as long as this is true, the Air Force will continue to study the problem."

While pondering this problem, Robert

L. Unger, who is now a technical writer for the Republic Aviation Corp., of Farmingdale, L. I., began to wonder how long such strange things had been appearing in our sky. Unger flew B-25s in the Pacific theater of operations during the war, and later did graduate work at Yale. While there, he began prowling through the long history of "saucer stories."

He reports now that he has found evidence that men have been seeing things which resemble saucers for at least 355 years. He has collected, he says, 300 such reports as the one from Captain Banner that mystified the Royal Meteorological Society 80 years ago.

Mystic's Work Started It

The books of a man named Charles Fort, half scientific writer, half mystic, who died in 1932, inspired Unger to continue this fascinating research. Fort had paged through hundreds of scientific journals, some of them dating from the sixteenth century, and extracted accounts of strange happenings in the sky that science had never been able satisfactorily to explain.

Unger, beginning in 1948, followed in Fort's path, eagerly picking out the reports that sounded like current newspaper accounts of flying-saucer sightings. He carefully tracked down every source, and found at least half again as many new ones. The 300 accounts he has gathered date from 1907 back to the late eighteenth century.

Of all the baffling reports that the Air Force has received since 1947, when "flying saucer" entered the language, some of the hardest to explain have been those concerning the Lubbock Lights. That is the name that has been given to mysterious groups of luminous spots which several responsible citizens of Lubbock, Tex., repeatedly saw travel noiselessly across the night sky in 1951 at tremendous speed and in distinct flying formation, usually V-shaped.

Seen by Navy in 1904

When Unger read the first reports from Lubbock, he immediately remembered an experience reported to the *U. S. Monthly Weather Review* in 1904 by Lieut. F. H. Schofield, aboard a Navy supply vessel at sea.

Shortly after six o'clock on the morning of February 28, the lieutenant and two members of his crew were staggered to see



"METEORS" FLYING IN FORMATION and behaving most eccentrically were seen at sea in

what appeared to be three meteors hurtling towards the ship in a tight little group from the northwest.

"At first," Schofield reported, "their angular downward motion was very rapid and their color a rather bright, glowing red. But as they approached the ship they suddenly soared upward at an angle of 45 degrees and passed through the clouds. After rising above the clouds their angular motion became less and less until it ceased, when they appeared to be moving directly away from the earth at an elevation of 75 degrees and in a west-northwest direction."

The largest meteor, which Schofield said looked as large as six suns, was egg-shaped and led the formation. The two others were perfectly round, one appearing to be the size of two suns, the other the size of the sun itself. When they shot away from the ship in the direction from which they had

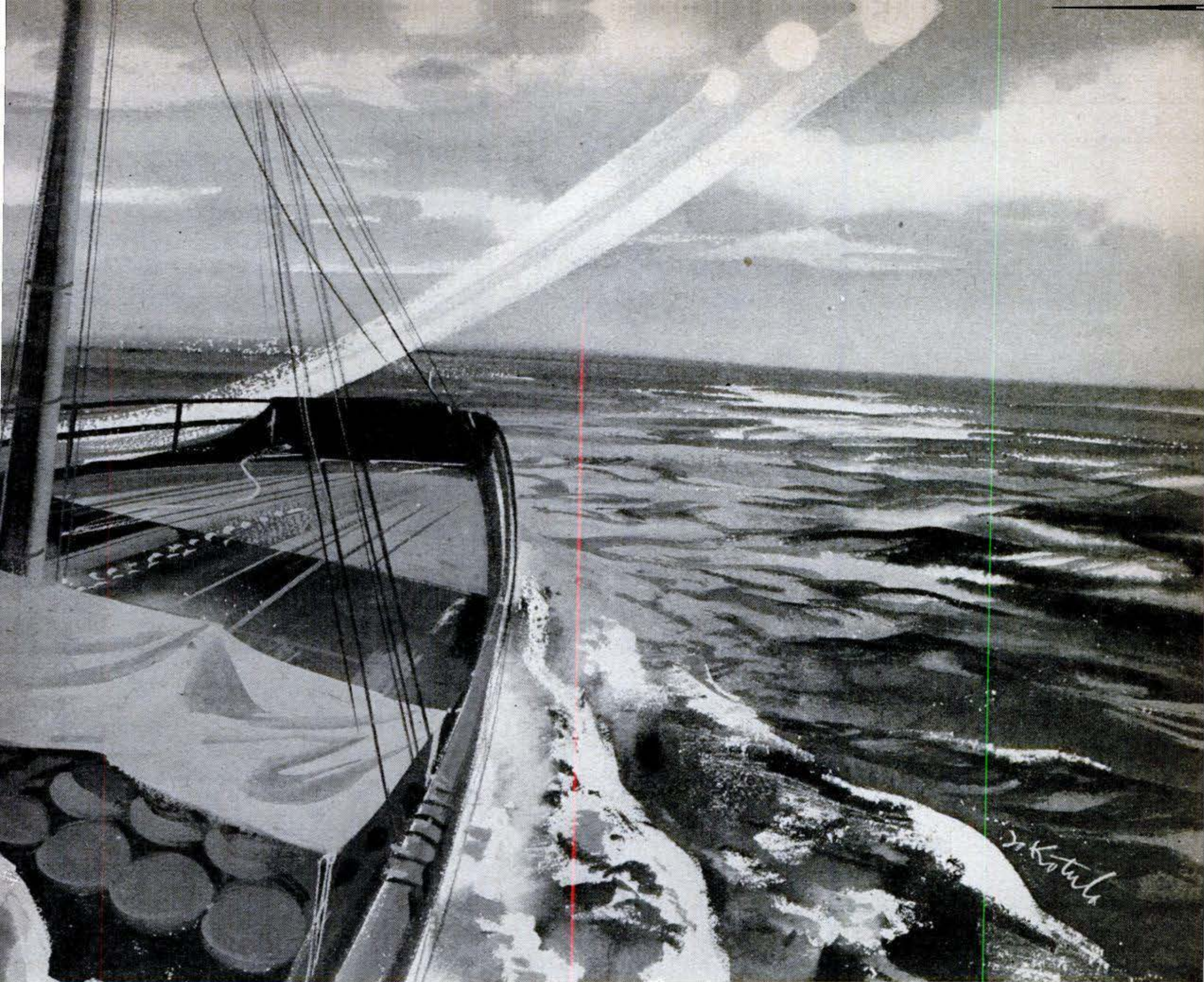

1904. Unger has found that nineteenth- and twentieth-century reports of "saucers" all

fall into three categories; disks, cigar-shaped objects and fast-moving, inexplicable lights.

come, "there was no change in their relative positions."

When the newspapers, beginning in 1948, told of terrifyingly bright green fireballs that hundreds of people in the Southwest had seen flash across the bare hills in straight, silent, horizontal flight, Unger recalled a strikingly similar account that he had come across in an old issue of a magazine called *The Observatory*. The writer, a professional British astronomer, said the most remarkable experience he had ever had took place one clear evening in the autumn of 1882.

"A Disk of Greenish Light"

"A great circular disk of greenish light suddenly appeared low down in the east-northeast, as though it had just risen, and moved across the sky, as smoothly and steadily as the sun, moon, stars, and planets move, but nearly a thousand times as quick-

ly," he wrote. As it moved, in "a steady, uniform progress from east to west," it lengthened out. "When it crossed the meridian and passed just above the moon, its form was that almost of a very elongated ellipse, and various observers spoke of it as 'cigar-shaped,' 'like a torpedo,' or a spindle or shuttle."

Like the distinguished German rocket designer, Dr. Walther Riedel, and Dr. Maurice A. Biot, a top U. S. aerodynamicist, Unger is convinced that flying saucers, "cigars," and unexplainable lights in the sky at night are all evidence of visitations from some other world. The objects may not be manned; they may be radio-controlled, pilotless craft rigged up with some other world's notion of television to record what we are up to. Judging by the similarity of the reports since 1597, they may have been watching us a good, long time. **END**



"A NEW KIND OF WEAPON for a new kind of beach-head," the *Courier*, loaded with radio transmitters and secret electronic equipment, has sailed off to help work out ways to overcome Russian jamming.

By Wesley S. Griswold

NOT long ago the U. S. launched a new kind of battleship—a Coast Guard cutter armed with the most powerful radio transmitters that ever went to sea. The 5,800-ton, 338-foot *Courier* sailed off to a secret destination, but there was no secrecy about its mission. It is the country's latest weapon in the cold war of the air waves between the leading democracies and the Communist nations.

Flying its main antenna from a captive barrage balloon filled with helium, the *Courier* will anchor in friendly foreign ports as close to Russia as possible. From there its 150,000-watt medium-wave transmitter and two 35,000-watt short-wave transmitters will lob explosive messages of truth over the Iron Curtain.

Congress has been asked to provide the money for two more ships like the *Courier* but with greatly increased transmitting power. Meanwhile, the U. S. fires most of

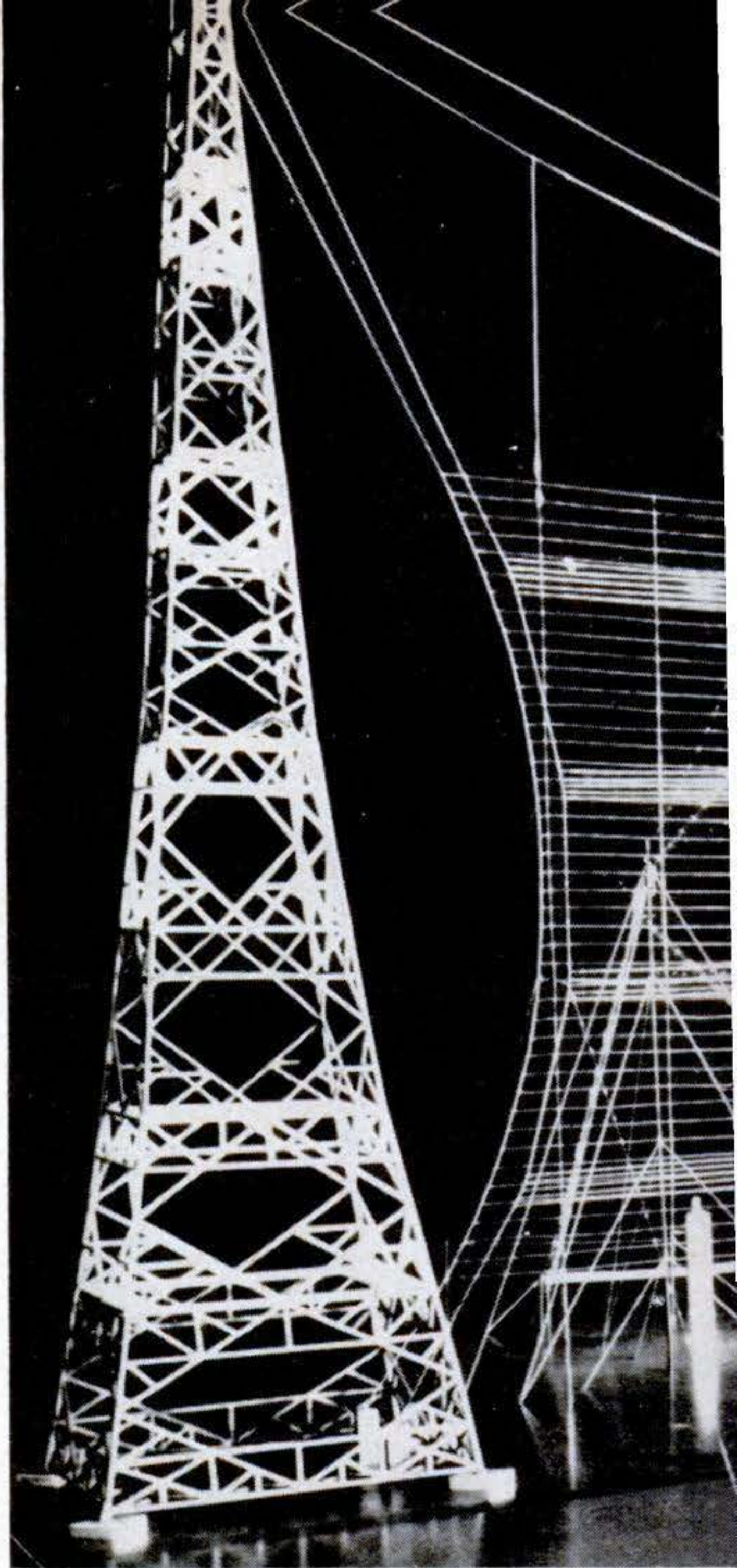

CURTAIN ANTENNAS two city blocks long, with towers 289 and 249 feet

its radio guns from home soil—44 transmitters, ranging in power from 50,000 to 200,000 watts, located in Massachusetts, New York, New Jersey, Ohio and California. Others are being forged, to be set up in North Carolina and the State of Washington.

Air War Rages Over Europe

The answering fire from the Reds that reaches the 96,000,000 receiving sets of North America is weak and spotty. The main battleground is in Europe, with secondary engagements being fought in Asia. Skirmishes occur from time to time in Africa. An occasional shot lands in South America and even in Australia.

In Europe, barrages and counter-barrages

Every minute of the day, a world-wide battle rages for men's attention. Here is the behind-the-microphones story.

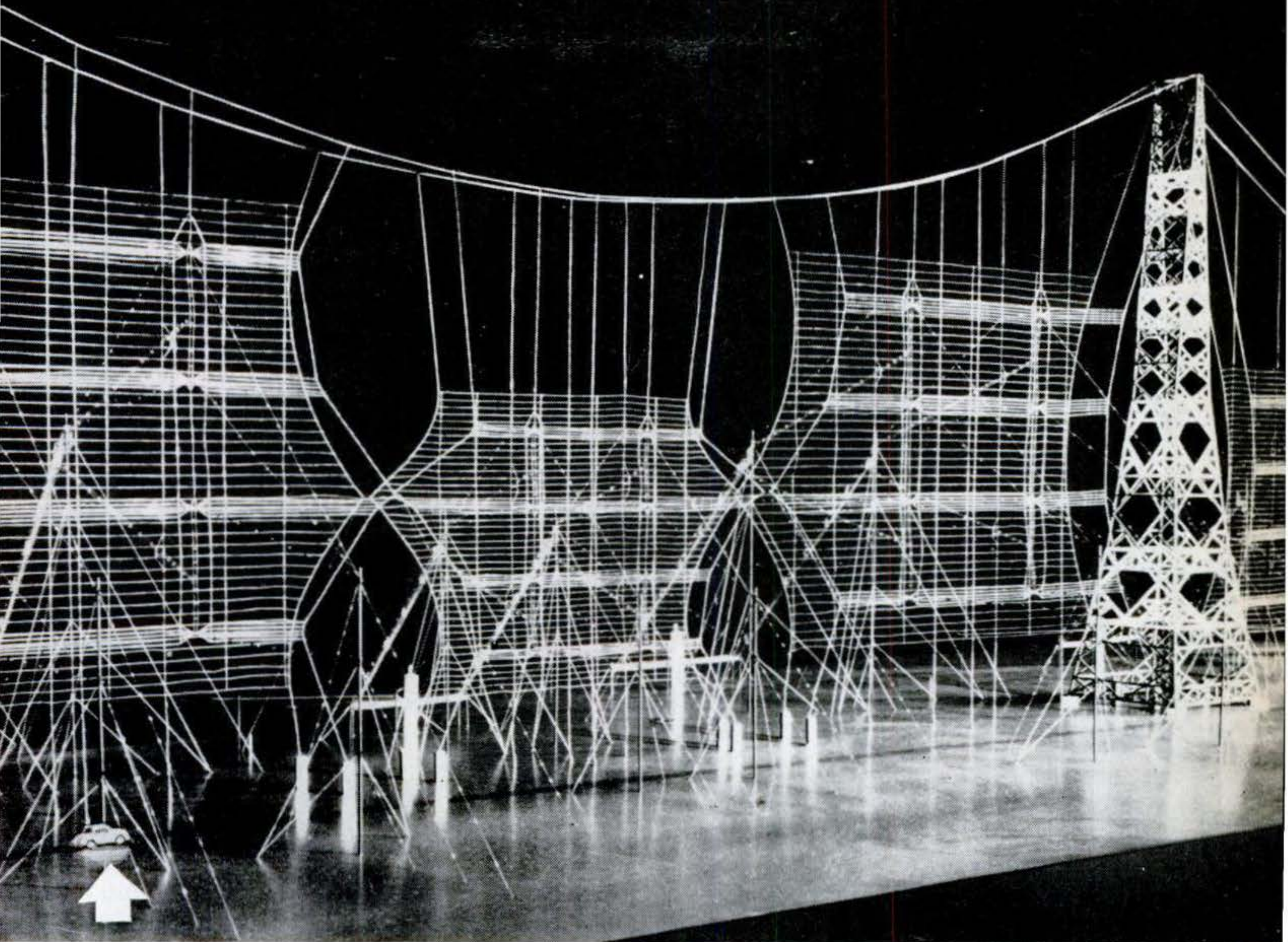

high, will soon give the U. S. the loudest radio voice in the world. Ten such antennas

are continuous and fierce. There the principal British and Russian battle lines are drawn, and the U. S. has moved up 29 transmitters to forward positions. Five of them are placed on the territory of our ally, Great Britain. Thirteen are located in Germany, one in Greece, four in Portugal and six in Tangier, just across the Strait of Gibraltar from Spain. More are being built.

For popping propaganda shells into Asia, the U. S. has set up two transmitters in Hawaii, four in the Philippines and one in Ceylon.

As ammunition, the Voice of America, which is the official and biggest U. S. battle unit in the war of the air waves, chiefly uses straight news and dependable intelligence reports of what is going on in Com-

are in use or being built. This model, with a toy car in scale, shows how they will look.

munist countries. It riddles the latest Red distortions of facts by telling the truth. It also tells the world what life here is like, and presents talks by leading citizens to explain what most Americans believe in. It seasons the whole mixture with the favorite music of many nations.

Refugees Supply Ammunition

Radio Free Europe, next in importance on the U. S. side, has the advantage of being unofficial and therefore able to fight rougher. It is a small and highly damaging body of American commandos, supported entirely by private contributions, who concentrate on Poland, Czechoslovakia, Hungary, Bulgaria, Romania and Albania.

Since RFE began broadcasting on July

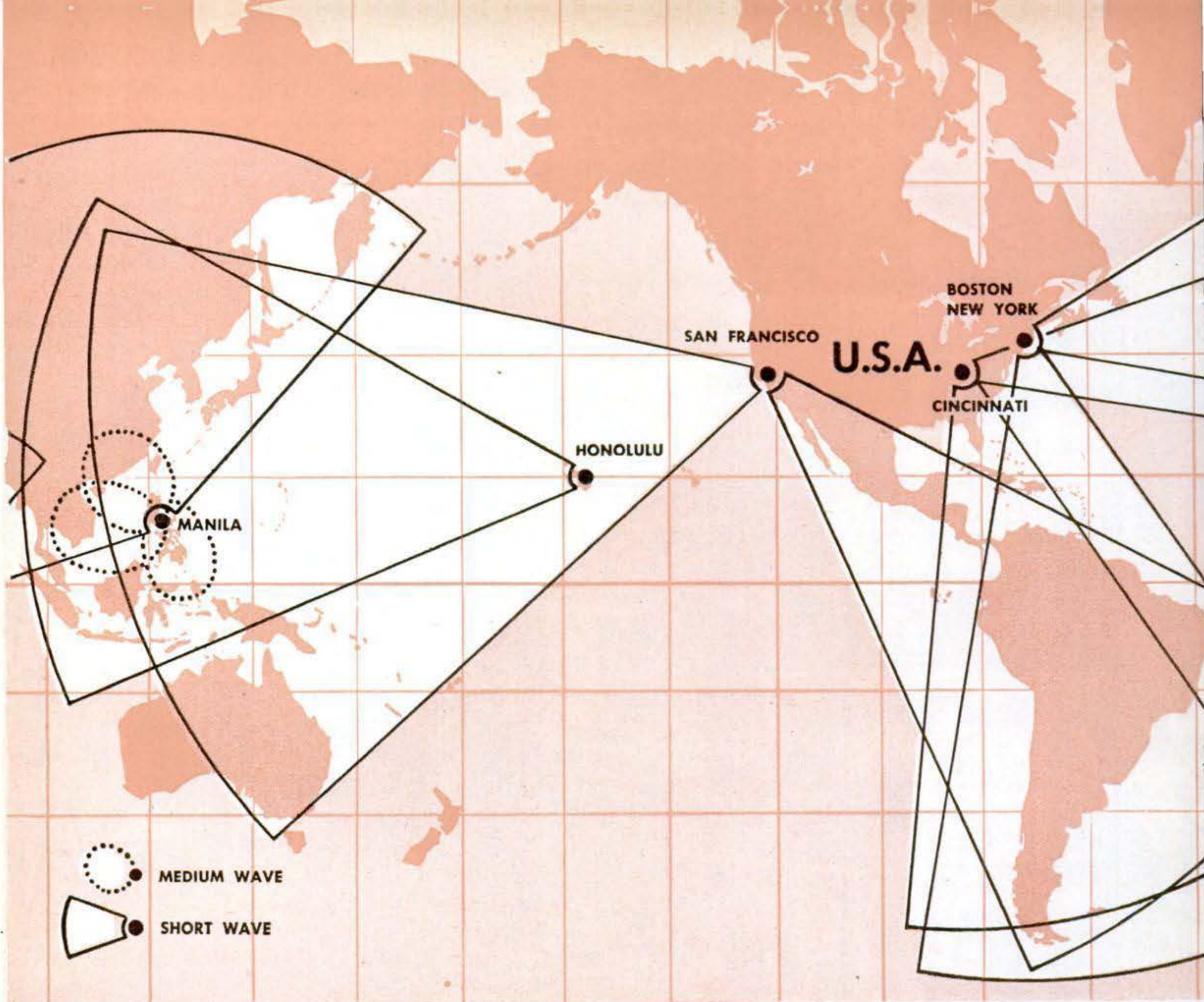

PLAN OF CAMPAIGN is to reach 340,000,000 pairs of ears, the estimated number of radio

listeners outside North America. Map shows areas that Voice of America bombards with

4, 1950, it has made the fullest possible use of anti-Communist refugees from the six Soviet satellite states of eastern Europe. Escaped Hungarians talk to the Hungarians back home, Poles to Poles, Czechs to Czechs. These people put the finger on Red agents and collaborators, reveal conditions that the regimes are anxious to hide from their own people as well as from the world, and do everything short of inciting armed revolt to weaken the power of the puppet governments that Russia installed.

It is hard to tell which side is ahead in the cold war of the air because the victories almost never win headlines. There have been a few striking exceptions. When two Russian military pilots flew out of the Soviet Union to freedom in the West, they said persuasive American and British broadcasts had convinced them that they should try to escape. The Czechs who drove a train and its passengers across the frontier

between their captive country and West Germany said the same thing. So did the Polish crew who sailed a mine sweeper to a safe haven in Sweden, and the Czech boys, forced laborers of the Soviets, who dug their way out of a uranium mine in East Germany and escaped.

Underground Stations Join Fight

The first evidence Radio Free Europe had that it was landing effective shots in Communist territory came when the Russians began broadcasting threats to hang every German they could get their hands on who had assisted Radio Free Europe in any way.

Anti-Communist radio stations have been overheard rebroadcasting RFE information inside Albania, Czechoslovakia, Hungary and Bulgaria. A mobile, unlicensed transmitter calling itself Radio Free Russia, and concentrating on Soviet troops in East Ger-

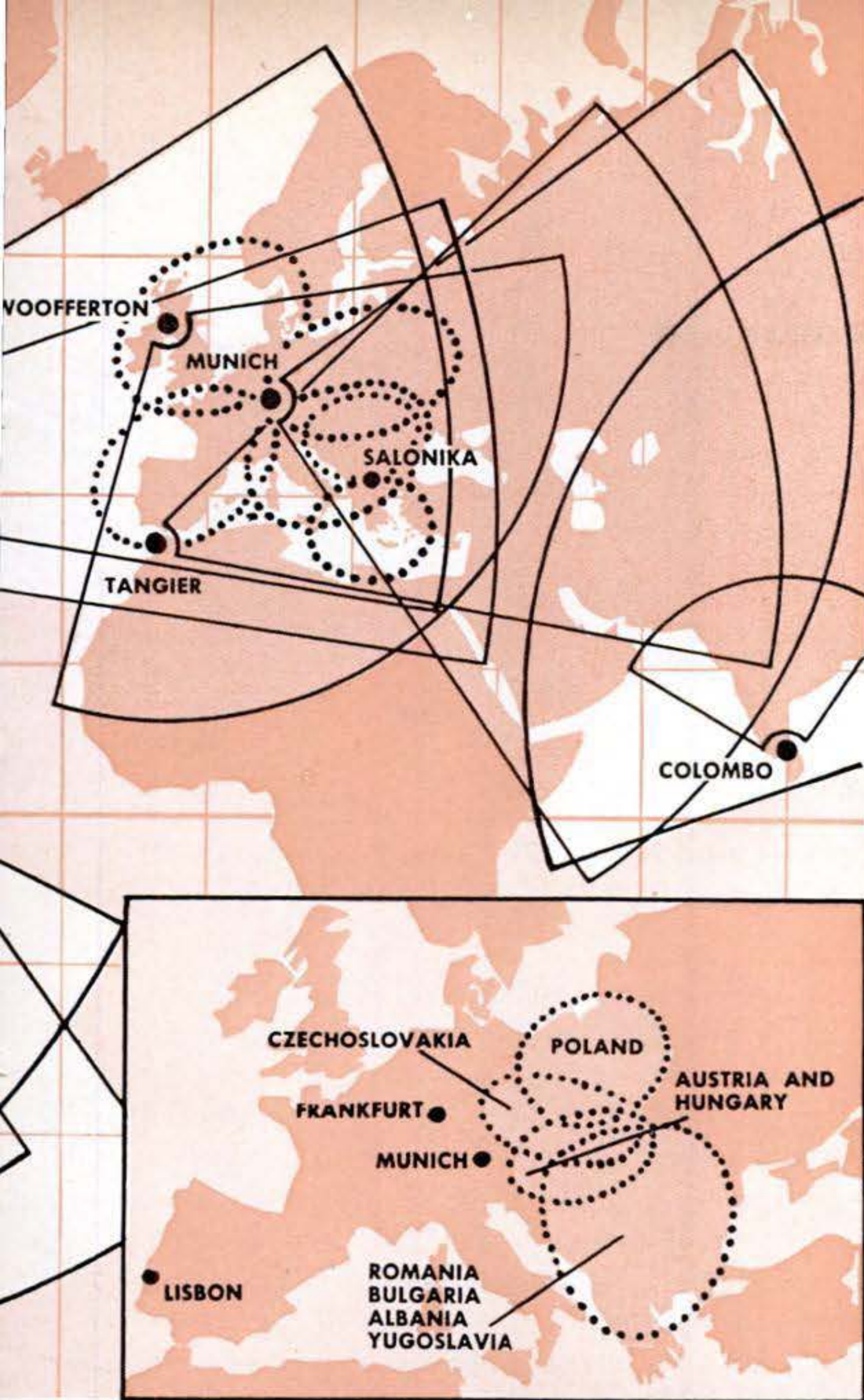

its 75 transmitters. Inset above shows areas that Radio Free Europe peppers with its nine.

many and Austria, started operating somewhere in western Germany a year ago.

Voice of America and Radio Free Europe campaign commanders obtain their best reports on battle progress from letters. VOA mail has reached a volume of 40,000 letters a month, from both sides of the Iron Curtain. A Russian who recently escaped to West Germany wrote VOA: "Your broadcasts undermine the Soviet regime and . . . are a weapon more powerful than the atom bomb."

After Radio Free Europe had accused 16 officials of the Ganz Electrical Works in Budapest of being informers, it promptly received a letter from one of the workers in the plant telling what happened:

"The factory went wild. Commies were running in and out. Secret conferences were held at all hours. And everyone was under suspicion. Morale sagged. Work practically stopped everywhere. It was a darned fine

job! It should be repeated—and often."

Another letter described how the inmates of a camp for political prisoners in Czechoslovakia had managed to hide a short-wave transmitter in the camp dentist's chair and broadcast accounts of what was going on in the camp to Radio Free Europe. When RFE later repeated the accounts in broadcasts to Czechoslovakia, Communist police tore the camp apart until they had tracked down and destroyed the telltale transmitter.

Enemy's Tricks Are Exposed

A Hungarian wrote of an extraordinary effort that the Communist regime there had made to discredit Radio Free Europe. RFE broadcasts had been telling how Red big shots were wasting the people's money in riotous, costly evenings at a Budapest club. One night, trucks and men suddenly descended on the club and completely removed it. The next day, the Communist radio jeered at RFE and invited Hungarians to see for themselves that no such club existed. The people of the neighborhood, however, told the true story, with great satisfaction, to everyone who asked.

An old man in Budapest wrote Radio Free Europe that of the 60 families in the apartment house where he lived at least 10 listened regularly, without fear, to RFE broadcasts. He could hear the broadcasts himself clearly on his four-tube set, he said.

With the aid of informants such as these, Radio Free Europe has been able to warn the people of Bulgaria that government men coming around to collect waste were frequently members of the secret police. It has been able to warn the Czechs of the Communist practice of erecting false frontier posts near the real ones and manning them with Red police in stolen American and German uniforms to trap citizens trying to escape to West Germany.

Reds Broadcast Wolf Calls

The Communists have reacted on the air with screams of rage, calling the Americans and British liars, cheats, wicked imperialists and bloody murderers at all hours of the day. They distort the news to make it appear favorable to their cause, and when this cannot be done convincingly, they omit it altogether.

Most of all, they try to prevent the Western voices from getting a word in edgewise. Mobilizing a formidable battery of 1,250 transmitters, the Russians endeavor to



THIS IS THE IRON CURTAIN. Propaganda signs in Red Czechoslovakia face West Germans.

Biggest sign reads "The world's workers well know the imperialists' crimes in Korea."

drown them out by continuously broadcasting Siberian wolf calls, the screaming of sea gulls, the roar of airplane engines and the hum of electric motors.

To overcome this jamming, British and American radio engineers rely, first, on the power, number and position of their transmitters. Whenever the budget allows, they gain signal strength by stepping up transmitting power and improving antennas. Occasionally they combine forces, using more than 70 transmitters simultaneously to land signals of tremendous strength on predetermined spots in the target area.

Russians Jam Own Broadcasts

One of the most effective counter-jamming techniques is called "cuddling." It is the process of beaming signals at Russia and her satellites on frequencies so close to the ones they use for domestic broadcasts that the jammers cannot smother the incoming signals without wiping out their own.

This is especially disruptive in Russia, for wire-transmission facilities are so inadequate that the national radio network is of far greater importance than it is in the leading Western countries. Newspapers in remote parts of Russia depend on the radio for their news and the latest official propaganda line from Moscow. Because of this, a really intensive jamming effort by Soviet radio engineers can bring about a news blackout in their own country.

Another way in which British and Amer-

ican technicians outwit the jammers is by bouncing signals off the ionosphere at a variety of angles so that they land in a checkerboard pattern. The highly directional signals arrive on their downward journey from the ionosphere with maximum intensity. There is no way in which the jammers can tell where or when such a signal will land, and in order to drown it out they must land a signal of equal or greater strength right on top of it. This is hard enough to do when the incoming signals are all landing in one area. When they are arriving in a checkerboard pattern, the problem becomes enormous. There are almost certain to be corners in each square where signals escape the jammers.

As a third device for penetrating the jamming defense, the Voice of America sends news to Russia in Morse code eight hours a day, at a rate slow enough to suit even a poor telegrapher. Code is far harder to jam than voice signals. It can be transmitted over a much wider range of frequencies. It is an interrupted signal and therefore harder to locate. Finally, while a weaker jamming signal can garble voice transmissions effectively, it does not obscure code. An experienced wireless operator can "read" the message right through the interference.

The Russians are impressively expert at jamming, but with all their transmitters they cannot lay a thick blanket of noise over the immense distances of their land. There are bound to be holes in the blanket.

[Continued on page 248]

This Is Better Than Whistling

WITH eye-catching results, 16-year-old Henry Koopman Jr., of Whittier, Calif., made over a 1950 Nash Rambler convertible. Aided by his brother Art, 21, he lowered the body, replaced the soft top with a removable one of steel and boosted engine power. A resplendent metallic red paint job and red-and-white leather upholstery prove irresistible to home-town girls looking for a lift, an effect not unanticipated by Henry. Electric push buttons open doors.

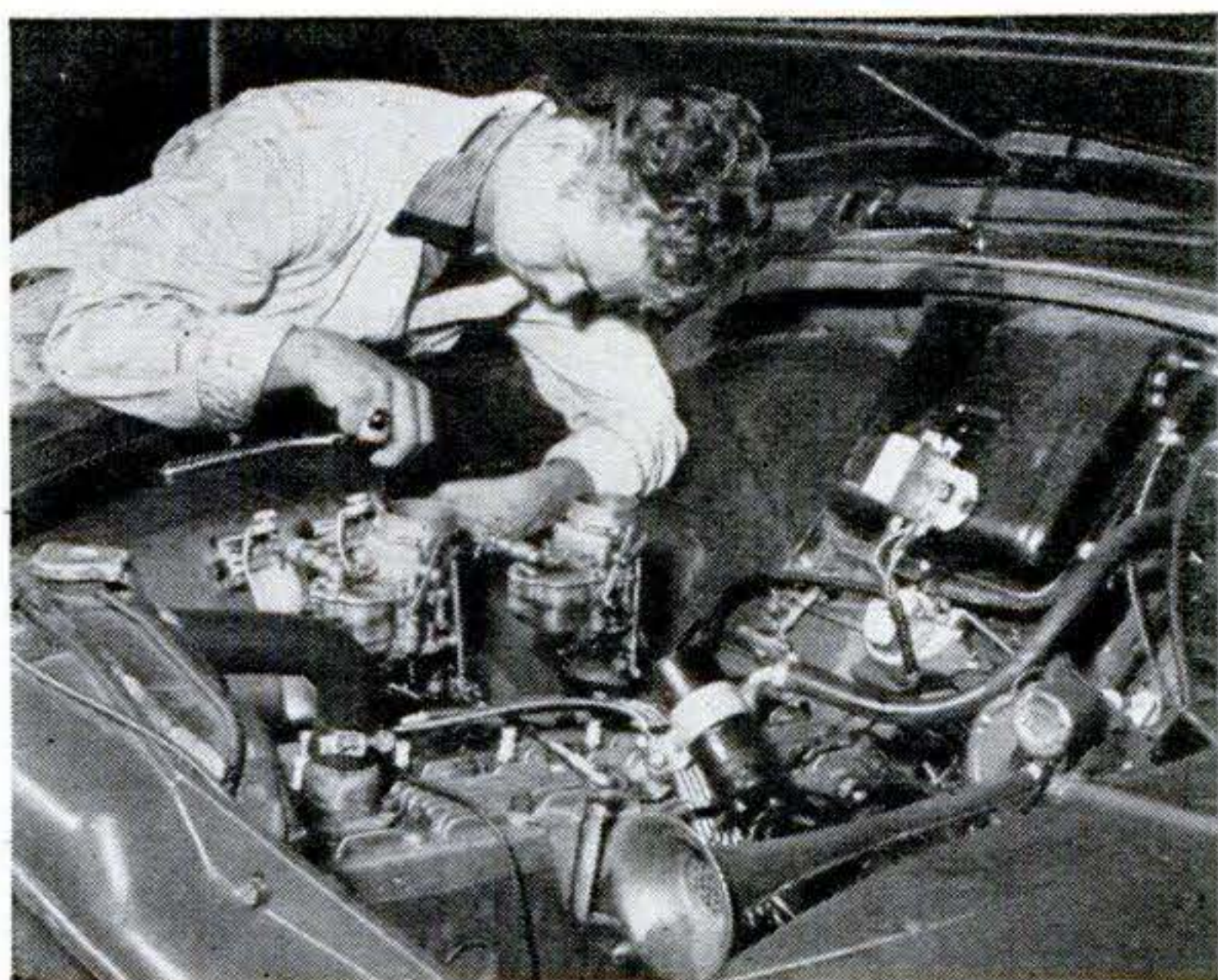

TWIN FORD 6 CARBURETORS are adjusted (above) by elder brother Art. Below, brother Henry takes wheel of the come-hither-styled convertible, with electric push buttons ready to open doors fast.



IN THREE MINUTES, hard top can be removed from remodeled Rambler. After unsnapping fasteners, the brothers lift off 200-pound top as above.



LOWERING BODY seven inches has enhanced trimness of car lines. Headlamps are faired into body. Parking lamps and chrome molding are gone.



STEEL TOP is attached by two clips at front and rod at rear. Interior has red-and-white leather upholstery to go with metallic red paint job.

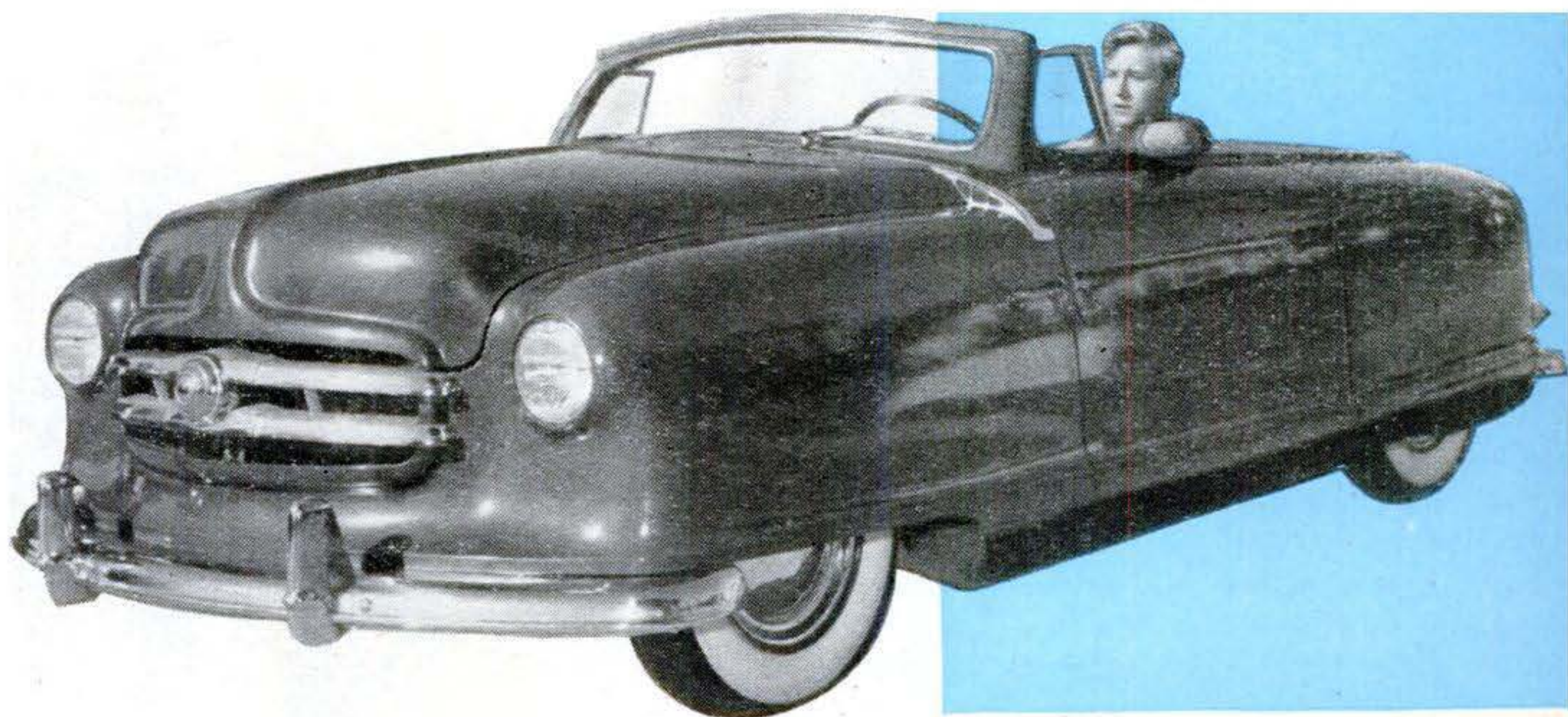

Side-Mounted Drill Press Makes Holes at All Angles

THE familiar drill press has been redesigned to do a better job in industry. Instead of straddling the column, the drill head clamps alongside it. This change allows angular swing of the head and adjustment of throat capacity—distance between drill and vertical column. It also minimizes the minute bending sometimes found under heavy loads in conventional drill presses.

Self-contained, automatic power-feed mechanisms are quickly attached to the heads. A steel-backed rubber "gear belt," fitted with lugs that mesh in recesses in special pulleys, delivers power from motor to spindle. Because it doesn't have the usual large four-step pulley, the spindle housing is narrower and the heads can be put closer together for multiple-drilling setups. The Magna Engineering Corp., Menlo Park, Calif., makes the tool.

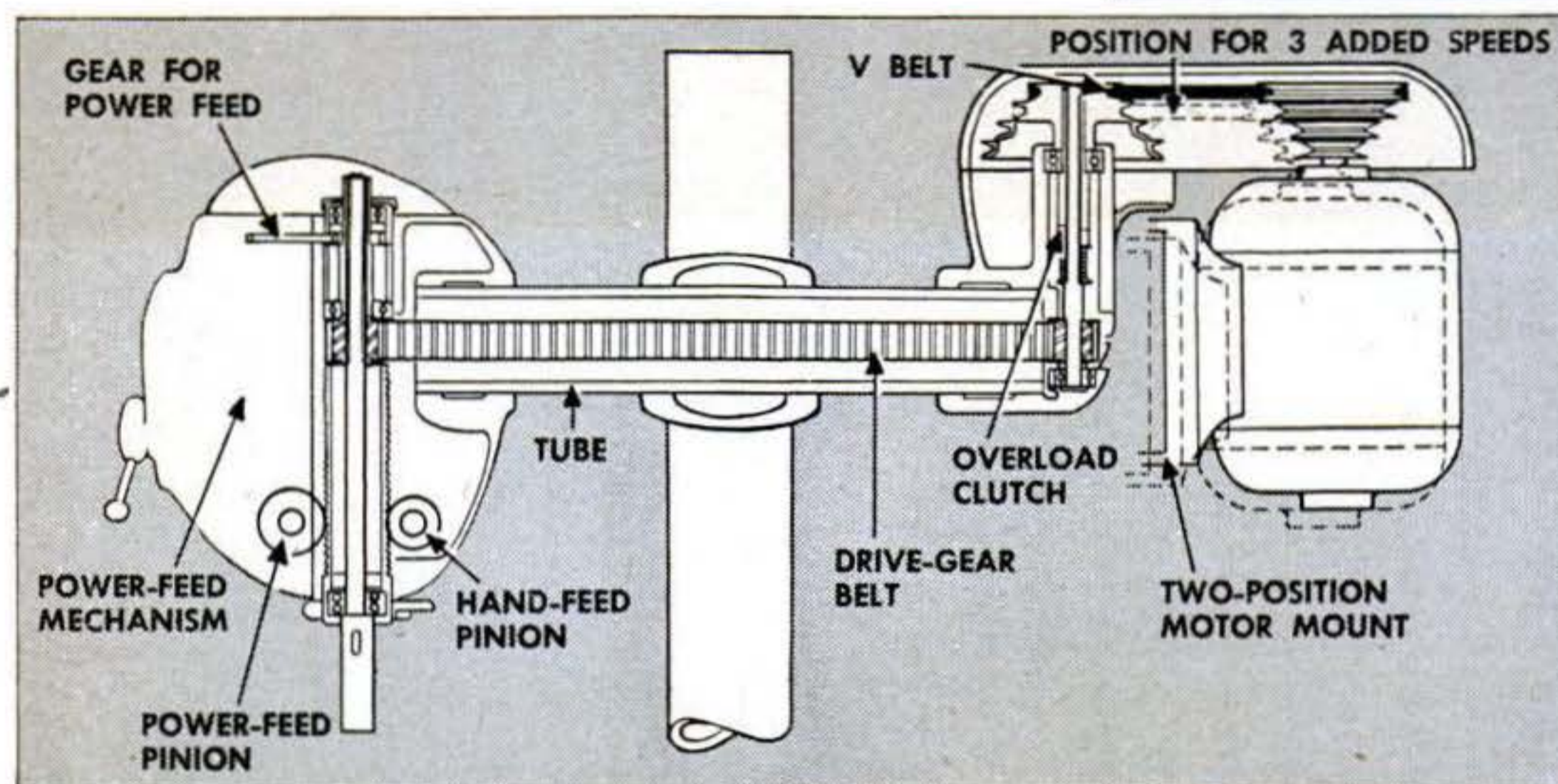
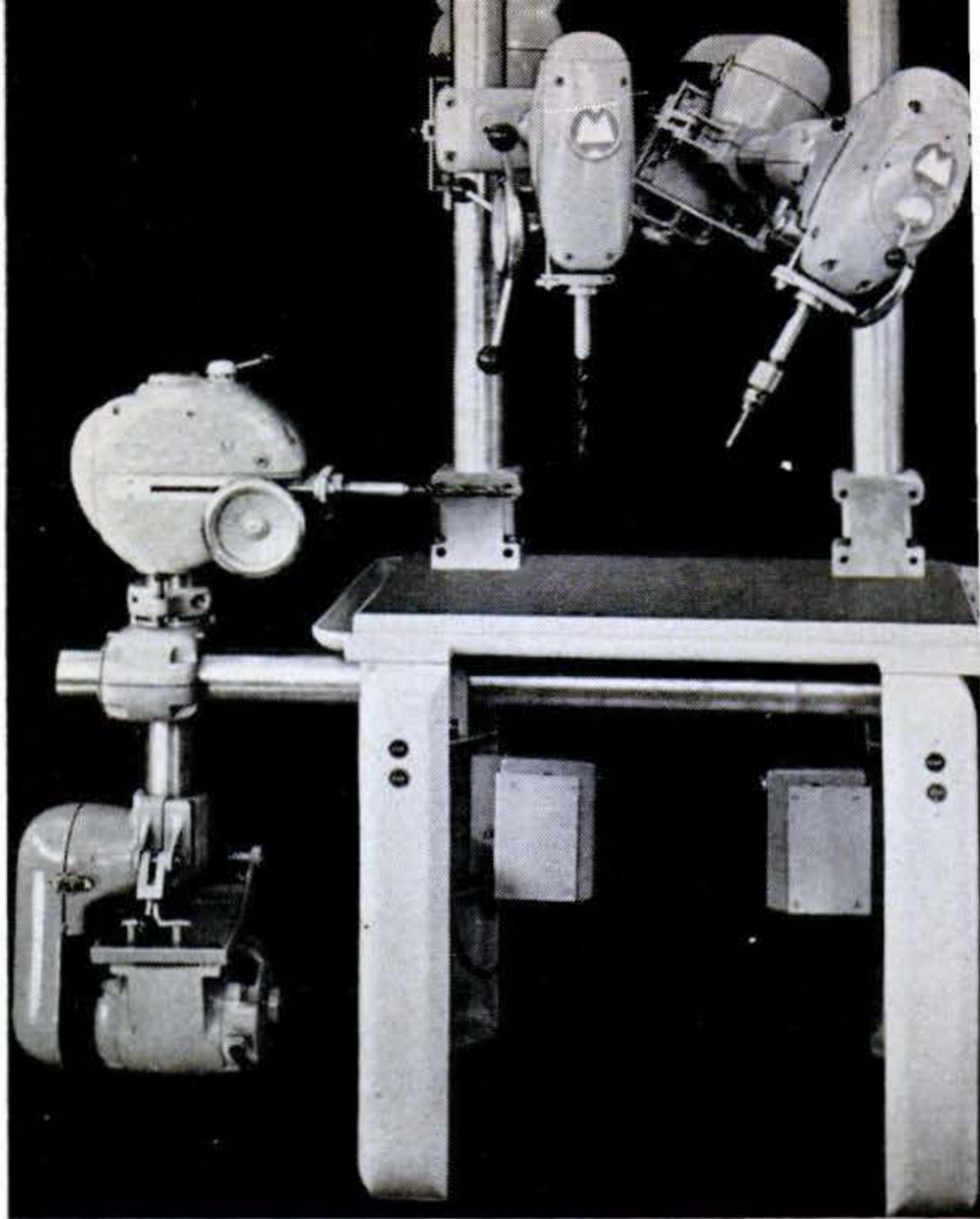

TABLE for multiple drilling of parts held in jigs has mounting bosses underneath, as well as on top, to permit horizontal drilling.

CAM RIG offsets motor one V-belt width, giving seven speeds from the four-step pulley. Spindle drive through connecting tube adds safety.

One-Man Helicopter May Be Army Workhorse—Pony Size

A collapsible 'copter that can be packed in a container and parachuted from a plane is being tested by the Army for air evacuation and observation. It can be unpacked and put in the air in about 20 minutes. Evacuees would ride litter carriers on outriggers. Two pulse-jet engines mounted on the tips of the blades (PSM, May '50, p. 116) give the craft a top speed of 80 miles an hour. The American Helicopter Co., Los Angeles, designed it.



How Experts Thwart Lightning

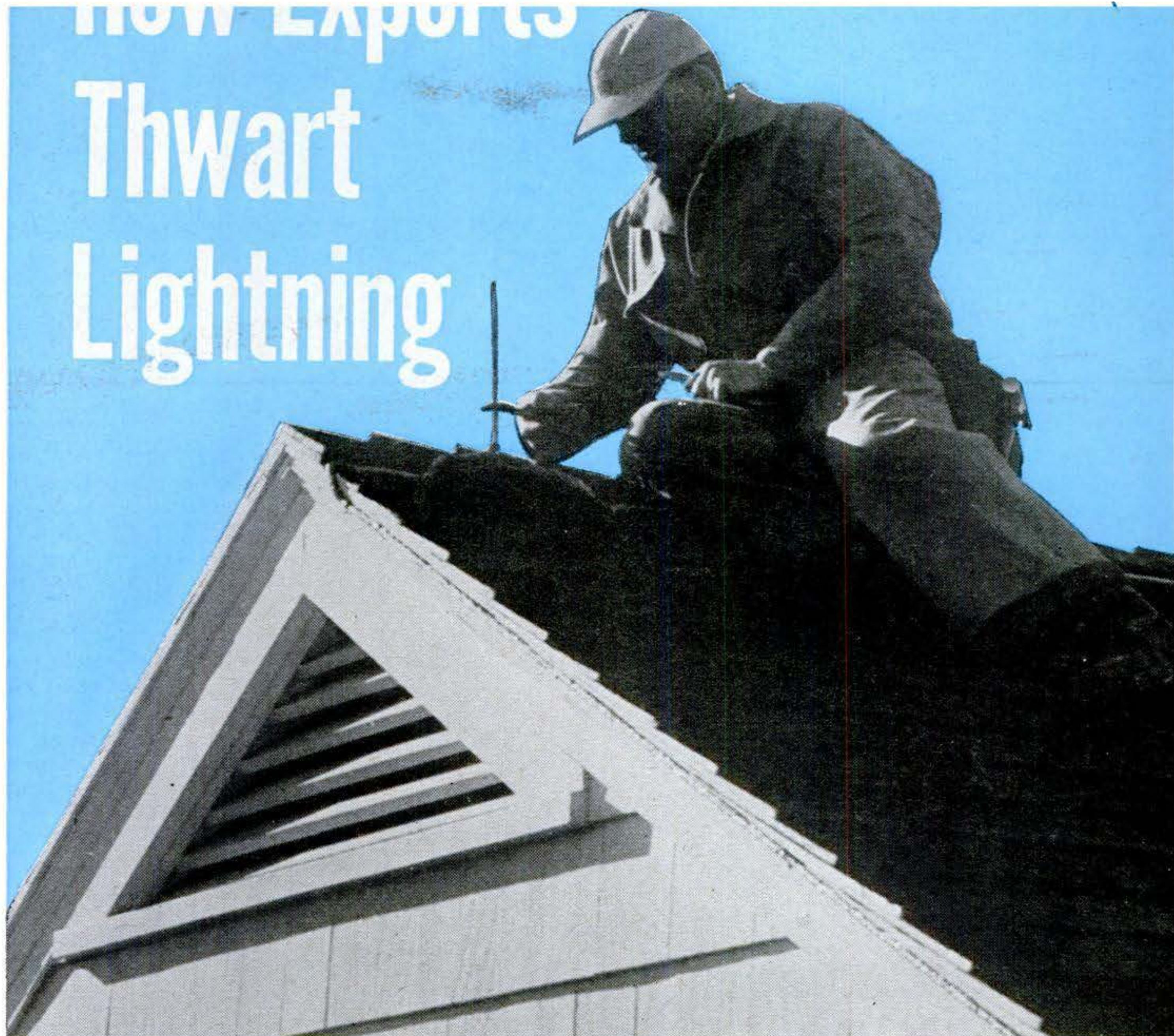

Ten-inch rods are only things that are visible from front. Cables all go down the back way.

A house is ready to shrug off the mightiest bolts from the skies when they finish installing rods and grounding pipes and wires.

PSM PHOTOS BY W. W. MORRIS

EVERY year lightning sparks fires that destroy more than \$52,000,000 worth of property in the U.S. In rural and suburban areas it is the No. 1 firebug. Cities are less hard hit, but throughout the nation, lightning is second only to defective flues as a cause of fires in homes.

You can't stop lightning but you can give your home better than 99-percent protection with a properly installed lightning-rod system. The photos on the next three pages show an expert installation by the Woods Lightning Protection Co., Shelton,

Conn., on the Long Hill, Conn., home of architect A. J. Hawley.

Lightning strikes when static electricity jumps the air gap between earth and a cloud. The electricity wants only to discharge itself and seeks the easiest path. Lightning rods perched on the high points of a building offer it an attractive road.

Lightning rods were invented by Ben Franklin just 200 years ago. They haven't changed much since then, but modern installers have added a whole bagful of tricks for concealing rods, cables and links so that they won't mar the appearance of a building.

Please turn the page for lightning-protection photos.

MAY 1952 155



1 CABLE IS STRUNG along roof and down both ends of house. Truck-workshop carries fittings to suit all structures.



2 RIDGE SADDLE nailed to peak will hold rod. Underwriters' Laboratories sets rules for number of rods and spacing.

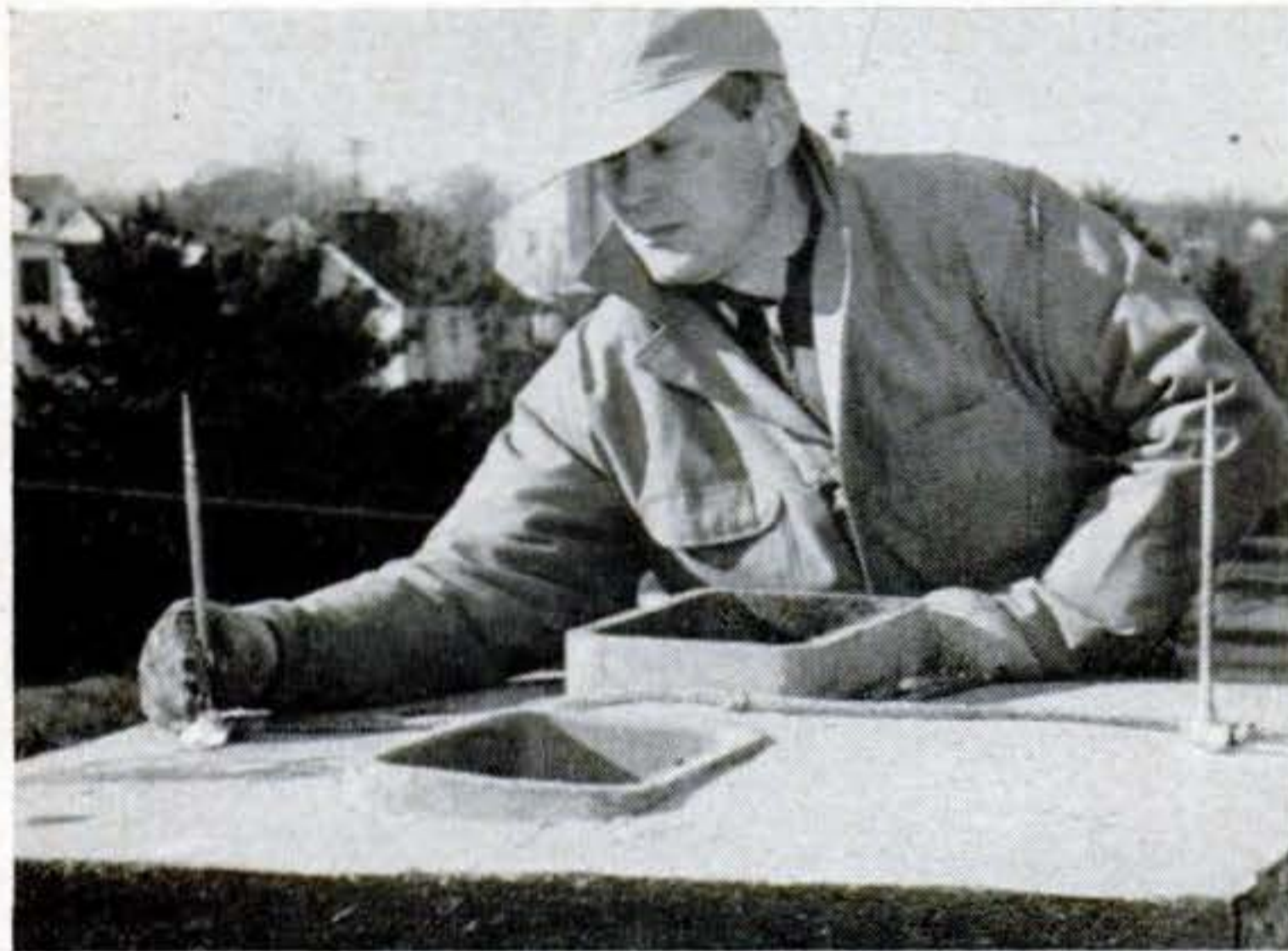

5 TWO TERMINALS are needed on this chimney. Rule is that rod must be less than two feet from any corner. Rods are cabled together.

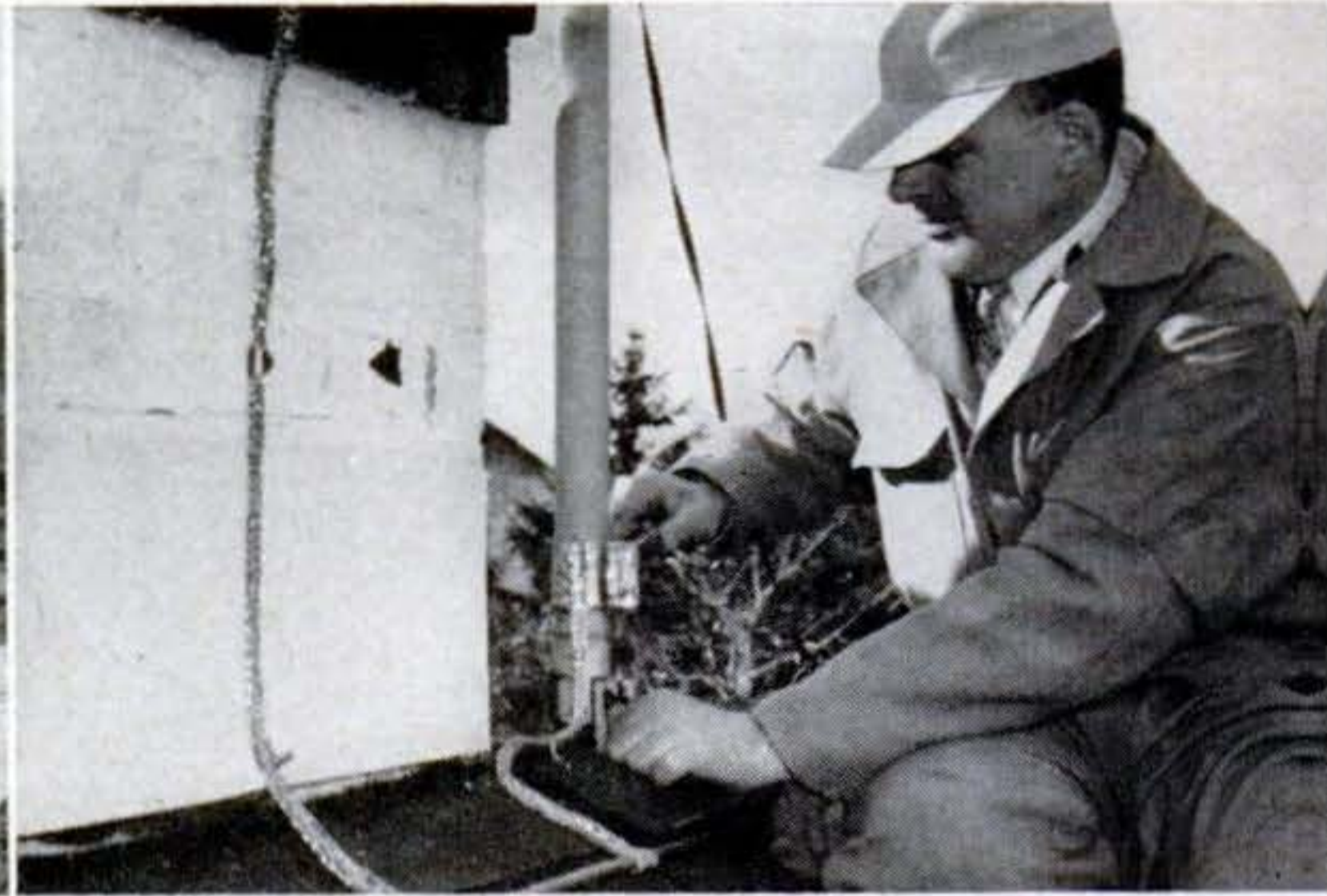

6 TV ANTENNA MAST is connected to rod circuit with copper strip. Cable, 32-strand, 17-gauge copper, can handle any stroke.



8 CABLE goes under eave. One man pulls it tight while another nails and clamps it. First paint job will hide it completely.

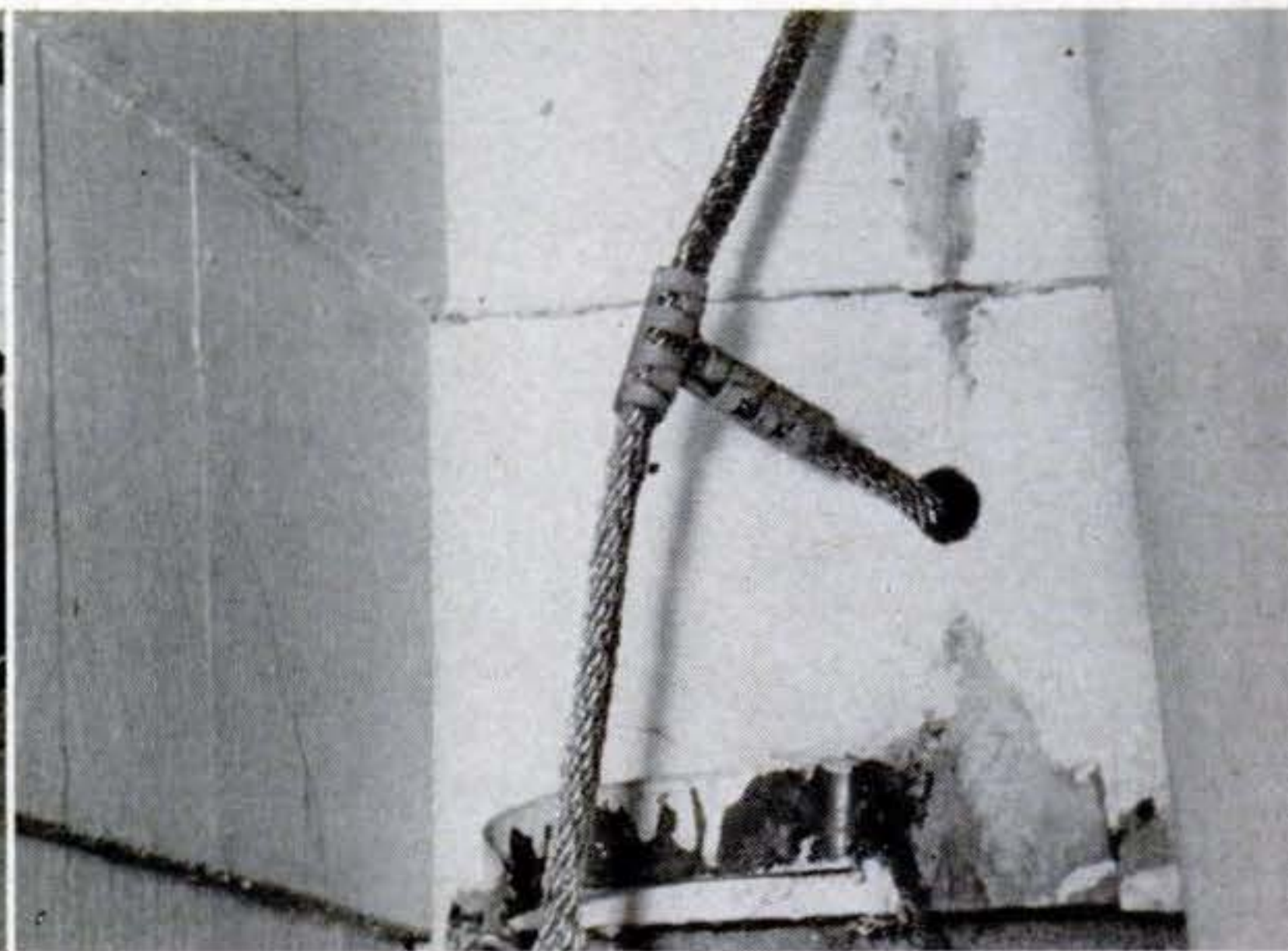

9 TEE CONNECTOR joins main cable with branch that goes through cellar wall. Downspout has been unhooked, moved to one side.

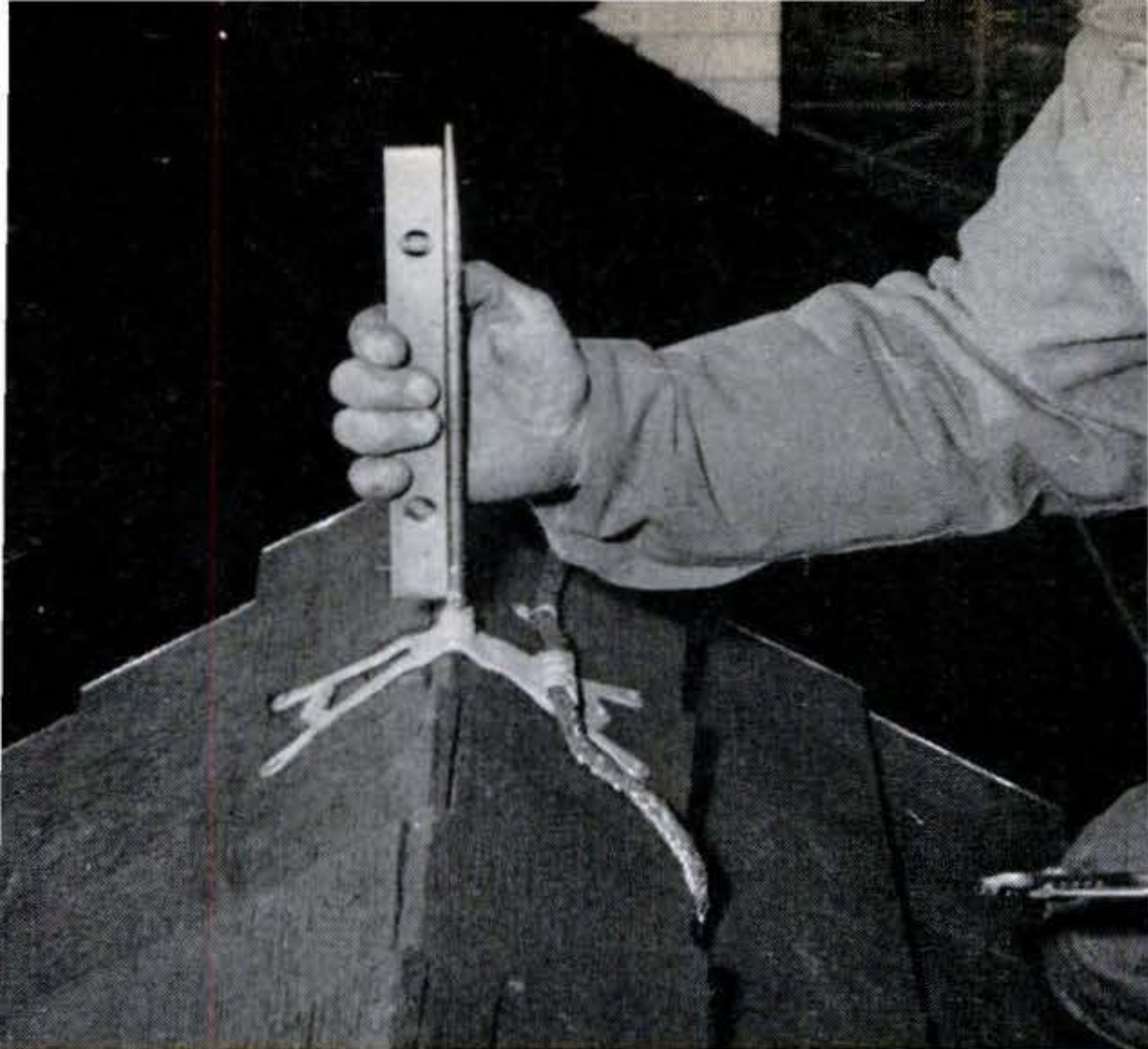

3 LIGHTNING ROD, called "air terminal," is threaded into saddle and leveled. Copper rods are lead coated to resist chimney fumes.



4 CHIMNEY IS DRILLED for lead anchors that hold masonry saddle. Chimneys, favorite lightning targets, are always rodded.



7 ROOF VENT is interconnected, or "cross-bonded," too. Metal like this acts as lightning rod but would carry charge into house.

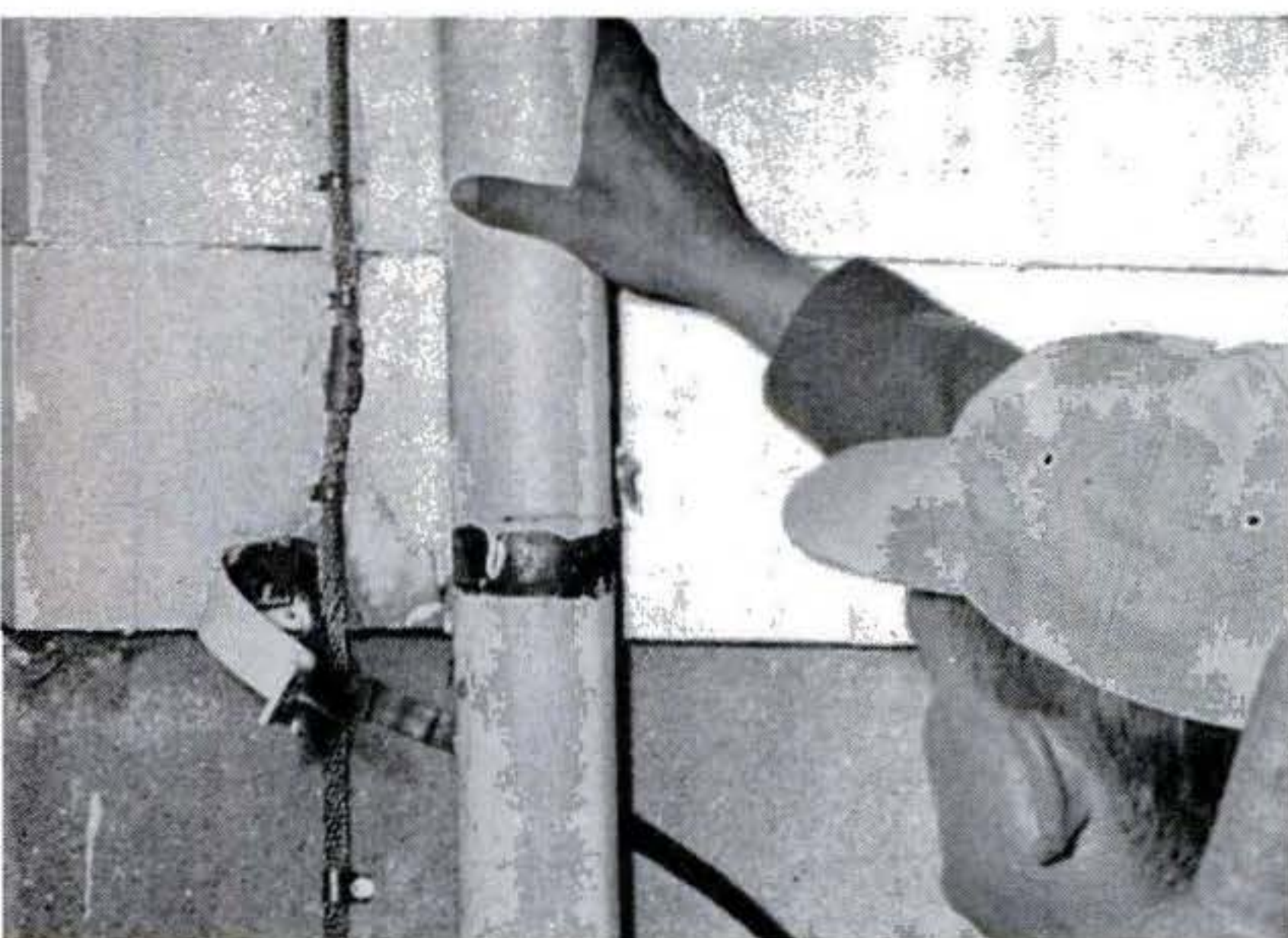

10 WOOD FILLER seals hole where tee goes through wall. When downspout is replaced, it will hide the cable.



11 GROUND BAR, a 10-foot copper rod, is driven with an electric hammer. It is joined to cable below ground as shown on next page.



12 GROUND-BAR CLAMP links cable and rod a foot or so below ground. At least two grounds are used; this house got three.



13 CELLAR BRANCH CABLE is bonded to water pipe. Clamps, tees and connectors are specially made, can stand 2,000-pound pull.

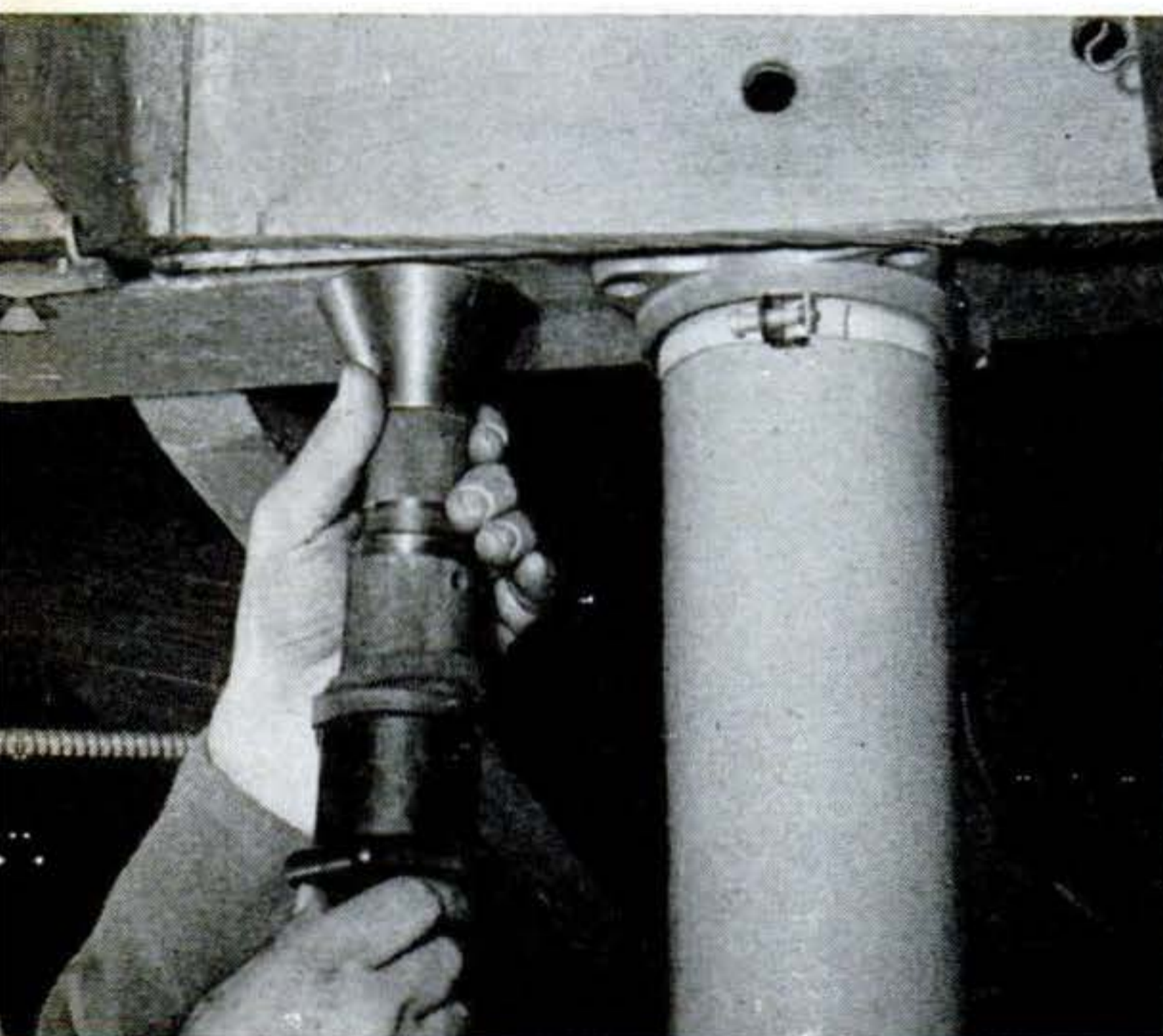

14 POWDER-OPERATED GUN shoots a threaded stud into steel girder for ground connection. Metal must be interconnected.

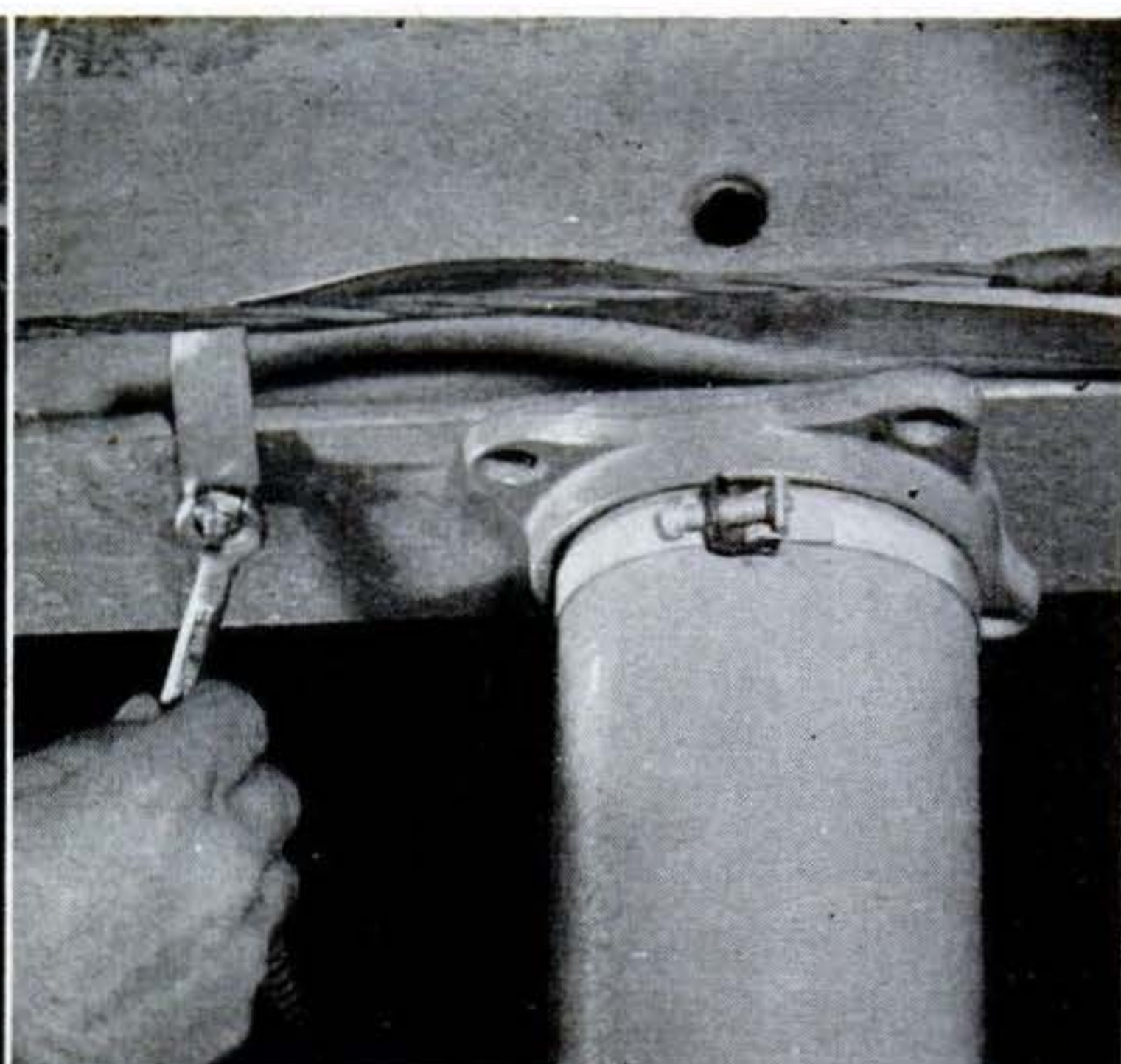

15 GIRDER and supporting columns are bonded into single ground system by copper strip bolted to threaded end of stud.

16 DRAINS are tied into circuit in cellar. Plumbing is cross-bonded at several places to by-pass any high-resistance joints.

17 HOUSE WIRING—already grounded—is bonded to complete circle. Now neither static nor lightning can spark metal. **END**

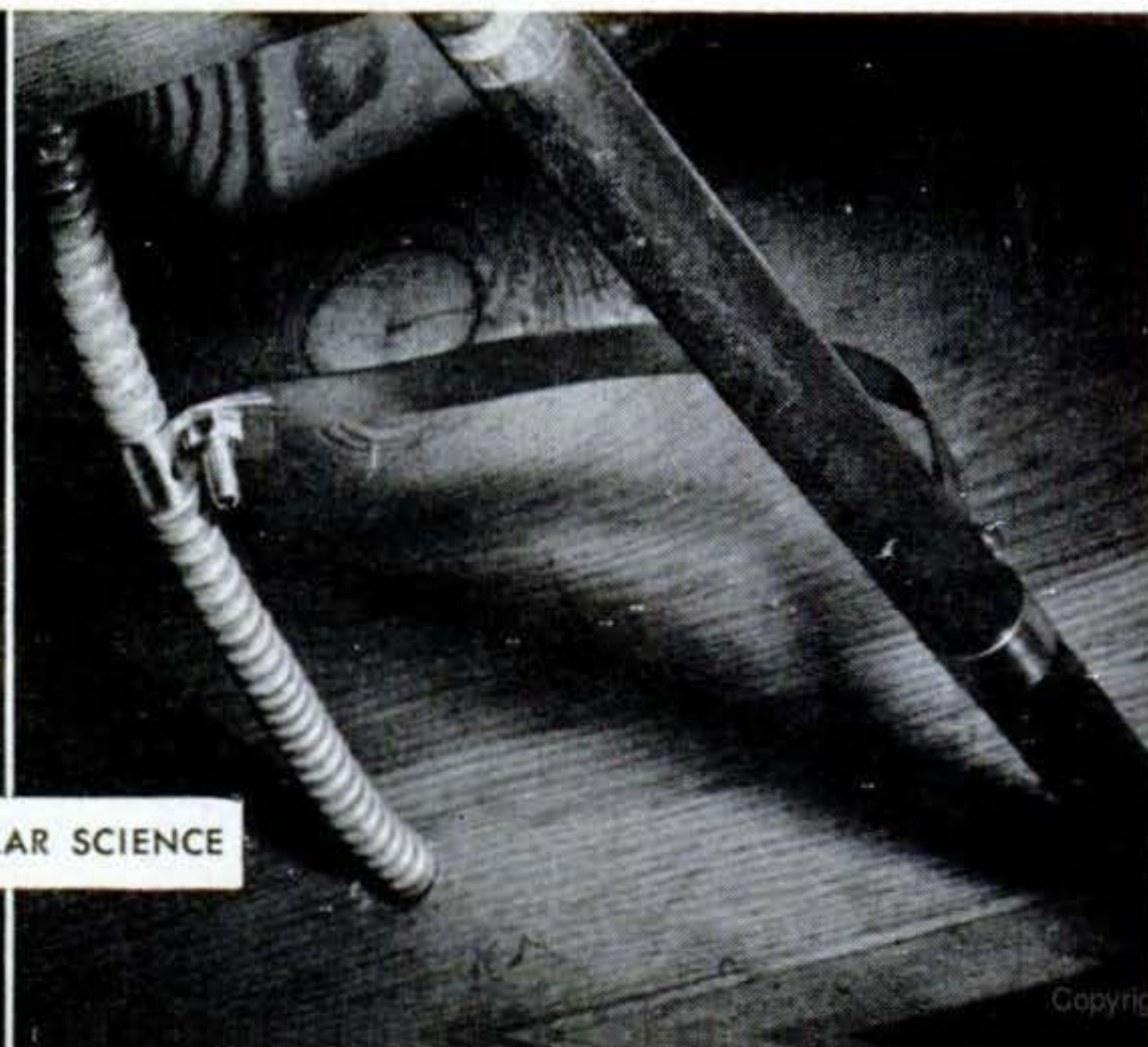
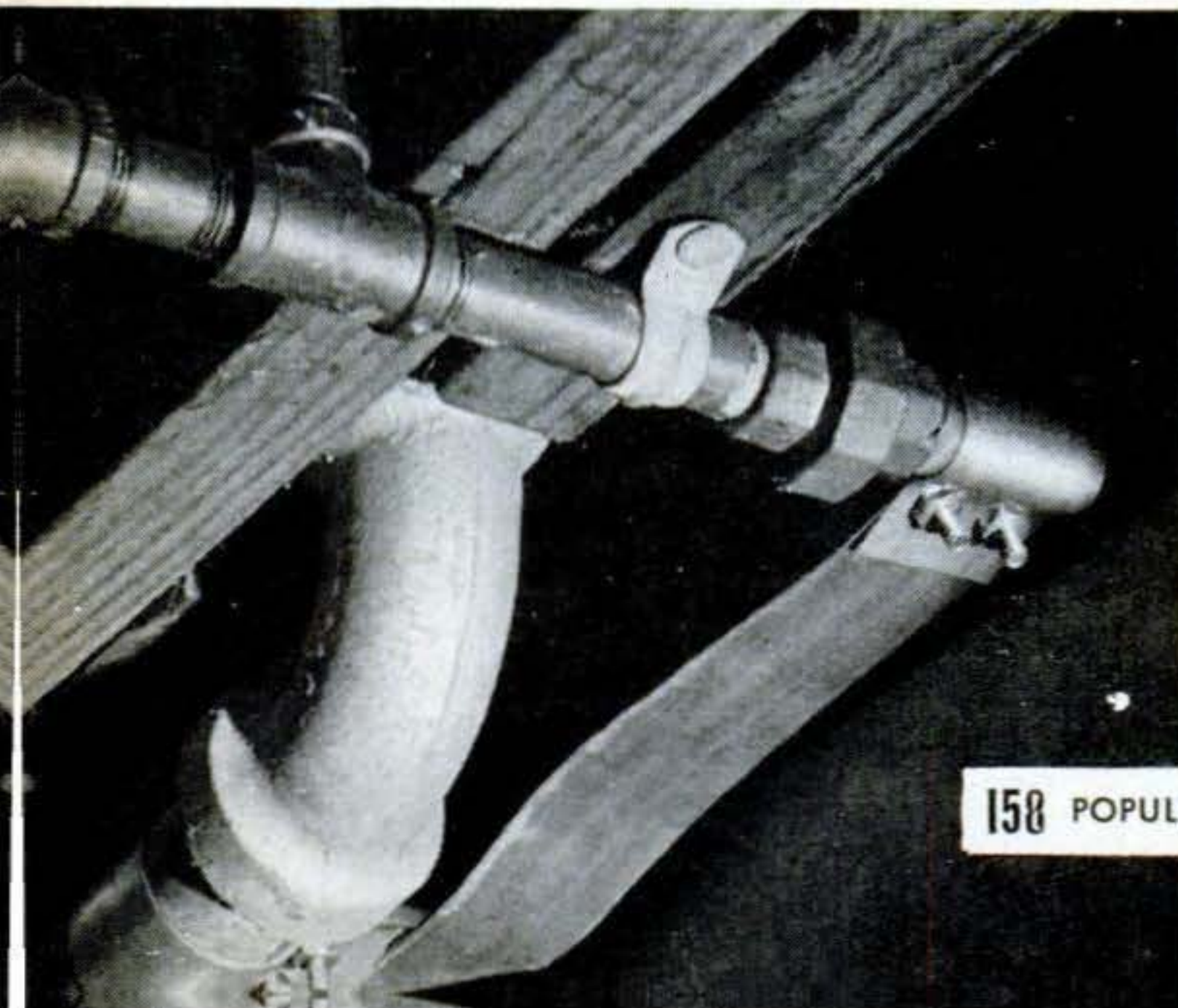

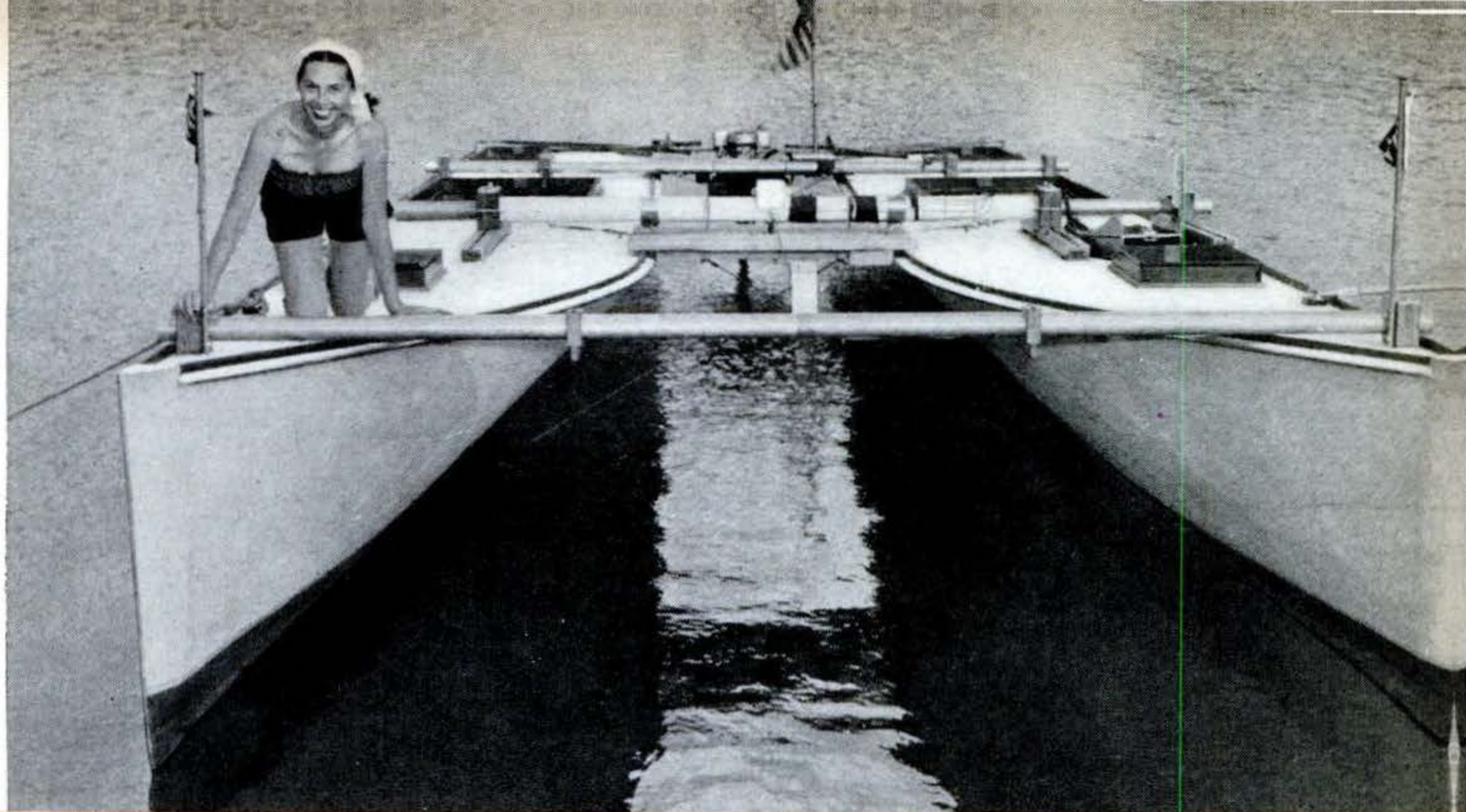

Bow view shows two 4½-foot hulls linked by aluminum tube and cable to give 12-foot beam.

Twin-Huller Built for Speed

MEET the latest in catamarans—the good ship *Tweedledum-Tweedledee* of Detroit. Her slim hulls, 35 feet long, are designed to give the cabin space and seaworthiness of a 28-foot, L-class sloop—but with twice the speed when under sail.

Owners and crew of the *T-T* are Dr.

Arthur Locke and his wife Dorothy (in photos). They built her with the help of friends, students and faculty at Wayne University, where Dr. Locke teaches aeronautical engineering. Like Gar Wood's *Venturi* (PSM, Nov. '49, p. 106), the *T-T* has hulls that are flat outside, curved inside.

Stern shot shows outboard mounting. When sails are added, craft will be sloop-rigged.

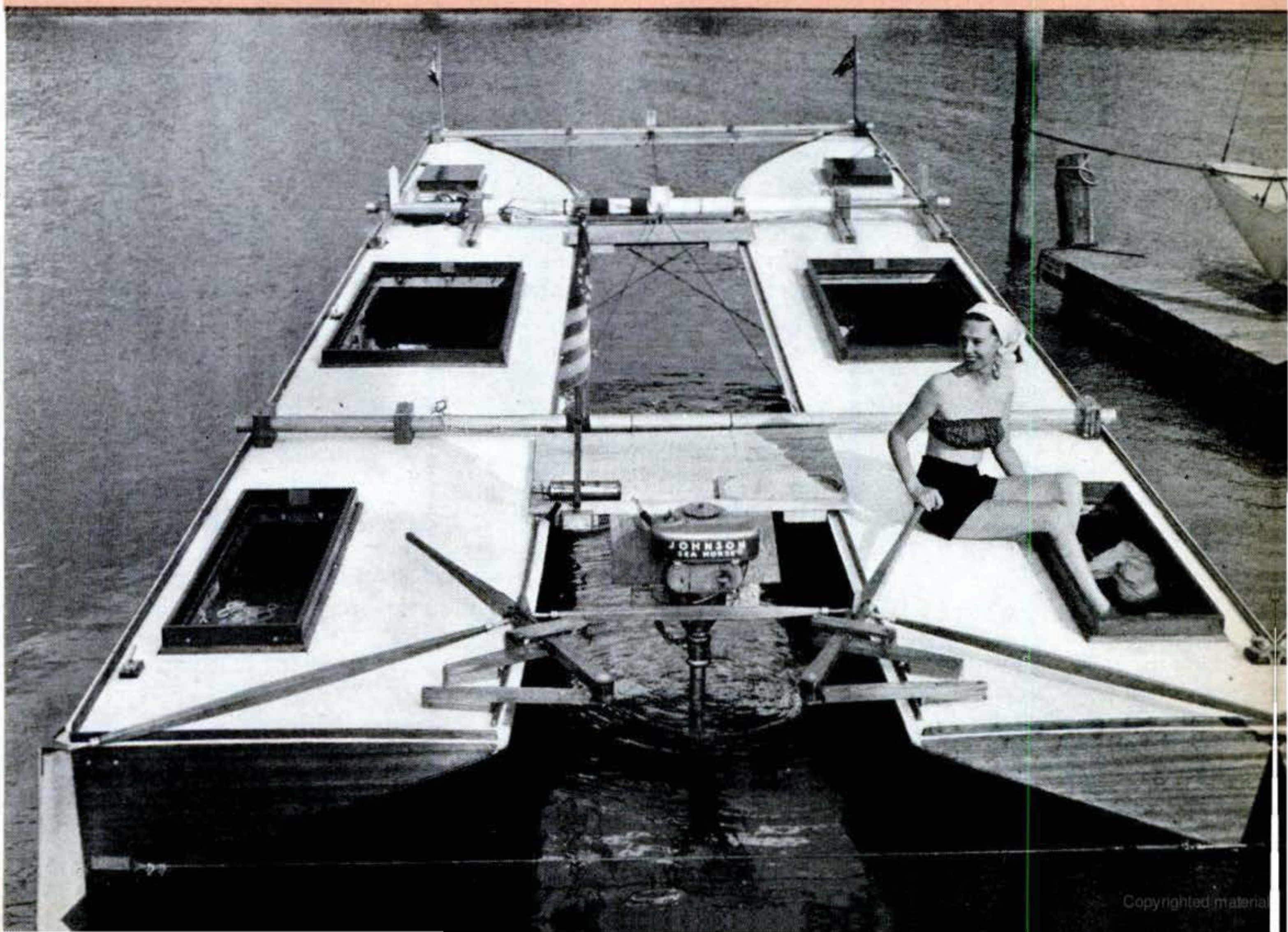

P.S.

Last minute news & notes...

SPACE-CADET SUITS will have to be made in smaller sizes--mice and monkeys are getting the first high-altitude rocket rides. They've ridden as high as 80 miles and survived gravity-less free falls with no significant effect upon heart and blood vessels.

AMONG THE STRONGEST WOODS known is a tropical hardwood from the kaneelhart tree, "Licaria cayennensis," of Central and South America, Prof. F. F. Wangaard of Yale University has discovered. He foresees its use for tool and utensil handles, thresholds for doorways and a variety of turned-wood articles. The exceptionally heavy wood can be finished mirror smooth.

TEN TIMES FASTER THAN SOUND is the record velocity of air in a wind tunnel at White Oak, Md., used by the Naval Ordnance Laboratory to study missile and projectile design. Supplied from a reservoir holding it under a pressure of 3,000 pounds to the square inch, the air must be preheated to prevent the wind tunnel from liquefying it.

RESILIENT CONCRETE FLOORS that won't crack, and "an ideal mortar" for brick or tile, are obtained by using concrete or mortar containing 20 percent of polyvinyl acetate (used to make plastics), MIT scientists report after trials of it.

STOVES that cook meals in a few seconds with ultra-high-frequency waves are one of the features of the coffee-shop cars on the new "Congressional" trains now plying the Pennsy's New York-Washington route.

THULIUM, rare-earth element, has a new use. Made radioactive in an atomic pile, it can replace bulky X-ray apparatus for making radiographs of patients' bones and teeth. Its rays do not harm body tissue.

NEW PRODUCTS: LEATHER MADE FROM BACON RINDS has yielded soft, pliable and low-cost work gloves for telephone linemen . . . A new CERAMIC PERMANENT MAGNET requires neither cobalt nor nickel, both strategic materials in short supply.

SPARE PARTS FOR THE HUMAN BODY still can't be ordered from a catalogue, but developments over the past few years have made possible an ever-increasing number. Like the blood bank, there are now banks for eyes, bone, cartilage, arteries and veins. Entire organs, such as kidneys and bladders, have been transplanted or constructed from a patient's own tissue. And now man-made organs, like the mechanical heart and kidney, are keeping alive the spark of life until natural organs can be repaired.

NEW ANTI-TB DRUG took a million man-hours and a million and a quarter dollars in research and experiment, reports Squibb, which developed it simultaneously with Hoffman-La Roche. The drug, isonicotinic acid hydrazide, was found to kill TB germs in a routine test after it was synthesized for other purposes.

FIRST ALL-JET AIRLINE SERVICE is just starting. British Overseas Airways is putting de Havilland Comets on the London-Johannesburg run May 2. Cruising up to 490 m.p.h., the jets will make the 6,724-mile trip in 23 hours 40 minutes--clipping 13 hours off the present schedule.

SCIENCE FICTION'S favorite stuff--"contraterrene," matter containing positive electrons instead of the negative ones all earthly matter is made of--has actually been discovered. At least a man-made "element" very like it was described to the American Physical Society by MIT's Prof. Martin Deutsch. He calls it "positronium" and says it consists of just two electrons (one positive, one negative), making it the only "atom" without a nucleus. Just as the science-fiction boys predicted, this form of CT blows up --in 1/10 of a millionth of a second or less.

The Editors



MECHANICS *and* HANDICRAFT

REG. U. S. PAT. OFF.

How Good Are Your Gutters?

Here's the low-down on roof-drainage systems: what you need; what's available; how to repair, install or even make them.

RAIN on the roof may come down as drops, but it runs off as gallons. That's a lot of water over the eaves, and if it pours off them without benefit of gutters, you'll soon have a miniature moat around the house. Water-soaked ground by the foundation walls is a good start toward a damp basement.

Just having gutters isn't 100-percent insurance against these troubles. Like practically everything else, gutters need loving care. Without it, they clog, leak, spill water and sag to give a house a raffish, unshaven look. The bright part of the picture is that the problem isn't hard to lick: if you don't have gutters, they are fairly simple to install, and if you do have them, repairs are

mostly routine ladder work, not at all difficult once you get at it.

Kinds of gutters. In selecting new gutters, consider the style of your house, how much you want to pay and how much maintenance you are willing to put in. These are the kinds you'll have to choose from:

Galvanized. This is the cheapest gutter, costing roughly \$2 for a 10' length. It will rust through, though, and isn't recommended for damp climates, coastal areas or places with industrial or railroad smog. If painted at least once a year, galvanized will nevertheless last for years. The material takes solder beautifully, but if you aren't a hot man with an iron, you can use slip connectors. These are short sections with a zigzag

THIS WON'T DO. Roofer's version of painting yourself into a corner is leaning ladder on the

eaves where gutter has to go. This lad must come down with gutter and reset the ladder.

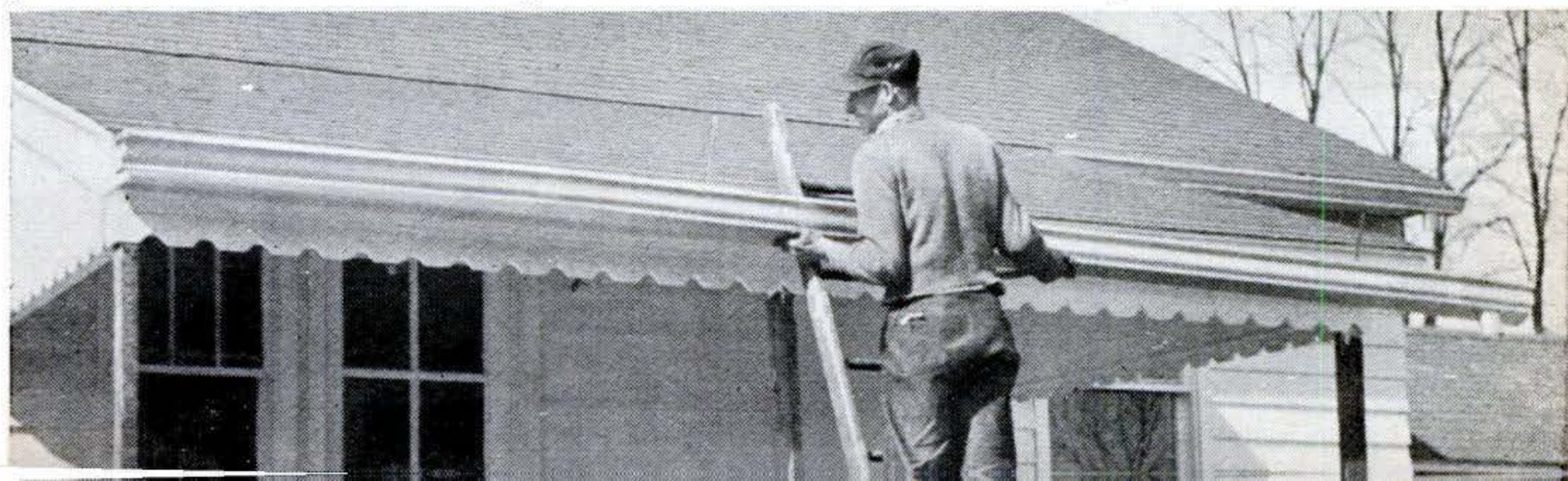

fold on each side that you push the gutter troughs into.

Aluminum. This will cost you about twice as much as galvanized. But it needs no painting, lasts a long time, resists corrosion and won't stain or discolor house walls if it should leak. Its light weight makes it easy to install, which may be important on a one-man job.

Being soft, aluminum gutter must be handled with care. It also requires hangers closer together (and therefore more of them). It can't be soldered, but is assembled

with slip connectors. Both a smooth and an embossed or hammered finish are available.

Stainless Steel. This costs about two and a half times as much as galvanized. But it requires no painting, doesn't stain and resists corrosion. It is the strongest metal gutter, and so withstands ice, snow and abrasion by tree branches better. It can be soldered or installed with connectors.

Copper. Copper gutter has been used for centuries. It costs about three times as much as galvanized. Defense needs have stopped the manufacture of it now, but you may

Slip Connectors Make It Simple to Install New Metal Gutters

You'll save time and energy by finding yourself a helper with a second ladder. However, if you must work alone, build the temporary support shown at the bottom of the facing page.

Roofers often solder gutter together before

hanging it. Slip joints won't hold full lengths securely enough for this, but you can attach outlet sections, miters and end caps on the ground. Smear the grooves of the slip connectors with cement and force the parts in.

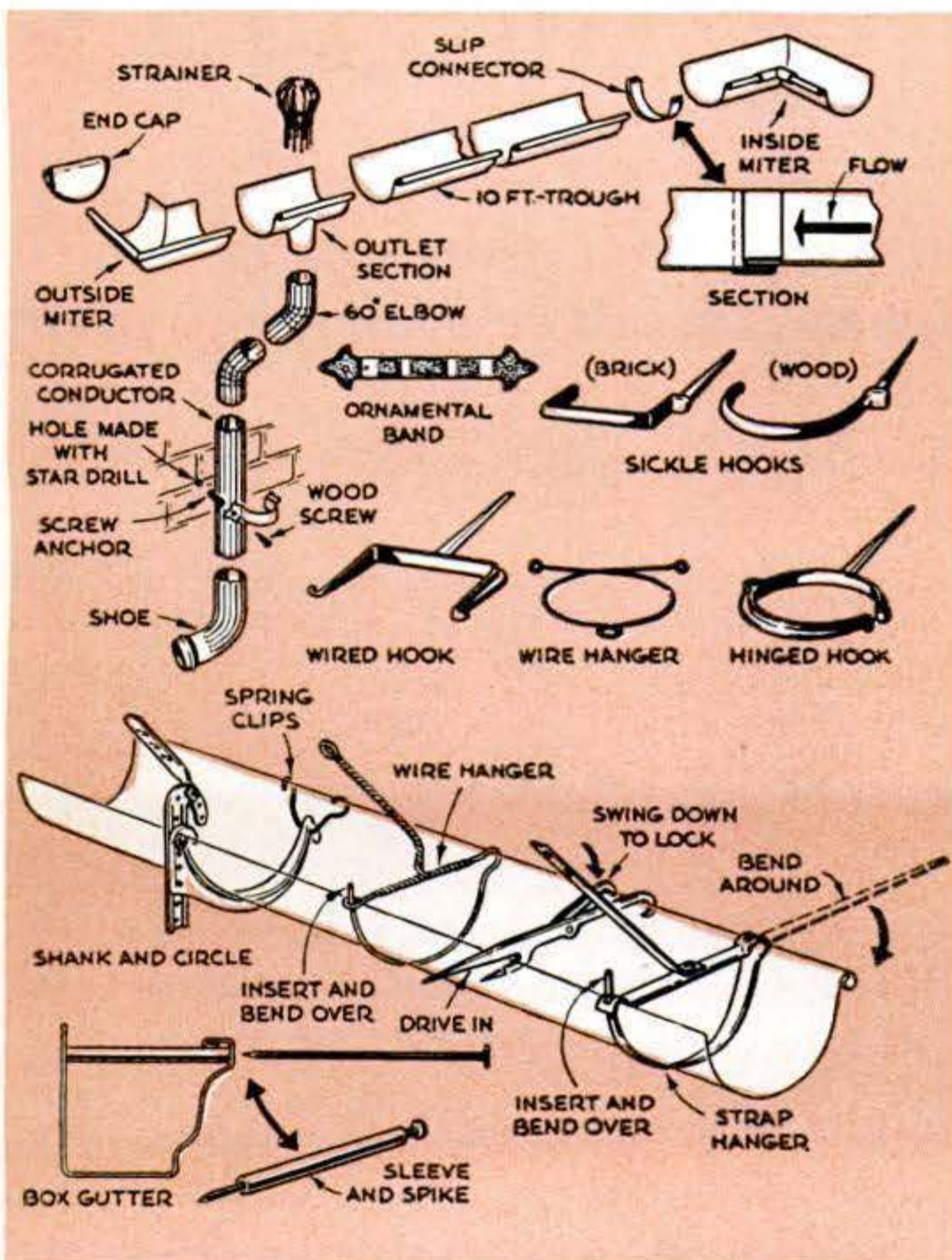

IF HANGERS ARE NAILED over the shingles, don't fail to embed the heads in sealing compound. Drive nails only part way, apply asphaltum cement around and under heads, and drive in.



CORRECT PITCH, or slope toward outlet end, assures runoff in metal gutters. As little as 1/16" in 1' will serve. There should be no low spots for water to collect in.

IF YOU SOLDER joints, be sure to neutralize the flux. Rinse with a solution of washing soda. Roofers use a soldering iron. A torch may burn the zinc off galvanized iron.

SLIP CONNECTORS make you an expert in joining gutter sections. Here's how an outlet section is connected to a 10' length. Put cement in the connector grooves first.

TO CUT ODD LENGTHS of gutter, first saw through the rolled edge like this. Use a fine hacksaw blade (32-tooth). Finish by cutting from the opposite edge with tin snips.

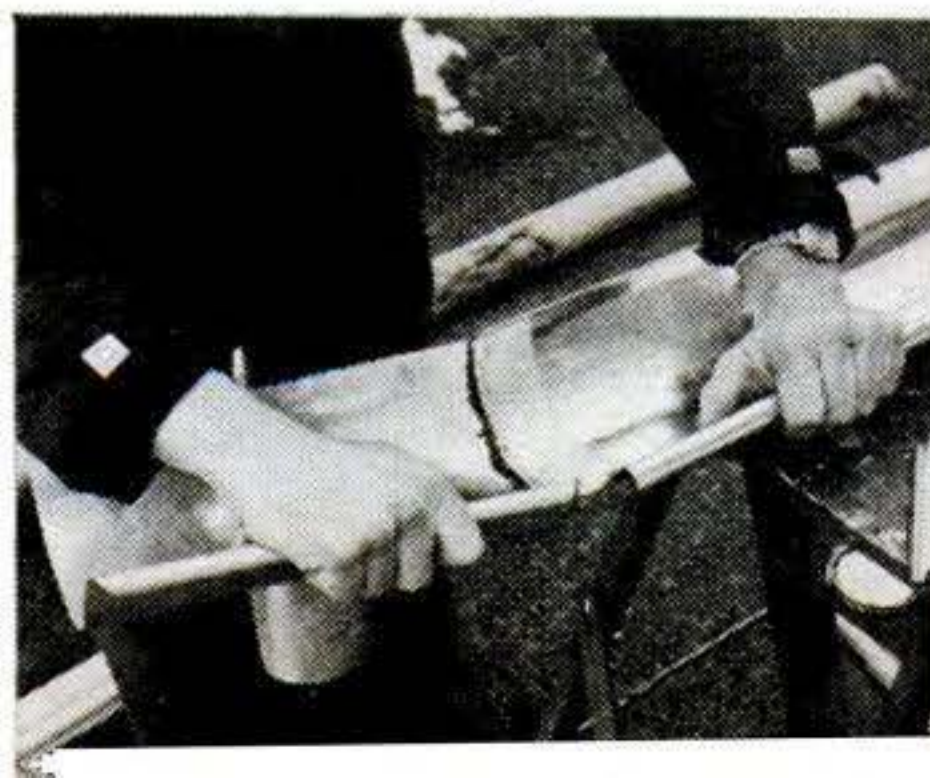

find some in dealers' stocks. It needs no painting, and weathers to a soft green. But it may stain light-colored walls if leaks occur. This can be prevented by varnishing or lacquering the gutters, but the coating must be renewed from time to time.

Copper solders well and is easy to work. However, long runs should *not* be soldered, because expansion may spring the joints. Slip connectors permit expansion.

Wood. This is also an old stand-by, and remarkably durable. Costing about the same as stainless steel, wood gutter is made mainly

from fir, but sometimes of red cedar. Architects often prefer it because it can be installed without any slope, preserving the horizontal lines of a house.

Wood gutter is very strong and unaffected by damp or corrosive atmospheres. It must be painted regularly. Joints are made by nailing or screwing sections together, but since lengths run up to 40', fewer joints are needed. Metal downspouts are usually used, but wooden ones are available.

Your pick of shapes. Wooden gutters usually have a molded front. Metal gutters

If you use hangers that clamp around the gutter, put them on now—no more than 30" apart for aluminum, 36" for other metal gutters. Shank and circle hangers are attached to the roof, and the gutter laid in.

With soldered joints, it is important to neutralize the flux immediately. Flush with a solution of washing soda. Even stainless steel can corrode if this isn't done.

Lift the gutter into place and secure it temporarily with just a few nails. Put on the next connector and press in the following length of gutter. It is usually best to put up an entire run without driving fasteners in all the way. Then pitch can be checked by pouring water in at the high end. Correct any low spots, and drive the fasteners tight.

Nail strap hangers to the roof, over rafters if possible. Although hangers should go under the shingles, you can nail them on top if you smear roofing cement liberally under the nailheads before driving them down. Where practicable, the gutter can also be nailed to the rafters or frieze board. Finally, calk the inside of the slip joints with roofing cement.

Use a pair of elbows to bring the downspout flush against the wall. Always assemble downspout with the upper section inside the lower. On masonry walls, downspout bands or wire hangers must be held by screws driven into lead anchors. Various drive hooks are also available, both for masonry and for wood. These are simply hammered in.

Remember that bands, hooks, nails and all other fasteners should be of the same metal as the pipe. Where pipe or gutter must touch another metal, coat it heavily with asphaltum.

To lead water away from the foundation, a reinforced elbow (called a shoe) emptying on a stone or concrete splash block is a minimum arrangement. A run of buried drain tile with open joints is good in sandy soils, or water may be led to a storm sewer or dry well (PSM, Feb. '51, p. 183).

The oil left on metal in the rolling process must be cleaned off with gasoline or naphtha before painting. Galvanized gutter must then be washed with dilute acid, such as vinegar. Some roofers recommend doing this and letting the gutter weather a few months before painting it. Use a primer and regular outside paint on the exterior, primer and asphalt paint inside.

V Gutters Made of Stock Lumber

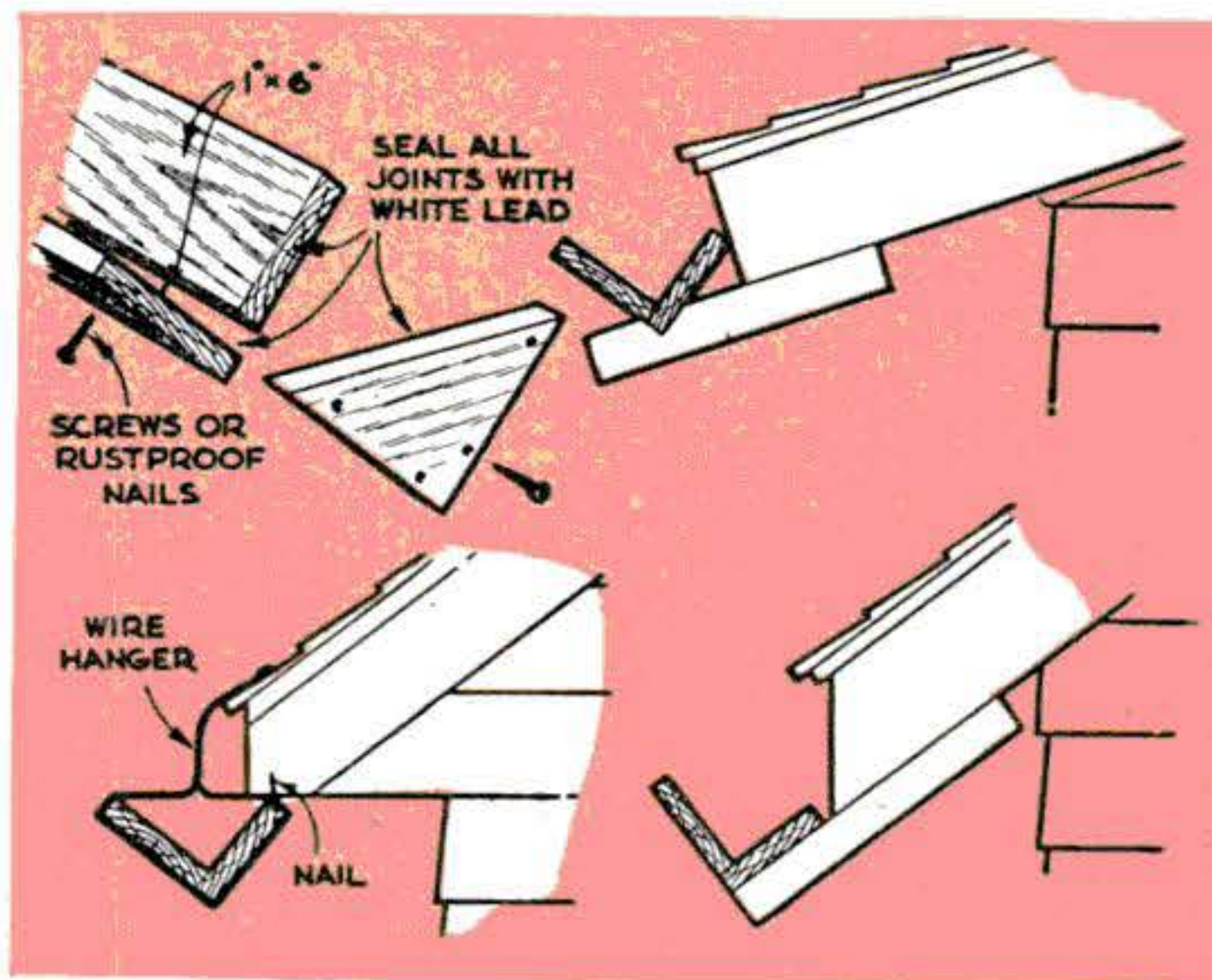

HOMEMADE V GUTTER is serviceable if well built and properly installed. Remember ice will add a heavy load in winter, so secure the inner edge with rustproof nails or screws. Calk the long joint with asphaltum cement.

A SIMPLE but practical V gutter can be made from stock lumber. Far from being a mere makeshift, this type has been used from Colonial days, and is often specified by architects today on Colonial-style houses.

Red cedar is excellent, but fir or cypress will do also. Coat joining surfaces with white lead before screwing them together. Prime all over with linseed oil, and calk the inside of the joint. You can use metal downspouts or make square ones out of wood.

SET LADDER OFF from eaves to hang gutter. A piece of wood bolted to each rail as at left below does the trick. The brace isn't needed if the spacer is short. A temporary support made from three pieces of wood (right below) will hold one end of gutter on a one-man job.

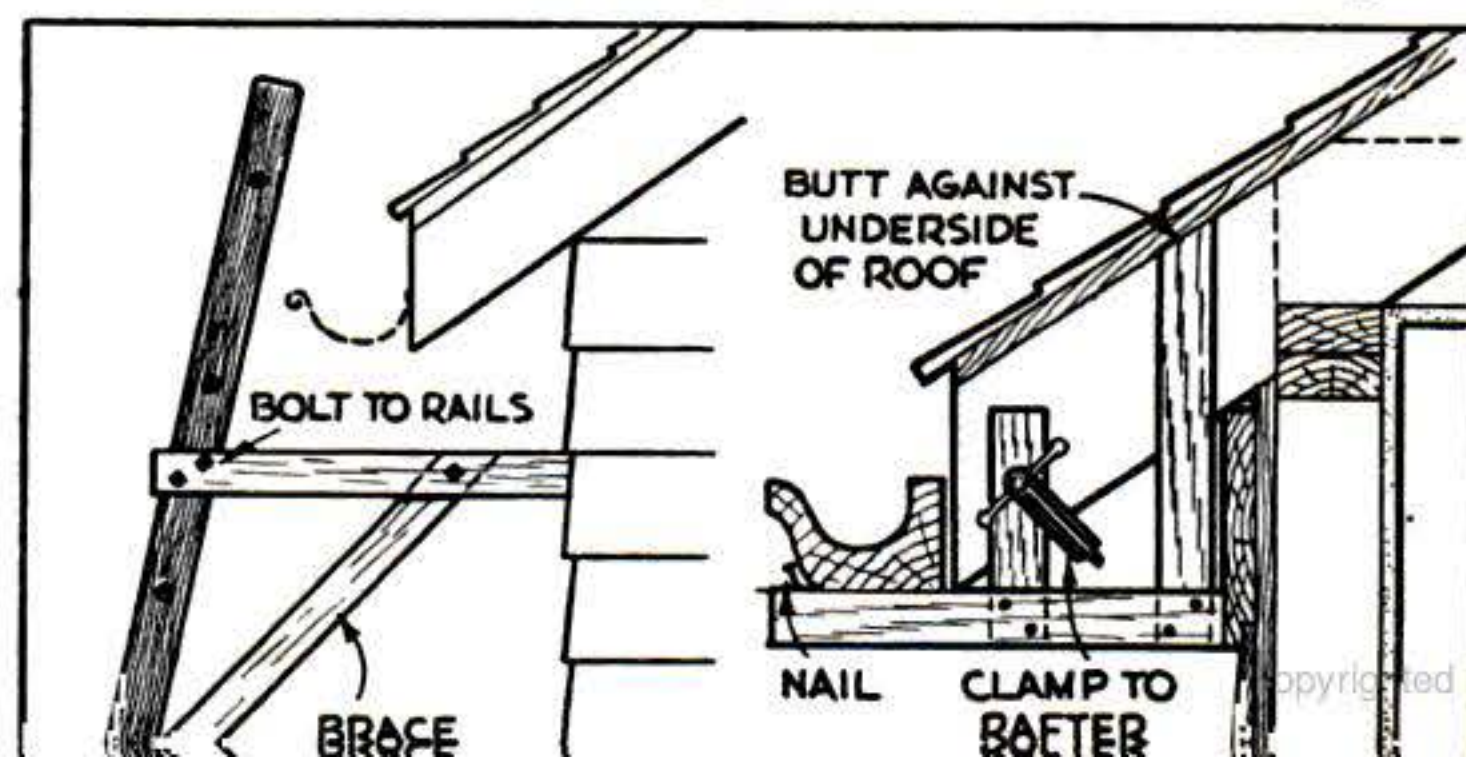

How to Install New Wood Gutters

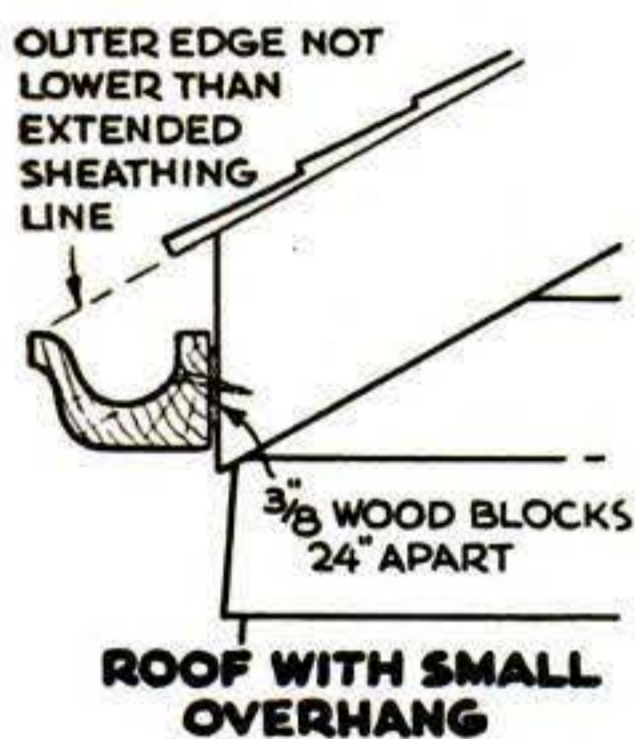
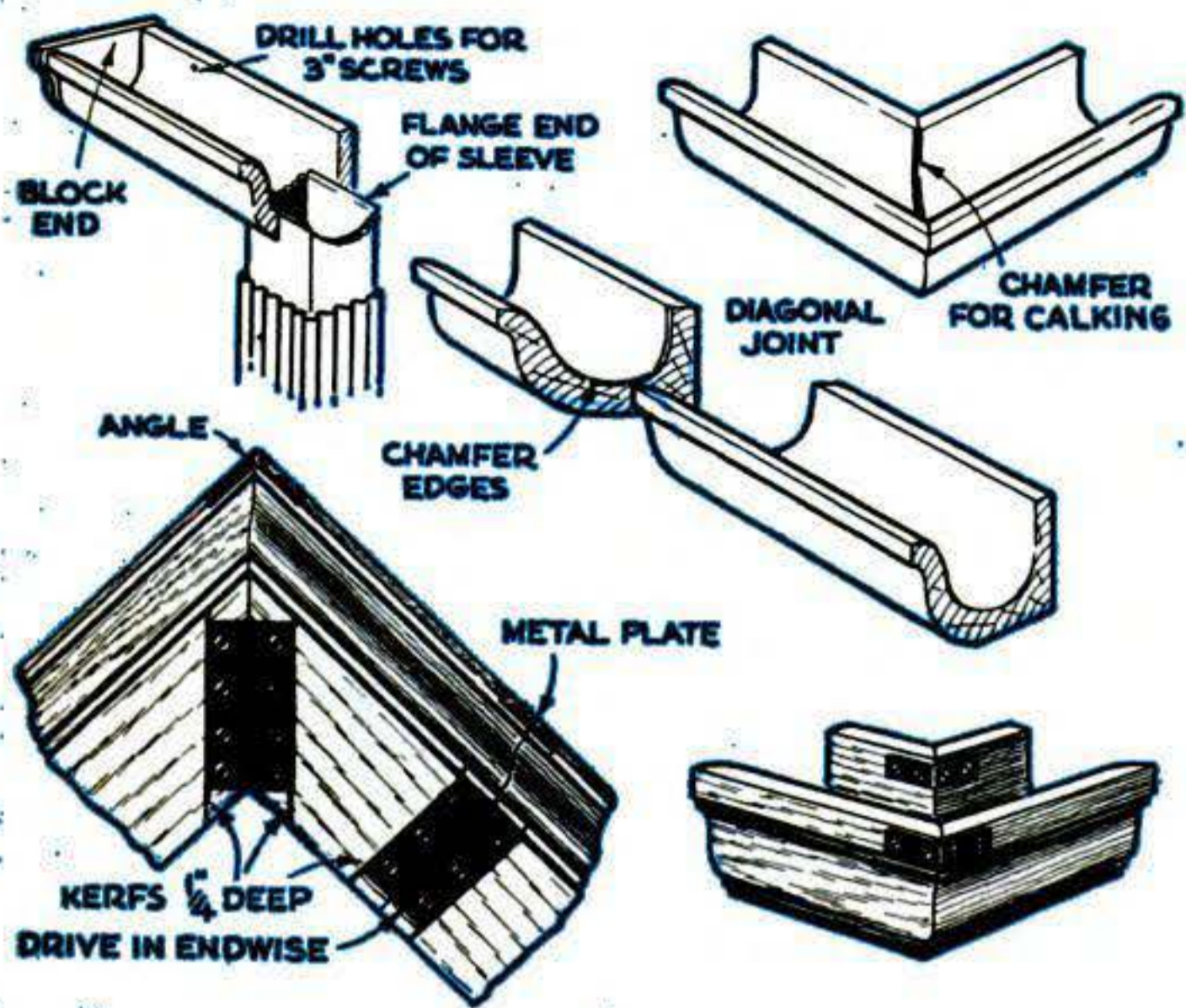

WOODEN TROUGHS can be protected with linseed oil alone. You can use asphaltum too, as above, but watch it for cracking and renew it as necessary. Chamfer all joints for calking.

BECAUSE wood gutter is heavy, a helper is almost a must. Cut, fit and make joints on the ground. Smear the edges of all joints with white lead and assemble with rustproof nails or, better still, countersunk brass screws. For the metal fasteners shown in the drawing, a kerf must be cut in each piece.

Wood gutters are nailed or screwed directly on the house. The drawings show two methods of attaching them. It's well to coat the back edge with white lead before putting up the gutter. In climates where ice forms, set the gutters off with $\frac{3}{8}$ " or thicker blocks so that accumulated water will spill over instead of entering the wall.

Wood gutter can be put up without any slope, and will drain satisfactorily provided it is kept clear of leaves.

For downspouts, cut a hole in the gutter and set in the metal outlet sleeve with white lead or roofing cement.

Manufacturers recommend priming the wood with white lead and linseed oil on the outside and then painting it, but using oil only on the inside. Soak exposed ends with linseed oil too. Calk the inside of all joints with roofing cement or calking compound.

come in half-round, square and box shapes. The latter has a curved front and a square top edge, like a molding. Half-round is the cheapest. Others cost about 25 percent more.

Don't mix metals. You can use part wood and part metal gutter, but don't join two kinds of metal gutters. Acids in the atmosphere will set up an action similar to that in a battery, disintegrating the metal. Even nails and screws should be of the same metal as the gutter. Beware also of letting gutter touch dissimilar metal it passes.

Timely Repairs Save You Money

IN ITS own quiet way, a clogged gutter may route water into your living room for a long time without serving notice. Rather than wait for plaster to fall, you should routinely check that gutters are clear and drain as they should.

You can rest a ladder against wooden gutters. For others, use a ladder short enough to brace against the wall just under the gutter, or attach standoffs to the ladder as shown in drawing on page 163.

Leaves should be cleaned out of gutters in the fall right after trees are bare. If any have worked into downspouts and jammed the elbows, break them up with stiff wire (or a plumber's snake in bad cases). Then stick a hose down the pipe and turn the water on full to flush away the residue.

There should be a strainer in the outlet above each downspout. They're cheap and easy to install, and can save you a lot of trouble. Just push them in.

You may find downspout pipes bulged where water stood at a point clogged with leaves and then froze. If the seam is not split, you can probably force the metal back into shape. Split pipe should be replaced, but a temporary repair can be made by smearing thick roofing cement over the break. For large splits, use a cloth-reinforced patch as shown for gutters in the photos at the bottom of the facing page. It can be wired in place for extra strength.

Except on aluminum, holes and splits can be permanently repaired by soldering. Be sure to neutralize the flux with a weak solution of washing soda immediately after, or you'll soon have new leaks.

Winter loads of ice and snow may give metal gutters a permanent sag. Try to bend the gutter back into shape. Install a new hanger or two to hold it if necessary. Ice and snow guards, which keep such loads off the gutters, are a good investment if you have been troubled with such accumulations.

Paint galvanized gutters inside with asphaltum once a year, and with regular house paint outside as often as needed. Before painting, surfaces should be dry, and the inside should be cleared of leaves, twigs and the pigment residue from shingles that often gathers there. Brush off rust and scale. If old asphaltum is cracked and loose, scrape it out before repainting.

Cracked wooden gutters may have to be cut

Figuring downspout sizes. In areas of average rainfall, each square inch of downspout area can handle runoff from 100 sq. ft. of roof. If yours is a region of light or heavy rainfall, better check local practice or look at other drainage systems. The maximum roof area (measured on the slope) to be drained by a 3" round downspout is 700 sq. ft. For 3" corrugated pipe it's 600 sq. ft.

Thus, if your roof is 25' from eaves to ridge and 50' long, the area of 1,250 sq. ft.

can be drained by two 3" round downspouts, one at each end. You could also use a single 4" downspout at the center, pitching the gutter down toward it from both ends. Downspouts can also go on outside corners (where the gutter turns the corner of a house). It's generally best not to put them on inside corners or directly under roof valleys. **END**

Next Month: Expand that attic—saw a flap in the roof, raise the flap to make a dormer—and there's room for a whole apartment.

out and replaced. Make joints as shown in the installation drawings on page 164. Small splits can be repaired with roofing cement and fabric like metal gutters. Paint the inside with linseed oil or asphaltum once a year, and the outside whenever the house is painted. Check the joints to see if calking is cracked or broken away. If it is, scrape the joint out and recalk it, first driv-

ing tight any loose nails or replacing them with wood screws.

Where downspouts enter tile drains, freezes may break the cement seals. Asphaltum cement will repair cracks, but if badly broken, the cement should be replaced. Wrap wire or screening around the downspout just below the tile pipe to keep the new mix from falling in.



OVERFLOWING GUTTERS may put stains like this on the house paint. To prevent it, clear out leaves after trees have shed, and watch during the winter for accumulations of ice and snow that may make water stand and spill over the trough.



NAILS MAY WORK OUT of joints in wooden gutters. At right, the end cap has loosened. Drive the nails back and recalk the joints inside with roofing cement. If the nails won't drive tight, replace them with brass wood screws.



ROUND DOWNSPOUT at far left split when water accumulated and froze over a leaf stoppage. Corrugated pipes will withstand the action of such freezes better than plain ones.

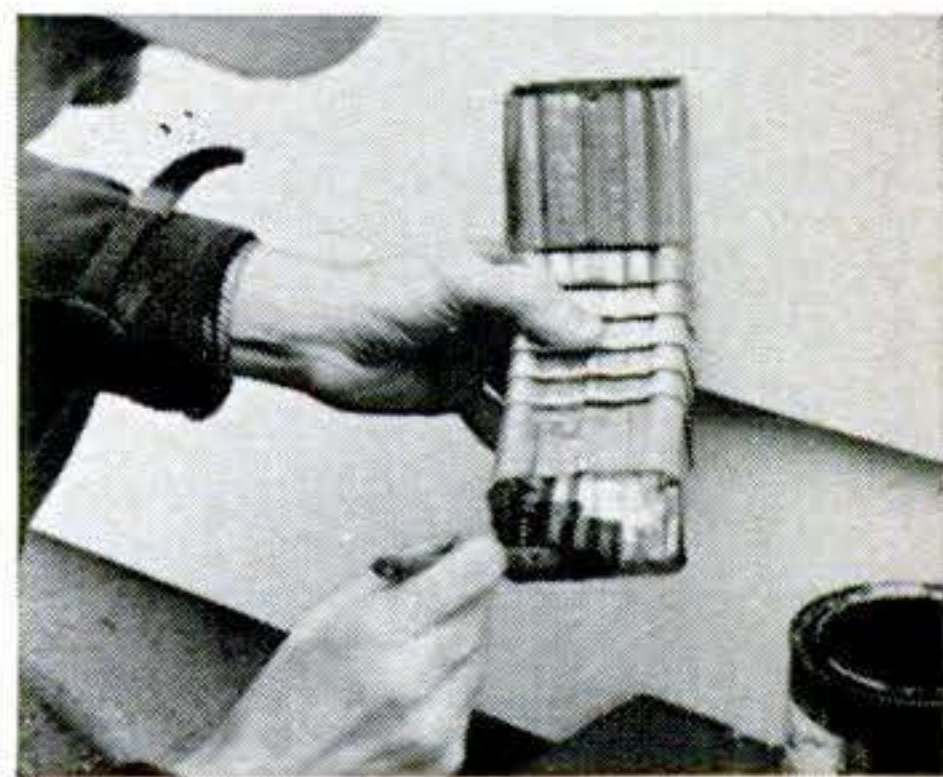

ELBOWS LAST LONGER, especially galvanized ones, if they are painted inside with asphaltum. Their shape makes them more prone to clogging than pipe.

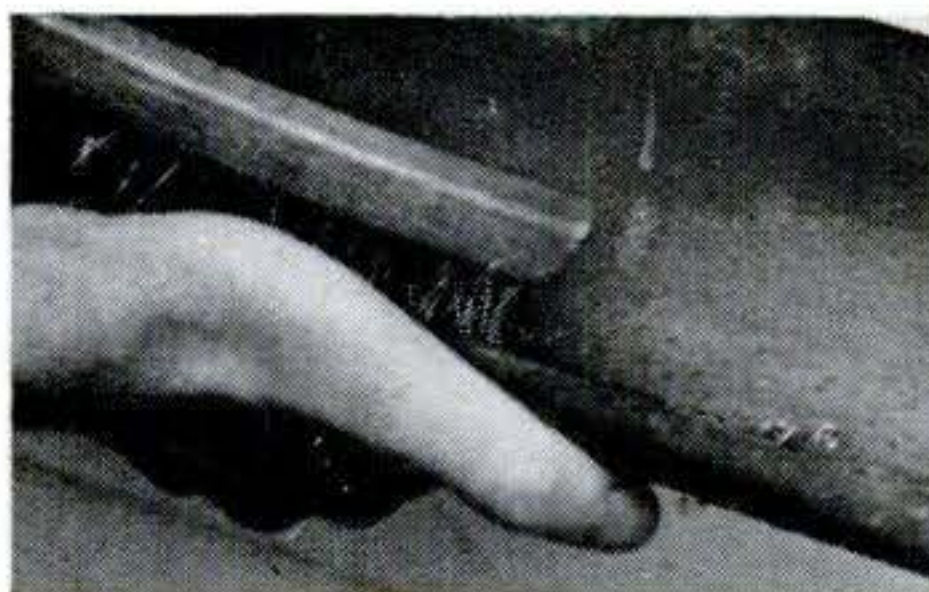

TO PATCH HOLES, first wire-brush off all loose rust and scale (left above). Spread roofing cement or asphaltum well over and around the



break. Lay a piece of heavy cloth in the cement, pressing it down with the fingers (center). Then brush cement on patch, well over edges.

CRAFTSMEN IN UNIFORM

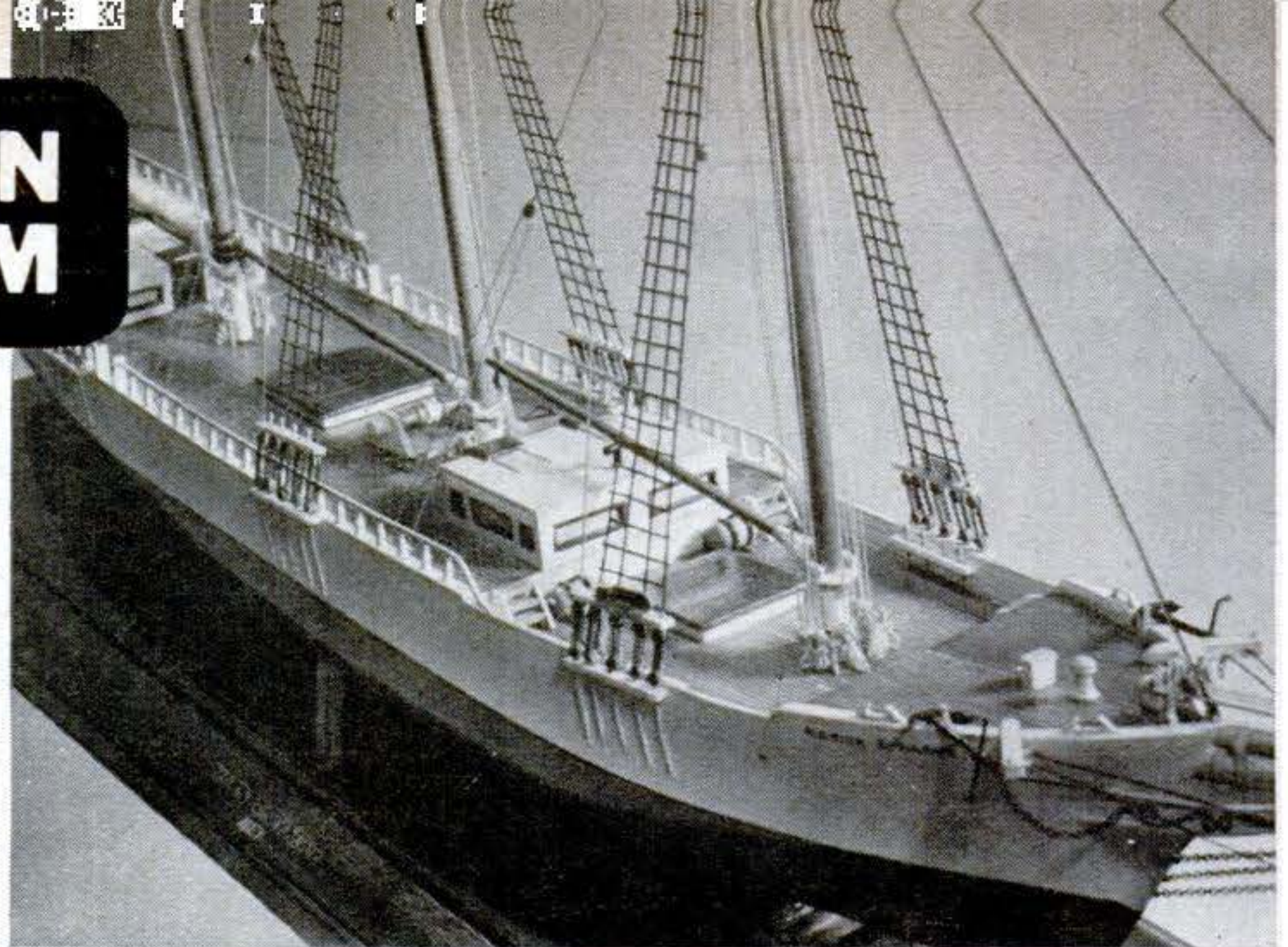
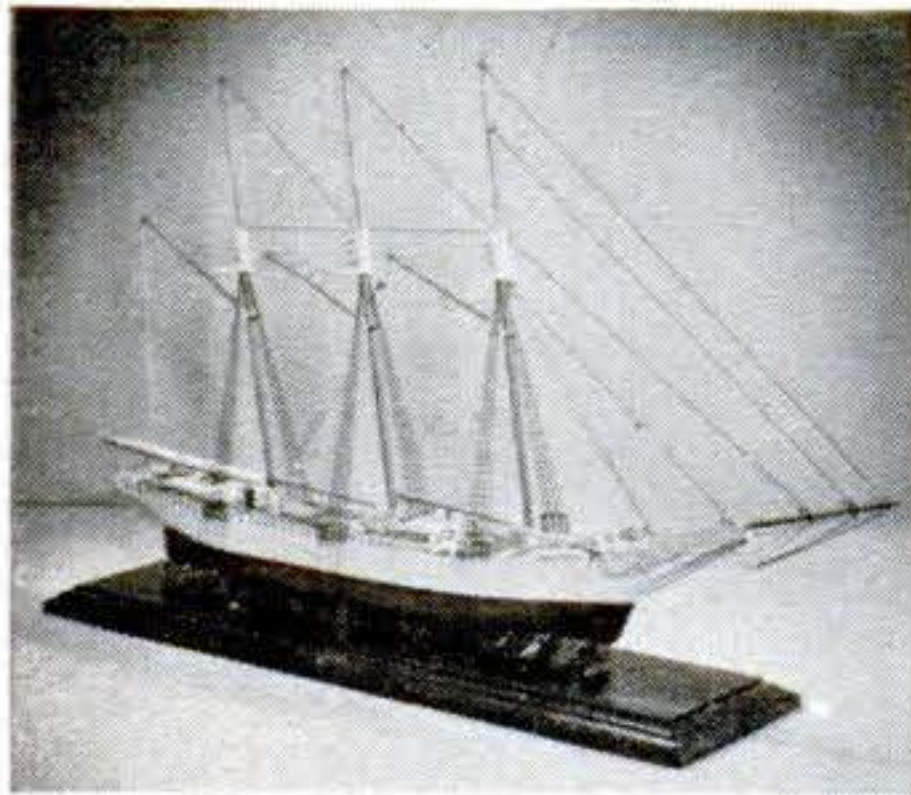

Ship Model. The three-masted schooner *Marion Sprague*, which sailed the seas in the Nineties, has been reproduced on a scale of 3/32" to the foot by M/Sgt. Victor Patacca, Army Signal Corps.

Sgt. Patacca, a member of the Utilities Section, 9404 Technical Services Unit of the Signal Student Regiment at Fort Monmouth, N. J., built the schooner of balsa wood. Note fine detail in deck fittings and rigging.

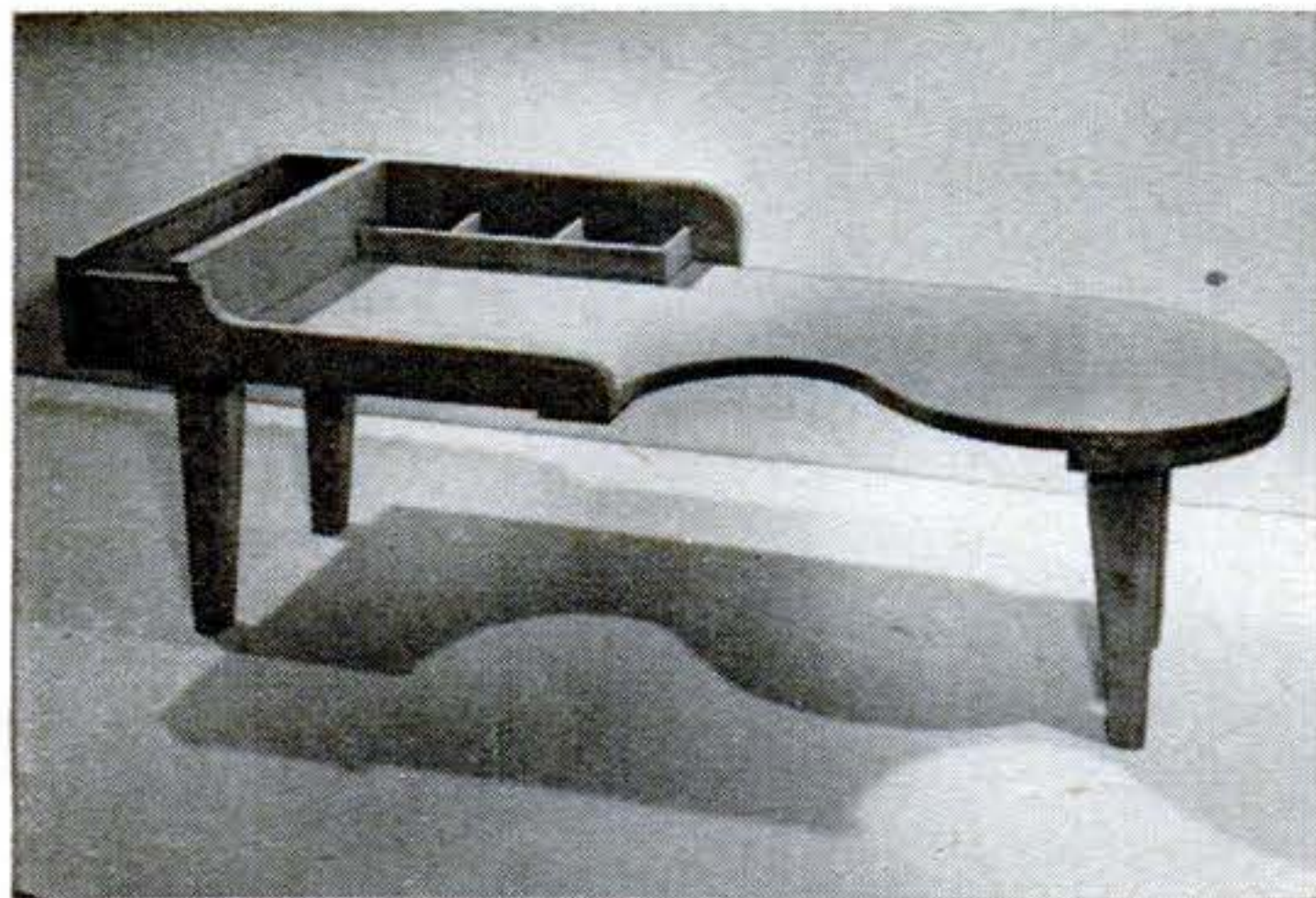

Cobbler's Bench. This 4'-long reproduction of an old-time cobbler's bench makes a fine coffee table. Air Force 1st Lieut. James S. Taylor, assistant special services officer at Mitchel Air Force Base, Long Island, N. Y., built the bench of Philippine mahogany. Working without plans, he spent a couple of months on the project, although his actual working time totaled only about five days. Lieutenant Taylor hasn't decided yet whether to line the end compartment with copper for use as a planter.

Flying Model. When S/Sgt. William H. Early of the Air Force isn't worrying about big planes he builds little ones. The gas-powered number he is holding in the picture below has been repeatedly modified as he thinks up new ideas. Sgt. Early is attached to 568 Installation Squadron at McGuire Air Force Base, N. J.

Game Board. The playing board for chess or checkers shown below is made from contrasting squares of black walnut and white maple, mounted on pine plywood. The board was made by Sgt. Ray Mowdy of the Army Signal Corps, who serves with Headquarters Company, 9400 Technical Services Unit at Fort Monmouth, N. J.

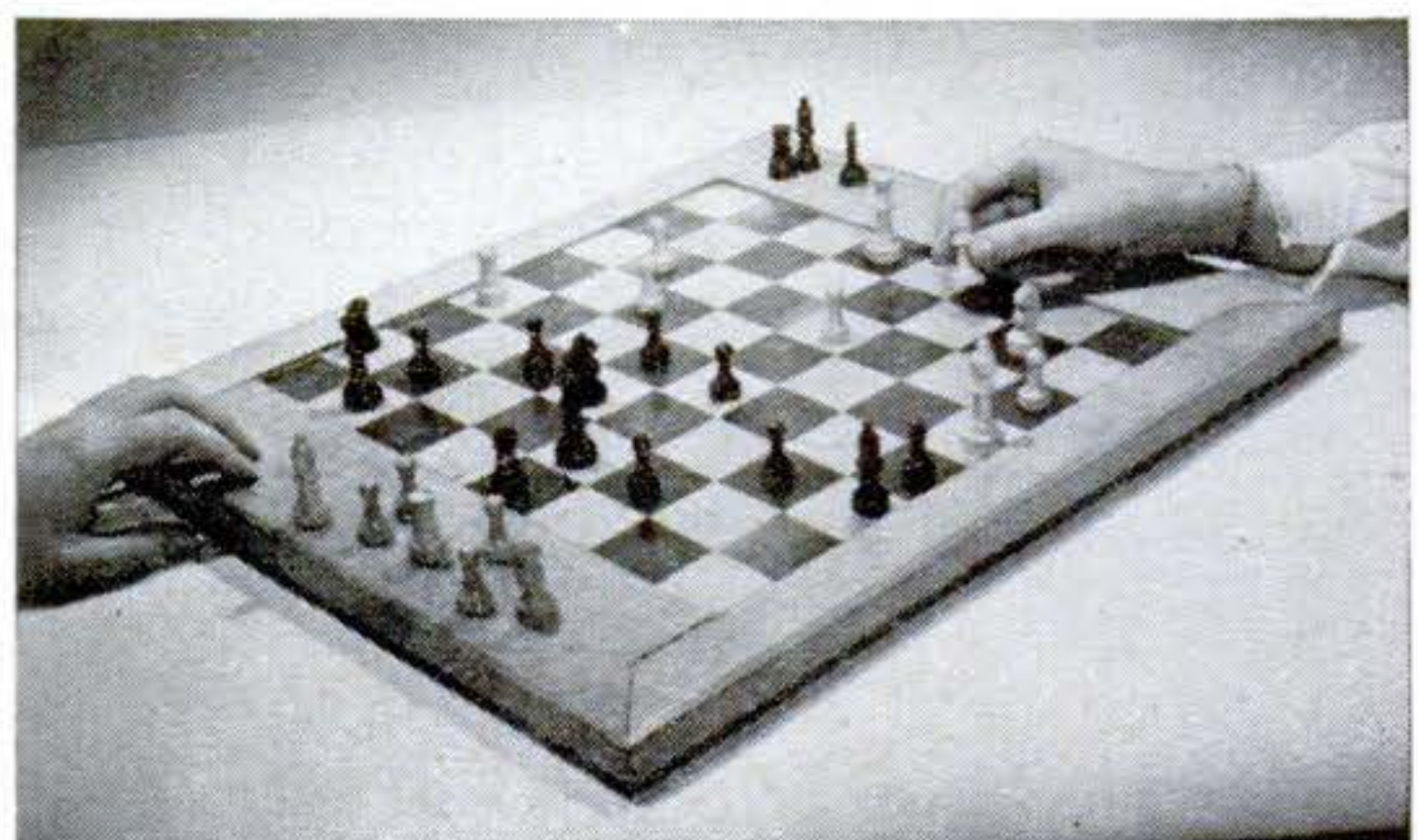



Tooled Leather Pocketbook. Here's a shoulder bag really big enough for all the junk that a gal just has to carry. M/Sgt. John F. Bellantoni of the Army Signal Corps made the pocketbook from cowhide and lined it with sheepskin. Sgt. Bellantoni, attached to Headquarters Company, 9400 Technical Services Unit, Fort Monmouth, N. J., says the bag took about two days' solid work, spread over a couple of weeks.



Radio-Phonograph Cabinet. Lieut. Col. Jacob A. Herrmann, Air Force, is shown above finishing a cabinet that will house a radio, a record player and a wire recorder. The door on the central shelf folds down to hold the recorder and player, which slide out. Colonel Herrmann, of 2500 Base Headquarters, Mitchel Air Force Base, Long Island, N. Y., also made the wire recorder that will be used in the cabinet.

Craftwork Pays Off for Men in Uniform

Riding his craft hobby during off-duty hours will earn some serviceman the King Midget car at right.

CRAFTSMEN IN UNIFORM, consisting of photographs of craftwork by men or women on active duty with the Armed Forces, will be published throughout the coming summer. For each contribution accepted, POPULAR SCIENCE MONTHLY will pay \$18.75. And the manufacturers of the King Midget will send one of their 500-pound cars—shown on the cover of PSM last November—to any address in the continental U.S. named by the contributor of the most interesting example received by August 1, 1952.

Contributions should be addressed to Craftsmen-in-Uniform Editor, Popular Science Monthly, 353 Fourth Avenue, New York 10, N. Y. Do not send anything except photographs and descriptive information. PSM will try to return contributions accompanied by postage, but assumes no responsibility for this. The editors will be the sole judges of the most interesting item. Their decision will be final.



Miniature Roller. You ride while you roll with the Motoroller (right). It is intended for use on lawns and tennis courts, and also when putting down hot- or cold-asphalt drives. The 2½-hp. unit weighs 425 lb. dry; 1,000 lb. with ballast. *E. Horton & Son Co., Windsor Locks, Conn.*



No need to strain your back with engines to furnish muscle. These

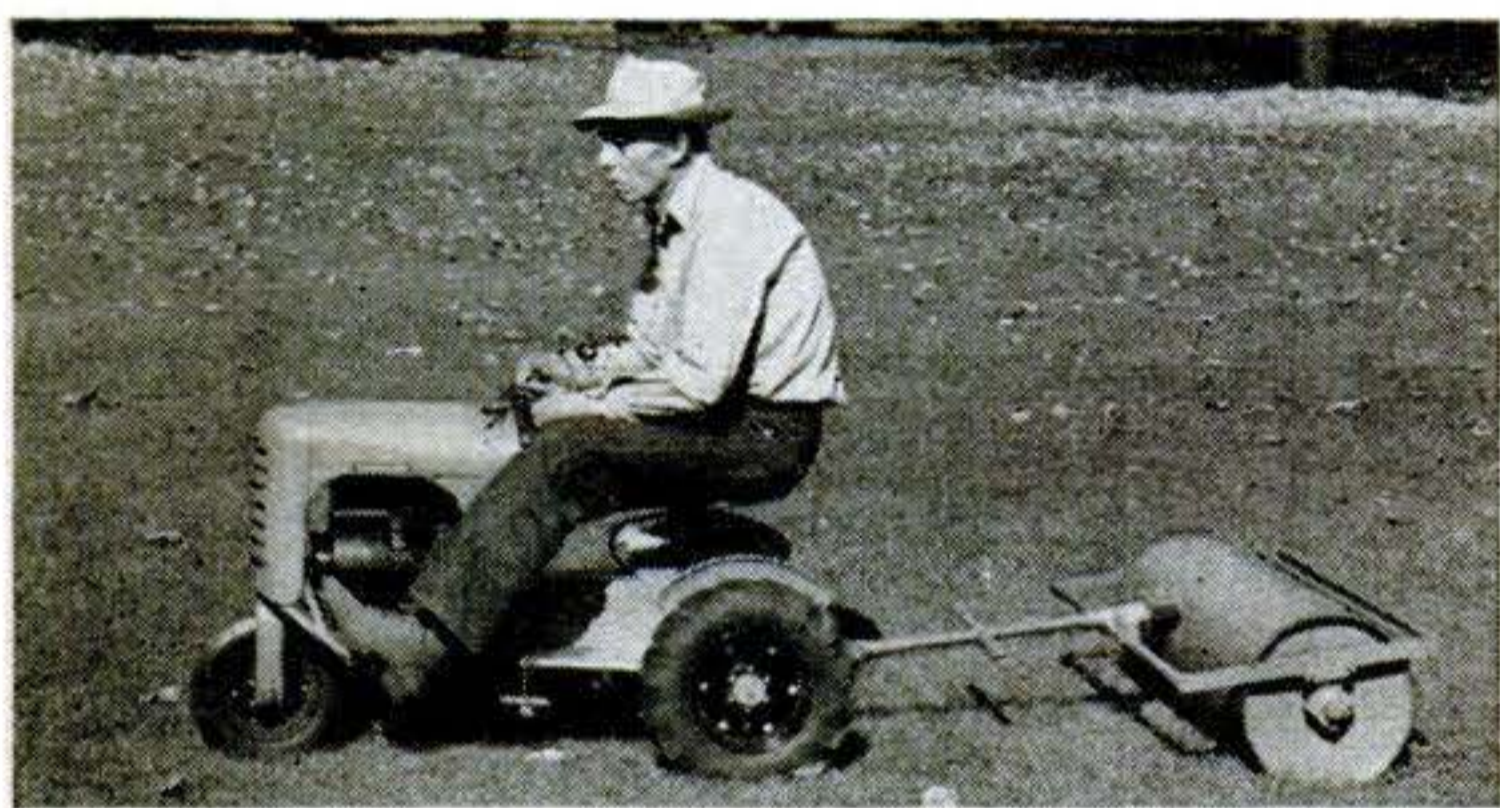

Tiny Tractor. In the spring the midget tractor at left pulls a cultivator or disk harrow; in the summer, a gang mower, lawn roller or spiker; in the fall, a leaf sweeper; and in the winter, it will push a snowplow. Also available is a trailer that will take loads up to 800 lb. The Standard-Bantam is powered by a 3-hp. engine, has a two-speed transmission and auto differential. *Standard Mfg. & Sales Co., Lebanon, Ind.*

Ride-On Mower. Sit-N-Cut (below) is powered by a 3-hp. engine that swings a rotary cutter underneath. Power is transmitted to the blade by two V belts, and to the rear wheel by gears. *Aircapitol Manufacturers, Inc., Wichita, Kan.*



Mower Also Pulls Roller. Besides cutting the grass with a rotary cutter, the Mow-Cycle (above) will pull a roller, lawn sweeper or cart. It is available with either a 2- or 3-hp. engine. *Musgrave Manufacturing Co., Springfield, Ohio.*

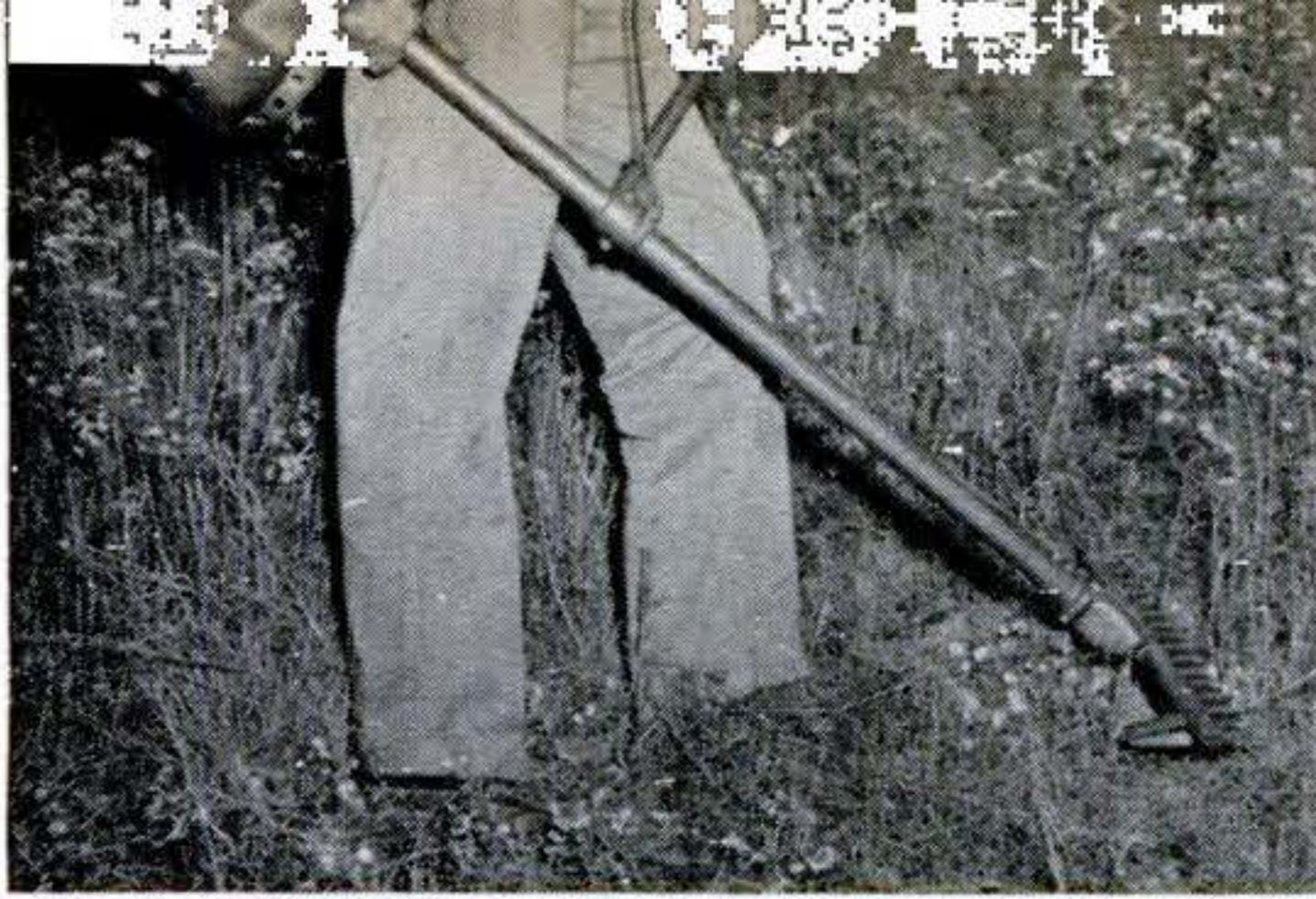

Power Scythe. A 1¼-hp. engine is the muscle behind this scythe. A shoulder strap and handle bar make the 24-lb. tool easy to manage. It can be used on land or for trimming underwater weeds from a rowboat. The tool is 54" long and cuts a 20" swath. The motor will run up to six hours on a gallon of gas, the manufacturer reports. *Hoffco, Inc., Richmond, Ind.*



Baby Bulldozer. With the Mighty Mouse bulldozer you can grade and clear land, backfill, and carry loads up to 500 lb. The small machine is powered by a 6-hp. engine and has two speeds forward and one in reverse. Each track can be independently powered or braked. The scoop at the front is hydraulically operated. *Mead Specialties Co., Chicago.*

eight machines will do everything from sawing wood to bulldozing.

Sprayer-Cutter-Plow. With a 10-gallon spray attachment (right) bolted on in place of the sickle bar, this 1½-hp. scythe becomes a sprayer that will treat crops, control insects or disinfect farm buildings. A rotary snowplow attachment is also available. This unit is made in two models: with 1½- and 2-hp. engines. *Jari Products, Inc., Minneapolis.*

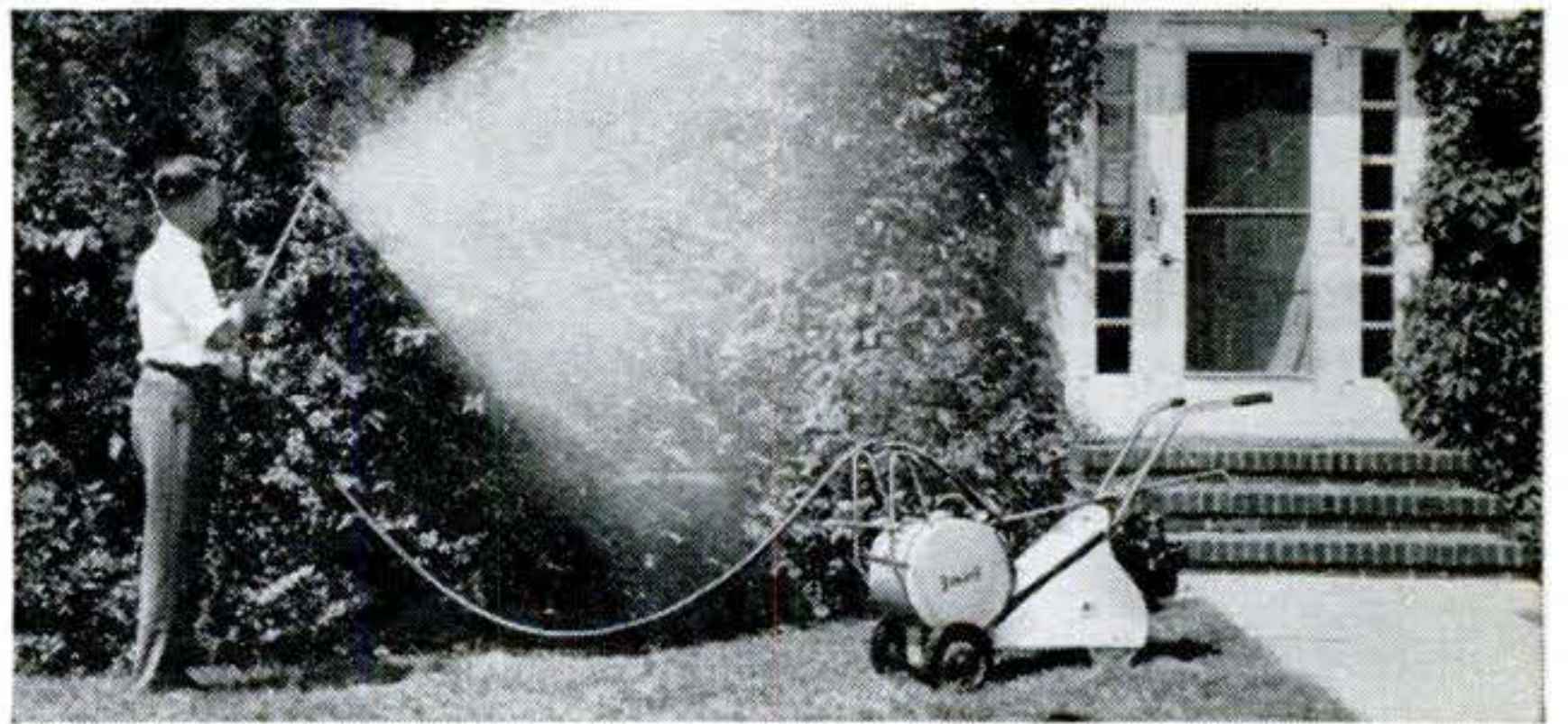

Cultivator Runs Generator, Saws Wood. These are only two of the many jobs the Rototiller will do. It can saw wood 14" in diameter. The generator attachment (left below) comes in two sizes—500 and 2,000

watts. Among the other jobs it will do are power grading and bulldozing, plowing, mowing, hauling, spraying, and pumping water. Engines of 1½, 2 or 3 hp. are available. *Rototiller, Inc., Troy, N. Y.*

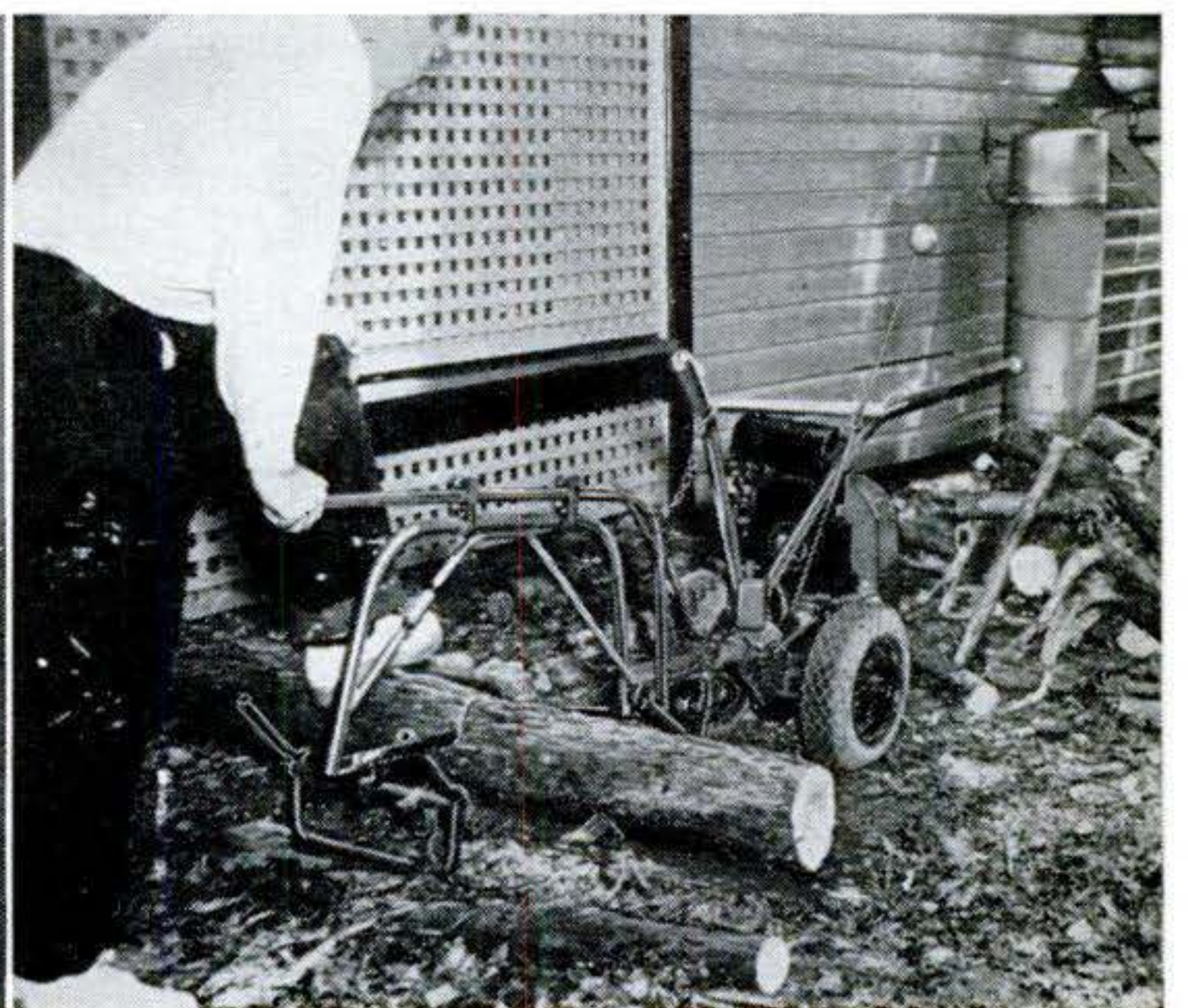
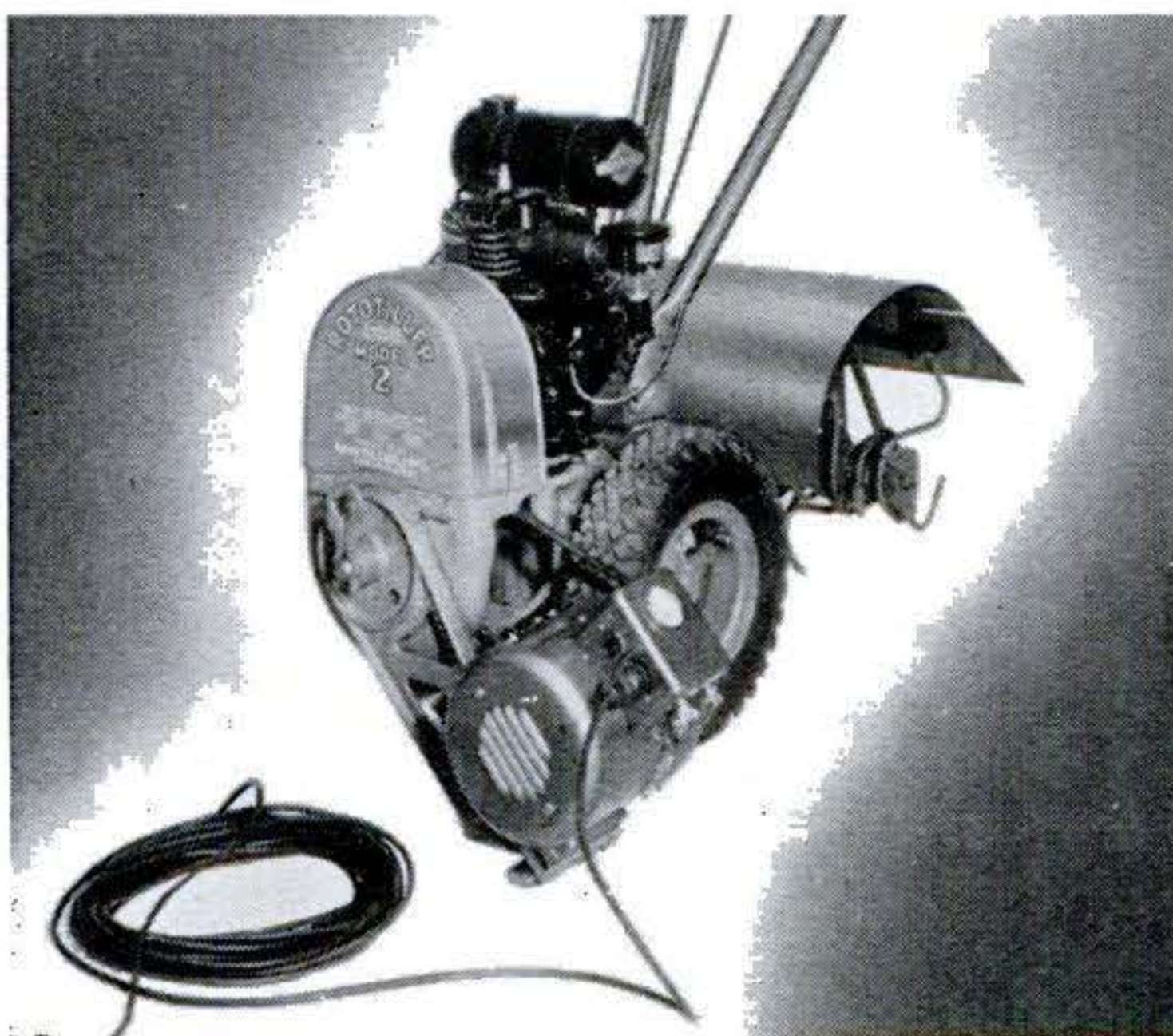

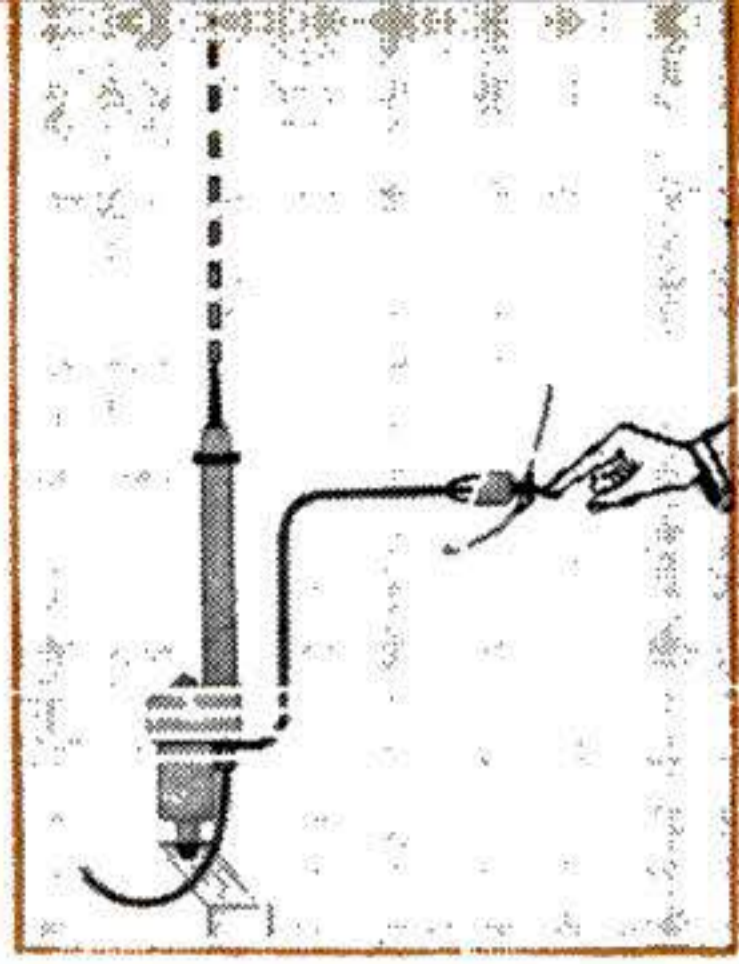

You can raise or lower them from the driver's seat just by pressing a button or turning a knob.

IT ISN'T that it takes much muscle to raise or lower a whip antenna; it's just a lot of bother. You clamber out, raise or lower the thing, wipe the grit off your hands, and then climb back in again. And if you don't, the whip either lashes through branches and whunks the garage door frame, or else protrudes so little that the music beats time to the spark plugs.

Three kinds of raising mechanisms are around now. In the newest, for Packards and Pontiacs, a flexible nylon cord inside a trombone-shaped cylinder pushes up or pulls down the telescoping mast sections when you start an electric motor. The other types, hand-controlled reels and vacuum antennas, have both been popular accessories for several years.

Like other mechanisms, automatic antennas sometimes get out of whack. So, if you now own or plan to get one, here are points to keep in mind.

Maintenance tips. On any antenna, including hand-operated ones, it is advisable to wipe road grime off the extended mast occasionally. You also will keep it working

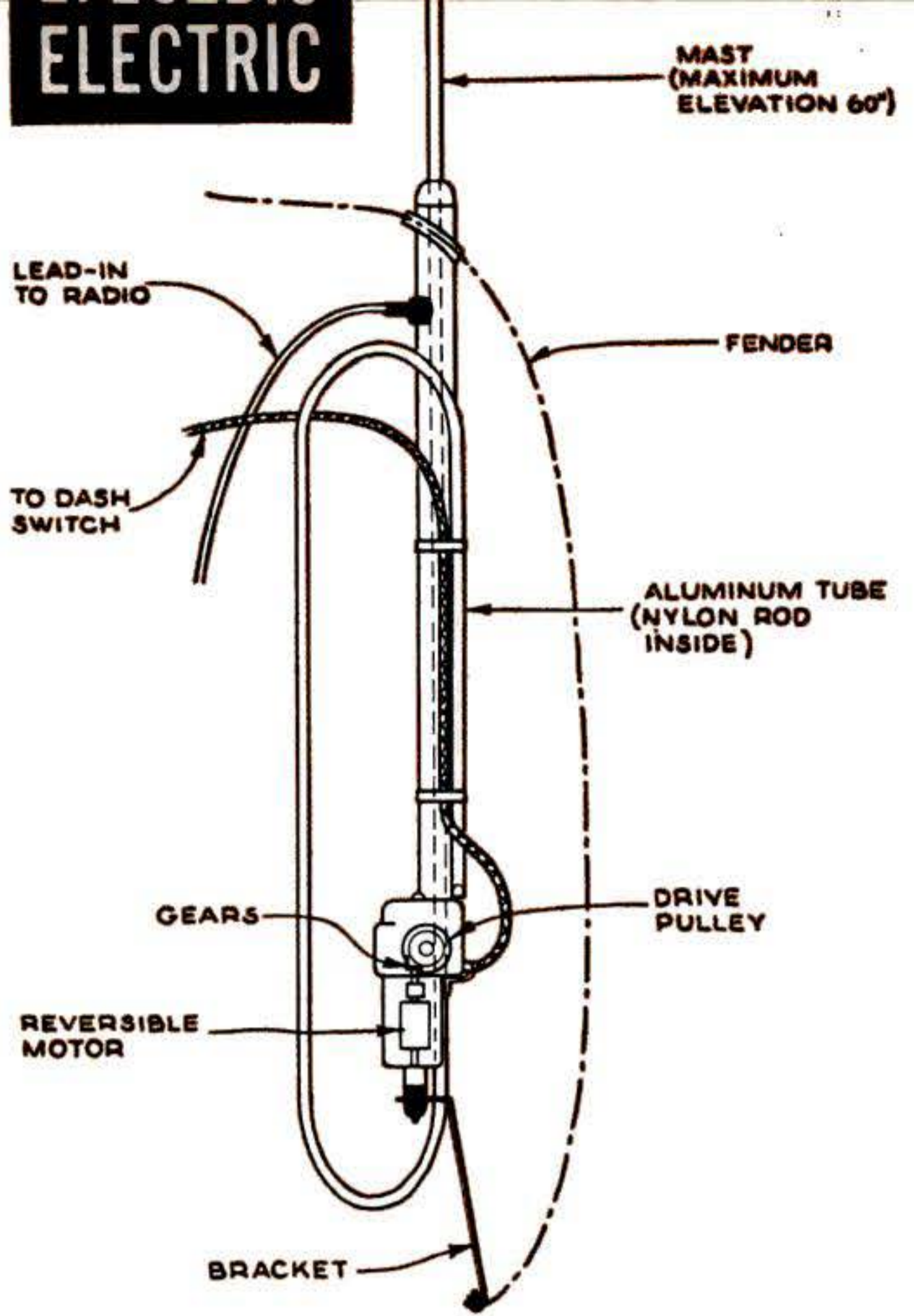

A FLEXIBLE NYLON ROD, housed in aluminum tubing bent to trombone shape, raises and lowers a three-section mast in new electric antenna. Gear-driven by an electric motor, a spring-loaded pulley bears against the nylon rod, driving it by friction. Whether the rod shoves up the mast or pulls it down depends on which direction the motor turns. A two-way dash switch determines this. Although flexible enough to coil up inside the trombone while mast is retracted, nylon rod is stiff enough to shove mast up to full height.

better by applying a light coat of lubricant. Petroleum jelly is excellent.

If you have an electric antenna, be careful never to hold the switch in operating position beyond the full travel of the mast sections, either up or down. Doing this will cause excessive wear of the drive mechanism. A bent mast may slow down or stall the motor. Should the antenna fail to operate, first check and tighten all electrical connections and check the fuse.

On vacuum antennas, it is possible for the hose to slip off the nipples on the control valve or cylinder. This is one of the first things to check if an antenna doesn't work.

On reel-controlled antennas, it may be necessary to turn up the clutch adjustment nut occasionally. Unless there is good tension, the clutch will not drive the cable.

VACUUM

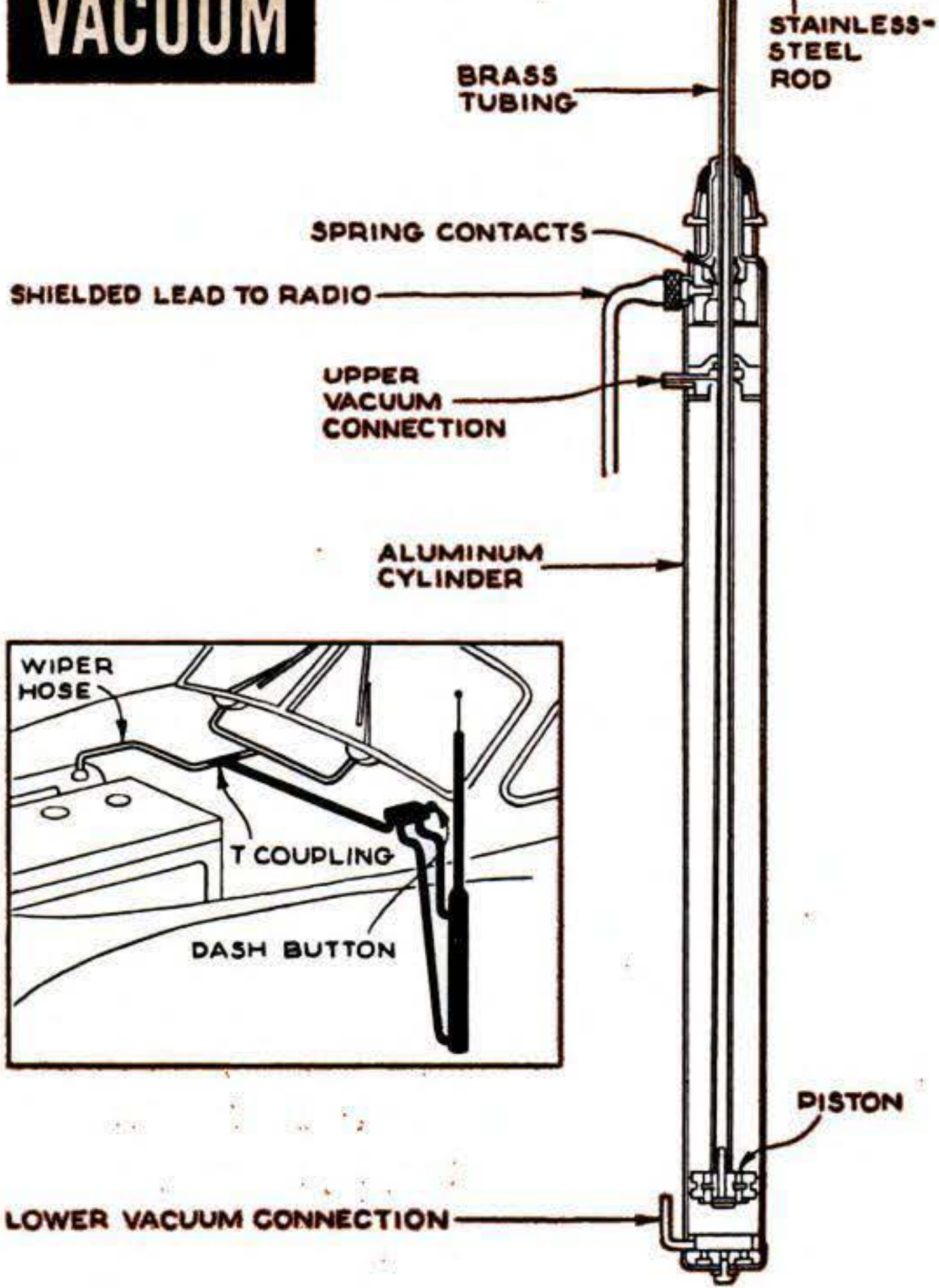

MANIFOLD VACUUM raises and lowers this antenna. Pushing in the dash valve opens the line to the top part of the antenna cylinder. This exhausts the cylinder, raising the piston and mast. Pulling out the dash control connects vacuum to bottom of cylinder—and the mast is pulled down. On some cars, pushing the control both turns on radio and raises antenna. Vacuum raises and lowers only the first section of mast, but the resulting drop of 27 inches is enough to clear most obstacles. Top sections of mast are raised and lowered by hand.

REEL

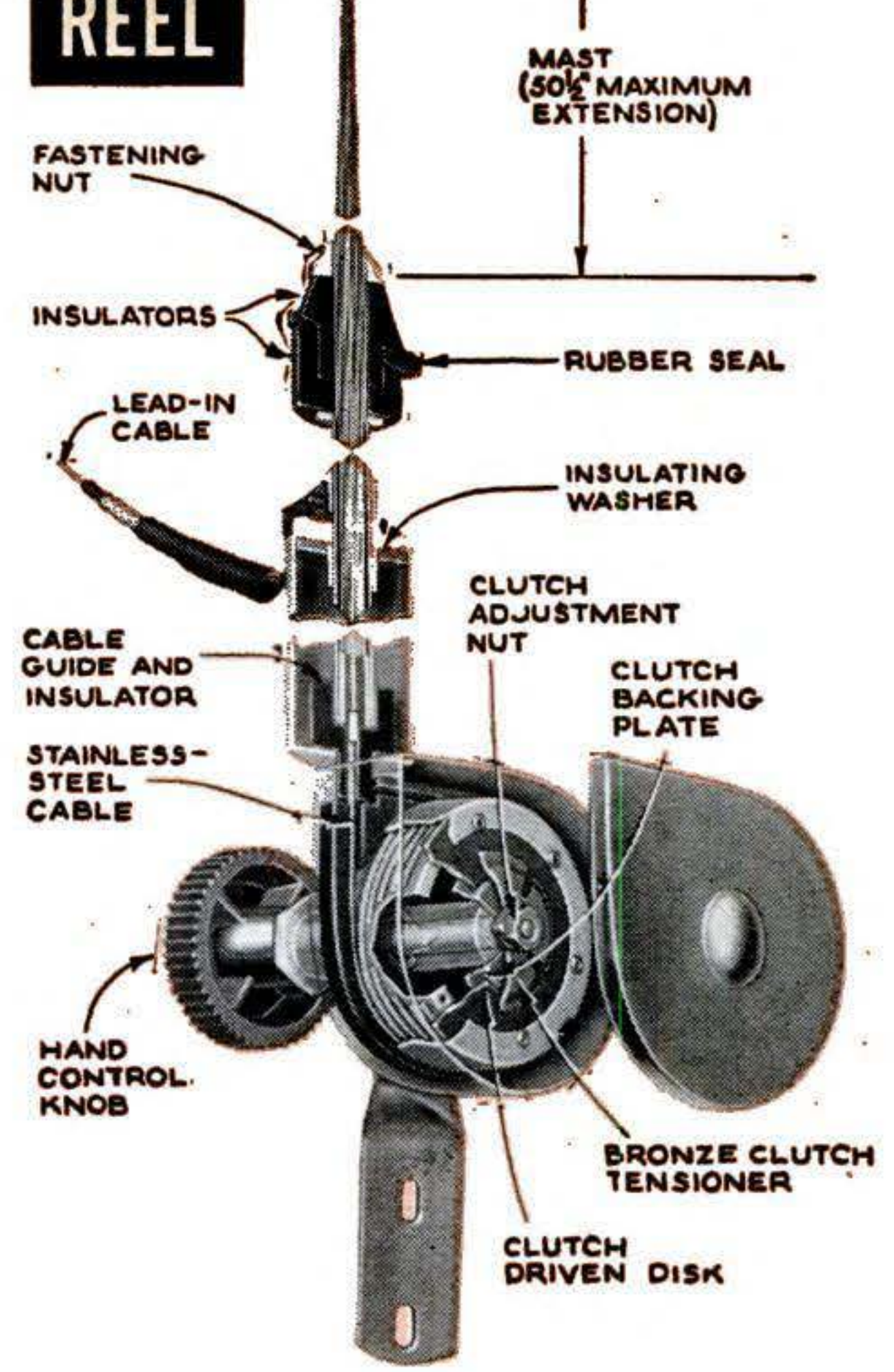

REEL-TYPE ANTENNA has been around for 10 years or more, but has recently been improved in several respects. The one shown here is a Studebaker-Philco unit. Turning a hand knob that projects into the driver's compartment raises and lowers three tubing sections and the solid tip of the mast. Close-fitting reel cover and a cable-guiding sleeve are designed to keep cable from kinking should the mast be forced down from outside car. If hand knob is turned beyond its normal limit, the clutch slips and no harm is done.

Emergency Fuel Can Fits Carburetor

INSTALLED in place of the air cleaner, this emergency fuel unit will get your car to a garage under its own power when lack of gas or fuel-system trouble stalls you on the road.

Containing a gallon of gasoline, the Gas-o-lator can be carried safely in a car. It is also used as a tow-truck accessory. Adapters will suit a single unit to the carburetor air horn of any car or truck.

After the unit has been clamped to the air horn, you turn on the gas with a protruding control. Revolving a cap on top adjusts the air flow to give the best fuel mixture. Both controls must be closed before the ignition is switched off. The Viking Tool & Machine Corp., Belleville, N.J., manufactures the unit.





PLASTIC-BODY SPORTS CAR weighs 1,050 pounds, 400 pounds less than Crosley station wagon from which it was built. With lowered chassis, car stands 31 inches high at cowl. Body kit contains brackets (left) to hold windshield. Instruments are mounted on center pedestal.



HOOD IS FITTED, as below, and all rough and protruding edges are smoothed before body kit is shipped to customer.



3 RADIATOR, lowered six inches, is bolted to strap-iron bracket welded to new body-support bracket. Engine, transmission and axles are left in their original positions.

4 PLYWOOD PANELS are installed as flooring. Molded-plastic wheel housings bolt to trunk-compartment floor. These come with body kit, as do instructions for cutting floor.

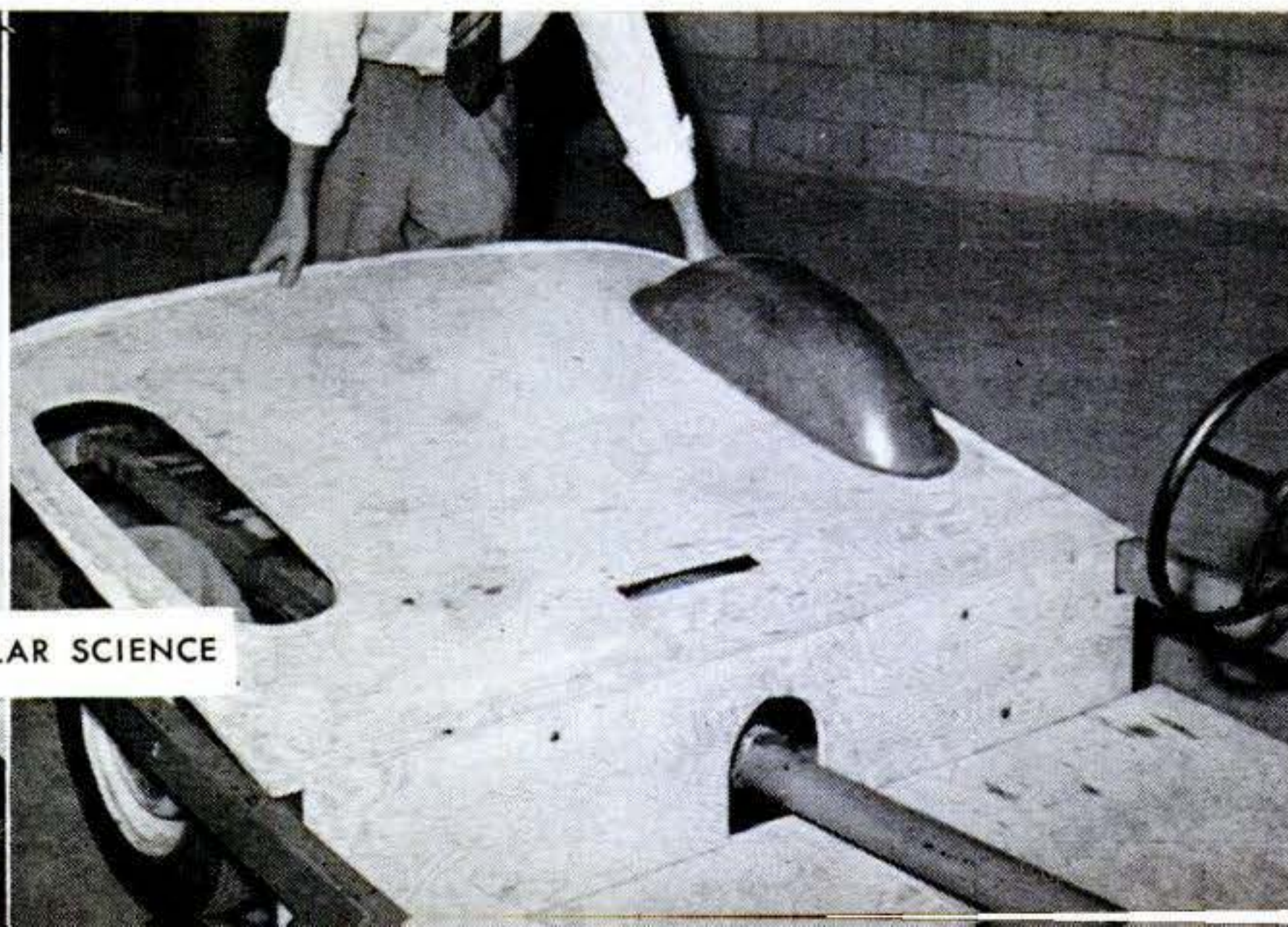
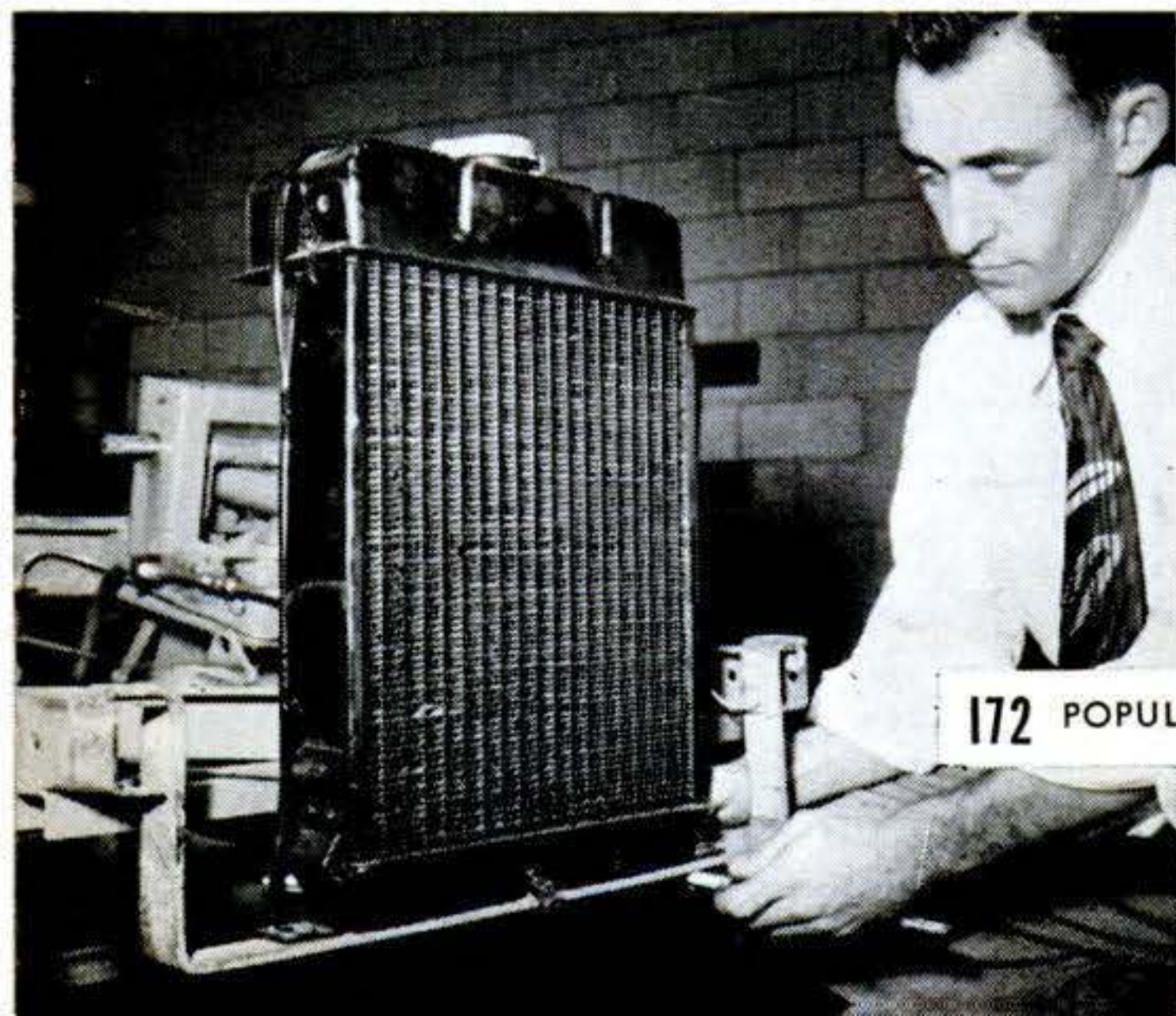

Come in Now

Parts so light that one hand lifts them fit together to form a roadster that will make necks turn wherever you go.

SPORTS-CAR builders who laboriously hand-form their custom bodies from sheet metal now have an easier out. They can buy snappy bodies made of plastic-impregnated Fiberglas that weigh only 100 pounds each.

At present, the only body kit available is for a Crosley chassis. But the manufacturers, John Wills and Ralph Roberts of Pasadena, Calif., plan to bring out designs tailored to other cars if the first one makes a hit. And it apparently will. Already a number of their

Skorpions are scooting around Southern California.

The partners figure a customer can have a handsome sports car for a shade under \$1,000. First, he buys a used Crosley. He also lays out \$445, plus tax, for the kit of plastic body parts. Then he removes the original Crosley body and changes the frame according to instructions in the kit. And shortly, the time depending on his ingenuity, he sports a sportster.

The kit includes four major parts—the main body, the hood, a wrap-around rear bumper section, and the deck lid. The material is so light that one person can easily handle any part.

Many popular accessories can be fitted to the car. If the plastic body is damaged in a collision, a repair kit soon makes it look like new. END

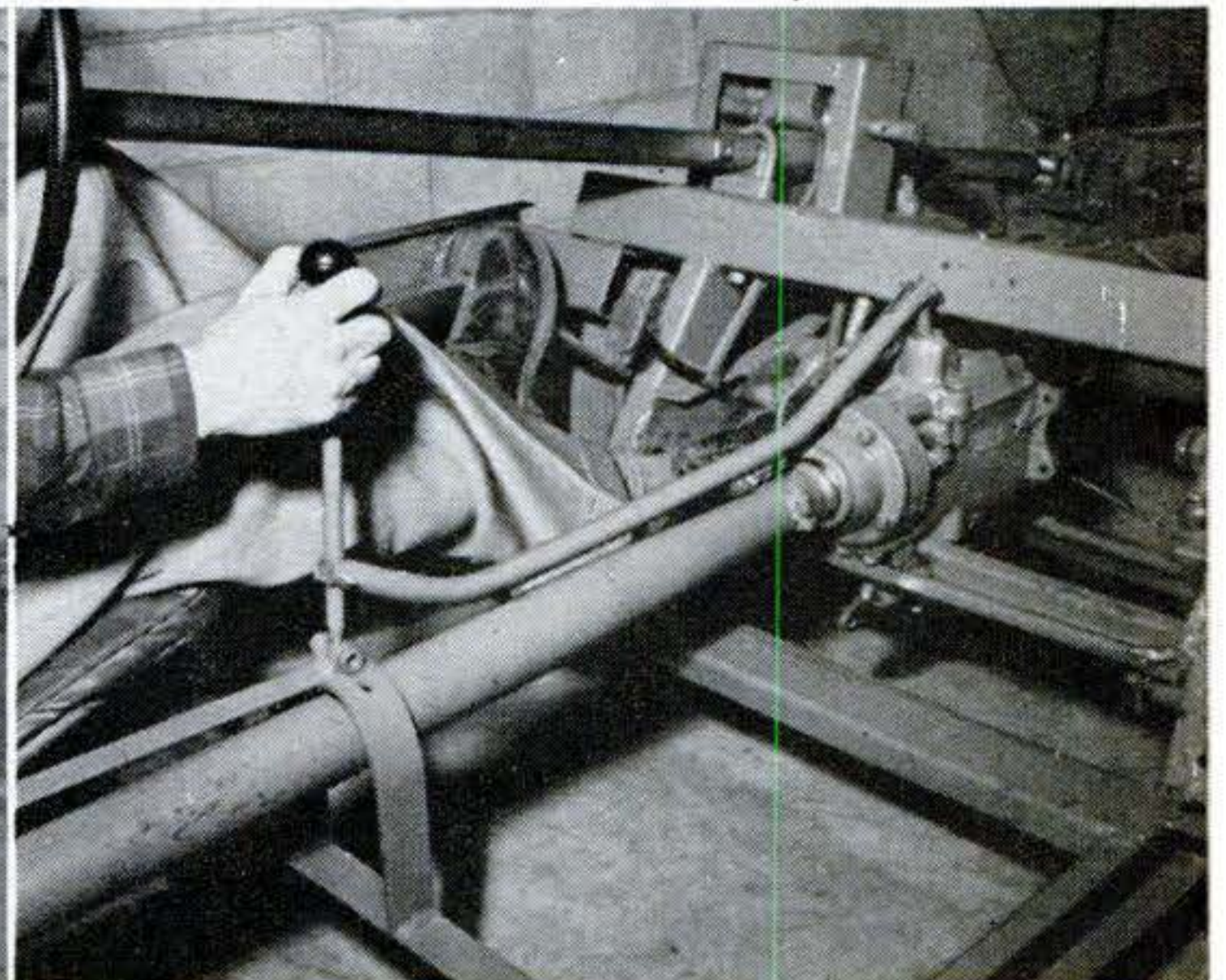
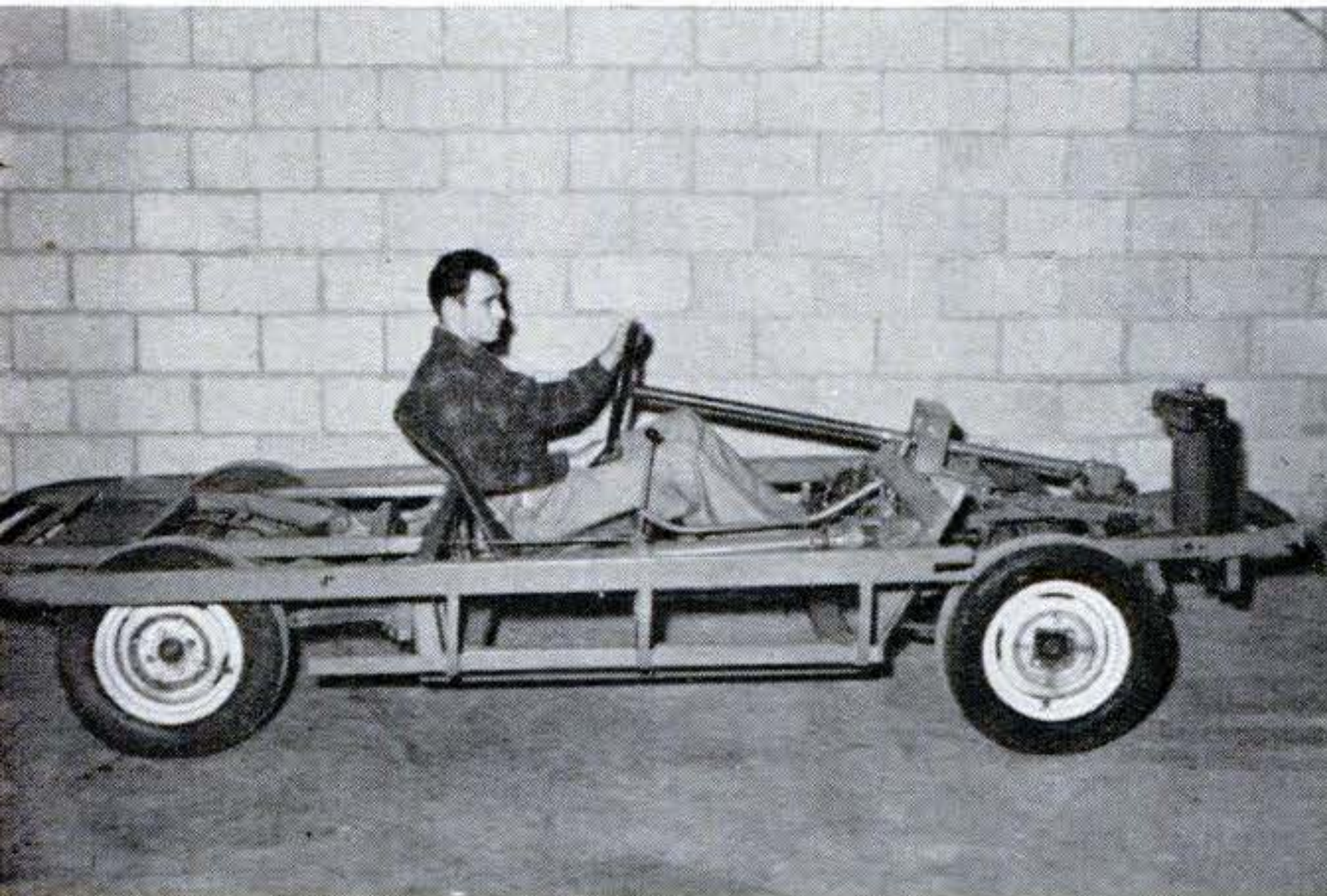

1 HOW CONVERSION IS MADE. Frame is lowered in cockpit section by welding basket-like framework between firewall and rear of seat. Main frame is cut out between these points. An outrigger frame is then added with side members outside wheels to support body.

2 SHIFT LEVER, moved back 18 inches, is mounted on ball joint and connects through tubular extension to transmission. Shift action remains the same. Steering column and pedals are pivoted down to suit lower seat. Floor is seven inches from ground.

5 FRONT PART OF BODY slides into place. Then come rear skirt and bumper panel. Four bolts embedded in plastic attach body to frame. Installation takes only a few minutes.

6 DECK LID is attached to bulkhead behind seat with leaf hinges. A piano hinge supports the hood. The body comes primed and can be quickly painted any desired color.

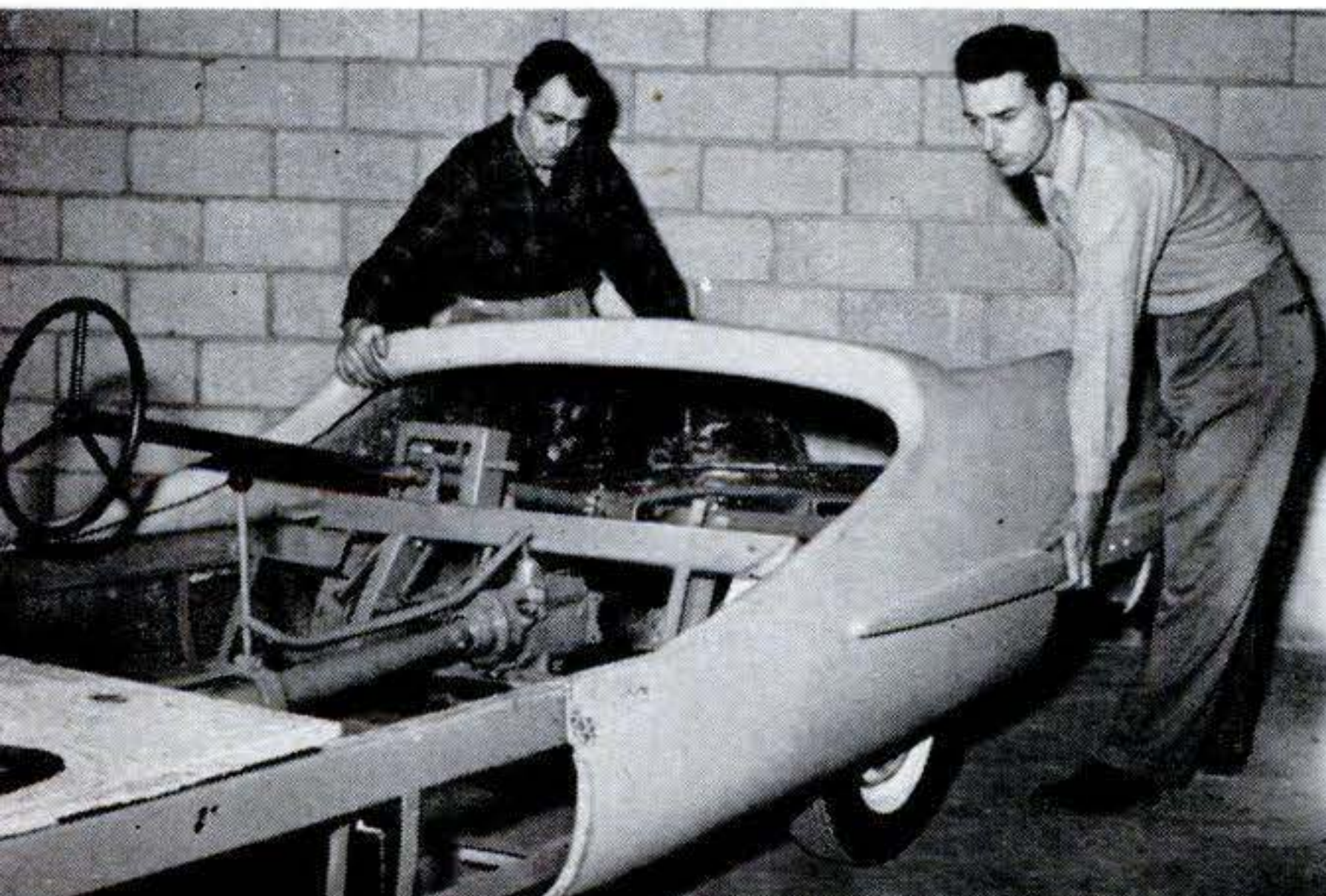

Cars Without Carburetors?

PASSENGER-CAR INJECTOR. Inventor Stuart Hilborn holds cover off test injector as he tries it for fit on a Willys F-head. The head was sawed in two for study of internal porting. Designed for gasoline, this injector was not complete when the photo was taken.

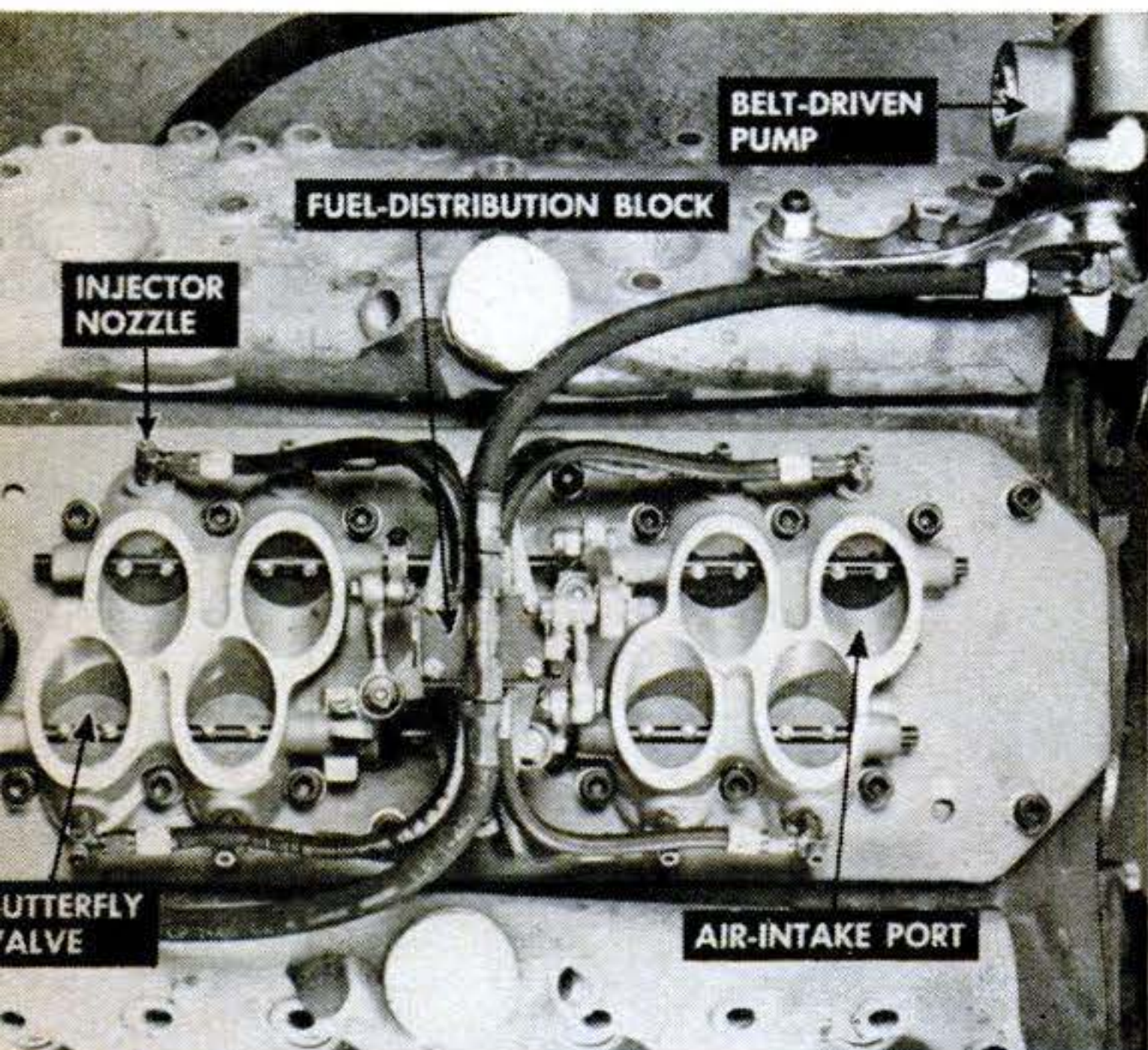
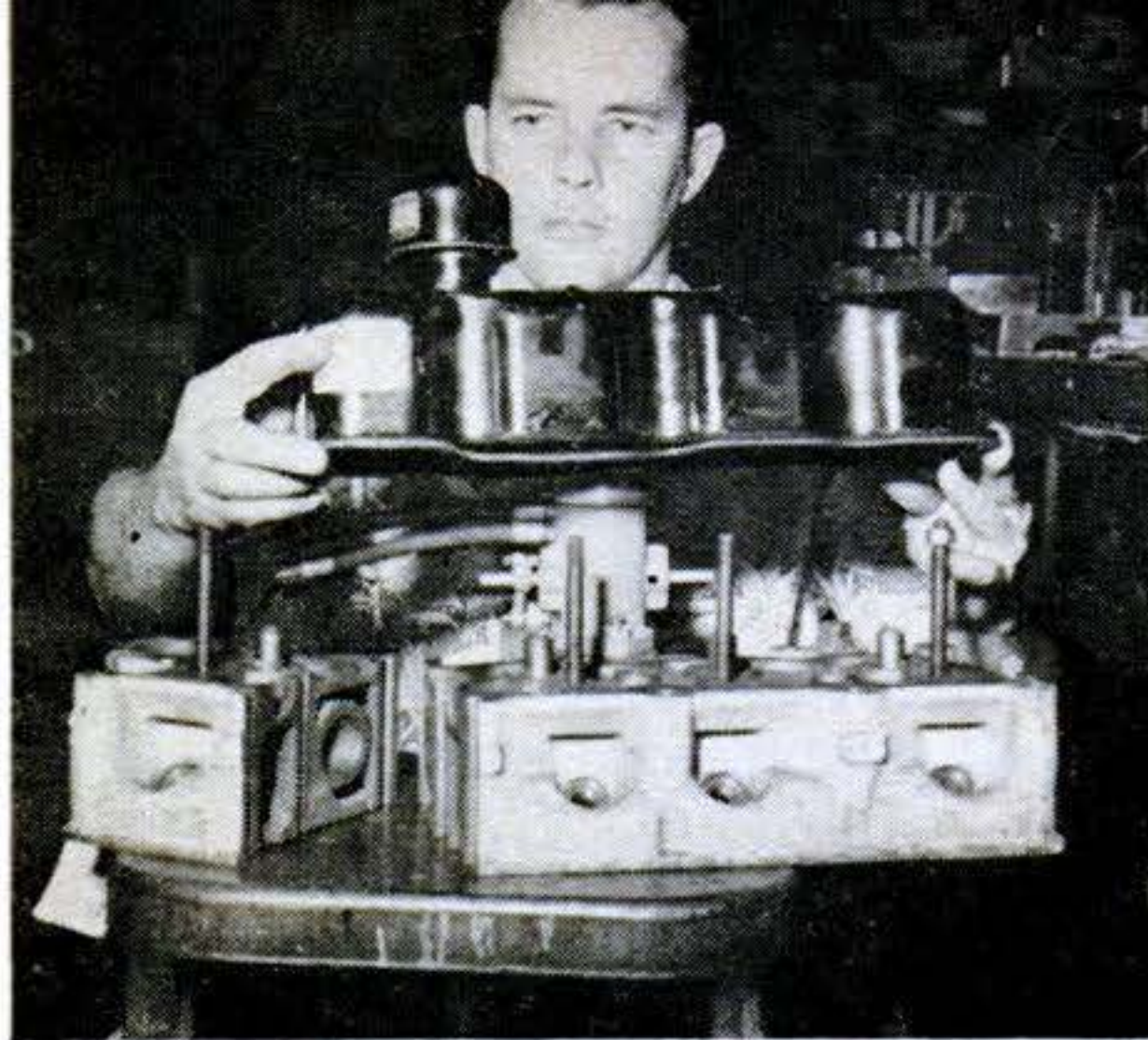

FORD V-8 RACING INJECTOR, seen from above, replaces conventional manifold and carburetor. Eccentric-vane pump forces fuel into distribution block, where a valve meters it equally to all cylinders. A nozzle sprays fuel into air entering each intake port. Butterflies control air flow. Through interconnected linkage, the accelerator varies fuel and air feed simultaneously.

FOUR-BARREL MODEL for an Offie engine has mesh air cleaners placed on intakes for dirt-track racing. Intake ports on base of assembly match those on engine.

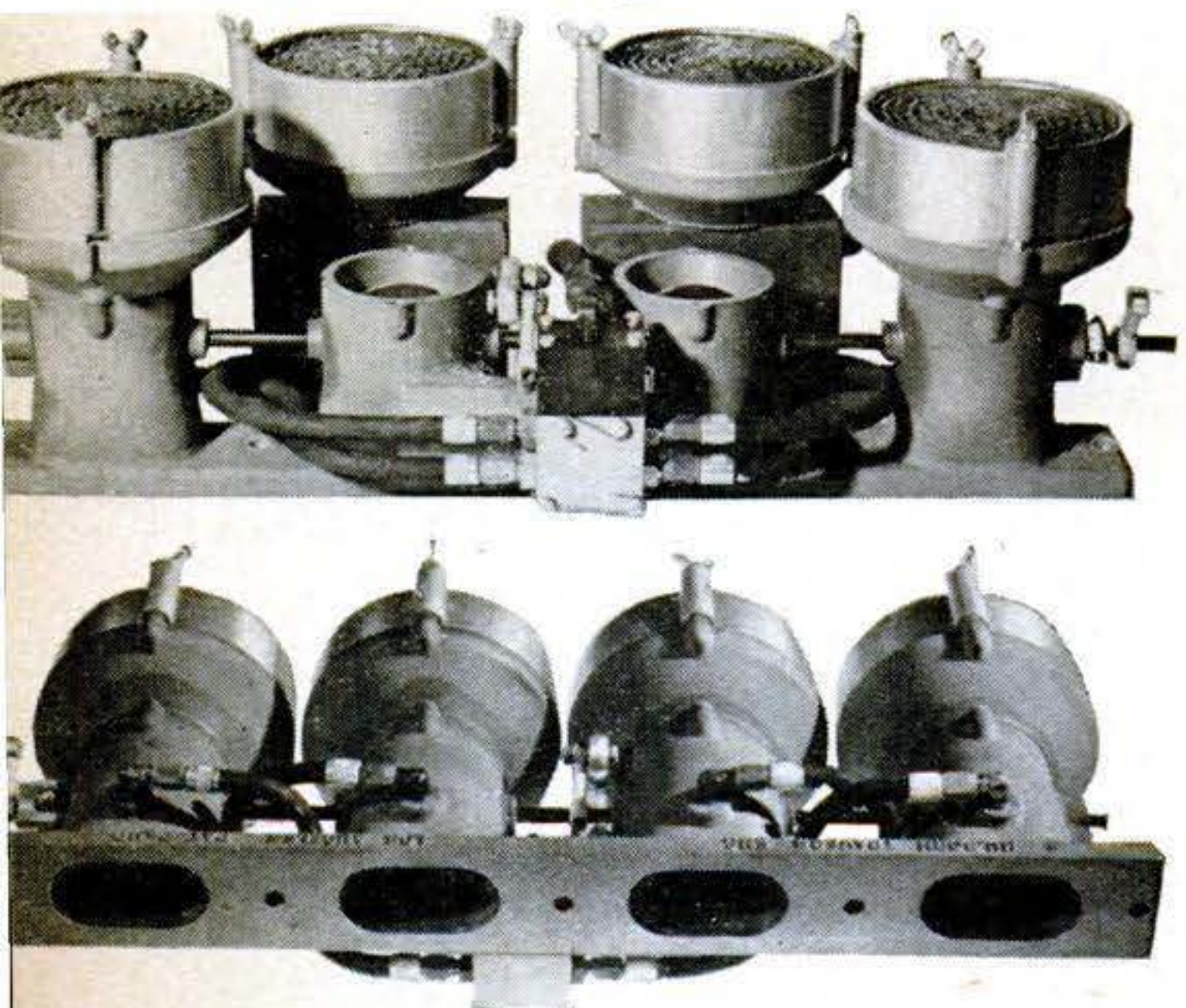

Fuel-injection system now used by many racing drivers may give the family bus greater power and cut gas consumption.

HORSEPOWER boosts of 30 percent, coupled with fuel consumption that is almost halved, may be on the horizon for passenger cars. According to proponents of fuel-injection systems, these spectacular results may be possible if a special injector is substituted for the familiar carburetor.

Invented for racing. A constant-flow fuel injector, invented by Stuart Hilborn, has already proved itself on alcohol-fueled racing engines. Of the first seven cars to finish at Indianapolis last year, six had Hilborn injectors.

Now the young inventor is at work on a modified injector for use with gasoline in passenger cars. Preliminary tests indicate horsepower and economy gains equal to those obtained with the racing injectors. Adapting the injector is primarily a job of calibrating the metering system to gasoline and adjusting the unit to an engine of lower r.p.m.

How it works. The injector makes its gains by improving volumetric efficiency of the engine. Unlike a manifold, it has no winding passages of unequal length. Air travels the same distance to each cylinder through intake throats of uniform diameter throughout their length. Matched nozzles feed fuel in equal amounts into each air stream. An accelerator linkage varies air-controlling butterfly valves and fuel pressure simultaneously.

At present, Hilborn's firm, the Fuel Injection Engineering Co., Culver City, Calif., is manufacturing alcohol injectors for Offenhauser, Ford and Mercury V-8s, and certain specialized engines. Prices for Ford and Mercury injectors run around \$225 FOB Los Angeles.



TURN AND WATCH when you raise the top to be sure the framework doesn't catch anything that might tear the fabric or strain the bows. Release the control knob when the top is about 6" from the windshield posts and let it drop the rest of the way itself. Keeping the power on too long may knock framework out of line.



SLIP OUT FLAPS from under the side rails (if your car has them) before lowering the top. Buttons and attachments are supposed to release automatically as the top is pulled away, but don't bank on it. Do it by hand to be safe.



SPOTS ON TAN TOPS can often be removed by a little work with an art-gum eraser. Just rub the spot vigorously with the eraser.

ALWAYS LOWER TOP SLOWLY, watching its progress carefully. If the framework has gotten out of line or if the pivots bind, rapid lowering can tear the pads or fabric.

USE WHISK BROOM occasionally to improve appearance of the top. Always use it before washing. Use a mild soap and rinse it off with hose. Let top dry in shade.

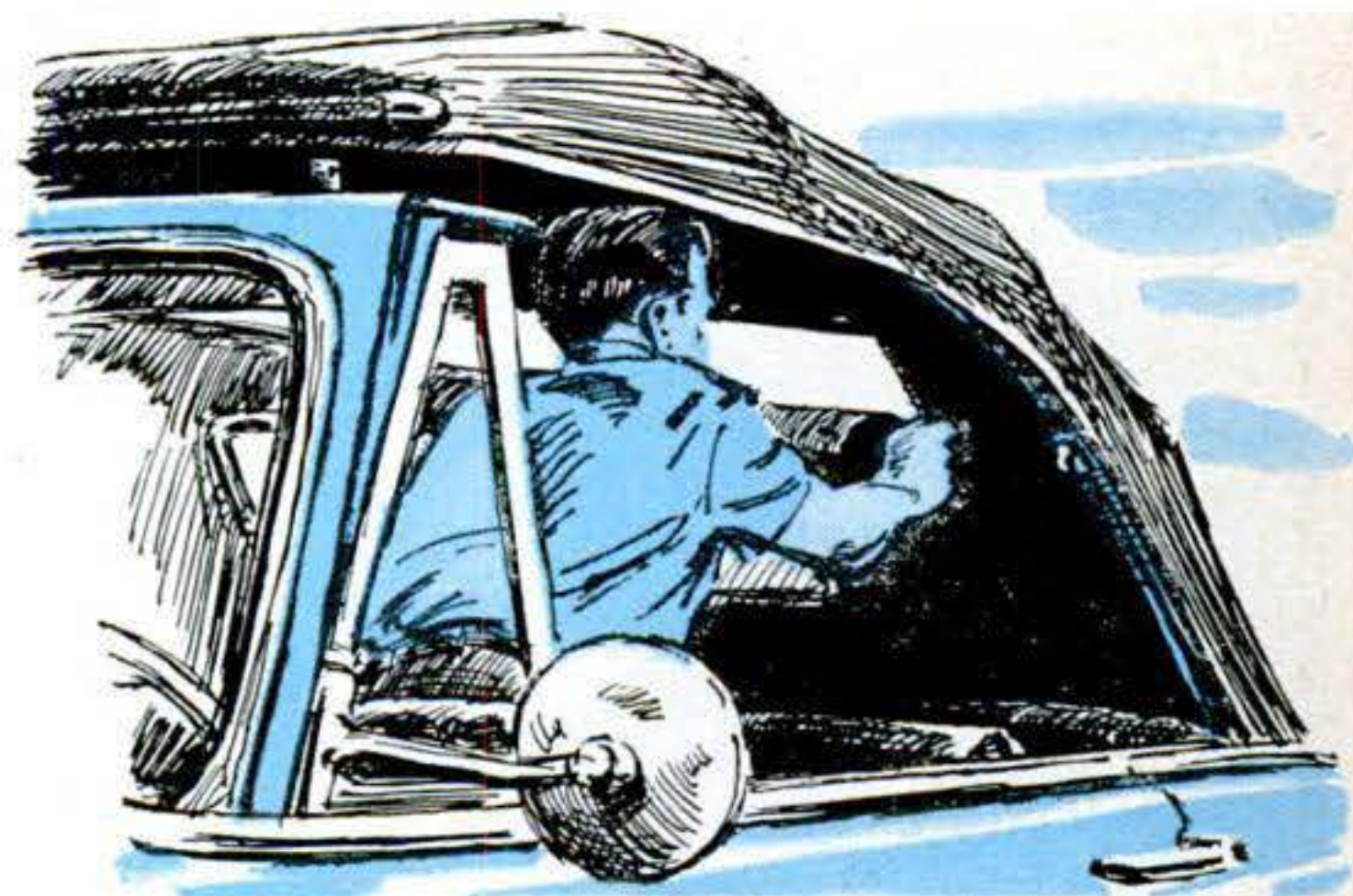

OPENING REAR CURTAIN is simplified if you unlock top at front to release tension. Zippers or snaps will then work more easily.

CLEAN PLASTIC WINDOWS by sponging with a soft, wet cloth. Do not rub dry; wipe off excess water with a clean, damp cloth. These suggestions are adapted from booklet put out by Atlas International, Chicago.

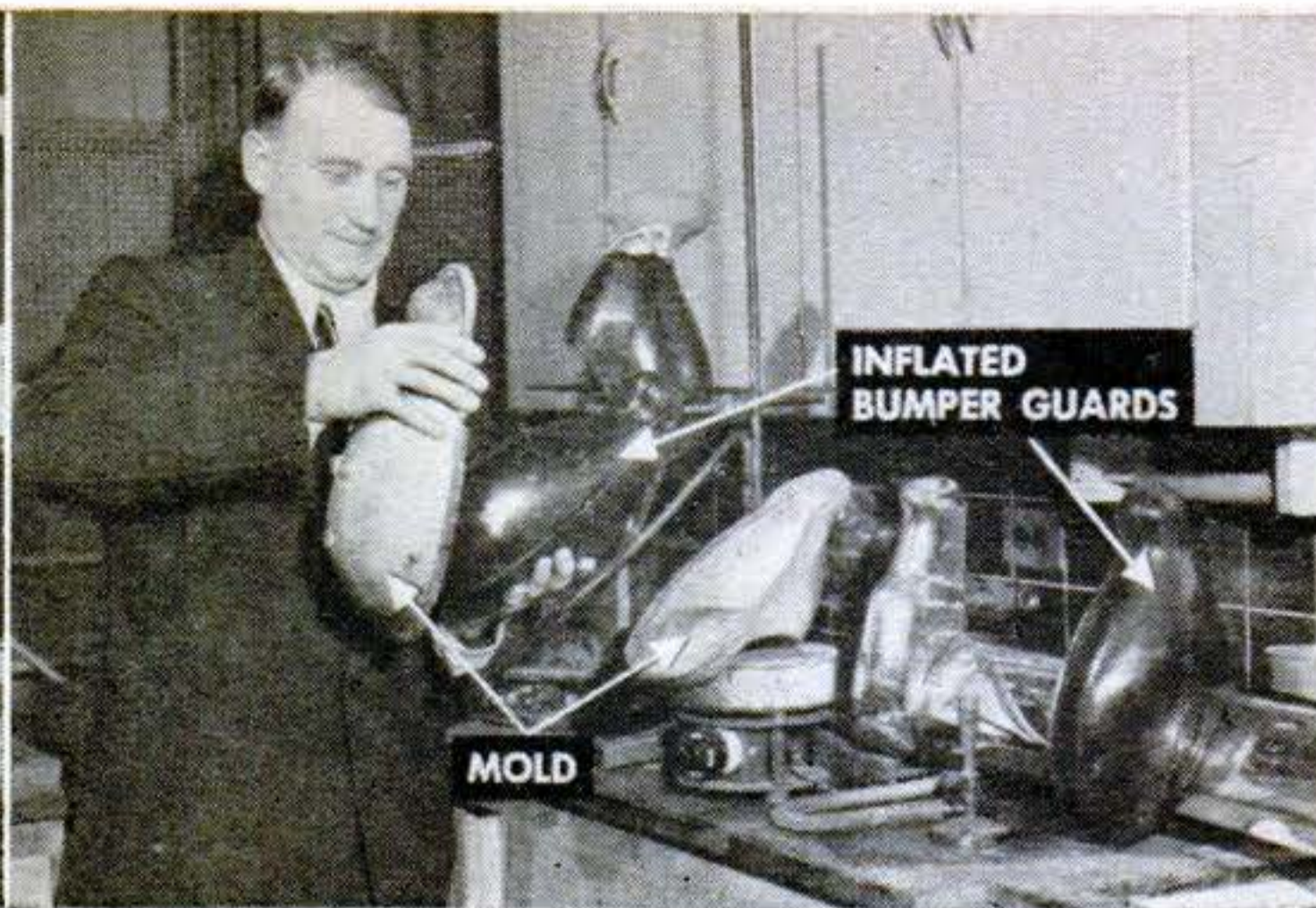

Rubber Bumper Bumpers Bounce Back Bumps

Now you can ease the bumps your bumpers get. New flexible guards molded (as shown at right above) from rubber or plastic give with the blow. Air trapped inside the

hollow guards absorbs the shock. The guards are clamped to the bumper bar by means of a steel plate on the back. *Hush Bumpers, Inc., Chicago.*

New Products for Your Car

Dirty "Pots" Cleaned in Place

SLUDGE and gummy deposits often restrict the narrow passages in carburetors ("pots" in hot-rod slang), causing poor engine performance. The treatment illustrated below is said to make it unnecessary to dismantle the carburetor for cleaning. A can of Gumout mixed with gas is attached to the carburetor, the fuel line is plugged, and the engine is run for a few minutes. *Pennsylvania Refining Co., Cleveland.*



Back Rest Keeps You Cooler



THIS lattice back rest lets air circulate behind you during hot-weather driving, keeping your clothing from sticking to the seat. Although designed for a car, it can also be used in a chair. *Frank Veale Mfg. Co., Columbus, Ind.*

New Sealer Stops Fuel Leaks

PLUGGING leaks in gas tanks is one of the many jobs intended for a new cement-like compound. Among the other uses claimed for Seal-All are: stopping leaks in radiator hoses and around windshields, repairing cracked distributor caps and battery cases, and waterproofing ignition systems. *Allen Products Corp., Detroit.*



Auto-Top Carrier

Loads at Side

EASY ACCESS is one of carrier's virtues. Side opening makes it unnecessary to scramble up the car when you want to get something out.



EXCESS vacation baggage won't be a problem if you put a carrier like this on the roof of your car. You can knock it together in a couple of hours. My son and I designed it with sloping ends to avoid a boxy look, and located a door on the side to make it easy to get at equipment carried inside.

Built of wood salvaged from a large packing crate, the carrier is bolted to two crossbars resting on vacuum cups. The crossbars, bought from an auto-supply store; a couple of hinges for the door; two screen-door hooks and a can of paint made up our entire expense.

In our case, we wanted the carrier chiefly for carrying extra gas and oil, the spare tire and a few odds and ends. We estimated the size needed by laying plywood crating on the ground and arranging on it the objects to be carried.

The carrier was assembled with nails. Oilcloth scrounged from the kitchen table provided a weatherproof top. (The table

needed a new covering anyway.) Paint to match the car was applied to the finished box.—*Delos L. Glossner, Xenia, Ohio.*

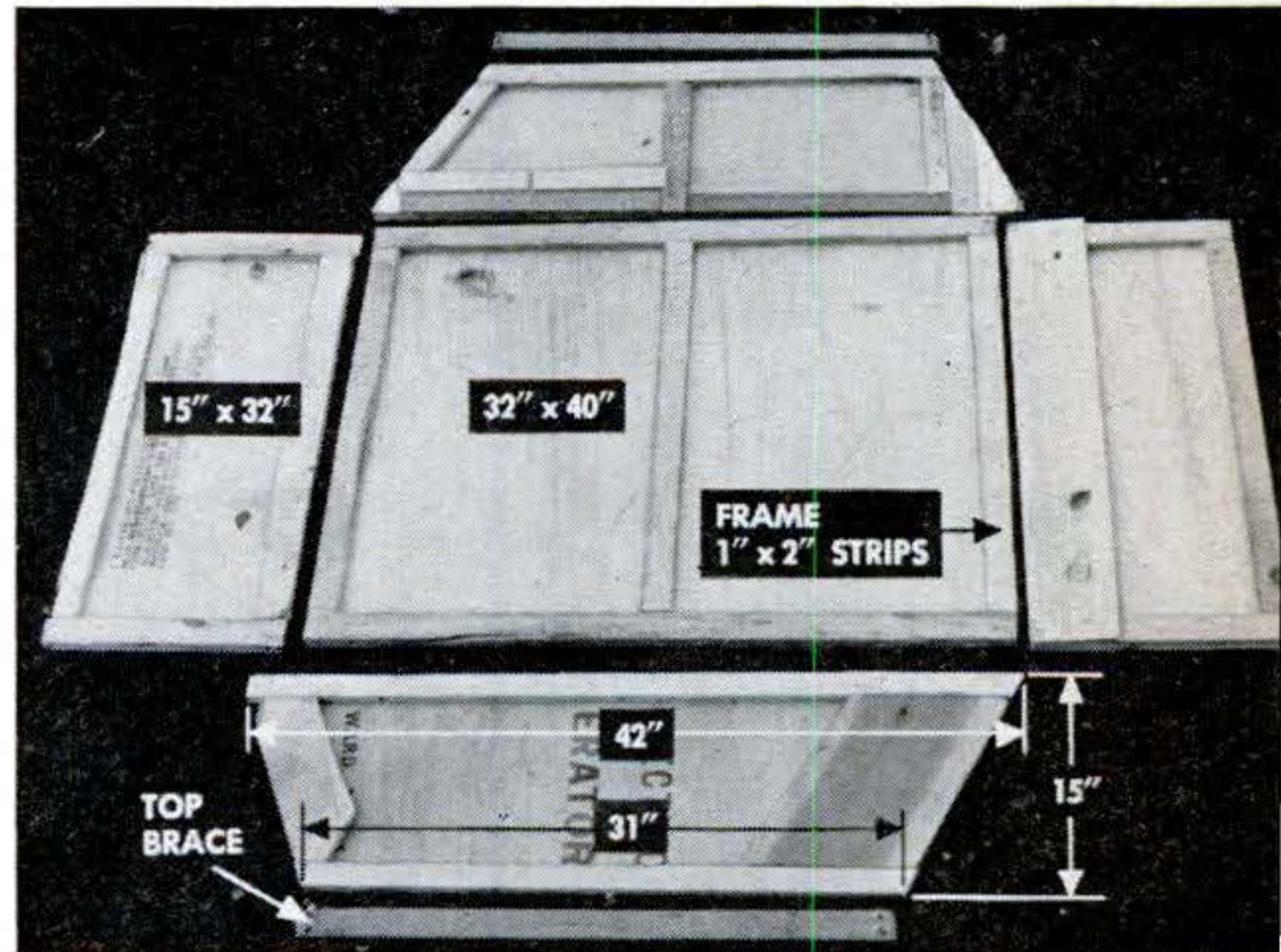

A REFRIGERATOR PACKING CRATE provided wood needed to build carrier. Parts look crude, but exterior paint after assembly concealed markings on wood. No top panel is needed.

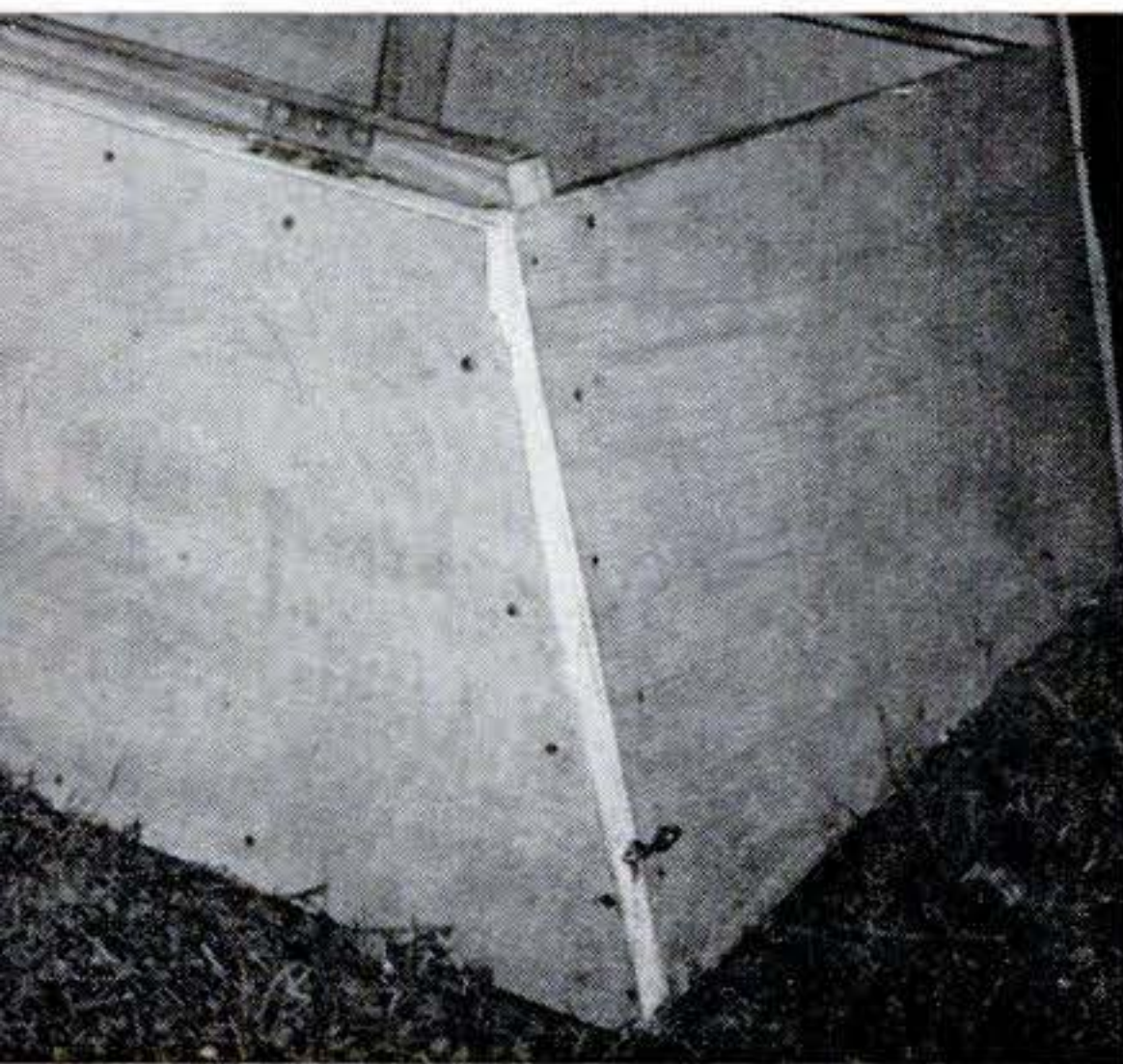

A SCREEN-DOOR HOOK at each end keeps the door fastened. Two butt hinges are screwed to one of two braces across the top. Two triangular braces strengthen the door opening.

OILCLOTH was used to cover the top of the carrier. Edges were turned under and tacked to sides and ends. Copper wire held by roofing nails keeps wind from whipping cover off.

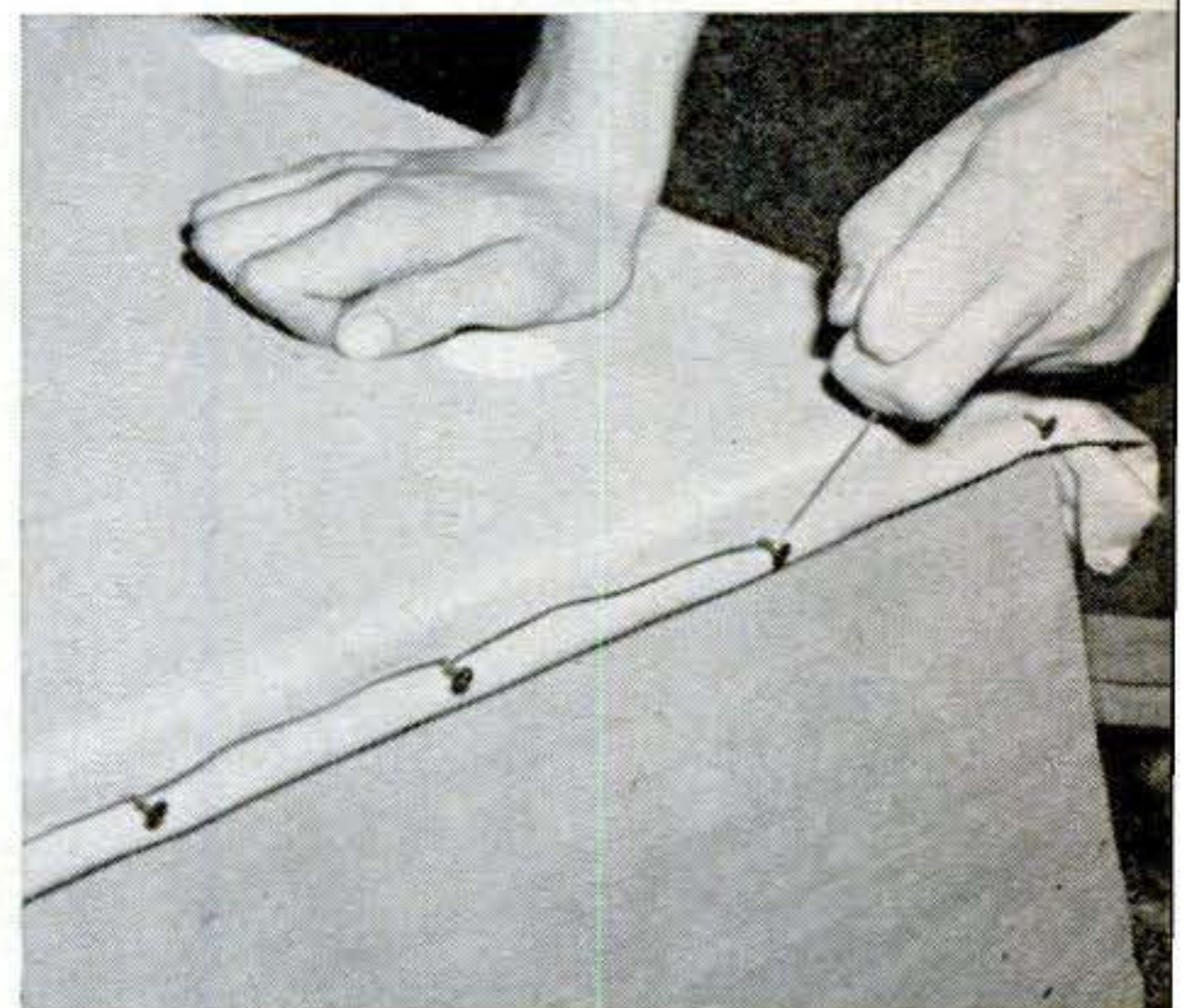

Gus Diagnoses



*"Whoa, Silas, not so fast.
What's the
youngster got to say?"*

RAY (X)IBET -

the Flat-Tire Case

A mysterious epidemic of flats had turned that old nickel nurser, Silas Barnstable, into the Model Garage's best customer—for free air.

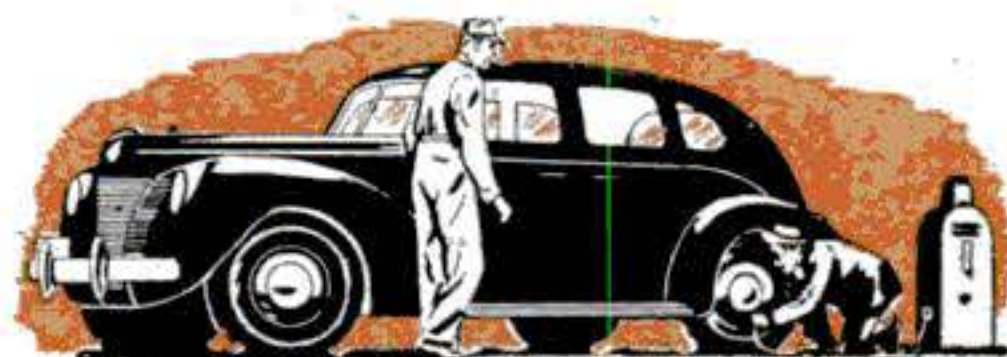

By Martin Bunn

GUS WILSON was feeling pretty happy. The first touch of spring was in the air and Gus was looking forward to all the things that warm weather brings—such as a chance to get in a little fishing now and then.

In this cheerful mood he chuckled good-naturedly at the sight of old Silas Barnstable, the town tightwad, helping himself industriously to the Model Garage's free air and water. Stan Hicks, Gus's helper, however, felt a little more strongly on the subject of Silas.

"Look at that old skinflint," he said disgustedly. "The only time he comes around here is when he can get something for free. Gas and oil he buys at the cut-rate joints. Air and water he gets here. Why, he even stops by and uses our liquid spray to clean his windshield."

"Oh, don't be so tough on the old boy," Gus commented. "Thrift is still supposed to be a virtue, isn't it?"

"Yeah, but you know what I caught the old penny pincher doing the other day? He was pawing through our junk box picking out old discarded bolts and things."

"So what? If he wants to rummage around to save a nickel or a dime, let him."

Gus Greets a Steady Customer

Gus slammed down the hood of Doc Marvin's car and strolled out by the gas pumps.

"Getting your tires up to pressure?" he asked the wry-faced, bespectacled little man crouched down beside his old sedan.

"Had a flat," replied Barnstable, who was as frugal with words as he was with money.

By this time, Barnstable was treating the tire in the trunk to a helping of Gus's free air. From the amount it took, Gus gathered that this was the tire that had gone flat and that, after repairing it, Barnstable had switched it with his spare.

Gus thought no more about Barnstable and his flat tire until the next morning. He was replacing a carburetor when he looked out through the open repair-shop doors. There was Barnstable putting air in his spare again.

Another Good Tire Goes Wrong

"Another flat?" Gus called.

"Yup," grunted Barnstable. "Can't understand it."

"You probably used a bum patch."

"Didn't patch it. Couldn't find any hole in the tube. Then this morning when I went out to look at the car I had another flat."

"Could be a bad tube. That's the trouble with used stuff."

"Now, none of your sarcasm, Gus Wilson. Besides, it wasn't the same tire. I put the one that went flat yesterday in the trunk as a spare. The one on this here wheel—" Silas poked the right rear wheel with his toe—"was flat this morning."

"Find a nail this time?"

"Nope. Same as yesterday. No nail, no cut, no nothin'. Just flat. So I switched it with the one in the trunk and drove over here to get some air."

Gus dipped his finger in the water can beside the gas pump and put a blob of water on the tip of the valve stem on the tire in the trunk.

"What you doin'?" Silas inquired suspiciously.

"Oh, just thought maybe you had a leaky valve, but it seems to be tight. No bubbles."

"Valve's all right. So's the tire." Barnstable waggled his finger at Gus. "I think I know what's goin' on. And I'm gonna find out."

The following morning, just as Gus drove up to the Model Garage, he saw old Barnstable's car pull out past the gas pumps and onto the road toward town. Immediately after, a large sedan drove up beside the first

pump. Gus recognized Paul Rodgers at the wheel. He was tight-lipped with anger.

"Fill 'er up," Rodgers said shortly. Then he nodded toward the road. "Wasn't that Barnstable's car that just pulled out of here?"

"I think it was," Gus admitted. "Why?"

"What did he want?"

"Don't know, I wasn't here. Hey Stan! Come out here a minute."

Stan approached the car, wiping grease off his hands.

"What was ailing old Silas' car this morning?"

"Same thing. Needed air. Had a flat again this morning, and boy was he hopping mad. Said something about 'catching the culprit' tonight."

"Why, that miserable old tightwad," exploded Rodgers. "You know, he lives near us out on Rolling Road. Keeps his car parked outside his house day and night because he's too cheap to use his own garage—rents it to someone else. Well, last night he came over to our place and accused my boy Dick of deliberately letting the air out of his tires."

"Why did he pick on Dick?"

"I don't know. Probably because he's the only teenager on the block. Barnstable claims he saw Dick leaning up against his car the other evening. Said he was going to prefer charges if he kept having flat tires."

"Oh, he's probably just letting off steam," consoled Gus.

Early the next morning, Gus was wheeling his tow truck back to the Model Garage, after a rush call for a rental battery, when he suddenly realized he was on Rolling Road. As he was wondering how old Silas and his epidemic of flat tires were getting along, he suddenly spied Silas himself holding young Rodgers by the nape of the neck.

"Hey, what the dickens is going on?" Gus called, braking the tow truck to a stop. As he got out he saw that Silas' car had another flat on the right rear tire.

"I caught him! I caught him!" Barnstable was shouting triumphantly. "He's the one who's been letting the air out of my tires. The police will take care of this."

"Whoa, Silas, not so fast. What's the

youngster got to say?" protested Gus.

"Honest, Mr. Wilson, I didn't do it," young Rodgers pleaded. "I was on my way to school and I dropped my baseball. It rolled under Mr. Barnstable's car so I reached down to pick it up. Next thing I knew he grabbed me."

Silas reluctantly loosened his hold on the youngster. "Tires don't just go flat of their own accord," he grumbled. "Somebody must be letting the air out of 'em."

"Not me," said Dick, with a little quaver in his voice. "And that's the truth."

"I believe you, Dick," Gus said. "But you better run along to school now." He turned to Silas. "Tell you what I'm gonna do." He grinned. "I'll put your spare on for you and you follow me back to the garage. If I can't find out what's causing your tire trouble you can call in the cops."

"Well, I ain't gonna pay for the work. Just remember that this is all your idea."

Back at the Model Garage, Gus lifted the flat tire out of the trunk and began inspecting it. No nails or cuts showed on the outside of the casing so he took it off the rim and examined the tube. Old Silas was right on one point at least—there wasn't a hole or a tear in it. Even a complete dunking in water failed to show any telltale bubbles.

Gus sighed and scratched his head.

"See, what did I tell you?" Barnstable chortled.

Gus said nothing. He dried the tube off, put it back in the casing and got the tire back on the rim.

"It's that young Rodgers rascal," Silas persisted.

"Could be, but I still doubt it. By the way, where's the valve cap for this tire?"

"Don't use none on that one. No dust in there. Valve caps cost money."

Gus shook his head in bewilderment. Just how miserly could a guy get?

"Satisfied?" snapped Barnstable.

"Not yet," Gus replied calmly. "Now let's go over this flat-tire business again. First of all, every flat has been on the right rear."

Silas nodded.

"Second, only two tires have been in-

No Choking Matter



A LADY in the Midwest complained to a gas-station attendant that she wasn't getting very good mileage. He noticed that her hand choke was out and asked why.

"Oh, I always leave it that way," she said. "It makes such a convenient hook to hang my purse on."



Hints from the Model Garage

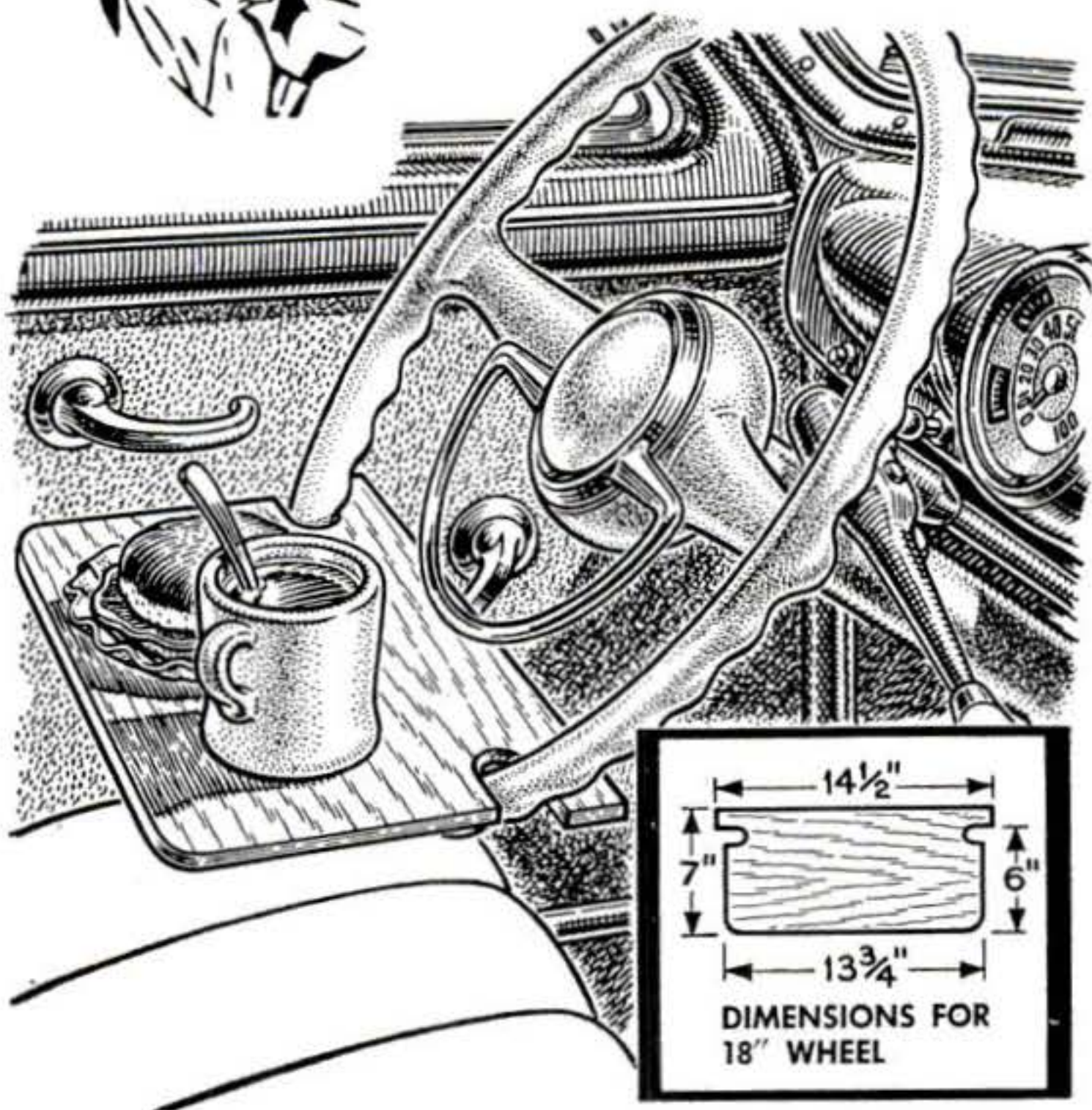

Lunch at the Wheel. For picnicking or eating at a drive-in, a tray like this will often be handy. Gravity and the protruding ears lock it to the wheel. For the other side of the car, the lowered glove-compartment lid makes a useful shelf.



Inner Tube Quiets Jack. A bumper jack won't rattle so much in the trunk if you store it this way. Raise the jack a few notches against an inner-tube rubber band. Cut a sleeve from a bicycle inner tube, pull it on the shaft, and slip in handle.

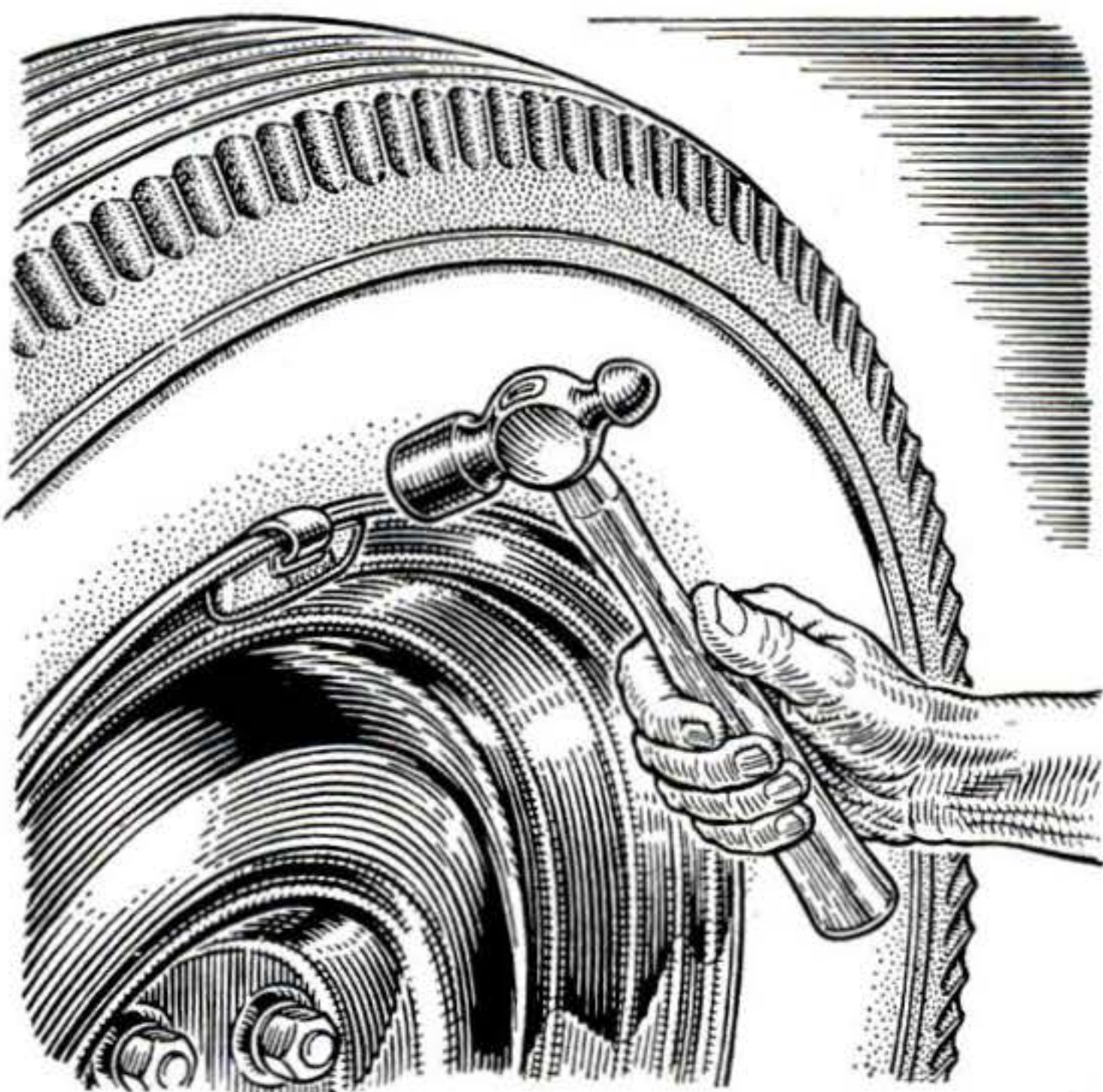

Seat Wheel Weights Carefully. When balancing a wheel, hold the weight in the correct position and give it one or two taps with a light hammer. Hitting too hard may crack the weight or tab. Centrifugal force at high speeds then will loosen it.

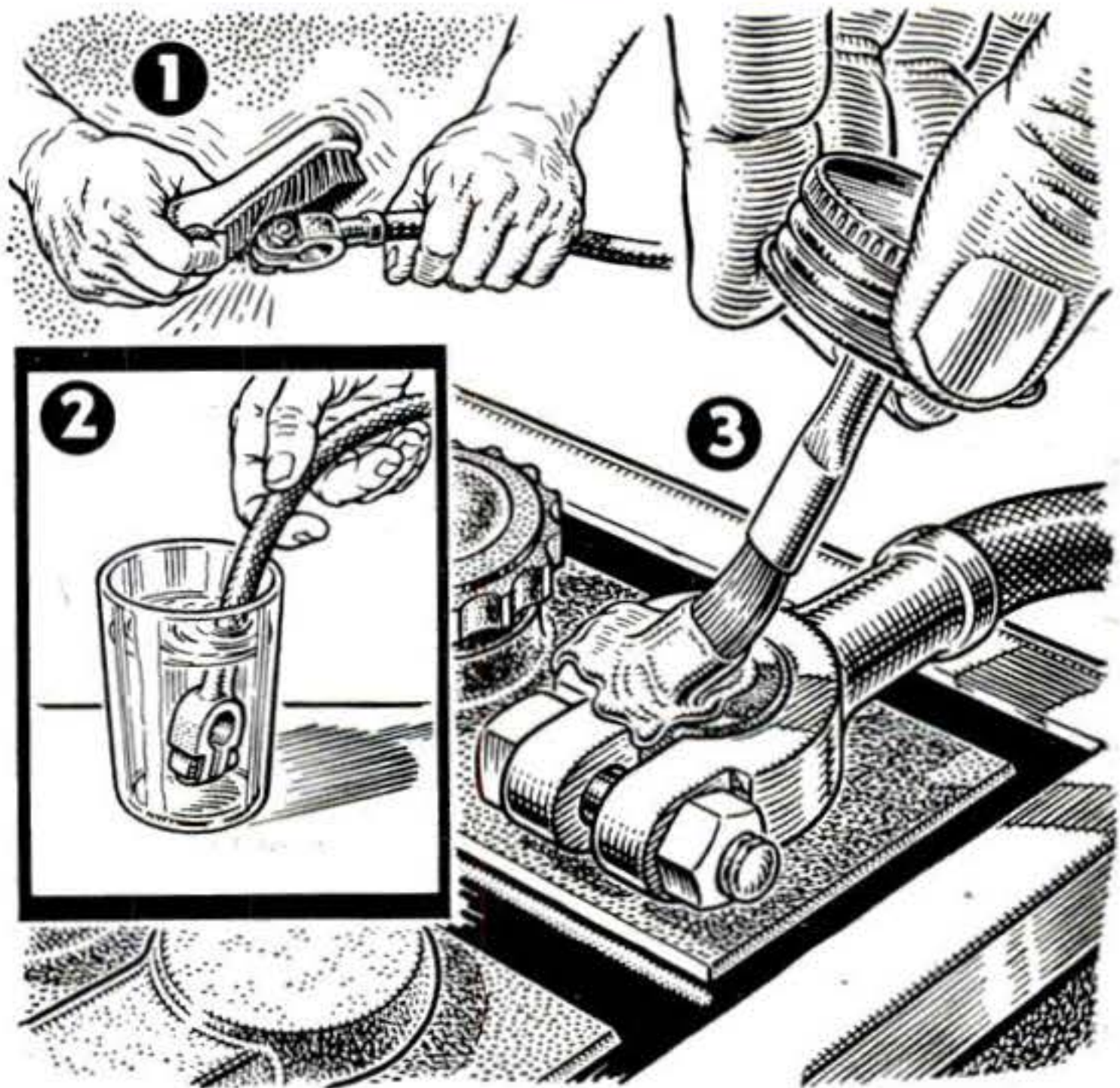

Rubber Cement Saves Battery. Irving J. Covert, Tarpon Springs, Fla., suggests this way to stop corrosion: wire-brush the clamps and terminals, dip them into or wipe on a baking-soda solution, and finally coat the terminal well with rubber cement.

Please turn the page for more auto hints.

MAY 1952 181

MORE Hints from the Model Garage

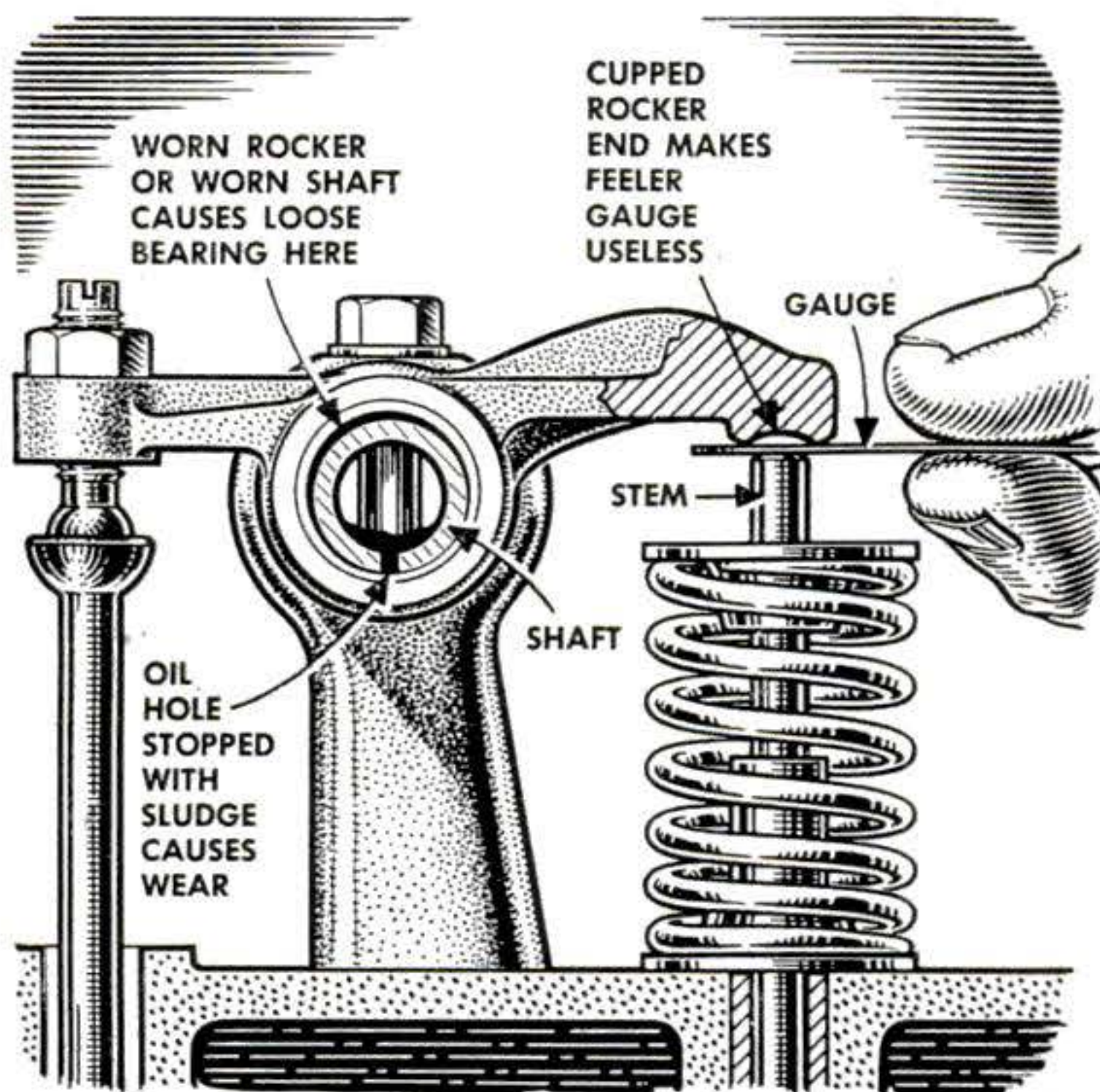

Things to look for in overcoming rough idle, noise or poor performance in an overhead-valve engine are suggested here. An oil-feed line plugged with sludge may cause wear of the rocker-arm bushing and shaft. Severe wear prevents accurate valve timing and proper clearances. The rocker-tip contact surface must be flat.

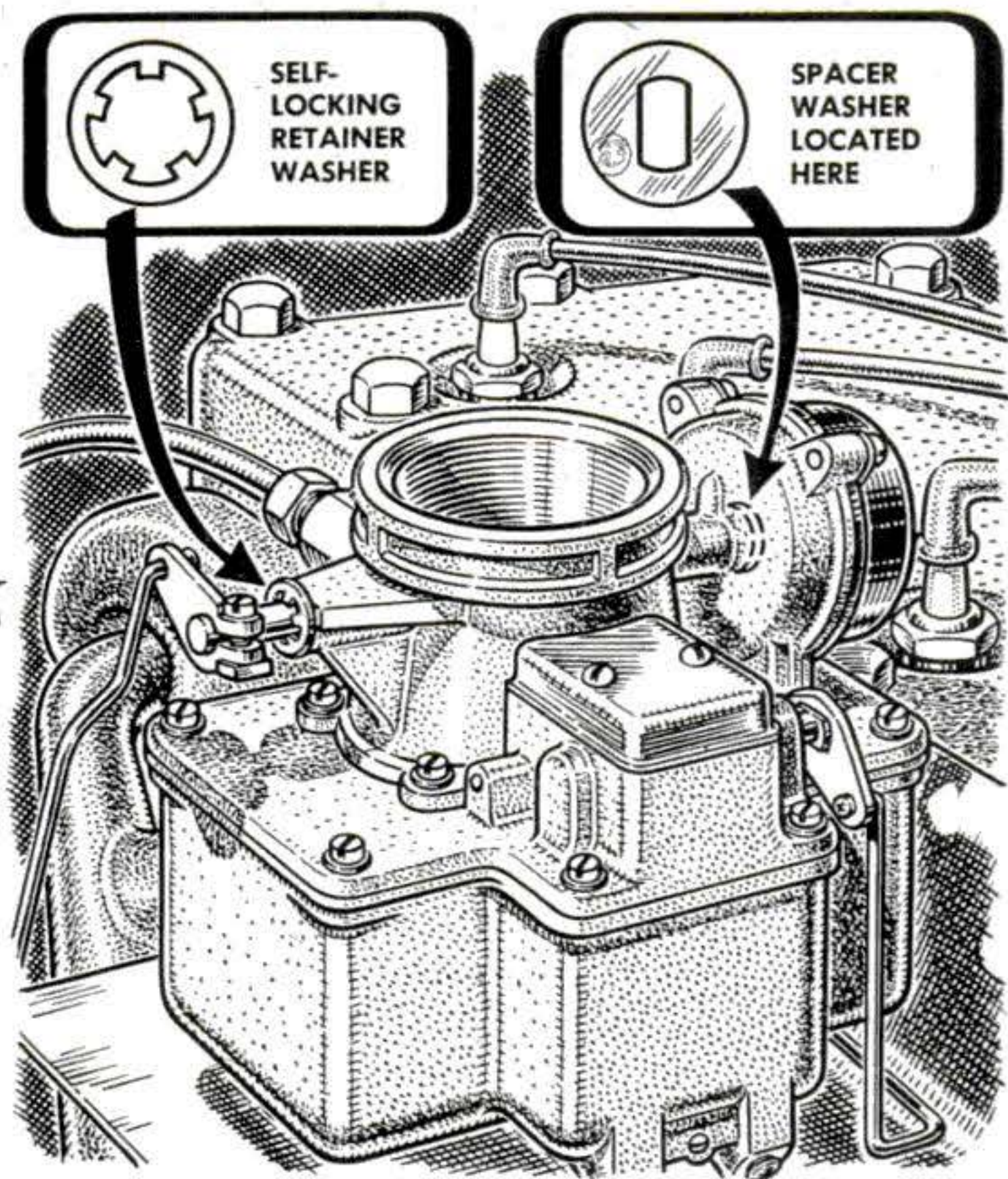

A buzzing carburetor can sometimes be traced to a vibrating choke valve. In the type of carburetor shown (with a spacer washer on the choke shaft), the noise can usually be stopped by seating the retainer washer tight against the air horn, but without causing binding. The lock washer must be placed with its prongs inclined outward.

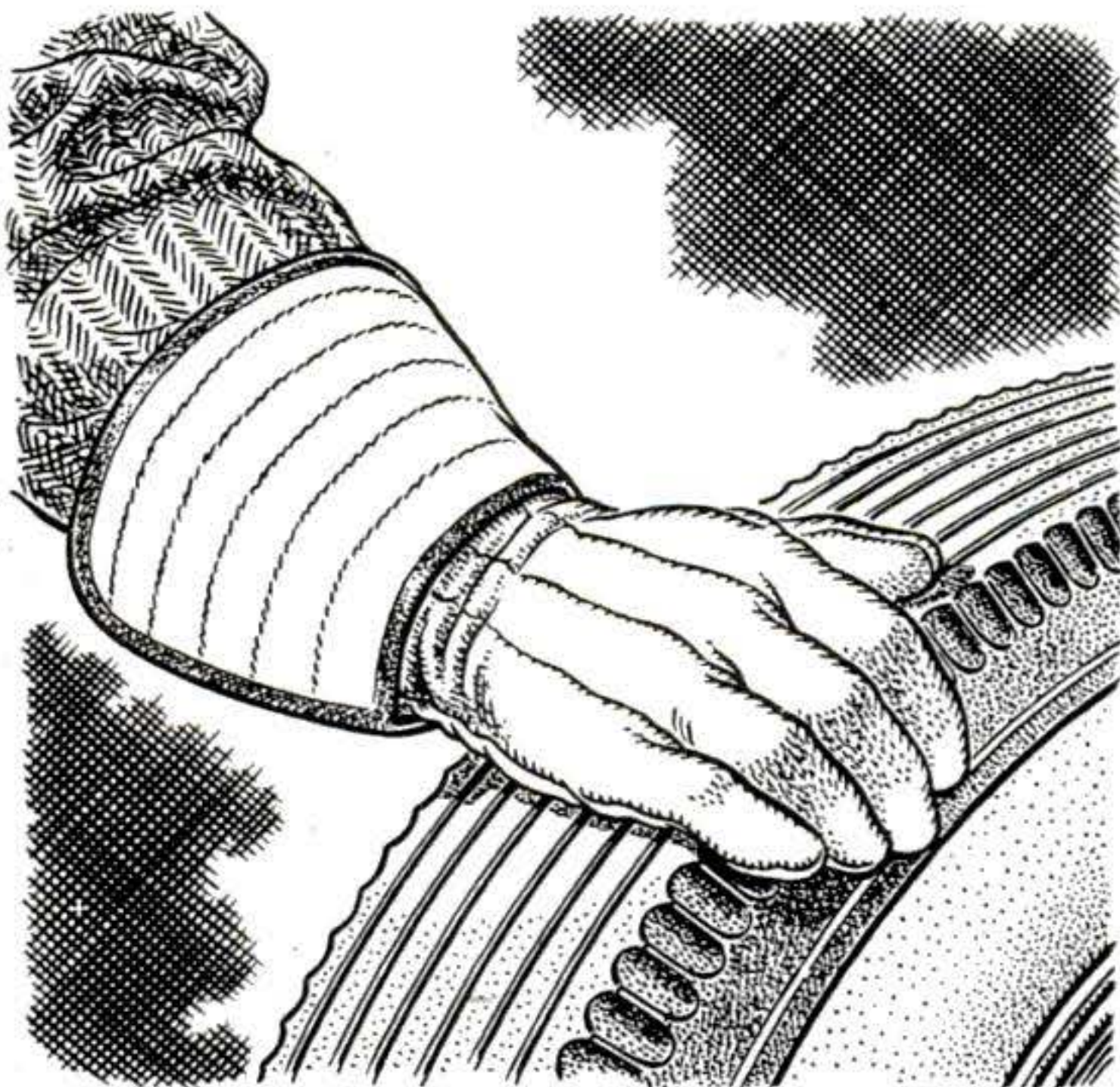

Gauntlet work gloves stored in the car will keep dirt from your hands and sleeves when you must make roadside repairs in your Sunday clothes. Be sure to get the kind that is long enough to reach beyond your wrist and cover your sleeves.

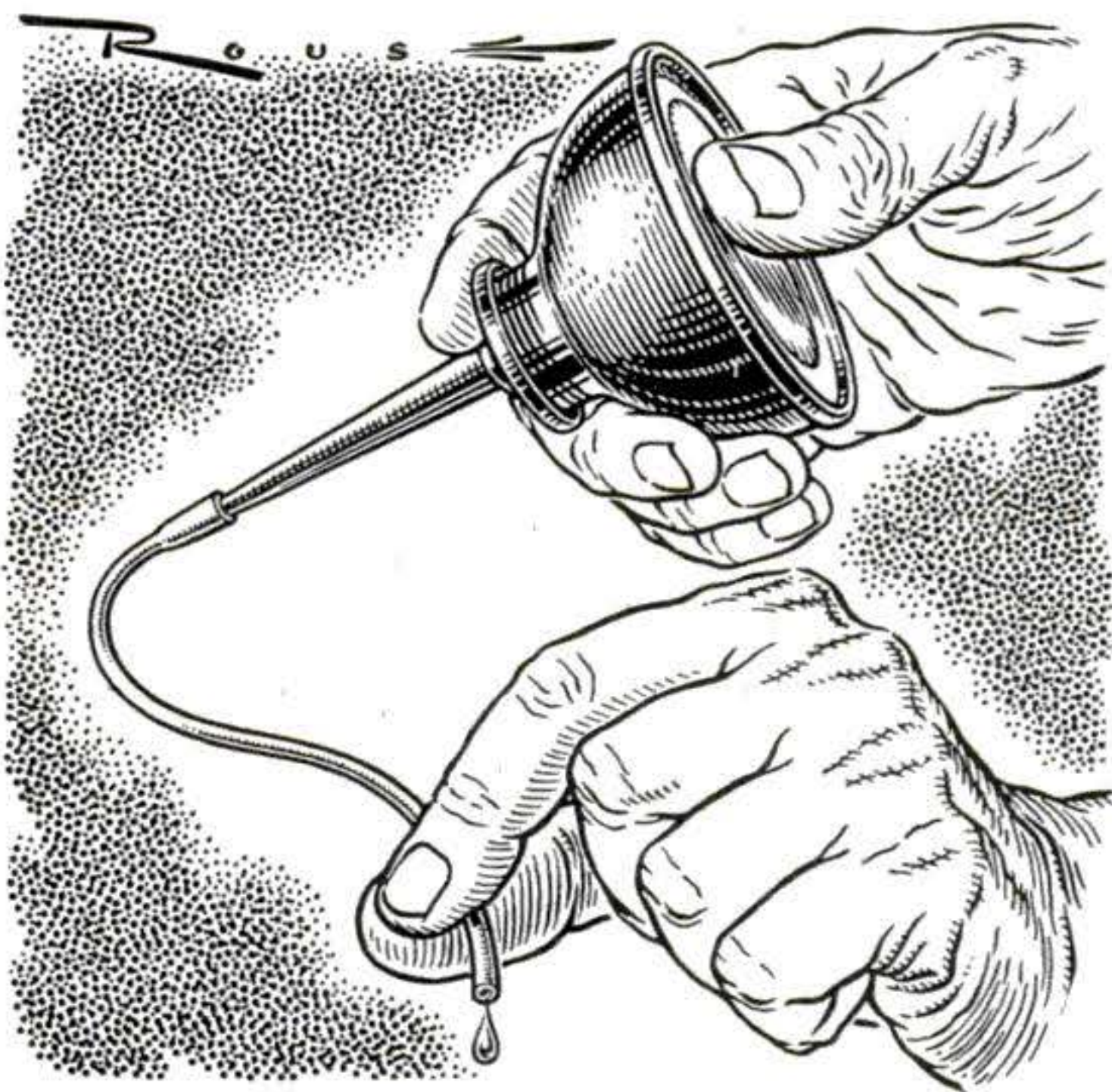

A long flexible extension on the spout of your oilcan will enable you to squirt oil into tight spots where the can itself wouldn't go. A length of model-airplane fuel line (neoprene) is just the right size and the oil won't damage it.

Spreader Sifts Lawn Fertilizer

This homemade garden tool spreads out an even, controlled swath as you stroll.



SPREADING fertilizer over your lawn is a walkaway with this easily made plant feeder. Just roll it over the ground and the job is done.

Wider than standard commercial models, this spreader covers more area in less time. It is made of scraps of wood and metal that should cost next to nothing.

Hopper. Cut out a 15½" by 25¼" sheet of galvanized or black

iron. Make the three right-angle bends shown by clamping the metal between wooden blocks and hammering it over with a mallet. Near the bottom of the V, drill a row of ½" holes spaced ⅞" center to center.

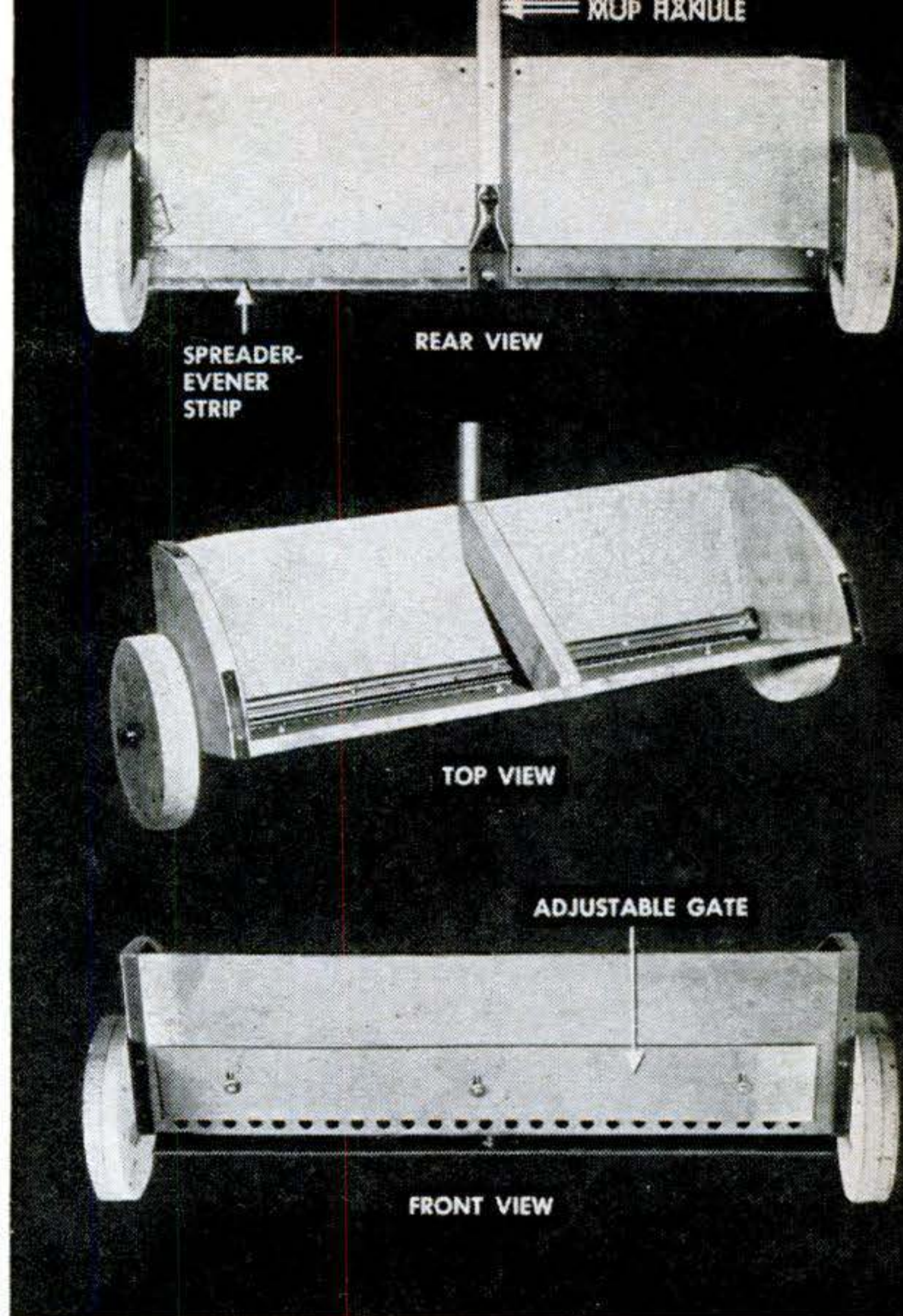
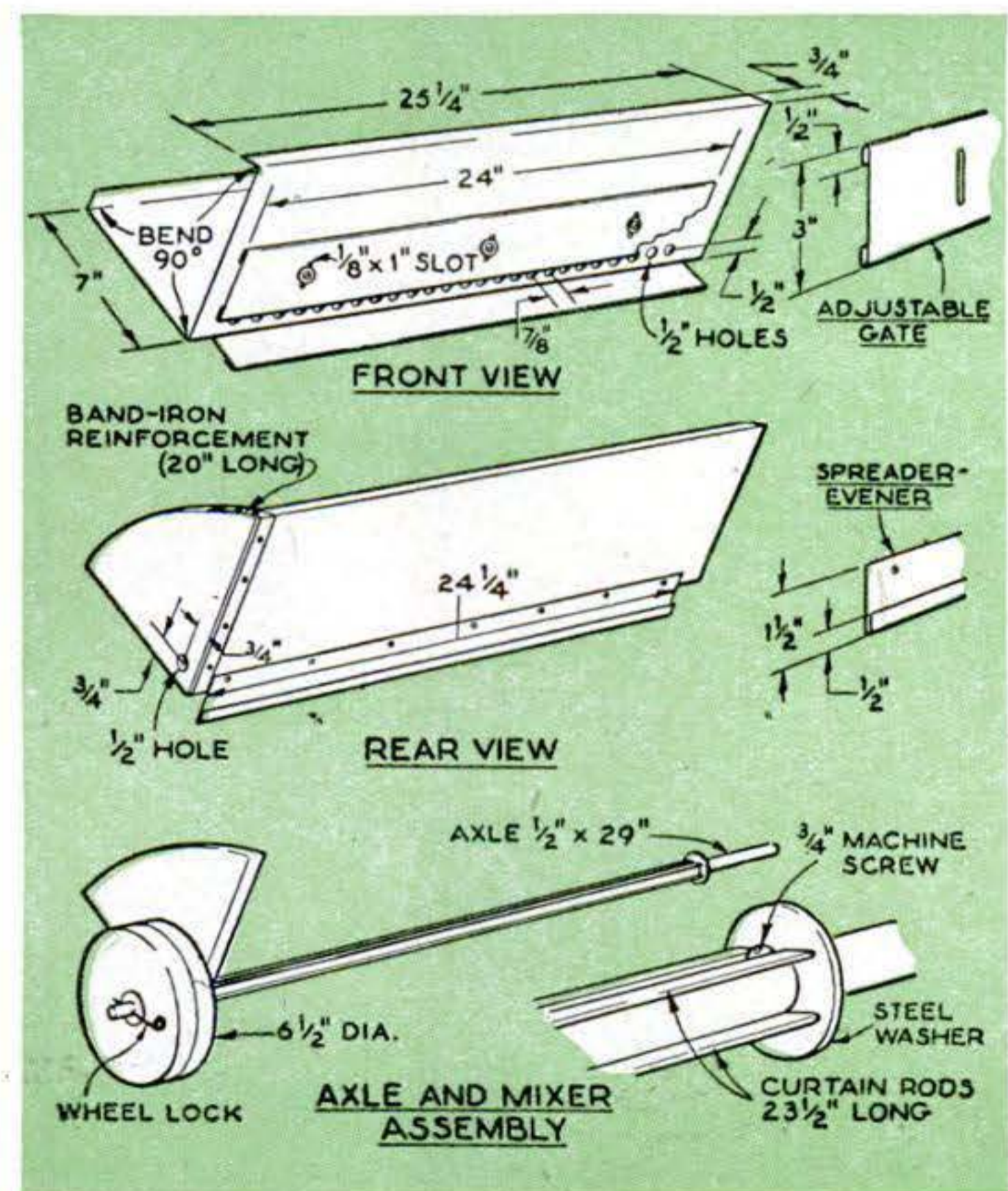

Jigsaw wheels, wedge-shaped ends and center braces from scrap wood. Make each wheel from plywood or else use two disks nailed together with the grain at right angles.

Axle. Use ½" rod about 29" long—it can be a trifle more or less depending on wheel thickness. Bolt two strips of flat curtain rod to it. Assemble wheels and washers as shown. Drill the axle ends, slip wire loops through the holes, and screw the loops to the wheels. Locking wheels and axle together causes the curtain-rod agitator to turn with the wheels. Stiffen both ends of the hopper with band-iron strips.

Gate. Bend the edges of the adjustable-gate strip double for stiffness. Cut three slots in the strip and bolt it above the sifter holes so it can be raised or lowered to regulate the flow. Double one edge of the evener strip and screw it to the back of the trough so it extends past the bottom of the V. Fertilizer pouring through the sifter holes should fall onto this strip and roll off in an even stream.

Bolt a mop handle to the box, brace and evener strip. Use rustproof bolts so that you can remove the handle easily when you want to store the spreader.—Glenn A. Wagner, Delmar, N.Y.

How You Can Use CHALKBOARD PAINTS



"YOUR kids are scribbling all over the walls in that back room," a visitor at my home told me. He shook his head. "Looks like a new paint job on those walls, too."

"It is," I said. "I just repainted that room last week."

"Don't you care?"

"No. That's why I repainted the walls. So the kids could mark on them. Keeps 'em busy."

What I had done, I explained, was to use one of the new chalkboard paints. They are designed to be marked on with chalk—like a blackboard. And you can erase the chalk marks on them just as easily as you can erase on a slate blackboard.

Any smooth surface that will take ordinary paint can be turned into a chalkboard. The photos show you some of the

Making a Framed Chalkboard



1 STIR THOROUGHLY. Since chalkboard paint contains fine grit that bites chalk to make sharp line, mixing is important.



2 APPLYING PAINT. Put thin first coat on composition-board panel. Let dry overnight, sand, and brush on second coat.

4 FRAME. For a big panel, use 1 1/4" by 2" stock rabbeted to take composition board. Join corners with glue, fasteners.

5 CHALK TRAY. Groove inner edge of bottom framing member. Here it is done with radial saw set slightly askew to line of pass.

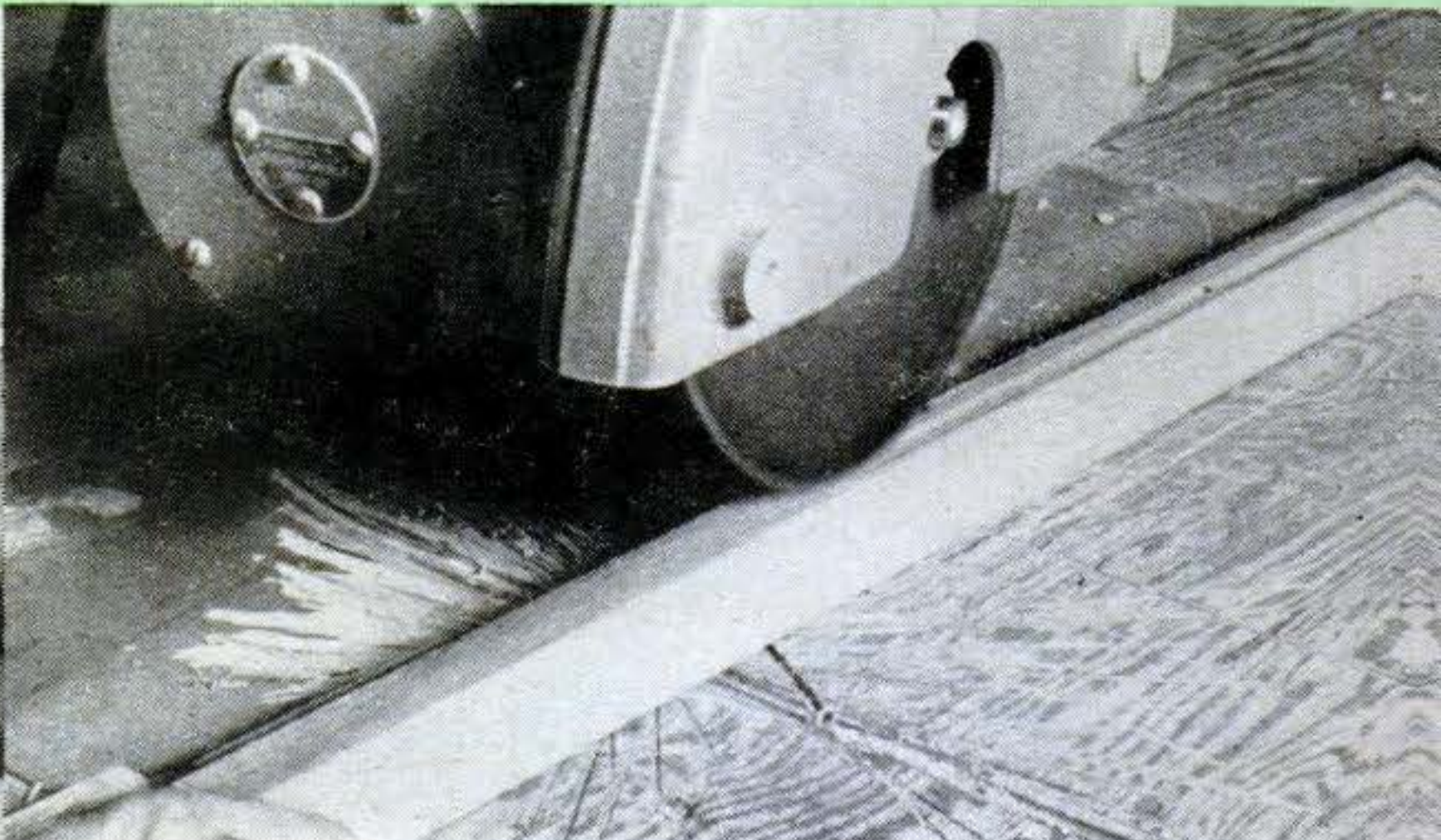
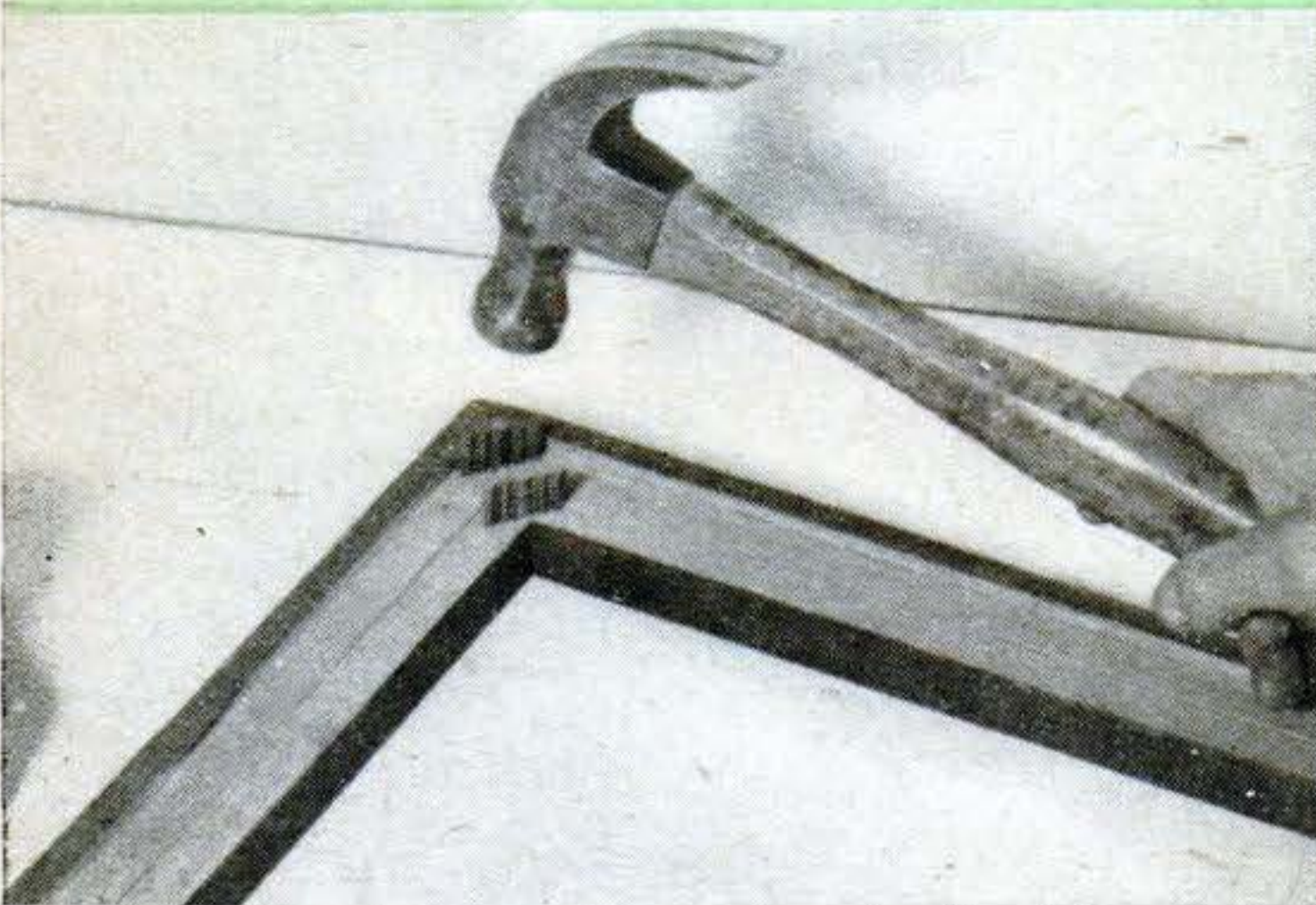

uses I found for the paint. You'll probably think of others. For instance: if milk delivered to your home is left in a box, paint the lid and you can write orders to the milkman on it. Wind can't blow the messages away and it's easy to change them daily.

On most surfaces, you can get by with one coat. But for a really good writing surface that will wear for a long time, I've found a second coat is necessary. On exceptionally porous materials—like some composition boards—you'll need three coats. You can substitute a primer for the first coat.

Chalkboard paints are available in black or green, and they can be brushed or sprayed just as ordinary paints are. The greens—the shades vary from one maker to another—are attractive as wall paints, too.—*Darrell Huff, Sonoma, Calif.*

More Chalkboard Ideas

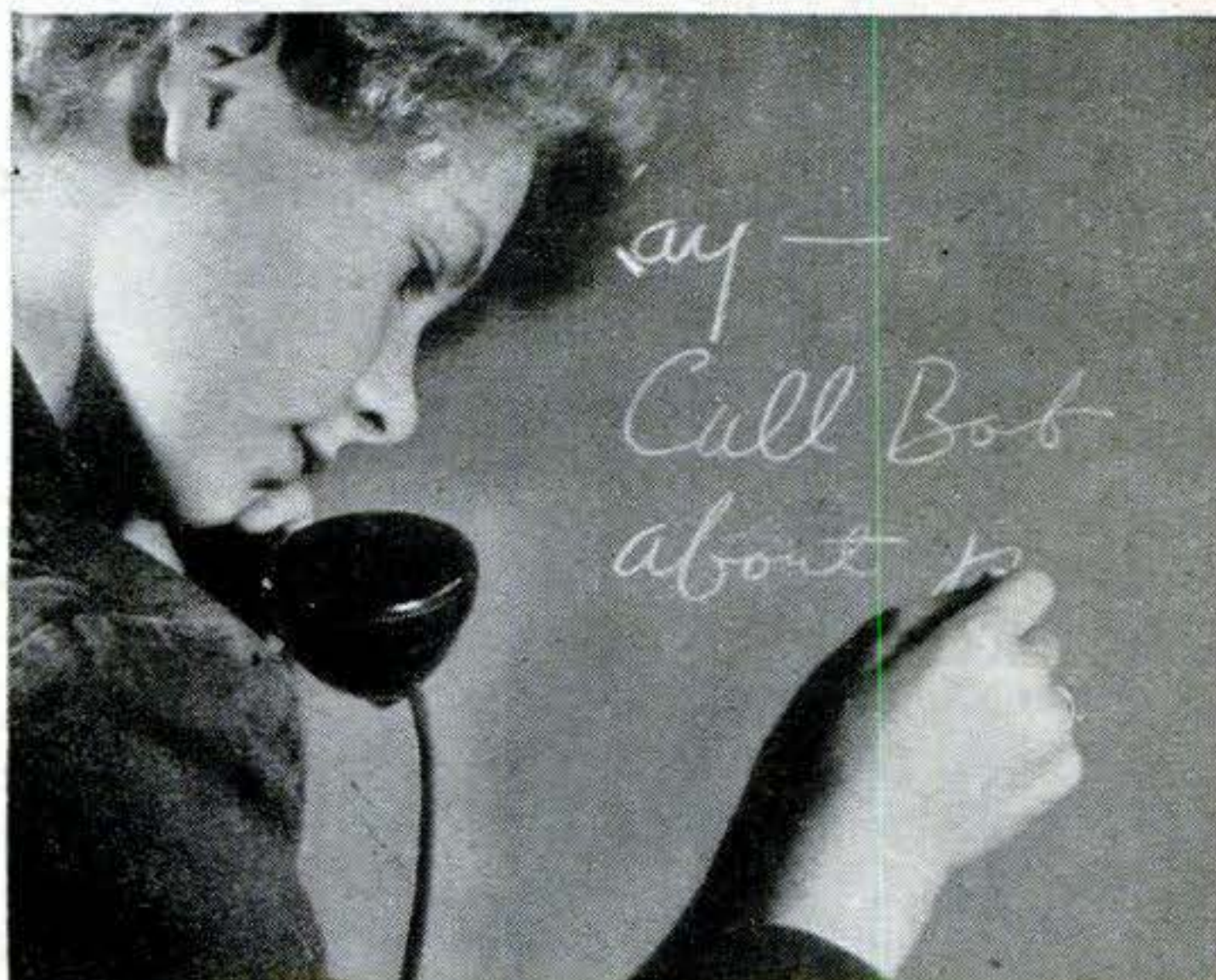

MESSAGE CENTER. Hang a piece of chalk-painted plywood or wallboard near the telephone for messages, or just paint a section of the wall.

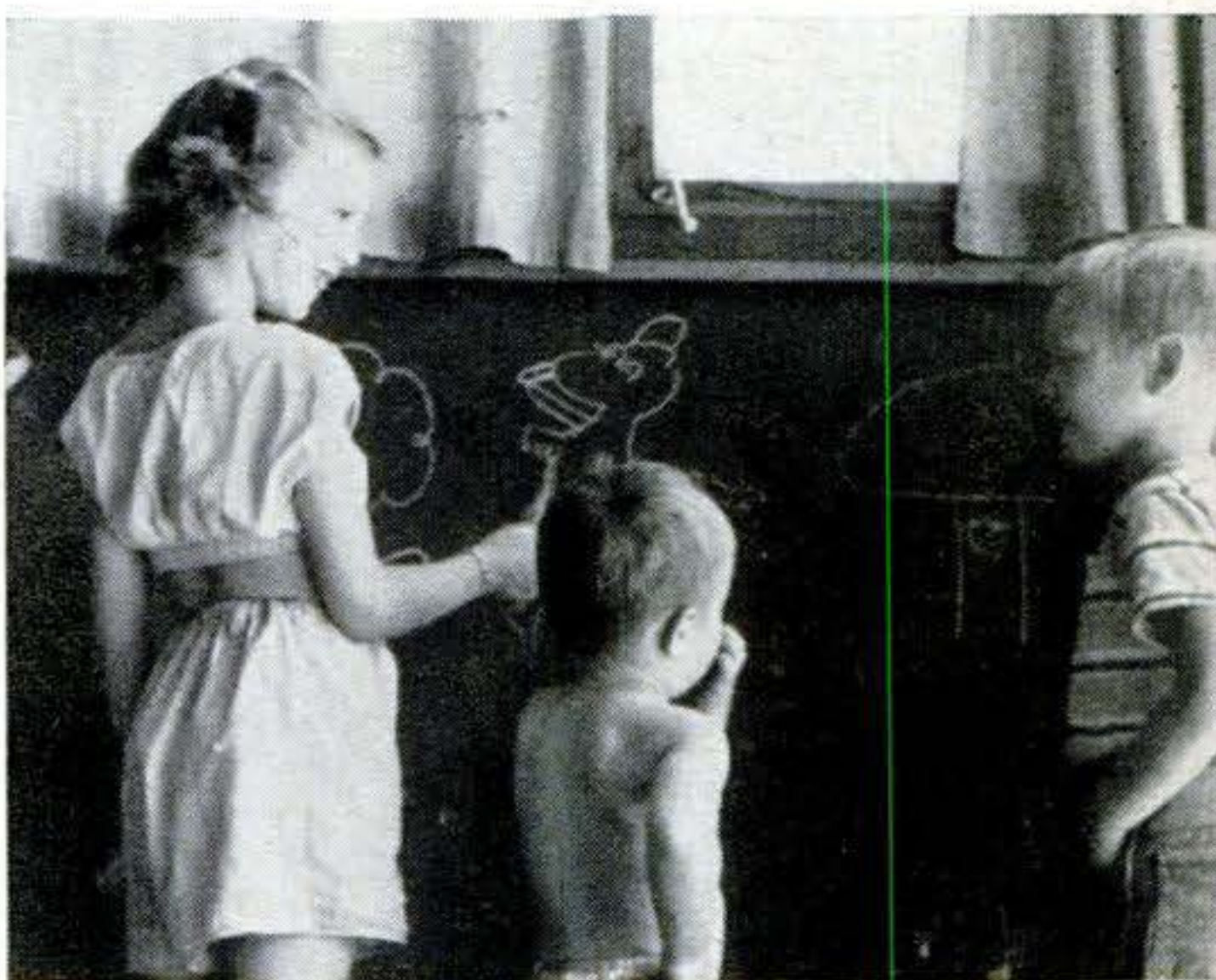

CHALKBOARD WALLS. Delight youngsters by turning entire wall of their room into a big chalkboard. Green is attractive, too.

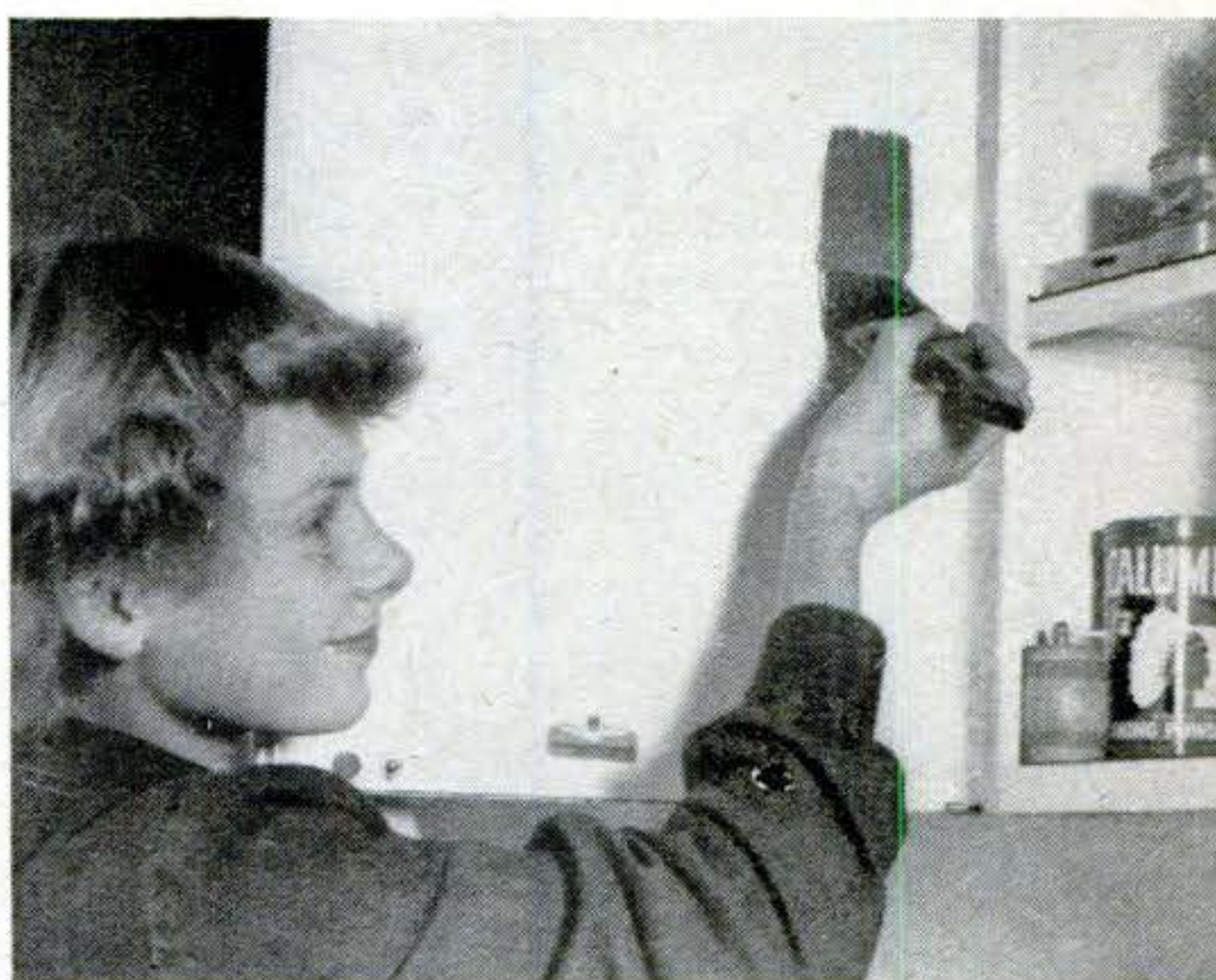

KITCHEN MEMO BOARD. Inside of steel cabinet door is ideal spot. Board can be used for market lists and chore assignments.

[Continued on next page]



DOOR CHALKBOARD. In your absence, callers can find your messages or leave their own. You can also leave notes for deliverymen.

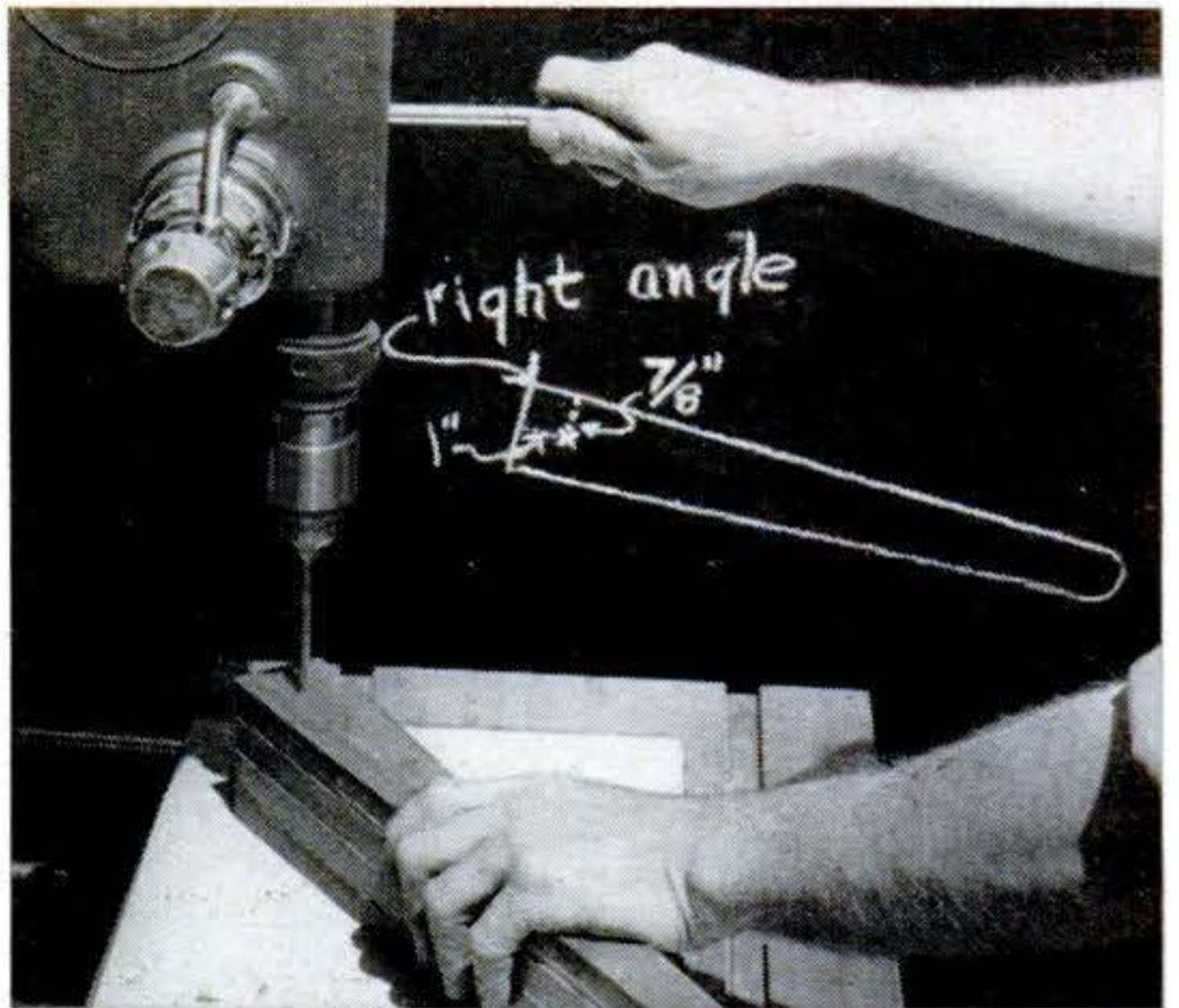

WORKSHOP USES. Chalk walls do many jobs in a shop. This one is used for sketching plans and drawings and for posting reminders.



DARKROOM USES. Here you can jot warnings about film changes, location of borrowed equipment and lists of needed photo supplies.



INDIVIDUAL CHALKBOARDS. Any fair-sized scrap of plywood or hardboard can become a slate. With colored chalk, children welcome them.

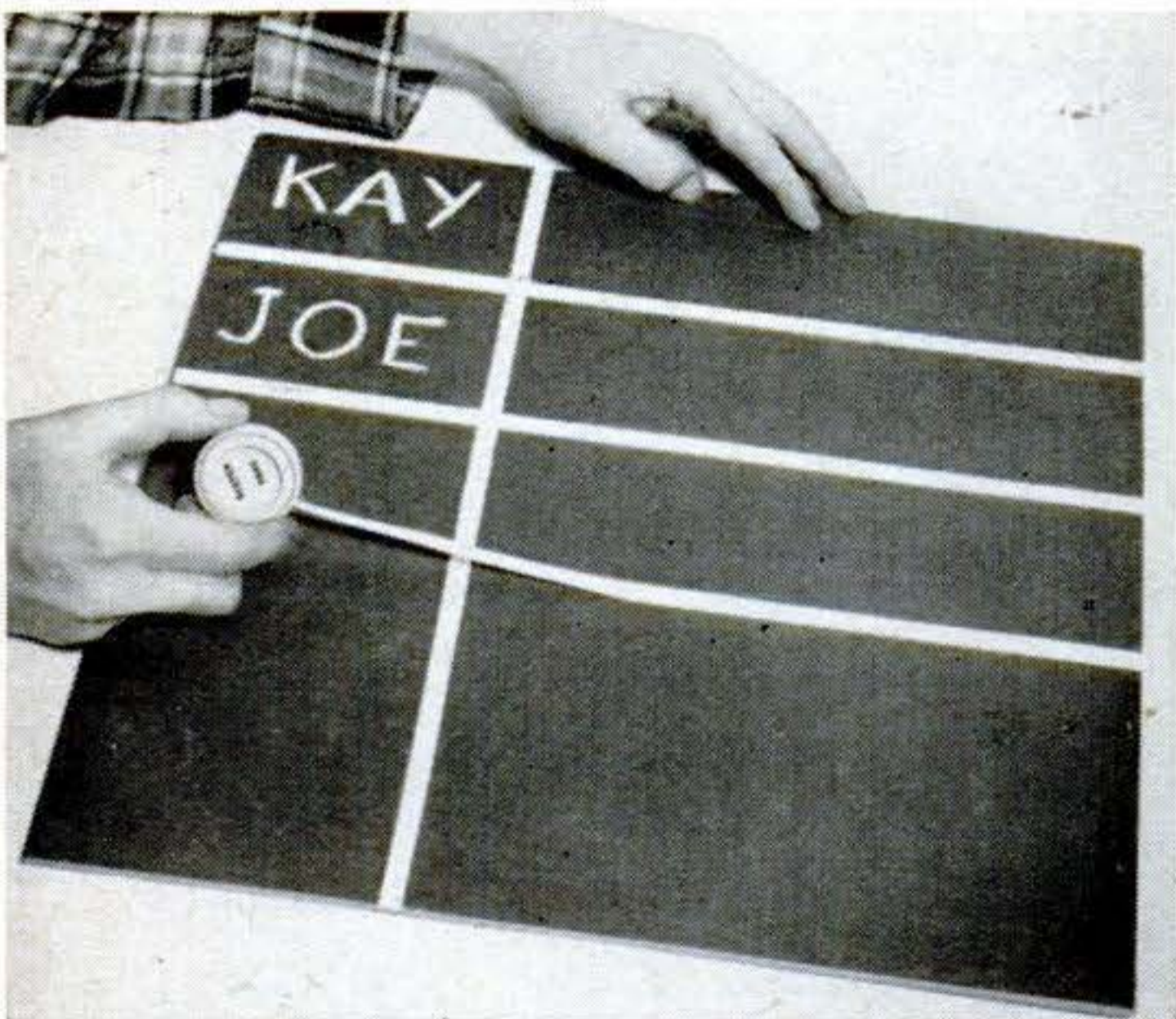

SCOREBOARD FOR GAMES. Reusable scoreboards for many games can be made by painting or taping white lines across a chalkboard.



PAINTING ON GLASS. Chalk paints take nicely on glass. An old picture frame can become a bulletin board to be hung anywhere.

Cramps Keep Stones Level

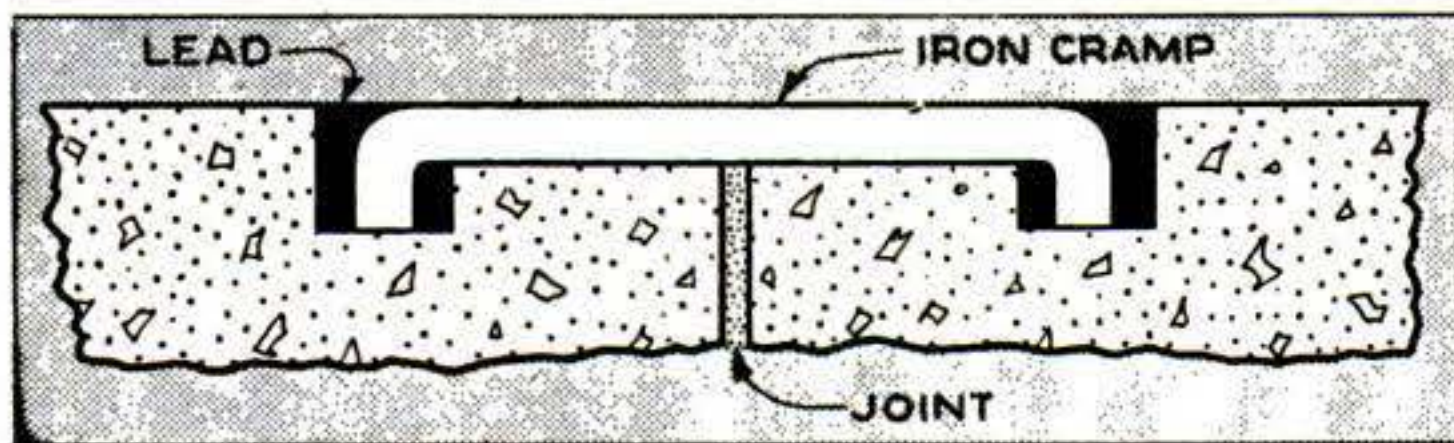
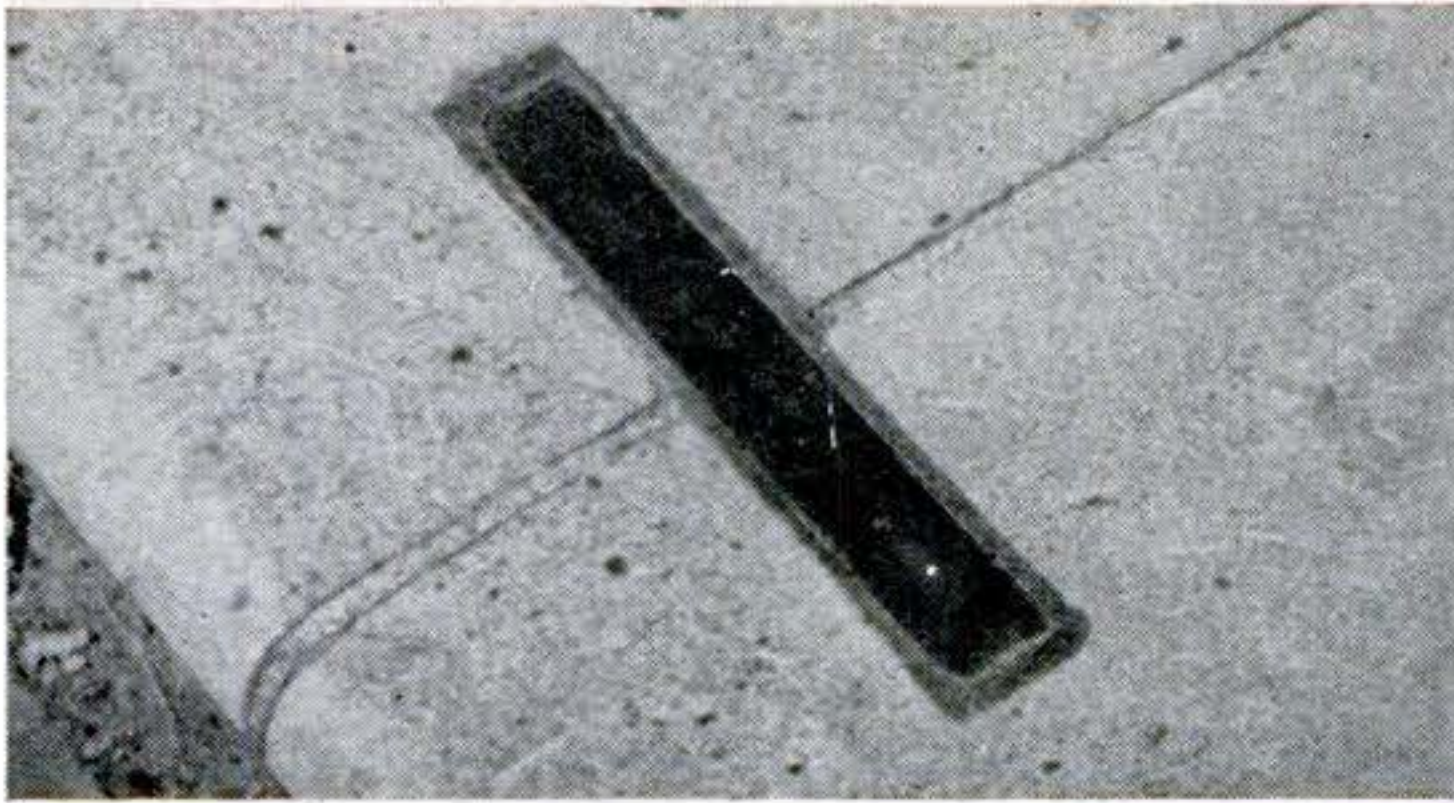

AN OLD-TIME stunt that can be adapted to present-day construction is the use of lead-embedded cramps. These are strips of iron that tie together sections of stone steps and other construction units. Holes are star-drilled and grooves chiseled as shown in the drawing. The cramp is put in place and molten lead poured around it. The cramps keep the sections of stone even with each other.—*Walter E. Burton, Akron.*

Flowerpots Held in Shelf

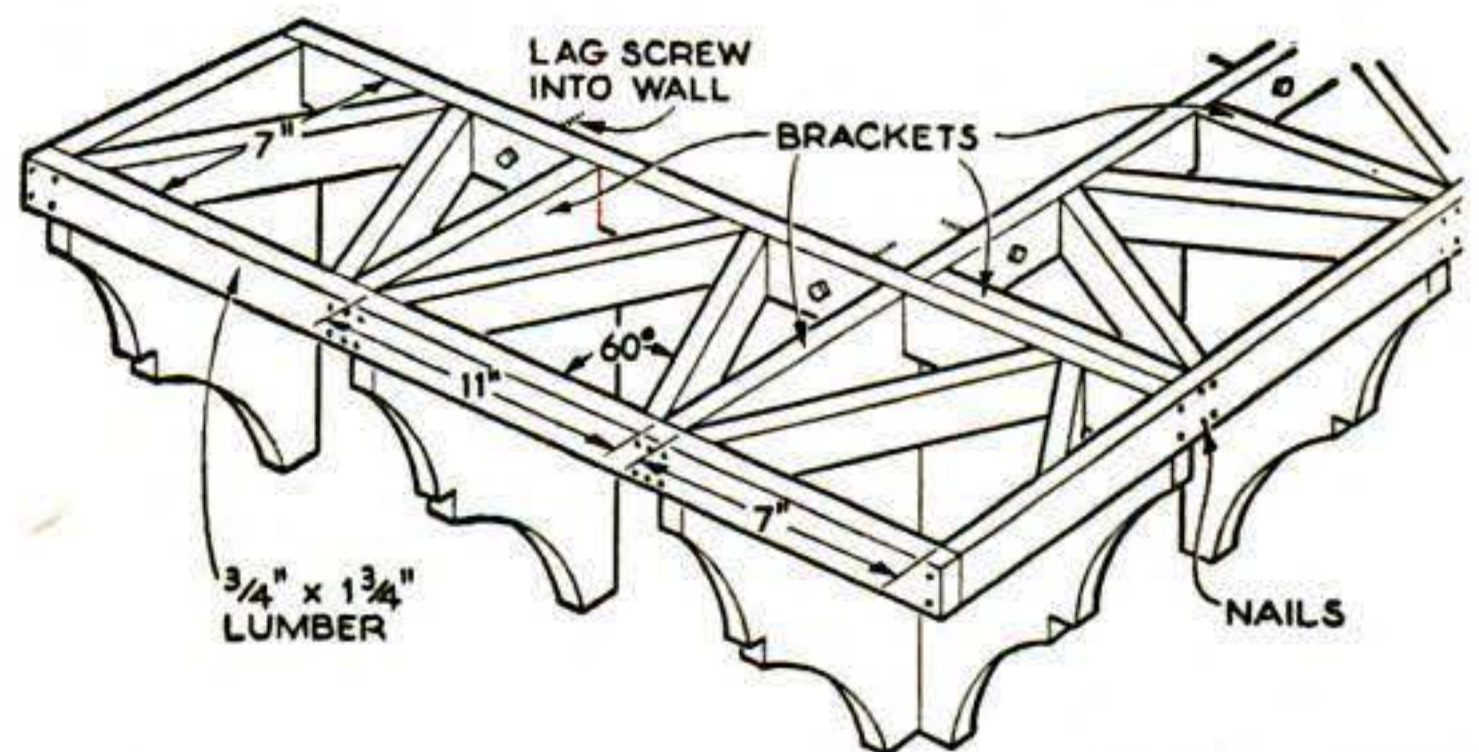
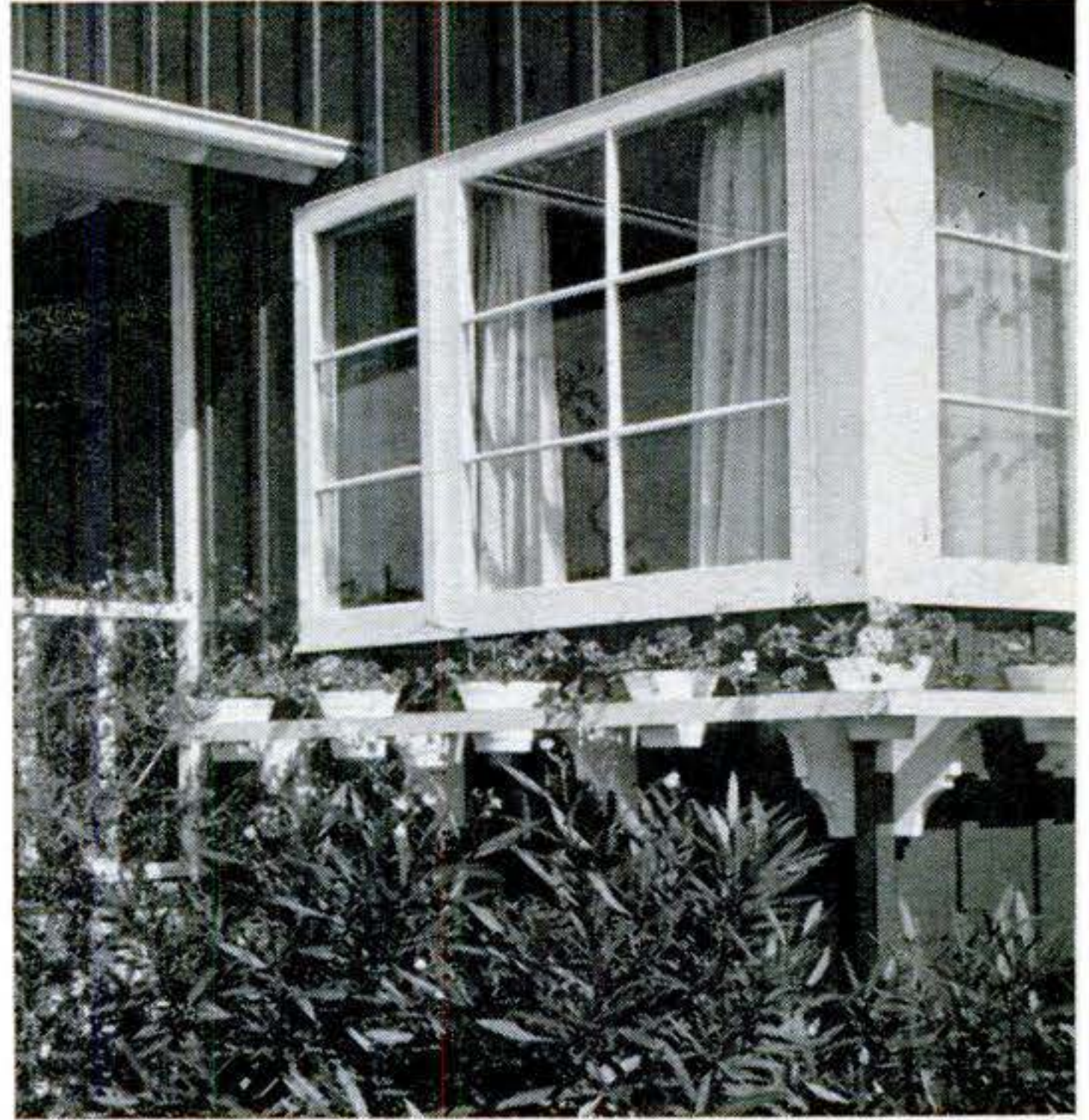

THIS unusual and attractive design for a flowerpot shelf is easy to build. The parts for the frame can be sawed with the aid of a miter box while the brackets can be jigsawed to shape. Vary the dimensions to suit the size of the pots you want to use. Lag screws hold the frame to the house.—*Hi Sibley, Nuevo, Calif.*

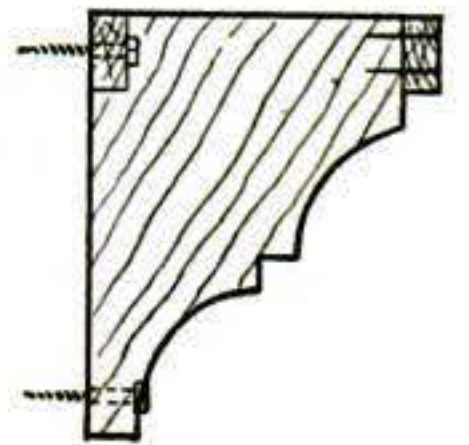

Storing Small Paintbrushes

IT'S easy to misplace small paintbrushes but you can keep them together like this. Thread a screw eye in the end of each handle and hang the brushes on a curtain-rod hook.—*J. J. Rea, Urbana, Ill.*

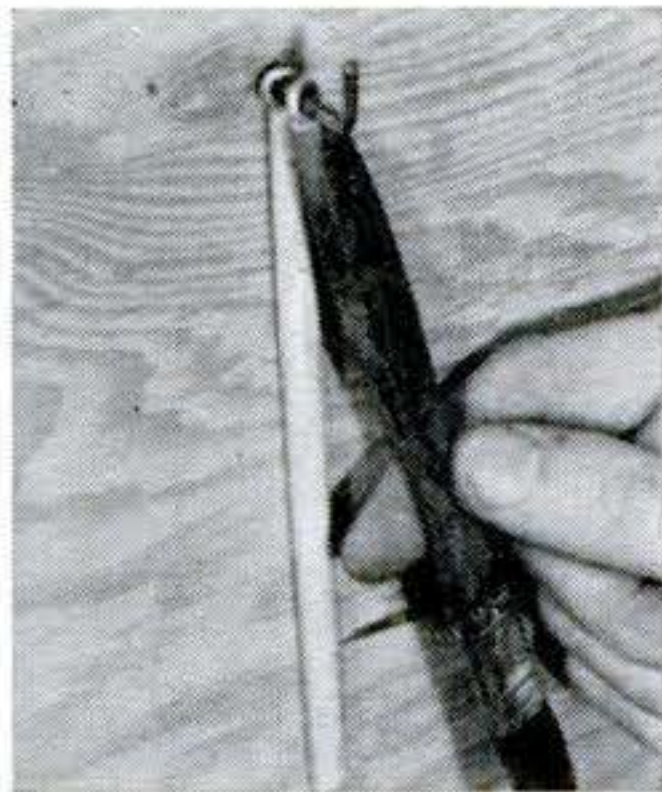

Solenoid Valve Lets This Poultryman Sleep Later

A SOLENOID valve serves as a hired hand for Kenneth Lane of Claremont, N. H., and lets him get a few extra hours of sleep. It turns on the gravity water system for his 24,000 hens. The time clock that operates the poultry feeders and the lights that give his hens a longer "working" day also operates the solenoid. Lane's right hand is shown on main-line valve, which allows rising water to pass and turn down tube to waterer. Other hand is at solenoid, mounted on by-pass. Although main valve is shut off at night, solenoid lets water through as long as lights are on.





A Kitchen Stool

This wooden one costs less than a cheap metal stool, has features that some of the costliest lack.

PLENTY of house chores keep your wife on her feet, but a stool will let her sit down to some kitchen jobs. This one has a swivel seat, an adjustable back rest and casters. With power tools, you can make it in a couple of evenings.

You need only $\frac{3}{4}$ " stock, if you do some extra gluing. The pivot block in which the seat turns, for instance, can be glued up from four $\frac{3}{4}$ " thicknesses.

Legs and seat. Half-lap the cross members at the center and glue them together. Cut the four legs to length, being careful to get the angles alike. If you have no wide stock, glue up the seat from narrower boards

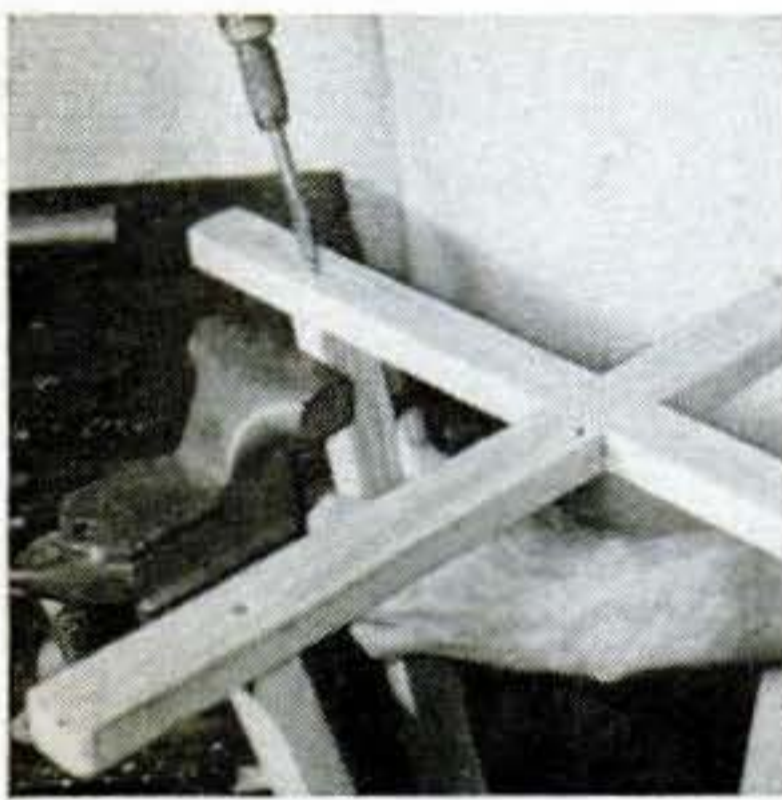

PUT PLENTY OF GLUE on ends of legs. Drill cross members and attach with a $1\frac{1}{4}$ " screw in each leg. Crosspieces shown at left were cut extra long. They need not extend beyond the legs.

FLUSH-MOUNTING CASTERS go on ends of cross members (right). They will be right under the legs if you use shorter crosspieces, as in the drawing. Mount casters with $\frac{1}{2}$ " No. 6 screws.

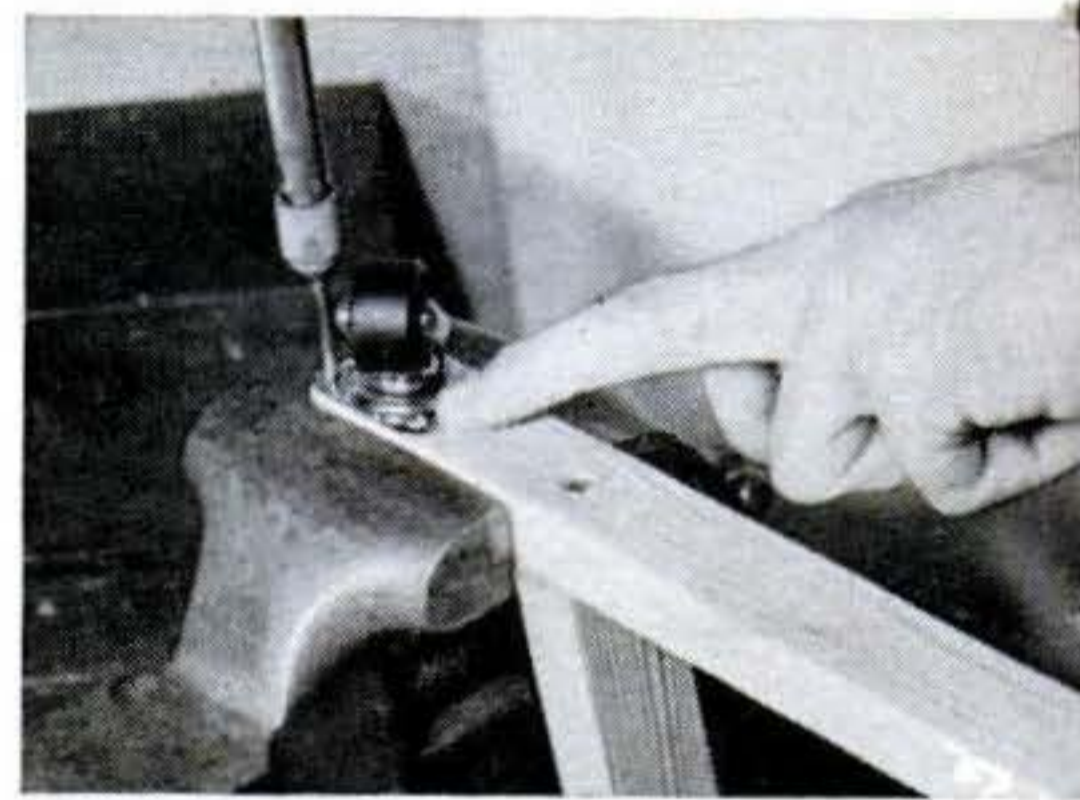

THERE WAS NOTHING WRONG with this chair except that you couldn't sit in it. The back and frame were still like new when the webbed seat gave way.

Clothesline and Foam Rubber Renew Damaged Webbing Seat

THAT extra chair you need may be stored in your attic. Many an otherwise good one is discarded because a woven seat of cane or webbing is torn.

Caning and webbing aren't available at every cor-

FRAME WAS STRUNG with plastic clothesline to make new seat support. Holes were first drilled 1 " apart in side rails with a $\frac{1}{4}$ " bit. The clothesline was laced through them and securely knotted at both ends.



for Your Wife

with dowel or spline joints. Round edges.

The slot in the back-rest support can be made with a router bit, or by dropping the piece over the circular saw and finishing with a handsaw. Another fast way of making the slot is to glue pieces of $\frac{3}{4}$ " stock after stop-recessing the inner faces $\frac{1}{8}$ ".

Curved back. You may be able to use a curved seat back from a discarded chair. Otherwise, bandsaw it from a block made of two $\frac{3}{4}$ " pieces. Lacking a bandsaw, you can cut off waste with a handsaw and then plane, rasp, joint or power-sand it.

Glue and screw the legs to the pivot block. The photos show the rest of the assembly job. After you've tried the stool out, don't forget it was meant for the kitchen. You can always build another to keep in the shop.—*John Rogers, Dallas.*

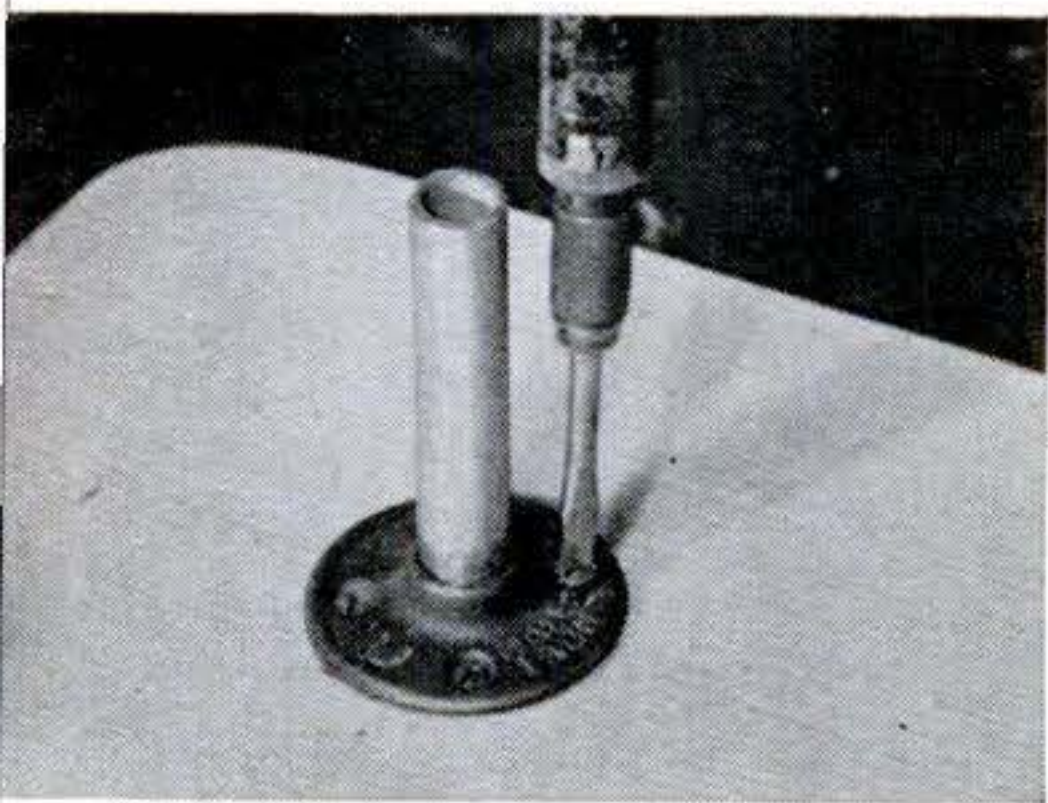
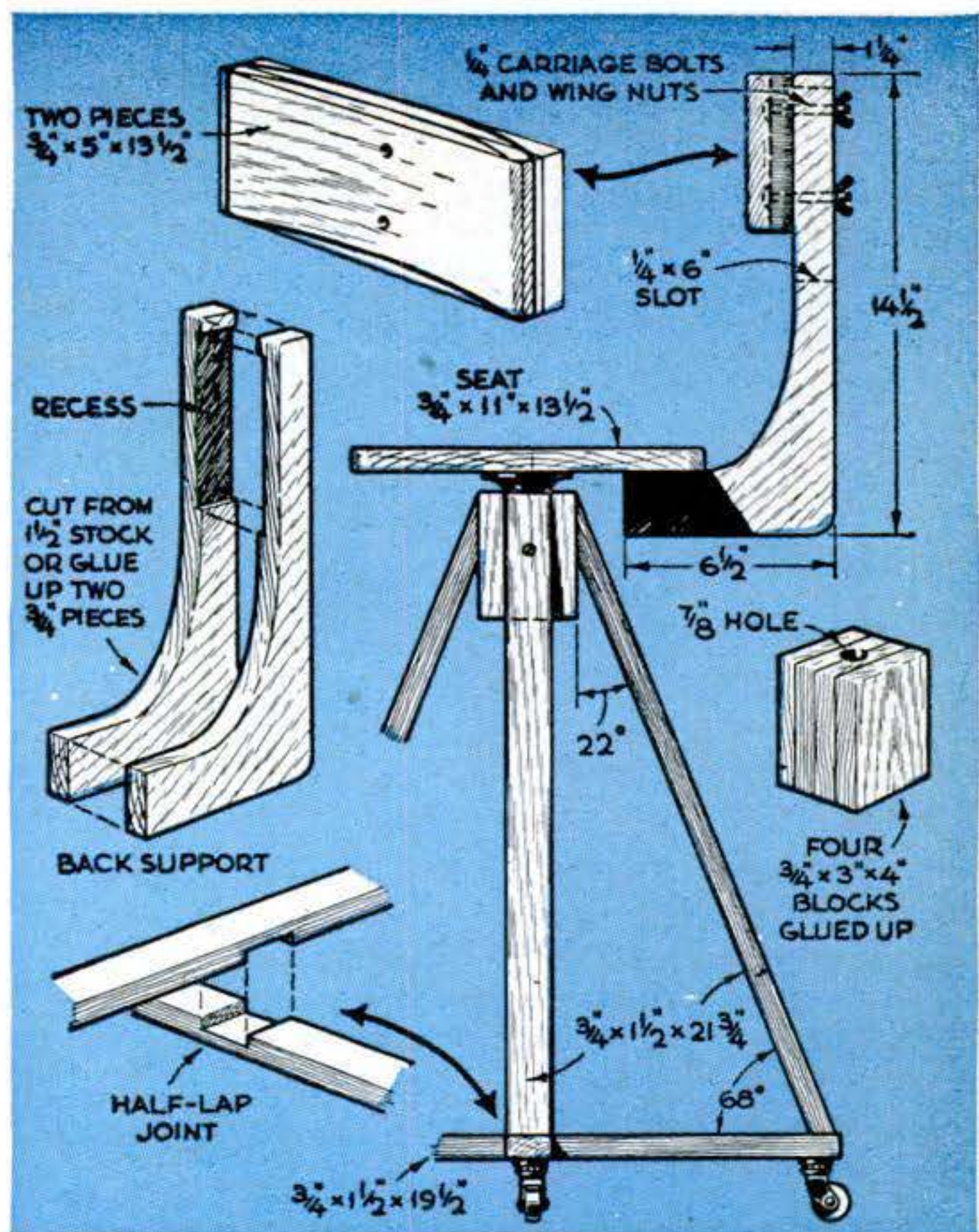

SWIVEL PIN is a 4" length of $\frac{5}{8}$ " pipe (left) screwed into a floor flange. Mount flange with four $\frac{1}{2}$ " No. 8 screws. Attach seat-back support with glue and $1\frac{1}{4}$ " screws.



STOOL CAN BE FINISHED with clear lacquer, stain and varnish, or color to match kitchen cabinets. To fit seat, drop pivot pin into block (right). Grease or graphite will stop squeaks.

ner hardware store, but plastic clothesline is. The photos show how this durable, waterproof material was used to rebuild the seat in a patio chair.

Foam rubber can be bought for home upholstery or in the form of kneeling pads. Inserted in a flat bag made of old carpeting, it becomes a seat pad that adds a lot to the comfort of the chair. If it gets dirty, you just pull out the rubber pad and wash the covering bag.—*Darrell Huff, Sonoma, Calif.*



SEAT PAD WAS MADE by sewing an envelope of old carpeting (cotton bouclé here) to fit chair. Pad of 1" foam rubber is inserted and flap tucked in. It's a cinch to remove pad to wash the cover.



NOW IT'S SITTABLE AGAIN. New seat is more comfortable, and adds color to the chair. This one is pale green, which goes well with gray webbing.

Keeping the Home Shipshape

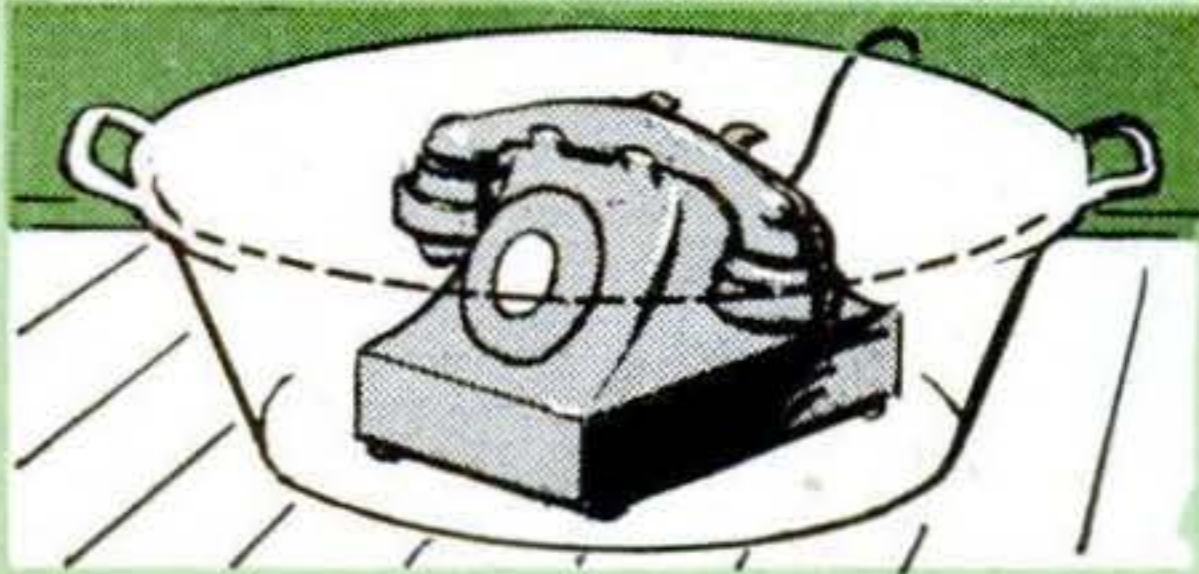

YOU'LL HEAR THE PHONE when it rings upstairs while you are working in the basement, even with shop machines running, if you stand it in a metal pan and place it on the floor.

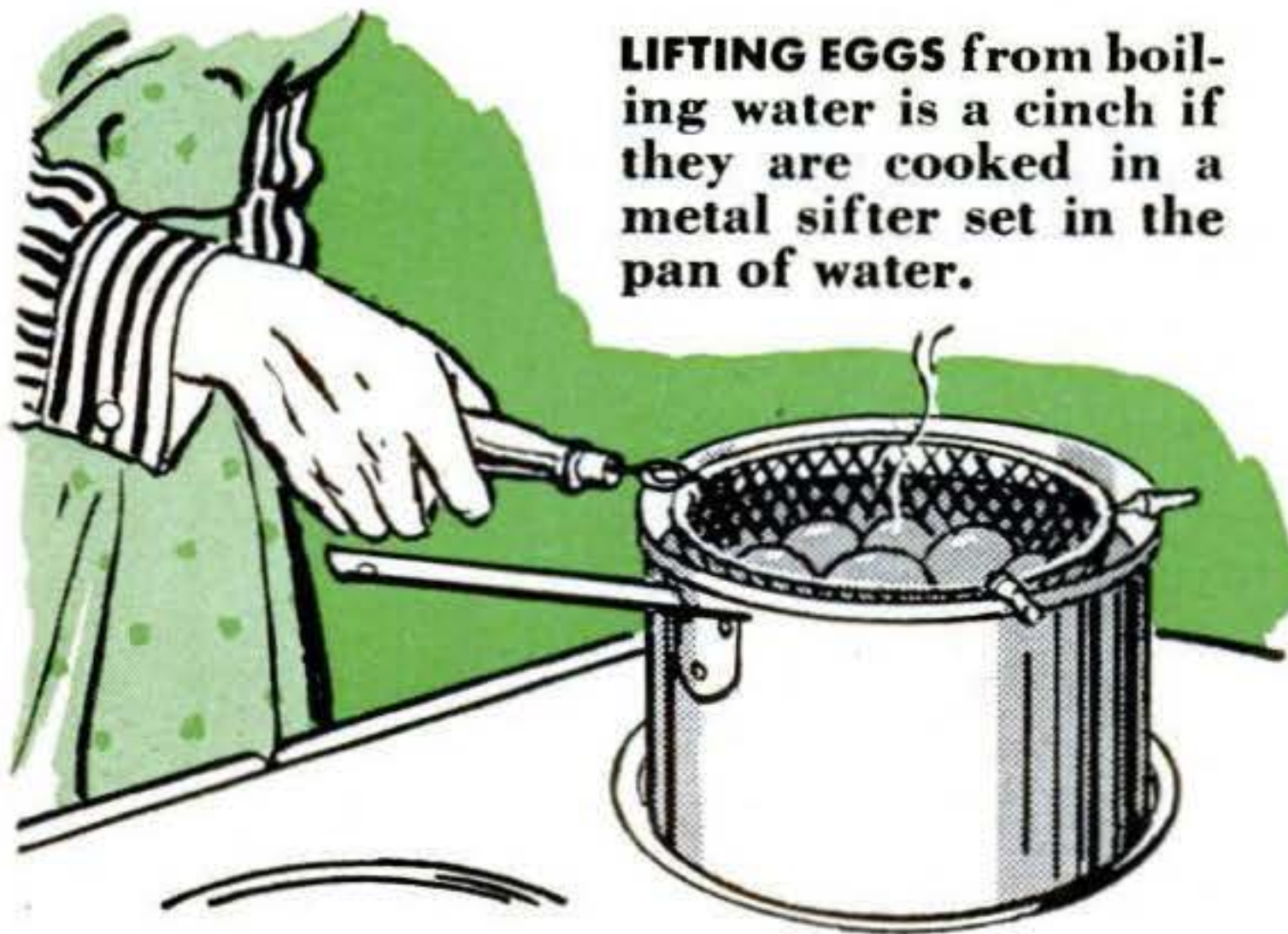

LIFTING EGGS from boiling water is a cinch if they are cooked in a metal sifter set in the pan of water.



WATER SPOTS on a newly painted white ceiling can be made less conspicuous by covering them with one or two coats of liquid white shoe polish. It does an adequate job until you repaint.

TO PLANT SEEDS of very small size, try using a salt shaker. It spreads them evenly, and you can vary the flow by how much you tilt it.

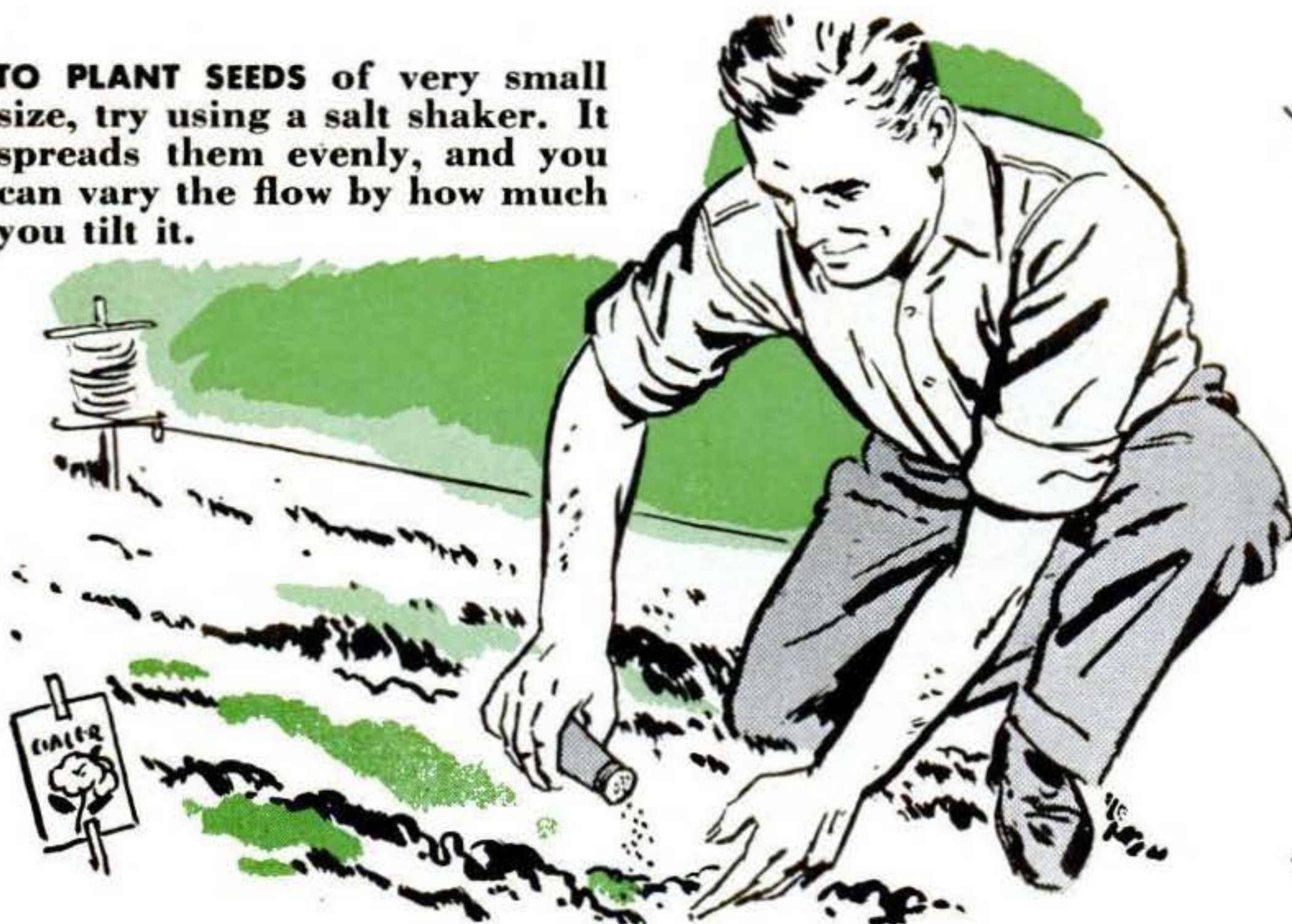

A BROKEN COVER need not end the life of a casserole dish. Aluminum foil bent tightly around the sides of the dish will serve just as well as a lid.

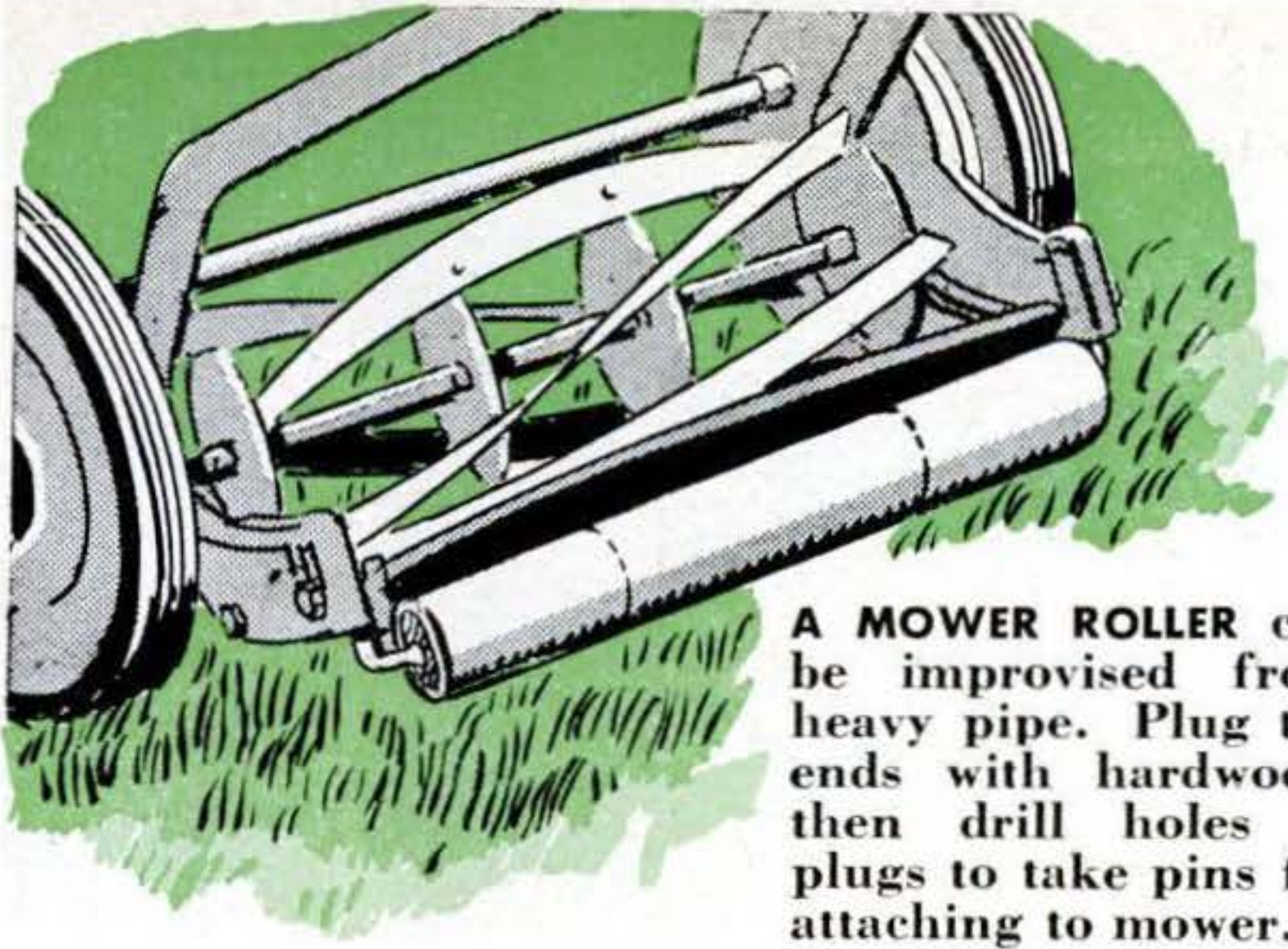

A MOWER ROLLER can be improvised from heavy pipe. Plug the ends with hardwood, then drill holes in plugs to take pins for attaching to mower.

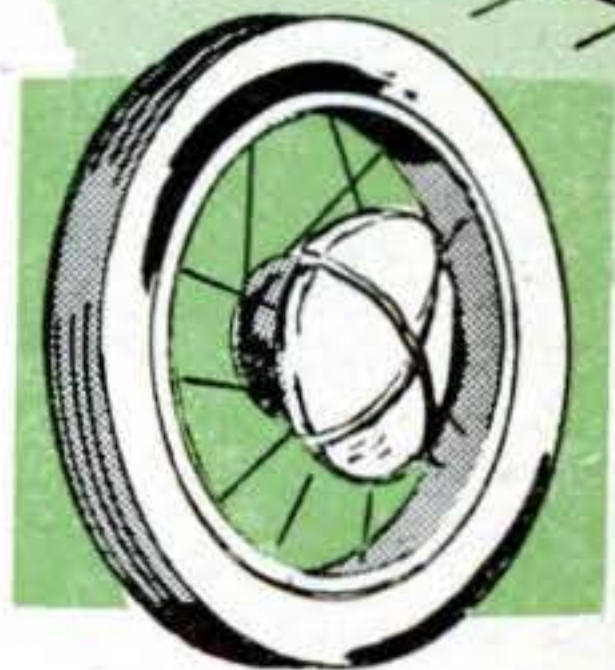

CARRIAGE HUB CAPS often scratch woodwork when passing through doorways. Sponge-rubber powder puffs tied over the hub caps will eliminate this problem.



WHEN STORING BLANKETS of wool, clean them and place on top of the storage pile so they remain porous and fluffy. Crushed or soiled blankets lose the air cells which make them warm.

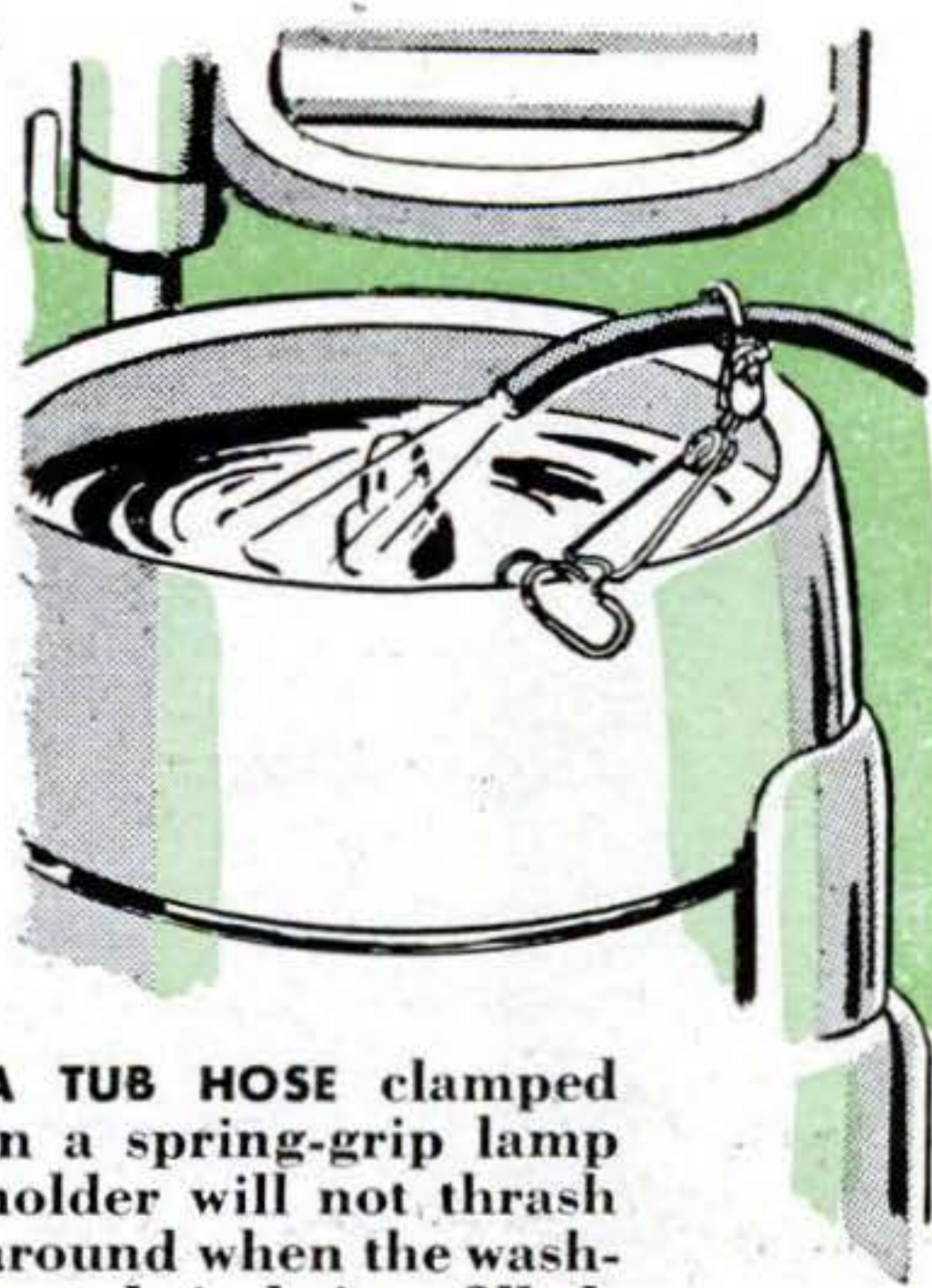

A TUB HOSE clamped in a spring-grip lamp holder will not thrash around when the washer tub is being filled.

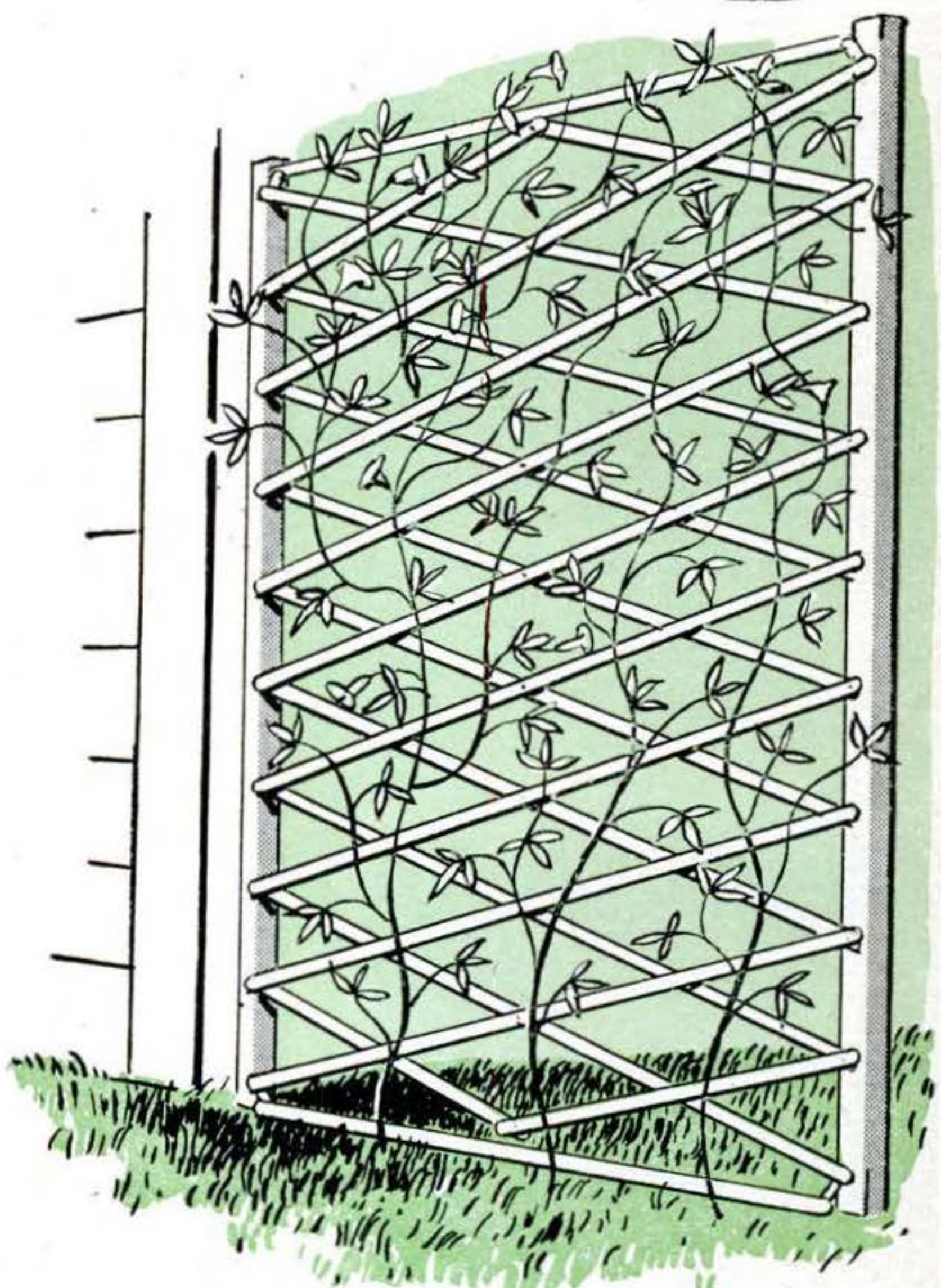

A GARDEN TRELLIS for climbing vines can be made easily from a folding stairway gate. Open it to its full width and hang it vertically to the side of the house or to two upright posts set in the ground.

Making Your Own Black-Top Driveway



Ready to use right out of the drum, liquid asphalt poured over stone makes a tough, long-wearing surface.

HOW much of your gravel driveway did you shovel away with the snow last winter?

If you're tired of feeding your driveway a load of gravel or crushed stone every couple of years, you can use a cold-asphalt binder to lock the next load down for keeps. You'll have a driveway with a hard, long-wearing surface besides.

The binder is the same asphalt used to build highways and airport runways, but it's now available in small quantities—52-gallon drums. Called Colas, it is made by the Shell Oil Co. It's an asphalt emulsion—tiny bits of asphalt suspended in water. Be-

cause water is used, there is no fire hazard and the mixture won't kill grass or shrubs. It comes ready to use from the drums. You don't have to heat it.

The photos show you how to put a hard top on an existing driveway. If you're starting from scratch with a new driveway, it's best to put down form boards at each side. Then excavate about 8" deep for the driveway. Put in 5" of fill—cinders or gravel. Roll or tamp the fill.

Spread a 2"-thick layer of 1" stone on the fill. Roll the stone. Pour Colas—about three-quarters of a gallon per square yard—over the stone. Follow with $\frac{3}{8}$ " stone, spreading about 25 lb. over each square yard. Roll again. Pour on more Colas. Put on another layer of $\frac{3}{8}$ " stone and roll it again. Wait about two hours before using the drive.

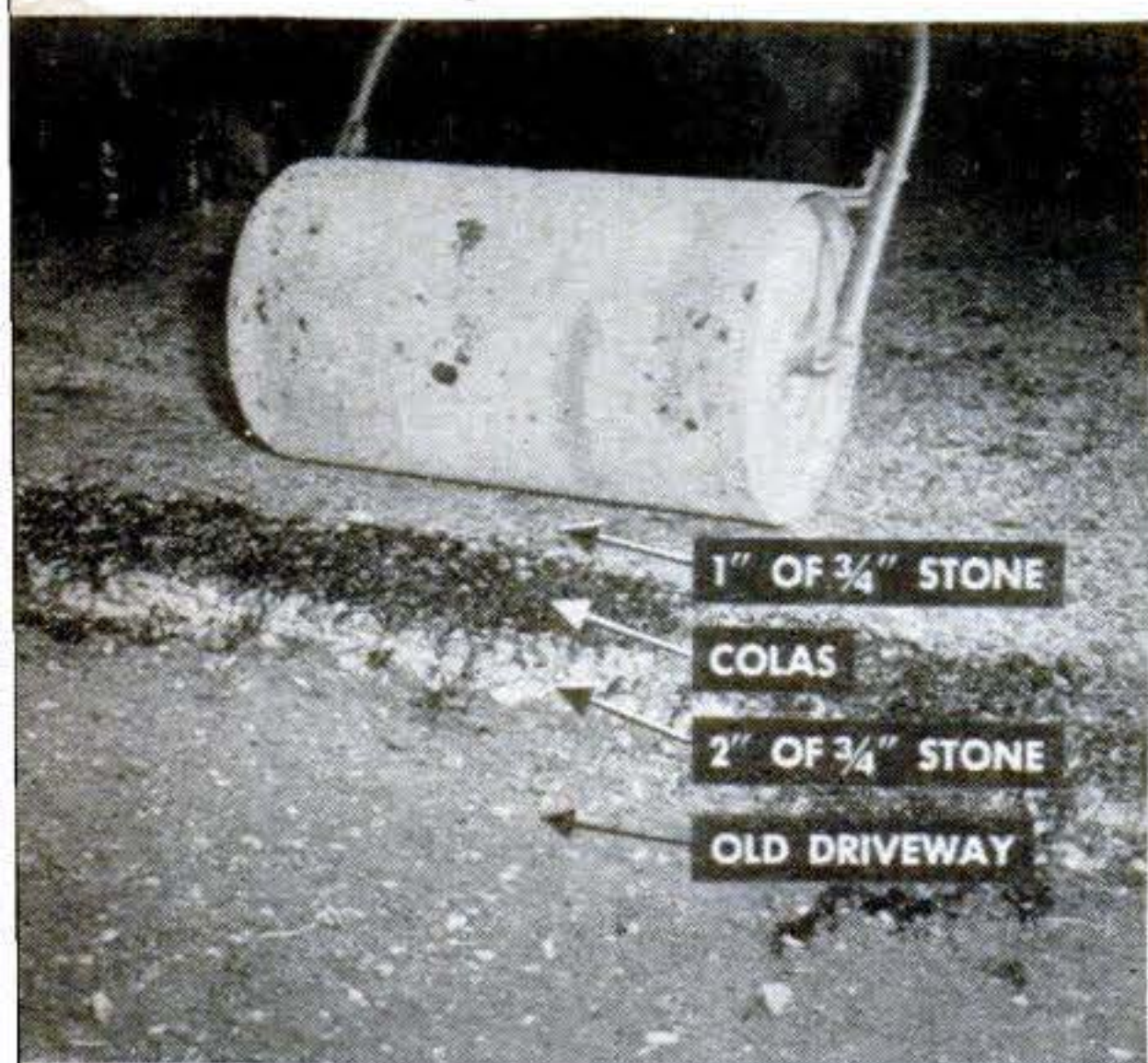

CROSS SECTION. These two photos show layers of stone needed for waterproof driveway. (Note that top layer in photo at left is same as bottom layer in photo at right.) Old driveway was raked to fill holes and to grade it for drainage. Colas was sandwiched between each layer of stone and the stone rolled. Final layer is $\frac{3}{8}$ " stone.

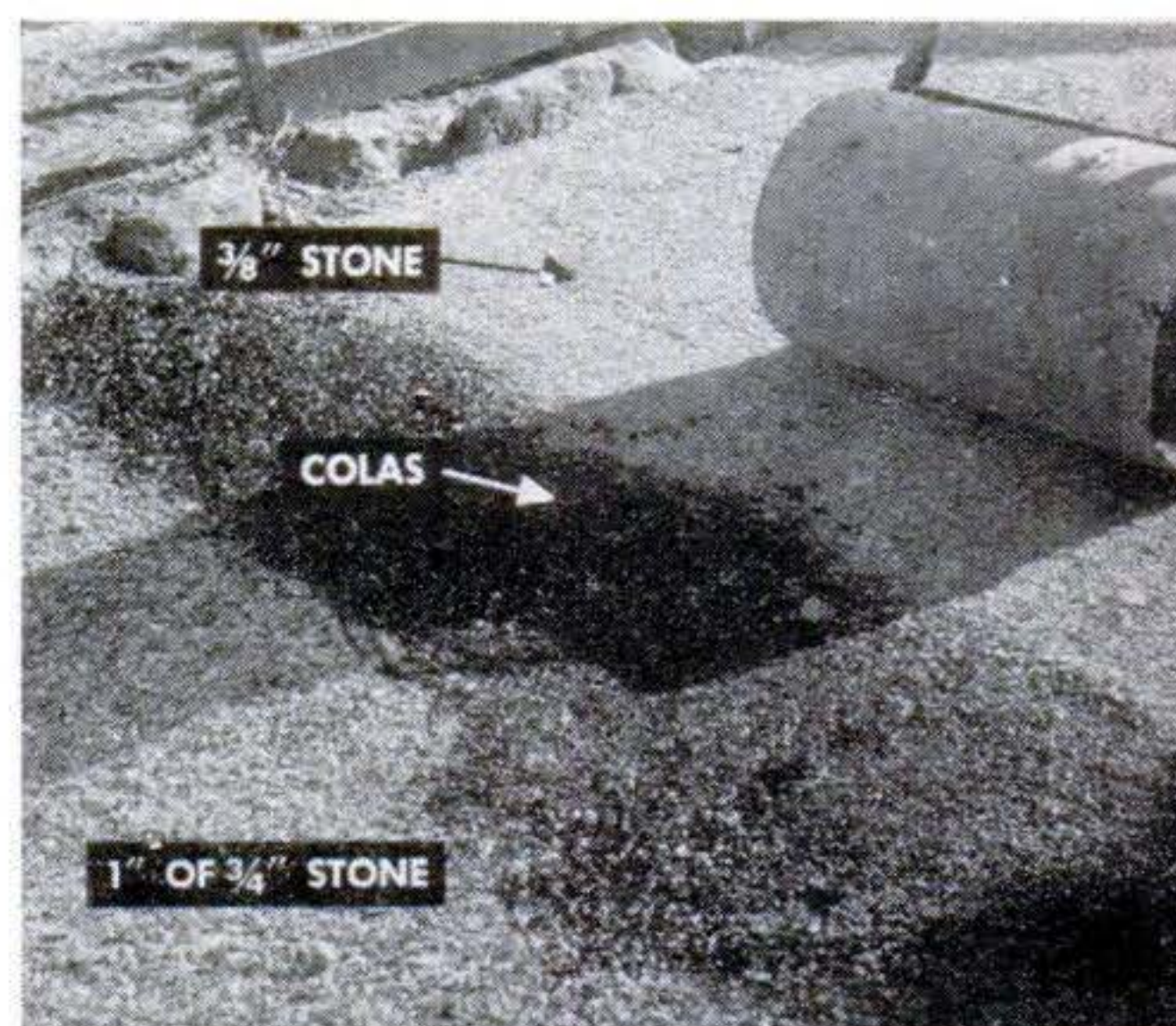



POURING. Garden sprinkling can with spout made from old tin can gets Colas on evenly. Big can with holes punched in bottom will do. Kerosene cleans Colas off tools.



SMOOTHING. Shovel will handle spreading of stone, but push broom is good for final leveling before rolling. Water-filled lawn roller was used to pack stone.



PROTECTING CONCRETE. Sidewalks, curbs and garage aprons can be protected (above) from Colas stains by covering them with building paper or a layer of sand.

TAMPING. In spots where roller won't go—such as against this concrete walk—use tamp to set stone solidly. This one was made of one-by-threes and block of heavy wood.



Safe Swing for Small Fry

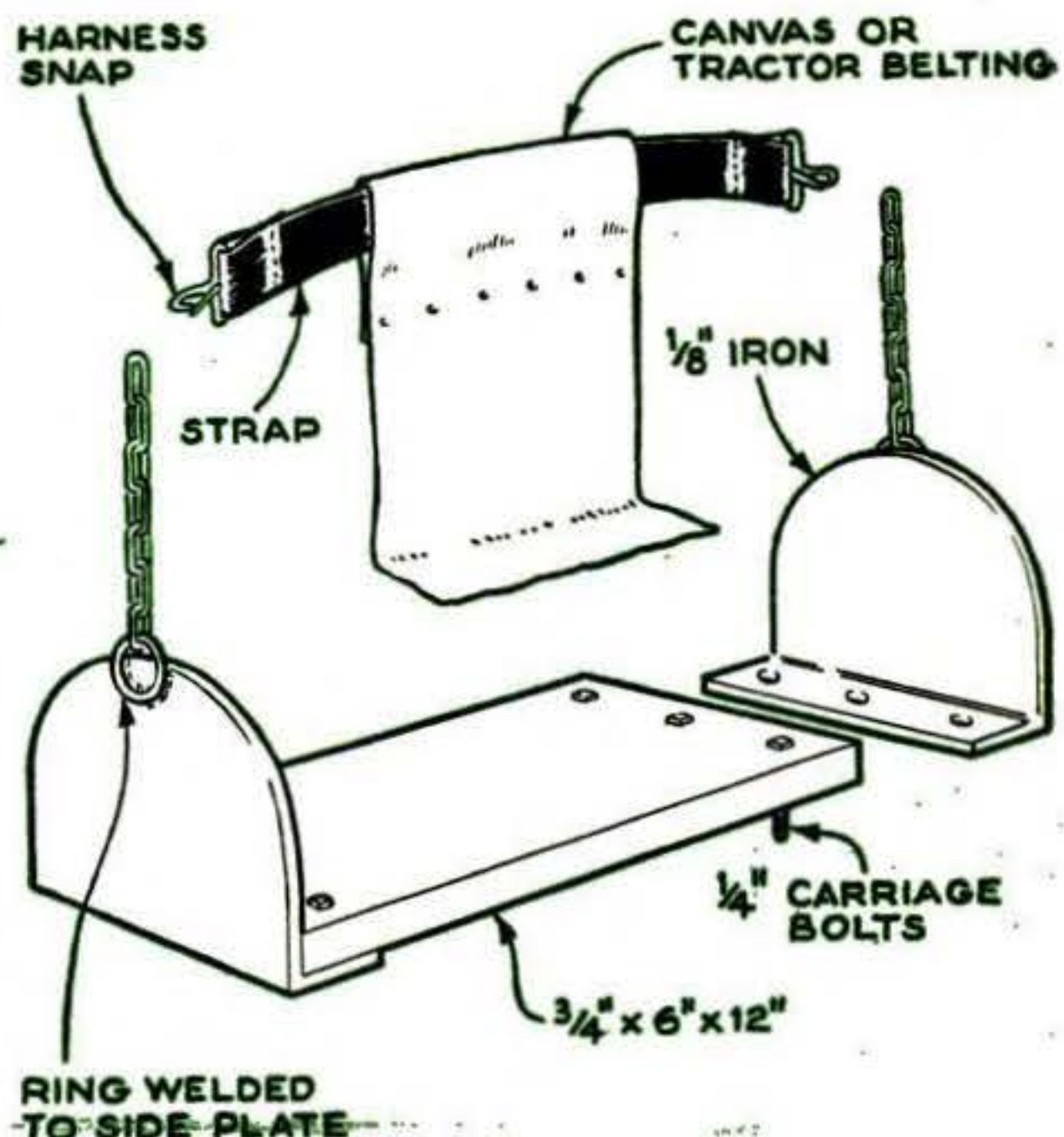

WITH this seat, a small child cannot fall backward out of the swing. The back support is comfortable because it will yield to the child's weight. It can be made mostly from junk-box materials.—Hi Sibley, Nuevo, Calif.



Jar Caps Cast Lead Weights

LAMPS, book ends, doorstops and many other projects require additional weight for stability. Jar lids make ideal molds for casting flat weights of lead, which can be melted right in the jar lid on the kitchen range. The weights are easily drilled to make holes for screws that attach them to the project.—N. Mocharniuk, Gilboa, N.Y.

Clothespins Make Wood Pegs

WOODEN pegs look better than nails or hooks for hanging clothes. Clothespins, sawed off as shown and driven into drilled holes, make good pegs. Drill the holes a little smaller in diameter than the pegs to insure a tight fit, and dab on glue.—V. H. Lamoy, Upper Jay, N.Y.

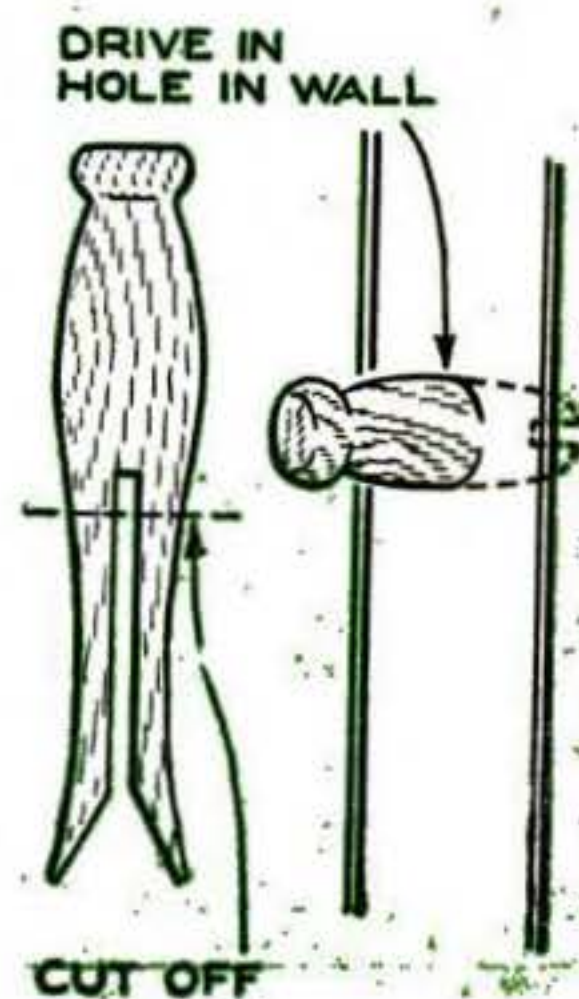

Platform Rings Doorbell When Pet Wants to Come in the House

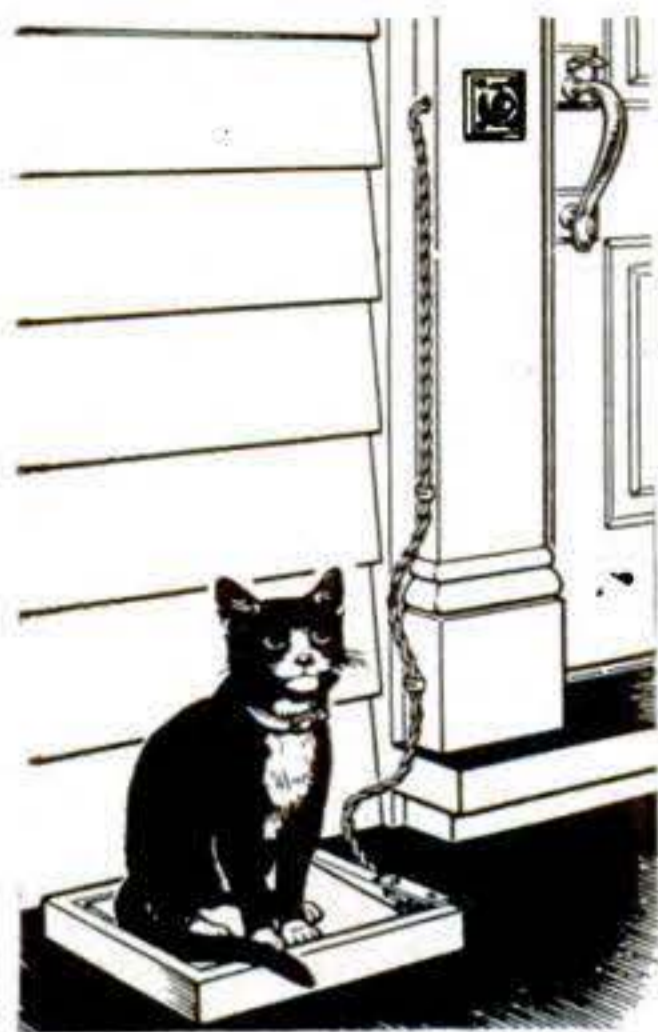

OUR cat doesn't claw the screens or scratch the woodwork to let us know he is waiting to get in. He announces himself by perching on this platform bell ringer. It gives one short ring when he climbs on, but does not ring continuously.

I made the plywood platform 1' square.

This size doesn't clutter the porch and is just right for most pets; those too large to sit on it can work it with their front paws.

The platform is in a frame and hinged at one edge. At the other edge I attached a spring that yields under the animal's weight but levels the platform when he steps off. I notched a corner of the frame for two springy contacts and wired them to my doorbell. A metal pin in the platform brushes both contacts as it passes between them.

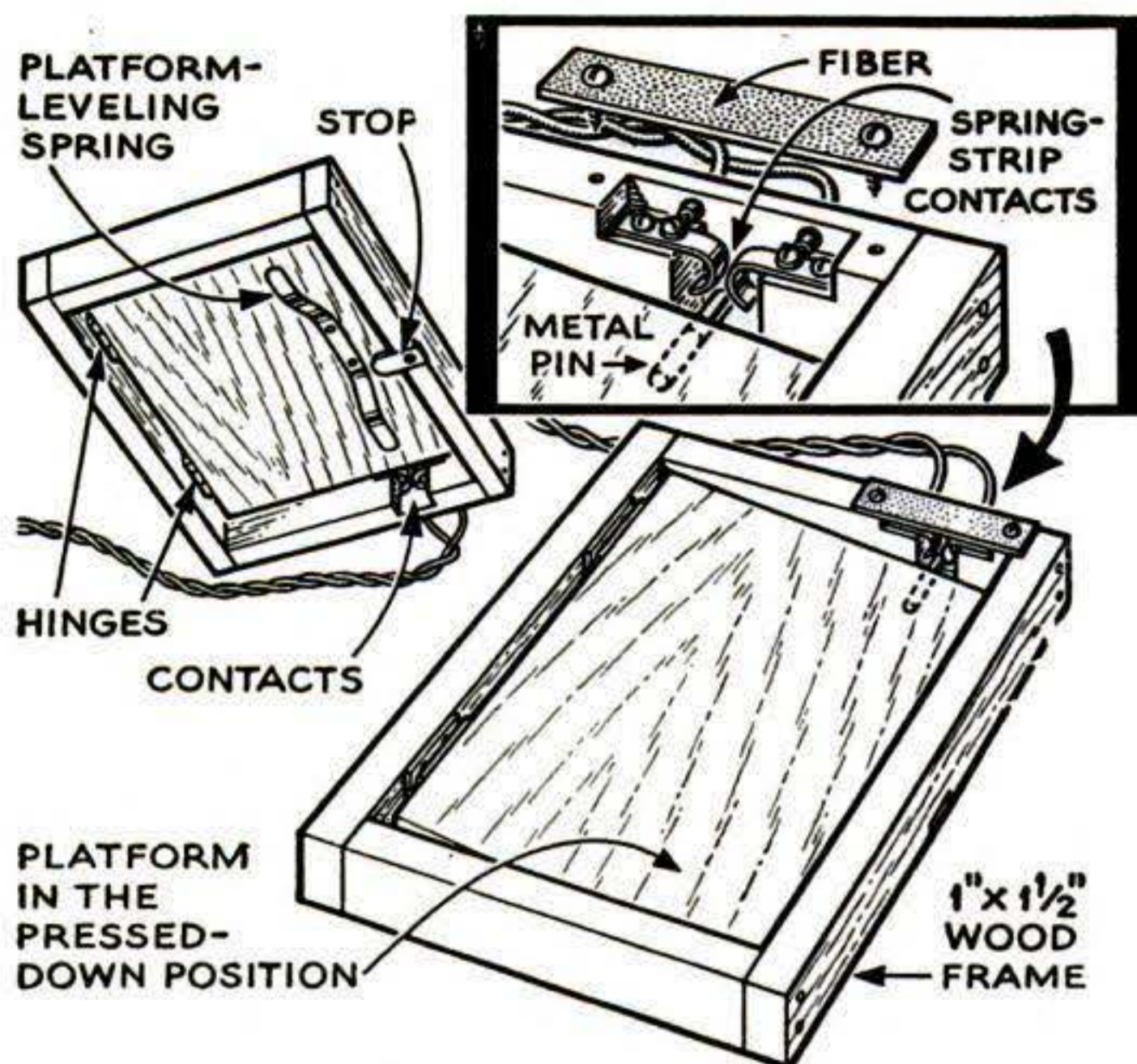

The ringer is placed out of line of door traffic and a coat of light paint makes it visible even in shadows. Other members of my family find the toe-operated signal useful when they come home from shopping with armloads of parcels.—*Hugh Lineback, Stillwater, Okla.*

Old Awnings Make Pup Tent



A SMALL tent for a child's play yard can be made from discarded awnings. Cut the fringed edges—if any—from two awnings. Sew them together at the top and at one end. Leave the other end open. A couple of poles and stakes complete the tent.—*C. V. Mobberly, New Matamoras, Ohio.*

Weed Guards Made from Tires



WEEDS and stalks can be kept out of plow-beam notches by sections cut from old tires. Carl Bieri of Latham, Mo., wires the tire sections to the beams, as shown above. Weeds are brushed off by the rounded faces of the tires.—*L. H. Houck, Jefferson City, Mo.*

Eave Trough Serves as Nail Tray

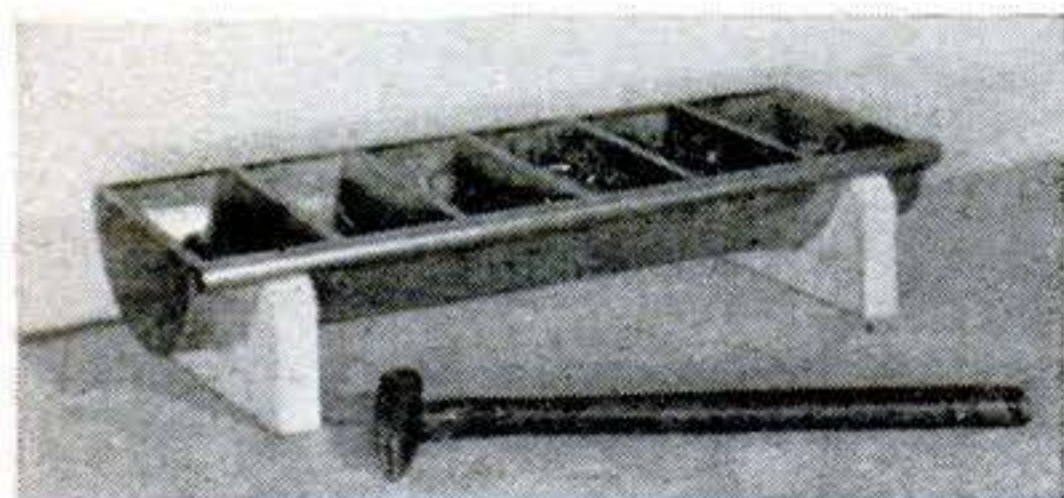

WITH a scrap of eave trough and a pair of concave blocks you can turn out a handy nail tray. Suit yourself about the length and the number of compartments. The partitions can be made of $\frac{1}{4}$ " or $\frac{3}{8}$ " plywood.—*Victor H. Lamoy, Upper Jay, N.Y.*

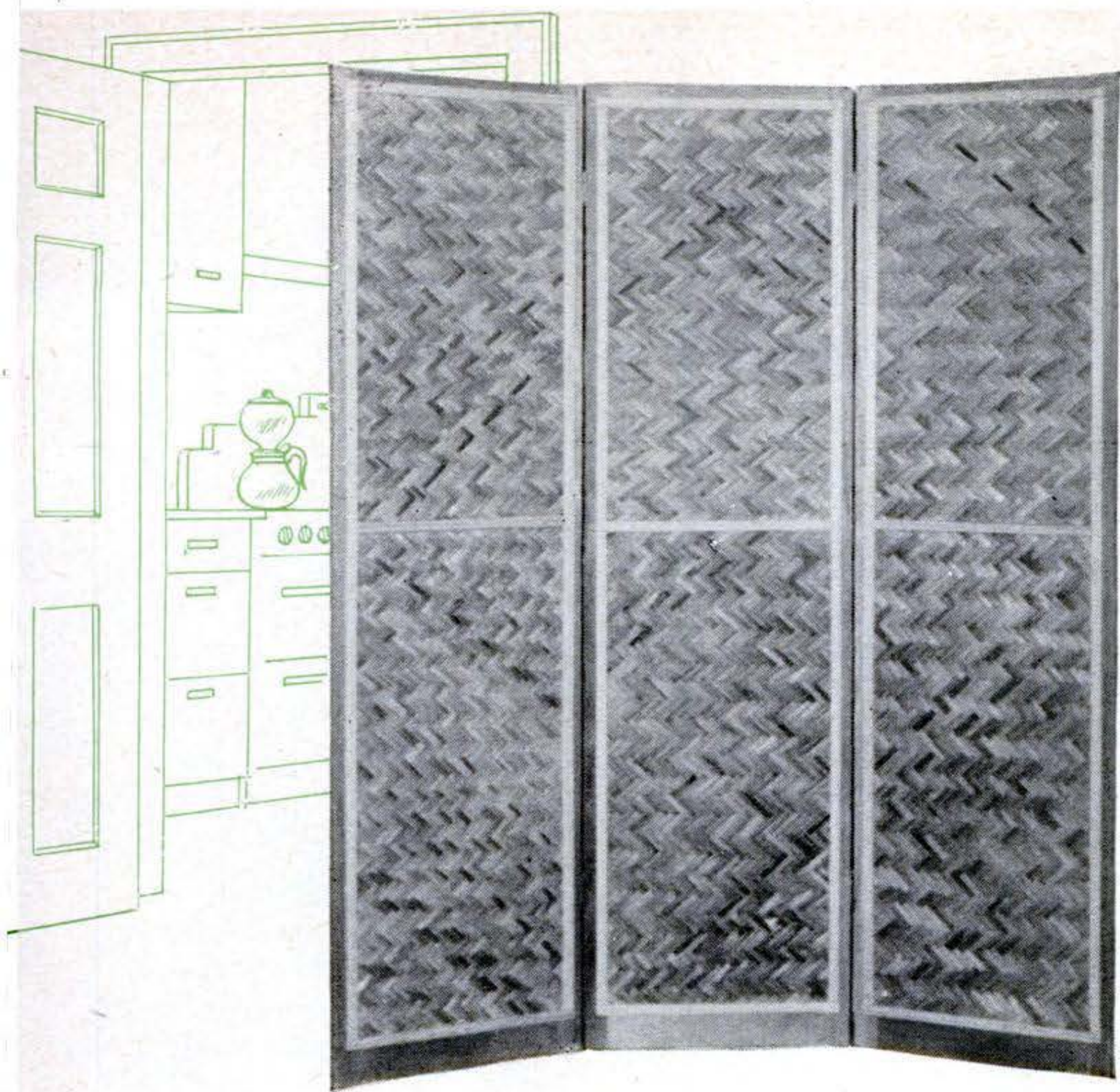

Folding Screen Is Hammer-and-Saw Job

Straw mat on a wood frame makes this room divider.

A MODERN folding screen not only makes two rooms out of one, but decorates each. Building it is a simple hand-tool job.

I covered this screen with straw matting because it has a cool look, keeps its shape and is easy to clean. To suit your decorative scheme you could substitute burlap, painted canvas or stiff cardboard trimmed with wallpaper. Construction is the same for all.

I used 1" by 2" redwood for all frame members except the bottom rail. A 3½" strip across the bottom gives the screen greater stability. The joints were glued and butted and reinforced with corrugated fasteners. This method is simple and plenty strong for a light frame; but if you use heavier stock or more sections, it would be better to dowel or tenon the joints.

After sanding the frame smooth I laid sheets of straw matting over it and fastened them to the frame with molding strips and 1" brads. Hinging the sections and spraying the screen with clear lacquer finishes the job.—*John Rogers, Dallas.*

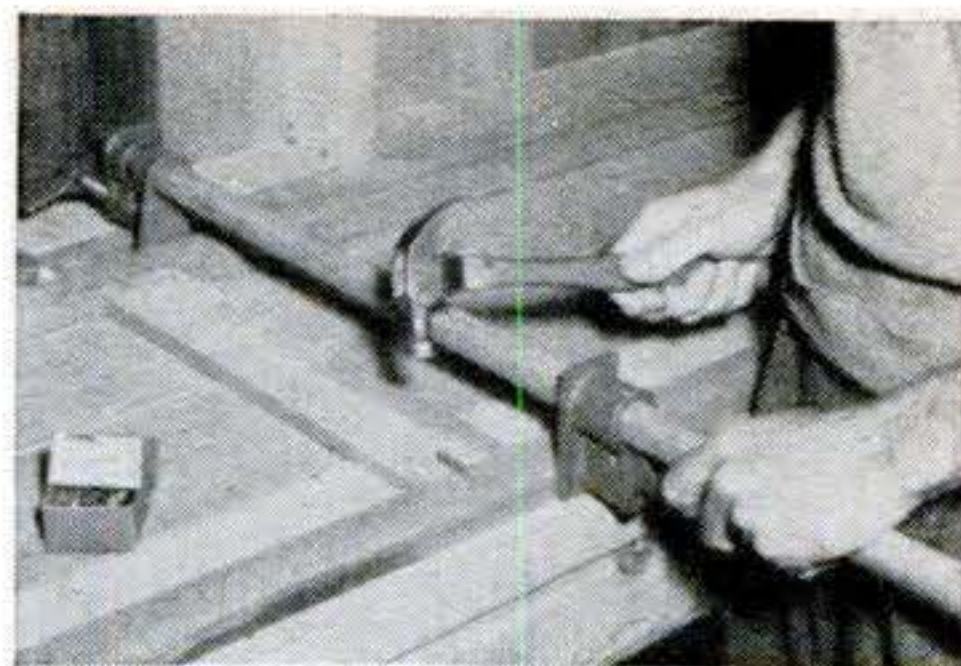
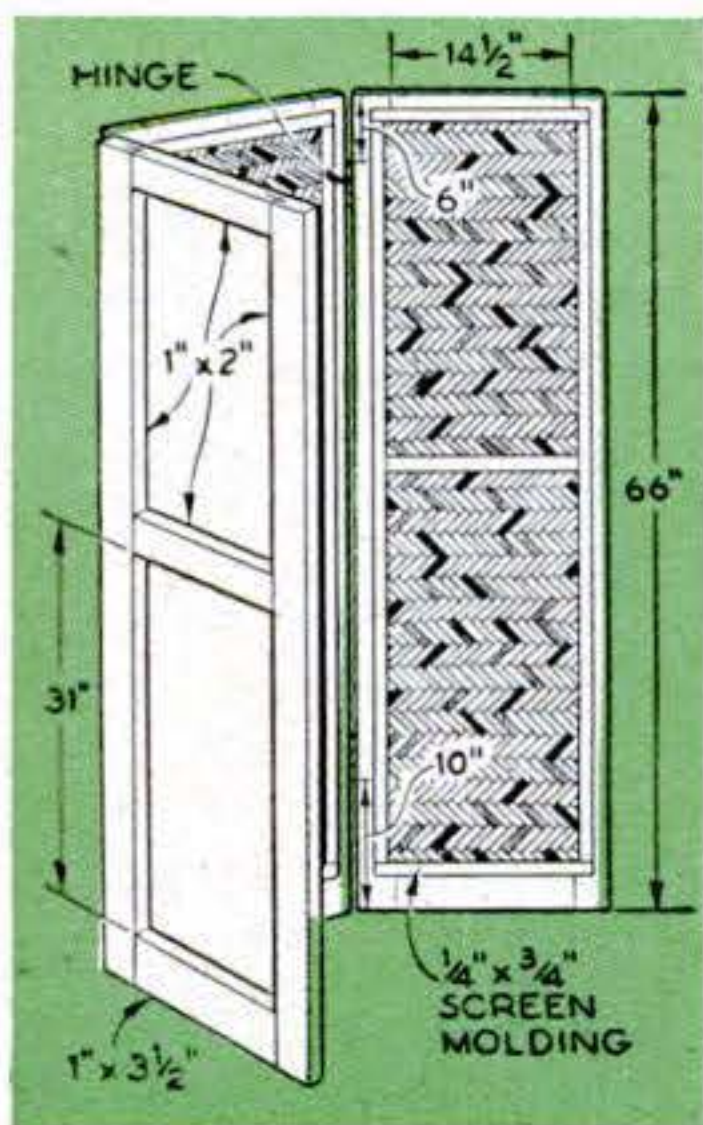

GLUE AND CLAMP each frame. Measure the corners diagonally to make sure that they are square, and reinforce the butt joints with corrugated fasteners. Dowel heavier screens.

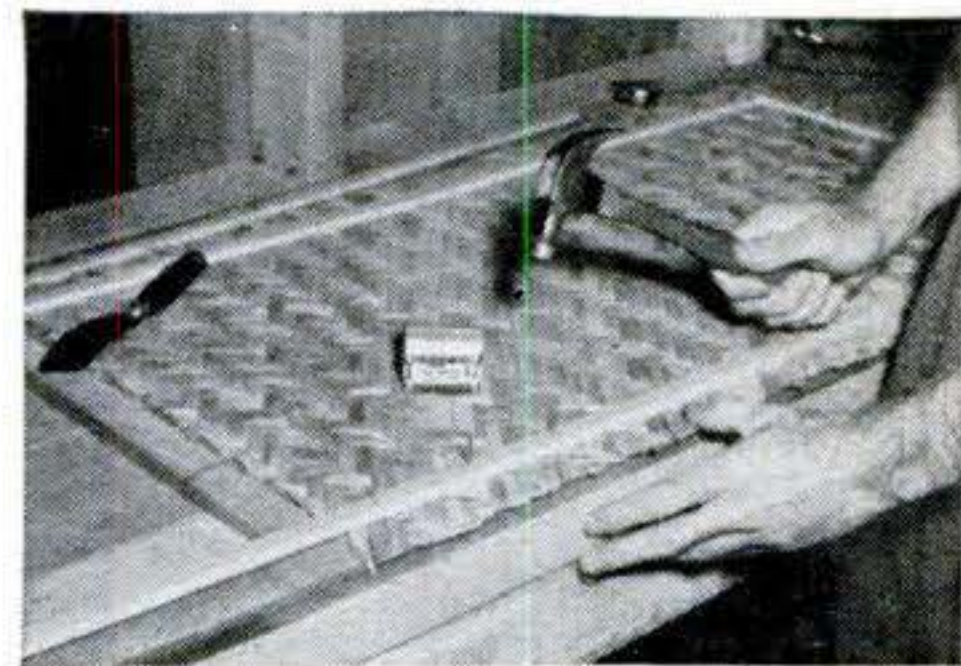

COVER THE FRAME with straw matting. Leave enough excess so that you can pull it tight as you nail the molding. If you need two pieces of mat, butt them under center molding.

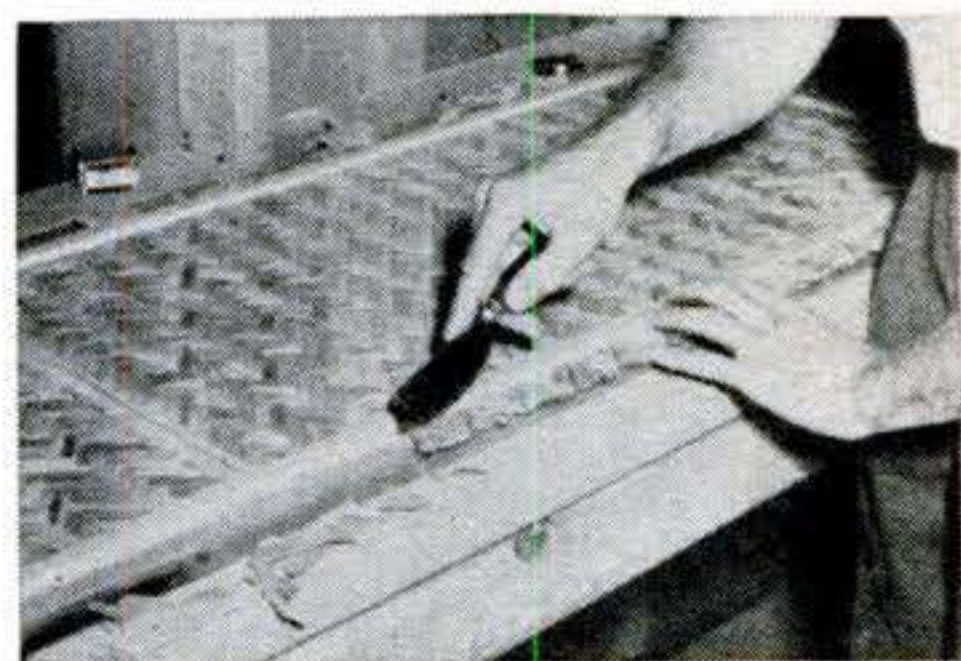

TRIM EXCESS MATTING with a sharp knife or razor. Test the screen for loose edges. If you find any, drive a few extra brads to hold it securely all around the frame.

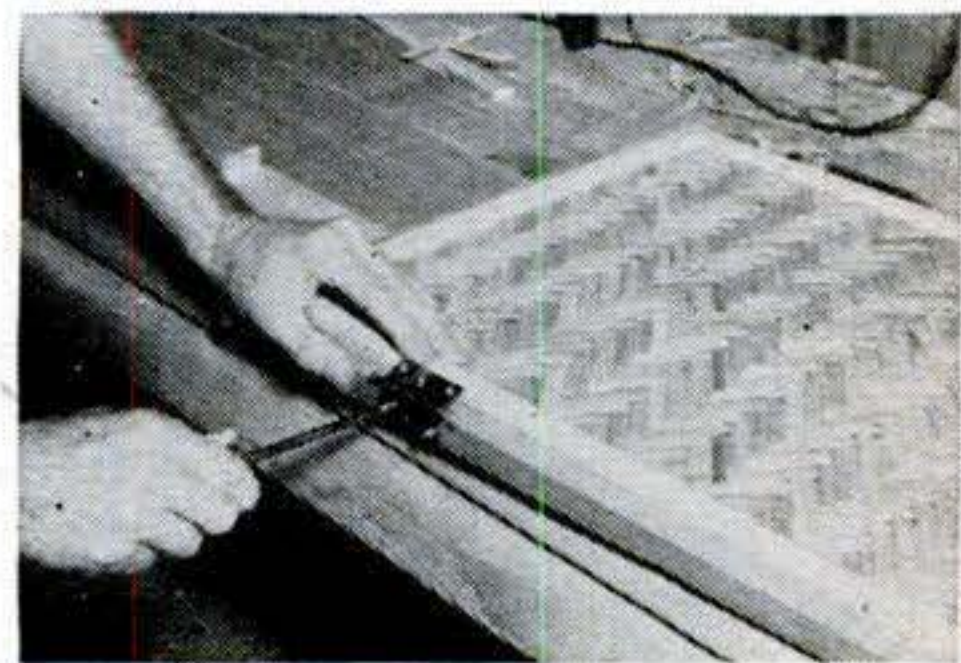

HINGE THE SECTIONS with 1 3/4" by 2" brass butts. Turn them so both wings fold in the same direction; for some uses a back-to-back Z arrangement might be better.

Putting Inboard Power in a Rowboat

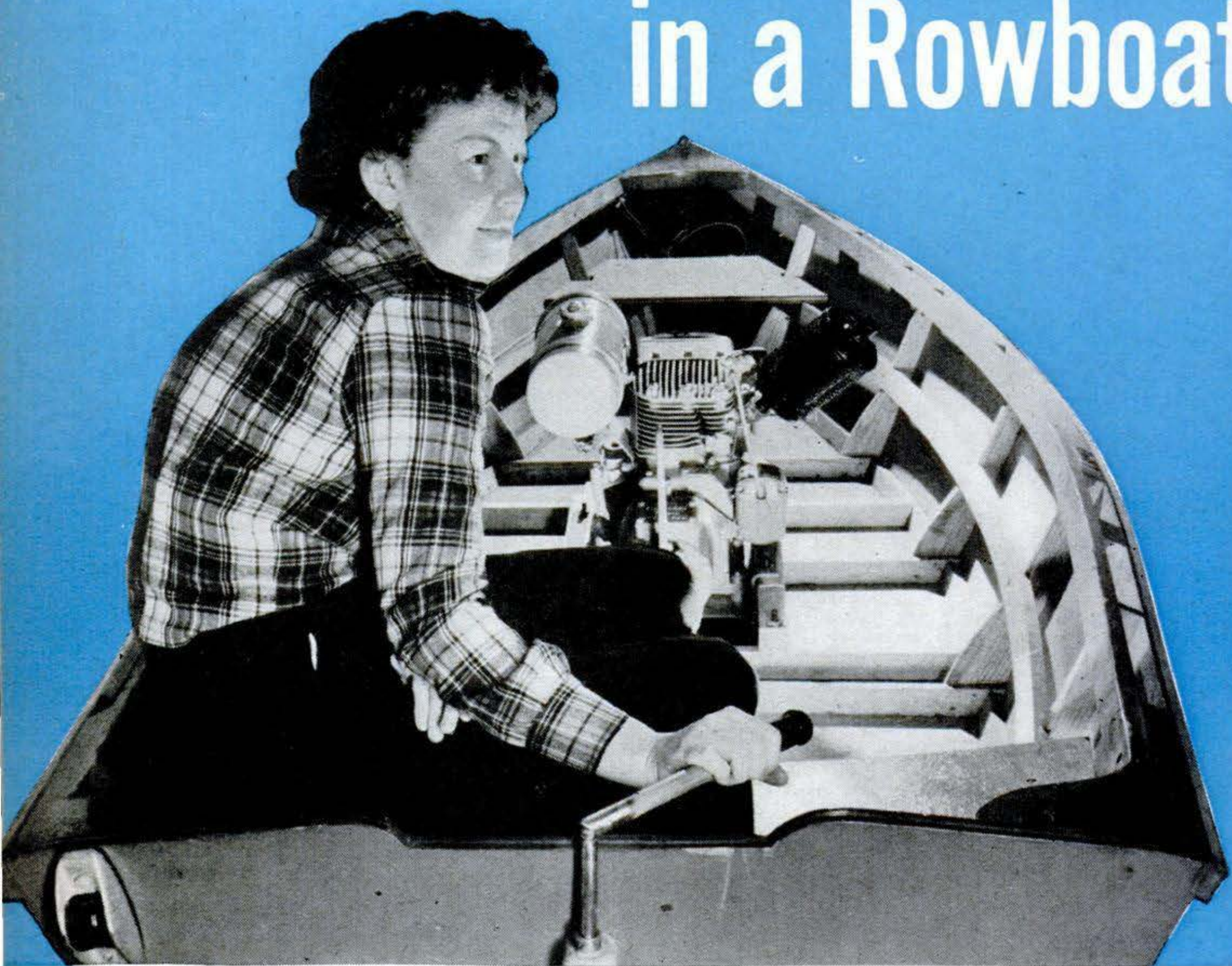

You can stow away the oars next time you go fishing if you install one of these small air-cooled engines amidships.

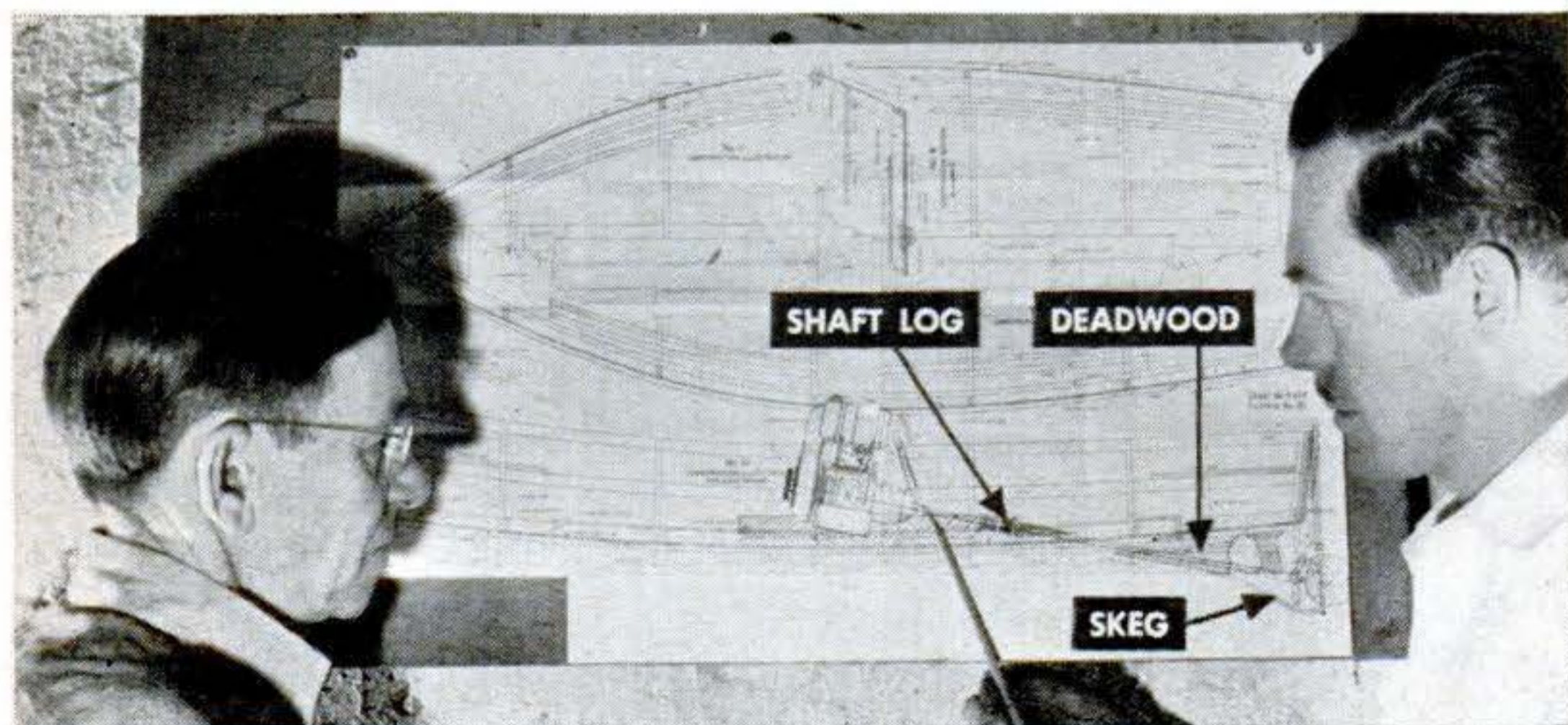

LAYOUT. Much can be learned from plan of boat and motor. Paste side view of engine on profile of boat. Drawings must be same scale. Engine was photographed from manufacturer's bulletin and scaled with enlarger.

By E. F. Lindsley

LIKE most of the fishermen I know, my yen to seek out the big ones at the other side of the lake is often frustrated by a white-collar constitution powering the oars. An in-board power plant for my row boat, using a fast-starting, heavy-duty engine that could

put out horsepower all day long, appealed strongly to me.

From the beginning, it was a choice between the economy of a secondhand put-put without a reverse gear and the higher cost of a new or rebuilt engine with a reverse gear, bronze fittings and stainless steel shaft.

Combinations. More important than

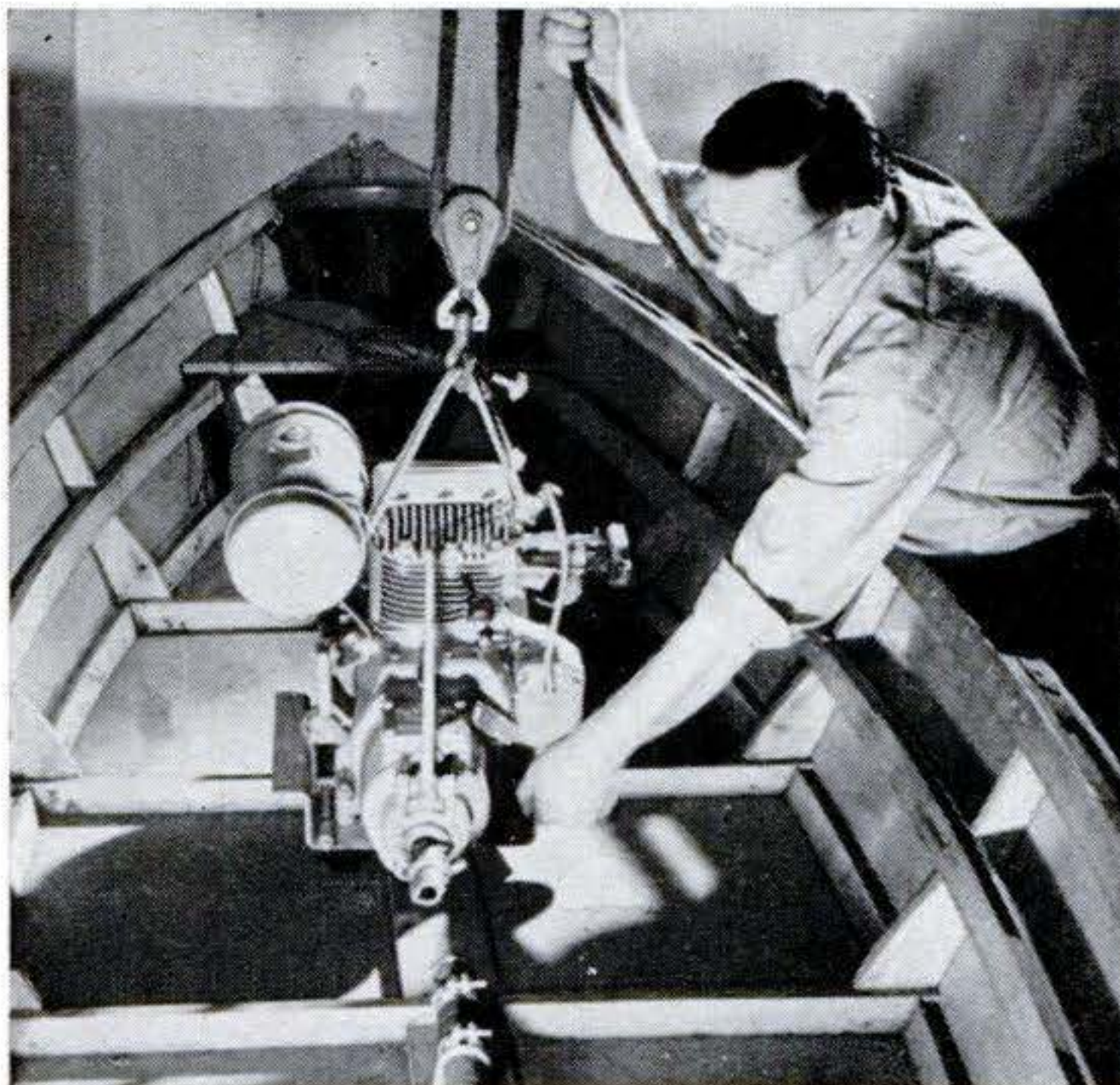

1 ENGINE LOCATION. Lower engine into experimental location to help visualize what's needed for engine mounts. Approximate location of shaft log also was noted.

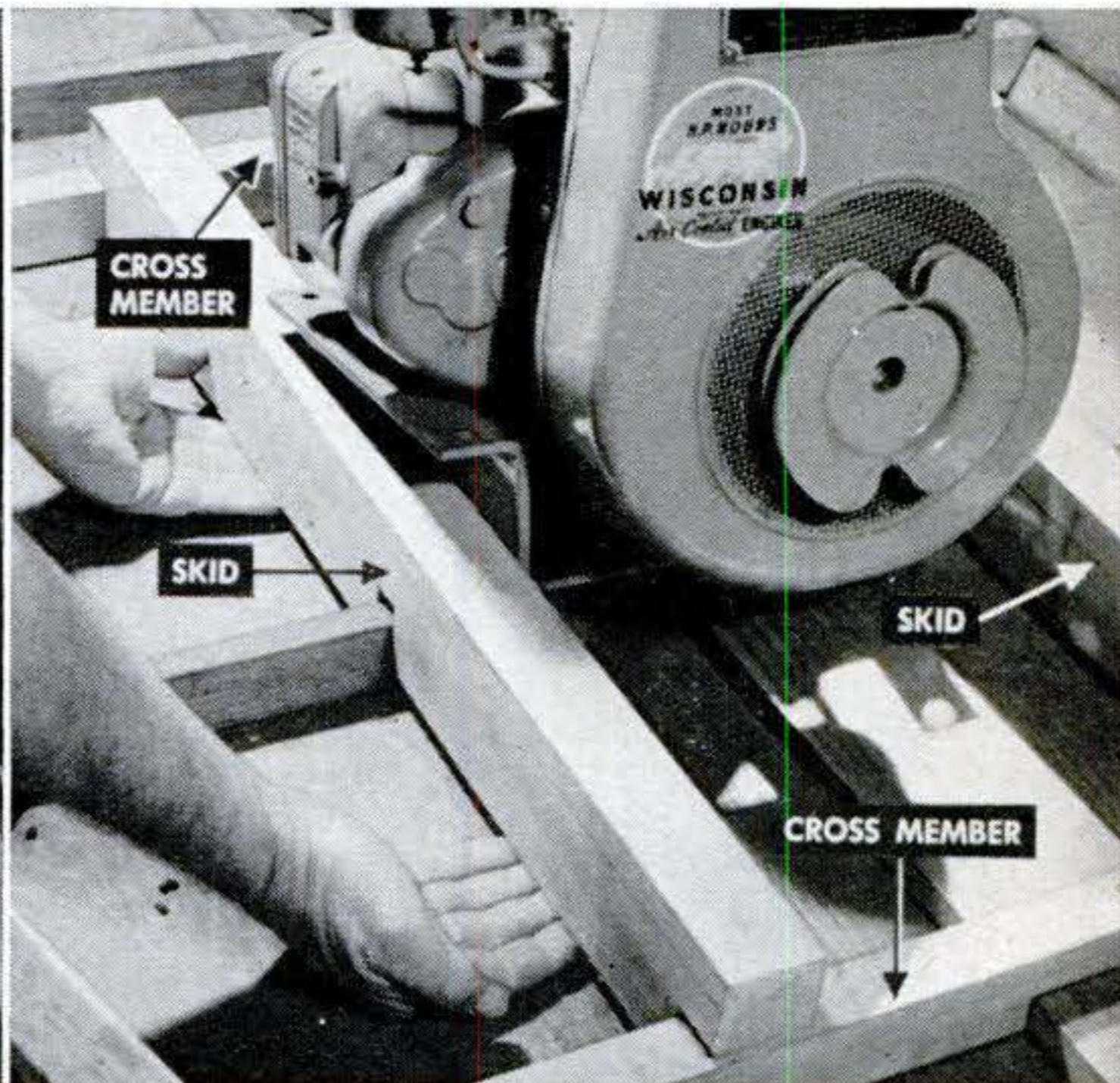

2 ENGINE SKIDS. Made of hardwood, skids and cross members must be fitted to match boat structure. Clearance under skids permits flushing of oily bilge.

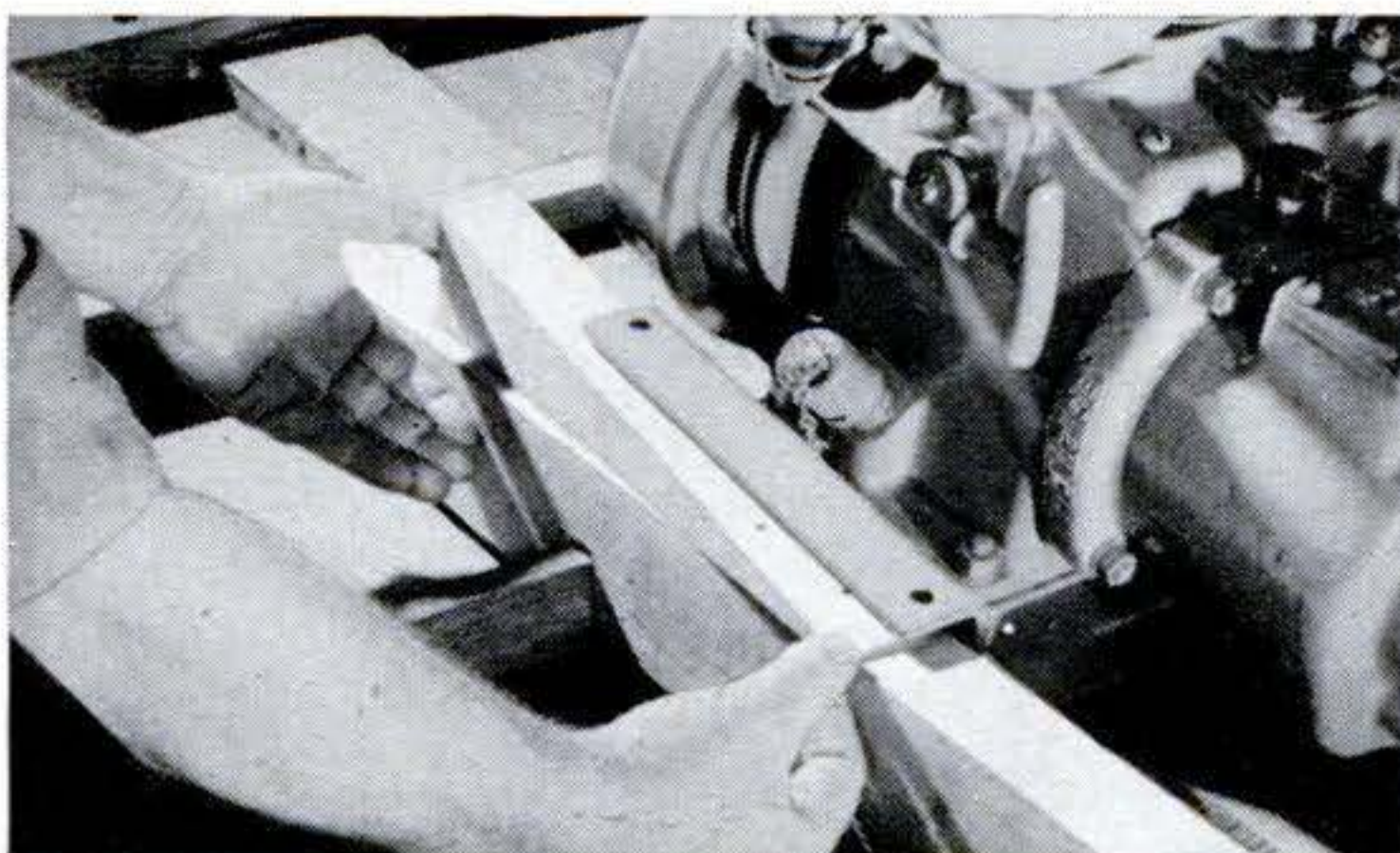

3 WEDGES. Cut wedges to angle specified by engine maker. These are 11° . Engine builder said to stay under 15° . Angle will be greater when boat is under way.

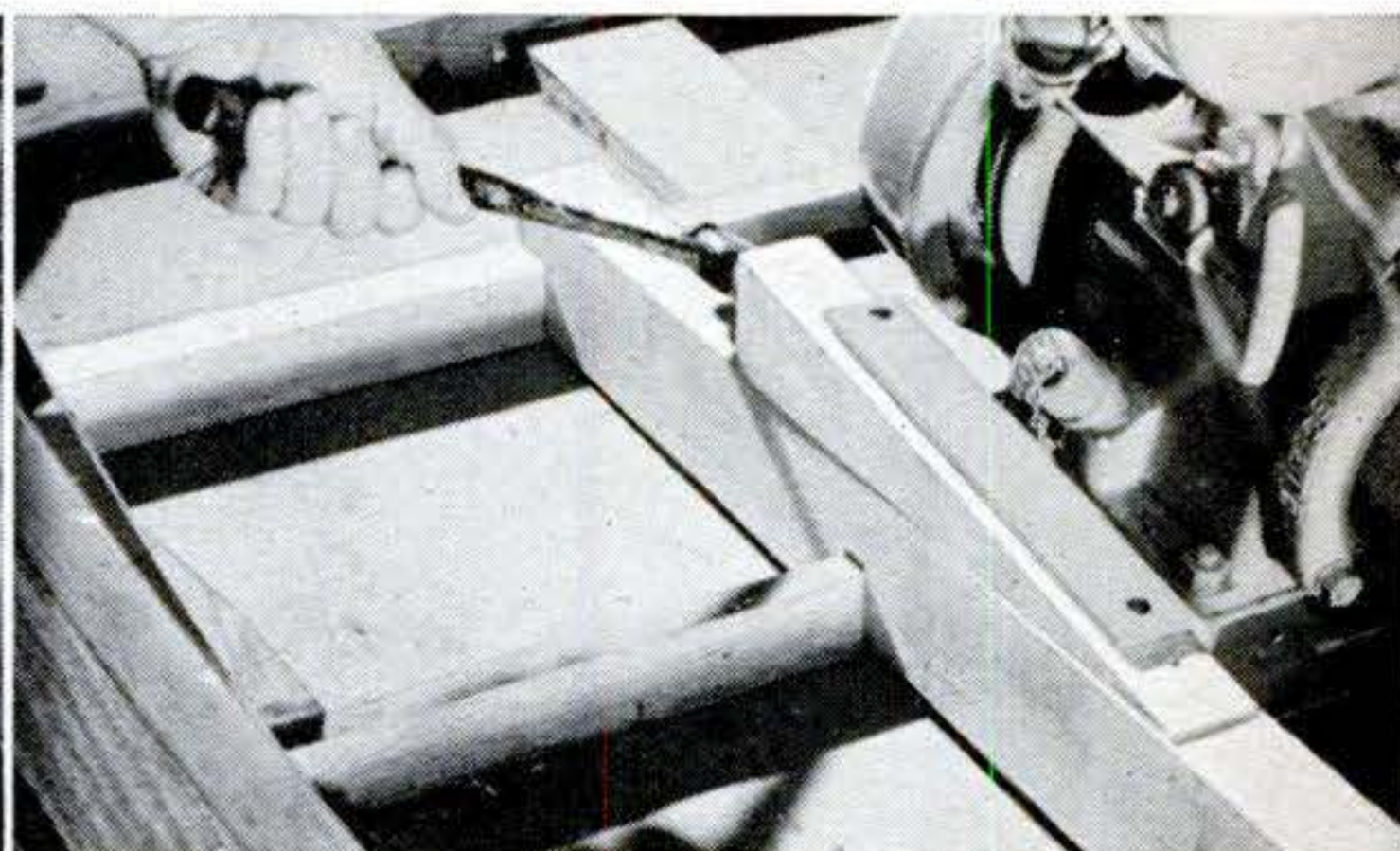

4 FINAL LINE UP. Locate engine accurately so shaft will be on center and run true without offset. When properly lined up, mark bolt-hole locations and make alignment marks.

5 ASSEMBLED ENGINE MOUNT. Bolt engine to mount and try assembly for final fit. Don't bolt mount to boat framing members since next step requires turning hull upside down.

6 OLD KEEL. Saw off old keel and hacksaw any screws to provide true working surface for mounting rear strut and deadwood. After sawing, plane and sand surface smooth.

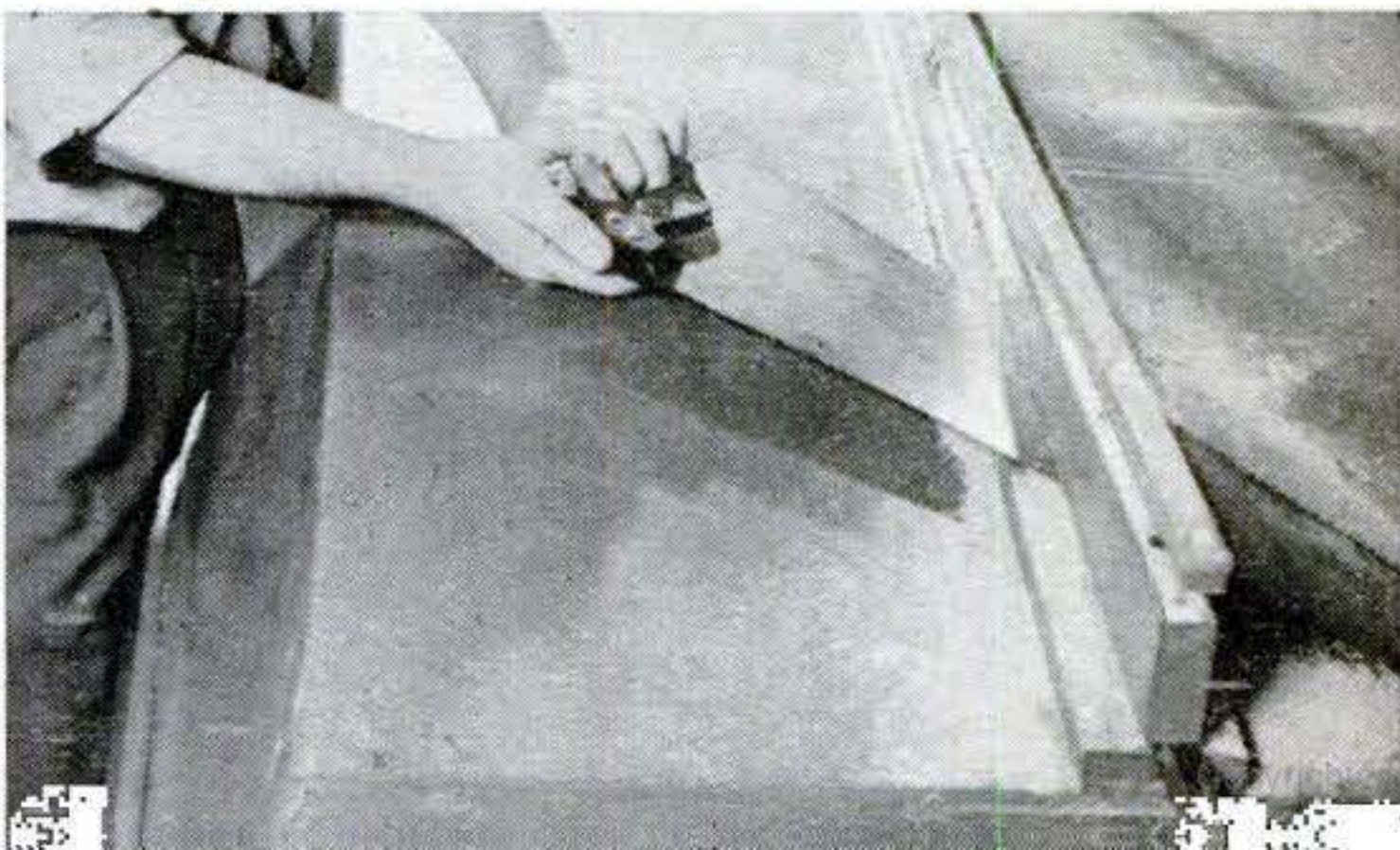
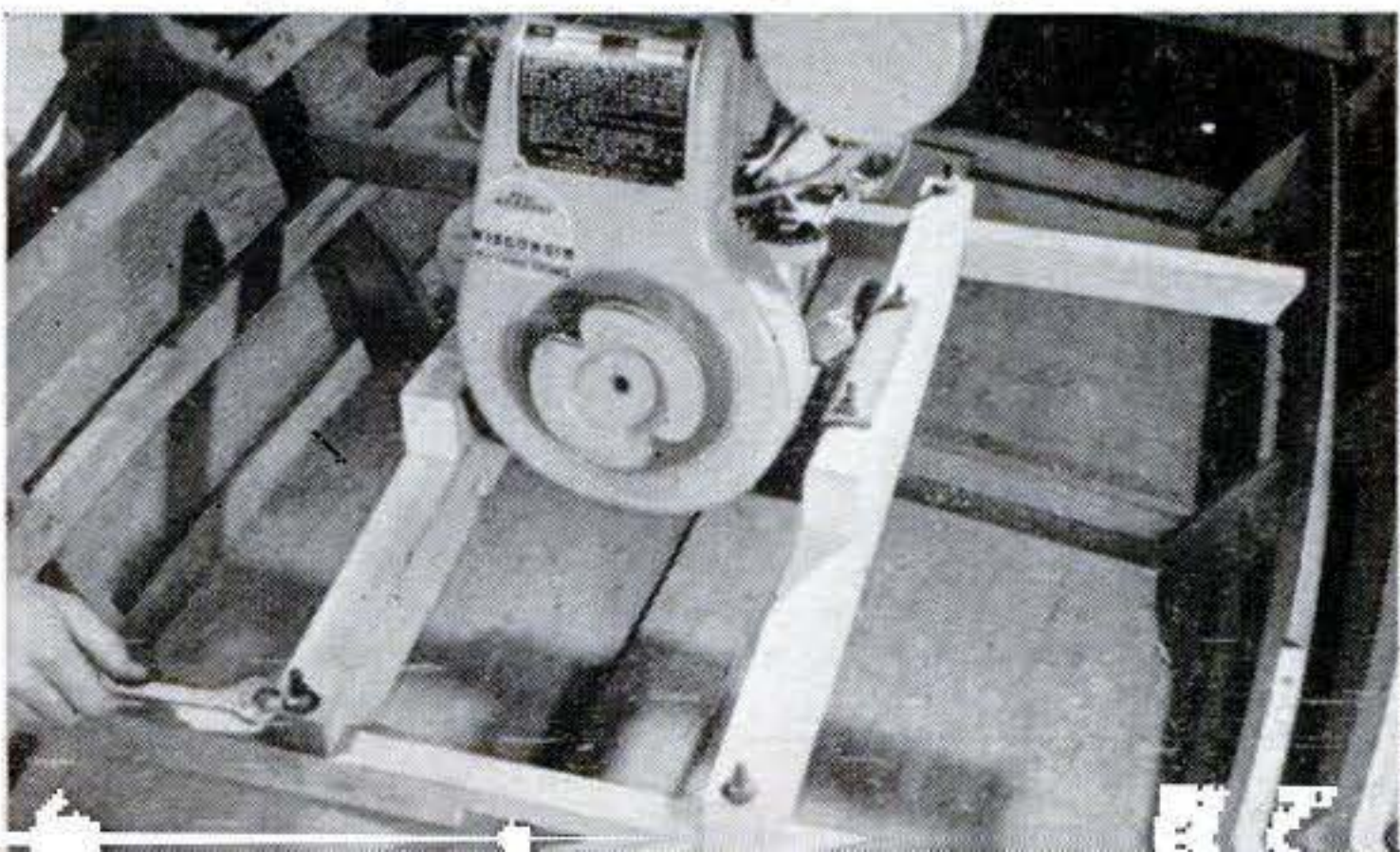

my own calculations were the bits of advice I got from a marine-equipment dealer. He pointed out the possible combinations I could make up: an open propeller shaft with a strut-mounted stern bearing, a simple stern bearing mounted on a deadwood, a self-adjusting shaft log for water sealing within the boat, or a plain bearing and pack-type seal mounted on a block and serving the same purpose as the shaft log.

The setup shown here is a compromise because I am experimenting with different engine-and-propeller combinations. Thus, the stern bearing with an adjustable angle permits slight changes at the engine end with the boat structure left as is. Even so, some of my friends say the deadwood might have been dispensed with on a boat as small as mine. I felt that it added rigidity that was partially lost when the original keel was removed. It also is a lot of protection against a bent shaft when the boat is beached. After all, working out a design that suits your own kind of boating is half the fun.

Power plant. The engine location slightly ahead of midships worked out about right for shaft angle. It was selected to provide good balance while I sat in the stern and trolled. The engine and reverse gear together weigh 105 pounds, put out a top of 5.8 hp. at 3,200 r.p.m. and will cruise with a 3-hp. output, at 1,600 for long trips.

Regardless of the engine selected, there are certain features that should be added if the engine has not been built for marine use. For safety, and to comply with the law on waters under Federal supervision, the carburetor intake must have a flame arrester. Some form of shielded exhaust pipe is a good idea. The one shown will prevent burns in case I fall or brush against it. A water-jacketed exhaust with an underwater outlet would be still better. A center-bowl carburetor intended for use on engines subjected to tipping to various angles will help reliability, and a good fuel filter ahead of the carburetor will do much to prevent stalling.

Gearbox. The reverse gear is a feature that is worth what it costs to most boatmen. It can't be beat for convenient starting, maneuvering out of tight spots, quick slow-downs and unwinding weeds from the propeller.

The boat pictured is strictly for inland waters. Its shallow draft and light weight work out well for sneaking into the low-water weed beds after bass in the evening. The engine, however, is capable of handling

a much larger and heavier boat very easily.

The same thing applies to the materials selected. I used stainless-steel shafting, stainless tubing for the rudder post and galvanized sheet steel for the rudder. The latter is protected by antirust paint. For salt-water use, a bronze rudder with integral shaft is better.

A salt-water sailor might also want to

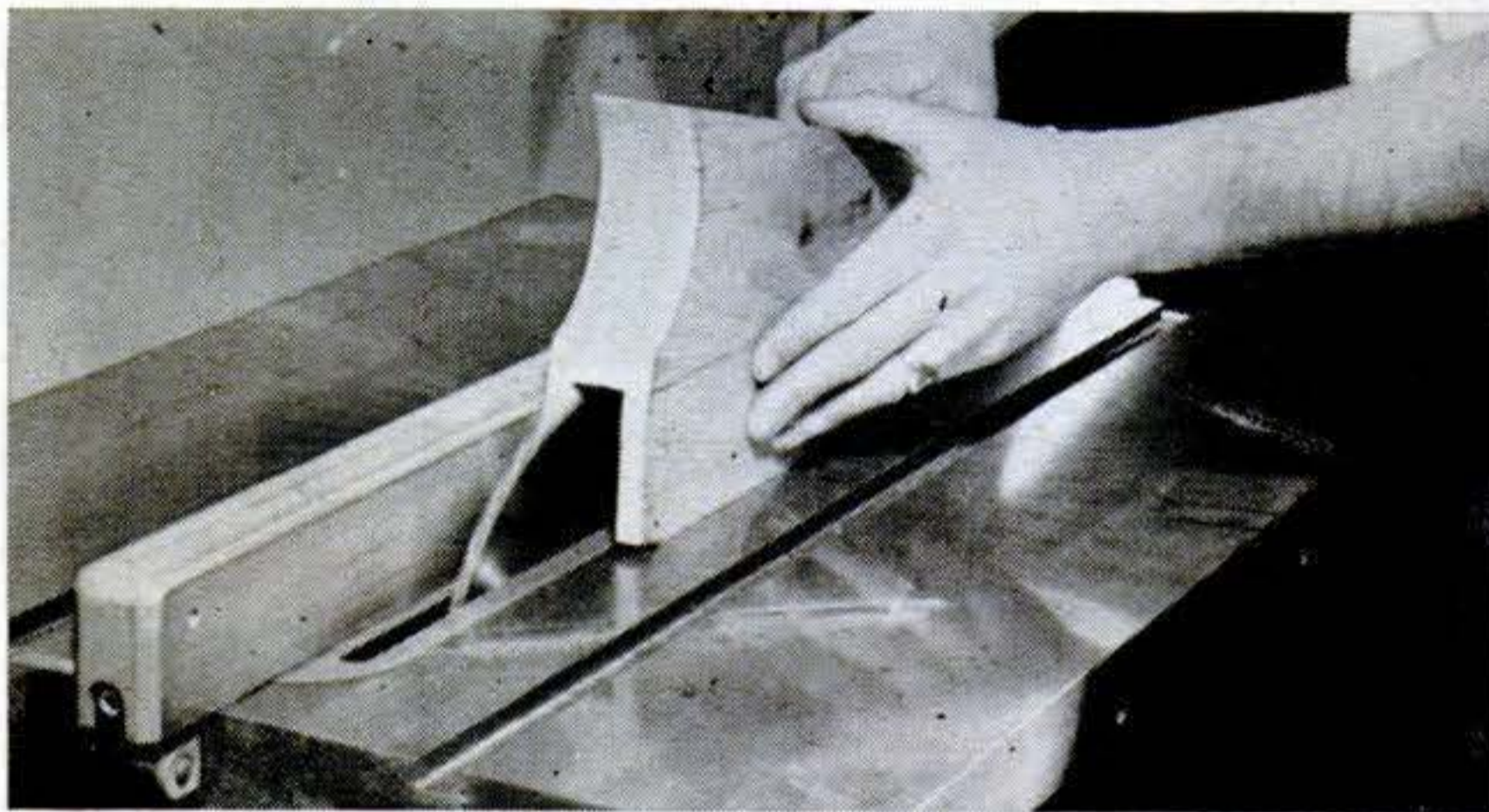

7 DEADWOOD. This is triangular member made of hardwood, through which propeller shaft runs. You can slot it as I did (above) or drill hole for shaft.

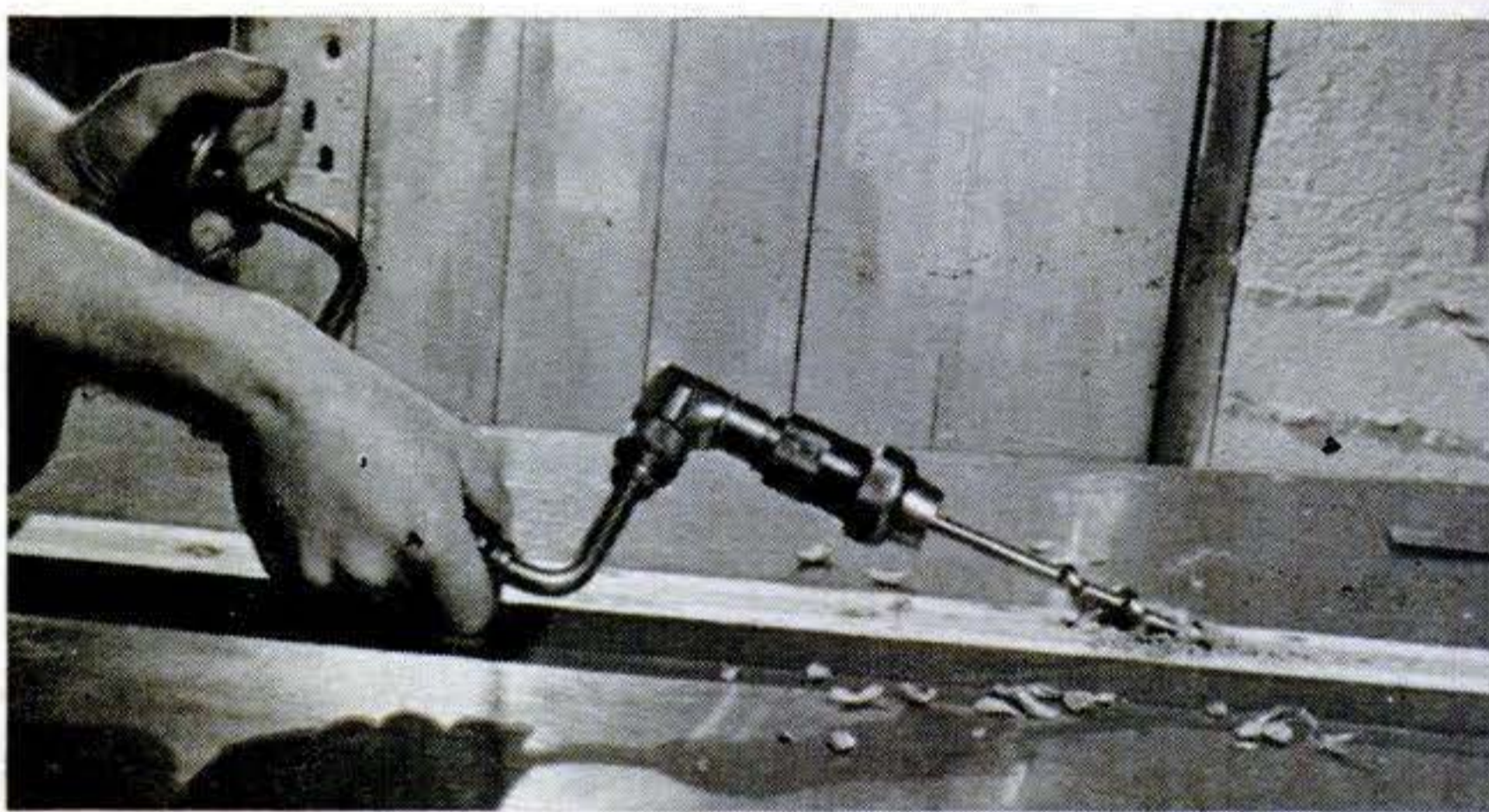

9 SHAFT HOLE. Cut into keel with chisel to give auger bit or drill a square bite. If hole in hull is not drilled at exact shaft angle, you may have to open it with chisel.

12 RUDDER-POST SUPPORT. Shape this of oak. I used a length of stainless-steel tubing inside as a bushing for rudder post. Tubing fits in channel between split rudder-post support. Work calking compound into channel.

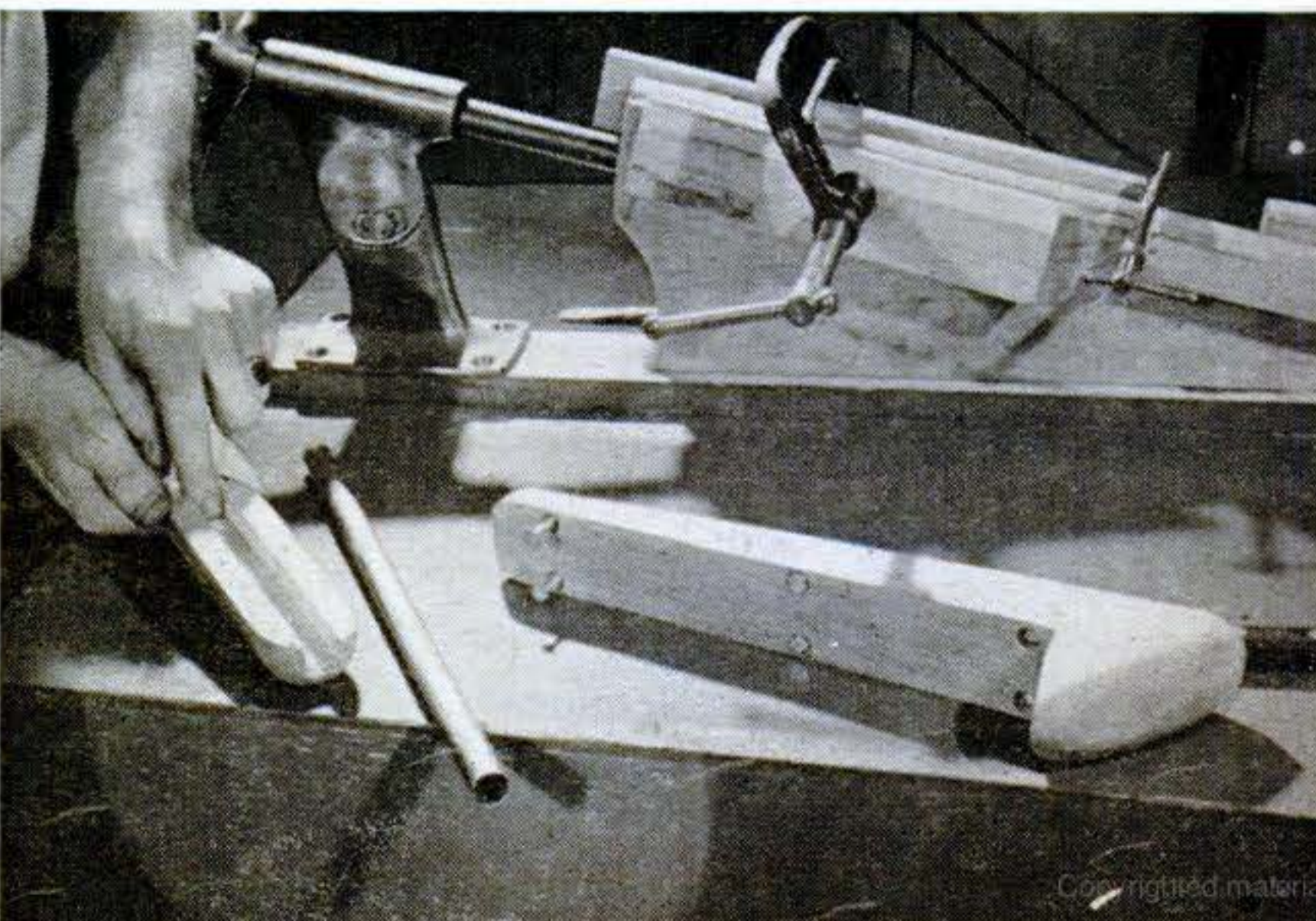

build a doghouse—well ventilated but adequate to keep water off the engine. Then, too, he might want a generator and battery for the running lights needed on Federal waterways.

If I had built for salt water, I would have used: all brass screws, bronze or stainless-steel bolts and fittings in the engine mounts, and a fully enclosed and sealed throttle-

control cable to prevent corrosion and the resulting sticking. I might even go for fresh-water tanks under the seats and an underwater exhaust.

With an inboard engine installed, you must register your craft with the Coast Guard. You'll also want a copy of the regulations—the Coast Guard supplies it—governing your craft.

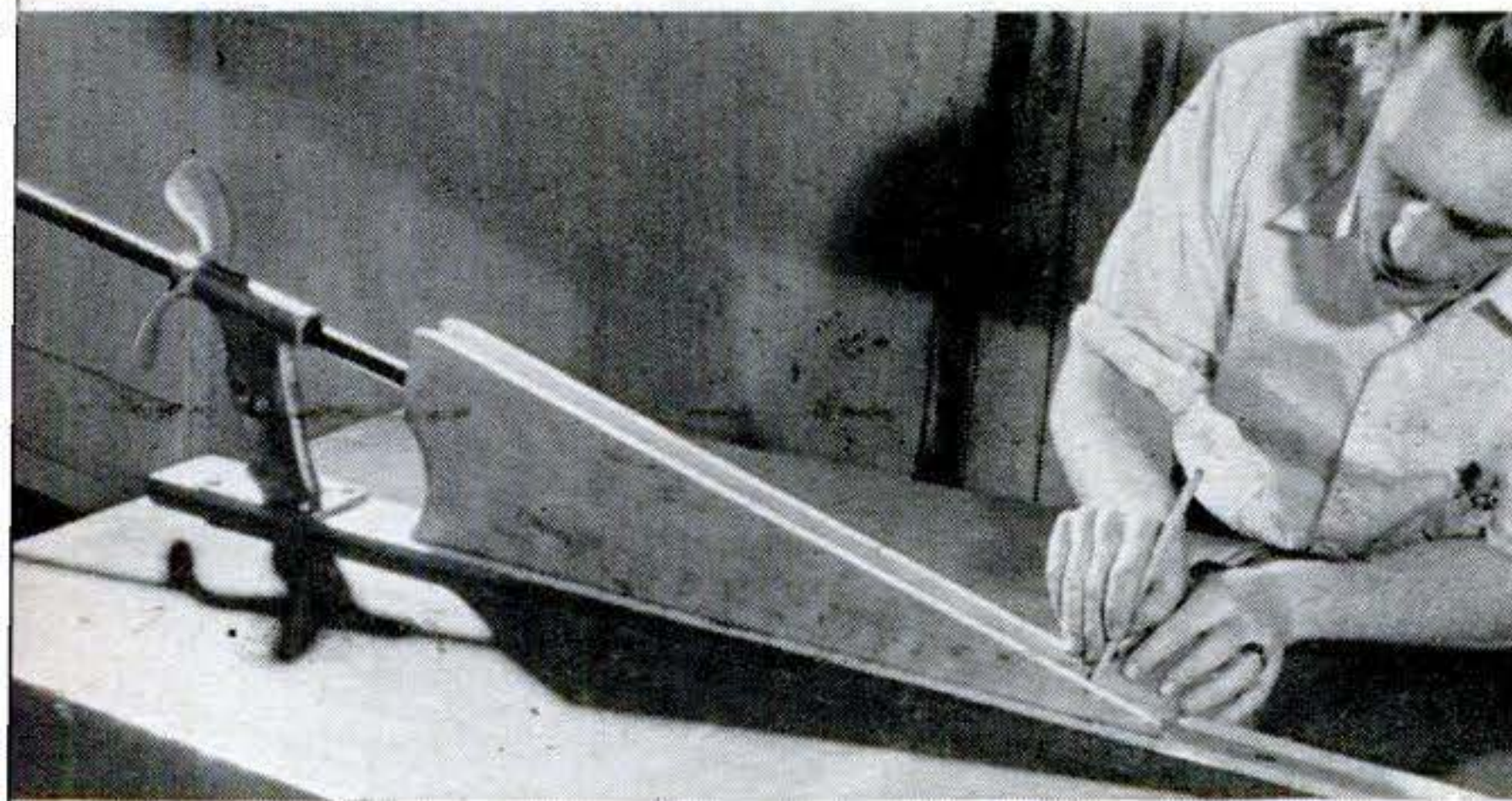

8 SHAFT LINE-UP. With rear strut and deadwood setting the angle, line up propeller shaft. Then mark location of hole through keel for shaft at forward end of deadwood.

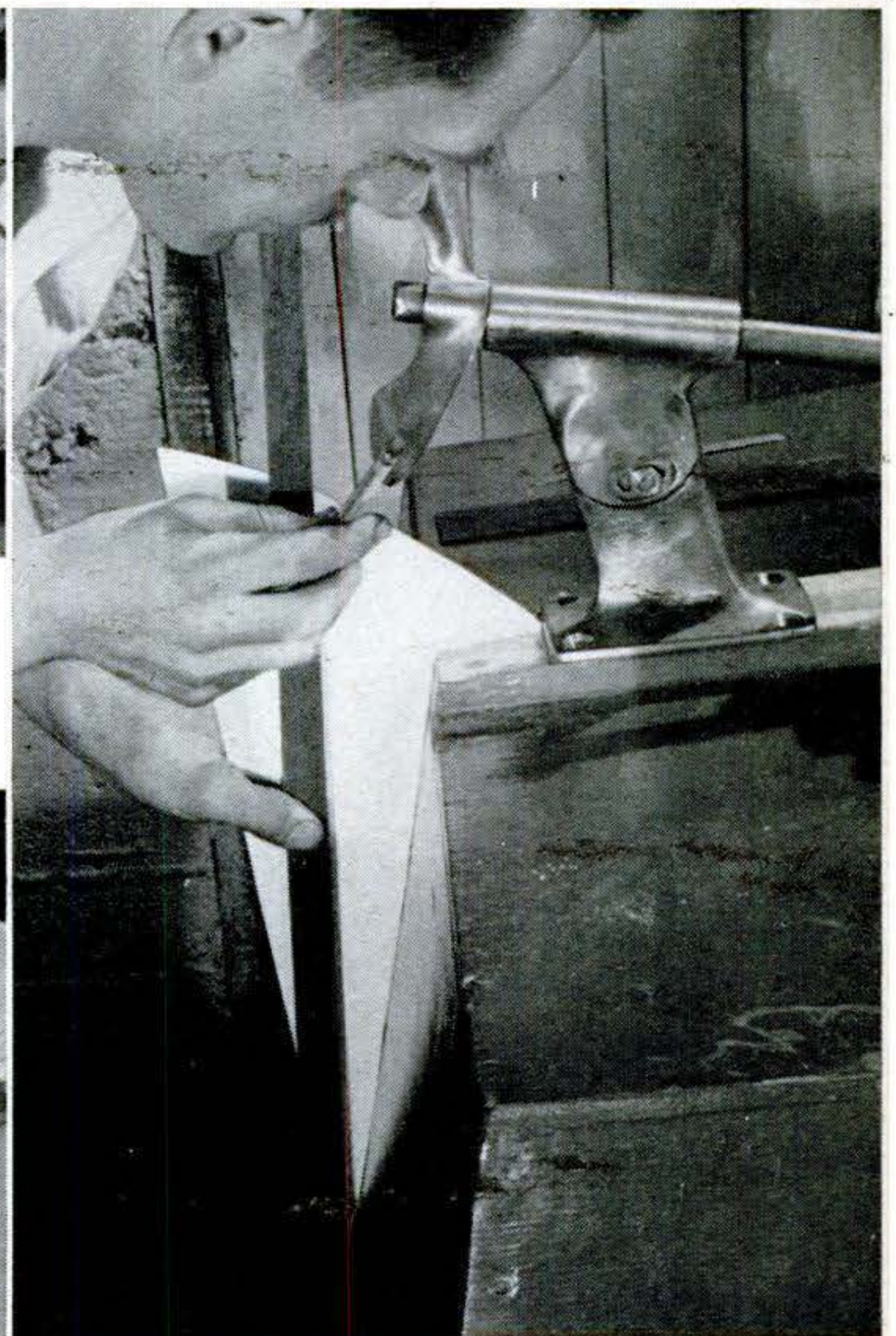

11 RUDDER POST. Make cardboard template to work out size and shape of rudder post. Be sure to locate post so propeller can be removed without unshipping the rudder.

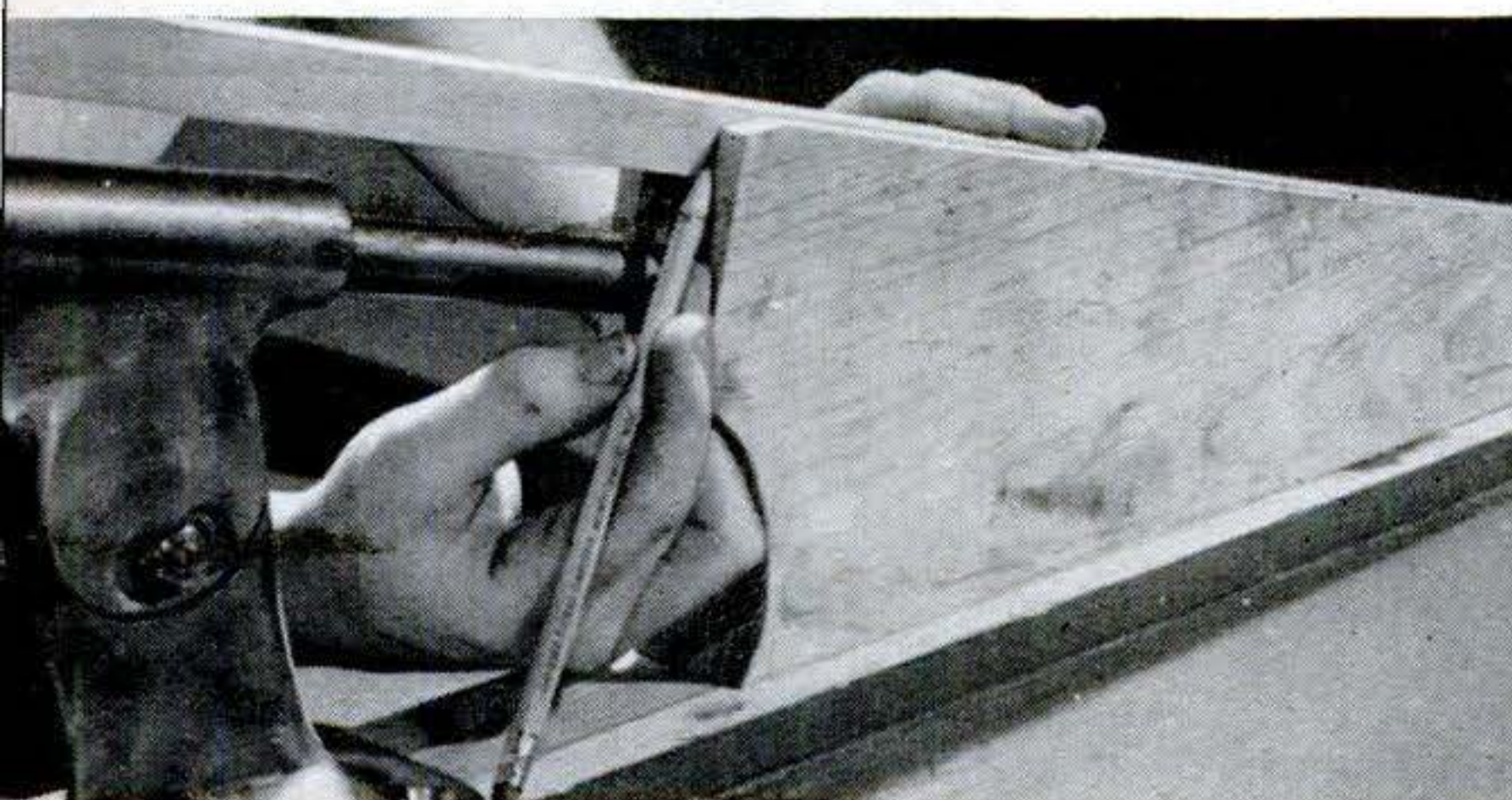

10 FILLER STRIP. Fasten deadwood to keel with marine glue and with screws from inside boat. Close slot with filler strip. Fasten filler strip with glue and brass screws.

13 RUDDER. You can cut this from .050" steel (below) or $\frac{3}{4}$ " or $\frac{5}{8}$ " marine plywood. Align accurately on same center as shaft. Metal rudder is riveted in split post with about one-fifth of rudder ahead of post.

14 SKEG. This is nautical equivalent of tail skid. It protects screw and rudder if boat is run aground. Bend it from $\frac{1}{2}$ " cold-rolled steel. Braze threaded stud in bottom of split rudder post. *(Continued on next page)*

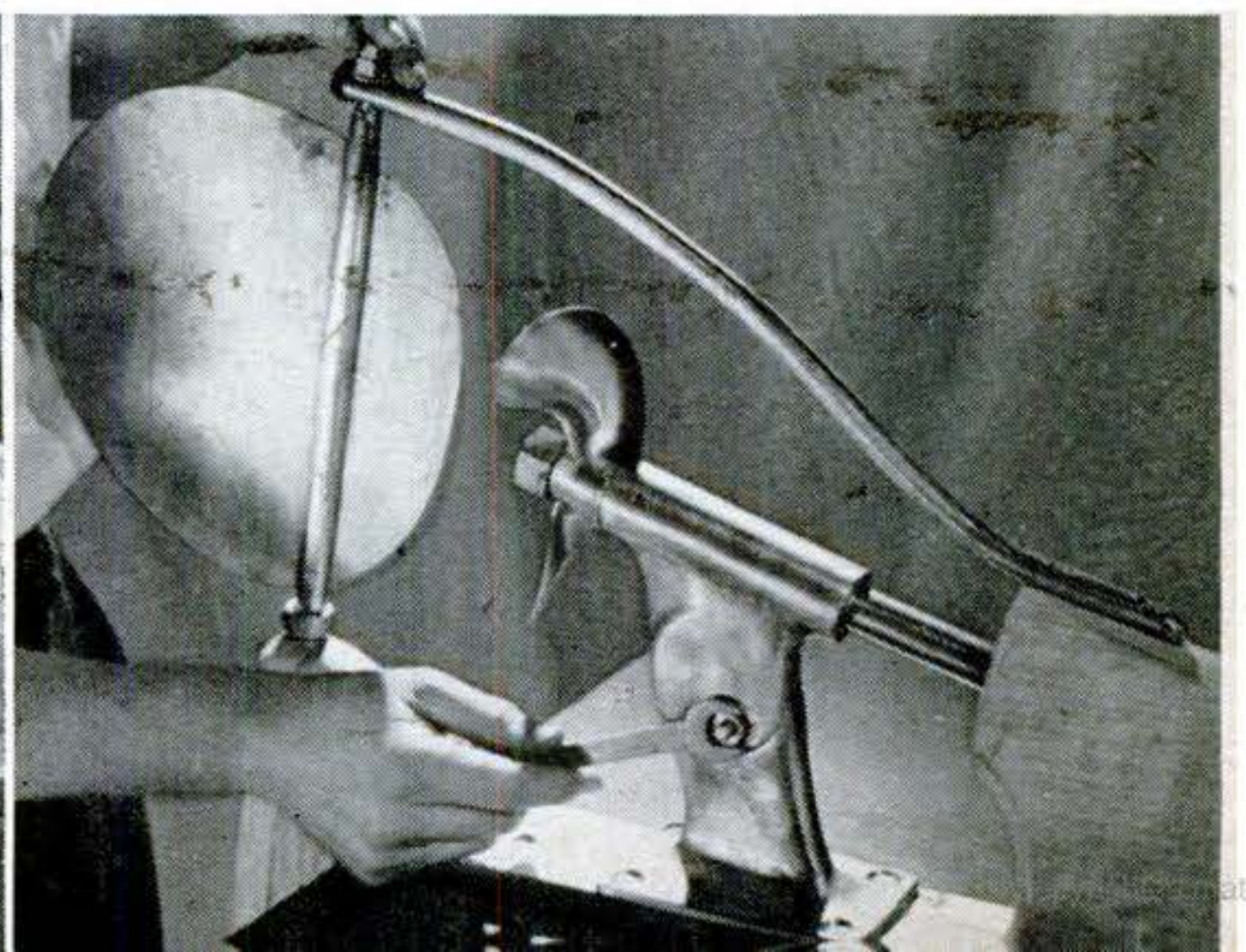
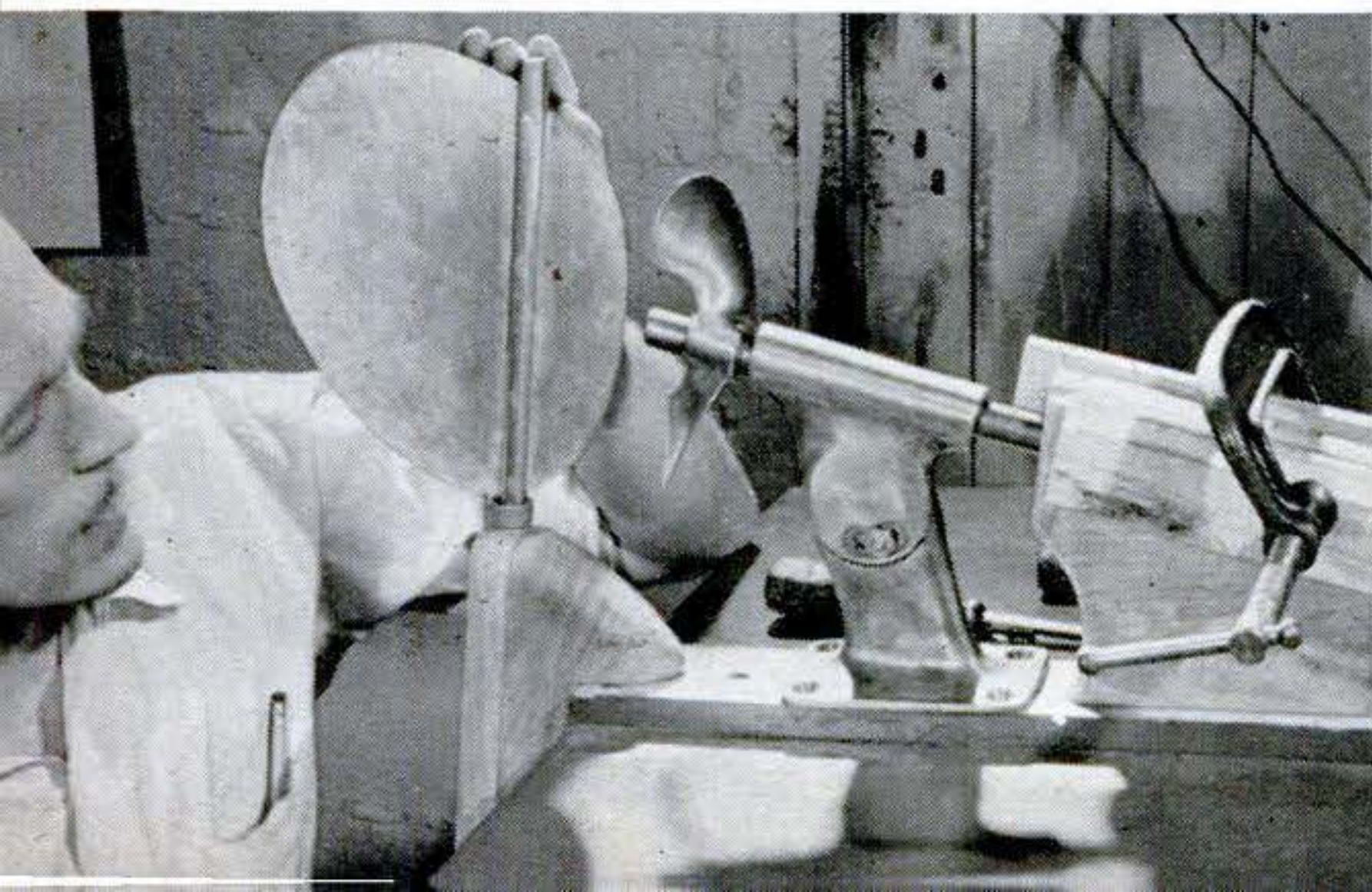

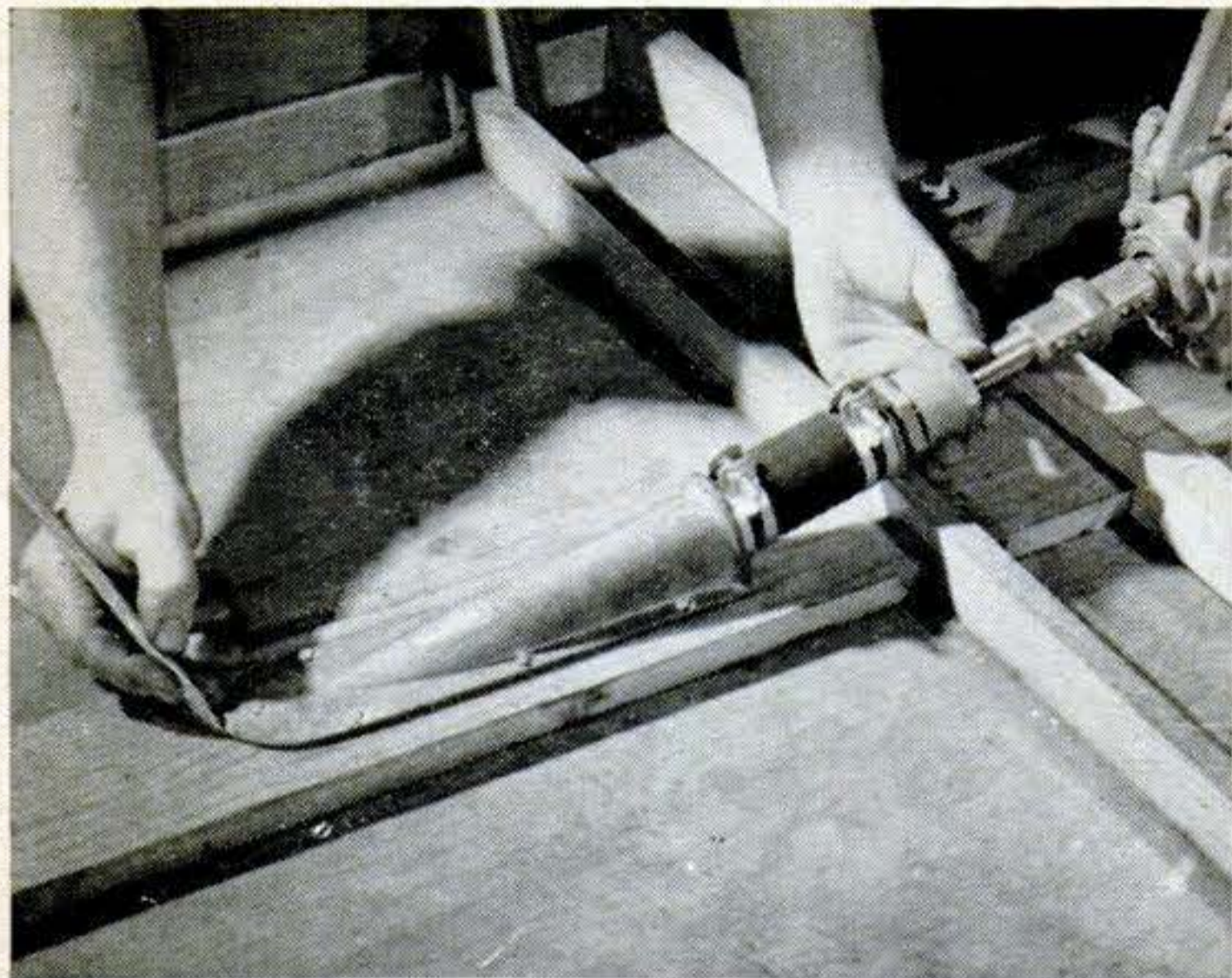

15 SHAFT LOG. Locate log where shaft will spin freely in bearing. Leave packing out of log and key out of shaft so you can spin shaft with fingers to make this location check.



16 SHAFT-LOG SEAL. Cut canvas gasket for shaft log and soak gasket in paint. Smear thick marine paint around opening before screwing down log. Don't overtighten screws.

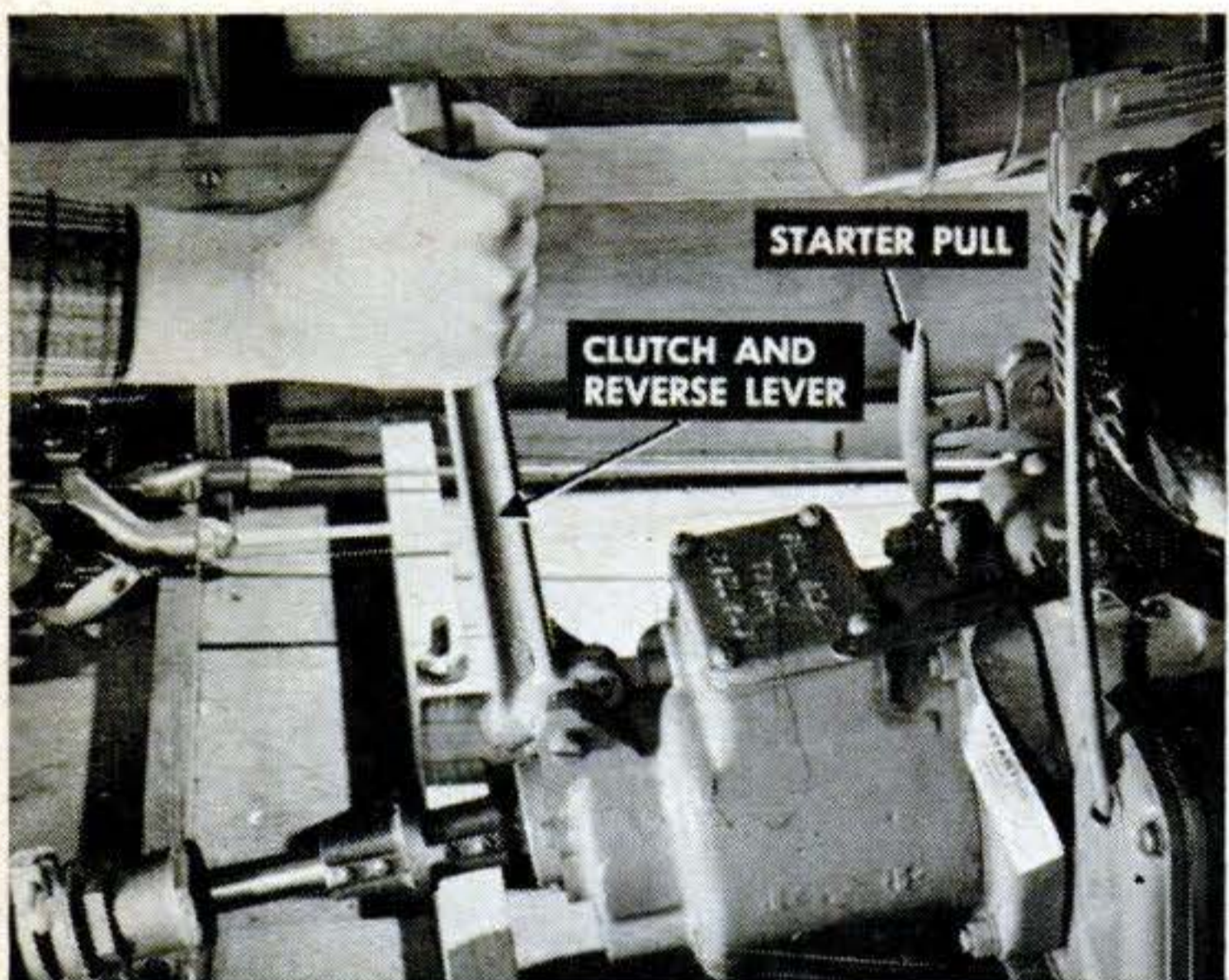

17 REVERSE GEAR. Rugged unit has constant-mesh gears and thrust bearing to take push of propeller. Clutches, simple cone type, are readily adjustable. Unit is shown in neutral.

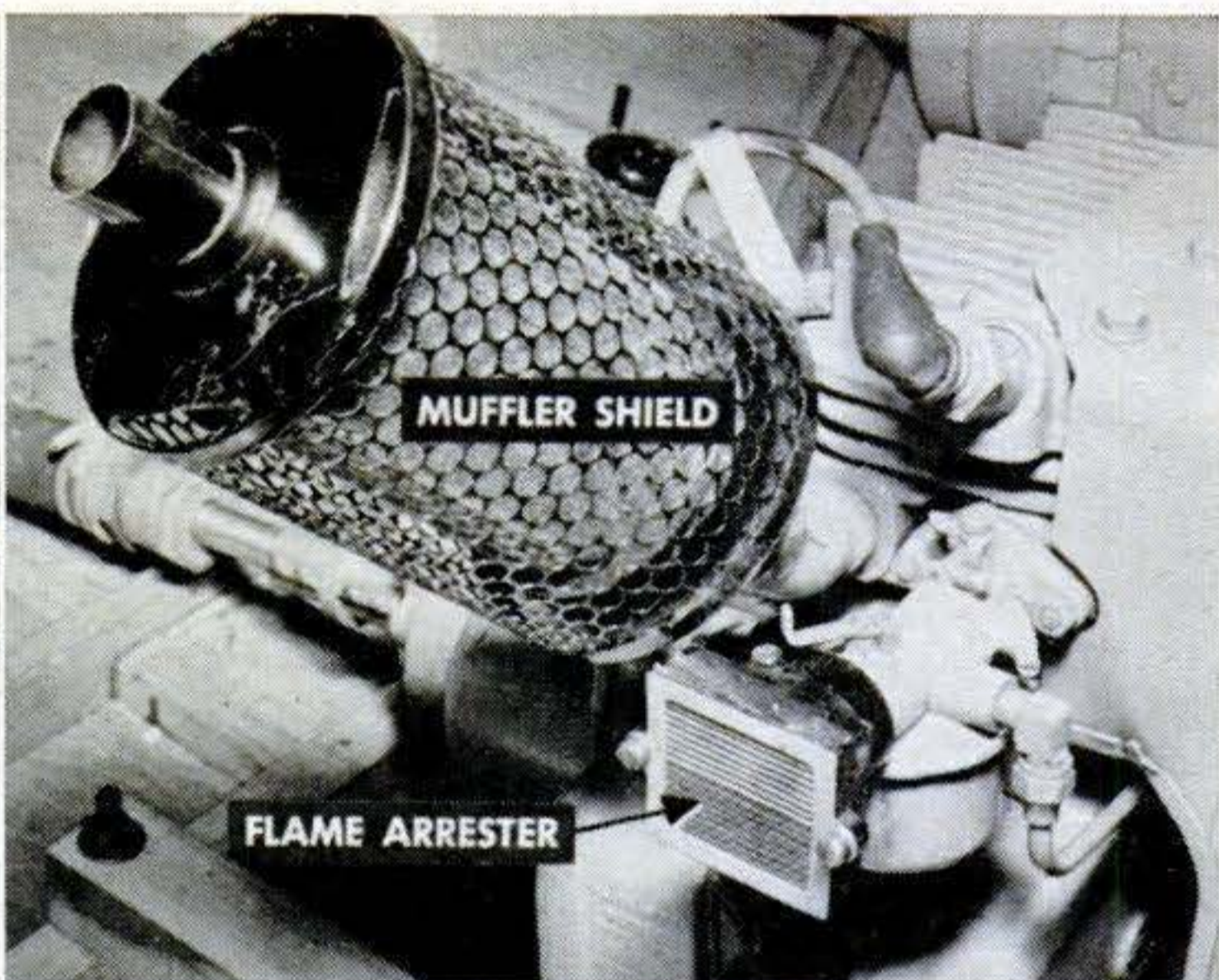

18 MUFFLER SHIELD. This is protection against burns if you should brush against hot exhaust. Flame arrester is required on all engines used in boats on Federal waterways.

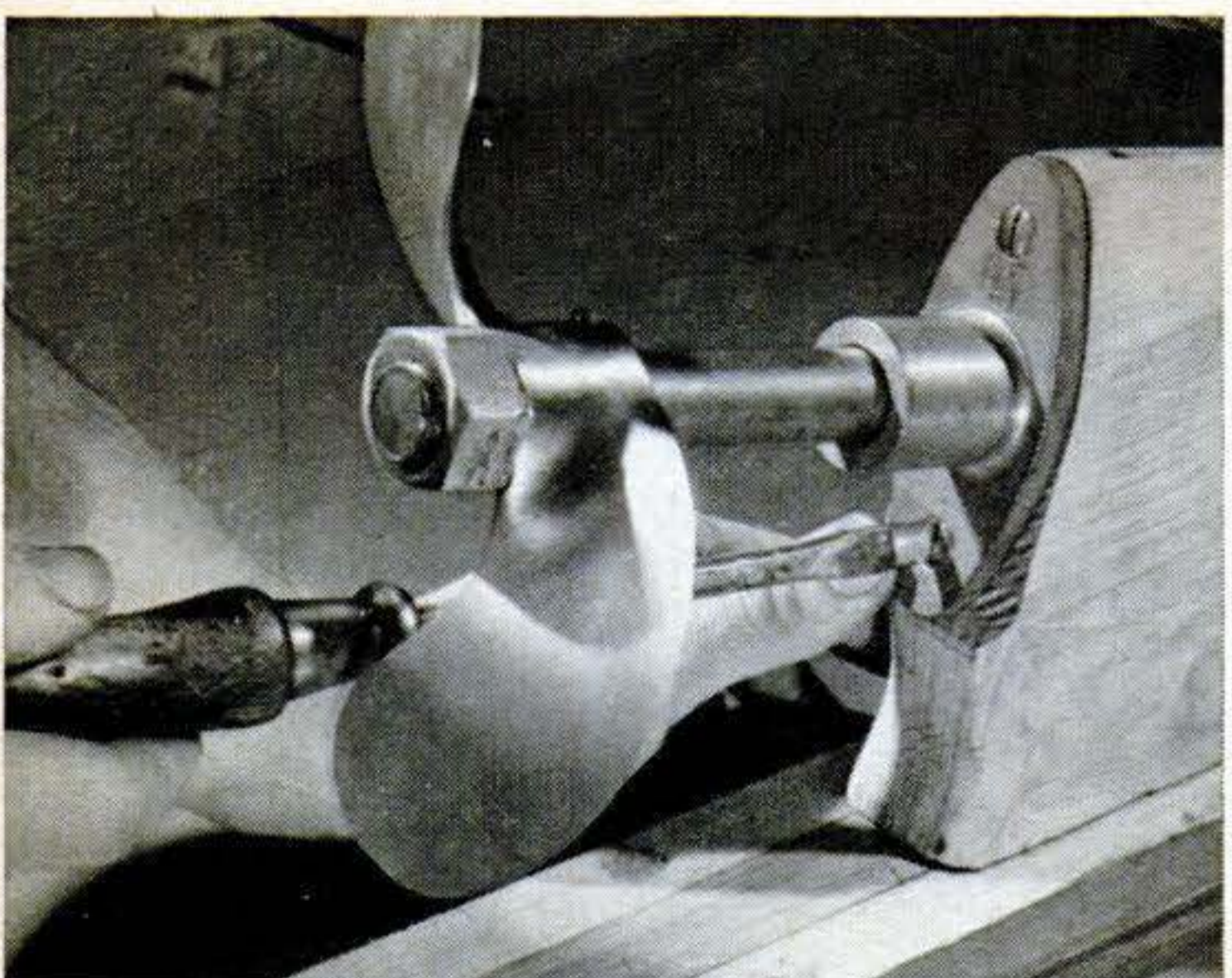

ALTERNATE SHAFT MOUNTINGS. A simple rear bearing like the one at left above costs much less than adjustable rear strut, but cannot be realigned without removing and trimming

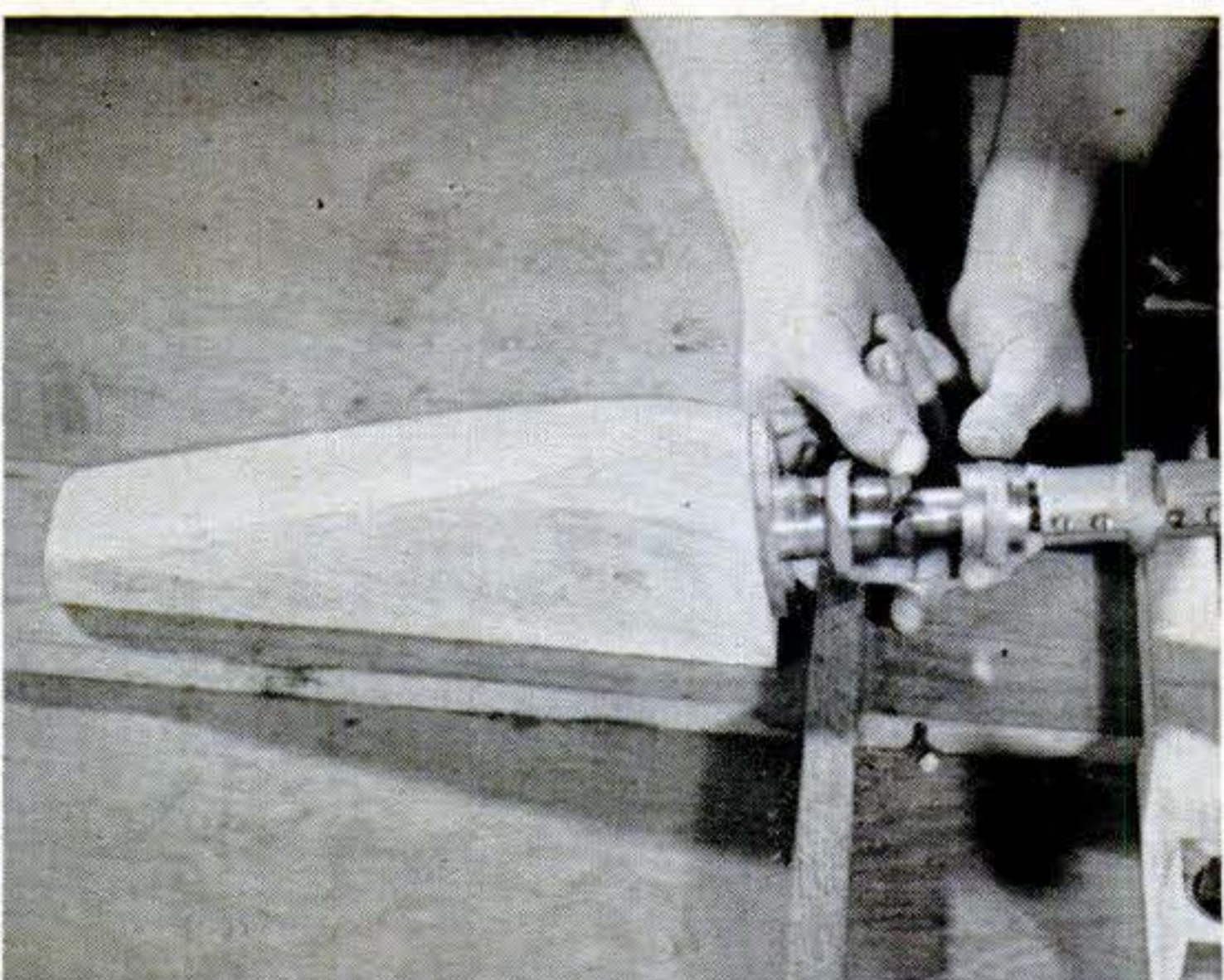

deadwood. To go with the plain rear bearing, a seal and front bearing were combined in this wooden block (right above). This eliminates the need for the regular shaft log. END

Are You Saving PSM Data Cards?

HOME and shop problems are a cinch to solve if you have a file of PSM data cards near your workbench. During recent years, information on hundreds of subjects—from the sizes of nails to servicing an electric dishwasher (below)—has been published

on these handy data cards. The cards are always printed the same size—just right for pasting on 3" by 5" file cards. Start a file now with the two cards printed on this page. Then you will have this and other valuable information always on hand when you need it.

ELECTRIC DISHWASHER

If it does not wash satisfactorily, the dishes may not have been precleaned properly or loaded correctly. If ordinary soap is used, the dishwasher may not do a good job. The proper type and amount of detergent must be used. Incorrect water temperature may also cause washing failure.

If enough water does not accumulate, the signal or outlet-valve solenoid may be defective, or a defective valve may be letting the water drain away.

If water drains slowly, the drain valve may not be opening sufficiently or the plumbing line may be partly closed.

If dishwasher is noisy, the motor may be out of alignment. An impeller or spray nozzle that is loose or out of alignment will also cause noise. A bent dish rack may

touch the rotating impeller or nozzle. Worn or dry bearings are another cause of noise.

If automatic dishwasher does not follow proper operating cycle, the automatic timer is defective, the wiring is incorrect, or else the control solenoid or relay is not operating properly. This trouble is almost always electrical.

If the door leaks, the gasket is either loose or worn.

If washer will not run, the circuit is open in the unit, the cord or the plug. First check the outlet itself to make sure the house circuit is okay. The open could be due to a defective switch or timer, or to broken leads or loose connections. (From *Electrical Appliance Servicing*, by William H. Crouse.)

FOR YOUR POPULAR SCIENCE MONTHLY INFORMATION FILE

HARDBOARD LAP SIDING

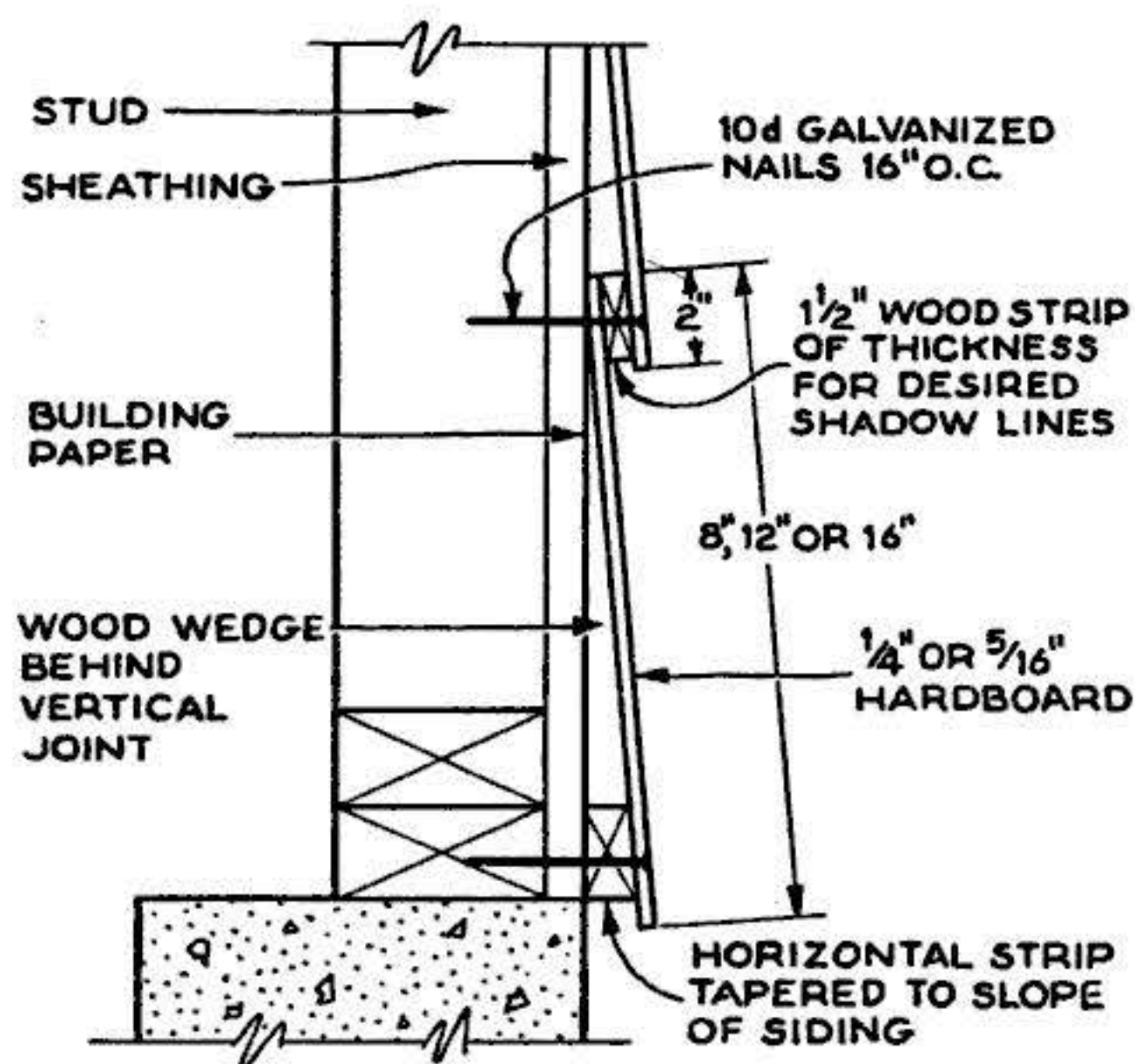

FOR YOUR POPULAR SCIENCE MONTHLY INFORMATION FILE

Hard-surfaced composition board in widths of 8", 12" or 16" can be used as lap siding. It is strong, durable and weather-resistant, and holds paint well. Either 1/4" or 15/16" tempered hardboard is recommended by the Masonite Corp. Before applying, thoroughly wet hardboard siding by scrubbing the back with cold water and a stiff broom. Wet it until it turns a dark chocolate brown. Stack the siding back to back, cover it with a tarp and let it stand at least 24 hours before use. Apply the siding while it is moist. Wetting is necessary so that the siding won't expand and buckle when it is rained on after it has been nailed to the sheathing. Only paints suitable for exterior use on wood should be used—a prime coat and then two additional coats.



Building an

It does double duty—as an icebox to take on picnics and as a storage box for foods when you defrost the freezer.

PACK drinks and sandwiches in this box and you're ready for a picnic. A little dry ice in the box will keep drinks cold and food fresh for a long time. The secret is insulation—2" of mineral wool on all sides and in the lid.

When it is not doing duty as an outdoor ice chest, you can use the insulated box in your home. Store frozen foods in it while you defrost your freezer or refrigerator; the food packages will stay firm and fresh until defrosting is finished.

Construction. Actually, this portable cooler is two boxes—one inside the other. Build the inner box first, joining the parts with 1¼" flathead, nickel-plated wood

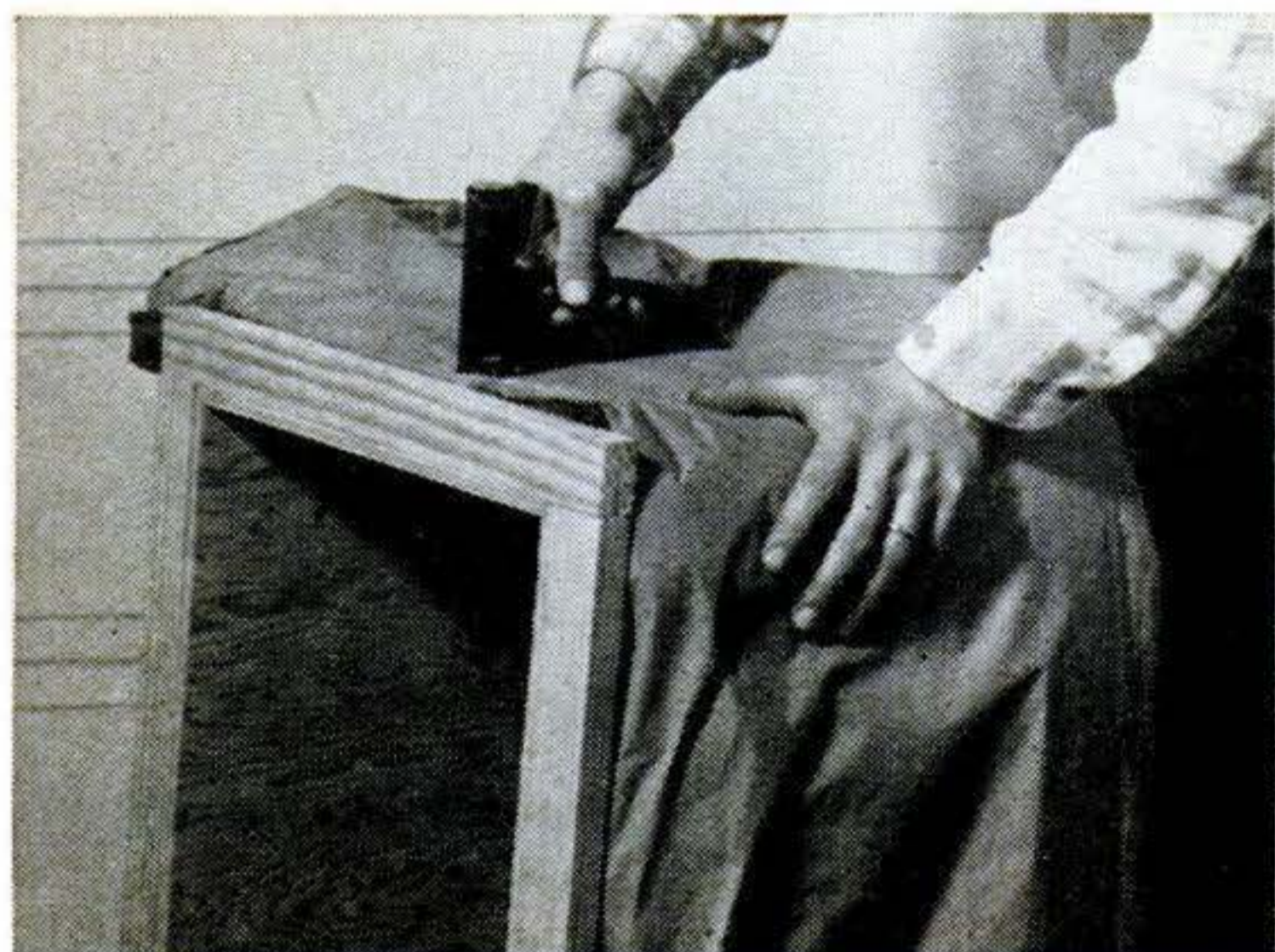

INNER BOX. Brad ¾" plywood parts together. Draw brads singly and replace with 1¼" screws. Cover inner box with 2" batts.

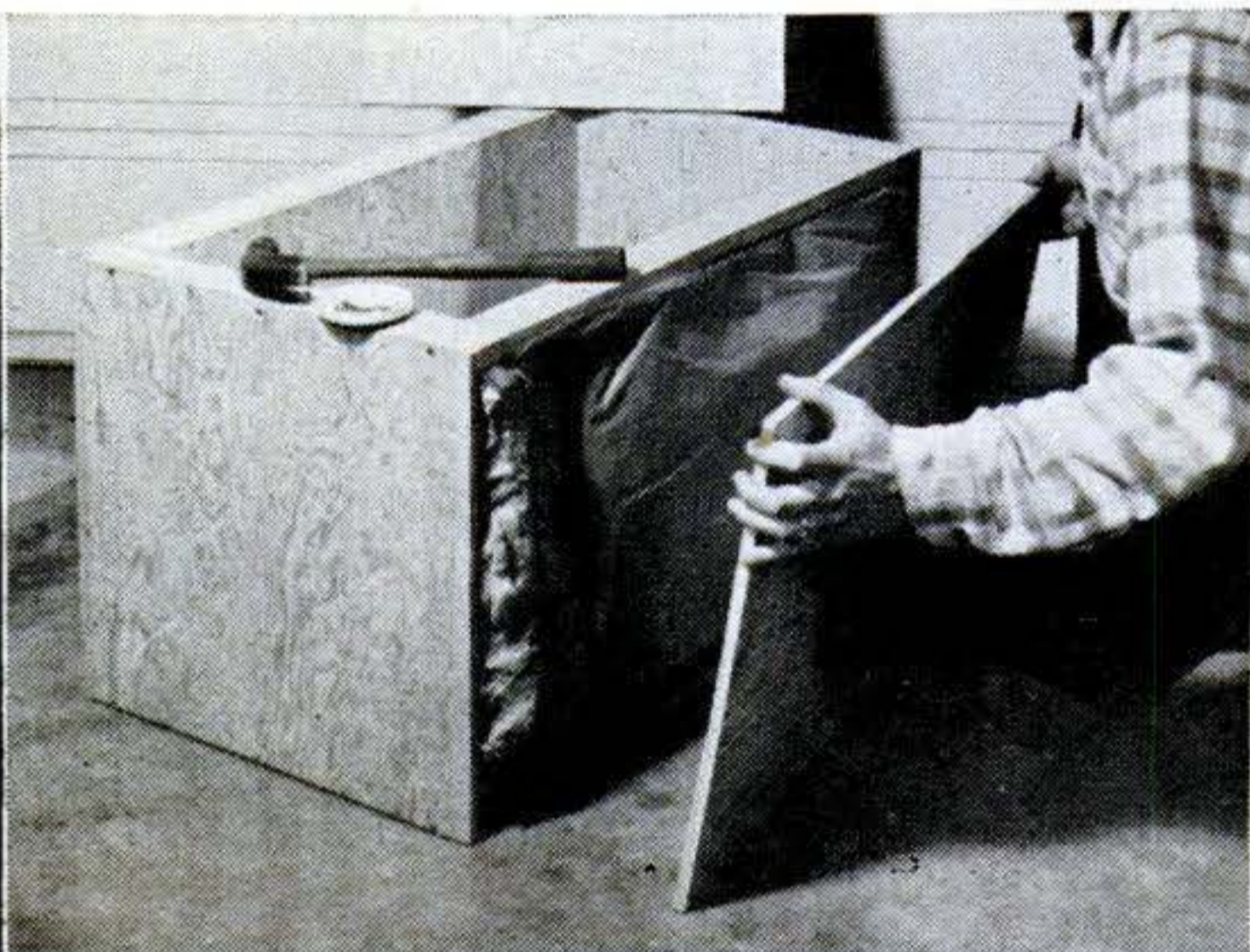

OUTER BOX. After stapling batts to inner box, build outer box around it. One-by-twos serve as spacers between two plywood walls.

LID CONSTRUCTION. Rectangle of one-by-twos forms part of lid that fits inside box. Put insulation in lid, cover with ½" hardboard.

HARDWARE. Use heavy-duty handles on top and at each end. You may want to lift box when it is loaded with food and drinks.

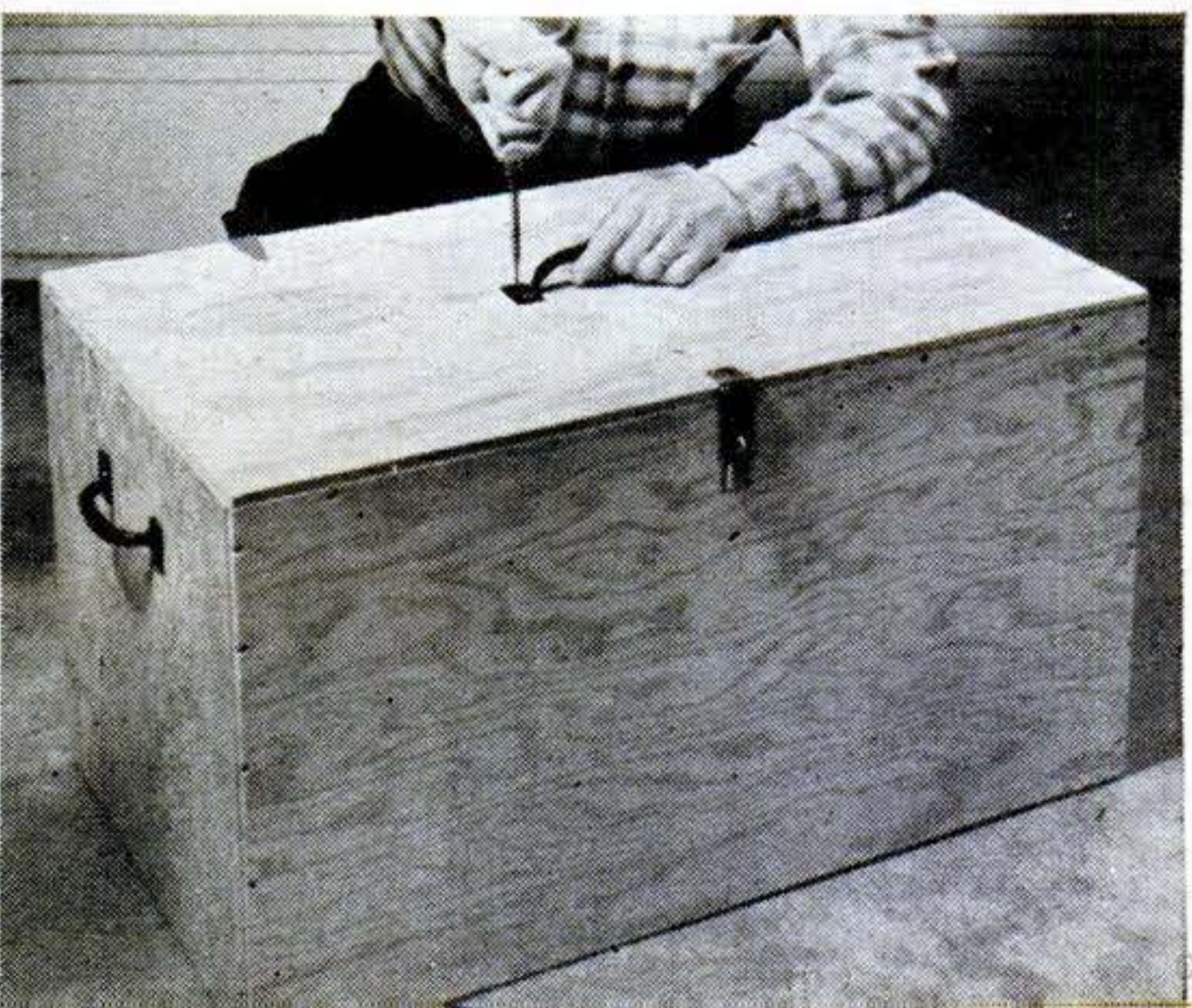
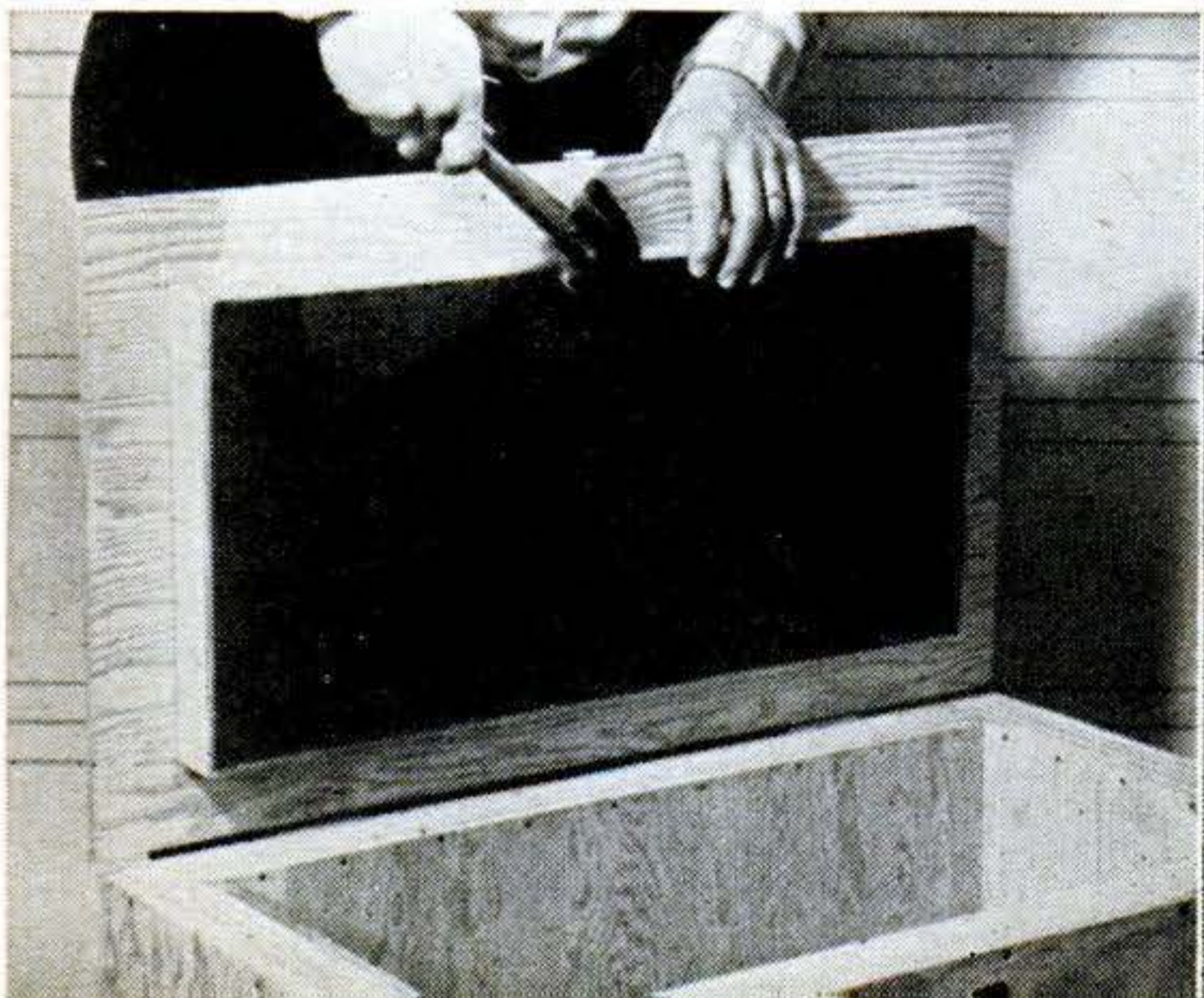

Insulated Picnic Box

screws. Assembly is easier if you brad two panels together, drive the screws and then draw the brads. Rim the top with the one-by-two spacers and staple the insulation in place. Use 15"-wide mineral-wool batts. Then screw the parts of the outer box together and to the one-by-twos.

Lid construction. Fit the top and mark the insulated offset that will fit into the box as the top is closed. Attach a rectangle of one-by-twos to the lid and pack the space with insulation. Cover this insulation with $\frac{1}{8}$ " hardboard.

Bend a pair of T hinges at 90° $\frac{3}{8}$ " from the joint. Screw them to the lid first. Put the lid in position and sit on it—to make a tight fit—

while screwing the hinges to the box. Add a hasp to the box and a chain inside to keep the lid from tipping back too far. Three handles complete the hardware.—*Carlton Strickland, Roanoke, Va.*

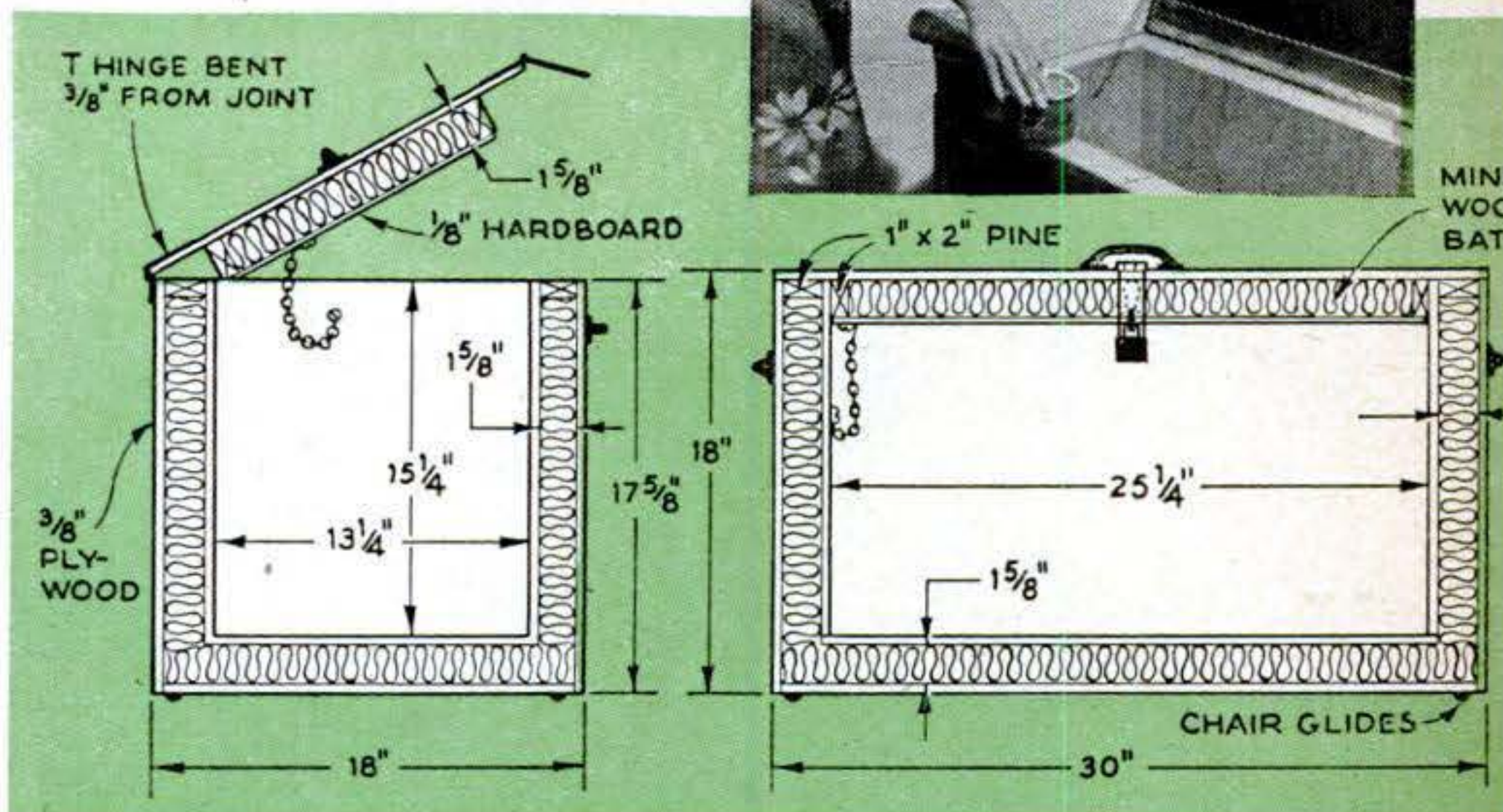

Friction Chuck Turns Disks

THE next time you have to turn a quantity of disks, try this sandpaper dodge to avoid mounting flat work on a faceplate. You'll save time and trouble—and avoid those deep screw holes.

Attach a single driving disk to the faceplate and turn it to a diameter slightly smaller than the required turnings. To this, glue a disk of coarse sandpaper.

Scribe circles of the desired diameter on the material, and bandsaw the turning blanks, preserving the center marks.

To turn the blanks to size, press the center mark against the tailstock center (below), and then bring up the ram until the blank is pressed firmly against the sandpaper-surfaced driving disk. Lock tailstock and set the lathe in motion.—*W. Haase, Hartford, Conn.*



My Most Ingenious Solution

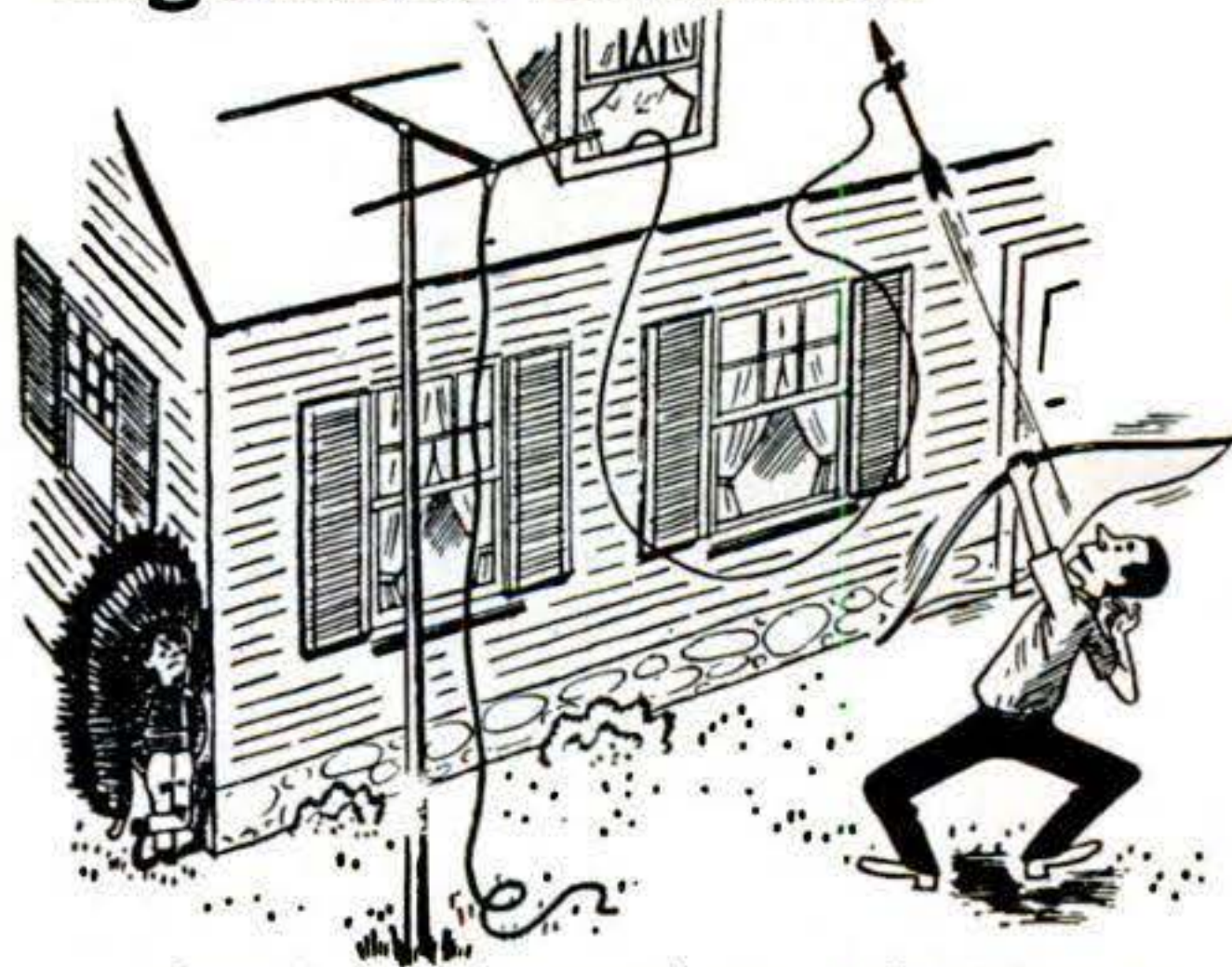

After I had erected my television antenna, I was faced with the problem of getting the lead-in over the peaked top of my house. The roof is hard to climb, and I had no ladder handy. How did I get the wires across?

I borrowed my son's bow and arrow and payed out a length of fishing line from an upstairs window. I tied the line to the arrow and shot them both over the rooftop. Then I tied the lead-in to the fishline and pulled it across.—Paul Sander, Lomita, Calif.

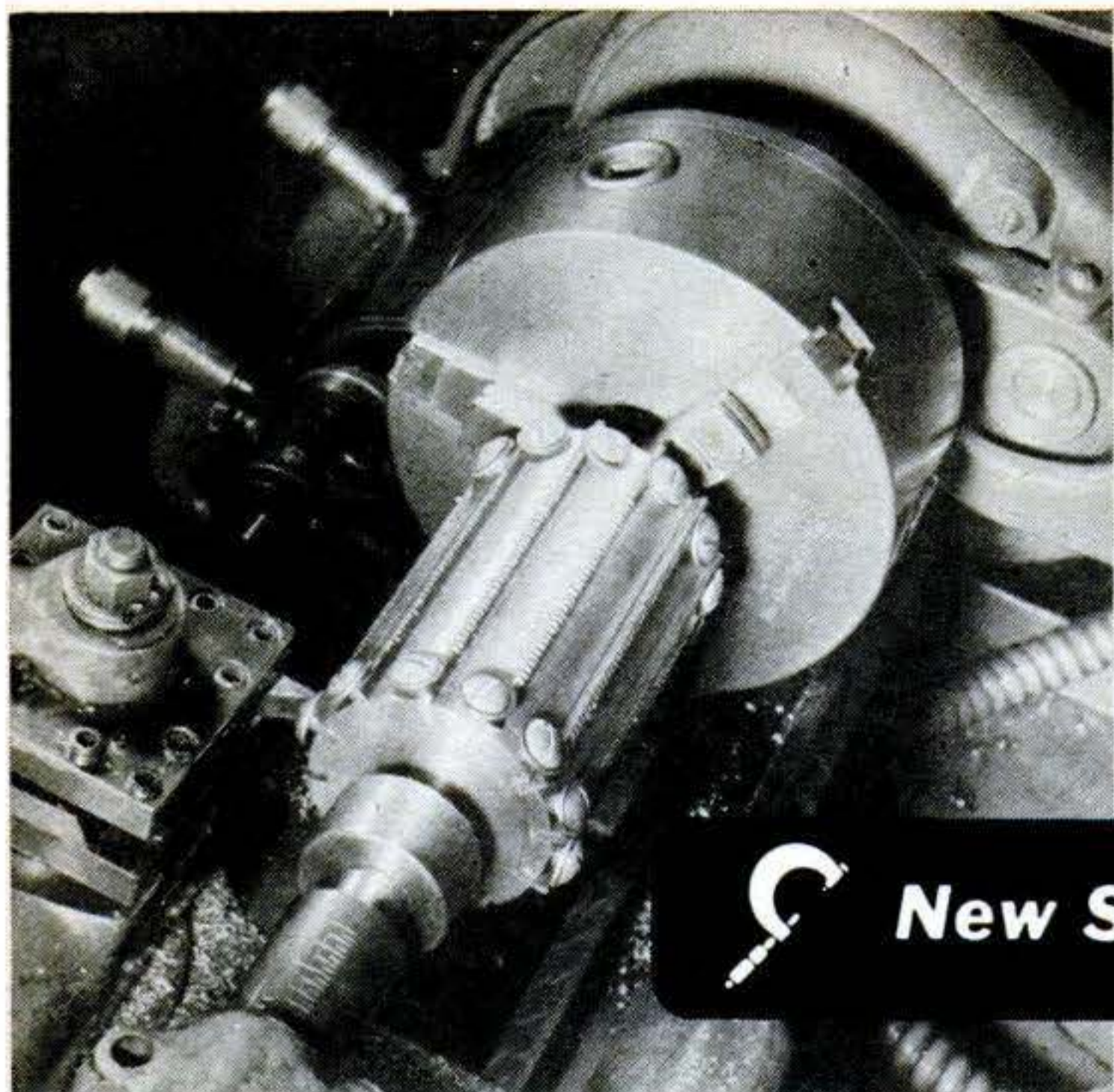

New Shop Ideas

Racks Cut on Lathe. Workable racks for pinions can be cut singly or on a production basis using this setup in a screw-cutting lathe.

Turn the mandrel or holding fixture from 2" cold-rolled steel and cut grooves in it to hold the blank strips. The mandrel illustrated was made to cut 12 racks at once—you need only a single groove for cutting individual racks. Use machine screws and washers at each end to clamp the blanks securely in place.

To determine the teeth per inch for a given pinion, roll the pinion firmly on blotting paper and count the tooth depressions per inch. Then set the lathe gears to a corresponding number of threads per inch. Grind the cutting bit to the approximate shape of a pinion tooth, but leave it very slightly larger to provide tooth clearance. Try the pinion as the cutting progresses to determine the depth of cut.—*Floyd McGuckin, Ridgewood, N. J.*

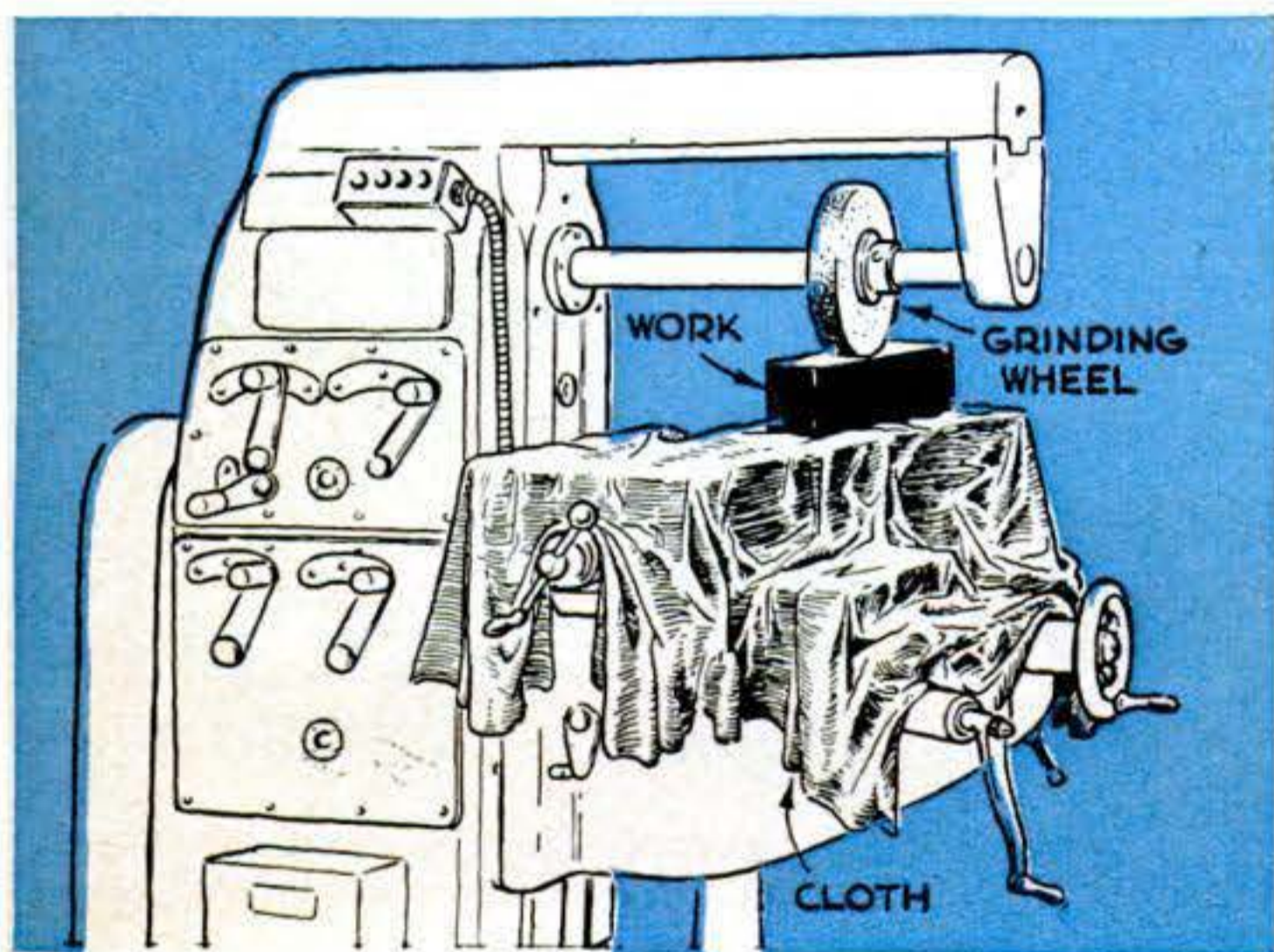

Surface Grinding in a Miller. Your milling machine can pinch-hit as a slow but accurate surface grinder to put a smooth finish on occasional fussy machining jobs.

Mount a grinding wheel on the milling arbor and, using the fastest spindle speed, feed the table back and forth manually. Advance the cross-feed after each lateral pass under the grinding wheel.

Cover the milling table completely with a tightly woven cloth, leaving only the work surface and feed controls exposed.

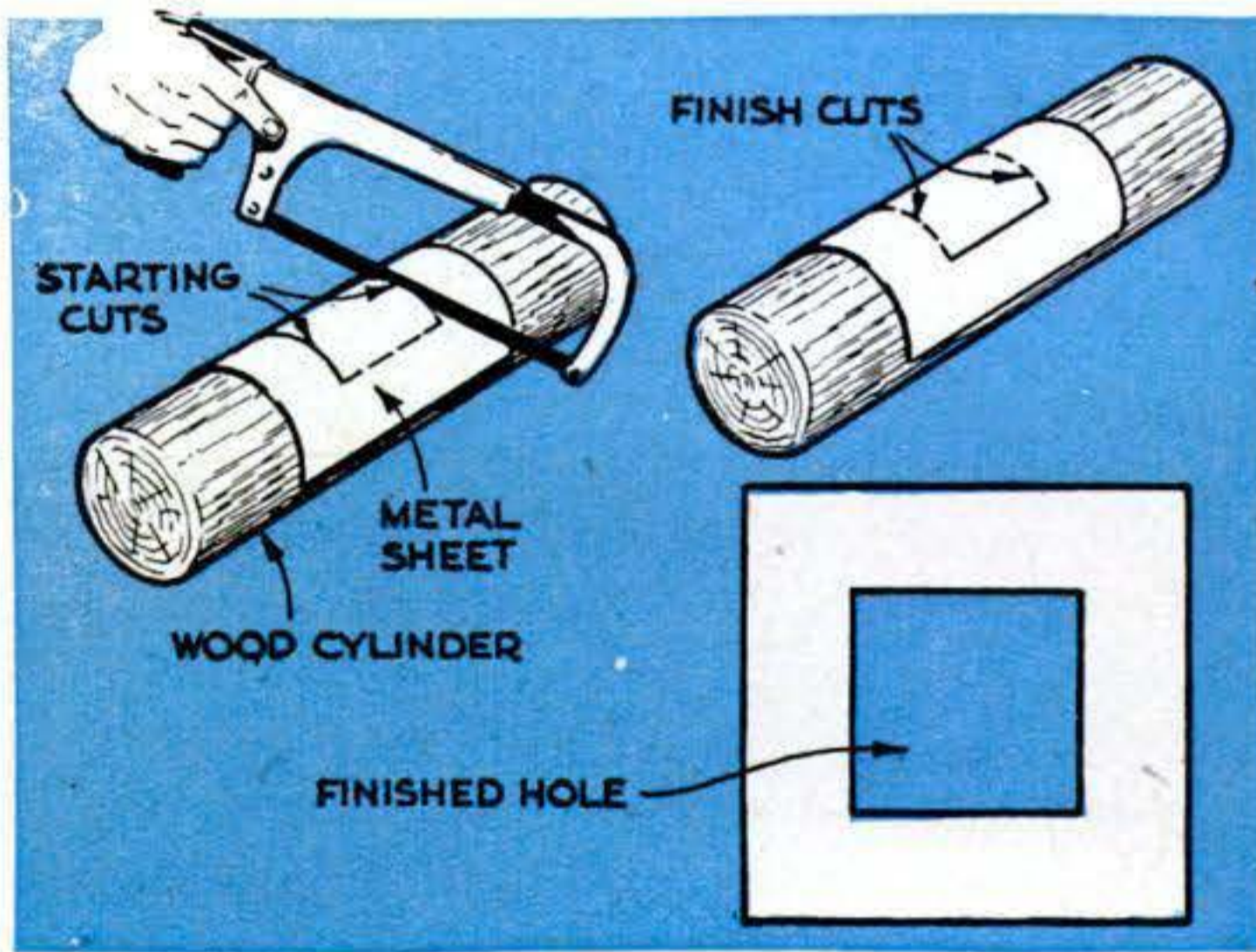

Cutting Square Holes in Sheet Metal.

You can use a hacksaw to cut neat rectangular holes in thin sheet metal without having to drill a starting hole by using the dodge shown above.

Bend the material over a wooden cylinder and cut two edges of the rectangle. Give the sheet a quarter turn and bend it over the cylinder again to make the two final cuts.

Use a fine-tooth hacksaw blade to avoid snagging the teeth in the thin metal.—*Hugh Lineback, Stillwater, Okla.*

Springs Made to Order. A small stock of music wire, in various sizes, will provide the makings for winding a wide variety of springs.

L. W. Bonnell of Fort Worth suggests an easy method of winding springs by hand. Select a mandrel about 10 percent smaller than the desired inside diameter of the

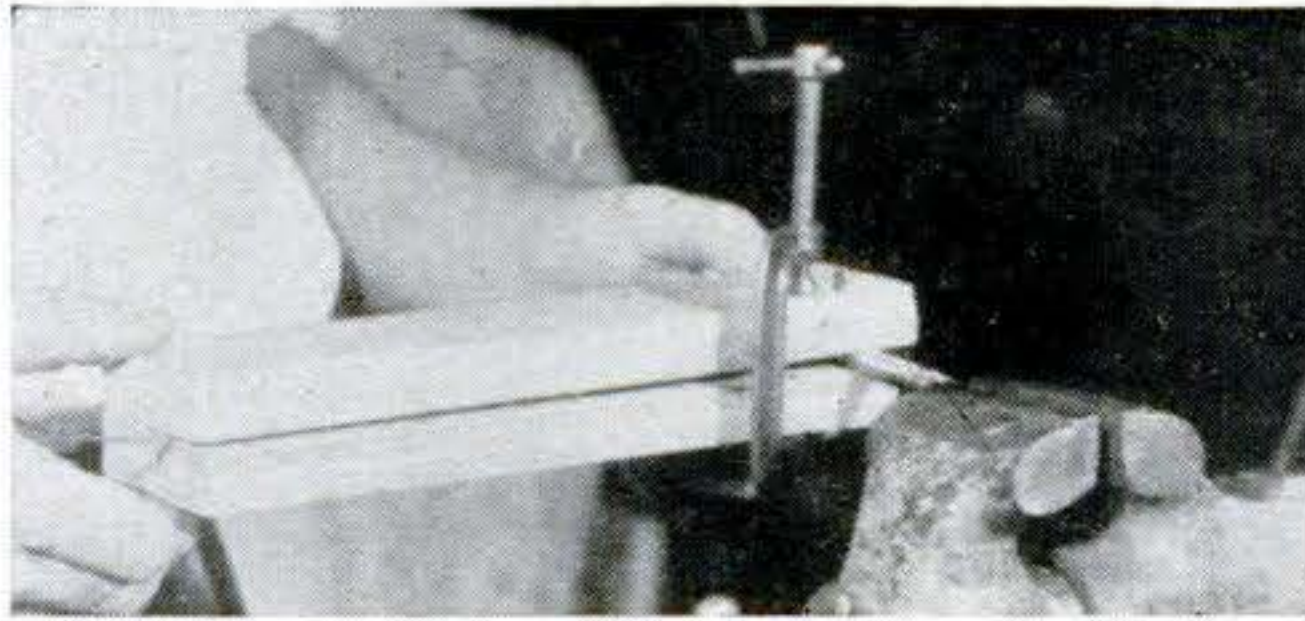

spring. This can be a nail, a drill shank or a piece of drill rod. Wrap a few turns of wire around the mandrel and clamp it in a vise. Clamp two pieces of wood over the wire and mandrel, as shown above. Rotate the clamped pieces of wood around the mandrel to wind the spring, holding the free end of the wire out at a slight angle to the mandrel to keep the turns tight. Stretch it for use as a compression spring or use it as is for a tension spring.

To wind springs on a lathe, Charles Manson of Columbus has devised a wire-feeding tool with a tension adjustment for making springs really tight (right above). Notch one end of a hardwood block to bear against the mandrel, and screw on two strips of hardwood so that the block will fit snugly in the tool holder and yet provide a clearance channel for the wire. Run the wire between a thin brass washer and a steel washer tightened slightly by a $\frac{1}{4}$ " stove bolt to adjust tension. The thin brass washer distorts under

Drill Press as Shaper. Slots and keyways that ordinarily call for a shaper or milling machine can be cut in a pinch with the drill press. This is of course a strain on the feed mechanism but will do no harm if you make light cuts.

Fit a boring bar with a cutter bit ground like a cut-off tool, and chuck it in the drill press. Clamp the spindle as shown so that it cannot rotate, and feed it down against the vise-held work. After each light cut, advance the work a trifle. A milling-table vise is ideal for the work, but you can use a regular drill-press vise that is bolted down, advancing it after each cut by light hammer taps. —Walter E. Burton, Akron.

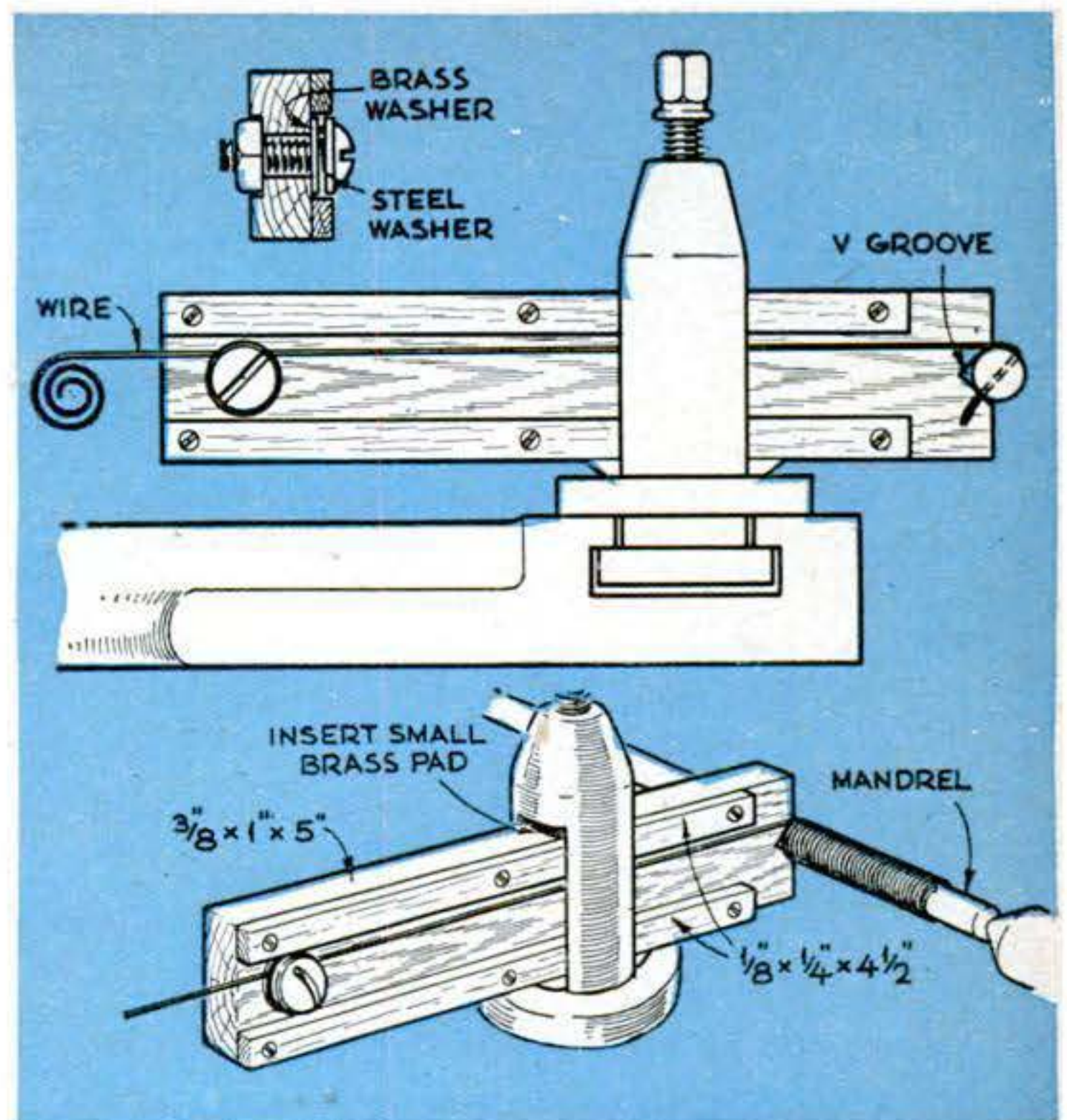

pressure of the bolt to form a running groove for the wire.

Drive the lathe carriage by the lead screw with the gears set to follow the winding. As an example: .025" wire should wind 40 turns to the inch, but to play it safe and keep the windings from overlapping, set the gears for approximately 36 threads to the inch.

Tension springs need a loop at each end. W. Thomas, Webster, N.Y., bends the spring end over by laying it across a block so that one complete turn overhangs the edge (right). A tap with a hammer bends this turn over to form the loop.

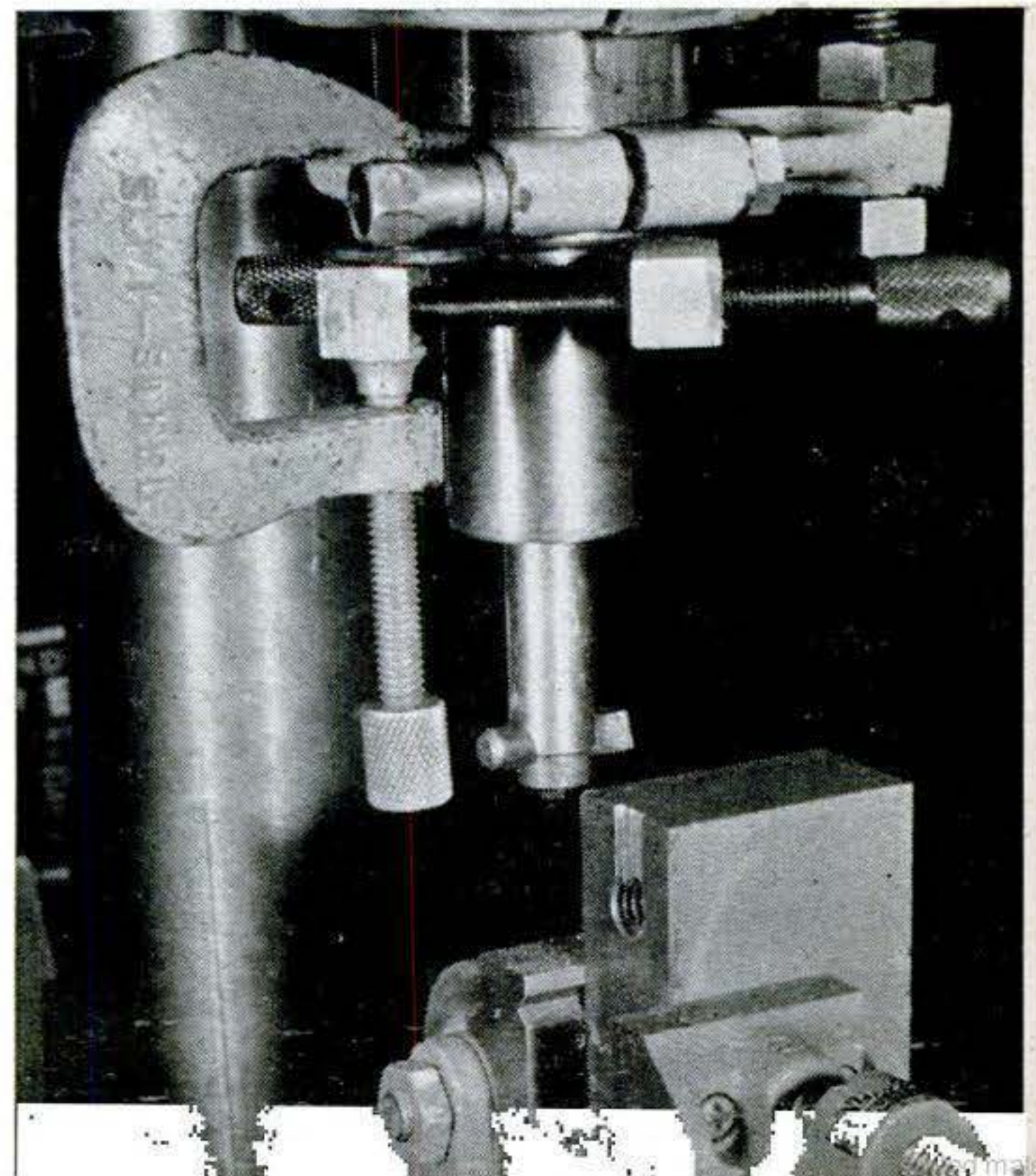
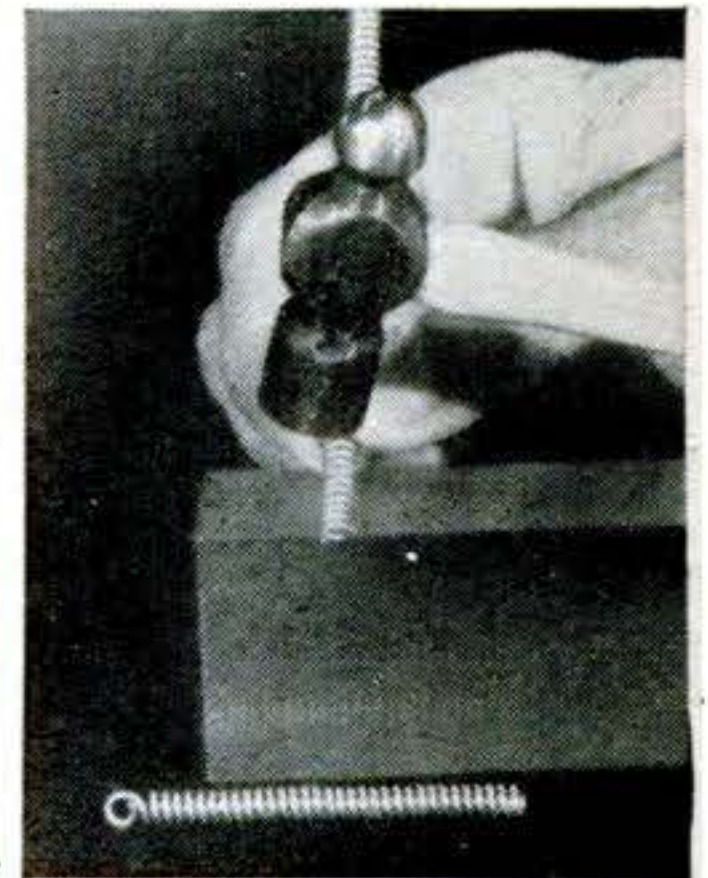



Vacation-Time Camera Check

Buying film isn't the only thing you need to think about for good holiday pictures. A lens smudge or a light leak can ruin every one you take.



LENS Blow off dust with a syringe, or use a camel's-hair brush. (If wiped with cloth, dust may scratch lens or coating.) Then use tissue and cleaner bought at photo store. Do this even if your lens isn't removable.

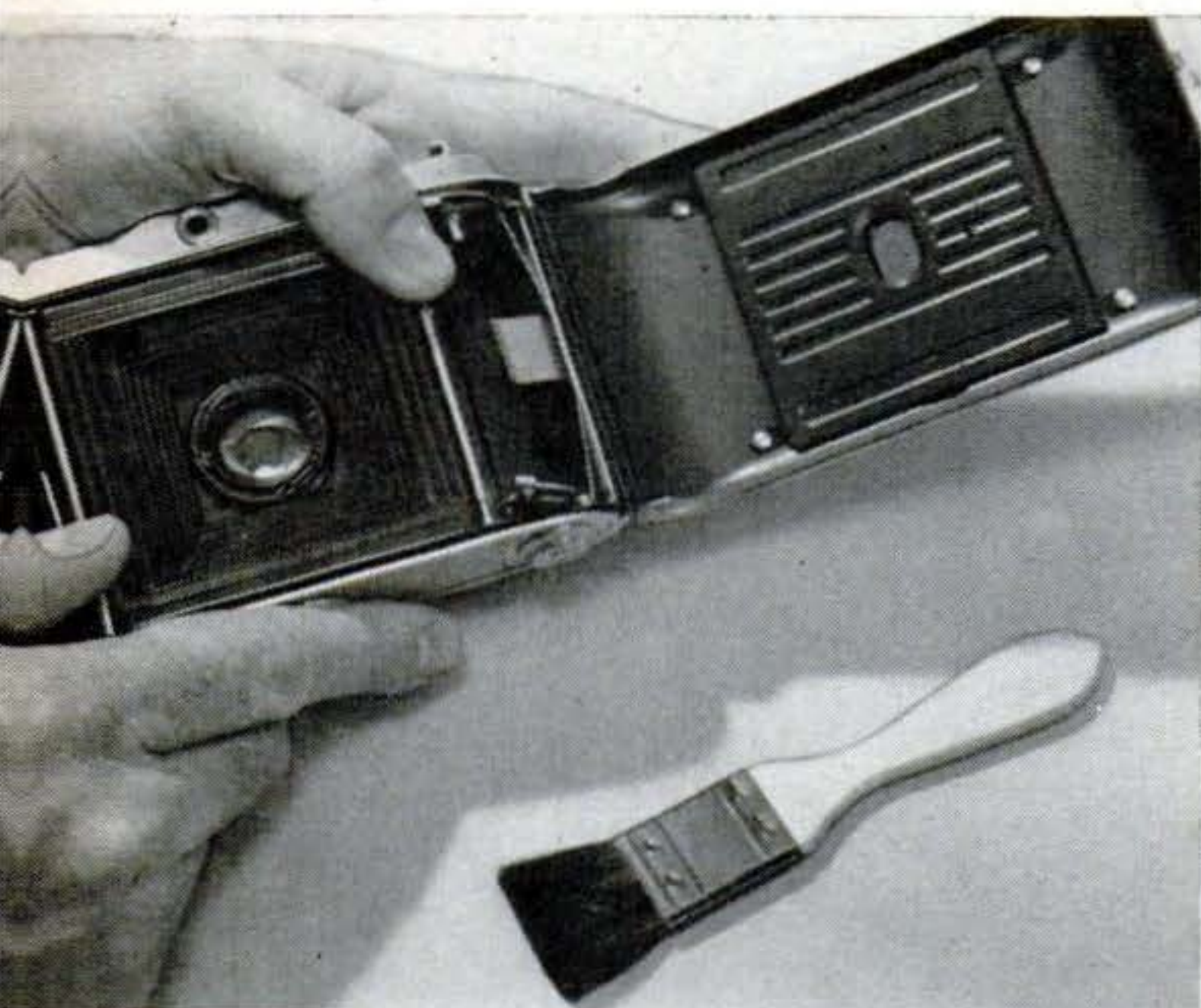

INTERIOR Use soft brush to clean out dust. Be sure film rollers run true and free and that pressure plate has good tension. And don't forget to clean rear surface of lens. A fingerprint can etch lens.

BELLOWS Check for light leaks with flashlight in darkened room. To preserve bellows, apply petroleum jelly sparingly to outside only, and wipe clean.

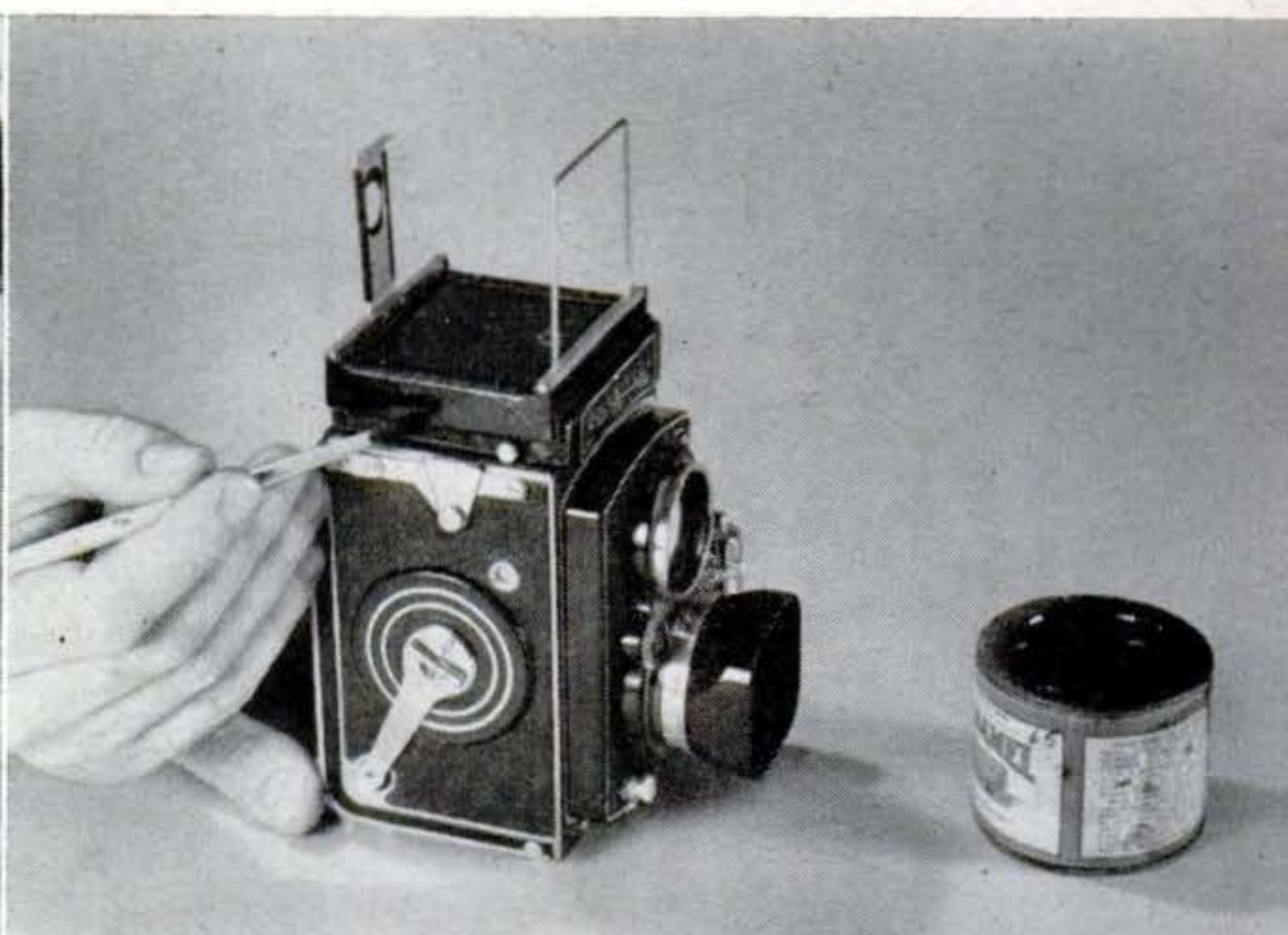

SCRATCHES Marks on exterior metal can be touched with black enamel to spruce up a camera. Apply several thin coats, letting each one dry completely. On metal inside, use only flat black paint.

LEATHER Dressing applied with brush or wad of cloth will restore luster—and keep your old camera looking new. Fasten loose leather with rubber cement.

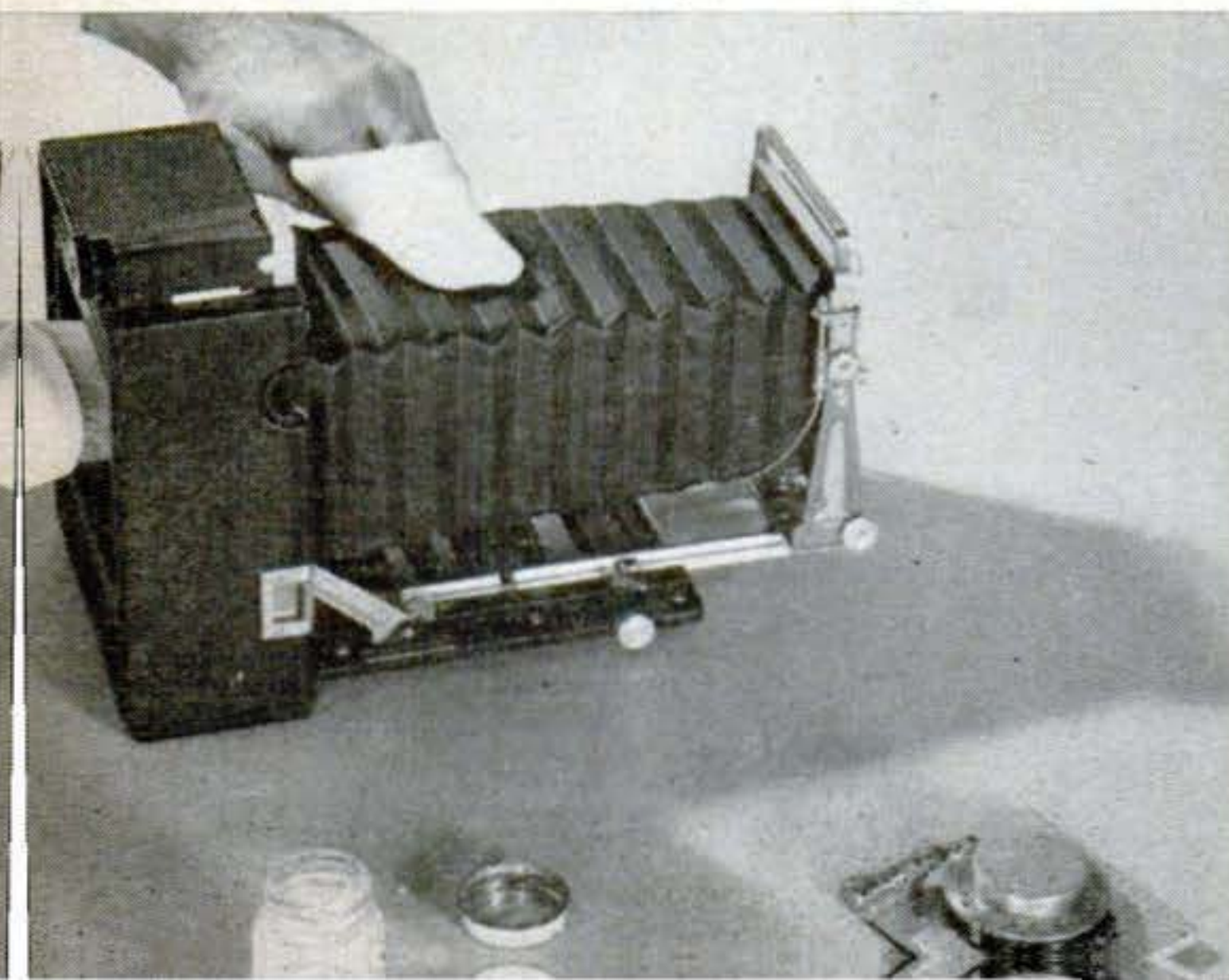

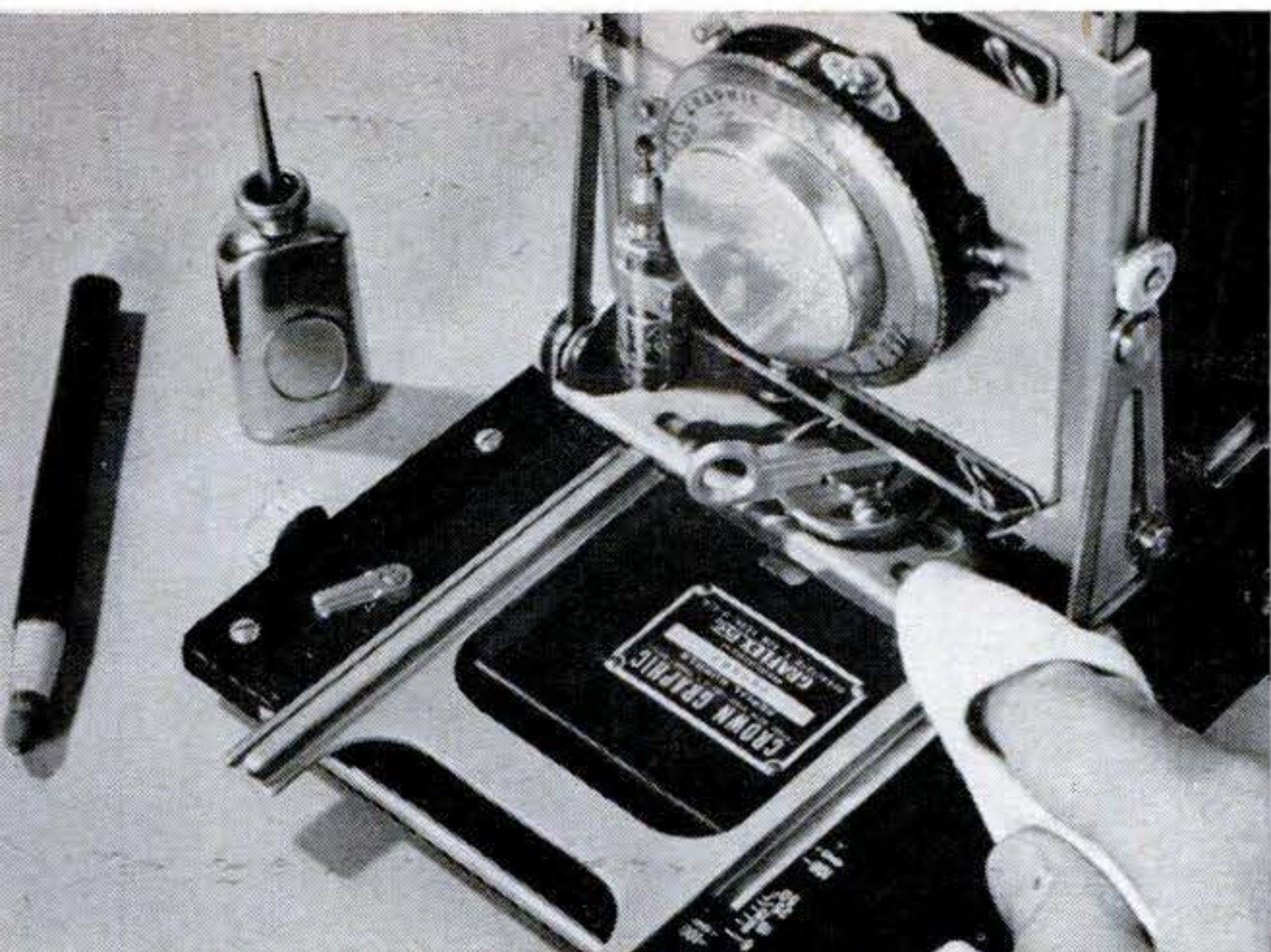

BRIGHT METAL This can be protected with a coating of light oil. Apply it with a soft cloth and then remove all you can. A rubber eraser will often remove corrosion. Never lubricate a camera shutter.



ALUMINUM These surfaces can be cleaned with carbon tetrachloride. For a tripod, dampen a cloth in this fluid, rub cloth across paraffin, and wipe on the parts. The wax will act as lubricant.

Vacation-Time Camera Hints

Take care to guard your camera against sand, salt spray and dust.

Do not store it in a car glove compartment. The temperature in there gets too high for anything as delicate as a fine camera or film.

Carry it in a good gadget bag or on a strong strap. Avoid knocks and bumps.

Keep a cap on the lens.

Stifle any temptation toward penknife-and-tackhammer repairs.

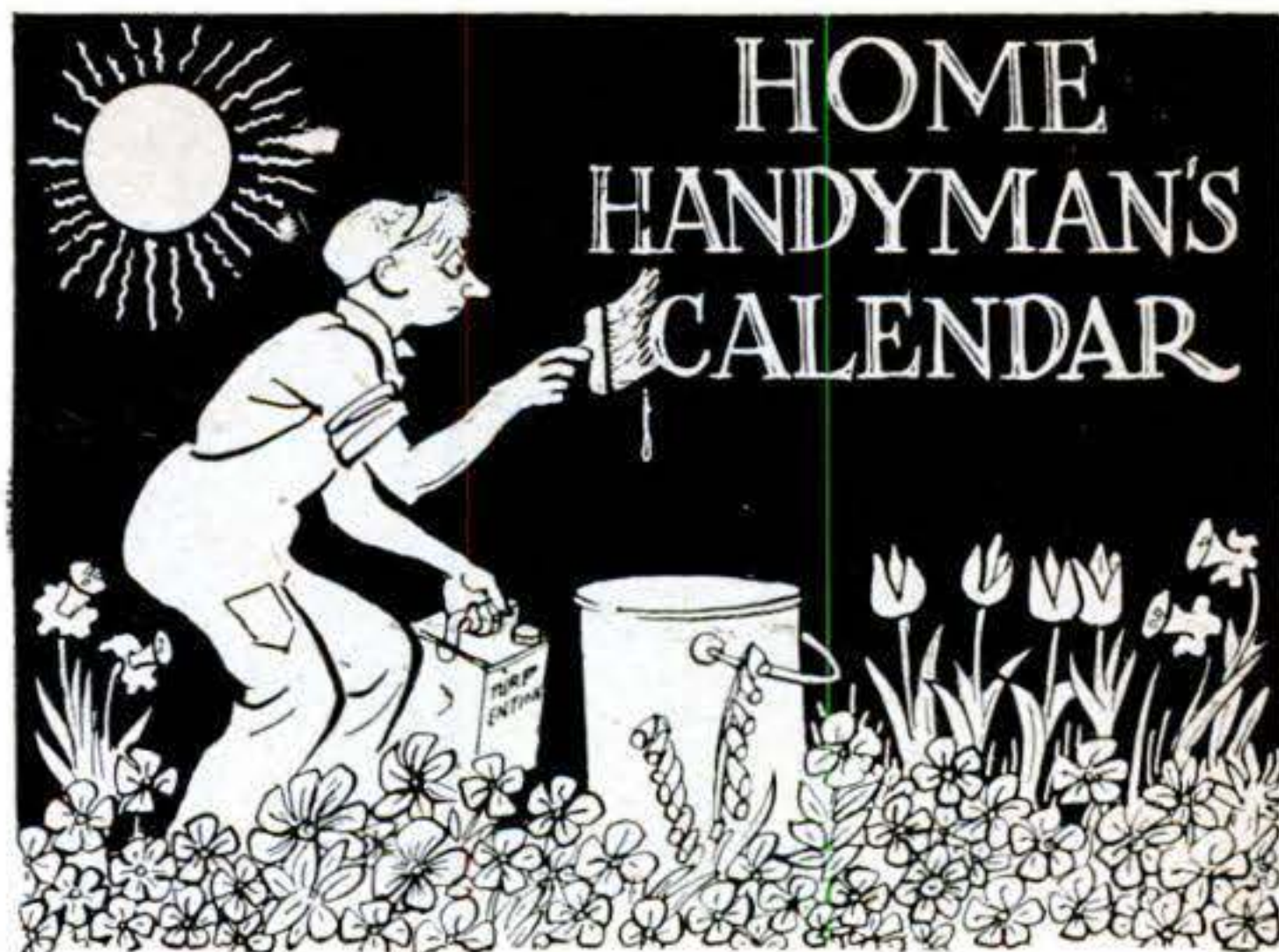

May For the poet this is the month of blossoming flowers. For the homeowner it is a time of bright, clear days—and plenty of outdoor work.

- If you have outside painting to do, get it done now before summer insects arrive, and console yourself with the thought that a good paint job should last five or six years. At the same time, inspect masonry for loose mortar, open joints, cracked or loose stucco. Check woodwork for splitting, rotten spots, open connections or joints, sagging or loose pieces. Replace damaged window or door glass. Renew crumbling putty.

- Look over your grounds. Fill any sunken or washed-out spots you find and roll the lawn. Repair gates and outdoor latches and locks. Replace rotten fence posts. Paint fence if necessary. If you have an outdoor grill, make sure it is ready for the cook-outdoors season.

- Inspect your radio and TV antennas and lead-ins to make sure all connections are firm and tight. Open all attic windows or louvers and basement windows for summer ventilation. This helps discourage dry rot and vermin. Check clotheslines. If they are frayed, replace them before one breaks under a wash-day load.



How Did the Birds Get in the Fishbowl?



You might think birds and fish would not mix any better than oil and water, but in this aquarium they live feather to fin. Nor is this a taxidermist's dream; both the tropical fish and the parakeets are alive.

There is no trickery about the picture, which was taken by a PSM photographer. How can fish and fowl live together and like it? See next month's issue of POPULAR SCIENCE MONTHLY for the answer.

Sanding Belt Brushed Clean

ROLLING a circular wire brush over a sanding belt from time to time will keep the belt clean and sharp. The sharp wire ends dig out packed material on a loaded-up belt, and rotation of the brush prevents excessive wear. A scrap of hardwood jigsawed into fork shape holds the brush, which spins loosely on a through bolt.—*Lyell D. Henry, Ames, Iowa.*

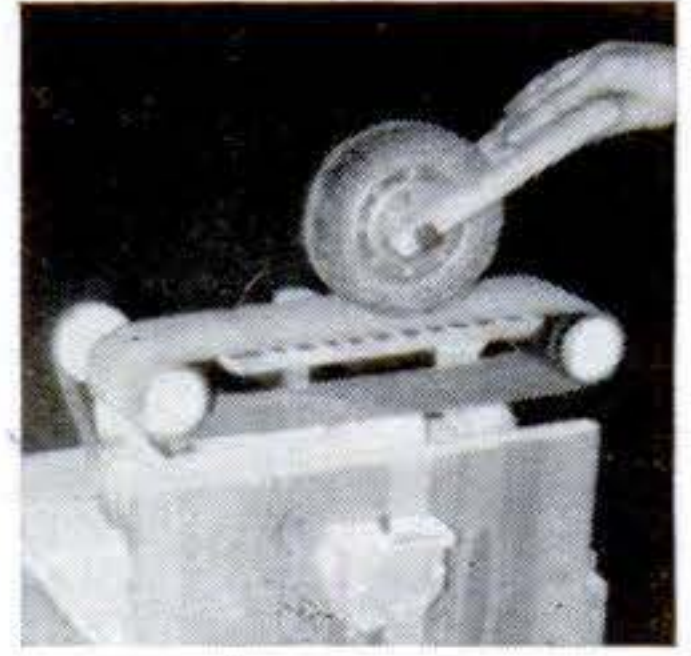

Edge Titles "Index" Magazines



I USUALLY want to keep at least one article in an issue of POPULAR SCIENCE MONTHLY in my future-reference file. Instead of cutting up my copy I label the magazine edge so I can quickly find the one I want.—*Tom Griberg, Moline, Ill.*

Insert Stops Splintering When Dadoes Are Cut on Saw

THIS wooden support, added to the dado insert plate of your table saw, can be set to support work right up to the blade. This

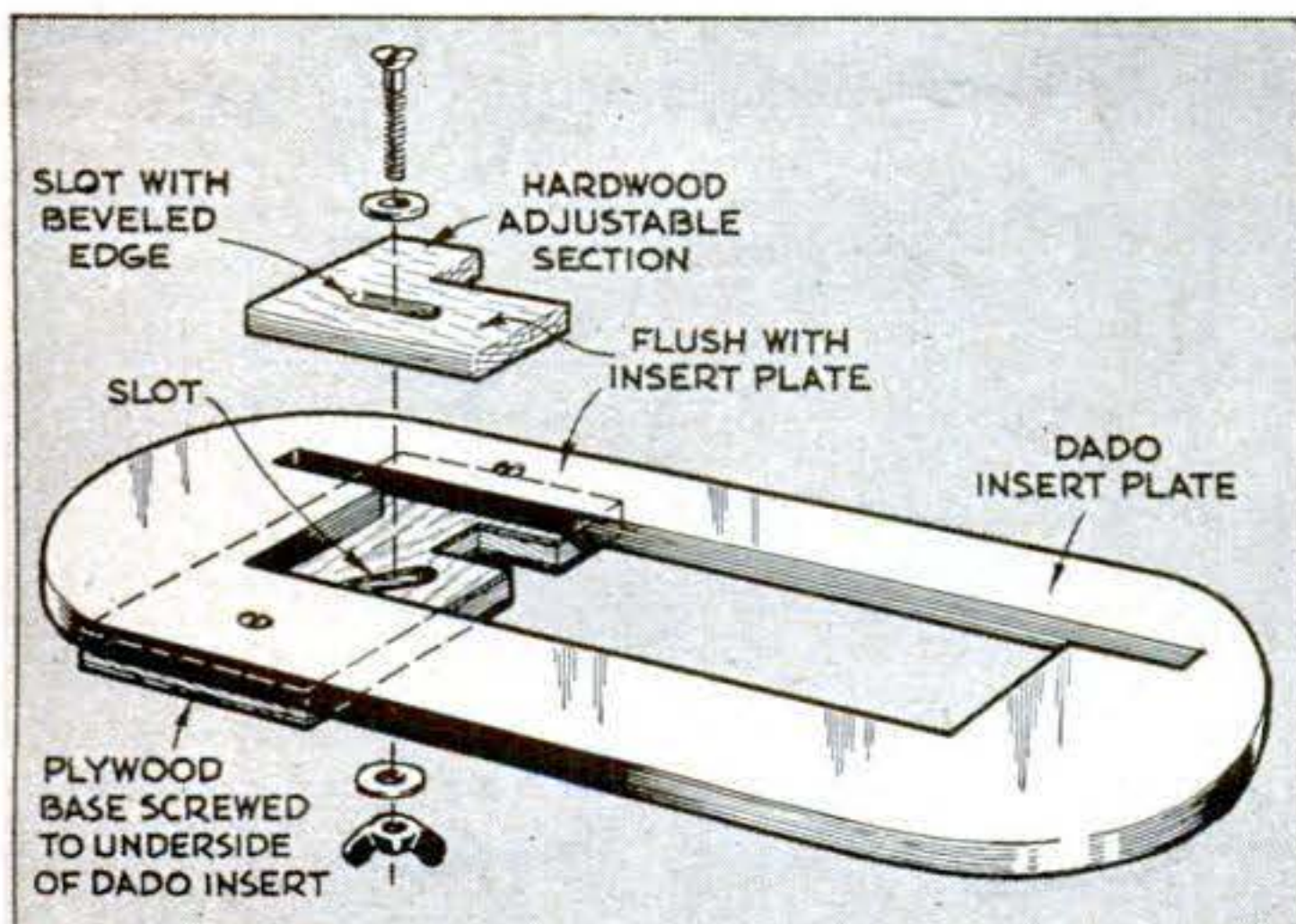

makes it possible to cut clean rabbets or dadoes across the surface grain of fir plywood, and prevents the blade from tearing out slivers. It is adjustable to any combination of dado cutters.

The $\frac{1}{2}$ " plywood base, slotted diagonally for the adjusting screw, is attached to the underside of the insert plate with two countersunk wood screws. The hardwood adjustable insert, slotted parallel to the line of cut, rests on the base with its surface flush with the top of the plate. The adjusting screw, with wing nut, rides in the two slots and permits you to move the adjustable section close to the saw blade, regardless of the blade depth-of-cut setting.—*Joseph Williams, Erie, Pa.*

Shop Wall Desk Folds Flat

A drafting board and storage space for plans and drawing tools are built into this compact unit.



ONE of the handiest tools in my home workshop is my planning center. It's a wall-hung box that stores and organizes notes, drawings, booklets, plans for projects, magazines and my PSM data file.

In pigeon holes and in the lid are places for drawing tools and instruments. A flip of the lid converts it into a slanted drawing

board. This is particularly handy, too, for holding plans where I can refer to them while doing a job.

It is a pretty simple piece of shop equipment to build: basically just frames of standard lumber hinged together and covered with hardboard to provide a smooth surface.—Paul Corey, Sonoma, Calif.

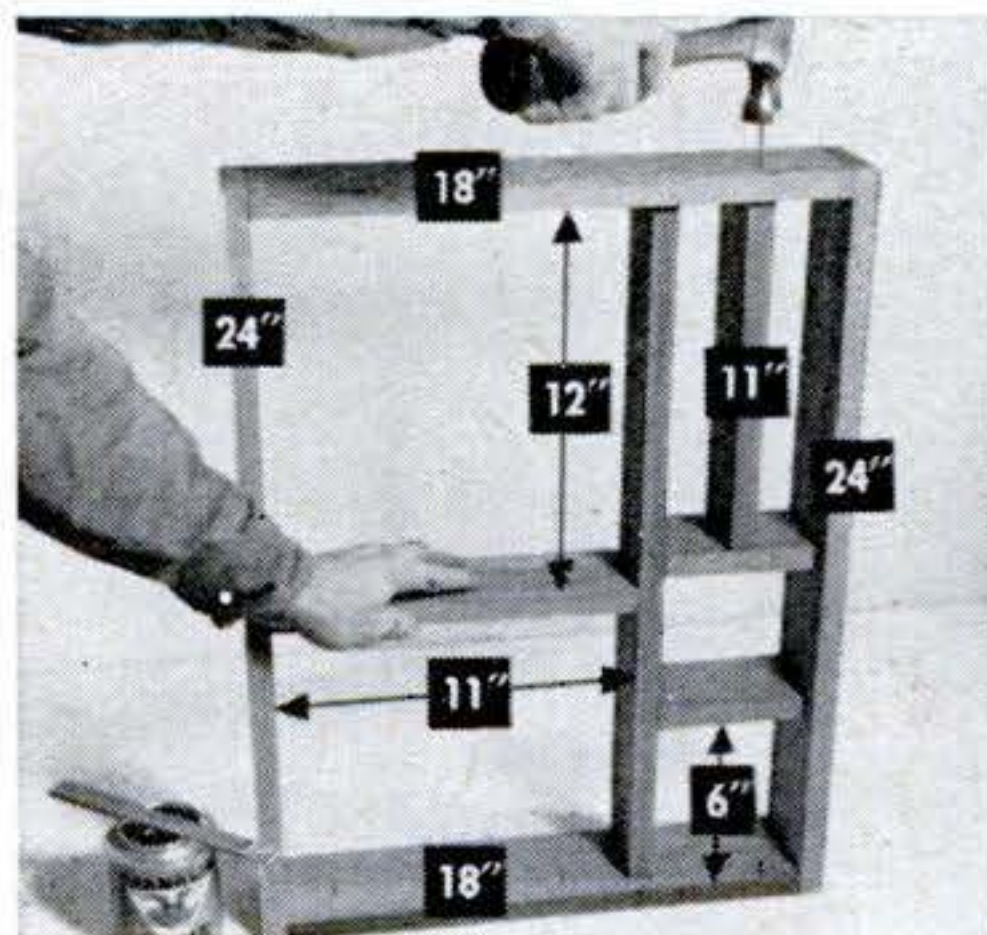

FRAME. Build it of standard 1" by 4" lumber, gluing and nailing the joints. Make partitions $\frac{1}{4}$ " narrower than the frame pieces.

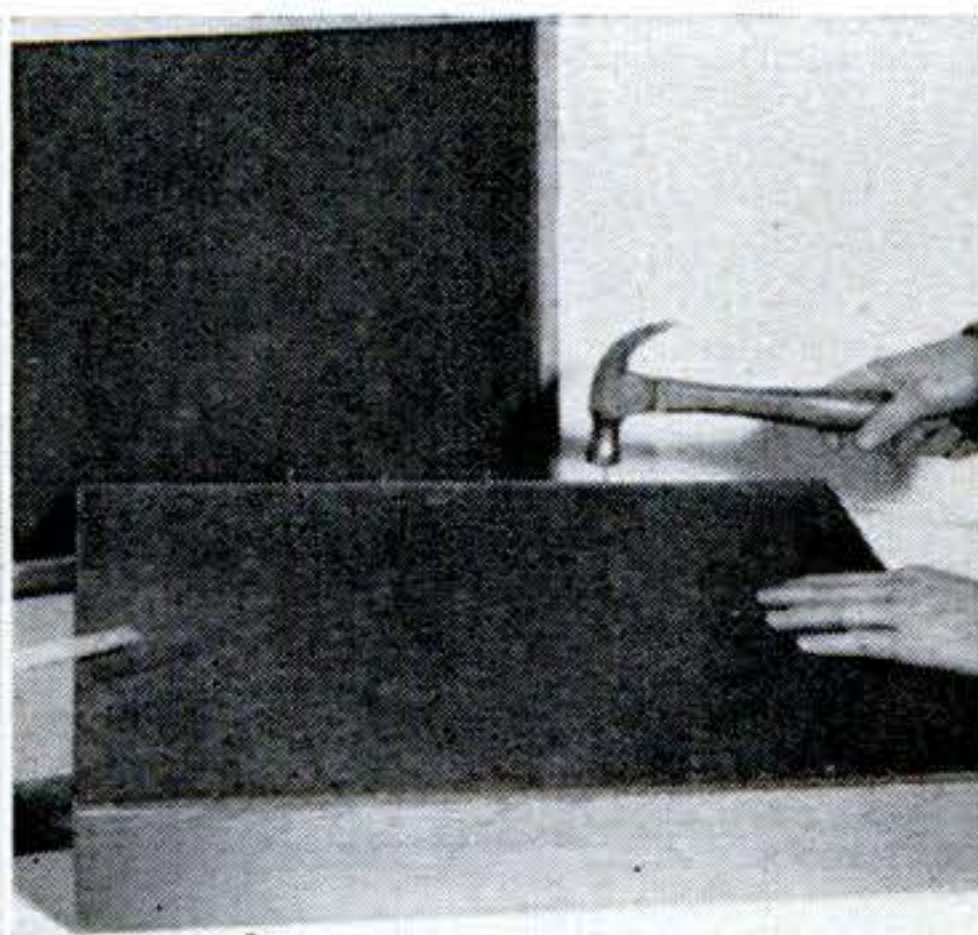

FRAME COVER. Brad $\frac{1}{4}$ " hardboard to one side of the frame. Build a lid of $\frac{3}{4}$ " stock, nailing and gluing it. Cover it with hardboard, too.

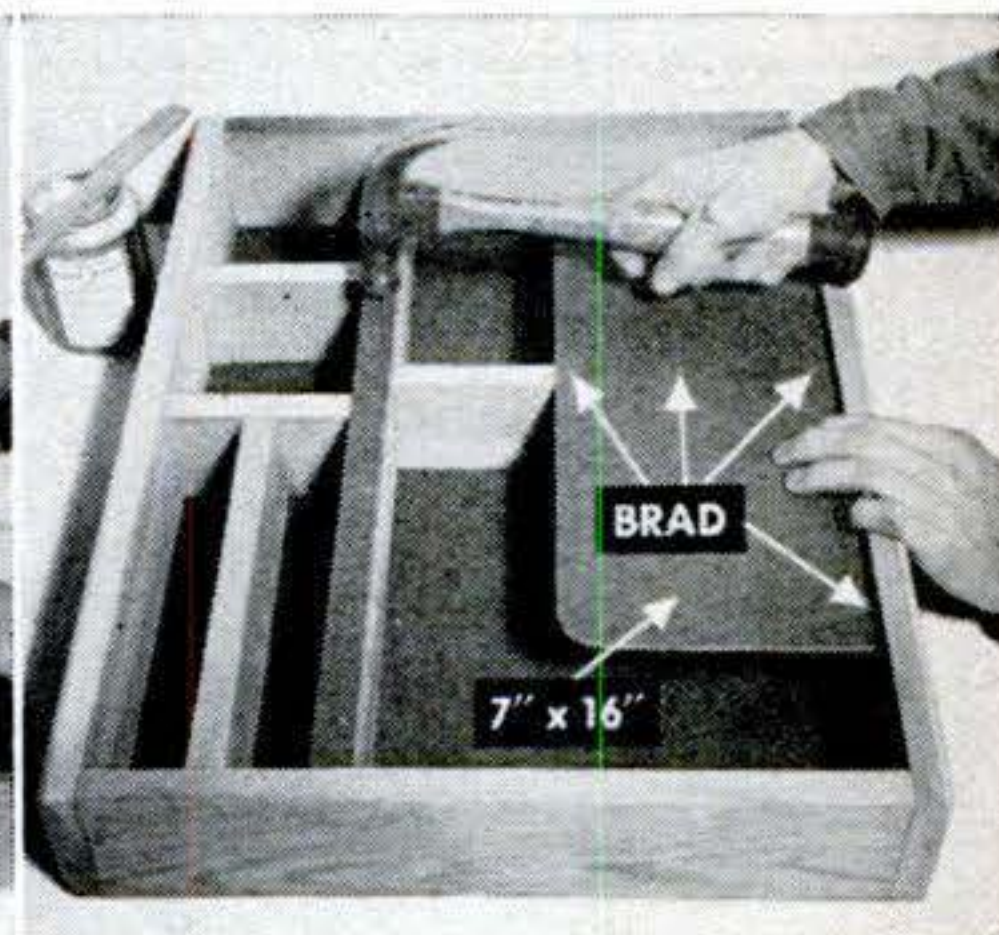

INTERIOR. Edge the long shelf with 1" strip of hardboard to keep pencils from rolling off. Piece of 7" by 16" hardboard holds plans, papers.

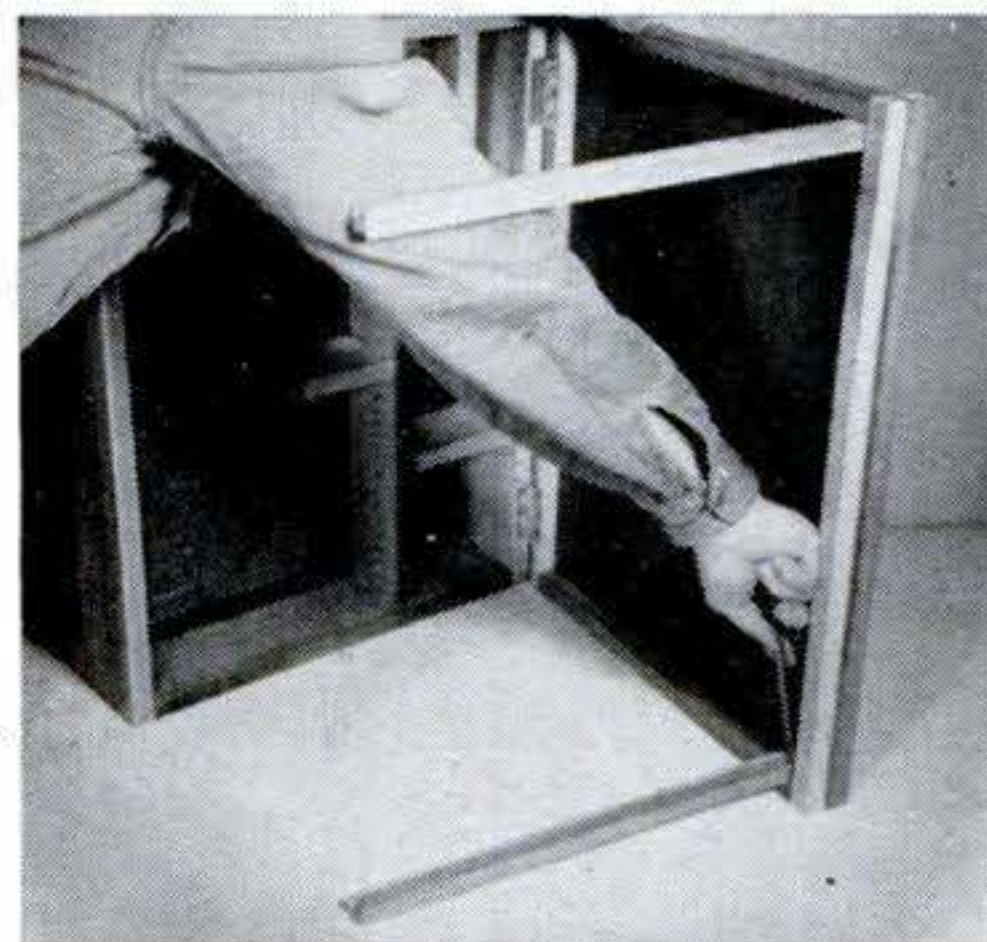

ASSEMBLY. Hinge lid to box. Fasten lid props with one screw in each. Props are $\frac{3}{4}$ " square and 16" long. Notch one end of each prop.

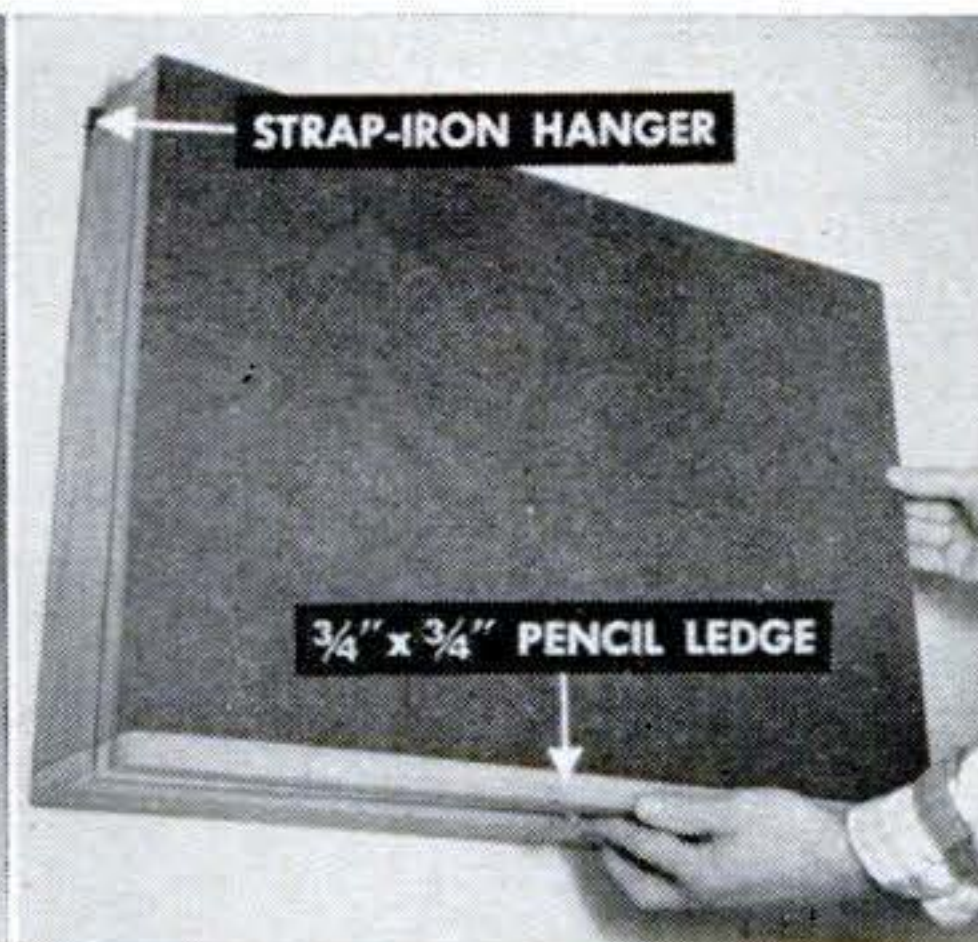

MOUNTING. Screw two pieces of strap iron to top of back. Holes in straps slip over nails or hooks in wall. Flat hook holds lid shut.

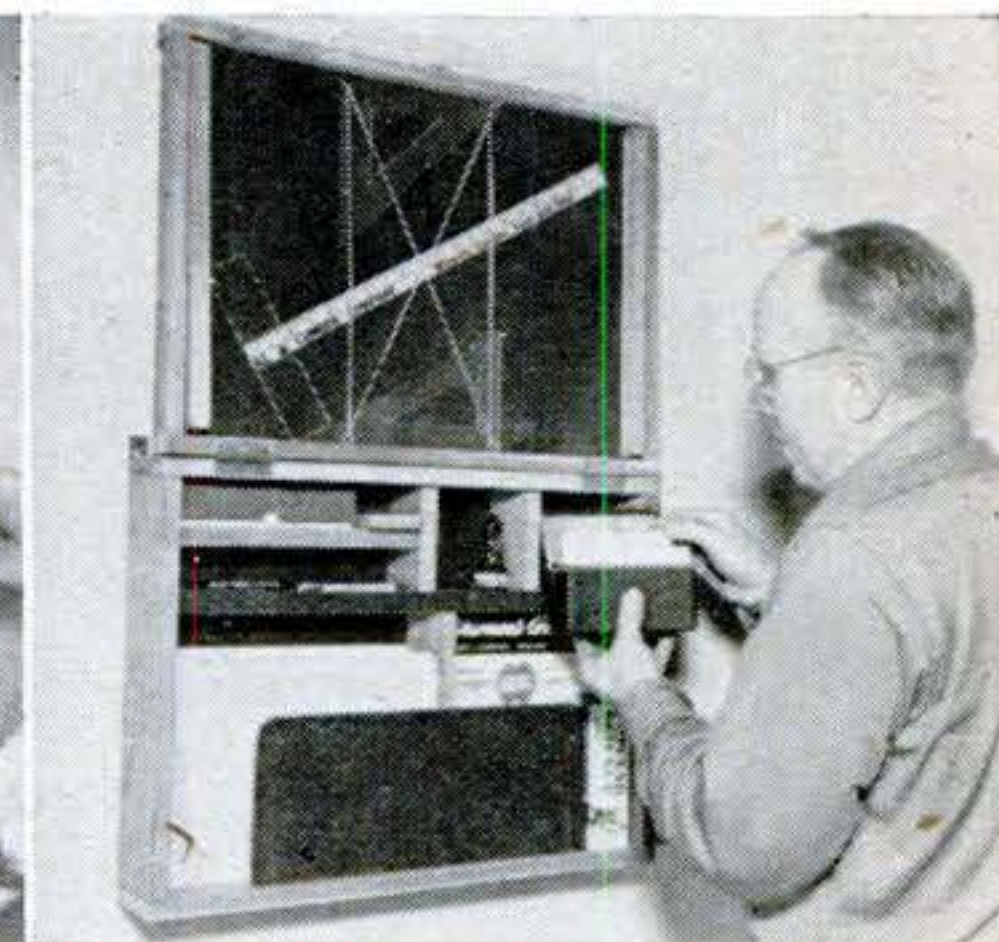

PLANNING CENTER AT WORK. Rubber bands stretched between eyes hold drawing tools in lid. Compartments hold other instruments.



Putting in an Electric Outlet Yourself

A floor socket keeps cords out of the way and can be installed without cutting plaster or fishing wires through walls.

TO START the day right, you want the morning toast popping up no farther away than your elbow. A floor outlet under the table will bring the toaster, coffee maker or waffle iron right alongside your coffee cup.

You may hesitate to wrestle with kilowatts, feeling that this is a job for experts only. But like burning trash or driving to the drugstore, it's just as safe as your common sense makes it. You can do simple wiring with complete safety both to yourself and your home, once you know how.

But is it legal? It's a big country, and

building codes vary from town to town. But it is generally recognized that the homeowner has a right to do such work on his own property so long as he uses approved materials and methods. In some communities, you must get a permit for the job and have an inspector check it when it is done.

If the work then doesn't comply with regulations, you will have to correct the violations to get an okay. But all this is routine, and if you hired an electrician he would go through the same procedure. Meeting code requirements will assure you that you've

DRIVE A NAIL through floor (or drill a small hole) where receptacle is to go. Push a short wire through to locate hole in cellar. If it's nearer a joist than 1½", outlet box may not clear. Plug hole and try another spot.

MEASURE RECEPTACLE, set expansive bit to the size and bore a trial hole in scrap. The hole should just take the box. This receptacle is an Arrow No. 5016; you can also use a Westinghouse No. 494 or equivalent.

PASS THE CABLE through floor from cellar. Expose wires and strip insulation off ¾" from ends. Push cable through box. Bend white wire clockwise around nickel screw, black wire similarly on brass screw. Tighten well.

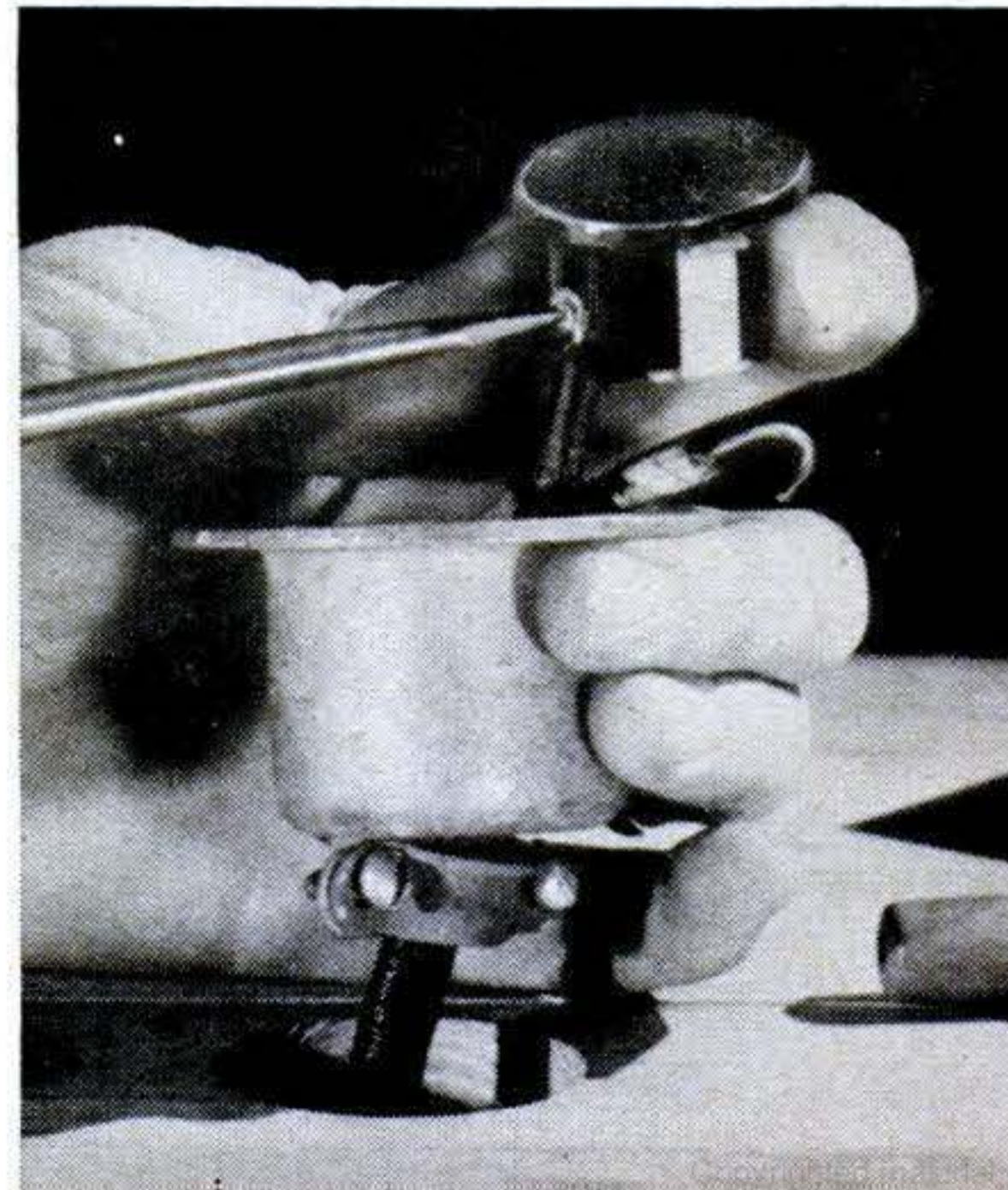
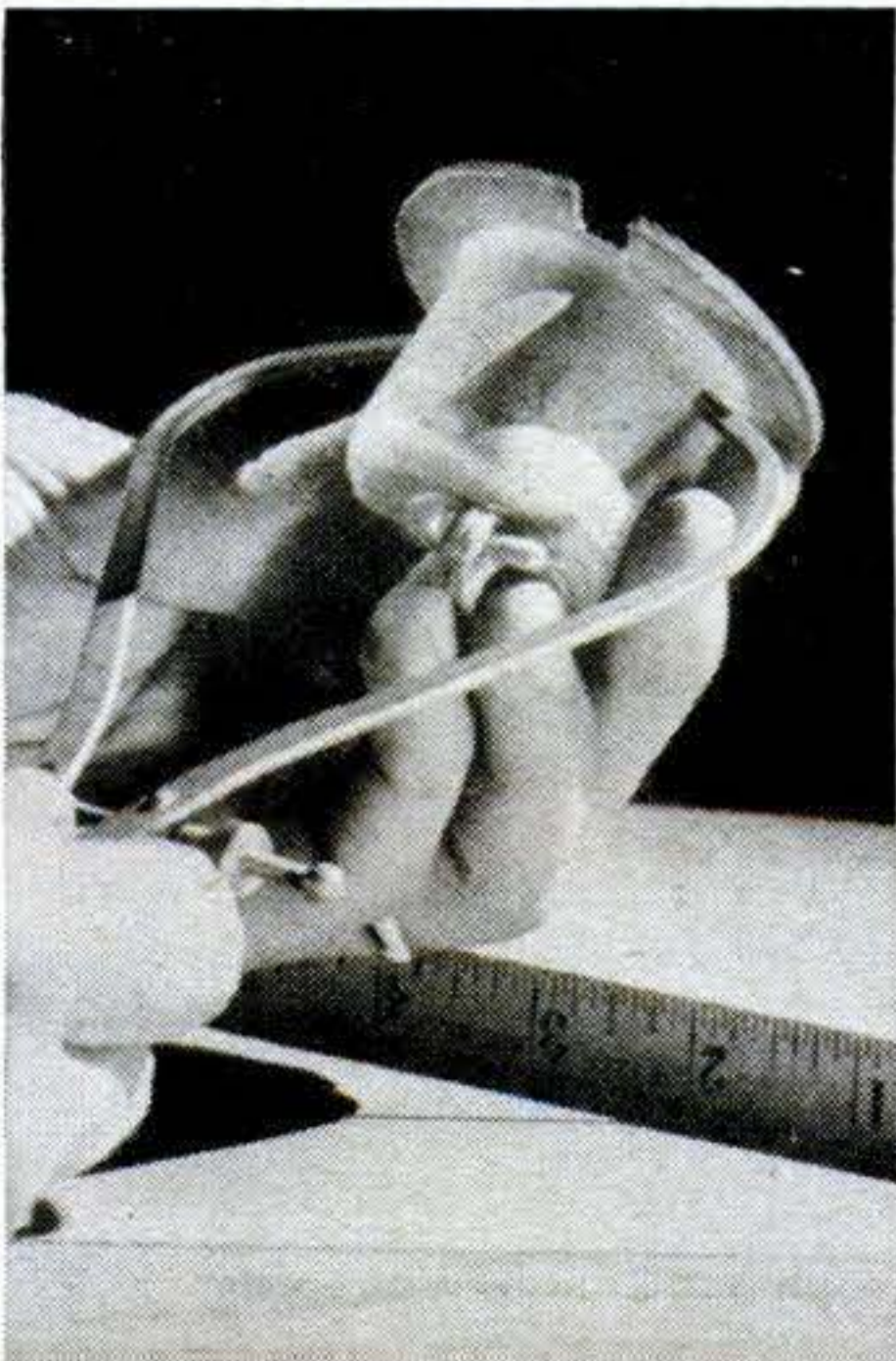
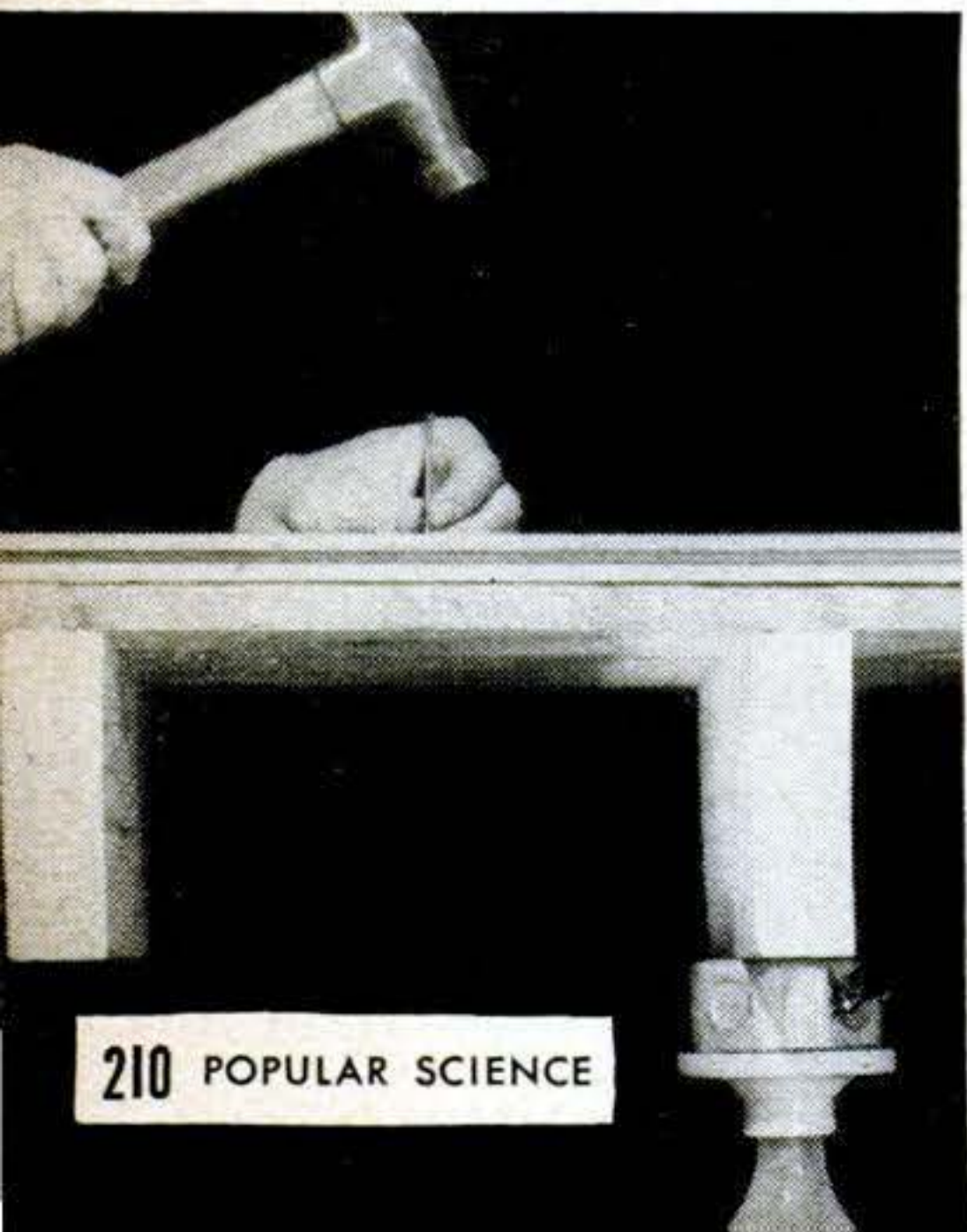

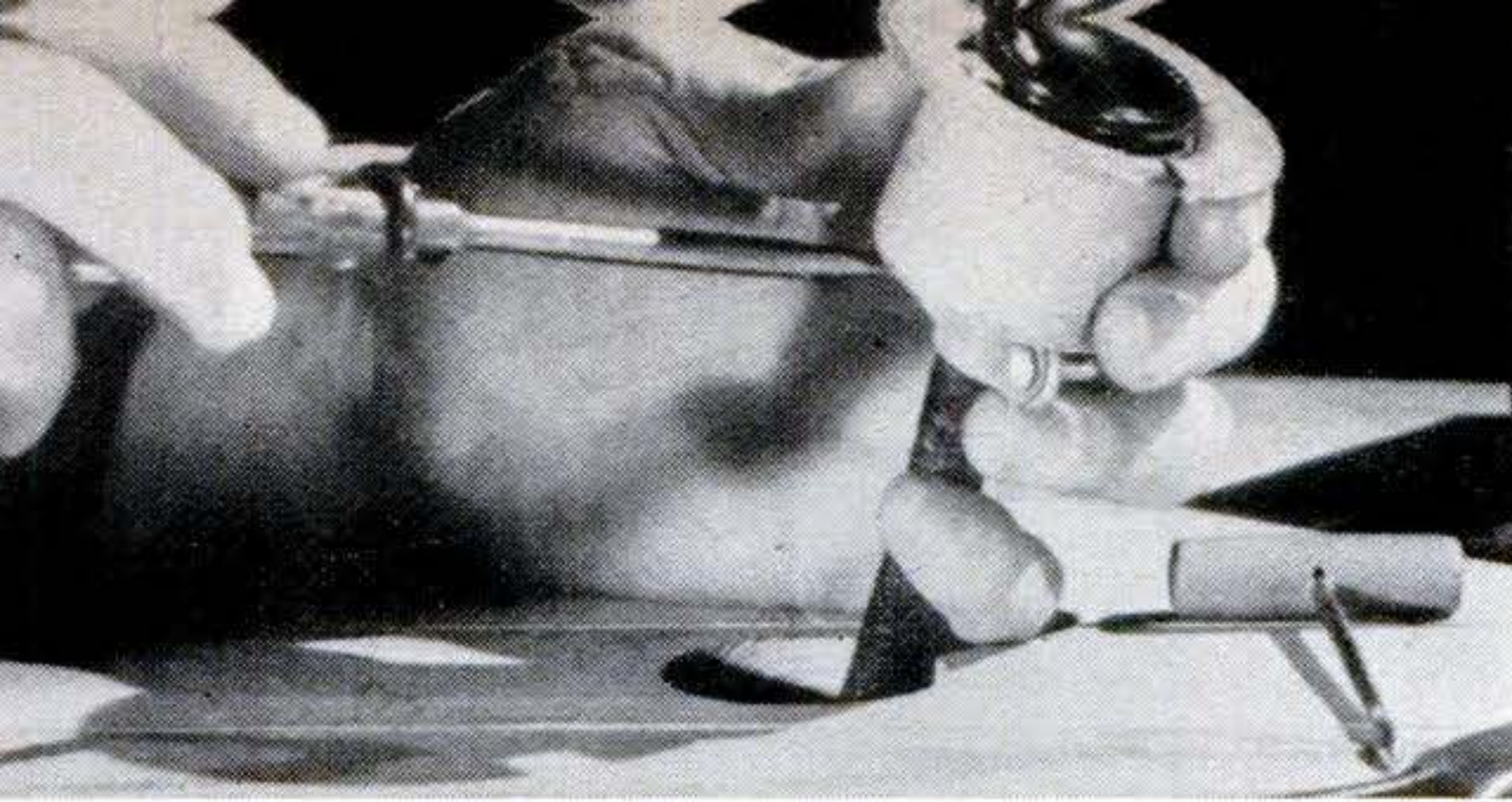

TIGHTEN THE SCREWS on connector (cable clamp) at bottom of receptacle box before putting it into hole. Then insert it, fit cover plate over it, and secure plate with flathead screws as at top of facing page.

done a good job and keep you on good terms with your insurance company.

Find the right spot. Locate the floor receptacle out of traffic areas, where the cord won't trip anyone. Try to pick a spot between two floor joists (you can sound them out by tapping with a hammer). Drill a small hole, or drive a nail through at the spot. If you get into a joist, or so near one that there wouldn't be clearance for the receptacle, plug the hole and try again.

Where to get juice. In the basement, find the junction box or ceiling light nearest the nail hole. If it is a light controlled by a wall switch, you can use it *only* if the power cable from the fuse box runs to the light first, not to the switch. If the switch is between the fixture and the power source, don't hook up at that fixture, or you'll have toast only when the cellar light is burning.

A toaster or waffle iron takes a lot of juice, so don't hook the new receptacle into a circuit on which you have the refrigerator, oil burner or clothes drier. The total current may be more than that circuit should carry.

To check this, turn on a lamp in the fixture you want to take juice from. Then loosen one branch fuse after another until the lamp goes out. Retighten the other fuses,

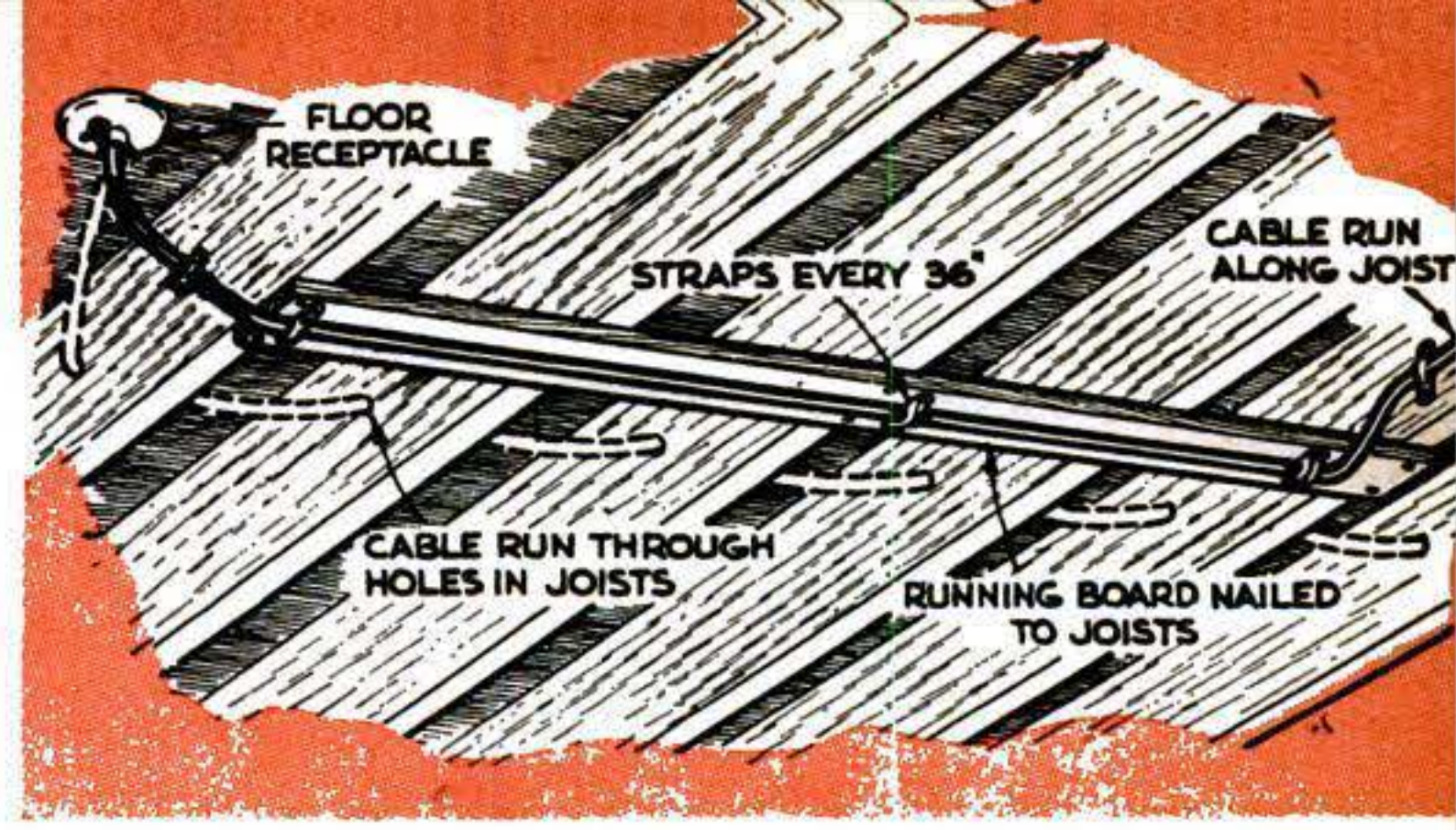

TWO WAYS TO RUN either nonmetallic or BX cable across joists are shown above. Either cable can be run *along* a joist. Use straps or staples for BX, but only straps for nonmetallic cable. Be sure to put one within 12" of boxes.

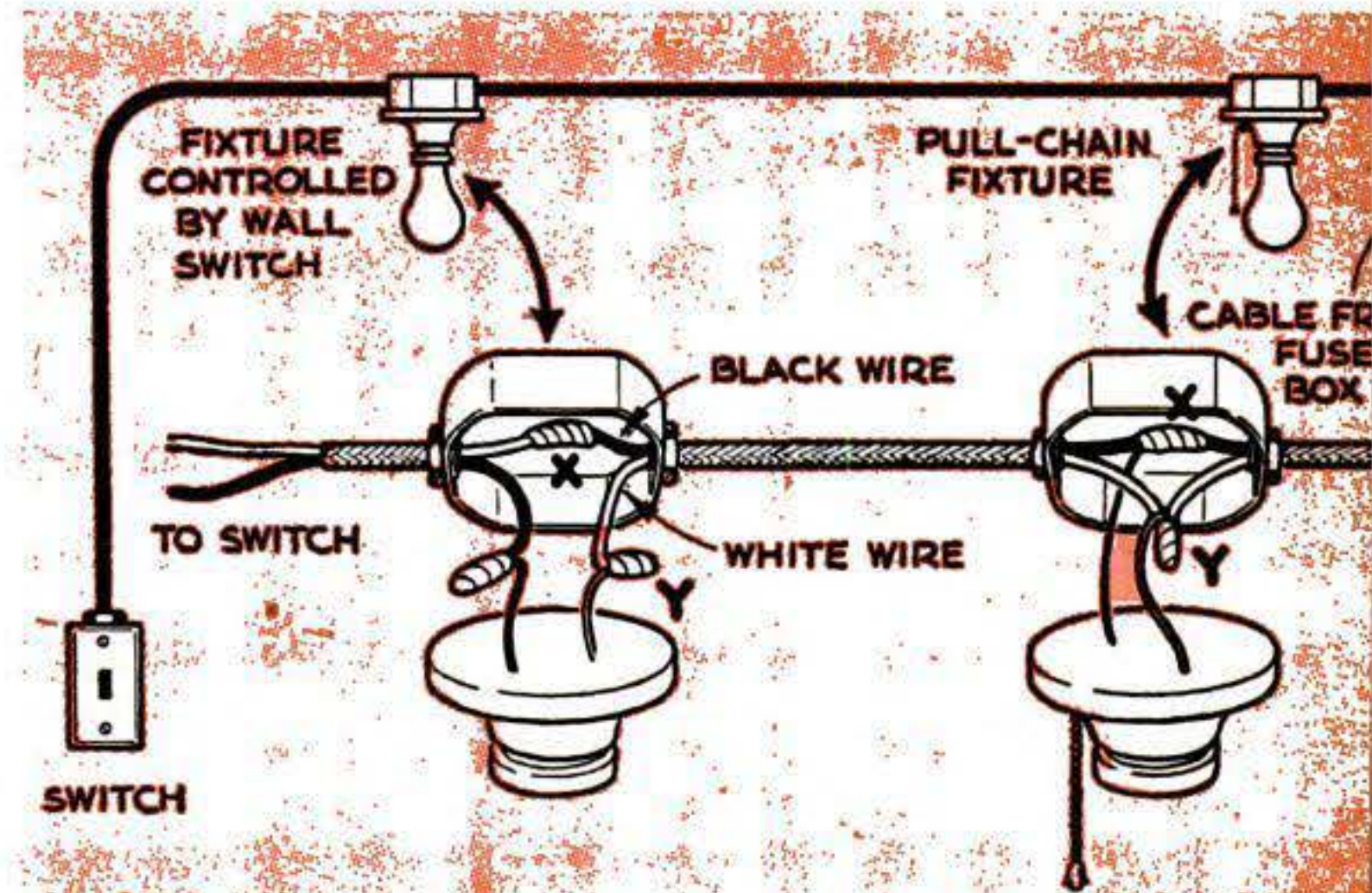

TAP POWER at a junction box, receptacle or light. Examples above show how to wire into two types of fixtures, a switchless socket (left) or a pull-chain socket (right). In both, new wires go to points x and y.

but leave this one loose while you see whether the refrigerator or other appliances will still run. If so, they are on another circuit and you're okay.

What to wire with. Most wiring today is done with conduit (steel pipe with wires inside), BX (which has a flexible metal armor), or nonmetallic cable (which is covered with impregnated fiber and is often known by the trade name Romex). Find out

HOW TO STRIP ROMEX

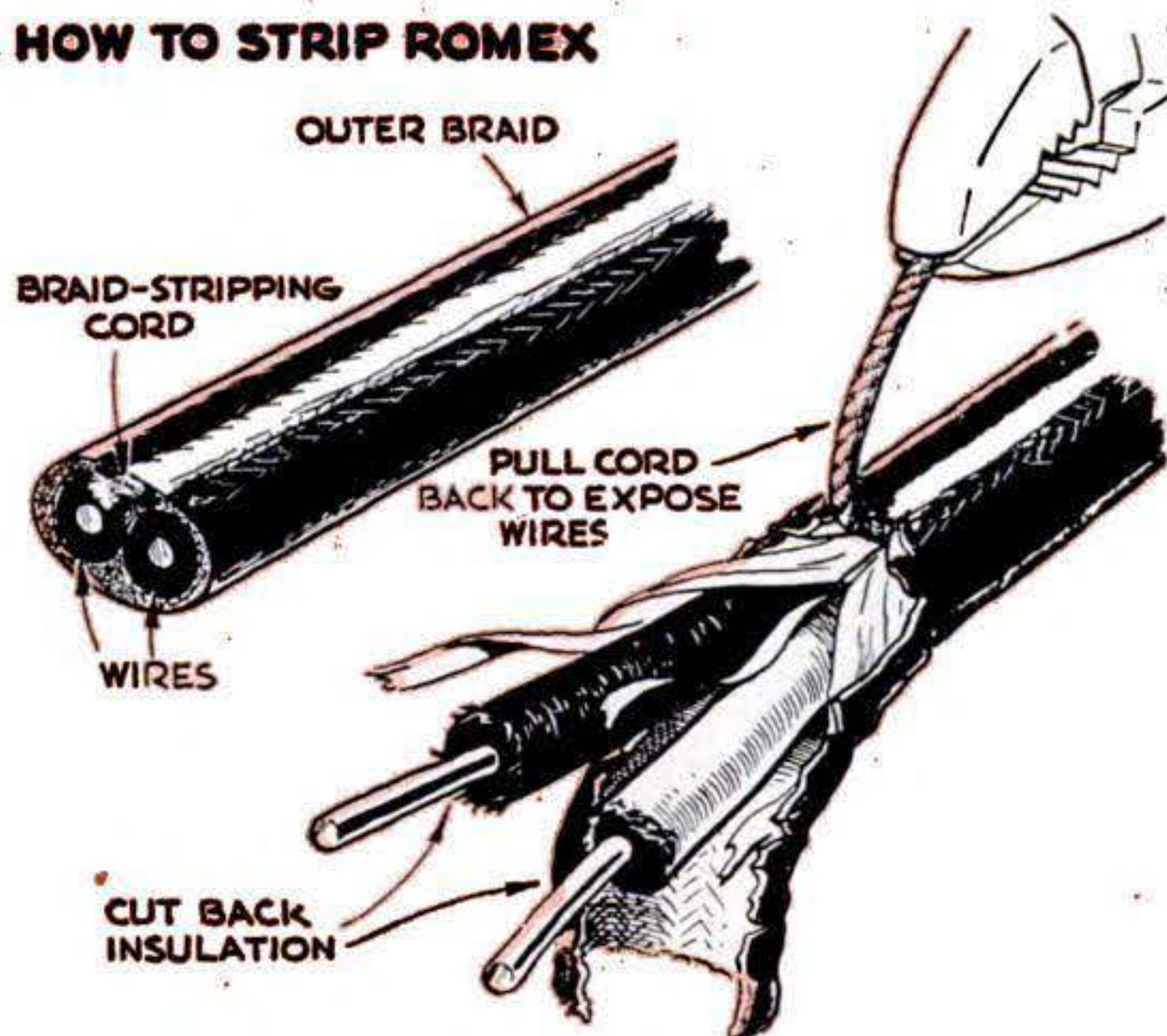

HOW TO CUT BX

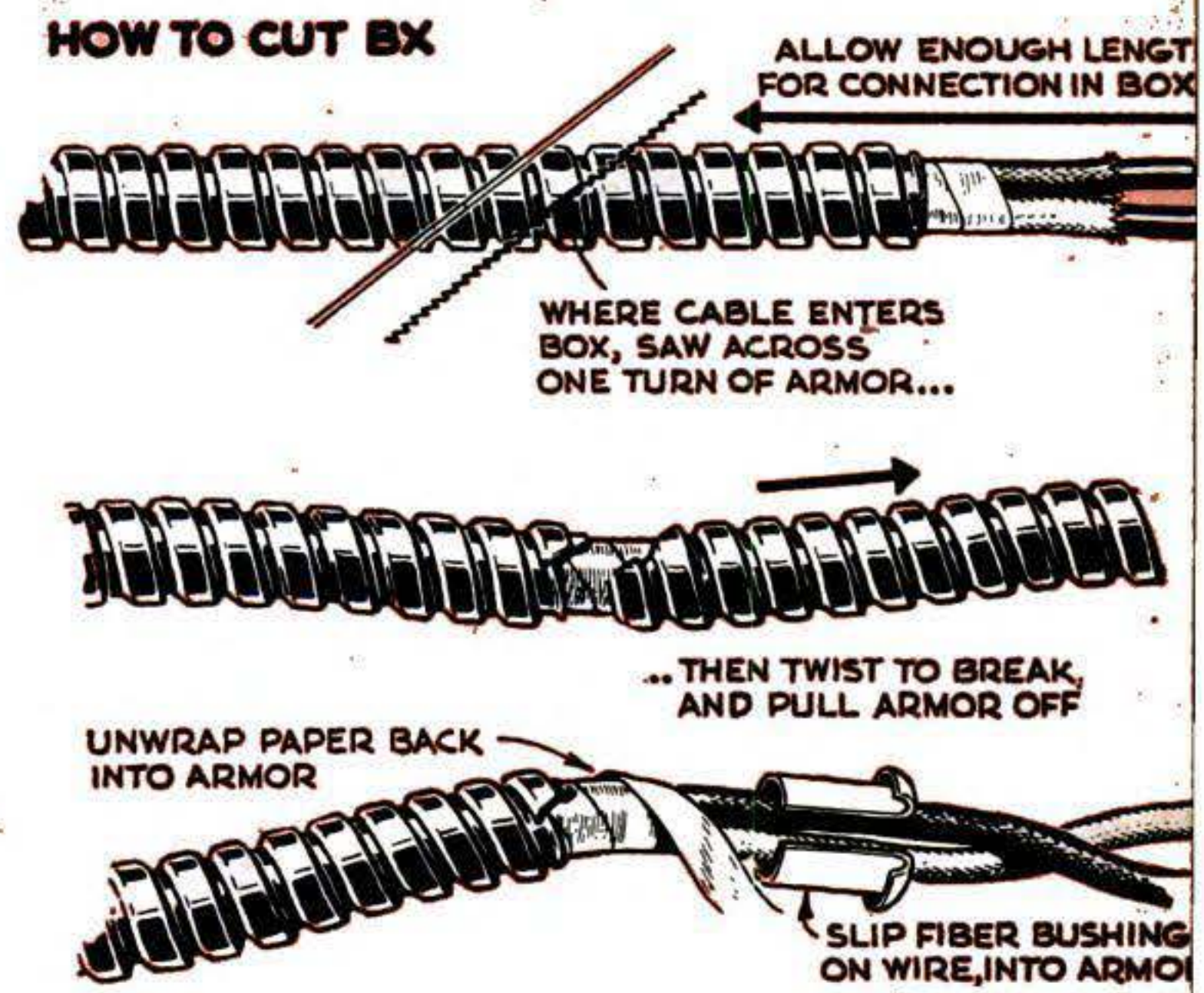

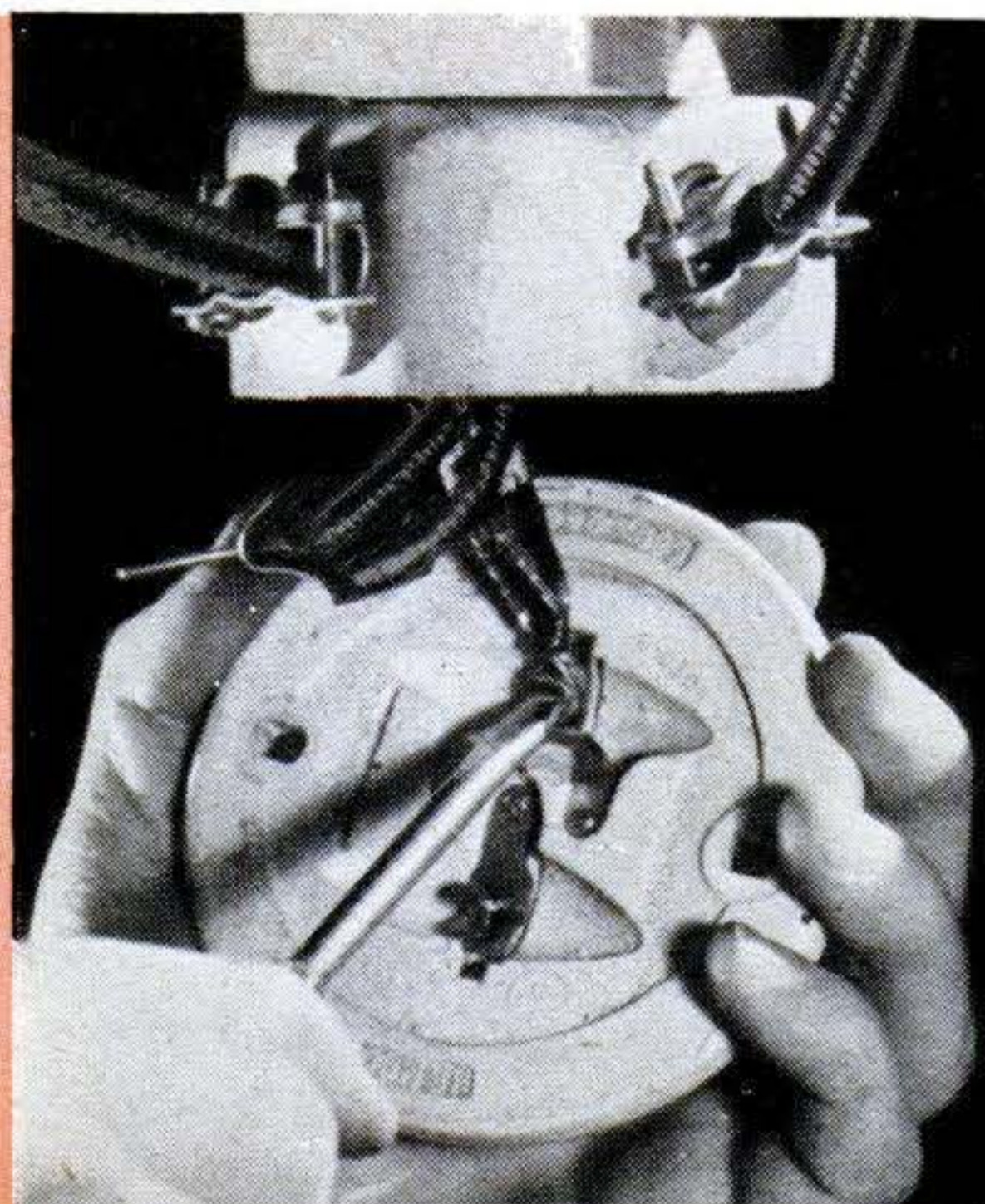
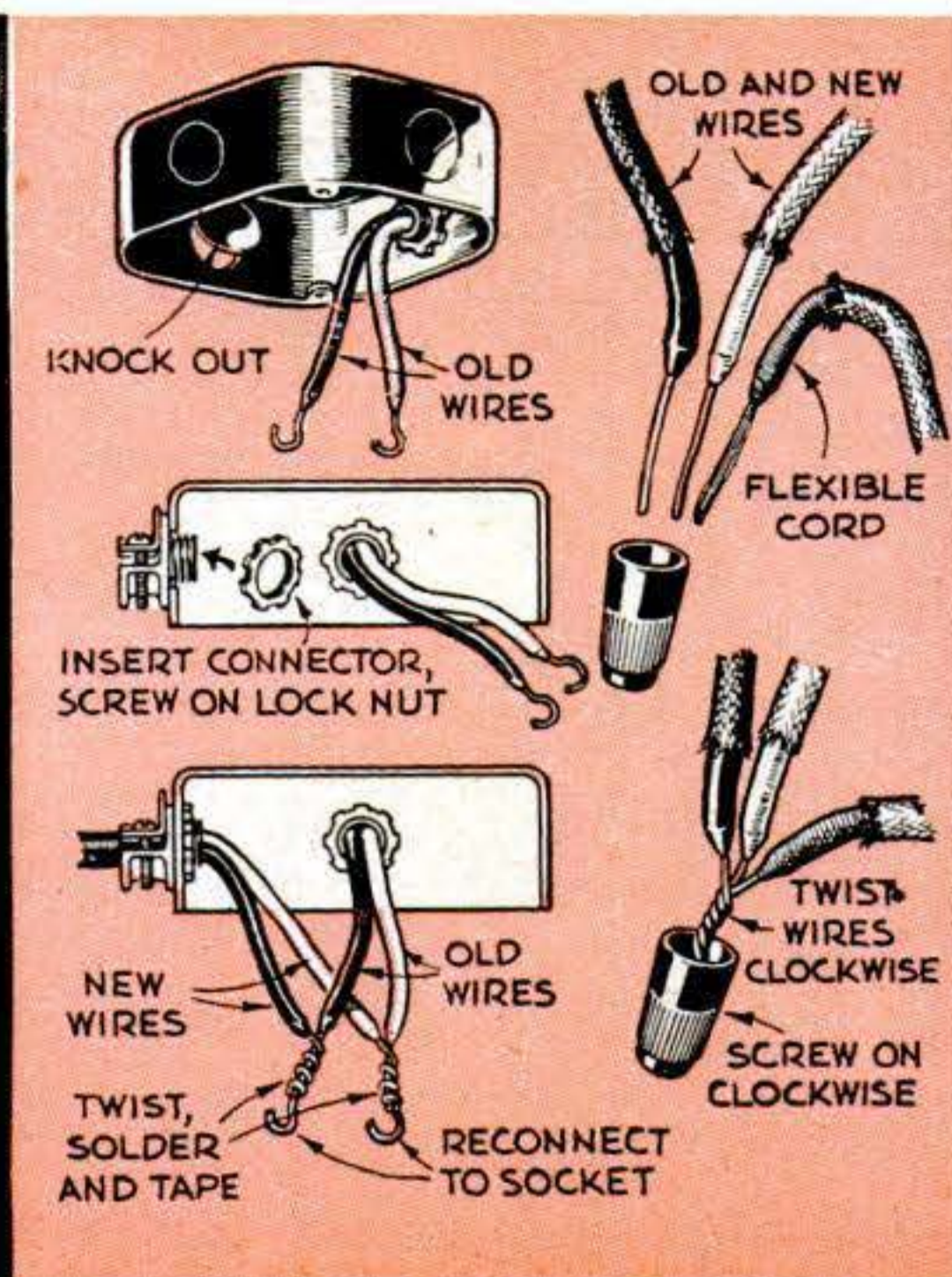
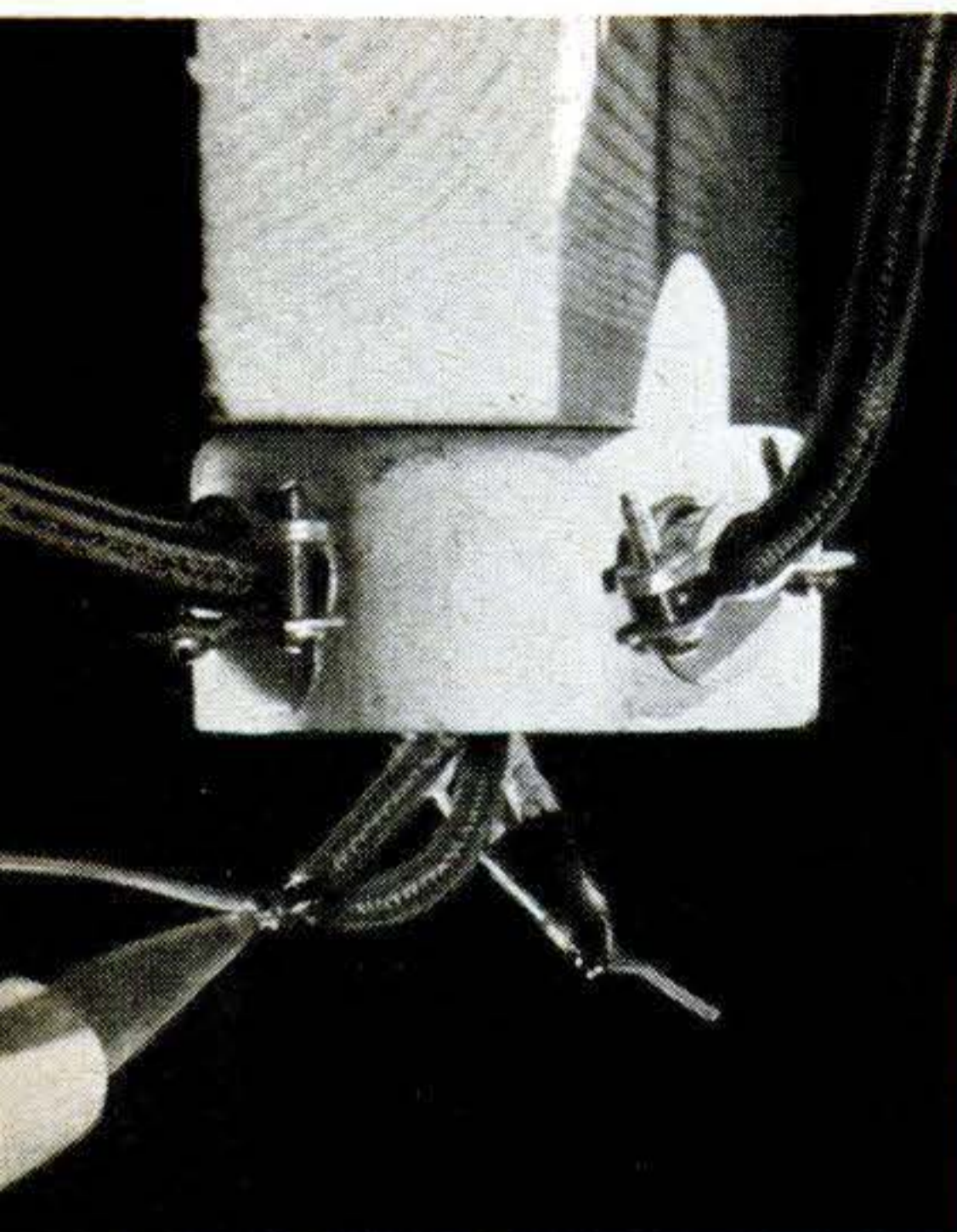

REMOVE BRANCH FUSE or pull main switch. Disconnect lamp socket. Knock out a hole blank, screw in a new connector and feed new cable through. Bare wires and twist new black wire around old black one, white wire around old white one, letting enough of old wires project to reconnect them to the socket. Sol-

der joints and wrap first with live-rubber tape, then friction or plastic tape. Tighten end of black wire under brass socket screw, white wire under nickel screw, as at right. For solderless joints, twist old and new wires together with short flexible leads. Screw on a wire nut. Run flexible leads to the socket.

whether your local code permits nonmetallic cable. It's easy to install and quite safe.

BX is only a little harder to use, so don't hesitate if your code requires it. The only trick to it is cutting the armor, and that is shown in a drawing. Don't forget to insert the fiber bushing also shown.

Conduit involves pipe fitting and threading. If you can get conduit cut and threaded to order, you can do the rest. However, it may be possible to use cable even if the rest

of your wiring is conduit. Check your code.

The wires inside the cable must be at least No. 14, and some codes require No. 12, which is larger. Use No. 12, or check to make sure your code permits No. 14.

Making box connections. The rule is that a joint must be mechanically strong as well as electrically sound. The cable must be clamped in one of the holes in the box with a connector and lock nut and securely strapped along the way.

Before making connections inside a box, be sure it's "dead." Pull the main switch, if you have one. Peel back the insulation (being careful not to nick the wire) and twist the bare wires together. Solder the joint, using noncorrosive flux. Then wrap it with live-rubber tape (the kind that stretches) pulled snugly around and well overlapped. Finish with a tight wrapping of friction tape and bend the wires to fit them into the box.

Soldering is easy and fast, but joints can also be made with wire nuts (also called solderless connectors). These are ceramic or plastic sleeves with metal inserts and come in various sizes to accommodate two, three or more wires. Simply screw them on the twisted wires.

END

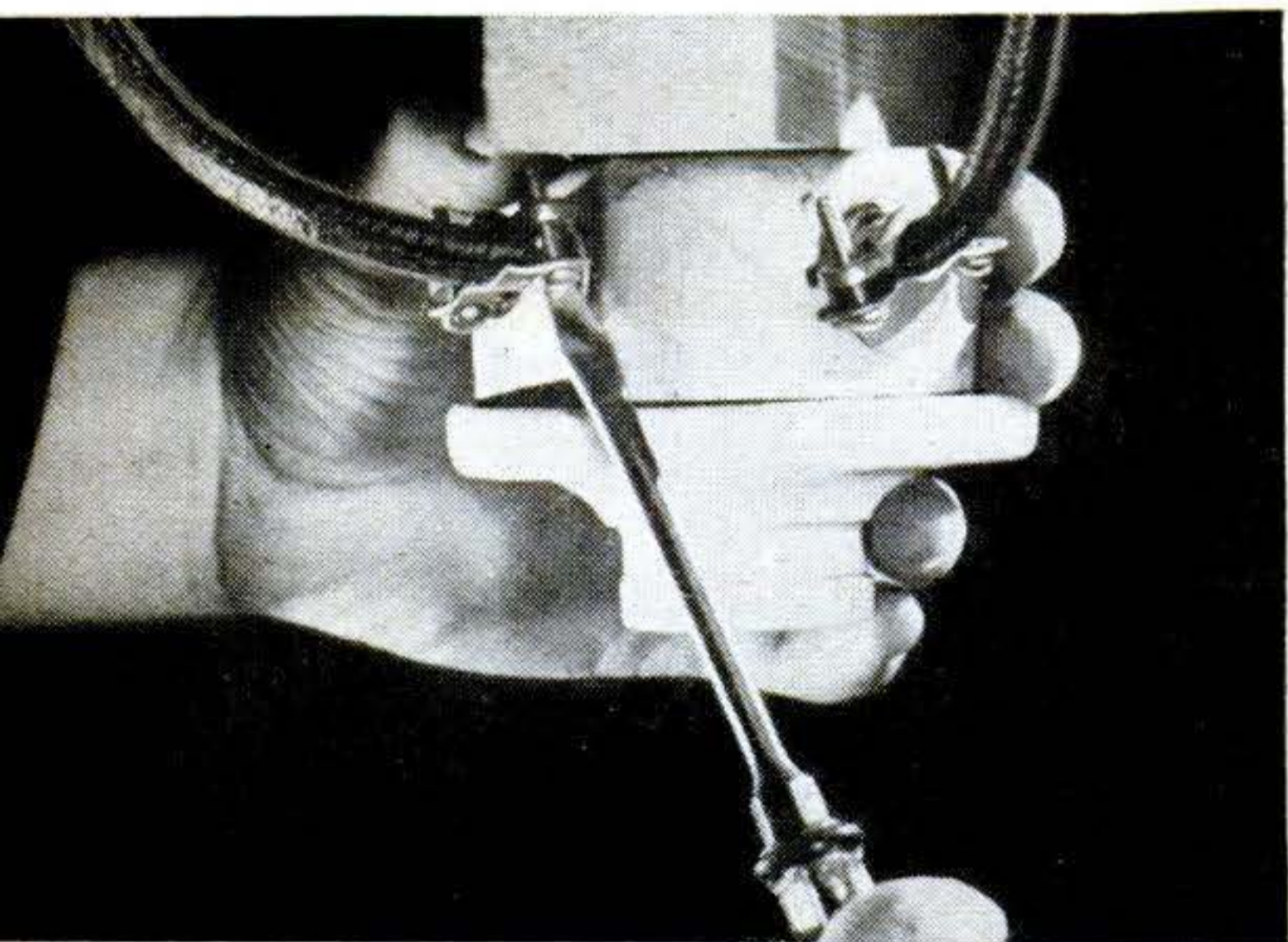

TIGHTEN CLAMP SCREWS on connector to secure the cable where it enters the box. Then tuck all wires well into the box and replace lamp socket. Finally, put the branch fuse back or close the main switch.

Next Month: Fun with a poker chip that won't cost a thing. Make a magnetic motor of it.

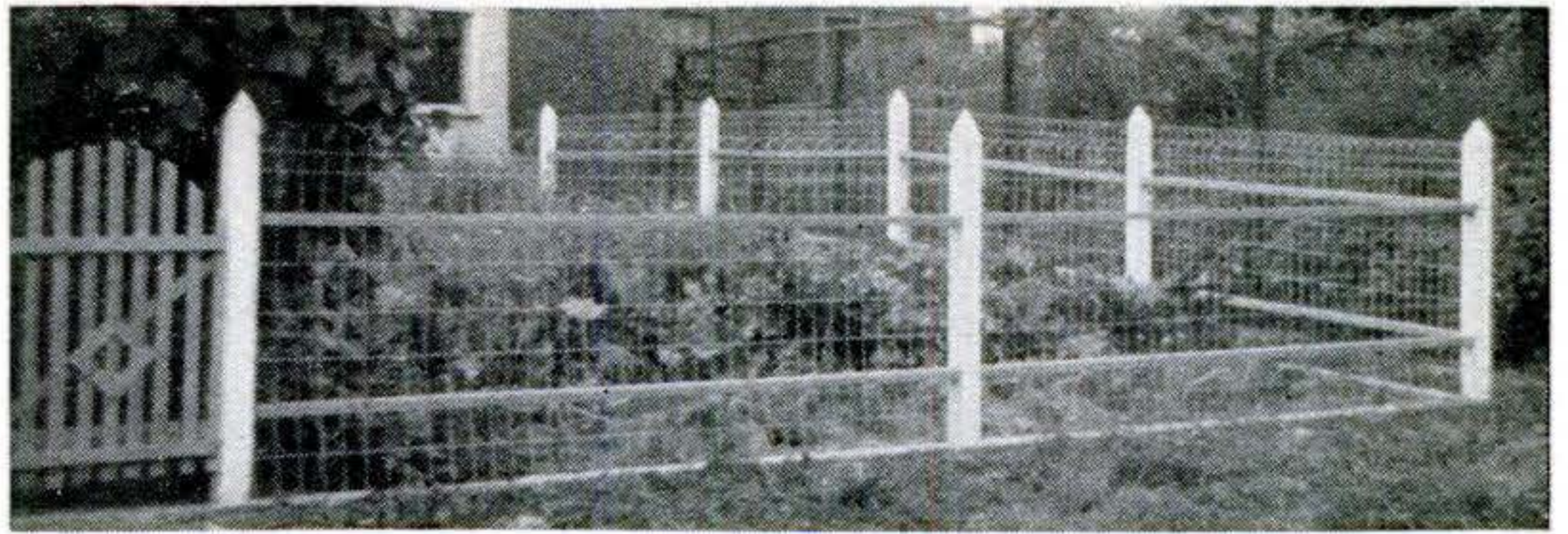
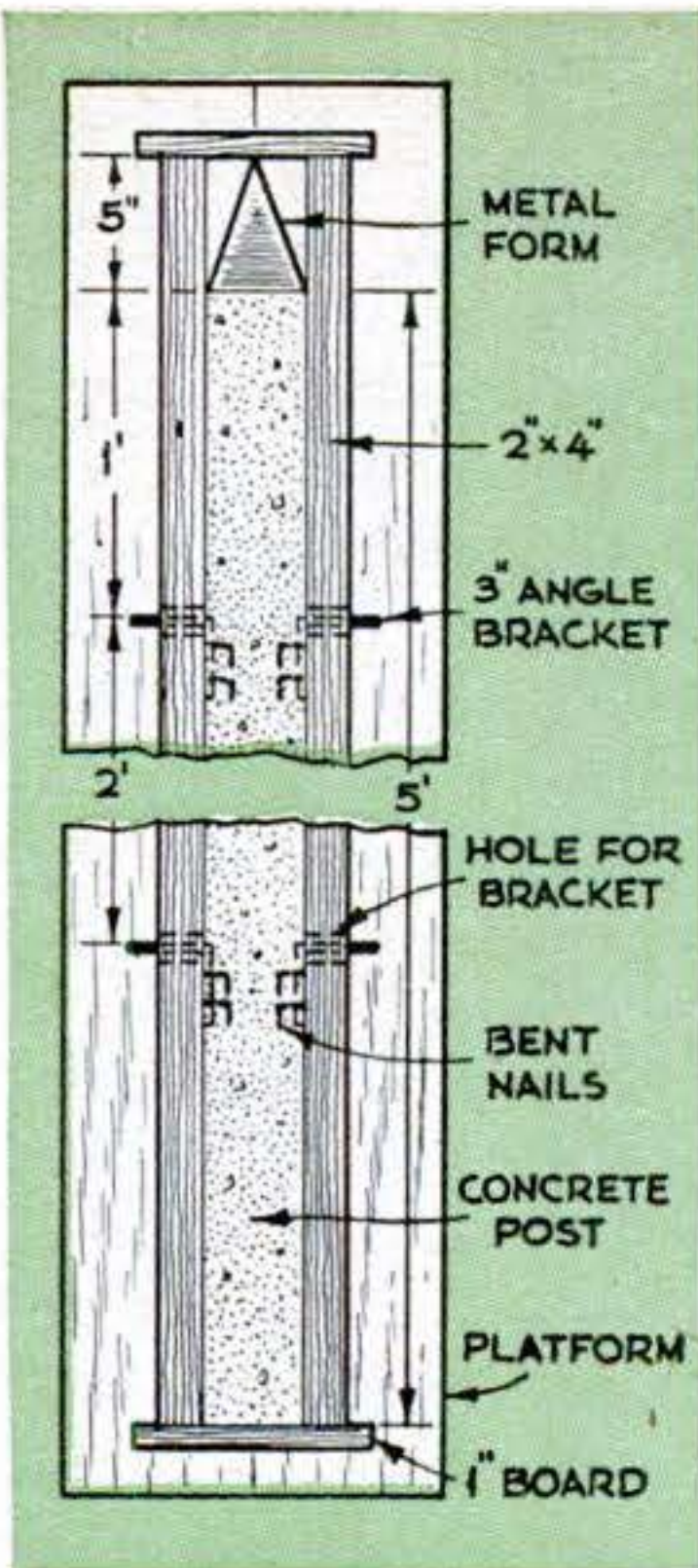

Forms for Concrete Posts Reused as Rails

CONCRETE fence posts, set in a concrete curb, lick the usual fence ailments—rot and termites.

A fence like this is economical to build, too. The two-by-fours for forms to cast the posts can be used later for fence rails. The curb along the base of the fence, while not absolutely necessary, helps reinforce the post setting and also keeps the bottom of the fencing away from the earth. Make the concrete of one part cement, 1 1/4 parts sand and two parts gravel.—*Andrew A. Nelson, The Bronx, N.Y.*

Big Panels Cut on Small Saw

LARGE boards and plywood sheets are almost impossible to cut accurately without the help of a good-size saw-table extension. Lacking such an extension, I devised this setup, which guides large or irregularly shaped pieces into the saw blade with safety and hairline accuracy.

I first obtained two steel strips, about 3' long, that fit the miter-gauge grooves in the saw table. Hardwood strips might also do. With the aid of a template, made up to locate them, I nail the strips to the underside of the work. It is then a simple matter to start the strips in the grooves to support and guide the panel across the table.

I find that kickbacks are completely eliminated as the saw cut is held apart by the guiding strips.—*Irvin Baird, Upper Darby, Pa.*

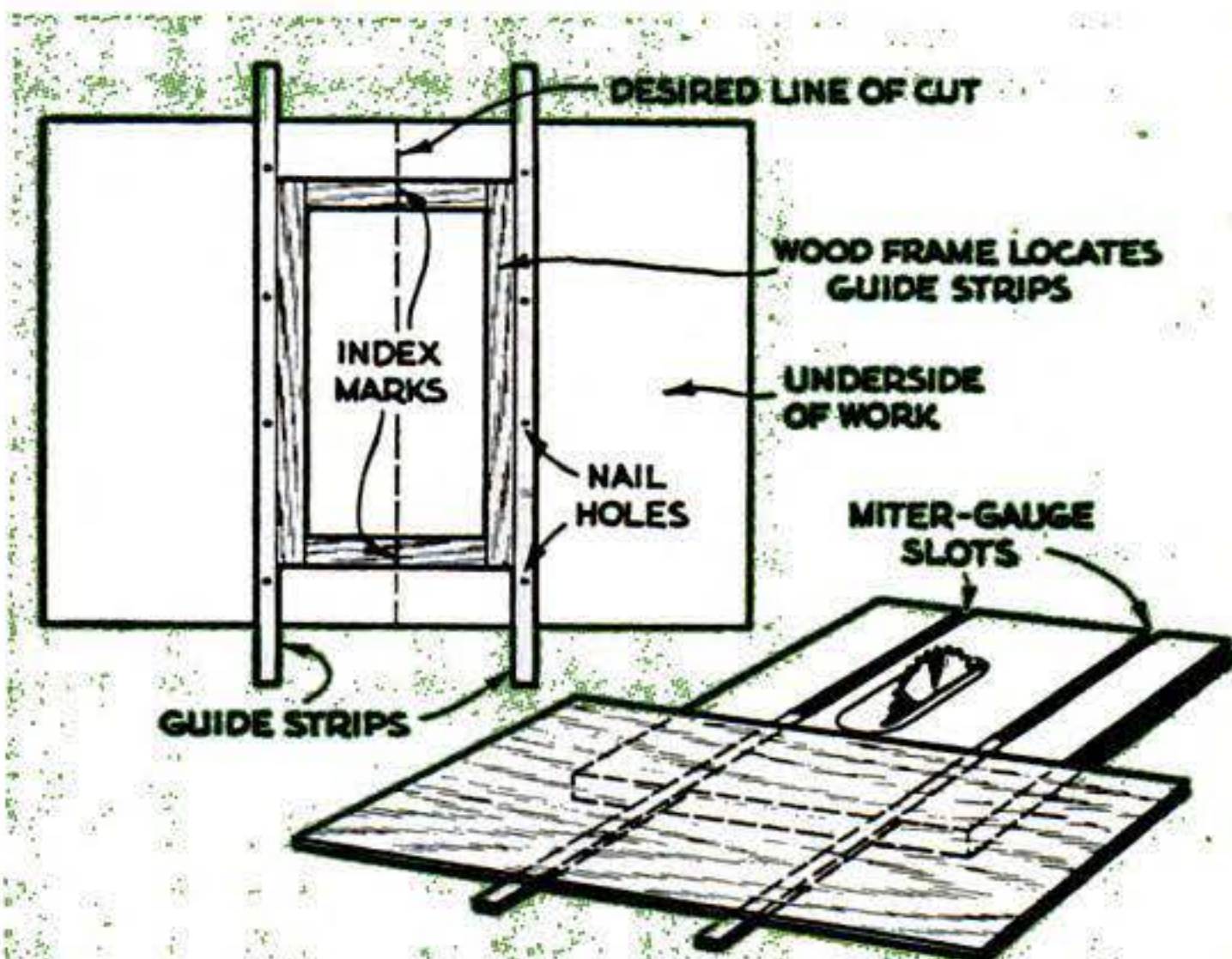

Paint Cans Hung from Joists

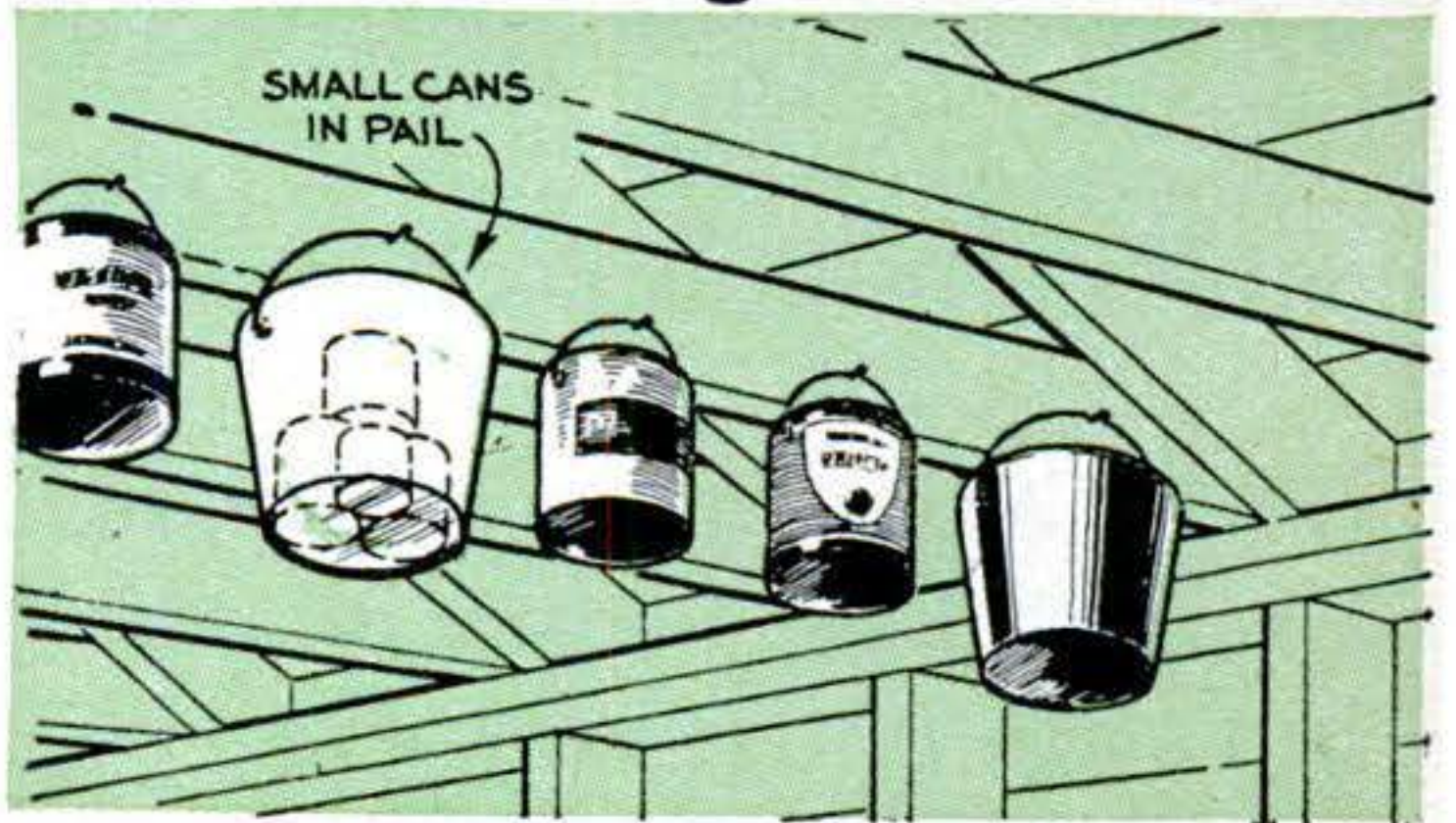

IF YOU are cramped for storage space, utilize the joists in your garage to store paint cans. Drive large nails in a joist and tilt the heads upwards. Smaller cans—half pints, pints and quarts—can be put in a bucket and the bucket hung from a nail.—*Thomas P. Ramirez, Fond du Lac, Wis.*

Workshop Wisdom



*Here lies an electrician named Binger
No longer with us does he linger.
The cellar was wet
But just on a bet
He checked a hot line with his finger.*

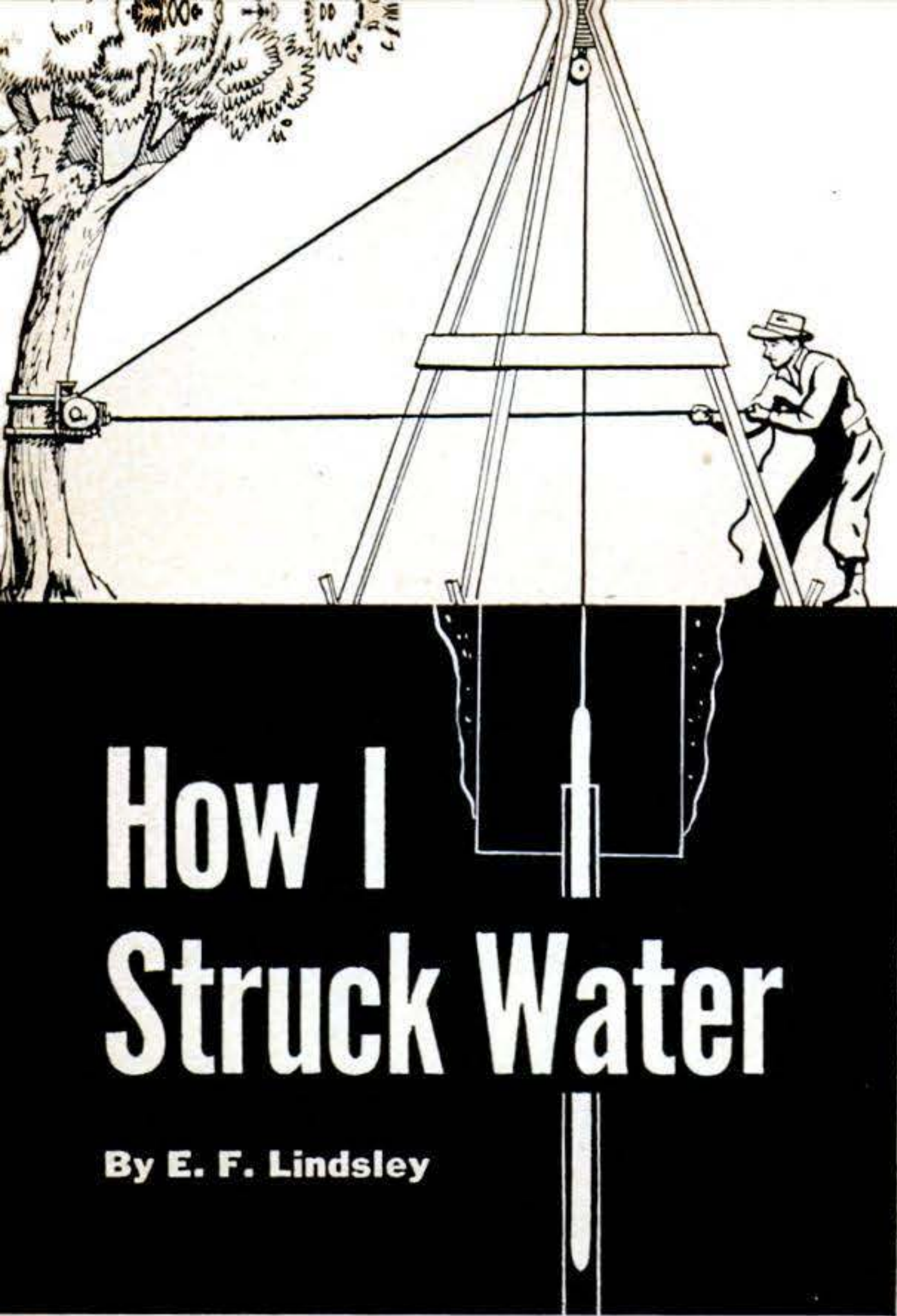

How I Struck Water

By E. F. Lindsley

Tapping an underground supply is worth all the weeks of effort it takes to drill a well.

STRIKING water is always the big moment when you drill a well. I can't imagine that even finding gold would give me more of a kick. And completion of my back-yard drilling project was actually equal to turning up a bit of treasure. The job saved me around \$200.

Getting started right has a lot to do with

how easily an amateur drilling job will go. I learned from bitter experience what every professional driller knows—that even a shallow well requires a carefully assembled drill rig.

An A frame, anchored to a nearby building or tree, or a tripod frame can be set up to support the overhead pulley through which the drilling rope runs. I used the first type. As explained last month, tightening the rope around a constantly revolving drum causes a one-lung engine to haul up the drill tool. Loosening the rope lets the 100-pound tool drop for a pile-driver blow.

Frame assembly. It is important that the frame be very solid. Block or stake the lower ends of the legs. Bolt and chain the top ends together so they can't give. Unless you do, the frame may shift while you are drilling, carrying the pulley away from its center above the casing and perhaps canting the casing. The pulley should be bolted to the apex of the frame.

Don't underestimate, as I did, what it takes to keep a small engine and hoist drum on the ground. Mounted on a pair of cedar-post skids, the engine, gear box and drum seemed brutally heavy when I grunted them into position. Just to be sure, I poised a washtub of rocks as ballast on the rear and flopped a 300-pound flagstone on the front of the skids.

But the little four-horse Cushman engine, geared down to 19 to 1, proved a better man than I. When the wet rope fouled on the drum after a shower, the whole shebang—engine, skids and ballast—took off like a rocket-powered raft. In a flash, the engine cranked itself up the rope, swung gracefully under the A frame, broke loose and dropped into the well pit.

That convinced me rock ballast was not enough. My solution consisted of two



START IT STRAIGHT. Unless the casing is vertical, you'll have trouble. Writer pulls on rope to strike gentle starting blows and checks with bubble and square to keep casing straight. Note drive collar on drill tool.

EXTRA WEIGHTS of bar stock and railroad iron are bolted to the driver above the collar. They helped force casing through hard rock. At such times, drilling progress may be measured in fractions of an inch. Perseverance pays.

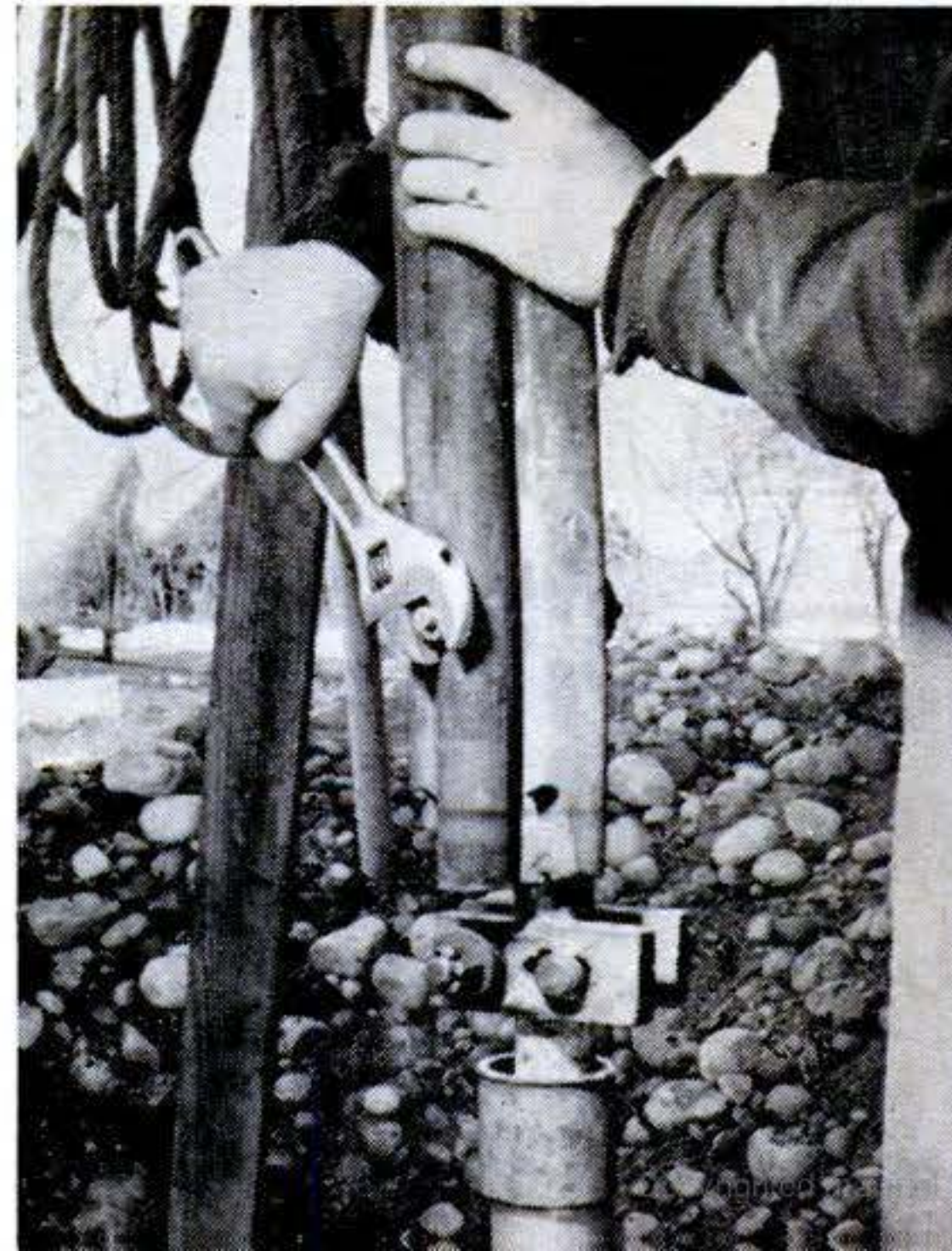

angle-iron fence posts running from the skids to the A-frame legs in a V-shaped arrangement. With these, a solid mechanical brace was established. In addition, I installed a shear pin between the hoist drum and its driveshaft.

Before starting to drill, I dug a well pit to get below the bushel-basket-size boulders. I had to go down nearly 15 feet before I ran out of boulders. Fellows at the other end of my town have drilled wells without going below post-hole depth for a start. The geology under my back yard just happened to be against me.

After digging the hole, I dropped a pair of old oil barrels without tops or bottoms on top of each other to form a protective wall around the casing. The shock of a drilling tool causes caving quite rapidly in a poorly shored hole.

Starting to drill. Using the drill tool as a plumb bob, I located the spot under the pulley where the casing should go. Then, using a square and level to keep the pipe vertical, I started driving the casing by hand until it was on its way.

As you drill, you must add water to the hole through the casing—but not too much. The drum and rope must be kept clean and dry for a snappy release of the rope so the tool will drop quickly for hard impact. The usual practice is to keep turning the rope by hand as the tool falls so the drill strikes at a new angle each time.

Under continued pounding of the drill, soil and rock in the bottom of the casing break up into bailable mud by virtue of the water added or already present. Too much water in the casing hole cushions the impact of the tool.

A distinct ring comes up the casing when the drill strikes stone. The sound becomes duller as the solid matter gives way. Eventually the stuff becomes mushy. Pulling up the tool at this stage usually shows a thick coating of mud and rock chips.

Bailing out the muck. If the mud you get is thin and watery, you are probably battling a stubborn rock, and bailing is not much use for a while. If the mud is very thick, add a little water, drop in the tool and churn things up a few minutes so the bail bucket has a better chance of slipping the mud through the check valve.

You'll know you have struck water when you discover that the tool is more or less floating in the casing and a solid blow cannot be struck. The bail bucket will bring

up more water than you have added. The water will be clearer each time. This experience may occur several times before you get deep enough. A well that pumps freely in the spring and fall may contain only surface water and turn into a dry hole in the summer. In many areas where an impervious layer such as limestone or hardpan runs like a floor under gravel and sand, unsafe surface water often collects in pumpable quantities just above it.

Drilling in rock. With persistence, it is usually possible to drill through these tough strata into much better water-bearing material. But such drilling is not for the easily discouraged. Several hours of hard pounding may net only an inch of progress. In such stubborn going, it is essential that all the impact the drill tool can muster be delivered to the point. You can help this by standing at the casing and giving a quick downward



IF CASING BENDS, you're in for some extra work. It happened to the writer soon after he started, and a 12-ton truck jack and log chain (above) had all they could do to yank out the casing. Then, after he had driven almost to water level, a boulder caused enough bending to prevent easy passage of drill tool. To get down final six feet, he made multi-jointed tool at right. Tool was severed into segments with a cutting torch. Segments were strung together with loosely fitted studs and welded-on heads.



How the Pump Was Installed



1. FOOT VALVE was attached before first section of suction pipe was lowered into casing. This is required only if a jet pump is offset more than 50', but author put it on to hold water in pipe to check joints for leaks as each section was added.

2. FIRMLY CLAMPED to prevent dropping, each section of suction pipe was filled with water and left for a while before next section was screwed on. If water fell, pipe was raised and joint tightened. Airtight couplings are vital to good pumping.

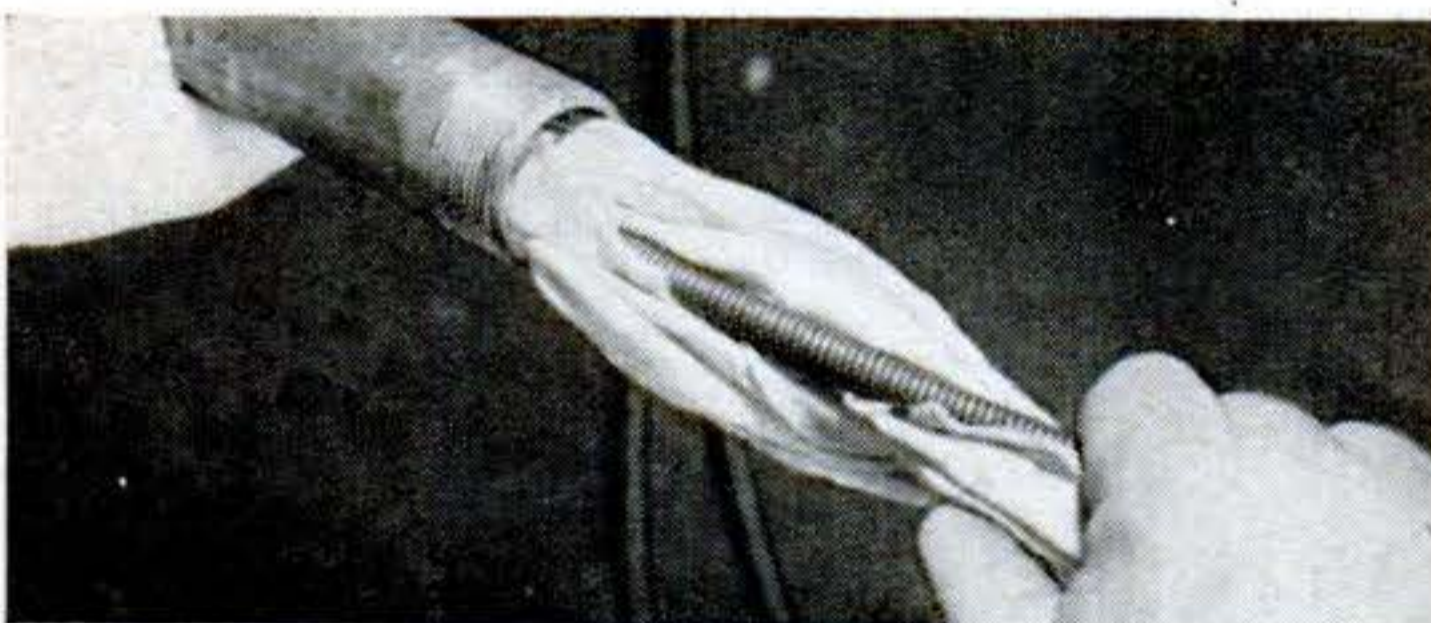
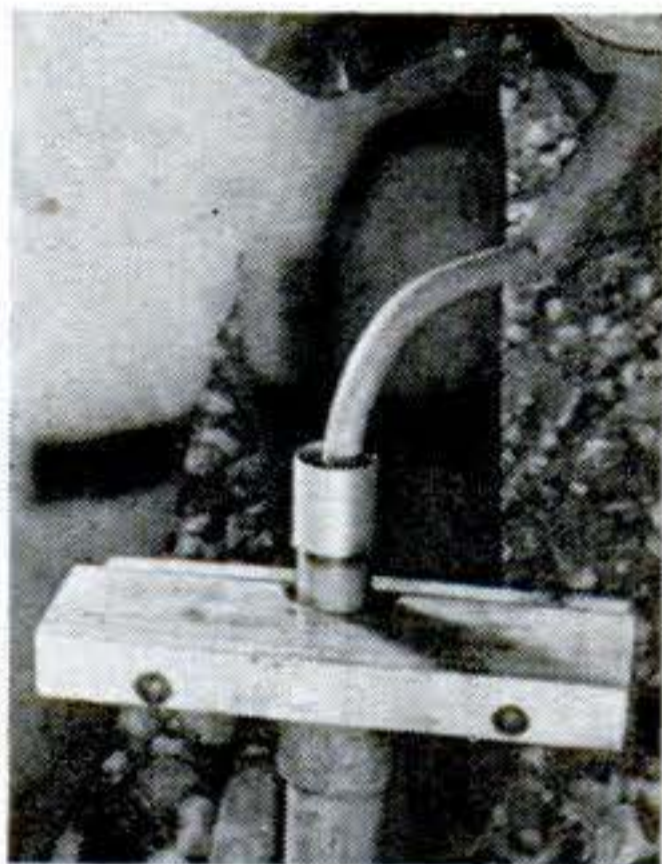

3. A CLOTH and a plumber's cleaning rod were used to swab out each pipe length before installation. This protects pump against metal particles and threading chips.

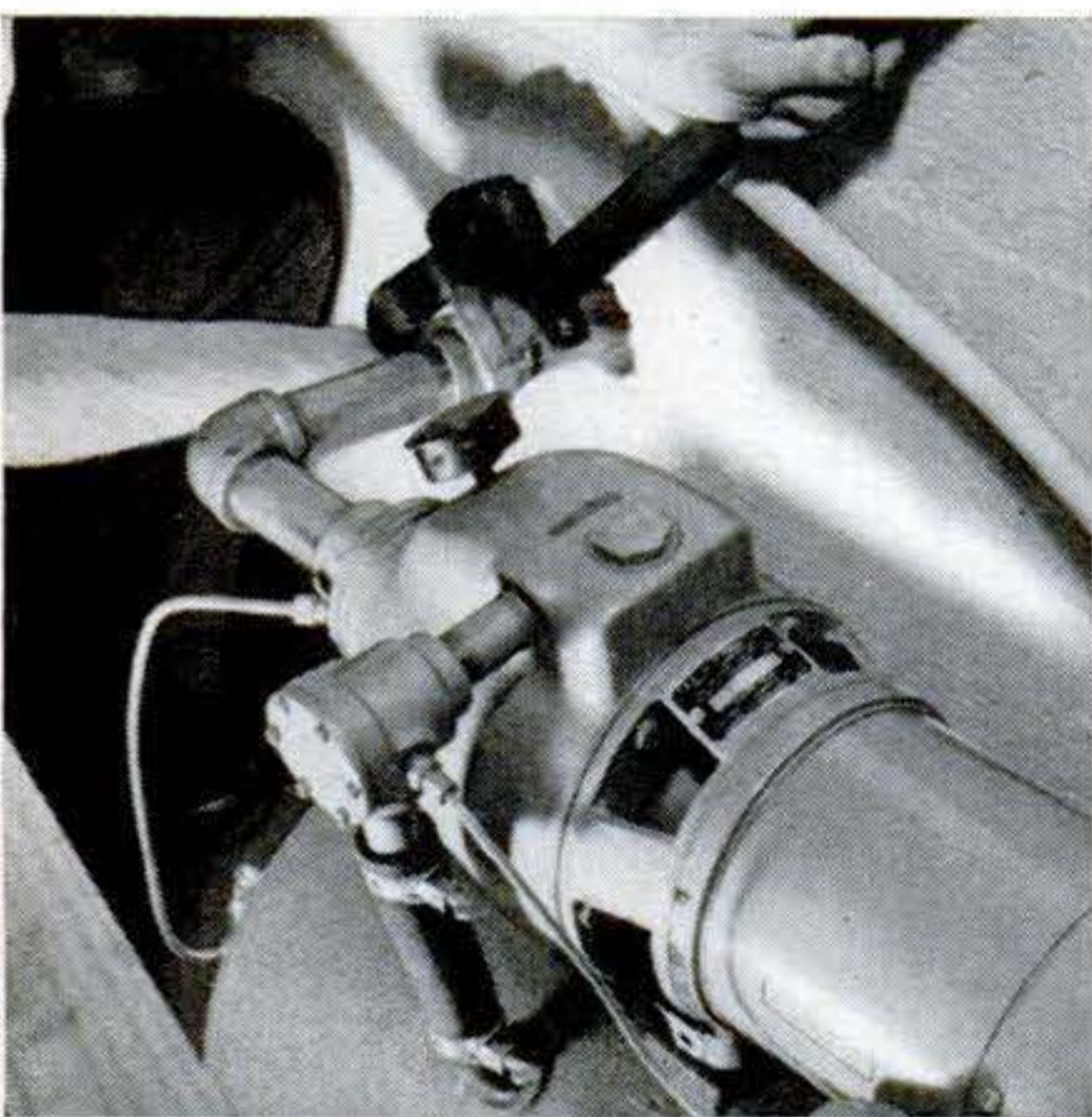

4. JET PUMP was installed in basement for best cold-weather protection. Pipe runs to well through hole in wall. Pump is shown here set up for shallow-well operation.

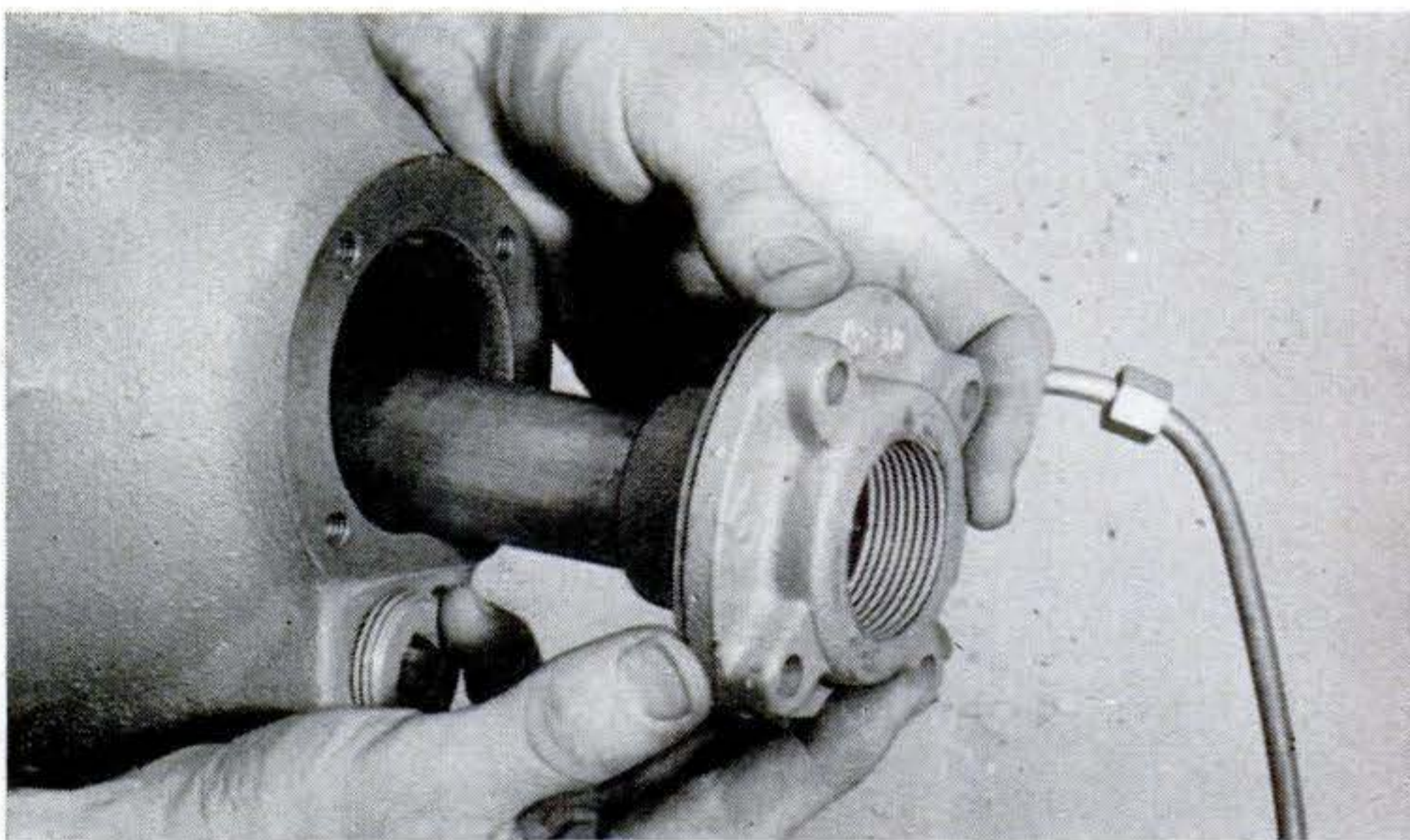

5. PUMP WAS CONVERTED to deep-well operation because writer felt water level might not stay high enough for shallow-well suction. Conversion, made with special kit, includes substitution of tube and adapter for jet and check valve formerly inside pump.

tug on the rope at the same time you release the tension.

When you're using the drill tool to drive the casing, you must also get all the oomph you can on the casing collar that takes the impact from the drive collar on the drill. The collar I used was a malleable iron coupling of the extra-heavy-duty type made for well casing.

I ran into several viewpoints on whether you should drill a hole ahead of the casing and drive the casing down into the hole, or first drive the casing about all it would go and then drill the material from the inside. I worked mostly by the latter method.

How drive shoe works. The drive shoe acts as a funnel to cut through and guide any fairly soft sand or small gravel to the inside of the casing where the tool can get a square smack at it. But the same slanting, funnel-shaped surface on the inside of the drive shoe often acts like a wedge lock, or roller clutch, when you drill ahead and a small round stone jams between the drill and shoe.

I would be plugging along nicely some 8" or 10" ahead of the shoe when a sudden shudder and groan of the rig would announce that the tool was stuck. This is a frightening experience. Each time, luckily, I was able to jar the tool loose by heavy side blows of a lead hammer at the top of the casing.

Tape shows depth. After a few of these scares, I worked out a system where I drilled until the slightest tendency to hang up showed I was starting to get ahead of

the shoe. Then I drove the casing, sometimes 6" or 7", sometimes a foot or more, depending on how easily it went. Next I'd bottom the tool and tape the rope flush with the top of the casing. Thus, by watching how deep the adhesive tape was getting into the casing later on, and by comparing this distance with the measured distance I'd driven the casing, I always knew about when I should start being cautious about sticking. In strata rock and hardpan, drilling ahead a short way is necessary.

Test pumping. Once into an apparently satisfactory supply of water, the common practice is to put on a temporary pump and see what kind of water volume you can pull without lowering the water level too far. If you have friends on the local fire department, or are a volunteer, the pumper makes a good test outfit, providing you throttle down a bit. The firemen will love it, and so will all the kids in the neighborhood.

An important thing to look for, in addition to pure and adequate water, is the type of material in which the casing ends. Sand or soft material does not ordinarily seal the open end of the casing effectively. Within a short time, the sand works up in the casing to the foot valve or jet, and then the job of well servicing starts. A commercial driller likes to seal off in rock that opens into a water vein. Large gravel, sandstone or other mixed stone may also be good.

Installing the pump. In the beginning, I set out to install a shallow-well jet pump. Later, I got to thinking about the possibil-

ity of the water level dropping during the summer and converted the pump to a deep-well type. With a shallow-well jet pump, the venturi-shaped jet is mounted in the pump near the impeller. The deep-well member of the family has its jet in the well casing below water level. When a big 4" or 6" casing is used, the deep-well jet should have two pipes, one pressure and one suction. When a 2" casing is used, there is no room for a second pipe. To get around this problem, a special packer-type jet is clamped inside the casing by a rubber seal ring. The space between the inner wall of the casing and the central pipe then serves as a second pipe.

If you install your pump in the basement, be sure the pipe has a slight downward slope to the well. And remember to install a good joint coupling in an accessible spot, in the basement, so the pump can be disconnected and moved for service when that is necessary.

Electrical connections. Like oil burners, well pumps deserve their own electrical circuit, with private circuit breakers or fuses and a switch readily accessible for emergency shut down by some member of the family less familiar than you with electrical systems. If you have to depend on yourself for fire protection until a pumper can arrive from a nearby town, give some thought to protecting the pump and its electrical supply even though the basement may be ablaze. A separate, well protected circuit to keep the pump running may save your home and belongings. END



6. PACKER-TYPE JET and foot valve at bottom of suction pipe were also needed. If casing is larger than 2", a two-pipe jet can be used. Without room for two pipes, space between casing and suction pipe serves as a pressure pipe.

7. SANITARY SEAL was clamped to top of casing. Two pipes were then run from seal to pump, one for suction, one for pressure.

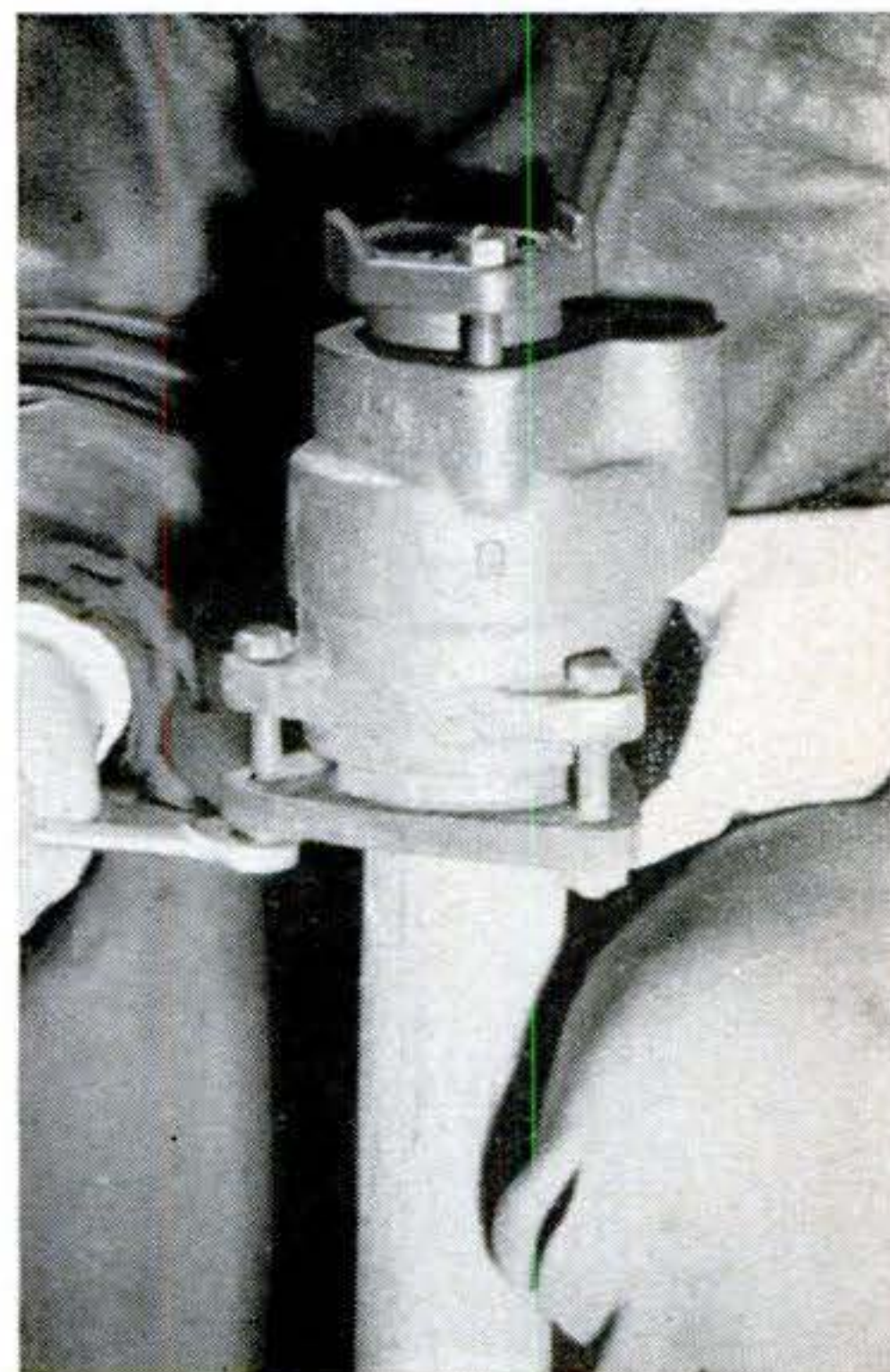

New Products for Handymen

Sliding Door Floats in Air

BECAUSE there are no tracks at top or bottom, this door is easy to operate and practically noiseless. It floats in and out of the wall—suspended by a steel scissors-like mechanism. The adjustable balance spring lets the door move at the slightest touch. Increasing tension on the spring makes the door self-closing. It can be installed in a standard 4" wall during construction of a new home or remodeling of an older house. The hardware can be removed for repairs without disturbing the wall section. The unit fits doors as large as 3'6" by 7'. *Ezway Sales, St. Paul, Minn.*

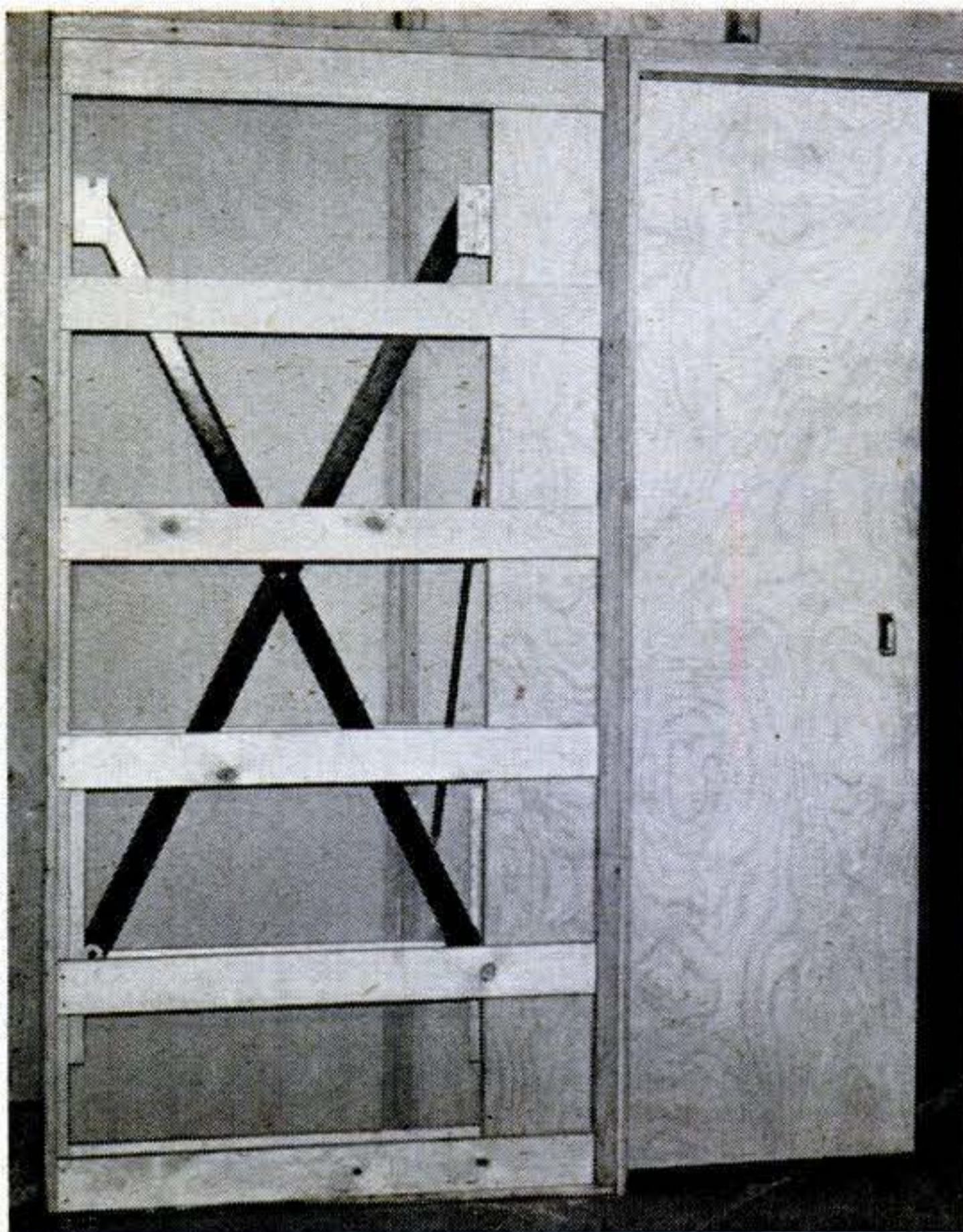

Brackets Drive in Like Nails

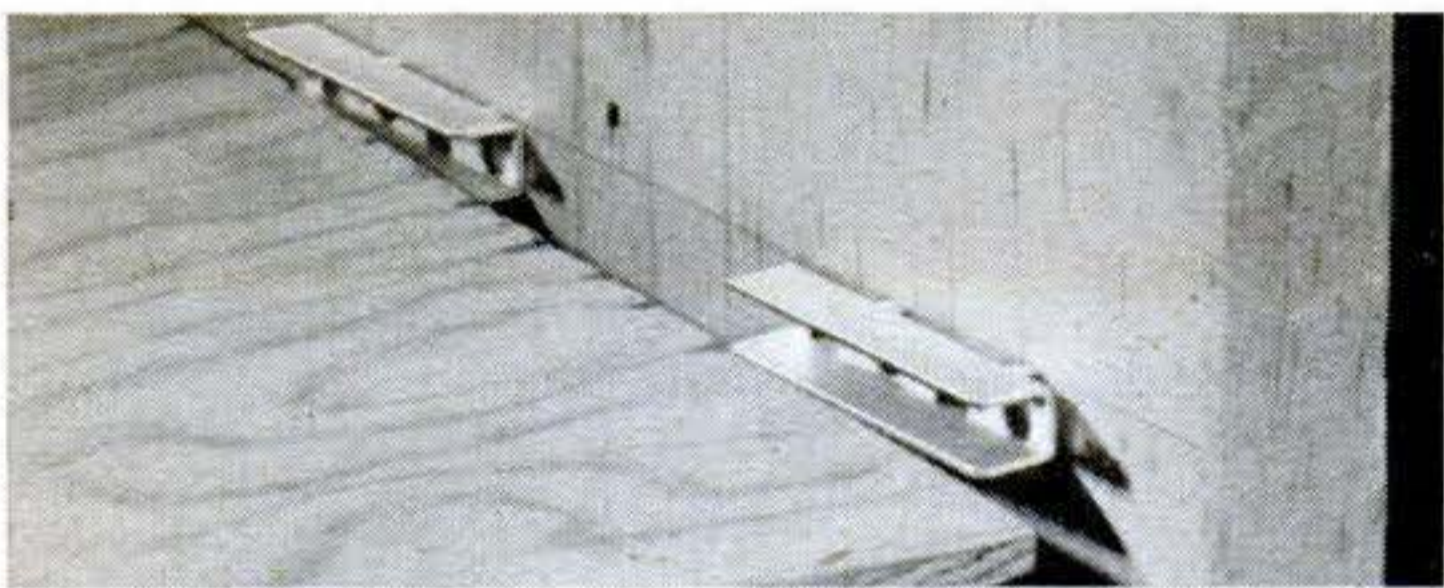

WHEN the four prongs on the back of these clips are hammered into wood, the clips form supports for shelves. Designed to take $\frac{1}{4}$ " material, they are made of 22-gauge steel and are $1\frac{1}{4}$ " long by $\frac{5}{16}$ " deep. *Asa D. Scott Industries, Chicago.*

Wrapped Cubes Color Paint

ACCURACY in matching colors is insured by this method of coloring paint. A pre-measured cube of color concentrate is dropped, wrapper and all, into a can of base paint. A solvent in the oil-base paint dissolves the film that encloses the $1\frac{1}{4}$ " cube. This system gives you a choice of 108 colors that can be matched exactly. *McCabe Paint & Varnish Co., Irvington, N. J.*



Hook Lowers Screens

PUTTING up or taking down screens and storm sash from second-story windows is easier with this clamp. You can lower or raise them on a length of rope. A metal slide prevents the clamp from opening and also serves to release its grip. *Household Gadgets, Inc., New York City.*

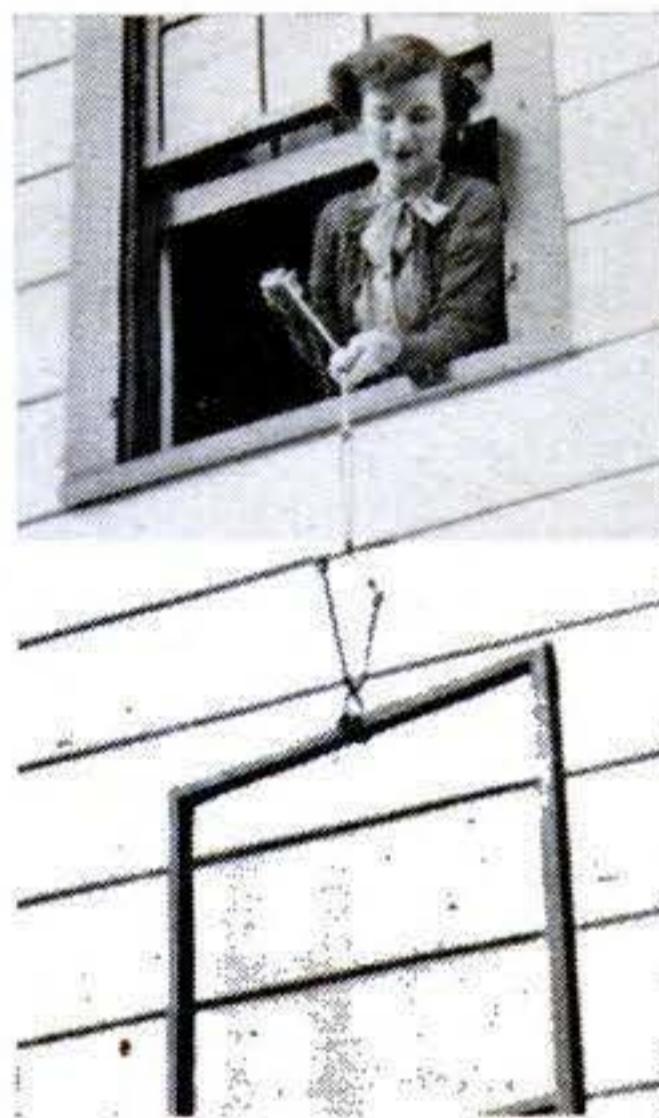

Attachment Ends Paint Drips

THIS plastic accessory stops paint from running down the side of the can. It also serves as a brush rest and can carrier, and keeps the rim and groove clean to permit tight resealing. In use, the ears of the bail fit under the rim. The Norloc Paint Boy is available in two sizes—for quart and gallon cans. *Norton Laboratories, Lockport, N. Y.*



Water Can Help Ease Out Stuck Fence Posts

OLD fence posts, often difficult to remove, will come out easily if you apply simple hydraulics.

Sink a subsoil irrigator into the ground under the post, turn on the water pressure and rock the post. It will practically float out of the ground. Or drive a piece of pipe under the post, withdraw it and force a garden hose into the hole. A portable spray rig could also be used to haul a supply of water and provide the necessary pressure.—W. H. McClay, Pasadena, Calif.

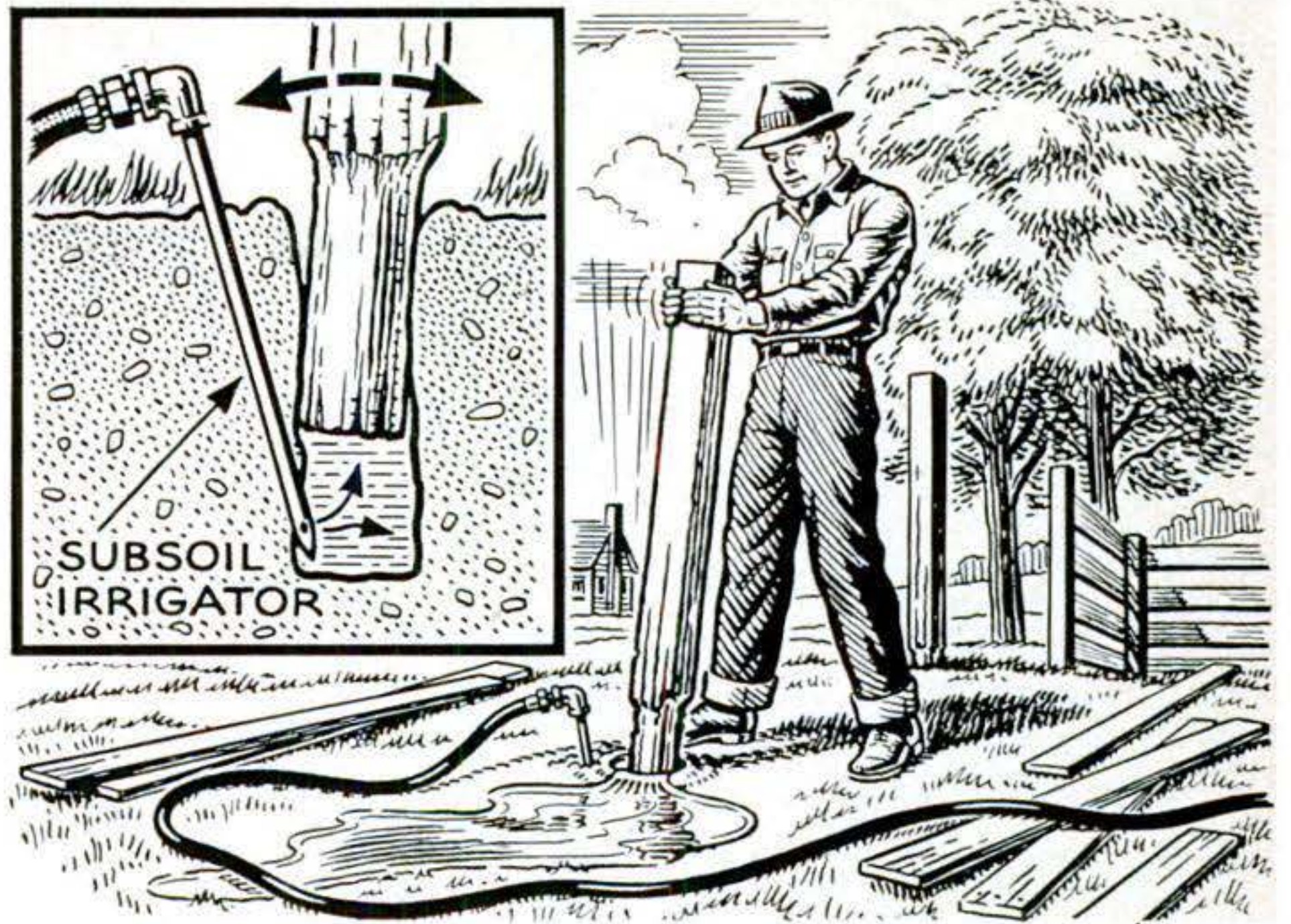

Bandage Box Holds Cigarettes



FOR a rugged cigarette case for camping trips, try a small-size bandage tin. It will take regular or king-size cigarettes.—W. S. Head, El Cajon, Calif.

Auto-Body Solder Fills Wood

THE metallic lacquer-base filler used in auto-body work is good for filling dents and cracks in wood that's to be painted. It will stick to both new wood and old finishes. Having a very fine grain, it can be applied so smoothly that little or no sanding is needed. It is not porous and requires no extra primer.

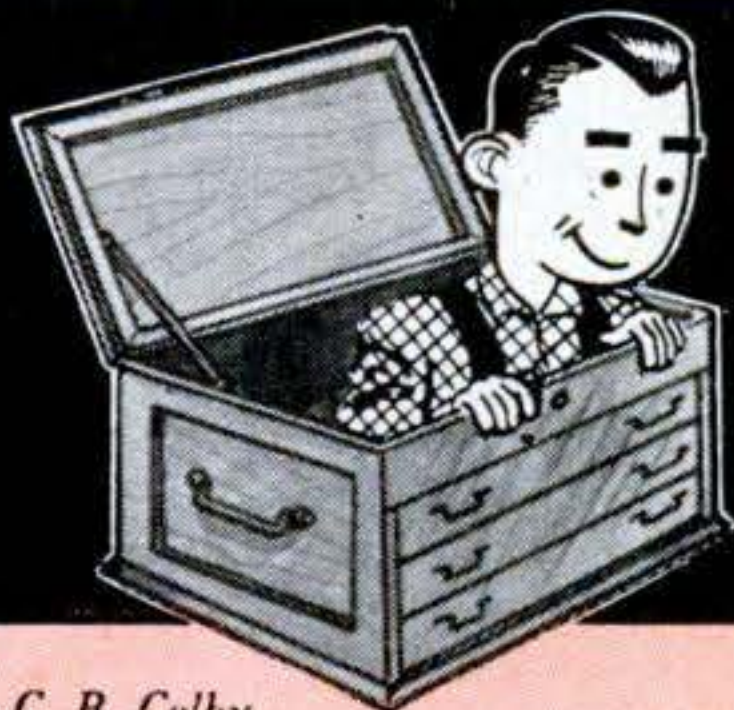

By C. B. Colby

TOOLBOX TEST

Sharpen up your knowledge of shop tools. Name these and invert the page to score yourself.

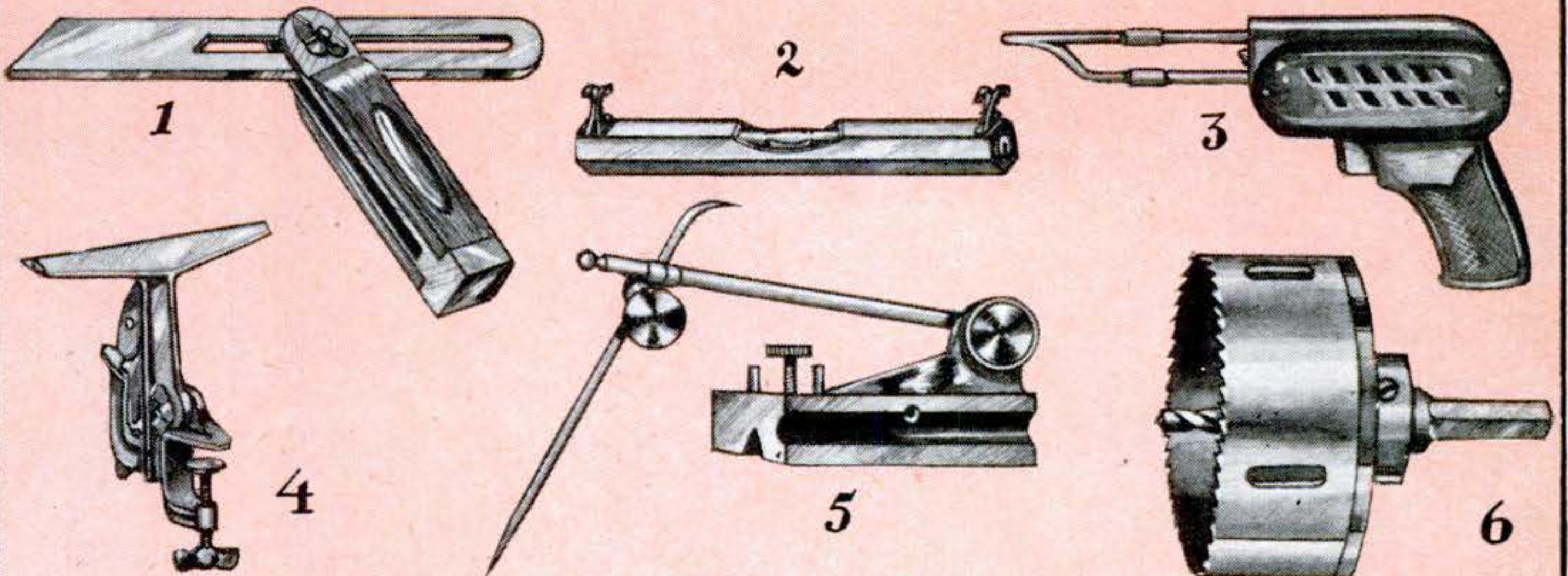

1. Adjustable bevel; 2. line level; 3. quick-heat soldering gun; 4. saw vise; 5. surface gauge; 6. hole saw.



New Tools

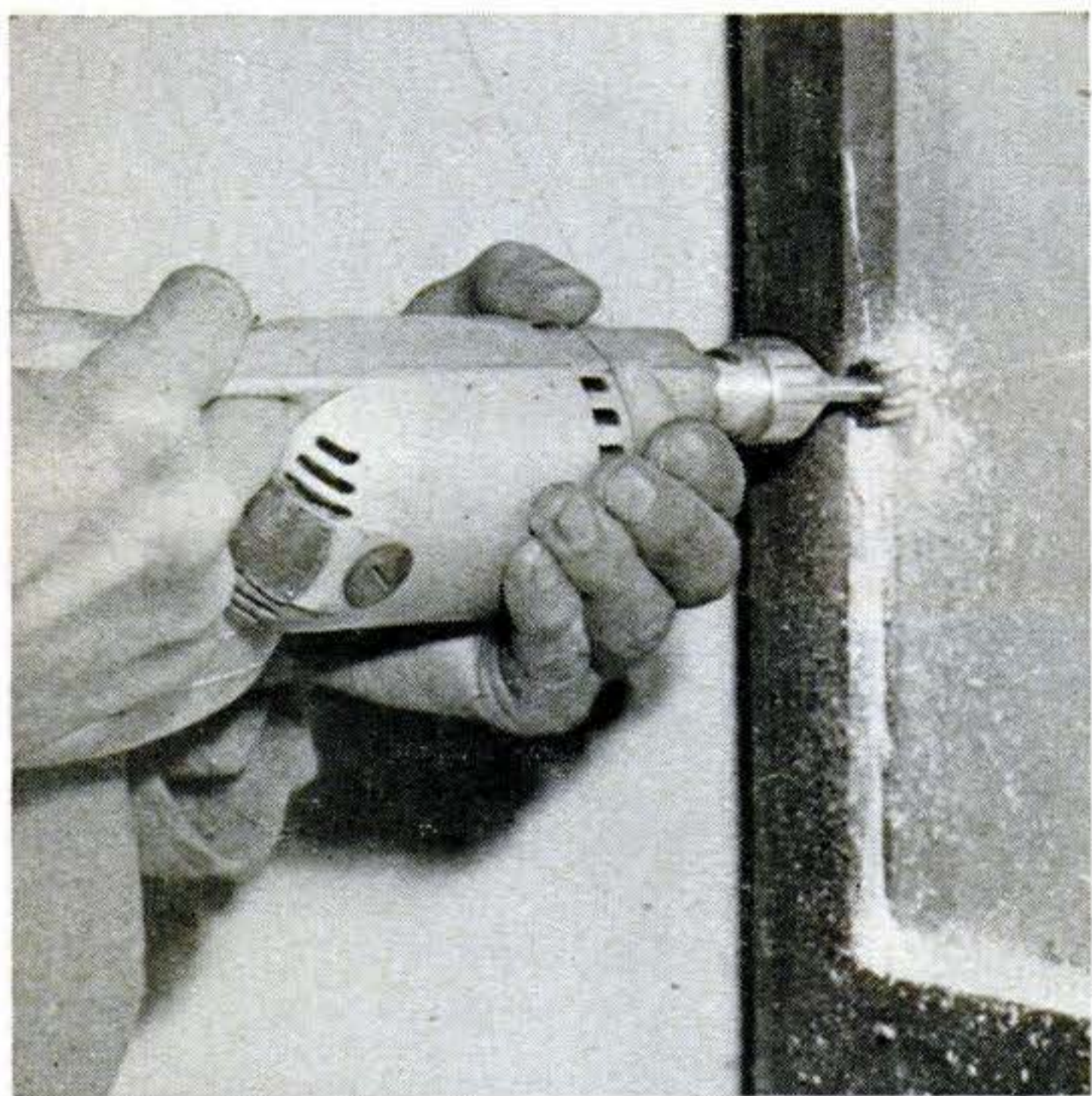

Tool Removes Old Putty. Chucked in an electric drill, this cutter quickly removes old putty from window sash. A guide pin, which rides the molding to prevent overcutting, is removable for cutting close to the glass. *H. E. Watkins Co., Oakland, Calif.*



Ratchet Knob Turns Screwdriver. The steel grip of this screwdriver can be locked stationary or set to turn left or right. When not needed, the ratchet grip can be pulled off the Tenite handle of the screwdriver. *Kipton Industries, Kipton, Ohio.*

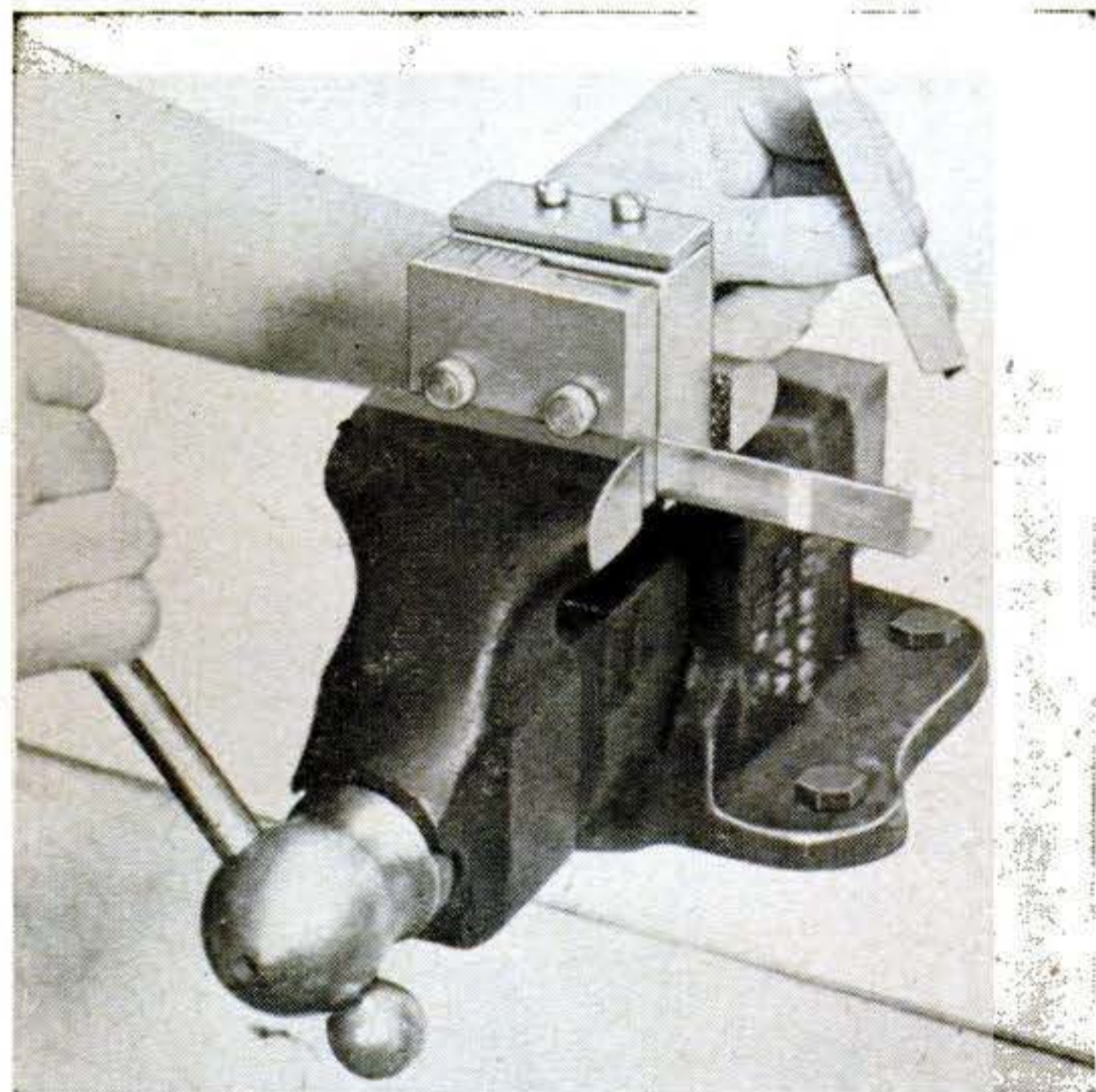

Juggling Blocks. This tool, when locked in a vise, bends accurate offsets in metal strips. It is available in three sizes to handle metals from .016" to .051" and provides calibrations from 1/8" to 1". The side plates that hold the leg of the angle can be adjusted with a screwdriver. *M-M-A, Inc., Lancaster, Pa.*

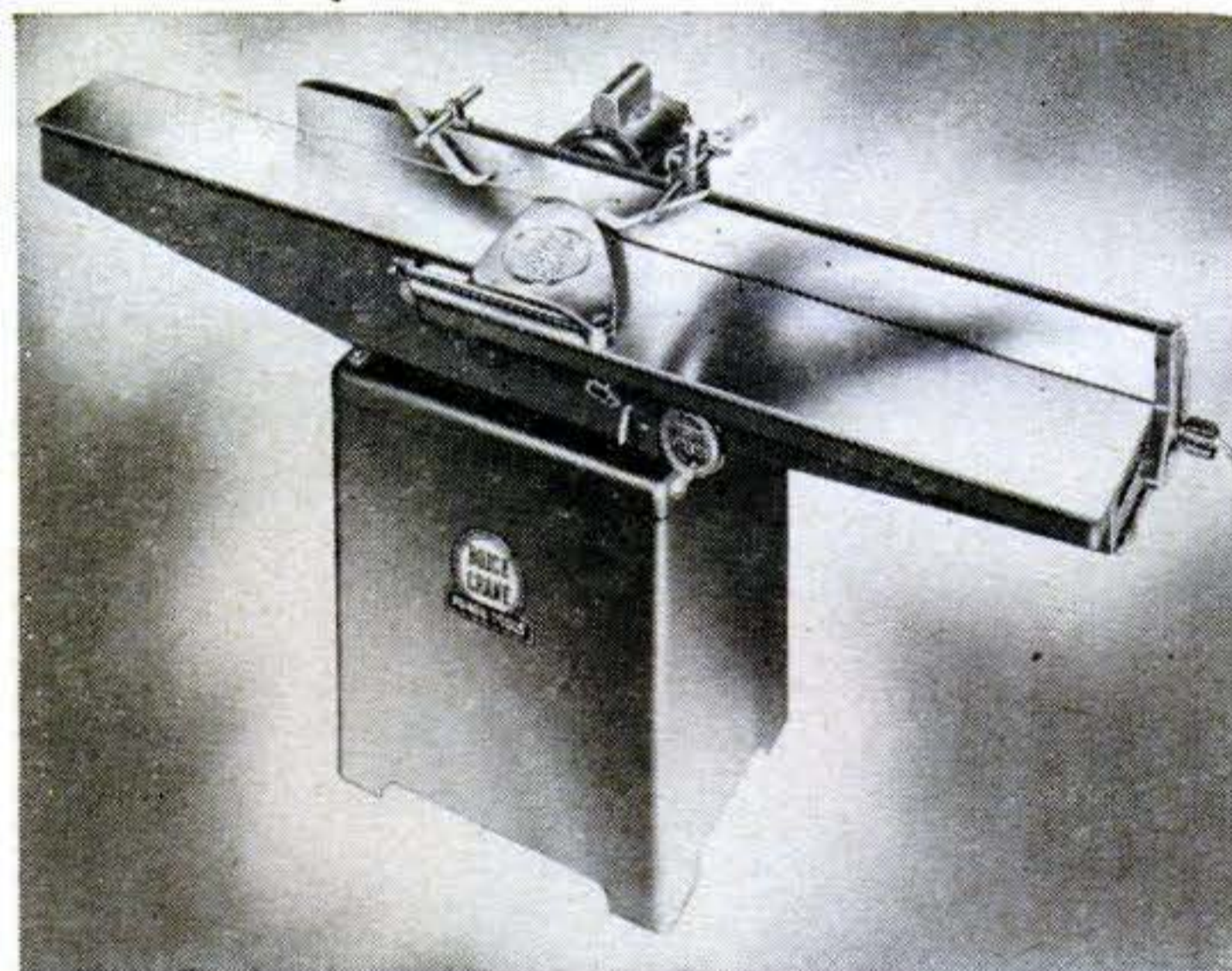

Welded, All-Steel Jointer. Using steel, which is 2½ times as strong as cast iron of the same thickness, permitted extending the tables of this jointer without increasing its width, thickness or weight, or the floor space it requires. The machine is made in three models: two 6" jointers with 36" and 60" tables and an 8" model with an 84" table. The 8" jointer has four knives and the 6" models three knives. All the knives, according to the maker, cut to the same depth within .002" to .003". *Boice-Crane Co., Toledo.*



Parts Rack Has Sorter Funnel. To select parts from a jar in this rack, you dump the contents in the wide-mouth funnel that comes with the rack. To put them back, you just hold the funnel over the jar and slide open a slot in the funnel bottom. The rack comes in three sizes—20, 30 and 45 12-ounce jars. A 15-jar unassembled kit is also available. *Toolcraft Products Co., Denver.*



Socket Wrench Is Adjustable. By turning the knob on the shank, you can make this wrench fit any bolt or nut from 3/16" to 5/16". The tool is especially useful in radio work since it will hold a nut or bolt to thread it into hard-to-get-at spots in a radio chassis. Turning the knob extends or retracts the shank to open or close the jaws. *Adjusto Tool Co., Miami.*

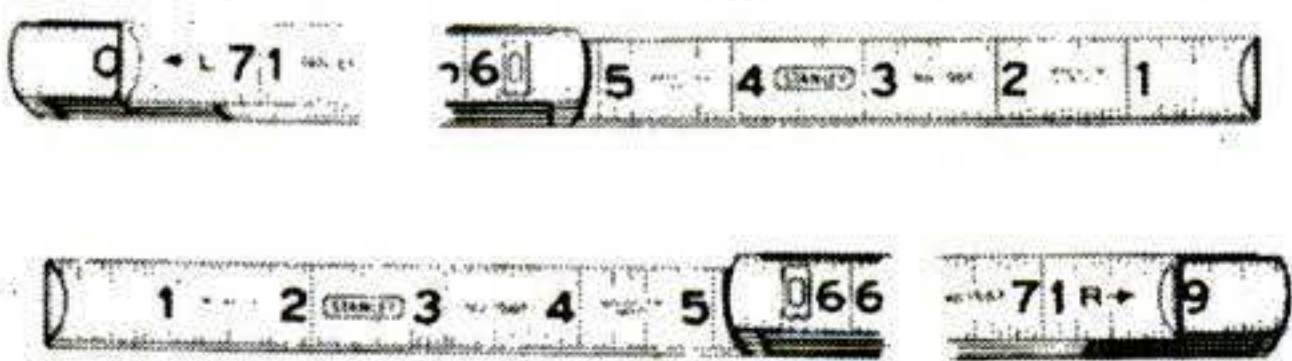

Rule Can Be Read Two Ways. You can read this 6' folding rule from left to right or from right to left by simply flopping it over. Numbers on the reverse side appear right side up, instead of upside down as on regular rules, so they can easily be read without turning the rule end for end. *Stanley Tools, New Britain, Conn.*

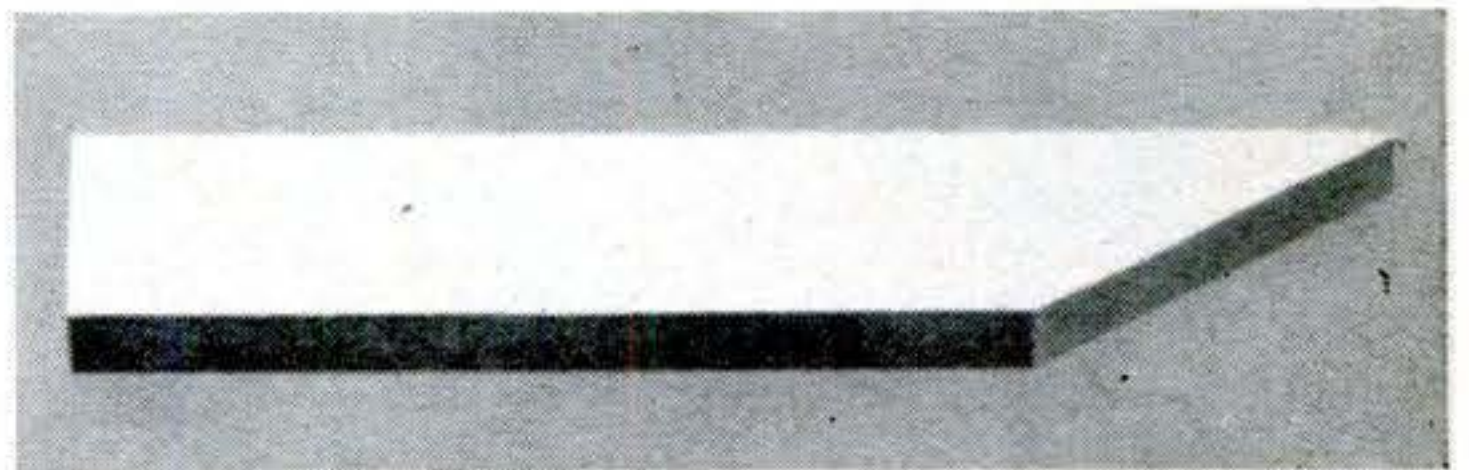

Tungsten Carbide Scriber. When laying out lines on very hard materials, such as hardened steel or glass, the tungsten carbide point of this scriber cuts sharp, well defined lines. It is available in two sizes to fit 10", 18" and 24" Starrett height gauges. It is interchangeable with standard scribers on these gauges. *L. S. Starrett Co., Athol, Mass.*

Files Reach Tight Spots. The larger file at right can be bent to fit the work or to get around corners. It has a soft core permitting easy shaping without heating and comes in six diameters from 3/32" to 1/4". The smaller file fits into holes and corners too small for other files. Both cut metal, wood and plastic. Western distributor is Tec Imports, Van Nuys, Calif. Eastern distribution is by Thriftool Sales Co., New York City.

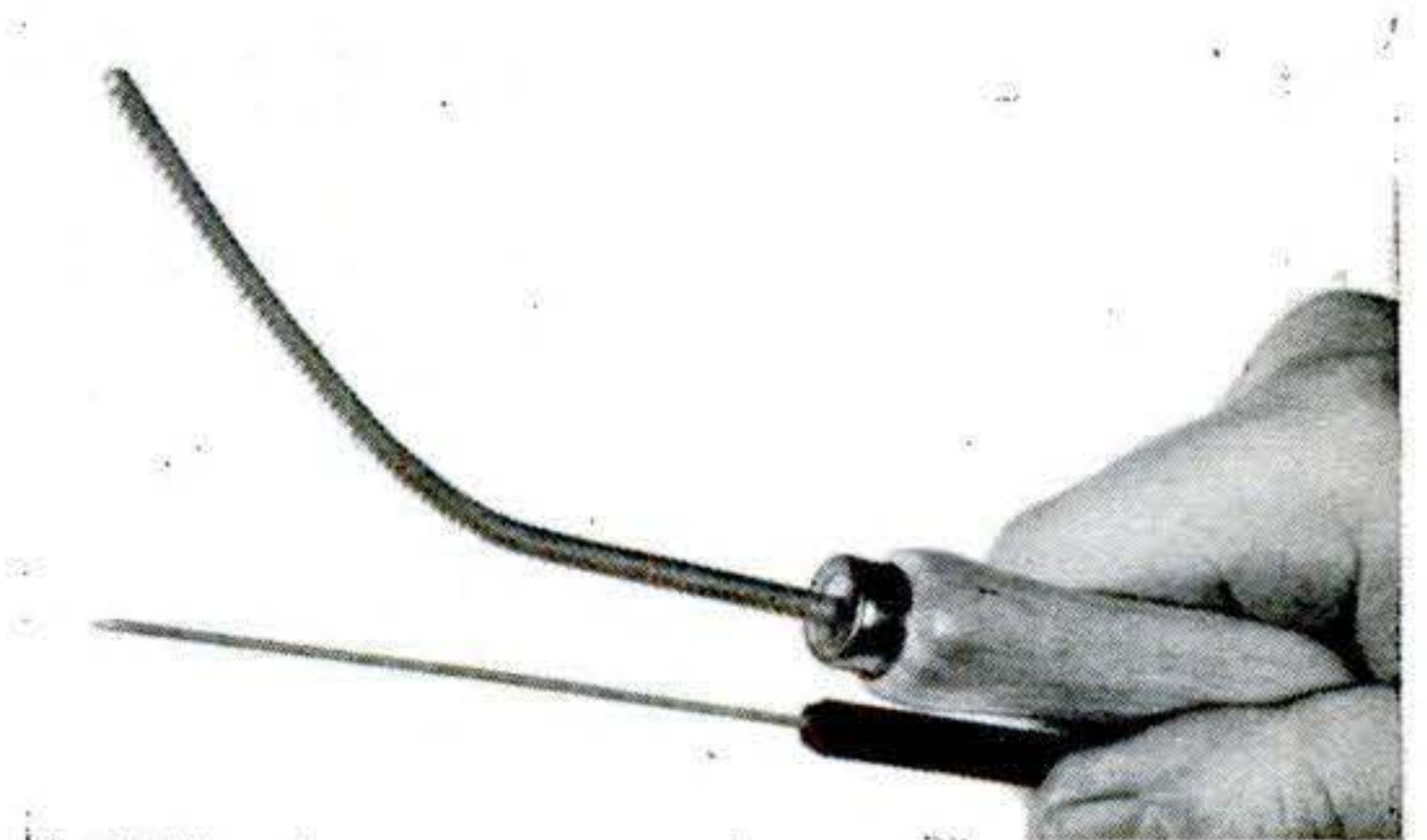

Tailor-Made Storage



Remodeled Cupboards and Drawers Eliminate Catchalls

It's not how much room but how well it is divided that makes the difference between a junk-shop jumble and easy-to-get utensils. Pictures on this page show how some lumber, hardboard and hooks make extra room by organizing the utensil-storage space.

TWO-LEVEL, SIDELESS DRAWER holds a lot of big hard-to-store appliances. Nearly any under-counter cupboard with a swing-out door can be made over into a pull-out drawer, making the back as accessible as the front. This one slides in ball-bearing races on wooden tracks.

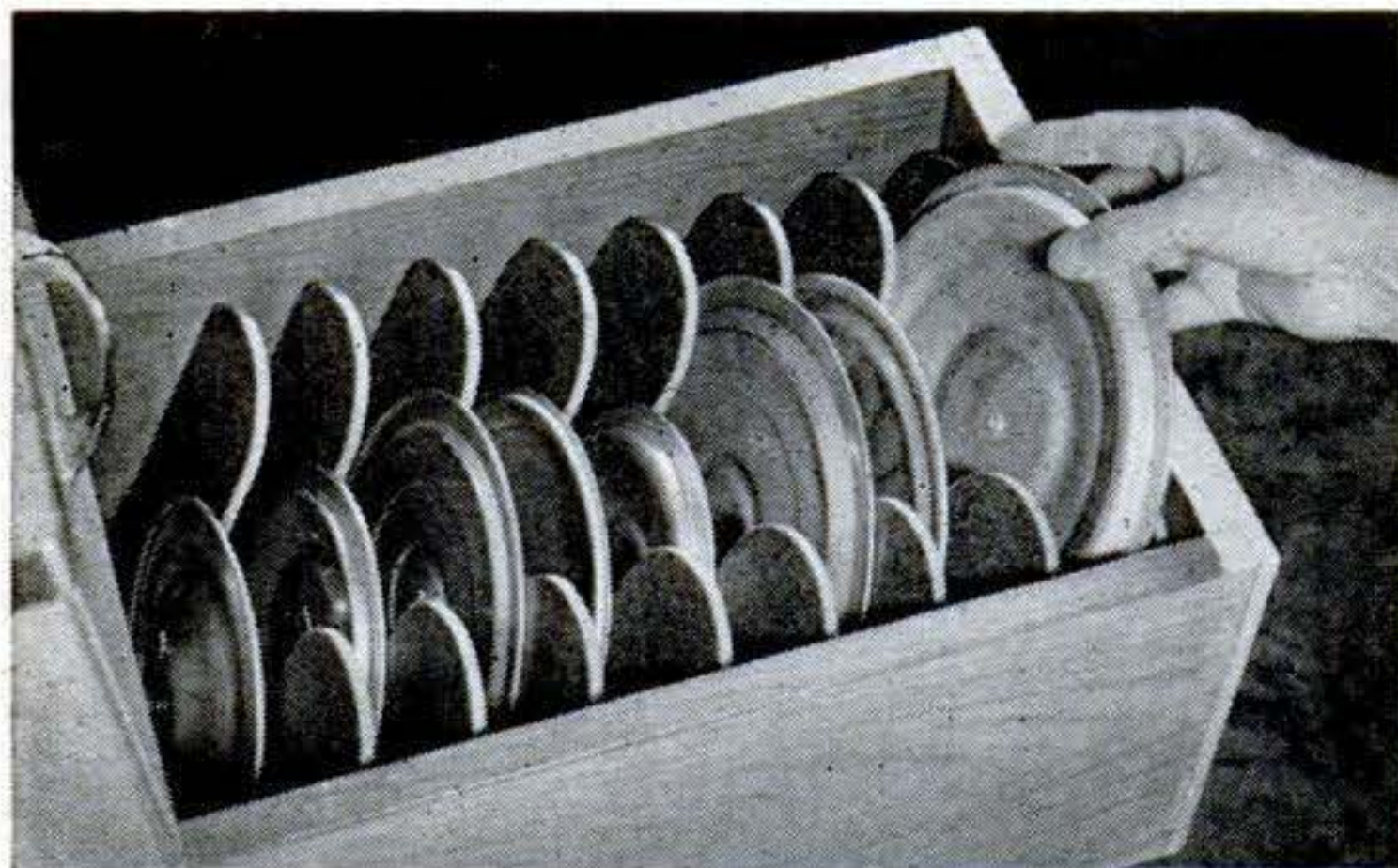

POT-LID DRAWER has composition-board spacers to keep covers neatly arranged. Hardwood dowels pass through angled holes drilled in

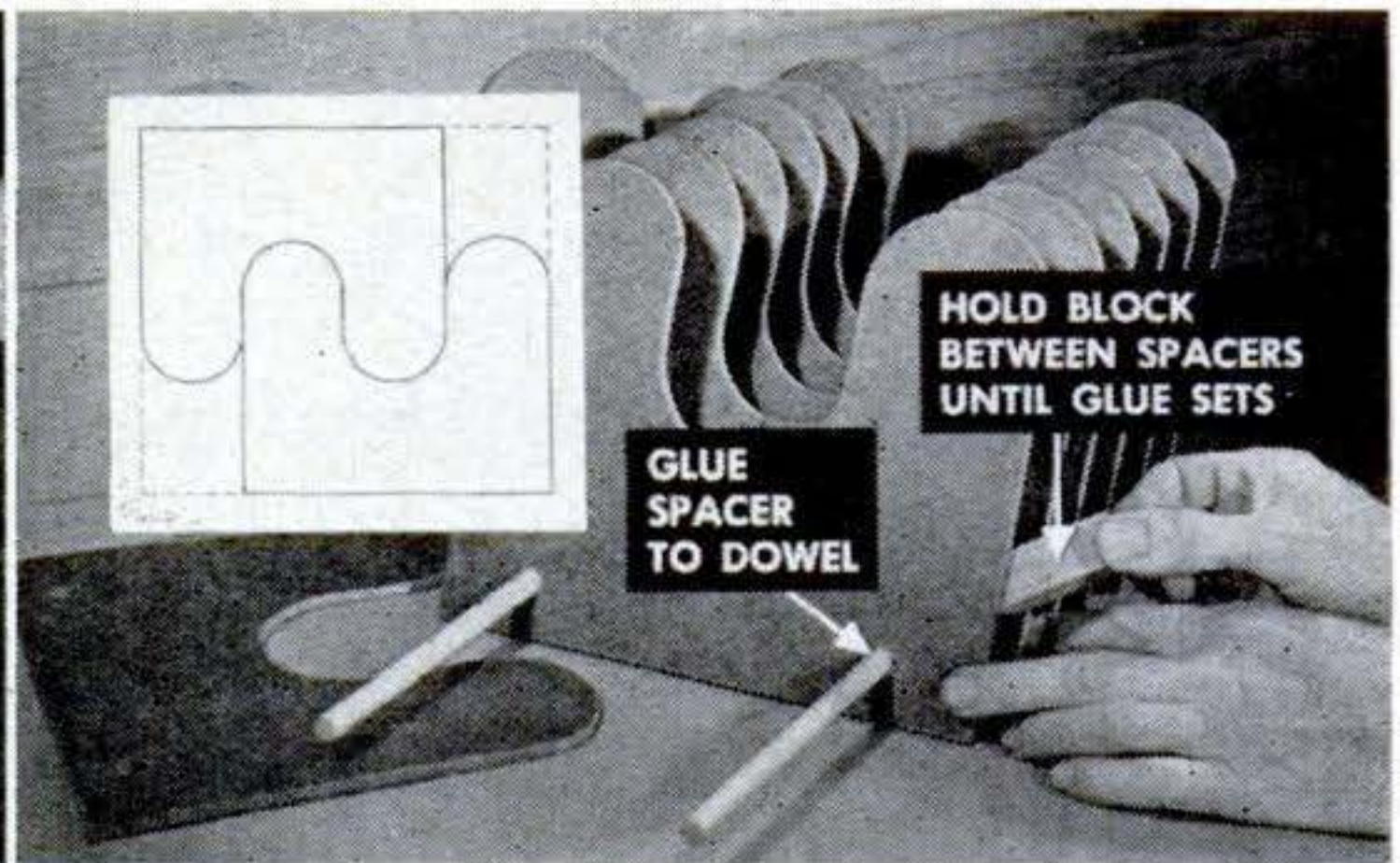

the spacers. The lines on the inset drawing show cutting pattern that makes two spacers from one piece of composition board.

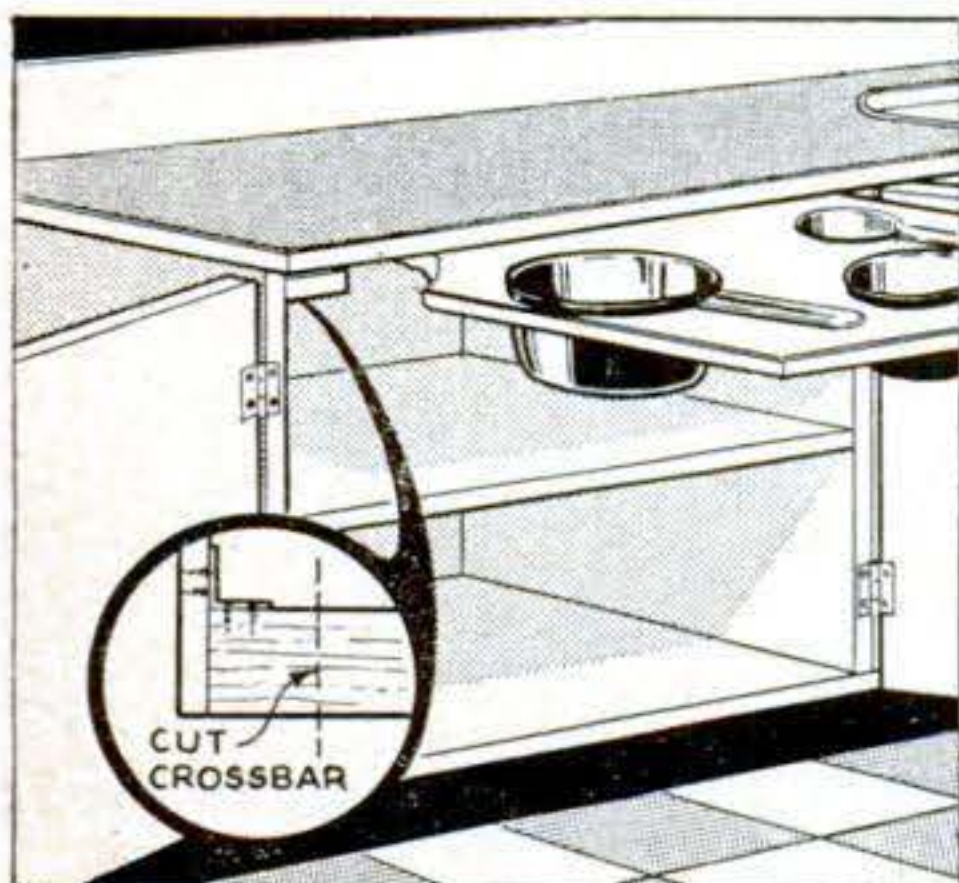

PULL-OUT SHELVES make it easy to reach the back of a storage cabinet. A work-table extension that isn't needed for working can serve as a nesting tray for odd-size pots (left). Cut outs are scrollsawed to fit the pot rims.

Or you can add storage space without giving up working surface by hanging pans from the underside of a pull-out (center). Lids fit

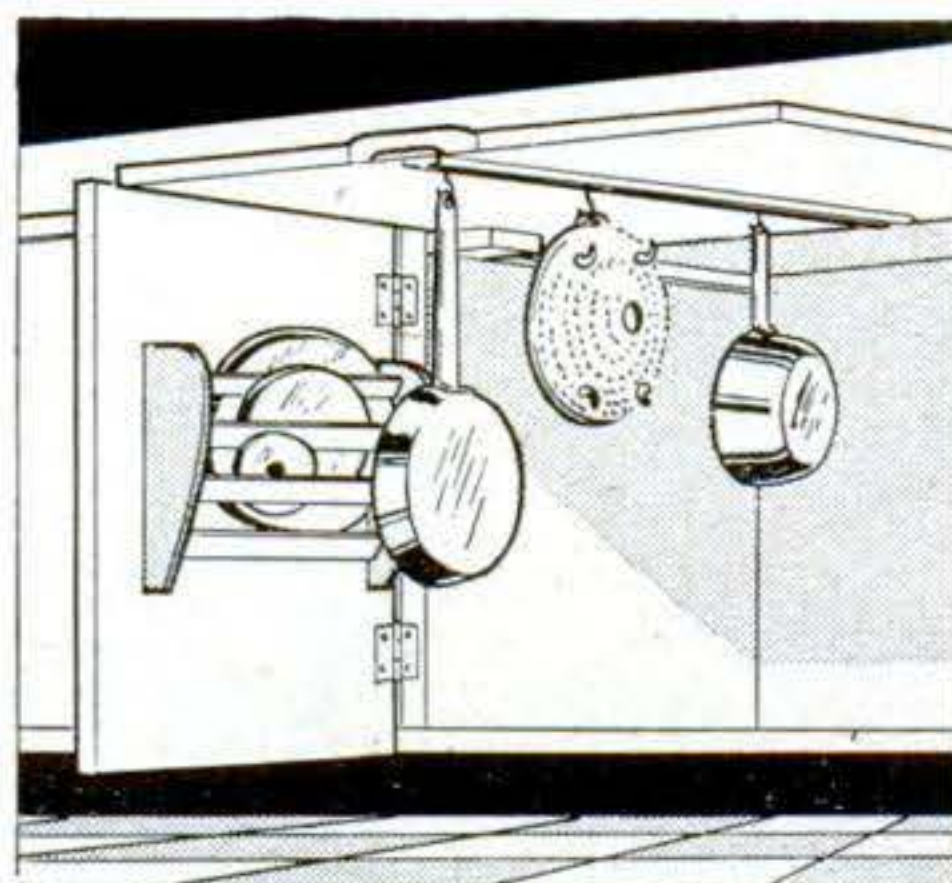

in slats on door. In both arrangements you have to cut away the crossbar from under the shelf. Metal angles installed as shown give it back its old strength.

Hinged arms near the front of a cupboard (right) keep pots handy. You can swing them out of the way to get at things stored on the shortened shelves in back.

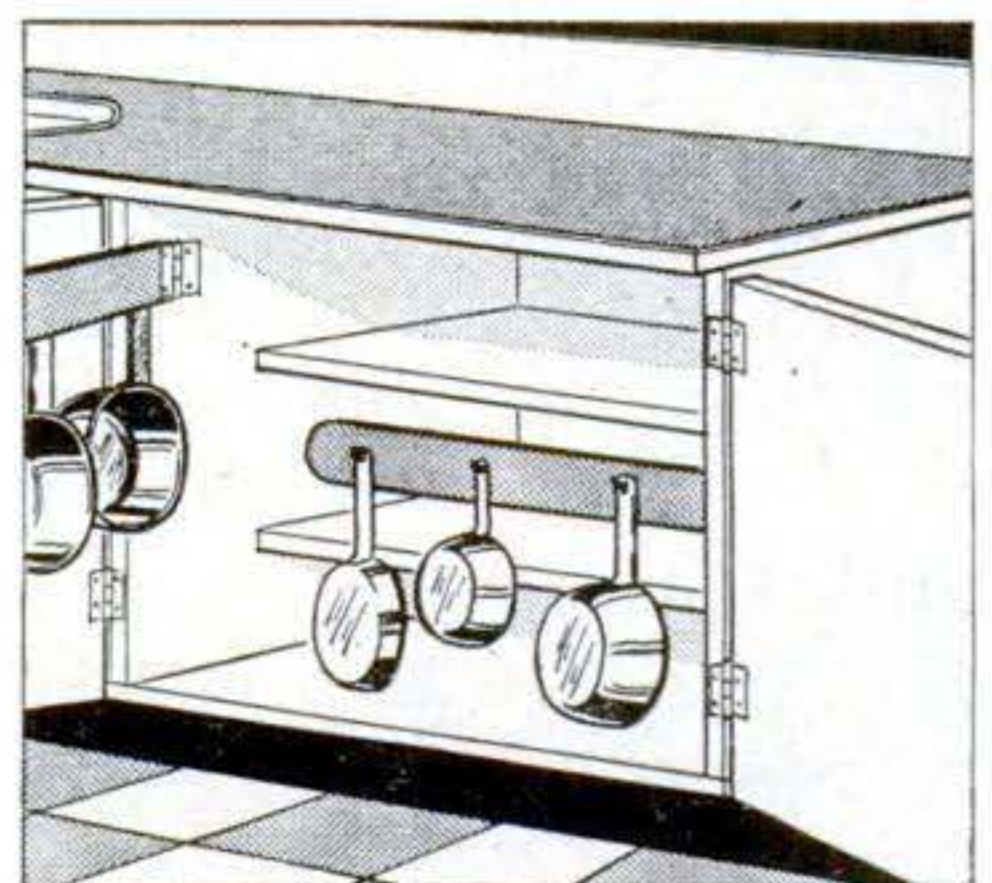

for Your Kitchen

Special Racks Keep Knives Sharp—and Safe

RACKS are the answer for cutting tools. Three examples are pictured on this page—one for the wall, two for drawers. All will keep the knives handy to the cook but away from the children, and protect the edges from dulling nicks.

A SHALLOW DRAWER can be fitted for proper storage of carving and paring knives. A length of dowel, cut to fit between the drawer sides, is slotted for the blades. The $\frac{1}{2}$ " strip at the front of the drawer supports the handles of long knives, keeps their points from tipping up.

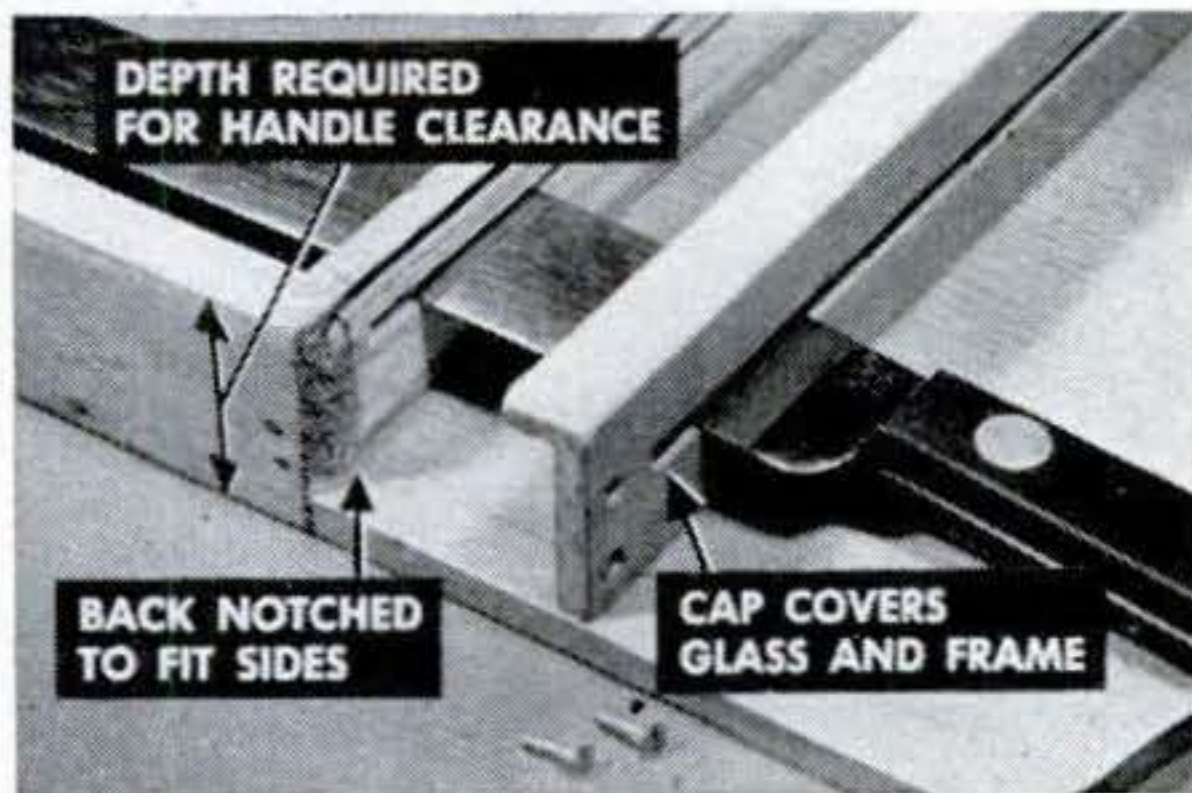
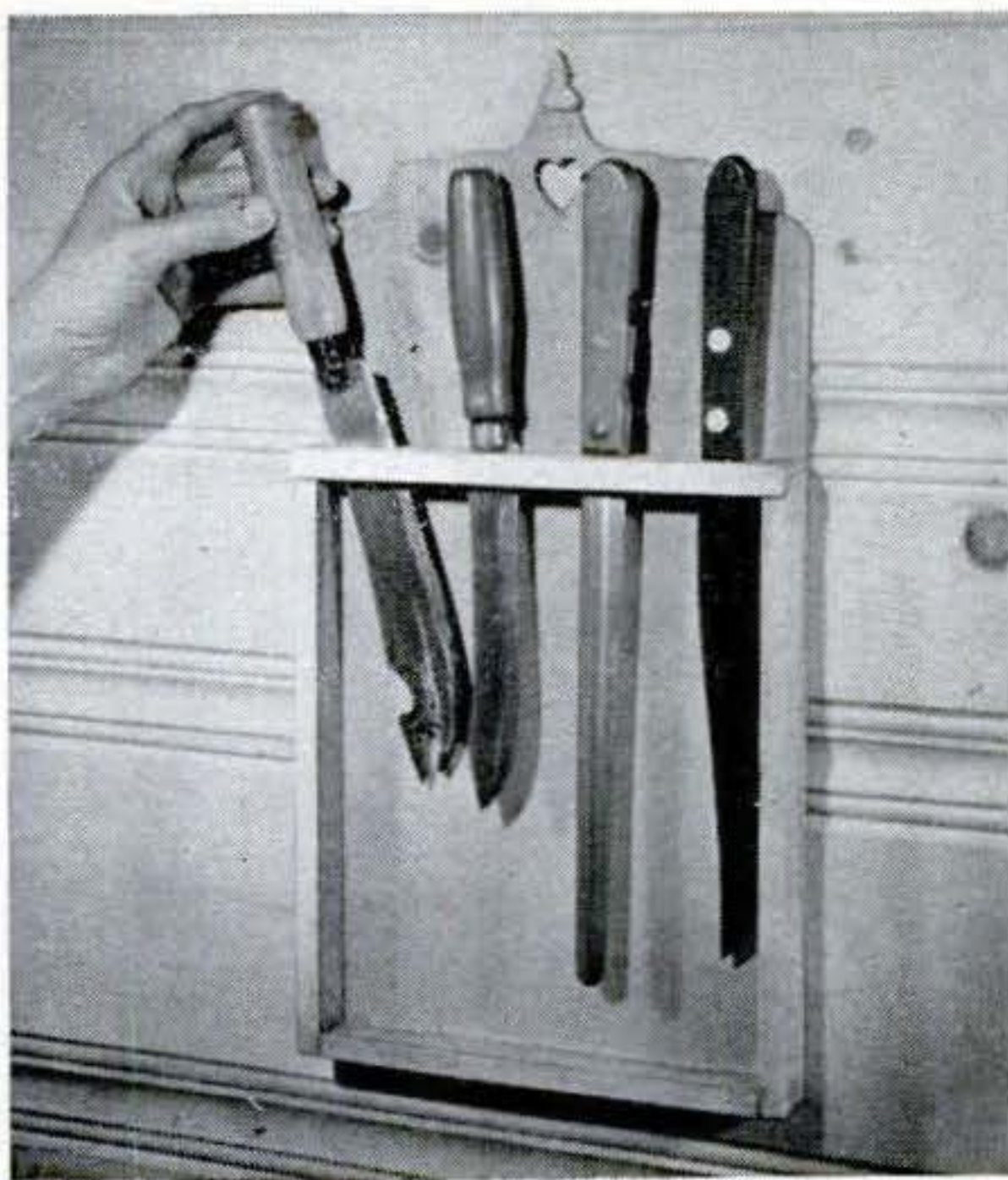

FRAMED WALL RACK has glass front to keep out dust and dirt. The sides are grooved for single-weight window glass. A slotted cap is placed over the top crosspiece as shown in the lower photo to give extra thickness and hold the knives upright.

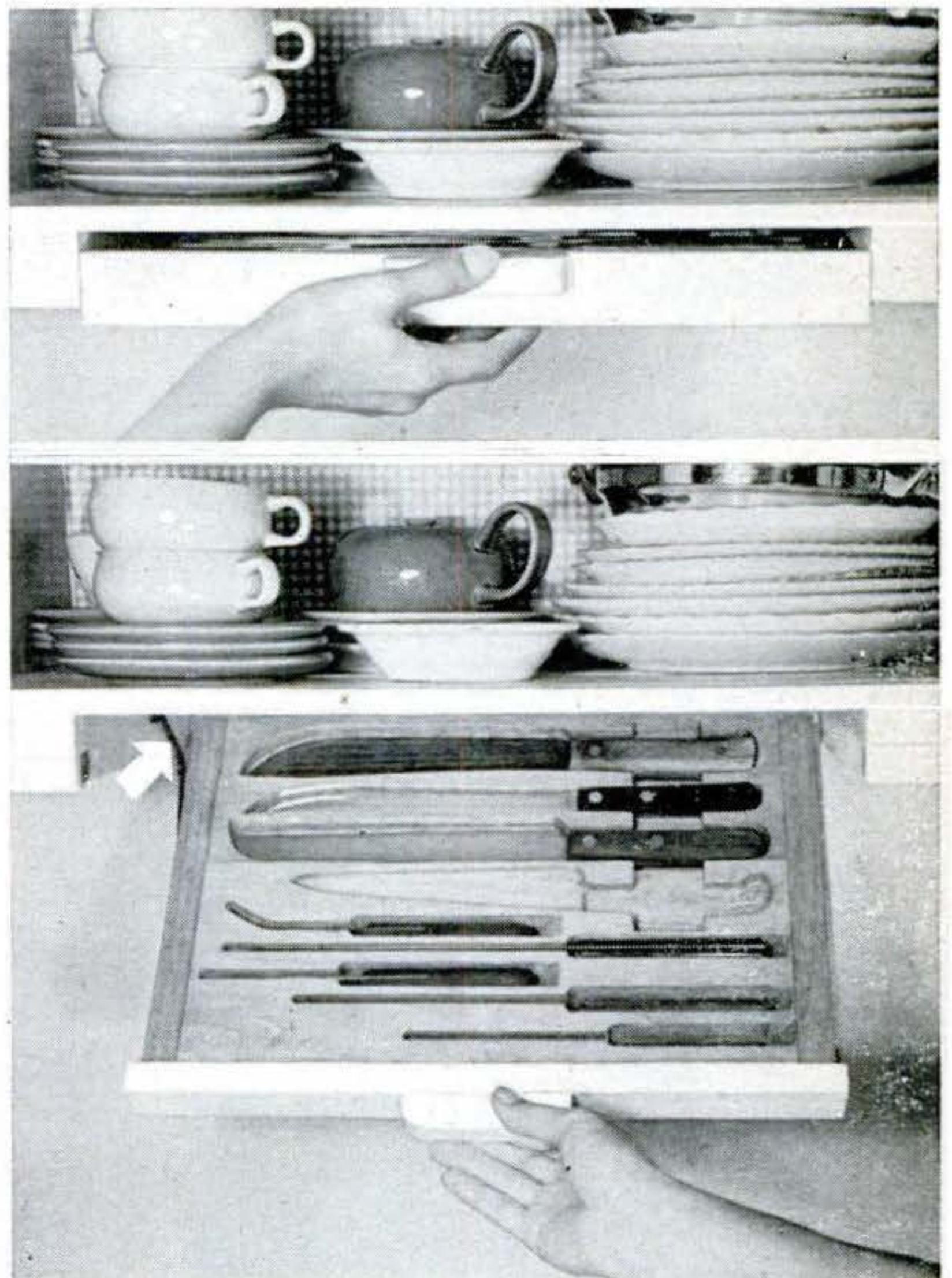

HIDE-AWAY DRAWER slips into the bottom trim of an over-counter cupboard. This one tips down to a 30° angle, is held open by the cabinet-lid support (arrow). Bullet catches lock the drawer in closed position. Knife cut outs routed in a softwood insert tray keep the knives from sliding out of position when the drawer is opened and closed.

Helpful facts about filters...

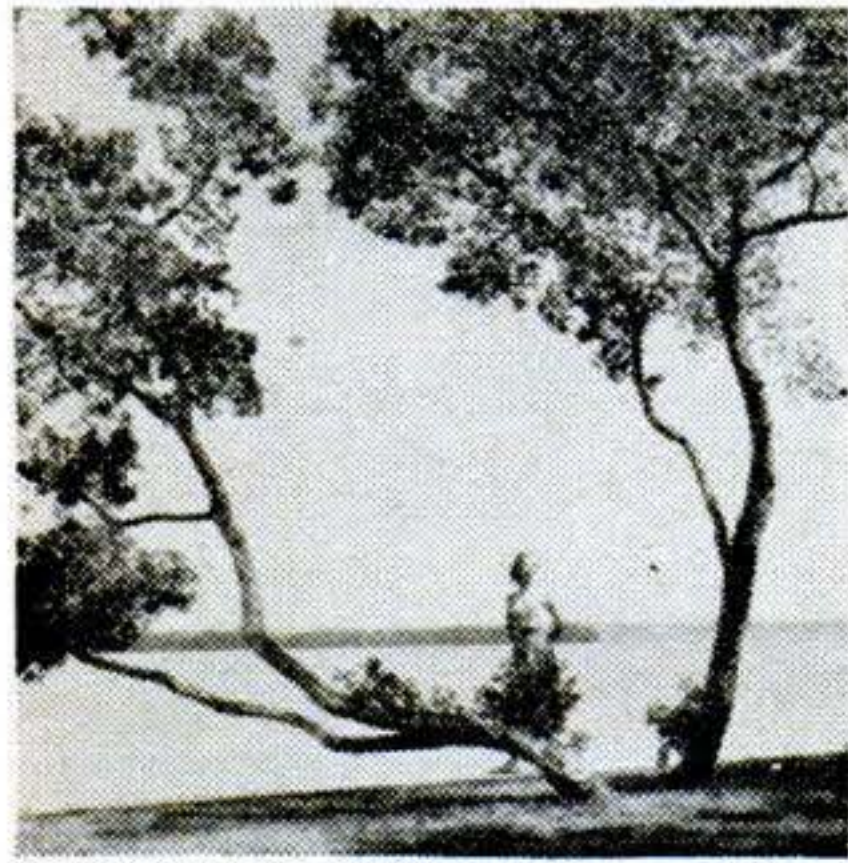

Normal photograph



Taken with Yellow (K2) Filter

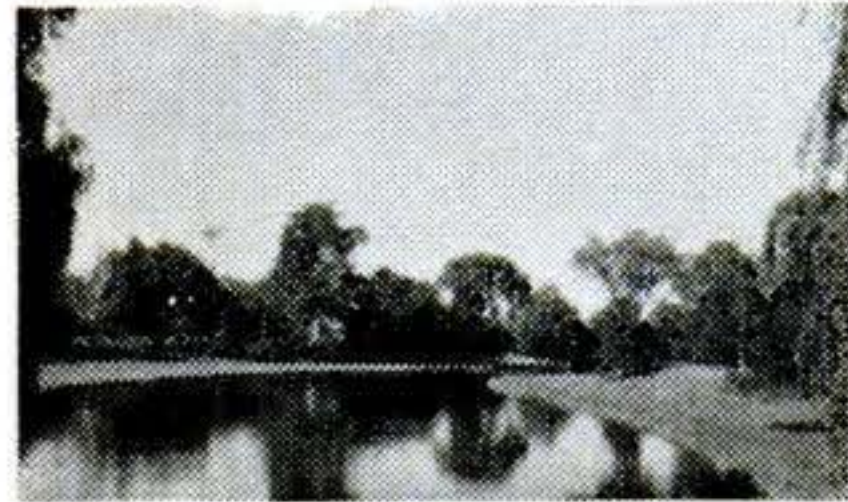

Normal photograph

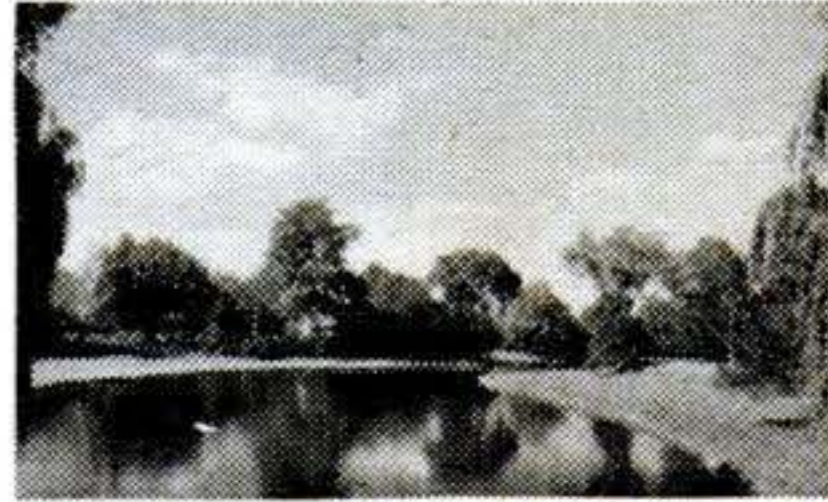

Taken with Yellow (G) Filter



Normal photograph



Taken with Green (X1) Filter



Normal photograph



Taken with Red (A) Filter

Why they do so much for your snapshots

Taking snapshots without a filter can be like eating flapjacks without butter—their full flavor and appeal are often not brought out.

Examples of what some of the most popular Kodak Wratten Filters will do are shown on the left. For instance, the K2 Filter is perfect for making clouds look like clouds—white and fleecy. And for more dramatic sky emphasis, you have the more powerful dark yellow G Filter. Yellow filters, including the new Kodak Cloud Filter for use with inexpensive cameras, may be used with orthochromatic or panchromatic films.

For emphasizing background foliage and clouds—and at the same time giving a pleasing natural modeling to faces photographed against a blue sky—you can use the green Kodak Wratten Filter X1 (with panchromatic film only). And for the most spectacular, thrilling sky rendition of all, try the red A Filter (panchromatic and infrared films only).

As you use and enjoy filters, you will want to add to your collection. So be sure to see your Kodak dealer for a complete list of Kodak Wratten Filters. Prices start at \$1.65 (Kodak Cloud Filter, any size, \$1.72).



Warm up your distant color shots with a Kodak Skylight Filter—With this filter you reduce the bluish cast that often appears in distant scenes. Use it to get warmer-tone pictures of mountains, seascapes, sunlit snow scenes . . . pictures made in open shade under a clear blue sky and on overcast days. Requires no change in normal exposure. Prices start at \$1.65.

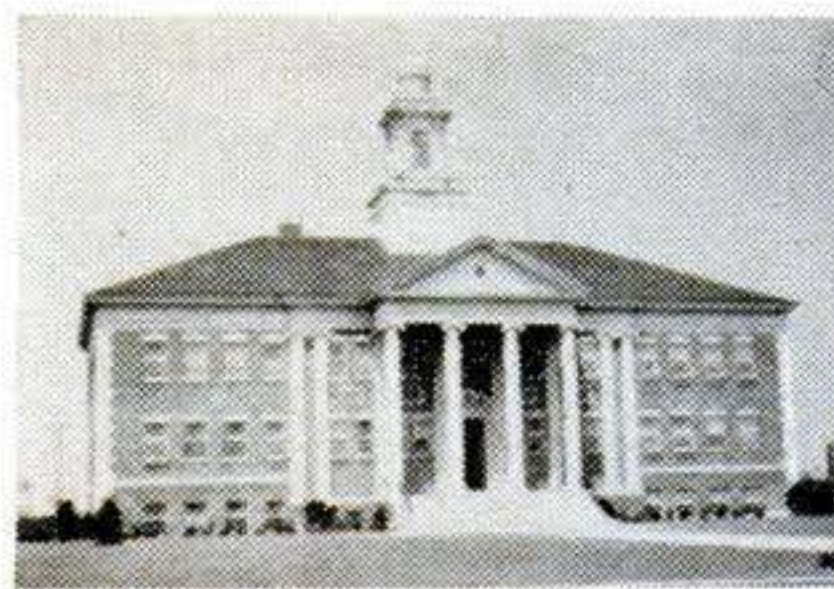

Reproduction from normal color transparency



Reproduction from color transparency using Kodak Pola-Screen

Darken the sky in your color pictures

—A Kodak Pola-Screen does the trick—in color or black-and-white. Also offers the only sure way to subdue reflections from glass, wood, water, and other nonmetallic surfaces. The effect your Pola-Screen will have on the picture may be predetermined by looking through the Kodak Pola-Screen Viewer—a miniature screen which fits over the indicator handle of your Pola-Screen. Varying degrees of sky-darkening can be obtained by rotating the screen. Price of Viewer, \$6.75; Pola-Screens, from \$6.75.



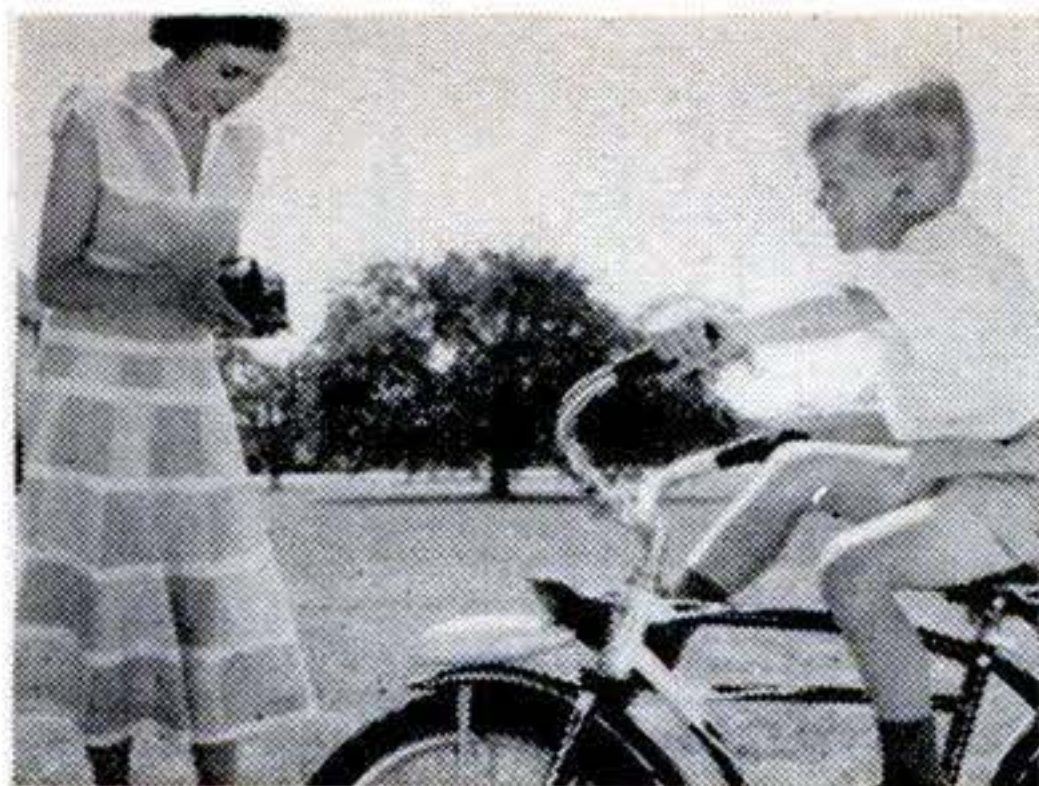

A Kodak Close-Up Attachment gives you pictures like the one above at right

Move in on your subject this easy way — Slip an inexpensive Kodak Close-Up Attachment over your lens and you'll give your camera new picture-taking ability. You can "shoot" at closer range than is normally possible with a fixed-focus camera, and get big, clear images.

Use the attachment for head-and-shoulder pictures, close-ups of pets and flowers. The little story above shows you how easy it is—how pleasing the results. There are sizes to fit most Kodak, Brownie, and fixed-focus Cine-Kodak Cameras. Any size, \$1.63.

An inexpensive supplementary lens does wonders too

For extreme close-ups—Kodak Portra Lenses 1+, 2+, and 3+ give pronounced close-ups of subjects with both still and movie cameras. When you place one in front of your camera lens you step up its power for short-range photography of people, nature studies, and

table-top subjects. Kodak Portra Lenses are graduated in power as their numbers indicate. To secure even stronger effects, the lenses may be used in combination. A 2+ lens and 3+ lens combined give the effect of a 5+ lens. From \$2.59.



Normal Close-up



With Kodak Portra Lens 1+



With Kodak Portra Lens 2+



With Kodak Portra Lens 3+



With Kodak Portra Lenses 2+ and 3+

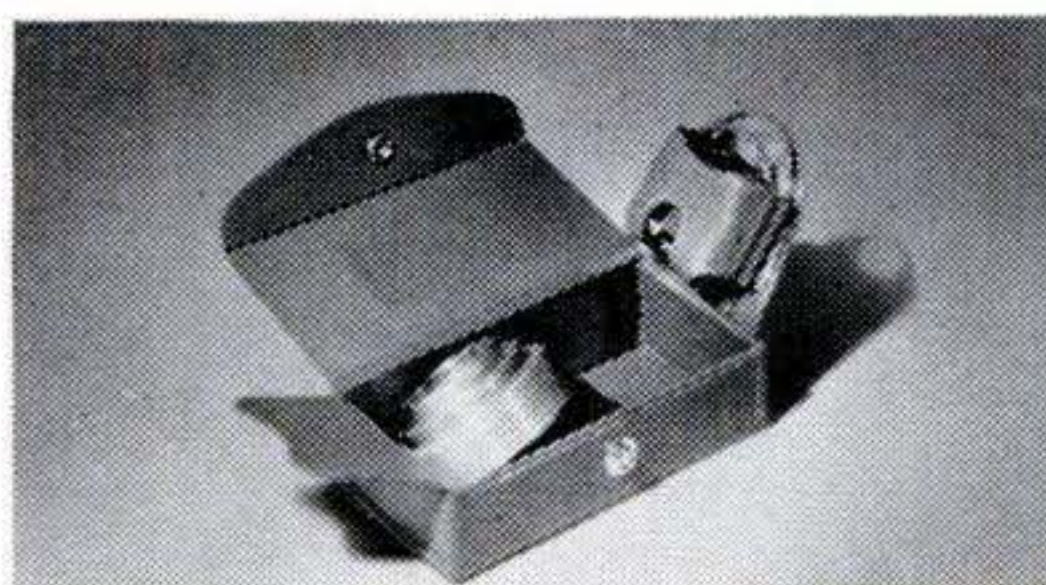

Protect your filters this easy way —Kodak Combination Filter Cases are handsome leather cases that protect lens attachments and provide a convenient way to carry them. One compartment holds a Kodak Adapter Ring, Filter, Lens Hood; the second, three filters. Series V, \$4.25; Series VI, \$4.95.



Shade the eye of your camera—A Kodak Lens Hood helps to guard against light-streaked photographs by making it easier to keep sunlight from striking your lens directly. It also serves to reduce sky "flare" when pictures are side-lighted by the sun or by photo lamps. From \$1.65.

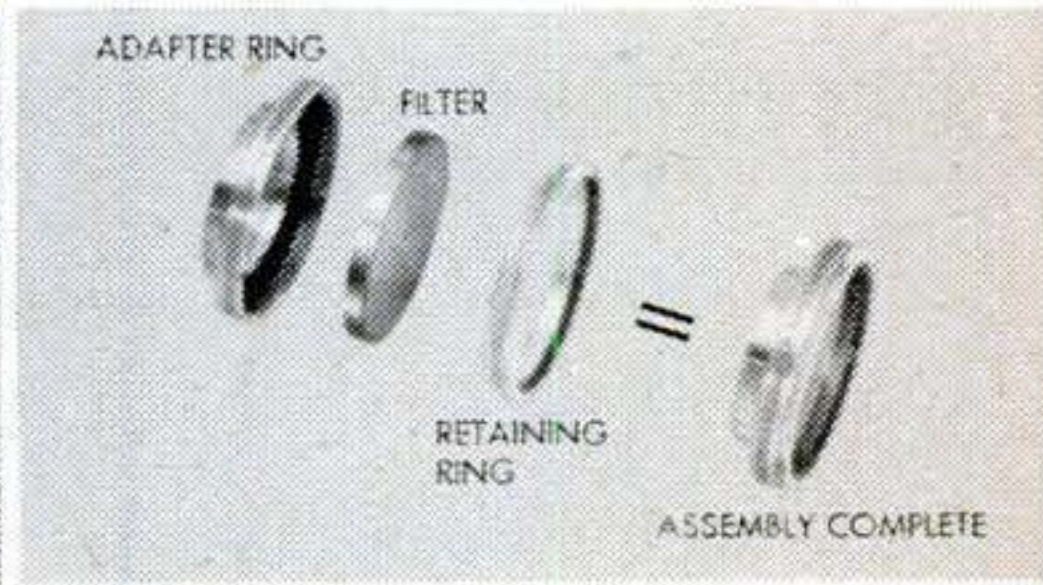

A single Adapter Ring accepts filters and other lens attachments —The two-element Kodak Adapter Ring is the basic unit of Kodak Combination Lens Attachments. Its nonrusting chrome plating matches perfectly the quality finish of your camera. Available in all series sizes. Prices start at \$1.29.

Your Kodak dealer is fitted by training and experience to give you valuable help in your hobby of photography. He'll be happy to "talk shop" any time.

Prices are subject to change without notice

EASTMAN KODAK COMPANY, ROCHESTER 4, N. Y.

Kodak
TRADE-MARK

How Belanger Builds Winners

[Continued from page 94]

remark to a visitor with a tincture of complaint. "We never sit down around here."

Belanger hires three more mechanics during the racing season. That's not counting Belanger himself, who, on the testimony of his grooms, is the best mechanic of them all. Nobody touches a piece of plumbing—fuel, water and oil lines—on his cars but Belanger. He won't allow it.

He is perfectly willing to gamble on a change in his cars, but his risks are calculated.

Improvements Are Constant

Traditionally, cylinder walls in all automobiles have been mirror-smooth to save friction and wear and maintain compression. Belanger's aren't. They're deliberately scored. Oil lodges in the scratches. He found out, by trying, that it gave him better lubrication at high speeds.

Improvements in the cars are constant. At San Jose last year Bettenhausen broke a rear-brake hydraulic line at the 16-mile mark of a 100-mile race. Braking on three wheels would have thrown the car out of control. He drove the rest of the race without brakes.

He had a shutoff valve for his front brakes but none for the rear. Now, on his recommendation, there are shutoffs on both sets.

At Indianapolis last year Wallard, too, had brake trouble. A nut holding the right-rear brake cylinder to its bracket failed. He was only 12 laps from the finish, but the fright in the Belanger pit as he skidded through turns without brakes led to a change in the type of nut used.

Drivers Picked with Care

A championship stable takes good chauffeuring. From personal experience at the wheel, Belanger knows how to pick his drivers. He started earning his living in his late 'teens by washing cars at a dollar a day. In time he bought a Ford and hopped it up. For four years he drove the Ford in dirt-track races. To keep an anxious mother from finding out, he entered his jalopy under another name.

Belanger's chauffeurs are shrewd and knowing. Melvin Bettenhausen—everybody knows him as "Tony"—has driven more 100-mile races than anybody else in the business. Slight-framed, wiry, nervous, he runs a small farm and an automobile agency in

Tinley Park, near Chicago, between racing seasons.

Like horse jockeys, the chauffeurs of gasoline alley have their preferences in men and mounts. Tony regards George Salih, chief of the Belanger pit crew, as one of the greatest racing mechanics alive. Salih was named the outstanding racing mechanic of the year in 1951. Tony feels the same toward Dale "Tiny" Worley, one of the grooms in the stable. Tiny weighs 250 pounds and more without the weight of a cylinder block in his hands, but he moves like lightning during the pit stops.

At the start of the season Belanger drops his work at his automobile agency, his lumberyard, his feed store and his two farm-equipment stores, and dons coveralls to work alongside his drivers and mechanics. He takes his business accountant with him to keep meticulous records on his cars during all races.

Records Kept of Every Lap

The performance on every lap of every race is recorded. He can tell you how much time a particular mount required on the 11th lap at Syracuse in 1950. He can tell you its carburetor settings, magneto timing, gear ratio, fuel mixture, how many pounds of weight each wheel carried, and the number of pounds of air in each tire. The tires are extra important. A soft tire flexes too much. Flexing causes heat. Heat destroys tires.

The record book serves another purpose, too. It's source material to answer questions in letters, telephone calls and telegrams after each race run on a dirt track normally devoted to horse racing. The inquiries run the gamut of subjects from valve diameters to fuel capacities. Horse-track habitués will bet on anything. END

Trick Simplifies Thread Cutting

WHEN you set the lathe compound at 30° to cut a 60° thread, multiply the single depth of the thread by 1.1547 to determine the compound feed for proper thread depth.

The same trick is handy in accurate turning. With the compound set at 30°, a movement of .001" on the graduated dial of the compound will advance the tool only .0005".
—J. C. Magee, Schenectady.

on every *Pontiac*

1926

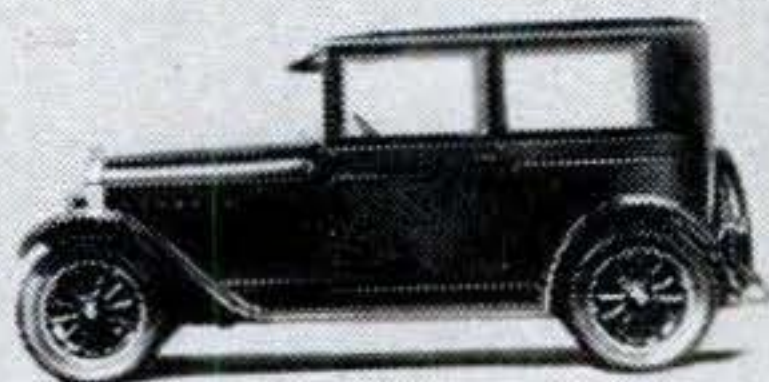

1933



1940



...Since the First *Pontiac* Was Introduced in 1926

This Pontiac-AC partnership has been in existence for 26 years -- with Pontiac supplying the power -- and AC providing the spark that helps convert this power into mile after mile of motoring pleasure.

Pontiac relies on AC for split-second starting -- for smooth-sailing performance -- for day-in and day-out reliability. And AC, only Spark Plug with patented *CORALOX* Insulator, brings about these desired results -- not only for Pontiac, but for all other makes of cars as well.

Are you getting top performance out of your engine? To be sure, specify ACs the next time your car needs spark plugs.

PATENTED
CORALOX
INSULATOR

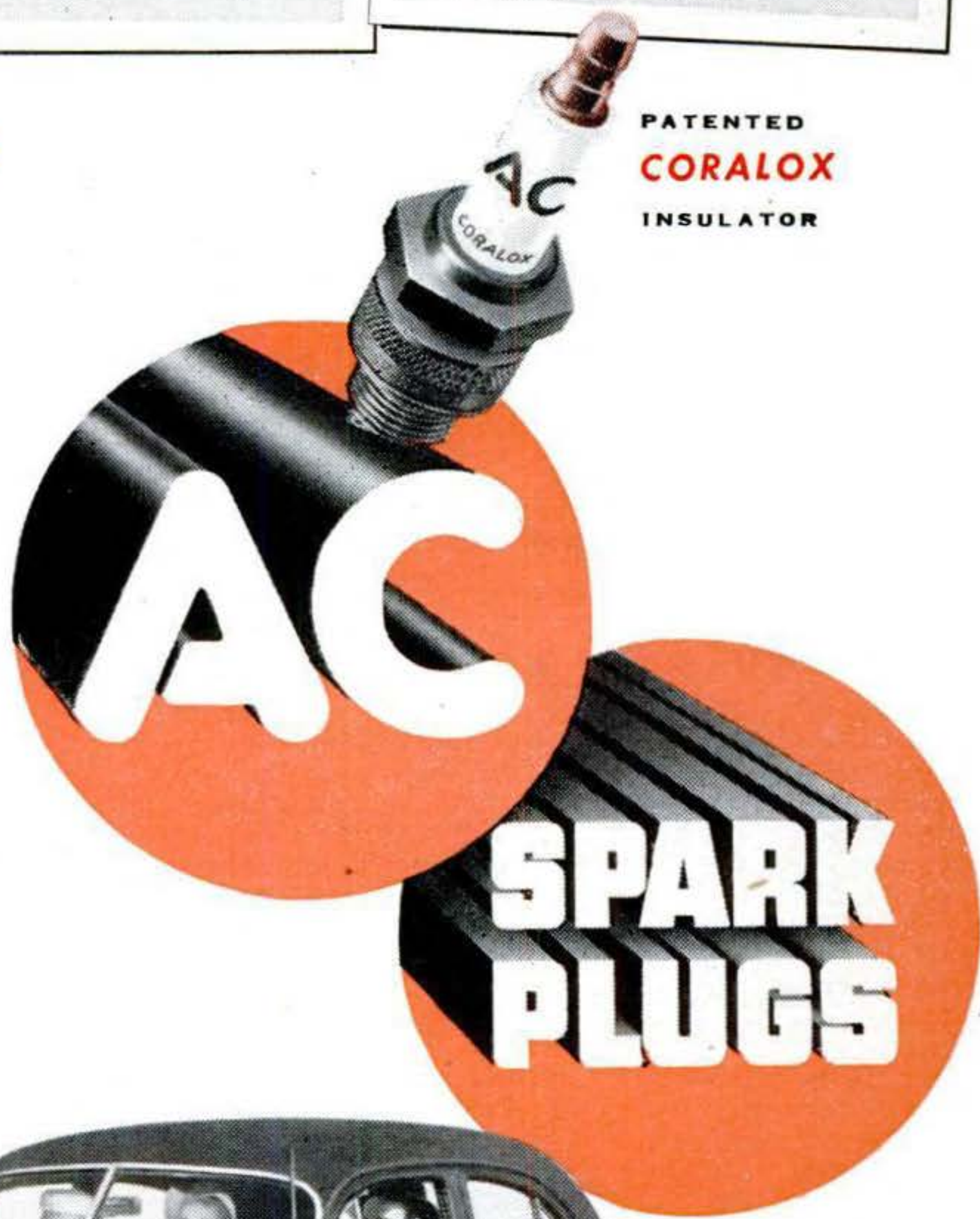

1952 CHIEFTAIN
DELUXE EIGHT

AC SPARK PLUG DIVISION



GENERAL MOTORS CORPORATION

MAY 1952 227

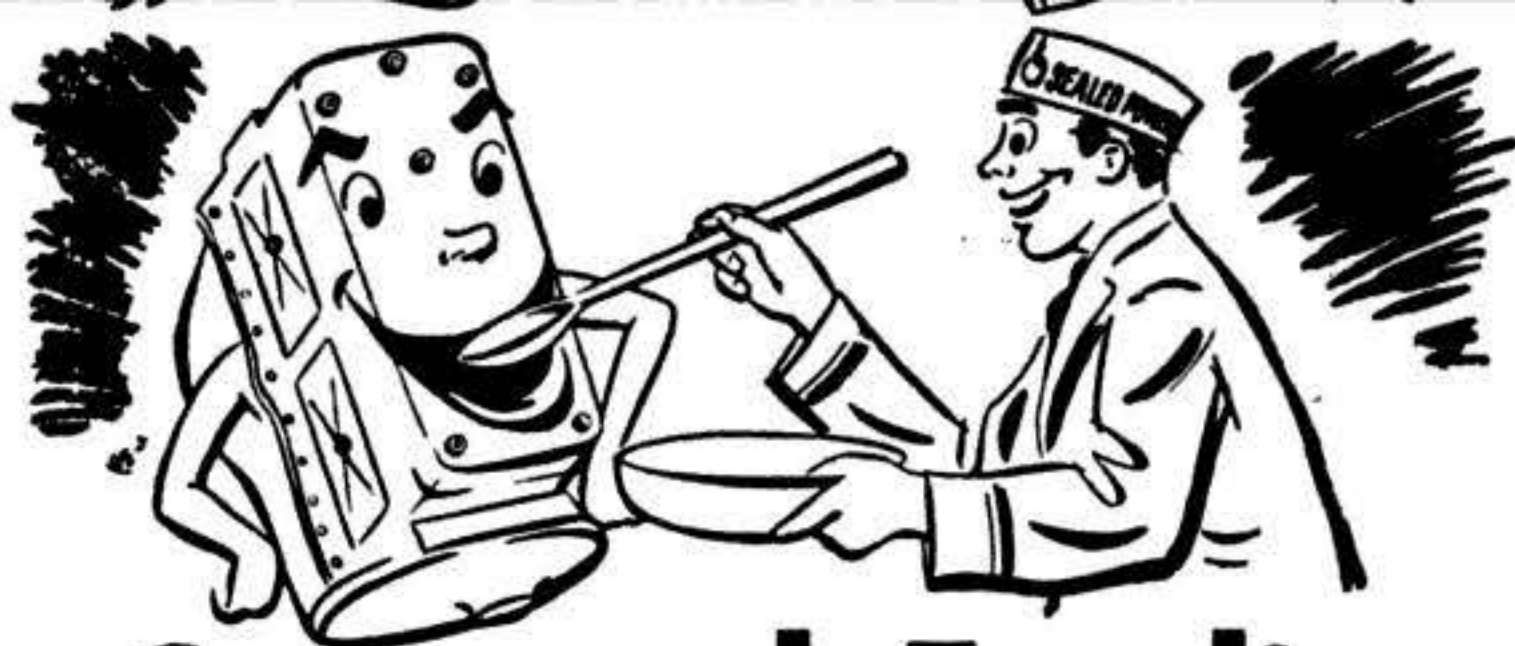

Care and Feeding of Engines

BY S. P. CORP

MAKE CHROME LAST LONGER

Chances are that calcium chloride or salt were used to melt ice and snow on your pavements last winter. Both have a chemical action on chrome plating. You may find your bumpers and other chrome parts pitted with small rust spots.

To improve appearance, and to prevent rust damage from spreading, borrow your wife's kitchen scouring powder and remove those rust spots. Then give all your chrome a coating of good wax. In fact, the chrome will last longer if you wax it every time you wash your car.

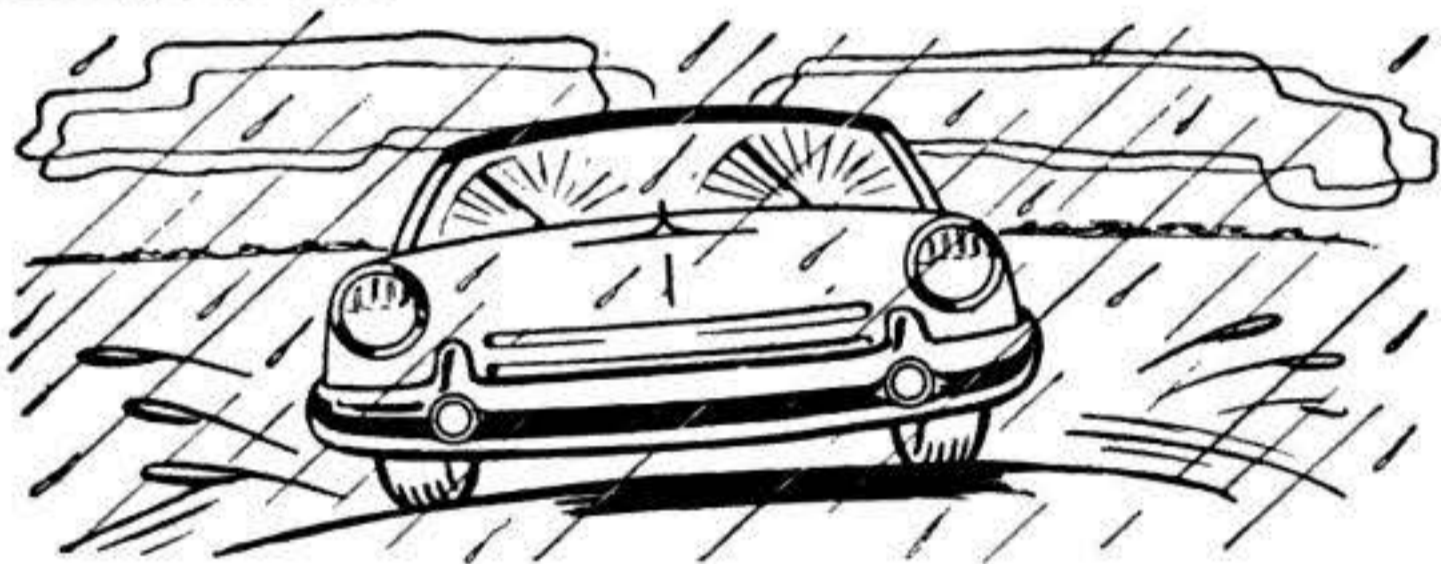

ROAD TAR AND OIL

Don't let spots of road tar or oil remain on the finish of your car. Use tar cleaner to remove them. If you use gasoline, be sure it's white gasoline—and be very careful with it. This is part of the thorough washing your car deserves. So is the job of washing away all salt accumulations under fenders, particularly where sheet metal is fastened together. Use a good polish to restore lustre, and don't worry if a little color shows on your polishing cloth—it is dead pigment, and is not a sign of damage.

CLEAN YOUR OIL PAN

Water always accumulates in the crankcase in winter. The wise way is to buy a set of oil pan gaskets, then drop the oil pan and give it a thorough cleaning. Clean gasket surfaces on both oil pan and engine block. Coat oil pan gasket surface with shellac, and, when tacky, place gasket on pan. Install all pan bolts before tightening any of them, to allow for movement in aligning bolt holes in engine block. Replace your oil filter at this time, too, so your new oil will have a fresh, clean start. Clean oil makes rings, bearings, and bearing surfaces last longer, and makes your driving a lot more fun.

USE SEALED POWER KROMEX RING SETS

Late model cars and trucks operate at higher engine speeds and higher combustion temperatures. Sealed Power KromeX Ring Sets are built for those conditions. Top compression ring and steel rails of oil ring have solid chrome faces to fight heat, friction, corrosion, abrasion! Write Dept. H-5, Sealed Power Corp., Muskegon, Michigan, for your free copy of the valuable new booklet, "More Power, Less Oil, Less Gas."



How Your Shape Shapes Your Life

[Continued from page 119]

Alcohol accentuates his aggressiveness. When troubled he has recourse to action—he takes a long trip in his car, builds something, goes on a spending spree. For him the best time of life is the strenuous period of youth. His sexual drive is greater than the fatty's, but less than the nervous ectomorph's.

● The extreme nervous type is restrained in posture and movement; he is round-shouldered when standing or sitting; he walks as though he were treading on thin ice. He loves to be alone.

Although his health is quite good, he worries about it constantly. He doesn't want to reveal his emotions to others in an obvious fashion. As a result, he is often misunderstood. He lacks poise in social situations. His inhibitions prevent him from being free and easy. Small, closed-in spaces make him feel at home. He is more concerned with his own mental life than he is with what goes on in the outer world.

Alcohol makes him feel more strained and miserable. When in trouble he needs solitude. The ideal time of life to his way of thinking is maturity or old age—periods when he hopes to be more free from nervous tension and emotional insecurity, and to understand better the enigmas of human existence. His sexual drive—believe it or not—is very high.

Traits Match Build—or Else

These, of course, are thumbnail sketches of extreme cases of each type. Most of us are not extreme cases. You are much more likely to be a 4-4-4 than a 7-1-1.

In developing this scale of temperament, Dr. Sheldon observed the persons to be rated for at least a year in as many different situations as could be arranged. He conducted a series of 20 or more analytic interviews of one hour each. Each trait was rated on a seven-point scale, and the rating was revised repeatedly. Finally, an index of temperament was computed for each individual.

This index number may be identical with the somatotype number. If there is a difference for any one component, it will usually not be more than one point. A man may be rated 5 for his muscular build, for example, and 4 or 6 on the temperamental expression of this component.

[Continued on page 230]

Beautify your home

with Modern Oak Floors

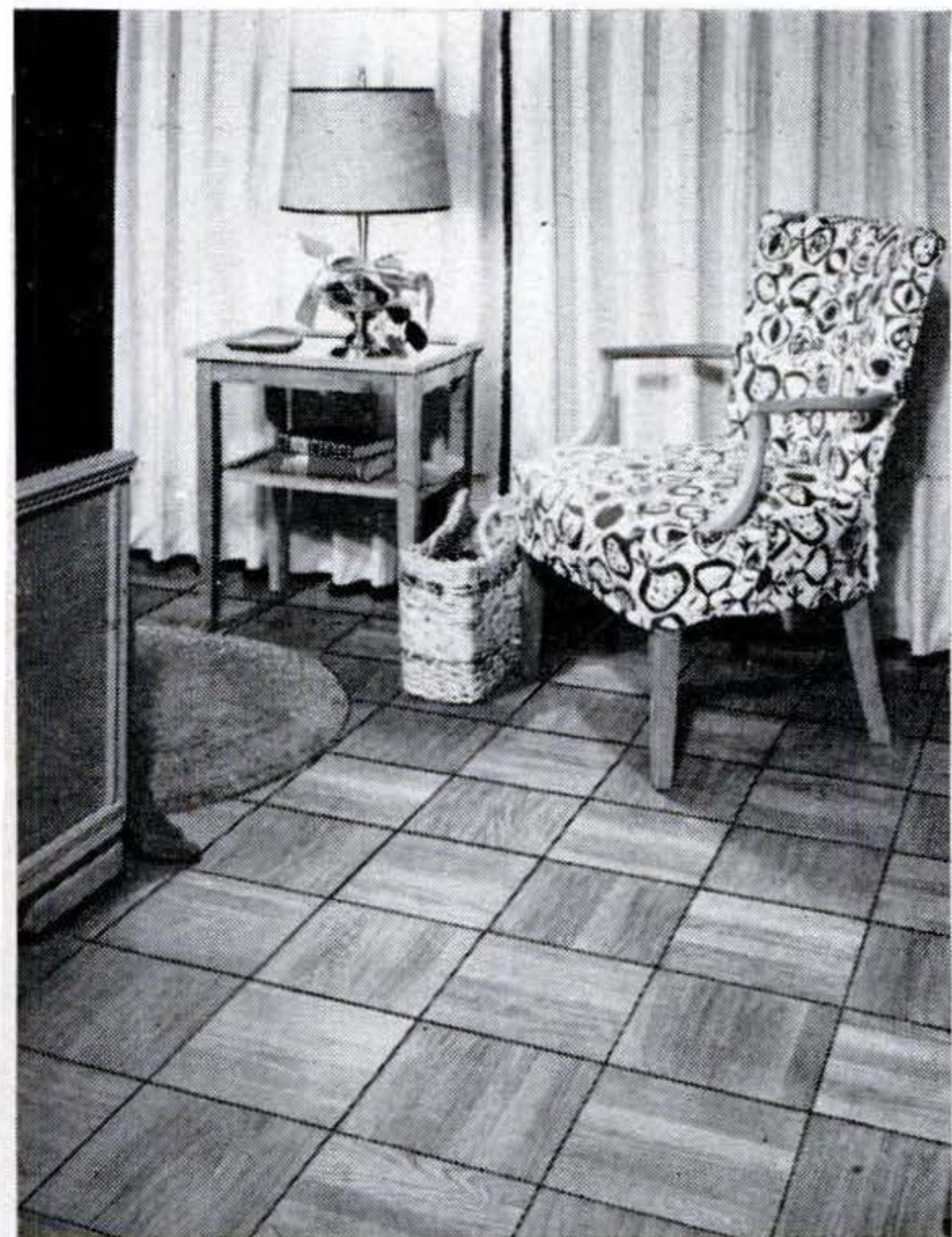

MODERN BLOCK, in solid oak, will give your home rich style and lasting beauty. This distinctive parquet-type floor can be laid over concrete or wood.

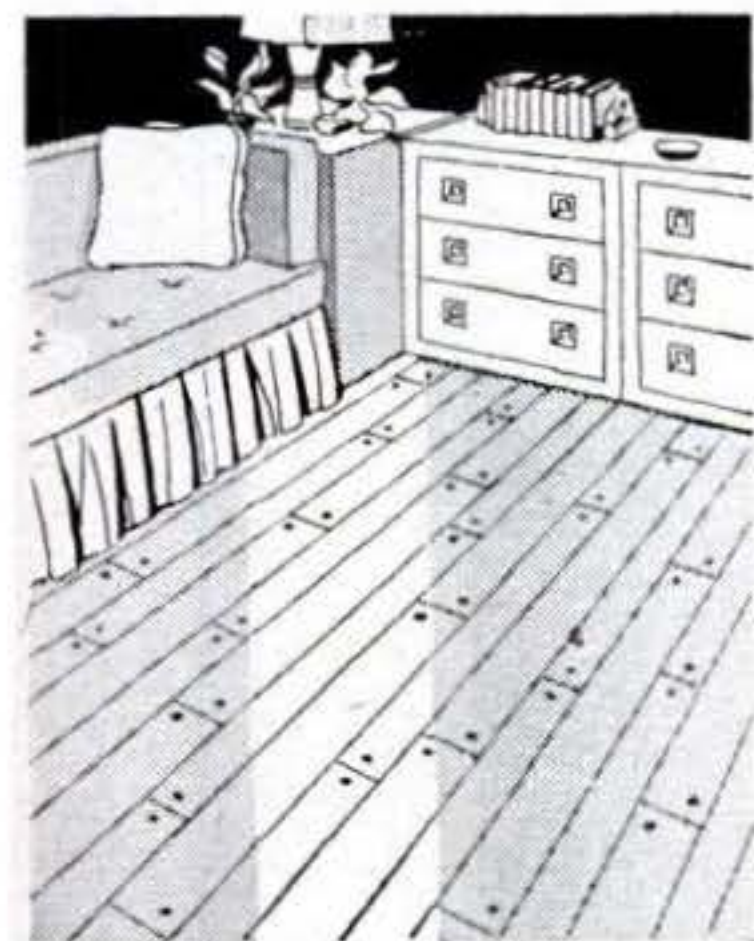

RANCH PLANK with walnut pegs gives the effect of a random-width floor at one-third less cost. The 2 1/4" and 3 1/4" oak strips are pegged and finished at the factory.

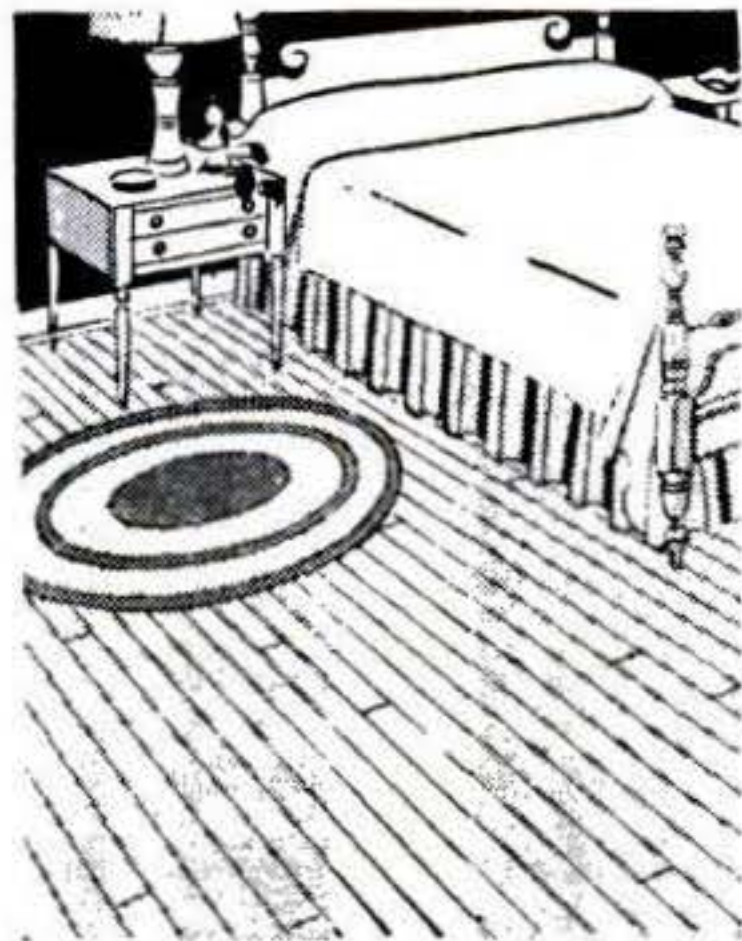

STRIP DESIGN is always in good taste . . . has been more widely used than any other hardwood floor. A Bruce Strip Floor gives your home life-time charm at minimum cost.

It's easy to lay
PREFINISHED Bruce Oak Flooring
right over your old floors . . .
it's already sanded and finished!

You can give your home new beauty at low cost with a *pre-finished* Bruce Hardwood Floor. Completely finished — even waxed — at the factory, this highest quality solid oak flooring can be nailed right over old floors. No sanding or finishing . . . no mess or smell. Your lovely new floor is ready for use as soon as it's laid. You have a choice of three designs: Block, Ranch Plank or Strip.



"Scratch-Test" Finish — This test (left) proves that the factory-applied Bruce finish does not scratch, chip or mar like a surface finish. It's baked into the pores of the wood . . . outwears ordinary finishes 3 to 1.



Moderate in Cost — A new Bruce Hardwood Floor will cost you less than a good rug or carpet. It's so easy to keep clean and beautiful . . . will last the life of your home. Just the thing to use in fixing up or adding a room. Let your lumber dealer tell you the reasonable cost. For free literature with photos of beautiful rooms in color, mail coupon to E. L. Bruce Co., 1668 Thomas St., Memphis 1, Tenn.



MAIL FOR FREE LITERATURE

E. L. Bruce Co., 1668 Thomas St.,
Memphis 1, Tenn.

Send color folders on prefinished
Bruce Hardwood Floors to:

Name _____

Address _____

City _____ State _____

BRUCE *Prefinished* HARDWOOD FLOORS

Products of world's largest hardwood flooring maker

MAY 1952 229

How a quality file is born

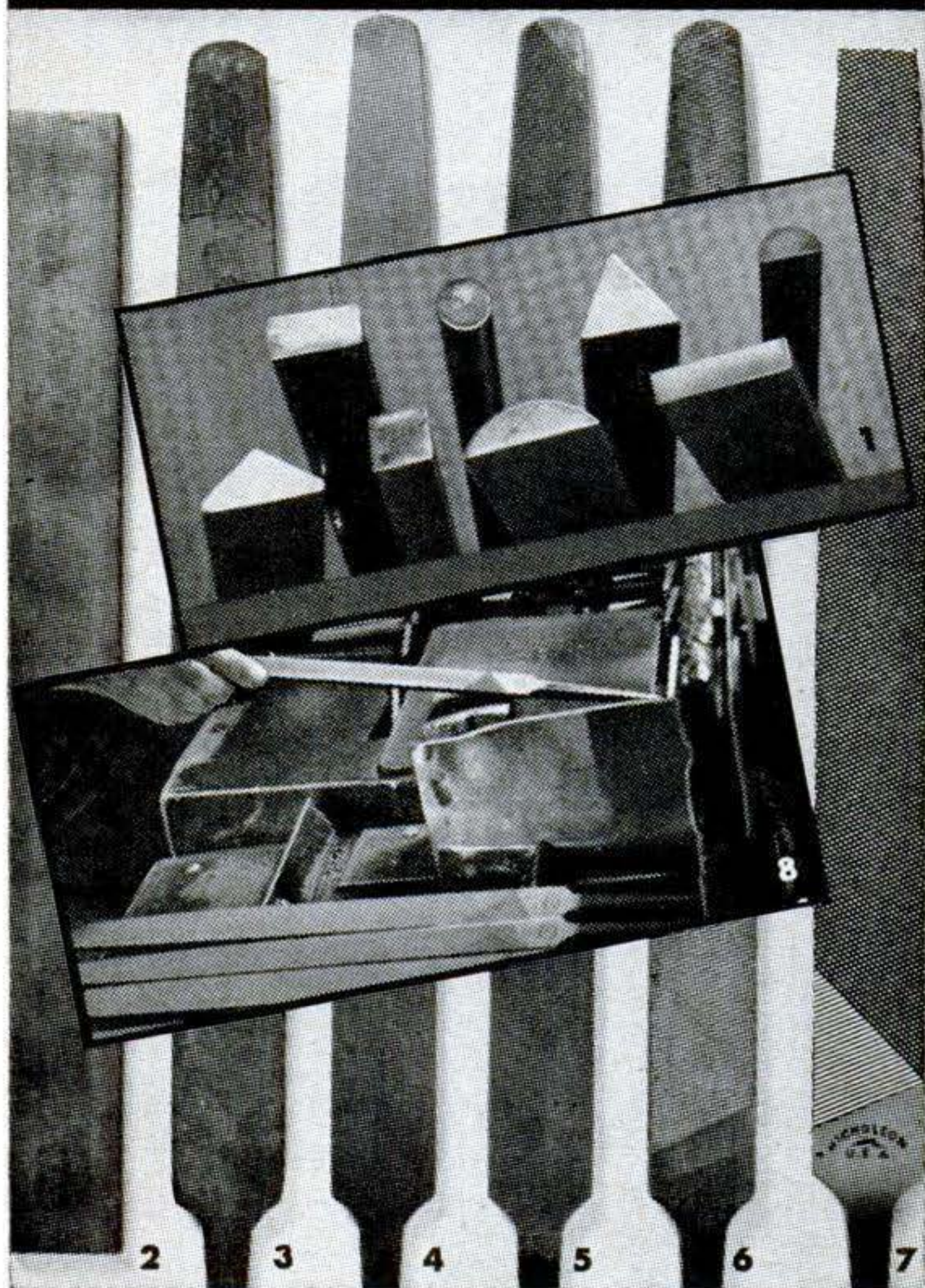

NICHOLSON file quality begins with steels (1) made to carefully determined specifications. . . . File blanks (2) are machine-forged to uniform shape (3). . . . For teeth cutting, blanks are annealed by precisely controlled heating and cooling (4). . . . Blanks are then straightened, ground to remove scale, precision-smoothed to assure teeth of even height and sharpness (5). . . . Teeth are cut by Nicholson-designed machines renowned for their accuracy (6). . . . A scientific process gives the teeth exactly the right uniform hardness—after which files are cleaned, further sharpened, tang-softened to prevent breakage, and oiled to prevent rust (7).

Every step of manufacture is checked. Furthermore, the finished files are given a series of final tests by trained inspectors (8)—after which these world leaders in quality files are ready for you to enjoy using. At hardware dealers everywhere.

FREE BOOK, "FILE PHILOSOPHY," tells lots more. Write.



NICHOLSON FILE COMPANY
19 Acorn Street, Providence 1, R. I.
(In Canada, Port Hope, Ont.)



NICHOLSON

A FILE FOR EVERY PURPOSE

How Your Shape Shapes Your Life

[Continued from page 228]

A difference of two points means that the individual is trying to be something other than himself. A very fat boy, for instance, may set his heart on being the world's heavyweight boxing champion. In consequence, he is living under a very severe strain.

Tailoring a House to a Man

Dr. Sheldon's classification can be applied to the study of human beings in many fields.

Furniture makers and decorators, for instance, would do well to remember Dr. Sheldon's comments: "The endomorph likes soft, overstuffed furniture, deep abyss-like chairs, inner-spring mattresses, luxurious general furnishing, and ceremonial eating equipment. The mesomorph craves spacious rooms without the overstuffing, and the ectomorph gravitates toward closed-in places and is content with a hard simplicity of furniture. Ectomorphs need chairs with high shallow seats which slope backward. They also appear to like stiff mattresses."

Architects can pick up a few pointers, too. The skinny nervous ectomorph does *not* want his house perched on a hill or on other prominent ground. He desires a hide-away in a valley or a hollow, or at least in the middle of protective greenery. Persons of this type "want small, snug houses with steep roofs and with attics and cellars." But the muscular mesomorph has a yen for a large home in an open place, preferably on a hill.

In medicine, studies indicate that certain constitutions are particularly susceptible to certain physical diseases. Mental diseases, according to Dr. Sheldon, are also closely associated with physical types.

Your Body Affects Your Job

A man's career and his body type, it has also been found, are definitely interrelated. Two Harvard scientists, Frederick L. Stagg and Prof. Earnest A. Hooton, have recently demonstrated this by applying Dr. Sheldon's classification to 2,631 Harvard graduates of the classes of 1876 to 1912.

They found that muscles are very important in engineering. If you aren't well muscled, the chances are that you'll drop out of engineering and go into some other line of work. The fellow with a superior

[Continued on page 232]



just what
fishermen
ordered!

[AND MAN, HOW THEY'VE ORDERED IT]

FLEETWIN

7.5 O.B.C. certified
brake H.P. at 4000
R.P.M. Price F.O.B.
Factory, subject to
change without notice,

\$210



IT'S FLEETWIN ... by Evinrude! It zoomed into the favor of knowledgeable fishermen the day it hit the water!

Its popularity rides up and up, for there's no motor like it. See how *much* of so many good things it offers you...

It's wonderfully *light*! Fleetwin weighs only a few pounds more than most "fives."

But... packed into those few pounds you'll find a noble bonus of 50% *more power*. Power that whisks you to your fishing spots miles, miles faster. The smoothest, sweet-

est, sharpest power you've ever handled!

How about *trolling*? You couldn't ask for a finer trolling motor... for *this* one, owners will tell you, is *perfection*.

With Fleetwin's Duo-Clutch you've got "press-the-button" handling ease... you start in neutral, and "idle" anytime.

SEE YOUR EVINRUDE DEALER—let him give you a show-down demonstration of *all* that Fleetwin offers against the field! Look for his name under "Outboard Motors" in the yellow pages of your phone book. **CATALOG FREE!** Write today for catalog of the complete Evinrude line.



EVINRUDE MOTORS

4812 N. 27th St., Milwaukee 16, Wis.

IN CANADA: Manufactured by
Evinrude Motors, Peterborough, Ontario

EVINRUDE

**Cut Like
the Wind!**



with **SIMONDS**
SI-CLONE

**...new low-priced, high-quality
SAWS for home workshops**

Yes, these new **SI-CLONE** Saws cut like the wind . . . and stay sharp longer. All types, including Easy-Cut and Carbide-Tipped, in all diameters up to 12". Furnished with any type or size of centre-hole . . . for use on any table, radial-arm or electric handsaw machine on the market. And remember **SI-CLONE** Saws are **SIMONDS** quality, backed by over 75 years of saw-making experience. So "blow in" to your hardware store today and ask for **SIMONDS NEW SI-CLONE SAWS**.

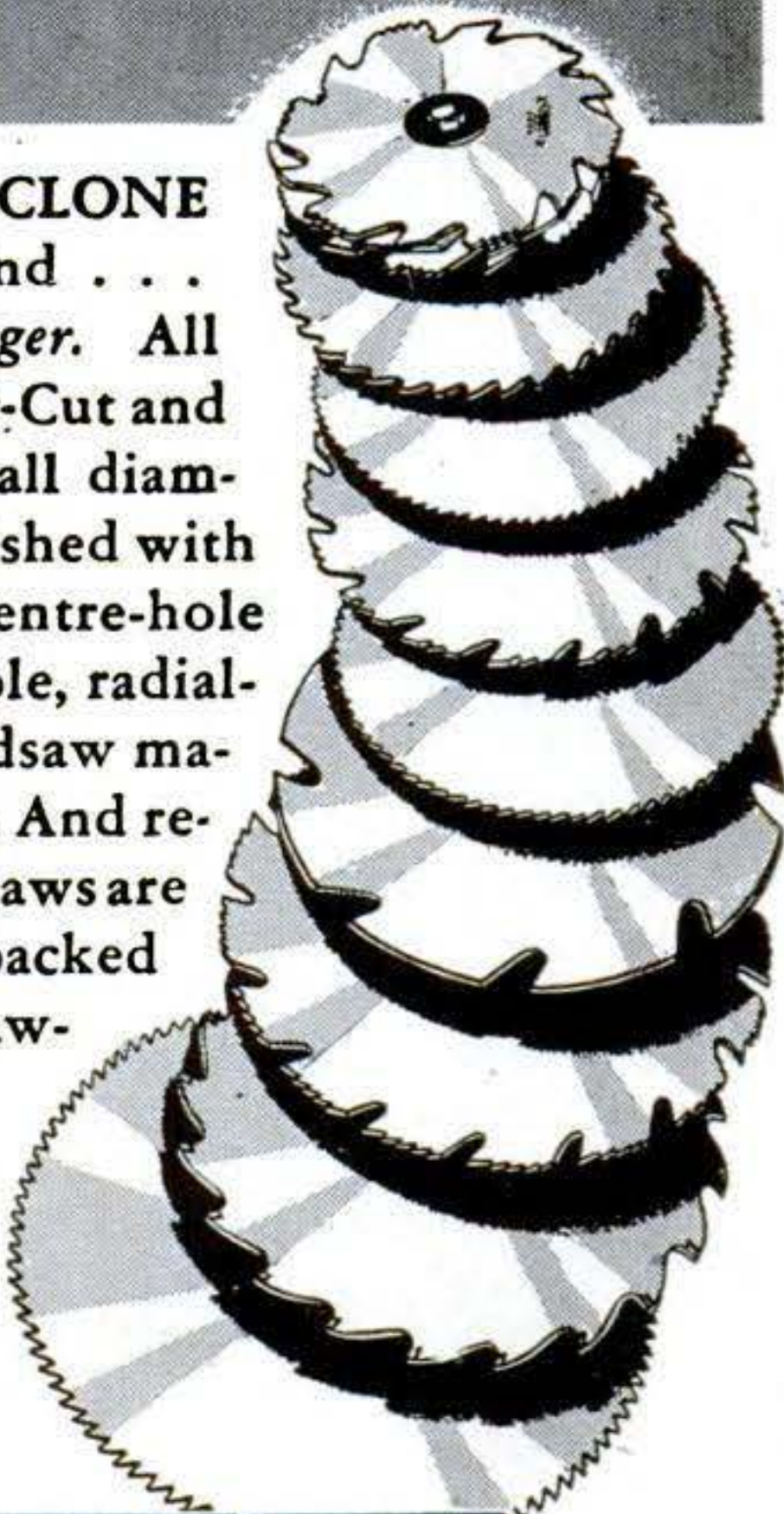

SIMONDS
SAW AND STEEL CO.

FITCHBURG, MASS.

Factory Branches in Boston, Chicago, San Francisco and
Portland, Ore. Canadian Factory in Montreal, Que.

How Your Shape Shapes Your Life

[Continued from page 230]

set of muscles has an advantage not only in engineering but also in science and business. Muscles are not so important, however, for lawyers, government officials, clergymen or artists.

During World War II, Dr. Sheldon studied pilots in the Army Air Forces and found that those who did best were mostly muscle men. He compared 200 high-ranking graduate fliers with 200 men who washed out early in primary training. He found that 76 percent of the successful group, but only 28 percent of the failures, were muscle men. In comparison, muscle men on a typical college campus make up only 38.5 percent of the male students.

The successful general, businessman or politician, according to Dr. Sheldon, is most often a man who has plenty of courage and is low in inhibitions—a muscle man, with a minimum of nerves. A fatty can try to sell hardware, but he'll probably accomplish more in the restaurant or entertainment fields. A muscle man may do fairly well as a civil servant, but he'll be likely to do better in professional sports or in the armed forces. A nervous type may be adequate as a general medical practitioner, but the chances are he'll be more than adequate as a research man.

Science from Common Sense

What is the basic significance of Dr. Sheldon's work? "Up to the present," says Aldous Huxley, well known British writer, "all the systems in terms of which men have attempted to think about human differences have been unsatisfactory." Each of these systems has suffered from one or more major defects: it has considered mind apart from body or vice versa; it has ignored exact measurement; it has had no significant relationship to everyday human behavior. Against this, Dr. Sheldon's work stands out, as Huxley says, as "a classification system more adequate to the facts and more potentially fruitful than any devised hitherto."

Dr. Sheldon and his coworkers thus have fashioned, in a quarter of a century of measuring how people look and how they act, a scientific tool for applying what is good common sense: That the man most likely to succeed is the one who picks a career which emphasizes his strong points and minimizes his weak ones.

END



GET SET
for Summer!

Install—

AMERICA'S FAVORITE
CHAMPION
SPARK PLUGS

These Great Laboratory



PETROCHEMICALS offer independent inventors great opportunity. Such synthetics as Nylon, Vinylite, Neolite are already indispensable to our expand-

ing economy—and new ideas in this area are at a premium today. If you have such an idea, the Sinclair Plan may help you develop it.

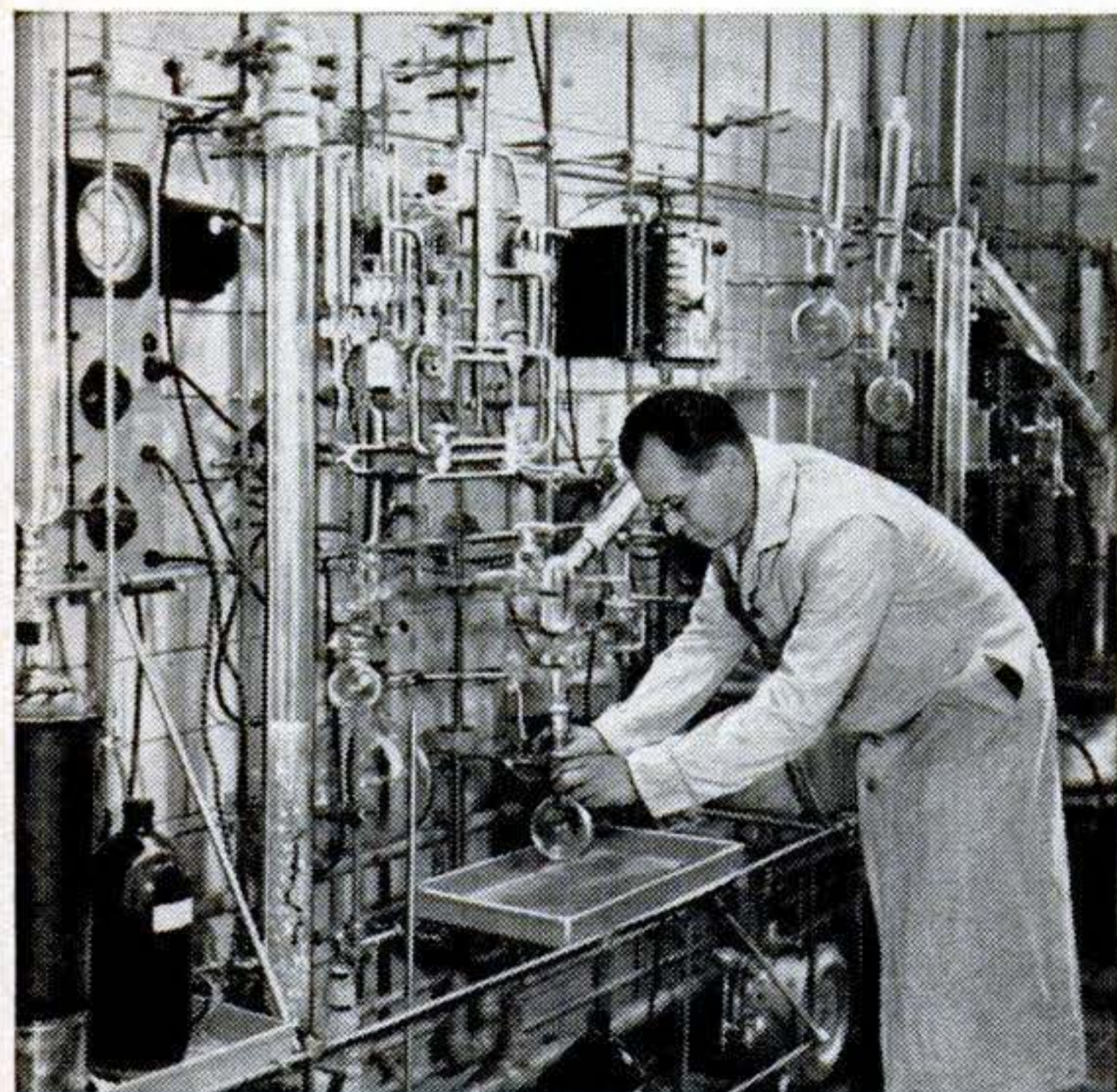

UNDER THE SINCLAIR PLAN, chemistry laboratories like these are now open to independent inventors.

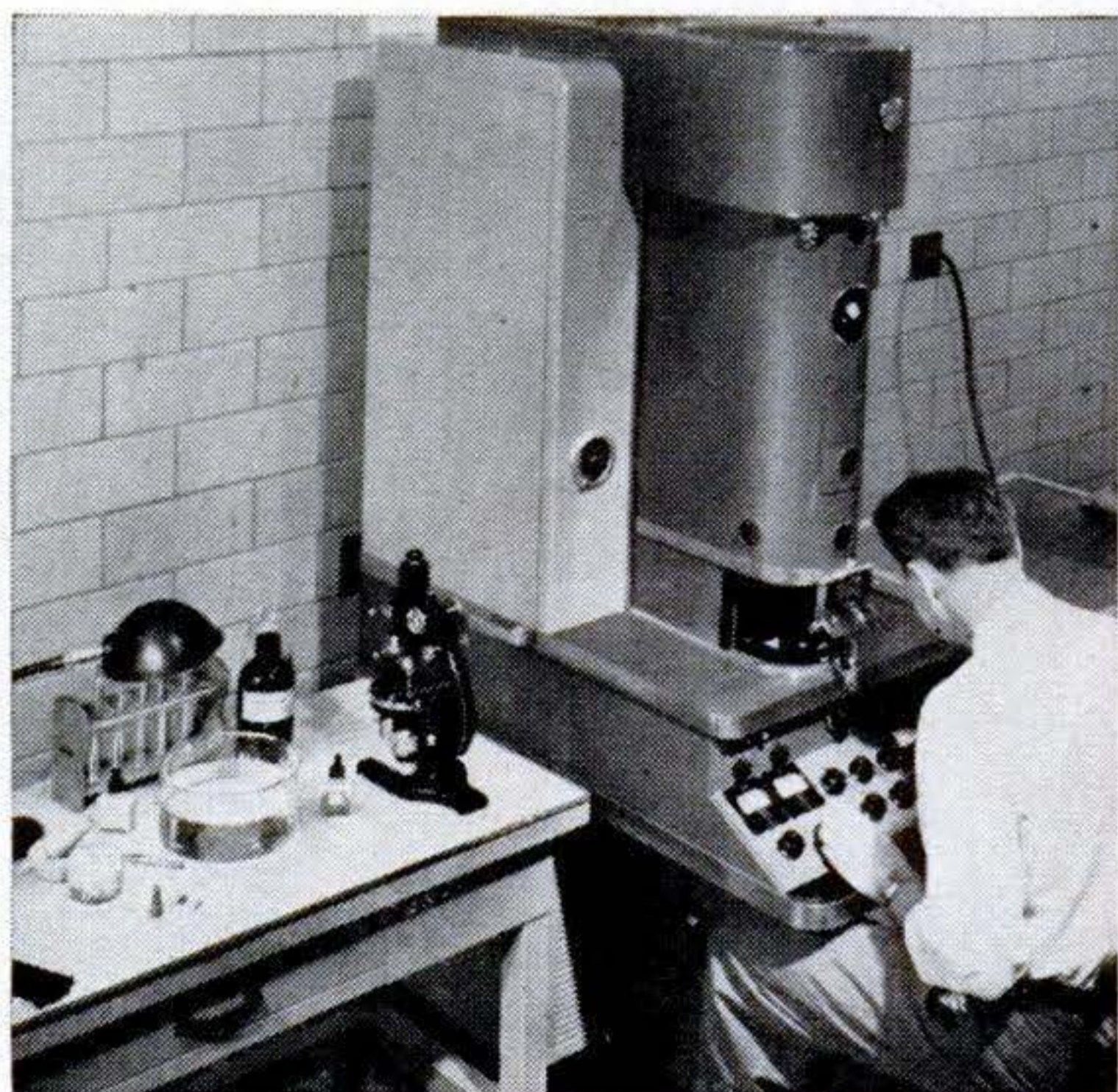

ELECTRON MICROSCOPE, capable of magnifying 100,000 times, is typical of the equipment available.

Facilities Are Open to You

Many inventive people have responded to the Sinclair Plan's offer of laboratory facilities—to others who wish to do so, a suggestion: There is promise and profit in oil-based synthetics.

EIGHT months ago, Sinclair turned over a part of its great laboratories at Harvey, Illinois, to independent inventors who had promising ideas in the field of petroleum products but who did not have the facilities needed to develop or prove out their ideas.

To date nearly 5,000 people have submitted ideas to the laboratories, and the Plan is recognized as a valuable service to independent inventors. As a result we have made the Sinclair Plan part and parcel of the long-range operation of our company.

There may be inventive people interested in this Plan but wondering what sort of ideas or what areas would be profitable to explore. *To those people we suggest the field of petrochemicals. Such things as plastics, synthetics and new materials made from petroleum offer great opportunities for invention and reward.*

If you have an idea of this sort—or in the general area of petroleum products or applications—you are invited to submit it to the Sinclair Research Laboratories. In your own interest,

each idea must first be protected by a patent application or a patent.

The inventor's idea remains his own property

If the laboratories select your idea, they will make a very simple arrangement with you: In return for the laboratories' work, Sinclair will receive the privilege of using the idea for its own companies, free from royalties.

This agreement in no way hinders the inventor from selling his idea to any of the hundreds of other oil companies for whatever he can get. Sinclair has *no control* over the inventor's sale of his idea to others, and has *no participation* in any of the inventor's profits.

HOW TO PARTICIPATE: Instructions are contained in an Inventor's Booklet available on request. Write to: W. M. Flowers, Executive Vice-President, Sinclair Research Laboratories, Inc., 600 Fifth Avenue, New York 20, N. Y.

IMPORTANT: *Please do not send in any ideas until you have sent for and received the instructions.*

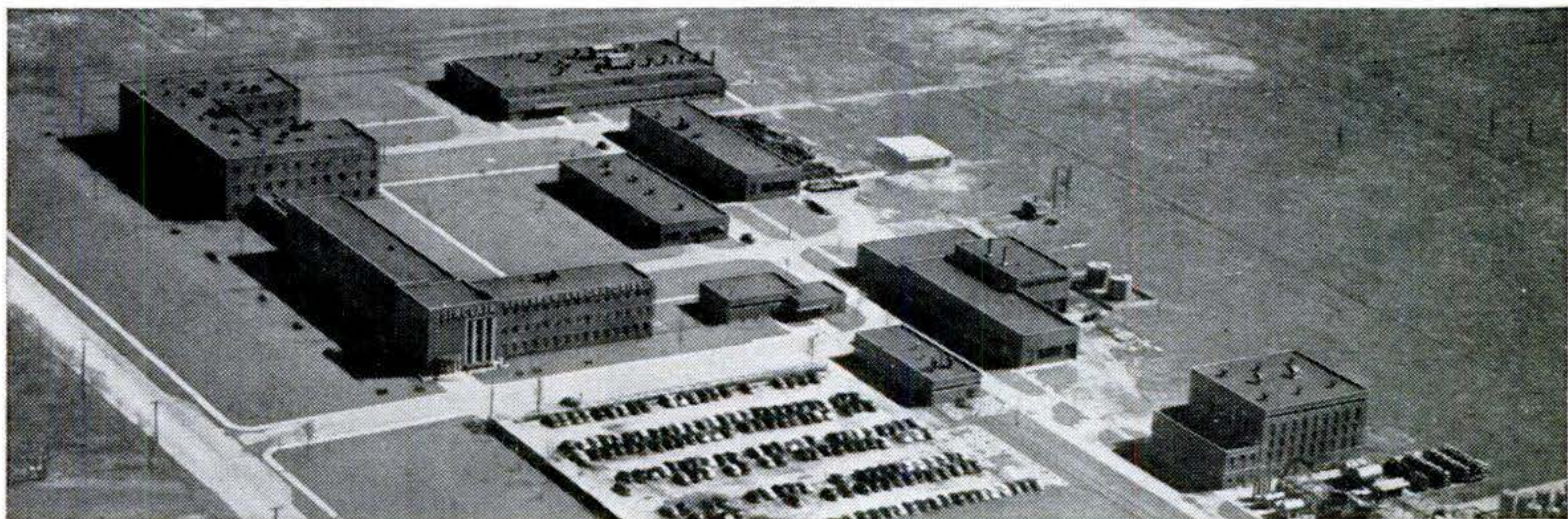

SINCLAIR RESEARCH LABORATORIES—nine buildings containing the most modern testing equipment known—have contributed many of today's most important

developments in petroleum. Under the Sinclair Plan, part of these laboratories is available to work on the promising ideas of independent inventors.

SINCLAIR—for Progress

MONEY MAKER FOR MOTOR MECHANICS

CYLINDER GAGE No. 452-B

Automatic centering, rigid-toggle handle, locking mechanism.

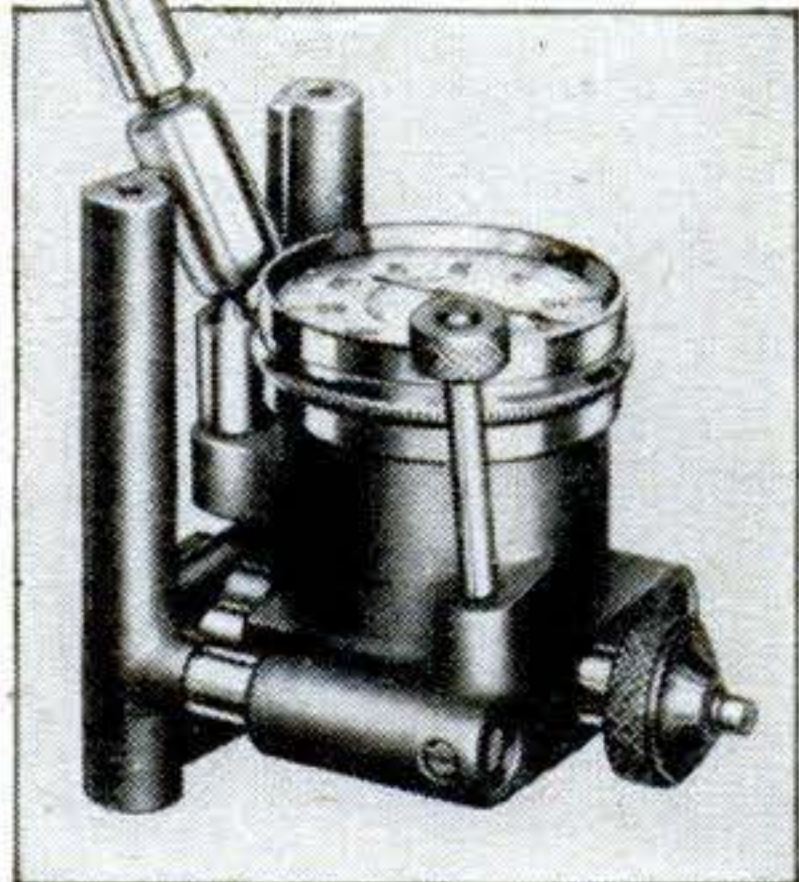

Starrett Cylinder Gage No. 452-B checks cylinders for taper or out of round — gives the whole story on cylinder condition in thousandths of an inch. It is one of a complete line of Starrett Precision Tools designed for better, faster, *more profitable* automotive, aviation, marine and farm equipment maintenance. See them at your Starrett Tool Distributor's.



Ignition Spacing Gage No. 571

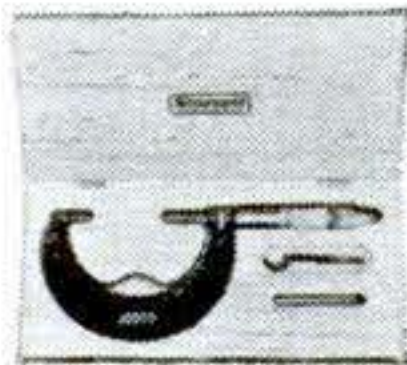

Crankshaft Micrometer No. 436



Out-Of-Roundness Gage No. 681

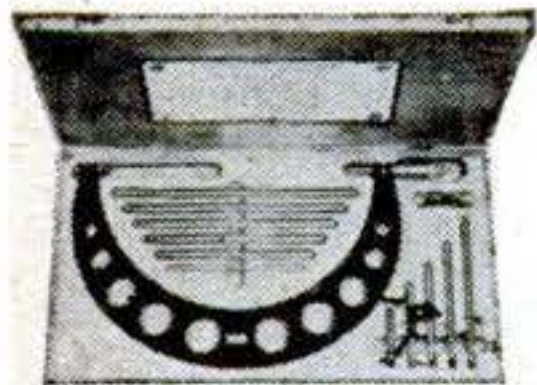

Micrometer No. 224 With Interchangeable Anvils

SEND FOR IT — IT'S FREE

Starrett Automotive Tools Catalog A

42 pages of helpful service hints plus description of the complete Starrett line of precision tools for better, more profitable servicing. Write today. Address Dept. PS



THE L. S. STARRETT COMPANY • ATHOL, MASS., U.S.A.



TRADE MARK
Starrett
REG. U.S. PAT. OFF.

SINCE 1880
WORLD'S GREATEST TOOLMAKERS

BUY THROUGH YOUR DISTRIBUTOR MECHANICS' HAND MEASURING TOOLS AND PRECISION INSTRUMENTS • DIAL INDICATORS • STEEL TAPES • PRECISION GROUND FLAT STOCK • HACKSAWS, BAND SAWS and BAND KNIVES

Down the Alaska Highway on a Scooter

[Continued from page 124]

His sleeping bag zipped up so that only his mouth, his nose, his eyes and part of his cheeks were not covered. He usually slept straight through, from dark till seven or eight a.m. when the sun would be high in the sky. Then he would roll up the bag, lash it on the scooter and start off again.

Some animals that he saw—moose, foxes and such—broke the loneliness. Others that he did not see he thinks were watching him all the time, day and night. "Whether you see them or not," he says, "they're there."

Alaskan Bears Are Fast

He feared two animals: "A bear with cubs or a cow moose with a yearling. These are vicious." He was out in the open on the scooter, not protected by a steel automobile body. He carried no weapon. He did not think he could outrun bears on the scooter because he had heard that Alaskan bears have been clocked at 40 miles an hour.

Bulstrode got to the southern end of the Alaska Highway, at Dawson Creek, B.C., 1,523 miles from Fairbanks, on August 14, after 12 days of travel that averaged 126 miles a day. He had become the first man to ride the Highway on a scooter. He was sure of it because the natives along the road obviously had never seen a scooter before. He had proved the ruggedness of his tiny vehicle.

Hard-Surface Road at Last

He had not had a flat tire. He had thrown the chain on his scooter several times when rocks got caught under it, but he had had no engine trouble. "I kept it well oiled and greased."

Although Dawson Creek was the end of the Alaska Highway, more miles of dirt road were ahead. Twenty miles north of Edmonton, Alberta, he at last reached hard-surface road—the first he had seen. "I was happy," he says. "I sat on that scooter crosswise. I could ride it any way. I no longer had to lash myself to it."

He entered the United States at Sweetgrass, Mont. He was now about four weeks from Fairbanks and his beard had grown. It had helped keep his face warm, but it had not kept his face from being chewed up by the dirt and gravel and wind.

There was another untoward develop-

[Continued on page 238]

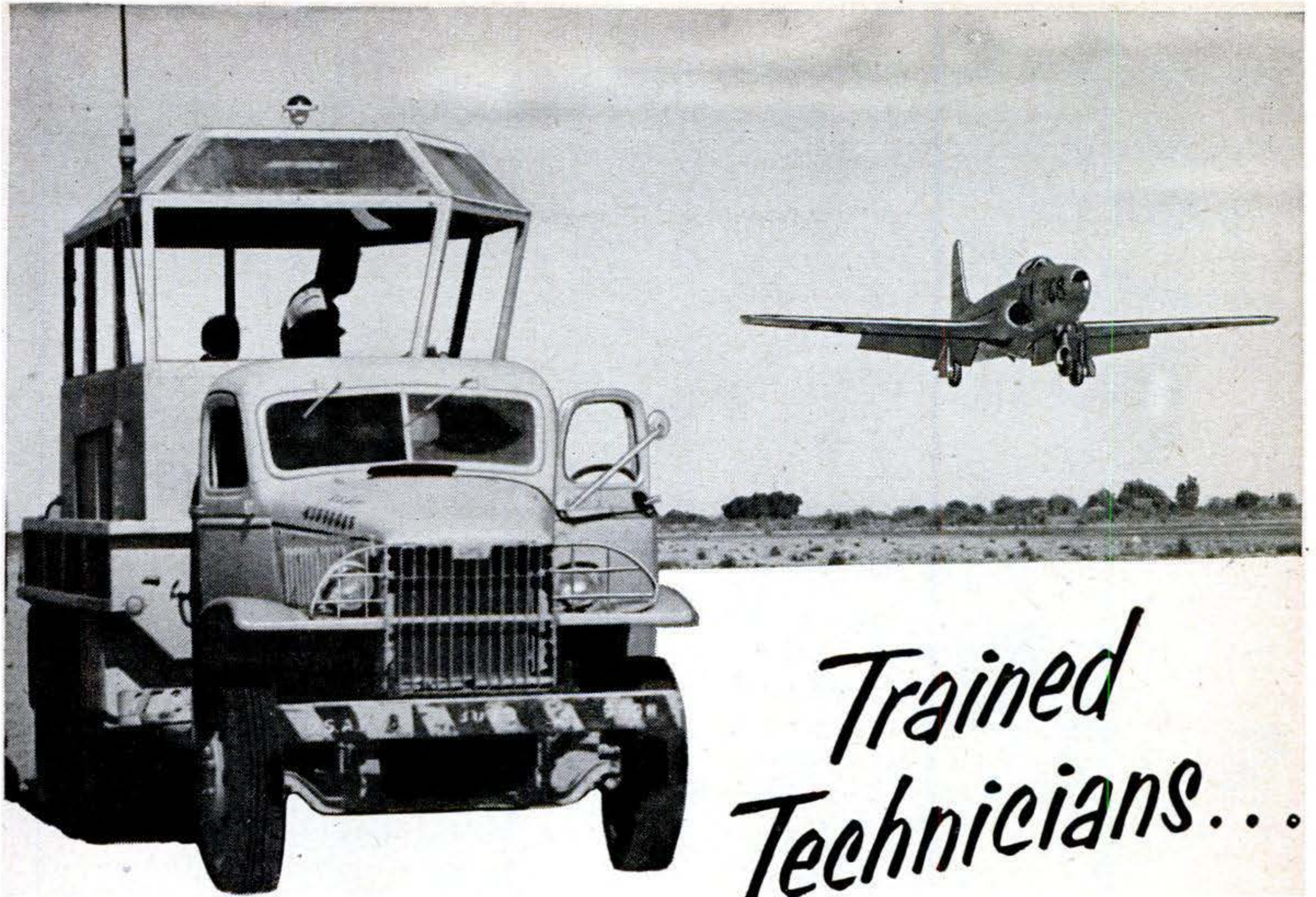

Trained Technicians...

ARE CLEARED TO COME IN!

Special skills expertly maintain the global operations of our expanding United States Air Force. It is special skills of trained craftsmen, behind the flying skills, that keep our modern air power aloft to defend our nation.

Men with training as former specialists in any Service . . . or non-veterans with special technical talents . . . are needed *now* to support our ever-growing air might. Radio, radar and other communications specialists, weather, armament, automotive maintenance, medical technicians and many technical skills are urgently needed . . . now . . . today!

For your specialized "know-how," your

Air Force offers greater opportunities for advancement, security and a rewarding sense of an important job well done.

Here, briefly is the story: If qualified, you can enter the Air Force in an attractive grade, according to your present ability. The Air Force will tell you exactly what your initial rank and pay grade will be before you join-up. Veterans, if qualified, enter in their old grade or better and will skip basic training and be assigned initially to a nearby Air Force Base.

For the rest of the story in detail, consult your local U. S. Army-U. S. Air Force Recruiting Station immediately, or *mail coupon today!*

MAIL COUPON TODAY for Full Information

AIRMAN PROCUREMENT
Headquarters, U. S. Air Force
Washington 25, D. C.

Please send me details about U. S. Air Force specialists.

NAME _____
ADDRESS _____
CITY _____ ZONE _____ STATE _____
SPECIALTY _____

U.S. AIR FORCE

**Extra Power...
Extra Speed...
EXTRA HANDY FOR
HOME JOBS!**



BLACK & DECKER
Utility
5" Sander-Polisher
only **\$32.95**
(including useful accessories.)

**It drills, sands, polishes, grinds,
sharpens, buffs, burnishes, cleans!**

THIS Black & Decker Tool has extra power to handle heavier-duty drilling in wood, metal, masonry and plastics . . . a 3000 R. P. M. spindle speed that pays off in faster, smoother sanding . . . and unmatched versatility for driving a whole raft of other attachments! Comes complete with 1/4" Jacobs drill chuck, sanding discs, lambswool bonnet, auto polish and wax. Compact, perfectly balanced, weighs only 3 1/2 lbs., operates on AC or DC, quality-built for years of service.

Try it yourself today at your hardware, appliance or department store. Write for free catalog to: **THE BLACK & DECKER MFG. CO., Dept. H5S, Towson 4, Md.**

B&D SANDER-POLISHER KIT (\$49.95)

Has everything for home jobs—in a handy steel carrying case you can take to the job! Accessories listed above, plus 7 high-speed bits, 4 wood augers, countersink!



Black & Decker

UTILITY TOOLS

**PORTABLE
ELECTRIC
TOOLS**

1/4"-1/2" DRILLS • SANDER-POLISHERS • SAWS

Down the Alaska Highway on a Scooter
[Continued from page 236]

ment. The beard provided a warm home for insects that got caught in it. The most common insects in his beard, he says, were called *no-see-ums*, a bug you cannot see individually because there are so many of them. They bit. Mosquitoes also cuddled up in his beard.

Visit from a Rattlesnake

At Havre, Mont., he went to see a barber about his beard. The barber used clippers and then, with special attention to the torn-up condition of Bulstrode's face, shaved it off. His dark hair, because he could never keep a hat on, had turned straw-colored.

In North Dakota one night a rattlesnake slithered along his sleeping bag. One morning—again in North Dakota, and again in the sleeping bag—something struck him in the middle of the forehead. He thought it was a rattler and was disconcerted when he realized he couldn't suck the blood from a wound in the middle of his forehead. He cut the wound open, and squeezed it like fury. Then he saw a big bee. He thinks it was the bee that stung him.

Speed on the Homestretch

On concrete U.S. highways he got the scooter up to 55 miles an hour—his top speed. Now he sometimes rode at night. He rolled on across South Dakota, Nebraska, Iowa, Illinois, Indiana, Ohio, the peak of West Virginia, Pennsylvania, New Jersey, then into New York.

Despite his speed on these roads, it took him more than six weeks to get to Long Island from Fairbanks. His brother, who had left Fairbanks by car a day ahead of him, had arrived home four weeks earlier.

Bulstrode says he didn't feel tired from the six weeks of scootering when he got home. He did, however, find it pleasant to sit quietly around the house for two weeks.

END

Next Month. Huck Finn wouldn't know the Mississippi now, with radar-eyed Diesel tow-boats plying the stern-wheelers' routes.

Eat Appetizer Last!

You should have an appetizer toward the end of a meal instead of at the beginning, according to flavor expert Ernest C. Crocker. It's then that the taste buds begin to tire and need added stimulation.

GOOD-BYE TO THIS COST!..GOOD-BYE TO THIS WORRY!..GOOD-BYE TO THIS DANGER!



1 Paying Out \$10 to \$30 A Month for "little" engine repairs? Burning up dollars — in gas and oil? Then you're *paying* for a WIZARD-IZED Engine.



2 Afraid To Take Your Car out for fear the engine will "conk-out"? Put your money in a WIZARD-IZED Engine — not in towing and repair bills!



3 Engine Too Sluggish And "Old" to provide the power to pass other cars safely? Your repair money could pay for your WIZARD-IZED Engine!

Now You Can **"NEW-ENGINE"** Your Car For About The Price Of An Overhaul!

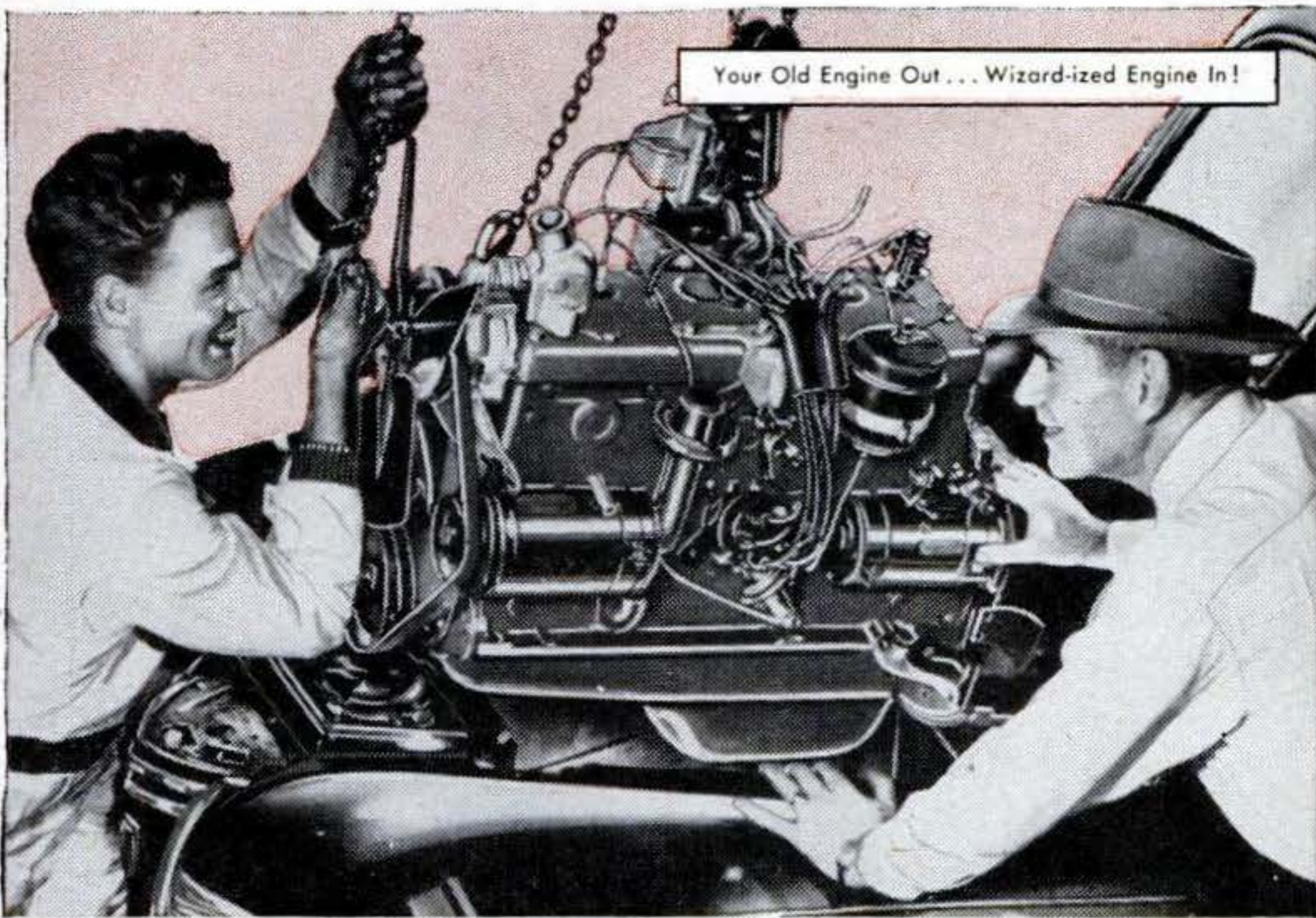

Instead of merely overhauling, "new-engine" your car this easy WIZARDIZED way — for about what you'd pay for an overhaul. Expert installation by trained me-

chanics in fully-equipped garages. And your old engine is worth a generous **guaranteed** trade-in allowance. See your Western Auto man — now!

And A Factory Remanufactured **Wizard-ized Engine** Has A New Engine Guarantee!

That's right! Why pay \$150 to \$180 for a bearing-ring-and-rebore overhaul, and have all the other "tired" old parts left in your engine?—when the same money can buy you a completely remanufactured Wizardized Engine? Why take 10,000 to 15,000 engine miles for your money—when you can get up to 50,000 miles or more.

Here's what we mean by remanufactured: It is not just your old engine, overhauled and put into your car! Your Wizardized Engine is precision remanufactured, using original factory block, in one of five large factories that handle no other work. Every part meets new-engine tolerances.

Every moving part is brand new or fully remanufactured to function like original equipment.

NEW CAR ENGINE GUARANTEE—backed by Western Auto, the most trusted name in auto parts—plus free 500-mile inspection!

SO BEFORE YOU BUY any overhaul, see how much more you get in a Wizardized Engine!

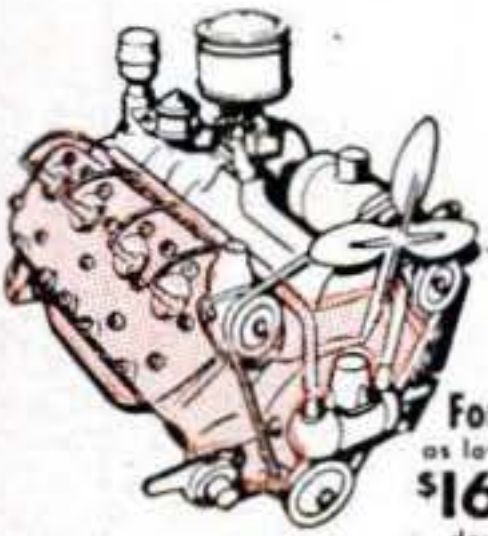

Ford
as low as
\$16⁰⁰
down

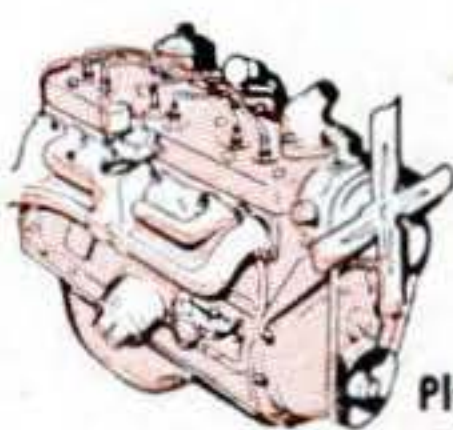

Plymouth
as low as
\$17⁰⁰
down

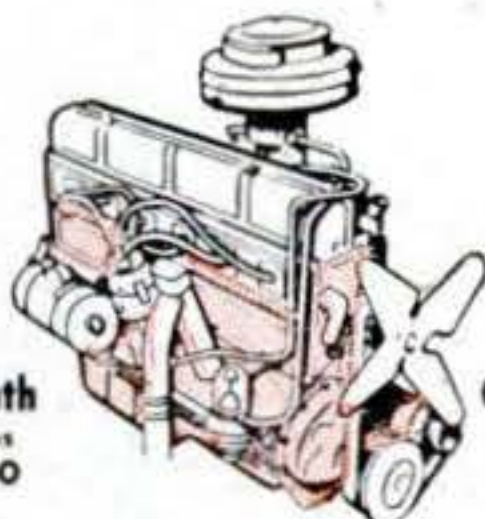

Chevrolet
as low as
\$14⁰⁰
down



For location of your nearest Western Auto Store, write WESTERN AUTO SUPPLY CO., 2107 Grand, Kansas City, Mo. © 1952

Wizard-ized Engines

FACTORY REMANUFACTURED

The Engine You Can Buy with New Car Confidence!

Sold Only By **WESTERN AUTO** STORES & ASSOCIATE STORES

NOTE: Western Auto Associate Dealers own their own stores and set their own prices, terms and conditions. Prices may vary due to differences in local conditions. (PS52)

There is **ONE**
SURE, SAFE Way
 to repair an innertube



BOWES *Chemical* **PROCESS** **TUBE REPAIR METHOD**

• There are other methods of tube repair . . . the "cold patch" . . . the "vulcanized patch" . . . and . . . in most cases they work—but

**If You Want the ONE SAFE,
 SURE METHOD . . . Drive In
 Where You See BOWES
 This Emblem . . .**



• When you go to a station that displays the BOWES emblem, you are assured of *Sure, Safe* Tube repairs by the BOWES Chemical Process tube repair method.

Don't take chances . . . look for the BOWES emblem and be **SURE** of **SAFE** tire repairs.

BOWES "SEAL FAST" CORP., INDIANAPOLIS 7, IND.

240 POPULAR SCIENCE

Gus Diagnoses the Flat-Tire Case

[Continued from page 180]

volved—the right rear and your spare, which you've switched back and forth each time you've gotten a flat."

"That's right."

For a few minutes Gus just stood there sucking on his pipe.

"Well," Barnstable snorted impatiently, "if you've no more bright ideas I'll be on my way and you can bet that little Rodgers scamp will have to answer for his pranks."

"Hold it a minute, Silas. About these valve caps of yours. You've only got four?"

"Yep."

Gus reached down and unscrewed the cap on the right rear tire. "Where'd you buy this cap?"

"Well—uh—" Barnstable hesitated, embarrassed. "I didn't."

"What do you mean, you didn't?"

"Well, I just happened to see some old valve caps in that junk box of yours a few days ago and I borrowed a couple."

For the next few moments Gus couldn't talk, he was laughing so hard. "Well, you borrowed yourself three flat tires in the bargain," he came out finally, still chuckling. "Take a look." There, wedged in the top of the valve cap was a small lock washer.

Silas Swallows His Pride

"You just happened to 'borrow' a valve cap that just happened to have a lock washer jammed up in it. Every time you put it on a tire valve, the washer pushed the valve stem down a bit and prevented you from screwing the cap down more than a couple of threads. The combination of a slow valve leak and a cap that wasn't screwed on tight added up to flat tires."

"Humph," grunted Barnstable, staring fixedly at the ground. "Guess maybe I owe you an apology and—" he swallowed audibly, "a little something for your time."

"Forget the apologies and the money," said Gus cheerfully, digging the lock washer out of the valve cap with his screwdriver and handing the cap back to Barnstable. "But I think it might be a good idea if you stopped in town and bought young Dick Rodgers a new baseball. I noticed this morning that the one he has is kind of beat up . . . And Silas," Gus warned, "no bargains this time—get the boy a good one." **END**

Next Month: Gus cures the mysterious cough afflicting a European road-racer.

Get the most for your money

INSTALL YOUR OWN KENTILE FLOOR



Only **\$19.95***
and you can have a
KENTILE FLOOR
like this!

HERE'S America's most popular floor-covering for homeowner installation... low-cost, easy-to-lay, long-wearing. Dirt and stain-resistant... gleams like new with occasional, no-rub waxings. Don't make the mistake of buying floor-coverings with just a colored surface that wears off with use. Kentile's 26 wear-proof colors go right through each tile—its durability is assured by this written guarantee. (If you prefer, your Kentile Dealer will install your floor.)

Only Kentile Dealers offer you these low-priced Guaranteed Kentile Floors

*Price quoted is for a Kentile Floor approximately 9' x 10' installed by you. Your Kentile Floor may cost less or slightly more, depending on size of room, colors and freight rates. See your local Kentile Dealer... he's listed in the classified phone directory under FLOORS. *In Canada, T. Eaton Co., Ltd.*

Write for your FREE Kentile Color Book showing all the colors of low-cost Kentile and easy-to-follow instruction booklet

KENTILE, INC., 58 2nd Ave., Dept. H-7, B'klyn 15, N. Y.

Mrs. William A. Loock Jr. shows you how easy it is to install long-lasting Kentile

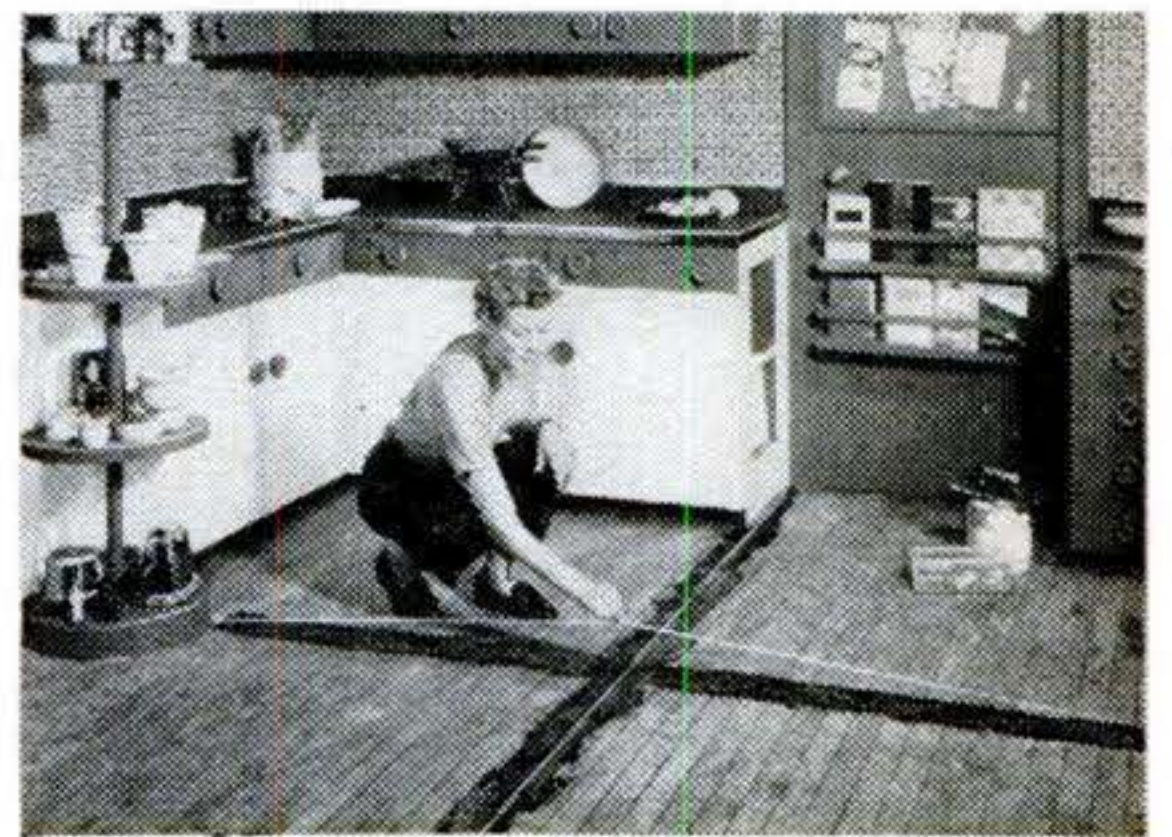

Here Mrs. Loock is finding the center of the floor. Next, she'll spread Kentile Adhesive over half the floor before laying the tiles in place.



With half the floor installed, Mrs. Loock spreads Kentile Adhesive to cover remaining half. Then it's simply a matter of putting tiles in place until entire floor is completed.

KENTILE

GUARANTEE

FOR SELF-INSTALLED KENTILE

Kentile, Inc. will provide new tile without charge for any Kentile that wears out... and on which colors wear off... during your own occupancy of your home wherein you have installed Kentile. This guarantee does not apply to damage caused by improper handling, or failure to follow the instructions for installation and maintenance available at your Kentile dealer's.

KENTILE®

The Asphalt Tile of Enduring Beauty

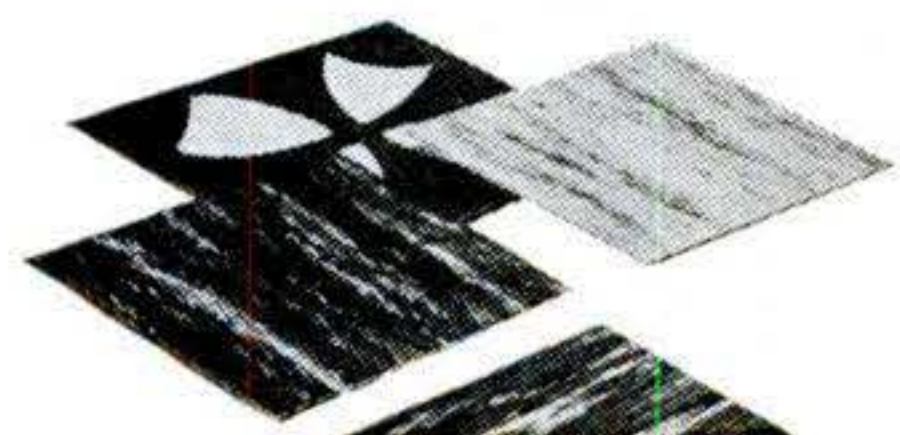

**Make
Fancy Cuts**

**Like an
Expert!**



PORTER-CABLE
Guild

ROUTER

only **\$49.50**

**Do Coving • Veining • Dadoing • Fluting • Rabbeting
Inlaying • Beading • Dovetailing • Make Cut-
Outs • Raised Decorations • Molding • Relief Work**

Now—make all the fancy cuts required in furniture, cabinet, built-in and molding making. Portable Guild Router is a professional tool priced for the home craftsman. Used extensively in woodworking shops because of its sturdy construction, extraordinary speed, hairline accuracy.

All these advanced features:

Depth adjustment from $\frac{1}{64}$ " to 1" • Exclusive True-Spin chuck, $\frac{1}{4}$ " capacity • Extra heavy thrust bearings • High polish, die-cast aluminum housing and base • INTERCHANGEABLE MOTOR . . . 20,000 RPM motor also powers Guild Plane and Shaper.

**Save \$89.50
on this Tool Trio!**

Start with the Guild Router complete with base and interchangeable motor for \$49.50. Unit becomes a high speed Electric Plane by adding Plane Attachment for only \$25.00. Then an accurate Shaper by adding Shaper Table for only \$24.00. You get all 3 tools for \$98.50—eliminate the cost of 2 motors—and SAVE \$89.50 on this great combination!



See your Guild Dealer — or
mail coupon for full details.

PORTER-CABLE MACHINE CO.
6185 N. Salina St., Syracuse 8, N. Y.

Please send me complete information on Guild Router, Plane and Shaper . . . also name of nearest dealer.

Name

Address

City Zone State

In Canada, write: Strongridge, Ltd., London, Ont.

What Will They Think of Next?

[Continued from page 84]

ences, physiological sensitivity over various parts of the body, musical sense, Rorschach testing, artistic sense, speed of various perceptions, physical contour, ethical sense—and perhaps a hundred other vital questions and tests.

Compatibility to Be Determined

In addition to the questionnaire, the couple will undergo certain "linked" tests in close physical contact with each other, such as holding hands and kissing. This is an important test. There is a definite electric relationship between compatible and incompatible subjects, particularly between male and female individuals.

If the prospective marriage candidates have undergone all the necessary tests, the result will be added to the general questionnaire. All this information will then be transcribed by machine on special large punched cards. The prepared male and female cards will now be fed into a suitable electronic calculator—the so-called electronic brain—which will give the result in a matter of minutes.

Furniture May Have Heating Elements

Another advantage the future should bring is heat-conditioned furniture, in place of our present steam heat in the winter and air-conditioning in the summer.

There will be two different sets of electric elements in the furniture, one for heating, the other—an entirely different one—for cooling. The furniture will be cooled by the Peltier effect, discovered by that French researcher in the early 1800s. He observed that if a direct electric current is sent through a metal rod composed of bismuth and antimony, in the direction of bismuth to antimony, the point at which the two metals touch can be cooled below the freezing point. Thermostats on the furniture will enable the user to select the amount of cooling that suits him.

Finally, I predict that shortly we will have multiple-screen television sets. With a three-way screen people can group and disperse about a room in a normal manner rather than cluster like a swarm of bees.

The new type of set can consist either of three television image tubes, which is the more expensive way, or a single high-intensity television projector tube, already on the market, in conjunction with a three-way optical system. **END**

Light Weight—only 73 pounds. The gas tank's built in, no extras to carry.

Proved Full Jeweled* Power Head—the same basic "Super 10" Hurricane powerhead that set the whole outboard industry on its ear . . . that outperforms engines of two and three times its rated horsepower.

Reverse Gear and Neutral—engineered right for outboard use. The shift lever's up front where it should be.

Twist Grip Synchronized Spark and Throttle with new longer steering handle for ease of control.

New "Power-Thrust" Lower Unit—for more efficiency with heavy loads. Unicast one piece gear housing keeps lubricant in—water out.

Plus—all the famous features that make every Mercury the leader in its class by a nautical mile. See your Mercury dealer for a demonstration.



The outboard that has everything—does everything!

move up
to the new
KIEKHAEFER
**MERCURY
CRUISER**

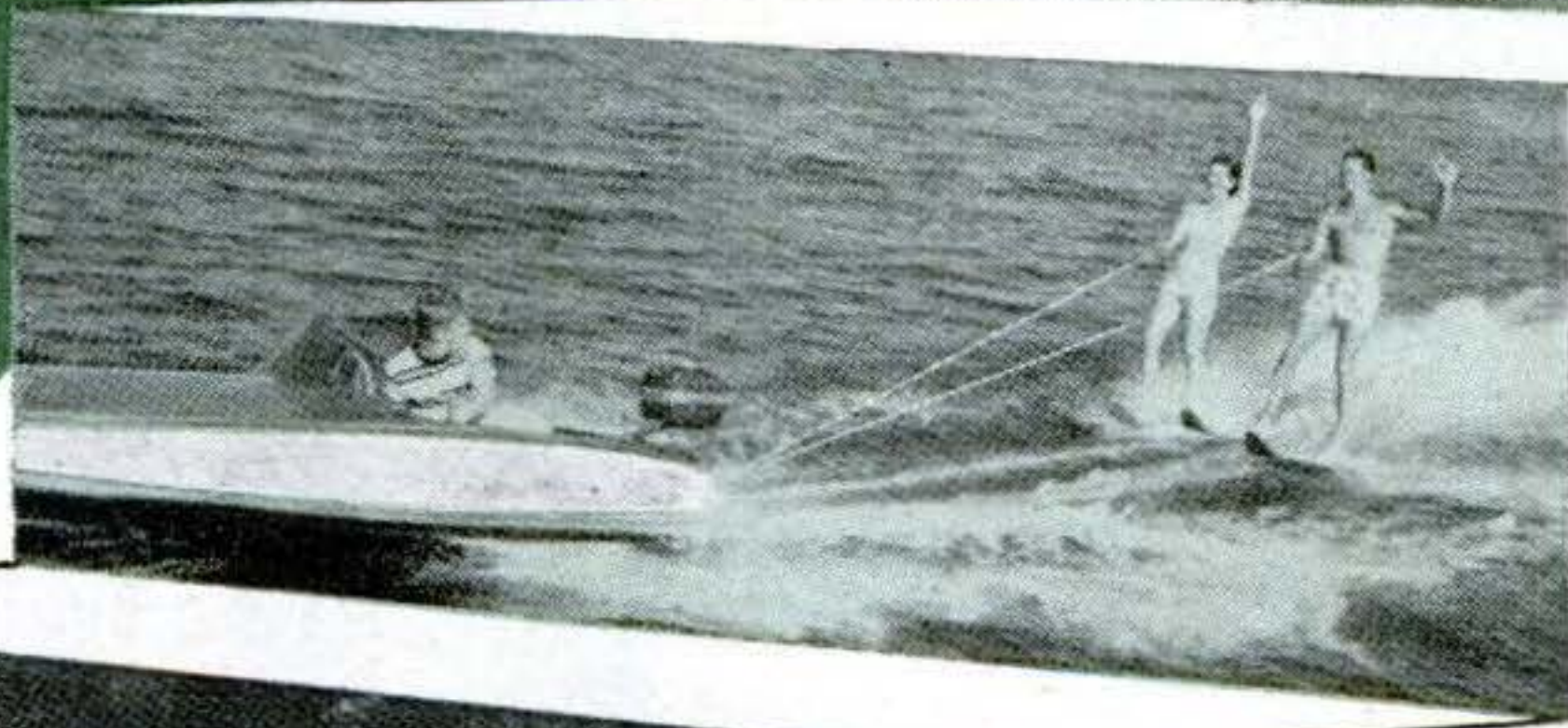

performance! Now — take the whole family in a big boat at runabout speeds. Plenty of muscle to power cruisers and work boats but light enough for one man to handle.

water skiing — Power to spare — actually pulls two skiers up out of the water and over ski jump!

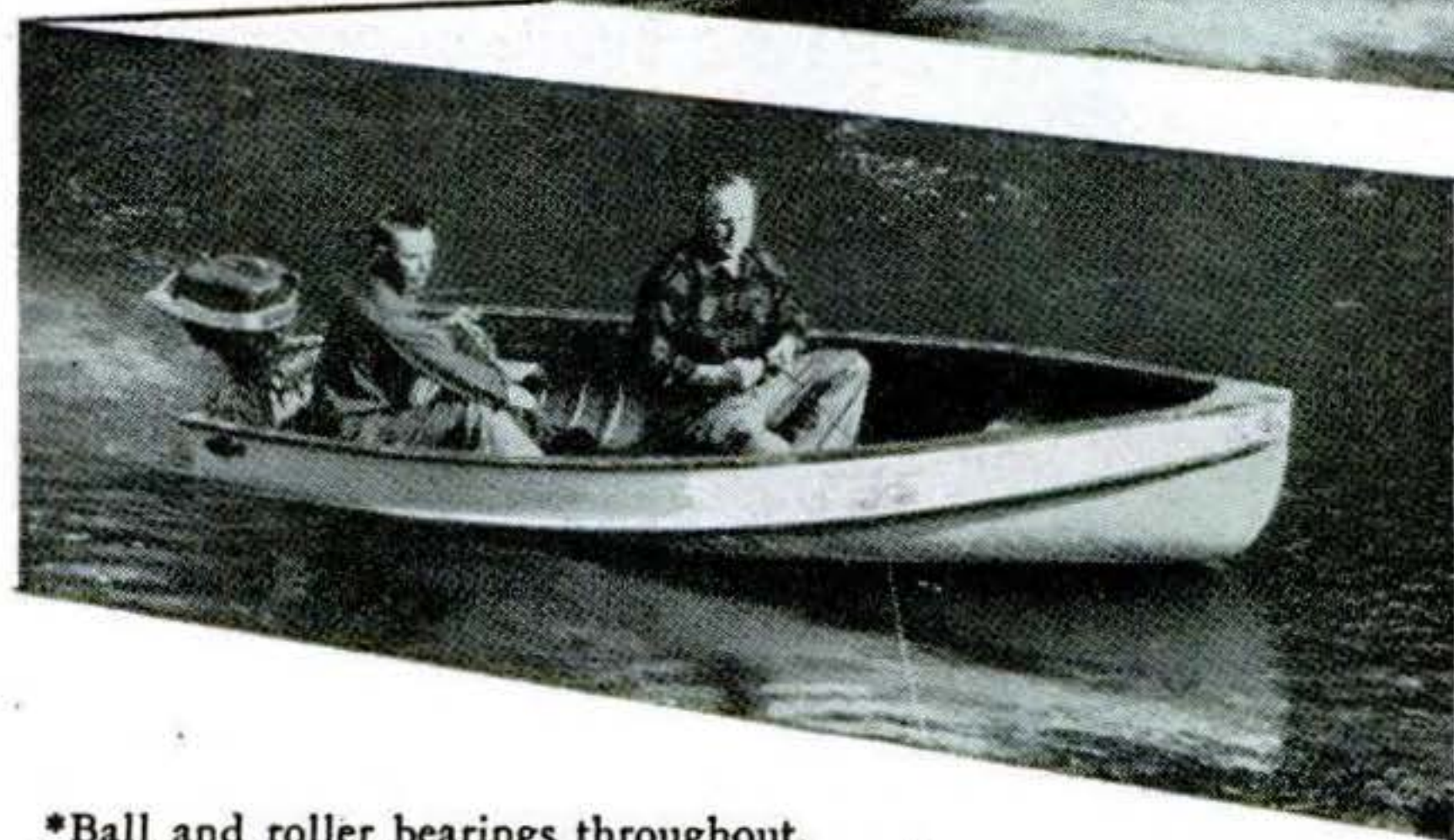

fishing — throttles down to a sweet slow troll but wings your party and gear home in a hurry.



Write for *free* illustrated catalogue "Move Up To A Mercury". Kiekhaefer Corporation, Fond du Lac, Wisconsin.

*Ball and roller bearings throughout. Features of Mercury Motors are protected by issued or pending patents.

*Do it Yourself
and Save!*

Assemble Your Own

BILT-WELL

Nu-Style Wood Cabinets



Your local Lumber Dealer will assist you in the purchase of Bilt-Well Cabinets.



Anyone can assemble Bilt-Well Cabinets as all parts are prefitted. Cabinets fit directly to wall surface.



You can decorate Nu-Style Cabinets any color. Re-decorate them anytime.

Why wait to buy what you can have now by doing the assembling, the installing and the decorating yourself? Bilt-Well Nu-Style Cabinets are completely machined, pre-fitted, and ready to put together. Don't wait until you "save up" for a new kitchen, do it yourself and save. Sold by leading Lumber Dealers.

CARR, ADAMS & COLLIER CO.
Dubuque, Iowa

CARR, ADAMS & COLLIER CO. Dept. S/2
Dubuque, Iowa

Please send me BILT-WELL cabinet booklet. Enclosed 25c to cover cost of mailing.

Name

Address

City

My Lumber Dealer is

City

Build Well
with



A PUSHOVER

for
driving-drawing
screws

It turns while you push—the "Yankee" No. 130A Spiral Ratchet Screw Driver speeds screws on their way—with ease. Quick-return spring holds blade in slot and returns handle after each stroke. See this and other handy "Yankee" tools on display at your dealer's. Write for "Yankee" Tool Book. North Bros. Mfg. Co., Dept. 5, 215 West Lehigh Ave., Philadelphia 33, Pa.



"YANKEE"
No. 130A
Spiral
Ratchet
Screw Driver

"YANKEE TOOLS
NOW PART OF



THE TOOL BOX
OF THE WORLD

NORTH BROS. MFG. CO., Philadelphia 33, Pa.

FREE! Plans Show How To Build A

POWER MOWER



Gasoline or Electric Type That
Pulls and Steers Itself!

Save time and work cutting grass and weeds—Build a whirl blade power mower, cheaply without special tools or equipment. Send postcard for FREE building plans.

For As Little As
\$1995

Whirl
Blade
Electric—slightly
more for gasoline
type

WRITE TODAY

T & H Mfg. Co., 811 E. 31 St., Dept. N150, Kansas City, Mo.

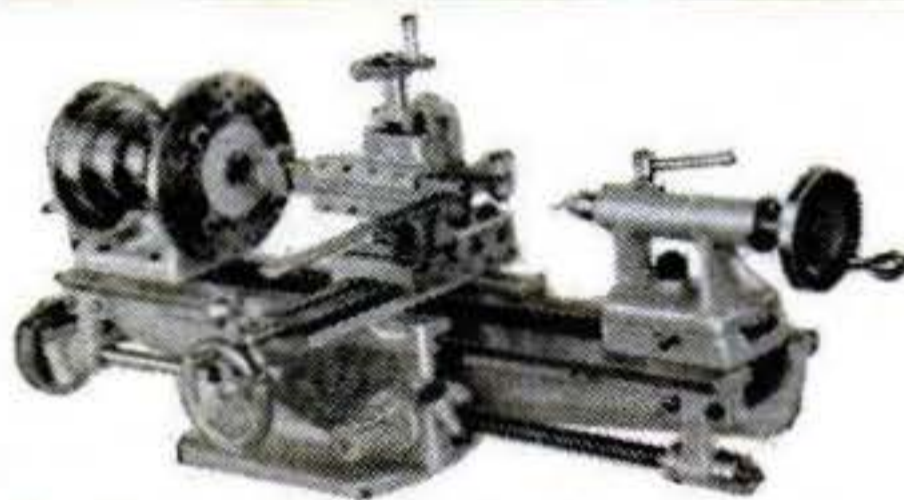

**BUILD
YOUR OWN
MACHINE TOOLS
CASTINGS-DRAWINGS**

Catalog with complete construction drawings of this 8 inch lathe with milling, grinding, shaper attachments, 25 cents postpaid, or send \$1 for drawings of three lathes, three milling machines and six inch crank shaper. Refund on castings order. **POOTATUCK CORPORATION, 104 Sammis Pl., Stratford, Conn.**



STOP BURNING OIL! RESTORE COMPRESSION!

Fisher's Compression SEAL

ONLY
\$395
PPD

Amazing Fisher's Compression SEAL will put new power & zip into your car. Because of friction, engines lose compression, become oil burners. A small amount of Fisher's Compression SEAL in each cylinder bore. Expands 30 times; restores compression, stops piston slap, and reduces oil consumption accordingly. Old, tired engines may not need expensive overhauling.

SATISFACTION GUARANTEED

If after having driven 400 miles, you are not completely satisfied with the new performance and oil savings obtained from Fisher's Compression SEAL, return the used tube for a full refund. \$25,000 indemnity insurance policy is your assurance that it will not harm the finest engine. Only \$3.95 postpaid. Write for free folder. Easily installed, send cash, check or money order today. Dealer Inquiries Invited.

ADVANCED ENGINEERING BOX 7013
Los Angeles 37, Calif. Dept. PS-5

GROBAN'S WAR SURPLUS SPECIALS!

PREPARE NOW ALL BRAND NEW • FULLY GUARANTEED IMMEDIATE DELIVERY
FOR SUMMER POWER SUPPLY • BRAND NEW • LARGE STOCK • MANY SIZES

GENERATING PLANTS

For COTTAGES • CAMPS • HOUSE TRAILERS • CONSTRUCTION • ROAD BUILDING, etc.
Plenty of emergency stand-by or general utility power from 350 watts to 25 KVA.



ITEM #183

WATT GENERATOR SET
Item #183 — 3000 to 4000
FEATURES—Power for your home or business. Simply connect to power panel or house circuit. • Constant voltage regardless of load. • Push button start or stop. • Easily made full automatic start or stop. **SPECIFICATIONS**—SIZES 19"x30"x48". Steel skids, weatherproof housing, requires no building. Wt. 725 lbs. • Hercules 4-cyl. 10 HP gasoline engine. Load governor. Oil filter. Quiet muffler. 6-volt starter, generator. • Hobart 115 volt, 60 cycle, 3,000 to 4,000-watt generator. Furnishes either single or three-phase power, 2 or 3 wire. • Panel contains oil gauge, voltmeter, ammeter, circuit breaker, voltage regulator, start button. Today's Cost Over \$1,200.00. SALE **465.00** PRICE F.O.B. Chicago

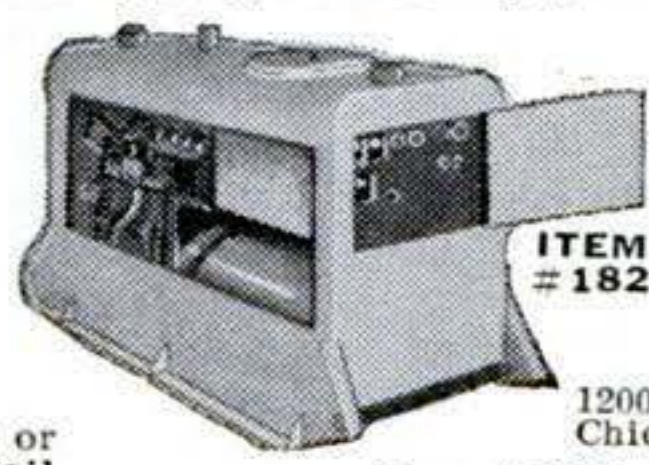

ITEM #182

1200 lbs. F.O.B. Chicago.....

Item #178—350 watt—110 volt—60 cycle A.C. direct coupled to 1 cylinder Midco engine. Shpg. Wt. 116 lbs. F.O.B. Chicago... **125.00**



Item #178

Item #182—Onan Generator—5KW—120 volt—60 cycle A.C. single phase, direct coupled to Ford 4 cylinder, water cooled engine with push button start, battery ignition. (Battery not included.) Shpg. wt. **795.00**



ITEM #180

Item #180—15 KW—127/220 volt—60 cycle AC—3 phase 1800 RPM. Brance & Krachy Generator direct coupled to International Harvester 4 cylinder, water cooled engine with magneto ignition—push button start. Panel has voltmeter, ammeter, 4-wire electrical system, belt driven excitor generator, rheostat voltage control. Engine and generator mounted on steel skids. Shipping wt. 2000 lbs. (Battery not included.) F.O.B. Chicago... **1650.00**



ITEM #199

mounted on steel skid. Weight 1885 lbs. F.O.B. Chicago.....

Item #199—Power Unit PE-99—7.5 KW—120 Volt—Single and 3-Phase—60 Cycle A. C. Master generator driven by a 4 cylinder, V-type, air cooled, Wisconsin engine with magneto ignition, push button start. The self-excited, drip-proof generator is driven from 5 parallel V-belts. Control panel contains engine and generator instruments, including circuit breaker, emergency start-stop buttons, volt meter, am-meters. Complete semi-enclosed unit **945.00**

Item #201—PE 95-G—10 KW—110/220 Volt 60 Cycle A.C.—Single Phase. Totally enclosed. Onan generator direct coupled to Willys Jeep, 4 cylinder, water cooled engine, push button start. Instrument panel with engine and generator instruments, circuit breaker, controls, etc. Uses 6 volt car battery. (Battery not incl.) Skid mounted. Ship. wt. 1500 lbs. F.O.B. Chicago... **1295.00**
Write for free information on other generators—350 watts to 25 KVA.

HEAVY DUTY HYDRAULIC EQUIPMENT

Large supply of new labor-saving, economical hydraulic equipment in many types and sizes. Use these positive, highly efficient smooth pressure hydraulics on presses, arbor, lifts, loaders, power control, positioning, brakes, plastic dies, auto frame alignment, etc., etc.



Item #126

ITEM #126—Four-way, open center control valve with built in adjustable relief valve. Factory set at 1000 P.S.I., spring loaded neutral position, for use with one double acting cylinder. In neutral position cylinder is locked and pump unloaded. Fully balanced plunger type, smooth, positive, easy operation, can be used as single unit or mounted in series of any combinations desired. Has 3/4" pipe thread inlet and outlet, 1/2" pipe thread cylinder ports. Newly manufactured to our specifications. Shipping weight 8 1/4 lbs. An outstanding Buy! F.O.B. Chicago... **21.50**



Item #160

ITEM #160—PESCO GEAR TYPE HYDRAULIC PUMP. Compact—Powerful—Reliable. Especially designed for belt drive from fan belt, power take-off, drive pulley, electric motor or small gas engine. Equally suitable for direct coupling. Pedestal type mounting with two bolt holes for 3/4" holddown bolts. Standard 1/2" pipe thread inlet and outlet ports. Delivers 4.5 GPM at 1000 PSI at 2800 RPM with 3 HP. Will actuate one Item #6, 3" bore, 24" stroke cylinder in 10 seconds. Hardened steel gears turn in dense ollite bronze bearings. Rotation—clockwise facing shaft. Guaranteed trouble-free service. Ship. wt. 6 lbs. F.O.B. Chicago... **22.50**

ITEM #127—Double acting hydraulic cylinder, 1" bore, 1" stroke, 1/2" diam. shaft, 1/4" tubing thread ports. Over-all length closed—6 1/2". Clevis mounting at both ends. Perfect for clamping and feeding. **5.95**

ITEM #16C—Double acting hydraulic cylinder, 1 1/2" bore, 26" stroke. Will lift 1760 lbs. with 1000 PSI line pressure. Weight 8 lbs. A \$55.00 value. Now only. **16.95**

ITEM #103—Double acting hydraulic cylinder, 2 1/2" bore, 17" stroke. Clevis mounting. Will lift 4900 lbs. with 1000 PSI line pressure. 1 1/4" diam. shaft. 3/8" tubing thread ports. Overall length closed 28". **21.50**

ITEM #126—Ship. wt. 11 lbs. F.O.B. Chicago... **21.50**

ITEM #42—Double action hydraulic cylinder 4" bore, 18" stroke. Rated lift capacity with 1000 PSI line pressure is 12,500 lbs. Shipping weight 30 lbs. F.O.B. Chicago. An Excellent Buy for... **32.50**

ITEM #6—Double action hydraulic cylinder, 3" bore, 24" stroke, will lift 7070 lbs. with 1000 PSI line pressure. Steel barrel, 1 1/8" stainless steel shaft. Gov't acq. cost \$176.00. Ship wt. 26 lbs. F.O.B. Chicago **28.00**

ITEM #29KJ—Gear Type Hydraulic Pump. Ideal in industrial applications and for operating all hydraulically powered farm implements including loaders, stackers, swathers, plows, etc. Delivers 1000 PSI (may be set at lower PSI if desired), 12 GPM at 400 RPM. Max. operating speed 800 RPM—rotation counter clockwise. Has built-in relief valve, permanent or torque bar mounting. 1" diam. shaft, 3/4" pipe tap inlet, 1/4" pipe tap outlet. Ship. wt. 22 lbs. F.O.B. Chicago... **45.50**

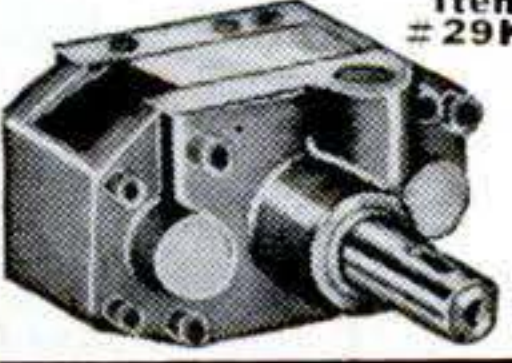

Item #29KJ

New Model 353 — Dual Range D. C. ARC WELDER

for Stationary or Portable Use. HEAVY DUTY RANGE TO 250 AMPS. NEW 'MAGIC TERMINAL' FOR LOW CURRENT 30 TO 100 AMPS. IDEAL FOR • FARM • FACTORY • GARAGE • WORKSHOP
These precision engineered D.C. Arc Welders contain the highest quality War Surplus aircraft components built to exacting government specifications. They are light in weight, have oversized lifetime grease-sealed ball bearings, air cooled commutator, dial type rheostat for easy pin-point control, a highlow rheostat switch, reactor coil for even arc and the new 'MAGIC TERMINAL' low current welding range for welding lighter materials. Designed for many years of trouble-free service. Run welder from drive pulley or power take off of a tractor or Jeep, 7 1/2 HP electric motor or 10 HP gas engine at 2500 R.P.M. Uses two V belts or flat belt. Continuous output rating 200 amps. Intermittent welding rating 250 amps, 30 volts. This sensational price includes double V or flat belt pulley and complete operating instructions. Shipping weight 107 lbs. \$350.00 Value. Item #65. F.O.B. Chicago. Now Only... **119.50**



Welds Anything From Auto Fenders To Tractor Frames

HYDRAULIC SPEED REDUCER

With Fingertip Control
USE FOR: • Reamer Drives • Midget Cars • Feed Mills • Canning Machines • Conveyors • Lathes • Milling Machines • Motor Boats • Cream Separators • Garden Tractors • Pumps
Variable output speeds from 0 to input speed available by moving control handle. Locking handle maintains setting. Internal relief valves prevent overloading. Use input power of 1/4 to 1/2 H.P. This Westinghouse-Oil Gear Unit converted to commercial use from 40 MM anti-aircraft traversing mechanisms consists of a variable displacement hydraulic pump feeding a fixed displacement hydraulic motor. Adjustable relief valves set at factory for 100 inch pounds of torque may be reset up to 180 inch pounds. Independent reverse control allows full output power and speed selection in either direction of rotation. Both input and output shafts measure 5/8" diam., include key-way. Input rotation is counter-clockwise facing shaft. Recommended input speed not to exceed 750 R.P.M. Over-all dimensions. 7 1/2"x7 1/2"x11 1/2". Gov't. acquisition cost, \$428.00. Shipping weight 31 lbs. Complete with 2 qts. of oil and full instructions. F.O.B. Chicago... **54.50**

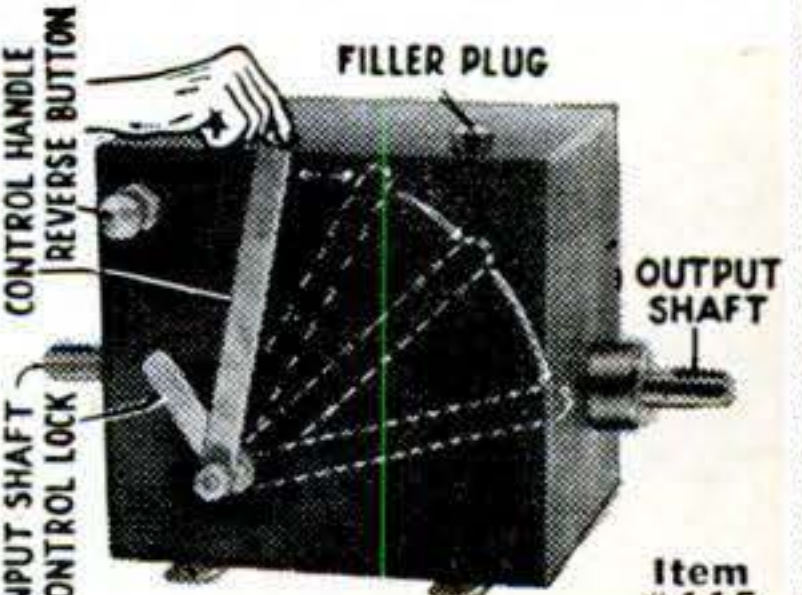

Item #115

GENERAL MOTORS — ALLISON CENTRIFUGAL PUMP



Item #130

Typical Performance Data

Suction Lift	Head Pressure	Gal. Per Min.	H.P.	R.P.M.
10'	75'	260	6.0	3500
10'	65'	200	5.2	3500
10'	80'	40	1.5	2500
10'	50'	140	5.0	3500
10'	30'	100	3.0	2500

• For Draining Basements • Fire-Fighting • Irrigation • Fuel Transfer • Swimming Pools • Home Water Systems • Dewatering This General Motors Allison Centrifugal Pump—designed for use on U. S. Air Force Mustang fighters, now converted for commercial, home, and industrial high volume pumping applications. Inlet 2 1/2" standard pipe thread, twin outlets with 1 1/4" pipe thread, ball bearing supported 3/4" shaft. Easy, fast simple priming. Rotation, counterclockwise facing shaft. Shipping wt. 35 lbs. Gov't acq. cost \$145.00. F.O.B. Chicago... **39.50** NOW ONLY

FREE! 1952 48-PAGE CATALOG

Chuck-full of unsurpassed War Surplus Bargains for the farm, home, factory & workshop. You save on everything.

WRITE, WIRE or PHONE Webster 9-3793

ORDER DIRECT FROM AD — SEND PAYMENT OR PURCHASE ORDER TODAY — SATISFACTION GUARANTEED

GROBAN SUPPLY CO. 1139 SO. WABASH AVE., CHICAGO 5, ILL. DEPT. PS-5

This \$315 modern dining suite only \$108*



Are you wishing for modern furniture . . . at an old-fashioned cost? Do what I did—and build it yourself! This dinette furniture, for instance, can be yours at a saving of better than 60% by following SKIL-Chart 108 (send coupon with 10¢).

You can build anything from a coffee table to a house with SKIL Home Shop Tools. SKIL Saws make fast work of ripping, mitering and beveling . . . Sanders give satin finishes quick . . . Drills and other SKIL tools take the drudgery out of building things. See your dealer—or mail coupon.

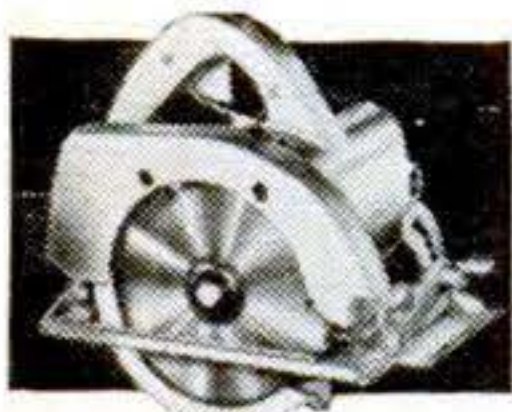

SKIL Home Shop Saw—Model 520. Accurate, powerful 6" saw. Quick, easy bevel and depth adjustments. \$59.50. SKIL Saw Table and accessories easily convert this saw to tilting arbo. bench saw, sander and shaper.

Prices subject to change without notice.
*For materials only. Local prices vary.



Made only by SKILSAW, Inc.
5033 Elston Avenue,
Chicago 30, Ill.

In Canada: Skiltools, Ltd.
3601 Dundas St. West,
Toronto 9, Ont.

Skilsaw, Inc., Dept. D-52
5033 Elston Ave., Chicago 30, Ill.

I enclose 10¢. Please send SKIL-Chart No. 108 showing how to build the above modern furniture.

Name _____

Street _____

City _____ State _____

Soapbox Racers Hit the Big Time

[Continued from page 106]

the inspection committee be doubtful about the car or the itemized price list submitted with it, the boy is asked about them.

One 11-year-old brought in such a sleek racer that the committee became skeptical that such a little fellow could have done the job himself. He showed 'em—went to the workshop in an Akron trade school and demonstrated what he could do.

Boys Have Big Week End

In Akron, the kids spend the four-day Derby week end in a camp outside the city. Besides a program of planned recreation and special outings, there's a chance for each boy to take a trial run down the track.

When the great day comes, the entries are lined up three abreast behind the starting line. Three cars race in each heat, and one is run off every 90 seconds, all afternoon. After three elimination rounds there are six cars left. These race in pairs in the fourth round, and the three winners of these heats race for the national title. The three fourth-round losers then run a special heat for fourth, fifth and sixth places. Other winners up to tenth place are picked on the basis of competitive times.

Worthwhile Prizes

The kids have something besides glory and handsome trophies to race for. The national championships are sponsored by the Chevrolet Motor Division and Chevrolet dealers. They provide a \$5,000, four-year college scholarship and a gold ring for first. Second place brings a Chevrolet sedan. The other winners share such prizes as cameras, binoculars, power tools and typewriters. There are also special prizes for the best built car, the best upholstered car, best designed car, best brakes, and the fastest heat. All Akron entrants get watches for winning their local elimination races.

On the day of the race, the stands are packed with spectators. As the noses of the first three are pushed gently against the baffles, the kids crouch down in their cars. The green flag is raised. The crowd is silent for a moment, then it roars as the flag drops and the three racers shoot down the hill.

No matter how the cars or the races change, there's one thing always the same—the excited small boy sitting in the driver's seat, gripping the wheel, wishing his racer down the hill with fierce intensity. **END**

Do 1001 Homecraft Jobs EASIER—FASTER

with



HI-POWER COMPLETE ALL-PURPOSE POWER TOOL KIT

Features Hi-Power $\frac{1}{4}$ " Electric Drill for use as a portable tool, and the easy handling PET Drill-Saw with 4" blade that takes the work out of cross-cutting and ripping boards up to 1". Also includes Horizontal Stand and bits, plus accessories for sanding, polishing, and mixing. This 22-piece Hi-Power Kit, Model 77-16, is a real thrill for anyone who likes to build or repair things around home, farm, shop. Complete with sturdy metal carrying case—only **\$26.60**

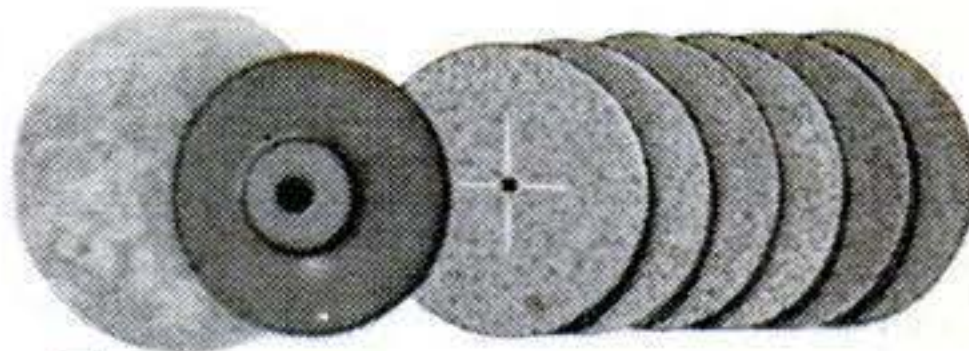

ZEPHYR ELECTRIC DRILLS—lightweight, modern streamline designs. Precision dynamically balanced, smooth running, AC-DC motors.

Model 510
 $\frac{1}{2}$ " drill—
\$38.75



Model 1950-H
 $\frac{1}{4}$ " drill—**\$18.95**



ZEPHYR 625-L ELECTRIC HAND SAW

Balanced, lightweight design for easy handling in any position. $6\frac{1}{4}$ " blade. Depth of cut $2\frac{1}{8}$ ". Adjustable for depth and angle. Includes graduated ripping guide. AC-DC motor. Price **\$47.50**



Write for name of nearest dealer and catalog on complete line of PET Tools

PORTABLE ELECTRIC TOOLS, INC.

326 West 83rd Street, Chicago 20, Illinois

In Canada: Portable Electric Tools, Ltd.
369 Danforth Rd., Toronto 13, Ontario

How We Fight with Words

[Continued from page 152]

Voice of America officials estimated a year ago that the Russian people were hearing about 20 percent of what the U. S. intended them to hear. The latest estimate is that improved facilities and techniques have stepped that figure up to 40 percent.

More Receivers Needed

The entry of the *Courier* into the counter-jamming campaign may soon raise the figure further. Besides being able to shift its position at will, it is equipped with certain electronic devices for counteracting jamming, the details of which are secret.

It would, of course, be a great advantage to the free countries if they could place more radio receivers in the hands of the people behind the Iron Curtain. There was an item of \$2,800,000 in the original Voice of America budget for 1951—the one that Congress eventually cut 90 percent—which was intended to accomplish that. For friendly countries, it proposed to provide large sets to be placed in taverns, clubs, schools and other public gathering places. It also proposed to purchase radios "of pocket size and operating on powerful miniature batteries of radically new design," which were "to be smuggled into countries where radio listening is the rough equivalent of treason."

Many Ways to Smuggle

Sets of suitable size have been in existence for several years (PSM, March '48, p. 132). The principal barrier to their use has been their cost. But a year ago David Sarnoff of RCA said that he thought it was possible to make miniature receivers for as little as two dollars apiece and that he had RCA engineers at work on the project.

Smuggling them into Iron Curtain countries might be done by balloon, as Radio Free Europe delivered propaganda pamphlets last year (PSM, Oct. '51, p. 124), or by methods developed during World War II. Then, British planes dropped tiny sets to the Czechs in matchboxes. The Dutch hid them in cut-out books, lamps and women's powder dusters. They even slipped one into a Nazi prison camp in a can of vegetables.

END

Next Month: PSM will take you on a grown-ups' game of cops-and-robbers—the weekly hunt for a hidden transmitter in Portland, Ore.

You'll find hundreds of time and money-saving uses for this

NEW 2 SPEED 100° ANGLE

BUFFING AND SANDING ATTACHMENT

A complete kit with 2-speed,
100° angle drive unit, 5" rubber
pad, 2 5" sanding discs
and 5" lamb's wool bonnet.

\$845*

*Price slightly higher in West and Canada



The Mark of Superiority

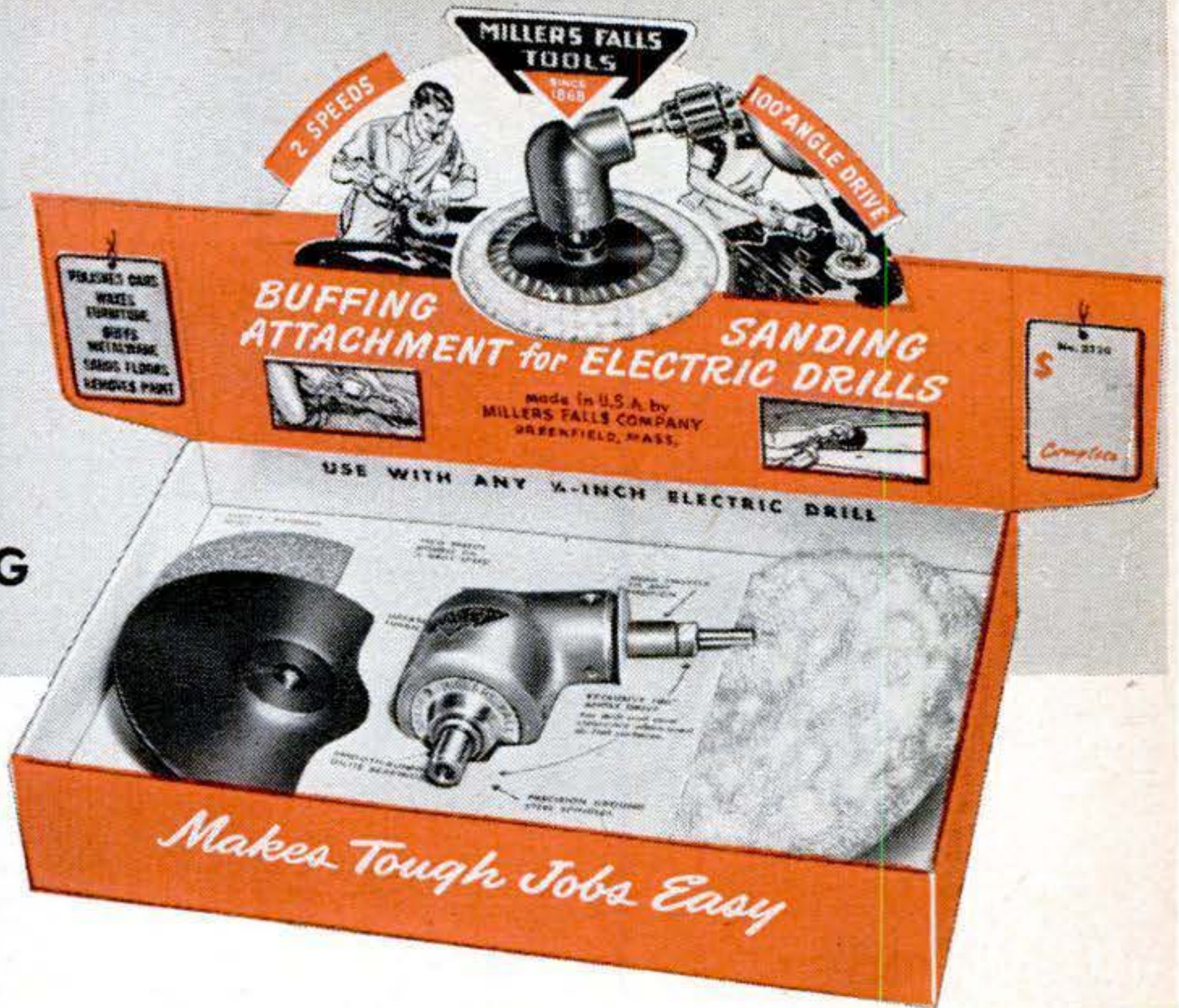

FITS ANY 1/4-INCH ELECTRIC DRILL and makes it an efficient rotary polisher and sander. Operates at 1/2 or twice drill speed. Exclusive 100° angle feature keeps drill and cord clear of work. A sturdy, smooth-running tool that makes countless jobs quick and easy. Grease sealed lubrication. Machine-cut steel gears. Ask for it at your hardware dealer's.

MILLERS FALLS COMPANY • GREENFIELD, MASSACHUSETTS

P & C Hot Forged Tools

Do the job **FASTER!**

You get down to business fast with P & C Tools. They're master craftsman designed to fit openings quickly... turn nuts and screws smoothly... get into tight places easily. And tough, too, with special analysis alloy steels scientifically heat treated. Look for the P & C rotary tool display unit at your favorite tool dealer's. He'll show you—"the best tools money can buy."

Write for
handy pocket
catalog. Complete
data on
some 300
P & C Tools.



**P & C Hand
Forged Tool Co.**
Box 5926 F
Portland 22, Ore.

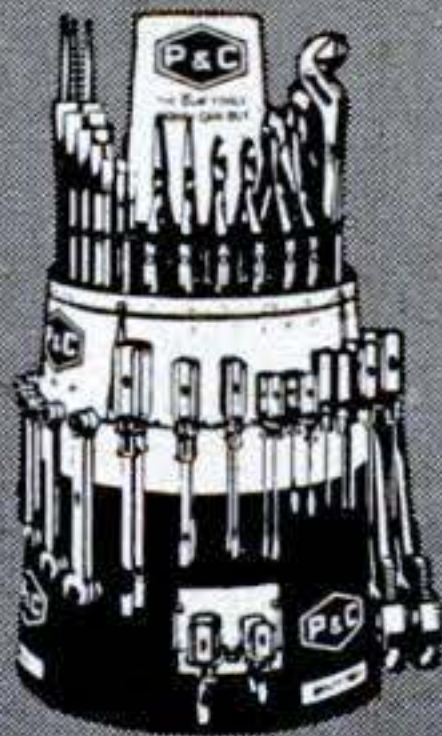

HERE'S THE ALL-PURPOSE CUTTING TOOL You've Always Wanted

**NEW
FORSBERG
WHIZ
SAW**



Precision Made for Precision Work

Home craftsmen will find Whiz-Saw useful for rough cutting jobs as well as precision work. Light in weight, but amazingly sturdy. Whiz-Saw quickly cuts wood, bone, plastic, fibre, pressed wood, hard rubber, etc. up to 1" thickness... it's scientifically designed for cutting inside shapes without first boring a starting hole. Ideal for jig or band saw use when inserted in handy Whiz-Saw table. See the Whiz-Saw at your dealers. Whiz-Saw Model #2, has greater capacity, cuts up to 2" thickness—\$130. Whirl-Saw, a 4 1/2" circular blade, cuts up to 1 1/2" thickness—\$49.00. Send for free booklet.

The Forsberg Mfg. Co. Bridgeport, Conn., U.S.A.

**WHIZ-SAW
\$5500**
Table \$18.95

7 saws in 1
RIP, CROSSCUT, KEY-
HOLE, COPING, SCROLL,
BAND OR JIG

the ideal
cutting tool for:
**HOBBYISTS
ELECTRICIANS
CARPENTERS
PLUMBERS
SIGN-MAKERS
MAINTENANCE MEN**

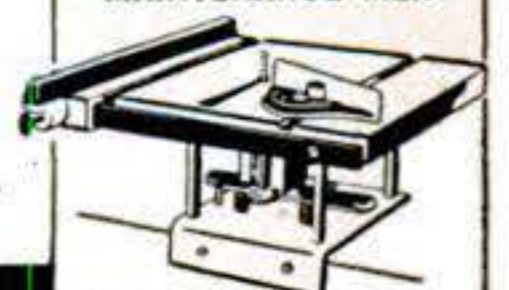

All-metal Whiz-Saw table may be secured with screws to wood bench or held in vise.

ANOTHER **Forsberg** PRODUCT
Makers of the Famous Whale & Viking Tools

BUILD YOUR OWN TILTING ARBOR SAW!

SAVE
\$50
OR MORE

Exclusive GIL-BILT Build-It-Yourself Features

- No machining—build easily with hand tools only
- No blueprint reading—step-by-step pictorial plans, full scale patterns, actual photographs
- Sturdy wood, aluminum, and steel construction
- Capacity and performance of commercial saws selling for \$60 and up

GIL-BILT 10-INCH TILTING ARBOR SAW



- 27x28 in. table, 13 1/2 in. capacity in front of blade
- 10 in. blade cuts 3 1/4 in. deep, tilts full 45 degrees
- Floor model 34" high, table always stays level

- New Departure ball bearing arbor, 3/4" precision shaft turned down for 5/8" bore blades, alum. housing, shipped ready to run
- Jackscrew and 4 1/2 in. dia. handwheel lowers and raises blade
- Cast aluminum miter gauge and self-aligning rip fence guide

GIL-BILT Metal Parts Kit includes Plans, ball bearing arbor, miter gauge and bar, rip fence guide, dado insert, lock knobs, jack screw mechanism and handwheel, and all other metal parts (less blade).....\$20.95
Same Kit with 10" Combination Blade\$24.90
Same Kit with 8" Combination Blade\$23.90

GIL-BILT 8-INCH TILTING TABLE SAW

- 21x27 in. table tilts full 45 degrees, 13 in. capacity in front of blade
- 8 in. blade cuts from 0 to 2 1/2 inches
- New Departure ball bearing arbor, 5/8" precision shaft turned down for 1/2" bore blades, alum. housing, ready to run
- Cast aluminum miter gauge and self-align. rip fence guide (same as above)



GIL-BILT Metal Parts Kit includes Plans, Ball Bearing Arbor, Miter Gauge and Bar, Rip Fence Guide, Machined Lock Knobs, Tilt Support Segments and All Other Metal Parts (less blade).....\$15.95
Same Kit with 8" Combination Blade.....\$18.90

GIL-BILT 12-INCH BAND SAW

- Cuts to center of 24 inch circle
- Handles stock up to 6 inch thick
- 18x18 inch table tilts 45 degrees
- Lower wheel and drive pulley runs on sealed New Departure Ball Bearings; Upper wheel runs on two 5/8" bore Oilite Bronze bearings
- Upper wheel tension and tilt mechanism of cast aluminum, completely assembled
- Upper and lower blade guides. Each has ball thrust bearing, self-lub bronze jaws
- Rigid cast aluminum wheels fully machined ready-to-install. Heavy rubber tires
- Uses standard 78 inch blades up to 3/8 in. wide
- Fully enclosed mechanism for utmost safety

GIL-BILT Metal Parts Kit includes Plans, rubber tires, aluminum wheels, 1/4 in. blade, ball bearing spindle, tilt mechanism, blade guides, table tilt segments, and all other metal parts.....\$21.95

GIL-BILT BELT SANDER

- 84 sq. in. sanding surface. Over 4 times the effective area of a 10 in. disc sander.
- Belt operates in either vertical or horizontal position, does all sanding operations.
- Driver drum and pulley turn on sealed New Departure ball bearings; tension drum turns on Chrysler Oilite bronze bearings.
- Spindle and tension mechanisms of cast aluminum, completely machined and assembled.
- Belt travels 1800 ft. per min. Over a MILE of straight sanding action every three minutes. Saves more "elbow grease" than any other tool.
- GIL-BILT Metal Parts Kit includes Plans, ball bearing spindle, 4 in. driver drum, 3 in. tension drum, tension mechanism, table tilt segments, rubber tires, cloth sanding belt, and all other metal parts.....\$16.95



COMPLETE
PLANS
only
\$100
EACH

NO DEALERS—ONE LOW FACTORY PRICE! Return in 10 days for refund of purchase price if not satisfied. Prices include postage within 300 miles. Over 300 miles add 5%. Send cash, check, or money order for parts kit, or send \$1.00 for Step-by-Step Plans and order kit later less cost of Plans. Plans sent postpaid anywhere in the world.

GILLIOM POWER TOOLS

P.O. Box 1-VE, Lambert Field, St. Louis 21, Missouri

INTERNATIONAL ROTARY HI-SPEED COPE-SAW DRILL-BIT IT DRILLS IT SAWS IT REAMS



DRILL, SAW, REAM . . . metal, pipe, wood, plastic, Transite, etc. Use with any electric drill, slow drill press, lathe or milling machine. Drills own starting hole—upper part of bit is used to cut, saw or ream circles, ovals, squares or scrolls. Easy to operate. Ideal for carpenters, mechanics, electricians, plumbers, hobbyists, many others. Abrasive resistant, high speed steel. Flutes ground from solid. Will withstand severe continuous use without breaking. Resharpener at no charge. Takes place of up to \$50 in tools. 1/2" diameter, 2" cutting sections, total length 3 1/2". Also available specially designed for wood or metal and in 2 3/8" and 1 3/4" lengths. Write for details. Specify all-purpose bit. Shipped same day. Money-back guarantee. Dealer inquiries invited.

SEND CASH, CHECK OR MONEY ORDER
Manufactured and distributed by:
INTERNATIONAL TWIST DRILL CORP.
618 Wyandotte, Rm. 691 Kansas City 6, Mo.

only
\$3.95
POST PAID

THE NEW WATERBORG

MILLING ATTACHMENT
FOR YOUR DRILL PRESS

MAKES AN IDEAL MILLING MACHINE FOR HOME AND SHOP

Do model work, tool making or experimental work in your spare time and earn extra money. Sturdy and accurate. Hardened and ground spindle, bronze spindle-bearing, bracket swings out of the way when not in use. 5"x12" table top, 10" longitudinal travel, 7" cross slide. Only \$77.75 complete with bracket for 13", 14", or 15" drill press. 17" bracket \$2.00 higher. Brackets or tables also sold separately. A few jobs will pay for the attachment. Illustrated Circular on request.

WATERBORG MACHINE CO. 2830 RAPIDS DRIVE
Dept. PS, RACINE, WIS.



Make Money
SELLING
Eshelman
Tractors
and doing
GARDEN
WORK

RAKES
PLOWS
CULTIVATES
HARROWS
HAULS
SPRAYS
SAWS
DOZER
MOWS
CUTS
ROLLS
TILLS
SNOW PLOW

ESHELMAN

FOR BETTER
LAWNS
and GARDENS
also POWER MOWERS
and RIDING TRACTORS
Women can operate it.

Also Power Reverse
Free Catalog. Write
ESHELMAN, Dept. 289
119 Light St., Balto. 2, Md.

Fast, EASY Way to REMOVE Paint



Just apply WONDER-PASTE Remover with a regular brush over paint, enamel or varnish . . . Then let it penetrate . . . The old finish quickly becomes a soft mass that comes off cleanly with every stroke of your putty knife. No hard scraping or sanding! Harmless to any type surface or your hands. Use Wonder-Paste outdoors or indoors. At paint and hardware stores.

WONDER-PASTE

Over 3,000,000 cans sold—it must be good!

Write for free leaflet and advice on your removing problems
Wilson-Imperial Company, 121 Chestnut Street, Newark 5, N. J.

BURN WATER IN YOUR CAR



With The OCTA-GANE INJECTOR

The famous Octa-Gane all bronze pressure injector burns up to 1 gallon of water to 10 gallons of gas. It has produced results for thousands of motorists who demand PREMIUM PERFORMANCE from regular gas. KNOCK-FREE acceleration and SUPER-POWER for fast take-offs and hill passing. U. S. Agricultural Dept. experts say: "The gasoline mileage of high compression automobile engines can be increased up to 30% with the use of water-alcohol-gasoline fuels." WRITE TODAY FOR YOUR FREE GOVERNMENT REPORT and Information on Our "Buy Without Money" Plan.

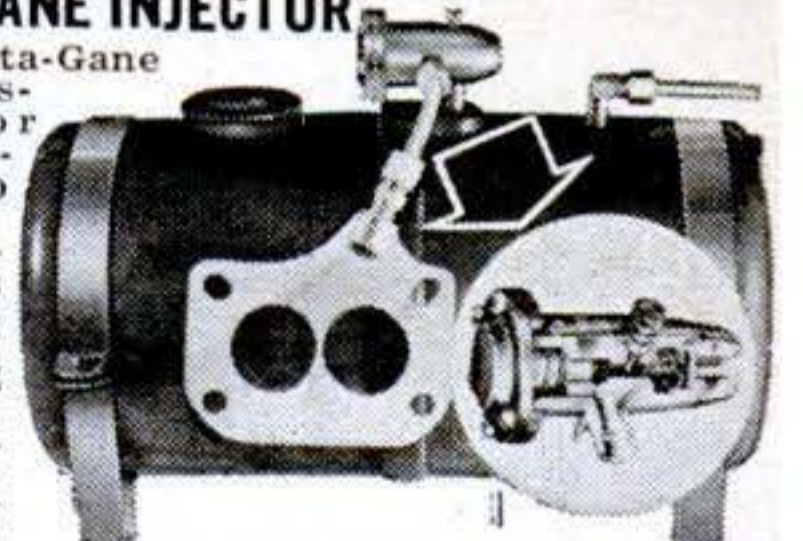

WRITE FOR:
FREE
ILLUSTRATED
LITERATURE

NARCO, DEPT. HG-5

VENICE, CALIF.

"HELIOS" ORIGINAL TOOLMAKERS VERNIER CALIPERS

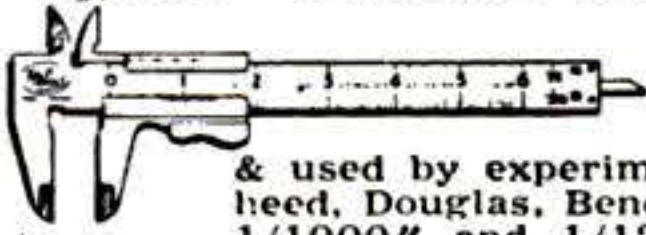

ULTRA PRECISION — Imported for the really critical mechanic who must have the best. Recommended & used by experimental & research machinists at Lockheed, Douglas, Bendix, GM, RCA, GE. ALL NEW. All with 1/1000" and 1/128" verniers... decimal equivalents in 8th, 32nd and 64th... graduation divisions engraved... extra heavy rule, hand-fitted sliding head, no side play... Rockwell C. 60 lapped measuring surfaces... Pliofilm carrying case.

No. 50F—inside, outside & depth measurements, length of graduation 6", handy thumb-operated slide lock, a \$37.50 value—SAVE 66%—only \$12.95.

No. 65—inside & outside measurements, with points, measuring range 8", a \$47.50 value for just \$14.95.

No. 65B—with 12" measuring range for \$16.95.

German-made Mauser Design Caliper for the production machinist, 0-6" in thousandths, just \$10.95 incl. leather case. Unbelievably low prices due to lower import duty. Money back guarantee!

IMPORTED "HELIOS" DEPTH GAUGE

Narrow measuring stock. 1/1000" & 1/128" Verniers. Graduation divisions engraved. Measuring range 6", length of jaws 4" (a \$27.50 value) for \$9.50. Measuring range 8", length of jaws 17/8" (a \$32.50 value) for \$10.50. Measuring range 12", length of jaws 37/8" (a \$39.50 value) for \$12.50. ALL NEW. All with money back guarantee.

U.S. BAROMETRIC ALTIMETER



This U.S. Gauge Altimeter is terrific for auto or airplane. Tells altitude accurately... guaranteed. It's NEW! Approx. Govt. Cost \$175. Cost from Airborne only \$9.95.

ALL NEW HIGH SPEED DRILLS

Fractional & numbered. Nationally known brand. Set of 30, assorted sizes, an \$18 value for only \$3.50 complete.

STRAIGHT SHANK DRILLS — 10 different sizes High Speed Straight Shank Jobber length drills. 1/4" to 1/2" (shank same diameter as drill). Here's a \$25 value you can have for \$3.50.

WIRE GAUGE DRILLS — From 45 to 60. Highest quality steel. You'll recognize the brand. Hard to get sizes valued at \$7.50. Airborne gives you a set of 12 for an even \$2.00.

Set from 1/4" to 33/64". Five sizes with 1/4" shanks. You'll surely want this set for the low, low price of \$3.00.

THOR PNEUMATIC SQUEEZE RIVETER



"C" Yoke Head. Size PRS-1. Model 4520. Shpg. Wt. 20 lbs. Approx. Govt. Cost \$250. Like new — guaranteed perfect! Just \$35.00.

10 LBS. ASSORTED MIX



A must for the hobbyist, machine shop or farm. Aircraft quality assorted nuts, bolts and washers. ALL NEW. Approx. value \$20, so how can you possibly go wrong at the Airborne price of \$2.75.

MAGNETIC BASE INDICATOR HOLDER

For all types of dial indicators with guaranteed lifetime ALNICO magnets. V-slotted base has a 45 to 50 lbs. pull, permits immediate application without clamps or special attachments and mountings can be made on cylindrical surfaces. For machinists, tool-makers and inspectors. Base 3 1/2" long by 1 1/8" wide. NEW. \$3.50 ea.



WILLARD WET PLATE BATTERY



Extra-long life, rechargeable battery. 2 V., 20 Amps. Great for portable radios, mobile units, bell circuits, alarm systems, rural telephones, Strobe bulbs, etc. Only 5" high. Visible ball float hydrometer built in Lucite case. Shipped dry (wt. 3 1/2 lbs.)... any battery service will supply standard battery electrolyte. Used singly or in multiples. ALL NEW! Now only \$1.95 ea.

LOW VOLTAGE CIRCUIT TESTER

Made for U. S. Ordnance Dept. to rigid specification. Portable steel hand-carrying unit is a self-contained trouble shooting device for making a complete & rapid check of the generator battery circuit, incl. any circuit & voltage regulators. Battery voltage, regulators, cut-out settings and generator performance easily determined. Terrific testing unit for garages, mechanics, truck fleet owners, boat and marine mechanics. Can be used on any 6 or 12 volt system. Approx. Govt. cost \$175. NEW, complete with instruction book, only \$32.50. Shpg. wt. 20 lbs.



AIRCRAFT NAVIGATIONAL DRAFTING MACHINE

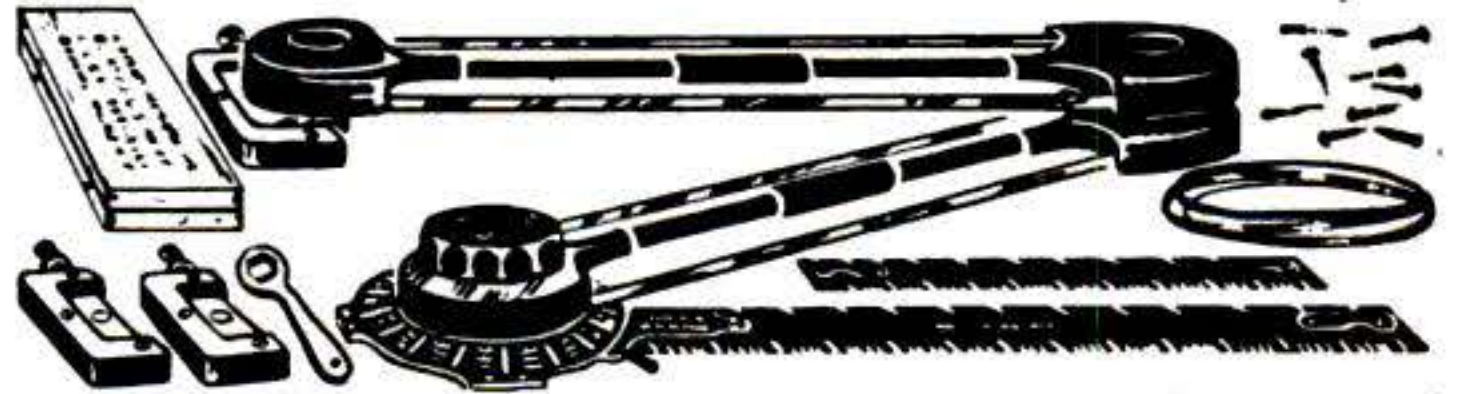

Designed for plotting navigation problems and adaptable to surveying layouts & general drafting room use. Limited quantity purchased from U. S. Navy (AN5750). Mfd. by Bruning Wallace. Non-magnetic, double-sealed type ball bearings of Beryllium copper require no attention. Non-magnetic K-Monel bands are not subject to corrosion. ALL NEW. Complete with fitted hardwood case incl. spare parts. Wt. 11 lbs. Approx. Govt. Cost \$150. WHILE THEY LAST! ALL yours for just \$47.50.

PORTABLE WELDER



Will weld, braze, solder & cut all metals up to 3/16". No experience needed, full instructions included. Weld iron, steel, brass, aluminum and other metals. Plug into any 110 Volt A.C. or D.C. line. Save 100's of hrs. and lots of \$\$ doing repair for yourself and others. Great for any mechanic, hobbyist, etc. Not a toy. Comes complete with electrode and carbon holders and an ample supply of electrodes, carbons, flux and necessary components to do a thorough welding job of any type. This ALL NEW unit can't be duplicated for many times its modest price of \$12.00.

D.C. GENERATORS



Finest aircraft quality... heavy duty... lifetime grease-sealed ball bearings. Terrific for truck and marine use, for welders, plating, D. C. Appliances, lights, etc. Type P-1. Mfd. by Ford, General Electric, Westinghouse & Delco-Remy. Rated 200 Amps., 28 Volts, 2500 RPM., can be "reved" up to 300 Amps. Shpg. Wt. 53 lbs. Approx. Govt. Cost \$350... New to you... \$21.50

CAMPER'S special 4 BRIAR PIPES, \$1



Sharp looking, brand new, genuine briar pipes. These beauties Approx. Govt. price \$2.50 to \$3 apiece. Complete set of 4 only \$1... WHILE THEY LAST!

NEW BIG 1952 CATALOG BARGAINS FOR EVERYONE • SEND 25c FOR YOUR COPY TODAY! ORDER from ad NOW! Check, Money Order or Cash. 25% deposit on C.O.D. orders. Prices F.O.B. Culver City, Calif., unless otherwise stated • AIRBORNE SALES CO., INC., DEPT. PS 552, 8501 STELLAR DR., CULVER CITY, CALIF. • SAVE \$\$\$

How to Always Have HOT WATER

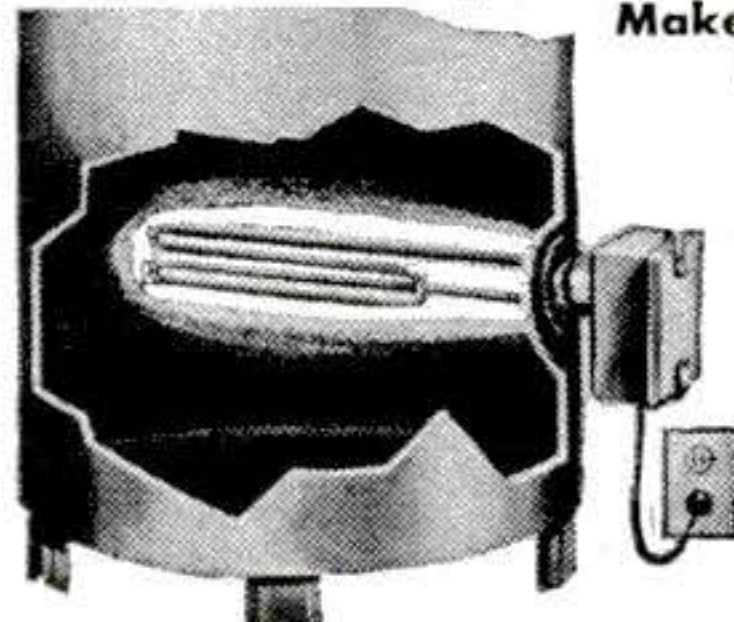

Make Your Own Automatic Electric Water Heater \$19.95 now for only

Install in 5 min. No disturbing or draining of tank or pipes

Why suffer without hot water? Enjoy lots of it to wash, bathe, shave. Heater keeps water HOT in your present tank. Turns ON when needed—shuts OFF when water is heated. No flue, dirt, fire! Ideal for 30-gal. tanks. Heater screws into any size boiler tap as shown. Plugs into outlet... 1320 w. 110 v. AC. (also 2000 w. 220 v. model for BX cable \$19.95)... works automatically thereafter. Temperature adjustable between 120 to 180 degrees. Replaces coal, oil, gas in home, store, summer cottage, green house, farm, barn, stock tank, poultry scalding, factory. Uses only 1/4 to 1/2c electricity per gallon hot water. Why burn expensive main furnace unit for hot water? Send check or M.O. NOW: save postage charges. ORDER NOW... TODAY. Money back in 10 days if not delighted.

ONE YEAR GUARANTEE
U. L. Approved Heater
Dept. PS5, 50 Church Street
New York 7, N. Y.

ELECTRIC MOTOR BARGAINS!



1/2 HP 1750 or 1975 3450 RPM
1 HP 3450 RPM 3900 RPM
1 1/2 HP 3450 RPM 4750 RPM
2 HP 3450 RPM 6500 RPM

Every Motor Fully Guaranteed
Heavy Duty, Repulsion Induction and Capacitor Types. 110-220 Volts, 60-cycle. Single-phase. Standard Makes (G. E., Wagner, Leland, Westinghouse, etc.). Rush your order TODAY—large stock of motors—1 & 3 phase. 32-v. direct current bargains also.

DOUBLE SHAFT MOTORS at 50% Saving

1/6 HP—\$10.00 1/4 HP—\$11.00
1750 RPM Split Phase—1 1/2"x3" Shafts
1/3 HP—\$14.00

1750 RPM Split Phase—5/8"x3" Shafts
These motors are new, shopworn, but all in perfect condition, and fully guaranteed. Resilient mounted for quiet operation on 110-volt, 60-cycle AC current. Ideal for Blowers, Grinders and Tool layouts.

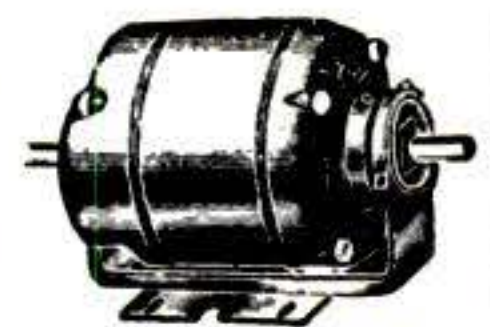

All prices F.O.B.

ROBERTS ELECTRIC CO., 849 W. Grand, Dept. 7, Chicago

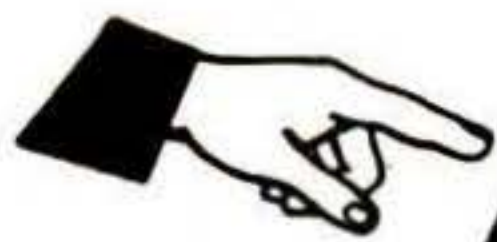

EXTRA BLADE
Bonus Special \$1.00

With every PTI blade you buy at the regular price ... you get an extra blade for only \$1 more. Ask your dealer.

PTI

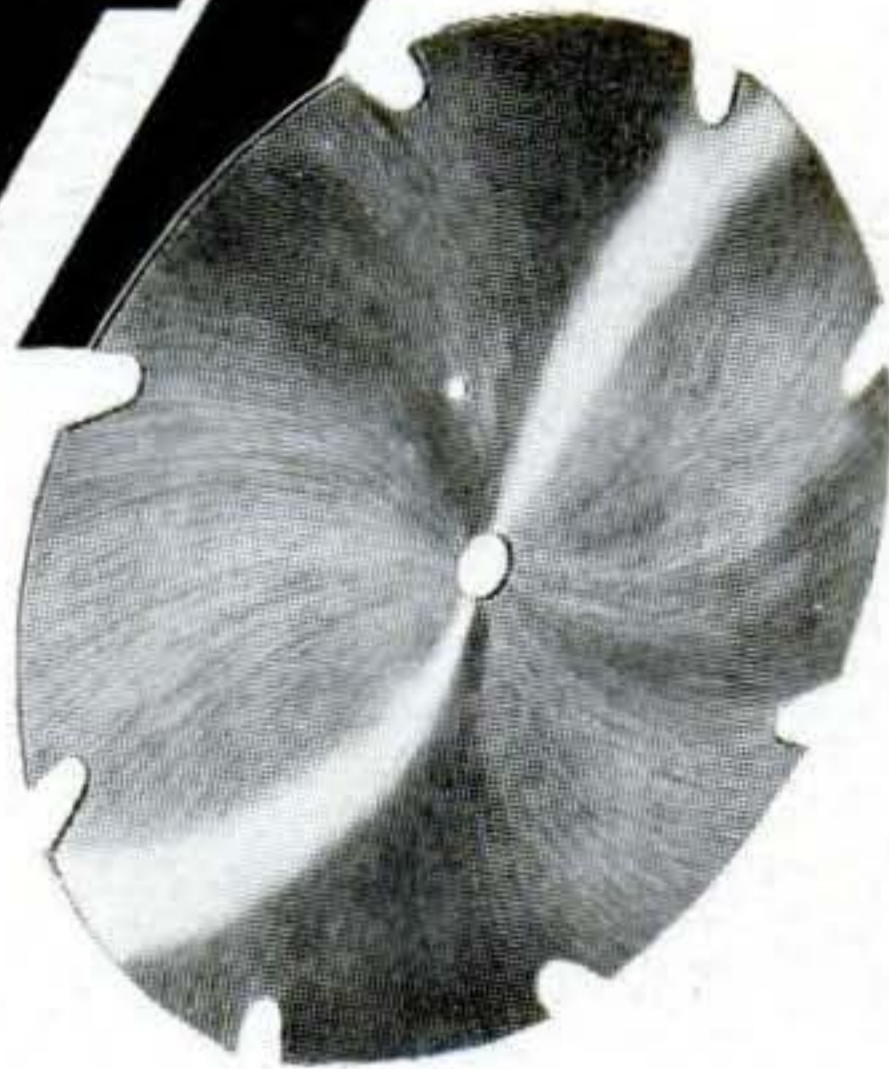

The ORIGINAL Safety Saw Blade tested and approved by the World's leading Laboratories

For a dependable safety saw blade that eliminates "kick-backs" from circular sawing — insist on the genuine PTI blade. (U. S. Pat. No. 2,559,355).

Precision made of chrome vanadium steel by one of the world's leading saw blade manufacturers. Cuts cleaner, quieter, smoother—and requires 30% less power. Available in sizes from 7" to 16" and for standard makes of portable saws.



Write for circular giving full details.

Incorporated, 401 Broadway, New York 13
 Preston PTI Sales and Service, Preston, Ontario, Canada.

It's NEW, BIGGER, Better
The DELTAGRAM...

• 6 GREAT ISSUES Only \$1.00 •

SEND FOR FREE "Get Acquainted" Copy

For only a dollar you get a whole year of Deltagrams—over 100 shop-tested plans, scores of fine projects and many valuable tips on home repairs and care of fine tools. Delta spent months and thousands of dollars to find out what you homecraftsman want in a magazine—and the new Deltagram is the answer to your demand: 6 wonderful issues each year—truly a treasure house of fun and profit. Send \$1.00 today for your 1 year subscription! Or, if you prefer, first write for a free "sample" copy. Delta Power Tool Division, Rockwell Manufacturing Co., 805 E. Vienna Ave., Milwaukee 1, Wisconsin.

FIRST NEW DIFFERENT MACHINE IN A DECADE
 *9 HANDY TOOLS IN 1
THE NEW PORTO-WELD MACHINE

- * • Welds
- Brazes
- Grinds
- Sands
- Polishes
- Buffs
- Brushes
- Motor Drive
- Quick Battery Charger



Here is an Economy Combination Tool that is of vital importance to any shop—garage—service station—plumber—boiler man—farmer or home workshop. PORTO-WELD has a SELF-CONTAINED MOTOR GENERATOR, just like the large industrial units. Just plug into any 110 Volt AC or DC line (any cycle) and it's ready for use. Easy to take to the job. Less sticking—even an amateur can weld like a professional. Can be used straight or reverse polarity. Its portable power unit can be used to operate saws, planers, etc. Other models available (150 Amp—225 Amp—Cart Model—etc.). Send for FREE literature. Fully Guaranteed in Writing. 10 Day Free Trial.

Porto-Weld Model 1-A
 Comes as illustrated above. Has four speeds and welds to 1/4" steel. Uses up to 3/32" rod (75 Amps). Ship. Wt. 40 lbs. F.O.B. **\$54.75**
 Chicago, Ill. Price Quick battery charger attachment **\$5.00** extra

Send Remittance with order: will ship C.O.D. (\$5.00 deposit)

Write for Dealer Territories

GENERATOR SALES COMPANY

1631 N. Damen Ave.

Chicago 47, Illinois



PROTECTS PAINT

... against blistering and peeling. Guards wood against moisture damage, fungus decay and termite attack.

Write for FREE Woodlife literature

PROTECTION PRODUCTS MFG. CO.
 P.O. BOX 747, KALAMAZOO, MICH.

HOBBYISTS! SHOPMEN! Special ONLY \$54.50

PALMGREN "HOBB-E" Rotary, Index, Milling Table

Ideal for Model Parts or Shop Work

Mill-Grind-Drill-Index-Rout curved or straight-Rabbit and Mortise on drill press or lathe. 8" Table, 4" Cross Feed, 360° Rotation, Accurately Graduated. Bolts to table. Order NOW! SAVE \$100. Only \$54.50. Less Rotary Feed \$43.75. Write for "HOBB-E" Tool Circular.

CHICAGO TOOL and ENGINEERING CO.
 8396 South Chicago Ave. Chicago 17, Ill.



LOOK! CHEVY OWNERS
"STOP ON A DIME!"

New Conversion Kit Doubles Chevrolet Braking Power. Easy 30 minute installation of this new kit converts present brakes to powerful "Bendix" type as used on Cadillac, Oldsmobile and Buick cars. Kit consists of 4 brake energizers which replace original anchor pins on all 1936 thru 1950 Chevrolets. Guaranteed for the life of your car. Only **\$3.75** post-paid

3 BOOKS FREE

With each order: Big "Speed Equipment Catalog," plus "Economy Driving Manual," plus famous "150 Miles Per Gallon Book"—a regular \$1.75 value free with order.



NEWHOUSE AUTOMOTIVE INDUSTRIES
 Dept. AC-5, 5805 E. Beverly Blvd., Los Angeles 22, Calif.



Two DREMEL Electric SANDERS with STRAIGHT LINE Action for Guaranteed SCRATCH-FREE Surfaces

POPULAR GIFTS for FATHER'S DAY!

Model 2000
\$24.50

Dremel Sanders are grand gifts to give or get. Compare them with any similar products made—point-by-point, feature for feature. Then you'll see why Dremel can guarantee more for your money in finer performance and longer life. You be the judge!

MODEL 2000 FOR HEAVY DUTY WOODWORKING PROJECTS—

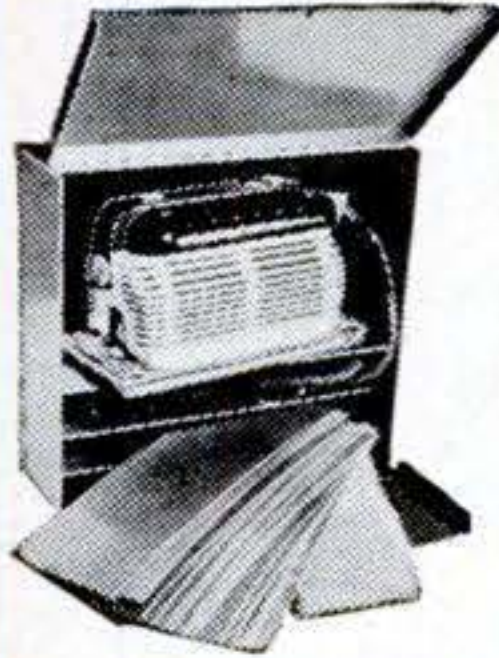

MODEL 2000 PRICE INCLUDES this sturdy steel storage case, 25 asst'd. abrasives, and sheepskin polish pad.

A high-speed, fast-cutting production sander for home and shop use. Its straight-line, **with-the-grain** action is ideal for redecorating jobs, furniture and cabinet making, boat building or refinishing. Great for building operations like woodwork, doors, stairways, dry-wall joints, etc. Also does a superb polishing job! Wt. 5 lbs.; 21 sq. in. sanding surface; over-all size 3 1/8" x 4 1/2" x 7". Finest sander value in the field and fully guaranteed!

BOTH MODELS FEATURE!

Only 2 moving parts; easy one-hand operation; 10-sec. paper change; 14,400 strokes per min.; 110-120 V., 60-cycle, AC.

ONLY STRAIGHT-LINE ACTION SANDS WITH THE GRAIN

Ask any professional woodworker about sanding action. He will tell you that only straight-line, with-the-grain sanding can produce a flawless finish. Follow his advice—insist on Dremel. **BEFORE YOU BUY ANY SANDER . . . COMPARE!**

ROTARY Action



ORBITAL Action

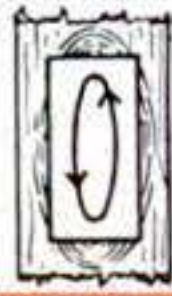

ARC Action

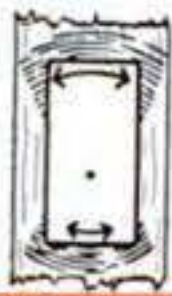

STRAIGHT-LINE Action

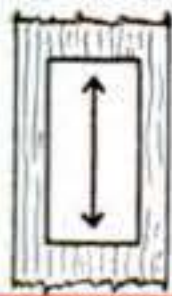

14,400 SANDING STROKES PER MIN.

MODEL "A" FOR HOBBIES, REFINISHING, REDECORATING—Dremel's lighter capacity, excellent all-purpose sander for home maintenance, unfinished furniture, hobby projects, etc. Wonderful wax polisher. A soothing massager! Only 2 1/2 lbs. with 12" sanding surface.

MODEL "A" \$14.85

Price includes 6 sandpapers, 1 sheepskin, 1 felt pad.

WHERE TO BUY—If dealer doesn't carry, remit in full for post-paid shipment. Or send only \$2 now, pay postman balance plus postage and C.O.D. fee. *Five-day trial, money-back guarantee!*
DREMEL MFG. CO. Dept. 122-E Racine, Wis.

Buy the Best...WISS!

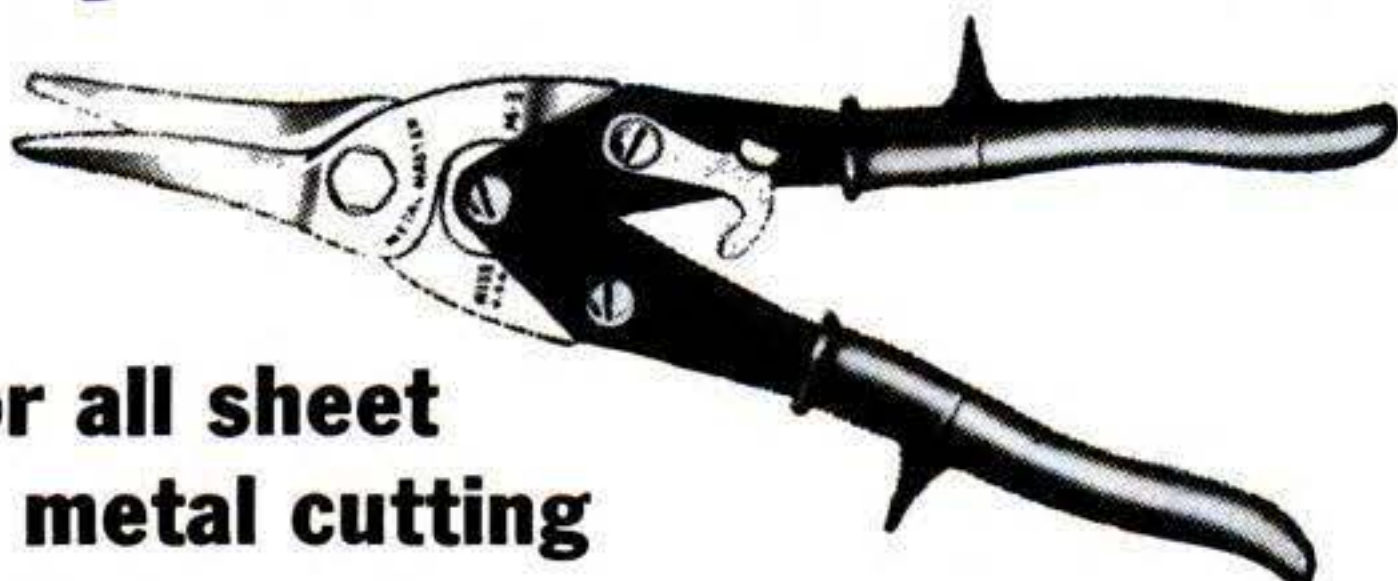

for all sheet metal cutting

WISS Metal Master Compound Action Snips

#M-3. Easily cuts 18 gauge sheet metal. Cuts curves and circles as well as straight. Ideal for the home workshop. \$4.25. Rubber grips recommended, 60¢ extra.

WISS Straight Cut Snips

#9. Crucible steel inlaid blades. The basic snips for straight metal cutting. Gun metal handles. Overall length 12 1/2". \$5.25.

WISS Combination Snips

#V-13. Solid steel, with gray japanned handles. Cuts curves and irregular shapes with ease. Handy pocket size. 7" long. Accurately tempered jaws and strong bolts. \$1.85.



Prices slightly higher Denver and West



Quality for more than a Century

J. WISS & SONS CO. • NEWARK 7, N. J.



Send for this BIG NEW
Hunt's
WOODWORKERS CATALOG NO. 18

NEW LOW PRICES **ONLY 15¢**

Offers greatest selection of fine domestic and imported woods--and hundreds of woodworkers items at bargain prices!

You'll save time and money with this big, new catalog. Contains everything wood craftsman needs. Shows 32 rare and fancy woods in color...43 veneer designs...275 scroll patterns...multicolor inlays, overlays, bandings...all kinds of tools, machinery, cabinet hardware, ornaments, mouldings...and pages of valuable tips, ideas, information, instruction. Send for your copy NOW. Only 15¢.

- 144 PAGES
- **QUICK DELIVERY**
- on maple, poplar, oak, mahogany, red cedar, cherry, walnut, and many others—all properly seasoned and kiln dried.

MAIL THIS COUPON-TODAY!

CRAFTSMAN WOOD SERVICE CO.
2729 S. Mary St., Dept. B5
Chicago 8, Illinois

Send me the big, new, money-saving Catalog No. 18. Enclosed is 15¢.

Name _____

Address _____

City _____ Zone _____ State _____

LOOK FOR THE NAME

UTICA



IT MEANS

INDUCTION HARDENED WRENCH JAWS

Ordinary adjustable wrenches, subject to hard usage, burr over at the jaw edges. UTICA's process hardens the jaws in just these vital areas (indicated by arrows). Tests show that UTICA's last up to 10 times as long as ordinary adjustable wrenches.

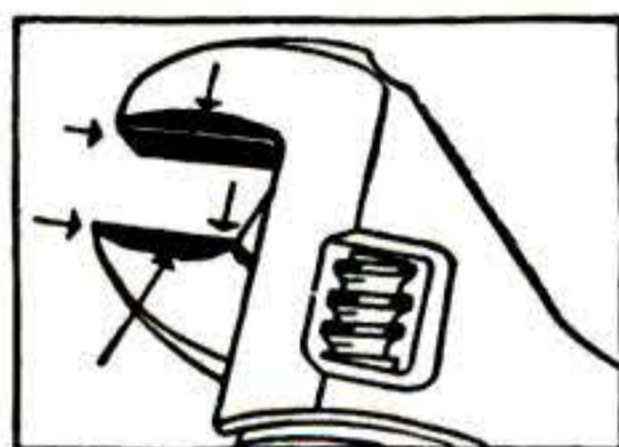

Dark areas are induction hardened for longer wear.

Your hardware dealer has UTICA adjustable wrenches or can get them for you. Insist on UTICA—the longer lasting adjustable wrench.



IT PAYS TO BUY QUALITY TOOLS and the world's best tools are made in U.S.A.

SAVE MONEY

on Home and Farm Repairs, Improvements

Do brick, stone, tile, cement and plastering work yourself—and save. Have fun while you save money.

Get this complete kit of 13 professional tools and how-to-do-it book.



- Cement Groover
- Cement Edger
- Brick Trowel
- Brick Jointer
- Brick Hammer
- Masonry Chisel
- Joint Filler
- Plaster-Cement Trowel
- Crack Scraper
- Plaster Patcher
- Pointing Trowel
- Water Brush
- Mortar Hawk

Kit also includes "Handbook of Masonry and Waterproofing" Profusely illustrated book covering all phases of concrete, plastering, brick and block construction for garages, barbecue pits, driveways, etc.

Only \$19.95 for entire kit. Reed's pays shipping costs. Satisfaction guaranteed or return kit within 10 days and money will be promptly refunded. Mail check or money order TODAY for immediate shipment.

REED'S MAIL ORDER MART
21 East 19th St. • Kansas City 8, Mo.

GET READY NOW FOR NEXT SUMMER'S DRY SPELLS

Sturdily Made—Hundreds of satisfied customers. Purchased and used by U.S. Dept. of Agriculture, U.S. Dept. of Forestry, U.S. Navy and many foreign countries. Fully Guaranteed. **LOW FACTORY PRICE, \$385.00;** less Motor F.O.B. Factory. Price includes drill, bailer and 100' cable, 200 ft. of additional length available at extra cost.

Drill your own wells for that needed water—as many as you need—outside—in the cellar—in the barn. The new improved CONSOL Driller—1951 Model—is equipped with a special replaceable Drill Head. It will drill through many feet of solid rock without resharpening. Simple to operate, easy to set up. Do the work yourself at small cost.

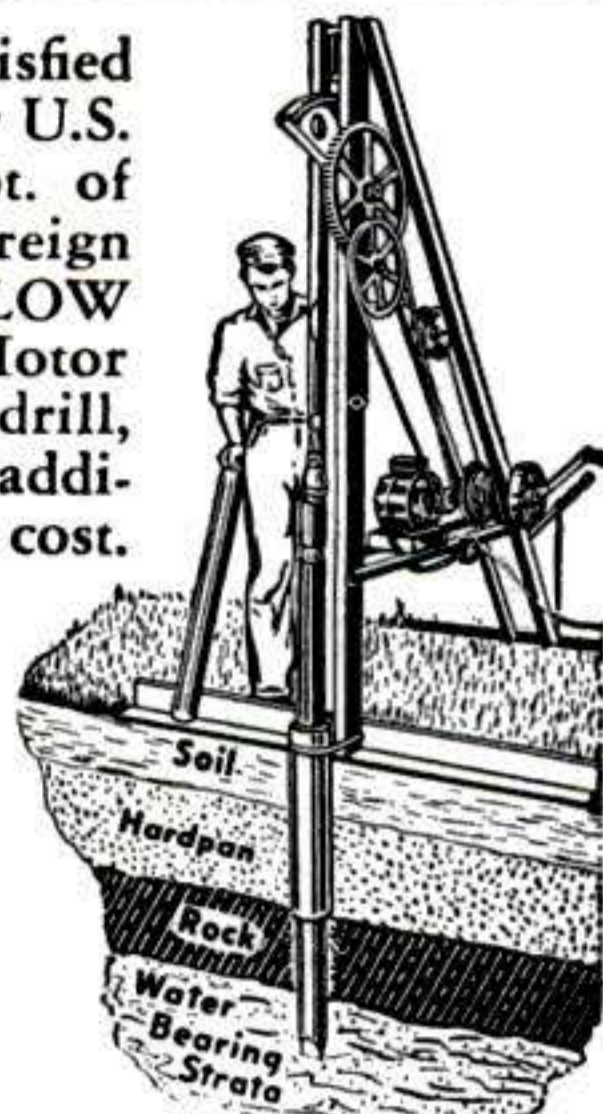

A HEAVY DUTY MODEL for 6" casings also available at \$1295, F.O.B. Factory, equipped with Gasoline Engine. Write for free information and booklet, Dept. PS



CONSOLIDATED INDUSTRIES
West Cheshire, Conn.

USE YOUR BENCH SAW

FOR JOINTING & CUTTING MOULDINGS

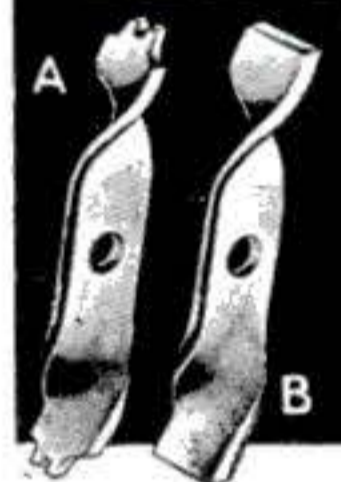

With our six inch tool steel cutters make mouldings, casings, drop-leaf tables, grooves beading and jointing. Moulding cutters, A 1 in. wide \$1.75. 1 1/2 in. \$2.25. Jointing cutters, B 1 in. \$1.75. 1 1/2 in. \$2.25. E 1 in. for drop-leaf tables. \$1.75. E 1 1/2 in. Makes 3/4 in. cove & Quarter. \$2.25. Postpaid. Guaranteed. State size hole. List & Folder free.

JOHN A. SANDSTROM
Rt. 2-P. Clearwater, Fla.

NO PARTS TO FLY OFF!!

STANDARD GARDEN AND SMALL FARM TRACTORS

Powerful Gas Tractors for Small Farms, Gardeners, Florists, Poultrymen, Fruit Growers, Suburbanites. **1 & 2 Cylinders** High Wheels. Rubber or Steel Tires. Walk or Ride.

Easy Terms — Free Catalog
STANDARD ENGINE CO.
MINNEAPOLIS, MINN.
4041 Como Avenue



NEW YORK, N. Y.
681 West 26th Street

ADJUSTABLE HOLLOW AUGER

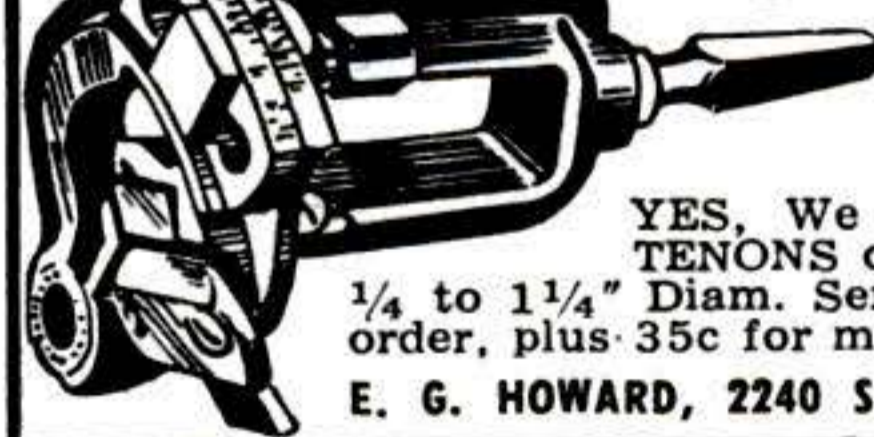

USUAL \$7 VALUE
\$2.00

YES, We said \$7 VALUE, CUTS TENONS on wheel spokes. Adjusts 1/4 to 1 1/4" Diam. Send cash, check or money order, plus 35c for mailing to

E. G. HOWARD, 2240 S.W. 19th Terr., Miami, Fla.

Amazing AUTOMATIC Refrigerator Defroster



PAYS SALESMEN UP TO \$210 A WEEK

Leave amazing new Automatic Refrigerator Defroster on FREE Trial overnight. Come back in 3 days and collect your profits. Housewives delighted when they see how plug-in D-Frost-O-Matic ends messy defrosting forever. Free Trial Plan. Write

D-FROST-O-MATIC 173 W. Madison Street
Dept. HX-140, Chicago 2.

SURPLUS MACHINE SHOP TOOLS AT PRICES YOU CAN AFFORD

SET 7A 12 Different Size H. S. Straight Shank Drills, $\frac{1}{4}$ " to $\frac{1}{2}$ ", lengths up to 7" Ppd. Only **\$3.98**

HIGH SPEED DRILLS
 $\frac{1}{4}$ " to $\frac{1}{2}$ " with $\frac{1}{4}$ " Shanks
 $\frac{1}{2}$ " to 1" with $\frac{1}{2}$ " Shanks

SET 35A 6 Different Size H. S. Drills, $\frac{1}{4}$ " to $\frac{1}{2}$ " all with $\frac{1}{4}$ " shanks... Ppd. **\$2.98**

SET 36A 10 of above... Ppd. **\$4.95**
Set 35A and 36A will fit any $\frac{1}{4}$ " drill.

SET 32A 5 Different Size H. S. Drills, $\frac{1}{2}$ " to 1" with $\frac{1}{2}$ " shanks... Ppd. **\$6.95**

SET 33A 10 Different Size H. S. Drills, $\frac{1}{2}$ " to 1" with $\frac{1}{2}$ " shanks... Ppd. **\$12.95**

These new and used H. S. precision drills with $\frac{1}{2}$ " shanks can be used in a $\frac{1}{2}$ " electric drill or a $\frac{1}{2}$ " capacity lathe or drill press.

HIGH SPEED WOODRUFF KEY SEAT CUTTER

SET 4A 5 different size cutters. Can be used as mounted milling cutter or circular saw. All with $\frac{3}{8}$ " and $\frac{1}{2}$ " shanks, widths up to $\frac{1}{4}$ " dia. up to 1". New and used. Ppd. **\$3.95**



NEW HIGH SPEED COMBINATION DRILL AND COUNTERSINKS

SET 2A 8 selected sizes from A1 to F2 ($\frac{3}{64}$ " drill x $\frac{1}{8}$ " body to $\frac{3}{16}$ " drill x $\frac{7}{16}$ " body) 60° angle of countersink. New cost on these countersinks 75c to \$2.50 ea. Priced to you Ppd. at only **\$3.98**

Money Back Guarantee—All Mdse. Mixture of New and Reconditioned Unless Specified New. All items (Except Those Specified Post Paid) Will Be Shipped F. O. B. Tulsa—Or, Add 10% and We Will Ship Your Mdse. PPD. Write For Free Catalog Describing Thousands Of Bargain Cutting Tools.

H. S. TAPER SHANK CHUCKING REAMERS



SET 12A 15 Different Size High Speed Morse Taper Shank Chucking Reamers up to $\frac{1}{2}$ " with No. 1 and 2 tapers. New and used. Priced at only **\$7.95**

SET 13A 8 Different Size High Speed Morse Taper Shank Chucking Reamers from $\frac{1}{4}$ " to 1". New and used. Priced at only **\$6.95**

SET 12A 10 Different Size High Speed Morse Taper Shank Chucking Reamers from $\frac{1}{2}$ " to $1\frac{1}{8}$ ". New and used **\$12.95**
\$65.00 value. Priced at only

HARDWARE BARGAINS

The following hardware items are new standard brands. Add 10% to prices and items will be shipped Ppd.

Hdwe. #1 $\frac{1}{2}$ " drive socket set consisting of: 12" flex, handle, 12" sliding T, 18" speeder handle, 10" extension, universal joint and 12 sockets, sizes $\frac{7}{16}$ ", $\frac{1}{2}$ ", $\frac{9}{16}$ ", $\frac{19}{32}$ ", $\frac{5}{8}$ ", $\frac{11}{16}$ ", $\frac{3}{4}$ ", $\frac{25}{32}$ ", $\frac{13}{16}$ ", $\frac{7}{8}$ ", $\frac{15}{16}$ " and 1" **\$7.50**

Hdwe. #6 Box end wrench set, six wrenches, long pattern, size range $\frac{3}{8}$ " to 1" **\$3.30**

Hdwe. #7 $\frac{3}{8}$ " drive socket set consisting of: 7 sockets: $\frac{3}{8}$ ", $\frac{7}{16}$ ", $\frac{1}{2}$ ", $\frac{9}{16}$ ", $\frac{5}{8}$ ", $\frac{11}{16}$ and $\frac{3}{4}$ ", 3 extensions, 5", 8" and 12", sliding T, speeder handle, flex, handle and ratchet **\$6.95**

Hdwe. #9 8" needle nose plier **\$1.25**

Hdwe. #15 5 piece open end wrench set, heavy duty, size range $\frac{5}{8}$ " to $1\frac{1}{2}$ " **\$3.25**

Hdwe. #16 5 piece plastic screwdriver set, plastic handles, blade sizes, $\frac{3}{16}$ x 3, $\frac{1}{4}$ x 4, $\frac{1}{4}$ x 5, $\frac{1}{4}$ x 6, $\frac{3}{8}$ x 8" **\$1.85**

Hdwe. #17 10 piece box end wrench set, long pattern, $\frac{3}{8}$ " to $1\frac{1}{2}$ ", heavy duty **\$6.75**

Hdwe. #18 1 doz. high quality Hack Saw Blades, 24-teeth, 12" long. German manufacturer **\$1.10**

Bargain Tool & Shop Mixes!—Ppd.

HOSE CLAMP MIX: 50 assorted, new clamps up to $1\frac{3}{4}$ " **\$1.98**

MILLING CUTTER MIX: Assortment of 4 various size H. S. milling cutters, all with 1" arbors; up to 3" dia. only **\$3.98**

NEW ROTARY FILE MIX: 7 different size H. S. files, $\frac{1}{4}$ " shanks. New cost as high as \$2.00 ea. Only **\$4.49**

FILE MIX—BRAND NEW: Set of 12 different files, lengths 6, 8, 10, 12 in. Half rounds, bastards, knife, mills, etc. First line Nichols, Heller and other brands **\$3.49**

GRINDING WHEEL MIX: 30 grinding wheels with $\frac{1}{4}$ " arbors, up to 3" in dia., plus mandrel, only **\$3.29**

TAP MIX: 8 different size H. S. standard thread Hand Taps up to $\frac{5}{8}$ ", including 2 std. H. S. pipe taps. Ppd. **\$2.95**

MIDGET REAMER MIX: 12 H. S. straight shank Reamers, $\frac{3}{16}$ " down, majority new. Just the thing for the instrument man., jeweler, etc. **\$2.98**

6 Slitting Saws with Mandrel

SET 34A 6 Different Size High Speed Slitting Saws, $\frac{23}{4}$ " dia. x 1" arbor. Thickness from .040 to .071. Cuts wood, aluminum, brass, steel, etc. PLUS SPECIAL MANDREL which enables use of saws in $\frac{1}{4}$ " or $\frac{1}{2}$ " elec. drill. \$25 Value. Ppd. Only **\$4.95**

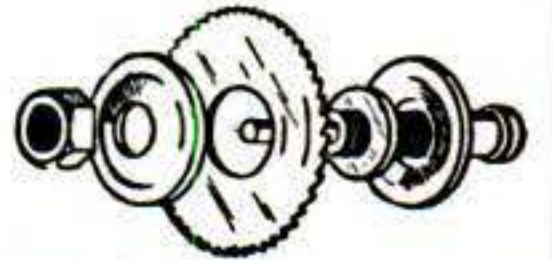

7 selected, sharp H. S. Slitting Saws as above to use on your own mandrel or milling machine. New and used. Ppd. A bargain at **\$4.95**

NEW 360° SWIVEL TYPE TOOL HOLDER AND BORING BAR

Here is a tool that will do the work of a left, right and straight tool holder, plus a boring bar, all for a fraction of its original cost.

TOOL A takes a $\frac{5}{16}$ " sq. bit or $\frac{5}{16}$ " dia. boring tool. Shank size $\frac{9}{16}$ " x 1" x $\frac{43}{4}$ ". Ppd. Only **\$3.29**

TOOL B takes a $\frac{3}{8}$ " sq. bit or $\frac{3}{8}$ " dia. boring tool. Shank Size $\frac{5}{8}$ " x $1\text{-}3\frac{1}{16}$ " x $5\frac{3}{4}$ ". Ppd. Only **\$3.95**

T & T TOOL 221 W. SECOND TULSA, OKLA.

HASTINGS STEEL-VENT PISTON RINGS

The best money you can spend on your car

5,000 MORE MILES From FRONT TIRES
"Educated Nut" Stops "Scuffing"—FREE TRIAL!

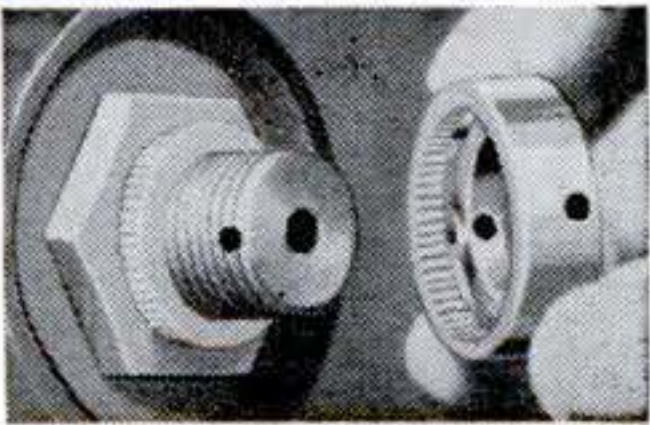

Long used by truck fleets (200,000 now in use) the "Educated Nut" is now available for all passenger cars. Allows you perfect adjustment on front wheel bearings every time. Replaces front wheel bearing nuts now on your car. When you "back-off" your present front wheel bearing nuts to insert cotter pin, you loosen your bearing adjustment enough to cause as much as $\frac{3}{8}$ " wobble on the tread. This causes "scuffing" and "snaketracking", costs you speed, rubber, gas, brakelining and \$\$\$\$.

THE EDUCATED NUT

- Adds up to 5,000 miles more tire life
- Stops bearing breakage
- Makes steering easier, safer
- Increases brake efficiency, stops 90% of all brake squeaks

HOW TO INSTALL
Screw threaded piece up to perfect adjustment (turn up tight, then back till wheel revolves free). Then line up cotter pin holes in cap with hole in spindle, snap on steel cap, insert cotter pin. You never "back-off" more and destroy adjustment to insert cotter pin as with old style nuts.

FREE TRIAL—Send no money. Just send name and address, make and year of car. A complete set of "Educated Nuts" (2 nuts, 2 caps, 2 pins) and instructions will be sent postpaid. Install and try. Feel the difference in driving immediately! Within two weeks, either return the complete set at no obligation or send just **\$2.98**

Dealer, truck owner, inquiries invited.
OLIZZI PRECISION PRODUCTS COMPANY Dept. 5-S
5024 Lankershim Blvd., No. Hollywood, Calif.

Precision Saw

No other 8" circular saw has 5-in-1 SHOPSMITH'S unique blade-to-fence adjustment, its big table area. Converts to lathe, sander, vertical and horizontal drill press. Write for free catalog.

SHOPSMITH, Dept. 182-A
12819 Coit Rd., Cleveland 8, O.

FINE TOOLS NEED FINE OIL!

- Lubricates
- Prevents Rust
- Cleans • Polishes

SOLD EVERYWHERE

3-IN-ONE Oil

BUILD IT FIX IT with AMBROID



Ready-to-use
Fast drying
High tensile strength
Transparent
Waterproof

IT STAYS STUCK
Dries entirely by evaporation of the solvent. Quick setting—no distortion. Ideal for assembling, repairing, home crafts, electrical work, factory, workshop or household use. Send postcard for free literature.

Try Ambroid in your business, too. For over 40 years recognized as the leading industrial adhesive of its type.

Art galleries, museums, and leading industrial concerns, rely on AMBROID

TRY A TUBE TODAY—At most hardware stores and hobby shops. If your dealer cannot supply you, send 25c for big 2 oz. tube, postpaid. Money back guarantee.

AMBROID 306 FRANKLIN ST. BOSTON 10, MASS.

PROTECT THE HOME YOU BUILD AND SAVE MONEY TOO!

USE NEVER-STAIN

ALUMINUM NAILS

- RUST PROOF
- ECONOMICAL
- SAVE PREMATURE PAINTING
- FHA APPROVED
- LAST A LIFETIME

WRITE DEPT. PS5 FOR FREE SAMPLES

NICHOLS WIRE & ALUMINUM CO.

DAVENPORT, IOWA

WORLD'S LARGEST MANUFACTURER OF ALUMINUM NAILS

WAR SURPLUS BARGAINS

HOT ROD SUPERCHARGER

Extra soup and go at a price you can't afford to miss! Mfr'd by Borg-Warner. Specifications: 7 1/2" deep, 7" high. Wgt. 17 lbs. Compact and sturdy, 4 base mounting holes, 3/4" outlet, 5/8" shaft with female Lovejoy coupling. Priced today at \$85. Our special SALE PRICE \$31.00



ALARM HORNS

and Sirens, 110 v. AC motor driven. Heavy duty with long life and adjustable tone high, med. and low. List \$47. NEW \$19.95



BRASS HAND PUMP.

Double acting pumps on forward and return strokes. Capacity 1000 gal. per hr. \$48 value, only \$18.50



LIGHT PLANTS

300 Watt 110-220 volt AC, Wgt. 40 lbs—portable \$99.
750-1000 Watt, 110 v. AC, Briggs & Str'n eng. \$169.
1000-1200 Watt 110 v. AC, only \$194
2500-3000 Watt 110 v. AC, Slow speed (1800 r.p.m.) Leland generator for longer life. Recond'nd and fully guaranteed \$295. NEW \$345.
Plants built in 1951 with tools and spare parts, \$426.
5000 Watt 120 v. AC, 4 cyl. gas engine, Hobart generator. List today \$1910.00. Used \$675.00. NEW, only \$895.00.

WINCHES

1,000 lb. cap. Hand oper. \$12.95
Hand operated ball-bearing model.
1500 lb. cap. 3-1 ratio, hand brake, 2 speeds.....\$39.50
6,000 lb. double drum. Hand operated.....\$49.50
1500 lb. electric drive...\$108.50
6000 lb. electric drive...\$188.50
Single drum, 3/4 HP motor 110 or 220 AC. Start-stop-reverse switch, belt pulleys & loose steel cable. Ratio 12-1. NEW.....\$125.00
Double drum model.....\$135.00

RUBBER HOSE

GOODRICH 2 ply 2" I.D. 25 ft. lengths worth \$25. Only \$4.95. 3 lengths for \$12.00.



Write today for free catalog. Thousands of \$\$ saving buys.

C&H ELECTRIC MACHINE Co. Inc.

436r W Juneau Ave., Milwaukee 3, Wisconsin

Auto Spark Intensifier Gets ROCKET Performance

The "Electronic Spark Intensifier" is just one item which can help you get MORE POWER, MORE SPEED, QUICKER STARTS and BETTER MILEAGE . . . when you want it!

FREE! FREE! FREE!
ACCEPT THIS \$2.00 ITEM ABSOLUTELY FREE!
Use it and enjoy its benefits without ever paying one red cent and with no obligation to buy anything at anytime. This is our way of introducing our family of high performance automotive products to you.

Easily installed in the center hole of the distributor cap of all cars, trucks and tractors, the intensifier boosts the high voltage passing through the distributor . . . giving a "hotter spark". This permits a wider spark gap which reduces misfiring . . . the cause of ring and cylinder wear.

OVER 10,000 OF THESE UNITS HAVE SOLD FOR \$2.00 EACH . . . ACCEPT ONE FREE WITH OUR COMPLIMENTS. THIS OFFER IS LIMITED TO ONE INTENSIFIER PER CAR OWNER AND SINCE THE SUPPLY IS LIMITED AND THIS OFFER MAY NEVER BE MADE AGAIN, WRITE TODAY!

ELECTRONIC DEVELOPMENT CO., Dept. FE, Box 17716 Los Angeles 34, Calif.



AMAZING NEW SAFE SAW MOST POWERFUL OF ITS KIND!

CUTS 1" WOOD, thin metal, plastic! New "201" Syncro QUIET for apartment use, SAFE for kids. POWERFUL for Dad's use. Any length cuts. Stroke adjustable. Portable. COMPLETE with BUILT-IN Motor, \$22.95 at dealers or postpaid. Write for Free circular today!

SYNGRO

ELECTRIC JIG SAW

SYNGRO Corporation, Dept. G-52, Oxford, Michigan



64" Flexible Shaft

WOVEN WIRE CORE

USE AS ELECTRIC DRILL

REAL BARGAIN—cannot be duplicated for \$15.00. Coupling fits 1/2" motor shaft; other end fits standard chuck. Durable, heavy. Use it for grinding, polishing, buffing, drilling, etc. Chuck for same—\$1.25.

only \$5.95

SEND NO MONEY—ORDER TODAY. This low price can't last. Pay postman—plus postage. Send check or money order and we will ship P.P. prepaid. Money refunded if not satisfied.

HARRY W. RETTEW

400 WEST AVE., JENKINTOWN, PA.



**THE
Ace of
LOW COST
TRANSPORTATION**

Cushman

- 75 miles per gallon
- 50 miles per hour

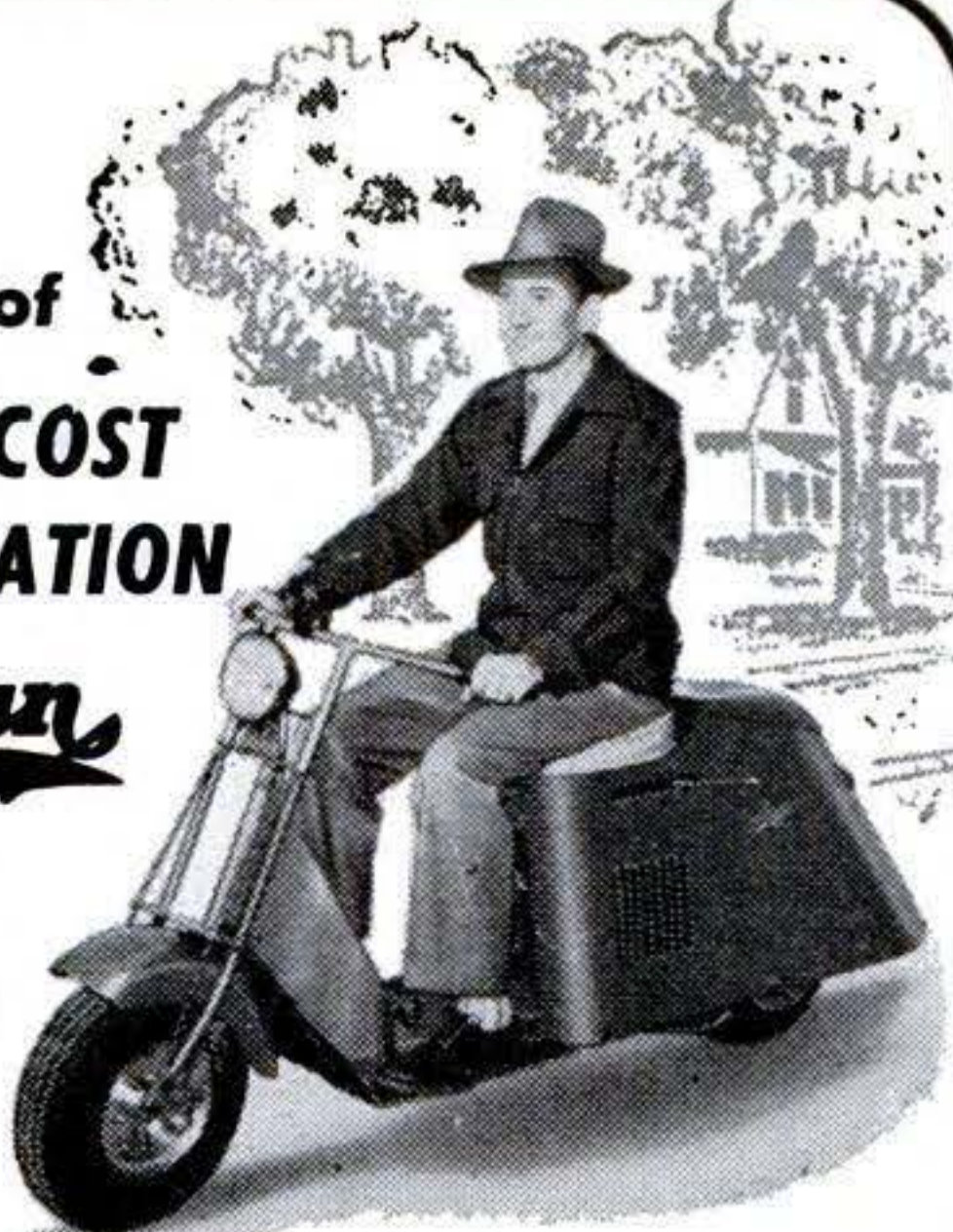

Cushman is the "Trump Ace" of speedy, convenient, low cost transportation. Ride it to work, ride it for pleasure, quick trips around town. Ideal in traffic, no parking problems. Eliminates the second car in the family. Operate your Cushman for less than one penny per mile! Over fifty years of engineering experience gives you maximum power, maximum economy. Go Cushman in '52!



Write today for FREE illustrated literature
CUSHMAN MOTOR WORKS, INC.
917 E ST. • LINCOLN, NEBRASKA

ROTO-HOE

The Pioneer Complete, High Quality, Low-Priced Garden Tool

2 H.P. ROTO-HOE (as shown) only \$134.00

A complete tool for the garden—Tills, Cultivates, composts (also a portable power unit)

YEAR ROUND ATTACHMENTS

- 20" ROTO CUTTER—for excellent lawn care. (only \$40 extra)
- 12" TRIMMER-MULCHER (\$24 extra)
- 17" SNOW BLOWER—saves 75% time and work on snow removal (only \$34.50 extra)

Ask your Dealer for a Demonstration. Write today for FREE folder.

ROTO-HOE & SPRAYER CO.
Box 18 NEWBURY, OHIO



America's MOST USABLE GARDEN TOOL!

Regular Price of a Slide Rule \$4 and up

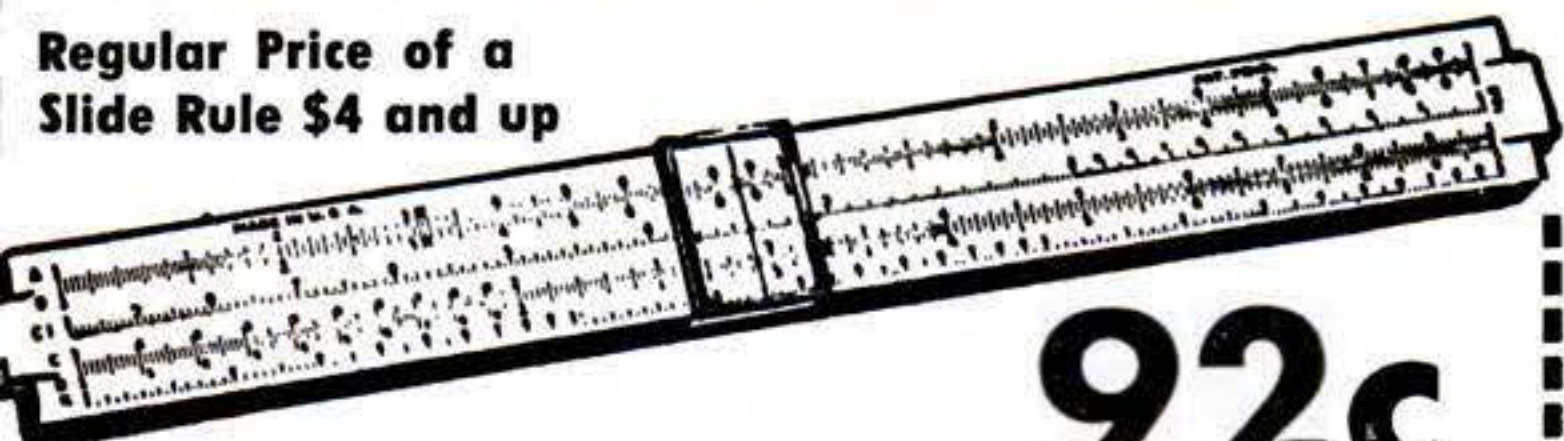

Slide Rule

92c

and this coupon Add 8c Postage

If you know how to use a pencil you can use a slide rule For bookkeepers, accountants, salesmen (figuring commissions, cost, etc.), farmers, housewives, etc. For Armed Forces highly important. Men's most useful tool. Easy to calculate instantly. Multiplying, proportions, division, extracting roots, etc. "High Vision" Clear View Slide. Full 10" Rule. A, B, C, D, CI and K scales. FREE 28-page instruction book on how to get correct answers instantly without pencil or paper.

Gene Loewy, 545 5th Ave., Dept. 144-C, N. Y. 17
Limit three rules to each coupon

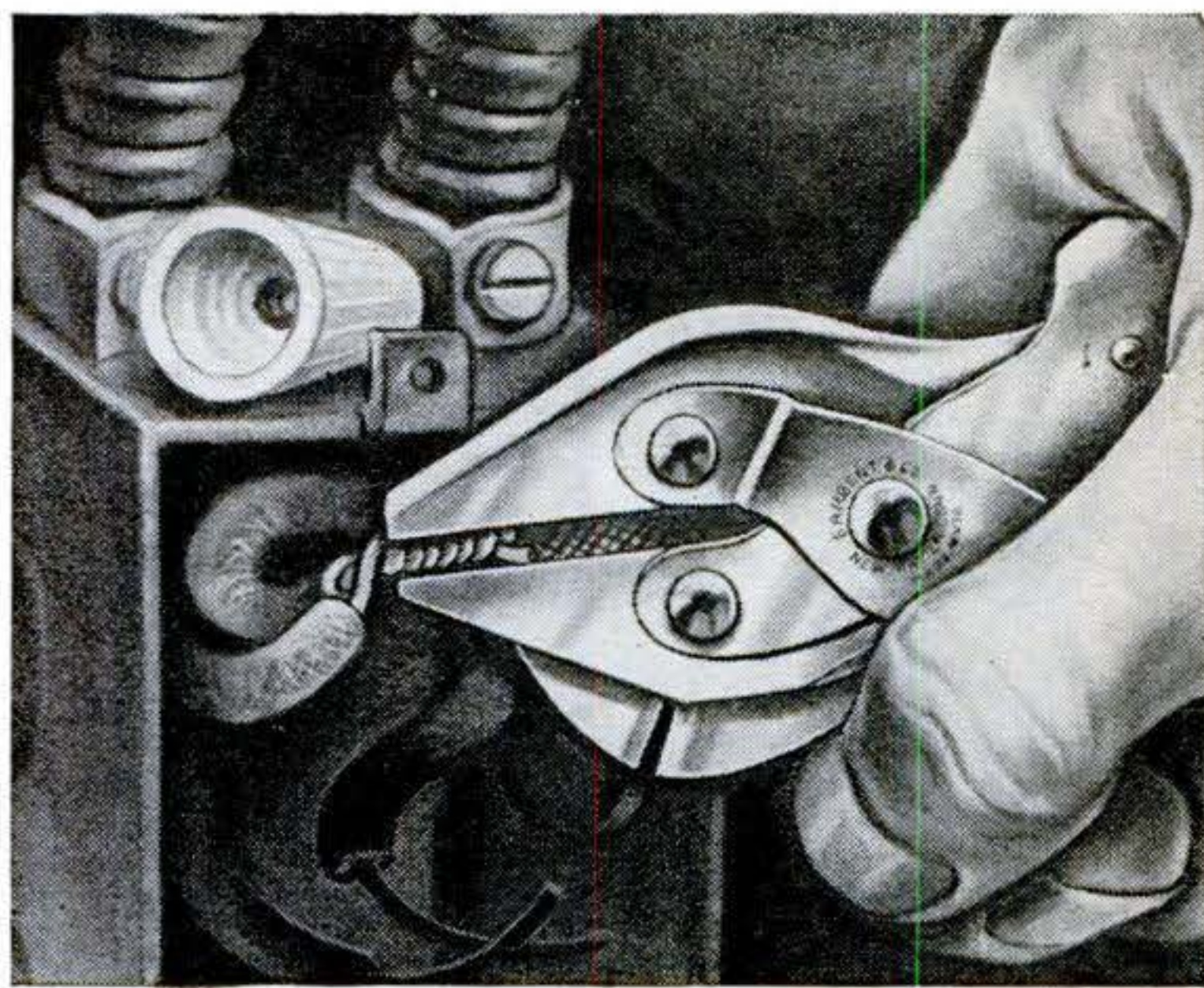

This single tool is...

- A PLIER
- A CUTTER
- A WRENCH



...with the non-slip jaws of a vise

This Sargent No. 102 Outside Cutting Plier makes tough jobs easy...



- **Extreme Gripping Power** is developed by multiple fulcrum... parallel jaws grip throughout their length.
- **Outside Cutter Blades** make it the only plier that will even cut wire which lies tight against a flat surface.

- **Open Throat** allows wire to run between jaws from either end... to straighten or pull wire.

Available in 4½", 5½", 6½" and 8" lengths.

See it at your hardware dealer, or write for full details. Dept. 26 E **Sargent & Company**
New York • New Haven, Conn. • Chicago

SARGENT TOOLS FOR EVERY PURPOSE



Long Nose Cutting Plier No. 574



Aviation Metal Snips No. 888



Diagonal Cutting Plier No. 177



The Tops in Tools
The Latest in Locks

Builders Hardware and Fine Tools since 1864

NEW!

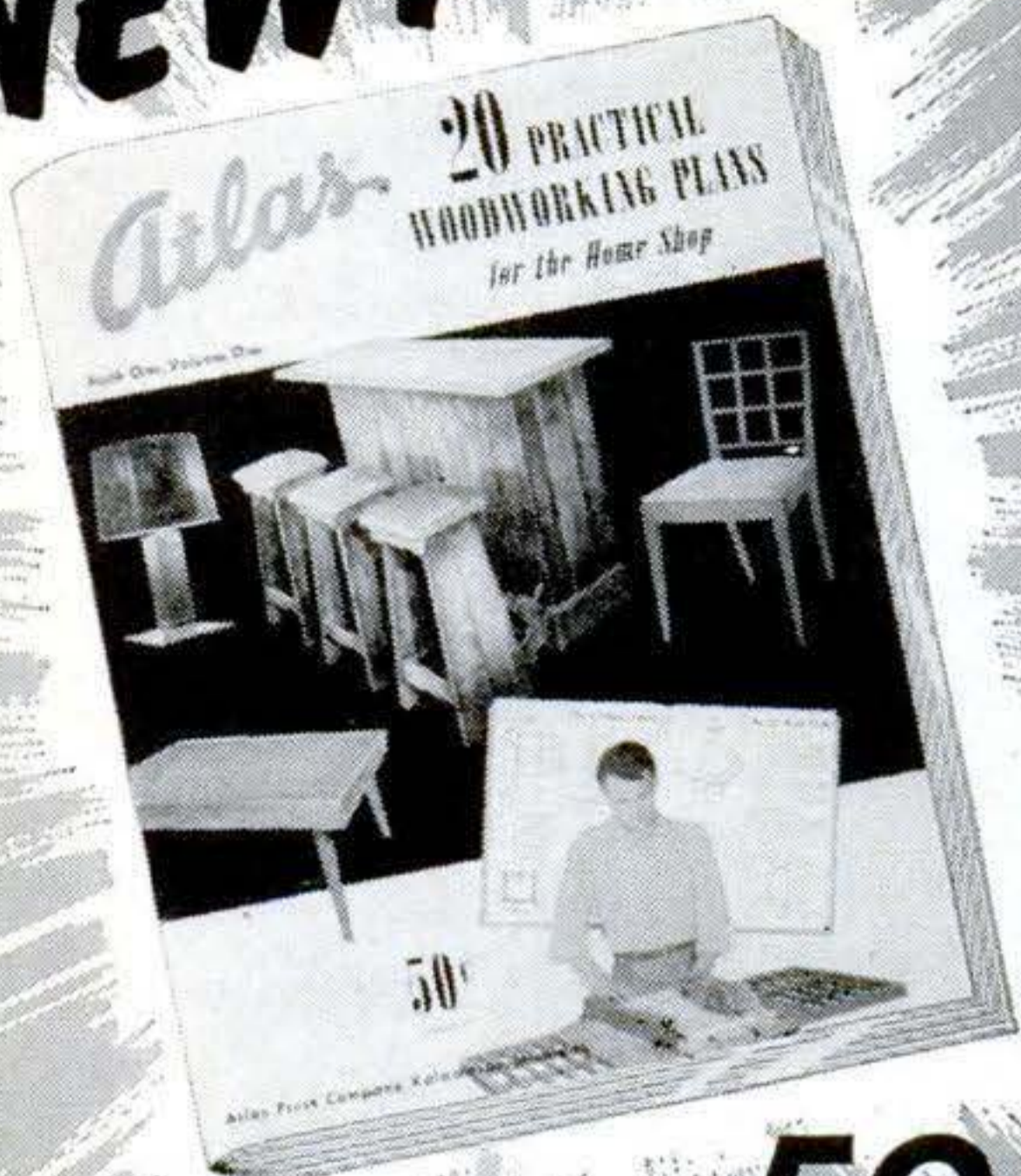

- and only 50¢

20 original projects . . . drawings, photos, step-by-step instructions . . . tips on joinery, gluing, finishing . . . send \$.50 cash (no stamps) per copy, \$.65 outside U.S.A. Limited first edition, order today.

ATLAS PRESS COMPANY

Atlas 555 North Pitcher Street, Kalamazoo, Michigan
DEPENDABLE QUALITY TOOLS SINCE 1911

Get STRYPEEZE

. . . the only Guaranteed
PAINT REMOVER

Removes All
Finishes QUICK

STRYPEEZE is guaranteed to stay wet longer and remove more coats of finish per application, indoors or out, than any other remover, or your money back! Clings to upright surfaces.

HARMLESS
to hands

Buy it where you
buy paints.

FREE, Send for Folder
"How to Remove Paints, etc."



Pint only 75c

SAVOGRAN CO., Dept. 46, 25 Huntington Ave., Boston 16, Mass.

258 POPULAR SCIENCE

THIS WIRE HAS NOT BEEN OVERSEAS
This high quality two conductor communication wire offered in No. 18 and No. 22 gauge is ideal for intercoms, lead-ins, telephones, indoor and outdoor speaker extensions, doorbells, signal and burglar alarm systems, shot firing, etc. etc. **SAMPLES ON REQUEST.**

U.S. GOV'T CLOSEOUT

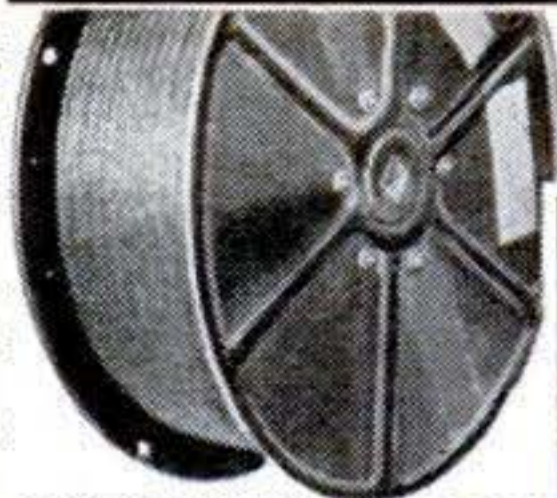

Wire
**U. S. Signal Corps
Communication Wire**
\$3.50 per 1000 ft. TWISTED TWO CONDUCTOR No. 22 STRANDED
\$3.50 TWISTED TWO CONDUCTOR No. 18 STRANDED per 1000 ft.

ABSOLUTELY NEW AND PERFECT
Mfgd to rigid Signal Corps specifications

Won't Last Very Long at These Prices
Stock Up Now — Subject to Prior Sale — Order Today
W-110-B—TWO CONDUCTOR #18 STRANDED (four steel and three copper strands) rubber covered plus weatherproof cotton braid and twisted. 5,280 feet per steel reel. Only \$3.50 per thousand feet (3/5c per ft.) or \$18.25 per reel.
W-130—TWO CONDUCTOR #22 STRANDED and twisted (one copper and six steel strands) in your choice of rubber or plastic insulation. 10,000 feet per steel reel. Only \$3.50 per thousand feet (3/5c per ft.) or \$35.00 per reel.
(Note: Steel strands are incorporated for extra tensile strength and are tinned and treated for efficient conductivity.)
All these way below market prices, our stock will not last long. Take advantage of this exceptional closeout and **STOCK UP NOW!** Minimum order—one reel.

Prices F.O.B. Chicago. Include approx. postage on orders paid for in advance. C.O.D. orders enclose 25%, balance sent C.O.D. WRITE FOR FREE ILLUSTRATED CIRCULAR.

U. A. S. Corp. Dept. PS-5 5637 W. 63rd Pl. Chicago, Ill.

FIX LOOSE CHAIRS

Amazing "Chair-Loc" S-W-E-L-L-S Wood!

NOT A GLUE



FREE Instruction Booklet

Penetrates wood fibres—makes them e-x-p-a-n-d, locking chair rungs, dowels, legs, handles, knobs, ladders, joints, drawers **TIGHTLY** in place. Use no metal devices or cements. **NOTHING LIKE IT!** Quick, clean, easy. Not necessary to take parts apart. Lasts years. Over 300,000 sold! **CRAFTSMEN'S SPECIAL—1 pt. \$1.50 postpaid. Money back guarantee.** Or small size 35c at Hardware and 5 & 10's. Order NOW from Chair-Loc Co., Lakehurst 8A, N. J.



CASH IN YOUR SPARE TIME! BIG MONEY IN OWN BUSINESS

YOU CAN MAKE UP TO \$40 a DAY sharpening and setting circular saws for factories, builders, lumber yards—with **LIFE-TIME SECURITY YOUR OWN BUSINESS**
NEW BELSAW COMPLETE CIRCULAR SAW SHOP. Low Cost, only \$15 down, sharpens 4 to 5 saws an hour. No experience needed! Instructions Furnished. Send Postcard Today for FREE BOOK. BELSAW MACHINERY CO. 4405 Field Bldg. Kansas City 2, Mo.

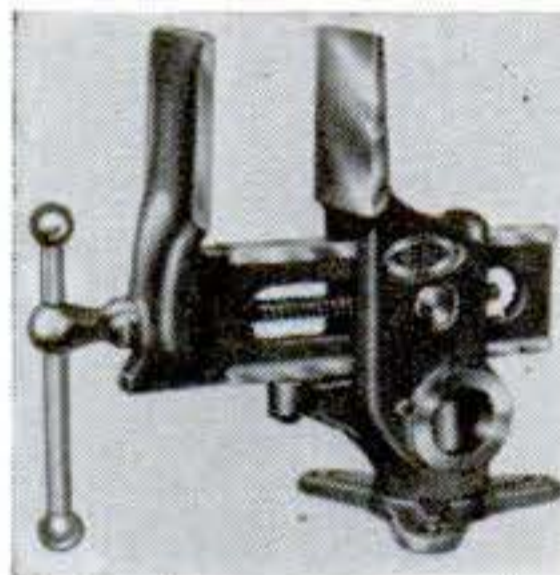

DESIGNED FOR THE HOME WORKSHOP

Here's the ideal vise for those hard-to-do jobs. Use upright (as shown), flat on its side, turned to any angle. Order now—only \$9.95 f.o.b. factory, or send for folder. Money-back guarantee.

THE WILL-BURT CO.
Dept. PS Orrville, Ohio

MODERN LAWN MOWER SHARPENER

Service departments of leading Lawn Mower manufacturers use the Modern Lawn Mower Sharpener. One lever moves lawn mower into grinding position. Gasoline and oil remain in engine while sharpening, no dismantling of wheels, roller or handle. The Modern is a precision bed knife grinder—no extra grinder to buy. Imitated but never equaled—Compare before you buy. If it isn't a Modern it can't be Modern

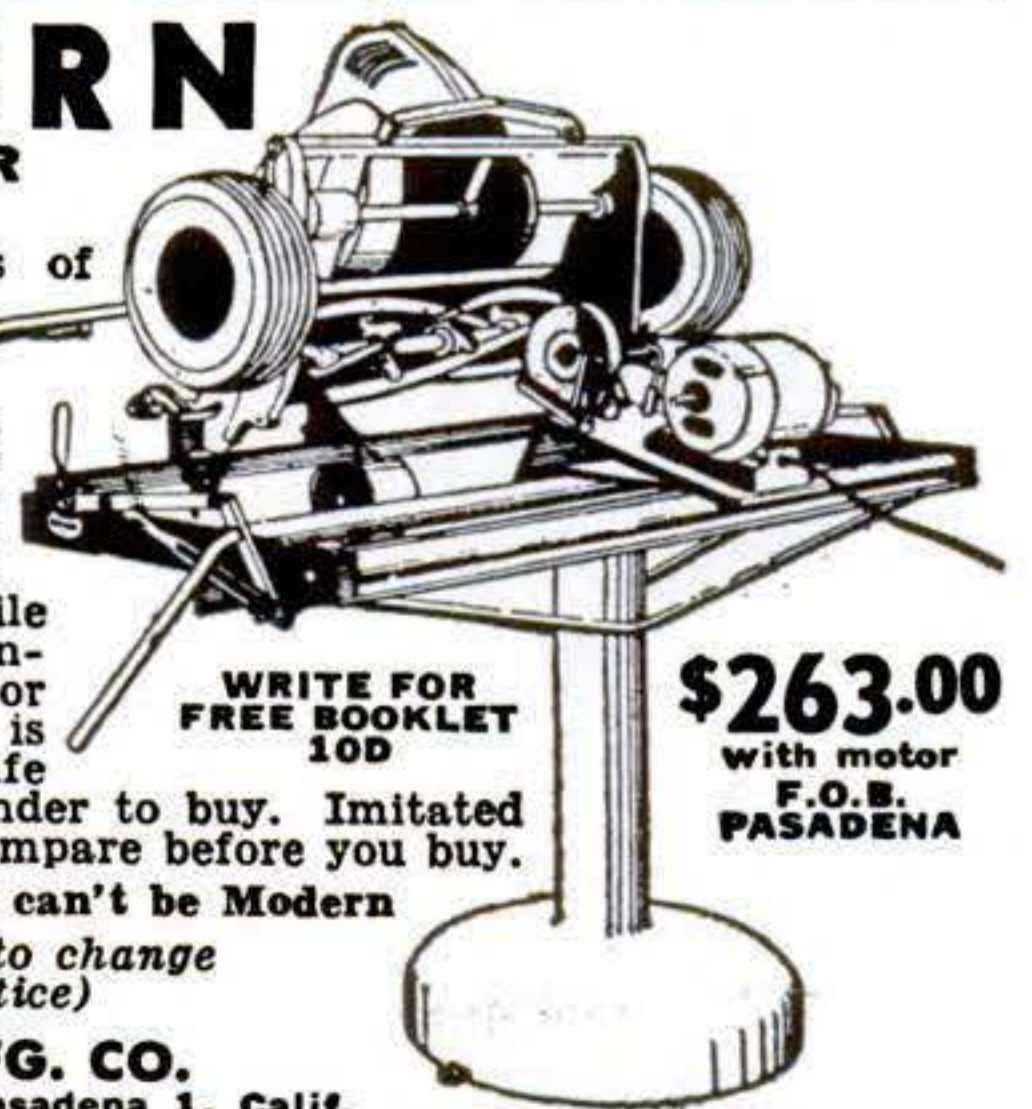

WRITE FOR FREE BOOKLET 10D

\$263.00
with motor
F.O.B. PASADENA

(Prices subject to change without notice)
MODERN MFG. CO.
160 N. Fair Oaks - Pasadena 1, Calif.

GIGANTIC CLEARANCE MAIL SALE

WAR SURPLUS EXCESS INVENTORY BANKRUPT STOCK



● TREMENDOUS INVENTORY SALE

● WE PAY SHIPPING CHARGES

AIR COMPRESSOR UNITS

Paint, blow up tires, control termites, use in shop, etc. Build your own unit.

- **DeLuxe Kit.** Build your own. Save 50%. Consists S.S. 12"x24" (400 lb. test) tank, 1-cyl. piston 3 c.f.m. compressor, valves, gauge, fittings, hose and excellent paint gun, dust gun, tire chuck, "How-to-Build" instructions \$45.90
- **Quincy Portable Compressor.** 110-v., 60-c., 100 lbs. pressure, 1-cyl. 2-wheel, with tank, gauge, hose and paint gun, tire chuck, etc. Ready to use. Special.....\$74.95
- **Air Components.** Piston compressors (a) 1-cyl. \$20.50, (b) 2-cyl. \$49.50. Adj. Auto Pressure Switch, (on 50 lb., off 75 lb.) \$4.95. Pres. Regulator, (0 to 250 lbs.) \$2.65. Gauges (60, 100, 160 lb.) \$1.89. Pressure tanks, 6"x24", \$5.49, 12"x24", \$11.95. Adj. Safety Valve, \$1.95. Air hose with fittings, 25' \$3.35. 50 ft. special...\$6.29. Air blow gun...\$1.21

Write for useful Air Data-Catalog



POWER GREASE GUNS

● **Genuine Lincoln.** Automatic. Powerful, quick, work on any air compressor. Complete. Mfr. price \$61. SALE.....\$29.85

WINCHES and HOISTS

- **Boat, dock, utility hand winch.** 1-4 gear ratio. 1500 lb.....\$19.95
- **Industrial light duty.** Hand 1-3, 1-9 ratio. 2000 lb.\$29.95
- **Cable** 1/4", 50', with load hook\$8.95
- **Contr. hvy. duty, hand,** 10,000 lb. 1-5, 1-27 ratio\$89.95
- **Heil Power Winch.** 15,000 lbs. with 150' 1/2" cable. Cost \$290\$179.00
- **Coffing Chain Hoist.** Lever ratchet type, 3000 lbs. 100s of uses. Special value.....\$19.95

G. E. DICTATION MAGNETIC RECORDERS

● 110-v, 60-c. For home or office-child training, etc. A four-star buy! SALE.....\$29.50

WATER PUMPS and SYSTEMS

Save 60%. Expert advice on problems, wells, irrigation, sprays.

- **Centrifugal Pumps.** Cast iron case, bronze impeller, stainless shaft, ball bg. To 140 g.p.m. Pressure to 30 lb. 3/4", \$18.90, 1", \$28.90, 1 1/4", \$35.60.
- **Rotary Pumps.** Low pressure: (to 25 lbs.) Self priming, Hy-Car impeller. To 20 g.p.m. 1/2", \$12.75, 3/4", \$16.95, 1", \$22.95. High Pressure type: Positive displacement. Pressures to 150 lbs. To 20 g.p.m. 1/2", \$14.50, 3/4", \$20.95, 1", \$27.95.
- **Burdex Shallow Well Water System.** 110-v. 1/4 h.p., 300 g.p.m. 40 lbs. pressure \$69.50

PRECISION HYDRO-JET PUMP

● Wonderful surplus value! Brand new standard unit. Designed for orchard, garden, yard, farm, brush and tree (kill) spraying. 30 to 80 lbs. pressure. 1 to 3 gal per min. Self priming. 25' lift. Can also be used as low pressure (1500 gph) pump. Leading make. Clinton 1.5 h.p. engine. 15' hose, spray jet nozzle. Wt. 65 lbs. List \$149.50. SALE \$99.70

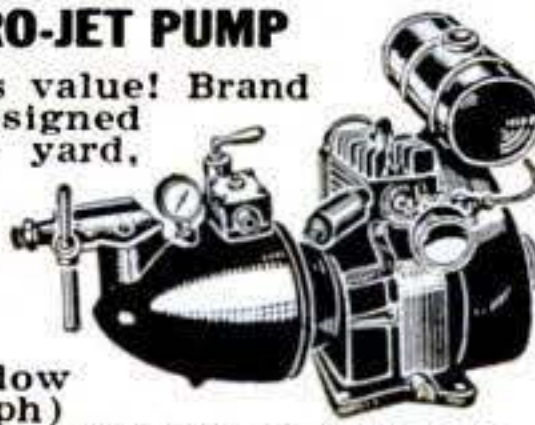

Write for special Water Pump catalog-data

TRACTOR WEED SPRAY OUTFITS

● **Farm Special** (good to June 1 only.) 5-row all brass T-jet boom. P.T.O. bronze gear pump, hose, all fittings and controls. Universal mounting. Regular \$140.50.....\$79.50



WIND DRIVEN POWER PLANTS

● Ideal for lights, radio, battery charging. Fine for remote camps, farms, etc. Complete, 6-volt, 30 amp. D-C generator. 7-ft. propeller, relays, 6-ft. steel tower, etc. Brand new. Original cost \$95. SALE \$33.95



POWER PLANTS & GENERATORS

- **Kato Generators.** 5-kw, 115-v, 60-c. \$259.60
- **Burdex Generators.** 115-v, 60-c. 1 ph. 500-watt, \$94.50. 1000-watt, \$134.90. 2000-watt\$159.50
- **Master Plants.** 5-kw, 115/230-v. 60-c. 1 ph. 4-cyl. water-cooled engine...\$597.90
- **Onan Plants.** 1-kw, 115-v, 60-c. 1 ph. Full automatic start-stop. Special. \$291.50

Send for Power Plant and Generator bargain list

HI-INTENSITY FLOODLIGHTS

● G. E. Sealed Beam air force long-life extra hi-intensity parabolic precision reflector units. 24-v, 250-w. 8" size. Equivalent 2500-w ordinary lite. Use 5 in series on 110-v for 800,000 candle-power illumination effect. Light building fronts, parking lots, ball parks, constr. jobs. Original cost, 5 units, \$39.00. SALE, 1-unit, \$1.95. 5-units, \$7.49.



PLANE PROPELLER

● New perfect beautiful laminated polished hardwood brass-tipped-edged air force propellers. 90" long. Wt. 75 lbs. Wonderful den or club decoration, wind chargers, ice sleds and cars, planes, etc. Govt. cost \$112. Sale.....\$12.95

PHONES—CITY and RURAL

- **Rural Magneto.** Compact oak case. Wall. (a) 3 bar, 1000-ohm, \$9.95 (b) 4-5 bar, 1600-ohm, \$13.90. CITY up-right desk, with bells \$4.99. Phone only, \$2.69.

MISCELLANEOUS BARGAINS

- **Imersion Heaters.** 800-w, 110-v. ..\$ 3.98
- **Battery Chargers, G.E.** 110-v, Selenium\$ 4.95
- **Tachometer, Direct rd.** 0-4000 r.p.m. \$ 6.79
- **Compass, Air Force.** Cost \$59.....\$ 8.95
- **Chain Saw, Electric,** 110-v, 8-amp. \$115.00
- **Chain Saw, Demstrtr.** Gas, 4 h.p. \$289.70
- **Hand Saw, Electric,** 6 1/2", 110-v. ..\$ 37.40
- **Drill, Electric,** 1/2" cap. 110-v.\$ 26.95
- **Drill, Electric,** 1/4" cap. 110-v.....\$ 11.76
- **Burglar-Fire Alarm,** magnetic unit..\$ 1.49
- **Hydraulic Cyl.** 3"x31", 19" stroke..\$ 18.49
- **Fire Alarm Control**\$.99
- **Abrasive Stones** (Kit of 10) 1/2" bore\$ 3.53
- **Heater Coils,** 2000-w, 110-v.....\$.99
- **Barometer,** Beautiful precision unit \$ 5.95
- **Bolt-Screw-Nut Mix.** A buy! 6 lbs. \$ 1.99
- Hundreds other bargains in tools, electronic items, radio, etc.

ORDER FROM AD or Write for Free Catalog!

BURDEN'S 30-Year Policy: ● Everything guaranteed to satisfy. ● We pay all shipping charges in U.S.



BURDEN SALES COMPANY

827 "O" ST.,

LINCOLN, NEBRASKA

NEW 1952 KING MIDGET AUTO

WORLD'S LOWEST PRICED 2 PASSENGER CAR. Drive it for 75c per week. Amazing performance. Surprising comfort. All steel construction. Full accessories, top and heater. Ready to run or assemble it with our bolt together parts. Rider agents wanted, earn your car Free. Send 25c for detailed literature or \$1 (refunded first order) for actual assembly book and service manual filled with photos, drawings, specifications, etc.

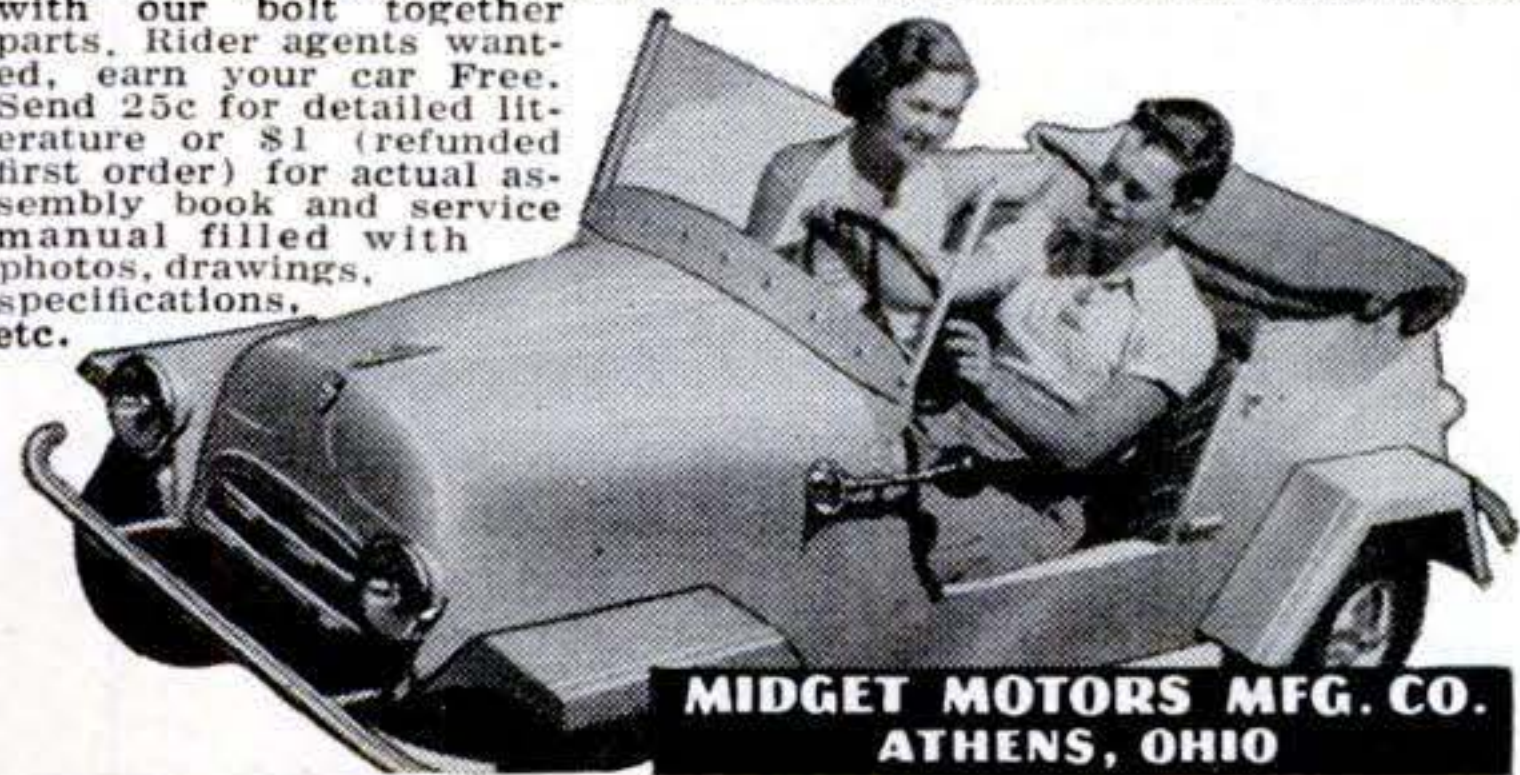

MIDGET MOTORS MFG. CO. ATHENS, OHIO

SAVE MONEY-ON PAINTING

FREE BOOK TELLS how to get better paint results at no extra cost. Given free by America's leading aluminum producer so you can get full value and satisfaction from aluminum paint. Written by experts... packed with facts... write for "Paint it Bright."

Aluminum Company of America, 1717E Gulf Bldg., Pittsburgh 19, Pa.



Start Your Own Welding Business with a HOBART "Simplified" arc welder



Go after WELDING jobs that Pay Big Money!

Write today for complete details on this Profit Making Equipment No Obligation

Never before has the demand for welding been so great—the profits so large. That's why smart operators everywhere are setting up their own welding business... and you can do the same.

SIMPLY CHOOSE from our complete line, the welder that best suits your needs—gas or electric drive—portable or stationary. The big pay jobs are waiting, so don't miss this opportunity. Write today.

"One of the world's largest builders of arc welders"

HOBART BROTHERS CO., Box P-52 Troy, Ohio



DRIVE FOREVER AND NEVER CHANGE YOUR OIL!

WITH GUARANTEED **TISSU-PAK** OIL FILTER

Absolutely New! Write for FREE Catalog.

HENDERIZE, INC. ● 5667-IP Freeport Blvd. Sacramento, California

Wellworth BARGAINS

ALL BRAND NEW EQUIPMENT

at a GREAT SAVING!

The BIG 3-Wellworth COMPRESSORS

1 YEAR GUARANTEE

FEATURES: 2 compression and one oil ring, aluminum alloy connecting rod. Stainless steel valves with brass seats and retainers. Cool-flo cylinder head, spray mist lubrication to every moving part. V-groove fly wheel.



MODEL W800	MODEL W3	MODEL W7
2" bore, 1 3/4" stroke. 2 to 2.8 c.f.m. up to 150 lbs. pressure. Operates with 1/4 or 1/8 HP motor.	2 1/2"x2". 2.55 to 4.80 c.f.m. up to 150 lb. pressure. Operates with 1/8-1/2-3/4 HP motor.	2 cylinder 2 1/2"x2". 5.10 to 8.50 c.f.m. up to 150 lb. pressure. Operates with 1/2-3/4-1-1 1/2 HP motor.
\$20.50	\$27.95	\$54.50
Shipping wt. 16 lbs.	Shipping wt. 24 lbs.	Shipping wt. 45 lbs.

BIG 3 SPRAY GUNS

Sold only by WELLWORTH



W20—Pressure feed. Internal atomizing. Fan, round and angle nozzles included. Qt. cup. Wt. 5 lbs. **\$7.50**

W103—External atomizing. Flat and round spray. Qt. cup. Maintains 35 to 40 lbs. at 2 to 4 c.f.m. working pressure. Filter built in handle. Wt. 6 lbs. **\$9.95**

W28—2-way, internal and external mix. 4 nozzles, 2 fluid tips. Requires 2 to 4 C.F.M. at 30 to 50 lbs. pressure. Qt. Cup. Wt. 6 lbs. List \$18.50—Only..... **\$12.95**

AIR TANK

and Accessories
6"x24" tank, air gauge and chuck, 20 ft. hose, pop-off valve, copper tubing with 4 brass flared fittings, 4 way cross, 3 nipples. Price



\$12.45
Tank Only
\$6.25
Same outfit as above with 12" x 24" stainless steel tank, 400 P. S. I.
\$19.75
Tank Only
\$14.50

PRICES F.O.B. CHICAGO. MONEY BACK GUARANTEE. SEND CHECK OR MONEY ORDER TODAY. PROMPT SHIPMENT. WRITE FOR OUR CATALOG OF GENERATORS, LIGHT PLANTS, BLOWERS, ETC. SEND 10c FOR POSTAGE.

WELLWORTH TRADING CO.

1832 S. Wabash Ave.
Dept. B-552
Chicago 16, Ill.

5 BIG POWER TOOLS



RETAIL PRICE \$125.00
FACTORY TO YOU \$79.95

SUPERSHOP is a PRECISION-BUILT WORKSHOP. 100% ball bearing. All running parts precision ground. Big capacity. Extra rugged. Amazing value. Write for FREE catalog.

BUY ON EASY PAYMENTS

POWER TOOLS, INC. 235 YATES AVENUE, BELOIT, WISCONSIN

VERTICAL DRILL PRESS

ALNICO MAGNETS LIFT 225-lb.

AMAZING PERMANENT MAGNETS—WILL NOT WEAKEN! NON-ELECTRIC. Retrieve guns, tackle, tools and other steel items from lake, river, plating tanks, drains or other hard-to-reach spots. Recover drills, taps, etc. from floor sweepings. Clear alley of harmful tacks, nails. Many other uses listed. Pays for itself quickly. **GUARANTEED: Try any magnet one week. Money refunded if you are not well-pleased.**

No. S-725 (Weights 54 Oz.) Has a pull of 225 lbs. on a steel block... **\$15.00**
No. S-675 (Weights 49 Oz.) Has a pull of 175 lbs. on a steel block... **\$10.50**
No. S-650 (Weights 41 Oz.) Has a pull of 150 lbs. on a steel block... **\$ 8.50**
No. S-550 (Weights 14 Oz.) Has a pull of 50 lbs. on a steel block... **\$ 4.00**
No. S-530 (Weights 8 Oz.) Has a pull of 30 lbs. on a steel block... **\$ 3.00**
No. S-30 Hobbyist assortment of six small magnets..... **\$ 1.50**

Send Money Order or Check. We pay postage. No C.O.D. Shipments.
MIAMI MAGNET CO., 3240 N. W. 27th Ave., MIAMI 42, FLA.



BRONZE FOUNDRY

Schools and Home Workshops

Make your own castings of aluminum, copper, bronze, silver. Foundry sets are available in three sizes including 2400 Deg. F. blast Furnaces, \$22.50; \$29.50; and \$42.00. f.o.b. Kansas City. Free Circular.

KANSAS CITY SPECIALTIES CO. P. O. BOX 6022, DEPT. S-5 KANSAS CITY, MO.



TRANSFORMER WELDER \$18.95 FOB QUINCY

Complete with everything. Ready to plug in. 110 volts A.C., 15-30 amps. 5 heats. Welds metal from 1/16" to 1/4" using 1/16" to 1/8" standard rods. One year guarantee. 10-day trial. No C.O.D. We also make welder for 16-22 gauge metal, \$3.95; 1/8" metal \$6.45.

ESSAY MFG. CO., INC., Dept. 47, Quincy 69, Mass.

WANT TO SAVE GAS? 1/2 MILLION NOW USE GANES

AMAZING GANE NEEDLE TRY ONE FREE IN YOUR CAR!

TRY BEFORE YOU BUY! FREE

MANY GANE NEEDLE USERS REPORT UP TO 25% more mileage, faster pickup, easier starting and smoother idling.

NOW TEST A GANE NEEDLE IN YOUR CAR for ten days, then compare your mileage and performance. If satisfied, send \$1.50 per needle (8 cyl. cars take 2). If not satisfied, just return it—fair enough? Since authorities differ on its merits and some users report no improvement. **TRY BEFORE YOU BUY!** (Gane Needle replaces idling adjustment screw in carburetors—easily installed in a few minutes.)

WRITE TODAY. ENCLOSE NO MONEY. PAY POSTMAN NOTHING. Just send us your name, address, and make and year of car.

NATIONAL AUTOMOTIVE RETAIL CORP., Dept. H-5
350 W. Washington Blvd. Venice, California

DO IT EASIER --- FASTER --- BETTER

with a **SHAW "DU-ALL"**

Walking or Riding Tractor

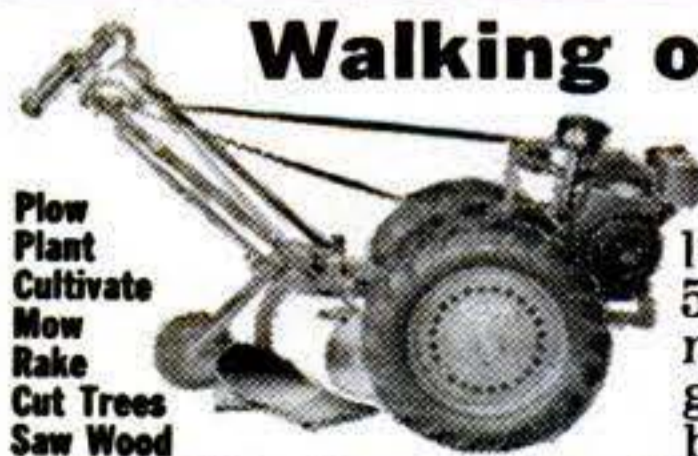

Plow
Plant
Cultivate
Mow
Rake
Cut Trees
Saw Wood

1 1/2, 2 1/2, 3 and 5 H.P. walking tractors for all large and small gardening. 5, 8 and 12 H.P. riding models that will handle good sized farms. Quality built for 50 years. All

wanted tools and attachments. See the Shaw dealer. Write for **FREE CATALOGS**, low prices on complete Shaw line. Address

SHAW MANUFACTURING CO.
5705 Front St., Galesburg, Kansas
668-PS N. 4th St., Columbus, Ohio

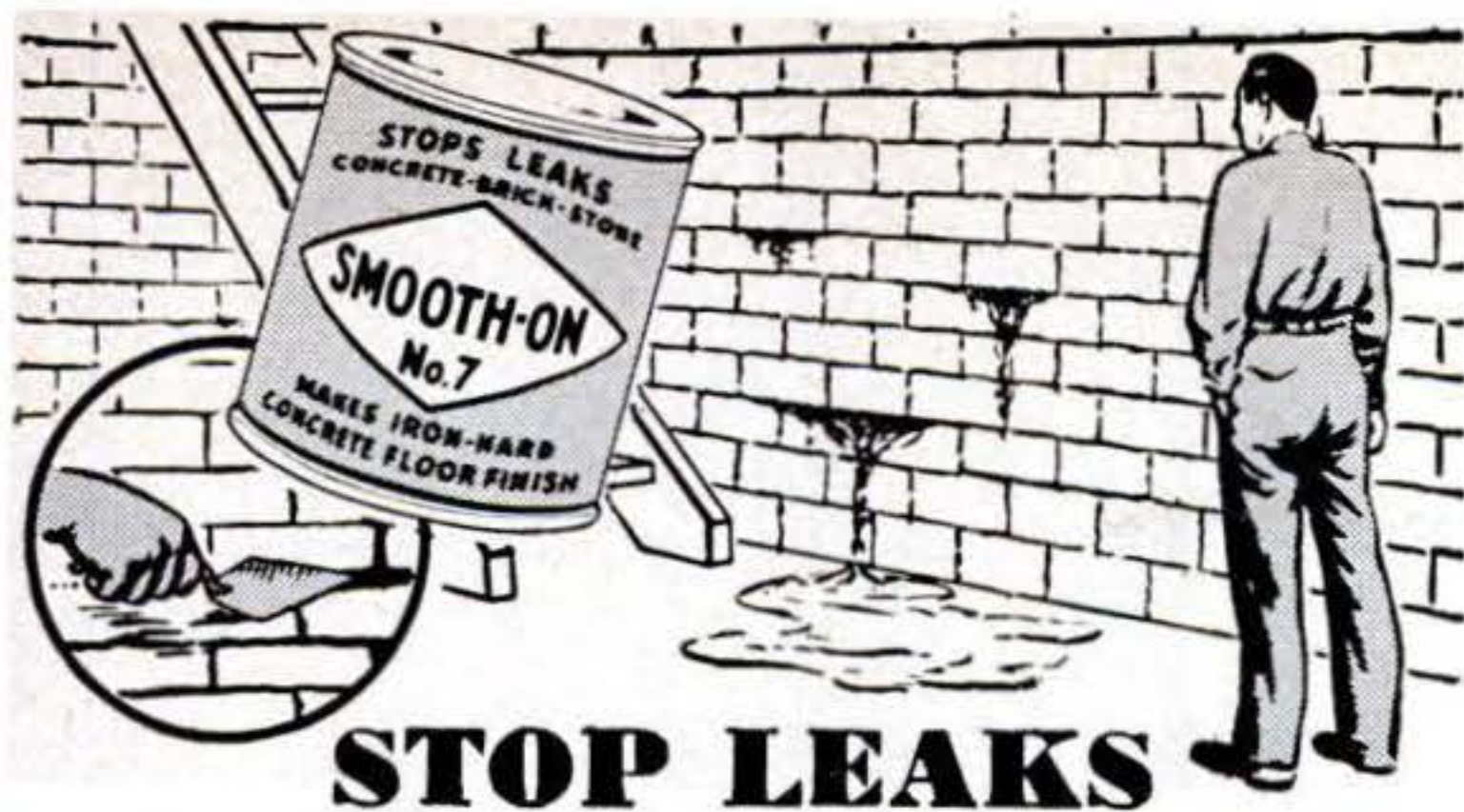

STOP LEAKS IN CELLAR WALLS

Do it with Smooth-On No. 7 Cement! Apply with trowel or stiff brush to leaky cracks, holes, porous spots, seams or other leaks in concrete, brick or stone walls and floors. The leaking will stop and Smooth-On will "stay put", for it expands slightly as it hardens. May be applied to wet or dry surfaces, indoors or outside. Use Smooth-On No. 7, too, to seal openings around pipes passing through walls. Buy Smooth-On No. 7 by name and number in 1-, 5-, 20- or 100-lb. size. If your hardware store hasn't it, write us.

FREE Leaflet and Handbook

We'll send you leaflet showing No. 7 uses, also the famous 40-page Smooth-On Repair Handbook describing other Smooth-On Cements and showing many helpful home repairs. 170 illustrations. Write today.

SMOOTH-ON MFG. CO., Dept. 58-E
570 Communipaw Ave., Jersey City 4, N. J.



Do it with
SMOOTH-ON
NO. 7 CEMENT

NOW—40 different CUTS with

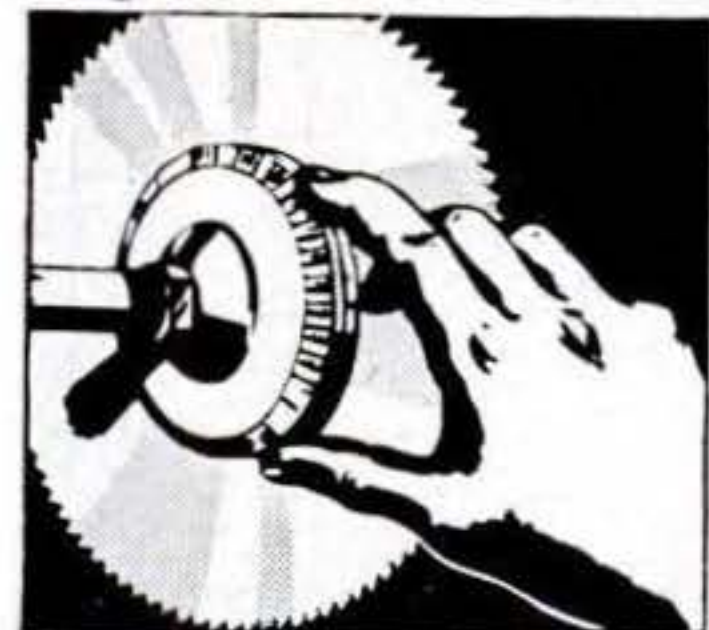

AMAZING, NEW *Warren*

DADO SAWING WASHERS On Your Saw Blade

Just dial widths to cut parallel grooves perfectly smooth. No warp, vibration

or trick screws. Strengthens blade, perfect balance. **GUARANTEED!** At your dealer's or order direct. Give arbor size— $\frac{1}{2}$ ", $\frac{3}{8}$ ", $\frac{3}{4}$ ", 1".

Send for free booklet
WARREN WASHERS COMPANY
Dept. 45, Box 98, North End Station, Detroit, Mich.

ONLY
\$4.95
PER SET

PRECISION CALIPER



This Trade Mark
guarantees highest
quality

Model #30-78



M.Z.B. precision vernier calipers, made by the people who organized the finest precision tool factory the world over, always guarantee the highest accuracy for any kind of precision work. This model is cheaper than our famous #30-61 without the factory having sacrificed any of the essential quality features, such as: glass hard on all finishing surfaces, it is made of special chrome steel, spring tempered throughout. Measures inside, outside, depth and thread to $\frac{1}{128}$ " and $.001$ ", but it has not got the famous M.Z.B. cam lock, which is the only difference. This is the first time M.Z.B. has entered the popular price field and your first opportunity to buy an M.Z.B. precision tool at this price. Other models available of course. Shipment from stock. Genuine leather cases \$1.00 extra. You pay postage on COD orders. Money back guarantee.

\$9.75
POST PAID

INTER-CONTINENTAL TRADING CORP.
90 WEST STREET • NEW YORK 6, N. Y.

FREE



★
1952
ALLIED
RADIO & TV CATALOG
EVERYTHING IN RADIO
AND TV AT LOWEST PRICES!

SEND FOR IT

212 PAGES
Value - Packed

Everything for
Experimenters, Builders, Amateurs,
Servicemen, Engineers, Soundmen...

Save money on every Radio and TV need! Get the big 212-page 1952 ALLIED Catalog featuring the world's largest selections of top-quality electronic equipment at lowest, money-saving prices. See the latest in TV, home radios, Amateur equipment, P.A. systems and Hi-Fidelity custom sound, recorders, test instruments, builders' kits—plus thousands of parts, tools, books and diagrams. Get more for your money from the World's Largest Radio Supply House. Send today for your FREE 1952 ALLIED Catalog!



Save on
Everything
in Radio & TV



FREE
CATALOG

SEND FOR IT TODAY

ALLIED RADIO

ALLIED RADIO CORP., Dept. 7-E-2
833 W. Jackson Blvd., Chicago 7, Ill.

Rush FREE 1952 ALLIED 212-Page Catalog

Name _____

Address _____

City _____ Zone _____ State _____

ATLAS Rotary Type POWER KEEN-MOWER

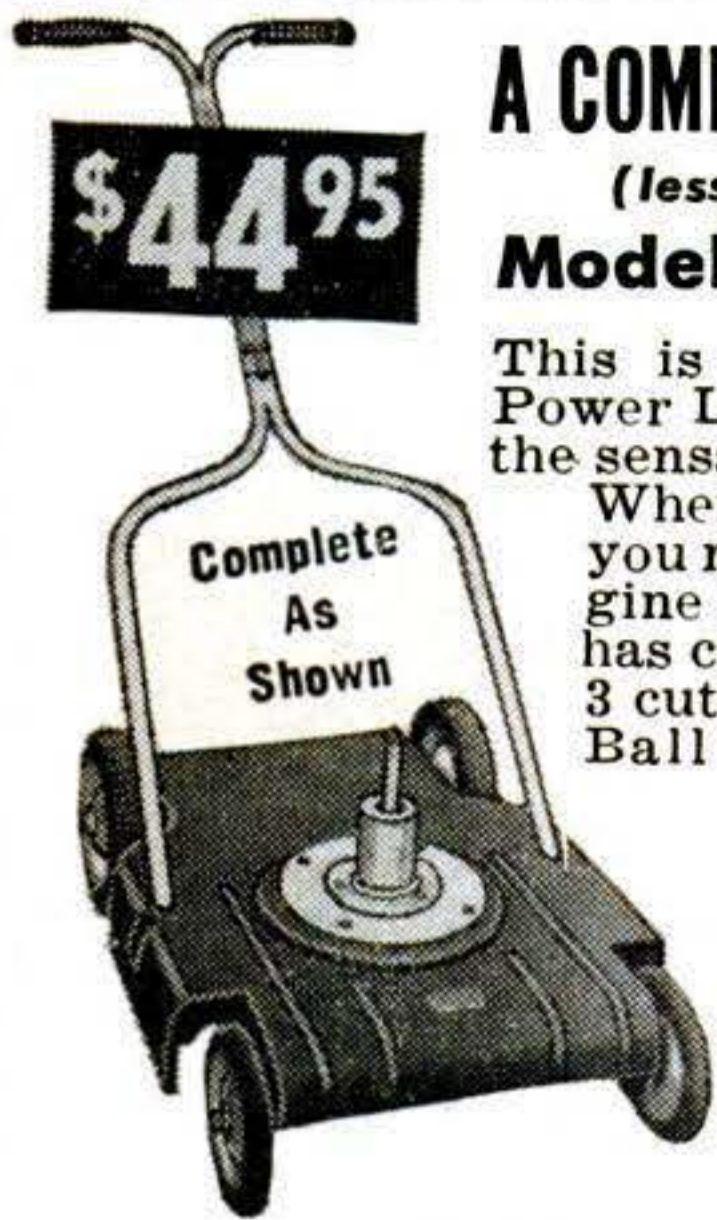

A COMPLETE POWER MOWER

(less elec. motor or engine)

Model 50M as illustrated

This is one of America's finest Power Lawn Mowers . . . offered at the sensational low price of \$44.95. When you receive mower all you need do is add your gas engine or electric motor. Mower has concealed blade for safety, 3 cutting heights, 1½" to 3½". Ball bearing rubber tired wheels. 18" cut and cuts to within ½" of sidewalk. Weighs only 48 lbs. Shipped FOB, Kansas City. Send check or money order

ONLY..... **\$44.95**

Make Your Own

POWER LAWN MOWER

with this DRIVE CUTTER ASSEMBLY

Constructed for those who desire to build their own mower or to replace your old cutter assembly. Complete with 18" blade and double ball bearing drive. only.....

Add 50c to cover handling & shipping. Send check or M. O.

\$12.95

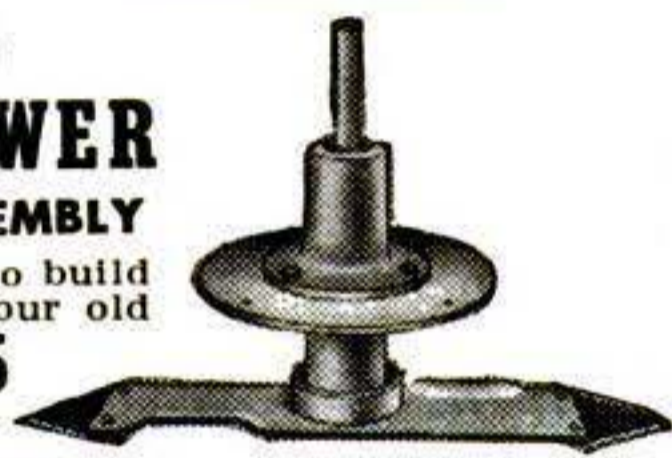

ATLAS KEEN MOWER

229 S.W. BLVD.

Dept. PS-5

KANSAS CITY, MO.

OVERHAUL YOUR MOTOR *in 10 minutes*



The Amazing Motor "RENEW" KIT

- INCREASES COMPRESSION
- STOPS PISTON SLAP
- STOPS OIL BURNING

• FREES VALVES, RINGS AND PISTONS
PREPARE NOW FOR SUMMER DRIVING!

RENEW WITH "COMPRESSION SEAL" →



This proven motor treatment gives up to 15,000 miles of powerful, knock free performance to any car. Squeezed into cylinders, it forms a long wearing, lubricating seal by filling in worn places between cylinder walls and pistons. This increases engine compression, cuts oil and gas waste and eliminates the need of costly overhaul and ring jobs.

CLEANSE WITH MOTOR "PURGE" FORMULA

Your engine will run smoother, cooler and more efficiently once flushed with Motor "Purge". It cleans, quiets and frees rings, valves and pistons from gums, carbon and varnish, when poured into cylinders.

A MOTOR "RENEW" KIT TREATMENT . . . REVITALIZES AND INCREASES THE LIFE OF ANY ENGINE!
FREE AUTO MANUAL WITH EACH ORDER!

Manual tells how to save gas, oil, brakes and tires through simple economy secrets . . . introduces many new products. Kit treats all 4, 6, 8 cylinder cars up to 1947. 8 cyl. cars from '48 to '52 require a DUAL KIT. . . \$11.90 ppd. (deposits)

\$6.95 Postpaid (\$1 C.O.D. deosnt)
FULL 10 DAY "MONEY BACK" GUARANTEE!
DEALER INQUIRIES INVITED!

CONSOLIDATED ENGINEERING Dept. PSK-5

10407 W. Washington Blvd.

Culver City, Calif.

FILE SAWS the RIGHT WAY

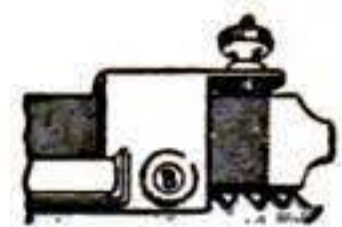
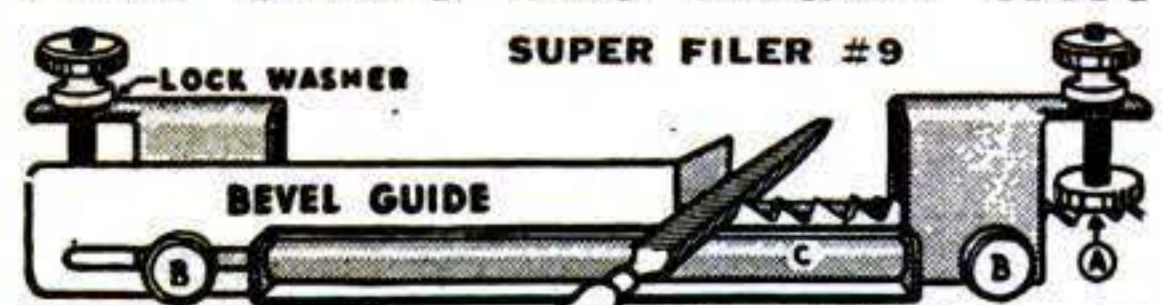

USED AS
JOINTER

SO EASY with this new filing jig and jointer anyone can now sharpen any handsaw like new! When file hits hardened steel rollers teeth are finished and EXACTLY THE SAME HEIGHT. All teeth cut and saw runs true and smooth. Jig and instructions \$2.95 postpaid. FREE FOLDER.



SHARPEN YOUR CIRCULAR SAWS

The RIGHT WAY on your own saw table. Sharpens rip, cutoff, hollow ground and combination blades—6" to 10". Saws stay round with correct bevel. Easy to use. GUARANTEED. TRU-CIRCLE JIG #7 \$8.95. Includes \$3.00 Grinding wheel.

"TRU-CIRCLE" saw set automatically sets teeth at 10° or more. **\$2.95**

AT DEALERS OR POSTPAID

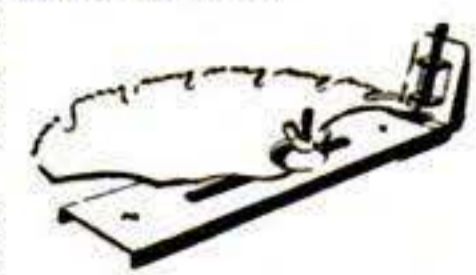

A. D. McBurney, 317 E. 4th St., Los Angeles 14, Cal. Dept. S-17



7" Tilting Arbor Saw

One of Shopmaster's complete line of quality-built tools at the remarkably low price of **4795** Slightly lower zone 1



SHOPMASTER, INC.

1214 Third St. S., Minneapolis, Minn.

SHEET METAL BRAKES

Forms angles, flanges and Pittsburgh locks. 26 gauge steel, heavier aluminum. Cam locking. Portable, can be bolted to bench, or clamped to edge of truck. All steel, reinforced. Shipped Exp. Coll. 30" size. Wt. 54 lbs.. \$26.50. 36" Wt. 66 lbs. \$31.00. 48" Wt. 100 lbs. \$45.00. Floor mountings, portable, 32" high, 30 lbs.. \$7.00. 12" BRAKE. Fits in vise to form difficult compound bends. up to 20 gauge steel. Not illustrated. . . . \$12.50 P.P.



30"—36"—48"

IRON BENDER. Forms hooks, angles, eyelets, etc. Capacity, ¼x2", 5/16x1½". 10 parts all steel. . . . \$10.00 Post P. Immediate delivery. Order direct, cash or C.O.D. or send for folder.

VYKE BRAKE CO., S-1116 So. 27th St., Omaha 5, Nebr.

DRAINS Cellars, Laundry Tubs; CIRCULATES Oil; IRRIGATES Gardens

Original "Type P" Pump has 2400 GPH capacity. 360 GPH 75' high, or 1500 GPH from 25' well. Use any ⅛ to ½ HP motor. DOES NOT CLOG. 1" intake; ¾" outlet.

Only \$6.95 postpaid if cash with order. (West of Mississippi, add 50c.) **\$6.95** Motor coupling included. SATISFACTION GUARANTEED OR MONEY BACK!



LABAWCO PUMPS, BELLE MEAD 3, N. J.

ONE-MAN SAWMILL LOW \$50.00 AS . . . 50.00 DOWN

Take BELSAW Portable Sawmill right to the trees—turn out valuable lumber for local yards—do "custom sawing" for neighbors. BELSAW lasts a lifetime. No crew needed. Power with old auto engine. Beginners get excellent results. Send postcard for FREE BOOK, "How To Make Lumber."

BELSAW MACHINERY CO
8464 Field Bldg. Kansas City 2, Mo.

WELD BRAZE, SOLDER, and CUT → ONLY \$1475 F.O.B. complete!



No experience needed. Follow simple instructions, weld on iron, steel, bronze, brass, aluminum, and other metals. Plugs into any properly wired 110 volt A.C. or D.C. line. Make or save time and money doing repair work for yourself and others. Repair men, farmers, tin-smiths, home and auto owners, hobbyists, etc., say FOUR-WAY pays for itself over and over. Order today or send for Free details.

FOUR-WAY WELDER COMPANY, Dept. F3-EC
2326 So. Michigan Ave. • Chicago 16, Illinois

LARGER EQUIPMENT AVAILABLE ON REQUEST

ORDER NOW 10 DAY TRIAL

**PROFESSIONAL
DISSECTING KIT**

\$4.95 postpaid
For Microscopic
Slide Work In
**BIOLOGY
BOTANY
ZOOLOGY**



A special purchase for our microscope customers. The professional equipment in this complete kit is worth more than \$15—made to the specifications required by researchers and biologists. Ten pieces in fitted hardwood case; two fine steel scalpels, two prof. dissecting instruments, one magnifying glass, one special scissors, one special tweezers, three blank slides. Perfect for universities, doctors, students. Postpaid \$4.95.

**IMPORTED 300 POWER
MICROSCOPE \$14.95!**

POSTPAID

**LABORATORY MODEL
Triple Revolving Turret Has 100,
200 and 300 Power Objective Lenses**

No frills, just excellent optical qualities, delicate adjustment and solid construction. Its quality and price astounded biology instructors. A lifetime bargain for students, schools, labs, research, amateurs. *Anyone can now own one!* (Performance cannot be duplicated for \$75.00.)

FEATURES: Fine micro adjustment, adjustable plano substage mirror. Dovetail hardwood case included free.

USES: Animal, plant and mineral research. Study plant cells, microscopic animal life, crystalline structure, etc. See the complex anatomy of tiny insects, larvae, eggs. 300 magnifications makes a fly look as large as a bird. If you are not amazed by the quality of this microscope, send it back in 10 days. Your money will be refunded immediately. \$5.00 deposit on C.O.D.'s. Send check, cash or money order for \$14.95.



**"HUNTING WITH THE
MICROSCOPE"**

Gaylord Johnson's intensely interesting 93 page book—how to hunt microscopic big game, micro detective work, how you see the oddities of the invisible world. Postpaid... **60c**



**HALF PRICE SALE — IMPORTED
MAGNIFYING GLASSES**

2" dia. \$1.00 2 1/2" dia. \$1.35
3" dia. \$1.95 3 1/2" dia. \$2.25
4" dia. \$2.50 (all postpaid)



NAVY TYPE MARK XX

20 POWER TELESCOPE

\$30 value. Fine optically ground achromatic lenses, fully coated. Same power as standard artillery observers spotting scope. Precision all metal construction. Extends to 15 1/4 inches. Rust and salt-spray resistant. A valuable ship and boat owners possession now at a price everyone can afford! Shipped in fitted hardwood case. Postpaid \$9.95.



\$9.95
ppd.



**8X COATED
PENSCOPE \$4.95**
ppd.

Pocket Telescope fits in your pocket like a fountain pen, extends to form a powerful scope for spotting game, watching sports, etc. 8 power coated lens, more powerful than standard army binocular.



**20, 40, 60X POCKET
MICROSCOPE**

You select power, then focus with spiral ring. Finest optics, a new precision instrument for field use!
Postpaid..... **\$4.95**

the AKRON 4400 SUNSET BLVD. OPTICAL DEPT. **5-S**
LOS ANGELES 27, CALIF.

Money-back 10 day guarantee on all items. Send check, cash or M.O. Free catalog on request or included with your order. Calif. residents add 3% state tax.

**MAKE
OLD FURNITURE
NEW AGAIN**

**ARCHER
Pol-mer-ik**

100% PURE LINSEED OIL

FREE BOOK
Refinish, beautify, polish all woods. "101 Handy Hints." Send for today.

ARCHER • DANIELS • MIDLAND CO.
603 Roanoke Building, Minneapolis 2, Minn.

send for **FREE CATALOG**

America's Foremost
money-making
**MECHANICS'
TOOLS**

It's easy to own the same "pay-off" tools used and endorsed by America's top-earning mechanics throughout the automotive, aviation and industrial fields! Snap-on tools help you handle every repair job faster, easier, better. And they LAST... pay for themselves over and over again! Start building your own tool set now with basic Snap-on units—add others any time. Genuine Snap-on tools are never sold in stores—direct to users only. Mail coupon for free catalog.

Snap-on Tools
THE CHOICE OF BETTER MECHANICS

SNAP-ON TOOLS CORPORATION
8060-E 28th Ave., Kenosha, Wisconsin

Send me free catalog of Snap-on tools.

Name _____
Address _____
City _____ Zone _____ State _____

NOW! YOU CAN SAW ^{OVER 100,000 SOLD}
8 TIMES FASTER with . . . **ARCO SAW**



No. 445
"ARCO-SAW"
\$11.50 with
**ALL GAGES &
 "HYCARBON"
 Crosscut
 Blade.**

SAVE TIME & EFFORT!

Toss away your old handsaw!
 Convert your drill in 1 minute
 to a rugged PORTABLE SAW.
 Whiz through wood, wallboard,
 plastic, etc. You'll be amazed
 how accurately "ARCO-SAW"
 rips, crosscuts, bevels, dados.

**FITS ANY
 1/4" DRILL**

**CAN BE USED
 WITH ONE HAND!
 THE ONLY SAW WITH
 PRECISION**

GRADUATED GAGES:
 Depth gage—0 to 1 1/4"
 Bevel gage—0 to 45°
 Adjustable rip gage,

**Visual guide, RIGHT ANGLE GEAR
 DRIVE, Safety-yoke,
 CUTS 1 1/4" or 2x4 by turning over.**

90-DAY
 FACTORY
 GUARANTEE

No. 444 "ARCO-SAW"—Has same expensive
 features as No. 445—less gages **STILL ONLY \$9.95**
 Depth-Bevel-Rip Gage for No. 444 "ARCO-SAW" . . . \$1.95
 Extra Blades—4" Crosscut or 4" Combination . . . \$1.60

**UNCONDITIONAL
 10-DAY MONEY
 BACK GUARANTEE**

**START SAWING THE EASY WAY,
 ORDER YOUR "ARCO-SAW" TODAY!**

DEALERS: Write
 for nearest jobber.

Insist on "ARCO-SAW" at your dealer.
 If not available, send us check or M.O.
 (Postpaid). C.O.D.'s postage extra. Write
 for literature of other tools.

ARROW METAL PRODUCTS CO.

DEPT. PS-5, 140 WEST BROADWAY, NEW YORK 13, N.Y.

**AT YOUR HARDWARE
 DEALER'S**

CORBIN

**CABINET
 LOCKS**

**For: DESKS
 CHESTS
 CABINETS
 WARDROBES
 DRAWERS**

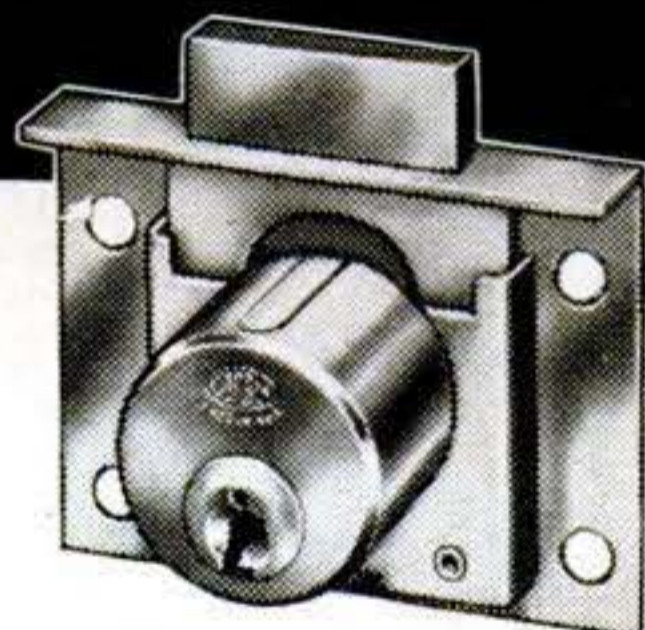

Put easy-to-install Corbin Cabinet Locks on all your
 cabinet work and you'll enjoy both pride of crafts-
 manship and real security!

They keep valuable papers secure . . . protect guns
 and tools . . . medicines and caustics.

CORBIN

There's a Corbin Cabinet Lock or pad-
 lock for every purpose. Ask for them at
 better hardware stores everywhere.

CORBIN CABINET LOCK DIVISION

The American Hardware Corporation, New Britain, Conn., U.S.A.

SAVE GAS

**WITH A
 FUEL PRESSURE REGULATOR!**

THIS REVOLUTIONARY NEW ACCESSORY
 STOPS GAS WASTE CAUSED BY FUEL
 PUMP PULSATION. ELIMINATES CARBU-
 RETOR FLOODING AND FUEL "SURGE."
 STOPS THE ANNOYANCE AND POWER LOSS
 CAUSED BY "MOTOR CUT-OUT." Many users
 claim up to 25% gas saved. Regulator s-m-o-o-t-h-s
 fuel flow...prevents vapor lock and percolating.
 It pays for itself in a few weeks with gas saved,
 by eliminating frequent carburetor tuning and
 by reducing engine and
 carburetor wear. Fits
 all cars and trucks.



3 BOOKS FREE! With
 each order: Big "Speed
 Equipment Catalog" plus "Economy Driving
 Manual" plus famous "150 Miles Per Gallon
 Book"—a regular \$1.75 value free with order.

NEWHOUSE AUTOMOTIVE INDUSTRIES
 Dept. AR-5, 5905 E. Beverly Blvd., Los Angeles 22, Calif.



BEFORE AFTER
 only \$5.95 postpaid

Scrape paint quickly
 ask your dealer for
Red Devil
 Wood Scrapers



RED DEVIL TOOLS, IRVINGTON 11, N. J., U. S. A.

Insert Installed

LEAKY FAUCETS?

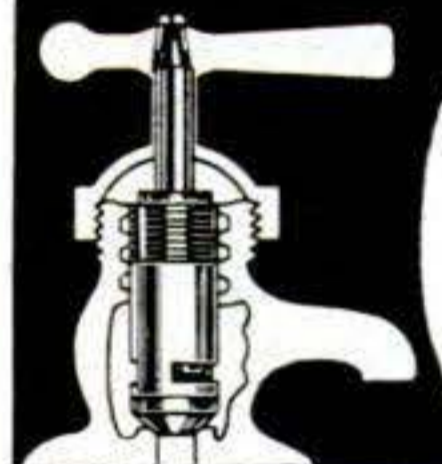

SUPERIOR FAUCET INSERTS stop leaks
 permanently. Provide all new working
 parts. Make worn-out faucets better than
 new. Easily installed. Guaranteed. Two
 Million Satisfied Users. Brass Model 854,
 Chrome \$1.00. Specify "hot" or "cold." At
 hardware, plumbing dealers.

SUPERIOR VALVE MFG. COMPANY
 738 SUPERIOR, W., CLEVELAND 13, OHIO

**BUILD AN ARC WELDER FROM OLD
 GENERATOR**

WE SHOW YOU HOW
 Light or Heavy Work

Produces 75-200 amperes. Takes no
 previous experience or hard work
 to make one of these welders. Com-
 plete plans 35c. Send for your
PLANS today. We'll include Big
 Catalog of electrical bargains & sur-
 plus items. Or, send 10c for Catalog.

LEJAY MFG., 1323 LEJAY BLDG., MINNEAPOLIS, MINN.

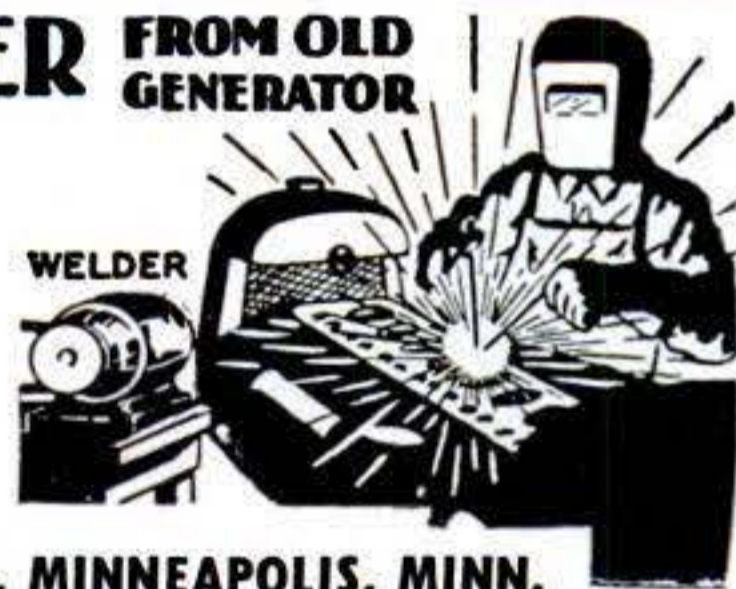

NEW Saw Sharpener

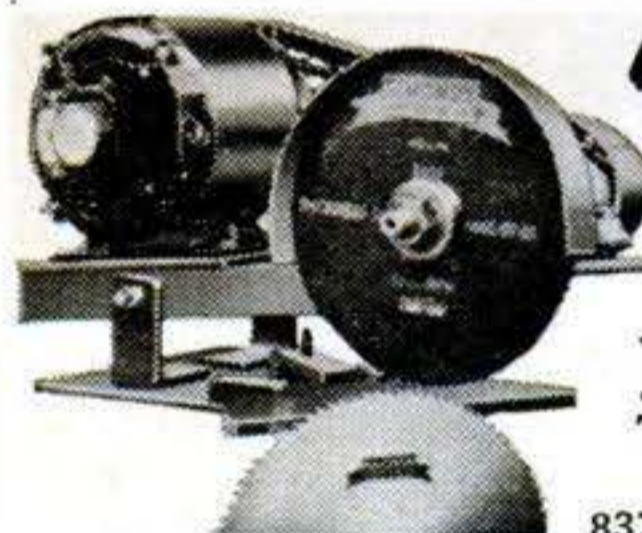

Improved #64 Hand Gummer
 sharpens all types circular saws
 4" to 20" diam. Ideal for saw
 shops. Self-Centering adjustment
 for quick, easy set-ups. Complete
 with 1/4 HP motor, 1 grinding wheel
 & cord. **\$79.50** FOB Portland. Wt.
 70#. SEND FOR FREE LITERATURE.

P. T. HOBBS MACHINERY
 8375 N. Interstate Ave., PS-52, Portland 17, Ore.

NU-WAY HEAVY DUTY CUTTING UNIT
 with Timken Roller Bearings

PRICE
\$16.50
WHY PAY MORE



Build your own rotary type
 lawn or weed cutter.
 Take the hard work out of
 weed cutting. Build yourself
 an up-to-date weed and lawn
 mower with the Nu-Way
 heavy duty unit.

Write Dept. PS-5 for Free Circular—We Supply Cutting Unit Complete
TRACTOR-LITE MFG. CO., Spirit Lake, Iowa

BUY DIRECT - MASTER MECHANIC - UP TO 85% DISC.

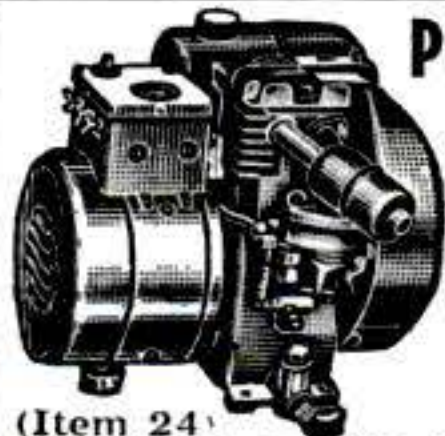

Portable LIGHT PLANT

PUSH BUTTON START
500-700 watts 110-120 v. — 60 cyc. A.C. Powered by a sturdy dependable, easy starting, air cooled 1 3/4 hp. gas engine. No wiring necessary, just plug in and operate. Plenty of current for any oil burner, freezer, brooder, pump, emergency lights, etc. which require up to 700 watts. Ideal for Civil Defense, Fire Depts; trailers & camps. Complete with Voltmeter and built-in winding to charge 6 v. auto batteries. Wt. 85 lbs. Fully guaranteed. Be prepared if war or storm knocks out power lines.

(Item 24) etc. which require up to 700 watts. Ideal for Civil Defense, Fire Depts; trailers & camps. Complete with Voltmeter and built-in winding to charge 6 v. auto batteries. Wt. 85 lbs. Fully guaranteed. Be prepared if war or storm knocks out power lines.

Reg. \$275.00 value. **\$143.50**
700-800 Watt Plant (Item 44) **\$169.95**
Same as above but greater output.
1000-1200 Watt Plant (Item 45) same as Item 24, but larger generator & engine. **\$199.50**

GIANT 2000-2500 WATT PLANT
(Item 31) 110-120 V. 60 cyc., A.C. Absolutely the best made—exclusive dynamically balanced armature; heavy windings develop up to 5000 watt overload for motor starting. Skid-mounted — portable. Powered by easy starting Briggs or 6 hp. Wisconsin engine — complete with all accessories; engine easily disconnected for other uses. Big outlet box, voltmeter, no wiring necessary. Ample current for all purposes. Factory warranty and instructions included. Wt. 220 lbs. Reg. \$585.00. Special at. **\$299.50**

With Electric Self Starter (Item 179) **\$359.50**
GENERATOR ONLY and control box. **\$169.50**
Drive it with your engine or tractor.
TRANSFORMERS—(Item 197) Convert 110 v A.C. to 220 v. Capacity 2 kva. Simple hook-up. Regularly \$55. Our price—when purchased with light plant. **\$27.50**
Purchased separately \$34.50.

3000-3500 WATT PLANT
(Item 198) Wis. eng., push button starter, 110-120 v. — 60 cyc. A.C. heavy duty for continuous or standby use. (Wt. 370 lbs.) **\$439.50**

HI-LINE 6000 WATT PLANT

(Item 162) Push Button Start, 115-230 v. 60 cycle A.C. A brute of a power plant with a rugged 13 hp. Wisconsin engine. Plenty of electricity for ranges, water heaters, freezers, pumps, machinery, etc. Affords both 110 and 220 volts. Ideal where heavy current is needed. Wt. 590 lbs. Easily worth \$995.00. With self starter. **\$645.00**
Factory Spec. **\$345.00**
Generator and control box only, belt driven. Use your engine or tractor. Wt. 240 lbs. **\$345.00**

Buy Wholesale—Direct From Factory—World's Largest Direct Sellers of Light Plants.

You can pay more — but you can't buy better

MALL ELECTRIC CHAIN SAWS

Amazing labor saver. Fells and cuts up 36" trees in minutes. Wonderful for pruning and trimming. Use portable light plant for power. Item 202, 12" Saw Wt. 12 lbs. **\$115.00**
Item 203, 18" Saw Wt. 20 lbs. **\$130.00**

IMMEDIATE DELIVERY—ALL ITEMS HEAVY DUTY D-C ARC WELDER

Use as portable or shop welder. Up to 300 amps. Senior model. Made for years of trouble-free, continuous service. Will handle light or heavy jobs. Easily welds up to 3/4" plate using 1/4" rods. Built-in air-cooling system. Arc is easy to strike and hold, because of specially designed arc stabilizer. Hi-lo switch and dial control gives wide range of welding heats. Run welder at 2600 rpm. with tractor, jeep or 15 hp. gas engine, or 7 hp. elec. motor. Complete with instructions, guar. and double V belt or flat pulley. You can pay more, but you can't buy a better welder. Wt. 110 lbs. \$400 value at. **\$99.75**

DUAL CONTROL MODEL same as above but with built-in dual rheostat for low heat soldering, brazing, welding. Spec. **\$119.50**

WELDING KIT. Two 10 ft. leads, welding helmet, electrode holder, ground clamp. Sold only with welder at. **\$10.50**

EXTENSION CORD

(Item 16) 40 ft. heavy duty, made of specially insulated No. 14 2-conductor wire. So tough that you can drive over it and yet flexible and easy to handle. Resists oil, grease or water. Extends electricity up to 400 ft. without voltage drop. Use indoors or out. Complete with heavy rubber plug and outlet. Wt. 2 1/2 lbs. Usually \$4.50—Special 40 ft. **\$1.99**
Comb: 2-40 ft. and 1-20 ft. (total 100 ft.) **\$4.95**
100 foot length (one piece) **\$4.85**

WIRE ONLY (Item 50) No fittings, 100 ft. **\$4.00**
HEAVY DUTY POWER CABLE
#12—2 Cond.—stranded, very flexible, rubber covered, special outside cond. for grounding power tools, etc. Finest heavy duty power cable made. U.S. Surplus.
50 ft. (Wt. 8 lbs.) Item 199. **\$6.95**
100 ft. (Wt. 16 lbs.) Item 200. **\$12.95**

POTTERS WHEEL
(Item 47) Complete prof. equip. for making finest ceramics and pottery. New design, larger, non-breakable, Alemite bearings. Large dynamically balanced cast-aluminum reversible turntable with variable speed drive (38 to 140 rpm) controlled by foot-pedal. Built-in adjustable arm rests, water cup and wedging wire. 18x18" enclosed throwing table—ample area for largest pieces. Req. 1/4 hp. motor (not incl.). Complete with pulleys, belts and instructions. Wt. 26 lbs. \$145 value at. **\$59.95**
Westinghouse 1/4 h.p. motor for above. **\$19.50**

SAVE ON CATALOG ITEMS
We have hundreds of bargains. Send 10c for catalog for information on following items: Variable Speed Selectors, Trouble Lights, Air Tanks, Fire Extinguishers, Electric Hot Water Htrs., Rubber Hose, Electric Tools, A.C. Arc Welders, Heating & Ventil. Fans, Potters Wheels, Paint Sprayers, Sleeping Bags and many, many other useful articles.

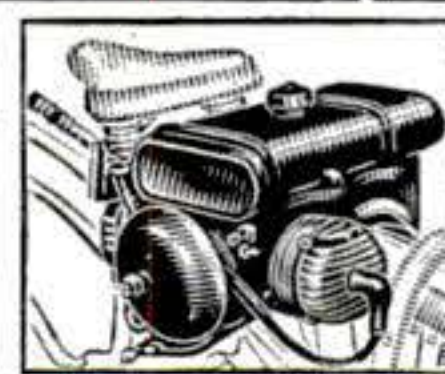

COMMANDO BIKE MOTOR

(Item 90) New, super-modern 1952 model. This job is the Cadillac of all bike motors. Sensational Auto-Clutch prevents killing motor at each stop. Also selects proper ratio on hills. Mounts behind and drives rear wheel with Dynarotor. Free Wheeling lever permits pedalling if desired. Rear Mounting eliminates fumes, heat, dirt, and hard steering. Easily installed in 15 minutes with home tools. Sturdy, trouble-free, easy starting, light weight. Airplane type engine; up to 150 miles per gallon. Fully guar. Ride for fun or profit. Ideal for deliveries, paper routes, messenger service, etc. Ride to work and save. Dealer inquiries invited.

The Commando Captain, 1 cylinder 1 1/2 hp. **\$99.75**
The Commando General, 2 cylinder 3 hp. (Item 91) **\$125.00**
All Commandos shipped prepaid in U.S.

HEATING & VENTILATING FAN

(Item 10) Easily installed in furnace pipes. Forces even heat to all rooms. Over range, removes kitchen smoke and odors. Powerful continuous duty motor, 110-120 v. A.C. Quiet, super efficient fan moves huge volume of air (400 to 600 c.f.m.) 8" Fan, wt. 5 lb. **\$6.35**; 9" Fan, wt. 6 lbs. **\$7.45**; 10" Fan, wt. 7 lb. **\$8.45**; 12" Fan, wt. 8 lbs. **\$9.45**



32 pc. SOCKET SET

32-pc. Socket Set (Item 59) Highest quality guar. non-breakable sockets made by Husky. Beautiful, matched chrome alloy, absolutely the best. Complete range of 21 sockets from 1/4" thru 7/16" in 1/4" drive and 7/16" thru 1-1/16" in 1/2" drive; 2 extensions, reversible 1/2" ratchet, adaptor bit, slide head, all angle coupling, 2 end wrenches, 1/4" speeder handle and sturdy metal tool box. For prof. mechanics who want the best. Wt. 14 lbs. Easily worth \$41.50. While they last. **\$16.95**

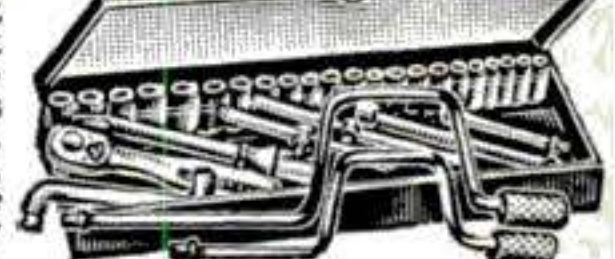

3/8" DRIVE 15 Pc. SOCKET SET

(Item 201) Same top qual. as above—includes 7 sockets 3/8" thru 3/4", reversible ratchet, extension, flex. handle, cross bar, 3 punches, metal tool box. Wt. 5 lbs. List Price \$18.96. Our Spec. **\$9.95**

DUAL TUBE LIFE SAVERS

(Item 54) NEW APPROVED TYPE made by Genl. Tire for Navy. Each has 2 rubber tubes for double protection. Easily inflated by mouth to 55 in. Wear one around waist as comfortable life saver. Adjustable safety buckles fit adults or children. Tie several together for raft or big luxurious mattress. Invaluable on boats or beach. Wt. 2 lbs. each. Our spec. (a fraction of cost) 99c each, 6 for. **\$5**

MANUFACTURERS AND JOBBERS — Write us about your surplus items

All items brand new. Prices f.o.b. Chicago area. 10 day Money back guarantee. Send check or M. O. **MASTER MECHANIC MFG. CO., DEPT. 54A Burlington, Wis.**

it's **EASY** **NOW** to make fine furniture in your spare time



With Rogers simplified project sheets, it's easy to make fine furniture for gifts or your own use. Just 15c will bring you these valuable instructions plus a full-size bottle of Rogers famous Gorilla Grip Glue — the glue with lasting strength. Send to Rogers Isinglass & Glue Co., Gloucester, Mass.

Ask for Rogers at your local hardware store.



Genuine **WISE-GRIP** WRENCH

Jaws LOCK To Work with Ton-Grip —Leave Hands Free

Does jobs no other tool can do. Easily turns rusted or battered nuts, bolts, screws—makes ideal hand-vise—hundreds of other uses. LOCKS, CLAMPS, TWISTS, TURNS, PULLS, CUTS, RATCHETS, HOLDS! With Cutter—No. 7W, 7", \$2.25; No. 10W, 10", \$2.60. Without Cutter—No. 7C, 7", \$1.95; No. 10C, 10", \$2.25. Straight Jaw model—No. 7, 7", \$1.85; No. 10, 10", \$2.15.

Order Genuine VISE-GRIP From Your Dealer. **PETERSEN MFG. CO., Dept. M-5, DeWitt, Nebr.**

best
white tape
made

ONLY
98¢*



The new "Evans White-Tape" has everything you'll find in tapes costing over \$1.50—plus.

- snow-white blade with bold, legible, jet-black numerals and graduations. Graduated in 32nds for first 6 inches.
- sturdy die-cast case heavily chrome-plated, calibrated for quick reading inside and outside measurements.
- blade 1/2" wide made of finest high carbon steel—tempered—Bonderized—enamelled—baked.
- blade replaceable in seconds—without tools—without even opening case. And Evans replacement blades cost far less.
- every "Evans White-Tape" is unconditionally guaranteed.
- exclusive Evans automatic brake gives smoother push-pull action with absolutely no "creeping" of tape into case.
- underside is white, too. Mark with ordinary pencil, remove mark with flick of thumb.
- unheard-of low price*: 10-ft. \$1.49; 8-ft. \$1.19; 6-ft. 98¢. Prices higher in far west and Canada.

Evans & CO Elizabeth, N. J., Montreal, Que. © 7429
Makers of Evans 6-ft. Folding Rule and "Folding Yardstick"

Sold only through retailers.

TAKE LESS THAN 1 MINUTE TO

Keep Paint Brushes

Like **NEW!**

Store Them Dry.
They Stay Soft
and Flexible
**READY FOR
INSTANT USE!**

PROCESS 33
INSTANT PAINT BRUSH CLEANER

- Quickly cleans fresh paint from a paint brush or roller.
- You can paint instantly with another color—or store brush dry—it will stay soft.
- Economical—can be used again and again.
- Safe for all brushes and rollers.

Pint 59¢ Quart 98¢ Gallon \$3.25

Wherever Paint is Sold

BeMaCo Dependable

**AUTOMATIC
SAW SET**

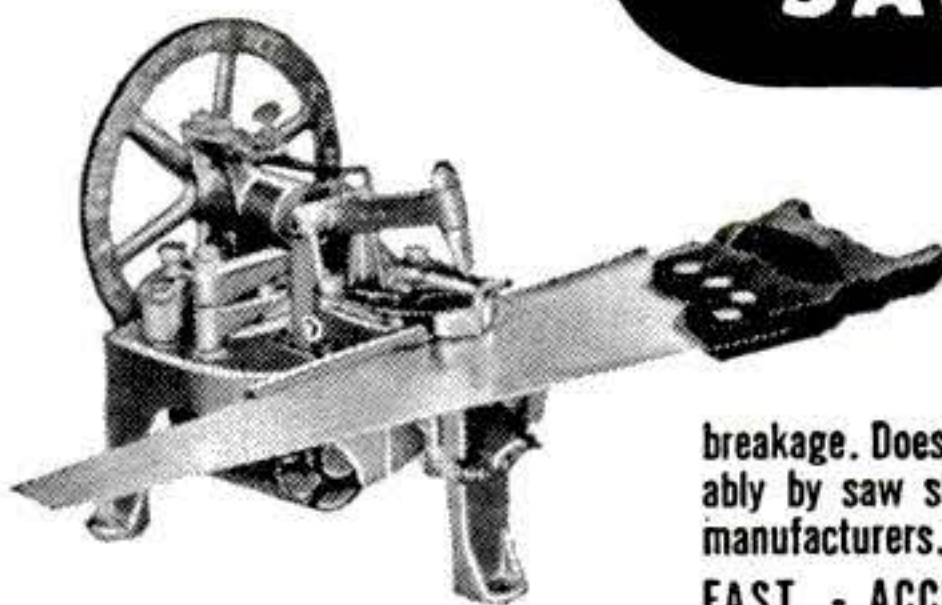

Sets 400 teeth per minute on hand or band saws 4 to 16 point. Hammer and anvil action sets teeth accurately and uniformly. . . No tooth

breakage. Does a perfect job. Used profitably by saw shops everywhere and saw manufacturers. Every machine guaranteed!

FAST - ACCURATE - DEPENDABLE

★ INCREASES
PROFITS

BEAVER MFG. CO.

SAW MACHINE Div. 12-A
800 SOUTH ISIS AVE. • INGLEWOOD, CALIF.

Build Your Own Power Mower...

SAVE HOURS OF LAWN CARE TIME

Send for catalogue of our complete gasoline and electric mower construction kits. We feature Timken blade spindle with cutting height adjustments for any kind of grass. Change cutting height in two minutes. You'll want our triple strength whirling blade that chops clippings to a fine mulch. . . eliminates raking. Also ballbearing wheels, steel tube handles, plywood mounting board. You can build a big 18" mower for \$39.00. Send for FREE catalogue.



KIT-MO COMPANY Box 217 Omaha 7, Neb.

**NONE
BETTER!**

SUPER DRILL GRINDER

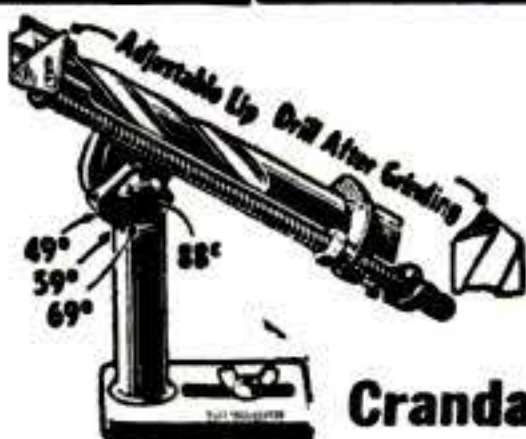

Sharpens round shank drills from 3/32" to 1/2" in diameter, up to 6" long. Grinds old drills like new in 4 different point angles, using hand or power grinding wheels. Money-back guarantee.

Price only \$2.95
At Dealers or Postpaid

Crandall Mfg. Co. 1512 W. Stauson, Dept. S-5, Los Angeles 44, Calif.

WATER-COOLED

DUST MASK



Cool, clean, water-washed air while sanding, grinding, paint spraying. Why breathe harmful dust, smoke, fumes? Guard against harmful dusts, coal, cement, metal, lint, grain dust. Order now!

Jerry Bryant, 919 N. Michigan Chicago 11, Illinois

\$3

POSTPAID

**NEW, IMPROVED CALCULATOR
FOR WOODWORKERS only 25c**

Instantly gives information on lumber, nails, concrete mixes, painting materials, etc. Convenient, simple to read. Just set dial for nail specifications, to convert linear to board feet, find bit sizes for screws, compare characteristics of woods. 6" diameter heavily varnished cardboard. Send 25c, no stamps, please to Greenlee Tool Co., 2125 Columbia Avenue, Rockford, Illinois.

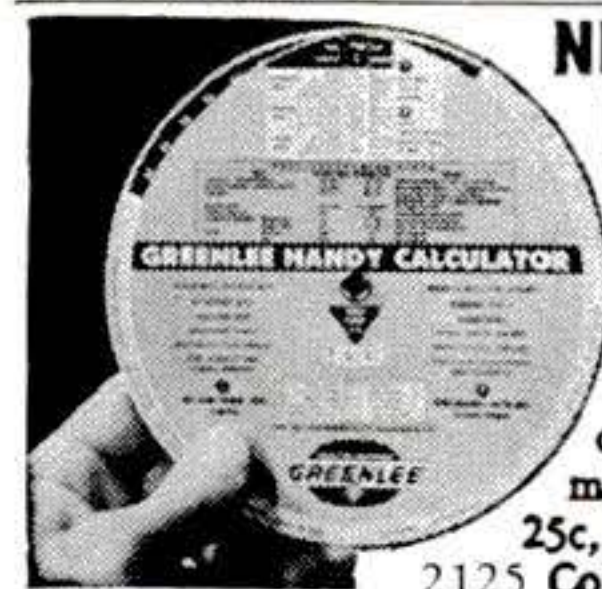

HOT WATER
From ANY
COLD WATER FAUCET!

only
\$4.98

INSTANTLY—Yes, you can now have continuously running HOT water with the JET INSTANT HOT WATER HEATER, in kitchen, summer cottage, camp, office, factory or farm. Regulates from LUKEWARM to REAL HOT with a turn of the tap. A cinch to attach. . . No tools needed. 110 Volt AC DC. Durably constructed of gleaming chromed steel and porcelain. 8 foot U.L. Cord.

10 DAY MONEY BACK GUARANTEE!

Send only \$1.00 deposit, balance C.O.D. plus postage. Send \$4.98 and we pay postage. THE JET must give you satisfactory service!
SUCCESS PRODUCTS, 246 Roebling St., Dept. H-309, Brooklyn 11, N. Y.

General SALVAGE CO.

THE BIGGEST SURPLUS BARGAIN Sale!

IN YEARS
BUY DIRECT FROM AD!

BUILD YOUR OWN ARC WELDER OR LIGHT PLANT

P-1
Westinghouse
D-C GENERATOR

Save \$250 to \$500

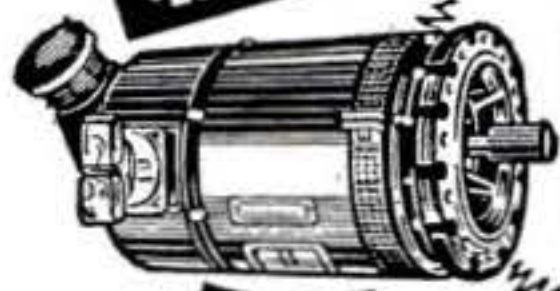

\$15.50
Instructions included. Rated 200 Amps 28 Volts 2500 R.P.M. Ship. wt. approx. 50 lbs. Stock No. 707

PRICE F.O.B. K.C., MO.

CONVERTS TO ARC WELDER 200-250 AMP. OR LIGHT PLANT CAP. LOAD 5000 WATTS

Stock No. 711 D. C. Generator R-1 Jack & Heintz, rated 300 Amp. 30 Volts. Gov't cost \$300.00. Instruction for converting to welder or light plant incl. Also instructions and diagram for converting the R-1 or P-1 generator to Combination Welder and Light Plant included. Only... **\$25.50**

CARBON PILE GENERATOR VOLTAGE REGULATOR
For use with 24 or 32 Volt D. C. Generators. Also recommended for the P-1 and R-1 type generators in "build your own" Light plant. Only... postpaid **\$6.95**

R-21 HEAVY DUTY RHEOSTAT
Brand New for regulating voltage on ELECTRIC WELDERS, model trains, electric blankets, lights, control photoflood lamps, etc. Rated 16-32-ohms. Size 3 1/2" x 2 1/2" postpaid... **\$6.95**

WEAVERS HYDRAULIC HAND PUMP
BRAND NEW INCL. BUILT IN CHECK & RELIEF VALVE. For hydraulic Jacks, presses, hoist, etc. For operating hydraulic cylinders to pump oil or hydraulic fluid under pressure, and is capable of delivering 1000 lbs. pressure. Wt. 10 1/2 lbs. A \$50.00 post-value. Instr. incl. Price... **\$12.95** paid

Valuable Gears — Bargains — Speed Reducers
10-1 or 5-1 ratio, 90 degree angle. Shaft driven 1/2" spline Shaft with 3 mounting holes 5/16". Gears held in forged and machined aluminum housing with two needle bearings, one bronze bearing, and three high speed shielded bearings. Rated 2 H.P. at 1750 R.P.M. **\$5.95** post-paid

New Amplidyne MOTOR GENERATOR
#5AN31NJ18A—Use as 24/32 Volt D.C. motor, pulls 1/2 H.P. or 0/60 V. D.C. Can be adapted to 110 V. A.C./D.C. 10,000 R.P.M. 1/2 H.P. by simple changes in connections. This unit can be adapted to independent and rural lighting, power, etc. Instructions incl. (Stock #790). Gov't cost \$140.00. Wt. 30 lbs. Only... **\$7.95**

SENSATIONAL SELSYNS
Two or more connected together, work perfectly on 110 V. A.C. For weather vanes, rotating directional antennas or controlling distance operations. Complete with diagram and instructions. Wt. 3 1/2 lbs. PER PAIR... **\$7.95** Postage paid

Hydraulic Solenoid Control Valve BENDIX, No. 81560 24V. D.C. For remote control operation and to operate one single action or double action hydraulic cylinders with 24 V. D.C. Recommended pressure 800 to 1500 P.S.I. connections are .550"-18thd. Diagrams and Instruction, to adapt valve to 110V. A.C. included. \$35.00 value. **\$3.50** ea. **\$6.50** per pair

RIGHT ANGLE DRIVE with 1 to 4 ratio through 90 degree bevel gears. Drive and take off shaft are 3/8" dia., Self lubricating. Size 3 1/2" x 2 1/2" x 1 1/4". Rated 1/8 H.P. at 1750 R.P.M. Ideal for use with power tools, etc. Has three 3/16" mounting holes on 1-5/16" center. Price **\$3.50**

CUNO OIL FILTER — Brand New
Aircraft type. Filters oil without cartridge replacements. Just turn handle and cartridge is clean. Standard 3/8" inlet and outlet ports to accommodate 12 gallons per minute. STOP CHANGING OIL. Instructions \$4.95 post-incl. **\$4.95** paid

SEND CHECK OR MONEY ORDER—All Prices F. O. B. Kansas City, Mo.

ELECTRIC MOTOR 1/2 H.P. 24 Volt D.C. R.P.M. 2500. Amp. 22 #HCA24. Gov't cost \$75.00. Brand New... **\$5.50**

ELECTRIC MOTOR 1/4 H.P. 28 Volt D.C. R.P.M. 4000 #2832 with simple instructions to convert to 28-32 Volt A.C. Gov't cost \$82.84. Brand New... **\$4.95**

ELECTRIC MOTOR 1/8 H.P. 24V. D.C. 2000 R.P.M. Applicable for 115V. A.C. Instructions incl. Stock #4949... **\$3.95**

ELECTRIC MOTOR 6 Volt D.C. Delco — Ideal as wiper motor, car heater motor, toy applications 1/4" dia. 1 1/8" long shaft. 2 mounting studs. Plus \$.35 Only... **\$2.35** Postage

AIR FILTERS. Aircraft type. Removes dirt, dust, etc. For industry, home & laboratories. For forced warm air, conditioning units, etc. Made of heavy metallic mesh with metal frame. Permanent, needs no refills. Size 4 1/2" x 6 5/8" x 2" Wt. approx. 8 lbs. \$25.00 Value...ea. **\$2.95** F.O.B. K.C.

ECLIPSE MOTOR & GEAR UNIT
Brand new including built in 24 V. D.C. motor. Has 1-horizontal and 1-vertical take off shaft. Gear ratio to motor is 40-1, can be adapted for 2-1 or 20-1 ratio. Ideal as OVERHEAD GARAGE DOOR OPERATOR, DRIVE FOR HOIST, WELL PUMP JACK, LAWN MOWER DRIVE, DRIVE FOR POST DRILL, etc. Wt. 23 lbs. Gov't. cost, \$221.00 including simple directions for converting unit to 110 V. A.C. to be belt driven by a separate motor. **\$12.95** f.o.b. KC, Mo.

UTILITY PUMP ROTARY VANE TYPE
FOR WATER, OIL, INSECTICIDES. Also applicable as Automobile Crankcase Drain Pump. Pressures 70 lbs. 12 gal. per minute at 200 R.P.M. Using 3/4 HP as vacuum pump for milking machines, compressors, lab. use, etc. Delivers 26" vacuum, 8 cu. ft. per min. at 1500 RPM using 3/4 HP., rotates either direction. 1/2" pipe thread ports. .650 splined shaft. Data & instructions incl. Stock #27 **\$12.95** paid Utility pump stock 75 is the same as #27. Has about once and half time the volume. Wt. 12 lbs. **\$15.50**

Pesco Centrifugal Heavy Duty Electric Pump
With built in 1/4 H.P. MOTOR included. BRAND NEW. COMPLETE. Self Contained, Explosion proof. Ideal for Gasoline, Oils, Water and non-corrosive liquids. Applicable for 24 V. D.C./A.C. or on 110 Volts A.C. The Discharge is for 3/4" hose connection. Capacity 400 G.P.H. For Cottages, Basements, Laboratories, Boats, etc. Instructions incl. \$85.00 value. Stock #659. Only **\$12.95** F.O.B. K.C.

PESCO FOUR VANE ROTARY LARGE VOLUME UTILITY PUMP
For Water, Oil, Insecticides, etc. including built in relief and by pass valve. Capacity 400 G.P.H. 1/2" drive spline shaft. 3/4" pipe inlet and outlets. Rotates either direction or in any position. Ideal for gasoline, oils, water and various types of sprayers. Engineering data incl. (Stock #600) only **\$7.95** post-paid

BEAM ROTATOR MOTORS For ham TV, FM antennas, telescopes, etc. Reversible light weight motor for 12 Volt D.C. also applicable for 110 V. A.C. Diagrams and instructions incl. \$50.00 value. (Stock #6918-3). **\$7.50**

HYDRAULIC PRESSURE GAUGE Calibrated reading 0 to 2000 lbs. Sq. In. pressure **\$3.50** post-paid

Adel Self-Priming ELECTRIC PUMP
For pumping light oils, oil burners, fluid metering, fuel pump, tool post grinder, coolant, pressure lubricating pump, etc. 1/30 H.P. rated 12000 R.P.M. Applicable for 24 V. D.C./A.C. or use on 110 Volt A.C. Size 6 3/4" x 3 1/2" x 3 1/4", rated 3 G.P.H. Diagram and instr. incl. \$50.00 val. **\$9.95** post-paid

FIRE EXTINGUISHER or INSECTICIDE PUMP SPRAYER. Four Gallon size includes approx. 3 ft. of high pressure hose with fine mist nozzle. Ship. wt. 15 lbs. via Express or Freight. Used, good condition. f.o.b. **\$3.95** ea. for **\$6.95** K.C., Mo.

Stratopower Constant Displacement HEAVY DUTY PUMP
For operating Hydraulic cylinders, hydraulic motors on tractors, Bulldozers, Construction machinery. Lift trucks. For fuel or oil transfer. Industrial applications, etc. Delivers up to 400 G.P.H. at 3750 R.P.M. Rated 1250 to 1400 P.S.I. 3750 to 4500 R.P.M. HAS BUILT IN RELIEF AT HEAD. Rotator either direction without adjustment. \$100.00 value. Engineering data and instr. incl. Stock #37. Wt. 8 lbs. **\$17.50**

AIR OR OIL HYDRAULIC CYLINDERS
Stock #429. Double action hydraulic cylinder 1 1/8" Bore, Stroke 1 5/8", Shaft 1/2" dia. including hinged mounting base. Overall length 10" Capacity 1000 lbs. with 1000 P.S.I. **\$5.50** post-paid

Stock #512. Double action hydraulic cylinder 2 1/8" Bore, 4" Stroke, Dia. 3/4" shaft including built in Hydraulic control valve which may be operated with rod or lever. Clevis mounting. Overall length shaft retracted 14". \$75.00 f.o.b. value. Wt. 9 lbs. **\$12.95** KC, Mo. Stock #11. Double Action 1 1/2" Bore, 6" Stroke, 5/8" Dia. Shaft. Clevis mounting base and shaft end. Capacity 1160 lbs. with 1000 P.S.I. input. Has a capacity of 1625 lbs. with our STRATOPOWER 1400 P.S.I. A \$50.00 value. Postpaid only **\$8.95**

Stock #303—Double Action 2" Bore, Stroke 1 1/4". Dia. 1 1/2". Overall length shaft retracted 23". 2000 lbs. capacity with 1000 PSI gives 2800 lbs. with our stratopower. Wt. 14 lbs. **\$14.95** f.o.b. KC, Mo. Stock No. 12 Hydraulic Cylinder Double Action output 12560 lbs. with 1000 P.S.I. input. Gives 17584 lbs. with our STRATOPOWER PUMP 1400 P.S.I. or will produce 34168 lbs. with 3000 line pressure. Can also be operated on low pressure system. 4" Bore, 10 3/4" Stroke, 1-5/16" Shaft, clevis mounting. O. Eq. Gov't. cost \$300.00 **\$27.50** f.o.b. KC, Mo.

Pesco Hydraulic Flow Equalizer & Pressure Balancer Valve. Brand New. Guarantees equal flow and equal pressure for Two cylinders or Two systems. Capacity 360 G.P.H. 1500 P.S.I. Data & instructions incl. A \$75.00 value. Stock 1-D-397 only **\$14.50** postpaid

HYDRAULIC CONTROL VALVES
Adel precision #B-10329. For controlling 2 single action or 1 double action cylinder. Including built in toggle lever. When lever is in one direction it puts pressure on one cylinder connection and opens exhaust, from opposite cylinder. When lever is released it returns to the neutral position and locks cylinder. Brand new. A tremendous bargain! **\$8.95** post-paid

VICKERS Four Way Hyd. Control Valve #137
For two double action cylinders allowing operator to raise or lower the both cylinders simultaneously or raise one and lower the other at predetermined rate. Post-and speed, \$75.00 value... **\$14.50** post-paid

Pesco Pressure and Relief Control Valve
Brand new. Designed with 3 ports and external pressure adjustment. Relief valve is spring loaded, and adjustable for controlling pressure regulation. Has two ports for normal flow, one for relief line to fluid supply or to pump inlet. No. 575 Engineering data incl. A terrific bargain! Only... **\$4.95** post-paid

Hydraulic Accumulators — Bendix Ball Type
Dia. 5 1/2". Built to stand 2000 P.S.I. Stock #A-65. Wt. 4 lbs. only **\$5.50**
BENDIX ACCUMULATOR. Ball Type. Dia. 10". Built to stand 2000 P.S.I. Wt. 15 lbs. Stock #A-85. Only... **\$17.50**

ALTERNATING SHUT-OFF VALVE
Brand New. High pressure. Operated by worm-gear cam operating poppets to alternately close & open either pair of four ports. Standard 3/8" pipe post-ports. \$50.00 value only... **\$5.50** paid

Vickers Pressure Relief Valve
Brand new adjustable for protecting hydraulic systems using positive displacement pumps. 1/2" AC tube size. Tapped 3/4"-18 thread. Stock No. 501. Postpaid... **\$5.50**

VICKERS UNLOADING VALVE Brand New—By passes full amount output of the pump while the cylinder is not in operation. Takes starting load off of electric motor driving the pump. 1/2" AC TUBE PORTS (3/4"-18) thread. Price... **\$8.95** post-paid



GENERAL SALVAGE CO., 2922 E. 27 St., Dept. 325 Kansas City, Mo.

The easy way to paint!

Speedy Sprayer



ONLY \$32.50 LESS MOTOR

Favorite of home owners and craftsmen for 20 years! SPEEDY SPRAYER gives your work that professional paint finish everyone admires. Sprays paint, enamel, varnish, lacquer, etc. . . . 4 to 7 times faster than hand brushing! Lightweight, portable, uses any 1/4 H.P. motor. Improved diaphragm principle assures clean, oil-free air. You'll find dozens of time and money saving uses for SPEEDY SPRAYER, including spraying insecticides 2-4-D and DDT. Complete outfit, without motor, only \$32.50.

At leading hardware, lumber, and auto supply dealers.
FREE—write for handy booklet "How to Spray."

W. R. BROWN CORPORATION
 2637 N. Normandy Ave. • Chicago 39, Ill.

Make \$20 to \$30 a Week EXTRA MONEY!

With the high prices of food, clothing and everything else, just think what you could do with extra money every week! Turn your spare time into CASH—sharpening saws with a Foley Automatic Saw Filer pays up to \$3 or \$4 an hour. Start in your basement or garage—no experience necessary. "The first saw I sharpened with my Foley Filer came out 100%"—writes Clarence E. Parsons. No canvassing—"I advertised in our local paper and got in 93 saws"—says M. L. Thompson. With a Foley you can file all hand saws, also band and cross-cut circular saws.

FREE BOOK
Shows How to Start

It explains how you can get business from home owners, farmers, carpenters, schools, factories, etc. "I get work from 20 and 30 miles away"—says Charles H. Smith. Free Book, "Money Making Facts," tells how to start. Send coupon today—no salesman will call.

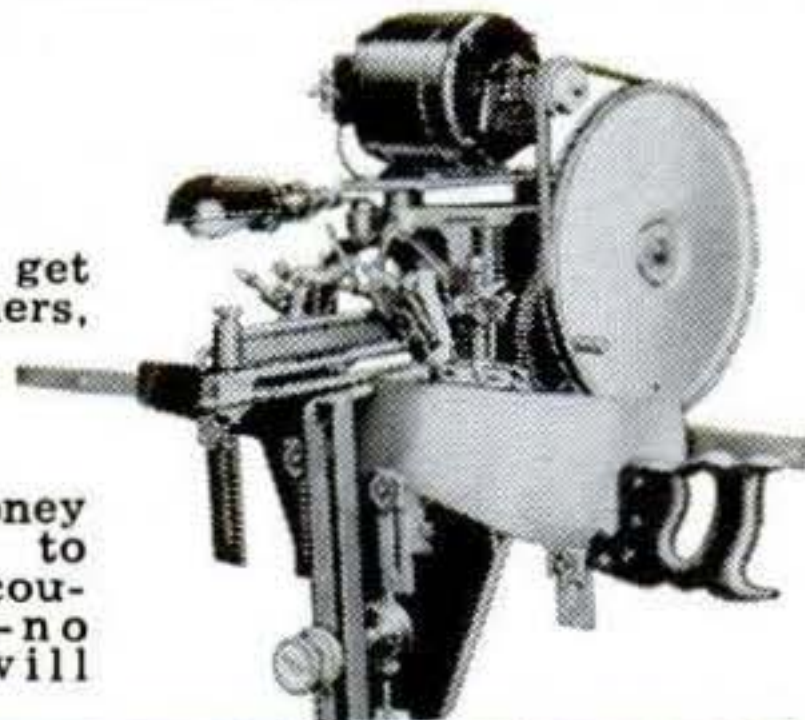

Send Coupon for FREE BOOK

FOLEY MFG. CO.
 519-2, Foley Bldg., Minneapolis 14, Minnesota
 Send FREE BOOK—"Money Making Facts."

Name.....
 Address.....

MONEY MAKING FACTS

USE KESTER METAL MENDER
 (GENUINE TIN LEAD SOLDER)

For all Metal Repairs

FREE: "Soldering Simplified." 16 page illustrated booklet. Get your copy now.



Kester Solder Company
 4254 Wrightwood Ave.
 Chicago 39, Illinois

VARIABLE SPEED HYDRAULIC POWER TRANSMISSION



It has Infinite Speeds 0 to 550 Reverse Automatic Overload Protection; Adjustable Torque up to 180 inch pounds. 5/8" Input and Output Shafts. It will handle 1/4 to 1 1/2 H.P. Motor. Case measures 7 1/2" long 7" high 6 1/2" wide. VALUE OVER \$300. Shipping Wt. 25#. On **only \$54.50** C.O.D. Orders we require a 10% Deposit. **Fob. Chicago**

DIRZIUS MACHINE SHOP "N" 1423-25 So. 52nd Ave., Cicero 50, Ill.

JUST OUT!



1952 EDITION

It's New! It's Different! Get world's largest Auto Accessory & Parts Catalog and save money. Over 50,000 items, including Hollywood Accessories, Hi-Speed Equipment, Rebuilt Engines, all parts & accessories for all cars & trucks. We have that Hard-To-Get part! Jam packed with bargains. Completely illustrated. (100 pages) Send 25c (refundable).

J. C. WHITNEY, 1917-F Archer, Chicago 16

DO MORE PLANING JOBS \$215.00 WITH LOW-COST BELSAW



AMAZING 12 1/4-IN. PLANER Does All Ordinary Planing Mill Jobs. Provides attachments for Jointing, Rabbeting, Tongue, Groove, Matching. 12 1/4 x 6-in. capacity, 3-knife solid round all-steel cutterhead. Power feeds at 24 feet per minute, 42 cuts per inch. Provides for full line of accessory attachments—Grind and Joint knives IN THE CUTTERHEAD WITHOUT REMOVING.

BELSAW MACHINERY CO
 1022 Field Bldg., 315 Westport Rd., Kansas City 2, Mo.

FREE BOOK

Magnetic Layout Punch



Ideal for Toolmakers and Hobbyists needing speed plus .001" accuracy. Precision ground and hardened assuring years of dependable service. **FREE** "Shortcuts to Layout Work" with Alnico Layout Punch only \$3.85 postpaid.

Magnet Hold Perfect Center Punch Co.
 Dept. 5 837 Central Park Ave. Yonkers 4, N. Y.

POWER MOWERS & KITS

LOW FACTORY PRICES DIRECT TO YOU

Build your own quality mower with our LOW COST KITS, Parts, Engines. Free Plans guide you, 3 and 4 Wheel Kits, complete. Parts precision finished, ready to use. Write TODAY for Free Plans. Low Prices, Parts List and Guarantee.



3 & 4 Wheel Model **4 Wheel Direct Drive**

3-WHEEL KIT NO. T-800



America's Finest Power Mowers completely assembled in 3 and 4 wheel models. Belt or direct drive. 18" and 20" sizes. Nationally known make engine. Latest improved features, sturdy construction and money back guarantee fully described in color folder. Write Today.

TRIANGLE MANUFACTURING CO., Box S-13, Fort Scott, Kansas

HYDRAULIC CYLINDERS

HYDRAULIC CYLINDER SPECIAL

Gives 20,000 lb. thrust (push-pull) using 1500 PSI line pressure as obtained from our hyd. pumps. Or will produce 40,000 lb. thrust with 3000 lb. line pressure. CAN ALSO BE OPERATED ON LOW PRESSURE AIR SYSTEMS. 4" bore, 1 1/2" dia. piston shaft, 18" stroke, length: 30 1/2". Equipped with ball bearing loaded clevis type mounting and swivel type high pressure steel pipe bracket for easy use. Ideal for road, farm & shop machinery, presses etc. Cost gov't \$390.00



2995

No. 3 DOUBLE ACTION CYLINDER—Bore is 1" - Shaft is 1/2". Has a stroke of 2 1/2" to 4". Stroke can be adjusted with internal sleeve stops. Overall length is 8 1/2". Will take 1500 lbs. continuous duty. 3000 lbs. intermittent. Will lift or push up to 1100 lbs.

575

No. 9-E DOUBLE ACTION HYDRAULIC CYLINDER—Has a bore of 1-3/8" and shaft of 1". Stroke is 9". Overall length 15 1/4". Built for 1500 lbs. continuous duty. 3000 lbs. intermittent. Will lift or push up to 2300 lbs. Can be adapted to hundreds of uses.

975

We carry the World's largest supply of Special Hydraulic Equipment featuring over 20,000 cylinders in 61 sizes and types. Can also supply all accessories such as Pumps, Valves, Tanks, Hoses and Fittings. Write for information.

SAVE UP TO 85% ON WAR SURPLUS AT "GADGETEER'S HEAVEN"

SURPLUS COMPUTER GUNSIGHT

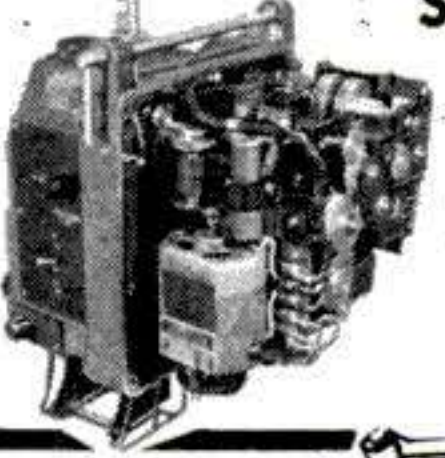

GADGETEERS! HOBBYISTS! INVENTORS! SCIENTISTS! Here is the 'Buy' of a Lifetime! Here, in one unit is approximately 60 precision bearings in many sizes, differential gears, miniature, matching bevel gears, spur gears, worm gears & drive shafts. Two constant speed mechanical governors, one 24 volt motor (1/50 HP, 3000 RPM), switches, optically perfect mirrors & lenses & a host of other parts. The Best That Money Can Buy! Cost the Gov't approx. \$1700. **NOW ONLY 2750**

HYDRAULIC POWER UNIT!!

Complete hydraulic pumping unit. All necessary parts assembled & ready to work at a great saving in time and cost to you. Delivers 3 1/2 GPM at 1500 PSI at 1800 RPM. (other volumes and pressures can be attained by simple adaptations) Unit consists of a gear pump driven by a 2 1/4 HP, DC motor (4000 rpm max.), relief valve, pressure unloading switch, filter, accumulator, reservoir with sight gauge & complete plumbing. Mounted on 19"x 25" aluminum panel. Complete with 24V-DC motor. (Other motors of any current can be adapted)

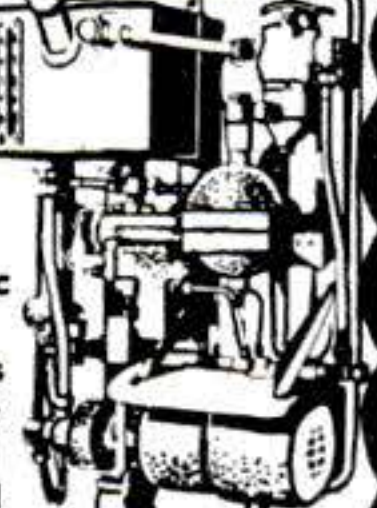

4995

FAMOUS PALLEY GADGET MIXES

A valuable "stock pile" of small parts & supplies for the hobbyist, mechanic, etc. Each item packaged separately in generously assorted sizes and types of --- **SCREWS, NUTS, BEARINGS, ABRASIVES, HINGES, SPRINGS, PULLEYS, RIVETS, FILES, ETC.** Have these assorted mixes handy when you need them. **SAVE TIME & MONEY!** Write for complete, illustrated literature and special, **LOW PRICES!**

3 SPEED TRANSMISSION
Converts a high RPM, low power input into low, RPM, high torque output. Has 2 take-off shafts at 4 to 1 & 16 to 1 ratio. Gear box has worm drive bronze gears & throw-out clutch. Will operate forward or reverse directions. Adaptable to many uses on power machinery.



1995

VICKERS HYDRAULIC TRANSMISSION
Self contained, 2 H.P. constant torque at all speeds with variable volume reversible, piston pump (controlled by outside lever) supplying piston hydraulic motor. Automatic pressure, dash pot for smooth control. Power output RPM -0 to 1/3 input RPM in both directions. Input RPM 1800 continuous. 4000 intermittent. Dash pot can be removed for greater RPM. Ideal for lathes, duplicator set-up of mills, conveyors, small cars, drives, gearings, etc.



9000

250 PR

The two transmissions above can be combined to make an excellent "power booster" or speed controller for many types of power machinery.

4 WAY VALVE
Poppet, piston type. Off at neutral. Built-in relief valves for limit of cyl. stroke. Inlet & outlet 5/8" AN tube
Cyl. ports 1/2" AN tube.



975

STRATO-POWER PUMP
With built-in variable flow control valve in head. Positive displacement piston type. Displaces .450 cu. in. per revolution. 2 gal. per min. cap. at 1500 RPM at 1250 PSI. Pressure limit, 1250 PSI continuous, 1400 PSI for 15 sec. Operates at 3750 RPM, intermittent maximum 4500 RPM. Rotates either direction without adjustment



1950

VICKERS HYD. VARIABLE DISPLACEMENT PUMP
Will deliver maximum volume at any pressure setting between 600 & 900 PSI. Desired pressure settings obtained with adjusting screw. Pump housing serves as reservoir for system. Has built-in compressed air supercharger which makes system independent of outside atmospheric pressure. Rotation is left hand only. Maximum speed for continuous duty is 3750 RPM. Displacement is .484 cu. in. per revolution or approx. 4 GPM at 1750 RPM.

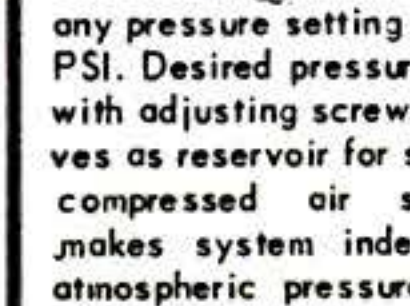

3250

AIRCRAFT CABLE
Rust resistant, alloyed steel. Extra flexible. Pre-formed, 7 x 19 strand. On reels.
1/16" - 4 1/2 ft. 7/32" - 10 1/2 ft.
5/64" - 5 ft. 1/4" - 12 1/2 ft.
3/32" - 5 1/2 ft. 9/32" - 15 ft.
1/8" - 7 ft. 5/16" - 16 1/2 ft.
5/32" - 7 1/2 ft. 3/8" - 18 ft.
3/16" - 9 1/2 ft. 1/2" - 20 ft.

SPECIAL 3/16" cable, 18 feet long, with turnbuckle ends.99¢
Stainless Steel Cable - Pre-Formed
1/16" - 6 ft. 5/32" - 20 ft.
3/32" - 14 ft. 1/4" - 26 ft.
Bronze Cable - Not Pre-Formed
1/16" - 5 ft. } 3/16" - 23 ft.
1/4" - 17 ft. } 1/2" - 38 ft.

ROPER HYDRAULIC PUMP UNIT
Here's a complete Hydraulic pump unit. Has a Roper Pump which delivers 300 GPH at up to 60 PSI. A 1/3 HP, Leland, heavy duty motor which operates on 110V AC- 60 cycle current and is coupled to pump with rubber universal joint. Unit is mounted on aluminum base with carrying bar. Ideal for transfer pump, power for small hyd. press, irrigation pump, crop spraying, etc.

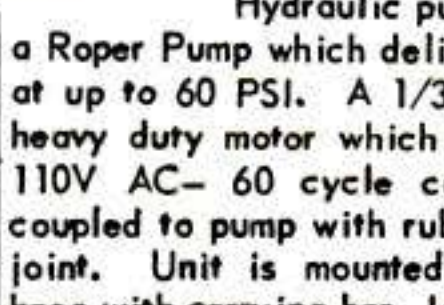

9795

CARBON PILE VOLTAGE REGULATOR
The most dependable type voltage regulator used by the Armed Forces. Suitable for use with any 24 to 28 volt generator (see above). Accurately regulates flow of voltage at any setting between 20 and 30 volts. Comes complete with mounting base.



ONLY 675

MAKE YOUR OWN ARC WELDER



2795

Use this top quality, precision built R-1 generator. An aircraft generator that originally cost the government approximately \$400. Gives 300 to 400 amps at 27 volts. Ideal to convert for all welding, light or heavy up to 5/8" thickness. Free conversion instructions with each unit.

OTHER AIRCRAFT GENERATORS
X-10 . 12 to 15 Volts 50 Amps \$12.95
X-11 . 27 VOLTS . . 200 AMPS \$15.95
X-12 . 27 VOLTS . . 100 AMPS \$25.00
X-13 . 27 VOLT. 140 AMP. **1695** X-14 . . 27 VOLT. 75 AMP. **1595**

NEW ILLUSTRATED 230 PAGE - 1952 CATALOG



Packed with SENSATIONAL VALUES in WAR SURPLUS, FACTORY CLOSE-OUTS and GENERAL MERCHANDISE! 1000's of items for the Mfr., Mechanic, Sportsman, Photographer, Hobbyist, Home Owner etc. **BIG SAVINGS** on clothing, housewares, hardware, foam rubber, hand and power tools, outdoor & camp equipment, industrial tools & supplies, aircraft parts, metals, plastics, gadgets and a huge stock of hydraulic supplies—cylinders, pumps, valves, motors etc.

Send Only 50¢ (for handling & mailing)

PALLEY SUPPLY CO NEW MAIL ADDRESS 2263 E. VERNON AVE. Dept. PS-5 LOS ANGELES 58, CALIF.

ELECTRIC MOTORS



LEAR ELECTRIC MOTOR. 24 volt, 6 amps, series wound reversible motor . . . with overload clutch. Motor turns 11,000 RPM. Has 11 to 1 gear reduction box turning 1000 RPM at take-off. Adaptable to flex or rigid drive. Limit switch box. Size: 10" x 4"

795



SAMSELL MOTOR 27 volts, 16 amps, 1/5 H.P. reversible, series wound on motor. 3800 RPM, shaft 9/32" diameter. 12-spline. 4-1/8" x 2-3/8"

395 ONLY

SURPLUS MOTORS
No. 500 - New 1/2 HP - 27 volt, DC-AC. This motor can be readily adapted to deliver up to 1/2 HP on 110 volts AC by the simple method of rearranging armature brush-leads. Free Diagram with each order. A SENSATIONAL VALUE.



595

No. 500-A - Converted to 110 Volts, A.C. Equipped with plug and 3 1/2 ft. heavy duty cord

849

GEAR HEAD MOTORS
Heavy duty G.E. Gear Head Motor. 1 1/2 H.P., 24 volt D.C., 125 Amp. reversible motor will drive reduction gear box unit 44.5 to 1, resulting in 168 RPM at 5/8" diameter take-off shaft. Motor contains electro magnetic brake.



UNIT COMPLETE **1095** MOTOR **495**
GEAR BOX ALONE **795**

LEAR GEAR HEAD MOTOR - Lear 24 volt DC, 7.6 amp, series wound reversible motor with overload clutch. Motor turns 11,000 RPM driving thru a 10 to 1 gear reduction box which turns the final take-off shaft 1100 RPM. Adjustable limit switches control limit of travel. Take-off shaft adapts to flex or rigid drives.



1750

ELECTRIC ACTUATOR
Hundreds of uses for any mechanical device needing controlled 2 way action. Opens, closes, raises or lowers doors... windows..gates..valves.



CTU-2 Foote Linear Actuator. 24V AC or DC, 8500 RPM, 1/6 HP - series wound motor. 4-1/2" stroke in 13-1/2 seconds. Compression & tension loads up to 750 lbs. Adjustable micro switch for limits of travel. Overall lgth. retracted 11 inches.

EA-E1 - EASTMAN ACTUATOR— Has a 1/8 HP, 24 volt DC, 10,200 RPM motor and push-pull actuator. Actuator has 4" travel through a reduction gear box. Has adjustable limit switches & forward & reversing relays. Overall lgth. extd. 20", retracted 15 1/2".

1295

FIRE EXTINGUISHER
Kiddie Lux - CO² Type. Built to Gov't specifications. Heavy, shatter-proof case. Recent hydro-static test. Reconditioned and fully charged. LIKE NEW! READY FOR INSTANT USE!!



2 lb. size with Swing Nozzle . . . 13.75
3 1/2 lb. size with Swing Nozzle . . . 17.95
7 1/2 lb. size with Horn 23.75
10 lb. size with New Squeeze Grip Handle & 3/2 ft flex hose with Horn. **29.75**
15 lb. size with Squeeze Grip hdl, 4ft. flex hose, plastic hom. **\$42.50**
15 lb. size with Wheel Control . . . 37.95

Order Fro. This Ad. Pay by M.O. or check. P.O.'s. accepted. from D&B firms. 1/2 deposit with C.O.D.'s. All Prices FOB Los Angeles. All Sales Final.

DC Battles AC to Pull Heavy Loads

[Continued from page 100]

70 loads and 11 empties strung out behind. That's 6,975 tons.

Obviously, General Electric units 4941-4942 are not overloaded on this run. Your Jersey City-bound freight is climbing past the 40-m.p.h. mark before you have rolled three miles. Within another three she is up to 50. You roar past an interlocking tower and fireman Alex Defontes swings a flashlight beam at the dimly lighted window, gets a wigwag in return.

Right now, General Electric engineer Parsons is working his own flashlight over the rumbling, black cab interior. He shows you the massive steel posts that protect the crew down in the semicircular nose section; points out that the bridgelike flanks of the locomotive itself weld the whole unit into a tough steel channel. By adding only five percent to the weight of the outside panels for this purpose, some 40 percent of the heavy floor-frame tonnage of previous electric engines has been lopped off, with no lessening of structural strength.

GE Engine Packs Power to Spare

Under the decks, unseen, but responding smoothly to the slightest change in the controller, are the eight new AC traction motors which are the heart of the GE design. Each develops its 625 horsepower within space limits believed impossible 10 years ago. Each, through the use of silicone insulation instead of ordinary putty and varnish, shrugs off the heavy overloads.

Like Westinghouse, GE has provided electric braking. In both systems the motors are changed into generators to produce a powerful drag on the driving axles. As generators, both types turn out direct current, which naturally could not be fed directly back to the AC trolley wires. So both manufacturers have borrowed a trick used in Diesel locomotives. They simply shoot the juice into resistance grids and blow the heat out through a grille in the roof of the cab.

The GG-1 Is Hard to Beat

This is the AC part of the freight-locomotive story. But it doesn't quite wrap up the case for either manufacturer. Special Duty Engineman Baldwin, who is riding with you as far as Philadelphia, points out that there is a third contender in the ring.

"Back in 1934," he says, "Westinghouse and GE stacked the cards against them-

selves. They cooperated with us on a super passenger engine—the GG-1. Everything about that job was built for speed. Streamlined jacket; AC traction motors; low gear ratio. But she turned out almost too good. A double-forked thunderbolt, you might say. Whips a quarter of a mile of Pullmans over the road at 100 miles an hour. Then she latches onto a freight. Walks away so fast the crew back in the cabin car get nervous. Think they climbed aboard the Congressional by mistake.

"Result: We were sold on the one, all-purpose locomotive design. Got a fleet of 139 of the mighty Gs right now. Believe me, one of these new babies has got to be good to make us change our minds." **END**

Next Month: PSM tells how all trains west of the Rockies may run on hydroelectric power.

New U. S. Liner Challenges Queens

[Continued from page 112]

Behind all these innovations is the genius and drive of a man generally considered the country's No. 1 naval architect. He is William Francis Gibbs of the New York firm of Gibbs & Cox. Designer of the *America*, the country's largest passenger ship now in service, and other major merchant craft as well as many types of naval vessels, he has for many years advocated such a supership as the *United States*—in the top class for speed, completely fireproofed, air-conditioned, luxurious. It took a lot of persuading, over the years. But his dream began to turn to reality on April 7, 1948, when the Government's Maritime Commission and the United States Lines agreed on a financing plan and the Newport News yard was given the word to go ahead with the construction. The original contract price was a little under \$70,000,000; modifications at the behest of the Government have raised that figure considerably.

For its money the nation has a lot of ship to show. In peacetime the *United States* will maintain its North Atlantic express run and few doubt that it will take a shot at the record now held by the *Queen Mary*—3 days 20 hours and 40 minutes, east-bound. All this means prestige and patronage. In wartime the ship, as the nation's largest transport, could carry 14,000 to 16,000 troops as far as 10,000 miles without a stop. Peace or war, a lot of ship. **END**



Hose it —

MARFAK stays put, won't drip off!

★ This Hose Test is convincing proof of why *Marfak* lubrication lasts longer — does a *better* job of protecting your car's chassis. *Marfak* is specially compounded to withstand the "washing action" of rain, road water. That's mighty important this time of year. And bulldog-tough *Marfak* clings to points of wear and friction, resists jar-out, squeeze-out. As a result, *Marfak* lasts for 1,000 miles or more. And *you* enjoy "cushiony" driving that *lasts!* Get *Marfak* lubrication today. See your Texaco Dealer, *the best friend your car ever had.*



THE TEXAS COMPANY
TEXACO DEALERS IN ALL 48 STATES

Texaco Products are also distributed in Canada and in Latin America

TUNE IN . . . TEXACO STAR THEATER starring MILTON BERLE on TV every Tuesday night. See newspaper for time and station.



KEEP CLOSE-TOLERANCE MACHINING EFFICIENT!

South Bend PRECISION TURRET LATHES

South Bend 2-H Precision Turret Lathe—1" collet capacity, 16 1/4" swing, 96 power turret feeds, 48 cross slide feeds, 48 carriage feeds, 48 thread cutting feeds.

South Bend Precision Turret Lathes keep efficient the machining of small duplicate parts. Their remarkable accuracy and positive controls simplify the holding of close tolerances with only normal machine handling care. Finishes are commonly produced that otherwise would require additional operations. Simplicity of tooling makes job changes quick and economical. Wide ranges of power feeds and thread cutting feeds assure maximum efficiency on every job. They are particularly suited for second operations. Available in 3 sizes: 1" collet—16" swing; 1" collet—10" swing; 1/2" collet—9" swing.

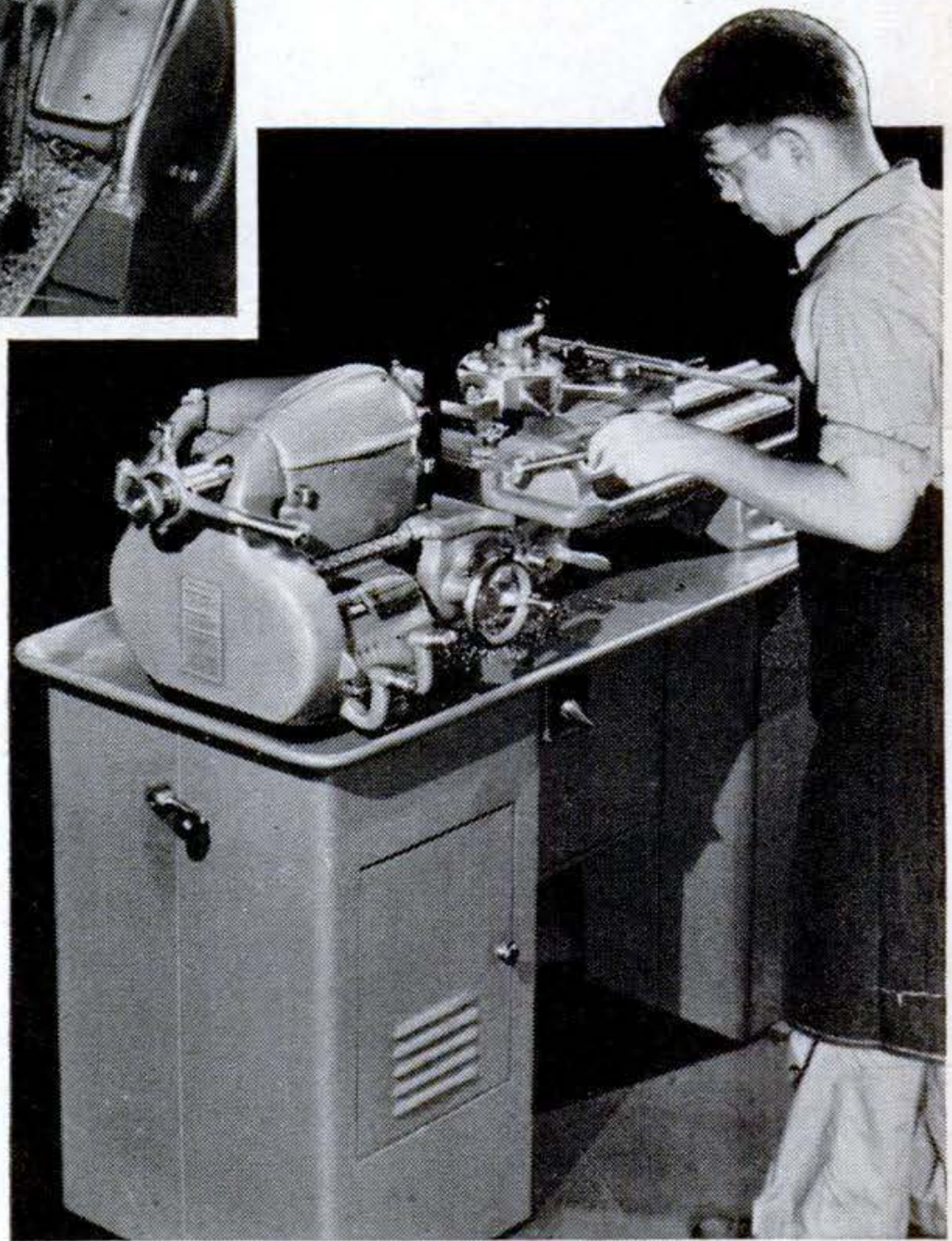

South Bend CL930-Z Precision Turret Lathe—1/2" collet capacity, 9 1/4" swing, 48 carriage feeds, 48 thread cutting feeds, handlever cross slide, handlever turret.



SOUTH BEND LATHE

South Bend 22, Indiana
Building Better Tools Since 1906

Send Information Checked:

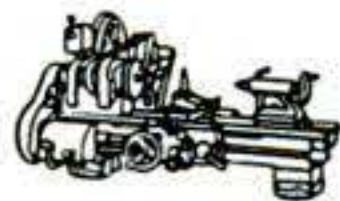

9" and 10" BENCH LATHES

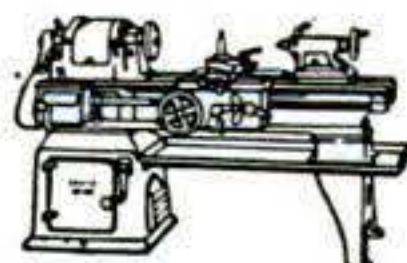

10" to 16-24" FLOOR LATHES

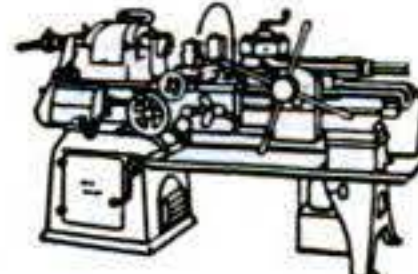

1/2" and 1" Collet TURRET LATHES



14" DRILL PRESSES

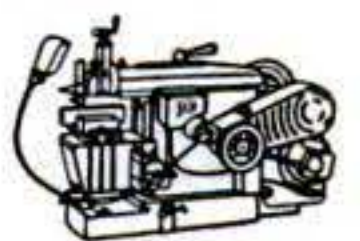

7" BENCH SHAPERS

Name _____ Company _____

Street _____ City & State _____

\$15²⁰ an hour!

This is the average earning reported by Presto salesman **WILLIAM F. WYDALLIS**. "The sky's the limit" on Presto profits because of America's serious need for this new fire extinguishing discovery.



WILLIAM F. WYDALLIS

"Most specialty salesmen are always on the lookout for a 'natural.' The 'natural' of this decade is the PRESTO FIRE EXTINGUISHER... because it is handy in size, simple to operate, and in the right price range.

"For every hour I have devoted to the Presto, I find that I have earned an average of \$15.20 an hour. I am now convinced that extraordinary money can be made in this safety field. I am devoting more of my time to this product now since I have discovered that the earnings on this item are greater than any item I have handled in the past."

—William F. Wydallis
Van Wert, Ohio



CHARLES KAMA

This Presto salesman from Texas was featured as "Salesman of the Month" on the front cover of a sales magazine. He told the magazine's reporter:

"I think I've succeeded pretty well. I'm making more than a thousand dollars a month—and I haven't touched bottom yet."

Folks Are Amazed when you Tell Them This New Kind of Protection Costs Only **\$3.98**

WOULDN'T YOU like to be making the kind of money William F. Wydallis is making? His story (printed at right) is just one example of the brilliant success that Presto salesmen are meeting everywhere! A Florida salesman earned \$600 in one month. An Ohio man earned \$2100 in 2 months. A New York salesman earned \$1500 in one month. A New Hampshire salesman added the Presto as a *sideline* and picked up an extra \$1800 in 20 months.

What is the Secret?

PRESTO contains an amazing new chemical "Chlorobromomethane" or "C.B." developed as a secret defense against fire during the war.

In comparing the effectiveness of "C.B." in fighting various kinds of fires an authoritative testing laboratory states: "It has been proved that 'C.B.' is about 1.5 to 6 times as effective as other common extinguishing agents on an equal weight basis."

This extra effectiveness of "C.B." means that Presto can be made light and handy enough for even a woman or child to use. Just a twist of the knob . . . and flames disappear! "Sells on sight" to civil defense workers, owners of homes, cars, stores, farms, service stations, boats, motorcycles, factories, offices and to stores for re-sale.

Why Large Presto Profits Are So Easy

Everyone is terrified at the very thought of FIRE! Every year fire kills more than 11,000 people. Most people who see Presto in action want one or more — ESPECIALLY WHEN THE PRICE IS ONLY \$3.98 EACH!

You can demonstrate Presto in a few minutes, and every sale will net you \$1 or more. We refill your demonstrator free . . . and we give you dramatically powerful printed sales material to "talk from" . . . free certificates testifying that Presto is GUARANTEED FOR 20 YEARS.

Over One Million Already Sold

YOU DON'T NEED TO INVEST A PENNY. Just collect and keep \$1 or more every time you write an order—we collect the balance and deliver the extinguisher. (Or if you wish, you can buy from us at extra-low wholesale prices and then make up to \$2.18 profit per unit supplying both dealers and retail customers—we'll send you free details.)

Start Now—Mail Coupon

Get started in this rich new field now. Don't "put it off"! Every day you hesitate may cost you \$10, \$15, or even \$50 you could otherwise be making. Mail the coupon at right NOW for everything you need to get started right away!

MERLITE INDUSTRIES, Inc., Dept. 115, 201 East 16th Street, New York 3, N. Y.

Best Selling Months Just Ahead! Don't Delay—Mail Coupon Now!

**MERLITE INDUSTRIES, Inc., Dept. 115
201 East 16th Street, New York 3, N. Y.**

Please send me illustrated sales literature, liberal profit plan, order blanks—everything I need to get started making good money introducing the Presto Fire Extinguisher in my locality.

CHECK HERE IF YOU WISH TO ORDER A REGULAR PRESTO TO BE USED AS A DEMONSTRATOR (\$2.50). Pays for itself many times over in increased sales. Can be returned as often as you like for FREE re-fill. You needn't enclose any money now—we'll send Demonstrator C.O.D. (Or if you wish to save money, enclose \$2.50 and we'll pay postage.)

Name.....

Address.....

City..... Zone No. (if any)..... State.....

IN CANADA: Mopa Co., Ltd., 371 Dowd Street, Montreal 1, P.Q.

Only Presto Has All These Features!

- Ends Fire as Fast as 2 Seconds
- Chemical Contents 1.5 to 6 Times More Effective than Others on an Equal Weight Basis
- Weighs Less Than 1 Lb.
- Easily Held in One Hand—Even by a Child
- Needs No Inspection or Re-Charging—Does Not Corrode or Deteriorate
- Costs Only \$3.98—Yet Outperforms Bulky Extinguishers Costing Several Times as Much
- Automatic Pressure — No Pumping
- Guaranteed for 20 Years — Certificate is Packed with Every Presto



These baseball stars pick **Camels**

FOR FLAVOR
FOR MILDNESS



Ed Lopat Yankee 21-game winner has tried different cigarettes. Says Ed, "I picked Camels for mildness and flavor. No other cigarette gives me so much smoking pleasure!"



Early Wynn 20-game winner for the Indians is a Camel smoker, too. Early reports: "For steady smoking, my choice is Camels! They're mild and they taste great!"



Allie Reynolds Yankee pitcher of double "no-hit" fame. Allie stated, "I've smoked Camels a long time and I know how mild a cigarette can be! Camels taste great!"

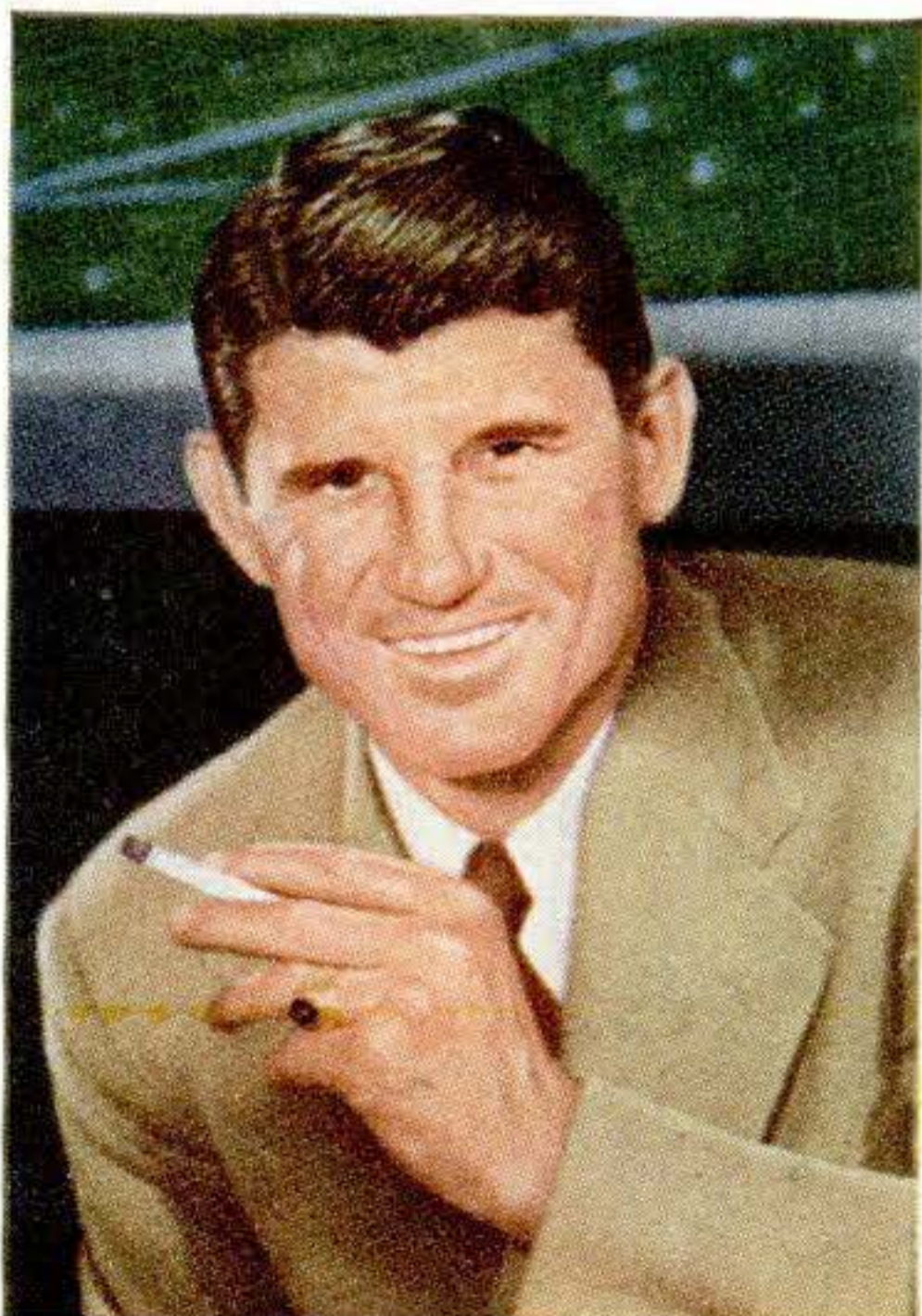

"Preacher" Roe (22-3 in 1951) and other Dodgers—Carl Furillo, Clem Labine, Clyde King and Billy Cox—are Camel smokers. "We all agree on Camel mildness," says "Preach."

TEST FOR **MILDNESS**...TEST FOR **FLAVOR**...SEE WHY

CAMEL IS AMERICA'S MOST POPULAR CIGARETTE
— BY BILLIONS!

Smoke Camels for 30 straight days. See how flavorful Camels are, pack after pack... See how mild Camels are, how well they agree with your throat as your steady smoke. You'll know why Camel is by far America's most popular cigarette!

R. J. Reynolds Tob. Co.,
Winston-Salem, N. C.

Make your own sensible 30-Day Camel Mildness test in your "T-Zone"
—T for Throat...T for Taste

