

POPULAR SCIENCE

INCLUDING **MECHANICS** AND HANDICRAFT

APRIL • 35¢ Monthly

X-Ray View of America's Latest Jetliner

TO SEE THE WHOLE PLANE, UNFOLD HERE 



Stupid Traffic Rules Trap Decent Drivers
5 Ways You Can Lick That Tired Feeling

PAGE 142

PAGE 132

Huge DC-8, America's second jet transport,

Half a football field in length, the DC-8 stretches 150 feet, six inches from end to end and spreads its remarkably flexible, swept-back wings nearly as far: 139 feet, nine inches. The great hollow wings, whose elasticity cushions air turbulence as if they were giant springs, hold more than 57 tons (17,600 gallons) of kerosene, which is what jets burn. Yet they can be pressure-filled, from underneath, in 15 to 20 minutes.

The first DC-8s will have four P. & W. JT3 engines, driving them to 561 m.p.h. They make enough electricity for 60 homes.

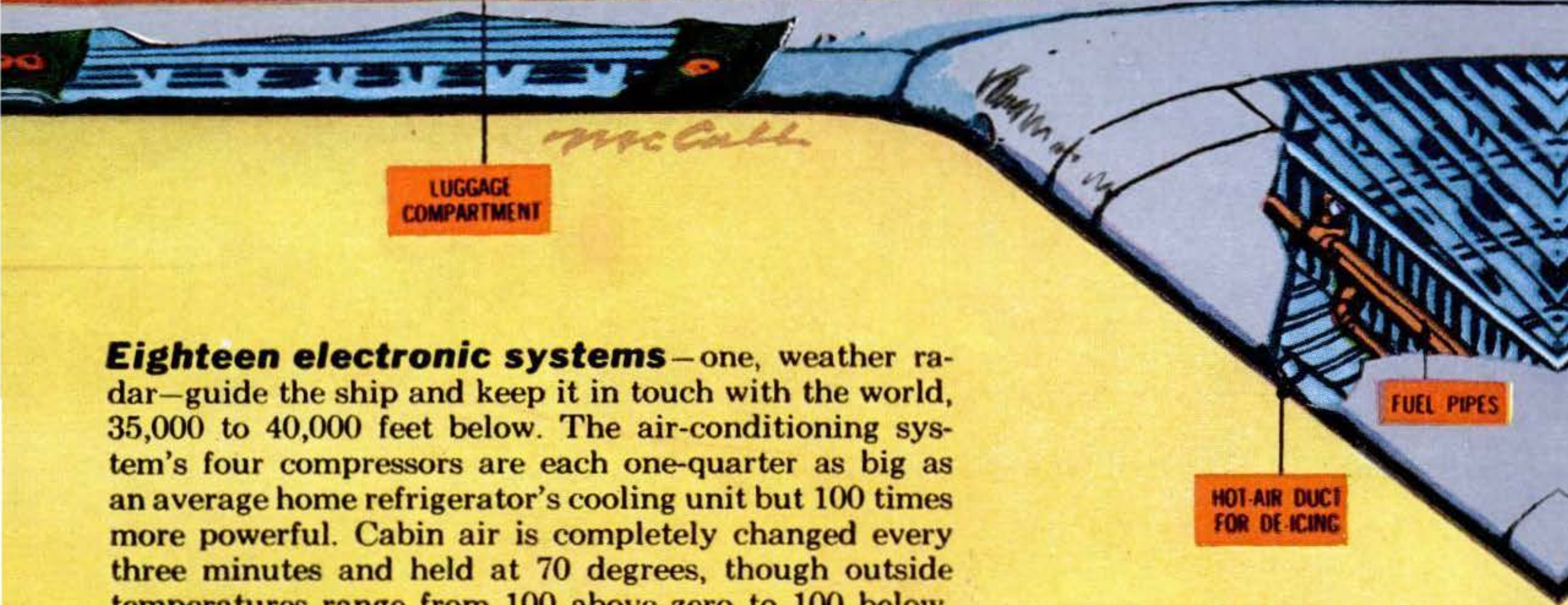

Eighteen electronic systems—one, weather radar—guide the ship and keep it in touch with the world, 35,000 to 40,000 feet below. The air-conditioning system's four compressors are each one-quarter as big as an average home refrigerator's cooling unit but 100 times more powerful. Cabin air is completely changed every three minutes and held at 70 degrees, though outside temperatures range from 100 above zero to 100 below. Engine sound suppressors incorporate clamshell-door thrust reversers to shorten the landing roll.

starts service next fall. Four engines develop

TURN

LIFT SPOILERS
IN LANDING POSITION

LUGGAGE
COMPARTMENT

TOURIST
SECTION

FUEL

FLAPS

MAIN WHEELS
IN LANDING POSITION

24,000 hp. to lift 132-ton plane that can ca

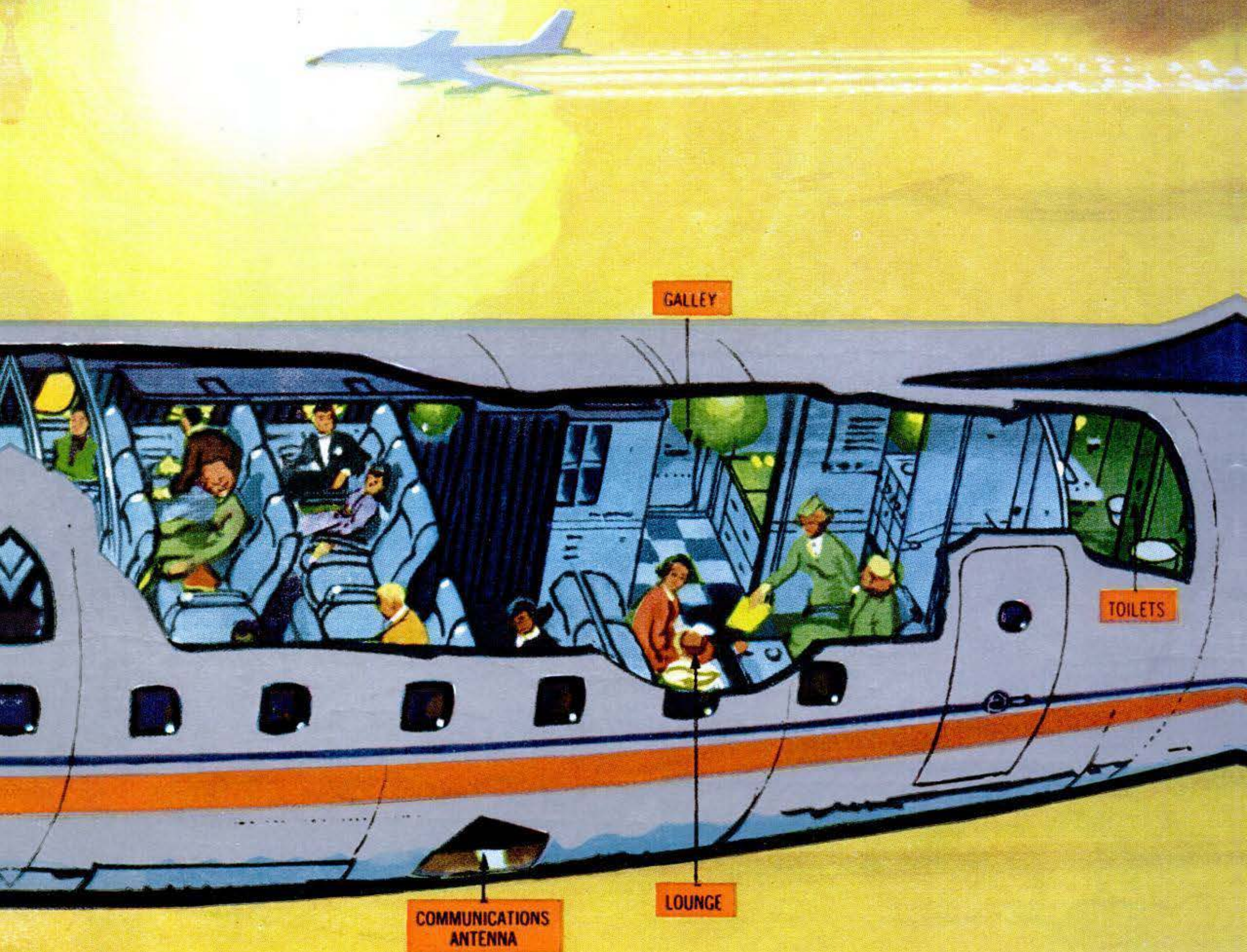

Chairs and bulkheads are on tracks, making it easy to vary the interior plan several ways, from the 119-passenger, mixed-class arrangement (above) chosen by United Air Lines for the first domestic DC-8 flights, to an all-tourist version seating 176. Each seat has a reading light, cold-air outlet, call button, aisle light, ash-tray, table and emergency oxygen outlet. A hi-fi system carries announcements and music to the quiet cabin, which is pressurized so that a sea-level atmosphere is maintained to 23,000 ft. At 34,000 ft., cabin pressure equals that of 5,000 ft.; at 40,000 ft., that of 6,700 ft. Two large compartments in the plane's belly hold nearly seven tons of luggage and cargo. Compartments are loaded from the starboard side while passengers use two port-side doors.

carry 176 people



The plane's soaring tail rises more than 42 feet above the ground. Hot air bled from the engines is circulated through ducts along the leading edges of wings, tail surfaces and engine pylons to prevent icing. Another thermal system keeps engine inlets, air-conditioning scoops and the radome ice-free. Blasts of hot air will clear the electrically heated windshields of rain and snow.

There are four wheels, mounted in tandem pairs, on each leg of the main landing gear. The rear pairs swivel, to make taxiing easier. Main wheels and nose wheels (two) will drop by gravity in case the hydraulic system fails.

The flight crew, with 120 instruments to watch, will contain a navigator only when the DC-8s start making ocean crossings.



In planes as in passenger cars, Champions deliver full-firing power.
Above: DC-7 gets set for flight from Idlewild to Paris.

- Q. Why do 98% of the world's airlines use Champion spark plugs and jet igniters?
- A. In the air, *dependable* power is vital! To get that same dependable power in your car, put in new Champions every 10,000 miles. You'll save gasoline, too!



World's favorite spark plug—engineered for every car built by Ford, General Motors, Chrysler, American Motors, Studebaker-Packard and every major foreign maker.

CHAMPION

"MIRACLE MILD" PHILLIES

Now-The Best Selling Blunts in the U.S.A.

The advertisement features a central image of a pack of Phillie Blunts. The pack is white with a black spine that says "PHILLIES" vertically. The top of the pack says "BLUNT" in large, bold letters. A circular window on the pack shows four blunts, each with a "PHILLIES BLUNT" label. A black price tag on the right side of the pack says "NOW 39¢". Below the window is a large red oval with the word "PHILLIES" in white. A single blunt is shown horizontally across the bottom of the pack, with a "PHILLIES BLUNT" label. Below the pack, the text reads "MIRACLE MILD" and "Blended with Havana" in a cursive font. To the right of the pack is a black and white photograph of a man in a suit standing in a room with large windows.

"MIRACLE MILD" Phillies Blunts — the first cigar mild enough for *all* smokers. Never before has smoking offered so much pleasure for so little cost. Pick up a pack today!

NEW LOW PRICE!

5 for 39¢

Other Phillies sizes . . .

IMPERIALS-DOUBLE PERFECTOS-KING SIZE-2 for 25c • PERFECTOS-10c • PANATELLAS-5 for 39c • JUNIOR PHILLIES 5c

APRIL 1959 |

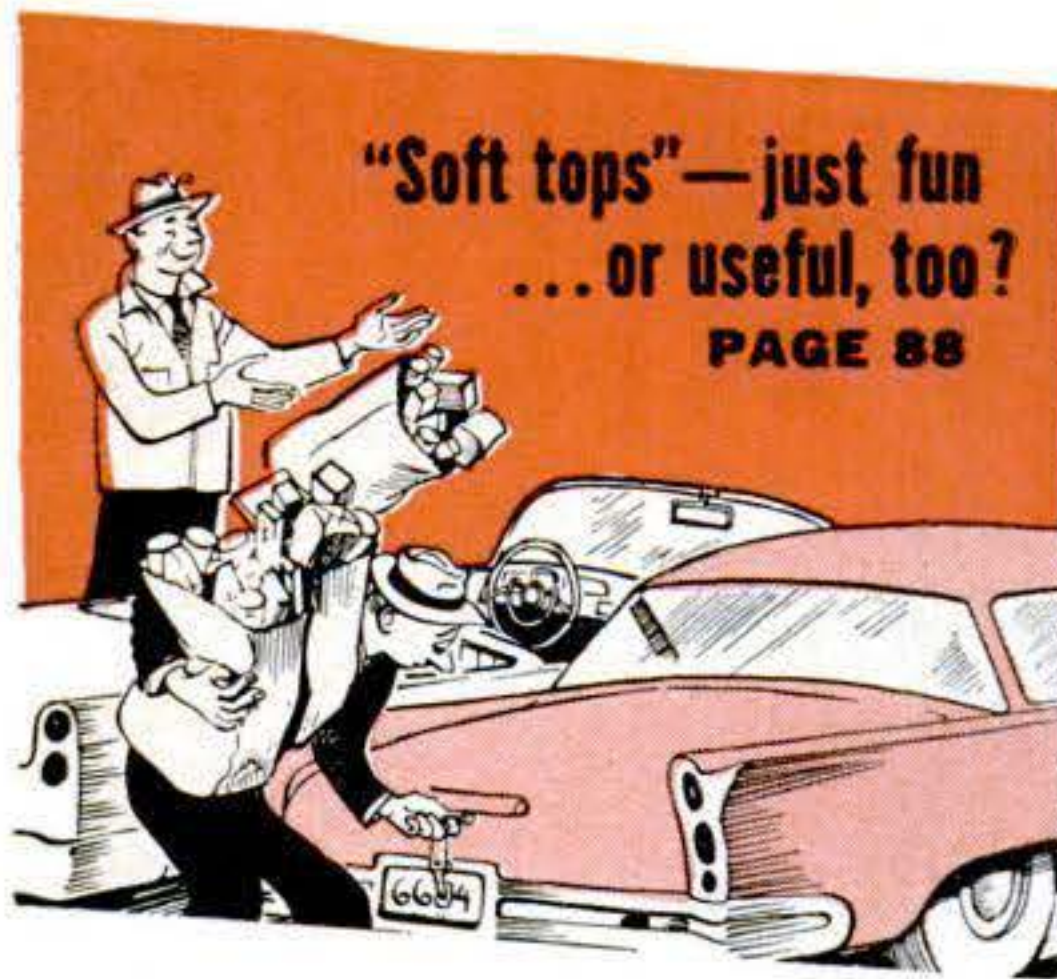

"Soft tops"—just fun
... or useful, too?
PAGE 88



The day they
smash the bottle
PAGE 98



But keep it
off the pikes
PAGE 153

Founded in 1872 Vol. 174: No. 4

Mechanics and Handicraft REG. U. S. PAT. OFF.

Popular Science

April, 1959

Cover painting by Bob McCall

CARS AND DRIVING

- I Say Convertibles Make Sense..... 88
 Little Borgward Has Big Ideas.....120
 Russian Cars: Stylish but Lazy.....138
 Stupid Traffic Rules.....142

SCIENCE AND INDUSTRY

- Talking Satellites to Speed Mail.... 83
 TV Tubes That Won't Burn Out.. 94
 How Silent Sound Works for You 148

CONSUMER NEWS

- New for Car, Home and Shop.....124
 Which Spray Outfit Is for You?....163
 A New Look at Fast Photo Films..180
 Report on Indoor TV Antennas....216

SPECIAL FEATURES

- Inside the DC-8: Cover and Foldout
Delicate Job of Launching a Ship.. 98
Tattoos Help Cops Catch Crooks..104
What's New in Boating.....108
How a Spinning Reel Works.....128
Ways to Beat That Tired Feeling..132
Right Way to Heft an Outboard....185
11 Fishing Tips.....221

DISCOVERIES AND INVENTIONS

- Now They Make Rifles of Nylon....110
Our Supersonic Cargo Rocket.....115
Diesel Outboard Weighs 1½ Tons 135

AUTO UPKEEP

- If Your Power Steering Acts Up....223
Gus and the Electronic Marvel.....226
Hints from the Model Garage.....231

Editor: HOWARD ALLAWAY

Managing Editor FRANK ROWSOME JR.

Art Director HOWARD C. JENSEN

Assistant Managing Editors

Kendall W. Goodwyn
 Robert P. Stevenson

Senior Editors

Devon Francis, Martin Mann
 Everett H. Ortner, Harry Walton

Technical Editor

Hubert Lockett

West Coast Editor

Wesley S. Griswold

Associate Editors

Erik H. Arctander, Alden P. Armagnac
 Henry B. Comstock, Frank Dorr
 Sheldon M. Gallager, James T. Howard
 Herbert O. Johansen, Herbert R. Pfister
 Joan Steen, Ruth Westphal

Editorial Assistants

Rosa Lee Beeland (Chief)
 Anna Dallas, Bebe Lipson,
 Roberta Marks, Georgette Sparks

Art Editors

Herbert Anthony, Reginald A. Hawley
 Harry Samuels

Art Associates

Bertrum Green, Eric A. Karminski Jr.
 Henry W. Kazmirowski, Richard J. Meyer
 Dana B. Rasmussen

Photography

W. W. Morris (Chief)
 Robert D. Borst, Orlando Guerra

EDITORIAL OFFICES: 355 Lexington Ave., New York 17, N. Y.

Who says it's the driver's fault?

PAGE 142



Shifty top makes 3-in-1 furniture
PAGE 168

What've they done to rabbit ears?

PAGE 210

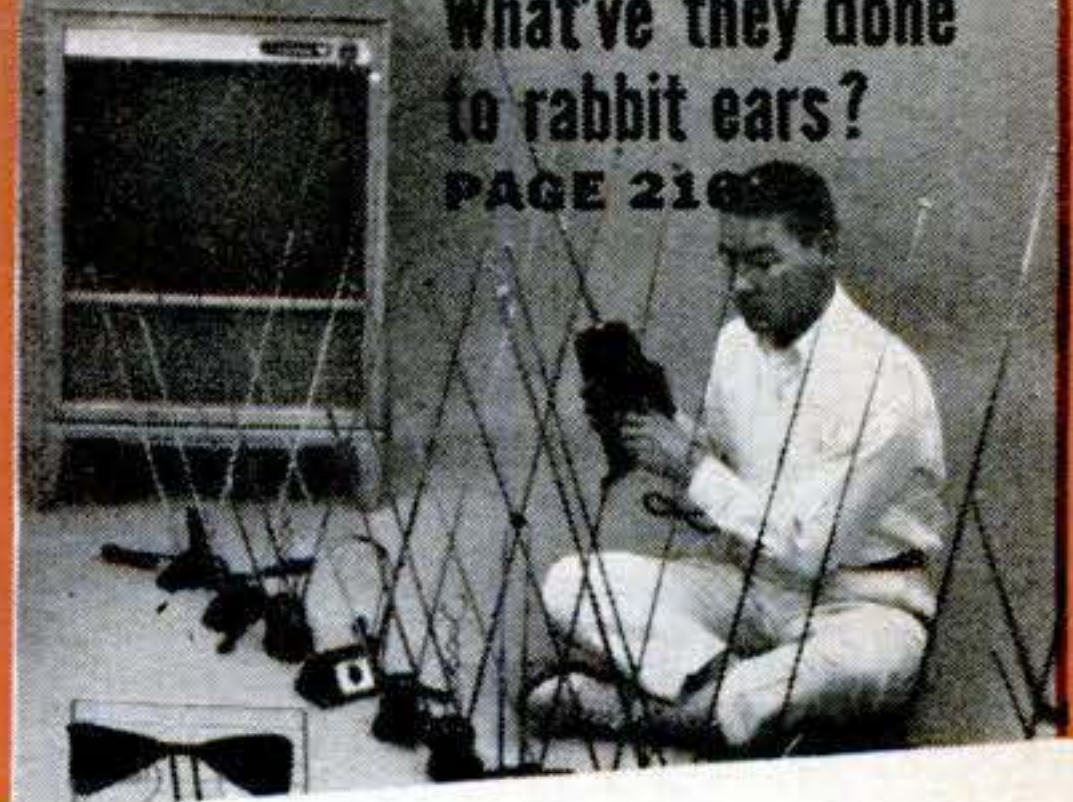

CONTENTS

Monthly

America's Leading New-Idea

Magazine for 87 Years

PICTURE NEWS

- [Making Burgers by Automation....118](#)
- [Dream City on Old Fair Site.....130](#)
- [Sailing Spaceship to Tap Sun.....136](#)
- [Spiked Tires Tame Skids.....140](#)
- [Hurricane-Spotter 86 Miles Up....147](#)
- [Retriever for Paratroopers.....151](#)
- [Hot-Cold Light Warms or Cools....152](#)

SHORT CUTS AND TIPS

- [How to Saw Accurate Miters.....161](#)
- [Touching Up Table-Saw Blades....162](#)
- [Trapping Moles the Sure Way.....167](#)
- [Making Chisels Out of Bamboo....171](#)
- [Dies for Cutting Dowels.....179](#)
- [Safety Igniter for Oven Burner...184](#)
- [Hollowing with a Drill Bit.....215](#)
- [Clay Clamp for Soldering.....233](#)

FOR HOME AND SHOP

- [Building Kids' One-Lung Cars.....153](#)
- [Furniture You Use Three Ways....168](#)
- [More Uses for Countersink Bits....172](#)
- [Building a Metal Tether Jet.....176](#)
- [Extra Life for Your Dry Cells.....191](#)
- [Fix-It File: Door Repairs.....207](#)
- [Materials File: Counter Tops.....209](#)
- [Know-How File: Siding Finish.....213](#)
- [4 Painting Tips.....214](#)

EVERY MONTH . . .

- [PS Readers Talk Back..... 4](#)
- [The Month in Science..... 14](#)
- [Have You Heard?..... 18](#)
- [I'd Like to See Them Make..... 97](#)
- [New Ideas from the Inventors.....112](#)
- [5 Budget Savers.....160](#)
- [Wordless Workshop174](#)

Publisher GODFREY HAMMOND

Advertising Manager LEE P. ADAMS

Circulation Director EUGENE WATSON

ADVERTISING OFFICES:

NEW YORK—355 Lexington Ave.
 CHICAGO—360 North Michigan Ave.
 DETROIT—2810 Book Bldg.
 SAN FRANCISCO—114 Sansome St.
 CLEVELAND—636 B. F. Keith Bldg.
 LOS ANGELES—711 South Vermont.
 PORTLAND, ORE.—520 S.W. Sixth Ave.

SUBSCRIPTION SERVICE:

Address all subscriptions and correspondence concerning them to: Popular Science Subscription Department, 355 Lexington

Ave., New York 17, N. Y. Allow four weeks' notice for change of address. Please give both old and new addresses, including zone numbers. Published monthly at 355 Lexington Ave., New York 17, N. Y., by Popular Science Publishing Co., Inc., Godfrey Hammond, Chairman of the Board; Franklin E. Parker Jr., Secretary; Eugene Watson, Vice-President; Robert D. Beals, Treasurer and Business Manager. Second-class postage paid at New York, N. Y., and at additional mailing offices. Entered as second class matter at the Post Office Department, Canada.

Printed in U.S.A. Copyright, 1959, by Popular Science Publishing Co., Inc. All rights reserved in the United States, Great Britain, and in all the countries participating in the International Copyright Convention and Pan-American Copyright Convention. Single copy 35¢. Subscriptions to United States, its possessions, and Canada, 1 year \$3.40 (2 years \$6.00, 3 years \$8.00). Elsewhere, 1 year \$6.00 (2 years \$11.00, 3 years \$16.00). Send notice of undelivered copies on Form 3579 to Popular Science Monthly, 355 Lexington Avenue, New York 17, N. Y.

PS Readers

TALK BACK

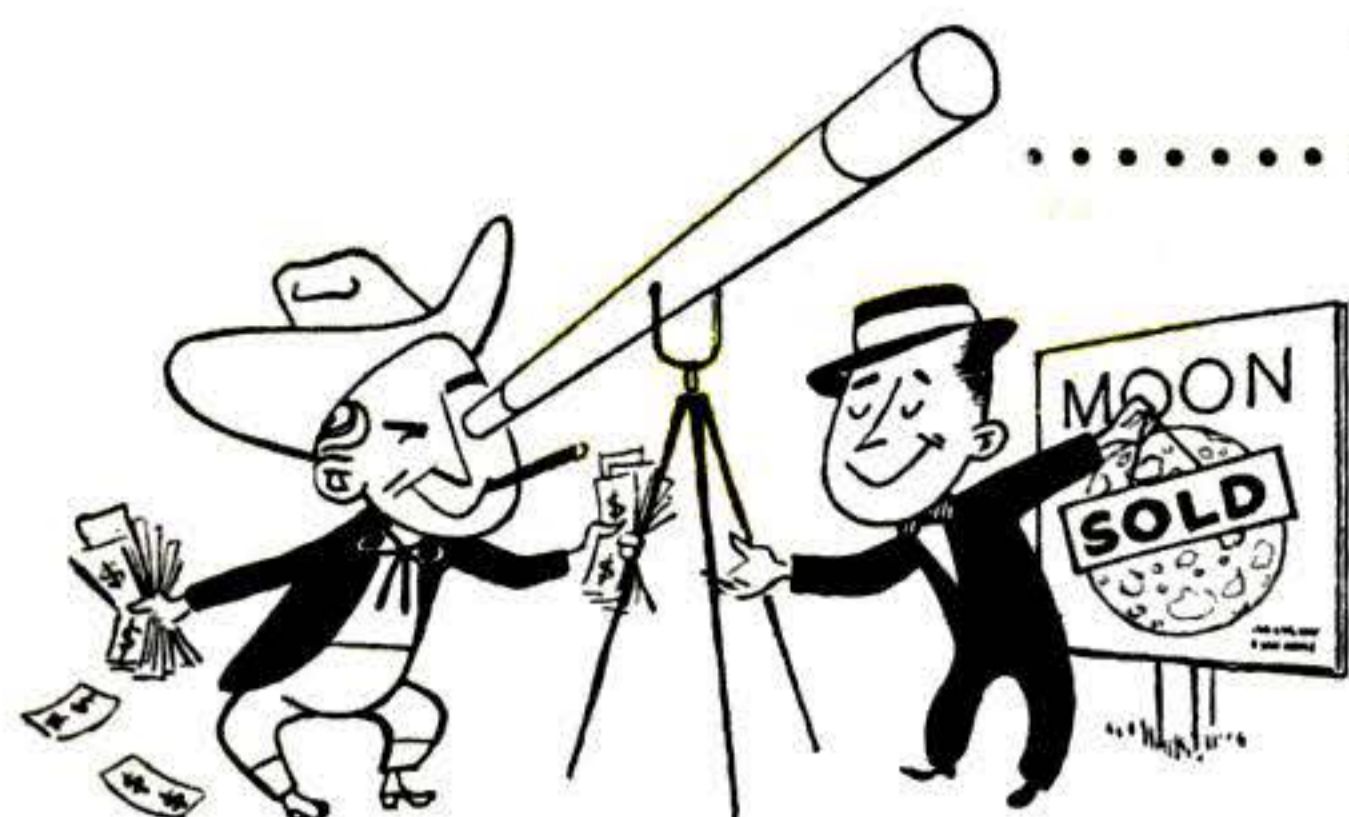

Covered Wagons to Blast Off?

RECENTLY I got hold of a copy of *Our Public Lands*, a magazine published by the U.S. Bureau of Land Management. I was much amazed to discover in it that for some years our government has been getting letters from citizens intent on staking out claims in space.

One hopeful applying for 160 acres on the Moon says he prefers "the shores of waterless Mare Crisium—eventually it may be made into a nice artificial lake." Another, anxious to pioneer on Mars, wants grazing rights to five sections of land. There's also a wistful character interested in Moon acres. He asks: "Any taxes?"

JOSEPH HANSCOM, NYC.

The Bureau of Land Management has a form letter, headed "About Land on the Moon or Planets," with which it replies to such requests. It says, in part: "It is not possible for anyone to make application for or obtain rights to land on the Moon or planets through the United States Government. This country has as yet made no claim to any territory beyond the Earth. There are no provisions of National Law covering the acquisition of private rights in Outer Space."

Problem of Brake Fade

I'VE just read "The Baffling Problem of Brake Fade," [Jan.] in my newly-subscribed-for POPULAR SCIENCE. I think the presentation was clear, objective and devoid of eyewash. This is the type of reporting that appeals to me as an engineer because it puts our problems before the layman in terms he can understand.

F. R. L. DALEY, Staff Engineer
Buick Motor Division, Flint, Mich.

... While reading about brake fade, I wondered if anyone has considered a combination of metallic brake lining for one half of the brake and organic fiber for the other half.

I remember once coming down the dangerous descent of Palomar Mountain (Cal.) when the temperature was very high. We ended up with nothing working but the low gear—and that was about ruined. The same thing happened coming down Gibraltar Pass near Santa Barbara.

If a suitable combination could be made, people who drive between excesses of temperature could be safer. Perhaps one type could be used in front, the other in the rear. Has this been tried?

RALPH MORSE, Berwick, Me.

Almost every conceivable combination of metallic and organic linings has been tried or is being tried now by brake engineers. They have even gone so far as to alternate metal and fiber pads on the same shoe. As yet, no combination is ready for release to the public.

Woes Vs. Blessings

I AGREE with Paul W. Kearney ["A Safety Expert Looks at the '59 Cars," Jan.]. A working model of a guillotine in the hands of children is no more danger-



ous than a car—as made and operated today.

This leads me to a solution for the problem of population control: Since it has become a challenge to break the death record of each previous holiday, why not establish a few more holidays? Guaranteed to work or your life refunded!

E. R. HOLTZ, Hastings, Pa.

... See here, Kearney! If your blast at U.S. cars is so right, it's too bad you

"I SAW MYSELF 10 YEARS FROM NOW!"



It happened one payday...

Fred worked on the line next to me. Nice guy. Married. Two children. Been on the same job 10 years.

As we walked away from the pay window together he said, "Funny. Each week I get to feel like I'm letting my family down. You know. Not getting ahead so I can give them the things they need."

His words hit me all of a sudden. I could see myself saying the same thing—*10 years from now!*

Not only that. I could see the same job. Same thin paycheck. Same worries.

I thought about Fred all day. Then that night

I saw an ad for I.C.S. It told about the job opportunities that open up with I.C.S. training. How people had found new careers and job success.

I mailed the coupon and that was the start. In just a few months my boss discovered I was an I.C.S. student. He was so pleased he decided to move me off the line. A year and two raises later I was made an assistant supervisor.

What about Fred? He's still working on the line. Still hoping for the future.

I told him about I.C.S. But so far he hasn't done anything. I guess some people never will.

How about you?

For Real Job Security—Get an I. C. S. Diploma!

I. C. S., Scranton 15, Penna.

Accredited Member,
National Home Study Council

INTERNATIONAL CORRESPONDENCE SCHOOLS



BOX 89641D, SCRANTON 15, PENNA.

(Partial list of 259 courses)

Without cost or obligation, send me "HOW to SUCCEED" and the opportunity booklet about the field BEFORE which I have marked X (plus sample lesson):

- | | | | | |
|--|--|--|---|---|
| <p>ARCHITECTURE and BUILDING CONSTRUCTION</p> <ul style="list-style-type: none"> <input type="checkbox"/> Air Conditioning <input type="checkbox"/> Architecture <input type="checkbox"/> Arch. Drawing and Designing <input type="checkbox"/> Building Contractor <input type="checkbox"/> Building Estimator <input type="checkbox"/> Carpenter Builder <input type="checkbox"/> Carpentry and Millwork <input type="checkbox"/> Carpenter Foreman <input type="checkbox"/> Heating <input type="checkbox"/> Painting Contractor <input type="checkbox"/> Plumbing <input type="checkbox"/> Reading Arch. Blueprints <p>ART</p> <ul style="list-style-type: none"> <input type="checkbox"/> Commercial Art <input type="checkbox"/> Magazine Illus. <input type="checkbox"/> Show Card and Sign Lettering <input type="checkbox"/> Sketching and Painting <p>AUTOMOTIVE</p> <ul style="list-style-type: none"> <input type="checkbox"/> Automobile <input type="checkbox"/> Auto Body Rebuilding and Refinishing <input type="checkbox"/> Auto Engine Tuneup <input type="checkbox"/> Auto Technician | <p>AVIATION</p> <ul style="list-style-type: none"> <input type="checkbox"/> Aero-Engineering Technology <input type="checkbox"/> Aircraft & Engine Mechanic <p>BUSINESS</p> <ul style="list-style-type: none"> <input type="checkbox"/> Accounting <input type="checkbox"/> Advertising <input type="checkbox"/> Business Administration <input type="checkbox"/> Business Management <input type="checkbox"/> Cost Accounting <input type="checkbox"/> Creative Salesmanship <input type="checkbox"/> Managing a Small Business <input type="checkbox"/> Professional Secretary <input type="checkbox"/> Public Accounting <input type="checkbox"/> Purchasing Agent <input type="checkbox"/> Salesmanship <input type="checkbox"/> Salesmanship and Management <input type="checkbox"/> Traffic Management <p>CHEMICAL</p> <ul style="list-style-type: none"> <input type="checkbox"/> Analytical Chemistry <input type="checkbox"/> Chemical Engineering <input type="checkbox"/> Chem. Lab. Technician <input type="checkbox"/> Elements of Nuclear Energy <input type="checkbox"/> General Chemistry <input type="checkbox"/> Natural Gas Prod. and Trans. <input type="checkbox"/> Petroleum Prod. and Engr. <input type="checkbox"/> Professional Engineer (Chem) <input type="checkbox"/> Pulp and Paper Making | <p>CIVIL ENGINEERING</p> <ul style="list-style-type: none"> <input type="checkbox"/> Civil Engineering <input type="checkbox"/> Construction Engineering <input type="checkbox"/> Highway Engineering <input type="checkbox"/> Professional Engineer (Civil) <input type="checkbox"/> Reading Struc. Blueprints <input type="checkbox"/> Sanitary Engineer <input type="checkbox"/> Structural Engineering <input type="checkbox"/> Surveying and Mapping <p>DRAFTING</p> <ul style="list-style-type: none"> <input type="checkbox"/> Aircraft Drafting <input type="checkbox"/> Architectural Drafting <input type="checkbox"/> Drafting & Machine Design <input type="checkbox"/> Electrical Drafting <input type="checkbox"/> Mechanical Drafting <input type="checkbox"/> Sheet Metal Drafting <input type="checkbox"/> Structural Drafting <p>ELECTRICAL</p> <ul style="list-style-type: none"> <input type="checkbox"/> Electrical Engineering <input type="checkbox"/> Elec. Engr. Technician <input type="checkbox"/> Elec. Light and Power <input type="checkbox"/> Practical Electrician <input type="checkbox"/> Practical Lineman <input type="checkbox"/> Professional Engineer (Elec) <p>HIGH SCHOOL</p> <ul style="list-style-type: none"> <input type="checkbox"/> High School Diploma | <ul style="list-style-type: none"> <input type="checkbox"/> Good English <input type="checkbox"/> High School Mathematics <input type="checkbox"/> High School Science <input type="checkbox"/> Short Story Writing <p>LEADERSHIP</p> <ul style="list-style-type: none"> <input type="checkbox"/> Industrial Foremanship <input type="checkbox"/> Industrial Supervision <input type="checkbox"/> Personnel-Labor Relations <input type="checkbox"/> Supervision <p>MECHANICAL and SHOP</p> <ul style="list-style-type: none"> <input type="checkbox"/> Diesel Engines <input type="checkbox"/> Gas-Elec. Welding <input type="checkbox"/> Industrial Engineering <input type="checkbox"/> Industrial Instrumentation <input type="checkbox"/> Industrial Metallurgy <input type="checkbox"/> Industrial Safety <input type="checkbox"/> Machine Shop Practice <input type="checkbox"/> Mechanical Engineering <input type="checkbox"/> Professional Engineer (Mech) <input type="checkbox"/> Quality Control <input type="checkbox"/> Reading Shop Blueprints <input type="checkbox"/> Refrigeration and Air Conditioning <input type="checkbox"/> Tool Design <input type="checkbox"/> Tool Making <p>RADIO, TELEVISION</p> <ul style="list-style-type: none"> <input type="checkbox"/> General Electronics Tech. | <ul style="list-style-type: none"> <input type="checkbox"/> Industrial Electronics <input type="checkbox"/> Practical Radio-TV Eng'r'g <input type="checkbox"/> Practical Telephony <input type="checkbox"/> Radio-TV Servicing <p>RAILROAD</p> <ul style="list-style-type: none"> <input type="checkbox"/> Car Inspector and Air Brake <input type="checkbox"/> Diesel Electrician <input type="checkbox"/> Diesel Engr. and Fireman <input type="checkbox"/> Diesel Locomotive <p>STEAM and DIESEL POWER</p> <ul style="list-style-type: none"> <input type="checkbox"/> Combustion Engineering <input type="checkbox"/> Power Plant Engineer <input type="checkbox"/> Stationary Diesel Engr. <input type="checkbox"/> Stationary Fireman <p>TEXTILE</p> <ul style="list-style-type: none"> <input type="checkbox"/> Carding and Spinning <input type="checkbox"/> Cotton Manufacture <input type="checkbox"/> Cotton Warping and Weaving <input type="checkbox"/> Loom Fixing Technician <input type="checkbox"/> Textile Designing <input type="checkbox"/> Textile Finishing & Dyeing <input type="checkbox"/> Throwing <input type="checkbox"/> Warping and Weaving <input type="checkbox"/> Worsted Manufacturing |
|--|--|--|---|---|

Name _____ Age _____ Home Address _____
 City _____ Zone _____ State _____ Working Hours _____ A.M. to P.M. _____
 Occupation _____

Canadian residents send coupon to International Correspondence Schools, Canadian, Ltd., Montreal, Canada. . . . Special tuition rates to members of the U. S. Armed Forces.

This Amazing New Home Training Plan in Auto Repairing

starts you earning spare-time money in weeks—makes you an expert mechanic in months!

No longer need you stand by as experienced mechanics take their choice of the 100,000 job openings in the auto repairing field. Now you can get ready for the big money—the bright future—in just a few months. Now you can have new CTI training.



This wonderful new home study course is better written, more clearly illustrated, more understandable. It offers more up-to-date, fresh, usable knowledge. It includes finer tools, more costly testing instruments. And it's so practical that you can put your training to work soon after you enroll—you can actually fix cars spare time and earn good money. Many students earn \$20 to \$50 a week.

Auto mechanics in the large cities average \$3.00 an hour. If you prefer, you can open a shop. An expert says that America is short 25,000 repair shops. Discover how easily you can qualify for a top-pay job in America's No. 1 industry. Mail coupon below for the new CTI catalog and sample lesson.

Get Experience Using Tune-Up Kit & Tools

(included with training)



CTI sends you a Tune-Up Kit, the kind that skilled mechanics use to locate engine troubles. You receive a Compression Tester; Vacuum Gauge & Fuel Pump Tester; Ignition Timing Light; portable steel case. You also get mechanic's tools, including socket set. You acquire experience using kits.

DIESEL MECHANICS OR BODY-FENDER REBUILDING

instruction is also yours—at no additional cost. But get all the facts on CTI training. Discover how we train you in Tune-Up; Overhaul; Electric, Cooling & Lubricating Systems; Power Brakes; Power Steering; Automatic Transmissions; Clutches. Mail coupon for 2 free booklets.—Commercial Trades Institute, Chicago 26, Ill.

MAIL TODAY • TWO FREE BOOKS

COMMERCIAL TRADES INSTITUTE

1400 GREENLEAF AVENUE DEPT. A-1051
CHICAGO 26, ILLINOIS

Mail me your two opportunity booklets: *Big Money in Auto Mechanics*; and *Sample Lesson*. Both FREE.

Name _____ Age _____

Address _____

City _____ Zone _____ State _____



didn't get it in last year when it would have been more appropriate.

Specifically, what's this bit about roll-overs? According to your figures, the Detroit boys are a bunch of blockheads. You give no credit to those few who stretched the width of the Pontiac. You get yourself a '59 Pontiac, take it to the Cornell group that's studying wrecks and let them try to flip it!

J. H. ANDERSON, San Francisco.

... Praises to Kearney! Let's face it—Detroit hears only the quiet crunching of the folding buck. The crunching of cars lacking safety features goes unheard.

Car makers spend considerable time and money for some character to decide whether the fins go up or down—he's making a fish—and if safety spoils the dream, forget it. Many a teen-ager with a few dollars, a little time and some hand tools takes a relic and comes up with something that looks better, probably is faster and certainly is safer than any new stock car.

Until the car builders come up with a safety package at a reasonable price (less the fishmaker's salary), I refuse to buy.

D. L. COCHRANE, Cambridge, Minn.

He's Flexible on Rules

THE rule wanted by the author of "Choosing a Flexible Rule" [Jan.] would be nice. I, too, would like a 16-footer that extends up eight feet without bending and carries markings for both running inches and feet and inches. But frankly, I'll settle for one that can be carried daily in my business suit without too much bulk.



JACK HANLON, Rochester, N.Y.

Checking for a Hot Wire

MAY I add a warning on using a neon test light to distinguish the hot from the neutral wire ["Short Cuts and Tips," Dec.]? For safety, anyone following this procedure should be aware that the test isn't absolutely conclusive. There may be cases, as I've found in my house, where



To those who want to enjoy
an **ACCOUNTING CAREER**



FREE SAMPLE LESSON

IF you're that person, here's something that will interest you.

Not a magic formula—not a get-rich-quick scheme—but something more substantial, more practical.

Of course, you need something more than just the desire to be an accountant. You've got to pay the price—be willing to study earnestly, thoroughly.

Still, wouldn't it be worth your while to sacrifice some of your leisure in favor of interesting home study—over a comparatively brief period? Always provided that the rewards were good—a salary of \$5,000 to \$10,000 and up?

An accountant's duties are interesting, varied and of real worth to his employers. He has *standing!*

Do you feel that such things aren't for you? Well, don't be too sure. Very possibly they *can* be!

Why not, like so many before you, investigate LaSalle's modern Problem Method of training for an Accounting position?

Just suppose you were permitted to work in an accounting firm under the personal supervision of an expert accountant. Suppose, with his aid, you studied accounting principles and solved problems day by day—easy ones at first—then more difficult ones. If you could do this—and could turn to him for advice as the problems became complex—soon you'd master them all.

That's the training you follow in principle under the LaSalle Problem Method.

You cover accounting from Basic Accounting right through Principles and Cost Accounting. As you go along, you absorb the principles of Accounting Systems, Federal Income Tax, Certified Public Accountant Training, and prepare for the CPA examinations.

Your progress is as speedy as you care to make it—depending on your own eagerness to learn and the time you spend in study.

Will recognition come? The only answer, as you know, is that success *does* come to the man who is really *trained*. It's possible your employers will notice your improvement in a very few weeks or months. Indeed, many LaSalle graduates have paid for their training—with increased earnings—before they have completed it! For accountants, who are trained in organization and management, are the executives of the future.

**Get Free Sample Lesson—Also
"Opportunities in Accounting"**

For your own good get all the facts about this completely new and modern accounting training. Write for Free Sample Lesson—also latest book "Opportunities in Accounting." They will prove that Accounting offers brilliant futures to those who aren't afraid of serious home study, and will show

the wide range of opportunities that exist today. No cost or obligation. If you want a position of higher income, greater prestige and professional standing . . . MAIL THE COUPON NOW!

**Over 4,500 Certified
Public Accountants among
LaSalle alumni**

Accredited Member, National Home Study Council

LASALLE EXTENSION UNIVERSITY
A CORRESPONDENCE INSTITUTION

417 S. Dearborn St. Dept. 483H Chicago 5, Ill.

I want to be an accountant. Send me without obligation, Free Sample Lesson—also "Opportunities in Accounting."

Name.....Age.....

Address.....

City, Zone & State.....

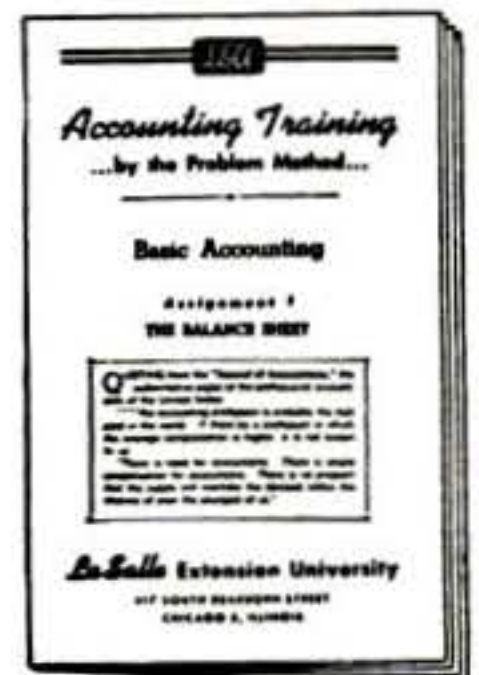

AUTO-LITE[®]

RESISTOR SPARK PLUGS WITH

POWER TIP



AT LOW SPEEDS
Power Tip is hot to burn
fouling deposits away clean.

AT HIGH SPEEDS
Power Tip is cool to check
costly pre-ignition.

**"FIRE UP" AT
ALL SPEEDS
WITH
AUTO-LITE[®]
POWER TIP**



*— the spark plug that cleans
itself while you drive!*

the metal box or cable sheath is not necessarily in contact with the ground. In such instances the light won't glow, thus giving a false reading.

J. J. ANTHONY, Melrose, Mass.

Is Mixing Fair?

YOUR tradition-block problem ["Boosting Your Output of Good Ideas," Jan.] has at least one other solution. To measure out a quart of water, working with a six-quart bucket of water, a two-quart bucket of gasoline and an empty three-quart bucket:

Pour the two quarts of gas into the empty three-quart bucket. Pour water from the six-quart bucket into the two-quart bucket. Pour off from the two-quart bucket enough water to fill the three-quart one. Result: One quart of water remains in the two-quart bucket.

DAVID GOMBERG, Chicago.

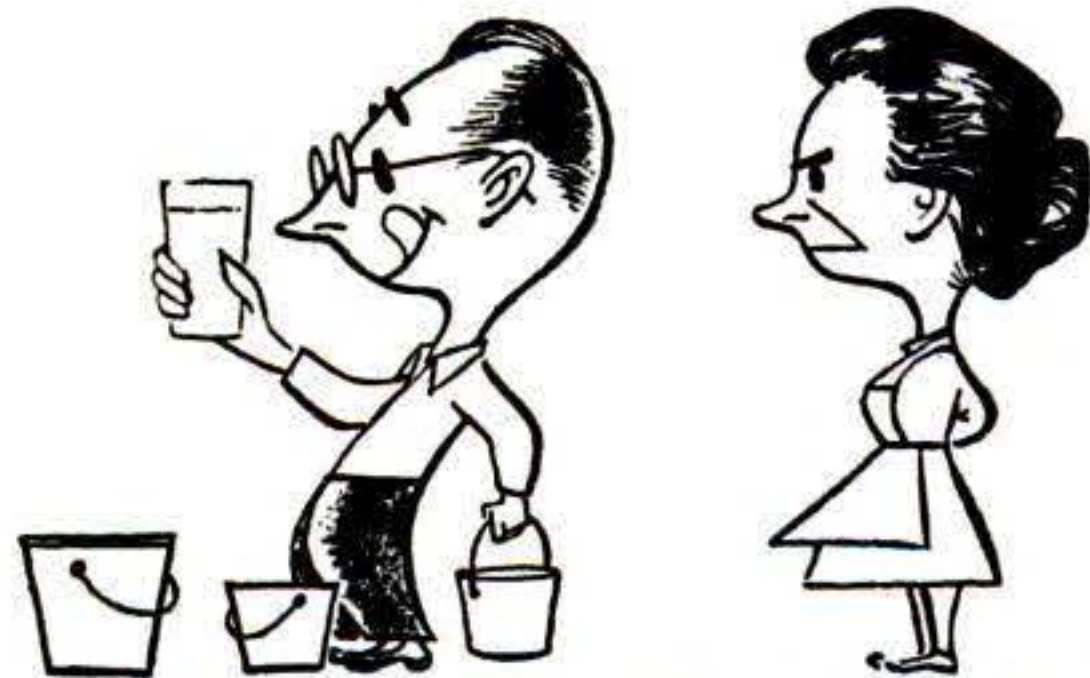

. . . That tradition-block problem is loaded with a "false-requirement" block, too. Nowhere does it state that the water and gasoline must not be mixed, leaving a far easier solution possible than the one you give.

J. R. CLAGHORN, Neenah, Wis.

. . . Why not 1) pour the gasoline in the two-quart bucket into the empty three-quart bucket; 2) fill the three-quart bucket with a quart of water from the six-quart bucket; 3) wait a few minutes for the two liquids in the three-quart bucket to separate, then decant the upper layer of gasoline into the two-quart bucket.

If the remaining quart of water is to be used for drinking purposes, add two parts bourbon and a little ice.

DICK GUERNSEY, Chicago.

Just Generous

THE statistician who handled your car survey ["What You Think of the '59s," Jan.] was a lulu. Under predictions of car sales, the report says 47 percent of

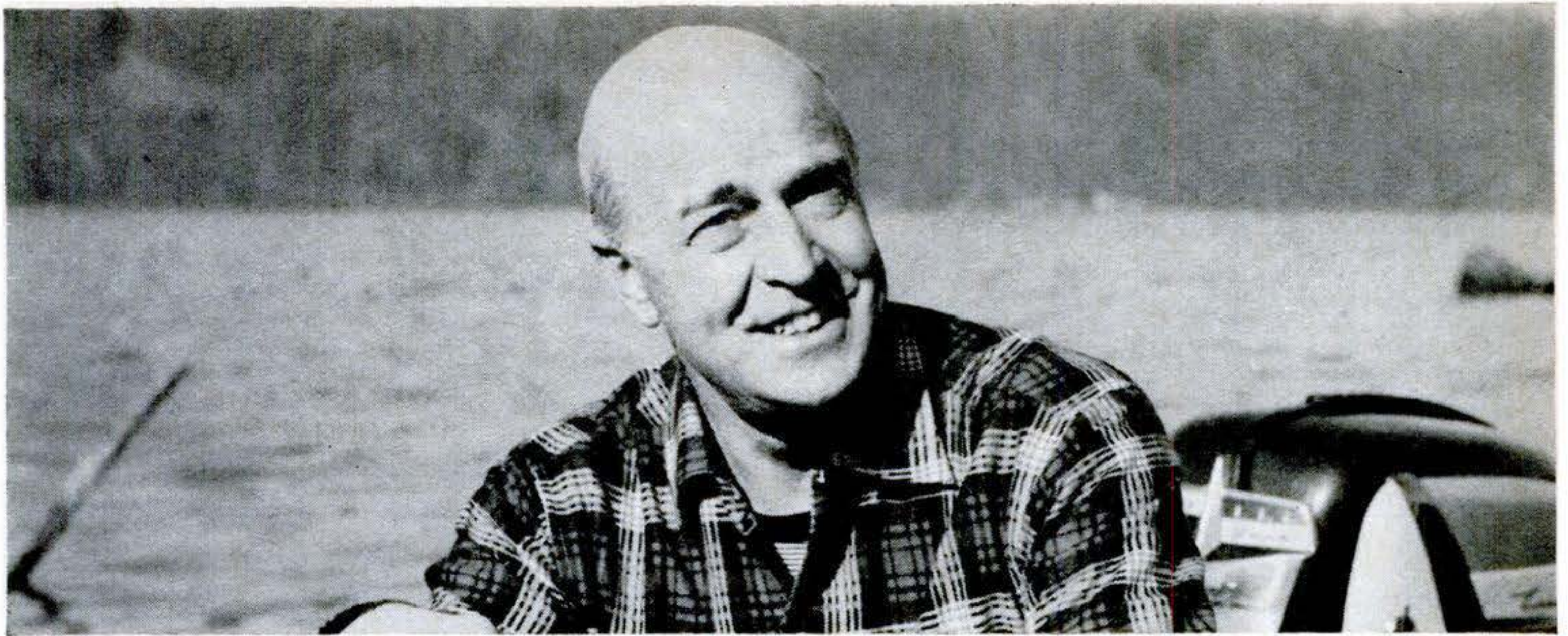

How I retired in 15 years with \$300 a month

“Here’s one Yankee who’s fallen in love with the South! When I retired, I moved to the Florida West Coast. I go fishing in the inlets. It’s a tropical paradise, yet it’s near enough to drive into Tampa often. I’m beginning a new life—all because of the check for \$300 I get each month.

“My retiring came out of a business trip to Tampa in 1944. I was dining at a restaurant and happened to notice Don Nelson, a friend of mine from New York. I went over to wish him a wonderful vacation.

“‘Vacation? Why, didn’t you know we moved down here when I retired?’

“I was amazed. ‘But you’re too young to be retired!’

“‘Nonsense!’ he smiled. ‘It’s what I’d been planning for fifteen years.’

“Don invited me out to his home the next day. ‘I sure envy you,’ I said. ‘I know I never could save enough money.’ Then Don explained that he never could have retired on what investments or savings he had. But he had a good salary and he had found a way to make part of his salary buy a retirement income. It was called the Phoenix Mutual Retirement Income Plan.

“Flying home, I noticed a Phoenix Mutual ad in a magazine. Sure enough, I could get a retirement income guaranteed for life if I started young enough. When I got home, I cut out the coupon and sent for the booklet telling all about Phoenix Mutual Plans. In a few days it came by mail. And there was exactly the plan for me. If I started right then—at

40—I’d be able to retire in only fifteen years with \$300 a month.

“I felt more and more pleased and secure as those fifteen years went by. I decided on the West Coast of Florida because I had old friends in that area. And as soon as my first check for \$300 arrived, I was off. Now that I’m settled, the real fun’s just beginning.”

Send for Free Booklet

This story is typical. Assuming you start at a young enough age, you can plan to have an income of \$20 a month to \$3,600 a year or more—beginning at age 55, 60, 65 or older. Send the coupon and receive, by mail and without charge, a booklet which tells about the Phoenix Mutual Plans. Similar plans are available for women. Don’t delay. Send for your copy now.

ESTABLISHED 1851

PHOENIX MUTUAL

Retirement Income Plan

GUARANTEES YOUR FUTURE

OVER 100 YEARS OF LIFE INSURANCE PROTECTION
FOR BUSINESS AND FAMILIES

COPYRIGHT 1959. BY PHOENIX MUTUAL LIFE INSURANCE COMPANY

PHOENIX MUTUAL LIFE INSURANCE CO.
297 Elm Street, Hartford 15, Conn.

Please send me, without obligation, your free 28-page book showing new retirement income plans.

Plan for Men Plan for Women

Name _____

Date of Birth _____

Business Address _____

Home Address _____

APRIL 1959 9

LEARN RADIO-TELEVISION ELECTRONICS

by Practicing at Home in Your Spare Time

N.R.I. gives you equipment like this. You learn by doing—get practical experience.



Fast Growing Field Offers Good Pay—Bright Future

Bigger than ever and still growing. That's why Radio-TV Electronics has special appeal. The technical man is looked up to. He does important work, gets good pay. Keep your job while training. You learn at home in your spare time. NRI methods have proved successful for 45 years; can provide training quickly.

Add to Your Income Soon \$10-\$15 a Week Extra in Spare Time

"I was repairing Radios by 10th Lesson. Now have good TV job." *M. R. Lindemuth, Fort Wayne, Ind.*



Soon after enrolling, many NRI students earn \$10-\$15 a week extra fixing sets. Equipment NRI gives you brings to life things you study.



"Doing spare time repairs on Radio and TV. Going into full time servicing soon." *Clyde Higgins, Waltham, Mass.*

Find Out What NRI Offers

NRI is the OLDEST, LARGEST home study Radio-TV school. Mail coupon below for Lesson and 64 pg. catalog. National Radio Institute, Dept. 9DB, Washington 16, D. C.

"I had a successful Radio repair shop. Now I'm Engineer for WHPE." *V. W. Workman, High Point, N. C.*



SEND FOR BOTH FREE

National Radio Institute

Dept. 9DB, Washington 16, D. C.

Please send me Sample Lesson of your Radio-TV Electronic Training and Catalog FREE. (No salesman will call.)

Name _____ Age _____

Address _____

City _____ Zone _____ State _____

Accredited Member National Home Study Council



the people polled said "Better than last year," 36 percent said "Same as last year," and 18 percent said "Worse." Add this all up and it comes to 101 percent. Ah well, maybe they'll turn out to be 101 percent wrong.

J. N. BIERMAN, St. Louis.

This is a common statistical mishap that occurs when the decimals on such figures as 46.6, 35.7 and 17.7 are rounded out.

Better Shop Light

YOUR sliding shop light ["Wordless Workshop," Jan.] is good—but dangerous. I have accomplished the same results using a 10-foot length of Bulldog

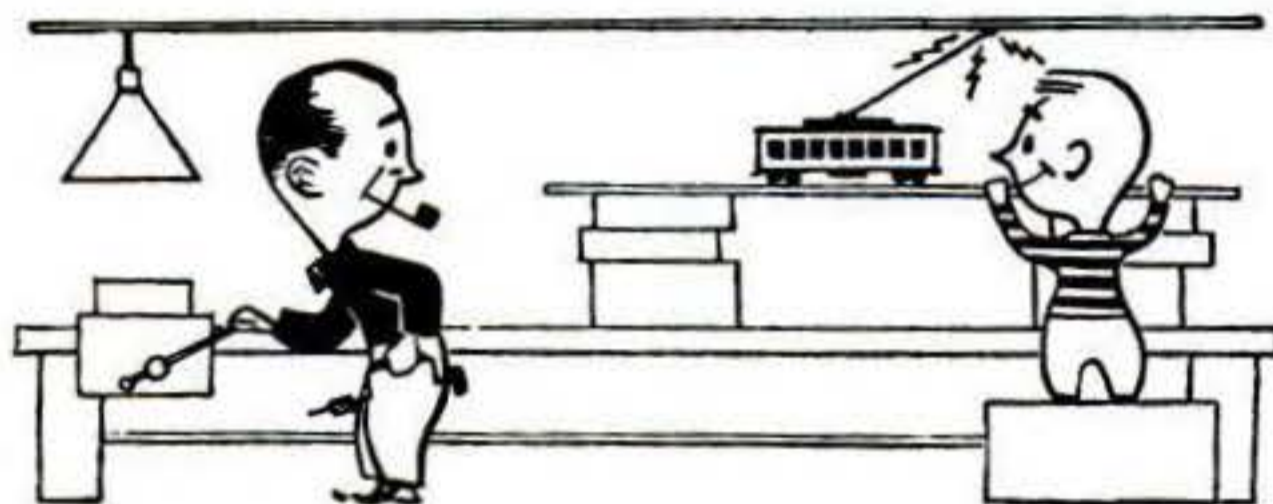

50-amp trolley duct with a fixture suspended from a trolley. It is simple to install, approved, and possibly less expensive.

R. BERLING, New Monmouth, N.J.

Sound and Hot Air

How come sound travels faster in warm air than in cold air? Since cold air is denser than warm air, this would seem to contradict the fact that sound travels fastest in dense materials.

JAMES LEGLER, W. Hartford, Conn.

Two factors determine the speed of sound in a material: density and elasticity. Greater density slows sound down (the reverse of your notion); higher elasticity speeds it up. Thus, sound will travel faster in warmer (thinner) air. And thus too, although a solid such as iron is denser than gas, its elasticity is enormously greater and sound will travel faster in it.

The Short and the Long of It

IN THE article "How Nautilus Hit the Bull's Eye" [Jan.], you say sidereal, or star, time is more exact than sun time, "though each day is four minutes longer."

This should read "each day is four minutes shorter." A sidereal day is 23

New 4-in-1 Storm Kit Protects You Head to Foot in Rain & Sudden Shower!

HANDSOME, TAILORED RAIN COAT OF GENUINE VINYLFILM BY

GOODYEAR

The Greatest Name in Rain Gear!

SPECIAL ADVERTISING OFFER TO READERS OF POPULAR SCIENCE!

Here's the bargain of the year! World-famous GOODYEAR quality, plus smart BAROMETER tailoring—at a sensational low price that will take your breath away! This fine raincoat will give you years and years of service—same water-repellent protection as coats costing \$19.95—yet you pay only \$6.98! And that's only the beginning! You also receive 3 gifts FREE! 1) Pair of sturdy, longlasting GOODYEAR Pliovic Rubbers—\$2.98 value—yours FREE! 2) Well-designed adaptable Hat Cover for straw or felt hats—\$1.00 value—yours FREE! 3) Water-proof Carrying Case—light, flexible, handsome—\$2.00 value—yours FREE! Yes, you pay only \$6.98 for your raincoat and you receive \$5.98 worth of FREE gifts! In essence, the raincoat costs you only \$1. But you must act fast! This is a special advertising offer to readers of POPULAR SCIENCE—and it's for a limited time only! We can guarantee this amazing bargain only while supply lasts! Rush coupon below for your 3 FREE GIFTS plus 10-day FREE Trial!

Get complete head to foot protection in rain, sudden shower, storms! Remember, the entire outfit weighs only ounces and folds into the compact case. Fits easily into brief case or fold and fit into jacket or pocket. You have fingertip protection in case of sudden showers or rain!

Raincoat in Textured GABARDINE Finish with Electronic Welded Seams for Longer Wear!

You'll like this Barometer-Tailored Raincoat at first sight. So handsome in textured GABARDINE finish! Latest gun-metal color for men of action! Big, luxurious built-in pockets . . . tailored fly front . . . vented underarms for even greater comfort. Latest patented electronic lap welding process—seams just CANNOT RIP APART in normal wear! This quality garment outlasts old style butted seam raincoats—yet costs no more. Please do not confuse with inferior, transparent polyethylene raincoats that may rip, tear after a few wearings in the rain. This Barometer-tailored, Goodyear vinylfilm will give you YEARS and YEARS of service!

Raincoat Remains Waterproof and Never Needs Dry Cleaning!

If you've ever bought the regular tan colored poplin-type raincoat you know that it dirties fast—needs constant dry cleaning—and CAN LOSE ITS WATER REPELLENCY feature! Your handsome Barometer Raincoat NEVER NEEDS DRY CLEANING—wipes clean with a damp cloth—REMAINS WATERPROOF FOREVER! You SAVE many, many dollars on dry cleaning bills alone—and you always know that water CAN'T SEEP THRU!

WEAR IT TEN DAYS FREE!

Frankly, you've got to see this smart new raincoat to really appreciate its true value. That's why we ask you to enjoy FREE 10-day home examination of the complete 4-in-1 Storm Kit . . . raincoat, rubbers, hat cover and carrying case. You must be satisfied in every way or your \$6.98 comes back to you. But you must order your Raincoat now. This special offer may be withdrawn without notice due to our limited supply. Mail the FREE-Trial, FREE-GIFT coupon below direct to the bargain house of FIVE MILLION satisfied customers! Check box for desired size. Small, Medium, Large and Extra-Large.

Do NOT compare or confuse with inferior, thin, transparent plastic raincoats. This is rugged GOOD-YEAR quality. Won't rip or tear like polyethylene raincoats!



6⁹⁸

ALL 3 FREE!

Free!

1 Rubbers of Tough, Durable
GOODYEAR PLIOVIC

2⁹⁸
VALUE

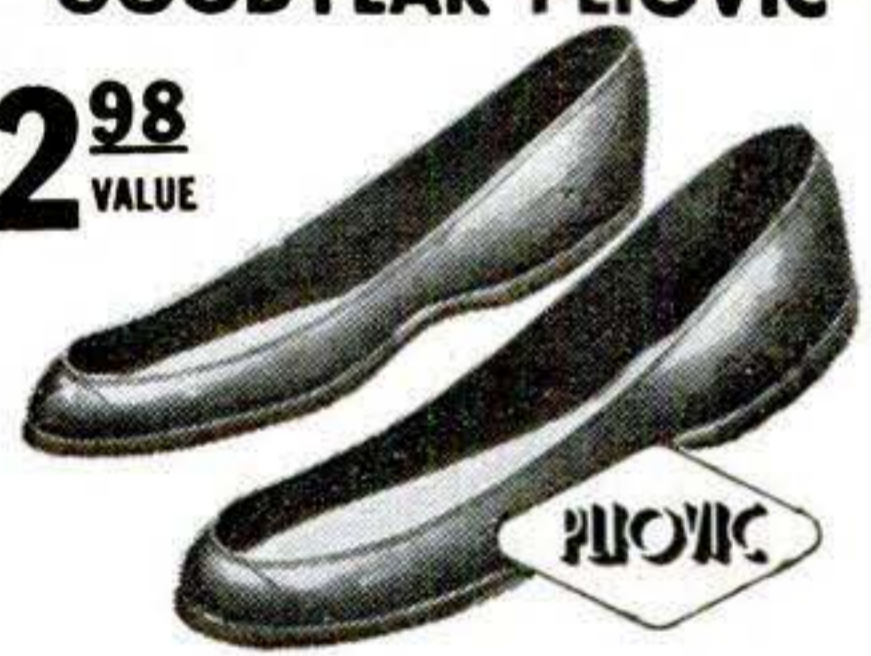

Pebble finish rubbers . . . positive footing on wet, slippery surfaces! Attractively styled and lightweight—yet sturdy and they s-t-r-e-t-c-h! They stretch over shoes for snug, ultra-comfortable fit. Price separately: \$2.98. Yours FREE with Raincoat!

This offer available only by mail, only from Thoresen's, Dept. 7-D-38, 585 Water St., N. Y. 2, N. Y.

Free!



2

HAT COVER

1⁰⁰
VALUE

Sturdy, durable. Won't crack, peel or stain. Electronically sealed. Neat appearance. Keeps hat dry, clean, well shaped.

Free!

3

COURIER CASE

1⁹⁸
VALUE



Lightweight, flexible and handsome. Constructed from GOODYEAR VINYLFILM. zippered top. WATERPROOF! Price separately: \$1.98. Yours FREE with Raincoat.

**THORESEN, Inc., Dept. 7-D-38
585 Water Street, New York 2, N. Y.**

Rush the handsome new GOODYEAR Vinylfilm Raincoat at the sensational low price of just \$6.98. Include my 3 FREE Gifts—pair of stretch-size GOODYEAR quality Rubbers, plus Hat Cover and Courier Carrying Case. If I'm not satisfied with this 4-in-1 Storm Kit, I'll return it in 10 days for complete refund.

Check Size Raincoat Desired:

- Small Medium Large Extra-Large
- Check, cash or money order enclosed. Send postage paid.
- Send COD plus COD fee and postage costs. (ENCLOSE \$1 deposit now.)

PRINT NAME.....

ADDRESS.....

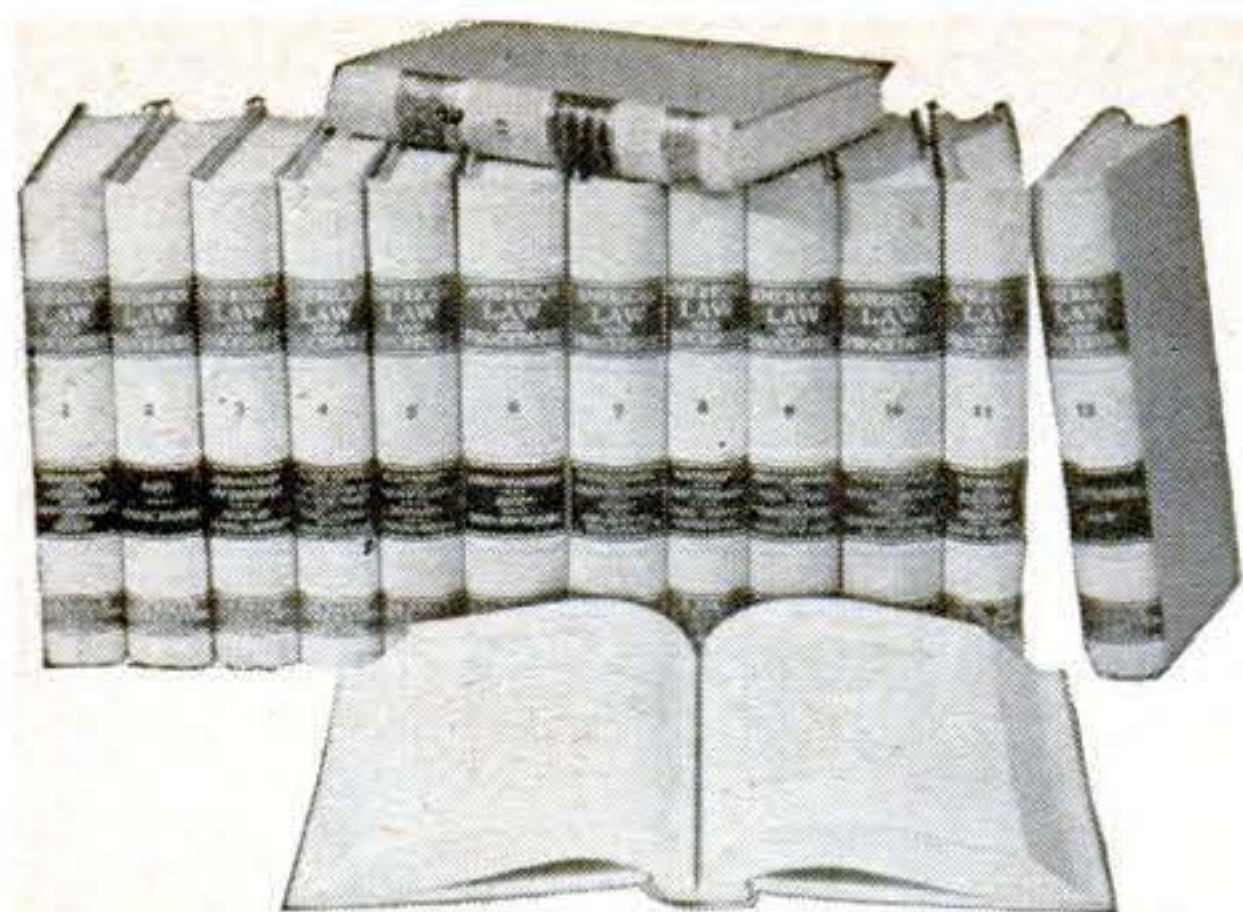

LAW TRAINING

FOR BUSINESS

(In spare time at home)

Earn L. L. B. Degree

Thousands of men and women who never intend to practice Law are studying it in spare time at home as an aid to business advancement.

Today Law is involved in practically every business decision. In many lines of work it is almost indispensable. Law training develops keen, clear, quick, correct and decisive thinking.

You can study LaSalle's American Law and Procedure right in the privacy of your own home—progressing as rapidly as your time and ability permit. For more than 50 years we have helped over 1,400,000 ambitious people get ahead in the business world.

A MOST UNUSUAL LAW LIBRARY

This training includes the 14-volume LaSalle Law Library—AMERICAN LAW AND PROCEDURE—that is the basis of all our instruction service. This library has been compiled by leaders in the field of Law. It covers the whole field in an orderly and simple manner that is easy to learn and understand. Collateral reading and printed lectures, furnished at regular intervals, supplement the texts. Law instructors personally supervise your program. Under the LaSalle method you learn by actually solving legal problems—not just memorizing rules.

WRITE FOR TWO FREE BOOKS

Send the coupon below TODAY and find out how you can qualify for the many fine openings available to the law-trained man. In our FREE books "Law Training for Leadership" and "Evidence" you will find answers to your questions about the study of Law and the LaSalle method.

Accredited Member, National Home Study Council

—MAIL COUPON TODAY—

LA SALLE EXTENSION UNIVERSITY

A Correspondence Institution

417 S. Dearborn St. Dept. 483L Chicago 5, ILL.

Please send me, FREE, "Law Training for Leadership" and "Evidence."

Name.....Age.....

Address.....

City.....Zone.....State.....

hours, 56 minutes, 4.091 seconds of mean time. Thus, there are 366.24 sidereal days in a mean solar year of 365.24 days.

LESTER BARSTOW JR., Melville, N.Y.

Right.

Gus on the Firing Line

DISCUSSING a V-8 ["Gus Rescues a Rookie," Jan.] Gus says: "Your firing order is 1-5-4-8-6-3-7-2, starting with the front right as 1, and going 1-2-3-4 on the right. 5-6-7-8 are on the left bank, again starting at the front."

Shouldn't this read 1-3-5-7, starting with right front; and 2-4-6-8, starting with left front bank?

JOE SCHIRO, Pueblo, Colo.

Rookie Newman drove a Ford. Most other cars use the system you describe.

Wanted: Twice as Many Eyes

I'VE seen a number of amazing statements in "New Ideas from the Inventors," but the one relating to reversible neckties [Jan.] takes the prize.

The writer says that by lining the wide end with a different design you'd get "twice as many changes with half as many ties." Twice as many changes with the same number of ties I can see, or the same number of changes with half as

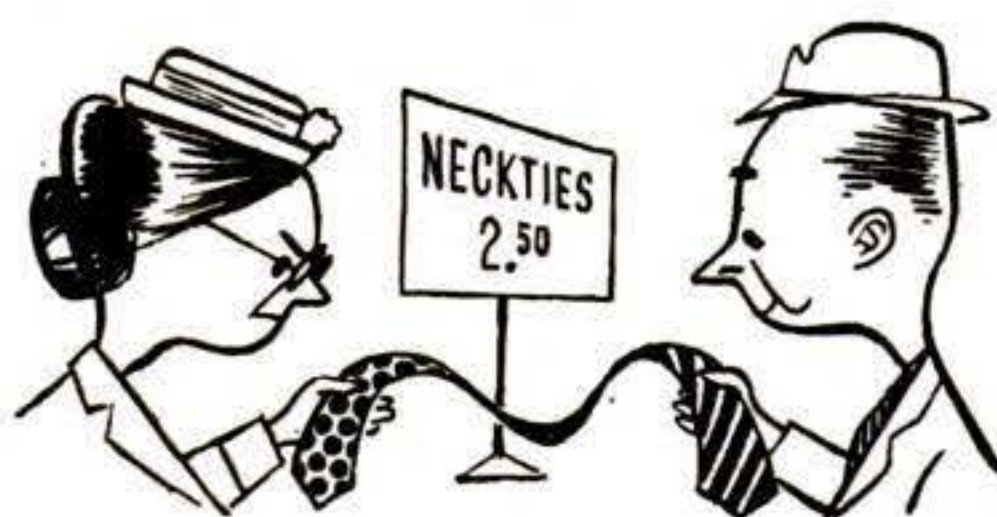

many ties I can understand. But twice as many changes with half as many ties—that, someone will have to explain!

C. L. SKINNER, Madison, Wis.

Why Proofreaders Turn Gray

WHAT happened to the tread width of the Pontiac ["Pontiac Goes Classy," Nov. '58] after your magazine went to press? You say the width of the front tread is just short of five feet—or less than 60 inches. But the owner's manual lists a front tread width of 63⁵/₈ inches, rear tread width of 64 inches.

GEO. SHELDON, Greenville, Mich.

The author says, ruefully, "Mr. Sheldon is absolutely right."

I'll Train You at Home for A BUSINESS OF YOUR OWN —OR A BETTER JOB

—R. C. Anderson, President of CTI

**25
BIG KITS**
to build
**AIR CONDITIONER
REFRIGERATOR
FREEZER or
MILK COOLER**

**No other training like it! You work on
10 trouble-shooting and repair projects**

Only CTI sends you 25 training kits! At no extra cost, you get all parts and tools to assemble a heavy-duty, commercial-type, 1/4 h.p. high-side (illustrated above). You work on 23 shop-type programs, do 10 trouble-shooting and repair projects—all in your own home!

MORE OPPORTUNITIES—LESS COMPETITION IN AIR CONDITIONING AND REFRIGERATION

You've read about the amazing growth of the air conditioning and refrigeration industry. It's one of America's largest opportunity fields because over 150 million units are in use. Last year, 3 million refrigerators, 2 million air conditioners, and a million freezers were sold. All this adds up to a big demand for trained technicians who can install, repair and service. They make good money, work steady, enjoy security. Many open their own shops—become independent.

You can get ready for one of the top-pay jobs in just a few months. CTI will train you at home in spare time. You'll train with real kits, get practical experience as you go along. Be sure to mail coupon below for the full story on how you can succeed in this old, established, but growing industry!

You Get Experience as You Train with Kits

You practice as you train, thanks to CTI Shop-Method Home Training. CTI trains you in months, not years—eliminates a long period of low-pay apprenticeship. At left are photos of but two of the 25 big kits you get—along with easy-to-understand, illustrated lessons.

YOUR BIG OPPORTUNITY TO OPEN A SHOP!

Students often build up a list of customers which includes not just homes, but office buildings, shops, food stores and industrial plants. They contract to do servicing on a fee basis, or simply answer calls. The Air Conditioning and Refrigeration field offers plenty of opportunity for independence. Own a shop—Be the boss! Mail coupon today!

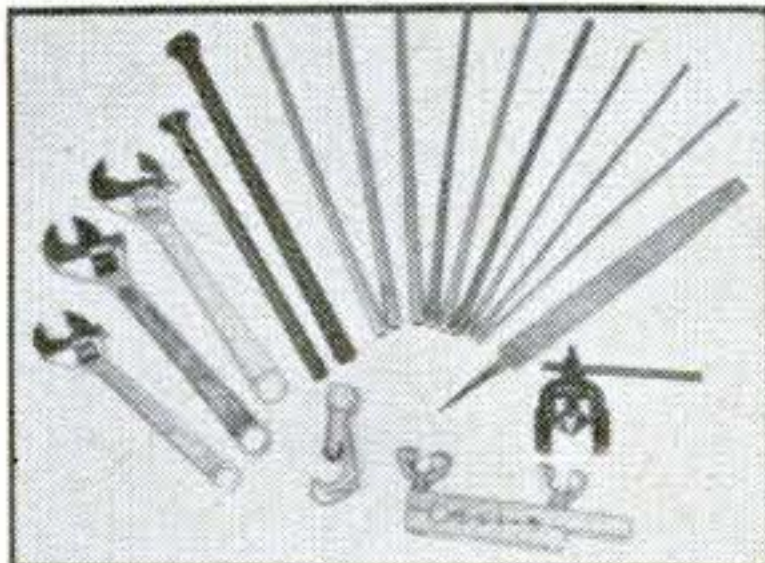

Many Students Earn Extra Money as They Train

Many students, soon after they start training, do repairing in spare time. They work with local dealers evenings and week-ends. Others go "on their own." They earn extra cash, get added experience. Some land full-time jobs while students, and quite a number open shops. All this is possible because CTI training is so practical.

FIRST GET THE FACTS—THEN DECIDE

The Air Conditioning and Refrigeration industry is growing so rapidly that 20,000 newly-trained mechanics are needed each year. You owe it to yourself to investigate your opportunities. You can have all the facts—FREE—by just filling out and mailing coupon. But be sure to act today!

COMMERCIAL TRADES INSTITUTE
1400 Greenleaf Avenue • Chicago 26, Illinois

**MAIL
TODAY
FOR
FREE BOOK
AND
SAMPLE
LESSON**

COMMERCIAL TRADES INSTITUTE

1400 GREENLEAF AVENUE DEPT. R-570
CHICAGO 26, ILLINOIS

Tell me how I can qualify for a better job or a business of my own. Send booklet, *Success in Air Conditioning & Refrigeration*, and Lesson Sample. Both FREE.

Name _____ Age _____

Address _____

City _____ Zone _____ State _____



The month in science

Spaceship under the sea. Atomic submarines are already showing how space pioneers will keep alive and happy on long, hazardous voyages. Like a spaceship, an atom sub seals its crew away from the atmosphere for long periods (60 days is the record). The men have to breathe, and they insist on smoking, too. The Navy has just divulged the ingenious systems that make this possible.

Oxygen is only one problem, but a big one. The sub's 100-man crew burns up 100 cubic feet an hour! Tanks of compressed oxygen replenish the submarine airspace now, but they are clumsy. So the Naval Research Laboratory is trying trickier methods:

► **Oxygen candles.** A mixture of sodium chlorate and finely divided iron powder, they burn like ordinary candles but give off oxygen.

► **Batteries.** Regular nickel-cadmium storage batteries can be rigged so that they give off oxygen when they are charging and hydrogen when discharging. (The hydrogen comes in handy, too—see below.)

► **Absorption tanks.** Electricity (there's plenty from the atom engine) decomposes a sodium sulfate solution. Out come hydrogen, oxygen, sodium hydroxide and sulfuric acid. The sodium hydroxide absorbs carbon dioxide from the air (the crew exhales 100 cubic feet of that every hour, and it has to be gotten rid of somehow). This reaction forms sodium carbonate, which is next mixed with the acid. That gives back the sodium sulfate you started with, plus pure carbon dioxide gas, which can now be dumped into the sea.

► **Algae.** These microscopic green plants, which grow in ponds, take in carbon dioxide, use it to make sugar, and give off oxygen that's left over. This solves both oxygen and carbon

dioxide problems, and, if they can ever develop algae that taste good, might feed the crew, too.

Eliminating possible poisons from the air is even tougher. Besides carbon dioxide, the only one present in quantity is water vapor, which the air conditioners squeeze out. But then there are smaller yet troublesome amounts of:

► **Carbon monoxide** (from all those cigarettes and pipes). This is burned to dioxide by blowing the air over a hot catalyst in a hydrogen flame (that eliminates the hydrogen, too).

► **Organic compounds.** Even the slow evaporation of thinner from the painted walls builds up. A switch to water-base paint would

How A-Sub Crews Will Get Air to Breathe

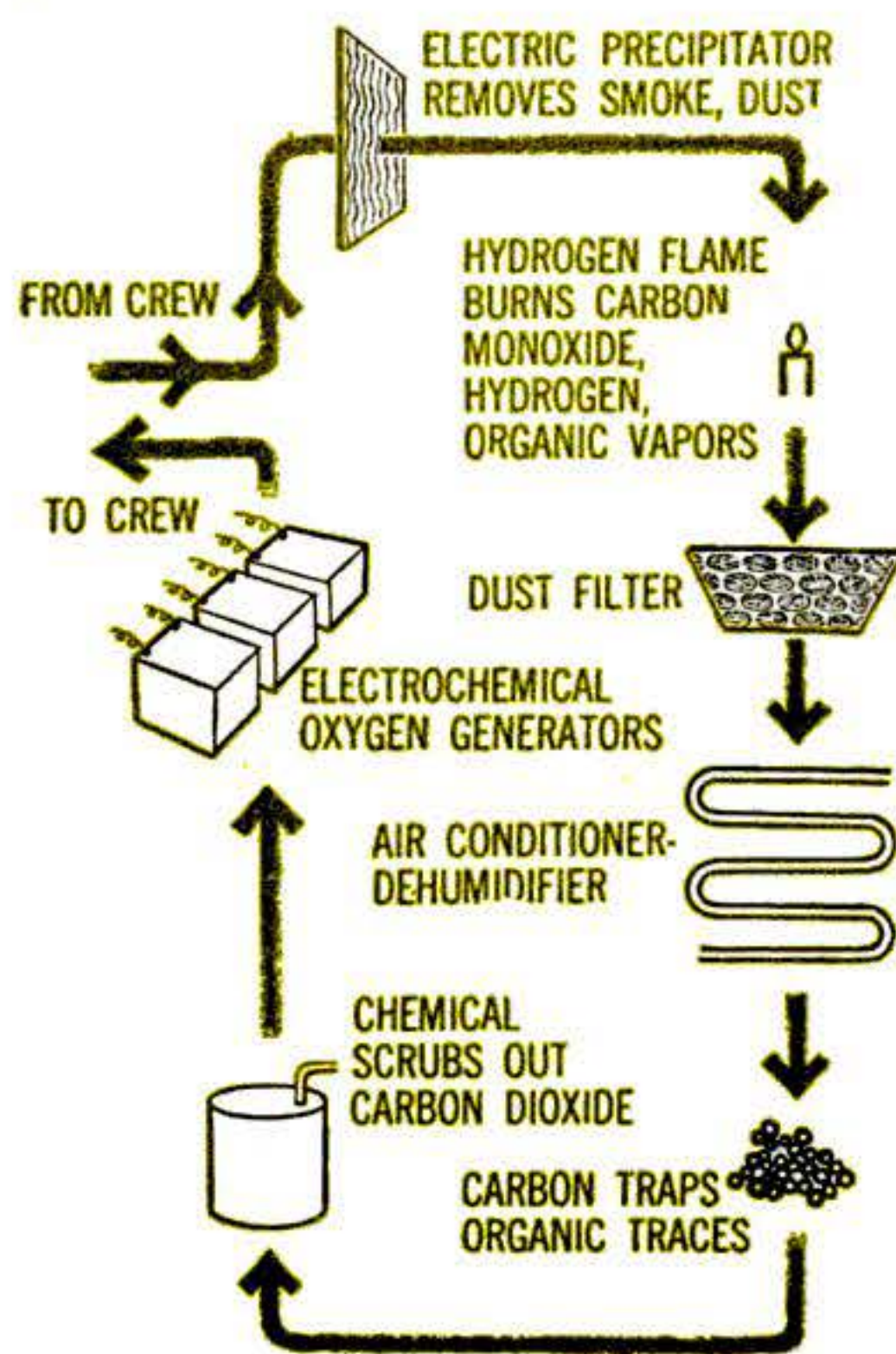

EARN WHILE YOU LEARN

NOTHING ELSE LIKE IT!

See How DeVry Tech Prepares You for a Good-Paying Career in

TELEVISION RADIO ELECTRONICS

Hundreds of men, 17 to 55, started to make money in the Electronics field before they even finished their DeVry Tech program. Many made the training pay for itself as they learned! Because DeVry Tech's program is so practical, YOU should be able to do the same. You work scores of projects; you learn by watching home training movies; you follow clear, step-by-step instructions. You really learn principles and master many skills. No wonder DeVry Tech men are found in so many real-pay, bright-future jobs in this great, growing field!



A BIG DeVRY EXTRA!

Build Your Own 6-Speaker Stereophonic & Hi-Fi Sound System

NOW, you may build and keep your own top quality High Fidelity 6-Speaker Stereophonic Sound System, as shown below. You Learn-By-Doing for a BETTER JOB or to ADD TO YOUR PRESENT INCOME. As a bonus, you and your family can enjoy the thrills of this marvelous sound system for years to come.

Special **SHORT COURSE** in High Fidelity Sound Reproduction including Stereophonic Systems also available. Ideal for hobbyists, music lovers and men seeking **NEW OPPORTUNITY**. Mail coupon.

GET A BETTER JOB OR BE BOSS OF YOUR OWN BUSINESS

NO ADVANCED EDUCATION OR PREVIOUS TECHNICAL EXPERIENCE

NEEDED! At home in your spare time, you use the same basic method followed by students in our Chicago and Toronto laboratories. You learn to use tools, follow diagrams, when you build any or all of this valuable equipment: the STEREO SYSTEM . . . or a 5-INCH OSCILLOSCOPE and VACUUM TUBE VOLTMETER . . . or a 21-inch TV SET. You have many choices! DeVry Tech's program is so thorough that you will likely be surprised at your progress. Send the coupon for details.

EMPLOYMENT SERVICE



Frequently, we simply don't have enough graduates available to fill all the jobs on our list! DeVry Tech has an Employment Service that really works. It is available to graduates without additional cost.

MILITARY SERVICE

If you are subject to military service, you will find the information we have for you very helpful. Mail the coupon today and get the facts.

GET TWO FREE Booklets!

"POCKET GUIDE TO REAL EARNINGS" and
"ELECTRONICS AND YOU"



Real down-to-earth details are presented to help the man who wants to get ahead. Both booklets are yours FREE! Fill out coupon and mail today.



MAIL TODAY FOR FREE FACTS

DeVry Technical Institute
4141 Belmont Ave., Chicago 41, Ill., Dept. PS-4-P
Please give me your two FREE booklets, "Pocket Guide to Real Earnings" and "Electronics and You," and tell me how to prepare to enter one or more branches of Electronics.

NAME _____ AGE _____
PLEASE PRINT

STREET _____ APT. _____

CITY _____ ZONE _____ STATE _____

Check here if subject to military training.

DeVry Tech's Canadian Training Center is located at
2051 626 Roselawn Avenue, Toronto 12, Ontario

DeVRY Technical Institute

4141 BELMONT • CHICAGO 41, ILL. • Formerly DeFOREST'S TRAINING, Inc.

Accredited Member of National Home Study Council



"One of America's Foremost
Electronics Training
Centers"

ONE OF THE BIGGEST OPPORTUNITY FIELDS OF THE CENTURY!

The month in science

fix that, but there are many other hydrocarbons (mostly unidentified) in the air that have to be burned or filtered out.

- ▶ Aerosols. These are fine particles suspended in air—three-fourths of them tobacco smoke. Subs now carry electrostatic precipitators (similar to electronic filters in some home air conditioners) in their galley stove exhausts, but bigger ones will be needed.

New cars—1980 models. Plymouth chief engineer Jack E. Charipar tuned up his time machine recently for a sharp look at the automobile of the future. The picture he got was a big, slick and fast dream wagon:

- ▶ Very high speeds, made possible by superhighways and automatic driving controls. This calls for true streamlining with big fins for stability. Windows will be flush and fixed—perhaps covering the entire top of the car with “transparent steel.”

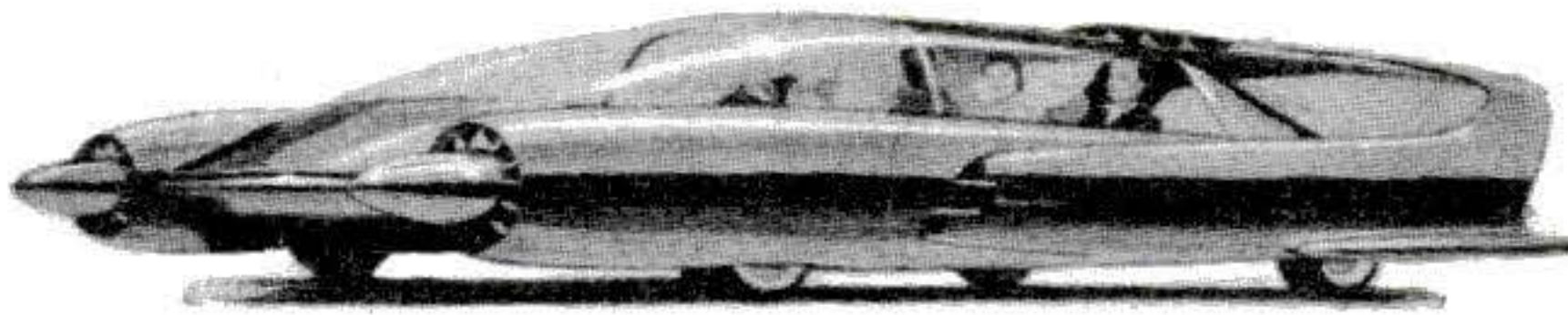

- ▶ Only two basic bodies—sedan and station wagon. Still, all kinds of options will let you order anything from two-

door utility carriers to a “magnificent suburban land yacht.”

- ▶ Hotter engines, but smaller and lighter (less than 800 pounds). They’ll be mounted forward because only one chassis design will be used, and that must suit wagons and sedans both.
- ▶ Slightly lower bodies—down to around 51 inches, which is the limit unless passengers lie prone—but not much change in length or width. The hood and deck may drop below the wheels, leaving fender “blisters” sticking up like the ones on the salt flats speed-record cars. This will cut road clearance to four or five inches, so low that utility vehicles will need adjustable suspensions to increase clearance for rough going.
- ▶ Wraparound sheet metal—with color fused into it instead of sprayed on—even enclosing the underside.
- ▶ No gas tank. Instead, plastic fuel containers will be tucked away in odd nooks and crannies (quarter panels or front fenders).
- ▶ Brakes mounted away from the wheels for better cooling. Even so, they’ll need an assist on high-speed stops from aerodynamic flaps that open out of the fender fins.

One thing Charipar doesn’t expect to change is the need for change (to sell cars). He counts on a complete redesign every two years—a cycle made economical by a machine that automatically builds dies directly from drawings. Such a fantastic robot is even now not very far from reality.

Bald birds. There’s a glimmer of hope for vain men-over-25. Scientists have at last found a guinea pig for lab experiments on baldness. It’s the wattled starling (adult male, naturally), an African bird that loses feathers from the top of its head—permanently—the way men lose their hair. That’s all the good news though, men. So far, the cause and cure of baldness are as elusive as ever.



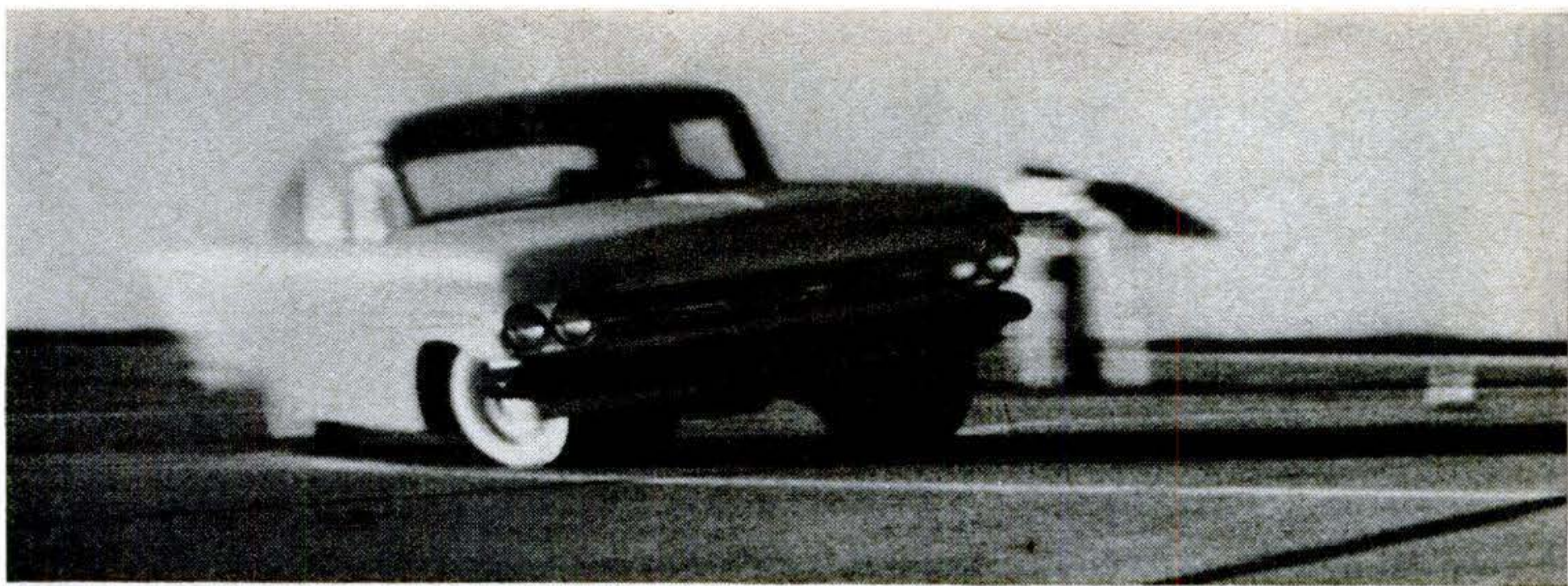

Firestone tire stability on proving ground turning pads wins car makers' top approval.

Firestone Rubber-X* surpasses car makers' toughest tests



Firestone tires give you the turn control, skid-safety and stability you need for today's driving.

to prove Firestone brings you extra safety in tires!

Proof of performance makes Firestone tires number one choice of car manufacturers. Again for '59, more cars will roll off assembly lines on Firestone tires than on any other make. On the proving grounds of the world's most competitive industry, nothing about tires is left to chance. Hard-to-convince engineers cramp screaming wheels into tight maneuvers on special turning pads. They measure noise, skid-safety, cornering stability and ease of control. They race test tires to the limit over everything from high-speed tracks to broken pavements.

From carefully controlled brand-for-brand tests like these, automotive engineers see which tires perform best. Again this year, auto industry testing has made Firestones first choice tires for original equipment. When you're thinking about tires for your new or present car, remember that Firestones, alone, offer the test-winning performance of Firestone Rubber-X, the longest wearing rubber ever used in Firestone tires. Buy now, on convenient terms if you wish, at your nearby Firestone Dealer or Store.

Enjoy the Voice of Firestone every Monday evening on ABC television

Firestone

BETTER RUBBER FROM START TO FINISH

Copyright 1959, The Firestone Tire & Rubber Company



**Firestone Rubber-X is compounded specifically for each type of car, truck, farm implement and construction equipment tire.*

APRIL 1959 17

Have you heard...?

Psst . . . wanna buy a boat . . . cheap? You can. This season out-board makers are going overboard plugging the boat-on-a-budget . . . some for as little as \$1,000. Here's how one company (Kiekhaefer) suggests you can make a family of four amphibious:



14-ft. aluminum runabout	\$ 375
22-hp. motor (sufficient for cruising and pulling one adult or two kid water skiers)	410
Accessories: (hardware, lights, fire ext., etc.)	90
Trailer	125
Total	\$1,000

- ▶ Willing to spend a little more? Then figure on a more elaborate runabout, maybe fiberglass or plywood (\$500 up to \$1,200 if you want 16 feet of boat with upholstered seats, convertible top, windshield). A 45-hp. motor with electric starter and generator will run to about \$700. Your total's now \$1,800-\$2,500.
- ▶ But for a little more you might decide to go to a weekender. Budget for a rig like that might be:



16-ft. cruiser	\$1,600
Motor of 50 to 70 hp.	750 to 950
Steering, remote controls, battery	150
"Head," some bunk cushions, hardware and lights, sleeping bags for the kids	250
Trailer	350
Total	\$3,100 to \$3,300

- ▶ What about accessories? Here's a rundown on the most vital:



Life jackets for the kids	\$6 or \$8 each
Buoyant cushions (that will double as seat pads) for adults	\$5 each
Lights: red-green combination bow light and white stern light	\$25
Anchor	\$10 to \$15
Whistle or horn	\$2 to \$25

A gasp of priceless air—about ¼ ounce worth—was the sole cargo of a little Norwegian sailing vessel returned from a Far North trek. The air blew across "Greenland's icy mountains" many millenniums ago and was trapped in pockets of ice. Specialized techniques were used to melt more than 200 tons of glacial deposit to get at the rare residue. With its little bit of dust, pollen, organic material (maybe breaths of long extinct animals), scientists hope to be able to date it (by Carbon 14 count), then determine what climate and life was like then.

Car briefs . . . There's talk of an increase in replacement-tire prices. Sales boomed beyond belief in the last few months. (Winter

**HOW AMERICA'S NUMBER ONE CARBURETOR
SHORTENS EVERY MILE . . . STRETCHES EVERY GALLON!**

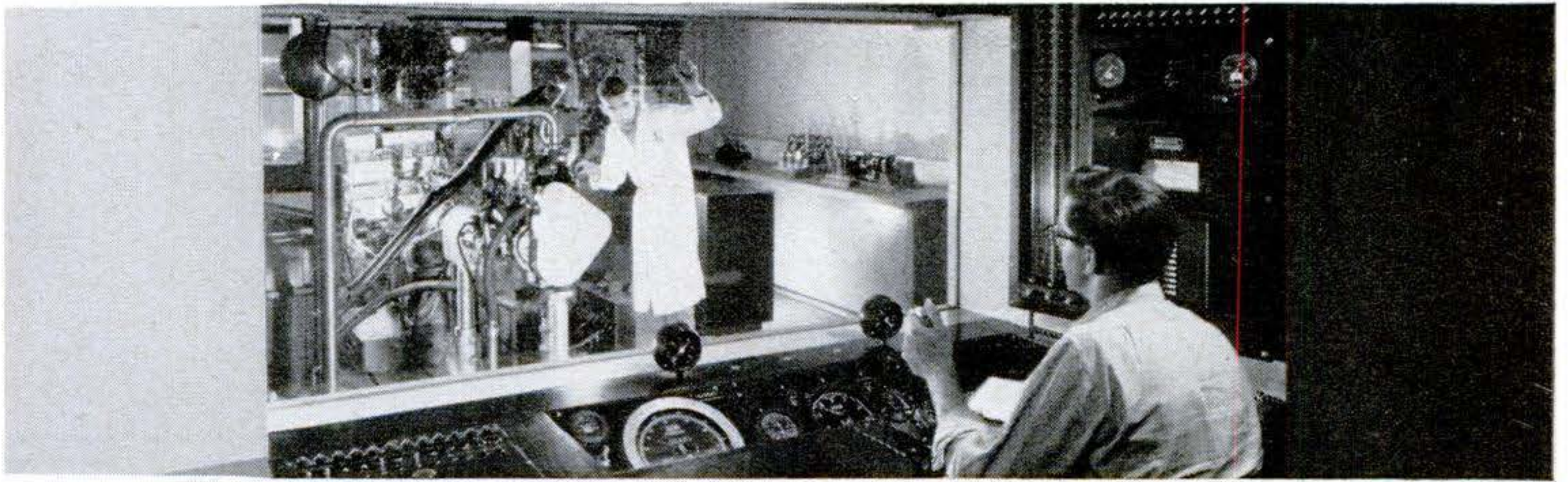

Engineers using the vast facilities of the General Motors Technical Center, are working on tomorrow's carburetor design today. Such years-ahead planning and research means better performance for you.

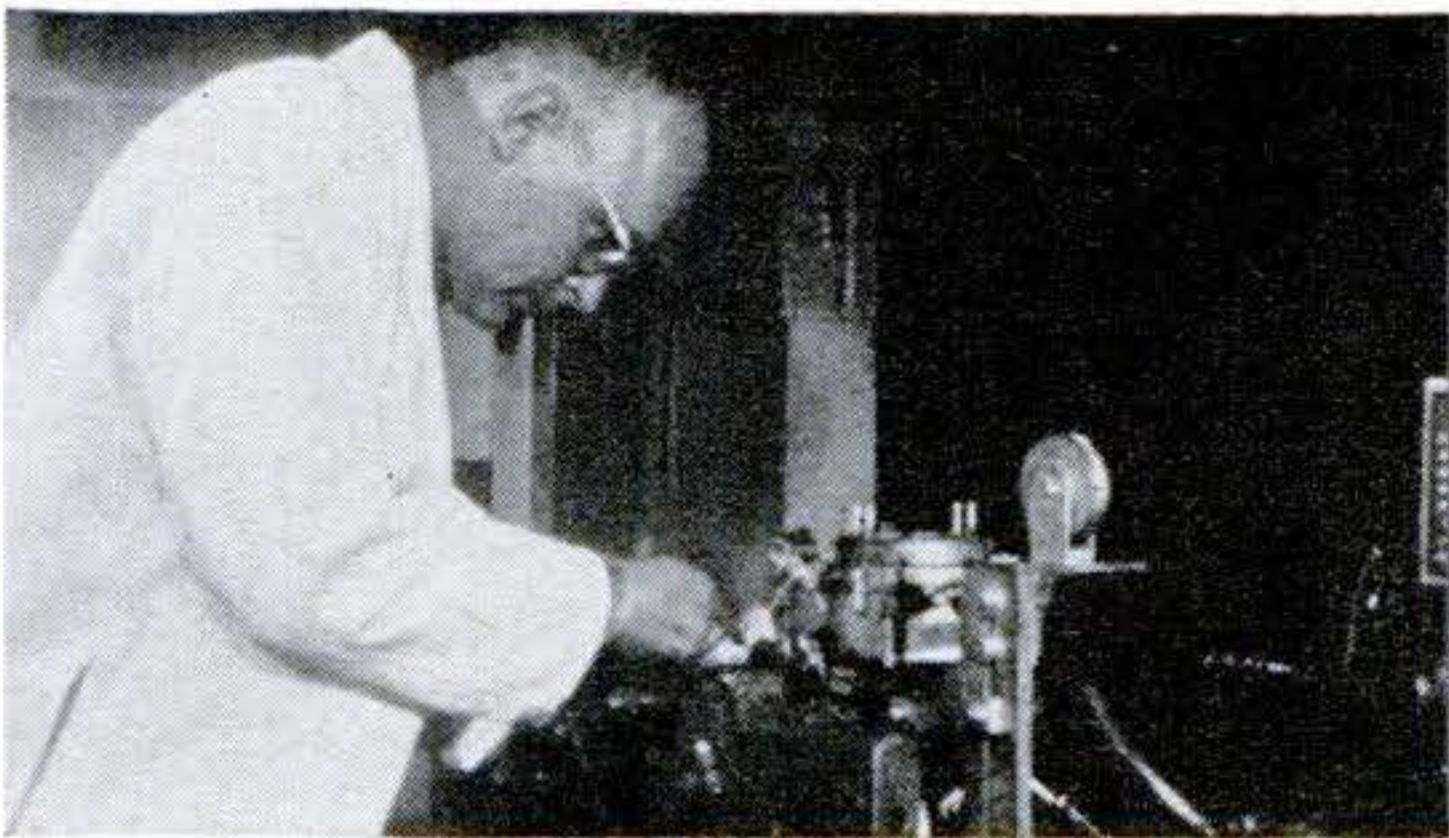

At Rochester Products, these carburetors are manufactured under the industry's highest standards of quality control, assuring dependability and longer, trouble-free service.

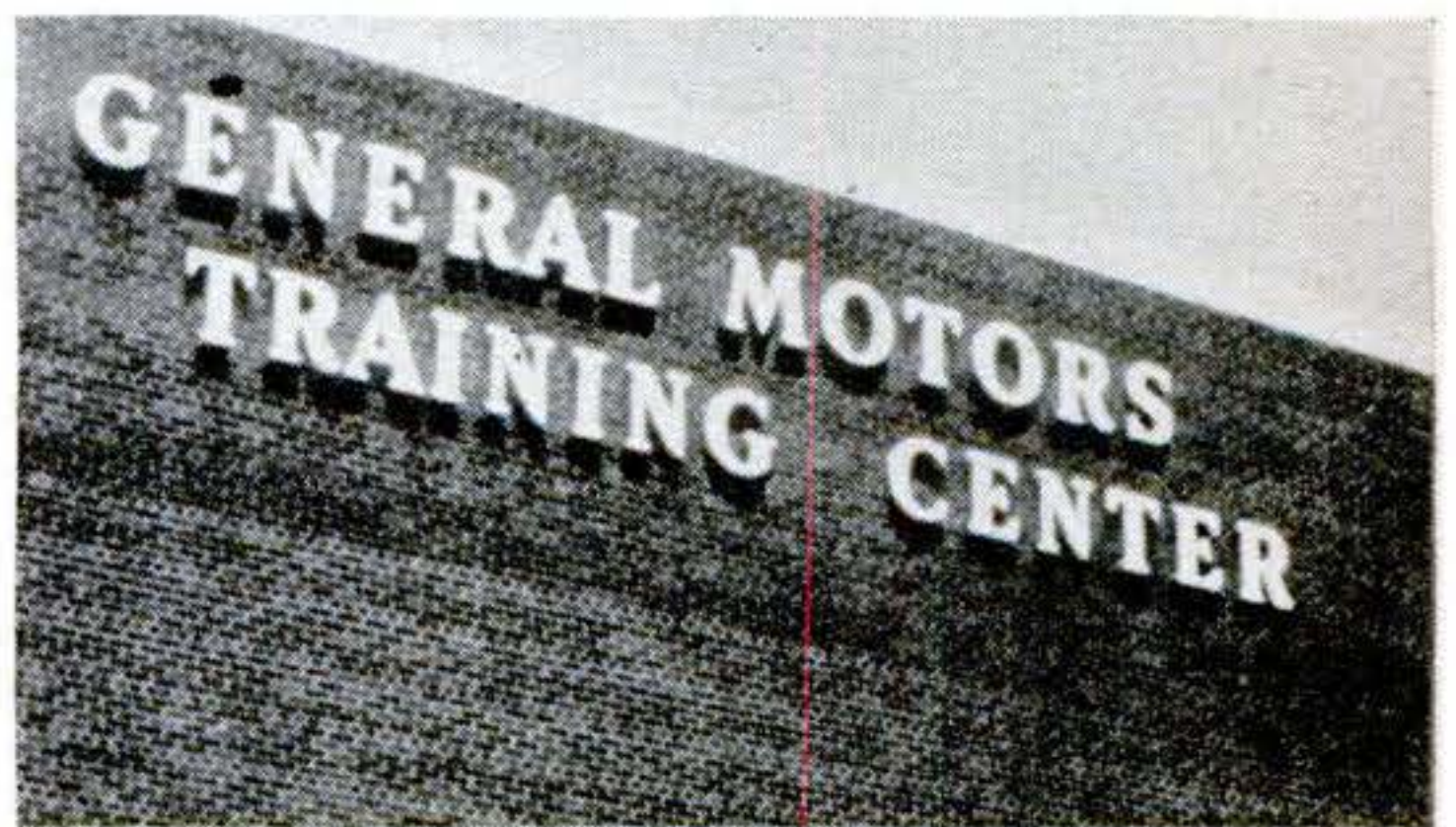

Thirty General Motors Training Centers across the nation offer the finest training available. Mechanics are taught modern, time-saving methods of servicing carburetors.



Rochester-GM Carburetors are tested on the world's toughest proving grounds. Millions of test miles are put on these carburetors before they are accepted for use on today's highways.

New highs in efficiency in the Rochester-GM Carburetor seem to make every mile shorter. And every gallon of gas does a lot more work! That's because new carburetor advances have been engineered, researched and tested for exclusive use on General Motors cars. These carburetors are also backed by an army of factory-trained experts who are fully qualified to keep your Rochester-GM Carburetor in perfect operating condition. See your nearest Rochester-GM Carburetor specialist for peak performance and economy. *Rochester Products Division of General Motors, Rochester, New York.*

ROCHESTER  **CARBURETORS**

America's number one original equipment carburetors

GENERAL MOTORS

Have you heard...?

storms sent people on a snow-tire binge for one thing.) Though prices have been stable, Akron is beginning to grow restless.

New gas taxes spur interest in electric cars. Besides the Stinson Town-About [PS, Feb.], trucks are in production in Cleveland. These sell for \$4,500, less batteries which rent for \$30 a month. Dairies, bakeries and utilities are among the takers. Utilities

predict operating costs of under a penny a mile.

Octane ratings have reached new highs according to a Government survey of service stations. Average regular gas rated 90 compared with 80.2 a decade ago. Premium averaged 98 vs. 86.2, and super-grade, not available 10 years ago, averaged 101.1.

The market abounds with car gimcracks and doodads. Latest are candy-striped hubcaps (\$8.45 a set). Another is the Protektador rubber stopper. Attached to the door's edge, it's to guard against damage inflicted by adjacent car doors on parking lots. Wildest of all is a wildcat—a facsimile animal head clamped under the rear window. Its eyes luminously shine when another car approaches at night—to make driving safer. The firm's sales

GAS OCTANE RATINGS			
	Regular	Premium	Super
1948	80.2	86.2
1949	80.5	86.5
1950	82.4	89.0
1951	83.7	89.5
1952	83.1	90.0
1953	84.0	90.9
1954	84.7	91.9
1955	86.2	93.6
1956	88.1	95.6
1957	89.8	96.7	100.7
1958	90.0	98.0	101.1

Source: U. S. Bureau of Mines

have been so good they're planning to expand to leopards, elephants, lions and panthers.

Mint-it-yourself toothpaste. Is it okay to brush your teeth just once a day, as some toothpaste makers say? No, says the American Dental Association, which contends that much of today's advertising discourages proper dental hygiene. Testifying before a Congressional committee on false and misleading advertising, dentists stated that there is no substitute for brushing the teeth after every meal. Want their recipe for a perfectly fine dentifrice? Mix table salt and baking soda. Flavor to taste.

What do you save with an "economy" car? PS Senior Editor Harry Walton, who has poked over, pried into, driven and evaluated more than 30 foreign and domestic cars for his new book, "Popular Science Standard Guide to Economy Cars," lists many savings that might not occur to you. Among them: smaller tires; halved costs on oil, antifreeze and spark plugs. And working on the little engines is so simple, usually, that you could—for instance—even tackle your own valve grinding. Careful readers of the book, now on the stands, will have no trouble identifying those makes Walton is crazy about and those he thinks should be melted down into paperweights.

ONE OF THE WORLD'S GREAT ROAD CARS IS INVITING YOU TO COME FOR A TRIAL RUN

It's the one and only production car of its type in the entire low-price field—the exciting Plymouth Sport Fury '59.

Tested against a famed European Gran Turismo car (priced above \$7000) on our own western mountains, FURY performance caused a famed automotive magazine editor to write that *he'd take the Plymouth!*

Yet this Plymouth Sport Fury '59 serves beautifully as a family car as well. That's because it's built with true American func-

tionalism in mind—plenty of hustle, combined with roomy luxury for family travel and ample luggage space for long runs.

Try Fury, with its flat cornering and satisfying sure-footedness. You'll find it's unmatched in the field for sheer *performance!*

.....
POWER FOR YOUR PLYMOUTH? *You pick that from Plymouth options. For genuine tops in go, try the New Golden Commando 395, biggest V-8 engine in its field.*

Plymouth

Today's best buy . . . tomorrow's best trade





Proved way...

to get more miles
per gallon of gas

If your carburetor is dirty (and it probably is) you are wasting gas.

Gum deposits can reduce your gasoline mileage by as much as 10%. At today's prices that costs you about three cents a gallon.

You avoid this waste when you **CLEAN YOUR CARBURETOR WITH GUMOUT.** Gumout is a special solvent. When added to your gas tank, it mixes with the gasoline and provides a powerful detergent action. As you drive, it completely cleans your carburetor, eliminates crippling gum and varnish deposits.

Ask your serviceman to add Gumout to your gas tank now. Then use Gumout every two or three months. Your carburetor will stay clean and you will get more miles for your gas dollar.

On sale at
service stations
and auto supply stores

GUMOUT DIVISION
Pennsylvania Refining Co.
2670 Lisbon Road
Cleveland 4, Ohio



**EARN \$100
A WEEK AND UP**

**BE AN AUTO-DIESEL
MECHANIC...EARN
WHILE YOU LEARN**

Many of our graduates earn \$100 a week and up. You learn fast in our school and shops because you learn with tools on real equipment. Experienced instructors explain WHY and show you HOW, then you DO IT YOURSELF. One of the best equipped technical schools in the United States. Thirty-nine years' experience training men. Successful graduates in 48 states and many foreign countries. Approved for veterans. Day and evening classes. Free bulletin—write today.

NASHVILLE AUTO-DIESEL COLLEGE
226 7th Ave. N., Dept. 42 Nashville, Tenn.

CABINET MAKING



Write for
Free Booklet

**LOW COST HOME TRAINING COURSE
FOR BEGINNERS & ADVANCED CRAFTSMEN**

Make money. Learn skills and secrets of fine woodworking and tool use. Professionally prepared shop method training tells and shows how. Covers everything. Easy to master.

INTERSTATE TRAINING SERVICE
DEPT. F-2, PORTLAND 13, OREGON

MINIATURE SHIP MODELS

Authenticast

Made from Govt. Blueprints

UNUSUAL -
PRECISION
DETAILED



SEND FOR
CATALOG—35¢

HEAVY CRUISER \$2.00

COMET METAL PRODUCTS CO., INC.
RICHMOND HILL 18, NEW YORK, N.Y.

"YOU ARE UNDER ARREST!"



Help Bring Crooks to Justice Through Scientific
CRIME DETECTION!

We have taught thousands this exciting, profitable, pleasant profession. Let us teach you **in your own home.** Learn Finger Printing, Firearms Identification, Police Photography, Secret Service Methods thoroughly, quickly, at small cost. Over 800 of all American Bureaus of Identification employ I.A.S. students or graduates. Write for FREE "Blue Book of Crime."
(A Correspondence School Since 1916)

INSTITUTE OF APPLIED SCIENCE, 1920 Sunnyside Ave., Dept. 1364, Chicago 30, Ill.

THE ORIGINAL PACKAGED BOAT KITS

MADE ONLY BY *Custom & Craft*



• World's Largest Line—New Fiberglass Hulls. Over 200 styles Boats-Kits, Formed-Hulls, Semi & Custom finished. All types: Prams, Cruisers, Racers, Inboards, Outboards. Easy to build. Professional results. Dealers - Agents Inquire.
Send 25¢ for 3-Colored Catalogs 52 pg. Kit Catalog plus 20 pg. Hardware and 8 pg. Armor Glass books. **(SPECIAL OFFER!)**
All 3-colored CATALOGS plus "Boating Handbook"...all for \$1.

CREDIT
TERMS

★ **BOAT
PLANS, PATTERNS
FRAME PACS**

• Over 400 Plans-Patterns, Frame Pak Kits, Prams, Kayaks, Racers, Runabouts, Catamarans, Cruisers-In-Outboards (6' to 40') Wood, Plywood and Steel. **Send 35¢ for 120 pg. Plan Catalog.** Catalog plus "Boat Building Handbook"... Send \$1.00.

CUSTOM • CRAFT Buffalo 7M, N. Y.

INVENTORS

Learn how to protect your invention. The U. S. Patent Laws provide that any new and useful art, machine, article of manufacture, or composition of matter, or any new and useful improvement thereof, may be patented if the act of invention is involved. Therefore, every inventor with a valuable invention should take advantage of the Patent Laws and proceed for patent protection in order to safeguard his rights.

A patent gives the inventor the exclusive right to prevent others from making, using, or selling the invention claimed in the patent for a period of seventeen years.

The Patent Laws were enacted for the benefit of the inventor to give him protection for the features of his invention which are patentable. These features must be properly and concisely set forth and claimed in a formal application for patent, in order to comply with the requirements of the Patent Laws. For that reason, unless the inventor is familiar with patent matters, he should engage a competent registered patent attorney or agent to represent him. We are registered to practice before the U. S. Patent Office and are prepared to serve you in the handling of your patent matters.

A specially prepared booklet entitled "Patent Guide for the Inventor", containing detailed information with respect to patent protection and procedure, together with a "Record of Invention" form will be promptly forwarded to you without obligation upon request.

CLARENCE A. O'BRIEN & HARVEY JACOBSON

Registered Patent Attorneys

92-D DISTRICT NATIONAL BUILDING
WASHINGTON 5, D.C.

HOW TO FIX ANY PART OF ANY CAR

QUICKLY--EASILY--RIGHT!

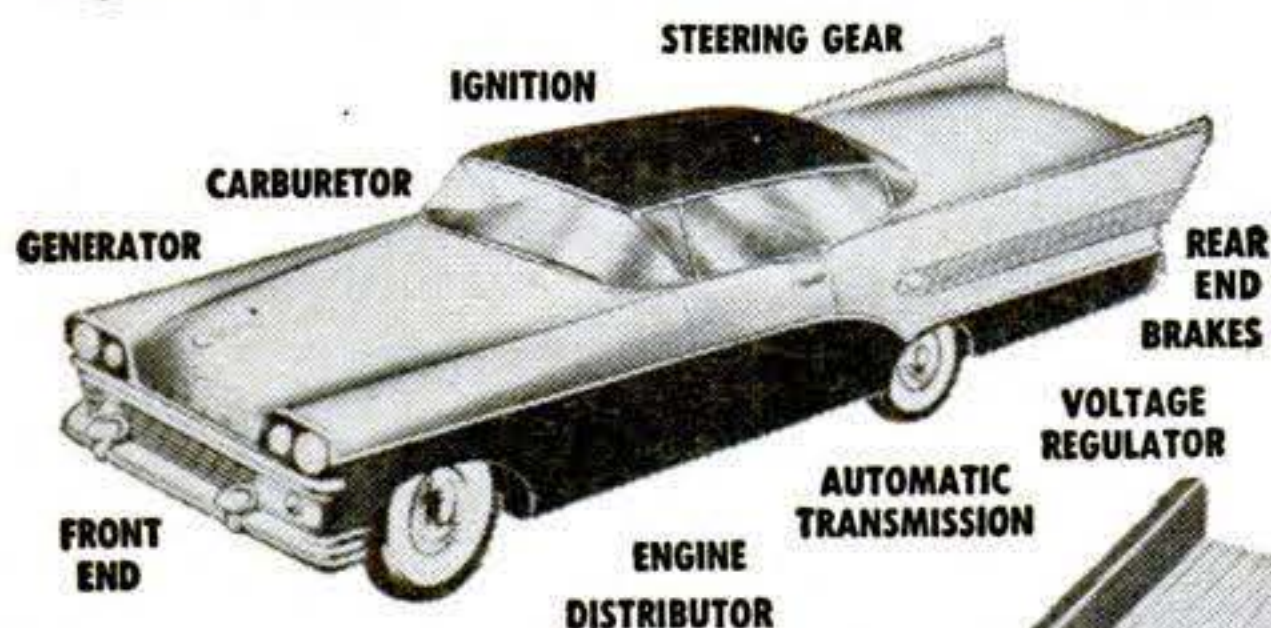

FREE 7-DAY TRIAL

Whether you're a beginner or an expert mechanic — now you can "breeze through" any "fix-it" job from simple carburetor adjustment to complete overhaul. Just look up job in index of MOTOR'S Brand-New Auto Repair Manual. Follow simple step-by-step directions, clear pictures. Presto—the job is done!

No guesswork! MOTOR'S MANUAL takes you from "scratch" — shows WHERE to start, WHAT tools to use. Covers EVERY job on EVERY car listed — from 1952 thru 1959!

Everything You Need to Know "Boiled Down" from 176 Official Shop Manuals

BIG NEW, REVISED, ENLARGED, Edition contains the "meat" from 176 OFFICIAL shop manuals — simplified for YOU. 23,436 essential repair specifications on 24 different makes. 1,120 big pages. More than 2,900 "this-is-how" pictures. 225,000 service and repair facts. Leads beginners every step of the way. Time-saving factory repair procedures for experts. Instructions and pictures so clear you CAN'T go wrong. Used by U. S. Army and Navy.

Try Book FREE 7 Days

Just mail coupon. (Attach it to postcard if you wish.) Make Manual prove what it's got. Unless you agree this is the greatest time and work saver you've ever seen—return book in 7 days, pay nothing. Mail coupon today to: MOTOR Book Dept., Desk 924, 250 West 55th Street, New York 19, New York.

MOTOR'S AUTO REPAIR MANUAL

Covers ALL Models —1952 thru 1959

- | | |
|-------------|-------------|
| Buick | Jeep |
| Cadillac | Lincoln |
| Chevrolet | Mercury |
| Chrysler | Nash |
| Clipper | Oldsmobile |
| Continental | Packard |
| De Soto | Plymouth |
| Dodge | Pontiac |
| Edsel | Rambler |
| Ford | Studebaker |
| Hudson | Thunderbird |
| Imperial | Willys |

Same FREE Offer On MOTOR'S New Truck Repair Manual

Covers EVERY job on EVERY popular make gasoline and Diesel truck made since 1952. FREE 7-Day Trial. Check proper box in coupon.



MAIL COUPON NOW FOR 7-DAY FREE TRIAL (Attach to Postcard if More Convenient)

MOTOR BOOK DEPT.

Desk 924, 250 W. 55th St., New York 19, N. Y.

Rush to me at once (check box opposite book you want):

MOTOR'S New AUTO REPAIR MANUAL. If O.K., I will remit \$2 in 7 days, \$2 monthly for 2 months and a final payment of \$1.95 (plus 45c delivery charges) one month after that. Otherwise I will return the book postpaid in 7 days. (Foreign price, remit \$10 cash with order.)

MOTOR'S New TRUCK REPAIR MANUAL. If O.K., I will remit \$3 in 7 days, and \$2 monthly for 3 months, plus 45c delivery charges with final payment. Otherwise I will return book postpaid in 7 days. (Foreign price, remit \$11 cash with order.)

Print Name..... Age.....

Address.....

City.....Zone.....State.....

Check box and save 45c delivery charge by enclosing WITH coupon in envelope entire payment of \$7.95 for Auto Manual or \$9 for Truck Manual.) Same return-refund privilege.

Works in seconds!



Loosens Rusted Bolts nuts, screws, "frozen" parts!
LIQUID WRENCH
SUPER-PENETRANT

The super-penetrating rust solvent that quickly loosens rust and corrosion.

AT ALL HARDWARE AND AUTO STORES
RADIATOR SPECIALTY COMPANY
CHARLOTTE, NORTH CAROLINA

"ALWAYS USE ME TOO!"
LIQUID WRENCH SUPER OIL

The very finest lubricating oil available for watches, sporting goods, sewing machines.



SMALL! POWERFUL!
ECONOMY TRACTOR

Unequaled value! Low price! America's finest tractor. Ruggedly built. Easy to operate. 790 lbs. Borg-Warner clutch, trans. and diff 140 to 1 reduction. 40% more drawbar pull than ordinary tractors 8-1/4 H. P. engine. 20 quick change implements. HOOD, FENDERS.

Thousands In Use Write for complete details.
Engineering Products Co.
915-A-4 Niagara St.
Waukesha, Wisconsin

GET INTO ELECTRONICS

V.T.I. training leads to success as technicians, field engineers, specialists in communications, guided missiles, computers, radar, automation. Basic & advanced courses in theory & laboratory. Assoc. degree in 29 mos. B.S. obtainable. ECPD accredited. G.I. approved. Graduates with major companies. Start Sept., Feb. Dorms, campus. H.S. graduate or equivalent. Catalog.

VALPARAISO TECHNICAL INSTITUTE
DEPT. S VALPARAISO, INDIANA

Would You Like to Make **\$1,000 A MONTH?**



That's what Stanley Hyman made selling the amazing new Presto Fire Extinguisher! Many others "cleaning up"—so can you! Amazing tiny new extinguisher ends fires fast as 2 seconds. Guaranteed for 20 years! Sells for only \$4.95. Write for Free sales kit.



Merlite Industries, Inc., Presto Div.,
114 E. 32nd St., Dept. P-16X, New York 16, N. Y.

FREE THE HISTORY OF THE COMPASS SEND FOR YOUR COPY

New **DINSMORE** *Celebrity* COMPASSES



in Beautiful **GOLD OR SILVER**

A jeweled, precision instrument—designed for modern cars. Full, indirect illumination. Sharp, clear letters. Silver or gold Celebrity models \$6.95, standard models \$5.45, illuminated \$6.45
APPROVED BY AUTO MAKERS
Fine Quality Compasses for over 31 Years



DINSMORE INSTRUMENT CO.
1804-27 Kelso St., Flint 1, Mich.

Write for Folder

INVENTORS

If you believe that you have an invention, you should find out how to protect it. The first step is to have a search made of the prior pertinent U. S. patents. If a report on this search indicates that the invention appears patentable you can apply for a patent, and the specifications and claims should be prepared.

The firm of McMorrow, Berman & Davidson, with offices in Washington, D. C., is qualified to take the necessary steps for you. We can make a preliminary search on your invention, advise you whether we think it can be patented, and prepare your application for patent.

Unless you are fully familiar with the U. S. Patent Laws, we recommend that you engage the services of a Registered Patent Attorney to protect your interests. The patent laws are *your* laws. A patent gives you the right to prevent others from making, using or selling the invention claimed in your patent for a period of 17 years.

Use these patent laws for your protection. Investigate whether your invention can be patented. If you have what you believe to be an invention, we suggest that you have this firm make a search for you.

Send for a copy of our Patent Booklet entitled "How To Protect Your Invention," containing information about patent protection and patent procedure. Along with this we will also send you an "Invention Record" form, for your use in writing down and sketching details of your invention. We will mail them promptly. No obligation. They are yours for the asking.

McMORROW, BERMAN & DAVIDSON

Registered Patent Attorneys

PATENTS • COPYRIGHTS • PATENTS

1422 VICTOR BUILDING, WASHINGTON 1, D. C.

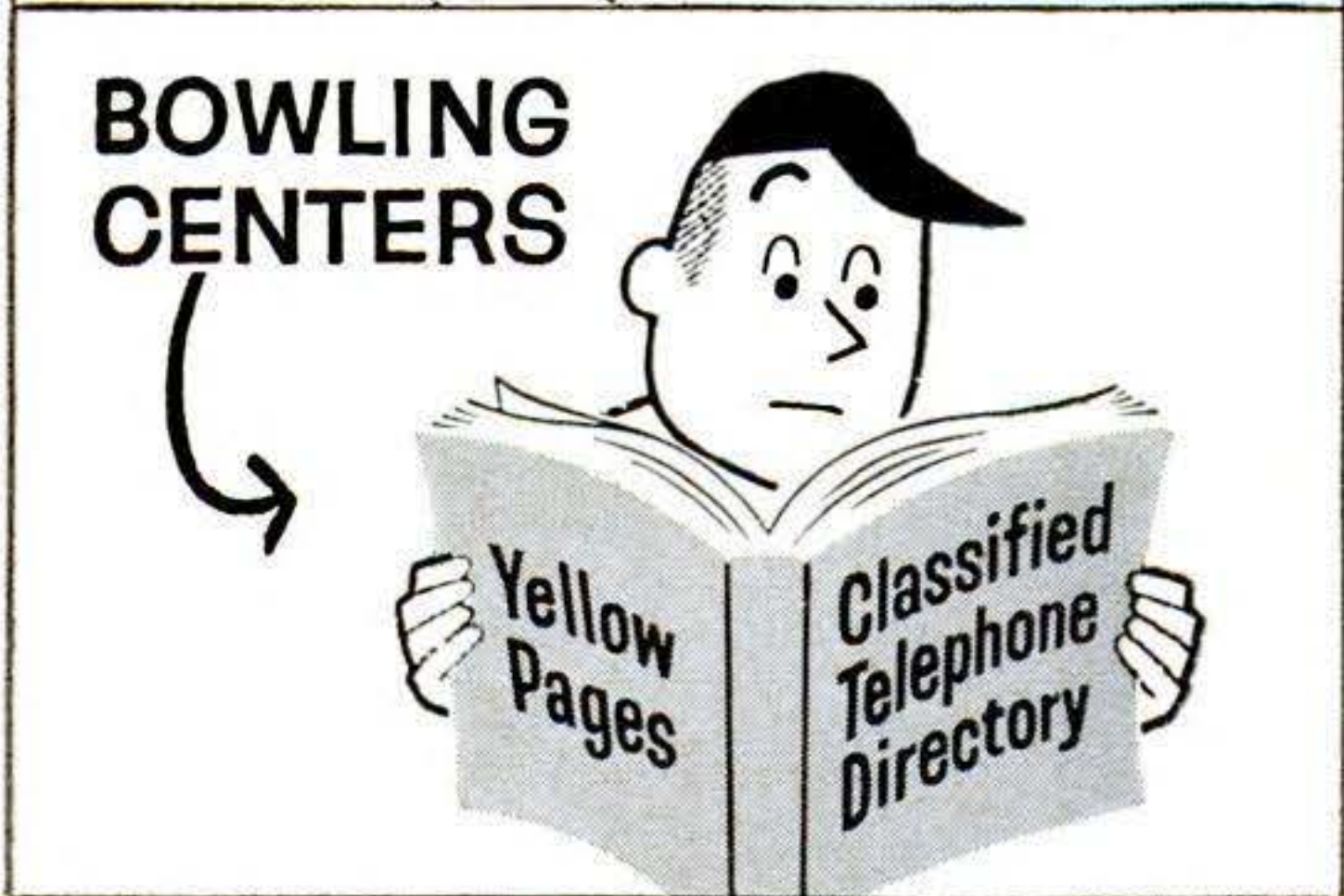
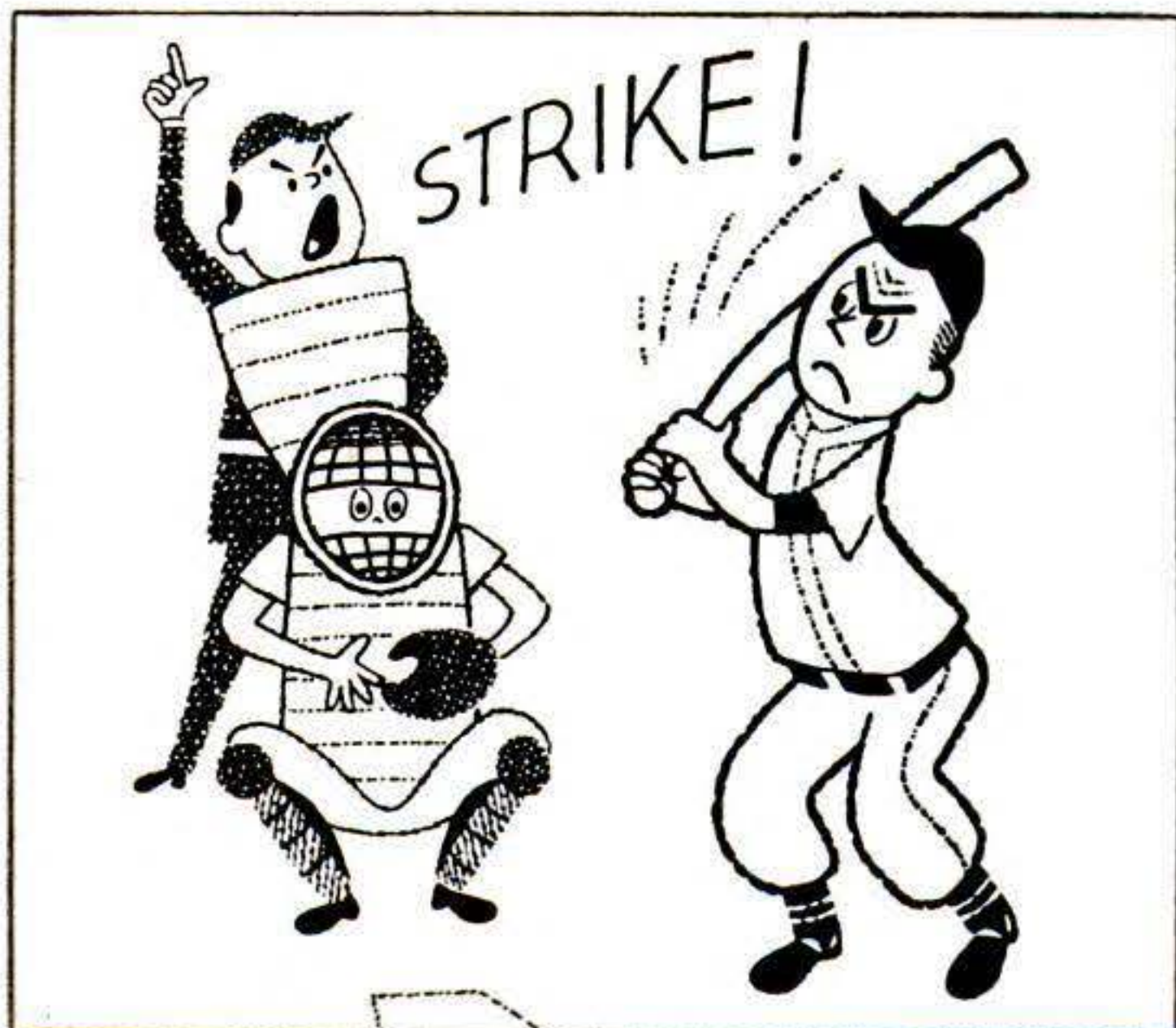

sporting goods, photographers,
pets, florists, upholsterers
whatever you need—



Advertisers displaying this emblem make your shopping easy.

ACCORDION PRICES SMASHED

SAVE 50% AND MORE DURING THIS GREAT SALE

5 Days' FREE TRIAL
Hurry! Get in on these sensational accordion values. America's largest exclusive accordion dealer selling out finest brand new accordion overstock! Fabulous savings. Leading brands in more than 30 new models. Small down payment. Easy terms. Trade-ins accepted. Chance of a lifetime.

FREE
for promptness . . .
● FREE Lessons
● Music Stand
● Deluxe Case
● Lifetime Guarantee

FREE COLOR CATALOG & Wholesale Prices
Learn how easily you may own and play a fine accordion. Rush name and address for big FREE Color Catalog and new low wholesale price list. No obligation. **WRITE TODAY!**

ACCORDION MANUFACTURERS AND WHOLESALE OUTLET
2003 W. CHICAGO AVE., Dept. P-49, CHICAGO 22, ILLINOIS

NO JOB WORRIES

PLASTEX INDUSTRY needs manufacturers on small scale for big production of Lamps, Clock Stands, Art Goods, Novelties in Plastic Marble imitation. No Experience necessary. 1/2c material makes regular 10c store sellers. Moulds furnished for fast production. Small investment brings good profit. Big wholesale orders now being placed. Ambitious men have chance for real prosperity and job security. Our NEW FREE booklet will interest and benefit you.

PLASTEX INDUSTRIES, Dept. 2, 3400 Third Ave., New York 56, N.Y.

BARBELLS

100 POUND SET \$12.80
Extra Plates Only 12c Pound

140-Pound, CHROME DELUXE Barbell-Dumbbell set only \$19.80.
This is our feature set and is the finest ever manufactured. Training with adjustable weight is the BEST way to keep fit; the ONLY way to develop great strength and a perfect body. As the oldest and best equipped barbell company, BUR gives value and prices no one can equal.

SEND FOR FREE CATALOG.
BUR BARBELL CO.
Lyndhurst 5, New Jersey

LAW FREE BOOK THE LAW TRAINED MAN

Write today for a FREE copy of illustrated law book, "THE LAW-TRAINED MAN," which shows how to earn the professional Bachelor of Laws (LL.B.) degree through home study of the famous Blackstone Law Course. All necessary books and lessons provided. Moderate cost; convenient monthly terms. Write for FREE law training book today.

Blackstone School of Law, 307 N. Michigan Ave.
Founded 1890 Dept. 124, Chicago 1, Illinois

only **\$7.95*** Puts "Get Up and Go" In Your Go-Cart

GIVES YOU LOW and HIGH GEAR

V-PLEX CLUTCH

End push starting—stop car with engine running—actually provides true transmission acceleration. V-Plex Clutch will actually outlast your engine. Standard equipment on leading carts. Put new performance in your cart or quarter midget. Write for literature. See your engine distributor.

*Slightly higher west of Rockies.
V-PLEX CLUTCH CORP. Hagerstown Indiana, U. S. A.



LET RCA TRAIN YOU IN ELECTRONICS

RCA Institutes celebrates Fifty Years of Electronic Training by introducing its newest Home Study Course . . .

ELECTRONICS FOR AUTOMATION

. . . Now you have four comprehensive courses for your electronic training . . . from basic electronic theory to the more advanced principles of color TV and Automation.

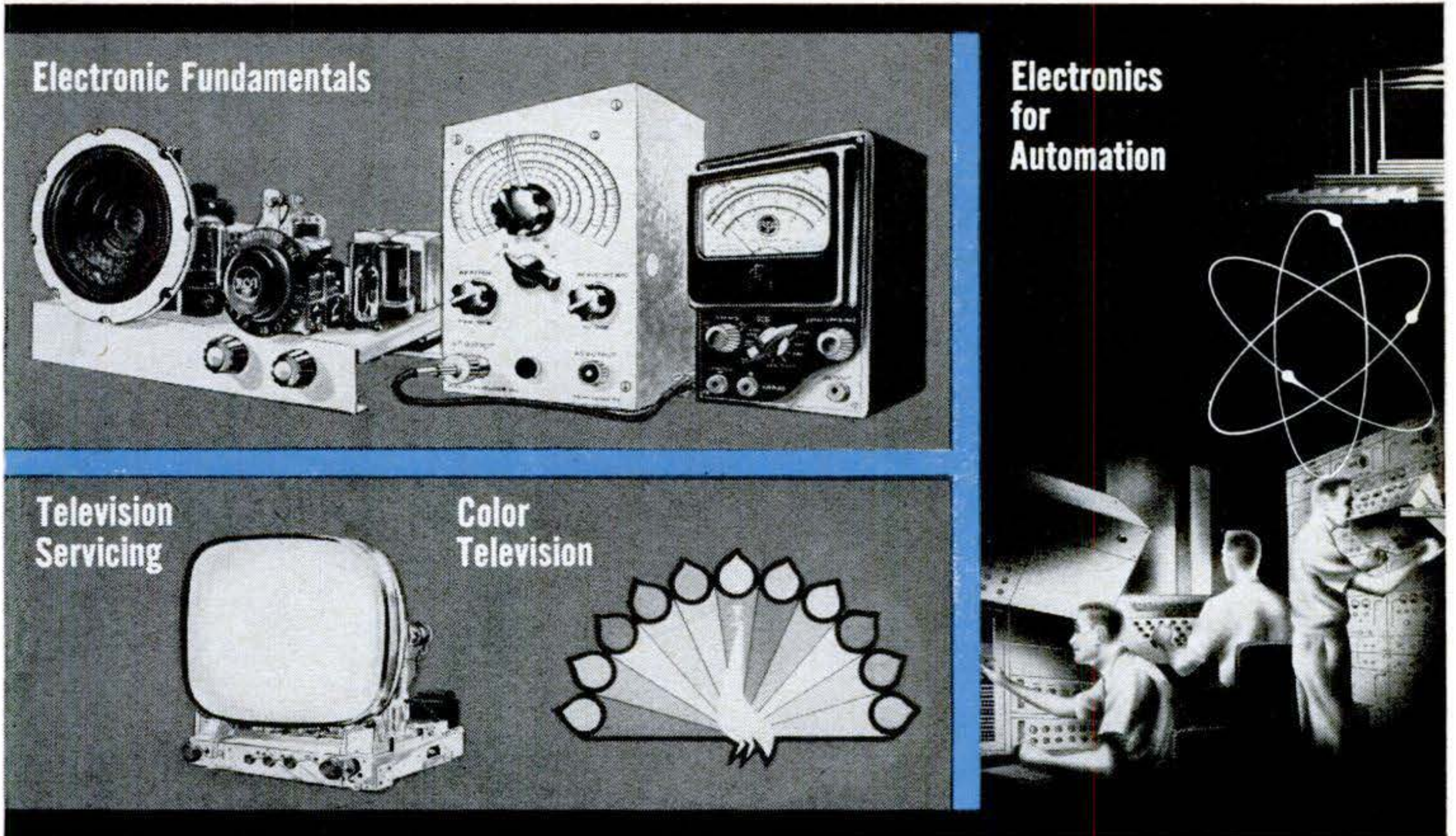

Send for our 64 page Home Study Catalog

FREE!

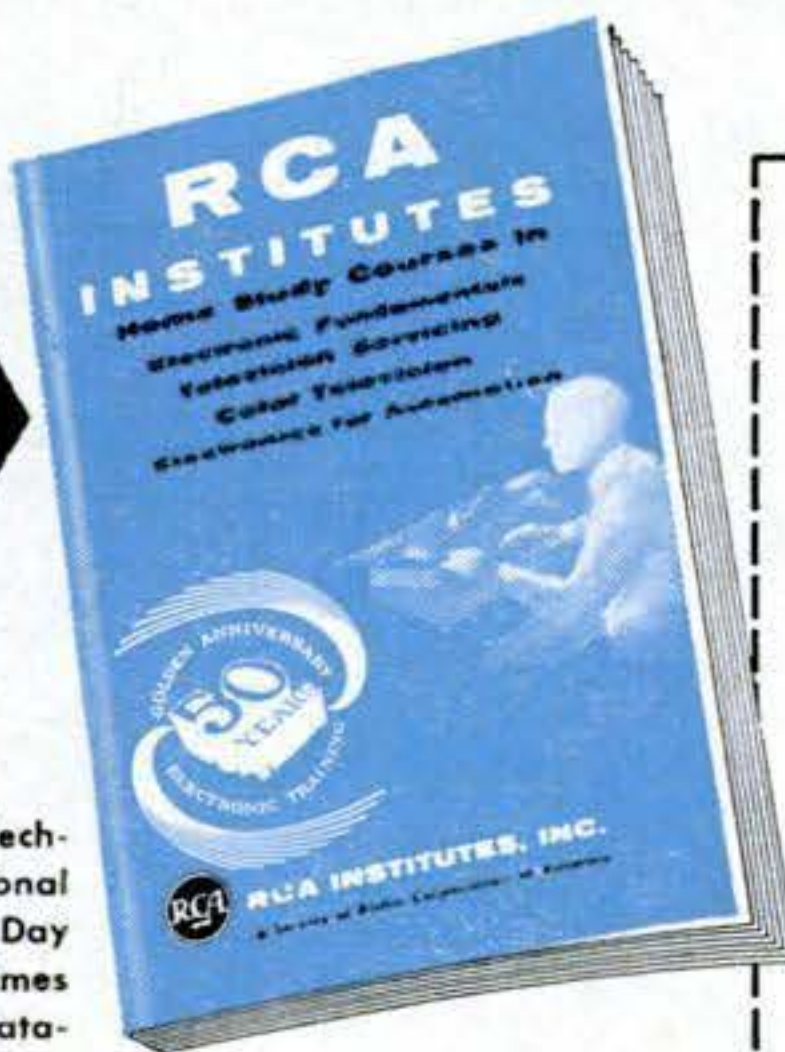

RESIDENT SCHOOL offers Technical Institute and Vocational School Courses in Electronics. Day and Evening classes start 4 times each year. Resident School Catalog sent free on request.

Practical work with the very first lesson. Pay-as-you-learn. You need pay for only one study group at a time.

RCA INSTITUTES, Inc. Home Study School, Dept. PS-49

A Service of Radio Corporation of America

350 West Fourth Street, New York 14, N. Y.

Without obligation, send me the FREE catalog of Home Study Courses. No salesman will call.

Name Please print

Address

City..... Zone..... State.....

Korean Vets! Enter Discharge Date.....

CANADIANS — Take advantage of these same RCA courses at no additional cost. No postage, no customs, no delay Send coupon to:

RCA Victor Company, Ltd., 5001 Cote de Liesse Rd., Montreal 9, Quebec

To save time, paste coupon on postcard

Complete Training

... AT ONLY A FRACTION OF THE PRICE YOU MIGHT EXPECT TO PAY



LEARN ELECTRIC MOTOR REPAIR (INCLUDING COMPLETE REWINDING)

Train for good pay in this uncrowded field! Learn at home to service and rewind practically any electric motor—from home appliance motors to big industrial motors and generators and their control equipment. This 560-page **ELECTRIC MOTOR REPAIR** guide explains every step by text and ALSO by more than 900 how-to-do-it pictures.

Quick guides show how to handle specific jobs. When a certain motor comes for repair, just look it up. **ELECTRIC MOTOR REPAIR** shows you exactly what to do. Right down the line, it explains troubleshooting, repair, rewinding and other maintenance in a way you can understand even without a lot of previous electrical training. Price only \$6.95. See money-saving offer. Money-back guarantee.

LEARN TO REPAIR ANY ELECTRIC APPLIANCE

This 370-page Rinehart **ELECTRICAL APPLIANCE SERVICE MANUAL** shows you how to do the toughest repair jobs as well as the easy ones—even if you've never fixed an appliance before. Gives specific instructions on every modern appliance. Includes refinishing methods. Handy charts help you locate troubles fast. Simple test instruments you can make yourself are explained. Tools, wiring problems and electrical principles are fully described. Gives you the "know how" you need to earn spare-time money fixing appliances—or, to build a full-time repair business. Only \$5.00 separately—or see money-saving offer in coupon.

SPECIAL OFFER . . . you save \$1.00!

If written in "lesson" form and sold as a course, you'd regard these two great books as a bargain at \$100 or more! Together, they form a 930-page electrical repair library that makes it easy to train for this good-paying modern profession. Under this new offer, you save \$1.00 on the regular price of the two books. And you can pay in easy installments!

PRACTICE 10 DAYS . . . FREE!

Dept. PS-49, RINEHART & COMPANY, INC.
232 Madison Ave., New York 16, N. Y.

Send books checked for 10-day free examination:

ELECTRIC MOTOR REPAIR (\$6.95) **ELECTRICAL APPLIANCE SERVICE MANUAL (\$5.00)**

MONEY-SAVING OFFER—Save \$1.00

Send both books at special price of only \$10.95 (regular price \$11.95). Payable at rate \$4.95 after 10 days if you decide to keep books and \$3 per month for 2 months. (SAVE! Remit price with order and we pay postage. Same 10-day return privilege with money refunded.)

Name.....

Address.....

City, Zone, State.....

realize your dream

Become a graduate engineer. Then promotion will not pass you by. Share rewards awaiting college men . . . higher income, rapid advancement. Important firms interview seniors here regularly. Approved for Veterans.

Graduate Engineer in 27 months

B.S. degree in Electrical Engineering (with either Electronics or Power major), also in Mechanical, Civil, Chemical, Aeronautical Engineering. In 36 Months a B.S. in Business Administration (General Business, Accounting, Motor Transport Management majors). For earnest, capable students. Small classes. More professional class hours. Mature students. Well-equipped labs. Modest costs. Year-round operation. Enter June, Sept., Jan., Mar. Write J. F. McCarthy, Director Admissions, for Catalog and "Your Career" Book.

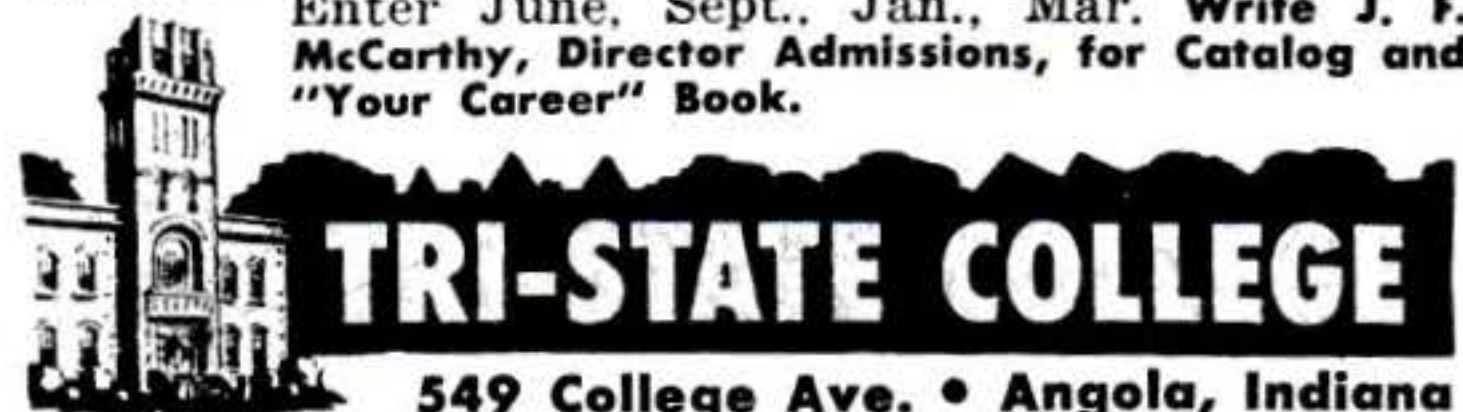

75 POWER TELESCOPE \$3.98

New 3 in one telescopes, 3 variable 25X-45X-75X magnification, Brass bound, 25 power for ultra bright images 45 & 75 power for long range. Guaranteed to bring distant stars, moons, objects, sports 75 times closer. Most powerful scope sold anywhere near this amazing low price. American made, 5 sections. Opens 36" closes 1 ft; contains 4 ground & polished lenses. Can also be used as powerful compound microscope. Directions included. Mass production enables us to offer telescope complete at \$3.98 postpaid. Money back guarantee. Get yours now.

CRITERION CO., 331 Church St., Hartford, Conn., Dept. PSB-70

Do FALSE TEETH Rock, Slide or Slip?

FASTEETH, an improved powder to be sprinkled on upper or lower plates, holds false teeth more firmly in place. Do not slide, slip or rock. No gummy, gooey, pasty taste or feeling. **FASTEETH** is alkaline (non-acid). Does not sour. Checks "plate odor" (denture breath). Get **FASTEETH** at any drug counter.

A TRADE THAT PAYS IN MANY WAYS CLOCK AND WATCH REPAIR

Wide Choice of Opportunities in Precision Instrument Fields for the Trained, Skilled Watchmaker.

Aviation, Electronics, Defense, and other Technical Fields. Watchmakers are Rated High by Industrial Personnel. Write today for your Copy of "THE VITAL ROLE OF THE WATCHMAKER IN DEFENSE."

KANSAS CITY SCHOOL OF WATCHMAKING
1220 Admiral Blvd. Kansas City 6, Missouri

You can have a HE-MAN VOICE

STRENGTHEN your voice this tested, scientific way. Yes—you may now be able to improve the POWER of your speaking and singing voice . . . in the privacy of your own room! Self-training lessons, mostly silent. No music required.



FREE BOOKLET Write today for Eugene Feuchtinger's great booklet "How to Develop a Successful Voice." It's absolutely FREE! You must state your age. Booklet mailed postpaid in plain wrapper. No salesman will bother you. Send your name and age RIGHT NOW!

Prefect Voice Institute, 210 S. Clinton St., Studio DR-1, Chicago 6, Ill.

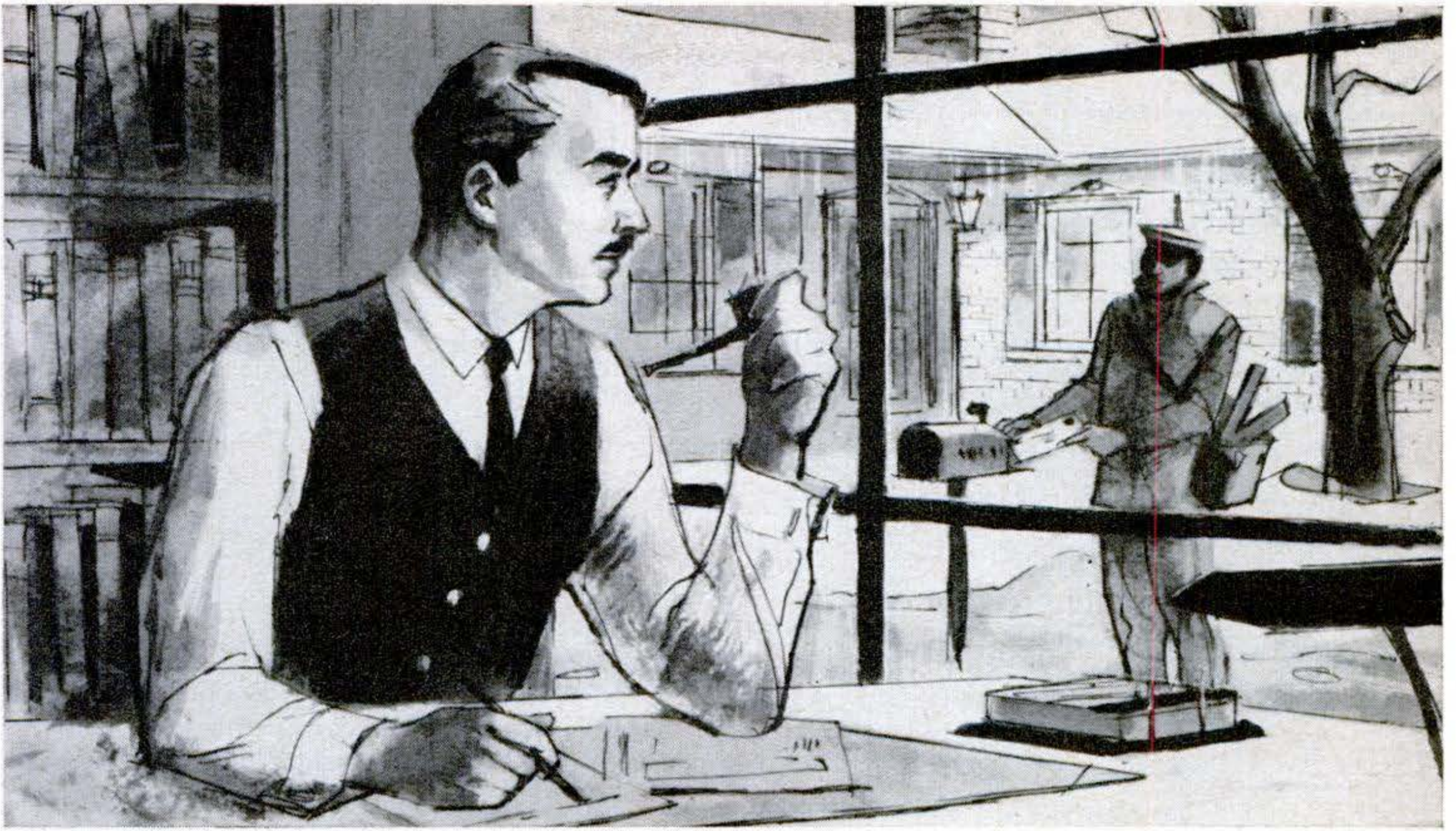

**"I save by mail and earn 5% a year
It's safe . . . and so much easier . . .**

I work hard for my money, so when I chose a savings account I had to know my money was safe and working hard for me. At First Western my savings have earned 5% a year, with interest paid every quarter. That means I can easily withdraw funds without losing interest, or I can let the interest remain in the account for compound earnings, every three months.

Few savings institutions can offer so much. First Western can do it because it is located in the fastest growing area in the country, where dollars are needed to finance expansion. Of course, I checked them out thoroughly and found that First Western is the largest savings and loan association in Nevada, with total resources over \$25,000,000.00. Their officers and directors are all community and state

leaders of long standing. They have always paid withdrawals instantly, and have a history of dependable performance as well as above-average earnings.

Another important point. Saving by mail is the easiest way to save, no traffic, no waiting in line, no wasted time. I find I save more, and earn more by transacting my savings business from my own home, with a First Western Savings Account."

You can open a save-by-mail account with as little as \$1.00. Accounts under \$5,000 earned 5% a year, accounts of \$5,000 or more earned 5 $\frac{1}{4}$ % on December 31, 1958. Interest is paid quarterly on all accounts. Funds received by the 15th of any month earn from the 1st.

Write or mail funds to:

FIRST WESTERN SAVINGS

AND LOAN ASSOCIATION, DEPT. G,

118 So. Fifth St., Las Vegas, Nevada • A. G. NEUMEYER, Pres.



Inventors

The following are the usual preliminary steps to take toward patent protection.

You are advised first, to make a disclosure of your invention. Date, sign and have this document witnessed by two or more persons who are capable of understanding your invention. The "Evidence of Invention" form mentioned below, we offer as a convenience in making your disclosure and in starting action leading toward patent protection.

Mail your disclosure to the registered patent attorney or agent whom you select to assist you, together with a letter authorizing him to conduct a

preliminary search among previously granted U. S. patents for similar types of invention. He then prepares for you a report on the probable patentability of your invention and, if the report is favorable, recommends the further course you should take.

This firm is registered to practice before the U. S. Patent Office and is available to assist you in the preparation and prosecution of patent applications. We shall be glad to send you without obligation, the "Evidence of Invention" disclosure form mentioned above and our instructive booklet, "Patent Protection for Inventors".

VICTOR J.
EVANS & Co. *Merlin M. Evans*
REGISTERED PATENT ATTORNEY
540-D MERLIN BUILDING, WASHINGTON 6, D. C.

HOME PAINTING TIP NO. 49

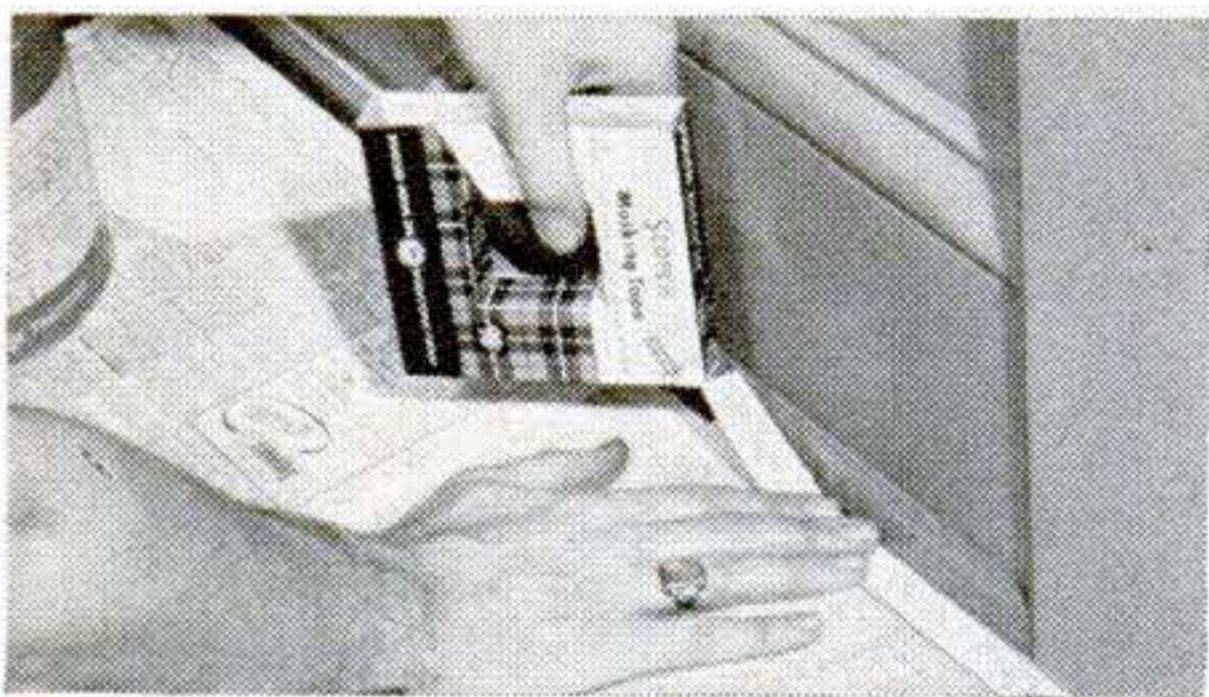

For neat, professional-looking paint jobs use "SCOTCH" Brand Masking Tape. Sticks tight, stretches to hug curves or irregular surfaces. Paint won't bleed through. When paint has "set" (but not fully dried), "SCOTCH" Masking Tape strips off quickly and easily, leaves a clean sharp edge. An invaluable aid for painting with brush, roller or spray can. Ask for "SCOTCH" Brand Masking Tape in the handy cutter-edge carton—35¢, 69¢, 98¢, \$1.69 sizes—wherever paint is sold!

"SCOTCH" and plaid design are registered trademarks of 3M Co., St. Paul 6, Minn. © 3M Co. 1959.

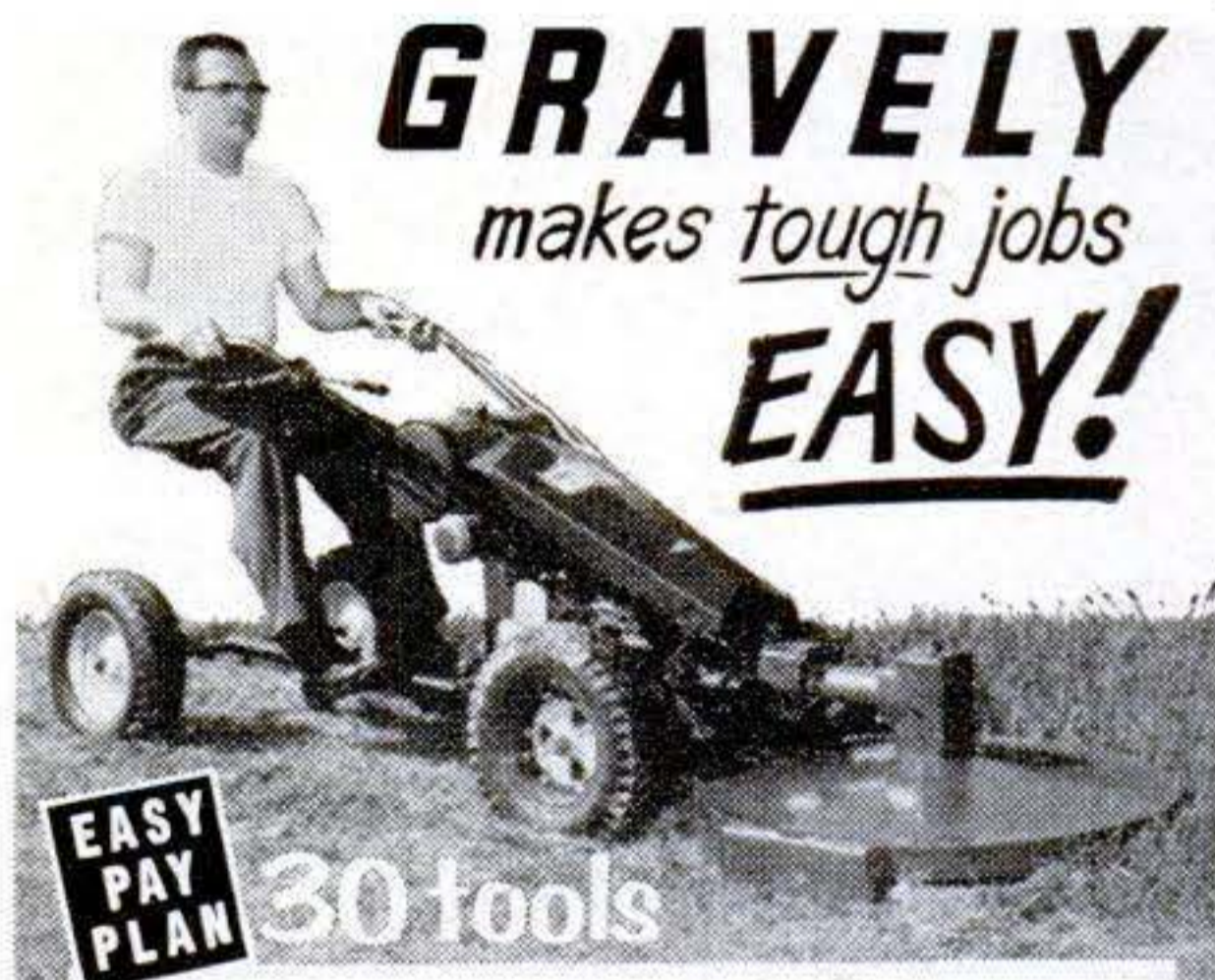

GRAVELY
makes tough jobs
EASY!

EASY PAY PLAN 30 tools

UNMATCHED PERFORMANCE!

Rotary Mower attachment mows-mulches the finest lawns or roughest weeds *faster, easier, better!*

Just one of 30 year-round, job-proved tools. Gravely, with *more* power... *more* performance... *more* tools, does the jobs others can't!

All-Gear Drive, Power Reverse, Optional Electric Starter. Riding or Steering Sulky.

Write for FREE 24-page "Power vs Drudgery" Booklet TODAY!



GRAVELY TRACTORS, INC.
P.O. BOX 602-D DUNBAR, W. VA.

FIELD-TESTED SINCE 1922

NOW! YOU CAN PLAY RIGHT AWAY!

... here's fun for the whole family ... playing this new imported Italian

Philharmonic
ELECTRIC

CHORD ORGAN

IMPORTER TO YOU PRICE

only **\$99⁵⁰** for popular Chordmaster model ...

the first choice for every musical occasion!

BUY DIRECT—SAVE 1/2

Dad, Mother, Children, Everyone ...

PLAY IN MINUTES WITHOUT LESSONS

Amazingly simple Easy-to-Play Method—Given FREE with your organ—has you playing old and new songs in matter of minutes. No lessons; no long hours of practicing; no special talent needed! So easy a child can play at sight. Plenty of music included as bonus gift!



PAY ONLY \$19⁵⁰ DOWN
E-Z Terms on Balance ... just pennies a day

FREE! YOU GET ALL THESE EXTRAS WITH YOUR ORGAN!

- Big Solo Album ... filled with special easy-play arrangements of your favorite melodies
- Contour Designed Plastic Protective Cover
- Sturdy, Expandable Music Portfolio
- Chemically Treated Organ Polishing Cloth
- LIFETIME GUARANTEE ... gives you 100% certified protection

Built by Italy's Finest Craftsmen

Hand craftsmanship brings out tonal perfection found usually in organs selling 4 or 5 times our low importer-to-you price. Reeds are fashioned of prime Swedish steel ... NOT inferior plastic. A fine instrument made to create a lifetime of music!



FULLY PORTABLE!

Your Philharmonic is your happy companion no matter where you go. Its gay, happy music is welcome everywhere. It's light, easy to carry. Weighs less than most portable TV sets!

PHILHARMONIC ORGAN CORP.

2003 West Chicago Ave., Dept. PS-49
Chicago 22, Illinois

5 DAY FREE HOME TRIAL

Why miss out on all the fun! Good music makes good times—gains popularity! Even if you never played a note of music in your life, you'll be playing your new Philharmonic Electric Chord Organ right away! A new, astonishingly easy way to play. Makes music fun—from the start! Discover the satisfying thrill of playing music yourself. Entertain others and bring the family closer. Friends will be startled and delighted when they hear you! The Philharmonic is a full-range fine quality organ, complete in itself. Our low wholesale price is possible only because you buy direct from the importer ... *you actually save a full 50%!* Pay only a small amount down ... balance just pennies a day. TRY THIS EXCITING NEW ORGAN IN YOUR HOME FOR FIVE FULL DAYS FREE TRIAL! Only then can you appreciate fully how much fun the Philharmonic can bring into your home. A giant in volume—yet it's light in weight and fully portable. Superb tone satisfies the most critical musical ear. Choose from complete selection of models. Guaranteed for LIFE. Get Free color catalog and details of Free 5 Day Home Trial. Rush coupon.

RUSH COUPON FOR FREE HOME TRIAL PLAN

Philharmonic Organ Corporation

2003 West Chicago Avenue, Dept. PS-49, Chicago 22, Illinois
Rush color catalog and wholesale prices on Philharmonic Electric Chord Organs ... plus FREE NO RISK HOME TRIAL PLAN!

Name

Address

City Zone State

WOOD

PLIOBOND

CANVAS

SYNTHETIC RUBBER

"BONDS

PLASTIC

GLASS

ANYTHING

LEATHER

COMPOSITION BOARD

TO

ANYTHING!

STAINLESS STEEL

EASY TO APPLY. PLIOBOND requires no mixing, brushes on, dries rapidly.

EXCELLENT ADHESION. PLIOBOND exhibits exceptional strength — up to 1600 lbs./sq. in. in shear tests.

EXTREMELY DURABLE. PLIOBOND resists age, heat, cold, water, chemicals, oils.



Pliobond
BY
GOOD YEAR

Pliobond—T. M. The Goodyear Tire & Rubber Company, Akron, Ohio

Beauty...

backed by
**SCIENTIFIC
MARINE
ENGINEERING**



Every Penn Yan is built to scientific principles of marine design. As a result, Penn Yans are superbly maneuverable,

fast, durable and safe. They are built—as they have been for nearly 40 years—to give greater satisfaction longer.



Free Brochure describes complete new line. Write Penn Yan Boats, Inc., 35th St., Penn Yan, N. Y.

Penn Yan Boats

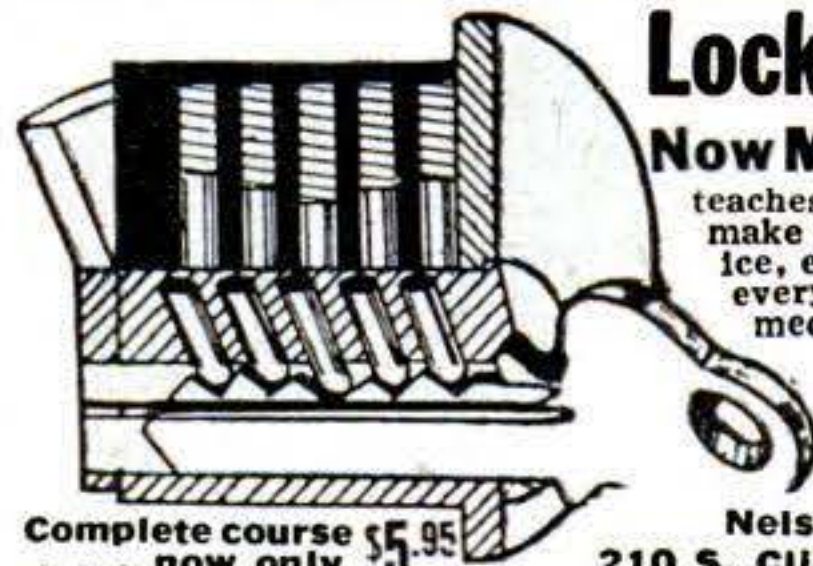

Locksmithing AND KEY MAKING

Now Made Easy! Practical up-to-date course

teaches you how to pick locks, de-code, make master keys, repair, install, service, etc. New self-instruction lessons for every handyman, homeowner, carpenter, mechanic, service station operator, fix-it shop, hardware dealer, gunsmith. 53 easy illustrated lessons. Full price only \$5.95, post-paid; or C.O.D. plus postage. Satisfaction or refund guaranteed.

Complete course \$5.95
... now only \$5.95

Nelson-Hall Co., Dept. DR-1
210 S. Clinton St., Chicago 6, Ill.

INVENTORS

Send for
**PATENT INFORMATION
Book and
INVENTOR'S RECORD**
without obligation
GUSTAVE MILLER
49-PS Warner Building
WASHINGTON 4, D.C.

**REGISTERED PATENT
ATTORNEY**
ASSOCIATE EXAMINER
U. S. PAT. OFF. 1922-1929
Patent Attorney & Advisor
U. S. NAVY DEPT. 1930-1947
PATENT LAWYER

INVENTORS

Whether an invention is patentable can be substantially determined by a search of the U. S. Patent records. Without obligation, write for information explaining the steps you should take to secure a patent.

JOHN N. RANDOLPH

Registered Patent Attorney
805-Victor Building Washington 1, D. C.

INVENTORS

U. S. Patents protect your inventions. Our free book of "Instructions on Patent Procedure for Inventors," also "Certificate of Invention" form sent without obligation.

C. A. SNOW & CO.
REGISTERED PATENT ATTORNEYS
426 SNOW BUILDING WASHINGTON 1, D. C.

INVENTORS

**PROTECT YOUR INVENTION BY A
U. S. PATENT. SEND FOR FREE
"INVENTION RECORD" FORM AND
"PATENT INFORMATION
EVERY INVENTOR SHOULD HAVE".**

CARL MILLER
REGISTERED PATENT ATTORNEY
WOOLWORTH BLDG., 36th FLOOR, 49C
NEW YORK CITY

America's Newest Sports Car



FOR
DOWNHILL
RACING THRILLS



CONVERTS
TO BOBSLED
FOR WINTER
USE



Ruggedly
Constructed

Royal Norseman

CONVERTIBLE
Pushmobile

COMPLETE
BASIC UNIT

\$39⁹⁵



STURDY ENOUGH
FOR FATHER, TOO!

Have fun year 'round with this safe Rocco Pushmobile—it's America's fastest growing sport! Husky steel-tube 6-ft. long frame holds a 240 lb. person. The 4 semi-pneumatic tires are just like Dad's. Can be converted to a Bobsled for winter use.

CONVERTS TO RACER WITH POWERFUL MOTOR!

Enjoy the thrills of real power-racing. Use in backyard or on any available smooth surface.

Learn How To Start Your Own Royal Norseman RACETRACK ... write for literature!

● **Motor Mounting Kit** WITHOUT MOTOR \$19⁹⁵ and \$29⁹⁵

● **Motorized Pushmobile Complete**

With motor-mounting kit and 2-cycle Clinton motor **\$99⁹⁵**

With motor-mounting kit and 4-cycle Briggs-Stratton motor **\$129⁹⁵**



ROCCO PRODUCTS, INC. 2916 4th Ave. So., Minneapolis, Minnesota

(Check the Kind of Body YOU Want!)

RIGHT IN THE COUPON BELOW

...and I'll Show How EASILY You Can Have It!

Charles Atlas

Twice winner and holder of the title "The World's Most Perfectly Developed Man."

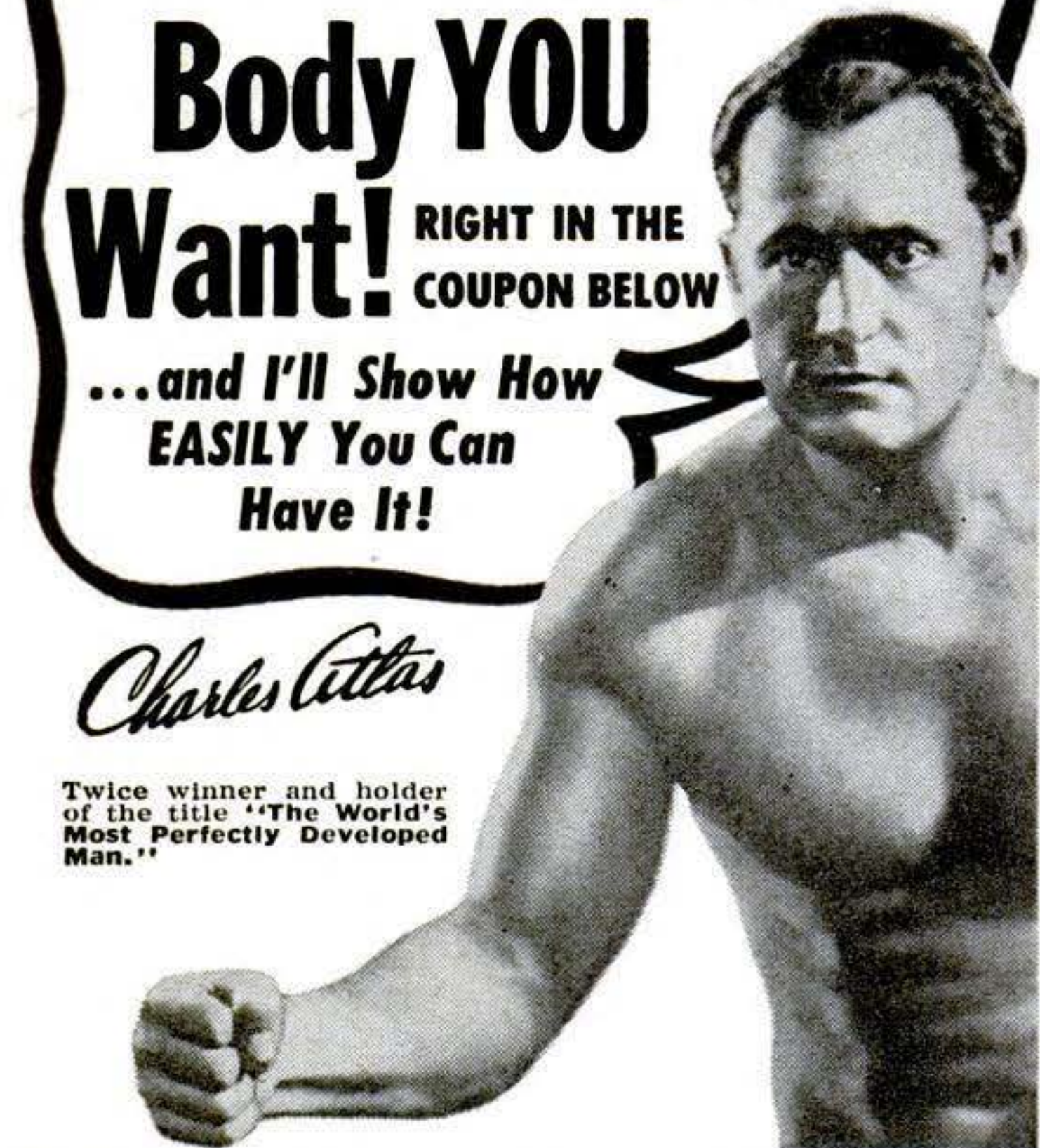

JUST tell me where you want it—and I'll add SOLID Inches of powerful muscle SO FAST your friends will grow bug-eyed with wonder. I'LL SHOW HOW you can be a new man in just 15 minutes a day—in your own home—or it won't cost you a penny!

I myself used to be a 97-lb. weakling. Men called me "Skinny." Girls made fun of me. THEN I discovered my great new muscle-building system—"Dynamic Tension." It turned me into such a specimen of MANHOOD that today I hold the title "THE WORLD'S MOST PERFECTLY DEVELOPED MAN."

"Dynamic Tension" is the easy, NATURAL method you can practice in your own room—JUST 15 MINUTES A DAY—while your chest and shoulder muscles begin to swell . . . those arms and legs of yours bulge . . . and your whole body starts to feel "alive," full of zip and go!

FREE My 32-Page Illustrated Book Just Mail the Coupon

Send NOW for my famous book showing how "Dynamic Tension" can make you a new man. 32 pages, packed with photographs, valuable advice, answers many vital questions. This book is a real prize for any fellow. Yet I'll send you a copy absolutely FREE. Just glancing through it may change your life! Rush coupon to me personally: **CHARLES ATLAS, DEPT. 1D, 115 East 23rd St., New York 10, N. Y.**



**CHARLES ATLAS, Dept. 1D,
115 East 23rd St., New York 10, N. Y.**

Dear Charles Atlas: Here's the Kind of Body I Want:
(Check as many as you like)

- | | |
|--|--|
| <input type="checkbox"/> More Weight—Solid—in The Right Places | <input type="checkbox"/> Powerful Arms and Grip |
| <input type="checkbox"/> Broader Chest and Shoulders | <input type="checkbox"/> Slimmer Waist and Hips |
| | <input type="checkbox"/> Powerful Leg Muscles |
| | <input type="checkbox"/> Better Sleep, More Energy |

Send me absolutely FREE a copy of your famous book showing how "Dynamic Tension" can make me a new man. 32 pages, crammed with photographs, answers to vital health questions, and valuable advice. I understand this book is mine to keep and sending for it does not obligate me in any way.

NAME.....
(please print or write plainly)

ADDRESS.....

CITY.....ZONE.....STATE.....

\$8 750 FIRST YEAR—IN YOUR OWN BUSINESS



Start Part Time—We Furnish Everything

We locally train you to run your own business, furnish all equipment and supplies to clean and moth-proof rugs and upholstery **on location** by world-wide process. No shop needed, you become quickly established. Just 2 average jobs a day bring \$8,750.00 NET profit in year. Employ others and **multiply** your earnings. As member of world's largest organization of its kind you are backed by National Advertising, receive 25 regular services to help build your business. You'll be only one in town whose process bears famous Parents' seal. Business grows rapidly due to recommendations and repeat jobs. **EASY TERMS.** Send TODAY for fascinating FREE BOOKLET with complete details.

DURACLEAN CO.

9-184 Duraclean Building • Deerfield, Illinois

STUDY TO BE A DOCTOR of Psychology or Metaphysics

Obtain a Ps.D., Ms.D., or Ph.D. Be a Teacher, Lecturer or Accredited Practitioner. Teach others how to achieve Health, Happiness and Contentment. Chartered by State. Correspondence courses only. Write for FREE book telling how.

THE NEOTARIAN FELLOWSHIP

Desk 5, Pickwick Building

Kansas City 6, Missouri

REAL ESTATE BE A BROKER

PAYS BIG! SEND FOR FREE, BIG, ILLUSTRATED CATALOG NOW! Graduates report making substantial incomes. Start and run your own business quickly. Men, women of all ages, learn easily. Course covers Sales, Property Management, Appraising, Loans, Mortgages, and related subjects. **STUDY AT HOME** or in classrooms in leading cities. Diploma awarded. Write TODAY for free book! No obligation.



Approved for World War II and Korean Veterans
WEAVER SCHOOL OF REAL ESTATE (Est. 1936)
20205 Grand Ave. Kansas City, Mo.



\$3.25 OR 2 FOR \$6.00

With 40 ft. of wire.

TESTED AND GUARANTEED

Write for free list of all types of telephones. Shipments F.O.B. Simpson, Pa.

TELEPHONE ENGINEERING CO.

Dept. 4A9

Simpson, Pa.

I MADE \$1,000

... On Imports! In one day that was profit on small mail orders shipped from abroad. I show you how to start this big profit business from your home in spare time. (No merchandise investment needed). Write today for Free details and list of 157 imports to: **B. L. MELLINGER, Dept. X244, 1717 Westwood Blvd., Los Angeles 24, Calif.**



WORLD'S LOWEST PRICED CALCULATOR! NEW! NEW! NEW!

TOM THUMB ADDING MACHINE

With beautiful Leatherette carrying case. **MADE IN AMERICA BY AMERICANS** Beware of cheap imported imitations. Adds Up To One Billion—1,000,000,000 Subtracts—Multiplies—Divides Mistake Proof—Positively 100% Accurate—Lightning Fast—Shock Proof Solid Steel Mechanism **GUARANTEED FOR YOUR LIFETIME**

Ideal for Housewives, Shoppers, Students, Engineers and Tax work. Take it to the Super Market—Save \$\$\$ every week. We pay postage if you send check, cash or money order—or just send your name & address and pay postman \$1.97 plus postage. Immediate Delivery—10 Day Free Trial—Satisfaction Guaranteed money refunded by return mail. **Special Gift Offer: 2 Machines for only \$3.49** Agents Wanted—Make easy money selling a Top Quality Calculator at our unbelievably low price. **TOM THUMB ADDING MACHINE** R.O. Box 5066, Dept. A-29, Philadelphia 11, Penna.

Not \$3.95 But Only **\$1.97** \$2.03 in Penna. including 3% Tax.



CHROME VANADIUM 29 Pc. DRILL SET

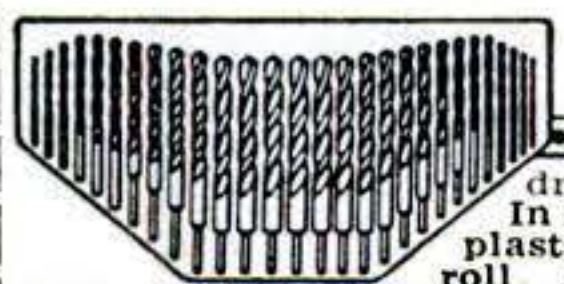

Specially made for speed drilling. In sturdy plastic tool roll. Finest alloy steel drills hardened and precision ground to the sharpest, longest lasting cutting edge obtainable; will easily and cleanly bite through hardwoods, plastics, aluminum, iron and the toughest steels. Unconditionally guaranteed for thousands of drillings. Full jobber lengths. Sizes by 64ths from 1/16" to 1/2".

NOW... **\$6.49** ppd.
Also available with Turned Down Shanks to fit all 1/4" drills. In individual pocket roll... **\$8.95** ppd.

60 Pc. Set Wire Gauge CHROME VANADIUM DRILLS



Top quality German import high test Chrome Vanadium Drills designed for speed drilling through toughest steels, woods, plastics, iron and aluminum. Precision ground, long-lasting cutting edges. Guaranteed to give years of satisfaction. A full 60 pc. set. Nos. 1 through 60. A \$14.95 value—

NOW ONLY... **\$5.40**
PLUS 35c PP. & HDLG.

Same set above available with Huot Metal Index container. PLUS 35c PP. & HDLG. **\$6.65**

Also Available
20 Pc. Set — Nos. 61-80
WIRE GAUGE DRILLS

In plastic kit with marked pocket for **\$2.50** ppd.

EYELET PLIER with 300 EYELETS



Now, for the first time, a big, unwieldy shop machine has been reduced to a precision-made hand-tool! New EYELET PLIER does a neat-looking professional job every time... saves you big money on new articles and repairs. Works on fabric, leather, plastic, cardboard, paper, oilcloth. Great for: Belts—Shoes & Sneakers—Binders—Deck Chairs—Sun Shades—Shower Curtains—Luggage Straps—Sports Equipment—Tents & Tarpaulins—Air Conditioner covers—Sails—Duffel Bags—Camping Equipment—Wall Maps, Charts & Place Cards—Campaign & Promotion Material—Banners & Bunting—etc. Eyelets prevent tearing of material, for re-use over and over again. Wonderful tool for smaller shop, hobby, office, handcraft, professional therapy. Complete with 300 eyelets in assorted colors. **\$1.98**

300 extra eyelets 75c plus 25c for postage & handling

Send Check or M.O. C.O.D. fee extra **MONEY BACK GUARANTEE**

SCOTT-MITCHELL HOUSE, INC. Dept. E-4, 415 S. Broadway
Yonkers, New York

300 POWER.....



Complete Telescope Lens Kit only **\$3.98** postpaid

Conquer Space, Explore the Universe, Planets, Moon craters, New Stars, etc. Complete Lens Kit consists of 80 inch focal length ground and polished objective lens, eyepiece lenses for 50 POWER, 100 POWER, 150 POWER, 200 POWER, 250 POWER, 300 POWER, and all necessary lens fittings. Easy to make from simple step by step instructions. (Tripod and mount not included.) Money back guarantee.

BUSSE SALES CO., Hartford, Conn., Dept. PS-75

"MINIATURE MACHINE SHOP

No Bigger Than A Typewriter, Outperforms Machines Many Times its Size!"

That's what Mechanix Illustrated says about UNIMAT in their 3 page feature story in the May issue. If you want a reprint of this story plus complete information about this amazing 10 in 1 combination precision tool write to:



AMERICAN EDELSTAAL, INC., UNIMAT DIV., Dept. 139, 350 B'way, N.Y. 13

GROW MINIATURE TREES FREE! SEEDS & PLAN



New Fascinating HOBBY or HOME-BUSINESS OPPORTUNITY! Learn little-known techniques for growing living "Ming" Trees only inches high. Beautiful Elm, Cherry, Orange, Cypress, Peach, etc., that BLOSSOM AND BEAR TINY TASTY FRUIT. Help fill demand for these sensational dwarfed Trees. FREE SEEDS (8 kinds) and Plan. State your age. Write:

MINIATURE TREE NURSERIES, Dept. U-4, (Home-Growers Division) Gardena, Calif.

STOPS OIL BURNING!

MOTOR MEDIC

for MAXIMUM ENGINE POWER

Provides lasting oil film strength. Reduces friction, increases compression. For autos, trucks, tractors...

AT SERVICE STATIONS, GARAGES, AUTO ACCESSORY STORES

RADIATOR SPECIALTY CO. CHARLOTTE, N. C.



\$1.95

APRIL 1959 35

MAKE MORE MONEY

these two **FREE** books will tell you how
SEND COUPON TODAY



TELEVISION & RADIO

19 KITS
OF EQUIPMENT,
YOURS TO KEEP

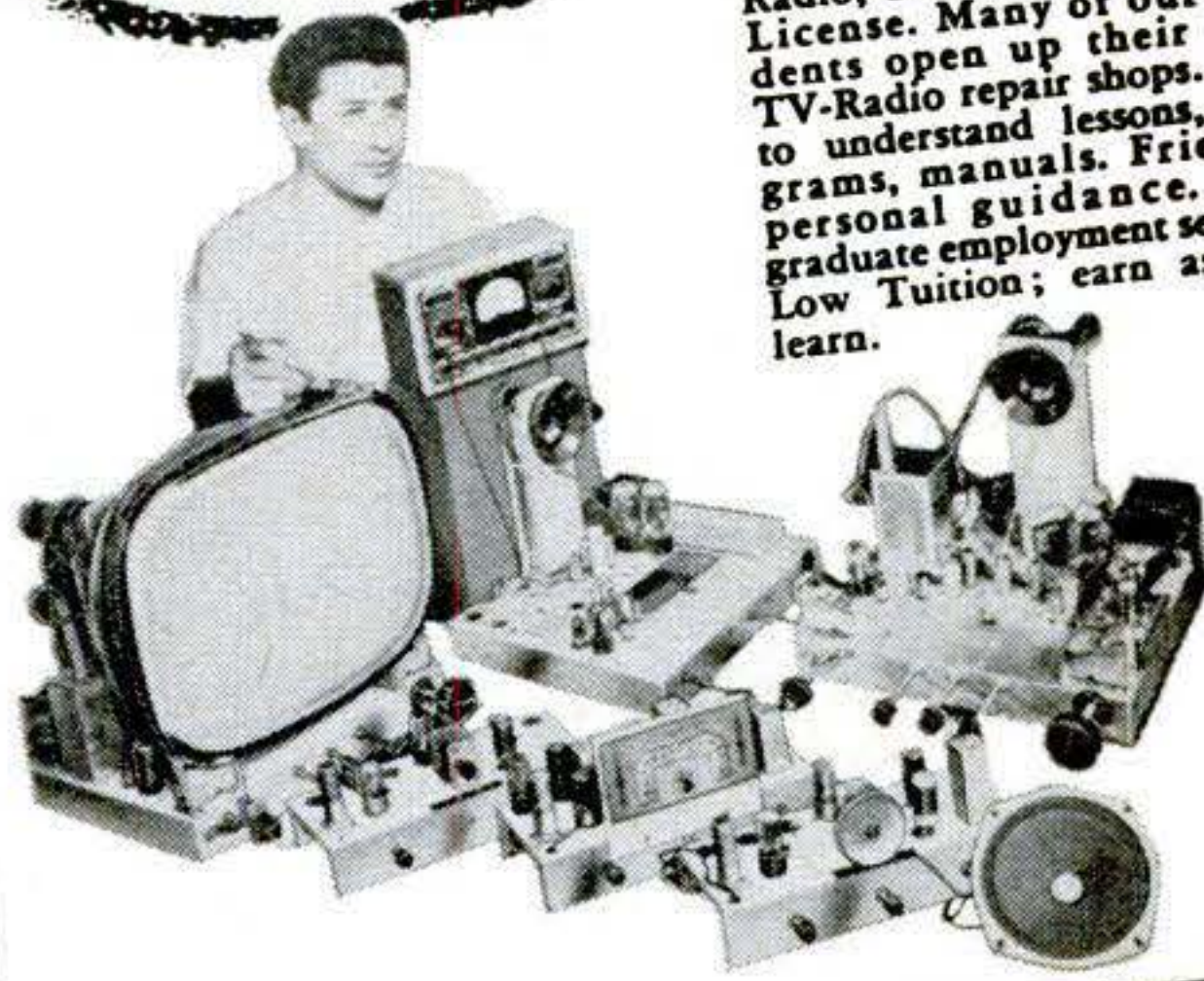

NATIONAL SCHOOLS of Los Angeles, a leader since 1905, brings its famous training shop methods right into your home, in your spare time — gives you everything you need to make more money in a top-pay job. Course covers all phases of the industry including Color TV, Automation, AM-FM Radio, Hi-Fidelity, F.C.C. License. Many of our students open up their own TV-Radio repair shops. Easy to understand lessons, diagrams, manuals. Friendly personal guidance. Free graduate employment service. Low Tuition; earn as you learn.

AUTO MECHANICS & DIESEL

You are needed in auto garages, airplane factories, farm shops, experimental and government labs, wherever cars, engines, and trucks are repaired and serviced. National Schools Shop Method Training prepares you, in your own home, in your spare time for these fascinating opportunities. You get everything you need, including lessons, diagrams, manuals, consultation privileges, graduate employment service. Low tuition; pay as you learn.



YOU GET AND KEEP ALL THIS EQUIPMENT



Complete set of professional tools and tool box.



"Motor Analyzing Set" plus case and instructions.



Professional Socket Wrench Set for all Engines.



NATIONAL SCHOOLS
Los Angeles 37, California

MEMBER



NATIONAL SCHOOLS
TECHNICAL TRADE TRAINING SINCE 1905
LOS ANGELES 37, CALIFORNIA

NATIONAL SCHOOLS, DEPT. C-49
4000 S. Figueroa St., Los Angeles 37, Calif.

Please rush **FREE** Book and Sample Lesson checked below. No obligation, no salesman will call.

- "My Future in TV-Radio-Electronics"
- "My Future in Auto-Mechanics and Diesel"

Name _____ Age _____

Address _____

City _____ Zone _____ State _____

Check here if interested **ONLY** in Resident Training at Los Angeles.

VETERANS: Give date of discharge _____

SEND
COUPON
TODAY!

No
salesman
will call!



COMPARE America's Greatest HIGH-POTENCY VITAMIN- MINERAL FORMULA and SAVE MONEY NOW

NO VITAMIN PRODUCT ANYWHERE . . . AND
WE MEAN ANYWHERE . . . Even
Comes Close to this Tremendous Value!

Try FRESHLY-PACKED Guaranteed-Potency OPTIMS today,
at a cost of only \$2.75—not for the usual 30-day supply—
but for a complete 100-DAY SUPPLY—One a day gives you
the massive potencies shown below!

OPTIMS SUPPLIES 42 NUTRITIVE FACTORS in a single Capsule!

Each OPTIMS Capsule Contains:

21 VITAMINS		12 MINERALS	
Vitamin A	15,000 Units	Iron	30 Mg.
Vitamin D	1,500 Units	Iodine	0.1 Mg.
Vitamin E	5 Int'l Units	Calcium	75 Mg.
Vitamin B-1	10 Mg.	Phosphorus	58 Mg.
Vitamin B-2	5 Mg.	Magnesium	5 Mg.
Niacinamide	40 Mg.	Copper	1 Mg.
Vitamin C	100 Mg.	Potassium	1 Mg.
Vitamin B-6	0.5 Mg.	Manganese	1 Mg.
Folic Acid	0.25 Mg.	Zinc	0.5 Mg.
Vitamin K	0.1 Mg.	Molybdenum	0.1 Mg.
Vitamin B-12	5 Mcg.	Cobalt	0.04 Mg.
Choline	35 Mg.	Nickel	0.04 Mg.
Inositol	20 Mg.		
Rutin	10 Mg.		
Paba	10 Mg.		
Lemon Bioflavonoid Complex	10 Mg.	5 AMINO ACIDS	
Cal. Panto.	5 Mg.	dl-Methionine	20 Mg.
Biotin	5 Mcg.	Glutamic Acid	20 Mg.
Hesperidin	200 Mcg.	l-Lysine	10 Mg.
Linoleic Acid	5 Mg.	Nucleic Acid	10 Mg.
Intrinsic Factor Conc.		Betaine	5 Mg.
	1/50 U.S.P. Unit		

In A Natural Base Containing:

Brewer's Yeast	10 Mg.	Soy Bean Lecithin	10 Mg.
Liver Desiccated	10 Mg.	Rose Hips Extract	10 Mg.

COMPARE OPTIMS with any food supplement you have ever used and SEE HOW MUCH MONEY YOU SAVE!

Buy the larger sizes for greater savings!

100 CAPSULES, \$2.75 500 CAPS, \$11.75
250 CAPSULES, 6.25 1000 CAPS, 22.00

BUY IN CONFIDENCE! All orders supervised by Qualified Pharmacists. OPTIMS ARE SOLD ONLY AT THE ADDRESSES BELOW. Order C.O.D., or save all charges by sending check or money order. We pay all postage. Money back if not satisfied.

VITAMIN-QUOTA

Prescription Specialists and one of the world's largest distributors of vitamins. Estab. 1923. Serving over 2,250,000 families, coast-to-coast.

Dept. T-612, 880 Broadway, New York 3, New York or
Dept. T-612, 1125 Crenshaw Blvd., Los Angeles 19, Calif.

Sales in California add 4% to total of order

WHY DEPEND ON SOCIAL SECURITY!



ADD TO YOUR INCOME • UP TO \$5.00/HR. SHARPENING ALL TYPES OF LAWN MOWERS

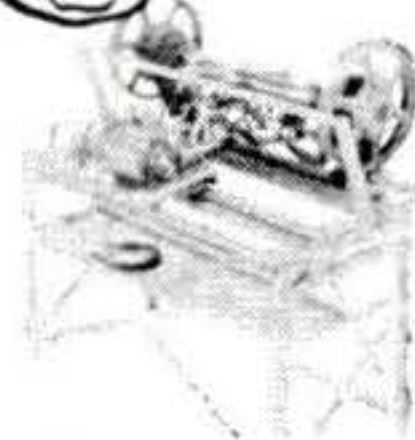

Modern Manufacturing's precision Lawn Mower Sharpener and Bed Knife Grinder makes it easy for you to earn extra cash on a full or part time basis. Many mowers need sharpening. Do it in your basement or garage. Anyone can learn to operate this sharpener. Write today for free brochure. Dept. 11

MODERN MFG. CO.

\$27500
F.O.B. Pasadena

160 N. Fair Oaks Ave.
Pasadena, Calif.

Secrets of VENTRILOQUISM Now Revealed!



Easy to learn in 60 to 90 days with our Home Study Course. RESULTS GUARANTEED. Make Money! Be Popular! Have Fun! Big Opportunity! Radio, Television, Stage Appearances! For Free Information regarding price and terms, WRITE. You must state your age. Dummy Catalog 25c. MAHER HOME COURSE OF VENTRILOQUISM Box 36, Studio PS-4, Kensington Station Detroit 24, Michigan

"\$7,10850 First Year SERVICING RADIATORS!"



NEW!
— Hank Konter, Newcastle, Wyo.
Make good money servicing auto-truck-tractor radiators with new Inland 1-Piece Radiator Shop. Easy to test, clean and repair radiators. Inland, world's largest radiator equipment mfr., trains you free. Small down payment starts you. Proved merchandising assures volume. Profitable dept. for garage or service station. Write

INLAND MFG. CO., Dept. PSM 4, 1108 Jackson St., Omaha 2, Nebr.

UNITED STATES STAMPS

Good Copies, Satisfaction Guaranteed.

2c Black Jack #73, used copy	.75
1c-10c Columbians, #230-7, used copies	\$2.15
1c & 2c Columbian, #230-1, Mint copies	.56
1c-10c Louisiana, #323-7, used set	\$4.83
1c-5c Jamestown, #328-30, used set	\$1.49
1c-5c Pilgrims, #548-50, used set	\$1.49
1c-5c Walloons, #614-6, used set	\$1.49
\$5.00 Hamilton, #1047, used copy	.59

Approvals included if desired.

SHELTON CO. P.O. BOX 907-P New York 8, N.Y.

Find HIDDEN TREASURES

GOLD, SILVER, PRECIOUS METALS with the Famous Model 27 Metal Detector. Lightweight, ultra-sensitive, low cost. None finer. Also GEIGER COUNTERS for uranium and the VIOLITE for tungsten. INFORMATION FREE

THE *Detectron* CORP. Dept. 40
5528 Vineland Ave., No. Hollywood, Calif.



PEE WEE BATTERYLESS "LIFETIME" RADIO



GUARANTEED—FOR YOUR LIFE!

AS LONG AS YOU OWN IT! NO TUBES, BATTERIES, TRANSISTORS OR ELECTRICAL PLUGS NEEDED! Will never run down or burn out! SMALLER THAN A PACK OF CIGARETTES! RECEIVES LOCAL RADIO STATIONS MOST ANYTIME—ANYWHERE YOU GO! Easy thumb tuner. NO DANGLING EARPHONES. HAS BUILT-IN SPEAKER PHONE! Black gold plastic cabinet, semi-conductor wave detector. NOT IMPORTED. MADE AND GUARANTEED BY AMERICANS—You can always get service.

Send Only \$2.00 (bill, ck, mo) and pay postman \$4.99 COD postage on arrival or send \$6.99 for postpaid delivery. SENT COMPLETE READY TO LISTEN—NOTHING EXTRA TO BUY EVER! FREE LONG DISTANCE ANTENNA if you order now. Available only from: MIDWAY COMPANY Dept. WPS-4 KEARNEY, NEBRASKA



HIGH WAGES!

High Wages can be yours as an Operating Engineer of heavy construction equipment! Learn NOW to operate our diesel engined bulldozers, draglines, cranes, back hoes, scrapers and motorgraders! Machines of major manufacturers are used in our training program. Contractors are on our advisory staff. Contractors need trained operators and pay high wages to our graduates.

We invite comparison and inspection of the nation's original construction equipment operator's training schools.

NEW! Announcing resident and non-resident courses in Heavy Construction Management. Write for details.

Budget plan available. VETERANS: Ask about G.I. Benefits

Write TODAY for FREE School Catalog,
no obligation, to either address

THE NATIONAL SCHOOLS of HEAVY EQUIPMENT OPERATION

Dept. A-18, P.O. Box 8415, Charlotte, N.C.

Dept. A-18, P.O. Box 510, Weiser, Idaho

DOES GETTING UP NIGHTS MAKE YOU FEEL OLD?

NEW YORK—Special: Thanks to new, scientific laboratory formulation, thousands of men and women now escape feeling old, tired, irritable and depressed from losing sleep and worrying about "Bladder Weakness"—too frequent, burning and itching urination, Bed Wetting, Getting Up Nights—or Strong Cloudy Urine, due to common Kidney or Bladder Irritations, which often result in secondary Backache, Headache and Nervousness. In such cases *New Improved* CYSTEX usually gives quick, calming relief by combating irritating germs in acid urine; and by relaxing, analgesic pain relief. Safe for young or old. Get CYSTEX at druggist. Feel better fast or money back.

ENGINEERING

DEGREE IN 27 MONTHS

Students given option of studying engineering under accelerated program leading to *Bachelor of Science Degree in 27 months*; or the standard four-year program leading to *Bachelor of Engineering Degree in 36 months*. The B. S. degree in Mathematics, Chemistry, or Physics (including Nuclear Physics) may be earned in 36 months. By attending classes year-round, students can graduate in 3 years and have one year of experience and income in the time usually needed to complete a four-year college course. Preparatory courses. Thorough, practical program. Individualized instruction.

Keeping pace with progress in science and engineering

Campus. Dorms, gym, playing fields. Superior faculty. 2,000 students. New Dana Science Building. Low tuition. Earn board. G.I. approved. Enter June, Sept., Dec., March. Students from 48 states, 40 foreign countries. Send coupon for free catalog, full information. Enroll now!

INDIANA TECHNICAL COLLEGE

649 E. Washington Boulevard, Fort Wayne 2, Indiana

Please send me free information on 27 mo. B.S. DEGREES in:

Aeronautical Chemical Civil Electrical
 Mechanical Electronics

on 36 mo. B.E. DEGREES in:

Aeronautical Chemical Civil Mechanical
 Electrical (Power or Electronics) Metallurgical

on 36 mo. B.S. DEGREES in:

Mathematics Chemistry Physics

Name.....

Address.....

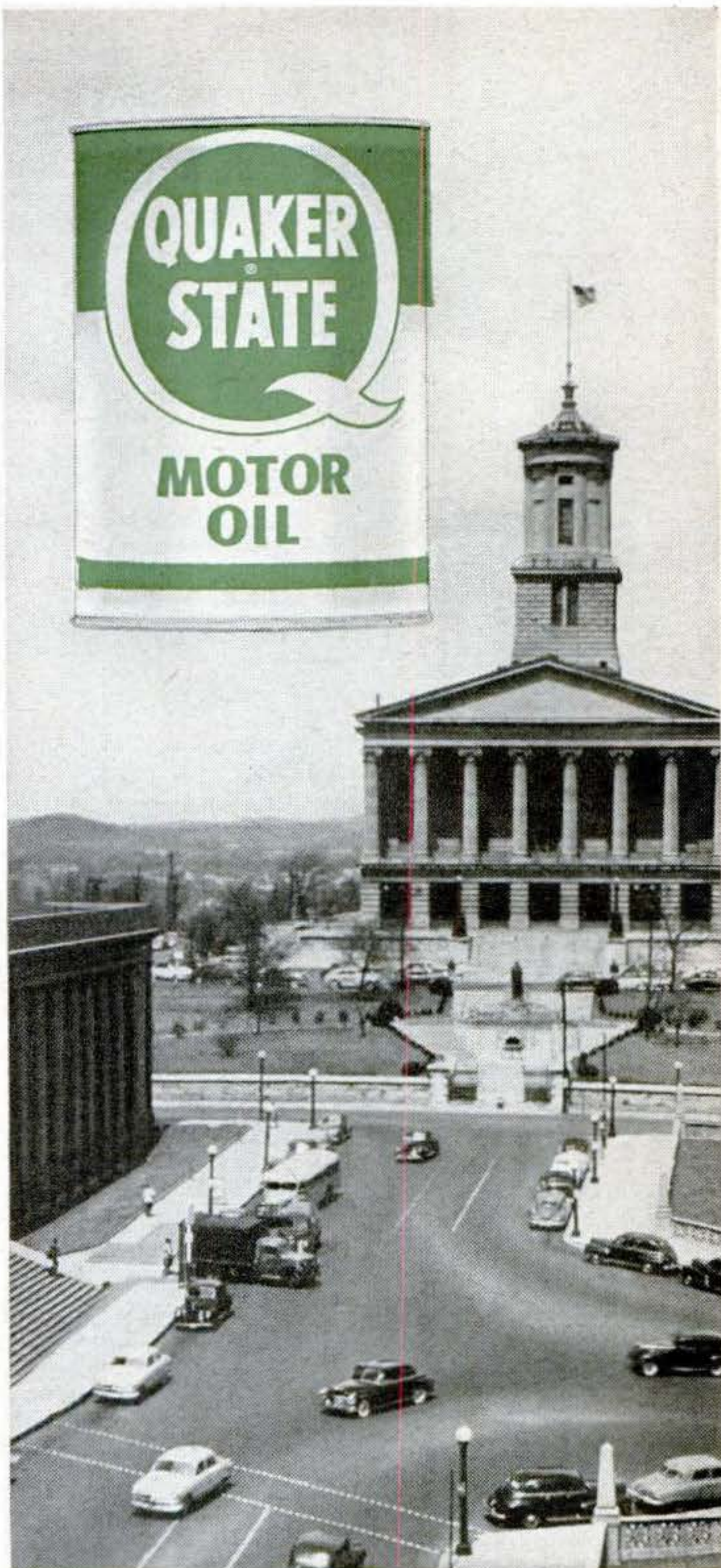

VICTORY PARK AND CAPITOL BUILDING, NASHVILLE, TENN.

On tour or around town, drive with Quaker State, the oil that cuts engine wear, prevents engine breakdown. Fortified with anti-wear detergent additives, this pure Pennsylvania oil stops rusting and corrosion, eliminates sludge, carbon deposits and damaging acid action. Result: moving parts work smoothly and friction-free under all driving conditions! Next oil change, insist on Quaker State.

QUAKER STATE OIL REFINING CORPORATION, OIL CITY, PA.

Member Penn. Grade Crude Oil Assn.

1859— 100th Anniversary of Drake Oil Well —1959
and Founding of the Petroleum Industry

BOLENS



big tractor design is yours in the new 7 hp Ride-a-matic, with push-button starting, Versa-matic drive, automotive steering and differential. Over 20 time-saving attachments.



... and this is the Power-Ho, most versatile garden tractor of its kind. Three models, 3 to 6.6 hp, rugged, easy to handle wide choice of attachments.

BOLENS

Use this coupon to get free full-color literature and the name of your nearest Bolens dealer.

Check the catalogs that interest you, and mail to Bolens with your name and address.

- LAWN MOWERS UTILITY TRACTORS
 TILLERS CHAIN SAWS
 POWER-PAK (Tiller-Mower-Snow Plow Convertible)

BOLENS PRODUCTS DIVISION
 Food Machinery & Chemical Corporation
 Port Washington D3, Wisconsin

New Popular Science book shows you How to Make Your Own Built-Ins and Space Savers

Here, at last, is the book that shows you how to expand your home by transforming unused space into compact, attractive living areas. Bill Baker, nationally known designer and furniture maker, brings you his original designs for 15 complete, space-saving projects. Step-by-step photos, hundreds of easy-to-follow instructions, exploded views and diagrams make every project easy to build.

Shows you how to cut costs with inexpensive plywoods, how to finish them with modern wood trims, laminates, plastics. You'll learn cabinet makers' secrets, acquire know-how about a wealth of techniques for indirect lighting, panelling, and much, much more!

- Low-cost, Luxury Kitchen
- Hideaway Bar
- Home Theater Unit—TV, Hi-Fi, Radio
- Woman's Dream Sewing Center
- One-wall Complete Workshop
- Ten Others
- 160 Pages
- 560 Step-by-Step Photos!

Order your copies of **How to Make Your Own Built-ins and Space Savers** NOW on the coupon below. Satisfaction guaranteed. only...

\$1.00



Popular Science Publishing Co.
 355 Lexington Ave., New York 17, N.Y.

Rush me _____ copies of **How to Make Your Own Built-ins and Space Savers**, at \$1.00 each. I enclose \$_____. Books may be returned for prompt refund, if I'm not completely satisfied.

Name _____

Address _____

City _____ *Zone _____ State _____

*Avoid Post Office delay. Include zone number, if any. PS-459



FOR TALL MEN ONLY!
SHIRTS
 WITH YOUR EXACT
 LONG SLEEVE LENGTH

BIG FREE CATALOG!
 Shoes, size 10AAA to 16EEE! Fine quality in smartest new dress styles. Also sport and work shoes, boots, sox, slippers. All FOR BIG MEN ONLY! A postcard brings you big color Catalog, FREE! Write today!

PERFECT FIT IN your big size! Sleeve lengths to 38, neck sizes to 18½! Ivy League stripes, plaids, solid-tones, whites in Sport and Dress styles. New wash-and-wear fabrics! Bodies cut 4" longer than ordinary shirts! Not sold in stores — by mail only! We are America's best-known specialists for BIG MEN ONLY! Finest quality at amazingly low prices! Satisfaction Guaranteed! Write for FREE Catalog!

191 Brockton

KING-SIZE
 INC

Massachusetts



ADD UP TO 25 POUNDS
 of SOLID MUSCLES or you pay NOTHING

FREE CATALOG!
\$10 Body Mold course included FREE with Dan Lurie Barbells. Only Dan Lurie Barbells and "Body Mold" courses produce such amazing results. 15 minutes a day can make you a bigger man. Send today for details. Order now at lowest factory price.
 50 lb. set \$ 8.98 150 lb. set \$21.98
 100 lb. set \$14.98 200 lb. set \$27.98
 Semisteel sets approx. 10% higher. Extra wts. 14c per lb. Send 50% cash, balance C.O.D. F.O.B. Plant. Dan Lurie Barbell Co., 52 S4 Bristol St. Dept. 970-D Brooklyn 12, N.Y.

MAIL ORDER BUSINESS

How to Start a Profitable Business of Your Own at Home or in a Small office. Amazing new instruction course shows you how to run a good mail order business, spare time or full time. Up-to-date, practical training—a treasure-house of the best plans and practices being used TODAY by successful operators. Only \$5.95. Complete—Satisfaction Guaranteed! This is BIG. You get 34 money-making lessons in 5 separate volumes, all in one shipment. You must be satisfied or your money back immediately. Full price only \$5.95, postpaid—or C O D plus postage. Nothing more to pay! Order "Mail Order Course" today.



Nelson-Hall Co., 210 S. Clinton St., Dept. 9DR-1, Chicago 6, Ill.



LEARN MEAT CUTTING

Train quickly in 8 short weeks at Toledo for a bright future with security in the vital meat business. Big pay, full-time jobs—HAVE A PROFITABLE MARKET OF YOUR OWN! Pay after graduation. Diploma given. Job help. Thousands of successful graduates. Our 36th year! Send NOW for FREE catalog. No obligation. G. I. Approved. NATIONAL SCHOOL OF MEAT CUTTING, Dept. 51-R, Toledo 4, Ohio

FLY YOUR OWN Bensen HELICOPTER

Simple to fly — build it yourself, with engine or as inexpensive glider type which can be mounted on floats or boat. Order 3-view drawing, specs and photo of Glider for \$1 or motor powered Gyro-Copter \$2. Building plans and kits also available—



Send \$1 or \$2
 Name
 Address

Name
 Address

These men are getting practical training in ...

Electronics

ELECTRICITY

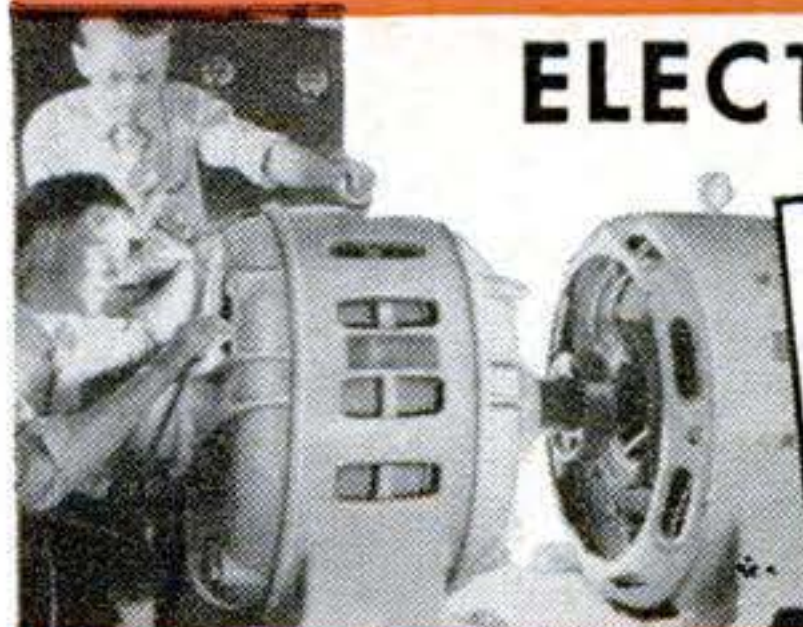

ELECTRONICS

ON REAL

Motors • Generators
 Switchboards • Controls
 Modern Appliances
 Automatic Electronic
 Control Units

TELEVISION

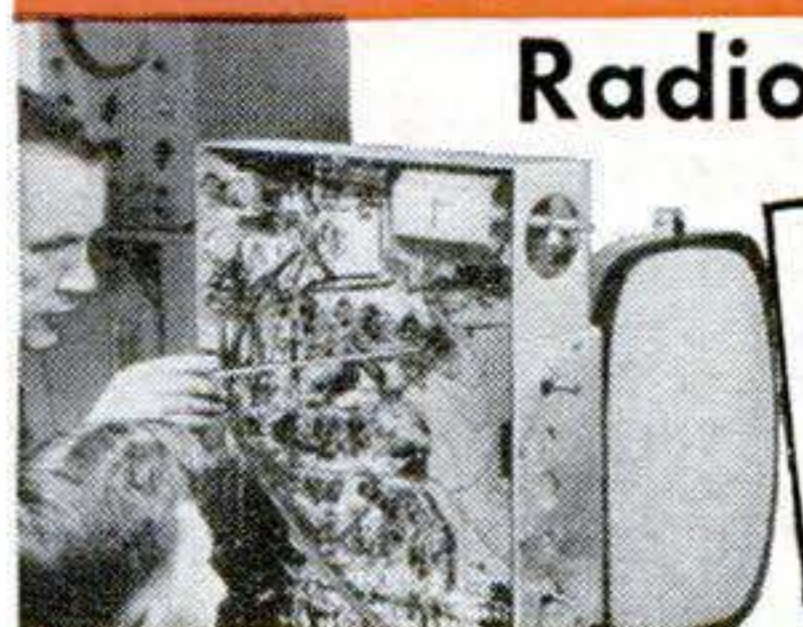

Radio Electronics

ON REAL

TV Receivers
 Black & White and Color
 AM-FM and Auto Radios
 Transistors • Printed
 Circuits • Test Equipment

Train in NEW Shop-Labs of

COYNE

In Chicago—Electronic Center of the World. Prepare for a better job and a successful future in TOP OPPORTUNITY FIELD. Train on real full size equipment at COYNE where thousands of successful men have trained for 60 years—largest, oldest, best equipped school of its kind. Professional and experienced instructors show you how, then do practical jobs yourself on more than a quarter of a million dollars worth of equipment. No previous experience or advanced education needed. Employment Service to Graduates. Start Now—Pay Later—Liberal Finance and Payment Plans. Pay most of tuition after graduation. Part-time employment help for students. Choose from nine yearly Starting Dates.

Mail Coupon or Write to Address Below for Free Book — "Guide to Careers." Whether you prefer ELECTRICITY-ELECTRONICS, TELEVISION-RADIO ELECTRONICS or COMBINED ELECTRONICS TRAINING, this book describes all training offered.

Information comes by mail. No obligation and NO SALESMAN WILL CALL.

B. W. Cooke, Jr., Pres.

Founded 1899

COYNE ELECTRICAL SCHOOL

Chartered as an Educational Institution Not for Profit
 1501 W. Congress Pkwy., Chicago 7, Ill., Dept. 49-4A

MAIL COUPON OR WRITE TO ADDRESS BELOW

COYNE ELECTRICAL SCHOOL
 New Coyne Building, Dept. 49-4A
 1501 W. Congress Pkwy., Chicago 7, Ill.
 Send BIG FREE book and details of all the training you offer.



Name _____
 Address _____
 State _____ City _____
 (I understand no Salesman will call)

You Never Sold Anything That Sells So Fast As

PERMAPLAST

Mica-Miracle

100% PROFIT on the spot
with Dramatic
10-Second "MAGIC SHOW"



Amazing New Chemical Discovery
ENDS WAXING FOREVER!

One swish of an applicator—you've made the sale—and a handsome profit! Dull floors sparkle like new. No more weary wax applications, buffing, polishing. No more stained, discolored floors.

MILLIONS OF PROSPECTS!

Everyone ready to buy after sensational 10-second demonstration! Housewives, stores, offices, industrial firms, institutions—millions waiting to grab Mica-Miracle! Only \$2.49 for 22 oz. Every first-time buyer a steady repeat customer... one to a dozen cans every call back! Steady stream of referrals from customers' friends and neighbors!

NEW SECRET FORMULA

Discovered by top-level research chemist... developed to meet need for high-gloss, virtually indestructible coating for industrial floors. Subjected to every rugged "torture test" in the book, MICA-MIRACLE came thru with flying colors in every laboratory trial. Withstood all types of wear and tear, retained original brightness and newness for over a year. Refused to crack or chip or peel, even under extreme conditions. And now—for the first time—this mica-hard plastic coating—applied instantly with the swish of an applicator—is available to the public!

MICA-MIRACLE IS GUARANTEED

NON-SLIP, NON-SKID	PRESERVES PAINTED SURFACES
ONE APPLICATION FOR ANY SURFACE	TOUGH AND DURABLE
ENDS WAXING AND POLISHING DRUDGERY	EASY BEAUTY, PROTECTION
DRIES TO HARD GLOSS	HIGHLY RESISTANT TO FOOT TRAFFIC, CLEANING MATERIALS, JUICES, SALTS, ETC.
WON'T DISCOLOR WITH AGE	

Here's Why MICA-MIRACLE SELLS LIKE MAGIC... With 10-second demonstration. Whatever you're selling—Whoever your prospects—here's the sure-fire money-maker you've been looking for! Make 1959 your Year To Shine! Watch your profits grow with New, Quick-Sales Mica-Miracle... with every swish of the applicator!

RUSH COUPON TODAY • ENJOY 100% PROFIT WHILE SPECIAL OFFER LASTS!

INTRODUCTORY NO-RISK OFFER!

Demonstrator Offer. Enclosed find \$2.49. Rush me my sample demonstration pint can of Mica-Miracle, and Sales Kit.

- AGENTS
- DEALERS
- DISTRIBUTORS

Inquiries Invited

PERMAPLAST CORPORATION
601 W. 26th St., N. Y. 1, N. Y. PS-22

Name _____
Street _____
City _____ Zone _____
State _____

MEN PAST 40

Afflicted With Bladder Trouble, Pains in Back, Hips, Legs, Nervousness, Tiredness.

If you have these troubles, particularly bladder trouble, then your condition may be traced to Glandular Inflammation... a constitutional disease. Neglect of this condition often leads to premature old age and sometimes incurable malignancy.

The Excelsior Medical Clinic has a New Free Book that tells how thousands of men have been successfully treated here at Excelsior Springs for Glandular Inflammation by **NON-SURGICAL Methods**. They found soothing relief and a new outlook in the future of life.

This Free Book may prove of utmost importance in your life. Write Today. There is no obligation.

Excelsior Medical Clinic Dept. B6229 Excelsior Spgs., Mo.

MEN WANTED

Earn \$100 Per Week and up
AUTO DIESEL MECHANICS

Master a trade with a future—learn Auto-Diesel mechanics in our shops. You learn with tools on real equipment. Earn while you learn. Many of our graduates earn \$100 per week and up. No previous experience necessary. Day and night courses. Approved for veterans. Write for free bulletin.

NASHVILLE AUTO-DIESEL COLLEGE

226 7th Ave., N., Dept. 41

Nashville 3, Tenn.

make your own Gems 36⁵⁰ FOB

The Gem Maker comes complete with all necessary equipment, including a super-charged diamond blade for sawing, and all the wheels for grinding, shaping and polishing; also complete instructions. The complete equipment as shown, less motor and belt for only \$36.50, f.o.b., Burlington, Wisconsin. Write today for information and literature.

B&I MANUFACTURING CO.
Dept. S, Burlington, Wis.

FIX home & car APPLIANCES YOURSELF

NEW! EICO® READI-TESTER KIT \$12.95 Factory-wired \$15.95

All-in-one MULTI-RANGE ac/dc voltmeter, ammeter, ohmmeter, wattmeter, leakage checker. Locates defects in irons, fans, refrigerators, mixers, air-conditioning, TV & radio tubes and parts, batteries, generators, etc. Easy Instruction Book has introduction to electricity & procedures for common repair jobs. Examine EICO's complete line of 50 professional instruments & kits—Write for FREE Catalog PS-4

Electronic Instrument Co., Inc., 33-00 Northern Blvd., L.I.C. 1, N.Y.

When Writing to Advertisers Please Mention Popular Science

BUY DIRECT—SAVE UP TO 100%

101 ASSORTED SPRINGS
Quality tempered music wire compression, extension, & torsion springs in a wide variety of sizes. Packed in a transparent plastic box to store in drawer, tool chest or cabinet. Guaranteed. Only \$1.50

DRILL KIT. Polish copper and brass, clean away rust and scale and sharpen knives and tools with this handy 4 piece electric drill kit. Big 3" wheels fit on the 1/2" glanged arbor, anodized and plated 1/4" shank. Thick grinding stone, double thick muslin buffer and sturdy wire wheel all included. Only \$1.98

HAND VISE. Hold firmly while repairing, soldering, sharpening. The 6" vise of forged iron & hardwood handle is extra handy for sportsmen too, for fly tying, barb sharpening, repairs on lures & tackle. Fine for radio work to hold small parts for welding. \$1.50

TAPE MEASURE has built-in precision spirit level. Unbreakable spirit level is built into the top of the fine quality 6' metal tape measure. Case functions as a square to form 90 degree angle for shelf alignments. Palm-size, light-weight plastic case. Guaranteed. Only \$1.98

STANDARD AMERICAN SUPPLIERS, Dept. PS-4, 1 PARK AVE., NEW YORK 16, N.Y.

NOW IT'S
EASY
TO LEARN

DRAFTING

AT HOME - QUICKLY - IN YOUR SPARE TIME

HERE'S YOUR CHANCE! No matter where you live . . . no matter what your present job is, you too can soon be cashing big pay checks and enjoying an assured future in drafting! Never before has there been such a demand for trained draftsmen . . . the key men in all industry. No profession has a brighter future! Draftsmen get top pay . . . are in line for promotion to executive positions.

NO EXPERIENCE NEEDED! Cleveland Engineering Institute Courses are the most modern, practical, thorough, drafting courses available. They are fully illustrated; prepared especially for Home Study. If you can read this ad, you can learn drafting under C.E.I.'s guidance. Ours is a tested, proven, up-to-date course that has helped thousands of others on the road to success (many with only grammar school training).

EARN WHILE YOU LEARN! Keep your present job while learning drafting at home in your spare time at the speed that is best for YOU. Many students, as they advance, earn extra money by doing part-time drafting. Many graduates earn more in a single



After completing the C.E.I. course I became foreman . . . salary increased 50%.
Wm. Reichers



First job after taking C.E.I. course increased my salary from \$350 to \$820 per month.
G. T. Wiseman



Thanks to C.E.I. I was promoted ahead of 4 other men with a good pay increase.
W. K. Andersen



The drafting job I got with C.E.I.'s assistance has given me a real start.
R. Eisenbart

week, as draftsmen, than the entire cost of the course.

FREE! After you graduate, 50 hours of extra training at the Institute in Cleveland. This post-graduate training is optional.

WE HELP YOU GET THAT JOB! After you have graduated, C.E.I. will help you find a position. Our Job-Finding-Service is the only one of its kind offered by a Home Study School.



PROFESSIONAL EQUIPMENT included at no extra cost!
VETERAN APPROVED

WHAT CAN DRAFTING OFFER YOU? Find out how a C.E.I. DIPLOMA can bring you a better life — more security — the respect of your employer and people in your community. Without obligating yourself in any way, write for the Cleveland Engineering Institute Success Book and a Sample Lesson FREE. Industry needs men of action! This means YOU.

MAIL THE COUPON RIGHT NOW!

CLEVELAND ENGINEERING INSTITUTE



CLEVELAND ENGINEERING INST., Dept. PS-4J
6300 Euclid Ave. Cleveland 3, Ohio
FREE Success Book & Sample Lesson.

Architectural Aeronautical Mechanical

My Name

Address

City.....Zone.....State.....

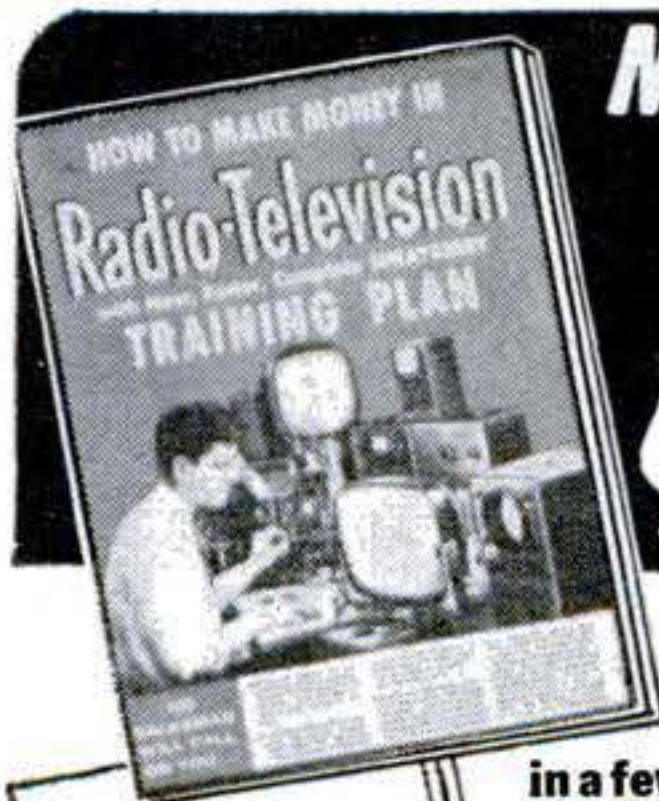

MEN! Get this Book

FREE!

Just Mail Coupon

Tells how you can become a well-paid Radio-Television Service Technician in a few short months in spare hours at home

EARN WHILE YOU LEARN!

The man who knows how to service and repair RADIO and TELEVISION sets is king today. This is the big pay field where many more men are needed at once to fill the jobs now going begging. It doesn't matter what you've done before or what kind of work you're doing now . . . you can learn Radio-Television at home during spare time. Earn good money fixing sets part time while learning! The time-proved Sprayberry Plan gives you the practical experience you need, working with kits we send you. Build Radios, Testers, TV—all yours to keep. New 60-page book gives all the facts . . . plus actual sample lesson . . . all free! Rush coupon. No salesman will call.

SPRAYBERRY ACADEMY OF RADIO-TELEVISION
Dept. 55-U 1512 Jarvis Ave., Chicago 26, Ill.

RADIO TELEVISION Sample Lesson

Also FREE!

Along with book, we'll send you an actual sample lesson to read and study. See how easily you can learn Radio-Television, even without a bit of previous experience.

Sprayberry Academy of Radio-Television
Dept. 55-U, 1512 Jarvis Ave., Chicago 26, Ill.
Mail FREE SAMPLE LESSON and Big Book.

NAME

ADDRESS

TOWN.....ZONE.....STATE.....

RUSH COUPON Today!

Converting to

STEREO?

Change for the Better

Change to V M



The Stereo Record Changer With Transcription Turntable Performance Quality stereo reproduction starts with the record changer. Depend on

V-M for precision performance — as so many leading manufacturers do. V-M Stere-O-Matic® Automatic four-speed record changer, Model 1201, with stereo cartridge and stylus, dual outputs and stereo/monaural switch. Model 1202, with four-pole motor and plug-in head for GE and other magnetic stereo or monaural cartridges. Both available on matching base pan as Models 1226 and 1228.

See your dealer now.

World Famous for the Finest in Phonographs, Tape Recorders and Record Changers.

V-M CORPORATION · BENTON HARBOR, MICHIGAN

the VOICE of MUSIC

Free!

ALLIED'S

MONEY-SAVING 1959

ELECTRONIC SUPPLY CATALOG

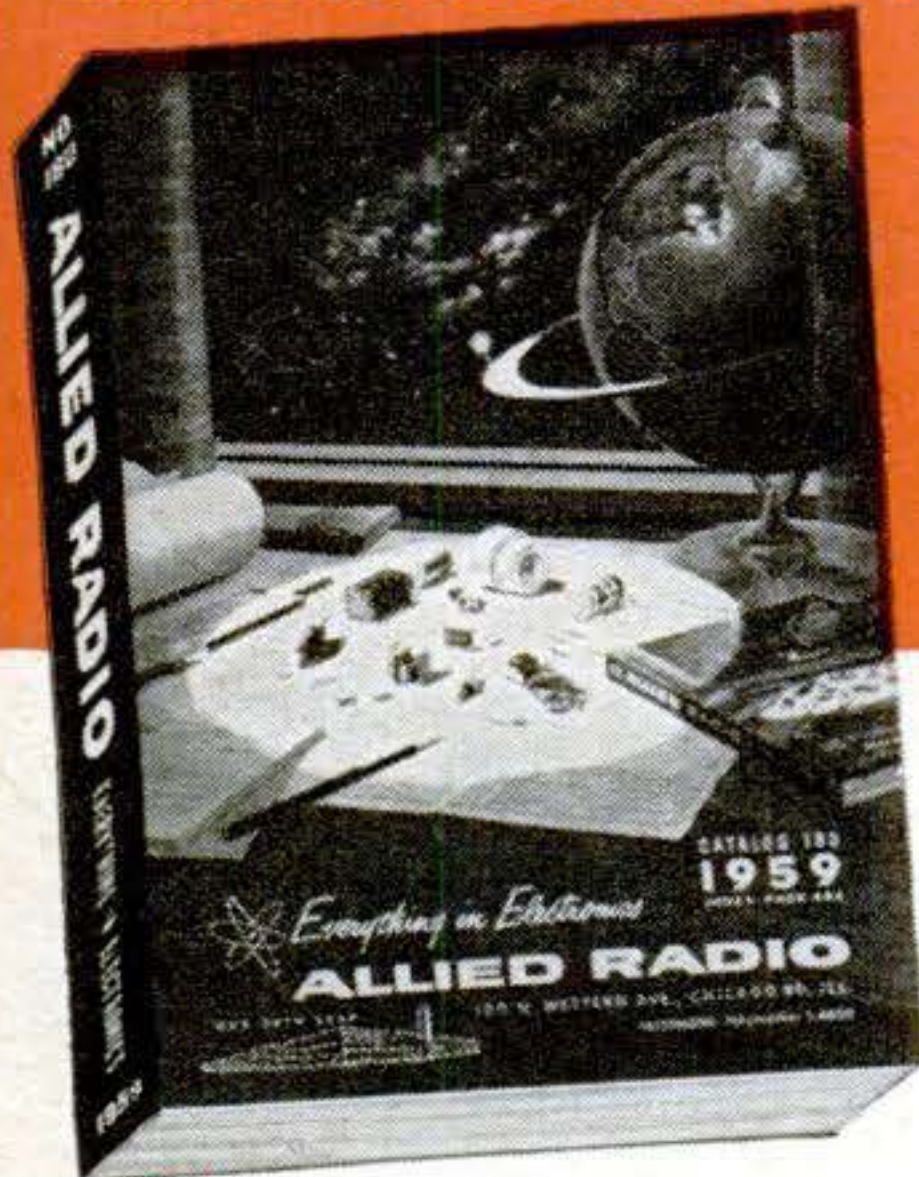

452

value-packed pages

send for it!

SAVE

ON EVERYTHING IN ELECTRONICS

EASY TERMS AVAILABLE

WORLD'S LARGEST STOCKS

Here is the complete guide to everything in Electronics for Experimenters, Builders, Amateurs, Servicemen, Engineers and Hi-Fi enthusiasts:

- Amazing Build-Your-Own KNIGHT-KITS
- Everything in STEREO Hi-Fi
- Hi-Fi Music Systems & Components
- Recorders & Phono Equipment
- Public Address & Paging Systems
- TV Tubes, Antennas, Accessories
- Amateur Station Equipment
- Latest Test & Lab Instruments
- Industrial Electronic Supplies
- Parts, Tubes, Transistors, Tools & Books

SAVE on everything in Electronics at ALLIED—get fast, dependable service, expert personal help, guaranteed satisfaction. Send today for your FREE 1959 ALLIED Catalog.

Everything in Electronics From One Reliable Source

OUR 38th YEAR

Send for FREE Catalog

ALLIED RADIO

- ALLIED RADIO, CORP., Dept. 7-D9
- 100 N. Western Ave., Chicago 80, Ill.
- Rush FREE 1959 ALLIED 452-Page Catalog

Name _____

Address _____

City _____ Zone _____ State _____

How to get more fish... revealed in great \$1.00 book!

"Worth its weight in gold!"—that's what you'll say about the OUTDOOR LIFE FISHING BOOK by P. A. Parsons. This fact-and-photo filled book tells how, where, and when to get more trout, bass, panfish, muskie, salmon, grayling, pike, pickerel, walleye, and every other fresh water sport fish in America! Over 100 pictures, 25 chapters jammed with practical show-how data on fly casting, bait casting, spinning, trolling, wet and dry fly know-how, bugs and poppers, natural baits, ice-fishing, knots, boats, and lots more. And the OUTDOOR LIFE FISHING BOOK is yours for JUST \$1.00 post-paid! Send name, address, \$1.00 to:

Outdoor

Life

Dept. PS-459

353 4th Avenue, New York 10, N. Y.

Get a goldmine of hunting and shooting know-how in great \$1.00 book

Jack O'Connor, Shooting Editor of Outdoor Life Magazine, and America's top gun expert, hands you a million dollars worth of gun and shooting know-how in his OUTDOOR LIFE SHOOTING BOOK. It's packed with inside tips, expert advice on small-bore rifles, big game rifles, shotguns, handguns, ammunition, scopes, sighting, chokes and patterns, plenty more. Lavishly illustrated with 100 photos, diagrams, trajectory tables, ballistics charts, etc. Large format, fully indexed, handsomely printed—worth its weight in gold! And the OUTDOOR LIFE SHOOTING BOOK is yours for JUST \$1.00 postpaid! Act fast! Send name, address, \$1.00 to:

Outdoor

Life

Dept. PS-459

353 4th Avenue, New York 10, N. Y.

America's "BEST BUY" Riding Mower! ROTO-HOE'S "Islander"



Combines others' best features with many new exclusive advantages of its own. Big 4 1/2 h.p. engine at rear — you get far less fumes and heat. Spring seat, extra wide natural rubber double drive wheels, 26" cutting width with close trimming, outrigger wheels to prevent side hill tipping. All for only \$229.50 (subject to slight changes in some areas). Built and guaranteed by America's Leader in Power Lawn & Garden Equipment. Write today for FREE FOLDER and nearby dealer's name for demonstration.

**INTERESTED
DEALERS,
WRITE**

ROTO-HOE, Dept. P-18, NEWBURY, OHIO



CASTING SECRETS REVEALED!

Now you can learn how to make big money by casting thousands of perfect plaques, book ends, figurines, etc., with X.L. rubber molds. **NO EXPERIENCE. VERY LITTLE CAPITAL NEEDED**
X.L., Rubber, Pts. \$2.50; Qts. \$4.00 (postage extra). Molds and enough rubber for three molds, \$1.50 prepaid. U.S. only. Send 25c (refunded with order) for informative catalog (40 pages) describing this wonderful, exciting Profit-making business.

**HUGE
PROFITS!
MORE
MONEY!**

PLASTIC ARTS STUDIO 3403 S. MADISON, DEPT. 3
MUNCIE, INDIANA

Hotels Call for Trained Men

Record-breaking travel means nation-wide opportunities and a sound substantial future for trained men in hotels, motels, clubs, apartment house positions. Fascinating field; fine living; quick advancement. You can qualify at home or through resident classes in Washington. Previous experience proved unnecessary. Placement Service FREE. Write for FREE Book. Course Approved for ALL Veteran Training. 43rd Year. LEWIS HOTEL TRAINING SCHOOL, Room ED-9712, Wash. 7, D.C.

NOW Science shows you how to Learn by "EAR"

ladies & gentlemen...

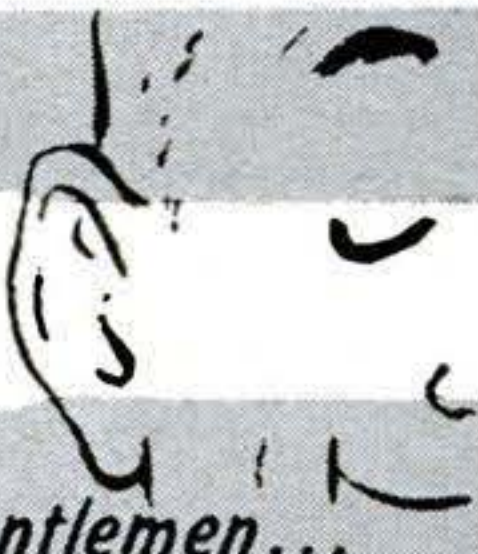

NOW YOU CAN LEARN WHILE YOU SLEEP

Now, at last, science gives you an easy shortcut to learning. With university-tested Dormiphone you "start" to learn while awake—then this amazing tool takes over, continues the learning process for you while you go off to sleep. Do you want to learn a language—Memorize a speech or an array of important facts, figures, formulae—Correct your speech—Break bad habits? The Dormiphone SAVES YOUR TIME—EFFORT. So simple to use, children benefit—so helpful and practical it is used by educators, psychologists, people of all ages, occupations. Write for FREE Book or call for FREE DEMONSTRATION—Get the Scientific Evidence Today.

MODERNOPHONE, INC., 262-049, Radio City, N. Y. 20, N. Y.
Please send me your FREE Book. I am interested in learning more about the DORMIPHONE and what it can do for me. No obligation—no salesman will call.

NAME.....
ADDRESS.....
CITY..... ZONE..... STATE.....

My main interest in Dormiphones is for:

<input type="checkbox"/> Learning a Language	<input type="checkbox"/> Speech Improvement
<input type="checkbox"/> Memorization	<input type="checkbox"/> Sleep Inducement
<input type="checkbox"/> Habit Correction	<input type="checkbox"/> School or College Work

FREE CAREER BOOKLET

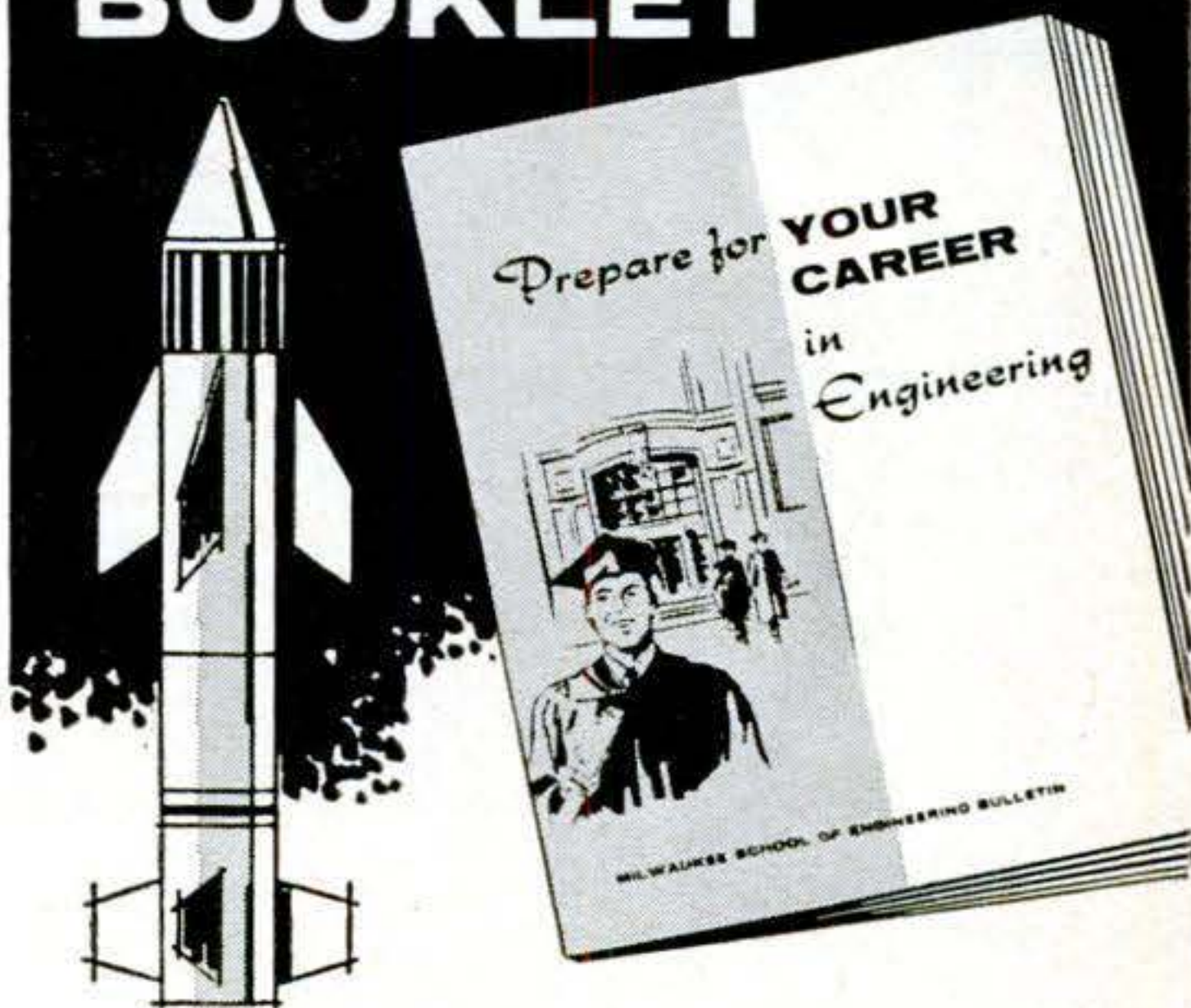

**To guide you to a
successful future in**

ELECTRONICS RADIO-TV COMPUTERS ELECTRICAL ENGINEERING

This interesting pictorial booklet tells you how you can prepare for a dynamic career as an Electrical Engineer or Engineering Technician in many exciting, growing fields:

**MISSILES • AVIONICS • AUTOMATION
SALES • DEVELOPMENT
ELECTRICAL POWER • ROCKETRY
RADAR • RESEARCH**

Get all the facts about job opportunities, length of study, courses offered, degrees you can earn, scholarships, part-time work — as well as pictures of the Milwaukee School of Engineering's educational and recreational facilities. No obligation — it's yours free.

MILWAUKEE SCHOOL OF ENGINEERING

MAIL COUPON TODAY!

Milwaukee School of Engineering
Dept. PS 459, 1025 N. Milwaukee St., Milwaukee, Wis.

Please send FREE "Your Career" booklet
I'm interested in

Electronics Radio-TV Computers
 Electrical Engineering Mechanical Engineering

Name..... Age.....
PLEASE PRINT

Address.....

City..... Zone..... State.....

I'm eligible for veterans education benefits.
Discharge date..... MS-117

Not everyone does as well, but T. N. CODY, who started a business of his own, reports...

For 12 months I've averaged

\$800
per month income

— most of it clear profit for me!



Many men have discovered how to be independent, to be free of layoffs and bosses. C. G. Naples grossed more than \$200 his first week. A father-son combination grossed \$44,000 their second year. H. Lemon says, "I netted \$133 in one 8-hour day."

How much you make depends largely on you. You need no special skill, no large investment. Start part time if you wish.

NO SHOP NECESSARY • Our Electric Deterger shampoos rugs, carpets right on floor—removes dirt and grime and helps to show their natural color and beauty. So efficient and safe it is used by largest railroads and hotels.

This is not a lease proposition. You own the machine, you work when and where you please and all the money you take in is your own. No risk. Machines fully guaranteed.

Mail
Coupon
Today
for
FREE
Book

VON SCHRADER MFG. CO.,
411 "R" Pl., Racine, Wis.
Without obligation send me **FREE** booklet about your RUG DETERGER and tell me how I can start my own permanent, profitable business.

Name _____
Address _____
City _____ Zone _____ State _____



C-10

**Beauty by
Colorcrete
Can Earn
High Incomes**



Beautifying buildings by Colorcrete is a business opportunity awaiting men of modest capital everywhere. Owners of homes, stores, motels, schools — almost any type of construction—are looking for means to give lifetime eye-appeal to drab or dirty concrete, stucco and similar masonry surfaces. Colorcretors can do such jobs, in little time and at little cost, and pocket generous profits. Colorcrete is a cementitious material, applied by air pressure. Tough, tenacious, enduring; 30 colors. Investigate this low-investment enterprise by writing for the Opportunity Book.

COLORCRETE INDUSTRIES, INC.
572 Ottawa Ave., Holland, Mich.

COLORCRETE

NEW WONDER AUTO GLAZE

with **Miracle DOW CORNING 200 Fluids**

Gives You \$55.00 a Day Clear Profit . . . on Your Own Exclusive Route!



GUARANTEED to outshine, outlast and outperform ANY wax polish on the market today—or money back! **FAST, REPEAT SELLER!** Needed by 45,000,000 car owners. Demonstrates like magic. Just apply, wipe off. No hard rubbing. Keeps car and chrome like new for months! **OVER 175% PROFIT!** Retail \$2.00 pint (year's supply). Your profit can be over \$1.35 each pint. **FREE SAMPLE** sent to try on your car. Rush name for **FREE** money-making details. No Obligation! *Exclusive Franchises Available*

ROYALTONE PRODUCTS CORP., Dept. PS-4
1035 E. 10th St., Brooklyn 30, N. Y.

The skilled hand of the German gunsmith is responsible for this .22 caliber, 6-shot repeater automatic with self-ejecting clip. Just 4" long, fits easily into pocket or purse. Ideal for sporting events, stage use.



(Not available to California residents).

Comes for \$6.95 ppd. from
BEST VALUES
Dept. G-671, 403 Market, Newark, New Jersey

NEW BOOK, JUST OUT!

Popular Science Standard Guide to

ECONOMY CARS

By **HARRY WALTON**

The latest and most complete handbook in the exciting economy car field. This 160 page guide is jam-packed with valuable information. Includes easy-to-read descriptive text, over 300 photos, scaled dimension drawings, diagrams, specifications, prices, options, miles-per-gallon, etc., for all makes. Extra features include glossary of terms, list of manufacturers and distributors, and index for easy car-comparison.

NOW, all the facts about every U. S. and foreign make.

- | | | |
|-----------------------|---------------|-----------|
| Volkswagen | Opel | Isetta |
| Renault | Peugeot | Goliath |
| Rambler American | Volvo | Moretti |
| Metropolitan | Saab | NSU Prinz |
| English, German Fords | Borgward | DAF |
| Austin | King Midget | Lloyd |
| Morris | DKW | Toyopet |
| Fiat | Citroen | Datsun |
| Simca | Triumph | Wartburg |
| Studebaker Lark | Goggomobil | Skoda |
| Vauxhall | Messerschmitt | Riley |

If your newsstand is sold out, send \$1.25 to POPULAR SCIENCE PUBLISHING CO., 355 Lexington Avenue, New York 17, N. Y.

NOW ON YOUR NEWSSTAND!

\$1.25

Shrinks Hemorrhoids New Way Without Surgery Stops Itch—Relieves Pain

For the first time science has found a new healing substance with the astonishing ability to shrink hemorrhoids and to relieve pain—without surgery.

In case after case, while gently relieving pain, actual reduction (shrinkage) took place.

Most amazing of all—results were so thorough that sufferers made astonishing statements like "Piles have ceased to be a problem!"

The secret is a new healing substance (Bio-Dyne*)—discovery of a world-famous research institute.

This substance is now available in *suppository* or *ointment* form under the name *Preparation H.** Ask for it at all drug counters—money back guarantee. *Reg. U.S. Pat. Off.

FIX OUTBOARD MOTORS

POWERMOWERS, AND ALL SMALL 2 & 4-CYCLE GASOLINE ENGINES

MAKE EXTRA MONEY— or, repair your own equipment and SAVE! Fully illustrated, easy-to-understand, Home Study Course. Write today for FREE information.

LINCOLN TECHNICAL INSTITUTE
SUITE 4G, 472 MARKET STREET, NEWARK 5, N. J.

SIGN PAINTING

Home-Study Course—Only \$5.95

Teaches you commercial sign painting and sign building as it is being done TODAY in leading shops all over the country. Complete practical course for self-instruction. Shows latest methods of truck lettering, office doors, wood letters, reflecting signs, plastics, sprayed signs, gold leaf, silk screen process, up-to-date alphabets, money-making business information, etc. **SATISFACTION GUARANTEED OR REFUND!** Contains all the instruction of a high-priced correspondence course. Full price, only \$5.95, postpaid. Or C.O.D. plus postage. No risk—order today. Satisfaction or money back! Order "Sign Painting Course."

NELSON-HALL CO., 210 S. Clinton St., Dept. 2DR-1, Chicago 6, Ill.



EARN WHILE YOU LEARN
SEND FOR FREE BOOKLET



Be a LOCKSMITH

Learn fascinating, profitable trade from experts in spare time at home! Age no disadvantage. Year 'round, steady income. Full or part time. Practical, illustrated lessons. Make money even while learning! All materials and special tools supplied.

Locksmithing Institute, Dept. 204-9
150 Park Ave., East Rutherford, N. J.

Lic. by N. J. State Board of Ed. Apprvd. for Vets

WANT A BETTER JOB? BECOME AN ELECTRONIC ENGINEER

ONLY 32 MONTHS TO EARN A BACHELOR OF SCIENCE DEGREE IN ELECTRONIC ENGINEERING

Class enrollment limited to allow for individual instruction. Chartered by State of California. Nonprofit-non-sectarian, coeducational—established 31 years. Either day or evening classes.

APPROVED FOR VETS—ENROLL NOW!

PACIFIC STATES UNIVERSITY, Dept. 49
1516 S. Western Ave., Los Angeles 6, Calif.

Please send your FREE CATALOG.

Name.....

Address.....

APRIL 1959 45

Be A Master Technician



AIR CONDITIONING-REFRIGERATION ELECTRICAL APPLIANCES

NOW ONE Modern Master Home Training Course IN ALL 3 PHASES ALL AT ONE LOW TUITION

Only National Technical Schools gives you this complete training at no extra cost!

YOU GET AND KEEP ALL THIS EQUIPMENT



Incomplete training limits your earning power, even disqualifies you for top-pay jobs. The big service companies require complete, all-phase training. If you open your own shop, you'll be called upon to service and repair all types of refrigerators, air conditioners and appliances. With complete training — as only N.T.S. gives you — you can accept every job, make big profits all year round.

Future Bright For Trained Master Technicians

Over 30,000 new technicians must be trained annually. You are needed to help service and repair the 50 million air conditioners, refrigerators and electrical appliances that will need fixing this year alone. No wonder the Master Technician has steady work, at high pay, year after year. He can go places in his own business or with a manufacturer, dealer, distributor or department store. Armed with all-phase training, his earning power is unlimited.

The Most For Less

We give you illustrated Shop-Tested Lessons and Manuals . . . many other training aids . . . privilege of CONSULTATION with our instructors and engineers. Every lesson, every manual has been SHOP tested and approved.

Job Training At Home

You get Professional Tools, Precision Instruments, PLUS a Factory-Made APPLIANCE TESTER! A shop-full of PRACTICAL, professional equipment. Use them to conduct over 100 experiments . . . also in Spare Time Work and ON THE JOB. It is all yours to keep . . . no EXTRA MONEY DEPOSITS . . . no EXTRA COST on your equipment kits.

Earn As You Learn

We show you how. Many of our students pay for their entire course — and more — in Spare Time while learning. So can you. Graduate Advisory Service, too.

FREE!



ILLUSTRATED FACT BOOK and ACTUAL LESSON
Clip Coupon now

NATIONAL TECHNICAL SCHOOLS
WORLD-WIDE TRAINING SINCE 1905
4000 SO. FIGUEROA ST., LOS ANGELES 37, CALIF., U. S. A.

N.T.S. also offers training in TV - RADIO - ELECTRONICS and AUTO MECHANICS - DIESEL

NATIONAL TECHNICAL SCHOOLS
WORLD-WIDE TRAINING SINCE 1905

MAIL NOW TO

National Technical Schools, Dept. CC-49
4000 S. Figueroa St., Los Angeles 37, Calif.

Rush FREE Air Conditioning—Refrigeration—Electrical Appliances "Opportunity" Book and Actual Lesson. No Salesman will call.

NAME _____ AGE _____

ADDRESS _____

CITY _____ ZONE _____ STATE _____

Check here if interested ONLY in Resident Training at Los Angeles.



MEMBER

DRAFTSMEN



**CASH BIG
PAY CHECKS!**

Train Now for
more success,
greater security

**LEARN AT HOME IN SPARE TIME
(or at college in Chicago)**

Check the want ads in any newspaper—SEE the big-pay opportunities open to you as a draftsman. What's more, you can learn this well-paid, prestige profession at home—quickly, easily! No special talent needed! Get complete, step-by-step Chicago Tech lessons in the mail, spend a few pleasant hours studying each week. In a short time you'll be a well-trained draftsman, ready to take your pick of many good jobs. Act now!



FREE INFORMATION—MAIL COUPON TODAY!
Get **FREE TRIAL LESSON** plus information about C.T.C. practical training. Learn what successful Chicago Tech graduates say about high pay and opportunities in drafting. No charge, or obligation.

CHICAGO TECHNICAL COLLEGE

D-227 Tech Bldg., 2000 So. Michigan Ave.
Chicago 16, Illinois
Mail me **FREE Lesson** with information about big opportunities in **DRAFTING**.

Name.....Age.....
Address.....
City.....Zone.....State.....



The glue for joints subject to water, weather, acids, alkalis and molds. Forms a bond stronger than the wood itself! Best you can buy for outdoor use. ● Get free copy of "Elmer's Guide to Good Gluing". Send stamped, self-addressed envelope to Elmer, The Borden Company, Dept. 4-H, 350 Madison Ave., New York 17, N.Y.

BORDEN'S PRODUCTS FOR THE HOME HANDYMAN

For sportsmen 6 to 60!
Broad line of models — complete kits from **\$39.95**
Send 25¢ for catalog.

Dealer & Distributor inquiries invited.

MIDGET CAR HEADQUARTERS
ARNOLD-DAIN CORP.
Box 80, Mahopac, N. Y.

Look first at **AERO-CRAFT**
America's FIRST Production Aluminum Boats

Guaranteed for **LIFE**
(Against hull punctures in normal use in water)

31 models ranging from \$149.00

Write Dept. M-4 for fact-filled AERO-CRAFT story!

AERO-CRAFT DIVISION OF HARWILL, INC.
ST. CHARLES, MICHIGAN

HYDRAULIC JACK REPAIRS

Earn While You Learn at Home
Millions of jacks in gas & auto-service stations, truckers, body-shops, riggers, factories, farms need servicing. We show you **HOW**—easy step by step directions—what tools to use. **EARN UP TO \$5** an hour, in spare time, in your own basement or garage. Start your own business **NOW**. Write for folder No. PS-4 & free bonus offer.

Institute of Hydraulic Jack Repair
P.O. Box 50, Bloomfield, N. J.

NOW! **A MOTORLESS BILGE PUMP POWERED BY BOAT MOVEMENT**

Just throw it overboard and ball away—pump obtains power as your boat moves thru the water. No special tools or holes in your boat are necessary—installs in one minute and is guaranteed for one year. The Newbek Automatic Bilge Pump weighs only 4 lbs. and is capable of working on any type of craft—pumping capacity is great—will lift water in excess of 5 feet with no effort.

Fresh water model \$14.95
See your local dealer or write . . .

Riverside Machine Shop, 154 South Main Street, Homer, N. Y.

POLAR EXPLORATIONS and NATO

Two new U. S. Commem stamps will appear in April to mark these important anniversaries. For only 50¢ we will send you two different beautifully engraved envelopes, posted for you on the **FIRST DAY OF ISSUE** of each of these new stamps. They will become historical souvenirs in *any* collection. Ask for our **Free lists** of other First Day and First Flight covers.

K. M. Walsh Box 308-A Tuckahoe, New York

BUILD AND FLY YOUR OWN HIGH PERFORMANCE SPORT PLANE!

BEAT THE HIGH COST OF FLYING. JOIN THE HUNDREDS OF OTHER "HOMEBUILDERS." Simplified detailed construction prints now available. **FOUR** proven, economical designs to choose from. (1) Single place Playboy, low wing, rugged and fast, designed for aerobatics. (2) Two place Playboy, side-by-side, low wing, comfortable cross country and aerobatics. (3) Two place Flut-R-Bug, tandem, mid-wing, tri-gear. Very short take off and landing, high altitude fields. Wings easily removed for towing. (4) Two place Sky-Coupe, side-by-side, high wing, cabin, tri-gear. All purpose general utility and personal airplane. For complete details on all four, with descriptive brochures, photographs, 3-views and F.A.A. regulations on homebuilt airplanes, mail \$1.00 (packaging and postal expenses) to **Stits Aircraft, P. O. Box 3084S, Riverside, California.**

Hair problem got you out on a limb?

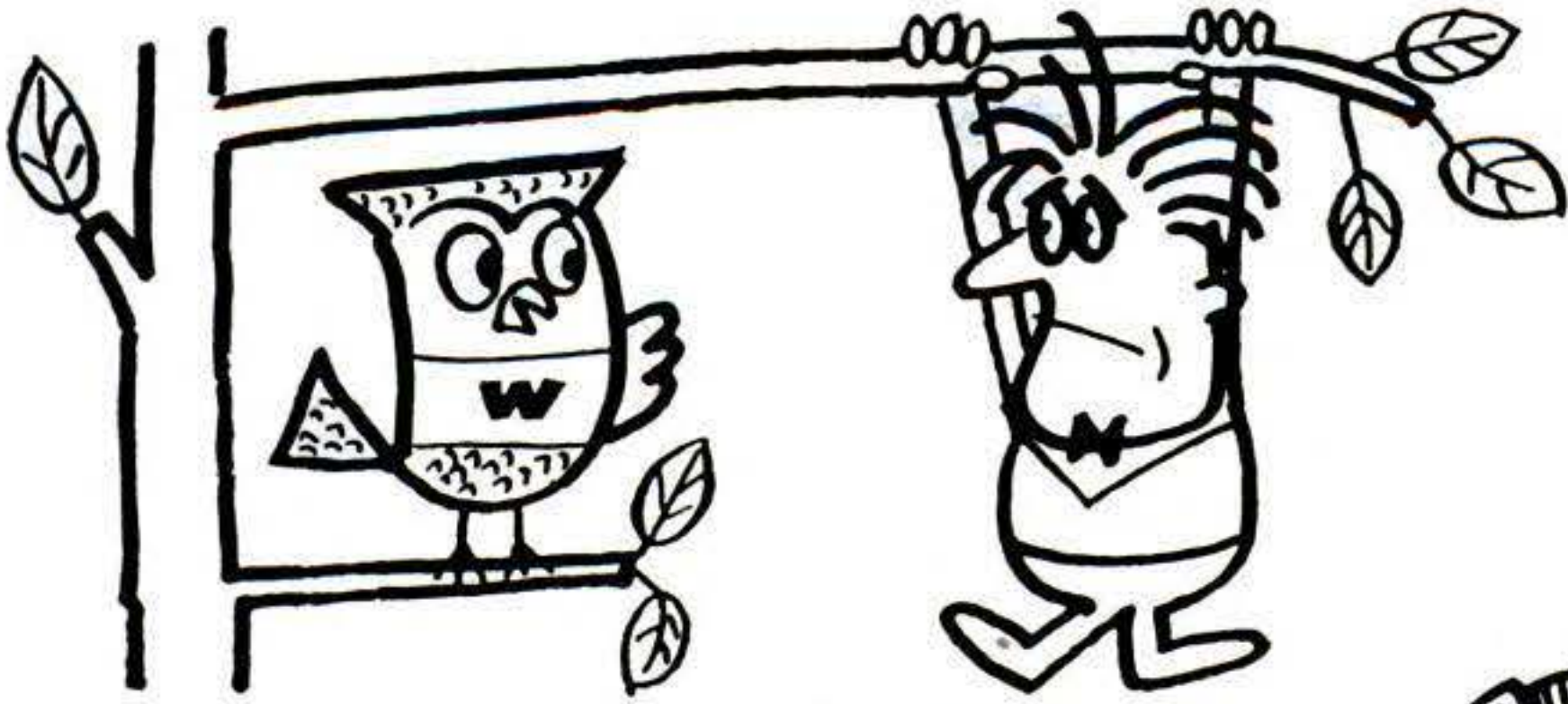

Get Wildroot
Cream-Oil Charlie!

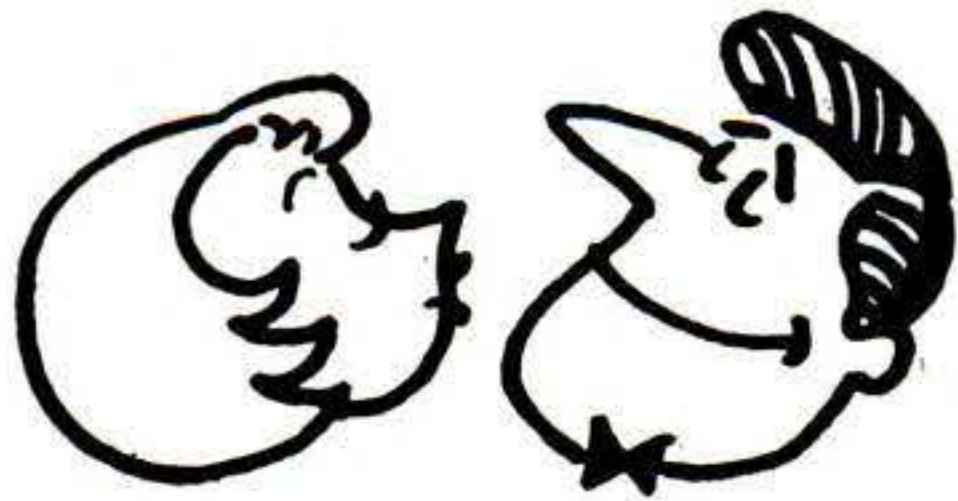

Just a little bit
of Wildroot
and... WOW!

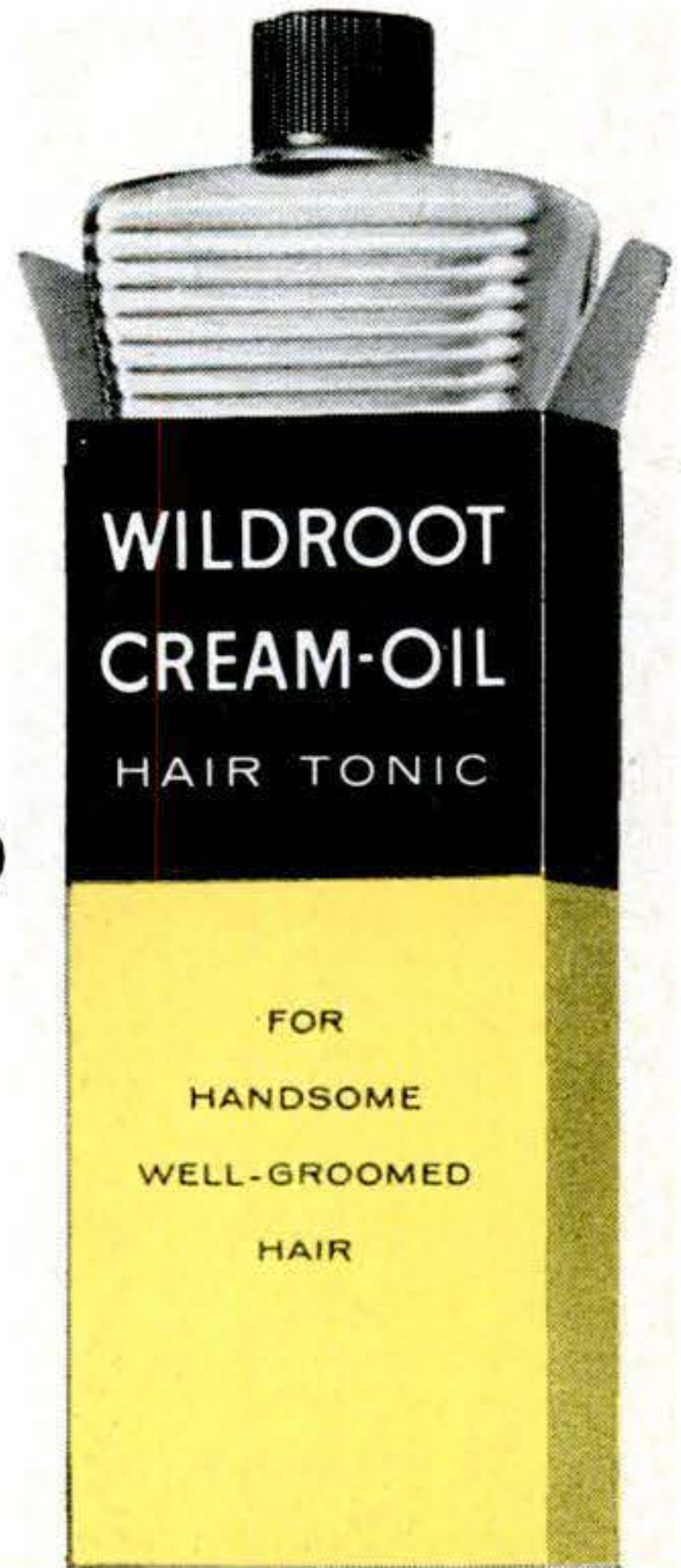

I'll show YOU...how to Draw **CARTOONS**

Learn in one day even if you have no previous training or art ability!
Cartoonists Earn Up To \$10-\$25 and More Per Hour

I have imported a revolutionary new patented system of learning to draw. This new short-cut method, although simple and easy to master has, in a few short weeks, made big pay cartoonists out of thousands of my students around the world who previously couldn't even draw a straight line!

After many requests from advertising agencies, magazines and many other types of firms who need cartooning talent so desperately, I have decided to disclose these long sought-after secrets—the Manual System—to American men and women of any age, in the hope that the sharing of these secrets will help fill the urgent need for cartoonists in the U.S. Since my agreement with my overseas agents limits the number of students I can accept, I have decided to hold this offer open to people who answer this advertisement without delay.

YOU MAY MAKE BIG PROFITS AT ONCE!

The amazing Manual System of cartooning is an entirely new concept in art instruction. There is no tedious home study—you learn by doing. And, you learn well—even though you may have never tried to draw before. Without wasting time, you can start making big, full or spare time profits with your very first lessons—whatever your age or training. You don't have to move, or even quit your job unless you want to. Throughout your training, you receive individualized and unlimited consultation service. As soon as you graduate, you receive employment assistance, if you desire.

CONTINENTAL SCHOOLS, INC.
Dept. A-4, 4201 So. Broadway, Los Angeles 37, Calif.

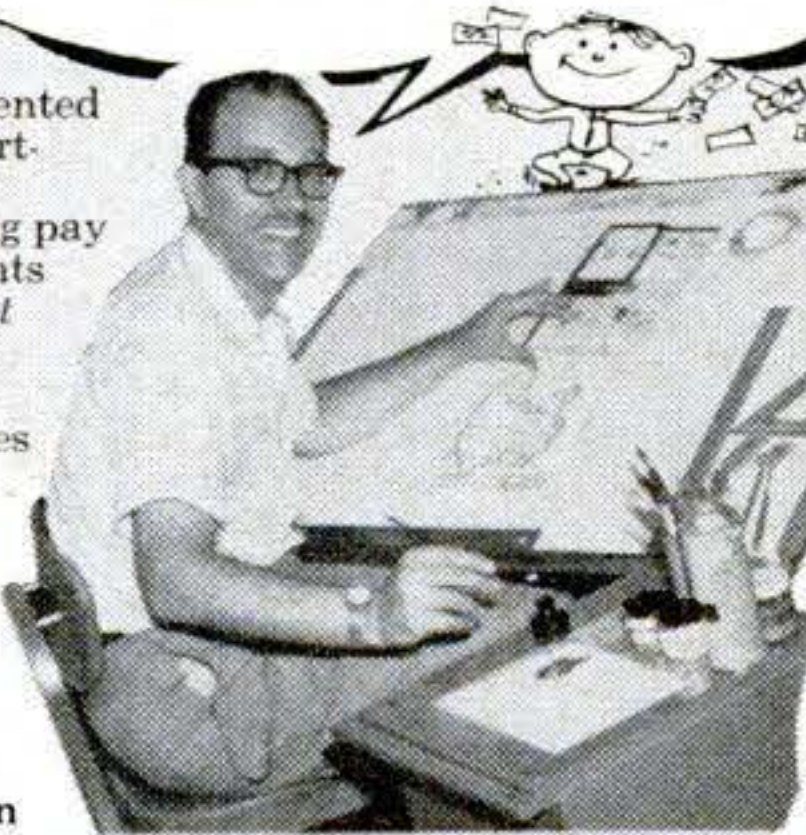

FREE of Extra Cost! 15 PIECE PROFESSIONAL KIT! Contains all the equipment you need during your instruction. Later on, valuable for your professional use

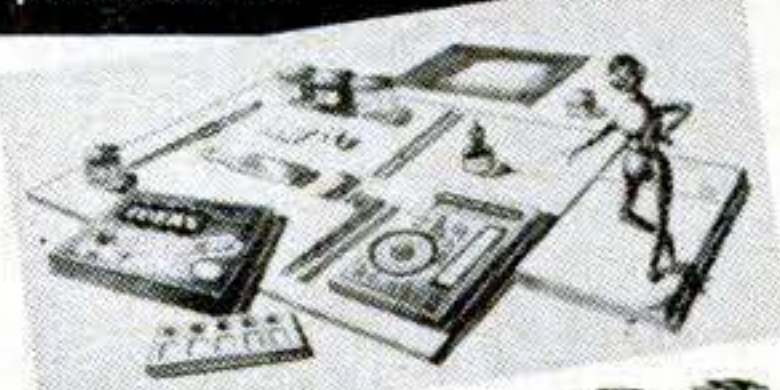

Help Fill Huge Demand for **BIG-PAY CARTOONISTS!**

COMICS "Syndicated comic strips looking for fresh talent. Pay up to \$1000 per week and more."

ANIMATION "Thousands men, women are needed to produce animated cartoons for Hollywood Studios. Live in California! Earn up to \$150 a day!"

TV COMMERCIALS "Hundreds animated commercials, signs made daily in every town that has TV. Associate with top TV personalities. Pay up to \$15 per hour."

MAGAZINES & NEWSPAPERS "5,000 magazines, 24,000 newspapers now published. Almost all use cartoons. Some pay up to \$2500 assignment accepted."

ADVERTISING AGENCIES "Ad agencies demand more cartooning talent. Cartoons used more and more in magazine, newspaper, billboard, TV ads."

SIGN SHOPS "Help fill huge demand for signs everywhere. Start your own shop! Sell \$1 worth of materials for \$25. Help fill Today's demand for Cartoonists!"

But you must hurry! Airmail the coupon and I'll rush you my free book, details on the secrets of the revolutionary new "Manual Short Cut System" to cartooning and how to attain the 15 piece Professional Kit — ALL FREE! No obligation. No salesman will call. Write today!

J. Berman PRESIDENT
Continental Schools, Inc.
(Schools in 8 Foreign Countries)

SEND FOR FREE BOOK!



AIRMAIL COUPON TODAY!

CONTINENTAL SCHOOLS, INC.
Dept. A-4, 4201 So. Broadway, Los Angeles 37, Calif.

Mr. Berman: Prove to me that your students can make Big Money cartooning. Rush me your free book, details on secrets of revolutionary new system, and how to receive 15 piece Professional Kit — ALL FREE. I understand there's no obligation, now or ever, and that no salesman will call.

NAME _____

ADDRESS _____

CITY _____ ZONE _____ STATE _____

Ekotape®
TAPE DECK

You can record and play-back all tapes — four-channel stereo, two-channel stereo and monaural.

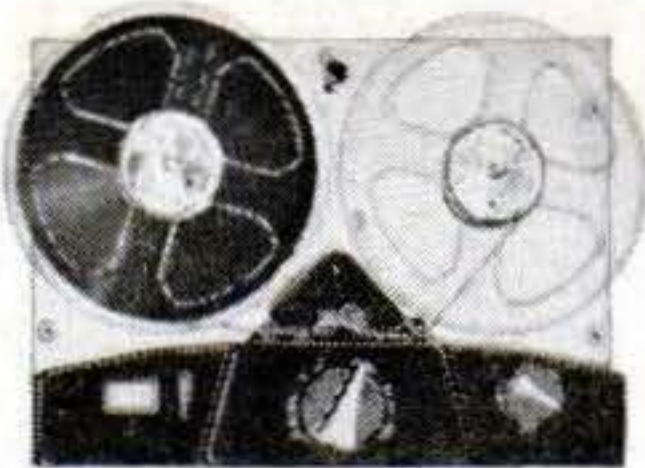

One precise control adjusts head for half-track or quarter-track. Horizontal or vertical mounting. 3 3/4 and 7 1/2 ips, in-line head with independent dual erase, manual stop-start button. 12 3/4" wide x 9" deep x 7 1/2" high. Styled in gold and black.

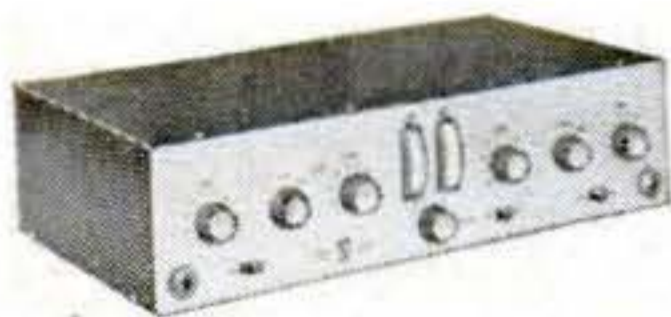

Ekotape
STEREO
RECORD-PLAYBACK
PREAMP

Dual channel control center for playing stereo disks, and for recording, erasing and playing stereo tapes. Volume control, record/playback switch, speed compensating switch, erase switch, on/off switch and VU meter for each channel. 6 inputs, 4 outputs. Response: 30 to 15,000 cps. Gold and black.

Ekotape
AUDIO AMPLIFIER



Ideal for converting hi-fi to stereo. Compact. Inputs: one high impedance. Output impedances: 4, 8, 16 available on screw terminals. Frequency response: at 10 watts output, flat within .5 db, 20 to 22,000 cycles.

See your dealer
or write direct



R-140

**High School Course
at Home** Many Finish in 2 Years

If you did not or cannot finish high school, here is your opportunity. Study in spare time at home. Go as rapidly as your time and abilities permit. Course equivalent to residential school—prepares for college exams. Standard texts supplied. Credit for subjects already completed. Single subjects if desired. Diploma awarded. Be a High School graduate. Start studies now. Free Bulletin. Write today.

AMERICAN SCHOOL, Dept. H446
Drexel at 58th, Chicago 37, Illinois
Accredited Member NATIONAL HOME STUDY COUNCIL

**AMAZING
MUSIC DISCOVERY**

PLAY ANY INSTRUMENT

— even if you
don't know a
single note now!

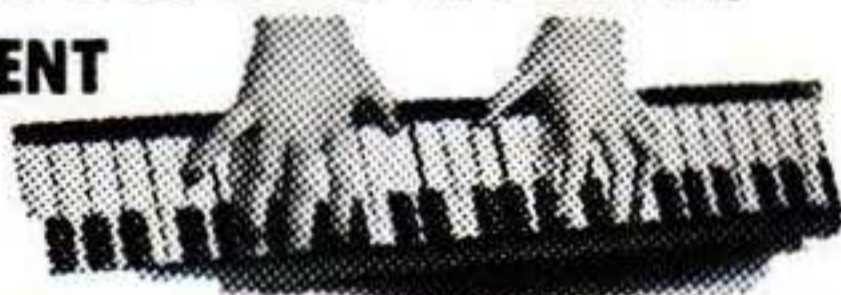

Now it's EASY to learn ANY INSTRUMENT—even if you don't know a single note now. No boring exercises. You play delightful pieces RIGHT AWAY—from very first lesson! Properly—by note. Simple as A-B-C. You make amazing progress—at home, in spare time, without teacher, same way TV Star Lawrence Welk did!
FREE BOOK shows how easy it is to learn music this modern way. Write for it. No obligation; no salesman will call upon you. U.S. School of Music, Studio A154, Port Washington, N. Y. (61st successful year.) Tear this Ad out as a reminder.



48 POPULAR SCIENCE

**MODEL CHANGEOVER SALE!
1958 MODEL—BELOW COST!**

**8" TILT ARBOR SAW
BLADE TILTS—TABLE
REMAINS LEVEL**

Heavy duty all cast iron and steel construction. Precision ground cast iron table. Price includes massive cast iron mitre gauge and patented motor drive that fits any motor. Cross cuts, rips, bevels,



**NOW
\$9.95
Was \$24.95**

Shipped Complete as shown Less Blade

mitres, dados, cuts compound angles — everything expected of saws costing four times as much. Depth of cut adjustable; 0" to 2 1/4" — table always level. Send check or M.O. \$2.00 deposits on C.O.D.'s.

SPECIAL BARGAIN — This saw is our 1958 model. Each saw is brand new — sent to you in factory sealed cartons. Sold and guaranteed direct from the factory to you at a fantastic bargain.

FREE 10 DAY TRIAL — MONEY BACK GUARANTEE
Try this famous saw 10 days. If you are not satisfied that it does the work of any tilt arbor saw, regardless of price, return for immediate money back refund.

Sent Express Collect.

We reserve right to refund money if stock is exhausted
AMERICAN MACHINE & TOOL CO.
ROYERSFORD 48, PA.

**NOW OVER 7000 TERMS
IN MATHEMATICS**

At Your Fingertips

**Plus Invaluable Translations of
Foreign-Language Terms**

THIS BRAND-NEW revised edition of the great James "Mathematical Dictionary" puts over 7000 mathematical terms at your fingertips. Completely up-to-date. Includes latest terms in fields of linear and dynamic programming . . . numerical analysis and computing . . . number theory . . . vector spaces . . . analytical mechanics . . . plus hundreds of others. Just turn to term you want for complete definition and concept behind each term.

IDEAL time-saver for mathematicians, scientists, engineers, students. Invaluable feature is **FOUR** glossaries of math terms in German, French, Spanish, Russian—arranged alphabetically, with English equivalents.



**FREE
14-Day Trial**

SEND NO MONEY

To examine copy **FREE**, simply tear out this ad and mail with your name and address. Use it on the job, in class. If not satisfied, return book within 2 weeks and owe nothing. Otherwise, send \$15.00—easy terms if you prefer. **D. Van Nostrand Co., Dept. 354, 120 Alexander St., Princeton, N. J.** (Established 1848.)

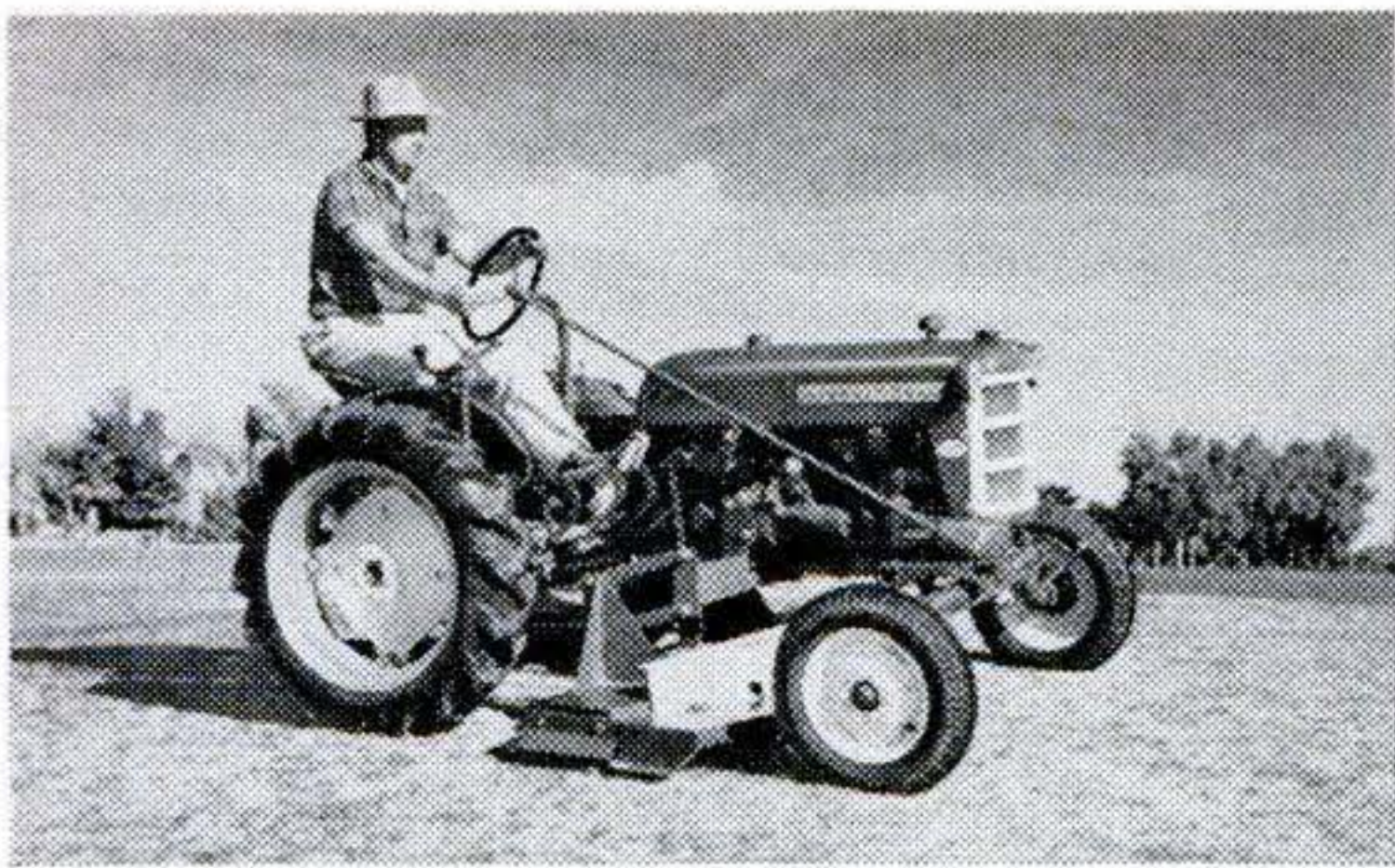

Mower: International Danco

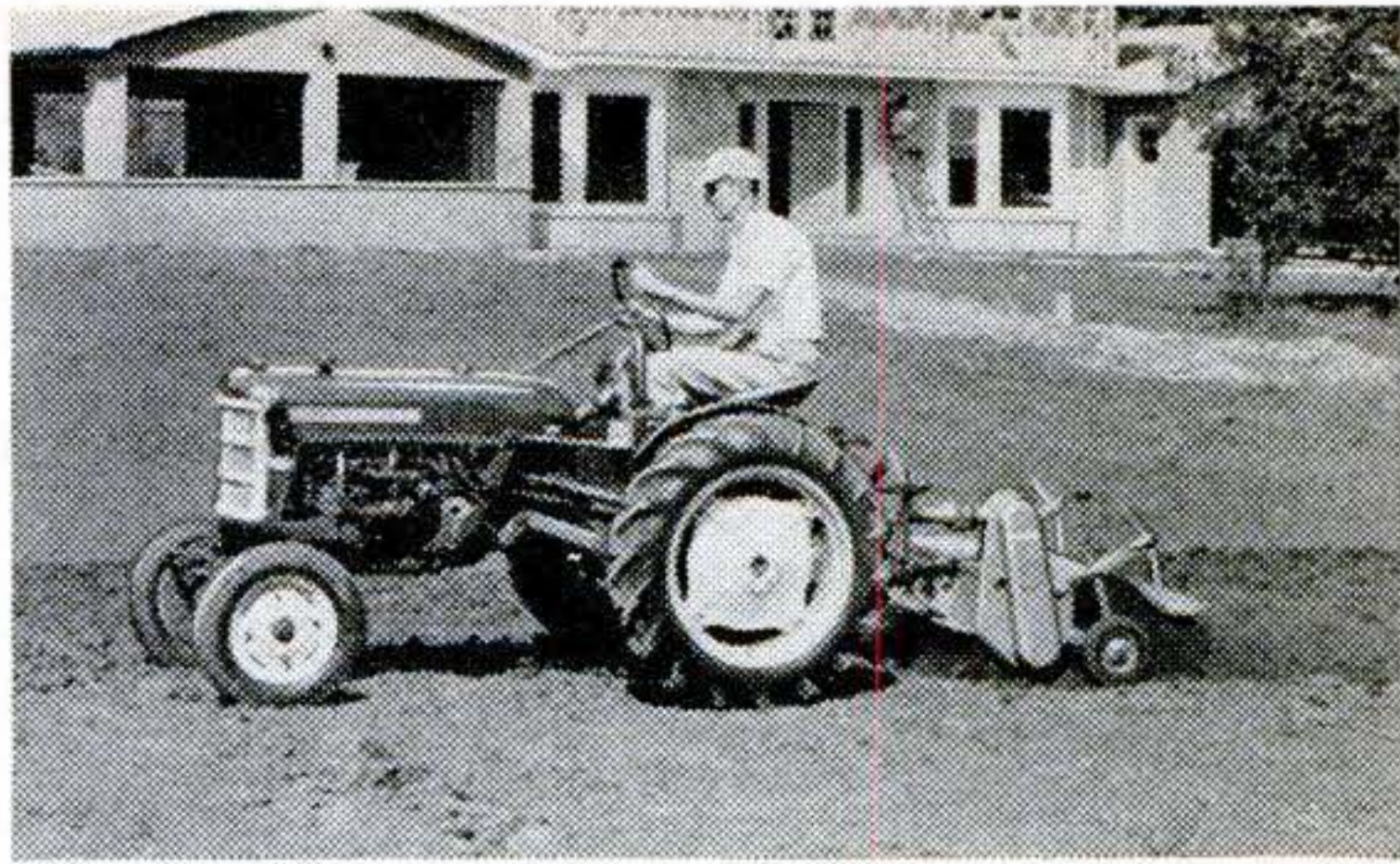

Rotary Tiller: Howard Rotavator

EXTRA INCOME all year 'round with an International® CUB Lo-Boy®!

There are dozens of opportunities close to home for you to earn extra income with a low-cost, 13.4 hp Cub Lo-Boy tractor. Lawns to mow... grounds to landscape... gardens to plow... snow to remove from sidewalk and parking lots... jobs to keep you busy the year 'round. As little as \$250 down can start you in a business of your own. Send for free information kit.

The Cub Lo-Boy is ideal for maintaining estate and suburban acreages. This full-fledged, man-size tractor does so much more—so much easier than walking-type equipment.

Send for free catalog today!



**INTERNATIONAL
HARVESTER**

® Dept. PS-4, Box 7333, Chicago 80, Illinois

Make \$500 an Hour CASH PROFIT THE DAY YOU START!

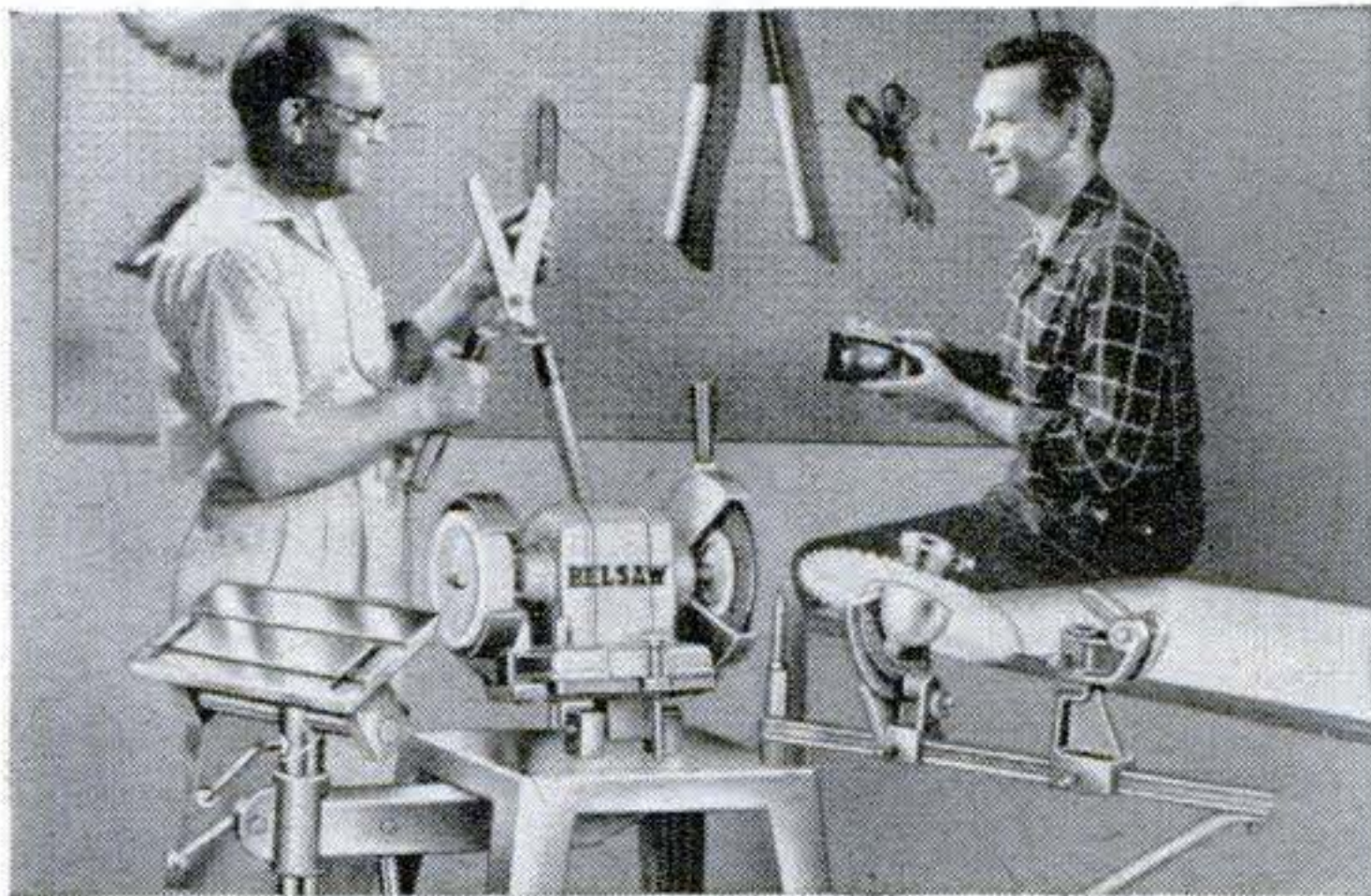

START YOUR OWN BUSINESS AT HOME... SHARPEN HOUSEHOLD, GARDEN AND SHOP TOOLS IN SPARE TIME

Now you can turn spare time into Big Cash Profits with new Belsaw Sharp-All. Sharpen knives, scissors, shears, snips, ice skates, mower blades, hedge trimmers, grass whips, axes, chisels, screw drivers, scrapers and saws... just about any household, garden and shop tool. Your own CASH business with no inventory. No calls to make. No experience needed.

Learn how easily you can start your own spare time business. Amazing low cost easy-payment plan. Send postcard for FREE BOOK.

BELSAW SHARP-ALL CO
709 Field Bldg. • Kansas City 11, Missouri

**FREE
BOOK**

ENGINEERING

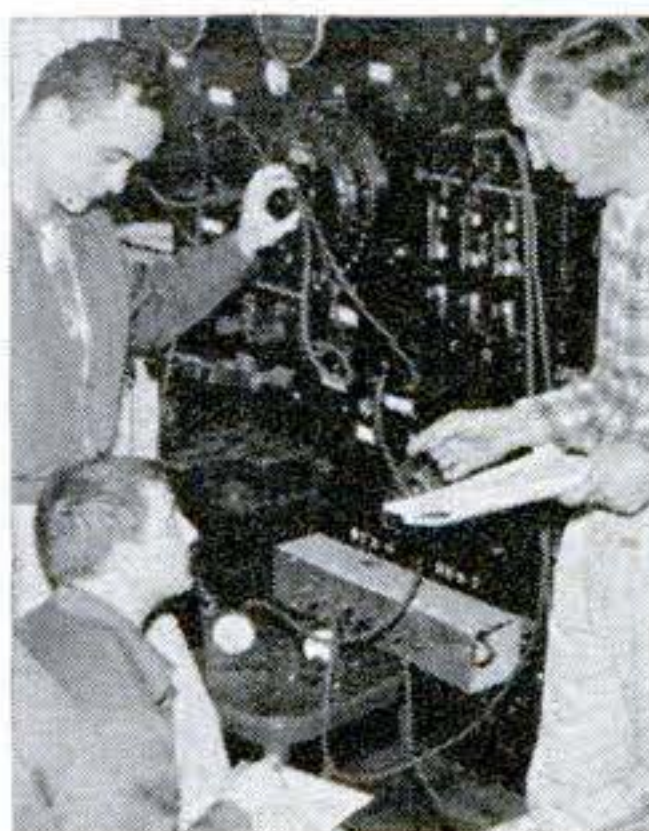

Photo of Heald Students
in Electrical Laboratory

*Heald Trained Engineers
are Moving Ahead and
Winning High Positions
Throughout American
Business and Industry.*

BACHELOR OF SCIENCE DEGREE, 27 MONTHS

Degree Courses:

- Radio-Electronic Eng.
- Electrical Engineering
- Highway Engineering
- Mechanical Engineering
- Structural Engineering
- Civil Engineering
- Architecture

Diploma Courses:

- TELEVISION Color TV
- Radio-Electronic Tech.
- Industrial Electronic Tech.
- Tool & Die Design
- Architectural Drafting
- Mechanical Drafting
- Structural Drafting

Approved for Veterans

Enroll Now for New Term

*Heald College Ranks FIRST
West of the Mississippi
in "Who's Who in America"*

Send for FREE Information

Heald Engineering College

Est. 1863
Van Ness at Post, Dept. P5459
San Francisco, California

NAME _____
STREET _____
CITY _____
STATE _____

No Wonder
We Sell
So Many!

Taft BOAT KITS

**FREE
COLOR CATALOG**

World's finest line of top quality kits...cruisers, runabouts, fishing boats... at mass production prices!

RUNABOUTS

New! 16-ft. "Big Motor" Runabout

One of 12 Taft runabouts that deliver more speed, safety and comfort! Taft runabouts start at \$99.00



CRUISERS

Taft has 9 cruisers—day, express, overnight! Advanced design, quality materials assure utmost family comfort and luxury!

YOU CAN PAY MORE, BUT YOU CAN'T BUY BETTER!

Taft MARINE WOODCRAFT

Dept. PS-459, 636 39th Ave. N.E., Minneapolis, 21 Minn.

NEVER AT THIS LOW PRICE!

GENUINE 150-POWER ACHROMATIC TELESCOPE

with Achromatic Lens and
4-POWER FINDER attached

ONLY
\$18.95
PREPAID

EXTRA BONUS GIFTS:

- 273 page book, "Handbook of the Heavens"
- Magic Star Finder Dial
- 220X & 400X Eyepiece lenses



5 Magnifications 18X—35X—65X—85X—150X

Never before has an ACHROMATIC 150X telescope with range finder and tripod sold for anywhere near this amazing low price. POSITIVELY SHOWS planets, stars, craters, people and all distant objects. Compound Achromatic coated lens guarantees performance. Adjustable 18X—35X—65X—85X—150X for any condition of brightness, greater range of powers, color free needle-sharp views only possible with Achromatic corrected lens. Trimmed with gleaming brass extends to 43", 4X finder scope (30MM LENS) gives brilliant clear views. Brings difficult objects on target before viewing. 5 ft. folding tripod with heavy cast iron head fitted with Criterion's famous universal 360 degree aluminum mount assures stability, locks in any position. Remote controls. This amazing 150X Achromatic Telescope obtainable only from Criterion. Shipped ready for use together with 4 bonus gifts: 273 page "Handbook of Heavens," Magic Star Finder, also 220X & 400 eyepiece lenses free for experiments. Shipped complete, nothing else to buy at amazing price of \$18.95, without tripod \$14.95.

ALSO SPECIAL 40X—80X—120X TELESCOPE WITH TRIPOD

\$11.95
POST PAID

5 section telescope with 5 precision lenses, opens to 36" closes to 12", 5 ft. hardwood tripod, cast head, aluminum 360 degree mount. Erect clear images. Bonus gifts: 273 page Handbook of Heavens, Star Finder. You must be completely satisfied with these instruments or money promptly refunded. Send cash, check or money order today.

Dept. PST-32, CRITERION MFG. CO., 331 Church St., Hartford, Conn.

BIG
BOOM
\$4.40

CARBIDE CANNON

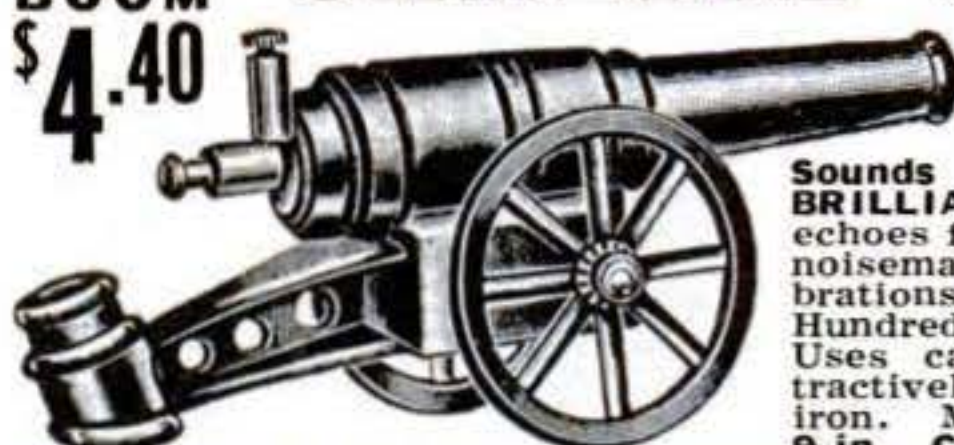

Sounds like dynamite blast! BRILLIANT FLASH! Mighty roar echoes for blocks. Fine July 4th noisemaker, starting gun, celebrations, etc. Safe. No recoil. Hundreds of shots for few cents. Uses carbide. Fast firing. Attractively made of heavy cast iron. Money back guarantee. 9-in. Cannon \$3.95 plus 45c

post, SEND \$4.40. 17-in. \$8.95 plus 55c post, send \$9.50. Ammunition 39c tube (500 shots); 3 tubes \$1.00 postpaid.

JOHNSON SMITH CO.

DEPT. 775

Detroit 7, Michigan

Catalog of 2900 Novelties 10c

New

Send 10c for amazing catalog of novelties, live animals, scientific supplies, hobbies, funmakers, planes & boats, looms, magic tricks, joke articles, unusual seeds, gadget timesavers, cameras, optical goods, projectors, movies, lucky jewelry, religious novelties, disguises, musical instruments, stamps, coins, puzzles, fortune tellers, radios, auto & bike accessories, telescopes, magnifiers, compasses, banks, smokers' gadgets, artists' supplies, printing sets, engines, motors, shockers, knives, billfolds, fireworks, guns, rifles, sports, books, games, plants, etc. Send name, address & 10c to:

JOHNSON SMITH & CO., Dept. 775

Detroit 7, Michigan

NEW
LUCKY
FISHING
ROD
HOLDER
\$1.98



For the fisherman of the family... a handy holder for his prized rods. Lucky Rod Holder in cast aluminum, keeps rods safe and prevents warping. It holds three rods. Buffed aluminum raised lettering on dull black finish. Rod hooks will not damage guides. Completely assembled. Sensational Value! Only \$1.98 plus 25c postage & handling.

MEDFORD PRODUCTS, INC., P.O. Box 39, Dept. 888 Bethpage, N.Y.

LEARN
EARN
MORE
MONEY

UPHOLSTERY

YOU'RE IN BUSINESS RIGHT OFF—Practical course, complete upholsterer's tools, materials, frames, all you need to earn while you learn AT HOME. N. Y. State-approved training in upholstery, slip covers, etc. Big Opportunity Field in good times and bad. FREE Illust. Catalog, FREE Sample Lesson. Write Today. Approved for Vets.

Upholstery Trades School, Dept. HD-1612, 721 Broadway, New York 3, N.Y.

EXCLUSIVE DOUBLE-BEARING HEAVY DUTY PUMPS



IRRIGATE • DRAIN • CIRCULATE • SPRAY
Use 1/4 HP motor or larger... 1 HP for up to 7,500 GPH; 1,000 GPH 60' high; or 3,000 GPH from 25' well. 1 1/4" inlet; 1" outlet. Stainless shaft. TYPE X—2 oil-less bronze bearings. Won't rust. \$10.95
TYPE XB—Ball bearing model. \$12.95
Best for belt drives.

Postpaid if cash with order.
Don't delay—send for yours today!
MONEY BACK GUARANTEE
Centrifugal and Gear Pumps in All Sizes
LABAWCO PUMPS, Belle Mead 4, N. J.

RUPTURED

BE FREE FROM TRUSS SLAVERY

Surely you want to THROW AWAY TRUSSES FOREVER, be rid of Rupture Worries. Then Why Do you put up with wearing a griping, chafing and unsanitary truss the balance of your life? If you do, it will NOT be through necessity but through choice on your part.

Now there is a new modern Non-Surgical treatment that is designed to permanently correct rupture. These Non-Surgical treatments are so certain, that a Lifetime Certificate of Assurance is given. Write today for our New FREE Book that gives facts that may save you painful, expensive surgery. Tells how non-surgically you may again work, live, play, love and enjoy life in the manner you desire. There is no obligation.

Excelsior Medical Clinic, Dept. H6224, Excelsior Springs, Mo.

Join the

CUSHMAN[®]

Fun-Parade!

The Smart

Road King

The All-New 1959

Super Eagle



Swing into the saddle, ease open the throttle, and learn a new definition of fun. New body styling and mechanical advances for 1959 (such as the tapered roller bearings now on both wheels) make Cushman Scooters more distinctive than ever. Famous Cushman Husky 4-cycle engine delivers up to 50 miles per hour, up to 100 miles per gallon.

Ask your dealer for a FREE demonstration ride or write for new colorful booklet today.

Sold and serviced nationally . . . Replacement parts immediately available . . . Dealer inquiries invited

CUSHMAN MOTORS

A subsidiary of Outboard Marine Corporation

927 No. 21st, Lincoln, Nebr.

Please send FREE Scooter booklet.



NAME _____

ADDRESS _____

CITY _____

STATE _____

ABSOLUTELY FREE!

Amazing 48-page muscle-building course, with photos of Champs! HOW TO DEVELOP A

HE-MAN BODY!

TRADE IN that skinny, scrawny, milk toast body of yours for a jet-charged WEIDER physique — rippling with mountains of mighty muscle, oozing confidence and virility out of every pore! Now get my SENSATIONAL INTRODUCTORY MUSCLE-BUILDING COURSE — not for \$100, not for \$50 but ABSOLUTELY FREE if you act now!

Mail this coupon for your FREE COPY. See how easy it is to have a DYNAMIC HE-MAN BODY in just 15 minutes a day in your own home! Hurry, while offer lasts! Mail today!

JOE WEIDER, Dept. 37-49M
801 Palisade Ave., Union City, N. J.

Rush FREE Power-Packed Muscle Building Course. I enclose 10¢ for handling and postage. (offer limited to men over 16)

Name _____

Address _____

City _____ State _____ Age _____

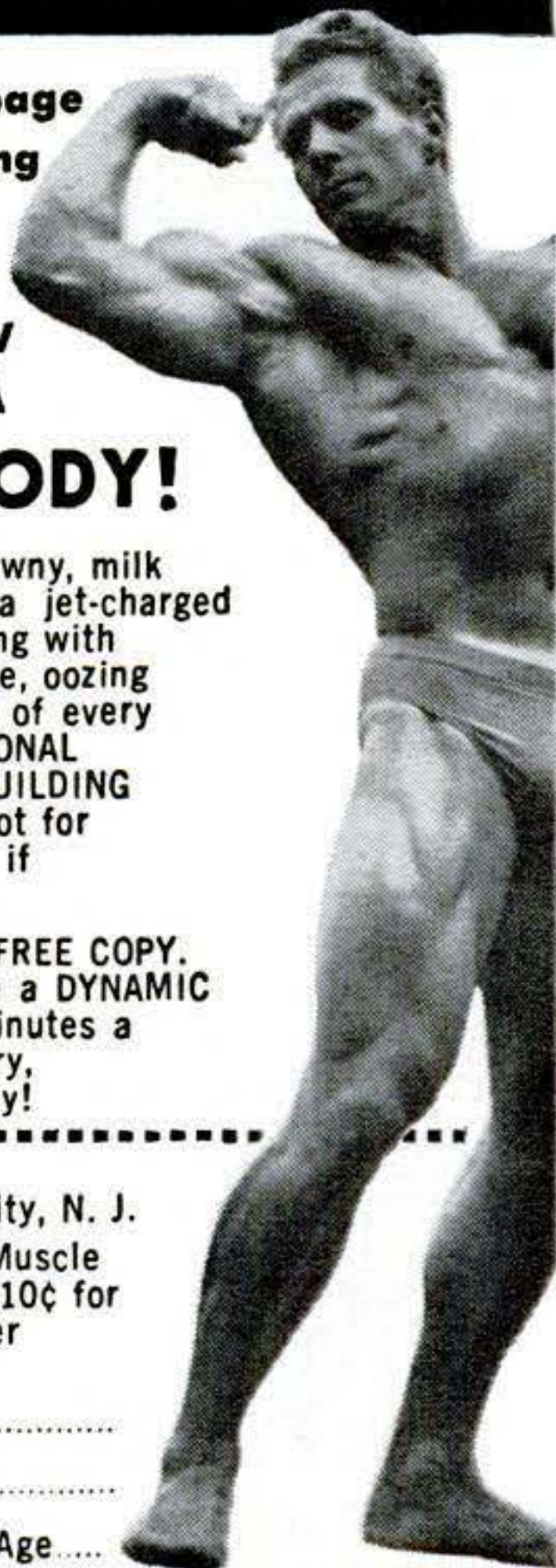

AUDELS GUIDES

MATHEMATICS MADE EASY

A COMPLETE HOME STUDY COURSE — Starting with the first principles of arithmetic, advancing step by step through the various stages of mathematics, including the rules and calculations for mechanical and electrical problems. New EASY correct methods. Includes plane and solid geometry, trigonometry, algebra, calculus, etc. Practical tests, reference tables and data. How to use slide rule. 752 Pages. 550 Illustrations. Priced at only \$3.
CIRCLE NO. 11 IN COUPON

AUTO MECHANICS

Big, practical book gives full information with working diagrams. Covers principles, construction, ignition, service and repair of cars, trucks and buses. Diesel Engines, Hydramatic and Fluid Drive fully explained. Priced at only \$6.
CIRCLE NO. 1 IN COUPON

1696 Pages
1500 Illus.



PRACTICAL ELECTRICITY

A COMPLETE HANDBOOK — Quick, simplified, ready reference. Complete instruction and practical information on the rules and laws of electricity — Maintenance of Machinery — A.C. and D.C. Motors — Armatures — Wiring Diagrams — House Lighting — Power Wiring — Meters — Batteries — Transformers — etc. Simple to understand. 1520 Pages. 2600 Illustrations. Priced at \$5.
CIRCLE NO. 4 IN COUPON

REFRIGERATION & AIR CONDITIONING

FOUR BOOKS IN ONE — basic principles, servicing, operation, repair of: 1. Household Refrigeration. 2. Special Refrigeration Units. 3. Commercial & Industrial Refrigeration. 4. Air Conditioning Systems. A GOLD MINE of essential information. Completely up-to-date. 1360 Pages. Fully illustrated and indexed. Priced at only \$6.
CIRCLE NO. 14 IN COUPON



HERE IS ALL YOU DO

IT'S EASY TO ORDER: In the No-Risk Mail Order Coupon below you need only draw a circle around the number of Audel Guides you want. We will send them to you at once. If you are not completely satisfied, return the books to us.

COMPLETE CATALOG SENT FREE!
CHECK BELOW

MAIL THIS COUPON TODAY!

THEO. AUDEL & CO. — Self Improvement Publishers Since 1879
49 W. 23rd Street, New York 10, N. Y.

S-4

Please mail me for 7 days' FREE EXAMINATION the books I have circled. I agree to mail \$2 in 7 days on each book or set ordered, and to further mail \$2 a month on each book or set ordered until I have paid the purchase price, plus shipping costs. If I am not completely satisfied with my Audel Guides I may return them.

NAME _____

ADDRESS _____

OCCUPATION _____

EMPLOYED BY _____

1 4 11 14

Check Here for Free Complete Catalog

SAVE SHIPPING COSTS! Check here if you enclose complete payment with order. We pay postage charges. You have some return privilege.

UNUSUAL BARGAINS



CLOSE OUT! MECHANICAL DRAWING SET

Regular Price \$18.00
Our Price Only \$6.00 Pstpd.

American mfr. couldn't compete with foreign imports—thus you get a terrific bargain, even far below import prices. 10 handsome pieces in velvet-lined case. Nickel plated brass—precision American-made. We guarantee you'll be satisfied or money refunded.

Stock No. 50,200-N.....\$6.00 Postpaid
Quantity Price: 5 Sets for \$5.50 each Postpaid
10 Sets for \$5.00 each Postpaid

GIANT MAGNETS! TERRIFIC BARGAINS!

War Surplus—Alnico V type. Horseshoe shape. Tremendous lifting power. 5 lb. size. Dimensions:—A—3 1/4"; B—2 3/4"; C—4 3/16"; D—1 1/4"; E—1 1/4"; F—2 5/8". Strength is about 2,000 Gauss. Will lift over 125 lbs.

Stock No. 70,183-N.....\$8.50 Postpaid

15 1/4 lb. size. Approximately 5,000-6,000 Gauss rating. Will lift over 250 lbs.

Stock No. 85,088-N.....\$22.50 F.O.B.
Shipping wt. 22 lbs. Barrington, N. J.



TWO-STAGE ROCKET TOY —

Simple, safe—demonstrates principles of jet rockets. Uses water and air as fuel. First stage soars up 200 to 300 ft.—then 2nd stage is automatically released, going still higher. A 2nd stage satellite is also included and may be substituted. Made of Butyrate plastic. Set includes fuel supply tank and air injection pump.

Stock No. 70, 157-N.....\$2.98 pstpd.

ANASTIGMAT 35MM. CAMERA LENS & SHUTTER—

F/3.2 . . . f.1. 44mm. A \$24 value—American-made.
Stock No. 30,311-N . . . Synchronized for flash. . . . \$9.50 pstpd.
Stock No. 30,312-N . . . not synchronized. 8.50 pstpd.

SEND 25¢ FOR GIANT CATALOG "N-2"

... We'll include FREE a piece of amazing DIFFRACTION GRATING REPLICA (13,400 lines per inch—see all colors of spectrum). 96-page Catalog is a treasure house of bargains in Telescopes, Microscopes, Binoculars, Magnifiers, prisms, lenses, optical parts and accessories!

ORDER BY STOCK NUMBER. SEND CHECK OR MONEY ORDER. SATISFACTION GUARANTEED!
EDMUND SCIENTIFIC CO., BARRINGTON, N. J.

Free! SCARCE TRIANGLE COLLECTION



Start TODAY to enjoy an exciting new hobby! Get this big, valuable collection of gorgeous, multi-colored triangle shaped postage stamps . . . brought to you from strange and mysterious lands in the wilds of Africa, enchanting Europe, exotic Latin America, etc. All genuine, all-different—picturing man-eating reptiles, jungle birds, action-packed sports, ancient clipper ships; PLUS scarce airmails, fabulous commemoratives, giant and midget-sized stamps. EXTRA! Bargain Catalog, "Collector's Manual" plus other exciting offers for your inspection. Enclose 10c for mailing costs. Supplies limited. ACT NOW!

JAMESTOWN STAMP CO. DEPT. H49PS JAMESTOWN, N.Y.

RUSH my Free "Triangle" Collection and other offers.
I enclose 10c for mailing costs.

Name

Address

City & State

IT'S THE REAL, GAS DRIVEN Kidsmobile

BUILD-IT-YOURSELF CAR-KIT



- Single lever drive and brake control
- Automobile-type steering
- Chain drive—Heavy duty frame
- Simple, easy to follow plans

- K-1 Economy Kit—mechanical parts only. Builder supplies body, parts and engine. . . . \$44.95
- K-2 Deluxe Kit—all parts for car except engine \$59.95
- Brand new 2 h.p., 2 cycle engine with remote throttle control. \$29.95

AL-BAR PRODUCTS CO. 702 W. Burlington Ave. La Grange, Ill.

NEW MAGIC RADIO WALKIE TALKIE!

YOUR OWN POCKET SIZE RADIO STATION!
BROADCASTS TO ANY HOME OR CAR RADIO WITHOUT WIRES OR HOOKUPS! Wt. only 5 oz. Size (1 1/2 x 2 1/2 x 4 1/2"). Built-in telescoping antenna. Powerful Transistor-sensitive microphone, frequency setter, break-in switch! Runs for weeks on self-contained flashlight batteries. Durable plastic case. With this Radio Talkie you CAN TALK TO YOUR FRIENDS UP TO A BLOCK OR MORE AWAY! OR BETWEEN CARS! INSTANT OPERATION! No license needed! Uses inductive field magnetic radiation. Useful and real fun in a million ways! GUARANTEED TO WORK. 1 YEAR SERVICE GUARANTEE.

SEND ONLY \$3.00. (cash, ck, mo) and pay post-man \$9.99 COD postage or send \$12.99 for prepaid delivery. COMPLETE READY TO OPERATE with instructions and hundreds of ways and tricks for broadcasts thru any radio you desire. Price may go up soon, so get your NEW POWERFUL RADIO-WALKIE TALKIE NOW. Available only from: WESTERN RADIO, Dept. RPS-4, KEARNEY, NEBR.

GOVERNMENT OIL LEASES LOW AS \$1 PER ACRE.

You do no drilling, pay no taxes, may realize a king-size profit without ever leaving home. Write for free map and literature.

AMERICAN OIL SCOUTS, Dept. PS
8350 Santa Monica Blvd. Los Angeles 46, Calif.



GIANT 6 FOOTERS 59¢

FOR PARTIES AND FUN



FOR ADVERTISING

A special purchase makes it possible to offer these GIANT 6 FOOTERS at a fraction of their value. New, genuine neoprene govt. surplus. Great for advertising, you paint your message on 'em, inflate & fly. Attracts crowds to sales, displays, openings, stores, gas stations. Fun at home for young & old and just the thing for any party or school prom. Perfect for beach or picnic. They're BIG and they do a BIG job! Order yours today!

6' dia.-59c ea.....2 for \$1
8' dia.-\$1.25 ea.....5 for \$6
13' dia.-\$1.95 ea. 15' dia.-\$2.95 ea.
18' dia.-\$3.95 ea.

Postage pd. on ppd. orders.
Cal. res. add sales tax.

FRANK SALES, Dept. PS459
3930 Sunset Blvd., Los Angeles 29, Calif.



GIVE YOUR CAR MARVEL ENGINE PROTECTION

Add years of trouble-free, smooth-running life to your engine...and start enjoying amazing economies in gas and oil.

From the very first treatment you'll "feel the difference" in just 15 minutes.

At service stations, car dealers and garages everywhere.

MARVEL DIVISION — EMEROL MANUFACTURING COMPANY, INC.
331 North Main Street Port Chester, New York

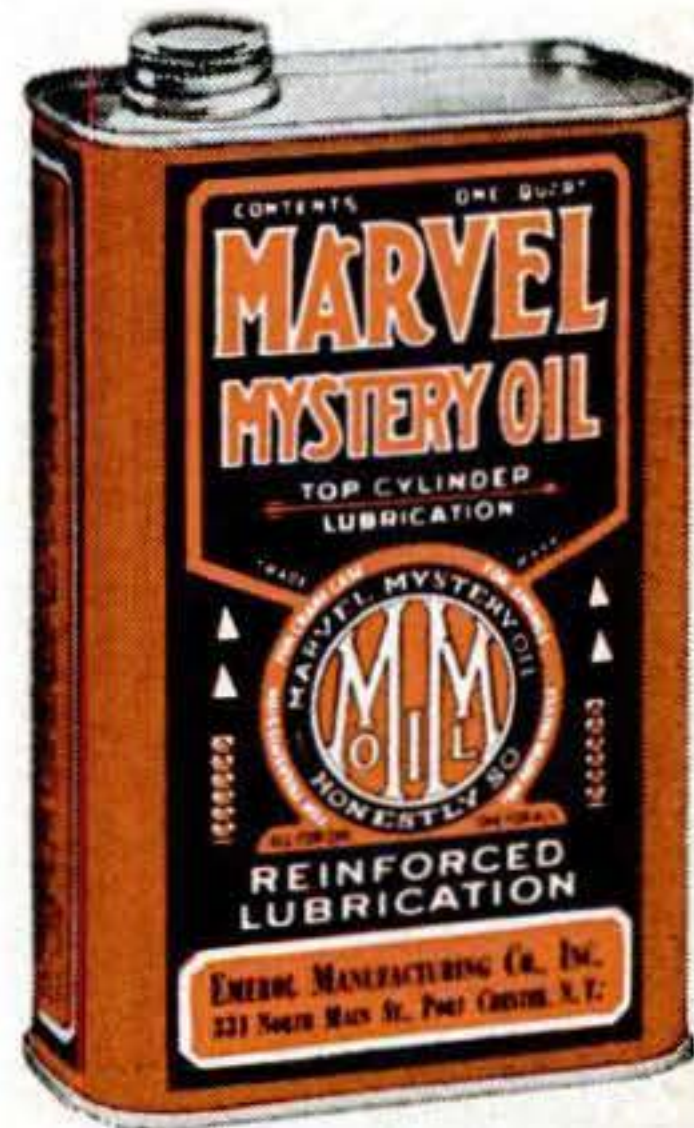

AIR LIFT AIR SPRINGS

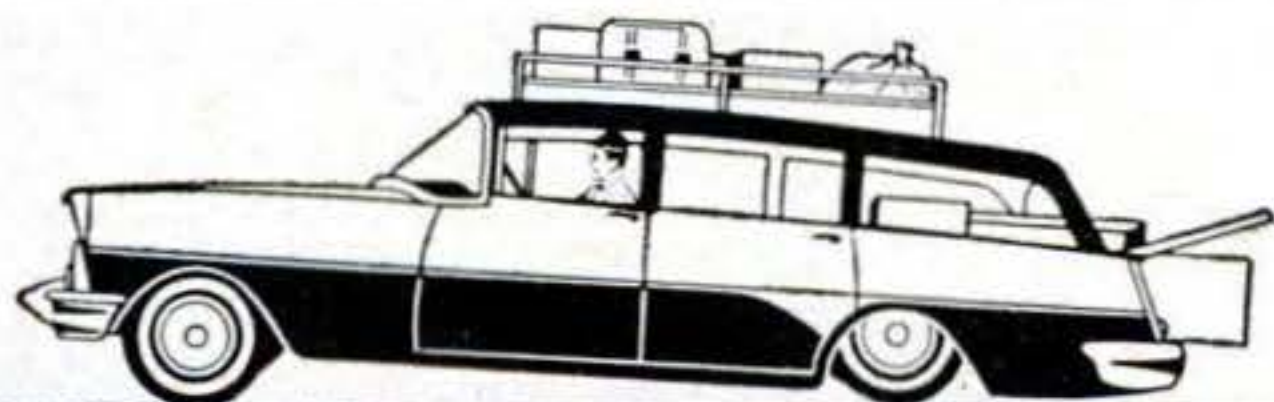

HANDLE ANY OVERLOAD

✓ The *only* air-adjustable overload spring — fits any car or light truck.

✓ A safe, level ride for vacationers, sportsmen, businessmen, trailerites.

✓ Quickly installed — no parts removed from car.

Write for FREE Literature: Dept. 134

OVER 1,000,000 SETS IN USE

LOW AS
\$18⁵⁰



AIR LIFT COMPANY
Lansing, Michigan

In Canada: 18 Hook Avenue Toronto 9, Ontario

TRAINED MEN NEEDED!

IN INDUSTRY — ARMED FORCES
BIG PAY! — GOOD FUTURE!

- DIESEL
- ELECTRONICS
- AUTO
- AUTOMATION

NEVER BEFORE has the opportunity been so good for the properly trained mechanic and technician to step into BIG PAY POSITIONS with rapid advancement and future security virtually assured.

YOUR SUCCESS depends on the quality of training you receive... and the reputation of the school you attend.

YOUR GUARANTEE we are giving the best in mechanical and technical training is proved by the fact... High pay jobs in Industry, and ratings in the Armed Forces now waiting for our graduates.

RESIDENT SHOP TRAINING is easier and costs less than you may think! We provide you with housing and part-time jobs while in school, plus free nation-wide placement service for graduates.

Check subject above in which you are interested and mail for

FREE BOOKLET

Your future
IN
ELECTRONICS
AND
AUTOMATION

BAILEY
Technical Schools

Veteran Approved

1650 S. Grand, St. Louis 4, Mo.

Your future
in...
DIESEL and
AUTO
MECHANICS

Name _____ Age _____
Street _____
Town _____ Zone _____ State _____

YOUR NEIGHBORHOOD NEEDS AN ELECTRICAL APPLIANCE



TROUBLE SHOOTER

Men needed to repair and service all kinds of Electrical Appliances—**AUTOMATIC WASHERS · DRYERS · IRONS · VACUUMS · TOASTERS · REFRIGERATORS · FANS · HOME FREEZERS · AIR CONDITIONERS**—home and industrial motors, etc., also home and industrial wiring.

Big, Year-'Round Profits!
HELP US FILL HUGE DEMAND

MODERN BIG PROFIT ONE-MAN BUSINESS YOURS AT HOME — SPARE OR FULL TIME.

No previous experience needed. New, visual "Shop-Practice" method quickly shows you how. Hundreds of plain-as-day "How to" photos and drawings make it easy. A corner of garage, porch, attic, or basement is all the space needed. No costly leases—no big overhead. We show you how to make business come to you.

NEW 30-DAY INCOME PLAN!

Shows you how to start your own Big Profit Business without investment—no big overhead

Send for this **FREE BOOK!** AIR MAIL COUPON NOW!



BIG MONEY, SECURE FUTURE—INDEPENDENCE.
F. V. in N. Y. says, "I made \$800 in 3 months while studying." T. E. H. in W. Va. says, "Made \$14 a day while learning."

EVERYTHING FURNISHED—Including BIG TOOL KIT
Instructions are complete and include a Tool Kit and Appliance Tester. Everything furnished to help you build your own big-profit business at home. Our new 30-day income plan shows you how to start making money almost at once. Send no money—just your name and address on coupon below. I will rush you FREE complete success plan with full details. Do it NOW—BE FIRST!

PACIFIC TRAINING SCHOOL, Dept. S-594
11029 So. Vermont Ave., Los Angeles 44, Calif.

PACIFIC TRAINING SCHOOL, Dept. S-594
11029 So. Vermont Ave., Los Angeles 44, Calif.

Gentlemen: Rush me postpaid your FREE plan for success in the Appliance Repair Business and the Free Book Entitled "The Appliance Repair Business and You" and remember I am under no obligation.

Name _____
Address _____
City _____ Zone _____ State _____



... Swiss or American

Unique Sweazey System starts you making repairs right away. Develops your skill step-by-step. Teaches simplified modern shop methods . . . professional short cuts. Learn by spare time home study from professional trade school. Low terms. Free Sample Lesson. No obligation. Write today!

CHICAGO SCHOOL OF WATCHMAKING
2330 Milwaukee, Dept. 449, Chicago 47, Ill.

New Table Top Invention Puts You In... PROFITABLE RUBBER STAMP BUSINESS

Home Operators now make **\$9.40 AN HOUR** in business once monopolized by a few big companies

Special rubber stamps bring high prices—cost only pennies to make on new, low-cost table top machine. Take 27 cents worth of material, make perfect stamps, the kind businesses and offices now buy by the dozen at \$1.80 each. Make up to \$9.40 an hour. Start in spare time in your own home. Run machine on kitchen table using ordinary electrical outlet. Make any kind of stamp. We'll send you free information without obligation about this established, highly profitable business, now open to individuals for the first time. For free information send name today on a post card to Rubber Stamp Div., 1512 Jarvis Ave., Dept. R-3-D, Chicago 26, Ill.



BOAT KITS

8'-18': 50 Models

\$41.75 up;

Fr. Pd.

EASY MONTHLY PAYMENTS



FREE COLOR CATALOG

Cruisers, convertibles, runabouts, fishing. Easily assembled by anyone. FREE Catalog has natural color photos, complete details, Fiberglass, accessories hardware, paint. Write Today.

LUGER INDUSTRIES, INC., Dept. A-4
9200 Access Road, Minneapolis 20, Minnesota

EARN GOOD MONEY IN SPARE OR FULL TIME.

Up to \$30 a day With a Universal Grinder

Have a business of your own in your garage or basement, sharpening lawn mowers. Be your own boss. Small investment. We furnish everything you need to start. Write FREE Dept. P-49 today for complete details

ROGERS MANUFACTURING CO.
LINDSEY, OHIO



SUPER JU JITSU

Now get tough double quick!

A course of instruction in the art of practicing and using this method of applying LIGHTNING-QUICK Super Ju Jitsu. Be Dangerous! These amazing lessons show you how it's done . . . in a big illustrated home-study course. The weapons are just your BARE HANDS—they can be used effectively if you know how and practice the art. Easy to learn; quick. Full 76-lesson course only \$5.95 postpaid—or COD, plus postage. Satisfaction or your money back guaranteed! Order "Super Ju Jitsu Course." Nelson-Hall Co., 210 S. Clinton, Dept. 8DR-1, Chicago 6, Ill.

When Writing to Advertisers Please Mention Popular Science

Your Dollar Will Feed A Refugee

War and political refugees overseas urgently need the direct help, the personal encouragement, of CARE food packages—\$1 for 22 lbs. of farm staples, **Delivered In Your Name.** Mail your dollars to "Refugee Campaign," CARE . . . today!



660 First Ave.
New York, N. Y.

Printed as a public service

Comforting Facts about **WOLVERINE WORK SHOES**



PLUS THESE COMFORT FEATURES—



- FOAM RUBBER CUSHION
INSOLE WITH SWEAT-PROOF
LEATHER COVER • RIBBED
STEEL SHANK • CHOICE OF
SOLES TO FIT YOUR JOB

WOLVERINE
ROCKFORD, MICHIGAN

Service Oxfords
Work Shoes • Boots
Safety Shoes

you can always
BE SURE OF A JOB

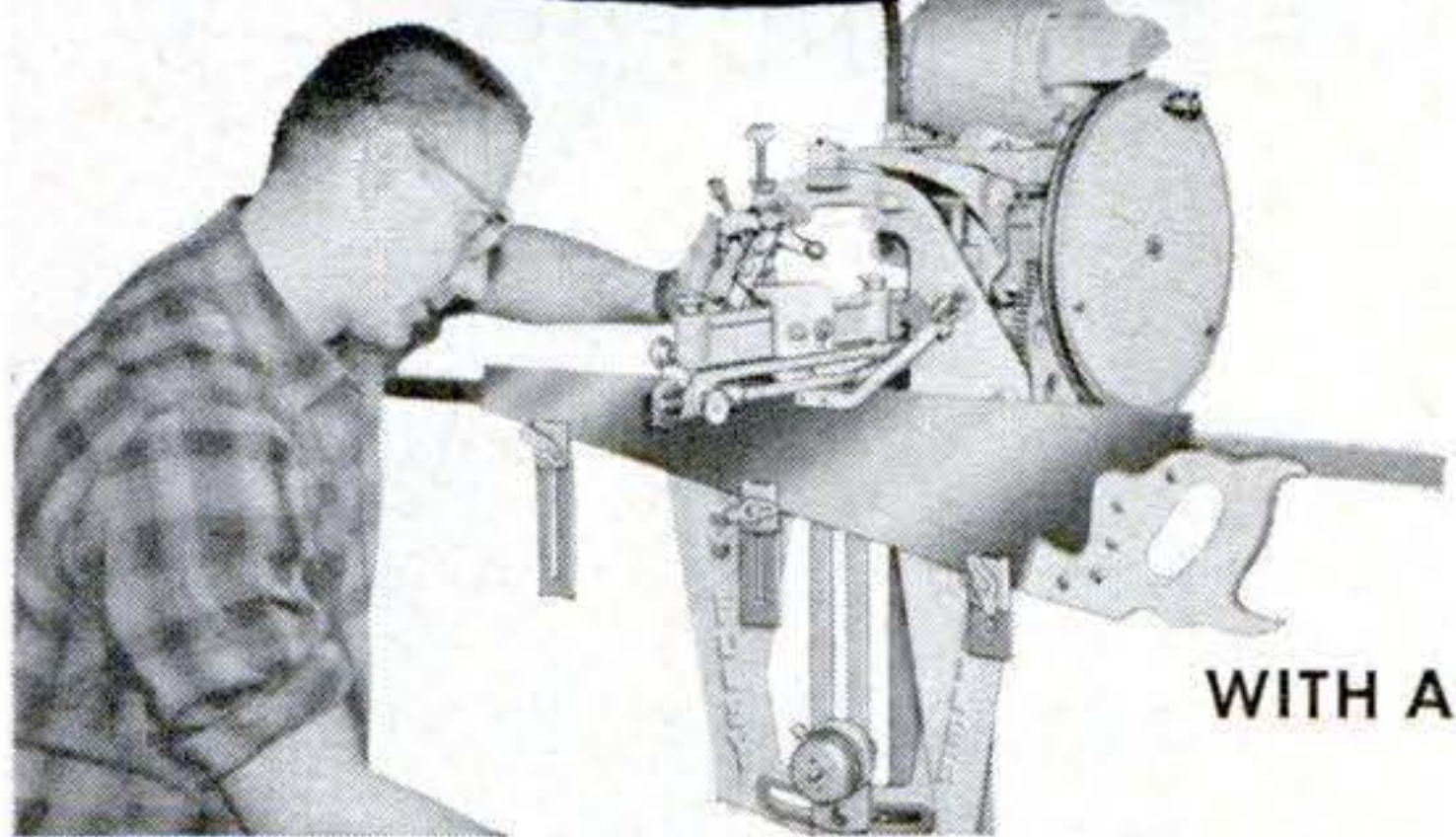

WITH A

FOLEY SAW FILER

Have you been laid off—or afraid you may be? If you want security, plus a bigger income too—don't look for a job—start your own spare time business. In his first 2 months J. P. Robitaille earned \$300 with his Foley Saw Filer. From his starting day R. T. Hart made \$600 in 4 months. Frank P. Layne wrote—"In our town of 2,800 instead of 200 to 300 saws I did over 1,500 the first year, averaging about \$1.50 each."

FREE booklet "MONEY MAKING FACTS" shows you how to get business. The new 1959 Foley sharpens hand, band and both "combination" and crosscut circular saws. Use our Time Payment Plan—pay for the machine out of your CASH profits. Send coupon today—no obligation, and no salesman will call.



FOLEY MFG. CO., 419-9 Foley Bldg., Minneapolis 18, Minn.

Send Free Booklet and Time Payment Plan on Foley Saw Filer.

Name _____
Address _____
City _____ State _____

"Now, I must tell you, I have heard a speaker system that approaches the authenticity of concert hall performance"

MISCHA ELMAN



UNIVERSITY'S TOTALLY DIFFERENT STEREO SYSTEM—THE NEW 'TRIMENSIONAL' TMS-2

- Two complete speaker systems in one enclosure
- Unprecedented compactness—only 30" wide
- A third dimension to stereo sound . . . DEPTH
- Placement anywhere in a room
- For monophonic and stereophonic reproduction
- Uncompromised quality at an attractive price

Send for **FREE 16 page brochure**, An informative guide to high fidelity stereo and monophonic speaker systems and components. Write Desk B-8, University Loudspeakers, Inc., White Plains, N. Y.



FAMOUS MEN OF MUSIC CHOOSE UNIVERSITY

FREE! LAFAYETTE'S

1959 CATALOG

260 GIANT-SIZED PAGES



Everything In Electronics

The Complete Catalog Featuring The Best Values Obtainable

CONTAINS

HUNDREDS OF EXCLUSIVE LAFAYETTE ITEMS NOT IN ANY OTHER CATALOG OR AVAILABLE FROM ANY OTHER SOURCE—SEND FOR YOUR COPY NOW!

See the newest and finest in Stereo Tuners, Amplifiers, Cartridges and Music Systems

- TAPE RECORDERS • PUBLIC ADDRESS SYSTEMS • AMATEUR EQUIPMENT
- INDUSTRIAL SUPPLIES • RADIO & TV TUBES AND PARTS • INSTRUMENTS
- TELESCOPES, BINOCULARS, MICROSCOPES & CAMERAS

LEADERS IN HI-FI

OUR

38th

YEAR

The most complete electronic supply catalog crammed full of everything electronic at our customary down-to-earth money-saving prices.

The largest selection of hi-fi components and systems; greatest savings on Lafayette endorsed "best-buy" complete systems.

EASY PAY TERMS AVAILABLE — 10% DOWN — UP TO 18 MONTHS TO PAY

Lafayette Radio

P. O. Box 511
JAMAICA 31, N. Y.
DEPT. KD9

CUT OUT AND PASTE ON POST CARD

Send FREE LAFAYETTE Catalog 590

Name.....

Address.....

City..... Zone..... State.....

Superior's New Streamlined Model TD-55

TUBE TESTER

Quickly and Efficiently Tests Radio and TV Tubes Including: Seven Pin Miniatures; Eight Pin Sub-Minors, Octals and Loctals; Nine Pin Novals



YOU CAN'T INSERT A TUBE IN THE WRONG SOCKET.

It is impossible to insert the tube in the wrong socket when using the new Model TD-55. Separate sockets are used, one for each type of tube base. If the tube fits in the socket it can be tested.

"FREE-POINT" ELEMENT SWITCHING SYSTEM.

The Model TD-55 incorporates a newly designed element selector switch system which reduces the possibility of obsolescence to an absolute minimum. Any pin may be used as a filament pin and the voltage applied between that pin and any other pin, or even the "top-cap."

CHECKS FOR SHORTS AND LEAKAGES BETWEEN ALL ELEMENTS.

The Model TD-55 provides a super sensitive method of checking for shorts and leakages up to 5 Megohms between any and all of the terminals.

ELEMENTAL SWITCHES ARE NUMBERED IN STRICT ACCORDANCE WITH R.M.A. SPECIFICATION.

One of the most important improvements, we believe, is the fact that the 4 position fast-action snap switches are all numbered in exact accordance with the standard R.M.A. numbering system. Thus, if the element terminating in pin No. 7 of a tube is under test, button No. 7 is used for that test.

Model TD-55 comes complete with operating instructions and charts, and streamlined carrying case. Only **\$26⁹⁵** NET

SHIPPED ON APPROVAL
NO MONEY WITH ORDER — NO C. O. D.

Try it for 10 days before you buy. If completely satisfied then send \$6.95 and pay balance at rate of \$5.00 per month for 4 months — No Interest or Finance Charges Added. If not completely satisfied, return to us, no explanation necessary.

MOSS ELECTRONIC, INC.
Dept. D-588, 3849 Tenth Ave., New York 34, N.Y.
Please rush Model TD-55. If satisfactory, I will pay on terms specified. Otherwise I will return tester.

Name.....
Address.....
City..... Zone..... State.....

All prices net, F.O.B., N. Y. C



TEN delightful, exciting MOVIES

FANTASTIC OFFER
ALL TEN MOVIES IN 8mm FOR ONLY **\$2**
(16mm—\$4)

The movie buy of a lifetime! Ten subjects, all different, brand new and thrilling, and all yours for only 20c each. You must be delighted or your money back! Rush \$2 (cash, check or money order) to:
SENSATIONAL MOVIE OFFER
Box 46856, Dept P-9
West Hollywood 46, Calif.

TESTS BLOOD PRESSURE



at home with guaranteed results. Check yourself daily with a simple mercury gauge. It's not as elaborate as a doctor's, but it does the job accurately. An illustrated manual tells how to test and what to do to avoid or reduce the damaging effects of high blood pressure. There are years of dependable service in this apparatus, which now includes a professional stethoscope for accurate testing. Complete new tester just \$9.75 plus 25c postage, or C.O.D. plus charges.

RESEARCH SPECIALTY CO.

2035-G N. Western Ave. Chicago 47, Illinois

BOAT PLANS - PATTERNS FRAME KITS

A modern up to date series of inboard and outboard designs for the amateur builder. State specific size and type or send 50c for BIG NEW CATALOG.



marine **GLEN** designs

9152-P Rosecrans, Bellflower, Calif.



Million Dollar Inventory — All Famous Brands



SAVINGS NEVER LESS THAN 50% UP TO 70% OFF REGULAR PRICES
HEADQUARTERS FOR ALL SPORTS CAR TIRE SIZES
➔ SEND FOR YOUR FREE CATALOG! ➔

RELIABLE TIRE CO. • 730 MORGAN BLVD. CAMDEN 4, N. J.



BENDIX ELECTRIC FUEL PUMP PROVED AT

150° above zero and 65° below zero

In government-supervised tests, the Bendix* Electric Fuel Pump worked perfectly in temperatures ranging from +150°F. to -65°F.—a record no other fuel pump anywhere near its price class could match. This best-on-the-market Bendix pump prevents vapor lock, delivers a constant flow of fuel. You'll *start* and *go* better in any weather with Bendix.

Bendix-Elmira
Eclipse Machine Division
Elmira, N. Y.



*REG. U.S. PAT. OFF.

MANUFACTURE THIS BEAUTIFUL CONCRETE OUTDOOR FIREPLACE

Right In Your
Own Backyard

**\$4.00 Worth of
Sand & Cement
produces this
Attractive
Fireplace.**

**Sells on Sight
from \$60. to \$80.
Easy to start your
own Profitable
Business.**

The General Fireplace
Molds and Process are the most
amazing and foolproof ever invented.
Simple to operate. Two men can produce five fireplaces a day.

BIG DEMAND!!

Sell all you produce to Department Stores, Homeowners, Parks, Nurseries and Picnic Groves. Fireplaces sell on sight. No experience necessary. We supply full operating instructions and equipment plus the know-how that spells **BIG PROFITS**. This is an outstanding opportunity for men of vision and small capital to get into a busy rich paying field. Don't delay, be the only exclusive manufacturer in your own home town. Mail coupon at once for full details as to how you can reserve your territory. **Molds sold only on exclusive franchise.**

GENERAL ENGINES CO., Inc., Dept. SF-49
ROUTE 130, THOROFARE, NEW JERSEY

Mr. Tor of Philadelphia writes:
Sold 250 in first 4 months. Selling to Sears Roebuck, John Wanamaker, and Gimbel Bros. in Philadelphia area.

Name

Address

City Zone

State

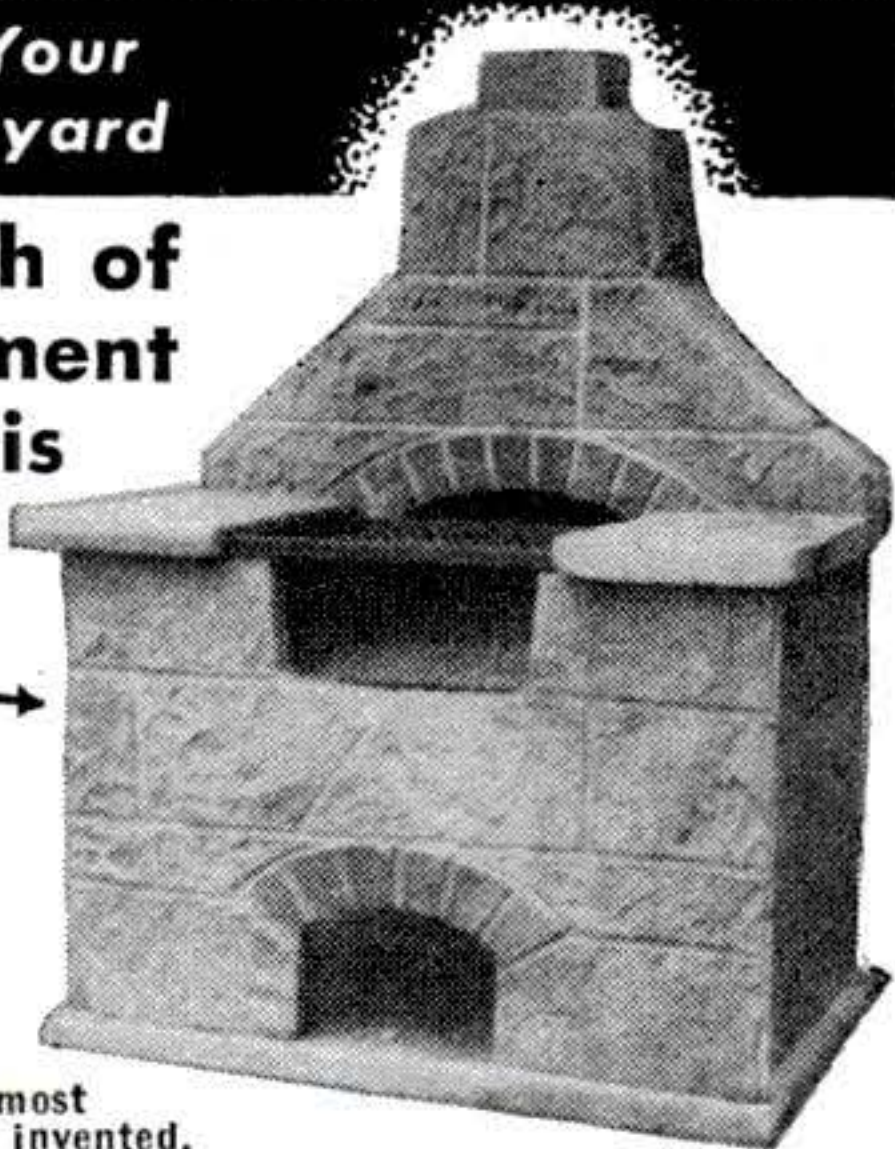

EARN MORE-LEARN AUTO DIESEL MECHANICS

OR TRAIN WITH OTHER GREER DIPLOMA COURSES

- | | |
|--|---|
| <input type="checkbox"/> AUTO MECHANICS | <input type="checkbox"/> REFRIGERATION |
| <input type="checkbox"/> DIESEL MECHANICS | <input type="checkbox"/> AIR CONDITIONING |
| <input type="checkbox"/> BODY & FENDER REPAIR | <input type="checkbox"/> MACHINIST TRADE |
| <input type="checkbox"/> GAS-ARC WELDING | <input type="checkbox"/> ADVANCED MACHINIST |
| <input type="checkbox"/> PIANO TUNING & REPAIR | |

Skilled men are needed in every part of the country. Earn top pay in established shops or start your own business. Greer's expert instruction and actual shop training teaches you how. You learn by doing—quick, easy courses using the latest tools and equipment. Day, evening and part time instructions available.

Job placement and convenient living accommodations are yours while training. Contact **GREER'S FREE JOB PLACEMENT SERVICE** when you enroll if you wish part time or full time employment.

ENGINEERING DEGREE COURSES

- | |
|--|
| <input type="checkbox"/> DIESEL AUTOMOTIVE ENGINEERING 27 MONTHS |
| <input type="checkbox"/> REFRIGERATION & AIR COND. ENGINEERING 18 MONTHS |
| <input type="checkbox"/> WELDING ENGINEERING 18 MONTHS |

All Courses Approved Civ. or G.I.

Please rush me free literature on the trade indicated at no obligation.

NAME _____ AGE _____

STREET _____

TOWN _____ ZONE _____ STATE _____

Established 1902

**GREER SHOP
TRAINING**
BOX D, 2238 S. MICHIGAN AVE.

Chicago 16, Illinois

When is a "Hi-Fi" not a Hi-Fi

**FIND OUT BEFORE YOU BUILD OR BUY WITH
POPULAR SCIENCE Hi-Fi test records**

EACH RECORD SERVES ITS OWN PURPOSE...

TEST RECORD VOL. 1

"Testing with Sine Wave Frequencies," uses electronically produced tones to analyze each component in your hi-fi set.

TEST RECORD VOL. 2

"The True Sounds of Musical Tones," consists entirely of life-like tones of the actual instruments of a symphony orchestra — employed in a unique way to let you hear how your set gives out with real music.

AVOID DISAPPOINTMENT WHEN YOU BUILD OR BUY NEW EQUIPMENT

- Tune speaker enclosures just right — by ear.
- Discover how quiet or noisy a turntable is.
- Show up worn stylus or poor tone arm.
- Test the setting of equalization controls.
- Challenges you to name common sound effects.
- Check transient response and dynamic range.
- Explore the personality of orchestral instruments.
- Test bass response with actual music.
- Shows how the high frequencies give realism to music.

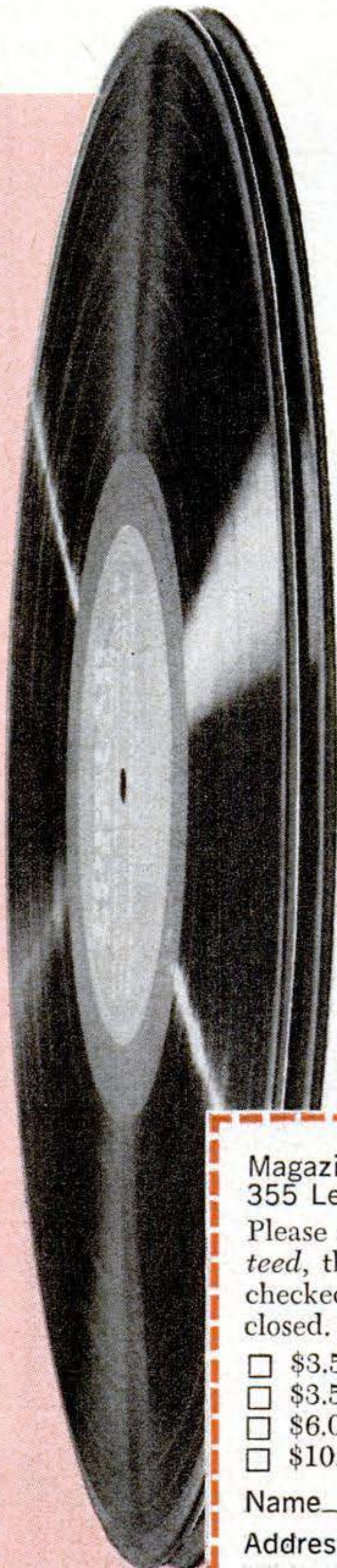

**VOL 1 • VOL 2
ONLY**

\$3.50
EACH
List Price
\$3.98 each

\$6.00
SPECIAL
Price For
Both Volumes

YOU MAY WANT TWO OF EACH! SPECIAL DISCOUNT ON SECOND SET! TWO SETS COST YOU ONLY \$10.00

Extra Hi-Fi Test Records make unusual and welcome gifts or you may want to keep them, unplayed, as a reference standard to check the ones you use regularly.

Attractive Albums and Full Instructions

The records come to you in protective dust sleeves and enclosed in attractive albums. Complete instructions for using the records are printed on the back liner of the albums.

Magazine Services, Inc. Department R 459
355 Lexington Avenue, New York 17, N. Y.
Please send me, *postage free*, and *fully guaranteed*, the Popular Science Hi-Fi Test Records checked below. Check or money order is enclosed.

- \$3.50 for Vol. 1
- \$3.50 for Vol. 2
- \$6.00 for both Vol. 1 and 2
- \$10.00 for 2 sets Vol. 1 and 2

Name _____

Address _____

City, Zone & State _____

Here it is! THE NEW 1959 DEXON "DRAGON" WITH UNITIZED BODY! EASY TO ASSEMBLE... SAFE TO DRIVE... APPEALS TO ALL AGES!

A Real Pace-Setter At A Pace-Setting Price

This is it! Never before a car like this "spanking-new" 1959 DEXON "DRAGON"!

This is no "toy kit" car. This is the real thing—designed for youngsters yet cannot be out-grown. The 1959 DEXON "DRAGON" is professionally-engineered and sets a new standard for style, performance and strength.

The DEXON "DRAGON's" loaded with style. Sleek and streamlined, it's available in gleaming aluminum or in tough, durable fiberglass.

It's sturdy . . . the "DRAGON's" unitized body and frame are built entirely in one piece. There's nothing to work loose and rattle.

The DEXON "DRAGON's" easy to assemble . . . just put on the wheels and go! No tedious bolting or welding is required. The "DRAGON" comes to you completely set up.

The new "DRAGON" is strong enough for adults to drive—completely safe for youngsters, too—and built to give years and years of trouble-free fun.

POWER PACKAGE SPECIAL!

CLUTCH, FOOT THROTTLE, CHAIN DRIVE AND CLINTON A-400 OR BRIGGS & STRATTON ENGINE WITH CAR ORDER \$59.95



ONLY \$7950
(less engine)

CHECK . . . AND DOUBLE CHECK . . .
The 1959 "DRAGON's"
Built-To-Last Features:

- Automotive Design, Front-End with Caster-Camber Toe-In.
- Full Steering Wheel.
- Motor Mount Designed for Single or Twin-Engine Installation. Direct Chain Drive or Pulley Jack Shaft for Desired Speed.
- 10" x 2 3/4" Heavy-Duty Ball-Bearing Wheels.
- Wide 30" Tread—44" Wheel Base. (3" Road Clearance).
- Aircraft-Type Spot Brakes, With Man-Size Pedal.
- Also Designed for High-Speed Performance.

Complete line of accessories, including front-end, steering equipment, available for all "chugs." Write for descriptive literature. Enclose 25 cents to cover cost of handling.

Send \$25 with order—balance C.O.D.

Dexon MANUFACTURING CO.
P. O. Box 792 • Minneapolis 40, Minnesota

Better Than
Your Own

SHOE STORE AT HOME



Two-Eyelet Hit With Cushioned Comfort

No investment, no experience needed. Just show magic cushion comfort to friends, neighbors, co-workers. Advance commissions to \$4.00 a pair, plus Cash Bonus, Paid Vacation, \$25.00 Reward Offer. Outstanding values for men, women, children. Money back guarantee. Shoe samples supplied without cost. Write TODAY for FREE new 84 page catalog and full details.

TANNERS SHOE CO., 132 BROCKTON, MASS.

U-MAK-IT BOAT KITS AND FRAME KITS

FIRST AND OLDEST KIT BOAT MANUFACTURER

Most complete line of PRAMS, ROWBOATS, OUTBOARDS, CABIN CRUISERS and new Lapstrake kits.

Send for BIG New ILLUS. CATALOG Showing all models 8' to 23' BOAT KITS, FRAME KITS, LAPSTRAKE KITS, FIBERGLAS, Accessories, Paints, all you need to build your own.

MAIL 50c (coin) for Postage & Hdlg.

U-MAK-IT PRODUCTS
DELAND, FLA.—DEPT. 11

REDUCED PRICES • SAVE UP TO 25%



PREPARE FOR BETTER JOB, BIGGER PAY IN SPARE TIME AT HOME

Today, choose the job you want—and prepare for it in time you might otherwise waste. Or if you are already in the work you like best, start training now for quicker promotion and increased pay. During the past 62 years AMERICAN SCHOOL has helped ambitious people to reach higher goals. Check subject that interests you and mail coupon for full information.

AMERICAN SCHOOL, Dept. G446, Drexel at 58th, Chicago 37, Ill. Without obligation, please send FREE and postpaid, full particulars about the subject checked below.

- | | | |
|--|---|---|
| <input type="checkbox"/> Accounting | <input type="checkbox"/> Contracting | <input type="checkbox"/> Mechanical Engineering |
| <input type="checkbox"/> Apprenticeship Courses | <input type="checkbox"/> Diesel Technician | <input type="checkbox"/> Mechanical Technology |
| <input type="checkbox"/> Architecture & Building | <input type="checkbox"/> Drafting—Building Trades | <input type="checkbox"/> Metalworking Courses |
| <input type="checkbox"/> Automotive Technician | <input type="checkbox"/> Drafting—Machine Trades | <input type="checkbox"/> Plumbing—Practical |
| <input type="checkbox"/> Better Foremanship | <input type="checkbox"/> Electrical Engineering | <input type="checkbox"/> Private Secretary |
| <input type="checkbox"/> Blueprint Reading | <input type="checkbox"/> Electricity—Practical | <input type="checkbox"/> Retail Merchandising |
| <input type="checkbox"/> Bookkeeping | <input type="checkbox"/> Electronics—Industrial | <input type="checkbox"/> Salesmanship—Outside |
| <input type="checkbox"/> Business Management | <input type="checkbox"/> HIGH SCHOOL COURSES | <input type="checkbox"/> Sheet Metal Work |
| <input type="checkbox"/> Civil Engineering | <input type="checkbox"/> Machinists | <input type="checkbox"/> Tool Making |

NAME..... OCCUPATION.....
HOME ADDRESS..... AGE.....
CITY..... STATE.....
Accredited Member NATIONAL HOME STUDY COUNCIL

MAIL COUPON NOW

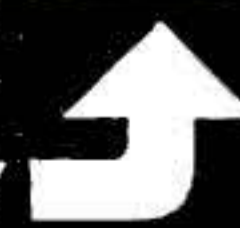

FOR *EASY* LAWN AND
YARD CARE . . . THE NEW 4½ H.P.

Ariens MULTI-
PURPOSE
Imperial

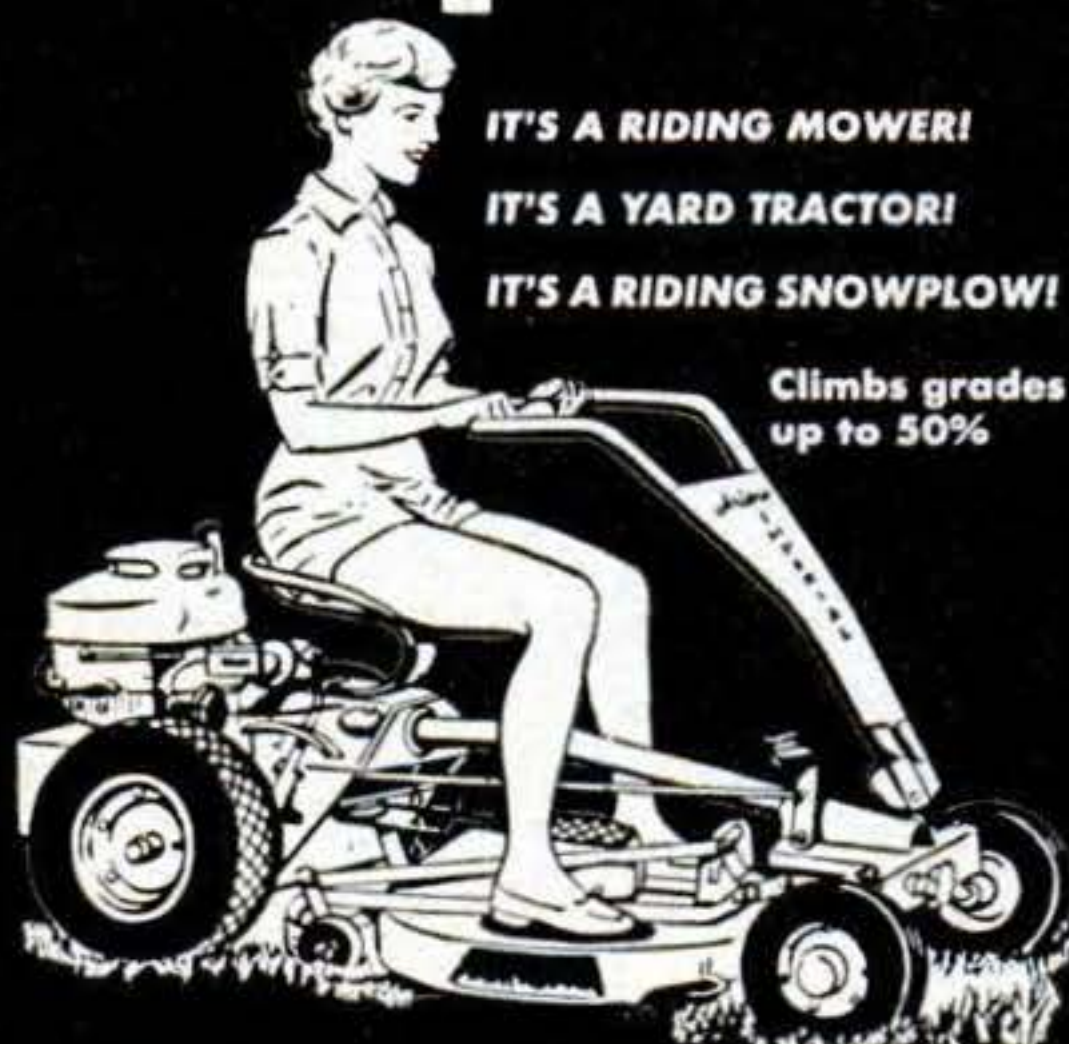

IT'S A RIDING MOWER!
IT'S A YARD TRACTOR!
IT'S A RIDING SNOWPLOW!

Climbs grades
up to 50%

Save time . . . work with Ariens 4½ h.p. IMPERIAL! With interchangeable attachments it's a 26" rotary mower, 30" reel mower, snowplow or yard tractor. Fingertip controls, optional electric starting. For full information, write:

Ariens

ARIENS COMPANY

159 Calumet St. Brillion, Wisconsin

HEAR CLEARLY AGAIN

Nerve deafness may cause words to sound unclear to you. You may strain to understand what is being said. Hearing strain may lead to tiredness, irritability and fatigue. Yet hearing strain is easy to take care of. A new booklet is out, telling all about how to correct hearing strain. It's called "Naturally, you can hear again". Send for your free copy. No obligation. (Sent to you in a plain wrapper.) Write

Acousticon
Your Golden Circle of Sound

INTERNATIONAL
DICTOGRAPH PRODUCTS INC.
95-25 149th St., Jamaica 35, N. Y. • Dept. POP.

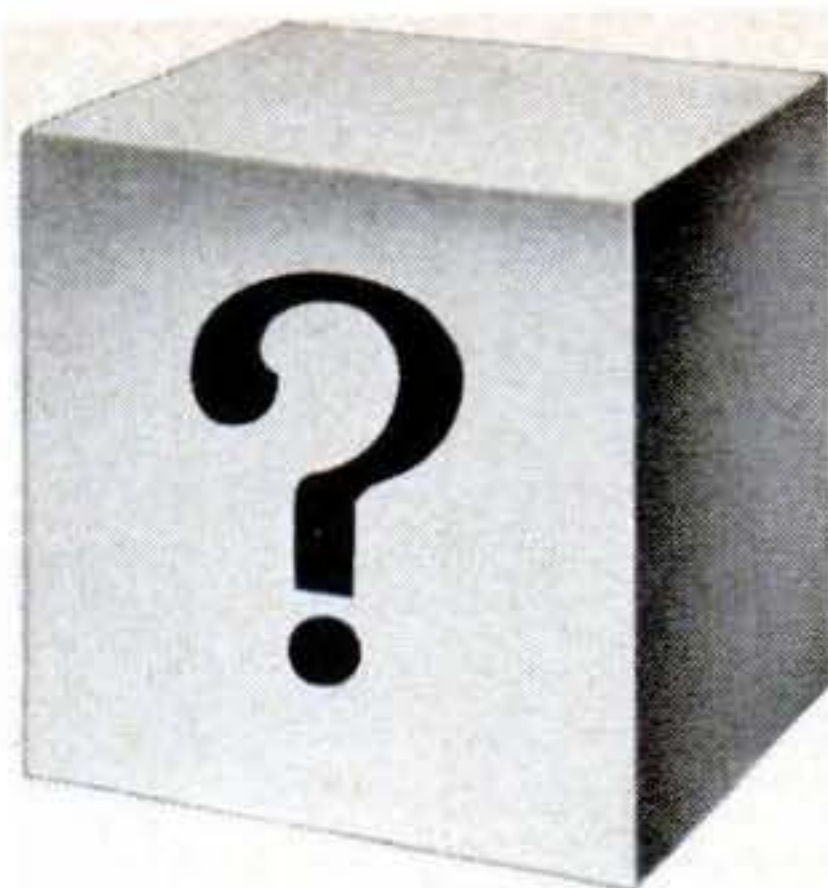

What a Brand Name tells you

A Brand Name says you can buy with assurance because you'll get the quality you expect.

Brand Names are built on your confidence. You and your neighbors dictate the standards a Brand Name product must meet to consistently deliver the value and service you want.

A respected Brand Name is a manufacturer's most valuable asset and he spares no effort to protect it by constantly testing and bettering his product.

A Brand Name is the maker's guarantee of satisfaction *doubly endorsed* by the dealer who sells it.

For dependable quality and complete satisfaction you will do better with the brands you know, get to know those you see advertised in this magazine.

To get the most for your money buy by Brand Name and be sure!

*A Brand Name is a
maker's reputation*



Buy the Brands you trust
at the store you know
Brand Names Week
April 12-19

BRAND NAMES FOUNDATION, INC.
437 FIFTH AVENUE, NEW YORK 16, N.Y.

Rip Van Winkle Couldn't Sleep with Nagging Backache

Now! You can get the fast relief you need from nagging backache, headache and muscular aches and pains that often cause restless nights and miserable tired-out feelings. When these discomforts come on with over-exertion or stress and strain—you want relief—want it fast! Another disturbance may be mild bladder irritation following wrong food and drink—often setting up a restless uncomfortable feeling.

For quick relief get Doan's Pills. They work fast in 3 separate ways: 1. by speedy pain-relieving action to ease torment of nagging backache, headaches, muscular aches and pains. 2. by their soothing effect on bladder irritation. 3. by their mild diuretic action tending to increase output of the 15 miles of kidney tubes.

Find out how quickly this 3-way medicine goes to work. Enjoy a good night's sleep and the same happy relief millions have for over 60 years. Ask for new, large size and save money. Get Doan's Pills today!

HOW TO GROW

ORCHIDS

AT HOME

Learn Special Conditions of Light, Temperature & Humidity Needed!

"Most enjoyable hobby I know. People drove 100 miles to see this plant ... 10 flowers 8 1/2 inches across."

THOS. HURST, Utah

WORLD'S MOST THRILLING HOBBY - PROFITABLE HOME BUSINESS. SUCCESSFUL HOME GROWER offers COMPLETE illustrated instructions. Tells HOW TO START. Explains everything you need to know about growing Cattleyas, Cymbidiums, Odontoglossums and others. Many Orchids GROW WITHOUT SOIL, get food from the air. Instructions include real BLOOMING-SIZE ORCHID PLANT. FREE - full details and 3-months Subscription to the "Orchidian," the "show-how" publication for home Orchid growers. WRITE TODAY! Airmail reaches us overnight.

TROPICAL FLOWERLAND, Dept. 24-A, 100 S. Vermont, Los Angeles 4, Cal.

FREE! 3-months Subscription to The "Orchidian"

OPTICAL BARGAINS

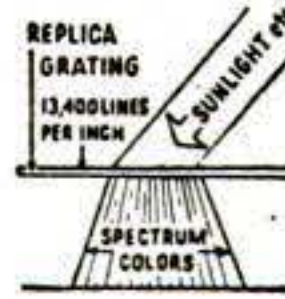

REPLICA GRATING—Low, Low Cost

Take Unusual Color Photos at Night!
It's here—after decades of effort. Replica Grating—on film—at very low price. Breaks up white light into full spectrum colors. An exciting display. 13,400 lines per inch. Diffraction Grating has been used to answer more questions about the structure of the material world and the universe than any other single device. Use it for making spectroscopes, for experiments, as a fascinating novelty. First time available such large size—so cheaply. Comes in clear plastic protector.

Stock No. 50,202-N . . . includes 2 pieces 8" x 5 1/2"-1 transmission type, 1 reflecting type. . . . \$ 2.00 Pstpd.
Stock No. 50,180-N . . . 1 piece transmission type 8 in. x 6 ft. . . . \$ 5.95 Pstpd.
Stock No. 50,203-N . . . 1 piece reflecting type 8 in. x 6 ft. . . . \$10.95 Pstpd.

SALE! TERRIFIC WAR SURPLUS BARGAINS! AERIAL CAMERA LENSES



Big variety . . . at a fraction of Government cost!
f6, 24" f.1. with shutter, diaphragm and lens cone—used. Weight 25 lbs.
Stock No. 85,059-N . . . \$39.50 F.O.B. Utah
Same as above, but new. Weight 25 lbs.
Stock No. 85,060-N . . . \$59.50 F.O.B. Utah
f8, 40" f.1., no mount or shutter. Weight 6 1/4 lbs.
Stock No. 70,186-N . . . \$49.50 Postpaid
f5.6, 20" f.1. telephoto with shutter. Weight 6 1/4 lbs.
Stock No. 70,187-N . . . \$65.00 Postpaid
f4.5, 6 3/8" f.1. with shutter and diaphragm. Weight 1 lb., 6 ozs.
Stock No. 70,189-N . . . \$24.50 Postpaid

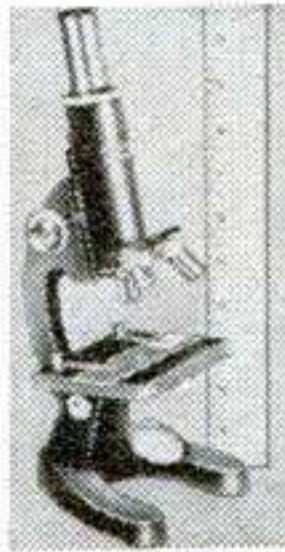

50-150-300 POWER MICROSCOPE

Amazing Value—Equal of a \$75.00 Instrument! 3 Achromatic Objective Lenses on Revolving Turret! Imported! The color-corrected, cemented achromatic lenses in the objectives give you far superior results to the single lenses found in the microscopes selling in this range. Results are worth the difference! Fine rack and pinion focusing.

Stock No. 70,008-N . . . \$14.95 Pstpd.

MOUNTED 500 POWER OBJECTIVE

. . . Threaded for easy attachment on above microscope. Achromatic lenses for fine viewing. 3 mm. focal length. **Stock #30,197-N** . . . \$5.00 Pstpd.

SEND 25¢ FOR GIANT CATALOG "N-2"

We'll include FREE a piece of amazing DIFFRACTION GRATING REPLICA (13,400 lines per inch—see all colors of spectrum). 96-page Catalog is a treasure house of bargains in Telescopes, Microscopes, Binoculars, Magnifiers, prisms, lenses, optical parts and accessories.

ORDER BY STOCK NUMBER. SEND CHECK OR MONEY ORDER. SATISFACTION GUARANTEED!
EDMUND SCIENTIFIC CO., BARRINGTON, N. J.

New
FANTASTIC
BUSINESS
HOBBY

PLASTIC VACUUM FORMING MACHINE "HOBBY-VAC"

Now you can create thousands of original 3D items at a cost of about 10c each. Possibilities are unlimited. Hobby-Vac Forms—Draws—Skin Packs—Bubble Packs. It reproduces Pictures—Signs—Plaques—Coasters—Dishes and many more items in brilliant metallic gold, silver, copper, plain or colored plastic. Natural objects may be used for forming. Hobby-Vac is simple to operate. A 110 volt outlet and a home vacuum cleaner is all that is needed.

(PICTURED ON THE RIGHT IS THE SMALLEST SIZE HOBBY-VAC)
HOBBY-VAC MACHINES AVAILABLE IN THESE SIZES

Free 3-D Sample and Literature on request	7" x 7" . Picture size 6" x 6" x up to 3" deep.. \$ 39.50
	7" x 14" . Picture size 6" x 13" x up to 3" deep.. 79.00
	14" x 14" . Picture size 13" x 13" x up to 3" deep.. 160.00

ORBIT of CALIFORNIA 211 Los Molinos, San Clemente, California

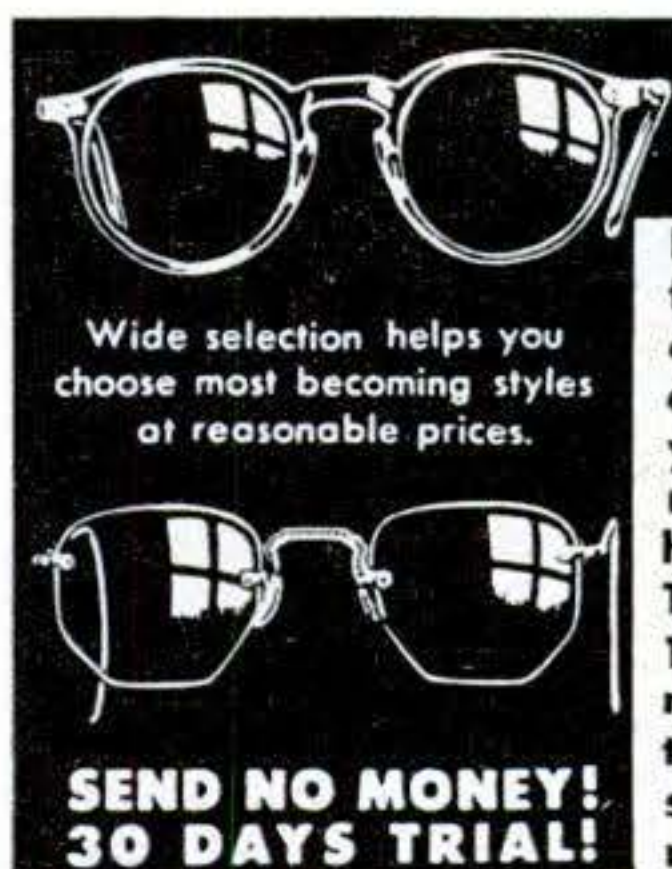

Wide selection helps you choose most becoming styles at reasonable prices.

**SEND NO MONEY!
30 DAYS TRIAL!**

EYE GLASSES BY MAIL? IT CAN BE DONE!

Buy from the oldest established firm offering this service. Reading-magnifying or bi-focal glasses for far and near. Recommended for folks approximately 40 years or older who do not have astigmatism or disease of the eye, and who have difficulty reading or seeing far. Thousands of customers! We furnish 14-lens sample card with many combinations and other styles priced to meet your budget.

as low as
\$1.95



SEND FOR
FREE catalog

attractive styles
for men
and women

name _____
street _____
city _____ state _____ DEPT. PMS

ADVANCE SPECTACLE CO., INC.
537 S. Dearborn St., Chicago 5, Ill.

Dr. Grabow PRE-SMOKED PIPES

Cool, sweet and mild
from the first puff.
No breaking-in
because they're
mechanically
pre-smoked.



Imported
briar

Starfire
\$3.50

other Dr. Grabows
from \$1.50 to \$10

♠ trademark of quality

For informative booklet write:
Dr. Grabow Pipe Co., Greensboro, N.C.

MAGIC MAIL PLAN

that comes with this Little Machine
CAN MAKE YOU \$5.00 AN HOUR



The machine is turning
out a job that will bring
operator \$2.58, by mail.
Material cost, only 11c!

Write today for free facts about the
newest and most fascinating of all
new home operated businesses. For
the first time, a simplified machine
brings the fabulous profits of Plastic
Sealing and Plastic Laminating with-
in reach of the small operator. Any-
one can learn to operate it with a
few minutes practice. Then—with
our MAGIC MAIL PLAN—can get
mail orders pouring in daily with
cash in every envelope.

No Canvassing or Selling

Fill orders at home in spare time to
start. Then expand to full time busi-
ness. We even supply circulars to
bring back cash and orders. Rush
name for all the facts you need to
start. A postcard will do. No charge.

WARNER ELECTRIC CO., Dept. L-3-D
1512 Jarvis, Chicago 26, Illinois

BLASTS MOLESTERS...THUGS! *Amazing* **TEAR GAS PENCIL**

100% PROTECTION!

SELLS EASY TO SERVICE STATIONS, BAR, CAFE WORKERS,
SMALL STORES, SHOPS, LOAN OFFICES, BANKS, HOMES.

Tear-Gas Pencil discharges clouds of tear-gas to
instantly stop, stun and incapacitate the most vicious man or beast.
Effective substitute for dangerous firearms; leaves no permanent in-
jury. No selling experience needed. Handle as profitable sideline
... soon you'll sell it full time. Start now. 5 easy sales net \$25.00
a day—up. Send \$5.95 for complete demonstration kit of Automatic
Tear-Gas Pencil, 10 demonstrators and 3 Powerful Tear Gas Car-
tridges. NOT SOLD TO MINORS. STATE AGE WITH ORDER.
HAGEN SUPPLY CORP. Dept. P-49, Saint Paul 4, Minnesota

**BEGIN COUNT DOWN...
DESTINATION:
Your FUTURE!**

ENROLL NOW IN NORTHROP INSTITUTE'S
TWO YEAR COURSES IN

**AERONAUTICAL OR ELECTRONICS
ENGINEERING TECHNOLOGY**

BACHELOR OF SCIENCE DEGREE—if you elect,
you may continue an extra year and earn
a B.S. Degree in the field of your choice.
TIME IS MONEY! You save time with Northrop
Training . . . become employed sooner . . .
begin earning a good salary sooner! Thou-
sands of Northrop graduates are success-
fully employed in the Aircraft, Electronics,
Missile and Space Technology Industries.



**MAIL
COUPON
TODAY
FOR
FREE
CATALOG**

NORTHROP INSTITUTE OF TECHNOLOGY
1157 W. Arbor Vitae Street, Inglewood 1, Calif.

Please send me immediately the Northrop catalog, employment
data, and schedule of class starting dates. I am interested in:

- Aeronautical Engineering Technology
- Electronic Engineering Technology
- Aircraft Maintenance Engineering Technology
- Airframe and Powerplant Mechanic
- Jet Engine Overhaul and Maintenance

Name _____ Age _____

Address _____

City _____ Zone _____ State _____

Veterans: Check here for Special Veteran Training Information.

make it with 60c worth of sand & cement!

SELL IT FOR \$2000

every home a prospect for these "LIFETIME"

**CONCRETE
INCINERATORS**

Make big profits manufacturing rust
proof, fire proof, almost indestructible
concrete incinerators in your own back-
yard or garage . . . full or part time.
Sell to home-owners, hardware, de-
partment and garden supply stores.
Phila. manufacturer doing big volume
with Sears, Roebuck; large department
stores. Easy to follow instruc-
tions and all needed equipment
supplied. Exclusive protected
franchise—No competition! Ter-
ritories going fast. Write im-
mediately for full details.



Dept. PS-49, T. K. TOR
318 Rancocas Ave., Delanco, N. J.
Gentlemen:
Rush full information about your
concrete incinerator protected
franchise offer.

Name _____

Street No. or R.D. _____

City _____ Zone _____ State _____

World's greatest classified

opportunities

80 DIFFERENT
CLASSIFICATIONS . . .
P. S. SELLS TO ALL

POPULAR SCIENCE MONTHLY
355 LEXINGTON AVE.
NEW YORK 17, N. Y.

Classified Ads only \$1.10 per word insertion, payable in advance. Minimum ad 10 words. To be included in June issue, copy should be in our office by April 20. No cancellations accepted after April 15. Address orders to O. K. Kelly, Classified Adv. Mgr.

1 AUTOMOBILES & MIDGET CARS

HOT Cart Racer—\$129.00 up. 2 to 4 hp. Wheel options. Free folder. Dept. 35, Box 9405, Richmond 28, Virginia.

RETAIL prices on all 1959 automobiles and accessories. \$1. Gordon Dill, 115 South Shore Drive, Decatur, Illinois.

HUNDREDS of automobile catalogs—American, antique, foreign; dealer books, glossy photographs, shop manuals; free motor magazines listed by non-profit organization. Write immediately; get on free mailing list. Auto Maniacs, Stockbridge, Michigan.

CROSLY or Foreign car parts catalogue. Parts discount club. Box 7, Elmont, New York.

FIBERGLASS Bodies for children's Cars. Racers, Sport Car. Literature 25c. Amroc Engineering, Island Park, N. Y.

ATTENTION New Car Owners! Are you getting all you paid for? Are you interested in obtaining information concerning your car on: List of Factory Modifications: How to get service problems requiring factory authorization answered. List make and model. Send \$1.50 to Car-Info, P.O. Box 118, F.M. Sta., Flushing 65, New York.

1959 CATALOG on Parts Kits for Golf Buggy or Jr. Sports Car 25c. Indus Corporation, 1815 Madison, Indianapolis.

MIDGET Car, Two Passenger. Plans, price list of parts 35c. Sypher Co., Sta. F, Toledo, Ohio.

NEW Catalog on Power Cams and Flywheels 25c. Weber Cams, Box 33175, Los Angeles 33, Calif.

2 AUTO SUPPLIES & EQUIPMENT

SAVE money on Jeep and army truck parts. Large inventory. Catalogs for Jeep and G.M.C. owners. American Auto Parts Co., 1830-PS Locust, Kansas City, Missouri.

1909-1934 FORD parts. Illustrated catalog 50c. Mark, Layton, New Jersey.

1959 GIANT Auto Parts Catalog. Thousands Accessories Stores Don't Handle . . . Gadgets, Custom Equipment. Send 25c (Refundable). Newhouse Automotive Industries, 5805-PS-4, Beverly, Los Angeles 22, Calif.

1959 EDITION. It's New! It's different! Get world's largest auto accessories and parts catalog, save up to 50%. 308 pages, over 85,000 items for 1920 to 1959 models including Hollywood accessories, custom styling and Hi-Speed Equipment. All parts and accessories for all cars and trucks. We have that hard to get part. Jam packed with bargains, Completely illustrated. Send 25c (refundable). J. C. Whitney, 1919 PS-4 Archer, Chicago 16, Ill.

AUTO shop welding repair training in world's largest non-profit school. Low tuition. Free booklet. Hobart Welders, Box P-491, Troy, Ohio.

HAVE comfort with your driving. Install a magnetic traffic signal finder only \$1.49 postpaid. W. Westra, 11 Grove Street, Tonawanda, New York.

CHEVROLET, G.M.C. Accelerator motor noise silenced. Kit \$3.00. Dawley, B-473, Arbuckle, California.

ENGINE Hot? Radiator Dirty? Cool and Clean While Driving. Proven Water Filter and Conditioner. Satisfaction Guaranteed. Free Literature. Rahl Co., Box 5303M, El Paso, Texas.

USE THIS HANDY INDEX TO FIND WHAT YOU WANT

Advertising, Agencies for Advertisers . . .	53
Agents Wanted	43
Antique, Relics & Indian Goods	29
Artists Supplies	76
Astronautics	5A
Authors Service	52
Auto Supplies & Equipment	2
Auto Trailers	3
Automobiles & Midget Cars	1
Aviation	5
Batteries, Generators, Etc.	6
Boats, Outboard Motors	11
Body-Building Courses, Jiu Jitsu, Etc.	12
Books & Magazines	23
Business Opportunities	37
Business Service, Information, Name Lists	50
Buy It Wholesale	38A
Cameras, Photo Supplies	34
Camping Equipment & Tents	16
Cartooning, Sign Painting, Chalk Talks	54
Coins & Currency	26
Color Photo Finishing	32A
Contests	46
Detectives	47
Do-It-Yourself	66
Dogs, Birds, Hamsters & Pets	17
Educational & Instruction	45
Electrical Supplies & Equipment	7
Engines, Motors, Etc.	10
False Teeth	78A
Farm Machinery	10A
Farms, Other Real Estate	19
Field Glasses, Telescopes	14
For Inventors	60
For Sale Miscellaneous	71
For the Home	69
Formulas, Plans, Etc.	39
Frog Raising	18A
Geiger Counters, Treasure Finders	77
Help Wanted	42
High-grade Salesmen	44
Hobbies, Collections	31
Home Craftsman	65
Hypnotism	24
Inventions Wanted	61
Investments	27A
Jokes, Games, Novelties, Etc.	24A
Language Outfits	48
Live Bait	18
Machinery, Tool Supplies, Etc.	9
Magic Tricks, Puzzles, Etc.	25
Manufacturing	63
Minerals & Precious Stones	30
Miscellaneous	79
Models, Model Supplies	64
Money-making Opportunities	38
Motion Pictures, Slides, Sound Equip.	33
Motorcycles, Bicycles & Supplies	4
Music, Song Writers & Records	35
Of Interest To Women	70
Old Gold, Jewelry, Watches	67
Old Stamps Wanted	27
Patent Attorneys	59
Patents For Sale	62
Personal	80
Photo Finishing, Photocopies, Etc.	32
Plastics	40
Plays, Stories, Etc.	49
Poultry & Supplies	21
Printing, Multigraphing, Etc.	57
Printing Outfits, Supplies	58
Profitable Occupations	22
Radio, TV, Supplies & Equipment	36
Razor Blades, Shavers	74
Rubber Stamps & Office Supplies	56
Science & Chemistry	41
Special Services	51
Sporting Goods, Guns, Fishing Tackle, Etc.	15
Stamp Collecting	28
Swap	79B
Tattooing Supplies	75
Taxidermy	13
Tobacco & Pipes	68
Trees, Shrubs, Roots & Herbs	20
Trigonometers	9A
Typewriters & Office Machines	55
Wanted to Buy	72
Watch Repairing	78
Wearing Apparel	73
Welding, Soldering	8
Western Merchandise	79A

NIGHT driving glasses, eliminate headlight glare, eye fatigue. Make night driving a pleasure. Details, write, Consumer Products, Box 91, Toledo 14, Ohio.

FORD "T" parts headquarters. Free catalog. Ernie Hemmings, Quincy, Illinois.

RING-Valve job while driving, \$6.00. Free details. Motaloy, Grantham 27, Penna.

PREVENT Power Loss! Get quicker, dependable engine starts by boosting, fuel pump efficiency up to 30% more with inexpensive, automatic Control Valve. New Thermal-Hydraulic principals provide maximum engine performance free from Vapor problems. Easy installation at pump inlet, fittings included. Send only \$3.00 cash or money order. Production Engineering, 5 Franklin, Needham Heights 34, Massachusetts.

DUAL Auxiliary Accelerator Left Foot Gas Pedal. \$6.95. Lehner Company, Ness City, Kansas.

MERRYMAN Pistons all Makes and Models 1902, 1959—for nearest dealer Write—Box 422, Ontario, California.

3 AUTO TRAILERS

TRAILER Manual tells how to: buy, travel, pull, remodel, repair trailers. Complete How-T-Do-It book. Indexed and illustrated. \$1.98. Satisfaction guaranteed. Trail-R-Club, Box 1376W, Beverly Hills, California.

BUILD Expanding eight foot trailer. Accommodates five. Literature 10c. Framar Company, Wilmington, Massachusetts.

4 MOTORCYCLES, BICYCLES AND SUPPLIES

RECONDITIONED Motorcycles and motors. Chromium accessories. Complete stock Indian parts. Expert rebuilding. Fast service. Indian Motorcycle Sales, Kansas City 27, Missouri.

DOODLEBUG motorscooter \$35, Servicycle \$18, Midget Car \$45, Whizzer Motorbike, 2 extra engines \$50, Electric outboard \$5, engines \$2.50 up. (Mailorder only). Send 25c (35c for First Class Mailing) for Directory-Catalogue Number 88 just out, listing these and hundreds of other bargains in midget cars, motor-scooters, homebuilders parts, plans, etc. Midget Motors Directory, Athens, Ohio.

MOTORSCOOTER \$6.00; Indian Motorcycle \$30.00; Whizzer \$7.50; Briggs (Kick Starter) \$12.75. Send 25c (35c first class mail) for catalog #33 jammed with sensational bargains in motors, motorscooters, midget cars, motorbikes, construction plans. Gail, 1313 Jefferson, Toledo, Ohio.

WANTED—Rider agents in small towns and rural districts to sell Jawa Motorcycles and Scooters at fine profit. Get into business of your own with small capital only for your demonstrator at agent's price. Widest range of small to middleweight motorcycles and scooters at extremely low prices. Dealers in larger towns and cities also wanted. Write for catalog-B. West of Mississippi write Cycle Imports, 1325 South LaBrea, Los Angeles 19, California. East Mississippi World Trade Motors, 299 Bruckner Blvd., New York City 54.

1000 MOTORCYCLE Bargains, Parts—Equipment. Buy, Sell, Trade Anything. Catalog 25c. Bunico, 146AB, Covington, Virginia.

5 AVIATION

RAMJET Helicopter—build inexpensively. Plans only \$1.00. Wooster Engineering, Box 259, Wooster, Ohio.

POPULAR SCIENCE OPPORTUNITIES

NEW Plotter gives ground speed, wind, miles off course, and change course anytime. Guaranteed. \$5.00. Tac Corp, Box 5, Salisbury, Maryland.

PROPELLERS, plans, supplies for airboats and snowplanes. Latest designs, prompt delivery. Catalog 25c. Banks-Maxwell, Box 3301G, Ft. Worth 5, Texas.

HOME BUILT Helicopter Handbook \$1.00. Homebuilt Helicopter Directory \$1.00. Urshan, Box 4332 N.P. Station, San Diego 4, California.

HELICOPTER, Kits, Plans. Free Brochure. Adams, Box 6042-N, Lakewood, Calif.

FLYING Platform. Three Drawings, \$2.00. Rotron, Box 573-N, Bellflower, Calif.

HELICOPTER, Blue Prints and Technical Construction Data. Send \$2.00 for 3 view drawing. Pioneer Helicopter Company, Box 357, Hallandale, Florida.

5A ASTRONAUTICS

ROCKET Amateur's Guidebook. 24 pages vital research, design, construction, career information. \$1.00. Space Products, PS-2, 38 East 57th St., New York 22, New York.

6 BATTERIES, GENERATORS, ETC.

PROFIT! Battery Repair Manual \$3.00. Bayer, 938S Betty, Neenah, Wis.

7 ELECTRICAL SUPPLIES & EQUIPMENT

ELECTRIC Pencil: Engraves all Metals, \$2.00. Beyer Mfg., 10511-C Springfield, Chicago 43.

REPLACEMENT Parts, all rectifiers, DC Power Supplies. Build-it-yourself kits for all applications. Electrical Division, 1624-K East First, Los Angeles 33, California.

ELECTRICIANS! Bend conduit easily, correctly. Latest "Simplified System" \$3.00. William Goforth, Box 455A, Clarksville, Tenn.

BOOK 200 Electric Stunts \$1.00. Cuttington, 26278 Arastradero, Los Altos, California.

APPLIANCE Parts Wholesale, Catalogue 25c. Seco, 26 South 20 Street, Birmingham 3, Alabama.

LAMP parts, Wholesale. Thousands of items for repairing, converting. Catalog 25c. Brown Lamp, Box 305-D, Clayton 5, Missouri.

HUNDREDS rebuilt electric motor bargains. Single, three phase. Money-back guarantee after trial. Free price-list. Temps Motors, 7024 Myrtle Avenue, Brooklyn 27, New York.

FREE Instrument Screwdriver! Get-acquainted offer. Just send name and two stamps. Laircraft, Box 5008-BM, Detroit 35, Michigan.

8 WELDING, SOLDERING

WELDERS, 110/220. Welds 1/2". \$39.50. Morris, 1070 Inner Drive, Schenectady, New York.

ACETYLENE Welding Outfits new \$54.50; Arcwelders \$56.50; Eagle Welding, Dept. 42, 5085 Broadway, Chicago 40, Ill.

FREE Catalog, welders, welding kits. Build 350-ampere welder using aircraft generator, plans 25c. Agents wanted. Dunbar Manufacturing, Minneapolis 8, Minnesota.

9 MACHINERY, TOOL SUPPLIES, ETC.

POWERED Portable Concrete Mixer, Patented. Free literature. Beran Mfg. Co., 906 Dullnig, San Antonio 10, Texas.

WE insulate, protect, your plier handles with tough, durable vinyl. \$1.25 each. Mail with check or money order. Biggs Products, 4481 Malcolm Ave., Oakland, Calif. No C.O.D.

SHARPEN Chain Saws two models \$15.40, \$18.60. Precision filing easy. S&M Manufacturing, Sidney, Iowa.

9A TRIGONOMETERS

ENGINEERS, Draftsmen, Students: Triangulator Makes Trigonometry Easy. \$1.25. No C.O.D. Trical, Box 67, Buffalo 15, New York.

10 ENGINES, MOTORS, ETC.

DIESEL Injector Parts and Fuel Pumps Wanted GM51-71-110. Mayer, 7120 Carnegie, Cleveland 3, Ohio.

REWIND Motors Yourself. Complete Instructions, \$1.00. Lewis Mfg., Howell 11, Michigan.

10A FARM MACHINERY

SENSATIONAL Garden Tractor. Hoes between plants and rows, including strawberries. Eliminates hand hoeing. Standard in size, yet entirely different. Patent 2742840. Also tills. Fantastic offer to first few inquiries. Auto Hoe, DePere 69, Wisconsin.

LAWRENCE 10-Ton Farm Truck Hoist, electric or PTO models. Low Direct-To-You Prices. Can use Agents. Lawrence Manufacturing, 261 Elroy, Minneapolis 8, Minnesota.

11 BOATS, OUTBOARD MOTORS

NEW, used, rebuilt marine motors. Marine conversions, fittings. Free Catalog. Stokes Marine Supply, Dept. 23, Coldwater, Mich.

FREE big catalog; Boat Kits save 1/2 to 2/3 "factory built" prices. 8' through 18' outboards designed for amateur assembly. Trailers, Fiberglass, Hardware, Accessories. Luger, Dept. K-4, 9200 Access Rd., Minneapolis 20, Minnesota.

SAVE Money. New, used outboard motor parts. Send wants. Stamp appreciated. Outboard Motor Mart, 229-M State, Boston 9, Mass.

FULL size, shape-cut boat patterns, blueprints, 7 1/2-38 feet. Send 50c for 88-page illustrated "Build a Boat" catalog of all types, Naval-architect-designed, boats. "How to Build a Boat" booklet, \$2.50. "Hardware & Equipment," \$2.00. Cleveland Boat Blueprints, Dept. A-77, Box 1651, Cleveland, Ohio.

BUY Direct From The Factory. Custom Made "Core-Glass" and Molded Fiberglass Boats. Fishing and Runabout models—14 to 18 ft. Boat Trailers—400# to 2000# capacity. Tremendous savings on complete package of Boat, Motor and Trailer. Free Wholesale Catalog. Osage Manufacturing Co., Box 117-C, Osage, Minnesota.

SAVE! Save! Save! World's Finest Boat Kits—25% less. Satisfaction Guaranteed! Write for free color catalog. Dept. PSM-459, Taft Marine Woodcraft, 636 39th Ave., N. E., Minneapolis, Minnesota.

BOAT Plans—Full Size Patterns—Frame Kits. Modern Inboards and Outboards for amateur builders. Complete New Catalog 50c or specify requirements. Glen Marine, 9152 Rosecrans, Bellflower, Calif.

POWER Putty. Miracle plastic kit. Speeds shop, boat, engine repairs. For home and hobby. Free laminating resin and instructions. PP \$2.98, COD. Huntress Pro., Atascadero, California.

BOAT Power Steering Simplified Easily Constructed. Instruction Booklet, Plans. \$2.00 P.P. Guaranteed. Adex Engineering, 8533 E. Callita St., San Gabriel, California.

NYLON Rope, lines, cords, nets, seines. Every description for commercial, sportsmen and household use. Finest quality. Free catalog. Beebe Cordage Co., Cranford 7, N. J.

FIBERGLAS Boat Covering, wholesale prices. Free literature and samples. Seifert's, Box 31X, DePere, Wisconsin.

BOAT Plan Catalogs: Powerboat 50c, Sailboat 25c. Marinecraft, Box 161-P, Brighton, Mass.

12 BODY-BUILDING COURSES, JIU JITSU & ATHLETIC EQUIPMENT

BUILD powerful arms, chest, shoulders! 22 exercises, \$1. Fonsad, Box 601-C, 1100 Market, Wilmington 99, Delaware.

EXTRA Heavy Tension 5-Spring Chest Exerciser \$6. Yankee Sales, Box 245, Bangor, Maine.

SKINNY? Overweight? Want to gain or lose weight, develop beautiful, muscular body? Complete 20-lesson course, plus Jiu Jitsu, only \$5.00. Results guaranteed. American Health Club, Box 3024, Oklahoma City 5, Oklahoma.

PUSHED around? Don't take nonsense from bullies. Surprise them. Easy when you know Police Jiu Jitsu. Complete fully illustrated course in one volume as taught police and armed forces. Send \$1 now. Satisfaction guaranteed. Books Publishing Co., Amityville 39, New York.

BIG Strong Healthy Muscles 4 Courses 25c. Results fully Guaranteed. 12 Courses \$2.00. Personal Supervision. Sid's System, P.S., Southgate, California.

BARBELLS, Exercise Equipment, Courses Booklet, Souvenir Photos 25c. Reading Barbell Co., Reading, Pennsylvania.

BARBELLS, Dumbbells, Courses. Apparatus. Booklet 10c. Good Barbell Co., Siloam Springs, Arkansas.

KARATE Kung Fu, deadly oriental Defense. Power that Breaks planks Barehanded. Illustrated Manual \$3.98. J. Yim Lee, 584 Valle Vista Ave., Oakland 10, Calif.

14 FIELD GLASSES, TELESCOPES

DYNASCOPE—amazing world famous reflector telescope. Request free brochure. Criterion., Dept. DS-59, Hartford, Conn.

WAR Surplus bargains! Millions of lenses, instruments, telescopes, binoculars, components and complete line of astronomical telescope items. World's greatest optical market place! Send only \$1.00 for beginner's 10-lens kit and big instruction booklet Stock 2-CN. Write for catalog-CN Free. Edmund Scientific Co., Barrington, New Jersey.

FREE Catalogue! Thousands war surplus optical bargains. Lenses, Prisms, Telescopes, Binoculars, etc. Send \$1.00 for 10 Lens Hobbyist Set and Project booklet. G. Jaegers, 691 West Merrick Road, Lynbrook, New York.

BUILD your own Reflector Telescopes, complete kits; Mirrors, Eyepieces, Tripods, all other accessories. Request free illustrated literature. Criterion Manufacturing, Dept. KP-52, Hartford, Conn.

REFLECTOR Telescopes from Esco. Assembled and "do-it-yourself" telescopes from \$7.50 (3") to \$175 (12"). Complete line of optics and accessories. Send for free illustrated booklet. Esco Products Company, Oakridge, N. J.

SPECIAL winter sale, precision binoculars. Amazing prices. Folder "Binocular Selecting," catalog free. Prentiss Importers, Mercury Bldg., West Los Angeles 25, Calif.

FREE 48 Page Science Catalog Covers everything. Research Scientific, 126-T4, West 23rd St., New York 11.

BINOCULARS, Telescopes, Microscopes. Terrific values \$3.98 up. Request free money-saving catalog. Criterion, Dept. S-77, Hartford, Conn.

STAR—Atlases, astronomical books, free list. Herbert Luft, 69-11 229th St., Flushing 64, N. Y.

TELESCOPES, Binoculars—all sizes. Complete optics, parts, accessories for telescopes. Free catalog. Suffolk Science, Mattituck, New York.

REFLECTING Telescope completely assembled. 60X. Guaranteed Observatory clearness. Free information. The Skyscope Co., P. O. Box 55, Brooklyn 28, New York.

15 SPORTING GOODS, GUNS, FISHING TACKLE, ARCHERY TRAPPING

100,000 PRODUCTS Wholesale—Free catalog! Send postcard: Econ-O-Mart, Whippany 16, New Jersey.

FREE . . . Wholesale Catalog. Beads, Spinners, Lure parts, Sinker molds, Jigs, Reels, Finny sports, (PE), Toledo 6, Ohio.

HOW To Catch Fish With Smell, 25c. Johnson's, 312 Lake Avenue, Ithaca, New York.

SPECIAL! To all Gun Lovers! 5 year subscription to The Gun Digest, only \$10.00 postpaid. Lifetime \$50.00. Start with either 1959 or 1960 Edition. At your local dealer or order by mail from the publisher. Gun Digest Company, Dept. PS-4, Chicago 6, Illinois.

CROSSBOWS! Hunting—Bows! Factory Prices! Jayco, Box 1355, Wichita, Kansas.

5,000 BARGAINS, firearms, binoculars, war relics, catalog 50c. Smith Museum, Runnemed, N. J.

GUNS — Swords — Knives — Daggers — Flasks. Big list 25c coin. Ed Howe, Coopers Mills 26, Maine.

NEW spinlure kit \$1.00, sample 35c. Hank's, 1860A Shevlin, Ferndale, Michigan.

JAP rifles altering American shells \$6.00. Jap shells \$3.95, catalog 10c. TP Shop, West Branch 10, Michigan.

BUY Wholesale: 1959 Catalog—Send 10c. Merchandise 100% Guaranteed. Fishing Tackle Mart, Box 6737, Dept. 64, Chicago 80, Illinois.

MOLDS for Fisherman's Sinkers, Jigs, Squids, Casting and Spinning Lures. Free Catalogue. Sweet's Molds, Tonawanda 3, New York.

POPULAR SCIENCE OPPORTUNITIES

HUNTING Slingshot, Ammo, Accessories, \$1.95. Ammo, 5 bags \$1.00. Lachter, 151-71 25th Ave., Whitestone 57, New York.

16 CAMPING EQUIPMENT & TENTS

TENTS (200 styles). Sleeping Bags (25 styles). Air Mattresses (26 styles). Tarpaulins, Flies, Boat Covers, Ground Cloths, Canvas Yard Goods, Netting, Aluminum Tent Poles, Stakes, Cots, Stools, Folding Tables, Refrigerators, Stoves, Lanterns, Ovens, Heaters, Grids, Nested Cook Sets, Canteens, Mess Kits, Water Bags, Buckets, Packs, Rucksacks, Axes, Toilets, Knives, Saws, Compasses, Ponchos, Station Wagon Screens and Porches, Dehydrated Foods, Camping Books. Send 25c for new 160 page catalogue (includes Camp Sites and Camping Hand Book). Print name-address. Morsan, 10-15G 50th Avenue, Long Island City 1, New York.

CAMPERS . . . "Equipment we like Best" catalog, camping equipment handbook and buyers guide. 25c postpaid. Merritt Products, Box 104, Des Plaines, Illinois.

CAMPING Trailer two wheel sleeps 4-6. Detail plans \$3.00. Illustration dime. Surinak, 13100 West Cleveland, Waukesha, Wisconsin.

DON'T buy anything until you've seen the "New Look" in camping. New camp trailer, a new car top camper, new camp kitchen. Free illustrated brochure. Write: Heilite Trailers, Inc., Dept. P.S., Lodi, California.

17 DOGS, BIRDS, HAMSTERS, RABBITS & PETS

RAISE rabbits on \$500 month plan. Plenty markets. Free details. White's Rabbitry, Delaware, Ohio.

HAMSTERS—golden: young, \$3.00 pair; fully-developed, \$4.00 pair. Adirondack Hamstery, Prospect 23-D, New York.

LIVE Reptile List And Instructions on Keeping. 25c Stamps or Coin. Snake Farm, Laplace, Louisiana.

CHINCHILLAS—Equipment Reasonable—Write. Swihart, 824 Newark St., West Palm Beach, Florida.

MAKE Big Money Raising Nutria, Chinchillas, Cavies, Mink, Rabbits, or Pigeons for us. Free information. Keeney Brothers, New Freedom, Pennsylvania.

FLYING Squirrels—Beautiful Pets. Send 10c for literature, prices and pictures. Greeson's Flying Squirrel Ranch, 905 North Monroe St., Arlington, Virginia.

CROWS make comical talking pets. \$4.95 COD and express. Logston's, Box 3045, Fort Worth, Texas.

RAISE Rabbits For Us—Profitable, easy! Particulars free. Grinsteads Co., Edwardsville, Illinois.

18 LIVE BAIT

FREE Literature — Make Big Money Raising Fishworms and Crickets. Carter Farm-12, Plains, Ga.

\$10,000 YEAR possible, earthworms. 32 Page booklet tells how 40c. Missouri Earthworm Research, Box C-6851, Kansas City, Missouri.

\$1,000. MONTHLY Possible, raising Earthworms—African Giants. Backyard, Garage, Basement. Complete Illustrated Booklet explains raising, feeding, packing, marketing. Only 25c! Ozark Worm Farm-V, Willow Springs, Missouri.

19 FARMS, OTHER REAL ESTATE

LAKEFRONT, Highway, Acreage and Trailer lots, from \$295.00. Fifteen central Florida developments. Monthly terms. Box 2005, DeLand, Florida.

CANADIAN Tax Sale Lands, average price four dollars an acre. Small monthly payments. Farms, timber, hunting and fishing camps, minerals. Limited number of properties. Write at once for free catalogue. Tax Sale Service, Room 113, 120 Bloor Street, West, Toronto 5, Canada.

FLORIDA—2½-acre Ranchos—\$15 monthly. Beautifully wooded. All-weather roads. Established community. Gulf resort area. Also 80-foot homesites \$290—\$10 monthly. Write Douglas Wood, Fountain, Florida.

FLORIDA—Nice homesites, \$345 at \$10 monthly. Folder Free. Winfree Vernor, DeLand, Florida.

SALE, Canadian Tax Lands; Farms, Bush Lots, Hunting Camps, Cottages, Lake Frontage. Including free information about Crown Lands. For this month's list send 50c. Sovereign, Box 33, Toronto 4, Ontario.

CENTRAL Florida Lakefront Homesites, \$795 at \$15 monthly. Literature. Grace Parker, Paisley, Florida.

FLORIDA'S Biggest Lot Value! No Money Down! \$5 monthly. Full price only \$133. Between Orlando and Ocala. High, Dry, adjoining city, streets, electricity, phones, churches, schools, shopping. In heart of 3000 lakes. World's best fishing! Write for Free photos. Adries Huysman, Box 467, Belleview, Florida.

NEW Strout Spring Catalog Just Out! Mailed Free! Bigger than ever, 3,599 bargains, 36 States, Coast-to-Coast. Farms, Homes, Businesses. World's Largest! 59 Years Service. Strout Realty, 251-ZB 4th Ave., New York 10, New York.

20 TREES, SHRUBS ROOTS, HERBS

RAISE Your Shrubs, trees from seed. Free planting guide, price list. Woodlot Seed Company, Norway 46, Michigan.

GINSENG, Goldenseal. Roots bring up to \$14 pound. Full information. F. G. Collins, Viola, Iowa.

GROW Sunflowers: Send 10c For Seeds. Powers, 616 Kickapoo, Leavenworth, Kansas.

EVERGREEN Seedlings, ornamentals, flowering shrubs and fruit trees. Free price list and planting guide. Flickingers' Nursery, Sagamore 13, Pa.

22 PROFITABLE OCCUPATIONS

INVESTIGATE Accidents—Earn \$750 to \$1,000 month. Thousands of airlines, insurance companies steamship lines urgently need Claim Investigators. We train you home spare time. Placement counsel and help. Free book! No obligation. Write: Universal Schools, B-4, Box 8202, Dallas 5, Texas.

SAVE Money! Buy Wholesale! Free Catalog General Merchandise. Norris, 487-H Broadway, New York.

\$5000 FROM Half Acre growing Ginseng, crop bought. Particulars 10c. Associated Growers, Sperling, Manitoba.

EARN Money At Home raising fishworms for us! Backyard, garage, basement. We buy your crop! Inquire. Oakhaven-7, Cedar Hill, Texas.

YOUR own Income Tax/Business Tax Service. Licensed training. Union Institute, Hoboken 1X, N. J.

BECOME independent with your own franchise business. Thousands earning handsome incomes. Request interesting facts today. National Franchise Reports, PS-528, 333 North Michigan, Chicago 1.

VENDING Machines—No Selling. Operate A Route of Coin Machines and Earn Amazing Profits. 32-Page Catalog Free. Parkway Machine Corporation, Dept. 17, 715 Ensor Street, Baltimore 2, Maryland.

POWER Putty. Miracle plastic kit. Speeds shop, boat, engine repairs. For home and hobby. Free laminating resin and instructions. PP \$2.98, COD. Huntress Pro., Atascadero, California.

\$6,000 FOR Mister, Mrs.: \$3,500! Free "Secret Journal" Plan. Magical! Work home! Publico-N14 Oceanside, Calif.

FREE Literature — Make Big Money Raising Fishworms and Crickets. Carter Farm-10, Plains, Ga.

HOUSEWIVES, others, \$30-\$70 weekly sparetime assembling and distributing our pre-polished rockhound jewelry, retailing unnecessary. Vikingcraft, A-41, Inglewood 4, California.

TREE-mushroom pioneers! Spawn, Instructions, \$1.00. Ohga, PS145, Sigakenkusatu, Japan.

FREE Book "609 Odd, Successful Businesses." Work Home! Box 1001-PSC, Evanston, Illinois.

NEW Soilless Method. Raising Night-crawlers, Red worms. Three Oaks Ranch, Dresden, Tenn.

FREE Book "505 Odd, Successful Businesses." Work home! Pacific-37C, Oceanside, Calif.

EARN Money at Home. Not a Mail Order Business! Complete Plans \$1. W. Anderson, 3933-PS North Clarendon, Chicago 13, Illinois.

23 BOOKS & MAGAZINES

BOOKS, One Dollar. Send for list. Dollar Book Supply, P. O. Box 1132-P, Evanston, Illinois.

GOOD Used Books, 50c-\$1. Free Lists. Editions, Dept. PS, Hempstead, New York.

BRITISH Book Bargains. Any subject. Catalog free. Transbooks, Box 1-PTN, Wantagh, N. Y.

WORLD Shoppers Guide—Shop the world from home. Free brochure. Schmidt, 1524 Connecticut Avenue, Washington 6, D. C.

MAGAZINES—Wholesale—Retail Catalog 10c. Backdates, 1181 East Lombard, Baltimore 2, Maryland.

"PROPHET Elijah Coming Before Christ" Wonderful Book Free. 58 Megiddo Mission, Rochester 19, New York.

BOOKHUNTERS: All Subjects. Send Wants! Jaher Book Service, 183 Hazelwood Drive, Westbury, New York.

1,000,000 BOOKS—10c Each! Every Subject Under The Sun! 2 Catalogs—120 Pages—Dime! Modern Mailway, Box 124-PSS, Stuyvesant Station, New York City 9.

HANDLE Subscriptions All Magazines Special Offers. Good Commissions. Cassell Agency, Boynton Beach, Florida.

SECRET-Of-Success, Guide, \$1.00, Gross Prices. Padgham 213 W. Douglas, Midwest City, Oklahoma.

FREE Catalog—over 1,000 "How-To" Books. Artcraft, Baldwin, Maryland.

BOOKS, Free General Catalog, 100 pages. Text, vocational, educational, instructional subjects. Millions of volumes, new and used. Bargain prices. Books bought. Est. 1902. Long's College Book Co., Dept. PS, Columbus 1, Ohio.

HI-Fi. Yes? No? See ad on page 58 for further information and valuable coupon.

24 HYPNOTISM

FREE Illustrated Hypnotism. Selfhypnosis Catalogue. Write: Hypnotist, 8721 Sunset, Hollywood 46P, California.

FREE Catalog! Hypnotism, Autohypnosis! Books, Tapes, Records! Drawer PS697, Ruidoso, New Mexico.

XRAY Mind! Hypnotize, one glance. Guaranteed \$3.00. Wamsteker, Box 10, Ottery, Cape, South Africa.

HYPNOTIZE Self Others while asleep with amazing hypnotic phonograph records, tapes. Catalog free. Research Association, Box 24-G, Olympia, Washington.

HYPNOTIZE with guaranteed success system \$3.00. Dunlop, 156 Cameron Ave., Hamilton, Ontario.

EFFORTLESSLY overpower others! 78 rpm spellbinding records, "Group Hypnosis," "Self-Hypnosis," \$2.98 each. Both records, \$3.98. A. Milillo, 106 Dunwoodie, Yonkers, New York.

HYPNOTIZE Successfully! Learn Easy, Fast, Modern Methods. Complete, Illustrated Course, including self-hypnosis and "Secret Nerve Pressure Technique" (Guaranteed Harmless)—\$1.00. H. Fowler, 608 No. Broad Street, Woodbury, New Jersey.

"HYPNOTIZE . . . One word . . . One fingersnap," on stage. Satisfaction—or refund. \$2. Hypnomaster, 846-S6 Sunny-side, Chicago 40.

HYPNOTIC Comedy Act Routine \$3.00. R. La Barre, 12683 Terry, Detroit 27, Michigan.

WHIRLING Hypno-Coin, hypnotize others in minutes with this fascinating plastic invention. Complete with revealing secrets, instructions. Only 99c. Money back if not delighted. Hypnotic Aids, PS-4, 1133 Broadway, New York City 10.

VALUABLE books, suggestion records can be yours. Free List. Collins, Box 67, Appalachia, Virginia.

25 MAGIC TRICKS, PUZZLES, ETC.

HOUSE of 1000 Mysteries! Professional and Amateur Magic! Pocket Tricks! Self-working Miracles! Illusions! Secrets! Mindreading! Tricks with balls, coins, silks, cigarettes, cards, rope, apparatus. Jokers Novelties! Puzzles! Brainbusters! Two big catalogs combined into one terrific Giant Deluxe Edition! Rush only 50c for this dollar edition! Everything Illustrated! Free trick included! Vick Lawston, 202-4 Pinewood, Trumbull, Conn.

WORLD'S finest professional magic. Joker novelties. Giant illustrated catalog 10c. Top Hat, Evanston 13, Illinois.

3100 NOVELTIES, Jokes, Tricks, Gadgets, Funmakers, Hobbies. Big catalog 10c. Johnson-Smith, D-490, Detroit 7.

3000 TRICKS, pocket, parlor, stage. World's Finest Magic Catalog (408 pages). \$2.50. Kanter's, S-1311 Walnut, Philadelphia 7.

POPULAR SCIENCE OPPORTUNITIES

500 TRICKS, Douglas famous catalog just 10c. This book of 120 pages describes magic tricks for pocket, parlor and stage. Magicians, both professional and amateur depend on Douglas for fastest service. Amaze your friends—send 10c today. Douglas Magicland, Dept. (S), Dallas, Texas.

WIN, Dice, Cards, Catalog 10c. Book. Box 671, St. Louis 1, Missouri.

INVISIBLE Ink Concentrate \$1.00 Postpaid. Bi-Mail Products, 1273 Central, Albany 5, New York.

SMOKEPOT. Safety Signals, 25c. 7 for \$1.00. 4463-PS Greene, Philadelphia 44.

WHOLESALE! Thirty 10c Trick Novelties \$1.00! (Profits!) 1746-SW Market, Philadelphia 3.

"HYPNODISK" 50c. "25 Lessons Hypnotism" Book 50c. Box 1352-H, Philadelphia 5.

"VENTRILLO" Voice Thrower 25c. Ventriloquist's Puppet 75c. Box 971-PS, Philadelphia 5.

MAGIC Catalog plus Free Samples. 35c. Lachter, 151-71 25th Avenue, Whitestone 57, New York.

BE a magician! Large professional catalog of latest tricks, 35c. Ireland, F-109 North Dearborn, Chicago 2, Illinois.

26 COINS & CURRENCY

BARGAINS!—United States Large Cent over 100 years old—\$1.00. Before 1915—\$3.00. Half Cent—\$4.00. Eagle Cent—\$1.00. White Indian Cent—\$1.00. Indian Cent Before 1880—\$1.00. 2c Piece—\$1.00. 3c Silver—\$1.00. 3c Nickel—\$1.00. Halfdime—\$2.00. Shield Nickel—\$2.00. First Liberty Head Nickel—\$1.00. 1913—Nickel—\$1.00. Dime Before 1838—\$2.00. Before 1892—\$1.00. 20c Piece Rare—\$7.00. Quarter Before 1839—\$5.00. Before 1892—\$2.00. 50c Before 1840—\$4.00. Before 1879—\$3.00. Silver Dollar Before 1804—\$25.00. Before 1874—\$10.00. Trade Dollar—\$7.00. Our Large Illustrated Complete Buying—Selling Catalogue \$1.00. Worthycoin Corporation (C-101-D), Boston 8, Massachusetts.

GET Profit And Pleasure in collecting old coins. Send 20c for 68-page illustrated coin catalog. You'll be delighted with it. Send for it now. B. Max Mehl, Box 750-C, Costa Mesa, Calif. Oldest rare coin establishment in U.S. Established 59 years.

COINS from Formosa, Vatican, etc., plus foreign banknote, 10c with coin approvals. Littleton Coin Company, Littleton S2, New Hampshire.

WANTED urgently! Coins! Now we pay even higher prices! Confidential 1959 Buying Guide. \$1.00. Sullivan, 128-BB Frontier Bldg., St. Paul 1, Minn.

GENUINE Mexican Silver Dollars 50c Each, Three For \$1.00. Universal Service, Box 675A, San Antonio 6, Texas.

GOLD, U.S. and Foreign Gold Coins wholesale list 10c deductible. Booklet listing prices paid for U.S. Coins all types 50c includes wholesale list free. Samuel Kisin, 720 Flushing Ave., Brooklyn 6, New York.

NEW Coin Album holds 800 Pennies, Nickels, Dimes, Quarters. Gives number minted and approximate value each coin. Guaranteed. Postpaid, \$2.50. Lesco, Box 6023, Arlington, Virginia.

SELLING Private Collection. Write stating interests. J. Dazynski, 6445 232 Street, Bayside 64, New York.

SIX Different Barber Quarters \$2.00. Bargain Lists Free. Sayers, 1000 Unaka, Johnson City, Tennessee.

FREE List! U.S. Coins. Lowest Prices. Hugh's, Box 361-KL, Hickory, North Carolina.

LINCOLN Cents: 1910-S—\$1.25—1911-S—\$2.75—1912-S—\$2.25—1913-S—\$1.50—1915-S—\$1.50—1926-S—\$1.00—1923-S—\$1.00. Condition Fine. Berry, Box 306, Westminster, California.

1959 CANADIAN silver dollar \$1.50. Marles, Dept. 16-S, Box 833, Calgary, Canada.

CASH Paid for Gold Coins. Write "Coins", Box 6184, Albuquerque, New Mexico.

NICKELS—1928S—1929S—1930S—Jefferson 1938 S&D—1939 S&D—1942D—Five Different \$1.00. Schoenke's, 061 Walnut, Mundelein, Illinois.

PENNIES Wanted. List Free. Foreign Coin 25c. Wayne Coin, 1205 California Ave., Fort Wayne, Indiana.

25 LINCOLN Pennies 1909 To 1940 \$1.00. 15 Different Buffalo Nickels \$4.00. Box 222, Howard Beach 14, New York.

INDIAN Cent plus Bargain Lists 10c. Hutchinson's, Box 4747, Philadelphia 34, Penna.

TWENTY Different Indian Cents \$2.50; Ten Different \$1.00. Collector's Bargains, Box 356A, New Hope, Penna.

BEAUTIFUL Uncirculated sets — In Holders—Roosevelt dimes \$15.85; General MacArthur \$3.75; Tahiti \$1.50. World's Greatest 92-page Bargain Catalogue \$1.00 (Deductible first \$10.00 order). Bebee's, 4514 North 30th, Omaha 11, Nebraska.

BIG Catalogue Foreign Coins, Currency—25c (Refundable). Jolie, Roslyn Heights, New York.

BARGAIN List, Indianhead cent, 10c. Free bonus offer included. Economy Sales Company, Mansfield, Massachusetts.

LINCOLN Cents—20 Different 1909-1939 in Whitman Folder \$1.25. Grooms, 433 Espanola N.E., Albuquerque, New Mexico.

SIXTEEN page price list of USA and Canadian coins free. Selling prices on thousands of coins and supply items. Bryson Inc., 612A White, Toledo 5, Ohio.

FOREIGN Gold Coins, mint, wide assortment, reasonable, for American & Canadian Collectors. Write for list. Box 41, Islington P.O., Ontario.

50 ASSORTED Coins, \$1.00. 50 Assorted Bills, \$1.00. 111 Assorted Coins and Bills, \$2.00. Oddehon, Box 482, St. Louis, Missouri.

BUYING. Selling Lists. Postage Please. Lund, 200-So. Sycamore, No. Platte, Nebraska.

COIN Magazine, 200 pages. Sample 40c. Numismatic, 7320 Milwaukee, Chicago 31.

WANTED—Coins. Send 10c for Buying List. Holcomb, 4127 Centinela Avenue, Los Angeles 66, California.

15 GENUINE Foreign Coins, bills—25c. Interesting lists. Musser, Box 505-A, Dunbar, West Virginia.

PENNIES—1943 P.S.D.—only \$1.00. Scott, 1205 W. Winnebago, Appleton, Wis.

5 UNCIRCULATED Lincoln Cents, 5 Canadian Cents, and 4 Liberty Nickels \$1.00. Catalog free. Joray's, Box 38, Shouns, Tennessee.

U.S. coin list 10c Contains over 100 illustrations; over 5,000 delightful bargains. Stoney, 260 Washington, Boston 8, Mass.

RARE 1880 to 1885 CC Dollars, \$5.00 ea. Coin Catalogue 25c. Shultz, Salt Lake City 10, Utah.

1959 PROOF Set Mint Sealed \$2.60, 1958—\$3.25, 1957—\$3.00, 1956—\$3.75, 1955—\$5.50. Satisfaction Guaranteed. Thomas Lavin, 6751 Paschall Ave., Phila. 42, Pennsylvania.

"EAGLET" Numismatic Magazine 35c, subscription \$3.00 year. Dept. E, 229 South 11th St., Newark 7, New Jersey. Free gift.

27A INVESTMENTS

AMAZING Profits made investing in unused Commemorative Postage Stamps, with as little as \$2.50 weekly. No experience necessary. Professional advice Free to clients. Vatican City "Vacant Seat" (Stamps issued after death of Pope Pius XII) increased from 20c to \$1.50 in 30 days. Complete details \$1.00. Satisfaction or Refund. Columbia, 8203 Grubb-PC, Silver Spring, Maryland.

28 STAMP COLLECTING

225 STAMPS For only 10c! This mammoth value includes Airmails, Pictorials; stamps from strange Countries cataloguing up to 25c each! Also Approvals. Mystic Stamp Company, Camden 55, N. Y.

UNITED States commemorative collection containing 33 different—10c. Approvals. White, 516-W Avenue L, Brooklyn 30, New York.

307 WORLDWIDE different stamps only 25c. Approvals. Niagastamp, St. Catharines 672, Ontario.

WOW! 110 All Different Germany 10c Zeppelins, Semi-Postals, Airmails, High values, etc. Giant Catalog, bargain lists included with beautiful approvals. Jamestown Stamp, Dept. A49PS, Jamestown, N. Y.

100 DIFFERENT Belgium Free. UPU, Brussels Fair, Railroad Stamps Free. Approval Applicants Only. Trylon, Box 179-S, Forest Hills 75, N. Y.

ALBUM only 10¢! Hundreds of spaces! Stampmart Company, Hartford 1, Connecticut.

AMAZING Offer! 200 U.S. stamps—including commemoratives, airmails, high denominations to \$1.00—only 10c to Approval Applicants!! Illustrated Bargain Lists free. Mystic Stamp Co., Dept. 55, Camden, New York.

1000 DIFFERENT Worldwide Stamps \$1.00. Valued over \$20.00. Universal, Box 6, Kenosha 6, Wisconsin.

102 DIVERSIFIED Worldwide stamps 10c. Approvals. Linstamp, St. Catharines 619, Ontario.

80 DIFFERENT U.S. Stamps. Includes 19th Century, Commemoratives, High Values. Plus 1943 Flag Stamp of occupied Nations. All for only 25c. Approvals included. Willett Co., Box 338-Y, Yorktown Heights, N. Y.

NUDES set (4)—Unusual Approvals 10c. Atlas, Eisenhower, Racine, Wisconsin.

U. S. Stamps. Giant Bargain Catalog—15c. Raymax, 35-VX Maiden Lane, New York City 38.

FREE! Eight Sided stamp, Triangle, Diamond, Midget, Mammoth, to approval buyers. Plymouth, Dept. A-3, Bell, California.

105 DIFFERENT worldwide from Liberia, Macao, etc., cataloging over \$2.75 only 10c. Approvals. Goliath, Bethlehem J2, New Hampshire.

FREE! Giant Bargain Catalog—New Edition listing thousands of bargains including U. S. and B. N. A. stamps, packets, mixtures, albums, accessories and supplies; sent with beautiful approvals. Jamestown Stamp, Dept. E49PS, Jamestown, N. Y.

103 DIVERSIFIED British Colony Stamps only 10c. Approvals. Niagastamp, St. Catharines 672-A, Ontario.

TERRIFIC Stamp Bargain! Israel—Iceland—Vatican Assortment—plus exotic triangle set—Also fabulous British Colonial Accumulation—Plus large stamp book—all four offers free—Send 10c to cover postage. Empire Stamp Corp., Dept. PR, Toronto, Canada.

TOPS! Free book, "How To Collect Stamps." Send for your copy today! Approvals. Littleton Stamp Co., Littleton E2, N. H.

77 DIFFERENT U.S.—25c Approvals. Utechts, 1143A North Keeler, Chicago 51.

FIRST Day Cover approvals! Artcraft; Artmaster. Included free; valuable airmail flight cover. Myers, Coopersburg, Pennsylvania.

FREE—Mint British Colonies from Brunei, Solomon Islands, Negri Sembilan, Sarawak, St., Christopher, Nevis, Trengganu, Gilbert Ellice. Free with approvals. Viking, Great Neck 5, New York.

CHINA, 25 different, unused Beauties, 5c. Approvals. Northern, Box 13, West Fort William, Ontario, Canada.

DEALERS Wholesale Catalog. Postage 4c. Franksco, 5031 Queensbury, Baltimore 15, Maryland.

FREE Fifty Different To New Approval Customers. Surf Hobbies, 2110 Mermaid Ave., Brooklyn 24, New York.

FREE! 100 World-Wide Stamps, just released! United Arab, Antarctica, Morocco, Zanzibar, many more! Mammoth collection never offered before plus Collector's Guide, Approvals, 10c for handling. Garcelon Stamp Co., Calais 12, Maine.

FREE stamp exchange! Send 100 large U.S. Commemoratives receive 300 different worldwide. Other collections available swap—buy. Banthos, Box 122PS, New York 4, New York.

100 DIFFERENT Stamps, 10c with approvals. Smith, 508U Brooks, College Station, Texas.

25 DIFFERENT large American Commemoratives 10c. With approvals. Linstamp, St. Catharines 619-A, Ontario.

FREE Mint Set! Approvals Follow. Mintco, 5151 Princeton, Memphis 17, Tennessee.

UNITED Nations free scarce postcard! Approval selections. Teddie, Crystal Beach, Florida.

POPULAR SCIENCE OPPORTUNITIES

QUEEN Elizabeth On Stamps . . . A beautiful collection of 50 different stamps from 22 countries—all bearing the portrait of the Queen of England. Absolutely free with approvals. Capital Stamp Co., Ferrysburg 10A, Michigan.

PRICE List U.S., Foreign. No Approvals. Allen, 5000 Miami, St. Louis, Missouri.

INTERESTING Worldwide Animal stamp collection 10c. With approvals. Niagara Stamp, St. Catharines 672-B, Ontario.

200 DIFFERENT 10c with approvals. Idle Hour Stampco, Greeley, Colorado.

PENNY Approvals! Regardless Catalogue! Kloster, 4164-52nd St., San Diego 5, California.

25 ATTRACTIVE Pictorials Worldwide different 10c. Approvals. Linstamp, St. Catharines 619-B, Ontario.

SUPERIOR worldwide mission mixture! Amazing variety! Six ounces \$1.50. Pound \$3.75. Bay Nielsen, 4545A Harvard, Montreal 28, Canada.

FREE 26 diff. British Empire when requesting our Attractive British Col's. U. S. General foreign Approvals. Discounts, Bonuses. Individual service for serious collectors. Send 10c for handling. Jeans Stamps, A.S.D.A., 42 Evergreen Road, North Fort Myers, Florida.

FIRST Cover Alaska Statehood Stamps. Scenic, -50c. White, Box 702, Juneau.

FREE—Your choice 100 different Canada, 100 different Philippines, 100 different countries, each collection over \$5.00 catalogue value, plus many other terrific offers Free when you buy our sensational foreign approvals. Topval, Box 486(C), Redlands, California.

10 CANAL Zone 25c! Approvals! Merkel Stamps, 30 Grandview, South Hadley Falls, Mass.

LAOS, elephants. Arab republic, etc. 10c Approvals. Frank's, 19366 Danbury, Detroit 3, Michigan.

25 INDONESIA 10c with Approvals. Salsman, Box 702, Berkeley, California.

TERRIFIC, Illustrated, Latest Edition, United States Price List Free! Bailey, 45H Bromfield, Boston, Massachusetts.

EXCEPTIONAL, 125 different, cataloging \$3.00, includes triangles, commemoratives, 10c, approvals. Reeves, Box 37597P, Miami 37, Florida.

FREE! Twelve Beautiful British Ceylon bi-colored with temptingly priced approvals. Beaman's, 116 Mississippi Ave., Joliet, Illinois.

FREE—Your Choice Any Volume Scott's International Albums. Scott's 1959 Catalogues, Even Master Global Albums. Free When You Buy Our Sensational Foreign Approvals. Bargain Stamps, Redlands, California.

1000 DIFFERENT stamps free to regular buyers from our price lists. No approvals. Write for details. Lucas Stamps, 612 White, Toledo 5, Ohio.

100 DIFF. Large U.S. Comms. \$1.00, approvals. Buckey, Box 292, Bladensburg, Maryland.

AMAZING "Strange Countries" packet free with approvals! Saxon, Orange, California.

ICELAND 10 different beautiful stamps for only 10 cents to applicants for our good old fashioned approvals. Old Colony Stamp Co., Dept. B, Milford, Conn.

1000 DIFFERENT, \$1.00 with approvals. Golden's, 6721 Eastwood, Philadelphia 49, Pennsylvania.

TERRIFIC Value, Eight Complete Mint Sets 10c With Approvals. Beatles, 58 Glenagar, Islington, Ontario, Canada.

100 DIFFERENT Austria 10c. Approvals. I. Aronson, Box F, Newton Centre 59, Massachusetts.

U.S., Canada, Catalogue send only 20c. New-Way Stamp, Lawrence (3), Massachusetts.

U.S. #230, +25 others, 10c. Ciovacco, 179 Park Ave., Brooklyn 5, New York.

TREMENDOUS selection old U.S. flags, presidents, commemoratives with approvals, free gift, 10c handling. Metropolitan Stamps, Box 312PN, Jackson Heights, New York.

FREE!! Kelantan, Jaipur, Orange River Colony, Tanganyika. New South Wales. Inexpensive approvals accompany. Nade's, 6316 Crescentville, Philadelphia 20, Pennsylvania.

HARD To Get China Stamps To New Customers 10c. Truvalue Co., Box 2098, Santa Ana, California.

50 DIFFERENT Stamps free! Approvals. Marford, Box 48, Queens Village 29, New York.

1500 STAMPS \$1.00 On and off paper. Good variety. World wide. Many pictorials. No approvals follow. Satisfaction guaranteed. Whalen, 1435 First Ave., Oakland 6, Calif.

U.S. Mint Famous Americans, 1c, 2c, 3c (21 stamps). Special—\$1.00. Free list. Brooks, 2323-T Avenue X, Brooklyn 35, New York.

UAR Mint Set Free With Approvals. W-B Stamps, Wilkes-Barre, Pa.

FREE Sample! Interesting, illustrated. National Stamp News, Anderson 696, South Carolina.

GIANT-Sized Issues collection: Laos elephant set, Brussels Fair, Olympics, Jet aircraft, Boy Scout, Somali Animals complete, Romania Flags, Togo set, Diamond Popes, United Nations set, etc. Plus Big Stamp Dictionary & Approvals. Everything 10c. Stampex, Box 47-KP, White Plains, New York.

TRADE your duplicates toward our approvals! (Foreign only.) Complete information, 10c. (Refundable.) Variety Stamps, Box 98-S, Newton Highlands 61, Mass.

SCARCE Foreign \$2. Cat. 10c Approvals. Bill Reid, 441 N. 6, Allentown, Pennsylvania.

FREE 11 Japan War Stamps. Approvals. Schroeder, 1486 1/2 Sherburne, St. Paul 4, Minnesota.

FIPEX. Newfoundland, Israel, Animals, Birds, Sports, 10c with approvals. Tropicana, Box 449S, Hollywood, Florida.

FLAG, Ship, Animals, many pictorials. Free with Approvals. Wirth, Route 6, Norwich, Conn.

14,000 DIFFERENT! Amazing new plan builds your collection systematically, country by country. Only 50c weekly. Free details. L. G. Ware, Stepney 70, Conn.

FREE United States Illustrated Catalog. H-S, 45-S Bromfield, Boston 8, Massachusetts.

PENNY Approvals jammed with Bargains. For better values, try Putnam Stamp Company, Mahopac, New York.

FREE 200 Different stamps! Gift Magnifier! Free "PhotoNotes" subscription! Approvals. Rush 10c postage. Philatelics, Dept. TA, New Paltz, New York.

OLD scarce U. S. seconds on approval. Slightly defective, bargain prices. Hearnfeld, Clintonhill Station, Newark 8, N. J.

BRITISH Colonies; Approvals; Bargain Prices. Connelly, 404 N. Andrews, Fort Lauderdale, Florida.

60 DIFFERENT U.S. (30 Commemoratives) 25c. No approvals. Seidenberg, Appleton, Wisc.

SELECT U.S. on approval. Mint, used. Kingsbury Stamps, Groton, Vermont.

BARGAIN U.S. 100 Different 25c with U.S. approvals. Stamps, Kennebunk, Maine.

GIANT Approvals Thousands Different 1c and 2c each. Wahl's Stamp Exchange, 7008K Farragut, Chicago 31, Ill.

ONLY 10c—Packet containing stamps cataloging over \$2.00. Approvals. Stamp Service, Box 1811, El Paso, Texas.

FREE! 50 British Empire, 5c Handling. Approvals. Kensington Stamps, Buffalo 15, N.Y.

PARTICULAR? Want unusual stamps on approval. Try Bayou Stamps, Box 4126, Pensacola, Florida.

EVENT of the Century. First Moon Rocket (scarce) First and Second Sputniks, 49 other fine all different free with interesting approvals. Stamp Imports, Dept. PS2, Peterboro, Ontario, Canada.

FOREIGN F.D.C.'s Mailed direct! Around the World Service. Free offer to New subscribers. Brumsey, 209 Main, Peoria, Illinois.

1000 DIFFERENT With Approvals \$1.00. Jacobsen, 4395 Broadway, New York 40, New York.

THE Gods of Ancient Greece; Russia Sputnik; U.S. National Parks; Israel; U.N.; Sets; Packets; Surprises; Free with purchases. Approvals. Stamp Farm, S1-12 Oxford, Wisconsin.

LATIN American Approvals Only. Thomas Waterman, Box 65, St. Louis 19, Missouri.

FREE U.S. catalog. Contains almost 1,000 illustrations, over 10,000 delightful bargains. Stone, 260 Washington, Boston 8, Mass.

233 DIFFERENT worldwide plus 66 different U.S. 25c. Approvals. Casto, Box 357, Dunbar, West Virginia.

U.S. Mint Singles, Blocks Approvals. Kuehl, 3125 East K, Tacoma 4, Washington.

RED Russia—28 all different unused, high catalog, 5c. Approvals. Hamilton, 912 North Mesa, El Paso, Texas.

ROOSEVELT Memorial; Egyptian Jets; Croatian Legion in Action; U.S. Norse-American; Grab Bags; New Issue Sets; Free With Purchases. Approvals. Stamp Farm, S1-13, Oxford, Wisconsin.

100 OLD U.S. Stamps between 1861 and 1935 \$1.00. Rousch Stamps, 51 Chestnut, Mansfield, Ohio.

50 CHINA 10c; Approvals; Gifts. Coast, P. O. 2187S, Santa Ana, California.

U.S. approvals. Low prices. Eagle Stamps, Romine Ave., Pittsburgh 26, Penna.

UNITED States, Canada, Approvals, Enclose 10c. Peterson, Box 31, St. Paul 2, Minnesota.

MINT 1936 Navy Set. Complete 25c. Leonard, 51-S Fourth Ave., East Orange, New Jersey.

29 ANTIQUES, RELICS & INDIAN GOODS

AFRICAN Woodcarvings. \$1.00 brings sample and catalog. Drewco, Narberth, Pennsylvania.

ANTIQUE Firearms. Sensible Prices. \$12 up. Indian Relics. Bargain List 25c. Tonntz's, Elsinore, California.

SELLING 100,000 ancient Arrowheads, Spearheads, Tomahawks, etc. List free. Lear's, Glenwood, Arkansas.

30 MINERALS & PRECIOUS STONES

ROCKHOUNDS—Visit Rockhound Paradise. Circular—Heike's Agate Shop, Wena, Illinois.

HIGHGRADE! Selected ore specimens. Visible Gold. \$2.00. Box 82, Zebellos, B.C., Canada.

ROCKHOUNDS—Gem Cutters—Jewelry Makers . . . new Free catalog—just off the press! Biggest supplier to hobbyists and craftsmen offers you tools, materials, equipment, introductory bargains and know-how. Free Catalog . . . Write Grieger's, Dept. C-13, 1633 E. Walnut, Pasadena, California.

EARTH Science—Rockhounds National Magazine. Subscription \$2.00. Sample 35c. Box 1357-PS, Chicago (90), Ill.

"GEMS & Minerals Magazine," largest rock hobby monthly. Field trips, "how" articles, pictures, ads. \$3.00 year. Sample 25c. Box 687S, Mentone, California.

CINNABAR, genuine sample approx. one inch long. 50c Postpaid. Quicksilver, 88-9th Street, San Francisco 3, California.

SAPPHIRE and four more uncut gems, \$1.00. Ten polished gems, baroque-shaped, \$1.00. Free gem list. Lapidary catalogue 25c. O'Brien's, 1116N Wilcox, Hollywood 38, Calif.

GEMCUTTING—Silvercraft magazine. Learn to cut gems, make jewelry. Ads give sources equipment, gems for cutters, collectors. Free literature. Sample copy 25c. Lapidary Journal, Del Mar 3, California.

IMPORTED Semi-Precious uncut stones. Star ruby and two other gems \$5.00 Supply Limited. List of other gems. C&H Importers, Dept. C, 3113 N. Tom Green, Odessa, Texas.

TWELVE N. Mex. Minerals \$2.00. Six Fluorescent \$1.06. Five Crystallized Specimens \$1.06. Fools Gold 35c. Hartson, Winston 5, New Mexico.

FIVE Semi-Precious Gems \$1.00 Postpaid. Also list of Specimens from 1c up. Marilyn Fahs, 2425 Sunset Road, York, Pennsylvania.

31 HOBBIES, COLLECTIONS

INVENTING can be an interesting and profitable hobby. Write for complete particulars. Institute of American Inventors, Dept. 30-E, 635-F St., N.W., Washington 4, D. C.

POPULAR SCIENCE OPPORTUNITIES

POWER Putty. Miracle plastic kit. Speeds shop, boat, engine repairs. For home and hobby. Free laminating resin and instructions. PP \$2.98, COD. Huntress Pro., Atascadero, California.

COLLECTORS Matchbook covers. 100 Different unused \$1.00. Catalog 25c. Album \$3.00. Charles Edelman, 1311-P East 84, Cleveland 3, Ohio.

CASTRO'S Officers Armband \$1.00; Cuban Revolutionary emblem 50c; German Iron Cross \$1.50; Medal Catalog 25c. Hobbies, Box 71A, Rockaway Park 94, New York.

PREHISTORIC Shark's Tooth, And Literature 50c. Three For \$1.00. Seamon, 112 Glenrae, Baltimore 28, Maryland.

HI-FI. Yes? No? See ad on page 58 for further information and valuable coupon.

32 PHOTO FINISHING, PHOTOCOPIES, ETC.

TWELVE Exposure rolls 49c. Wallets 20 for \$1.00. Lincoln Studios, Dept. L, Box 13, Lincoln, Nebr.

KODACOLOR trial offer: enlarged color prints from your Kodacolor negatives, 15c each with this advertisement. Bell Color, Dept. PS, Englewood, New Jersey.

ENLARGEMENTS! Two 5x7's, beautifully sepia toned; in attractive folder frames—only \$1.00. Satisfaction guaranteed. Send your favorite negative now! Photo Specialties, 1921 Arctic, San Leandro, California.

UNBELIEVABLE! B&W roll developed 8 5x7 enlargements \$1.00; 12 exposure roll \$1.50. Mortimer Photo, Salyersville, Kentucky.

ENLARGEMENTS! Eight 5x7's or Five 8x10's from negatives, \$1.00. Wilart, Box 975, Little Rock, Ark.

ROLL Developed 4X6 or 4X4 prints, 8 exposure 50c; 12, 70c. 5X7 prints; 8, \$1.00; 12, \$1.40. Hagner, 1318 West Columbia, Philadelphia 22, Pennsylvania.

32A COLOR PHOTO FINISHING

FAST, Custom, Processing. Kodacolor, eight prints, \$2.25, twelve prints, \$3.25; Anscochrome-Ektachrome, \$1.00; Kodachrome, 8mm, 35mm, \$1.25. Photo Service, Box 111, Syracuse, New York.

FREE Bonus Certificate with developing. 8mm movie, 35mm-20 Exposure Ektachrome, Anscochrome, Kodachrome \$1.25. Write for mailers. National Color Corporation, Box 12155-E, Atlanta 5, Georgia, Box 8370-E, Chicago 80.

33 MOTION PICTURES, SLIDES SOUND EQUIPMENT

MOVIE Camera Film 8 mm roll \$1.50. 16mm 100' \$3.00. Free processing. Better Films, 742 New Lots, Brooklyn, N.Y.

RECORDERS, Hi-Fi. Free Wholesale Catalogue. Carston, 215-PS East 88, New York City 28.

FREE catalog. Save \$\$\$ Fresh 8mm, 16mm B&W and color film. Home processing equipment. Superior Bulk Film Company, 442-448 No. Wells, Chicago 10.

FREE: Blackhawk's big sale catalog 8mm, 16mm, movies, 2"x2" color slides. Biggest selection anywhere! Projectors, cameras, supplies—big discounts! Get free, every three weeks, 12-page newspaper size bargain list! Blackhawk Films, Davenport 15, Iowa.

TAPE recorders, Hi-Fi components, Sleep Learning Equipment, tapes. Unusual values. Free Catalog. Dressner, 69-02 174 Street, Flushing 65, New York.

HI-FI components, recorders, tape, records. Wholesale catalog free. Audio Fair, 1799M 1st Avenue, New York 28, New York.

MOVIE Film! Free catalog! Eso-H, 47th Holly, Kansas City 12, Mo.

16MM sound films. Sold, Exchanged. Berkow, Box 503, Perth Amboy, New Jersey.

FREE Catalogues. 5,000 8-16MM Films. International Films, Greenvale, New York.

16MM Sound Films Features \$20.00. Bedner, 5300 So. Talman, Chicago.

SOUTHSEAS—2X2 colorslides, Catalogue, sample, 30c. Avery, 4818A Placidia, North Hollywood, Calif.

16MM Sound Films, Bargain Bulletin. Duquette, 97-R Snow, Fitchburg, Mass.

HI-FI. Yes? No? See ad on page 58 for further information and valuable coupon.

34 CAMERAS, PHOTO SUPPLIES

FREE! 72 Page photographic bargain catalog. Dept. 4-A3, Central Camera Company, 230 S. Wabash Avenue, Chicago, Illinois.

8MM Action Viewer Including Accessories \$9.40. Free Literature. Par-Kee Company, 6518 Honore, Chicago 36, Illinois.

35 MUSICAL INSTRUMENTS, SONG WRITERS & RECORDS

SONGPOEMS and lyrics wanted. Mail to: TinPan Alley, Inc., 1650 Broadway, New York 19, N. Y.

POEMS Wanted for New Songs and Recording. Immediate Consideration. Send Poems. Songcrafters, Box 6145, Acklen Station, Nashville, Tenn.

SONGWRITERS: Recording Company Wants new songs. Royalty basis. National sales, promotion if selected. No charge for melodies. Send material. Music Makers, Dept. G-46, Box 2507, Hollywood, California.

SONGS Into \$\$\$\$\$\$—Share \$33 million dollars yearly for New Songwriters, Song-poets. Any subject, songs composed, published, promoted by largest firm. Information, appraisal Free. Send Nurdyke Music Publishers, 6000 Sunset, Hollywood 28PS, California.

SONGWRITERS! Protect your ideas! Hold all poems, songs! Write for safe, correct procedure! Song Service, Dept. PS, 333 W. 56th, New York 19.

POEMS Wanted for musical setting and recording. Send poems. Free examination. Crown Music Company, 49-P West 32 Street, New York 1.

ACCORDIONS—1959 Models. Lowest wholesale prices. Save up to 75%. Free home trial. Trades accepted. Big color catalog free. Accordion Manufacturers, Box P, 2003 Chicago, Chicago 22.

SONGWRITERS, with publisher contacts, want song ideas. Share royalties. No fees. Send poems: Songwriters' Associates, 507 5th Avenue, New York 17.

ELECTRIFY player pianos and reed organs. Lee Mfg., 10630 Hillhaven, Tujunga, Calif.

GUITAR Making, books, plans, imported woods, tools. List 10c. Wildwood, 510 East 11th Street, New York 9, N. Y.

ELECTRIC Guitars, amplifiers, wholesale. Free catalog. Carvin, PSM, Covina, California.

POPULAR Piano — Rapid Instruction Course. Young Studios, 121 Miller, Mount Clemens, Michigan.

HI-FI. Yes? No? See ad on page 58 for further information and valuable coupon.

36 RADIO, TELEVISION SUPPLIES & EQUIPMENT

CURE T.V. trouble with Handee Guide. Pinpoints troublesome tube. Send \$1.00 make and model. Handee, Box 146, Brooklyn 19, New York.

FIX Your Own TV The Easy Way, and Save 80%! Send 10c for new, illustrated TV Trouble Shooter Chart showing which tubes to replace, for all common TV picture troubles. We'll include latest Wholesale Tube Price List free. Zalytron Tube Corp., Dept. PS, 220 West 42nd Street, New York City.

T.V. Booster good picture beautiful cabinet only \$24.95 prepaid. Bisted, 921 Ivy, Brainerd, Minnesota.

TRANSISTORS! Terrific! 5 top brands, plans build 100 items. \$9.95. Microlec, Box 5254, Pasadena 10, California.

KITS; Shortwave Radio \$3.50—Sensitive Crystal Radio 75c. Alliance, 2059 60th, Brooklyn 4, New York.

ELECTRIC Guitars, amplifiers, wholesale. Free catalog. Carvin, PSR, Covina, California.

CRYSTAL Radio Kit \$1.00: Preassembled \$1.25; Phone \$1.75: Catalog. Clearco Crystal Company, 2966 No. 4th, Milwaukee 12, Wisconsin.

GOVERNMENT Surplus Snooperscopes, Ham Gear, Mine Detectors, Parabolic Reflectors, Telescopes. Picture Catalog 10c. Meshna, Malden 48, Mass.

FREE Instrument Screwdriver! Get-acquainted offer. Just send name and two stamps. Laircraft, Box 5008-BN, Detroit 35, Michigan.

HI-FI! Yes? No? Popular Science has the answer! Now! Two amazing test records! Developed by the editors and electronics engineers of Popular Science Monthly. A pair of Hi-Fi tools that no Hi-Fi fan can afford to be without—completely different 33-1/3 l.p. test records! Avoid Disappointment When you build or buy new equipment. Popular Science Test records work as a team to give a Hi-Fi system the most thorough workout. When you buy or build new equipment or to get the best out of your present rig, play the P.S. Records and listen to the sound from your own loudspeaker-pinpoint faults that mar your listening pleasure. No fault can hide from the revealing tests that you can make yourself with these two records. Each record serves its own purpose. . . Test Record Vol. 1, "Testing with Sine Wave Frequencies," uses electronically produced tones to analyze each component in your hi-fi set. Here are just a few of the features: Tune speaker enclosures just right—by ear.—Discover how quiet or noisy a turntable is.—Show up worn stylus or poor tone arm.—Challenges you to name common sound effects. Test Record Vol. 2, "The True Sounds of Musical Tones," consists entirely of life-like tones of the actual instruments of a symphony orchestra—employed in a unique way to let you hear how your set gives out with real music. Here are just a few of the features: Check transient response and dynamic range.—Explore the personality of orchestral instruments.—Test bass response with actual music.—Shows how the high frequencies give realism to music. See ad on page 58 for further information and valuable coupon.

37 BUSINESS OPPORTUNITIES

IMPORT-Export opportunity, profitable, world-wide, mail-order business from home, without capital; or travel abroad. Established world trader ships instructions for no-risk examination. Experience unnecessary. Free details. Mellinger, X694, Los Angeles 24.

\$70 WEEKLY—Home, spare time. Simplified mail bookkeeping. Immediate income—easy! Auditax, 34757D, Los Angeles 34.

11,000 NEW Prospects Daily. Baby record books, shoes, albums. Sell mailorder. Use our literature. Write: No-Co-Ro, Capitola, California.

BRONZE Baby Shoes: Instructions, Equipment and Mountings for genuine Electroplating Process. Largest Supplier of all Plating Equipment, Supplies. Free Catalog. Hollywood Bronze Supply, Dept. B-1, 1624 East First, Los Angeles 33, California.

YOUR Own High Profit Business. Sell Name Brands, full or part time. No inventory—no investment. More than 2000 Name Brand items; lowest wholesale prices. Watches, jewelry, cameras, hi-fi radio-phonos., appliances, housewares, hardware, power tools, luggage, musical instruments, garden equipment, sporting goods, toys, many others. 8 Floors of Name Brands. Million dollar inventory. Orders shipped complete within 24 hours. Send for Free beautifully illustrated catalog Now! Separate dealer price list. H. B. Davis Corp., Dept. 14, 145 West 15 St., New York 11, N. Y.

YOUR envelopes addressed accurately, reasonably. Fast service. We have capable addressers in your city. Glenway System, Box 6568, Cleveland 1, Ohio.

NEW Home-Import Mail Order Profitability! Your mailbox stuffed with money! No Selling. No experience. No investment. We supply everything. Free Details. Mail Order Distributors (Import Division), 15201 South Broadway, Los Angeles 61B16, Calif.

YOUR Own Import Mail Order Business! Deal with over 400 manufacturers, exporters of the world. Complete Import procedures, international drop-ship methods. Capital unnecessary. Free details. Associated, Box 2068-P8, Sioux City 4, Iowa.

OPERATE profitable mail order business. Write Walter Service, 4159-B East 112th, Cleveland 5, Ohio.

FREE Catalog. Contains hundreds of businesses, farms and income properties throughout U.S., Canada. Specify type and location desired. Deal direct with owners. U.I. Buyers Digest, 1608 Hillhurst, Dept. PS-1, Los Angeles 27, Calif.

BRUSH Plating Outfits for plating articles in the home and shop. No tanks necessary. Silvering Mirrors, spare or full time. Free Particulars. Gunmetal Co., Ave. E, Decatur, Ill.

POPULAR SCIENCE OPPORTUNITIES

\$250.00 WEEK profit possible. Earn at home spare time with fascinating Printing method. \$5 starts you—send no money now. Free Confidential Facts and Valuable Samples. Screen-Print AL, Los Angeles 61.

QUICK profits, with no capital! Take orders for magazines your neighbors like, want. Make cash on the spot! We show how with Free kit. Get yours now. Write McGregor Magazine Agency, Dept. 341, Mount Morris, Ill.

"50 NEW Home-Business Ideas" Booklet, sample Free. Spray exotic Velvet-Suede on anything. Flokcraft-AL, Los Angeles 61.

EARN Money At Home raising fishworms for us! Backyard, garage, basement. We buy your crop! Inquire: Oakhaven-42, Cedar Hill, Texas.

\$100.00 WEEKLY spare room. Raise red-worms soilless way. Odorless. Charlie Morgan, Box 116C, Bushnell, Florida.

GROW Orchids at home. Profitable, fascinating. Successful home grower explains special light, temperature and humidity conditions orchids need. Free—Full details. Orchids, 100 S. Vermont, Los Angeles 4.

PLATE Baby shoes, jewelry, gifts, bronze and colored pearl. Free booklet. Bronzkrafters, 11029 South Vermont, Los Angeles 44.

FIX Typewriters. Free Repair Course. Home operated. Remit 25c for book explaining Free Course and Agency Appointment. Athey, Tarentum, Pa.

MAKE Extra Money—Big Cash Commissions plus premiums for you and your customers. Sell Advertising Book Matches—sensational new Tenorama, Glamour Girls, Hillbillies; dozens others. All sizes—Quick daily sales; big repeat business. Free Master Kit makes selling easy—no experience necessary. Superior Match, Dept. PX-459, 7530 Greenwood, Chicago 19, Illinois.

WHOLESALE Catalog—shoes, shirts, pants, underwear, hosiery, etc. Bostonian, 14-DB Dock Square, Boston 8, Mass.

YOUR own service business, part time. No investment. Write Small Business Reports, Box 735, Anderson, Indiana.

BARON Rothschild became wealthy buying stocks "nobody wanted." So can you! Get free Folder PS-2. Forecasts, Box 87, Pelham, N. Y.

PLASTERCRAFT molds, liquid rubber, plasters, flocks, candle supplies. Catalog and manual free. Jayhawk Plasters, Blue Rapids, Kansas.

MINK Raising information free. Complete. Lake Superior Mink Farm, Superior E E5, Wisconsin.

EARN \$20,000 a year from your own mail-order business, at home. Write at once for free details of proved program. DeLang Research, Box 52-C, Burlington, Iowa.

FREE Book: "609 Odd, Successful Businesses." Work home. Institute, Box 1001-PSB, Evanston, Illinois.

GROW living Miniature Forest (only inches high)—or orchard that bears tasty tiny fruit. Learn amazing Dwarfing secrets! Fascinating hobby! Profitable Home-business Opportunity! Free Seeds and Plan. (State your age.) Miniature Nurseries, Dept. AL, Gardena, California.

SHINE Cars Without "Polish." New invention. Lightning seller. Cars gleam like mirror. Samples sent on trial. Kristee, 108, Akron, Ohio.

GAME Warden, Government hunter, Forestry, Park and Wildlife Services announce job openings. All states. Enjoy outdoor work, good pay, real security. Complete information Free! Write Forestry & Wildlife Course, Dept. CC-184, 1038 S. LaBrea, Los Angeles 19, California.

MAILORDER to motels, restaurants, churches, institutions. Complete individual setup, not just instructions. Hermes Advertising, 152-G West 42, New York City 36.

FREE "Franchise Profit Letter" describes nationwide opportunities. Exclusive distributorships, dealerships, agency operations. Write today National Franchise Reports, Y-528, 333 North Michigan, Chicago 1.

WATCH Out: Interested operating a route of vending machines? Don't lose money. Read "Pitfalls of Vending" \$2.00 complete. Danx Researchers, Box 141, Rockaway Park Station, Long Island, New York.

BUY Direct From Factories—Appliances, Cameras, Watches! Free details! Cam Company, 6810PS-20th Ave., Brooklyn 4, New York.

VENDING Machines—No Selling. Operate A Route of Coin Machines And Earn Amazing Profits. 32-Page Catalog Free. Parkway Machine Corporation, Dept. 18, 715 Ensor Street, Baltimore 2, Maryland.

MAKE money addressing. Details Free. Ruth Heron, Rt. 1, Box 280, Wilton, California.

LEARN Christmas Lycopodium and sparkled cone Wreath flocking. Samples 24c. Lycopodium Foundation, St. Paul 13, Minnesota.

MAIL Order! Succeed with proven, positive money-making program. Complete setup. Quick results—lifetime income. Free details. Erol Slater, 305 West Eighth, Los Angeles 14, California.

INTERNATIONAL mailorder business made easy. Individual setup service, not just instructions. Hermes, 152-R West 42, New York City 36.

OWN Local Collection Agency. Pays Big! Franklin Credit, Roanoke, Virginia.

MAKE Moulded Terrazzo Monuments. Terrific Profits. One Man Operation. No Machinery. Local Material. Granitex Monuments, Dyersburg 1, Tennessee.

FREE Business, Franchise protected. Have own office. Self-employed. No merchandise to buy or sell. Nationwide. Details free. Pippin & Company, Box 87, Benham, Kentucky.

SELL Books by mail. 400% profit. Royal, Box 368-M, Cleveland 27, Ohio.

HAVE Home Mail Business—Real Merchandise. We Supply Literature, Names—Fill Your Orders. Information Free. Buckingham, 689 "F" Street, Hampton, Virginia.

LEARN Showcard Writing In Spare Time. Fascinating, Profitable, Business of Your Own. No Special Skill Needed. Interesting Information Free. Sherwood, 200 Summer, Boston 10H, Mass.

PIANO Tuning learned quickly at home. Tremendous field! Musical knowledge unnecessary. Information free. Empire School of Piano Tuning, Champaign, Illinois. (Founded 1935.)

RAISE Earthworms For Profit. 31 Page Booklet For 35c Tells How. Angler's, P. O. Box 265, Malibu, California.

MAKE Durable building plastic easily. Beautiful — 101 uses — 800% profit. Bays Laboratory, Keams Canyon, Arizona.

MEN, Women needed! No selling! Vital! Profitable future! Free Details! Director, Box 675, Oak Terrace, Minnesota.

MAIL Order opportunity magazine 10c. Moritz's Fireside Shopper, Saginaw, Michigan.

EARN Good Money sharpening chain saws, scissors, cutters, knives. Free Manual. Treyco, North Tonawanda 1, New York.

FINANCE Specialist. New, exceedingly profitable. Complete instructions. Tucker, 3633 Warder, N. W., Washington 10, D. C.

\$10,000 ANNUALLY possible, operating successful "collection agency". Box 1346-PSX, Denver 1.

\$250 WEEK reported! Free book "505 Odd, Successful Businesses." Work home! Expect something Odd! Pacific-36C, Oceanside, California.

OPERATE profitable mailorder business!! Write: Bond, 1637-R West Vernon, Phoenix, Arizona.

COLORGLAZED Concrete pottery made without molds. Patented method. Cemetery products, novelties, tiles. Basement leak-sealing. Money-making projects. Booklet, details free. Men only. National Potteries, Grand Rapids, "Minnesota."

OPPORTUNITY to earn \$15,000-\$30,000 annually. Franchise protected. Granted on \$12,500 basis. Live at home. No merchandise to buy. Selfemployed. One of most exclusive and noncompetitive Businesses in United States and Canada. Send for free explanatory booklet. Harrell and Company, Box 8-D, Louisville, Illinois.

QUICK-brick. Home improvement bonanza. Speedy production, our methods. High profits. Work from Home. Free book. Stone-Craft, Box 856-C, St. Louis, Mo.

\$34.70 TWO Hours. Manufacturing Concrete Products. No Selling. Carlayn Castings, 1803 Fremont, Rapid City, South Dakota.

\$5,000, MEN, Women! Work Home! Sparetime! Free "Confidential Plan." Scott, Box 388, Great Neck, New York.

FREE Folio "\$5,000-\$45,000; Unlimited Vacations." No merchandise. Unknown! Work home! Haylings-S-16, Carlsbad, Calif.

FREE Literature — Make Big Money Raising Fishworms and Crickets. Carter Farm, Plains, Ga.

SERVICE stores with novelty toy displays part or full time. (Small investment triples yearly.) Fried, Incorporated, Box 22PS, Brooklyn 25, N. Y.

\$340.00 MONTHLY with jigsaw. Details. Elkman, 346 North Summit, Sioux Falls, South Dakota.

MARKETS Everywhere. Make Artistic concrete birdbaths, pottery. Best coloring. Home workshop. Hundred varieties. Hollywood Cementcraft, 8527-N Wonderland, Hollywood 46, California.

\$6,000 FOR Mister, Mrs.: \$3,500! Free "Secret Journal" Plan. Magical! Work home! Publico-N33, Oceanside, Calif.

BEFORE starting any mailorder business read "Mailorder Laws and Regulations" and "Mailorder Rules for Beginners." \$2.00. Licenses, taxes, legal requirements explained. Tasker, Box 3131, Alexandria, Virginia.

MEN or Women up to \$25.00 daily sharpening scissors, pinking shears with amazing electrically driven machine, experience unnecessary. Easisharp, 4217-A Rocky River Dr., Cleveland 35, Ohio.

25c TO \$25.00. 1101 Moneymaking Plans, Formulas, Ideas. Catalog free. Charles Company, 42-DND, Norwood, Ohio.

HOMEWORK! \$150 Monthly addressing envelopes! Complete instructions \$1, refundable. Chez Bonnie, Box 290, Great Neck, New York.

WE buy figurines you manufacture. Free details. SunLong, Box 382, Lockport, New York.

START Profitable Stamp Machine Route. Sanipak, Box 31, Medford 56, Massachusetts.

BIG Money—Operate own Fix-it Shop. Service household appliances, motors, mowers, saws, skates, etc. Free Book. Christy Trades School, A-8201, 3214 Lawrence, Chicago 25.

AMAZING Opportunity! Service, repair Air Conditioning, Refrigeration. Easy, practical. Tested Trouble Charts. Observations, possible causes and remedies. No studying, profitable, experience unnecessary. Start spare, full time business. Free Consultations. Complete price Now \$3.00. Authentic. Satisfaction Guaranteed. Limited Quantity. Cioffi, 101 Sawmill Street, No. Haledon, New Jersey.

BRAND New, profitable distribution method for carded, high volume, money maker. Sells on sight. Every retailer your customer. Immediate income. Send 50 cts. for valuable Plan Booklet today. Besco, 3031 North 24th Street, Phoenix, Arizona.

LIQUID Molding Rubber, Free Sample. Shellcraft Supplies, Chaney's, 1907-C East Road, Jacksonville 11, Fla.

CANDIED Popcorn and Potato Chip Equipment. Eakins, Box 933-B9, Springfield, Ohio.

BOSS your own home business. Profits 1200% to 3000%! Make, distribute stunning Shellcraft jewelry. Sells itself wherever displayed. Big repeat demand! Details free! Shellcraft, Dept. E, Box 804, Panama City, Florida.

"\$75.00 WEEKLY in your own mail order business." Complete Beginner's Plan. Home operated, spare-full time. Everything supplied. Wayne's Service, 3016-N Channing N.E., Washington 18, D. C.

UNLIMITED Import-Export Opportunities! Earn big money from home. No experience. Capital unnecessary. Free Import Bulletin. Foreign Traders, 7814-SI Forsyth, St. Louis 5.

MILLIONAIRE in 5 yrs. your own business. \$300 guaranteed in 15 days. Information \$1.00. Stark, 14321 Wentworth Chicago 27.

POTTERY—Made without molds! Self-hardening, no firing! Colorful statuary, novelties, tile. Particulars free. Marbleize Service, Edwardsville, Illinois.

WHOLESALE Prices. Nationally Advertised Brands. Free Information. National Wholesale Service, Dept. H, Box 397, Buffalo 5, New York.

POPULAR SCIENCE OPPORTUNITIES

NATURAL Molding Rubber: Extra Thick. Free Sample. W. Wooley, 1016-B Donald, Peoria, Illinois.

MAKE flexible molds. Cast plaques, figurines. Free sample. Tooker, 1045-A Fairview, Hamilton, Ohio.

MAKE \$46 From Square Foot Plywood; Jigsaw necessary. Free Details. Woodarts, Bridgewater, Mass.

MAIL Order Business. Comprehensive Guide to starting your own mail order business tells what to sell; how, where to get free publicity; where to find drop-ship and syndicated catalog services; what to say to manufacturers; how to advertise; pitfalls to avoid. Packed with hundreds valuable tips. Money-back Guarantee. Send \$1 to Mail Order Institute, 920 Sansom St., Dept. 558, Philadelphia, Pennsylvania.

METALIZE Baby Shoes; Repair Dolls; Rebuild Batteries; Catalog "75 ideas" Free. Universal. Box 1076-B, Peoria, Illinois.

38 MONEYMAKING OPPORTUNITIES

MEN - Women! Start Money-Making Plastic Laminating Business at home in spare time. Material that costs 11c brings back \$2.58. No canvassing or selling but mail orders bring in \$20 a day. Write for full particulars Free. Rush name on postcard to Warner, Room CL-3-D, 1512 Jarvis, Chicago 26, Ill.

DETECTIVES—Work home—Travel. Experience unnecessary. Detective Particulars free. Write Wagoner, P-125 West 86th, New York 24.

EARN cash at once, sending us easy orders for magazines your friends, neighbors want. Instant profits! We show how. For Free kit, everything you need, write McGregor Magazine Agency, Dept. 351, Mount Morris, Ill.

SELL Titania Gems: far more brilliant than diamonds. Catalog 10c. Diamonite, 2420-S 77th, Oakland 5, California.

HAMMER? Saw? Drill? \$100 Weekly. Jett, Box 422, Escondido, California.

"HOW to Build a Mail Order Business" —instructive booklet 25c. Harmon, Box 2, Defiance, Ohio.

SELL Yourself-Neighbors. Distribute Aluminum Awnings! Factory prices! Groff, P.O. Box 10254, Tampa, Florida.

MAKE \$5,000 yearly sparettime raising mink, chinchillas, nutria, etc. Free booklet reveals proved plans. Write: Furs, 588 Mt. Pleasant Road, Toronto 2, Canada.

3 MONEYMAKING Manufacturing Opportunities Can Be Manufactured At Home Cheap. Full Details Send \$1.00. Manufacturing Specialties, Box 92, Sicklerville, New Jersey.

IDEAL sparettime homework. 3-Way plan 25c. Clarence Sage, Box 476, Springfield, Massachusetts.

MAKE Money Writing Short Paragraphs. Information Free. Barrett, Dept. C-86-D, 7464 No. Clark, Chicago 26.

NEED money? Write R. W. Buckingham, 689 F, Hampton, Virginia.

START Big-Pay business at home in spare time. No experience needed to operate little table-top machine for bronzing baby shoes. Make \$5.46 profit on every pair. Full particulars free. Send postcard to Mason, 1512 Jarvis, Room CM-3-D, Chicago 26, Illinois.

NEW Magazine shows you how to make mail order pay. Free details. Mailorder Income, 2639-34 Howard, Chicago 45, Illinois.

EXTRA money home typing. Instructions \$1.00, refundable. Olds, 4428 S. Kilpatrick, Chicago 32, Illinois.

AMAZING successes through franchises! Become exclusive franchise holder your territory. Information rushed. National Franchise Reports, SP-528, 333 North Michigan, Chicago 1.

VENDING Machines—No Selling. Operate A Route of Coin Machines And Earn Amazing Profits. 32-Page Catalog Free. Parkway Machine Corporation, Dept. 19, 715 Ensor Street, Baltimore 2, Maryland.

MANUFACTURE highly salable specialty wire products easily. Start own business at record low cost. Let us prove it. Get free brochure from Jon-Cee Products Co., 1203 Ford Rd., Cleveland 24, Ohio.

\$15.00 THOUSAND! Addressing envelopes for advertisers! (We make no false claims.) Details 25c. Barrie, Box 1247, Jamaica 21, New York.

REPAIR Hydraulic Jacks—Learn High Paying Trade—Follow Simple Instructions In Illustrated Trouble Shooters Manual Covering All Models \$3.98. Hydraulic Parts Supply, Box 8695, Washington 11, D.C.

\$35.00 WEEKLY addressing envelopes. Instructions \$1.00 Refundable. Adservice, Spring Valley, New York.

PROFITS by mail sparettime. Details free. Grimson, Dept. B, 9421 Harper, Detroit 13, Michigan.

"SURE-Fire" Mailorder Plan Shows How!! Write—G. Merrill Hestand, Hatfield, Pennsylvania.

START building that fortune you dream about now! You can. Exciting new booklet "Founding A Fortune on a \$10 Bill" shows how fortunes are made and how you can plan your program for financial independence. Mailed free on request. Stephen Matuszak, 79 Wall Street, Dept. 1304, New York 5, N. Y.

MAIL Trade Magazine has moneymaking opportunities galore. Sample 25c. Donovan, 79-PS Greenbelt, Levittown, New York.

FREE Literature — Make Big Money Raising Fishworms and Crickets. Carter Farm-11, Plains, Ga.

100% PROFIT Mailing Postcards. All Supplies Furnished To Start \$1.00. Details 25c. Pco, 322½ Brady, Davenport 3, Iowa.

\$30-\$60 WEEKLY Addressing Envelopes. Instructions \$1.00, refundable. Ryco Service, 210 Fifth Ave., Suite 1102-S, New York 10.

MONEY Making and Saving Catalogue. Write, Adams Exchange, 210 5th Avenue, New York 10, New York.

FREE Folio. "\$5,000-\$45,000; Unlimited Vacations." No merchandise. Unknown! Work home! Haylings—S16, Carlsbad, Calif.

EXTRA Money Ahead! Through Choos- ing Hobby. Way Shown. Success, A-5, RDR #2, Nixon, N. J.

SELL Newspaper clippings for cash. I tell you where. Russell Tupper, Sandwich, Mass.

80 CENTS And up in Five Minutes. Clean Venetians with Slat-O-Mat. East American Supplier, Niantic, Conn.

FREE plan and help. Home mail order business. Anyone can do this. Allen Cole, 217 West 49th, Bradenton, Florida.

MAKE Money, Operating Mail Order Business, Selling Business Cards. Vosacek Printing, 4444PS Ute, San Diego 17, Calif.

SELL Jokes, Magic, By Mail. Details, Samples, Catalog \$1.00. Lachter, 151-71 25th Ave., Whitestone 57, New York.

CIGARETTES—Improved roller makes 20 for 9c. All types pipe tobaccos. Facts free. Moberly, Box 911, Owensboro, Kentucky.

MAIL Order Trade Paper, home profit opportunities galore, 10c. Fisher's, 3801 Riverside, S.W., Cleveland 9, Ohio.

MAKE Money Clipping Newspaper Items. Detailed plan. Newscraft, PS-983-E. Main, Columbus 5, Ohio.

GET Dollars Daily. Work Home. Rowe, 2317 Marshall, Chicago 23, Illinois.

38A BUY IT WHOLESALE

SNARE Distributing Company, featuring "Quality Merchandise at Quantity Prices." Write us today for 100 Page Catalog of Nationally Advertised Merchandise—Jewelry, Appliances, Cameras, Typewriters, Tools, Ect. Send 25c—Refundable on first order. Box 2371-PS4, Jacksonville 3, Florida.

ACCORDIONS wholesale! Save ½. Home trial. Free catalog. Accordion Warehouse, Dept. 49-PW, 2003 Chicago, Chicago 22.

NEW Multicolor Wholesale Catalog! Housewares, appliances, clothing, silverware, cookware, luggage, binoculars, shavers, radios, phonographs, cameras, projectors, recorders, typewriters, sewing machines, furniture, power tools, toys, sporting goods, watches, diamonds, jewelry, automobiles, etc. Name brands. Huge discounts. Postcard: Selbyco, Decatur 167, Illinois.

LARGEST Wholesale Supply Source in U.S. Get free catalogs. Furniture, clothing, appliances, autos and accessories, farm equipment, tools, housewares, hobby supplies. Free details. Associated Wholesalers, Box 2068-C, Sioux City 4, Iowa.

DIAMOND Rings! Earrings Below Wholesale. Distributors, Box 106U, Hudson, New York.

8 SELECTED Wholesale Catalogs: \$3.00 Everything! Pins to Mansions! Discounts to 75%! 5 cat. \$2.00. Consumer's Supply Company, Box 606, Rock Island, Illinois.

BUY Wholesale: 100,000 Nationally Ad- vertised Products. Appliances, Cameras, Sporting Goods, Housewares, Watches, Typewriters, Tools, Clothing, etc. Discounts to 80%. Buy-Rite, Box 258, Hawthorne 108, New Jersey.

BUY surplus jeeps, tractors, farm imple- ments, winches, tools, pumps, hydraulics, wholesale direct from Government. List and procedure \$1.00. Aviation Surplus, Dept. 34, Thomasville, Pennsylvania.

ELECTRIC Guitars, amplifiers, whole- sale. Free catalog. Carvin, PSW, Covina, California.

HOW to obtain over 100 free Wholesale Catalogs. 200,000 Nationally Advertised Products. Wholesale Buyers, Tegethoff Building—CC, St. Louis 5.

BALLPOINT Pens, Retractable Firsts, 85c Dozen! Fantastic. Westco, 1617-PS Mermaid, Brooklyn 24, New York.

SELLING Out many items less than wholesale. Catalog 10c. (Refundable). Cewco, 5921 Lowell Road, Everett, Washington.

39 FORMULAS, PLANS, ETC.

FORMULAS—All kinds. Latest products. Literature free. Kemico, Park Ridge 15, Ill.

LATE Modern Manufacturing Formulas List Free. Chemical Service, Martville, New York.

OPPORTUNITIES, Unlimited! Formu- las, processes, trade secrets of latest specialty products. Exciting details, free! Alpha-Midwest, LaPorte, Indiana.

SPECIAL Formulas for latest money- making discoveries. New! Good! Profitable! Valuable Literature Free! Miller, Chemist, 1517-N, Tampa, Florida.

LARGE Formula Catalog 10c Big Sur- prise. Western Chemical, Salem, Oregon.

40 PLASTICS

LEARN Plastics Fabrication For spare time income. Low cost home training now available. Write for free booklet. Interstate Training Service, Dept. D-2, Portland 13, Oregon.

NEW Liquid casting plastic, clear, col- ors. Embed real flowers, butterflies, photos, coins. Send 25c for two handbooks "How to Cast Liquid Plastics" and "How to Make Extra Money at Home." Castolite, Dept. D-102, Woodstock, Illinois.

PHOTO-Seal. Complete electric laminating kit for wallet size photos, cards. \$14.95. Refills available. Therm Appliance, St. Charles, Illinois.

POWER Putty. Miracle plastic kit. Speeds shop, boat, engine repairs. For home and hobby. Free laminating resin and instructions. PP \$2.98, COD. Huntress Pro., Atascadero, California.

NEW Do-It-Yourself casting and Mold- ing Plastics! No Experience or Machinery Necessary. Send 25c for Big 64 page catalog. Castacraft Corp., Dept. D-12, P. O. Box 555, Palo Alto, California.

LAMINATING Supplies. Price List Free. Solomson, 46 Cornhill, Boston 8, Mass.

PLEXIGLAS. Square foot cost, 1/16"—\$1.20; 1/8"—\$1.52; 3/16"—\$1.86; 1/4"—\$2.21; 3/8"—\$3.23; 1/2"—\$4.36. Colors add 10%. Send 15% for postage. Aristocrat Plastics, 23 Sussex Avenue, Newark, N. J.

ELECTRIC Laminating Kit. \$14.95 Complete. Photos, etc. Laminated. Burr, 330 East Centre, Kalamazoo, Michigan.

PLEXIGLAS — Any thickness — Clear —Colors—Cut to size—Clear Rods—Tubing. McClarin Plastics, P.O. Box 168B, Hanover, Pennsylvania.

CELLULOID Sheets, Scrap, colors, sizes. Plastics, Box 8096, Newark 8, New Jersey.

41 SCIENCE & CHEMISTRY

MICROSCOPE slides, anatomical. Free list. Bay, 409 Roosevelt Way, San Francisco 14, California.

ILLUSTRATED Catalog; Chemistry, mineralogy, biology 25c. Tracey Laboratories, Evanston, Illinois.

QUALITY chemicals in small quanti- ties, glassware, apparatus, books, biology supplies. Catalog 25c. Winn Chemicals, 124P West 23rd Street, New York 11, New York.

ROCKET Supplies and Chemicals. Catalog and Plans 25c (Refundable). Central Rocket Company, 89S, Waupaca, Wis.

POPULAR SCIENCE OPPORTUNITIES

AMAZING New Book Of Science Experiments, Formulas, and Catalogue of Laboratory Supplies. Only 25c. National Scientific Co., Dept. PS-4, 11 E. St. Charles Road, Lombard, Illinois.

CHEMICALS and apparatus for industrial, analytical and private laboratories. Catalog 25c. Dept. M-26, Biological Supply Co., 1176 Mt. Hope Ave., Rochester 20, N.Y.

EDUCATIONAL Books! "Chemistry," "Science," "Physics," "Biology." \$1.10 Each. Information free. Franks, 3121 South Racine, Chicago 8.

CATALOG with 3000 illustrations of laboratory and physics apparatus sent for \$2.00 Postpaid. Laboratory Materials Company, 1328 E. Hyde Park Blvd., Chicago 15, Ill.

EXPERIMENTERS—"Bargains Galore Catalog,"—25c (Refundable). Hagenow Laboratories, Manitowoc, Wisconsin.

42 HELP WANTED REPORTS

AMERICAN Overseas Jobs. High Pay. Men, Women. Transportation Paid. Free Information. Transworld, Dept. 13C, 200 West 34th St., New York 1.

JOBS—High Pay; USA, So. America, The Islands. All trades. Many companies pay fare. Write Dept. 71L, National Employment Information, 1020 Broad, Newark, N. J.

FOREIGN Jobs—Latin America, Alaska, Canada, up to \$1500 monthly. Up-to-date 1959 Foreign Service Directory gives complete information; hot list of firms hiring for Military and Civilian Construction, Aircraft, Oil, Exporters-Importers, Mining. How-When-Where to apply. 11th Successful year. \$1.00. Global Reports, Box 8873-P, Los Angeles 8, California.

COPYRIGHTED Reports. Best paying jobs with travel, adventure, promotions. Construction, aviation, shipping, oil fields, laborers, clerical, trades, supervisory, factory, unusual opportunities. Skilled—unskilled. Foreign—stateside. Men—Women. Only \$2.00 (\$2.25 Airmail). (C.O.D.'s Accepted), including registration-advisory service. Satisfaction guaranteed. Included free: Special reports on Alaska-Venezuela-South American opportunities—Husband & wife foreign jobs. Research Services, Suite 514-PS, Meramec Building, St. Louis 5, Missouri.

JOBS on Ships. Write for free information. World Wide Seamen Service, Box 1445-PS, New York 1, N. Y.

CARPENTERS — Laborers — Drivers. All Occupations, Foreign Project. Bonus Pay. Free Information. Employment Headquarters, 79 Wall Street, Dept. 4-C, New York 5.

INFORMATION — USA Overseas Jobs, High Pay, Transportation—Futures, Dept. P, 215 West 34th Street, New York City 1.

JOBS and Opportunities in Sunny Arizona, details dollar. Arizona Opportunities, Box 48, Chandler, Arizona.

SOUTHERN California: Highest wages, best living conditions, Employment opportunities \$1.00. Dextron, Box 1371, Beverly Hills, California.

CONSTRUCTION Workers, truckers, oil workers, tradesmen, business and professionals, others—Alaska and B.C.. America's last great frontier is under major development. For information write Opportunity Service, 385-W Winnipeg Street, Prince George, B. C.

JAPAN! Many hi-paying jobs available. Full, complete details \$2.00. Walts, Box 903, C.P.O., Tokyo.

ALASKA: Hourly Scale: Laborers \$4.16; Truck Drivers \$4.45; Carpenters \$4.38; Plumbers \$5.00; Electricians \$5.00. Construction Projects over \$335,000,000.00. Names and addresses of companies hiring; Total contracts awarded; location; wage scale; also information on Homesteading. Send \$1.00 to Alaska Employment Opportunities, Box 1032, Anchorage, Alaska.

JOBS Overseas! Write Jancek Development Co., 109 Hub Station, New York 55, N. Y.

BOOMING Latin America! Fabulous Brazil, Venezuela—Only hours from the States. New data regarding jobs, opportunities, conditions. American companies employing, etc. All skills required. Salaries to \$1,650.00 monthly—U.S. Tax exempt. Bonuses, living allowances, travel expenses, exciting vacations, and more! First hand information direct—\$2.00 (\$2.35 Airmail) checks, money orders OK! Paul B. Smith, Avenida 16, No. 68-49, Maracaibo, Venezuela

CERTIFIED Foreign USA Jobs Reports. Highest wages Travel. Bonuses. Adventure. Wanted; construction workers, oil fields, clerical, laborers, aviation, teachers. All trades. Only \$2.00. Guaranteed by Foremost Job Researcher All Trades. Plus Free complete reports on South America, Alaska, Venezuela. Universal Researcher, Box 4912, Baltimore 20, Maryland.

COMING to Florida? Send for complete report, jobs, salaries, cost of living. Information you need. \$2.00. Survey, 904 Chamber of Commerce Bl., Miami 32, Fla.

JOB Seekers! (Alaska, Canada, U.S.A. Foreign) Available—many sources of free employment information, job listings. Write for "Directory of Free Employment Services"—enclose \$1.00 handling charge (airmail \$1.25). Opp. Services, 385-W Winnipeg, Prince George, B.C.

JOBS on Ships and Yachts Traveling Foreign Countries. Davenport's, 1354, GPO New York 1, New York.

43 AGENTS WANTED

GOLDMINE of 600 money-makers. Free copy. Specialty Salesman Magazine, Desk 6B, 305 North Michigan, Chicago 1, Ill.

YOUR own business—Suits \$1.50; Overcoats 65c; Mackinaws 35c; Shoes 12½c; Ladies' Coats 30c; Dresses 15c; Enormous profits. Catalog Free. Nathan Portnoy Associates, 2109-J Roosevelt Road, Chicago 8.

AGENTS—300% profit selling genuine gold window letters: stores and offices. Free samples. Metallic Sign Letter Co., 1217-E West Newport, Chicago.

IF you're interested in making money in selling, see the hundreds of exceptional opportunities in Salesmen's Opportunity Magazine. Send name for your copy, absolutely free. Tell us what you're selling now. Opportunity, 848 N. Dearborn, Dept. 18, Chicago 10, Illinois.

GOLD or Silver letters, numbers. Windows, Doors, Trucks 1" to 6". 500% Profits—Free Samples. Atlas-U, 544 West 79th, Chicago 20.

START Your Own Business On Credit (U.S. and Canada). Your own boss. 1425 Dealers sold \$5,000 to \$32,000 in 1957. We supply stocks, equipment on credit. 200 home necessities. Sales experience unnecessary. Pleasant profitable business backed by world-wide industry. Write Rawleigh's, Dept. D-U-PSC, Freeport, Ill.

SALESMEN—Big money every day showing nationally known drain cleaner. No chemicals. Nothing like it. Minute demonstration. Commissions paid daily. Sample furnished. Campbell Co., (Est. 1928), Rochelle 605, Illinois.

AMAZING New Liquid keeps hands clean forever! Not a cleaner—not a detergent—not a soap, but a sensational new chemist's discovery that vigorously resists soil of all kinds. Terrific 60-second demonstration sells on sight. Big extra profit details Free! Jet Products, Wampum 2, Penna.

CASH commissions at once, taking orders for magazines every family wants! No experience needed. For Free money-making kit, with everything you need, write McGregor Magazine Agency, Dept. 331, Mount Morris, Ill.

BUY Wholesale—shoes, shirts, pants, underwear, etc. Complete catalog. Bostonian, 14-D Dock Square, Boston 8, Massachusetts.

SEEKING New Products? Get my outfit 47 money-making specialties. Latest conveniences for home, car. Send no money. Just your name. Kristee, 62, Akron, Ohio.

60% PROFIT On Cosmetics—Famous nationally advertised Hollywood Cosmetics pay 60%! Make \$25-day up! Hire others. For free samples, details, write Studio Girl, Glendale, California, Dept. 1194-G.

NEW Car Thief Signal. Lightning Seller. Samples sent on trial. Northwest Electric, 111, Mitchell, South Dakota.

FREE Sample! Beautiful Feather Pictures. Send 14c stamps mailing. Sylvial, Apartado 9036, Mexico 1, D. F.

EVERY Man A Prospect. Request Free Sales Kit showing line of belt buckles, tie clasps, money clips, cuff links, lapels, individualized with customer's name and emblems, also cap badges for trucking, bus, taxi, police, firemen. Choice 3,000 emblems. Hook-Fast, Box 1425-PS, Providence, Rhode Island.

BUSINESS of your own. Earning potential as high as \$40,000 annually. Issued on \$12,500 base. No merchandise to buy. Send for free explanatory booklet. Harrell & Company, Box 8-DD, Louisville, Ill.

CALENDARS, Advertising Novelties, Matches. All styles, including Religious. Varnished 12 sheet. Girls. Hundreds of Advertising Novelties. Book Matches, etc. Fleming Calendar Co., Promotional Division, 6539 Cottage Grove, Chicago 37, Ill.

TURN Your Spare Time Into Cash! No "selling" needed with items like these—you just sit back and take orders during your spare time! Over 700 fascinating items—gifts, gadgets, toys, greeting cards, and novelties that sell themselves on sight. Write today for details and free, colorful catalog. Samples on approval. Greetings Unlimited, 9-319 Park Square, St. Paul 1, Minnesota.

WILL you wear new suits and topcoats without one penny cost and agree to show them to friends? You can make up to \$30.00 in a day even in spare time, without canvassing. J. C. Field & Son, Inc., Dept. N-1826, Harrison & Throop Sts., Chicago 7, Illinois.

EARN big commission full or part time. Build profitable business of your own selling America's largest line low priced business printing. 360 page catalog samples hundreds of items used daily by business people. Advertising Specialty line features imprinted ball pens low as \$9.95 for 100. Calendars low as \$5.95 for \$100. Free Sales Kit. National Press, Dept. 9, North Chicago, Illinois.

BIG Profits — Stamp Social Security Plates Key Protectors. Sample—50c. Catalog Free. General Products, 188-PS State, Albany 10, N. Y.

BIG Money In Imported Paintings. Buy Direct At Low, Low Prices. Free Details. Hrebenvar Company, 4436-D Hamilton Scipio Road, Hamilton, Ohio.

DISTRIBUTORS, Jobbers, Salesmen: \$500.00-\$5000.00 Monthly possible. Sell beautiful "Spiritual Birth Certificates," Protected Territory. Write—Spiritual Birth Certificates, Red Springs, North Carolina.

WHOLESALE Catalog Appliance Housewares. Vikari, 468S 3rd Avenue, Salt Lake City 3, Utah.

EARN \$12,000 Yearly—only two sales daily. World's Best Seller, The Holy Bible. (Illustrated) Protestant or Catholic. Margareta's, P. O. Box 92, Hazleton 6, Pa.

SELL Champion, AC, Autolite spark plugs. Reconditioned, electroplated, guaranteed 10,000 miles. 100% profit. Free sample. Lee Plugs, 1608-C Roberts, Houston 3, Texas.

44 HIGH-GRADE SALESMEN

AD Match Sales! Your own business—without investment! Sell for world's largest direct selling manufacturer of advertising matchbooks. Big spot cash commission. Start without experience—our tested sales kit tells where and how to get orders. Men, women—part or full time. Match Corporation of America, Dept. PS-49, Chicago 32.

\$1,000.00 A month for making dramatic 3-second demonstration of amazing lightweight Presto Fire Extinguisher. New chemical used by airforce snuffs out fires instantly. Only \$4.95. Terrific commissions. Millions want it. Free Kit. Merlite, 114 E. 32nd, Dept. P-66X, New York 16.

GET New Shirt Outfit Free; make \$90.00 weekly on 5 average orders a day. Famous quality Made-To-Measure dress and sport shirts at \$3.95 up, sell fast to all men. No experience needed. Full or part time. Write: Packard Shirt Co., Dept. 847, Terre Haute, Ind.

MAKE Extra Money—Big Cash Commissions plus premiums for you and your customers. Sell Advertising Book Matches—sensational new Tenorama, Glamour Girls, Hillbillies; dozens others. All sizes—Quick daily sales; big repeat business. Free Master Kit makes selling easy—no experience necessary. Superior Match, Dept. P-159, 7530 Greenwood, Chicago 19, Illinois.

AMAZING opportunity. New low priced fire alarm protects homes, farms, offices, factories, etc. No wiring—hangs like picture. Pays up to \$1,100 a month. Free kit. Merlite (Alarm Div.), 114 E. 32nd St., Dept. F-66X, New York 16, N. Y.

EARN Big Money! Selling commercial shelving-parts bins-cabinets-shop equipment. Sold everywhere! Terrific commissions. Free 32-page catalog. Jobber discounts. BFC Corporation, 2807E. Hedley, Phila. 37, Pa.

EARN \$50.00 daily listing past due accounts for National company. Instructions free. 304Y Pickwick Bldg., Kansas City 6, Missouri.

45 EDUCATIONAL & INSTRUCTION

BOOKKEEPERS! Increase your earnings! Operate your own simplified "Dollar-A-Week" Bookkeeping and Tax Service. Full or spare time. Details Free. No obligation. Ellis, Box 203, Cedar Grove, North Carolina.

BE a Real Estate Broker, Study at Home. Write for Free book today. GI approved. Weaver School of Real Estate, 2018R Grand, Kansas City, Mo.

MASTER Watchmaking at home. Free sample lesson. Chicago School, 2328-WQ, Milwaukee, Chicago 47.

WANT a Diesel Job? New Opportunities to increase income. Higher Pay. More Money. We can help you Qualify. Tools Shop method home training. Write today! Diesel, Tractor, Heavy Equipment Division. Interstate Training Service, Dept. B-2, Portland 13, Oregon.

EARN While You Learn Auto and Diesel Mechanics. Master this top paying trade. Many graduates earn \$100 a week and up. Approved for Korean veterans. For free information write Dept. No. 262, Nashville Auto-Diesel College, Nashville 3, Tenn.

ENGINEERING Degrees Earned through Home Study. Electronics, Electrical, Mechanical, Civil, Physics. When writing, specify course desired. Pacific International College of Arts & Sciences primarily a correspondence school. Resident classes also carried. 5719-A Santa Monica Blvd., Hollywood 38, California.

HIGH School Diploma at home. Licensed teachers. Approved materials. Southern States Academy, Station E-12, Atlanta, Ga.

USED Correspondence Courses and Books sold and rented. Money back guarantee. Catalog free. (Courses Bought.) Lee Mountain, Pisgah, Alabama.

STUDY For Doctor's Degree of Psychology, Metaphysics and Divinity. Correspondence courses only. College of Divine Metaphysics, Dept. P-S, 2811 North Illinois, Indianapolis 8, Ind.

LEARN While Asleep with your recorder, phonograph or amazing new "Electronic Educator" endless tape recorder. Details free. Research Association, Box 24-NN, Olympia, Washington

"**HOW To Train Horses**"—A book everyone who likes horses should have. Free. No obligation. Simply address Beery School of Horsemanship, Dept. 584, Pleasant Hill, Ohio.

WELDERS earn big money. Easy to learn Arc-Gas-Automatic Welding. Non-profit school—low tuition, GI approved. Free booklet. Hobart Welding School, Box P-492, Troy, Ohio.

DRAFTING, Design, Blueprint Reading. Good paying. Easy to learn at home. Minimum age 17. Write Utilities Engineering Institute, Dept. TM-12, 2525 Sheffield, Chicago 14.

LEARN Piano Tuning Easily At Home. Our graduates lead field. Our 60th year. Free Booklet. Niles Bryant School, Dept. S, 3711 Stockton Blvd., Sacramento 20, California.

LEARN Civil and criminal investigation at home. Earn steady good pay. Institute Applied Science, 1920 Sunnyside, Dept. 334, Chicago 40, Illinois.

USED Correspondence Courses (Bought and Sold) Money Back Guarantee. Gem, Dept. 4-S, Linwood, New Jersey.

HIGH School At Home in spare time with 62-year-old school. No classes. Standard high school texts supplied. Single subjects if desired. Credit for subjects already completed. Progress at own speed. Diploma awarded. Information booklet free... write today! American School, Dept. X446, Drexel at 58th, Chicago 37.

LEARN Chinese at home. Six-month course. Doctor degree. Free catalogue. Chinese Language Institute, P. O. Box 270, Taipei, Formosa.

REAL Estate Brokers Homestudy Course. Low Cost. Big Income. Free descriptive literature. Gordon-Howard Institute, 322 Glover Building, Kansas City 5, Missouri.

CALCULUS, Practical. First Four Easy Lessons \$1.00. Space-Age Mathco, 4256 Minmoor, Cincinnati 17, Ohio.

ELECTRONICS-TV! New home study course developed to train our own men. Available soon. Free information. Nixon, P. O. Box 5063, Philadelphia 11, Pa.

ILLUMINATING "World-Famed" Leavitt Letters Awaken Powers Within! Teach Laws of Life—Mental Mastery. Educational—Helpful—Inspirational! Free Letter Listing. The Leavitt Science, Clinton, Illinois.

STUDY high school and college mathematics via easy-to-follow Home Study courses. Write for free bulletin. Technical Training Service, POB 146, Brooklyn 14, New York.

THE Intended health service; Drugless, Co-Ordipathy, Ogilvie Building, San Antonio 5, Texas.

EARN Degree. Free bulletin. Homestudy only. Midwestern Bible School, 1060 Broadripple, Indianapolis.

LEARN Sign Painting At Home. Free Talent Test. Ben Kerns, Box 812-K, Greenville, S. C.

VOICE! Secrets! Free! Astonish! Amaze! Everyone!—Stud.o. 14356W South Jersey, Norwalk, California.

MEMORY improvement! Earn more money! Impress your boss, customers, friends with an extraordinary memory. New method now available by mail. You will be successful regardless of age or education. Write today for free details to Dr. Bruno Furst Course in Memory and Concentration, Dept. SP-1, 365 West End Avenue, New York 24, N.Y.

EARN College Diploma, degrees, by mail—most subjects. Write: Aureob, Central Valley, New York.

PENMANSHIP Corrector: Improve poor penmanship quickly. Details free. Ozment, Box 665 35, St. Louis, Mo.

PHYSICAL Therapy and Massage. Home Training. Practice privately or work with doctors and hospitals. Free Catalogue. National Institute, Box 4, 159 E. Ontario, Chicago, Illinois.

DYNAMIC Singing, Speaking, Self-Training. Thrilling! Canfield Voco-Records, 2018-C Fifth Avenue South, Minneapolis 4, Minnesota.

EDUCATIONAL Books! High School Subjects. Information free. Franks, 3121 South Racine, Chicago 8.

FINISH Degree course by correspondence. Metropolitan University, Institution Combination Residence—Correspondence Instruction, 111 East Broadway, Glendale 5, California.

LEARN Piano Tuning At Home! Only \$32.95 Including Tools. Write Tunecraft, Box 5074-S, St. Paul, Minnesota.

HI-Fi. Yes? No? See ad on page 58 for further information and valuable coupon.

46 CONTESTS

WIN contest money. General Contest Bulletin gives hundreds of tips. Lists current contests, rules. Sample magazine 25c. General Contests, 1609-A East 5th, Duluth 12, Minnesota.

WIN Contests! Complete information, 10c. Spence, Box 11569, St. Petersburg, Florida

PRIZE Contests! Fabulous Home Income Opportunity! How and Where to Win Your Share! Latest Contest Books! Send Stamp! National Contest Bulletin, Box 2685-PS, Miami 16, Florida.

\$10,000,000 YEARLY—Contests. Win Helps. United. 25 Earl, Red Bank, New Jersey.

47 DETECTIVES

DETECTIVES—Work home—Travel. Experience unnecessary. Detective Particulars free. Write Wagoner, P-125 West 86th, New York 24.

DETECTIVE Training. Phillips Secret Service System, 1917-C North Kenneth, Chicago 39, Ill.

PROFESSIONAL Investigators Home Study. Badge, diploma, future. Box 41197, Los Angeles 41, California.

BE A Detective. Write for free details. State Age. National Detective Academy, Dept. A, P. O. Box 1082, Scottsdale, Arizona.

COMPLETE 20 lesson course in criminology and investigation \$15.00. Details and I.D. Card Free. Box 434, Saint John, N. B., Canada.

48 LANGUAGE OUTFITS

LEARN world interlanguage endorsed by Unesco. Free lesson. Esperanto Now, Middleton, Wisconsin.

50 BUSINESS SERVICE, INFORMATION, NAME LISTS

500 NAMES new mothers \$2.00. Saffer, 26-B St. Pauls, Jersey City, N. J.

51 SPECIAL SERVICES

ALL-Languages Translation Services and Schools. Box 1995, Dallas 21, Texas.

52 AUTHORS SERVICE

WRITERS! Become published authors. Free illustrated brochure reveals secrets of subsidy publishing, publicity, sales, for fiction, non-fiction authors. Address Paul Scott, Exposition Press, 386 Fourth Avenue, New York 16, N. Y.

WRITERS: Book Manuscripts invited for publication on our cooperative plan. Greenwich Book Publishers. (Atten. Mr. Ibsen), 489 Fifth Avenue, New York 17, New York.

WANT Your Book Published? Learn how we publish, advertise, promote, distribute. Many successes. Free booklet PS. Vantage, 120 West 31, New York.

WRITERS! Hollywood Market. Complete list of writing opportunities, rates, etc. Elite Services, 6919 Camrose, Hollywood 28, California.

53 ADVERTISING, AGENCIES, ETC., FOR ADVERTISERS

FREE expert assistance for mailorder advertisers. Ratebook leading newspapers, magazines, 10c. Chicago Advertising Agency, Chicago 4.

ADVERTISE: 24 words, 100 Canadian Newspapers, \$5.50. Lists Free. Advertising Bureau, 10511-P Springfield, Chicago 43.

"**BETTER Business Letters**" Amazing book shows how. Write Avalon, 322 W. Van Buren, Chicago 7, Illinois.

FREE! Rate-Data-Guide "How to Make Your Ads Pay off." Seidel Advertising, 5032-B Lankershim, North Hollywood, California.

54 CARTOONING, SIGN PAINTING, CHALK TALKS

"**HOW To Make Money With Simple Cartoons**"—A book everyone who likes to draw should have. It is free, no obligation. Simply address: Cartoonists' Exchange, Dept. 194, Pleasant Hill, Ohio.

CARTOON Your way to success! Internationally known instructor, Raye Burns, will personally teach you to create original, salable cartoons at home. Cost of Course is very low. Write for free details. Raye Burns School, Box 3583-S, Cleveland 18, Ohio.

LEARN Sign Painting At Home. Free Talent Test. Ben Kerns, Box 812-PS, Greenville, S. C.

YOU can Entertain with Chalk Talks. Catalog 10c. Cartoonist Balda, Oshkosh, Wisconsin.

PAINT Signs—Master die cut, outline letter patterns. Complete assortment, 1½" to 12" high, prepaid \$2.00. Eyerly, P-583, Newton, Iowa.

56 RUBBER STAMPS & OFFICE SUPPLIES

THREE Line Stamp \$1.50. Pad 75c. Harwell, 459, Byrdstown, Tennessee.

THREE line metal or plastic pocket case \$1.00. Hand stamps to 3"x5". Mated Mailers, P. O. Box 494, Buffalo 5, New York.

INDEXED Cushioned 3 Lines \$1.00, 4 Or 5 Lines \$1.50. (Script, Print or Old English) Stock Stamp circulars 25c, refundable. 1 Day Service. Stamp Racks. Check Protection Machines \$14.95. Youngers Stamp Shop, Princeton, Iowa.

3 LINE rubber stamp metal case \$1.80, plastic \$1.00. L. Watson, P. O. Box 162, St. Charles, Illinois.

DOLLAR Special: 2" Stamp, Desk Pad, Dealer Catalogs. Joseph's, Barnesville, Georgia.

57 PRINTING, MULTIGRAPHING, ETC.

BUSINESS Printing. Samples. Prices Free. Howprint, 723-W Eunice, Webster Groves 19, Missouri.

500 ENVELOPES no. 6¾ printed, \$3.50 Postpaid. B&R Printing Co., 126 East Pacific, Appleton, Wisconsin.

100 6¾ ENVELOPES, 100 5½x8½ Letterheads printed, \$2.35. M. Fortney, R3, Dillsburg, Pennsylvania.

OFFSET Printing: 24-Hour Service. 8½x11, 16-lb. White bond \$6.75-1000; \$18.50-5000. National Letter, 304 West 43 St., New York 36.

POPULAR SCIENCE OPPORTUNITIES

TWO Color Printed Postal Labels, 200—\$1.95. Hamilton's Enterprises, Hatch, New Mexico.

FREE Catalog Postpaid printing, Rubber stamps. D M Press, Sebastopol, Calif.

1,000 BUSINESS Cards. "Raised Letters" \$3.95. Samples. Pioneer, PS-4, Island Park, N. Y.

500 3/4x2 1/4 FOUR line gummed stickers 50c. Red Border \$1.00. Moritz Printer, Saginaw, Michigan.

LETTERHEADS, Circulars, etc. Price list. Valatis, 1705 South 2nd, Phila. 10, Pa.

1,000 EMBOSSED Business Cards \$3.50 Postpaid, Samples. Ellis, 5909 Highlandview, Sylvania, Ohio.

QUALITY Printing, Mimeographing, Giant Catalog Free. V. Vincente, Skippers, Virginia.

BUSINESS Cards With Glamour. Reasonable. Samples. Mention Business. Heavener's, Colmar, Pennsylvania.

OFFSET Printing: 1,000 8 1/2x11—\$5.50; 5,000—\$17.00. Fast! Art, Varityping. Promotion, 385-P4 Broadway, New York City 13.

58 PRINTING OUTFITS, SUPPLIES

DO your own printing. Save money. Simple rules. We supply everything. Print for others; good profit. Raised printing like engraving too. Have home shop. Details free. Kelsey Presses, V-8, Meriden, Conn.

RUBBER Stamp Presses, Hydraulic Operated. Electrically heated. Sizes 5"x8", 8x12", 10x15", starting outfits, supplies. Printing Presses, supplies. Custom Manufacturing, 507 N. Jefferson, Springfield 2, Missouri.

RUBBER Stamp Makers Supplies. Kiewiet, 2025 Barney Road, Kalamazoo, Michigan.

MAKE Your Own self-molding rubber stamps and printing cuts. Plexirubber, Argyle 2, Wisconsin.

PRINTING Presses, Type, Supplies, Lists, 4c. Turnbaugh Service, Mechanicsburg, Pa.

59 PATENT ATTORNEYS

C. A. Snow & Co.—S-427, Snow Building, Washington 1, D. C. Registered Patent Attorneys. Write for information.

INVENTORS — Take these preliminary steps toward patent protection. Sketch and describe your invention. Sign, date and have this disclosure witnessed by two people who understand your invention. Have us make a preliminary search among U.S. patents already granted for similar types of invention. We report on the probable patentability of your invention and recommend your further course of action. Write for our instructive booklet, "Patent Protection for Inventors" and Convenient evidence of Invention disclosure form. Victor J. Evans & Co., 541-D Merlin Building, Washington 6, D. C.

INVENTION Record form free and "Patent Information Every Inventor Should Have." Carl Miller, Registered Patent Attorney, Woolworth Building, New York.

INVENTORS: Without obligation, write for information explaining the steps you should take to secure a Patent. John Randolph, Registered Patent Attorney, 807 Victor Bldg., Washington 1, D. C.

INVENTORS: Learn how to protect your invention. Unless the inventor is familiar with patent matters, he should engage a competent registered patent attorney or agent to represent him. We are registered to practice before the U. S. Patent Office and prepared to serve you in handling your patent matters. "Patent Guide for the Inventor" containing detailed information concerning patent protection and procedure with "Record of Invention" form will be forwarded to you upon request—without obligation. Clarence A. O'Brien & Harvey Jacobson, Registered Patent Attorneys, 92B-D District National Building, Washington, D. C.

INVENTORS—If you believe you have an invention, you should find out how to protect it. The firm of McMorrow, Berman & Davidson, with offices in Washington, D.C., is qualified to take the necessary steps for you. Send for copy of our Patent Booklet "How to Protect Your Invention." We will also send you an "Invention Record" form. No obligation. They are yours for the asking. McMorrow, Berman & Davidson, Registered Patent Attorneys, 1439 Victor Building, Washington 1, D.C.

"INVENTOR'S Guide" and "Record of Invention" free on request. Frank B. Ledermann, 154 Nassau Street, New York City.

60 FOR INVENTORS

INVENTORS, if you have an invention for sale, patented or unpatented, write Institute of American Inventors, Dept. 30A, 635-F St., N.W., Washington 4, D. C.

INVENTION Record form free and "Patent Information Every Inventor Should Have." Carl Miller, Registered Patent Attorney, Woolworth Building, New York.

INVENTORS: Without obligation, write for information explaining the steps you should take to secure a Patent on your invention. John Randolph, Registered Patent Attorney, 806 Victor Bldg., Washington 1, D. C.

INVENTORS—Send for free Patent Information book and Inventor's Record. Registered Patent Attorney, Associate Examiner, Patent Office 1922-1929; Patent Attorney & Advisor, Navy Department 1930-1947. Gustave Miller, 49-PSI Warner Building, Washington 4, D. C.

INVENTORS Don't sell your invention Patented or Unpatented until you receive our offer, write Cowgill, Box 298, Marion, Ohio.

INVENTORS—This firm is registered to practice before the United States Patent Office and available to assist you in the preparation and prosecution of your patent application. "Patent Protection for Inventors" booklet containing detailed information and steps to take toward patent protection sent promptly upon request. No obligation. Victor J. Evans & Co., 542-D Merlin Building, Washington 6, D. C.

INVENTORS: Learn how you can protect your invention. A specially prepared booklet "Patent Guide for the Inventor" containing detailed information concerning patent protection and procedure together with "Record of Invention" form will be promptly forwarded to you upon request—without obligation. We are registered to practice before the United States Patent Office and are prepared to serve you in the handling of your patent matters. Clarence A. O'Brien & Harvey Jacobson, Registered Patent Attorneys, 92A-D District National Building, Washington, D. C.

INVENTORS! Have you good patentable ideas? Write Mr. Metzler, 130 West 42nd, New York.

INVENTIONS wanted now by my Manufacturer Clients. Patented. Unpatented. Write Gilbert Adams, Patent Broker, 80-B Wall Street, Financial District, New York City.

PATENT Searches including copies of nearest patents. \$6.00. Reports airmailed within 48 hours. More than 100 registered patent attorneys use my service. For Free invention protection forms, write Miss Ann Hastings, P.O. Box 176, Washington 4, D. C.

WE have the markets if you have the ideas. Harvey Engineering, Cambridge 1, Maryland.

PATENT Searches \$6.00. 48-hour service. Free Invention Protection forms. Write Raymond L. Smith, Patent Searcher, 620 Sheraton Building, Washington 5, D. C.

PATENT Searches \$6.00. 48-hour airmail service. Invention Protection forms free. Write Patent Engineering Service, 711 14th Street N.W., Washington 5, D.C.

INVENTORS—If you believe you have an invention, you should find out how to protect it. The firm of McMorrow, Berman & Davidson with offices in Washington, D.C., is qualified to take the necessary steps for you. Send for copy of our Patent Booklet "How to Protect Your Invention." We will also send you an "Invention Record" form. No obligation. They are yours for the asking. McMorrow, Berman & Davidson, Registered Patent Attorneys, 1438 Victor Building, Washington 1, D.C.

"INVENTOR'S Guide" sent free. Frank B. Ledermann, 154 Nassau Street, New York 38, N.Y.

INVENTORS, Engineer with 15 years experience will review, do research or Customer Contact for you. Box 9358, Akron, Ohio.

61 INVENTIONS WANTED

INVENTIONS Wanted: "Patented"—"Patent Pending." 28 Years experience Promoting Inventions. National Service Bureau, 3122 Meramec, St. Louis 18, Missouri.

INVENTORS: Hundreds of manufacturers have requested our assistance in locating marketable new products. Complete information free. Institute of American Inventors, Dept. 30C, 635-F Street, N. W., Washington 4, D. C.

INVENTIONS wanted. Patented; unpatented. Tremendous Manufacturers lists. Global Marketing Service, 2420 77th, Oakland 5, Calif.

INVENTORS Don't sell your invention Patented or Unpatented until you receive our offer, write Cowgill, Box 298, Marion, Ohio.

INVENTIONS needed immediately for manufacturers. For additional information write Kessler Corporation, 74-IW, Fremont, Ohio.

ARE you interested in offers from reliable manufacturers for your invention? Patented, unpatented. Harvey Engineering, Cambridge, Maryland.

INVENTIONS wanted now by my Manufacturer Clients. Patented. Unpatented. Write Gilbert Adams, Patent Broker, 80-B Wall Street, Financial District, New York City.

INVENTIONS Wanted for Manufacturers. Free Details Write—Allen, Dept. D, 712 Davis Bldg., Dallas 2, Texas.

FREE List Needed Inventions. Protection Form. Sales Engineering Bureau, Box 4973, Washington, D.C.

INVENTORS . . . Get The Best Offer First! patented or unpatented. Write Carl Sommer, Director, Inventors of America, 3136-B Sylvania Avenue, Toledo 13, Ohio.

SUPERIOR promotions. Patented, unpatented inventions. Information booklet, free. Superior, 338-342 North Rodeo, Beverly Hills, California.

63 MANUFACTURING

BIG Money In Foam Plastics. Home Manufacture Toys, Cushioning, Sponges, Sports Equipment, Etc. Introductory "Kit" containing Chemicals, Hand Mixing Instructions, Our bulk Chemical Prices. Send only \$3.00 To "Kit" Foam Products, Dept. 459, Box 427, Warner Robins, Ga.

CUSTOM Models, Parts, Tools, Instruments. Henry Herman, 350 Hewes, Brooklyn 11, New York.

MANUFACTURER Fishing Lures. Plastic, none better. 20 Models, Pennies. Free circular. Quaker, 3514-24 N. Lawrence, Phila. 40, Pa.

64 MODELS, MODEL SUPPLIES

SHIP Models. Most complete line in New England. Kits, fittings, plans, books, tools, engines, motors. Illustrated catalog 35c. James Bliss and Co., Inc., Dept. PS, 342 Atlantic Avenue, Boston 10, Massachusetts.

SHIP and yacht model fittings; blueprints. Send 35c for Illustrated catalog =29 listing hundreds of items. A. J. Fisher, 1002-2 Etowah Ave., Royal Oak, Michigan.

"POWER Drives Handbook"—36 pages illustrating many types motor drives for model autos, boats, displays, turntables, etc. Mail 25 cents cash, returnable first order \$3.00 or more. Wilson's of Cleveland, Dept. PS, 425 Lakeside N.W., Cleveland 13, Ohio.

SCALE model materials for building model homes and architectural buildings of any type. 1/4" and 1/8" scale. Send 25c for catalog. A&B Model Builders, Dept. S, 454 Donovan Road, Kansas City, Kansas.

SHIP Model Kits and Fittings: Fishermen, Clippers, Frigates, Schooners, Brigs, Tugboats. Also half-hull models for interior decoration. Send 25c for 1959 catalog and booklist. Model Shipways, Folio C. Bogota, New Jersey.

LIVE Steam Model Locomotive Catalogue 25c. Friends Steam Models, Topsfield, Massachusetts.

POWER Models. Unusual steam, gasoline and traction engines, fittings, metals. Miniature steam pressure gauges. Comprehensive Catalog \$1.00. Charles Cole, Ventura, California.

ROCKETS, fuses, solid propellant. Easily made. Complete instructions. \$1.00. Rocket-Craft, P. O. Box 13, Pottsville, Pa.

"ST" Steam Engine Castings, Fittings Catalog 15c. Ship Models Ltd., 186 Summer, Andover, Mass.

LIQUID Rocket 50 lb. thrust 6' long. Complete plans \$2.00. Missile Research, Station 1, Provo, Utah.

65 HOME CRAFTSMAN

WOODWORKING and Cabinetmaking course for beginning and advanced home craftsmen. Only complete low-cost home training program available. Write for free booklet. Interstate Training Service, Dept. G-2, Portland 13, Oregon.

FREE Leathercraft Catalog. Quality Kits, Leathers, Tools. Handcrafters, Box 427, Montrose, California.

FREE "Do-It-Yourself" Leathercraft Catalog. Tandy Leather Company, Box 791, Z28, Fort Worth, Texas.

89 JIG saw patterns. Beautiful shelves, Ornaments, Novelties. Plus "How Where to Sell" \$1.00. Mastercraft, 44S, 7041 Olcott, Chicago 31.

LEARN Art Metalcraft and jewelry making. Complete, inexpensive, home training course now available. Special tools and materials furnished. Write for free booklet. Interstate Training Service, Dept. L-2, Portland 13, Oregon.

KNOCKDOWN Cedar Chests Also Over Fifty Kits. Catalog 25c. Giles Kendall Co., Huntsville, Alabama.

SHELLCRAFT Supplies. Lowest prices! Large illustrated Catalogue 25c. Pace's, Box 279, Bradenton, Florida.

POWER Putty. Miracle plastic kit. Speeds shop, boat, engine repairs. For home and hobby. Free laminating resin and instructions. PP \$2.98, COD. Huntress Pro., Atascadero, California.

!!**FREE!!** Leathercraft catalog. Hundreds of new items. Write MacPherson Bros. Leather Company, Dept. A, 730 Mission St., San Francisco 3, Calif.

LINCOLNS Cape Cod Patterns. Man Sawing Wood, Scotch Lady Churning Butter and 30 Lawn Ornaments \$1.00 Postpaid. Lincolns Craft Studios, Columbia, Conn.

STYLECRAFT "Pretraced" leather kits. Handbags, Billfolds, Filigree Belts. Patterns on leather. Just carve, assemble and lace. "Precarved" kits also available. Send 25c for catalog, free folder. Refunded first order. Apache Leather Company, 2804 E. Washington St., Phoenix, Arizona.

SQUAREKNOTTERS: Make belts, handbags, lanyards, dog leashes, etc. Special offer! Beginner's book, catalog and quality cord samples 25c. P. C. Herwig Co., Dept. 71-P7, 39 Henry St., Brooklyn 1, New York.

KNOCKDOWN cedar chest and lumber, free price list. Bedford Lumber Company, Shelbyville, Tennessee.

HI-FI. Yes? No? See ad on page 58 for further information and valuable coupon.

MAKE Repair Fluorescent Fixtures from Inexpensive Kits, Parts. Free Catalog. Shoplite, 650S Franklin, Nutley 10, New Jersey.

WALNUT, Cherry and Maple. Squares Rough and surfaced lumber. Free list. Midland Lumber Co., P.O. Box 262, Savannah, Missouri.

66 DO IT YOURSELF

EIGHT Built-in lighting plans 50c. Lighting Design Services, Chesterland, Ohio.

LATHE-Indexing square turret completely made on any lathe-Plans, Instructions \$2.00. Harvey Rinier, Darby, Pennsylvania.

LEARN by Mail to mount Birds, Animals, Heads, Horns, Fish, Tan Skins. Have Fun! Make Money! Over 400,000 students; extremely low fee. Rush Postal for your copy of strange, Free Book. State Age. No Obligation. Northwestern Taxidermy, Dept. 2604, Omaha 2, Nebraska.

60% SAVINGS. Formica and furniture legs. Details 15c. Designs 10-\$1.50. Woodcrafters, Box 844C, Evergreen Park 42, Illinois.

BUILD this revolutionary cabin, beach-house, shelter for less than \$100! Complete plans, material list, instructions \$1.00! Delta, 415 43rd, Boulder, Colorado.

HOT Water Instantly Every Faucet. Complete, Easy Instructions \$1.00. Ammann, Argonia, Kansas.

ENLARGE any picture, pattern, design. Simple, foolproof. \$1.00 postpaid. Stretchograph, Box 811B, Adelphi, Maryland.

GLASSHOUSE Controls low cost Simplified Automatic Controls. Instruction Booklet, Plans. \$2.00 P.P. Guaranteed. Adex Engineering, 8533 E. Callita St., San Gabriel, California.

DO-It-Yourself Books. Hobbies, crafts, home improvements, etc. You name it! Free list! Carpenter & Son, 8754 Glenwood, Pinckney, Michigan.

HI-FI. Yes? No? See ad on page 58 for further information and valuable coupon.

67 OLD GOLD, JEWELRY, WATCHES, ETC.

USED and new watches \$2 up. Free List. Southern Watches, 5-PS So. Wabash, Chicago 3.

FREE catalog. Costume jewelry parts. Supplies. Reasonable prices. Fast service. Guaranteed quality. Unique merchandise. Folsom's, Box 52, Medford 55, Massachusetts.

COSTUME Jewelry Supplies. Settings, Rhinestone, etc. 88 page illustrated catalog. 30c. Milady, Box 1328 G.P.O., New York City (1).

HIGHEST Cash For Old Gold, Broken Jewelry, Gold Teeth, Watches, Diamonds, Silverware, Spectacles, Platinum, Mercury. Free information. Rose Refiners, Heyworth Bldg., Chicago 2.

HIGHEST Cash Paid for Old Gold, Jewelry, Gold Teeth, Diamonds, Watches, Silver, Mail Articles Today. Information Free. Chicago Gold Refining Co., 6 E. Monroe, Dept. 1257, Chicago 3.

BEST Blue White Diamond 100% Clean, convenient prices. Kobler, D. Exporter, Neufeldstrasse 141, Bern, Switzerland.

GOLD, silver, platinum, jewelry, watches, spectacles, teeth, rings, coins wanted. Highest cash immediately, information free. Wilmot's, 1067B Bridge, Grand Rapids 4, Michigan.

INEXPENSIVE jewelry making supplies. Literature 10c. Myles, Box 176-PS, New York 8, N. Y.

10 SWISS Watches \$18.00. Catalog 25c. Berkowitz, 1150 Castlehill, New York City 62.

68 TOBACCO & PIPES

REQUEST fine pipes catalog. Free. Herbert, 340 East Park, Huntington, Indiana.

69 FOR THE HOME

FOAM rubber furniture cushions—Factory seconds 50% discount. Free catalog. Perma-Foam, 390-A Nye Ave., Irvington, New Jersey.

WEATHERVANES. Cupolas, Yard Numbers, Post Signs, Estate Signs; Free Catalog. Home Industries, 330 Athens Street, Jackson, Ohio.

UMBRELLAS. 15' and 21' diameter. Perfect for pool and patio. Canvas cover-sturdy frame. Can be dismantled. Free information. McFarland "Great" Umbrella Co., 742 S.W. 8th St., Miami, Florida.

QUICKIE—new spray shoe polish. Shines instantly without buffing or brushing. One can does all colors. Helps leather. Six months supply, \$1.49. Hare Products, Whitinsville, Massachusetts.

BUY Aluminum Awnings Wholesale From Factory. Box 6271, Jacksonville, Florida.

HI-FI. Yes? No? See ad on page 58 for further information and valuable coupon.

CESSPOOLS, septic tanks, clogged drains. How they function and how to keep them working. Free literature. Chemical Cesspool and Drain Cleaning Co., Boston 34, Mass.

NOVEL, beautiful lanterns made from old Church Windows. Free brochure. Box 67, Lorain, Ohio.

70 OF INTEREST TO WOMEN

MAKE \$25 to \$35 weekly addressing envelopes. Our instructions reveal how. Glenway, Box 6568, Cleveland 1, Ohio.

MAKE life-like wood fiber flowers. Beginners' kit, \$1.00. Hauser House, Box 6524-PS, Phoenix, Arizona.

\$200. MONTHLY Possible. Sewing Babywear! No house selling. Free Information. Send name to Cuties, Warsaw 14, Indiana.

\$15.00 THOUSAND addressing envelopes, postcards, home-longhand, typewriter. Particulars free. R. Economy, Box 2580, Greensboro, N. C.

\$1,000-\$5,000 YEARLY Possible, addressing envelopes, postcards, for advertisers! Further information free. Mann, 427-C, Woodcliff Lake, N.J.

HOUSEWIVES—earn \$60 weekly at home. No selling. Dignified work. Opportunities. P.O. Box 8057, Fort Worth, Texas.

71 FOR SALE MISCELLANEOUS

VITAMINS Write today for free 12 day supply vitamin mineral family formula also wholesale prices six other potent formulas. Wholesale Vitamins, Factory Street, Kalamazoo 2, Michigan.

POCKET Size Pliofilm Cover Protects Against Radioactive Fallout. \$2.00 Postpaid. Free Information On Defense Against Atomic Attack With Order. Atomic Aid, 215 West 34th Street, New York City 1.

DIRECT From Scotland. Special Offer of Handwoven Harris Tweeds, made in the Scottish crofters own homes, at less than half price—10/-per yard (only \$1.40). Each length has been dried over a peat fire to preserve the famous Harris odour. Write air mail for free patterns. Special Sale Offer of all wool full size Tartan Rugs, in Royal Stewart, Hamilton, Robertson, Fraser, and Wallace (reds), Black Watch and Macdonald (blue/greens), Buchanan (yellow), Dress Stewart (white/red), and Macphersons (browns). For travel, trailer, or bedcovers. Reduced to 47/6d each. (\$6.65). Were 69/- (\$9.66). Ladies Fair Isle Yoke Lumber Jackets or Golfers in fawns and grey backgrounds with lovely traditional designs, sizes 32" to 44" bust, price 69/- each. (\$9.66). Special sizes or designs made to order. Harris Wool Socks, all wool, vegetable dyes, sizes 7" to 12" foot length 22/6d for three pairs (\$3.15). Heavy sleeved Harris Wool and Norwegian pull-overs or sweaters, suitable for fishermen, hunters, lumber jacks, drivers, mechanics, sizes 34" to 48" chest, price 87/6d (\$12.25) each. Oiled wool, semi-waterproof and wear for years. Remit by personal cheque, dollar drafts, American Express, postal orders; add 1 dollar for postage and insurance on orders of up to 5 dollars, 2 dollars up to 20 dollars. Money back guarantee. Price list of Harris tweeds, tartans, sweaters, kilts and children's wear free on request. Hebridean Crofter Weavers Ltd., Dept. P.S., Muir of Aird, Benbecula, Outer Hebrides, Scotland.

72 WANTED TO BUY

***SCRAP** Mercury (Quicksilver) containers supplied—Tantalum, Tungsten, Silver, Platinum. Metallurgical Products Company, Established 1909, 35th & Moore Sts., Phila. 45, Pennsylvania.

QUICKSILVER, platinum, silver, gold. Ores analyzed. Mercury Terminal, Norwood, Massachusetts.

74 RAZOR BLADES, SHAVERS

DOUBLE Edge Razor Blades 99c per 100. \$2.75 for 300. Gryders, Box 187, Barberton, Ohio.

75 TATTOOING SUPPLIES

LEARN profitable, fascinating Tattooing. Illustrated Information \$1.00. Zeis, 728-B Leslie, Rockford, Illinois.

77 GEIGER COUNTERS & TREASURE FINDERS

TRANSISTOR Treasure Detectors, underwater detectors. Many models. Free catalog. Gardiner Electronics Co., Dept. 1, 2545 East Indian School, Phoenix, Arizona.

GOLD-Silver Detectors. Geiger Counters. Violites for tungsten, etc. Best available. Guaranteed. Information Free. Detectron, 5528 Vineland Ave., Dept. 32, North Hollywood, California.

FIND buried battle relics, coins, silverware. Transistorized M-Scope electronic locator. Guaranteed. From \$59.50, Easy Terms. Free Catalog. Fisher Research, Dept. C-2, Palo Alto, California.

INDICATOR: Locates Uranium, oil, gold and minerals. Price \$25.00. Dirt tested Free for oil. Horton Surface Oil Survey, Belle Rive, Illinois.

TREASURE information, books, maps, free catalog. Big map, 445 locations, \$1.00. Anchor Archives, Rye, N. Y.

WATERPROOF, Transistorized, Metal Locators for ground and Underwater Detection. Kits Available. Mineralight Geiger Counters. Free Literature. Electronic Applications, Dept. S, Box 8, Arlington 10, Virginia.

FIND Treasure! Handbook 25c. Locators. Howe, 811 Kansas, Atchison, Kansas.

MONEY for you in buried treasure—coins, gold, silver . . . can be found with Goldak Transistorized Locators. Five models including Underwater Locator priced from \$79.50. Free literature . . . Authentic books of known treasures available. Goldak Company, 1540 West Glenoaks Blvd., Glendale 1, California.

POPULAR SCIENCE OPPORTUNITIES

78 WATCH REPAIRING

WATCH and clock repairing books. Free catalog. North American, 2320-BD Milwaukee, Chicago 47, Illinois.

WATCHMAKERS', Jewelers', Requirements; Watchmaking Courses From \$25.00. Catalog (100 + Pages) 25c. Bengal Wholesalers, Culver City, California.

WATCHMAKERS' Tools, Materials, Supplies. Watches. Catalog. Gales, Box 1000, Chicago 90, Illinois.

WATCHMAKERS Journal contains instructions in watch repairing. Sample copy 25c. Dean Co., Box 3218-S, Daytona Beach, Florida.

79 MISCELLANEOUS

ELECTRONIC Sleep Inducer. Completely harmless. Free literature. Gardiner Electronics Co., Dept. 26, 2545 East Indian School, Phoenix, Arizona.

NEW! Send 25c for Klein's Bargain Sports Catalog containing hundreds of great values in fishing tackle, camping, new and used guns, etc. Klein's, Dept. PS-4, Chicago 6, Illinois. When in Chicago, shop Klein's 5 Chicago Stores for Sport.

RAISE money playing "Good Bingo." Write on your Organization letterhead for our Free Bulletins telling you the easy ways to do it. Bingo King Company, Dept. 32, Littleton, Colorado.

PERSONALIZED Hand-Tooled leather goods. Designed for modern living. Wonderful gifts. Free catalog. Piel, 4724-PSA, North Drake, Chicago 25, Illinois.

IMPORTED Rechargeable Flashlights \$3.95. Gaiser, 1105 W. Mulberry Street, Kokomo, Indiana.

SAMPLE Poly-Ethylene Bag. -50c. Stauffer, Box 63, Arcade, New York.

SNOW Cone Machines. All Prices And Sizes. Special For Grocery Stores. Box 7803, Dallas, Texas.

BOOKS on antiques and their prices! Free circular! E. Warman, Publisher, Uniontown, Pa.

FREE Vitamin Catalogue—Feel more vigorous, better—younger. For better, healthier living get potent formulas, quality capsules—like doctors, hospitals buy. Buy direct—save! Vitacenter, Drawer 2318-E, Detroit 31.

MOVIE Star Home Addresses, complete directory, TV, Movies—50c. Elite Services, 6919 Camrose, Hollywood 28, California.

RECEIVE—Magazine Samples, Mails, Catalogues, Bargains From Everywhere. Get Listed 25c. Rorick's, Cincinnati 26, Ohio.

ALASKA Booklet, Pictures, Information and Alaska Gift Catalog, 25c. Alaska Specialties Company, Box 81-PS, Ketchikan, Alaska.

HI-Fi. Yes? No? See ad on page 58 for further information and valuable coupon.

79A WESTERN MERCHANDISE

FREE Catalog. Western Wear, Saddles, Boots, Leather Supplies. Silver Spur, Box 1785-Z27, Fort Worth, Texas.

79B SWAP

READ, "Trading Post Magazine" 10c. Thorne's, 525 Dewey, Jackson 35, Michigan.

80 PERSONAL

BORROW By Mail. \$100-\$600. Anywhere. Air Mail Service. Postal Finance, 200 Keeline Building, Dept. 16E, Omaha 2, Nebraska.

BORROW \$50 to \$600 By Mail. Quick. Easy. Private. No Co-Signers. Repay in 24 small monthly payments. For the amount you want write today to Dial Finance Co., 410 Kilpatrick Bldg., Dept. D-1, Omaha 2, Nebr.

MEXICAN Legal Matters. A. Espejo, Box 234, Hermosillo, Sonora, Mexico.

PSORIASIS Sufferers: Discouraged? Here's help! You pay nothing unless satisfied. Free details. Pixacol, Box 3583-SP, Cleveland 18, Ohio.

REMAILS N.Y.C. or Jamaica 25c. 1 Month \$3.00. Seabron, 119-48 194th St., St. Albans 12, New York.

LOANS By Mail. \$50 to \$500 for any purpose. 2 years to repay. Employed men and women eligible. American Loan Plan, City National Bldg., Dept. PS-4, Omaha 2, Nebraska.

LEARN how I conquered dandruff and saved my hair, after years of suffering, \$1.00. Mrs. Osworth, S. Rockwood, Michigan.

KNOW the real truth about mind, personality, sickness. Free facts. 20th Century Publications, 2354-A Topanga Canyon Blvd., Topanga, California.

SAVE attorney's fees! Send \$1 for a "Last Will & Testament" form. When witnessed, no better legal instrument available. Lewisco, 144 Roberts, Glenside, Pennsylvania.

ST. Petersburg, Florida. Remails 25c. Page International, Box 10981, St. Petersburg 33, Florida.

SECRET Mail Address. \$3.00 Month. Hedgpeth, Box 830, Alhambra 24, Calif.

"RULE Others with your Thoughts." Telepathy. (Details — stamp.) Clarion, 846-S6 Sunnyside, Chicago 40.

MAIL Received, Forwarded, 25c letter. \$3.00 month (old address good). Lloyd Moffitt, 2911 N. Flagler, West Palm Beach, Fla.

HOLLYWOOD remails from glamor capital, 25c; monthly \$3.00. Elite Services, 6919 Camrose, Hollywood 28, California.

REMAILS Miami Beach 25c letter. Receiving, forwarding \$3 monthly. Kadison, 18410 N.W. 5 Ave., Miami, Florida.

"HOMEBREWED Wines, Etc." Complete Book \$1.00. ABC Publications, Box 849, San Francisco 1-DG, California.

MEXICAN Law. Attorney Cenicerros, Apt. 79—Cd. Juárez, Chih., Mexico.

WAKE Up your mind with life-changing best seller. "The Hidden Persuaders." 242 pages. Send 40c coins to Box 1924-X, Louisville 1, Kentucky.

SUPER memory overnight! Success guaranteed! Bijou, Box 1727-V, Hollywood 28, Calif.

Portable 115 V. power plant only \$129.95

1200 watt continuous duty, 60 cycle a.c. complete with 3 hp Briggs & Stratton 4 cycle engine on lift-off mount

FOB Minneapolis
(Shipping weight: 90 lbs.)

Here's the power plant buy of the year! A 1200 watt, 60 cycle a.c. 115 volt generator (with 15 amp. overload fuse and duplex receptacle for 110 volt outlets) complete with 3 hp Briggs & Stratton engine for only \$129.95 fob Minneapolis! It's all brand new! Engine and generator are mounted on 14-gauge steel platform with two semi-pneumatic 8-inch wheels for easy transport. Engine lifts off special mounting base (no tools needed) for use on other jobs around your farm, home or cottage. Extra mounting bases are available.



Send check or money order for \$129.95 today to

Now you can have your own portable electric power source for use wherever or whenever public power is not available—in the field, or during emergencies caused by floods, hurricanes and other crippling storms. You can use the engine alone, too, on other equipment—like the pump unit illustrated.

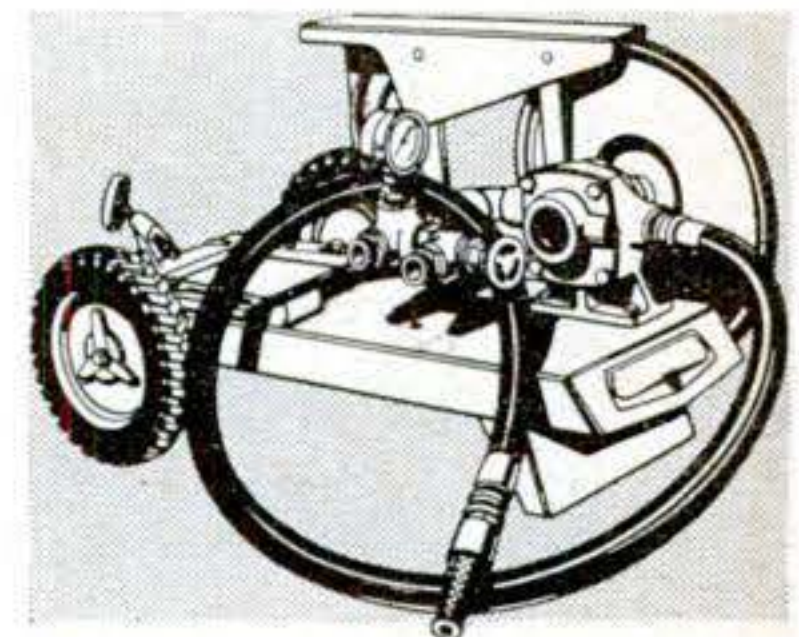

PUMP UNIT has mounting base for generator engine. Capacity: 810 gals. per hr. \$49.95 (less engine) fob Mpls.

Power Supply, Box 5106, Minneapolis 6, Minn.
TELEPHONE PARKWAY 9-7304

SHOOTERS

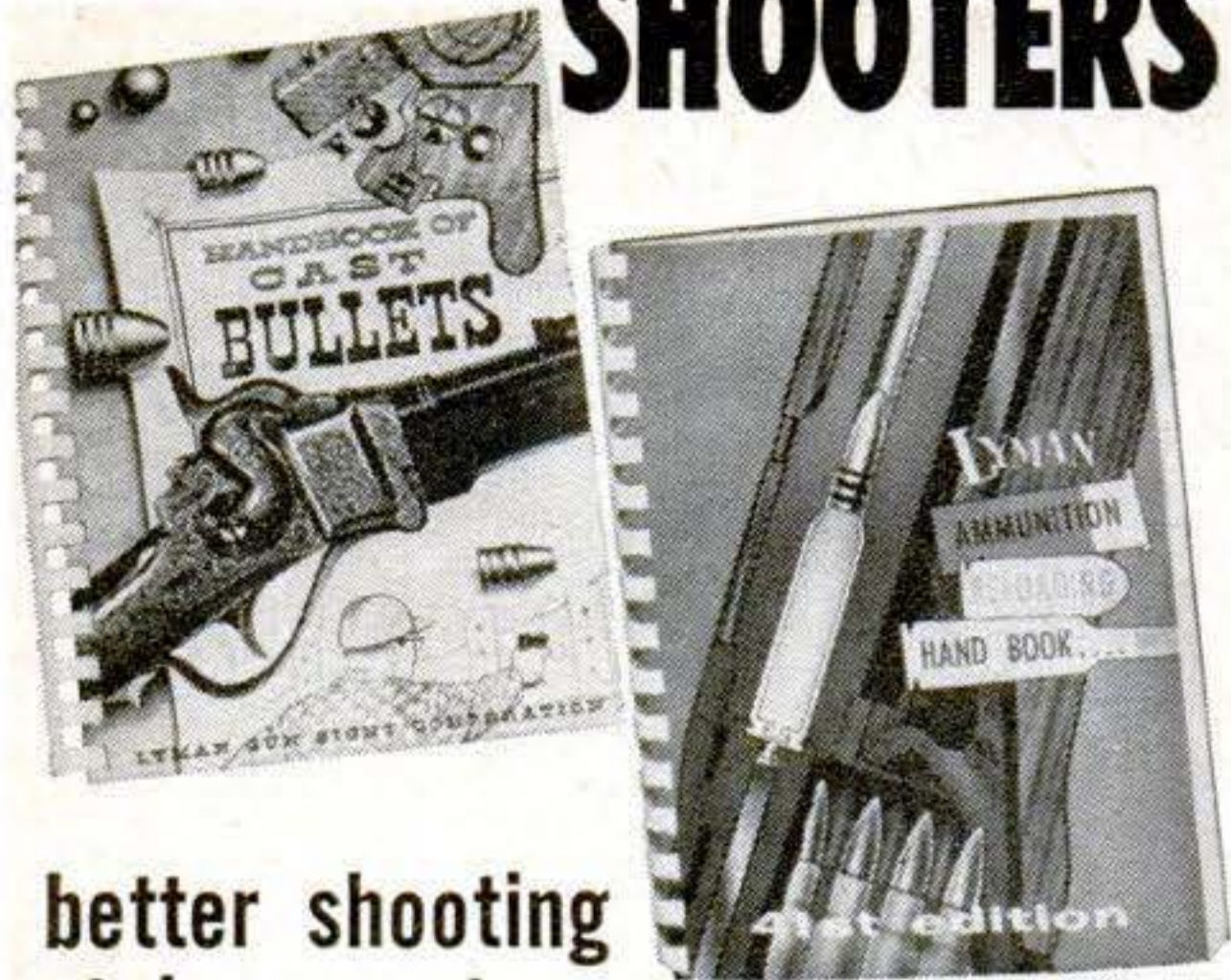

better shooting
at less cost

● **Handbook of Cast Bullets:** All about making your own bullets—for the first time available in a single book. Hundreds of bullet designs, metals, lubricants, powders, moulds. Sample articles: TIPS ON CASTING BULLETS • BULLETS IN SHOTGUNS • BULLETS OF THE CIVIL WAR • SELECTING YOUR GUNPOWDER. Over 400 drawings and photos, 230 pages.

● **Lyman Reloading Handbook:** Basic ammunition book for every shooter—the reloader's bible. All reloading steps, recommended loads for hundreds of bullet designs. Articles packed with practical tips on reloading for hunting and target shooting, by gun editors of Outdoor Life, Sports Afield, Field and Stream, and other experts. Over 280 illustrations—200 pages.

See your sporting goods dealer, or order direct—each book only \$2.00 postpaid. Write to Dept.154



Everything YOU WANT TO KNOW ABOUT INDOOR & OUTDOOR Fireplaces AND BARBECUES

76 PAGES — 220 ILLUSTRATIONS

A complete handbook of designs, layouts, plans, equipment... everything in indoor and outdoor fireplaces and barbecues. Only \$1 ppd. Send for yours now!

The **Majestic Co., Inc.**
527 Erie St., Huntington, Indiana



WARN HUBS ON YOUR Jeep

STOP FRONT DRIVE WEAR



Over a billion miles of service is *proof* that free-wheeling 2-w.d. with Warn Hubs means big savings in gear, engine, tire wear, gas, *plus* more pep, performance, power in high and easier steering. Now, with Warn Lock-O-matics, you have economical, drag-free 2-w.d. or tractive 4-w.d. *automatically, as you shift!* Ask your local 4-w.d. dealer to install Warn Lock-O-matic or Locking Hubs today. Fully guaranteed. Write for free literature.

WARN MFG. CO., Riverton Box 6064-B4, Seattle 88, Wn.

JEEP OWNERS

RE-POWER NOW with a V-8 engine—Use
FORD • CHEVROLET • MERCURY

in 2 or 4 Whl-Dr. Jeeps, Jeepsters, Sta-Wgn, Trucks, H.J. and Kaiser cars. Conversion Kits \$43.25 to \$59.85. If you want fast action tell us which engine you wish to use, give us year, Model, (2 or 4 Whl-Dr), of your vehicle. Send Min. \$15.00 Dep. and we will ship correct kit. Bal. COD. Send full amt. for Prepaid shipment. Wire, phone or write for free details. (Also kits for Ford 6 engine.)

HOOSIER MACHINE PRODUCTS CO.
314 S.E. 6th St. Phone CR6-3442 Pendleton, Oregon

Other "BUYS"
Check Here
.....1/4 Ton
Utility Auto
.....GOLF CARS
Electric or Gas
.....Rocket
Boats
.....Children's
Gas Autos

ESHELMAN TRACTORS

LOW AS
\$99

For Better Lawns and Gardens, investigate Eshelman Riding Rotary Movers, Tillers, Tractors. Advertised in Good House-keeping. Thousands of Satisfied users. Write For Free Literature. Dept. 69, Eshelman, Baltimore 2, Md.

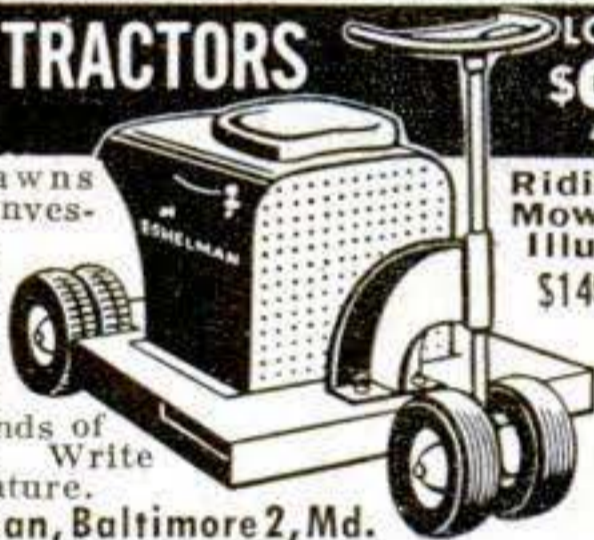

Riding
Mower
illus.
\$149.

WRITTEN
GUARANTEE

Buy and Hold U.S. Savings Bonds

Speed,
spunk
and a
cushion-
soft
ride!

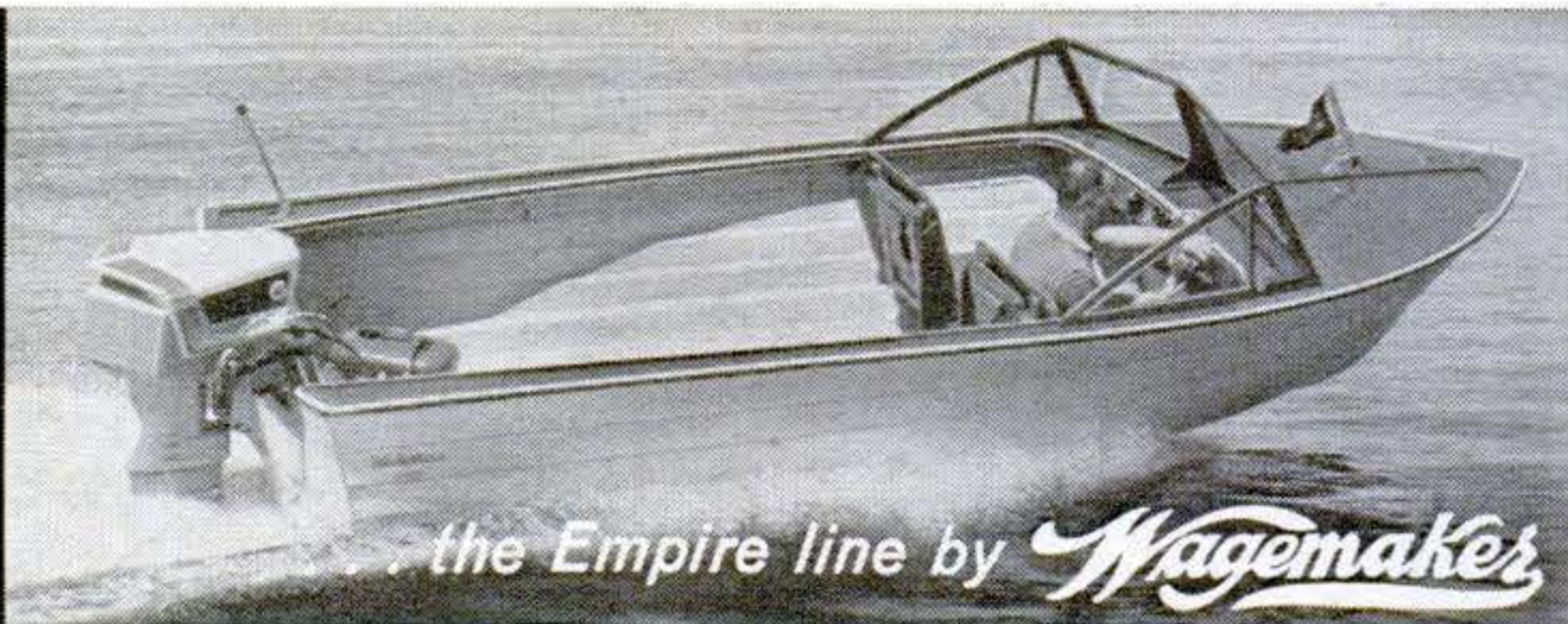

The EMPIRE Clipper, one of ten fibre-glass models for all-weather performance, safety and beauty. Here's a family of distinguished outboards offering pride of ownership, assurance of advanced engi-

neering, design and lifetime stamina. Write us for details also on WOLVERINE wood and CADILLAC aluminum. Wagemaker Company, 579 Market St., S.W., Grand Rapids 2, Michigan.



PACE-SETTING DESIGN . . .

THE LARK [➤] *BY STUDEBAKER*

➤ The Lark combines a number of unusual qualities in a manner that is a tribute to engineering. ➤ Its 108 inch wheelbase is long in relation to its 175 inch overall length. ➤ There is virtually no overhang, front or rear, so that handling and cornering is of continental calibre while interior space (seats six) is typically U.S.A. ➤ Ride is comfortably firm, but not hard, due to an interesting suspension system. ➤ Variable rate coil springs surround hydraulic shocks up front, while asymmetrically mounted semi-elliptics combine with outward angled hydraulic shocks at the rear, boost cornering ability, cut "squat" when accelerating and provide all around stability. ➤ The economical 170 cu. in. "6" utilizes an entirely new combustion chamber shape for amazingly smooth combustion on low grade fuel. ➤ The V-8 is available with 4-barrel carburetor and dual exhausts. With this combination, performance is *exceptionally good*. The car really digs in and goes. ➤ Many options are available. ➤ And if you enjoy tinkering with your own engine, The Lark's a pleasure. Peek under the hood and look at the labor-saving working space. ➤ In fact, drop in at your Studebaker Dealer's and enjoy a demonstration drive.

The Lark is available as a 2-door and 4-door sedan, hardtop and station wagon.

APRIL 1959 77

SAVE 1/2 OR MORE

Build this six transistor portable radio

No other portable gives you so many features at such a low price: 4" x 6" speaker, 500 to 1000 hr. battery life, two-tone molded plastic case, plus high quality, all-transistor circuit.

\$29⁹⁵

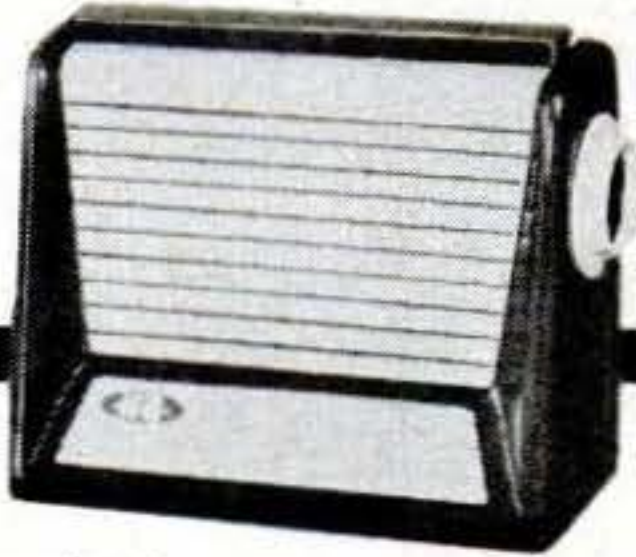

IT'S EASY, FUN, EDUCATIONAL

No special tools or skills required. Clearly illustrated step-by-step instructions guarantee your success—and you learn about electronics the easy way—BY DOING!

SEND FOR FREE CATALOG

..... Describing nearly 100 other "do-it-yourself" HEATHKITS for hobby, hi-fi, ham radio or professional.



HEATH

pioneer in "do-it-yourself" electronics

COMPANY

BENTON HARBOR 16, MICH.

a subsidiary of Daystrom, Inc.

name _____

address _____

city & state _____

FOCUS YOUR EYE on BENJAMIN

SMOOTH BORE BB OR RIFLED 22 - AIR OR GAS GUNS - ROUND LEAD AMMO EFFECTIVE UP TO 100 FT.

AMAZING NEW Line of REPEATERS

WITH THE LATEST IMPROVEMENT IN FAST, SURE, GRAVITY LOADING ACTION AND PIGGY-BACK SHOT MAGAZINE

\$18.95

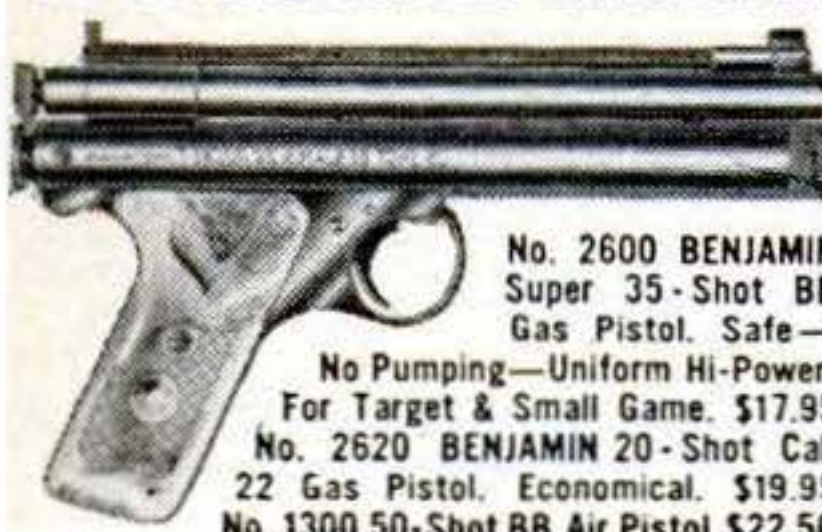

No. 2600 BENJAMIN Super 35-Shot BB Gas Pistol. Safe—

No Pumping—Uniform Hi-Power. For Target & Small Game. \$17.95

No. 2620 BENJAMIN 20-Shot Cal. 22 Gas Pistol. Economical. \$19.95

No. 1300 50-Shot BB Air Pistol \$22.50

No. 1320 BENJAMIN 35-Shot Cal. 22 Air Pistol \$24.50

No. 3600 BENJAMIN Super 100 Shot BB Gas Rifle. Non Toxic—Safe—Convenient—Uniform Hi-Velocity Power.

No. 3620 BENJAMIN Super 85 Shot Cal. 22 Gas Rifle . . . \$20.95

No. 3100 Super 100 Shot BB Air Rifle. Adj. Shooting Force \$23.95

No. 3120 BENJAMIN Super 85 Shot Cal. 22 Air Rifle . . . \$25.95

FREE Catalog All Models Benjamin Single Shot & Repeaters—Cal. BB or 177 or 22. Also, Special Hunting & Fishing Knife Offer.

BENJAMIN AIR RIFLE CO. 852 MARION ST., ST. LOUIS 4, MO.

KIT BOATS Boat Plans Patterns Frame Kits



KIT CATALOGS—Over 50 Models—Pre-assembled. Runabouts, Cruisers, Fishing (8' to 19'). Anyone can assemble. Complete Marine Accessories, Fiberglass plastics, trailers, paint, etc. Also CATALOG on 50 Modern Plans and Patterns. Prefab Frame Kits—All types best for the amateur builder.

SAVE 2/3

FREE FREIGHT CREDIT TERMS

SEND 10¢ FOR 2-COLORED CATALOGS—NOW

Tonawanda 1 M.N.Y.

Craig Craft Name _____ City _____ Address _____ State _____

Your boat is safe

with

"PERMA-DOCK" MOORING BARS

Small craft are safely, conveniently moored to docks with Perma-Dock Mooring Bars. Strong springs attach to bow and stern . . . boat rides easily with waves yet never bumps or rubs dock. Bars are easily attached to dock . . . fold flat when not in use.



"PERMA-DOCK" METAL BRACKETS . . . offer a quick, low cost way to erect and take down a stronger dock without ever working in water!

Write for Circular on "Perma-Dock" dock brackets, float brackets, mooring bars, ladders, outboard motor carts and hoists.



Central Machine Works Co. 1236 Central Avenue, Minneapolis 13, Minn.

IN SPRING, A YOUNG MAN'S FANCY TURNS . . . CAN BE WRONG TURNS

He needs a HULL AUTO COMPASS, the original motoring guide, that reveals wrong turns, the instant they happen, for thousands of motorists every day. \$5.50 and \$6.95. At your dealer's or write for literature.



FAMOUS COMPASS MAKERS FOR MOTORISTS AND BOATERS

HULL MFG. CO., P.O. BOX 246-E-4, WARREN, OHIO

164 PAGE PHOTOGRAPHIC BARGAIN CATALOG

Thousands of money saving photographic bargains. Illustrated and carried in stock by Central Camera Company—the largest photographic store and largest photographic mail order supplier in the middle west. Send 25c for your copy. Credit will be given on first order for \$3.00 or more.

BIG SAVINGS!

SEND 25c FOR COPY. CREDIT GIVEN ON FIRST ORDER

CENTRAL CAMERA CATALOG

PHOTOGRAPHIC HEADQUARTERS SINCE 1899

CENTRAL CAMERA COMPANY

230 SO. WABASH AVE. - CHICAGO 4, ILL. DEPT. V5-4

Do it...Say it:



MULTIPLE SCLEROSIS RESEARCH - CLINICS PATIENT AID

NATIONAL MULTIPLE SCLEROSIS SOCIETY
257 Fourth Avenue, New York 10, New York

If your spirit is WHEELING



there's a
HARLEY-DAVIDSON
motorcycle for you

You name it! Whether you're looking for luxurious riding comfort, thrilling sport or lightweight economy — Harley-Davidson has the right wheels for you. DUO-GLIDES offer cruising comfort for one or two. SPORTSTERS give you jet-propulsion on or "off the road." HUMMERS and MODEL 165s give more *smiles* and *miles* to every gallon. In all, there are 7 sensational models to choose from. See them at your Harley-Davidson dealer or fill out the coupon for free, colorful folders.



DE-LUXE DUO-GLIDE — The luxury cruiser of motorcycles. Available in the FL series or super-power FLH's.



JET-STREAM SPORTSTERS — H model (pictured) for jetaway acceleration on highways and byways. Also Sportster CH for "off-the-road" competition.



LUXURY LIGHTWEIGHT 165 — Smart styling combined with thrifty operation. Not shown is the economical Hummer — up to 100 miles to the gallon.

Harley-Davidson

MOTOR CO.
DEPT. PS, MILWAUKEE 1, WISCONSIN
Dealerships Available. Write For Information.

HARLEY-DAVIDSON MOTOR CO.
Dept. PS, Milwaukee 1, Wisconsin
Please send me information on
 Duo-Glides Sportsters Lightweights

Name.....Age.....

Address.....

10 years

from now you'll be glad you bought

ALUMA

Craft



THE MARK OF QUALITY

Wherever boating enthusiasts see the Aluma Craft name it is instantly accepted as the mark of quality . . . the guarantee of fine design, precision construction and quality materials. Aluma Craft also means excellent performance. It stands for the speed, stability, safety, and strength that assures years and years of boating pleasure.

MORE FUN AND LESS WORK

Owning an Aluma Craft is practically all fun with no work. Your Aluma Craft is always ready to give you a day, a week or a season of pleasure. They are strong and sturdy, yet light and easily handled. They require little or no upkeep and are easily trailered or car-topped. Winter storage problems are mostly eliminated.

WARRANTED

Every Aluma Craft comes to you with a nine year warranty . . . a complete guarantee of quality materials and construction. Send for new catalog showing the new models in our top-flite line for '59. All in full color.

ALUMA CRAFT BOAT CO.

1521 Central Avenue N. E.
Minneapolis 13, Minnesota



● Please send catalog showing Aluma Craft's top-flite line for '59.

NAME _____

ADDRESS _____

CITY _____ ZONE _____ STATE _____

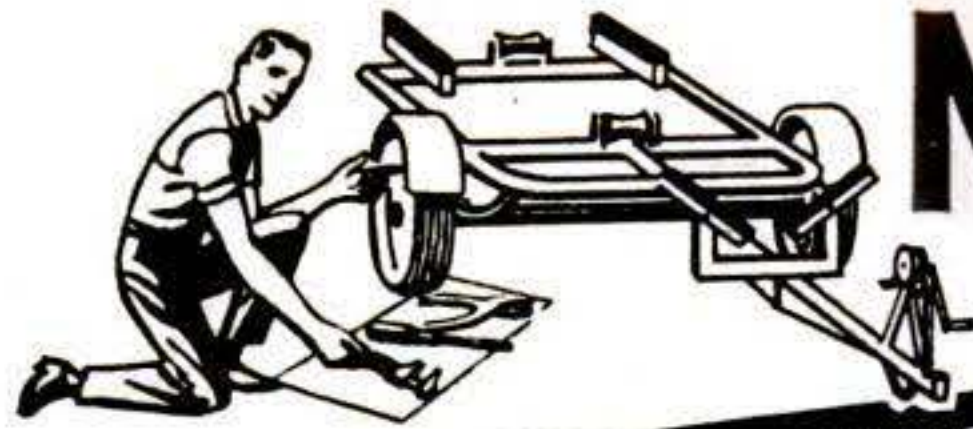

NOW!

ASSEMBLE YOUR OWN BOAT TRAILER

SAVE \$50 OR MORE

Hurricane Trailer Kits

● Assemble in 4 hours! Easy to follow instructions . . . need only a few basic tools . . . no welding . . . factory painted. Hurricane Trailers are precision engineered for boats 12 to 25 feet . . . custom kits available. Rugged, lightweight with a special tilting action for fast loading plus built-in roadability makes Hurricane your best trailer buy and you save at least \$50 by assembling it yourself. Write for complete catalog and price list.

**FROM \$125
EASY TERMS
PAY OVER 12 MONTHS**

HURRICANE TRAILER CO.

1630 Canal Road South Daytona Beach, Florida



1/4 MIDGETS

The little league of family racing. \$449.00 complete. Write for free literature. Dealerships now available.

RACE-CRAFT

RACE-CRAFT MIDGET CARS
8476 E. Garvey Boulevard
South San Gabriel, Calif.

A SWIM POOL FOR \$500.00!

In only about 2 weeks' time you can build a beautiful concrete pool with deluxe coping and tile trim, at an unbelievable price. Various methods completely described in, "SO YOU WANT TO BUILD A POOL," the only book of its kind ever written. Positively nothing else like it. 220 pages, 160 illustrations. \$3.00 postpaid. Get started now for pleasant swimming this summer!

FRANK REED, 1009 N. Raymond, Pasadena 3, Calif.



Deluxe Model

FRONTIER DERRINGER

Exact replica of old, original Remington Derringer — brand new! Now our Deluxe model at no extra cost increase. Beautiful hard, chrome finish — twin firing pins. Single automatic ejector — the finest at this low price. .22 cal. **\$24.95** .38 Special **\$34.95**

HY HUNTER • Burbank P-2, California

ANNOUNCING NI-BRAL UNBREAKABLE PROPELLERS



MICHIGAN'S new NI-BRAL props, for large motors only, may be nicked but virtually never bent or broken . . . carry 5 year guarantee against breakage . . . eliminate repair lay-ups. Send card for FREE 1959 catalog giving propeller recommendations for motors of 5 HP and larger which by actual test provide far MORE SPEED, BETTER SKIING or LOAD CARRYING than original prop . . . other helpful data. MICHIGAN WHEEL CO., Grand Rapids 2, Mich., Dept. PS-4.

A pleasant addition to the art of fishin'



Photographed at Florida's Silver Springs.

dependable **MERCURY OUTBOARDS**

There's been *new* progress in fishing motors by Mercury . . . *new* freshness of design in the forward *Glide-Angle* look . . . more dependability . . . a water pump specially designed for operation in weeds and mud.

Automatic Transmission that puts shift, throttle and steering control in *one hand!* Weedless *Glide-Angle Design* slides safely over submerged objects. There's no "wrassling" to fix broken shear pins because

Mercury got rid of them years ago, introducing modern propeller clutches! So go *where* you please, *when* you please! Your Mercury is rugged, reliable — and quiet as a good fishing companion should be. See your Mercury dealer now for a *free* demonstration ride. Choose from three *Glide-Angle* twins — 22 hp Mark 28A, 15 hp Mark 15A, 10 hp Mark 10A. They're easy to look at, easy to own with the Mercury time payment plan.



MARK 28A
22 hp

Single-Lever Control and Ride-Guide Steering available for remote operation. Safe single-line, vacuum-fed fuel system eliminates dangers of pressurized fuel tanks.



MERCURY—the 50,000-mile outboard, the world record line for '59!
Twins—6 hp, 10 hp, 15 hp, 22 hp. Fours—35 hp, 40 hp, 45 hp.
Sixes—60 hp, 70 hp. "Full Jeweled"® Power throughout!

Write for FREE Catalog and 28-page Booklet, "Fishing with an Outboard". Address Dept. PS-4. © 1959 Kiekhaefer Corporation, Fond du Lac, Wisconsin.

Get satisfying flavor...So friendly to your taste!

NO FLAT "FILTERED-OUT" FLAVOR!
NO DRY "SMOKED-OUT" TASTE!



© A. T. Co.

See how Pall Mall's famous length of fine tobacco travels and gentles the smoke—makes it mild—but does not filter out that satisfying flavor!

HERE'S WHY SMOKE "TRAVELED" THROUGH FINE TOBACCO TASTES BEST



1 You get Pall Mall's famous length of the finest tobaccos money can buy.



2 Pall Mall's famous length travels and gentles the smoke naturally . . .

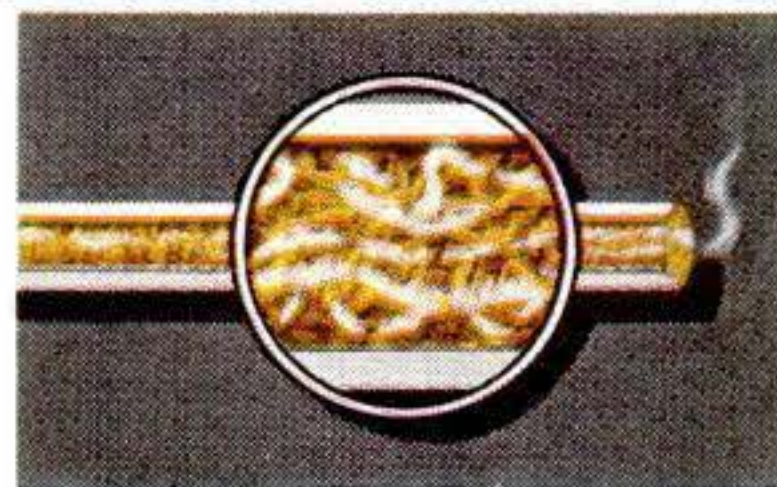

3 Travels it over, under, around and through Pall Mall's fine tobaccos!

Outstanding . . . and they are Mild!

Product of *The American Tobacco Company* — "Tobacco is our middle name"

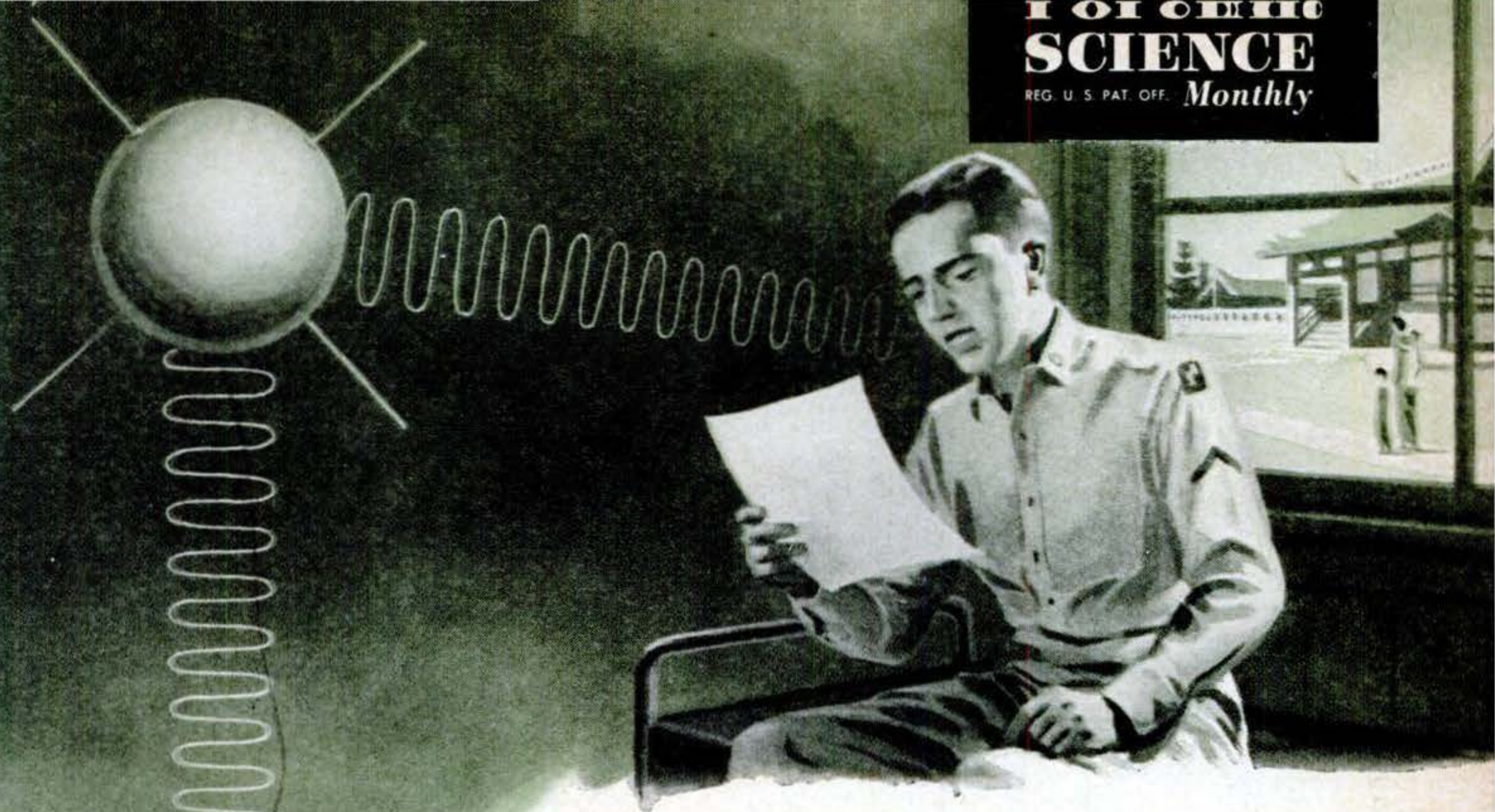

Talking Satellites to Speed Mail

Relay stations in space will send your messages overseas—and let you see Europe on TV **By Martin Mann**

PRACTICAL, down-to-earth uses for space satellites are coming faster than anyone thought possible. First job: communications.

The talking birds will relay radio messages around the globe, bring you your first look at European television *live* through a transatlantic TV network, and eventually flash your letters overseas by way of a fantastic space post office combining written messages, electronic facsimile and a “stationary” satellite.

Futuristic as these ideas seem, they are already

LETTERS FROM HOME flash overseas electronically in half the time, via space post office.



worked into detailed plans. The Atlas satellite that broadcast President Eisenhower's Christmas message from space last December was a test, not a stunt.

How soon? Government space agencies have revealed a timetable that changes over rapidly from experimental to working satellites that will earn their keep as routine elements of a worldwide communications net. Here's what will happen:

- 1959—this year—The first big plas-

tic-balloon satellite will be launched. It will be aluminum-coated to bounce radio signals back to earth.

- 1960—Three satellites carrying receivers and transmitters will continue last December's test of "repeating" messages.

- 1961—Repeater satellites for actual use in Signal Corps overseas communications will be in orbit.

- 1962—A five-ton satellite with equip-

[Text continued on page 242]

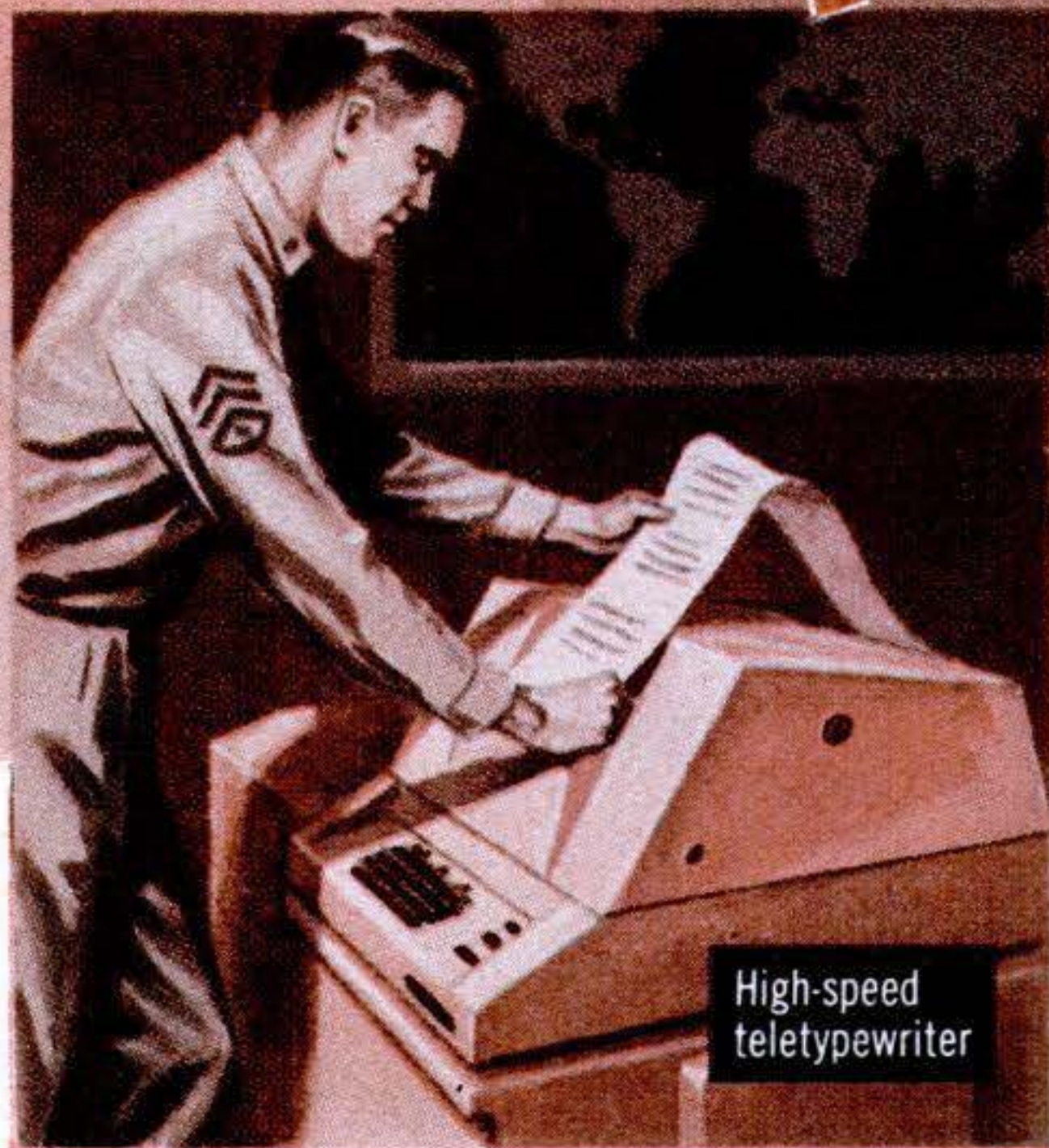
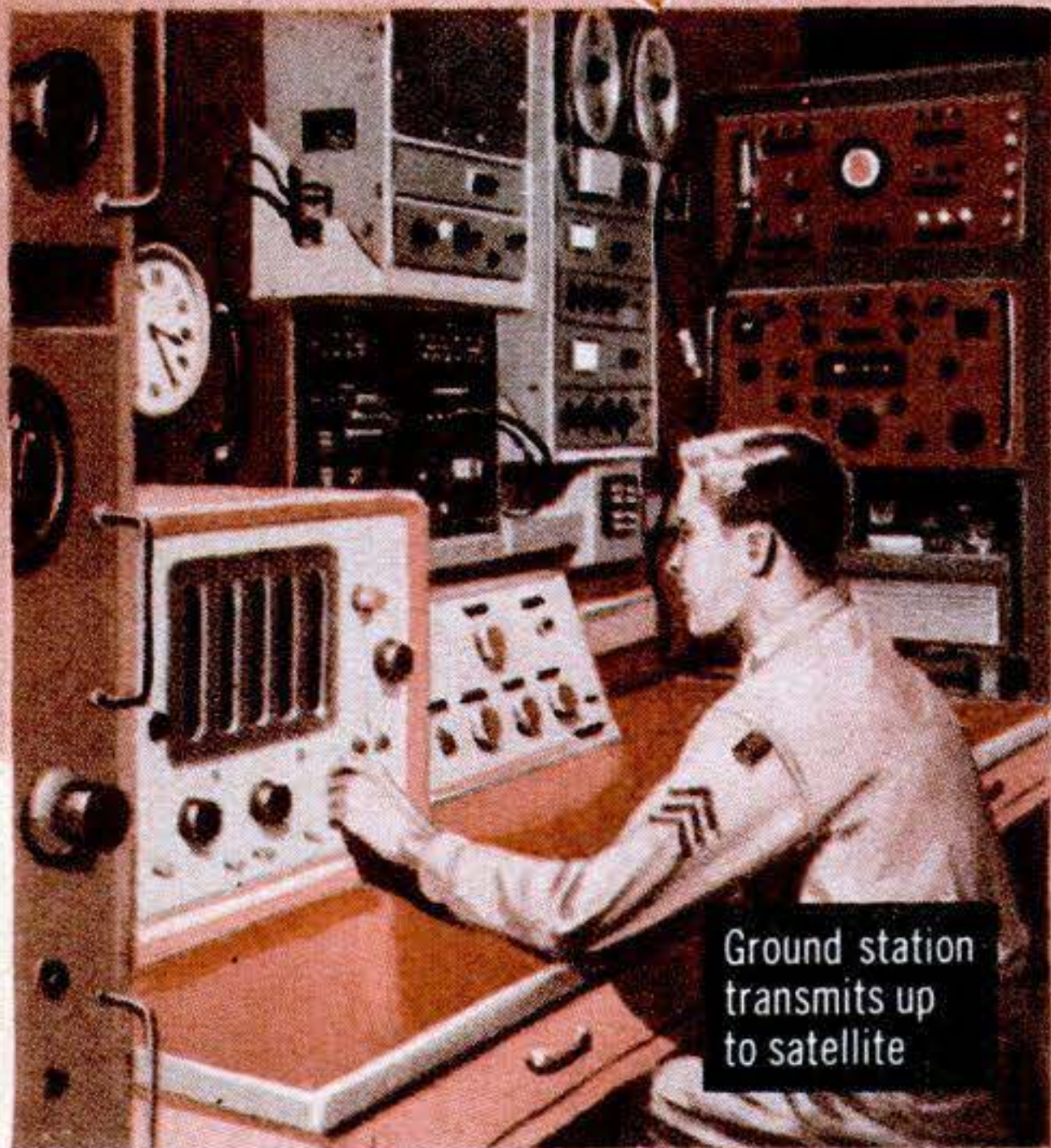
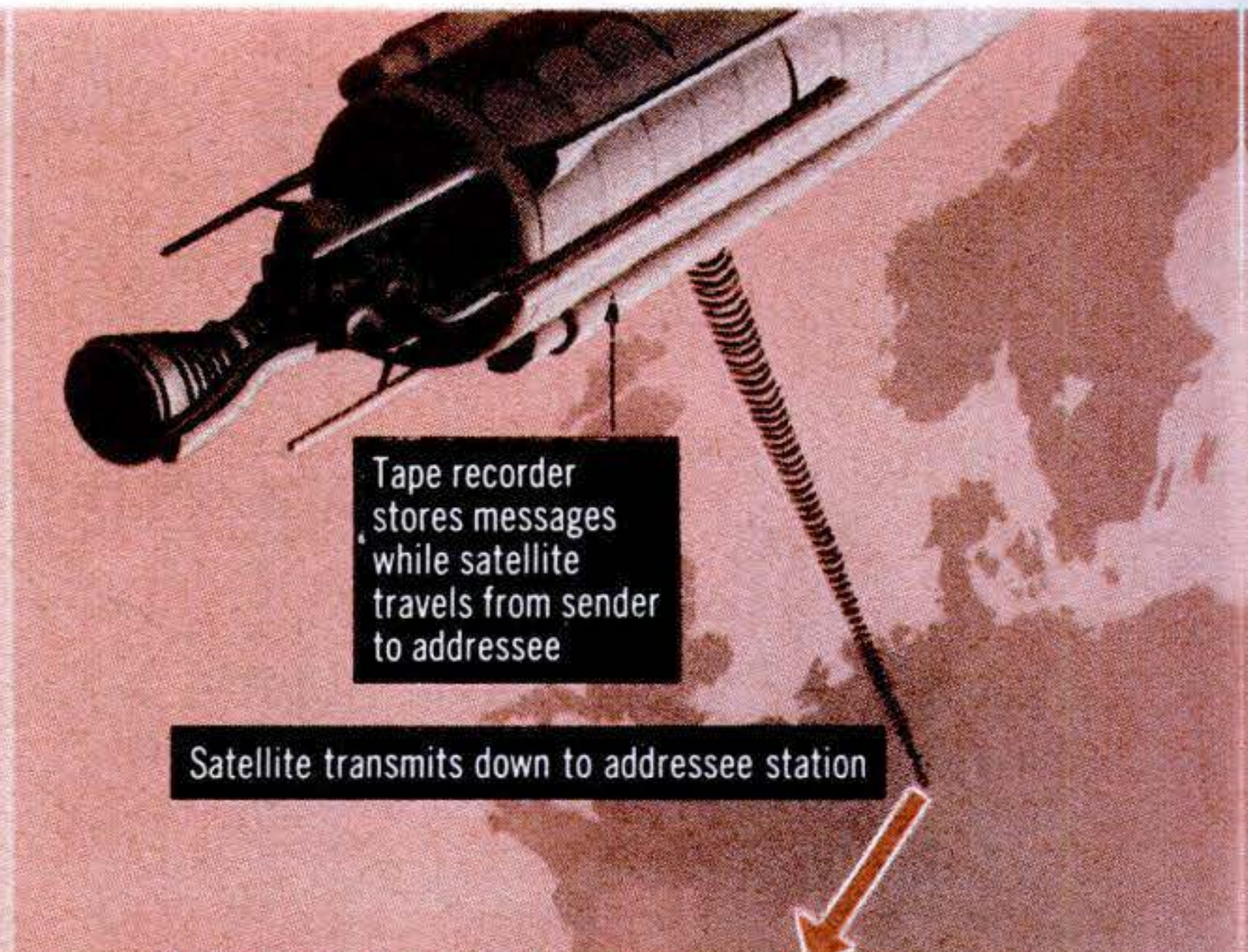
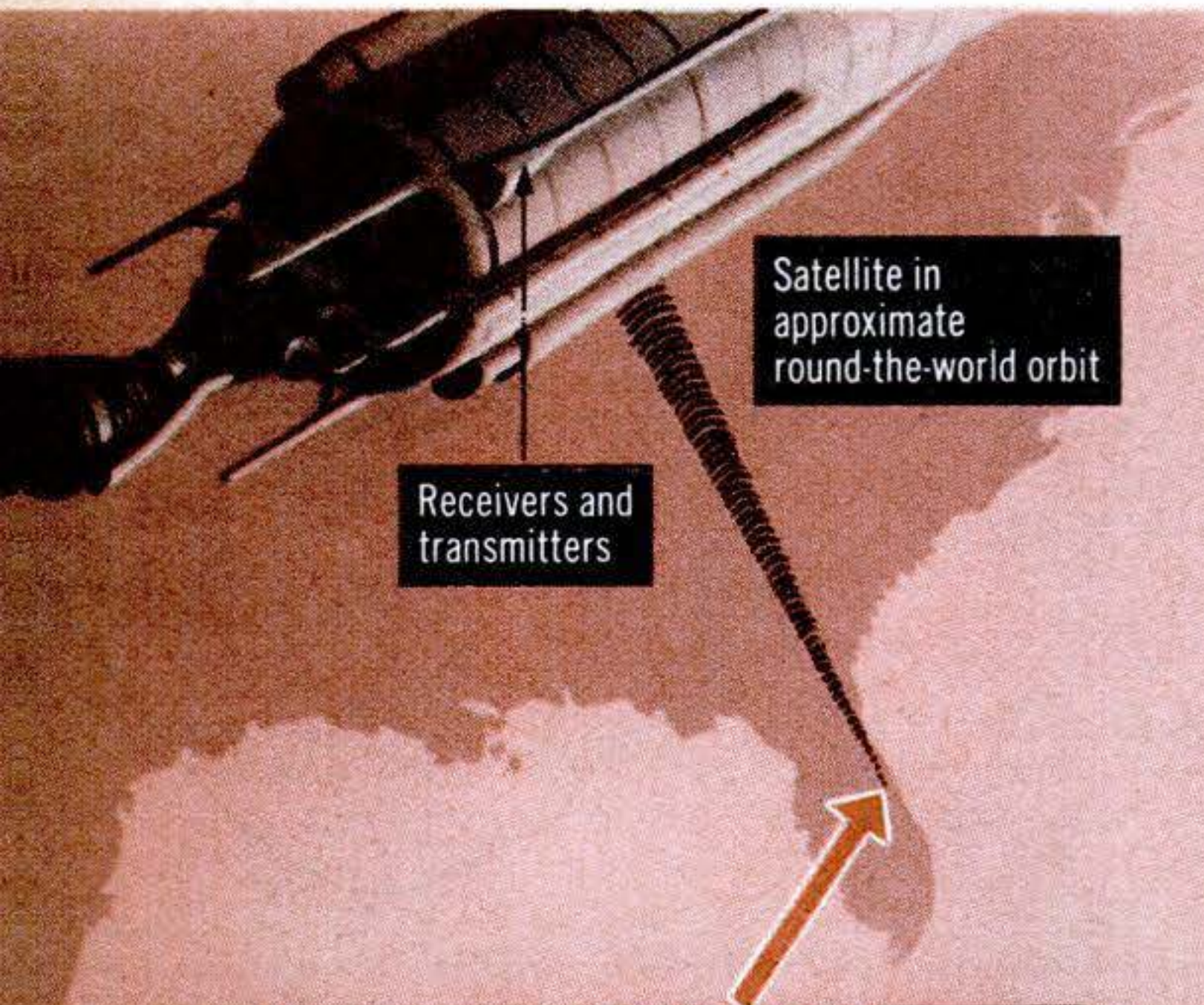

Project Courier will pick up messages at one point, deliver them somewhere else. Satellite carries radio receivers and transmitters plus tape recorder. Ground stations track it (aided by beacon transmitter in satellite), and transmit outgoing messages when it comes into range.

Tape recorder takes them down. Farther along in orbit, as satellite comes into range of another ground station, that station signals for its messages to be read off tape and transmitted down to ground. This is a scheme that the Signal Corps plans to have in operation by 1961.

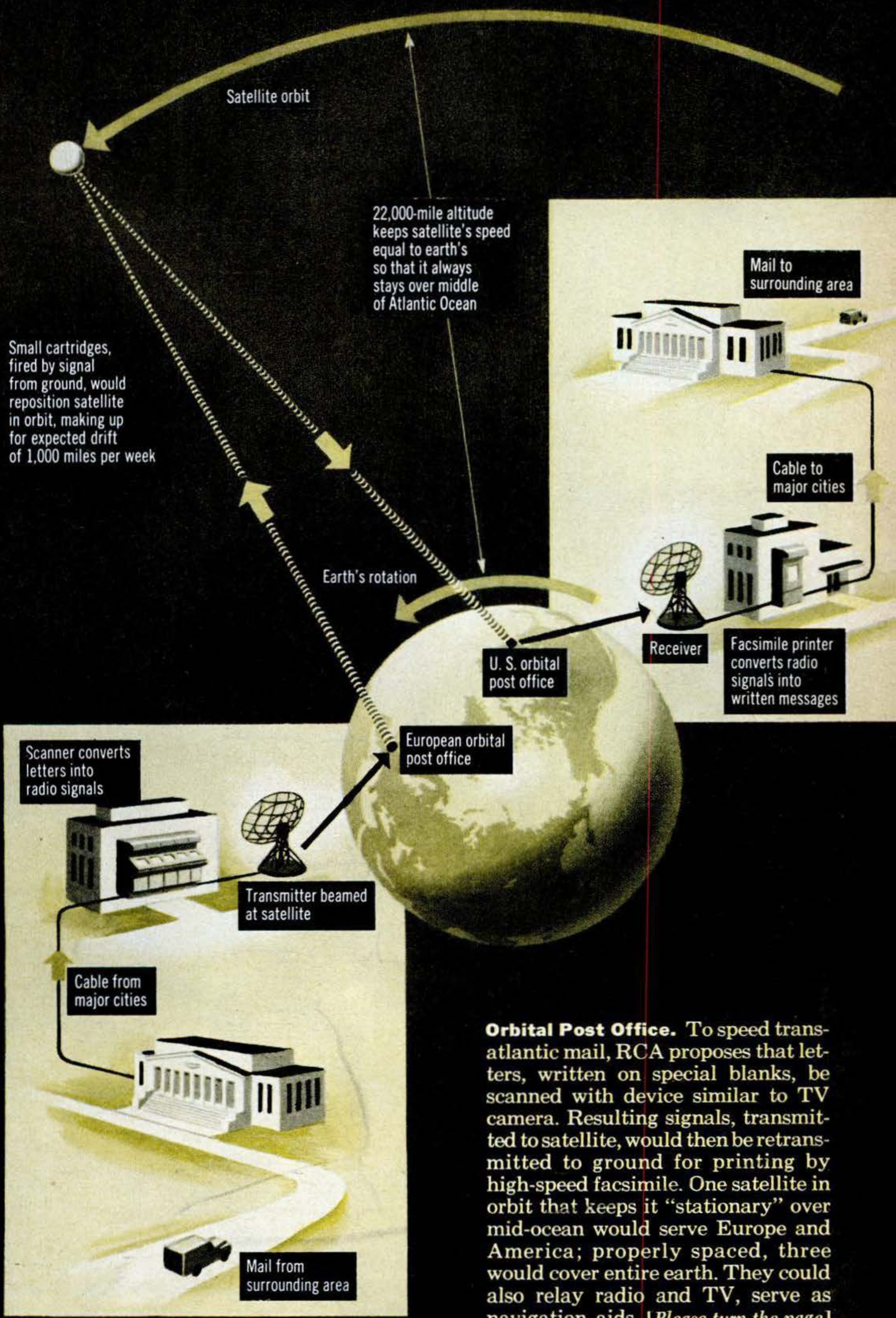

Orbital Post Office. To speed transatlantic mail, RCA proposes that letters, written on special blanks, be scanned with device similar to TV camera. Resulting signals, transmitted to satellite, would then be retransmitted to ground for printing by high-speed facsimile. One satellite in orbit that keeps it "stationary" over mid-ocean would serve Europe and America; properly spaced, three would cover entire earth. They could also relay radio and TV, serve as navigation aids. *[Please turn the page.]*

100-foot balloon of thin Mylar plastic



Covey of 24 balloons, circling 3,000 miles above earth pole-to-pole, would always put one within range of both American and European ground stations

One antenna bounces TV, telephone, telegraph signals off satellite overhead

Second antenna picks up "rising" satellite, ready to use it when first satellite drops below horizon

Transmitter, receiver, and computer that aims antennas

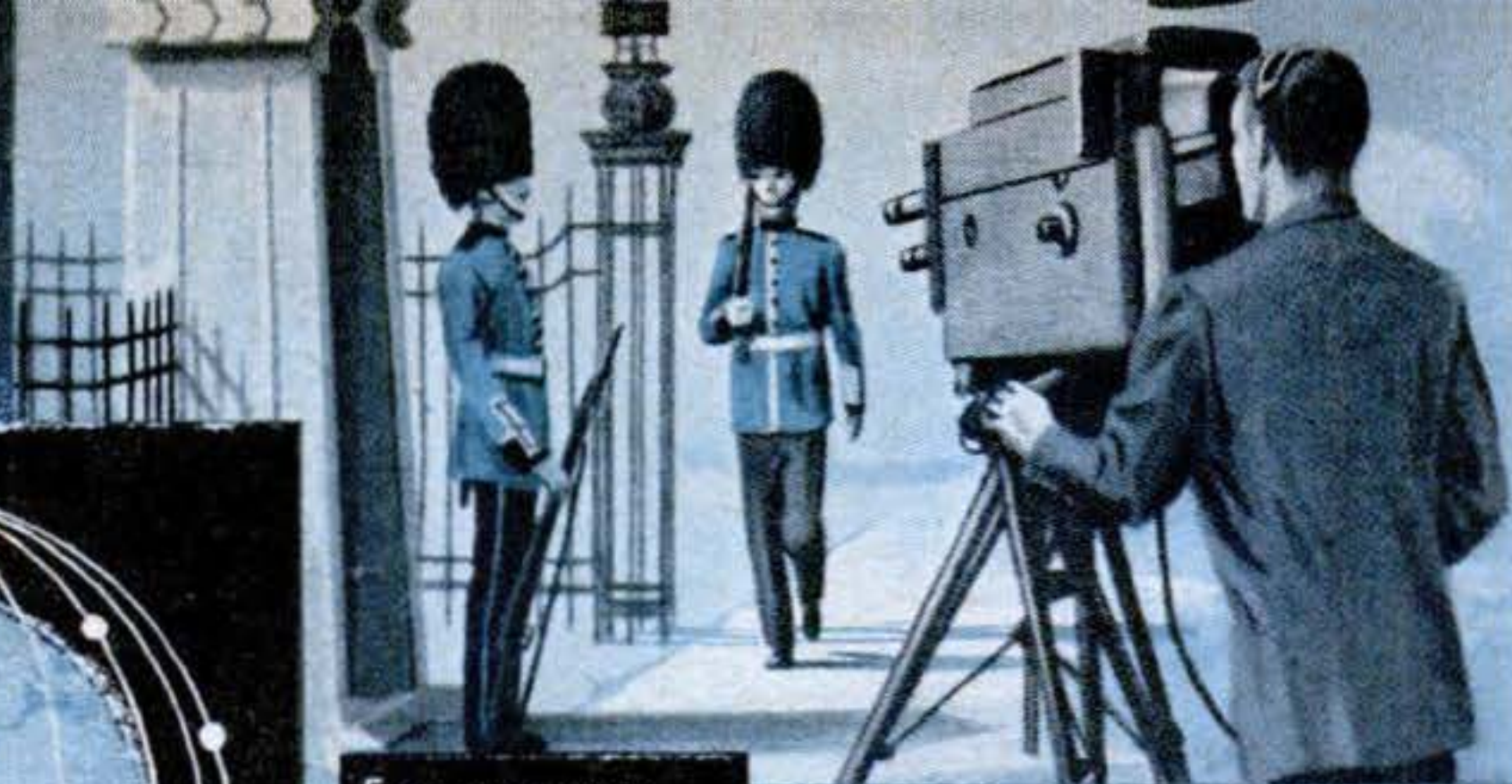

European scene televised live to American homes



Mirrors in Space. Simplest way to relay heavy load of transatlantic TV and phone traffic is to bounce short radio waves off big shiny satellite, the way light is reflected by a mirror. All radio apparatus is on ground, none in satellite. This gives nearly limitless capacity since

ground stations can use many channels at different wave lengths. Reflected signal would be extremely weak, and ground equipment becomes very complex: ultrasensitive receivers with molecular amplifiers, giant antennas, computers to predict where mirrors will be.

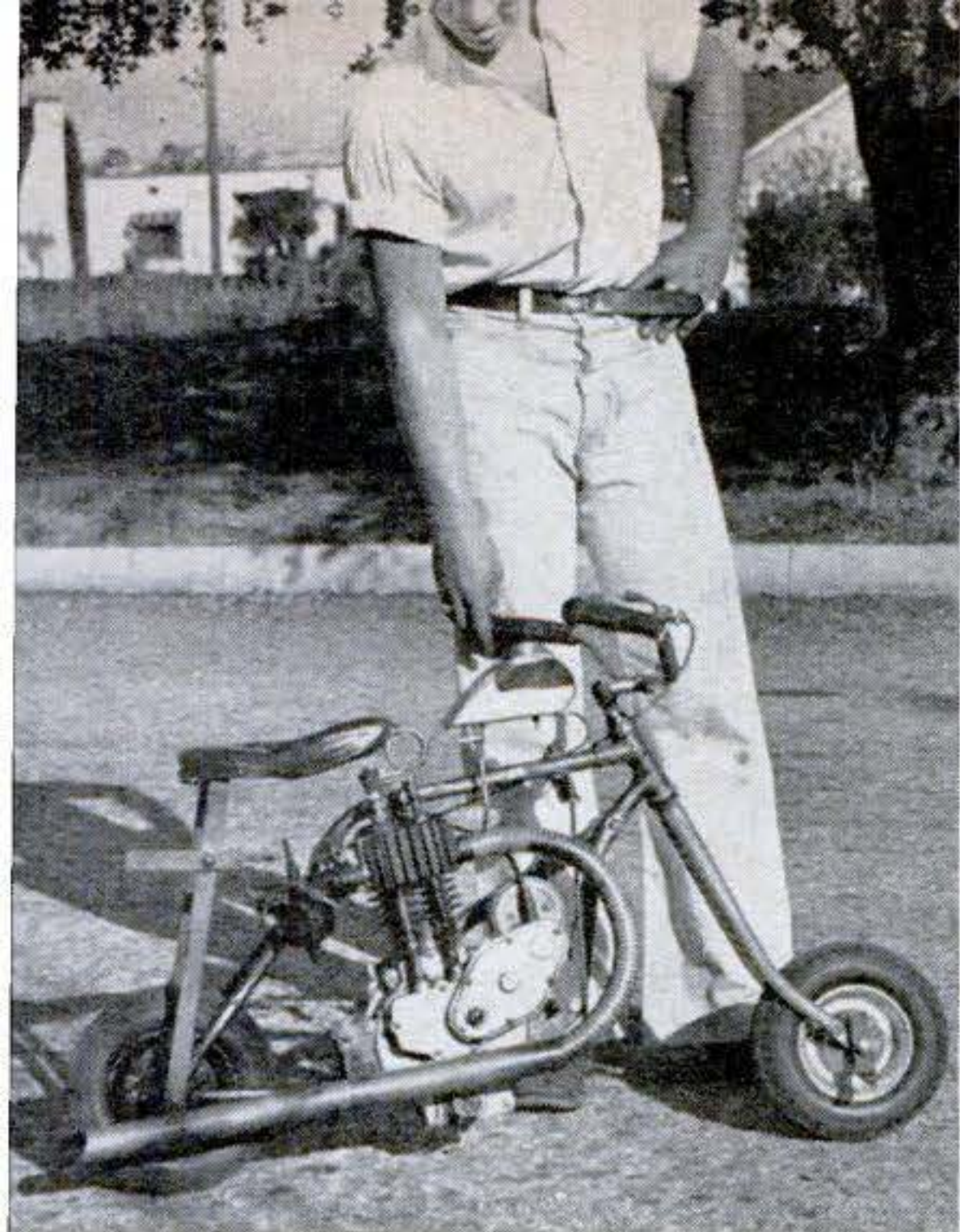

MIDGET CYCLE. A seven-hp. motorcycle engine powers this half-pint, homemade motorbike. Quick on the take-off, it can do 40 m.p.h. It has no brake. To stop, you put both feet on the ground and lift the machine.



NIGHT LANDING. Floating high-intensity lights here mark a safe channel for seaplanes approaching the modernized seadrome at the Naval Air Station at Norfolk, Va. The new all-water runway is 13,500 feet in length.



TRAFFIC TIMER. A flashing electric sign under the traffic signal light above ticks off seconds to let Tokyo motorists know time left before the green light changes to red, and vice versa. The installation cost \$1,400.

DRIVE PATTERN. Time shot of a light on the selector lever of Ford's new tractor transmission shows (right) operation for 10 forward speeds. The power-shift unit needs no clutch pedal.

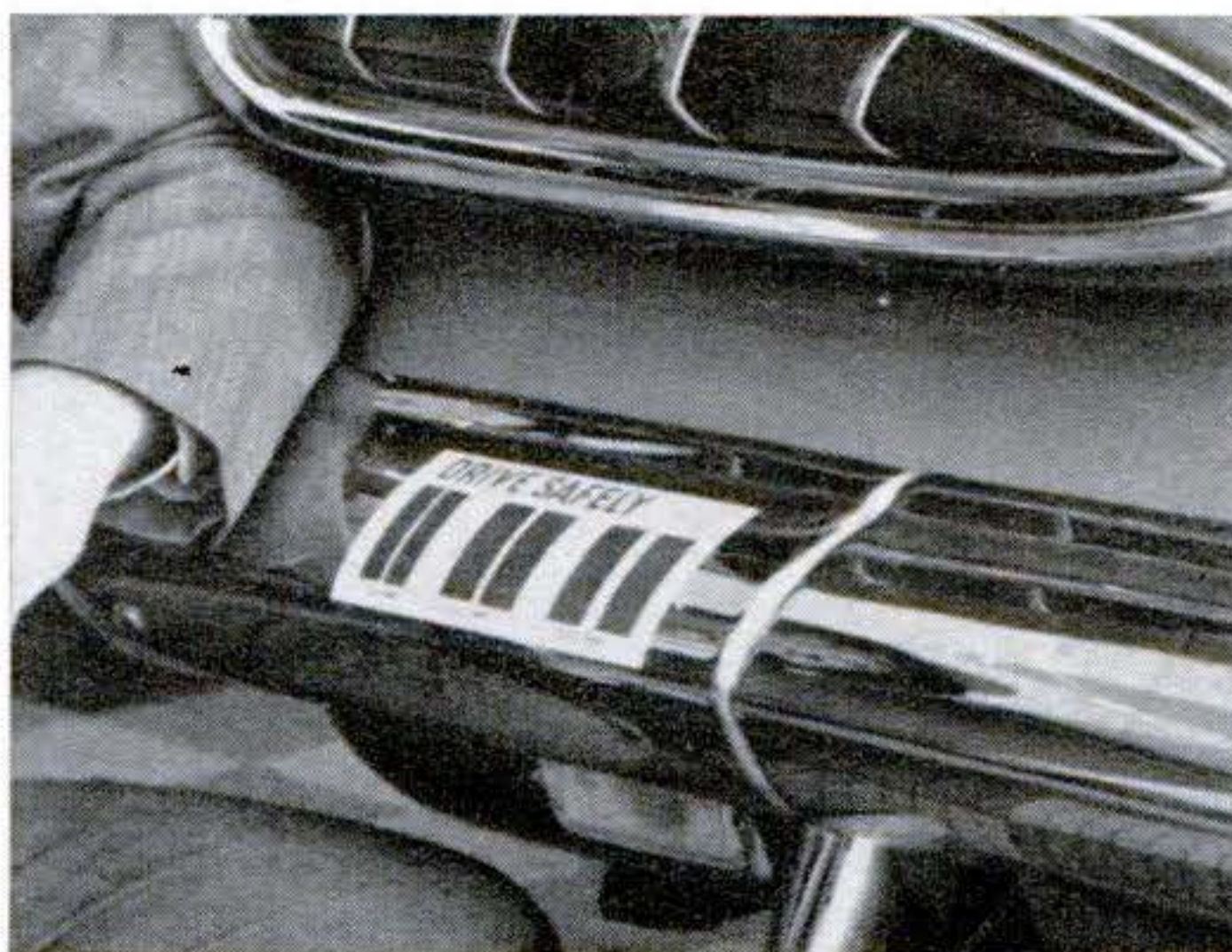
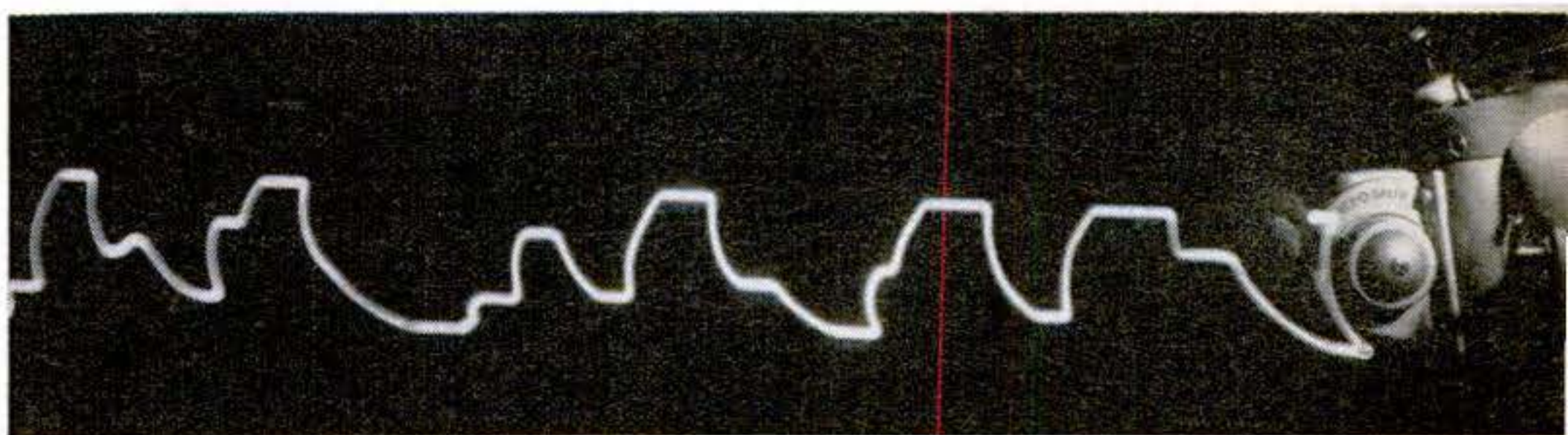

ANTI-TAILGATER. The pairs of vertical lines on this bumper strip warn a trailing driver of his distance. Each pair looks like a solid line until he is (right to left) 300, 150 or 75 feet away.

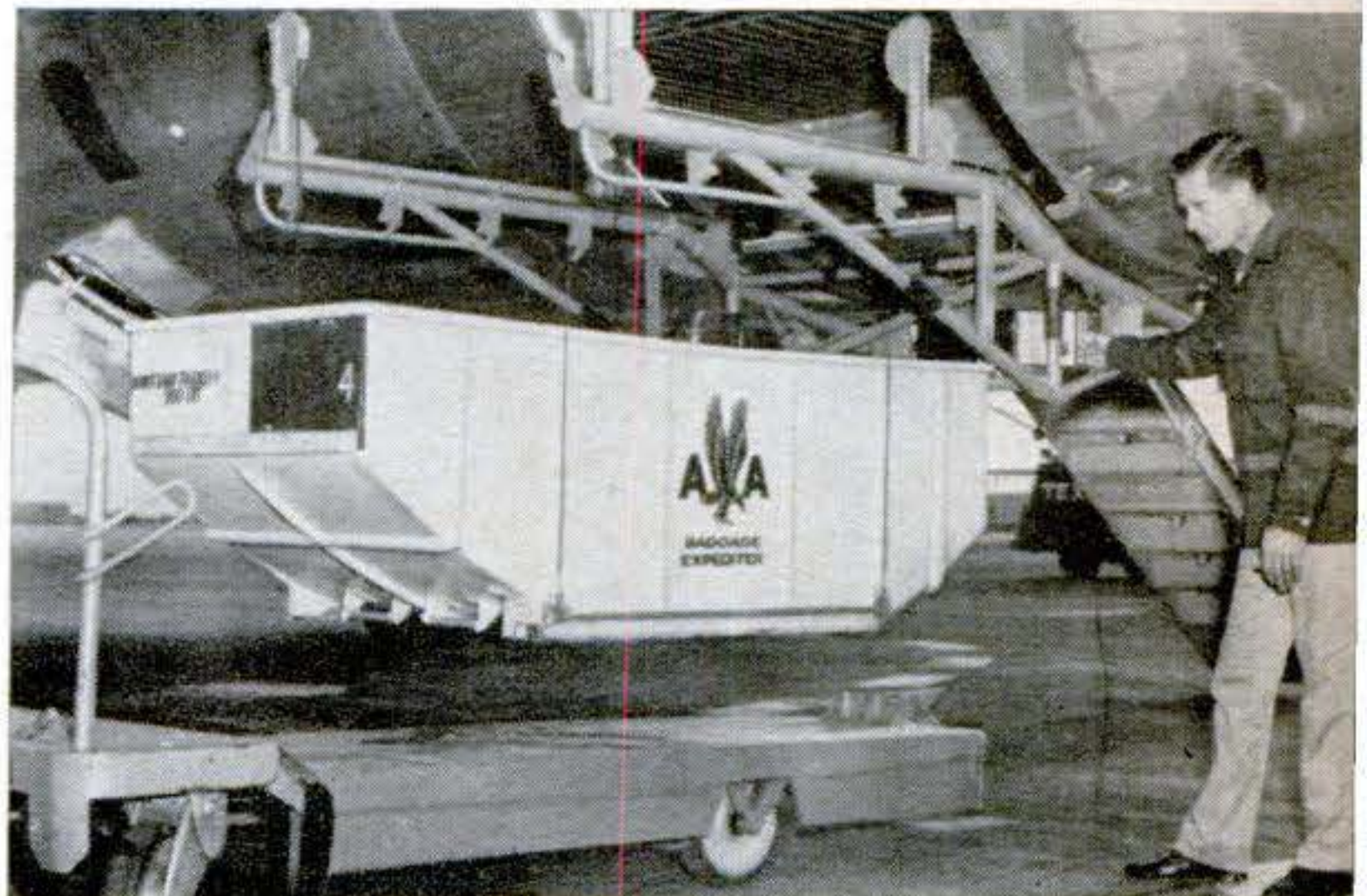

LUGGAGE EXPEDITER. Containers holding 20 bags fit the contour of the cargo compartment of American Airline's Electra turbojets. They speed loading and unloading of passengers' belongings.

Bored with traveling in a living room on wheels? Don't let folklore stop you from buying that convertible you covet

I Say Convertibles Make Sense

By Hubert Lockett

CONVERTIBLES have much in common with those movie starlets whose curves often decorate the pages of the tabloids, but whose faces you never see in the movies. They can claim the dubious distinction of being the most looked at, but most neglected in the department that pays off. They seldom get a chance to show their real talents to the paying customers.

Chances are, if you are like most people with a lively interest in hobbies and more than a passing interest in automobiles, you are one of those who looked, admired, and secretly coveted a converti-

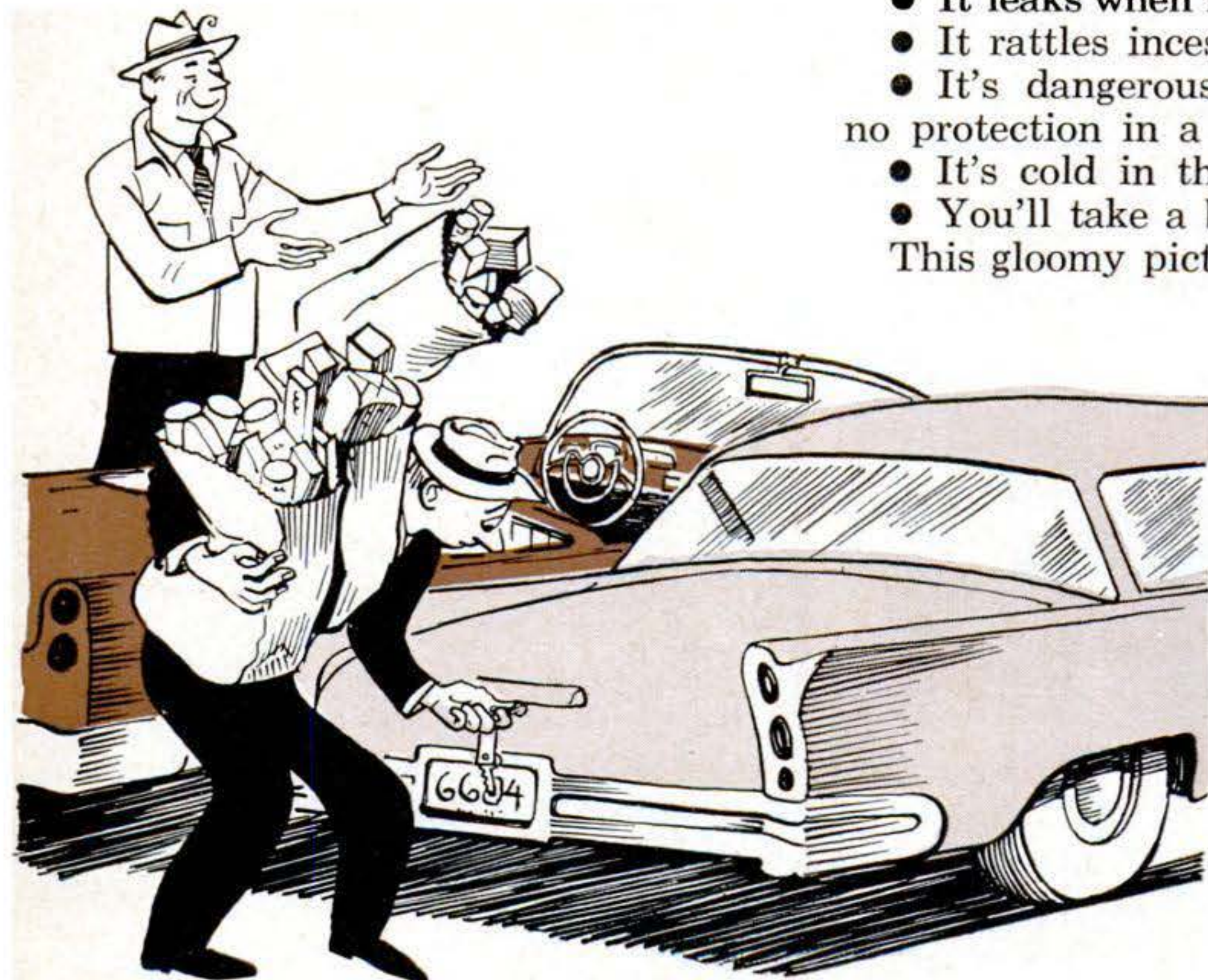

You'll be giving the paintwork

ble—but bought something else. Your dreams of four-wheeled glory were no match for the tired, but durable folklore perpetuated largely by curbside experts who have never owned what they derisively call a “rag top.”

They say:

- You have to buy a new top every year.
- The operating machinery always gives trouble.
- It leaks when it rains.
- It rattles incessantly.
- It's dangerous—the soft top gives no protection in a roll-over.
- It's cold in the winter.
- You'll take a beating on trade-in.

This gloomy picture of the convertible

Weekend errands can be almost a pleasure. One boon: no package-juggling to free a hand for the door handle—just dump them over the side into the back seat.



a last loving swipe, while your neighbor is still laboring on acres of sheet metal.

is painted mostly from eyewash, and based on "information" that is as dated as a straight-eight engine. But if this is not enough to stop you, there is always the chap who gets the latest word on everything. He'll confide that Motivation Research has discovered that owning a convertible is the expression of a secret desire to keep a mistress. If you like to think of yourself as a practical, mature and reasonably moral citizen, you don't stand a chance of getting away with buying more fun with your car dollar.

From one who owns one. About the only ally you can find is a contented owner who has bought a convertible in the last couple of years. The car makers themselves are not much help. In their sales pitch they use a convertible much the way other advertisers use pictures of pretty girls: as an eyecatcher for their more prosaic products.

I have talked to many car buyers since I bought a convertible a little over two years ago. Of course the overwhelming majority owned station wagons, hardtops or sedans. With tiresome regularity, when the subject of convertibles is brought up, they will recite the dismal catalogue of woes listed above. An occasional more imaginative type may add one or two to the list. And yet, except for a handful who had owned a convertible back in the '30s or '40s, not one of

these "experts" had first-hand experience to verify the imagined ills a convertible is heir to. On the other hand, there is only one complaint out of this list that was mentioned by convertible owners: It is prone to rattle.

I'll go along with this from my own experience. My convertible rattles almost as much as my neighbor's hardtop of the same vintage. On a rough road the din is only slightly less than the rumble in my brother's station wagon.

What about safety? This angle is a tough one to get a hard answer on. But, a canvass of the major safety agencies and insurance companies failed to turn up any evidence that convertibles are any more dangerous than any other car. Cer-

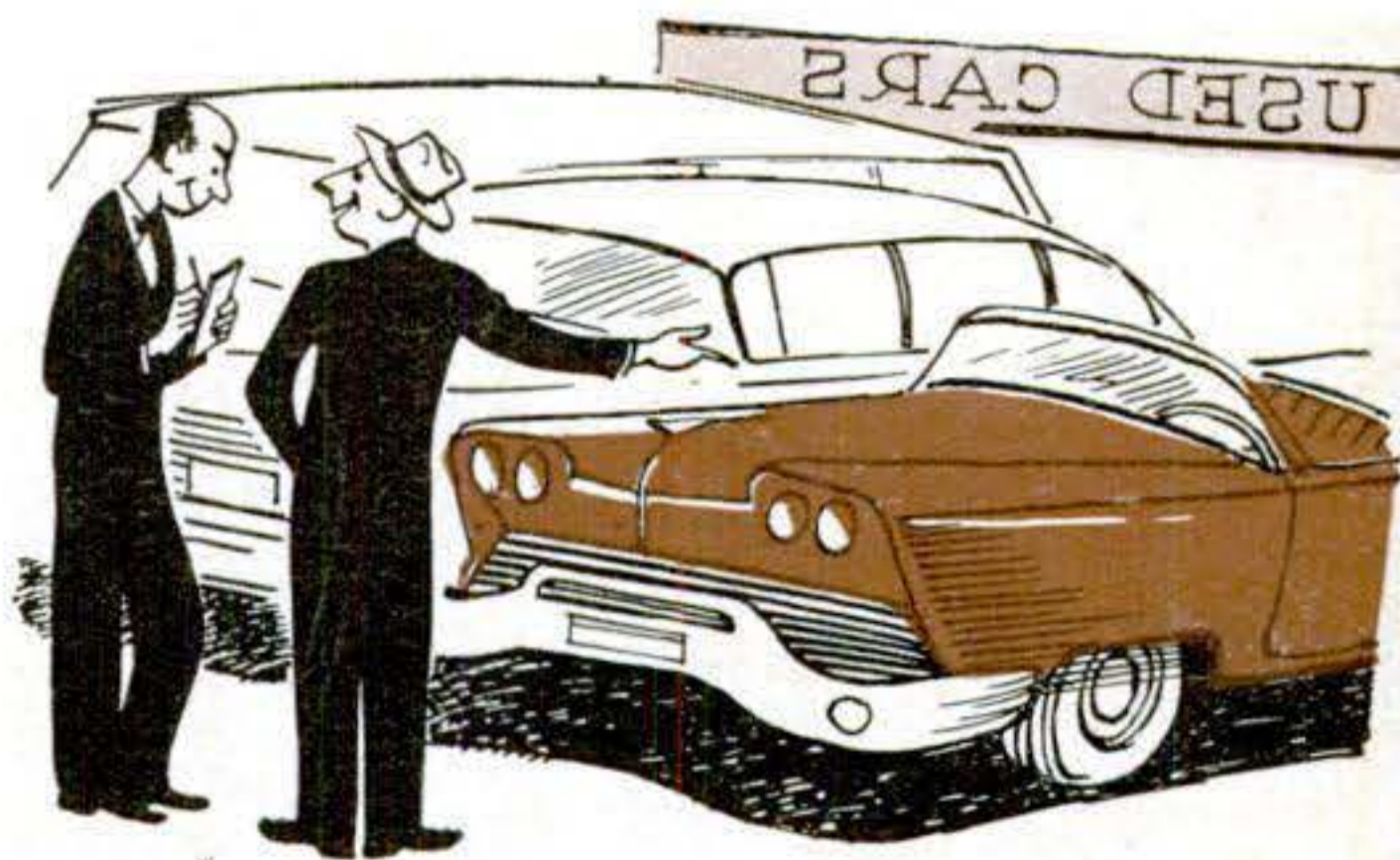

Poor resale value? Just a fiction. Dealers' book of Official Used Car Valuations shows that convertibles fare as well or better than other models.

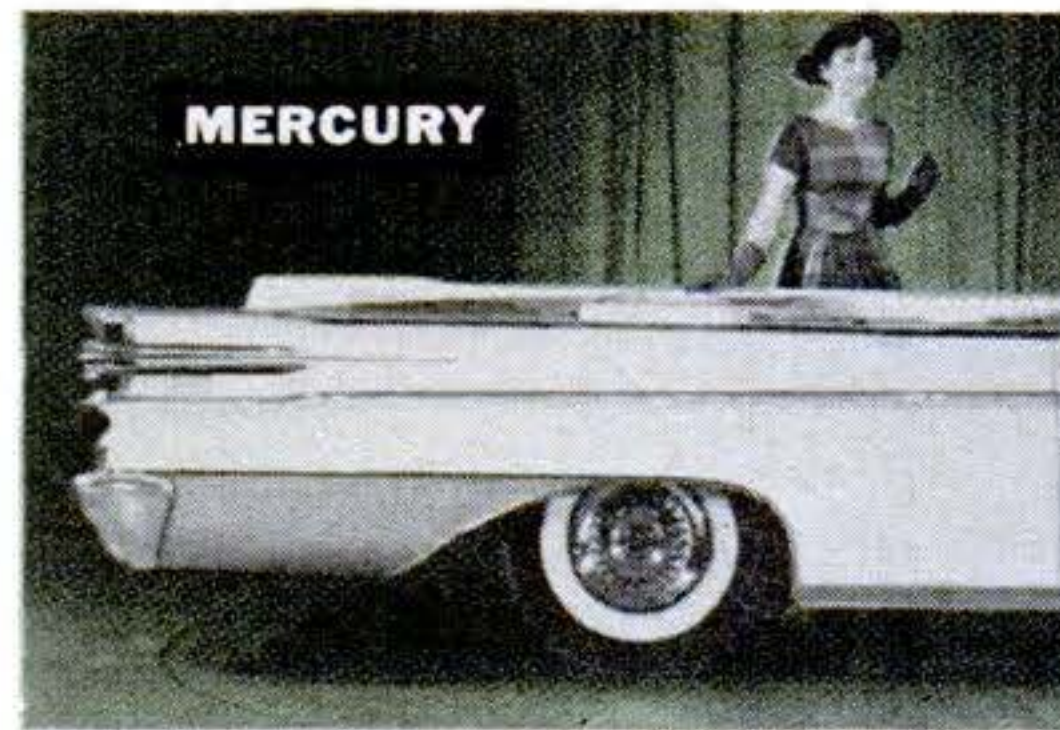
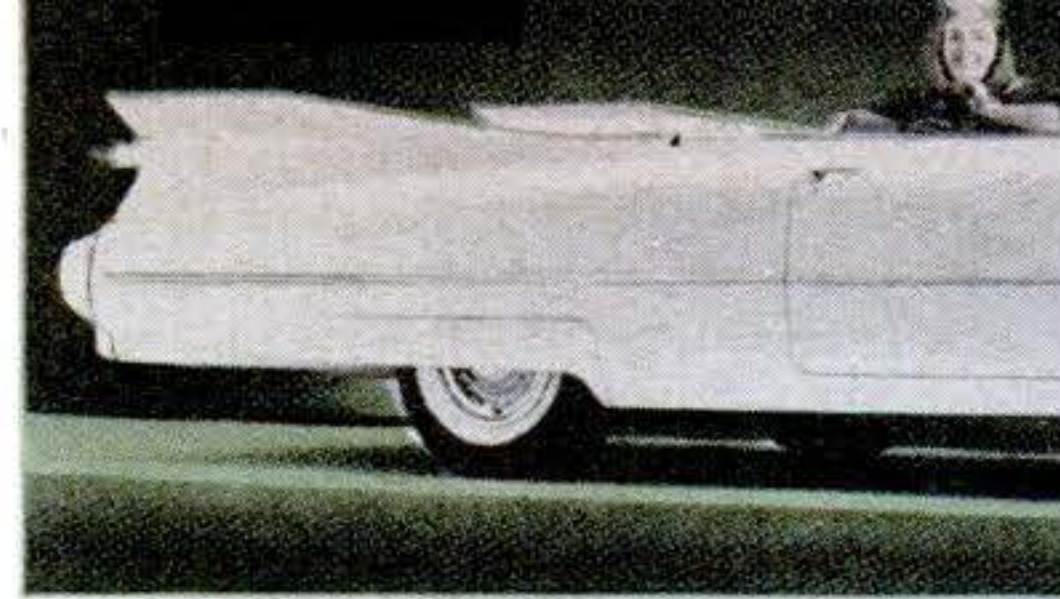

Here are a dozen ways to buy more fun along with transportation. While still less

tainly, as far as a hardtop is concerned, any engineer will tell you that the protection afforded by that thin, unsupported piece of sheet metal is largely illusion.

The story of poor resale value is pure fiction. A check of the used-car dealers' book of *Official Used Car Valuations* shows that convertibles fare as well and sometimes better than other body types.

The champions of the soft top won't take much of your time just rebutting

arguments. They are likely to take it for granted that you know you can be just as snug and comfortable in a closed convertible during bad weather as in any other car. The point is not that it is just as good as any other for routine duty-driving, but that it gives new dimensions to the pleasures of owning a car, along with unsuspected practical advantages.

Proof of the pudding. Suppose you had bought that convertible. The first

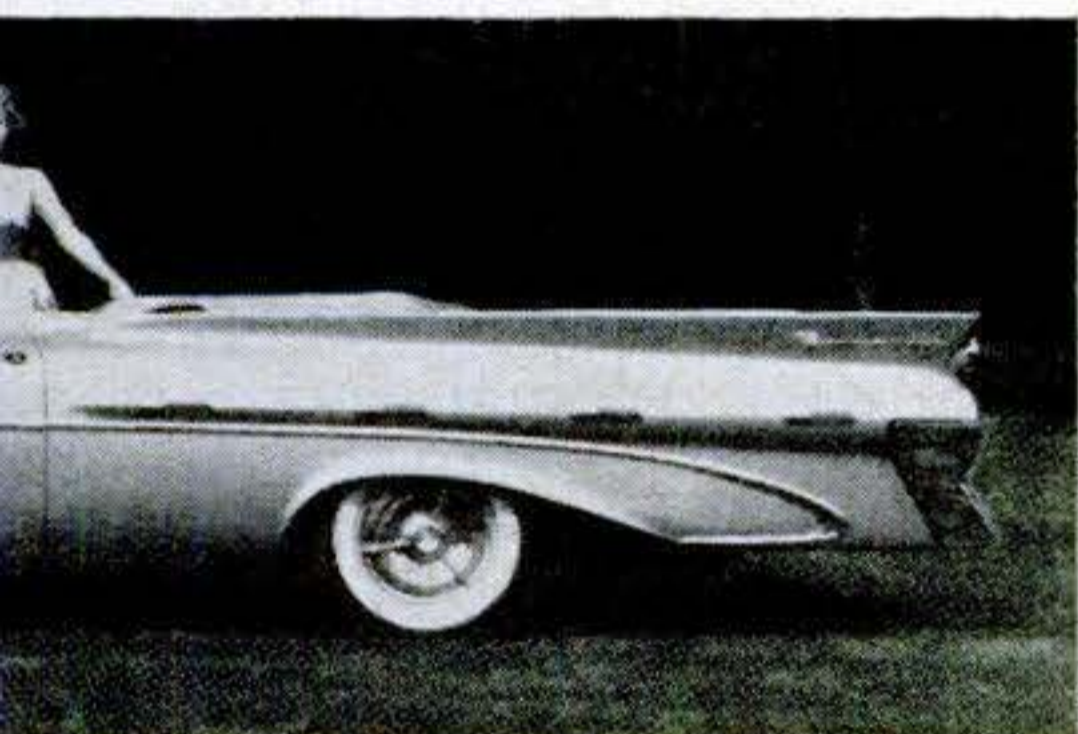
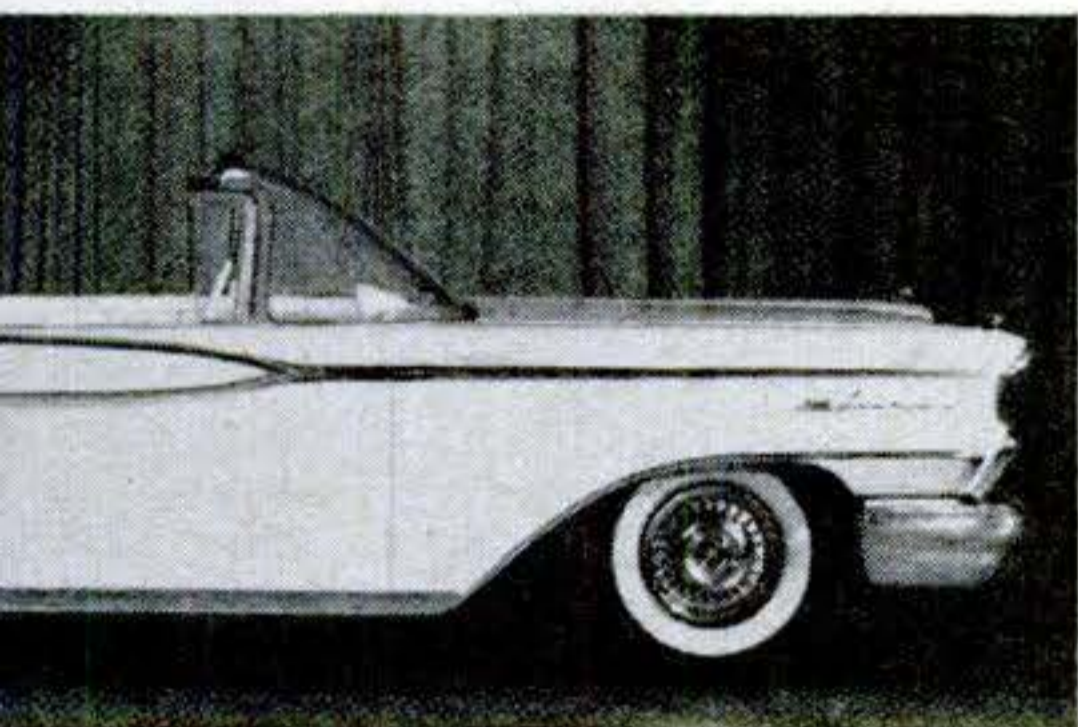
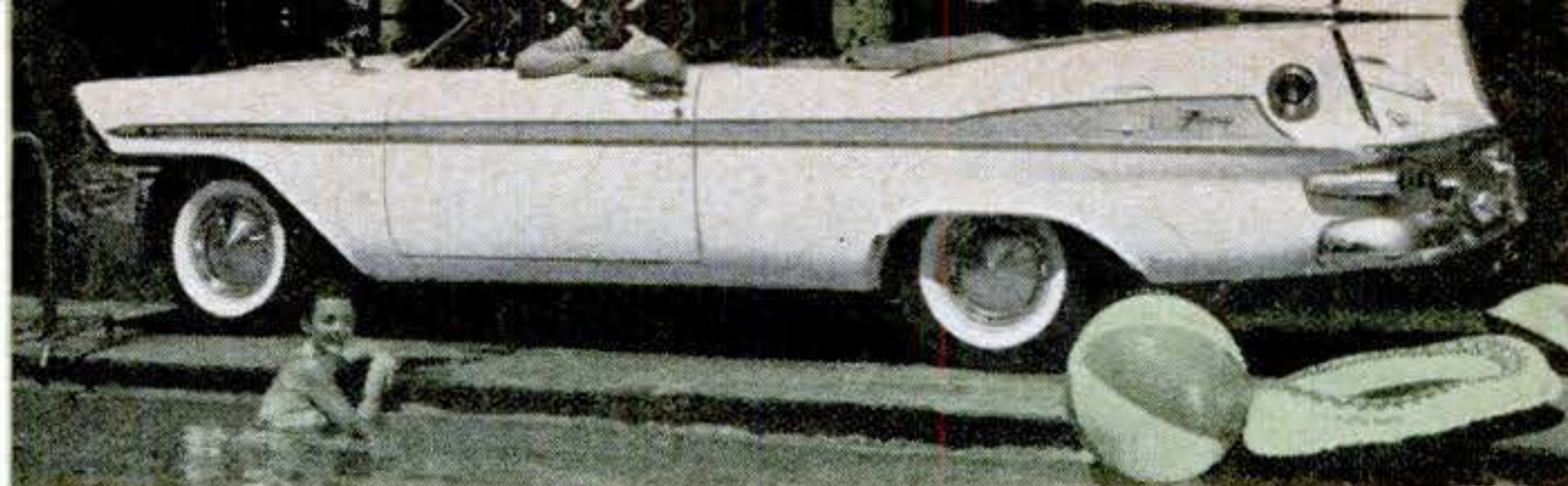

than five percent of the total, convertible sales have climbed from 2.9 percent in '56.

warm weekend in spring would probably find you, like other householders up and down your street, out early Saturday morning polishing your car. You'll be giving the paintwork a last loving swipe while your neighbor over the hedge is still laboring on the acres of sheet metal on his station wagon and your buddy across the street is just mounting a step stool to polish the roof of his sedan.

Snug the boot down over the folded top and you're ready to drive away in a

smart, trim car that many of your friends won't even recognize as the same car you drove all winter.

Count your blessings. First off, there's the matter of weekend errands for the wife—the cleaners, shoe store, post office, supermarket, newsstand, drugstore—perhaps a dozen stops in an hour's time. Shoehorning your way in and out of parking spots is no problem when you can see exactly what you're doing, and it is surprising how the bother of climb-

It's equally adept at more masculine chores. Toting big panels or long boards is a cinch.



ing in and out of a car disappears when you don't have to fold double to get out from under a roof. When you return to the car with arms loaded, there is no juggling of packages to free a hand for the door handle—just dump them over the side into the back seat.

It's equally adept at more masculine chores. Have a hurry-up need for a four-by-eight plywood panel? Just toss a couple of old cushions in the car and take off for the nearest lumberyard. With the cushions to hold the panel off the folded top and protect the paint on the rear deck, the panels will ride easily, placed lengthwise over the rear seat and out over the trunk. If it's long two-by-fours you're after, you can carry them safely even with the top up. Just unzip the back window and they can extend from the front seat to beyond the rear bumper.

If you're the boating type or have any other frequent need to haul a trailer, you'll find the open convertible gives you a rapport with that sometimes troublesome vehicle that makes maneuvering it a breeze.

Then there's the kind of furniture mov-



Auto ads scarcely soothe a Puritan conscience. They use convertibles as other advertisements use pretty girls.

ing that no family man can reasonably hope to avoid. Whether it's returning a baby carriage to Aunt Suzie, bringing home that bargain TV set from the discount house, or coping with the grandfather's clock that your wife simply couldn't resist at the auction, every family car frequently has to make like a moving van. The convertible does this more gracefully than most. Remove the rear seat and cover the top-elevating machinery with a piece of plywood, and you have the next thing to a pickup truck. With the top down, you can walk upright into the car with your burden or hoist it over the side. Headroom is limited only by low-hanging tree branches.

And amateur photographers will find that the top-down convertible gives them access to more different and exciting pictures than a police pass. Standing in a convertible, you can shoot over the heads of a crowd, get pictures from the middle of a busy street and grab shots from dozens of vantage points where you wouldn't be permitted afoot.

These are but a few of the hidden talents of a convertible—enough to soothe the Puritan conscience and satisfy the hard-headed practical man. But the real reason that the convertible appealed to you in the first place is that it promises an end to the humdrum monotony of carrying your own private little environment with you no matter where you travel. It lets all of your senses bring you the pleasures to be had in the going. The warmth of the summer sun, the cool of the mountain air, the sweet smell of honeysuckle, the salty taste of ocean breezes, the chuckle of a roadside brook, the rumble of the restless surf—no matter where you go there is a wealth of sensations that, added to the unimpeded view, brings quiet new joys to the pleasures of motoring. END



MAKE-DO BRIDGE. GIs in field training at Fort Hood, Texas, improvise from what they have. Above a pontoon is made of sticks lashed in pup-tent halves; at right rope and sticks make the tread.

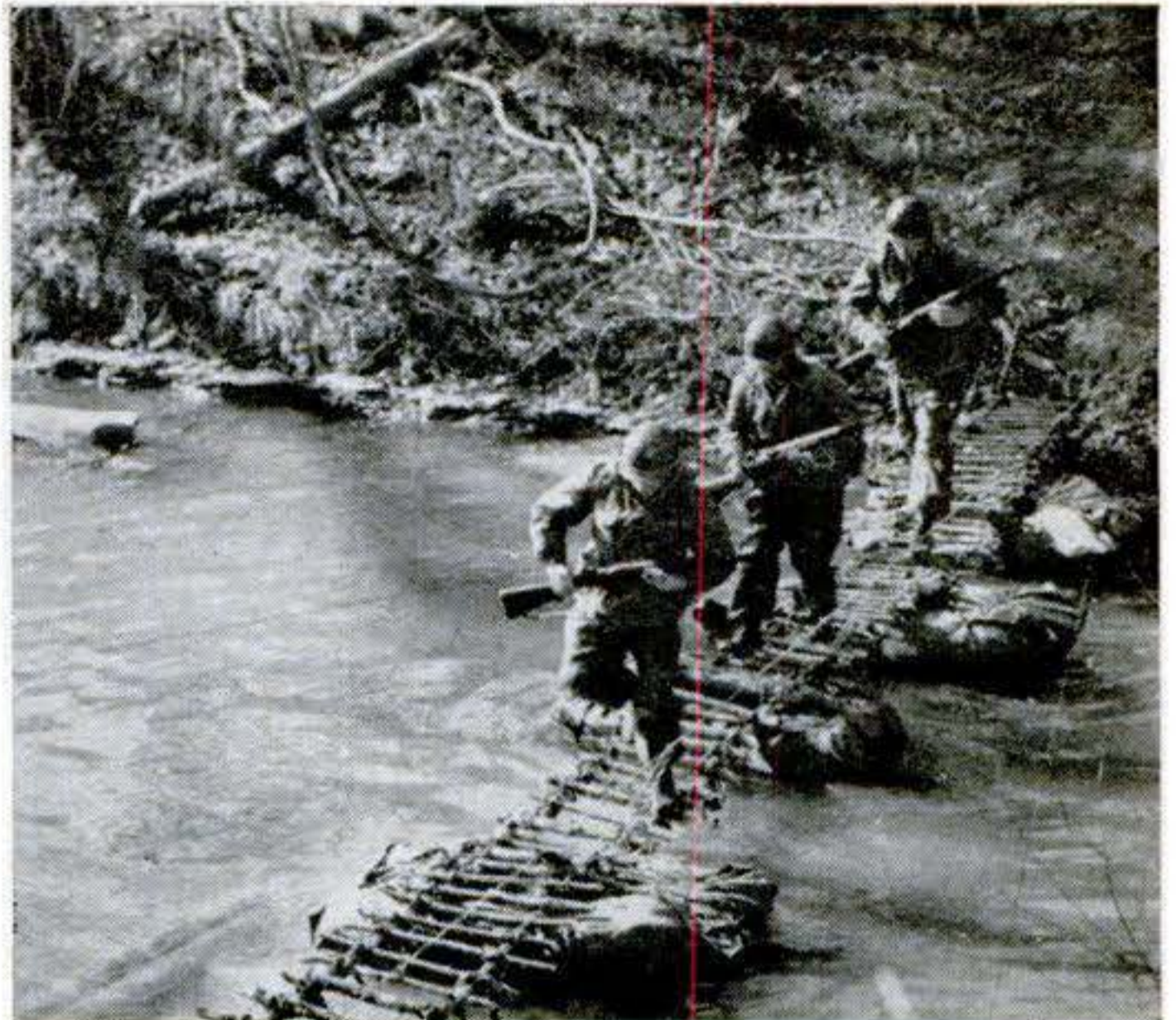

ROCKING SEAT. Passengers on Sabena's transoceanic jets will be tilted back horizontally with knees up so they can absorb shock and escape injury in case of a crash landing. The new seat, designed by a Sabena engineer, can be adjusted to any position for reclining or sleeping. A sudden impact will automatically tilt it all the way back.

PARIS IMPORT. The 1959 Vedette Beaulieu at right, latest in the Simca line, is a six-passenger, four-door sedan with a 106-inch wheelbase. Competitive with Lark and Rambler, the French car has an 84-hp. Aquilon V-8 engine, very similar to the old flat-head Ford V-8.

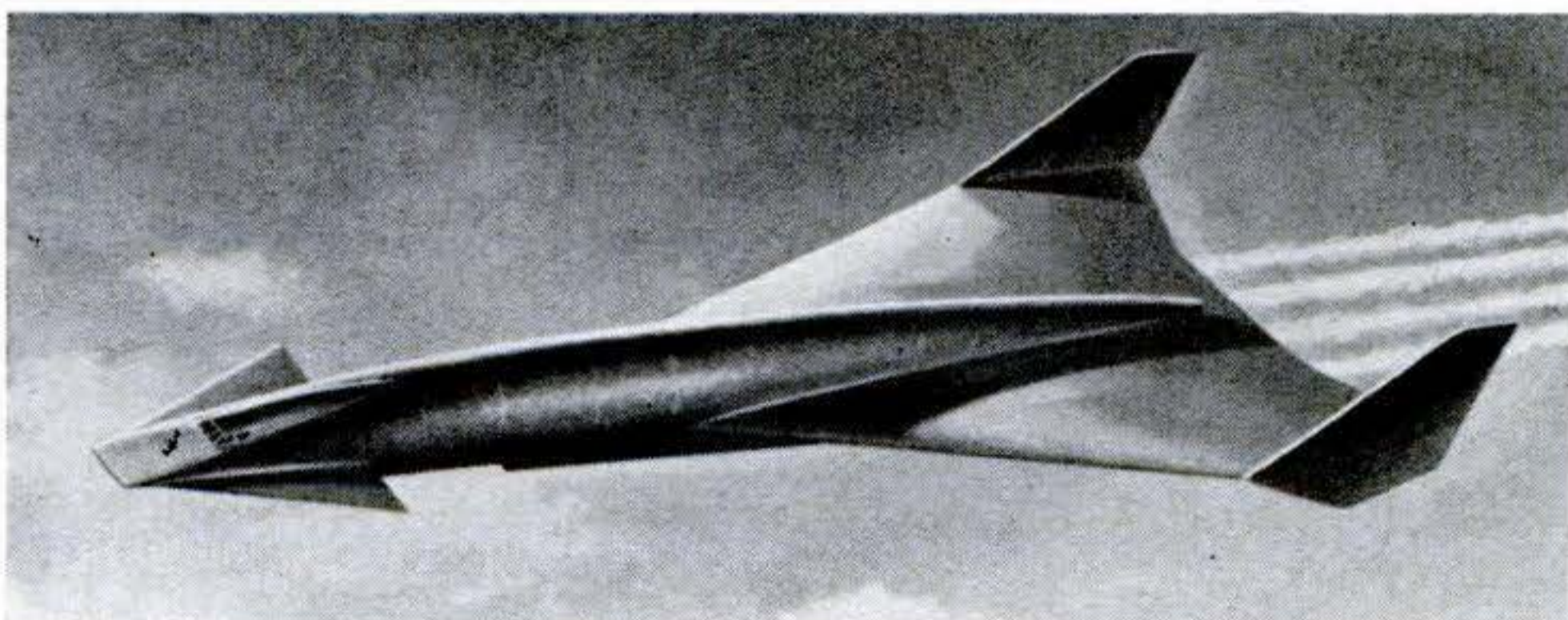
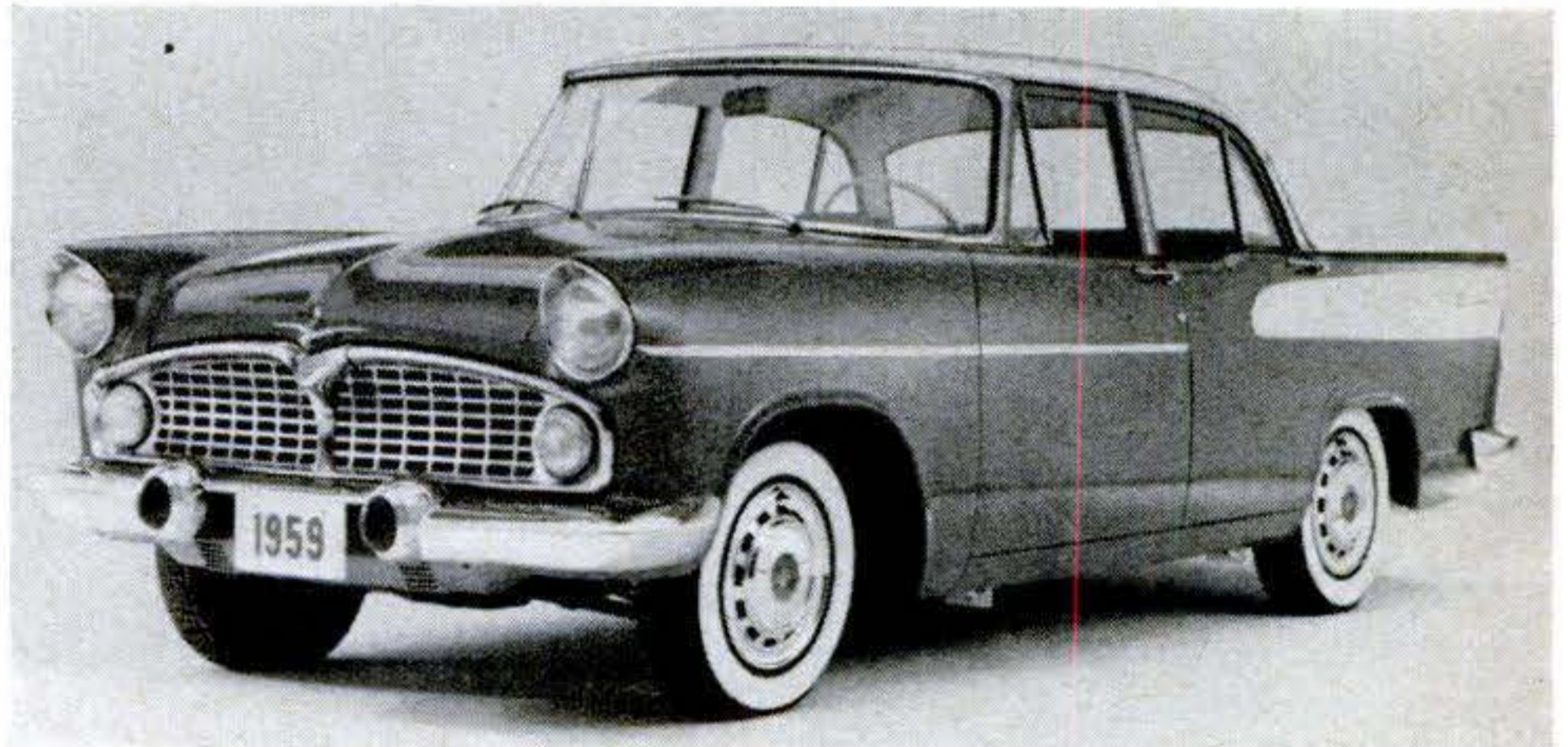

DREAM JET. This concept by Conqair of an airliner designed for 1970 would streak the skies 60,000 feet or higher at a speed three to five times as fast as sound. Various configurations are now undergoing wind-tunnel tests.

Discovery of cold cathode promises new electronic magic, including—

TV Tubes That Won't Burn Out



ICY BLUE GLOW is the hallmark of new cold-running vacuum tube, contrasting with red-hot incandescence of ordinary tube. Blue light comes from electrically "excited" atoms in cathode of

TANTALIZING electronic dreams are coming true fast because of a brand-new kind of vacuum tube. Unlike ordinary tubes, which run hot, this tube runs cold. That's the only big difference. But it means:

- Really portable TV sets—run by batteries.
- Radio and TV tubes that don't burn out, never have to be replaced.
- Lights, like fluorescents, but brighter and much longer-lasting.
- On-the-wall picture tubes for TV, very brilliant and as big as you want.
- Good portable radios much cheaper than present ones.
- A super-powerful amplifier that will make radios and TV sets perform far better with fewer tubes.

Coldness counts. The hot parts of present tubes burn out, like filaments in light bulbs. This is what usually happens when a tube goes dead in your radio or TV set. Cold tubes should last indefinitely; one experimental model is still going strong after operating continuously for a year and a half.

Just heating the hot parts of an ordinary tube takes most of the electricity that the tube needs. Cold tubes use only a tenth as much power and operate happily on small batteries. Their advantage over transistors is that they are easy to mass-produce.

The cold tubes clear both the bottlenecks that have been holding up truly portable TV:

1. Transistors for TV's high frequencies are difficult to make. High-frequency tubes are not.
2. Picture tubes (you can't make them out of transistors) draw a lot of power, requiring expensive batteries. You can make picture tubes out of the new cold tube, and their appetites are slim.

Cold tubes don't have to warm up, naturally, so they start working quickly ($\frac{1}{4}$ second or so) and can be made to start almost instantaneously (.001 second) by holding them ready with a trickle



**Electric attraction-repulsion
pushes electrons in cold tube**

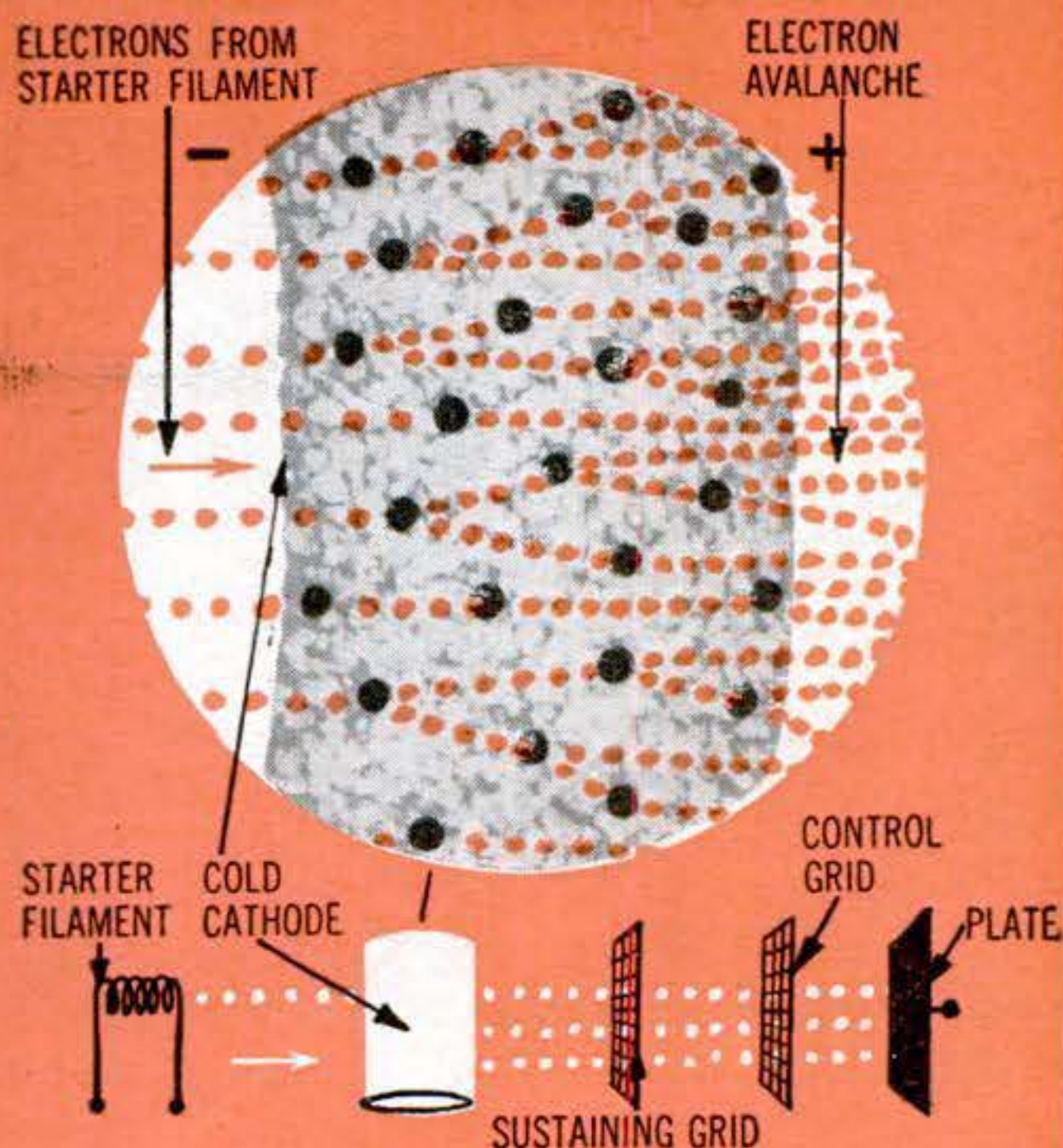

HOW IT WORKS: An electron from starter filament (which is hot) sets off avalanche of electrons inside cathode coating, and many electrons fly out. Loss of negative electrons leaves surface positively charged. This electric force, plus that from sustaining grid, keeps electrons flowing after starter filament is shut off. Tube then runs cold.

new tube, which uses less power, starts quickly and should last indefinitely. Both tubes above are audio amplifiers with their outside plates removed so you can see the cathodes.

of "keep-alive" current—only .00001 ampere. Quick starting is just a convenience in radios and TVs, but is important to gadgets like garage-door openers.

They're ready to go. The first of these handy vials of electrons was demonstrated only this winter. But Tung-Sol Electric, the Newark, N.J., tube and lamp maker that developed them from a Signal Corps discovery, said mass production could begin tomorrow on its regular machines—it's that easy. Actually, they won't be made in quantity until next year, when enough different types to outfit a whole radio will be ready. And then the military has first call for use in satellites and computers.

Kicking electrons loose. The new tubes, instead of boiling electrons out of a cathode with heat, pull the electrons off with electric force. The first models use some heat (from a filament) just for starting, but even that isn't essential—

hitting the cathode with other electrons, or shining a light on it, will also start it spewing electrons.

Dr. Dietrich Dobischek, the thin-faced Signal Corps scientist who stumbled on the cold tubes (yes, the discovery was an accident, but you'd have to be as expert as Dr. Dobischek to know when you've had this kind of accident), explains their operation this way:

Energy from outside—a flying electron, a ray of light or heat—knocks loose an electron inside the cathode (a thin, porous layer of magnesium oxide, the stuff in milk of magnesia). This freed electron starts an avalanche inside the material, knocking loose several electrons, each of which knocks loose several more. Many fly out of the surface of the cathode.

The surface loses so many electrons, which are negative electricity, that it becomes positively charged. This positive charge on the surface pulls more electrons from inside the cathode material (unlike charges attract, remember). So the avalanches of electrons continue, and



INVENTOR: Dr. Dietrich Dobischek of Signal Corps research lab at Fort Monmouth, N. J., discovered the everlasting tube "accidentally" while working on super-amplifier tube.

the cathode continues to emit a stream of electrons.

From that point on, the cold tube works like any other. But the fact that it needs no heat fits it for several new kinds of uses:

Flat picture tubes. The cathode, now unheated, can be spread out flat, as big as the picture area, then placed close behind the phosphor screen that glows with the picture. A wire grid near the cathode would make it emit electrons in the shape of the picture. The stumbling

block, which keeps on-the-wall TV in the dream stage, is control of that grid.

Lamps. These would be tubes coated with whitish phosphor. A long cathode running down the center would emit electrons that make the phosphor give off light.

Super amplifier. The cold cathode also looks like the missing piece to the puzzle of the secondary-emission amplifier, an always-promising but never-quite-successful idea that has been kicking around the labs for years. It is a vacuum tube with two (or more) cathodes, the electrons from the first triggering an electron avalanche from the second. The trouble has been that parts of the hot first cathode evaporated off onto the second and "poisoned" it, a difficulty which obviously is eliminated by cold cathodes.

The big advantage of this super tube is not simply that it can do the work of four or even 16 present amplifiers (as it can). If you gang ordinary amplifiers, each tube adds its own noise to the output. (Noise is the natural variation of electron flow that you see as "snow" in a TV picture or hear as a hiss in radio sound.) The super tube multiplies the amplification without multiplying the noise. This means a sharper TV picture and clearer radio program as well as a big saving in the number of tubes that sets need.—*Martin Mann.*



BIG GUN. This oversize replica of a Winchester rifle calls attention to a new sports shop near Burlington, Vt. Made of sheet metal to exact scale by a local tin-smith, it's 32 feet long from muzzle to butt and mounted on iron pipes.



MULTI-JET TRAINER. The four-engine swept-wing jet above was developed by McDonnell for the Air Force for use as a low-cost trainer and transport. It has a range of 2,500 miles at 550-m.p.h. cruise speed, performs like a big bomber.

"I'd like to see them make..."



A DUAL-PURPOSE CARPORT. With oversized plastic sprinkler hose on the enclosed side and along the roof, the carport could double as a home car wash.—*Tom Rizzo, Brooklyn, N. Y.*



A LAWN ROLLER WITH TWO OPENINGS. A drain on one side and an air intake on the other, both with plugs, would make emptying a roller faster and easier.—*Joseph P. Izzo, Providence.*

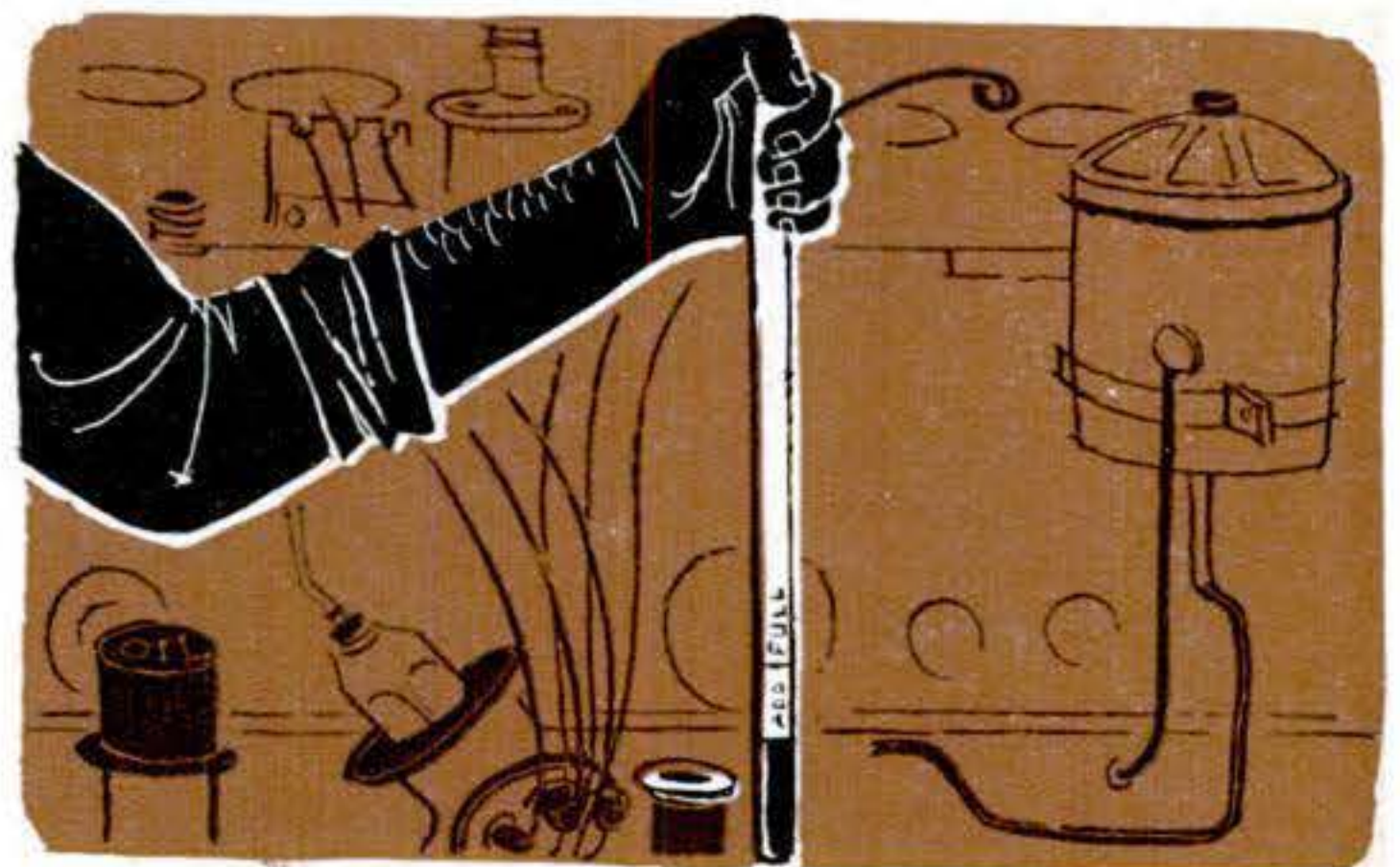

A TUBULAR DIP STICK of clear plastic. You'd use it like a pipette to check oil level: Insert it, put a thumb over the top and lift out a slug of oil for an easy reading.—*A. P. Connor, Baltimore.*

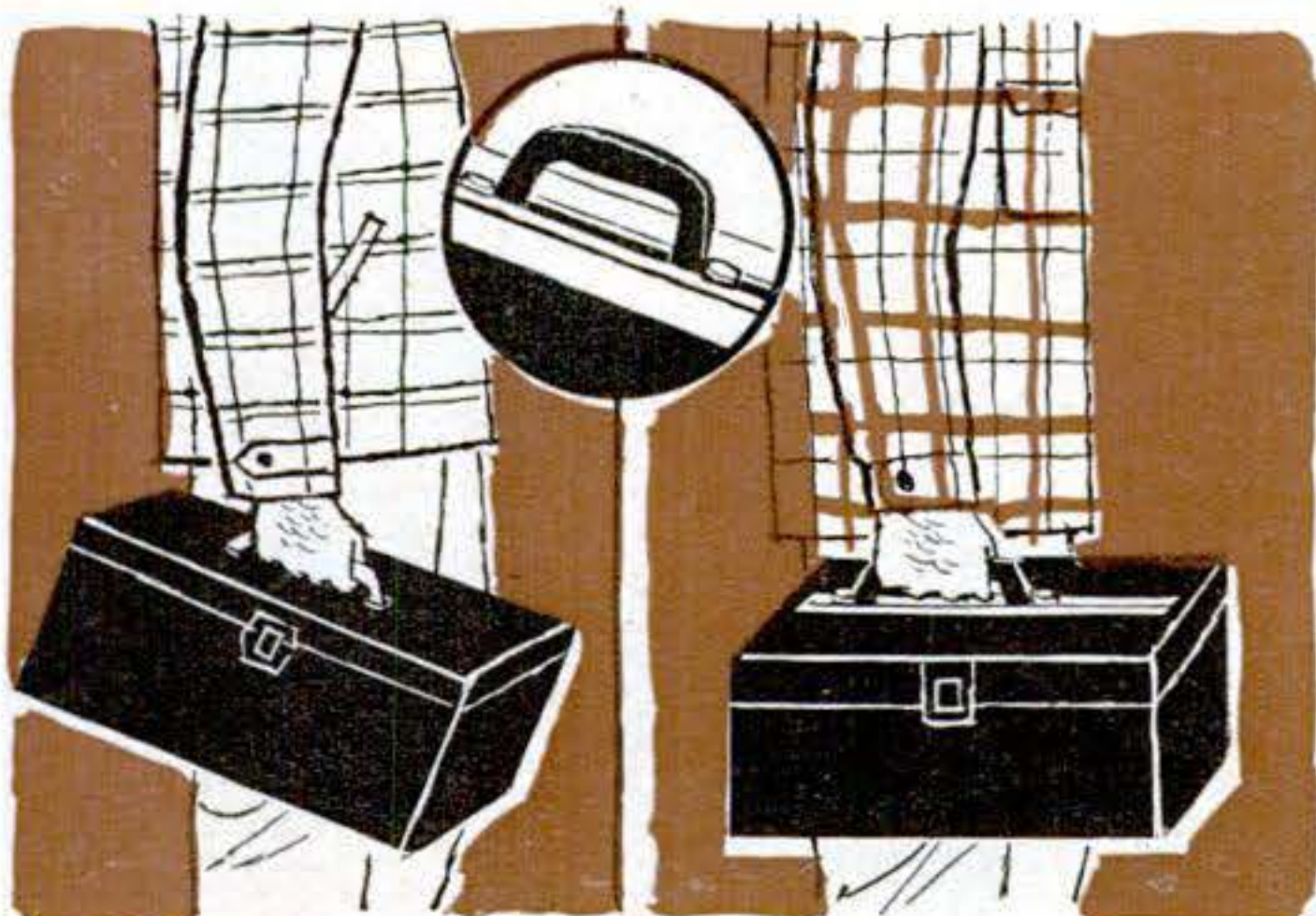

A TOOLBOX WITH A SLIDING HANDLE. To balance an off-center load, you could move the handle along tracks on the top and lock it in the new position.—*Joe Burke, Bay Port, Mich.*



ALUMINUM-RIBBED BOATS IN KIT FORM. The metal ribs could be bolted to plywood, eliminating screws that so frequently pull out or break off.—*K. N. Croshier, Poughkeepsie, N. Y.*

Everyone has his own pet idea of a gadget that he would like to see in general use. The five ideas illustrated above were suggested by POPULAR SCIENCE readers. What's

yours? We will pay \$5 for each one published. Please use Government postcards only. Write name and address clearly. Contributions cannot be acknowledged or returned.

The Delicate Job of Launching a Ship

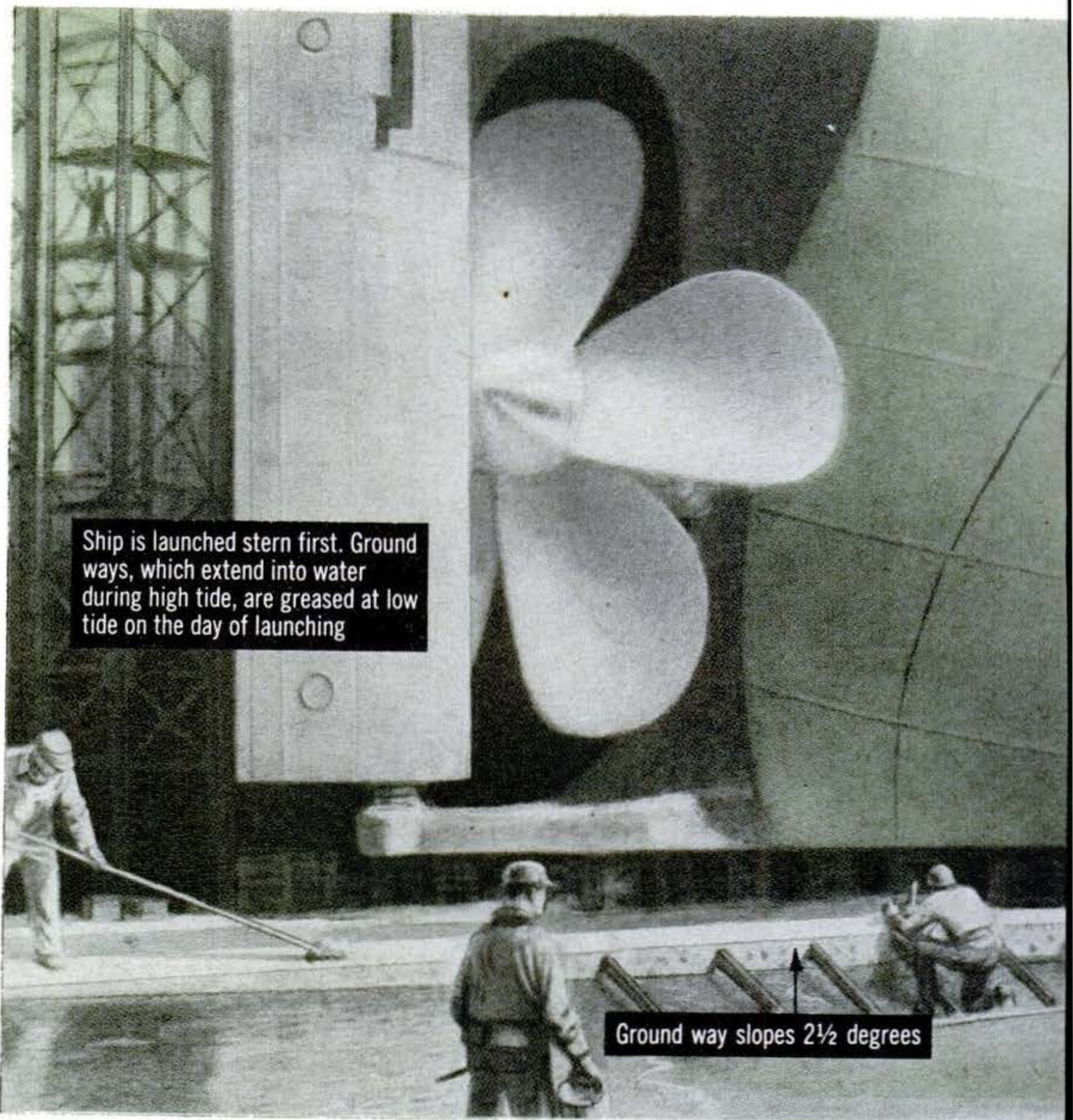
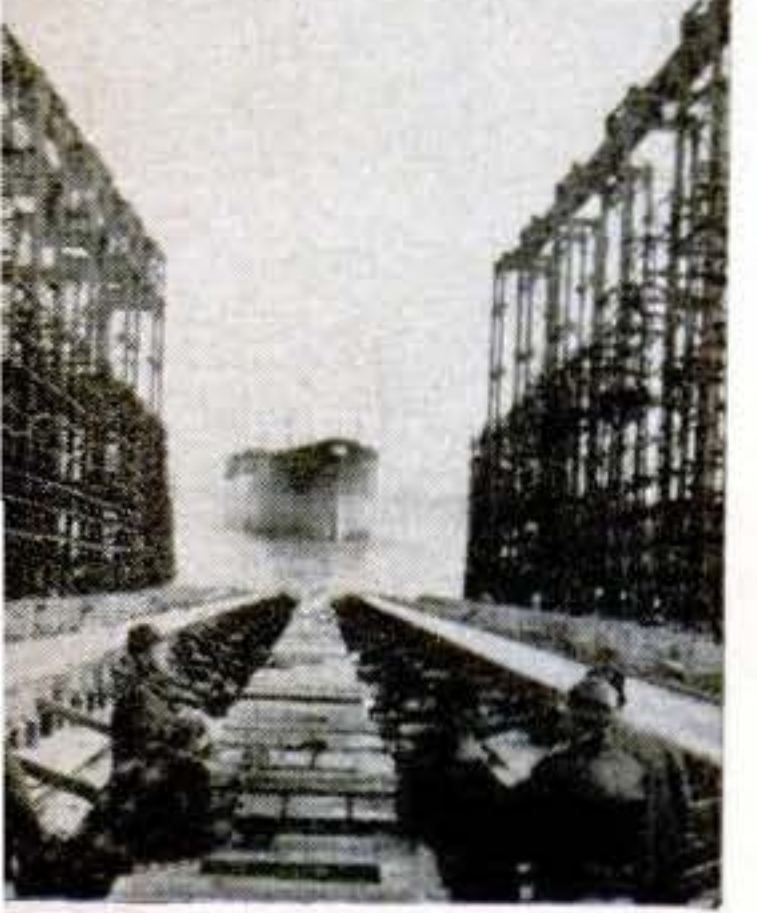
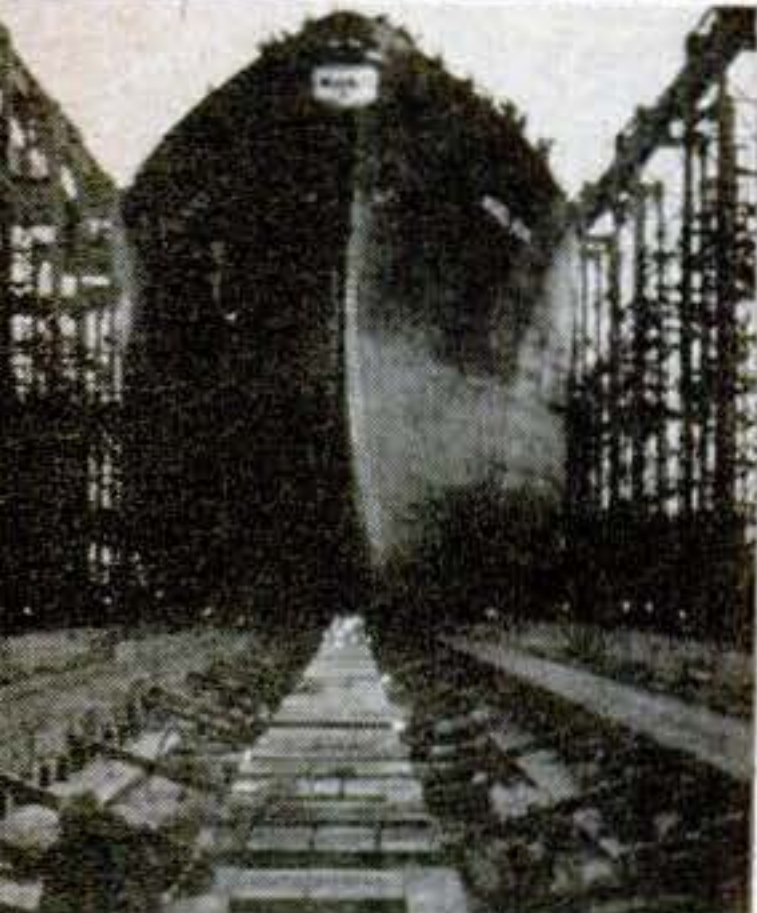

Ship is launched stern first. Ground ways, which extend into water during high tide, are greased at low tide on the day of launching

Ground way slopes 2½ degrees

Shift from construction supports to launching ways is the big job

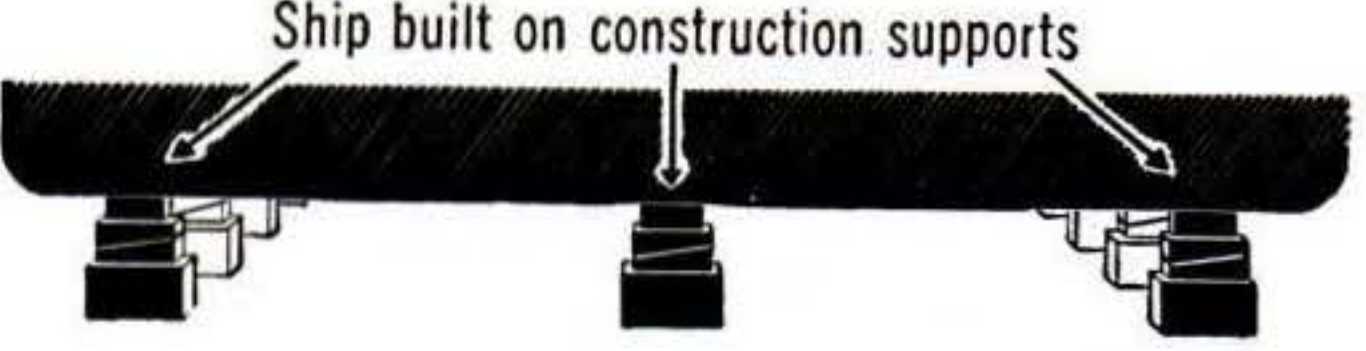

1

When a ship slides down the ways, it's hats off for the men who did the job. It takes brains, brawn—and oceans of grease

By Herbert O. Johansen

AT 4:10 in the afternoon, a bottle of champagne was broken over the bow of the 30,000-ton Mobil Aero at the Sun Shipbuilding and Dry Dock Co., Chester, Pa. The great hull slid slowly and majestically down into the Delaware River.

Below the flag-draped sponsor's platform, along each side of the more-than

600-foot stretch to the river's edge, stood a hundred-odd weary men in work clothes, many with their safety helmets and hats doffed, a silent prayer on their lips. They knew that it takes more than a bottle of sparkling wine to launch a big ship. That dramatic moment was the payoff for an agony of work and planning.

Preparations began a month before when the launching ways were installed under the hull, between construction sup-

A keel's-eye view of what goes on under the hull of a ship on launching day

The weight of the ship is transferred, from the hundreds of supports—shoring timbers and keel blocks—that held it while it was being built, to the launching ways. When this has been done, the hull is wedged into a sled consisting of parallel wooden sliding ways running the length of the ship, and wooden cradles that have been built up fore and aft to conform to the curved sides of the hull. When the ship is released, this sled, gripping the hull, slides down on top of greased ground, or permanent, ways. Three-inch lips on the outer edge of each ground way keep it on the track. As the ship floats free, ground-anchored snubbing cables pull away the launching framework, which is recovered and used again.

[Please turn the page.]

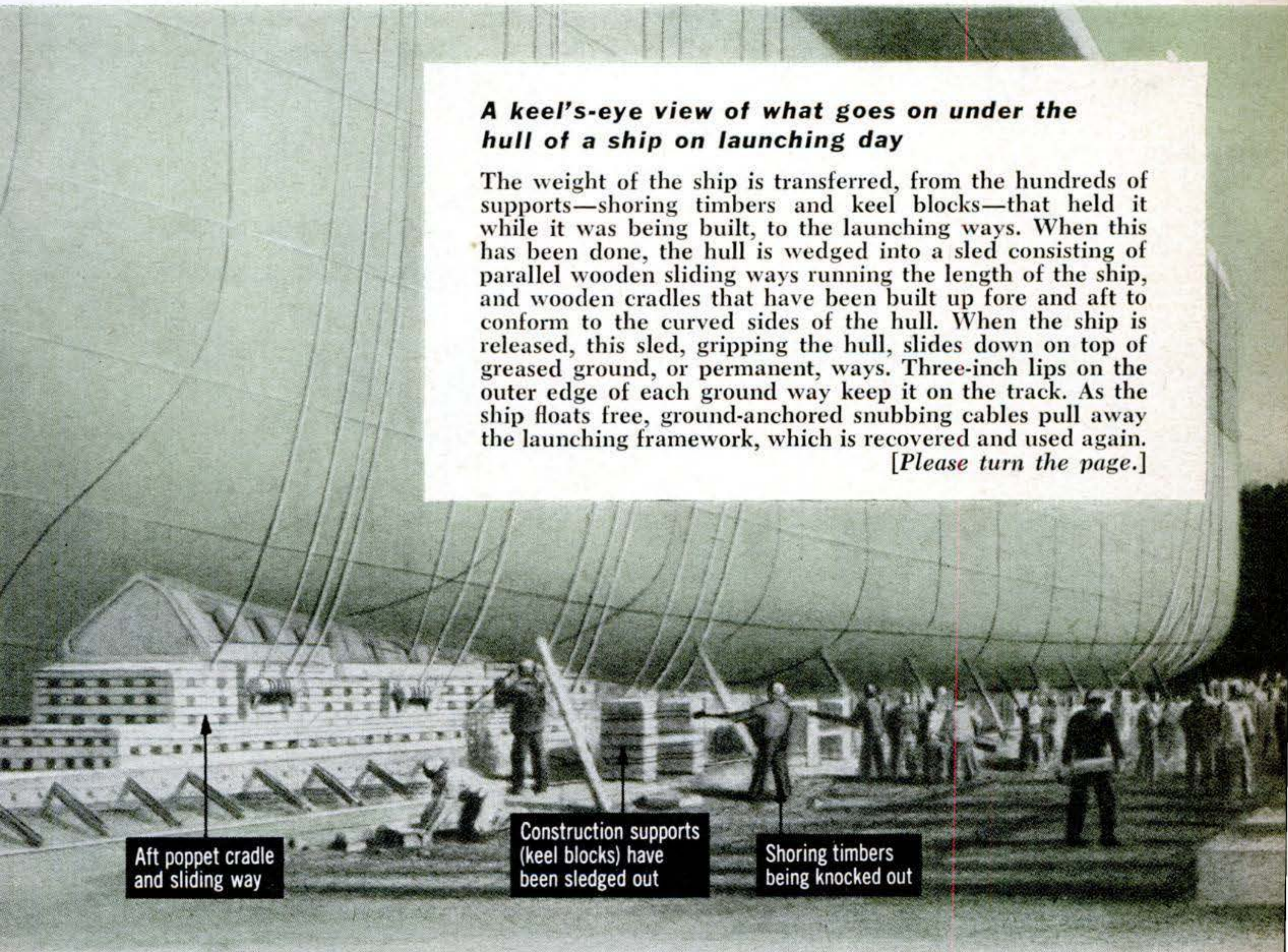

Aft poppet cradle and sliding way

Construction supports (keel blocks) have been sledged out

Shoring timbers being knocked out

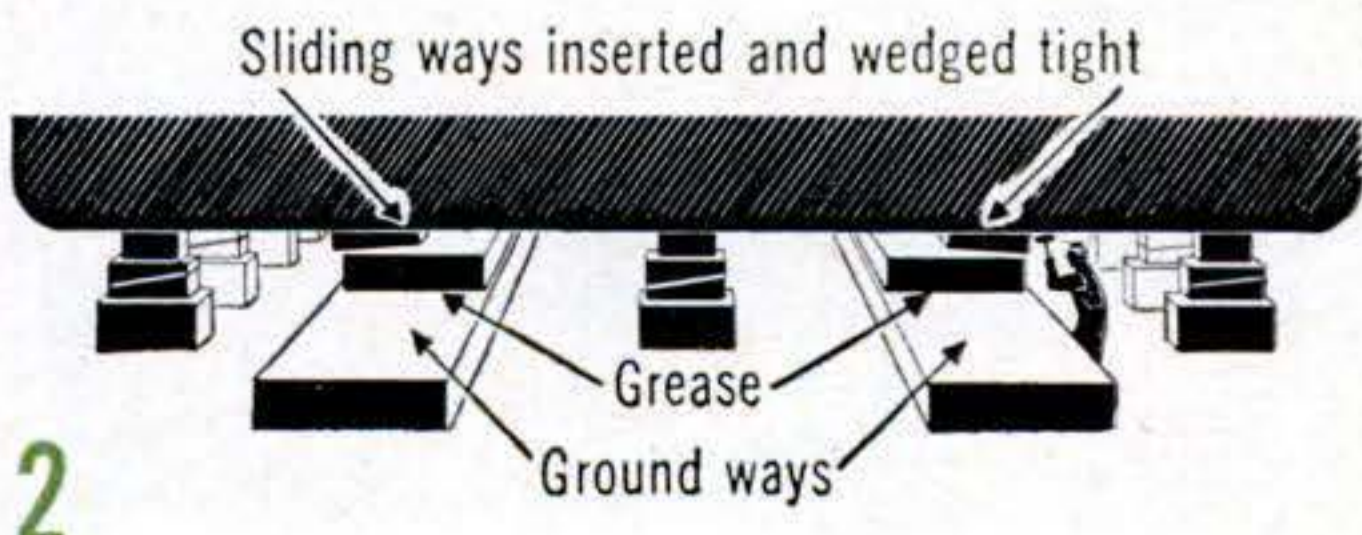

2

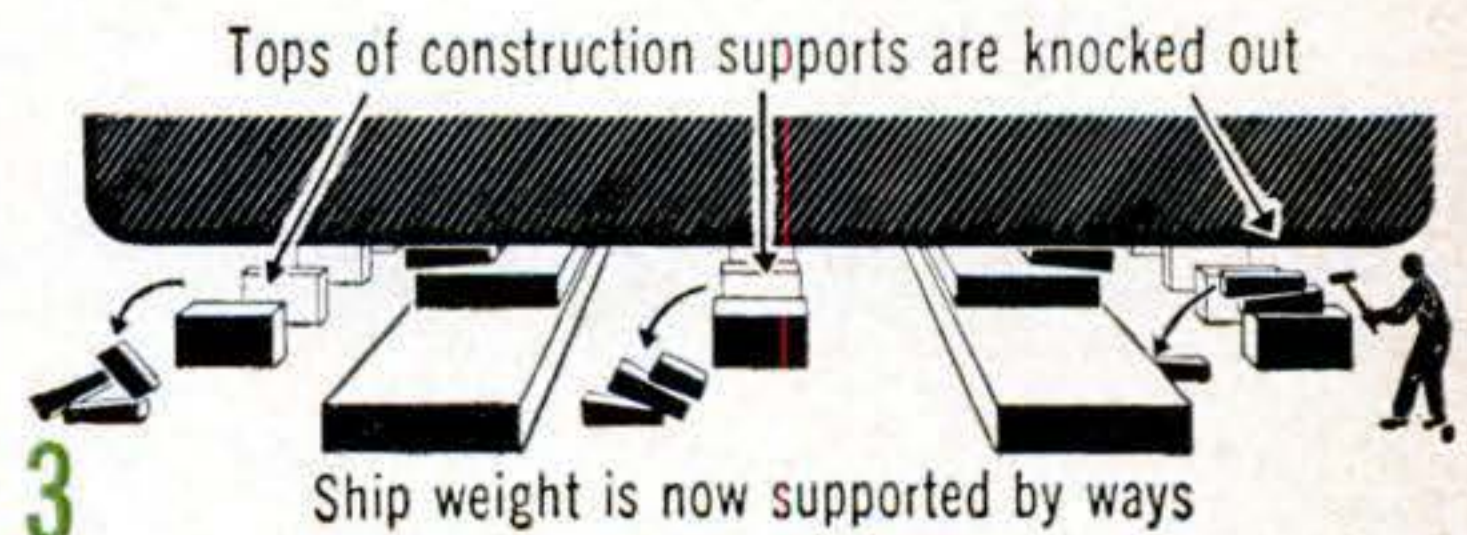

3



1 AS THE TIDE EBBS LOW, about seven hours before the slack of high tide when the ship will be launched, ground ways that extend into the river are greased. On the wood planks, previously dried by gas torches, a base coat of hot grease is poured from buckets and spread with brooms. Over this a slip coat of lighter grease is applied by hand (above, right). All launching-day activities are carried on simultaneously on both sides of the ship's hull.

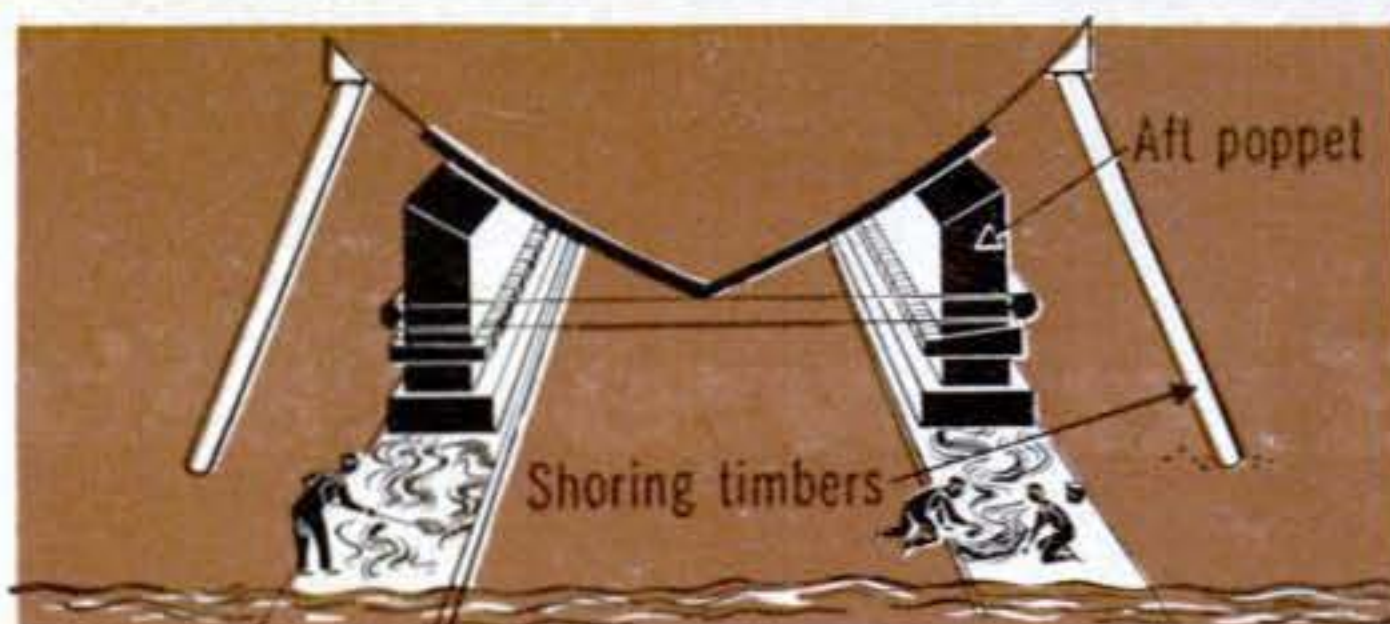

3 SHORING TIMBERS are another construction support. To remove these, welded metal clip plates at the hull end are burned off by acetylene torch. Some timbers can then be sledged out; stubborn ones call for battering rams. After chipping hammers have removed weld residue (not shown), "scars" are covered by three quick-drying primer coats and one red finish coat. Paint rollers do the job quickly.





2 AT THE SAME TIME, work starts on knocking free hundreds of under-hull construction supports that have taken the weight of the ship during building. These are called keel blocks. Here a tie bolt holding together the top unit of a keel block is loosened (left), then sledged out (right). Construction supports are knocked out according to a precise timetable so that the 18,000,000-pound weight of the hull is transferred evenly to the launching ways.

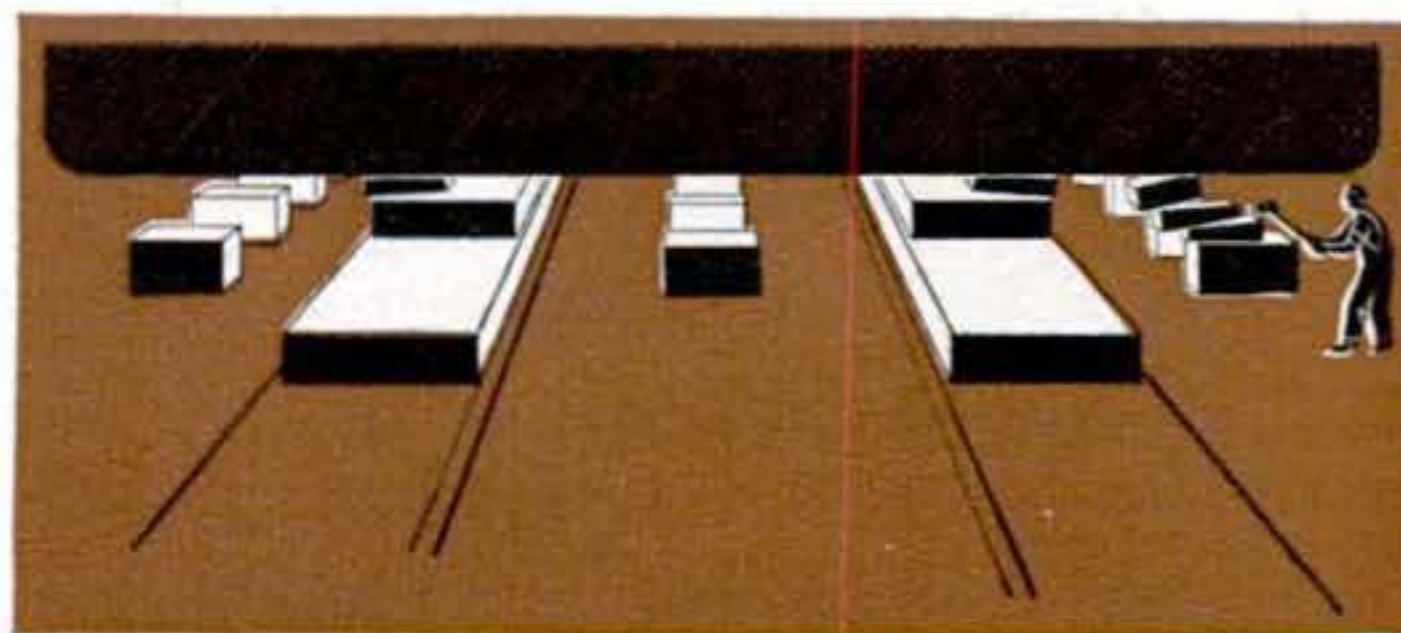

ports. The hull of a ship never touches the fixed ground ways, made of parallel planked tracks, underneath. Instead, it rides on a sled—sliding ways with wooden cradles (poppets) fore and aft—that on launching day is wedged to grip the hull tightly.

The ground ways are made of heavy white oak and pine in 40-foot lengths, 53 inches wide and 14 inches thick. They are bolted together to form tracks on either side of the keel. These ways are

dried with gas torches and then coated with hot, liquid grease. This hardens to a five-eighth-inch thickness. Over it is put a slip coat of lighter grease that stays soft.

Then the sliding ways, 49 inches wide, 18 inches thick, and also in 40-foot lengths, are laid on top of the ground ways. Wedges, 24 inches apart, are inserted between the sliding ways and the bottom of the hull. Just before launching these are rammed in.

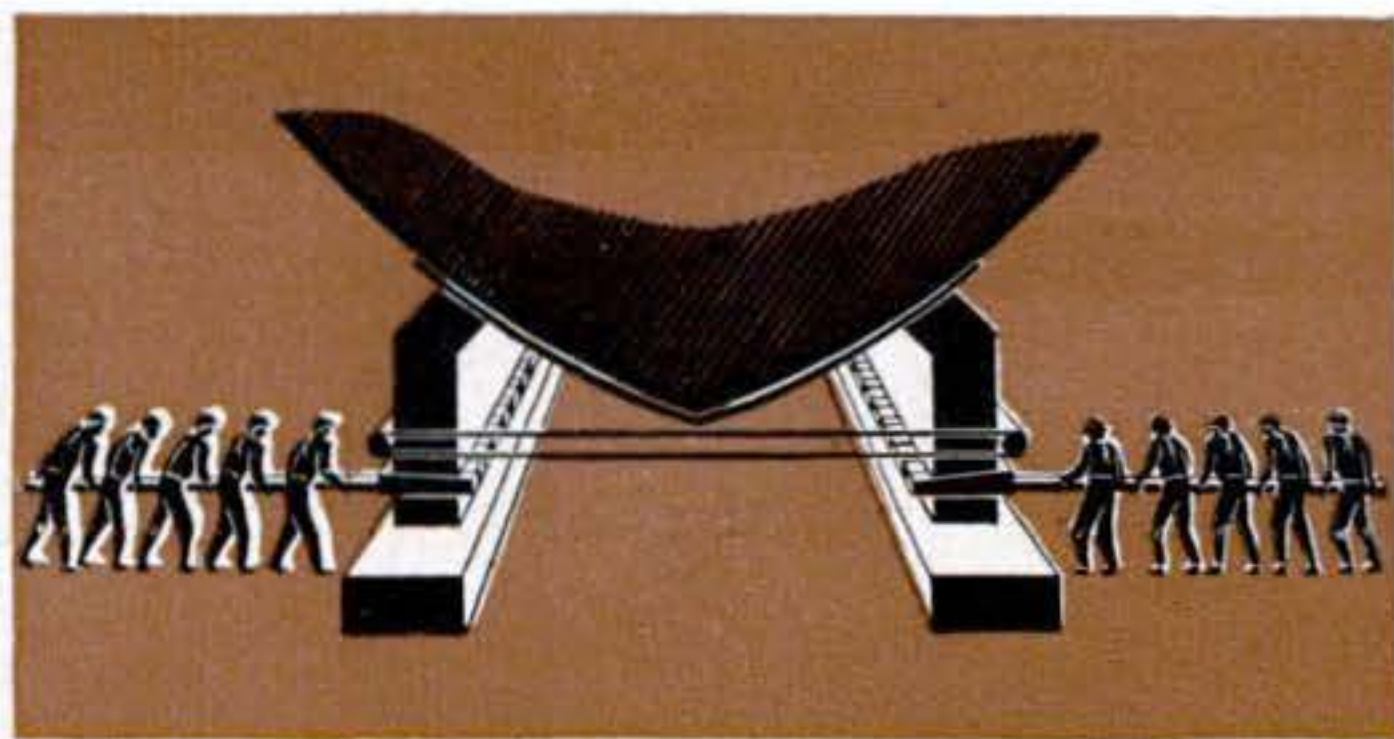

4 AS THE WEIGHT IS TRANSFERRED from the construction supports to the launching ways, 15-man ramming crews hammer in wedges that tighten the sliding ways and the fore and aft poppet cradles to the hull. These form a double-runner sled on which the ship will go down the ground ways. [Please turn the page.]

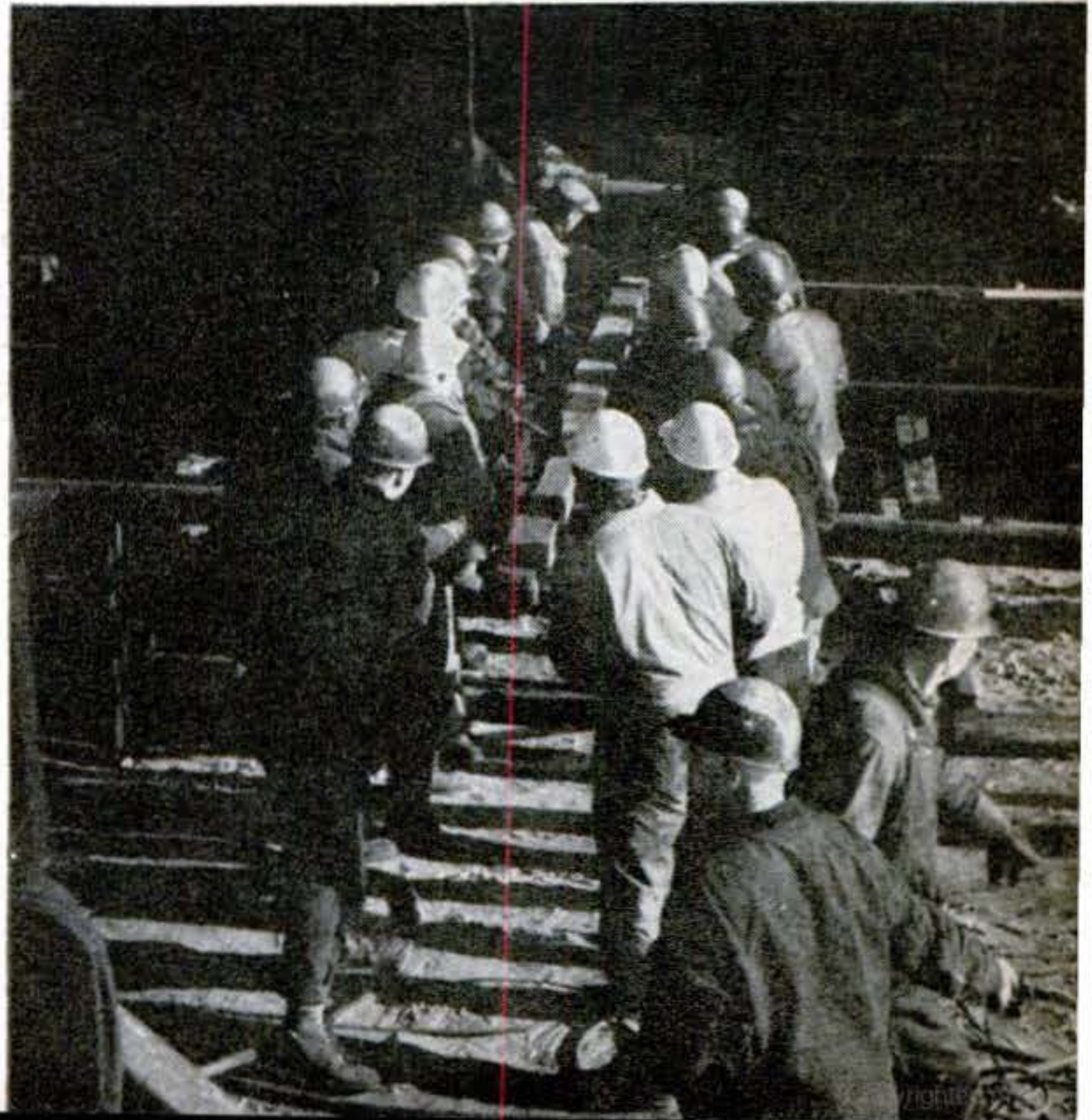

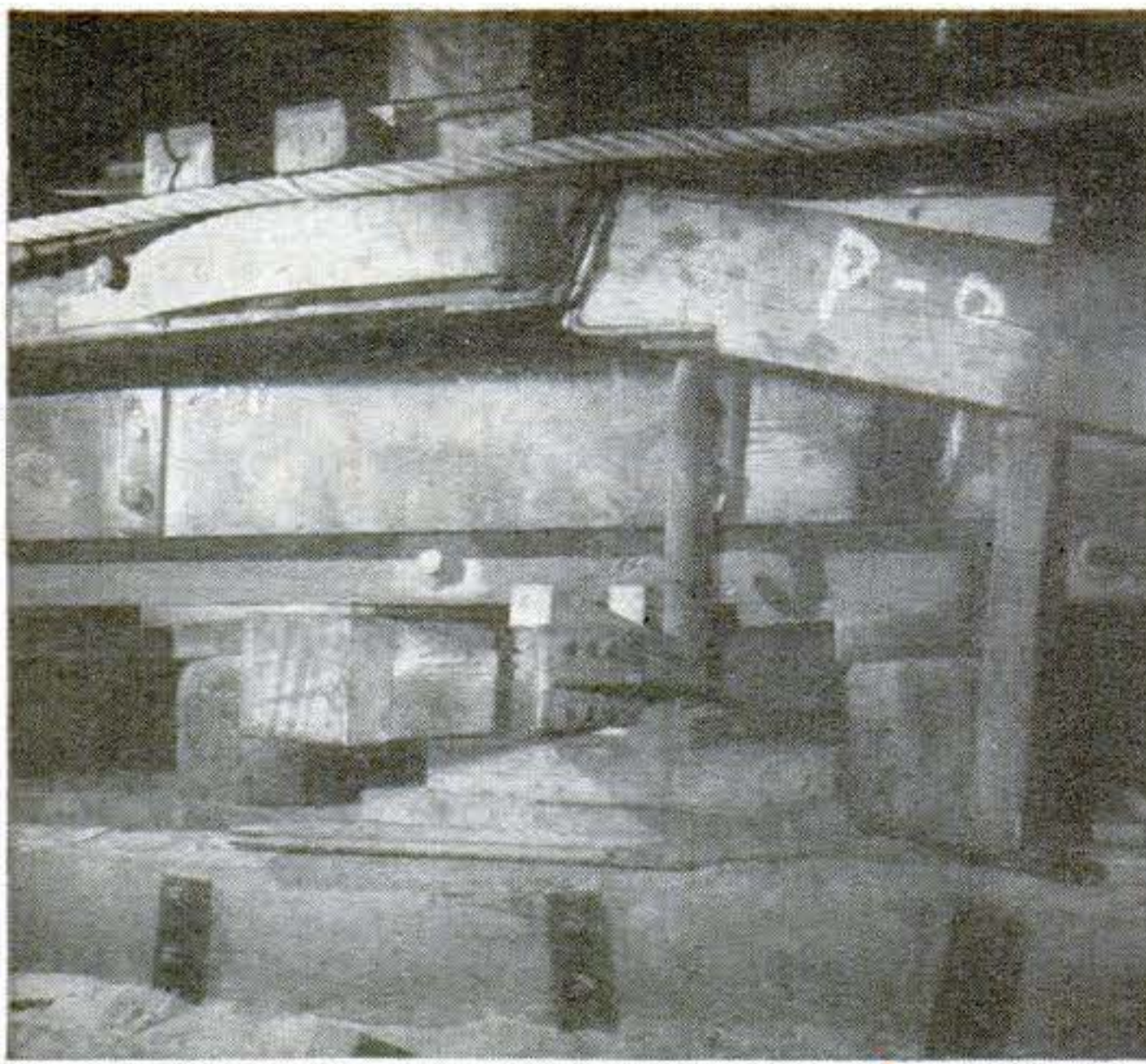

When the ship slides down the greased ways, its hull is snugly cradled in a launching sled

5 LAST CONSTRUCTION SUPPORT has been knocked out, leaving only "trip" shores amidships (heavy timber set at angle in photo left). Notched into the upper half of the sliding ways, they act as parking brakes to restrain the now almost-free hull. At five minutes before launching, ramming gangs knock out steel pins that hold the trip shores, which drop (right). Now only two steel plates at the bow keep the ship from sliding down the ways.

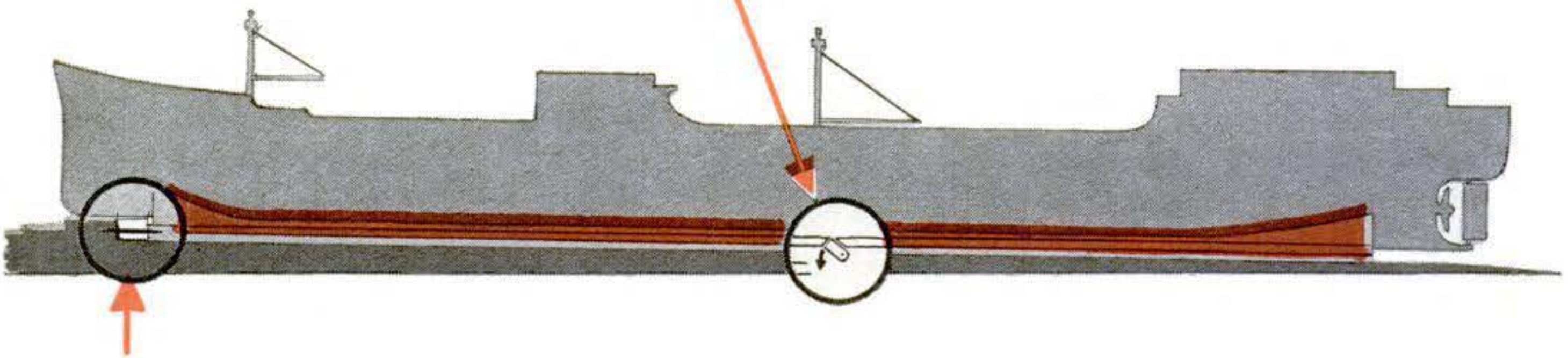

6 LAUNCHING SLED gripping the hull is held only by two steel cut-off plates, which are anchored in concrete. Torch-burning of the plates by teams at either side of the bow is split-second timed so that both break off at the same instant. The ship is launched. END

.....

Supertankers Are Ocean Giants

.....

RIVALING in size the largest ocean liners afloat are the new supertankers that carry crude oil from oil fields and pipe-line terminals throughout the world to refineries. Although the 641-foot-long Mobil Aero, newest ship to join the Socony Mobil fleet, is not the largest of these, it is a \$10,000,000 giant. With a cargo capacity of 30,000 tons, it can take on 251,000 barrels of oil. Its speed of 17.5 knots (20 m.p.h.) is greater than that of standard tankers with less than half the cargo capacity. Only three additional crew members are needed, for a total of 58.

.....



"AIRBORNE" GAS STATION. Built by an ex-Air Force man who liked the atmosphere of a cockpit, this masonry version of a plane in Cincinnati looks as if it is poised for a takeoff. It first carried full wings, but they were stubbed when they proved low bridge for big trucks.



CAR-TOP BED. Two can sleep in comfort in the double bed atop the car above without the bother of setting up a tent at camping stops. It folds flat and stays on its perch for highway travel. It's the invention of a British trailer dealer.

HALFWAY HOUSE. At Oberwesel, Germany, when highway builders found the house at right in the way of a new roadbed, they lopped off half. The rest was left standing for temporary lodgings while the family hunted a new home.

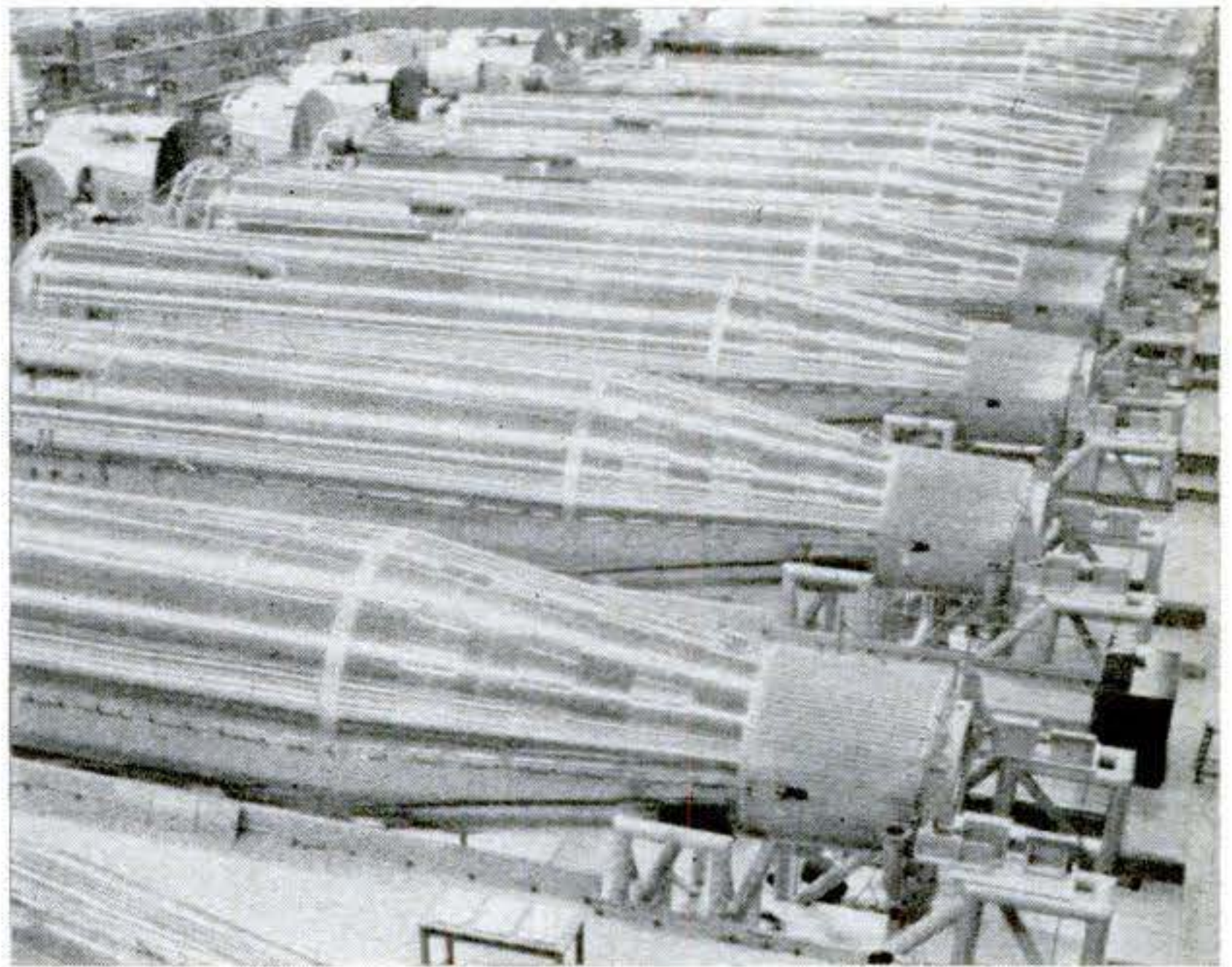

ATLAS PRODUCTION LINE. Air Force intercontinental ballistic missiles are assembled here before delivery to test sites and operational squadrons. The 75-foot stainless-steel rockets rest in test racks at Convair's San Diego plant.



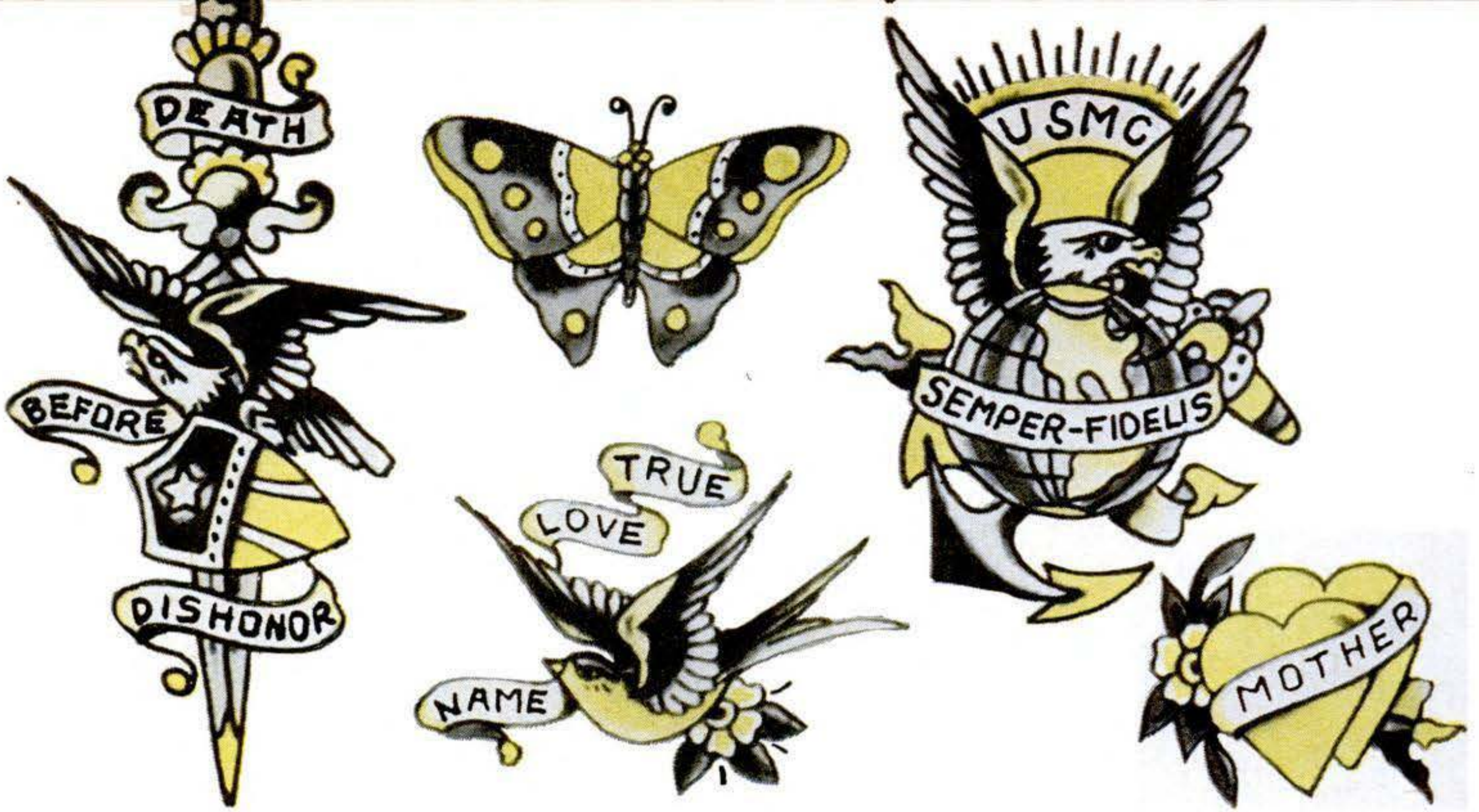

How Tattoos Help

Unique file of more than 90,000 designs often leads
 Los Angeles police to decorated criminals in a hurry

By Sam Lynch

THE other day, a motorist near San Francisco gave a hitchhiker a lift—only to have the ingrate take his car and money at knifepoint.

The police soon found the car abandoned. But the chances of capturing the culprit were slim, they pointed out. All they had was a general description, which would fit innumerable people, and the curious fact, noted by the motorist, that the hitchhiker had a tattoo of Felix the Cat on his right wrist.

That tattoo, as it turned out, was quite enough to trap the criminal.

The San Francisco police had sent out an all-points teletype containing all the information they had about the hitchhiker. One of the points notified at once was Los Angeles, whose police department has a most remarkable tattoo file. No other law-enforcement agency, except possibly the FBI, is believed to have anything like it in size and scope. In the file, every tattoo found on the more than 200,000 people arrested by Los Angeles police each year is described and indexed, along with all available informa-

tion about the wearer. The file also lists tattoos mentioned in wanted-person bulletins from other parts of the nation.

The ability of this file to identify a criminal promptly—if he or she has a record and a tattoo—can be amazing.

It outdid itself in the speed with which it helped nab that hitchhiker. For there in the file were a description of his tattoo and its location, a picture of him, evidence that he had a criminal record, and his address. Almost too patly, he lived in Los Angeles! So the police were waiting for him when he got home.

On another occasion, a Los Angeles store detective caught sight of a shoplifter at work. The thief managed to slip away, but not before the detective had spotted a tattooed star on the back of the man's left hand. The detective telephoned the police. They checked their tattoo file, and shortly arrived at the store with photographs of several petty thieves, each sporting this particular tattoo. The store detective identified one as the shoplifter, whereupon the police drove to the latter's house and arrested him.

L-O-V-E. It is not usually that easy. More typical was the case in which Los

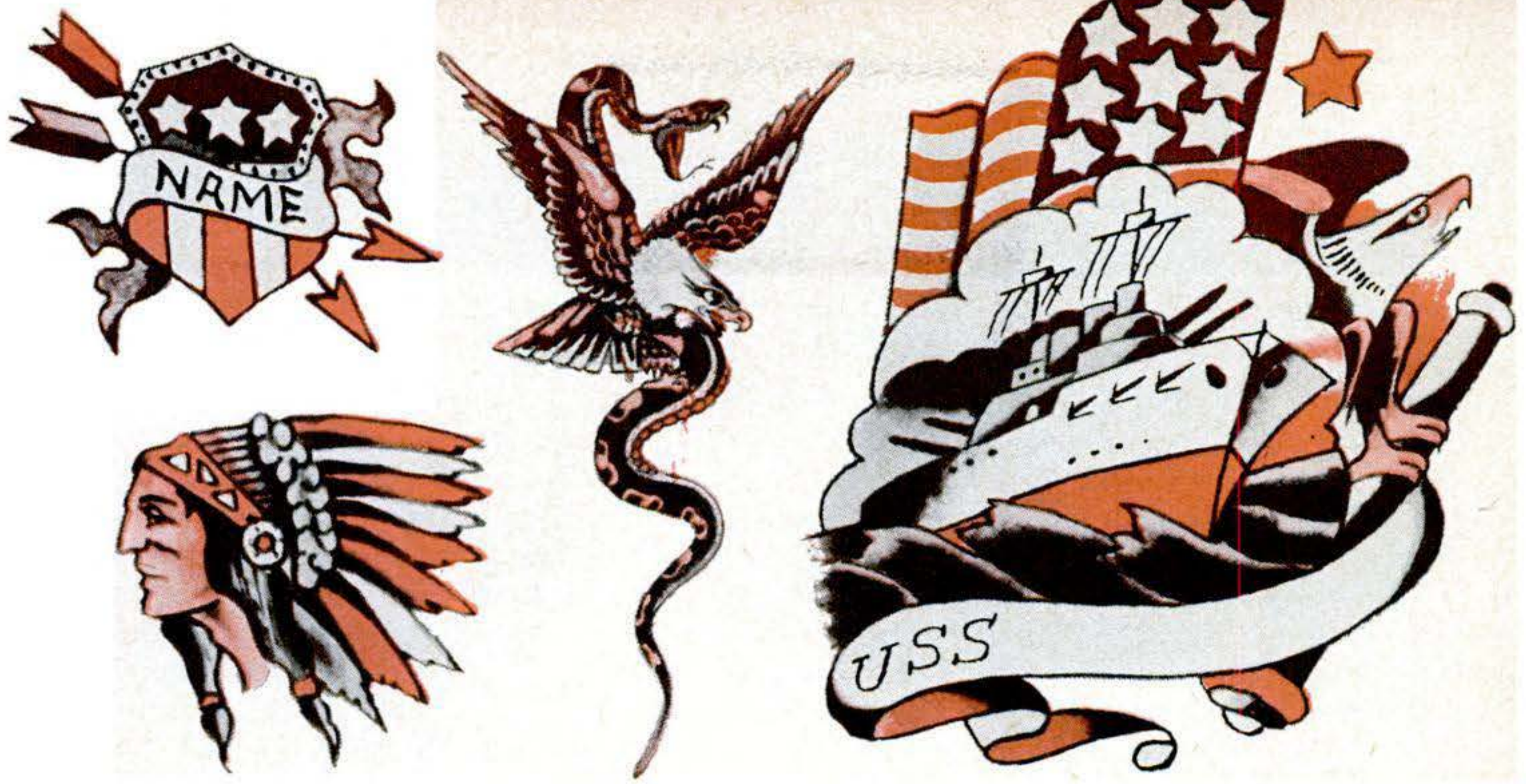

Cops Catch Crooks

Angeles and Mexican police were harassed by a ring of auto thieves who were stealing cars in Southern California and driving them into Mexico to sell. Finally, the Mexican police came up with a clue. The ringleader had L-O-V-E tattooed across four fingers of each hand, one letter to a finger.

This is a fairly common tattoo, and the L. A. file produced a dozen suspects. Gradually, the police eliminated all but one. He was hard to find, but when the police caught up with him, he turned out to be their man. Furthermore, through him the entire ring was apprehended.

The Los Angeles police began their extraordinary file 10 years ago. Today it contains more than 90,000 index cards. Each lists a tattoo and its location on the body of the wearer, whose name and brief description are given. The card also lists the number of a pertinent "criminal folder," in which is kept a more detailed description of the tattooed person, with his police record, photographs, fingerprints, known aliases, addresses, haunts, associates, relatives, etc.

From Anchor to Zoo. The index cards are filed under Designs, Words and Letters, and Numbers. Designs run from Anchor to Zoo. (One man has an entire menagerie pricked into his skin!)

Under each heading, the cards are

filed by location, from Scalp to Toe and including the strangest places.

Since there are often scores and even hundreds of cards under the headings of certain popular designs, such as Anchors or Flags, and commonplace locations, the tattoo file has lately had to be divided into four racial groups, subdivided according to sex and even height.

But the speed with which this detailed index can make an identification is sometimes uncanny.

A convivial man the other night re-

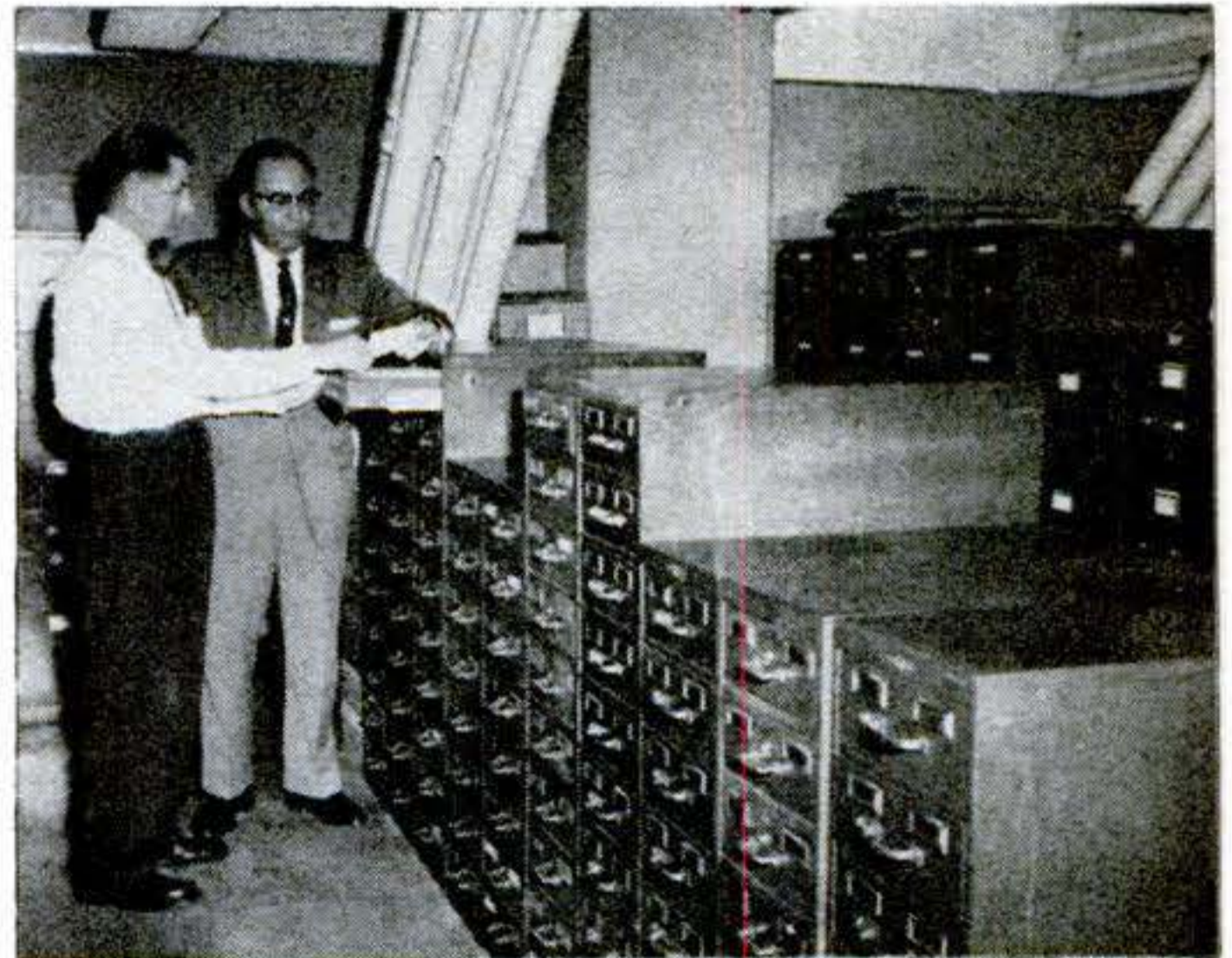

PICKING UP THE TRAIL of a wanted man in Los Angeles frequently begins here at the Police Department's mammoth tattoo file. Pneumatic tubes (rear) shoot data to detective divisions.



Indiscreet tattoos like these, which are quite common, led to the capture of a ring of thieves.

ported dejectedly to the Los Angeles police that he had picked up a friendly girl at a bar, made the rounds with her and later found that his wallet was missing. The police offered little consolation—until he mentioned that she had had **GYPSY** tattooed at the base of her throat. The officer taking the report asked the man to wait while he checked the tattoo file. Very soon, the cop returned with a photograph. Was this, he asked the man, the bar fly who had stung him? The astonished victim said it was indeed. The police then drove around to the address given on her file card, and nabbed her. Within 30 minutes, the man had his wallet back and the girl was in jail.

While such a case dramatically illustrates the potential of the tattoo file, the police emphasize that rarely does the file solve a case all by itself.

Thus, when a gunman held up a Los Angeles bar, and the bartender noted the initials **RV** tattooed on the hand that held the gun, the file quickly identified the criminal. Finding him, however, was something else. Then, one day a long time afterward, a local traffic cop stopped a speeding motorist. There were the tattooed initials **RV** on the speedster's right hand! The cop, who, like the rest of the force, had been told to be on the watch for this tattoo, attempted to make an arrest. The gunman bolted. There was an exchange of shots, but the fugitive escaped. With his driving license and the license number of his

car as additional clues, however, the police soon rounded him up.

The tattling tattoo. In another instance, a man was arrested for passing bad checks. He was known to have a woman accomplice, but the police didn't know who she was until they found the name **CONNIE** tattooed on the man. The tattoo file then tattled on Connie and led to her apprehension.

Tattoos are a form of exhibitionism, psychologists say, and experiences of the Los Angeles police support this opinion. For instance, a youthful purse snatcher in that city was so proud of a tattooed rattlesnake on his left arm that he wore short-sleeved shirts—which, thanks to the file, shortened his criminal career.

Certain tattoos also apparently reflect a psychotic quirk. A man with a long criminal record is listed in the tattoo file as having **C-R-I-M-E** imprinted across the thumb and fingers of his right hand. **SIN** beams from the Adam's apple of a juvenile delinquent. A sex offender advertises **BORN TO LOVE** on his chest.

Other tattoos have a distinctly ironic twist. **LIBERTY OR DEATH** is tattooed indelibly on many a man living behind bars. **DEATH BEFORE DISHONOR** is a tattooed standard that thousands of individuals listed in the file have obviously failed to meet.

Ships, eagles, prancing steeds. The file catalogues many masterpieces of the tattooer's art. A full-rigged schooner with the name **Flying Cloud**, surrounded

Tattoos Have Been Popular Since Man's Earliest Days

TATTOOING—pricking a design into the skin to make the decoration more permanent—dates back at least 6,000 years, anthropologists say.

A thorn and soot were the original tattoo needle and dye. Soot and red-clay dust are

still widely used for coloring tattoos, though the better tattoo "artists" pride themselves on secret dyes. Only the very best tattooers offer more than two or three colors, however. The steel needle has replaced the thorn, and electric propulsion of the needle (or of groups of needles for coloring large expanses of skin) was developed late in the 19th century. Finer needles and better electrical control of speed today make tattooing sometimes al-

by mermaids, sails across a felon's chest. On the back of a twice-convicted thief, a Raphaelic Virgin Mary is watched over by hovering angels. The skin of a forger is the canvas for a foot-high cross with an eagle perched on top of it and a ship sailing through its center. Across the epidermis of several lawbreakers, a battleship plows through an inky sea with the words Sailor's Grave emblazoned below. On the broad chest of a Texas renegade prance four beautiful steeds, their manes flowing. Eagles, black panthers in pairs, leaping tigers, peacocks with brilliantly spread tails, and Indians spectacularly feathered and colored are popular examples of tattoo art listed in the Los Angeles police file.

Tattoos on women criminals are more common than might be supposed, but less gaudy than those that men favor. A tattooed necklace or bracelet is a common female choice.

Dots that say "I belong." A tiny dot or cross on the web of a hand, or on a cheek or forehead, or beneath an eye are mysterious tattoos whose meaning the Los Angeles police have never discovered. They are often found on youths who are members of gangs. The marks apparently are not related to any particular gang, and the police believe they may simply advertise to one and all that "I belong."

Los Angeles police are grateful to individuals who have had identifying Social Security or military serial numbers tattooed on their bodies. Thousands are listed in their file! Occasionally,



A MYSTIFYING MARK favored by members of youthful gangs, a tattooed dot between the eyes has been the undoing of many a delinquent.

most painless. But the hand needle is still used exclusively in some places, and by the best tattooers everywhere for fine details.

Sailors are especially fond of tattoos, but even European monarchs, including the late King George V of England and the last German Kaiser, have shared the yen. Odd designs chosen have ranged from family portraits, copied from photos, to wills. Movie stars and society matrons have been among

Tattoos: How to Get Rid of Them?

FOR all modern surgery and science, the honest tattooer and surgeon will tell you, there is no way to remove most tattoos without leaving some blemish or scar. Tattoo removers pride themselves on secret bleaches that will destroy most, and sometimes all, of the color—but also bleach the natural coloring of the skin. Tattoo dyes are impressed so deeply that sandpapering the skin makes no impression on them. Surgeons do cut out tattoos, either covering the removed area with a skin graft or, when possible, gathering and stitching the two sides of the incision so that they will grow together. But these methods leave scars of some sort. Not infrequently, a person who has had a tattoo removed returns to the tattooer—to have another design pricked over the scar left from the removal of the first one!

too, they find a prison number tattooed on a man.

Chief William H. Parker, of the Los Angeles Police Department, points out that the tattoo file has also proved valuable in quickly identifying unknown dead or unconscious injured persons. It has even helped find missing ones.

Once it worked almost too well. A local woman reported that her husband had vanished. Under "identifying marks," she listed several tattoos. This led to a search of the file, where it was found that the same tattoos were listed for a man of identical description but different name and address. His criminal folder revealed that he had been arrested a couple of days before for a sex offense and was now in jail. A trip to jail verified that this man of another name was the "missing" husband. He had given the police a false name and address in an attempt to hide his shame from his wife. END

the clients of Lee Roy Minugh of Los Angeles, a noted tattooer. People of all classes come to Minugh to be tattooed for cosmetic reasons—to hide scars and blemishes, emphasize eyebrows or imitate hair on a balding scalp. Some men have come to him for a quick "mustache," which changes their appearance immediately.

"I ask no questions—like a doctor," Minugh says.

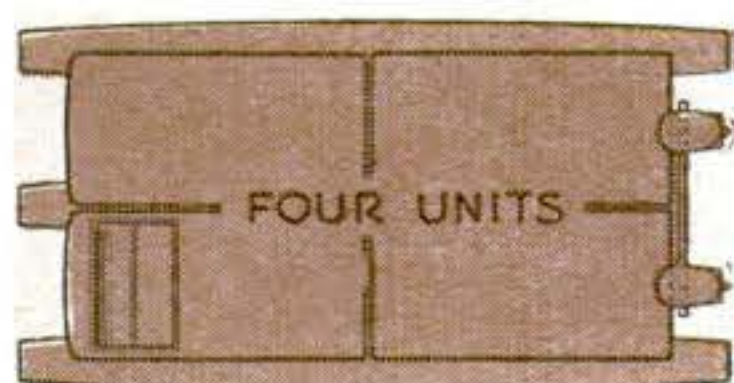
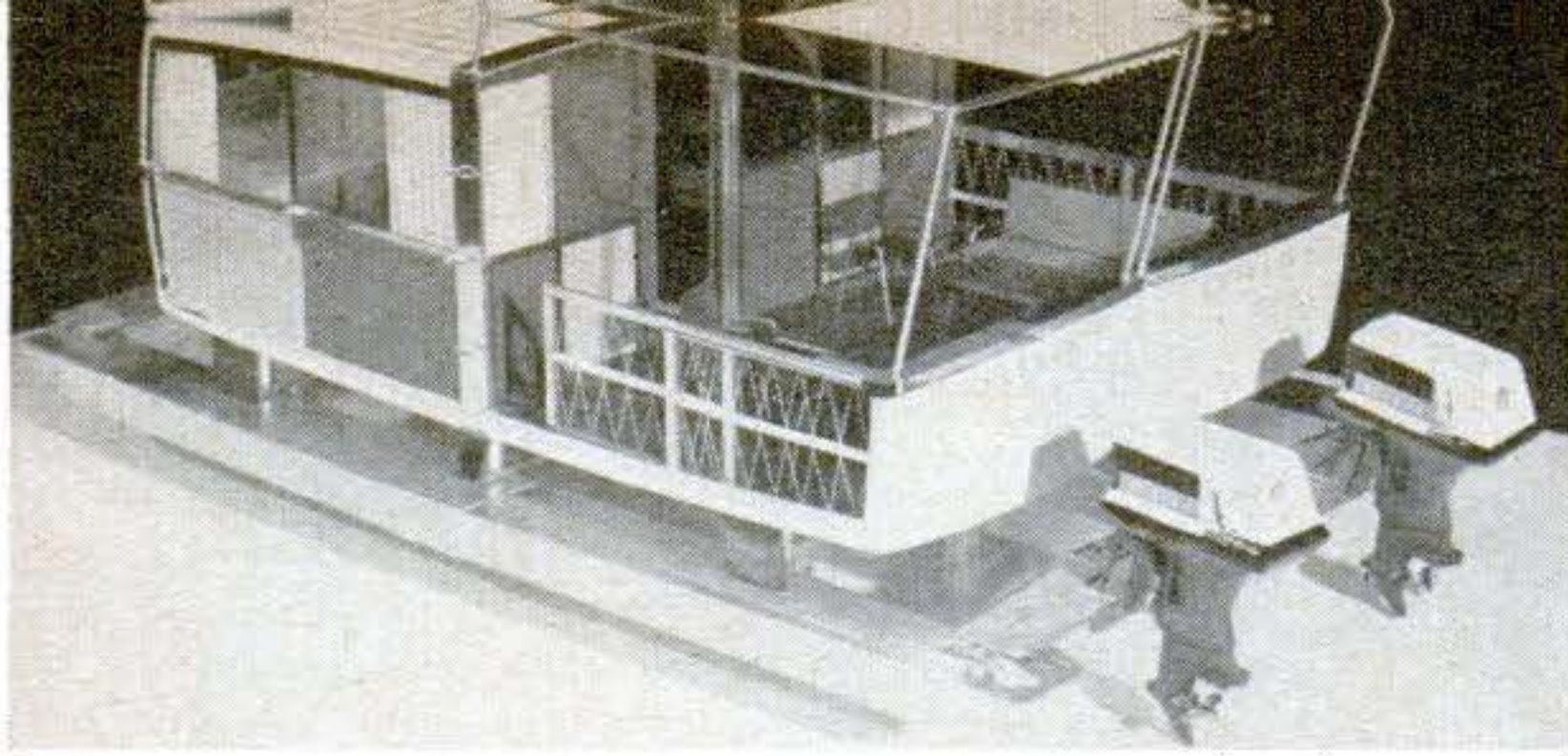

Houseboat of the future can be expanded as you need more space by adding on extra sections. Each unit is 7' by 11', can be either enclosed cabin or retractable-roof sundeck. Designed by Brooks Stevens for Evinrude, the pontoon craft may be adopted by boat builders soon.



Convertible switches from fast outboard to racing sailer in minutes. The 18½' Swedish import has a bunk, sells for about \$2,000 from Duncan Sutphen, 342 Madison Ave., NYC.

What's New in Boating

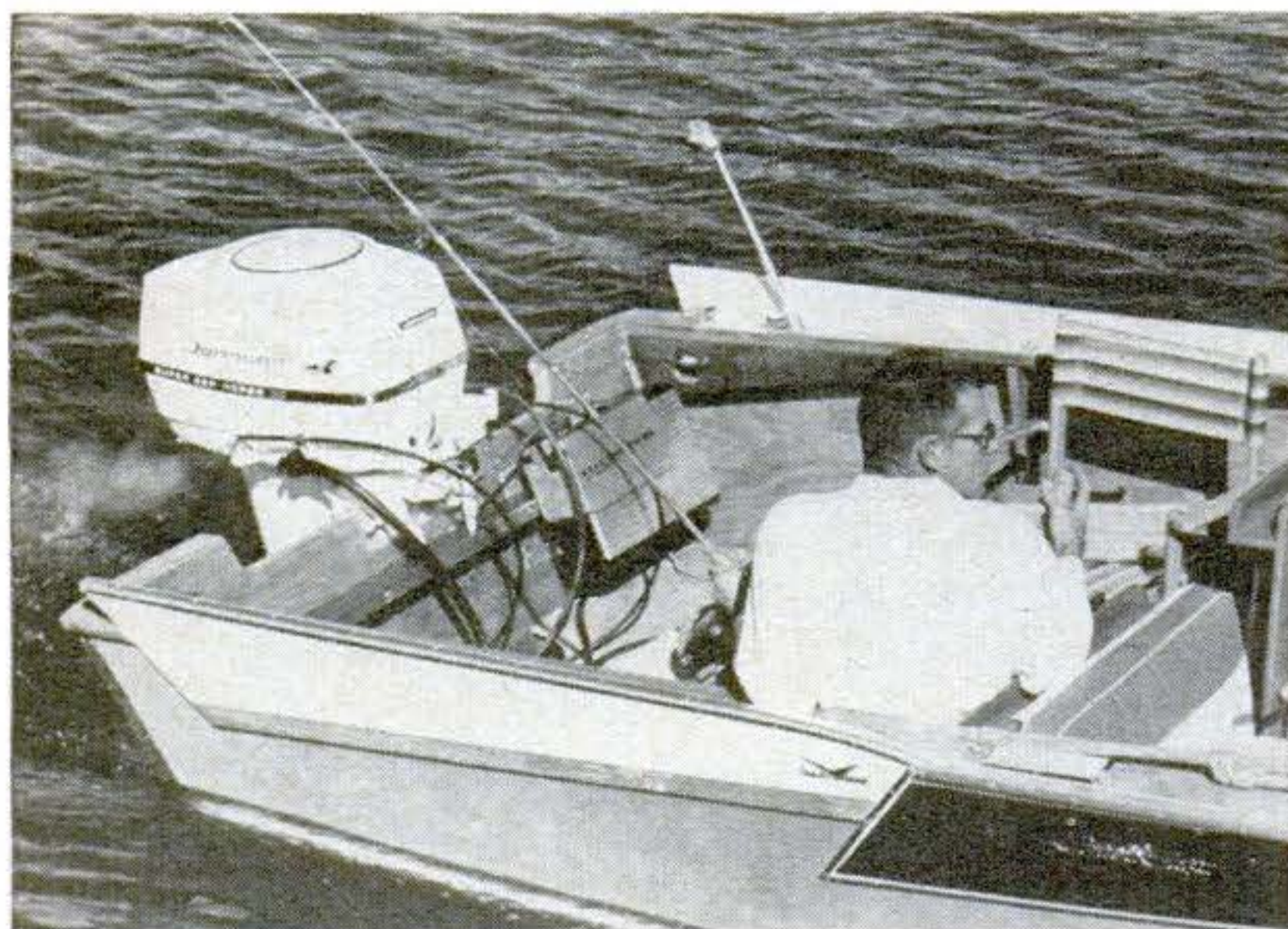

Portable helm lets you steer from any point in a boat while fishing or navigating tricky waters. Hand-held switch (arrow) operates a tiny reversible motor linked to a steering arm. Hupp Corp., 7450 Melville Ave., Detroit, sells it for about \$70.

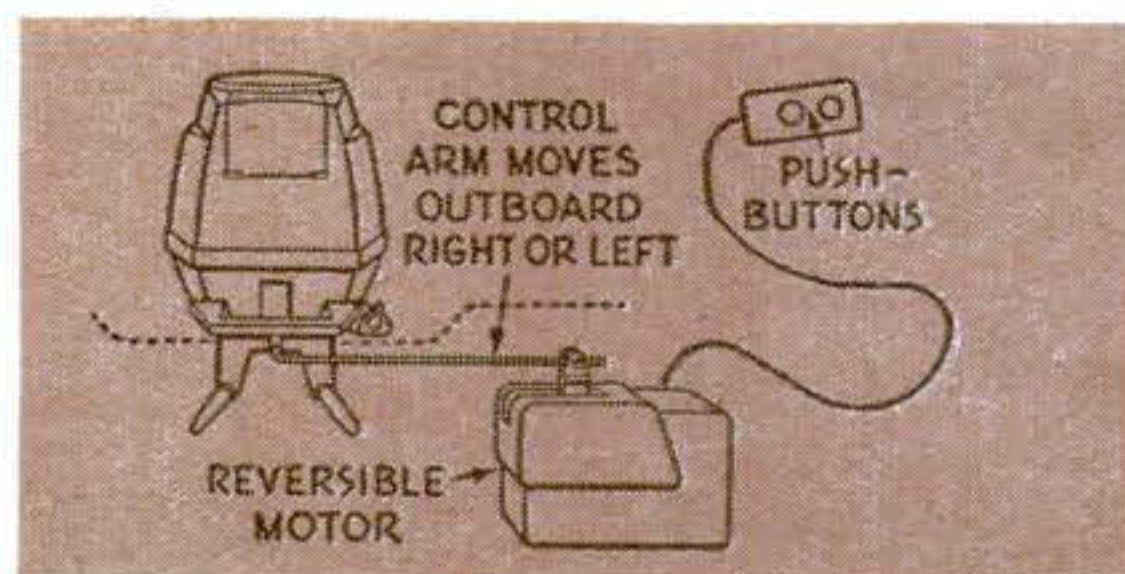

Dream boats run on, under or out of water

Fantastic new thrills may be on the way, according to dream-planners at Scott Outboard. One-man sub (near right) runs on air-driven props recharged through snorkel tubes—you wouldn't even have to come up to refuel. At center, cruiser would back up to shore and blow out inflatable living quarters for the whole family. Amphibious runabout (far right) rolls on land on retracting wheels.

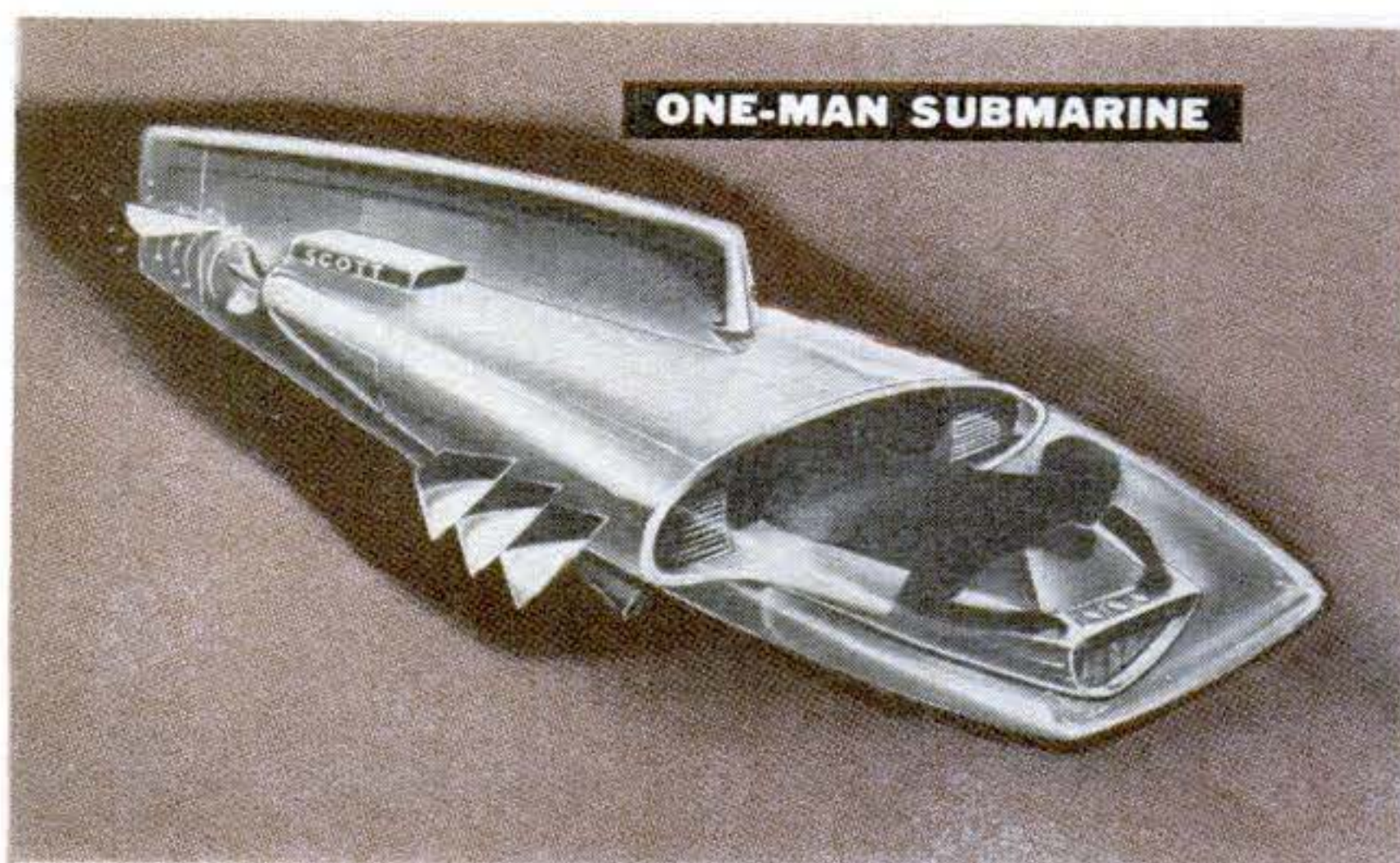

New inboard-out-board pairs a Swedish Volvo engine with a unique tilting prop. The prop swivels right to left for steering, up for beaching and hauling. The 80-hp., four-cyl. engine is said to give outboard speed on as little as one-third fuel. For hulls 16' to 30', it sells for \$1,385 from Volvo Import, Englewood Cliffs, N. J.

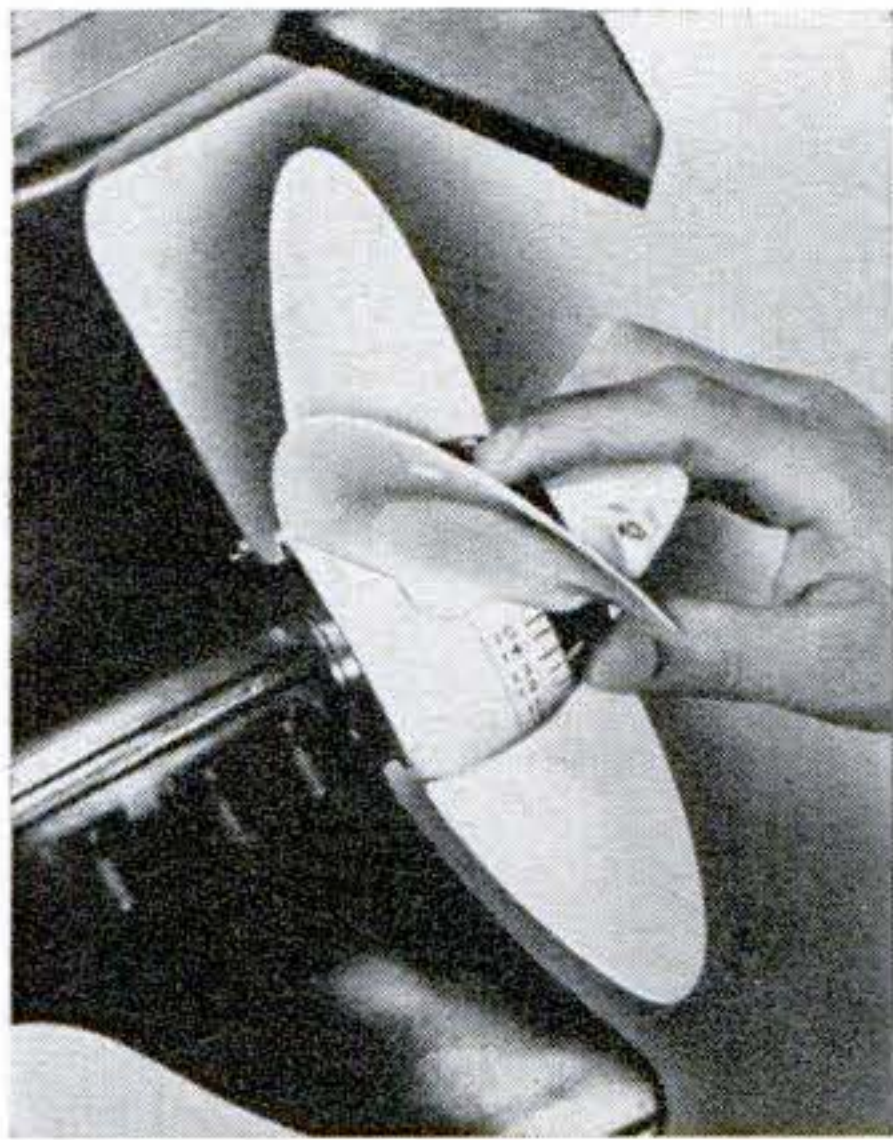
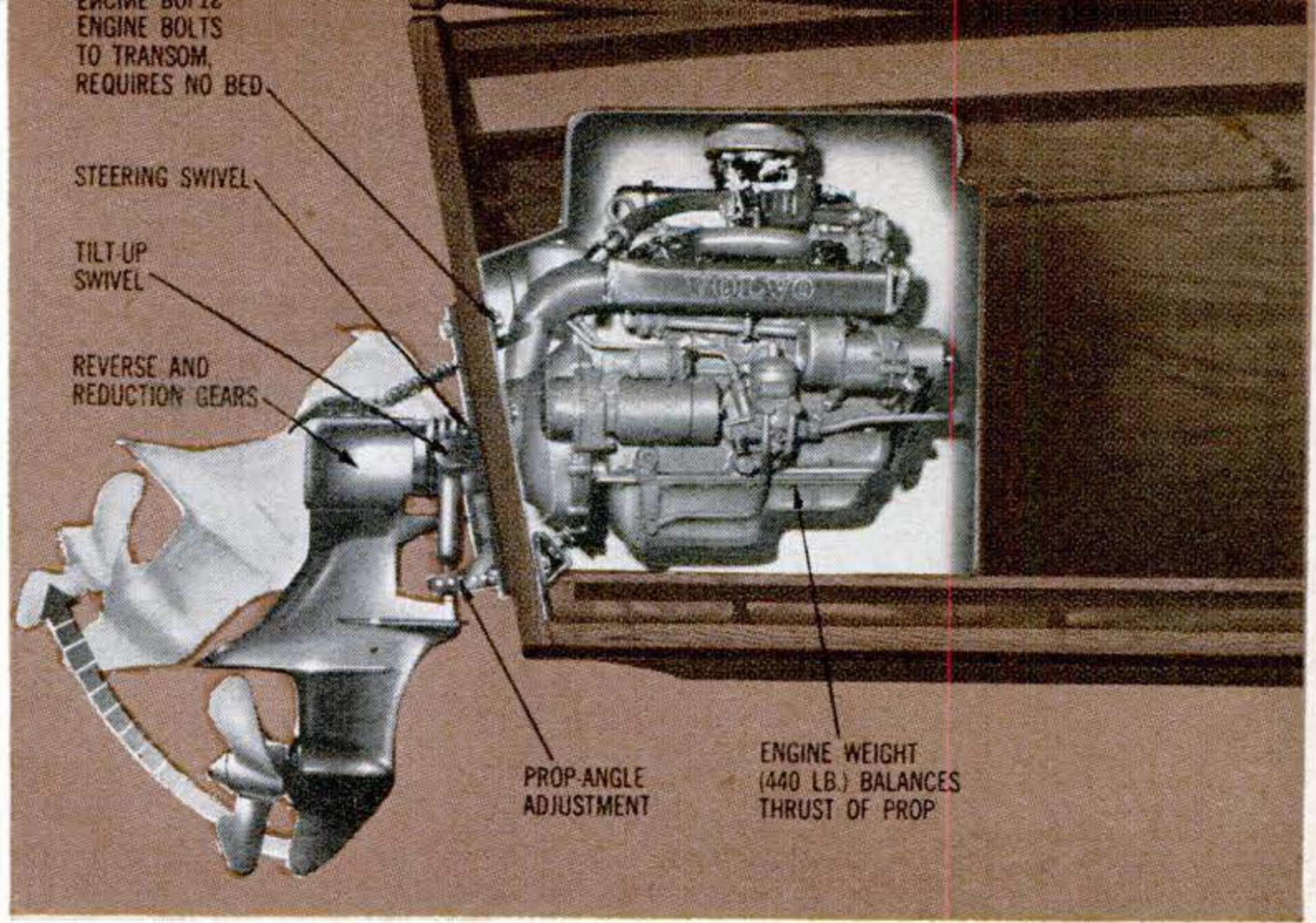

Variable-pitch prop for outboards lets you "dial" best of seven blade angles for racing, skiing, other power demands. Price is \$27.75 from Lesnor Maehr Marine, Floral Park, N.Y.



Clamp-on wheel makes it easy for one person to roll a boat to water. L and R Products, Framingham, Mass., sells sizes for transoms up to 1 3/4" for \$16 to \$19.



Upside-down outboard is a cinch to work on with this swivel vise. Motor rotates and slides in and out for easy access. Price is about \$47 from Panish Controls, Bridgeport, Conn.



HOUSE TRAILER

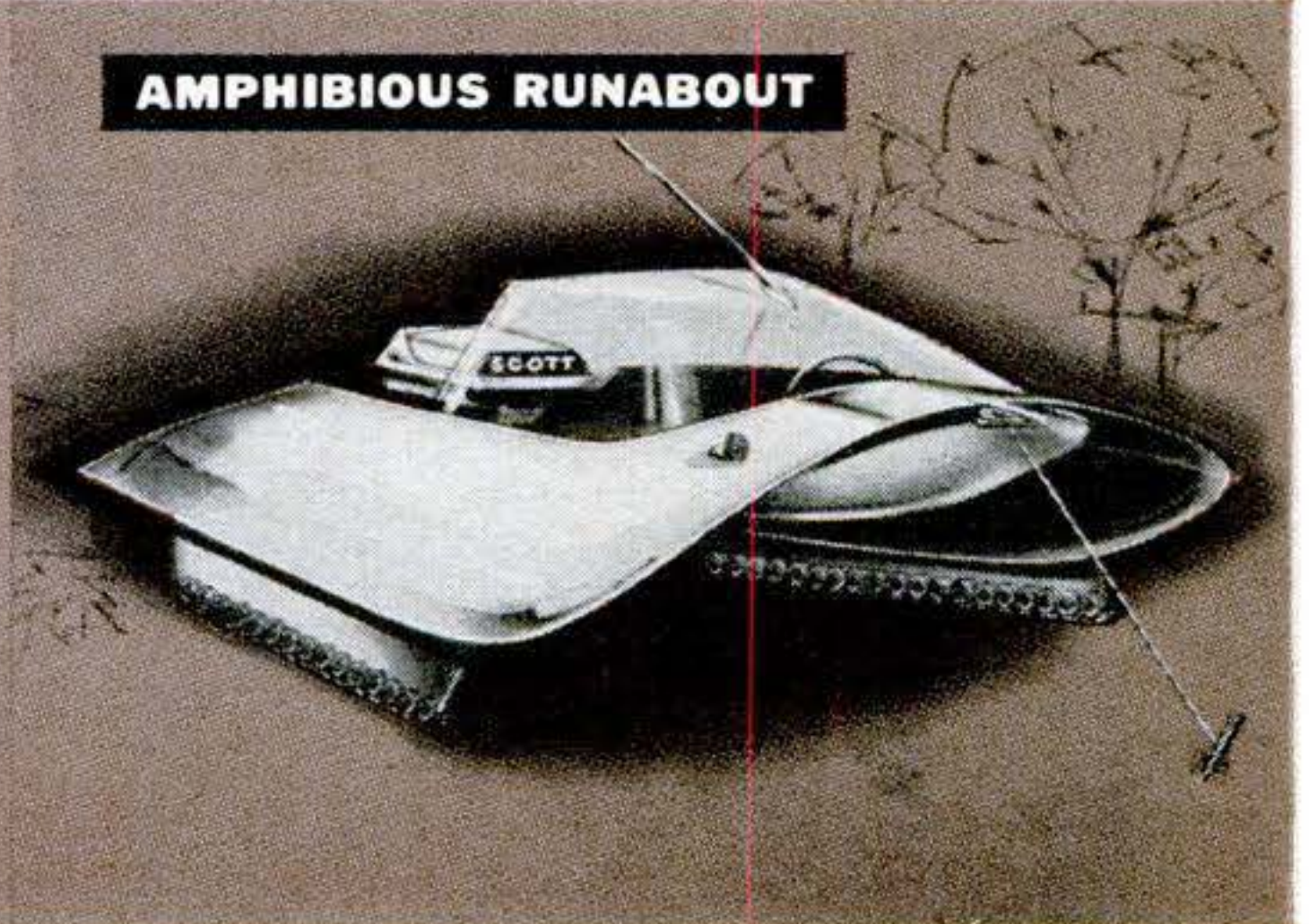

AMPHIBIOUS RUNABOUT

Now They're Making Rifles Out of Nylon

ON YOUR left, you're looking at the world's first rifle made of the same nylon plastic that more cozily clads ladies' calves. It weighs only four pounds—up to 50 percent lighter than conventional rifles (six to eight pounds) such as the one shown at right.

The new rifle, which will go on sale this spring, is a snub-nosed, high-styled, rapid-fire .22 semi-automatic. It fires 15 shots as fast as you can pull the trigger.

Remington designed the gun for more than lightness. They've run over it with cars, dropped it out of four-story windows, frozen it solid, dunked it in mud—and still it fires. Under all normal conditions—and a good many abnormal ones—you can't break it or jam it. Under destructive tests, the plastic—a tough, structural form of nylon developed by Du Pont and called Zytel—was going strong long after ordinary wood stocks had shattered.

The barrel, breechblock and a few other small parts are the only concession to steel. Even the receiver, in which the metal parts slide, is self-lubricating plastic that eliminates the need for dirt-collecting oil. The deceptively stubby barrel, only $19\frac{9}{16}$ inches long, is designed for maximum velocity from .22 long-rifle cartridges, which reach peak acceleration within that length.

A single machine can spit out fully molded, one-piece stocks at a near one-a-minute rate—an important military consideration. The design is so simple that if either barrel or stock should become damaged, you—or a soldier carrying a spare—could replace it instantly.

What future rifles might be like is anybody's guess. The present model, available in wood-grained brown or green, could be molded in white for Arctic troops, in tan for desert use, or even, says Remington, "in pastel pinks and polka dots if housewives want them." Right now, the new gun's name is "Nylon 66." It's priced at \$49.95 by Remington Arms Co., Bridgeport, Conn.—*Sheldon M. Gallager.*



4 lb.

6 lb.



STRIPPED OF METAL, the entire one-piece nylon stock weighs little more than a pound. Metal parts in foreground are: barrel, receiver cover, breechblock, firing-pin assembly, magazine.



TO LOAD, cartridges are inserted in tubular magazine that runs from receiver to butt. Spring-loaded inner tube then puts pressure on cartridges. When last cartridge is fired, bright yellow magazine follower shows up in receiver as an "empty" signal. Magazine holds 14 shots, plus one in chamber. Rifle takes only long-rifle .22s.

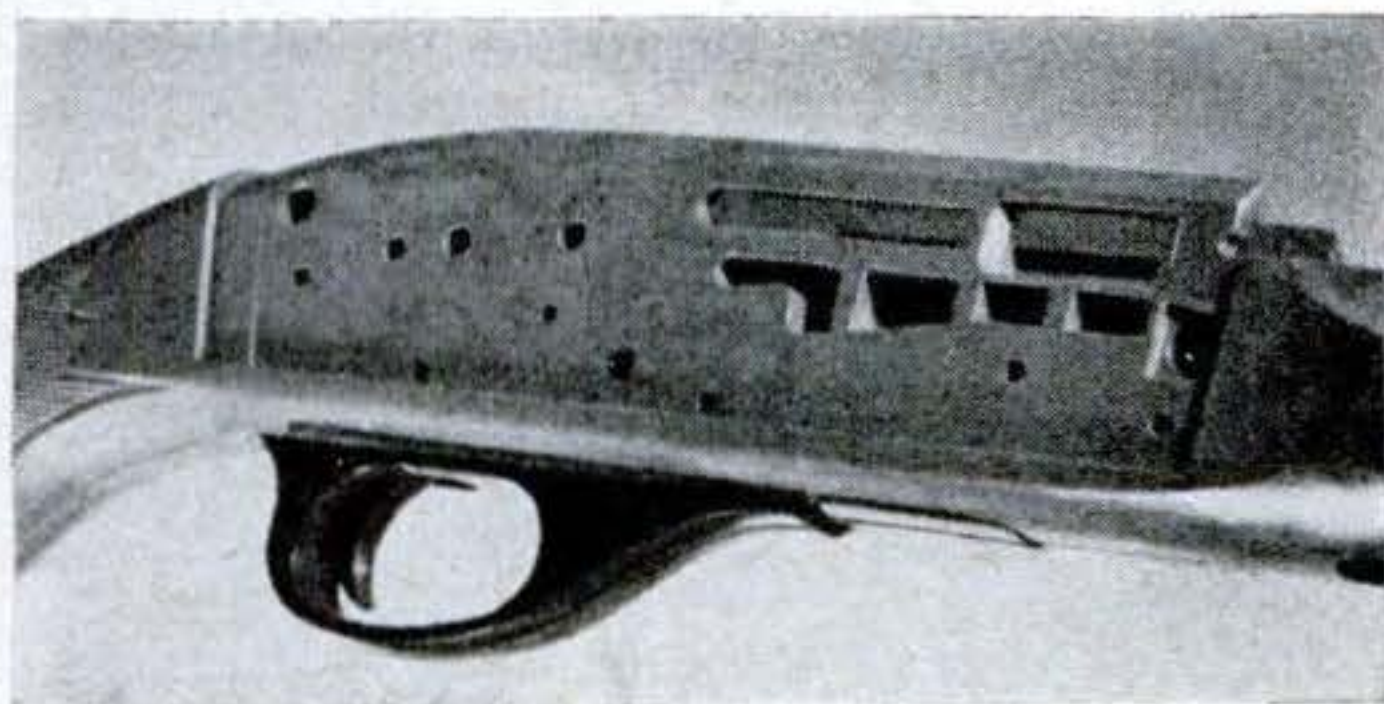
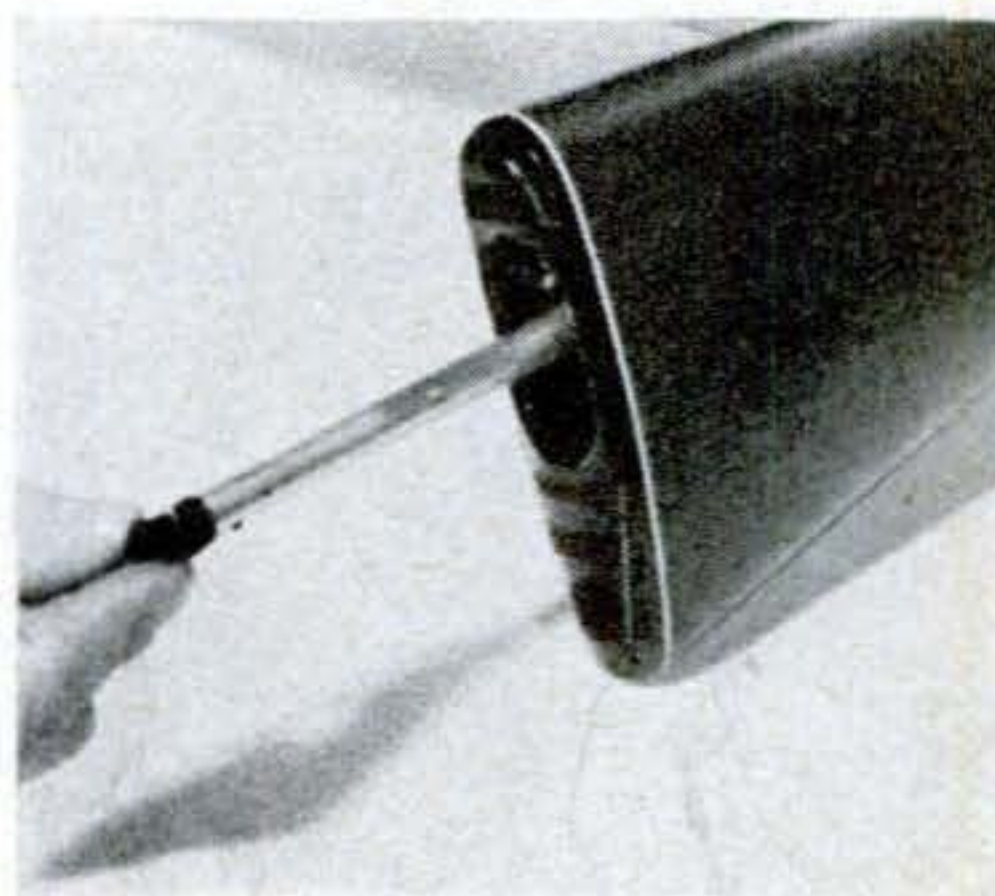

INTRICATE DETAILS are molded in one pass, require no machining. Tolerances proved so tight that metal parts had to be made more accurate.

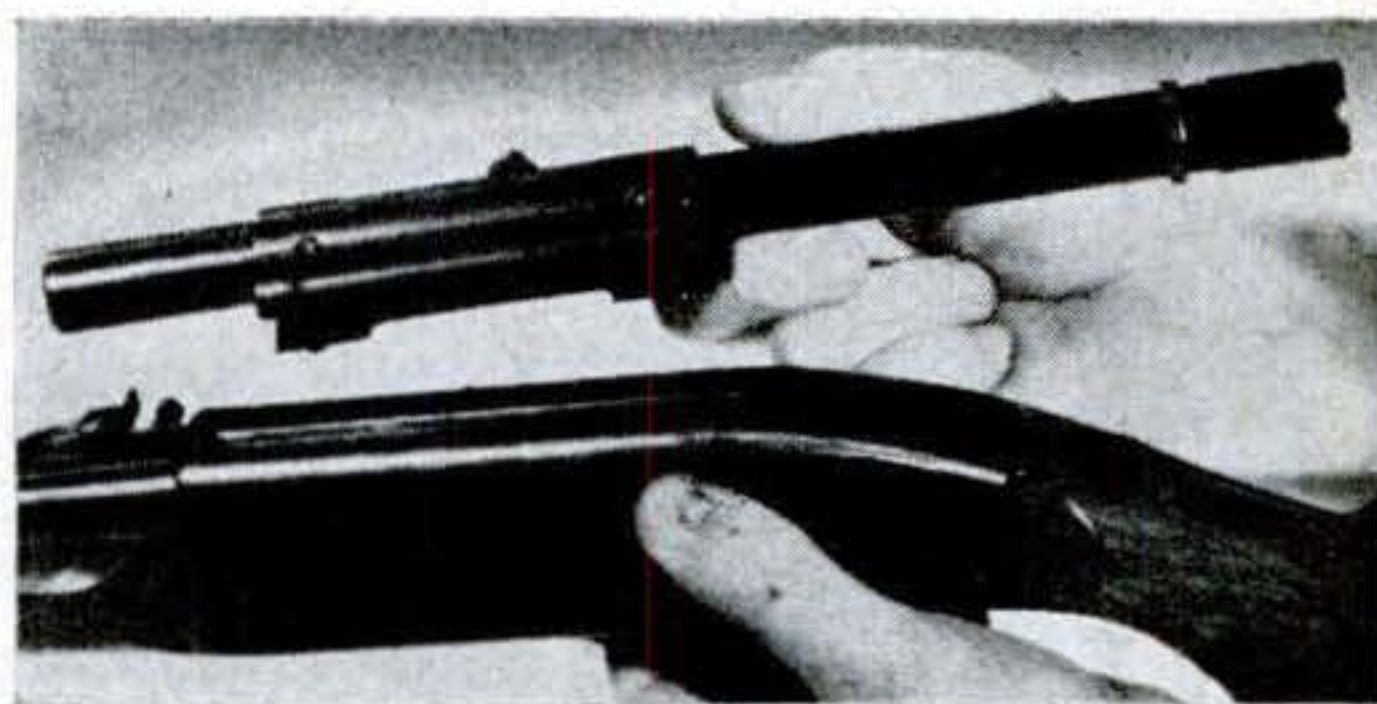

SCOPE SIGHTS FIT ON FAST using newer clamp-on mount that eliminates drilling for screws. Gun also comes with fully adjustable open sights.

QUICK-RELEASE BARRĒL can be removed in less than a minute. You take out three screws, then simply twist muzzle (below, left) to unlock

barrel from receiver and slide it out (center). Fully removed (right), barrel can be cleaned easily, even replaced if it becomes worn.



New Ideas from the Inventors

.....

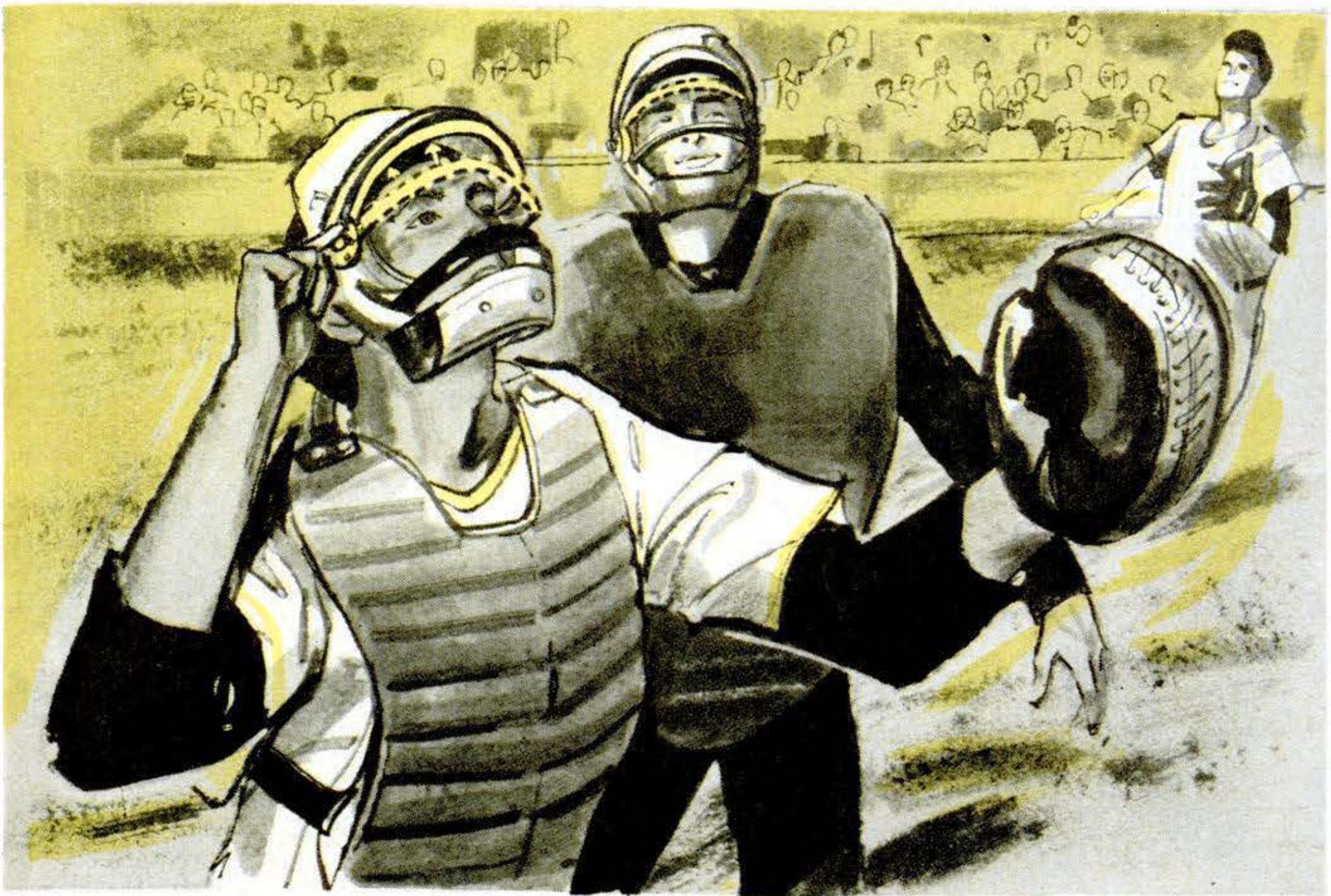

1 Mask Pops Up for Pop-Ups. Catchers and umpires wouldn't have to rip off this recently patented mask before snagging fouls or calling close plays at the

plate. At the touch of a button the protective bar would snap up to broaden the wearer's view; pulled down, the bar would lock securely in position.

2 Pillbox Watch Signals Doses. You couldn't forget to take your medicine if you carried it in a locket-like container hinged to this watch. The timepiece could be an alarm watch or an elapsed-time indicator with buzzer, but either way it would sound off at preset intervals.

3 Decanter Pours Ice Cubes. Drink cooling is usually unhygienic, says this inventor, because "nobody uses ice tongs." To remedy the oversight, he'd store cubes in a U-shaped tube so they could be poured. A hole in the base of the U would drain melted ice into a cradle stand.





4 Door Lights Flash Warning. Two flasher lights in the left door of a car would warn approaching drivers if you had to fix a flat on the danger side. Wired to flash automatically when the door was opened, they would also protect when you enter or leave a car on the left.



5 Opener Peels Tear Strips. Unwinding a metal sealing strip with a conventional slotted key is a slow operation and can be dangerous if the sharp strip comes uncoiled. By guiding the strip to prevent slipping, this crank-wound opener would speed the job and make it safer.

6 Hook-On Fins Steady Boat. Let down over either or both sides of a small boat, these stabilizers might prevent rocking, tipping and pitching. The lead-

ing edges of the fins would be feathered to minimize drag while the boat was in motion, but for higher-speed travel they could be cranked parallel to the sides.

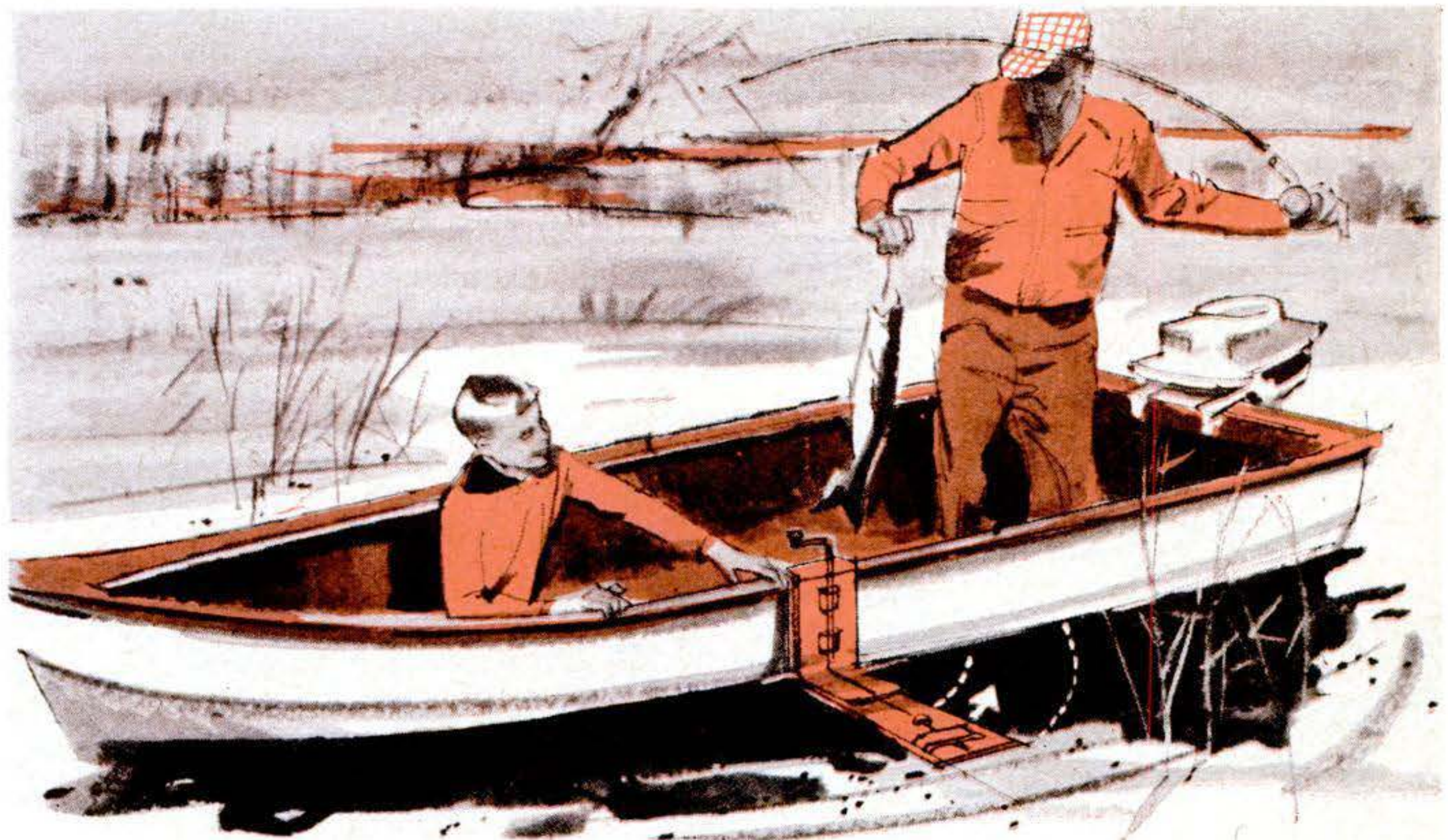

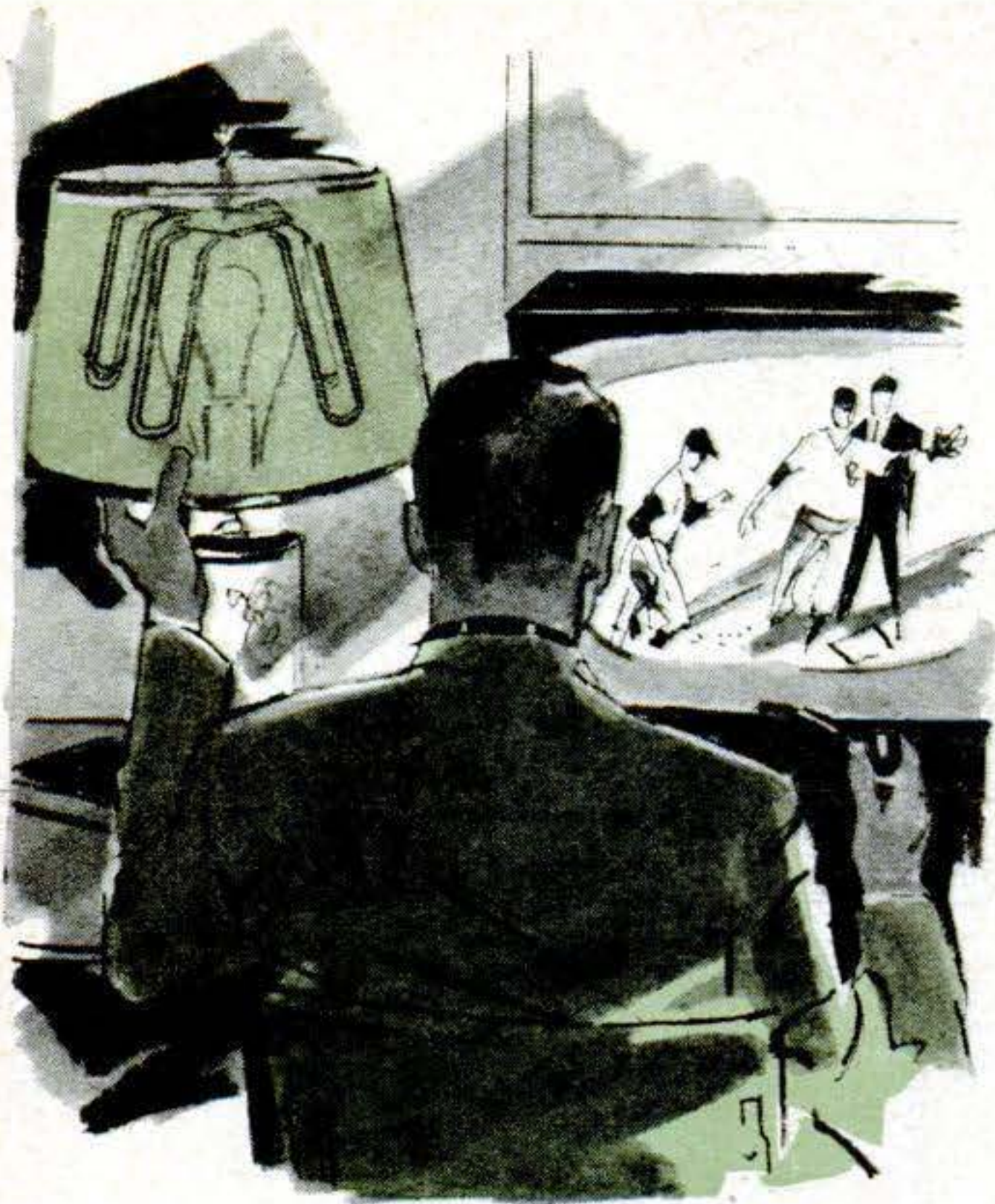

7 Shade Hides TV Antenna. Double dipoles, bent as shown, might serve as a frame for a removable lampshade cover. An insulating block at the center would join the antenna shade to a conventional lamp harp, and you could rotate the antenna by turning either lamp or shade.

8 Bed Pad Warms Your Feet. Fitted over the lower part of a bed, this electrically heated pad might warm your feet without overheating the rest of you. A thermostat would provide just the right toastiness, and with separate controls for each side of a double bed, couples made up of one cold- and one warm-footed partner might sleep comfortably.

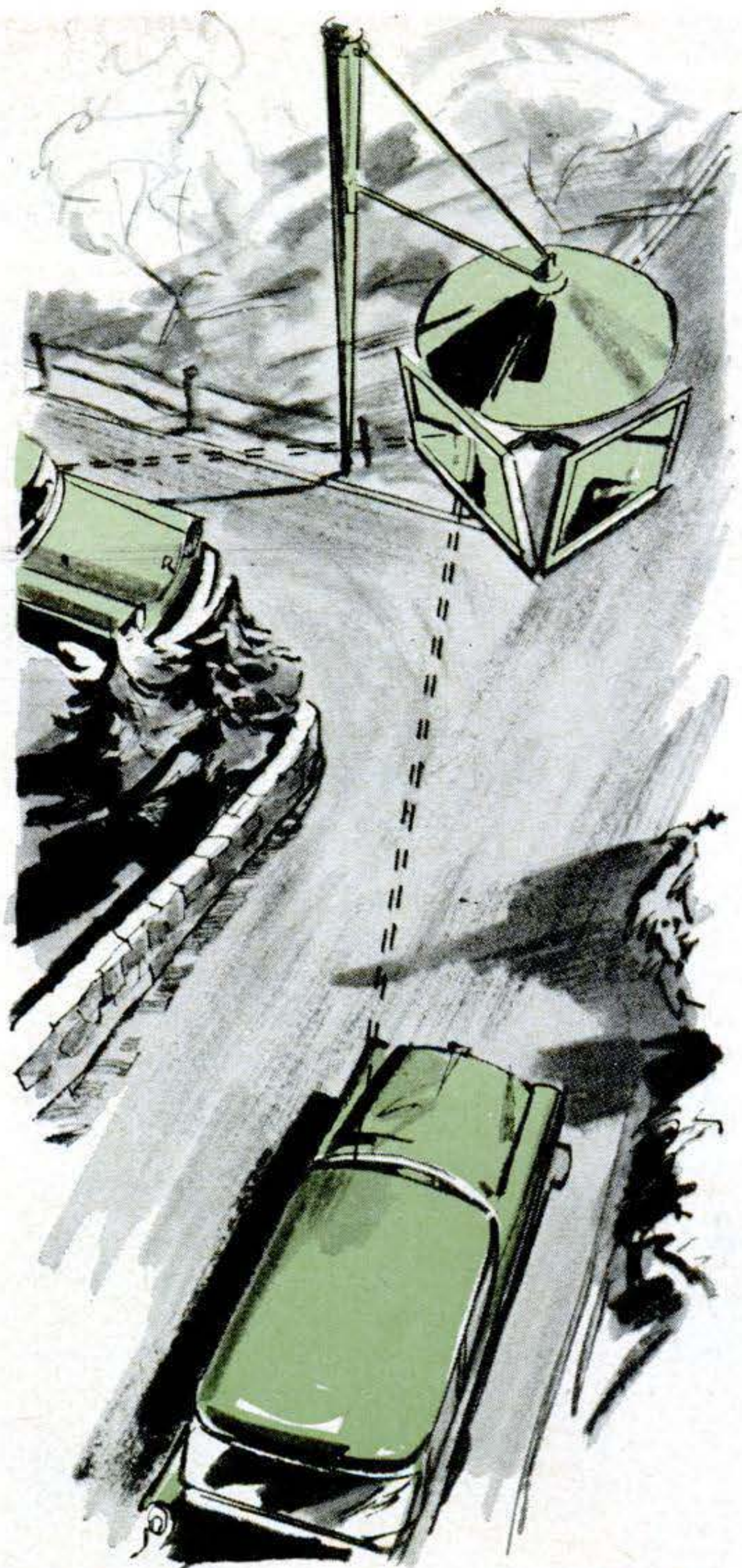

9 Road Mirrors Show Cross Traffic. An overhanging mirror to let you see if other cars were approaching a tree-shaded or blind intersection might eliminate a common cause of accidents. With each angled to reflect cars (or lights) around a 90-degree bend, four mirrors would give visibility in all directions.

The following patents have been issued on these inventions: 1. Patent No. 2,839,755 to John L. Steriss, NYC; 2. No. 2,853,182 to Harry E. Barnett, Chicago; 3. No. 2,762,203 to Peter Schlumbohm, NYC; 4. No. 2,844,810 to Gordon H. Steele Jr., Washington, D.C.; 5. No. 2,829,797 to Henry J. Christopher, Detroit; 6. No. 2,752,874 to Ben Held, Bemidji, Minn.; 7. No. 2,850,731 to Claude A. Carlson, Chicago; 8. No. 2,850,617 to Helen J. Coldren, San Diego, Cal.; 9. No. 2,662,448 to Georges A. Couture, Quebec City, Quebec, Canada.

Copies of patents may be ordered, by number, from the Commissioner of Patents, Washington 25, D.C., at 25 cents each. To write to an inventor, if the address given above is insufficient, you may address him (by name and patent number) in care of the Commissioner of Patents.

America's Supersonic Cargo Rocket

Hurting at 1,500 m.p.h., the Lobber can carry 50 pounds of emergency supplies six miles

By Wesley S. Griswold

WHEN a part of the U. S. First Army was cut off and surrounded by German divisions during a battle in August, 1944, American units beyond the encircling Nazis stuffed rations and other emergency equipment into 105-mm. howitzer shells and fired them over the enemies' heads to the be-

TYPICAL LOBBER CREW
of four soldiers can easily tote the three-part, lightweight Lobber, a standard cargo, and aluminum launcher.



The cargo-carrying missile is fired like a mortar,



SETTING UP STAKES (left) is the first job at the firing point. The launcher is aimed by sighting it along a row of stakes lined up with the target. These are set up by compass if the target is not in view.

CHECKING THE CARGO in the missile's center section (right), in which it has been transported to the launching site, these men will next attach the section to its nose and tail cone, containing a rocket motor.



sieged soldiers. This roughly effective way of delivering certain vital military supplies in a hurry has now inspired Convair Division of General Dynamics, makers of the Atlas ICBM, to create a light, simple ballistic cargo missile, the Lobber. It can hurl food, medicine, small ammunition or communications equipment to troops in such a predicament.

The nine-foot Lobber, driven to a speed of 1,500 m.p.h. by a little, short-firing, solid-fuel rocket motor, can fling a 50-pound payload six miles. Bigger loads and greater range are feasible, the builders declare.

Quicker than the eye. Whooshing up to an altitude of more than 10,000 feet before starting its downward plunge, the Lobber travels so fast that no foe will be likely to see it in flight and judge where it is coming from. First warning of its presence will be the blossoming of a special landing parachute from its tail, letting it down faster and harder than the usual air-drop chute does. A shock-

absorbing nose cone cushions the jolt of plumping it down at its destination.

For a "stupid" missile—so-called because it is so simple, being controlled by launch angle and spin-stabilization—the Lobber finds its way with remarkable accuracy.

Of the first three fired in field trials at Yuma, Ariz., two landed within 60 paces of each other, six miles from the launching site.

The relatively small Lobber is made of aluminum and laminated glass fibers. It weighs only 135 pounds when loaded and ready to shoot.

A four-man squad can carry Lobber, cargo and launcher. One lugs the nose and motor-fitted tail cone, another the loaded cargo section, and the two other men the launcher, which is also made of aluminum. The recoilless launcher, a tube that looks like a fat stovepipe, is mounted on a tripod with broad feet of perforated metal, which take a firm stance even in sandy or muddy soil. The



Postmaster General foresees U. S. mail-carrying rockets

AMERICA stands on the threshold of an era when its mail will be delivered by rockets, Postmaster General Arthur E. Summerfield declared recently. Perhaps with fore-runners such as the Lobber in mind, he predicted that, before man travels to the moon, "your mail will be delivered within hours from New

York to California, to England, to India or to Australia by guided missiles." This, he said, would be "the greatest peaceful use of missile development."

If Congress provides the money, he added, mail-carrying missiles will be painted red, white and blue, like many present mailboxes.

and 70 percent of it can be saved to shoot again

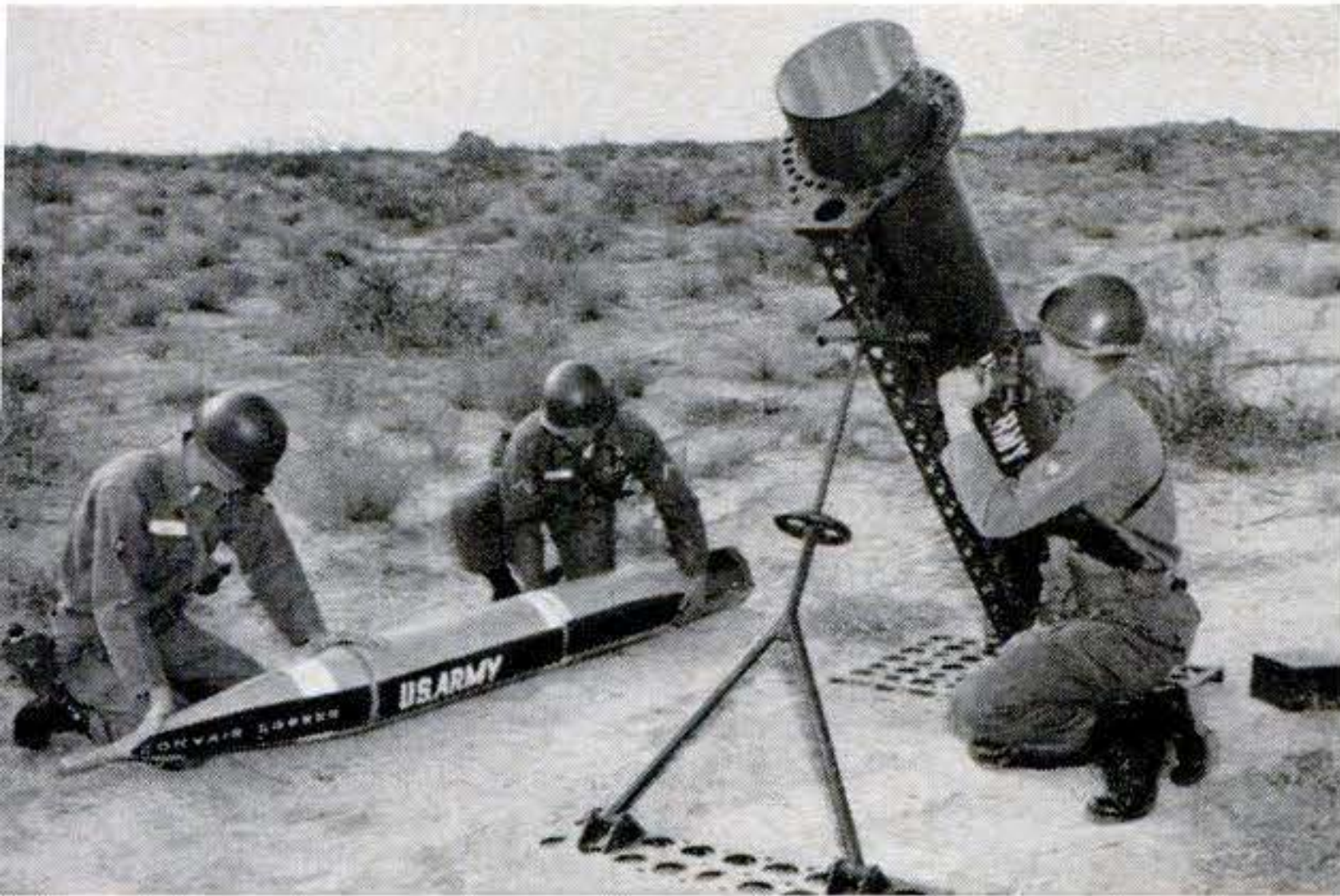

LEVELING AND AIMING the launcher, whose perforated baseplates hold it firmly in the sand, is done while the missile is being assembled.

Lobber can also be launched easily from the floor of an armored personnel carrier, from a landing ship or even from the back of a stake-bed truck, as was done during initial trials.

One of the most mobile Lobber units, its developers point out, would be a Mechanical Mule—the Army's smallest operational vehicle—and its driver. The Mule could tote six loaded missiles and their launcher, which the driver could set up, load, aim and fire (with a flashlight battery) all by himself. One of the Army's big transport planes could carry eight missile-packed Mechanical Mules.

Easy to learn. A Lobber is launched very much like a mortar shell. Any infantryman who can learn to set up and fire a mortar can just as easily learn to do the same jobs for a Lobber, the Convair-San Diego engineers say.

The Army, which was closely consulted in the development of this first ballistic cargo missile, suggests that cargoes could be prepackaged and stored in Lobber center sections, which are attached to nose and tail cones at launching sites. The sections can vary a few feet in length, depending on the type of cargo. Cargoes, their contents identified by number or label, could gain extra protection from landing damage by being embedded in foam plastic when packaged.

In war and peace. Army specialists believe that in addition to delivering emer-

[Continued on page 236]

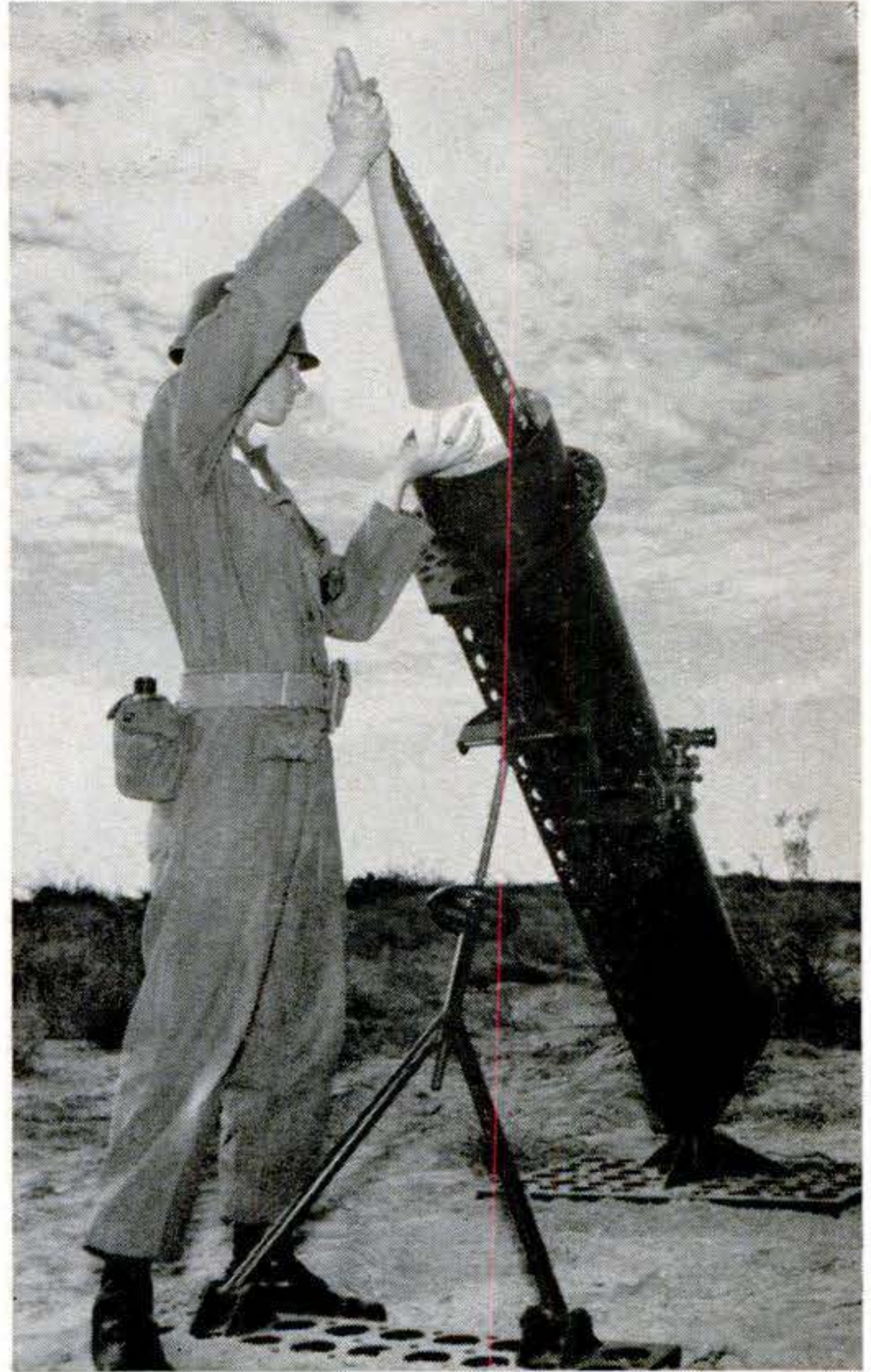

READY FOR FIRING, the Lobber above has just been slid into its launcher. The crewman's right hand clasps the special shock-absorbing nose, which cushions the landing jolt.



SPECIAL DELIVERY presages a day when bigger missiles may carry mail and express. A spent Lobber awaits pickup, draped in the parachute that opened when rocket fuel burned out.

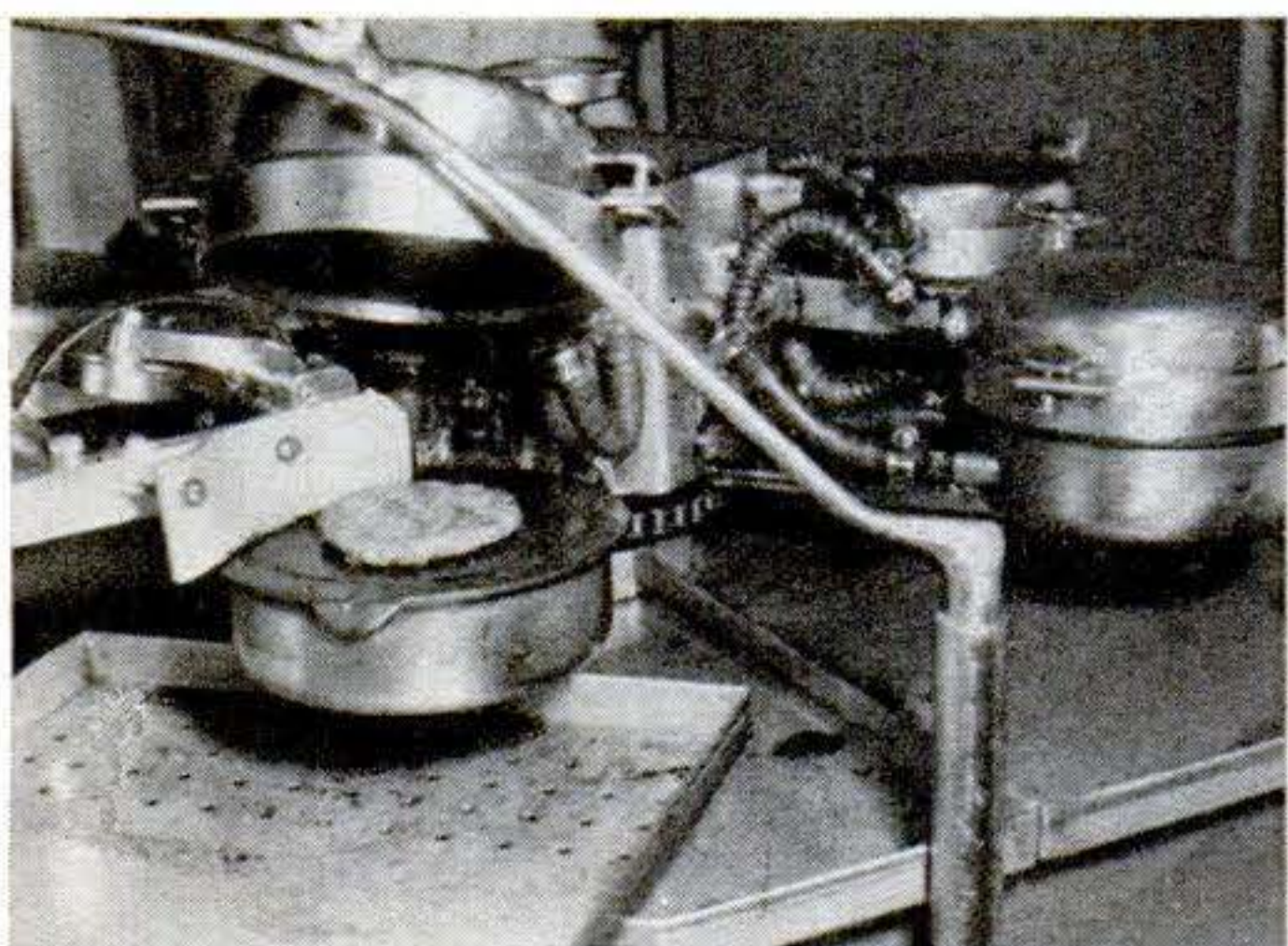
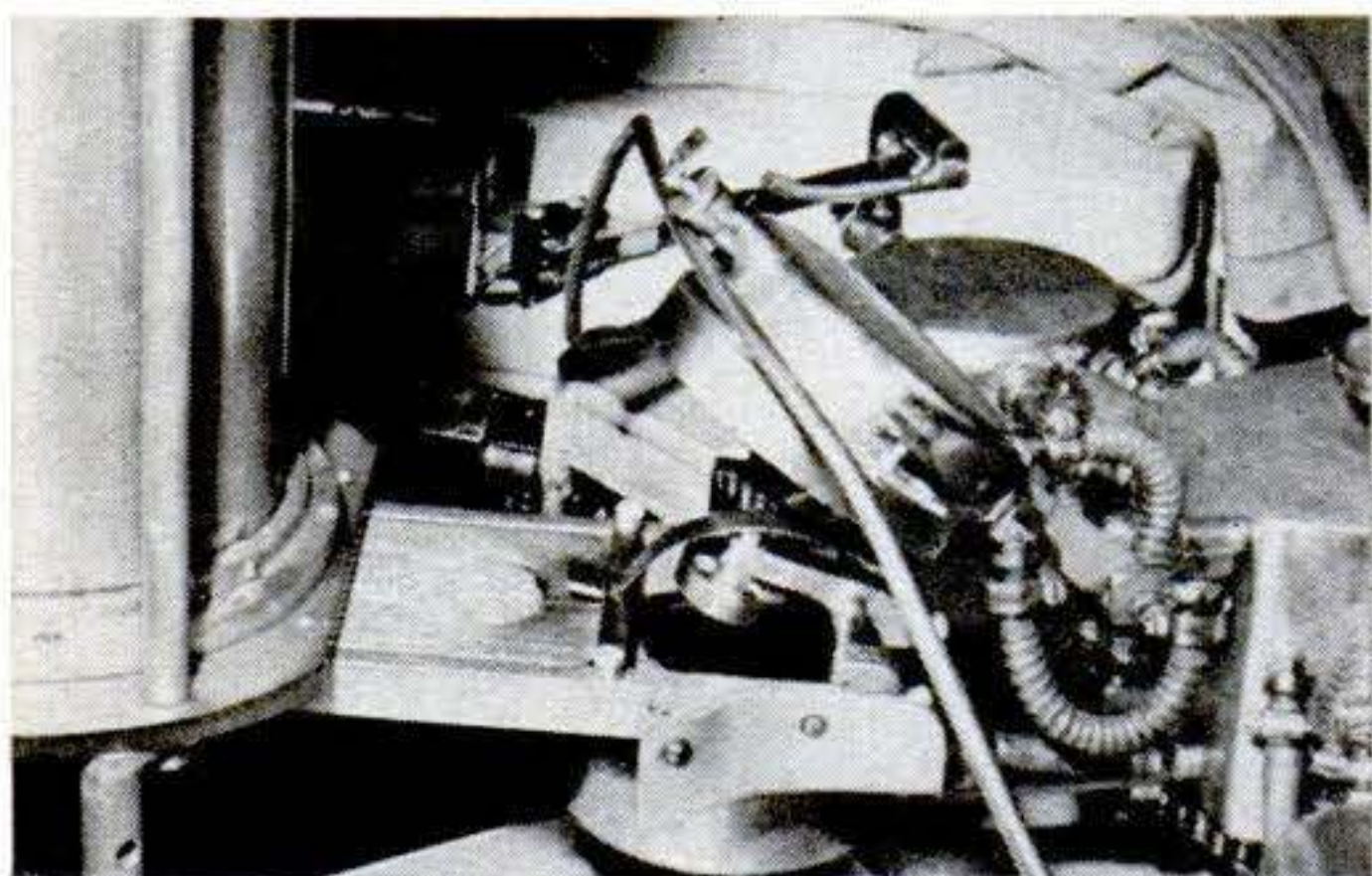
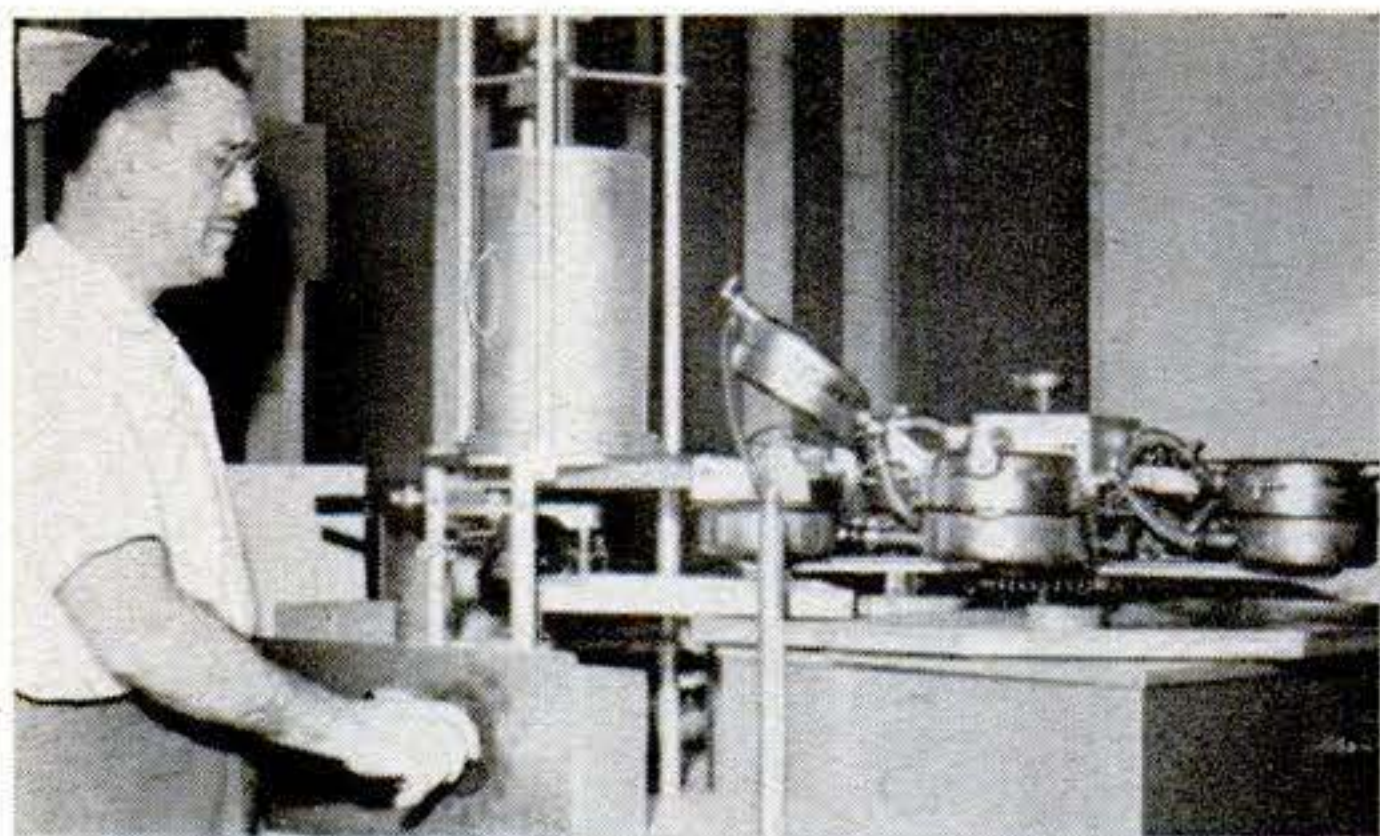

BURGER AUTOMATION. Frank Nanna of San Jose, Cal., built this rotating broiler to cook five hamburgers a minute. Up to 20 pounds of ground beef in the storage cylinder (top photo) is ejected automatically in patties on a slide (center). Moved to one of five broilers, lid lifted momentarily to take it, the burger is cooked in one minute, then scraped, as the broiler opens again (bottom), onto a waiting tray, ready to serve.



DIVING AID. Towed by this battery-powered British Sub-Aqua-Jet, a skin-diver need only operate the trigger to swim or dive effortlessly. It's equipped with a camera and lights, does one knot hauling a diver at 100-foot depth.



AIR-RAID SHELTERS. Do-it-yourself bomb protection is now furnished on Formosa. These reinforced-concrete shelters sell to civilians for \$11 single and \$17 double. The buyer digs a hole, puts his bin in, packs it in with earth until only the lid shows, crawls in to sit out raids.

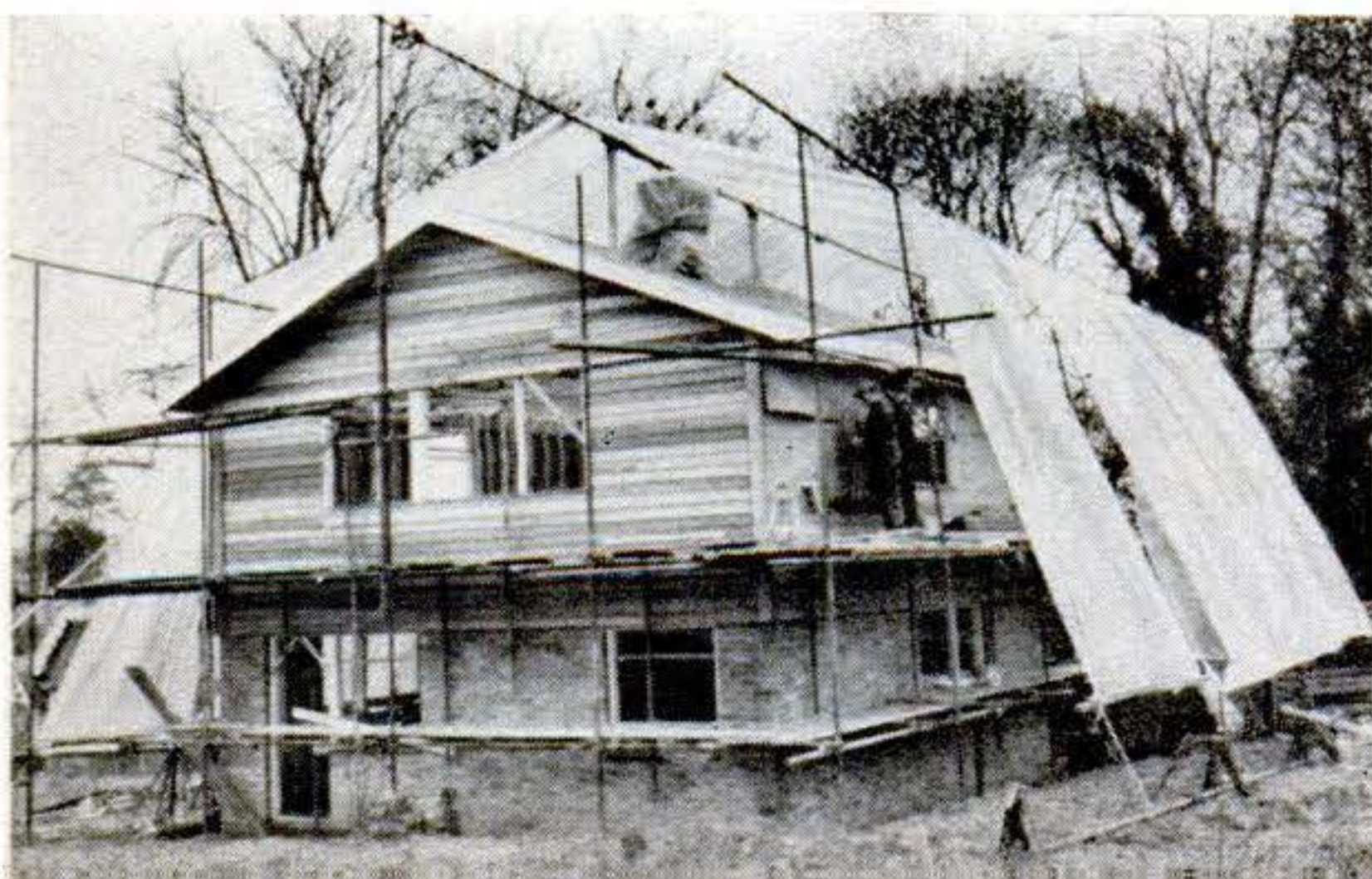

TENTED HOUSE. The tent at left was erected before the builders in Sussex, England, started on the house. Covering the construction with rainproof plastic saved them more than 70 working hours that would have been lost because of bad weather.

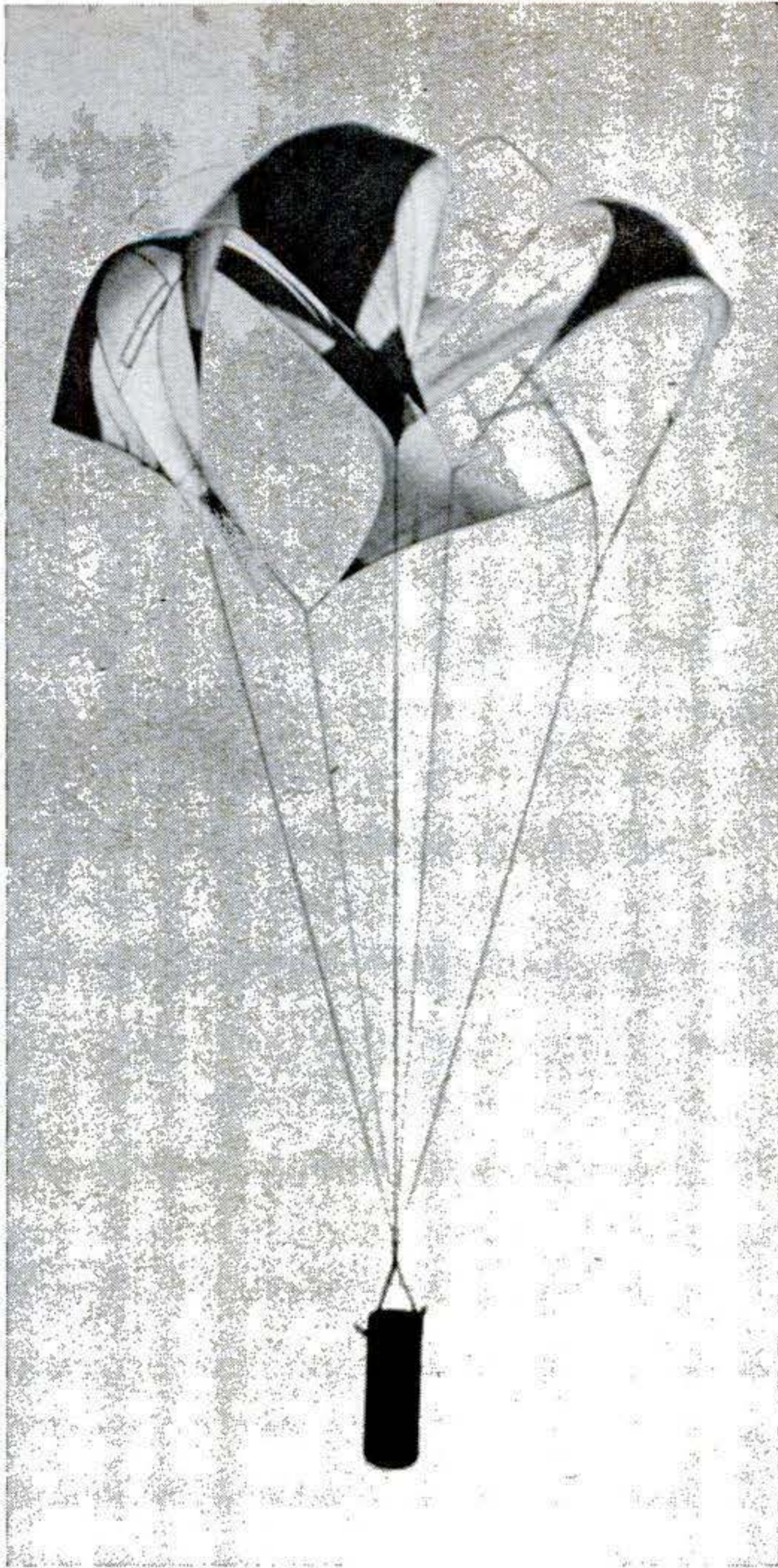

PINWHEEL PARACHUTE. Spinning on a swivel joint, the four sails on this new parachute reduce opening shock, give better control. David T. Barish of New York designed the chute for cargo drops, paratroopers, jet landing brakes.



CAR LIFT. The drive-on ramp of this British four-car transporter is an elevator that rises to the upper deck. One man loads and unloads the cargo with the aid of foot controls (lower photo). The ramp then folds forward for highway travel.

ANTI-SUB SUB. First nuclear submarine designed for underwater seeking and destruction of enemy subs, the Tullibee at right is under construction by General Dynamics. It is 260 feet long, will displace 2,175 tons—smallest atomic submarine yet built. Complex equipment includes new electronic hunt-kill devices.

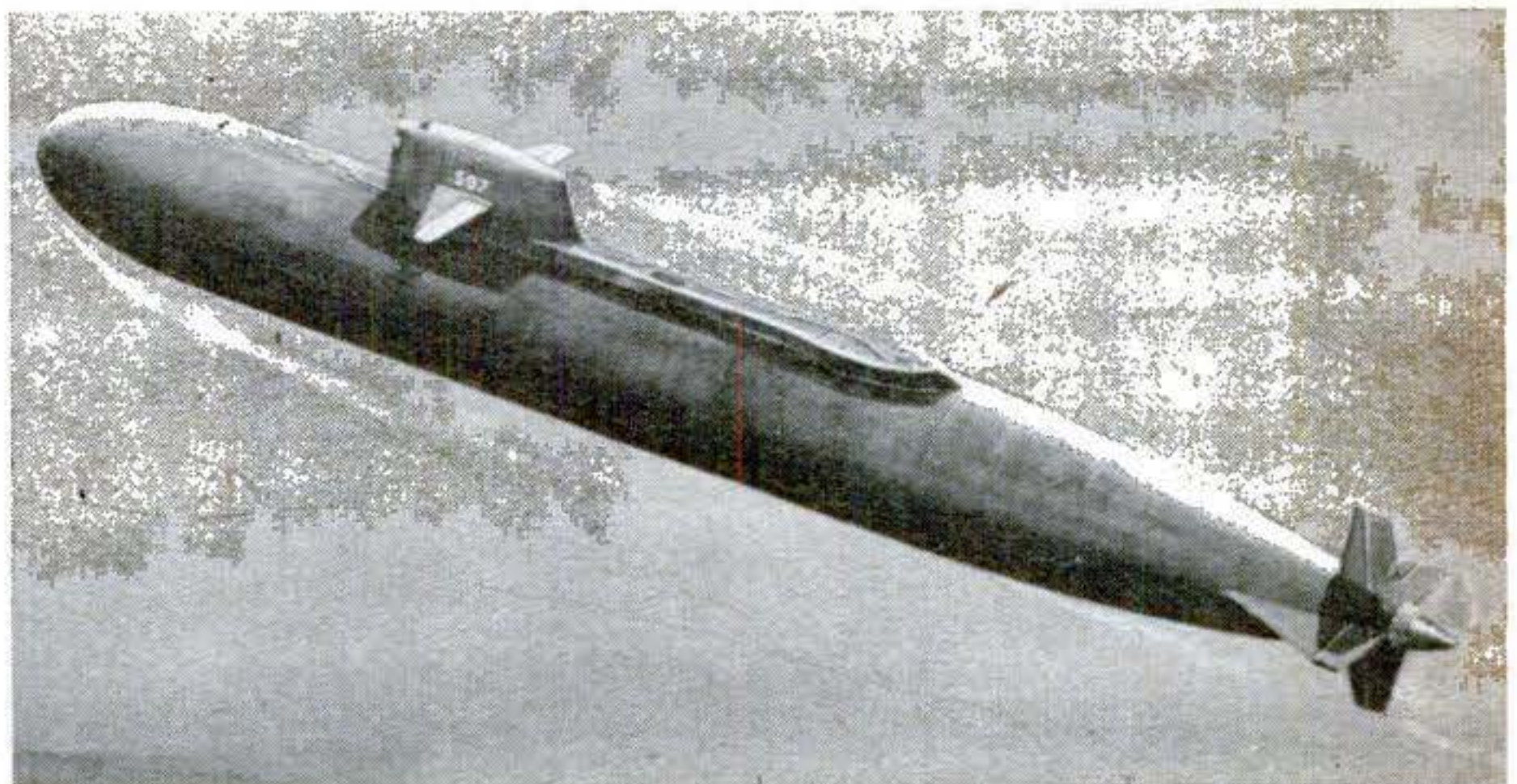



Borgward...



Little Car

This West German husky is just about tops for cross-country driving—but it has its faults

WHEN an auto engineer turns manufacturer, you expect something different. The German Borgward is that—a quality automobile built for hard going, a family sedan with sports-car engineering, a luxury car that is miserly with fuel.

Carl F. W. Borgward, at 67 one of today's few independent auto makers, also builds the Lloyd and Goliath. His Borgward-Isabella has been rolling off assembly lines in Bremen only since 1954.

The Buick of Europe, it's bigger and costlier than the well-known Volkswagen. American buyers price-shopping a Borgward find the two-door sedan tagged at \$2,495, the station wagon at \$2,685.

This 102-inch-wheelbase car is a fair example of what a middle-income Euro-

pean looks for when car hunting. Herr Schmidt expects (and gets in the Borgward):

- A ride that shrugs off rough roads.
- Cornering that makes him feel like a Fangio or Trintignant.
- Power to cruise at 65 or 70—and to climb mountain grades.
- Brakes to handle those same grades.
- Fuel economy in the upper 20s.
- Seating comfort for five.

Budget permitting, the Borgward buyer can move up from the 66-horsepower sedan and wagon to the Touring Sport at \$2,845 or the Sport Coupe at \$3,750. In these the same basic engine is fitted with bigger valves, special bearings, a two-barrel carburetor and higher compression. It puts out 82 horsepower.

The engine is up front, the differential in the rear but fixed to a cross member in the unitized body. Two swing axles, set on coil springs, carry the wheels, cutting unsprung weight to a min-

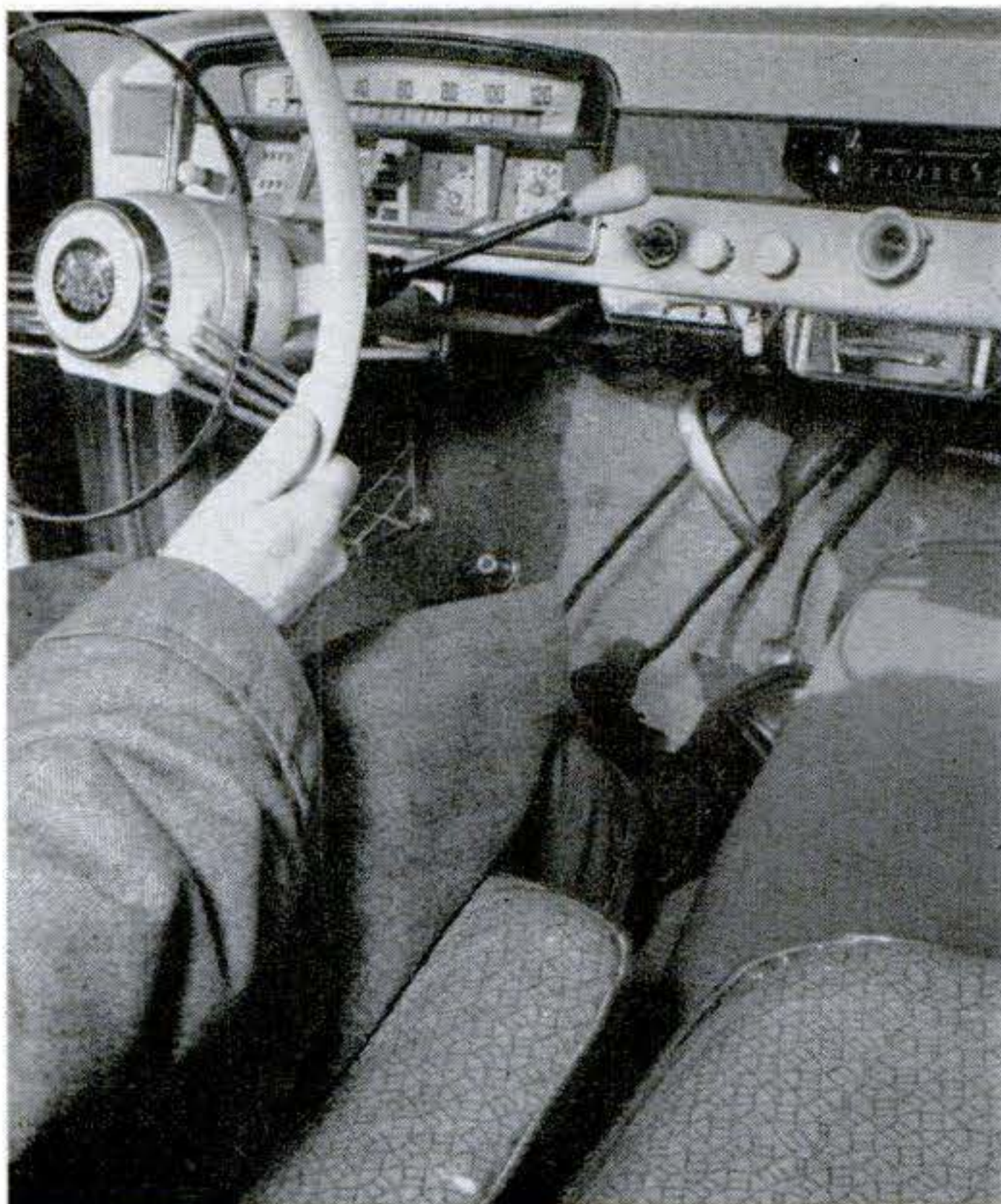

ON THE DASH, there's a moving-line speedometer, trip and total-travel odometer, fuel gauge, temperature gauge (with a warning light that glows at 212 degrees) and an electric clock. High-beam, generator, and low-oil-pressure warning lights are in pyramid grouping.

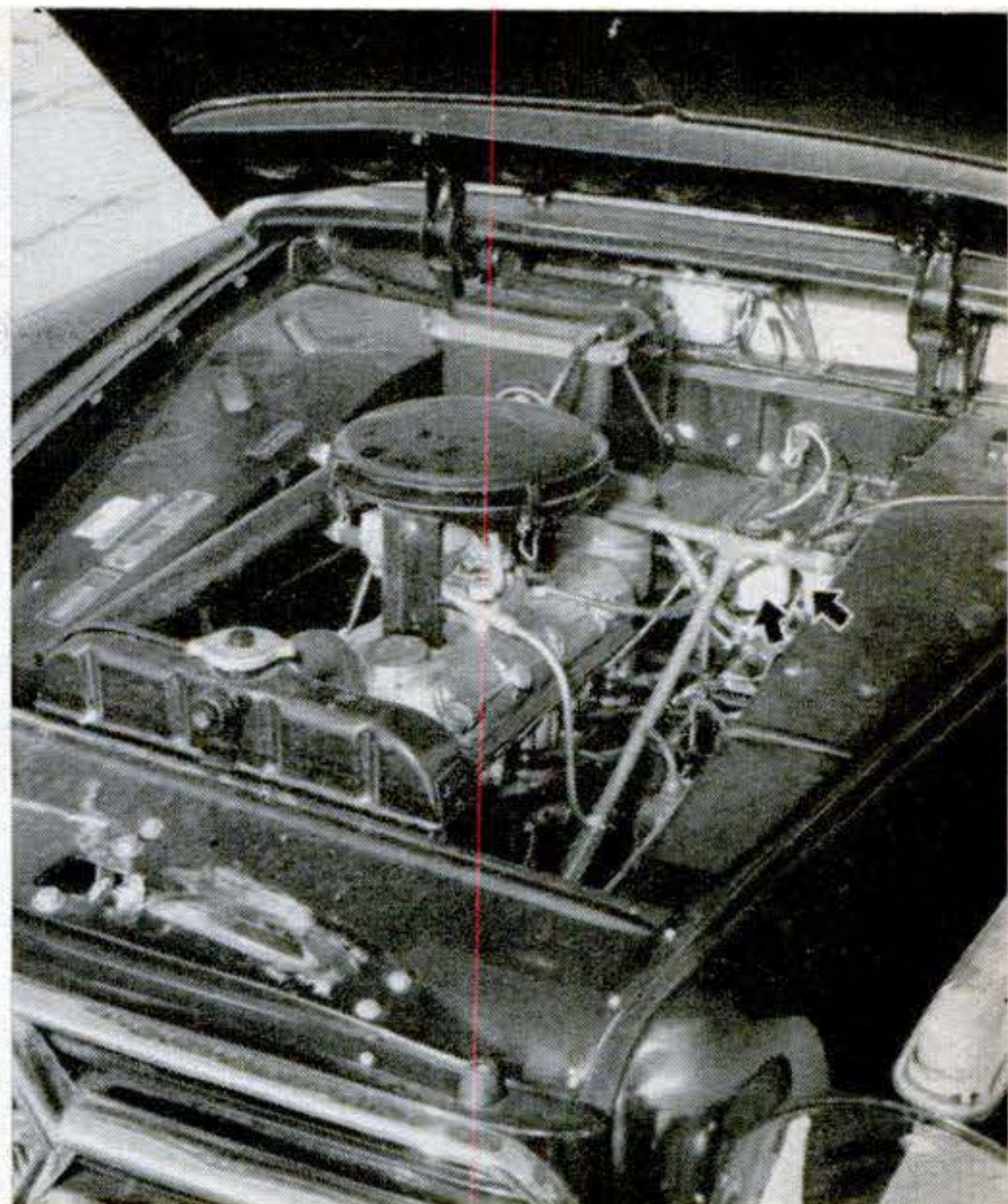

SNUGGED DOWN DEEP in the unit-body shell, the four-cylinder long-stroke engine has overhead valves in an aluminum head. T-shaped pipe on the right returns water from twin heaters. Two reservoirs (arrows) behind it hold fluid for the hydraulically operated clutch and brakes.

with Big-Car Ideas

imum—a big factor in the Borgward's excellent ride and road behavior. (It's the only kind of drive suspension worth having, some race drivers will tell you.) All four wheels are dynamically balanced.

Mounted on another cross member as one detachable unit are the front suspension, engine and transmission. The overhead-valve power plant has a bore of 2.95 and a stroke of 3.32 inches. Displacement is a meager 91 cubic inches (the Lark six's is 170, the Rambler American's 196). Compression ratio is 7:1 (8.2:1 in the boosted version). But with a 3.9:1 rear-axle ratio, the Borgward engine delivers 25 to 29 miles per gallon. Good mileage? *Natürlich*.

To find out more about the Borgwards, I borrowed a standard sedan and the more powerful Touring Sport from Fergus Motors in New York.

Bodies are the same, except for fender lights and a little more chrome on the higher-priced car. The Borgward is com-

pact, but not small. Less than 173 inches long overall (38 less than a '59 Chevrolet), it's at least a foot narrower than typical American cars.

There is no gee-whiz about Borgward



SHORTER BY FEET than the 1959 Ford wagon beside which it is lined up at the rear, the Borgward turns in a 36-foot circle. Browed headlights are single. Fender lights are worn by the Touring Sport and Sport Coupe only.

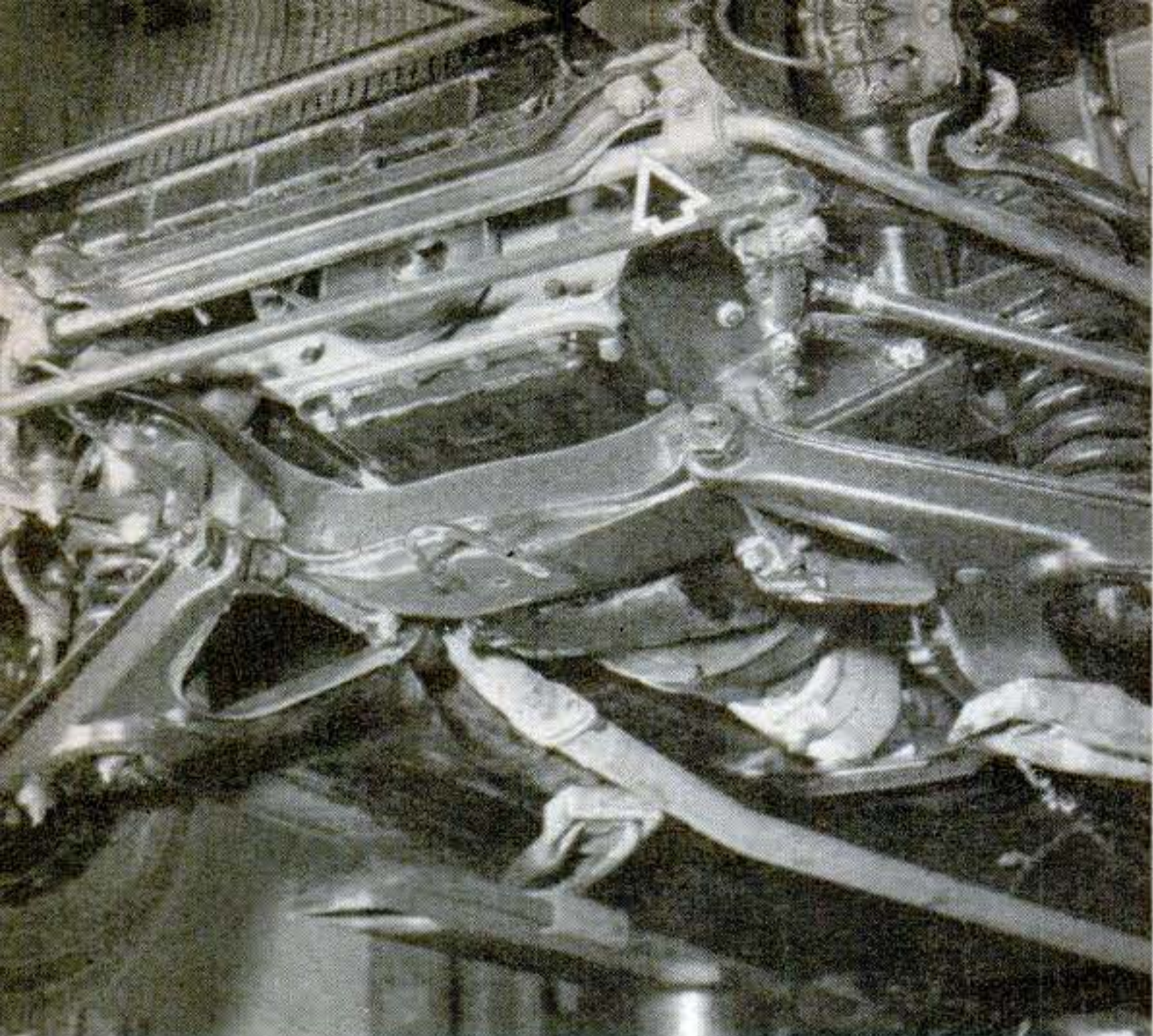

FRONT WHEELS ARE SPRUNG on conventional wishbones and coil springs, with an anti-sway bar across them (arrow). The engine, wheels and transmission are all mounted on the heavy crosspiece shown, and can be removed as a unit.

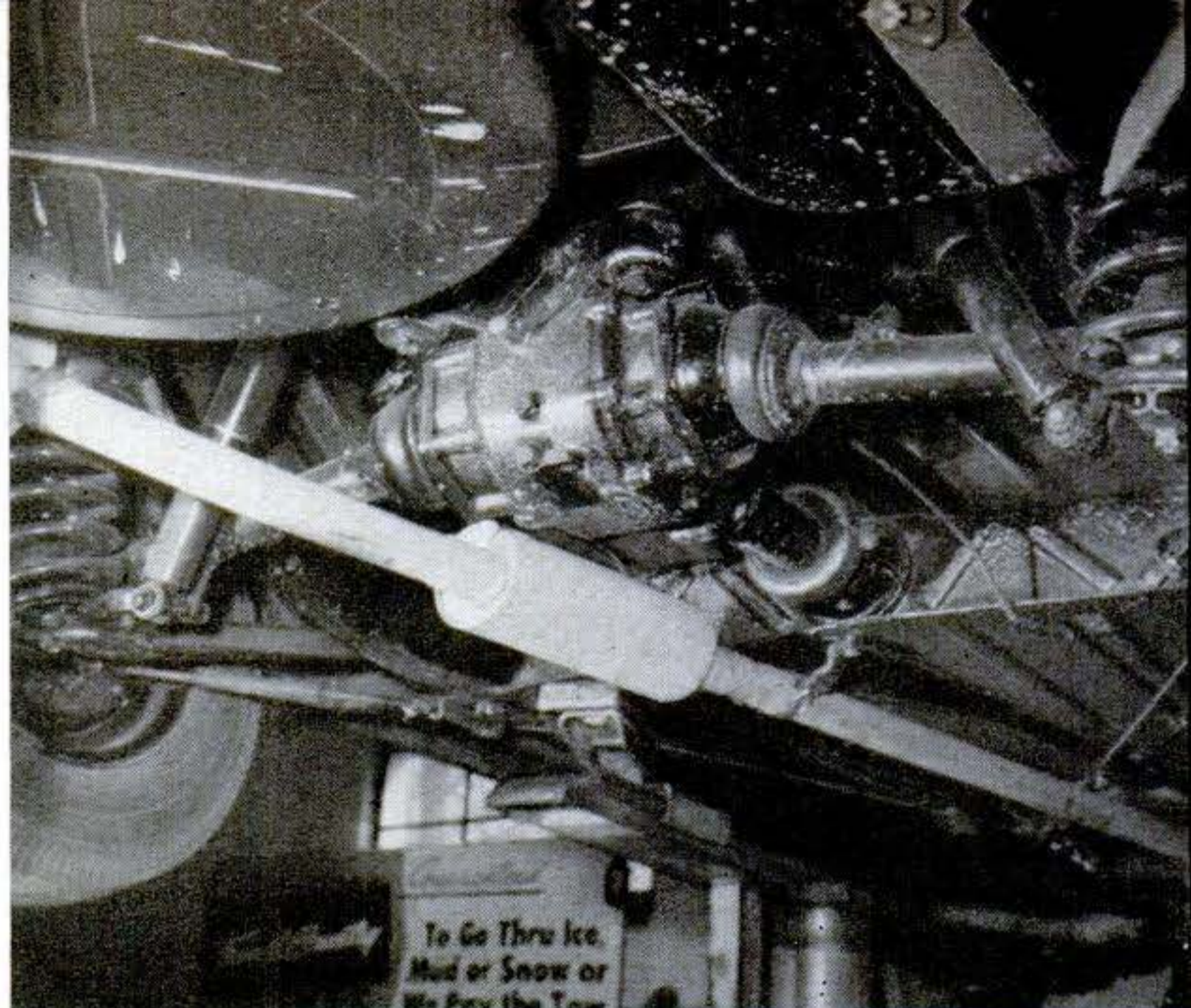

MOUNTED ON RUBBER but firmly fixed to the body-chassis, the differential drives the rear wheels through short swing axles, with radius arms taking the torque thrust. Gas tank is visible at top right, spare-wheel well at left.

styling. The car doesn't look like an arrow in flight. But it does avoid both the broad-hipped appearance of the American product and the shrunken small-car look of some imports. The body is enclosed underneath, and coachwork is so good that, as the manual quaintly puts it, "It is advisable to open a window a little when closing doors, which otherwise might be difficult due to air compression."

Up front inside, the Borgward has a gratifying big-car feel to it. A big man can stretch; leg room is a generous 46 inches, headroom a decent 36½. The front bucket seats in the Touring Sport

REAR WHEELS DROOP when off the ground, like those of the Volkswagen and Mercedes, and swing up and down on rough roads. Despite what would appear to be a scuffing action, tread wear up to 40,000 miles is reliably reported.



are superb. They have a micrometer tilt adjustment to suit the most finicky sacroiliac, and you can change it at a touch.

Except for a central hump, the floor is flat right up to the firewall, which it joins at a right angle. Pendant pedals leave the foot area clear. They're on the small side, but not so close together that you climb your own instep using them.

Looking for beefs, I found one in the shift linkage. Its throws are longer than ideal. Perhaps because the Touring Sport was brand new, getting into reverse proved tricky. Just a notch up from first, it requires a pull-out action of the lever, which inexplicably wound up in first gear at times. But as car and driver wear in, this trouble probably vanishes. All other shifts are a cinch.

Engagement of the hydraulic clutch is so smooth that even uphill starts are uneventful. You can wind up to 60 m.p.h. in third gear (or 70 with the heftier engine). Third is also the right ratio for quick traffic maneuvering.

The overall top gear ratio of 3.9:1 makes for quiet high-speed cruising. Throughway driving is no strain. On hills, you learn what the four-speed, fully synchronized gearbox is for. In view of the modest engine power, top gear amounts to an overdrive. But third will let you crest most grades at 50, or provide extra passing zip on the level.

The Borgward ride on smooth pave-

ment about equals that of Detroit cars. Drop off onto a rough shoulder or take a bumpy road, and the German car comes in ahead as the four-wheel independent suspension shows its stuff. Most bumps and holes are flattened out somewhere between the wheels and the seat of your pants. Those that aren't are held strictly to account by four telescopic shock absorbers. A fifth one, on the steering linkage, keeps road shocks from reaching your wrists.

Rear-drive swing-axle cars are supposed to oversteer. The Borgward begins to show this only in fast cornering. Normal steering is so obedient and effortless that you feel like a passenger at the wheel. Should the inside drive wheel break loose on a turn, a little more gas will put it back down.

Braking is sure, thanks in part to the suspension. There are 119.4 square inches of brake area to the car's 2,204 pounds, or 18½ pounds of weight per square inch—a ratio better than the Plymouth's 18.6 or the Imperial's 18.8, and almost as good as the Chevrolet's 18.1 Borgward stops are straight and certain even after repeated hard braking.

On road behavior, I'd come close to picking the Borgward as the car I'd most like to have on a cross-country drive, whether by turnpikes or take-as-they-come highways. It's as relaxing a touring automobile as one could ask. But it isn't a car for stop-light drags. I couldn't do better than 15.1 seconds in zero-to-50 runs with the 66-horse engine. The 82-

TURNING A BIG KNOB on the outside of each front seat in the Touring Sport adjusts back tilt. Folded down, seats form a 59-inch-long bed, with extra foot space under dash. Front hip room is 58 inches, shoulder width 53½.

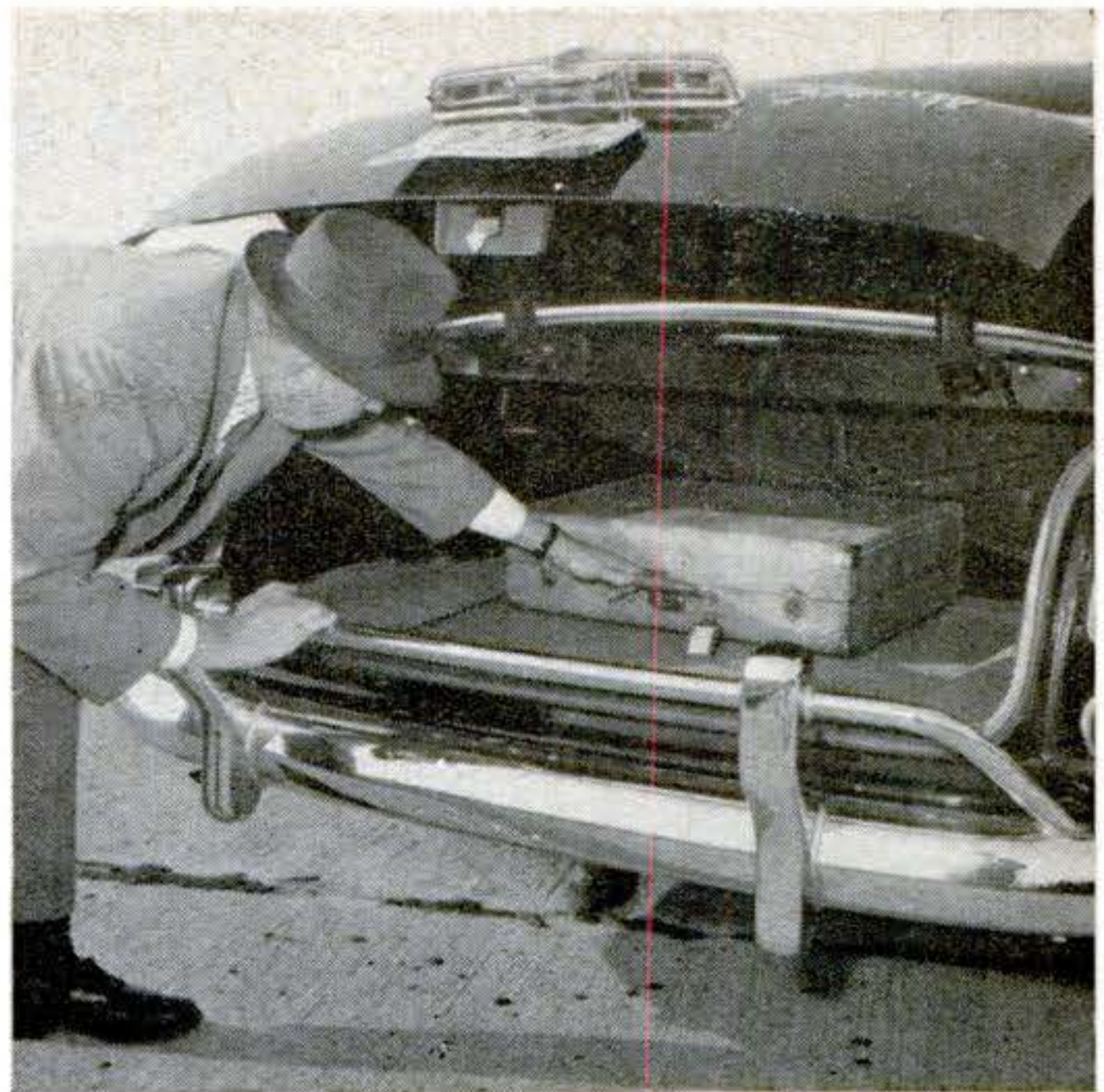

TRUNK GRIPE IS JUSTIFIED by the fact that the lid rises only 45 inches from the ground, making its edge and latch plate dangerous head bumpers. Trunk capacity is about 15 cubic feet. The spare wheel is under the floor mat.

horsepower car, too new for a legitimate acceleration try, would probably beat this by only a couple of seconds.

Docile parking manners proved a surprise—because of the Borgward's big-car feel. Pulling up alongside a station wagon that took every inch of its meter space, I got set for some close maneuvering to enter the one behind it. But the Borgward snuggled itself in at first try with no white knuckles on the steering wheel.

Looking closely at the inside of the Borgward, nobody could find fault with

[Continued on page 238]

TO OPEN TRUNK, pull the T handle under the left-hand armrest. No key is needed, and there's no lock that can be picked, but accidental release could be a hazard in heavy traffic. Rear windows are front-hinged, swing open.

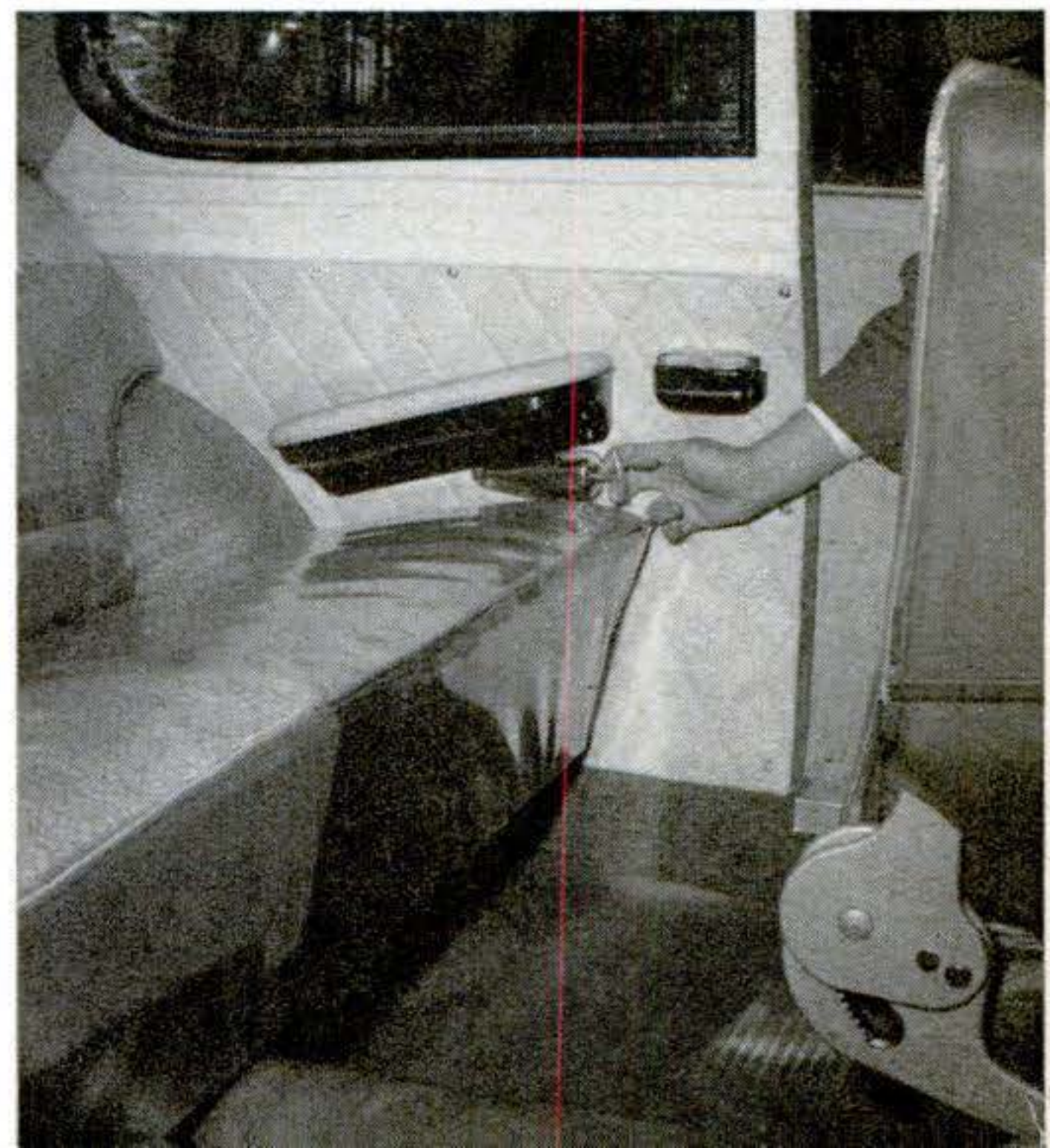

What's New



CAR-TOP CAMP tilts quickly off pivoted roof rack (top), can be set up as roadside picnic shelter in two minutes (center), or as full tent in seven minutes (bottom). Sky-Camp comes complete with two-burner stove, two beds, two chairs, tent, sink and water tank for \$660.

for the family car

It had to come: A rear-view periscope can now be mounted on your car's roof to give you an unobstructed view of traffic behind you. The scope also incorporates a wide-angle mirror in the conventional position inside the car to give you an additional view through the rear and side windows. National Safetiscope says their \$59.95 periscope can be installed in about an hour. Only problem encountered by those who've tried it is that looking where you've been is so fascinating you have to keep remembering to look where you're going, too . . . Anyone who has to change license plates frequently, such as auto dealers, can get a magnetic holder—you just slap the plate on and it sticks. Cleveland Products sells it for \$6 . . . Touch-up paints to match each year and make of car now come in spray cans by Dupli-Color for quicker, smoother results . . . Popularity of gold trim has also prompted Du Pont to bring out a metallic-gold touch-up. The Tip-on appli-

TRAVELING COFFEEPOT runs on house current or plugs into a car's 12-volt lighter socket. Price for Coffeequick is about \$19.



GAS-SAVER cuts fuel pressure at idle and cruise, reducing waste. The AC Spark Plug unit hooks into fuel line, sells for \$9.90.



cator with built-in brush sells for \$1 . . . New Lee oil filters contain a tiny rod of Feridium designed to act as a "sacrificial anode," similar to those found in water heaters. Metal-eating acids in the oil go after the Feridium instead of your engine, Lee says, and are neutralized by the chemical reaction. A pleated paper element performs the conventional job of mechanical filtering as well.

for your home

Baby concrete mixer holds five gallons and runs on a 1/3-hp. electric motor to speed masonry chores around the home. The Modern Mfg. Co., which sells it for \$59.95, says one man can mix 2 1/2 cubic yards a day with it . . . New ventilation fans designed to mount in the underside of roof eaves are claimed to cool better than conventional attic fans and cost less. Made by the Phil Rich Fan Mfg. Co., they're said to drop attic temperatures as much as 50 degrees on a 95-degree day outside . . . Pegboard is easier to put up now. New rubber wall spacers fit snugly over the mounting screws so they can't fall off just when you get the board halfway up. Masonite makes both the Pegboard and the spacers.

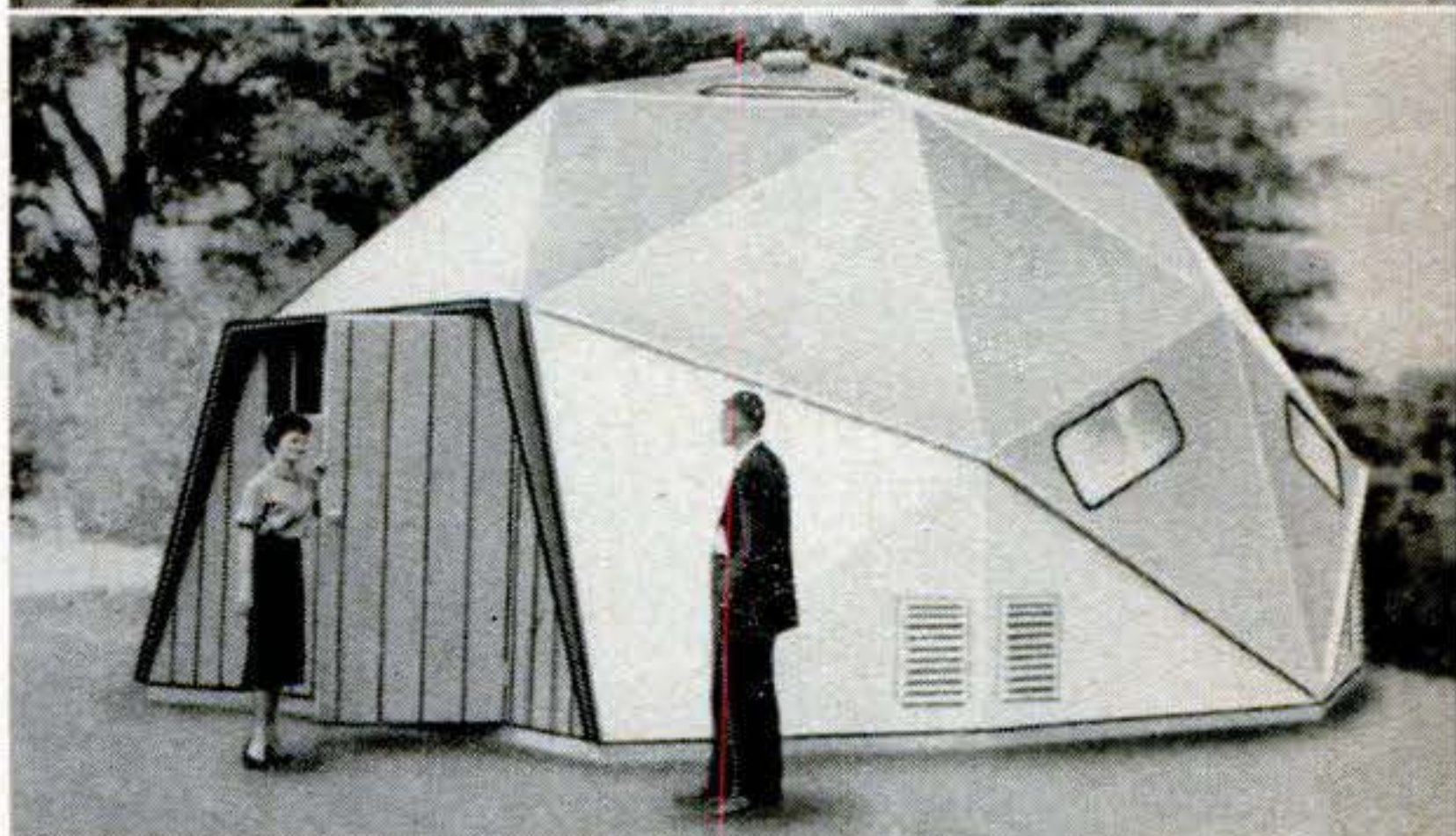

PORTABLE DOMES, based on geodesic principle, now come in kits for garages, summer cabins, other uses. Triangular plywood panels can be bolted together in 10 hours, taken apart later and moved with you. Pease Woodwork Co. sells the 13'-high, 26'-diameter dome for \$596.

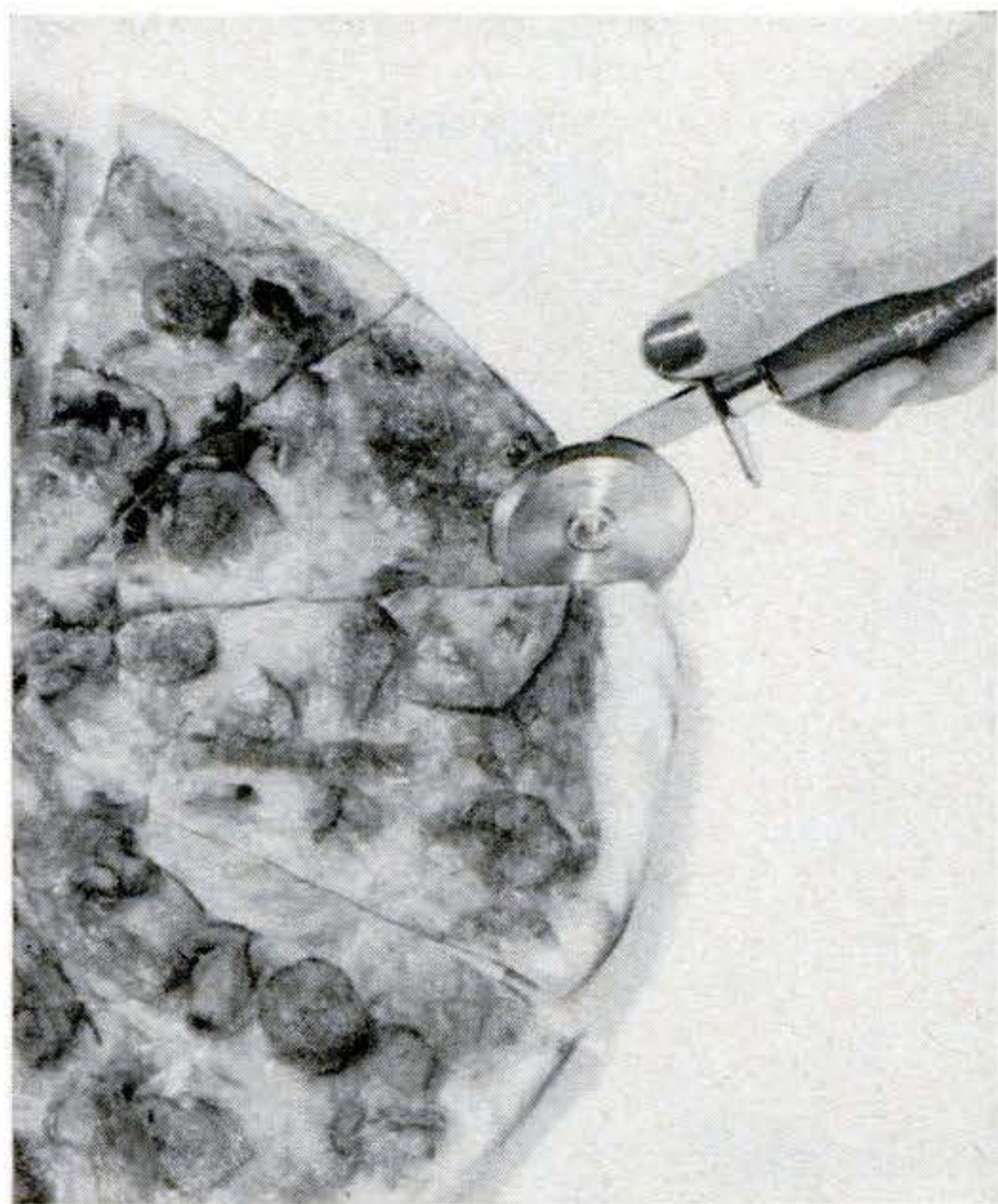

PIZZA CUTTER wheels in to cut a neat slice from a gooey, tacky pie. Hyde Mfg. Co., famous for wallpapering and other tools, sells the non-wallpapering cutter for \$1.59.



QUICK PUPS. Westinghouse cooker turns out six hot dogs in 90 seconds by "electrocuting" them between electrodes. Vital statistic: Americans consume 11 billion red-hots a year.

More new products on the next page

APRIL 1959 125

What's New (continued)

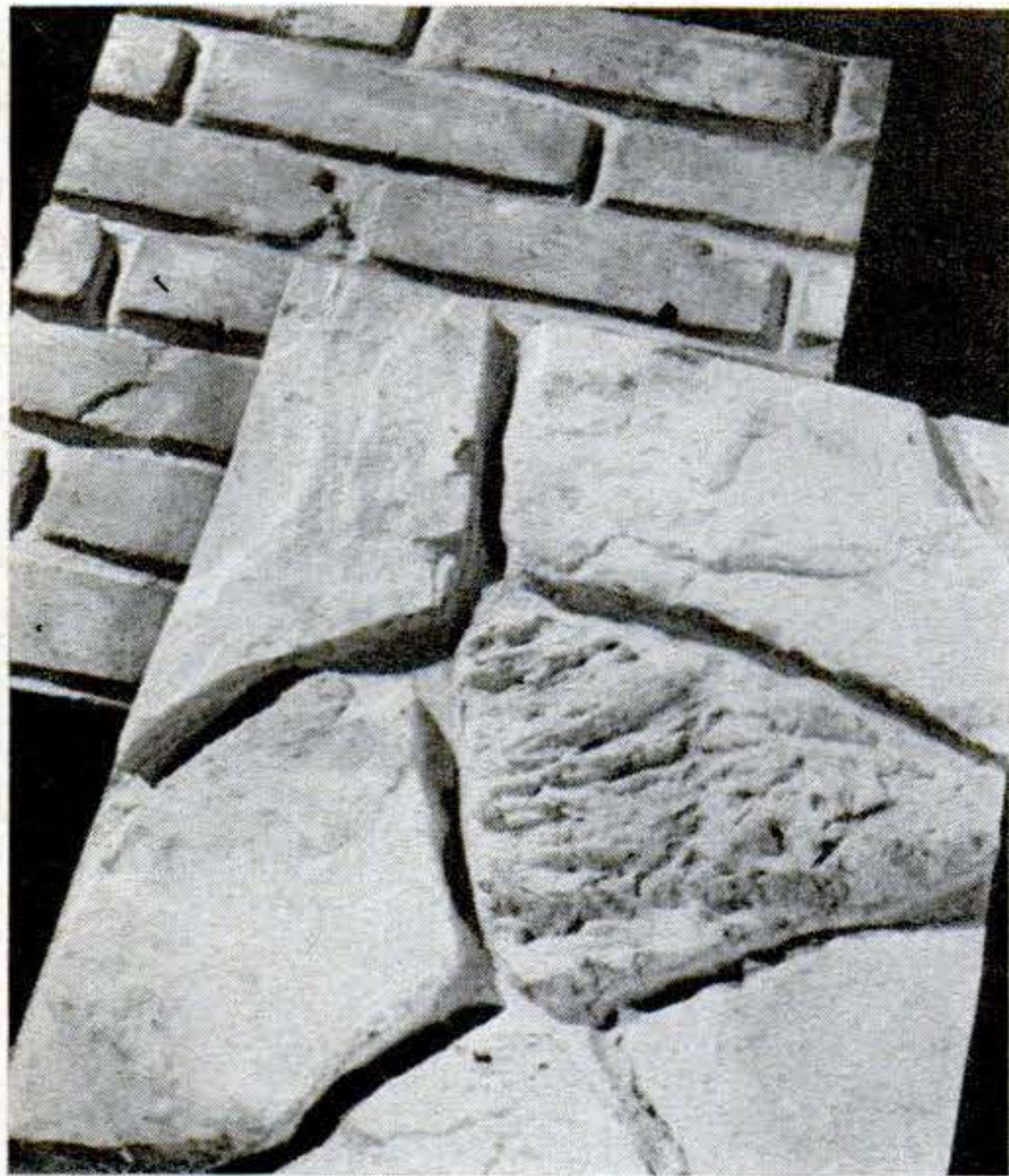

PLASTIC "STONE" now comes in special weather-proof type for facing exterior as well as interior walls. PanelStone sheets are 4' by 8', represent brick, fieldstone, other masonry.

BATTERY-RUN CLOSET LIGHT goes on when you open the door, needs no wires, can be slipped off mounting bracket for use as a flashlight. The Hollis Porta-Lite sells for \$1.25.

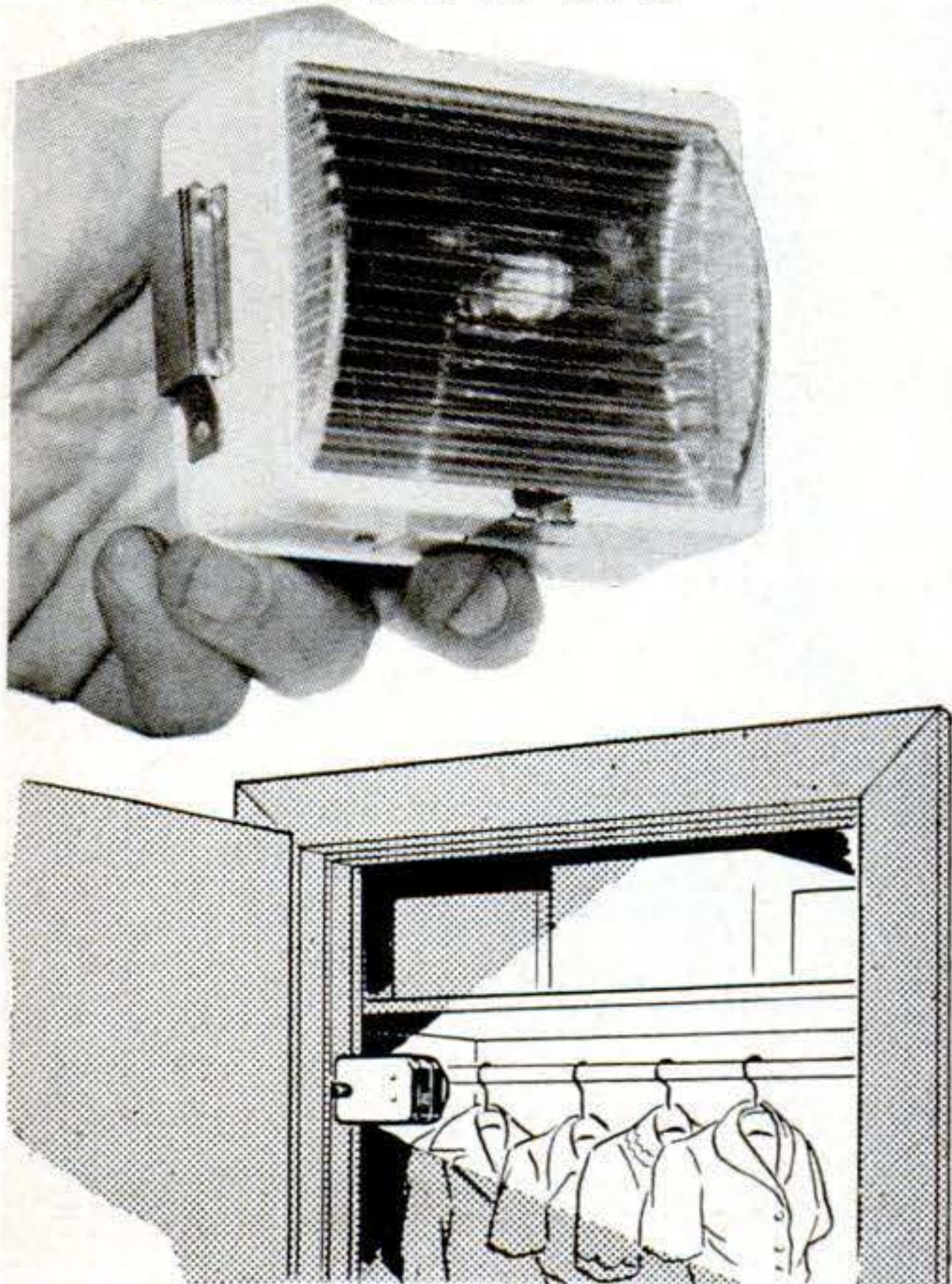

the latest in tools

New abrasive blades for portable saws by Clipper use glass-cloth reinforcement to speed cutting and guard against shatter on brick, block, tile and other masonry . . . Inexpensive bits for electric drills give you eight sizes of spade-type cutters from 1/4" to 1 1/4" that snap into one universal shank. A Parker bit set will cost you \$2.75 . . . Small-parts trays made to hang on perforated board are 18" long, sell for \$2 from Industrial Marketing Service . . . Quick-change motor mounts make it easy for one motor to serve several shop tools. A baseplate bolted to the motor slides into an interlocking plate on each tool. Basic kit of two tool mounts and one motor base is priced at \$4.95 from the Mercury Motor Mount Co. . . . If you keep losing tiny Allen wrenches, you can get a set of seven sizes that swing out of a holder like blades in a pocket knife. Upland sells it for 98 cents.

KITCHEN CONTROL CENTER lets your wife pilot up to six appliances at a time or keep them neatly stored in special racks. Sunbeam unit has clock timer, pushbutton circuit breakers.



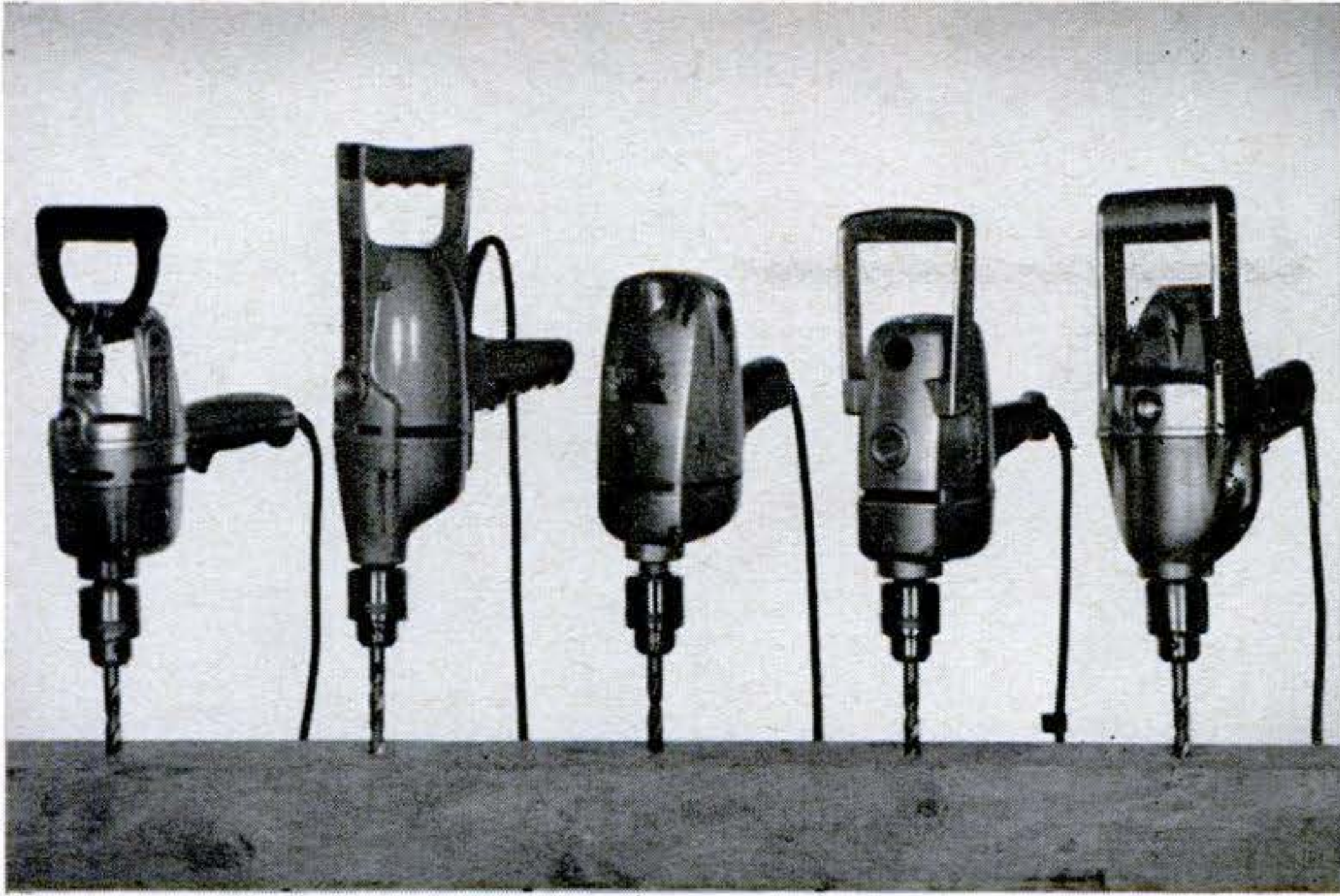

SLICKED UP, SLIMMED DOWN: New 1/2" electric drills, once considered strictly pro, are styled with a new eye on the home-shop market. Some weigh as little as eight pounds, sell for less than \$50. Left to right: Black & Decker, Millers Falls, Remington, Sunbeam, Thor.



TWO NEW BLADES, half-round and fine-cut, have been added to Stanley's line of Surform smoothing and shaping tools. Both fit either the plane or file holder, sell for 98 cents each.

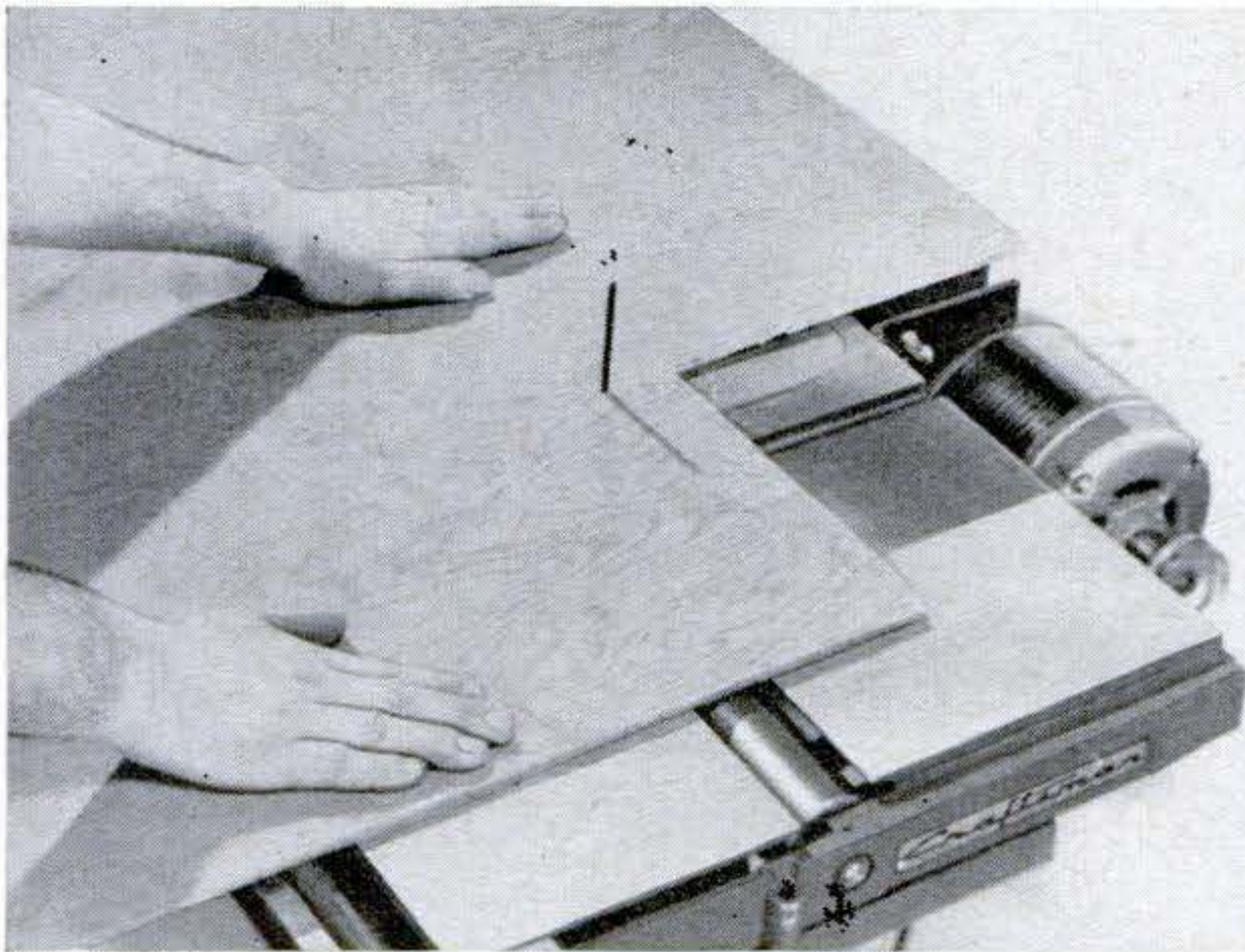

FIVE-IN-ONE-TOOL is Sears, Roebuck's new entry in the multipurpose field. Basically an 8" tilting-arbor bench saw, it sets up as a saber saw (above), jigsaw, disk sander and 4 1/8" jointer-planer. Center pedestal makes it easy to reach. Price: \$5 down, \$189.88 total.

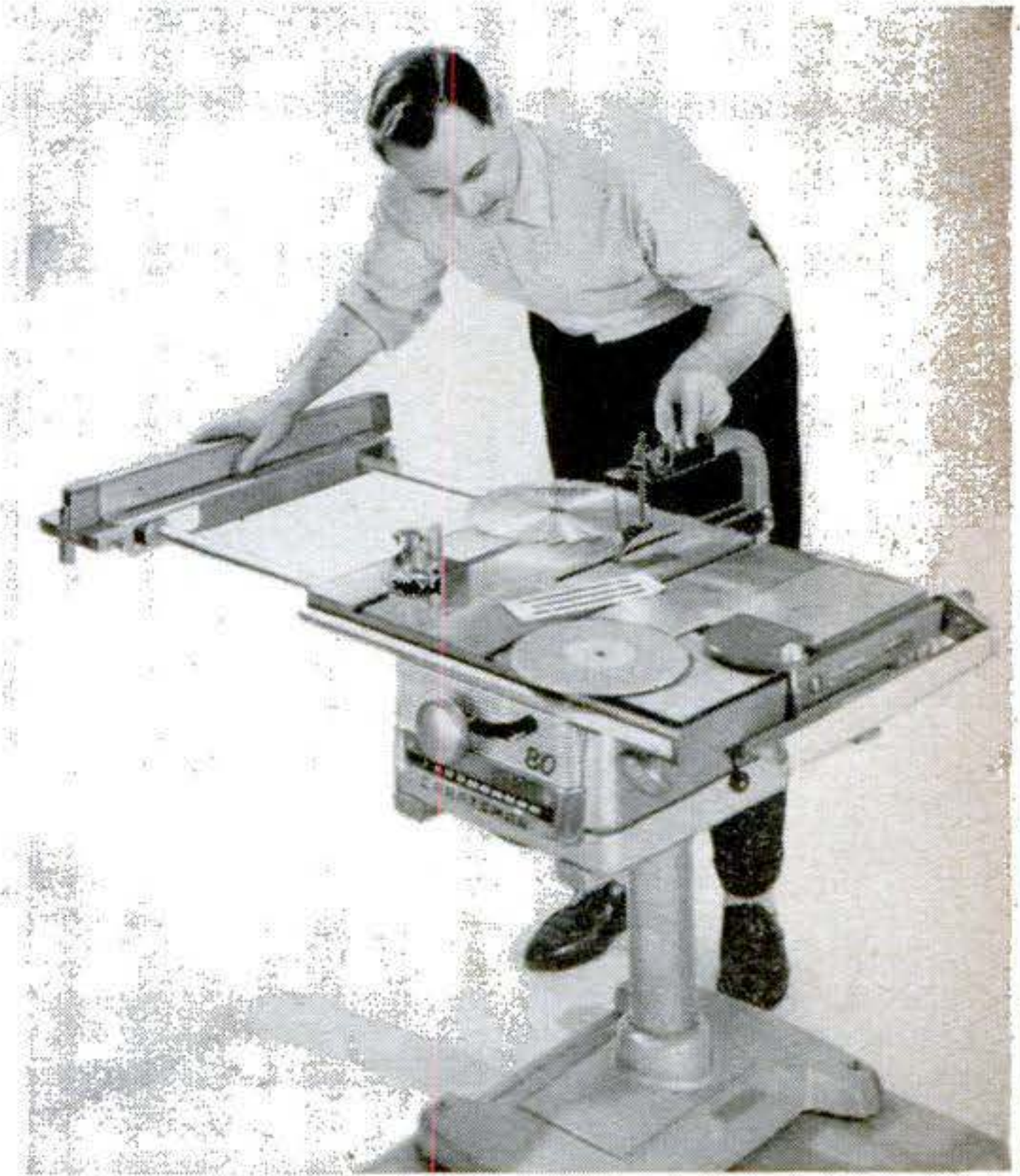

for more information:

Here's where to write if you can't get any item listed: AC Spark Plug Div., General Motors, Flint 2, Mich.; Black & Decker, Towson 4, Md.; Cleveland Products Co., Cleveland Bldg., Rock Island, Ill.; Clipper Mfg. Co., Kansas City 8, Mo.; Coffeequick, P. O. Box 643, Ithaca, N. Y.; Dupli-Color Products, Chicago 16; E. I. du Pont de Nemours, Inc., Wilmington, Del.; Hollis Co., 1133 Broadway, NYC; Hyde Mfg. Co., Southbridge, Mass.; Industrial Marketing Service, P. O. Box 2214-Ft. Dearborn Sta., Dearborn, Mich.; Lee Filter Corp., 41 River Rd., North Arlington, N. J.; Masonite Corp.,

Box 777, Chicago 90; Mercury Motor Mount, P. O. Box 48371, Los Angeles 48; Millers Falls, Greenfield, Mass.; Modern Mfg. Co., Pasadena, Cal.; National Safetiscope Corp., 206 N. Virginia St., Reno; PanelStone, 6111 Sylmar, Van Nuys, Cal.; Parker Mfg. Co., Worcester, Mass.; Pease Woodwork Co., Hamilton, Ohio; Phil Rich Fan Mfg. Co., 2900 Caroline St., Houston 4; Remington Arms, Bridgeport, Conn.; Sears, Roebuck, 925 S. Homan Ave., Chicago 7; Sky-Camp Stores, Inc., 9237 Long Beach Blvd., South Gate, Cal.; Stanley Tools, 111 Elm St., New Britain, Conn.; Sunbeam Corp., 5600 Roosevelt Rd., Chicago 50; Thor Power Tool Co., Speedway Mfg. Co. Div., La Grange Park, Ill.; Upland Industries, Upland 7, Pa.; Westinghouse Electric Corp., 246 E. 4th Ave., Mansfield, Ohio.

How a Spinning

When you cast

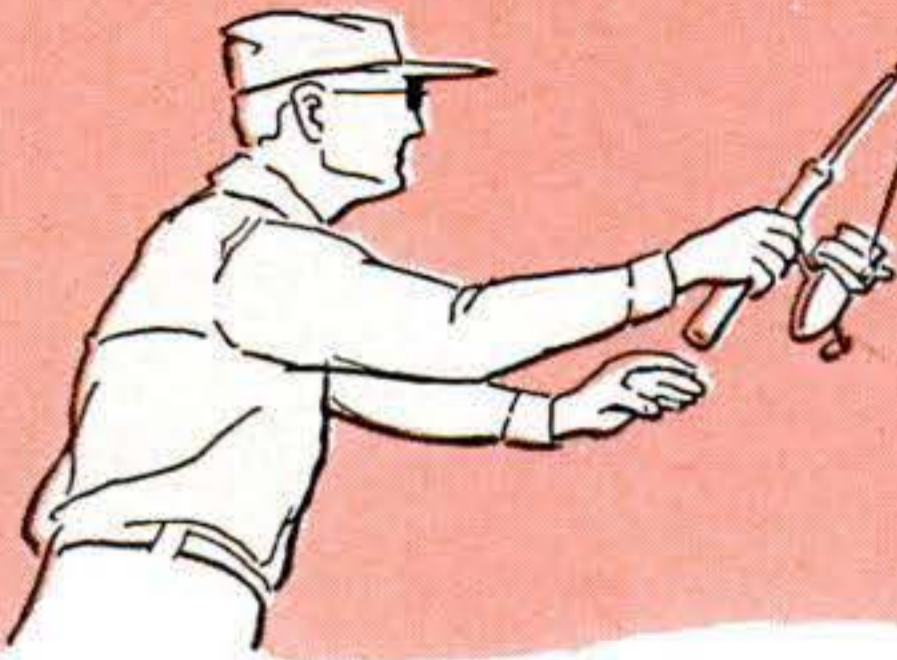

WITH THE BAIL SHOVED ASIDE and latched open against spring tension, line peels off the spool freely as you swing the rod forward. Because the spool doesn't move, line spills out only while the weight of the bait pulls it. To recover line, the bail must be closed.

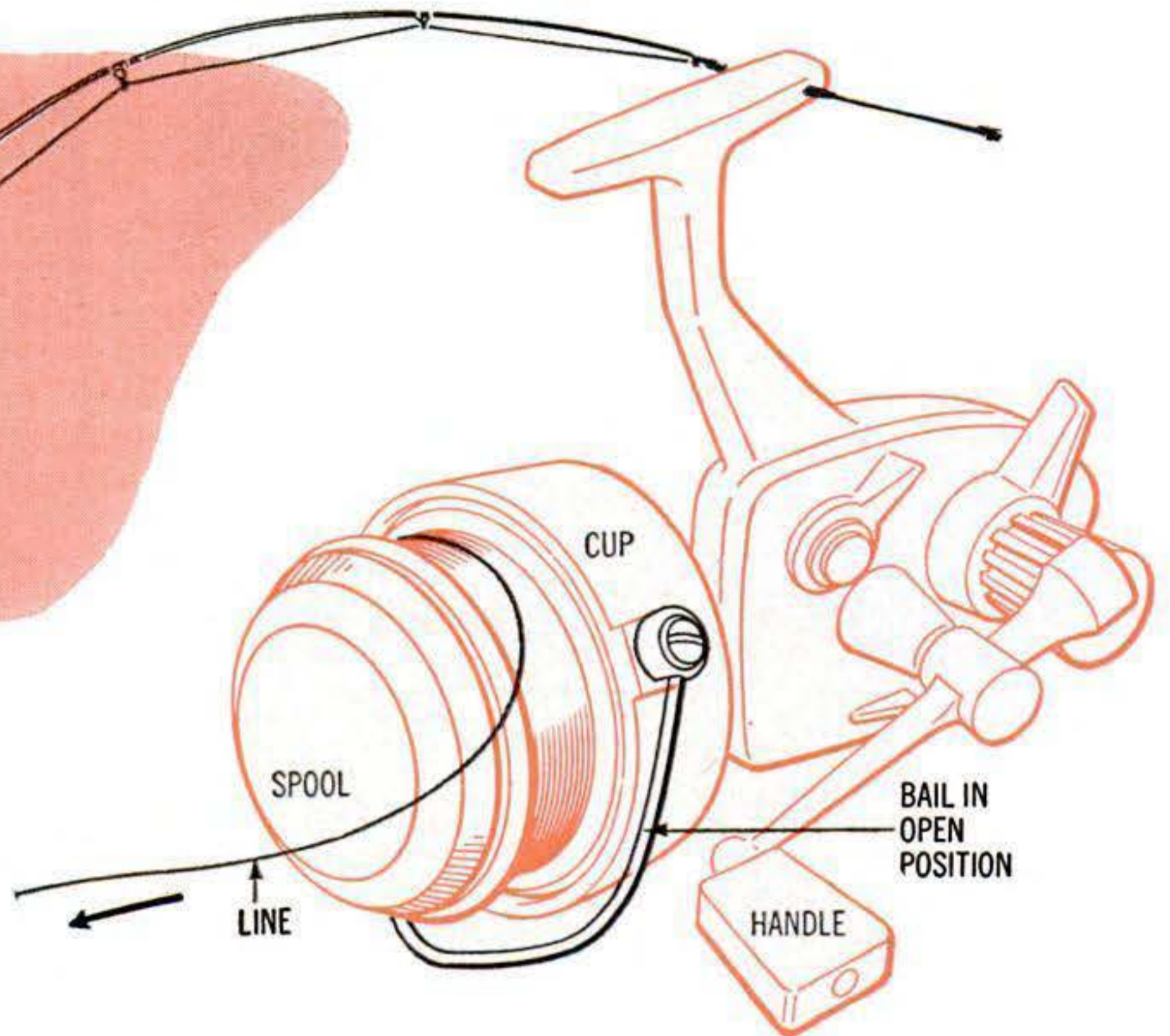

When you reel in

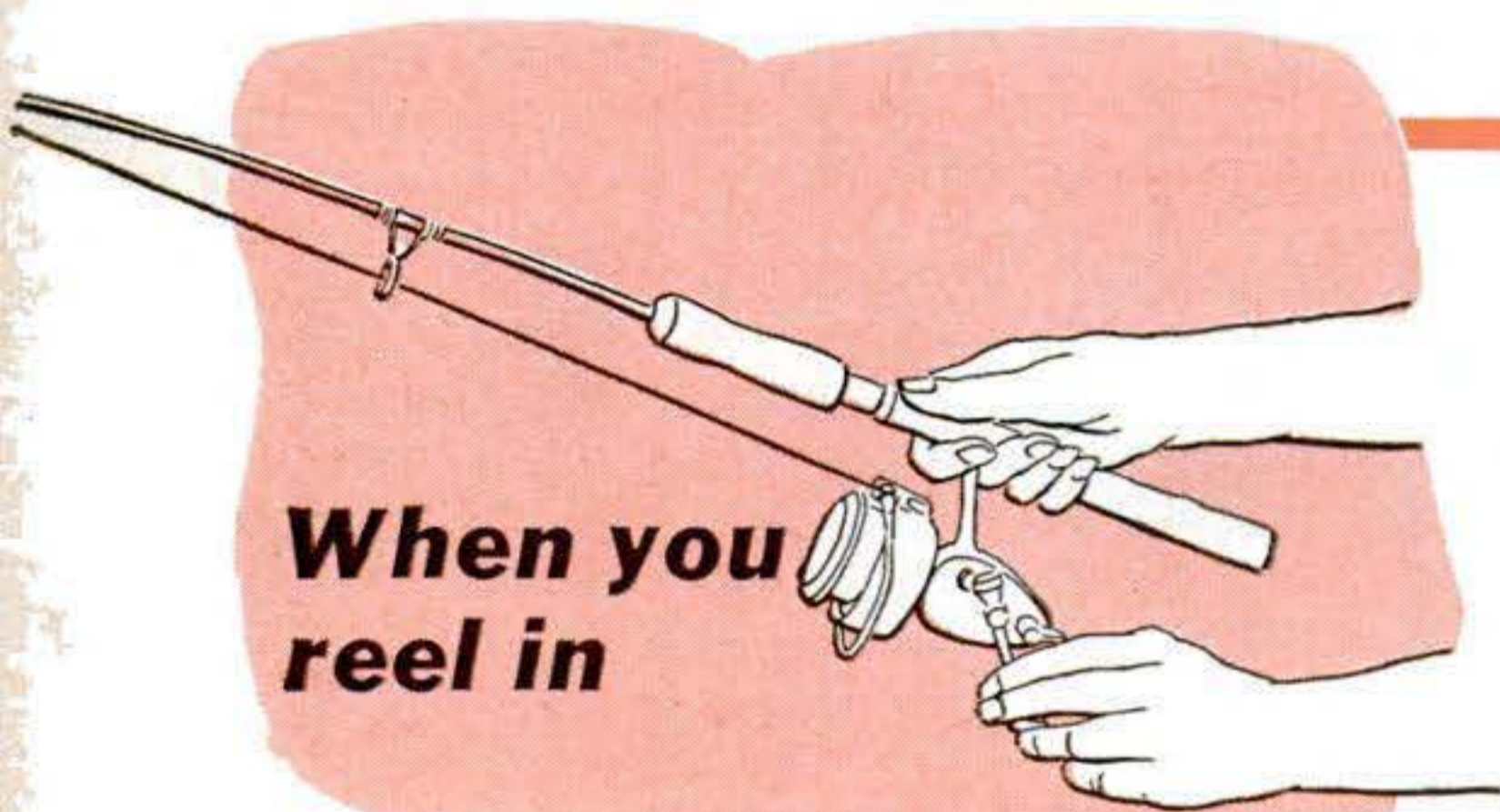

THREE THINGS HAPPEN: 1) Cranking the handle to reel in flips the bail closed first. The handle rotates the main gear, which turns the cup and attached bail by means of a pinion gear and hollow shaft. Before the cup makes one complete revolution, the bail latch (fastened inside the cup and protruding through a hole in the back of it) rides over a stationary ramp and is tripped. 2) As the bail snaps closed it intercepts the line, which rides onto a roller guide. The

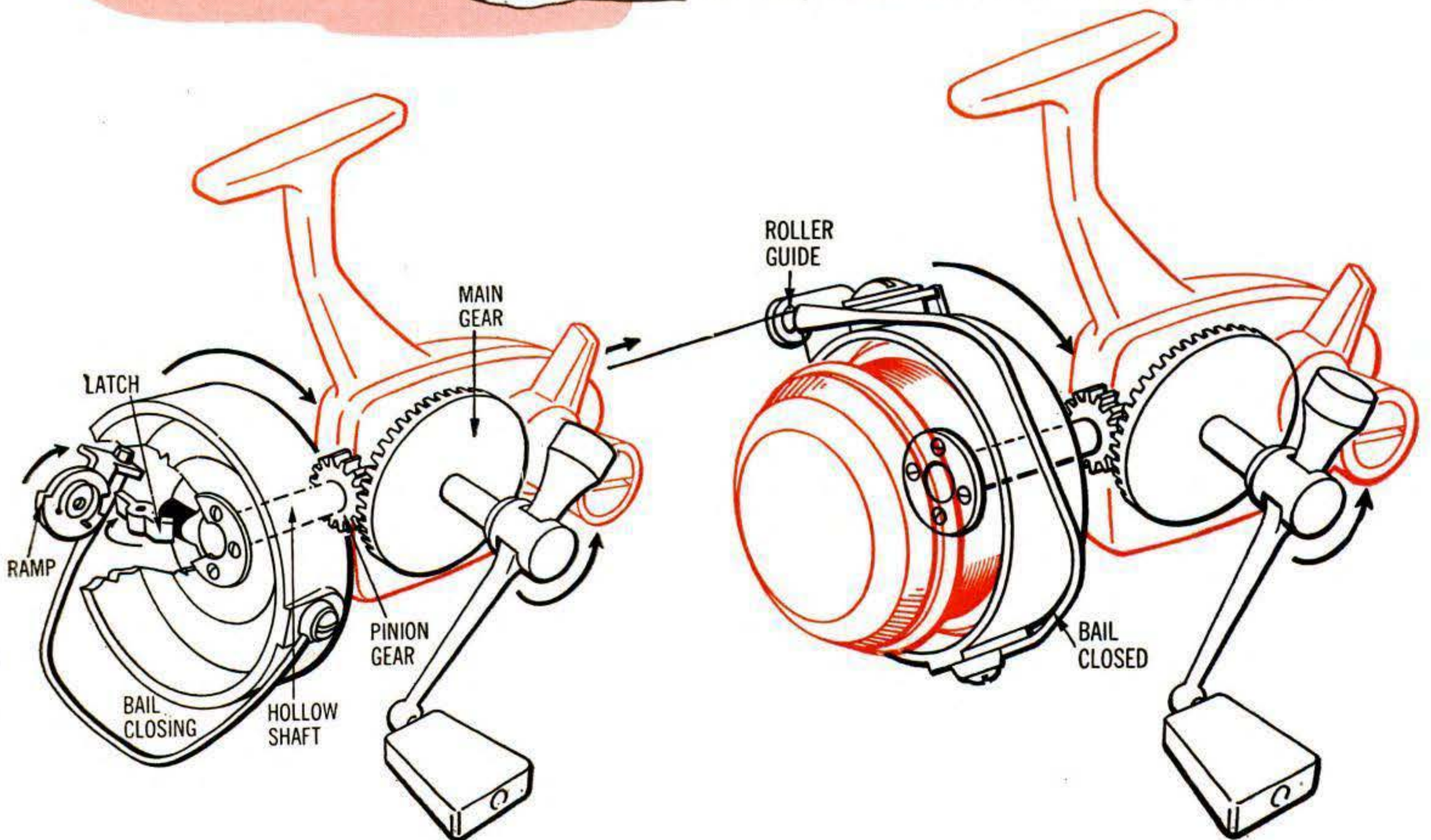

Reel Works

A COMPLETE dud at fishing, they say, can pick up a spinning rod and in 10 minutes learn to cast a good 100 feet. With a bit more experience he can drop a lure or piece of bait as light as $\frac{1}{16}$ oz. wherever he wants it, up to 150 feet away. Spinning reels are so easy to use because the spool stands still and the line spins off it; there is very little friction and no backlash at all.

Today every major tackle maker offers fresh- and salt-water spinning reels. The drawings used here are based on an Airex Larchmont. Spinning is popular now, and has been for a decade. But when the first reels were brought over from Europe in 1932 they had an uphill fight to win acceptance. Bait casters in particular, their thumbs educated to prevent backlash from fast-turning reels, were slow to try them.—*Erik Arctander.*

line is wound onto the spool by the rotating bail as you continue to crank the handle. The spool does not turn. 3) The spool moves in and out, however, to lay line on evenly. It's held onto the end of the main shaft by a spool nut. The main shaft, which passes through the hollow pinion shaft, has a yoke on the other end that rides on an eccentric pin on the main gear. Rotary motion thereby becomes reciprocal, in-and-out motion to spool the line on smoothly.

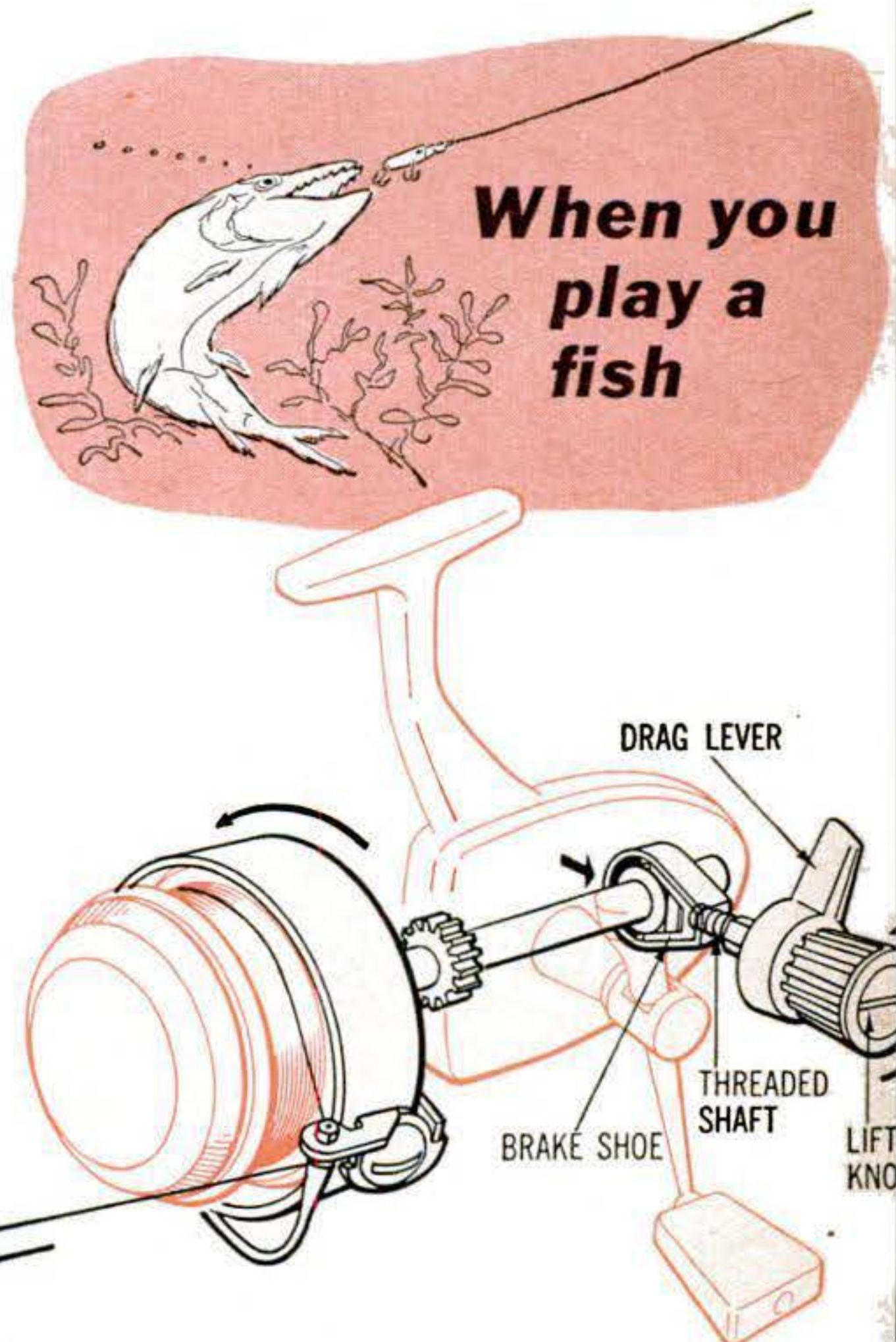
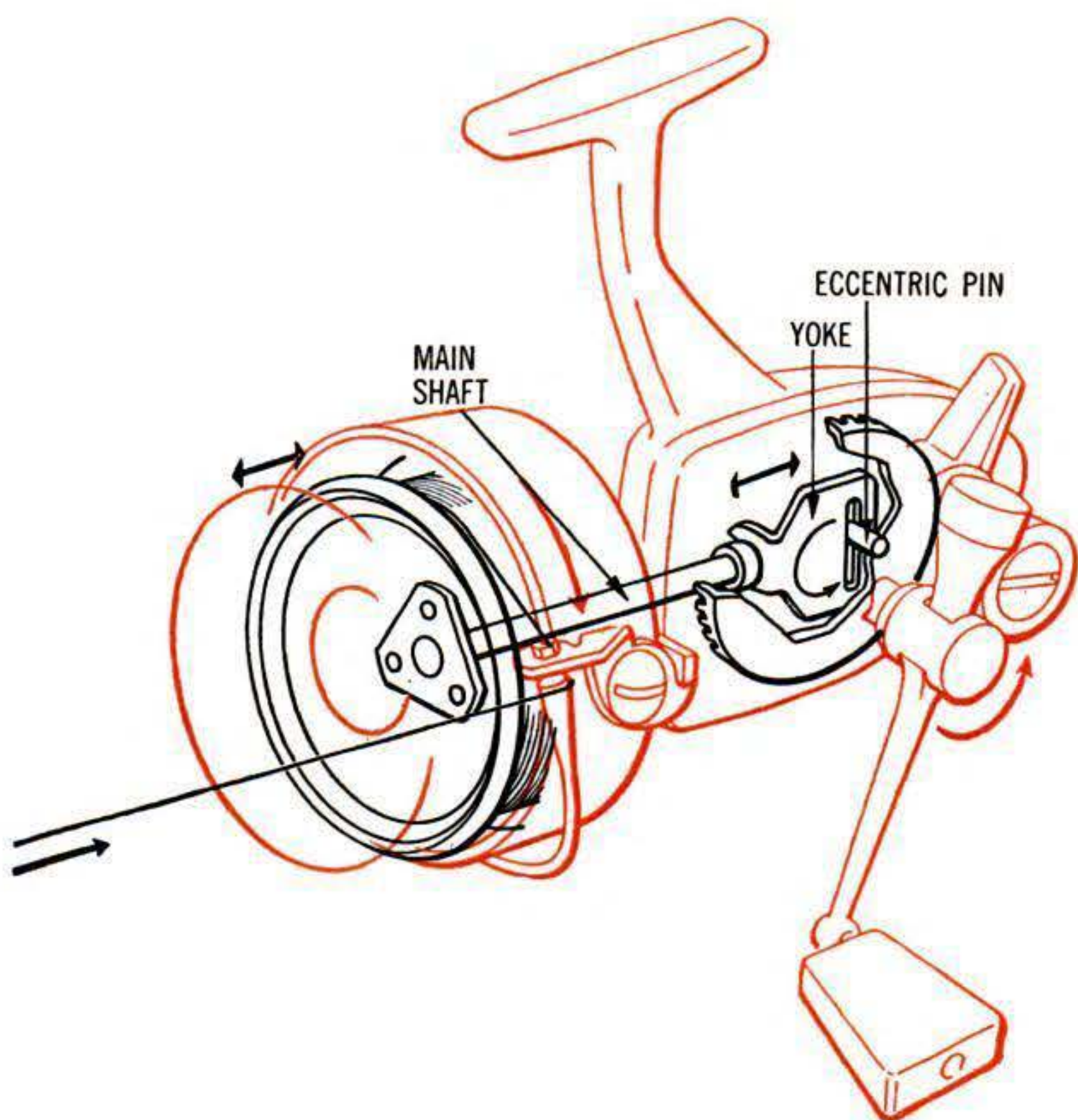

LINE PAYS OUT AS THE FISH PULLS while you are reeling in or have the anti-reverse lock on (see below). Because the bail is closed, the line rotates spool and main shaft as it unwinds. Flipping the drag lever ON screws in a threaded shaft and presses the brake shoe against the main shaft. The fish's pull is then resisted by friction between brake and main shaft. To adjust drag so it matches line strength you turn the threaded drag shaft with a pull-out knob that fits into the drag lever.

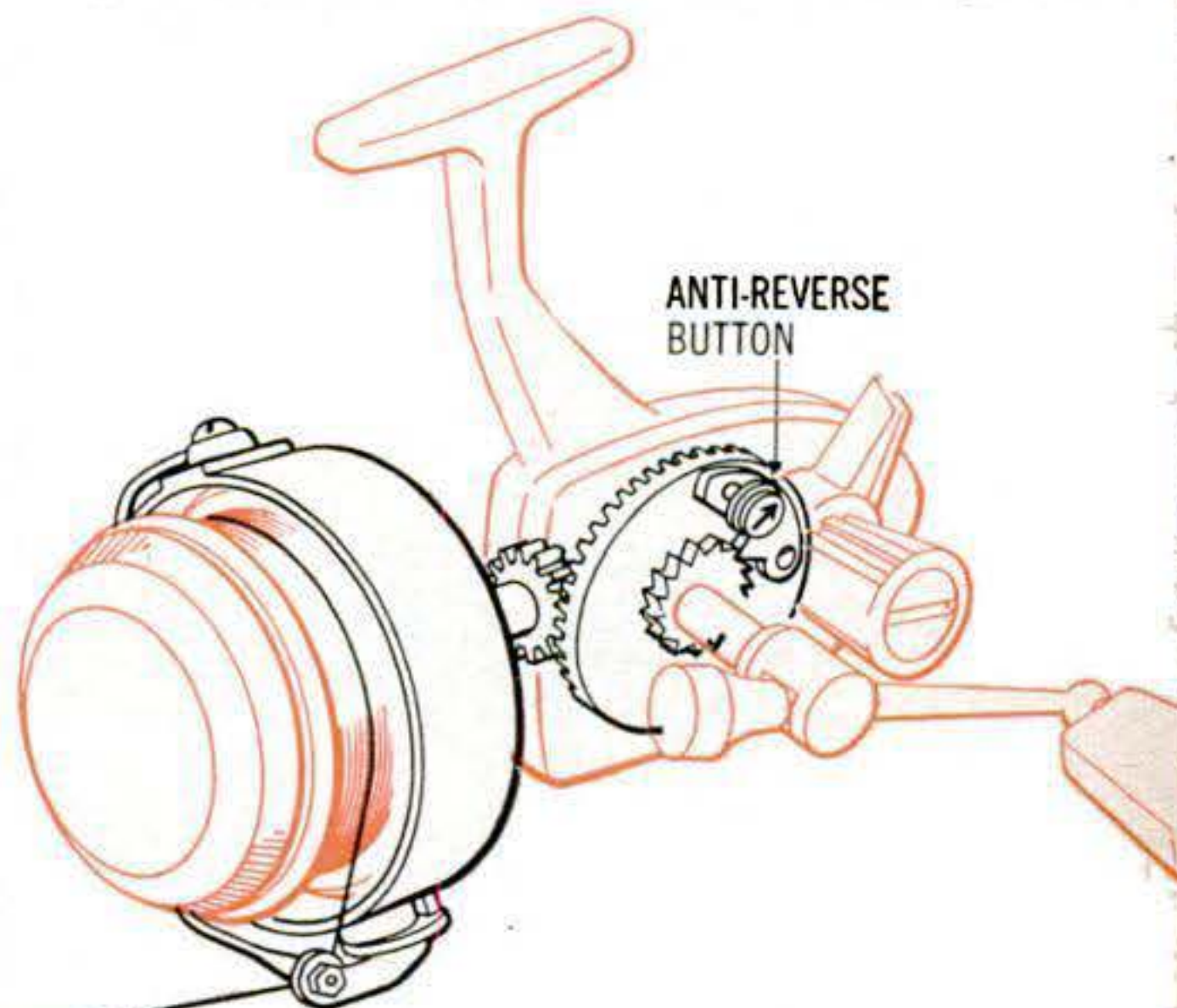

A PAWL ENGAGES A RATCHET on the same shaft as the main gear when you shove the anti-reverse button on. Now the handle and the bail driven by it will turn in only one direction—to reel in the fishing line.

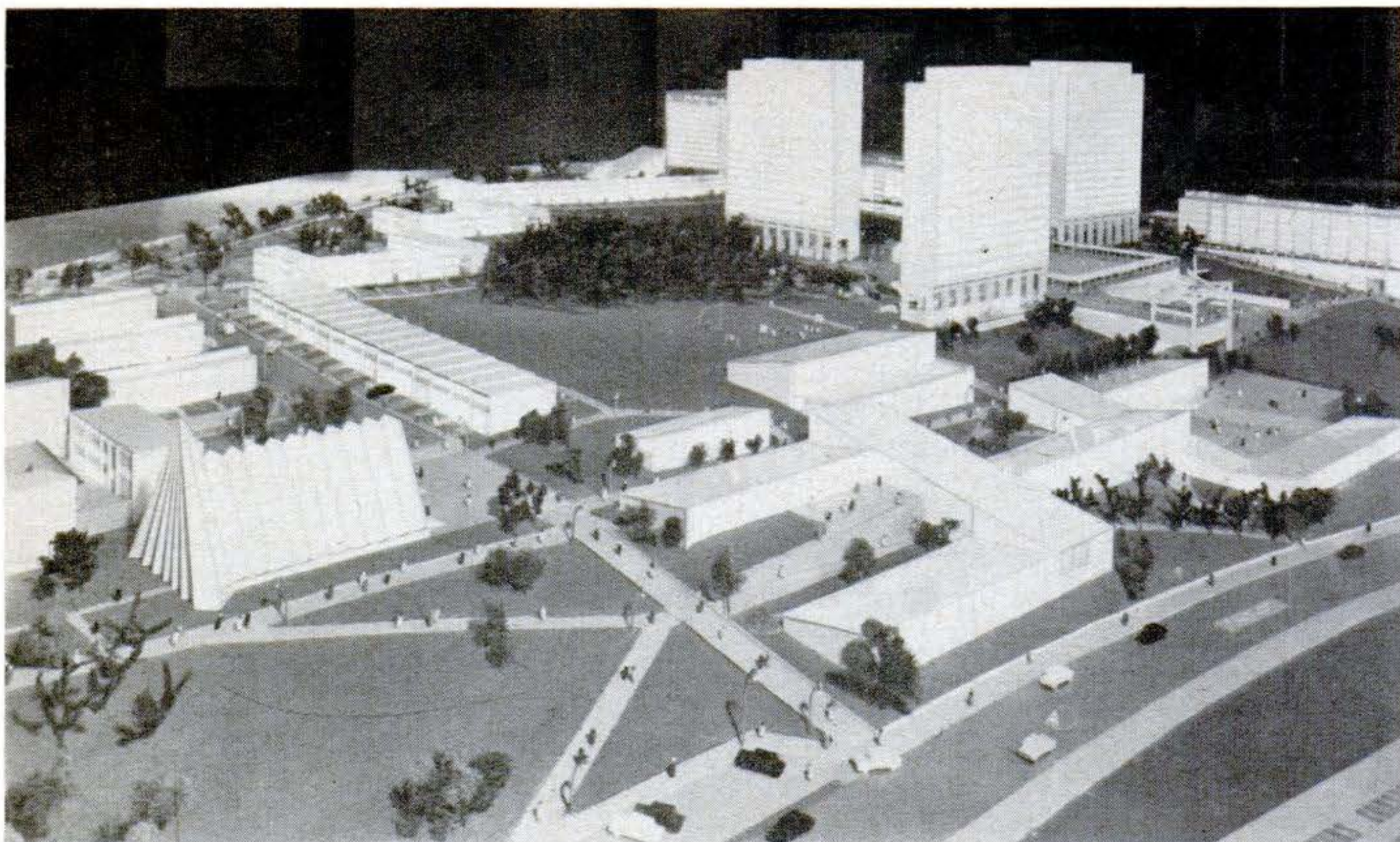

WORLD'S FAIR CITY. Belgium is planning an independent "city of the future," to be finished in 1961, on the site of last year's Brussels World's Fair. Shown in the architects' scale model here are a modern church (left foreground), school buildings behind it and tall apartment houses for 850 families (background). All garages will be underground.

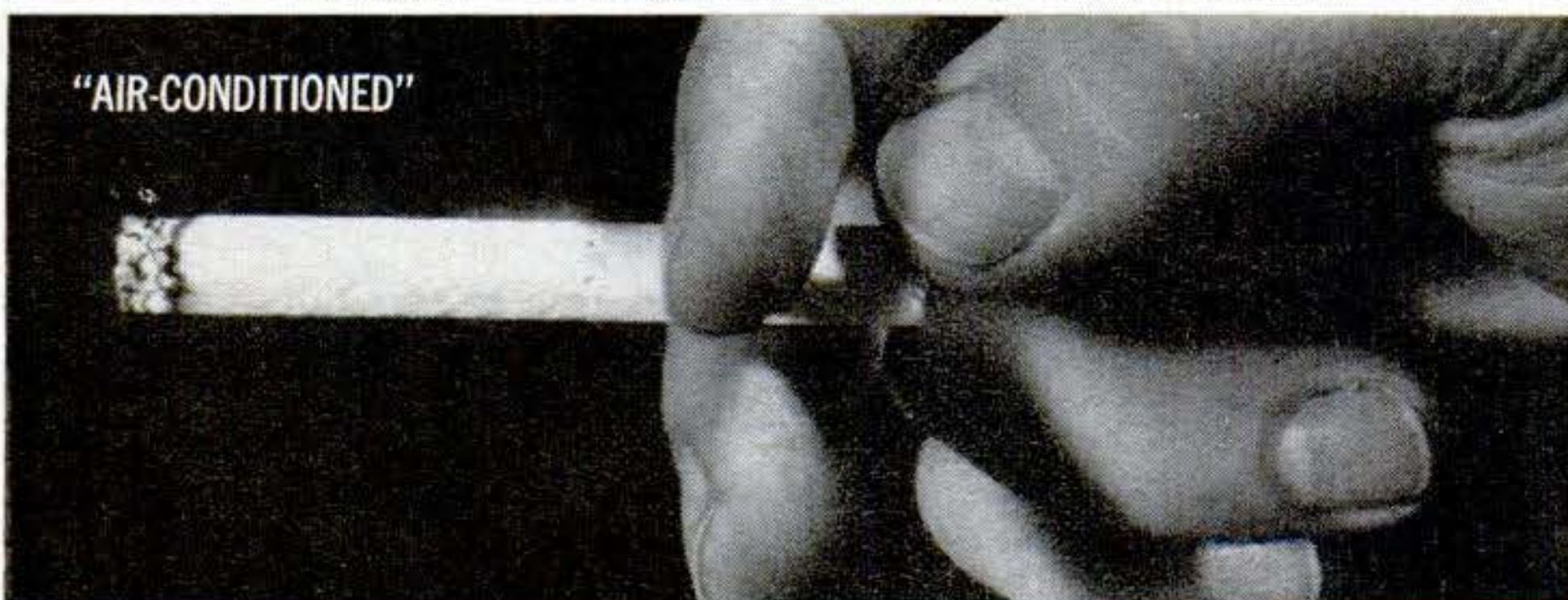
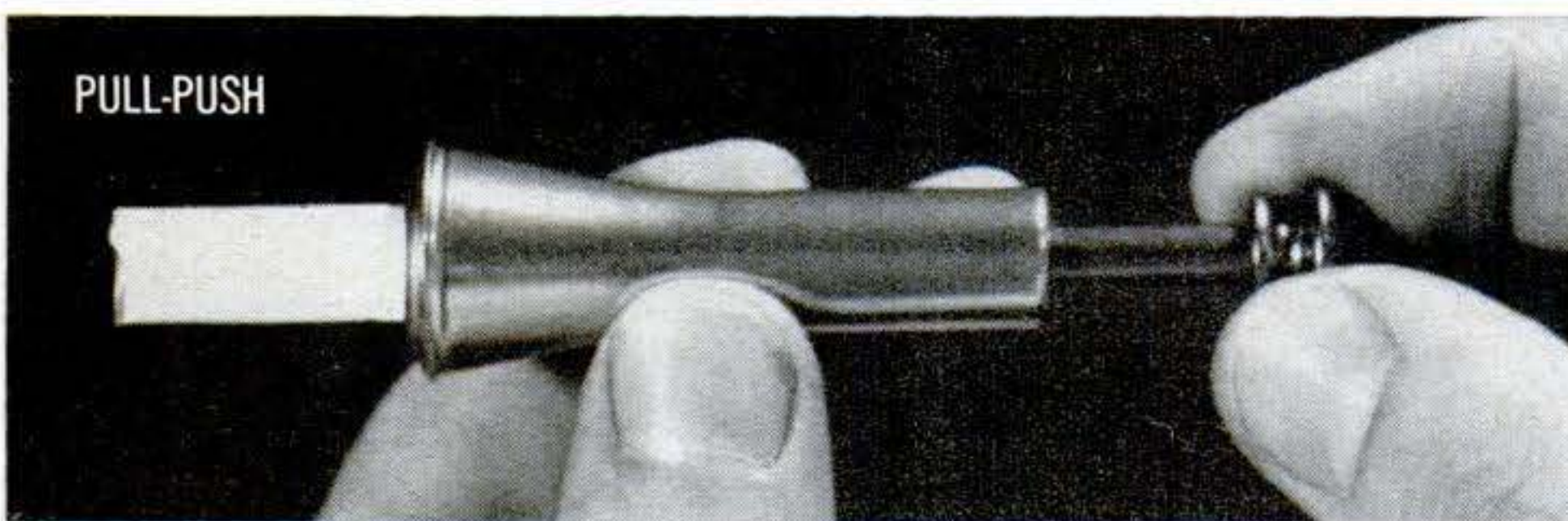

VENTED SMOKE.

This pocket gadget puts a ring of air holes in a cigarette to ventilate it as you draw, makes it burn longer and, says inventor Anthony P. Miller of Atlantic City, reduces the formation of tars by reducing heat. You place the cigarette—either a filter or non-filter type—in the cylinder, pull out the plunger, push it back in and, presto!—built-in air conditioning.



SPARROW WITH BIG STING. A split second after firing, a Sparrow III, newest Navy supersonic guided missile, streaks toward its target. Recently made operational with the Seventh Fleet in the Pacific, the deadly air-to-air weapon packs 50 percent more wallop than its predecessor.

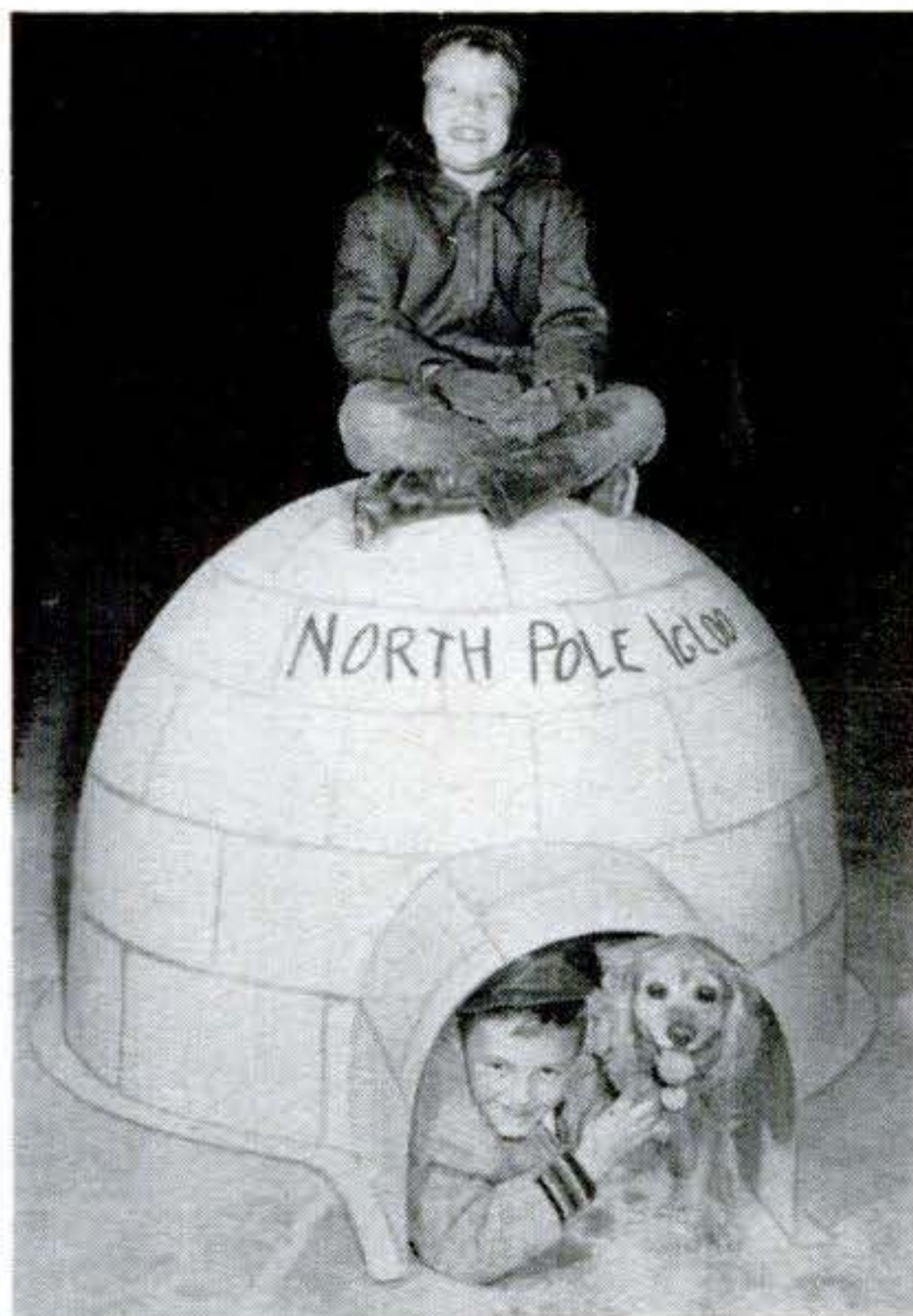

BOY-SIZE IGLOO. Semi-transparent walls of this fiberglass igloo admit light, provide good insulation, make it suitable for all-weather outdoor playing. A garden hose will clean it inside and out. The maker is D-C Reinforced Plastics Co., Denver.

DRY-FOOT BOAT. Built like an LST, the British boat at right has a hinged bow that drops down to serve as a gangplank. It lets passengers land on a beach or muddy bank without getting their feet wet; avoids clambering aboard over the gunwales.



RED-LIGHT BEATER. A car's speed is electronically measured as its wheels cross these twin channels—to hold the green signal and let the car get by. The system is being tested in London.



5 Ways

to Lick That Tired Feeling

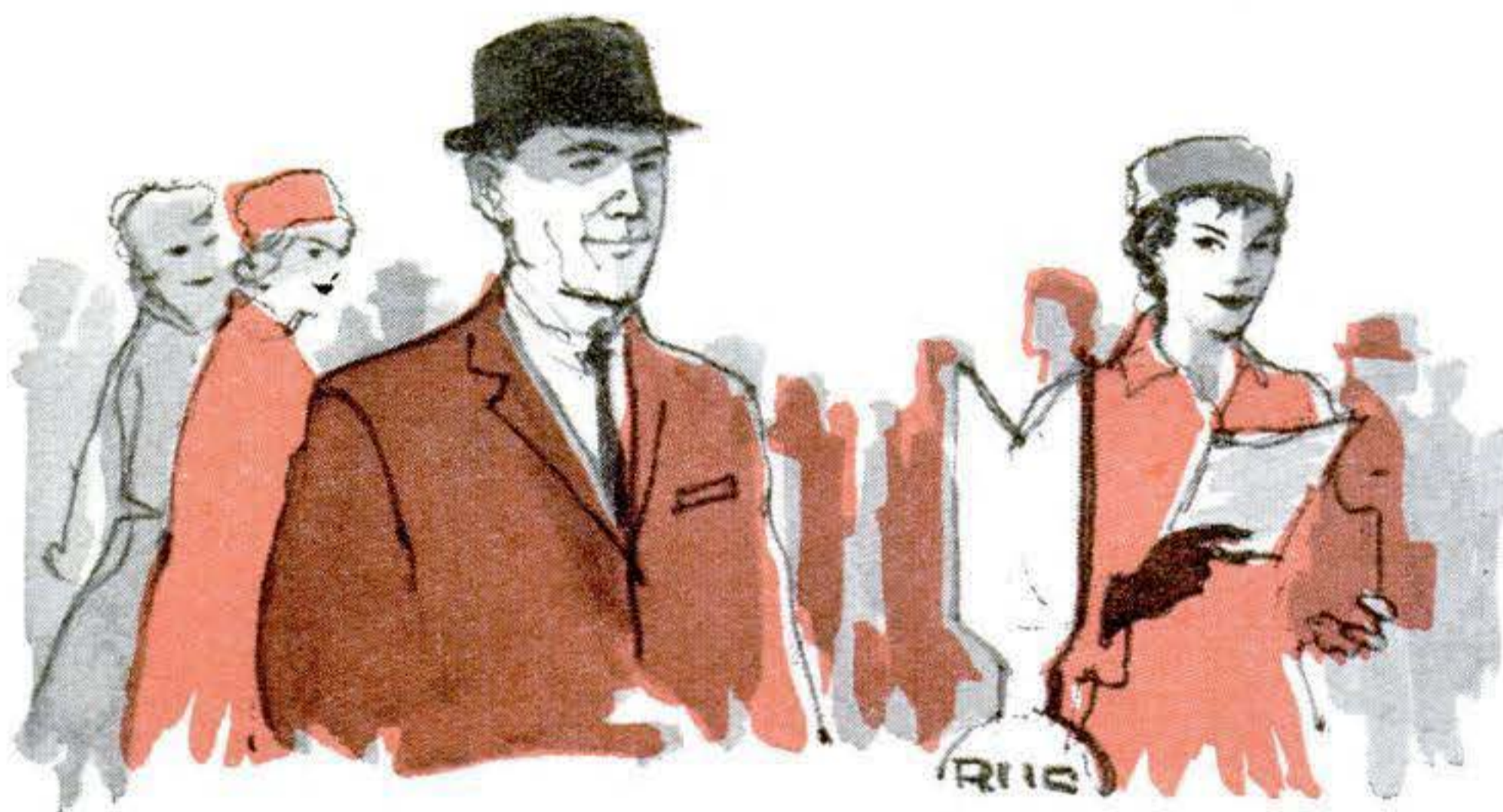

2 **Look energetic.** You model your actions on your mental image of yourself. So make the image a successful one: erect and neatly dressed; firm voice; plenty of healthy bounce.



4 **Plan ahead.** You get more accomplished with less effort if you budget your time—in writing. But don't set up an overly rigid timetable; you may waste energy keeping it.

Tire too easily? New discoveries show you how to tap stores of energy you didn't know you had

By John Kord Lagemann

IF YOU poop out too early, maybe you need vitamins. But maybe you just need to know the tricks of getting full use of the energy you have.

Today, scientists understand what makes you tired: why you *think* you're all played out when there is still plenty of get-up-and-go left in your machinery. You can use their findings to beat that tired feeling and get more done on the job or around the house—or just have more fun out of life.

What the scientists learned about fatigue is this:

- When you get tired, it's your brain

1 Keep healthy. Get the right amount of food and rest—too much is as bad as too little. Since fatigue may warn of illness, schedule a regular medical and eye examination.

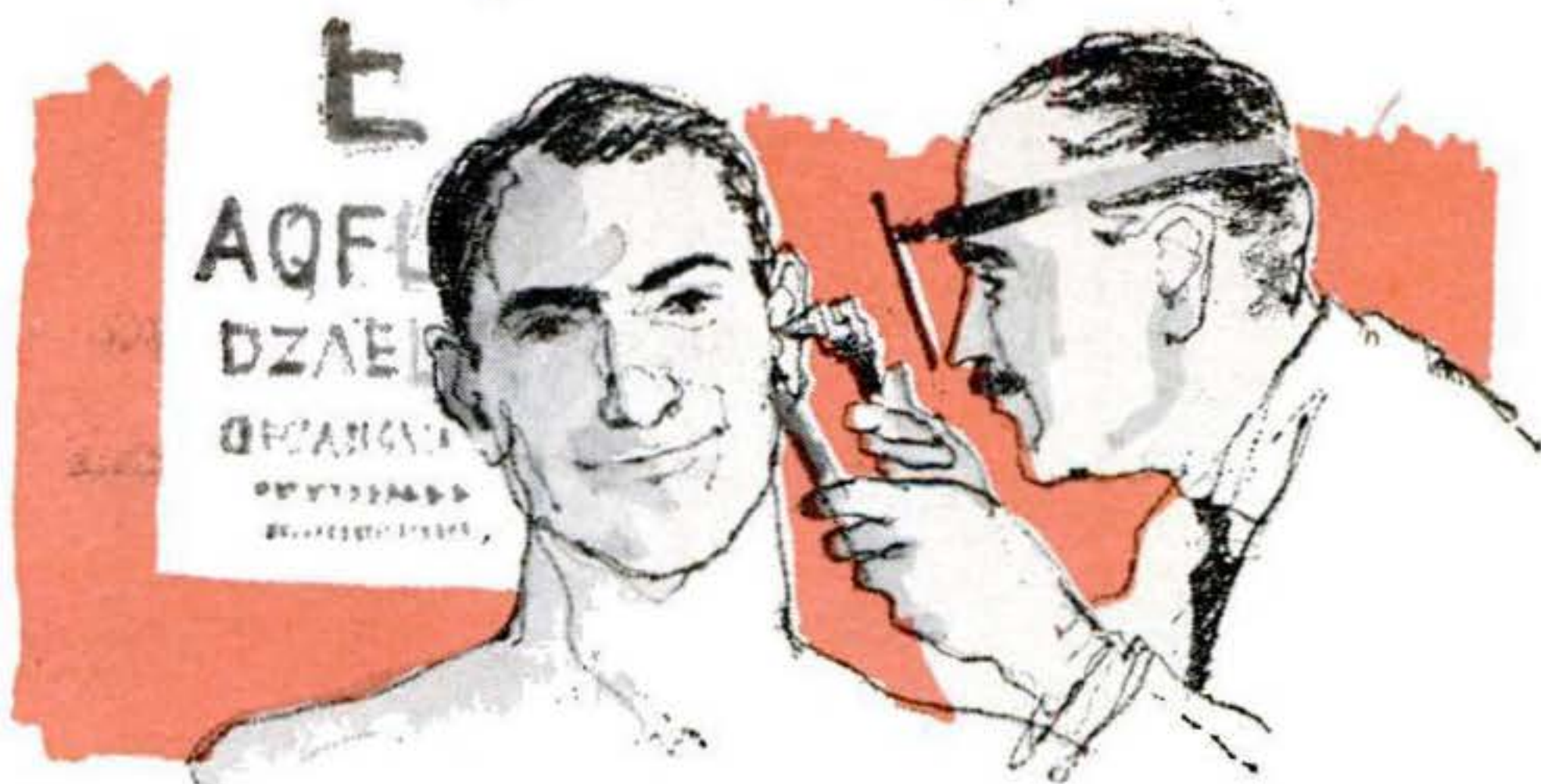

3 Think positively. Firm belief in your ability to do what you want to do helps you do it. But don't kid yourself—face your limitations and try realistically to overcome them.



5 Know your goals. Set definite—and reasonable—aims for yourself so that you can gauge your achievements. You'll advance from one to the next faster—and with less fatigue.



and not your body that says, "I've had enough."

- Two different signals can flash the tired sign in your brain. One is chemicals in your bloodstream, the waste products of exertion. This causes the healthy tiredness you feel after strenuous activity. The other signal is emotional. This causes the nervous exhaustion that overcomes you even when you've done no work.

- Both kinds of fatigue were designed

by nature to serve a useful purpose. But sometimes the signals go haywire and have to be reset. And this, it turns out, is not hard to do.

How tired is tired?

Long before Roger Bannister beat the four-minute mile, Dr. Robert S. Schwab predicted it would be done. It was no rash speculation. Dr. Schwab and his

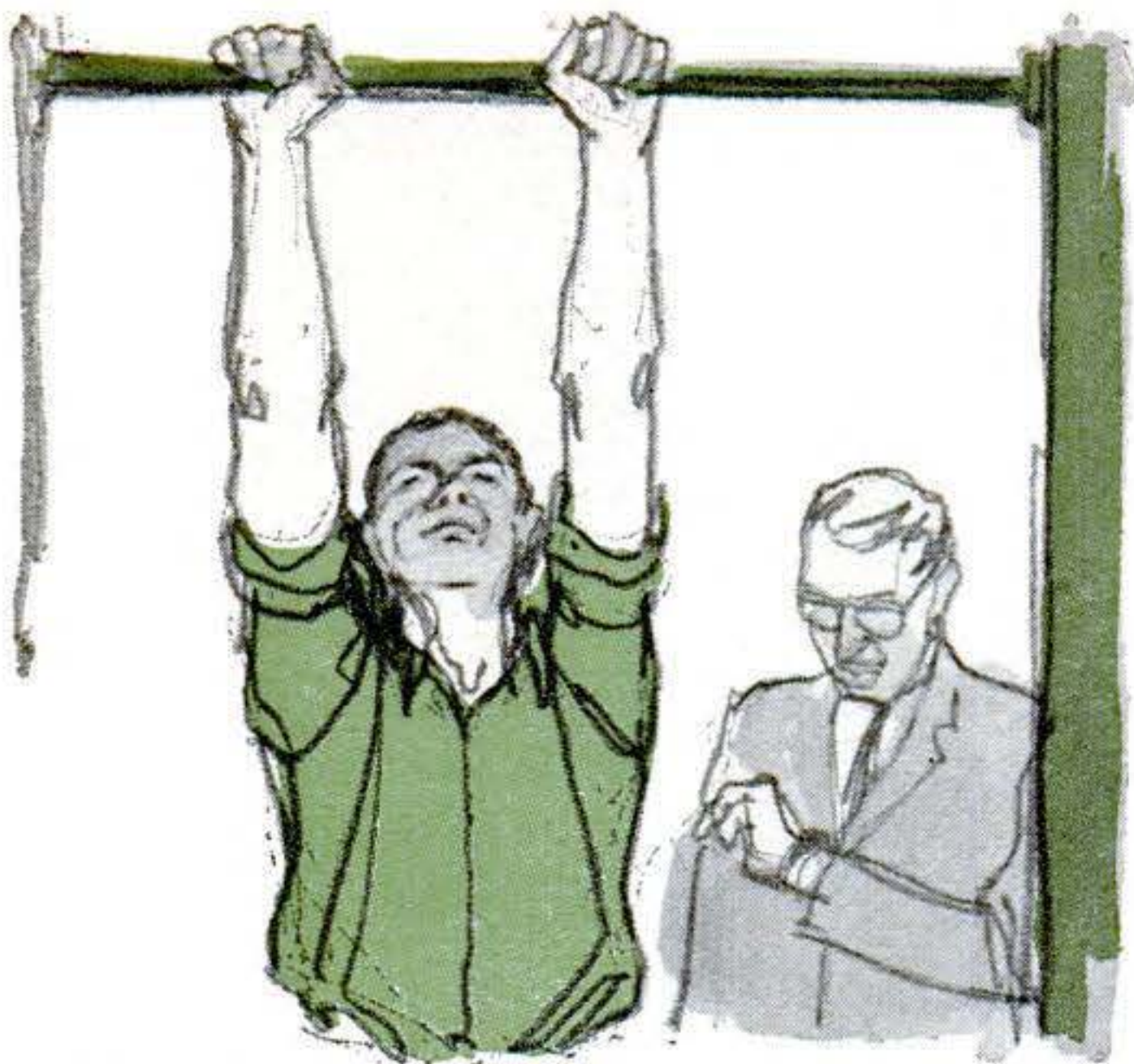

WHEN ARE YOU EXHAUSTED? It depends. Just for fun, a man can hold himself up one minute. But if there's a bet, he sticks it out for two.

staff of the Brainwave Laboratory at the Massachusetts General Hospital in Boston measured energy fluctuations in nerves, muscles and brain cells. They discovered that the brain says, "I can't," before the muscles use up all their energy. They had actually tested runners who fell exhausted. The athletes' legs still had plentiful reserves of energy.

Why didn't they go on using it? As muscles burn fuel, the "ashes"—lactic acid and carbon dioxide—are dumped into the blood. A certain concentration of these chemicals signals the brain to call it quits.

This is a vital safety device. A muscle that runs out of fuel completely takes 10 to 15 minutes to recover. Dr. Schwab points out, "You can't wait that long for an exhausted lung or heart muscle to start working again."

But nature's margin of safety is extravagantly wide. You could ignore the "out-of-fuel" warning signal (assuming your heart is okay) and exert your muscles much harder than you do. In fact, your brain itself holds back the signal when you're under stress. You can even force your brain to do that by convincing yourself that continued exertion is essential.

Dr. Schwab often demonstrates this. He points to a horizontal bar in the doorway of his office.

"How long can you hang by your hands?"

Ordinarily, an adult holds on for about one minute. If Dr. Schwab exhorts him

to do his best, he sticks on an extra half-minute. The offer of a five-dollar bill adds another half-minute.

"Nobody knows how long they'd hang on," says Dr. Schwab, "if I offered them a thousand dollars or if I pushed a vat of sulfuric acid beneath them."

Fatigue can cover up for you

But sometimes you get tired before you do anything. You're licked before you start. This is what doctors call nervous fatigue. It is not caused by physical exertion but by mental conflict. Yet there are ways to outsmart this kind of tiredness, too.

The most thorough recent research on nervous fatigue was carried out for the Navy by Dr. Harley C. Shands of the University of Virginia Medical School and Dr. Jacob E. Finesinger of the University of Maryland Medical School. Their study shows it to be a protective device that has gone berserk.

"Chronic fatigue occurs whenever a person feels rejected, frightened or angry, in circumstances which prevent any expression of these feelings," report Dr. Shands and Dr. Finesinger. The only way to overcome this kind of fatigue is to uncover and control the hidden feelings that are being blocked by the fatigue.

Suppose you're on a plane. The weather is fine and the passengers are actively talking and reading. Then you run into foul weather. Conversation falters. Many passengers slump in their seats. There is a good deal of yawning.

Here is the basic condition that brings on nervous fatigue—a problem that you can neither fight nor flee. The alarm brought on by bad weather keeps prodding you: "Do something." But to follow this impulse would lead you to useless and socially unacceptable behavior such as shouting or running up and down the aisle. Listlessness and yawning resolve this conflict by saying in effect, "You see, you don't have to worry. There's nothing you can do. You're too tired."

Up front in the cockpit, things are different. The bad weather also alarms the crew. But instead of getting tired, they become more wide awake. There is something they can do. It is only after landing safely that they feel tired.

[Continued on page 244]

Diesel Outboard Weighs 1½ Tons



THE Diesel-Cruisemaster is designed to power cruisers 28 feet long and up. A 97-hp., three-cylinder, two-cycle engine sits on end on the boat's floor and drives the propeller through a belt and shafting. To steer, you rotate the lower section of the drive unit. The propeller can turn 360 degrees. Turning it 180 pulls the boat astern. Murray & Tregurtha developed the Cruisemaster with GM Diesel. Price: about \$5,000.

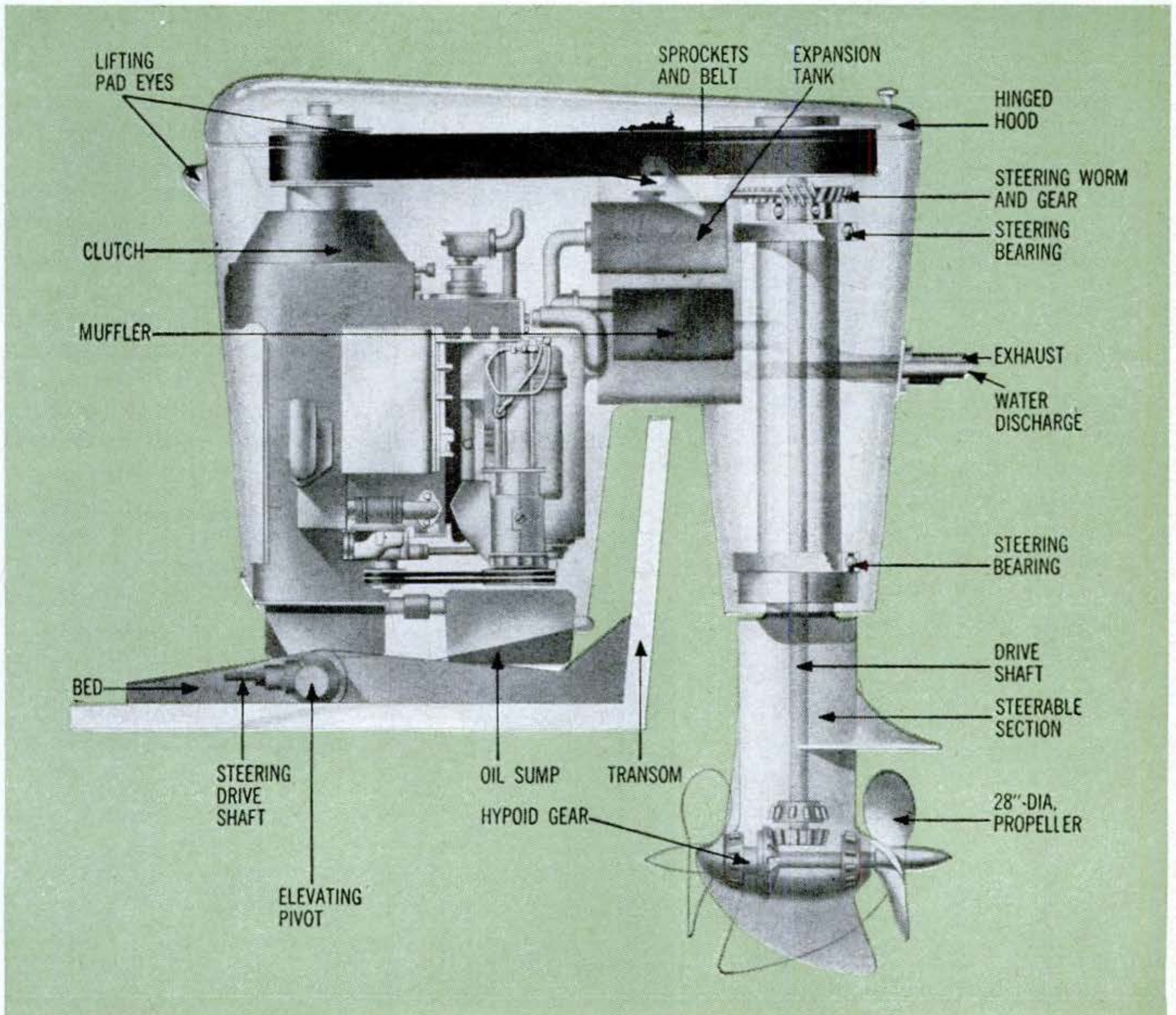
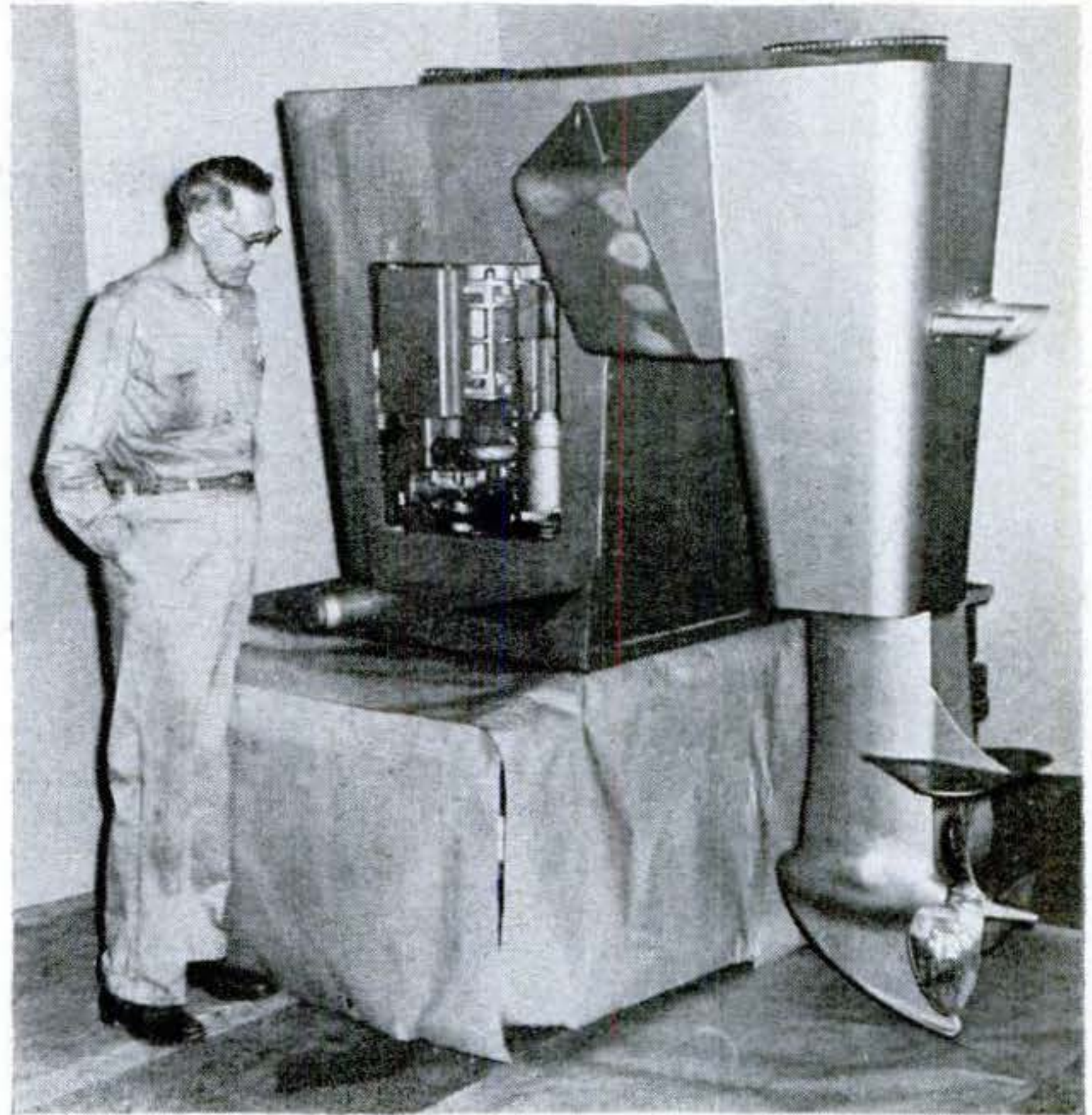

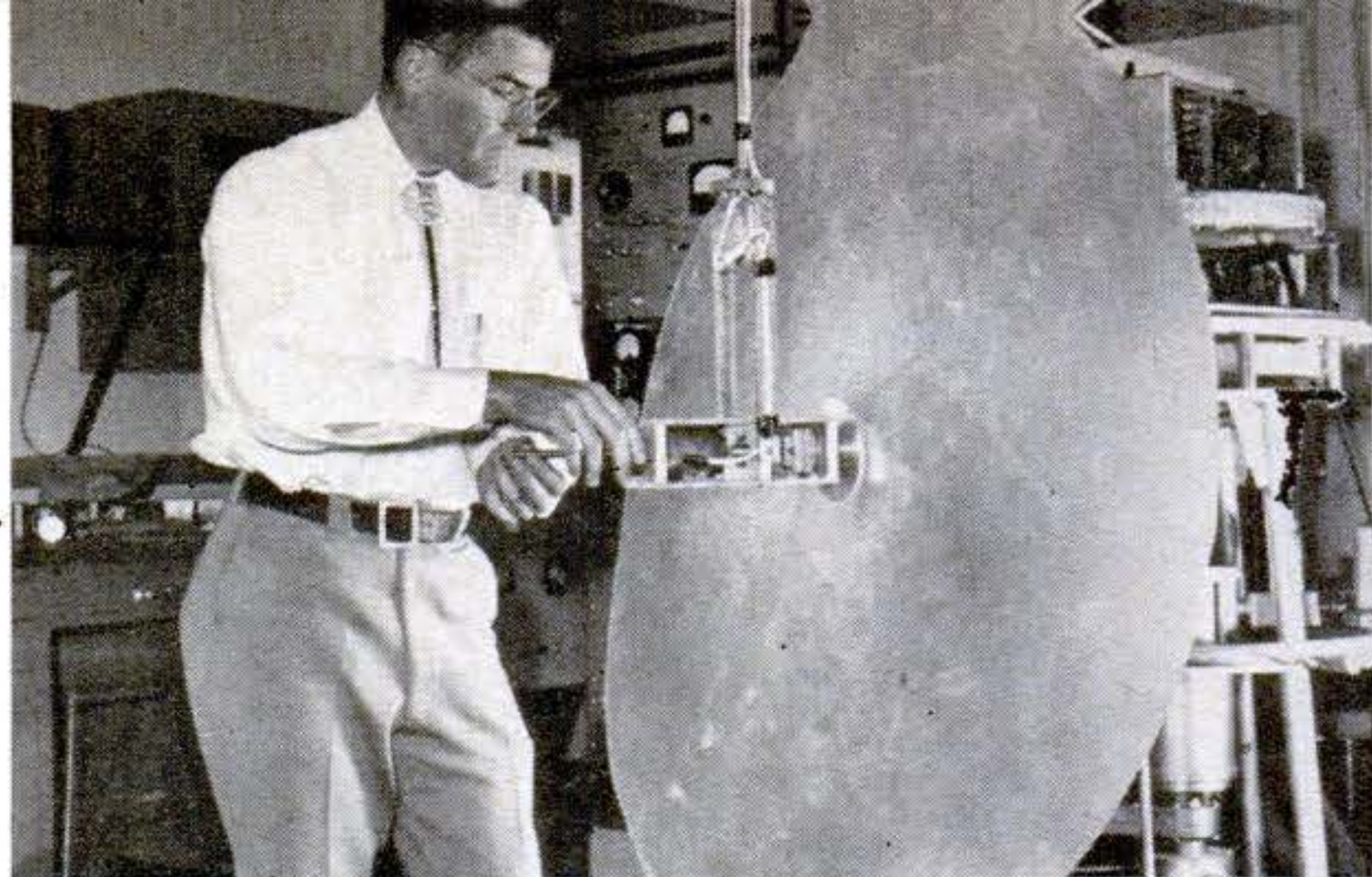
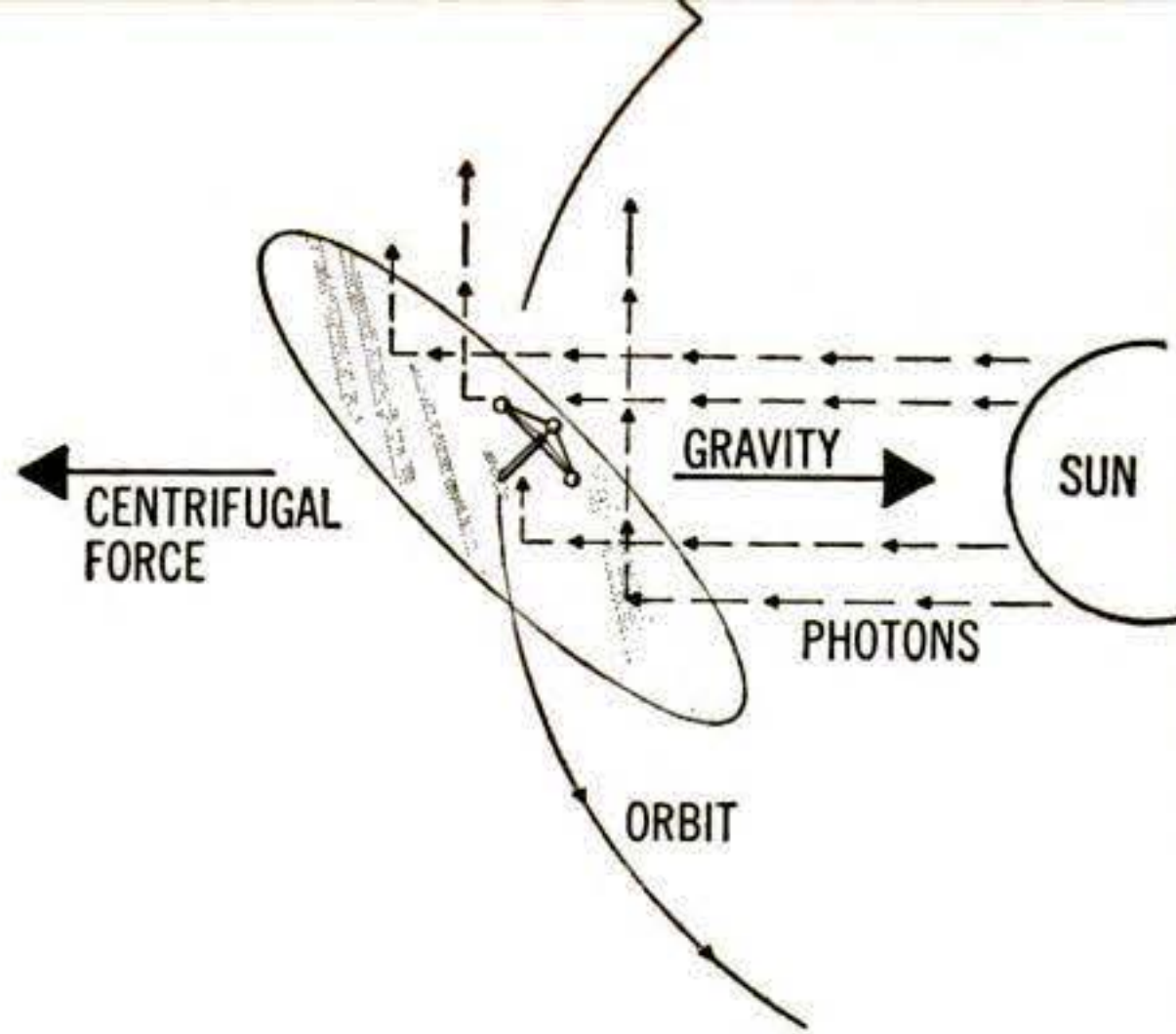

SAILING SPACESHIP. Unfurled in space, a huge aluminum-coated disk of plastic would become a solar sail, and harness the pressure of sunlight to propel a spaceship, say Los Alamos scientists who built this model. The sail, a quarter-mile across, would open when its 1,000-pound rocket carrier reached earth-orbiting position. Then, riding on the sunbeams, which exert a motive force of about 1/100 of a pound per acre of reflecting surface, the solar ship could cock its sail for a round trip to Mars.

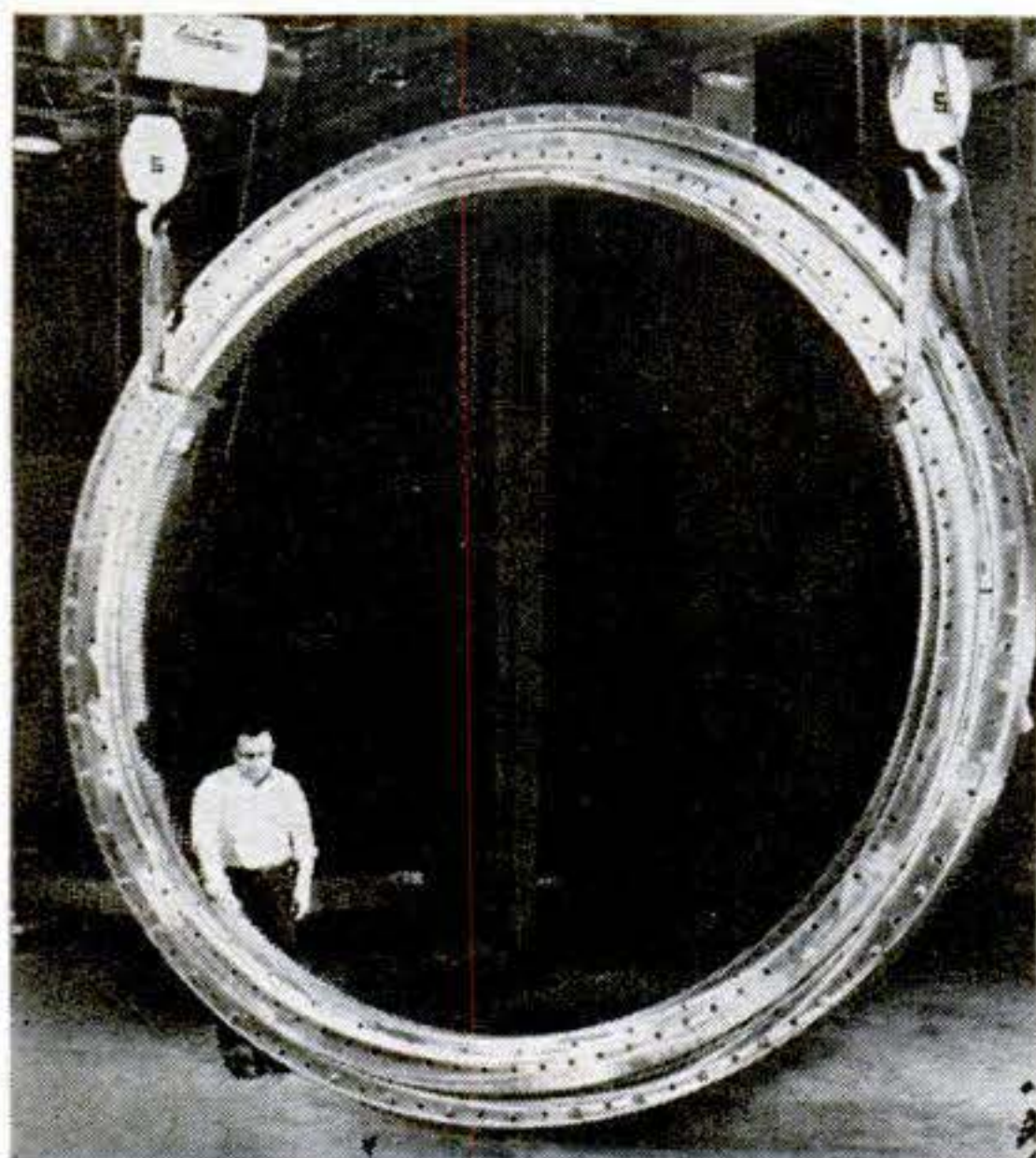

GIANT BALL BEARING. Inside this race, 13 feet nine inches in diameter, are 88 four-inch steel balls. The huge unit was designed by Kaydon Engineering, Muskegon, Mich., for use in the pedestal of the radar system for a Nike-Zeus ground-to-air missile.

SPEEDS MAIL. Mixed mail (batch on table in background) is lined up uniformly for post-marking and stamp cancellation (called "facing") by this automatic machine being adopted by the U. S. Post Office. An electronic eye recognizes adhesive stamps and triggers the positioning mechanism of the unit.

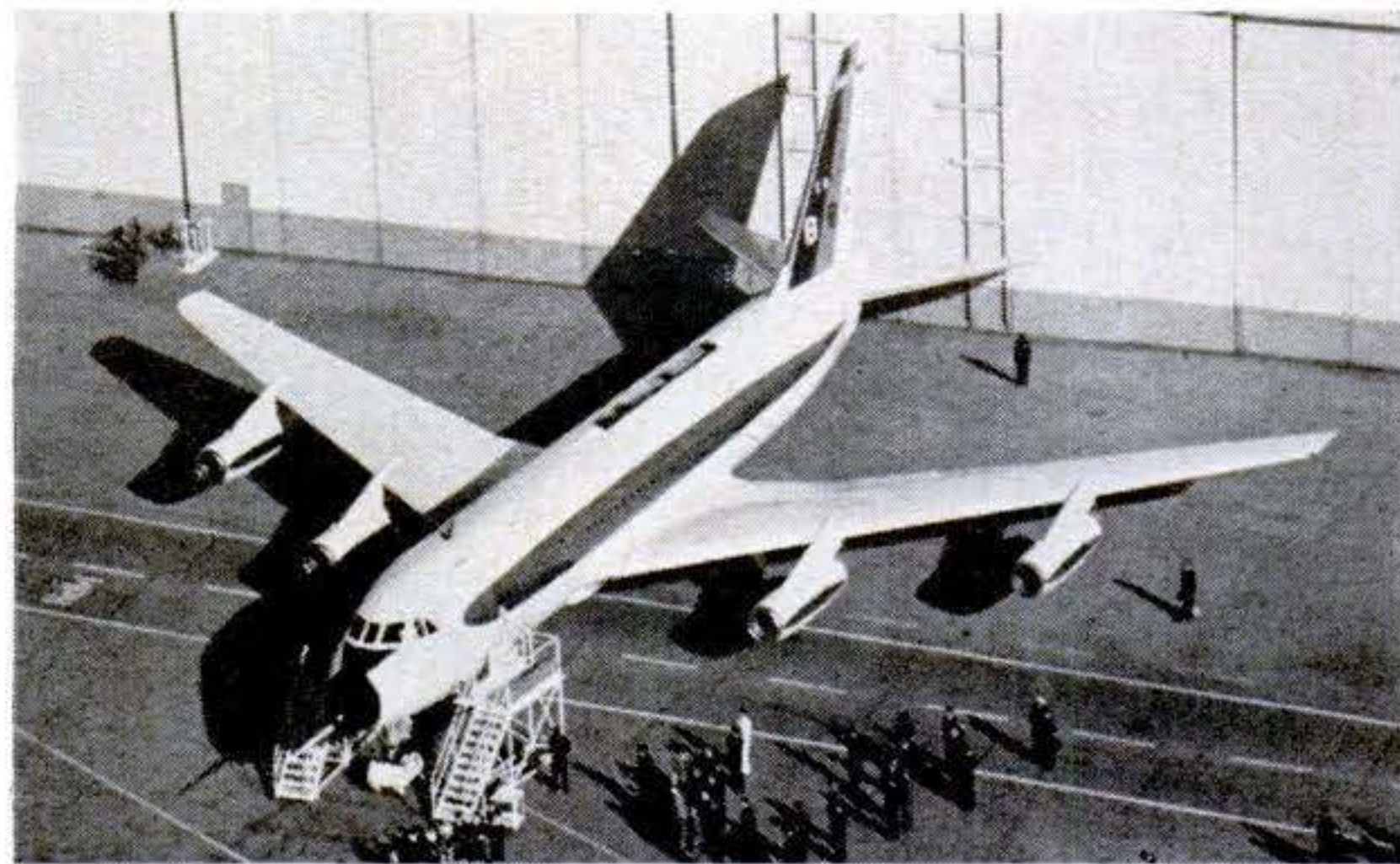

FASTEST JETLINER. Now undergoing flight test, the 615-m.p.h., medium-range Convair 880 will be the world's fastest when it goes into service early next year. In a two-abreast luxury seating version it will accommodate 88 passengers.



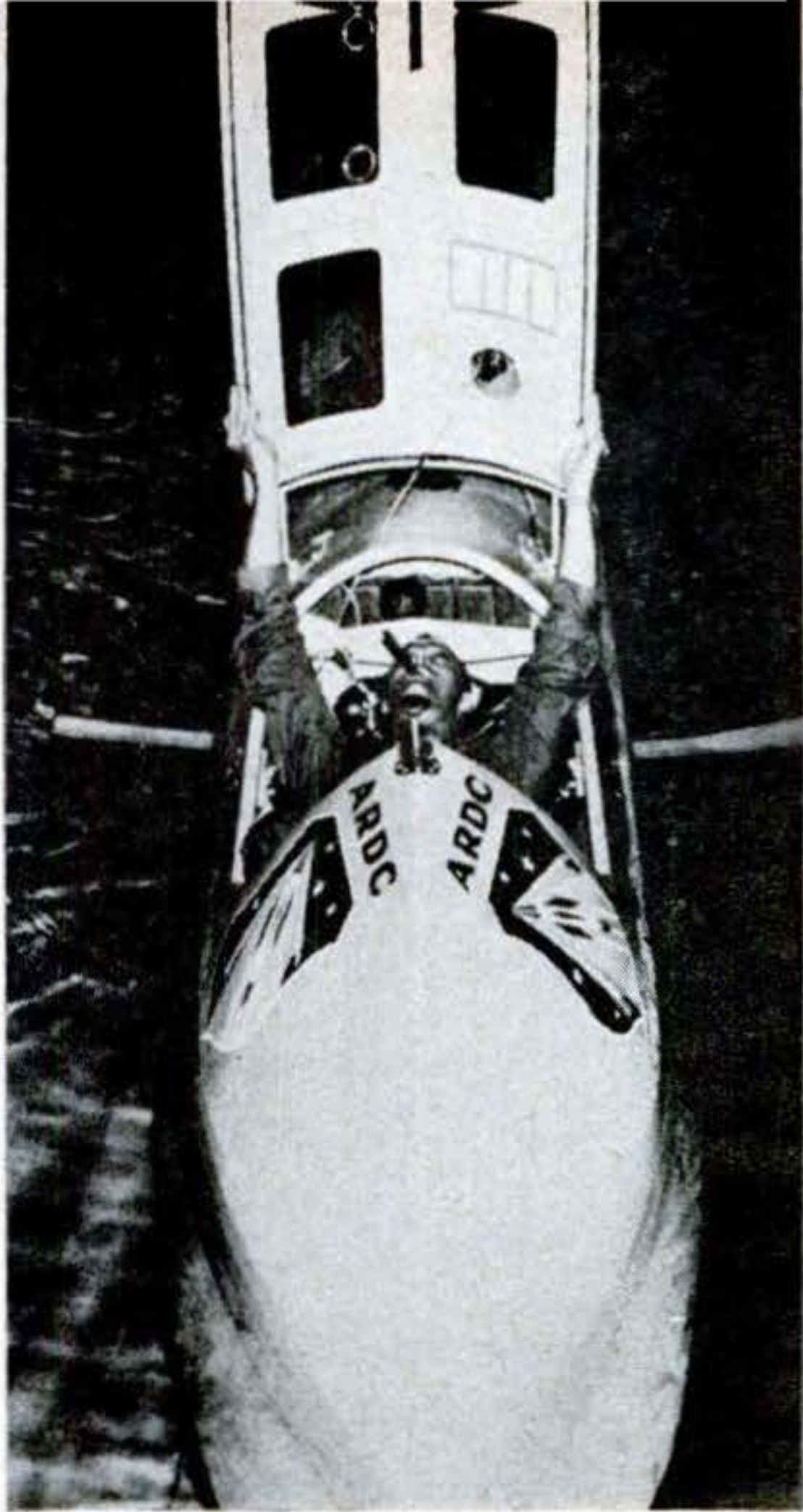

ESCAPE CAPSULE. This 12-foot sealed boat is intended by the Air Research and Development Command for the rescue of supersonic pilots down at sea. Its survival kit contains a powerful radio, emergency food and water for 72 hours or longer.



GAS TURBINE. Chrysler's latest experimental gas-turbine engine is lowered here into a 1959 Plymouth test car. On a 576-mile economy run, it averaged 19.39 miles per gallon at 38 m.p.h. on diesel oil, turbojet fuel and unleaded gasoline.

MAGIC DIAL. Set a number by dialing the telephone at right, and you can get it later by pushing one of its buttons. Models made to remember up to 100 numbers have been tested in Belgium and Switzerland where they will soon go into use.



NO-ICE ICE SKATES. Rubber rollers in a single row on the German skates above act as blades, make them useful for small fry learning to ice skate at home. They won't mark the floor.

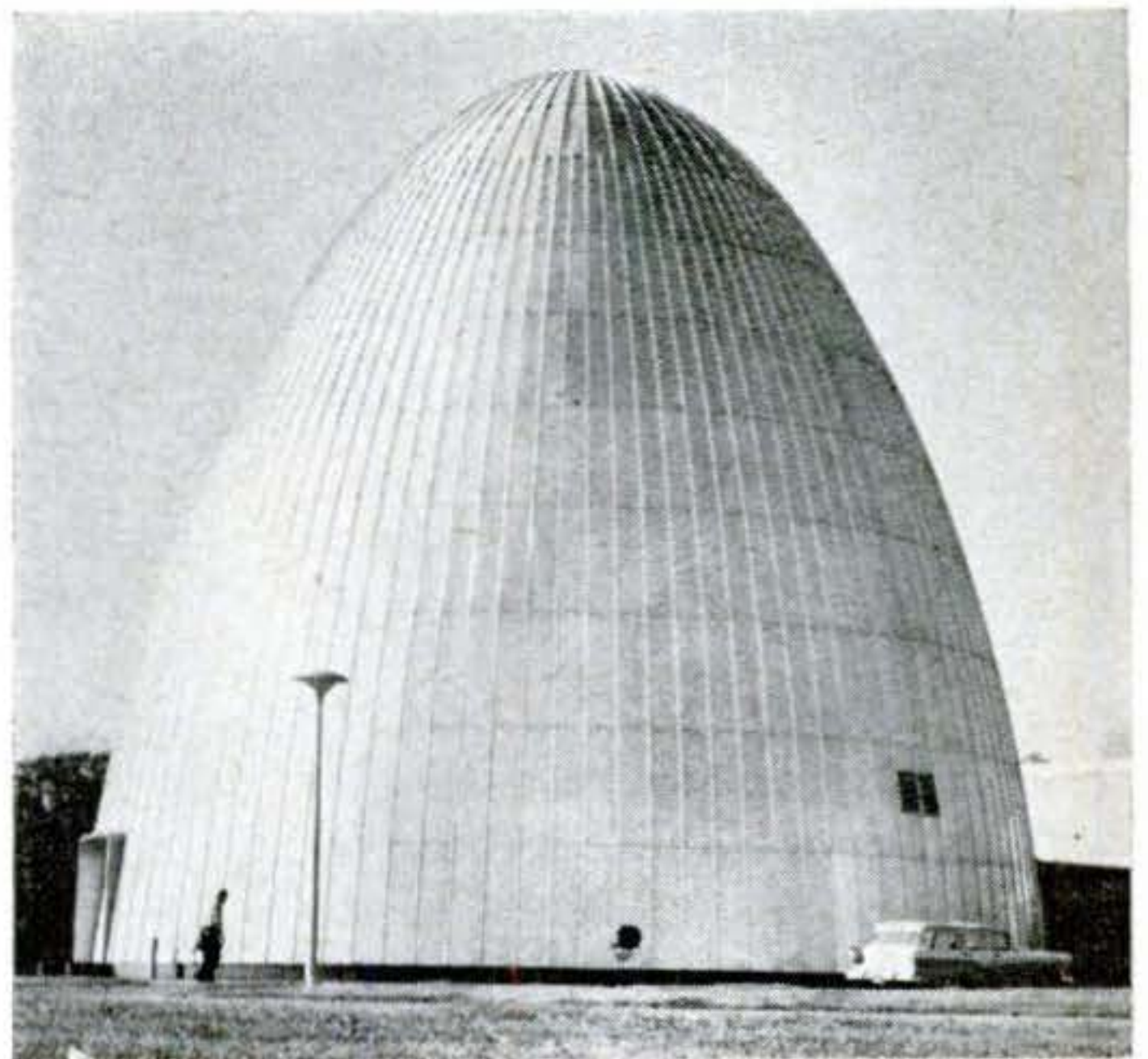

ATOMIC BEEHIVE. This 87-foot-high aluminum-sheathed concrete dome houses a 5,000,000-watt nuclear reactor at Plainsboro, N.J. Operated by 10 firms, it's the largest privately owned reactor.

Russia's Small Cars:



GRACEFUL AND FAMILIAR in looks, the Volga is five feet, nine inches wide and five feet, three inches high. Next model will have automatic transmission, Russians say.

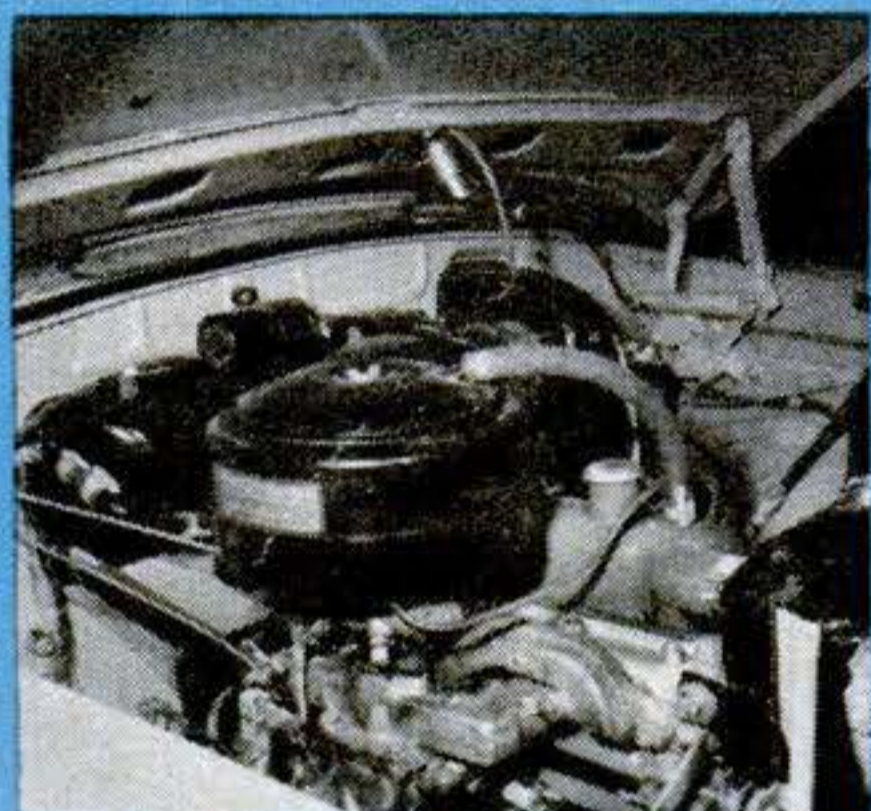

FOUR-CYLINDER ENGINE, with overhead valves and 149.15-cu.-in. displacement, is largely made of aluminum alloy.

THERE'S AMPLE ROOM in the trunk. A 16-gal. fuel tank is underneath. Bumpers are heavy and of good-quality chrome.

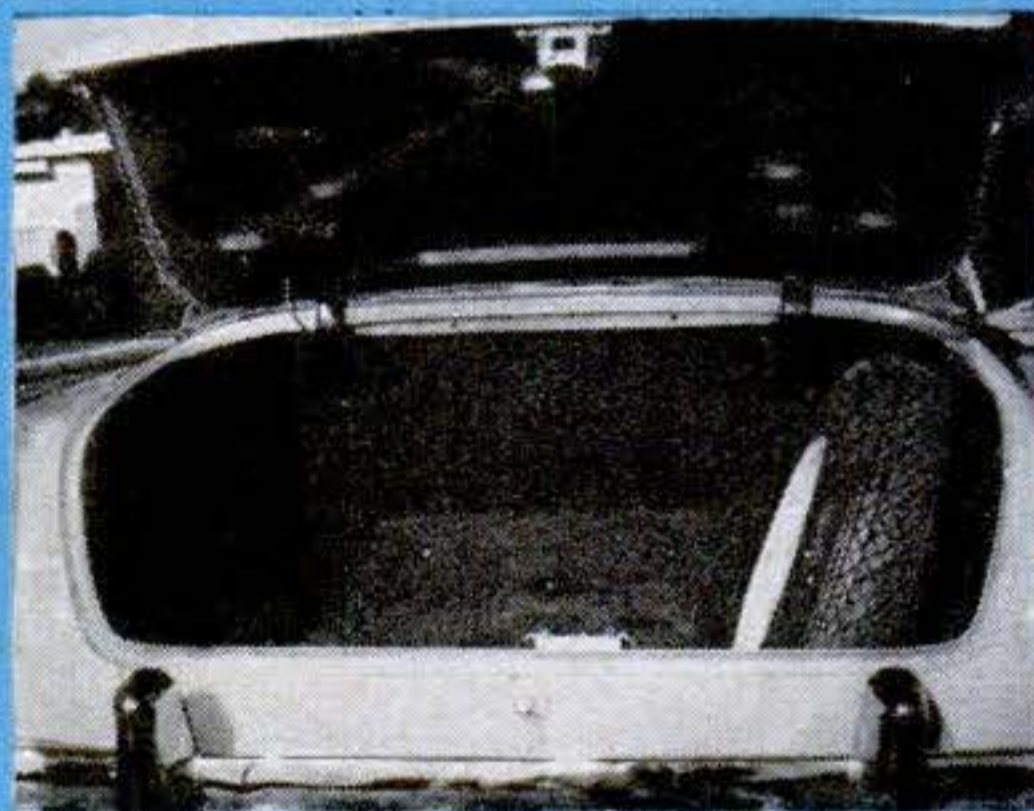

Little Moskvitch, bigger Volga are sluggish but surprisingly like U. S. cars in trappings

RUSSIAN cars are as rare as rubles in the U. S., so I was extraordinarily pleased to get a chance to look at and drive a low-priced pair of them the other day in Los Angeles.

One was the little Moskvitch, which is precisely the same length (13 feet, three inches) as the familiar Volkswagen sedan. The other was a Volga, which is somewhat bigger (15 feet, eight inches) and definitely fancier. Both are four-cylinder cars. On these pages, you can see how they look.

They are cars that a Russian with a

middle-size income is most likely to buy, when production permits. They are not for sale in the U. S., but were brought here by Stanley Slotkin, a Los Angeles businessman and importer, as interesting curiosities, which he put on display to help raise money for the March of Dimes.

For Russians, who pay 8,000 rubles for the four-passenger Moskvitch and 16,000 rubles for the five-passenger Volga (official rate: four rubles to the dollar), the cars are not cheap. For tourists, with the advantage of their special rate of 10 rubles to the dollar, they are alluringly inexpensive. Outside Russia, the cost drops even farther. Because of trade-war conditions, the Volga has sold in some countries for as little as \$530. Slotkin, on the basis of his own experience, esti-

Stylish but Lazy



PERT AND PRETTY, if underpowered, the Moskitch has a two-tone paint job, pleasing upholstery. It's five feet high; five feet, one inch wide. Claimed speed is 65 m.p.h.

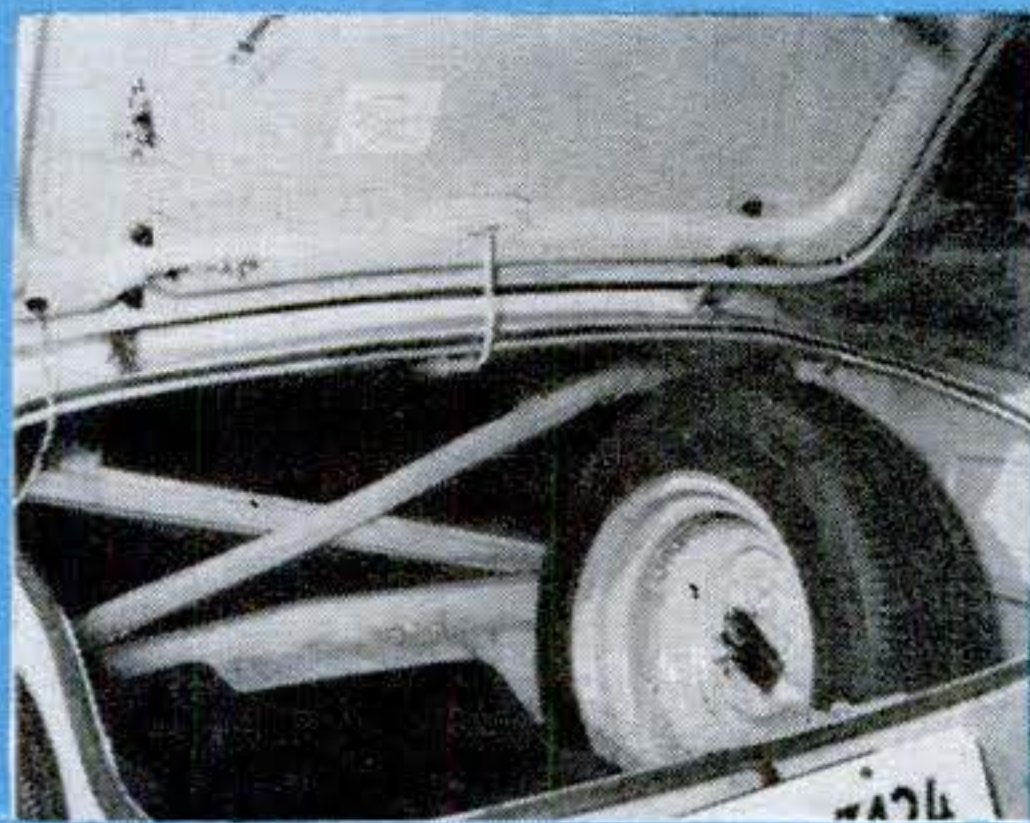

SCANTY TRUNK is unlatched by cable from inside the car. Fuel tank under the floor holds just over nine gallons.

THE FLAT-HEAD FOUR, with cast-iron block, has 74.42-cu.-in. displacement. Both Russian cars use 12-volt batteries.

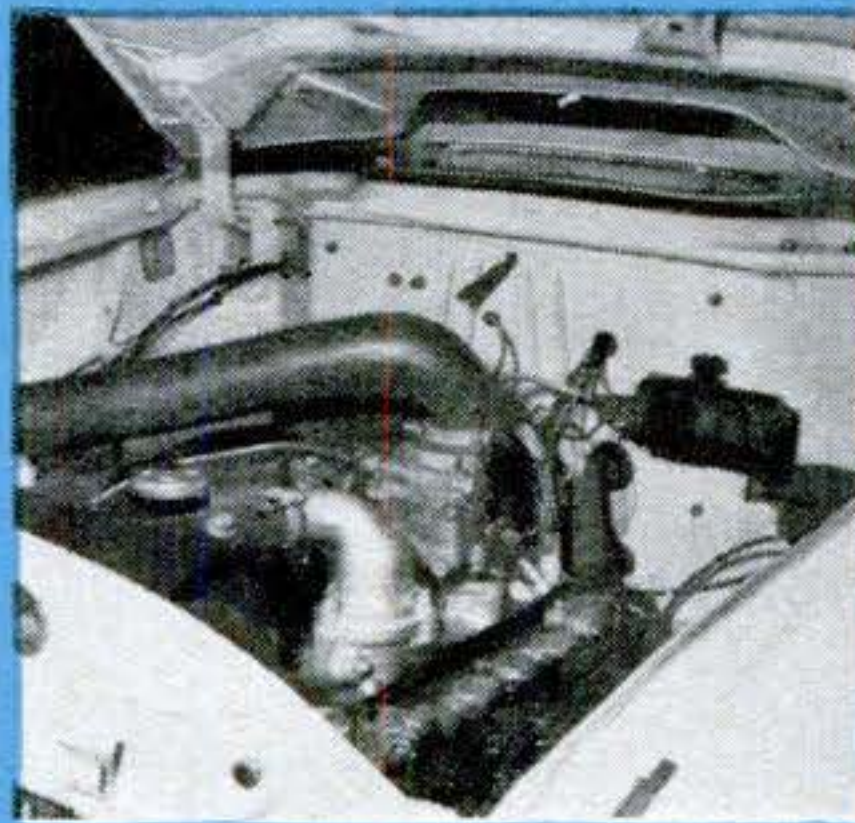

mates that shipping costs, import duties, excise taxes, and distributor and dealer profits would raise the Moskitch's price to \$1,200 and the Volga's to \$1,750 if they could be bought in the U. S.

Each car has a standard transmission, with the gearshift lever on the steering post. Both have four doors and two seats. The seats have the stiff, taut-spring feeling that my grandmother's horsehair sofa had but they make up into beds.

I was more impressed by the appearance of the Moskitch and the Volga than by their performance. The 35-hp., 2,160-lb. Moskitch is frankly lazy. The 80-hp., 3,218-lb. Volga, though smoother and brisker, is still no gazelle.

All the comforts. But they are remarkably like U. S. cars in their accessories

and controls. They have radios and heaters, ignition-key starters, American-type turn indicators and windshield defrosters, dome lights, sun visors and glove compartments, floor buttons to switch headlight beams, and pull-releases under their dashes to unlatch the hoods. The last, in both cars, is at the far right of the cockpit, well out of the driver's easy reach. Ivan had better have Natasha ride with him.

Unlike American cars, the Moskitch and Volga come equipped with a crank for emergency starting, two bags of tools, a tire pump, a flashlight and a spare set of radio tubes. Each car also has two huge maintenance manuals, one in Russian and the other in English (with ex-

[Continued on page 240]



SPIKED TIRES. Special steel wedges sunk into the treads of racing-car tires (above, right) are one way to help tame skids even on a treacherous track. They were used by drivers in the first European Grand Prix on ice (left) run last winter over the course at Cortina d'Ampezzo, Italy.



TANDEM TRAILERS. For long-distance moving in South Africa, a Cape Town hauler uses this giant road train. It carries 16-ton loads on trips of 1,500 miles or more. Tractor and two aluminum trailers make up a train over 60 feet long.

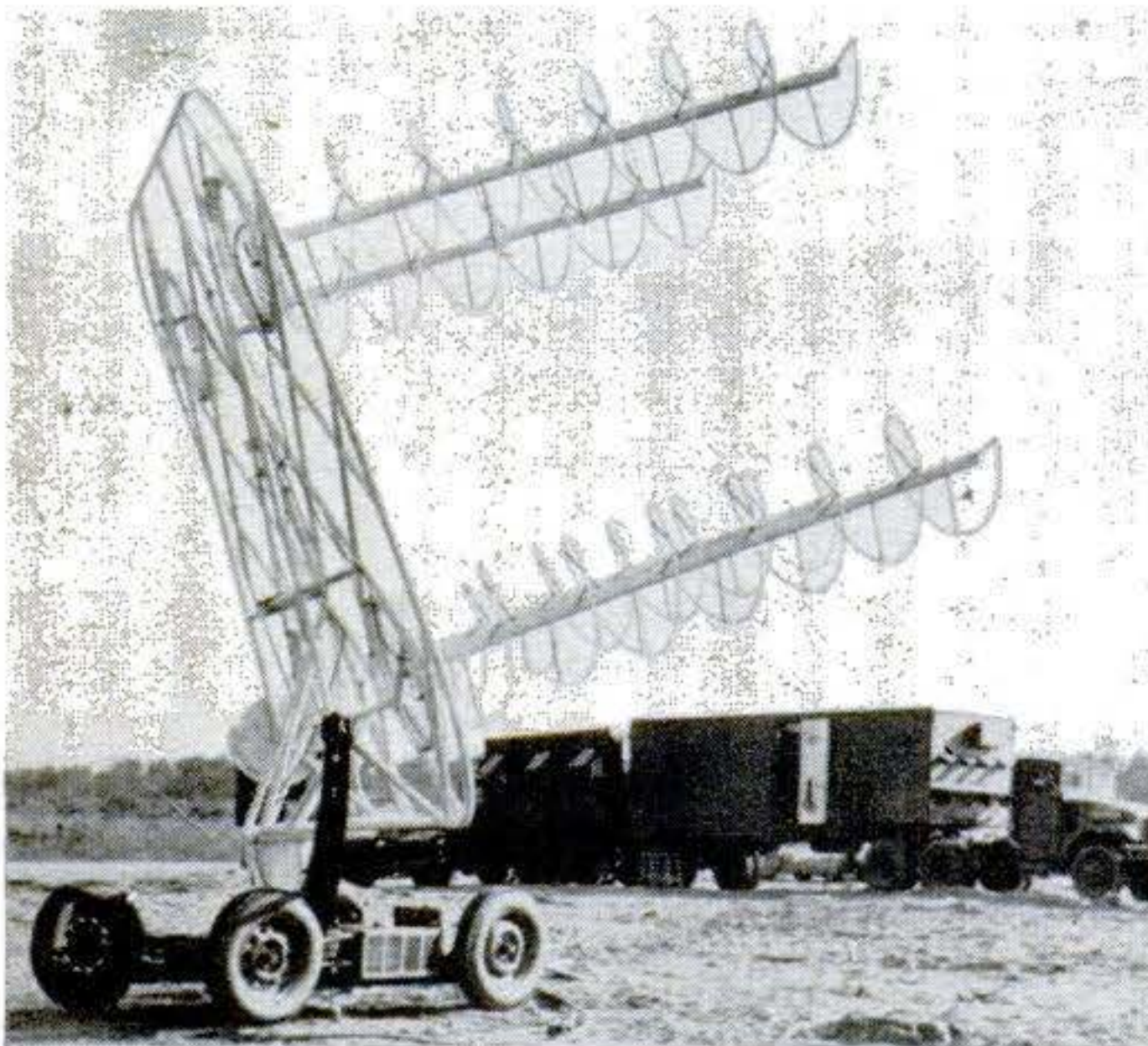

SATELLITE MOUTHPIECE. Antennas like this one at Fort Stewart, Ga., sent messages to and received them from the Atlas missile in orbit about the earth. The mobile unit is controlled from the station van in the background.



HOT LANCE. Intense heat—nearly 10,000 degrees—melts through a 1½-foot concrete wall (above) at Hill Air Force Base in Utah. The iron-pipe lance, consumed by its own heat, is replaceable. It does two weeks' work in a day.

GOING UP. There was not enough space between two adjacent houses to slide this five-room home between them, so Los Angeles house movers made the hard way the easy way. They jacked it high on stilts and took it over the top. The job required two days and cost \$1,650.

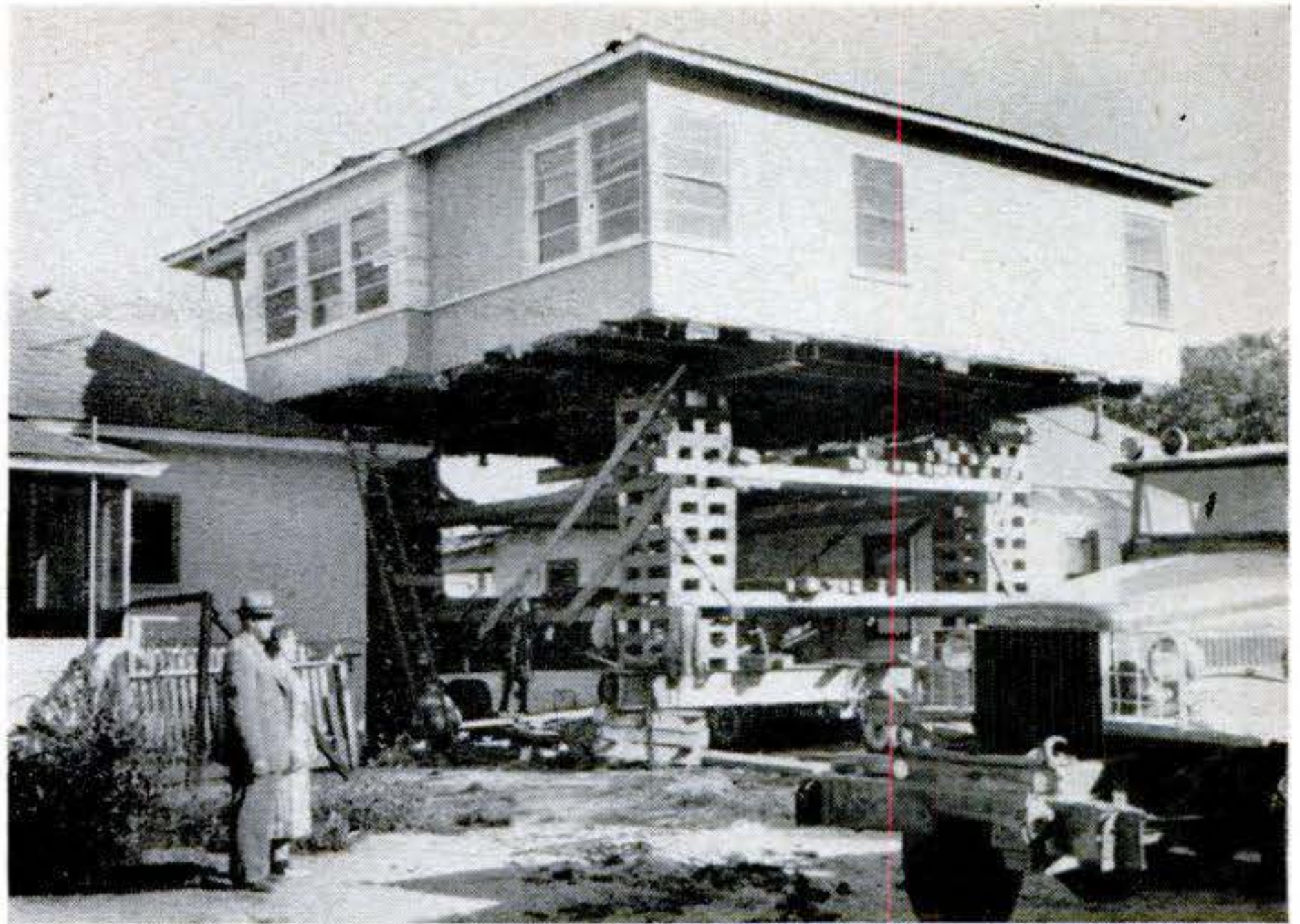

FLYING BLIND. To make their rest easier and more complete, passengers on all Air France long-distance flights are now given sleeping masks. They shut out light, enable weary travelers to nap as they lean back in reclining seats.



TEAMWORK. With a flight deck on the fantail, the destroyer Everett F. Larson and a helicopter are paired to counter submarines. When sonar picks up an enemy sub, the chopper is sent with depth charges to strike before it's aware.



DO-IT-YOURSELF TICKET. New pushbutton machines allow passengers on the Cleveland, Ohio, transit system to print their own transfers. During rush hours the jamproof automatic printer can issue 60 tickets a minute.



You're in trouble if you try to obey sign at this point

To turn left from right lane here, on U. S. 1 near New Brunswick, N. J., is sure suicide in pell-mell traffic. Confusing sign means only at crossroads.

Stupid Traffic Rules

make law violators of sensible drivers and actually increase auto accidents

By Edward D. Fales



An example of bad timing

Once a minute, this light on U. S. 13 near Marcus Hook, Pa., turns red, halting main traffic even though very few cars use the side road.



Misleading one-way arrow

This sign in Media, Pa., could cause a wreck. It seems to indicate a one-way street, but it really marks the entrance to a gas station.



Would you pass here?

A blind hilltop curve lies just ahead on High Ridge Road outside Pound Ridge, N. Y., yet the road is marked (broken line) for safe passing. Such errors invite disaster.

Can you find a signal?

Bill Toth parks along U. S. 22 south of King of Prussia, Pa., to hunt for a traffic light at a crossroads. In a jungle of signs, you may need a magnifying glass to find it.



HAVE you ever* been blamed (or arrested) for a highway tangle that you honestly felt was not your fault? Have you ever broken a speed law because you *knew* the limit was too low?

You have, of course, if you're like most drivers. And you may well have been in the right.

Traffic experts are beginning to point out that danger lurks in such things as faulty speed limits, bad signs and inept left-turn regulations. The other day, Frederick W. Hurd, a top U. S. engineer and head of Yale's Bureau of Highway Traffic, warned that "unrealistic controls" (1) turn good drivers into lawbreakers and (2) make them drive dangerously.

And in Washington, D. C., Donald S. Buck, the Army's deputy safety director, came to the defense of well-intentioned drivers who, he says, are often blamed when the real fault lies with the way we run our roads. Says Buck (a former Indiana trooper and one of the savviest men in traffic):

"Everybody points a finger of scorn at the driver: police, educators, officials, researchers and our highway engineers. The driver *can't* win. He's always at fault. He's damned as (1) stupid, (2)

reckless, (3) selfish, and (4) careless. He's told he 'gets a feeling of power over others' when he's behind his wheel."

In Chicago one day, Buck was bawled out by a cop for doing *only* 35 m.p.h., which happened to be the posted speed limit. Yet, on the same street, a few hours later, Buck saw a driver pinched for doing 40.

This started Buck thinking. Another day, on a fast road in Virginia, he saw a sign at a railroad crossing. It said, "SLOW TO 5 M.P.H. STATE LAW." He obeyed the law. Cars behind him screeched and skidded. A police car rushed up.

"Don't you ever do that again," thundered The Law.

"But, Officer," said Buck, "I was only obeying the sign."

Who's to blame? Since then, he has traveled all over the U. S. collecting a list of hazards forced on motorists by foolish laws, lights, rules, signs and engineering. His study suggests that many of the sudden risks you run on today's roads are *the fault of men (often untrained) who are paid to make your roads safe—and who are the drivers' worst critics.*

For example:

- How often do you come to curves

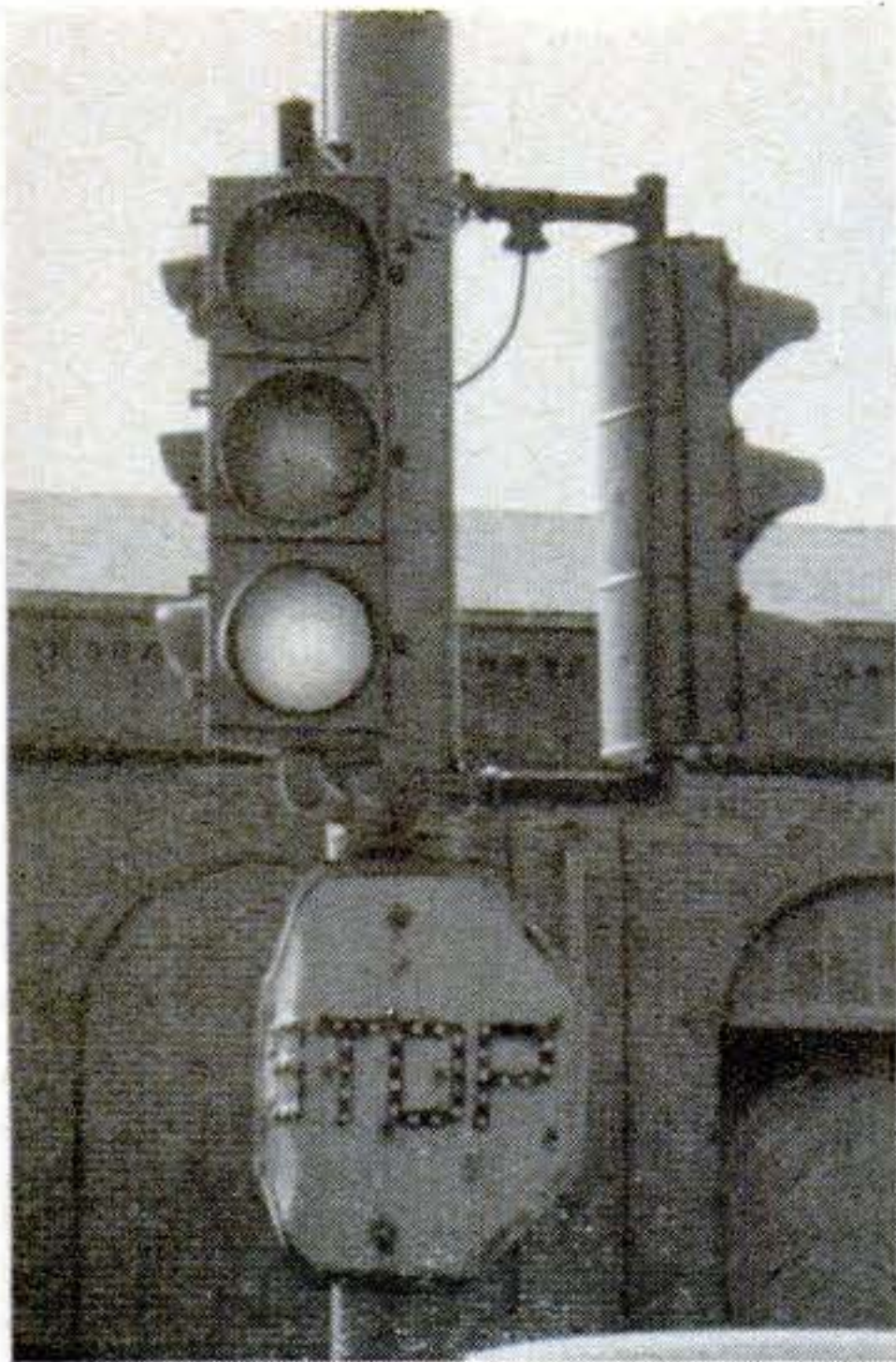

Empty—but still snail-paced

It's Sunday on deserted U. S. 13 outside Marcus Hook, Pa., yet an inflexible 30-m.p.h. limit invites lawbreaking.

Which one would you obey?

This light (left) in Wilmington, Del., is green, but the beat-up sign says STOP. If you hesitate, you may be hit.

marked (usually with a broken center line) for safe passing when you *know* passing can be suicide?

- How often do you slam on your brakes because someone has timed a traffic light to change too fast?

- And how often do you find a big yellow school bus dangerously loading children at a bus stop recklessly located just around a blind curve?

"The average motorist," says Buck, "survives in *spite* of such hazards. He does a terrific job, obeys all reasonable laws—and gets no credit."

To see at first hand what Buck and Hurd are talking about, I recently drove

from New Haven to Washington, through six Eastern states.

With me, for two days, rode William Toth, of the New York University Safety Center. We traveled in two cars, my Rambler and Bill's Thunderbird.

The silly signs. In our travels, we found signs that couldn't be read, arrows that appeared to point the wrong way, signs that lied ("MEN AT WORK" when nobody was working, "ROAD LEGALLY CLOSED" when obviously it was legal to use it, and "SPEED 40 M.P.H." when patrols were nudging traffic along at 50). We found traffic signals where none were necessary, stop signs that actually made



Why all those skid marks?

Here's vivid proof that hundreds of vehicles on fast U. S. 1 in Metuchen, N. J., have braked hard at a foolishly fast-changing signal light.

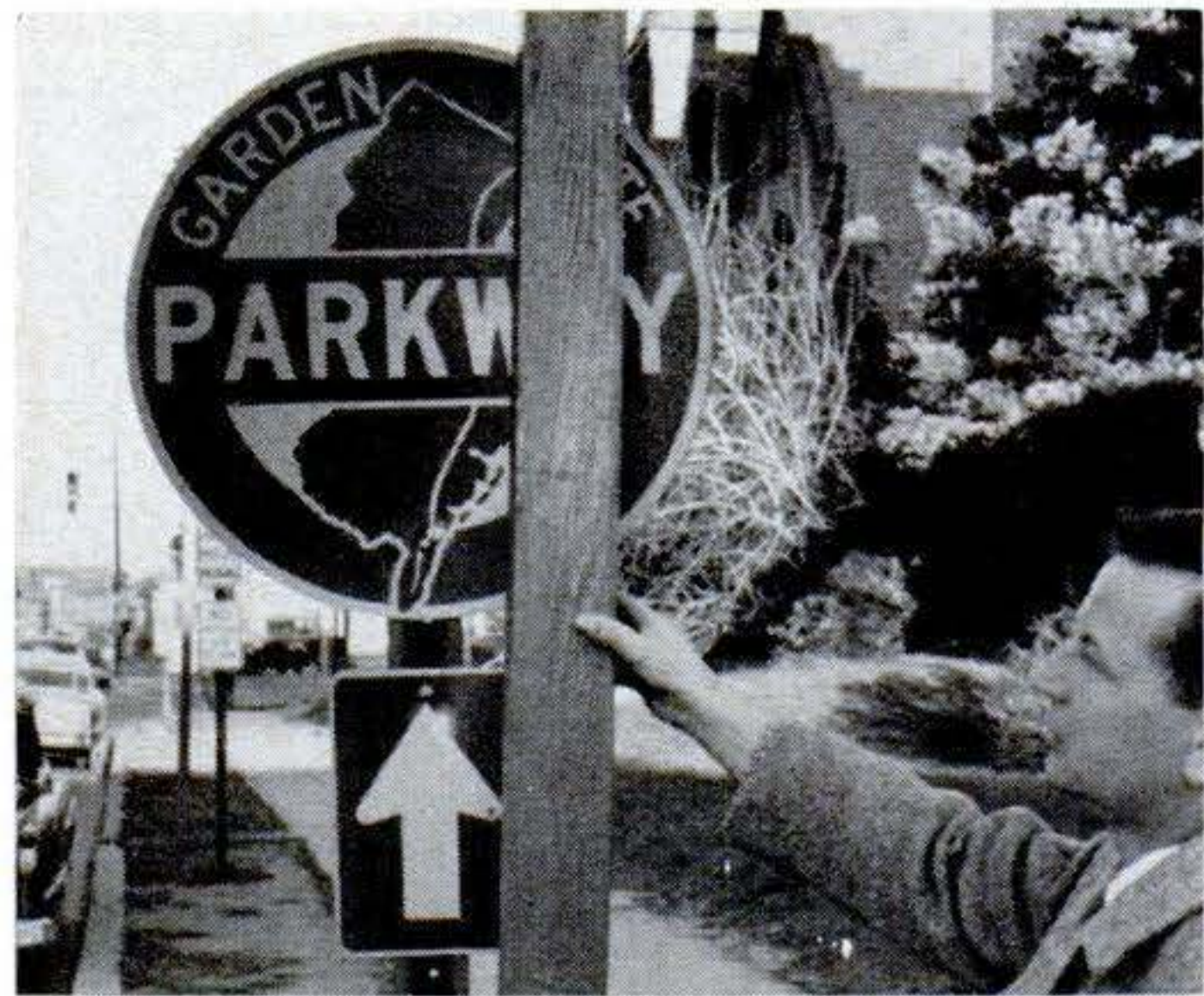

No wonder drivers wander

When guideposts are partly hidden, like this one on U. S. 22 in Highland Park, N. J., confused drivers may easily get into traffic trouble.



A fast downhill curve, and doom perhaps seconds away

Hidden below the hill, on U. S. 22 south of King of Prussia, Pa., is a "sudden death" traffic signal, yet warning sign is where it can't easily be seen.

it more hazardous to enter a main road, left turns that could have made our cars sitting ducks in fast traffic, and signs and signals that simply confused us.

In New Jersey, Bill and I cut over from the Turnpike—a fine road, well run—to U. S. 1. Traffic: roaring. Speed limit: 50 m.p.h. This meant that the police were probably tolerating 55 for anybody driving properly (as most drivers were).

Suddenly, at Main St., Metuchen, the traffic signal flashed yellow. I slammed on my brakes and counted . . . In exactly five seconds, the signal flashed red. In that breathless interval, all those tons of cars and trucks thundering down U. S. 1 were expected to stop. They'd *better* stop, because cars instantly began whipping in from the side road.

We got out and watched that light awhile. U. S. 1 was scarred with skid marks for hundreds of feet back. Each skid meant an emergency—thrown at motorists by the way that light was timed. Yet a five-second amber is common all over America.

Bill Toth and I drove off U. S. 1 into Highland Park, N. J. There, in the 25-m.p.h. business district, we timed the lights. They changed from red to green in five seconds.

"Exactly the same warning that high-speed traffic gets on U. S. 1," Toth commented, shaking his head.

Crossing the Delaware. Darkness caught us in Trenton. And there, trying

to follow little, hard-to-see signs, we got lost. Getting across the Delaware, we had more trouble than George Washington, but we finally made it and found ourselves trailing three cars up a hill on Route 422 near Norristown, Pa.

Suddenly: *Slam on your brakes. Quick!* Over the hill, with no warning, one of those maddening sudden-death traffic signals glared at us like an evil eye. The "stupid drivers" ahead managed to stop—and we did, too, but so abruptly that another car, breasting the hill behind us, had to pull to the right shoulder to keep from hitting the T-bird.

Let me stress: We were doing no bumper-chasing on this trip. We were driving with all the caution at our command. We went back over that hill and tried it



One car stops traffic twice

This car tripped a treadle to cross U. S. 22 in Media, Pa.; now halts traffic again by tripping a badly placed treadle on the other side.

again. You go over the top and there—with only seven seconds to stop—is Old Evil Eye. But the worst of it is those hidden stopped cars, lined up and cutting your margin down to perhaps three or four seconds.

After the five-second light on U. S. 1, this one might have seemed easy. But when you hit your brakes, you're already rolling downhill fast—so you need extra stopping time.

What you do here if there's rain—or a little ice—Toth and I never did figure out.

Next morning, near King of Prussia, Pa., we came to one of those STOP signs that can be seen only if you hunt through the bushes long enough. We came out of a side road and there it was—hidden, until the last instant, by overhanging shrubbery.

How anyone can get out into Route 22 safely from this sign when fast traffic is coming is a mystery. The sign is planted 28 feet back from the highway (Bill got out and measured it). If you stop where the sign says to stop, you can see down Route 22 to your left just fine—but on your right you're looking into a small jungle.

Keeping Pennsylvania safe? South on U.S. 22 is a huge billboard that says, "Let's Keep Pennsylvania the Safe Driver State." Less than a quarter-mile away is another of those sudden-death traffic lights, hidden around a curve at the bottom of a hill. You have six seconds to negotiate a safe stop on dry macadam, water or ice.

Bill Toth read the big safety sign again. "They should have spent their money to put up a big sign saying, 'DANGEROUS INTERSECTION AHEAD. PREPARE TO STOP.'"

Sure, there was a warning sign that read, "SIGNALS AHEAD." But it was all of four feet high, way over beyond the right shoulder, while your eyes were watching that curve to your left. After a snow-storm, it would be hidden in drifts.

Now and then, we saw traffic lights that were broken and not working. If you have a collision at such an intersection, it's usually your fault. But here's a tip: In one state a while ago, the courts found that local police had been passing a dead signal for hours without reporting it out of order. A collision occurred. The court held that neither driver was to blame and that both could sue the state!

In Wilmington, Del., we found a puzzler that may sound familiar to you. At a busy corner, on a pole, was a green traffic signal. We started through. Only then did we see a beat-up STOP sign—on the same pole. *Now* what do you do?

Most drivers (you've had the experience) hesitate, hit their brakes in slight panic, then figure it out: "The stop sign must mean what it says *only when the traffic signal is turned off.*" If, in that moment of hesitation, you get clobbered by the guy behind you (who is watching other cars and trying to be safe), you both may get a ticket. A couple of "foolish drivers," obviously.

I asked Toth about it. "Any thinking motorist could tell them what to do," he said. "Take down that stop sign and,

if they don't want to use the traffic lights all night, fix the red signal so it blinks. A blinking red in most states now means: *Stop, then proceed if safe.*"

Making scofflaws. On the outskirts of Marcus Hook, Pa., we found one of those speed laws that make violators out of honest citizens. Location: a fine, wide boulevard on U. S. 13. Time: 10 a.m. on a Sunday. Traffic conditions: not a car in sight.

Four beautiful, empty lanes—and a speed limit of 30 m.p.h. Cars crept down the vacant boulevard, looking foolish.

You've come to such roads and wondered what to do. Perhaps you slow down and obey the law. Then you see

[Continued on page 248]

Where'd it come from?



FATHOM: Dating at least as far back as Egyptian times, the fathom was the measure of a man's outstretched arms: 5, 5½, and now 6 feet in length. Because of its associations with sounding, or probing, it took on its familiar non-technical meaning. But not before its literal meaning acquired a romantic sense: to embrace!

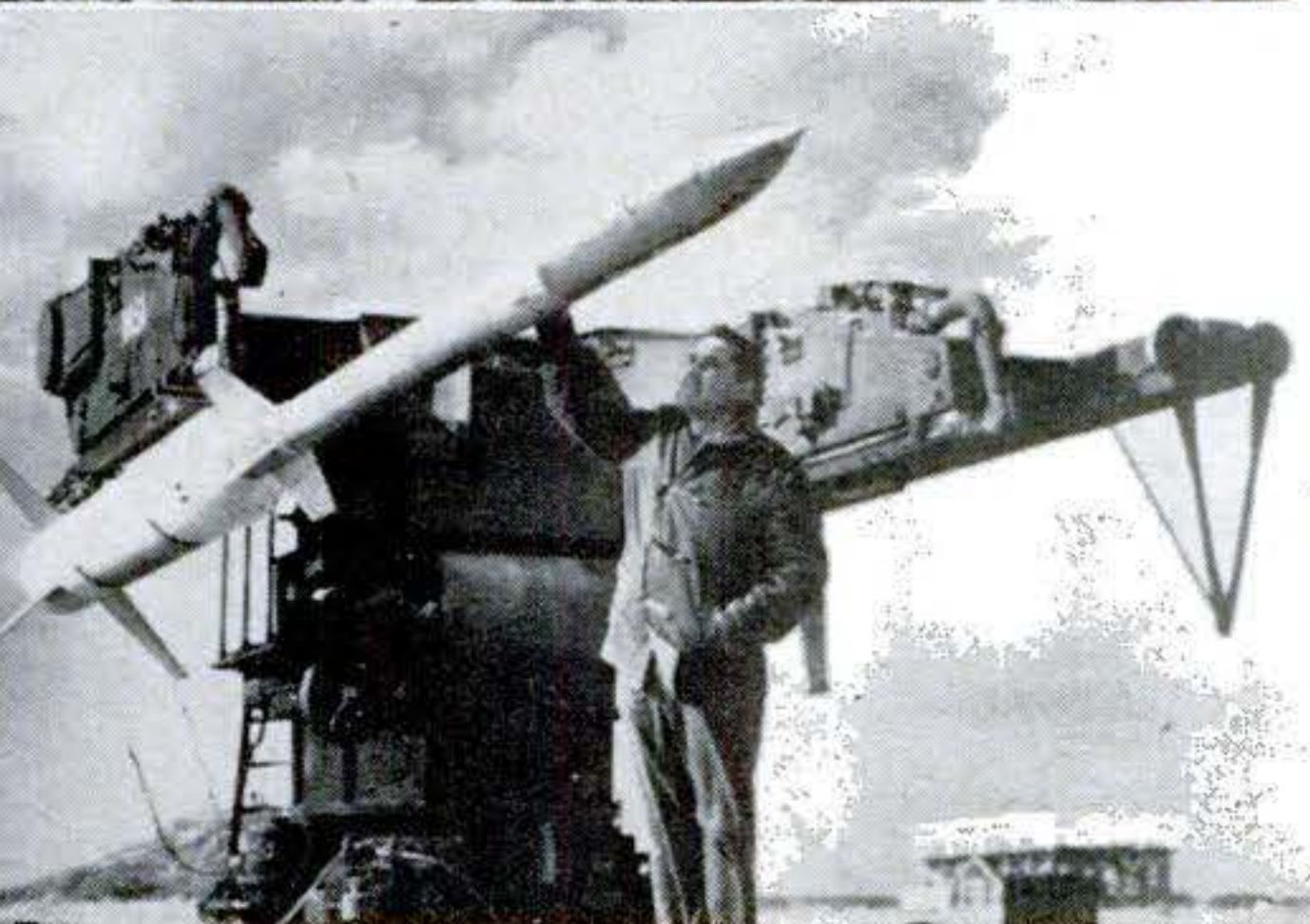

HURRICANE-SPOTTER. A movie-camera unit shot up 86 miles from Wallops Island, Va., in the rocket at left was recovered at sea after it had taken pictures of cloud formations from Florida to Maine. Navy and Weather Bureau expect the new technique to help give advance warning of tropical storms, such as the one shown at upper left in the photo-mosaic.

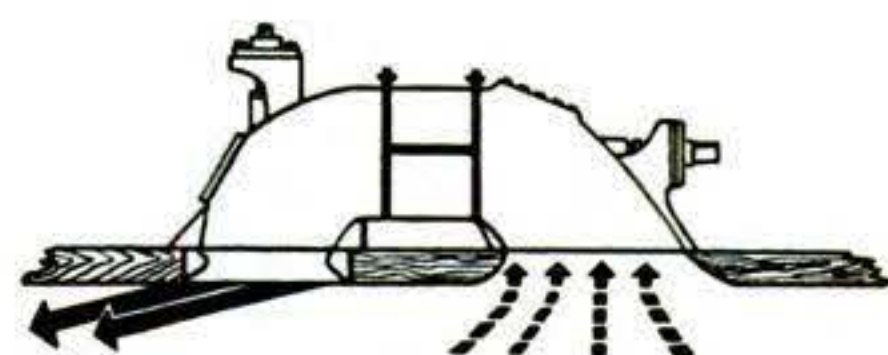
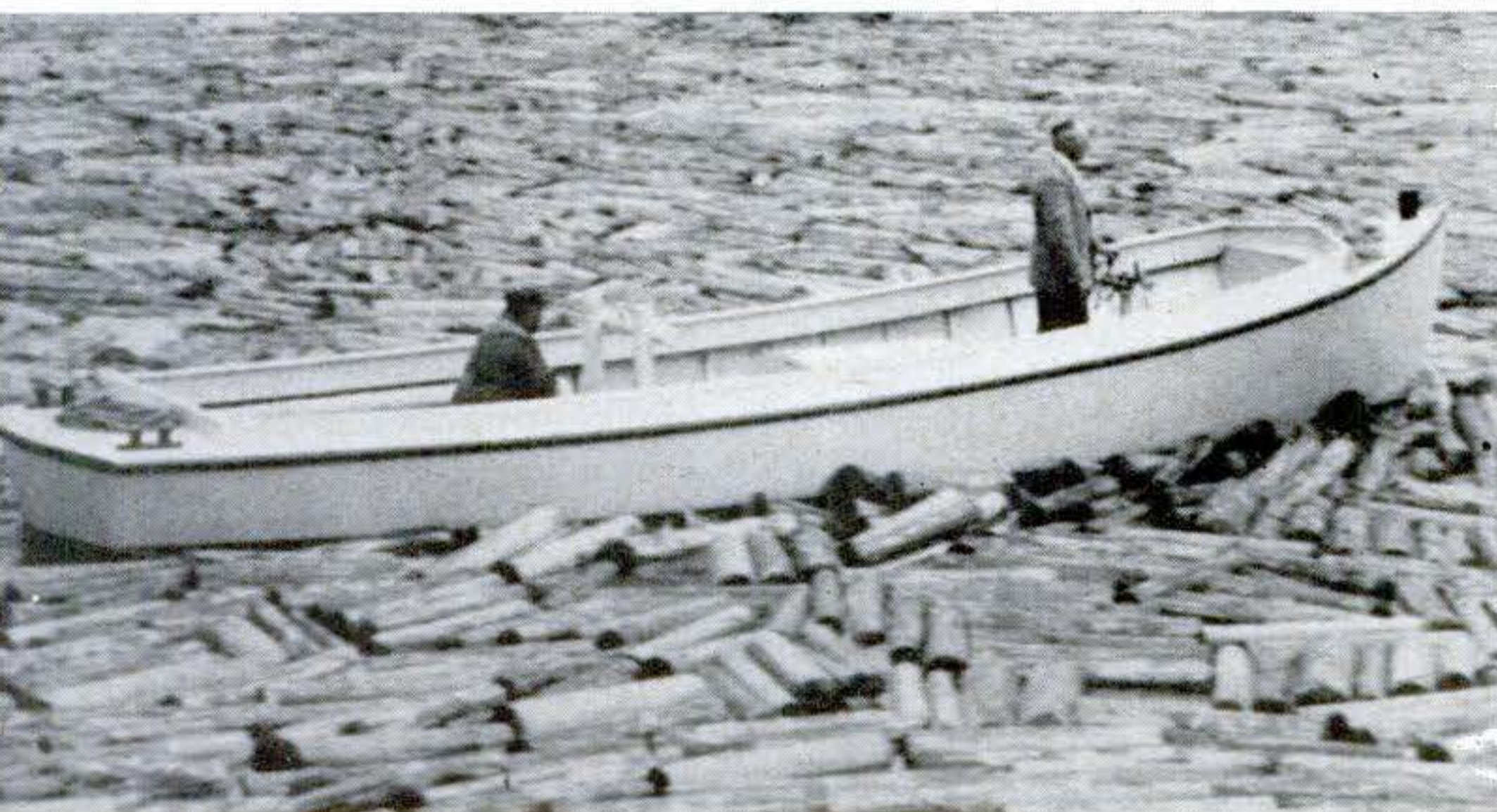

WATER JET. Engine of this British boat is an inverted U pipe, open at its two ends. A built-in pump sucks in water at the front, ejects it rearward to propel the craft through obstructed or shallow waters. Deflector vanes provide steering.

MIGHTY MITE. An air-cooled aluminum V-4 engine [PS, Feb.] powers this quarter-ton, four-wheel-drive vehicle being produced by American Motors for the Marines. The 1,700-pound car can be helicopter-lifted. It has a speed range from 2.5 to 62 m.p.h., can climb a 45-degree grade and ford water to a depth of 60 inches. The frame is of steel, the body of aluminum.



How Silent Sound Now Works for You

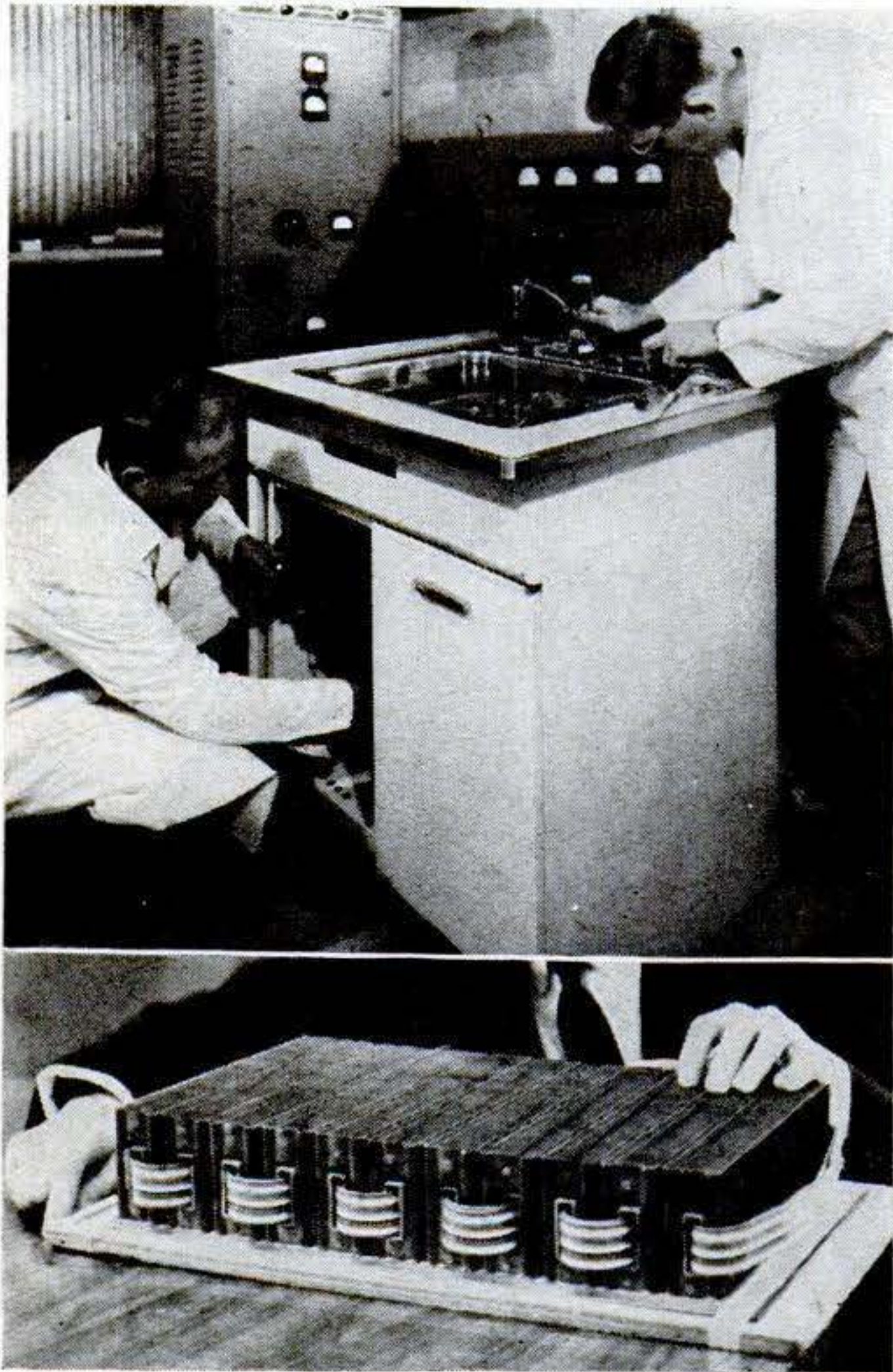

SINK THAT AUTOMATICALLY WASHES DISHES is a possibility. Experimental model has big electromagnet (lower photo) welded underneath to generate sound waves in water for cleaning. Other sound-wave dishwashers use sprays for rinsing, require conventional closed cabinets.

Washing dishes with sound is only the first of many uses for sonic magic in house and shop

SILENT sound, the strange power that can do everything from locating fish to welding aluminum, is now ready to work for you in your home. This year it's a brand-new kind of dishwasher—more effective and more convenient than present types. In years to come there'll be other sonic machines to lighten many ornery jobs around your house and shop.

Right now a sonic dishwasher stands waiting for the dishes in a model home in a suburban development outside New York City. This one, made by Narda Ultrasonics of Westbury, N. Y., should be on sale (\$500) later in '59.

Another firm specializing in sound machines, Acoustica Associates of Mineola, N. Y., expects to have a similar dishwasher on the market by the end of this year. And Westinghouse has shown dealers a preliminary model that may be in salesrooms before many months.

All these machines look like regular dishwashers. The big thing is that they wash the dishes better.

- They're faster (six minutes for the whole job in Narda's washer).
- They clean pots and pans—even real

Many tough jobs are made easy by new sound machines

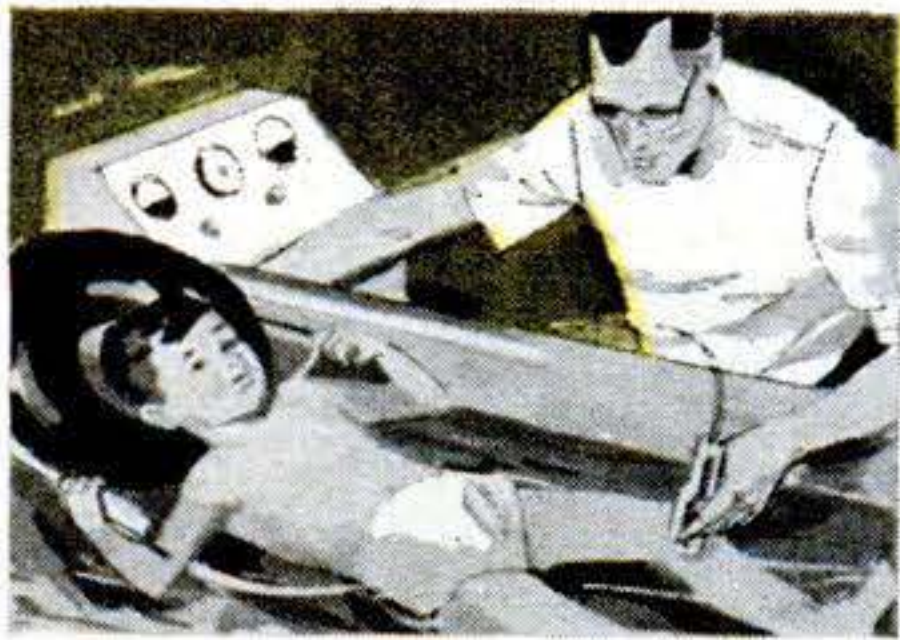

EASING PAIN. Doctors use very-high-frequency sound waves to treat patients with stubborn joint and muscle afflictions.

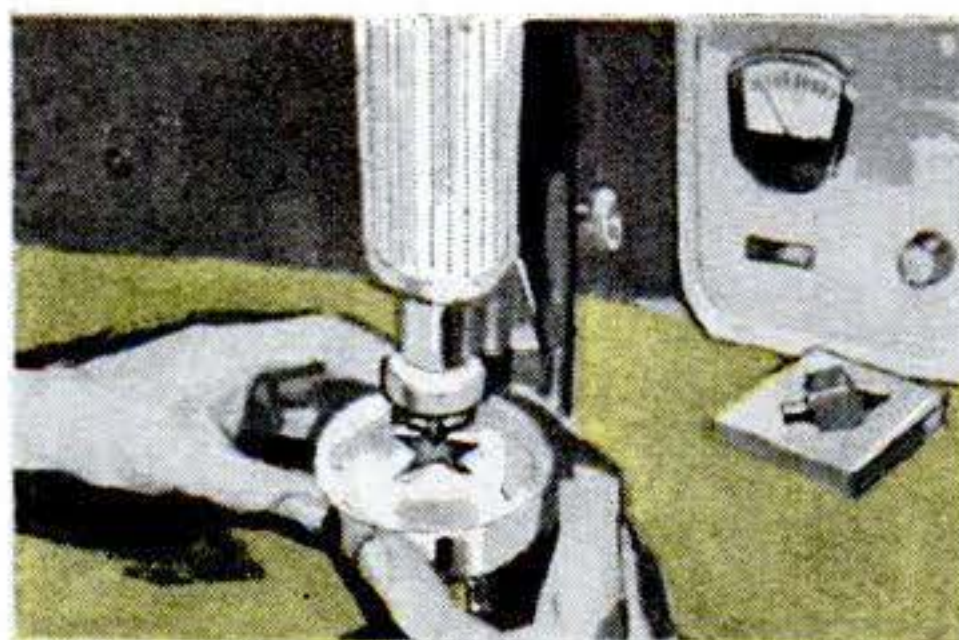

DRILLING HOLES. Sound generator "bit" vibrates abrasive to cut through hard materials. Hole copies shape of the bit.



CLEARING FOG. Powerful sound from horns cuts chimney smoke, is now being tested as a landing aid for fog-bound airports.

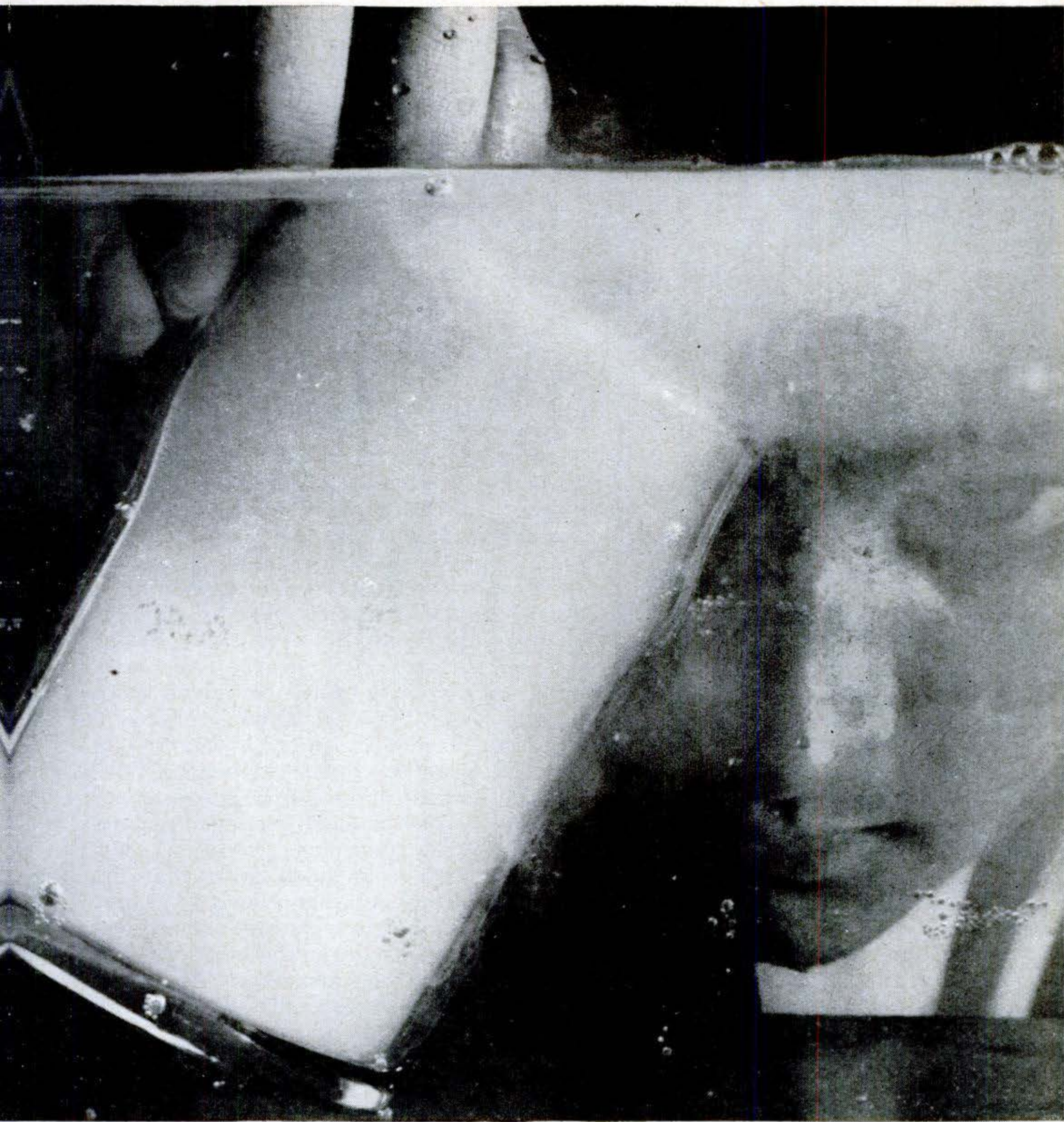

Powerful sound blasts dirt off glass by exploding water into tiny bubbles. It tickles fingers.



CATCHING THIEVES. Alarm installed in museum detects anything crossing invisible, inaudible "fence" of sound beams.

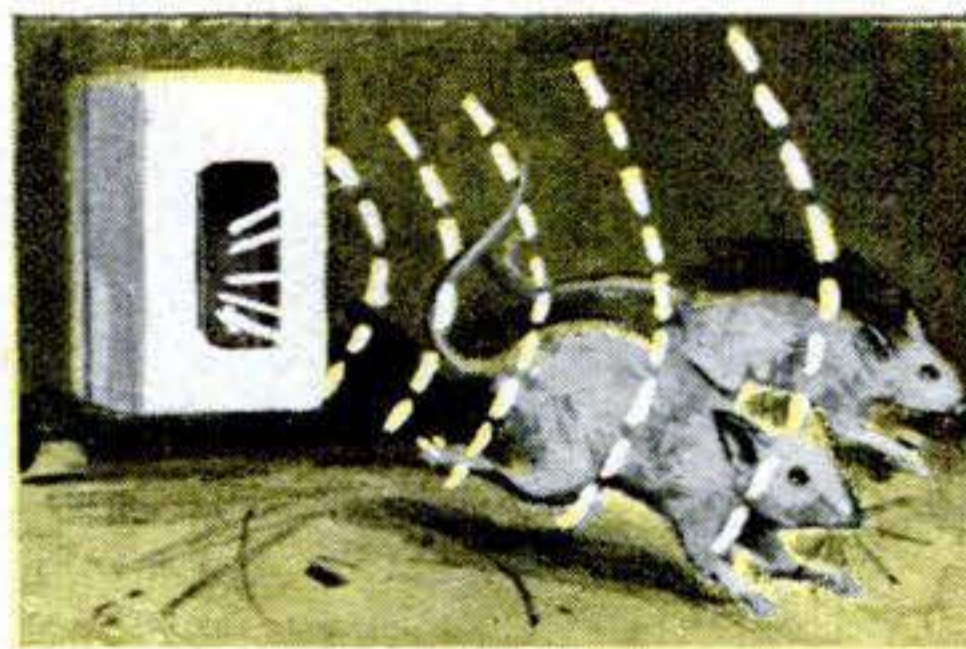

CHASING RATS. High-frequency sound, inaudible to men and other animals, bothers rats so much they leave—permanently.

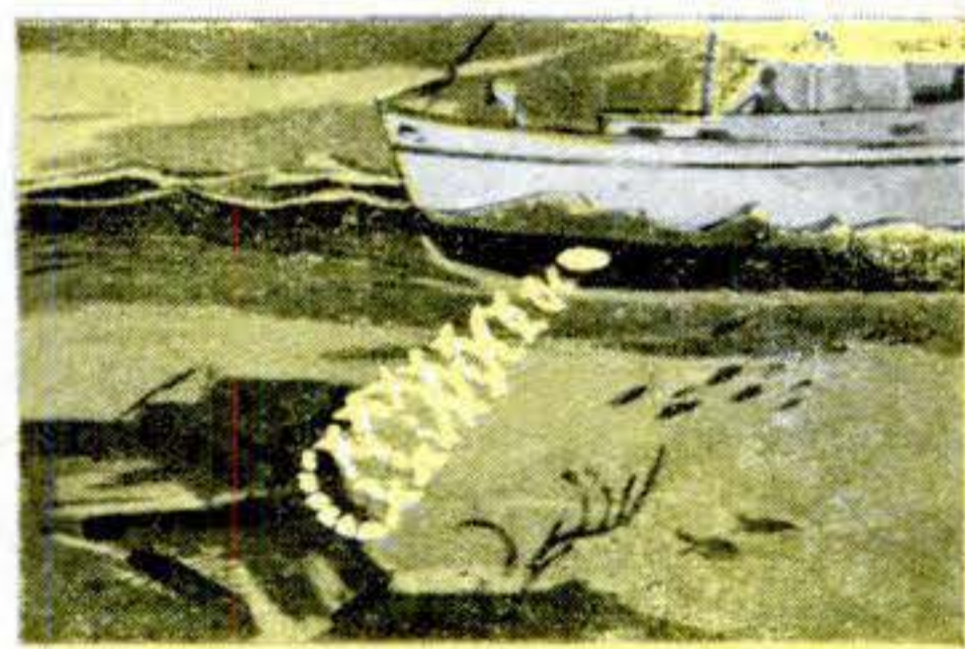

MEASURING DEPTH. Timing echo of transmitted sound locates the ocean bottom, submarines. Even schools of fish can be spotted.

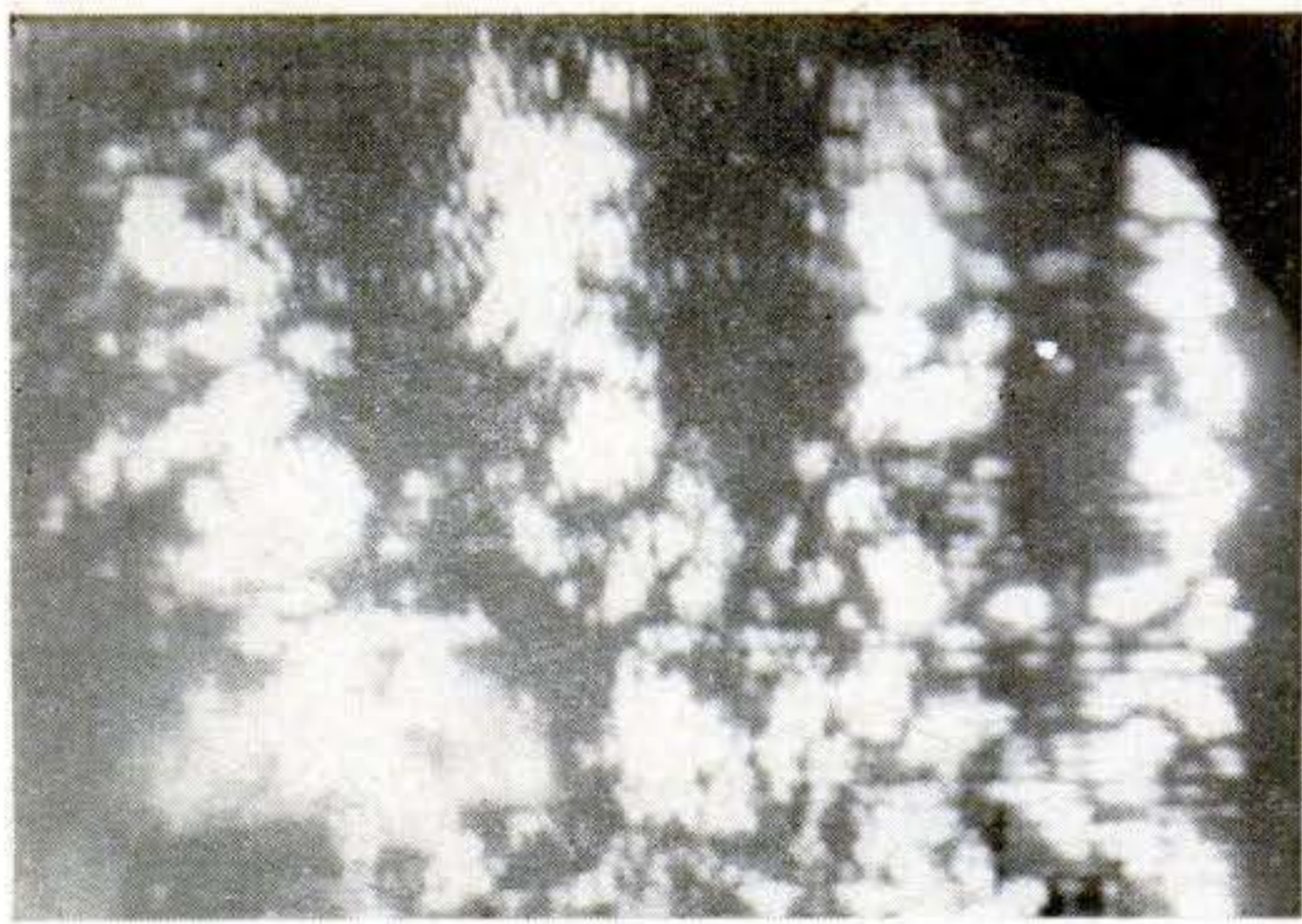

SONIC "X RAY" was made at Polytechnic Institute of Brooklyn by beaming sound waves through hand and displaying received signal on scope. Technique also spots flaws in metal.

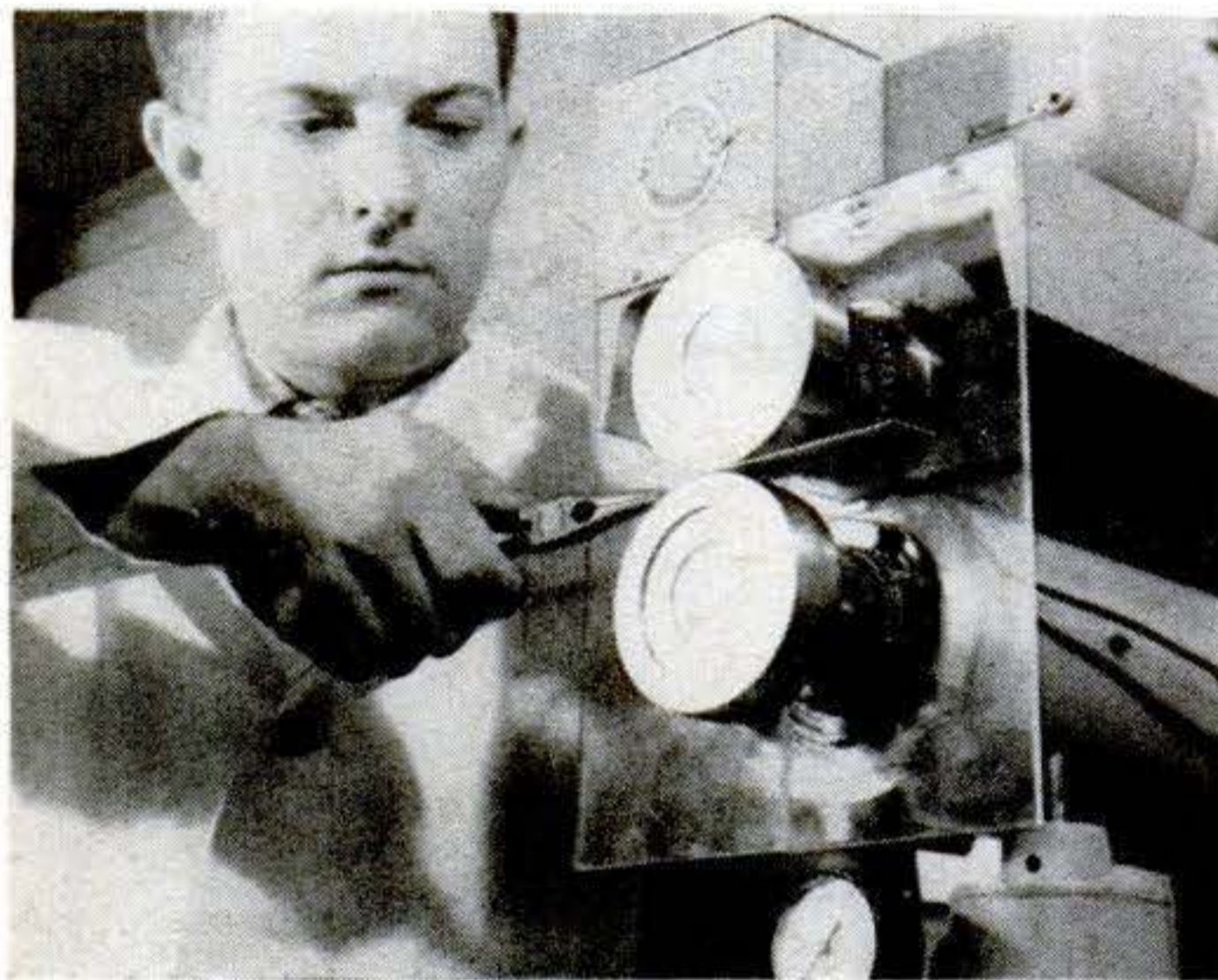

WHEELS VIBRATING WITH SILENT SOUND weld strips of metal as they pass through, beating their molecules together. This is newest Westinghouse machine; others are on the market.

dirty ones that present washers can't.

- You don't have to rinse the dishes off before the washer has at them.

The dishwasher is the first home use for sonic energy, but the sound waves have been making a big noise in industry ever since World War II. Besides spotting submarines (sonar set off the boom in sonics), they perform such weirdly different jobs as:

- Finding fish for fishermen.
- Drilling holes of any shape—square, even corkscrew—in hard, brittle materials such as glass and tungsten.
- Soldering and welding aluminum and other "difficult" metals.
- Cleaning small metal parts.
- Warning of burglars.
- "Seeing" flaws deep inside metal castings.
- Treating diseases that range from osteoarthritis to tennis elbow.

The sound that does the dishes and welds the aluminum is the same as the sound of Dinah Shore—almost. The differences are differences of degree.

Most important, this sound is more powerful (than Ethel Merman even). It takes 400 or more watts of sound energy to clean dishes, several times that to weld. At her loudest, Ethel Merman belts out around 3/100 watts.

Usually, working sound is higher in pitch (than Lily Pons even). The machines used in medicine run close to 1,000,000 cycles, far too shrill for the human ear to detect (15,000 is about tops for hearing). The Narda dishwasher works at 40,000 cycles, which only bats can hear. Westinghouse and Acoustica use 20,000 cycles, a little too high for people but just right to drive the dog out of the kitchen. (All these machines make some noise you *can* hear—harmonics caused by sound waves reflected off the tank walls. It sounds like a lathe bit cutting into steel, but is not very loud.)

How the dishwasher works. The powerful, very rapid vibration of sound tears water apart, literally. Millions of invisibly small bubbles are created and collapsed, a process called "cavitation." Cavitation generates tremendous pressure and heat: 75,000 pounds per square inch (5,000 times atmospheric pressure), and 20,000 degrees F. (much hotter than the surface of the sun). In effect, the water is exploding inside. The explosions blast dirt off china, glass and silverware.

That's why the sonic dishwasher cleans so fast and so thoroughly. It gets into the tiniest cracks and crevices. (Hospitals now use similar machines for instruments so intricate they cannot be cleaned any other way; they used to be junked after they were used once.)

How do you make this kind of sound? Underneath the tank is an electronic oscillator that converts 60-cycle house current into 20,000- or 40,000-cycle electrical energy. Fundamentally, it's not much different from a hi-fi amplifier—but it's bigger, a lot bigger. It puts out as much as 1,000 watts, 50 times more than even an expensive hi-fi rig.

This is electricity. You want sound, the mechanical movement of water. There are two ways to get it:

- Synthetic crystals (used by Narda

[\[Continued on page 268\]](#)

RETRIEVER. A paratrooper who gets entangled in chute lines as he leaps out of a C-130 (right) or C-123 can be reeled back aboard by a new Lockheed device. The reel is attached to the static lines that automatically open the chute. In case of trouble, the jumpmaster throws a switch to winch the man in.

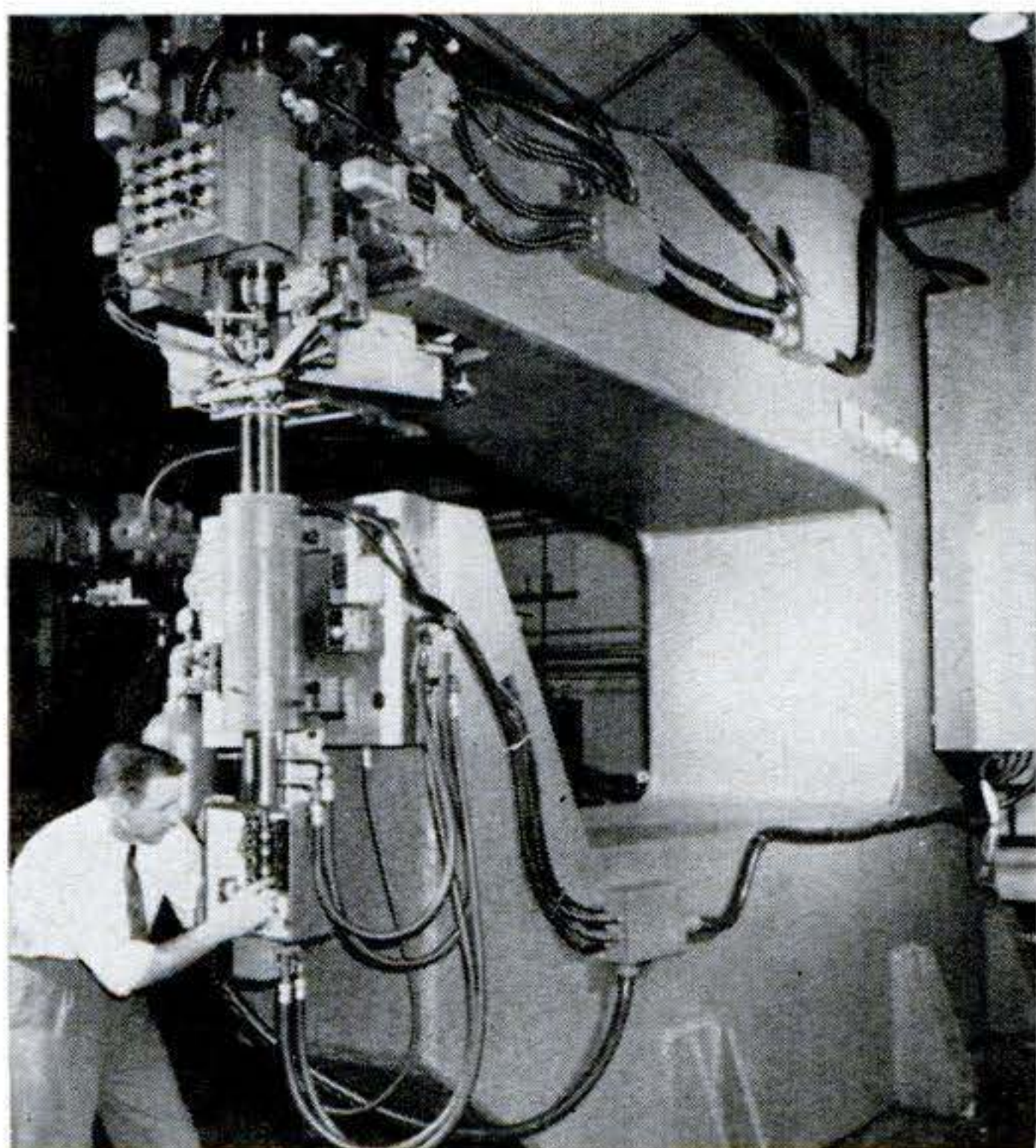
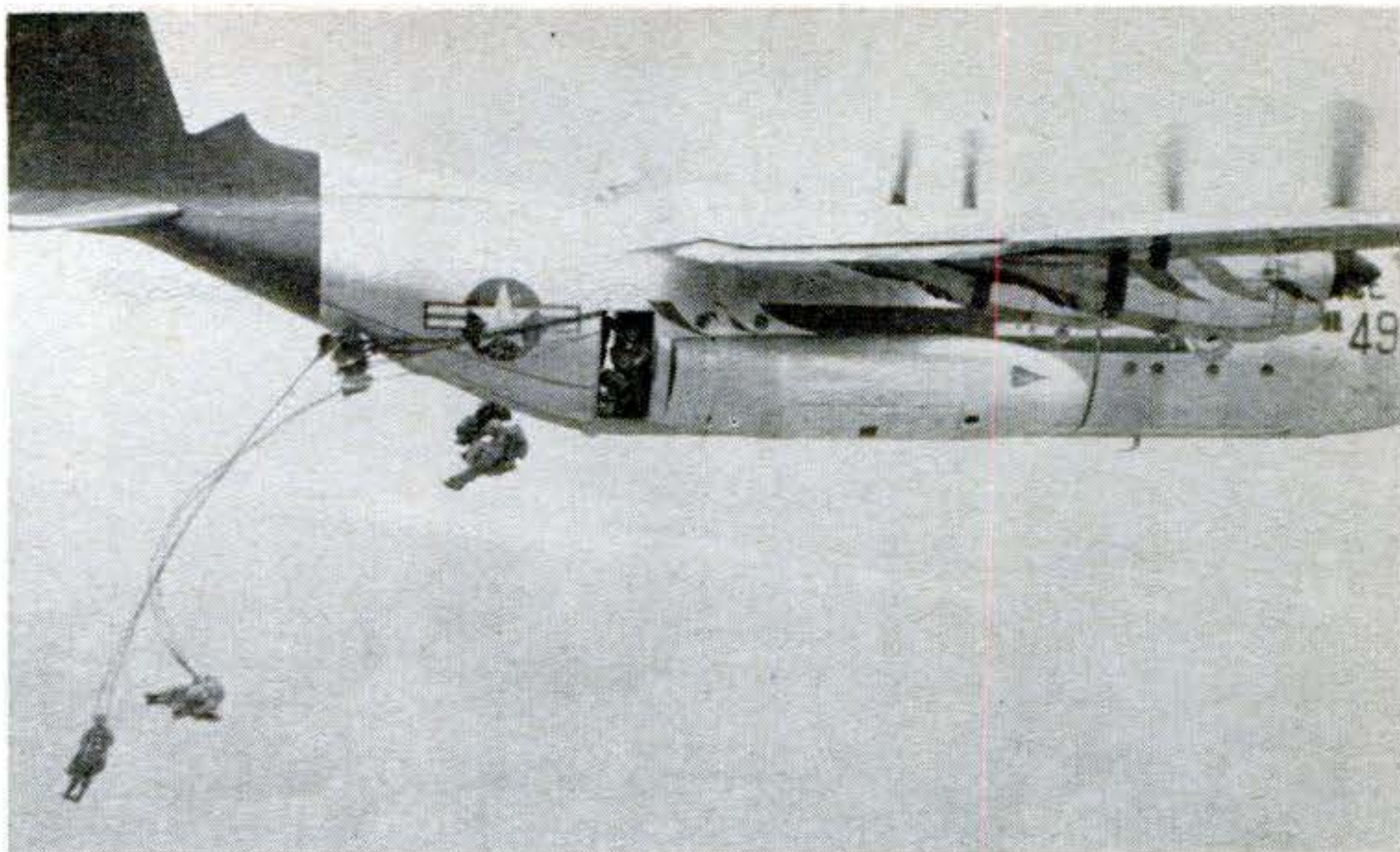

GIANT ROBOT. This 21-ton riveter automatically fastens skin and ribs of Convair 880 jetliners. It drills, inserts and finishes a rivet every 3½ seconds.



RESCUE ROCKET. The projectile held by a West Berlin policeman above helps save skaters who break through ice. Fired from shore, it carries a nylon line.

EXTRA EYES. A closed-circuit television camera (inset) back of the left rear end of each new Pontiac helps position bodies rolling off a conveyor correctly on the chassis. It gives an assembly-line operator a view of both ends at once, cuts down manpower, speeds work.





HOT-COLD LIGHT. This luminescent panel may not only light a room but heat and cool it, too. The aluminum cut-outs are part of a dial-controlled thermo-electric heating and cooling system under study by Westinghouse.



UNDER AND OVER. Here's a fork lift that lowers a three-ton load seven feet below the floor or raises it 12 feet above. This Towmotor model has a transparent heat shield, is used by a steel mill to dunk castings in a quench tank.

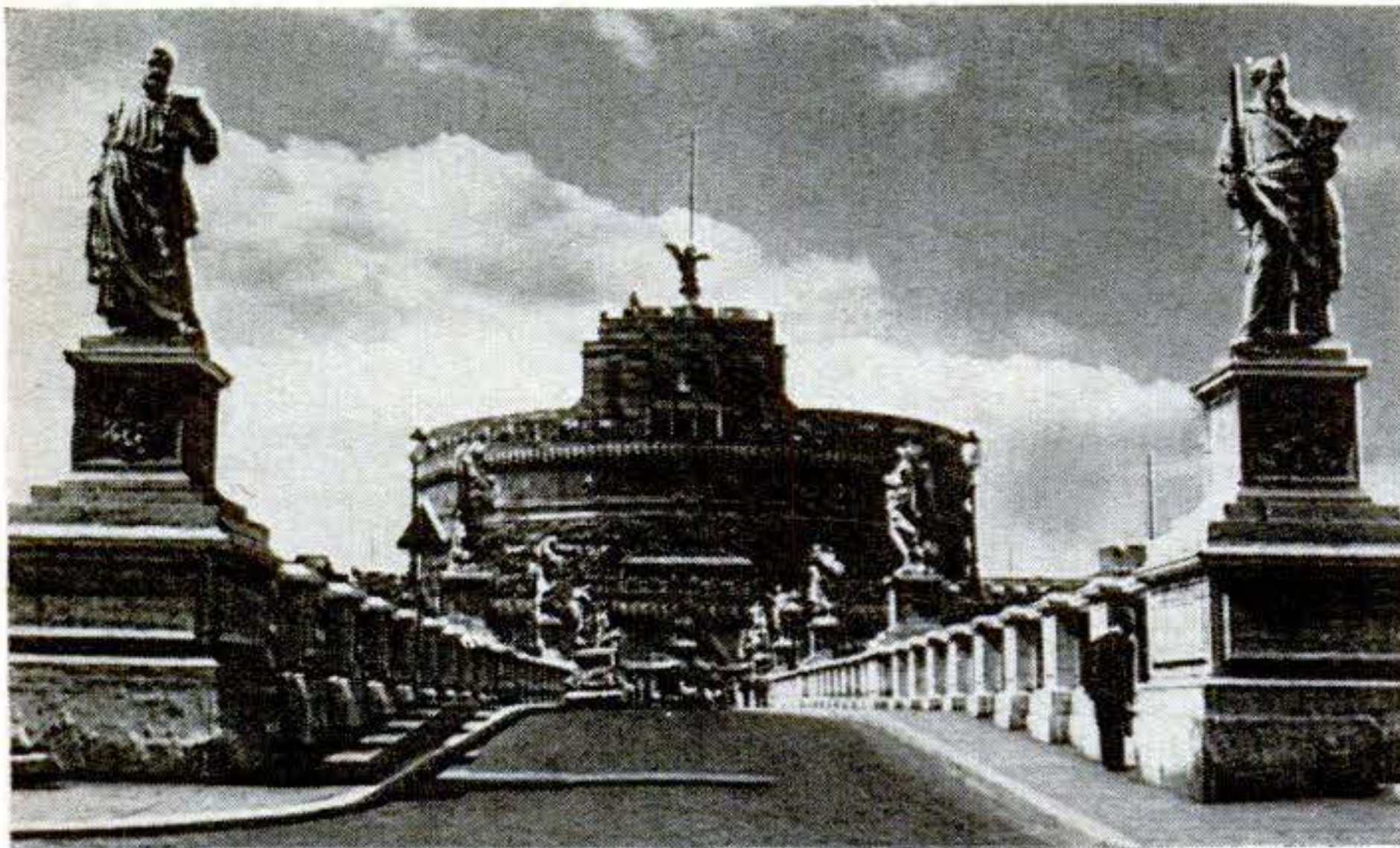

THREE-D PHOTO. This study in perspective of the statue-lined bridge leading to the Castel Sant'Angelo in Rome was taken with an ordinary camera. The negative was used to make a black-and-white transparency, or contact diapositive. Negative and transparency were sandwiched together, emulsion to emulsion, and slightly askew so the images did not match.

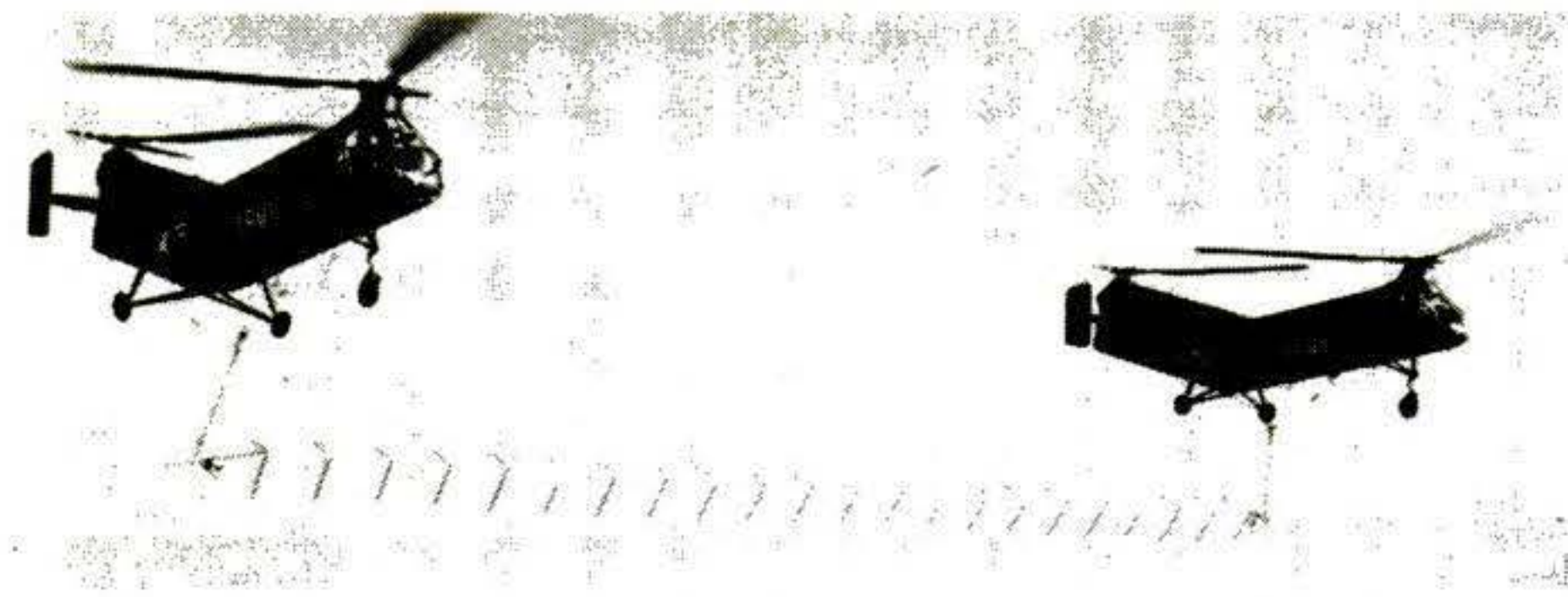

WHIRLYBIRD HARNESS. The aluminum-alloy frame slung under helicopters above was built by Vertol for combat hauls. Teamed as in the drawing, four or more could lift a big Army truck too heavy for one.

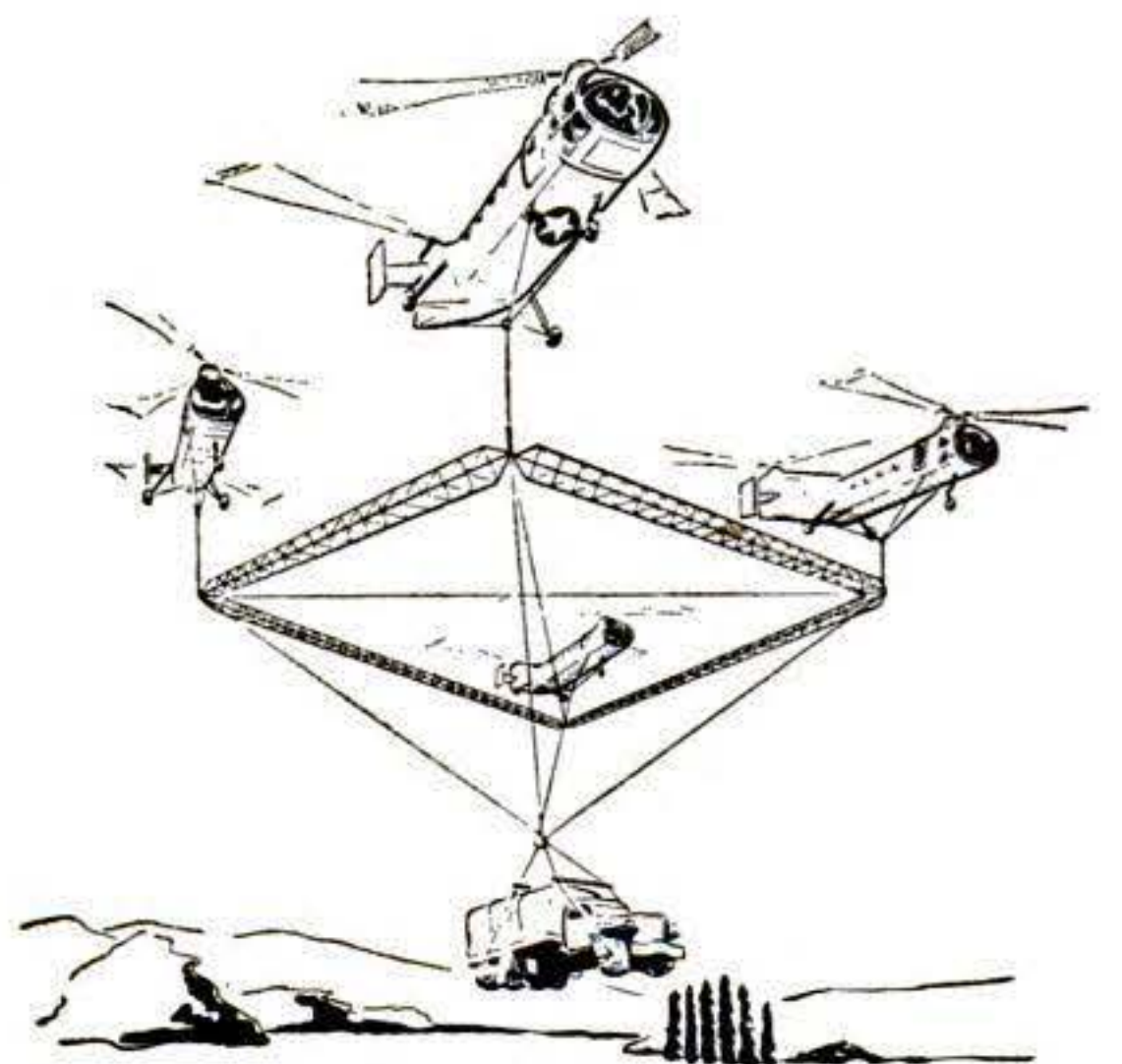

A wealth of practical ideas about—

Building One-Lung Cars for Kids

By Harry Walton

TOPPS in thrills for any youngster is a car he can drive to the purposeful bark and hot breath of a real engine. Building such a car is fun for all hands from the moment you start putting a one-lunger on wheels.

It can be simple. Boys build them with a plank for a chassis, a wooden axle pivoted on a spike for steering, and a clutchless push-and-hop-on drive. It can be sophisticated to the point of having



IT'S A FLIVVER, with a brass-bound radiator, a klaxon horn, a hand-rubbed lacquer finish and tin-lizzy fenders. Built by Robert Paul Moore of Tulsa, it has run 500 miles.



FOR YOUNG PILOTS, this Air Force jeep built by Capt. James Sparks Jr. can haul a trailer, too. A spring-loaded reel (under the lever) pulls idler to maintain driving-belt tension.

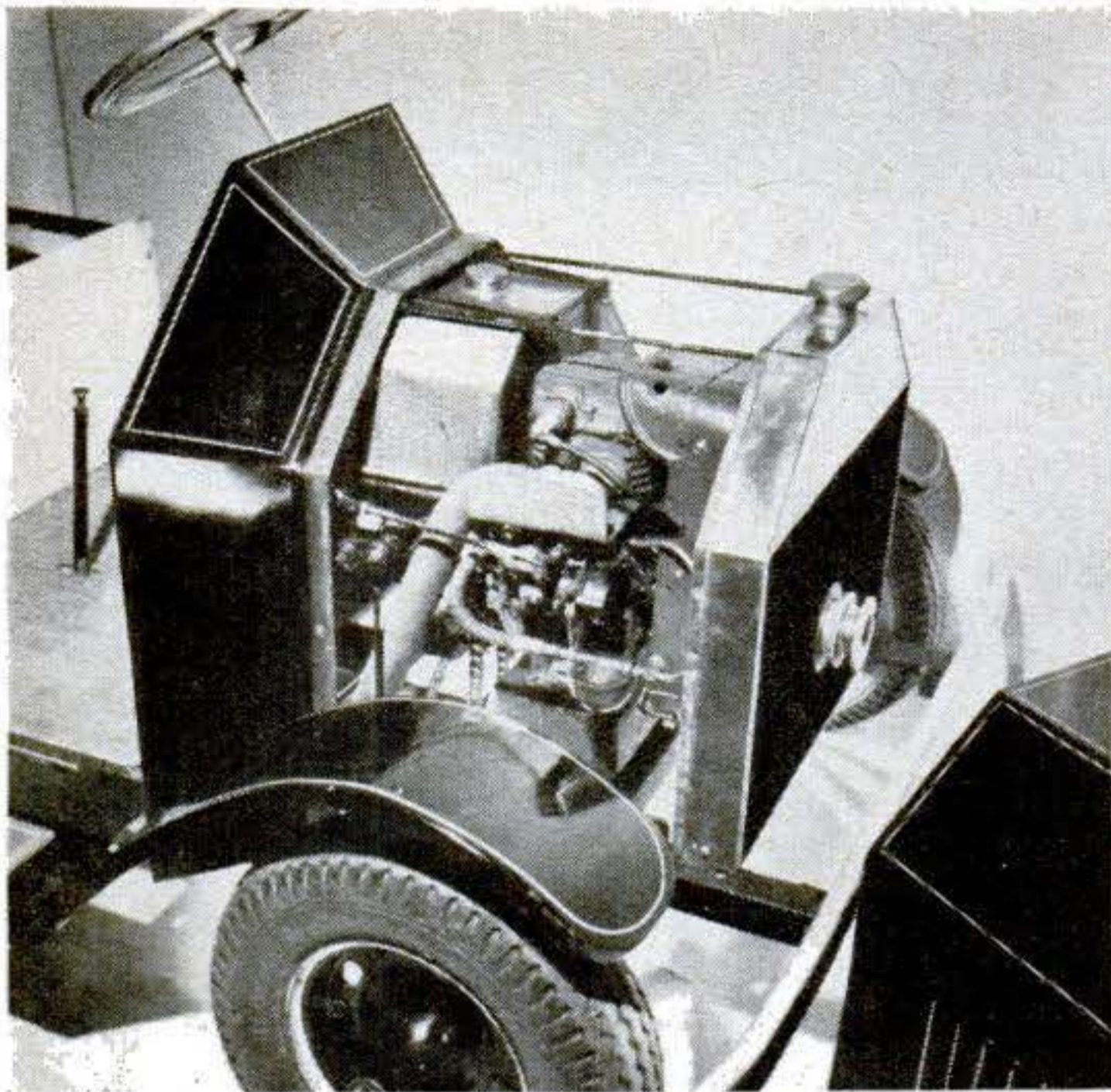

UNDER THE HOOD of the sleek flivver on the preceding page is a four-hp. engine. Through chains and a drive shaft, power goes to two identical right-angle gearboxes. So mounted

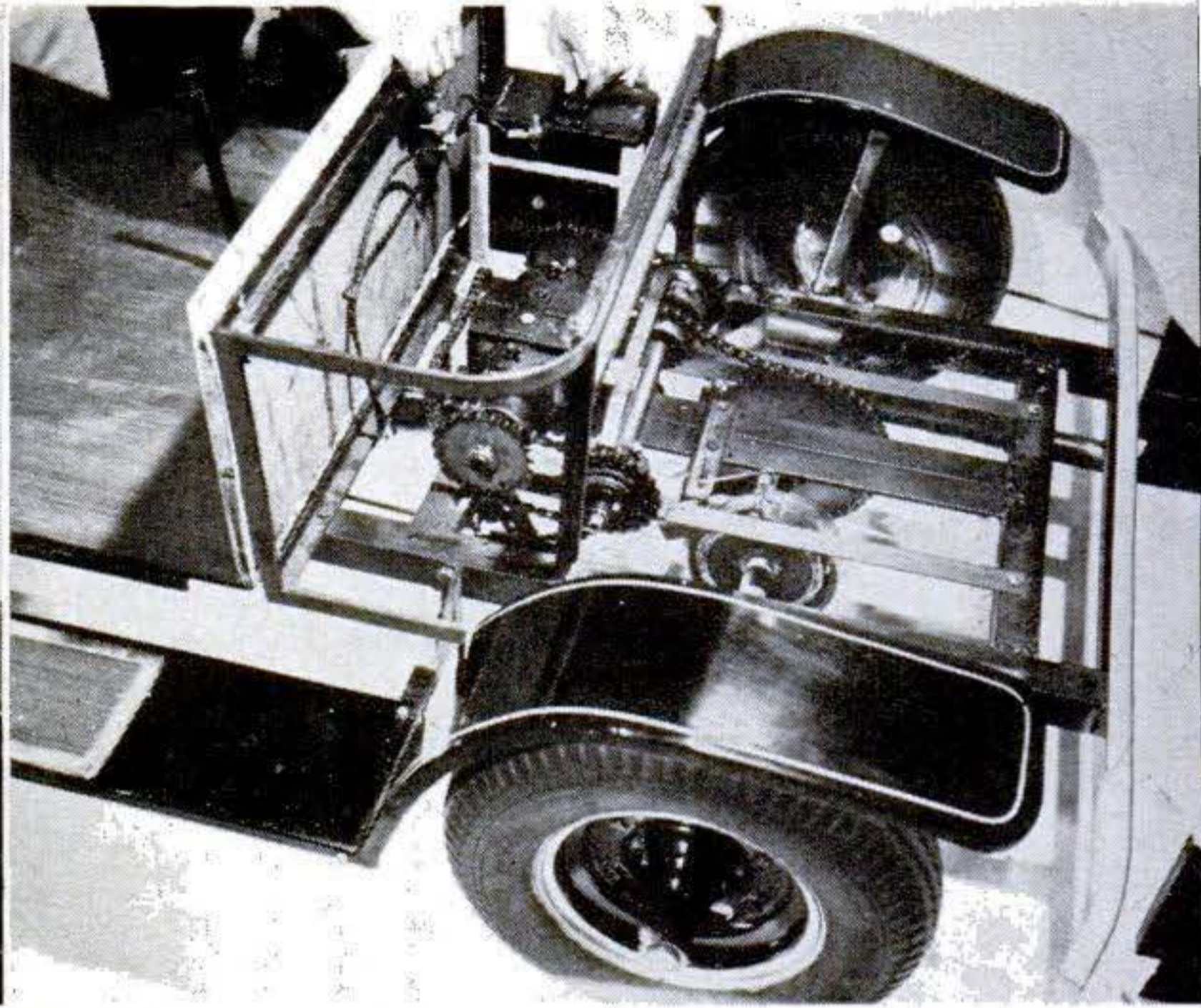

that their output shafts turn in opposite directions, these drive two clutches on the countershaft. Engaging one clutch sends car forward; engaging the other clutch reverses it.

a real gearshift (from a motorcycle or small car) and spring suspension.

In between there are many ways you can build a car that will deliver a lot of fun. Although it won't be legal for street use, there is usually a yard or driveway, a dead-end turnaround or a closed road youngsters can drive on.

The parts you'll need. Old power mowers are a prime engine source. Look for trade-ins at mower shops. Rubber-tired semi-pneumatic wheels with built-in ball or roller bearings are sold by mail-order houses, surplus dealers, and bicycle stores. The 1.75"-by-8" size will do. Better 2.75"-by-10" wheels cost about \$5 apiece.

Automatic clutches, pillow blocks, shafting, drive chains and sprockets are available from the same sources. Second-hand parts will serve. Don't overlook auto wreckers for control cables, brake, steering and body components.

There are kits, too, ranging from running-gear parts only, to those that include the drive mechanism and even the engine. You can spend as little as \$20 or as much as \$300.

What size engine? A speed of 10 m.p.h. (ample for children) can be attained with a 3/4-hp. engine. A 2 1/2-hp. engine will wheel a car at over 25 m.p.h. One with a horizontal shaft is easier to install than the vertical-shaft kind. (These re-

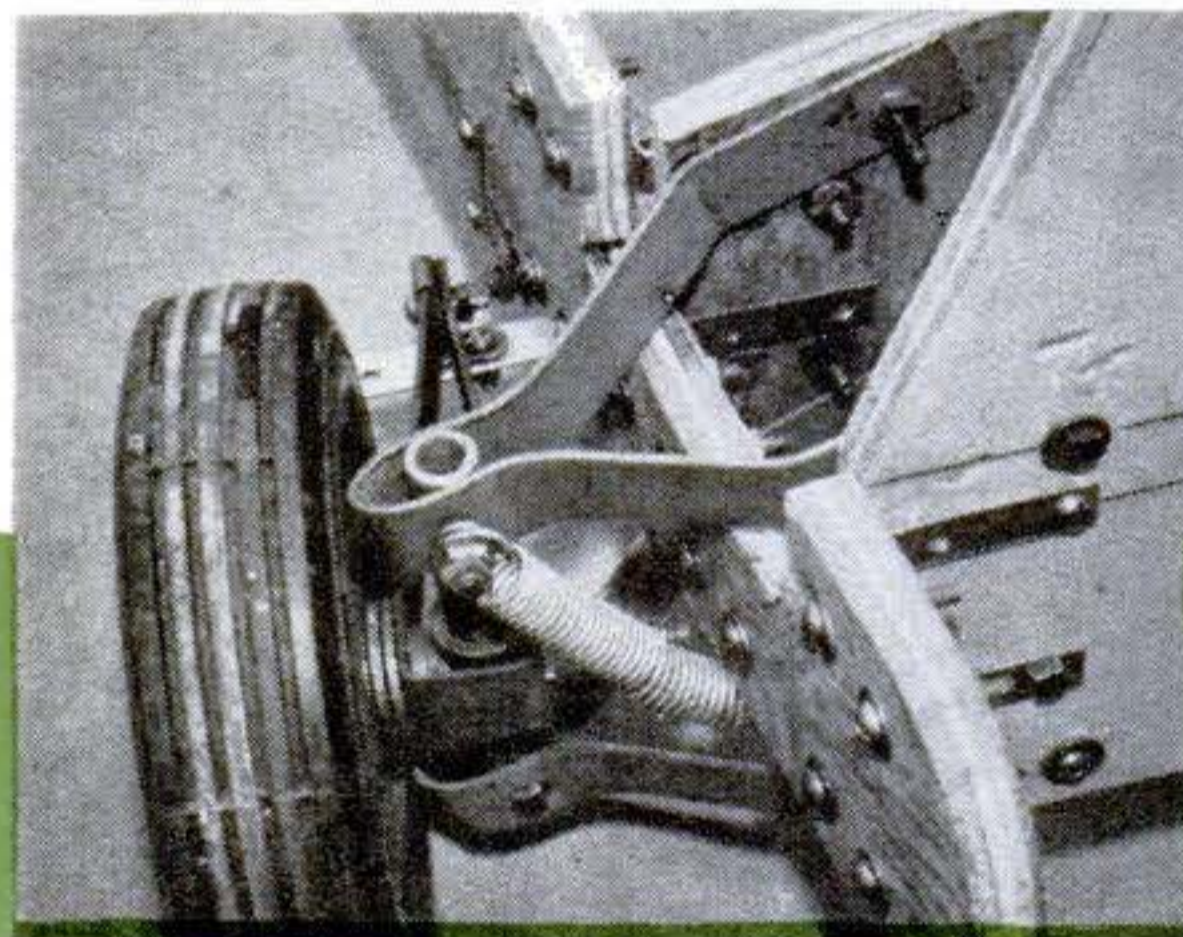

FOLLOWING AUTO PRACTICE, this ingenious wishbone arm and spring suspension devised by Sheldon Gallager of Chappaqua, N. Y., keeps wheels vertical. Pipe nipples pivot on crosspins, aligned by tee serving as the kingpin unit. No welding is required. Axle bolt goes through tee.

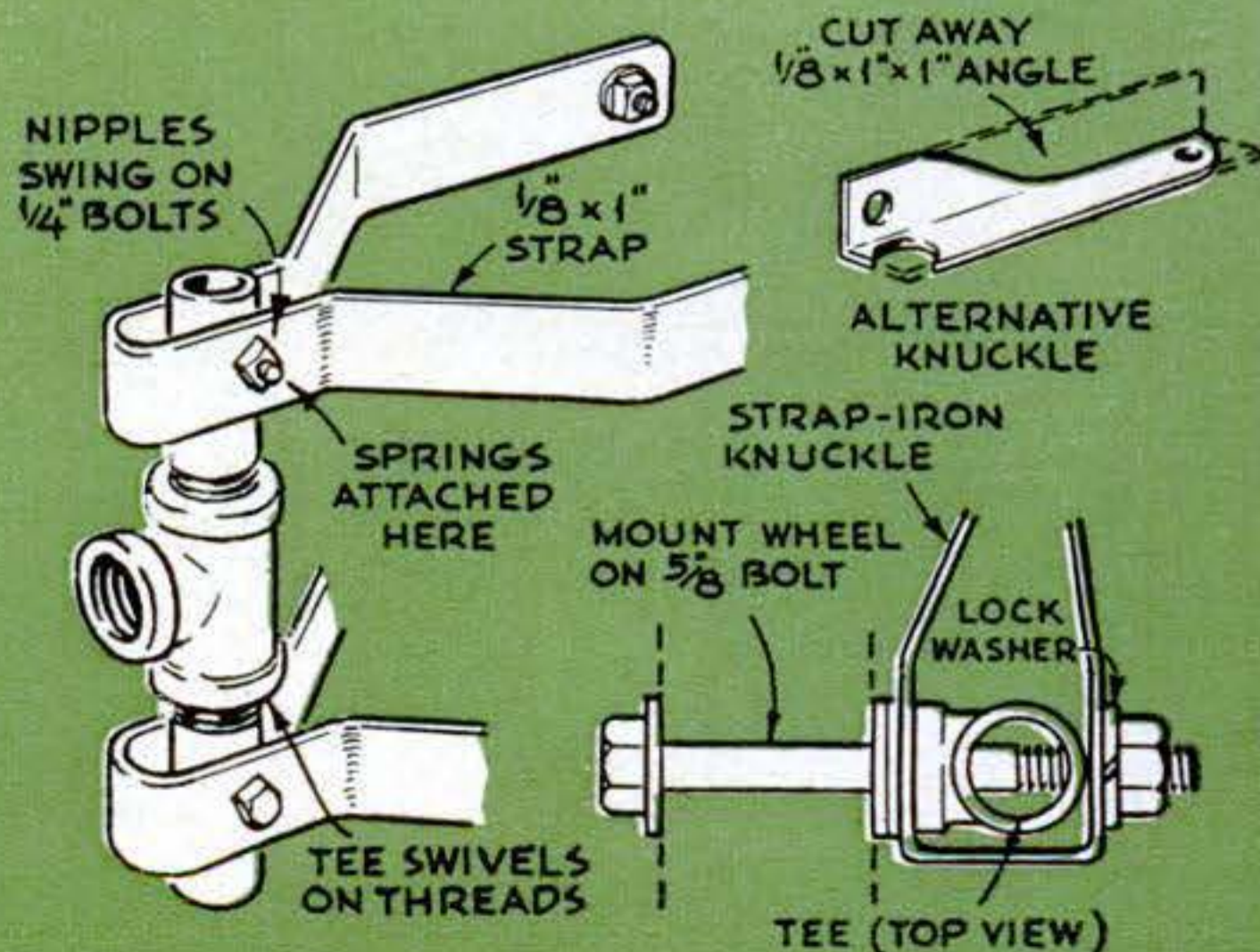

Ideas for a sturdy frame and front axles with real auto steering

HERE ARE SOME WAYS you might build the backbone of a car. The one at right, designed for a front-mounted engine, is made of $\frac{3}{4}$ " plywood. Wooden members can be joined with drawbolts as in the drawing. With welding equipment, you can use angle iron or electrical conduit.

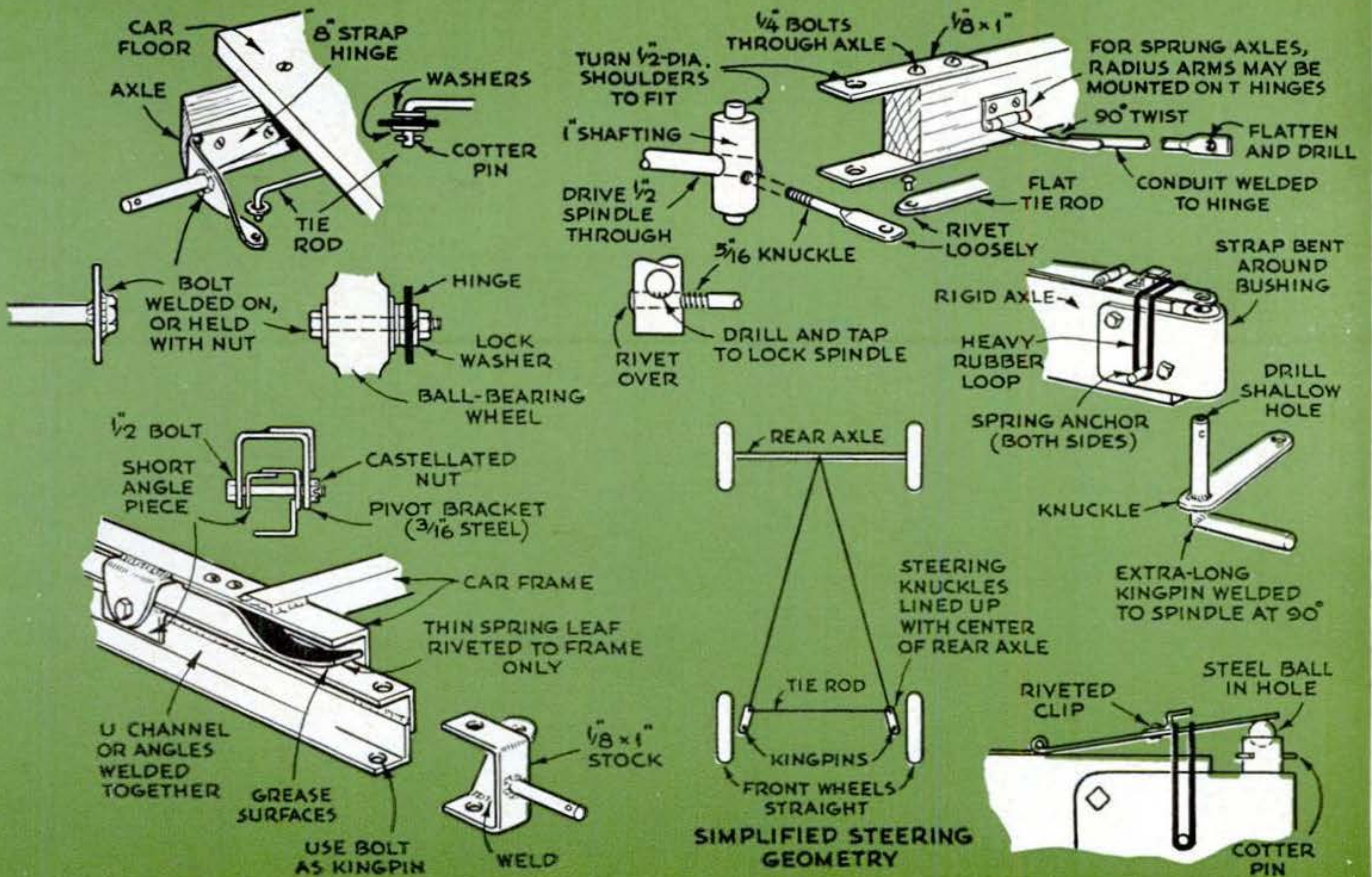
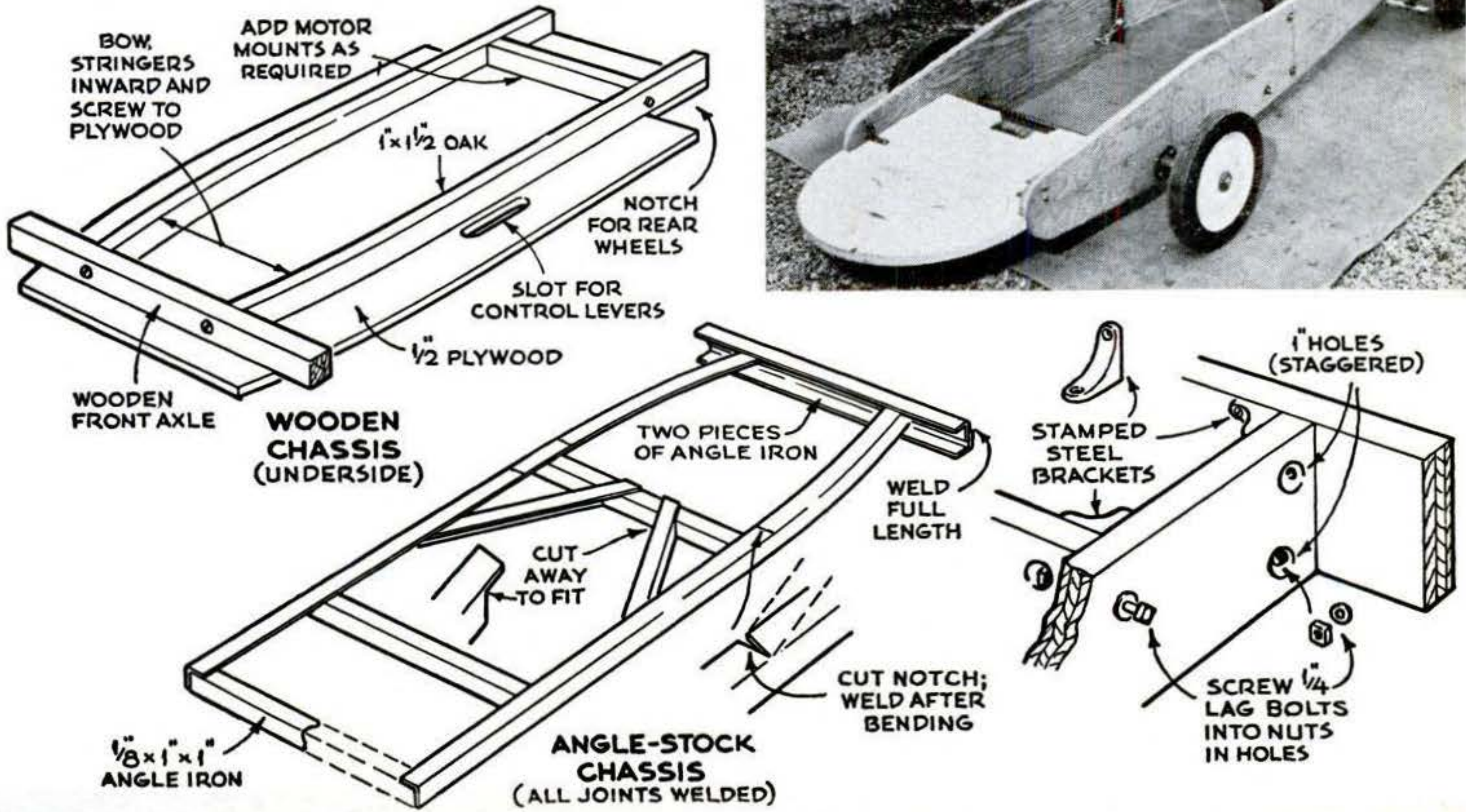
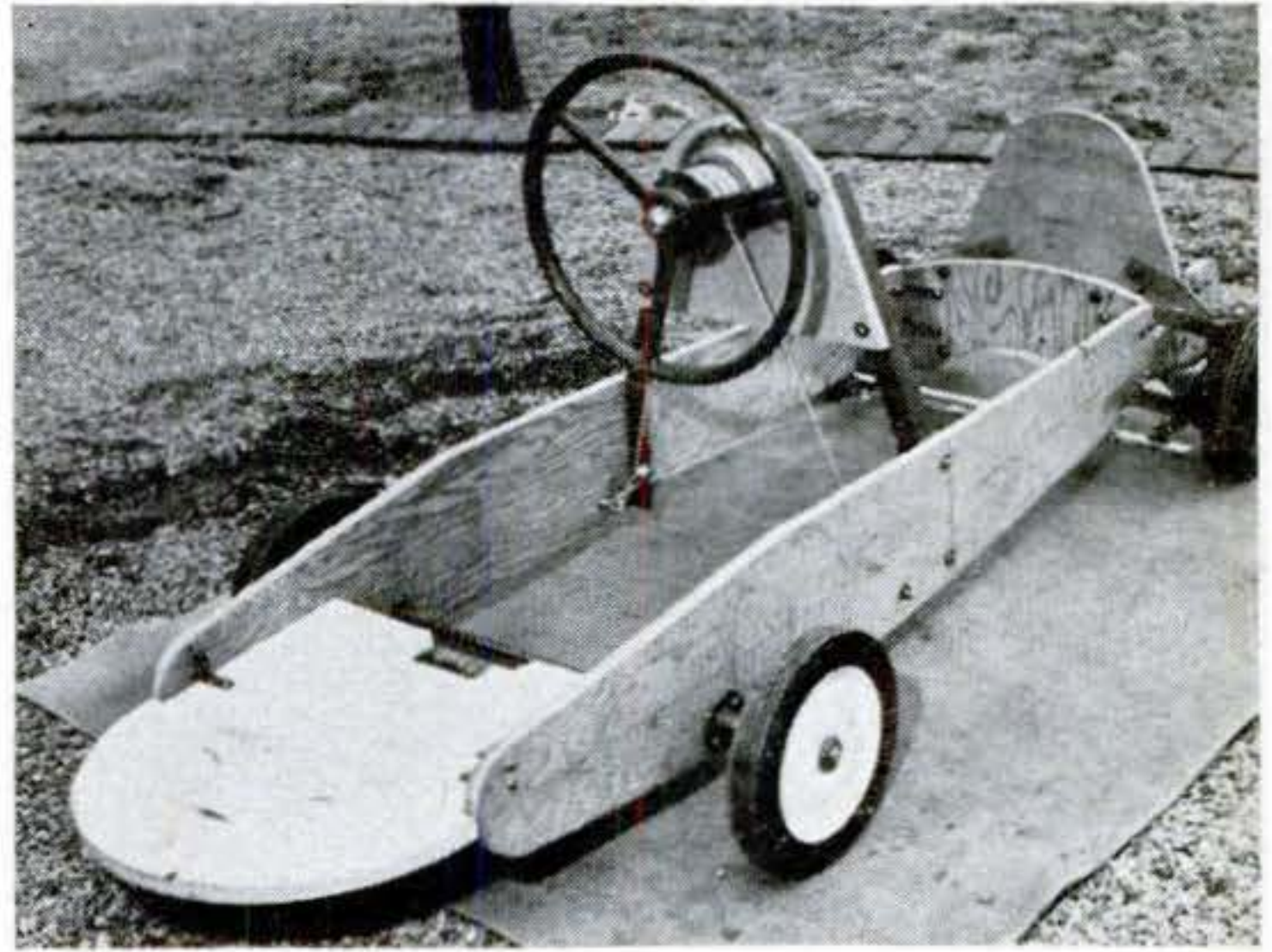

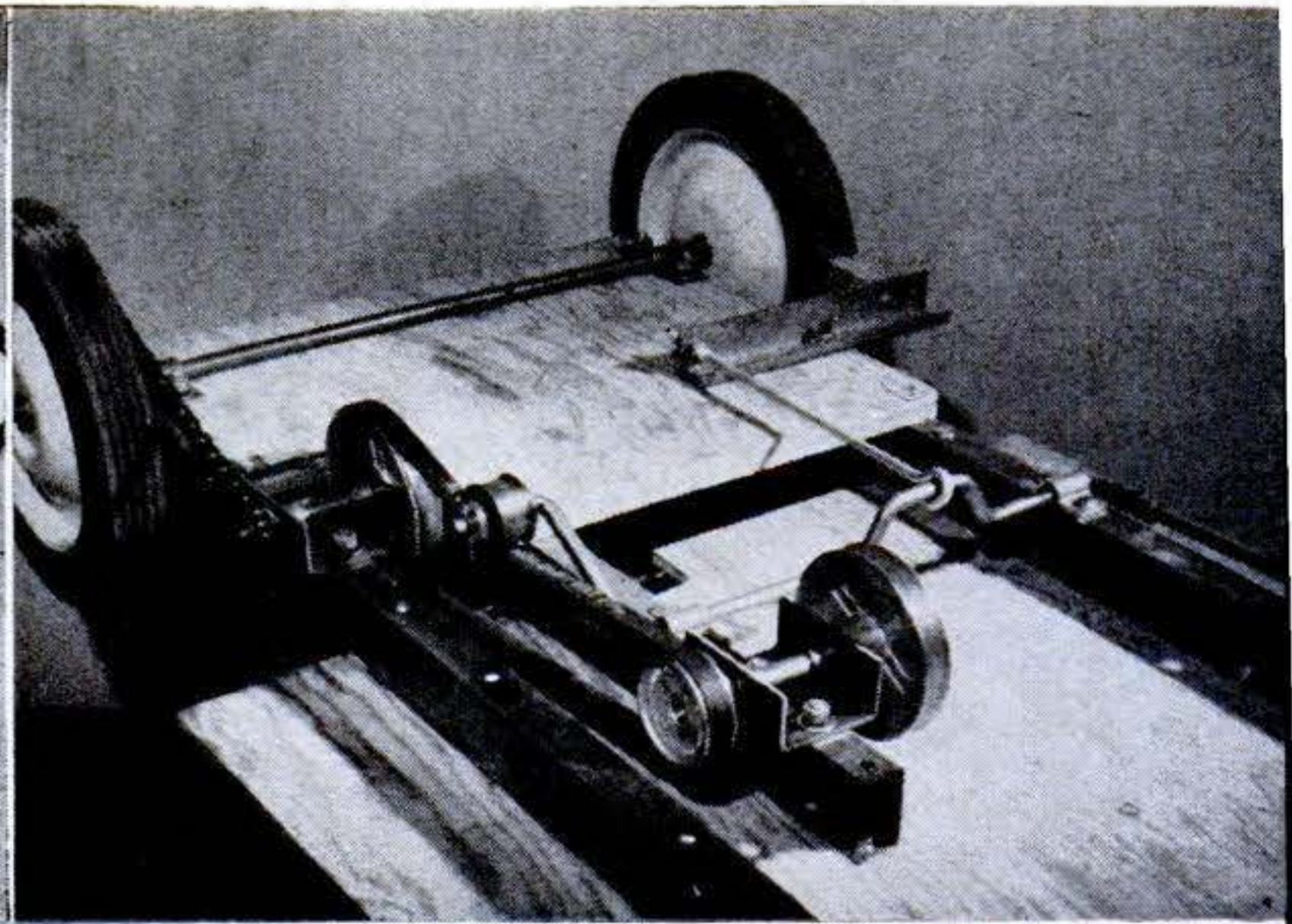
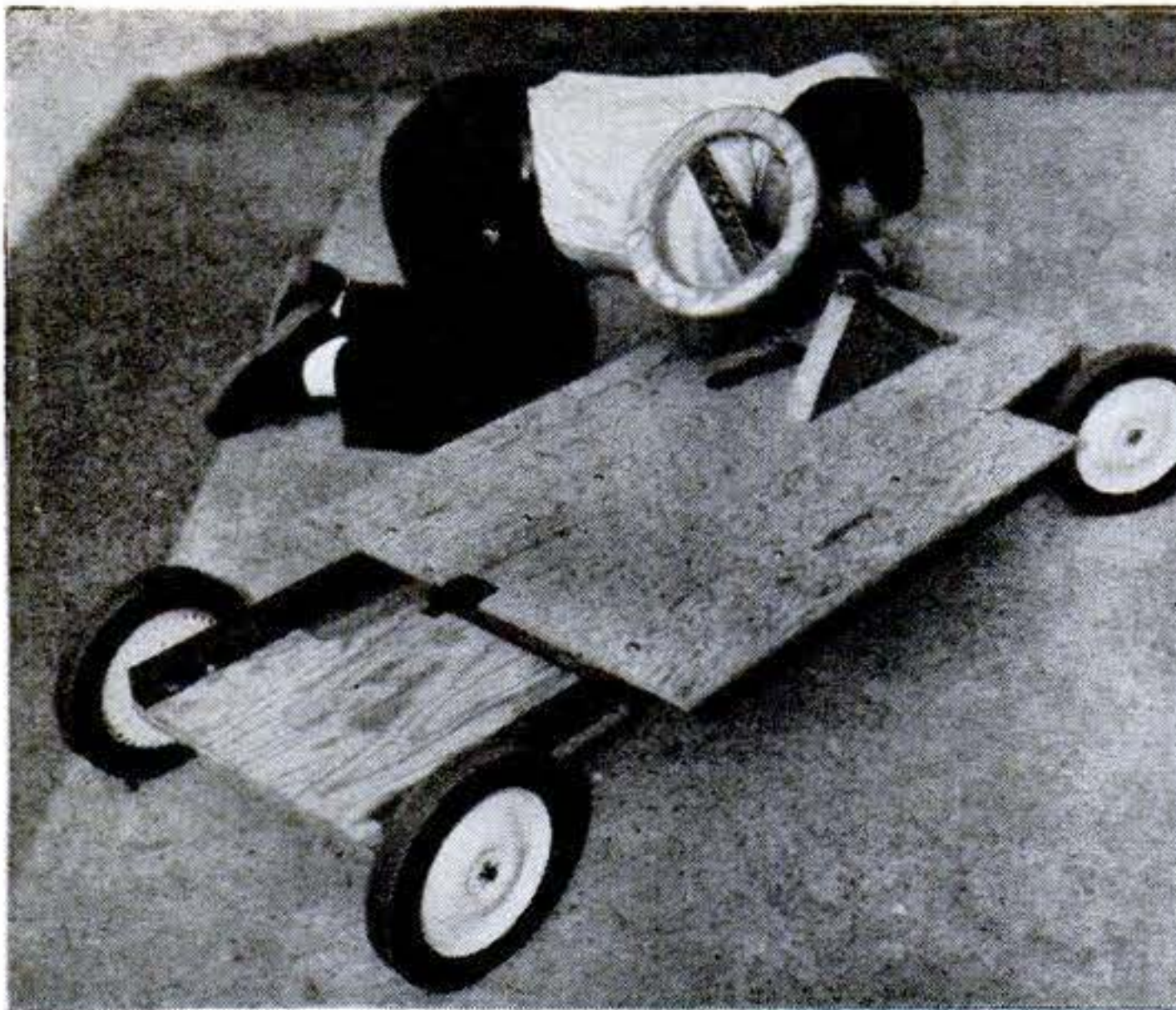

DOUBLE DECK OF PLYWOOD on two steel channels forms the chassis of this kit-built car. Steering is direct from a crank on the shaft. The drive, upside down above, takes horizontal- or vertical-shaft engines. Two countershafts and chain drive to the wheel have an overall ratio

of 13:1. The control lever tightens a flat idler against a belt or, pulled back, clamps a brake onto one wheel. Kacy Mfg. Co., Genoa, Ill., offers chassis parts shown for \$60, or with plywood body kit at \$85. It runs well on cast-off one- to three-hp. mower engines.

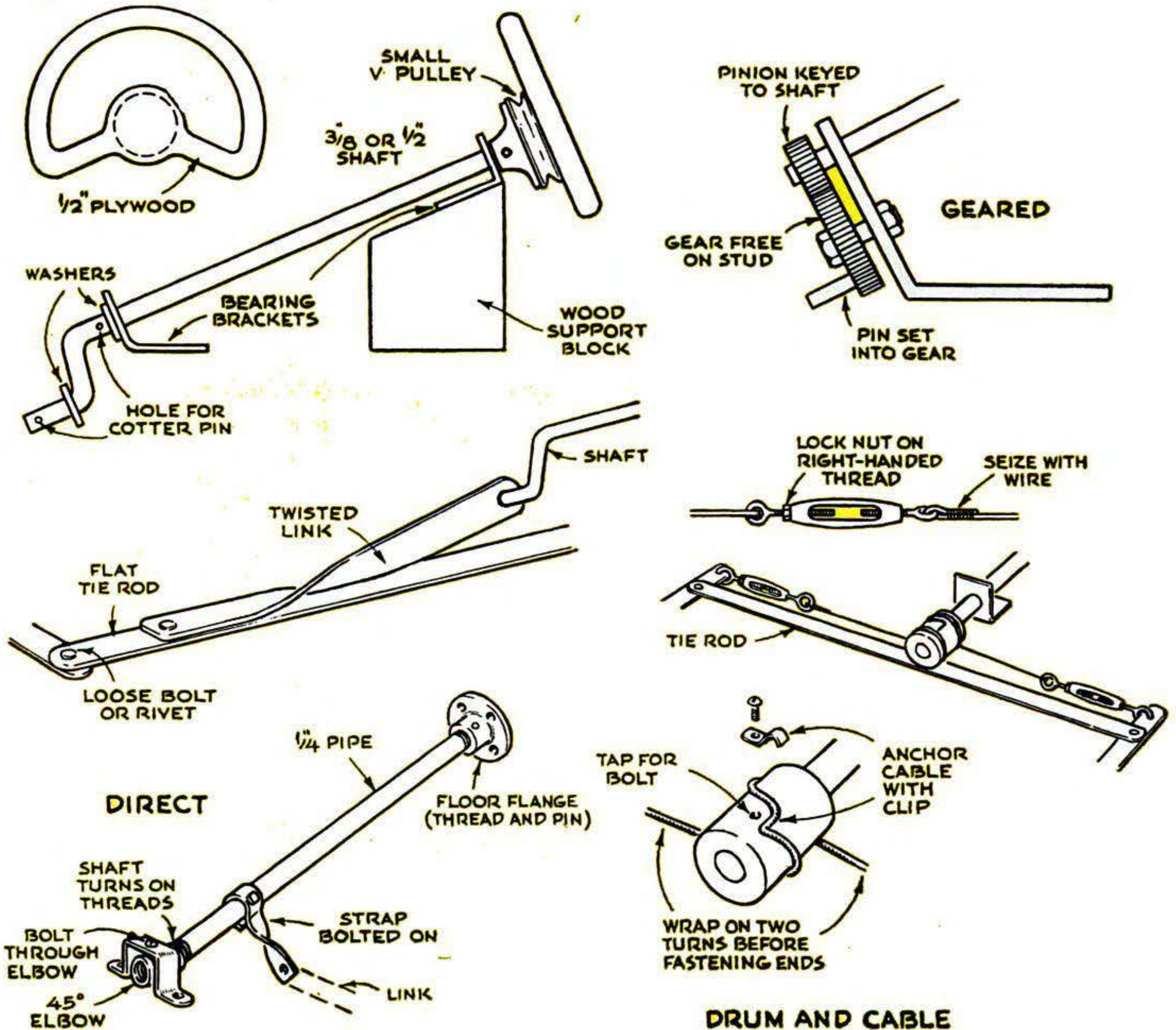

quire a long belt with a 90-degree twist.)

Checking the throttle action. If an engine has an air-vane governor, you may want to connect the control cable directly to the throttle for quicker response. Rig a return spring on the throttle arm so that if the control fails, the engine will snap back to idling.

Sizing up the chassis. The wheelbase may be from 40" to 60", the tread from 22" to 30". A short wheelbase turns more sharply; a longer one makes the drive easier to arrange, and affords more leg-room for growing youngsters.

Put the engine in back to simplify the drive and to add its weight for good traction. But don't mount it so far back that it tends to tilt up the front.

The frame need not be rigid; some flexing compensates for the lack of springs, helping to keep all four wheels

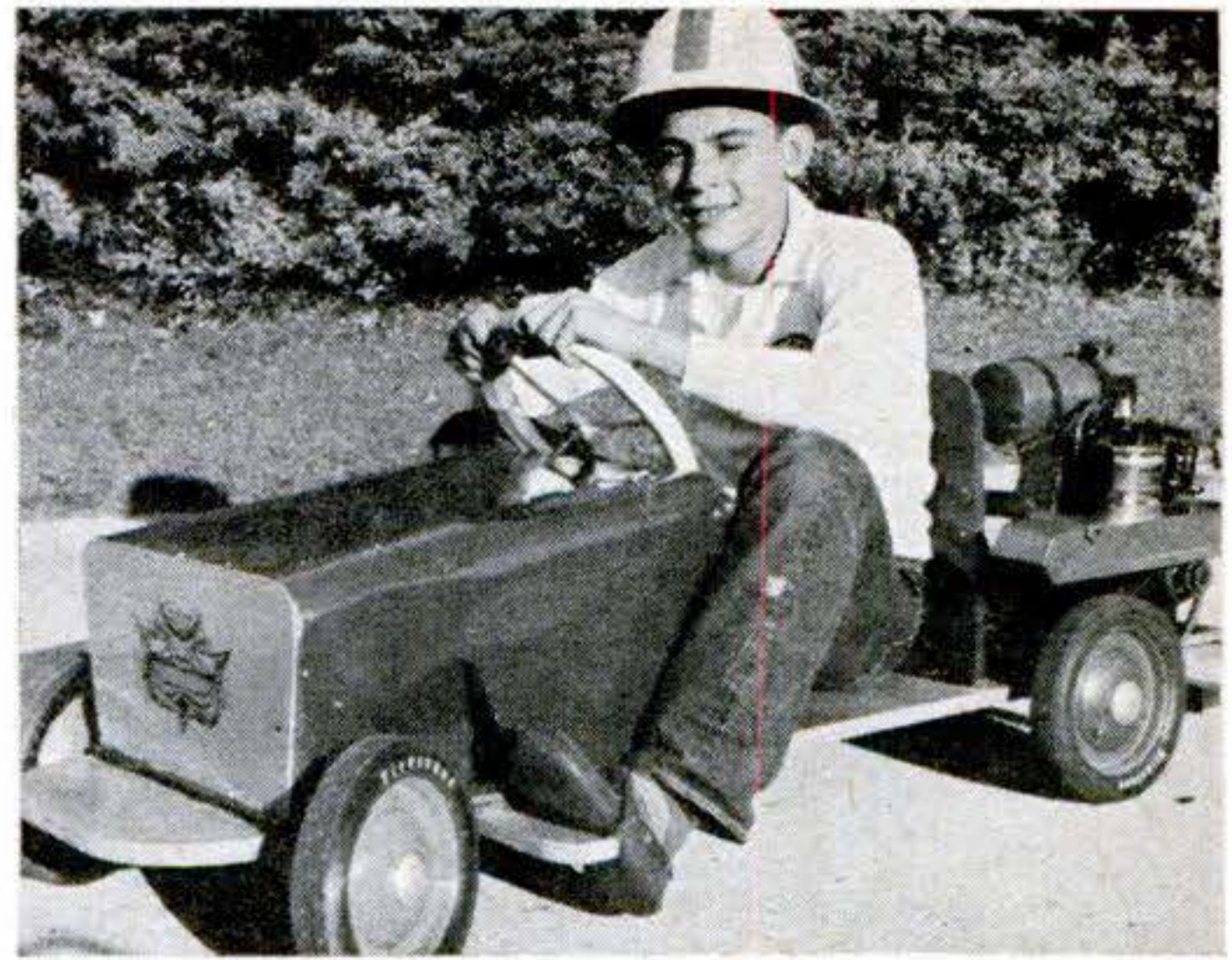

STRICTLY HOMEMADE, this car is the work of young Mike Zingarelli of White Plains, N. Y. It is built on a $\frac{3}{4}$ "-plywood platform, with a 41" wheelbase. A 2" centrifugal clutch on the two-hp. engine drives a 6" wheel pulley. This low ratio is speedy but wears the belt on starts. Mike helps out by pushing, then hops on. He made a good-looking steering wheel of a baby-carriage wheel by removing some spokes.

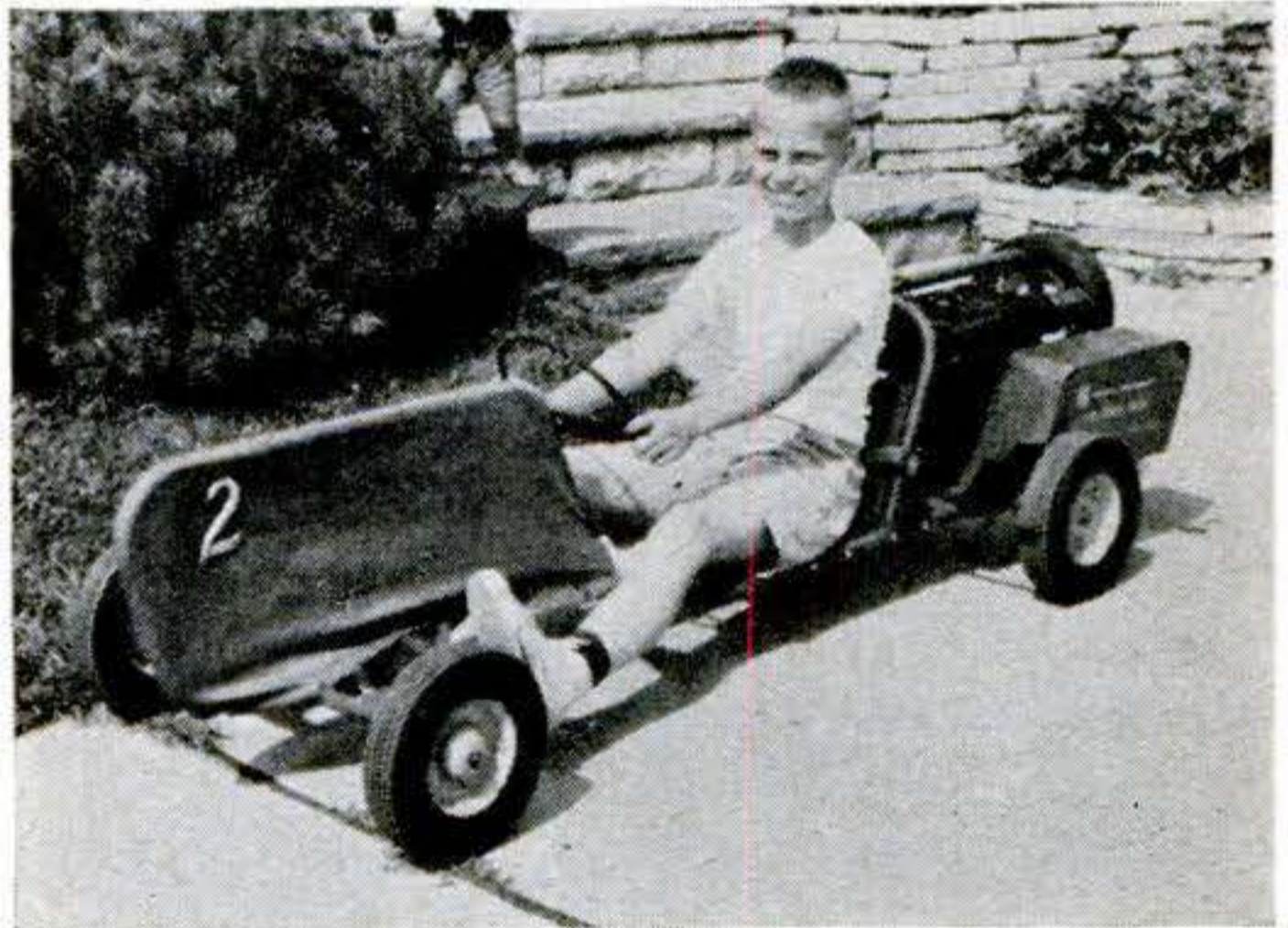

BUILT OF STEEL TUBING, this car comes ready-made with 1.75"-by-8" wheels at \$40, or with 2.75"-by-10" wheels at \$50. It has automotive steering and a brake acting on both rear wheels. Rocco Products, Inc., Minneapolis, Minn., offers drive kits for it less motor for \$20 and \$30, with motor at \$70 and \$90. Rack-and-pinion steering can be added to the assembly for \$10, and snow runners for an additional \$8.

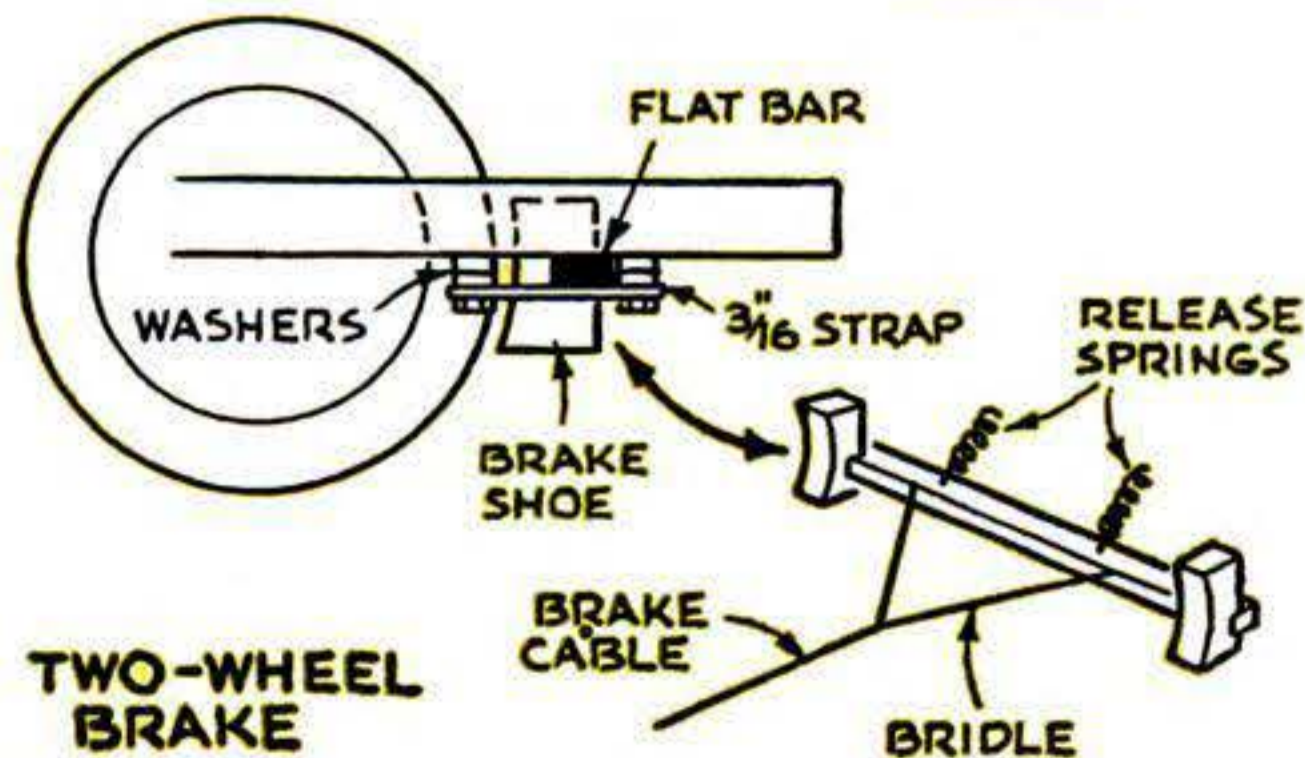
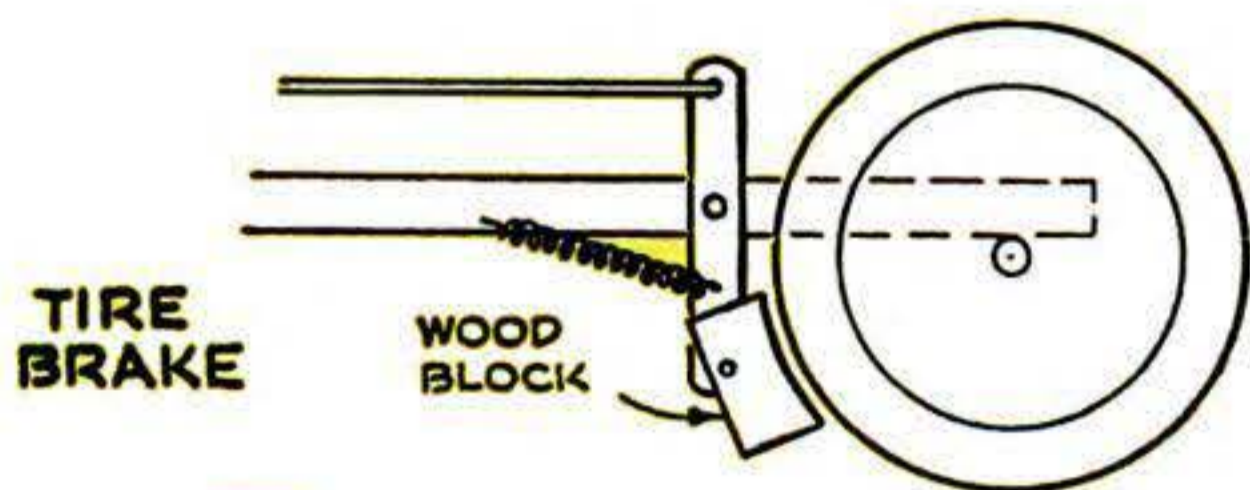
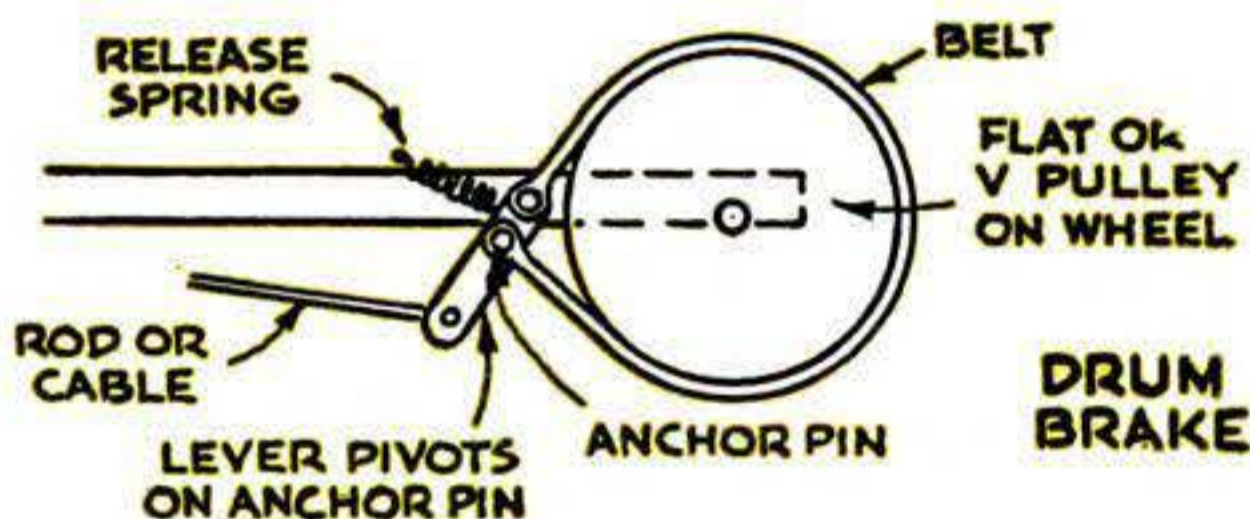
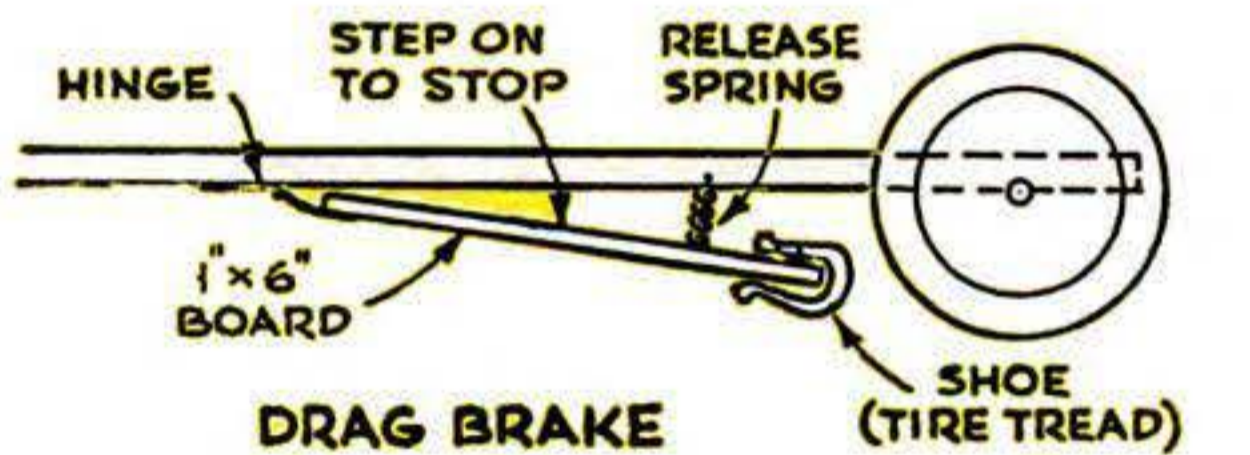

on the ground. Wood makes a satisfactory frame requiring only common tools.

Auto-type steering can be improvised from hinges, scrap iron or even pipe fittings, as shown. Angle the steering knuckles inward. This maintains correct radius in turns. Hold wheels on with husky cotter pins or by clamping the inner bearing race tight with a nut on a threaded spindle bolt.

The simplest steering with a step-down ratio is the drum-and-cable type. The drum must be concentric with the shaft and pinned to it. Use the $\frac{3}{32}$ " steel cable and end clips sold for power-boat tillers.

Brakes are a must. For modest speeds and level ground, a single one on the nondriving wheel suffices. Line wooden brake shoes with machine belting or tire tread. See that brakes release fully.

How to rig a drive. With an engine of two hp. or more, a single reduction of one to six or seven will roll the car too fast for children. An overall ratio of 10, 11 or even 13 is safer.

Drive one wheel only. You can key it to the axle, mounted in pillow blocks, and drive the axle, but it is simpler to fasten a "dead" axle solidly, let both wheels turn on it on their own bearings, and bolt the drive pulley on one.

To center a pulley or sprocket having a hole bigger than the axle, drill bolt holes oversize and mount the pulley with the nuts finger-tight. Spin the wheel on the axle to detect run-out. Tap the pulley or sprocket one way or the other until it runs dead true. Then tighten the nuts.

Be sure to mount the engine to drive forward. Pipe the exhaust downward and shield hot parts. Hang countershafts in pillow blocks or oilite bushings. With sprung rear axles, the countershaft must be so mounted as to maintain a constant distance between the drive pulleys.

A stepless ratio shift can be had with a transmission pulley. Not to be confused with an automatic clutch, this forces the belt to ride on a greater diameter as speed goes up. A spring-loaded idler or swinging countershaft is necessary to keep the belt taut.

Cut paper patterns as guides in shaping sheet aluminum or galvanized iron over the body. Old auto fenders can be cut down for parts requiring difficult compound curves. Metal plasterer's lath makes a neat radiator grille.

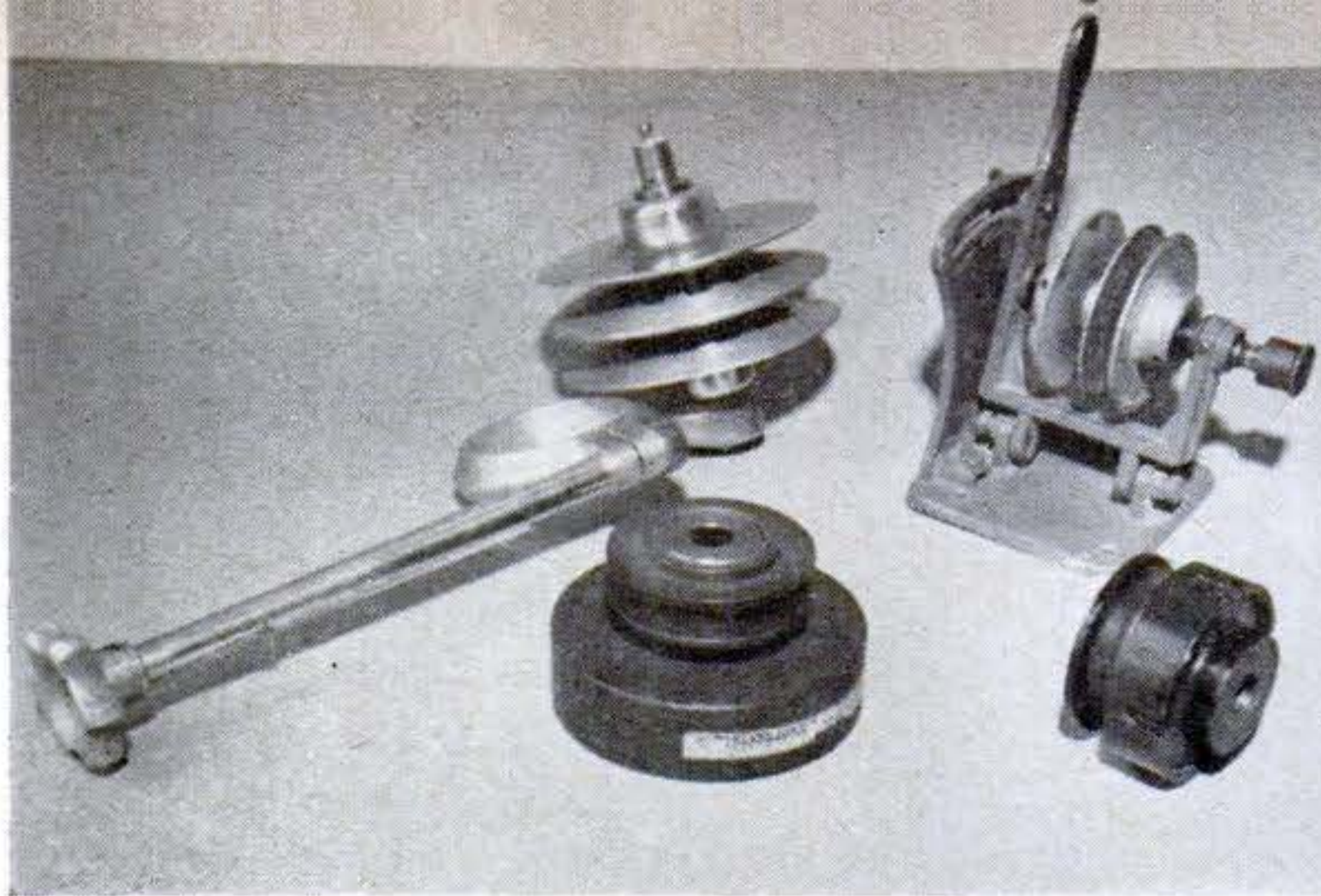

A DRILL-PRESS SPEED CHANGER (top left) or the similar device near it makes a compact variable-ratio drive. These shift one belt to a smaller, the other to a larger diameter as the lever is moved. Automatic clutches shown are (left) mercury and (right) centrifugal types.

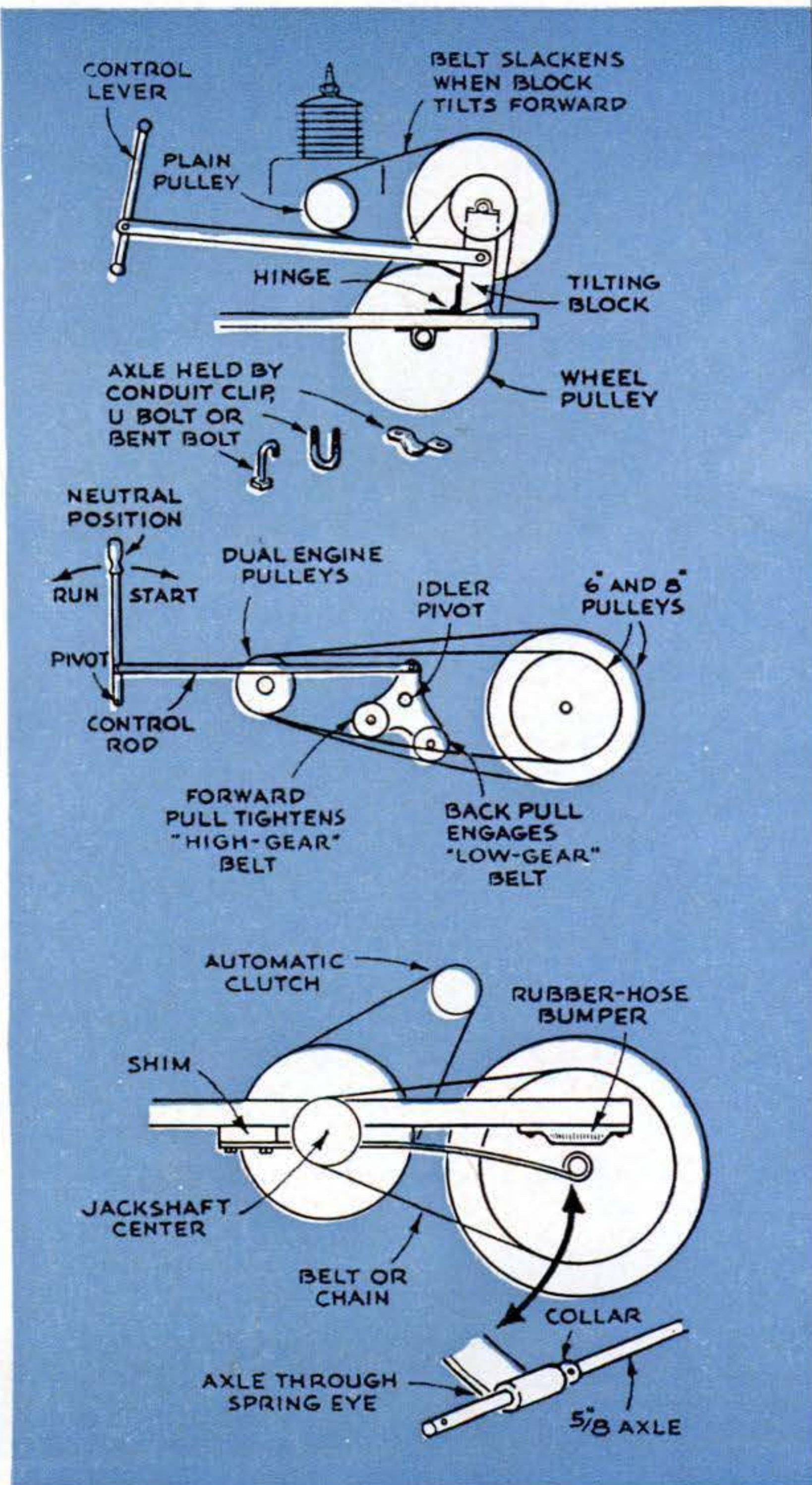

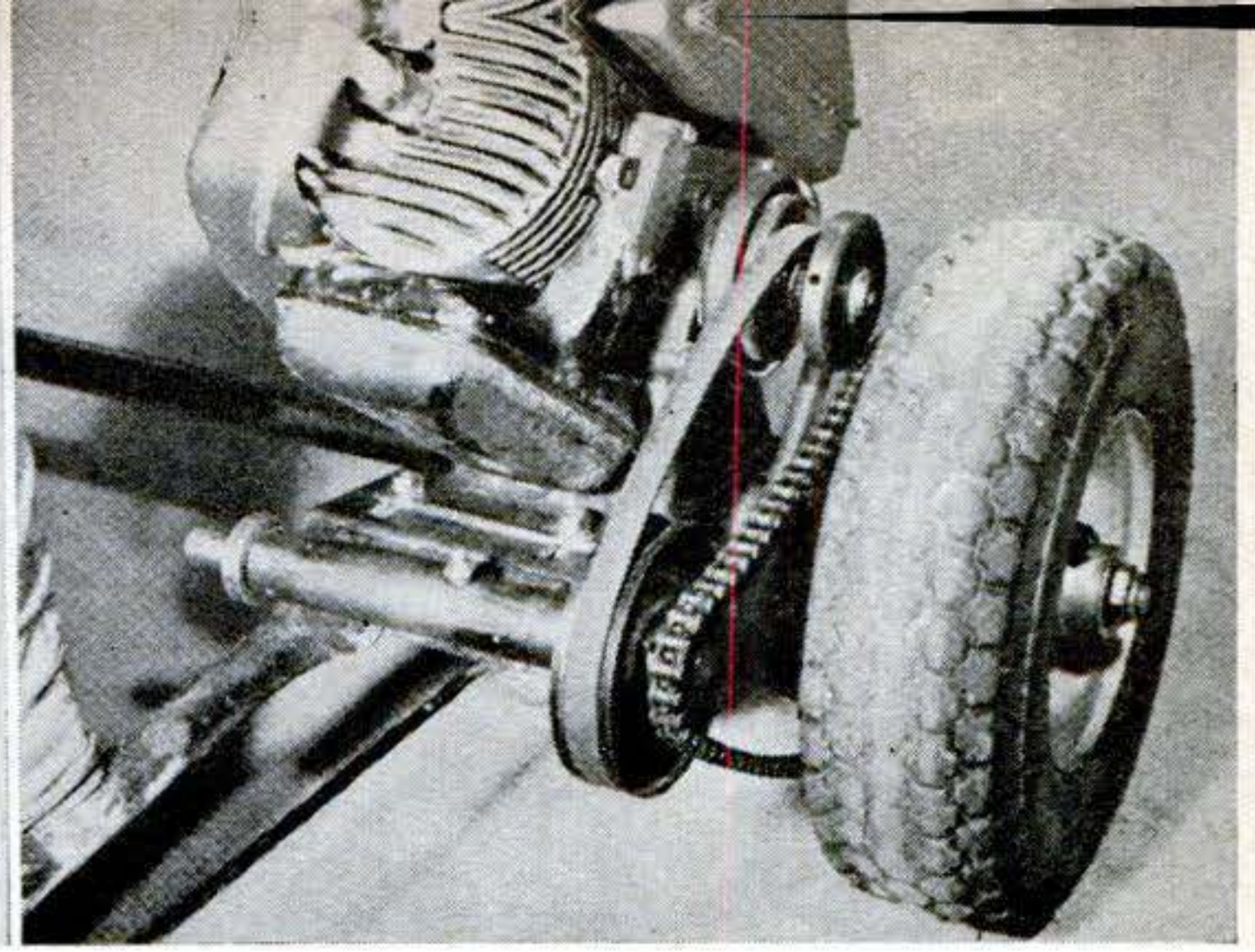
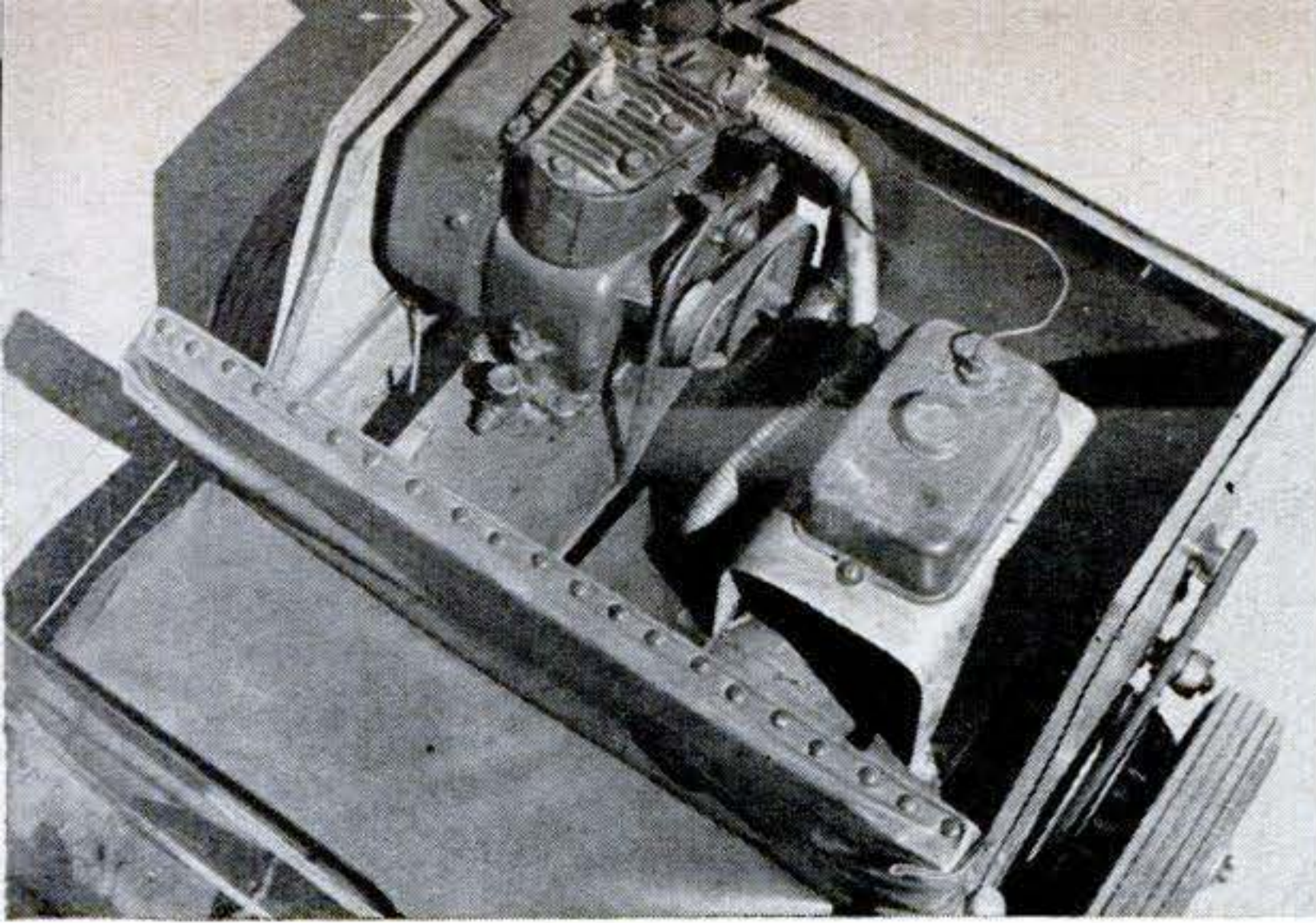

BOXED-IN ENGINE of Capt. Sparks' jeep drives a jackshaft extending over the drive wheel. The rear axle is mounted on half lengths of auto leaf springs. Spring-tensioned idler keeps the belt taut. Pushed forward, the control tightens a band brake on the other (nondriven) wheel.

SLICKLY PROFESSIONAL is this two-step reduction drive engineered by V-Plex Clutch, of Hagerstown, Ind. The jackshaft turns in a tubular crosspiece mounted on one frame member. As the engine revs up to 1,800 r.p.m., the centrifugal clutch engages the belt. **END**

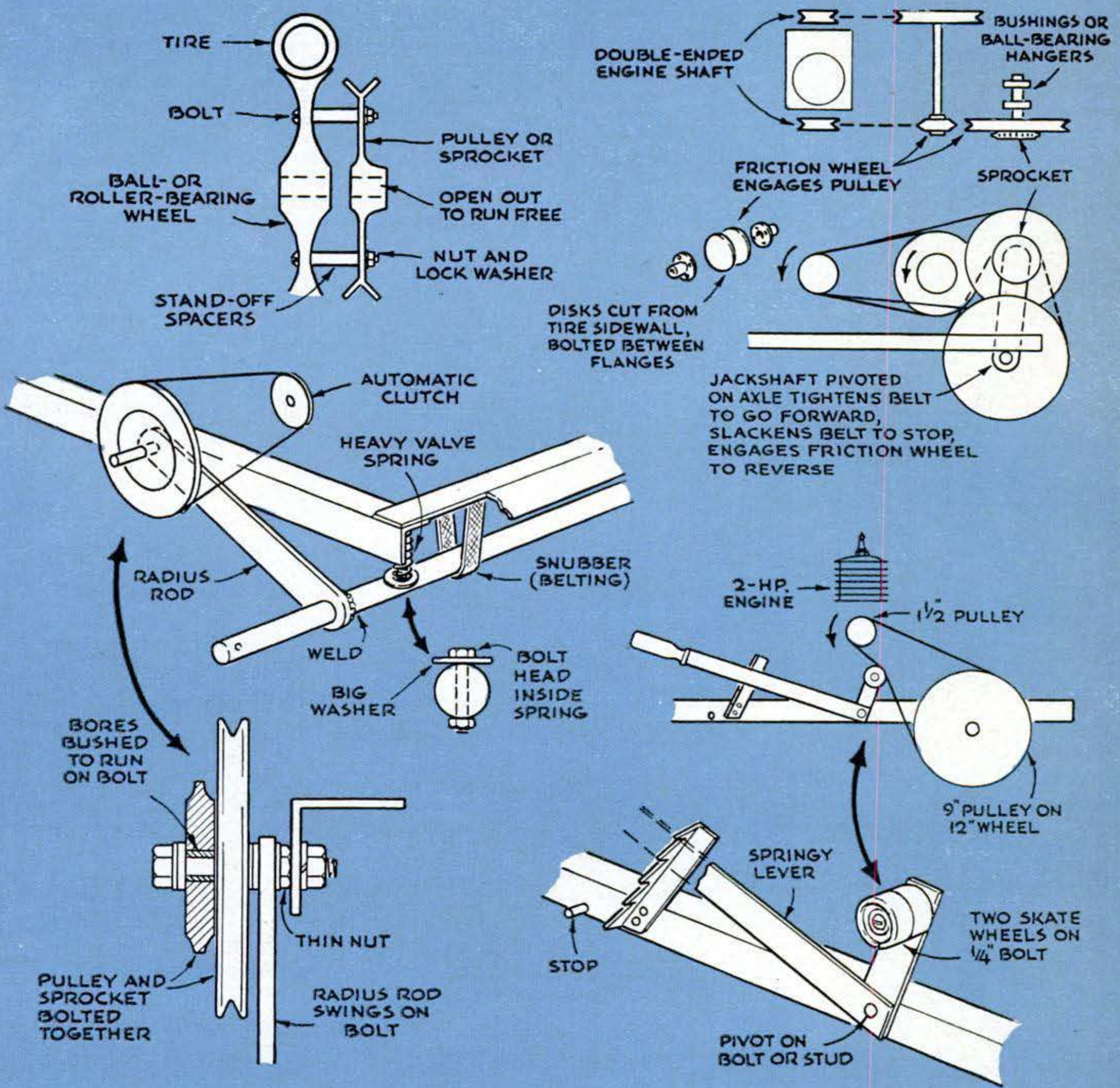

5 Budget Savers



1 Got a cat in your house? Save yourself work by hoarding empty milk and orange-juice cartons. Cut them off at the bottom to a height of about two inches to make disposable food and water dishes. They will eliminate dishwashing for a small dog or a puppy, too.

2 The edges of pockets on overalls and other work clothes can be saved wear and tear if they're coated with colorless fingernail polish. Dab on enough polish to provide a hard, smooth edge.

3 A bathroom hamper can provide space for an extra towel rack that will be within reach of a youngster. Make wooden brackets to take a length of dowel rod and screw them to the hamper through the wicker and into the internal frame. For even more towel space, racks can be put on the hamper sides, too.

4 Need handle grips for a trike? Cut two 4" lengths of $\frac{1}{2}$ " plastic hose and soak them in boiling water about five minutes to soften the plastic. Lift them from the water and drive them onto the handlebars with a rubber mallet (or piece of wood). After cooling, they'll be so tight you can't budge them.

5 If an appliance cord conks out because of a defective wire, use a radio to spot the break. Turn on the radio and adjust the dial so that no station is heard with the volume control on full. Now switch on the appliance and twist the cord along its length, about an inch at a time. When you hear crackling noises from the radio, you've found the break.

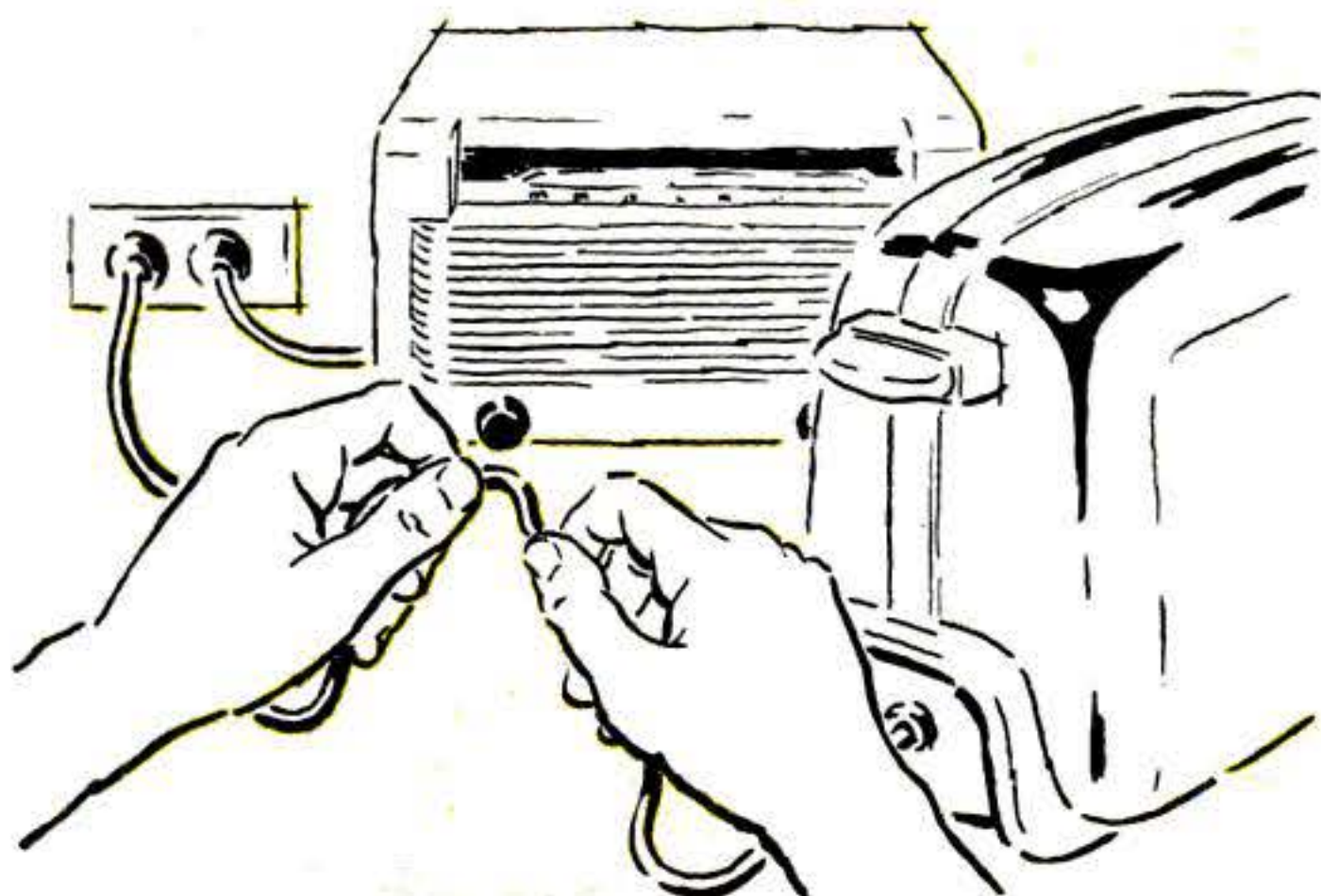
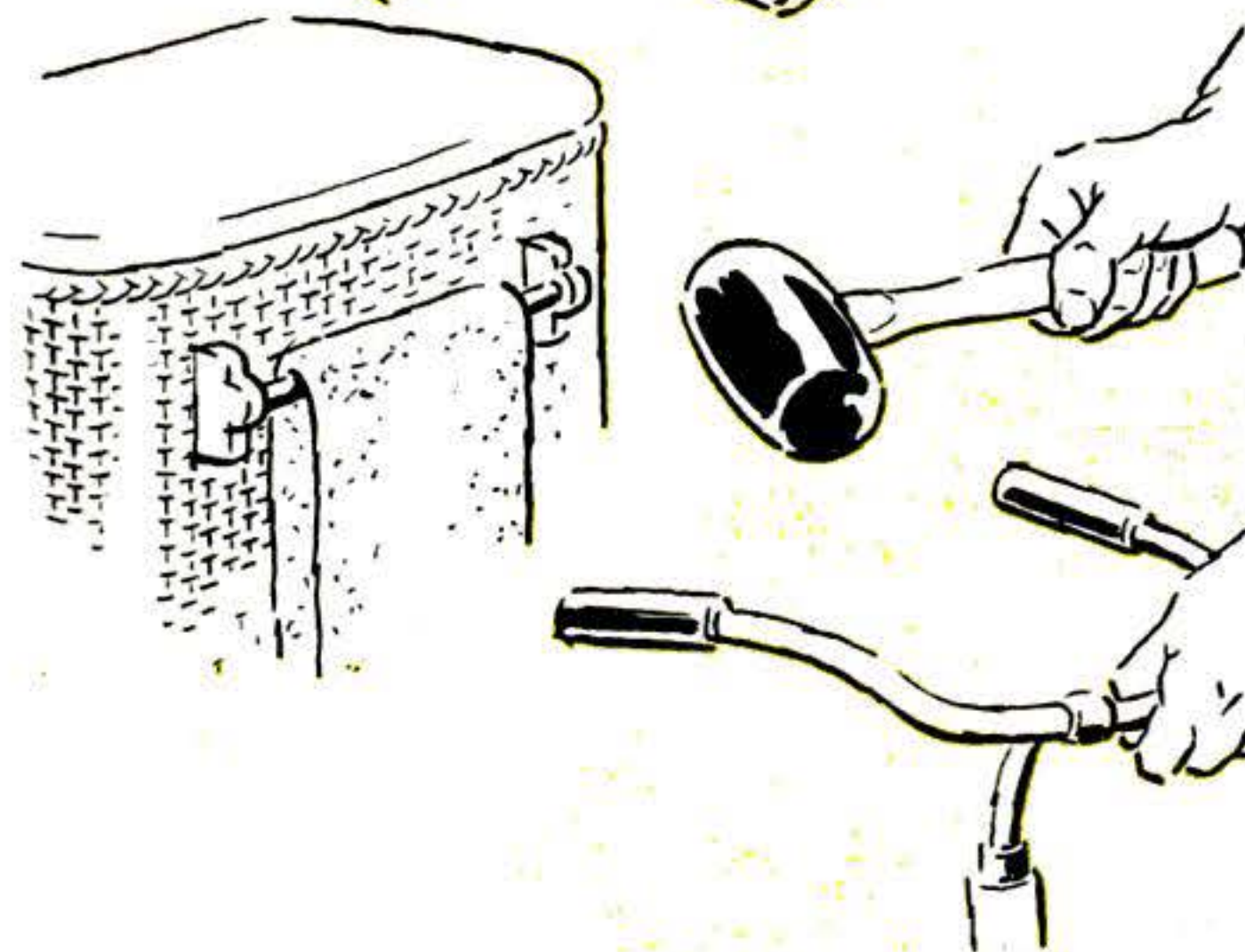
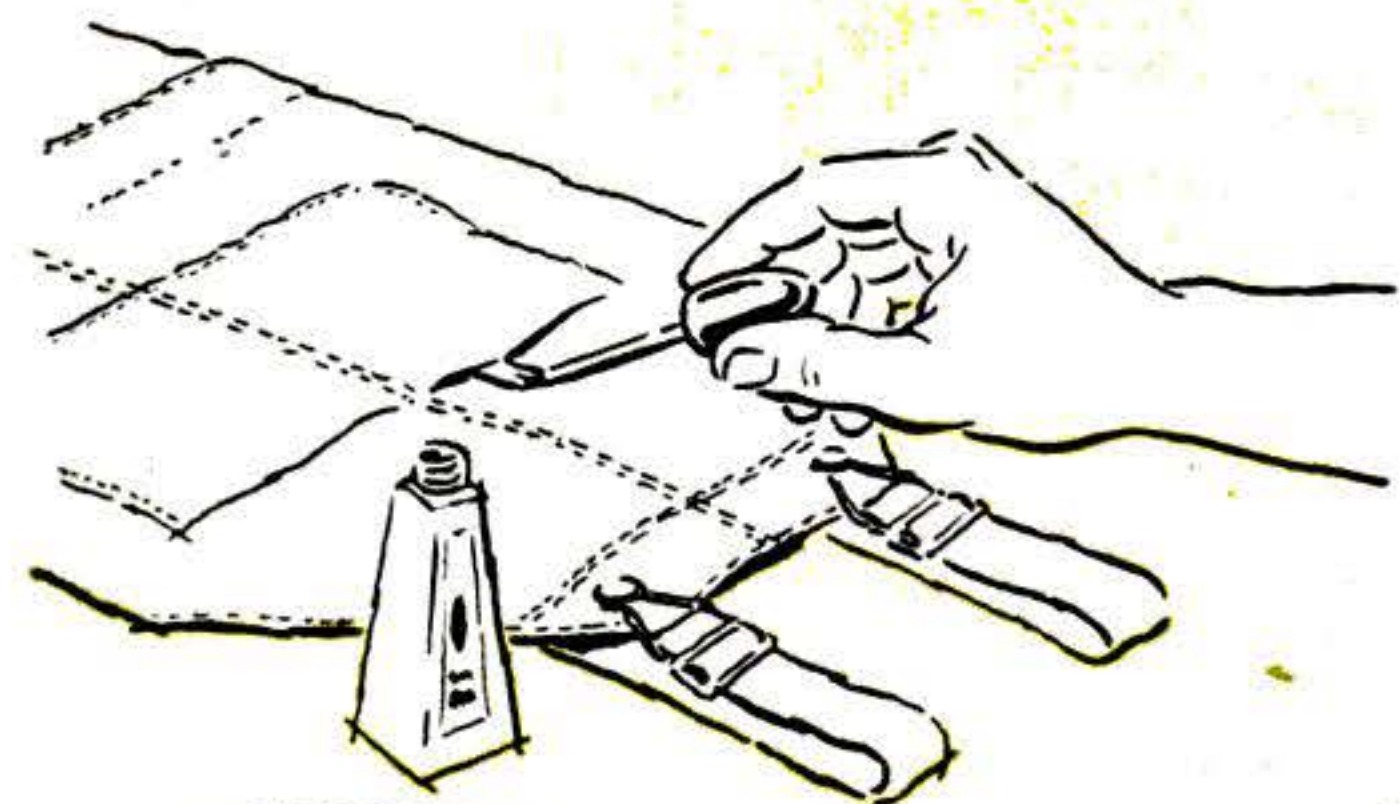

Short Cuts and Tips

FROM PS READERS

How to Saw Accurate Miters

CUTTING miters accurately will be simplified if you first saw all parts to the exact length needed and then miter the ends.

To be sure that you cut the same amount of material from each of these parts, clamp a scrap block to the saw table as a stop before cutting.—*R. J. De Cristoforo, Los Altos Hills, Cal.*

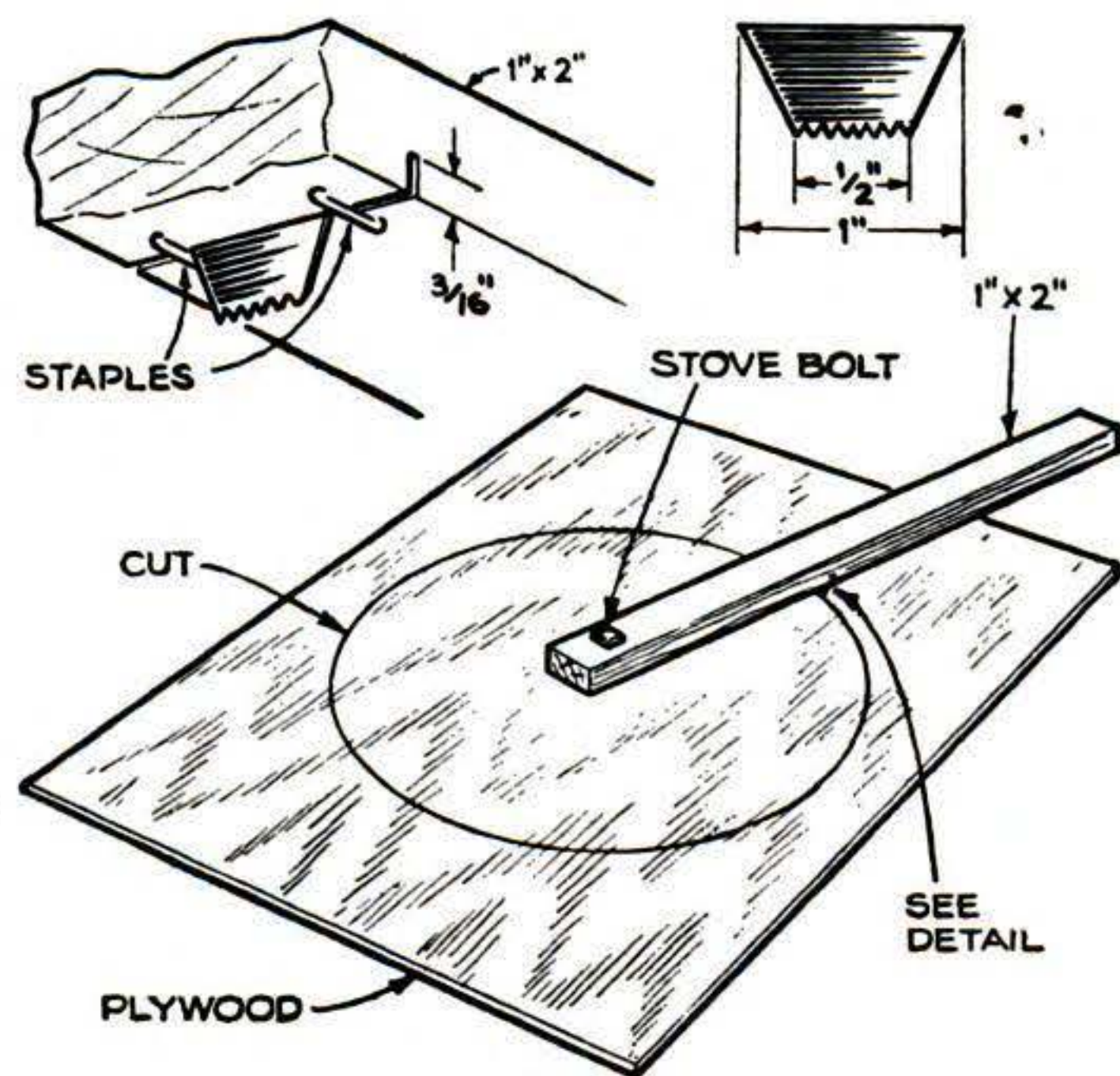

Cutting Circles in Plywood

IF YOU don't own a jigsaw and need to cut a large circle in plywood, you can make a true circle of any desired diameter with a piece of hacksaw blade and a 1"-by-2" strip of wood. Cut the strip to the length of the radius plus enough more for a handle. Then drill one end to take a stove bolt pushed through the work at the center of the circle to be cut.

The cutter is a 1" length of hacksaw blade ground to $\frac{1}{2}$ " at the teeth. Set it in a kerf the distance of the radius from the bolt hole and fasten with two staples.—*T. B. Edwards, Alexandria, Va.*

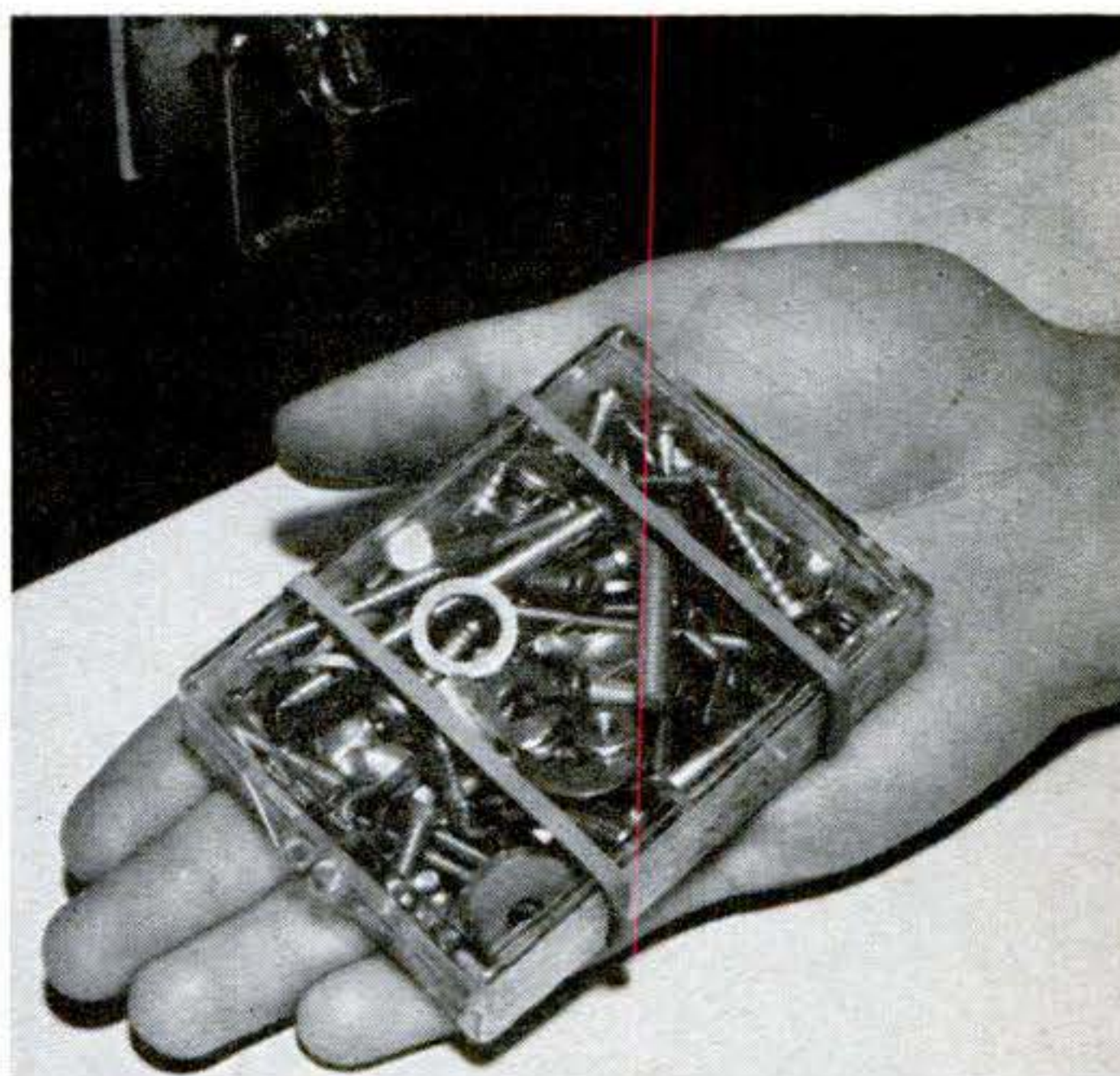

Keeping Small Parts Secure

THOSE plastic boxes used as containers for screws, nuts and other small hardware are fine, but when you carry them in a tool box the lid is apt to come off and let the parts scatter all over.

A couple of ordinary rubber bands over the box will hold the lid tightly in place.—*John A. Comstock, Wellsboro, Pa.*

▶▶▶REMEMBER that the rubber tread from a child's bicycle pedal can be slipped on a file tang as a temporary handle.—*Federico Strasser, Santiago, Chile.*

Short Cuts and Tips

FROM PS READERS

How to Touch Up Table-Saw Blades

SHARPENING a dull blade is a real job. To avoid it, keep your blades sharp with frequent touch-ups without removing the saw from the arbor.

Clamp a board between blade and rip fence; then dress and de-gum the teeth with a sharp triangular file. Be sure to maintain the original tooth angles and bevels of the saw.—*Joseph T. Burch, Seattle, Wash.*

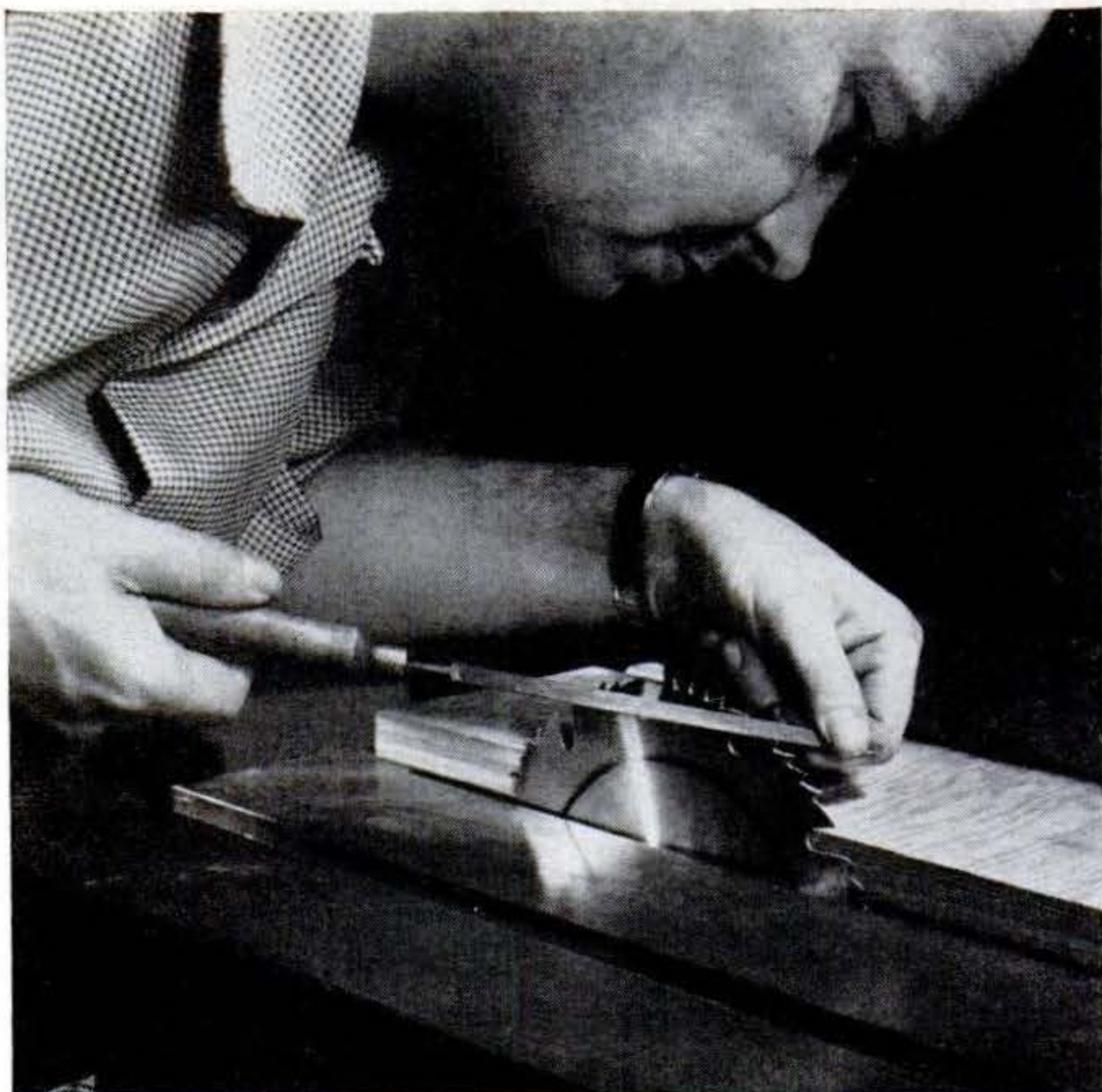

Clip for a Tape Measure

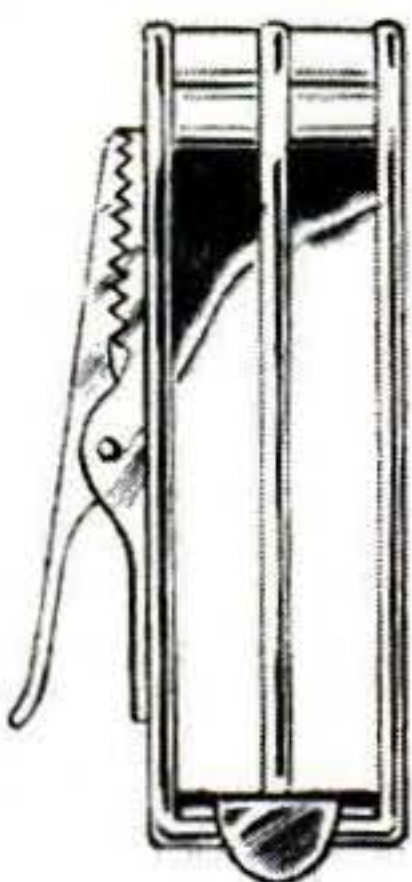
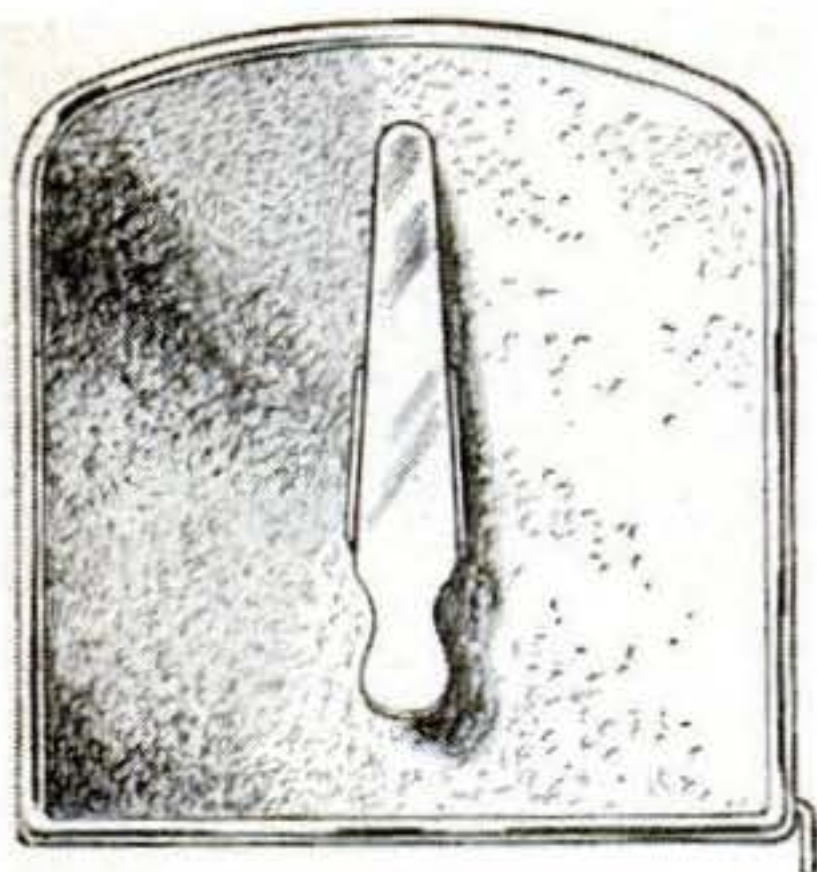

I USE a tape measure constantly, so I soldered an alligator clip to one side of the case. Now it's handy on my belt or a clipboard.—*W. W. Graf, Long Beach, Cal.*

Dripless Drawer-Knob Spraying

It is difficult to prevent paint drips when spraying drawer knobs in a horizontal position.

I get good results by threading their screws into them and setting them vertically in the necks of empty bottles so the drips run down to the face that will be hidden from view.—*William B. Eagan, Floyds Knobs, Ind.*

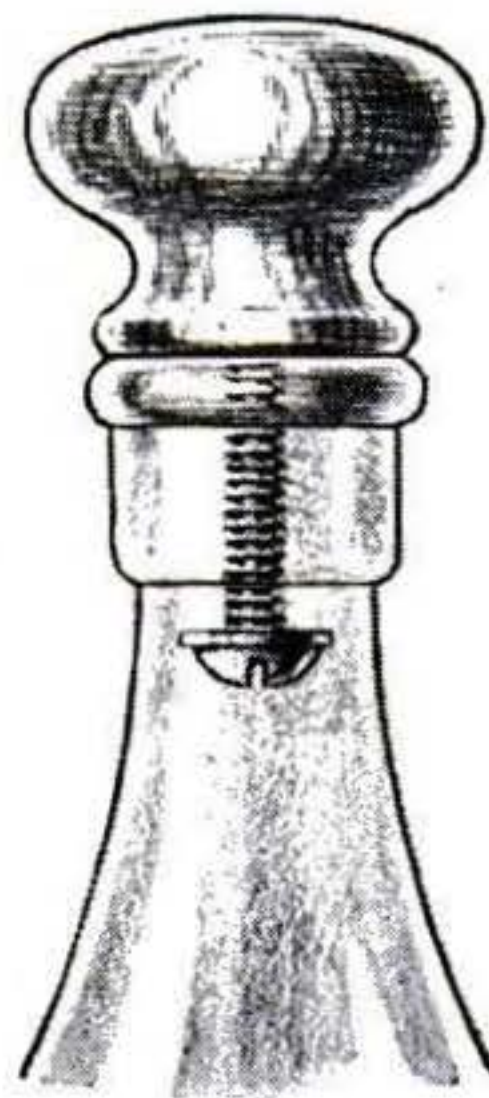

Restoppable Vent for a Metal Can

WHEN you vent a metal container that will be moved about considerably or stored for long periods between use, drill the vent for a metal screw.

This will allow you to tighten the screw after each pouring and seal the contents against leakage or contamination.—*Robert Maas, Portland, Ore.*

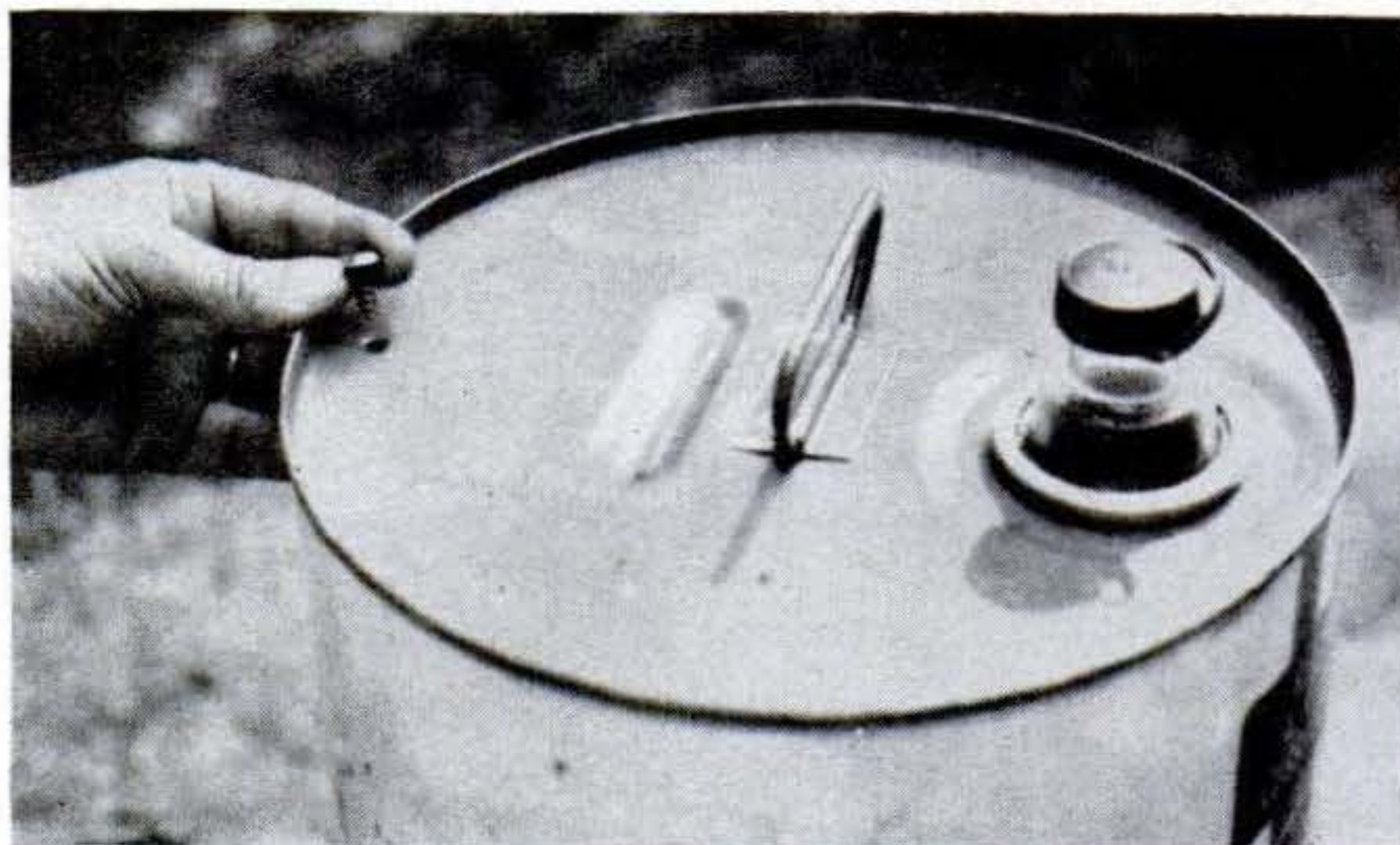

Which Spray Outfit Is Your Best Bet?

A gun is the fast and easy way. But it's important to suit the type to the work

By George Daniels

BETTER than 30,000,000 gallons of paint and lacquer went through America's spray guns last year—enough to coat more than 20,000,000,000 square feet of surface.

The spray gun got the job because no other painting tool is as fast and versatile at top-quality finishing. It can handle anything from heavy barn paint to liquid wax. And, even in the hands of an amateur, it works up to 10 times as fast as a paintbrush.

But the big question is: *Which* type of spray outfit is the best for you? You can pick from scores of makes, models and sizes. You can spend from \$5 to more than \$300. Not counting many small, self-contained guns and sprayer attachments, you'll be faced with such choices as:

- Three basic types of compressors.
- Two different types of spray guns.
- Two different types of nozzles.
- And two methods of air control.

If all this sounds confusing, it needn't be. The thing to remember is that each type has a particular job that it does best in its price class. How far up the price ladder you go depends on the *size* of the jobs you plan and the *kind* of paint you want to spray.

Price and size. For touch-up and general workshop jobs, you can choose units of two- to 24-ounce paint capacity priced at \$5 to \$50. Within their working range they'll do a professional-grade job.

But, in general, they're not fast enough for bigger jobs and aren't suited to heavy-bodied materials like thick house paint. The reason: It takes more power to spray paint fast, still more to spray thick paint. And you can't have both high power and low price.

For big jobs, prices start at around \$60. This gets you a motor, compressor, air hose, and gun, ready to use and capable of spraying practically any type of sprayable paint you can buy. From there on up, more money buys you greater capacity and greater convenience through special extras and accessories.

The important point: Buy an outfit equal to



Guns turn paint into spray in two different ways

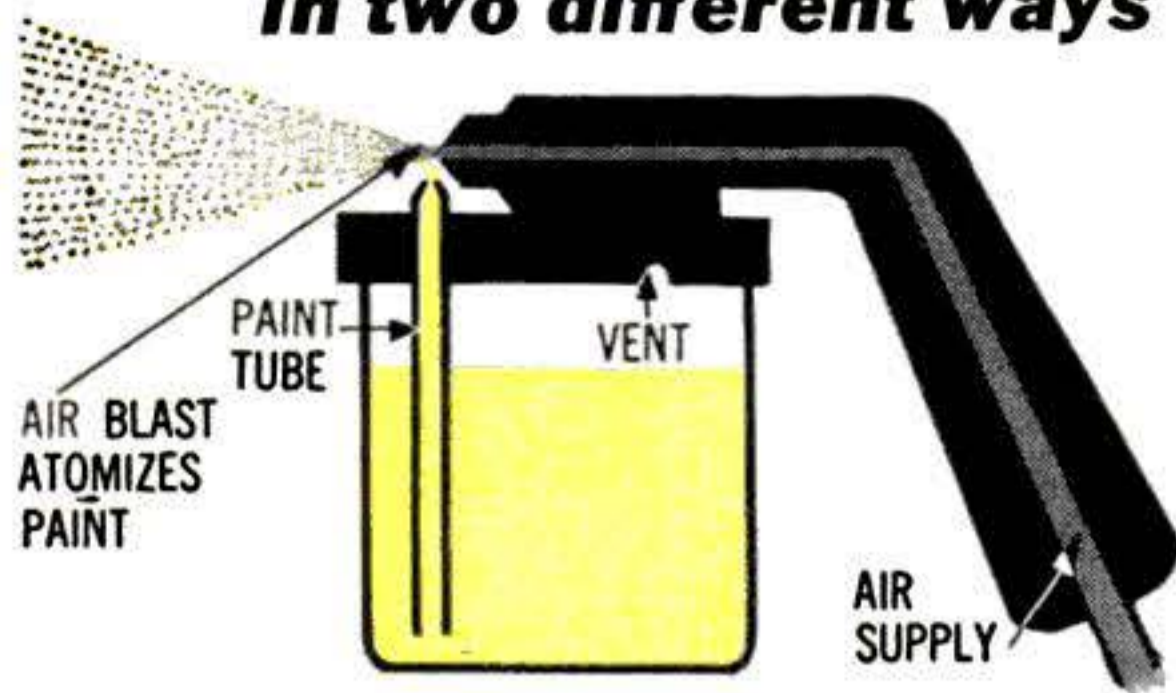

AIR PULLS PAINT out through nozzle by creating partial vacuum at top of paint tube in simple suction-feed gun. Vent hole lets outside air into container.

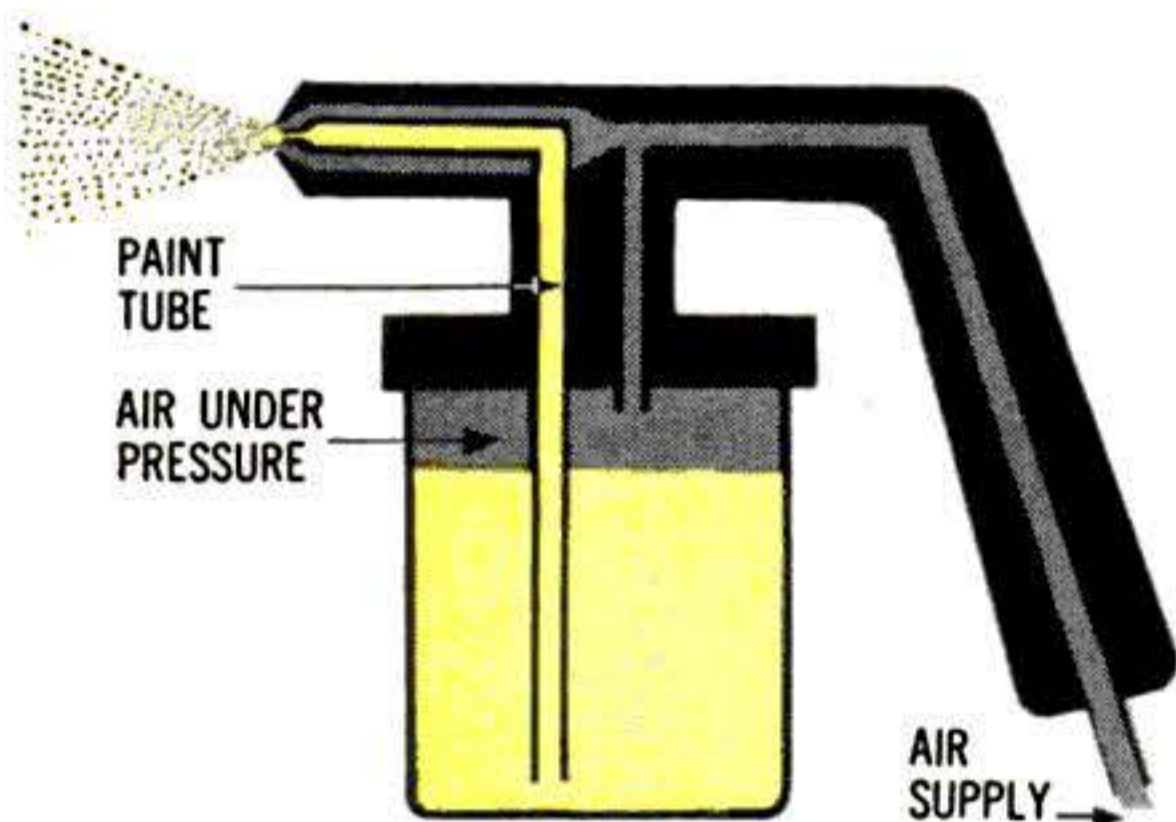

AIR PUSHES PAINT out through nozzle in more complex pressure-feed gun. In this type, air is fed into container, forcing paint down, then up and out tube.

the work you'll do. A small unit on a big job runs too long, wears too fast, and soon washes out initial cost savings. Here's how large and small compare:

Low-cost sprayers are made in five common types: vibrator, rotor compressor, gas cartridge, and car-engine and vacuum-cleaner attachments. Each has its own advantages, and a few have fea-

How You Lose Pressure with a Long Air Hose

Length of hose	Pressure drop with 1/4" hose	Pressure drop with 5/16" hose
5 ft.	6 lb.	2 1/4 lb.
10 ft.	8 lb.	2 3/4 lb.
15 ft.	9 1/2 lb.	3 1/4 lb.
20 ft.	11 lb.	3 1/2 lb.
25 ft.	12 3/4 lb.	4 lb.
50 ft.	24 lb.	8 1/2 lb.

tures that the big outfits can't equal.

The vibrator gun is self-contained and uses a cigarette-size vibrator-type motor to pump paint from the screw-on glass container and spray it through an adjustable nozzle (for fine or coarse spray) by direct pressure. It's easy to use—just fill the container with paint, plug in the cord, and pull the trigger to spray.

It handles varnish, shellac, lacquer, insecticides and the usual household paints. But don't count on it for heavy-bodied, hard-to-spray materials, and don't plan to paint the barn with it. Prices for a 24-ounce vibrator sprayer weighing less than three pounds run from \$10 to \$15.

The rotor-compressor sprayer provides around 20 pounds of pressure with a small, high-speed fan-like blower. The hose from compressor to gun is kept short—about four feet—to prevent loss of pressure, but that's long enough because you carry the four-pound compressor with you in a shoulder sling as you work.

As there are few moving parts, this type of compressor is long-wearing and suited to lengthy periods of operation. Numerous accessories are available to fit it for plant dusting and insecticide spraying. You can even get a hollow-needle attachment that permits the gun to shoot moth repellent deep into seat cushions. It has the same 24-ounce paint capacity as a typical vibrator sprayer and handles about the same material. Prices range from about \$30 to \$50.

The gas-cartridge gun uses the same type of carbon-dioxide cartridge as the familiar fizz-water bottle. It's self-contained and easy to use anywhere from the roof to a crawl space, as it needs no electricity and no trailing hose or extension cord. A single 11-cent cartridge (available at most drug stores) will handle a full 21-ounce paint container, and will spray insecticide, too.

This type of sprayer is not recommended for fine finishing like repainting a car, but it will do less exacting jobs nicely, such as painting outdoor furniture, trim, metal and masonry. A typical all-metal gun suited to home-owner use sells for about \$20 with 10 cartridges.

The car-engine gun is the fix-it type you've seen in auto-supply stores for more than 20 years. A simple one-way air valve with a threaded adaptor is screwed in place of a spark plug to use

your car's engine as a compressor. It uses a little syphon-type gun that works like a perfume atomizer.

A tire-valve adapter lets you spray paint, using a spare tire for air supply. Switch the fittings and you can use the spark-plug valve to pump up a flat tire.

These midget sprayers are designed mainly for touch-up work. They'll handle auto lacquer nicely and most household finishes, but aren't well suited to heavy-bodied materials. Prices start at \$5 for the smallest, with a four-ounce capacity (enough for a car door).

Vacuum-cleaner attachments are perhaps the most widely used of the small-job sprayers because just about anyone with a reversible vacuum cleaner can add one for \$3 to \$4. You simply hook the gun to the blower side of the cleaner.

Attachments of this type make the most of the low-pressure air supply by using a pressure-feed gun that blows the paint out of the canister, instead of sucking it out as in some other types. These do a fine job with average light-bodied paints and demoting sprays that don't require high pressure. A minor drawback is the short, fat air hose (the same as used for vacuum cleaning), not handy for lugging up a ladder.

When do you need a "big" sprayer? When your job can be measured in gallons of paint rather than pints or quarts, the chances are you'll want to consider a motor compressor and a suitable gun. Power ranges from 1/4 hp. upward.

If you buy a prematched unit, you need only be sure it can handle the kinds of paint you want to use. If you buy the parts separately, you add another important must: Your compressor's output must equal or exceed the requirements of the gun. Here's what you need to know:

Diaphragm vs. piston compressors. Diaphragm compressors give you the necessary big-unit output at a much lower initial price than piston compressors. While they don't have the top capacity of a piston unit, they'll deliver air at up to 45 pounds' pressure—enough to spray any paint you'll want to use around the home. The main bit of maintenance required is occasional replacement of the diaphragm (like those in your car's fuel pump). This takes only a few minutes.

Piston compressors are a good buy for professional use because they stand up

How compressors work

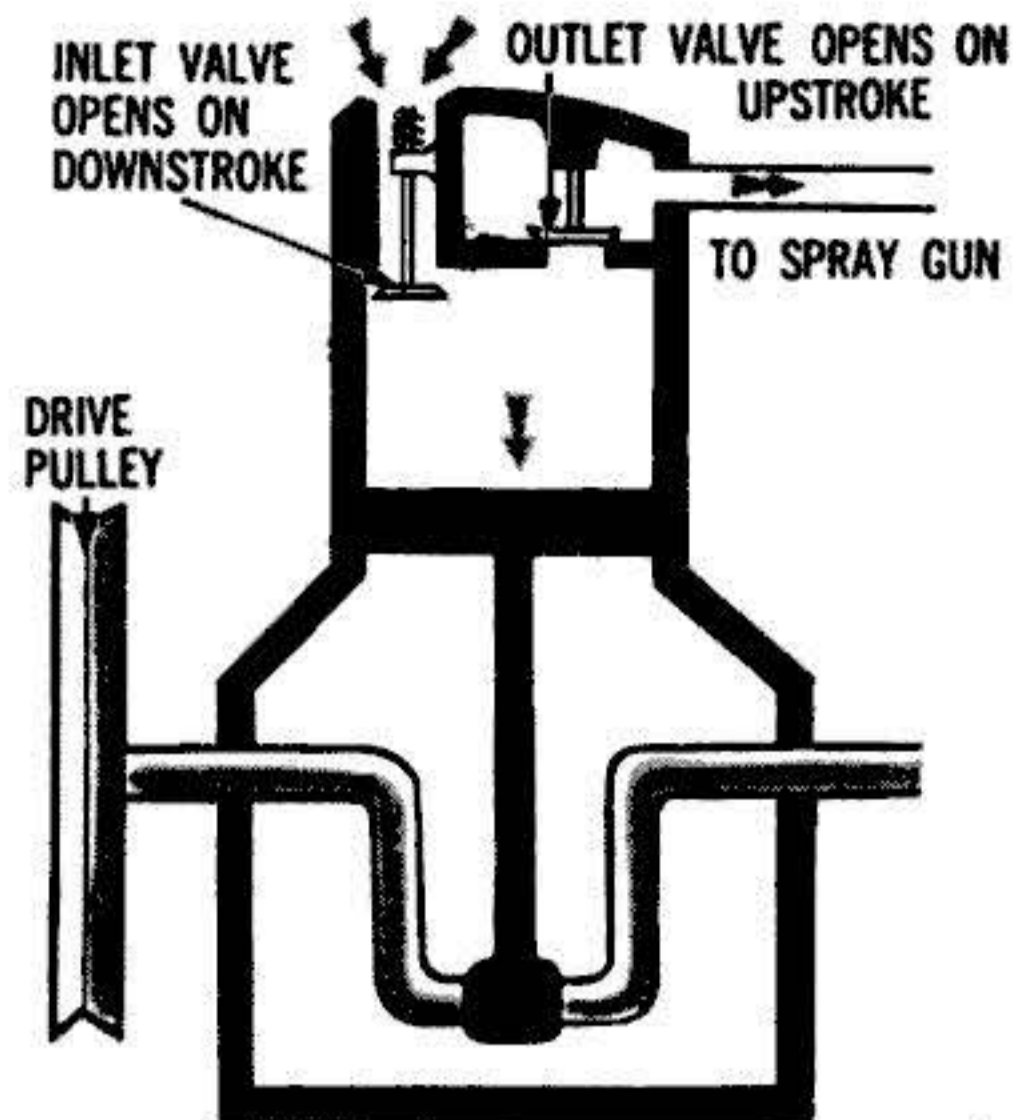

PISTON COMPRESSOR, most powerful and expensive, draws air in through inlet valve on downstroke, then forces it out through outlet on upstroke.

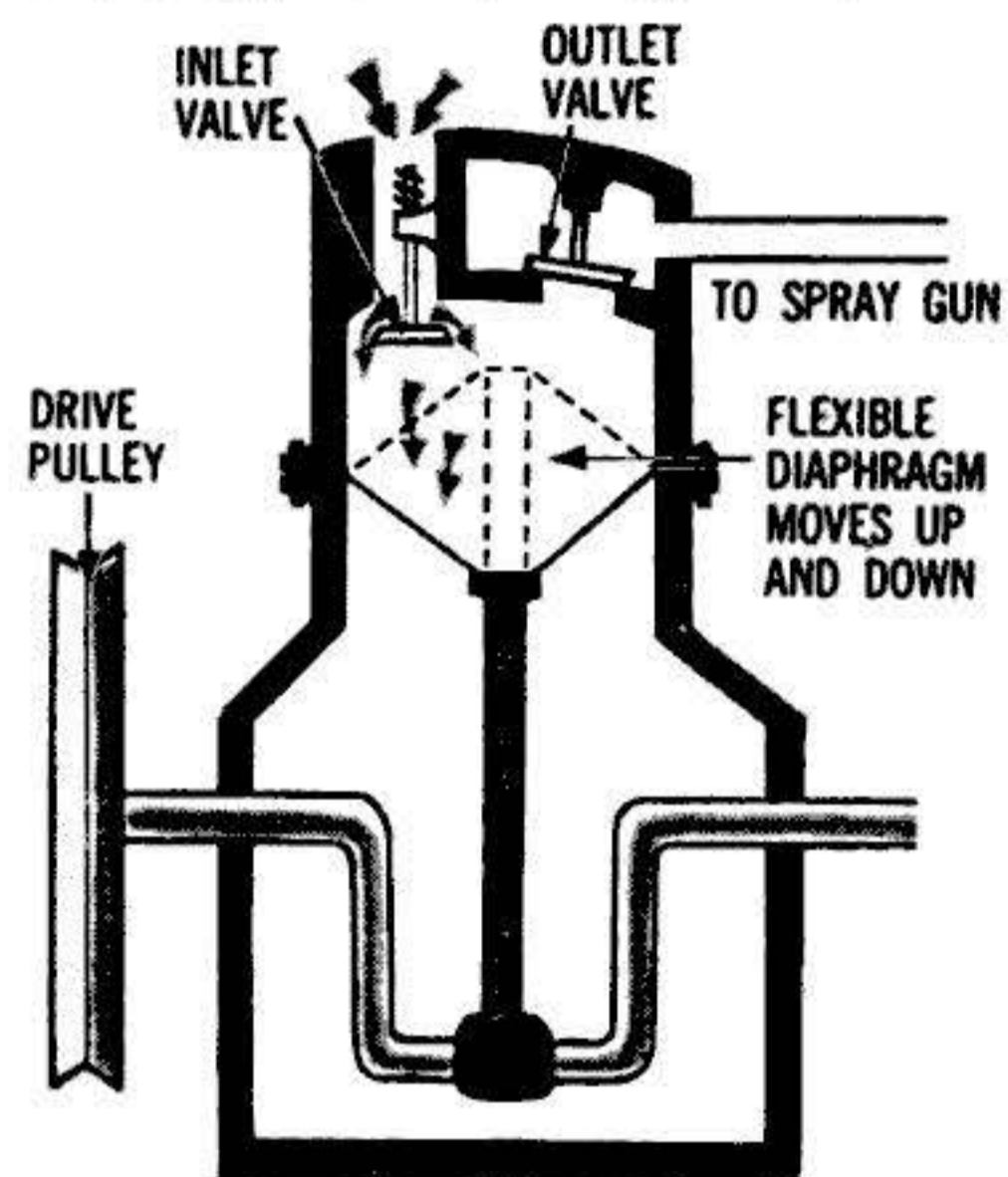

DIAPHRAGM COMPRESSOR is middle-priced, will handle most home jobs. It's similar to piston type, but needs occasional replacement of diaphragm.

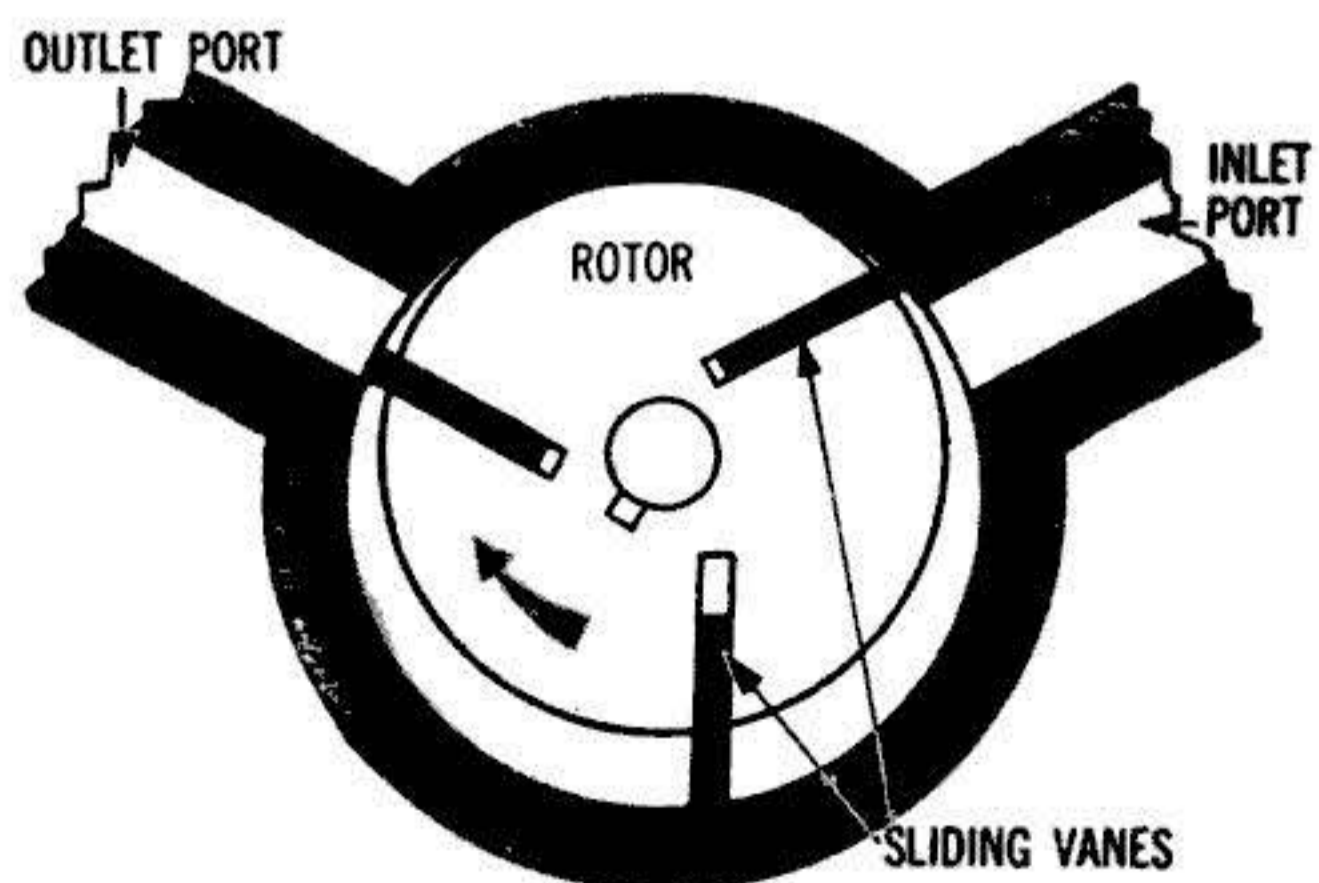

ROTOR COMPRESSOR is light, one of least costly, but is less powerful. Vanes in rotor slide outward, sweeping trapped air at high speed from inlet to outlet.

Two nozzles you can use

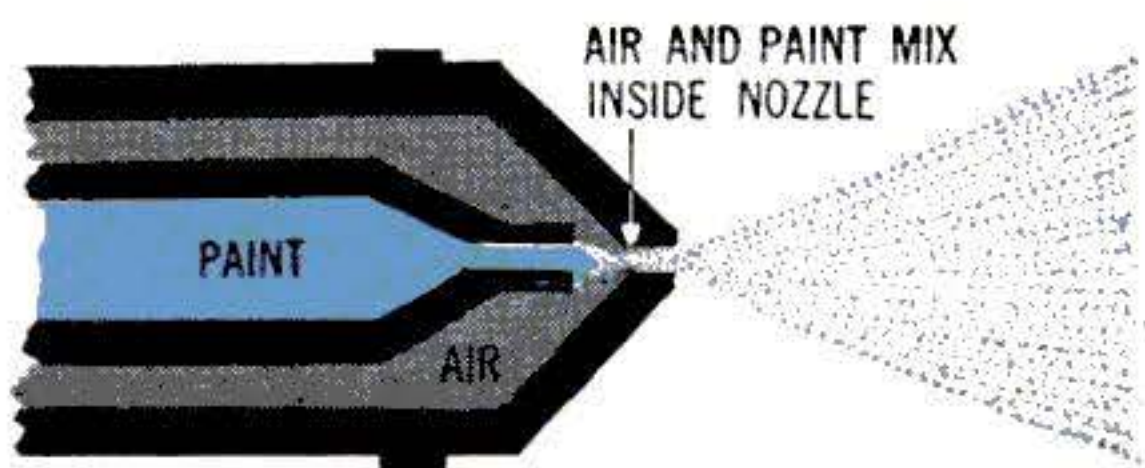

PAINT AND AIR MEET INSIDE NOZZLE in the internal-mix type, best for slow-drying finishes that won't clog. It can be used only with pressure-feed guns.

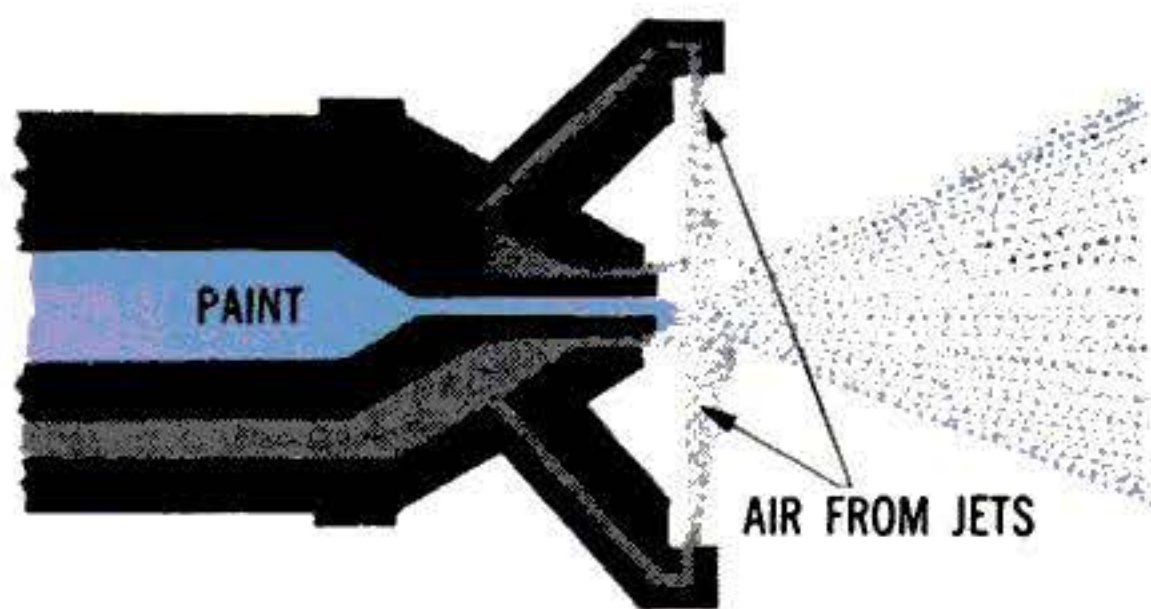

PAINT AND AIR MEET OUTSIDE NOZZLE in this external-mix type, best for quick-drying finishes. It can be used with either suction- or pressure-feed guns.

for years without maintenance and deliver pressures of 100 pounds or more. But they're a good deal more expensive. A typical diaphragm outfit, complete with gun and delivering 3.6 cubic feet of air per minute at 35 pounds' pressure, sells for \$133.50. A piston unit of the same make, delivering 3.2 cubic feet per minute at the same pressure, costs \$196.50. Either of them could spray-paint in two

days an average house that would require six days by brush.

How compressors and guns are rated. Compressors are rated according to the volume of air they can *supply* at a given pressure. Guns are rated according to the volume they *require* at a given pressure.

Terminology is important here as some compressors are rated according to *displacement*, others according to the actual *air delivery*. The air delivery is always the lower figure and the better performance gauge. A compressor with a displacement of about four cubic feet per minute may actually deliver to the gun only 2½—which is what you want to know. The difference between the two ratings is usually around 25 to 35 percent.

Gun requirements fortunately allow some leeway. A typical gun rating may vary from 1½ to 2½ cubic feet per minute on volume and from 20 to 45 pounds per square inch on pressure.

Where a compressor is just barely putting out the minimum that a gun requires, the length and diameter of the air hose become very important. Fifty feet of hose can actually cut pressure in half.

To minimize the loss of pressure, keep the hose as short as possible and favor a large diameter over a small one. If you buy a matched unit complete with hose, you usually need not worry. If you do your own matching, guide yourself by the pressure-drop chart printed with this article.

In some cases, guns are rated simply according to the power of the compressor required to operate them, as: "for use

[Continued on page 252]

How One Man Pumped Paint Between His House Shingles



IN PAINTING the exterior of my cedar-shingle house, I found it very difficult to force paint between the shingles with a brush.

Then I had an idea. I filled a regular pump-type oil can with paint—and *pumped* paint into the cracks. I first painted the shingle edges by going along with the pump can in one hand and a 4" brush in the other. Then I went back and finished the surface of the shingles. The work went twice as fast as it would have with a brush alone.—Gordon W. McPhail, Auburn, Maine.

Short Cuts and Tips

FROM PS READERS



Trapping Moles the Sure Way

IF MOLES in your lawn or garden are troubling you, find the raised tunnel and dig a hole through it big enough for a gallon can. Remove the lid and sink the can until the lip is below the tunnel bottom. Place a board over the opening. Moles using the tunnel will drop into the can, which will be too deep for them to escape from.—*John Krill, North Lima, Ohio.*

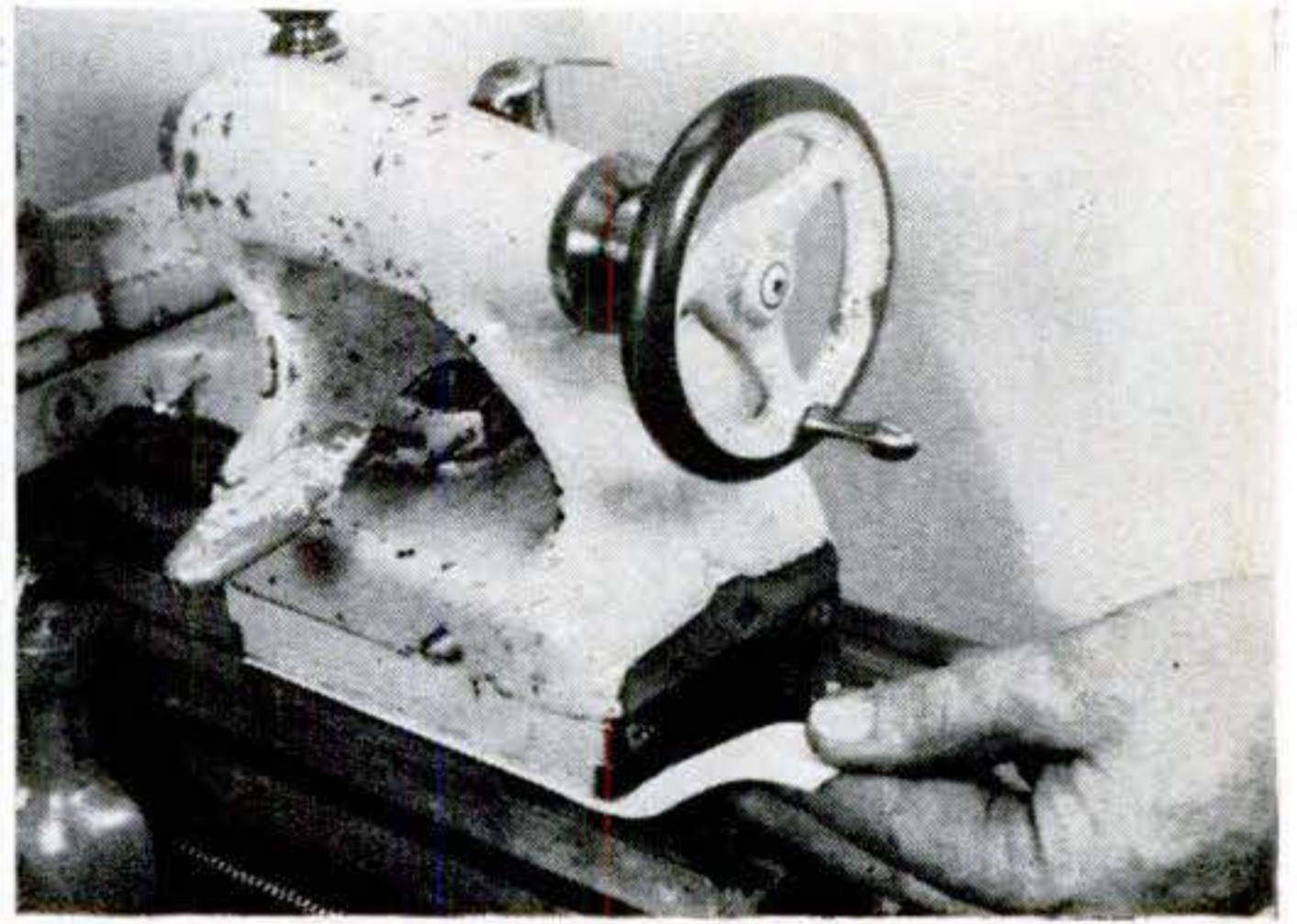

Offsetting for Slight Taper

WHEN you have need to turn a very slight taper, such as for the shank of a mandrel, try placing a thin paper or metal shim under the tailstock on the flat way of the lathe bed. It will tilt the tailstock off the true center axis and can be quickly removed when you want to return the lathe to normal parallel operation.—*H. J. Gerber, Stillwater, Okla.*

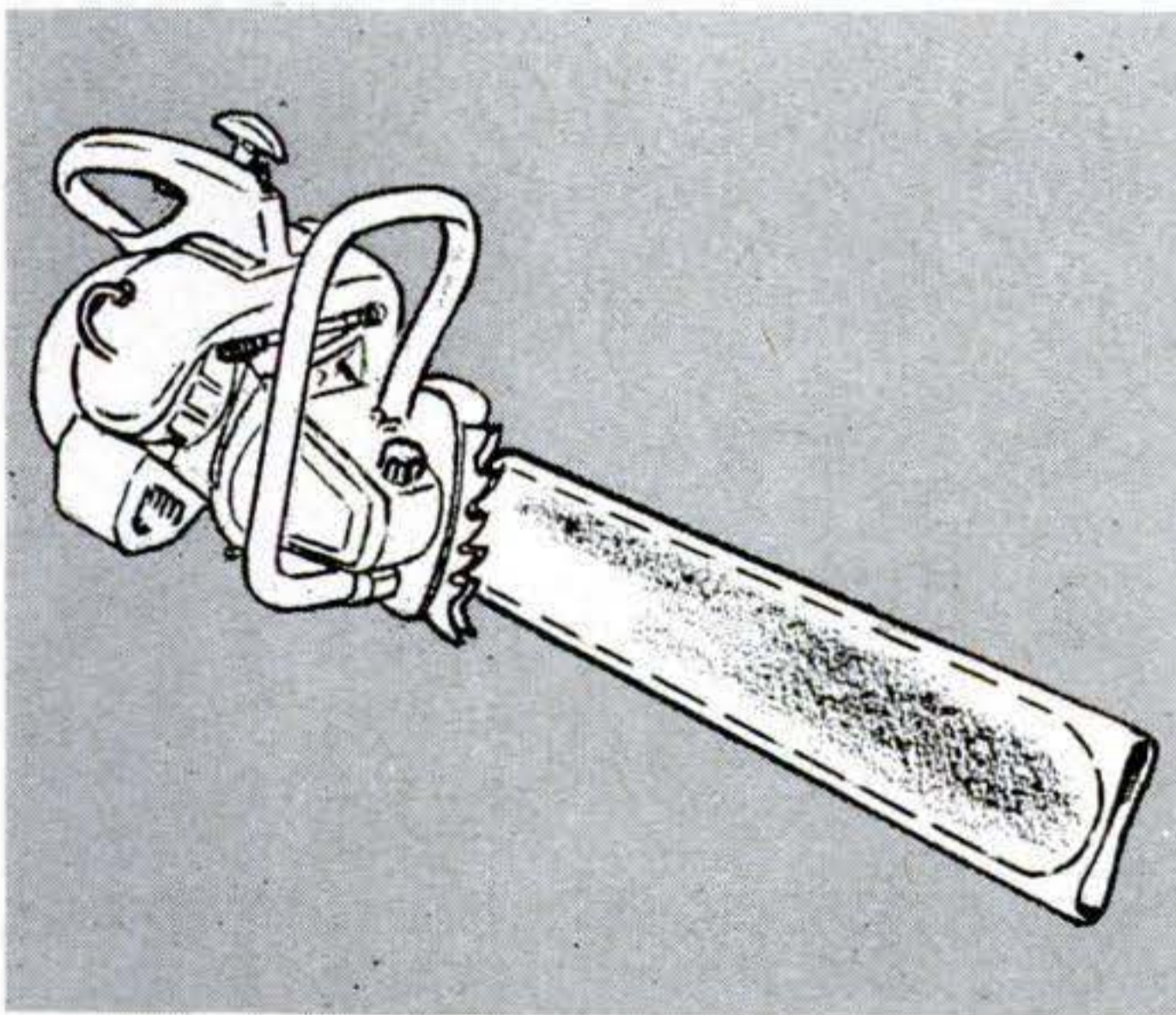

Guard for Chain-Saw Blade

HERE'S how you can protect your chain saw from dirt, damage and accidentally injuring someone. From an old truck inner tube cut a section about 10" longer than the blade and slip it on over the blade. It will keep the bar and chain clean and help to cushion knocks and jars.—*James Kane, Cleveland.*

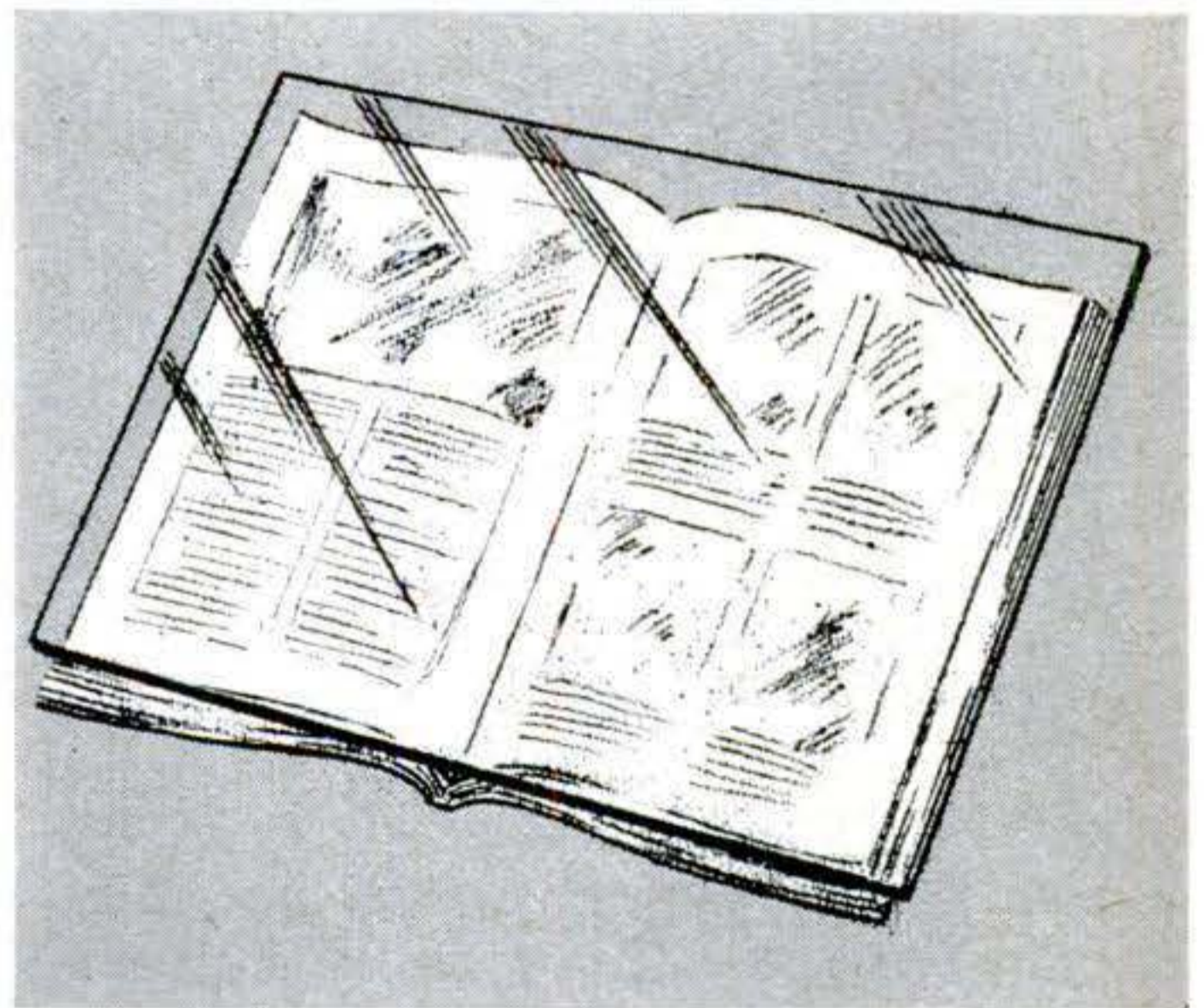

Protecting Magazine Pages

SOLDER-SPATTERED pages and oil spots on important dimensions are the fate of many issues of POPULAR SCIENCE when you build projects from its pages.

A small sheet of clear plastic $\frac{1}{8}$ " or so thick laid across the open magazine will hold the place and keep it clean.—*R. L. Clough Jr., Bristol, N. H.*

**It's a
dining
room
table—**

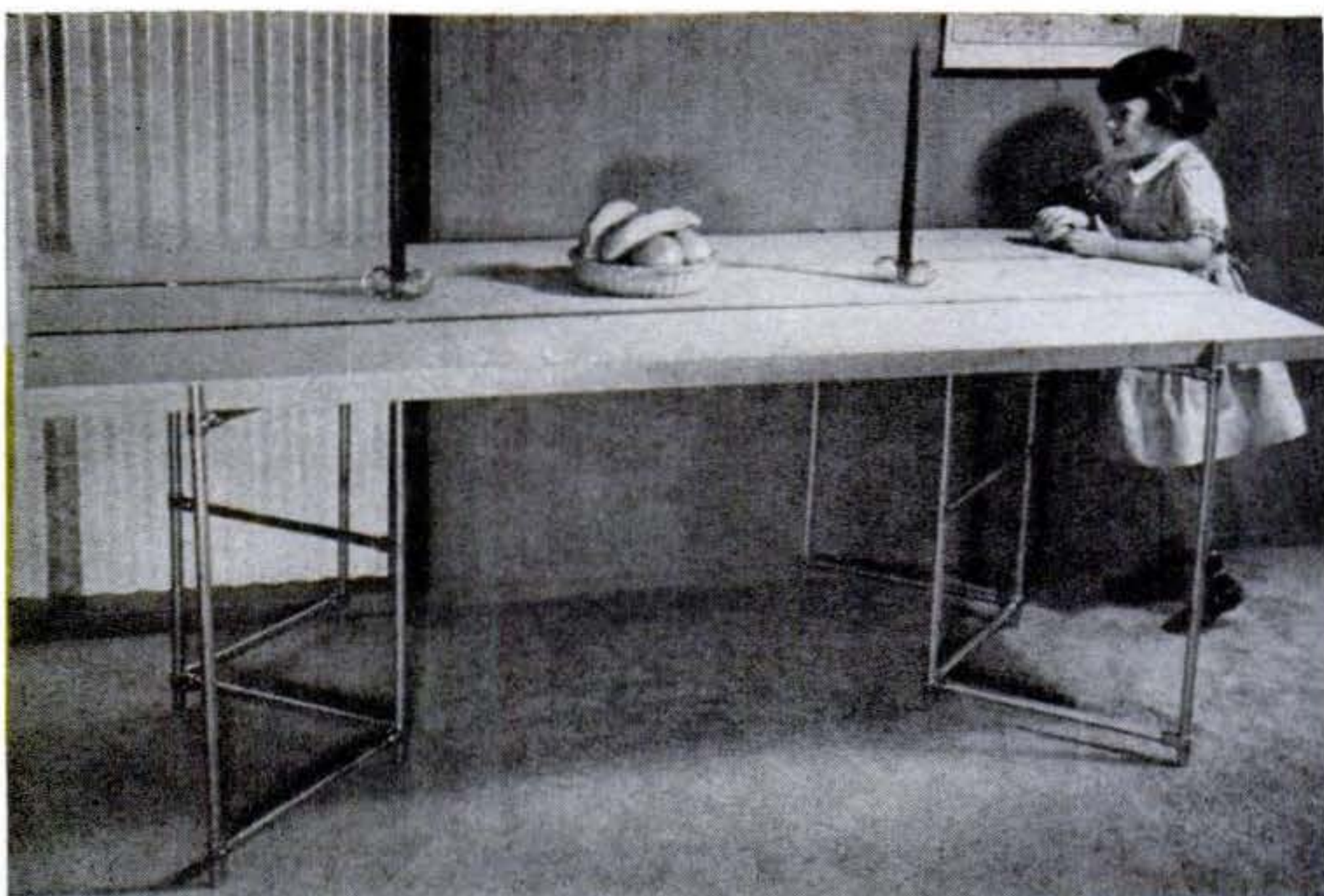
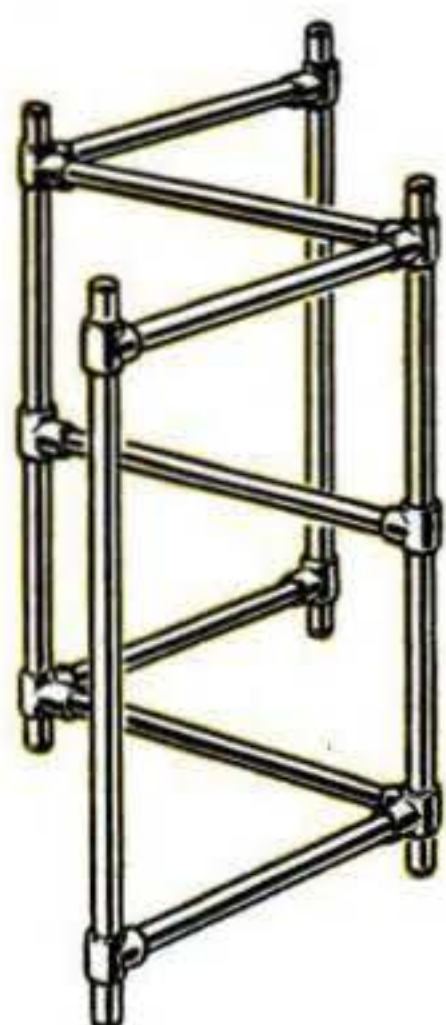

HOW YOU CAN BUILD

A Set of Triple-Use Furniture

By Paul Corey

A SET of shelves, a coffee table, a dining table—you can now assemble any one of three pieces of furniture from the same set of parts. You can also switch back and forth as often as you wish.

You may, perhaps, use the parts routinely as shelves. But when guests drop in, you can convert in a jiffy to a mammoth coffee table or a dining table for eight—whichever you need the most.

Depending upon the lumber and the pipe or tubing you use, the materials will run between \$40 and \$70. Admittedly, that's a lot more than you'd pay for the makings of a comparable set of shelves or either kind of table. But it's still a bargain price to pay for the convenience of having any one of the three at a moment's notice. Added to that, whichever way you arrange the components there's no makeshift look about them—each piece is distinctively styled. And where space is tight, you have two tables that can be stored in the open as shelves.

How it works. Two zigzag frames, made either of aluminum or iron pipe or tubing, are the supporting members for

the three-in-one unit. Facing one another in upright position, they hold a three-section plank at conventional dining-table height. Placed end-to-end, they provide a rack that spaces the planks to form a set of shelves. Flipped on their

WHAT YOU NEED

- 3 2"x12"x76" dressed planks
- 4 10' lengths $\frac{3}{4}$ " pipe or 1" tubing
- 12 $\frac{3}{4}$ "-pipe tees
- 8 $\frac{3}{4}$ " side-outlet pipe tees
- 16 $\frac{3}{4}$ "-pipe drive-in plugs

The slip-on fittings shown are available from John H. Hosking Co., 1704 Howland Ave., Cincinnati 23. They also offer cut-to-size, internally ribbed aluminum pipe.

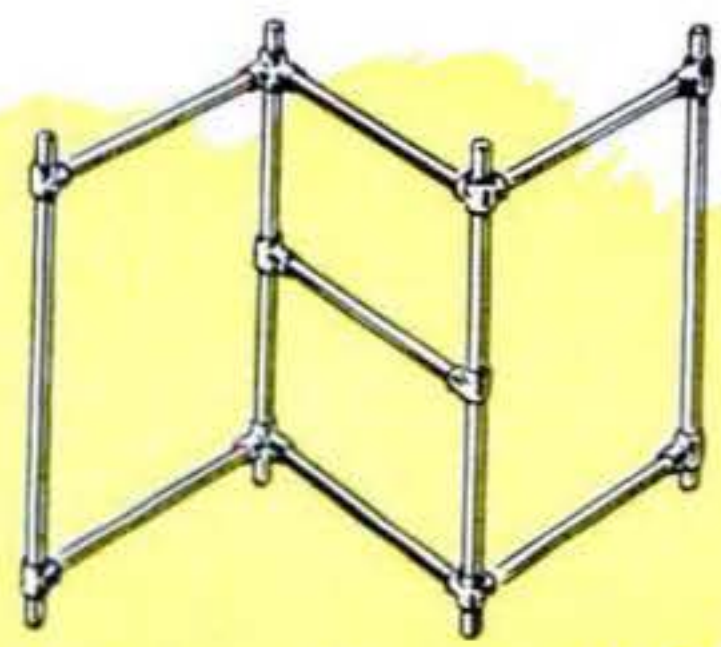

a set of shelves

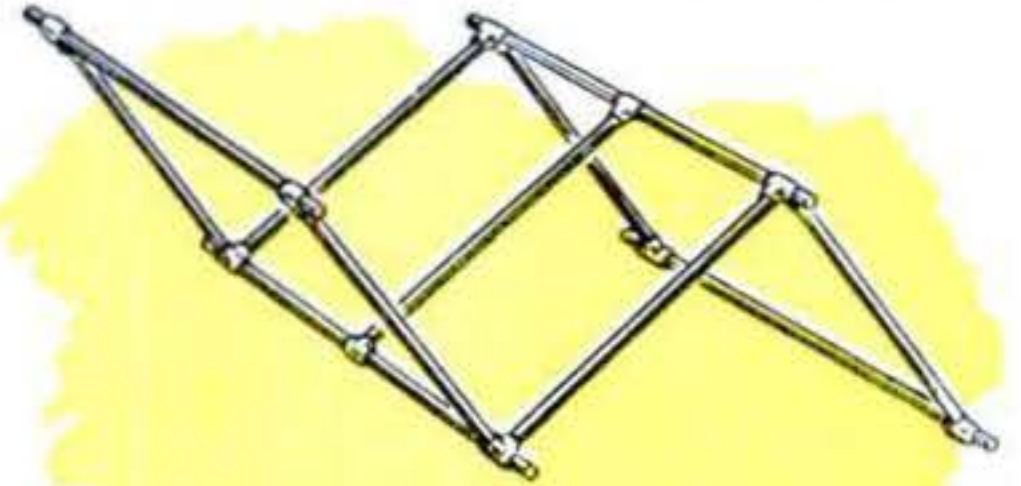

a coffee table

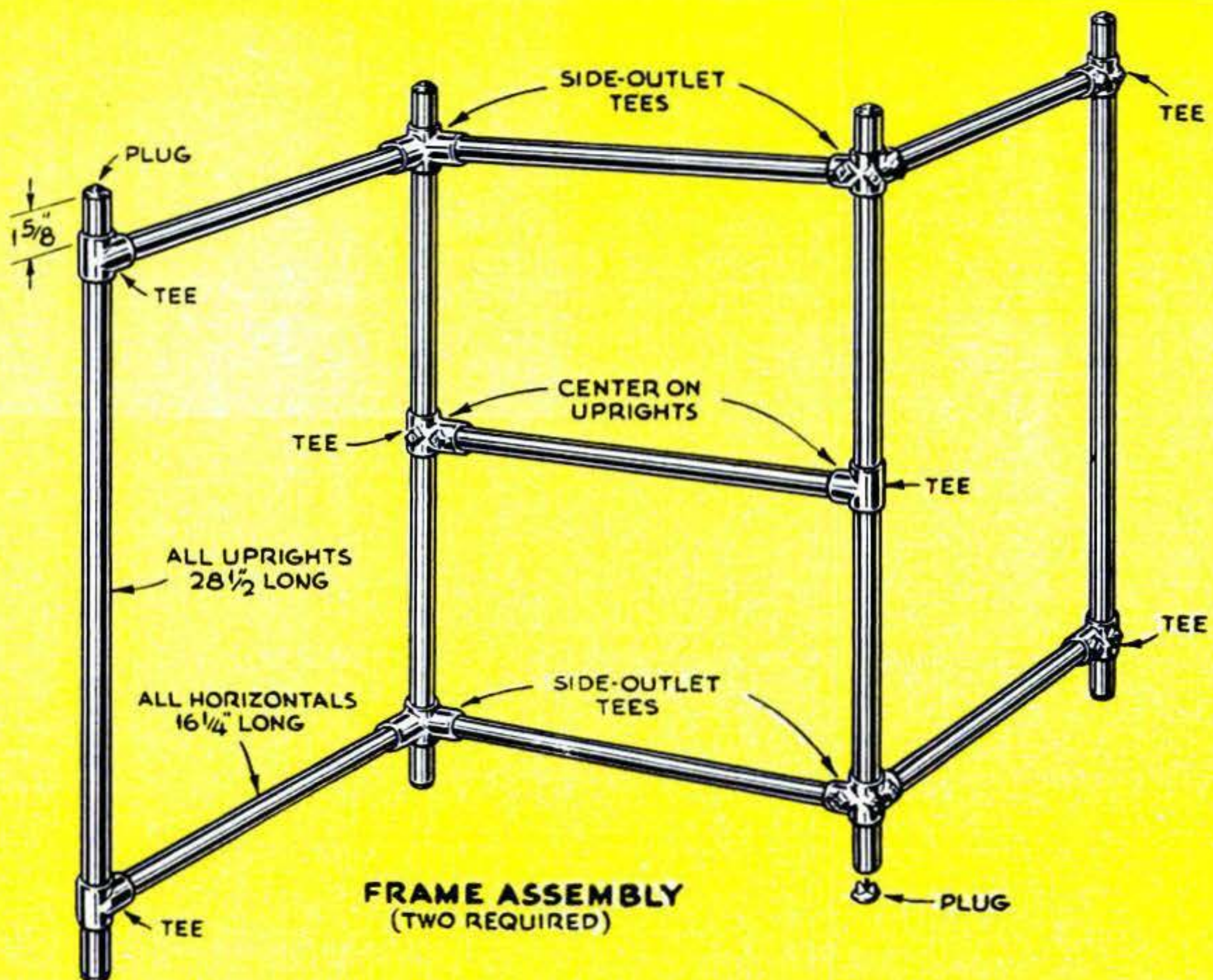
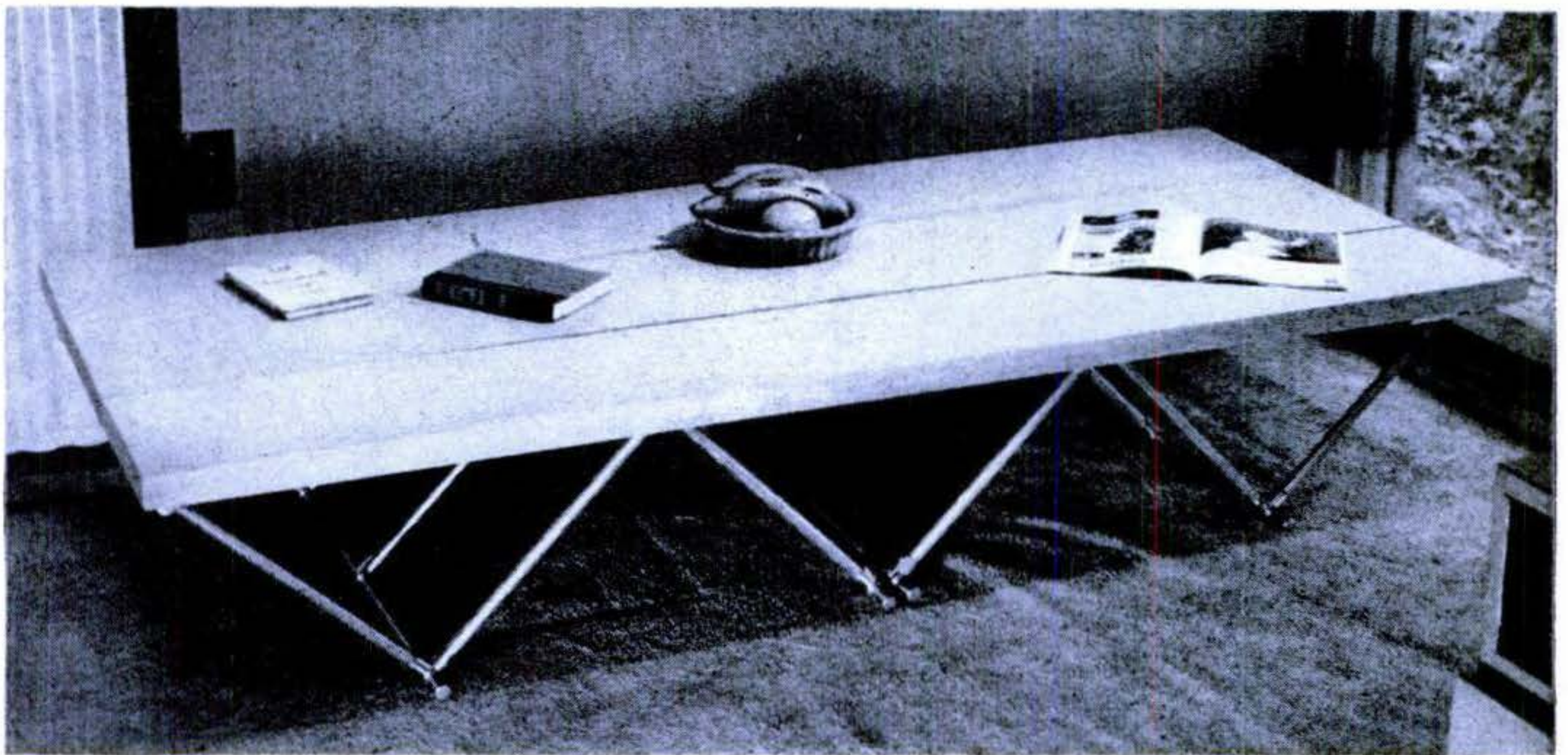

sides, they're the trestle legs for the coffee table.

Aluminum fittings speed the job. Even if you cut some of the parts yourself, you can build this three-in-one unit in just a few hours, using setscrew-fastened aluminum fittings of types now being offered for industrial scaffold and rack construction. The tees, side-outlet tees and end plugs you'll need come to \$23.

Four 10' lengths of $\frac{3}{4}$ " pipe or 1" tubing will take care of the framework—use two for the $16\frac{1}{4}$ " sections and the other

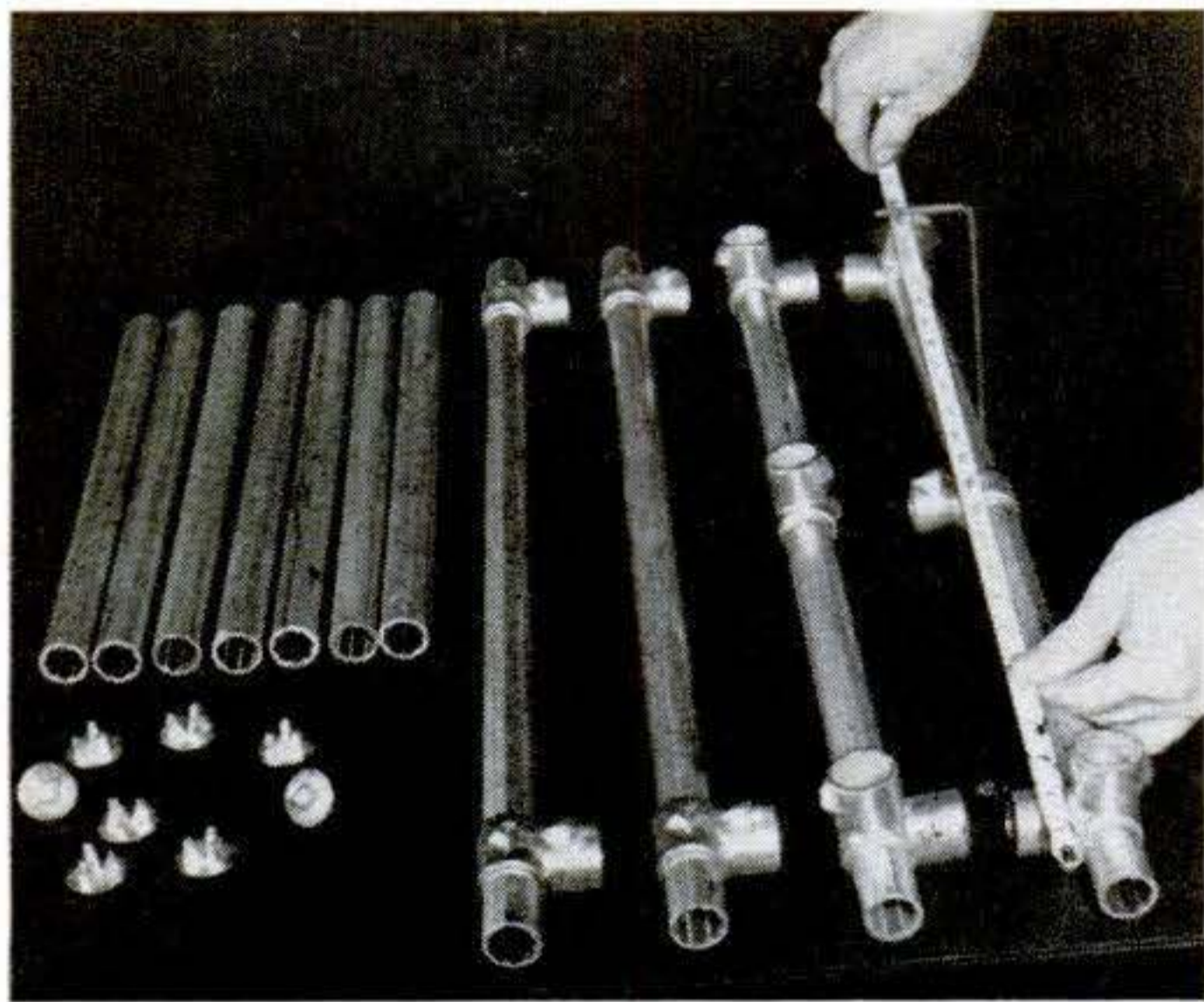

FOR EACH FRAME, use seven $16\frac{1}{4}$ " lengths of pipe or tubing and four $28\frac{1}{2}$ " lengths. Tees are fastened $1\frac{5}{8}$ " from the ends of two long pieces, at centers of the other two. Side-outlet tees are mounted $1\frac{5}{8}$ " from the ends of the latter sections. Plugs close off the ends.

pair for the $28\frac{1}{2}$ -inchers. Don't let pipe and tubing sizes confuse you. Pipe is identified by its nominal *inside* diameter, tubing by its *outside* diameter. One-inch tubing and $\frac{3}{4}$ " pipe have the same "o.d." and both are right for $\frac{3}{4}$ " pipe fittings.

Black iron pipe is cheapest—about \$7.50 for 40 feet. Galvanized iron costs a bit more, and light, 1" aluminum tubing will come to around \$11. A heavier, internally ribbed aluminum pipe is also available, in cut-to-length sections, for \$17. If you use aluminum, rub it down with 000-grade steel wool, then buff it. Flat-black lacquer is the treatment for iron pipe; leave the fittings in bright aluminum for contrast. Finish the framework by cutting four pieces of $\frac{3}{4}$ " garden hose, each 2" long. These are for coffee-table use. Slit and snap them over the two top end supports to keep the planks from slipping.

The wood you need. A 20' length of two-by-twelve gives you the material for three 76"-long shelf and table planks, with allowance for possible end checking. To save laborious planing and sanding, buy select, dressed stock. Redwood, white wood, sugar pine or oak are all good choices. Prices for these are about 70¢, \$1, \$1.20 and \$1.50 a running foot, respectively. Choose a finish to suit your room decor. If you want to get your three-in-one furniture in shape for use fast, give it two or three coats of clear lacquer.

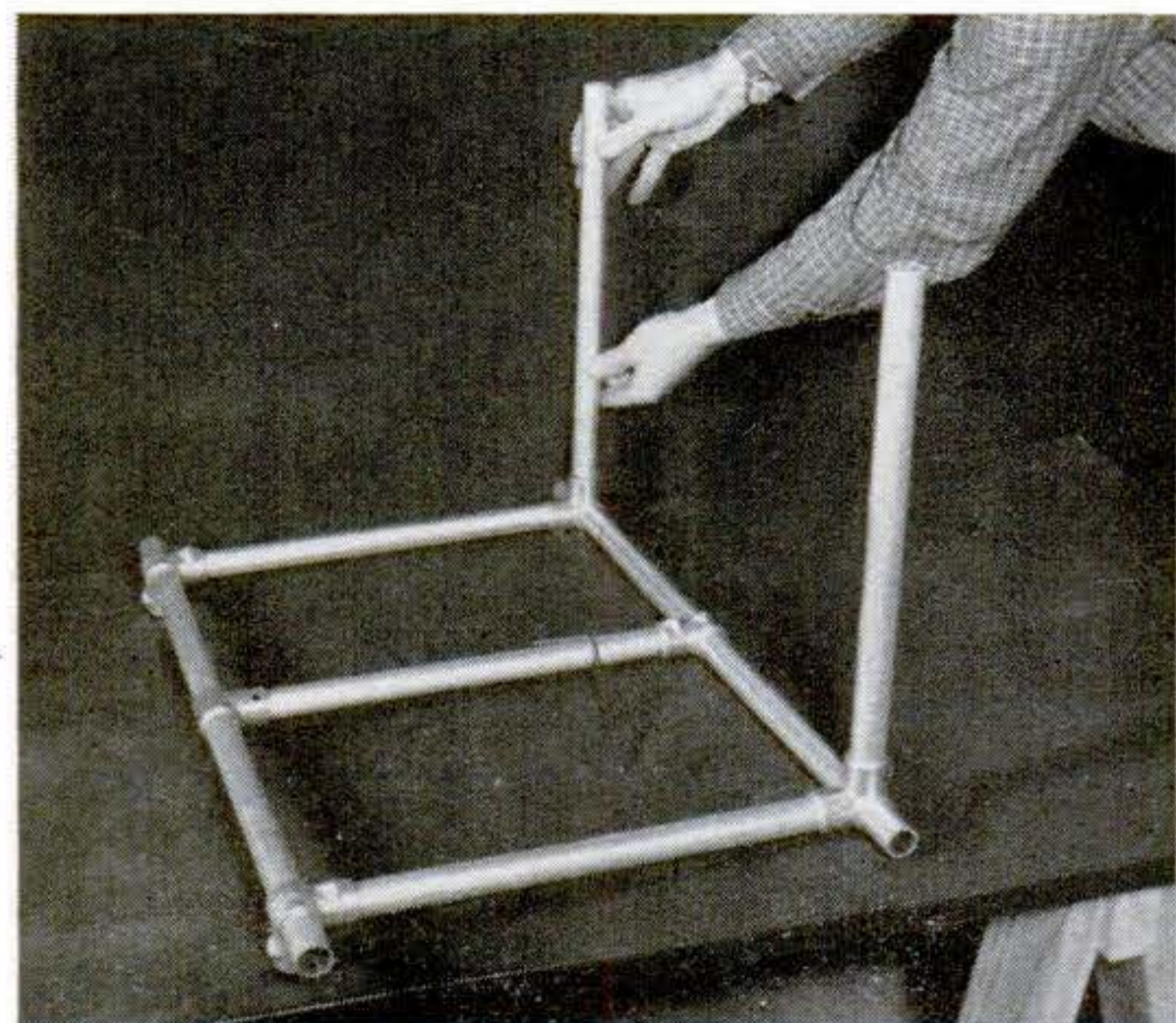

CONNECT THE THREE-FITTING UPRIGHTS with short pipe or tubing sections, reversing the direction of the side-outlet tees. Next, slip the ends of two more short sections into the upward-facing side-outlet tees. Then flip the assembly and attach the other two short pipes.

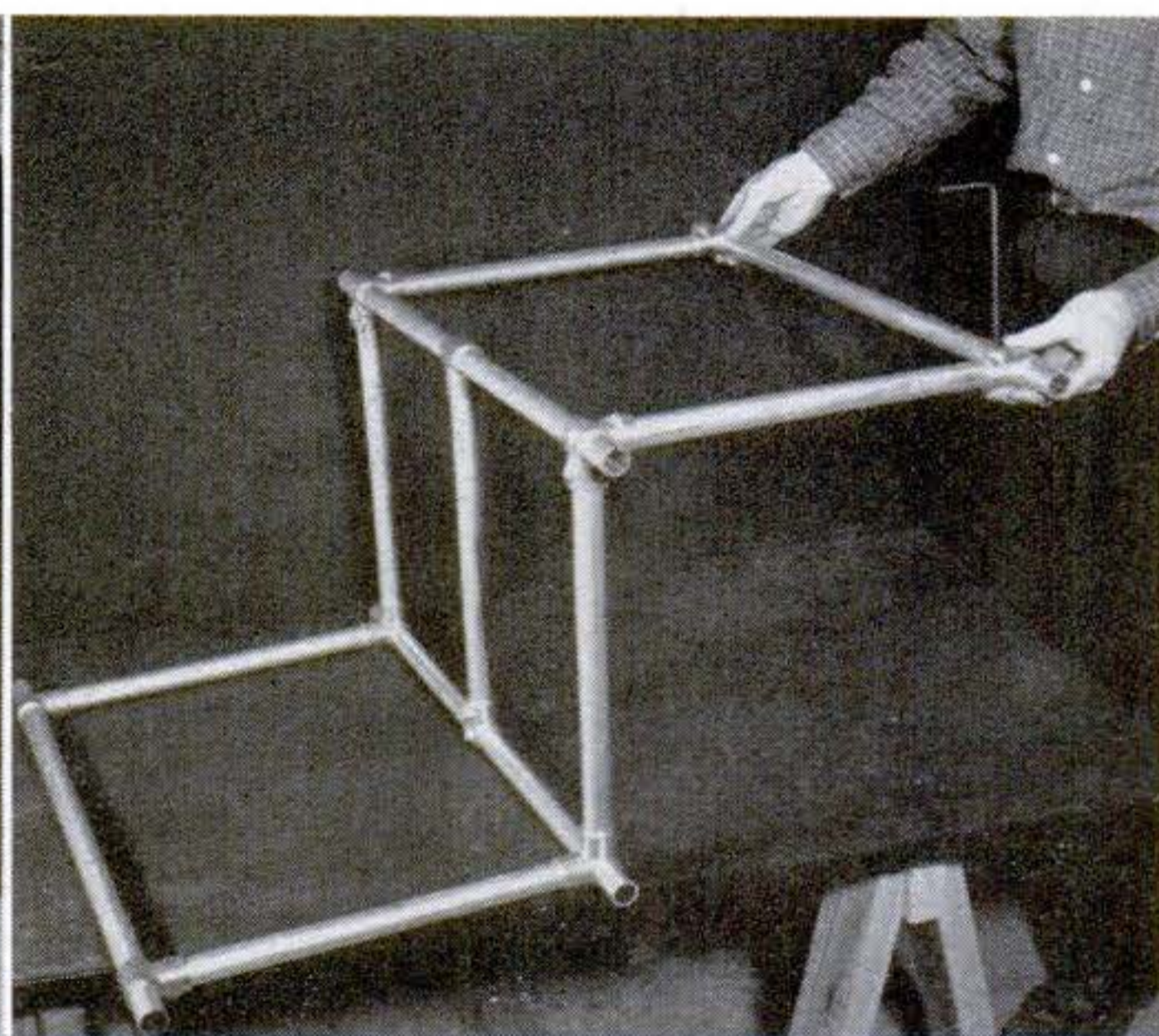

LONG SECTIONS WITH CONVENTIONAL TEES close off outer ends of each frame. During assembly make sure that setscrew positions conform with those shown in this photo for least conspicuous placement. Check alignment, too, before final tightening with an Allen wrench. **END**

Short Cuts and Tips

FROM PS READERS

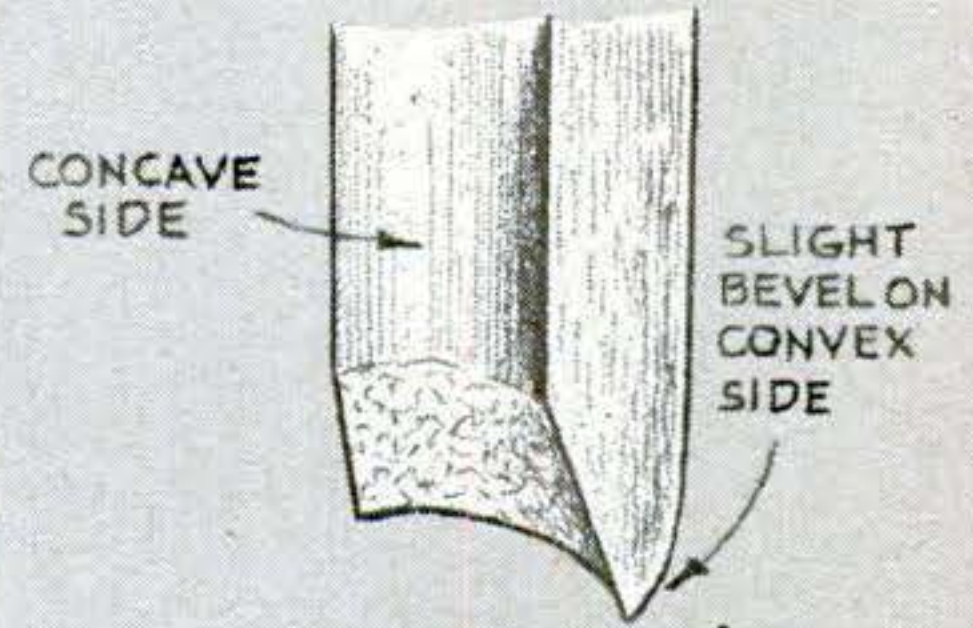
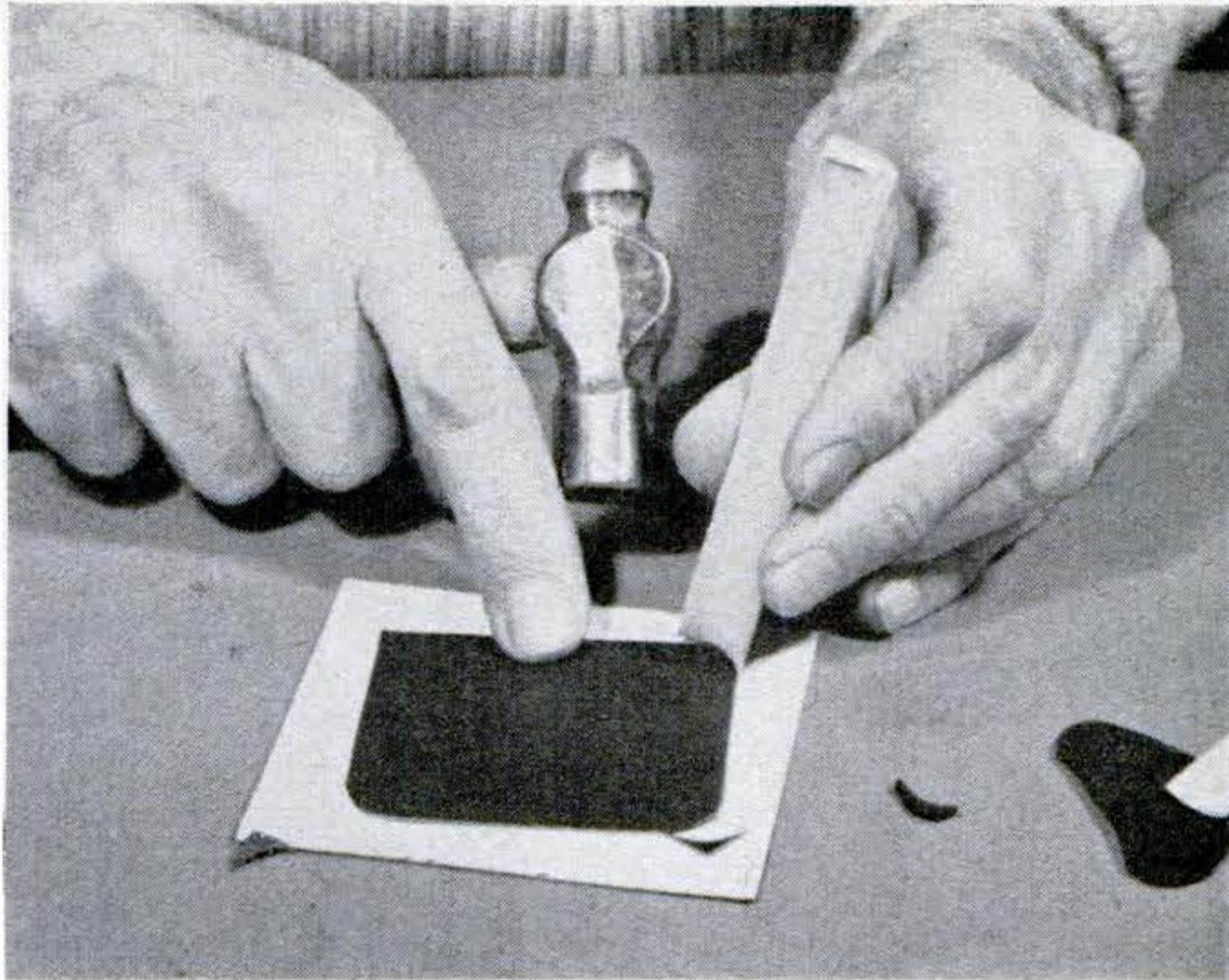

Making Chisels Out of Bamboo

EMERGENCY chisels for cutting leather, felt and similar materials can be made from bamboo. You will find them especially good for rounding corners. First split a 4" length into quarters, and then bevel the concave side of one end with a sharp knife to produce a cutting edge of about

35 degrees. Bevel the convex side slightly with fine sandpaper.

Rest the material to be cut on cardboard or paper over a hardboard sheet. Tap the chisel just hard enough to cut. The edge can be resharpened when necessary.—*Walter E. Burton, Akron, Ohio.*

▶▶▶QUICKER than with a hammer, you can sink glazier's points in cellar-window and storm sash with slip-joint pliers or a plier wrench. You can use the idea also for sinking points in the mullions and transoms of double-hung windows.—*Catherine Williams, Connellsville, Pa.*

▶▶▶A FAVORITE container for bolts, nails and other small parts is a glass jar, but it will often promote rusting. You can prevent this by prying the waxed cardboard out of the cover, dampening the inside with light oil, and then replacing.—*R. L. Clough Jr., Bristol, N. H.*

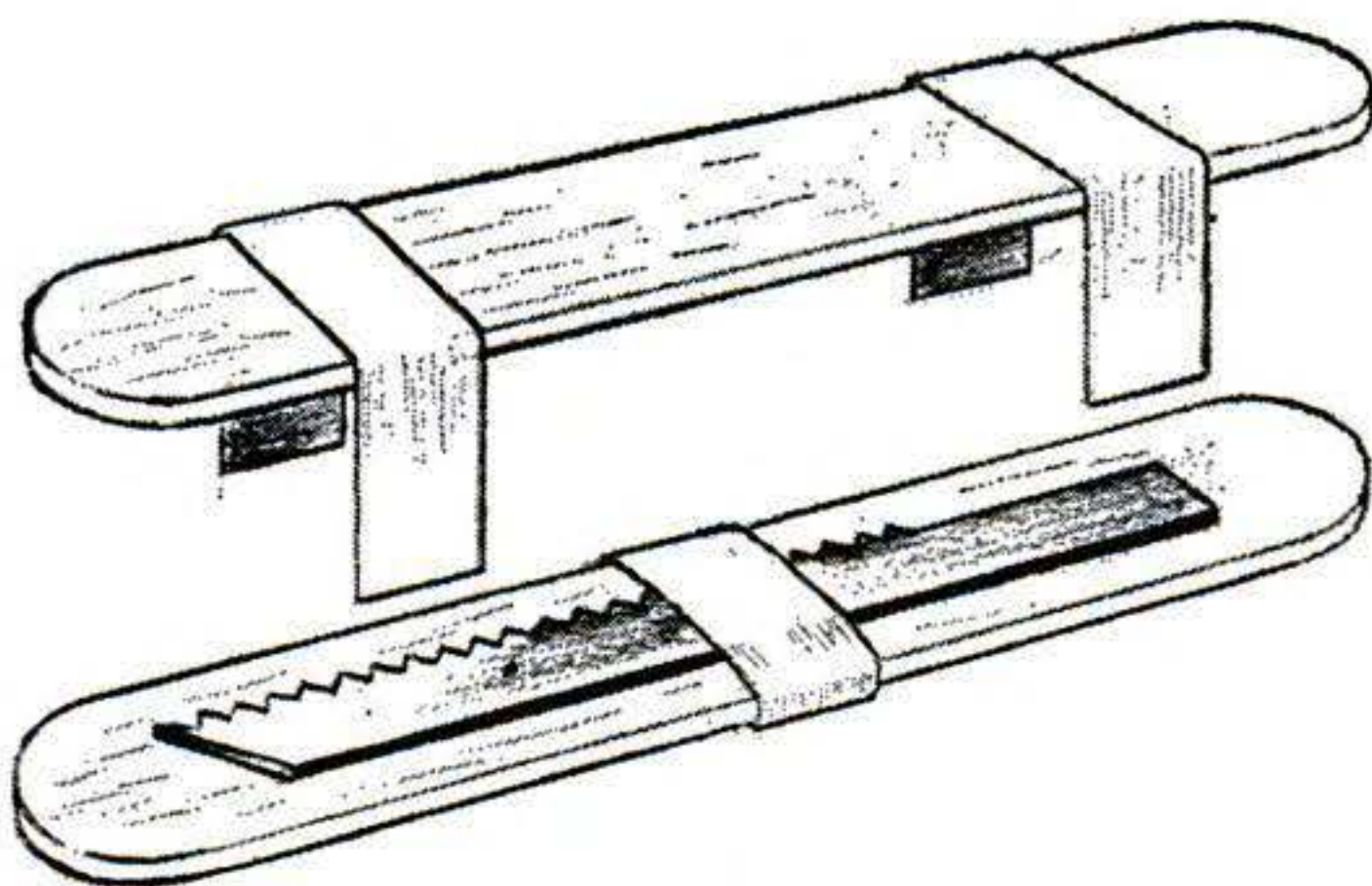

Protecting Small Saw Blades

TO PREVENT damage to saber-saw blades from other tools in my tool box, I tape them to tongue depressors. After taping a blade to one depressor, I place another depressor on top and tape the two into a sandwich that will protect the teeth.—*Donald Spichuk, Brooklyn, N.Y.*

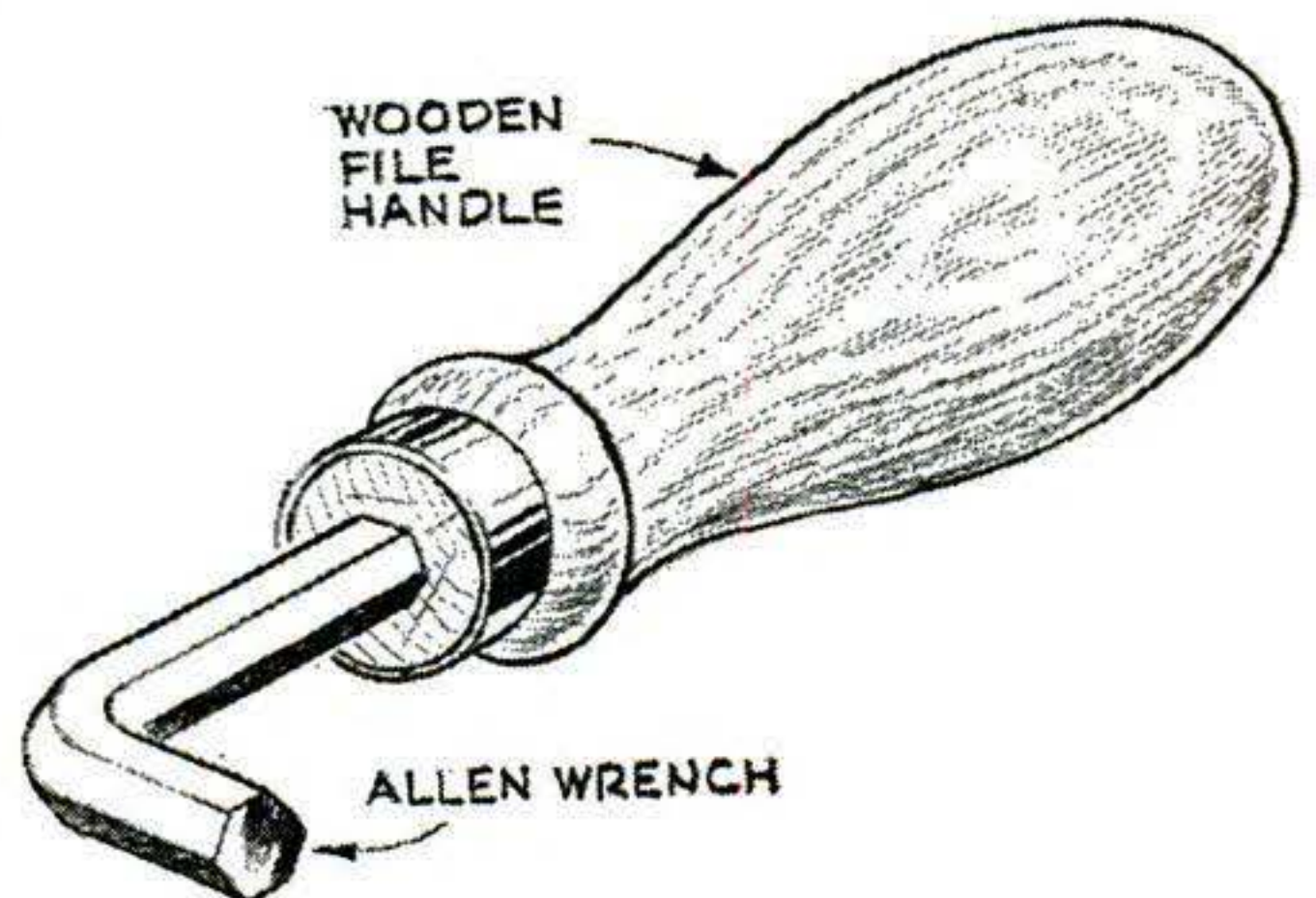

Handy Handle for Allen Wrench

IT TOOK me 15 years as a machinist to discover a convenient handle for Allen wrenches. A simple wooden file handle does the trick. I hit on the idea in desperation when I had to work inside a 6" hand hole in a tanklike structure.—*Herbert C. Myers Jr., Vermilion, Ohio.*



8 Extra Uses

1 Counterboring. When screw heads are to be covered with dowel plugs, continue countersinking until the bit has bored to the desired plug depth. While doing this retract it often—these bits have no provision for clearing waste.

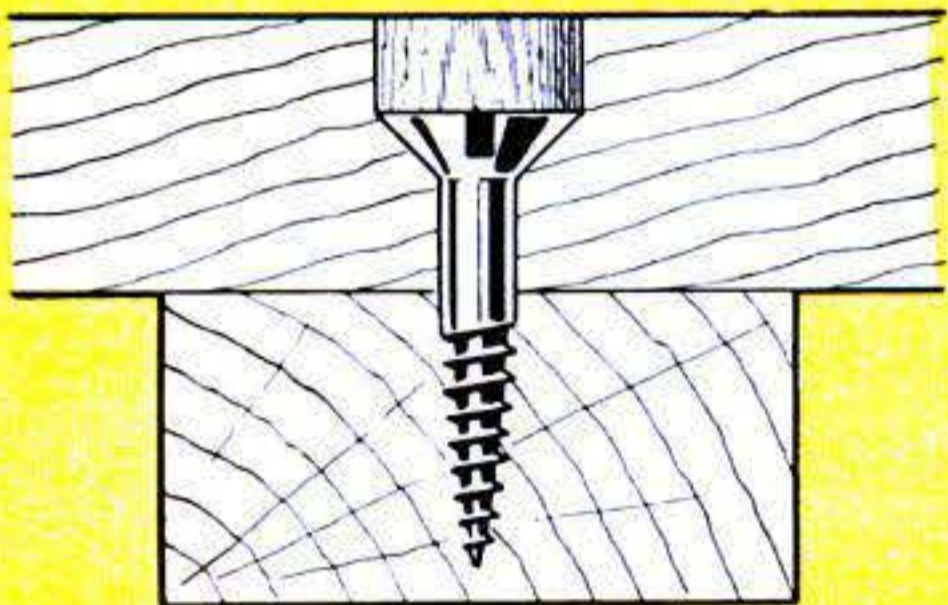

By
R. J. De Cristoforo

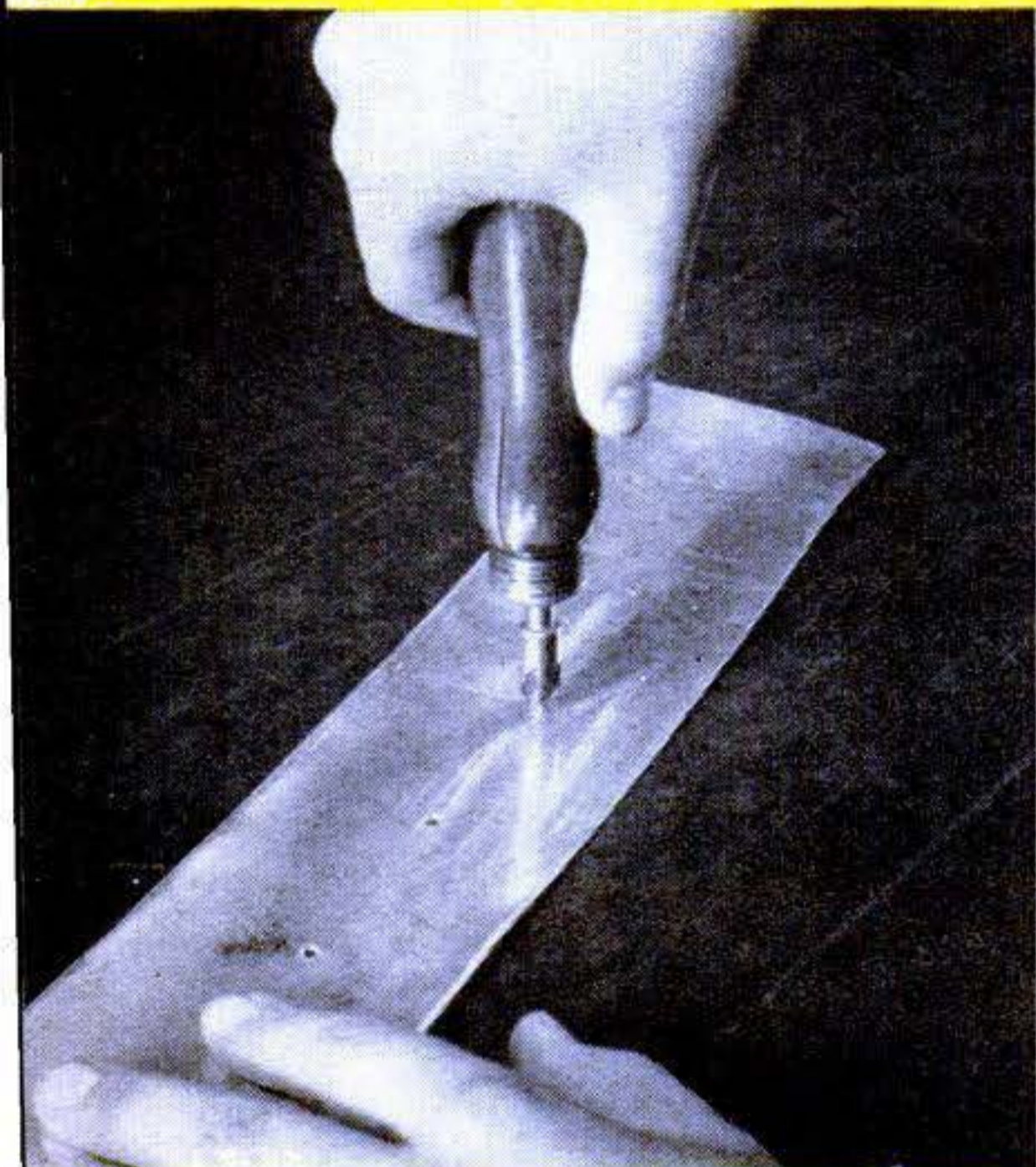
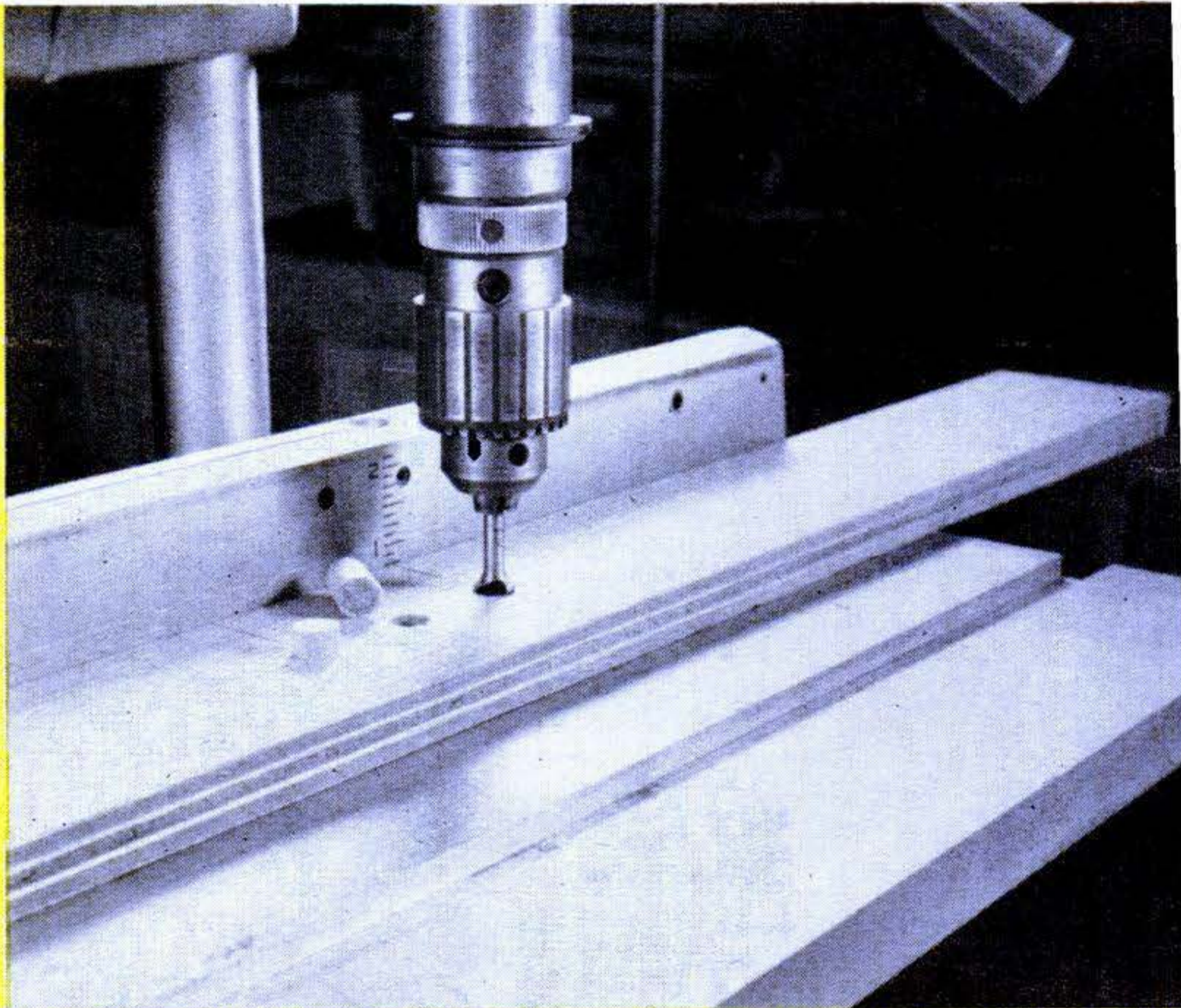

3 Deburring holes. Faster and neater than surface filing, a few twists of a hand-held countersink smooth off the rough, underside edges of holes drilled in thin metal. If you do much of this, put a file handle on the bit.

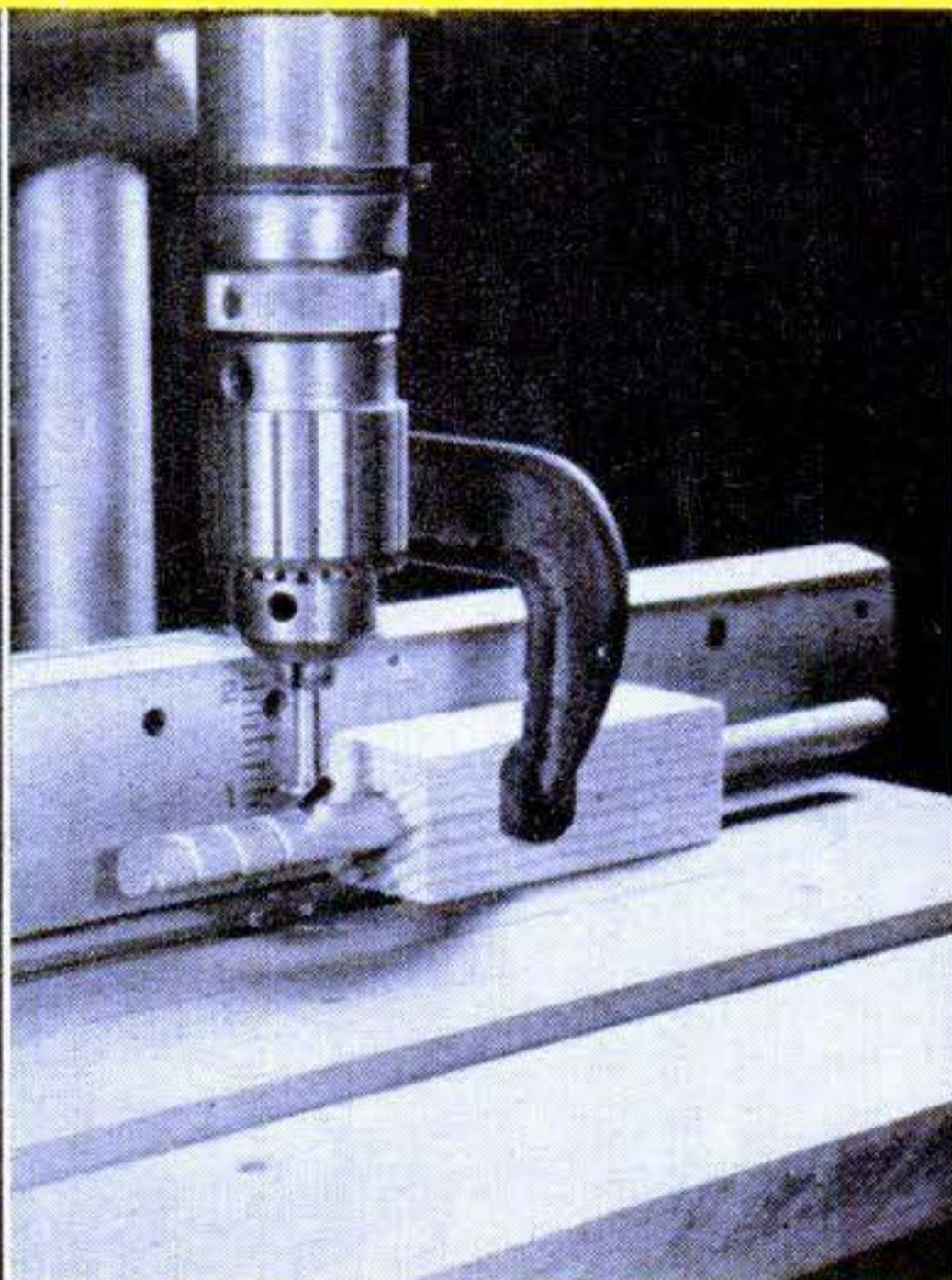

4 Cutting glue grooves. Joints hold better if dowels are channeled to let glue spread. With the setup shown here a countersink, centered above the dowel, grooves the pin as you push it forward, while you turn it at the same time.

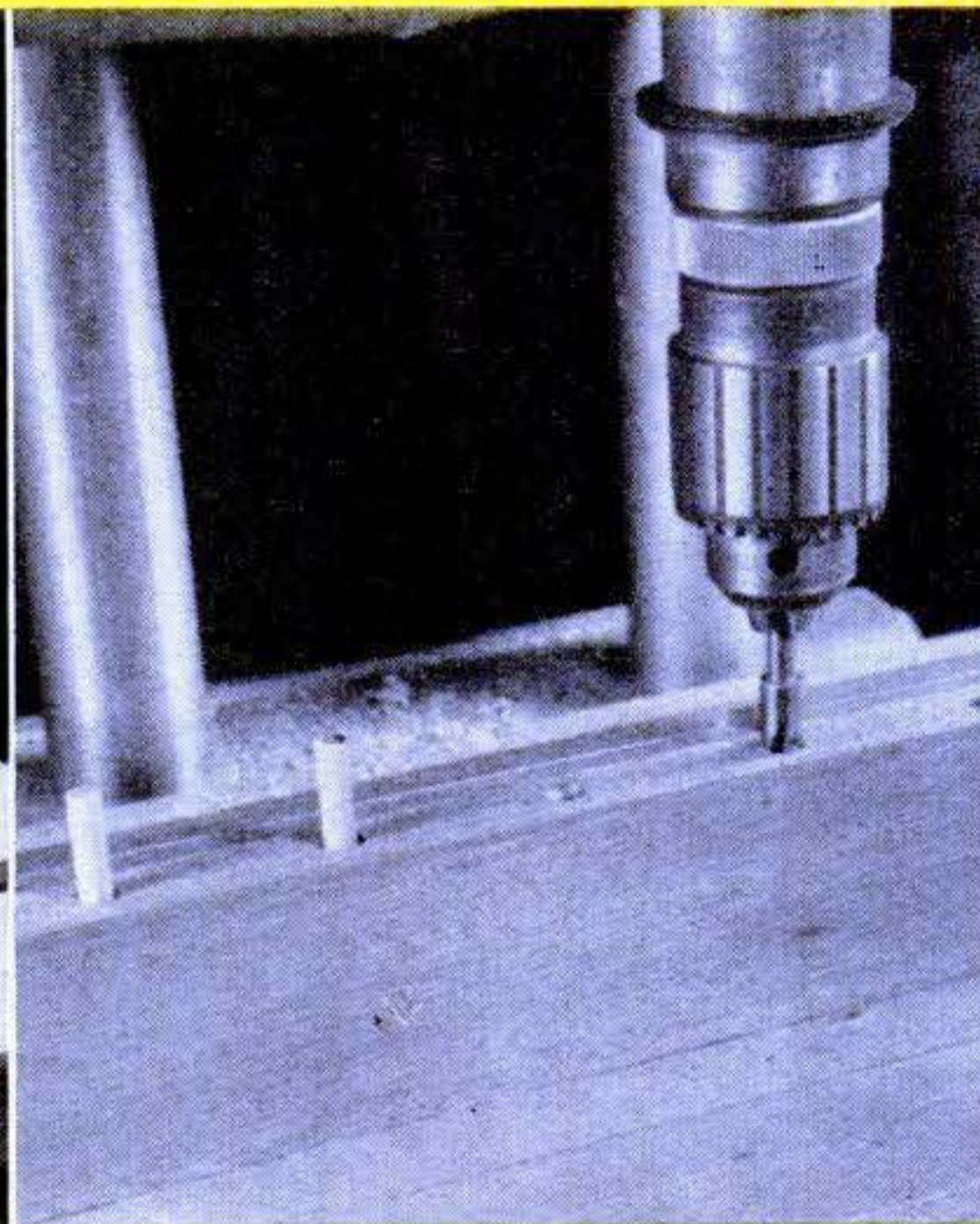

5 Easy joint assembly. When joining boards edge-to-edge with dowels, countersink the holes and the pins will be guided into any that are slightly mismatched. Countersinking also provides pockets to catch glue that is squeezed out.

for Countersink Bits

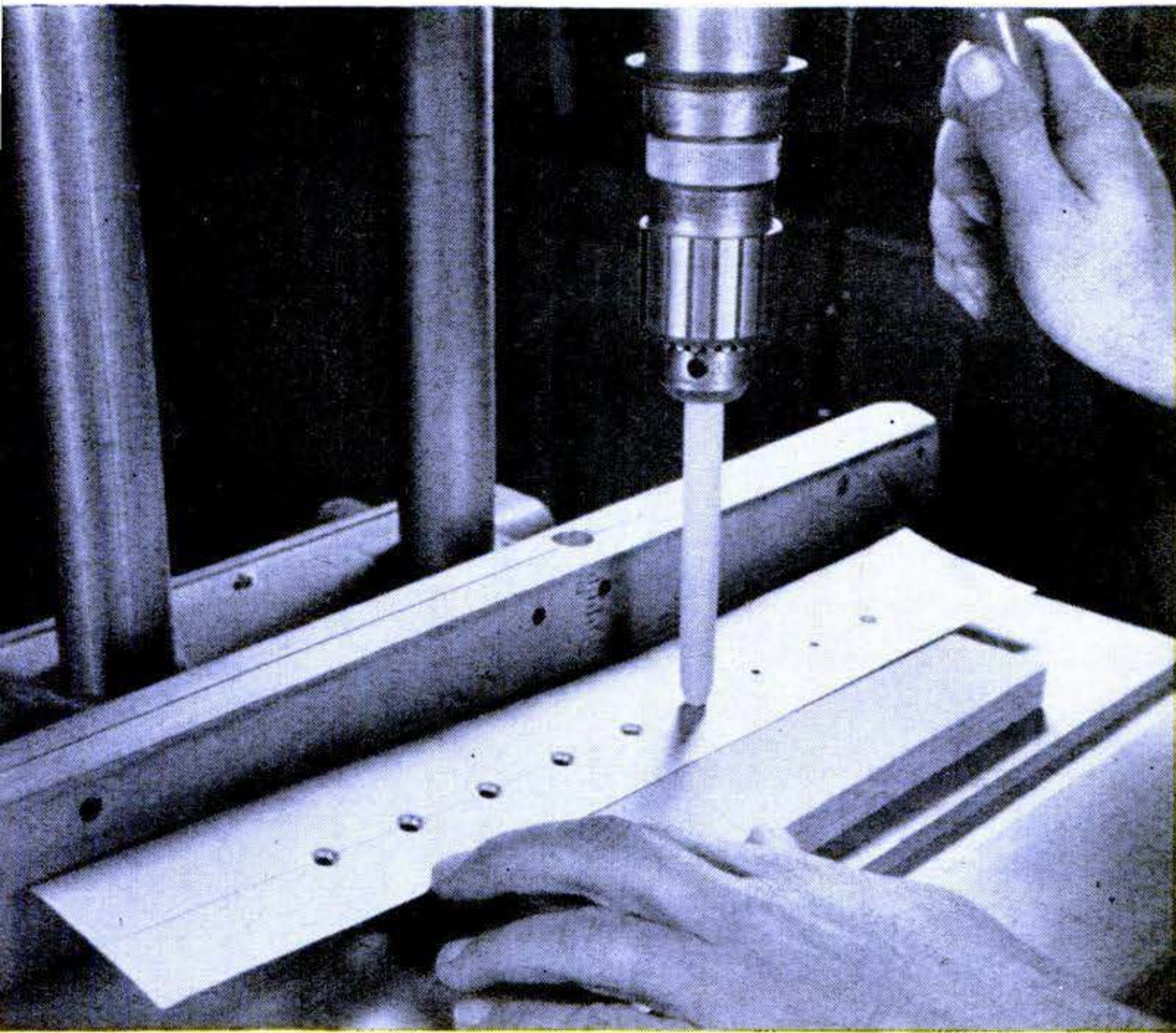

2 Dimpling metal for screw heads. Use this punch-and-die method: First, form a countersink in a scrap block. Then shape a dowel end to match. With the block in place, align the hole and countersink, and push the dowel down.

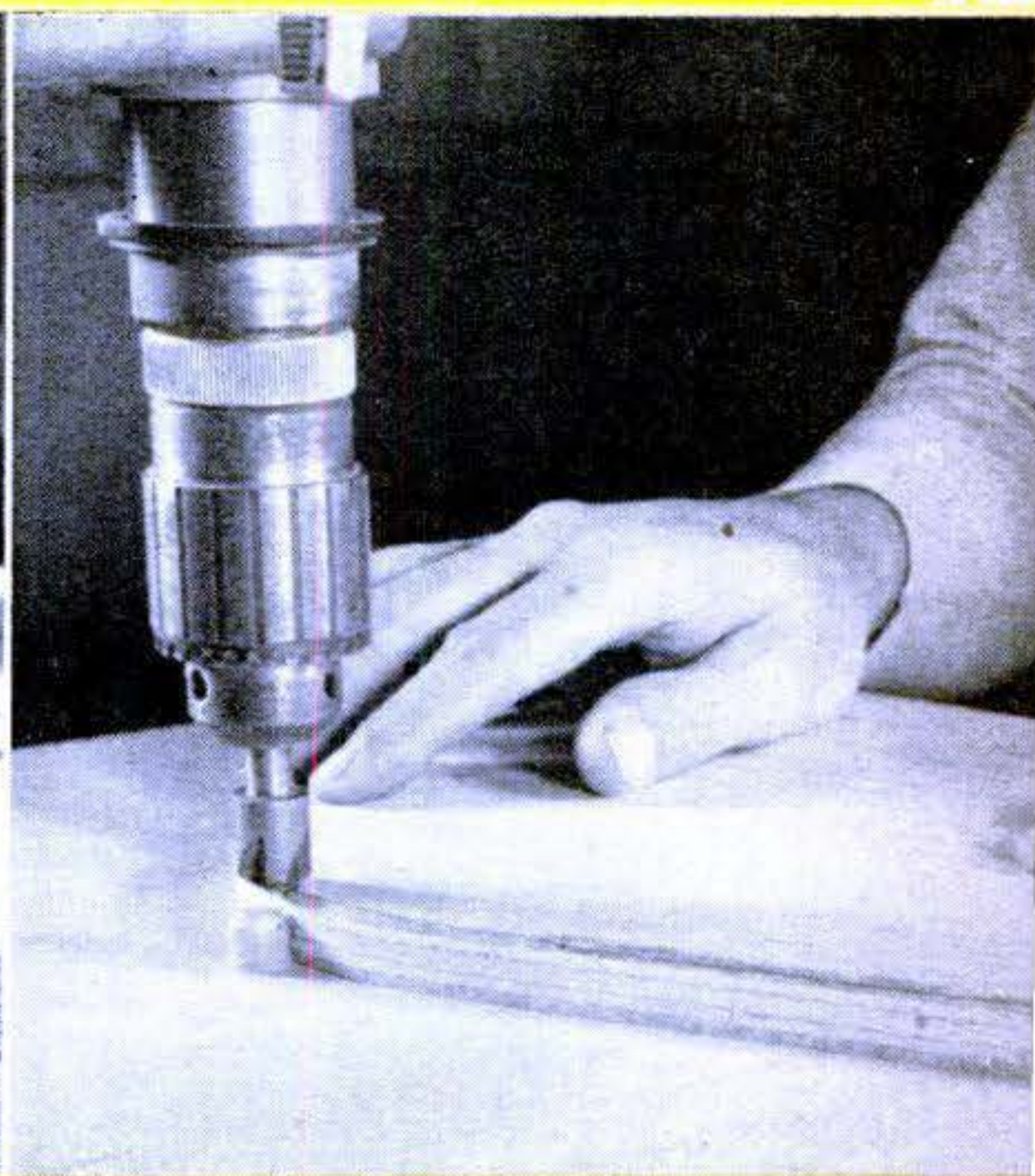
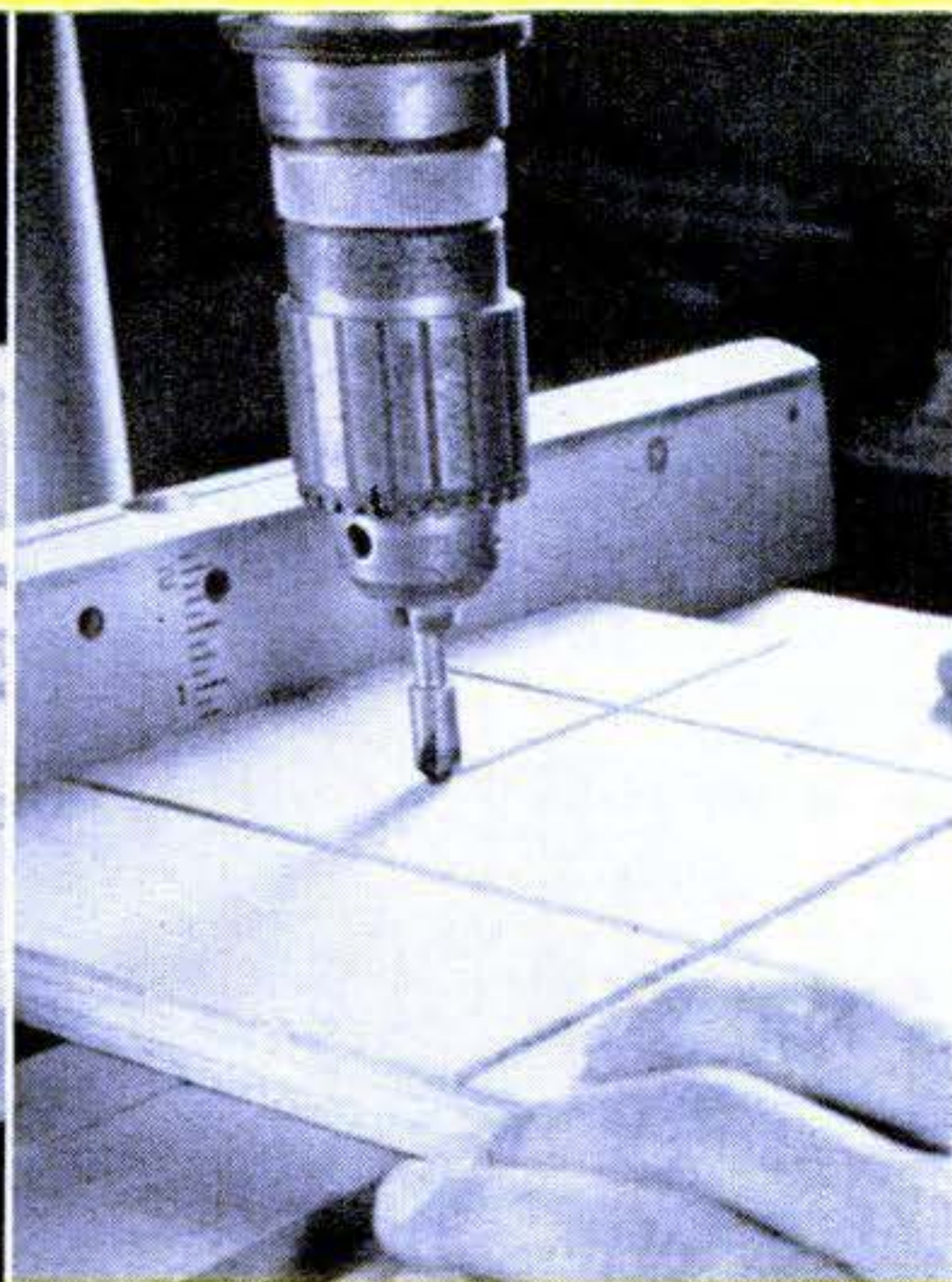
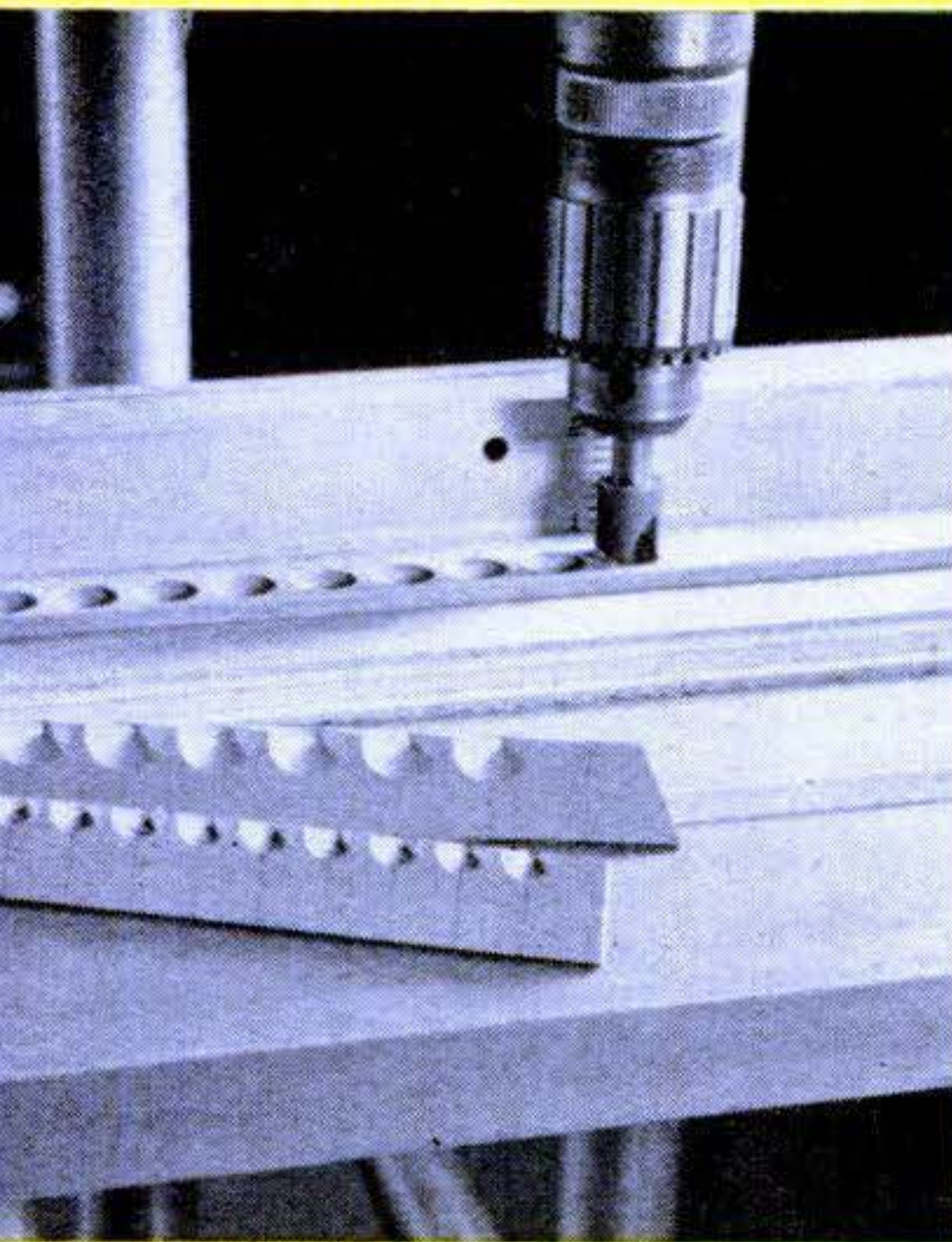
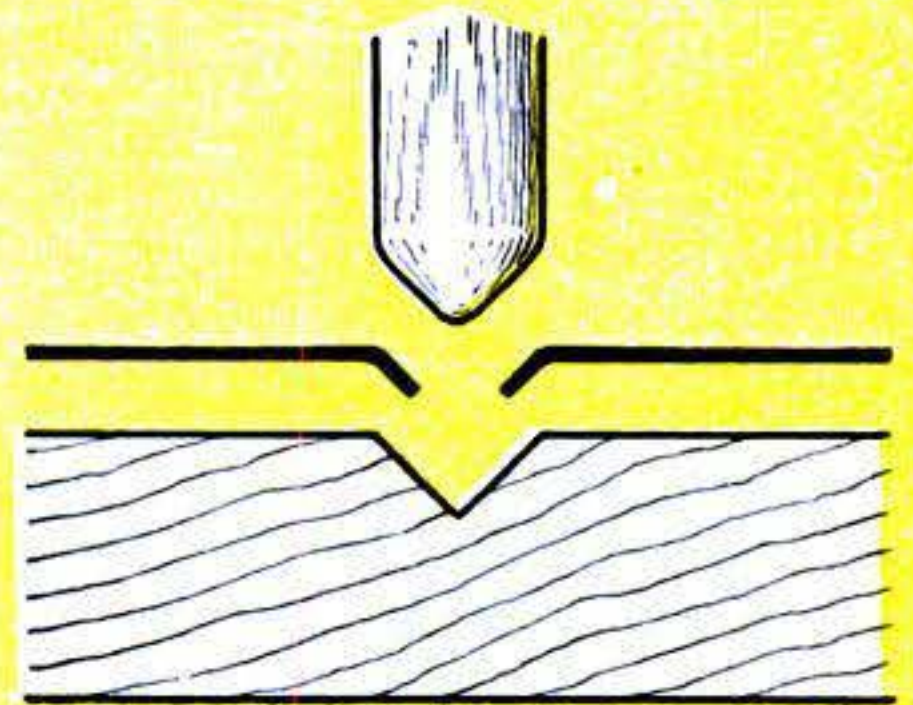

6 Making ornamental trim. Interesting scalloped edges are formed by countersinking equally spaced holes, then cutting along the centerline. By using bits of several sizes and vary the spacing, many types are produced.

7 Veining panels. Chucked in a drill press and turned at moderately high speed, a countersink can be used as a router bit to cut decorative V grooves. For ones over $\frac{1}{8}$ " deep, re-adjust the depth stop and make repeat passes.

8 Chamfering edges. Doubling as a cutter bit, a countersink does this accurately. A dowel pin embedded in a piece of scrap board clamped to the table may be used to control the position of the work in relation to the spindle center.

Wordless Workshop

By Roy Doty
and Frank Dorr

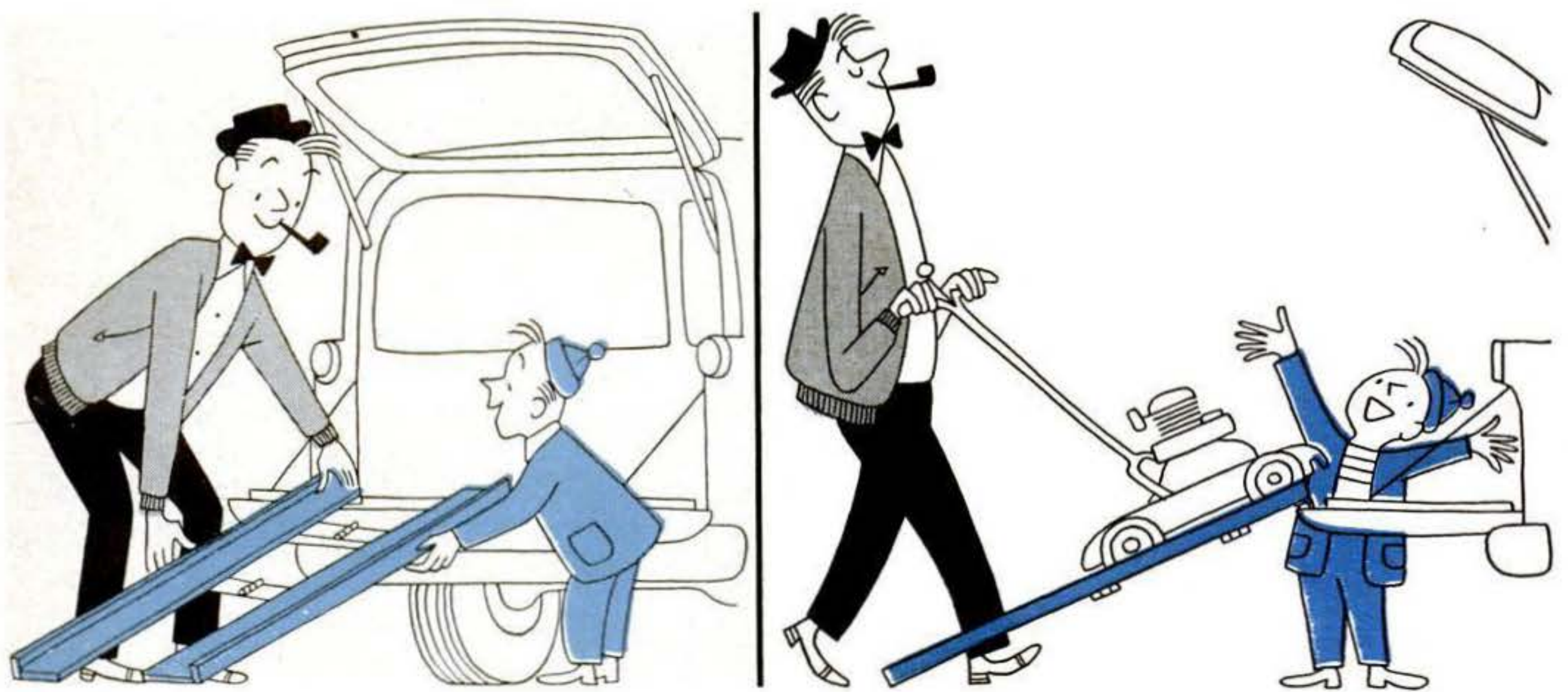
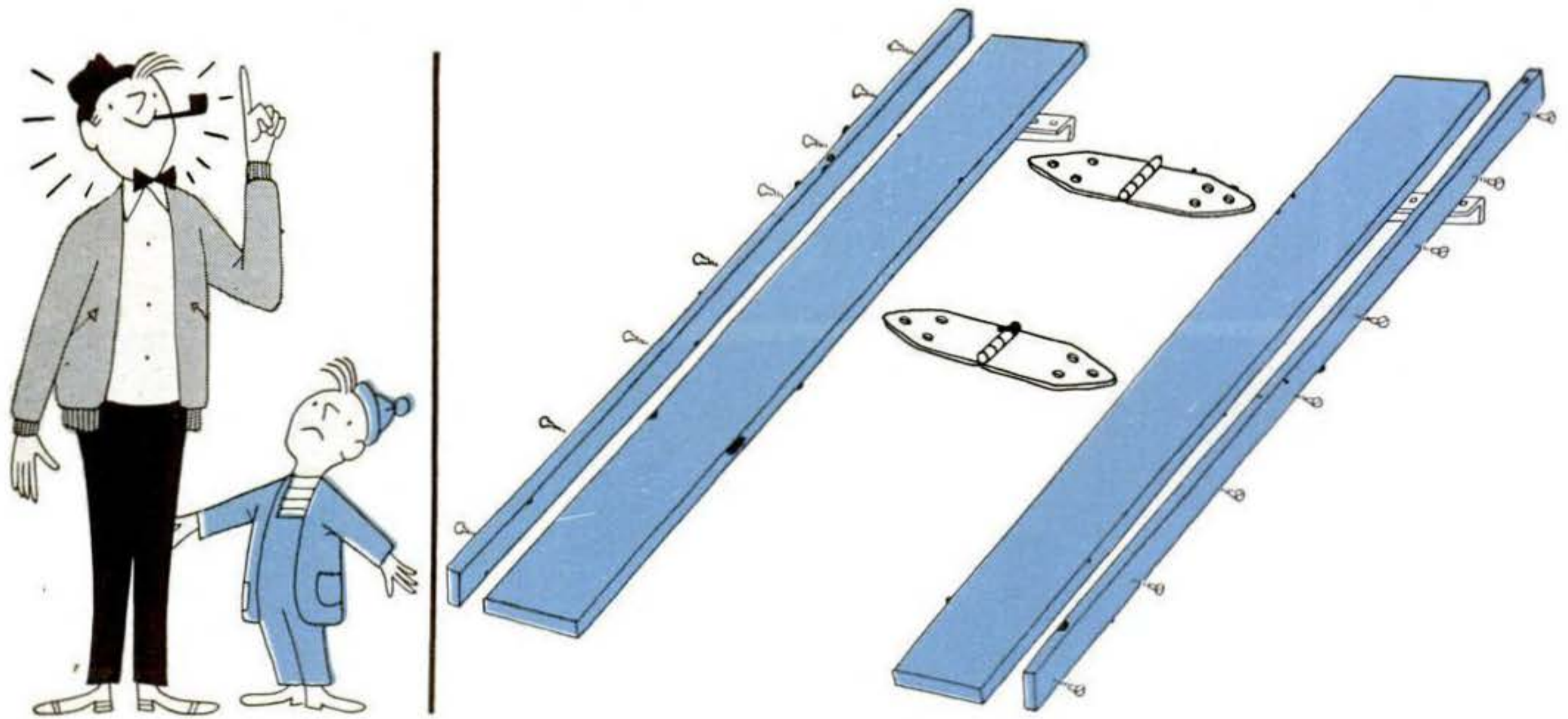
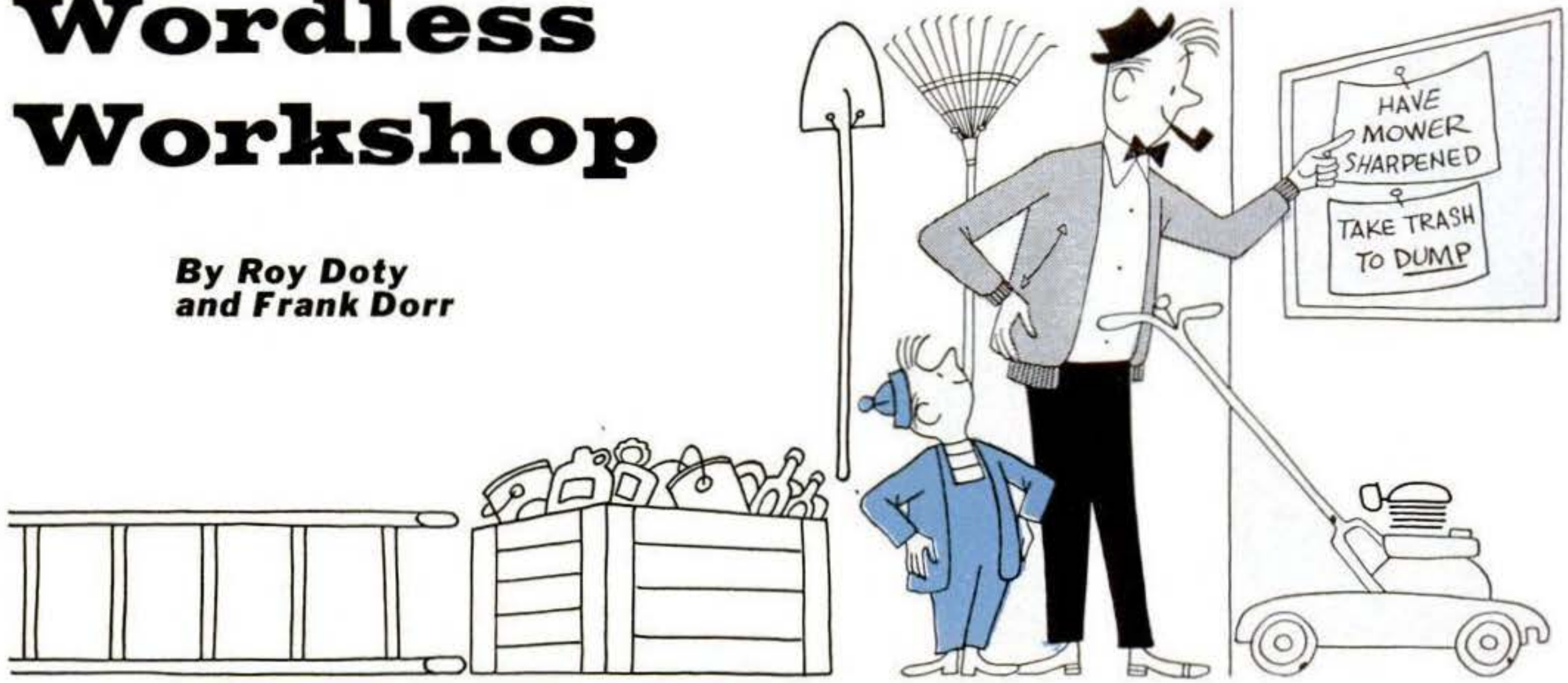

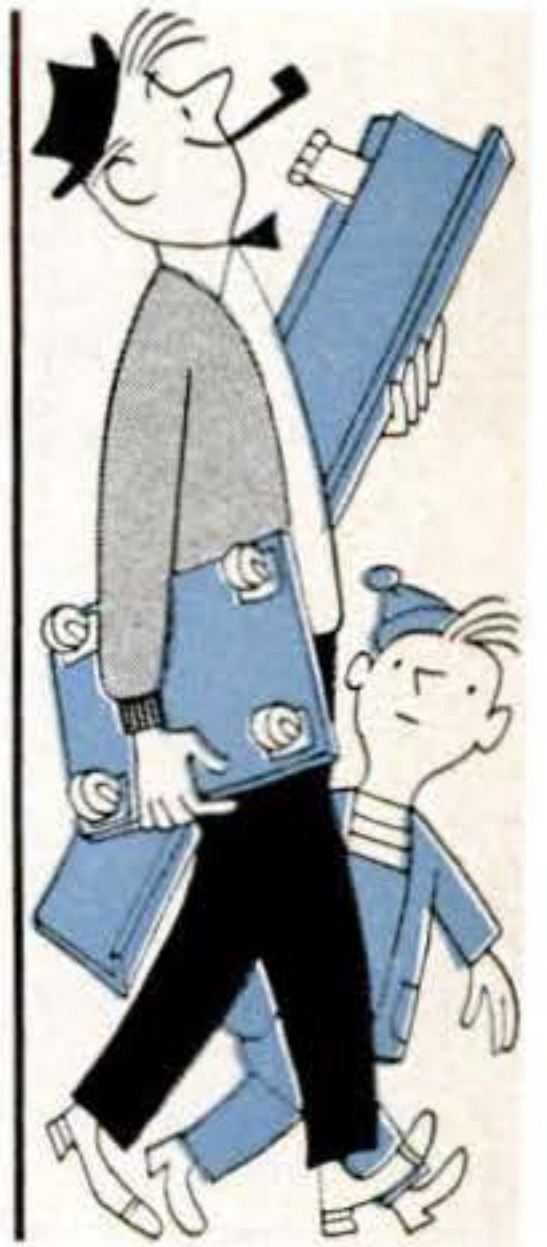
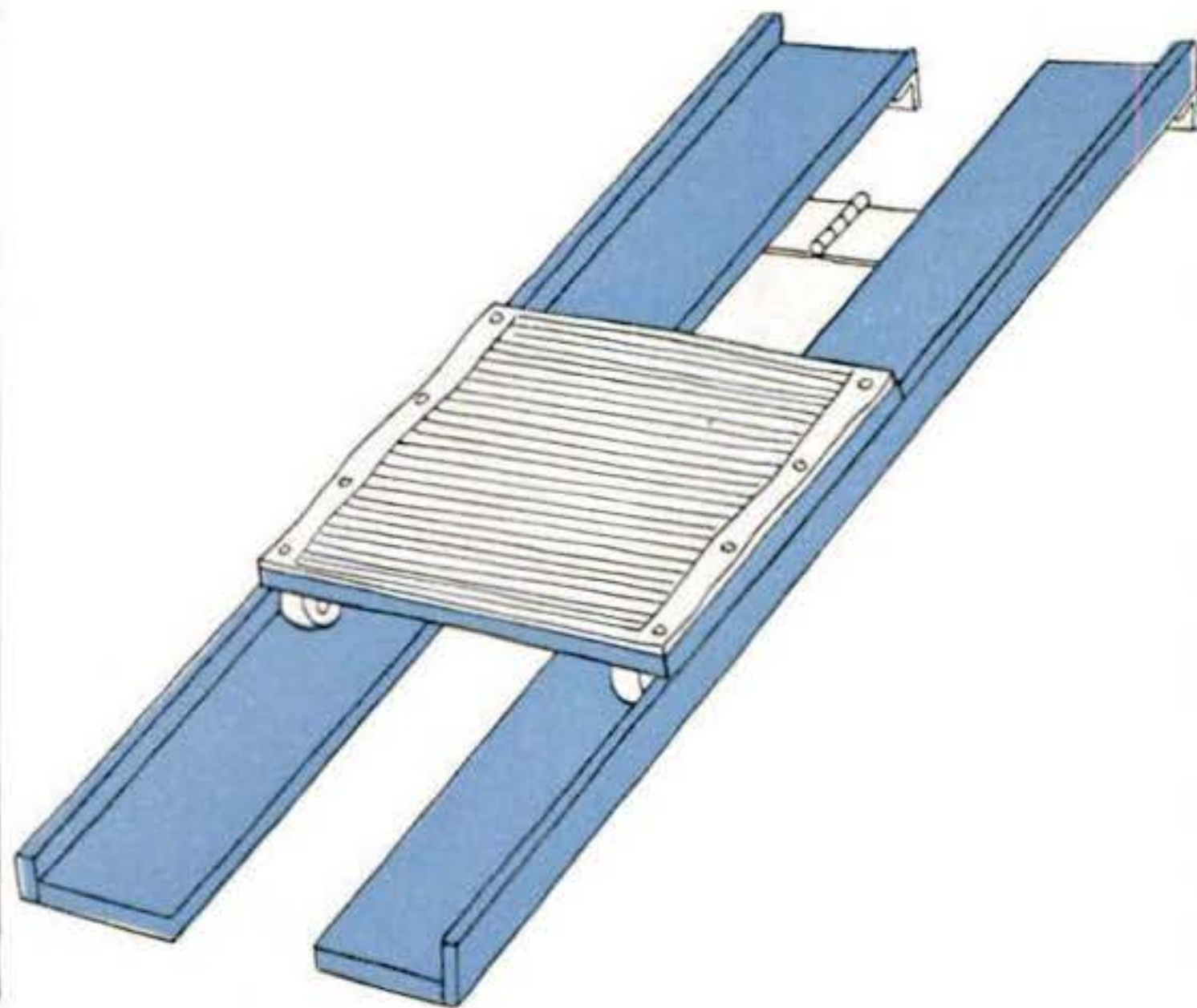
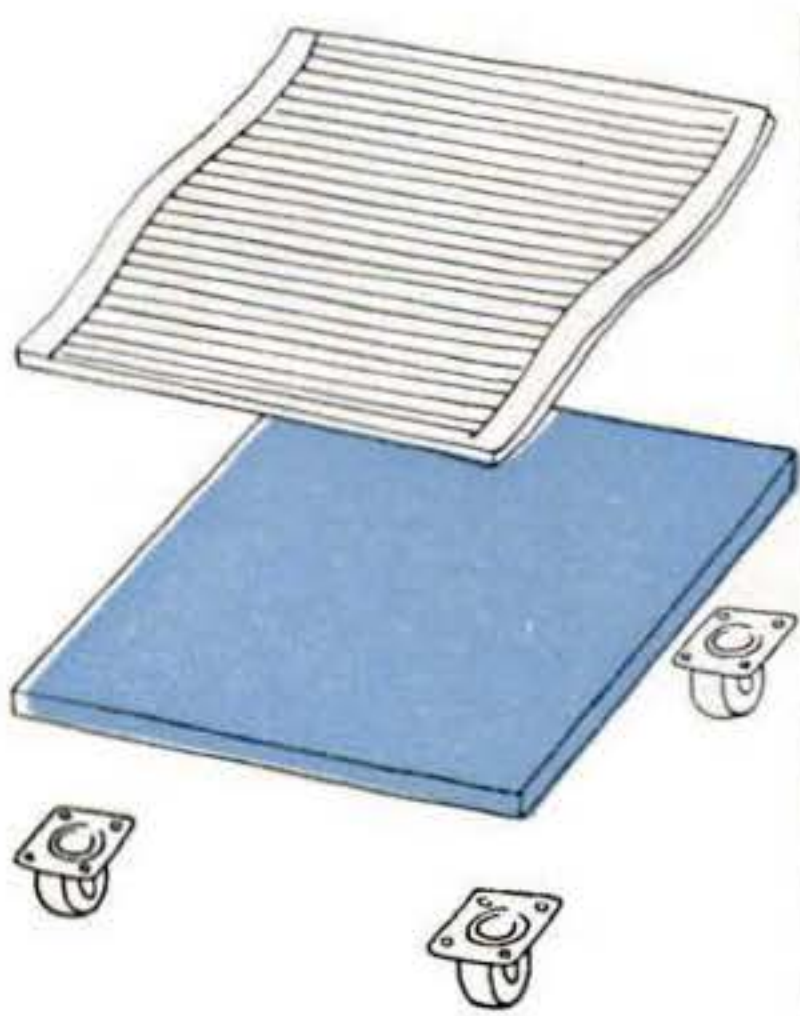

Next Month: A bicycle rack to park wayward two-wheelers

APRIL 1959 175

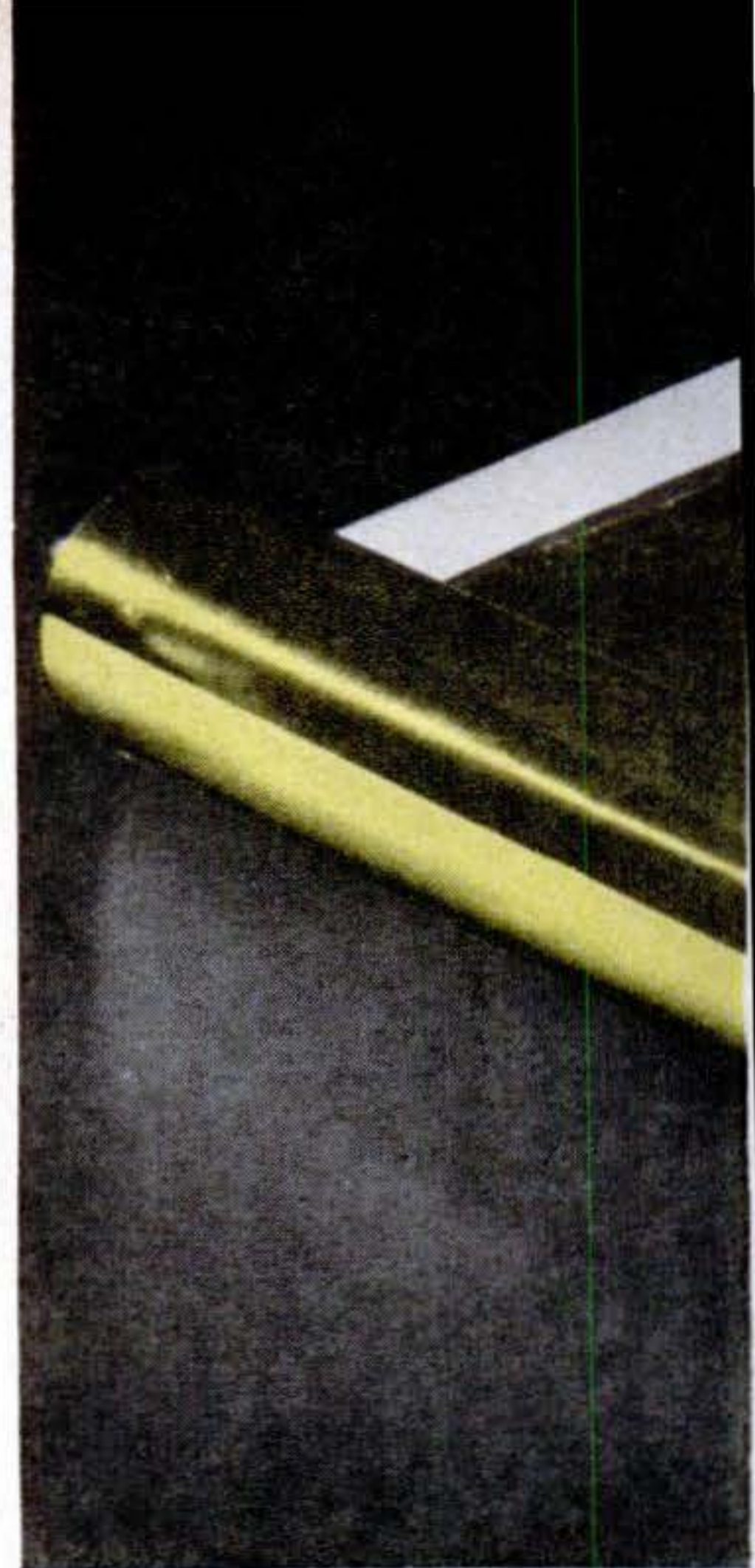
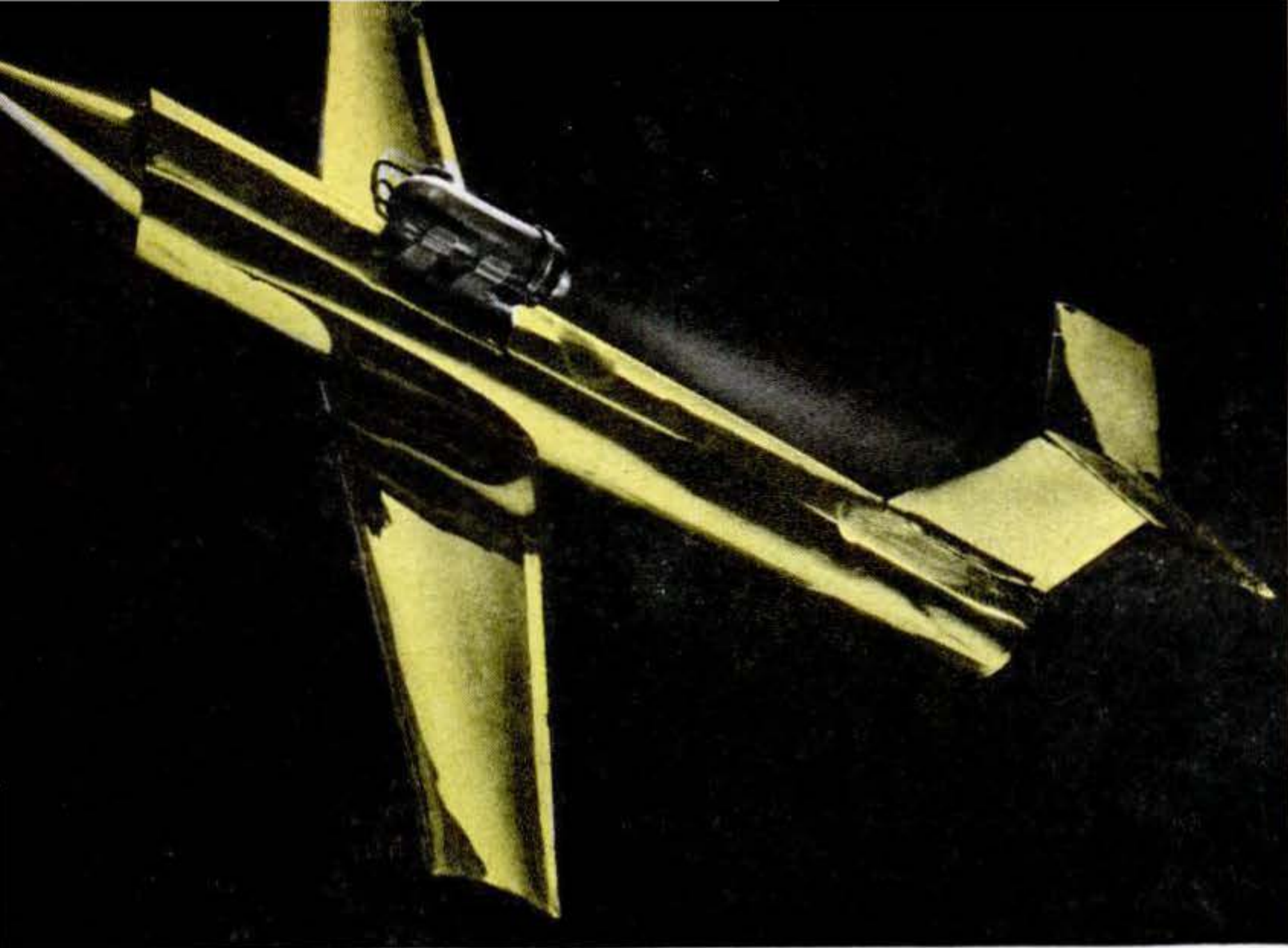

**There's a new craft material
that's just the thing for—**

Building a Metal Tether Jet

By Louis Boury

BRILLIANTLY colored sheet metal can be cut with scissors or a razor blade and assembled in an hour or so to make the fireproof model jet plane shown in simulated flight above.

The gleaming metal is about .003" thick—three times thicker than heavy-duty kitchen foil—and comes in practically all colors on one side only. The reverse side is always shiny aluminum. It can be cut and fabricated in the same way as ordinary construction paper, although it is more rigid. Contact cement or a vinyl glue such as "Elmer's" or "Sobo" can be used to join the foil. The prefinished surface requires no protection and can be washed with a damp cloth if soiled.

The colored foil is a craft material formerly used only by window dressers and display makers, but now you may find it at craft and hobby shops or de-

partment stores. You can get it by mail from Alufoil Products Co., Inc., 15 Ferry St., NYC 38. A 25"-wide sheet costs about \$1 a yard, or you can buy an economy roll 25" wide by 25' long for \$5.75.

To build the plane, tape a drawing of the parts to the reverse side of a sheet of foil and tack it to a smooth cutting board. Cut out all the parts, using a straight-edge and razor or modeler's knife.

Begin assembly with the fuselage. Cement the reinforcing strip across the front edge; then roll the foil to form the fuselage and cement it together along the bottom, allowing about $\frac{1}{8}$ " for overlap. Roll a dowel over the seam to make a secure bond. Assemble the tail section over thin ($\frac{1}{32}$ ") balsa reinforcement and glue it in place on the rail.

Fold the two wing sections over thin balsa and cement two 15-foot lead-out threads to the left-wing balsa. Then apply glue along the inside of the trailing edges and join. Don't press the wing

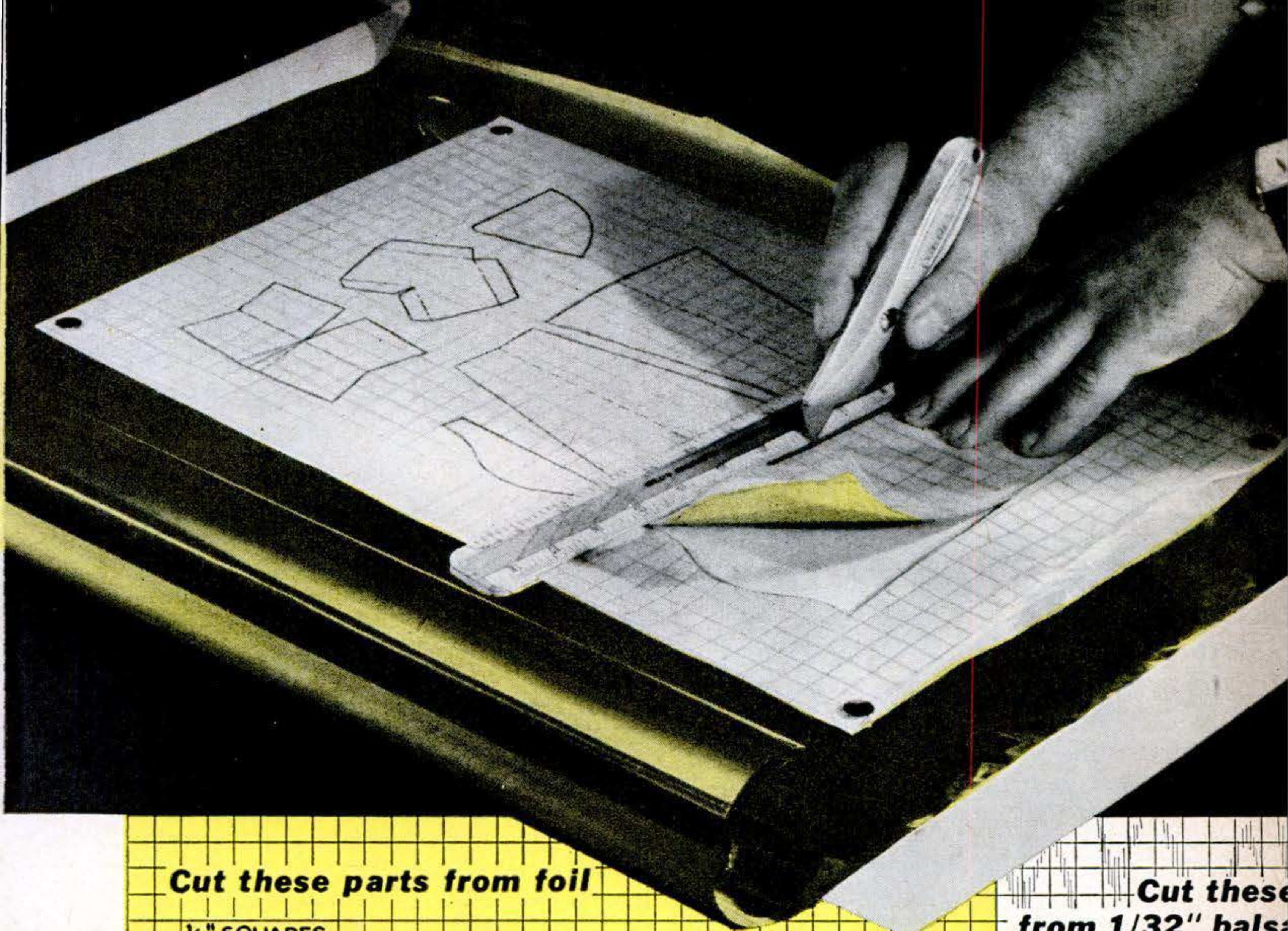

Cut these parts from foil

$\frac{1}{2}$ " SQUARES

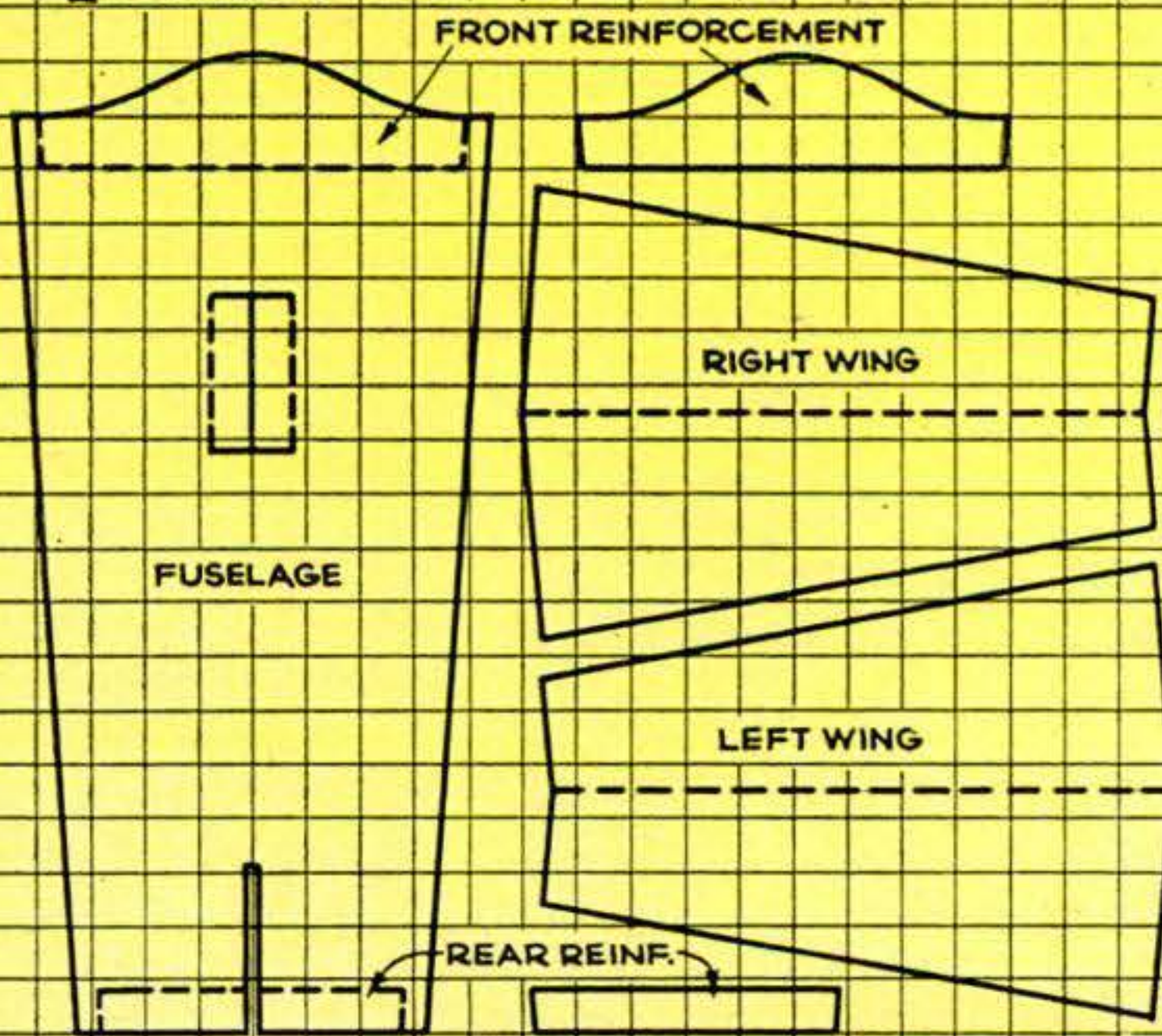

Cut these from $\frac{1}{32}$ " balsa

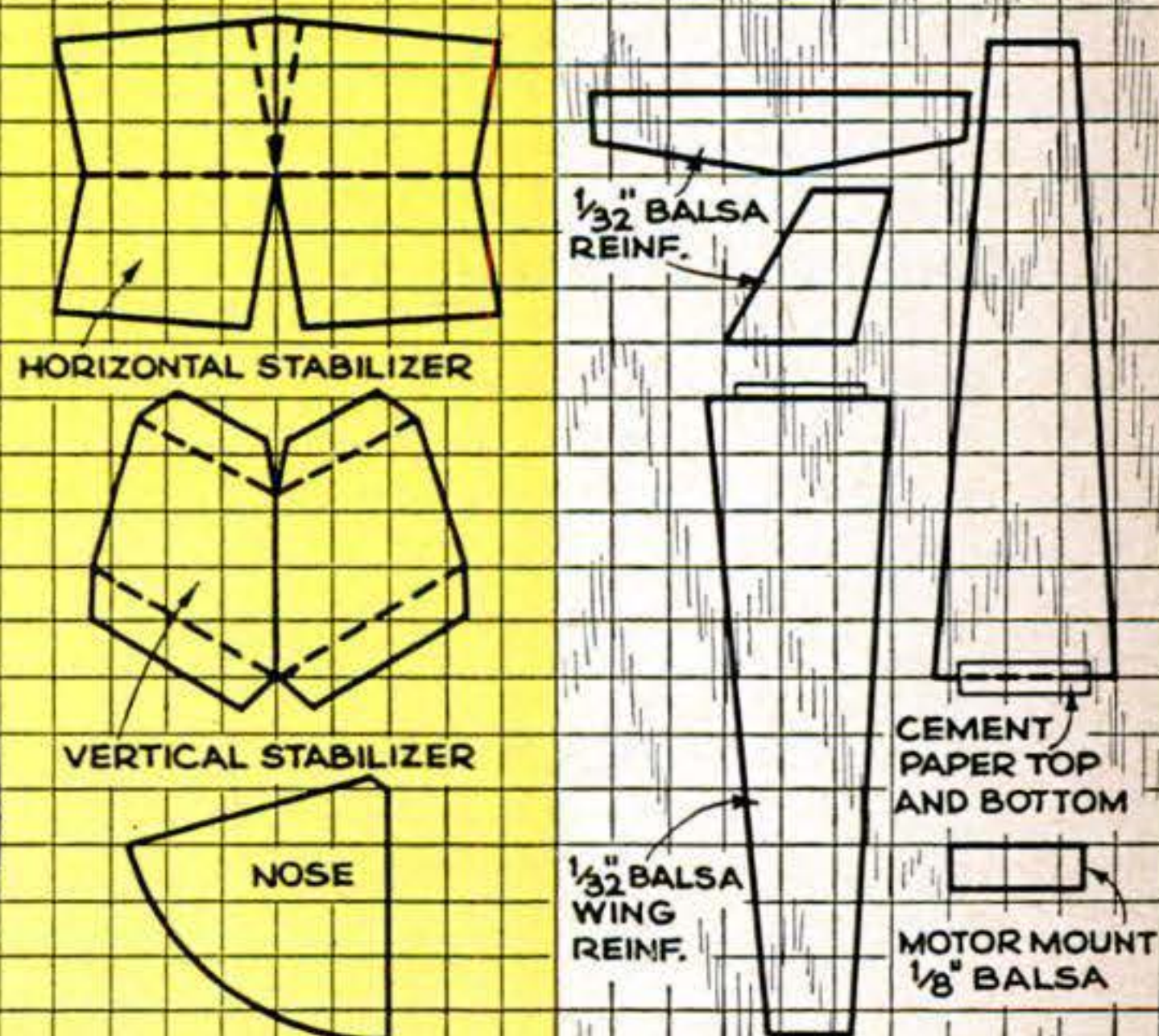

Draw these patterns on a sheet of paper ruled with $\frac{1}{2}$ " squares to make full-size cutouts.

material flat; the inherent springiness of the foil will create an airfoil shape along the surfaces. Glue the wings to the underside of the fuselage.

Form and cement the nose over a cone-shaped piece of balsa and glue it in

place in the forward fuselage opening.

A small set of wheels mounted on a plastic or tin frame makes the model complete. Glue them to the bottom of the wing near the leading edge.

Jet power for the plane is supplied by

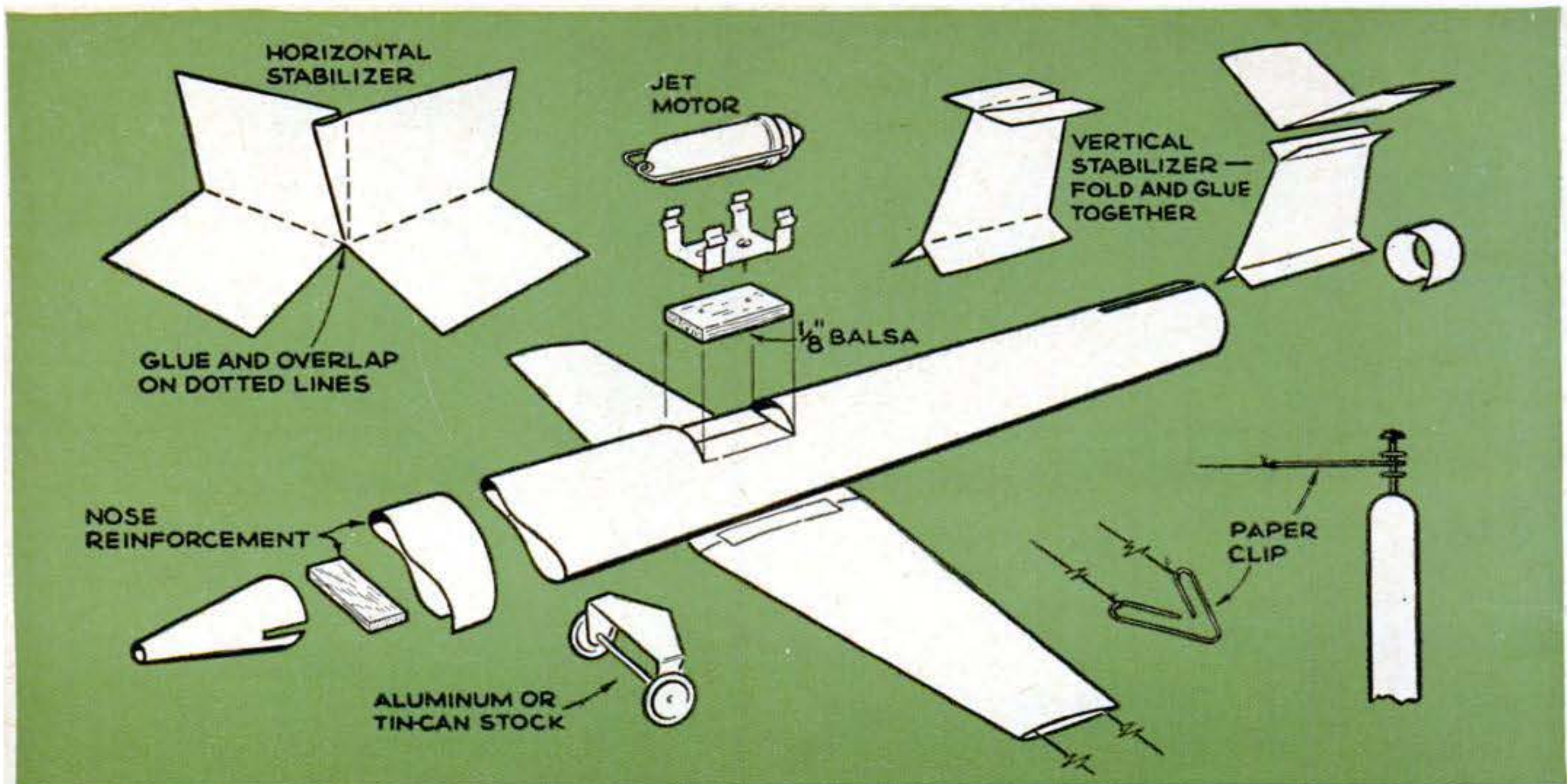

NO DIMENSIONS ARE NEEDED to assemble the parts. Simply cement them in their relative

positions as shown. The plane's balance can be adjusted by shifting the motor fore or aft.

a miniature reaction motor called Jetex. These tiny motors use pellets of dry fuel that generate gas under pressure when ignited by a threadlike fuse.

Jetex motors come in several sizes. The number 50B shown on the model supplies ample power for brisk flight. They're available at many hobby shops or direct from American Telasco Ltd., Huntington, N. Y.

Screw the motor clip to a small piece of $\frac{1}{8}$ " balsa, and glue the balsa in place over the flaps that form the "cockpit."

Before flying the plane under power, insert the loaded motor in the clip and

swing the plane around you while watching its attitude. If it seems nose heavy, slide the motor back a bit; if tail heavy, move it forward. Once the model is trimmed, attach the threads to a pylon. This can be a stake driven into the ground, or a 12" dowel nailed to a pie tin weighted with plaster or cement. A swivel can be bent from a paper clip.

Set the plane down at the end of the threads, ignite the fuse, and watch for a blur racing around the pylon. No control is needed as the airstream flowing through the tubular fuselage keeps the balanced plane flying level.

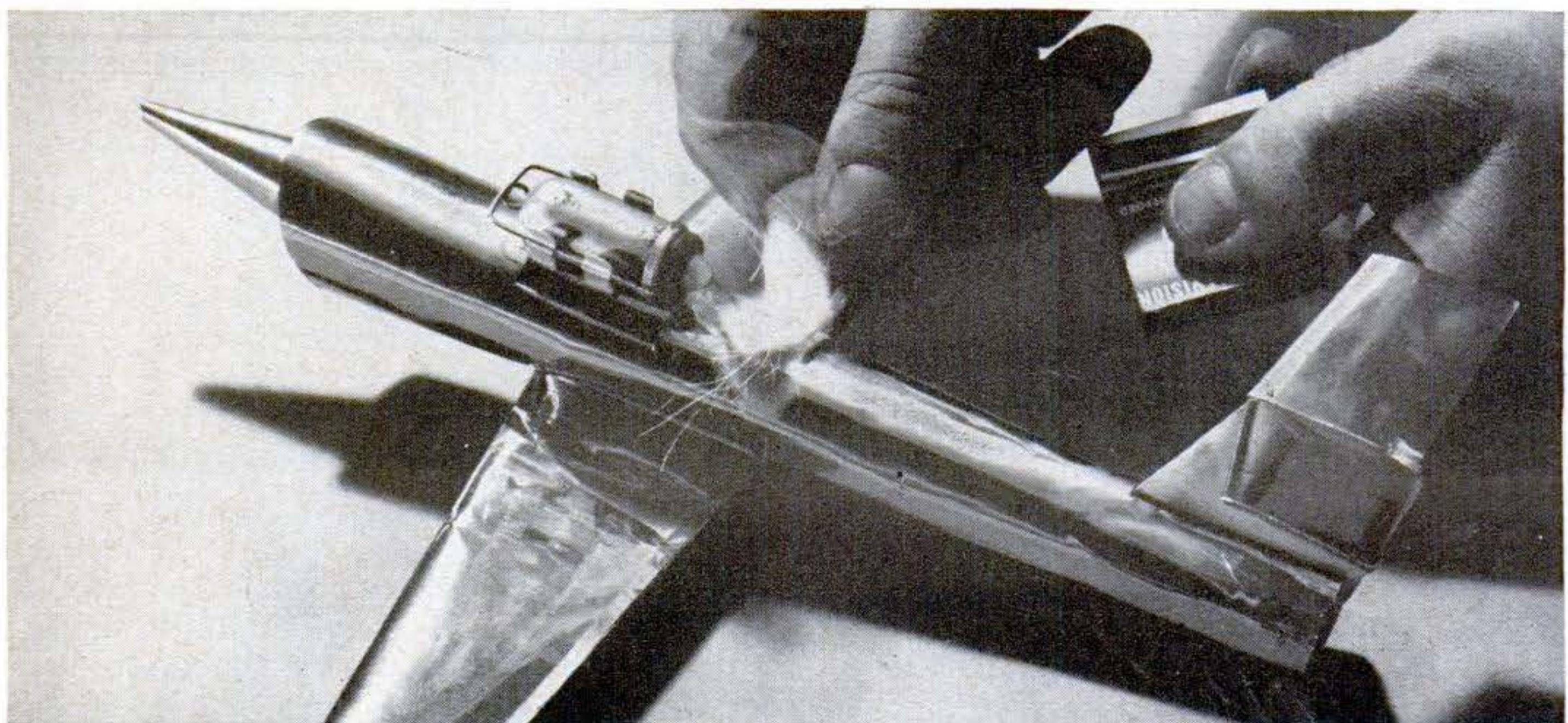

WHEN THE FUSE IS LIT, the tiny reaction motor thrusts the plane ahead to take off and fly in

rapid circles at the end of 10 or 15 feet of fishing line attached to a stake or dowel. **END**

Short Cuts and Tips

FROM PS READERS

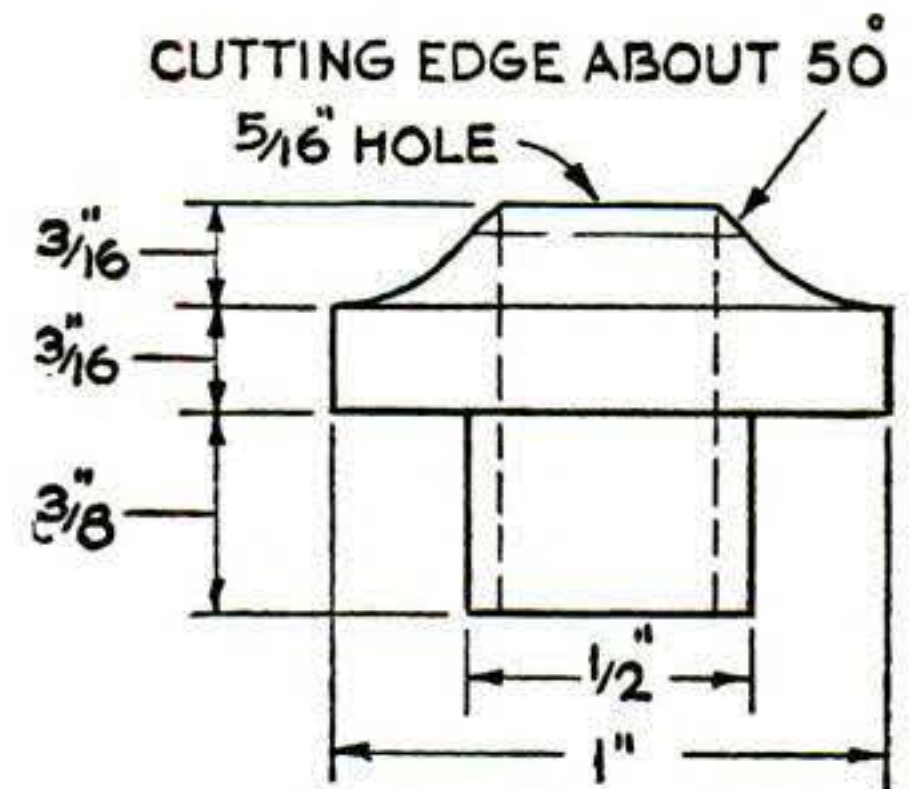
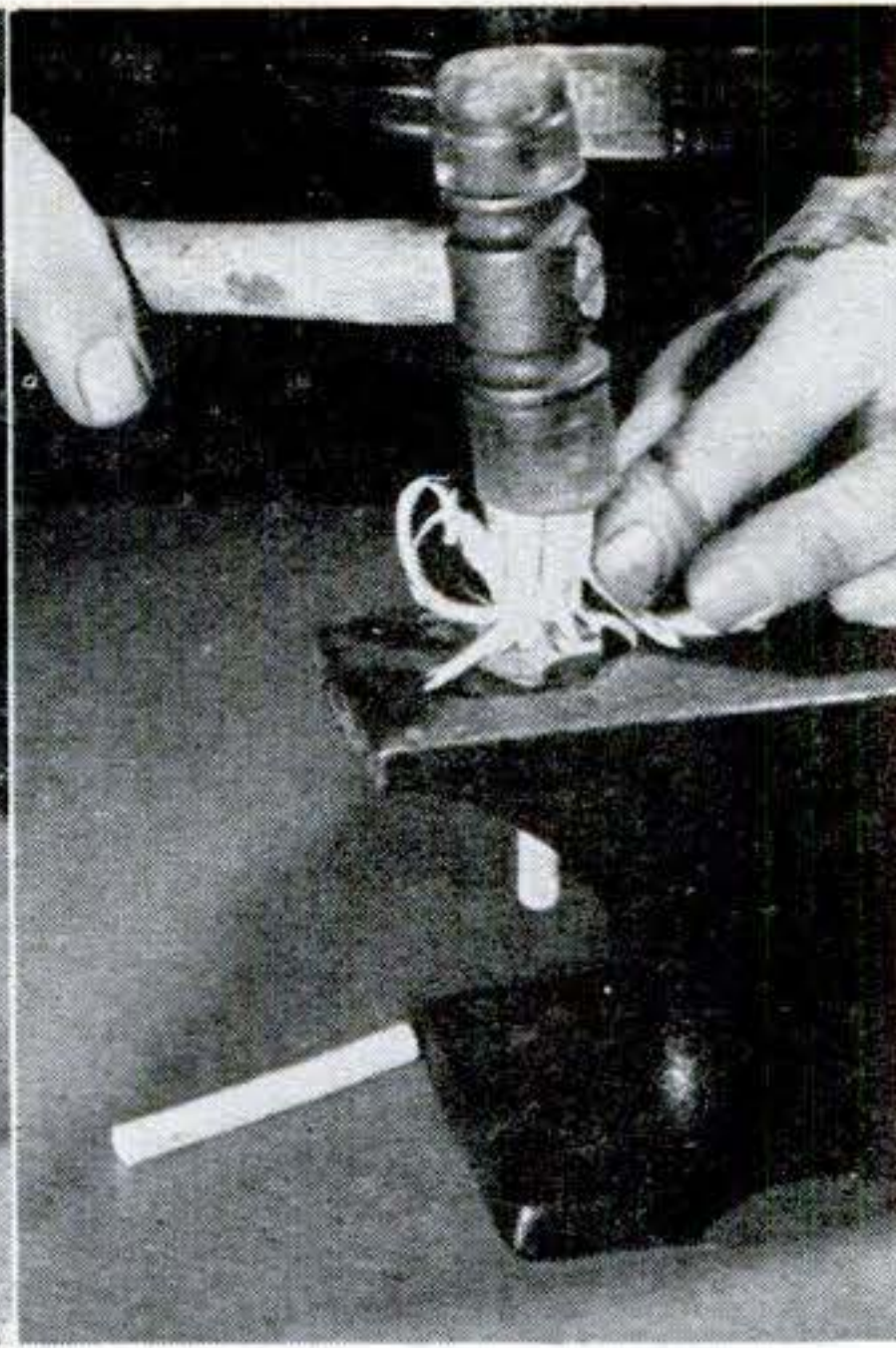
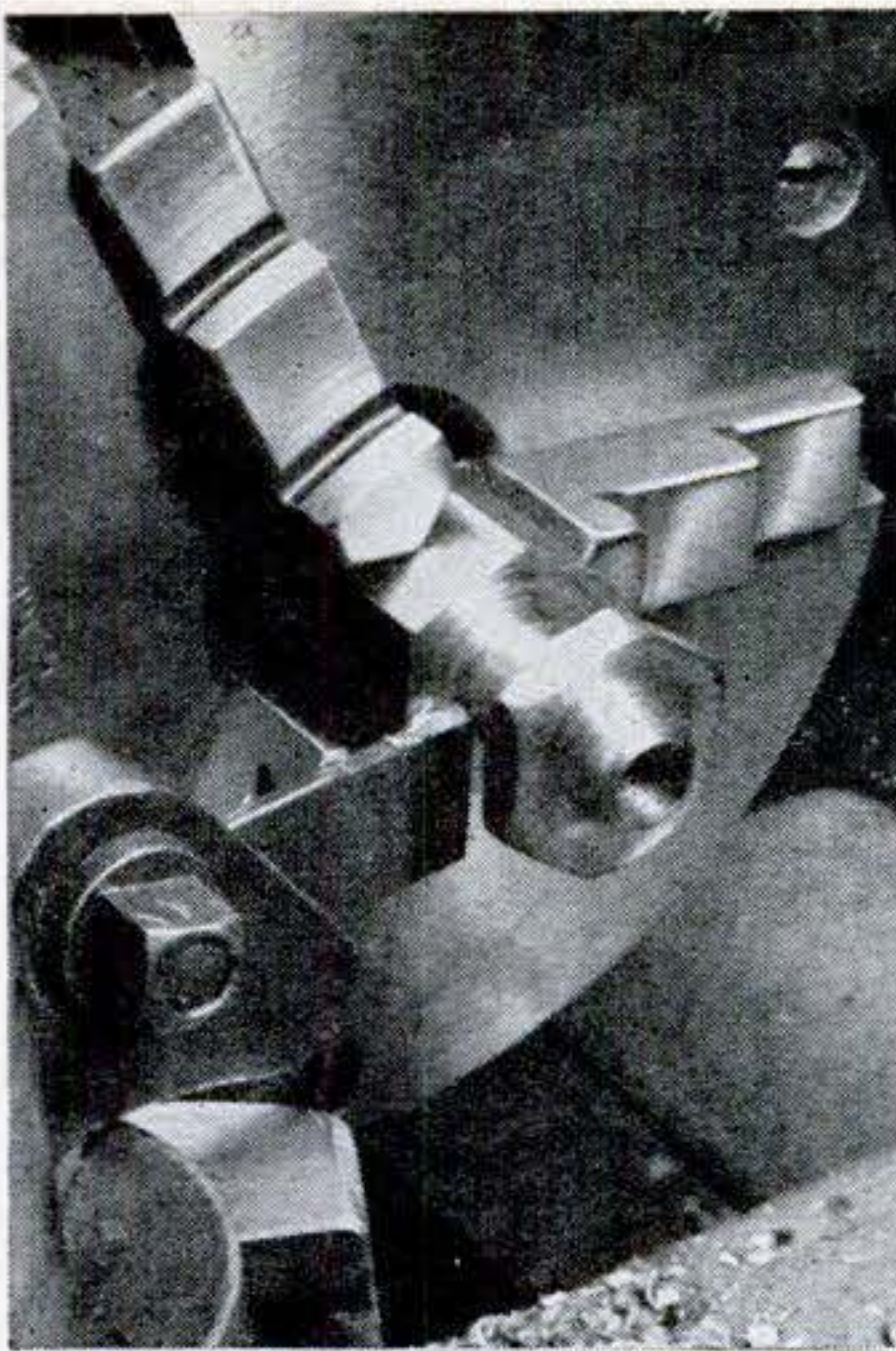

Dies for Cutting Your Own Dowels

You can cut wooden dowels as needed with simple dies machined from steel. Three or four will cover the sizes usually required in the average home shop.

Cut each die into a sort of button with a shank that will fit through a hole in a bench anvil or other sturdy support. The dowel is formed by driving a strip of wood through a cutting end shaped to curl the waste outward. Then force the end through with a punch or a length of smaller dowel or brass or aluminum rod.

The die can be machined from drill rod, hexagonal or round cold-rolled steel, or a large bolt. Then harden and temper the piece or treat it with case-hardening compound. You will find useful dowel sizes are $\frac{1}{8}$ ", $\frac{1}{4}$ ", $\frac{5}{16}$ " and $\frac{3}{8}$ ".—*Walter E. Burton, Akron, Ohio.*

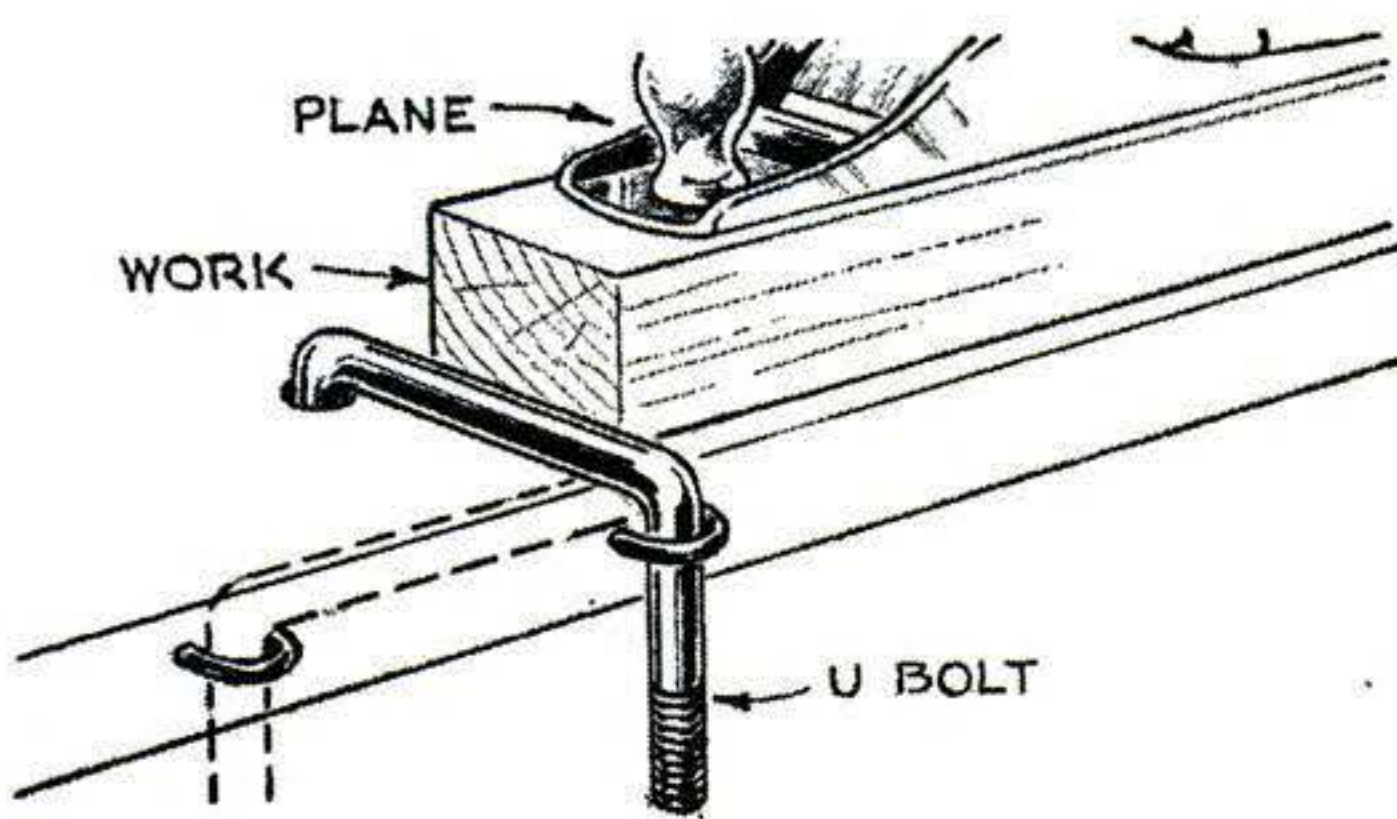

U-Bolt Bench Stop

A BENCH stop that will always be available when you need it, but can be swung out of the way when not in use, can be made from a large U bolt.

Drive two staples large enough to accommodate the bolt legs into one edge of the bench for supports, then bore a hole in the top to take one of the legs when the bolt is swung into position as a stop.—*M. Robert Beasley, Jackson, Mich.*

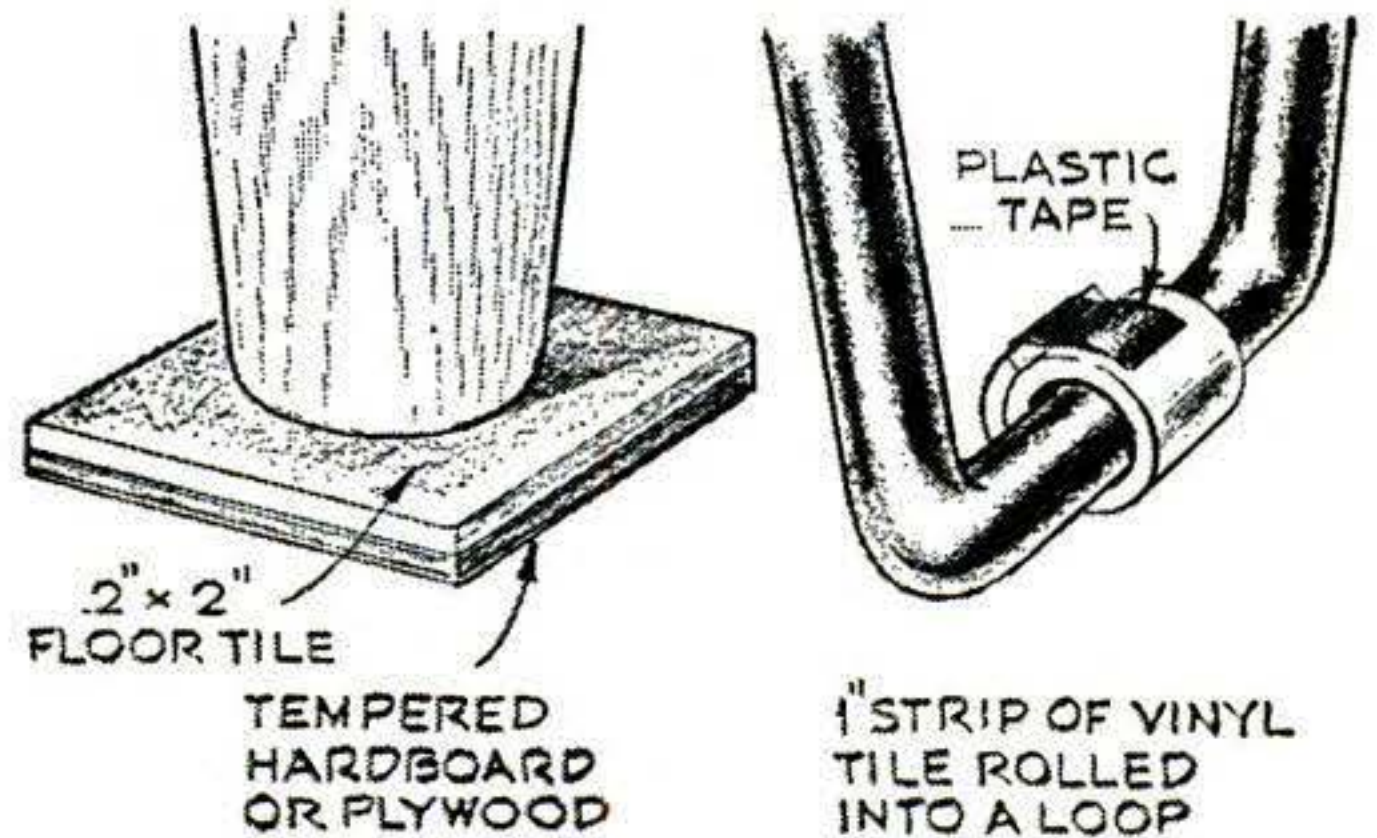

Keeping Dents Out of Floors

FURNITURE legs, either wooden or the wrought-iron kind, will dent any resilient floor in time. "Invisible" coasters for most legs can be made by backing a 2"-by-2" piece of spare tile with a square of hardboard. Hold with mastic.

Curved wrought-iron legs can be cushioned with a ring of bent tile held in shape by plastic tape matching in color.—*Preston Stedman, Kingsville, Tex.*



CANDLES SUPPLIED THE ONLY LIGHT for this hand-held shot at 1/30 sec., f/5.6. The fast shutter speed kept candle flames small; medium lens opening put both cake and faces in focus.

HOW FAST IS THE HIGH-SPEED FILM? Judge for yourself. The properly exposed negative is Royal-X Pan; thin one is Verichrome Pan. They were made indoors in New York's cavernous Coliseum. Both were exposed for 1/30 sec. at f/5.6, got the same development.

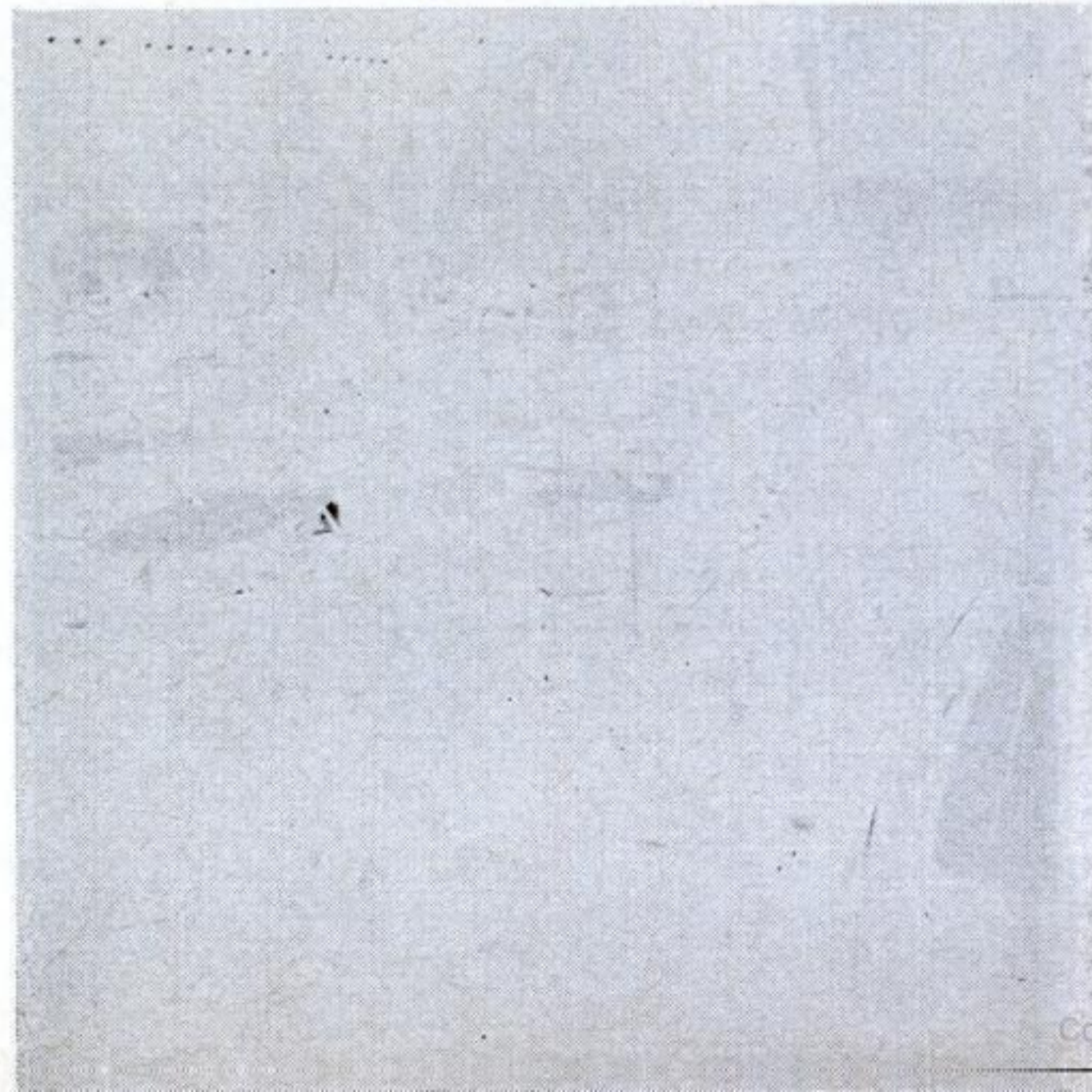
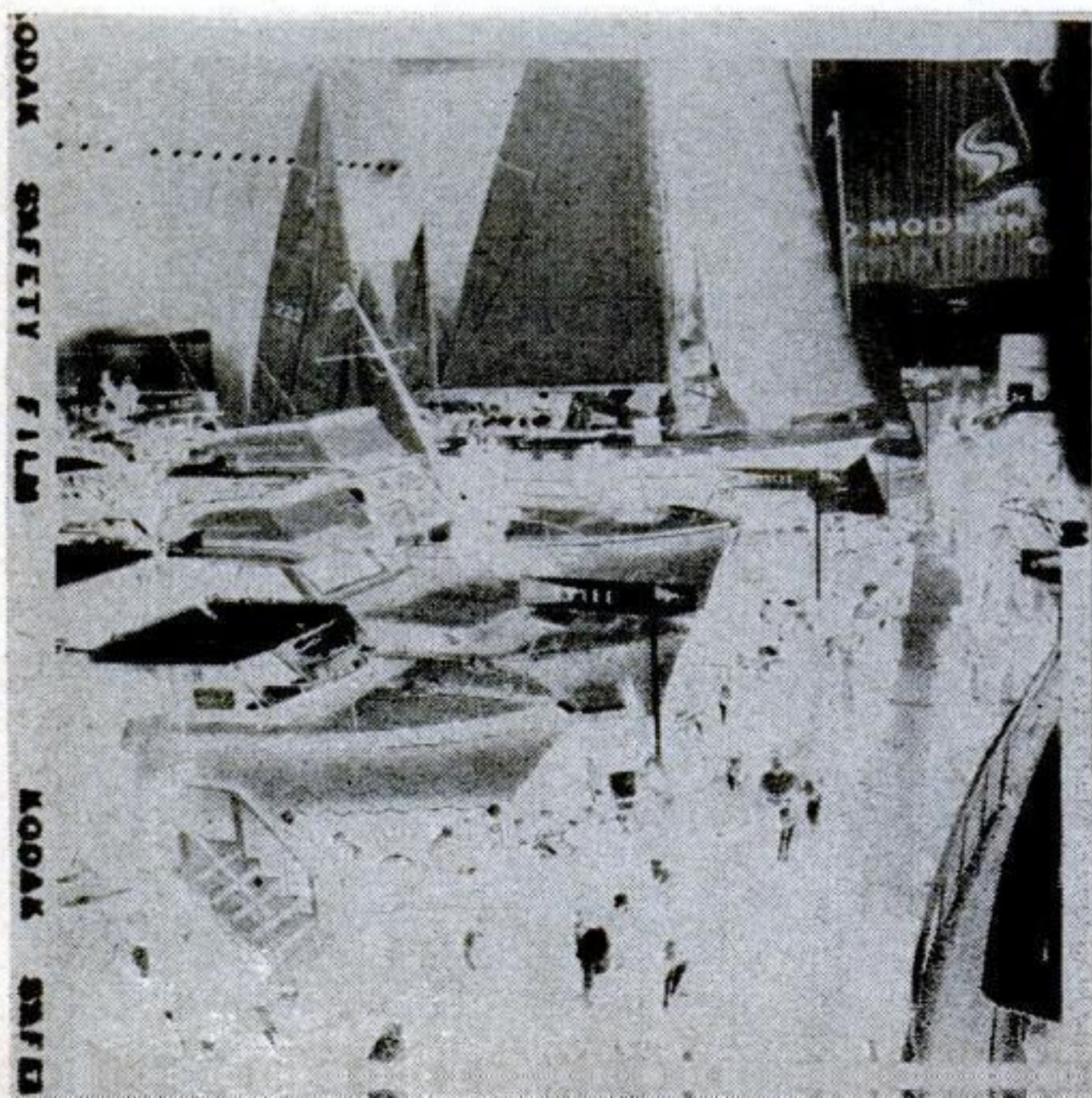

A New Look at the Fast Photo Films

Can dubs as well as pros use those new shoot-in-the-dark films? Sure. Try them and see

**By Erik H. Arctander
with photos by W. W. Morris**

MY NEIGHBOR'S photograph album tells the story of fast films. When you leaf back in it a few years, the indoor shots look as though a spotlight had pinned some ashen-faced people to a dark blanket. But the most recent prints are wonderfully natural. There's a close-up of his son raiding the refrigerator—taken by the light from inside it. Another caught his wife shaping cookie dough on the kitchen counter. There are dozens more, all shot by room light. The soft, even illumination gives them greater warmth than flash photos.

It's the amazing speed of the newer films that makes such photos possible. No tripod, expensive lens or exotic developer is necessary. The new emulsions record virtually anything your eyes see.

By following the tips given here, you can duplicate any photo on these pages, even with an inexpensive camera. Dim-light photography offers exciting possibilities for off-guard family pictures and off-beat experiments that were once impossible. Now your camera will make good photos:

In shadow. The soft, even daylight in the shade of a tree or building is very flattering for portraits. No need to pass up action pictures there, either.

On rainy days. Ordinary scenes take on a different look when glistening rain falls. You can catch action with a fast shutter or increase depth of focus.

At dusk. Go right on shooting the closing minutes of sports scenes, or backyard antics after the sun sets.

At night. Street, car and house lights focus attention dramatically on your subject—without flash. The darkness is like a backdrop that cuts out extraneous background details.

Indoors. Ordinary artificial light is all you need to take crisp action photos or off-guard portraits. A home, arena, theater, restaurant, auditorium, subway, etc., provides the setting.

Haven't photographs like this been made for years? Not really. Many pros forced the earlier films way beyond their designed sensitivity with special developing brews. They got startling "available light" pictures, but the clumps of grain on blowups looked like colonies of bacteria under a microscope.

The newest crop of fast films—ranging in speed from A.S.A. 200 to A.S.A. 650—is less than two years old. (Isopan Record, newest of *these*, came on the market just this month.) These eight

A DIM PHONE-BOOTH LIGHT was the sole illumination for this shot at 1/30 sec., f/5.6. The compact mirror in the girl's left hand reflects overhead light onto her face.

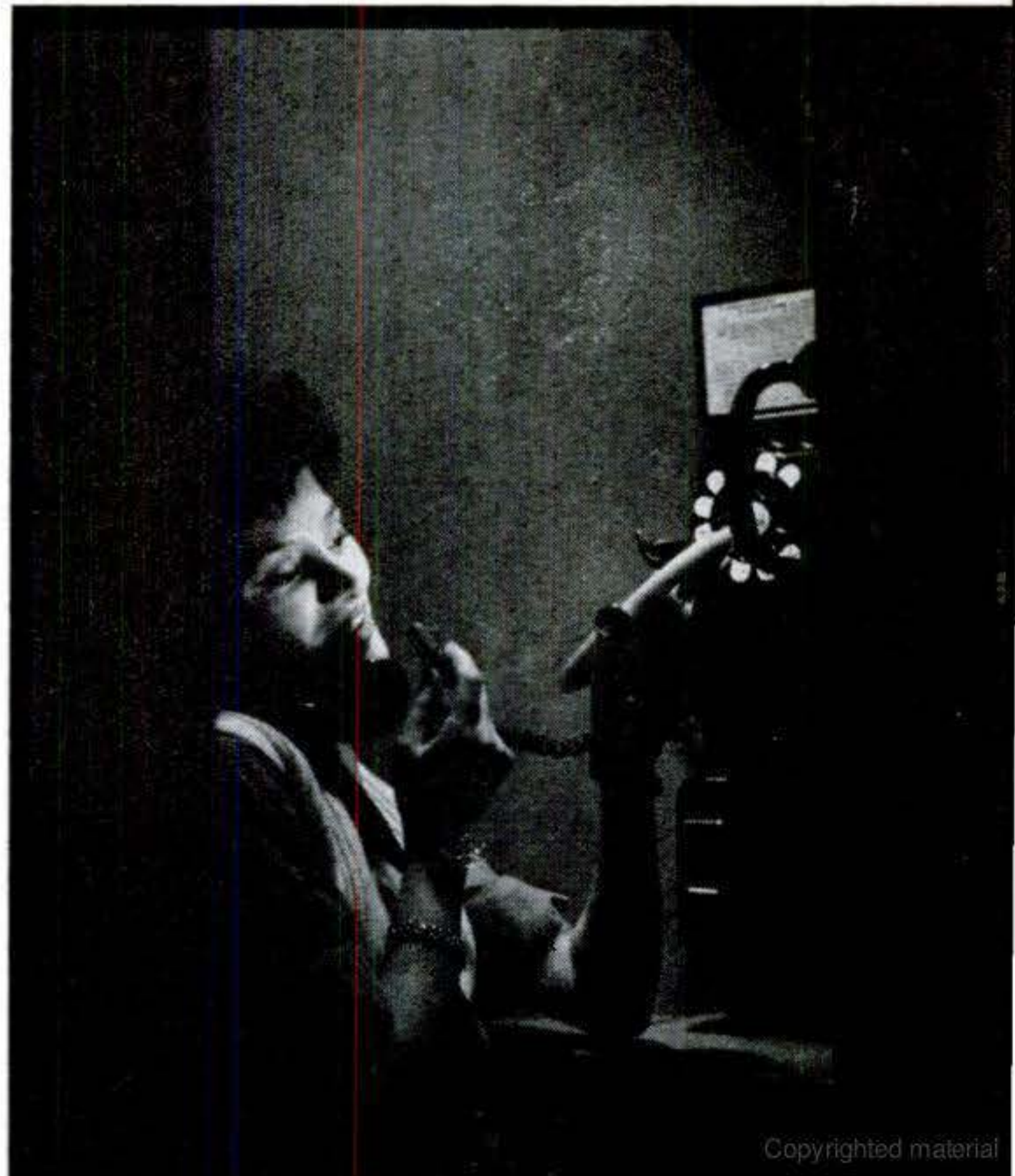



BRIGHT STORE WINDOW threw so much light that exposure was made at 1/60 sec., f/8. Stopping down put both the foreground and background in focus.



TWENTY FEET AWAY from the same store window, the light shining from it was still bright enough to snap a street scene at 1/30 sec. and f/8 opening.

black-and-white films offer speed plus good grain, even when commercially developed, if you expose at the rated index.

With a modest developing outfit you can try much higher film speeds. It's perfectly safe to at least double the exposure index. Because of a built-in 2-2½ safety factor, such forcing has only a small effect on the grain pattern. Pros often push the speed ratings as high as five times normal and overdevelop.

Forcing the one fast color film (Super Anscochrome) is a job for experts that you probably won't want to tackle. But the normal exposure index of 100 is plenty fast for most color shots.

Here are some tips to follow when you load the fast black and white.

Match film speed to light. The faster an emulsion, the more grain it shows. So don't use the very fastest film unless you really need the extra speed.

For fast indoor photos you might consider Agfa Isopan Ultra and Perutz Peromnia 25, which have been deliberately made more sensitive to artificial (tungsten) light than to daylight.

Watch the expiration date. The faster a film, the shorter its shelf life. Fast color is even more critical. It keeps best when stored below 55 degrees F. Buy only what you plan to use immediately.

Develop right away. A latent image fades faster on super-speed film. As one manufacturer put it: "You can't take a

picture of your wedding and the first child's christening on the same roll and expect both to come out well."

Read the instruction sheet. Unless you use a good exposure meter it's very easy to overexpose fast film. Average exposure suggestions are packed with each roll of film. Kodak goes so far as to warn box-camera users away from its superfast Royal-X Pan (despite the A.S.A. rating of 650, Kodak recommends an e.i. of 1,600, using a light meter).

Still, a camera with fixed speed and lens opening can handle most high-speed films if the owner has enough patience. The trick is to snap the picture where, according to the instruction sheet, the light available will give a correct exposure at 1/50 sec., f/11. That's the most common box-camera setting.

Expose consistently. Every frame on a roll will get the same development, so you can't switch exposure indexes in mid-roll. If you double the e.i., it must stay doubled all the way through. Sticking a piece of tape with the e.i. on it on your camera is a good reminder.

The pros make sure of getting something usable by bracketing the most likely opening with a stop lower and a stop higher. One of the three negatives that result is usually about right.

It costs less than a dollar to experience once more that original thrill of taking pictures. Have fun.



THE TOUGHEST PICTURE to take was this car interior. Several hand-held shots were made by domelight at 1/15 sec., f/3.5.



STOPPING ACTION IN POOR LIGHT is a natural for fast film. The subdued general lighting in the bowling alley was enough to freeze motion at 1/125 sec. Opening was f/5.6. **END**

Snapshotter's Guide to the Fast Films

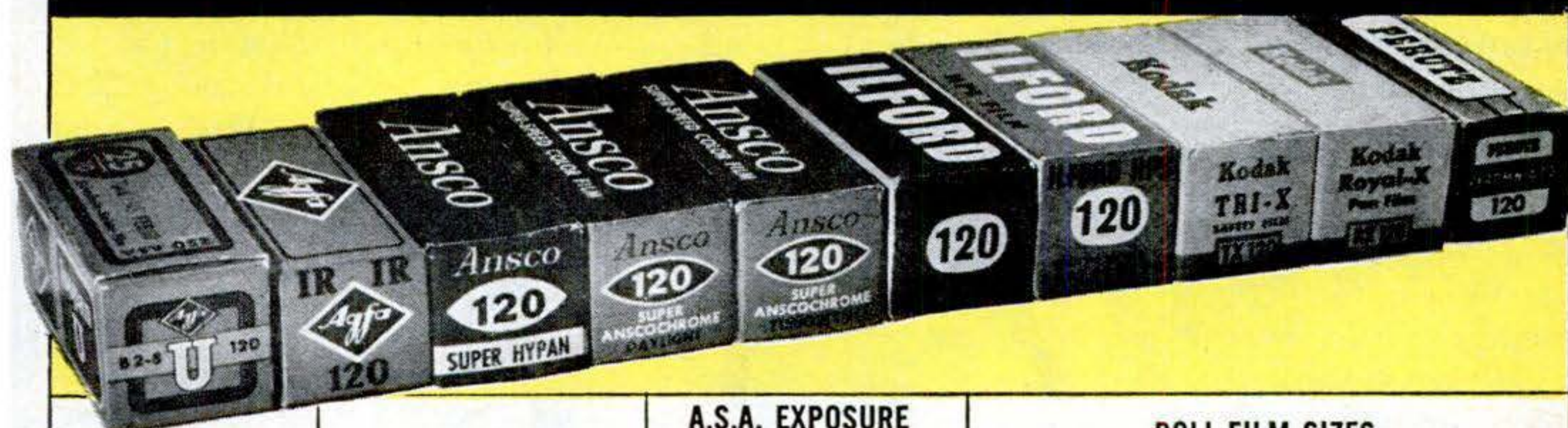

MAKER	FILM	A.S.A. EXPOSURE INDEXES		ROLL-FILM SIZES				
		Daylight	Tungsten	120	620	127	35 mm.	828
AGFA	Isopan Ultra	250	400	✓	✓	✓	✓	
	*Isopan Record	640	Not given	✓			✓	
ANSCO	*Super Hypan	500	400	✓	✓		✓	
	Super Anscochrome Daylight	100	—	✓			✓	
	Tungsten	—	100	✓			✓	✓
ILFORD	HP3	200	160	✓	✓	✓	✓	
	*HPS	400	320	✓	✓	✓	✓	
KODAK	Tri-X	200	160	✓	✓	✓	✓	✓
	*Royal-X Pan	650	Not given	✓	✓			
PERUTZ	Peromnia 25	250	320	✓	✓	✓	✓	

*Use only in adjustable camera

Short Cuts and Tips

FROM PS READERS

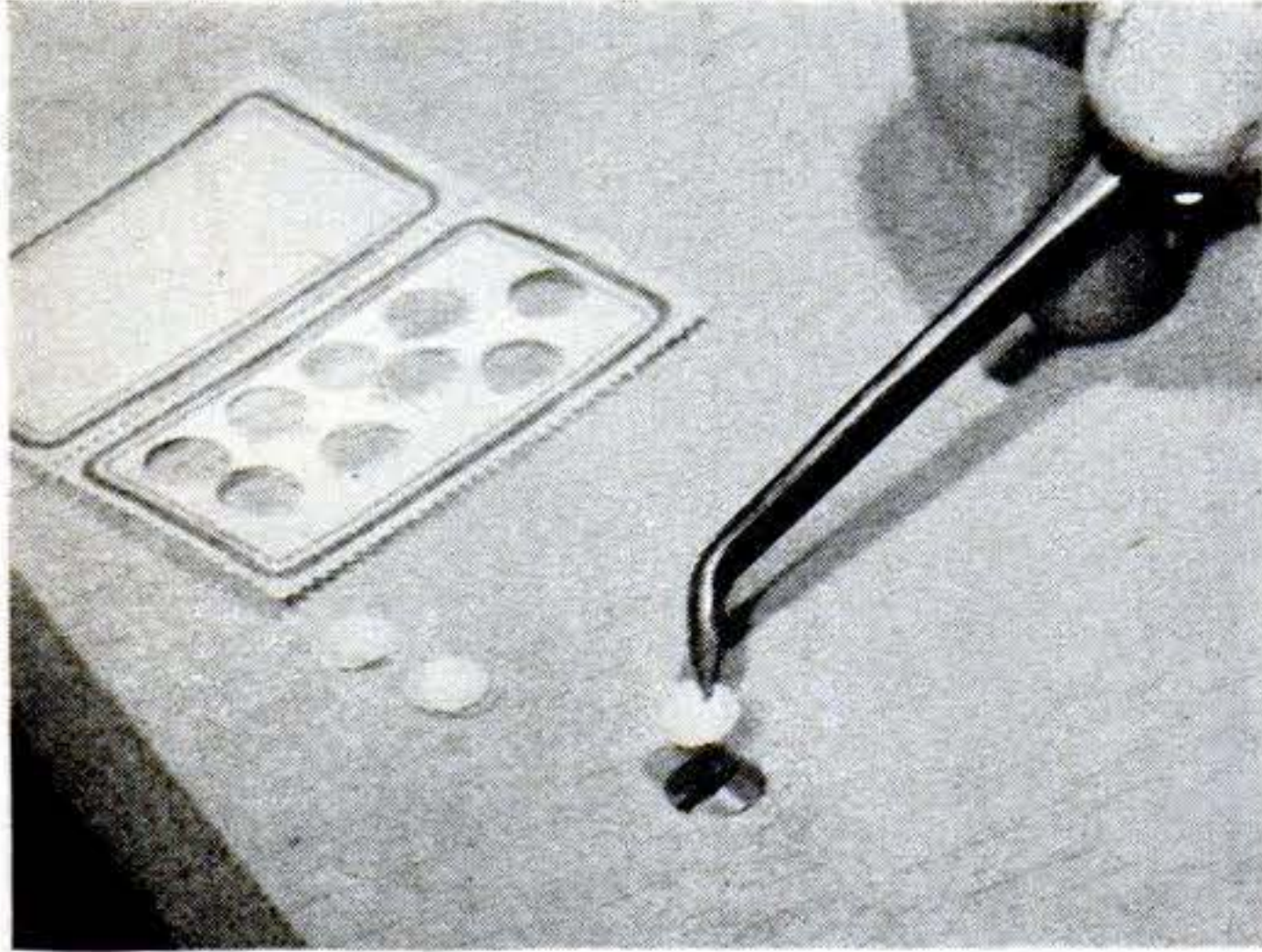

Painting Screwheads

WHEN you paint over countersunk flat-head wood screws that are likely to be removed later, it is best to keep the paint from filling the screwdriver slots.

One way to accomplish this is to cover the screwheads with disks of gummed paper before painting. You can cut them with a drive punch. The screwdriver will easily break through when a screw is to be removed.—*William E. Buchner, Toledo.*



Safety Igniter for Oven Burner

I FIND soda straws handy for lighting a kitchen-range oven. The waxed paper burns readily and is long enough to reach the burner without endangering my hand.—*Blanche Campbell, Rivera, Cal.*

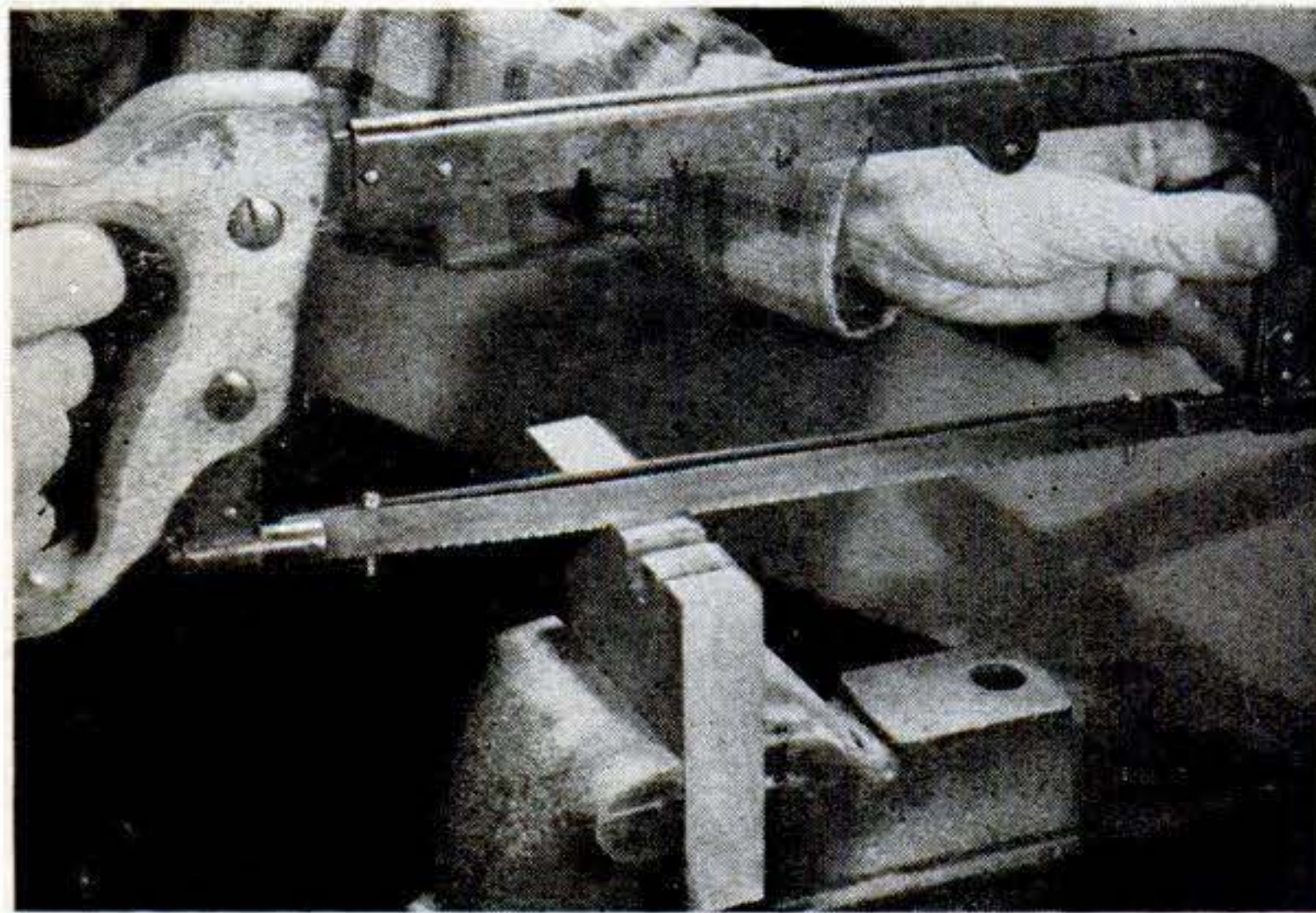

Using a Hacksaw to Cut Slots

AN EASY way to cut a slot in wood, plastic or metal is to use two blades in a hacksaw. You can spread them apart simply by inserting a screw, nail or other separator near each end. If a tendency of one blade to bow interferes with work, you can make a special separator like

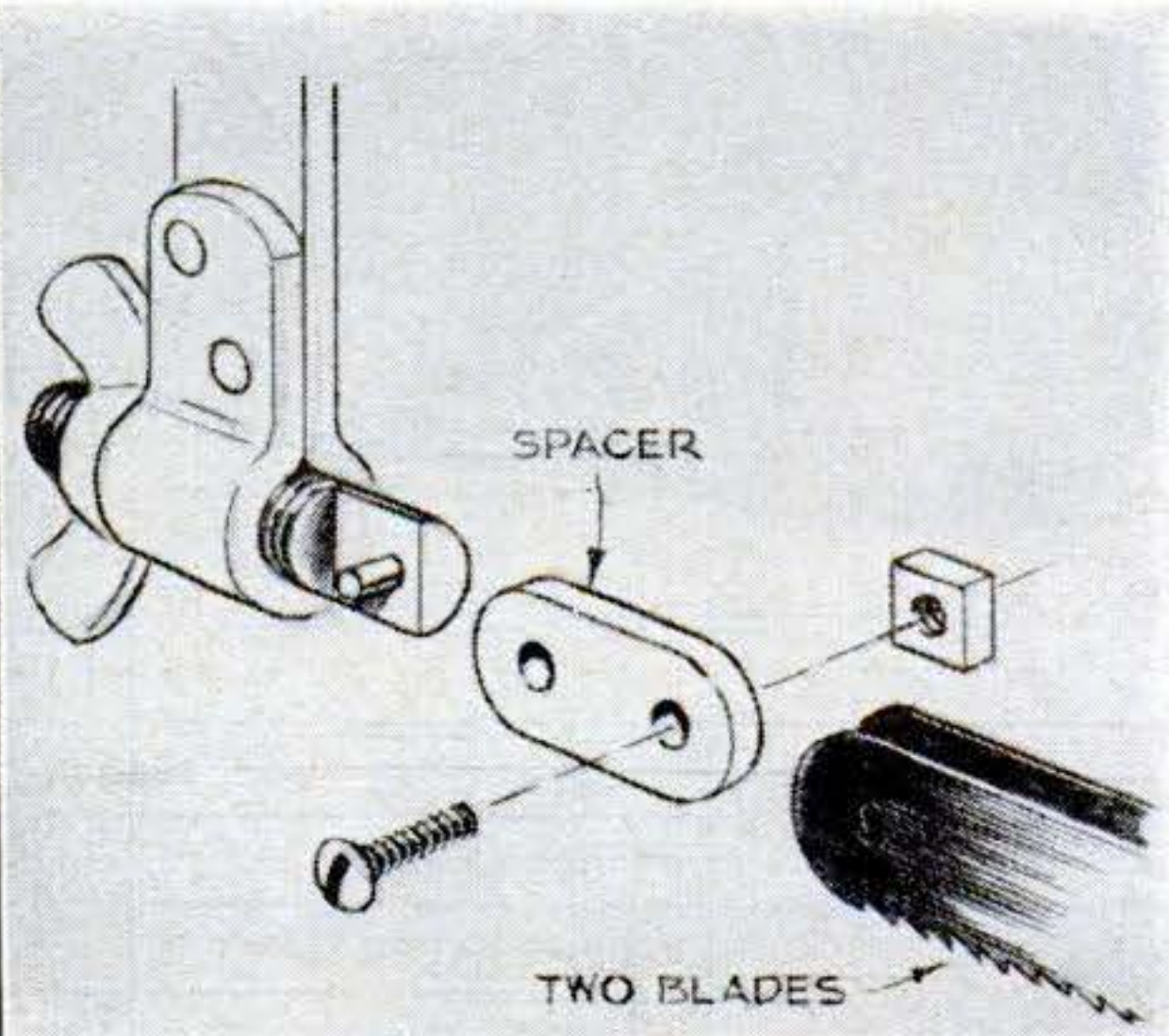

that in the drawing by drilling a short piece of metal to fit the holder and take a small bolt to hold the blades.

This setup is useful also for sawing large pieces of sheet metal. As the work progresses, bend the strip between kerfs down and out of the way so the back of the frame will go easily through the cut.—*Wilfred E. Berkeley, Cleveland.*

You'll have more fun afloat, and avoid trouble ashore, if you follow all the rules that add up to—

The Right Way to Heft an Outboard

ANY way you look at it, a modern outboard motor becomes a mighty awkward hunk of machinery when you remove it from a boat transom. For a really big one, some sort of dolly becomes a must. But you still have a fair amount of hefting to do, and observing the old rules of weight lifting will save your muscles and safe-

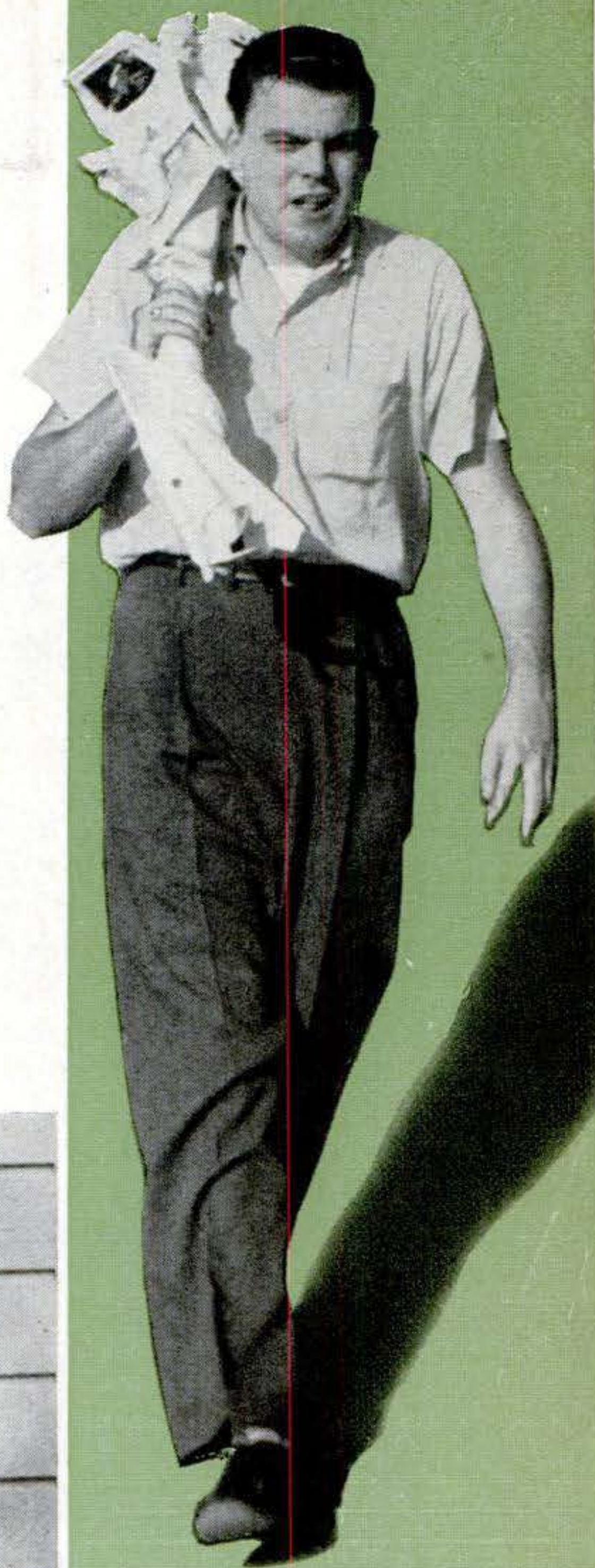

TAKE A TIP from veteran guides; the easiest way to carry a motor on a long trek is slung over your shoulder. Use a boat cushion or life preserver as a pad when you portage a big and hefty one.

OUTBOARD CARRIER makes the chore a breeze where the going isn't rough. Tilt the frame back far enough to put some of the weight on your arms. Otherwise a sudden bump may pitch the motor forward.

How to hoist an outboard on your shoulder

KNEEL BESIDE IT and grip the shaft housing with your nearer hand. Grasp the handle with your other hand and up-end the motor as you would a "choked" axe. Continue the arc until all the weight is on your shoulder. Shift it into comfortable balance; then straighten your legs.

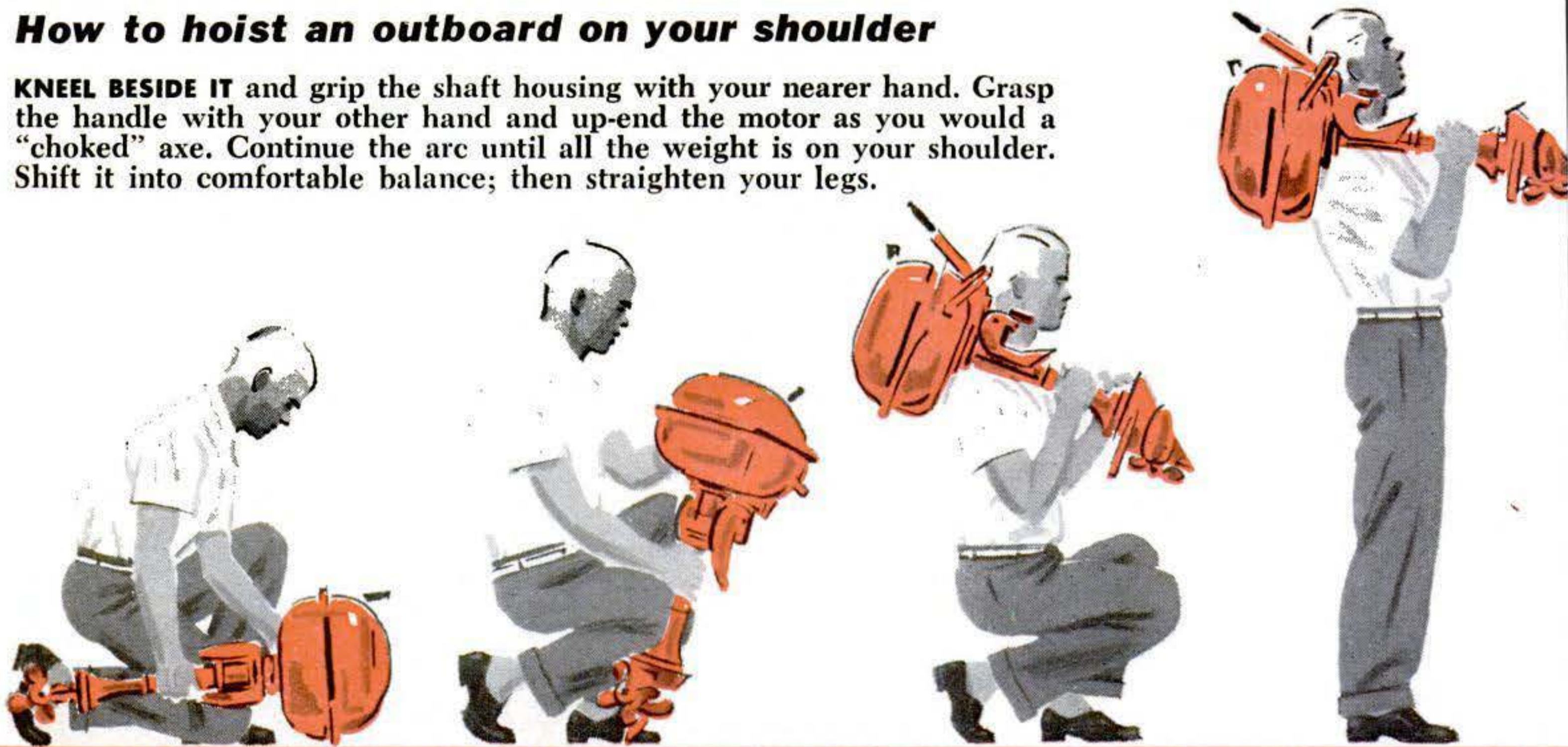

guard the motor. Equally important, don't try to take on a 200-pounds-plus baby without help. When one of these has to be carried over a rough trail or soft sand, clamp it to a two-by-four that's long enough to offer a convenient carrying handle on both sides. Then call on a partner to share the load with you.

How to use teamwork. Getting a big-horsepower job from a dock to a transom—or the other way around—requires teamwork, too. Do the lifting or lowering with one of you on the dock, the other on the afterdeck. Where a winch isn't available, slip a line—an anchor rope is fine—through the motor handle. Then bring the two ends around the shaft housing just under the hood. Knot these snugly at the rear of the motor and let

the dock man play out line or do the hoisting while the man in the boat guides the motor onto or off the transom.

The line serves another purpose, too: If the outboard gets away it's a simple matter to fish it out of the drink before any harm is done.

Another point almost too obvious to mention: If your outboard has an integral gas tank, don't fuel up until it's on the transom; it's easier to carry that extra 10 or more pounds as a separate load.

Finally, remember that while a dolly isn't necessary for a small motor, it still beats a strong right arm.

Do-it-yourself dolly. You can build one, with or without the help of a local welding shop, for \$10 or less. With a pair of 1.75"-by-8" utility wheels equipped with semi-pneumatic tires, it will accommodate any motor up to 50 horsepower. If larger motors are to be carried, you'll need industrial wheels with a tire capacity of 200 pounds each.

The frame can be made in two ways. The construction drawing on page 189 illustrates the welded method, using 1" steel tubing. If you question the need for a weld at the handle center, it's done for convenience. By making the two 90-degree bends on separate lengths of tubing and then trimming the ends to get the exact handle width and length required, you save a lot of fussy curve plotting. A conduit bender also comes in handy here.

Alternately, you can sidestep welding and bending by using 1/2" steel pipe, 90-

4 Basic Rules for Motor Lifting

1. Bend your knees, but keep your back straight—it's built to take much greater loads that way.
2. Hold a motor as close to you as possible—otherwise you'll add the force of leverage to its weight.
3. Don't twist your body to swing a motor around. Instead, use footwork to turn it.
4. Be sure of your footing.



UPSTAIRS AND DOWNSTAIRS: In both cases, the right way is with the motor hood facing *upstairs* to keep from banging the underwater element



against the stair risers. If it's a heavy motor, pick it up in your arms and hold it in close to you to avoid unnecessary leverage strain.



CAR LOADING: When you put a motor in a car or wagon, raise it to the trunk or tailgate edge and rest it there while you place one foot alongside. Then lift it the rest of the way up. Reverse the procedure when unloading, making sure the footing is firm behind you. Cradle a motor in an



inner tube inflated to 10 pounds and it slides easily into a wagon. You'll save the outboard's muscles, too, during drives over backwoods roads. Place the motor with projecting controls facing up, to protect them and prevent puncturing the cushioning inner tube.

Off the transom it can be an awkward hunk of machinery



BOAT BOARDING: Don't step into a boat carrying any but the lightest motor. Leave a larger one on the dock until you're aboard. Then, facing the motor with your feet planted one in front of the other, lift it in, hood toward the stern.



TURNING: Aboard or ashore, never twist your body while lifting. Use footwork to turn a motor for transom mounting. At the same time hold the motor close to you. Watch where you're going; step *over*, not *on*, obstacles that may be in your way.



TRANSOM MOUNTING: With one foot well back of the other and in line with the motor, you're braced to support the outboard as you position it on the transom. Bend at the waist only enough to maintain your balance; lower slowly with your knees.

degree elbows, and a pair of tees for the joints connecting the uprights and axle sleeve.

Either way, spot and drill the holes in the handle and other frame members to take the $\frac{1}{4}$ " bolts that assemble the carrier.

With a welded frame, drill $\frac{1}{2}$ " holes through the lower ends of the uprights in line with the axle housing. Slip the axle through, place a spacing washer on either end to provide clearance between tires and frame, and then mount the wheels temporarily. This will let you spot index marks for two small cotter-pin holes. Withdraw the axle again, drill the holes and, if necessary, trim the axle ends to provide clearance for the hubcaps. Use the same procedure with a pipe-frame carrier, omitting only the drilling of axle holes—with tee couplings there's no need for them.

The mounting board. This is cut from a length of two-by-four that's free from knots. After drilling $\frac{1}{4}$ " holes at each end, spaced to match those on the frame, fasten it in place with $\frac{1}{4}$ " carriage bolts. These should be either cadmium- or zinc-plated.

Note that wing nuts are applied to the lower ends of the handle braces. With this arrangement, the bolts can be removed easily, the handle inverted and the diagonal braces swung forward and down, shortening and flattening the carriage for compact storing.

After coating the welds and braces with rust-preventive paint, enamel the completed assembly as desired.

Short Cuts and Tips

FROM PS READERS

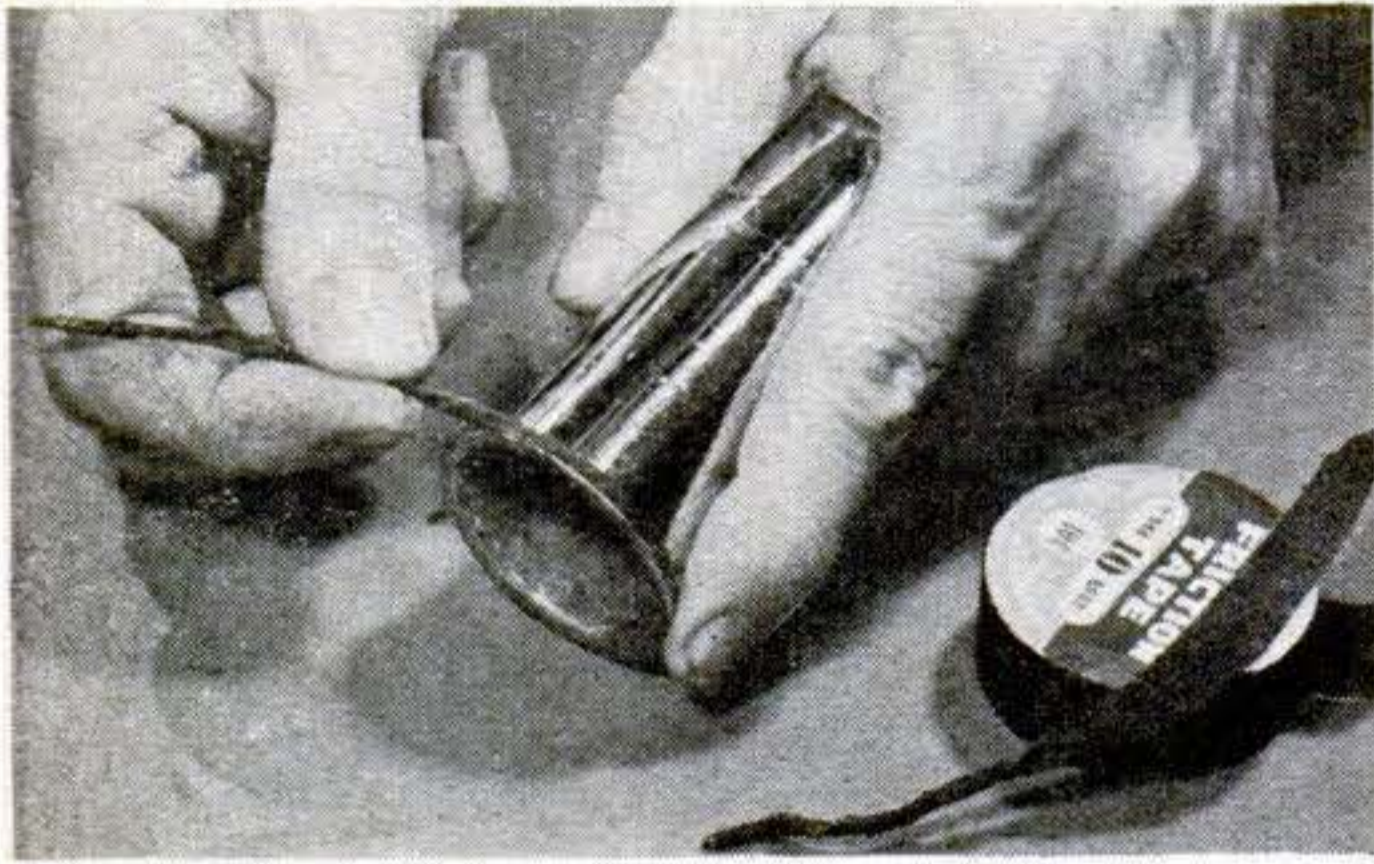

Friction-Tape Gaskets

EMERGENCY gaskets made from ordinary friction tape will substitute in a pinch for standard ones in pipe or tubing assemblies. You may find it handiest to tear the tape into narrow strips and twist them into cords for installation in the joint. They will give long service on such jobs as reassembled sink drain pipes.—*Walter E. Burton, Akron, O.*

▶▶▶ WHEN you carry pencils, screwdrivers, files and the like in your pockets, it is convenient to keep them in plastic toothbrush containers. Don't put more than one file in each container; the teeth may be damaged rubbing against each other.—*John Cullen, Springfield, Mass.*



Tip on Patching Cracks in Wall

IF YOU put a bright light on the floor near where you are patching a plaster wall, it will cast shadows that will make cracks and holes stand out so they're easy to see. Place the lamp a little to the side of the spot where you are working.—*Henry R. Thompson, Boston.*

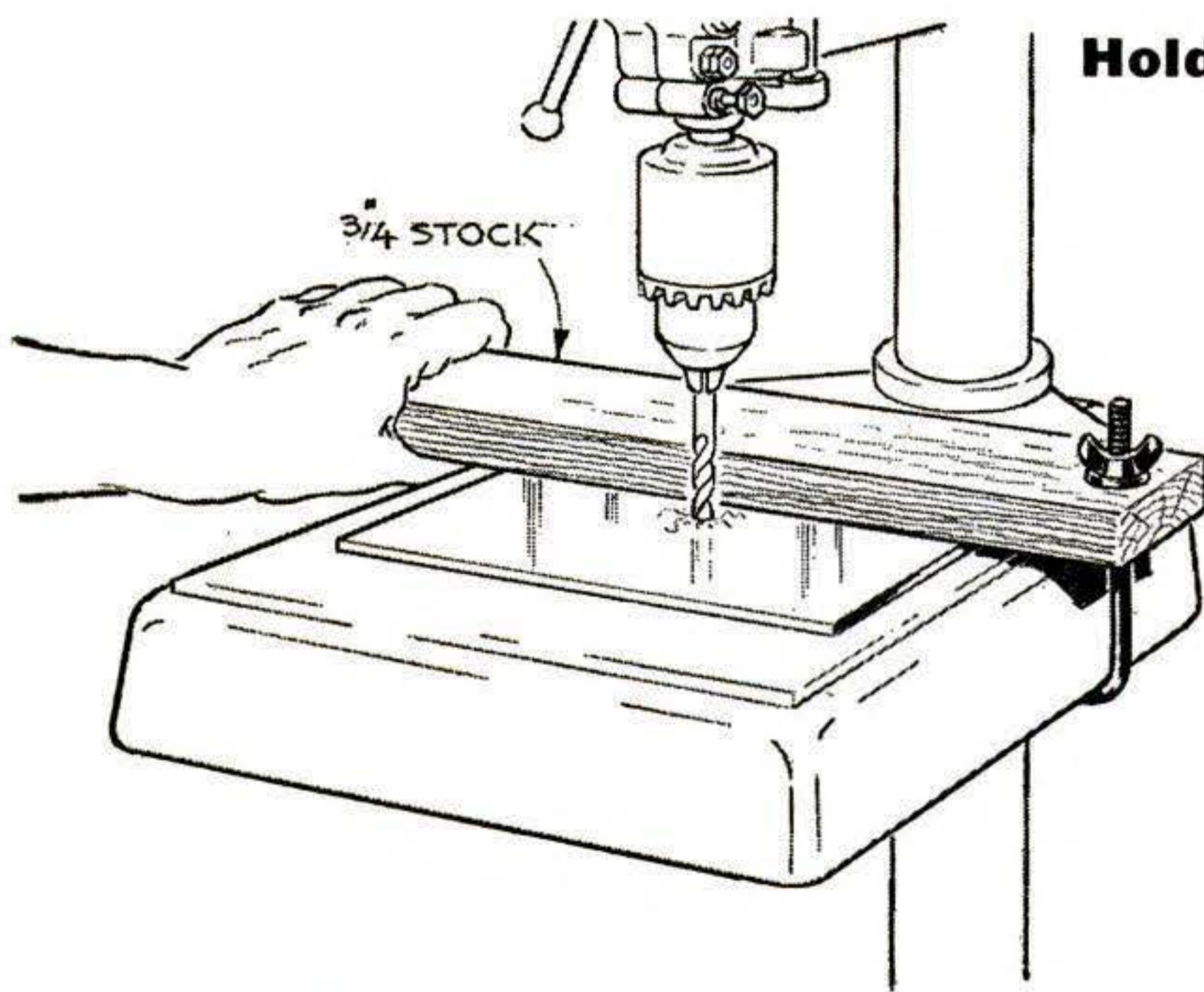

Hold-Down for Drill Press

You can hold small pieces of thin sheet metal on a drill-press table safely by using a simple clamp consisting of a handle cut from $\frac{3}{4}$ " stock and a bolt with a washer and wing nut. Bend one end of the bolt so the head can be hooked around the lip beneath the table and provide a firm grip.

Fabric belting tacked or cemented to the clamp's underside will prevent marring the work when pressure is applied to keep it from turning.—*Max R. Best, Detroit.*

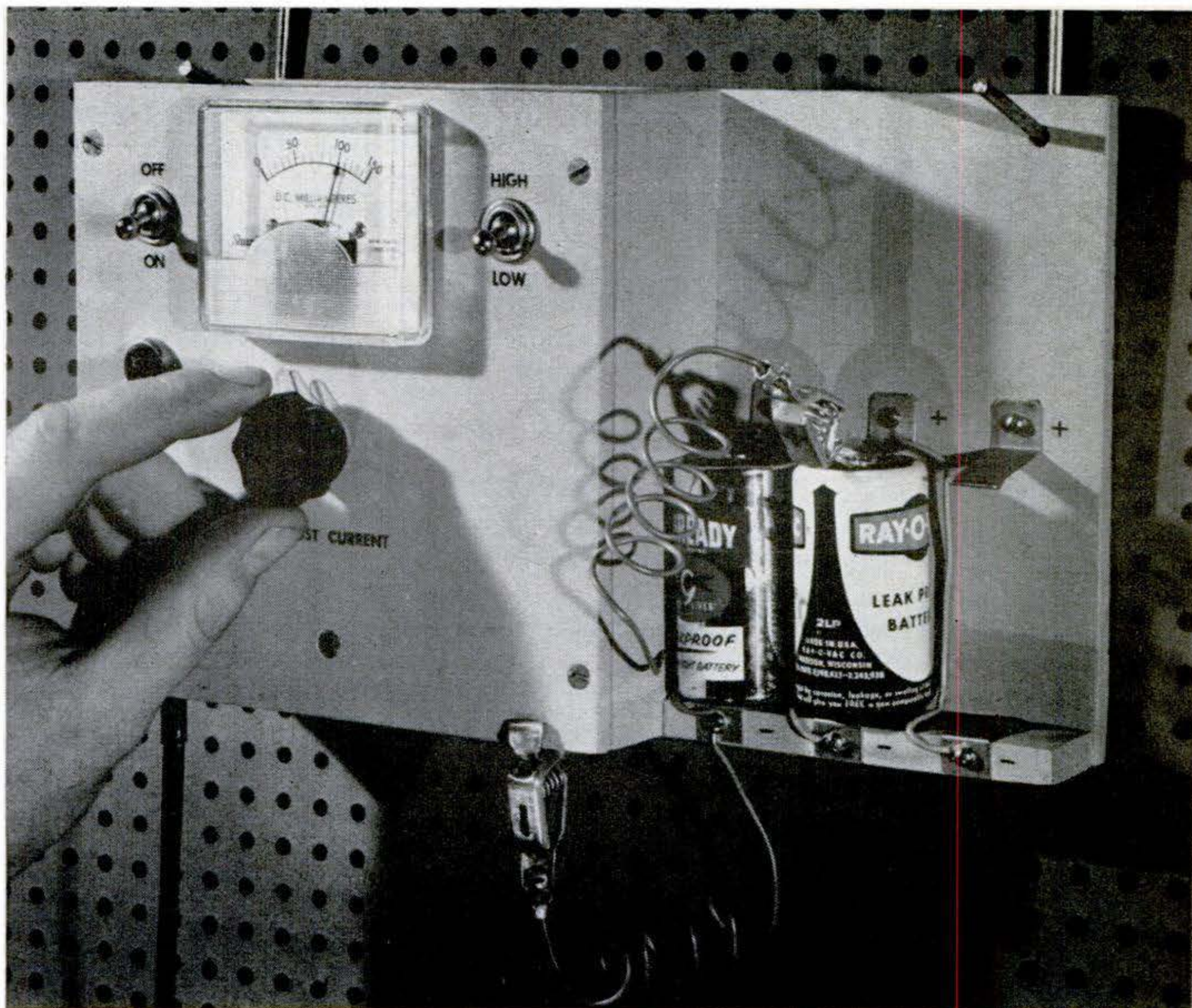

An easily made battery rejuvenator gives you a profitable bonus:

Extra Life for Your Dry Cells

By Howard G. McEntee

DOUBLING the life of the dry cells in use around your home is the next best thing to buying 'em wholesale. It halves the cost.

The battery rejuvenator shown has proven itself under test. It will *more* than double the life of a standard carbon-zinc cell. Tally up the number of cells that power your children's toys (many take four) and various household gadgets, and you'll find replacement costs add up fast

when you shell out 20 cents apiece.

The instrument resembles a battery charger, and its operation is similar—it forces moderate current into the cell. But dry cells cannot be recharged in the same manner as your car's battery.

How a dry cell is rejuvenated is the subject of some debate, but the basic idea is that forcing moderate current backwards through the cell tends to remove accumulated hydrogen from the carbon pole, and alters the chemicals in the cell to restore their activity. Most

An overnight trickle of house current makes tired

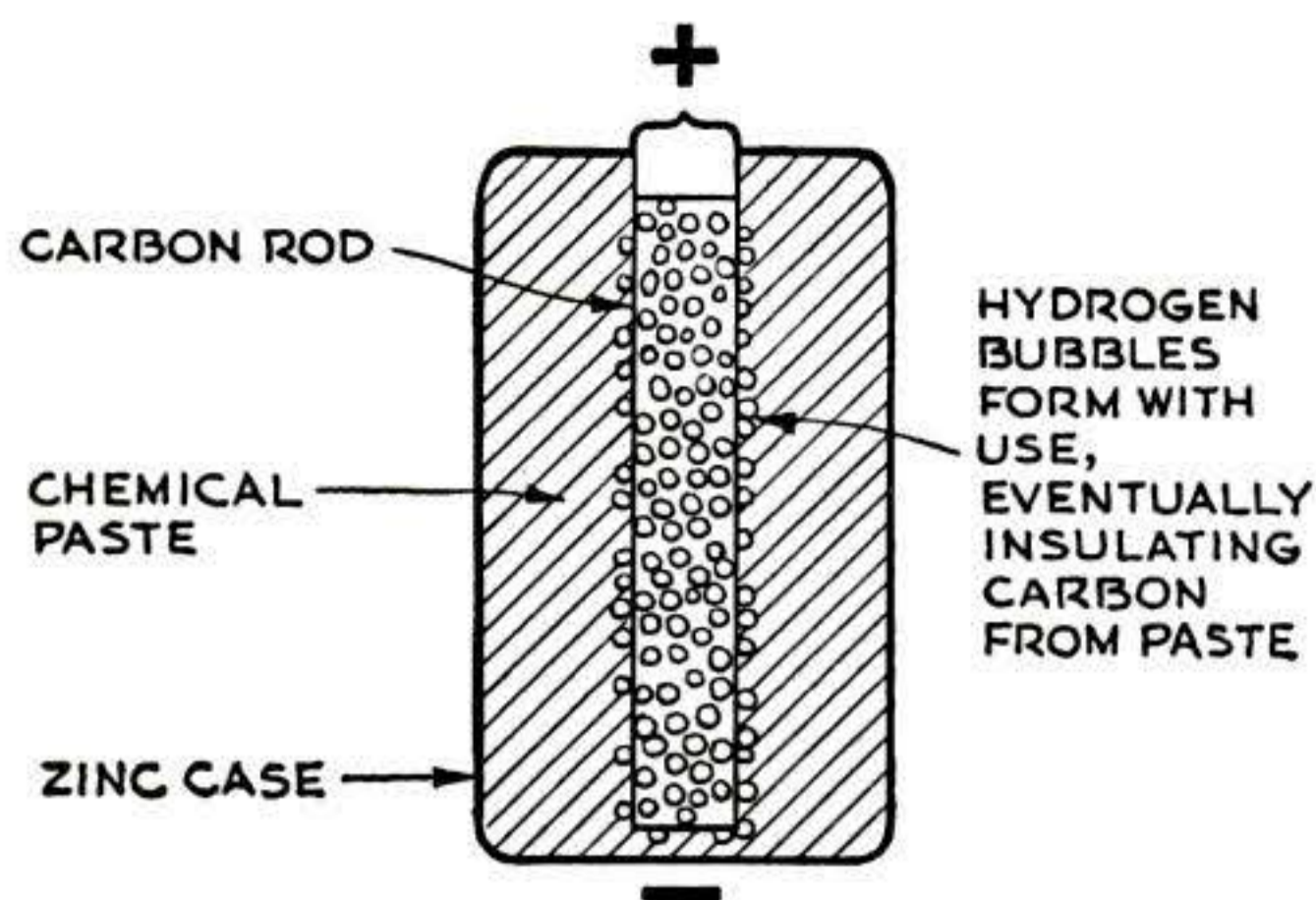

THERE'S PLENTY OF LIFE in many a dead dry cell, but hydrogen bubbles that form on the carbon pole insulate it from the still-active paste. Rejuvenating removes the unwanted bubbles.

important is the removal of hydrogen bubbles that tend to insulate the carbon from the chemical paste, eventually depolarizing the cell.

The materials you need to build the rejuvenator cost about \$8, but operating cost is negligible since it draws less current than the smallest night light.

The chassis can be built from small pieces of $\frac{1}{4}$ " plywood, with the electrical parts mounted on a $6\frac{1}{2}$ "-square panel.

To keep down the cost of parts, two inexpensive 6.3-volt filament transformers are used, but if you happen to have a couple of six-volt bell transformers in your junk box, they'll do as well. Connect their primaries in parallel to the 115-volt AC line and run the secondaries in series through a high-low switch (SW2). This will permit you to use a single transformer for one, two or three cells; or cut in both transformers to dou-



CAUTION!

DON'T try to rejuvenate any of the new alkaline or mercury cells. Unless you *know* your cells are the standard carbon-zinc type (the others cost much more and are labeled "energizer" cells) better not try to boost them. If you guess wrong, you could have a potent and messy explosion. The new cells don't need charging. They last up to 10 times longer than ordinary cells.



ble the output for rejuvenating four or more cells, or a single six-volt bell or lantern battery.

When wiring in the transformers, watch for one pitfall: It's possible to hook them up incorrectly so that you'll get zero voltage from them. The best way is to connect the primaries and the secondary of T1, temporarily leaving the secondary leads of T2 long. Connect a DC voltmeter across the output, set the high-low switch at low and turn on the juice. You should get a reading of six volts. Flip the switch to high and look for a 12-volt reading. If the reading drops near zero, reverse the secondary leads from T2. Other connections to the variable resistance, switches and meter are clearly shown in the pictorial diagram; just hook up the wires as shown.

The cell mounting clips can be strips of brass, as used here. If you're the lazy type, you can buy commercial battery holders in model-plane shops and radio-supply stores. Permanently connect the clips with jumper wires from positive to negative to put them in series. Connect the negative wire from the rectifier to the first negative battery holder and run from it a 15" extension wire fitted with an alligator clip. The positive wire running from the meter is 18" long and is fitted with an alligator clip. This is hooked onto the positive holder above the last battery in any group being rejuvenated to complete the series circuit.

Using the rejuvenator is largely a matter of feel and instinct. Generally the slower you "cook" the cells the better, but they can be given a fast boost if you check them every hour or so. If they become warm to the touch, reduce the current—overheating tends to evaporate the precious moisture within the cells, rendering them completely useless. When cooking three cells or less, begin with a setting of about 100 to 130 milliamperes on the meter with the range switch set at low. Four or more cells—or a six-volt lantern battery—require about the same meter setting, but flip the switch to high. Cooking time should be 12 to 16 hours in most cases.

Batteries will last longer and perk up faster if you give them an occasional

dry cells fresh and ready for use by morning

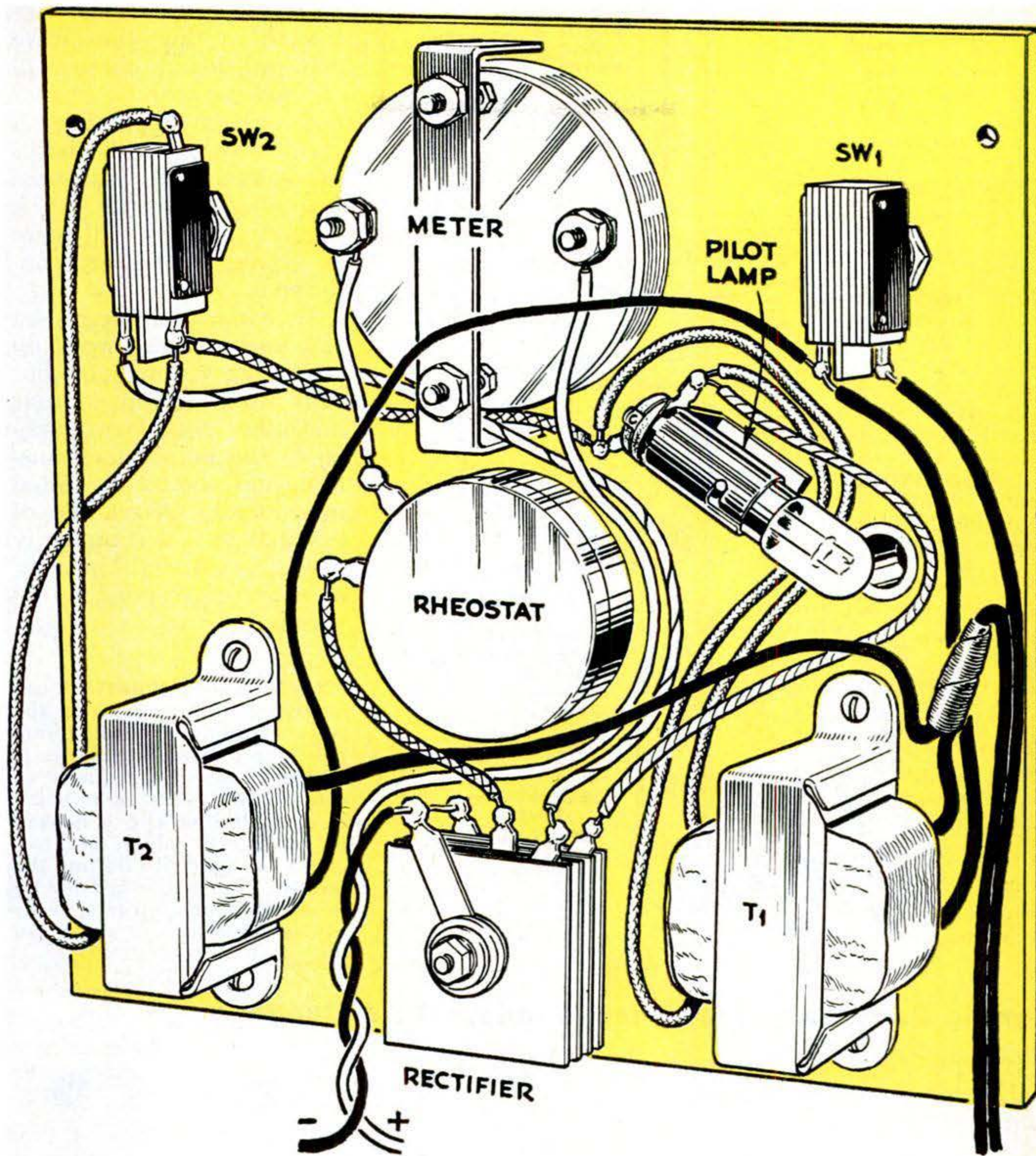

THE PARTS YOU'LL NEED

Symbol	Item	Type	App. Cost
T1, T2	6.3-volt filament transformers	Lafayette #TR-11	\$2.20
Rect.	Low-voltage bridge rectifier	Int. Rect. Corp. #B1B	1.50
M	150-ma. meter, square plastic case	Shurite #8308	2.00
R	100-ohm wire-wound rheostat	Mallory #M100RK	.80
SW1	On-off switch, SPST toggle	any	.50
SW2	High-low switch, SPDT toggle	any	.60
PL	Pilot lamp and socket	any #47	.30
	Knob for R, battery clips, line cord, panel decals		.40

Total cost \$8.30

PICTORIAL ARRANGEMENT of parts—easier to savvy than a schematic—shows how wires are connected. Light wire in twisted pair at right extends 18", is fitted with an alligator clip. Dark wire runs to first negative battery holder, then to a 15" extension as shown on the following page.

How to connect the batteries

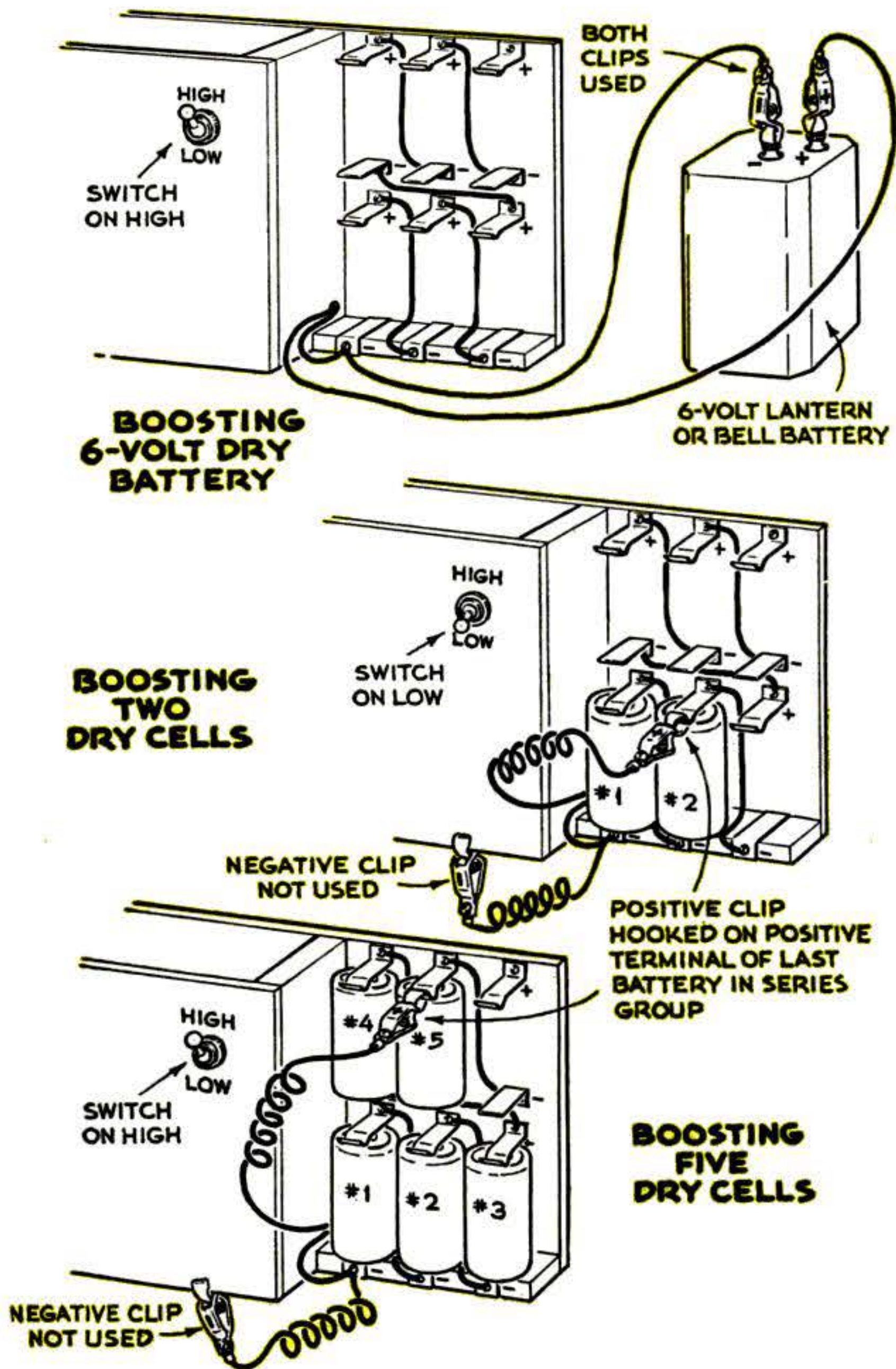

boost *before* they are run down completely. This can be done repeatedly, although in time the active material inside them will be used up, making further rejuvenation impossible. A small voltmeter with a built-in resistance—the type photographers use to check photoflash cells—will serve as a guide to battery condition.

In a flashlight, cells let you know they're weak by producing a dim light, but cells used in radios, toys and other equipment carry on to the point of exhaustion, and should be tested occasionally. A reading of 0.9 indicates a completely dead 1½-volt cell that may or may not respond to rejuvenation.

SIX-VOLT LANTERN BATTERY can be rejuvenated by hooking the two extension clips to its terminals (top drawing). Note series wiring of dry-cell holders. In center, two cells are being treated. Positive clip is hooked to No. 2 cell holder; negative clip is not used. By shifting the positive clip to the last holder in use (bottom), up to six cells can be boosted. **END**

Simple Continuity Test Checks Indoor TV Antenna

IF YOU suspect a bad antenna connection or a break in the ribbon lead, hold or tape a dry cell in contact with the antenna rods and touch the lead ends to a flashlight bulb as shown. The bulb will light if all is okay. If it flickers instead, there's a broken wire or loose connection. If it doesn't light at all, try replacing the lead.—*Art Trauffer, Council Bluffs, Iowa.*

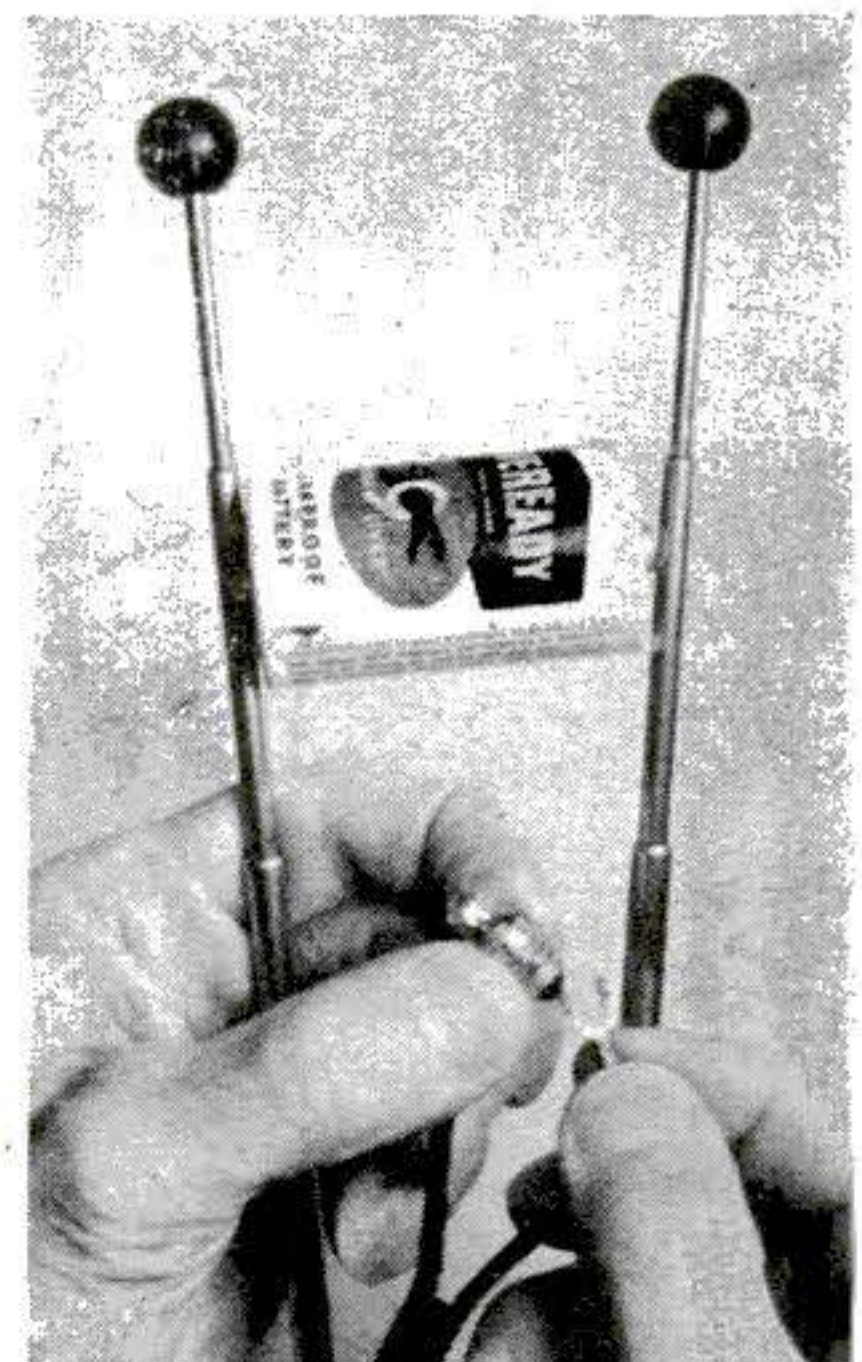
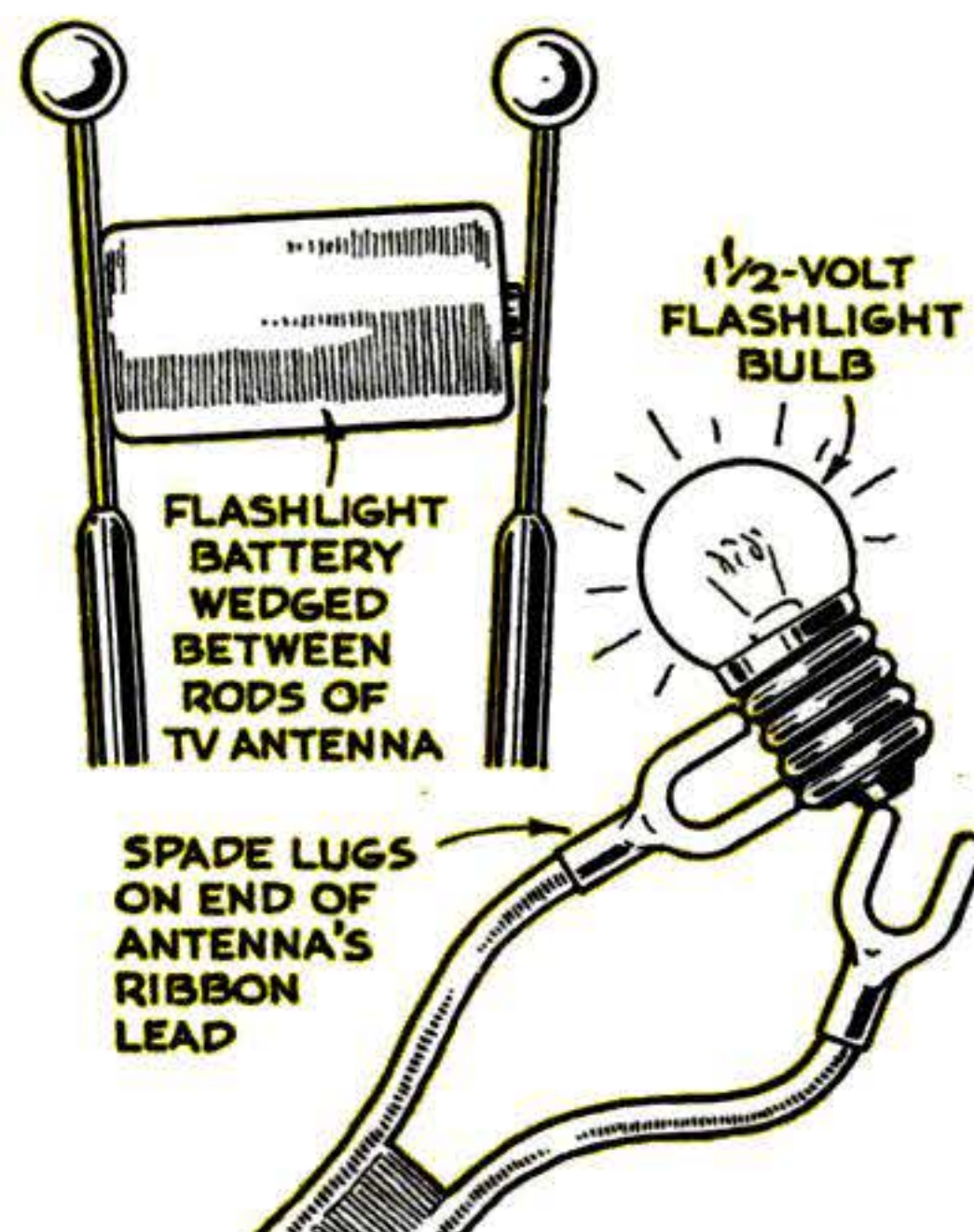

POWER TOOL MAGIC





THE ROUTER—*Miracle Woodworking Tool*

In many ways, the portable router can transform almost any hobbyist into a skilled woodworking artisan. Many of its operations were once confined to stationary equipment in furniture and millworking plants. But the professionals there quickly adopted the router, and now even the home craftsman, with a little practice, can turn out comparable professional work with ease and dispatch.

Basically, a router is a high speed

motor with chuck to accommodate specially shaped bits and cutters. There are over 200 of these bits and cutters in the Porter-Cable line. The router motor may be removed from its base, and used as a power source for a high speed plane and a stationary shaper. Both of these attachments are economical in cost since the one motor powers all these tools.

WHAT DOES THE ROUTER DO? It cuts grooves and dadoses, fancy inlays; puts



Typical bits and cutters used with the router. (Left to right) Roman ogee bit, beading bit, cove and bead cutter, surface bead cutter.

gracefully curved edges on ornamental molding, makes professional wood joints like the dovetail and tongue and groove. Hours of tedious, repetitious operations in fine cabinetmaking, are automatically eliminated.

The Porter-Cable router is extremely versatile. Accurate, too. The depth of cut can be controlled to within $1/64''$. With its motor turning at better than 20,000 rpm, it operates with phenomenal smoothness even on plywood. The whole machine weighs only about $5\frac{1}{2}$ lbs., so control is easy.

PRACTICE IS THE KEY, HOWEVER. This is particularly true since you'll use the router on work where mistakes can't be patched without showing. Experts often use templets and patterns. Many of these devices are readily made with your router itself, and once made, are used over and over. Where operations are repetitious, they save time; where critical, they save tempers.

STANDARD ATTACHMENTS ARE A BIG HELP. One is the Porter-Cable Magic Guide. This handy yet inexpensive accessory is actually five router guides in one. With it you can make perfect circle cuts, radius cuts, ornamental designs, accurately spaced slots and grooves and hundreds of other professional cuts. It even acts as an edge plane! Another attachment is the shaper table. It converts your Porter-Cable router into a stationary tool, holding the router in an inverted position. The

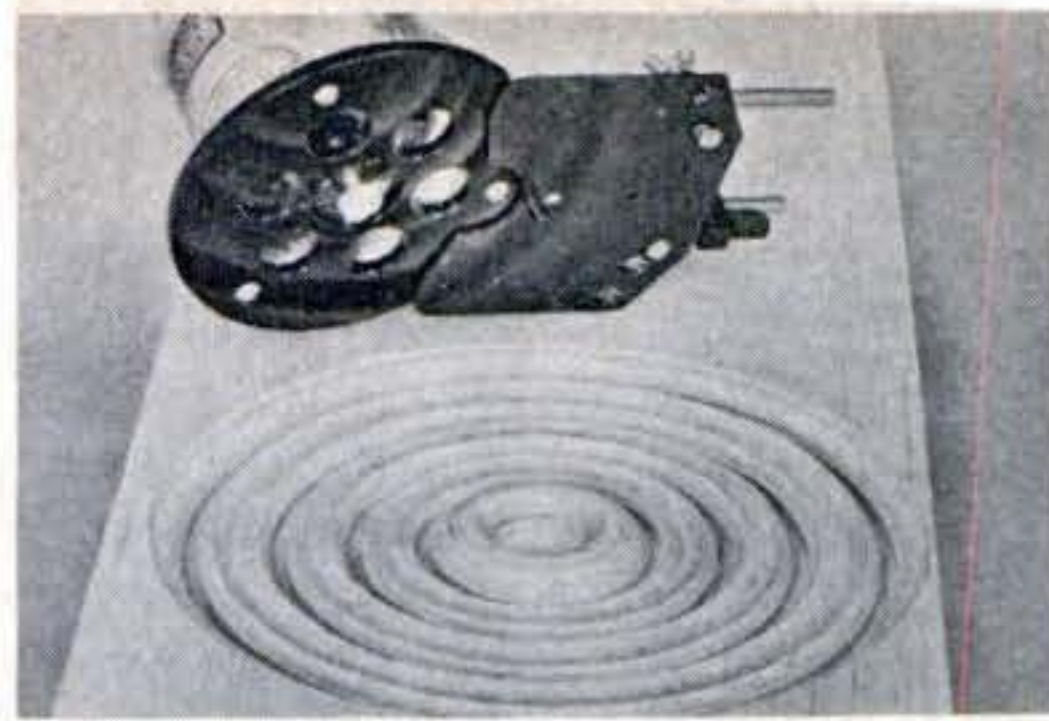

Used for circle cutting, the 5-in-1 Magic Guide cuts inside circles and produces ornamental work.



When producing shelving, the 5-in-1 Guide can be pre-set with accurately spaced slots.



For inlay work on curved pieces, 5-in-1 attachment acts as a radius guide. A simple adjustment converts it to a straight edge guide.

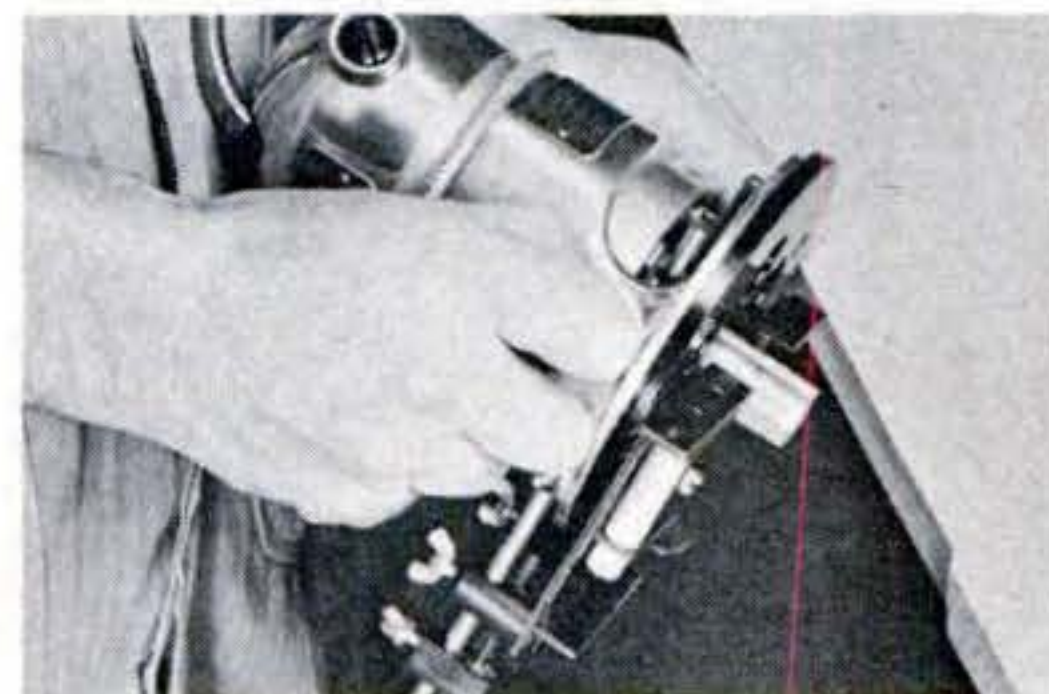

Magic Guide has adjustable shoes and micro-set adjustment for precision edge planing.



A rabbet or step cut being made with the shaper table. Router motors and cutters may be adjusted for varying depths of cut and hundreds of shapes.

cutter, therefore, remains in full view. The shaper table eliminates many freehand operations, and is useful on such pieces as long, narrow moldings, since the work constantly is aligned. With the plane attachment, your Porter-Cable router becomes a power plane at very minor cost. Besides



This 16" plane attachment features a long shoe base, patented chip disposal, fingertip depth adjustment up to 3/32" deep, bevel adjustment to 45°. High-speed router motor produces a glass-smooth edge even on glue-bonded plywood.

speed, you get a smoother, more precise cut than with hand planing. The router is constructed so that its power unit can be quickly installed on such accessories as the shaper table and plane attachment, and just as easily re-converted to its original purpose.



In using the dovetail templet, a perfect joint can be made in 12 seconds.

An example of the templets you can obtain for your Porter-Cable router is the dovetail templet. It is invaluable for making clean, close-fitting dovetail joints in record time. Once adjusted, it provides assembly-line speed, eliminating guesswork and time-consuming measurement.

This Porter-Cable 1/2 h.p. router is economical yet offers the same precision features incorporated in larger models . . . Model 162

\$49.95



THE PORTABLE POWER SAW . . .

**Magic Time
and
Money Saver!**



Porter-Cable Model 66..... **\$39.95**

If you do any volume of woodworking, a circular power saw will save time and labor worth a dozen times the cost. With today's modern materials a portable power saw offers the only quick, safe and handy way to cut panels of plywood, hard board, and other large pieces to size with any accuracy. It is also the answer to ripping and cross cutting long boards and heavy lumber. The Porter-Cable Model 66, with a budget price tag, has many of the features found in far more expensive saws. It makes a full cut through 2" dressed lumber, including compound

miter cuts. The famous Porter-Cable KickProof clutch protects you and the work if the saw jams. The telescoping blade guard is another safety advantage—only the teeth that are actually cutting are exposed when the saw is in operation, and the specially-designed lip on its leading edge prevents jamming when the saw enters the stock. Self-lubricating bearings on jackshaft and armature provide long service life. Instant depth and calibrated bevel adjustments give you complete accuracy with every type of cut. The 66 is a welcome addition to any workshop.

Canadian prices slightly higher for tools shown on this and other pages.

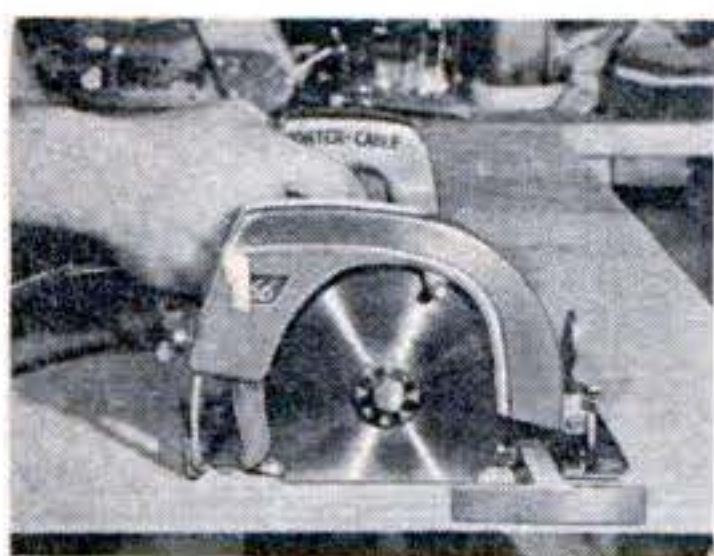

Powerful Model 66 has 8 amp power for all homecraft cutting.

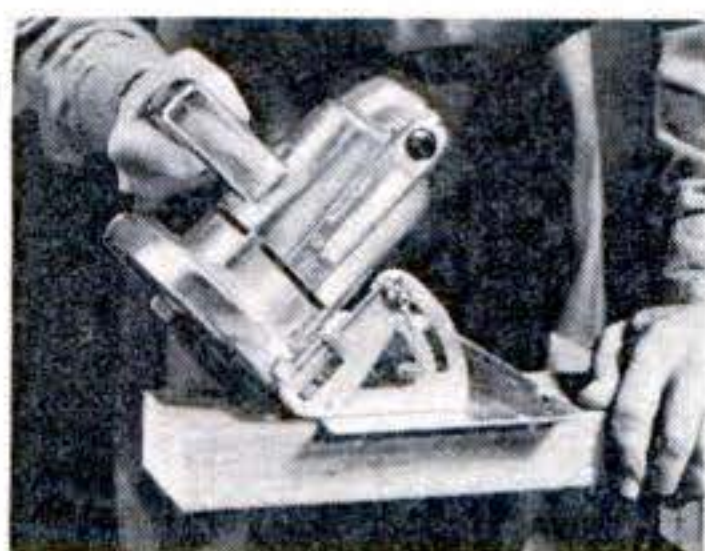

Model 66 bevel cuts 2" dressed lumber from 0° to 45°.

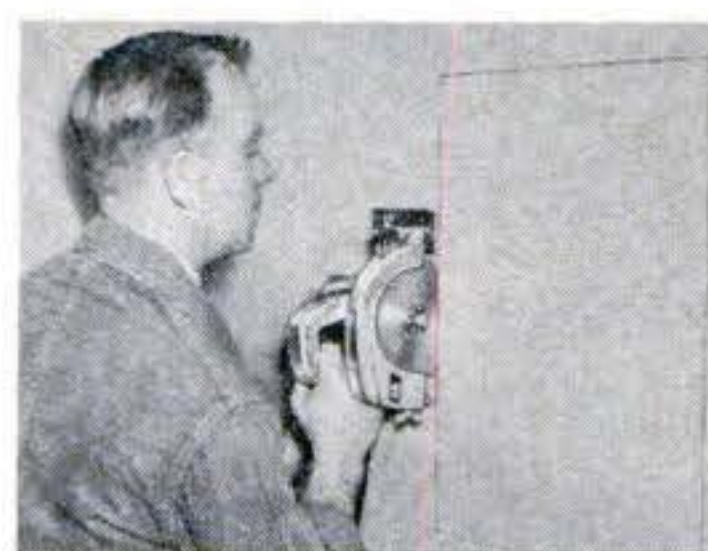

Pocket cuts are quick and easy with this handy saw, too.

Look what you can do with the ELECTRIC HAND SAW



Angle cuts—equipped with the angle base, quickly and easily cuts accurate angles up to 45°.

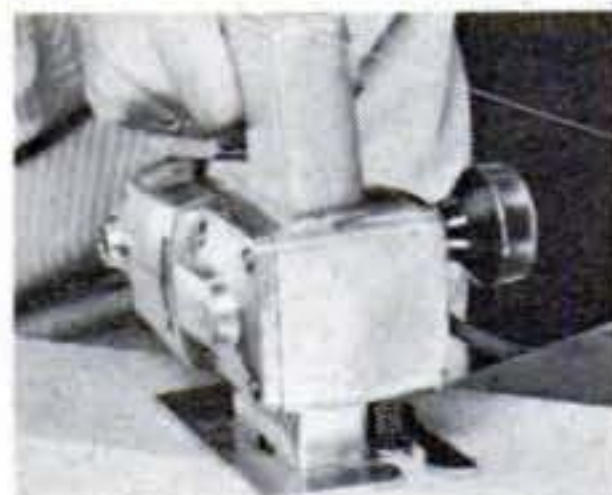

Scrollwork—makes easy work of intricate cuts—with professional results every time.



Metal cutting—sheet metal, pipe, bar stock, rods are quickly and accurately cut.

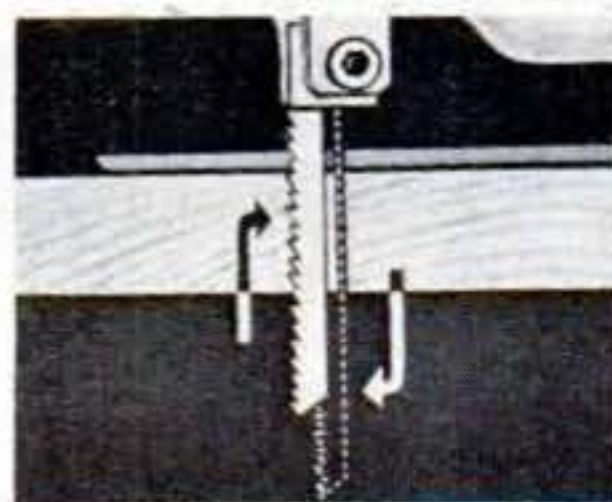

Fastest cutting saw on the market—improved orbital action does it. Cuts smoother, blades last longer.



Model 152
Hand Saw.....

\$54.95

The Porter-Cable 152 Electric Hand Saw can be one of the most essential tools in a home workshop. It's actually seven saws in one—a rip saw, crosscut saw, coping saw, keyhole saw, scroll saw, jig saw and hack saw. It cuts, rips, crosscuts and miters 2" dressed lumber, cuts steel, brass, aluminum, sheet metal, pipes, plywood, plastics, masonite and countless other materials. Best of all is the accuracy of the cut on all of these operations, since the Porter-Cable 152 saw has both a top handle and auxiliary side handle for awkward positions and intricate cuts. The king-size base gives stability on every cut and the sawdust blower keeps the cutting line clearly visible. When cutting plastic or wood laminates, the patented insert disc holds the work close against the blade and prevents shredding or chipping. Available in handy 10 piece wall kit 152K.....\$59.95.

These Leading PORTER-CABLE DEALERS will help you

ALABAMA

BIRMINGHAM Birmingham Saw Works
SCOTTSBORO W. J. Word Lbr. Co.

ARIZONA

TUCSON Choate's Hardware

ARKANSAS

EL DORADO The Tool Room
HOT SPRINGS NATIONAL PARK
Vaughan Hardware Company
PINE BLUFF Fox Brothers Hardware

CALIFORNIA

ANTIOCH Silvera Lumber Co.
AUBURN Alpha Hardware Co.
BAKERSFIELD Egland Lumber Co.
Ford Hardware
Pioneer Mercantile Co.
BERKELEY
Card's Dwight Way Hardware Co.
COSTA MESA Kerm Rima's Hdwe.
COVINA Builders Emporium
ESCONDIDO Churchill & Cassou Hdwe.
FORT BRAGG Lilley's Building Sup.
FORTUNA Fortuna Hardware
HAYWARD
Skaggs Hardware Supermarts
INGLEWOOD Brizzolara Hardware Co.
Inglewood Mercantile Co.
LOS ANGELES
Andrews Hardware & Metal Co.
Newland Hardware
PASADENA
John P. King Power Tools
PETALUMA Tomasini's
REDLANDS Bates-Carlson Hardware
REDWOOD CITY Progress Lumber Co.
RIVERSIDE Builders Emporium
Ken's Tool & Supply
SAN BERNARDINO Burford & Son
Cooley Hardware
SAN DIEGO D & D Saw Works
Point Loma Lumber Co.
SAN FRANCISCO
Shasta Hardware & Supply Co.
SAN JOSE Emery's Power Tool Mart
SAN LORENZO Village Building Sup.
SAN PABLO San Pablo Hardware
SANTA MARIA Holser & Bailey
Lahr Electric Motors
SANTA ROSA Dixon Hardware Co.
SOLANA BEACH
Lumber & Builders Supply Co.
TAFT M & N Supplies
UPLAND W. F. Rugg Lumber Company
VAN NUYS Builders Emporium
VISALIA Sequoia Saw Service

COLORADO

COLORADO SPRINGS
Bishop-Hill Tool & Paint Co.

DENVER Union Hdw. & Tool Co.
FORT COLLINS
Toliver-Kinney Mercantile Co.

CONNECTICUT

BRIDGEPORT Hawley Hardware
DARIEN The Tool Box
FAIRFIELD Tunxis Hill Hardware
HARTFORD Irvin Hdw. & Machinery
MERIDEN Colony Hdw. Co.
MIDDLETOWN Master Supply Co.
NEW HAVEN N & B Sosensky
Woodcraft Supply Co.
NEW LONDON Schneider Hdw. Co.
RIDGEFIELD D. F. Bedient Co.
SOUTH NORWALK
The Crescent Woodwork Company
Fox Cycle & Hdw. Co.
STRATFORD H. C. Lovell Co.
TORRINGTON Union Glass Co.
WALLINGFORD Colony Lumber Co.
WEST HAVEN West Haven Lumber Co.

DELAWARE

MILFORD Pierce Hardware
WILMINGTON
Bartley's Electric Service
Shields Lumber & Coal Co.

DISTRICT OF COLUMBIA

Barber & Ross Co.
Beisler Supply Co.
Fries, Beall & Sharp
R & M Saw & Tool Co.

FLORIDA

BRADENTON
Simmons Hardware Co.
CLEARWATER Nall Lumber Co.
DELRAY BEACH
Ocean City Lumber Co.
FT. LAUDERDALE Duncan-Edward Co.
FT. MYERS John J. Fohl Hardware Co.
FT. PIERCE Ft. Pierce Hardware Co.
GAINESVILLE
Contractors Supply, Inc.
HOLLYWOOD
Barry-James Hardware Co.
HOMESTEAD
Brooker Lumber Co. Inc.
JACKSONVILLE Mason Lumber Co.
Southside Hardware Co.
LAKE WALES
Townsend Sash Door Lumber
LAKE WORTH Leverenz Hardware Co.
MIAMI Alvin Builders Supply Co.
Bailey's Lumber Yards, Inc.
Gondas Corporation
Renuart Lumber Yards, Inc.
State Hardware & Builders Supply Co.
West Miami Key Shop
ORLANDO Bumby Hardware Co.
Thomas Lumber Co.

PENSACOLA Standard Hardware Co.
Taylor Hardware Co.

POMPANO BEACH
Pompano Lumber Co.

ST. PETERSBURG
Gulf Beach Paint Hardware
Pinellas Lumber Co.

SARASOTA Orange State Lumber Co.
Sarasota Hardware & Paint Co.
Shepard Lumber Company

TAMPA Tampa Hardware Co.

VERO BEACH
Crosby Builders Supply Co.

WAUCHULA Nicholson Supply Co.

WEST PALM BEACH
Sewell Hardware Co.

GEORGIA

ATLANTA
Every's Hardware
Williams Bros. Lumber Co.

IDAHO

BOISE
Safway Scaffold & Power Tool Co.
BURLEY McCaslin Lumber Co.
IDAHO FALLS Idaho Falls Hdw. Co.

ILLINOIS

BERWYN Framar Sales & Service
CHAMPAIGN Black's Hardware
CHICAGO AAA Saw & Tool Service
Advance Contractors Supply Co.
Alfa Products Co.
Andys Saw & Tool Service
Gee Co.
R. A. Ness & Co.

DECATUR
C. C. Hubbard Machinery Co.

DEKALB
Gordon Hardware & Supply Co.

ELMHURST Lichtenberger Bros. Inc.
FOX LAKE Normans V & S Hardware

GURNEE Gurnee V & S Hardware, Inc.
HAVANA Zempel Hardware

HILLSIDE Merchant's Hardware
JOLIET Barretts Inc.

MELROSE PARK Seegers Hardware
MONMOUTH
Patton's Seed & Hardware

MORTON Roecker & Dietrich
PARK RIDGE Bachmann Hardware

PEORIA Couch & Heyle
PERU Harry Debo & Son

QUINCY James Supply Co.
ROCK ISLAND
Rock Island Lumber Co.

ST. CHARLES Essig's V & S Hardware
WESTERN SPRINGS Village Hardware

WORTH Worth Hardware

INDIANA

ANDERSON Kaufman Hardware Co.
DECATUR Arnold Lumber Co. Inc.

ELKHART Watson Paint Co.
FT. WAYNE Umber's Ace Hardware

Model 165 Belt Sander

\$49.95

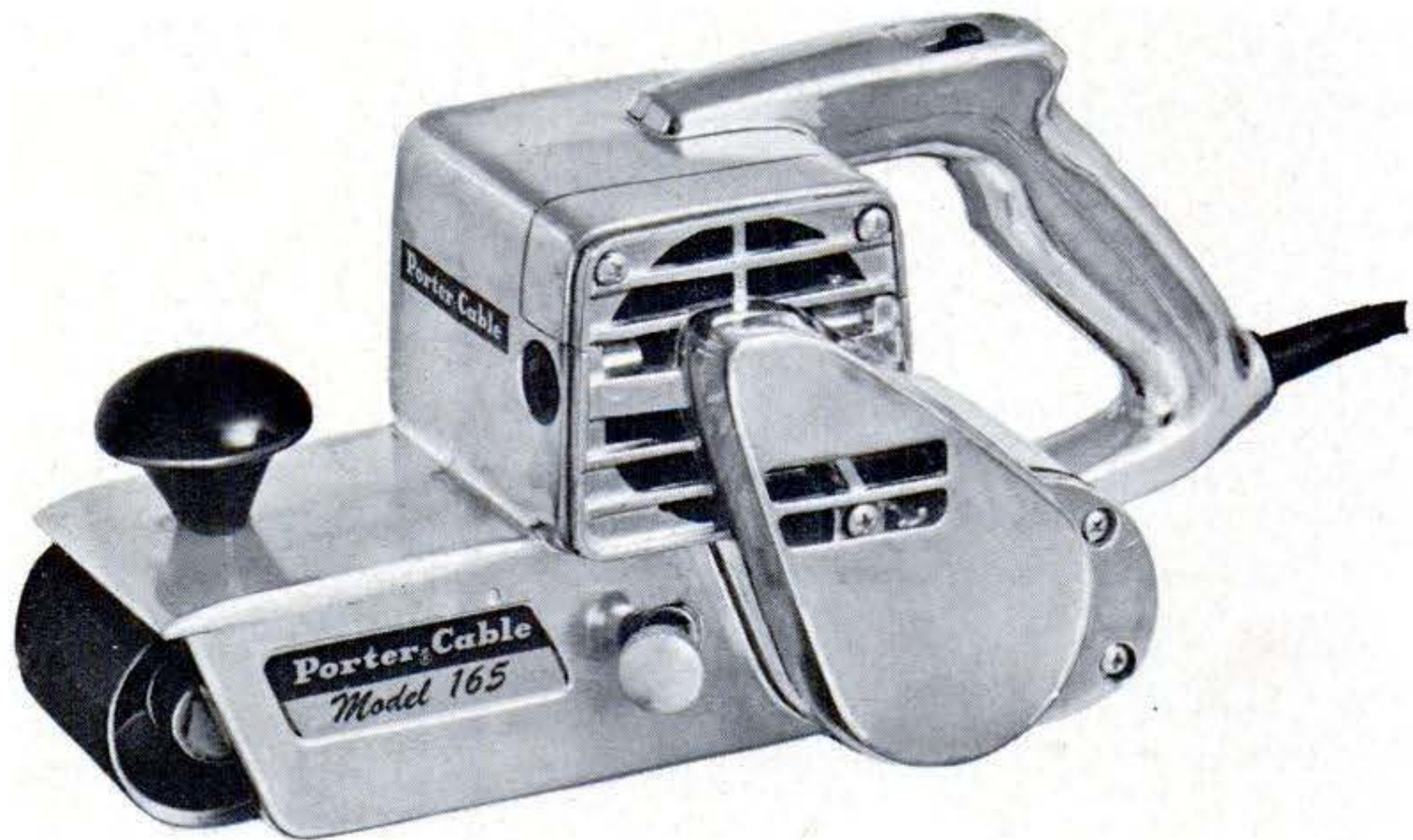

How to get professional finishes — FAST

This compact belt sander is the answer for fast stock removal and for fine even finishes on large surfaces. It will outperform ten men working at hand sanding—and do a better job. The Porter-Cable Model 165 weighs only 7½ lbs., evenly balanced to give positive control with less fatigue. Use it vertically, horizontally, or overhead. It takes standard 2½", 2¼",

or 2" belts, and you can change belts in seconds. An improved tracking mechanism keeps the belt perfectly aligned, and a patented device keeps them at proper tension. Other high-quality construction features include a powerful 5½-amp. motor, precision spur gears, specially-lubricated ball and sleeve bearings, and neoprene-covered drive pulley.



Light weight makes the 165 belt sander easy to use for such jobs as smoothing wallboard joints, ceilings, etc.

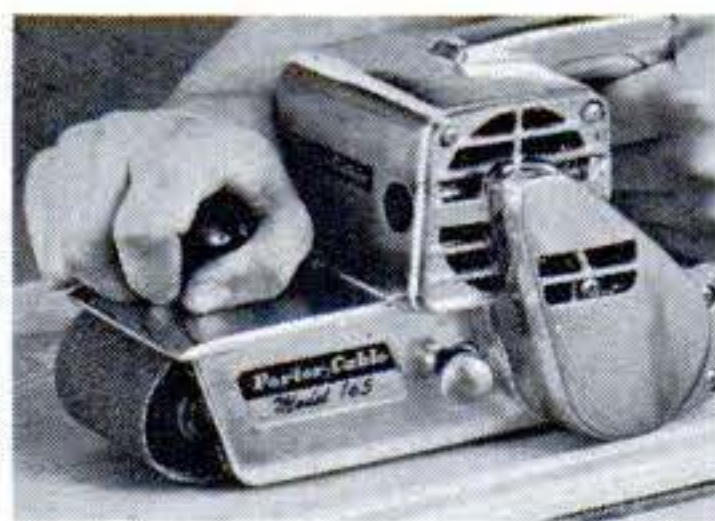

A real time-saver for stock removal, fine cabinetwork, paint and varnish removal.

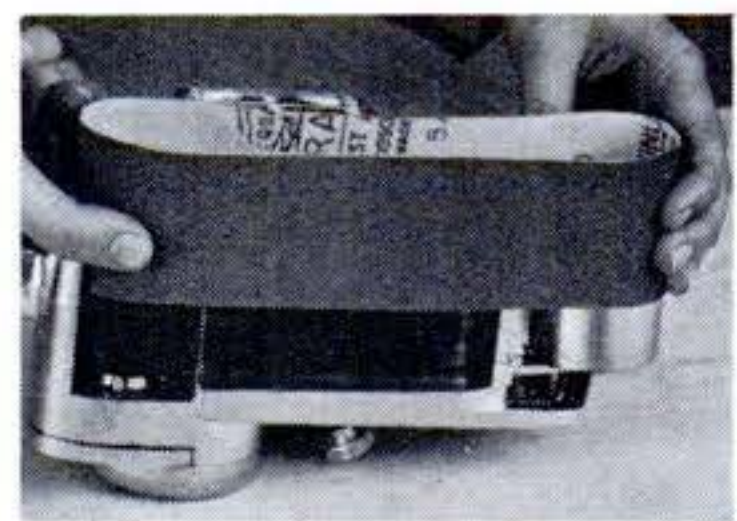

Belt changes are quick and easy. Abrasive belts come in fine, medium and coarse grits for every sanding job.

These Leading PORTER-CABLE DEALERS will help you

MAPLEWOOD Maplecrest Hardware Co., Inc.
 NEWARK Market Hardware Co.
 PARSIPPANY S. Cerbo & Sons Inc.
 PLEASANTVILLE Home-Handyman Center, Inc.
 POINT PLEASANT BEACH Point Pleasant Hardware Co.
 TRENTON Thomas M. Eagan & Son Inc.

NEW MEXICO

CARLSBAD The Big Jo Lumber Co.

NEW YORK

ALBANY Phillips Hardware
 Rutland Lumber Co. Inc.
 ALDEN Townline Lumber & Supply Co. Inc.
 BETHPAGE, L. I. Bethpage Lumber & Supply Corp.
 BINGHAMTON H. C. Collier & Sons
 Lou Rappaport
 BROOKLYN H & M Hardware Company
 BUFFALO Karle Saw Co., Inc.
 Schuessler Hardware Inc.
 Walden Hardware & Appliance
 Winiewicz Hardware Co.
 BURNT HILLS Burnt Hills Hardware Company
 ELMIRA Cory's Hardware
 FLORAL PARK, L. I. J. F. Best Hardware
 GARDEN CITY, L. I. Handy Andy Hardware
 GLOVERSVILLE House Beautiful Blinds
 GRANVILLE S. Weinberg Co.
 HAMBURG Kronenberg's Inc.
 HORNELL Hollands Lumber Company
 HUDSON Hudson Lumber & Supply Corp.
 ITHACA Robinson & Carpenter Inc.
 Snow Electric Company
 KENMORE Kenmore Renting Co.
 KINGSTON Shults Paint Company
 LACKAWANNA Midtown Hardware
 LEROY LeRoy Hardware Inc.
 NEW HYDE PARK, L. I. Oliver & Klass, Inc.
 NEW ROCHELLE Charles Librett Hardware
 NEW YORK ABC Tool Rental & Sales Co.
 Alco Hardware & Tool Co.
 Rudolf Bass
 Brown & Silver, Inc.
 Harold Dessau Inc.
 Garber Hardware & Paint Co., Inc.
 A. Greenberg, Inc.
 Kass Hardware & Supply Co. Inc.
 New Era Hardware
 OLEAN West State Hardware
 ORCHARD PARK C. Militello Floor Coverings Co.

PALMYRA Wayne Coal & Lumber Company
 PORT WASHINGTON Alper's Hardware
 POUGHKEEPSIE J. E. Andrews Hardware Co. Inc.
 ROCHESTER Arrow Materials Corp.
 Atlantic Millwork Company
 Clark's Hardware
 Country Gentleman Store
 Lester Hardware
 Ridge Lumber Company
 H. C. Schoenheit
 O. G. Schwarz Company
 SALAMANCA Dietrich Hardware
 SAUGERTIES P. C. Smith & Son
 SCHENECTADY Capitol Paint Stores
 David Mahoney Co., Inc.
 Mayfair Handy Hardware
 SENECA FALLS Scofield Hardware
 SYRACUSE Alpar Hardware
 Chapman Lumber Company, Inc.
 Alexander Grant's Sons
 Heaphy's Hardware
 Mid-State Contractors Equipt. Co. Inc.
 TICONDEROGA Moore's Hardware, Inc.
 UTICA Mather-Evans & Diehl Co. Inc.
 VALLEY STREAM Central Hardware

NORTH CAROLINA

CHARLOTTE Machinery-Supply Co.
 GOLDSBORO Live Wire Electric Co.
 Southside Hardware Co.
 SHELBY Paul Wray Machinery Co.
 THOMASVILLE Reed Supply Co.
 WILMINGTON Smith Builders Supply, Inc.
 WINSTON-SALEM Floor Products Distributors, Inc.

OHIO

AKRON Carter-Jones Lumber Co.
 W. E. Wright Shopping Center Stores
 CANTON Canton Hardware Company
 CINCINNATI Aufdemkampe Hardware Co.
 The Dettmer Hardware Company
 David F. Pohl & Co.
 CLEVELAND Bloom Bros. Hdwe. & Plumbing Supply
 Forest City Material Co.
 M. Freund Hardware
 Odziemski Hardware
 Sam Palevsky Hardware Co.
 Rock Island Lumber Co.
 WaySon Power Equipment Co.
 CLEVELAND HEIGHTS Kleinman Bros. Hardware
 COLUMBUS Cohagan Hardware
 Columbus Hardware Supplies, Inc.
 COLUMBUS GROVE Stechschulte & Son Hardware

CRESTLINE The Holcker Hardware
 DOVER Geo. B. Deardorff & Son Inc.
 ELYRIA Beal Lumber Co.
 EUCLID Gerdina Hardware
 FREMONT Winters Hardware
 GARFIELD HEIGHTS Parkway Hardware & Paint Co.
 JEFFERSON J. G. Laird Lumber Co.
 KIRTLAND Kirtland Hardware
 LIMA Stippich Hardware Company
 MANSFIELD Home Materials Co.
 MANTUA Mantua Lumber Co., Inc.
 MARION Baldauf & Sons Lumber & Hardware
 MILFORD Milford Hardware
 NILES Jensen Hardware Co.
 PARMA Fox Hardware
 RITTMAN Shook Lumber Co.
 ROCKY RIVER Sam Palevsky Hdwe.
 ROSSFORD Frautschi Hardware
 SYLVANIA The Chandler Hdwe. Co.
 TOLEDO Center Hardware
 Horn Hardware
 J. S. Janney Hardware
 Kuehnle Lumber Co.
 D. J. Marleau Hardware
 WESTLAKE The Bradley Supply Co.
 WILLOUGHBY HILLS Manakiki Hardware
 WILLOWICK Shoregate Hdwe. Inc.

OREGON

CORVALLIS Charnholm's Hardware
 EUGENE Scharpf's Twin Oaks Builders Sup. Co.
 HOOD RIVER Franz Hardware
 PORTLAND Saw Repair & Supply
 SALEM Salem Hardware Co.

PENNSYLVANIA

ALIQUIPPA Specht Hardware
 ALLENTOWN Allen Hardware, Inc.
 AMBLER G. M. Deck & Sons
 ARDMORE Smith Supply
 BANGOR Bangor Hardware & Paint
 BELLEFONTE Schaeffer Hardware
 BOSWELL Boswell Lumber Company
 BRADFORD E. W. Hardware Supply
 BRIDGEPORT Lloyd H. Daub, Inc.
 CARBONDALE Mills Brothers, Inc.
 CORAOPOLIS Coraopolis Hardware Co.
 CRAFTON Crafton Lumber & Supply Co.
 EAGLEVILLE George A. Salter Hardware
 EPHRATA Farmersville Equipment Co.
 ERIE West End Hardware
 GREENSBURG Cook Lumber Company
 HAMBURG Moyer's Hardware Store
 HARRISBURG H. D. Schriver Hdwe.
 HUMMELSTOWN E. B. Smith Hdwe.

These Leading PORTER-CABLE DEALERS will help you

GREENWOOD Greenwood Lumber Co., Inc.
 HAMMOND Stern's Woodmar Hardware, Inc.
 INDIANAPOLIS Klingstein Machinery, Inc.
 Southport Lumber Co.
 Urbancic Hardware
 LAFAYETTE Ace Hardware
 MARION Byrd Lumber Co.
 RUSHVILLE The Home Lumber Co.

IOWA

DAVENPORT Hanssen's Hardware
 DENISON Builders Lumber & Supply Co.
 MASON CITY Curries Hardware
 PELLA Vogelaar's Hardware
 SIOUX CITY Peete Hardware Co.
 WEBSTER CITY Parkhurst Hardware

KANSAS

GIRARD Breneman Auto Parts
 NEWTON Graber Hardware

KENTUCKY

PADUCAH Hannan Supply Co., Inc.

LOUISIANA

ALEXANDER John W. Ward Hardware Co.
 BATON ROUGE Industrial Hardware & Supply, Inc.
 HOUMA A. F. Davidson Corporation
 JENNINGS Capitol City Hardware & Implement
 LAKE CHARLES Home Supply Co.
 NEW IBERIA New Iberia Hardware Co.
 NEW ORLEANS Clayton J. Borne Hardware Co.
 C. T. Patterson Co.
 St. Bernard Hardware & Supply
 Vetter Hardware & Lumber Co., Inc.
 OPELOUSAS J. B. Sandoz Inc.
 SHREVEPORT McClamroch Machinery Co.

MAINE

BIDDEFORD McKenney & Heard
 PORTLAND The Harris Company
 Maine Hardware
 Woodfords Hardware Co.
 WESTBROOK Westbrook Hardware

MARYLAND

ABERDEEN Livezey Lumber Company
 ANNAPOLIS Sadler's Hardware
 ARNOLD Amplex of Md., Inc.
 BALTIMORE Fullerton Supply Co., Inc.
 The Hardware Fair
 Hobbywoods
 George Sack & Sons Inc.
 Skarie, Inc.

BEL AIR Courtland Hardware
 Kefauver Lumber Co.
 BETHESDA Community Paint & Hdwe
 Strosnider Hardware
 CATONSVILLE John S. Wilson Co.
 CUMBERLAND The Wilson Hardware Co.
 DAMASCUS Boyer & Cramer
 ESSEX Albert Milke & Sons, Inc.
 FREDERICK Seeger & Co.
 HAGERSTOWN Kauffman Manufacturing & Supply Co.
 KENSINGTON McIntire Hardware
 SEVERNA PARK Chesapeake Hardware

TOWSON Stebbins-Anderson
 UPPER MARLBORO Ford Lumber Co. Inc.

MASSACHUSETTS

CHICOPEE Lysek's
 HAVERHILL Haverhill Hardware & Plumbing
 Supply Company
 LAWRENCE T. J. Scanlon Company
 METHUEN Spence Hardware Supply Company
 NEW BEDFORD McGee's
 NORTH ADAMS Quinn's Wallpaper & Paint Inc.
 PITTSFIELD Carr Hardware Co.
 Pittsfield Supply Co.
 SOUTH HADLEY FALLS Street Supply Corp.
 VINEYARD HAVEN Hancock Hardware & Supply Co.
 WORCESTER C. C. Adams Hardware Corp.
 Edwards Paint & Wallpaper Corp.

MICHIGAN

ADRIAN Smith Hardware & Toys
 BIRMINGHAM A. L. Damman Co.
 DEARBORN Chase Road Hardware
 Hardware Depot
 DETROIT Beatty Electric Tool
 Bullock-Green Hardware Co.
 Cadillac Tool & Hardware
 A. L. Damman Co.
 Dewey's Lumberville
 Fromm's Hardware
 Gamalski Hardware
 DRAYTON PLAINS Keego Hdwe. Co.
 EAST DETROIT A. L. Damman Co.
 FARMINGTON Robertson Hardware Co.
 FERNDALE Keen Edge Saw Works
 GALESBURG Martin Motor & Machine Supply
 LINCOLN PARK The Renier Co., Inc.
 LIVONIA Cadillac Tool & Hardware
 MANISTIQUE C-L Hardware
 MT. CLEMENS A. L. Damman Co.

OWOSSO Himburg's Hardware & Plumbing
 PONTIAC McNabb Saw Service
 WYANDOTTE Jagers Hardware

MINNESOTA

AUSTIN Cleveland Hardware Co.
 FARIBAULT Minnesota Maintenance Co.
 HUTCHINSON C. H. Stocking
 MINNEAPOLIS G. C. Peterson Machinery Co.
 H. E. Seleen Co.
 Thompson Lumber Company
 Warner Hardware Co.
 MOORHEAD Red River Hardware Co.
 ROCHESTER Brumm Builders Hdwe., Inc.

MISSISSIPPI

JACKSON Addkinson Hardware Co.

MISSOURI

HANNIBAL Mark Twain Supply Co.
 JEFFERSON CITY Strong Bros. Millworks Lumber Co.
 KANSAS CITY Bunting Hardware Co.
 MONETT Wilks Lumber Co.
 ST. LOUIS Hathaway Paint & Hardware Co. Inc.
 Lang Saw & Equipment Co.
 The Geo. F. Smith Company
 SPRINGFIELD Springfield Mill & Lumber Co.
 WEBSTER GROVES Ace Supply Co.

MONTANA

ANACONDA Marchion Hardware Co.
 BILLINGS Stroup Hdwe Co.
 BUTTE W. J. Sewell Hardware Company
 KALISPELL Ostroot's Sharp Shop
 LIVINGSTON Builders Machinery Co.
 MISSOULA Kramis Hdwe Co.
 THOMPSON FALLS Pyatt Lumber Co.

NEBRASKA

GRAND ISLAND Grand Island Hardware
 LINCOLN Lawlor's

NEW HAMPSHIRE

LACONIA Laconia Electric Co.

NEW JERSEY

BELVIDERE L. E. Ritter Lumber Co.
 CAMDEN Highway Distributors Inc.
 Power Tool & Equipment Co.
 ELIZABETH S. Strassman Hardware & Paint Co.
 FLEMINGTON Flemington Lumber Co.
 GARFIELD Complete Saw Service of N. J.
 S. Meltzer & Sons Inc.
 HACKENSACK Zaentz Hardware

These Leading PORTER-CABLE DEALERS will help you

JOHNSTOWN Moxham Lumber Co.
 LATROBE Latrobe Hardware
 McKEESPORT Ungar's Hardware
 MEADVILLE Wolff's Hardware
 MENDENHALL
 Mendenhall Lumber Company
 OXFORD George Fredd & Son
 PHILADELPHIA
 Alco Lumber & Supply Co.
 Carpenters Machinery Company
 F. G. Reber Supply
 Tool & Equipment Corporation
 Weber Hardware
 PITTSBURGH Fort Pitt Hardware Co.
 Gil-Con Tool Co.
 PORT TREVORTON
 G. Flanders Keller Enterprises
 READING Merritt Lumber Yards, Inc.
 SCHUYLKILL HAVEN
 Haven Hardware Co.
 SCHWERKSVILLE
 Schmoyer's Lumber Co.
 SMETHPORT
 J. Alfred Johnson Hardware
 TITUSVILLE
 Reliable Builders Supply Co.
 WEST CHESTER
 M. S. Yearsley & Sons
 WILLIAMSPORT
 Hermance Machine Co.
 WYALUSING
 Glenn W. Arey Lumber Company

RHODE ISLAND

WEST WARWICK
 Majestic Hardware Company, Inc.

SOUTH CAROLINA

BEAUFORT Fordham Hardware Co.
 CHARLESTON
 Ashley Hardware & Supply
 ROCK HILL Rock Hill Hardware Co.

SOUTH DAKOTA

RAPID CITY Westside Hardware

TENNESSEE

KNOXVILLE
 Dick Wright Hardware Co.
 NASHVILLE Tennessee Machinery Co.

TEXAS

AMARILLO Amarillo Supply Co.
 BEAUMONT
 Newton Rental Tools & Hardware
 DALLAS E & L Service Shop
 Home Workshop Tools of Dallas
 T. Raymey Co.

FORT WORTH Leonards
 The Jno Muller Co.
 HOUSTON Buffalo Hardware Co., Ltd.
 Golfcrest Hardware
 Stettner Hardware
 Wessendorff, Nelms & Co.
 LAMESA Forrest Lumber Co.
 MARSHALL Logan & Whaley
 NACOGDOCHES Cason, Monk & Co.
 ODESSA Lynn Lumber Co., Inc.
 SAN ANTONIO
 Brannen's Tools & Machinery
 Joske's of Texas

UTAH

OGDEN Kammeyer's Sport Store
 SALT LAKE CITY
 Electric Motor & Supply Company

VERMONT

BRANDON
 Brandon Lumber & Millwork Co.
 RUTLAND Woodcraft

VIRGINIA

ALEXANDRIA Belleview Hardware
 Gaines Bros. Hardware
 Martin's Hardware
 ANANDALE Star Supply Co., Inc.
 ARLINGTON Dewey Hardware
 George M. Yeatman & Sons
 CLAREMONT
 The Star Supply Co., Inc.
 DANVILLE Link-Watson Corp.
 FAIRFAX Fairfax Hdwe & Supply Co.
 MANASSAS Manassas Lumber Corp.
 RICHMOND
 A. L. Lorraine Hardware Co., Inc.
 Puckett Hardware
 Guy Smith Hardware
 ROSSLYN Virginia Hardware
 SPRINGFIELD Springfield Hardware
 VIENNA Vienna Bldg. Supply
 WINCHESTER Miller Hardware Co.
 WYTHEVILLE R. P. Johnson Sons

WASHINGTON

HOQUIAM Ace Electric
 OPPORTUNITY Peters Hardware Co.
 PUYALLUP Lepley Lumber Co.
 SEATTLE Aronson's Hardware Co.
 SPOKANE Hoesly's Hardware, Inc.
 TACOMA Tucker & Sons
 Webster-Robinson Machinery
 & Supply Co., Inc.

WEST VIRGINIA

HUNTINGTON
 Chandler's Plywood Products, Inc.

WISCONSIN

BROOKFIELD Ralph T. Nitz Hdwe.
 FOND DU LAC Wisconsin Lumber Co.
 MANITOWOC A.A.A. Revenal Hdwe.
 MILWAUKEE
 Midwest Saw & Knife Company
 National Supply & Hardware Co.
 MONROE Fred Lanz Hardware Co.
 SPARTA Sparta Lumber & Fuel Co.

WYOMING

CASPER Casper Lumber, Inc.
 CODY Y Lumber Co.

CANADA

(Canadian Prices Slightly Higher)

ALBERTA

CALGARY
 Disher Equipment (Alberta) Ltd.
 EDMONTON
 Disher Equipment (Alberta) Ltd.

BRITISH COLUMBIA

KIMBERLEY
 Lloyd's Hardware Ltd.
 VANCOUVER
 Disher Equipment Ltd.
 VICTORIA
 Moore Whittington Lumber Co. Ltd.

MANITOBA

WINNIPEG
 Luke's Electric Motors & Machinery
 Co. Ltd.

ONTARIO

BRANTFORD
 Sherman's Merchandise Sales Co.
 FORT WILLIAM
 G. P. McEachern Ltd.
 HAMILTON
 The Garvin Hardware Co. Ltd.
 Tools & Equipt. Co. (Hamilton) Ltd.
 KENORA Williams Hardware Co. Ltd.
 MIDLAND F. W. Jeffery & Sons Ltd.
 OTTAWA
 Allied Building Supply (Ottawa) Ltd.
 W. A. Rankin Ltd.
 ST. THOMAS Hawke Hardware Ltd.
 TORONTO Aikenhead Hardware Ltd.
 L. S. Tarshis & Sons

QUEBEC

MONTREAL
 The J. Pascal Hardware Co. Ltd.
 SHERBROOKE
 J. S. Mitchell & Co. Ltd.

HAWAII

HONOLULU City Mill Co.

MEXICO

C.I.A. General Distribuidora, S.A., Ave.
 San Antonio Abad 236, Mexico City, D.F.

POWER TOOL MAGIC



Porter-Cable
Quality Power Tools

Tear This Out for Handy Reference

To remove this booklet, place your left hand on the facing magazine page, grasp the booklet with your right, and pull it gently away. After reading, file for future reference. You'll find it valuable on many home jobs.

Advertisement

NICKEL IS HANDY GAUGE for checking door clearances. A properly fitted door should have a nickel-thickness ($1/16''$) of space between door edge and jamb at sides and top. Bottom clearance may be more, depending on whether the door swings out over carpeting. If it's still balky after you've checked its alignment (see Door Repairs I, Mar. PS), you'll have to plane it to fit.

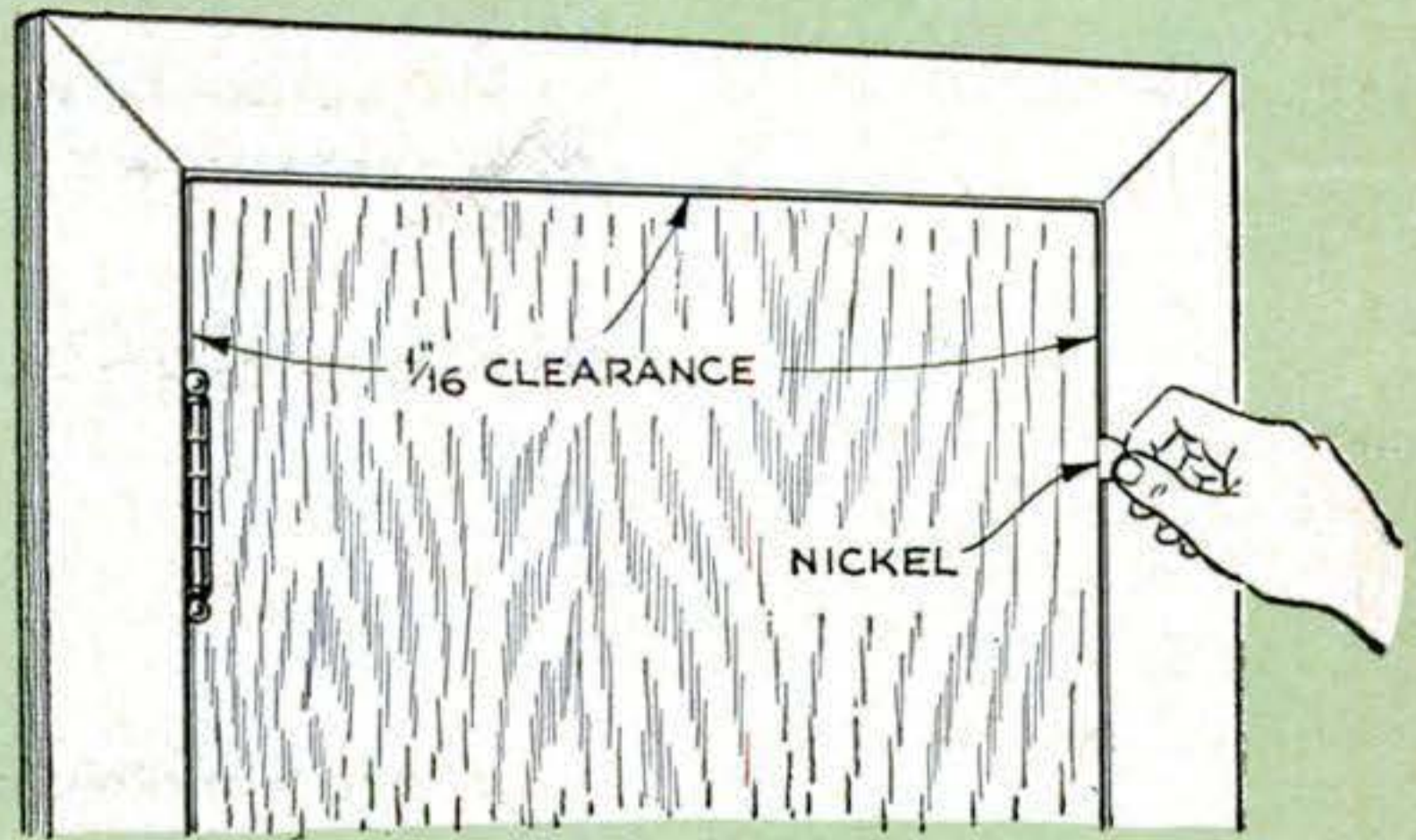

How to plane a door

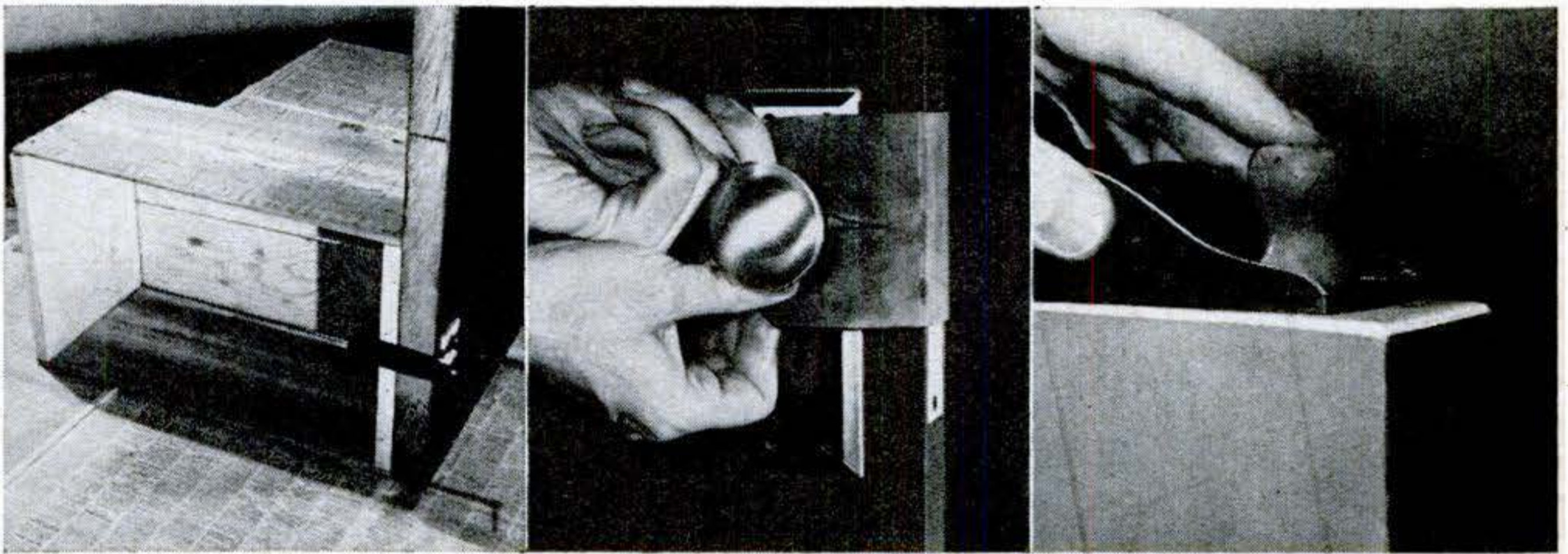

TO HOLD THE DOOR ON EDGE while you work, clamp a wood box to each end at opposite sides. Protect the finish with small blocks of wood between clamp and door. Slit a piece of inner tube and snap it over the door knobs to keep the latch from gouging the floor

(center). Lightly chamfer the corners to keep wood from splintering while you plane. Cut down the high spots first, then run the plane along the entire edge to smooth it. Caution: Check the edge frequently with a try square so you don't bevel it.

Deepen hinge gains after light planing

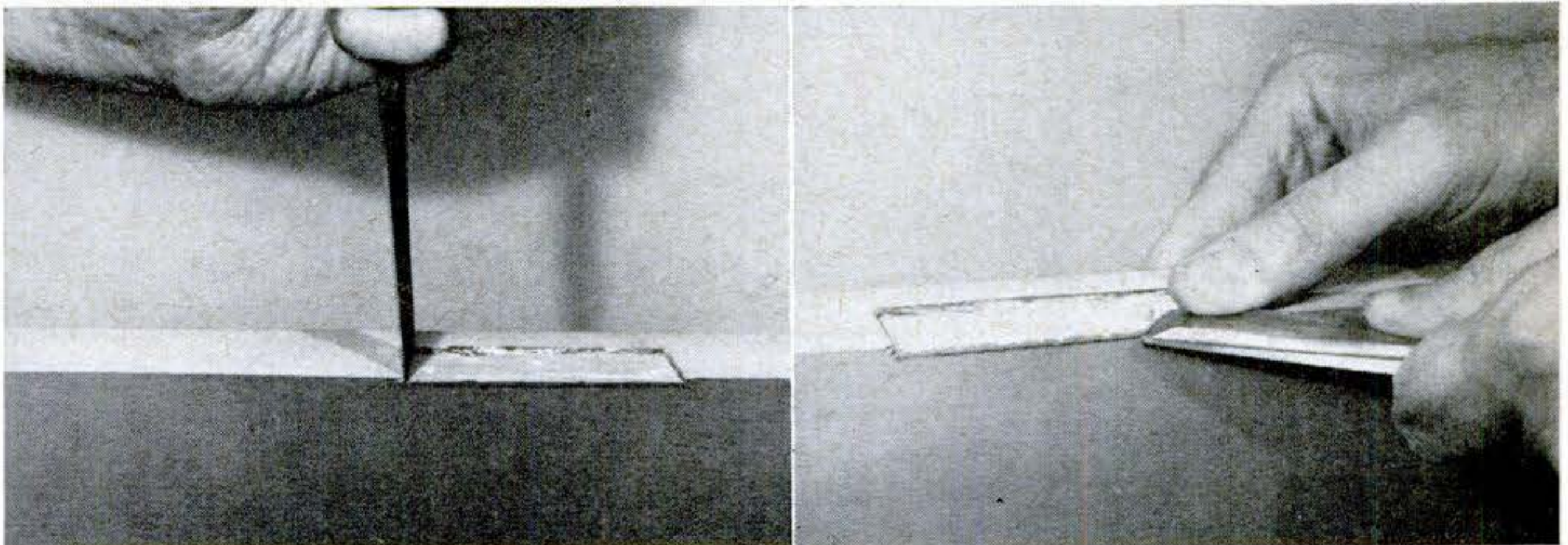

AFTER SHAVING DOWN THE HINGE SIDE, you'll find the gains are no longer deep enough to set the hinges flush. Deepen the outline by tapping the chisel straight down.

BREAK UP THE SURFACE of the recess with a series of chopping cuts. Then chisel away the wood until the hinge is once again flush with the door edge and screw it into place.

How to locate new hinge gains

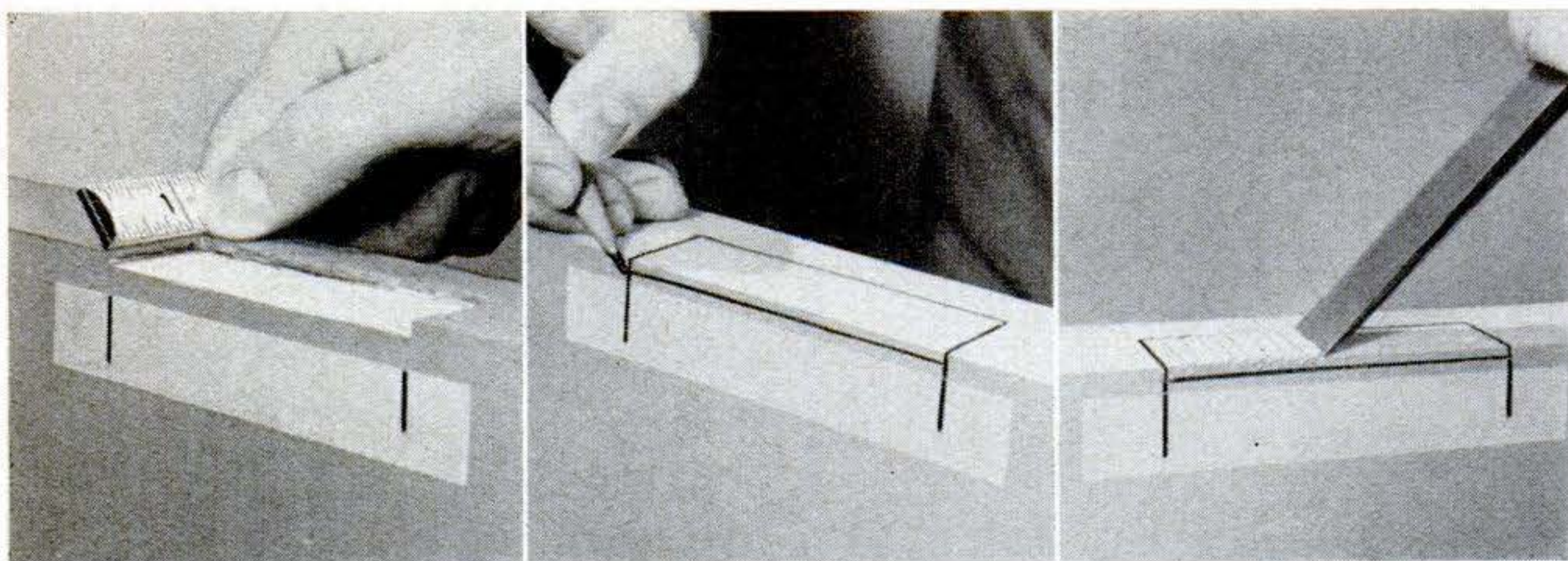

HEAVY PLANING may completely remove the hinge gains. Stick tape on the face of the door and mark the position of the gain, and note its width. After planing, extend the

marks on the tape to the edge and mark the width for a new cutting outline (center). Make a series of chopping cuts and chisel out to the thickness of the hinge.

How to shift the lock

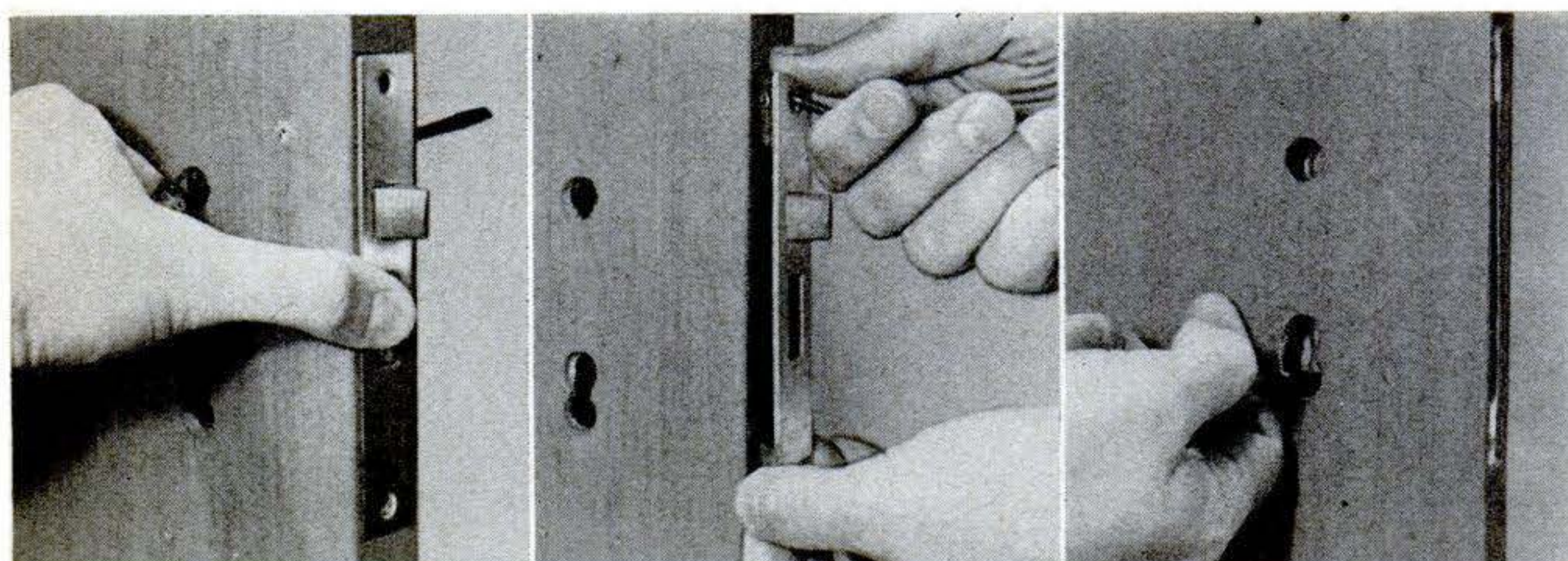

IF PLANING ON THE LOCK SIDE is necessary to keep a panel pattern centered, remove door knobs, side plates and screws holding lock face. Loosen lock by prying through knob hole with a thin screwdriver (left),

then hook a nail in the screw holes (center) and pull it out. After planing, deepen the mortise enough to reset the lock face flush, and elongate knob and key holes. Plug old screw holes if side plate won't cover them.

Trimming the bottom of a door

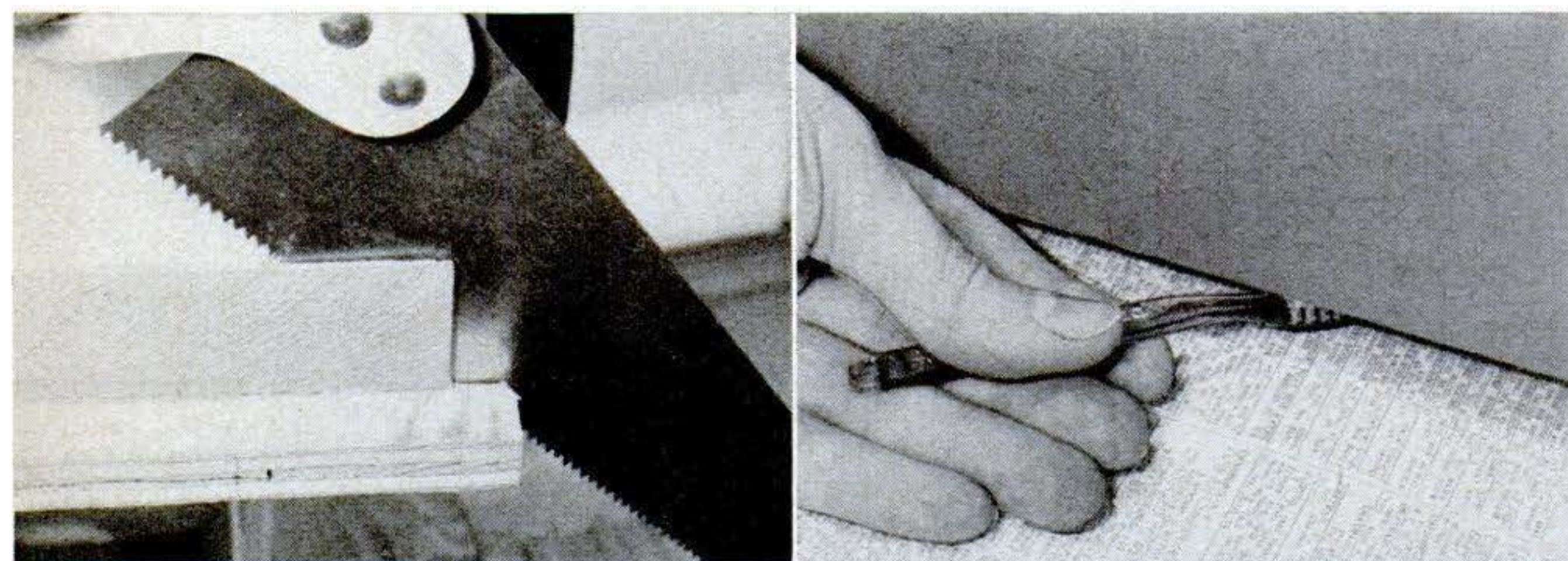

SAWING IS THE EASIEST WAY, probably, if much material must be removed from the bottom edge, as when new carpeting is installed. Clamp a strip of plywood under cutting line on door and saw through both.

RESEAL RAW EDGES WITH PAINT after planing or cutting. Top and sides are easy to reach with a paintbrush, but if you've already hung door to check fit, use an old toothbrush to spread paint over the bottom edge.

Background information on

Counter Coverings for the Home

CHOOSING a counter top is fun these days—yes, even fun for men—because there are so many different types to choose from. Perhaps you've wanted an eye-catching bar, a topping for a coffee table, a surface for the desk in the den. Your wife wants a chopping block, a pastry counter, a bathroom vanity.

Today, counters aren't just for kitchens—they're all over the house. You aren't restricted to just one or two materials. Wood, plastics, linoleum, ceramic tile, even marble and stainless steel, are all in the running—and at prices that aren't beyond the imagination or the pocketbook.

To get a counter that's just right for your particular needs, judge it by these points:

- Will it clean with a wipe?
- Is it stainproof and rotproof?
- Will it be used as a chopping block?
- Can hot pots or cigarettes mar it?
- Will it keep new-looking?
- Most important, does it have the qualities needed for the area in which it will be used?

Plastic laminates (such as Formica and kindred products) are the most popular counter surfacings. Laminate means made up of layers, like a sandwich, and that's exactly what these plastics are. Layers of paper are soaked in tough resins, molded together under high pressure and baked. The top layer of paper has the color or design you see in the finished product. In

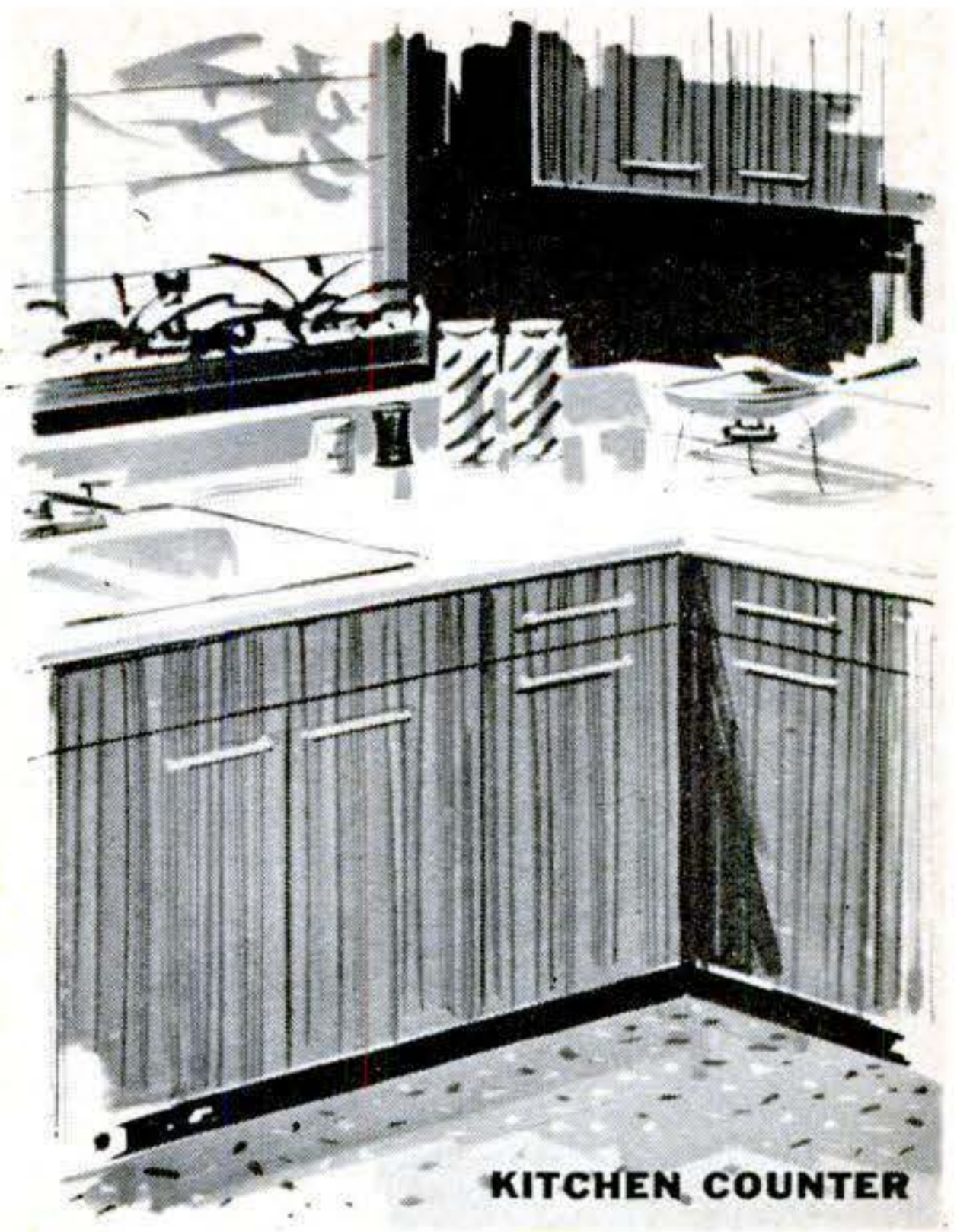

KITCHEN COUNTER



VANITY



TABLE TOP



BASEMENT BAR

some cases, instead of paper, real wood sliced 1/64" thin is used.

You'll find two kinds of laminates. The so-called high-pressure type, made with melamine, is rigid and is sold in sheets, usually 1/16" thick. Low-pressure laminates, made with polyester resins instead of melamine, are not as durable as the high-pressure type, but cost about one-third less.

You can tell the two apart because the low-pressure ones are 1/32" thick—half as thick as the high-pressure type—and are usually flexible enough to be sold in rolls. One advantage of their thinness is that joints are less conspicuous if you plan to edge your counter with the same material as the top.

Pros and cons. Plastic laminates wipe clean. They won't fade, spot or rot, and under normal use they should last 20 years or more. They take temperatures up to 275 degrees, so they are unharmed by boiling water, but you can't set a hot

pot or skillet on them. The plastic will bubble up and be ruined. You can't use it as a chopping block either—it scratches. A tip: Plain colors, especially white, are more likely to show scratches and knife cuts than patterns. Wood-grain and marble patterns, on the other hand, may be troublesome to match at joints.

Plastic laminates can be edged with strips of the same material or with snap-on chrome or stainless-steel moldings. Self-edging saves the cost of metal trim, gives a handsome modern look, but takes more time and skill to install. The joint at a counter's backsplash can be butted, but a metal cove makes a tighter fit.

If you're careful and painstaking, you can do your own installation. Manufacturers supply complete instructions. New water-soluble contact-bond adhesives eliminate any danger of flammable and toxic fumes. If you wish, you can buy the laminates prebonded to 3/4" plywood.

Plastic laminates are also available as

Three Ways to Buy and Use Popular Materials

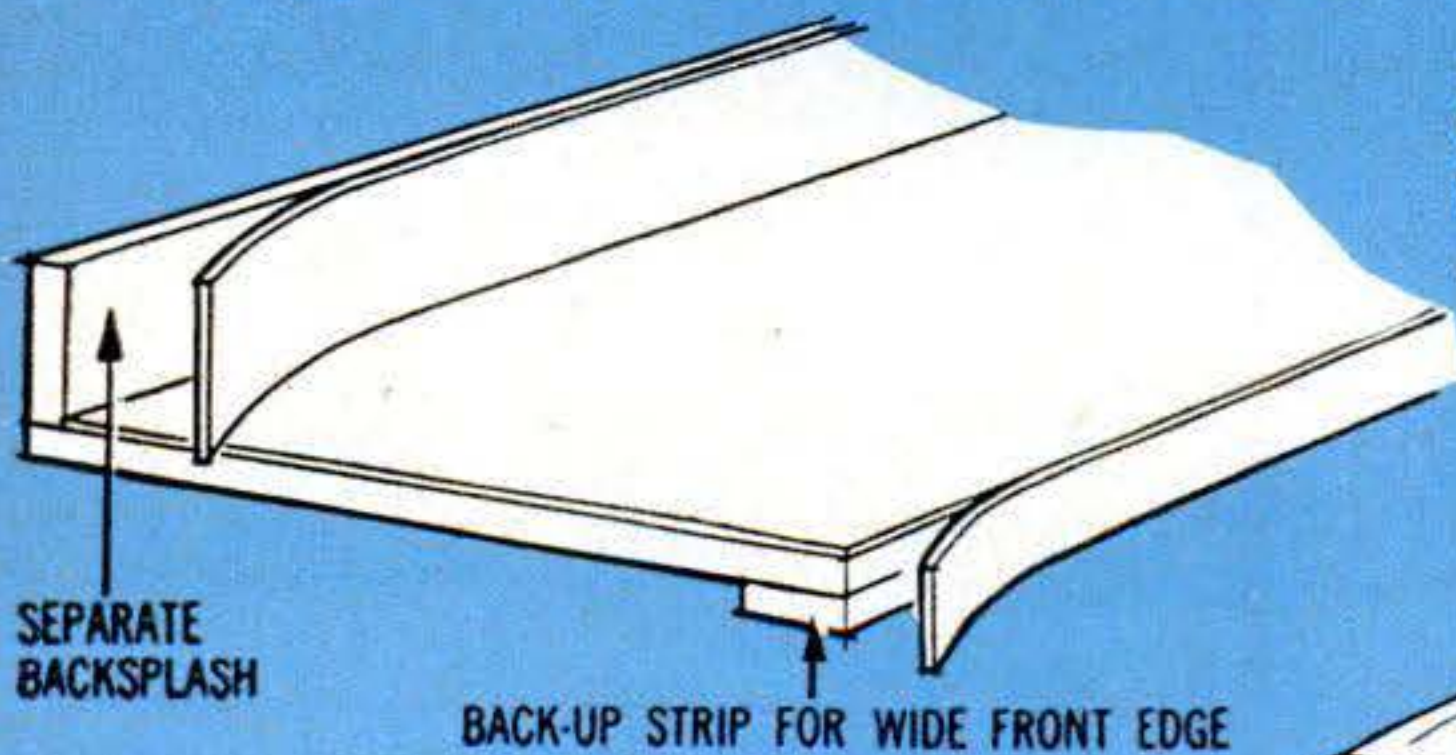

SEPARATE BACKSPASH

BACK-UP STRIP FOR WIDE FRONT EDGE

FLEXIBLE VINYL PLASTIC (at right) is less durable than laminates, but can be curved in one piece to make a rounded front edge and a seamless cove joint at backsplash. Linoleum can be shaped in the same way.

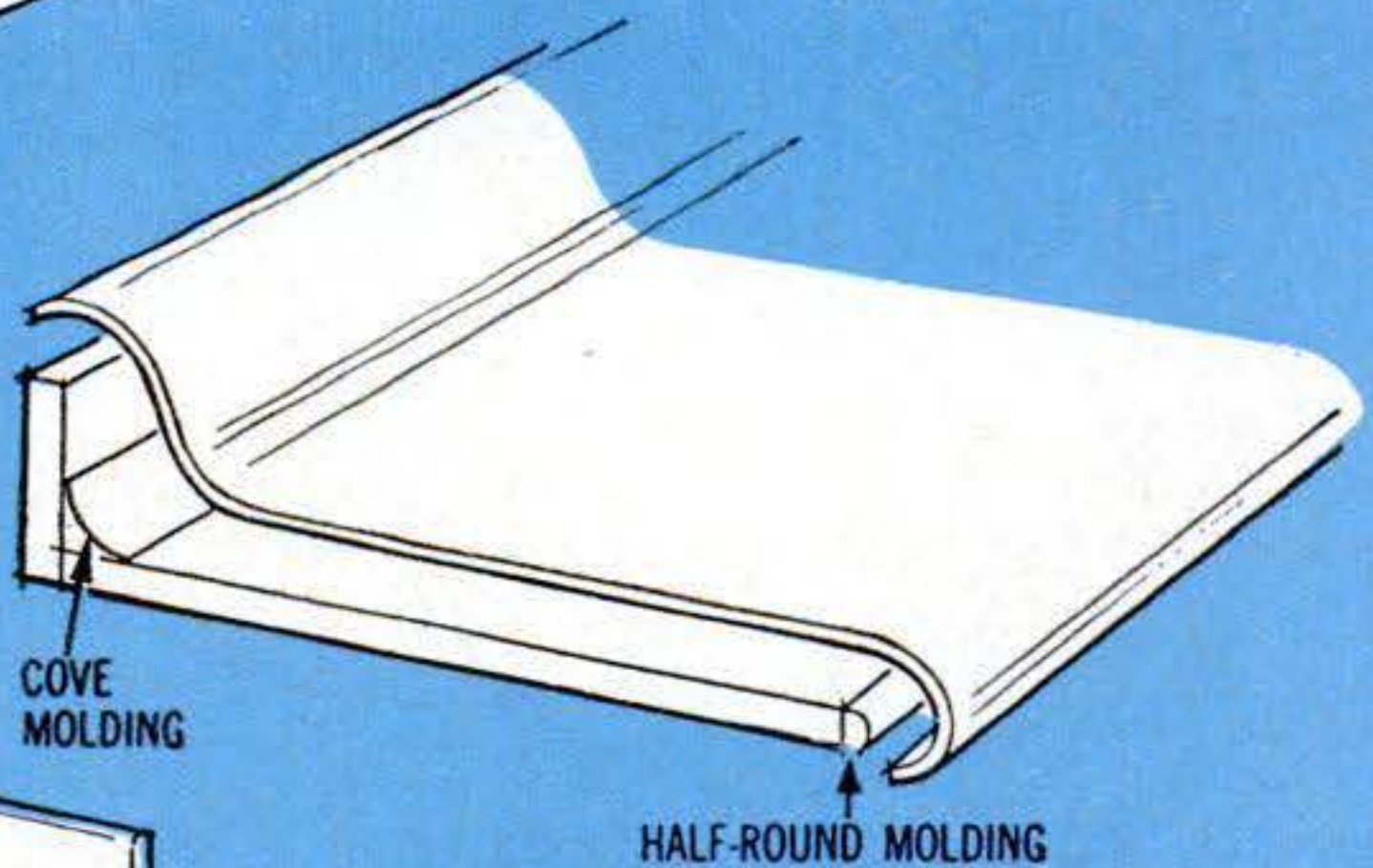

COVE MOLDING

HALF-ROUND MOLDING

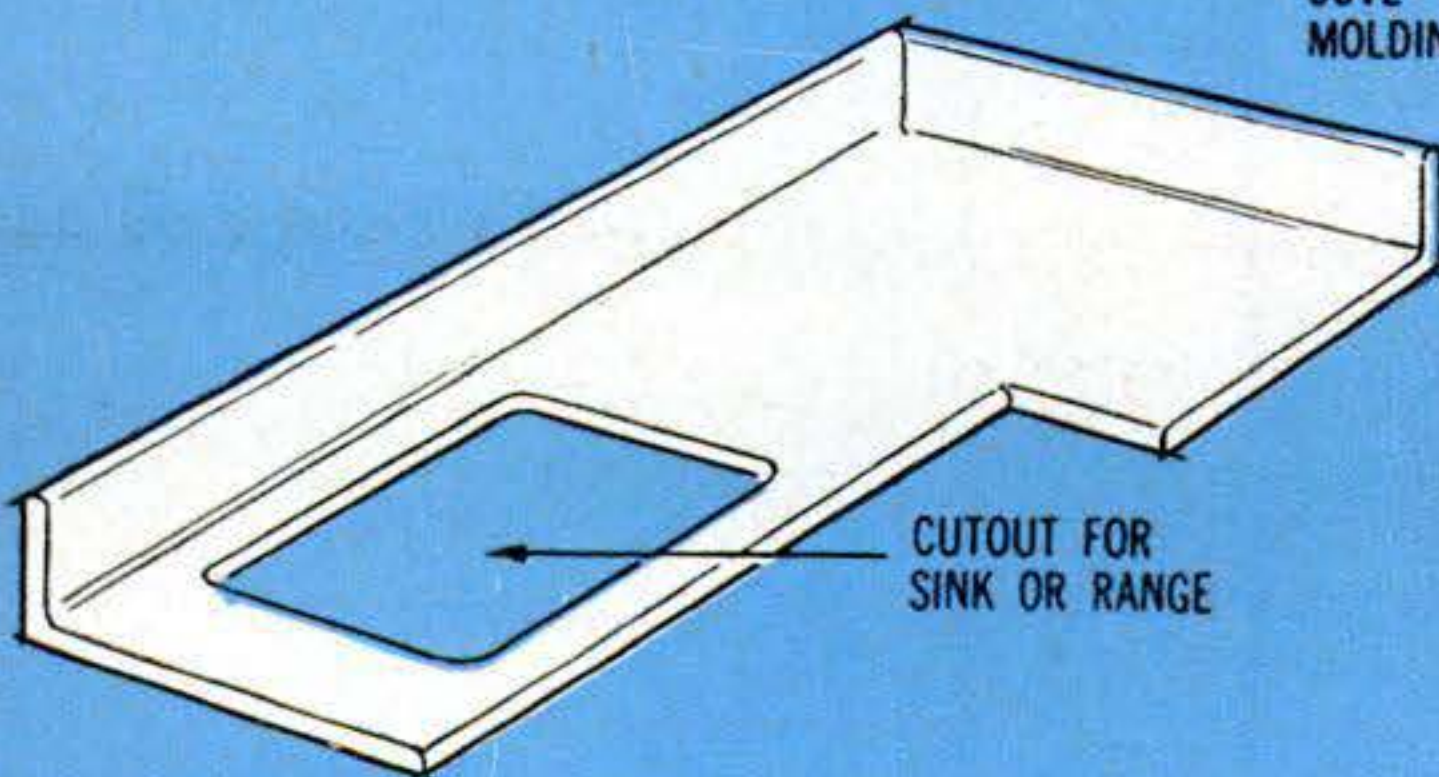

CUTOUT FOR SINK OR RANGE

RIGID SHEETS, called plastic laminates, must be applied as separate flat strips. Edges can be faced with the same material as the top or with quick snap-on metal trim.

PREFORMED COUNTERS come ready to install in straight and corner sections of varying lengths and with or without cutouts for sinks or cooking burners. The plastic type is seamless and has rounded edges; similar prefab stainless-steel sections are square-edged. Matching hardwood chopping blocks are also available to fit between sections.

complete, ready-to-install counter tops. The plastic is covered up at the backsplash and rounded down over the front edge to produce a completely seamless one-piece top. Often the front edge is raised slightly to keep anything spilled from running onto the floor.

Lacking seams, prefab counters are easy to swish clean, but they have some disadvantages. Sometimes it's difficult to make a machine-perfect counter fit into corners that aren't absolutely square and against walls where studs are somewhat in and out. Backsplash height is usually limited to 4" or 4½", while in on-the-job fitting you can run the backsplash up as high as you want.

Sheet vinyl is a newer material than the plastic laminates and costs only about half as much. It's flexible, comes in large rolls, and so can be run across the counter and up a wall in one piece. Backed by half-round molding, it can be bent around the counter's front edge.

Vinyls are more resilient than the laminates and quiet dish clatter better. Some manufacturers offer vinyls in patterns to match flooring. This is an advantage in a small room, for it will make it seem larger. The one drawback to vinyl as a kitchen-counter material is its poor resistance to heat. Hot pans stick to it and melt it. Cigarettes burn it. Even boiling water damages it.

Linoleum's big advantage until recently has been low cost, but now this is almost matched by the newer, low-priced vinyl coverings. Still, it has several good points. Like vinyl, linoleum is strong, quiet and not easily dented. Unlike vinyl, it does not melt under heat, although it can be scratched and scarred by very hot pans and cigarettes. Knife cuts and scratches also show up somewhat less than on vinyl.

Linoleum's main disadvantage is that it stains easily and absorbs water, which causes it to rot around a sink. With

How Counter Coverings Compare

MATERIAL	COMMON SIZES	ADVANTAGES	DISADVANTAGES
PLASTIC LAMINATES	Rigid sheets ¼" thick up to 4'-by-8' or larger	Won't stain, rot or fade; keeps new-looking indefinitely	Hot skillets, toasters, electric percolators, etc. may damage it. Knives will cut it
SHEET VINYL	In rolls 30" to 72" wide	Flexibility makes it easy to bend and produce seamless finish. Quiet, resilient, inexpensive	Low resistance to heat. Hot pans melt it. May stain slightly from some foods and medicines
LINOLEUM	In rolls ¼" thick, 72" wide	Low price; won't melt under heat; makes good surface for writing	Cuts easily, rots, fades, scratches, stains, mildews
STAINLESS STEEL	16 or 18 gauge	Extremely durable, sanitary, easy to clean. Resiliency minimizes breakage of dishes	Shows soil readily, lacks color. Not good for cutting and chopping—it dulls the knives. Will scratch
CERAMIC TILE	Many shapes from ½" to 12" squares and oblongs. Most common are 1" and 4¼" square tiles	Very durable. Immune to heat and staining. Fireproof	Noisy and unresilient. Glassware and dishes break easily
MARBLE	⅞" thick for self-supporting counters; ½"-thick tiles for use on base. Use only grades A and B	Beautiful, natural material. Superior for rolling out pastry or for hot pots. Needs no backup or moldings	Stains, scratches, is unresilient
WOOD	1½"-thick laminated maple or birch	Best surface for cutting and chopping	Stains easily. Difficult to clean and maintain

waxing and care, it may last 10 years or more, but usually requires replacement sooner. Linoleum is excellent, however, for retopping an old desk, table, workbench or drawing board where spilled liquids are not a problem.

Stainless steel's new popularity for counters stems from its good qualities as a kitchen sink. It's the most durable and the easiest to maintain of all counter materials. Nothing found around the house, including photographic chemicals, will stain it. That many health department codes require it in restaurants and public places is testimony to its sanitary excellence.

Most prejudice against stainless steel dates back to the use of Monel metal and German silver. Stainless steel won't spot like Monel. It doesn't have the copper content. Nor will it dent like German silver. Its surprising resilience is what makes it so kind to fine china and glassware. Anyone who still complains of stainless steel spotting and fingermarking hasn't discovered the trick of occasionally wiping it with lemon oil.

Factories prefab stainless-steel counters with sink, no-drip edge and backsplash all stamped out of one seamless piece. You can also get counters custom-made with the sink of your choice and stove burners flush-mounted anywhere you wish.

One problem with a stainless steel counter is to get a tight joint between the backsplash and the wall. In new construction, the best way is to flash the backsplash right into the wall, then bring the wall surfacing down over the flashing. Plastic laminates make an attractive wall surfacing for use with stainless steel for they can supply color and pattern.

Ceramic tile is greaseproof and stainproof. Hot pans can't hurt it; neither can spilled bleaches or nail polish. Sunlight won't fade it, and water can't penetrate it. Now a new waterproof grout also makes the joints between the tiles impervious to grease and staining.

The biggest drawback of tile is its lack of resilience. Glassware and dishes break easily, and pots clatter on its hard surface.

Either glazed or unglazed tiles make a satisfactory counter. Choose the glazed finish for an easy wipe-clean surface. New, tougher glazes have recently been

developed that are practically immune to scratching. You'll find them offered under such names as "Everglaze," "Dura-glaze," and "Crystalline glaze." Bathroom counters are not likely to be subject to much abuse, and ordinary glaze is acceptable there.

The natural beauty of marble is hard to beat, although it comes at a premium price and does have some drawbacks. Use it in the bathroom for a luxurious touch. In the kitchen, a section of marble counter provides an unexcelled surface on which to roll out dough or set hot pans.

Marble needs no backing or edging. A separate piece is used when a backsplash is required. The most practical marble thickness for home use is $\frac{7}{8}$ " , but up to 2" is commonly available. Use only grade A or B. Others are not sound enough and may crack. A special wax, available from marble dealers, helps protect marble from staining. Even so, it will stain only if spills are allowed to stand for some time.

Sinks installed in a marble counter are attached from underneath. The joint between sink and counter should be made with plaster, never putty. The oil in putty will stain the marble.

Recently introduced marble tiles, $\frac{1}{2}$ " thick, make it possible to use marble at about half the former cost. The tiles are set like ceramic ones over a wood base.

Wood is kind to knives and makes the best counter for cutting and chopping. Having a section made of it is more convenient than having to pull out a board. Wood counters, $1\frac{1}{2}$ " thick and made of laminated maple or birch, cost about the same as plastic-laminate counters. A section 15" to 18" wide is usually sufficient for most cutting purposes.

The best finish for cutting boards is a rub-down with hot mineral oil to seal out moisture and stains. If the counter is used for serving, or as a bar, then choose a clear, high-quality varnish or plastic-resin finish for a hard, impervious surface.

A combination of materials often provides the best kitchen counter. Use tile, marble, or stainless steel where hot pans and skillets are to be set. Use laminated wood in food-preparation areas, marble or wood in baking centers. Use a plastic laminate or a sheet vinyl for colorful and easy-to-maintain surfaces elsewhere.

How to mix

A Natural Finish for Wood Siding

YOU can make your own natural finish for wood siding—one that recent scientific tests have proved more durable than any other formulation. The apparatus you need to mix it is all easy to come by, and the ingredients—there are seven of them—are stocked by most paint stores. Finally, there's the formula—developed, tested and recommended by the U. S. Forest Products Laboratory, in Madison, Wis.

You may eventually be able to buy the finish under a manufacturer's label. But in the meantime, here's what you'll get if you mix your own:

- A protective covering that combines the durability of dull wood stains with the rich sheen of varnish-like finishes (but its sheen will last from three to four times as long).
- One-coat coverage on new wood, good for four or more years under normal weathering conditions.
- Renewal coats that can be brushed right over old ones of the same type, eliminating the troublesome scraping and sanding that must usually be done to prepare old surfaces for a good bond.

Two points of caution, though. When you apply this finish over older types that leave a glossy surface coating, these must be removed first. And if you ever decide to paint over surfaces that have previously been treated with the new finish, you must be sure that no traces of wax remain on the wood.

The accompanying red-cedar formula yields five gallons of the new finish—enough to cover an average three-room ranch-style house.

For effects other than red cedar, you can vary the amounts of colors-in-oil. To get a light redwood shade, use half a pint

WHAT YOU NEED

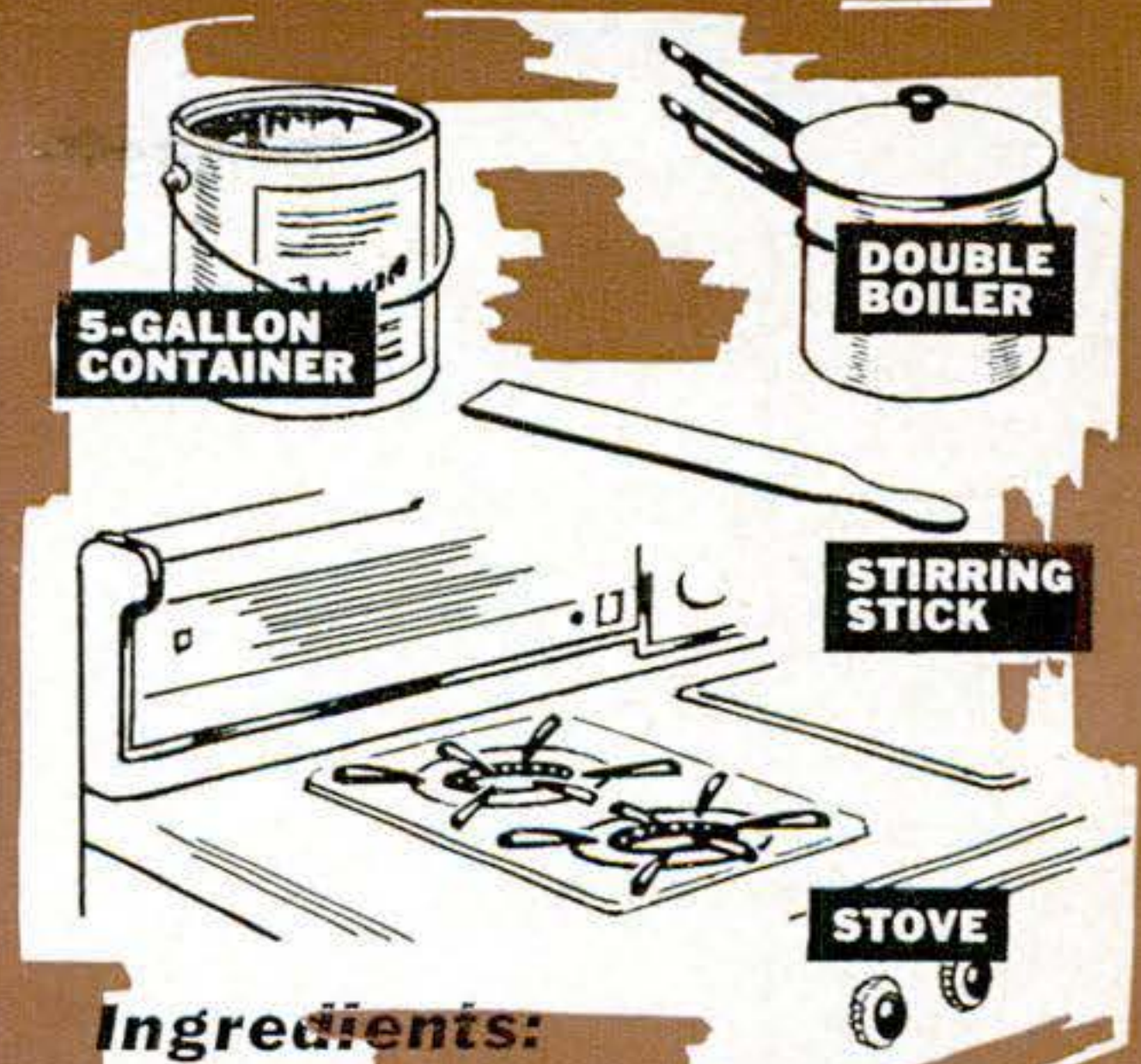

Ingredients:

Boiled linseed oil.....	3 gal.
Turpentine or paint solvent....	1 gal.
Burnt sienna colors-in-oil.....	1 pt.
Raw umber colors-in-oil.....	1 pt.
Paraffin wax.....	1 lb.
Penta concentrate, 10:1.....	1/2 gal.
Zinc stearate.....	2 oz.

of burnt sienna and two-thirds of a pint of raw umber; for dark redwood, half a pint each of burnt sienna and raw umber, and one pint of pure red iron oxide (Indian red). You can also prepare lesser amounts of the finish by simply reducing the ingredients proportionally. To estimate how much you'll need, figure on one gallon for every 400 to 450 square feet of smoothly planed wood, or one gallon for every 200 to 250 square feet of rough-surfaced wood.

Use care in mixing the ingredients. First pour the turpentine or solvent into a large container. In another room, melt the paraffin, mixed with the zinc stearate, in the upper half of the double boiler, keeping the flame that heats the water in the lower section low. When the mixture is uniform, pour it into the turpentine or solvent, stirring vigorously. Avoid any open flame while doing this.

After the turpentine-paraffin has cooled to room temperature, add the half-gallon of penta concentrate, then the linseed oil. Finally, stir in the colors-in-oil slowly. When the batch is of uniform consistency and color it's ready to use. Apply it to the siding with a wide brush, stroking with the grain.

Four Painting Tips

YOU can convert an aerosol spray can into a refillable pressurized sprayer, handy for many small jobs, and build up the pressure with a tire pump each time you want to use it.

Choose a can with a perfect nozzle. Then salvage a metal tire valve with two threaded nuts from an old inner tube—or buy one at an auto-accessories store. If the valve has a broad base or flange, hack-saw this off so the valve can be screwed directly into a nut soldered over a hole drilled in the center at the bottom of the can. Place a rubber washer over the valve stem and turn it and the second nut up against the first nut. (Make sure all gas has been exhausted from the can before drilling the hole.)

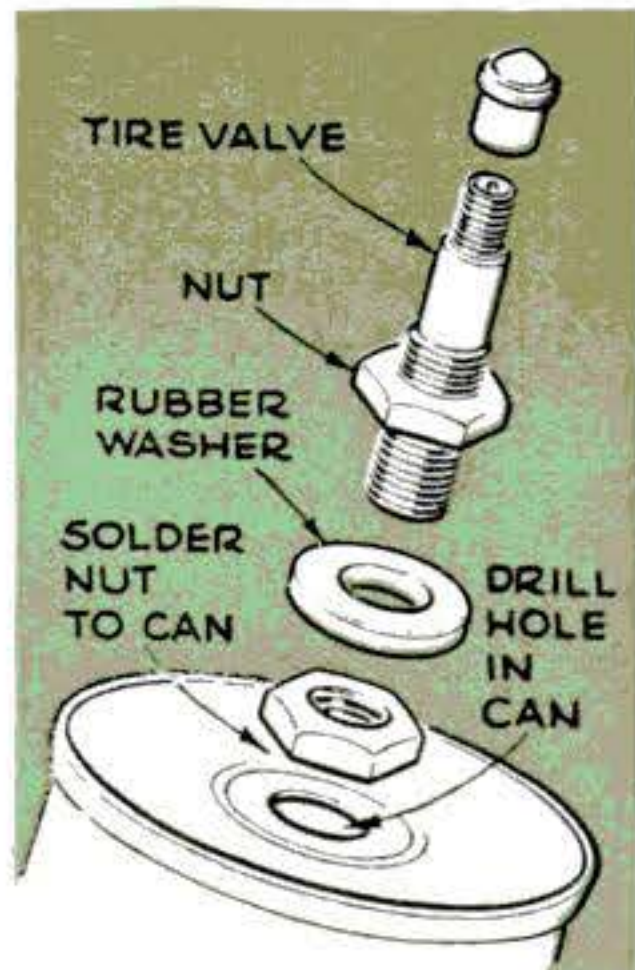

to half fill the can with properly thinned paint or lacquer. Replace the valve and inject air with a few strokes of a tire pump.—*Russell A. Dixon, Pittsburgh.*

To use the sprayer, remove the valve

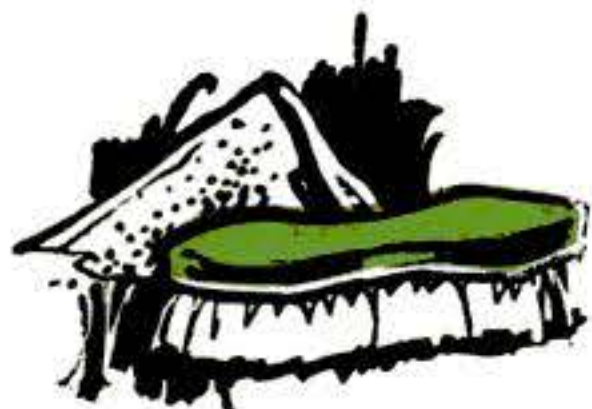

MY HUSBAND, who is a professional painter and decorator, says the following procedure

is the best he has ever used for removing paint from a piece of furniture:

First apply remover that's designed to wash off. Let it stand 10 to 20 minutes, giving it a good chance to lift the old finish. Don't be too hasty in taking off the remover.

In the meantime, prepare a pail of warm solution, using one of the powders sold for washing painted surfaces (such as Soilax). When the remover has done its work, douse the area with the solution, using a scrub brush. Next, dip the wet brush in clean, fine white sand and scour the area thoroughly, using firm pressure. Then flush off the loosened finish with water.

Repeat the process from the beginning if necessary to remove the last bit of paint. A one-pound coffee can half full of sand is enough to do a good job on an average chest or table.—*Mrs. George A. Musculus, Manistee, Mich.*



NEEED a good paintbrush? I did. So, meeting our local junk man one day, I offered to give him a nickel for every one that had a handle on it and

bristle, no matter the size or condition. A week later he sold me a bushel basket full. After cleaning them, I had a selection of brushes, from 1/2" to 6", that would have cost a small fortune when new.—*Robert M. Caulkins, Waverly, Ohio.*

HERE'S how I applied a linseed-oil finish to an old oak rolltop desk. After sanding off the old finish, I brushed on a wash coat of linseed oil and paint thinner (50-50 mix). A second coat of 75 percent oil and 25 percent thinner was added the next day and allowed to dry overnight. A quick rubdown then gave a pleasing finish, easy to maintain. Scratches can be gone over with a little oil.—*Everett Lasher, Seattle, Wash.*



Short Cuts and Tips

FROM PS READERS

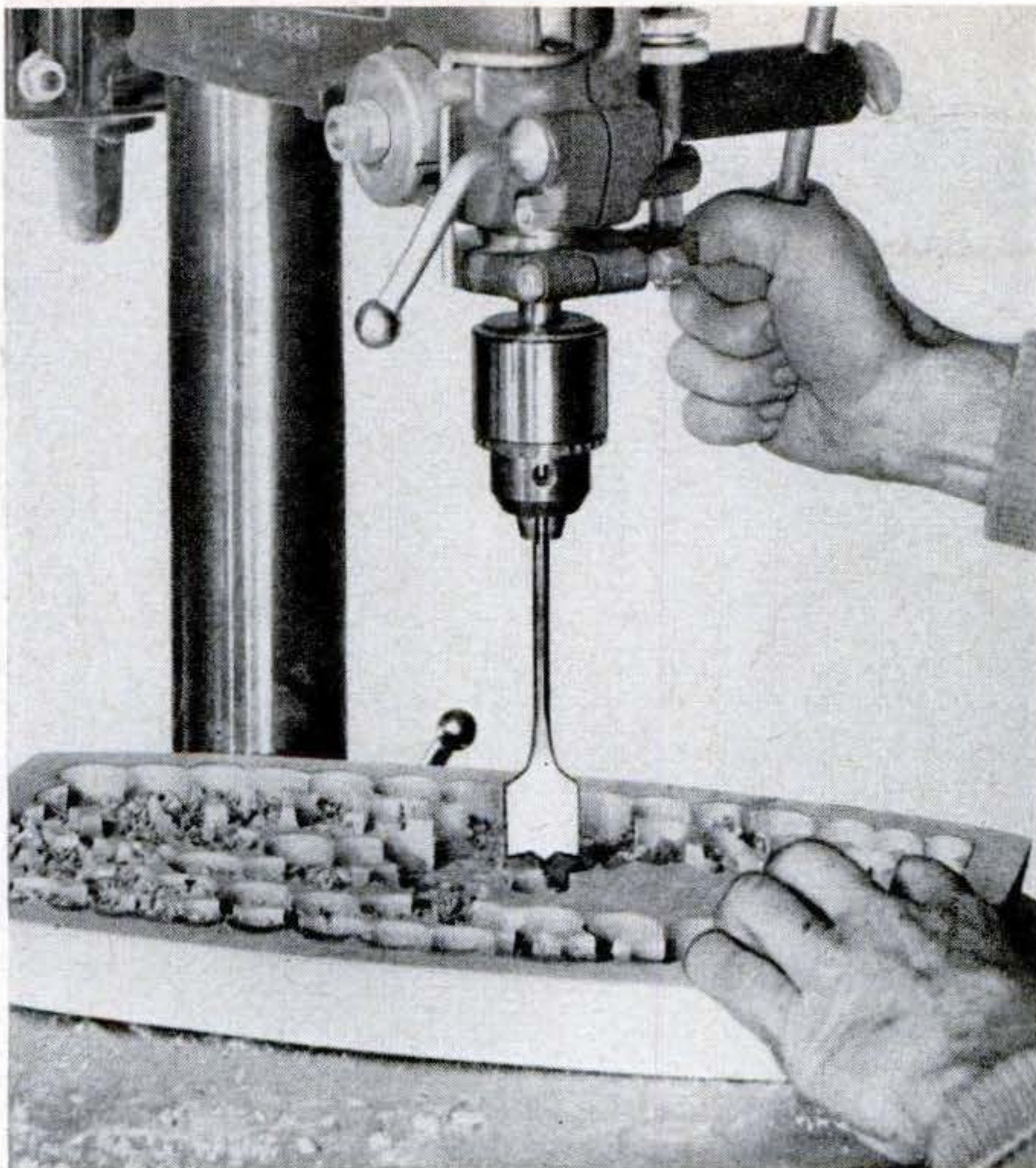

Rough Hollowing with a Flat Drill Bit

A FLAT drill-press bit cuts fast and makes a good roughing tool for hollowing wooden trays and bowls.

File down the center point of the bit until it is just a little longer than the outer spurs, and you can work close to the finished depth.

Bore slightly overlapping holes and knock out the blocks with a chisel and mallet. A light cut with a chisel or router will then flatten the bottom.—*Edwin M. Love, Palmdale, Cal.*

Collars Protect Tomato Plants



CARDBOARD cylinders cut from waxed-paper or toilet-tissue rolls will keep the cutworms away from your young tomato plants. Slit the cylinders down the side and snap them on the stalks, pressing into the ground.

Glue Clamp for Emergencies

WHEN all my glue clamps were in use recently on a big shop project and I needed one more to accommodate thin material, I tried a tennis-racket press. It worked fine.—*John A. Comstock, Wellsboro, Pa.*

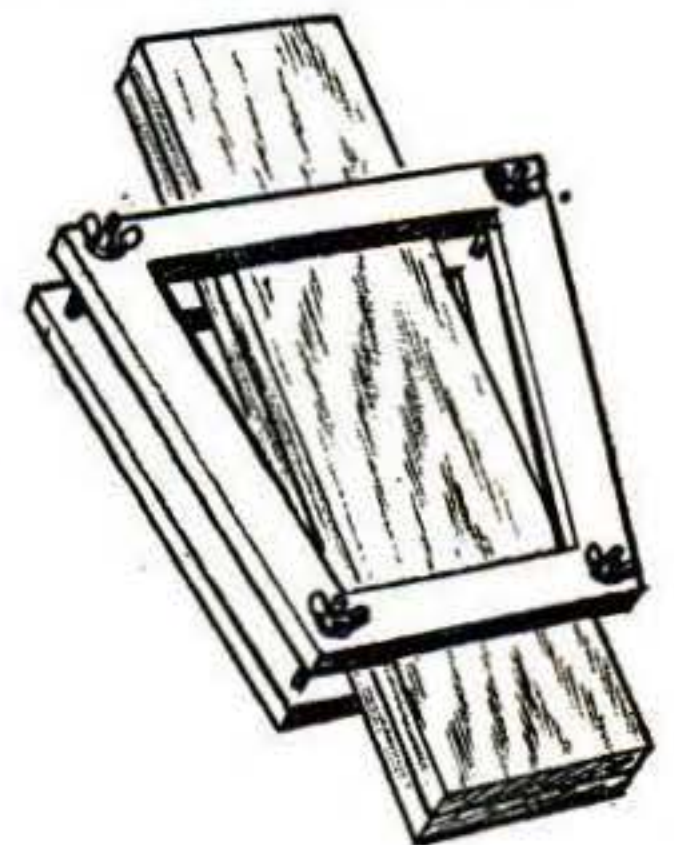

Long-Lasting Swing Oiler

BEING old-fashioned, we still have a porch swing—but it squeaks. I solved the problem of weekly oiling of the S hooks by forcing a wad of cellulose sponge into the screw eye and soaking it with oil. It now seeps without refill for months.—*Larry Fiedler, Cleveland.*

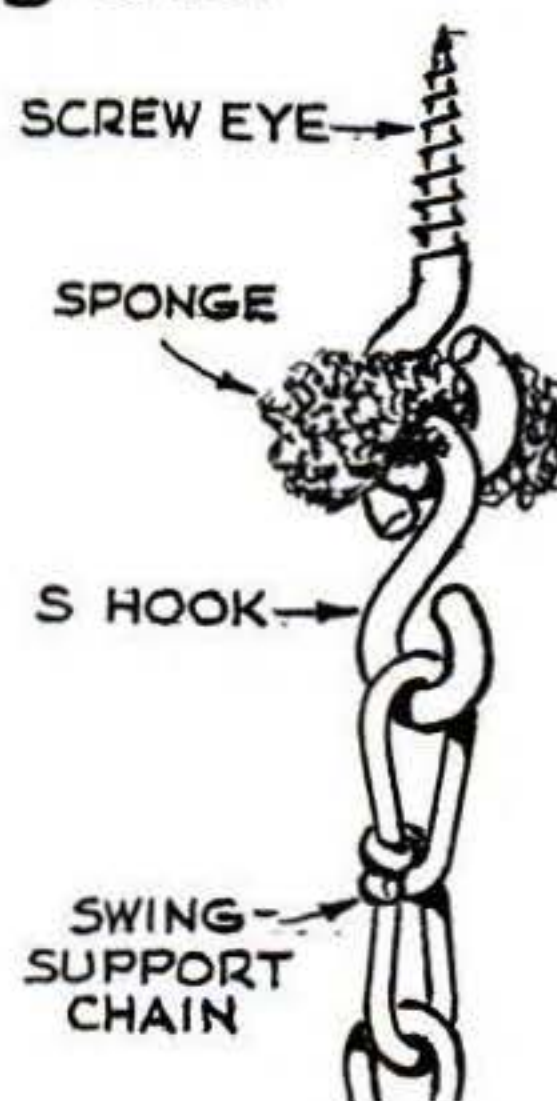

Getting Rid of Old Tin Cans

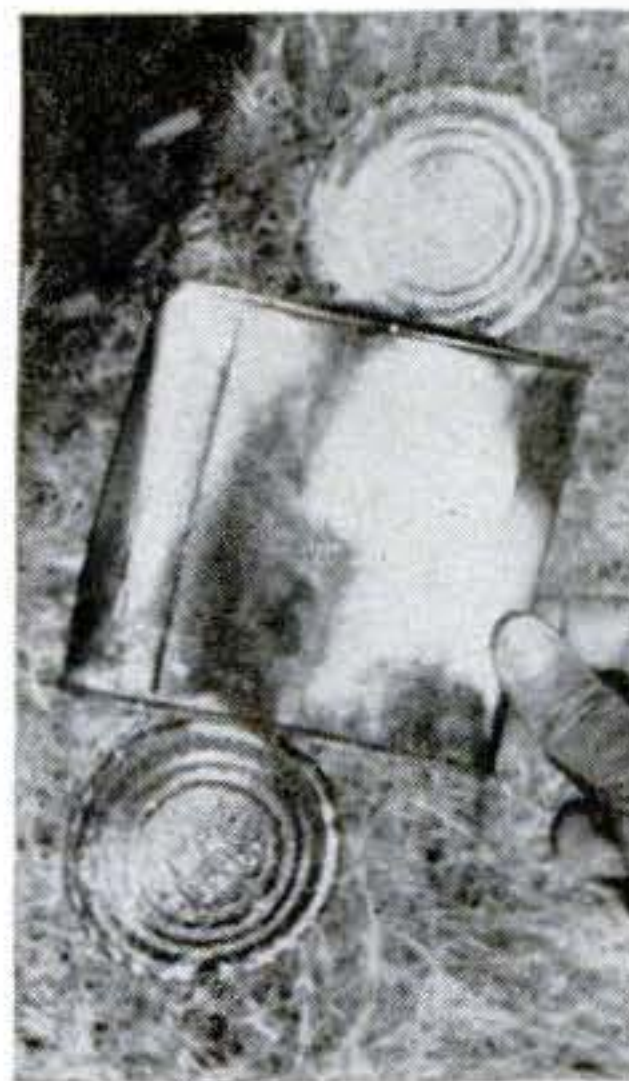

TIN cans accumulate rapidly on a camping trip and are difficult to dispose of.

One way is to cut open the bottom and flatten them. Then you can make them up into one or more small packages that can be easily carried home for the garbage pickup.—*Clinton R. Hull, Santa Ana, Cal.*

How Good Are Indoor TV Antennas?

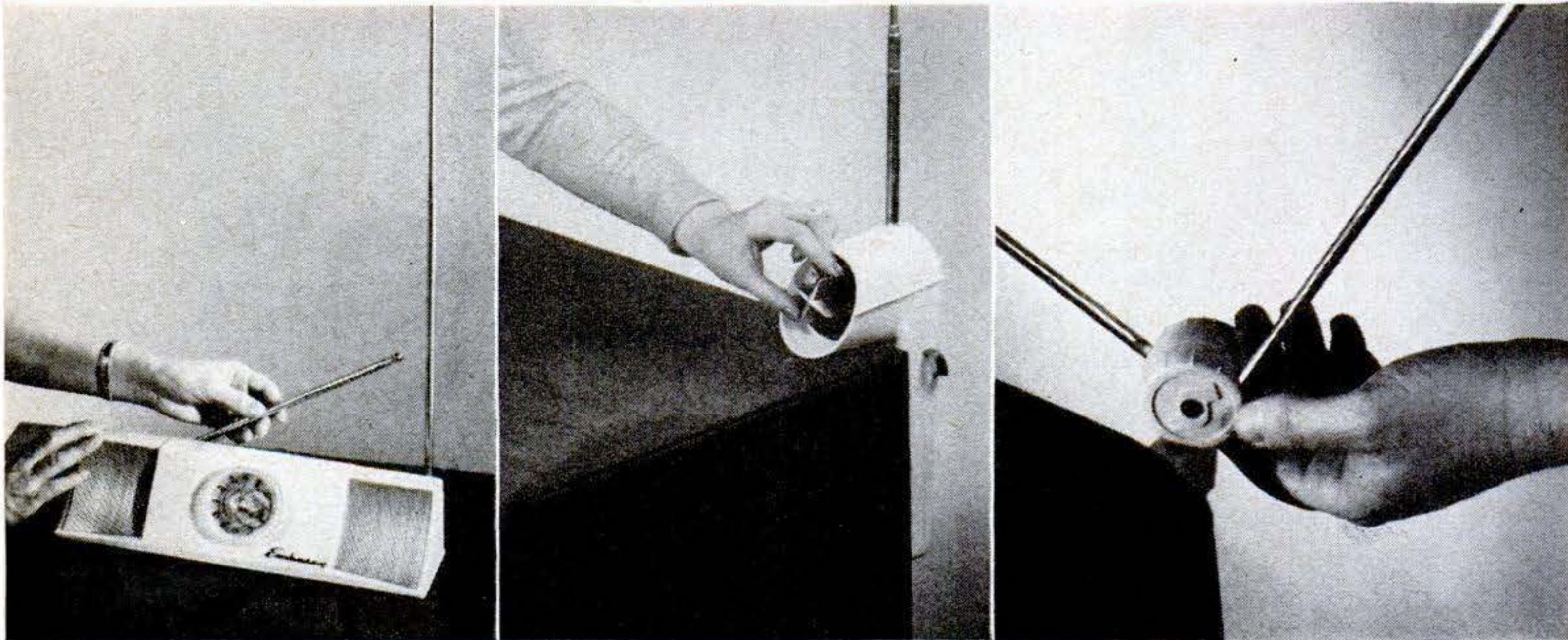

MODERN STYLING has done more than electronic design to fit antennas into the home. These full-length rabbit ears fold behind plastic case that houses switch and shorter loop.

A SINGLE POLE often works as well as two in strong signal areas and is easier to adjust. This model telescopes into back of set so that only the switch is visible when it's not in use.

RABBIT EARS that attach to set can be rotated or tucked down behind the cabinet. Disadvantage: You can't move the antenna around the room to test for locations of best reception.

Do they work? Sure. A few dollars invested in one may bring in all the signal your set needs. But be wary of phony claims

By Robert Gorman

BEFORE you spend money on a fancy rooftop antenna, it will pay you to see what a pair of modest rabbit ears will do.

Outdoor TV antennas are better—no question about that—but, like the highest octane gasolines, they sometimes deliver superfluous “quality” that is scarcely worth the extra cost and bother.

Today's stronger transmitters and more sensitive receivers make indoor antennas more practical than in past years. If you live in a strong-to-medium signal area—up to 20 or 25 miles from a transmitter—the chances are that a living-room dipole may have as much pulling power as your television needs for good reception.

The advantages: An indoor rig is low

in price, costs nothing to install, relieves your chimney of an unsightly nuisance, won't blow down or invite lightning, and can be moved anywhere you want it for best reception or portable use.

How useful are the gadgets, switches, coils and loops that festoon most current models? The answers may surprise you because many of the claims for indoor antennas are a lot of pure hokum.

Best without frills. The familiar tuned dipole has become a standard antenna design because it does two jobs well: It (1) plucks passing wave energy out of the air with high gain or “power,” and (2) relays this energy to the receiver with minimum “impedance mismatch” which produces fuzziness, ghosts, loss of signal strength and other troubles. The combined length of a dipole's two horizontal arms is, theoretically, equal to half

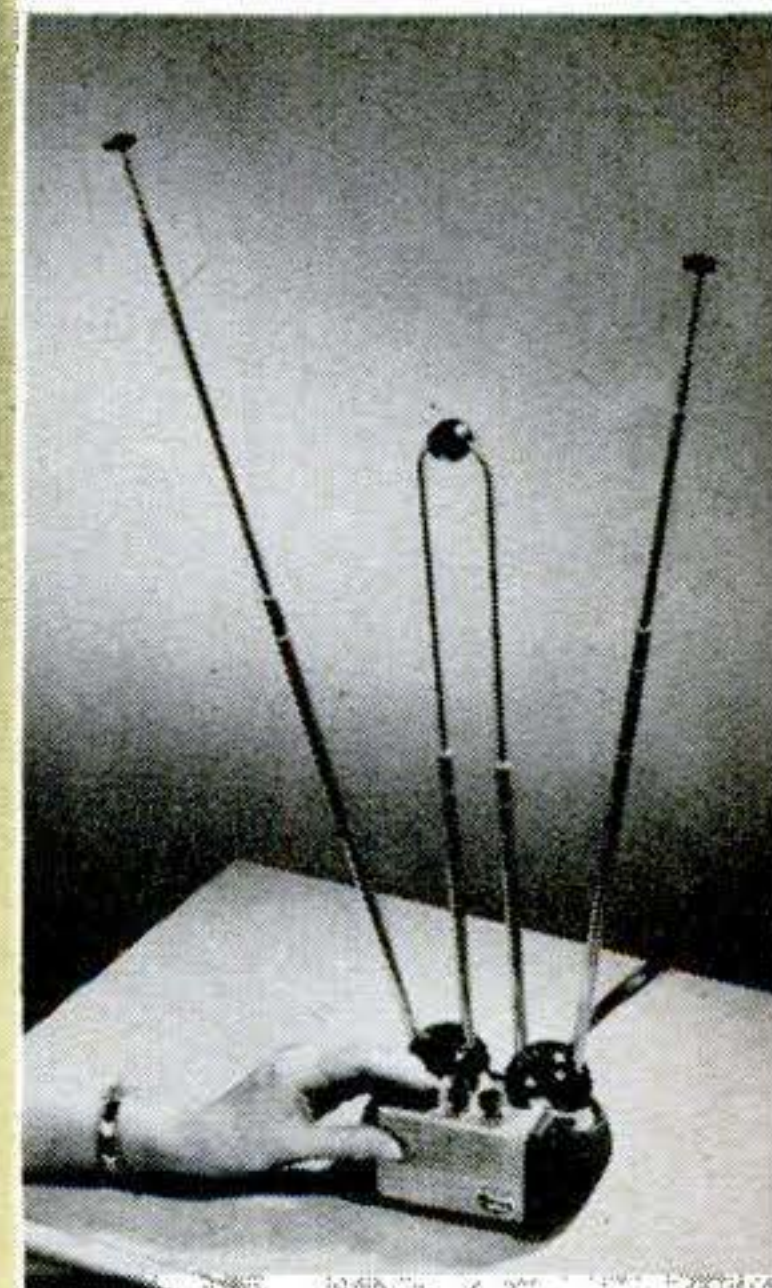
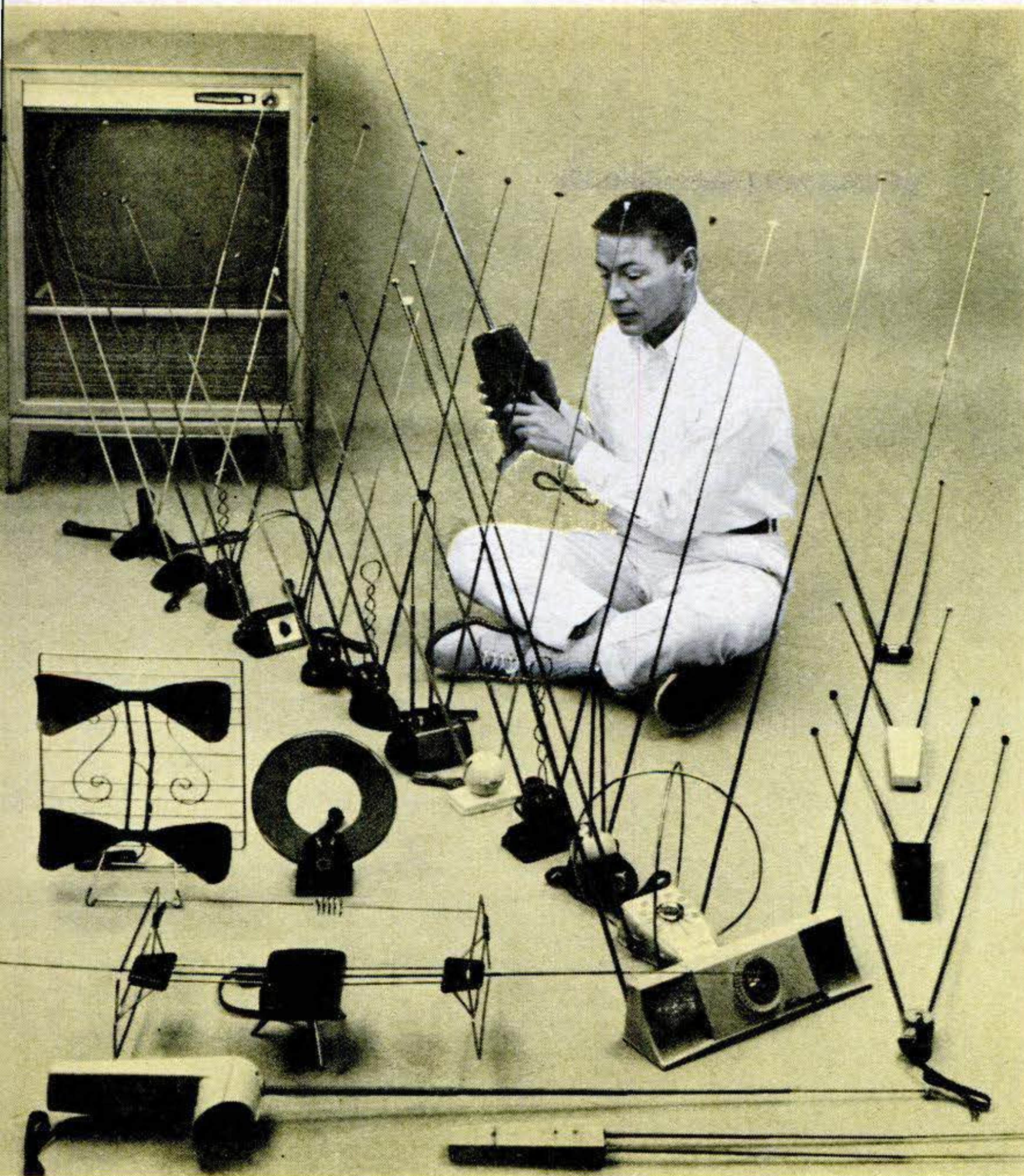

PUSHBUTTONS take place of rotary switches on these modified rabbit ears. Telescoping center loop is said to aid tuning and adjustment.

the signal wave length of the particular channel being received.

In outdoor antennas, engineers can increase signal pickup many times by adding stacks of extra arms of different lengths and carefully adjusting their angles to the incoming waves. But all this takes a lot of metal and a lot of space. There is just no practical way of providing this for an indoor antenna.

Despite claims of increased "power," gain or sensitivity, no indoor antenna yet invented can match the signal-grabbing ability of the simplest outdoor dipole. But the plain, no-frills, full-length rabbit ears comes the closest.

Are indoor rigs getting better? Basically, engineers have followed two main paths in their attempt to improve indoor reception. One school has tried to make antennas smaller and more maneuverable

without sacrificing too much signal gain as compared with full-length rabbit ears. The other school of antenna design has fiddled with anything that seemed to improve reception.

The first approach is based primarily on outdoor-antenna theory. Brought indoors, this means that, to function well, the arms of a dipole must be opened horizontally, turned broadside to the TV transmitter and extended to exactly half its wave length.

Since wave lengths range from 56" for Channel 13 up to 213" for Channel 2, it's obvious that few rooms would let you stretch an indoor antenna to even half a wave length without banging into walls and knocking over lamps. Moreover, few viewers know the right length for each channel or want to be bothered finding it out. So while rabbit ears may be

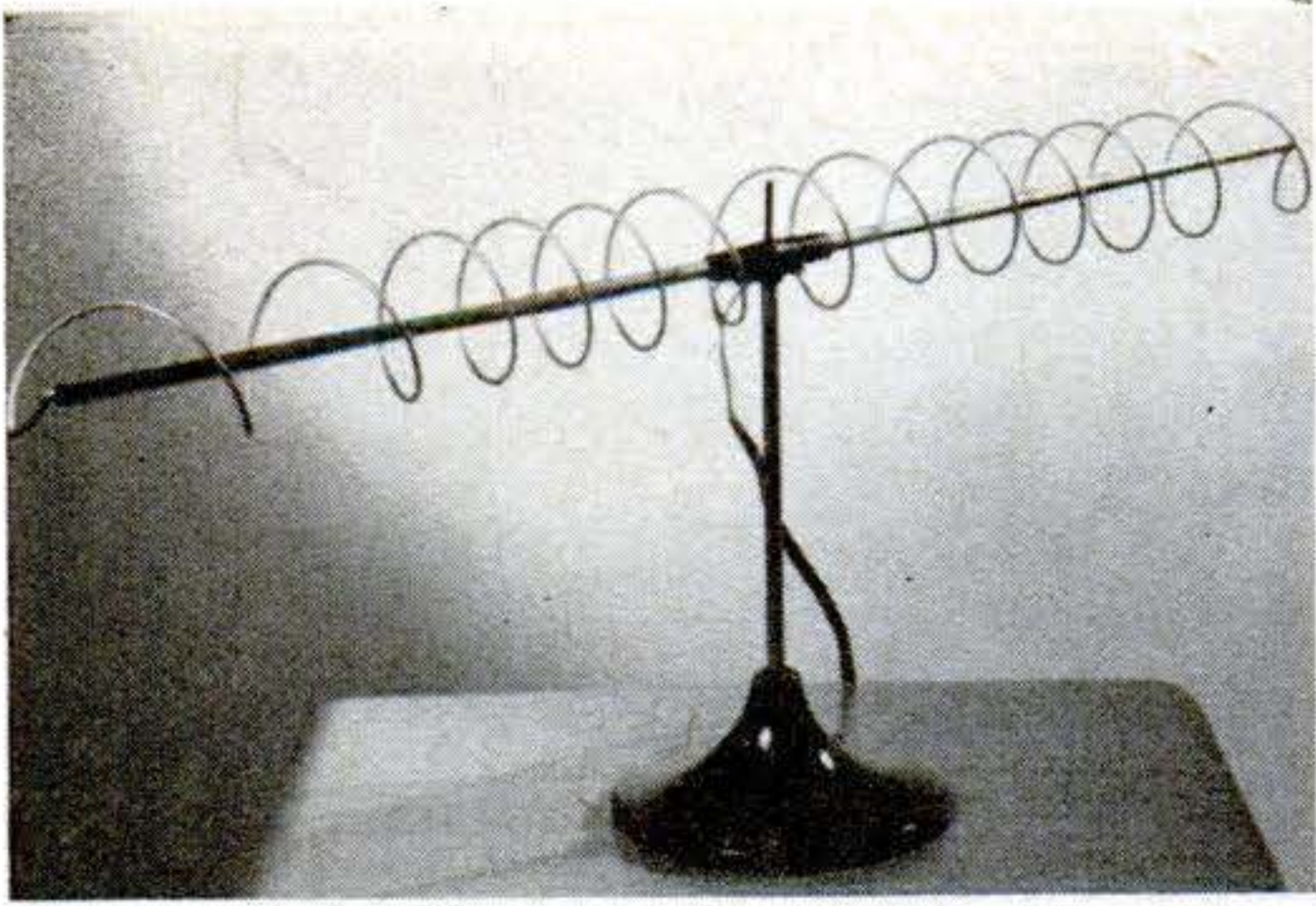

SPIRALING the long, low-channel element of this "Hi-Lo" antenna around the shorter high-channel element is said to give the same effective reception as a long straight-line dipole.

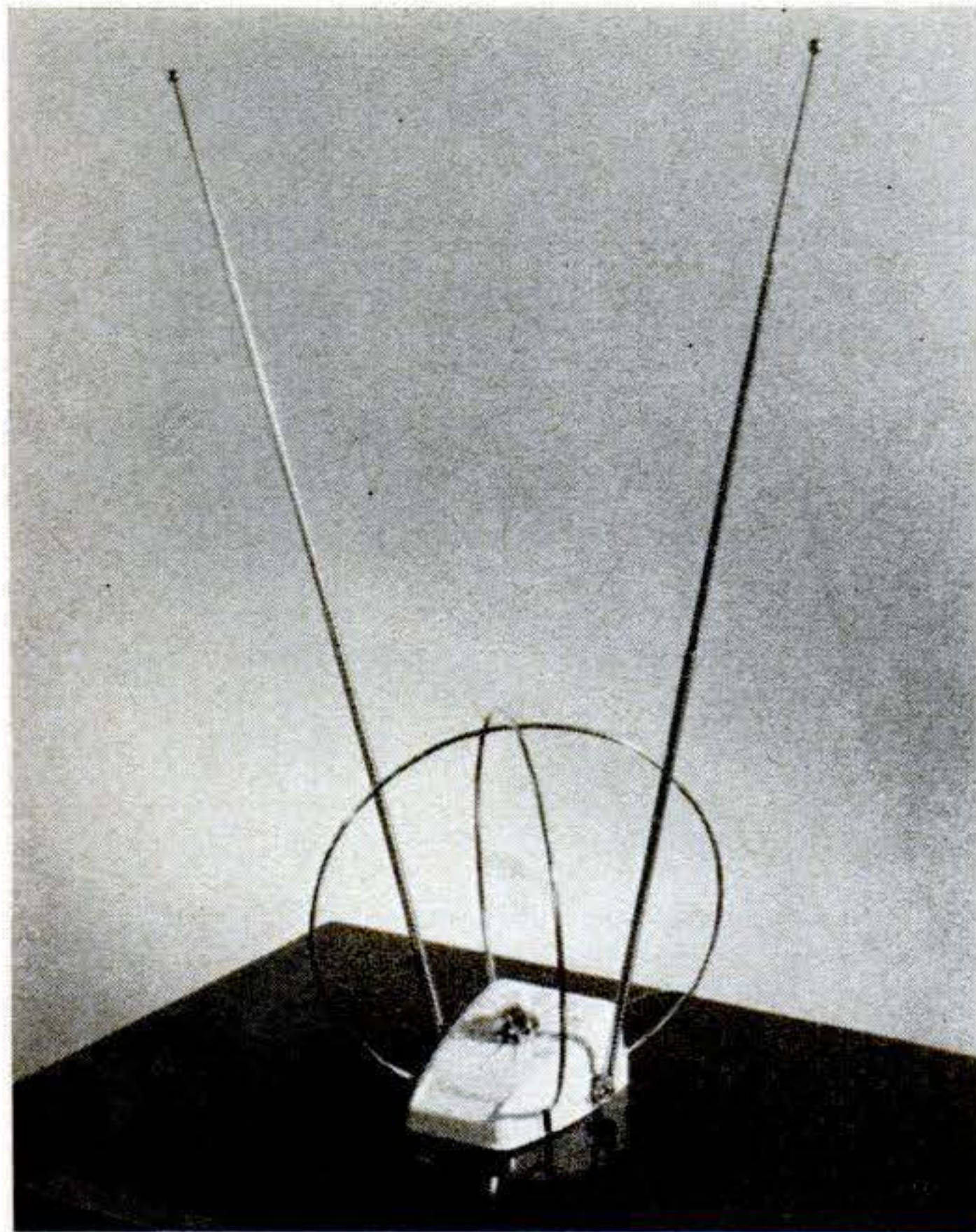

COILS AND LOOPS frequently help an indoor antenna pick a usable signal out of scattered waves that bounce around inside a room. Switches in many antennas connect loops and arms in various combinations to get best results.

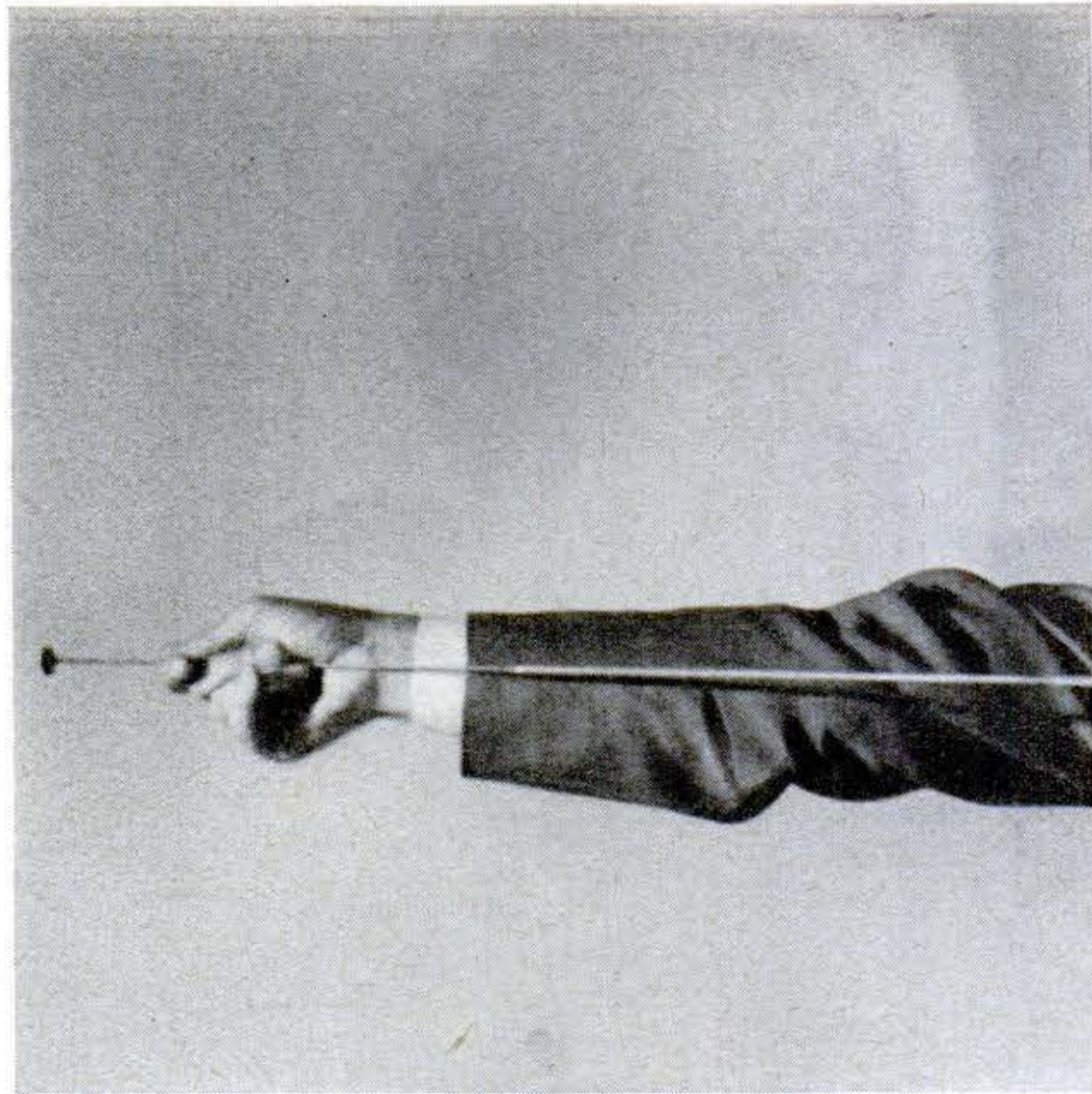
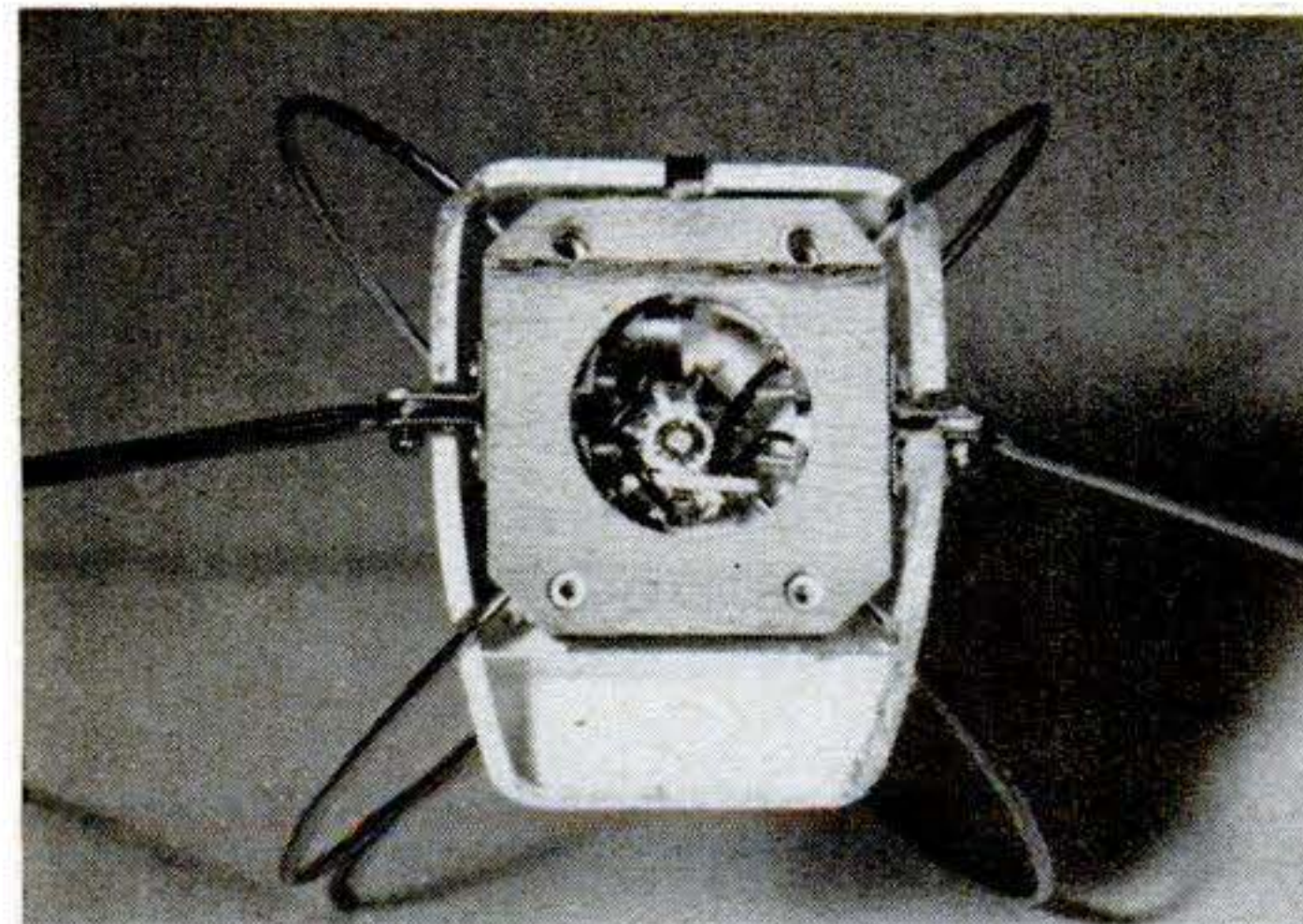

SPACE IS THE MAIN PROBLEM in orienting and tuning rabbit ears because performance is re-

tuned dipoles in theory, they seldom are in practice.

Making the long short. To compensate for this, some engineers have tried to squeeze rabbit-ear performance out of shorter antennas. One popular model spirals the long, low-band arms around the shorter high-band ones to save space. Others, such as Channel Master's "Showman" and Amphenol's "Vi-Fi," compensate electronically for the impedance mismatch that causes most of the signal loss in short-arm dipoles.

When the arms are less than half a wave length, an antenna acts as if a capacitor has been wired across its feed points. In both the Showman and the Vi-Fi, this unwanted capacitive effect is balanced by variable inductances—wire-wound coils with movable slugs. Both antennas also have built-in matching transformers to provide a closer match to receiver input than you would normally expect to get from even a full-length tuned dipole.

Other parties heard from. Engineers of what might be called the second or "tinker" school of antenna design take a dim view of applying outdoor theory to indoor use.

In the very process of passing through a wall, they argue, a TV signal breaks up. Even if a complete wave did get into

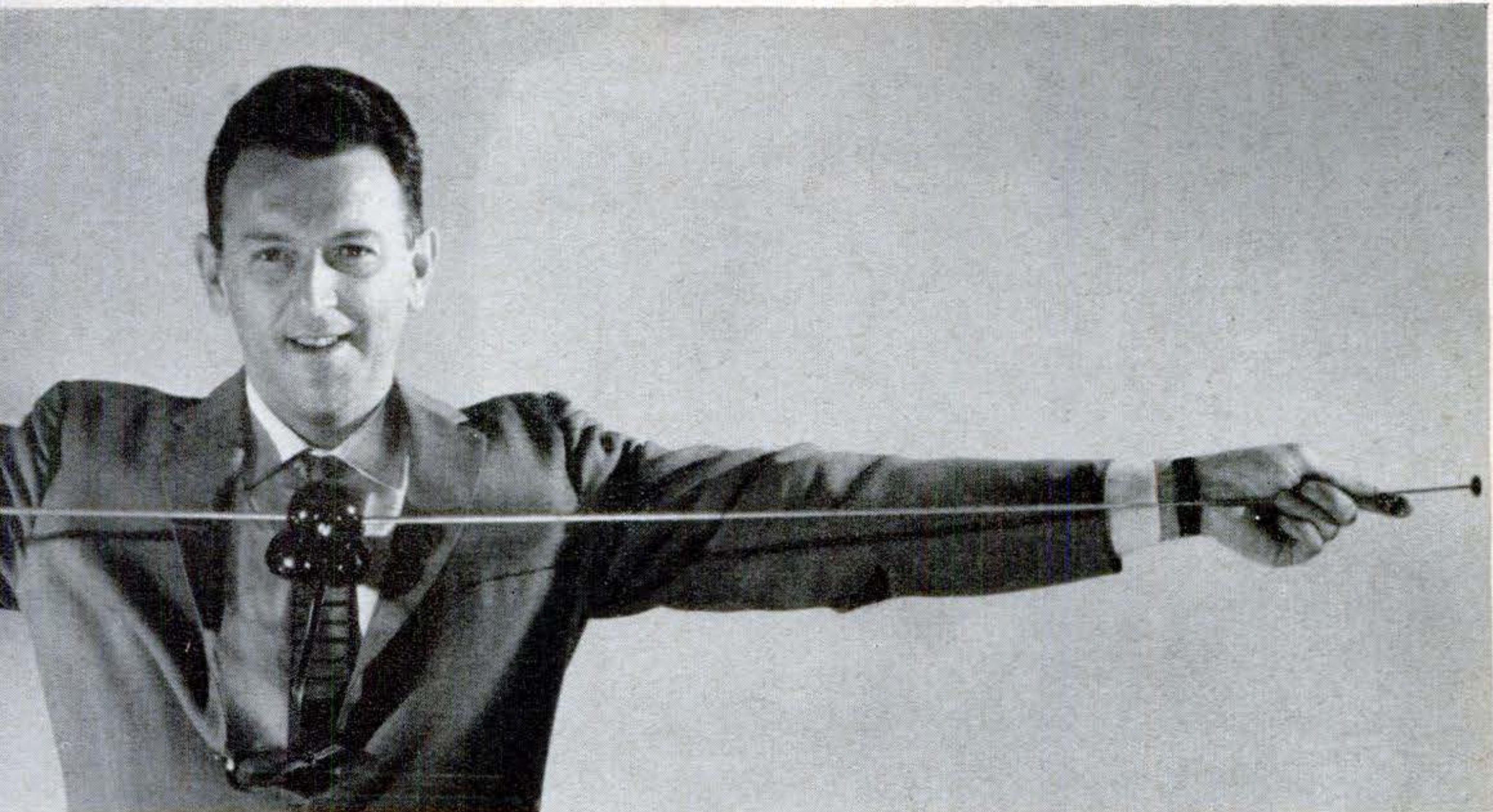

lated to the length of exposed metal. A half-wave dipole for Channel 2 would extend over 100".

These arms—like most—are much shorter, yet even a six-foot man can barely touch the ends.

a house, it would be scattered by bouncing off walls and furniture. Very often separate lobes of the same wave are reflected so as to cancel each other out.

Oddly, part of an antenna can often deal better with this kind of mess than a whole one. It gets less signal, but by blocking scattered reflections it may put a clearer picture on your screen.

This is why some manufacturers have tacked assorted switches, wire loops and other gimmicks onto standard rabbit ears. On all tricked-up antennas, there's one switch position that connects the arms in the conventional way. Other switch

stops connect the arms separately or in combination with a loop or coil that may have some load-balancing effect. Some even incorporate a "dead" switch position that shorts out the antenna completely—for whatever good that does to your reception.

The point is that these oddballs *do* work. By angling their arms, swinging them in different directions and fiddling with the switch, you frequently hit the bell-ringing combination that brings in a fine picture. In or near cities where weak signals aren't a problem but reflections are, such goofy-seeming contrap-



Check These Points Before You Buy an Indoor Antenna

- **Rabbit ears** should open out to at least 80", and longer ones would be better for tuning the lowest channels.

- **Telescoping rods** should be free of sharp points or edges. They should slide easily but not sloppily; loose rod contacts can cause "noisy," jumpy pictures. Arms of brass or steel will usually work best.

- **Ball or swivel joints** should permit horizontal (or nearly horizontal) adjustment. Some forward-V positions are also desirable for tuning out ghosts.

- **Free-standing antennas** of some makers may be prone to topple when arms are extended. If the base isn't weighted, check for balance.

- **Switches** rarely provide more than three or four significant choices, so extra switch positions probably won't do anything useful. If there's a switch, test it for solid, positive "feel"; loose contacts weaken the signal. (Slug-tuned models may have knobs but no switches, so these points don't apply to them.)

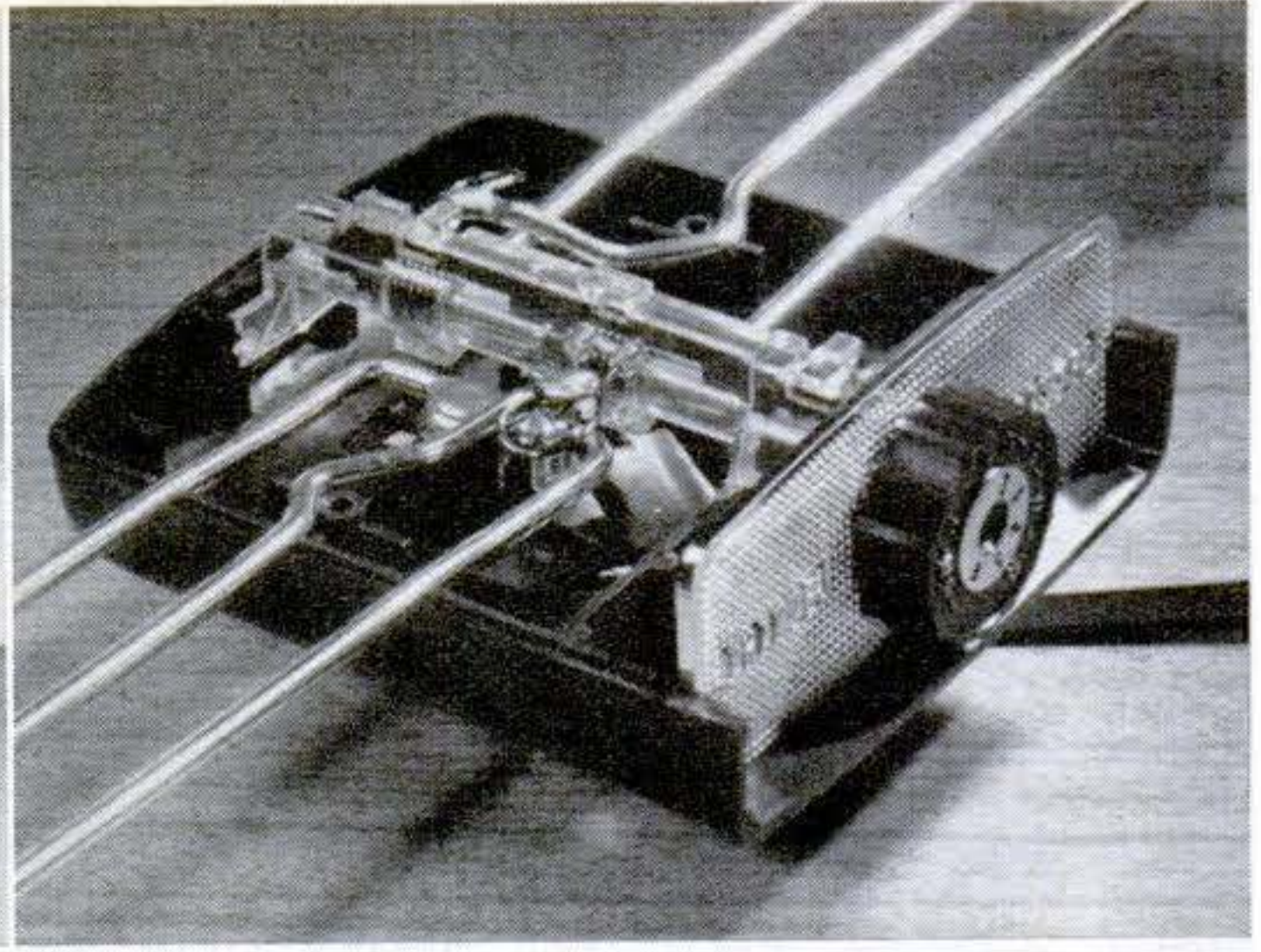
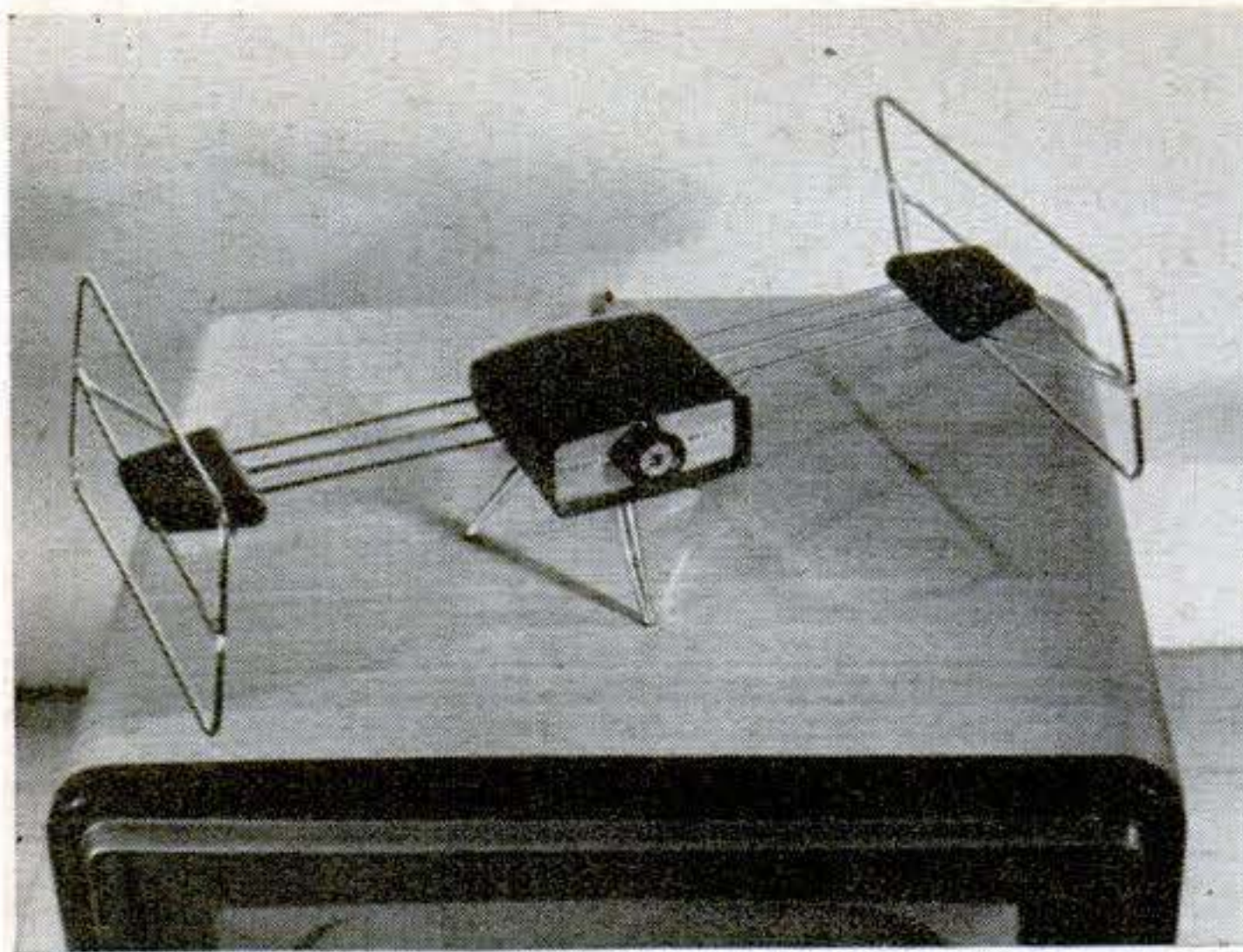

CHANNEL MASTER'S "Showman" is one of a few shorter antennas engineered to minimize signal loss. Rectangular wire "hats" on the ends add some electrical length, and impedance mis-

match is compensated by a built-in transformer and a variable-inductance tuner. The "switch" tunes the antenna by moving a powdered-iron slug inside a wire-wound plastic cylinder.

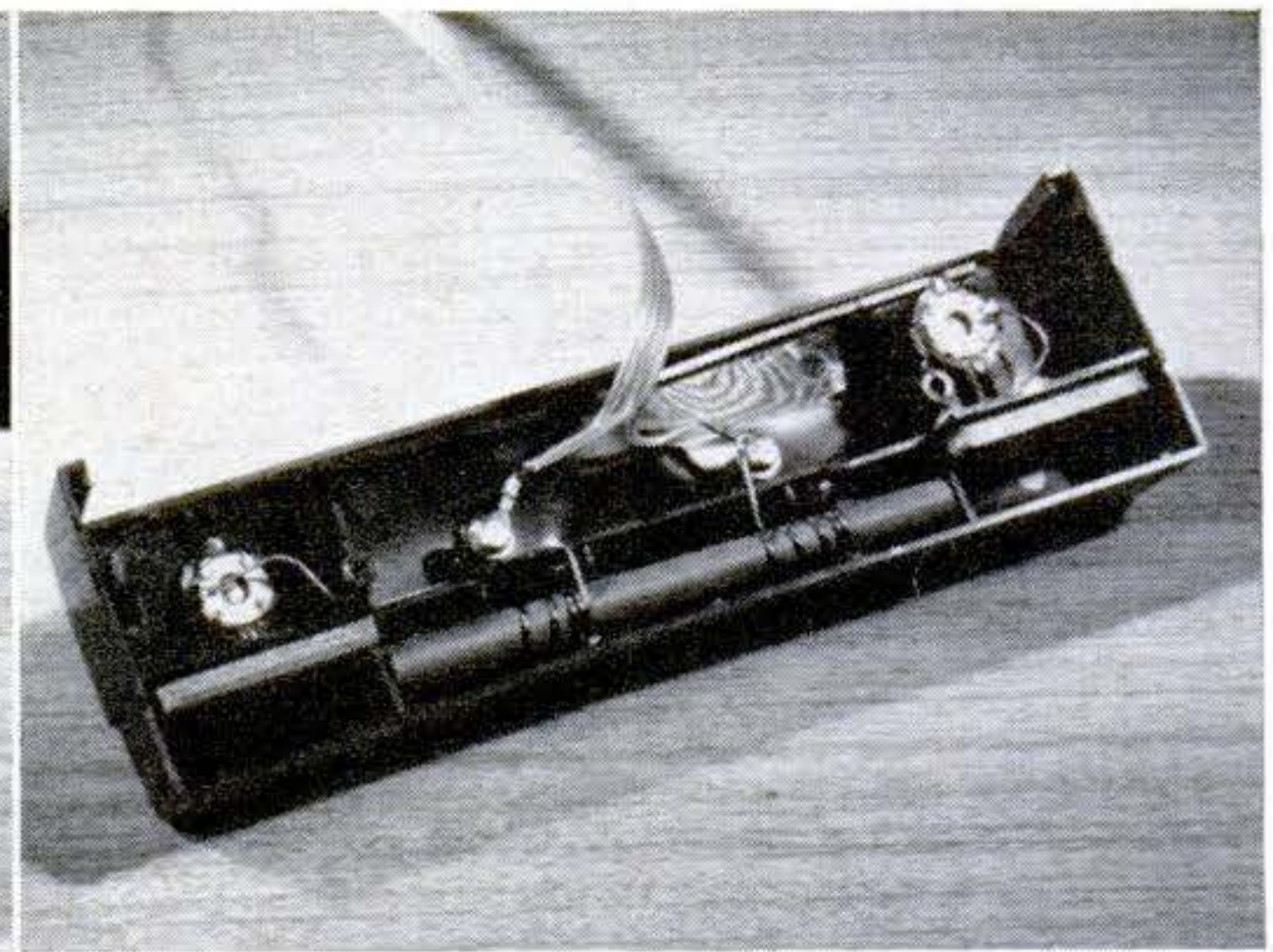
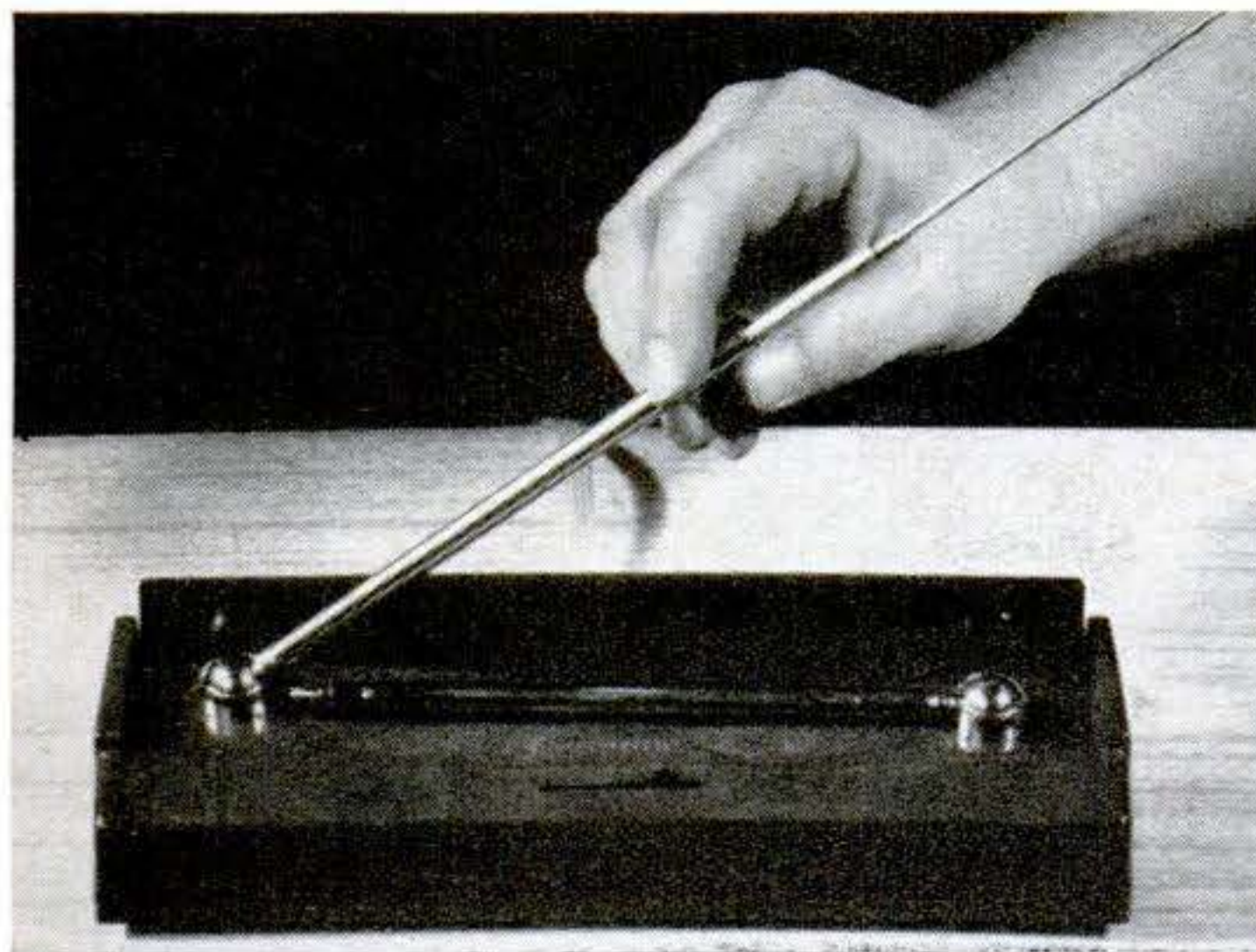

AMPHENOL'S "Vi-Fi" is theoretically similar, though different in appearance. It has two shortened (27") rabbit ears that telescope into a neat plastic case. A slide-rule type of variable-

inductance tuner helps to balance out the capacitive-loading effect of short-arm design. The four-wire, flat-ribbon lead-in incorporates an impedance-matching network.

tions may actually perform better than costly antennas because they let you "tune out" ghosts that plague a good but nonadjustable rooftop rig.

Picking the best. Both approaches to antenna design make sense, but individual models vary widely and some may solve your own particular problems better than others. Before you settle for one, try to arrange with your dealer to let you try three or four types, then return the ones that work the least well.

The so-called "hideaway" type that attaches permanently to the back of a set has become popular because it doesn't clutter the room when it's not in use. But, of course, you're prevented from moving it around. Stand-based models give you more opportunity to find the location for best reception. If you buy

the latter type, be sure the lead-in to the set is long enough to give you real freedom; skimpy leads keep the antenna tied too close to the set. Lead-in length is not critical within reasonable limits.

Surprisingly, outward appearances do talk. A good-looking, nicely finished unit is also likely to have better quality in the parts you can't see.

One caution, though: Don't let a big "discount" influence your choice. So-called "list prices" on most indoor antennas are 14-carat hogwash, simply jacked sky-high so dealers can sell you a "big bargain." Indoor antennas retail—with or without discounts—from about 75 cents up to \$10 or \$12 for the flossiest, best-constructed models. Three or four dollars should be about right for good-quality, switch-type rabbit ears. **END**

11 Fishing Tips



YOUR CATCH WILL STAY FRESH LONGER if you thread light rope through the gills and trail the fish upside. At the end of the day, haul them in and drop them into a plastic vegetable bag. Add a little water and tie the bag tightly with string.

KEEP FISH HOOKS SHARP by rubbing them on a disk of fine emery cloth cemented to your rod's butt.

LURES MUST BE IN TOP SHAPE to bring in the fish. Remove loose screw eyes and force plastic aluminum into the holes. Reset the eyes and let dry overnight. Apply auto paste wax to lures as well as metal spinners to keep them new looking.

A NEW RUBBERIZED GRIP can be applied to an old rod. Saturate heavy cord, such as mason's line, with plastic rubber and wind the cord around the handle. Allowed to cure in a warm place, it will set to form a ribbed grip.

POCKETS IN YOUR FISHING JACKET can be rubberized and made waterproof by pulling them inside out and working plastic rubber into the weave of the fabric.

FORGET THE MOSQUITO REPELLENT? Tuck short lengths of fishline in the band of your hat and let them dangle 8" over the brim to keep bugs away from your face.

A TELLTALE TRAIL often follows leader knots as they're pulled through the water. Press warm wax around the knots to streamline them and eliminate the warning bubbles.



A HANDY DRYER FOR FISHLINE can be made from a wire coat hanger. Bend it into a square, wind the line around it and hang it up to dry.

TO WATERPROOF INEXPENSIVE LINE, draw it through a wad of cotton moistened with silicone shoe dressing sold at shoe and department stores.

A DRIP DEFLECTOR saves tempers. Ever accidentally dip a cane pole in the water, then raise it and have water run up your arm? Cut a hole in one half of a rubber ball and slip it on the pole as a guard.

A STURDY CASE FOR A FAVORITE ROD can be made of aluminum tubing. Permanently close one end with a wood plug and cap the other with a large cork tied to the tube with a slack string.

Short Cuts and Tips

FROM PS READERS

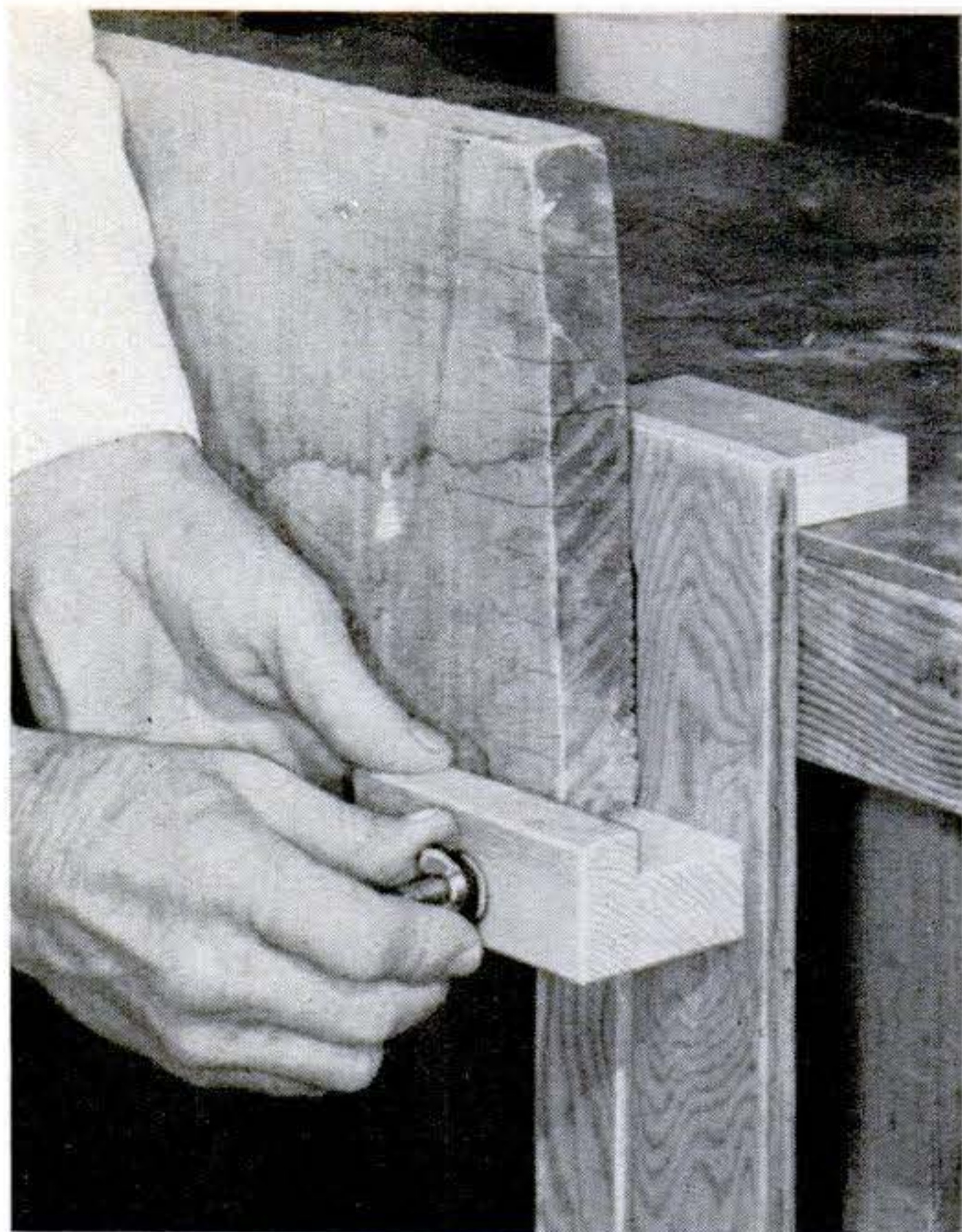
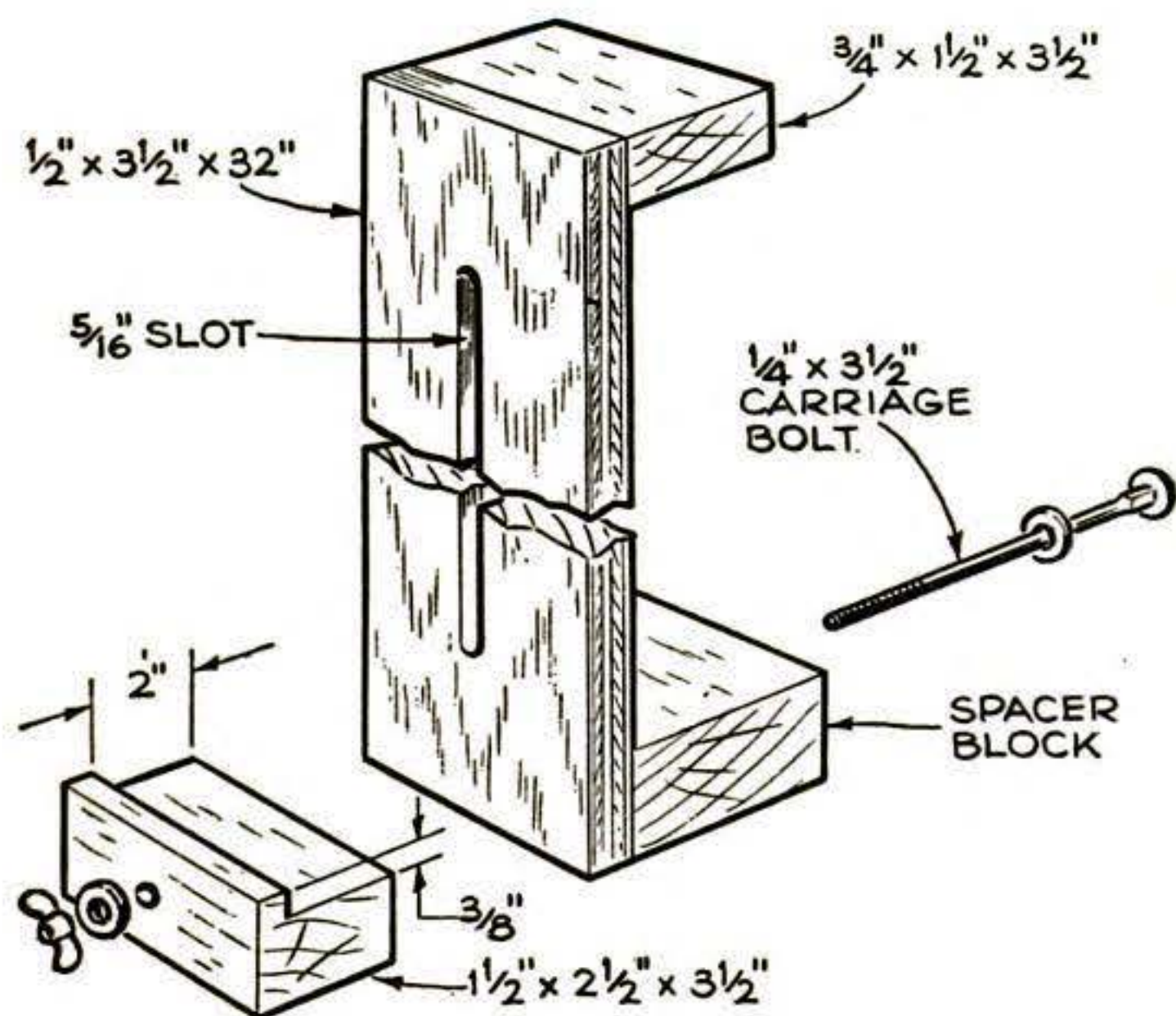

Adjustable Holder for Supporting Long Boards on Bench

It's hard to joint or rabbet a long piece when there is nothing to support the out-board end, but it can be easy if you make an adjustable holder that will work with boards, table tops and plywood.

Slot a $\frac{1}{2}$ "-plywood strip to admit a sliding $\frac{1}{4}$ " carriage bolt. Then glue a

$\frac{3}{4}$ " block to the upper end to hook over the bench and another at the bottom to hold the strip vertical against the front. In use, clamp one end of the board in the vise, slide the support up against the other and lock it in place with the wing nut.—*Edwin M. Love, Palmdale, Cal.*

▶▶▶It's easy to tighten a sagging cane chair seat. Shrink it with hot soap suds sponged on and then rinsed off with hot water. Let it dry thoroughly before use.

▶▶▶GROOVES between insulated ceiling tiles are a place for dust to collect. You can prevent this by applying a thin coat of white shellac between the tiles.

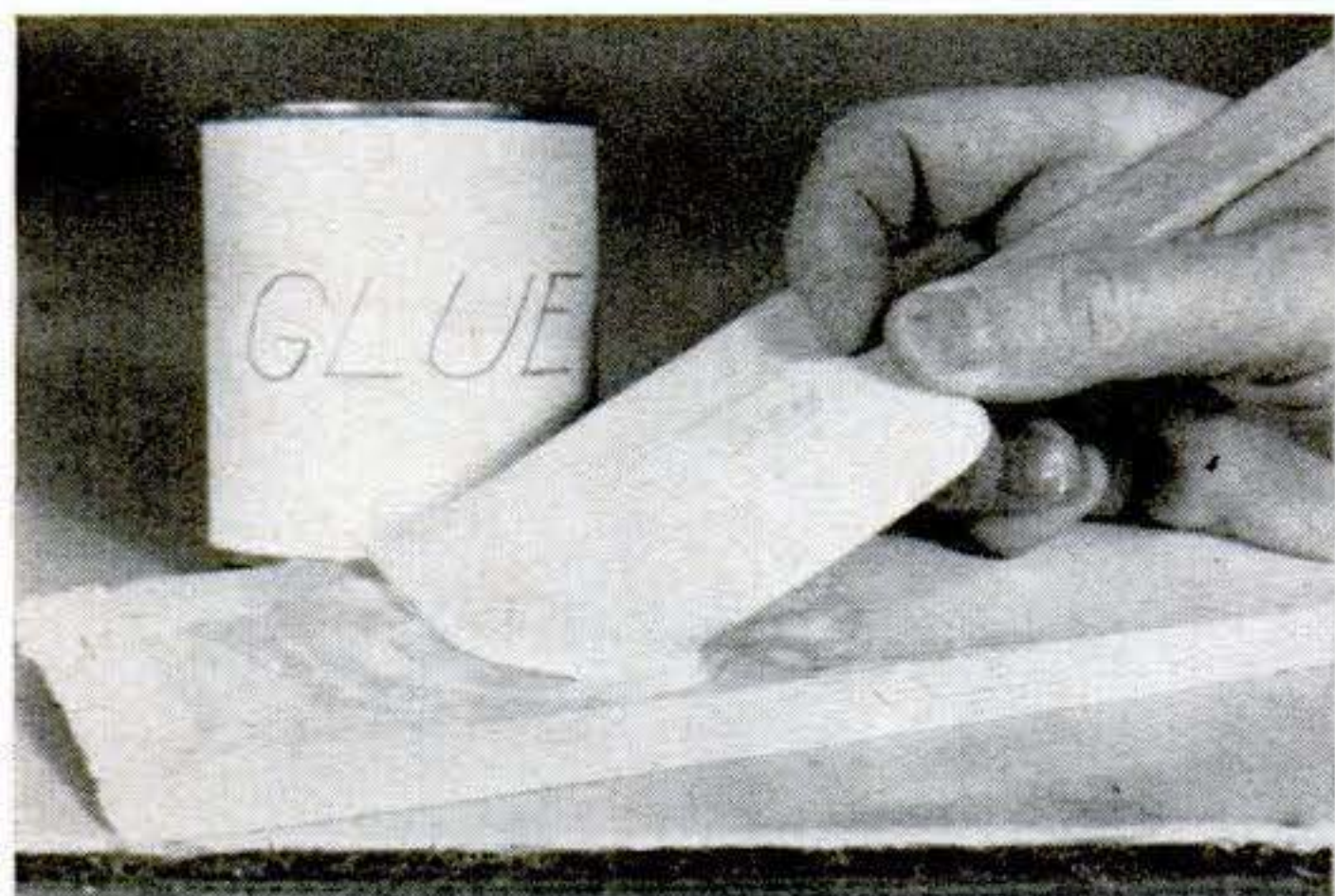

Spreading Glue with Spatula

A RUBBER kitchen spatula is useful for applying glue quickly over a large area. You can clean it easily, but if the glue does dry, it can be broken off by flexing the blade.—*C. C. Cooley, Detroit.*

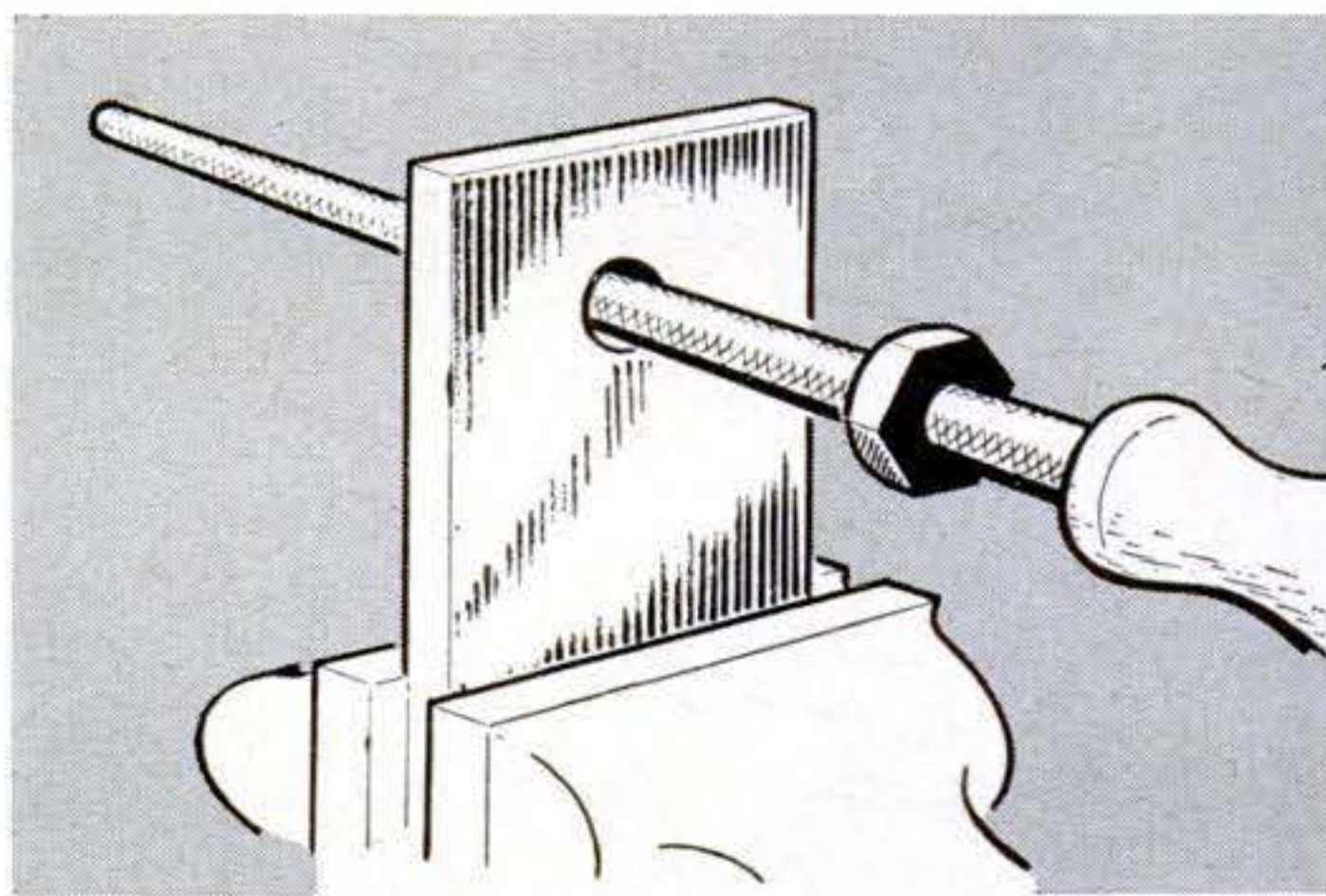

Stop on Rattail File

You can keep a round file from jamming in a hole you are enlarging by forcing a nut over it. This acts as a stop to keep you from pushing the file too far into the hole.—*F. Murray, Chicago.*

If Your Power Steering Acts Up...

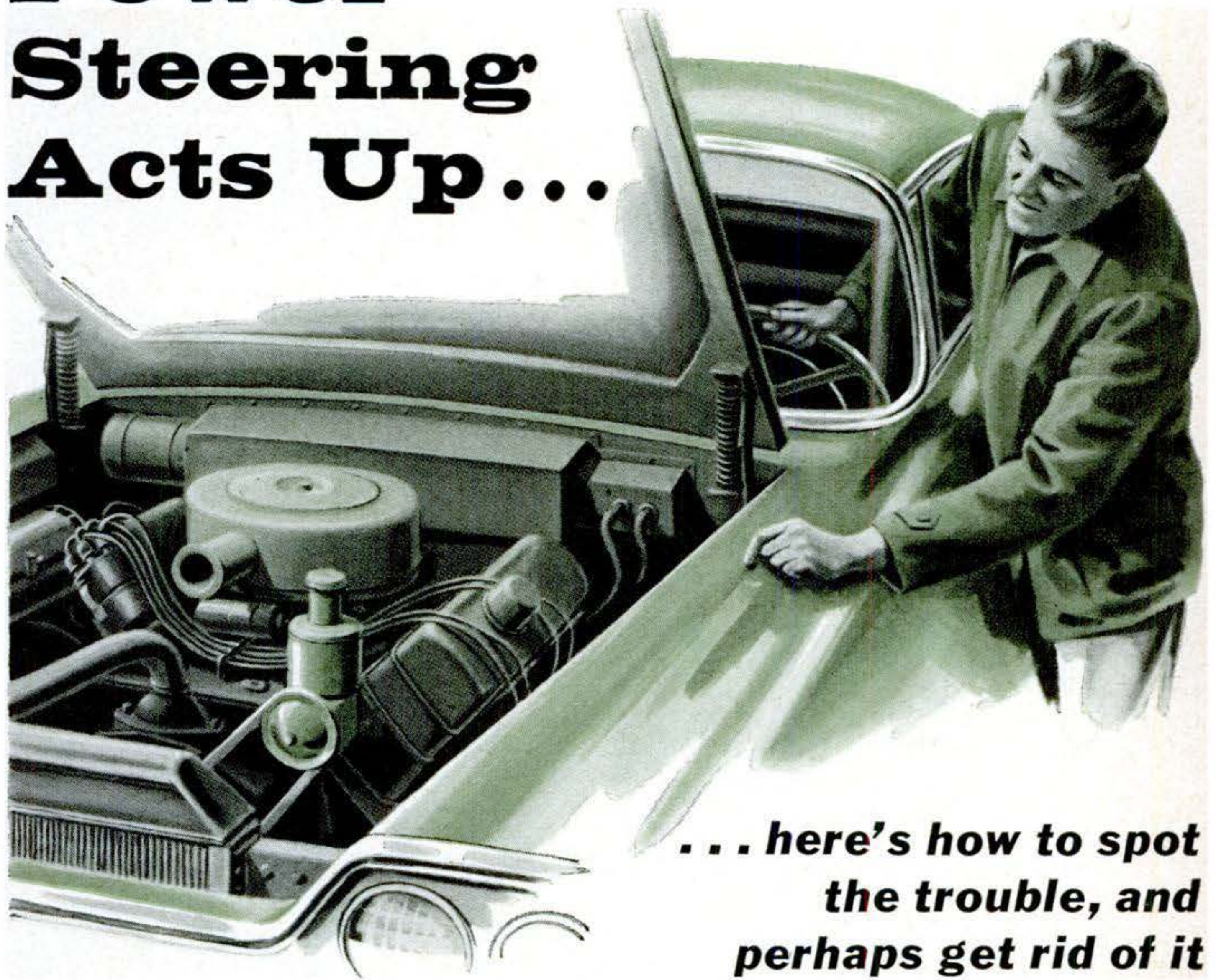

... here's how to spot the trouble, and perhaps get rid of it

WHEN the steering wheel seems to go dead in your hands, chances are that one of two things is wrong with a power-steering setup. The fan belt may be slipping. Or the fluid level may be low.

Check the fan belt

The fan belt is a key part of a power-steering setup. Besides the fan and generator, it drives a pump to force fluid under pressure through the steering-assist system. On some cars the pump may have a belt of its own. But either way, a belt transmits power from the engine—and it must be tight to do so.

You can check the belt by standing beside the car and turning the wheel hard over with the engine idling. This builds up maximum pressure in the system and if the belt is loose, you'll see it slip

over the pump pulley after you've held the wheel cramped for a second or two. You may feel it, too, because a slipping belt often makes the steering wheel wiggle in your hand as you turn it.

To tighten the belt, loosen the lock bolt and force (or pry with a stick) the generator or power-steering pump outward against belt tension; then hold it while you tighten the bolt.

If this fails to restore steering effort, the next step is to check for low fluid or air in the system.

Check the fluid

Whenever you turn the wheel, a valve opens to let oil from the pump press against a piston to help you steer. If fluid is low, the pump runs dry; and if there is air in the system the full hy-

draulic effort can't be applied to steering.

Remove the reservoir cover and add fluid to the full mark. If the level is very low, air trapped in the system may cause a dead spot in the steering. To bleed the system, run the engine at idle and turn the steering wheel quickly from side to side to the limits of its travel. This releases the air into the reservoir (you'll see bubbles rising), and you may have to add more fluid to replace the air that's been worked out of the hydraulic passages and again bring the level to the full mark.

Caution: When checking the power-steering fluid, take great care not to allow dirt to drop into the reservoir.

Check the tire pressure

Over- or under-inflated tires can create odd steering sensations. Too much air gives an oversensitive or "floaty" feel to steering, making you feel you're driving on ice. Soft tires make steering difficult. Power steering may lessen the effects, but it won't cancel them out.

Check the wheel alignment

Front wheels out of alignment, combined with lack of lubrication in the front-end linkage and ball joints, will make your power-steering unit—and you—work harder. Look for irregularly worn front tires as a tipoff to an alignment problem, and bounce the front end up and down while you listen for groaning bearings to tell you that they're dry. Failure to recover readily after a turn suggests the same ills.

Listen for noises

Whenever you cramp the wheel hard over, either to the limit of travel or against the curb, you will hear the light, hissing sound of the pressure-relief valve recirculating oil back into the reservoir. That's the only normal noise you should hear. Noises you shouldn't hear include:

- Loud chirping, a staccato squeal caused by a slipping belt.
- Thump or rumble, caused by a frayed belt that should be replaced.
- Chatter or hollow rattling, caused by low fluid level or air in the system—usually accompanied by intermittent loss of steering assist.

Any trouble that can't be cleared up by making these simple checks is probably a mechanical defect within the system, best repaired by a specialist. But at least you'll have the satisfaction of knowing you've checked the big trouble-makers before you go to a garage.

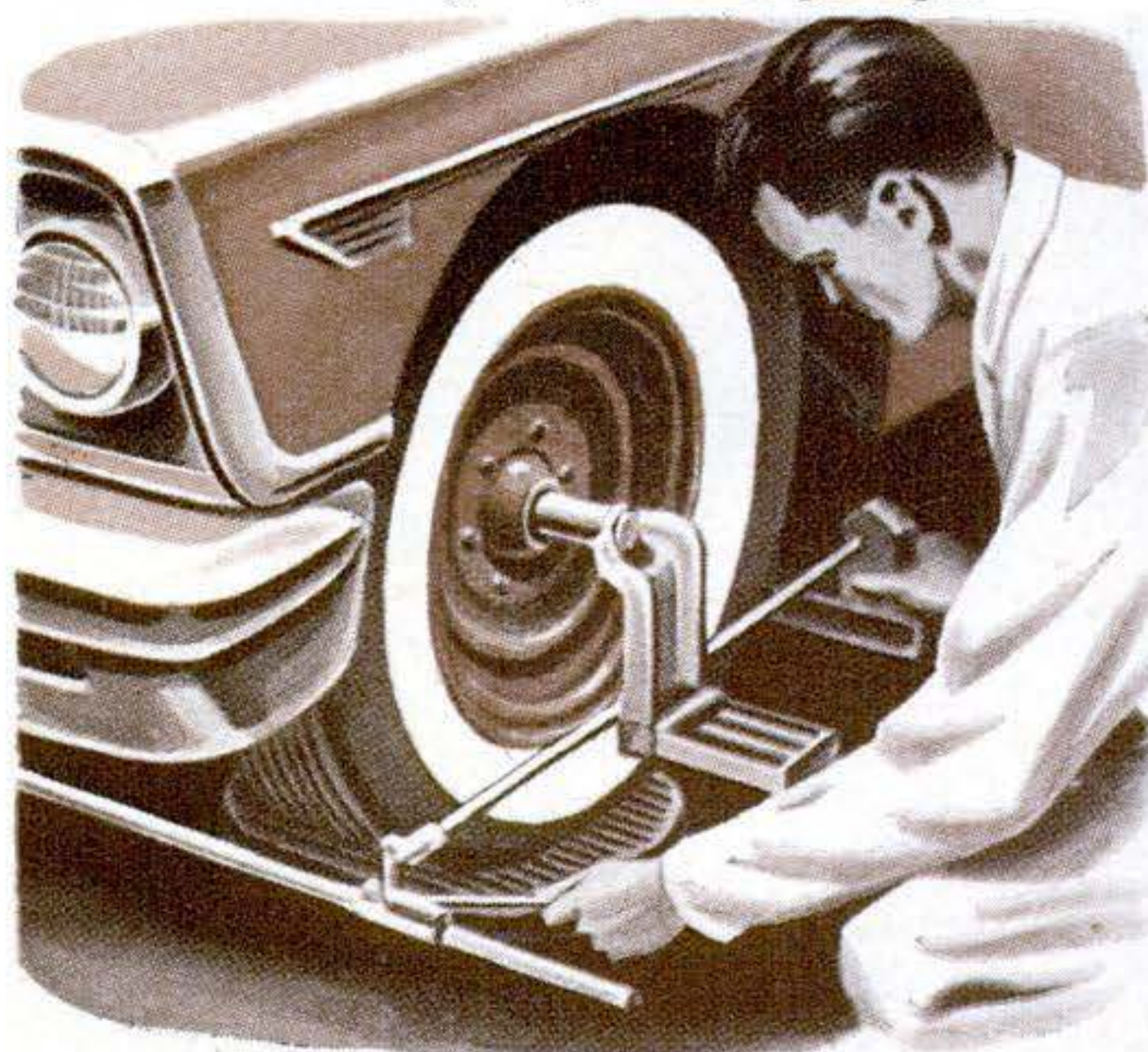

Four main points of power-steering upkeep

1 Check the fluid in the reservoir every 1,000 miles or so. If it's consistently low, look carefully for leaks along hoses and fittings.

2 See that hose doesn't touch the body or frame; besides danger of chafing, contact between hose and metal can transmit annoying pump noises to the inside of the car.

3 Check fan-belt tension occasionally. If your garageman has a torque wrench, have him apply it to the pulley bolt. The pulley should slip at no less than 25 foot-pounds.

4 Change the power-steering fluid every 25,000 miles. Any fluid that does enough work to get hot tends to break down after a long period of use.

Don't start this year's boating with last year's spark plugs!

Before you take to the water, replace those old plugs with new plated Champion marine spark plugs. You'll get full power . . . easy starting . . . and more hours of fun from a tank of gas!

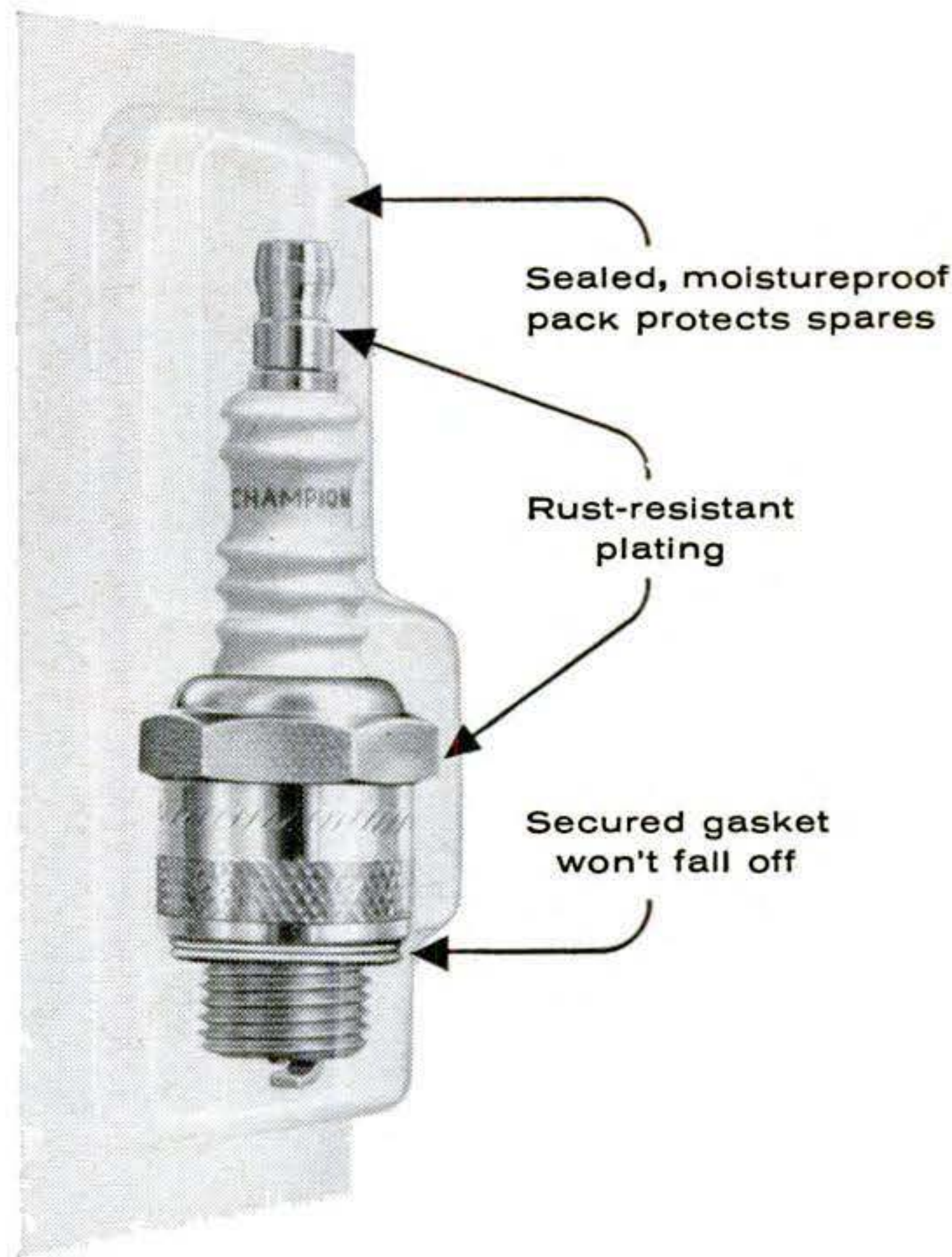

Those old spark plugs of yours have fired millions of times.

In an outboard, for example, during *one hour* of running at 4000 rpm, a plug fires 240,000 times. That's almost *two and one-half million* times in just 10 hours. And every single spark is like a tiny lightning bolt — slowly but surely blasting away the firing points of a plug. The gap between the electrodes finally becomes so big a spark can't jump it every time.

When that happens, your plugs begin to misfire. Fuel is wasted. Power is lost. Your motor runs rough. It's hard to start. But don't blame your motor. And don't blame your old plugs. They've done their duty. Retire them.

Replace them with *plated* marine Champions. All exposed metal surfaces of these new silver-colored Champions have a special protective

finish that guards against rust. Another special feature is a secured gasket that won't drop off during installations. These new Champions are excellent for carrying as spares, too. They're the *only* spark plugs in a completely waterproof pack.

And Champion Spark Plugs are tops in performance. For example, the last 13 Gold Cup races were won with Champions. In the 1958 National Stock Outboard Championships at Miami, 9 of the 10 class winners were powered by Champion Spark Plugs.

It costs very little to be *sure* of the power that can give you a million dollars' worth of boating fun. So start this summer with a fresh set of the world's finest marine spark plugs — *Champion Spark Plugs*.

CHAMPION SPARK PLUG COMPANY • TOLEDO 1, OHIO

DEPENDABLE 5-RIB

CHAMPION

SPARK PLUGS

EVERY MAJOR OUTBOARD MAKER USES CHAMPION SPARK PLUGS

APRIL 1959 225



Gus Challenges an Electronic Marvel

By Martin Bunn

THE middle-aged convertible, top down, rattled into the Model Garage. In the front seat were two young men. In the back was stowed enough fishing gear to equip a rod-and-reel club.

"Drop everything, Gus," said the driver.

"We're going fishing," said his companion.

Gus looked up from a tune-up job into the grinning faces of the Biddle twins, Tim and Tom, one crew-cut, the other shaggy-headed. They had been in Gus Wilson's hair on and off for years since he had fixed their first roller skates.

"Go and get lost," he said. "Just because you two are home from college for Easter vacation doesn't mean that other people don't have work to do."

"You promised to go fishing with us," said Tim.

"Our date was for the opening of the trout season next week," Gus said. "Now I've got a tough engine job to tackle."

"If the truth were known, Gus," said Tim, "I'd bet 10 to one your assistant, Stan Hicks, is the real mechanic here."

"He'd welsh on the bet," Tom put in, getting out of the car. "Remember last year how he wouldn't pay off when we bet we'd catch the limit before he did?"

"Pay off!" said Gus in mock indigna-



*"Ignition trouble?"
asked the salesman.
"Let me show
you the latest in
testing equipment."*

PROOF

ON YOUR DIPSTICK

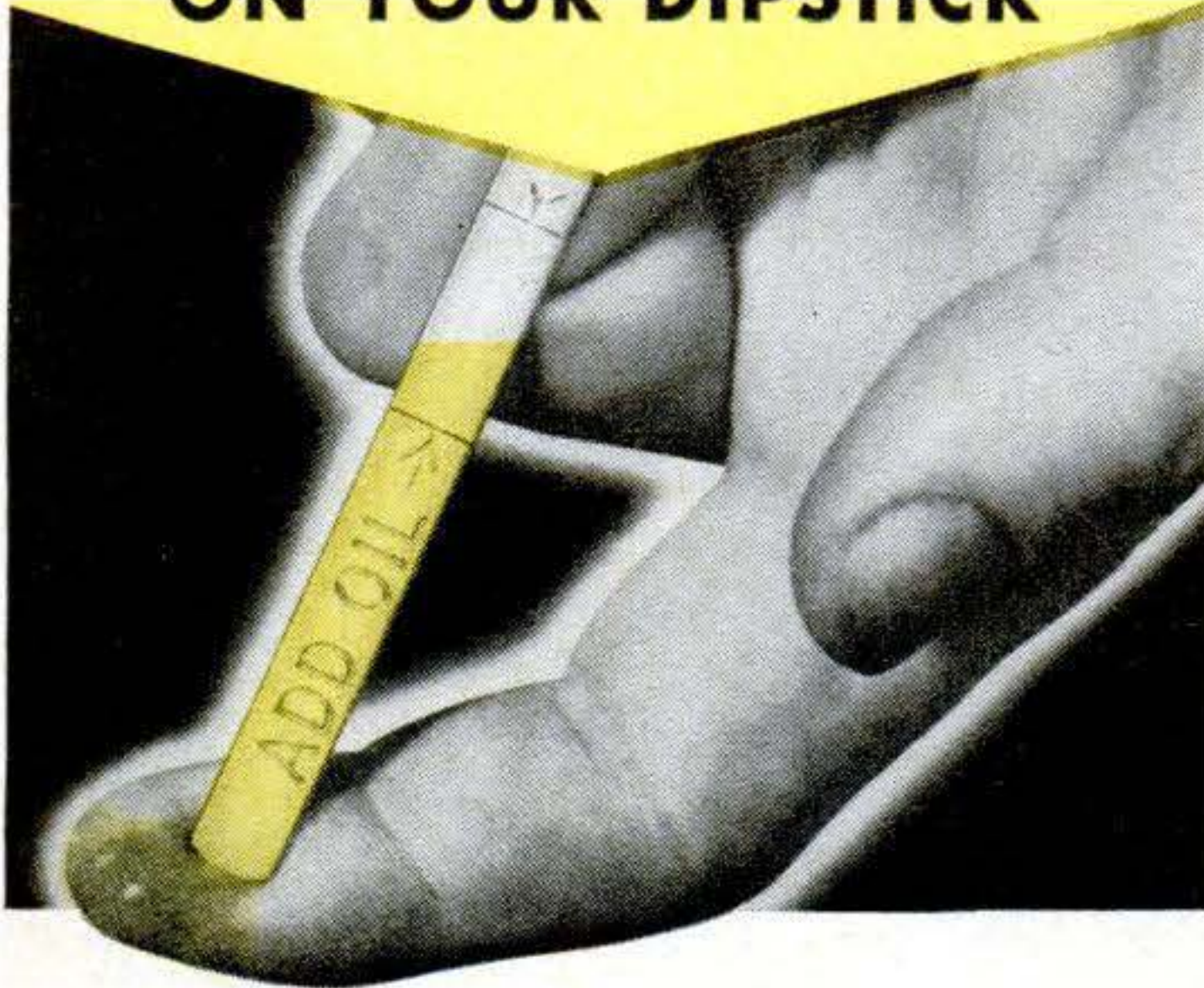

HASTINGS

KEEPS OIL CLEAN

Hastings Oil Filter Cartridges keep oil clean from filter change to filter change, when replaced as normally recommended*

That's because only Hastings has Densite filtering material, which traps and holds even the most microscopic dirt particles. The dipstick test proves it!

Just ask for Hastings—next filter change. Be sure of clean oil *all* the time.

* Proved by tests conducted in accordance with U. S. Bureau of Standards.

U. S. Patent Numbers 2,797,811 2,584,771

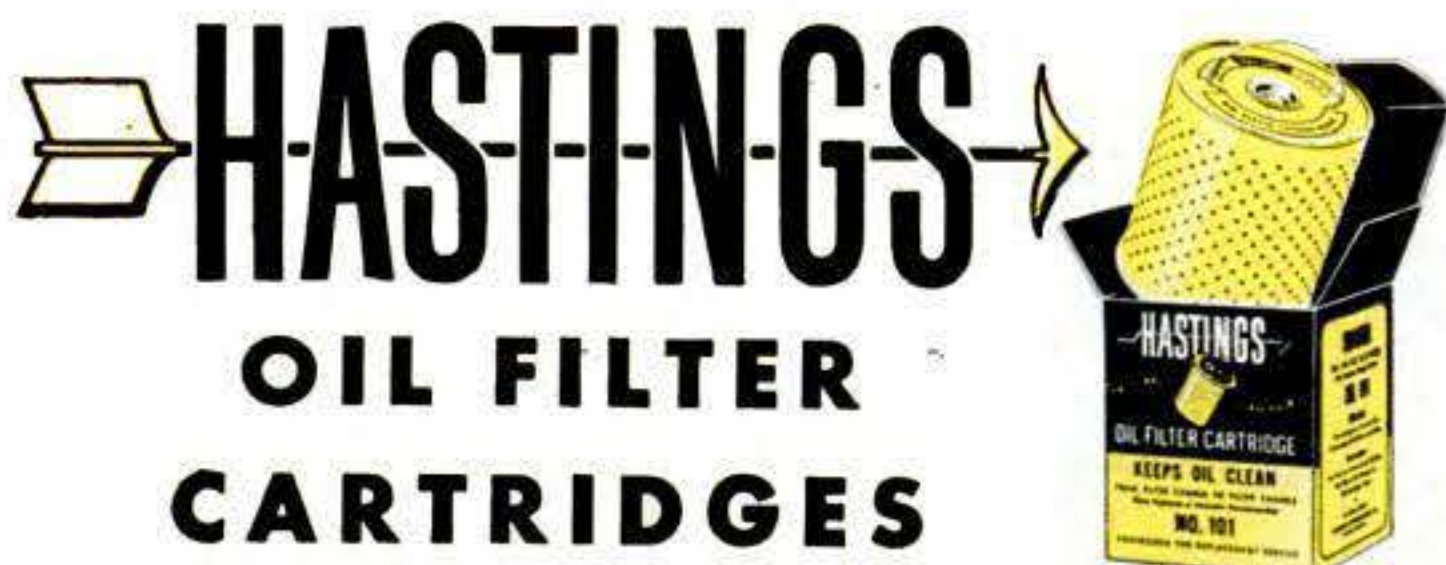

HASTINGS MANUFACTURING COMPANY
HASTINGS, MICHIGAN

tion. "After I found that you two cheaters had bought half your fish from a 10-year-old boy!"

The twins looked at each other and roared with laughter.

GUS grinned. "Why don't you double jokers go and bait some fish instead of me."

"Can't," said Tim. "We've got trouble."

"Car trouble," echoed Tom. "If you're a better mechanic than fisherman, Gus, fix it."

"Okay. Anything to get rid of you. Your old tin can did sound a bit rough coming in." He lifted the hood.

"Hold it!" came a peremptory voice. The trio turned and saw a small, rotund, round-faced young man, one arm raised and the other holding a small suitcase. He didn't look much older than the Biddle twins.

"Hold it!" he repeated, coming into the shop, lowering his arm and pointing toward the convertible. "Ignition trouble—I hope?"

"Could be," Gus said, "but . . ."

"Then let me show you the latest in testing equipment," continued the newcomer, setting his grip down. He reached out a pudgy hand that was lost in the garageman's oversize paw. "Gus Wilson, I presume. My name's Anderson—Bill Anderson. V&L Automotive Electronics."

"Yes," Gus said. "I had a letter from your company, but I expected . . ."

"An older salesman?" broke in Anderson. "We're a young firm, Mr. Wilson, in a young business. I'm just out of electronics school, myself." He hoisted his case on the shop bench, opened it, and lifted out a neat metal case with knobs and dials.

"A portable TV," said Tim Biddle.

"Wonderful," put in Tom. "Let's take it fishing with us—when you fix our car, Gus. You come along, too, Mr. Anderson."

"Behave yourselves, boys," Gus admonished. "This isn't a TV set. It's an oscilloscope. An ignition analyzer."

The salesman looked surprised. "Oh, you're familiar with this equipment?"

"A little," Gus said modestly, filling his pipe.

"Ah," said Anderson, going into his spiel. "Then you know that the electronic ignition analyzer is essentially the same

as the oscilloscopes that have been used for years in testing electronic equipment."

He paused, flustered. The Biddle twins were grinning, fascinated by the polka-dot bow tie riding up and down on the little salesman's plump throat as he spoke.

Anderson looked at some cards he had pulled out of his pocket, coughed and continued. "Rapidly changing electrical voltages are converted into a visible 'trace' across this TV-like screen. My scope dramatically portrays the sequence of events in the ignition cycle and reveals at a glance the faults that could otherwise be located only after a time-consuming, step-by-step procedure."

HE UNFOLDED a chart. "This chart pictorially shows what the sweep pattern looks like with various ignition troubles—bad spark plugs, coils, condensers, distributor points, wiring."

"That's very educational, Mr. Anderson," Tim Biddle said as the salesman put down the chart. "But we're on vacation and want to go fishing. How about some action?"

Anderson beamed. "Ah, yes, a demonstration. Now we'll analyze this engine electronically and get you young fellows on your way."

The salesman placed the instrument on a fender and hooked a test lead to a spark-plug wire. He explained how the pulse from the wire triggered a circuit to provide a horizontal sweep across the face of the cathode-ray tube.

"The wire across the distributor breaker points," he went on, "provides a varying voltage to the vertical sweep circuit of the instrument, showing the voltages across the ignition points at any instant. Now, if somebody will start the car . . ."

Tom Biddle obliged. Anderson made some knob adjustments as Gus listened to the roughly idling engine. Then he looked at the scope pattern. There were eight pips on the screen; all appeared to be of the same size and shape.

Anderson frowned. "Hmm. I expected to find one or more of the pips sloughed off, indicating bad plugs. Let's stretch out the presentation and examine each pulse more closely." He checked off: "Point spring tension regular, no condenser trouble, no excessive distributor-shaft wobble, wiring okay." He looked up. "Mr.

USING TOO MUCH OIL AND GAS?



IT'S TIME FOR HASTINGS

When your oil and gas bills start growing bigger—look out! Using too much oil is your first sign of worn-out piston rings. And worn-out rings mean power drop-off—costly waste of oil and gas—and expensive repairs later on!

The sooner you act, the less it will cost. See your motor specialist the minute oil-pumping warns you there's trouble ahead. When he recommends new piston rings, ask him for Hastings. They're engineered exclusively for replacement service . . . to provide the additional lubrication worn engines need . . . to stop oil-pumping, save gasoline, restore lost performance.

Get new car power and performance from your present car—with Hastings. Truly your best investment for many thousands of extra miles of trouble-free driving pleasure. Hastings Manufacturing Company, Hastings, Michigan. Piston Rings, Oil Filters, Casite, Spark Plugs.

HASTINGS

PISTON RINGS

TOUGH on oil pumping **GENTLE** on cylinder walls

HASTINGS MANUFACTURING COMPANY
HASTINGS, MICHIGAN

Piston Rings, Casite, Oil Filters, Spark Plugs

APRIL 1959 229

Wilson, the trouble with this car is not electrical."

"I'm no electronic marvel like this gadget of yours," Gus said, "but let me try something." He turned off the ignition, scanned the spark-plug wiring, and huddled over the distributor.

"There," he said. "Unless I miss my guess, the trouble *was* electrical." He hit the starter. The engine caught, ran roughly for a moment, then settled down to a smooth idle.

"April Fool, Gus!" Tim shouted glee-

home," Tom Biddle said. He took a playful punch at his twin. "You old cheat. No wonder you bet me that Gus would spot the trouble in less than 10 minutes."

ANDERSON slammed down the lid of his suitcase. "Screwballs," he muttered. "Why didn't you give me a hint, Mr. Wilson, before I made a fool of myself?"

"You hardly gave me a chance, Mr. Anderson. I've had an oscilloscope for quite a while. Had one of the first to come out. But like any tool, it's not a cure-all."

"I realize that, Mr. Wilson," admitted the salesman. "But about this trouble?"

"Why, you just backed right into about the only ignition trouble I've found that most oscilloscopes won't detect. Some of the more expensive ones will, but not yours or mine."

"If these characters had driven around the block a few times and fouled the plugs, your scope

would have picked it up immediately. In this case, it told only that the plugs were firing, not *where*."

"Thanks for the lesson, Mr. Wilson. Maybe I am kind of green."

Gus grinned at the salesman. "Are you a fisherman?"

"Yes. But why?"

"Because I'm charging these pixies eight dollars. That'll more than pay for our fishing licenses."

"We'll pay you in fish," Tim Biddle shouted over the roar of the motor as he backed the car out of the shop.

"It'll go on their bill," Gus said grinning, "just to teach them a lesson." He shook the salesman's hand. "I'm sorry for the hazing you took, Mr. Anderson. Stop by again. My scope won't last forever. And bring your fishing gear along."

"I'll have it, Mr. Wilson—and maybe a better sales line to tackle you with." END

Next Month: Gus cracks a tough nut.

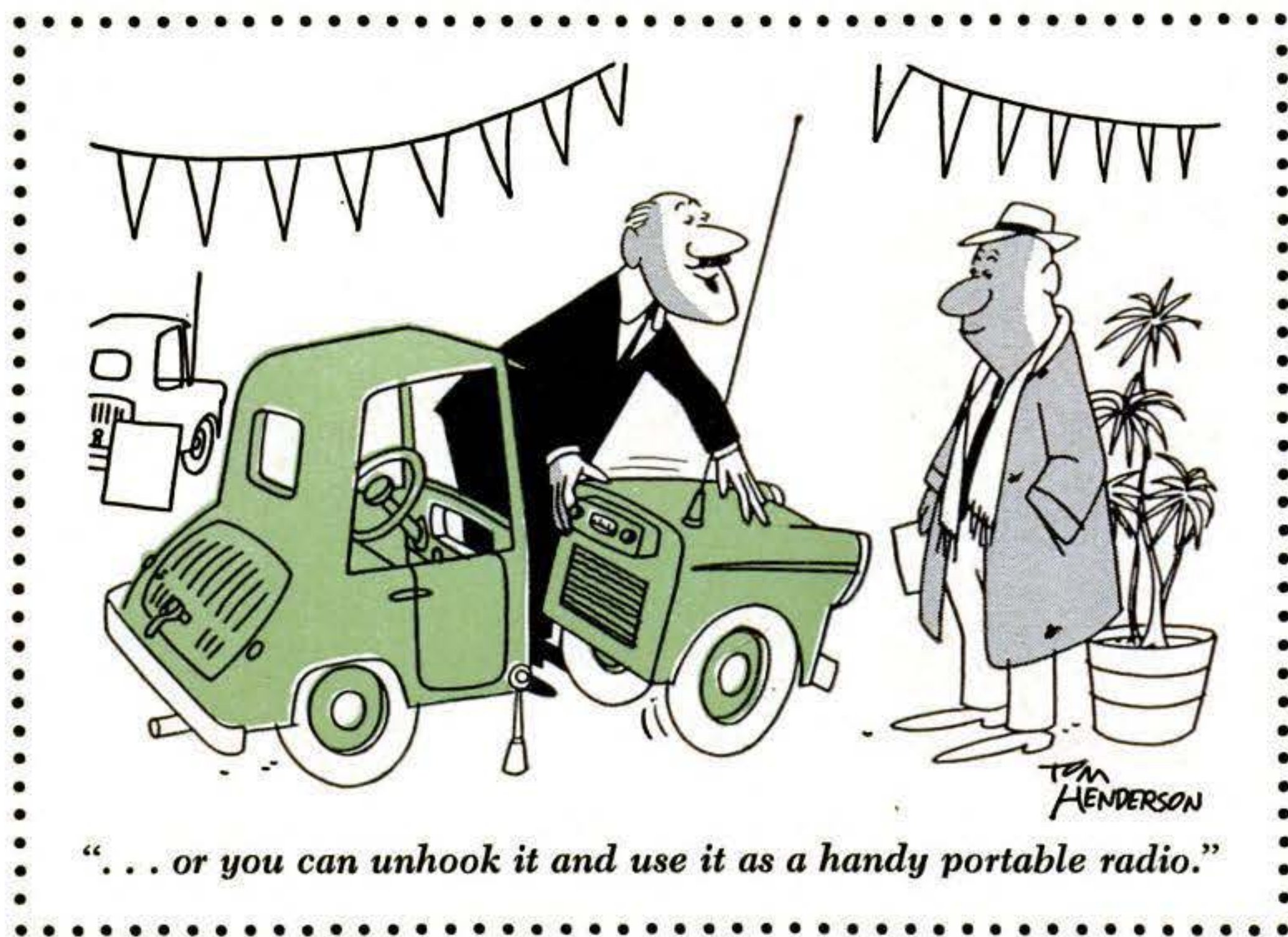

fully. "See, Tom, I said Gus could do it."

Gus groaned. "Oh, no! I should have guessed."

"Huh?" gulped a bewildered salesman.

"Son," Gus said, "you and I have been the victim of a practical joke. This is April first, and we've been April-fooled—but good."

The Biddle twins guffawed. Gus relit his pipe. Anderson replaced his instrument. "I know when I'm licked," he said.

"This has nothing to do with you," Gus said. "These two jokers have pulled the oldest automotive practical joke in the book. They switched two spark-plug wires. For years I've 'fixed' cars with that trouble the morning after Halloween."

"But how did you locate the trouble so fast?" Tom asked.

"Well, Tom, your brother had the car in here two weeks ago for a tune-up. New plugs, condenser, points—the works."

"That was the weekend I didn't get



Hints from the Model Garage

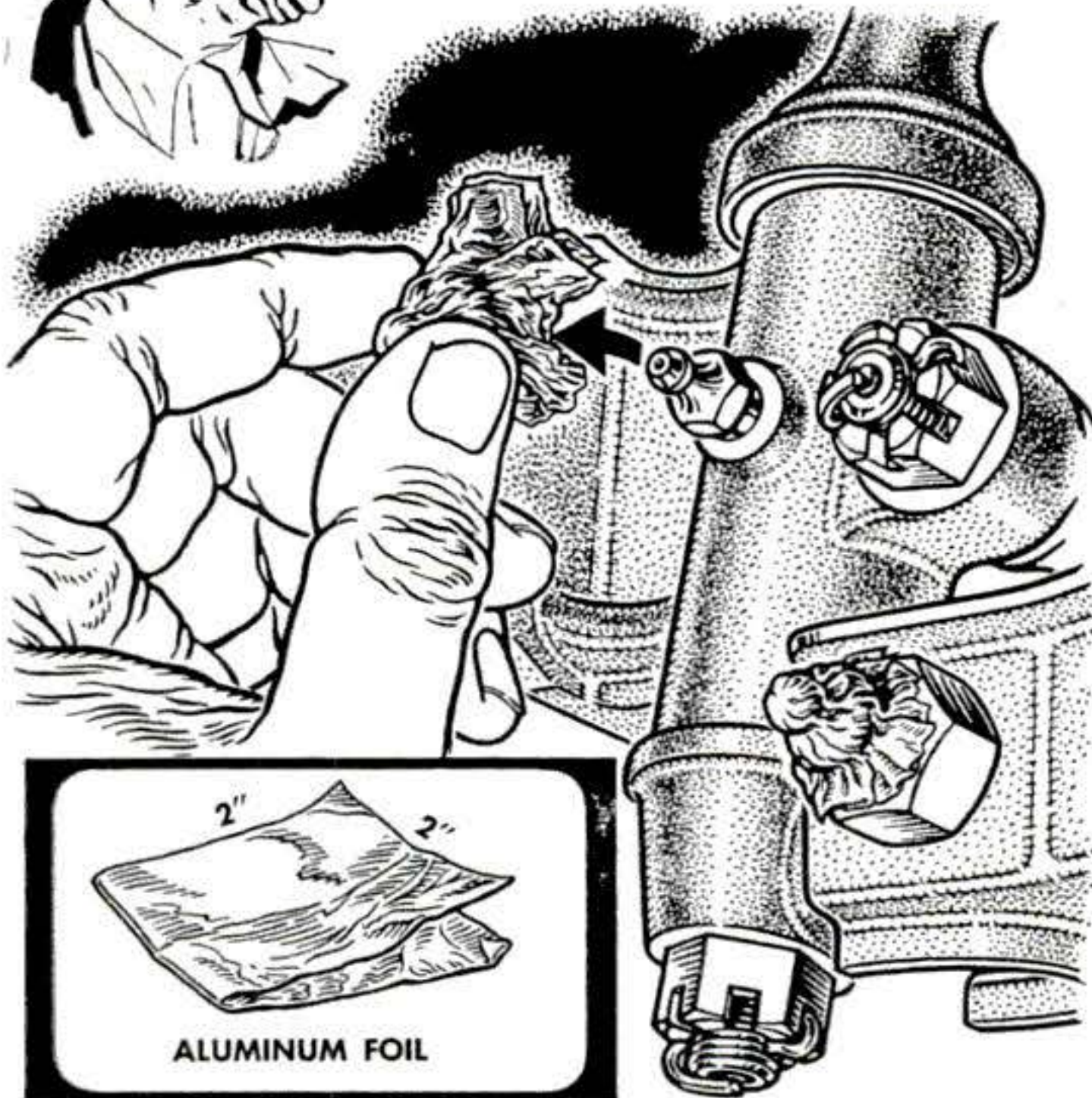

Grease fittings can be kept clean between lube jobs by pressing little squares of household aluminum foil over them. Covering the fittings takes no longer than wiping them clean, and eliminates the danger of forcing grit into the bearings.

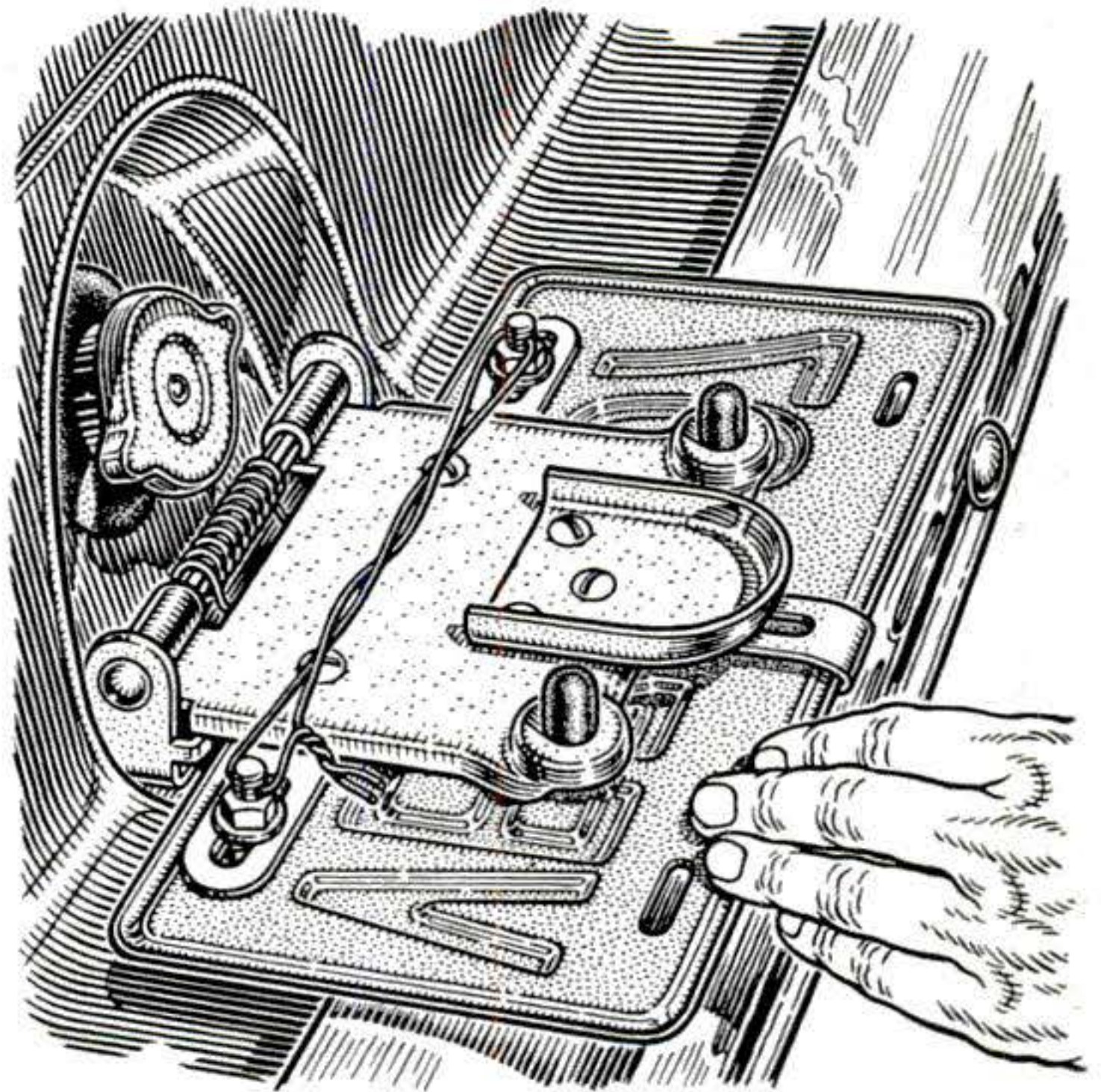

License plates can't be lost if you safety-wire the bolts as airplane makers do. Drill small holes through the bolt shanks and thread a loop of wire through the holes after tightening the nuts. Even if nuts loosen, they can't come off.

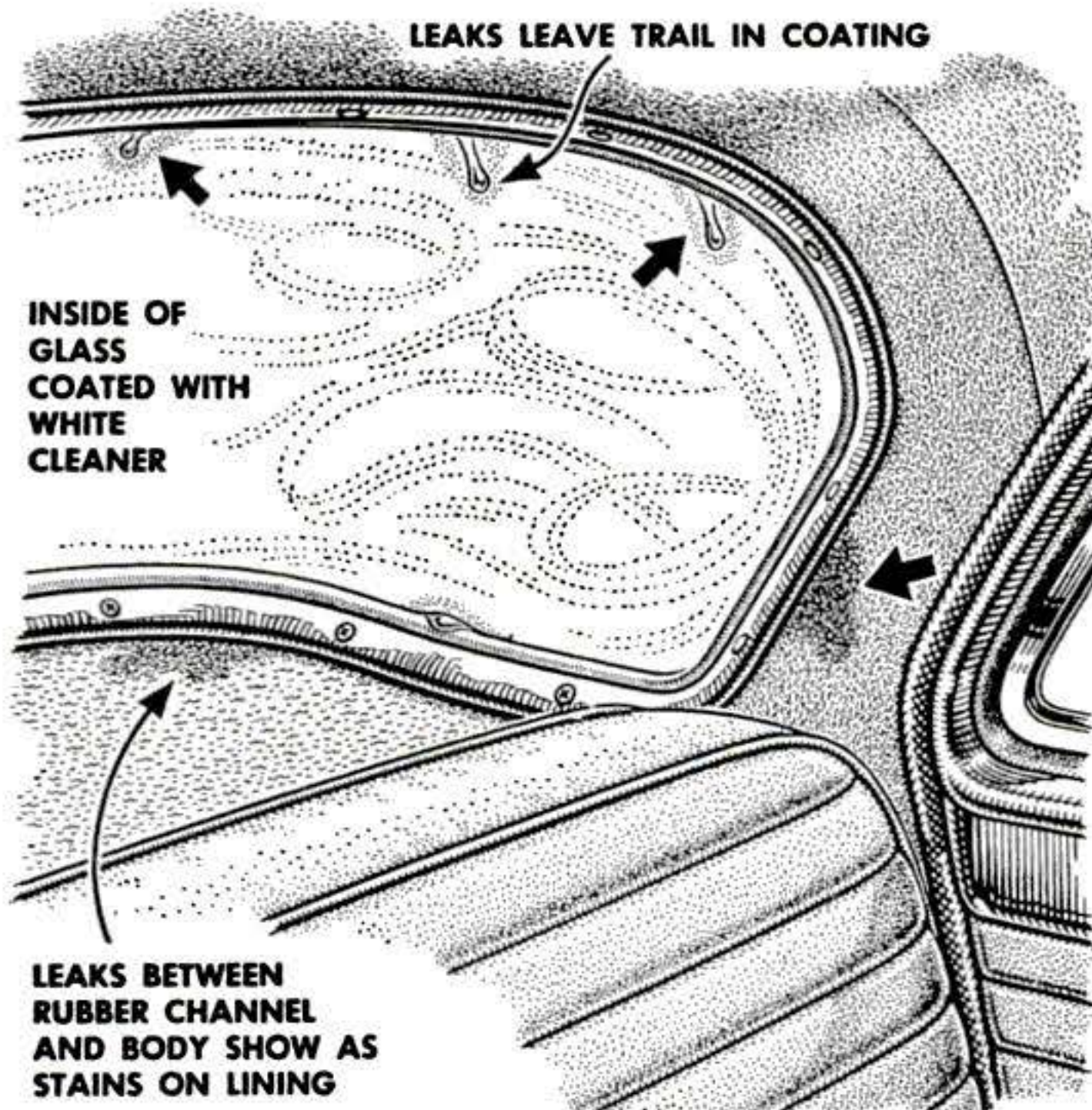

Hard-to-find leaks on rear window or windshield will leave a telltale trail if the inside of the glass is coated with a glass cleaner that dries to a white powder. After coating, play the garden hose over the outside of the glass to force water in.

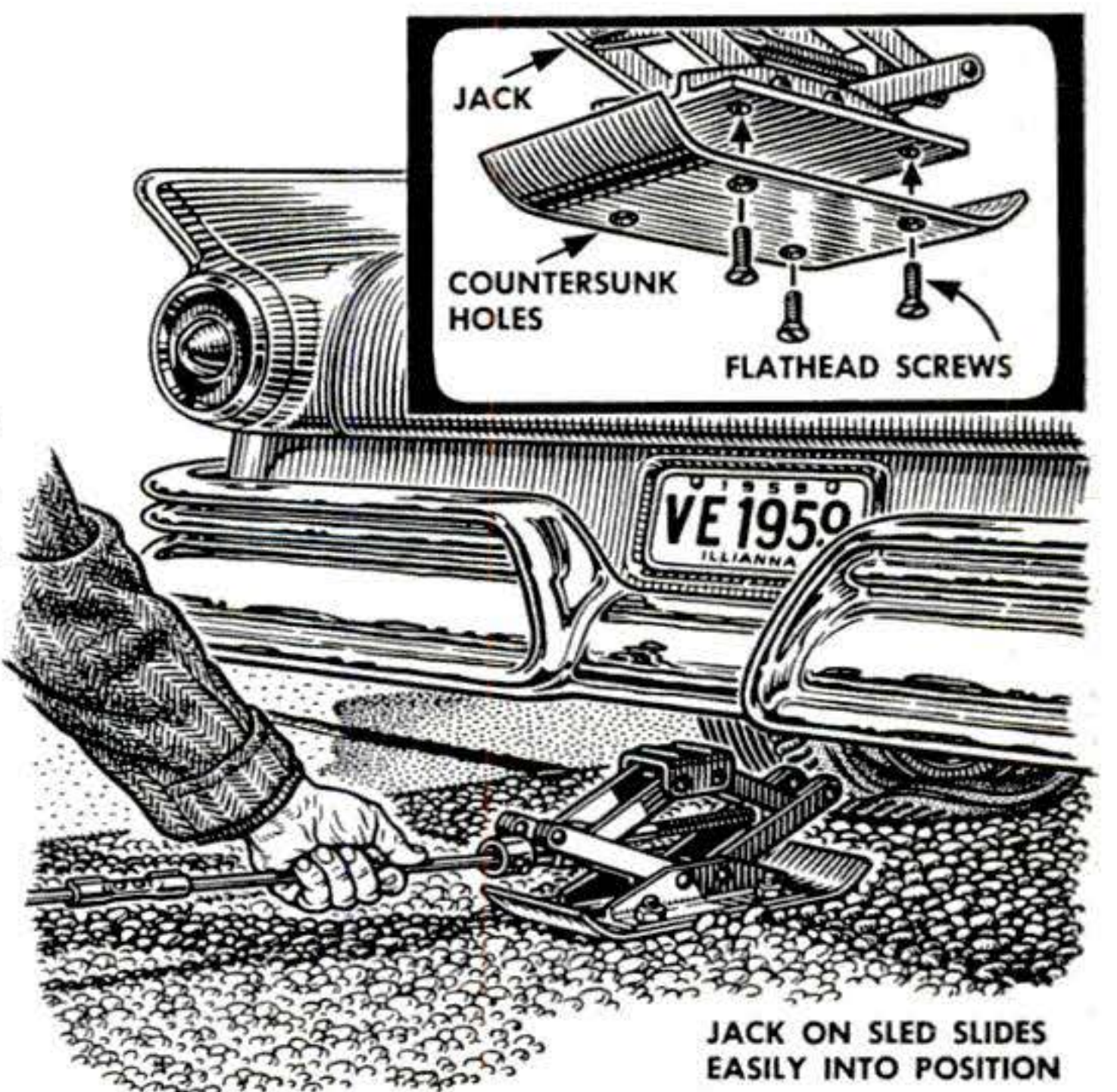

A sled-like base of heavy sheet metal fastened to the bottom of a jack will keep it from tipping and help it slide easily as it is pushed under the car over gravel or loose earth. The base also minimizes sinking into soft earth.

Please turn the page for more auto hints

More Hints from the Model Garage

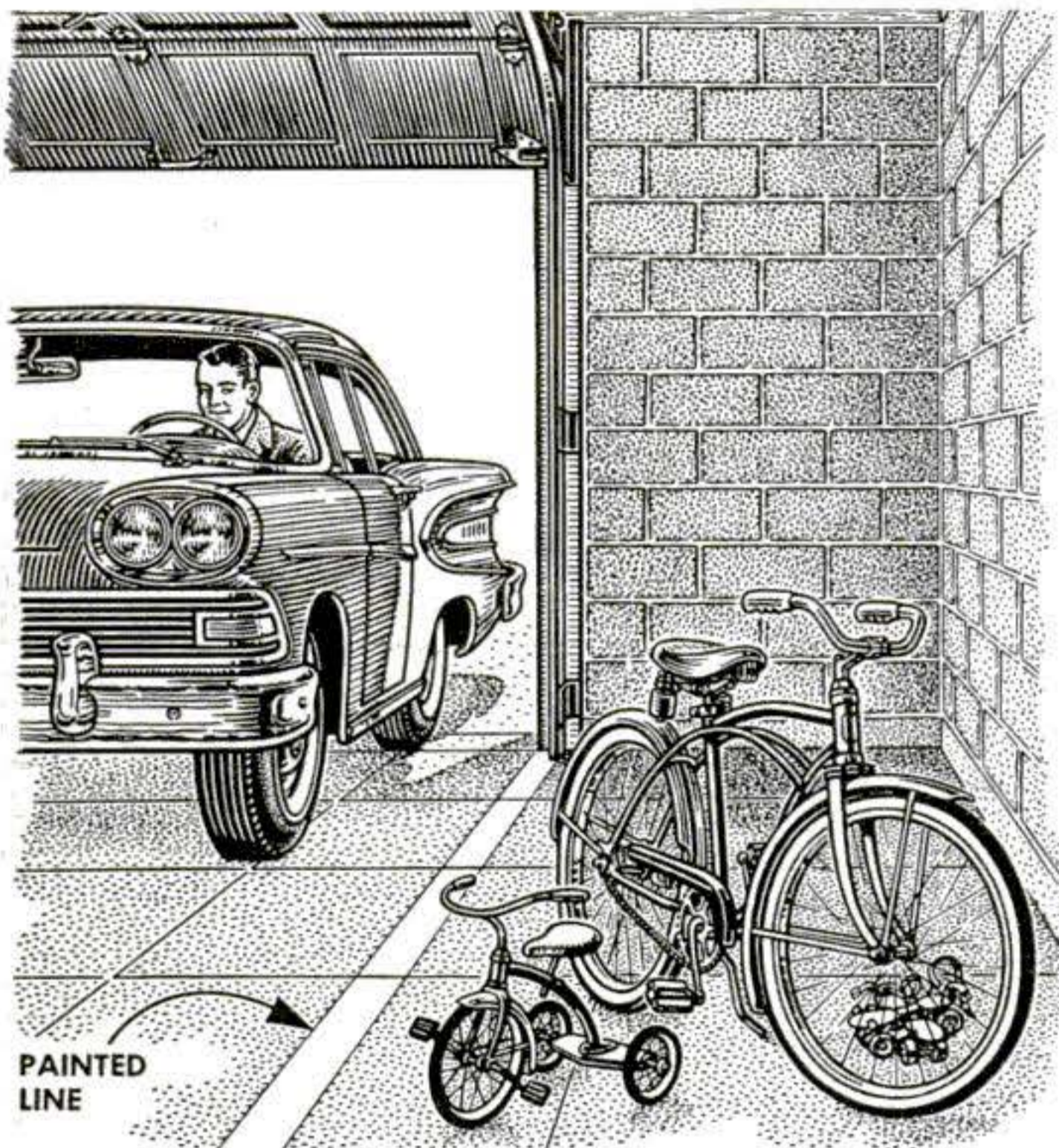

Painted guide lines that keep parking lots orderly can do the same for your garage. Using a board as a straightedge, roll or brush on two lines to indicate the space required for the car. Tell the kids the remaining space is theirs.

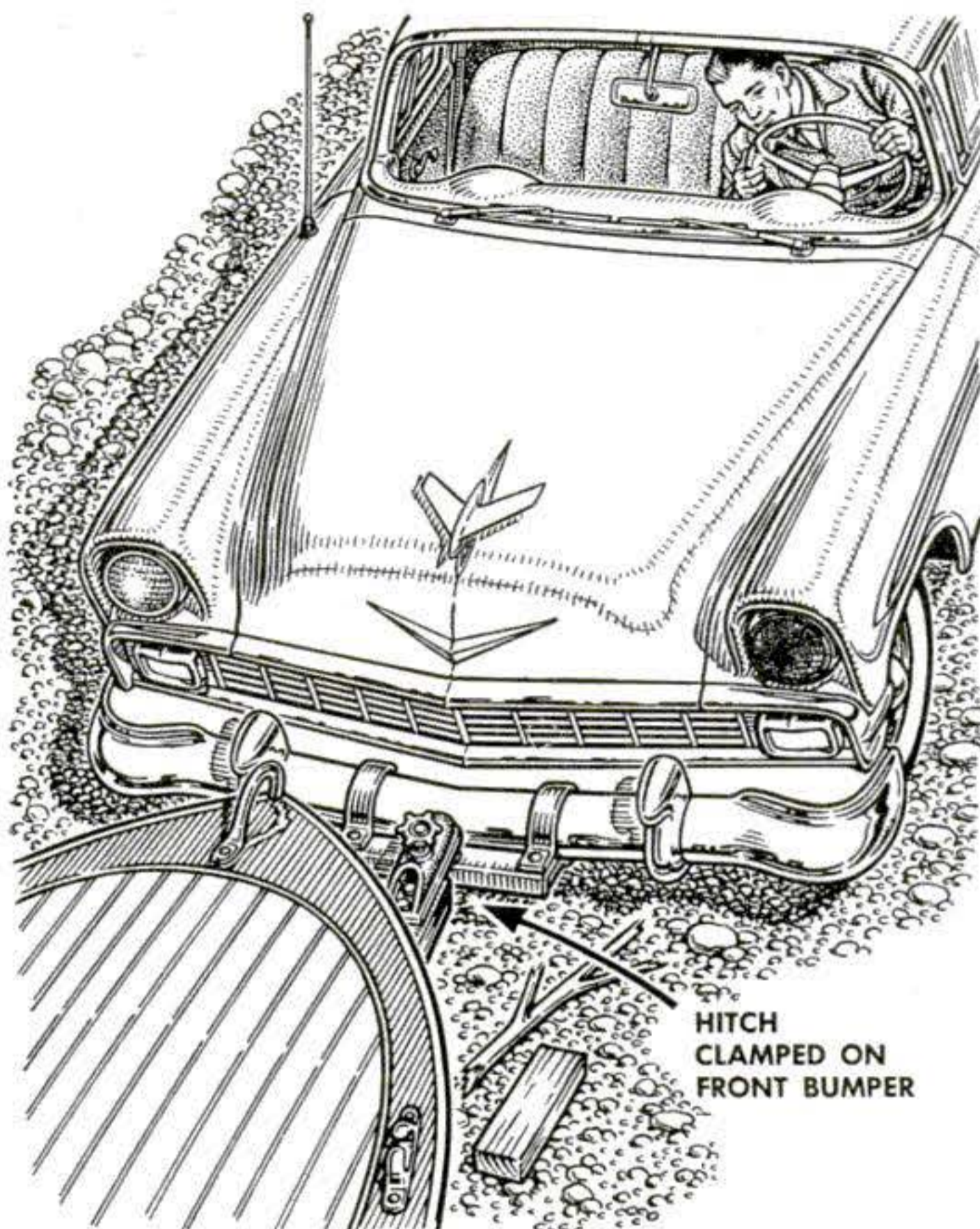

Where maneuvering is tight or the beach very shallow, try hooking your boat trailer to a hitch clamped to the front bumper. With this setup, you can quickly correct the trailer if it drifts off course, and push it right to the water's edge.

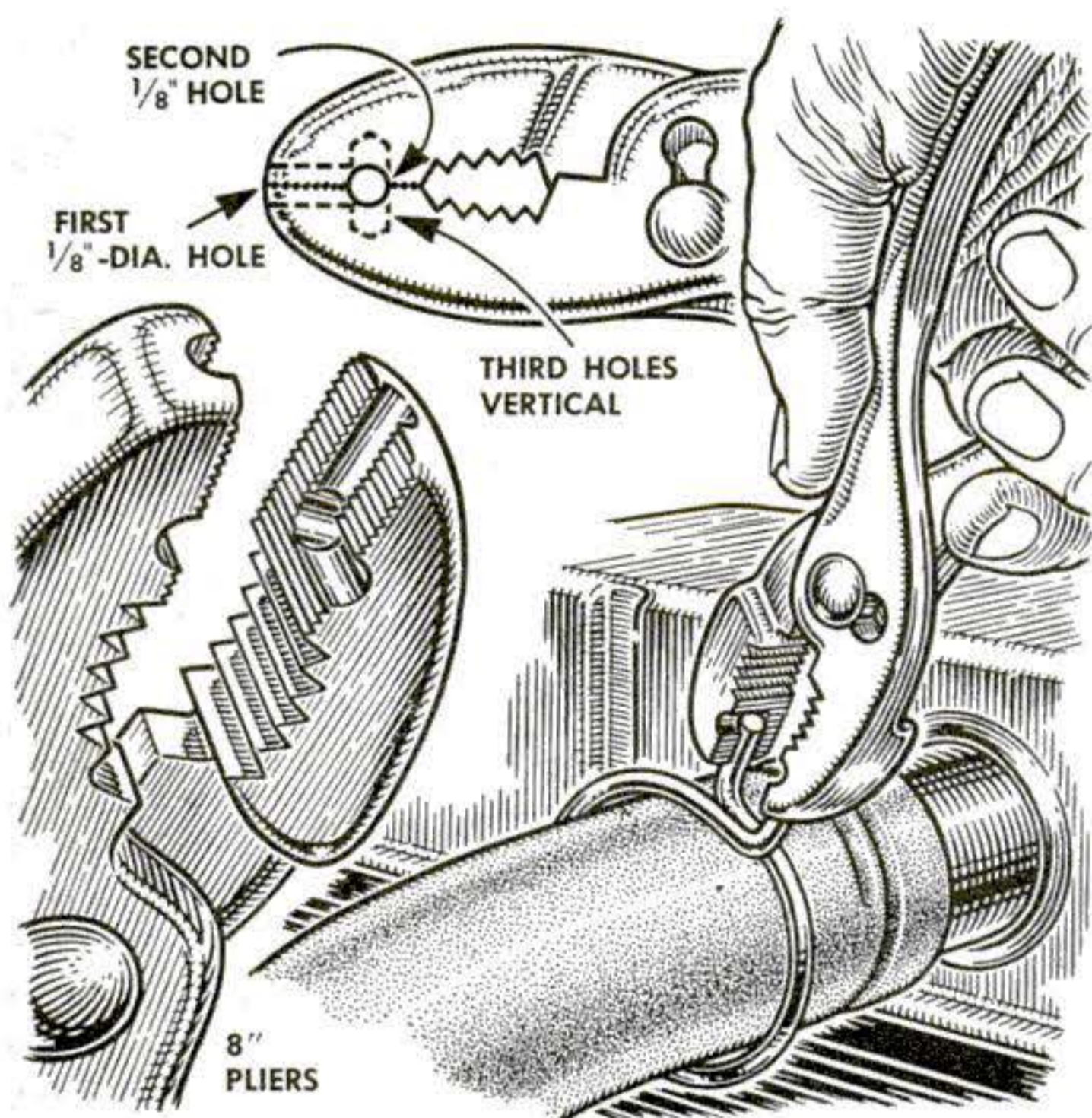

Make a handy hose-clamp tool from inexpensive slip-joint pliers by drilling three 1/8" holes. Clamp the jaws and drill one hole from the end, another in from one side. Open the jaws and drill each where the first two holes intersect.

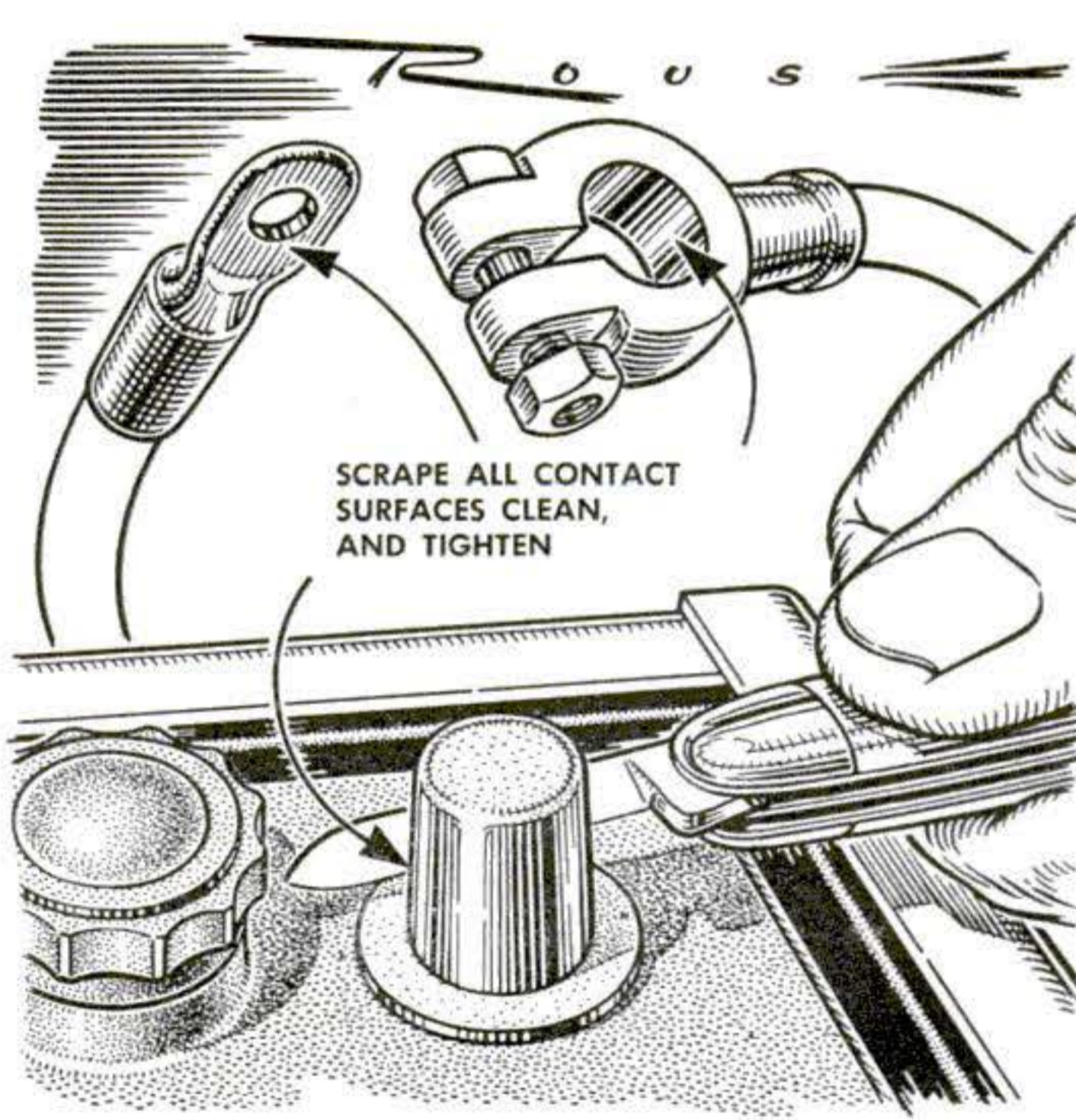

When lights burn out mysteriously, check for loose battery connections or a corroded ground strap. (An intermittent bad connection can result in generator-caused overvoltage.) Scrape all surfaces bright, and tighten for good contact.

Short Cuts and Tips

FROM PS READERS



Clay Clamp for Soldering

MODELING clay is indispensable for holding small or irregular-shaped objects for soldering. Pliable in your fingers, it conforms to any outline in clamping the work, is heavy enough for a good base and doesn't conduct heat. But don't let it touch the tip of the iron; it will stain.—*M. Robert Beasley, Jackson, Mich.*

Cornice Slips Off for Cleaning

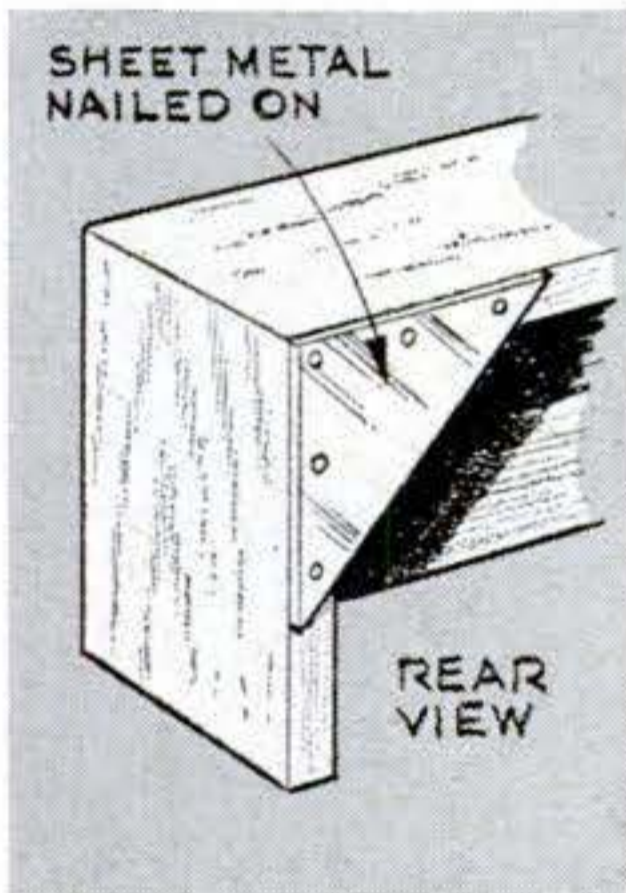

CORNICES can be hung quickly, and just as easily removed for cleaning and the like, if you nail a small metal triangle to each top corner. The metal holds behind the window trim.—*John Mihalick, East Liverpool, Ohio.*

How to Shorten a Small Screw

IF YOU have difficulty in grinding small screws shorter, try this. Push the screw through a small piece of sheet metal and, while holding it with a screwdriver, rotate it against the wheel.—*R. J. Phillips, Uncasville, Conn.*

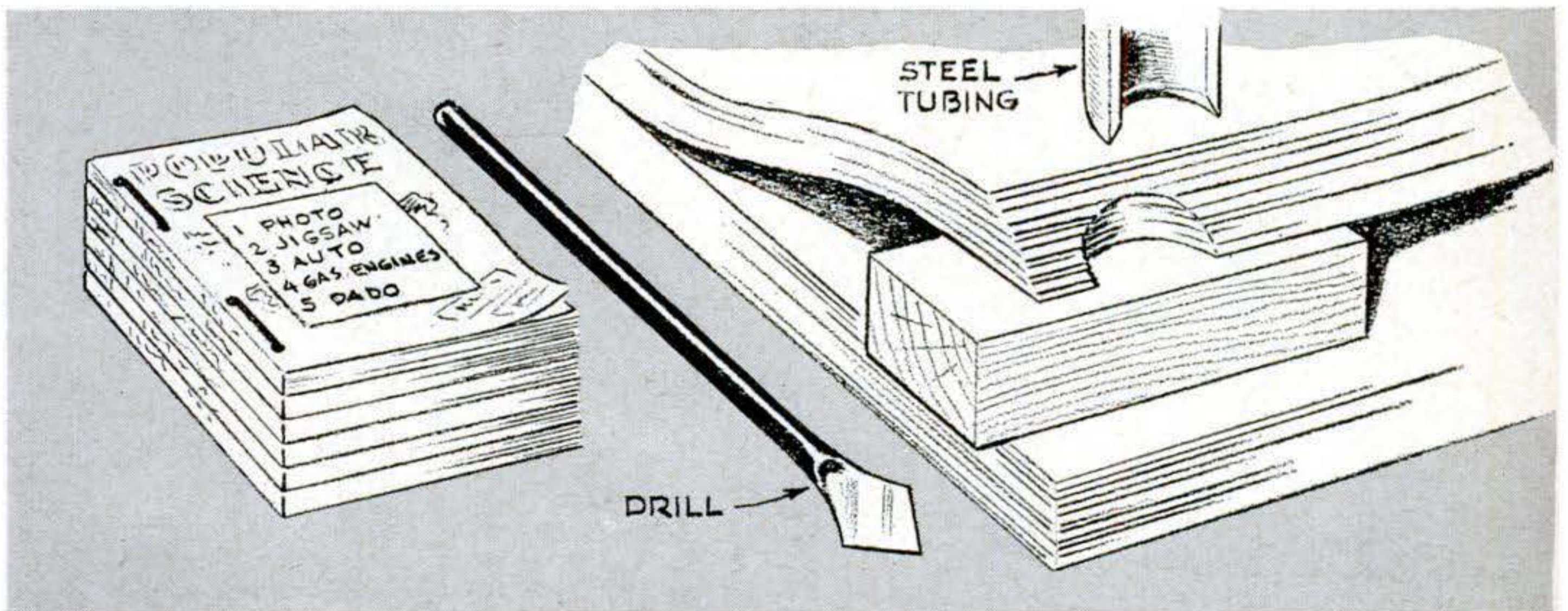
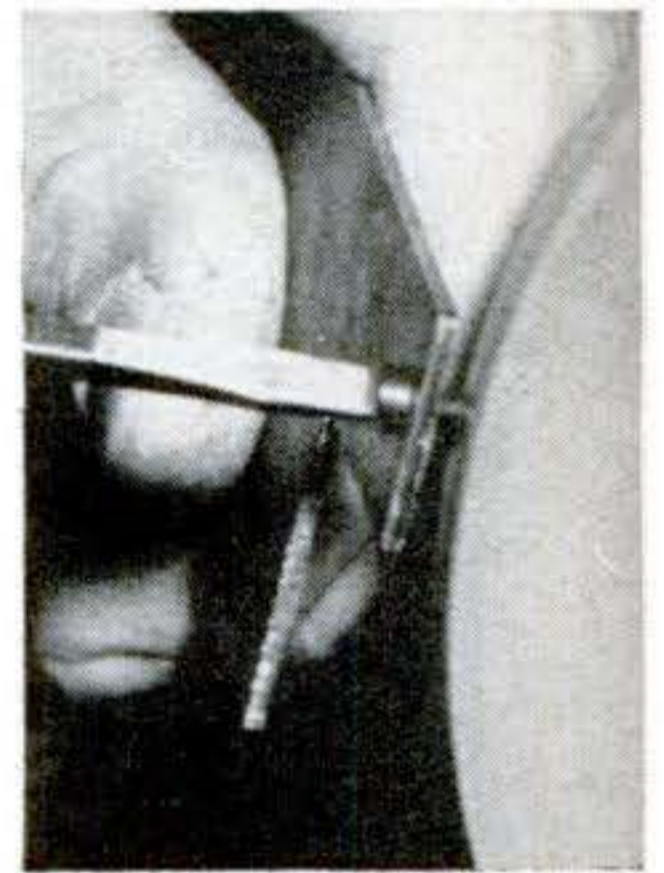

Easy-to-Make Binder for Keeping PS Issues

HERE is an easy way to bind back numbers of PS—a short cut on the excellent method described in July, '56.

I stack six months of issues beside a high fence on the drill press and make four holes in the stack $\frac{1}{4}$ " from the back. For a bit I use a length of coat-hanger wire flattened on one end and pointed

and ground for clearance. Then I thread with chalk line, using doubled bell wire as a needle, and knot it at the ends.

I index stories I want to refer to and notch the edges like a dictionary, fanning out about 150 pages so sharpened steel tubing will cut a tapered notch.—*F. Harry Loudon, Sarasota, Fla.*

Now... a camera built to THE KODAK SIGNET 80

Whether you work in wood, metal, or plastic . . . skin-dive or study the stars . . . specialize in sports cars or specimen roses . . . aircraft models or model rail layouts . . . electronic experiments or action photography . . . *this Kodak Signet 80 Camera should be your teammate and companion.*

It has a part to play . . . making your hobby better—more rewarding.

Precision camera? Yes. Expert's camera? Yes—but you don't have to be an expert to operate it. Kodak, in the American tradition, has created

a camera with all the features the experts demand—but easy-to-use in every feature.

See the superb new Kodak Signet 80 Camera at your photo dealer's. Examine the interchangeable lenses. Test the photoelectric meter, the "natural-size" finder, unique new "injection" loading, the connectors for both flashbulbs *and* electronic flash. It's *the* camera to team up with your hobby. Yours for only \$129.50, with 50mm *f*/2.8 lens—or as little as \$12.95 down.

Here are a few ways the Signet 80 Camera can make any hobby richer, more rewarding . . .



You get needle-sharp pictures with the coupled rangefinder—2½ feet to infinity! Couples to all lenses.

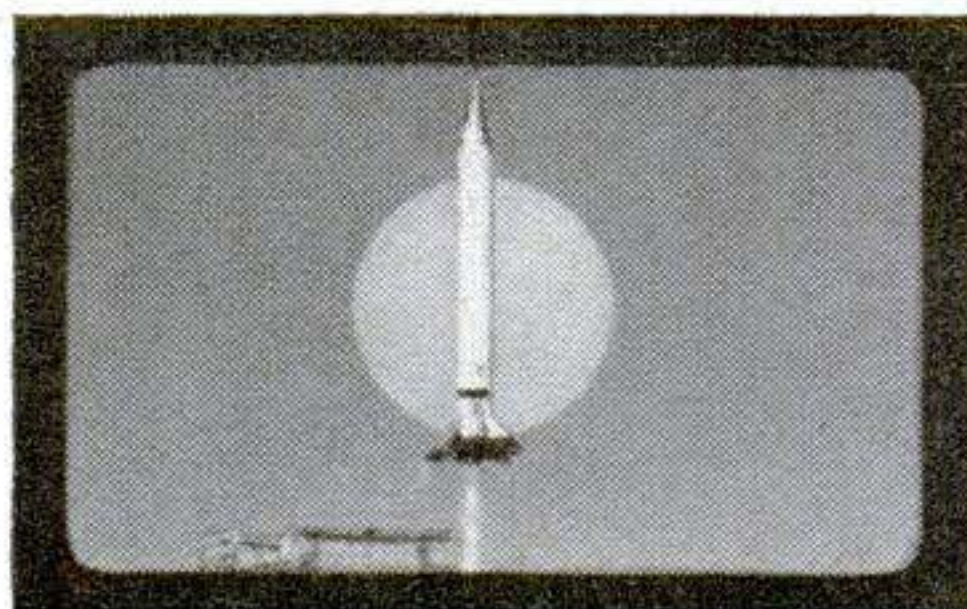

You shoot exactly what you see, with the brilliant big-as-life viewfinder. Image is life-size!



You read exposure easily—with ultra-sensitive photoelectric meter! Sets for all films.



You change lenses instantly—switch to wide-angle or telephoto. Just drop in, start shooting!



You pull in faraway scenes, take candid portraits with the telephoto lens. (90mm *f*/4, \$69.50)



You capture the broad sweep of a scene with the wide-angle lens. (35mm *f*/3.5, \$57.50)

EASTMAN KODAK COMPANY •

team up with your hobby...

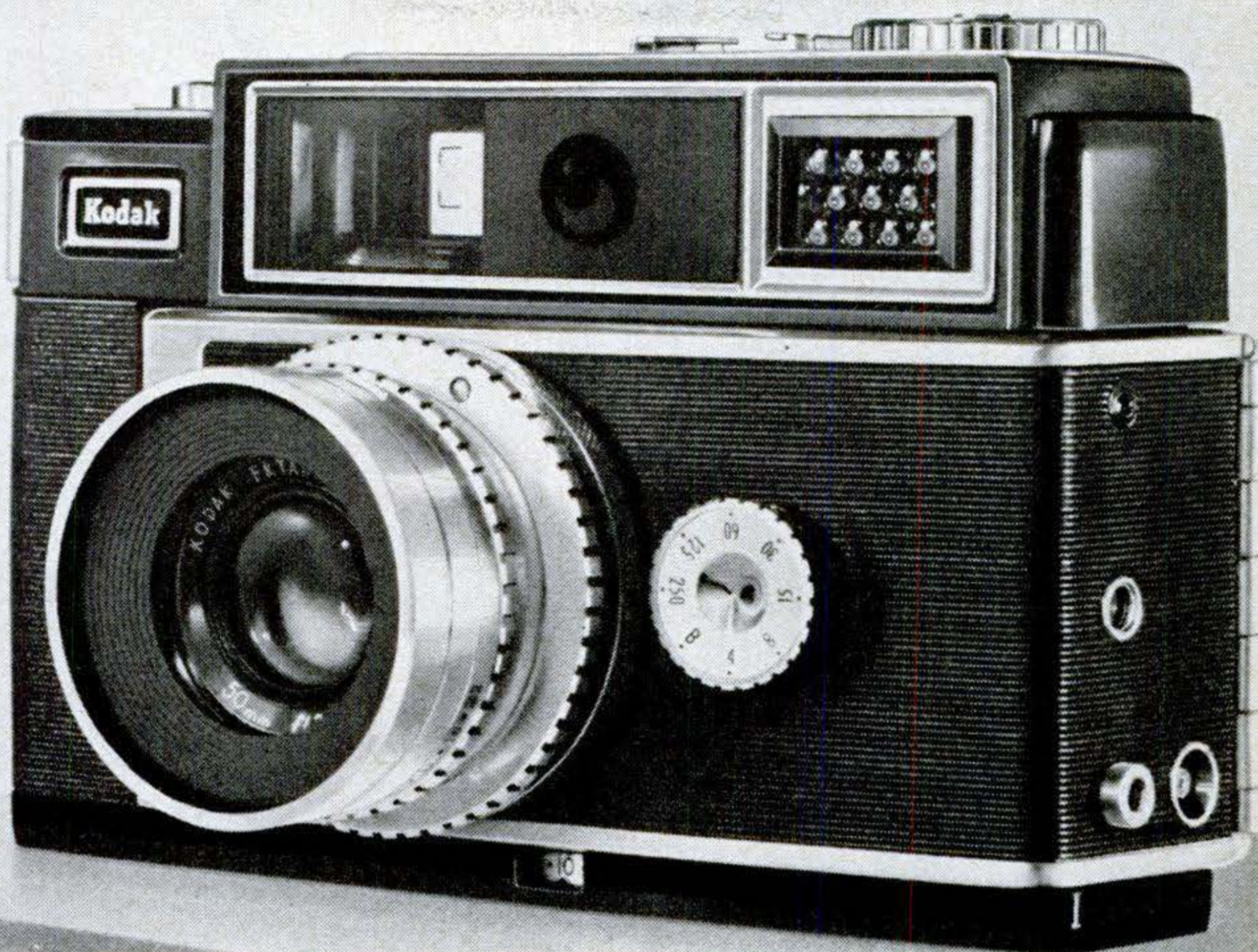

Want to shoot the moon? To team up your new Signet 80 with a telescope, write our Sales Service Division for "Telescope Pictures With Your Camera," Pamphlet C-20.

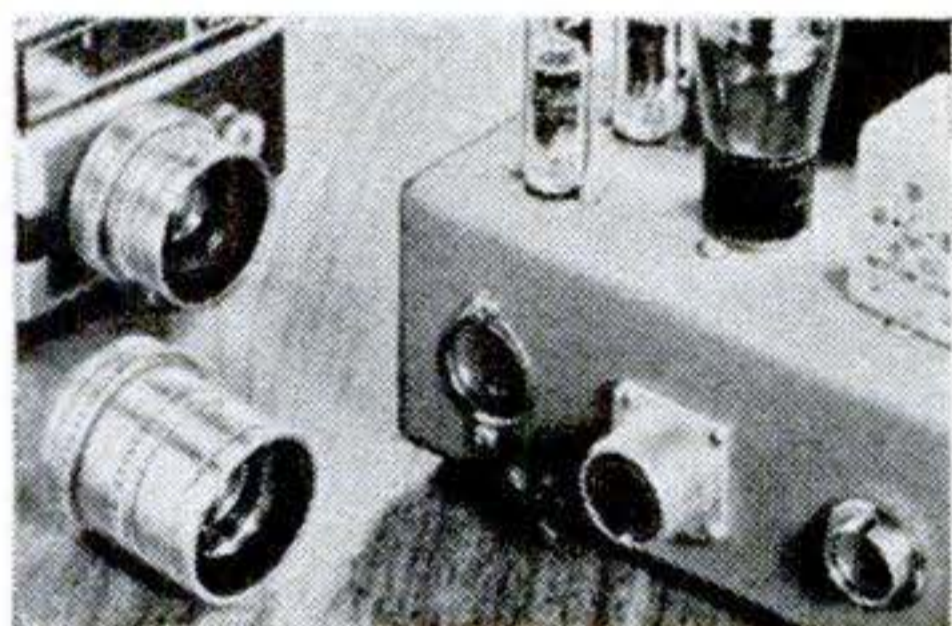

Near or far, you capture extra detail with Signet 80 rare-element-glass lenses. Superb for color.

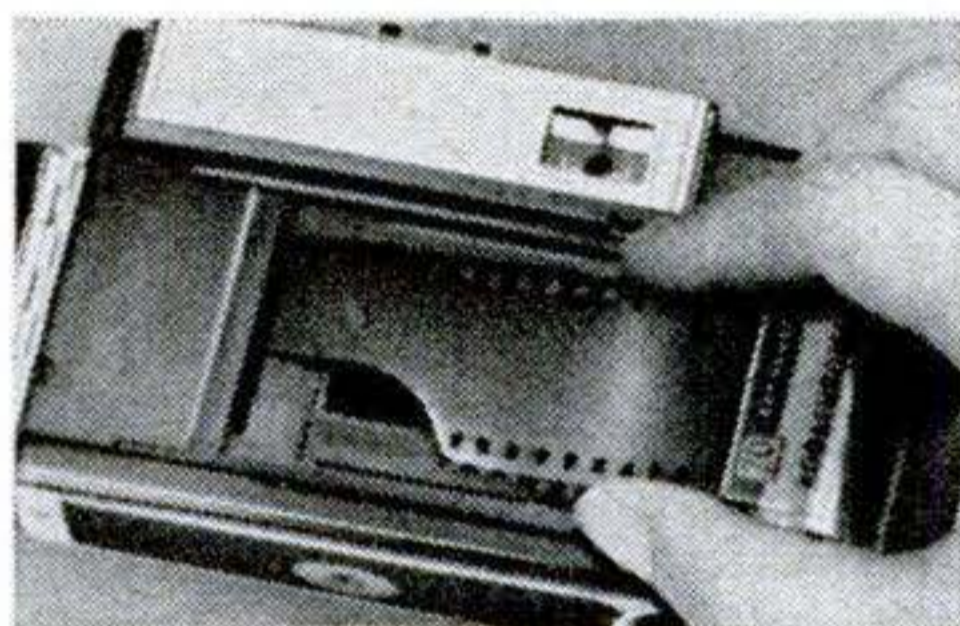

You load film fast—drop it in, close the camera. You can do it with one hand, blindfold!



You can make ultra-close-ups of specimens with low-cost Kodak Portra Lenses. Quick, easy.

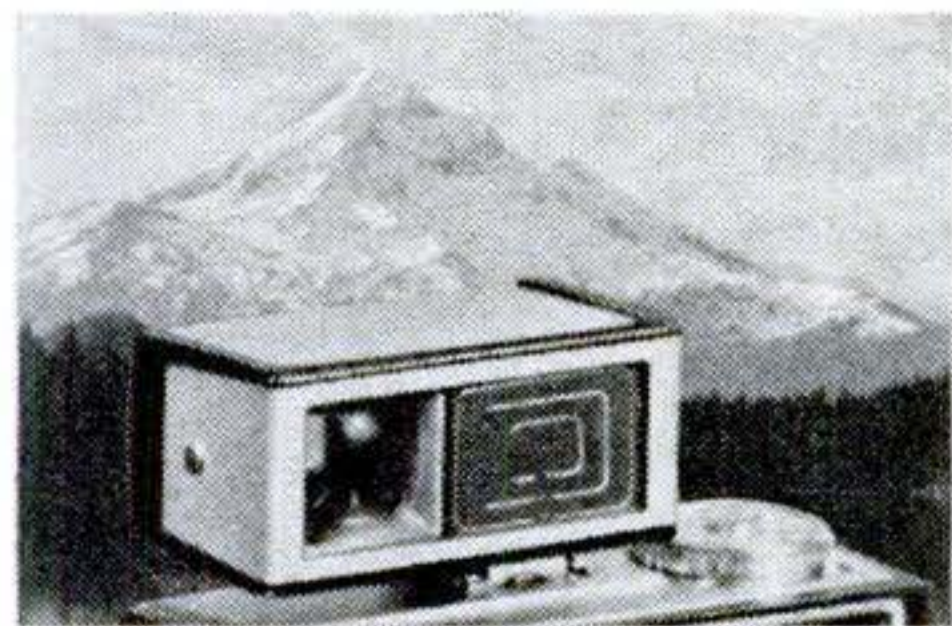

Multi-Frame Finder tells instantly which lens fits the scene best. (\$17.50)



You click off rapid-sequence shots with thumb-action film advance. Sets shutter too, counts shots.

See Kodak's "The Ed Sullivan Show" and "The Adventures of Ozzie and Harriet"

(Prices are list, include Federal Tax, are subject to change without notice)

Kodak
TRADEMARK

Rochester 4, N.Y.

APRIL 1959 235

FEEL Jet Rocket driving power

Swing this beauty by True Temper. Feel the precision balance and control that give you greater driving power than any wood-handled hammer can. Note the forged-steel head permanently locked to the tubular-steel handle. And it has a cushion grip that won't slip — even when wet. Here, for certain, is a great hammer buy. See the JET ROCKET at your hardware store now. True Temper, 1623 Euclid Avenue, Cleveland 15, Ohio.

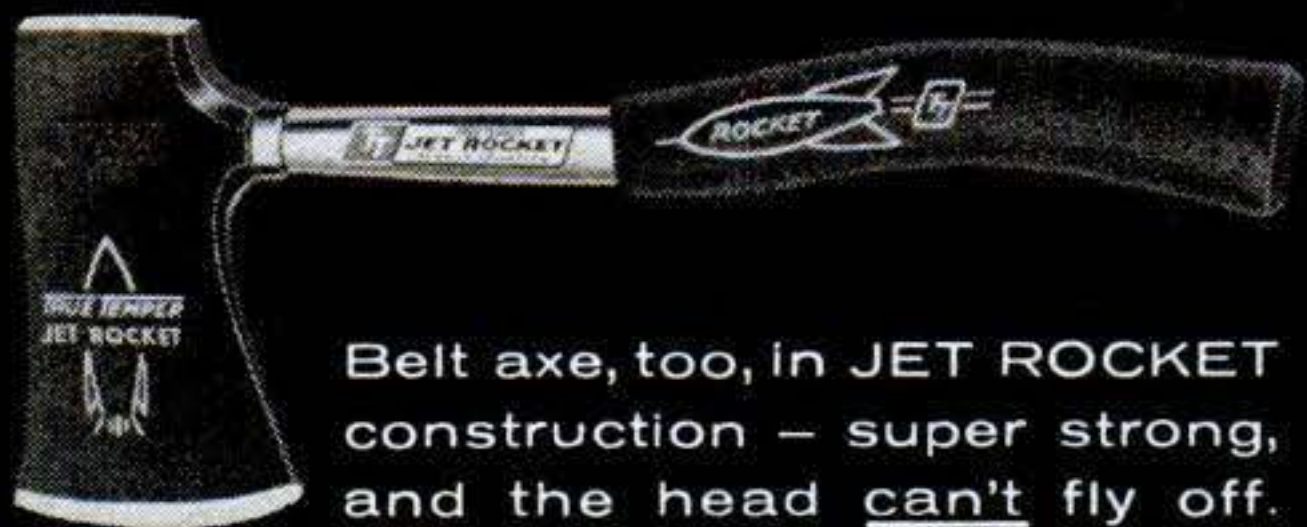

Belt axe, too, in JET ROCKET construction — super strong, and the head can't fly off.

TRUE TEMPER®

THE RIGHT TOOL FOR THE RIGHT JOB

America's Supersonic Cargo Rocket

[Continued from page 117]

gency supplies to isolated troops in seconds, Lobbers might be used to lay heavy smoke screens, send up huge flares to illuminate battlefields, hurl napalm, pay out wire for field telephones, drop radio receiver-transmitters ahead of fast-moving forces, or deliver high-explosive or nuclear warheads.

Convair engineers see the Lobber as the first of a family of ballistic cargo missiles, growing in size, range, and number of uses. They envision big, automatically piloted, boost-glide missiles for delivering fuel to stranded tanks, or replenishing heavy munition stores during a swift advance, or even, in vehicles of slower acceleration, transporting troops.

Peaceful versions of these ballistic missiles could be used to lob chemical or water bombs at forest fires, toss rescue lines to wrecked ships, or even deliver mail and express packages across the nation or oceans, the engineers say. **END**

Starter sends drone on way



To TURN over the engines of radio-controlled aerial targets for takeoff, mechanics roll up battery-operated motor starters like this one. The pilotless planes — 12-foot "clay pigeons" for AA gunners — carry a 72-hp., two-cylinder engine, giving a top speed of 220 m.p.h.

**"MEN WHO DO-IT-YOURSELF" YOUR
SKILLS
CAN MEAN
AN
IMPORTANT
FUTURE
IN THE
NEW
AGE OF SPACE**

If you like to build transmitters...or hot rods...or models...you can also build a real future for yourself by training in the U.S. Air Force. For in today's new Age of Space, it is the man with technical ability who will be the important man. *Only in the Air Force*, however, will you find so broad and complete a range of Space Age specialty training. In the Air Force, *the Age of Space* is now. For full details on your training opportunities see your local Air Force Recruiter now, or mail the coupon.



**TRAIN
IN
THE
U.S. AIR
FORCE**

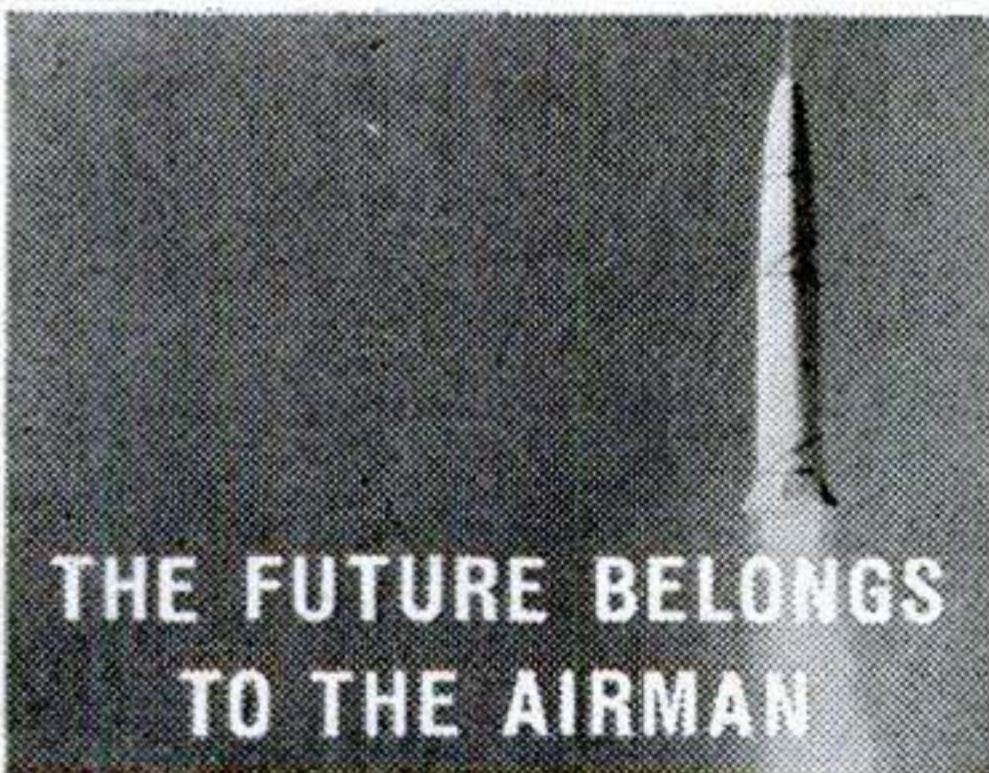
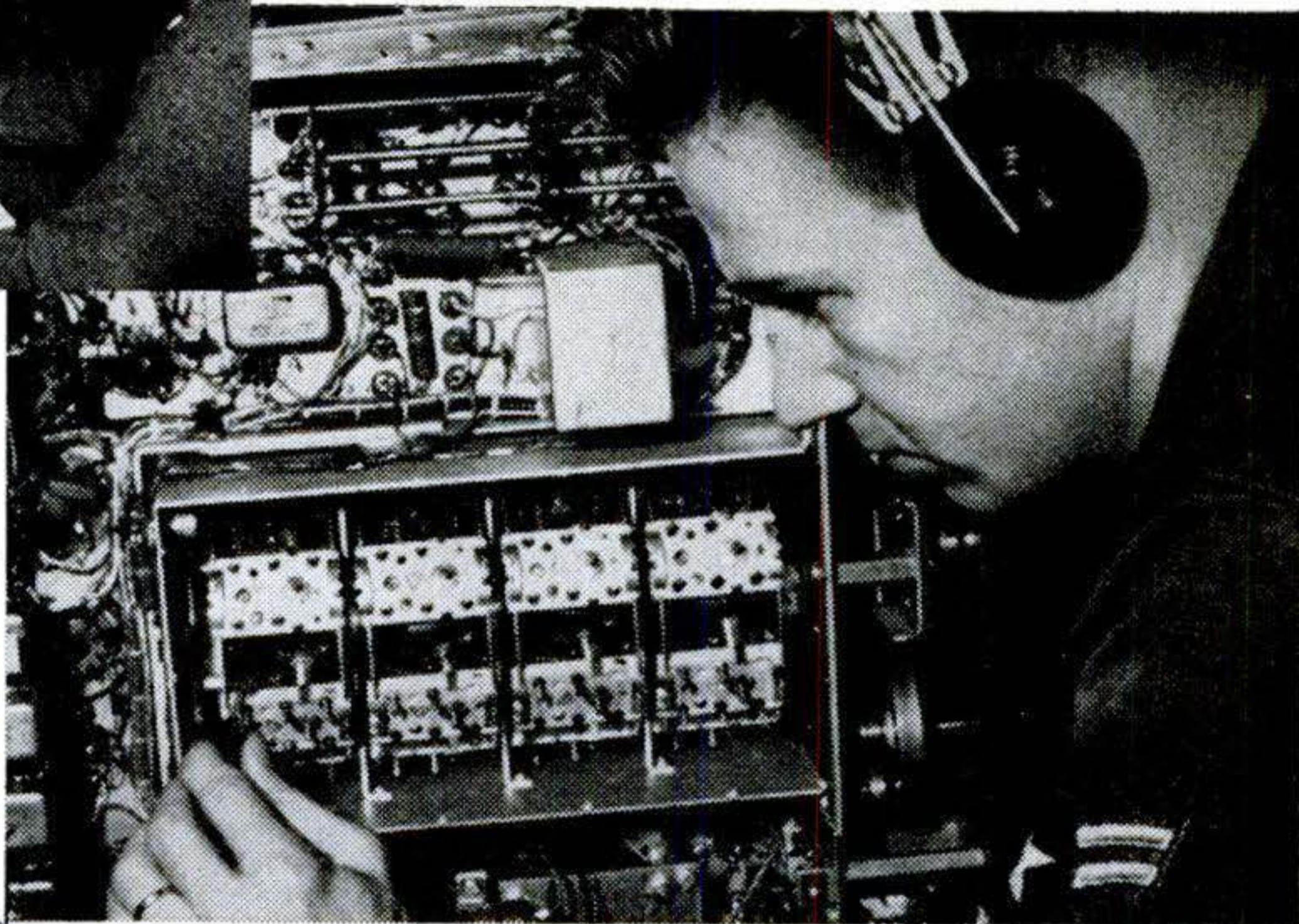

**THE FUTURE BELONGS
TO THE AIRMAN**

PASTE COUPON ON POSTAL CARD AND MAIL TO:

Airman Information, Dept. MPS-94
Box 7608, Washington 4, D. C.

Please send me information on my opportunities in the U. S. Air Force.
I am between the ages of 17-34 and reside in the U. S. A. or possessions.

Name _____

Address _____

City _____ Zone _____ State _____

Little Car with Big Ideas

[Continued from page 123]

the workmanship. It's excellent. But among good features there are some flaws. The safety factor provided by the recessed steering wheel, for instance, is offset by protruding dash knobs. And why, when you have to turn a car over to parking-lot jockeys, aren't these plainly marked? Also, in a car of this quality, why only one door that locks with a key?

On the Touring Sport, holding down the wheel button blinks the high-beam lights—a useful passing signal. But the front-window cranks seem designed for contortionists. You have to turn them with your far hand, not the nearer one.

The rear seat, as in many European cars, seems planned for in-laws only. Narrowed down by armrests, its usable width is 49 inches. Knee room depends on front-seat riders; in the Touring Sport it shrinks to six inches if they need maximum leg room—which few will.

Rear windows, hinged at the front, have a toggle latch you can work with two fingers. It locks in the over-center position, or holds the glass open at vari-

ous outward angles. One fault: crunchy-munchy noises as it swings past hold-open serrations. Silent amenities include two ashtrays, grab straps and coat hooks nicely designed into the strap mounts.

The car heater is a dual system, with two heat exchangers—one for each side of the car—and dual controls. But only the costlier Touring Sport has an electric blower to urge the tepid air into the car, and even with that the system is hardly up to warming the car on a frigid day.

The station wagon, no longer than the sedans, has the same excellent interior finish together with generous glass areas and load capacity. The Coupe, at \$3,750, sports a different instrument panel with a padded dash and keyboard switches marked by picture symbols. Only 52 inches high, it has a well-designed hard top with a wraparound rear window. Door cappings and interior window surrounds are of simulated wood veneer. As usual in European sports models, the rear seat is for luggage, a dog, or preschool children.—*Harry Walton.*

SHOPMATE®

Radial Saw

WITH PATTERNMAKER
PRECISION AND
"DUAL PORTABILITY"

FIRST RADIAL SAW WITH DUAL PORTABILITY
EVER OFFERED AT THIS LOW PRICE!

Shopmate—all the accuracy and twice the versatility of other radial arm saws. A rugged, big capacity precision instrument that produces an endless variety of professional quality work!

Powerful 1 hp automatic safety clutch saw makes all cuts easily: cross cuts, dados, rips, mitres, bevels, cove cuts, etc. Widely spaced ball bearing carriage, heavy-duty $\frac{3}{4}$ " Acme elevating screw, heavy steel U-beam base, treated hardwood table, precision calibrated scale adjustments with positive indent stops 45° left and right, anti-kickback in front of blade, finger-tip power control, 8-second blade coast-down, full 180° swing, and many other features.

At hardware and building supply dealers or write
PORTABLE ELECTRIC TOOLS, INC.
320 WEST 83rd STREET, CHICAGO 20, ILLINOIS



USE AS A PORTABLE SAW... 7" saw detaches in 8 seconds.



OR A RADIAL SAW makes every cut!



SAVE OVER \$100
\$149⁷⁵

SUGGESTED RETAIL

MAIL THIS COUPON FOR INFORMATION!
ON THE SHOPMATE RADIAL SAW!

Name _____

Address _____

City _____ State _____

TIPS FROM TEXACO



How to wring more mileage from every drop of gasoline

1 Keep your carburetor air cleaner thoroughly clean or replace it regularly. Dirt chokes air-flow and wastes fuel.

2 Clean accumulated dirt, oil and mud from your fan blades (or have your Texaco Dealer do it).

3 Accelerate gently. "Jackrabbit" starts use up to 60% more gasoline.

4 Reduce engine friction by having your crankcase drained and refilled with the motor oil that lubricates ideally in every season . . . all-temperature Havoline Special 10W-30! Get maximum protection against cold start wear, hot running wear, and power-robbing sludge and deposits.

5 Maintain a steady, light foot on your gas pedal, and allow engine compression to slow you down instead of braking hard.

6 Turn off ignition when you stop for more than a minute. Takes less gas to restart than idling for 45 seconds!

7 Make sure tire pressure is correct.

8 Keep your tank filled with *the* gasolines blended for top performance and economy . . . Texaco. Both Sky Chief Supreme and *regular price* Fire Chief are 100% Climate-Controlled for every one of 26 climate areas in the U. S.

THE TEXAS COMPANY



Buy the best . . . buy TEXACO



SUPREME VERSAMATE

Versamate . . . a wonderful tool that fits any power drill—reduces speed to give seven times more power. Drives screws of all sizes. Inexpensive extras make it a nut and bolt driver, heavy-duty drilling unit. See your tool dealer today!



\$995

For Portable Drill Users...
**CHOOSE THE
ATTACHMENTS
THAT DO THE
BIG JOBS!**

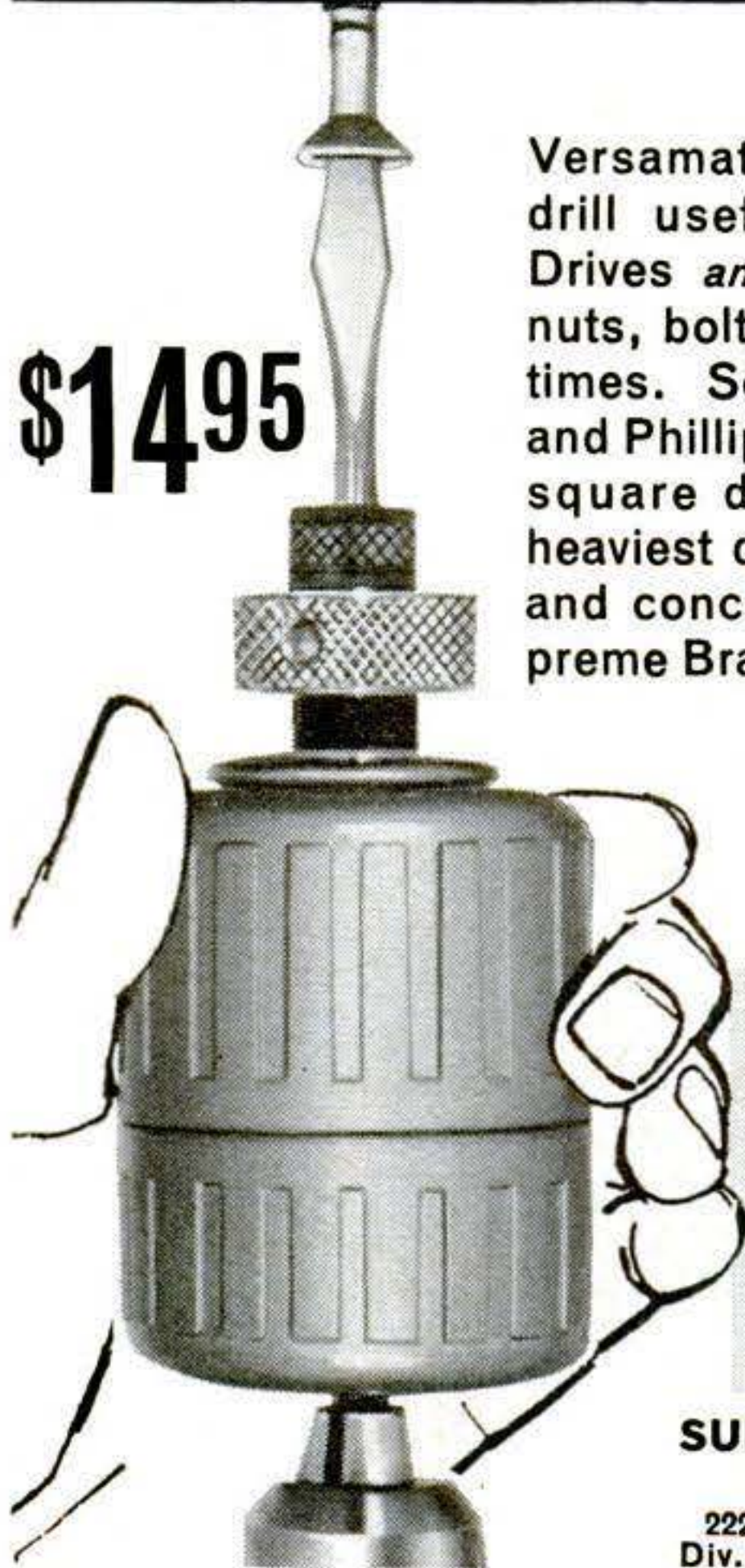

\$1495

Versamatic triples portable drill usefulness. *Reverses!* Drives and removes screws, nuts, bolts. Boosts power 7 times. Set includes regular and Phillips-type bits, and 1/4" square drive adapter. For heaviest drilling jobs in steel and concrete, add a 1/2" Supreme Brand Chuck.

SUPREME VERSAMATIC

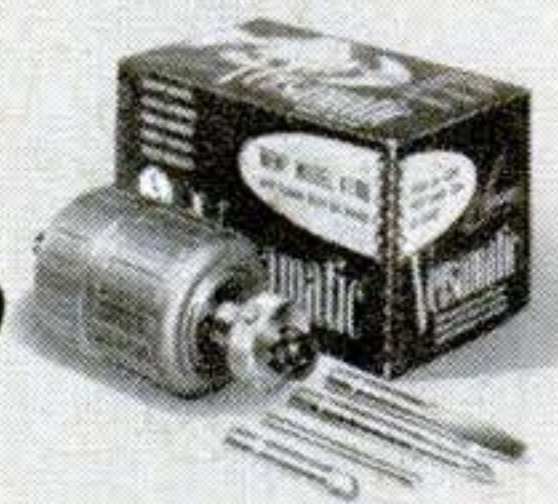

**SUPREME PRODUCTS
CORPORATION**
2222 S. Calumet, Chicago 16
Div. of A • S • R Products Corp.

Russia's Small Cars

[Continued from page 139]

port trade in mind). They are bound in hard covers, and are about the shape of a city telephone directory. The information in them is exhaustive.

The sleek but rather sluggish Volga has an electric clock, cigarette lighter, ashtray, tubeless tires, pushbutton tuning on its radio, plunger locks on its doors,

.....
Next Month: U. S. cars often change so much, year to year, you need the nameplates to identify them. Not so, the imports. But there are subtle changes. Find out what's new with VW, Renault, Hillman, Opel, Vauxhall, Fiat, Simca and such—in May PS.
.....

and a pedal, to the left of the clutch, that works a chassis-lubricating pump.

Speaking of clutches, I found them too close to the brake pedals in both cars. The soles of my shoes kept tripping on each other as I drove. And the brakes, though hydraulic, seemed awfully reluctant to take hold.

Gas mileage: 33 1/2. On the word of its English manual, the Moskvitch can go 65 m.p.h., with four people aboard, "on a horizontal section of smooth road in summer time." Maybe so, but in winter, alone and plagued by hills, I couldn't do anywhere near as well with it. However, the manual says it goes 33 1/2 miles on a gallon of gasoline "at speeds of 18-25 miles per hour over a level road section." I don't doubt it.

The Volga's manual estimated its top speed at 84 m.p.h. and its best fuel consumption at 25 m.p.g.

My feelings about the Moskvitch admittedly are colored by the fact that it died on me at a crowded street corner, just ahead of an impatient bus. I then had to push it across one of Hollywood's busiest intersections to a filling station. The proprietor, a local Gus Wilson who acted as if Russian cars limped onto the premises every other hour, fished around under the unfamiliar hood for a few minutes and then found a loose connection. In an instant, the impish Moskvitch was whirring again like a well-oiled sewing machine.

I will say this for it: It idles nicely.
—Wesley S. Griswold.

FROM THE MAKERS OF
SKILSAW PRODUCTS

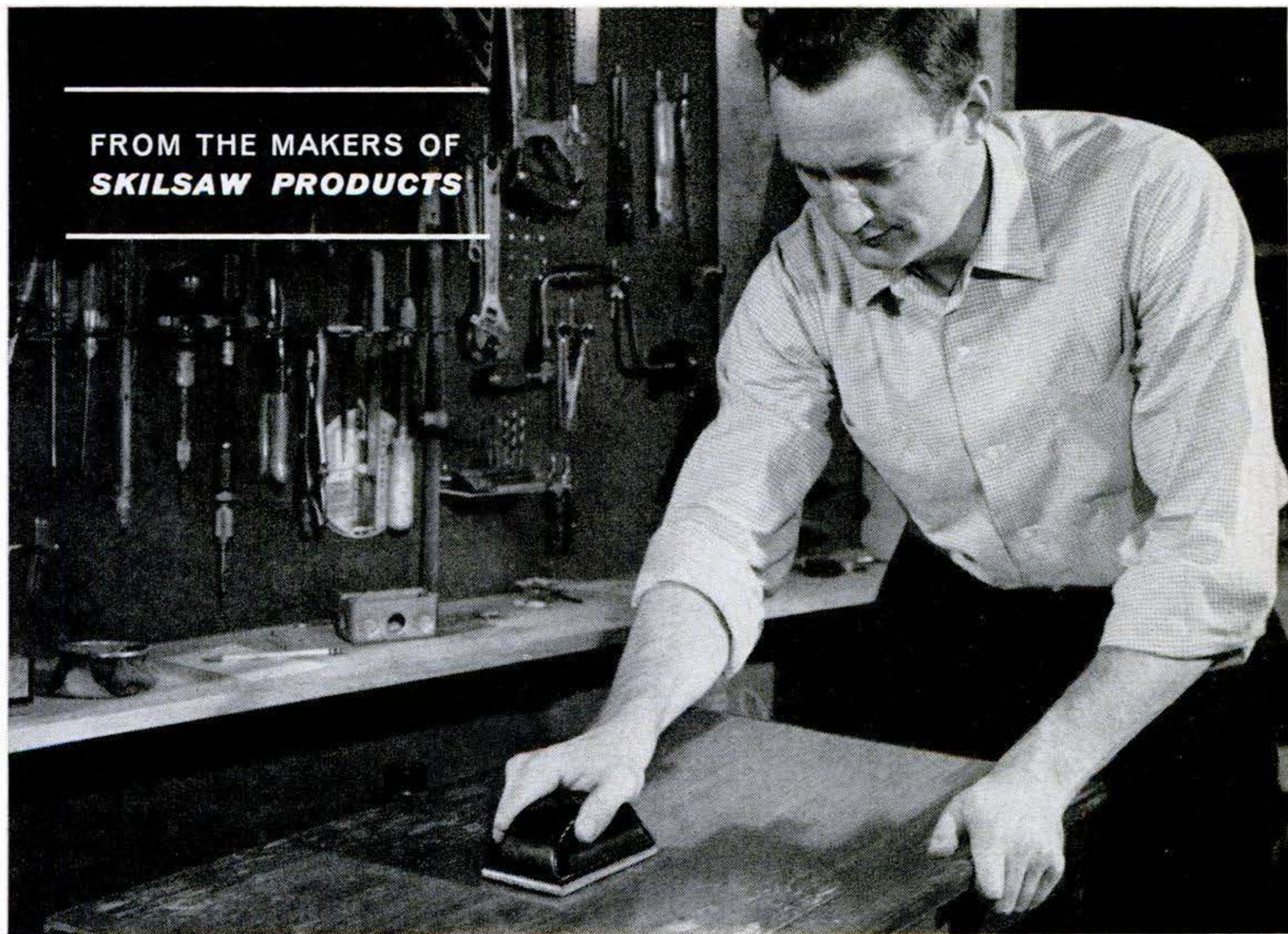

new PERMA-GRIT* hand sander cuts sanding time in half...

A wonderful, new workshop abrasive. Sands twice as fast as old-fashioned sandpaper. Can't be beat for removing old paint or enamel or for sanding wood, plastics, dry-wall, compositions.

Outlasts hundreds of sandpaper sheets — Made with tungsten carbide particles permanently bonded to steel. Always stays sharp and ready to use any time.

Deluxe Hand Sander Kit—Hand sander comes with two sanding sheets, one fine and one medium-coarse, at \$2.95. Sander with choice of either sheet, only \$1.95. Try a free demonstration at your local hardware, paint or lumber store.

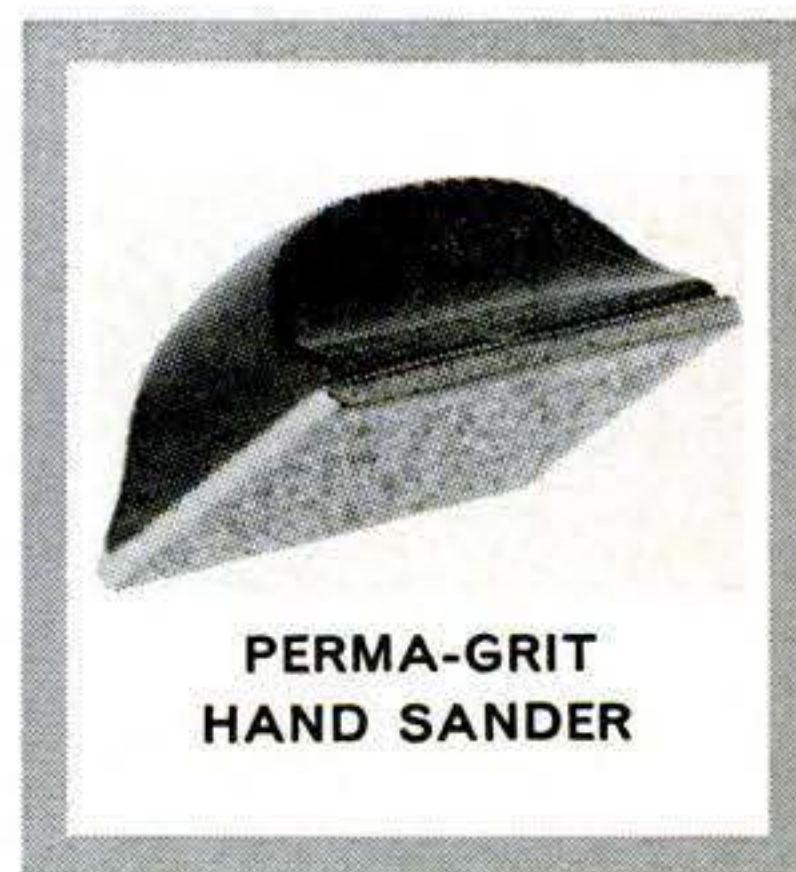

*A Trade Mark of SKIL Corporation

PERMA-GRIT FILES PLANE WHEEL

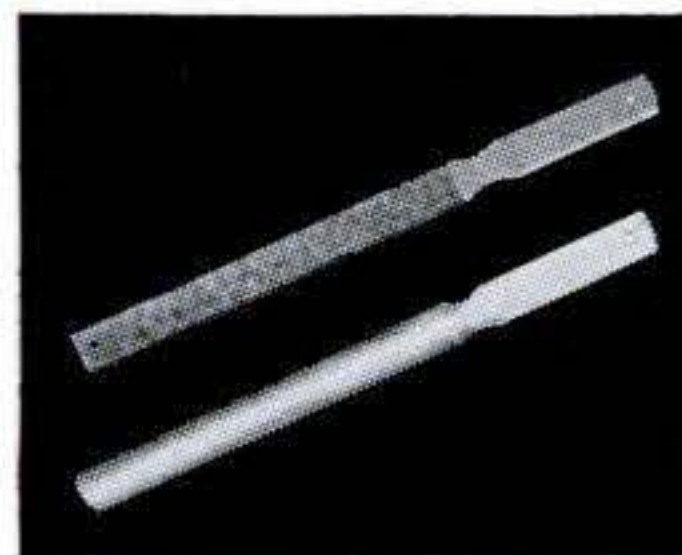

Flat or curved file,
twice as fast

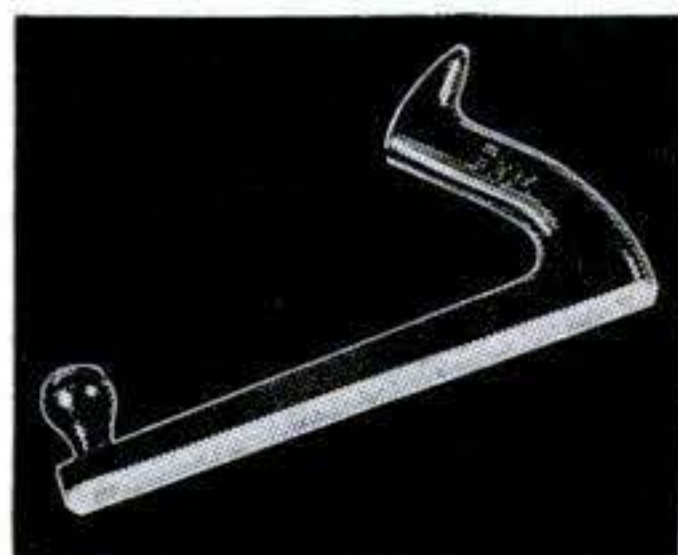

Files, sands, planes,
shapes or notches



Safe wheels for table
or portable saws



Made only by SKIL Corporation,
manufacturer of famous SKIL
and SKILSAW products, 5033
Elston Avenue, Chicago 30, Ill.

APRIL 1959 241

Look for **LUFKIN** tape rules

FIVE FEET OUT —
STILL WON'T BUCKLE

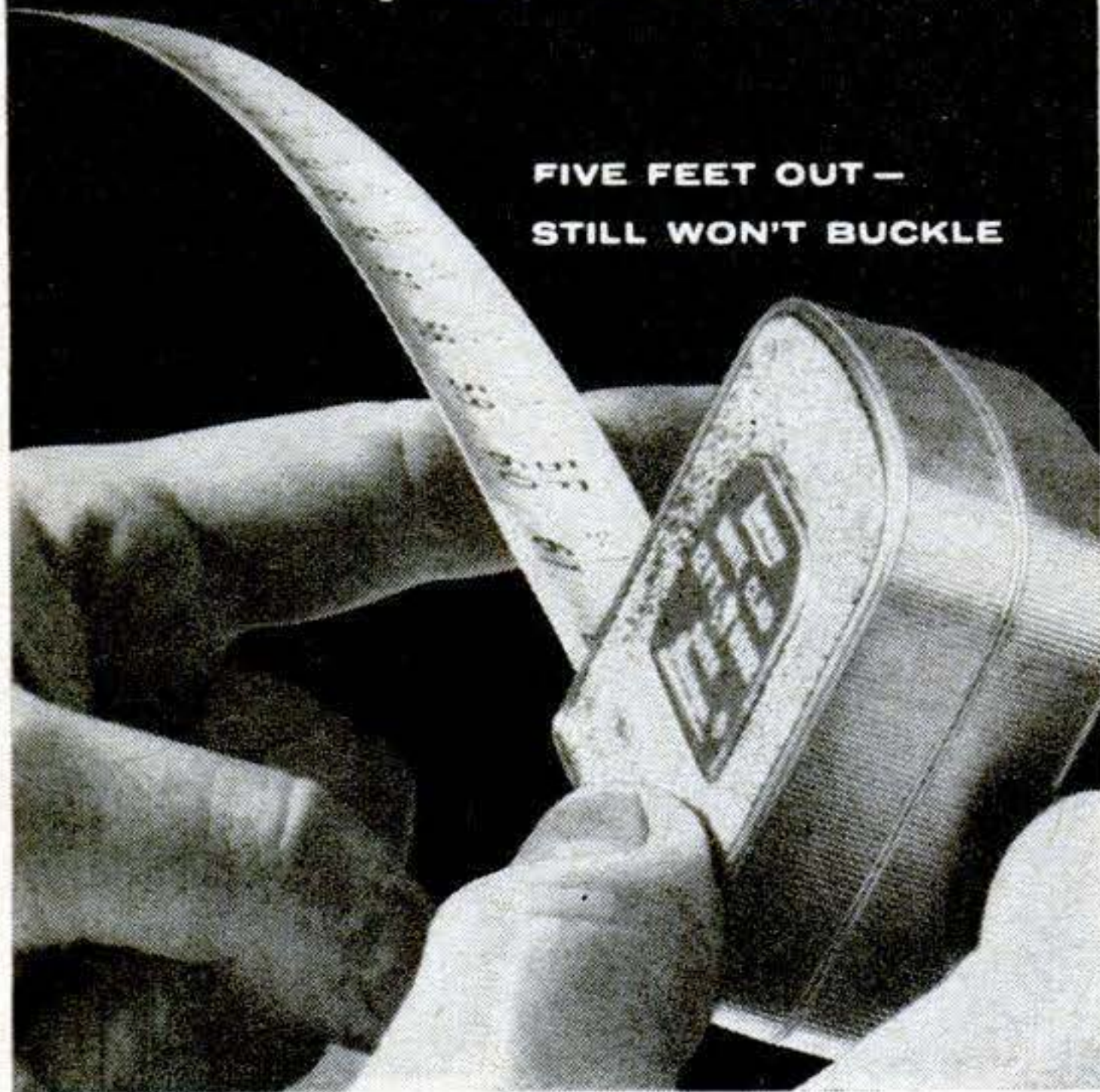

$\frac{3}{4}$ " SUPER MEZURALL

In the photo above, five feet of the steel blade are extended, yet the blade hasn't buckled.

And look at all these other features!

- Easy-to-read, black markings
- Shows both total inches — and feet and inches
- Self-adjusting hook, 2" case for inside measuring
- Blades quickly, easily replaced

Lufkin White Clad® Mezurall tape rules are available in both Regular $\frac{1}{2}$ " and Super $\frac{3}{4}$ " widths, with 6', 8', 10' and 12' lengths.

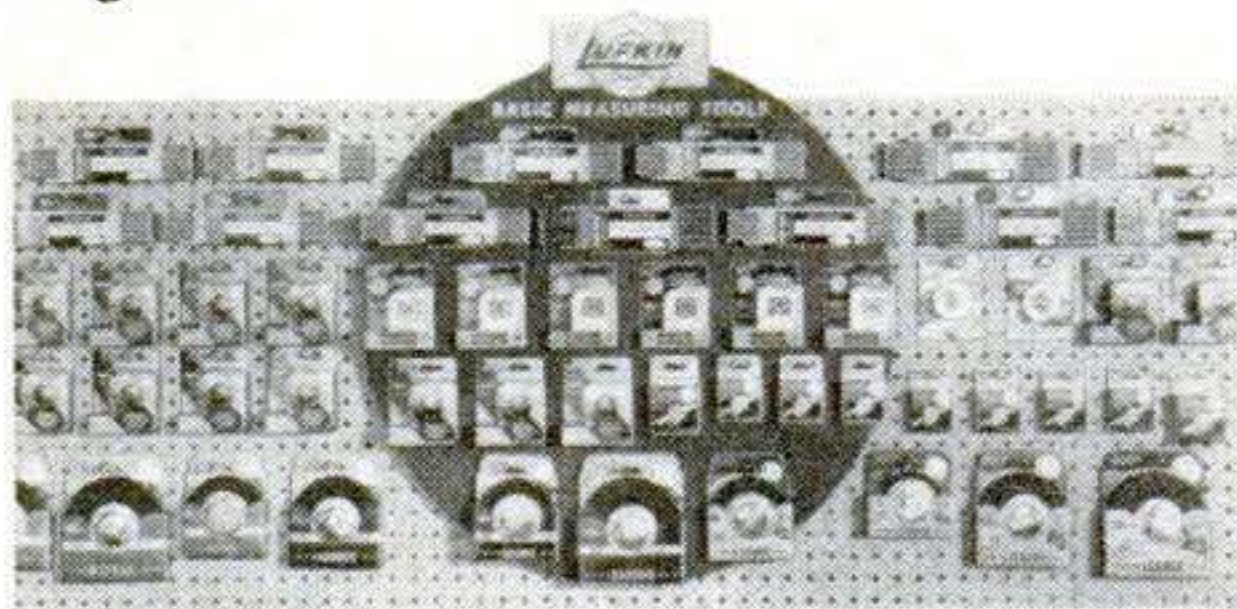

You'll find a world of Lufkin measuring tools at your hardware store.

LUFKIN TAPE RULES
TAPES RULES PRECISION TOOLS

Talking Satellites to Speed Mail

[Continued from page 84]

ment capable of relaying TV signals will be sent up. Its special path will keep it always over one spot on earth (probably mid-Atlantic). Rocketdyne already has an order for the giant engine needed to launch it—a cluster of eight rockets generating 1,500,000 pounds of thrust.

While these are all Government plans, commercial companies in the overseas communications business—RCA, Bell Telephone and International Telephone—are on the ball, too. RCA, which is building the black boxes for the Signal Corps' tests, worked out the satellite post-office scheme. Most published details on the use of plastic balloons for relaying TV come from one of Bell's top scientists, Dr. John R. Pierce (they represent his personal ideas, not Bell's).

Where private firms would get their satellites is apparently unsettled yet. (Rent from the Government? Buy their own rockets?)

Why satellites? Simply because they can do a communications job that can't be done any other way.

Transatlantic TV is impossible now. The TV wave contains too much information to squeeze through existing cables. To go through the air, it has to ride very short waves—and they travel in straight lines, like light, as far as the horizon and then off into space.

This is where the satellites come in. They can bounce the short waves back to earth, acting as relay stations in space. So they will make it possible to transmit such waves across oceans. These waves can carry great loads of information—TV shows, or vast numbers of telephone conversations and telegraph messages simultaneously. The military services, particularly, need more communications channels than present radio and cable circuits now offer.

And it's cheap. Comparatively, that is. The cost of orbiting several satellites for a good communications relay—able to handle 1,000 telephone conversations and several TV channels all at one time—will be around \$100,000,000. If that sounds like a lot of dough, remember that the recently completed transatlantic telephone cable—which carries fewer than 100 phone conversations and nothing else—ran to about \$40,000,000. **END**



IT'S A DRILL!



TWIST!

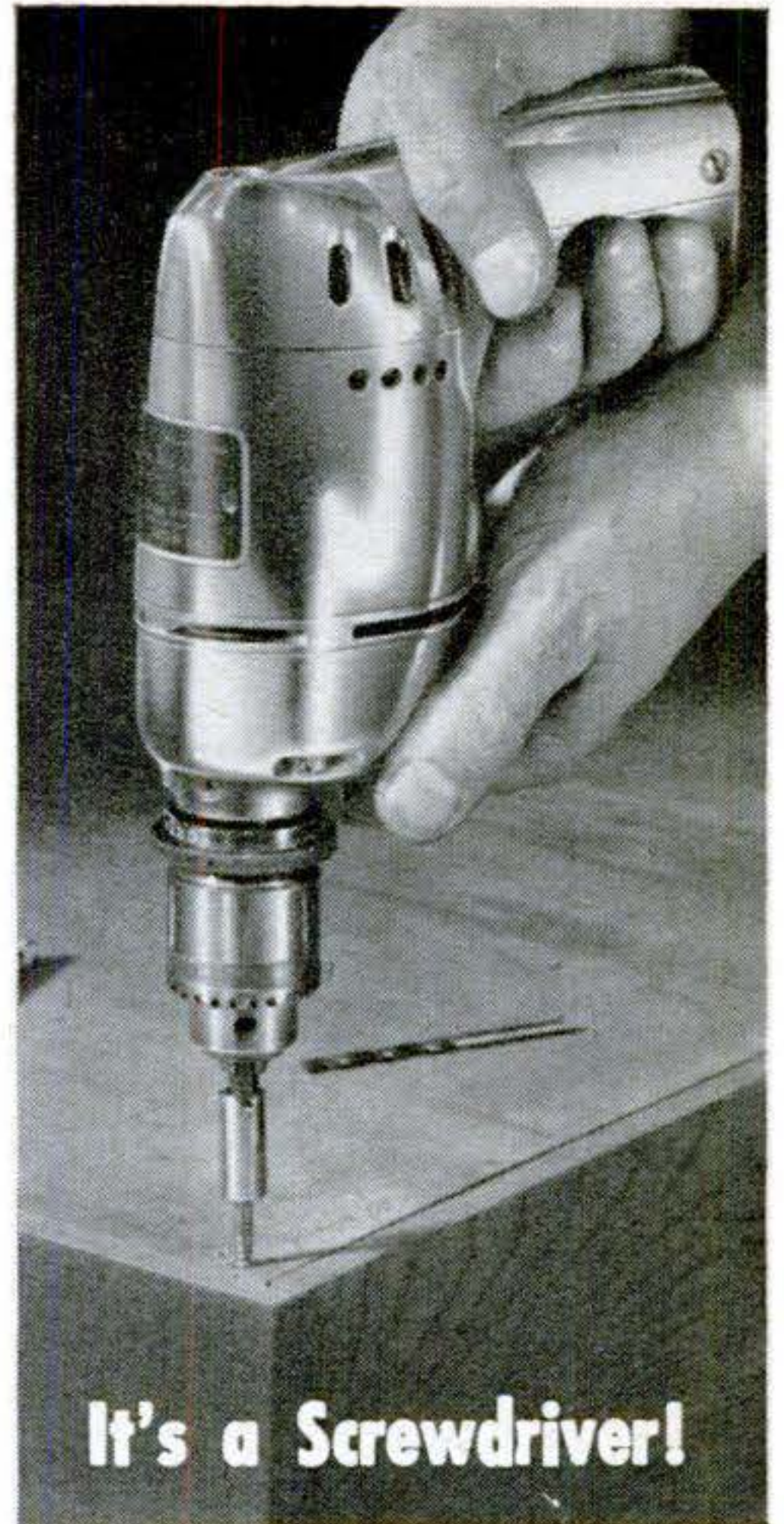

It's a Screwdriver!

It's the new B&D Scru-Drill!

Two-in-one, that's the new Black & Decker Scru-Drill! Set the adjusting collar on "DRILL" and you have a B&D $\frac{3}{8}$ " Drill. Twist the collar to "SCREW" and presto! With a screwdriving bit, the powerful B&D-built motor drives either slotted or Phillips-Head screws. Spindle clutch idles until pressure is applied and disengages when screw is

"home." Drives up to #10 by $1\frac{1}{2}$ " wood screws, #12 machine screws and nuts—in seconds! Now you can drill lead holes and drive screws with the same tool! Ask your B&D dealer about the new Black & Decker Scru-Drill. **Special introductory offer!** For limited time, 6-pc. Pilot Drill Assortment (reg. \$3.95) free with every B&D Scru-Drill!

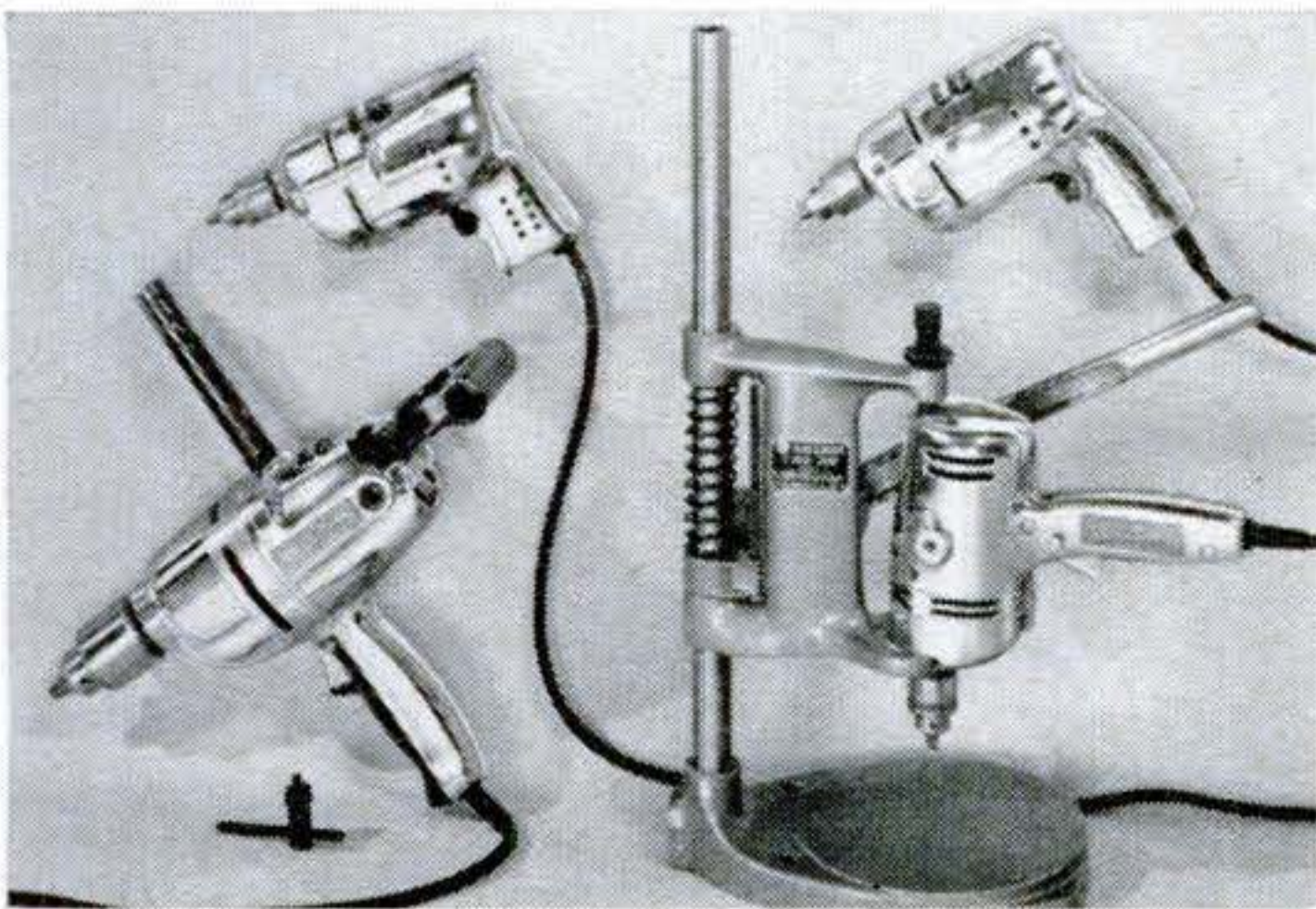

OTHER B&D DRILLS AND POWER UNITS: B&D $\frac{1}{4}$ " Utility Drill • B&D $\frac{1}{4}$ " Deluxe Utility Drill • New B&D $\frac{1}{2}$ " Deluxe Utility Drill • B&D Power Driver • Also Drill Stands for accurate bench work (shown with Power Driver).

Black & Decker®



makes the BIG DIFFERENCE
Towson 4, Md.

THE BLACK & DECKER MFG. CO.
Dept. 5049, Towson 4, Md.

Please send me descriptive literature on:

- New Black & Decker Scru-Drill
Drill

Name.....

Address.....

City.....Zone.....State.....

how submariners keep trim at forty fathoms



ATOMIC SUBMARINE USS SEAWOLF SSN 575

Duty aboard a Sub is rugged. Tension, boredom and anxiety are just a few of the problems facing the crew. Proper exercise necessary to stay in good physical shape is next to impossible.



A number of Medical officers in the Submarine fleet were familiar with Relax-A-cizor through their wives' use. One day at home, the Medical Officer of the Seawolf watched his wife using hers. Suddenly an idea came to him. If she could trim her hips and waist by simulated exercise, why wouldn't it work on the crew? That's how Relax-A-cizor went to sea.

On the record smashing voyage when the Seawolf submerged two full months, an experiment was conducted with a controlled

group of thirteen crewmen, appropriately dubbed the Seawolf "Charm Club." Each man used a Relax-A-cizor thirty minutes a day for six days a week.

Results of the clinical experiment conducted aboard the USS SEAWOLF, Aug. 7 to Oct. 6, 1958, as reported by the Medical Officer. Did the Relax-A-cizor have any physiological effect on members of the crew?

"Among the test users the average loss of waist measurement was one and one half inches."

What was the maximum physiological effect?

"One crew member lost 3 1/4 inches."

What indication was there that the machine actually simulated physical exercise?

"During and after use blood pressure and pulse rates were tested and the conclusion was that the electronic stimulation was similar to that derived from physical exercise. Comparable to a brisk walk."

Were any additional benefits experienced?

"Fifty percent of the users were able to go to sleep easier. They seemed better able to throw off the natural tensions of duty and relax quicker. 100% of the users found the Relax-A-cizor beneficial and expressed the desire to keep the units aboard."

Relax-A-cizors are now being used on the Skate and Nautilus! If you are "bulging at the seams" a bit... Relax-A-cizor is for you! You'll take inches off that waistline fast. No steam baths... starving diets... massages or workouts. Relax at home, read, watch TV, nap—while Relax-A-cizor's gentle, neuro-muscular stimulation eases off those bulges.

MAIL COUPON for FREE illustrated literature and reprint of the Relax-A-cizor and the Seawolf story as it appeared in the February issue of Esquire.

TELEPHONE TODAY

New York MU. 8-4690; Philadelphia LO. 4-2566; Boston KE. 6-3030; Chicago ST. 2-5680; San Francisco SU. 1-2682; Los Angeles OL. 5-8000; San Antonio CA. 6-4086; Seattle MA. 3-7690; Caracas, Venezuela 71 79 14; Mexico City 14 68 16; Honolulu 9-5276.

Representatives in most cities and rural areas

© Relax-A-cizor, 980 N. La Cienega, Los Angeles

RelaxAcizor

FREE — MAIL TODAY

Dept. 39-1

Los Angeles, Calif., 980 N. La Cienega
New York City, 711 Fifth Avenue
Chicago, Ill., Suite 800, 17 N. State St.
Toronto, Ontario, Suite 316, 57 Bloor St. W.

Please send FREE information about reducing size of waist, hips thighs, abdomen. No cost.

Mr. Mrs. Miss (PLEASE PRINT)

NAME _____

ADDRESS _____

TELEPHONE _____

CITY _____ ZONE _____ STATE _____

049 Use margin for more writing space.

5 Ways to Lick That Tired Feeling

[Continued from page 134]

Fear of actual danger is rare in ordinary life. But anxiety is very common. Here again, a feeling says, "Something must be done." But when the action is one you cannot take without seeming to step out of line, nervous fatigue takes over.

In the Navy study, Dr. Shands and Dr. Finesinger found that nervous fatigue often follows change—a new job, a marriage, the birth of a child. These events demand behavior that seems out of character with the persons we've always thought of ourselves as being. Fatigue is a way of avoiding the readjustment.

One clue for recognizing nervous fatigue is its association with certain occasions.

One doctor told me of a high-powered executive who went into a slump on Tuesdays and Thursdays. Those were the days for staff meetings presided over by his father-in-law, whom he hoped to replace. The patient confessed he had secretly "hoped the old man would kick off." It was to duck guilty thoughts like this that he became "so tired I can't think straight." When he faced his feelings, they no longer incapacitated him.

How to stay peppy

Whatever the cause of fatigue—actual physical exertion or mental stress—you can often get around it. Research at many laboratories has pinned down practical methods you can use to work and play harder and feel less tired. Here are five:

1. Check your health. To generate energy for a full life, you should be in top physical shape. Just knowing that you are gives you a boost. Since you use vision and hearing more than any other senses, be sure you have no hidden eye or ear defects.

2. Check your posture and appearance. Try this quick experiment: Slump in your chair and let your head droop. Notice how lethargic you feel. Now straighten your back, hold your head erect and square your shoulders. The lethargy disappears. The same thing happens when you spruce up with a shave and fresh suit. It's like driving a newly polished car. Psychologists explain that you impress yourself with good grooming;



10" Band Saw

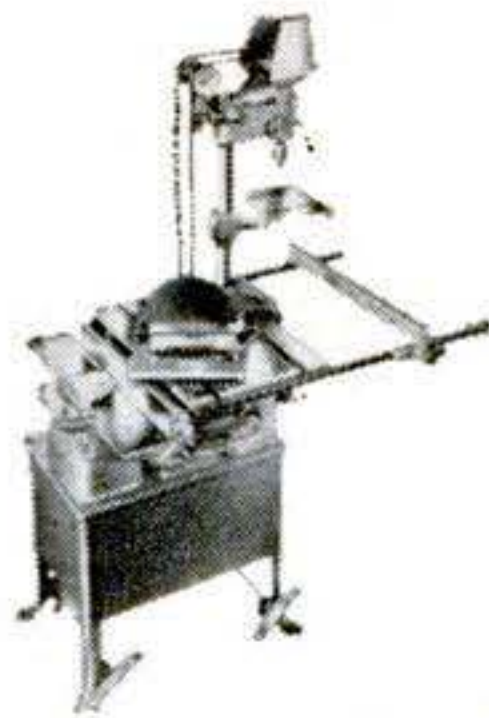

Delta Shop—combines Saw, Jointer, Drill Press, Sander.

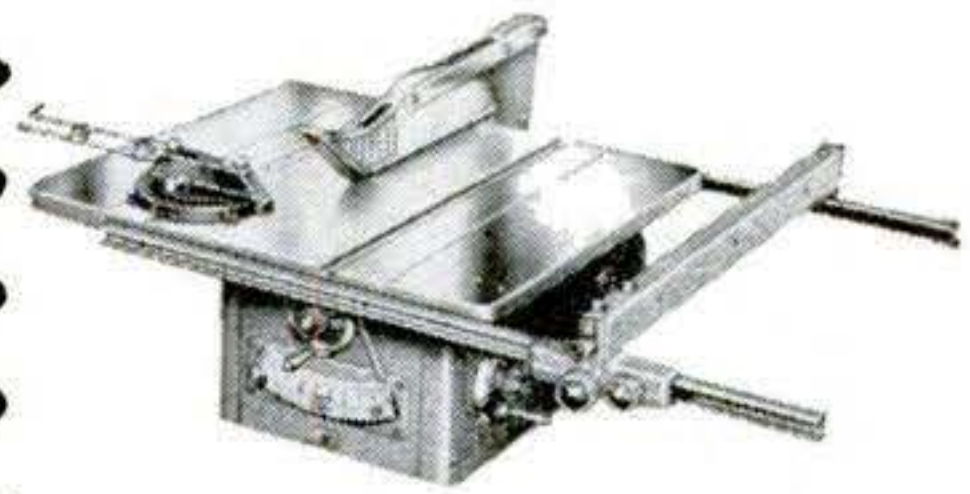

9" Tilting Arbor Circular Saw

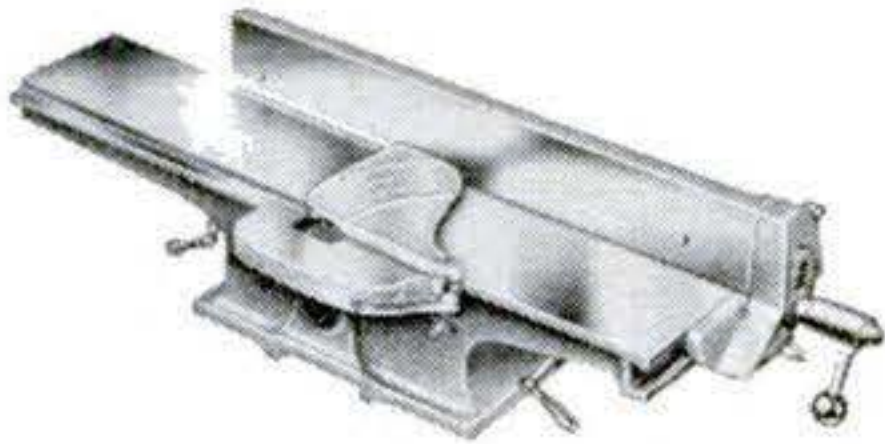

Deluxe 4" Jointer

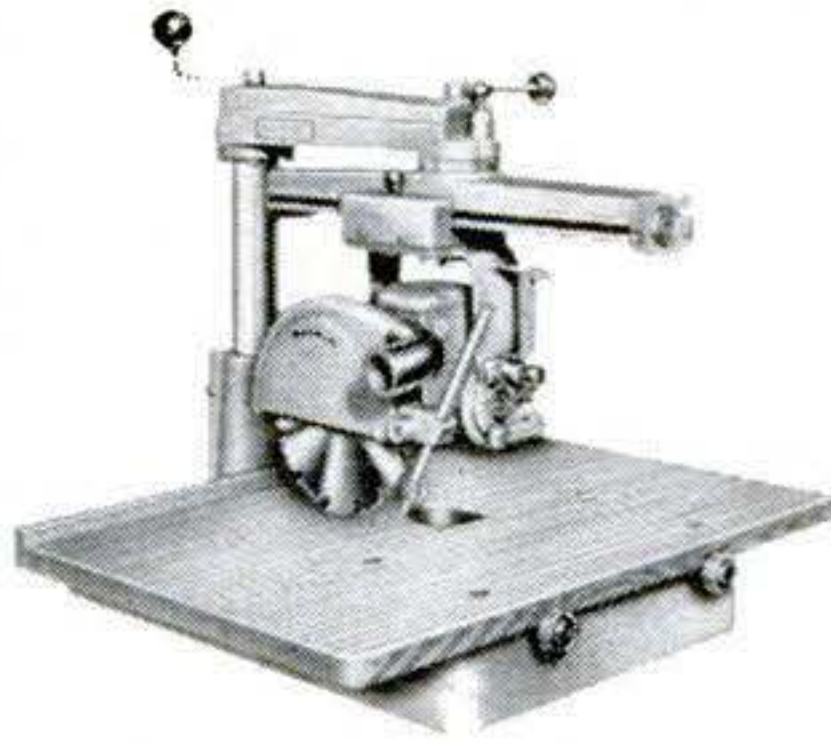

"Super 900" Radial Saw

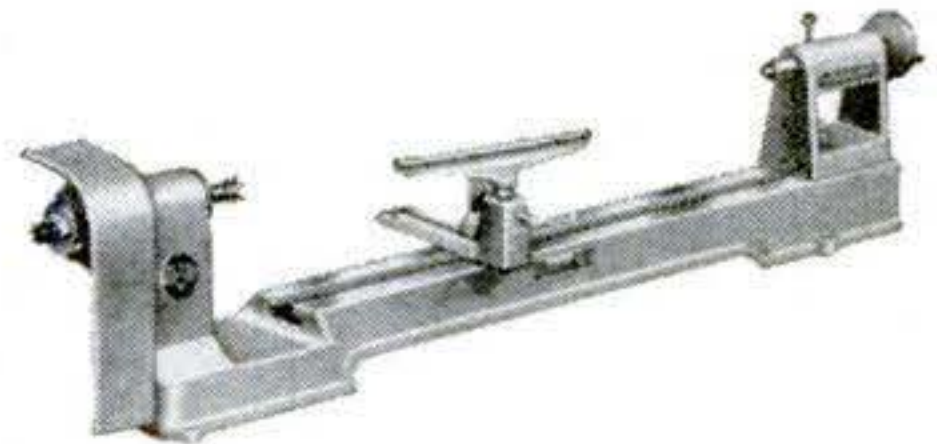

14/11 Lathe

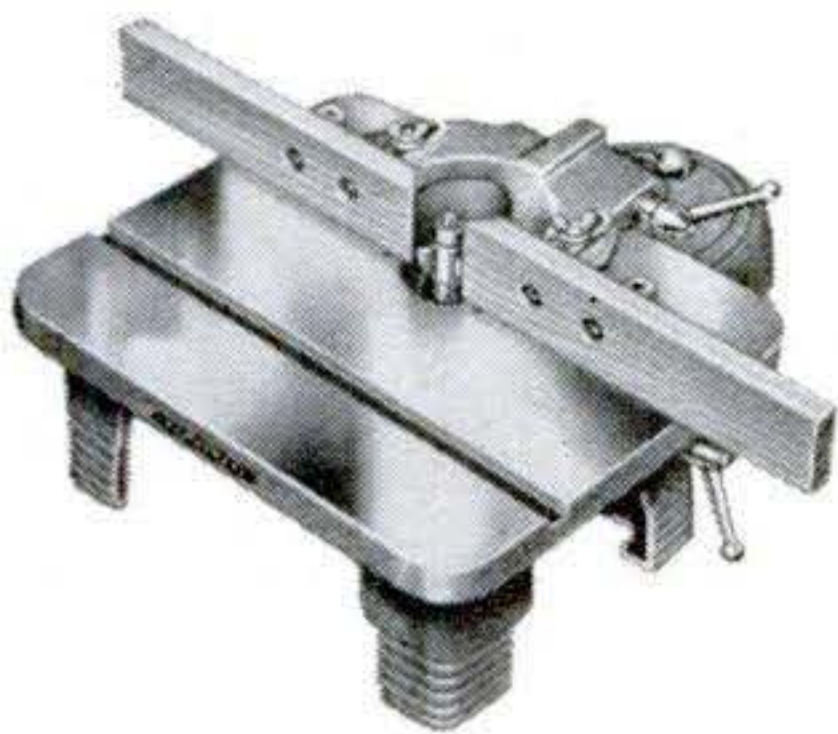

Heavy Duty Shaper



11" Drill Press

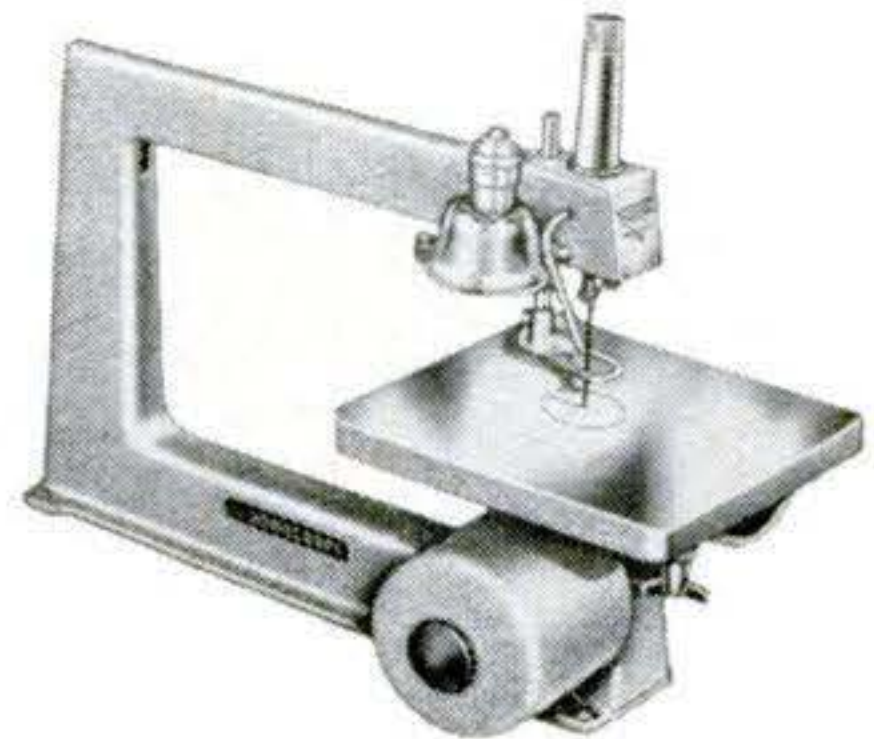

16" Scroll Saw

DELTA [®] HOMECRAFT TOOLS

put more of your skill to work

You're well equipped for *any* job—from a bird house to a boat—when you own the finest power tools money can buy! That's why more home craftsmen insist on the quality, capacity, and performance only Delta tools can give. And because Delta makes the world's most *complete* line, you can choose tools exactly right for your jobs.

No need to dream and wait, either—just add the tools you need NOW and pay on terms to fit *your* budget. See your Delta Dealer (he's listed under "TOOLS" in the Yellow Pages) or at leading Department, Hardware, and Building Supply stores.

Get this handy Homecraft Catalog FREE

Shows every tool complete; describes the hundreds of money-saving accessories; gives you valuable workshop hints. Also shows Saw-Jointer combination, Dust Collector, 6" Bench Grinder. Write: Rockwell Manufacturing Co., Delta Power Tool Division, 504D N. Lexington Ave., Pittsburgh 8, Pa.

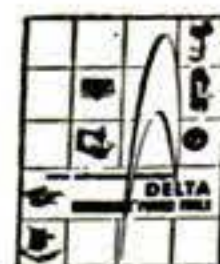

DELTA POWER TOOLS

another fine product by

ROCKWELL 

You'll DO THE JOB EASIER WITH THE RIGHT PLIER

CHAN NEL LOCK

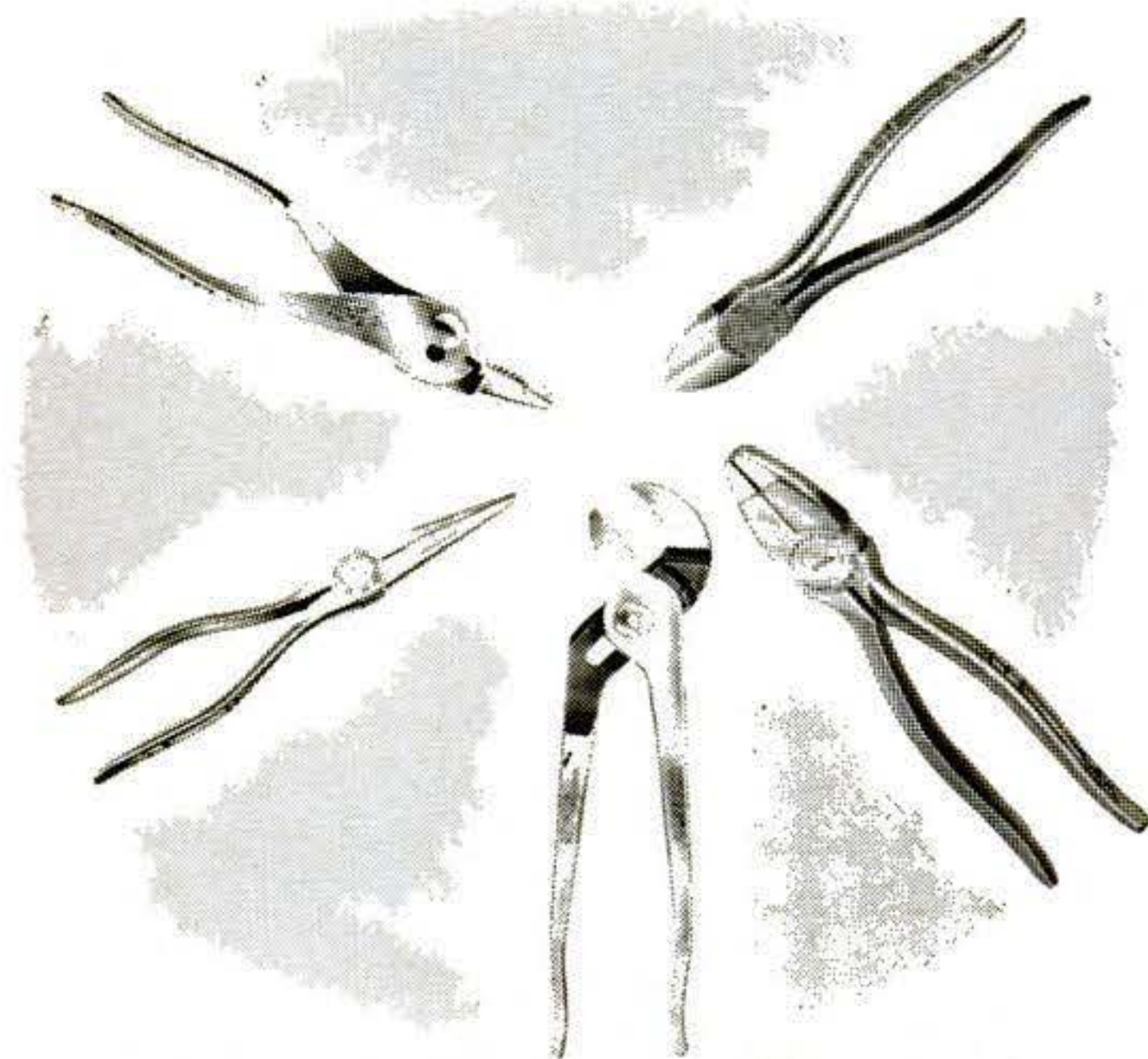

*Full Polish Finish
Quality Pliers*

Any job is a hard job without the right tools. These special purpose Channellock quality pliers will help you do hundreds of jobs easier, faster. They're precision-built of high grade drop forged steel to last longer, work better. And you'll like the gleaming, full-polished finish at no extra cost.

Ask for Genuine Channellock pliers by name.
Look for the trademark on the handle.

CHAMPION DeARMENT TOOL COMPANY
MEADVILLE, PENNSYLVANIA

5 Ways to Lick That Tired Feeling

you feel and act the way you look. Your voice also affects your pep: Clear, firm speech helps ready you for action.

3. *Check your attitudes.* At the University of Cincinnati, Dr. Arthur G. Bills blindfolded a coed and a football player and asked them to stand as long as they could with outstretched arms. The football player tired and dropped his arms after 10 minutes. The coed continued with no sign of strain. Before the experiment

.....

Next Month: Can you trick the roving eye of the highway police radarscope? Lots of motorists have tried—and some of their devices are worthy of an Edison. Only trouble: They don't work. Read "Why You Can't Fool the Cops' Radar" in May Popular Science.

.....

she had been told that the task was easy. The football player had been given the impression that nobody could endure this test for more than a few minutes.

"Most of the suggestions that make you feel peppy or tired come from within," says Dr. Bills. "By weeding out negative ideas you can work and play harder."

Some attitudes that make you tired: "I am unlucky." "Other people are so much smarter and better educated than I am." "The harder I try, the worse I do." "People don't like me."

4. *Program your day.* You'll concentrate better—with great savings in energy—if you plan what you have to do and when. Notes on a calendar pad are enough. But make your program flexible and varied—boredom tires you, too.

5. *Define your goals.* A sense of achievement erases tiredness. So mark your aims clearly. Psychologists advise four kinds of goals:

- The immediate goal of finishing the task at hand.
- The intermediate goal of gaining skill and experience for advancement.
- The ultimate goal of success in your field.
- An ideal goal that transcends personal ambition and gives meaning to your life.

Yet the most effective weapon against tiredness is the simplest: your sense of humor. One doctor says: "If you can't sleep off your fatigue, laugh it off." END

For faster hand sanding



There's a sharp-cutting,
slick-finishing

BEAR

BRAND

sandpaper
for every purpose.

The right sandpaper and the right grit makes the "professional" difference in any job . . . from rough sanding to fine cabinet finishing. And BEAR Brand, known to master craftsmen and industrial users as the superior line of quality coated abrasives, is available at your favorite hardware or hobby shop in a wide variety of sandpapers for all kinds of hand sanding and power sanding. In 9" x 11" Sheets and Handy Packs:

FOR WOOD

MOHAWK Flint Paper
GARNET Paper

FOR WOOD & METAL

ADALOX Paper & Cloth
TUFBAK DURITE Paper

FOR METAL

METALITE Cloth
EMERY Cloth



Write for
**FREE Professional
Sanding Tips** ▶

BEHR-MANNING CO.

TROY, NEW YORK

A DIVISION OF NORTON COMPANY



BEHR-MANNING PRODUCTS: Coated Abrasives • Sharpening Stones • Pressure-Sensitive Taper
NORTON PRODUCTS: Abrasives • Grinding Wheels • Grinding Machines • Refractories • Electrochemicals
In Canada: Behr-Manning (Canada) Ltd., Brantford. For Export: Norton Behr-Manning Overseas Inc., Troy, N. Y., U.S.A

BEHR-MANNING CO.
DEPT. PC-4
TROY, N. Y.
Please send me your free
Sanding Folder.



Name.....
Address.....
City..... State.....

STICK

WITH

LEPAGE'S[®]

TRADE MARK



TAPE AND GLUE

Everything for the Craftsman!

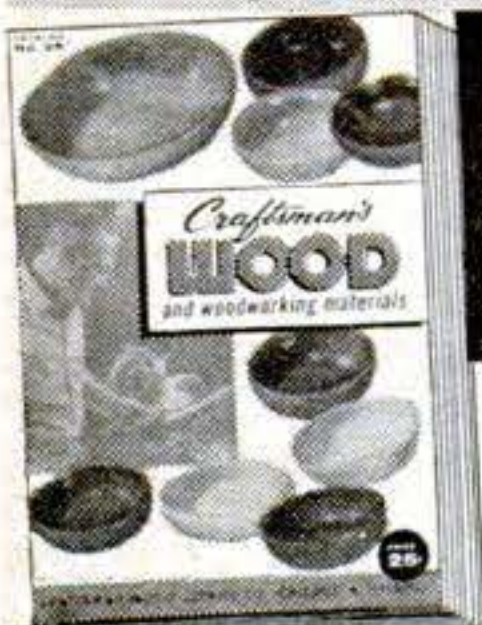

WRITE FOR NEW 132 PAGE

WOOD

AND HOME WORKSHOP CATALOG

Finest Domestic and Imported Woods
... Mouldings, Hardware, Tools ...
ALL AT LOW MONEY-SAVING PRICES!

Your complete wood buying guide and project book. Craftsman is your best, most complete source of finest kiln-dried domestic and rare imported woods, beautiful wood inlays, colorful bandings, matched plywoods, embossed mouldings, carved ornaments, newest woodworking tools, "hard to find" cabinet hardware and fittings... more than 1500 items! Packed with newest scroll saw patterns, project ideas and money making plans. Enclose 25c (refunded with first order) to help pay mailing, handling cost. Write:

Upholstery Materials;
New Tools; Lamp Parts;
Metal and Wood Legs;
Cabinet Hardware;
Music Boxes; Archery
and Water Ski Kits.
Over 1500 Items

CRAFTSMAN WOOD SERVICE COMPANY, Dept. B-4
2729 SOUTH MARY STREET - CHICAGO 8, ILLINOIS

Stupid Traffic Rules

[Continued from page 146]

local drivers passing you at 45 m.p.h. and seeming to be quite safe. Sometimes you even know you're delaying traffic by obeying the law—and anyone who blocks the normal flow of traffic is himself a hazard.

What to do?

Bill and I finally agreed: since speed laws *never* mean exactly what they say, most police now give you a "tolerance" of a few m.p.h.—if you drive carefully. Thus, 30 m.p.h. is now beginning to mean to most drivers and police, "30-mile range"—i.e., 30 to 38 m.p.h. And 50 m.p.h. often means "50-mile range," or, say, 50 to 58 m.p.h.

Most motorists, knowing this, abide quite well by this understanding of the law. They would do better, we agreed, if when a speed limit that seems low is posted, it were accompanied by signs explaining the reason.

Back in New York State, we had seen one quiet suburban road posted, without explanation, for 35 m.p.h. Result: You felt tempted to drive 50, which seemed safe. Near Paoli, Pa., we had seen another quiet road posted for 35. But here, in addition, was a big sign saying, "WATCH CHILDREN." Given the reason, you respected the law and complied.

The incredible light on Route 40. But none of the hazards and annoyances we had found so far could compare with a traffic signal we came to near Wilmington on Route 40.

The speed limit here is 55 m.p.h. Traffic: heavy, with many huge trucks, and rolling fast. A half-mile ahead, we saw the traffic signal for Route 7, a small Delaware road. As we approached, the light turned yellow, then red. We slowed down a bit to use up time, and when the light turned green we stepped on it, and so did a dozen other cars and trucks. Then, to our amazement, the light suddenly went red again.

We hit our brakes. Several cars slid to a skidding stop. A truck driver did a beautiful job of getting his rig under control in time. We all made it, to the tune of a few tire howls.

When the light turned green once more, we went on. But in our mirrors we saw, after a few seconds of green, the light *again* turn red, having stopped

What kind of a car do you want, exactly? Chevrolet has a choice of nine engines, five transmissions, two suspension systems, regular or Positraction rear axles, special cams, two air-conditioning systems, even Fuel Injection—the list of extra-cost options is tremendous. But what it means is that you can virtually design your own car, tailored precisely to your needs. Here's just one example:

“I ‘built’ my Chevy for top economy . . .
and extra easy running at 300 miles a day.”



“As a traveling salesman with a big Midwest territory I rack off about 300 miles a day—and, boy, how I love gas economy. But I like all the comfort I can get, too.

“I used to wish I could design my own car, until this year. That’s when my on-the-ball dealer friend showed me how I could ‘build’ just the right car out of Chevy’s terrific list of options. Look what I got:

“I picked a Biscayne two-door, ’cause I pay for my own auto and that’s right at the base of the price list. A Hi-Thrift 6 engine—that’s the world’s best workhorse. And Overdrive; with that high ratio you can just whisper down the road at good fast cruising speeds. No strain, hour after hour . . .

and that gas needle *never* seems to go down!

“Then I pampered myself a little bit. Foam rubber padding in the seats (I’m a big guy and I spend *hours* at the wheel); Chevy’s new throttle-holder where you just set your cruising speed for those long straights and the car holds it while you rest your right foot; the big ‘fresh-air’ heater. Man, you should drive my car. It fits me like a glove!”

There’s something to figure on, friends. Whatever kind of car you want—sports car, salesman’s car, town car—you can “design” it for yourself. But check your Chevrolet dealer and see how you can suit yourself to a T. . . . Chevrolet Division of General Motors, Detroit 2, Michigan.



UNUSUAL TELESCOPE BUYS

See the Stars, Moon, Planets Close Up!

3" ASTRONOMICAL REFLECTING TELESCOPE

60 to 160 Power—Famous Mt. Palomar Type! An Unusual Buy!



Assembled—Ready to use! You'll see the Rings of Saturn, the fascinating planet Mars, huge craters on the Moon, Star Clusters, Moons of Jupiter in detail. Galaxies! Equatorial mount with lock on both axes. Aluminized and over-coated 3" diameter high-speed f/10 mirror. Telescope comes equipped with a 60X eyepiece and a mounted Barlow Lens, giving you 60 to 160 power. Low-cost accessory eyepiece available for higher powers. An Optical Finder Telescope, always so essential, is also included. Sturdy, hardwood, portable tripod. Valuable STAR

CHART and 272 page "Handbook of Heavens." Stock No. 85,050-N\$29.95 postpaid

KNOW THE TRUTH ABOUT POWER. Telescope experts will confirm that an Astronomical Telescope will only give you practical powers to about 50 or 60 times per inch of objective diameter—powers above this only produce empty magnification—make viewing dim, difficult and unsatisfactory.

4 1/4" ASTRONOMICAL TELESCOPE!

UP TO 270 POWER!

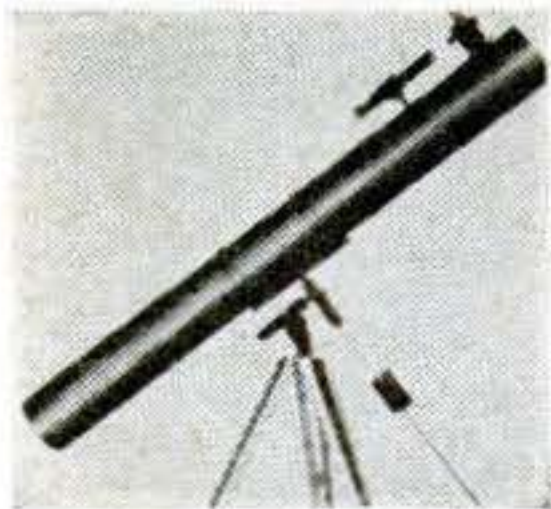

With this scope you can see everything as above but with greater power plus will split finer stars. Mirror has twice the light gathering power. Mirror guaranteed to give theoretical limit of resolution. Rack and pinion focusing, hardwood tripod, real equatorial mounting—only one adjustment follows stars! Aluminum tube. 6 power finder telescope. 2 standard size eyepieces and mounted Barlow lens give you powers of 40X, 90X, 120X, and 270X. Low-cost accessory eyepiece available for higher powers. Free handbook and Chart. Shipping weight 25 lbs. Stock No. 85,006-N.....\$74.50 f.o.b.

SEND 25c FOR GIANT CATALOG "N-2"

We'll include FREE a piece of amazing DIFFRACTION GRATING REPLICAS (13,400 lines per inch—see all colors of spectrum). 96-page Catalog is a treasure house of bargains in Telescopes, Microscopes, Binoculars, Magnifiers, prisms, lenses, optical parts and accessories!

ORDER BY STOCK NUMBER. SEND CHECK OR MONEY ORDER. SATISFACTION GUARANTEED!
EDMUND SCIENTIFIC CO., BARRINGTON, N. J.

Man! It's easy to seal cracks with America's finest



in handy Squeeze Tubes for small calking jobs!

Won't dry out, crack or run! Easy-to-use squeeze tube has built-in nozzle. Also comes in famous Speed Loads for calking guns!



And here's the perfect material for BOAT WORK OF ALL KINDS



M-D GLAZING COMPOUND

Always remains resilient, won't dry out or crack off. Clean and easy to handle.

At Hardware & Lumber Dealers

MACKLANBURG-DUNCAN CO.
OKLAHOMA CITY, OKLA.

Stupid Traffic Rules

mile-a-minute traffic three times within 90 seconds! We couldn't believe it.

Invitation to a bump. For the next hour we watched that incredible light. Now and then, a car or two did come out of Route 7. But, religiously, at least once and often twice a minute, the light turned red. Surprised drivers squealed to a stop, cars humping in protest.

We timed the light, but couldn't figure it out. Sometimes it changed to red after 30 seconds, sometimes after 50 seconds. The whole rhythm was complicated by a treadle control in the side road. Any car approaching Route 40 could trip the treadle and take control. The treadles were so close to Route 40 that they did not "collect" cars at all—but stopped Route 40 traffic for all comers—willy-nilly.

Importance of timing. In Washington, I interviewed another champion of the driver, engineer Burton Marsh of the American Automobile Association.

Marsh told the reason for those short amber lights: If they run longer than five seconds, drivers tend to run through them. But he also told how one city has coped with this: Pittsburgh's lights turn from green to "green-amber." (Both green and amber show for a few seconds.) *This warns you!* Then the amber shines alone for a few seconds and you stop easily.

Marsh, like Yale's Director Hurd, told me that many of our highly competent engineers *know* our road perils but often are blocked by lack of funds. Many such perils, Hurd said, are inherited from earlier days.

Nevertheless, we are still plagued by untrained traffic crews—and official blindness. One engineer not long ago pleaded for signs three feet high on one fast route. But a highway commissioner pooh-poohed the request saying, "Any driver who can't read our *one-foot* signs shouldn't be allowed on the road." He'd missed the whole point: at 60 m.p.h. today *nobody* can see a one-foot sign in time to act without imperiling other cars.

Meanwhile, with our new turnpikes we're getting there. BIG, clear signs; wide lanes; no left turns and no crossovers—these make travel safe and let drivers show what they can do, given *intelligent* instructions.

But we still have a long way to go. END



Beautiful wood-paneled walls that last a lifetime—go up in a weekend!

Charter Birch paneling, preserved by exclusive Weldwood lacquer finish, has the look and feel of luxury—only \$52 for a 12' x 8' wall.

Wood paneling does wonders for walls. These new Charter Birch panels, rich in swirls, burls and color variations, are cut to bring out the natural beauty of the wood. Change the style and color scheme of your rooms as often as you like—Weldwood wood paneling, guaranteed for the life of your home, flatters any color

scheme you choose and any furniture style you own.

Install in a weekend. The 4' by 8' random-plank styled panels go up fast with no on-the-job fuss with finishing. Weldwood prefinished panels come ready-made to brighten your home. If you prefer, you can buy Weldwood Paneling *unfinished* at lower cost. See more than 70 types and finishes of Weldwood paneling at your Weldwood lumber dealer's or any of our 115 branch showrooms in U. S. and Canada.

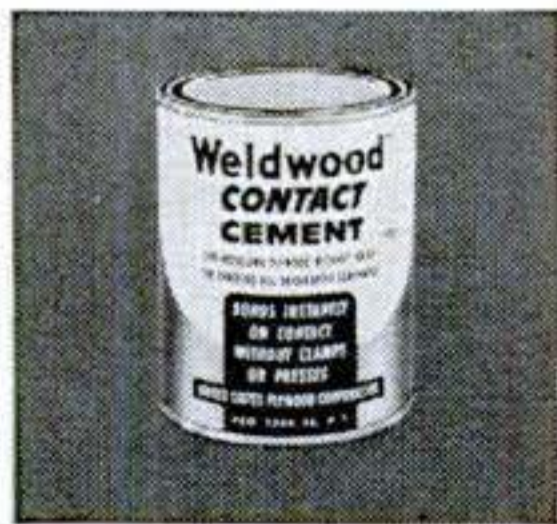

No nail holes mar your handsome wood paneling when you put it up with Weldwood Contact Cement. Gives a permanent bond to furring strips. No clamping necessary.

WELDWOOD® PANELING 

AND OTHER WELDWOOD PRODUCTS FOR HOME AND INDUSTRY.

----- SEND THIS COUPON TO GET DETAILS! -----

NEW PREFINISHED PANELING BOOK
United States Plywood Corporation
Box 61, New York 46, N. Y.

PS 4-59

Please send me a copy of the new full-color folder, "Presenting Weldwood Prefinished Paneling for Fine Interiors," which beautifully illustrates in color the 14 Weldwood prefinished woods and gives complete installation details. I enclose 10¢.

Name

Address

City State

APRIL 1959 251

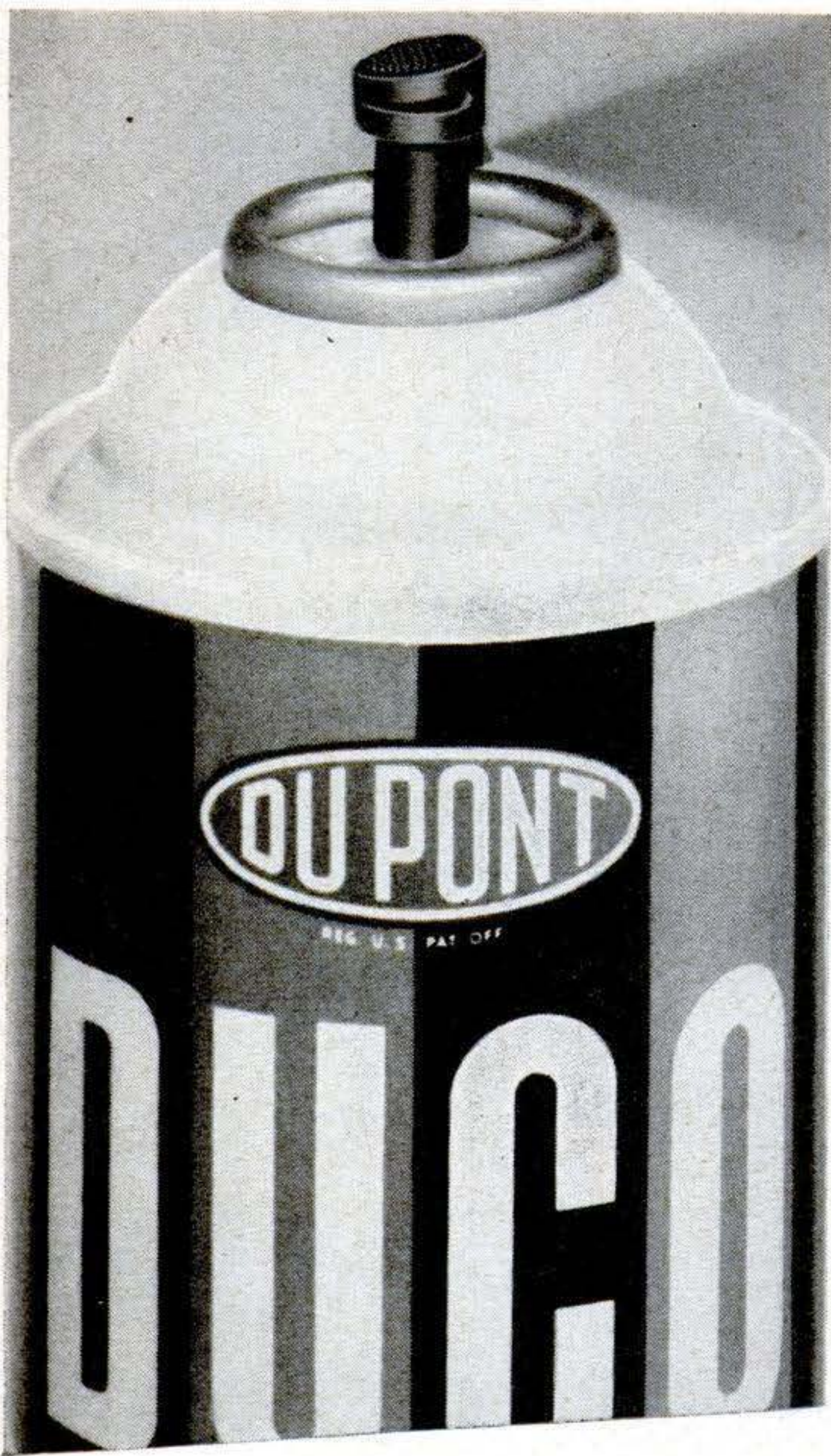

SPRAY MAGIC

the one and only DUCO Enamel now in a handy push-button can!

Quick, durable, beautiful... for inside or outside surfaces!

Ideal for painting and touching up tools, wrought iron, furniture, radiators, appliances, playthings, bicycles, decorations, bric-a-brac. Colors galore!

More for the money... big, generous 16-oz. can... 1/3 more than average 12-oz. can. And the beauty lasts!



Better Things for Better Living
...through Chemistry

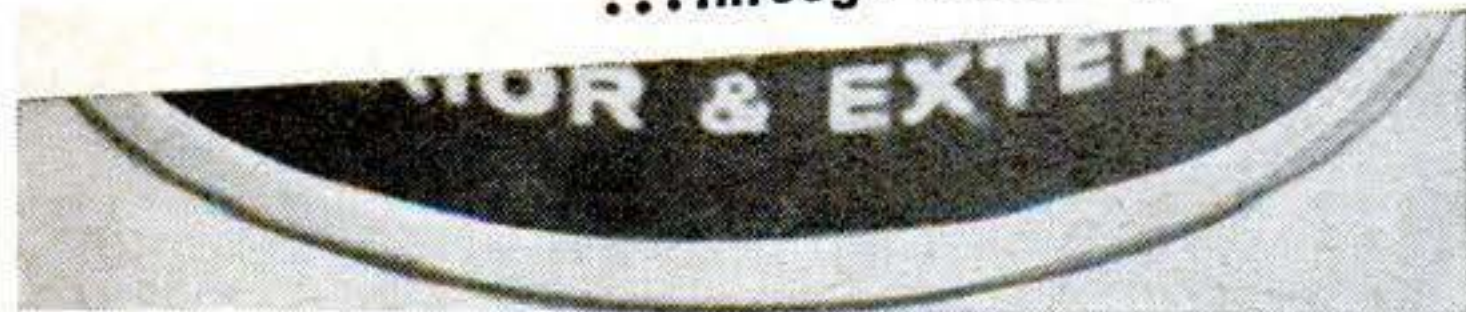

Which Spray Outfit Is Your Best Bet?

[Continued from page 166]

with 1/4-hp. compressors." A typical gun in this class may use as little as one cubic foot of air per minute at 20 to 25 pounds' pressure.

Which gun for what job? Six basic features determine what a spray gun can do: two different methods of feeding paint to the nozzle, two different methods of breaking it into a spray at the nozzle, and two different types of trigger control.

You can't have all these on the same gun at once, but for as little as \$20 you can have two guns that cover the entire group or one convertible gun that can combine the various features as needed. Here's how they work:

Suction-feed guns draw paint up to the nozzle by blasting a stream of air across the top of the tube that leads down into the container. This creates a partial vacuum that "sucks" out the paint the way an atomizer does. This is good with light-bodied paints, but not as good with heavy ones. It has a big advantage where frequent color changes are necessary: Stick the tube into any container, even a paper cup, and it will draw up paint.

Pressure feed. This is a more powerful system because compressed air is actually blown into the container to force paint up the tube to the nozzle. You need this for heavy-bodied materials like thick house paint, although it also works well on light-bodied finishes. A tight-fitting metal paint container is required to withstand the pressure, which means you can't switch colors as fast as with a suction-feed gun unless you buy extra containers.

Pricewise, you may find little differences between pressure-feed and suction-feed guns. Your decision here should be based on which types of paints you plan to use most: light or heavy.

Choosing the nozzle. In "external-mix" guns, the paint and air stream come together outside the nozzle, or air cap. The paint is fed out through a tiny hole in the cap, then is hit crosswise by two or more high-velocity air jets that break the paint into a fine spray. The paint feed may be by either suction or pressure.

You want external-mix if you're working with quick-drying materials such as automotive finishes because there's no chance for the dried particles to build



New Sea-Horse 5½, thermostat-controlled cooling . . . \$230

How Johnson engineers cured “chills and fever” in outboard motors!

Just as our human “machinery” works best at 98.6° F., there is also an optimum temperature at which an outboard delivers top efficiency.

In gasoline engines, the temperature is usually controlled by circulating water around the cylinders. Easy enough, you’d think, in an outboard motor running in water. But the very fact that an outboard motor draws its cooling water from the water it’s running in creates some special problems.

For example, lakes, rivers and oceans represent a wide range of water temperature from spring through fall. Obviously a system designed to cool a motor running at full speed in 80° summer lake water must not *over-cool* the same engine running in almost freezing water.

In 1958 when Johnson pioneered with outboard-ing’s first “V” engine it had a new thermostat-control on the cooling system. This unit was specially designed to hold engine head temperatures at an ideal 140°. It worked so well on the Sea-Horse V-50 and 35 that for 1959 similar thermostat-controlled cooling has been built into all models down through 5½ hp. The result is smooth running performance at any speed—and in water of any temperature.

New thermostat control is just one feature of Johnson’s exclusive Dynautical Design—to go better with your boat and make your boat go better. For full details see your Johnson dealer. He’s listed under “Outboard Motors” in the Yellow Pages.



Johnson

**FIRST IN SALES
FIRST IN DEPENDABILITY**

APRIL 1959 253

AIR PRESSURE FOR 101 JOBS!

JOHNSON RED HEAD PORTABLE AIR COMPRESSOR

for home, shop
and farm



There's simply no end to the jobs you can do with this new all-purpose unit! Red Head lets you do scores of chores better, faster, easier! For example:



SPRAY PAINTING—furniture, fences, siding, screens, porches, boats. Red Head gives smooth, professional quality results, cuts painting time up to 85% or more! Easily handles heaviest multi-color paints!

GARDEN SPRAYING—spray insecticides, fungicides, weed killers. Protect roses, shrubs, flowers, vegetables. Fine mist covers all surfaces. No waste.

INSECTICIDE FOGGING—enjoy outdoor living more. Use your Red Head to spray away pests and bugs around patio, fireplace, lawn.

AUTO CARE, HOBBIES—do your own greasing, waxing, refinishing. Cleans, sprays, blows, inflates. Every workshop needs a Red Head!

FARMS—sprays heavy machinery enamels easily. Cleans machines in a jiffy! Use Red Head *Insectospray* attachment for push-button barn fogging. Red Head saves time, money—pays for itself!

MOST EFFICIENT UNIT MADE!

Powerful Red Head delivers full 3.5 cfm free air and 50 psi pressure—easily out-performs many larger ½ hp units. Finest quality features throughout. Compare Red Head's price, quality and power with other compressor outfits. Fully portable. Only 10" high, weighs under 30 lbs.

COMPLETE KIT includes compressor, spray gun, 15 ft. air hose, pulleys, V-belt, tire chuck and fittings. Use any ¼ hp or larger motor.

NEW POWER AIRE Model

Model 105 offers the same rugged power and efficiency as the Red Head. Has built-in compact ½ hp GE electric motor. Delivers clean, oil-free air. Portable. Carry unit anywhere—weighs only 23 lbs. Sold with same complete kit as Red Head. Only \$67.50 including motor.

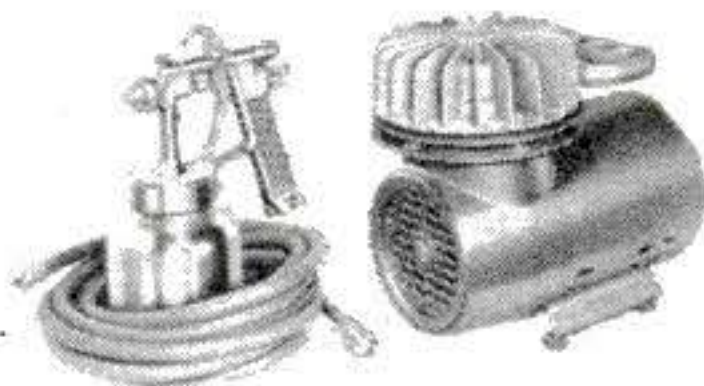

36 Other Models from \$30

Write for Catalog and Special Introductory Offer!

JOHNSON SERVICE CO.,

Dept. P, Milwaukee 1, Wisconsin

Please send free catalog describing the Johnson line of compressors and sprayers. Also your special introductory offer.

NAME _____

ADDRESS _____

CITY & STATE _____

Which Spray Outfit Is Your Best Bet?

up inside the nozzle and cause clogging.

In "internal-mix" nozzles, the paint and air come together inside the air cap and are jetted out a small opening. This sprays heavy-bodied materials well even at relatively low pressures. It's the type of mix you want for thick, slow-drying house paints where clogging isn't a problem. Because of its operating principle, it won't work with suction feed.

Types of triggers. You have two choices here. They have nothing to do with performance or quality, but are important to know about so you can match the right gun to the compressor you're using.

Guns known as the "bleeder" type have a trigger that shuts off only the paint, letting the air bleed through all the time the compressor is running, whether you're spraying or not. You want this kind of gun for use with the small, constant-running compressors that are the most common home-owner type. The reason: By bleeding air at all times, the gun eliminates back pressure on the compressor and possible motor overload.

"Non-bleeder guns" cut off both paint and air when the trigger is released. This is the system to use on pressure-regulated lines where the compressor builds up pressure in a storage tank, then shuts off automatically until the pressure drops below a preset level. The non-bleeder gun makes the most economical use of this kind of air supply. A bleeder type would simply waste air.

Convertible guns from about \$20 up let you switch to any of these features that the job happens to require. You change air caps for internal or external mix. You add a little attachment, often a conversion paint container, for pressure feed instead of suction feed. Some convertibles switch from bleeder to non-bleeder action with the aid of a screwdriver or a three-position trigger.

Where you are likely to use a wide variety of paints or equipment, the extra cost of a convertible may well pay off.

Spray patterns. The shape of the spray you get with a gun is either round or oval. On an internal-mix gun, a round nozzle makes a round pattern; a slotted nozzle, an oval or "fan" pattern. With most guns of this type, you get both a round and slotted nozzle, and some include an angled nozzle that slants the

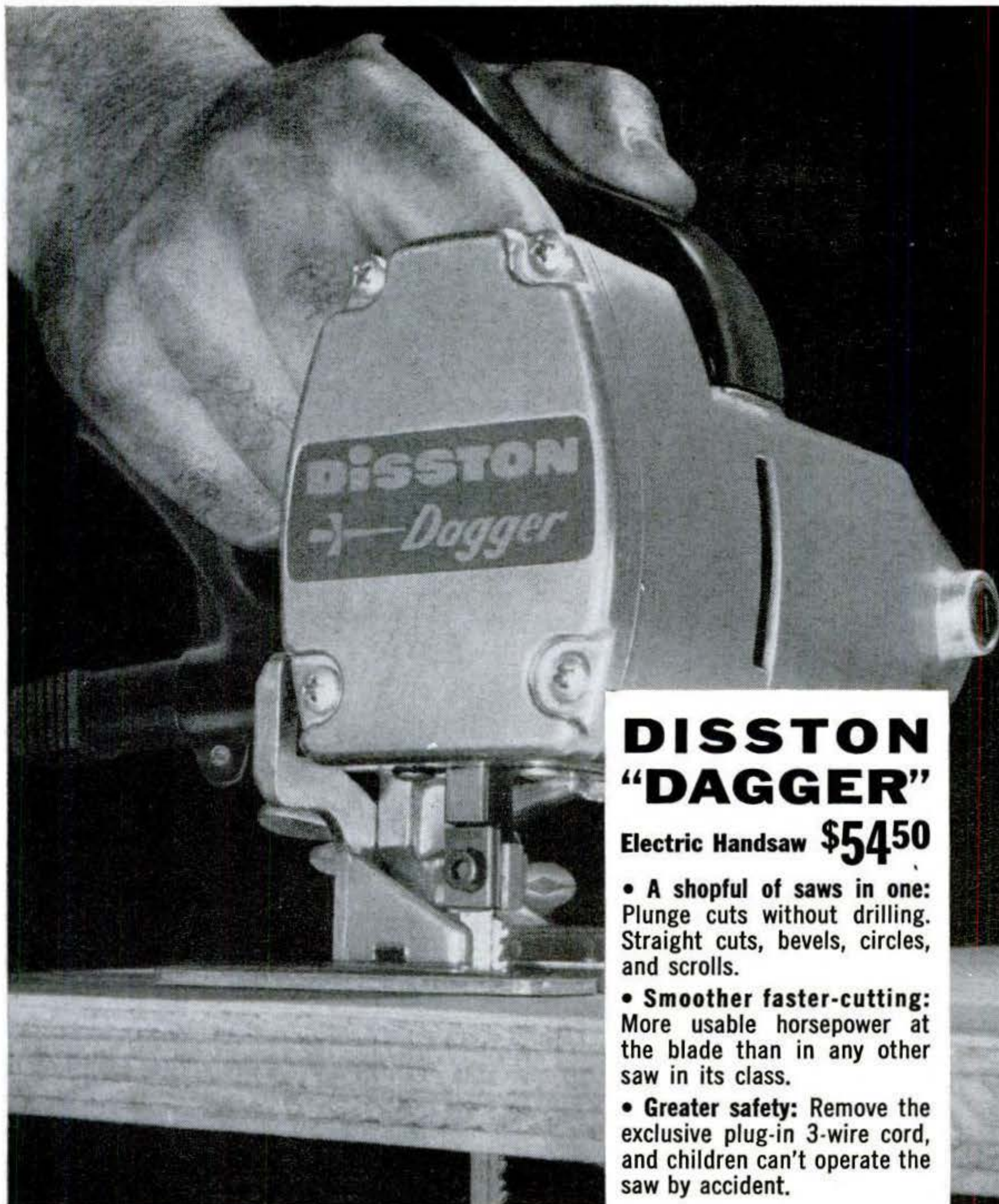

DISSTON "DAGGER"

Electric Handsaw \$54.50

- **A shopful of saws in one:** Plunge cuts without drilling. Straight cuts, bevels, circles, and scrolls.
- **Smoother faster-cutting:** More usable horsepower at the blade than in any other saw in its class.
- **Greater safety:** Remove the exclusive plug-in 3-wire cord, and children can't operate the saw by accident.

Fastest cutting saw of its type!

Now you can zip through home remodeling, home repairs, and workshop projects with the finest, most versatile sabre saw built for home workshop use.

Cutting speed jumps to 3600 strokes per minute, fraying reduces, and blade life lengthens with Disston's unique Orbite action. Blade bites on the upstroke, backs away on the downstroke.

The exclusive handsaw handle fits snugly in your grip . . . to reduce fatigue. It's plastic . . . to cut down heat and vibration. Side-mounted to give you greater visibility.

See the Disston "Dagger" Electric Handsaw at your hardware store. Comes complete with four blades.
Disston Division
H. K. Porter Company, Inc.
44 Tacony, Philadelphia 35, Pa.

DISSTON DIVISION

PORTER

H.K. PORTER COMPANY, INC.

DIVISIONS: Connors Steel, Delta-Star Electric, Disston, Forge and Fittings, Leschen Wire Rope, Mouldings, National Electric, Refractories, Riverside-Alloy Metal, Thermoid, Vulcan-Kidd, H. K. Porter Company (Canada) Ltd.

SHOP TALK

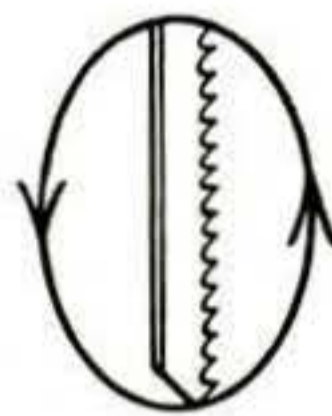

Cleaner, truer, faster cutting with exclusive Orbite action. Blade cuts going up, backs away going down.



Plunge cuts without drilling . . . makes work fast and easy on plumbing, electrical outlets and cutouts.

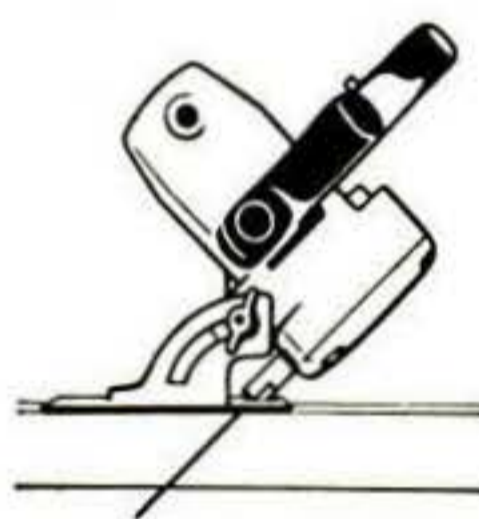

45° bevels in 2" lumber . . . adjustable shoe sets easily at any angle from 0° to 45° for beveling.

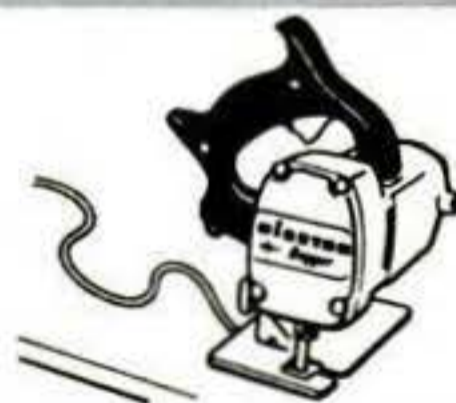

Cuts scrolls . . . curves, angles and figures . . . all types of scrollwork. Takes place of jigsaw on many jobs.

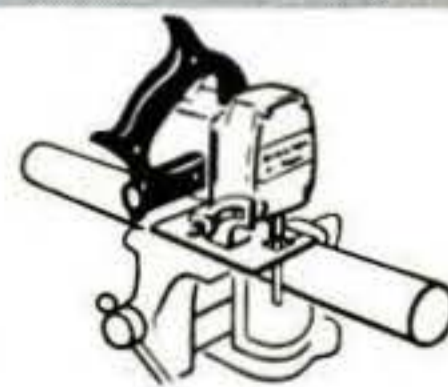

Cuts tubing and metal . . . as well as hard and soft woods, and plastics. 9 basic blades for a wide range of materials.



PAINTING YOUR HOUSE THIS YEAR?

For greatest economy when painting your house, use world-famous SWP House Paint. The super-durability of SWP will result in a paint job that will give extra years of beauty and protection. SWP's longer life can save you hundreds of dollars in repainting costs over the years.

Insist on SWP . . . the house paint that protects more homes in America than any other brand.



FREE BOOKLET

"How to Save Money When Painting Your House". Ask your Sherwin-Williams Dealer for a copy, or write The Sherwin-Williams Co., Dept. L, Cleveland 1, Ohio.

Which Spray Outfit Is Your Best Bet?

spray 45 degrees upward so you can paint ceilings without tilting the gun. You use the oval pattern like a wide brush for large areas and the round pattern like a round sash brush for narrow surfaces.

External-mix guns form a vertical oval when the projected air jets, called "horns," are horizontal. They form a horizontal pattern when the horns are vertical. The reason: The cross streams of air tend to flatten the normally round spray pattern. In many guns you can adjust the air supply to the horns to vary the spray pattern from oval to full round.

How much pressure do you need? For heavy-bodied paints, look for a sprayer that can work at around 35 pounds' pressure to avoid excessive thinning. Paint over-thinned to spray at low pressure may require an extra coat.

Many materials, however, spray best at low pressure. Multi-color paints give their best pattern at around 12 to 18 pounds' pressure. If your unit has no pressure gauge, test-spray some samples to find the desired effect.

Excessive clouds of overspray with light-bodied materials are the tip-off to too much pressure. This wastes paint and causes it to settle on surfaces you don't want painted. END

Tank rides on three flatcars

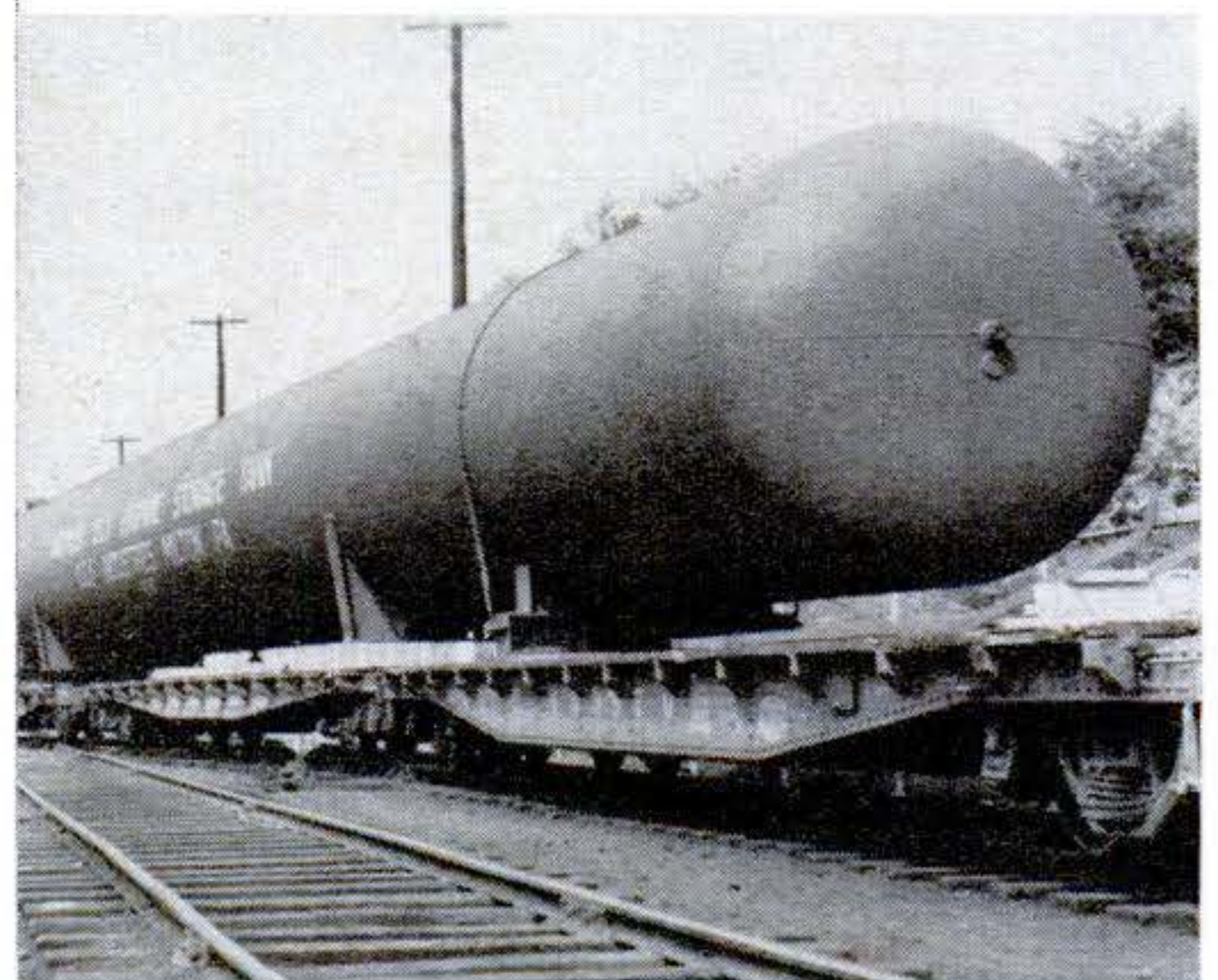

TRAVELING from Milton, Pa., factory to installation site in Keswick, Va., this propane storage tank required three flatcars and clearance on four railroads. It is 121 feet long and weighs 85 tons.

KEEPING PACE WITH THE DYNAMIC AUTOMOTIVE INDUSTRY

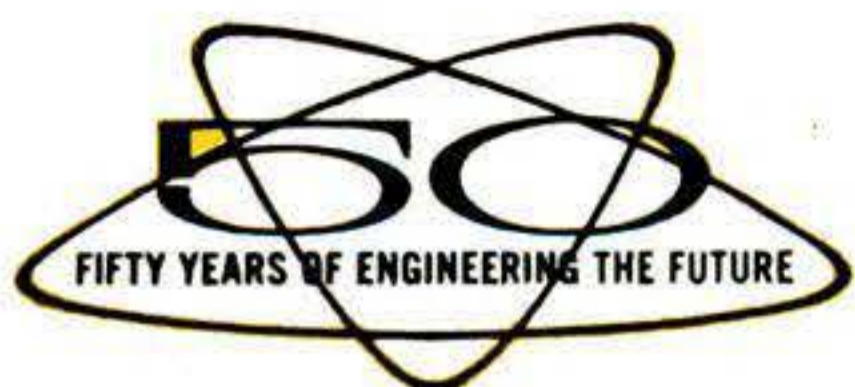

CARTER

... world's largest independent manufacturer of automotive fuel systems marks its first fifty years of engineering the future

CARBURETORS • FUEL PUMPS • FUEL FILTERS

Keep swift, sure power for years . . . have your car serviced regularly at the Sign of the Carter-Trained Expert. Look for the Carter sign or check the yellow pages of the phone book.



CARTER CARBURETOR

DIVISION OF **ACf** INDUSTRIES, INCORPORATED
ST. LOUIS 7, MISSOURI

HIGGINS BRONZE

CENTRIFUGAL PUMP



FOR IRRIGATION • SUMP PUMPING
• SEWER DRAINAGE

Item 414—PNB Model R, Marine bilge pump. Open Impeller design for handling muddy water. Delivers 75 gal. per min. @ 2400 RPM, 30 foot head with 3/4 H.P. motor. Pump and impeller of solid bronze, with alloy steel 1/2" dia. shaft, 1 3/4" long. Clockwise rotation. Inlet has 1 1/2" pipe thread. Plain 1 1/2" outlet for hose connection. 12" x 7" x 8". Shp. Wt. 23 lbs. **\$23.50**
F.O.B. Chicago.....

Hydraulic Transmission

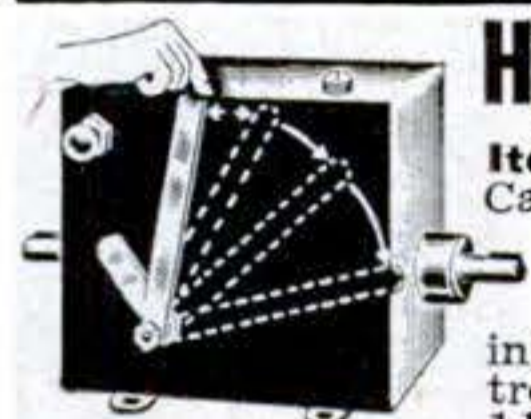

Item 115—For Reamer Drives, Midget Cars, Feed Mills, Canning Machines, Conveyors, Lathes, Milling Machines, Motor Boats, Pumps, etc. Variable output speeds from 0 to input speed available by moving control handle. Use input power of 1/4 to 1 1/2 H.P. Shafts 3/8" diam. Input rotation counter-clockwise facing shaft. Input speed 750 R.P.M. 7 1/2" x 7 1/2" x 11 1/2". Output rotation reversible. Shp. Wt. 31 lbs. Complete with 2 qts oil and instructions, F.O.B. Chicago. **\$72.50**

BOLT & WIRE CUTTER



Item 478—New! Extendable handles for extra leverage. Center cut type bolt cutter. Capacities: medium hard bolts in thread 3/8"; medium hard metals 5/16". **\$3.95**
ONLY 2 for **\$7.00** ppd.

BAIL PUMP



Item 491—For hand-pumping bilges, sewers, basements, ditches, etc. Heavy gauge sheet metal. Full length handle and spring valve for high volume with minimum effort. 60" long, 3" dia. Weight 22 lbs. **\$3.95**
F.O.B. Chicago.

FREE! New Catalog! Value-Packed Pages Galore! War Surplus, new equipment. Write today!

GROBAN SUPPLY CO. Dept. PS-4
1139 S. WABASH AVE., CHICAGO 5, ILL.



REPLACE YOUR WORN-OUT WOODEN HATCHWAY...

with an all-steel **BILCO** basement door



... and your basement entrance will be weathertight, good-looking — for a lifetime. A spring-balanced Bilco door floats open at a touch . . . locks securely . . . costs so little. And you can install it yourself — in just a few hours!

Bilco

The Bilco Co., Dept. R-104
New Haven 5, Conn.

Please send me your free illustrated folder and name of local dealer.

NAME _____

ADDRESS _____

CITY _____ ZONE _____ STATE _____

AMERICA'S FINEST BASEMENT DOOR

SQUEAKY

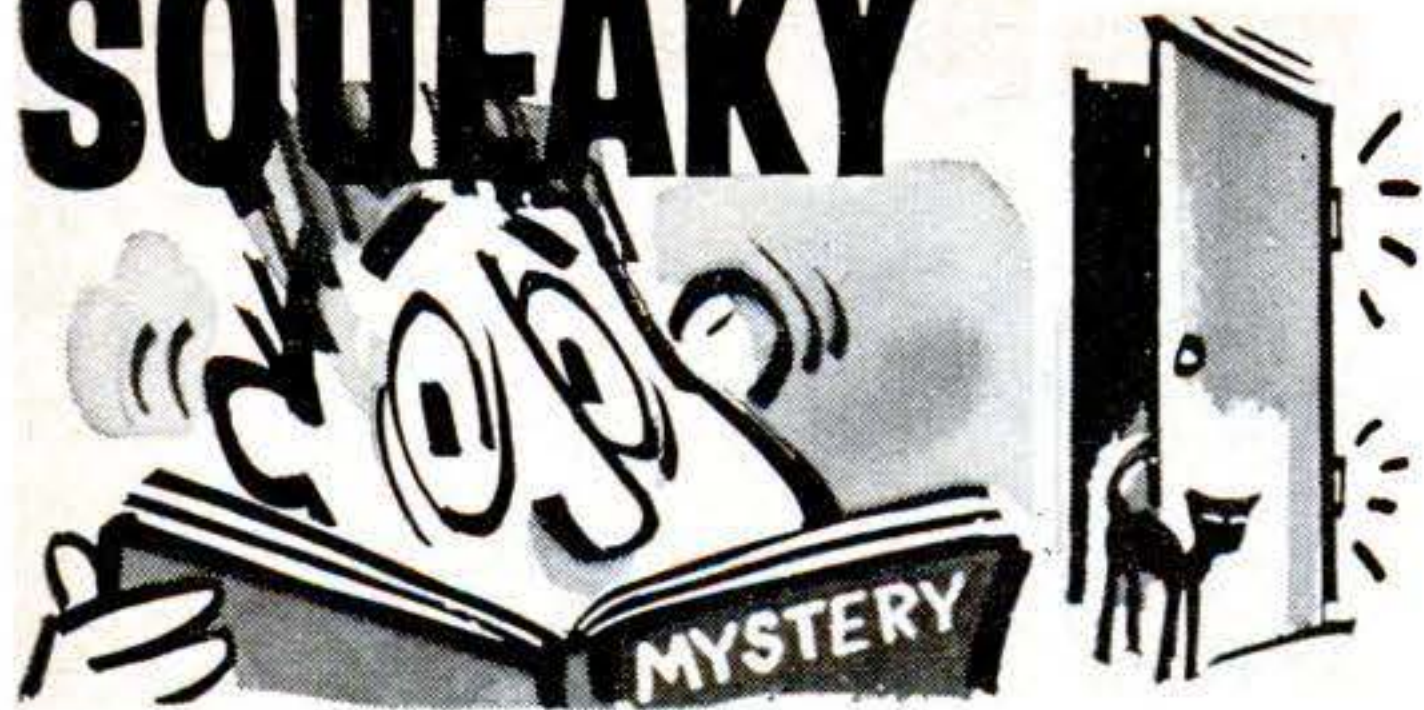

HINGES?



QUICK! Hush 'em up with handy 3-IN-ONE OIL. Just a drop or two and away go squeaks. Dozens of other uses.

3-IN-ONE OIL

REGULAR • OIL SPRAY • ELECTRIC MOTOR

WOODWORKERS!

Brand new 145th Anniversary Edition of Constantine's Manual for Craftsmen—130 pages, many in full color. Complete selection of rare and fancy imported and domestic woods, veneers, inlays, carvings, mouldings, hard-to-get items, hardware, upholstery supplies, plans, patterns and Do-It-Yourself Information. Send 50¢ (refunded on first order) for this big catalog and reference guide.

ALBERT CONSTANTINE & SON, INC.

2050 Eastchester Rd., Dept. E-6, New York 61, N. Y.



Picks speeder out of crowd

THE radar in the trunk of this British prowler car provides separate readings on autos as little as eight feet apart in traffic. It accurately translates beam reflections directly into miles per hour.

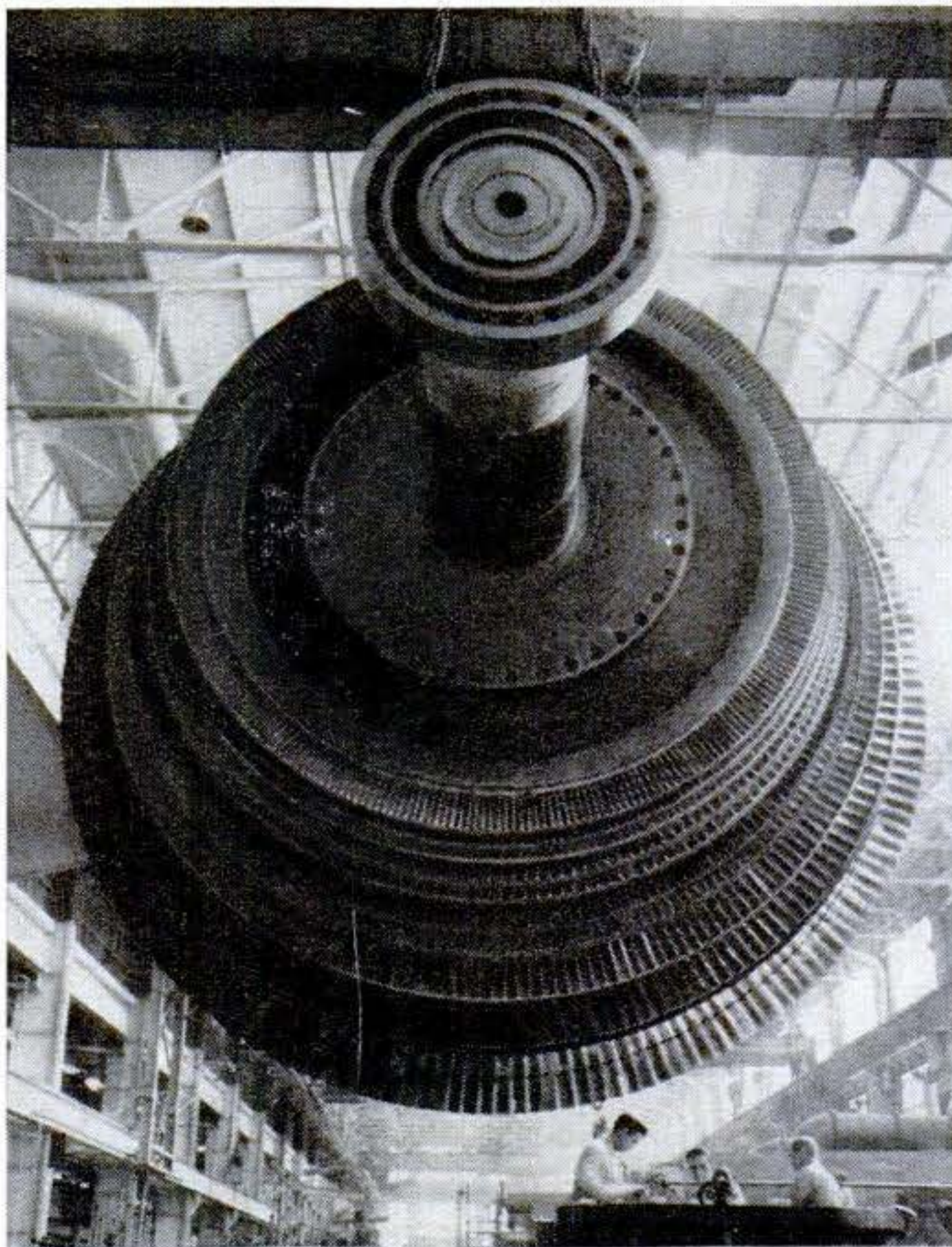

To turn in super generator

THIS big spindle, 14½ feet in diameter, carries blades 44 inches long—largest ever used by Westinghouse in a turbine. It's for a power plant at Eddystone, Pa., making 325,000 kilowatts of electricity.

PROTO TOOLS

PROFESSIONAL QUALITY TOOLS

YOU BUY
GUARANTEED
QUALITY
AT YOUR
PROTO
DEALERS

2203 Santa Fe Avenue Los Angeles 54, California
Jamestown, New York Canadian Plant: London, Ontario

PROTO IS A DIVISION OF PENDLETON TOOL INDUSTRIES, INC.
WORLD'S LARGEST MANUFACTURER OF HAND SERVICE TOOLS

WAR SURPLUS AND OTHER **SAVE UP TO 90%**

R1 GENERATOR - 300 AMP. Make your own arc welding and battery charging unit. Terrific source of power for all 24-32 V. equipment. Simple installation with our wiring diagram. All generators pre-tested in our own shop. Approx. GOVT. COST \$400. Like NEW. **\$16.50.**

GENUINE P1 GENERATOR - 200-250 AMP. Use for same purposes as above. Approx. GOVT. COST \$250. Like NEW. **\$14.50.**

GE GENERATOR - 400 to 500 AMP. Use for same purposes above. Approx. GOVT. COST \$550. Like NEW. **\$39.50**

ACCESSORIES FOR BUILDING ARC WELDER for above generators consisting of VOLTAGE Regulator, 300 AMP. ammeter, 300 AMP. shunt, heavy-duty welder's gloves, 50' welding cable, electrode holder, rheostat, welder's helmet (hood type), Giant Toggle Switch, 300 AMP. Reactor Coil Arc Stabilizer, Voltage Reg., reverse current relay, 1 pr. heavy-duty welder's gloves. All 12 items - Approx. GOVT. COST \$150. Like NEW - Complete **\$21.50.**



COMPLETE PACKAGE ACCESSORIES for arc welding and battery charging kit. Consists of 50' welding cable, 30 V. Voltmeter, welder's adjustable helmet (hood type), electrode holder, 300 AMP. ammeter, 300 AMP. Shunt, Rheostat, Giant Toggle Switch, 300 AMP. Reactor Coil Arc Stabilizer, Voltage Reg., reverse current relay, 1 pr. heavy-duty welder's gloves. All 12 items - Approx. GOVT. COST \$225. Like NEW. Complete with wiring diagram **\$31.50.**



WELDING CABLE DOUBLE-O heavy duty, neoprene jacket, fiberglass insulation. NEW. Approx. GOVT. COST \$40. Will handle 400 amps. or better. 50' lengths **\$14.50.** 100' lengths **\$26.00.**

WELDING REACTOR for all listed generators. 200 AMP. capacity or better. NEW. **\$7.95.** 300-400 AMP. NEW. **\$10.95.**

MICROMETER Black frame, smooth finish, clutch ratchet-type. Easy-to-read graduations in .001. NEW. **\$3.95** ppd.



HEAVY-DUTY RHEOSTAT Ideal for regulating voltage on electric welders. Rated 5.75 Ohms, 100 Watts with double windings & dual female 25 amp., 125 V. receptacles. 7" hi x 5 1/4" D. Shpg. wt. 2 1/2 lbs. Approx. GOVT. COST \$25. Brand New. **\$2.25** ppd.



FAMOUS NAVY MK14 AIR COMPRESSOR

Great for tree, termite, airbrush & paint spraying; filling tires, aquariums, etc. Dual & remote control electric receptacles, 115v 60 cycle AC, heavy duty HP. Westinghouse Motor. Direct drive. Water & explosion-proof. Built-in air filter, adjustable pressure setting up to 47 lbs. 3 cu. ft. per min. Self-contained switch. Mounting brackets. These units made under license of Sperry Gyroscope Co. Wt. 66 lbs. gross. Approx. GOVT. COST \$585. Like NEW. **\$21.95.**

With portable steel hand cart (shown), rubber wheels, specially constructed for mounting this unit. Incl. 25' rubber air hose, 6' extension cord with plug & fittings. Wt. 76 lbs. Complete with cart - **\$26.95.**

With new internal pressure spray gun with 3 adjustable spray tips. 1 qt. cap. **\$33.95** complete.



REVERSIBLE REDUCTION GEAR (250-1)

tremendous inertia power 6-12-24 volt winch with 2 power takeoffs! Use on boats, trucks, wreckers, etc. Fantastic power for pennies of original cost. Weight 55 lbs. Approx. GOVT. COST \$475.00 NEW - **\$14.95.**



11 PIECE CROWFOOT WRENCH SETS

Wrenches snap onto T-bar in 3 different positions. The only wrenches for hard-to-get-to places. Mfd. by Plomb Tool Co. for U.S. Armed Forces. Finest case hardened tool steel. No shop mechanic should be without this set. Approx. GOVT. COST \$47. NEW. **\$5.95** ppd.



COMMANDO BOLT & WIRE CUTTER

Folding extendable handles for extra leverage. Center cut type hole cutter for hard and medium rods, bolts, tough alloy wires and other metals. Cutting edge has equal bevel on each side for extra strength. Folded it fits in pocket or tool box. Safety latch locks closed. Approx. length 10 3/4"; extended 15 3/4". A must for mechanic or farm hand. Rugged construction. Made of Sheffield tool steel. NEW. **\$3.75.**

NEW CATALOG! Bigger & better than ever... 1000's of bargains in war surplus & other items! Send 25c in coin for your copy today! Ppd. prices USA only. Other prices FOB Culver City, Calif. Send cash, check or money order. 50% deposit on COD.



AIRBORNE SALES CO., INC. DEPT. PS459
8501 Stellar Drive, Culver City, Calif.

Cleaned LIKE NEW

IMPERIAL Rapid Brush Cleaner

is ready for instant use - no mixing, no long soaking of brush. Leaves brush like new - glossy, springy - never flabby. At paint and hardware stores.



Send 25c for illustrated Manual on Refinishing, or write for free folder "Care of Paint Brushes"

Wilson-Imperial Co., 121 Chestnut St., Newark 5, N. J.

PEEL OFF PAINT



- Remove old finishes easier, faster
- Non-inflammable and needs no afterwash
- For wash-off or scrape-off use

Heavy-Bodied KLEAN-STRIP

PAINT REMOVER

THE KLEAN-STRIP CO., INC.

2340 S. Lauderdale, Memphis 6, Tenn.

HEAVY DUTY TYPE ALLEN PUNCH PRESSES



Model BT-5
5 Ton
\$199.50
f.o.b.
Less motor

Hundreds of Different Model Combinations
1 to 12 ton capacities
Moderate in price
Fully guaranteed

See your supply dealer or write for Free catalog giving complete information and prices on our Bench Type Punch Presses.

ALVA ALLEN INDUSTRIES, Dept. PS, Clinton, Mo.

DO MORE PLANING JOBS WITH LOW COST BELSAW



Exclusive MONEY-MAKING Features: Full 12 1/4" x 6" capacity • Power feeds at 14' to 34' a minute • Provides for Grinding Knives in the Cutter-head • Attachments for Jointing, Rabbeting, Tongue, Matching, Groove. Convert low cost rough lumber into high priced stock. Easy to make flooring and popular patterns. Send Today for FREE Literature and Prices.

Belsaw Machinery Co., 2069 Field Bldg., K.C. 11, Mo.

LOW DOWN PAYMENT EASY TERMS

NOW! HOME CRAFTSMEN CAN OWN THIS PROFESSIONAL ARC WELDER

Now you can own a Trindl full 125 amp Industrial Welder at a price far less than smaller machines. With a Trindl 125A you can weld metals up to 1/2 inch thick. Operates off either 110 or 220 volt line, properly wired. 16 heat stages from 20 to 125 amps. Make and repair anything of metal around the home, garage, farm or shop, like a professional. No previous experience or training needed. Full "do-it-yourself" instructions with each machine. Complete only \$98.50 f.o.b. factory, or write for details. Trindl manufactures a complete line of heavy duty welding machines. Dealer inquiries invited.

TRINDL PRODUCTS Ltd., Dept. T3-D
1807 So. Clark St., Chicago 16, Ill.

EASY TERMS ONLY \$98.50 F. O. B.



FREE

WRITE FOR COMPLETE DETAILS AND EASY PAY PLAN



Guaranteed 12 MONTHS IN CONTINUOUS OPERATION

"VISE-GRIP SAVED MY FAMILY IN A BLIZZARD!"

The True Story of Stephen Lootz, Lindenhurst, N.Y.



"I was pulling a trailer during a snowstorm near Richmond, Va., when a trailer tire blew out! I couldn't find my lug wrench. A state trooper drove up... told me my family was in danger. Then I remembered my *Vise-Grip!* Quickly I loosened the lug nuts—changed the tire—and got moving before disaster struck. Thanks to *Vise-Grip!*"

VISE-GRIP Does More Jobs Easier Than Any Other Tool

You'll find *hundreds* of uses for powerful, all-purpose Vise-Grip. It's a pliers, wrench, clamp, hand vise, wire cutter—all in one tool! Ask for the new Vise-Grip with Easy Release at your hardware store. Only \$2.15 to \$2.95.



PETERSEN MFG. COMPANY
Dept. PS-4 DeWitt, Nebr.

BVI Painting is Easy! Electric PAINT SPRAYER

only **\$1295** complete with built-in motor
Fully Guaranteed

Just plug in, pull trigger and spray paint, varnish, enamel, garden sprays and insecticides. 3 to 7 times faster than painting with a brush! Features sapphire nozzle, instant adjustment for heavy or light spray. Foolproof and trouble-free! Available now at dealers everywhere!

Burgess Vibrocrafters Inc.
Grayslake, Illinois



READYCUT HOMES

\$2150 AND UP DIRECT FROM MILL

YOU SAVE the items which help make today's building cost expensive: high labor cost, contractor's profit and overhead, insurance, architect's fees. Cut-to-Fit eliminates usual lumber and material waste, also costly mistakes. Anyone can assemble. Simple, easy-to-follow plans furnished and each part numbered. Complete with all lumber, roofing, nails, glass, hardware, paint, doors, windows. Freight paid. Low-cost building plans sold separately if desired. 57 Homes and Floor Plans.



5 EASY PAY PLANS
COLOR CATALOG



INTERNATIONAL MILL & TIMBER CO.
Dept. PS 49 Bay City, Mich.

FAUCET WATER HEATER

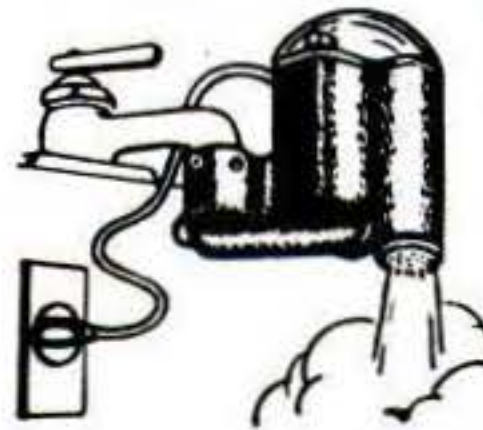

Instant hot water for just pennies—You just slip MASTER MECHANIC'S new Faucet Water Heater over any faucet—plug it in a wall outlet, and you've got steaming hot water instantly for dishes, shaving, washing baby's bottle, etc. Simple and safe—operates on ordinary 110 v. house current—costs only 2 1/2 cents per hour for hot water. Ideal for homes, shops, cabins, trailers, etc. Easily regulated from lukewarm to full hot. **Fully guaranteed.** (Item 408) Wt. 2 lbs. **\$4.95** Factory price.



ELECTRIC PUMP

DRAIN CELLARS—IRRIGATE

Powerful completely enclosed G.E. motor direct connected to 1" pump portable, pumps anything, std. thrd., use any hose, foot valve incl. free. 10 day money back guar. **\$29.50** Wt. 26 lbs. Item C853.

We have light plants, hydraulics, steam cleaners, fans and hundreds of other items at low low prices. Send 10c for big catalog.

MASTER MECHANIC MFG. CO., Dept. B49, Burlington, Wis.

TOOLS WHOLESALE

**\$1.00
PUTS YOU IN
BUSINESS**

Start your own business, sell tools to your friends and neighbors, or buy tools for your own use and **SAVE MONEY \$\$\$**

A MILLION DOLLAR INVENTORY AT YOUR FINGERTIPS. NO STOCK TO CARRY. ORDER AS YOU NEED IT.

Send \$1. for Tool Catalog today. **BUY AT WHOLESALE PRICES.** Extra \$25.00 profit on your accumulated purchases. \$1.00 is refunded if you are not 100% satisfied with our offer.

THOUSANDS!! of Nationally Advertised items of Hand Tools, Power Tools, Machinist Tools, Tool Chests, Paint Sprayers, Light Fixtures, Appliances, Guns, Gifts, Toys and other items too numerous to mention.

WE SHIP COAST TO COAST
Wholesale Discounts up to 50% OFF

SILVO HARDWARE CO., Dept. PS-4 107 Walnut St., Phila. 6, Pa.

200 Amp. PORTABLE GASOLINE ENGINE WELDER

Government Cost \$2,940.00

Yours **\$189.50**

Most compact welder obtainable for the big jobs in out of the way places. Generator is capable of delivery of double overload or continuous service at 200 Amps. use up to 1/4" welding rod. Engine is manufactured by Ranger Aircraft and is a 2 cylinder, 4 cycle 10 H.P. at 3200 RPM. Fully governed for varying loads. You need to supply only cables and electrodes for welding. Units weigh approx. 150 lbs. (less oil & gasoline) and are approx. 22" W x 33 1/2" L x 17" H. All units used but guaranteed and checked before shipment. Parts available both new and used.

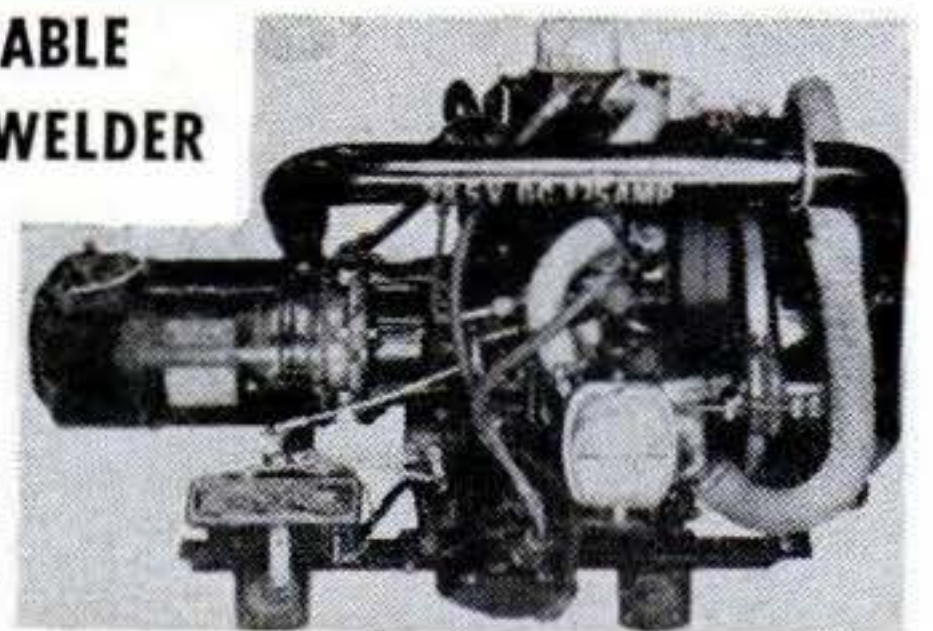

JEFFERSON AIR DEPOT

P. O. Box 798 N.M.S.
Madison, Indiana

GIGANTIC SURPLUS SALE

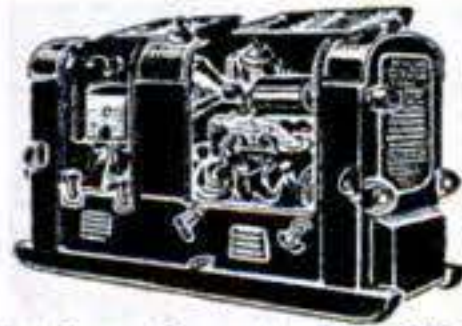

A-C POWER PLANT

● Item #669. Fortunate purchase allows us to again offer new condition famous M-5 power plants. Excellent for emergency standby or full time use for home, farm or business. Push button 6-v starting. Weather-proof housing.
● Generator Hobart 3000-w, 115-v, 60-c, 2-wire. Engine: Hercules 4-cyl, water cooled. Complete control panel, circuit breaker, voltmeter, ammeter, freq. meter, etc. Size 55"x25"x32". Wt. \$345 FOB 700 lbs. Cost Gov. \$1,248. SALE... \$27.95 FOB Transformer for 115-230-v power.



AC, DC ROBOT CONTROL MOTOR

● Item #540. Compact, powerful AC, DC rotary actuator unit. Use to operate remote valves and levers, steering control, door openers, switches, make small winch, open-close drapes, antenna rotator, etc.
● Reversible, ball bearing motor operates on 12-v DC or low voltage AC. Precision reduction gear train gives low speed, high torque. Limit switches control rotation to 90°. Easily changed to continuous rotation. Size 6"x5"x4". Weight 5 lbs. Govt. cost \$49.50. SALE... \$7.95 ppd.

115-VOLT AC WATER PUMP

● Item #246. Buy-of-the-year. Genuine Gorman-Rupp electric motor driven pump. Hundreds of uses such as pumping, draining, circulating, fluid transfer, etc. For hot and cold water, gasoline, milk, brine and many chemicals. Rustproof case and impeller.
● Pump direct driven by 115-v, 60-c. AC motor. Capacity to 500 g.p.h. 1" hose slips over inlet and outlet. Size 7 1/2"x4 1/2"x4 1/2". Wt. 5 lbs. List \$25.00. SALE... \$8.95 ppd.



DIAL PHONE

● Item #715. Modern hi-efficiency attractive dial phone. Use for extension to main line or private system. Use several for complete private system, etc. Complete with ringer, dial, etc. Work on any system. Cost \$24. \$9.95 ppd. SALE

We have phones for farms, contractors, mines, factories.

ORDER DIRECT FROM AD OR SEND FOR FREE CATALOG BIG, NEW 1959 EDITION

- SURVEYING
- ELECTRONICS
- POWER TOOLS
- TARPULINS
- CHAIN SAWS
- BINOCULARS
- SPORTING
- SEARCHLIGHTS
- METERS
- TRANSFORMERS

AC WORM GEAR MOTOR

● Item #575. Terrific buy! Brand new, leading make worm reduction gear motor at fraction of regular list. Many uses in home shop and industry. Window displays, slow speed grinders, etc.
● 115-v, 60-c, 1/50 h.p. AC motor, 36 to 1 reduction gear ratio. Output speed 200 rpm. Can be reduced to 50 rpm with rheostat (not furn.). High output torque. Step shaft has 5/16" and 3/8" diameters. Size 6"x4"x4". Weight 4 lbs. List \$20.00. SALE... \$8.69 ppd.



WELDING GENERATOR

● Item #672. Famous new-condition P-1 200-250 amp aircraft generator. Thousands of these giving excellent service as welders. Other uses are DC power plant, fast battery charge. Easy to adapt into portable welder, using 10-12 HP engine or drive off tractor pulley. 200-250 amp 24/30-v, 2500-4500 rpm. Size 15" x 6". Wt. 48 lbs. Govt. cost \$300. SALE... \$18.95 FOB

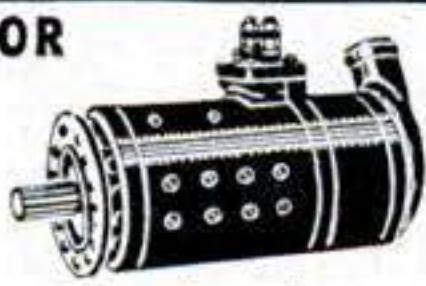

ELECTRIC TIMING CLOCK

● Item #123. Brand new 115-v timing clock will switch electrical appliances ON or OFF at any predetermined time. Excellent to control TV, coffee-makers, fans, air conditioners, lights, etc.
● 115-v, 60-c. Telechron movement. Switch will handle loads to 25-amperes. Dial shows time unit will switch OFF, remaining ON period. ON period adjustable from 15 min to 6 hrs. Can be mounted in wall, panel, cabinet, etc. Size 2"x4"x4 1/2". Wt. 2 lbs. List \$10.50. SALE... \$4.59 ppd.



PRESSURE AIR TANK

● Item #446. Steel alloy tank with many uses for skin divers, air supply outfits, hydraulic system reservoir, filling tires, etc.
● Pressure rated 400 p.s.i. Internal volume 280 cu. in. (1 1/4 gal.) 1/4" pipe thread port. Size 5 1/4"x13 1/2". Weight 5 lbs. Govt. cost \$9.00. SALE... \$3.45 ppd.

SEND CHECK OR M.O. 25% DEPOSIT ON CODs

SURPLUS CENTER
DIVISION OF BURDEN SALES COMPANY
DEPT. 826
LINCOLN, NEBR.

SATISFACTION GUARANTEED OR MONEY BACK

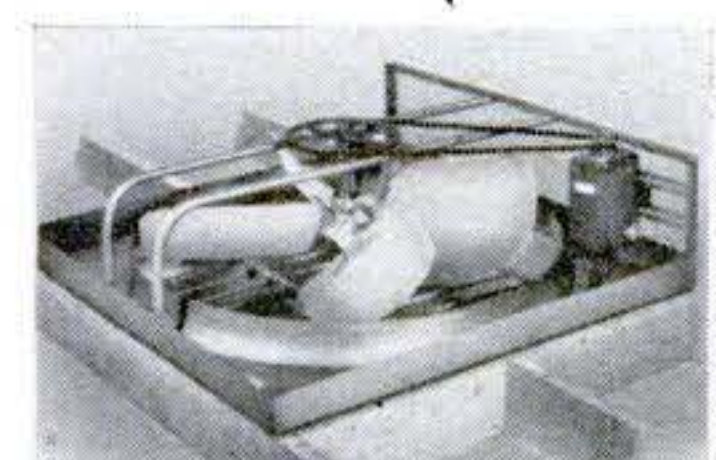
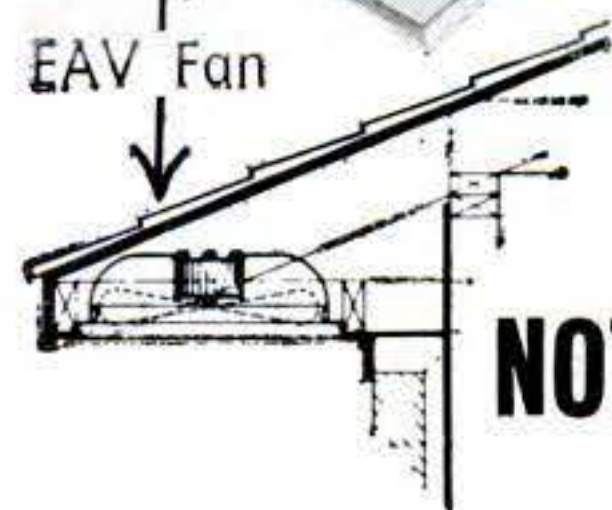
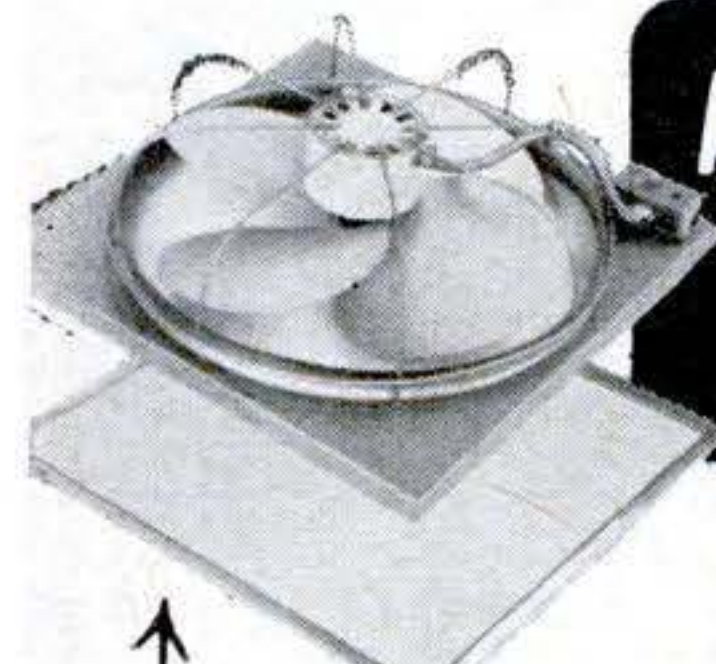

Air-Conditioned?

Add up to 1 ton of cooling for \$39.95

New, first-of-its-kind, Windmaker automatic EAV Attic Vent Fan reduces attic temperatures 50° or more. Adds to efficiency of your unit... cuts electricity costs... makes undersize unit cool better... gives more even floor-to-ceiling cooling. Comes complete with fan, thermostat, grille, screws. Easy to install in house eave or gable, porch, garage or breezeway ceiling.

NOT AIR-CONDITIONED?

Install summer breezes—Windmaker Attic Fan

Nationally advertised and sold, meets most rigid government and engineering specifications: Highest air delivery, lowest sound ratings, simplest to install, least maintenance. G. E. motor, welded steel frame, deep spun ventura. One of the finest Attic Fans made today... and the lowest priced.

Mail coupon for specifications, prices, installation instructions.

PHIL RICH FAN MFG. CO., INC., 2908 Caroline, Houston 4, Texas

Please send complete details on EAVE Fan Attic Fan

Name _____

Address _____

City _____ State _____

Mail Coupon Today!

WHEREVER YOU USE ENAMEL



JET-DRI

(Made with CCR-37)

DRIES IN 15 MINUTES

with superior...

- abrasion resistance
- acid, alkali, alcohol resistance
- exterior durability

Greatest advance in paint history! Paint anything... concrete, metal, wood or plaster with no effort, leaves no brush marks... and dries to a porcelain-like finish in 15 minutes. Perfect for indoors and outdoors. Non-toxic. Wide range of colors, including SEMI-GLOSS WHITE and SATIN-FINISH CLEAR.

Wherever paint is sold

CONSOLIDATED CHEMICAL & PAINT MFG. CO., INC.
456 Driggs Ave., Brooklyn 11, N. Y.



paint a floor with JET-DRI
WALK on it
15 minutes later!

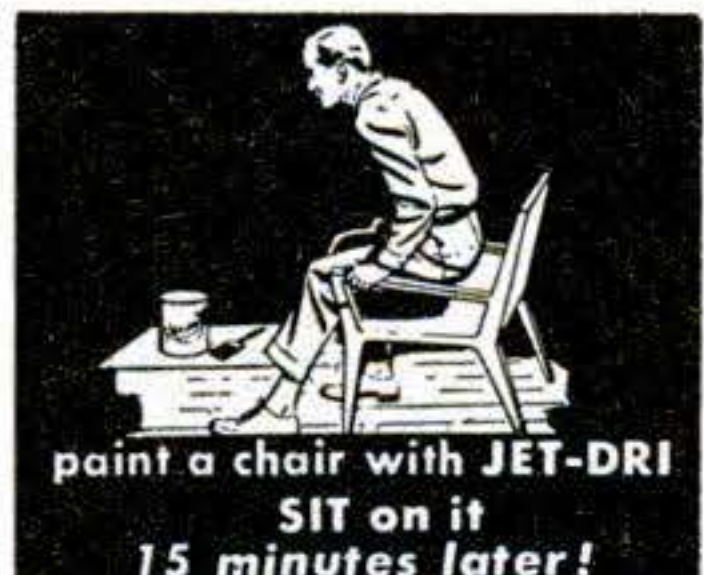

paint a chair with JET-DRI
SIT on it
15 minutes later!



paint toys with JET-DRI
PLAY with them
15 minutes later!

Bring your house up to date electrically

with the easy-to-install

Electrostrip

PATENTED

"4-FOOTER" KIT



ONLY \$2.95! And worth ten times its price in electrical convenience. Installs in minutes on walls, woodwork, counter or workbench. Gives you outlets you can move with a twist of the wrist. Ideal for kitchen, bedroom, den, workshop... anywhere you need multiple outlets in minimum space. Comes complete with screws, 3 twist-in receptacle plugs and polarized connector. Listed by UL. *Good Housekeeping* Seal. 4-Footer Kit and larger 15-Footer available at your hardware or variety store. Or send \$2.95 plus 50 cents postage to BullDog Electric Products Division, I-T-E Circuit Breaker Company, Dept. E. S., Box 177, Detroit 32, Michigan... and your 4-Footer Kit will be mailed to you promptly.

with sockets, *QUALITY* counts

P&C SOCKETS

Last longer, let you work faster, easier

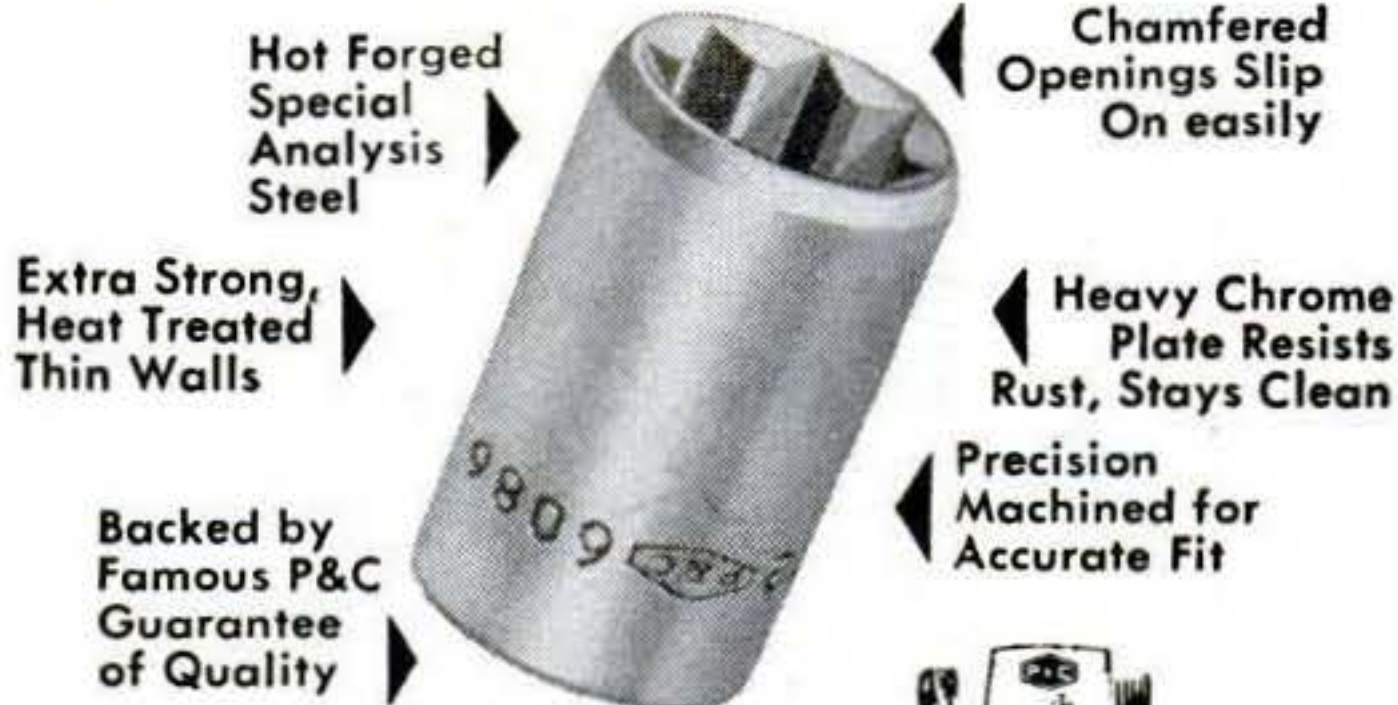

When you need sockets, buy good ones... P&C. Buy from the colorful P&C Merchandisers, 12,000 stores. Send 10c for tool catalog.



P&C TOOL COMPANY

Box 5926, Portland 22, Oregon
Warehouse: Schiller Park, Ill.

Subsidiary of Pendleton Tool Industries, Inc.

NOW! Adjustable CORNER CLAMP



AND MITERING VISE
Securely holds mitered or butt joints at 90° angle, or any angle, for nailing, stapling, gluing and splicing. ADJUSTS TO ANY ANGLE. Used for Picture frames, Screens, Storm windows, Shadow boxes. **\$1.75** or any place where wood is joined. **ppd.**

SAW SHARPENING IS EASY

Super Filer No. 11 joints and sharpens hand and circular saws 6" to 10" with all teeth correct in height, depth, pitch, bevel. When file hits steel roller, teeth are finished. Saw runs true with no side pull. Includes 8" file. **\$9.95** **ppd.**

Free Literature



"TRU-CIRCLE" saw set automatically sets teeth at 10° or more. **\$2.95** **ppd.**

MONEY BACK GUARANTEE



A. D. McBURNEY, 5908 Hollywood Blvd., Hollywood 28, Cal., Dept. S-49

WELD BRAZE SOLDER CUT 4WAY ONLY \$14.75 f.o.b. factory WELDER

Acclaimed by thousands of Homeowners, Mechanics and Hobbyists as the welder of 1001 uses. Easily operated from properly wired 110 volt AC or DC line. The ideal gift with a life-long use... Order today on 10 day money back guarantee.



Complete with Twin Carbon Arc Torch and accessories... to handle all metal-craft work.

FOUR-WAY WELDER CO., Dept. F3-D
1810 S. Federal St. • Chicago 16, Ill.

3 CU. FT. MIXER \$49.50

DIRECT FROM MFG.
Saves 3/4 cost of ready mixed concrete.
Pays for itself on first job.

3 Cu. Ft. Drum—
Mixes 2 Cu. Ft. Concrete..... \$49.50
5 Cu. Ft. Drum—
Mixes 3 Cu. Ft. Concrete..... 69.50

Motor and wheels extra. FOB Pulaski, N.Y.
Cash, Check or M.O. Money back guarantee.

UNITED STATES FORGE AND FOUNDRY CO.
Construction Equipment Div. Pulaski, New York

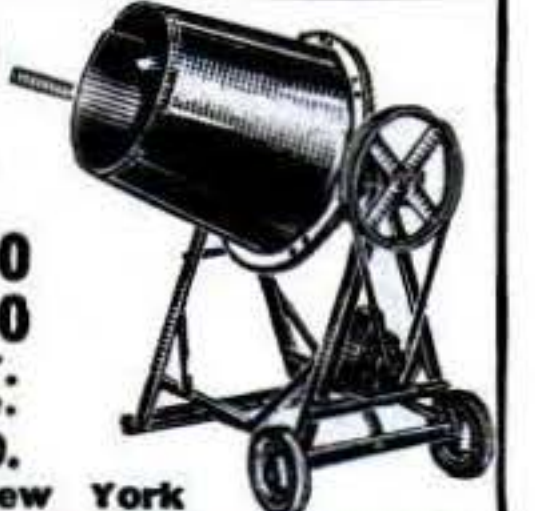

Print Your Own



Cards, Stationery, Advertising, Circulars, labels, photo and movie titles, church work, tags, etc. Save money. Sold direct from factory only. Raised printing like engraving, too.

Own a Printing Business

Print for Others. Good Profit. Have home shop. Junior press \$15; Senior \$29 up. We supply everything. Easy rules. Pays for self in short time. Write for free catalog of outfits and all details.

KELSEY PRESSES, C-33 Meriden, Conn.



More aluminum, lighter weight, better performance, beautiful styling. Still World's Lowest Priced Car. Drive it for 75¢ a week. Rider Agents Wanted. If no dealer near you send 25¢ for 32 page picture book, full details, dealer price, or send \$1 (refunded first order) for this and Service Manual plus Repair Manual and 15 5x7 photos of car and factory.

MIDGET MOTORS CORPORATION, Athens 2, Ohio

vacation cabin IDEAS

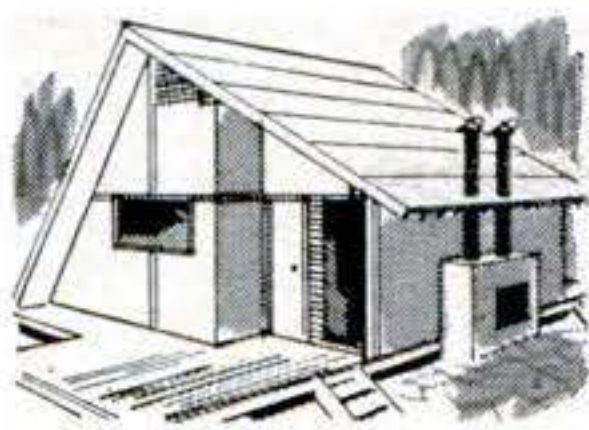
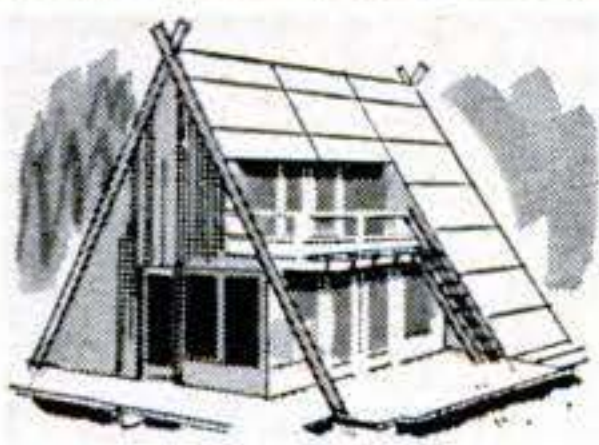

NEW full-color "plans and ideas" catalog shows 20 easy-to-build fir plywood cabins.

Here's the perfect source of ideas for anyone planning to build a vacation cabin. New catalog shows smart, modern designs by leading architects for cabins of every type and size—complete with full-color pictures, floor plans and building tips. Plans call for simple, straight-forward construction with big, easy to use panels of fir plywood, to save you time, money and trouble when you build.

Complete building plans available for all 20 cabins.

SEND 10c for new full-color catalog: (Offer good USA only)

DOUGLAS FIR PLYWOOD ASSOCIATION, Dept. 11, Tacoma, Wash.

pull the trigger...

spray paint

7 times faster than brushing!



Speedy Sprayer **ONLY \$32.00**
less motor

Paints anything from a house to a toy. Saves its cost on the first major job! Speedy Sprayer does in minutes what brushing takes hours. Finish is smooth, flawless. Uses any 1/4 h.p. motor with 1/2" shaft. No. 780 Outfit—10 ft. air hose, tire chuck, quart gun, less motor, only \$32.00. Every workshop should have it. At leading stores.

Free! Write for "How To Spray" Booklet and folder.

W. R. BROWN CORPORATION

Specialists in Portable Paint Sprayers for Over 37 Years
2637 N. NORMANDY AVENUE, CHICAGO 35, ILL.



7"-f/2.5 EASTMAN AERO LENS

Originally designed for K-21 & K-24 Aerial Cameras. A genuine Eastman AERO EKTAR, 178mm lens — Has f-stops from f/2.5 to f/16. Focal length 7 inches. Perfect for Color or B&W shots. Makes an excellent Telephoto Lens when used on 35mm or Speed Graphic Cameras. Fully coated and color corrected glass.

REGULARLY 69.95 NOW 29.95

MICROSCOPE 'BUY OUT' SALE



We made a tremendous 'BUY OUT' from our overseas supplier — He needed quick cash and work for idle machines. His LOSS is YOUR GAIN!

NEW 100 - 200 - 300X

Has fine precision ground and polished lenses. Triple revolving objective lens turret allows choice of 100X, 200X or 300X magnification. Has right and left hand rack & pinion adjustment. All-metal body inclines through 90°. Has sub-stage mirror and comes in fitted wood case.

12.50 Regular Palley Catalog Price \$7.95

VALUE SPECIAL SALE PRICE... 4.44

60-450 POWER MICROSCOPE

With precision ground & polished lenses. 2 interchangeable eyepieces of 6X & 15X. Triple revolving turret with 10X, 20X and 30X lenses. Patented sub-stage mirror has self-contained light for use without external light source. All metal body inclines 90°. In fitted wood case with 3 slides.



FREE! 8 PC. DISSECTING SET — Includes scalpel, scissors, slides, pins, tweezers, probe, & magnifying glass —

9.88 REG. 16.95



A \$25.00 VALUE



8 POWER ELBOW TELESCOPE

9.88

COST GOV'T \$150.00

Has 2" objective lens, a Kellner eyepiece & an Amici erecting prism. Illuminated cross hair. 3 built-in light filters. Has a field of 325 ft. at 1000 yds. Eyepiece alone worth \$12.



TARPS 20 OUNCE GOV'T SURPLUS HYV. DUTY TARPS 8'x14' 8'x18' 9'x10' 9'x12' 9'x16' 10'x12' 12'x12' 12'x20' 15'x15' 20'x30'

\$8.96 11.52 7.20 8.64 11.52 9.60 11.52 19.20 18.00 48.00

NOTE: This is only a partial listing of our stock of Tarps. Extra large sizes made to spec. at 8¢ per sq. ft.

STAINLESS STEEL AIR TANK BUYS

STAINLESS Tested to 400 PSI. For air chemicals, etc. 1/4" ports. Capacity 2 100 cu. in. 12 1/2" x 24", No. G-1U 12.95 No. G-1N — NEW condition .. \$16.95

D-2 Steel AIR TANKS — 400 PSI test. Capacity 500 cu. in. Size: 6 1/2" x 24" 4.95 D-2CU Carbon Steel — used... 5.95 D-2C Carbon Steel — NEW



SAVE ON GOV'T SURPLUS

- A — Swedish Army FOLDING BAYONET ... \$2.98
- B — Paratrooper FOLDING MACHETE ... 2.89
- C — 22" Vanadium Steel MACHETE with case 1.98
- D — British Army comb. PICK-HOE TOOL ... 1.49
- E — Officer's Lensatic POCKET COMPASS ... 3.49
- F — New Navy FIGHTING KNIFE with sheath 2.98



BENDIX GEAR PUMP & MOTOR

Delivers 3-1/2 gal. per minute. Up to 600 PSI pressure. Motor is 1-1/2 HP, 24 V., DC — use on 12 or 32 volts. Has built-in relief valve. Ports are 3/4" inlet, 1/2" outlet with standard pipe threading. Ideal for use on Hydraulic Lifts, Portable Loaders, etc. Catalog No. HPU-6USU **NOW 8.88**



1500 PSI HYDRAULIC CYLINDER Dbl. action. Has bore of 1", shaft 1/2", stroke 4", length 9". Ports 1/4" AN. Cost gov't approx. \$35 **4.88** Catalog No. H-5ASU ...



HYDRAULIC 4-WAY VALVE **3.95** No. H-V7A-1

Spring loaded, poppet type. Pressure balanced. Off in neutral. Has 1/4" tube ports. Cost gov't approx. \$30.



20,000 lb. THRUST HYDRAULIC CYL.

A Palley Hydraulic Bargain! A 1500 PSI Cylinder with 20,000 pounds of thrust. May be used with low pressure air systems. Bore ... 4" Shaft ... 1-1/2" Cat. No. H-29SU **NOW 4.95** Stroke ... 18" Length ... 31" OVERHAULED

SAVE up to 85% on HYDRAULIC Valves, Pumps, Cylinders, Motors, etc. We have the Largest On-the-shelf stocks in the country. Write for Cat. H-59

Pay by Money Order or Check. P.O.s accepted from D&B firms rated F2 1/2 or better. 1/2 deposit with C.O.D.s. Prices F.O.B. Los Angeles Whse.

palley's

2263 E. Vernoi Ave., Dept. PS-49 Los Angeles 58, Calif.

80¢ makes a hard job easy

 A few quick strokes with this 80-cent Red Devil Scraper File makes dull scrapers razor-sharp. You'll be astonished at the difference. If you really hate work, buy our replacement scraper blades instead — 20¢ to 50¢.

 You sand the wood instead of your hand with this comfortable Red Devil Sandpaper Holder that lets you bear down hard. 55¢, or a dime more with sponge rubber backing pad.

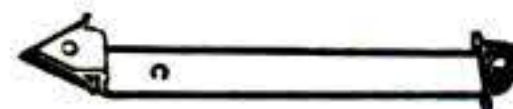
 Poor patching of plaster often results from inadequate scrape-out of cracks. So the expert uses a special Red Devil Crack Scraper. For 55¢, you can afford to do likewise.

 Glass cutting is easier than you think with a Red Devil Glass Cutter and a few tips in the booklet offered below. We make 15 kinds for professionals but the 55-cent No. 024 serves most amateurs nicely. Look for the red, white, and blue package.

It's always best to buy where Red Devil Tools are sold, for wider choice, top quality, correct "how-to" advice.

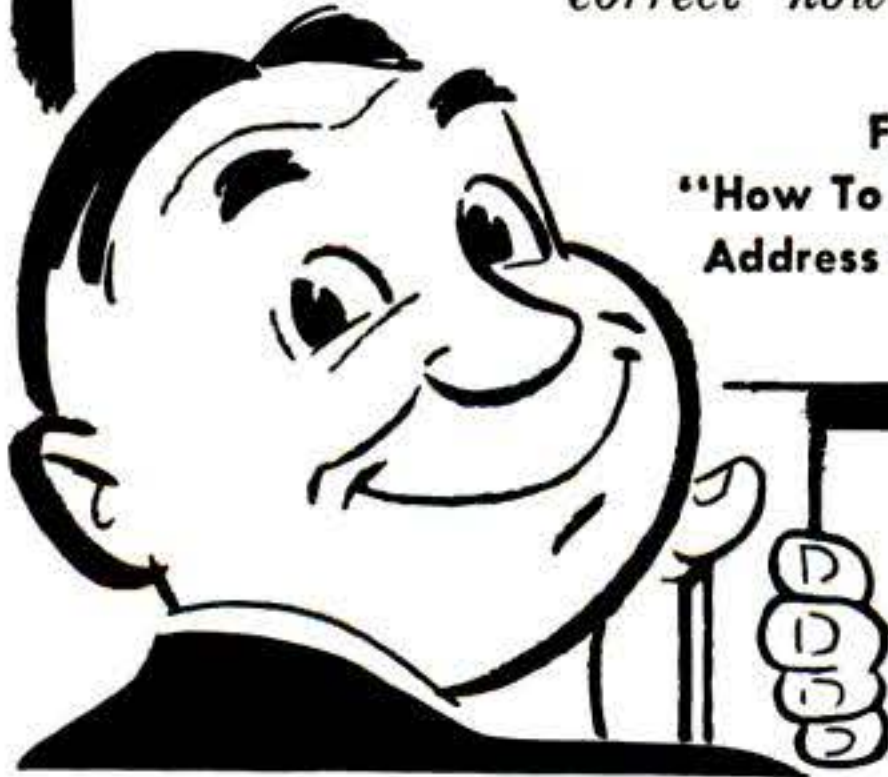

Free booklet, "How To Cut Glass." Address Dep't. D-4

4570

Red Devil Tools.

Union, N. J., U. S. A.

World's largest manufacturer of painters' and glaziers' tools.

RETAIL PRICE \$125.00
FACTORY TO YOU \$79.95

SUPERSHOP includes precision-built 8" tilting table saw, vertical and horizontal drill press, 30" lathe, sander, grinder. 100% BALL BEARING. Write for FREE catalog, full details, trial plan.
UNITED INDUSTRIES, INC.

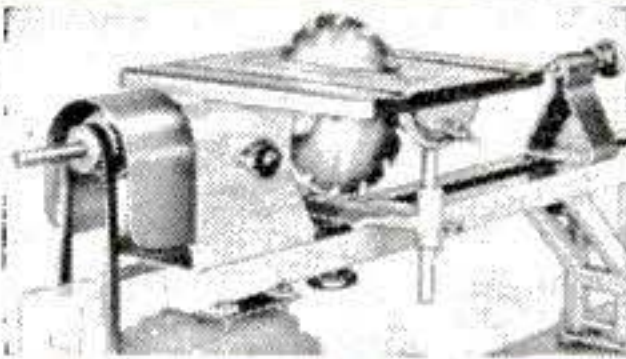

Power Tools Division
218 YATES AVENUE
BELOIT, WISCONSIN

NEW SURPLUS

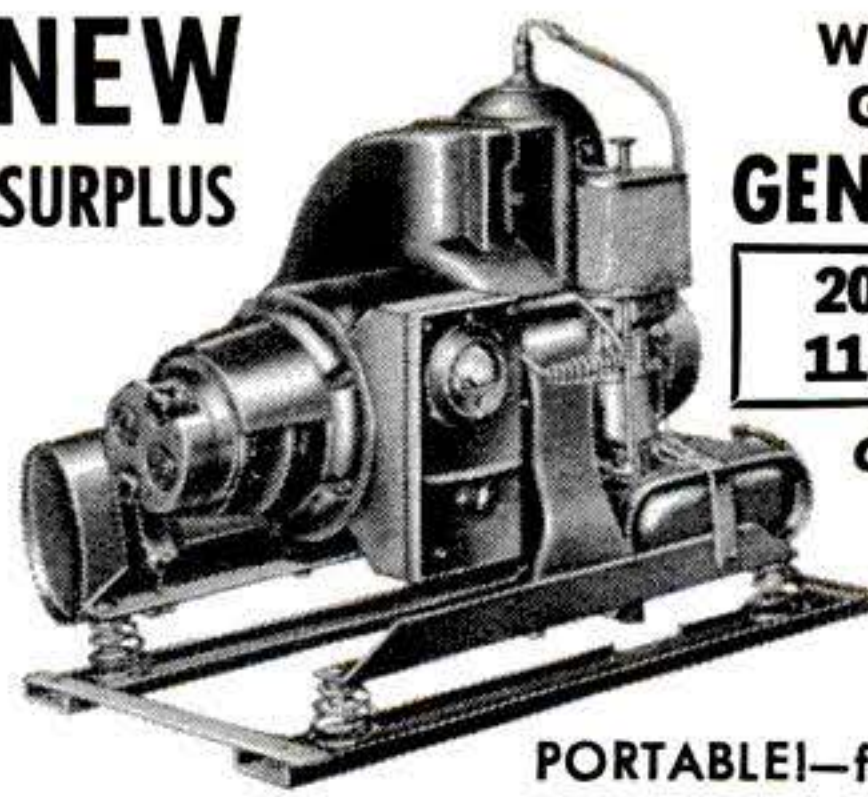

WISCONSIN 4-CYCLE Gas Engine Driven GENERATING PLANT

2000 WATT, 60 Cycle, 115 Volt, Single Phase

Gov't. Cost \$500.00

Only \$219.50 job

FULL 1-YEAR GUARANTEE
PORTABLE!—fits easily in car trunk!

PAYS FOR ITSELF! Saves time, labor and money. Provides on-the-spot power for CONSTRUCTION, etc., where none is available or expensive to run in. Large enough for Floodlights; Saws; Pumps; and many more labor-saving heavy-duty machines. Ideal as a stand-by emergency power plant to duplicate house current. Plenty of power for lights, refrigerator, deep freeze, oil burner, radio, etc. Specifications below. **CAN'T BE MATCHED** anywhere at this price!

GENERATOR 2000 Watts, 115 Volts, 17.3 Amps., 60 Cycle, single phase. Overload capacity well above its rated output. Excellent automatic voltage regulation plus Field Rheostat for even closer adjustment. Built-in Volt meter and receptacles.

ENGINE Famous WISCONSIN 5.6 H.P. air cooled engine, 4-cycle. Weather proof high tension magneto with impulse coupling for quick easy starting in any weather. Mechanical Flyball governor. Adjustable carburetor with automatic choke release. Timken roller bearings—self cleaning. Weighs 155 lbs. Over-all dimensions: 29" long, 19" wide, 20" high

SUPPLY LIMITED! IMMEDIATE DELIVERY! ORDER FROM AD
Free Catalog of War Surplus—Wholesale Equipment
ROBERTS ELECTRIC CO., Dept. PS-919, 849 W. Grand Ave., Chicago 22, Ill.

Remote Control Governor increases engine life by allowing engine to run at idle speed when load is removed from Generator.

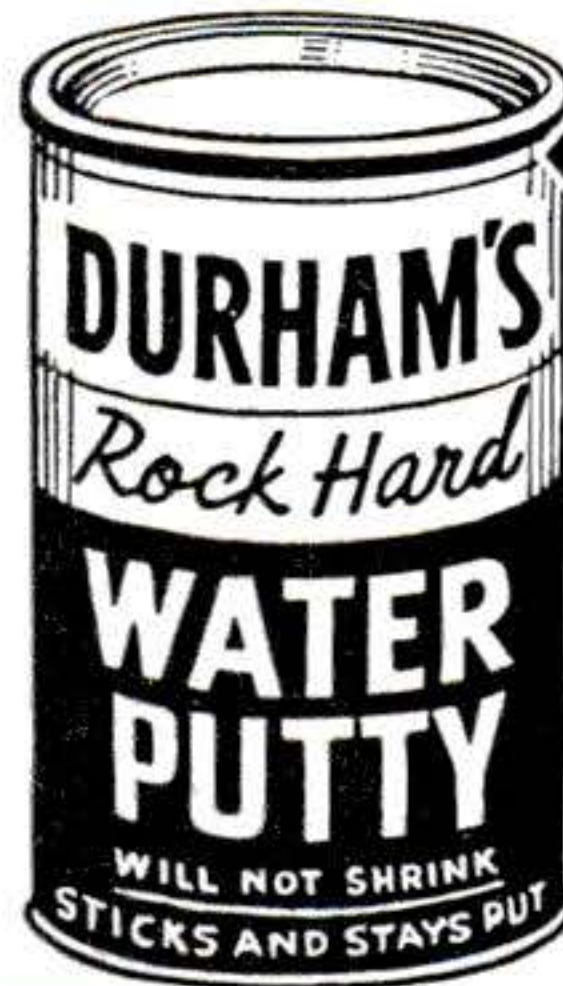

The Modern PLASTIC for lasting Home Repairs

PERMANENTLY mends cracks or holes in wood, tile, stone or plaster. Sticks and stays put—Does not chip, shrink or fall out. Easy to use. Economical. Mold it, chisel it, polish or paint it. The big 4-lb. can is obtainable from your lumber, paint or hardware dealer at \$1.40; or will be shipped direct postpaid (in U. S.) for \$1.75. Complete satisfaction guaranteed or your money refunded. Order now.

DONALD DURHAM CO.

Box 804-U Des Moines, Iowa



GEARS

In Stock—Immediate Delivery

Gears, speed reducers, sprockets, thrust bearings, flexible couplings, pulleys, etc. A complete line is carried in our Chicago stock. Can also quote on special gears of any kind. Send us your blueprints and inquiries.

Send for Complete Catalog No. 220
CHICAGO GEARWORKS
440-450 N. Oakley Blvd. Chicago 12, Ill.

DRAINS cellars, cisterns, wash tubs; IRRIGATES - CIRCULATES - SPRAYS

 1,001 uses. Stainless shaft. Won't rust or clog! Uses 1/6 HP motor or larger. . . 3/4 HP for up to 3000 GPH; 450 GPH 80' high; or 1800 GPH from 25' well. 1" inlet; 3/4" outlet. Coupling included free.
Heavy Duty Ball-Bearing Pump. Up to 7,500 GPH. \$12.95
1 1/4" inlet; 1" outlet.
Postpaid if cash with order. Also other sizes, types.
MONEY BACK GUARANTEE.
LABAWCO PUMPS, Belle Mead 3A, N. J.

Lowest Price
WATER SYSTEM
Completely Automatic!
\$49.95 less motor
With 1/4 HP motor, \$69.95
Bronze Gear Pump 275 GPH. 20-40 lbs. 3/4" fittings.
Free Circular

NEW shop type ac arc welder



NEW ac power or weld anywhere

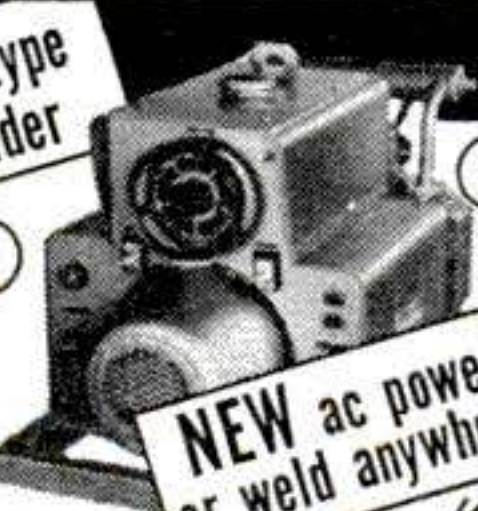

Here's how YOU can get those "Big Profit" Welding Jobs

① **Start a Big Paying Business of Your Own!**

Every day, men like yourself depend on Hobart welders like these to help produce big profits doing construction, repairs, metal fabrication, etc. You'll like Hobart's rugged strength and built-in features that assure long, trouble-free life—professional results, every time.

② **The 180 amp. "HUSTLER" is a complete welding package (including accessories). It welds, cuts, burns holes,**

hard surfaces and heats metal for bending and forming. Meets REA requirements . . . it's an all around shop welder.

② **The 200 amp. "POWER/WELD" furnishes DC current for welding and simultaneously supplies 110/220 volt power for running lights, tools, motors, pumps, sprays, etc. It can also be used as an emergency power source to run brooders, milking machines, etc.**

Write today ... HOBART BROS. CO., BOX "P-49, Ph. FE 2-1223

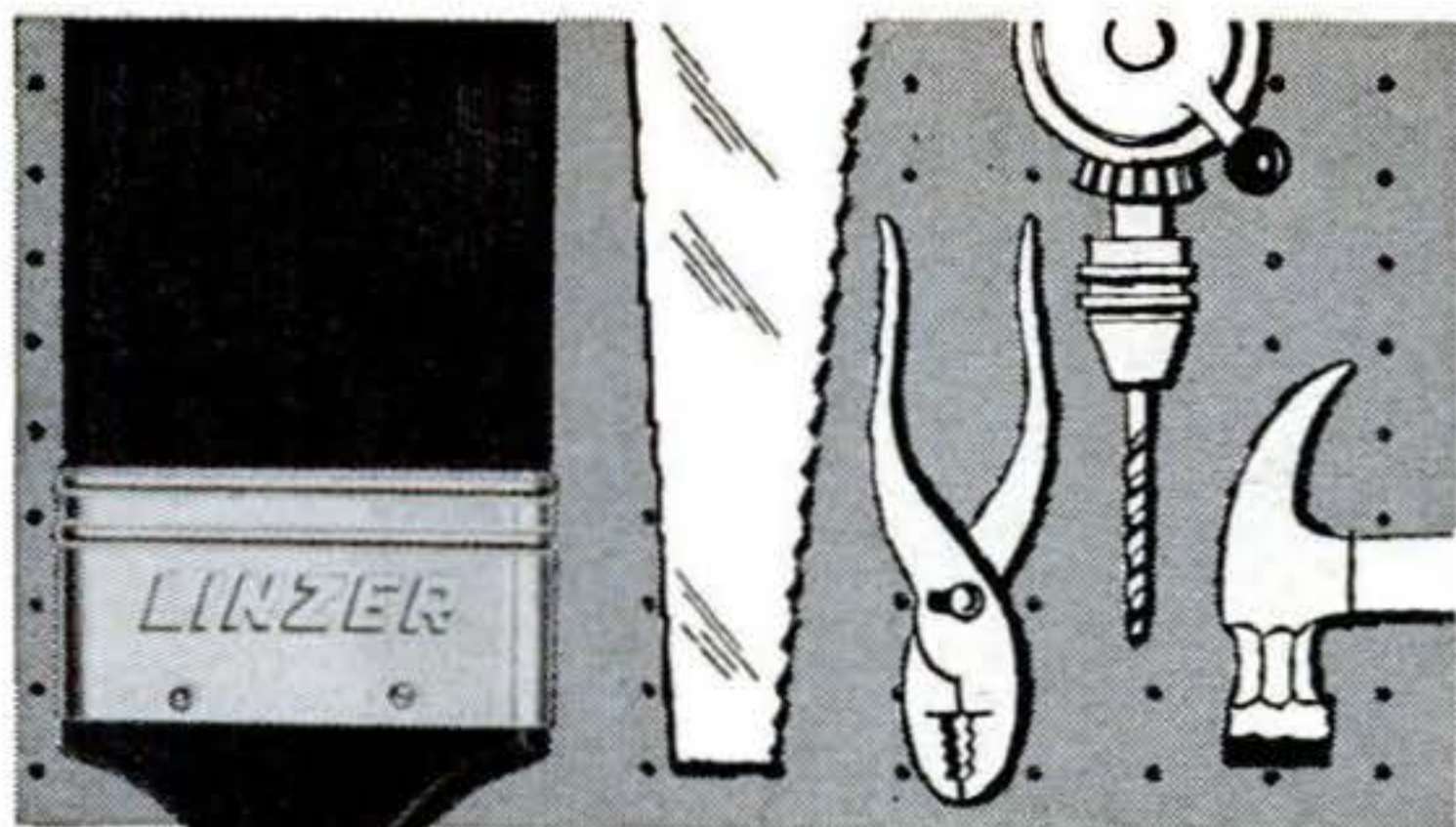

LINZER BRUSHES

belong with your other quality tools

The clue that identifies the good craftsman is the quality of tools he owns. And you're sure to see several LINZER brushes in his workshop because LINZER is the quality brush that puts the perfect final touch to his skill.

AS ADVERTISED IN
LIFE

Send 10c for "Painting Hints"

Since 1892

DAVID LINZER & SONS, Inc.
10-20 Astor Place • New York 3, N. Y.

Electrical Repairs?

Get the **VACO**® 1902 Tool



Cuts and strips wire, crimps solderless terminals and also shears 5 sizes machine screws . . . use it for all electrical work.

Complete kit also available. Includes tool, large assortment terminals and free plastic box. \$8.95, p.p.

\$3.95, p.p.

Free Catalog Available . . . Write

VACO PRODUCTS CO. • 317 E. Ontario St. • Chicago 11, Ill.

HOW TO

TURN
Concrete
INTO
Gold



A MUST FOR EVERYONE CONCERNED!

This MANUAL Tells You How To Make Handsome Profits From Concrete Items YOU CAN MAKE

All you need is a mold or two and a little determination. This Manual contains large, clear pictures, gives prices and description of more than 200 different molds you can buy direct from the manufacturer, AND . . . priceless trade secrets that make production a snap. Take the first step Today !!!

SEND ONLY \$2.00 FOR YOUR COPY
(Rushed to you by First Class Mail)

CONCRETE MACHINERY COMPANY, INC.
Dept PS Hickory, N. C.

Built to Last

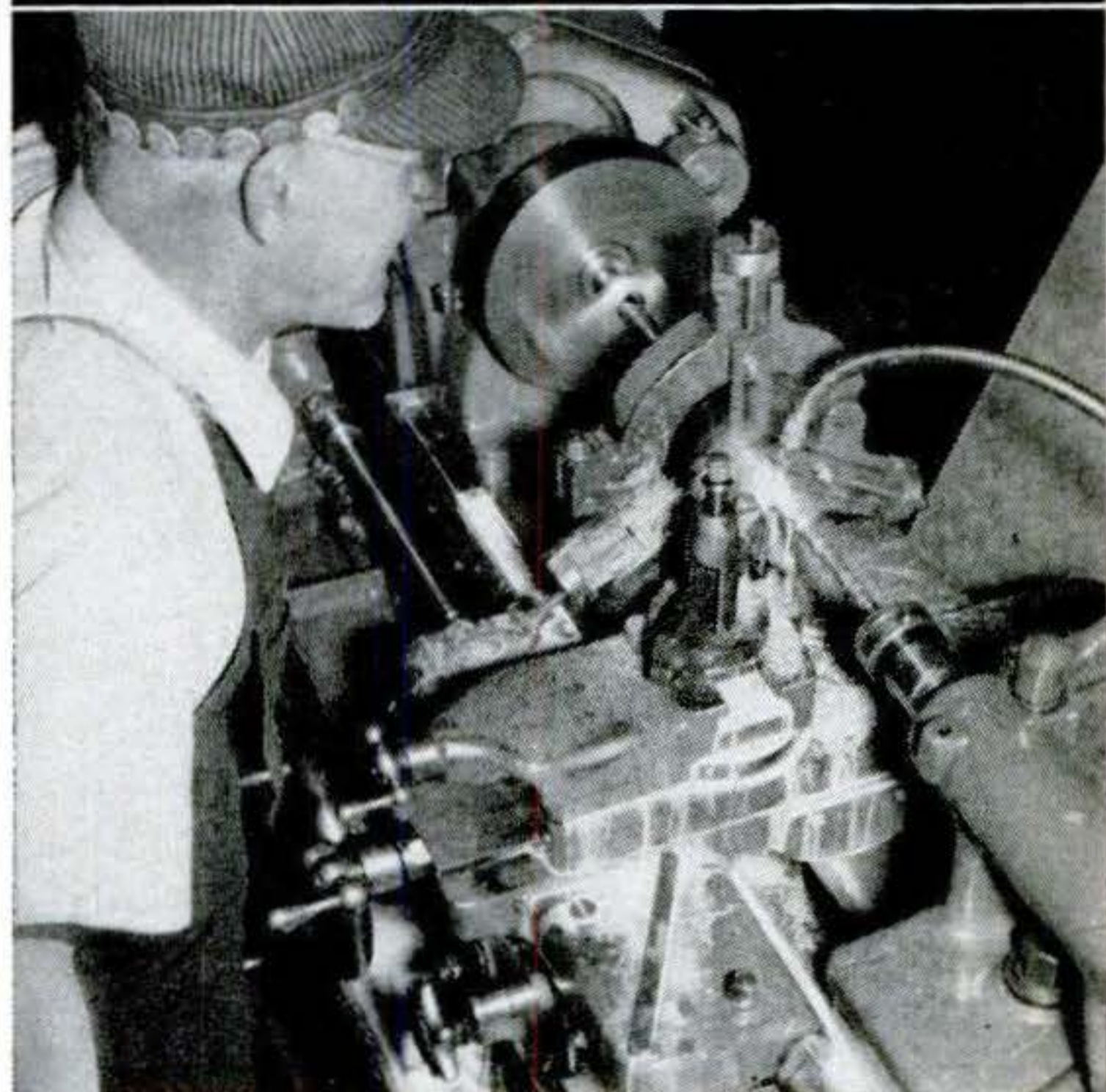

South Bend 13" and 14½" Lathes

Years mean nothing to these precision lathes, as they go on and on turning out accurate work at low cost with . . .

- Microfinished bearings with no metal-to-metal contact.
- Belt drive to spindle for vibration-free operation—no gear marks.
- Precision-cut gears and ground shafts for smooth power feeds.
- Rugged, rigid construction that will stand up under hard usage.
- Exacting workmanship by skilled craftsmen.

SPECIFICATIONS	13"	14½"
Swing over cross slide.....	7¾"	8¾"
Maximum collet capacity.....	1¼"	1½"
Spindle speed range.....	20-940	15-875
Shipping weight, 7' bed.....	1760 lbs.	2089 lbs.
Base price.....	\$1675	\$2074

Write for FREE 80-page catalog.

SOUTH BEND LATHE

South Bend 22, Indiana

Builders of Lathes, Milling Machines, Shapers, Drill Presses, Pedestal Grinders



Up to 24 months to pay.



MODERNIZE WITH MARLITE

For years of wear, minutes of care

Marlite is quickly installed over old or new walls with ordinary tools. Baked melamine plastic finish resists heat, moisture, grease, acids, stains; cleans with a damp cloth. Planks, Blocks, large Sheets available from building materials dealers in decorator colors, wood finishes, marble patterns. Look for the Marlite name on the back of every panel—your guarantee of satisfaction. For free decorating book, write Marlite Division of Masonite Corp. Dept. 426, Dover, Ohio.

5901

Marlite plastic-finished paneling

ANOTHER QUALITY PRODUCT OF MASONITE® RESEARCH



CLOGGED SEWERS? CLEANED INSTANTLY SAVES PLUMBING BILLS —

CHICAGO—April 1st. Just introduced is a Free Booklet on a New Discovery which enables the Home Owner, Janitor, or Factory Maintenance to clean any Clogged Sewer Drain. Yet anyone can operate this new Plumbers Flushing Gun which releases air pressure on a solid shaft of water cleaning the most stubborn stoppages up to 200 feet. TOILETS, SINKS, URINALS, BATHTUBS, FLOOR DRAINS, and HOUSE-TO-STREET SEWERS clogged with Grease, Rags, Sand, Roots, and paper melt away instantly when struck by the Hammer-like blow of this new unit. There is no need to remove wall or pipe, or Grease Trap. A special attachment allows water to flow from the faucet through the Gun while air is released on the pipe. Vents or stacks are no obstacle, as force tends to strike wherever the water lays. But now, what is this Plumbers Flushing Gun worth in COSTLY PLUMBING BILLS SAVED? Tear this Ad out—and write your name and address beside it for FREE BOOKLET. Obey that urge. No agent will call. A postcard will do (Chicago Phone Kildare 5-1702) MILLER SEWER ROD CO., DEPT. PS-4 4640 N. Central Ave., Chicago 30, Illinois.

ONE BIT FOR ALL

Handiest drill bit made. Use on any electric drill, lathe, drill press, etc. Made of finest American hi-speed steel. 3 1/2" long, 1/4" diameter. Has 2" side-cutting section. Cuts steel, wood, plastic, aluminum, etc. 3 types—specify types wanted. (1) All purpose, (2) Wood, (3) Heavy metal. \$2.45 each — 3 for \$7.00 — Postpaid. Money back guaranteed. Buy from your dealer or send check or Money Order and name of favorite tool dealer TODAY. (Makes ideal gift.)



.... DRILL
SAW • REAM
CUT

**BEAVER
HI-SPEED-SAW
DRILL BITS**

Jobber & Dealer
Inquiries Invited

BEAVER DRILL & TOOL CO., 3008-A McGee Trafficway, Kansas City, Mo.

266 POPULAR SCIENCE

STOP that DRAWER from STICKING Easy—Quick—Forever!

WITH

Roll-eez SET "A"

ROLLER BEARINGS FOR WOODEN DRAWERS

Eliminates friction of wood-against-wood, keeps drawers in proper alignment. Makes wooden drawers work like magic—even in hot, humid weather! Made with improved NYLON rollers mounted on steel frames. Each drawer set includes simple instructions and nails. Anyone can apply. Ideal for furniture as well as built-ins. Used by cabinetmakers to provide lasting convenience in homes of every price range.



49¢

SET FOR ONE DRAWER

Building? Remodeling? Insist on Roll-eez for Better Drawer Action — Lowest Cost!

At Hardware, Lumber and Building Supply Stores.

JOBBER DEALERS WRITE

Junior-Pro Prod. Co., Dept. P, 118 E. Marceau, St. Louis 11, Mo.

ELECTRIC WELD - BRAZE & CUT

REPAIR MOST EVERYTHING MADE OF METAL

Home Appliances, Auto parts, Farm-garden equipment, toys. Make and repair playground equipment, lawn chairs, tables, ornamental iron work, gates, wagons, etc. Solder, heat, bend, and straighten, with terrific heat from arc torch. Cut and weld up to 1/4" steel plate. A million uses for Home, auto, farm, inventors, factories, etc. Works from any home 110 volt plug-in. Complete with dark welder's mask, arc torch, supply of carbon welding and brazing rods and complete Welding Instruction Book. Efficient—durable—1 year guarantee. Wt. only 8 lbs.



SEND ONLY \$3.00 (cash, ck, mo) and pay postman \$9.95 plus COD postage on arrival or send \$12.95 and we will send postpaid. Ideal gift for mechanically minded home owners, relatives, friends. Order now for early delivery. Available only from: MIDWAY WELDER Dept. DPS-4 Kearney, Nebraska



10" TILT/ARBOR SAW BUILD-IT-YOURSELF from GIL-BILT KITS-PLANS

Sturdy wood, steel, and aluminum construction. NEW DEPARTURE ball bearings. Capacity and performance of floor saws selling for \$150.00 and up. Plans, all metal parts in kit with 10" comb. blade \$27.40, less blade \$23.95. F.O.B. St. Louis. Detail PLANS-PATTERNS only \$1.00 postpaid. Build-it-yourself 12" and 18" Bandsaws, 6" Belt Sander, Shaper. Simplified plans, build easily with hand tools only. Advertised and sold for 12 years, over 35,000 units in use. Money back guarantee. FREE CATALOG.

GILLIOM POWER TOOLS, Dept. 70-D, Lambert Field St. Louis 21, Mo.

CUT ANY SIZE — ANY SHAPE WITH Spearhead Cutter

Handy pocket size — cuts leather, asbestos, rubber, cork, etc. — round 1/4" to 6" — any size straight and odd shapes.



Send Check or Money Order!

9.35
POSTPAID

ZIMMERMAN PACKING — CINCINNATI 12, OHIO



GENUINE ALNICO MAGNETS

AMAZING, PERMANENT, NON-ELECTRIC. HIGHLY PRACTICAL. Conduct interesting experiments. Hundreds of uses. Retrieve valuable steel items such as guns, tackle from fresh or salt water; tools from tanks & drains. GUARANTEED. Try any magnet one week. Money back if you are not well-pleased.

No. S-710 (Wt. 53 oz.) Has pull of 225 lbs. on steel block \$18.00
No. S-625 (Wt. 70 oz.) Has pull of 125 lbs. on steel block \$10.00
No. S-575 (Wt. 18 oz.) Has pull of 75 lbs. on steel block \$ 7.00
No. S-500 (Wt. 13 oz.) Has pull of 50 lbs. on steel block \$ 5.00
No. S-300 Kit of Flat Bars 5 Pairs (10 Magnets) \$ 3.00
No. S-250 Kit of Round Rods 5 Pairs (10 Magnets) \$ 2.50
No. S-47 Hot Pad Magnets. 10 for \$1.00.....50 for \$ 4.87
No. S-35 Hobbyist assortment of 8 small magnets.....\$ 1.50

Send M.O. or check. We pay postage. Sorry no C.O.D.'s.
MIAMI MAGNET COMPANY, 3240 N.W. 27th Ave., Miami 42, Fla.

ONLY A SCREW HOLDS LIKE A SCREW

Nails and glues may be good enough in their place but when you need plenty of solid, permanent holding power, you need a Southern quality screw.

Southern Screws provide extra holding power and permanent grip because sharp gimlet points and smooth cutting threads help Southern fasteners to start right, drive right and hold tight!

Buy 'em by Name . . .
Buy 'em by Box and Save!

Sold Through Leading Wholesale Distributors, also Leading Hardware and Building Supply Dealers.



Wood Screws • Tapping Screws • Machine Screws & Nuts • Stove Bolts • Hanger Bolts • Carriage Bolts • Dowel Screws • Wood Drive Screws



32 PAGE BOOKLET
FREE!

. . . from your lumber, building material or hardware dealer . . . with step-by-step illustrations and directions for building, patching or repairing with Sakrete ready-to-use Cement Mixes. Each moisture-proof, dust-tite bag is individually mixed to insure smooth-working, high-strength concrete or mortar! Just add plain water, stir and use!

THERE'S NO SUBSTITUTE FOR
SAKRETE
ADVERTISED & SOLD NATIONALLY



OPTICAL BARGAINS

ERECT IMAGE LOW POWER MICROSCOPE

5X, 10X, 20X

\$80.00 Value — Only \$19.95



Extremely sturdy with rack and pinion focusing, color corrected optics, turnable microscope body for inclined viewing, three different powers, long working distance under objectives, sufficient eye relief for easy viewing. Made from war surplus optical instrument so that you actually get \$80.00 of value. Weighs 4 lbs., 13" high. 10-DAY FREE TRIAL. Accessory objectives available for powers of 15X, 30X, 40X.

Stock No. 70,172-N.....\$19.95 Postpaid

War Surplus American-Made 7x50 Binoculars

Big savings! Brand new! Crystal clear viewing—7 power. Every optical element is coated. An excellent night glass—the size recommended for satellite viewing. Individual eye focus. Exit pupil 7mm. Approx. field at 1,000 yds. is 376 ft. Carrying case included. American 7 x 50's normally cost \$195. Our war surplus price saves you real money.

Stock No. 1533-N.....only \$55.00 pstd. (Tax included)

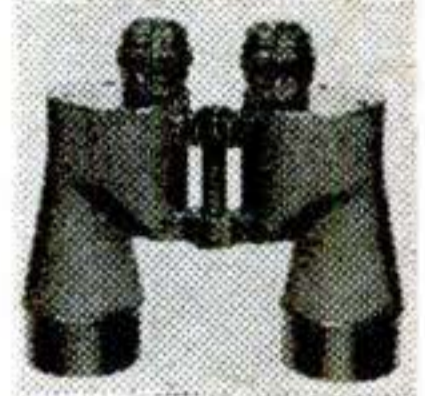

8 POWER ELBOW TELESCOPE

WAR SURPLUS

\$200 Gov't Cost—Only \$13.50

Big 2" objective, focusing eyepiece 28mm focal length—Amici erecting system—turret mounted filters, clear, red, amber and neutral—reticle illumination. Sparkling, clear, bright image—6° field (325 ft. at 1,000 yds.). Focus adjusts 15 ft. to infinity. 28mm f.l. eyepiece alone is worth more than \$12.50.

Stock No. 70,173-N.....\$13.50 Postpaid



STEREO MICROSCOPE — 23X and 40X

Stock No. 85,056-N.....only \$99.50 F.O.B. Barrington, N. J.

SEND 25¢ FOR GIANT CATALOG "N-2"

We'll include FREE a piece of amazing DIFFRACTION GRATING REPLICA (13,400 lines per inch—see all colors of spectrum). 96-page Catalog is a treasure house of bargains in Telescopes, Microscopes, Binoculars, Magnifiers, prisms, lenses, optical parts and accessories!

ORDER BY STOCK NUMBER. SEND CHECK OR MONEY ORDER. SATISFACTION GUARANTEED!
EDMUND SCIENTIFIC CO., BARRINGTON, N. J.

GUNK-it-yourself!

Gunk® G.P. removes grease from engines or concrete floors; cleans paint brushes, power mowers, or machinery completely, economically, safely. It's ready-to-use, rinses off with water, won't clog drains. Quart size with handy "Squirt Spout" top speeds application. Insist on the best degreaser—the original "GUNK" at better automotive supply and hardware retailers everywhere.

® REG. TRADE MARK.



GUNK CHICAGO CO., River Forest, Illinois
serving the Midwest and Southwest
RADIATOR SPECIALTY CO., Charlotte, No. Carolina
serving the East, Southeast and far West

CASH FILING SAWS

Make from \$3 to \$6 an hour spare time or start a full time business with the

FOLEY SAW FILER

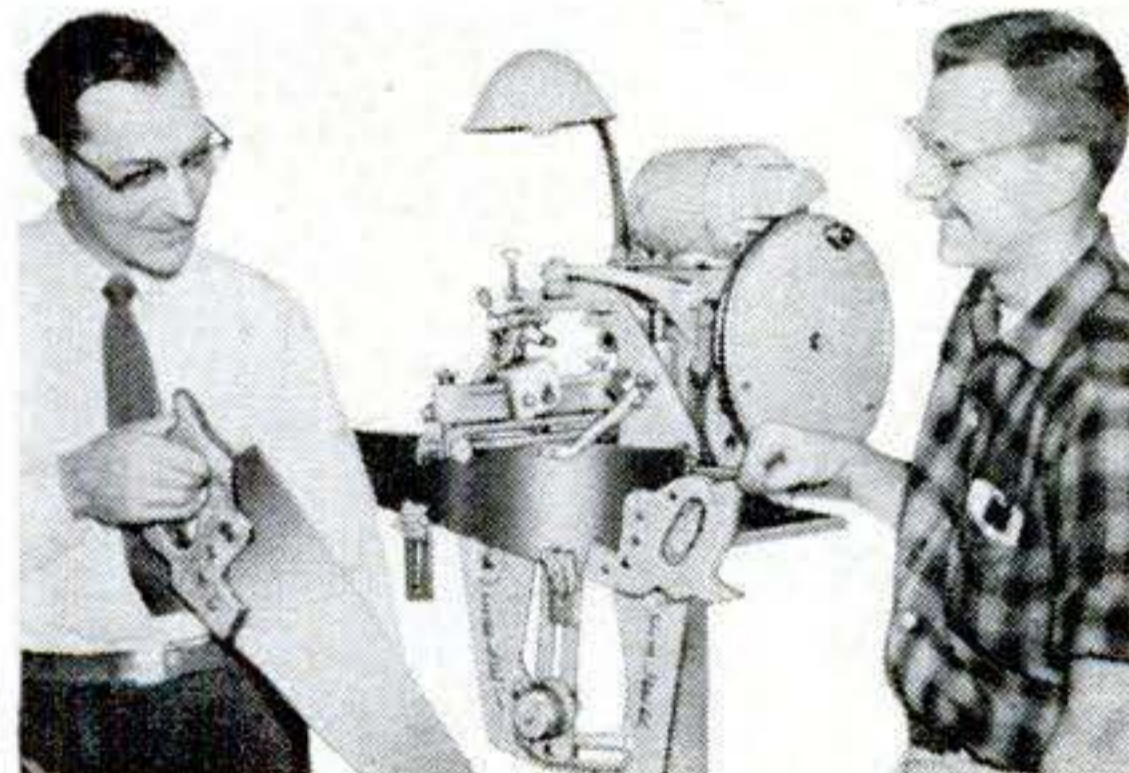

Here is a steady repeat CASH business you can start at home. No experience is necessary to turn out perfect cutting saws. With the new 1959 Foley Saw Filer you can file hand, band and both "combination" and cross-cut circular saws. Easy to operate—no eyestrain. You will find you can make from \$3 to \$6 an hour—\$20 to \$30 a week in spare time as a starter.

FREE BOOK
"MONEY MAKING FACTS" shows you how to get plenty of saws to file. Time payments if desired. Send coupon today—no salesman will call.

FOLEY MFG. CO., 449-9 Foley Bldg.
Minneapolis 18, Minn.
Send me free book "MONEY MAKING FACTS" and Time Payment plan.

Name _____
Address _____
City _____ State _____



APRIL 1959 267

How Silent Sound Now Works For You

[Continued from page 150]

and Acoustica) which expand and contract as they accumulate and release electrical charge. (The same crystals work in reverse in phonograph pickups.)

● The nickel-iron cores of electromagnets (Westinghouse) which expand and contract as they are magnetized and demagnetized.

Either way, the result is the same. An electrical vibration causes a mechanical vibration. The mechanical vibration is sound. It travels through the tank wall, into the water and through the water until it hits the dirty dishes.

Other sonic uses. This kind of short, fast and powerful vibration is the secret of the other tricks with sound.

For drilling, the sound goes to a bit that vibrates abrasive powder. The abrasive then cuts through anything—the harder the better. The hole it makes is the exact shape of the bit, so you can cut squares or any odd shape. The bit doesn't even have to be hard. (This leads to showy stunts: a fork cutting holes in glass, a penknife slicing tool steel.)

For soldering, a sonic bit shakes the oxide film off aluminum to expose bare metal for the solder to stick to. With more powerful sound, the molecules in two pieces of metal get jiggled so hard they fuse together into a weld.

Still more powerful sound—an audible and deafening scream generated by forcing compressed air through a special horn—makes dust particles in air clump together. (The particles get pushed back and forth so that they bump into each other.) These horns are used to eliminate smoke from factory stacks. And soon similar units will be lined up along an airport runway to clear fog away.

Since sound travels as a wave—somewhat the way light does—it can be focused into a beam, and the beam can be reflected. That's how depth finders, sub spotters and fish locators work. They send out pulses of sound and catch the reflections from the ocean bottom, a submarine or a school of fish. (It wasn't until after the physicists invented these machines that the biologists discovered that bats use the very same system—only better—to guide their flight.)

For probing people, too. Physicians are even using this idea to find flaws in-

side people. They get a picture (on a TV-like screen) that looks much the same as an X ray. Chief advantage: Soft organs, such as heart and lungs, show up better.

Doctors also use very powerful beams of very-high-frequency sound to treat many crippling afflictions. They're not sure why it works—it might heat the tissues inside the body, or simply jiggle them hard—but it often helps.

Breaking the cost barrier. Machines for these and many other jobs have been made by a number of companies (the industry did about \$40,000,000 worth of business last year). But they are professional units at high prices—the hospital instrument cleaner sells for \$3,000.

Westinghouse claims that its sound generator is both cheaper to produce and more effective. The nickel-iron core—the part that vibrates—is built like an automobile radiator, with thin, spaced plates. Narda and Acoustica also report development of less expensive, more efficient sound generators.

Presumably the new designs can be applied to home models of other sound machines. Hobbyists could use sound for soldering, welding or carving (present estimate of a machine for home soldering: \$200). For housewives, there might be a sonic air cleaner to trap dust before it settled on the piano. And sportsmen would like an inexpensive fish locator.

What about washing clothes? This is still in the labs. The trouble: Clothes are soft and vibrate with the sound. The dirt sticks unless the sound is extremely powerful—and that's too expensive.

One way around the problem, suggests Irwin Steinberg, general manager of Vibro-Ceramics division of Gulton Industries, a leading maker of sound machines, is to use a very low-frequency sound (simplifying the power supply), and inject it into the water very close to the clothes (or dishes). That's as far as he will elaborate. "We're trying to sell the idea to manufacturers right now."

One new sound machine that even an outsider can forecast is a sonic bathtub. The vibrations cause a pleasant tickling sensation (you feel it when you stick your hand in the dishwasher). Now if they could rig it so that it also takes the dirt off small boys. . .

END

WHY PAY \$700

for single-purpose power tools?



Get them all in a space-saving

YUBA



Mark 5

18-DAY SPECIAL OFFER
Save \$54.90
Only \$299.50 Complete
with Safety Grip and Casters
Certified \$354.40 value

... It's a Saw
... a Lathe
... a Sander
... a Drill Press
... a Horizontal Drill
... IT'S A BUY!



See **SHOPSMITH'S**
power partners

YARDSMITH
Rotary Mowers
Riding Mowers
Tillers and
Tiller-Mowers

Write Dept. SPS-4 for
FREE catalog.

SHOPSMITH . . . amazing multi-purpose power tool does everything and more than conventional power tools do — at one-half the cost, on furniture and home repairs. SHOPSMITH puts power at your fingertips . . . changes from job to job in seconds . . . lets you finish the job. Built-in precision makes craftsmanship easy. SHOPSMITH rolls to the job . . . stores in a bicycle's parking spot. Now . . . April 8th through 25th . . . the fabulous SHOPSMITH is yours with FREE extra equipment at a \$54.90 saving! At your SHOPSMITH dealer or nearest Montgomery Ward store.

YUBA POWER PRODUCTS, INC.

800 EVANS STREET CINCINNATI 4, OHIO

A subsidiary of

YUBA CONSOLIDATED INDUSTRIES, INC.



APRIL 1959 269

PUZZLE: FIND AL

Al's got himself lost in his job.

He does his work. He draws his pay. He gripes, and hopes, and waits. But the big breaks never seem to come.

You have to hunt hard for Al. He's in a rut!

Then, who's the figure standing out in the picture? That's Tom. Tom grew tired of waiting. He decided to act. He took three important steps:

1. Wrote to I.C.S. for their three famous career books.
2. Enrolled for an I.C.S. job-related course.
3. Started to apply—on the spot—what he was learning.

The others began to say, "Ask Tom, he knows." The supervisor began to take notice. The boss began to receive reports on Tom's progress. *And Tom began to move!*

It's a fact worth remembering: An I.C.S. student always stands out!

P.S.—You'll find men like Al everywhere—gripping, hoping, waiting—reading this and skipping on. But forward-looking fellows like Tom will take time to investigate, will mark and mail the coupon and get the three valuable career books free. They're men of action. And a few short months from now, you'll see them start to move!

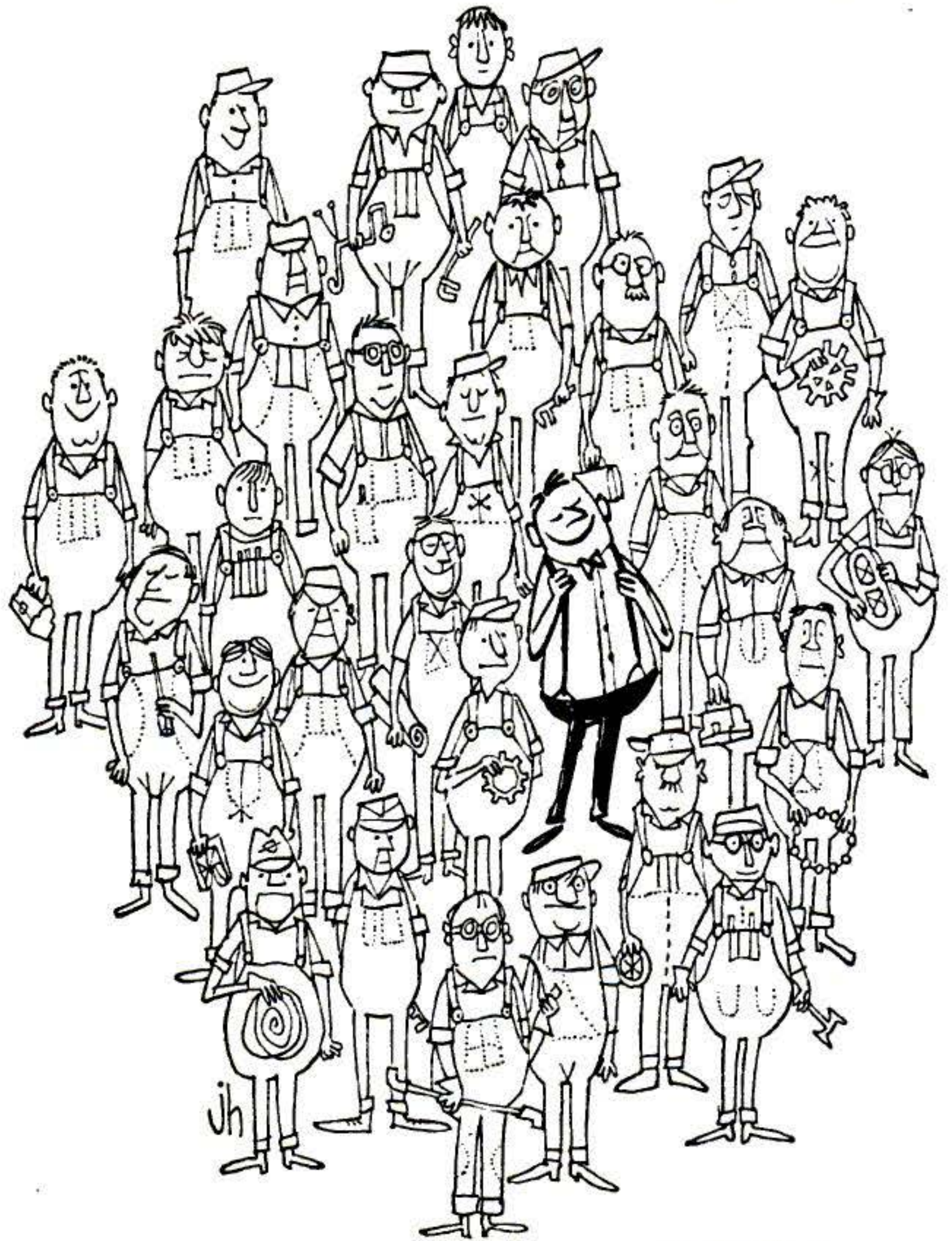

For Real Job Security—Get an I. C. S. Diploma! I. C. S., Scranton 15, Penna.

Accredited Member,
National Home Study Council

INTERNATIONAL CORRESPONDENCE SCHOOLS



BOX 03641D, SCRANTON 15, PENNA.

(Partial list of 259 courses)

Without cost or obligation, send me "HOW to SUCCEED" and the opportunity booklet about the field BEFORE which I have marked X (plus sample lesson):

- | | | | | |
|--|--|--|---|---|
| <p>ARCHITECTURE and BUILDING CONSTRUCTION</p> <ul style="list-style-type: none"> <input type="checkbox"/> Air Conditioning <input type="checkbox"/> Architecture <input type="checkbox"/> Arch. Drawing and Designing <input type="checkbox"/> Building Contractor <input type="checkbox"/> Building Estimator <input type="checkbox"/> Carpenter Builder <input type="checkbox"/> Carpentry and Millwork <input type="checkbox"/> Carpenter Foreman <input type="checkbox"/> Heating <input type="checkbox"/> Painting Contractor <input type="checkbox"/> Plumbing <input type="checkbox"/> Reading Arch. Blueprints <p>ART</p> <ul style="list-style-type: none"> <input type="checkbox"/> Commercial Art <input type="checkbox"/> Magazine Illus. <input type="checkbox"/> Show Card and Sign Lettering <input type="checkbox"/> Sketching and Painting <p>AUTOMOTIVE</p> <ul style="list-style-type: none"> <input type="checkbox"/> Automobile <input type="checkbox"/> Auto Body Rebuilding and Refinishing <input type="checkbox"/> Auto Engine Tuneup <input type="checkbox"/> Auto Technician | <p>AVIATION</p> <ul style="list-style-type: none"> <input type="checkbox"/> Aero-Engineering Technology <input type="checkbox"/> Aircraft & Engine Mechanic <p>BUSINESS</p> <ul style="list-style-type: none"> <input type="checkbox"/> Accounting <input type="checkbox"/> Advertising <input type="checkbox"/> Business Administration <input type="checkbox"/> Business Management <input type="checkbox"/> Cost Accounting <input type="checkbox"/> Creative Salesmanship <input type="checkbox"/> Managing a Small Business <input type="checkbox"/> Professional Secretary <input type="checkbox"/> Public Accounting <input type="checkbox"/> Purchasing Agent <input type="checkbox"/> Salesmanship <input type="checkbox"/> Salesmanship and Management <input type="checkbox"/> Traffic Management <p>CHEMICAL</p> <ul style="list-style-type: none"> <input type="checkbox"/> Analytical Chemistry <input type="checkbox"/> Chemical Engineering <input type="checkbox"/> Chem. Lab. Technician <input type="checkbox"/> Elements of Nuclear Energy <input type="checkbox"/> General Chemistry <input type="checkbox"/> Natural Gas Prod. and Trans. <input type="checkbox"/> Petroleum Prod. and Engr. <input type="checkbox"/> Professional Engineer (Chem) <input type="checkbox"/> Pulp and Paper Making | <p>CIVIL ENGINEERING</p> <ul style="list-style-type: none"> <input type="checkbox"/> Civil Engineering <input type="checkbox"/> Construction Engineering <input type="checkbox"/> Highway Engineering <input type="checkbox"/> Professional Engineer (Civil) <input type="checkbox"/> Reading Struc. Blueprints <input type="checkbox"/> Sanitary Engineer <input type="checkbox"/> Structural Engineering <input type="checkbox"/> Surveying and Mapping <p>DRAFTING</p> <ul style="list-style-type: none"> <input type="checkbox"/> Aircraft Drafting <input type="checkbox"/> Architectural Drafting <input type="checkbox"/> Drafting & Machine Design <input type="checkbox"/> Electrical Drafting <input type="checkbox"/> Mechanical Drafting <input type="checkbox"/> Sheet Metal Drafting <input type="checkbox"/> Structural Drafting <p>ELECTRICAL</p> <ul style="list-style-type: none"> <input type="checkbox"/> Electrical Engineering <input type="checkbox"/> Elec. Engr. Technician <input type="checkbox"/> Elec. Light and Power <input type="checkbox"/> Practical Electrician <input type="checkbox"/> Practical Lineman <input type="checkbox"/> Professional Engineer (Elec) <p>HIGH SCHOOL</p> <ul style="list-style-type: none"> <input type="checkbox"/> High School Diploma | <ul style="list-style-type: none"> <input type="checkbox"/> Good English <input type="checkbox"/> High School Mathematics <input type="checkbox"/> High School Science <input type="checkbox"/> Short Story Writing <p>LEADERSHIP</p> <ul style="list-style-type: none"> <input type="checkbox"/> Industrial Foremanship <input type="checkbox"/> Industrial Supervision <input type="checkbox"/> Personnel-Labor Relations <input type="checkbox"/> Supervision <p>MECHANICAL and SHOP</p> <ul style="list-style-type: none"> <input type="checkbox"/> Diesel Engines <input type="checkbox"/> Gas-Elec. Welding <input type="checkbox"/> Industrial Engineering <input type="checkbox"/> Industrial Instrumentation <input type="checkbox"/> Industrial Metallurgy <input type="checkbox"/> Industrial Safety <input type="checkbox"/> Machine Shop Practice <input type="checkbox"/> Mechanical Engineering <input type="checkbox"/> Professional Engineer (Mech) <input type="checkbox"/> Quality Control <input type="checkbox"/> Reading Shop Blueprints <input type="checkbox"/> Refrigeration and Air Conditioning <input type="checkbox"/> Tool Design <input type="checkbox"/> Tool Making <p>RADIO, TELEVISION</p> <ul style="list-style-type: none"> <input type="checkbox"/> General Electronics Tech. | <ul style="list-style-type: none"> <input type="checkbox"/> Industrial Electronics <input type="checkbox"/> Practical Radio-TV Eng'r'g <input type="checkbox"/> Practical Telephony <input type="checkbox"/> Radio-TV Servicing <p>RAILROAD</p> <ul style="list-style-type: none"> <input type="checkbox"/> Car Inspector and Air Brake <input type="checkbox"/> Diesel Electrician <input type="checkbox"/> Diesel Engr. and Fireman <input type="checkbox"/> Diesel Locomotive <p>STEAM and DIESEL POWER</p> <ul style="list-style-type: none"> <input type="checkbox"/> Combustion Engineering <input type="checkbox"/> Power Plant Engineer <input type="checkbox"/> Stationary Diesel Engr. <input type="checkbox"/> Stationary Fireman <p>TEXTILE</p> <ul style="list-style-type: none"> <input type="checkbox"/> Carding and Spinning <input type="checkbox"/> Cotton Manufacture <input type="checkbox"/> Cotton Warming and Weaving <input type="checkbox"/> Loom Fixing Technician <input type="checkbox"/> Textile Designing <input type="checkbox"/> Textile Finishing & Dyeing <input type="checkbox"/> Throwing <input type="checkbox"/> Warming and Weaving <input type="checkbox"/> Worsted Manufacturing |
|--|--|--|---|---|

Name _____ Age _____ Home Address _____

City _____ Zone _____ State _____ Working Hours _____ A.M. to P.M. _____

Occupation _____

Canadian residents send coupon to International Correspondence Schools, Canadian, Ltd., Montreal, Canada. . . . Special tuition rates to members of the U. S. Armed Forces.

Over and over again — It's the same old story...

Finally a formula that really works

I couldn't stop TORTURING him!

My poor husband. Living with me had become torture for him, I'd become such a nag. I felt so tired and worn-out — even an afternoon nap didn't help. When Phil came home from work, I was so nervous and irritable I jumped on every word he said. Instead of being an understanding wife, I started arguments over nothing at all. I could see the strain telling on Phil. "What's wrong?" he asked. "You're not acting like the girl I married. You're so tired and jumpy lately you ought to see the doctor!"

After examining me, the doctor explained that my condition was merely the result of a prolonged nutritional

deficiency. He told me that a lack of vitamins and minerals was actually making me tired and cranky, and recommended a good nutritional supplement.

I started taking Vitasafe High-Potency Capsules, and Phil and I soon noticed the wonderful difference. My tiredness disappeared, I wasn't nervous anymore — and thank goodness I stopped nagging!

If you are suffering from vitamin-mineral deficiency, why not see if Vitasafe Capsules can help you? Simply mail the postcard for a trial 30-day supply!



A dramatization posed by professional models.

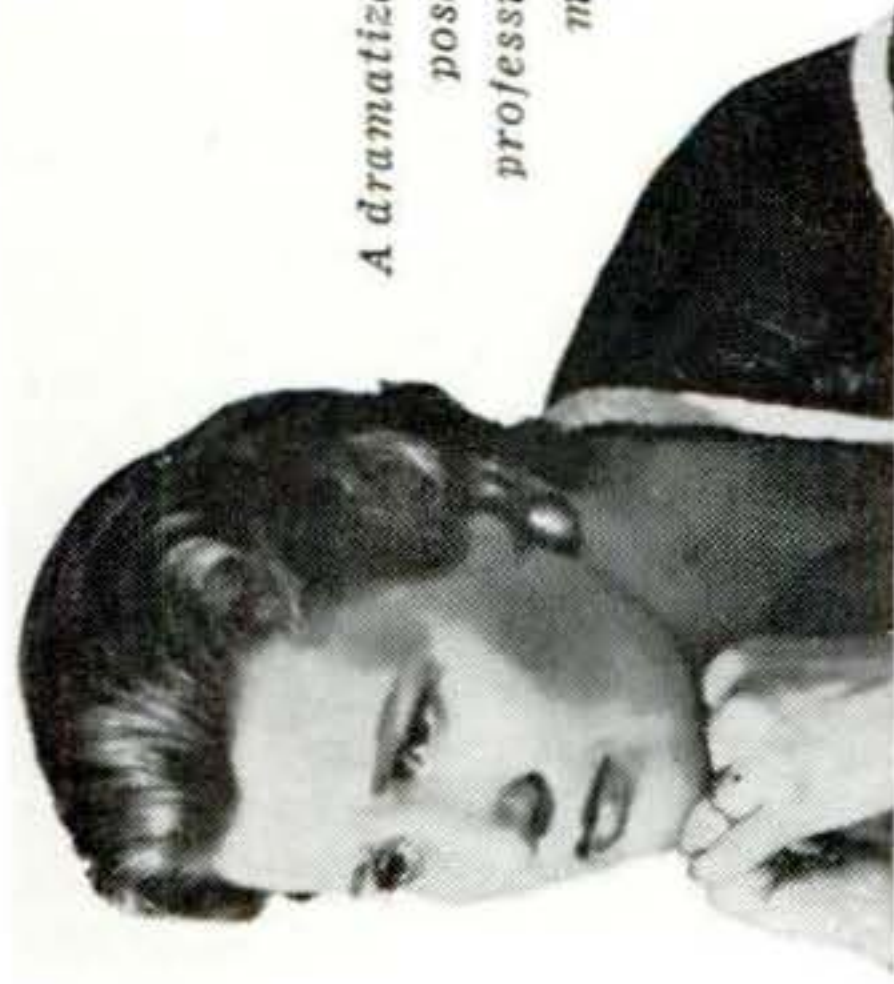

A dramatization posed by professional model.

Our fights have turned to kisses!

IT'S hard to believe that my wife and I used to fight. She would start nagging at me the minute I got home from work — dead tired—and I would snap right back at her! We argued and bickered so often that we suddenly realized our marriage was breaking up! There wasn't any real reason for it except that both of us felt so tired all the time that we got on each other's nerves.

Our family doctor gave us some advice that probably saved our marriage. Many people, he told us, may become worn-out, tense and short-tempered because their diets do not contain

enough vitamins, minerals and lipotropic factors. To correct this condition, each of us started taking Vitasafe High-Potency Capsules—just one a day. It wasn't too long until we had more pep, more energy—and our dispositions improved. Instead of fighting, we were back in each other's arms—just as we were on our honeymoon.

If you or your wife—or some other member of your family—have lost the pep and energy you used to have, you owe it to yourself to try proven Vitasafe High-Potency Capsules for 30 days at our expense and judge the results for yourself!

EACH DAILY VITASAFE CAPSULE FOR MEN CONTAINS

Choline Bitartrate	31.4 mg.	Niacin Amide	40 mg.
Inositol	15 mg.	Calcium Pantothenate	4 mg.
dl-Methionine	10 mg.	Vitamin E	2 I.U.
Glutamic Acid	50 mg.	Folic Acid	0.5 mg.
Lemon Bioflavonoid Complex	5 mg.	Calcium	75 mg.
Vitamin A	12,500 USP Units	Phosphorus	58 mg.
Vitamin D	1,000 USP Units	Iron	30 mg.
Vitamin C	75 mg.	Cobalt	0.04 mg.
Vitamin B ₁	5 mg.	Copper	0.45 mg.
Vitamin B ₂	2.5 mg.	Manganese	0.5 mg.
Vitamin B ₆	0.5 mg.	Molybdenum	0.1 mg.
Vitamin B ₁₂	2 mcg.	Iodine	0.075 mg.
		Potassium	2 mg.
		Zinc	0.5 mg.
		Magnesium	3 mg.

We invite you to compare the richness of this formula with any other vitamin and mineral preparation.

FREE 30 DAYS SUPPLY High-Potency Capsules

LIPOTROPIC FACTORS, MINERALS and VITAMINS

Safe nutritional formula containing 27 proven ingredients: Glutamic Acid, Choline, Inositol, Methionine, Citrus Bioflavonoid, 11 Vitamins plus 11 Minerals

POTENCY AND PURITY GUARANTEED

To prove to you the remarkable advantages of the Vitasafe Plan . . . we will send you, without charge, a 30-day free supply of high-potency VITASAFE C.F. CAPSULES so you can discover for yourself how much stronger, happier and peppier you may feel after a few days!

You can use these Capsules confidently because U. S. Government regulations demand that you get exactly what the label states — pure safe ingredients. The beneficial effects have been proven time and time again!



No place for second-best out here *... this is "Evinrude country"!*

Out where sky and ocean meet you want round-trip reliability. You'll get double pleasure out of a 1959 Evinrude . . . quiet, smooth, *sound-sealed* power plus "blue water" safety features like sea-tight powerheads that won't drown out in following seas . . . sea-going magnetos and fuel systems that don't depend on battery power . . . standby manual starting on electric starting models, ready for instant use . . . thermostat temperature control that keeps engine running at peak efficiency under all conditions, saves fuel and extends your cruising range.

Whether trolling for hours at a steady pace or slamming home through heavy seas, there's nothing like the feel of Evinrude's solid reserve power. Find out for yourself why big-water boatmen go for Evinrudes. Make a date for a "Revelation Ride" with your Evinrude dealer right away. Look for his name under "Outboard Motors" in your phone book. Ask for free catalog, or write: **EVINRUDE MOTORS**, 4145 N. 27th Street, Milwaukee 16, Wisconsin.

A Division of Outboard Marine Corporation
 In Canada: Mfd. by Evinrude Motors, Peterborough

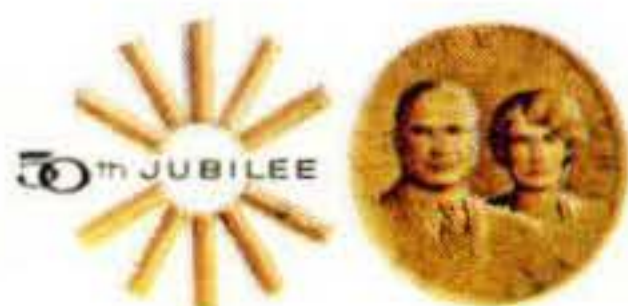

EVINRUDE

QUIET OUTBOARD MOTORS