

FEBRUARY 1963 35 CENTS

Popular Science

Answers to Your
Space Questions by
Wernher von Braun

How to do lathework
on a table saw

Monthly



FIRST LOOK AT '63 $\frac{1}{2}$ CARS

Detroit Goes **Back to the Races**



To see how this
picture turned out,
see page 61...

NEW! All About POLAROID COLOR

Get Lucky



**the taste
to start with**

**LUCKY
STRIKE**
IT'S TOASTED™
CLASS A
CIGARETTES

**the taste
to stay with**

The taste of a Lucky spoils you for other cigarettes. This famous taste is the best reason to start with Luckies . . . the big reason why Lucky smokers stay Lucky smokers. How about you? Get the taste you'll stay with. **Get the fine-tobacco taste of Lucky Strike.**

© A. T. Co.

Product of *The American Tobacco Company* — "Tobacco is our middle name"

Copyrighted material



Handling charge—\$6²⁴*

Is this ad for people who know all about cars? our Chief Engineer asked. Good. Then tell them about Tempest's suspension. No, not the standard suspension; these guys really drive. Fill them in on Group 634. (Ever notice how engineers have a thing about numbers?)

Heavy-duty springs and shocks is what Group 634 is, and a paltry \$6.24 is what the whole shebang costs, installed right at the factory.

What it does to a Tempest just plain mortifies those poor souls resigned to wallowing along in their Mushmobiles (a Mushmobile being any non-Tempest laboring under the delusion that curves are for getting flustered in).

O! 634 (this number business is catching) is just the start of a long string of low-extra-cost sporting options

for Tempest. Like (hold your breath): a tachometer . . . high-output Delcotron a. c. generator . . . aluminum brake drums . . . heavy-duty clutch and linkage packages . . . and oversize tires, to pick at random.

Then there are engines. And what engines! The big 4 of 115, 120 or (with auto. trans. only) 140 bhp—plus, at extra cost, the 166-bhp version of the 4 and the omigosh 326-cu. in. V-8 of no less than 260 bhp. Axle ratios? A no-extra-cost range, all the way from a stump-pulling 3.90:1 to a high-fuel-economy 2.53:1. Dry your moist, trembling hands and clamp them onto a Tempest steering wheel. You're only young once.

Wide-Track Pontiac Tempest

*Manufacturer's suggested retail price for specified optional equipment (including reimbursement for Federal excise tax). State and local taxes extra. Pontiac Motor Division • General Motors Corporation

Robert P. Crossley
Editor

JAMES M. LISTON
Executive Editor

KENDALL W. GOODWYN
Managing Editor

ROBERT P. STEVENSON
Director, Products and Projects

HOWARD JENSEN
Art Director

Senior Editors

Alden P. Armagnac, Wallace Cloud
Everett H. Ortner, Joan Steen

Automobile Editor
Devon Francis

Electronics and Technical Editor
Hubert Lockett

Photography Editor
Robert L. Hering

Boating Editor
Jim Roe

Home Workshop Editor
Sheldon M. Gallager

West Coast Editor
Wesley S. Griswold

Associate Editors
Frank Dorr, Herbert O. Johansen
Alex Markovich
Ruth Westphal

Editorial Assistants
Eleanor Crapullo (Chief)
Jeanne Cox, Anna Dallas
Barbara Weisheit

Art Editors
Herbert Anthony
Harry Samuels

Associate Art Editor
Richard J. Meyer

Art Associates
Robert Martin, Kenneth Buddington

Art Production Manager
Henry W. Kazmirowski

Photography
Robert D. Borst

JOHN R. WHITING, Executive Vice-President and Publisher

February 1963

Cover photograph by Robert D. Borst

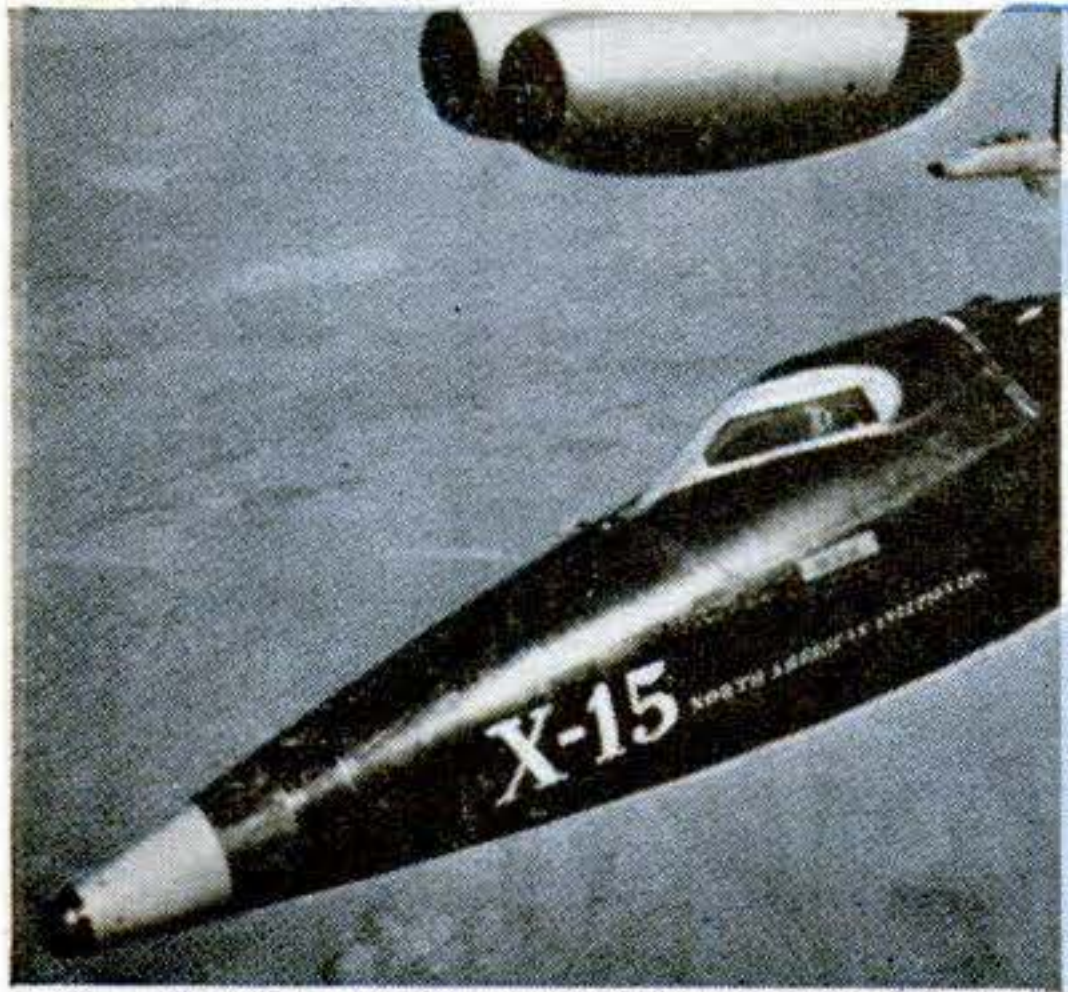

Fly with PS to the edge of space
in the incredible X-15. Page 78.

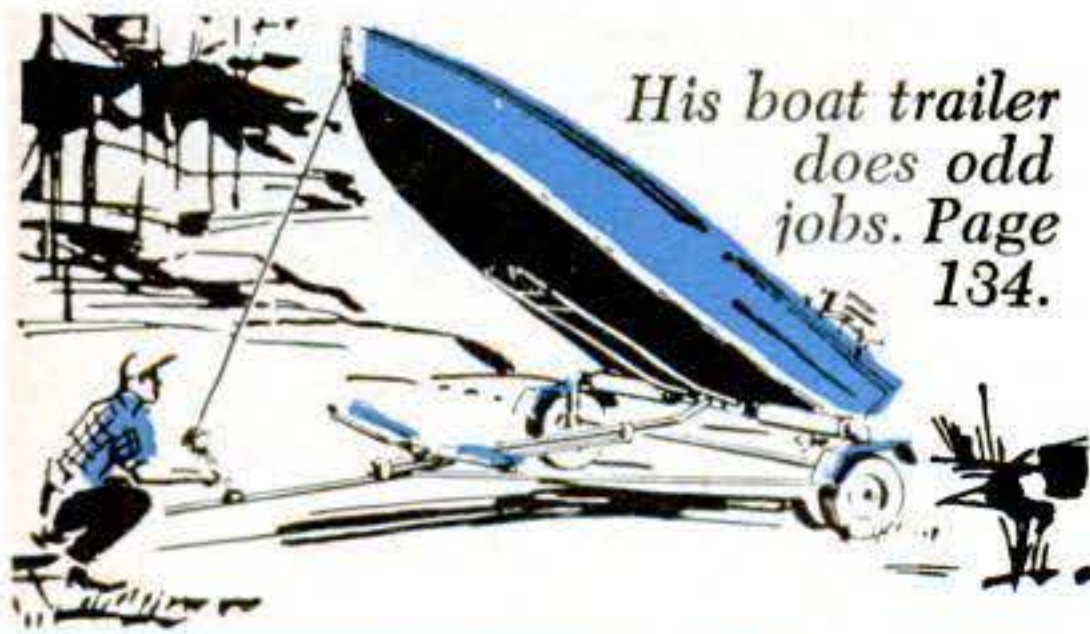

His boat trailer
does odd
jobs. Page
134.



Fluting and reeding on a table saw?
Easy as pie with this jig. Page 138.

PHOTOGRAPHY

*First report on amazing Polaroid color:
[Color Photos in 60 Seconds • 61](#)*

SPACE AND AVIATION

[The Incredible X-15 • 78](#)
[Strato II: Sky-High, Starry-Eyed • 86](#)
[Wernher von Braun on Space • 92](#)
[Plane Hurls Bomb from Tail • 118](#)

CARS AND DRIVING

[What's New in the 1963½ Cars • 65](#)
[Detroit Goes Back to the Races • 74](#)
[New for Your Car • 171](#)

SCIENCE AND INVENTIONS

[The Truth About Brain Drugs • 70](#)
[How to Survive a Blizzard in a Car • 83](#)
[Snowplow, Go Home! • 98](#)

ELECTRONICS

[How to Choose the Right Mike • 152](#)
[Back Talk on Your House Wiring • 155](#)
[New Transistor Stereo Amp Kit • 174](#)

SPECIAL REPORTS

[The Sergeant Shoots Off • 101](#)
[“American Kids Can Take It!” • 106](#)
[I Rode with the Avalanche Patrol • 112](#)

HOME AND SHOP

- [A Homemade Tile Cutter • 120](#)
- [Belt Disk Sander—a Tool to Own • 122](#)
- [Tips for the Home Shop • 137](#)
- [Doing Lathework on a Table Saw • 138](#)
- [Desk Set for a Youngster • 142](#)
- [Metalworking Tips • 143](#)
- [How to Anodize Aluminum • 144](#)
- [Four Special Jobs for a Saber Saw • 148](#)
- [Automatic Turning for Your Lathe • 168](#)
- [Trick Drive Speeds Up Saber Saw • 170](#)
- [New in Home Improvement • 172](#)

BOATING

- [Two-Man Underwater Cubmarine • 84](#)
- [Mississippi Steamboat on the Thames • 96](#)
- [New Way to Save an Old Boat • 127](#)
- [Trailer Does More Than Haul a Boat • 134](#)
- [What's New in Boating • 167](#)

AUTO REPAIRS

- [Hints from the Model Garage • 179](#)
- [Gus Tackles a Wee Bit o' Scotch • 182](#)

PICTURE NEWS

- [1902 Antique Car Race Re-enacted • 83](#)
- [Sporty New Walk-Through Scout • 84](#)
- [Uphill Skiing—on an Escalator • 91](#)
- [New Vespa Hides Its Spare • 95](#)
- [Wood Chopper Moves In on Logs • 96](#)
- [Newest Game—Space Ball • 110](#)

SHORT CUTS AND TIPS

- [Winter Job for a Barbecue • 131](#)
- [Hothouse in a Cellarway • 131](#)
- [A Low-Cost Magazine Rack • 142](#)
- [Repair for a Leaky Water Tank • 147](#)
- [Adding Rear-Seat Comfort to a Car • 151](#)
- [Pull Saw Cuts to Obstructions • 158](#)

EVERY MONTH

- [PS Readers Talk Back • 6](#)
- [The March of Science • 15](#)
- [Getting Ahead • 24](#)
- [Detroit Report • 56](#)
- [90, 60, 30 Years Ago in PS • 58](#)
- [I'd Like to See Them Make • 100](#)
- [New Ideas from the Inventors • 104](#)
- [Wordless Workshop • 132](#)
- [Shop Talk • 188](#)

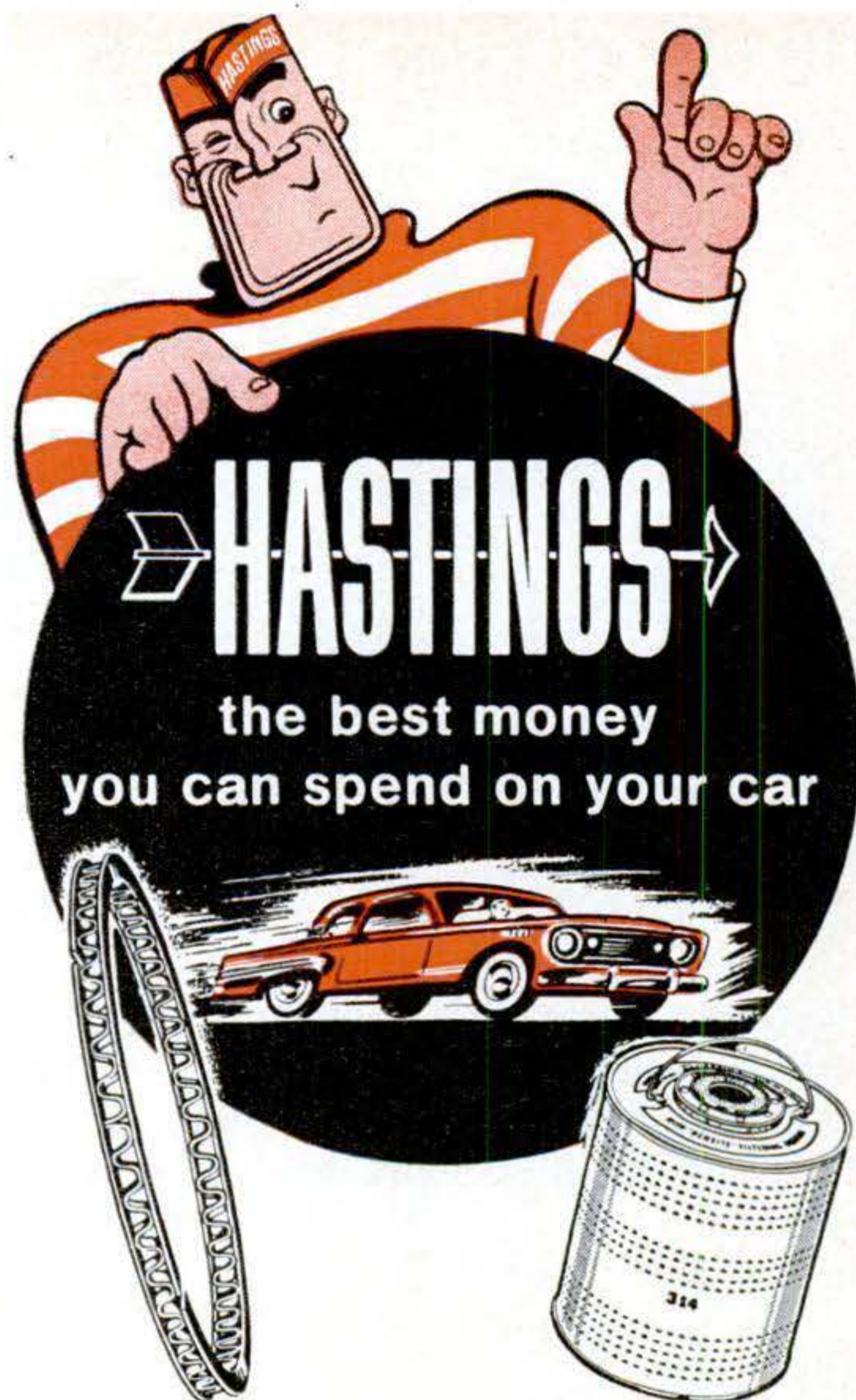

HASTINGS PISTON RINGS

Stop Oil Pumping

Get new car power and performance from your present car with Hastings Piston Rings . . . motor-engineered exclusively for replacement. Your Hastings re-ring job will pay for itself in oil and gas savings!

HASTINGS OIL FILTERS

Keep Oil Clean

The only filter made with DENSITE—a super-filtering material that keeps oil *visibly* clean and free of abrasives from one filter change to the next. Hastings is your best bet, too, in air, diesel fuel and gasoline filters.

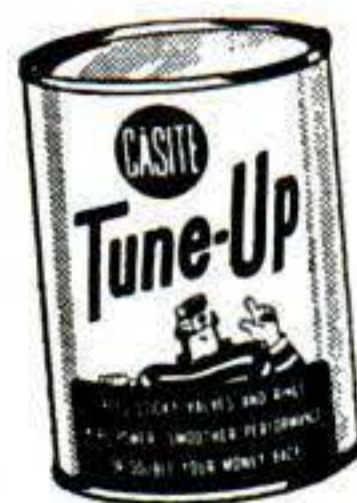

CASITE ADDITIVES

Make Your Car Run Better

Tune-Up frees sticky valves, rings, \$1.25. *Motor Honey* quiets engines, \$1.30. *3-C* stops hydraulic lifter noises, \$1.50. *Smooth-Seal* stops transmission leaks, jerks and jars, \$1.95. *Leak-Stop* stops cooling system leaks, \$1.00. *Stop-Rust* inhibits rust and neutralizes acids, \$1.00. *Results guaranteed or double-your-money-back.*

Ask Your Service Man for Hastings Products

HASTINGS MANUFACTURING COMPANY
HASTINGS, MICHIGAN

Cast your ballot for a successful future!

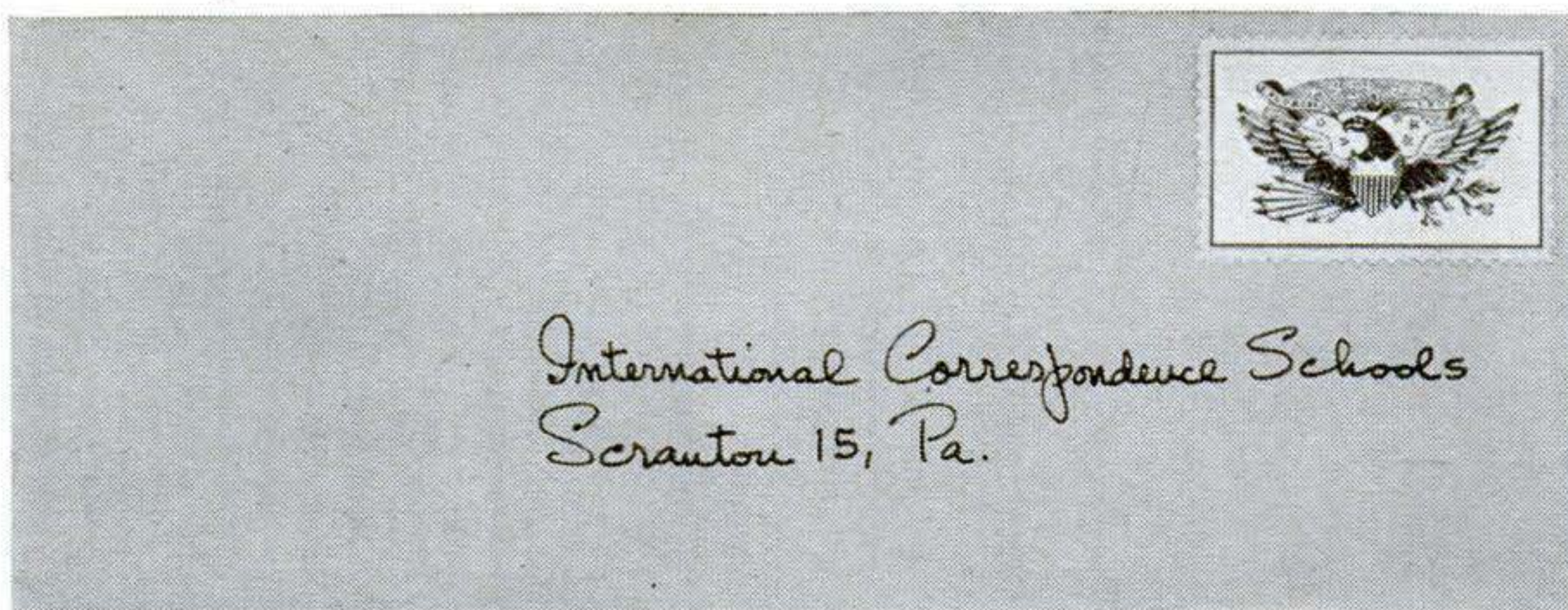

249 I. C. S. COURSES TO HELP YOU GET AHEAD FAST!

I. C. S., the oldest, largest school of its kind, has helped more than 7,000,000 men and women start the climb to success. Over 249 courses to choose from—high school, business, engineering, secretarial, radio-TV-electronics, many more. Courses, prepared by experts, tell what you must know to move ahead. Theory and fact plus practical application help you *earn* while you learn.

Read these true-life success stories of people once in the same boat you may be in right now—stuck in a dull, routine job with little future. Then follow their example. Mail the coupon that helped each of them—and thousands of others—find bigger pay, a better job, lasting security and a happier life. But don't put it off another minute. Cast *your* "ballot" for future success *today!*



Thanks I. C. S. for successful career. "Your engineering course stood me in good stead throughout a rewarding government career. Without it, I could not have passed rigid Civil Service exams which qualified me for steady advancement, good pay and challenging overseas assignments!"—W. J. Eichorn, San Francisco, Cal.

Calls courses "money in the bank." "I recommend the I. C. S. method to anyone who sincerely wants to get ahead. I completed my high school education through I. C. S. and am now studying Textile Engineering. I attribute my growing income to the fact that I. C. S. made me a valued employee."—Ezra Whitmore, Hogansville, Ga.



Housewife becomes house designer. "Less than 3 years ago I became interested in home designing, and wondered if it were possible for a housewife to compete in that field. Now, scarcely a year and a half after enrolling for Architectural Drawing, I have sold plans for 58 dwellings. It's almost too good to be true!"—Valerie J. Pack, Midway City, Cal.

Salary doubles since enrolling. "Mailing the I. C. S. coupon changed my entire life. My salary is now just about *double* what it was when I first enrolled!"—Ernest Garrett, Shreveport, La.

Says training pays for itself. "My initial investment has been returned to me many times over—in terms of a better job, higher pay, increased satisfaction. I owe it all to I. C. S."—J. B. Stone, Norwalk, Cal.

Free! 3 I.C.S. Success Booklets!

Yours for the asking—three valuable booklets to help you plan your career. No obligation.

- "How to Succeed," a 36-page guide to advancement that's loaded with helpful tips.
- Complete catalog outlining job opportunities and outlook in your field of interest.
- Sample lesson to demonstrate the success-proven I. C. S. method of spare-time study.

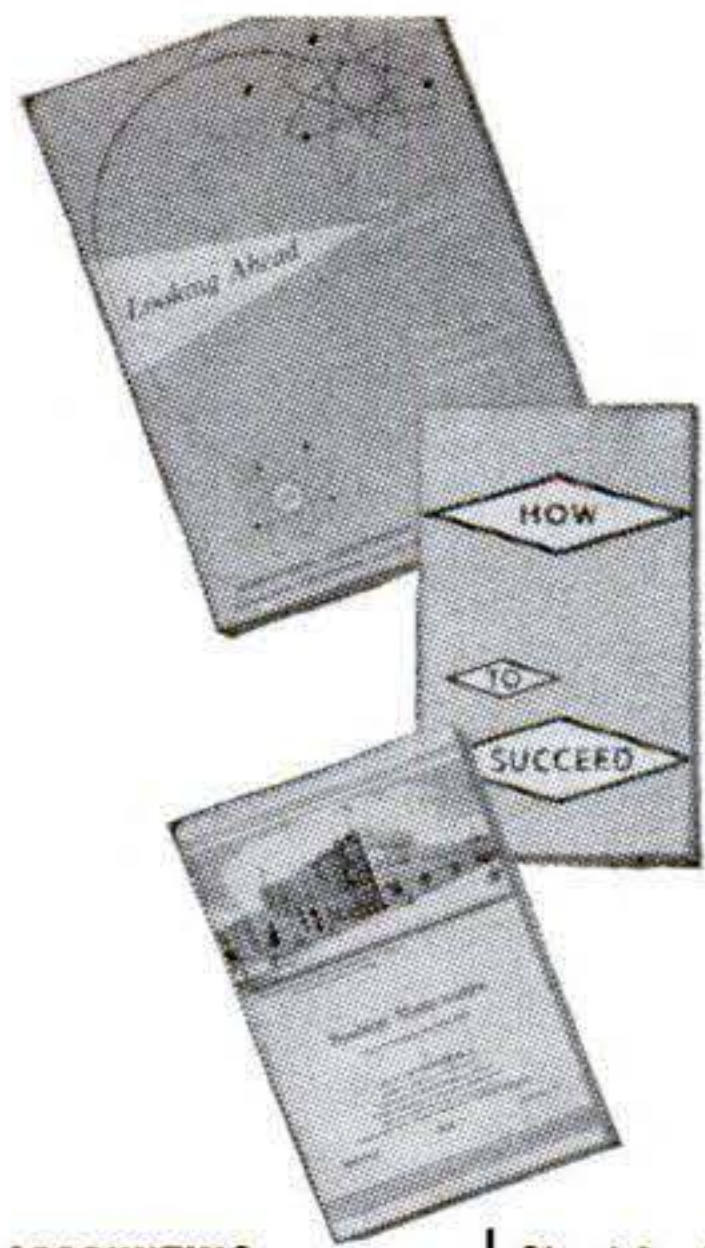

ACCOUNTING

Accounting
Auditing
Cost Accounting
General Accounting
Junior Accounting
Practical Accounting
Public Accounting

ADVERTISING

Advertising
Magazine & Newspaper Advertising

ARCHITECTURE AND BUILDING CONSTRUCTION

Architectural Drawing & Designing
Architectural Interiors
Architecture
Building Contractor
Building Contractor with Drawing
Building Estimator
Building Maintenance
Carpenter-Builder
Carpentry & Millwork
House Planning
Lumber Dealer
Mason
Painting Contractor
Reading Arch. Blueprints
Reading Struct. Blueprints

ART

Advertising Layout & Illustration
Amateur Artist
Commercial Art
Commercial Cartooning
Fashion Illustrating
Figure Drawing & Painting
Magazine Illustrating
Show Card & Sign Prod'n
Show Card Writing
Sign Painting & Designing
Sketching & Painting

AUTOMOTIVE

Auto Engine Tune-up
Automobile
Automobile Body Rebuilding and Refinishing
Automobile Electrical Technician
Automobile Technician
Diesel Engines

Diesel-Gas Motor Vehicle Engines
Gas Engines
Internal Combustion Engines

AVIATION

Aero-Engineering Technology
Aircraft & Engine Mechanic
Aircraft Mechanic
Aviation Engine Mechanic

BUSINESS

Business Administration
Business Correspondence
Business Law
Business Management
Business Management & Marketing
Business Management & Production
Business Psychology
Canadian Business Management
Clerk-Typist
Commercial
Condensed Business Practice
Federal Tax Course
Managing a Small Business
Marketing
Office Administrative Engineering
Office Management
Professional Secretary
Programming for Digital Computers
Purchasing Agent
Retail Business Management
Shorthand
Stenographic
Typewriting

CHEMICAL

Analytical Chemistry
Chemical Engineering
Chemical Engineering Unit Operation
Chemical Laboratory Technician
Elements of Nuclear Energy
General Chemistry
Industrial Analytical Chemistry
Industrial Chemistry
Professional Engineer—Chemical

PULP AND PAPER

Paper Making
Pulp & Paper Engineering

Pulp & Paper Making
Pulp Making

CIVIL ENGINEERING

Bridge & Building Foreman
Civil Engineering
Construction Engineering
Highway Engineering
Mine Surveying & Mapping
Principles of Mapping
Principles of Surveying
Professional Engineer—Civil
Railroad Engineering
Roadmaster
Sanitary Engineering
Section Foreman
Sewage Plant Operator
Structural Engineering
Surveying and Mapping
Water Works Operator

DRAFTING

Aircraft Drafting
Architectural Drafting
Drafting & Machine Design
Electrical Drafting
Electrical Engineer Drafting
Electronic Drafting
Industrial Piping Drafting
Junior Mechanical Drafting
Mechanical Drafting
Sheet Metal Drafting
Structural Drafting

ELECTRICAL

Elec. Appliance Servicing
Electrical Contractor
Electrical Eng'r'g (Power Plant option—Electronic option)
Electrical Engineering Tech.
Electrical Instrument Tech.
Electric Motor Repairman
Illumination Eng'r'g Tech.
Industrial Electrical Techn.
Power-House Engineering
Power Line Design and Construction
Practical Electrician
Practical Lineman
Professional Engineer—Electrical
Reading Electrical Blueprints

HIGH SCHOOL

Good English
High School Business
High School College Prep (Arts)

High School College Prep (Engineering & Science)
High School General
High School Mathematics
High School Secretarial
Modern Letter Writing
Short Story Writing

LEADERSHIP

Industrial Foremanship
Industrial Supervision
Personnel-Labor Relations
Supervision

MATHEMATICS

Mathematics and Mechanics for Engineers
Mathematics and Physics for Engineers
Mathematics and Physics for Technicians

MECHANICAL

Industrial Engineering
Industrial Instrumentation
Junior Mechanical Engineering
Mechanical Engineering
Professional Engineer—Mechanical
Quality Control
Introductory Technical Writing

PETROLEUM

Natural Gas Production & Transmission
Oil Field Technology
Petroleum Production
Petroleum Prod'n Eng'r'g
Petroleum Refinery Operator
Petroleum Refining
Petroleum Technology

PLASTICS

Plastics Technician

PLUMBING, HEATING, AIR CONDITIONING

Air Conditioning
Air Conditioning with Draw'g
Air Conditioning Maintenance
Domestic Heating with Oil & Gas
Domestic Refrigeration
Heating & Air Conditioning with Drawing

Heating, Drawing & Estimat'g
Plumbing
Plumbing, Drawing & Estimating
Plumbing & Heating
Plumbing & Steamfitting
Practical Plumbing
Refrigeration
Refrigeration & Air Conditioning
Steamfitting

RAILROAD

Air Brake Equipment
Car Inspector & Air Brake Diesel Electrician
Diesel Engineer & Fireman
Diesel Locomotive
Diesel Machinist
Railroad Administration
Railroad Car Repairer

SALESMANSHIP

Creative Salesmanship
Real Estate Salesmanship
Retail Merchandising
Retail Selling
Sales Management
Salesmanship
Salesmanship & Sales Management

SHOP PRACTICE

Boilermaking
Electric Welding
Foundry Practice
Gas and Electric Welding
Gas Welding
Heat Treatment of Metals
Industrial Metallurgy
Machine Shop Inspection
Machine Shop Practice
Machine Shop Practice & Toolmaking
Metallurgical Engineering Technology
Physical Quality Control of Metals
Practical Millwrighting
Reading Shop Blueprints
Resistance Welding Technology
Rigging
Safety Engin'r'g Technology
Sheet Metal Worker
Tool Design
Tool Engineering Technology

Toolmaking
Welding Engineering Technology

STEAM AND DIESEL POWER

Combustion Engineering
Power Plant Engineering
Stationary Building Eng'r'g
Stationary Diesel Eng'r'g
Stationary Diesel-Electric Engineering
Stationary Fireman
Stationary Steam Eng'r'g
Steam Engine Operation

TEXTILES

Carding and Spinning
Carding
Cotton Manufacturing
Cotton Warping & Weaving
Dyeing & Finishing
Hosiery and Circular Knitting
Loom Fixing
Spinning
Synthetic Fabric Manufacturing
Synthetic Throwing, Warping & Weaving
Textile Designing
Textile Engineering
Textile Mill Supervisor
Woolen Manufacturing
Worsted Manufacturing

TRAFFIC

Motor Traffic Management
Railroad Rate Clerk
Traffic Management

TV-RADIO-ELECTRONICS

Gen'l Electronics Technician
Industrial Electronics
Practical Radio-TV Eng'r'g
Radio Operating
Radio Servicing
Radio Servicing with Practical Training
Radio & TV Servicing
Radio & TV Servicing with Practical Training
Servicing Electr'n'c Devices
Servicing Sound Equip't
Practical Telephony
Telephony and Radio Communications
TV Receiver Servicing
TV Technician

For Real Job Security—Get an I. C. S. Diploma! I. C. S., Scranton 15, Penna.

Accredited Member, National Home Study Council

INTERNATIONAL CORRESPONDENCE SCHOOLS



BOX D9751B, SCRANTON 15, PENNA.

In Hawaii reply P.O. Box 418, Honolulu

Without cost or obligation, send me "HOW to SUCCEED," the opportunity booklet about the field I have indicated below, and a sample lesson

Name of the course in which I am interested _____

Name _____ Age _____ Home Address _____

City _____ Zone _____ State _____ Working Hours _____ A.M. to _____ P.M.

Occupation _____ Canadian residents send coupon to International Correspondence Schools, Canadian, Ltd., Montreal, Canada. . . . Special low monthly tuition rates to members of the U. S. Armed Forces.

PS readers talk back



Gus to the Rescue

I had a rattle in the dash of my '59 Chevrolet for nearly a year. One garageman told me that it was the throw-out bearing in the transmission. Another man said that it would probably also need a new clutch. The clutch seemed good and I didn't have the \$40 for the bearing so I did nothing. I checked the steering column and could find nothing wrong. Then I read "Gus Tackles a Noisy Problem" [Nov.], describing a job on a '59 model.

The next day I checked the shift link, as the article suggested, and it was loose. I took an old inner tube, cut out two washers, and put the linkage clamp back together. The rattle was gone. Your article and a piece of inner tube saved me many dollars and solved my problem.

REV. C. L. DOVERSPIKE, Jersey Shore, Pa.

Praise from the Source

I am pleased about the presentation of my book *Peenemünde to Canaveral* in your December issue [p. 67]. Considering that he worked from written description only, your artist did extremely well. It was also interesting to learn that the article serves as the opening to a series on space by Dr. von Braun. You will certainly have one of the most brilliant minds in this field at your disposition.

Space travel and rocket propulsion will increasingly occupy the minds and attention of those interested or active in science and technology. Due to the inherent complexity of many of the aspects, Popular Science, as a discipline as well as a magazine, will contribute materially to the future understanding of them.

I knew your magazine back in Germany, prior to WW II. It appeared to us that the availability of this type of inexpensive technical literature combined with the love (unrestricted by Prussian bureaucracy) to tinker with automobiles and radio transmitters were giving the U.S. a decided technological advantage.

DIETER K. HUZEL, Woodland Hills, Calif.

Nothing for Nothing?

I admire the courage and enterprise of the builders and backers of the "trigible" [Nov.]. I wish them every success.

However, somebody is going to have to disillusion them about "gratis up-and-down gravity power" and "gaining speed for free." You can't get something for nothing. Any forward progress they make through the heating-and-propoising maneuver will cost them as much propane fuel (probably more) as running that fuel, instead, through their engine propulsion system.

WARNER CLEMENTS, Beverly Hills, Calif.

Circulation Goes Up

I was doing fine cutting out the problems of the "Teach-Yourself Chase" [Dec.] to paste to cardboard for future use in math work. Then I came to pages 179-180—where you had problems back-to-back. Had to get me another copy to make out. I bet you did it on purpose!

OLIN MAPES, Jacksonville, Fla.



Biggest, Guttiest Locomotive

I am sure that many of the old young men who read PS couldn't miss enjoying Henry B. Comstock's farewell salute to the mighty Mal-

CONTINUED

E. S. DUFFIELD, President

JOHN R. WHITING, Executive Vice-President and Publisher

EUGENE WATSON, Vice-President, Circulation

CHARLES S. THORN, Vice-President, Advertising

EDITORIAL OFFICES: 355 Lexington Ave., New York 17, N. Y.

PUBLISHED MONTHLY by Popular Science Publishing Co., Inc., 355 Lexington Ave., New York 17, N. Y.

SUBSCRIPTION SERVICE. *New or renewal orders:* Send to Popular Science Subscription Department, Boulder, Colo. One year \$4, 2 years \$7, 3 years \$9 in U.S., its possessions, and Canada. Elsewhere, 1 year \$6.50, 2 years \$12, 3 years \$17. Single copy 35¢. *Subscription orders processed electronically.* • *All subscription adjustments:* Write to Robert Harlan, Popular Science, P.O. Box 1083, Boulder, Colo. For change of address allow four weeks; please give both old and new addresses. Notices of undelivered copies (Form 3579) to Mr. Harlan. • Second class postage paid at New York, N.Y., and at additional mailing offices. Entered as second class matter at the Post Office Department, Canada. Printed in U.S.A. • **ADVERTISING OFFICES.** NEW YORK: 355 Lexington Ave.; CHICAGO: 360 N. Michigan Ave.; DETROIT: 2810 Book Bldg.; SAN FRANCISCO: 703 Market St.; CLEVELAND: 1220 Huron Road; LOS ANGELES: 1709 W. Eighth St.; PORTLAND, ORE.: 520 S.W. Sixth Ave.; DENVER: 333 W. Colfax Ave.; SEATTLE: 101 Jones Bldg.

This Free sample lesson can start you on a high-pay career as **ACCOUNTANT, AUDITOR, or CPA**

This same lesson has started hundreds of thousands in one of the world's best-paid professions. Its simplicity will surprise you. Try it, enjoy it, without obligation.

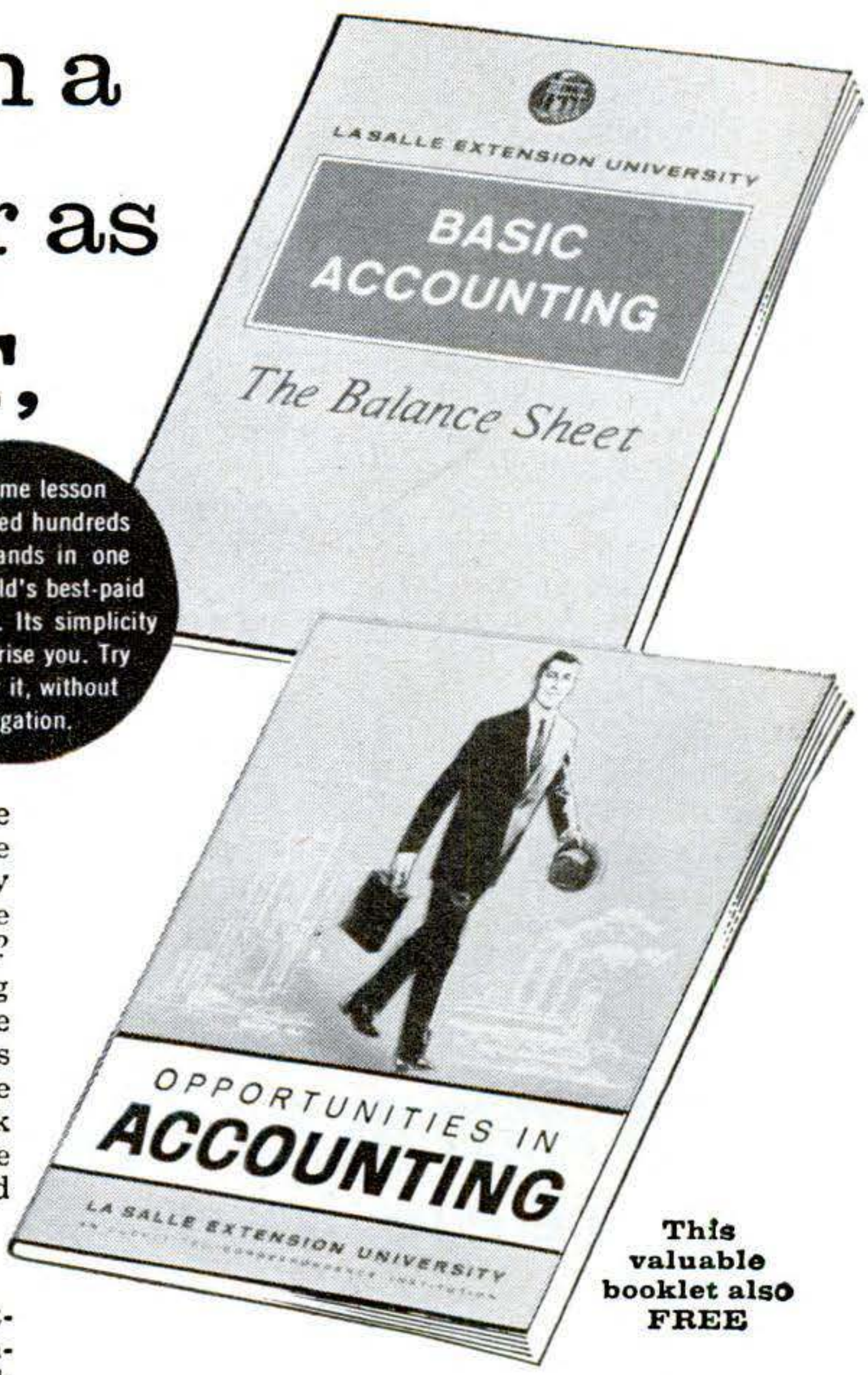

This valuable booklet also **FREE**

The demand for trained Accountants far exceeds the supply. Salaries keep going higher, promotions come faster. Why remain in a dull job with insufficient pay when you can qualify easily—in your spare time—for the big rewards offered to the men trained in Accounting?

To prove this to yourself, send for the interesting sample lesson which demonstrates the remarkable LaSalle method of home training. This lesson is yours free of cost or obligation. It will show you how you are guided step by step through actual Accounting work . . . how you learn by doing . . . how thoroughly you are prepared for every Accounting task you will be called upon to handle in the business world.

No previous experience required

LaSalle's distinguished faculty of expert Accountants and CPA instructors starts you right at the beginning . . . then supervises, corrects and grades your work all the way . . . right up to qualifying you for the Certified Public Accountant examination, if this is your goal.

You train in your spare time—at your own pace—without losing a single day from your present job.

Which of today's many Accounting positions do you want?

Regardless of your present job—if you want to qualify as expert Accountant, Controller, Auditor, Income Tax Specialist, Government Accountant, or Public Accountant, LaSalle has the exact plan to prepare you rapidly and inexpensively.

For over half a century, LaSalle has been a world leader in business education. It has trained at home more than 1,000,000 successful men and women. That is why a LaSalle diploma in Accounting is a credential respected by America's biggest companies. Mail the coupon now for your free sample lesson and the free booklet "Opportunities in Accounting."

LA SALLE
EXTENSION UNIVERSITY
A Correspondence Institution
417 South Dearborn St., Chicago 5, Ill.

LaSalle students report up to 56% increase in pay the first year



"My income has increased over \$100 a month since I began taking your course. I recommend it highly to anyone."
—W. G. Hensley, Memphis, Tenn.

"My salary has more than doubled since enrolling with LaSalle and due to my fine training, my salary is still growing."
—William T. Black, Canoga Park, Calif.

"As a direct result of my LaSalle studies, my salary has increased 400% since I first began my LaSalle success building program."
—Rudolf Urbatis, Port Chester, N.Y.

LA SALLE EXTENSION UNIVERSITY
A Correspondence Institution
417 South Dearborn St., Dept. 14-088, Chicago 5, Ill.

Please send me, free of cost or obligation, your sample lesson and illustrated booklet "Opportunities in Accounting"

Name.....Age.....

Address.....County.....

City & ZoneState.....

108

lets [Dec.] detailing the part they played in American railroading. Fine sketching, too.

CHARLES WOLFE, Port Chicago, Calif.

Markovich at the Wheel

The report on the Tempest [Oct.] states that the steering is painfully slow, and that it is six turns lock-to-lock.

The '63 specs say that the steering is 4.5 turns lock-to-lock. Who is right?

I would not call 4.5 so slow.

CHARLES LYON, Philadelphia.

Memo from auto writer Alex Markovich: "G.M. says it's 4.5 turns lock-to-lock for both manual and power steering. But when I drove the thing (with manual steering) I counted six turns. In fact, I distinctly remember counting the turns several times, while the engineer sat watching, red-faced and silent. This was a prototype, not a production car. Maybe they realized the error of their ways at the last minute."

Watch That Solder!

While reading John Burroughs' article ["Electroplating in Your Own Shop," Nov.] I noticed that he was doing some soldering requiring a paste acid flux. This is poor practice for soldering electrical connections because of corrosive action.

He should use rosin-core solder, which is

made especially for soldering electric parts.

STINIUS DAHL II, Knoxboro, N.Y.

Any Carb Experts Around?

I own a 1962 Dodge Lancer with 145-hp. engine, downdraft carburetor. After the motor reaches normal heating and I park the car from 10 to 20 minutes, I have a tough time getting



it started again. Apparently no one around here can solve this hard-starting problem, although it's definitely the carburetor. Maybe one of your readers has a solution.

RAYMOND JAKABCIN, Stratford, Conn.

Getting Synchronized with History

About your articles on the '63 cars [Oct.]: Ford may have made this country's first completely synchronized three-speed transmission, but they didn't do it for 1963. An all-synchro box was standard equipment in 1938.

BUD SCHLEMMER, Enid, Okla.

Ears are red at both PS and the Ford Motor

CONTINUED

Why Johnson built 2 new reels in one

"Build a reel that offers the best of BOTH spinning and bait-casting." That's what anglers asked for, and Johnson did it . . . built the Johnson "710". Here's the reel that gives you spinning ease on the cast, bait-casting power on the retrieve. THEN, when a big one runs and you want game-taming drag, simply SHIFT the handle back a fraction of a turn. Drag takes over automatically. Run's over, you resume normal retrieve. Keep the fun of catching fish . . . and keep your catch, too.

Ask your dealer to show you the Johnson "710".

BIGGER SABRA® LANDS THE LUNKERS. Want "710" action in a reel with super power? See the Johnson SABRA. Comes with 15-lb. monofilament on the reel, 20-lb. mono on extra spool.

WRITE for FREE 20-page, full-color booklet crammed with fishing tips, latest Johnson tackle.

JUST OFF THE PRESS . . . New 18" x 28" guide to look-alike fish, full color, shipped in tube. Send 50¢ to cover handling and postage.



"710"

Shifts from spin-casting to bait-casting reel in 1/10 second.

CAST: IT'S A SPINNING REEL! Long, clean casts. No backlashes. Easier to use because Johnson knows spin-casting.

RETRIEVE: IT'S A CASTING REEL! Good anglers want that "fish-on" feel, the control and power of direct-to-fish retrieve.

SHIFT: IT'S A SPINNING REEL! Back the handle a fraction of a turn and drag takes over automatically.

Johnson REELS/RODS

Johnson Park, Mankato, Minnesota

Manufactured by Denison-Johnson Inc.

Distributed in U.S.A. by Johnson Reels, Inc.



We helped break America's smoking habit

Remember when cars used to begin smoking at a very early age . . . burning oil because the rings were shot?

Today, piston rings last better than twice as long — thanks to a great extent to a number of Perfect Circle patents. Our research has helped change the piston ring from a simple casting to a carefully-engineered part that's made with the precision of a fine watch. And it's also brought us a lot of customers we're proud of.

Practically all vehicle and engine manufacturers in America install Perfect Circle piston rings as original factory equipment. You'll find preference

for Perfect Circle in everything from tractors to diesel locomotives. In all, 95 brands of cars, tractors, trucks and construction equipment use our rings.

Among the most dramatic of these are the great race cars. Twenty-eight of the last 35 Indianapolis winners have roared to victory with Perfect Circle rings. Year after year, more major USAC and NASCAR competitions are won by cars using PC rings than any other piston ring brand.

And these are regular *stock* Perfect Circles! The same power-packing rings you'll have on *your* car when, next time you re-ring, you insist on piston rings made by Perfect Circle!

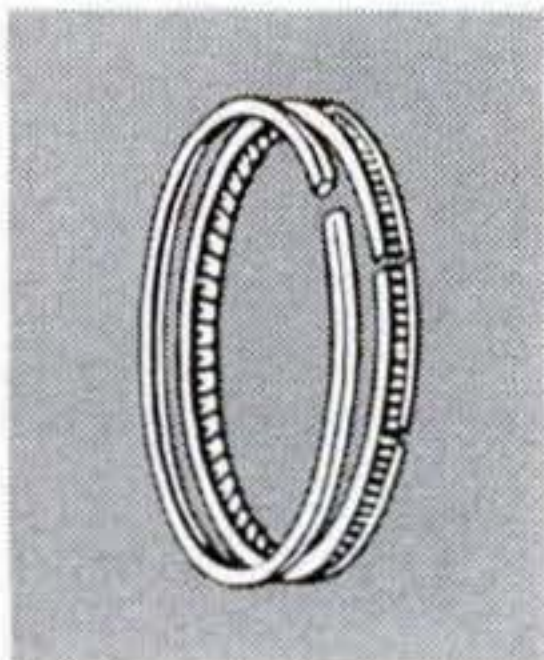

PERFECT CIRCLE

**Piston Rings • Cylinder Liners • Precision Castings • Turbine Blades and Wheels
Electronic Programming Equipment • Speed Controls • Hagerstown, Indiana**

Plants and Subsidiaries: HAGERSTOWN, RICHMOND, NEW CASTLE, TIPTON AND RUSHVILLE, INDIANA • THE PERFECT CIRCLE COMPANY, LTD., DON MILLS, ONTARIO, CANADA • SCHELLEN'S TRUE CORPORATION, IVORYTON, CONNECTICUT • PERFECT CIRCLE INTERNATIONAL, FT. WAYNE, INDIANA • PERFECT CIRCLE HOLLAND N.V. THE HAGUE, NETHERLANDS • Factories, Affiliates and Licensees in MEXICO, ARGENTINA, AUSTRALIA, BRAZIL AND FRANCE

**NOW YOU CAN
BUILD A FINE
*Schober Organ***

**FOR ONLY
\$550**



You can assemble this new Schober Spinet Organ for \$550 — or half the cost of comparable

instruments you have seen in stores. The job is simplicity itself because clear, detailed step-by-step instructions tell you exactly what to do. And you can assemble it in as little as 50 hours.

You will experience the thrill and satisfaction of watching a beautiful musical instrument take shape under your hands. The new Schober Electronic Spinet sounds just like a big concert-size organ — with two keyboards, thirteen pedals and magnificent pipe organ tone. Yet it's small enough (only 38 inches wide) to fit into the most limited living space.

You can learn to play your spinet with astounding ease. From the very first day you will transform simple tunes into deeply satisfying musical experiences. Then, for the rest of your life, you will realize one of life's rarest pleasures — the joy of creating your own music.

For free details on all Schober Organs, mail the coupon now. No salesman will call.

THE *Schober Organ* CORPORATION

43 West 61st Street, New York 23, N. Y.
Also available in Canada and Australia.

MAIL THIS COUPON TODAY

The Schober Organ Corporation, Dept. PS-13
43 West 61st Street, New York 23, N. Y.

- Please send me FREE booklet and other literature on the Schober Organs.
- Please send me the Hi-Fi demonstration record. I enclose \$2 which is refundable when I order my first kit.

Name.....

Address.....

City.....Zone...State.....

Co. Says Ford: "Mr. Schlemmer is right. No one around here remembered this. We had to check with the automotive-history department of the Detroit City Library to make sure. The all-synchro box was abandoned a year later."

Meteorologists, Please Note

The article "Wettest Days Follow the Moon" ["March of Science," Dec.] prompted this amateur astronomer to examine why more rain should fall in the weeks following new and full moons.

Using a working model of the earth, moon, and sun, I found that in the daylight hours of these periods, the atmospheric tide (barometric pressure) declined from a maximum in early afternoon to a minimum a few hours after sunset, an interval during which maximum temperature drop also takes place (just after sunset). The cumulative effect of the temperature drop and the pressure drop could bring on rainfall more readily.

W. T. THOMAS JR., Daytona Beach, Fla.



About the Caddy

As the manufacturer of the fan clutch referred to as a "gimmicky innovation" in November ["Caddy's New Engine"] we feel you are doing an injustice to the product. If you had had the opportunity of riding an air-conditioned Cadillac without this device, we are sure you would refer to it as a very necessary apparatus to make the car a nice, quiet, smooth automobile.

T. J. WEIR, Chief Engineer
Schwitzer Corp., Indianapolis.

Testing the Galaxie

Being a dyed-in-the-wool Ford-performance enthusiast, I feel it my duty to point out that the Ford pictured ["The Ford Stable," Oct.] is not equipped with the 405-hp. engine—a mill with three two-barrel carbs. The car shown obviously has four barrels.

If your test drivers are going to compare the Ford 406 with other super-super stockers, please give Ford a break—peek under that air cleaner and check for three Holley two-barrels, indicating that you have 405 lusty, honest horses under the hood!

G. E. LEMMON, University City, Mo.

Right. The photo at top of page 75 doesn't show the 405-hp. engine. But the test drive reported by Alex Markovich (bottom of the page) was made in a 405-hp. job. The two stories were written by different editors.

SALE!
118
PIECE SET

SOCKET WRENCH & TOOL SET THOR 1/4 H.P. POWER DRILL

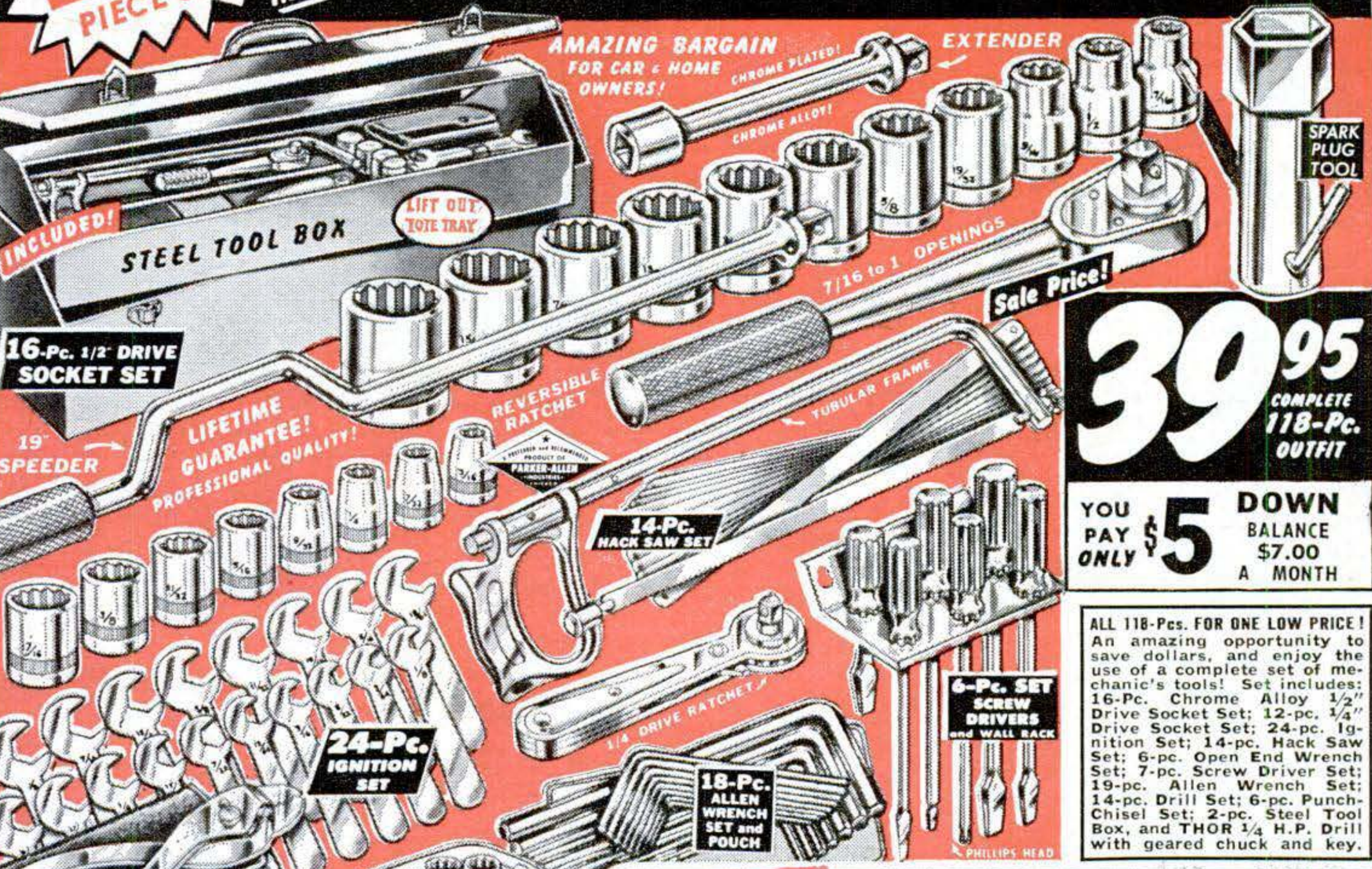

AMAZING BARGAIN
FOR CAR & HOME
OWNERS!

EXTENDER

CHROME ALLOY!

SPARK
PLUG
TOOL

INCLUDED!
STEEL TOOL BOX
LIFT OUT
TOTE TRAY

16-Pc. 1/2" DRIVE
SOCKET SET

19" SPEEDER
LIFETIME
GUARANTEE!
PROFESSIONAL QUALITY!

REVERSIBLE
RATCHET

14-Pc.
HACK SAW SET

TUBULAR FRAME

Sale Price!

39⁹⁵
COMPLETE
118-Pc.
OUTFIT

YOU
PAY
ONLY **\$5** DOWN
BALANCE
\$7.00
A MONTH

ALL 118-Pcs. FOR ONE LOW PRICE!
An amazing opportunity to save dollars, and enjoy the use of a complete set of mechanic's tools! Set includes: 16-Pc. Chrome Alloy 1/2" Drive Socket Set; 12-pc. 1/4" Drive Socket Set; 24-pc. Ignition Set; 14-pc. Hack Saw Set; 6-pc. Open End Wrench Set; 7-pc. Screw Driver Set; 19-pc. Allen Wrench Set; 14-pc. Drill Set; 6-pc. Punch-Chisel Set; 2-pc. Steel Tool Box, and THOR 1/4 H.P. Drill with geared chuck and key.

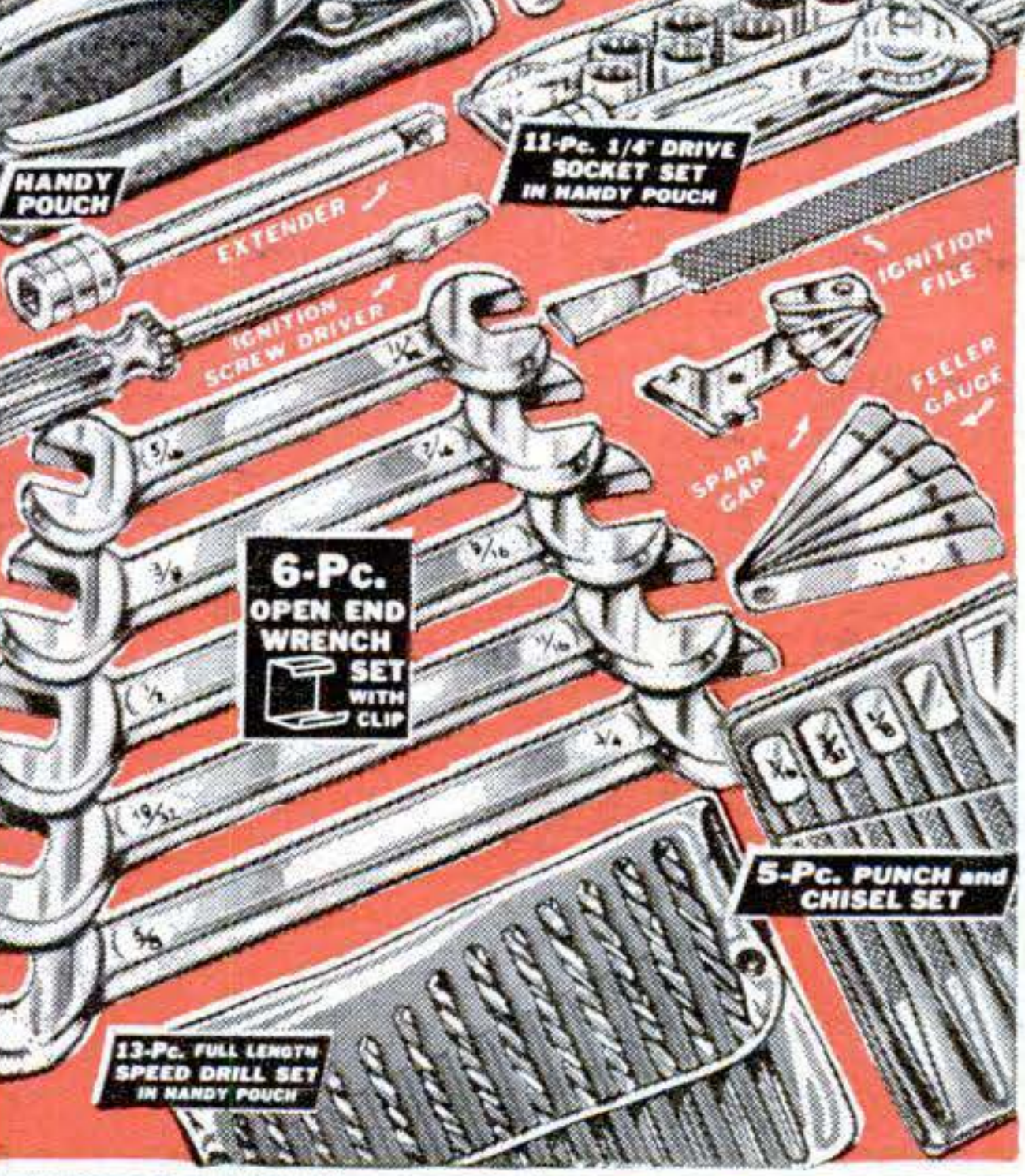

INCLUDED FREE OF ANY EXTRA COST!

1/4 H.P. NATIONALY FAMOUS THOR POWER DRILL SET

WITH THE MOTOR THAT
WON'T BURN OUT!

- 1/2" Capacity in Wood
- 1/4" Capacity in Steel

AUTOMATIC TRIGGER RELEASE

2.5 Amp.

PRECISION MADE GEARED CHUCK
And GEARED CHUCK KEY

13 PC. DRILL SET INCLUDED

U/L INDUSTRIAL RATED



YOURS FOR 30 DAYS FREE TRIAL MONEY BACK GUARANTEE—CASH OR CREDIT! DON'T WAIT! ORDER BY MAIL TODAY!

Klein's Sporting Goods

KLEIN'S—Dept. 357
227 W. Washington St.
Chicago 6, Illinois
Our 78th Year of Quality

I enclose \$5.00 Down Payment. Without obligation, please send me for 30 days FREE TRIAL the complete 118-piece Socket Wrench and Tool Set with FREE 1/4 H.P. Thor Power Drill Set. If I'm not 100% satisfied, I'll return the set—and you'll immediately refund my \$5.00. Otherwise, I'll send you only \$7.00 each month until the low price of only \$39.95, plus a small charge for shipping and credit is paid.
(Cash Orders Shipped Postpaid).

Credit Order (Enclose Credit Information Requested at Right)
(No Credit Sales to Persons under 21)
 Cash Order C.O.D. (10% deposit)

NAME

ADDRESS

CITY STATE

IMMEDIATE DELIVERY!

CREDIT CUSTOMERS: To speed your order, send name and address of your employer and name and address of 2 or more companies with whom you have (or have had) credit accounts. Also your age, occupation, number of dependents, date present job began, and your weekly salary. THIS INFORMATION IS REQUIRED ONLY ON YOUR FIRST CREDIT ORDER. No Credit Sales to persons under 21. SAVE MORE! Send your check for \$39.95 for one set, or \$74.95 for 2 sets, and we pay shipping and handling charges. Same FREE TRIAL privilege and guarantee.

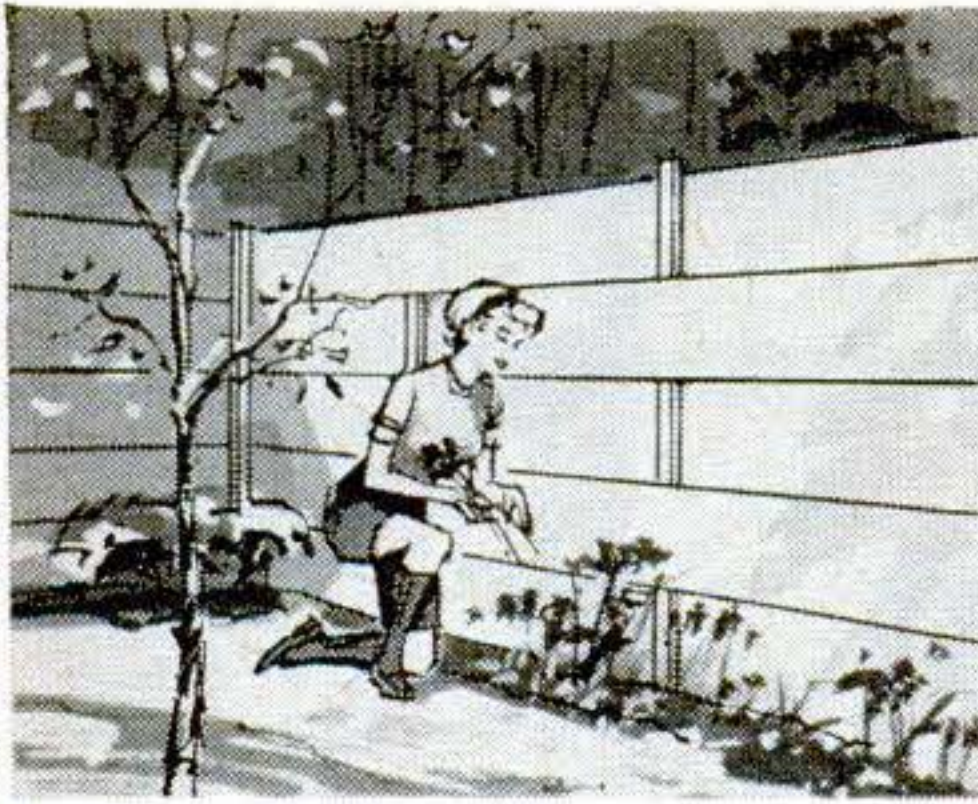

1. Fences of distinctive design

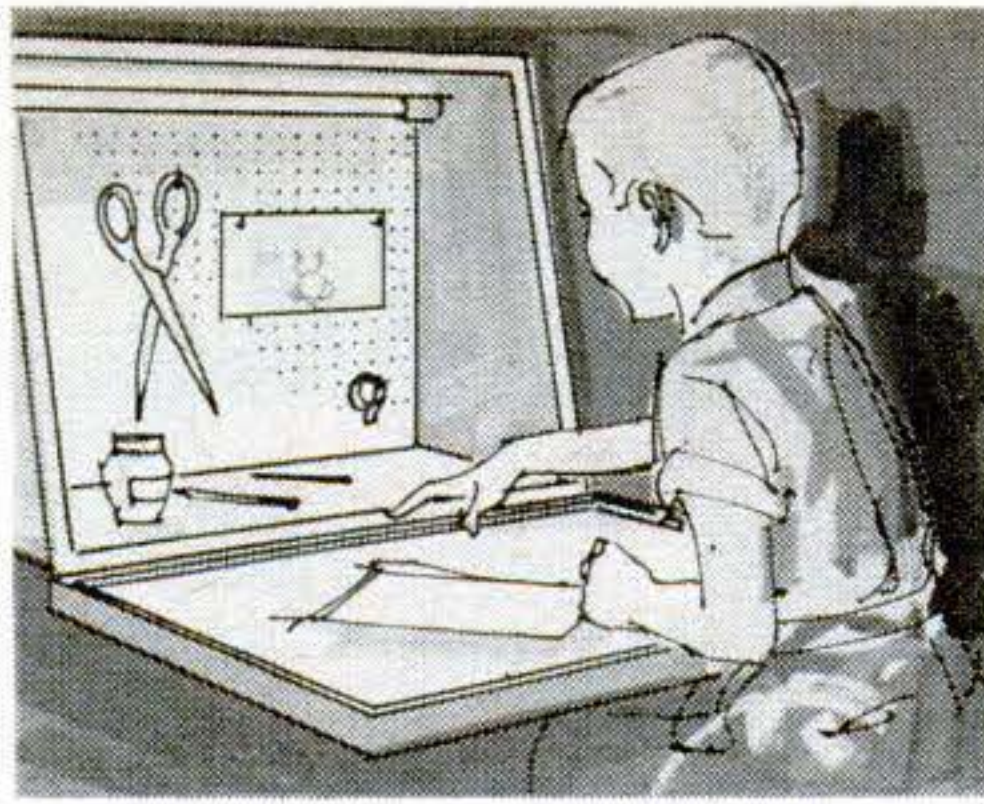

2. Wall desk with optional chalkboard front

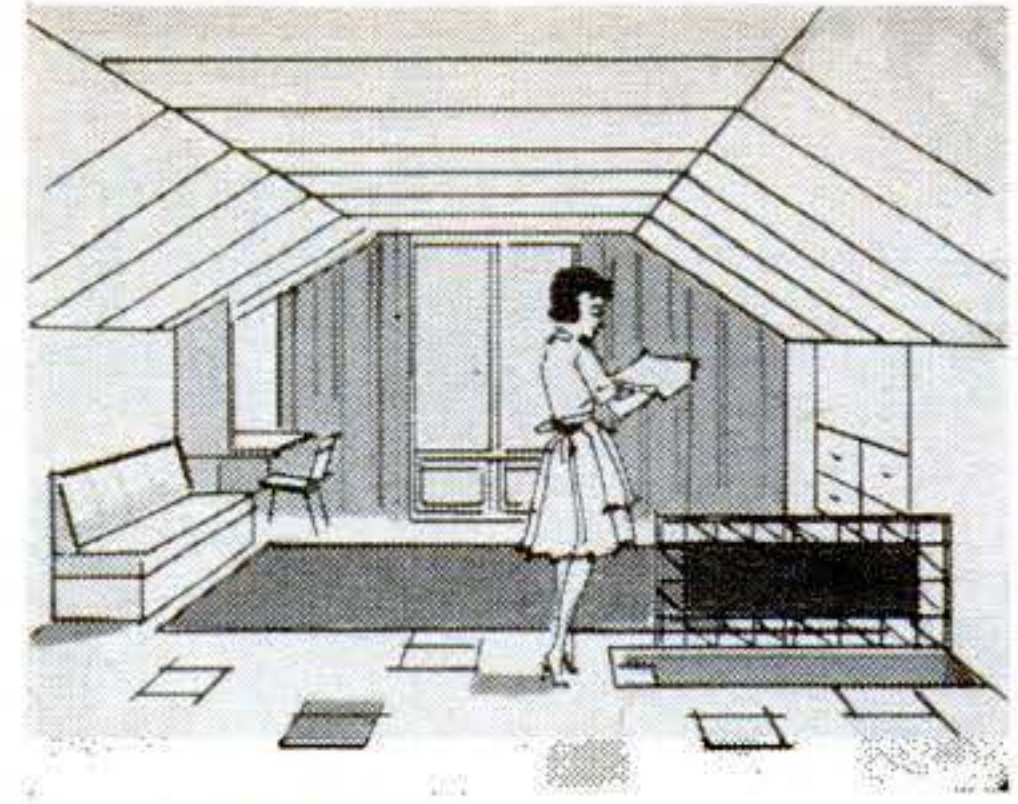

3. Remodeled attic

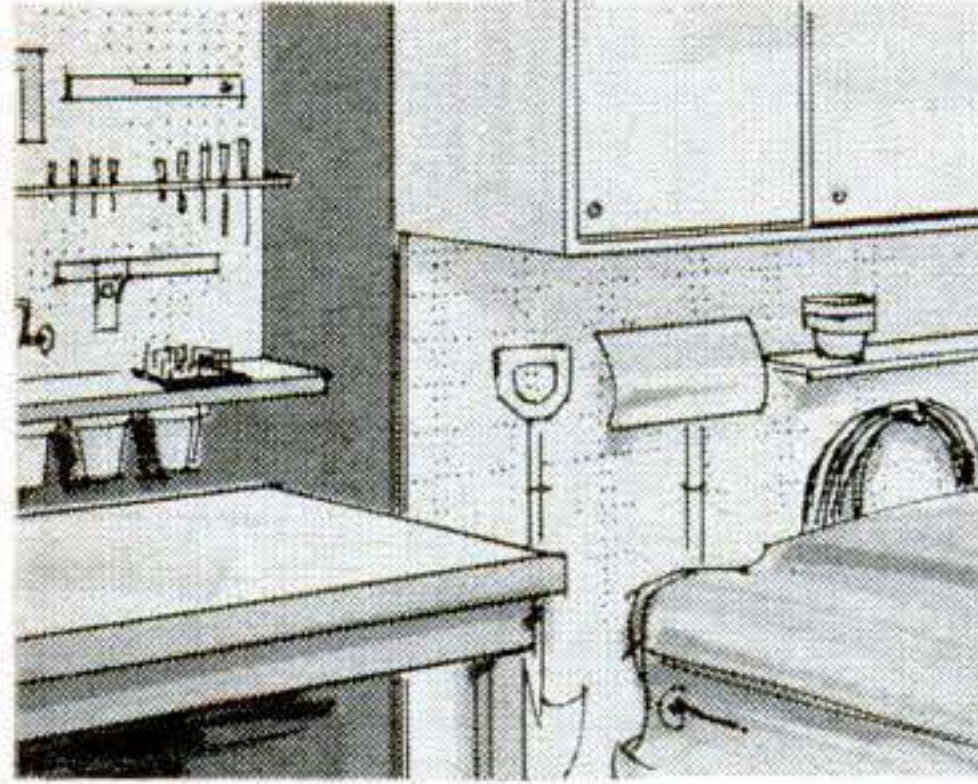

4. Garage interior remodeling

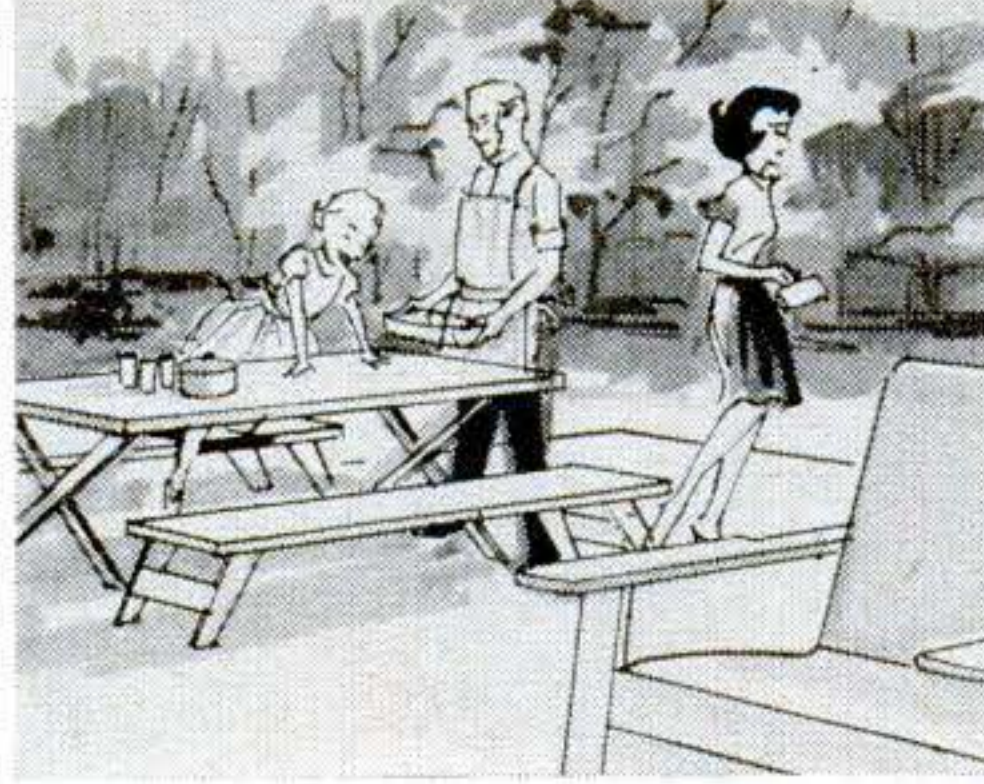

5. Picnic table and benches, lawn chair

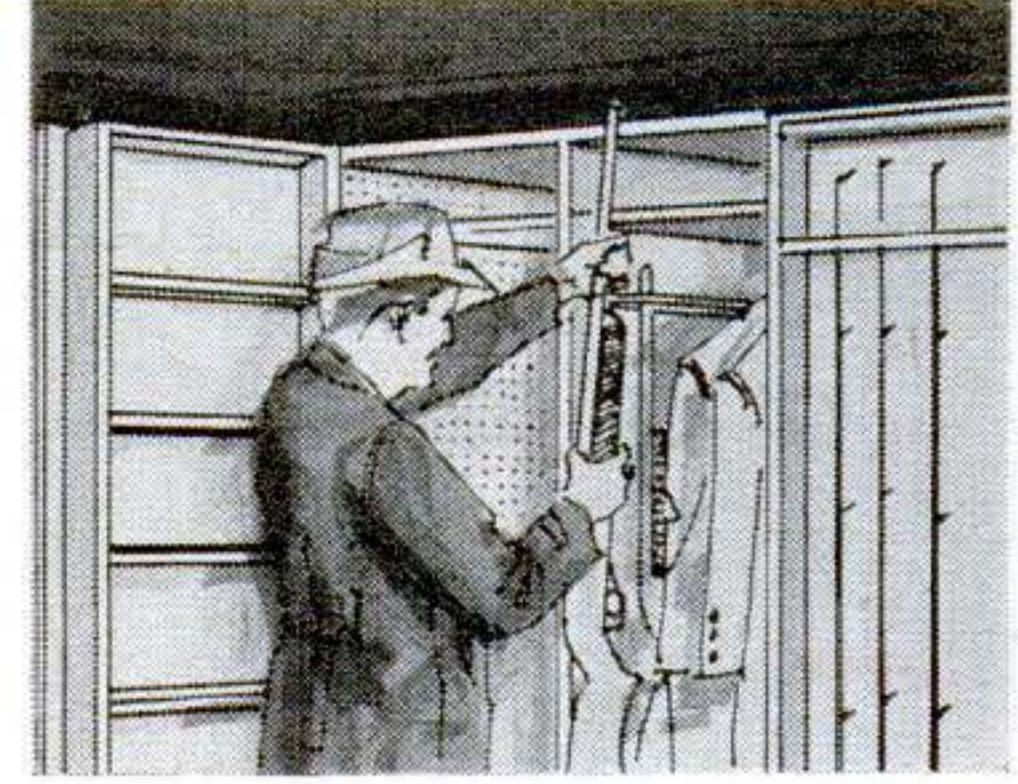

6. The sportsrobe

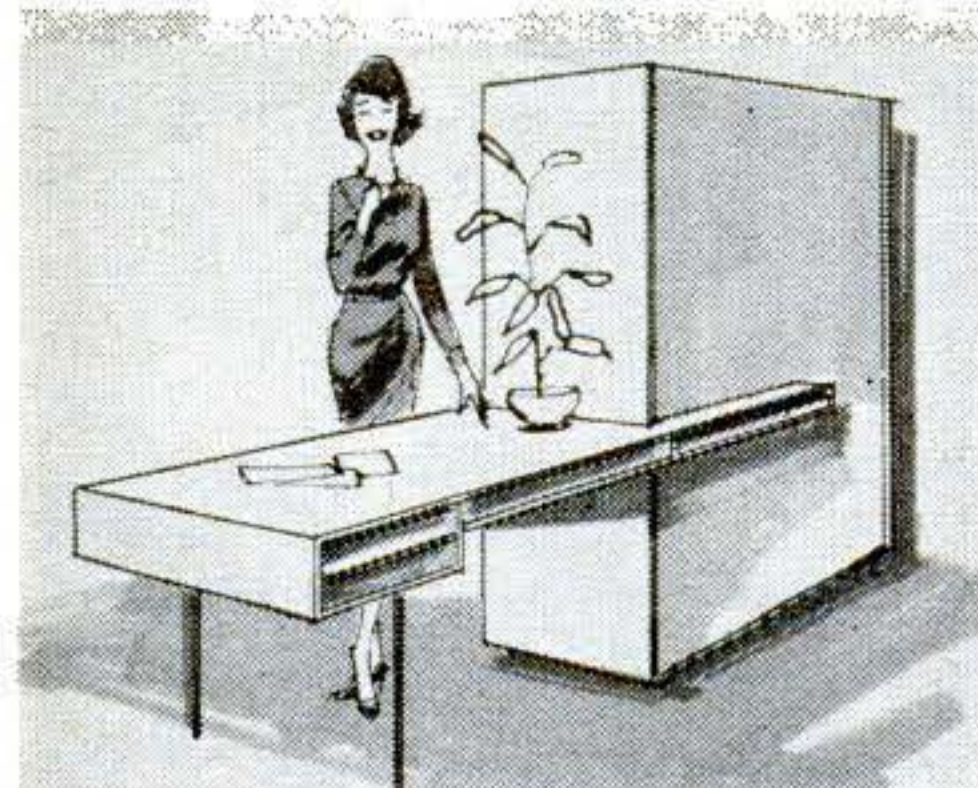

7. Room divider with desk and wardrobe

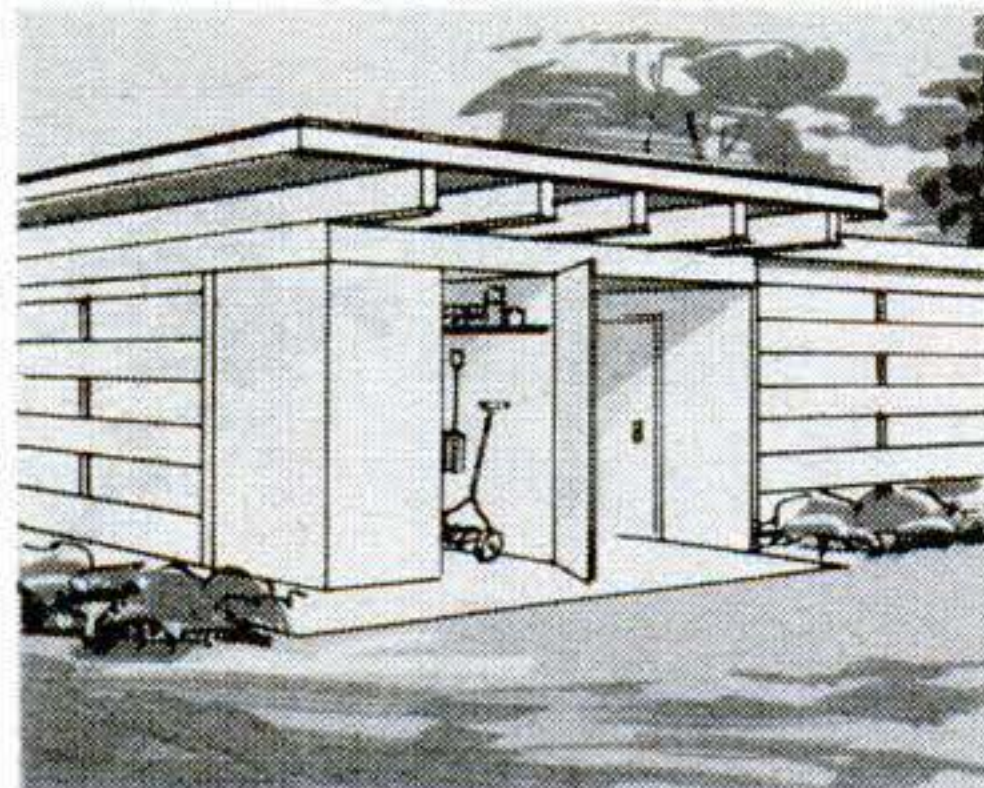

8. Woven carport wall with tool room

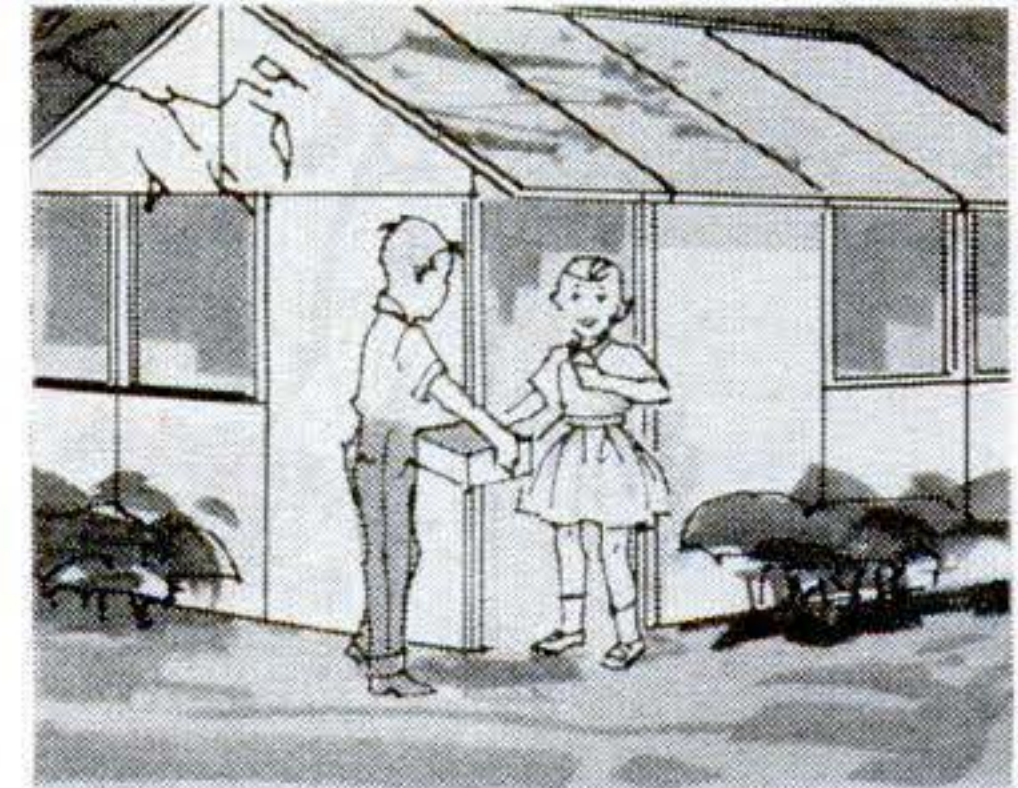

9. Playhouse plan for children



10. Home entertainment center
Family leisure hi-fi center

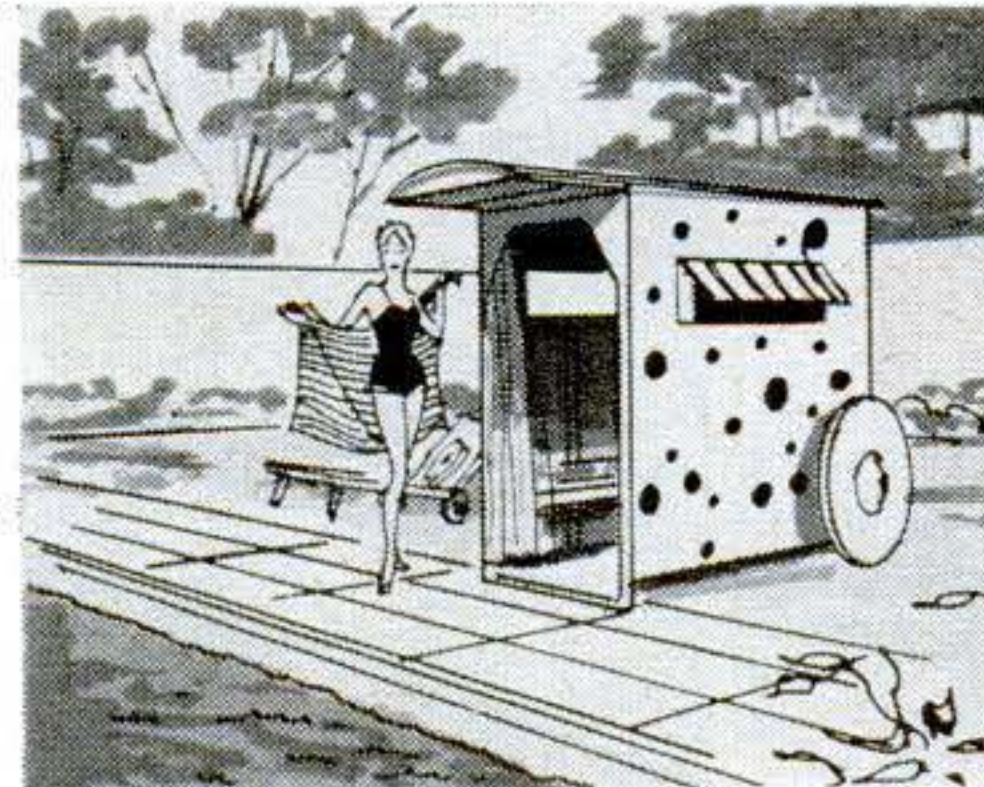

11. Roll-away cabana

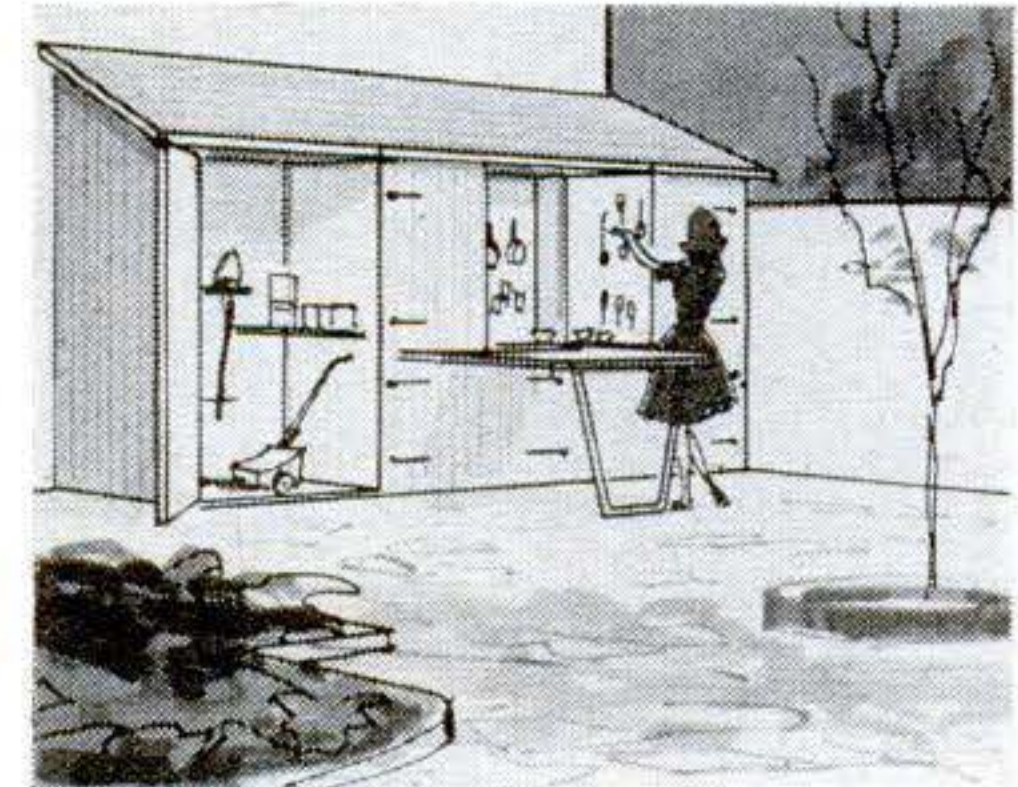

12. Outdoor living room

FREE from Masonite:

66 "IDEA PLANS"

to add to your family enjoyment

MASONITE shows the way!

Masonite is a registered trademark of Masonite Corporation



Masonite Corporation, Dept. PS-2, Box 777,
Chicago 90, Illinois

Please send me free "Idea Plans" booklet and
Plan No. ___ (one only).

NAME _____

ADDRESS _____

CITY _____

COUNTY _____ STATE _____

BUY DIRECT FROM OUR FACTORY

Save 80% ON THIS AMAZING *Amco* 8" TILT ARBOR POWER SAW KIT

RUGGED . . . PROFESSIONAL QUALITY . . . HEAVY DUTY . . . LIFETIME ENGINEERED
UNCONDITIONAL 10 YEAR GUARANTEE

GUARANTEED TO DO THE WORK OF \$50 BENCH SAWS

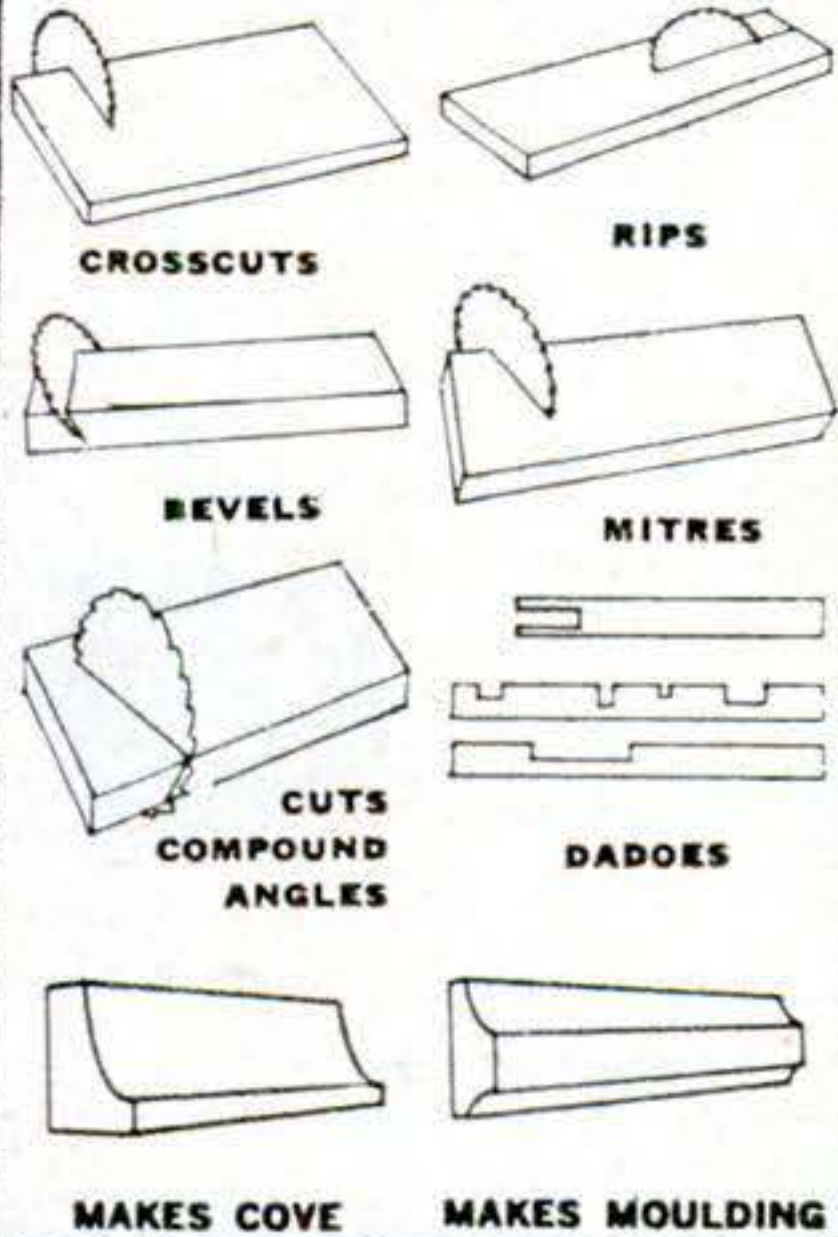

\$9.95

If desired; for easier work alignment, RIP FENCE \$3.50 add'l.



F.O.B. Factory
 Wt.: 12 lbs.

YOU GET:

- Complete blade carrying mechanism with depth of cut control
- Ground spindle with saw flanges
- Pre-oiled bearings
- Angle of tilt control
- Etched metal tilt indicator
- Complete mitre gauge
- Complete motor mount assembly
- All needed brackets, screws, nuts and bolts
- ABC assembly plans, plans for sturdy base, massive 20" x 24" table
- Full operating instructions.

REVOLUTIONARY NEW PATENTS . . . NEW DESIGN

A top quality full scale power tool with all the speed and accuracy of similar machines selling for as much as \$100! Even if you've never cut a piece of wood in your life, you can put this saw together in jig time. All you need are common household tools, about 1/2 sheet 3/8" plywood for table and base . . . about 2 hours of spare time. Because of metal saving economy design; because we save expensive assembly labor costs; special patents add to efficiency, accuracy, savings; all metal parts are made, sub-assembled and tested in our own factories . . . and because you buy direct from the maker . . . you enjoy a truly fantastic saving.

TABLE STAYS LEVEL, BLADE TILTS

Patented motor mount takes any standard 1/4 h.p. or larger motor . . . keeps belt tight, assures perfect alignment at any angle, transmits full power. Table stays level—blade tilts, locks securely at any angle to 50°, raises, lowers 0"-2 1/4". Patented tilt mechanism has accurate etched scale. Takes standard blade, saw insert removes easily for insertion of any STANDARD dadoe heads, cutters, etc. Accessories, when wanted, at factory prices.

BUILD ALL THESE

INDOOR FURNITURE

OUTDOOR FURNITURE

SHELVES & CLOSETS

CHILDREN'S TOYS

ALL HOME IMPROVEMENTS

AND SAVE AS YOU SAW

CLIP AND MAIL THIS MONEY SAVING COUPON TODAY!

Also ideal for boy scout troops, clubs and other groups. Share one with your neighbor.

NO RISK 10 DAY MONEY BACK GUARANTEE

You must be completely satisfied or return 8" power saw kit for full refund. Fair enough?

RUGGED, VERSATILE PERFORMANCE PROVED BY MORE THAN 500,000 USERS!!

Send for our FREE catalog of America's greatest power tool values.

SEND FOR YOURS TODAY!

**AMERICAN MACHINE & TOOL COMPANY
 DEPT. PS-23, ROYERSFORD, PA.**

- American Machine & Tool Co. Dept. PS-23, Royersford, Pa.
- Send 8" Tilt Arbor Power Saw Kit at \$9.95.
 - Incl. Rip Fence at \$3.50 (both for 13.45)
 - Payment in full enclosed \$..... or
 - \$3 dep. enclosed, balance C.O.D. I MUST BE FULLY SATISFIED OR WILL RETURN WITHIN 10 DAYS FOR FULL REFUND, no questions asked.
 - Please send free catalog of America's greatest power tool values.

NAME _____
 ADDRESS _____
 CITY _____ ZONE _____ STATE _____
 (Please print)

GET READY FOR THE SPACE and SCIENCE ERA! SEE SATELLITES, MOON ROCKETS CLOSE-UP



AMAZING SCIENCE BUYS

for FUN, STUDY or PROFIT



See the Stars, Moon, Planets Close Up!

3" ASTRONOMICAL REFLECTING TELESCOPE

Study Venus—the brightest star Probed by Mariner II Spacecraft. 60 to 180 Power—Famous Mt. Palomar Type! An Unusual Buy!



Assembled—Ready to use! You'll see the Rings of Saturn, the fascinating planet, Mars, huge craters on the Moon, Phases of Venus, Star Clusters, Moons of Jupiter in detail, Galaxies! Equatorial mount with lock on both axes. Aluminized and overcoated 3" diameter high-speed f/10 mirror. Telescope comes equipped with a 60X eyepiece and a mounted Barlow Lens, giving you 60 to 180 power. Low-cost accessory eyepiece available for higher powers. An Optical Finder Telescope, always so essential, is also included. Sturdy, hardwood, portable tripod. FREE with Scope:

—Valuable STAR CHART plus 272 page "HANDBOOK OF HEAVENS" plus "HOW TO USE YOUR TELESCOPE" BOOK.
Stock No. 85,050-N\$29.95 Postpaid

4 1/4" Astronomical Reflector Telescope!

255 Power. New Vibration-Free Metal Pedestal Mount.
Stock No. 85,105-N\$79.50 F.O.B.

ASTRO-COMPASS AND TRANSIT



War surplus! Astro Compass alone cost Govt. \$75. We have added a Sighting Level to improve versatility. Hundreds of uses in carpentry, brick laying, foundation work, grading, irrigation or drainage. Much below cost of ordinary surveying instruments. Ideal for do-it-yourselfers. 10 1/4" high, 6" long, 4" wide. Adjustable leveling platform—2 spirit levels for aligning—also spirit level in sighting attachment. A tremendous bargain.

Stock No. 70,267-N\$19.95 Postpaid

Exciting New Color Experiments . . .

FABULOUS DIFFRACTION GRATING REPLICA KIT



See Nov. "Popular Science" Article Featuring This Wonder Material in Christmas Lighting Projects.

This amazing material breaks up white light into deep, rich hues. Sparkles with all the color of the spectrum. Comes alive with the flashing brilliance of rainbow magic. Now you can create spectacular color-coordinated effects and decorations—inside & out—convert old, unwanted earrings, cufflinks, pendants, etc., into beautiful, iridescent pieces of jewelry. Real conversation piece, too. Kit contains 8 1/2" x 5 1/2" sheets of see-through (transmission) and reflecting type grating, mounted circular grating, unmounted transmission and reflecting types, round pieces of mounting, double-faced mounting tape, stereo viewer, and Edmund Diff. Grating Idea Book.
Stock No. 70,563-N\$5.00 Postpaid

'FISH' WITH A MAGNET

Go Treasure Hunting On The Bottom

Great idea! Fascinating fun and sometimes tremendously profitable! Tie a line to our 5-lb. Magnet—drop it overboard in bay, river, lake or ocean. Troll it along the bottom—your "treasure" haul can be outboard motors, anchors, fishing tackle, all kinds of metal valuables. 5-lb. Magnet is war surplus—Alnico V Type—Gov't. Cost, \$50. Lifts over 125 lbs. on land—much greater weights under water. Order now and try this new sport.

Stock No. 70,571-N 5 lb. Magnet\$12.50 Postpaid
Stock No. 70,570-N 3 1/2 lb. size\$8.75 Postpaid
Stock No. 85,152-N 15 lb. size, \$33.60 FOB Barrington, New Jersey.



MAIL COUPON for FREE CATALOG "N"

NEW! 1000's of Bargains—164 Pages
EDMUND SCIENTIFIC CO., Barrington, N.J.
Please rush Free Giant Catalog-N.

Name.....
Address.....
City.....Zone.....State.....



SCIENCE TREASURE CHESTS

For Boys—Girls—Adults!

Science Treasure Chest—Extra-powerful magnets, polarizing filters, compass, one-way-mirror film, prism, diffraction grating, and lots of other items for hundreds of thrilling experiments, plus a Ten Lens Kit for making telescopes, microscopes, etc. Full instructions included.

Stock No. 70,342-N\$5.00 Postpaid

Science Treasure Chest DeLuxe—Everything in Chest above plus exciting additional items for more advanced experiments including crystal-growing kit, electric motor, molecular models set, first-surface mirrors, and lots more.

Stock No. 70,343-N\$10.00 Postpaid

WOODEN SOLID PUZZLES



12 Different puzzles that will stimulate your ability to think and reason. Here is a fascinating assortment of wood puzzles that will provide hours of pleasure. Twelve different puzzles, animals and geometric forms to take apart and reassemble, give a chance for all the family, young or old, to test skill, patience, and, best of all to stimulate ability to think and reason while having lots of fun. Order yours now.

Stock No. 70,205-N\$3.00 Postpaid

LARGE SIZE OPAQUE PROJECTOR

Ideal for photographers, this low-cost unit projects 3 1/2 ft. sq. image at 6 ft.—7 1/4 ft. sq. image at 12 ft. Projects photos, drawings, sketches, clippings, any opaque copy up to 6" x 6"—larger pieces in sections. Lenses are 2 plano-convex, 3 1/2" dia. mounted in 5 1/4" barrel. Projector is 11 1/2" high, 13 1/4" wide, 9" front to back, pressed steel in black wrinkle finish, bakelite handle. Uses two 200 watt bulbs—not included. Complete with side platform to hold illustrations, 6 ft. elec. cord, heat resist. plate glass mirror.



Stock No. 80,066-N\$42.00 Postpaid

MINIATURE WATER PUMP



Wonderful for experiments, miniature waterfalls, fountains, HO gage railroad backdrops, etc. Tiny (2 3/8" x 1 3/4") electric motor and pump ideal for hobbyists, labs, schools. Pumps continuous flow of water at rate of one pint per minute at a 12" head. With 2 D Batteries in series will pump to 24" high. Runs 48 hrs. on battery. Works in either direction. Self-priming.

Stock No. 50,345-N\$2.25 Postpaid

OPAQUE PROJECTOR



Projects illustrations up to 3" x 3 1/2" and enlarges them to 35" x 30" if screen is 6 1/2 ft. from projector; larger pictures if screen is further away. No film or negatives needed. Projects charts, diagrams, pictures, photos, lettering in full color or black-and-white. Operates on 115 volt, A.C. current, 6-ft. extension cord and plug included. Operates on 60 watt bulb, not included. Size 12" x 8" x 4 1/2" wide. Weight 1 lb., 2 oz. Plastic case with built-in handle.

Stock No. 70,199-N\$7.95 Postpaid

BUILD A SOLAR ENERGY FURNACE



A fascinating new field. Build your own Solar Furnace for experimentation—many practical uses. Easy! Inexpensive! Use scrapwood! We furnish instructions. This sun powered furnace will generate terrific heat—2000° to 3000°. Fuses enamel to metal. Sets paper aflame in seconds. Use our Fresnel Lens—14" diameter . . . 14".

Stock No. 70,130-N.....Fresnel Lens.....\$6.00 Postpaid

11" SQ. FRESNEL LENS F.L. 19"

Stock No. 70,533-N\$4.75 Ppd.

NOW...AT A FABULOUS SAVING...MAKE A BIG BERTHA WITH WAR-SURPLUS LENSES



Aero Ektars and Tessars at Less than 5% of Original Cost

Sept. '62 feature article in "Popular Science" tells how you can make a fabulous Big Bertha telephoto lens and camera at sensational saving. Originally sold to the Gov't. for over \$1,000, F/6, 24 in. Focal Length Lenses with 23" Lens Cones now sell for \$32.50 new, \$25.00 used. Also for Richest Field Wide-Angle, Low-Power (12X to 48X) Telescopes.

Opaque Projectors, Camera Obscuras, Copying Cameras, or 48-power Table Top Telescopes. These K22 aerial camera units easily removed from cones . . . Focal plane 10" outside of cone. Clear front lens diam.—4", rear 3 5/8". Wt. of cone—25 lbs. Diaphragm F/6 to F/22 (adjustable from 1" to 3 1/2" by flexible shaft). Picture size 9" x 9". Lens elements—4 (2 to brass cell). Carrying case wt. 26 lbs. Shutter not included. Shipping wt.—51 lbs.

Stock No. 85,059-N Used—Was \$39.50 . . . now \$25.00 f.o.b. Utah
Stock No. 85,060-N New—Was \$59.50 . . . now \$32.50 f.o.b. Utah
Above lenses in cells—out of cone and diaphragm

Stock No. 70,190-N\$22.50 Postpaid.

ORDER BY STOCK NUMBER. SEND CHECK OR MONEY ORDER. SATISFACTION GUARANTEED!

EDMUND SCIENTIFIC CO., BARRINGTON, N. J.

The march of SCIENCE

By Martin Mann

Faur eεεeur reedingg

æ face	b bed	c cat	d dog	ee key	
f feet	g leg	h hat	ie fly	j jug	k key
l letter	m man	n nest	œ over	p pen	
r red	s spoon	t tree	ue use	v voice	w window
y yes	z zebra	ς daisy	wh when	ch chair	
th three	th the	sh shop	3 television	q drink	
a father	au ball	a cap	e egg	i milk	o box
u up	ω book	ω spoon	ou out	oi oi	

Some first-graders will soon be studying the strange-looking alphabet shown at left. It has 43 characters—one for each of the basic sounds in the English language—and is supposed to help children learn to read faster and better by eliminating confusion over sounds. Ordinary letters must be combined in more than 2,000 ways to represent English sounds, and some letters can stand for many different sounds. The new alphabet, called Augmented Roman, has been tried in England and is now to be tested on a few classes in New York City. It is not intended to replace the old 26-letter alphabet except in the beginning grades. Once the children learn to read, they will be shifted gradually over to the standard system.

Why the grass is green

The green grass just sits there, soaking up sunshine, sucking water from the ground, inhaling carbon dioxide from the air—and converting those simple substances into rich food. Photosynthesis is the most remarkable chemical process known, and the most puzzling. Now Dr. Melvin Calvin, a University of California chemistry professor who has devoted his career to unraveling its mysteries, thinks he is close to the ultimate secret. Photosynthesis turns out to be very remarkable indeed.

Inside the green leaf are tiny factory particles, too small to be seen except under a microscope. To work, each particle must absorb a whole package of light energy at a clip. The package for the organism is very big: 30,000 to 40,000 calories of energy. This huge load is the smallest bite the organism can take. It takes that much light energy and converts it into chemical energy without even getting warm.

By delicately measuring the change in magnetism that occurs when an electron moves in a molecule, Dr. Calvin has now shown that two separate operations are involved. One light package

CONTINUED

HOW TO GET THIS 50¢ CATALOG FREE

(Send for it!)



This 1963 catalog describes the complete collection of Shakespeare Braggin' Tackle (that's tackle you'll brag about) for all types of fishing. It's packed with information—over 40 costly full-color pages worth—photos, descriptions, and prices of 69 reels, 231 rods, 484 different lines. Tempting off-season reading for every fisherman who is dreaming about Opening Day—and wants to be ready for it!

Now is the time to go armchair shopping. Find the right tackle for your kind of fishing and your favorite fishing area.

Mail the coupon below, with your name and address, to Shakespeare. You'll receive free, the 1963 Shakespeare Catalog plus a complimentary Pocket Fishing Calendar showing Best Fishing Days throughout the season. Please send no money. We want your good will!

Shakespeare
Braggin' Tackle

Dept. PSM-100A, Kalamazoo, Mich. • In Canada: Rexdale, Ont.

Please send free 40-page, full-color 1963 Shakespeare Catalog describing the complete collection of Braggin' Tackle. Include free Pocket Fishing Calendar.

NAME _____

ADDRESS _____

CITY _____ ZONE _____ STATE _____

The March of Science . . . continued

knocks an electron free from a "donor" material and into a "hole"—a vacant electron position—in an "acceptor" material. A second light package picks the electron up (leaving behind a new hole) to add its energy to a new, chemically powerful compound that ultimately becomes carbohydrate food. Many intermediate steps are required, but the starting point—the fundamental change that converts light energy into chemical energy—is these down-and-up jumps of electrons.

The drifting continents

The old legend of Atlantis, the lost continent that supposedly sank into the middle of the Atlantic Ocean, dies hard. More and more scientists now believe that the myth may have some foundation in fact. For one thing, there is high if not dry land—an undersea ridge—running straight down the middle of the Atlantic Ocean. No other ocean has anything like it. Even more obvious and intriguing are the shapes of the continents of South America and Africa. The east

.....
 : Some jobs can be done better after stay- :
 : ing up all night, reports a British doctor. :
 : The lack of sleep keeps you from con- :
 : centrating too hard and getting so tense :
 : you can't work right . . . Soft urethane :
 : foam, which is popular as cushioning for :
 : easy chairs and sofas, is now replacing :
 : the springs as well. A slightly less resil- :
 : ient form of urethane is just glued into :
 : the furniture "deck." It costs less to as- :
 : semble and should last longer—no coil- :
 : tying cords to break. :
 :

coastline of South America fits almost exactly into the west coastline of Africa, as if the two had once been a single continent that split and moved apart, opening up the ocean in between.

How could such a fantastic change in the face of the earth come about? There are at least two theories:

1. Princeton's Prof. R. H. Dicke believes that all the distant matter of the universe generates a very weak force that affects the earth. This "scalar field"

If You Can't Beat 'Em



Start a new career in growing Industrial or Military Electronics.

This is an age of Automation. More and more, factory production lines, chemical plants, textile mills, food companies are replacing workers with Electronically controlled machinery and equipment. But automation only threatens the job of the man who is *NOT* trained. For

the man with technical know-how, Automation opens the way to higher pay, more interesting work and a brighter future in America's fastest growing industry—Electronics, Radio-Television.

Job Counselors Recommend

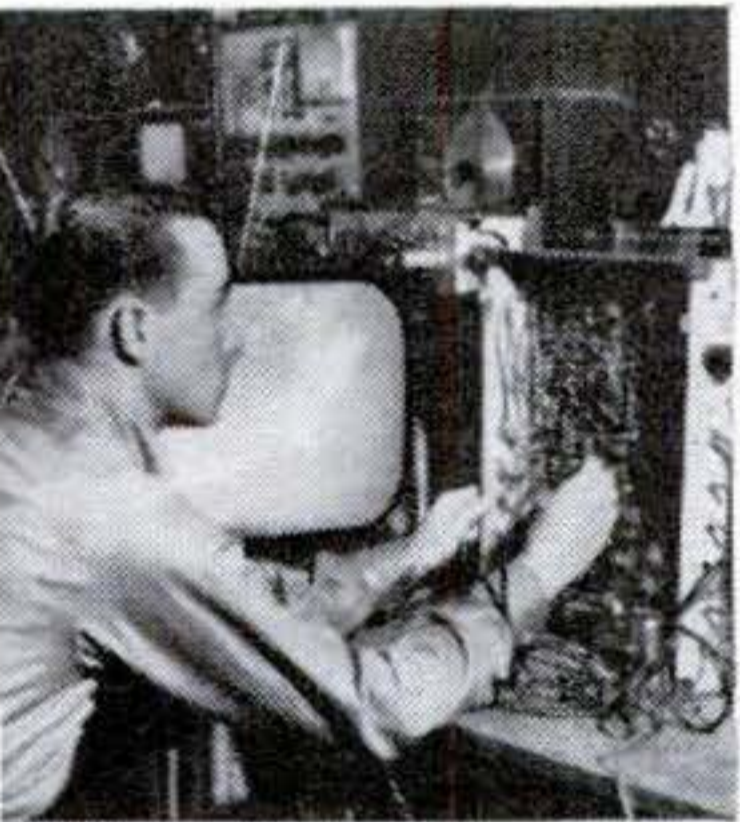

Have your own full or spare-time business in TV-Radio Servicing.

According to the U.S. Dept. of Labor, there will be a 42% increase in professional and technical jobs, but *absolutely no increase in jobs for men who are unskilled*. That's why job counselors advise the unskilled man, "for an interesting career, get into Electronics." You *must be trained* to get ahead in the next few

years, to insure your future, to have the money to buy the things you and your family want and need. And what better way is there than an easy-to-learn career in Electronics, with NRI training as your stepping-stone to success?

Train With the Leader

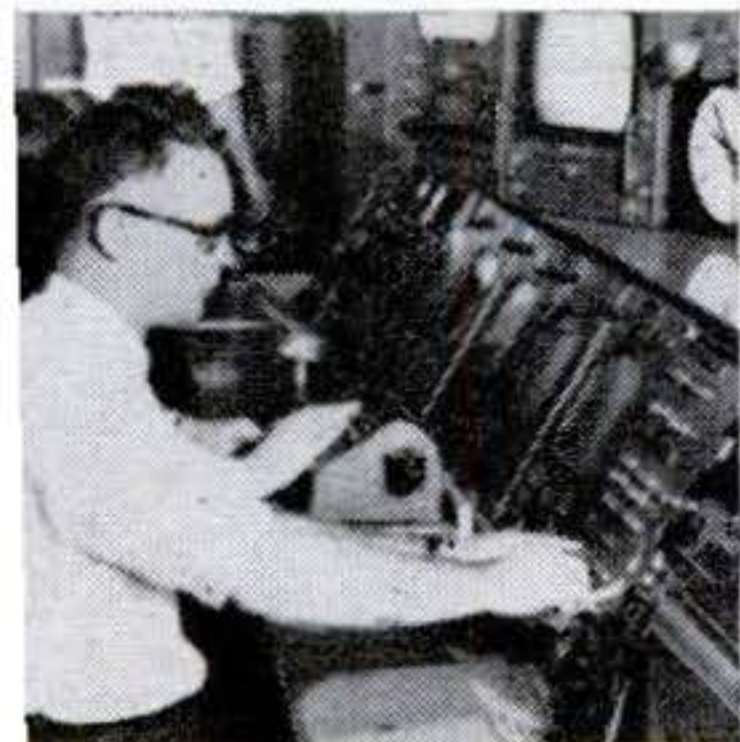

Prepare for good jobs in Communications. Earn your FCC License.

NRI training is practical—based on "learn-by-practice" methods using special training equipment included as part of your course at no extra cost. NRI is the largest home-study school of its kind. For nearly 50 years NRI has featured Electronics, Radio-TV training, offering complete

courses at low tuition rates. Make your move now to eliminate the threat of Automation and turn it into opportunity. Mail coupon for free catalog. National Radio Institute, Washington 16, D.C.



JOIN 'EM AUTOMATION MEANS OPPORTUNITY FOR THE SKILLED TECHNICIAN

Train Now at Home in Your Spare Time for a New Career in RADIO-TELEVISION ELECTRONICS

Mail Coupon for **FREE** CATALOG

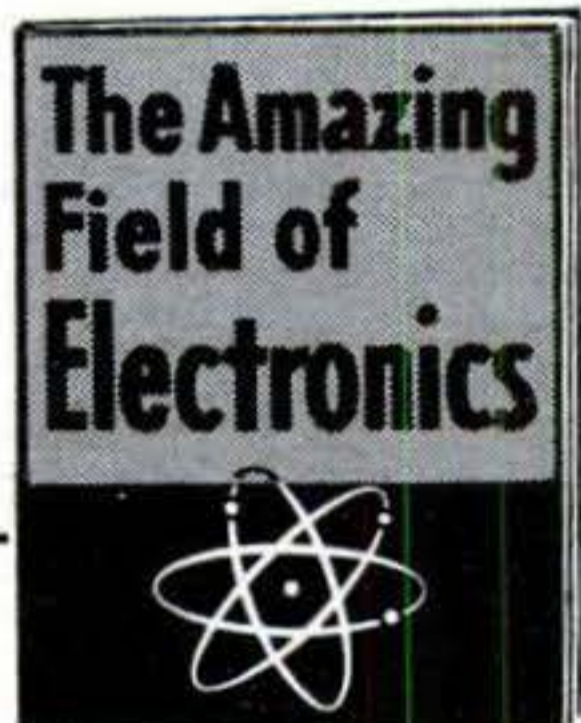

NATIONAL RADIO INSTITUTE
Washington 16, D.C. 3BB

Please send me complete information. (No representative will call) Please print.

Name.....Age.....

Address.....

City.....Zone.....State.....

Accredited Member National Home Study Council

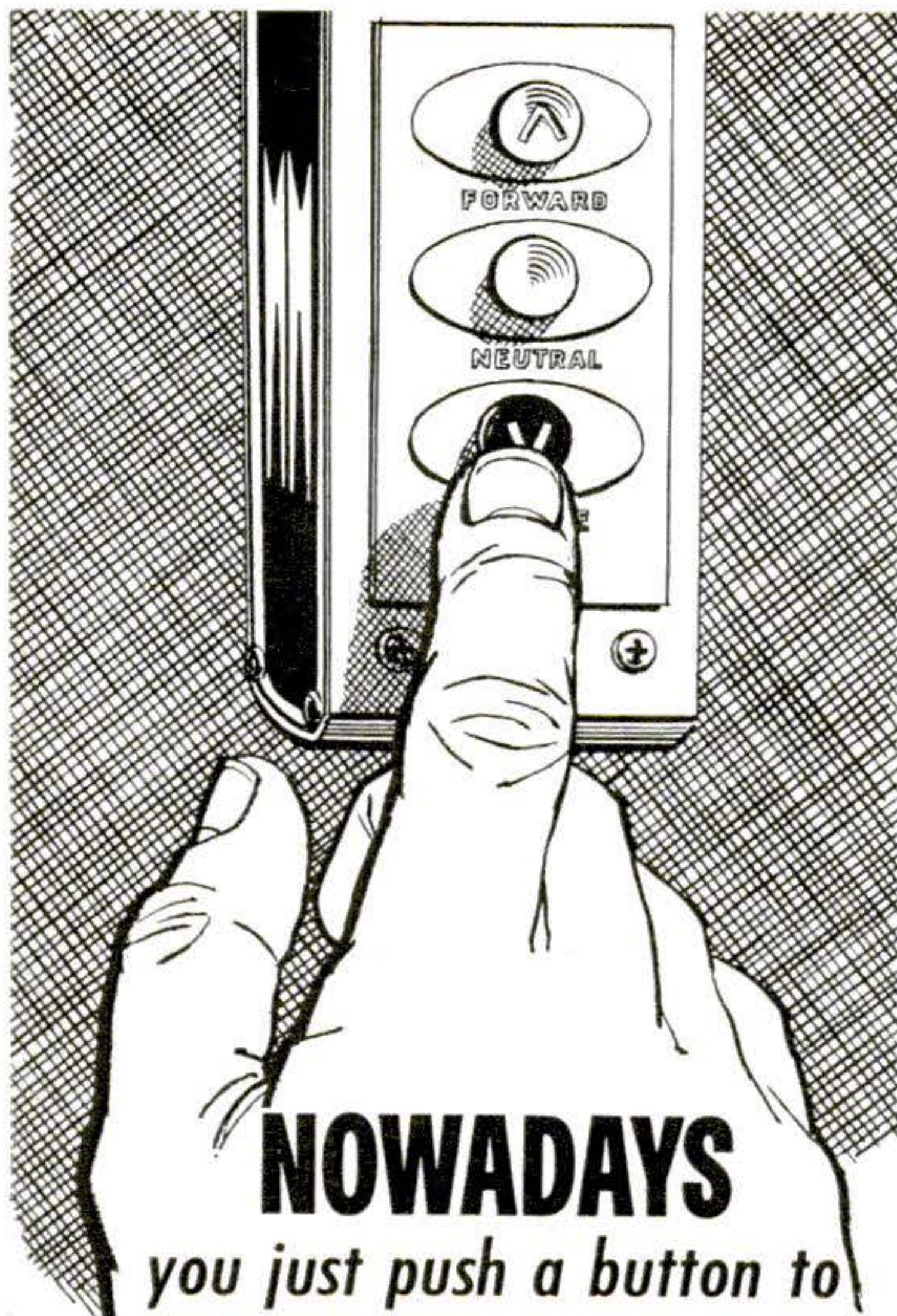

NOWADAYS

you just push a button to

- DOCK A BOAT • PLAY A FISH
- SHAKE A WEED • START A SKIER • MANEUVER ONTO A TRAILER

EVINRUDE PUSH-BUTTON ELECTRIC SHIFTING

Greatest advance in boating control since the driver moved up front! One button to go forward, one for neutral, another for reverse. Shifting is instant, automatic, electric! Ask your dealer for an eye-opening demonstration. Catalog FREE. Send coupon below.

EVINRUDE
FIRST IN OUTBOARDS

EVINRUDE MOTORS, 4018 N. 27th St., Milwaukee 16, Wis. Division of Outboard Marine Corp. Please send free 24-page catalog.

Name.....
 Address.....
 City.....Zone.....
 State.....

The March of Science . . . continued

would cause an extremely slow decrease in the gravitation that holds the earth in one piece; over millions of years, the loss in gravitation would let the earth expand, making it crack at the surface. Not many physicists believe in the scalar field. And even Professor Dicke regretfully concludes that it could not have expanded the earth fast enough to open up the Atlantic Ocean, which seems to be only about 200 million years old.

2. A number of scientists think that currents in the molten interior of the earth move the solid crust around, like rafts on a lake. The drift is very slow—about ½ inch per year—but it might have floated Africa and South America apart.

The hard evidence that can pin down the answer lies on the bottom of the sea—or under the bottom. Only in recent years, spurred by military interest in submarine warfare, have scientists begun to learn about the strange world beneath the water: submerged mountains, rivers, canyons, thick sediment beds. One of the most eminent of the oceanic explorers, Columbia's broad-shouldered, white-haired Prof. Maurice Ewing, was asked at a seminar last fall if his newest findings disprove the drifting-continent theory. Professor Ewing replied, rather ruefully, "I have the evidence now to refute *any* theory I can think up."

Machine learns to read

What may be the key to widespread use of electronic computers for all kinds of high-grade paperwork—language translation, automatic library searching, mail sorting, big-scale accounting—was demonstrated last fall by IBM. It is an experimental reader that can be taught to recognize almost any style of printing.

Reading is the bottleneck of much automation now. Most computers have to be fed the raw information by girls punching typewriter keys. There are some direct-reading machines, but they can decipher only a few styles of type. (The ones that banks use to read checks

CONTINUED

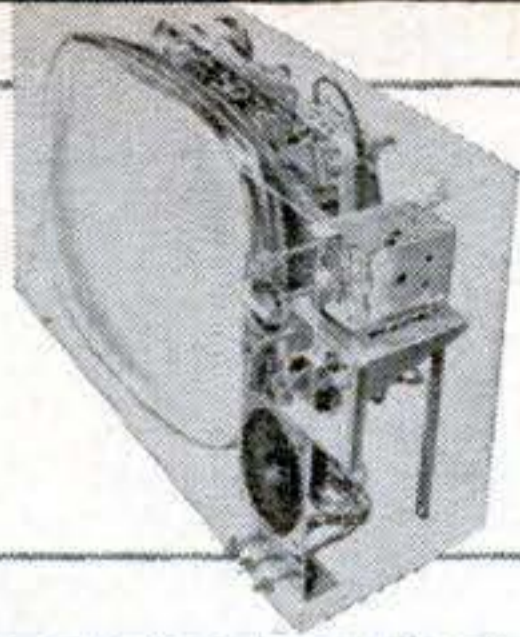

**TELEVISION
SERVICING**

**COLOR
TELEVISION**

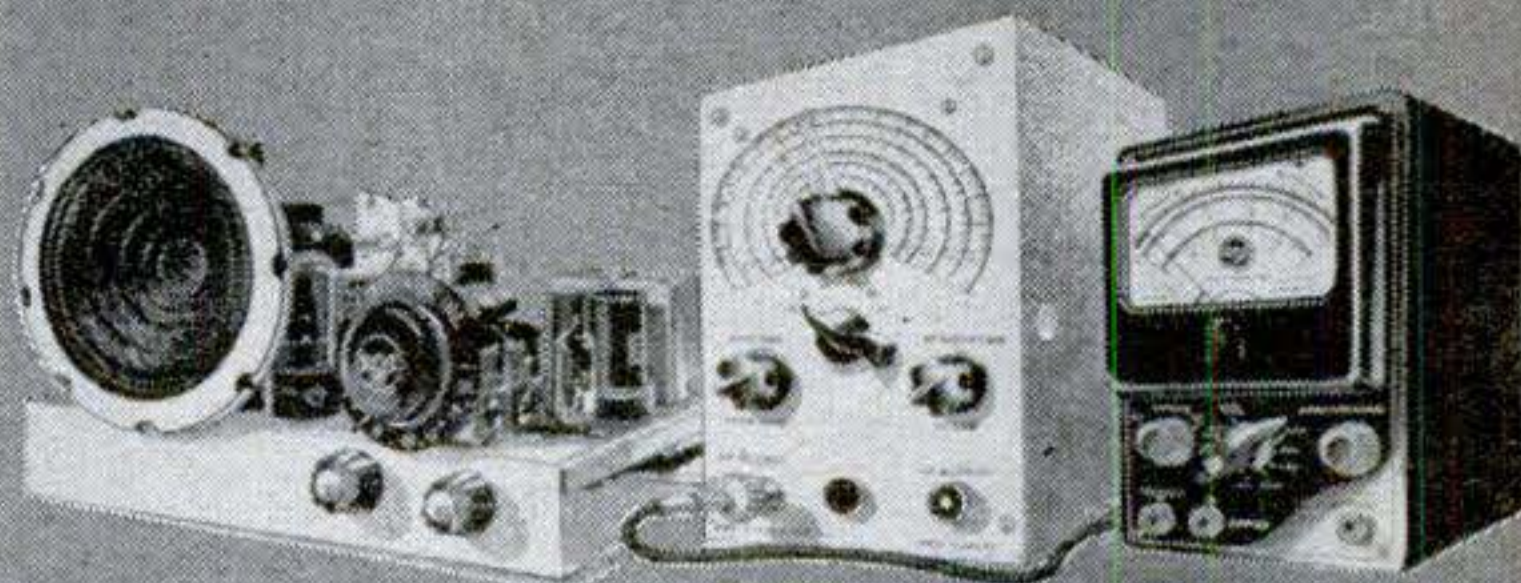
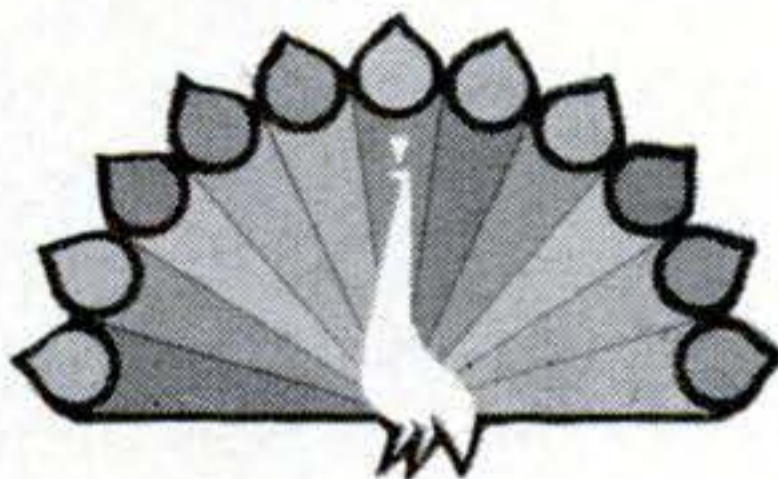

ELECTRONIC FUNDAMENTALS

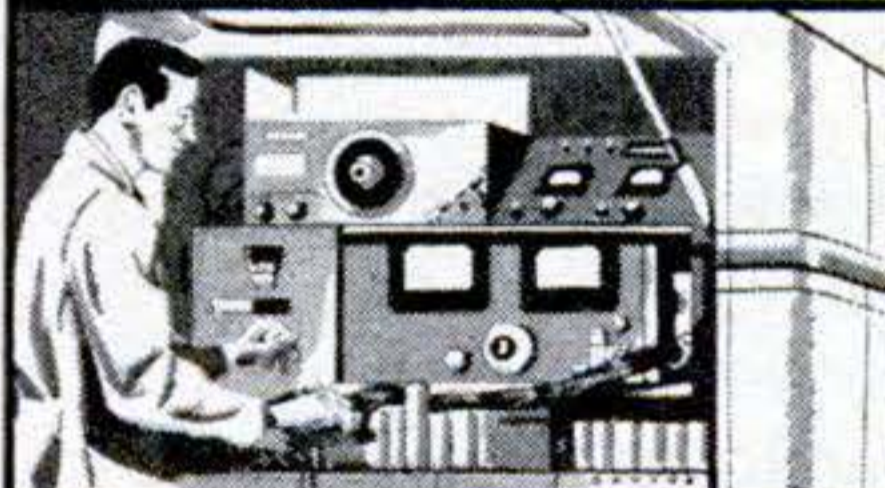

**COMMUNICATIONS
ELECTRONICS**

**RCA INSTITUTES
OFFERS A COMPLETE
SELECTION OF
HOME TRAINING
COURSES IN
ELECTRONICS**

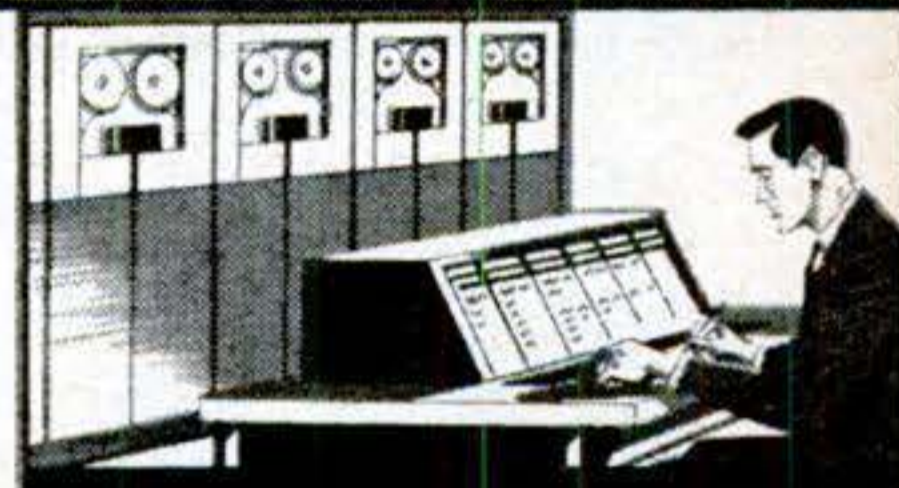

**COMPUTER
PROGRAMMING**



**AUTOMATION
ELECTRONICS**



TRANSISTORS

Prepare yourself for an exciting and profitable career in electronics. You need no special technical background to start your training. Even if you do not have high school training, you can start your training at home under the guidance of RCA Institutes. Choose from RCA Institutes' wide selection of courses including Electronic Fundamentals, TV Servicing, Color TV, Communications Electronics, Automation Electronics, Computer Programming, Transistors. Practical work starts with the very first lesson. You get

prime quality equipment that you keep and can later use on the job. You never have to take apart one piece of equipment to build another. Perhaps most important, RCA's liberal Voluntary Tuition Plan is the most economical home study method because you pay only for lessons as you order them. If you should interrupt your training at any time, you do not owe one cent. No other obligations. No installment payments required! Licensed by the New York State Department of Education. Approved for Veterans.

Act today! Send for this 64-page career book FREE!

CLASSROOM TRAINING

Classroom Training in New York City and Los Angeles. Day and Evening Classes start four times a year. In addition, Radio Corporation of America offers a limited number of basic courses in Chicago, Philadelphia, and Cherry Hill, N. J. (near Camden). Detailed information on request.

To save time, paste coupon on postcard

RCA INSTITUTES, INC. Dept. PS-23
A Service of the Radio Corporation of America
350 West 4th St., New York 14, N. Y.

Please rush me your FREE illustrated 64-page book describing your home training programs. No obligation. No salesman will call.

Name _____ Age _____
(please print)

Address _____

City _____ Zone _____ State _____

CANADIANS—Take advantage of these same RCA courses at no additional cost. No postage, no customs, no delay. Send coupon to: RCA Victor Company, Ltd., 5581 Royalmount Ave., Montreal 9, Quebec

RCA INSTITUTES, INC. Dept. PS-23
A Service of the Radio Corporation of America
350 W. 4th Street, New York 14, N. Y.
610 S. Main St., Los Angeles 14, Calif.



The Most Trusted Name in Electronics

NOW FROM RAMBLER—SPORTS-CAR ACTION!

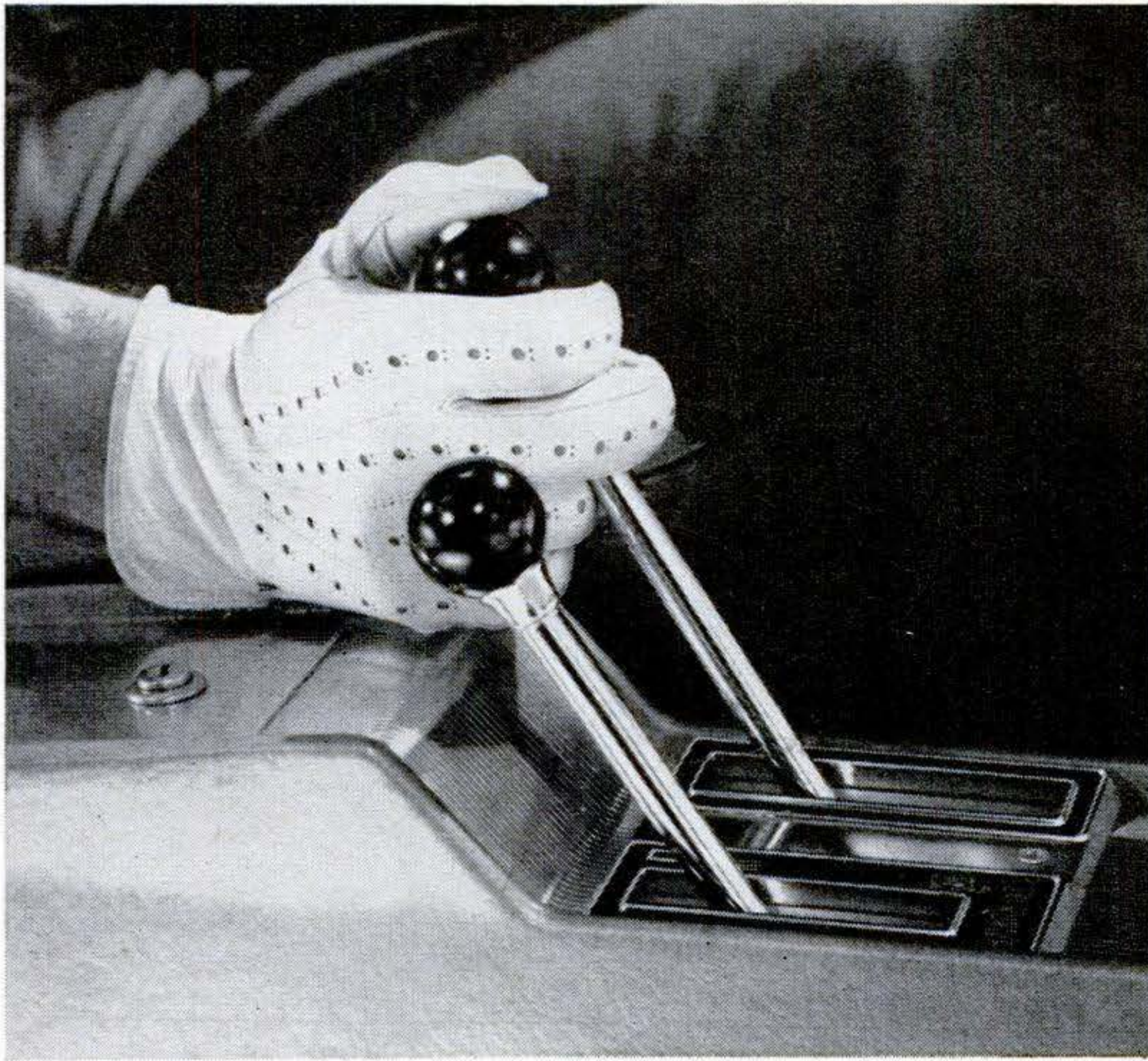

NEW TWIN-STICK FLOOR SHIFT WITH INSTANT OVERTAKE

You call the shots as never before when you operate from the bucket seat of a spanking new '63 Rambler with the new Twin-Stick Floor Shift transmission option.

Both stick shift and overdrive control lever are handsomely mounted on the sporty console, right at your fingertips.

And atop the stick shift you find a button that permits instant kickdown out of cruising gear and into sports-car-like action. In effect, *five* forward speeds can be quickly selected.

And that's only part of the

'63 Rambler story. The new Classic 6 and Ambassador V-8 also feature all new Advanced Unit Construction—new curved glass side windows—dozens of other far-ahead features that won Rambler the '63 "Car Of The Year" award by *Motor Trend Magazine*.

But come see for yourself. Sample the thrill of Rambler's new, exclusive Twin-Stick Floor Shift with Instant Overtake at your Rambler dealer. And while you're there, ask him for your free X-Ray Book comparisons of all the '63 cars.

RAMBLER

Motor Trend "Car Of The Year" for '63

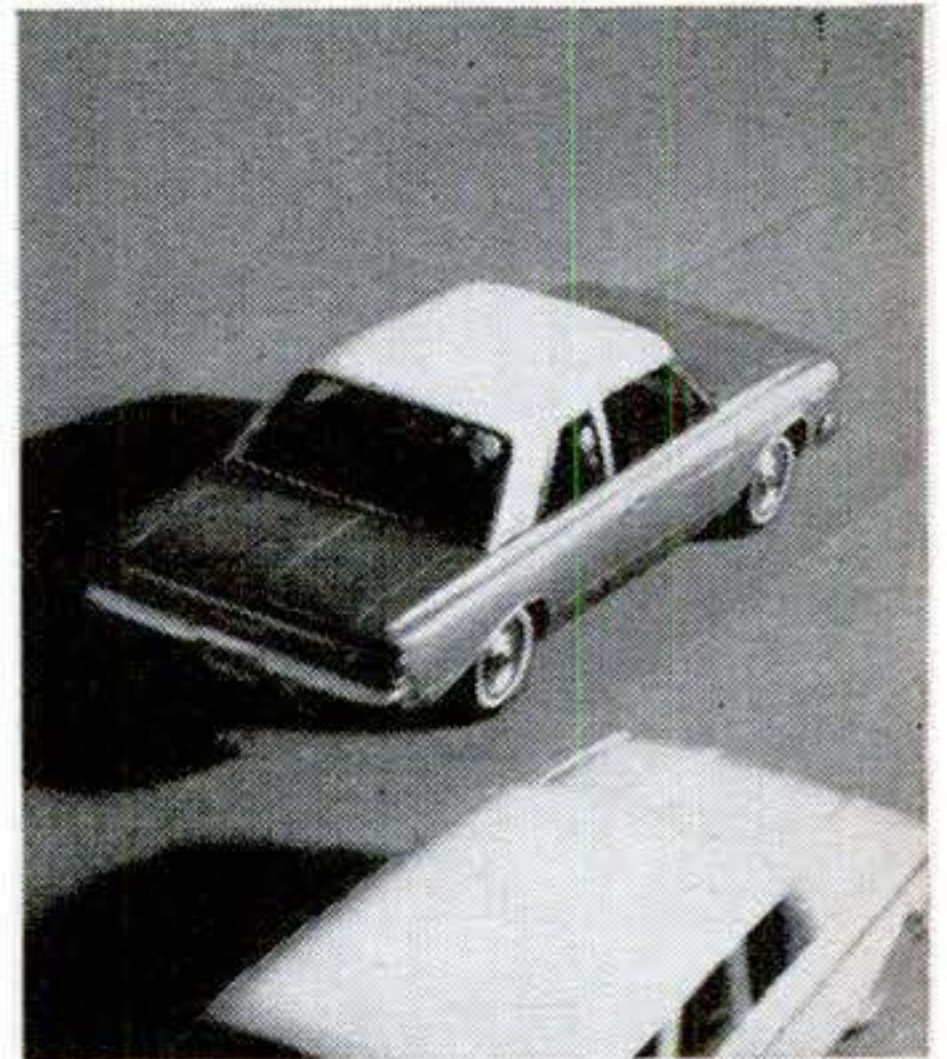

INSTANT PASSING ... because you're out of cruising gear and into passing gear at the touch of a button. Real sports-car action!



INSTANT EXTRA ECONOMY ... when you flick the convenient overdrive control lever right next to the gearshift.



AWARD-WINNING EXCELLENCE ... Rambler wins *Motor Trend Magazine's* '63 "Car Of The Year" award.

Available after 400 years!

valuable acreage on Old Spanish Land Grant

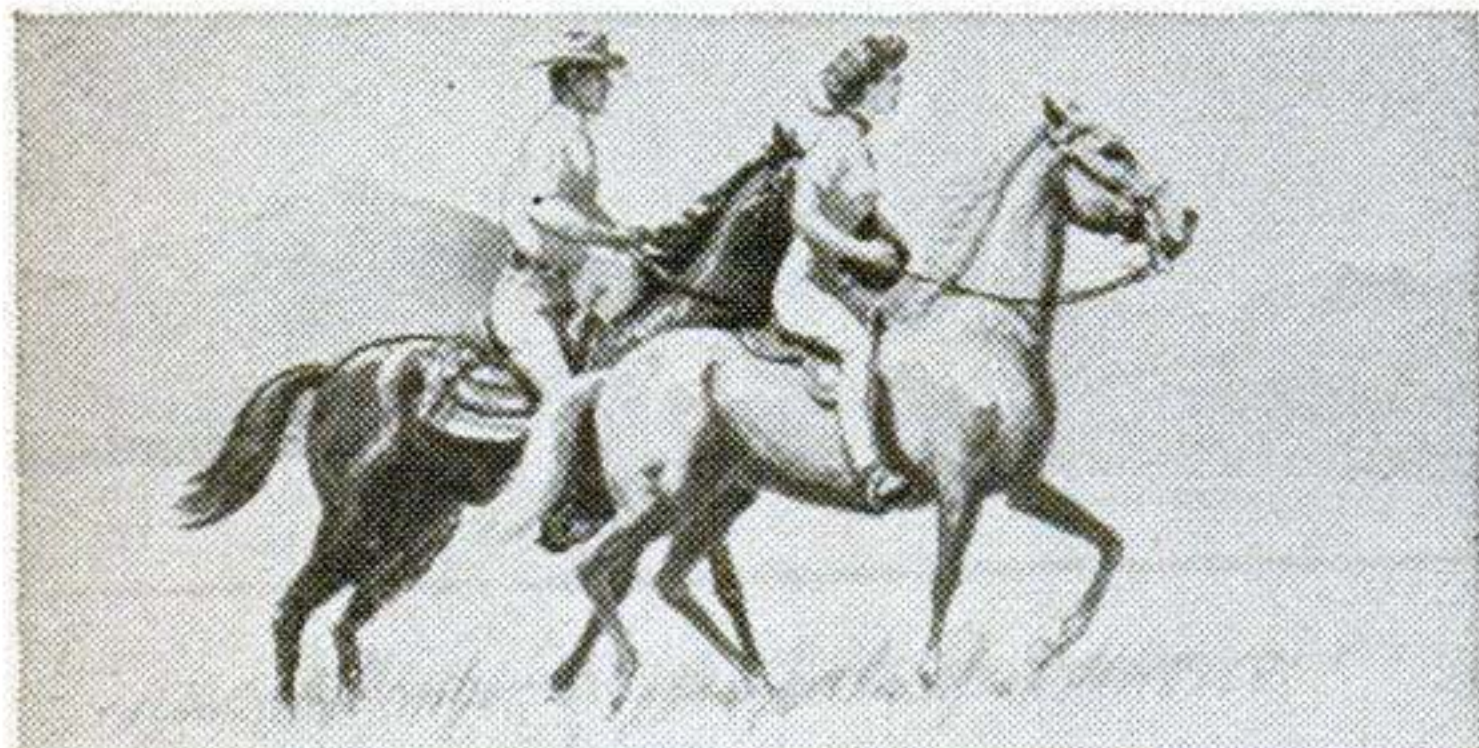

**Amazing land bargain at
booming ALBUQUERQUE, N.M.
—as little as \$10 monthly**

With 274,000 people now and streaking toward a million, fast-growing Albuquerque, New Mexico, now offers you the opportunity of a lifetime to own choice big-city homesite land at far below current market prices. Learn how you can actually be a big landowner here for only \$10 monthly and get in on the fortune-building potential of big-city land in this booming sunshine resort metropolis, famed for the best climate in the U.S.A.

For the first time in history, this beautiful old Spanish Land Grant is now being subdivided into big Western-size half-acre and full-acre homesites, and offered to land investors at discounts from all other current land prices in the entire Albuquerque area. Guaranteed ideal land for building, with roads, power, phones, water system already available to those desiring to build homes now or later.

RIO RANCHO ESTATES is located directly on the banks of the romantic Rio Grande River, *only five minutes from metropolitan Albuquerque*, and right next to a \$12,000-acre golf course development. Schools, churches, theatres, big-city shopping all just a few minutes downtown from property.

FOR INVESTMENT-RETIREMENT

Nowhere else in the entire Southwest can you buy choice land in such a prime location—so close to a major city—for as little as \$10 monthly. Complete price only \$795 per half-acre, \$1,495 per full-acre ranch estate. Remember—this is big-city land, with adjacent property already priced at \$4,500 to \$12,000 per acre. Act now! Land prices are starting to skyrocket in this "Sunshine Paradise" of the great Southwest. Rush coupon for FREE fact book, land maps, photos. No cost or obligation.

RIO RANCHO ESTATES

A Division of American Realty & Petroleum Corp.

RIO RANCHO ESTATES, Dept. 231-C
1429 Central Avenue, N.W.
Albuquerque, New Mexico

Please rush FREE fact book, land maps, photos, and details on your big-city land opportunity at Albuquerque, New Mexico.

Name.....

Address.....

City.....Zone.....State.....

© 1962 Rio Rancho Estates, Inc.

5R-1



The March of Science . . . continued

might sink and smother. New studies promise something more solid.

Stanford astronomers think the moon's surface is "cotton candy" or maybe "Cracker Jack." Their measurements of radio waves indicate that the moon is very porous to a depth of at least several yards. The material could be lightly matted filaments like cotton candy or crumbly cells like Cracker Jack.

Meanwhile Caltech scientists have been remeasuring the moon's temperature. The dark side gets colder than anyone suspected (270 degrees below zero F.) but there are a few spots that cool off surprisingly slowly. These warm spots are probably patches of solid rock—very good landing places.

Atomic rays vs. trees

You get a glimmering of what atomic war might do from this picture of the Biology Gamma Forest at Brookhaven



National Laboratory, N. Y. These dead trees are the casualties of six months' nearly continuous exposure to gamma rays from a very hot piece of radioactive cesium (on a pipe, circled in photo). Some trees can take it better than others: Pitch pine was killed by 20 roentgens per day; sedge stood up to 350 roentgens per day. Oddly enough, not all the trees were killed by gamma rays alone. Insects resist radiation better than plants, so the rate of destruction by insects goes up as tree vitality declines. ■ ■

BE THE MAN IN DEMAND

Train at home for a high-paying job in one of these 4 major fields



**N.T.S. TRAINED
TECHNICIANS ARE
HIGHER PAID ...
MORE RESPECTED ...
CONFIDENT
OF SUCCESS**

START NOW in one of these "Big 4" Industries, and be among the most sought after technicians in America. As an N.T.S. Trained Technician you can enjoy higher pay, rapid promotion, lifelong security.

N.T.S. TRAINS YOU RIGHT, FAST AND EASY!

Incomplete, "short-cut" training limits your earning power, even disqualifies you for top-pay jobs. N.T.S. gives you everything in *All Phases* ... to qualify you for any job in your field ... for greater profits the year round.

BETTER, MORE COMPLETE, LOWER COST TRAINING

N.T.S. Home Training is proved and tested in N.T.S. Resident School Shops and Laboratories — the oldest, largest school of its kind in the world. You learn *all phases*, and receive everything you need — Lessons, Manuals, Diagrams, big professional Kits with parts, tools, instruments for experimental, repair, service, troubleshooting projects. Yet N.T.S. Training costs less; only 1 Low Tuition. Other schools make several courses from the material in each of our Master Courses.

ELECTRONICS TELEVISION AND RADIO

YOU ARE NEEDED in All Phases of ELECTRONICS TELEVISION- RADIO ... Servicing, Communications, Broadcasting, Manufacturing, Automation, Radar and Micro Waves, Missile and Rocket Projects, plus all the other high-pay branches of this vigorous Industry. N.T.S. Shop-Tested Home Training gives you ONE MASTER COURSE ... at ONE LOW TUITION ...

INCLUDES RADIO SET, TV SET, MULTITESTER.

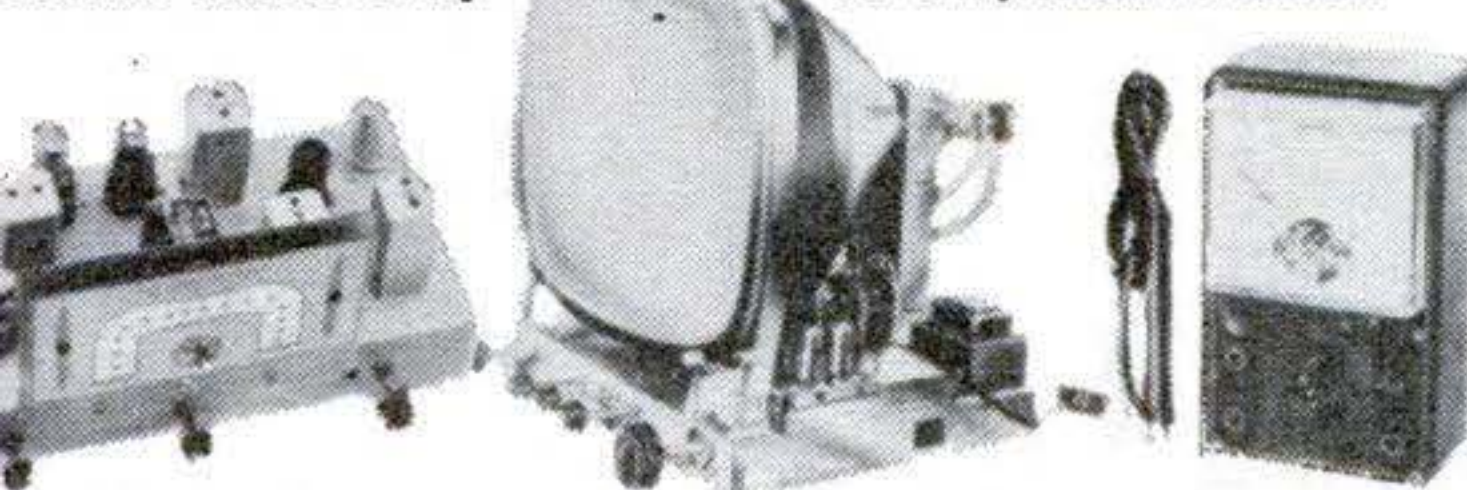

AUTO MECHANICS AND DIESEL

TAKE YOUR CHOICE ... be a successful all-around mechanic in cars, trucks and heavy-engines. Or specialize in your favorite field ... Tune-Up, Automatic Transmissions, Farm Mechanics, Trucks and Buses, Stationary Installations, Foreign Cars, or get into Auto Air Conditioning, Engine Rebuilding, Diesel, and other high-pay fields, or go into business for yourself.

INCLUDES SOCKET SET, ANALYZER, TOOLS.

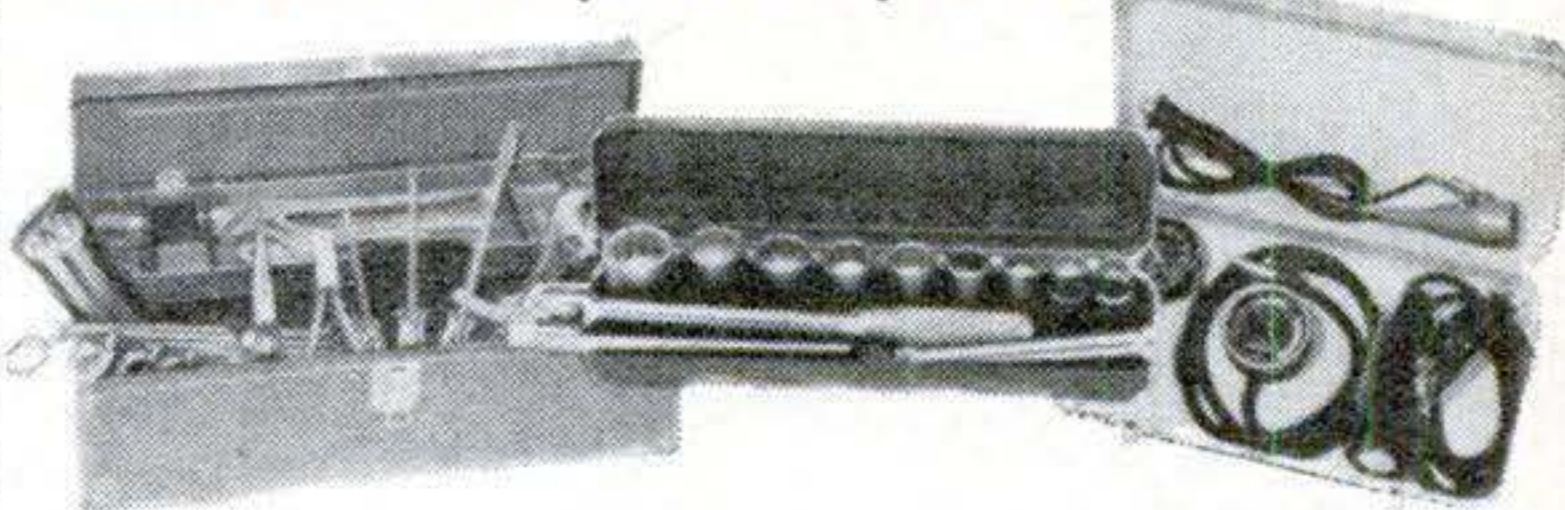

AIR CONDITIONING

**REFRIGERATION
ELECTRICAL
APPLIANCES**

FUTURE BRIGHT FOR TRAINED MASTER TECHNICIANS. Over 30,000 new Technicians must be trained annually. You are needed to help service and repair the million air conditioners, refrigerators and electrical appliances that will need fixing this year alone. You can go places in your own business or with a manufacturer, dealer, distributor or department store. With All-Phase training, your earning power is unlimited!

INCLUDES TESTER, GAUGES, TOOLS.

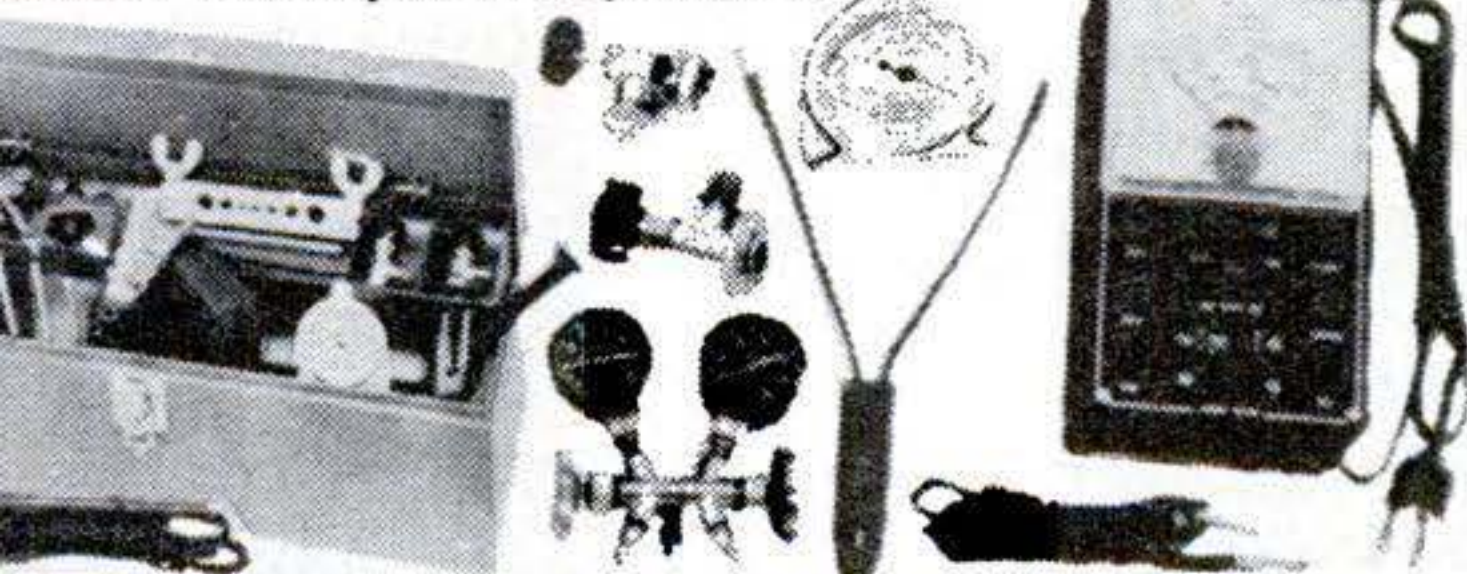

HOME APPLIANCE TECHNICIAN'S COURSE

MILLIONS OF HOME APPLIANCES NEED FIXING ... Every home is your market for Full-Time career or spare-time "Second Income." All you need is a workbench, spare time and N.T.S. Home Training. Costs less than \$1.50 per week. Repair any home appliance—from toasters, electric irons to washing machines and even room air conditioners — right in your own workshop. Or take a high-pay job with appliance manufacturer or large service company.

INCLUDES TOOLS, PROFESSIONAL TESTER, SOLDERING SET.



NATIONAL TECHNICAL SCHOOLS
WORLD-WIDE TRAINING SINCE 1905
4000 So. Figueroa St., Los Angeles 37, Calif.

Accredited Member
National Home Study Council

NATIONAL TECHNICAL SCHOOLS

WORLD-WIDE TRAINING SINCE 1905

National Technical Schools, Dept. C-23
4000 S. Figueroa St., Los Angeles 37, Calif.
Please rush FREE Book and Actual Lesson checked below.
No obligation. No salesman will call.

- Electronics — TV — Radio
- Auto-Mechanics & Diesel
- Air Conditioning, Refrigeration & Electrical Appliances
- Home Appliance Technicians Course

Name _____ Age _____
Address _____
City _____ Zone _____ State _____

Check here if interested ONLY in Resident Training at L.A.

RESIDENT TRAINING AT LOS ANGELES
If you wish to take your training at our famous Resident School in Los Angeles — the oldest and best school of its kind in the world — check special box in coupon.

SEND FOR **FREE BOOK** (fully illustrated) and **ACTUAL LESSON**



**NO OBLIGATION
NO SALESMAN
WILL CALL**



Getting Ahead

By Dr. Lewis R. Fibel

A monthly column to help you prepare yourself for a better job

Future Scientists of America take note: The National Science Teachers Association is again conducting a program aimed at discovering and encouraging students with the potential of becoming tomorrow's leaders in science and engineering. More than 30,000 high-school students are expected to take part, performing experiments and reporting results. More than \$10,000 in scholarships and savings bonds will be awarded to entries judged best at regional and national levels. The program ("Future Scientists of America") is sponsored by Ford Motor Co.

engineers, health physicists, radiation specialists, and others. If you are interested, write the Director, Division of Personnel, A.E.C., Washington 25, D.C.

"**Careers in Science**" is a fine 15-cent investment for high-school students interested in science or its applications as a profession. The pamphlet, available from the American Association for the Advancement of Science, 1515 Massachusetts Ave. N.W., Washington 5, D.C., describes specific careers and lists over 200 publications that give fuller details.

A special training course in the application of radioisotope techniques to the field of highway engineering has been announced by the Oak Ridge Institute of Nuclear Studies (P.O. Box 117, Oak Ridge, Tenn.).

"What opportunities are available for surveyors? How much would I make?"
—R.L.S., Provo, Utah.

Surveyors usually work with engineering, architectural, or construction firms. They use transits and other instruments to measure the earth's surface. They must be able to interpret the measurements, and draft plans and maps. A prime personal requisite is a liking for outdoor work. You should be in good health, have some mathematical ability and physical dexterity.

There are over 25,000 surveyors in the U.S., with every indication of a steady demand. Minimum training needed is a technical course in high school, but most jobs require additional training of the kind you might get in the armed forces or in a technical institute. Many states require a licensing exam for surveyors.

In industry, skilled surveyors are paid three or four dollars an hour.

Schools Awarding the Largest Number of Doctorates in Engineering (in order)	Research Income Received by the College of Engineering
---	--

1. M. I. T.	\$11.5 Million
2. Illinois	7.5 Million
3. Michigan	16.0 Million
4. Purdue	1.7 Million
5. Stanford	3. + Million
6. Wisconsin	0.9 Million
7. California	3.4 Million
8. Columbia	3.5 Million
9. Carnegie Tech	2.5 Million
10. CalTech	2.3 Million

Want to do graduate work in engineering? Then you'll be interested in the list above of the 10 schools that awarded the most doctorates in engineering last year. Also interesting is the comparison of research money flowing into those schools.

The Atomic Energy Commission needs you—if you have the know-how. They are out to recruit nuclear engineers, nuclear physicists, nuclear safety

featuring the
new 1963
knight-kit
CATALOG
(pages 1 to 69)

ALLIED ELECTRONICS for everyone

1963

our 42ND year

CATALOG 220
INDEX: PAGE 448

ALLIED RADIO
100 N. WESTERN AVE. • CHICAGO 80, ILLINOIS • MAYmarket 1-8800

Satisfaction Guaranteed or Your Money Back

FREE

ALLIED 1963 CATALOG

**464 PAGES
WORLD'S LARGEST
ELECTRONICS CATALOG**

**BIGGEST SELECTION
BIGGEST SAVINGS!**

see what's new in
STEREO HI-FI

top buys in
TAPE RECORDING

latest values in
**CITIZENS BAND &
SHORTWAVE RADIOS**

exciting build-your-own
knight-kits®

NO MONEY DOWN: Now! Get More
Buying Power with your
Allied Credit Fund Plan!

Satisfaction guaranteed or your money back

ALLIED RADIO

The World's Largest Electronic Supply House

SAVE MOST ON:

- Everything in Stereo Hi-Fi
- New All-Transistor Stereo
- KNIGHT® Super-Value Hi-Fi
- Tape Recorders & Tape
- Citizens Band 2-Way Radios
- Transistor & FM-AM Radios
- Phonographs & Records
- Ham Station Equipment
- PA Systems, Intercoms
- Latest Test & Lab Instruments
- TV Tubes, Antennas, Accessories
- Parts, Tubes, Transistors, Books, Tools

ALLIED EXCLUSIVES:
See special products
and values available
only from Allied—plus
all the famous makes!

FREE

SEND FOR YOUR COPY TODAY!

ALLIED RADIO, Dept. 24-19-B
100 N. Western Ave., Chicago 80, Ill.

Send FREE 1963 ALLIED Catalog

Name _____
PLEASE PRINT

Address _____

City _____ Zone _____ State _____

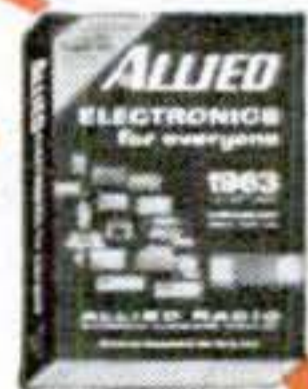

FREE CAREER BOOKLET

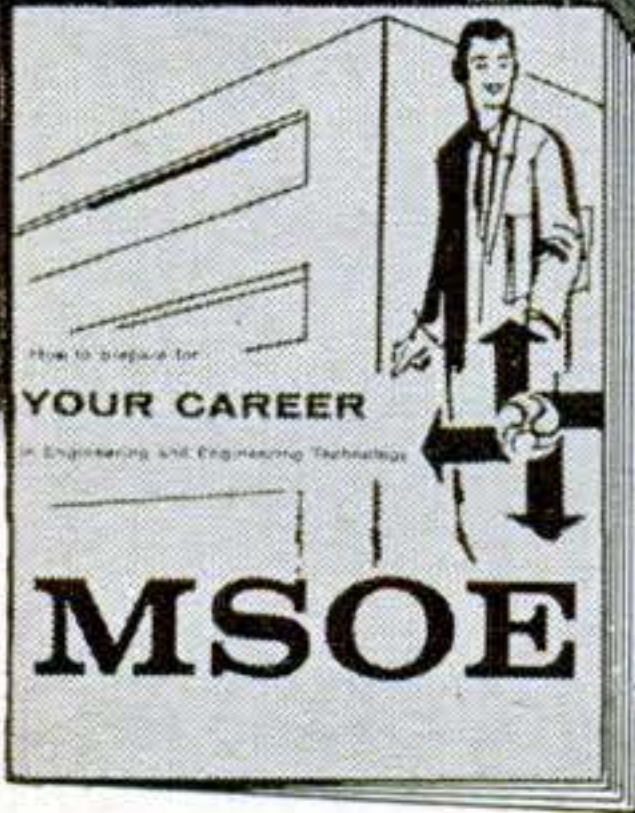

To guide you to a
successful future in

ELECTRONICS RADIO-TV COMPUTERS ELECTRICAL ENGINEERING

This interesting pictorial booklet tells you how you can prepare for a dynamic career as an Electrical Engineer or Engineering Technician in many exciting, growing fields:

**MISSILES • AVIONICS • AUTOMATION
SALES • DEVELOPMENT
ELECTRICAL POWER • ROCKETRY
RADAR • RESEARCH**

Get all the facts about job opportunities, length of study, courses offered, degrees you can earn, scholarships, part-time work — as well as pictures of the Milwaukee School of Engineering's educational and recreational facilities. No obligation — it's yours free.

MILWAUKEE SCHOOL OF ENGINEERING

MAIL COUPON TODAY!

Milwaukee School of Engineering
Dept. PS-263, 1025 N. Milwaukee St., Milwaukee, Wis.

Please send FREE "Your Career" booklet

I'm interested in

Electronics Radio-TV Computers
 Electrical Engineering Mechanical Engineering

Name..... Age.....

PLEASE PRINT

Address.....

City..... Zone..... State.....

I'm eligible for veterans education benefits.

Discharge date..... MS-117

"Can I learn locksmithing by correspondence?"—B.T., Pendleton, Ore.

Yes, this is entirely practicable. A systematic and comprehensive home study course is available through The Locksmithing Institute, 150 Park Ave., East Rutherford, N.J. The school is accredited by the National Home Study Council. The course provides equipment as well as instruction.

"Where can I study electrical construction and wiring? I am a high-school graduate."—C.W., Norfolk, Neb.

Organized curriculums are offered at 16 colleges scattered throughout the country. The schools nearest you are two in Illinois: Chicago Technical Institute (2000 S. Michigan Ave., Chicago) and Joliet Junior College (East Jefferson St., Joliet).

"I like to tinker with radio and TV sets. Do you think I should select electronics as a career? Where could I study?"—L.H.P., Kings Mountain, N.C.

If you like to tinker, you have some interest in the field. But electronics is a lot more than tinkering—and a lot more than radio and TV. For success as an electronics technician, you should be confident of your ability in mathematics, science, and English. Did you do well in these subjects in high school? If so, you might consider a career in electronics, perhaps one that involves testing and maintaining the complex electronic instruments used in the space and missile industries, or in communications.

A fine two-year course in electronics is given at Charlotte College (221 N. Cecil St., Charlotte, N.C.). Tuition for North Carolina residents is \$180 a year.

Many other colleges also offer electronics, and some courses are available by correspondence.

.....
Send your questions on careers and technical training to:

Getting Ahead Editor, POPULAR SCIENCE
355 Lexington Ave., New York 17, N.Y.
Not every question may be used. Questions cannot be answered by individual letters.

AUDELS

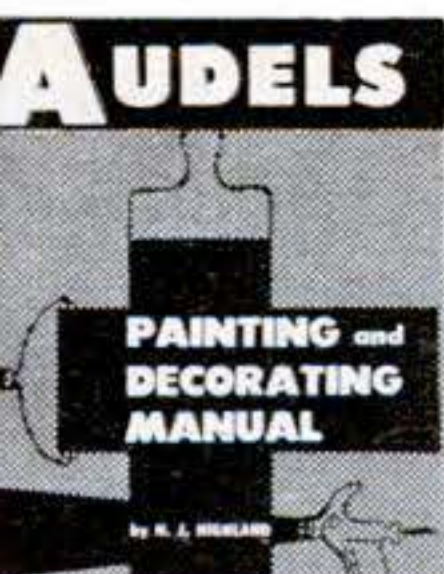

PAINTING and DECORATING MANUAL

Just off press! Practical, modern guide for painters, apprentices, home owners & all paint users. 585 Pgs. \$4.00
Circle No. 7 In COUPON

AUDELS

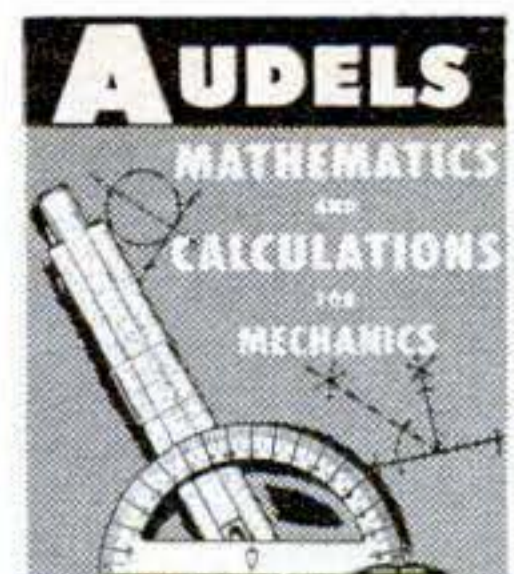

MATHEMATICS AND CALCULATIONS FOR MECHANICS

Study or reference. First principles thru all phases. Emphasis on mech. and eng. problems. Indexed. 550 Illus. 672 Pgs. \$4.00
Circle No. 11 In COUPON

AUDELS

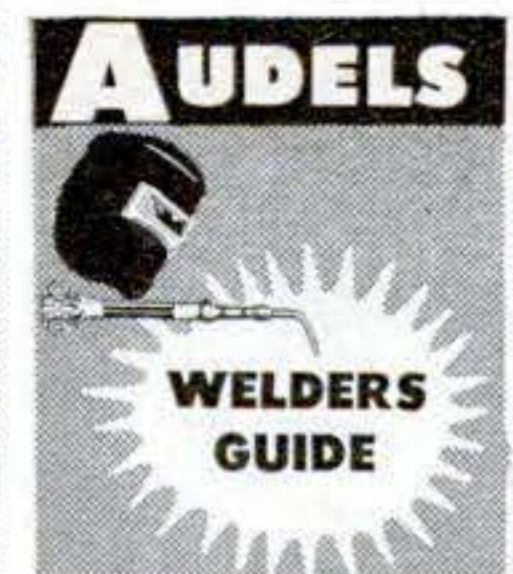

WELDERS GUIDE

Concise, practical guide to operation & maintenance of all welding machines. A must for all welders! Illus. 608 Pgs. \$4.00
Circle No. 10 In COUPON

AUDELS

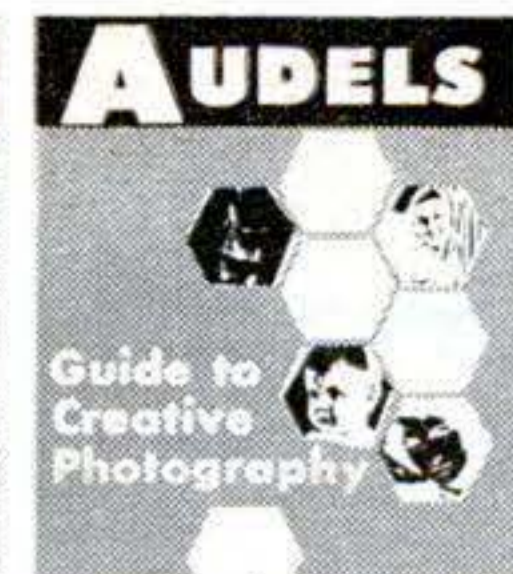

Guide to Creative Photography

Brand new! Simple picture taking, developing & printing, to lens optics, composition & color work. Illus. 416 Pgs. \$3.95
Circle No. 47 In COUPON

AUDELS

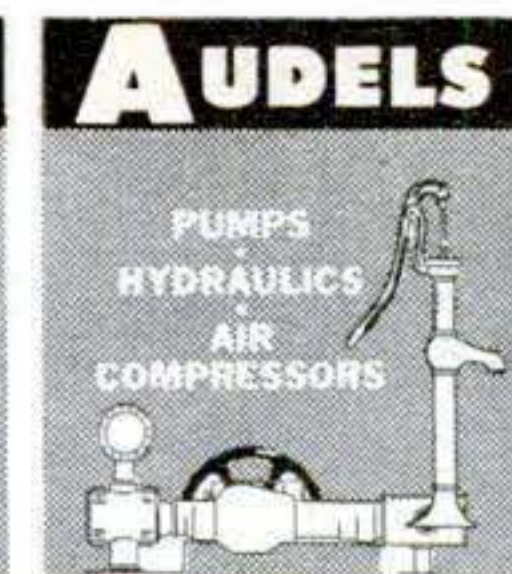

PUMPS HYDRAULICS AIR COMPRESSORS

Guide for engineers, operators, mechanics, students, etc. Questions & answers. 3 books in one! Illus. 1248 Pgs. \$6.00
Circle No. 40 In COUPON

AUDELS

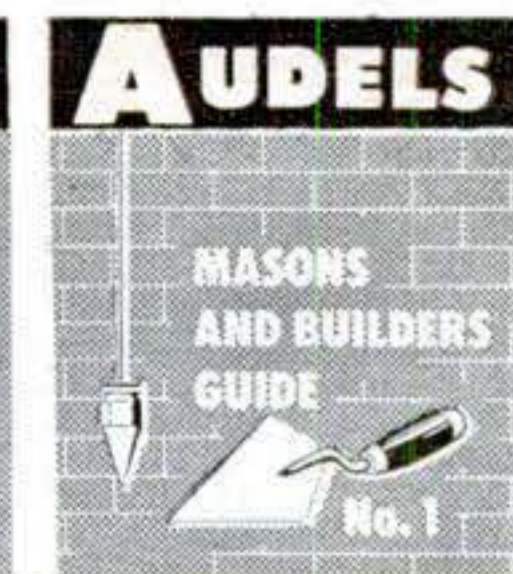

MASONS AND BUILDERS GUIDE No. 1

Four practical vols. Last word on construction for bricklayers, stone masons, cement workers, etc. 2067 Ill. 1100 Pgs. Set \$9
Circle No. 26 In COUPON

AUDELS

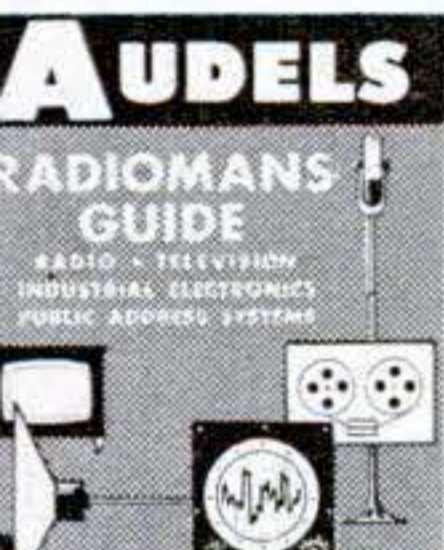

RADIOMANS GUIDE

Authentic, concise treatment of practical radio problems for engineers, service-men & amateurs. 100 Ill. 1088 Pgs. \$5.00
Circle No. 3A In COUPON

AUDELS

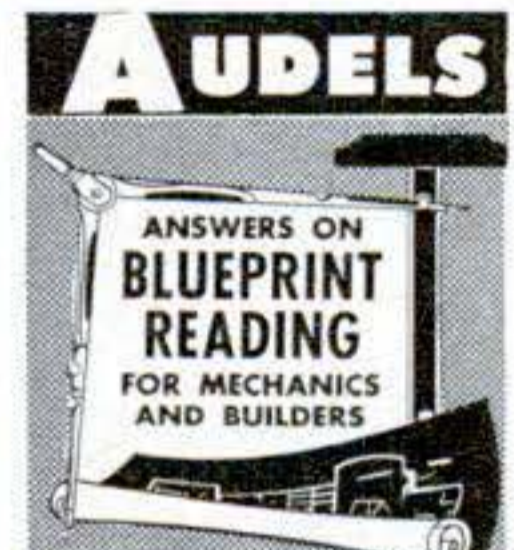

ANSWERS ON BLUEPRINT READING FOR MECHANICS AND BUILDERS

Secrets of blueprint reading, step-by-step in easy stages. All types covered. None other like it! Illus. 448 Pgs. \$3.00
Circle No. 25 In COUPON

AUDELS

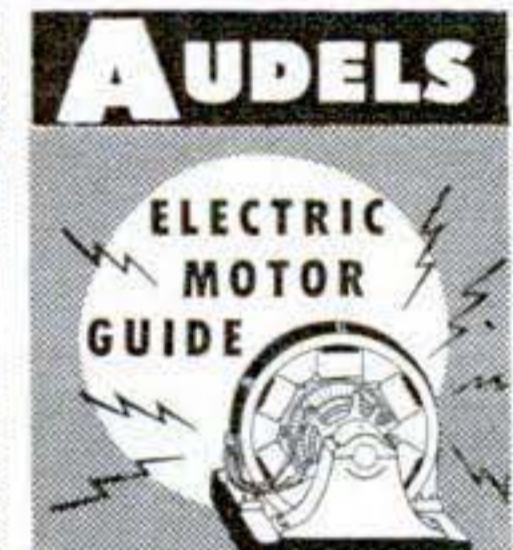

ELECTRIC MOTOR GUIDE

Entire subject in every detail. 31 Chapters. 617 diagrams, hook-ups and drawings. Indexed. Illus. 1000 Pgs. \$5.00
Circle No. 27 In COUPON

AUDELS

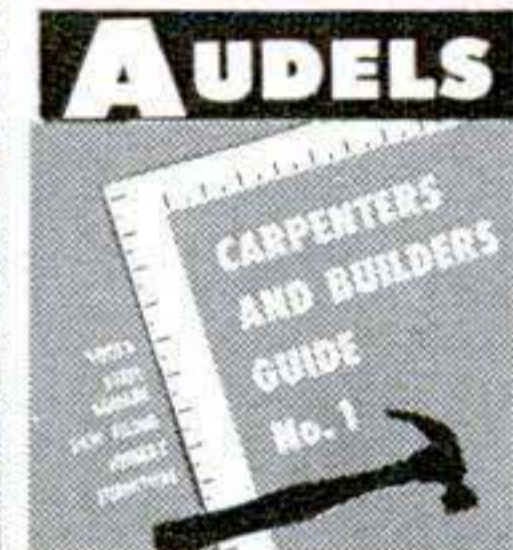

CARPENTERS AND BUILDERS GUIDE No. 1

Four all-inclusive vols. Modern construction for carpenters, builders, and all woodworkers. 3700 Ill. 1600 Pgs. Set \$9
Circle No. 8 In COUPON

AUDELS

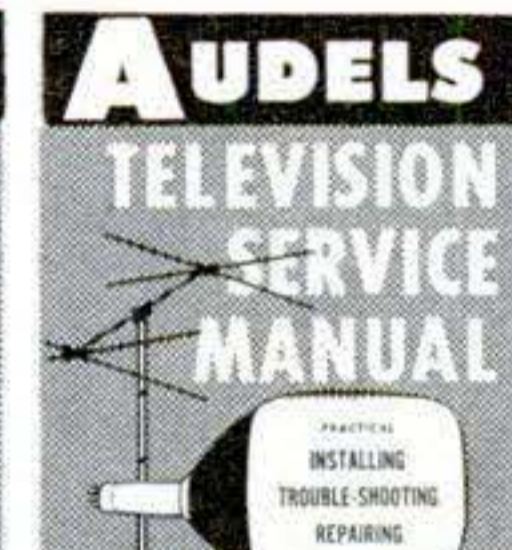

TELEVISION SERVICE MANUAL

Practical guide to installation, trouble-shooting & repairing. Inc. color systems. 18 Chapters. 225 Illus. 480 Pgs. \$3.00
Circle No. 3B In COUPON

AUDELS

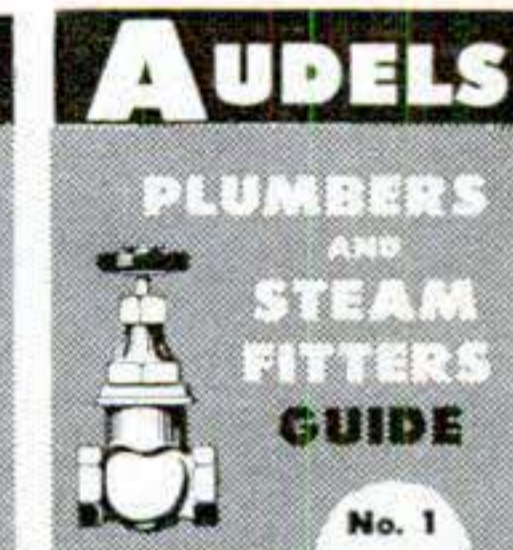

PLUMBERS AND STEAM FITTERS GUIDE No. 1

Four vols. of ready reference for plumbers, steam fitters, gas fitters, sheet metal workers, etc. 3642 Ill. 1670 Pgs. Set \$9
Circle No. 6 In COUPON

AUDELS

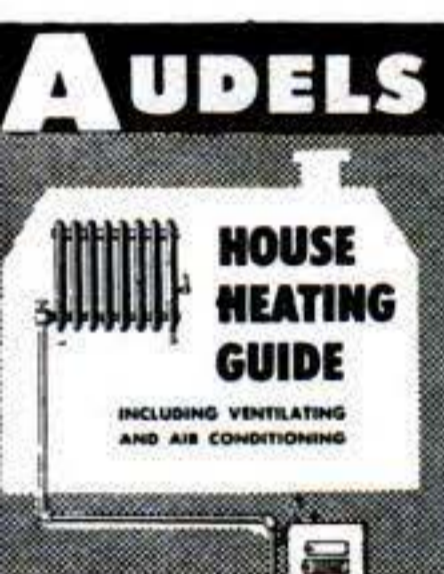

HOUSE HEATING GUIDE

Complete guide for heating, ventilating and air conditioning workers. 57 chapters. Trade secrets! 10 Illus. 966 Pgs. \$5.00
Circle No. 41 In COUPON

AUDELS

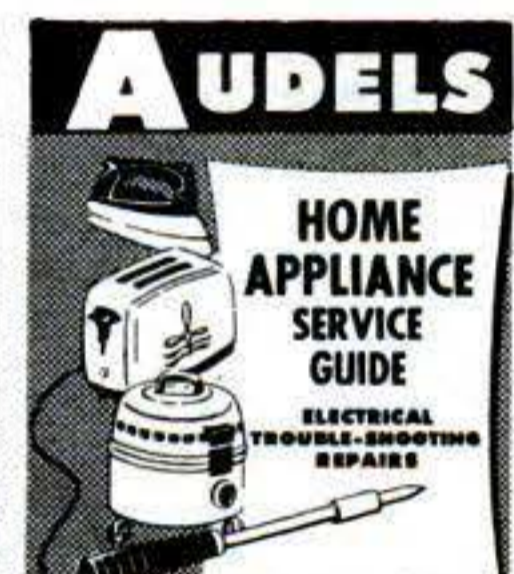

HOME APPLIANCE SERVICE GUIDE

How to fix elec. refrigerators, washers, ranges, toasters & all other gas & elec. appliances. 500 Illus. 864 Pgs. \$6.00
Circle No. 2 In COUPON

AUDELS

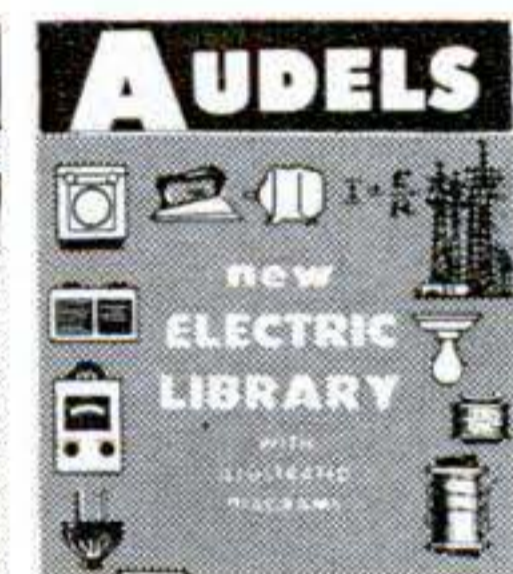

new ELECTRIC LIBRARY

Ten all-inclusive volumes. Complete electrcl. encyc. Questions & answers & trial tests for study. 9000 Ill. 5000 Pgs. Set \$22.50
Circle No. 15A In COUPON

AUDELS

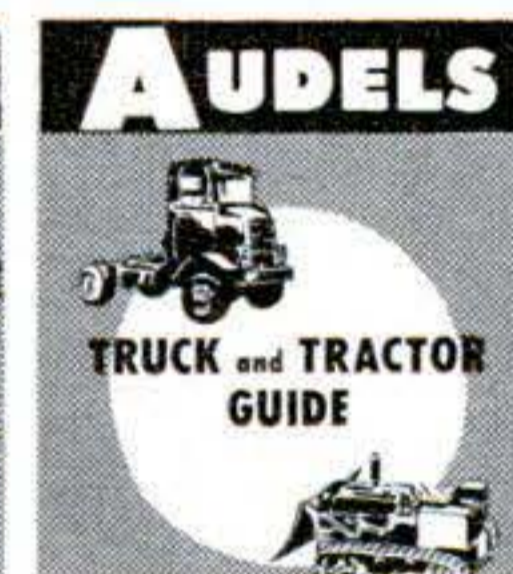

TRUCK and TRACTOR GUIDE

A guide for mechanics, drivers, trouble-shooters, etc. Both gas & diesel. 78 Chapters. Indexed. Illus. 1376 Pgs. \$5.00
Circle No. 5 In COUPON

AUDELS

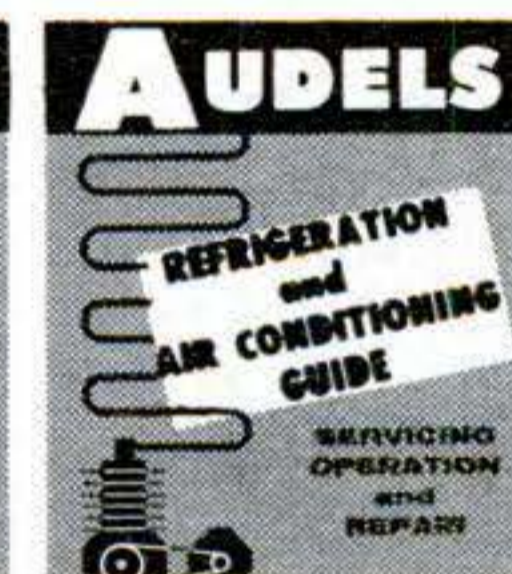

REFRIGERATION and AIR CONDITIONING GUIDE

Four books in one. Modern systems & machines. Inc. quick freezing, water coolers, etc. Indexed. Illus. 1360 Pgs. \$6.00
Circle No. 14 In COUPON

AUDELS



OIL BURNER GUIDE

New practical work on all domestic & industrial oil burners. Inc. elec. hook-ups & wiring. Indexed. 320 Illus. 416 Pgs. \$3.00
Circle No. 28 In COUPON

AUDELS

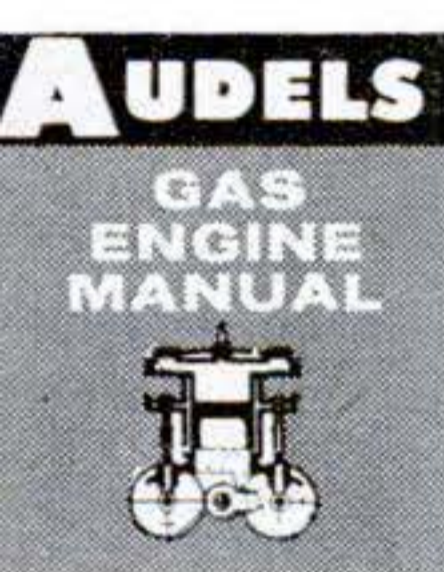

GAS ENGINE MANUAL

Brand new title! Construction, operation and repairs on all types of modern gas engines. Illus. 467 Pgs. \$4.00
Circle No. 48 In COUPON

AUDELS

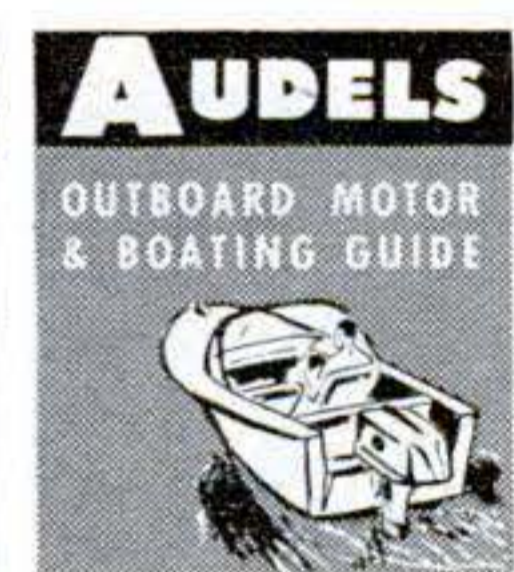

OUTBOARD MOTOR & BOATING GUIDE

Just off press! All phases of outboard motor repairs and maintenance. An essential boating tool! Illus. 400 Pgs. \$4.00
Circle No. 49 In COUPON

AUDELS

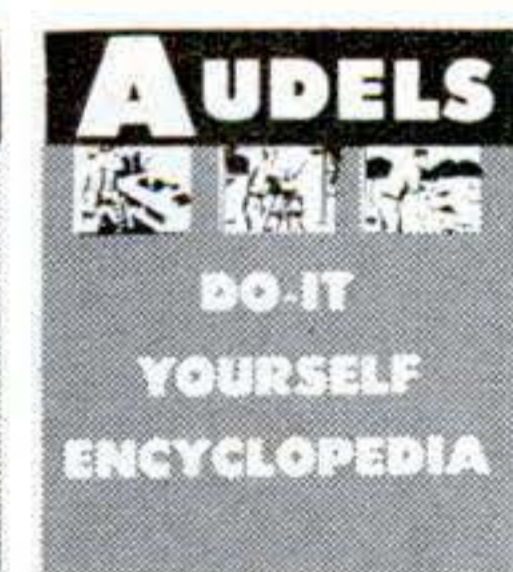

DO-IT YOURSELF ENCYCLOPEDIA

Two vols. New, giant home repair and project guide. Step-by-step plans and charts. Alphabetized. Illus. 1000 Pgs. Set \$8.95
Circle No. 43 In COUPON

AUDELS

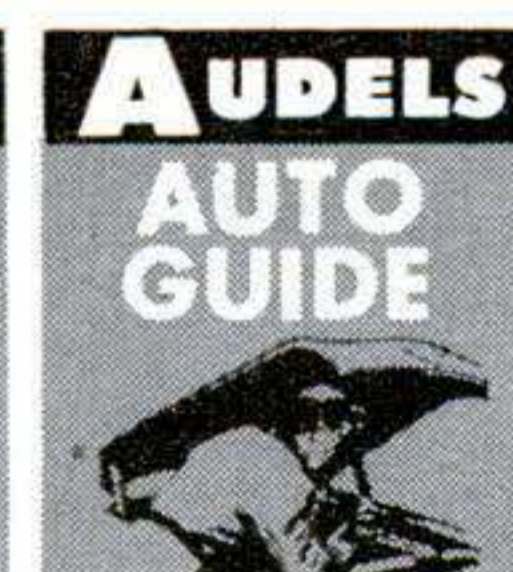

AUTO GUIDE

Ready guide for mechanics, stdnets. & car owners. Theory, construction and servicing of modern cars. Illus. 1132 Pgs. \$6.00
Circle No. 1 In COUPON

ADDITIONAL IMPORTANT TITLES

The following Audel Guides are all the best in their fields, written in clear, simple fashion, all lavishly illustrated. Circle the numbers wanted in the MAIL ORDER COUPON below. All books are sent for FREE EXAMINATION!

No. 4	HANDY BOOK OF ELECTRICITY, 1052 Pages	\$5.00
No. 9	DIESEL ENGINE MANUAL, 640 Pages	4.00
No. 12	MACHINISTS & TOOLMAKERS HANDBOOK, 1250 pages	6.00
No. 13	WIRING DIAGRAMS (Light & Power), 304 Pages	2.50
No. 29	SHEET METAL PATTERN LAYOUTS, 1152 Pages	7.50
No. 30	SHEET METAL WORKERS HANDBOOK, 448 Pages	3.00
No. 31	MECHANICAL DRAWING GUIDE, 192 Pages	2.50
No. 32	MECHANICAL DRAWING & DESIGN, 410 Pages	3.00
No. 34	ELECTRICIANS EXAMINATIONS, 272 Pages	2.50
No. 35	ELECTRIC POWER CALCULATIONS, 480 Pages	3.00
No. 36	ELECTRIC DICTIONARY, 9,000 Terms	3.50
No. 37	POWER PLANT ENGINEERS GUIDE, 1568 Pages	6.00
No. 38	ENGINEERS & FIREMANS EXAMS, 544 Pages	3.50
No. 42	MILLWRIGHTS & MECHANICS GUIDE, 1248 Pages	6.00
No. 44	NEW MECHANICAL DICTIONARY, 712 Pages	6.95
No. 45	MAGIC OF LANDSCAPING, 128 Pages	1.49
No. 46	WATER SUPPLY & SEWAGE, 436 Pages	4.00

7-DAY FREE EXAMINATION

SEND NO MONEY — Pay the postman nothing! We are glad to send you any of the Audel Guides for absolutely FREE examination in your own home. We take all the risks and leave all the decisions up to YOU. There is no obligation! If you decide to keep the books of your choice you may pay for them under our astounding easy-pay plan of only \$2 a month.

HERE IS ALL YOU DO

IT'S EASY TO ORDER: In the No-Risk Mail Order Coupon at the right just draw a circle around the number of Audel Guides you want us to send you for FREE EXAMINATION. We will send them to you at once to help you build a brighter future by increasing your SKILL. If for any reason at all you are not COMPLETELY satisfied, return the books to us, and that will end the matter! NO STRINGS OR CATCHES TO THIS OFFER.

THEO. AUDEL & CO.
49 West 23rd Street, New York 10, N. Y.

MAIL THIS NO-RISK COUPON TODAY!

THEO. AUDEL & CO. — Self Improvement Publishers Since 1879—
49 W. 23rd Street, New York 10, N. Y. \$2

Please mail me for 7 days' FREE EXAMINATION the books I have circled at right. I agree to mail \$2 in 7 days on each book or set ordered, and to further mail \$2 a month on each book or set ordered until I have paid the purchase price, plus shipping costs. If I am not completely satisfied with my Audel Guides I may return them.

NAME _____	1	2	3A	3B	4
ADDRESS _____	5	6	7	8	9
OCCUPATION _____	10	11	12	13	14
EMPLOYED BY _____	15A	25	26	27	28
	29	30	31	32	34
	35	36	37	38	40
	41	42	43	44	45
	46	47	48	49	

SAVE SHIPPING COSTS! Check here if you enclose complete payment with order. We pay postage charges. You have same return privilege.

MEN PAST 40

Afflicted With Getting Up Nights, Pains in Back, Legs, Nervousness, Tiredness

If you are a victim of these symptoms, your trouble may be due to Glandular Inflammation—a constitutional Disease that requires special types of medical treatment. Neglect of such Inflammation may cause men to grow old prematurely and often leads to Incurable conditions.

Most men, if treatment is taken in time, can be successfully NON-SURGICALLY treated for Glandular Inflammation. If the condition is aggravated by lack of treatment, surgery may be the only chance.

NON-SURGICAL TREATMENTS

The NON-SURGICAL treatments used at the Excelsior Medical Clinic are the result of discoveries in recent years of new techniques and drugs, plus over 20 years research by scientific technologists and doctors.

Men from all walks of life and from over 1,000 communities have been successfully treated here at Excelsior Springs. They found soothing and comforting relief and better health.

EXAMINATION AT LOW COST

When you arrive, our Doctors, who have years of experience in this field, make a complete examination. You then decide if you will take the treatments needed, which are so mild, hospitalization is not needed.

REDUCIBLE HERNIA
Is also amenable to a mild Non-Surgical Treatment available here.

RECTAL-COLON DISORDERS
are often associated with Glandular Inflammation.

Either or both of these disorders may be treated at the same time you are receiving Glandular Inflammation Treatments.

Write For FREE BOOK

The Excelsior Medical Clinic has published a New FREE Book that deals with diseases peculiar to men. It could prove of utmost importance to you. Write today. No obligation.

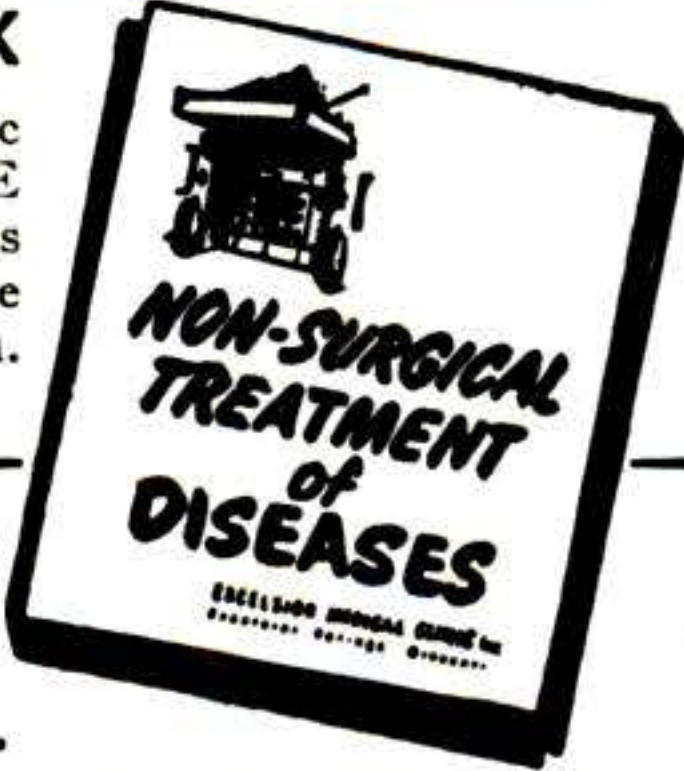

EXCELSIOR MEDICAL CLINIC
Dept. B6251
Excelsior Springs, Mo.

Gentlemen: Kindly send me at once, your New FREE Book. I am interested in full information. (Please Check Box)

- Glandular Inflammation Hernia
 Rectal-Colon

Name.....
Address.....
City..... State.....

Learn PACKAGING!

MAKE TO 2500% PROFITS AT HOME
YOU PACKAGE WE DO YOUR SELLING!

HERE'S PROOF
that Packaging means Big Profits for You!

Item	Bulk Cost	Sells For
Per Doz.		
Safety Pins	2 1/2¢	15¢
Balloons	3 1/2¢	19¢
Fish Hooks	2¢	50¢

Make profits like these on over 100,000 other products you can package right in your own home. We show you how!

Package products at home for nationwide sales force. You package bulk items in your own home. Salesmen do your selling coast-to-coast. FREE 'No Selling Plan' reveals thousands full, spare time big profit opportunities for beginners in self-service packaging, contract packaging, gift wrapping. We guide you step by step. Everything furnished.



Write today for FREE "10-STEP PACKAGING PROFIT PLAN", and full details. No salesman will call.

HOME PACKAGING CO., Dept. A244
807 Sunset Blvd., Los Angeles 12, Calif.

FREE BIG PLASTIC BAG SALE

10 EXTRA BAGS
50 for \$1.50 ppd. (You get 60 bags)

Large 9" x 15" size • Heavy Duty • Waterproof
Thousands of uses. Strong enough to last for years... cheap enough to throw away. Ideal for PROTECTING & STORING TOOLS, FOOD, EQUIPMENT. Used by boatmen, hobbyists, mechanics, homeowners, etc. SATISFACTION GUARANTEED. Cash, check or m.o.

PXD Products, Rm. 205, 5 Beekman St., New York 38, N. Y.

BUY FACTORY DIRECT!

HAWK by BIRD engineering \$99⁹⁵



\$10.00 Down
\$6.00 a Month
Complete welded Kit with Clinton 2 1/2 H.P. engine

Send 25c for brochure
Bird Engineering, Box 427, Dept. PS-H-2 Omaha, Nebr.



FILE HANDLE

Makes filing much easier, faster and more accurate. Fits any size, shape or style of file. Can be changed quickly from one file to another. Designed to fit the hand comfortably. Made of strong light weight aluminum and covered with soft rubber for comfort and better gripping. \$2.00 per pair (file not included).



Order from
Lanter Mfg. Co., R. R. #1-A, Bartlett, Ill.



OWN a Nationally Advertised Lifetime Business

that grows from Repeat orders

If Now Employed

you can profitably operate in spare time and build a permanent full-time business; no limit on income.

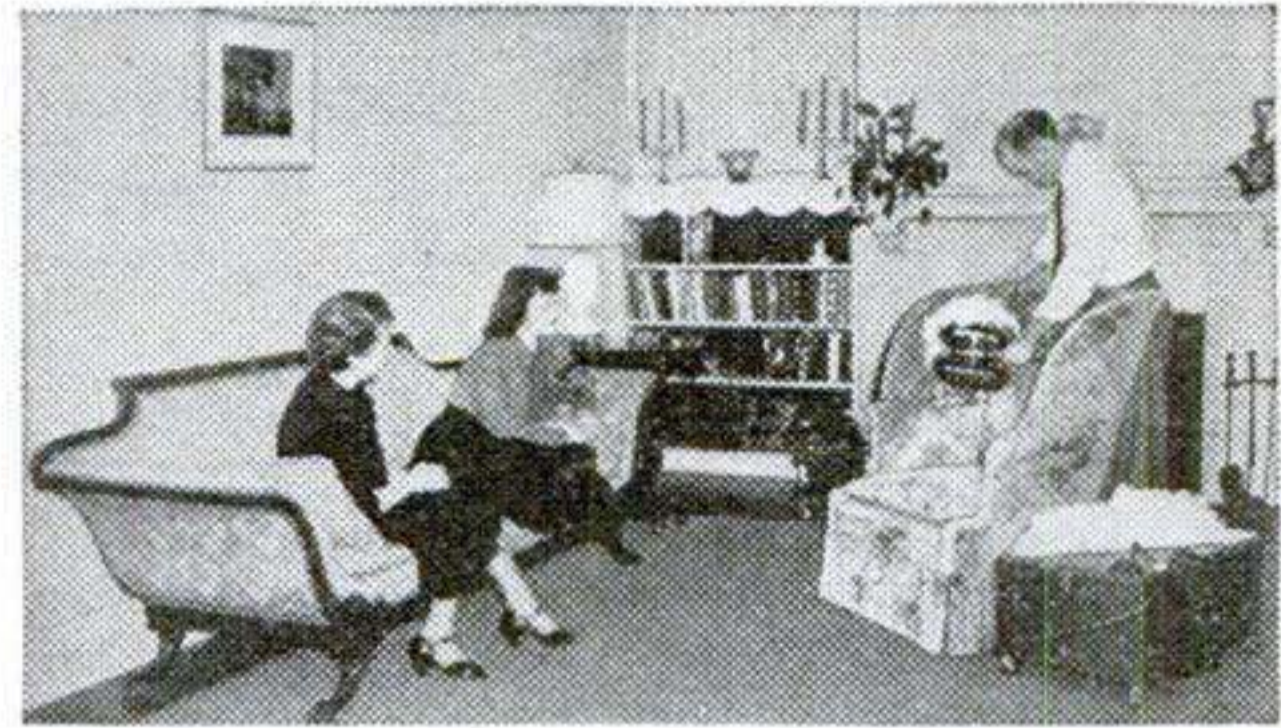

Start Part or Full Time Easy to Learn... No Shop Needed

We are NOW enlarging this worldwide system of individually owned service businesses. If you are reliable, honest and willing to work to become financially independent, we invite you to mail the coupon.

You become a fabric specialist... providing the proper care of floor coverings & furniture. No experience needed. We personally train you.

\$9 Hourly Profit... 6 Worldwide Services

Here is your opportunity to BE YOUR OWN BOSS... to become financially independent... have a fast growing income... and own a Nationally Advertised business.

Dealers (using National Price Guide) can earn \$9 hourly gross profit on service they render plus \$6 on EACH of their servicemen.

You have good profits on both materials and labor after paying servicemen.

You can stay at present job while customer list grows... then switch to full time, lining up jobs for your servicemen to do.

One small job a day brings a good starting income. With full or part time servicemen your income is unlimited.

Dealers operate from a shop, office or home. Equipment is portable... the electric Foamovator converts to a carrying case.

At the start, you may want to render service yourself. This business is easy to learn... easy to start... so easy to service that women dealers often do it. We prefer you have no experience... not have to "unlearn" old scrub methods.

You may write a Duraclean dealer if you like.

A Waiting Market

New "miracle" fabrics and light colors (which soil faster) have created a growing demand for the Duraclean quality of cleaning.

All services are rendered "on location" in homes, office buildings, hotels, theaters, clubs, churches and institutions. Car dealers buy your services to revive used car upholstery... also take orders for you. Almost every building houses a potential customer. The big demand (even small towns) assures dealership growth.

These superior, safer and convenient methods resulted in Duraclean dealerships throughout North and South America, Africa, Portugal, England, Israel, Norway and other countries. Only Duraclean dealers have this prestige.

Advertising, paid by International Headquarters, explains the superior merits of your services and develops customer confidence and job leads.

We Train and Assist You

A Duraclean dealer will train and assist you. He'll reveal his successful, proven methods and sales plans. He will WORK WITH YOU.

We show you 15 quick ways to get customers. You have pre-tested newspaper and yellow page ads, commercials, and a full mailing program.

Your services are backed by Parents' Magazine Seal, McCall's "Use-tested" approval and American Research & Testing Laboratories.

Duraclean dealers find voluntary and repeat

orders a major source of income. Customers are so enthused they tell friends and neighbors. Furnishings stores, insurance adjustors, and decorators refer jobs to Duraclean dealers. These year 'round services are in constant demand.

TODAY is the time to own a Duraclean dealership... before someone takes your location.

You Become an Expert in the Over-all Care of Upholstery and Carpeting

You have 6 vital year 'round services.

DURACLEAN not only cleans; it enlivens the fibers... revives dull colors. Pile rises with new life. Furnishings are used again in a few hours... a great customer convenience.

No machine scrubbing or soaking... Duraclean cleans by absorption. It eliminates roughened fabric, fiber-breaking and removal of rug sizing. It does away with harmful solvents and strong soaps. Mild aerated foam, lightly applied, cleans while restoring resilience to fibers. Dirt grease and many unsightly spots vanish like magic. Results are often almost unbelievable.

DURASHIELD retards soil and stains... retains the fresh, new look MONTHS longer.

DURAPROOF makes upholstery, carpeting, blankets, piano-felts and clothing repellant to moths and carpet beetles. It kills both. You give 6-year-warranty. The U. S. Government says, "Moths are in practically every household."

DURAGUARD flameproofs furnishings. Prevents fires starting from cigarettes, candles, etc.

SPOTCRAFT safely removes spots and stains.

TUFTCRAFT repairs cigarette burns, moth damage... often saves the carpet or rug.

We'll Help Finance You

A moderate payment establishes YOUR OWN business. A day's profit pays monthly payments. Your business can be operating in very few days. Men frequently take in partners.

We furnish electric equipment and enough materials to return your TOTAL investment. If you have good habits and know the importance of customer satisfaction, you can likely qualify for a Duraclean dealership.

It's been said, "Opportunity knocks but once at every man's door." This could be that one rare opportunity in your life.

It is surprisingly easy to learn this business. You can decide from the information we will send you whether to apply for a dealership. So, with no obligation, mail the coupon TODAY.

What Dealers Say

L. Broersma: "Have now completed 5 years with Duraclean. We have never had one complaint."

George Byers: "For University, bill was \$2,416. Total expenses \$814."

Ed Kramsky: "In 2 years, I now have two assistants, a nice home and real security for my family."

L. Babbit: "I average \$400 monthly part time. I'm starting full time."

Russ Day closed 19 jobs from 21 contacts.

W. C. Smith: "Earned \$650 one week. Volume keeps getting bigger."

L. Falls: "I cleaned 1,900 sq. ft. of carpet in one day. Made \$135."

Earl Davis: "Our sales increased \$17,660.00 this year."

A. Nebendahl: "Closed every sale where I used new slide projector."

N. Josseland: "Have made as high as \$200 in one day. Largest earnings for a single week, \$750."

Fabric Mills Endorse YOUR Service

Aldon Carpet Mills: "We approve this process. We are pleased with the texture restoration."

Patcraft Mills: "Fibers are not soaked by Duraclean. Best method of cleaning we have seen on tufted carpeting." **Croft Carpet Mills:** "The Duraclean method is superior."

Trendline Upholstered Furniture: "We recommend Duraclean as the safest and most effective method of cleaning fine furniture." **Kingston Mills:** "It is our intention to recommend Duraclean Service."

Modern Tufting Co.: "Duraclean is superior to any on-location cleaning process with which I'm familiar."

Painter Carpet Mills: "Duraclean is logical approach to carpet cleaning because the tufts are not subjected to the harsh treatment so prevalent in other methods."



Resale Service

If, because of illness, moving or for any other reason a dealer wants to sell, we maintain a service to locate buyers and help him sell.

Dealerships resell at up to 10 times the dealer's cost.

Find out Now! No obligation

With no obligation, we'll mail you a letter with 32 page booklet explaining these services... how and why your income grows... how we help finance you.

Then decide if this opportunity fulfills your dream of headway, independence and bigger income. Your location could be taken tomorrow... so mail coupon TODAY.

Mail this coupon TODAY It may put you in business

Duraclean Co., 3-182 Duraclean Bldg., Deerfield, Ill.

With no obligation, mail letter with 36 page illustrated booklet explaining how I can increase my income and family security with a Duraclean Dealership.

Name _____

Address _____

City _____ Zone _____ State _____

Stop wasting time in a dead-end job!
 Enjoy the big rewards offered
 the Law-trained man
 in business.

STUDY LAW

in your spare time
 as a way to
 increased earnings



Whatever your present position or previous schooling, you can qualify for rapid promotion and top salaries through LaSalle Law training at home.

A knowledge of Law is essential today in every activity of business. New problems of taxes, insurance, contracts, liability, employment, and much more — all require legally-trained men for key positions.

You can master "Law in spare time under supervision of LaSalle's distinguished faculty. Cost is low. Upon completion you are awarded a Bachelor of Laws degree, if qualified. Famed LaSalle Law Library of 14 volumes is given to you as part of the course.

Send for free booklet "Law Training for Leadership."

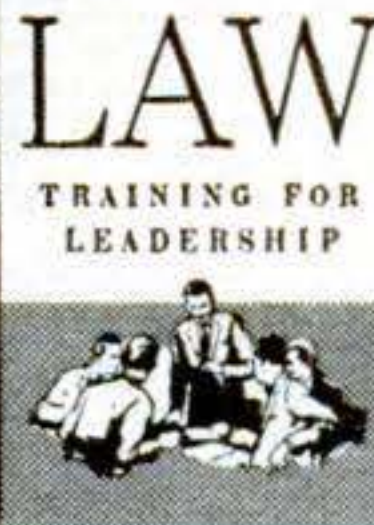

Mail
 Coupon
 for FREE
 Booklet

LA SALLE EXTENSION UNIVERSITY

A Correspondence Institution

417 S. Dearborn St., Dept. 14-038, Chicago 5, Ill.

Please send me your free illustrated booklet
 "Law Training for Leadership."

Name..... Age.....

Address..... County.....

City & State.....

Zone..... State.....

222

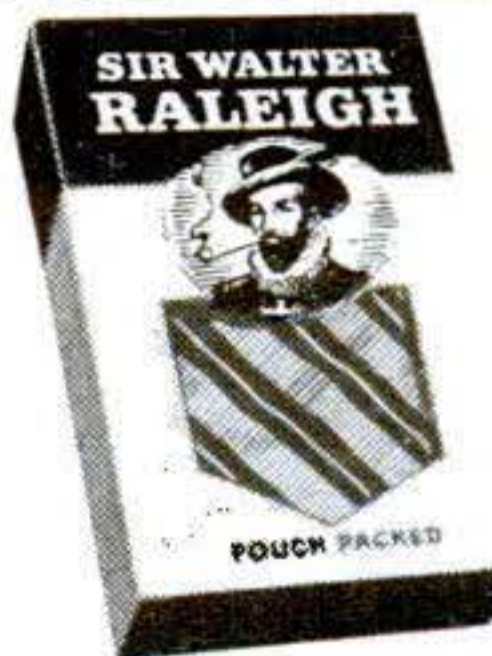

FOR THE MAN
 WHO ENJOYS
 A PIPE



Free POUCH PACK OF
SIR WALTER RALEIGH

If you're a judge of pipe tobaccos, you'll appreciate getting this full-size package of Sir Walter Raleigh free. Kept 44% fresher in the new pouch pack. It's choice Kentucky burley, extra aged. Smells grand, packs right, smokes sweet, can't bite. To get your free pouch pack, write:

Sir Walter Raleigh
 Dept. S, Box 355, Louisville, Ky.

new home-import business...



Tape Recorder \$9.75

- Hundreds more imports for high profits
- Transistor Radio... \$1.96
 - Derringer Pistol... 5.74
 - Star Sapphire Ring... 6.00
 - Cigarette Lighter... .17
 - Electric Razor w/case 3.40
 - Tailor Made Silk Suit 22.50
 - 17 Jewel Watch... 2.87
 - Binoculars... 1.20

Make BIG PROFITS with Dazzling Bargains Like These
 Importing offers you full or spare time profits beyond your wildest dreams. No previous experience or capital investment. You pocket profits before ordering merchandise.

New drop ship plan offers you first day profits. Deal DIRECT with the overseas sources at prices shown. Help fill huge demand for thousands new sparkling imports just like these.



ZOOM MOVIE CAMERA \$21.70

Airmail reaches me overnight



CARDIGAN SWEATER \$2.00

AM-FM RADIO \$10.95

They go fast to stores, mail order, premium users, friends too! I show you how to cash in on this money-making import-export boom today! Rush name for Free details and FREE BOOK, "How to Import & Export" to: **MELLINGER CO., Dept. J242**, 1554 South Sepulveda, Los Angeles 25, Calif.

SEND NO MONEY! DO NOT ORDER FROM ME. I show you how to get bargains like those shown and hundreds of others direct from overseas suppliers.

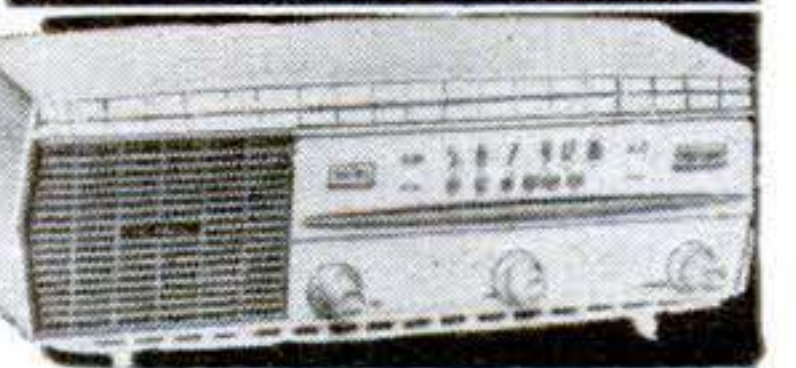

Train Now For BIG Pay Jobs!

EARTHMOVING EQUIPMENT OPERATOR

HEAVY EQUIPMENT REPAIR-REBUILDING

Greer TECHNICAL INSTITUTE



Get ready for a man's job in the booming road and construction industry. Operate cranes, "dozers," earth-movers, etc. Train "on the job" in 5 to 13 1/2 weeks. Classes start weekly; reserve space now. Approved for vets. Complete catalog and reservation facts FREE. Write today!

Atten. S. B. Hutch, Box 368, Braidwood, Ill.

MAGNET SALE!

- MW35 Pulls 35 lbs. (2 1/2 x 2 x 2 in./wt. 32 oz.).....\$3.75
 - R75 Pulls 75 lbs. (3 x 3 x 1 3/8 in./wt. 42 oz.).....\$4.95
 - R125 Pulls 125 lbs. (3 x 3 x 2 3/4 in./wt. 68 oz.).....\$6.95
 - M30 Alnico small bar (7/8 x 1/4 x 1/8 in.) 20 for.....\$1.75
- Sample pair (2) small magnets & sale catalog.....25c
MONEY BACK GUARANTEE / WE PAY POSTAGE
MAGNA MAGNETICS, 7777 Sunset, Los Angeles 46, Calif. Dept. P

GUNK® removes grease -- scourfully!
 cleans -- degreases -- freshens



- power mowers • engines
 - cement floors • kitchen walls • ovens • exhaust ducts
 - paint brushes • furnace filters • barbecue grills
 - implements • machinery
- AT AUTO SUPPLY, FARM & HARDWARE STORES!**

GUNK CHICAGO CO., River Forest, Illinois
 serving the Midwest and Southwest
RADIATOR SPECIALTY CO., Charlotte, N.C.
 serving the East, Southeast and far West

TUNE UP ELECTRONICALLY ANY CAR EVER MADE...

domestic or foreign; compact or limousine; 4 cylinder, 6 cylinder or 8 cylinder; 6 volt or 12 volt.

With New Improved Model AT-162

DWELL TACHOMETER



Specifications.

The Model AT-162 provides three dwell angle scales; 0 to 45 degrees, 0 to 60 degrees, and 0 to 90 degrees. The three dwell angle ranges specified above make this instrument suitable for making accurate dwell angle adjustments on all 4 cylinder, 6 cylinder, and 8 cylinder cars, both foreign and domestic.

The dual range tachometer is extremely versatile since it provides both a low range of 0 to 1000 RPM, necessary for making precise carburetor adjustments and the high range tachometer, 0 to 5000 RPM suitable for making all other tests at high engine speeds.

NOTE:
GIANT 6 1/2" METER FOR EASY, ACCURATE READINGS

At last a streamlined instrument designed to provide the most important services for "tuning up" any and every car ever made from a Model A Ford up to and including the current automatic transmission cars produced today.

The Model AT-162 includes the very latest design Dwell Meter, working in conjunction with a dual range Tachometer and incorporating all modern improvements in circuitry design.

Assure easy starts, optimum performance and maximum gas economy with Model AT-162.

The Model AT-162 will perform the services specified below in addition to many other tasks too numerous to mention:

- Assure precise adjustments of points that are slightly worn or pitted.
- Indicate the most effective point setting without removing the distributor cap.
- Indicate the correct settings for external adjustment type distributors. (A feeler gauge cannot be used for making correct adjustments on this type of distributor since many manufacturers' specifications do not list the point gap in inches. They list only the dwell angle in degrees.)
- Insure maximum gas economy and quiet engine running. Read the exact RPM while the engine is in neutral position. Then adjust the carburetor in conformity with the car manufacturer's recommendations.
- To locate a "miss" you need only disconnect or "short" the spark plugs one at a time with the Model AT-162 switched to the Tachometer position.
- Cars with automatic transmissions function efficiently only if the fluid pressures are correctly maintained and since manufacturer's instructions always refer to RPM, the Model AT-162 (or an equivalent tachometer) is required to properly service automatic transmissions.

The Model AT-162 is the most complete unit in its price range ever produced. It comes absolutely complete, ready to use. Only

\$29⁹⁵

SEND NO MONEY WITH ORDER PAY POSTMAN NOTHING ON DELIVERY

Try it for 10 days before you buy. If completely satisfied then send \$5.00 and pay the balance at the rate of \$5.00 per month until the total price of \$29.95 (plus small P.P. and budget charge) is paid. If not completely satisfied, return to us, no explanation necessary.

ACCURATE INSTRUMENT CO., INC.
 Dept. D-244, 911 Faile St., New York 59, N.Y.
 Please rush me one Model AT-162. If satisfactory I agree to pay \$5.00 within 10 days and balance at rate of \$5.00 per month until total price of \$29.95 (plus small P.P. and budget charge) is paid. If not satisfactory, I may return for cancellation of account.

Name _____
 Address _____
 City _____ Zone _____ State _____



LAFAYETTE RADIO ELECTRONICS

FREE FOR '63

1963 CATALOG 630
388 GIANT SIZE PAGES

The Largest Catalog in our 42-Year History

It's New—It's Big— It's Better Than Ever

It's from the "World's Hi-Fi & Electronic Shopping Center"

Here it is—the exciting, all-new 1963 Lafayette Catalog. 388 giant sized pages—everything in hi-fi and electronics for the audiophile, technician, hobbyist, student, engineer and serviceman. Thousands of items at lowest prices.

Now—buy the Easy Way with Easy-Pay.
No money down . . . up to 24 months to pay.

Lafayette Locations

Syosset • Jamaica • New York City • Bronx • Scarsdale
Newark • Plainfield • Paramus • Boston • Natick

MAIL THE COUPON FOR YOUR FREE CATALOG

Lafayette Radio, Dept. KB-3
P.O. Box 10, Syosset, L. I., N. Y.
Rush My FREE 388-Page 1963 Lafayette Catalog

Name _____

Address _____

City _____ Zone _____ State _____

Colorful NEW FREE Vacation Guide to TENNESSEE

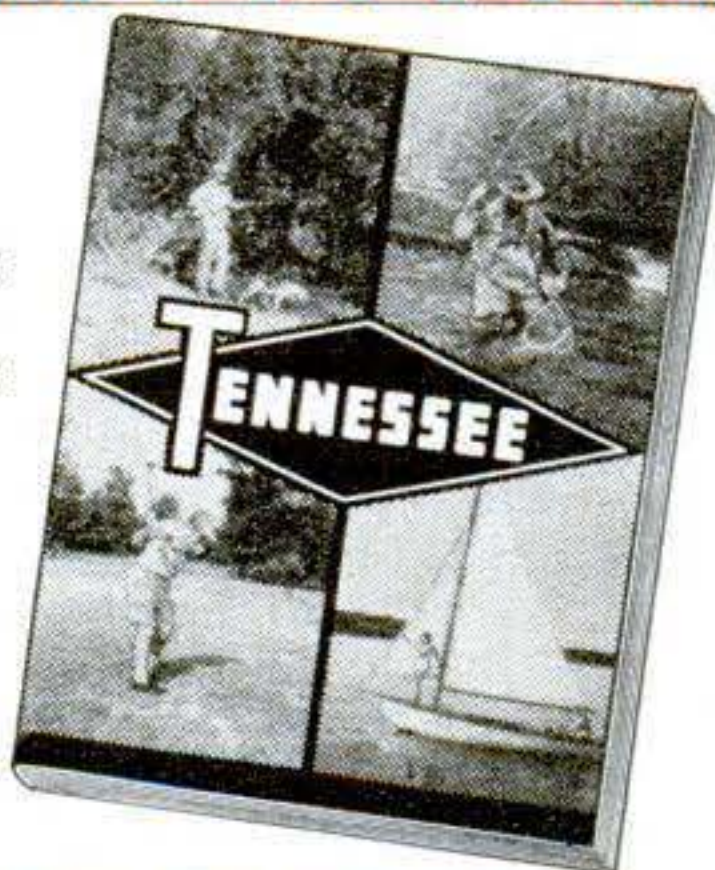

Colorful new picture book tells all about Great Smoky Mountains National Park, Tennessee's 22 Great Lakes with wonderful fishing and water sports, famous Civil War battlefields, homes of 3 presidents, and other features you'll see and enjoy!

MAIL COUPON TODAY

TENNESSEE DIVISION OF INFORMATION
771 Cordell Hull Building, Nashville, Tenn.

Please send free Vacation Guide.

NAME _____

ADDRESS _____

CITY & STATE _____



FREE! U.S. STAMPS PLUS COMPLETE U.S. CATALOG



4 SENSATIONAL OFFERS IN ONE — ALL FREE

. . . to Introduce You to the World's Largest Stamp Firm and America's Favorite Hobby

1. Genuine centennial postage stamp, as illustrated, picturing first U. S. A. (issued 116 years ago!)
2. Big collection of 25 all different United States — Ancient 19th century, \$1.00 stamp, etc.
3. Collection beautiful commemoratives: American Revolution, Wild West, 1893 Columbian, many others.
4. Collector's Guide; Big 1963 U.S. Bargain Catalog; exciting stamp offers for your FREE inspection.

Send 10¢ for mailing. **ACT NOW!**

H. E. HARRIS & CO., DEPT. C-308, Boston, Mass.

ECONOMY TRACTOR

DOES MORE KINDS OF JOBS

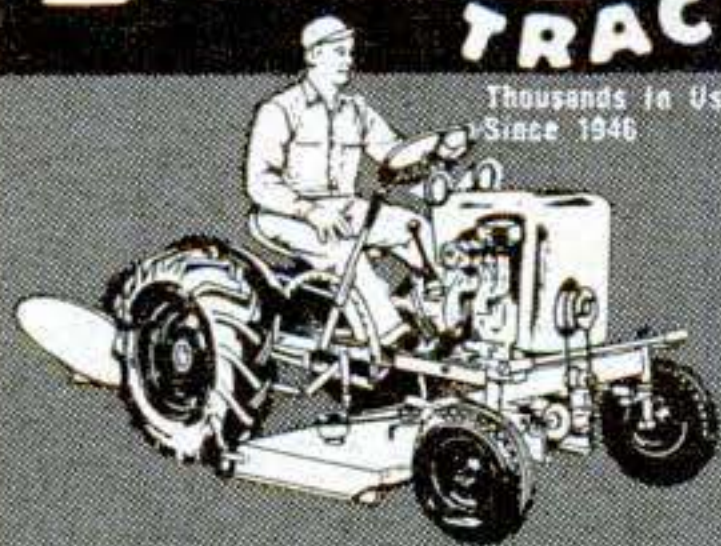

Powerful! America's big tractor value. Low price. Rugged, built-in quality. Easy to operate. 9 hp. ALL GEAR DRIVE incl. clutch, 3-spd. trans., diff., 176 to 1 reduction. Wt. 790 lb. 21 low-cost, quick-change tools for farm, lawn, snow, woodland. Write for FREE CATALOG & dealer name.

Engineering Products Co.
1005 A-2 Anoka Ave., Waukesha, Wis.



A BODY LIKE MINE IN SHORT TIME with famous DAN LURIE BARBELLS!

SEND FOR FREE GIANT CATALOG

Factory Prices	Cast Iron	Semi-Steel	
50 lb. Set..	\$9.48..	\$10.48	\$9.48
100 lb. Set..	15.98..	18.98	
150 lb. Set..	23.48..	27.48	
Extra Wts..	16c lb..	18c lb.	

Plus Free MONEY BACK GUARANTEE—Send 50% in check or money order F.O.B. Plant Brooklyn, New York. Balance C.O.D.

DAN LURIE BARBELL CO. 1661, S-2 Utica Ave., Dept. 370B, Brooklyn 34, N.Y.



DISCOUNTS to 40% BY MAIL NEW CATALOG READY!

More than 1000 famous U.S. products for home workshop, garden, boat . . . plus paint and painting supplies — all at great savings — in our new, expanded catalog! 80 fully illustrated pages. Each item guaranteed. Send only 25¢ for your copy.

GATES GENERAL CORPORATION

P.O. BOX 355 PS, FARMINGTON, CONNECTICUT

It's Like Having Auto Factory Experts Right Beside You...

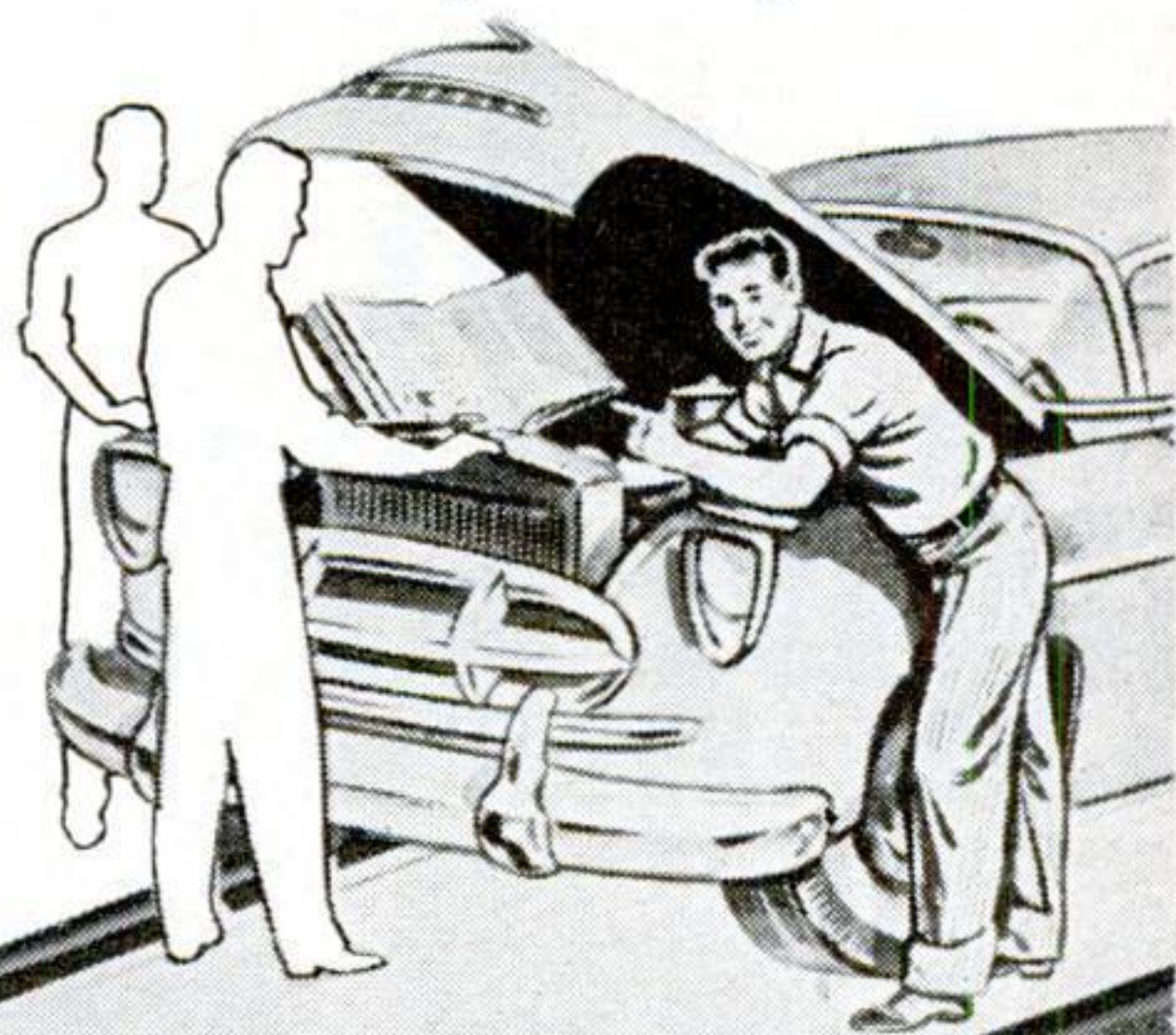

SHOWING YOU

HOW YOU CAN FIX 2,519 CAR MODELS!

NOW—Whether You're a Beginner or an Expert Mechanic—You Can "Breeze Through" Just About ANY Auto Repair Job—QUICKLY—EASILY—RIGHT!

SUPPOSE you had an automobile factory engineer standing right beside you . . . guiding your hands through every step of even the toughest car repair jobs! Think how you'd "whiz through" every job! No wonder, then, that 4,000,000 MOTOR'S Auto Manuals have been sold. No wonder so many thousands of beginner and expert mechanics alike are *already* using MOTOR'S brand-new AUTO REPAIR MANUAL. It shows you, in step-by-step words and pictures, factory-approved repair procedures for fixing practically ANY part of ANY car listed here — 1955 through 1963!

No guesswork! MOTOR'S Manual "starts from scratch" — leads you through entire job with easy directions. You CAN'T go wrong!

Engineers from every automobile plant in America worked out these time-saving procedures for their own motor car line. Now the editors of MOTOR'S have gathered together this wealth of "know-how" from 191 Official Shop Manuals and "boiled it down" into crystal-clear terms in one handy indexed book!

EXACTLY WHAT YOU NEED TO KNOW

Includes Automatic Transmissions, Overdrives, Power Steering, Power Brakes, Carburetors, Fuel Pumps, Starting Motors, 12-Volt Systems, Generators, Alternators, Voltage Regulators, Distributors, Axles, etc. Factory Specifications and Adjustment Tables. Tune-up Charts, Tables of Measurements and Clearances. Overhauling and Replacement Facts, etc.

Covers These Makes	
Buick	Jeep
B. Special	Lancer
Cadillac	Lark
Chevrolet	Lincoln
Chevy II	Mercury
Chrysler	Meteor
Comet	Monterey
Continental	Nash
Corvair	Oldsmobile
Corvette	Olds F-85
Dart	Plymouth
De Soto	Polara
Dodge	Pontiac
Edsel	P. Tempest
Fairlane	Rambler
Falcon	R. American
Ford	Studebaker
Galaxie	Thund'bird
Imperial	Valiant

TRY BOOK **FREE** FOR 10 WHOLE DAYS

SEND NO MONEY

Just mail coupon. (Attach it to postcard, for faster action.) Unless you agree this book is the greatest time- and work-saver you've ever seen — return it in 10 days, pay nothing. Mail coupon to MOTOR Book Dept., Desk 322, 250 West 55th St., New York 19, N. Y. (Schools, Bookstores: Write for Discounts).

MOTOR'S AUTO REPAIR MANUAL

- CARBURETOR
- GENERATOR
- FUEL PUMP
- ENGINES
- BRAKES
- DISTRIBUTOR
- AUTOMATIC TRANSMISSIONS
- STARTING MOTORS
- OVERDRIVES
- STEERING GEAR
- IGNITION
- MUCH MUCH MORE!

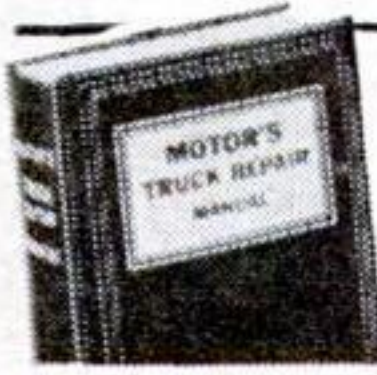

Same FREE Offer On MOTOR'S Brand-New Truck Repair Manual

Covers practically every job on gasoline and diesel trucks made since 1952! Over 2,000 pictures. 900 big pages. FREE 10-Day trial. Check proper box in coupon.

MAIL COUPON NOW FOR 10-DAY FREE TRIAL
(Attach to Postcard if More Convenient)

MOTOR BOOK DEPT.
Desk 322, 250 W. 55th St., New York 19, N. Y.

Rush to me at once **MOTOR'S New AUTO REPAIR MANUAL**. If O.K., I will remit \$2 in 10 days, \$3 monthly for 2 months and a final payment of \$1.95 (plus 45¢ delivery charges and sales tax) one month after that. Otherwise I will return the book postpaid in 10 days.

Print Name..... Age.....

Address.....

City..... Zone..... State.....

Also send me 10 days' Free Trial **MOTOR'S New TRUCK REPAIR MANUAL**. If O.K., I will remit \$11.00 plus delivery charge and sales tax in 10 days. Otherwise I will return book postpaid in 10 days.

Check box and **SAVE 45¢** delivery charge by enclosing **WITH** coupon in envelope entire payment of \$9.95 for Auto Repair Manual (or \$11 for Truck Repair Manual) plus sales tax. Same return-refund privilege.

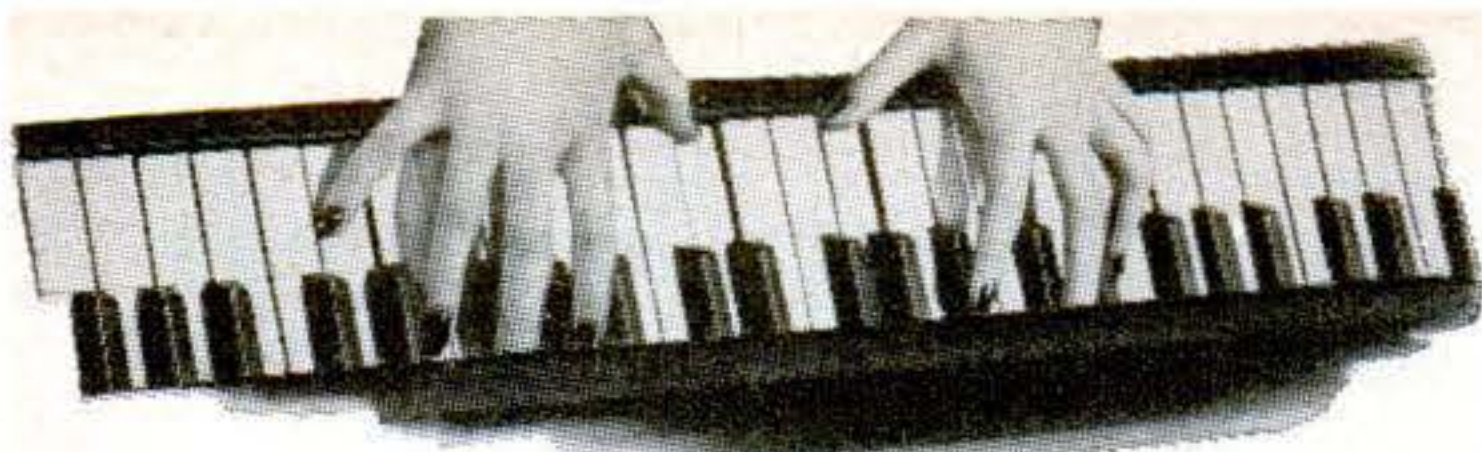

PLAY RIGHT AWAY ANY INSTRUMENT

— even if you don't know a single note now

NOW it's EASY to learn ANY instrument. No boring exercises. Even if you don't know a single note now you can start playing delightful little *pieces*—from your FIRST lesson! BY NOTE. Make amazing progress. No special "talent" needed. Learn at home in spare time. Without a teacher. Low cost! Soon you can play popular music, hymns, classical and any other music. Over 1,000,000 students all over the world.

FREE BOOK. Send this ad with your name and address filled in below, to: **U. S. SCHOOL OF MUSIC, Studio A151, PORT WASHINGTON, N. Y.** (No obligation, no salesman will call.) Est. 1898. Licensed by N. Y. State Education Dept. A152

Name.....
Address.....
City.....State.....
Be sure to include Zone No., if any.



**"Messenger" CB Transceivers...rated
BEST in Nation by Electronic
Distributor Salesmen'**

*New impartial survey by leading electronic magazine shows Johnson "Messenger" Transceivers rated "BEST"—BEST BY NEARLY 50% OVER SECOND CHOICE BRAND.

**4 feature-packed "Messengers" ... and
Selective Call System outperform everything!**

Compact, Hand-Held—100 milliwatt or 1 watt "Personal Messengers". Rugged and reliable—11 transistors, 4 diodes! Twice the sensitivity and 40% more range than similar units with conventional circuitry—more output than similar units with same rated inputs!

Mobile or Base Stations—performance proved Viking "Messenger" and new "Messenger Two". Punches your signal across the miles—high efficiency design makes full use of maximum legal power. Excellent receiver sensitivity and selectivity. Automatic "squench" control—5 or 10 channel coverage—easy to install anywhere!

Tone Alert—37 tone selective call system mutes speakers until one unit calls another—then automatically your stations receive audio note and indicator light flashes "On".



**NEW! 4-color
BROCHURE—write
for your free copy!**



E. F. JOHNSON CO

2003 10th Ave. S.W., Waseca, Minnesota

Please rush "Messenger" details to:

NAME.....
ADDRESS.....
CITY.....STATE.....

RUPTURED

BE FREE FROM TRUSS SLAVERY

Surely you want to **THROW AWAY TRUSSES FOREVER**, be rid of Rupture Worries. Then Why Do you put up with wearing a griping, chafing and unsanitary truss the balance of your life? If you do, it will NOT be through necessity but through choice on your part.

Now there is a modern **Non-Surgical** treatment that is designed to correct rupture. These Non-Surgical treatments are so dependable that a Lifetime Certificate of Assurance is given. Write today for our new **FREE BOOK** that gives facts that may save you painful, expensive surgery. Tells **HOW** and explains **WHY NON-SURGICAL** Methods of Treating Rupture are so successful today. No obligation.

EXCELSIOR MEDICAL CLINIC
Dept. H6238, Excelsior Springs, Mo.



**WANT MORE MONEY?
GET INTO PHOTOGRAPHY**

Coast to coast, high-paying jobs in photography are waiting for people with the "know-how" to fill them. You can quickly, easily qualify at home with the world-famous NYI Learn-by-Doing Method. Write today for free catalog. Also resident training in N. Y. Our 53rd Year. Approved for Veterans.

NEW YORK INSTITUTE OF PHOTOGRAPHY
Dept. 5 10 West 33 St. New York 1, N. Y.

MAKE YOUR FORTUNE



Sell famous Spring-Step Cushion Shoes for all the family. Earn big money daily plus Cash Bonus and Retirement Income with amazing 1-minute demonstration that sells on sight. Big repeat business. Full or spare time. America's biggest selection of shoes. Free outfit given. No investment ever. Fabulous insurance benefits—free to qualified dealers. Write today.

ORTHO-VENT Shoe Co., Inc.
432 Brand Road Salem, Virginia

LEARN PLASTICS



**COMPLETE LOW COST SHOP METHOD
HOME TRAINING NOW AVAILABLE**

Get in on Big Money opportunities in Plastic molding, casting, forming, carving, etc. Earn as you learn with Interstate's professionally prepared course. All plastic materials furnished.

**WRITE FOR
FREE
BOOKLET**

INTERSTATE TRAINING SERVICE
DEPT. C-2, PORTLAND 12, OREGON

BE A MAGICIAN!

Get started today! Become a popular man of mystery. Earn and learn in spare time. Magic is fun and profitable too. Be the Life of the Party Astonish your friends!

**RUSH 10¢ now for
PROFESSIONAL MAGIC CATALOG**
160 pages thick • 800 Illus. • 1000 Mysteries
Also Jokes, Puzzles, Secrets, Illusions.
FREE Magic Trick included

HOUSE OF 1000 MYSTERIES • Dept. PS2-63, MONROE, CONN.



**EASIER
THAN
YOU
THINK!**

EXCLUSIVE DOUBLE-BEARING HEAVY DUTY PUMPS



IRRIGATE • DRAIN • CIRCULATE • SPRAY
Use 1/4 HP motor or larger . . . 1 HP for up to 5,200 GPH;
1,000 GPH 60' high; or 8,000 GPH from 25' well. 1 1/4" inlet;
1" outlet. Stainless shaft. **TYPE X—2 oil-less \$10.95**
bronze bearings. Won't rust.....
TYPE XB—Ball bearing model. \$12.95
Best for belt drives.....

Postpaid (if cash with order,
Don't delay—send for yours today!)
MONEY BACK GUARANTEE
Centrifugal and Gear Pumps in All Sizes
LABAWCO PUMPS, Belle Mead 4, N. J.

3 to \$5 an Hour with Simple Tools!

FIX *Electric* APPLIANCES

AT HOME, SPARE TIME OR FULL TIME.
BIG OPPORTUNITIES. WE TRAIN YOU.



EARL G. REID, Jr.
Thompson,
Ohio

**\$510
EXTRA
IN ONE MONTH**

THE FREE Book offered below was a big first step for men like Reid, Clem and Adams, shown here — and many others! YOU TOO can have a steady, good-paying business of your own right in your home. Spare-time at start, full-time later. No experience needed, no big investment. Learn how to Repair Electric Appliances. Pays \$3 to \$5 an hour!

Get In On This "Boom" — NOW!

FOUR HUNDRED MILLION Electric Appliances, large and small, are in use right now in American homes. Seventy-six million MORE are bought each year. People need them fixed, good times or bad. YOU make good money doing it. Work in your own basement, garage, even on kitchen table. You need only few simple, basic tools. We train you, at home, to make steady money — earn while you learn.

Quick Way to Learn

Our 24-page FREE BOOK tells how you can "cash in" on America's Electric Appliance Repair boom.

FREE Sample Lesson shows how our easy, clearly pictured instruction prepares you for top earnings and a profitable future in this big field. All for less than 20¢ a day.

At no extra charge we provide all parts for your own Appliance Tester. It shows you where

to repair, speeds your work, makes sure each job is done right, ready for you to collect the money coming to you.

Here's the big-demand business you've been looking for! — and the chance to train for it with methods proved successful for over 45 years. Get your Free Book, Free Lesson now. Mail coupon, letter, or postcard to: National Radio Institute, Appliance Division, Dept. BB3, Washington 16, D.C. (No obligation, and no salesman will call on you.)

MAIL COUPON NOW

NATIONAL RADIO INSTITUTE,
Appliance Division, Dept. BB3,
Washington 16, D.C.

Please send me Free Book about your Electric Appliance Repair Course and a Free Sample Lesson. I am particularly interested in:

- Spare Time Earnings
- Business of My Own
- Better Job

Name.....

Address.....

City.....Zone...State.....

Accredited Member National Home Study Council

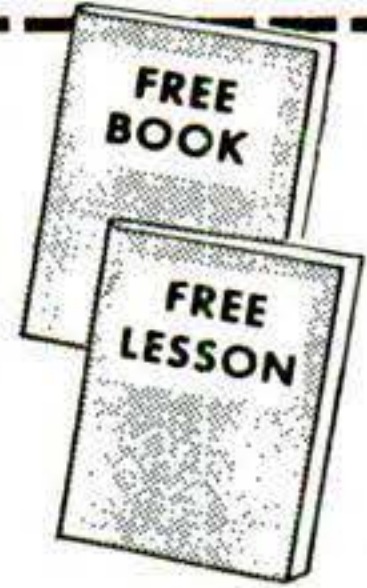

ED CLEM, Sr.
New Albany,
Ind.



**\$600
CASH
OR PART TIME**



ERNEST H. ADAMS
Dayton,
Ohio

**\$400
EXTRA
IN SPARE TIME**

HELP WANTED — SPARE TIME
SENSATIONAL NEW LONGER-BURNING LIGHT BULB. Amazing Free Replacement Guarantee—never again buy light bulbs. No competition. Multi-million dollar market yours alone. Make small fortune even spare time. Incredibly quick sales. Free sales kit. MERLITE (Bulb Div.), 114 E. 32nd, Dept. C-16D, New York 16, N.Y.

YOU CAN OPERATE A GARDENCRETE CENTER

GC-4



New Wayside Enterprise Offers High Income on Low Investment

You can make, display and sell Gardencrete — a line of decorative masonry rich in eye-appeal and use appeal. Many items — traditional and contemporary. Bird baths, lawn seats, flagstones, vases, screen block, brick and stone for building patios, walks, planters, barbecue pits, etc. Large color range. Easy to make; no experience necessary.

This is a franchise opportunity, giving you exclusive privileges in protected territory. Broad markets . . . generous profit potentials. A timely business, with fascination, interest and opportunity to capitalize on personal vision and aggressiveness. We supply all necessary instructions and much sales cooperation. Thousands of good territories now open. Write at once for prospectus "The Gardencrete Center Idea".



COLORCRETE INDUSTRIES, INC.
727 Ottawa Avenue
HOLLAND, MICHIGAN



FREE!
100
WORLDWIDE
STAMPS . . .
just released!

We'll send you this spectacular collection of new issues, FREE! 100 different stamps from world's far corners — new countries, new commemoratives, new pictorials. Get new issues shown PLUS giant multi-colors from Comoros, Mali, Senegal, Congo, many more. Wild beasts, exotic fish, famous people, savage warriors. EXTRA! New bargain stamp offers included. Send today for your valuable collection — enclose 10c handling.

GARCELON STAMP CO., Dept. PS2X

Calais, Maine. Rush free 100 Different Stamps, other offers. Enclosed 10c for handling. (PLEASE PRINT)

.....
.....
.....

COMBINATION HEATER-STOVE

*Keeps Cabins, Tents, Camps Warm in Coldest Weather—
Cooks Food Perfectly—Provides Controlled Heat Anywhere!*

Delivers Up To 3600 BTU's Per Hr.—Safe Indoors & Out
HEAT-PAL produces an astonishing amount of heat almost INSTANTLY—doubles as a top-quality cook stove. By adjusting the handy outside volume control you get complete range from low to intense high heat. Control slides out of sight when not in use.

HEAT-PAL is a scientifically-designed sturdy steel and aluminum unit—a product of Swedish precision engineering. Used and tested for years in far northern Sweden—one of the world's coldest, cruelest climates—where temperature drops to 60° below zero! Guaranteed to give a full lifetime of service with perfect safety. Steel fuel container is crammed full of non-inflammable absorbent that "soaks up" alcohol, then releases it as desired for heating or cooking in a series of "gas-like" flames. **NO OTHER STOVE USES THIS PATENTED PRINCIPLE.**

Portable, easy to use anywhere. Has handy carrying strap. Measures only 9" x 9" x 9". Weighs app. 5 lbs.

Steel body has red lacquered finish with upper portion made of heavy-duty spun aluminum. Special vents release maximum heat. For cooking you get the controlled, adjustable heat you need.

Windproof, Waterproof, Smokeless, Non-Toxic, Odorless, Economical

Uses inexpensive denatured alcohol (or alcohol solvent). Gives up to 20 hours of heat with 1 1/2 pints of fuel. Can be used anywhere—even in boats, on dry grass, in tents, cabins, even in child's bedroom! Will give you a lifetime of wonderful, dependable service. Completely guaranteed. Order today. Keep warm outdoors all winter long—every year—anywhere.

\$19.95
plus \$1
PP & Hdlg

EMPIRE MDSG. CO. Dept. PS 23, Marbledale Rd., Tuckahoe, N.Y.

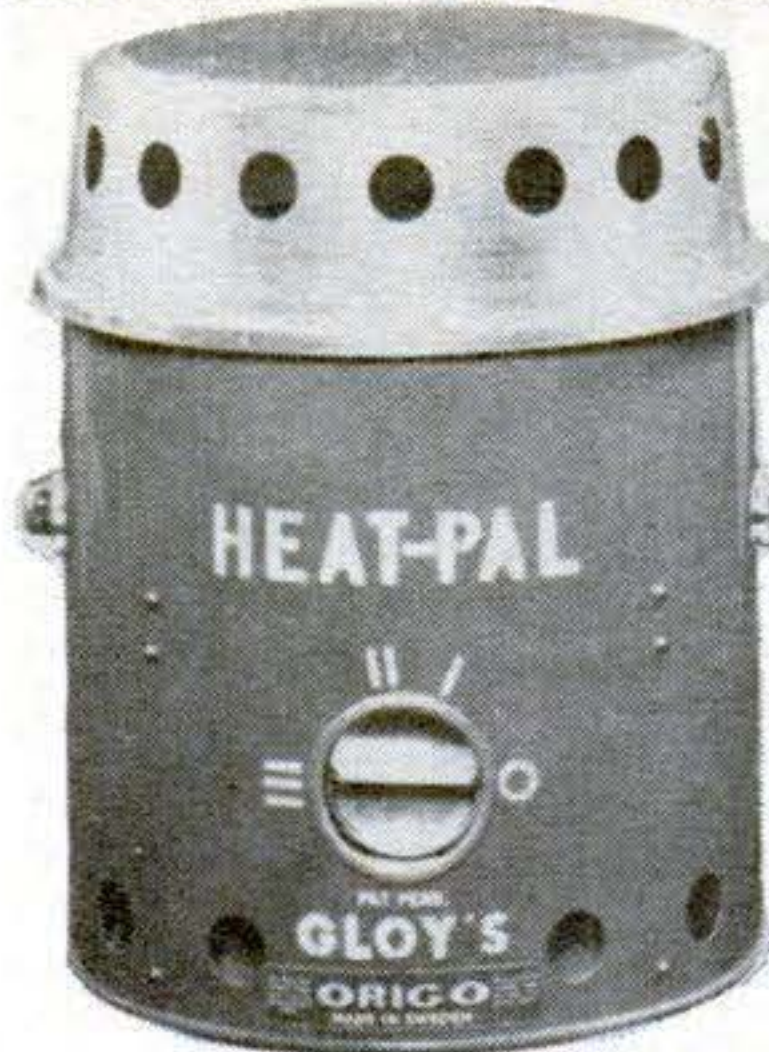

For Camps, Cabins, Tents Cooks & Heats



For Boats, Cars, Trucks, Etc.

ALSO AVAILABLE: Larger Unit—HEAT-PAL 5000, delivers

app. 5,000 BTUS per hr., \$27.95, plus \$1 PP & Hdlg. **BOAT HEAT PAL**—Heavy gauge aluminum, with all working parts, brass or stainless steel. Can't rust ever, enamelled in Boat Blue, otherwise same specifications as standard Heat-Pal, \$24.95, plus \$1 PP & Hdlg. **Reserve Fuel Container**, for carrying spare alcohol, 2 pint capacity, \$2.25.

OUTWORKS THEM ALL

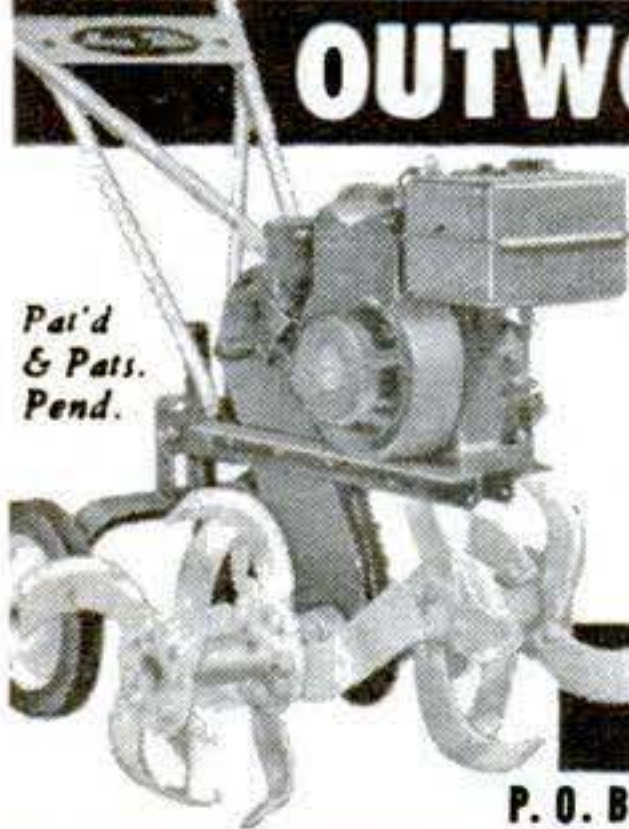

Pat'd
& Pats.
Pend.

5 action packed models with efficient chain drive that delivers equivalent of 2 extra hp! Prepare toughest soils in one operation, till to 12" deep—12" to 48" wide. Rotors, tractor tools for all jobs and soil conditions. Send for details.

MERRY TILLER

P. O. Box 370, 138-M Railroad Ave., Edmonds, Wn.

95% PROFITS YEAR 'ROUND

Be your own boss. Operate a **SIMPLEX** lawn-mower sharpening service in your community.

One compact machine grinds all mowers, sharpens cutlery. Low investment, 95% profit. Pays for itself in average month.

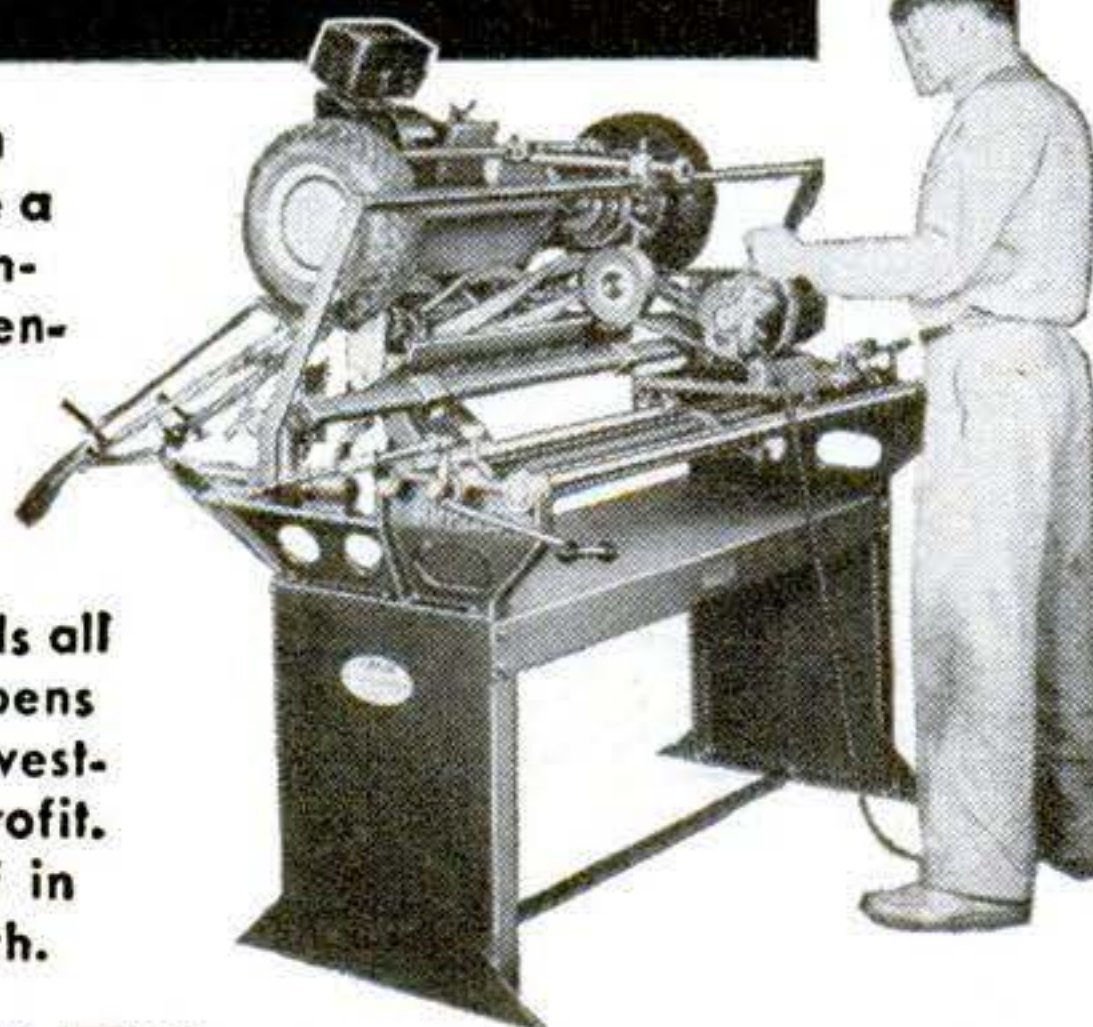

SIMPLEX—4 Machines in One!

- **Reel Grinder**—sharpens any mower reel in or out of mower.
- **Rotary Blade Grinder**—hollow grinds any rotary mower blade.
- **Bed Knife Grinder**—grinds with either round wheel or cup wheel.
- **Cutlery Knife Grinder**—sharpens cutlery, tools, scissors.

Send for free, money-making details!

The Fate-Root-Heath Company, Dept. PS-4, Plymouth, Ohio



MAKE MONEY IN ART Enjoy glamorous high-pay career or profitable hobby. Learn Painting, Commercial Art, Cartooning, Fashion Art, Lettering, TV Art. We train you at home, in spare time. **TWO 22-pc. art outfits (worth \$25) included, without charge. LOW COST—only 20c a day. Write for FREE 36-Page Book** describing easy course. No salesmen. **Washington School of Art, Studio 152, Port Washington, N. Y. (Est. 1914) Chartered by N. Y. State Education Dept.** Tear this ad out as a reminder.

TALK THRU ANY RADIO WITH THIS WALKIE TALKIE!



YOUR OWN POCKET SIZE RADIO STATION

Sends your voice to any car or house radio. Works up to 1-2 miles from car to car or 1-5 or more blocks house to house depending on local conditions. **Just Push Button to Talk—No Complicated Hookups or Wires—Anyone can use it.** Transistor powered by flashlight batteries. **No License or Permits Needed. Guaranteed to Work. 1 yr. Service Guarantee. Should Last for Years!**
SEND ONLY \$3.00 (cash, ck, mo) and pay postman \$9.99 C.O.D. postage or send \$12.99 for postpaid delivery. Ready to operate, with clear instructions. **Order your Radio-Talkie today—NOW!**
WESTERN RADIO, Dept. TPS-2, Kearney, Nebr.

NEW JET DRIVEN BOAT KIT



KIT INCLUDES BOAT and JET FOR AUTO ENGINE

FREE CATALOG \$22375 DOWN \$3804 PER MO. CONSTRUCTION DRAWINGS \$2.00

TAFT MARINE WOODCRAFT

DEPT. PS-263 • 636 39th Ave. N. E. MINNEAPOLIS 21, MINNESOTA

Start Your Own Business!

"Self Service" TUBE CHECKERS

\$39.95

Ideal for super-market and drug stores! These re-conditioned Tube Checkers have up-to-date charts, lighted back & locked compartment that stores up to 300 tubes.

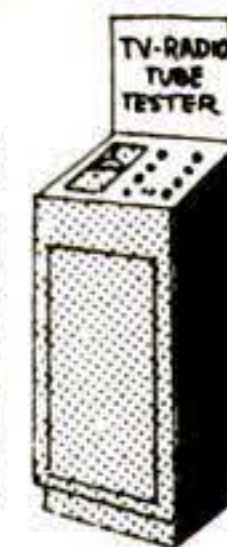

Tube Checker Complete With 200 Tubes **\$99.95**

USED TV CONSOLES

No Burned Out Picture Tubes or Transformers!

10", 12" and 14" **\$8.95** (as is)
16", 17", 19", 20" and 21" **\$16.95** (as is)



MONEY BACK GUARANTEE! Above items F.O.B., Harrison, N. J. Send for free complete TV tube and picture tube lists

TRU-VAC

406 Harrison Avenue, Harrison, New Jersey, HUmboldt 4-9770, PS 2

Not everyone does as well, but T. N. CODY, who started a business of his own, reports...

For 12 months
I've averaged

\$800

**PER
MONTH
INCOME**

—most of it clear profit for me!

Many men have discovered how to be independent, to be free of layoffs and bosses. C. G. Naples grossed more than \$200 his first week. A father-son combination grossed \$44,000 their second year. H. Lemon says, "I netted \$133 in one 8-hour day."

How much you earn depends largely on you, but we help you to start and work with you for your success. You need no special skill, no large investment. Start part time if you wish. Hire helpers as needed.

NO SHOP NECESSARY • Our **PORTABLE ELECTRIC DETERGER** shampoos rugs, carpets right on customer's floor. Wonderful results bring you repeat business, large fees. So efficient and safe, it is used by largest hotels and railroads.

NO LEASE ARRANGEMENT • You are free to operate in an independent manner. You sign no contract. You own the detergent outright and are always your own boss. And every dollar you take in is yours to keep. You pay no fees, or dues, or royalties to anyone. And you take no risk. Your detergent is fully guaranteed and enough supplies come with it to return far more than your investment. Many earn the cost of the detergent in a week or two. It costs nothing to get the details...write **TODAY**.

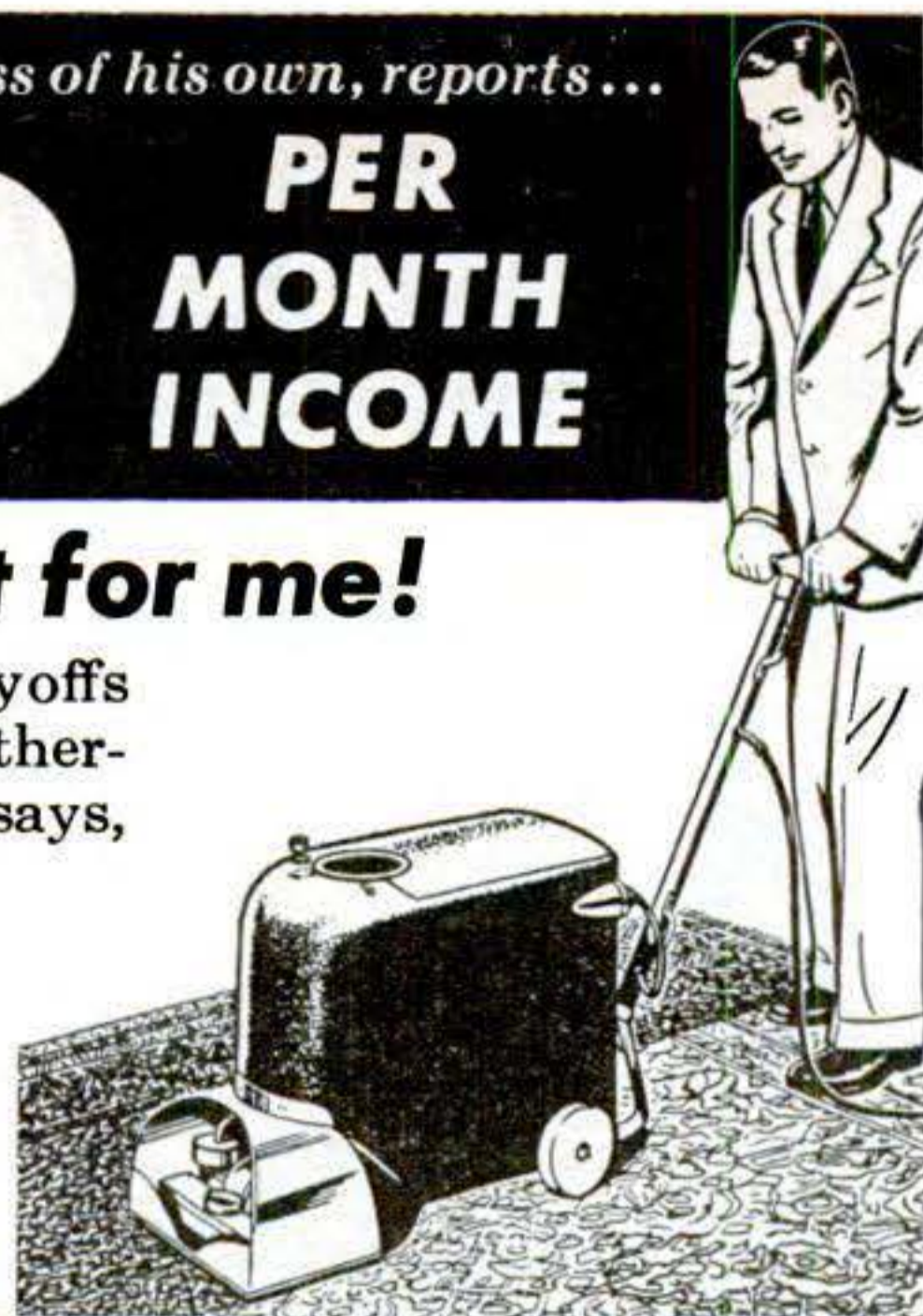

MAIL COUPON TODAY FOR FREE BOOK

VON SCHRADER MFG. CO.
211 "R" Pl., Racine, Wis.

Without obligation send me **FREE** booklet about your RUG DETERGER and tell me how I can start my own permanent, profitable business.

Name _____

Address _____

City _____ Zone _____ State _____

**BLUE BOOK
OF CRIME
FREE!**

**Given to men who want to get into
CRIME DETECTION
FINGER PRINT IDENTIFICATION**

Train at home, spare time. Join hundreds of I.A.S. graduates now employed by police and identification bureaus in every state. Learn finger print identification, crime investigation, firearms identification, police photography, other subjects vital to qualifying for good paying, secure, interesting jobs. "Blue Book of Crime" and details Free. Must state age.

Institute of Applied Science, Dept. 1362
A Correspondence School Founded in 1916
1920 Sunnyside Ave., Chicago 40, Ill.

**ENGINEERING
SCIENCE
MATH**

**B.S. DEGREE
IN 36 MOS.**



U.S. NEEDS 50,000 NEW ENGINEERS EVERY YEAR

EARN ACCREDITED B.S. DEGREE in Science or Engineering in months—year-round program optional. 27-month engineering diploma also available. Classes start March, June, September, January. **QUALITY EDUCATION.** Graduates employed throughout U.S. and foreign countries. Government approved for veteran training. Students from 50 states, 40 countries. 20 buildings; dorms, gym. Campus library and laboratories. Employment help provided. **SAVE TIME AND MONEY.**

Write for catalog and complete information.

INDIANA INSTITUTE of TECHNOLOGY

(Formerly Indiana Technical College)

1618 E. Washington Boulevard, Fort Wayne 2, Indiana

Please send free information on accredited B.S. Degree programs in Engineering and Science as checked:

- | | |
|---|--|
| <input type="checkbox"/> Aeronautical Engineering | <input type="checkbox"/> Mechanical Engineering |
| <input type="checkbox"/> Chemical Engineering | <input type="checkbox"/> Metallurgical Engineering |
| <input type="checkbox"/> Civil Engineering | <input type="checkbox"/> Physics |
| <input type="checkbox"/> Electrical Engineering | <input type="checkbox"/> Chemistry |
| <input type="checkbox"/> Electronic Engineering | <input type="checkbox"/> Mathematics |

Name _____

Address _____

City _____ State _____



**BAR MAID
WITH
Con-Tact®**
the world's LARGEST SELLING self-adhering plastic

Con-Tact® self-adhering plastic makes it easy to give a professional look to decorating, has a washable, easy-care surface that lasts for years. Wide pattern range available. Shown, bar and wall: Continental (top, Carrara). 18" wide. **49c yd.**

A product of United Merchants & Manufacturers, Inc.

Just Pick the Kind of Body YOU Want

CHECK THE COUPON BELOW

... Prove to Yourself How EASILY You Can Have It... Almost Overnight!

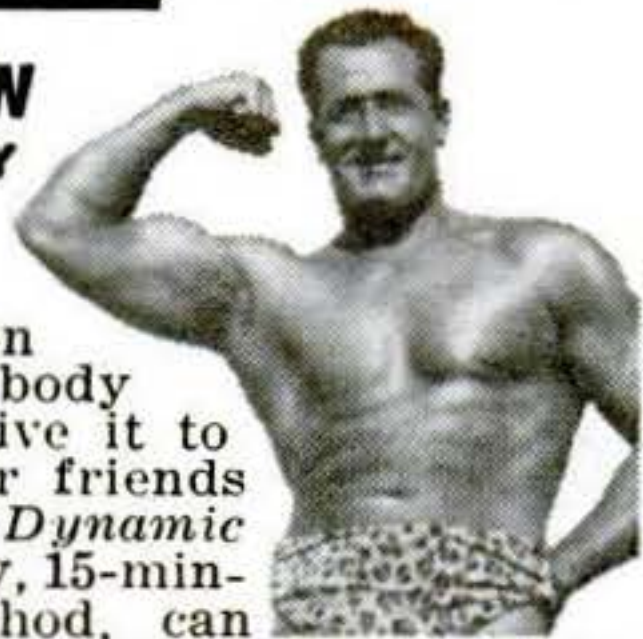

Just tell me, in coupon below, the kind of body you want—and I'll give it to you SO FAST your friends will be amazed! "Dynamic Tension," my easy, 15-minutes-a-day method, can make your chest and shoulders bulge... your arms and legs surge with power... your whole body feel "alive!"

FREE 32-page Illustrated Book

32 pages on how "Dynamic Tension" changed me from a 97-lb. weakling into "World's Most Perfectly Developed Man"—and what it has done for others. Mail coupon NOW! Charles Atlas, Dept. 12, 115 E. 23rd St., N. Y. 10, N. Y.



CHARLES ATLAS, Dept. 12, 115 East 23rd St., New York 10, N. Y.

Dear Charles Atlas Here's the Kind of Body I Want: (Check as many as you like)

- | | |
|---|---|
| <input type="checkbox"/> Slimmer Waist, Hips | <input type="checkbox"/> More Powerful Arms, Grip |
| <input type="checkbox"/> Broader Chest, Shoulders | <input type="checkbox"/> More Powerful Legs |
| <input type="checkbox"/> More Weight, Solid | <input type="checkbox"/> Better Energy, Sleep |

Send me, absolutely FREE, a copy of your famous book showing how "Dynamic Tension" can make me a new man. 32 pages, crammed with photographs, answers to vital questions, and valuable advice. No obligation.

Name _____ Age _____
(Please print or write plainly)

Address _____

City _____ Zone _____ State _____
In England, send to Charles Atlas, Chitty St., London W.1

EARN MORE-LEARN AUTO DIESEL MECHANICS

OR TRAIN WITH OTHER GREER DIPLOMA COURSES

- | | |
|---|--|
| <input type="checkbox"/> AUTO MECHANICS | <input type="checkbox"/> REFRIGERATION |
| <input type="checkbox"/> DIESEL MECHANICS | <input type="checkbox"/> AIR CONDITIONING |
| <input type="checkbox"/> BODY & FENDER REPAIR | <input type="checkbox"/> MACHINIST-TOOL & DIE |
| <input type="checkbox"/> GAS, ARC WELDING | <input type="checkbox"/> AUTOMATIC TRANSMISSIONS |
| <input type="checkbox"/> HELIARC WELDING | <input type="checkbox"/> MOTOR TUNE-UP |
| <input type="checkbox"/> DRAFTING | <input type="checkbox"/> Civ. or <input type="checkbox"/> G.I. |

Skilled men are needed in every part of the country. Earn top pay in established shops or start your own business. Greer's expert instruction and actual shop training teaches you how. You learn by doing—quick, easy courses using the latest tools and equipment. Day, evening and part time instructions available.

Job placement aid and convenient living accommodations are yours while training. Contact GREER'S FREE JOB PLACEMENT SERVICE when you enroll if you wish part time or full time employment assistance.

TECHNICIAN COURSES

- | |
|---|
| <input type="checkbox"/> DIESEL AUTOMOTIVE TECHNICIAN—21 MONTHS |
| <input type="checkbox"/> REFRIGERATION & AIR COND. TECHNICIAN—17 MONTHS |
| <input type="checkbox"/> WELDING TECHNICIAN—14 MONTHS |

Please rush me free literature on the trade indicated at no obligation.

NAME _____ AGE _____

STREET _____

TOWN _____ ZONE _____ STATE _____

Established 1902

GREER SHOP TRAINING

Box N, 2238 S. Michigan Ave. Chicago 16, Ill.

MAKE Big MONEY WITH THE

Universal LAWN MOWER GRINDER!

Enjoy a profitable lawn mower sharpening business. No previous experience needed. Place a hand or power mower on the Universal Grinder. With only one set-up you quickly grind the stationary blade and all of the reel blades to proper clearance without removing a single blade from mower. New Circular Saw Grinding Attachment Available.

PROOF G. Spurlock of Arkansas writes: "I have had my Universal Grinder only two months. Live 1½ miles from town. Yet have already made a net profit of \$227.00."

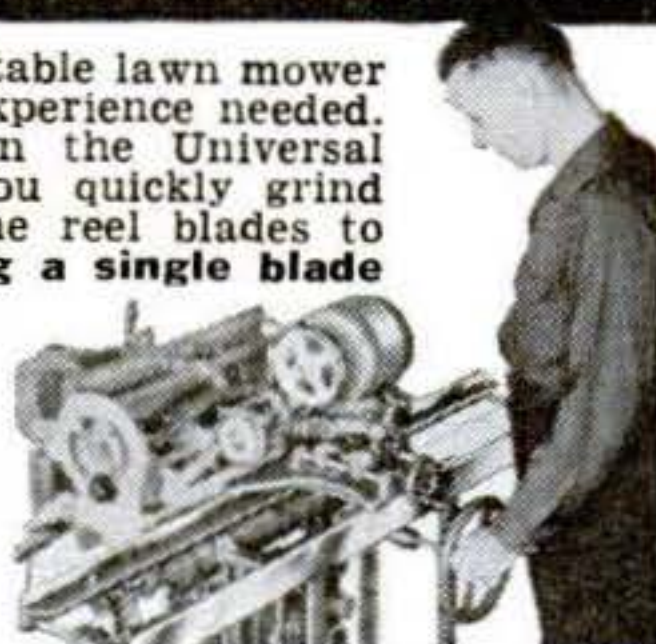

J. L. Peterman of Pa. writes: "Thank you for getting me started in this wonderful business... I averaged \$100.00 a week in May, and made \$1,000.00 spare time this season."

Write TODAY for FREE FACTS on Money-Making opportunities in Lawn Mower Sharpening and TIME PAYMENT PLAN. ROGERS MANUFACTURING CO., Dept. P-23, Lindsey, Ohio

FABULOUS! 75-15,000 CPS; .018 wow/flutter; 3 speeds; 6 lbs.; 7½" x 7"; self contained batteries. Portable professional "660" Tape Recorder, LIVING HIGH FIDELITY. Send 25¢ for booklet on uses of tape recorders. Audiophile Net: \$14950



Citroen Electronics Corporation 729 N. Highland Ave., Los Angeles

BIG Throwing Knife \$1.00 Special



PIERCES METAL

Specially weighted & balanced point zeroes right into bull's eye with a wallop! Positive accuracy! Deep penetration! Easy throwing! Hard hitting! Excellent for hunting game, self defense, fun. Cutlery steel, double edge. Big 10" long. Leather handle. You must be delighted or your money back. Price Postpaid \$1.00. DeLuxe Chrome Finish Model for Exhibition Purposes \$2.50. Leather Sheath 50c. Professional Knife Throwing Book 25c. JOHNSON SMITH & CO., Dept. 233, Detroit 7, Mich.

MAKE MONEY! REPAIR HYDRAULIC JACKS



Earn While You Learn At Home. Make up to \$5 an hour, full or part-time, in the competition-free field of Hydraulic Jack Repair. Millions of jacks in auto service stations, truckers, body shops, riggers, farms, need servicing. We show you HOW. Easy step-by-step directions.

Write for Folder PS2 and Free Bonus Offer

Institute of Hydraulic Jack Repair

P.O. BOX 50 • BLOOMFIELD, N. J.

A Correspondence School Licensed by N.J. Bd. of Ed.

POWERFUL NEW INVENTION, ONLY 2" LONG SHOTS THRU 100 PAGES-THIS BOOK! 'B-B SHOT'



MAKE THIS TEST... Load your 'BB Shot' and fire against this magazine. Notice that it drives BB's through more than 100 pages. Though only 2" long x 1" in diameter, this pocket-size device has amazing power and accuracy. Use it for targets, pests and hunting. Scientifically designed for high power, operating ease and safety.

FREE! Get the 'BB Shot' now—we'll include an extra Velocity Cone and FREE Target, BB's and Automatic BB Dispenser—all for only \$1.98 ppd. or 3 for \$5.00 ppd. Money Back Guarantee. Not sold to N.Y.C. residents or minors. GRAYSON CO. • Dept. E-34, 210 Fifth Ave., N. Y. C. 10

MONEY-BACK GUARANTEE

Name _____ Address _____ City _____ State _____

\$1.98 ppd

LEARN TO EARN!

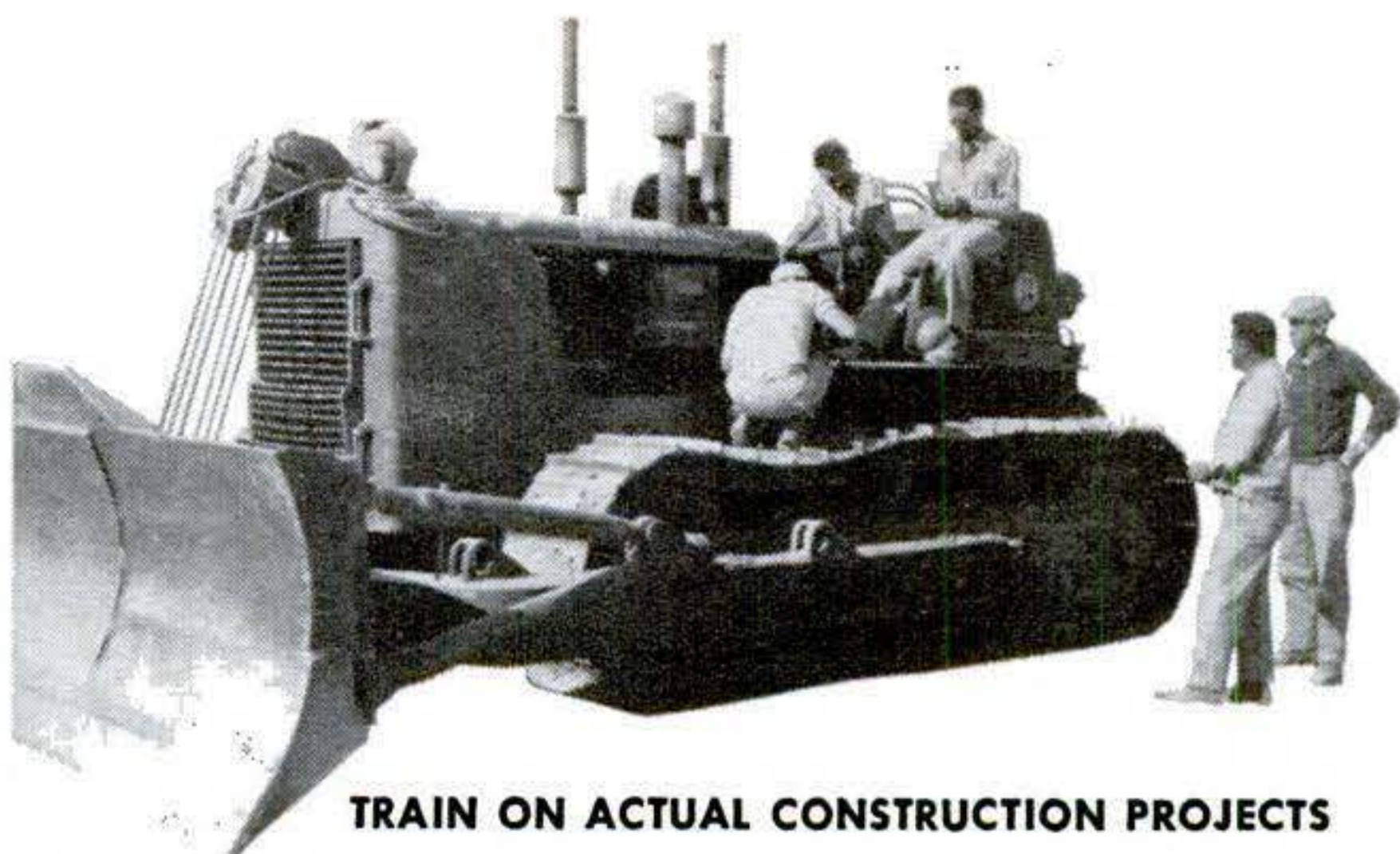

TRAIN ON ACTUAL CONSTRUCTION PROJECTS

NO CORRESPONDENCE OR HOME STUDY TRAINING

Our students are taught on the machines by qualified instructors. They do not learn from books, thousands of miles from the school. This means they are better qualified and more readily accepted for immediate employment by contractors.

• CONTRACTOR OWNED — V. A. APPROVED

Because Western School is the only contractor owned and operated school in the world, you get the "Real Thing" from the men who will eventually hire heavy equipment operators . . . the Contractors. Write today for FREE information.

WESTERN SCHOOL OF HEAVY EQUIPMENT OPERATION

Associate member of Associated General Contractors and A.R.B.A.
S-1 BOX 510 • WEISER, IDAHO



Please send me your
FREE BROCHURE

S-1

NAME _____
ADDRESS _____
CITY _____ STATE _____

LEARN IBM

AT LAST! With THOUSANDS of prestige positions waiting for new data processing technicians and PAY scales at a RECORD HIGH, A.T.C.'s exclusive methods are available to you in a SPECIAL HOME STUDY PROGRAM GEARED TO YOUR TIME AND BUDGET. No contracts to sign . . . you pay for each lesson only when you order it! Send for FREE BOOKLET "Your Future in IBM Data Processing"—No Obligation.

AUTOMATION TRAINING CORPORATION
7023 E. Kirby, Dept. P523, Detroit 35, Mich.

GET THIS NEW VALUABLE COLLECTION

Big beautiful North American collection, all-different postage stamps of Greenland (North Pole), St. Pierre, Newfoundland, Canada — Eskimos, Indians, scarce 1867 Confederation. 1862 British Columbia & Vancouver Is. Cent., Nova Scotia, Northern Territories. United Nations. U. S. Stamps — 19th Century, first Plane, Steam Boat, Pony Express, etc. ALSO, complete Colonial & Civil War Issues. PLUS full color flag stamps of 87 foreign countries. EXTRA Bargain Catalog; "How To Recognize Rare Stamps"; other exciting stamp offers for free inspection. Send 10c for mailing.

FREE!

SENSATIONAL GET ACQUAINTED OFFER

KENMORE STAMP CO.
Milford EF-439, New Hamp.

"I Have My Own Shop Now!"



Says Freeman J. Jeffress, Oklahoma City, Okla. "Your course is so good, I wouldn't take back the money I paid for it. I have a nice little shop set up in my home and it has already paid for itself!"

Be a LOCKSMITH

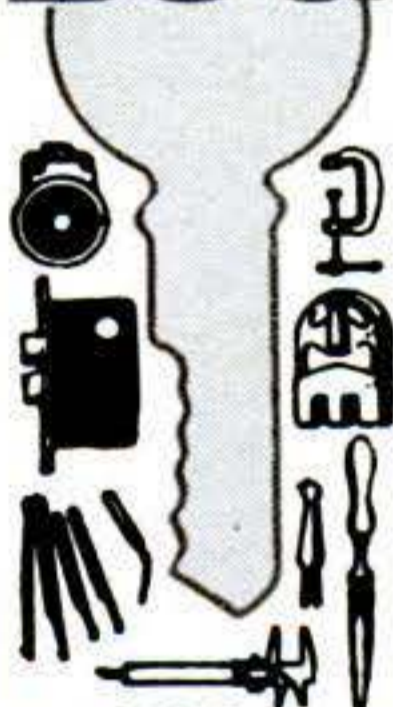

306 pieces of equipment — Locks, Picks, Tools & Parts FREE for use with course.

Add 50% - 100% to YOUR INCOME with easy spare time earnings. Cash in on nationwide shortage...in good times and bad. Quickly step into a big-pay opportunity job — high profit shop of your own.

Earn Extra Money RIGHT AWAY! All Special Tools, Supplies Furnished FREE. Age, education, minor physical handicaps don't matter in this growing trade. You can quickly qualify as a skilled locksmith. Study at home as little as one hour a week. Gain practical experience through well-illustrated lessons. Do real jobs on car locks, house locks, padlocks and safe locks, under guidance of experts.

FREE Illustrated Book

For a future as your own boss or in a high-pay job, send for FREE book and sample lesson pages. Only school of its kind. Lic. State of N.J. Acc'd NHSC. Vet. App'd. Locksmithing Institute (Division of Tech. Home Study Schools). Dept. 202-3, Little Falls, N. J.

MAIL COUPON NOW!

Please send, without obligation, FREE Book, "Big Money in Locksmithing," and Sample Lesson Pages. No Salesman will call.

LOCKSMITHING INSTITUTE, Dept. 202-3, Little Falls, New Jersey

Name _____ (Print here)

Address _____

City _____ Zone _____ State _____

Check if Veteran

Many others!

ACCORDION PRICES SMASHED!



SAVE UP TO 1/2

Buy Direct at **BIGGEST IMPORTER-TO-YOU DISCOUNTS!**

Save more than you have ever dreamed possible... up to 50% off retail prices for comparable accordions. Pay no teacher or salesman commissions.

EASY TERMS! For just a small amount down (or any old instrument in trade)... and pennies a day... you can own a new 1962 model famous accordion!

World's Largest Accordion Dealer offers biggest selection! Choose from over 35 models for students and professionals, standard or electronic... newest features. Amazingly high trade-in allowance on ANY used musical instrument. **FREE HOME TRIAL.** No Risk Offer—Satisfaction guaranteed or Money Back! **FREE BONUS GIFTS.** Mail coupon today for **FREE** Color Catalogs and Importer-to-You Discounts.

FREE 5-DAY HOME TRIAL!

ACCORDION CORPORATION OF AMERICA
2003 West Chicago Ave., Dept. P-23, Chicago 22, Illinois

FREE Color Catalog Rush Coupon

Accordion Corporation of America, Dept. P-23
2003 West Chicago Avenue, Chicago 22, Illinois
Rush **FREE** Color Catalog, Accordion Selection Guide, and the Importer-to-You Discounts.

NAME _____
ADDRESS _____
CITY _____ STATE _____
() I have an accordion to trade.

AEC 77 TRANSISTORIZED IGNITION SYSTEM

Increases power up to 10%... fast starts at low end... full power at high rpm... up to 20% more mpg... prevents fouled plugs... increases spark plug life 3 to 5 times over normal... 75,000 mile point life... instant starting in sub-zero weather... eliminates frequent tune-ups... 20 minute installation by anyone... cures ignition problems... radio ignition interference reduced 50%.

In conventional ignition systems, high voltage at the spark plugs falls off over 50% as engine speeds increase. Result: weak spark causing incomplete combustion, loss of power, fouled plugs & poor gas mileage. The rugged AEC 77 electronic ignition increases and maintains maximum high voltage output at the spark plugs with no high voltage fall-off at any speed. Its hot spark guarantees more efficient combustion, delivers full engine power at over 7,500 rpm with up to 20% more mpg.

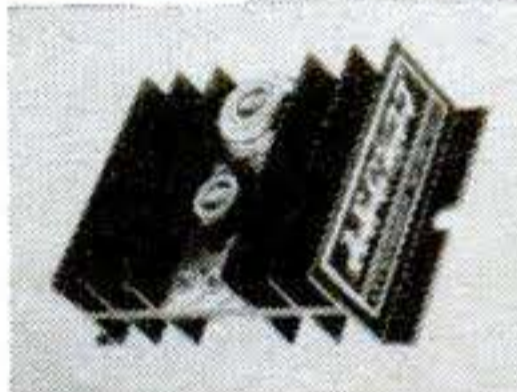

\$39⁹⁵

WORLD CHAMPION RACING DRIVER, PHIL HILL USES AEC 77... REPORTS—

"AEC 77's strong spark can make up for worn points or improperly gapped spark plugs. It will make your car run smoother, particularly at the low end and will appreciably improve its performance and economy."



Proven in over 2,000,000 miles of testing. AEC 77 is so dependable in performance design and engineering, that every unit is registered and **GUARANTEED FOR 3 FULL YEARS.**

AUTOMOTIVE ELECTRONICS CO.

387 PARK AVE. SOUTH, NEW YORK 16, N. Y. PS-2

() Please send me _____ AEC 77 Ignition Systems. I enclose check or money order for \$39.95 each.

NAME _____
ADDRESS _____
Make, Year, Car Model _____
Please send me further information on AEC 77

engineering degree in 27 months

Industry demands graduates. Enjoy higher income... advancement. Major corporations regularly interview and employ seniors. **BACHELOR OF SCIENCE DEGREE IN 27 MONTHS** in Electrical, Mechanical, Aeronautical, Chemical, Civil Engineering. **IN 36 MONTHS** a B.S. Degree in Business Administration (General Business, Accounting, Motor Transport Administration majors). One-year Drafting-Design Certificate Program. Small classes. More professional class hours. Well-equipped labs. Campus. Dorms. New library. *Moderate costs.* Founded 1884. Enter March, June, September, January. Write **J. F. McCarthy** for Catalog and "Your Career" Book. Learn more and you'll earn more.



TRI-STATE COLLEGE

523 College Avenue • Angola, Indiana

REAL ESTATE BE A BROKER

PAY BIG! SEND FOR FREE, BIG, ILLUSTRATED CATALOG NOW! Graduates report making substantial incomes. Start and run your own business quickly. Men, women of all ages, learn easily. Course covers Sales, Property Management, Appraising, Loans, Mortgages, and related subjects. **STUDY AT HOME** or in classrooms in leading cities. Diploma awarded. Write TODAY for free book! No obligation.

FREE BOOK TELLS HOW

Approved for World War II and Korean Veterans
WEAVER SCHOOL OF REAL ESTATE (Est. 1936)
3521S Broadway Kansas City, Mo.

"\$7,108⁵⁰ First Year SERVICING RADIATORS!"

— Hank Konter, Newcastle, Wyo.

Make good money servicing auto-truck-tractor radiators with new Inland 1-Piece Radiator Shop. Easy to test-clean-repair radiators. Inland, world's largest radiator equip. mfr., trains you free. Small down payment starts you. Easy-pay plan lets you pay from profits. Proved merchandising assures volume. Profitable dept. for garage or service station. **WRITE for Free Book.**



INLAND MFG. CO., Dept. PS-2, 1108 Jackson St., Omaha 2, Nebr.

NOW FOR THE FIRST TIME AT THIS RIDICULOUSLY LOW PRICE

\$5.95

Not sold to Calif. or N.Y. res.

22 Cal. Blank Cart. 6 Shot Revolver No Permit Required

Imported from ITALY "BLACK VENDETTA" Send \$1.00 on C.O.D.'s.

Latest model, not a toy. Gun is of solid steel construction. Lightweight and perfectly balanced. Fires 6 rounds in 2 seconds! Double or single action. Precision crafted, 5 1/2 inches long. Ideal for stage, sporting events, boating, protection. Revolver \$5.95, deluxe leather holster \$2.25.



BIG THREE ENT. INC. 1109 Sixth Ave., New York 36, N.Y. Dept. PS-263

BE A LANDSCAPE CONTRACTOR

LEARN MODERN LANDSCAPING for exciting hobby or profit. Thousands of spare or full time money making opportunities. Start a profitable business—we show you how. Study and earn your certificate at home.

Write today for Free Book. **LIFETIME CAREER SCHOOLS**
Dept. PS-23

11826 San Vicente Blvd.
Los Angeles 49, Calif.

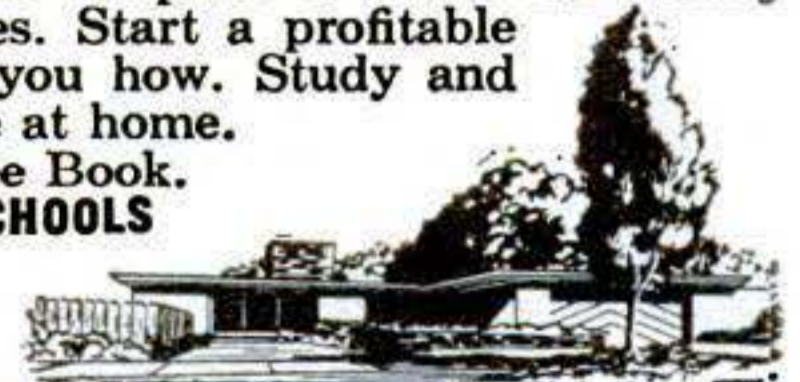

EYE GLASSES by MAIL As low as \$1⁹⁵

WRITE for FREE CATALOG with 14 LENS SAMPLE CARD

Thousands of Customers Est. 1939



QUALITY READING — or **BIFOCAL GLASSES** for FAR and NEAR Recommended for folks approximately 40 years or older who do not have astigmatism or disease of the eye, and who have difficulty reading or seeing far.

ADVANCE SPECTACLE CO. Inc., Dept. PS-2
537 So. DEARBORN ST. CHICAGO 5, ILLINOIS



C. O. Jones
Texas



J. McMahon
New York



W. Hardesty
Indiana



B. B. Becnel
Louisiana



P. Smith
Oregon



J. Huntoon
California



R. Felarski
Missouri

These men make big money in their own HOME SHARPENING SHOP . . . AND SO CAN YOU

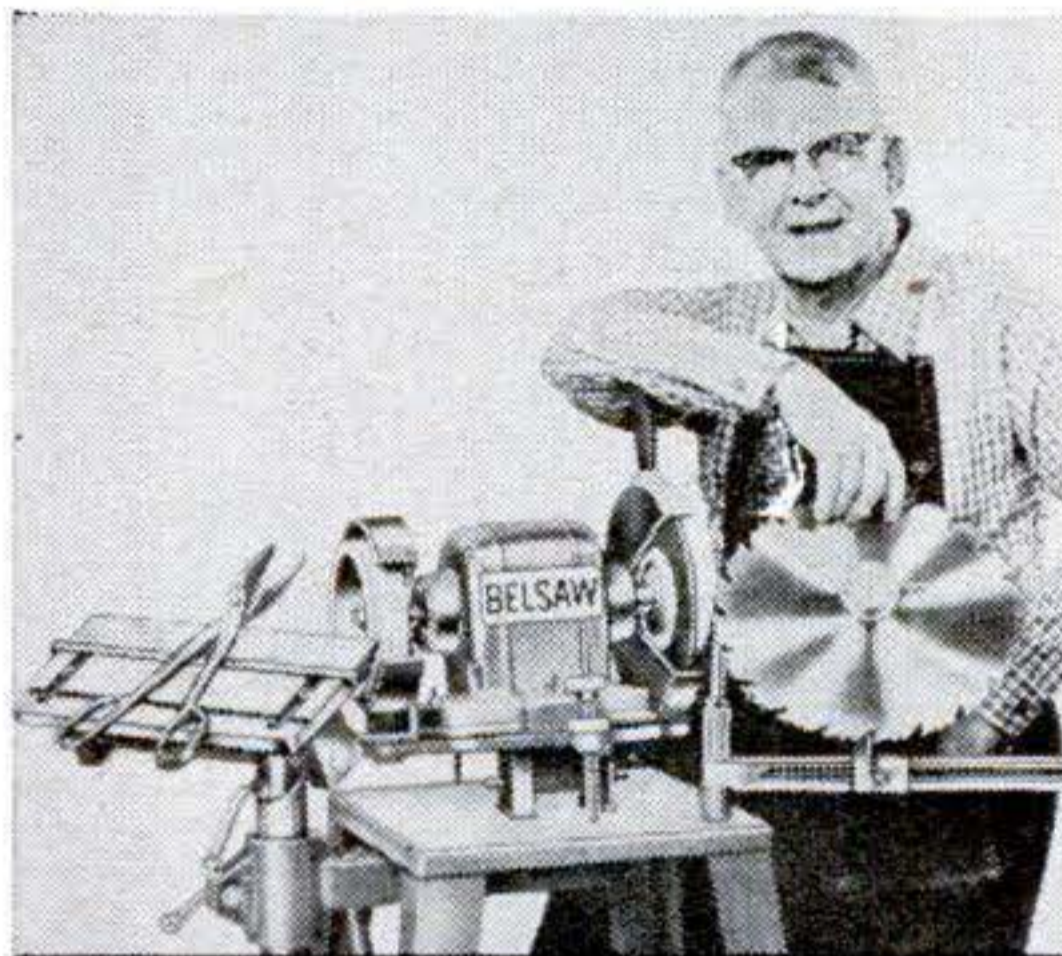

We have been helping thousands of men build their OWN profitable business for over 30 years. The Belsaw Plan is a proven guide to LIFETIME SECURITY. You get complete illustrated instructions on how to sharpen all popular tools, how to get profitable business, everything you need to know to start and build your own money making business. We even finance you while you're getting started.

Make \$5.00 an hour from the start

Anyone can learn to operate the SHARP-ALL expertly. Whether you want a spare time income or a full-time business, the SHARP-ALL is your answer. There's no inventory, no selling, no store space to rent. You operate out of your own home on a cash basis. Age and physical handicaps are no barrier to success in this business.

Send coupon today.



BELSAW SHARP-ALL CO.
 703A Field Bldg., Kansas City 11, Mo.
 Send Free Book "LIFETIME SECURITY." No obligation.

Name _____
 Address _____
 City _____ State _____

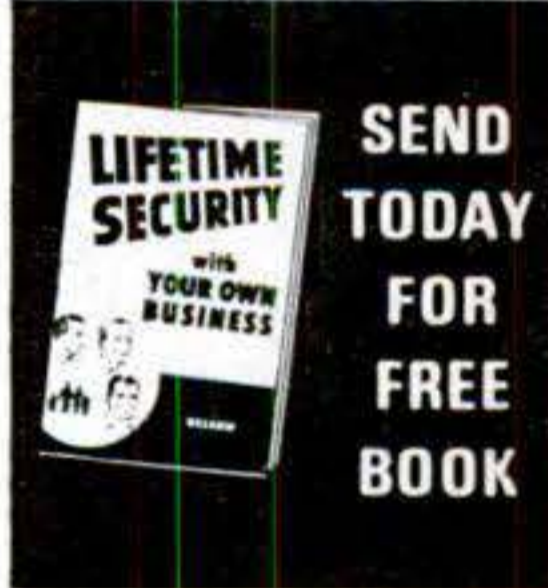

SEND TODAY FOR FREE BOOK

FREE CATALOG



MAKE YOUR OWN RODS AND LURES

Send for FREE Wholesale Catalog. The most complete and fully illustrated catalog of reels, rods, beads, spinners, jigs, lure bodies and parts, sinker molds, feathers, tools, hooks, rod blanks, rod parts, swivels, wire, etc. Over 170 pages.

FINNYSPORTS
1263X Sports Building Toledo 14, Ohio

Curious Coins! ODD PAPER MONEY!

Worth \$1 - But Yours
FOR ONLY 10c

SEND for this valuable packet of odd and curious coins, paper money—an exciting introduction to fast growing hobby! You'll find coins from Formosa (Free China—our ally), Austria, far-off East Africa, friendly Turkey, etc. Actual value at least \$1—but yours for only 10c on this special offer!

JOIN THE FUN RIGHT AWAY

Get your 10¢ packet of coins and money—plus \$100,000 Confederate Money *bonus*—together with lists of rare coins available and other interesting offers on approval. Just send your name and address now, with 10c to:



INCLUDED



\$100,000 in CONFEDERATE "MONEY"!

These lots-of-fun facsimiles are yours for promptness while the supply lasts.

LITTLETON COIN CO., Dept. PS-2
Littleton, New Hampshire

LEARN UPHOLSTERY

in your spare time

run your own business AT HOME



FREE BOOK with sample lessons

WITH COURSE YOU MAKE SLIPPER CHAIR



CLUB CHAIR OTTOMAN WITH SLIP COVERS Yours to Keep or Sell

BE YOUR OWN BOSS

Earn more from the start! Set up your own profitable business, in your own home, enjoy steady income, independence for life in the booming field of Custom Furniture Upholstery. **Right off, you start** upholstering with the tools, complete frames, fabrics and materials, supplied with your practical N.Y. State-approved UTS Home Study Training. You learn skilled professional custom upholstery, furniture finishing, repairs, how to make beautiful slip covers and draperies. **EARN WHILE YOU LEARN**, in your spare time **AT HOME** . . . the UTS easy way.

FREE ILLUSTRATED BOOK FREE SAMPLE LESSON Get ready for well-paid job and big profits, from steady work, as your own boss, running your own business. Mail coupon NOW for **FREE BOOK!** Training in N.Y. School also available.

N.Y. State Lic., accredited NHSC, Vet App'd

UPHOLSTERY TRADES SCHOOL
Dept. RB-1610, 721 B'Way, N. Y. 3, N. Y.
Please send me **FREE** book "Your New Way to a Successful Career," and **FREE** sample lesson. No obligation—no salesman will call.

Name _____
 Please Print Plainly
 Address _____
 City _____ Zone _____ State _____
 Check if Korean Veteran

make
gardening
fun!

Ariens
SUPER JET

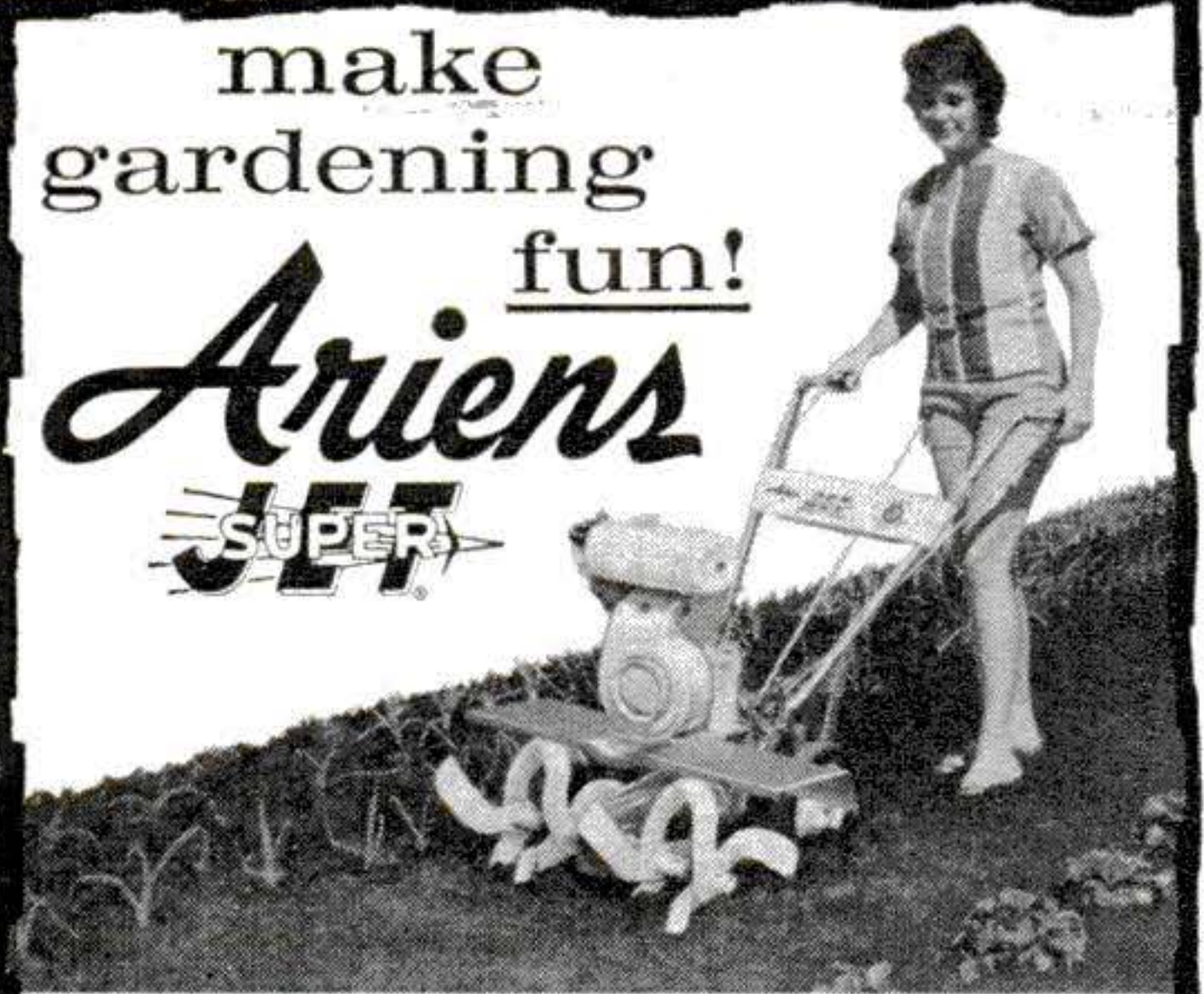

FROM SPRING TO FALL TILL
UP TO 5,000 SQ. FT. AN HOUR!

Let ARIENS SUPER JET do all the "digging" for you! Tills 24" wide; has fingertip controls . . . power tine reverse. Choice 5 engines: 3 h.p. to 5 h.p. for every tilling need. Unequaled for dependability, performance, value!

Write for free literature!
Ariens COMPANY

159 Calumet St., Brillion, Wis.



Earn **HIGH WAGES** as a
HEAVY EQUIPMENT OPERATOR

... and years of future security in the multi-billion dollar construction industry, in this country and overseas! Learn how at National, the original school of heavy equipment operation. For men ages 17 to 56. Amount of previous education no barrier. National is NOT a correspondence school, you train on school-owned diesel-engined machines at National's huge proving ground in North Carolina. Full 220 and 440 hour courses. Job Advisory and Counselling Dept. VA approved. Payment plans available, Write TODAY for FREE catalog.

Even if you are presently taking a course in heavy equipment operation, send for our catalog and compare the training you are receiving with ours.

**NATIONAL SCHOOL
OF HEAVY EQUIPMENT OPERATION Dept. A-34
P. O. Drawer 1686, Charlotte, N. C.**

Please send me FREE illustrated school catalog and complete information. I understand there's no obligation.

Name..... Age.....

Address.....

City..... Zone..... State.....

Bargain from London



**1962
STAMPEX
SHEET**

**Plus 105 Different
BRITISH EMPIRE 24¢**

Fabulous collection of 105 different British Empire - 98 yr. old Penny red QUEEN VICTORIA, plus issues from hard-to-get colonies: (Tristan and other unusual items.) PLUS - 1962 stamp exhibition souvenir sheet from London - official reproductions of 5 famous commemoratives. Covers 25 years - includes £1 ROYAL WEDDING, EUROPA, SCOUTS, OLYMPICS, JUBILEE. Most exciting page for any album! Export price - 24¢ to introduce overseas approvals.

IMPORT DIRECT. SAVE 20-60%. Buy direct - where dealers buy. Exciting selections, low prices this easy 14-day approval way.

SEND 24¢ IN UNUSED U. S. STAMPS (NO COINS)
SATISFACTION GUARANTEED. ASK FOR LOT XA-1.

BROADWAY APPROVALS, LTD., 50 Denmark Hill, London S.E. 5, England.

NEW Improved Accurate Scope-Shot

Price Complete with 50
DISINTEGRATING PELLETS
They crack like a rifle
when they hit - leave
mark - puff of smoke!
**\$1.95
P.P.**

World's Finest Precision
SLINGSHOT
Scope-type
sight!
Patent No. D-178,837

**ROOTS
PESTS!**

Big Bag of
250 EXTRA Pellets
98¢ P.P.

Pure gum
rubber slings.
Beautifully polished
cast aluminum stock.
Pistol grip. So powerful it kills
small game. Fits pocket perfectly!
Guaranteed. **FREE** shooting manual.

Price
without
pellets
**\$1.50
P.P.**

**Order
Now!**

Order NOW from: **GENERAL SPORTS**
4184-P2 Apple Street, Cincinnati 23, Ohio

GET INTO ELECTRONICS

V.T.I. training leads to success as technicians, field engineers, specialists in communications, guided missiles, computers, radar, automation. Basic & advanced courses. Electronic Engineering Technology, an ECPD accredited Technical Institute curriculum. Assoc. degree in 29 mos. B.S. obtainable. G.I. approved. Start Feb., Sept. Dorms, campus. H.S. graduate or equivalent. Catalog.

VALPARAISO TECHNICAL INSTITUTE
DEPARTMENT S, VALPARAISO, INDIANA

Print Your Own

Cards, Stationery, Advertising, Circulars, labels, photo and movie titles, church work, tags, etc. Save money. Sold direct from factory only. Raised printing like engraving, too.

Own a Printing Business

Print for Others, Good Profit. Have home shop. Junior press \$15; Senior \$35 up. We supply everything. Easy rules. Pays for self in short time. Write now for free details.

KELSEY PRESSES, Z-33 Meriden, Conn.

PROFIT IN YOUR SPARE TIME

SMALL ENGINE REPAIR PAYS BIG!

Outboard • Powermower • Chain Saw • Tractor
MAKE EXTRA MONEY — or fix your own engines and SAVE! Illustrated, easy-to-learn Home Study Course qualifies you as expert. Free information. Write today!



LINCOLN TECHNICAL INSTITUTE
Suite 2-G, 472 Market Street, Newark 5, N. J.

TREMENDOUS PROFITS

with Hagen's **EXCLUSIVE TEAR-GAS PENCIL!**
100% PROTECTION

SELLS EASY TO Drive-Ins, Nurses, Motorists, Restaurants, Gas Stations, Stores, Banks, Homes. Discharges tear-gas to instantly incapacitate the most vicious man or beast. Effective substitute for firearms; leaves no permanent injury. No selling experience. Handle as sideline, soon you'll sell it full time. Start now! Send \$5.95 for complete demonstration kit of Automatic Tear-Gas Pencil, 10 Demonstration Blanks & 3 Tear-Gas Cartridges. Not sold to minors, nor in Mich., N.Y., Calif. State age with order.

HAGEN SUPPLY CORP., Dept. P-23, St. Paul 1, Minn.



FATTEN YOUR WALLET WITH WATCH REPAIRING

Opportunities for full or part time earnings are the best in years

If you are always short of cash, watch repairing offers a sure way to add to your income. Trained, part time repairmen report earnings of \$5-\$6 an hour. You can start these dollars coming your way if you prepare yourself now. Skilled watch repairmen are in short supply and getting scarcer.

In these uncertain times, it's good job insurance to know a second trade like watch repairing. Strikes occur. Layoffs happen. Automation wipes out jobs overnight.

Sickness strikes and savings vanish. Retirement comes all too soon.

That's why a knowledge of watch repairing will stand you in good stead. It gives you a second income you can fall back on at any time. It's a light, clean trade needed everywhere watches are sold. It eases money and retirement worries for you can work at it all your life. Age is no barrier. And if you want a business of your own, it will lead you quickly to it.



CHICAGO SCHOOL OF WATCHMAKING **WILL TRAIN YOU AT HOME IN YOUR SPARE TIME**

The unique Sweazey System teaches you to repair Swiss and American watches step by step. No previous experience needed. Diploma awarded. Tuition? Just \$5 a month—a fraction of what it would cost to attend school in person. Send today for a free sample lesson. No obligation whatever. No salesman will call.

FREE SAMPLE LESSON

• **CHICAGO SCHOOL OF WATCHMAKING**
 • 2330 N. Milwaukee Avenue, Dept. 423, Chicago 47, Illinois
 • Please rush FREE SAMPLE LESSON and full information to tell me how I can learn watch repairing at home.
 • NAME AGE.....
 • ADDRESS
 • CITYZONE....STATE.....

CHICAGO SCHOOL OF WATCHMAKING

Founded 1908

2330 MILWAUKEE AVE., CHICAGO 47, ILL.



MADE ON
AMERICAN LASTS



FOR MEN WHO KNOW STYLE

The new—the different—imported footwear, in a handsome variety for street, dress, casual wear. Sizes 5 to 13; A to EEE. From \$12.95 to \$19.95.

#2001 Demi-boot slip on in the smart new ankle height.

Eleganza
IMPORTS

293 Freight St.
Brockton, Mass.

Write for FREE catalog TODAY!

STARTLING SECRETS TEACH YOU DISGUISED HYPNOSIS

CAUSE TRANCE WITHOUT SUBJECTS KNOWING!

Revealing manuscript tells jealously guarded secret techniques used to cause the "Indirect Trance". Read how subjects are hypnotized without their knowledge. Learn amazing shortcuts that make hypnosis fast and easy. Discover the safe "fake nerve pressure" technique... the "falling back" test and many others. Read how the author hypnotizes a roomful of people without their knowledge — using a common household cooking ingredient. This is so dramatic and effective it is worth the low price of the book alone. But that's not all, order now and get these FREE EXTRAS: The fun packed book "Entertaining with Hypnosis" and a clever Hypnotic "Trance-Fer" chart. This exclusive aid helps you cause the "Indirect Trance". All come to you in a plain wrapper

FREE 10 DAY MONEY BACK GUARANTEE **\$1.98**

ALLIED-AIDS, Dept. D-65, 1133 BROADWAY, N.Y. 10,



EVERY NEIGHBOR IS A CUSTOMER

IN PROFITABLE
MOWER
SHARPENING
BUSINESS

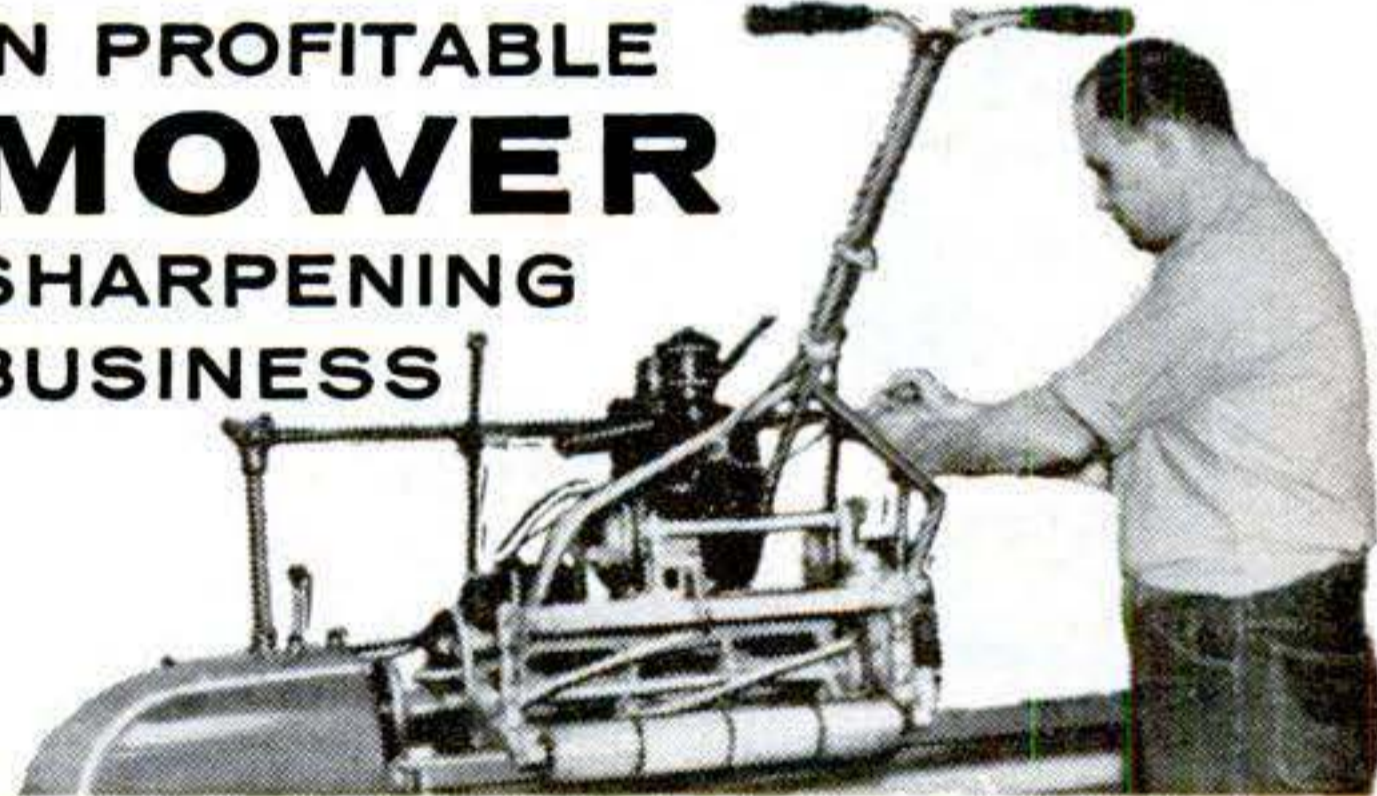

EARN \$5 AN HOUR

Earn extra cash right from the start—average \$5 an hour. The Foley Lawn Mower Sharpener is a complete shop in one machine. No experience is needed to start—anyone can operate it, and turn out professional-like jobs. All operations are done quickly, easily and accurately.

Start Sparetime Business

An ideal sparetime business—altho' many find it so profitable, they devote full time to it. For complete fact-filled booklet telling you how to start and how others have succeeded, send coupon. No salesman will call:



FOLEY MFG. CO., 208-3 Foley Bldg., Mpls. 18, Minn.
Send booklet on Lawn Mower Sharpening business.

Name _____
 Address _____
 City _____ Zone _____ State _____

FREE GIANT NEW 1963 CATALOG



BURSTEIN-APPLEBEE CO.

Dept. PS, 1012 McGee St., Kansas City 6, Mo.

Rush me FREE 1963 B-A Catalog.

Name

Address

City..... State.....

SEND FOR IT TODAY

FREE

BOAT KIT CATALOG FREE!

Fiberglass or Plywood



Over 50 Models—12' to 22' Cruisers, Houseboats, Runabouts, Convertibles, Family Boats

Rush coupon for your FREE copy of Luger's new 64 page catalog. See how you or anyone can build the boat you always wanted... save 1/2 to 2/3 the "factory built" cost by doing the assembly work in spare hours! Every part and section comes precision cut, precision molded, pre-formed or pre-assembled at the Luger factory. No fitting or guesswork. Direct Factory-to-You prices plus mass production methods give you far more boat for your money—plus the fun of doing part of it yourself!

Buy Direct-From-Factory. Assemble It Yourself... Save Hundreds of Dollars

Luger has exactly the boat you want! From luxurious 22' Caribbean Cruiser with 12' cabin... to 14'—16' Fiberglass runabouts you can assemble in just one evening with paint brush and screwdriver! Sturdy Naval architect designs for extra safety. NEW! Roomy 22' Houseboat Kit; handles like a cruiser! Lowest prices on trailers, hardware, accessories. Get FREE CATALOG TODAY. Write LUGER, 9200 Access Road, Dept. A-23, Minneapolis 31, Minnesota



20' Islander

16' Fiberglass

MONEY BACK GUARANTEE
Low Down Payment
EASY TERMS
Take 3 Years to Pay!

Rush Coupon
Free Color Catalog and Discount Prices

LUGER BOAT KITS, Dept. A-23
9200 Access Road, Minneapolis 31, Minn.

Please rush new 64 page Full Color Luger Boat Kit Catalog... FREE! Include latest direct-from-factory price list.

NAME

ADDRESS

CITY..... ZONE..... STATE.....

New Table Top Invention Puts You In... PROFITABLE RUBBER STAMP BUSINESS

Home Operators now make **\$9.20 AN HOUR** in Business once monopolized by a few big companies

Special rubber stamps bring high prices—cost only pennies to make on new, low-cost table top machine. Take 27 cents worth of material, make perfect stamps, the kind businesses and offices now buy by the dozen at \$1.80 each. Make up to \$9.20 an hour. Start in spare time in your own home. Run machine on kitchen table using ordinary electrical outlet. Make any kind of stamp. We'll send you free information without obligation about this established, highly profitable business. **We'll even help finance your start.** For free information send name and address today on a postcard to: Rubber Stamp Div., 1512 Jarvis Ave. Dept. R-3-B, Chicago 26

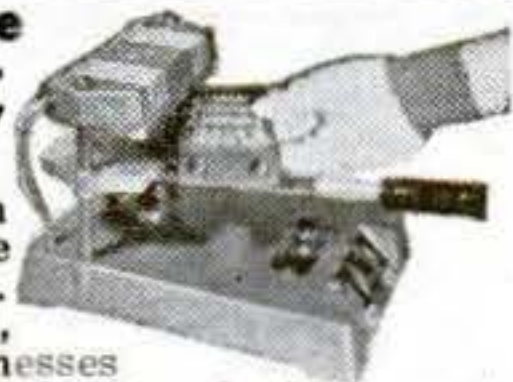

BARBELLS

140-Pound, CHROME DELUXE Barbell-Dumbbell set only \$19.80. This is our feature set and is the finest ever manufactured. Training with adjustable weights is the BEST way to keep fit; the ONLY way to develop great strength and a perfect body. As the oldest and best equipped barbell company, BUR gives great value and prices no one can equal. Buy from manufacturer.

100 POUND SET \$12.80

Extra Plates Only 12c Pound

SEND FOR FREE CATALOG
BUR BARBELL CO.
Lyndhurst 5, New Jersey

LAW FREE BOOK THE LAW TRAINED MAN

Write today for a FREE copy of illustrated law book, "THE LAW-TRAINED MAN," which shows how to earn the professional Bachelor of Laws (LL.B.) degree through home study of the famous Blackstone Law Course. All necessary books and lessons provided. Moderate cost; convenient monthly terms. Write for FREE law training book today.

Blackstone School of Law, 307 N. Michigan Ave.

Founded 1890 Dept. 132, Chicago 1, Illinois

TELLS HOW TO SELL YOUR INVENTION

If you have an invention that you believe has merit, write us at once for copy of copyrighted booklet "How to Go About Selling Your Invention." We work with manufacturers, and booklet reveals present markets, qualities of a saleable invention, current royalty rates being paid by manufacturers. Booklet is FREE, is offered to encourage new ideas we might submit to manufacturers. Just send name (no drawings, please) to **Kessler Sales Corporation, Dept. D72, Fremont, Ohio**

BUY FACTORY DIRECT!

WREN MINI-BIKE! \$99.95

Send 25c for brochure Many Models

\$10.00 Down \$6.00 a Month Complete with Clinton 2 1/2 H.P. engine

Order Now!

Bird Engineering, Box 427, Dept. PS-W-2 Omaha, Nebr.

AMAZING SQUEEZE BOTTLE GUN STOPS MAN OR BEAST INSTANTLY

Self defense for women, cab drivers, postmen, etc. Handy palm size squeeze bottle shoots amazing new scientific formula called Defendo up to 20 feet. Temporarily blinds and disables without permanent injury. Just send name and address for Defendo. Specify "clear" or with red stain to aid later identification. Pay only \$3.00 plus C.O.D. postage and handling. Cash orders add 25¢ and we send postpaid. Mail order today.

C & E SALES CO., Dept. 700, 3016 W. Van Buren St., Chicago 12, Illinois

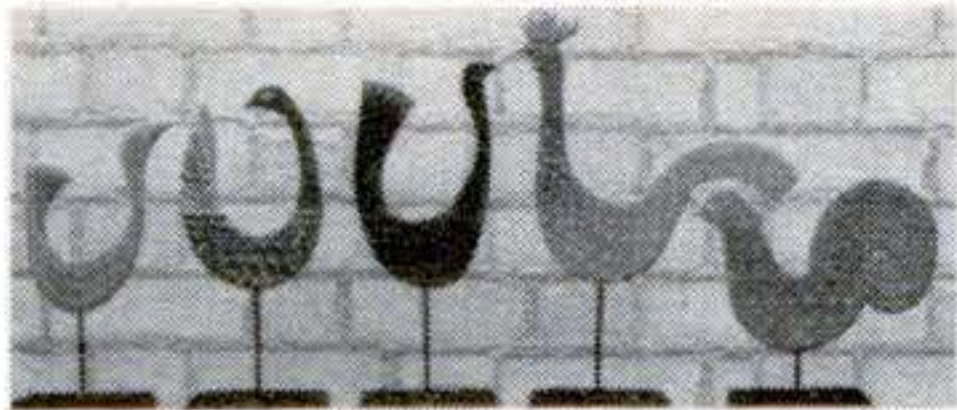

WILD LIFE FORMS AND STORY BOOK CHARACTERS
That You Can Make Yourself With Castoglas

The seagulls and flying geese are not paintings but dramatically handsome wood cut-outs which you color and glaze with Castoglas. Requires no heat. The translucent porcelain-like finish gives the forms the quality of fine art objects. The authentic bird cut-outs and the chicken, hen and rooster set are only a few of the more than 100 designs now available, complete with patterns and coloring charts. Write for "How to Make Wild Life Forms" and "How to Make Story Book Characters." Mail 25¢ to Dept. C-2.
THE CASTOLITE COMPANY Woodstock, Illinois

MAKE YOUR OWN TILES WITH LIQUID CASTOGLAS
Pours Like Honey—Sets Like Glass

Here are NEW tiles that are REALLY NEW and as simple to make as they are beautiful. The Japanese tray and tile with fish design were made with napkins on wood. Paper becomes invisible, design "floats" in Castoglas. Leaves embedded 20 years ago are as colorful as the day they were picked. Also laminate translucent glass panels and make coasters, trays and table tops with embedments of coins, fish flies, butterflies, seeds, photographs and others. For "Tiles and Laminating" remit 25¢ to Dept. C-22.
THE CASTOLITE COMPANY Woodstock, Illinois

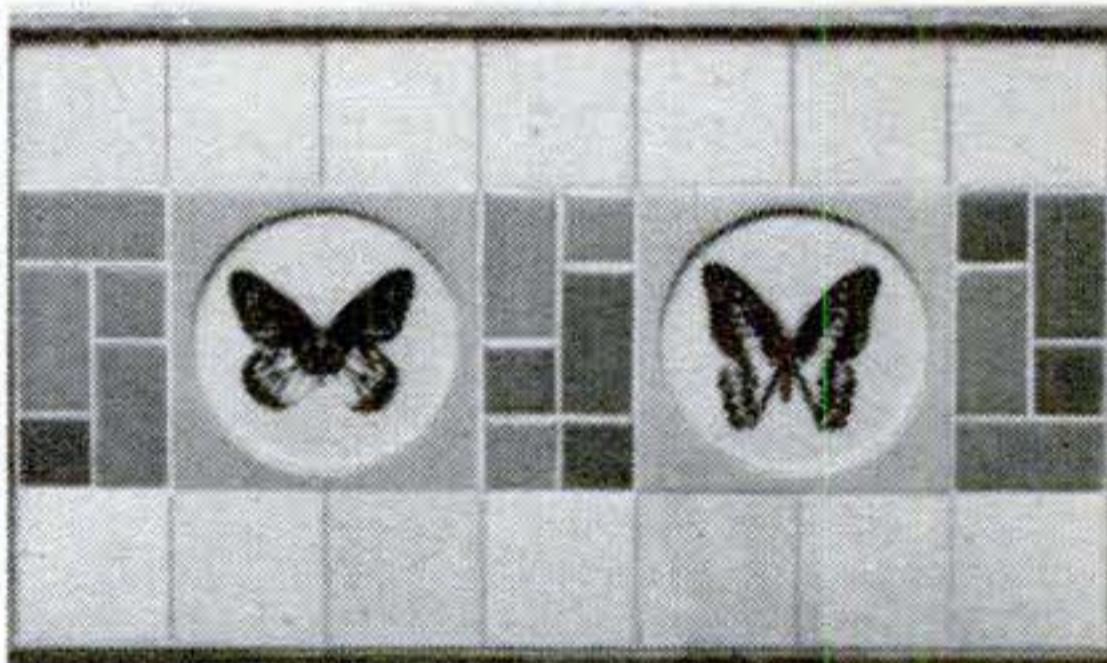
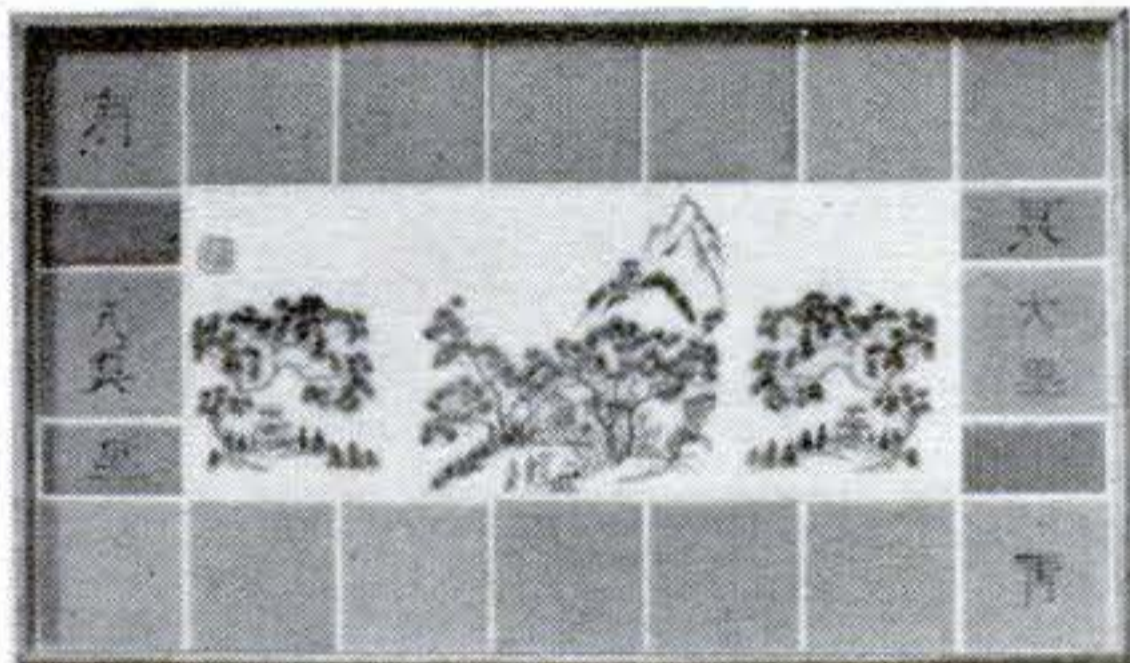

PROCESSING
OF

KODACHROME

(Licensed by Eastman Kodak)

also: EKTACHROME
ANSCOCHROME
KODACOLOR

KODACHROME I & II
8mm Roll or 35mm 20 Exp. Mtd.

\$ 1.00

8mm MAGAZINE75
35mm 36 EXP. MTD. 1.75

SEND FOR FREE MAILERS and our big FREE 25th Anniversary CATALOG of Film and Processing, Splicers, Titlers, Screens, Viewers, Cameras, Projectors at low discount prices.



SOLAR CINE PRODUCTS, Inc.

4247 S. Kedzie • Chicago 32, Ill. • DEPT. PS

EARN \$10,000 A YEAR

- DIESEL
- ELECTRONICS
- AUTO
- AUTOMATION

The average starting salary of students, completing our FCC License, Electronics Technician Course, and those completing our Diesel Automotive Training, is \$4,300 per year.

After becoming familiar with the industry, their salary usually increases to \$6,000 or \$7,000 per year.

After they become senior technicians, or master mechanics, they can earn \$8,000 to \$10,000 per year.

When they become specialists, or a part of management . . . or start their own business . . . they can earn considerably more.

RESIDENT SHOP TRAINING is easier and costs less than you may think! We provide you with housing and part-time jobs while in school, plus free nation-wide placement service for graduates.

Check subject above in which you are interested and mail for

← **FREE BOOKLET** →

BAILEY
Technical Schools

Veteran Approved
1626 S. Grand, Rm. 50, St. Louis 4, Mo.

Your Future
IN
ELECTRONICS
AND
AUTOMATION

Your Future
in
DIESEL and
AUTO
MECHANICS

Name _____ Age _____
Street _____
Town _____ Zone _____ State _____

NOW! EARN BIG MONEY IN
CARTOONING AND **COMMERCIAL ART!**

Amazing new system teaches you the secrets of professional drawing! Learn in your home—in spare time. Own your own business! Advertising, TV, Magazines, Card Co.'s, Printers, many more urgently need new art talent. Earn while you learn—we show you how! Many of our students start earning after a few lessons. This is your big opportunity to enter this exciting, highly-paid field. Artists in big demand! Send for your FREE Catalog. No salesman will call.

Continental Schools, Inc., Dept. E-15, 4201 S. BROADWAY, LOS ANGELES 37, CALIF.

Continental Schools, Inc., Dept. E-15, 4201 S. BROADWAY, LOS ANGELES 37, CALIF.

Please rush me your FREE Catalog. No obligation, no salesman will call.

NAME _____ AGE _____
ADDRESS _____
CITY _____ ZONE _____ STATE _____



CUT-TO-FIT HOMES CUT COSTS UP TO 40%

Save labor cost up to 100%, reducing completed home cost up to 40%. You can assemble any of 57 designs from easy-to-follow plans. No measuring or cutting . . . every piece precision machine pre-cut and marked. **BUY DIRECT FROM MILL.** Eliminate all between overhead, profit and labor

costs. Nothing to plan or figure. Complete with all lumber, hardware, paint, nails, glass, roofing, etc. Sterling Home quality material throughout. Freight paid most areas. Write today. Send 25c for illustrated, color catalog, floor plans and details.

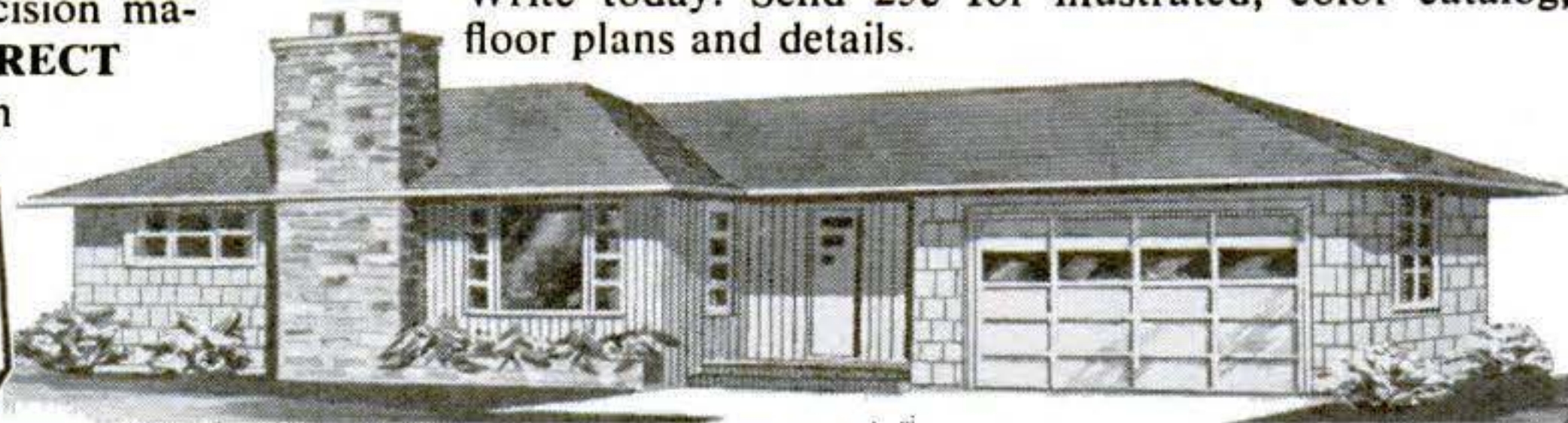

PRICED FROM \$2295 UP

CHOICE OF 57 DESIGNS

FIVE EASY-PAYMENT PLANS

INTERNATIONAL MILL & TIMBER CO. Bay City, Michigan, DEPT. PS 23

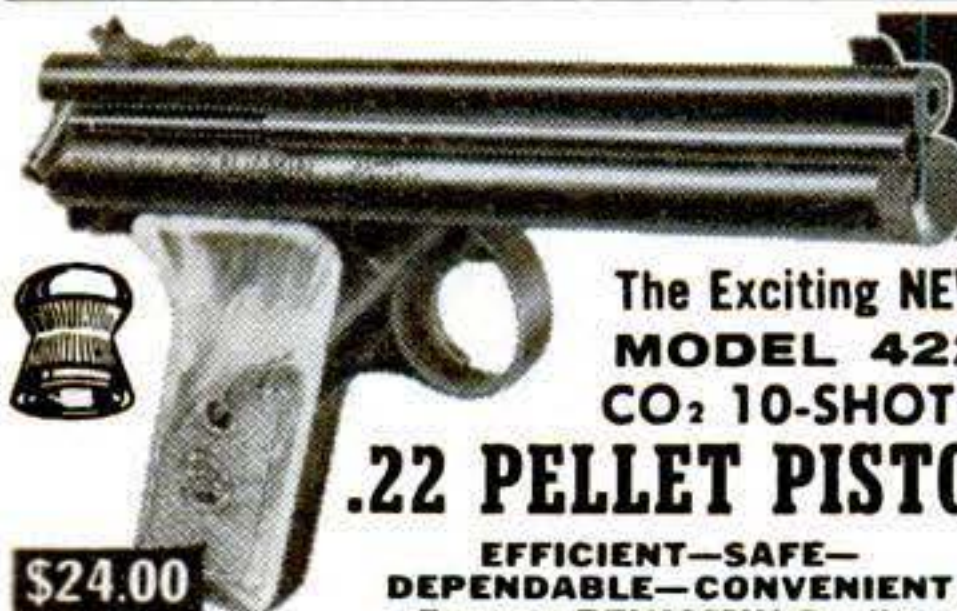

NEW HI-FI PERFORMANCE

The Exciting NEW MODEL 422 BENJAMIN CO₂ 10-SHOT SEMI-AUTOMATIC .22 PELLET PISTOL

\$24.00
Ask Dealer for Demonstration.

EFFICIENT—SAFE—DEPENDABLE—CONVENIENT
Famous BENJAMIN Quality

AT LAST—an Amazing New Handgun that incorporates the Characteristics Wanted for Serious Training, Plinking and Match Competition—Indoors and Outdoors—at LOWEST SHOOTING COSTS! Handsome, Dynamic, Mechanically Reliable, MODEL 422 combines Traditional BENJAMIN PEAK POWER and ACCURACY with Incredible Firing Speed—Smooth JAM-PROOF ACTION (no ramrod for cleaning pistol bore required)

WITH EXTRA MARGIN BENJAMIN'S Unique DOUBLE SAFETIES



KEEPS SHOOTING & SHOOTING & SHOOTING & SHOOTING AS FAST AS YOU CAN SQUEEZE THE TRIGGER!

FREE Write today! Complete Catalog Benjamin Rifles & Pistols—Single Shot & Repeaters—BB or 177 or 22. Also, Special Offer on Hunting Knives. Use Benjamin H-C Pellets in Model 422 for Accurate, Jam-Free Shooting.

BENJAMIN AIR RIFLE CO. 852 MARION ST., ST. LOUIS 4, MO.

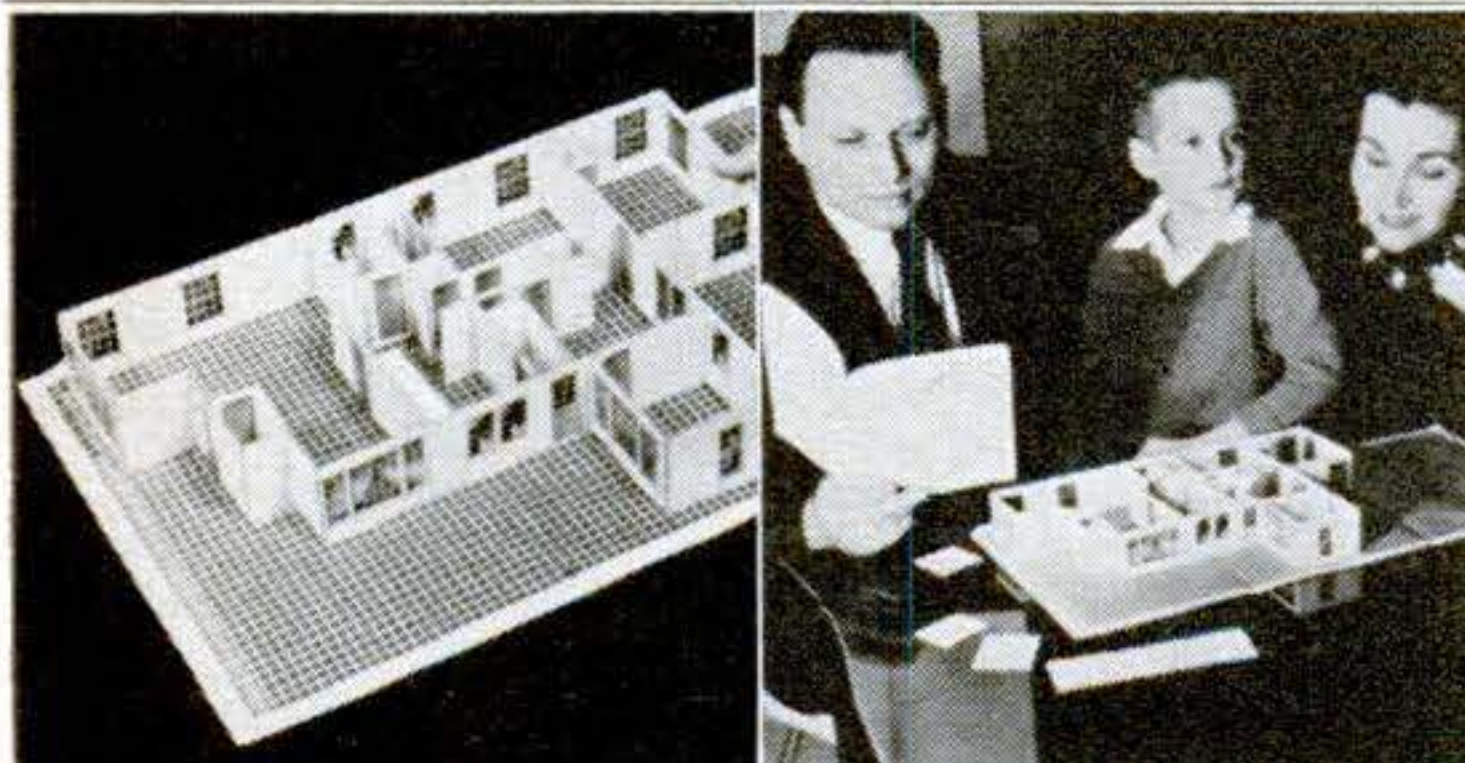

Build any number of floor plans in Minutes!

"Live" in your new home BEFORE you build!

"Home-a-Minute" Kit

If you're thinking of buying, building or remodeling a home, office or other place of business, adding an attic flat, extra bedroom, bath, den, studio, waiting room, garage or patio, you'll save yourself many dollars and hours with the Home-A-Minute Kit. It contains dozens of fiber partitions, doors, windows, kitchen cabinets; all made to 1/4" scale, same as blueprints. Includes a 65-page handbook to help you estimate actual costs, obtain financing, or even become your own contractor! Gives you a perfect three dimensional idea of how everything will look, how furniture and fixtures will fit. Shows how passageways and traffic lanes should be properly measured. Helps you to visualize architect's drawings, and select the proper materials. Enables you to build, dismantle, and rearrange any number of floor plans, large or small, to fit your pocketbook. Tells how an imaginative, even daring plan, need cost no more than a conventional arrangement. Lets you "live" in your new home before you actually build it, enabling you to avoid making costly changes after you really build! May be used for single or multiple story planning. Furniture may be simulated by using little blocks of balsa wood, styro-foam, or cardboard (not included), to help plan room arrangements. The white fiber partitions may be painted any color desired to aid in planning color schemes. Takes all the mystery out of building costs. And it's fun too, designing, building and decorating in fiber board, before investing any big money in the real thing! **\$3.95** (add 50c P.P.)

R.J. HALL & CO. 3112 HIDDEN HILLS DRIVE BROOKFIELD, WIS.

ADDING MACHINE

+ - × ÷
ADD - SUBTR. - MULT. - DIVIDE

Does all 4 operations quickly, accurately. Adds & subtracts to one billion! Easy to use. Carry in pocket or purse! Leatherette case. Quality made in America! Money back guarantee. Agents wanted. \$1.98; 2 for \$3.69. (Add 4% tax in Pa.)

TOM THUMB P. O. BOX 276. DEPT. F-23 BETHAYRES, PENNSYLVANIA

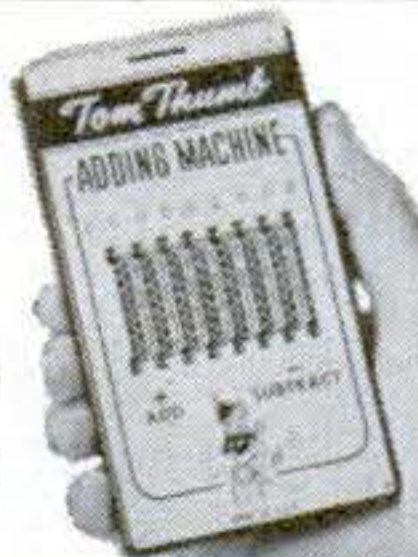

BUILD FINE GRANDFATHER CLOCK NOW



The simple sensible SPEEDE Red-i-Kut way as thousands have—FOR YOURSELF OR SELL AT A GOOD PROFIT. SAVE HUNDREDS OF DOLLARS. SHOP TESTED PLANS "SPIRIT OF THE CENTURY". Narrow waist 83" tall or stately straight side "SPIRIT OF AMERICA". EASY-TO-FOLLOW photopack PLANS & LIFE SIZE PATTERNS tell all—plus MOVEMENT BROCHURE \$42 up. heavy brass weight (Kuempel original) Westminster, tube Bell chime, movements, gorgeous bronze-silver MOVING MOON dials. LYRE pendulums. 3/4" solid-mahogany Jiffy Joint-Kwik-Bilt case kits. Send \$1.00 today—Both plans. Rush \$1.50 as folks have done for over forty years.



Kuempel Chime Clock Works, 5 Kuempel Bldg., Minneapolis 16, Minn.

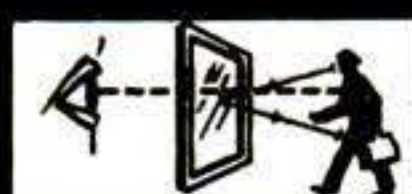

MAKE ANY WINDOW into ONE WAY GLASS

Now . . . with simple drug store materials you can treat plain window glass so YOU CAN LOOK OUT through it, but the person on the other side CAN'T LOOK IN AT YOU. To get your complete One Way Glass Formula send only \$1.00 to: E-Z FORMULAS Dept. 1591 5880 Hollywood Blvd., Hollywood 28, California

RUPTURED?

TEST THIS TRUSS FREE FOR 30 DAYS



Wear a Web for strong support and lasting relief of reducible inguinal rupture. If not satisfied after 30-day trial, purchase price refunded in full. Write now for free book on rupture care.

WEB TRUSS Co. Dept. PS-2, Hagerstown, Md.

FLORIDA CAMPSITES

Deep in the heart of the great (440,000 acre) Ocala National Forest where few individuals have the privilege of owning land. Isolated, yet accessible, with pavement and electricity. Best fishing, hunting. Warranty Deed. Unrestricted, pitch tent, park trailer, build lodge. FREE maps and photos.



AD60088-Q1

Winfree Vernor, DeLand, Florida

MEN...Get that Job!

OPERATING HEAVY EQUIPMENT



Thousands of additional men will be needed to operate the Heavy Construction Equipment that will be used to build the new Roads, Bridges, Dams, Industrial Parks, Subdivisions, Irrigation Systems, Pipe Lines, Missile Sites, Shopping Centers, Home Sites, Airfields in a rapidly growing America!

Complete practical training on OUR modern machines, at OUR California, Florida or Texas Resident Training Centers, gives you the background you need to get that job you want as a HEAVY EQUIPMENT OPERATOR with the help of our NATIONALLY RECOGNIZED PLACEMENT SERVICE.

MAIL THIS COUPON FOR COMPLETE INFORMATION

LEARN TO OPERATE

- BULLDOZERS
- SCRAPERS
- GRADERS
- BACK HOES
- POWER SHOVELS
- CLAM SHELLS
- DRAG LINES

CONTRACTORS

Write to our Placement Department for information about our trained operators. Men who spend their own money and time to learn to operate and maintain equipment, make your best operators.

ASSOCIATED HEAVY EQUIPMENT SCHOOLS, INC.
38-638 LITTLE RIVER STATION • MIAMI, FLORIDA

Please send full details immediately on your program of training for operators of Heavy Equipment.

Name _____ Age _____
Street _____
City _____ County _____ State _____
Phone Number _____ Time Usually Home _____

NO JOB WORRIES

PLASTEX INDUSTRY needs manufacturers on small scale for big production of Lamps, Clock Stands, Art Goods, Novelties in Plastic Marble Imitation. No Experience necessary. 1/2c material makes regular 10c store sellers. Moulds furnished for fast production. Small investment brings good profit. Big wholesale orders now being placed. Ambitious men have chance for real prosperity and job security. Our NEW FREE booklet will interest and benefit you.

PLASTEX INDUSTRIES, Dept. 2, 3400 Third Ave., New York 56, N. Y.

FREE Key Machine

Kind master locksmiths use. Sells for \$125, but yours FREE with Locksmithing Course



You Can Learn To Be A LOCKSMITH in your spare time

There's a big demand for skilled locksmiths. You can earn big money either full or part-time in your own home. Be your own boss; earn steady, year 'round income with no layoffs. The BELSAW INSTITUTE training, recommended by professional locksmiths, teaches you to make keys, open and repair locks on homes, cars and buildings. Easy, step-by-step illustrated lessons complete with all tools and supplies. We tell you how to get servicing jobs, how much to charge, how to earn while you learn and how to build a secure cash profit business.

Mail Coupon for FREE Book Today!

BELSAW INSTITUTE, 113 Field Bldg., Kansas City 11, Mo.
Send FREE book, "Keys To Your Future!"

No obligation. No salesman.

Name.....
Address.....
City..... State.....

75 POWER TELESCOPE \$3.98

NEW 3 in one telescopes, 3 variable 25X, 45X-75X magnification. Brass bound, 25 power for ultra bright images 45 & 75 power for long range. Guaranteed to bring distant stars, moons, objects, sports 75 times closer. Most powerful scope sold anywhere near this amazing low price. American made, 5 sections. Opens 36", closes 1 ft.; contains 4 ground & polished lenses. Can also be used as powerful compound microscope. Mass production enables us to offer telescope complete at \$3.98 postpaid. Money back guarantee. CRITERION CO., Dept. PSB-10; 331 Church St., Hartford, Conn.

NEW! QUICK CHARGE YOUR CAR BATTERY

In your car at home, on the highway, anytime, anyplace. No outside source of electricity needed.



Our device and your own generator will quick charge your battery right in your own car. Use on your first or second car. Works on 6 or 12 volt cars. Just clip it on. No tools needed. Simple directions. Guaranteed to work to your satisfaction or your money refunded. Keep your battery fully charged at all times. \$2.98 Post Paid. Cash, check or money order. No stamps please.

DAYCO MFG. CO., 19 Fitzherbert St., Bloomfield, N.J.

from Scott . . .

FREE STEREO KIT CATALOG

Have fun . . . save money . . . build the best! Now world-famous Scott stereo components come in easy-to-build kit form. You can build an FM Multiplex tuner, your choice of an 80 watt or 48 watt stereo amplifier, a preamp, power amplifier, and a speaker. Write for complete details.

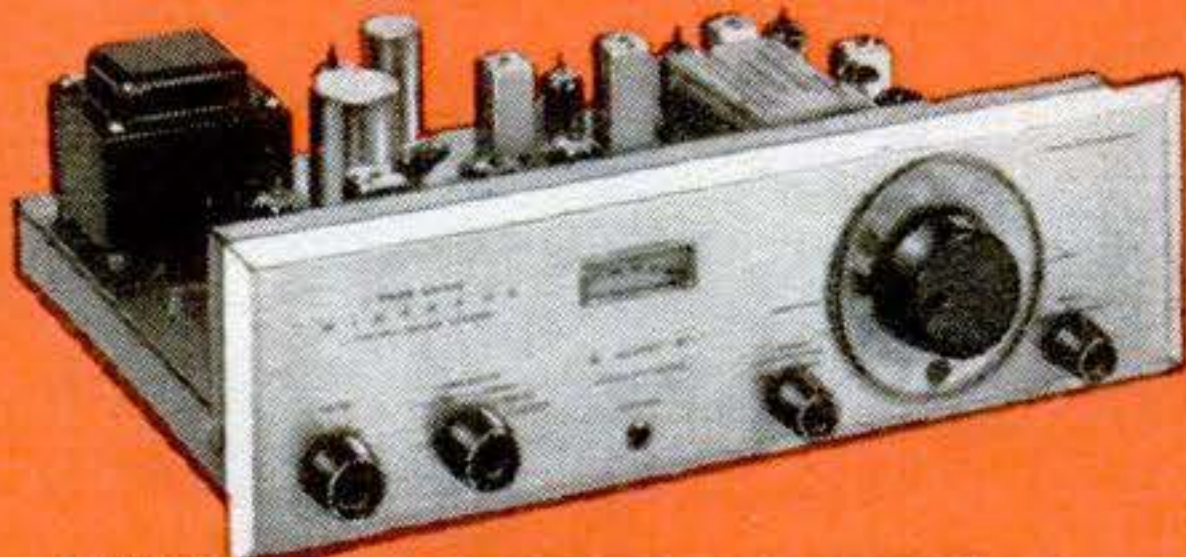

SCOTT® Dept. 540-2

H. H. Scott, Inc. 111 Powdermill Road, Maynard, Mass.

Rush me your new Kit Guide, 20 page "Guide to Custom Stereo" and your Free FM Stereo Demonstration Record.

Name _____

Address _____

City _____ State _____

Export: Morhan Exporting Corp., 458 Broadway, N.Y.C.
Canada: Atlas Radio Corp., 50 Wingold Ave., Toronto

Would YOU Like to Make \$1,000 A MONTH?



That's What Stanley Hyman Made Selling PRESTO Amazing Midget Fire Extinguisher



Sensational! Presto does job of bulky extinguishers costing 4 times as much. Ends fires fast as 2 seconds; fits palm of hand. Never corrodes; guaranteed 20 years! Sells for only \$4.95. Show it to owners of homes, cars, boats, farms, etc., and to stores for re-sale—make good income. Write for FREE Sales Kit.

MERLITE INDUSTRIES, Presto Div.
114 East 32nd St. • Dept. P-16D • New York 16, N.Y.
In Canada: Mopa Co., Ltd., 371 Dowd St., Montreal 1, P. Q.

GUITARS Big Discounts WHOLESALE-TO-YOU!

BUY DIRECT!

Famous Brands

E-Z TERMS

5-Day FREE Trial



SAVE! BIG DISCOUNTS! Nationally advertised guitars. Over 100 models, all styles, for students and professionals. Low as \$19.95! DIRECT from Wholesaler-to-You. Easy Terms, low as \$5.00 down! FREE Home Study Course and Bonus Gifts! Discounts on banjos, mandolins, ukes. Satisfaction or money back. Free Color Catalogs, low discount prices. Write:

GUITAR WORLD, Dept. P-23
2003 W. Chicago Ave., Chicago 22, Illinois

JEEP OWNERS

Re-Power NOW with a V-8 or 6 Cyl engine—Use

Ford - Chev - Mercury - GMC - Pont - Stude - Dodge or Plymouth in Jeeps, Jeepsters, Sta-Wgn, Trucks, Kaiser & H. J. cars. Conversion kits \$43.35 to \$56.90. Want fast action? Give us full information, send \$15.00 Dep. and we will ship correct kit. Bal. COD. Send full amount for prepaid shipment. Wire, phone or write today. Details FREE.

HOOSIER MACHINE PRODUCTS CO.

314 S.E. 6th St. Phone CR6-3442 Pendleton, Oregon



FREE

MUSCLE BUILDING INFORMATION

Sensational New Methods

Less Time—Less Effort—Better results

BODY-TONE, Box 638-E, North Miami 61, Fla.

make it with 60c worth of sand & cement!
SELL IT FOR \$2000

every home a prospect for these "LIFETIME"

CONCRETE INCINERATORS

Make big profits manufacturing rust proof, fire proof, almost indestructible concrete incinerators in your own backyard or garage . . . full or part time. Sell to home-owners, hardware, department and garden supply stores. Phila. manufacturer doing big volume with Sears, Roebuck; large department stores. Easy to follow instructions and all needed equipment supplied. Exclusive protected franchise—No competition! Territories going fast. Write immediately for full details.



T. C. TOR, Dept. PS-23
318 Rancocas Ave., Delanco, N.J.
Gentlemen:

Rush full information about your concrete incinerator protected franchise offer.

Name _____

Street No. or R.D. _____

City _____ Zone _____ State _____



MASONS!

Send today for free catalog of Masonic & Eastern Star books and rituals

EZRA A. COOK PUBLICATIONS, INC.

P. O. Box 796 Dept. D14 Chicago 90, Ill.

TRANSMISSION SCOOTERS, TRACTORS, SMALL CARS

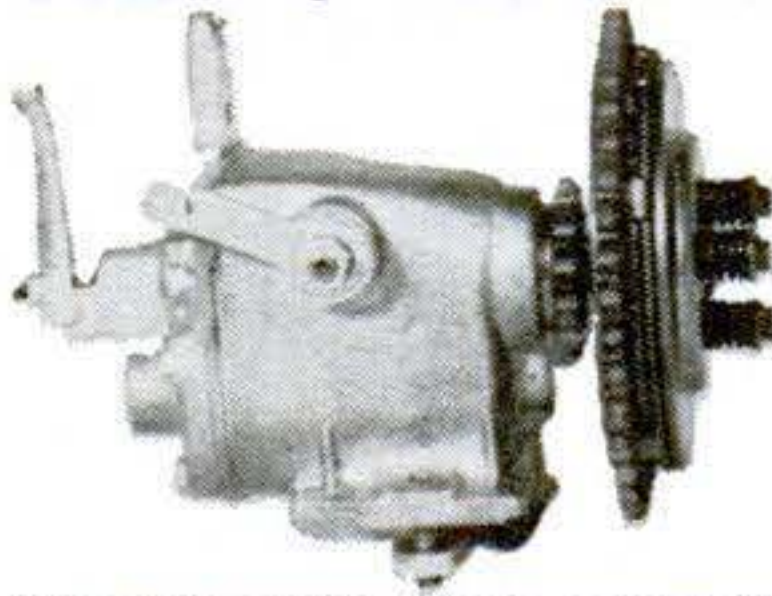

New 3 speed & neutral gear box: complete with clutch, gear shift, & sprockets, precision made, heavy duty, compact 12 lbs., for 1 to 10 hp engines (max. 17 ft. lbs. input torque). Unlimited uses for building your powered equipment: Model \$59.95 PPD. shown

Also available 3 speed & reverse heavier duty model \$95.00 PPD. MONEY BACK GUARANTEE

MOBILE MACHINE SUPPLY CO. 1812 116th Ave. N. E. Bellevue 1, Washington

LEARN MEAT CUTTING AT NATIONAL Pay After Graduation



The steady dependable trade of Meat Cutting taught easily in 8 short weeks. YOU LEARN BY DOING under actual meat market conditions in big modern school at Toledo.

For beginners or men with experience. Get a profitable store of your own. Remember PEOPLE MUST EAT! Big pay jobs. Free employment help. Thousands of successful graduates.

Buying, cutting, percentage, pricing, advertising, selling, etc. A complete retail meat education. National School established 40 years. Get National training NOW. Pay your tuition in easy weekly payments

after you graduate. Send coupon for FREE school catalog—TODAY. G.I. approved.

National School of Meat Cutting, Inc.
Dept. 51-P, Toledo 4, Ohio

Send me your FREE school catalog on National Training at Toledo in Meat Cutting, Meat Merchandising and Self Service Meats. No obligation. No salesman will call.

Name..... Age.....

Address.....

City..... State.....

Approved for Veterans

Shrinks Hemorrhoids New Way Without Surgery Stops Itch - Relieves Pain

For the first time science has found a new healing substance with the astonishing ability to shrink hemorrhoids and to relieve pain - without surgery.

In case after case, while gently relieving pain, actual reduction (shrinkage) took place.

Most amazing of all - results were so thorough that sufferers made astonishing statements like "Piles have ceased to be a problem!"

The secret is a new healing substance (Bio-Dyne®)—discovery of a world-famous research institute.

This substance is now available in suppository or ointment form under the name Preparation H®. Ask for it at all drug counters.

\$6.44 AN HOUR IN YOUR OWN BUSINESS



STEP INTO THIS BOOMING
\$19 BILLION A YEAR INDUSTRY

Hundreds of accidents and losses will happen this year in your community.

We'll show you how to investigate and adjust these losses for insurance companies, railroads, government offices. You buy NO tools or equipment. You do NO selling. You need NO prior

experience or higher education. And you can operate out of your own home. Right

now independent Accident Investigators average \$6.44 an hour. We'll train you quickly to do the same. Start part-time if now employed. Fill the need for an Accident Investigation specialist in your area. Colorful booklet explains everything. Absolutely no obligation on your part. No salesman will call. Write TODAY for FREE Booklet.

UNIVERSAL SCHOOLS, PS-2 6801 Hillcrest, Dallas 5, Texas

Magic Mail Plan-Make up to \$5 an Hour!



THIS MAN...
...is taking out of the machine a Plastic Sealing Job - ordered by mail - only 11c in material cost brings back \$2.58 in cash by mail. Capacity of machine: \$25.00 profit per hour of operation.

Get ORDERS and CASH from your mailman—do work in SPARE TIME at home—or expand into FULL TIME business. Send coupon for Free facts about the newest and most fascinating of all home operated businesses. For the first time a simplified machine brings the fabulous profits of Plastic Sealing and Plastic Laminating within the reach of the small operator. Anyone can learn to operate the machine with a few minutes practice—then with our Magic Mail Plan can get mail orders pouring in daily with cash in every envelope. No canvassing—no selling. We even

Get into PLASTIC LAMINATING at home

WE'LL EVEN HELP FINANCE YOU

supply the circulars you mail to bring back cash and orders, financing help, too. Rush name. We'll send you FREE and postpaid, pictures, prices, details, finance plan, all the facts you need. Mail coupon or send name on postcard. No charge.

Warner Electric Co., 1512 Jarvis Av., Dept. L-3-B, Chicago 26, Ill.

Make Thousands of Beautiful Art Creations

COSTUME JEWELRY • CIGARETTE BOXES TRAYS • CANDLESTICKS • COASTERS LAMP BASES • BOOK ENDS...ALL IN SPARKLING COLORED PLASTIC



WARNER ELECTRIC CO., 1512 Jarvis Av. Dept. L-3-B, Chicago 26, Ill.

At no cost to me, please rush full details and financing plan, postage prepaid. No obligation.

Name.....

Address.....

City..... Zone..... State.....

FREE INTERNATIONAL CATALOG



- Citizens Band Transceivers
- Citizens Band Antennas and Accessories
- Amateur and Citizens Band Crystals
- Commercial Crystals
- Transmitters/Modulators
- Frequency Alignment Equipment
- Power Supplies

Your 1963 Buying Guide for Precision Made Radio Crystals and Electronic Equipment.

International Crystal Mfg. Co. 563
18 North Lee, Oklahoma City, Okla.
Rush 1963 FREE Catalog.

Name _____ Please Print
Address _____
City _____ Zone _____ State _____

...TURN CONCRETE INTO GOLD!



MAKE UP TO \$75 A DAY IN YOUR OWN BUSINESS

If you want to have your own business — to start a business on your own — here's your big opportunity! New high speed, low cost General block machine produces up to 1,000 concrete blocks a day. Sell all you make to builders, supply houses, and others for homes, factories, buildings, garages. Cash in on the building boom! You can make profits of 100% to 150% — up to \$75. a day! General block machine equipped with 1/2 h.p. electric motor — or can be supplied with gasoline engine — works anywhere, in little space, indoors or out. Operates from ordinary house light socket. Simple, foolproof 3 step operation — so easy a child can do it. Makes superior 3 core blocks any size from 4" to 12". Also makes chimney, sash, corner and other types. Blocks meet any building code anywhere in the country. Materials — sand, water, cement, available anywhere. Simple illustrated operating instructions and mixing formulae for cement and cinder blocks supplied with each machine. Write for FREE folder with full information.

MOTOR DRIVEN

R. L. T. of New York City reports: "MY GENERAL BLOCK MACHINE PAID FOR ITSELF IN FIRST 2 WEEKS!"
Hundreds now in use the world over!
Write for FREE details today!

EXTRA Amazing illustrated

book gives floor plans for 6 sensational concrete block bungalows. Tells how to lay blocks, lay out building lines, mix concrete, build steps, porch and concrete floors all at great savings. Written by experts. Can save many times the cost of the machine! Get it now! No strings attached. Send \$1.

BOOK SENT FREE IF YOU BUY MACHINE.
\$1 REFUNDED IF YOU BUY LATER.

GENERAL ENGINES CO.

DEPT. S-23

ROUTE 130, THOROFARE, N. J.



You MAKE-IT and SAVE \$60 to \$100

SADDLE KITS

America's first real saddle kit. Easy to assemble, tool or leave plain. Thousands sold and in use today. No experience required with Tandy's easy to follow instructions. All parts pre-cut and punched. Nothing else to buy. Write today for full information and FREE 112-page catalog.

TANDY LEATHER COMPANY

P. O. BOX 791-TV FORT WORTH, TEXAS

Fires 75 Rounds NEW Automatic

75-Shot Rapid Fire Repeater

Exciting new 1963 model automatic . . . Holds and fires 75 rounds automatically from oversize chamber. Peak accuracy firing power to distances of 30 feet and more. Superbly balanced, smooth, jam-proof action guaranteed. No recoil. Non-lethal. No permit needed. Police use for target practice. Safe, great shooting fun for father and son. Send \$1.98 cash, check or money order plus 27c shipping charges and we include 50 silver shot-shells. Satisfaction guaranteed or money back. **Bargain Gun Co., Dept. J, 101 East 32nd Street, New York 16, N. Y. (200 shot-shells \$1) (500 shot-shells \$2)**



\$198

DON'T PAY FOR THESE GREAT BOOTS!

8" Boot—Quilted, Thermal-Insulated, Stormseal'd



Get them at no cost as a reward — plus the chance to develop on extra income. Show friends "all-day comfort" boots and shoes in spare time. No experience, no investment. Samples supplied. Write for FREE Outfit. Charles Chester Shoe Mfg. Co., Dept. B-6319 Brockton, Mass.

BUY DIRECT • SAVE ON • TILLERS • TRACTORS

Full line of attachments for mowing, gardening, farming. 2-3-4 H.P. TILLERS. 12"-16" CUT.

FREE CATALOG & PRICE LIST

5-6-7-9 H.P. 2 wheel &



4 wheel tractors

RED-E TRACTOR CO.

16th Street, Richfield, Wisc.



GEARS

In Stock—Immediate Delivery

Gears, speed reducers, sprockets, thrust bearings, flexible couplings, pulleys, etc. A complete line is carried in our Chicago stock. Can also quote on special gears of any kind. Send us your blueprints and inquiries.

Send for Complete Catalog No. 220 **CHICAGO GEARWORKS** 440-450 N. Oakley Blvd. Chicago 12, Ill.



PLAY GUITAR IN 7 DAYS

Or Your Money Back Guaranteed

SURPRISE FRIENDS, RELATIVES. ENJOY POPULARITY AND FUN GALORE!

In this introductory offer you get TOP RADIO GUITARIST ED SALE'S famous 66 page secret system worth \$3.00 which positively teaches you to play a beautiful song the first day and any song by ear or note in seven days! Contains 52 photos, 87 finger placing charts, etc. Shows how to tune, keep time, build chords, bass runs, dance chords, swing, etc., plus 110 popular and western songs, words and music; a \$1.00 Chord Finder of all the chords used in popular music; a \$3.00 Guitarist Book of Knowledge—TOTAL VALUE \$7.00—ALL THREE for only \$2.98. SEND NO MONEY! Just your name and address, pay postman \$2.98 plus Money-back Guarantee. ED SALE. Studio 154-R, Avon By the Sea, N. J.

This brand-new book shows you
**HOW TO FIX EVERY
 FOREIGN CAR**
 sold in America.
 Covers every model
 right up to 1963!

**SAVE
 \$1.55**

See below for
**SPECIAL
 INTRODUCTORY
 PRICE**



MOST foreign cars are easy to fix — IF you know exactly what you're doing! Engines, carburetors, transmissions, and other vital parts are often very different from American makes.

With the brand-new GLENN'S FOREIGN CAR REPAIR MANUAL, you will never have to work in the dark... never risk the costly damage a wrong guess can lead to. You will know exactly what to look for and what to do.

**Thousands of Pictures . . .
 Every Step Simplified**

This big, 1024 page book is filled with thousands of pictures . . . detailed drawings, diagrams, photos, and exploded views of all mechanical parts.

Everything you read in this book is illustrated with clear, how-to-do-it photographs—so that you can follow along step by step. It's as simple as 1-2-3 whether you are a skilled mechanic or just a beginner!

Here is what this book shows you:

- The design, workings, and specifications of every component of every foreign car.

- How to take each mechanism apart, inspect, clean, and repair it. Every part of the car—engine, fuel and electrical systems, power train, running gear—gets this same thorough going-over.

SPECIAL FEATURE: Complete factory-approved racing modifications for many sports-car models.

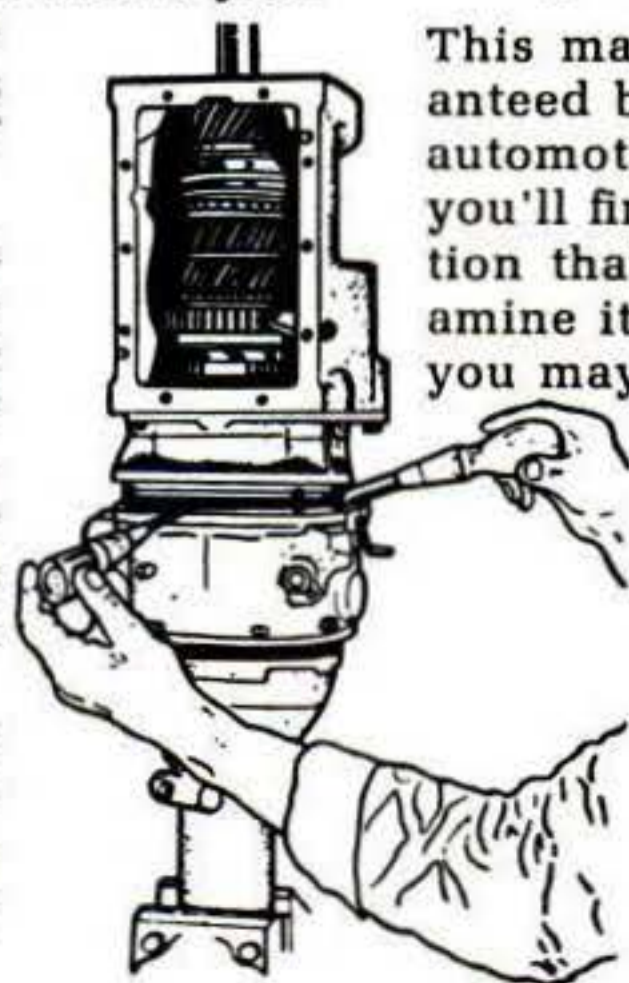

Watch This Book Pay For Itself!

GLENN'S FOREIGN CAR REPAIR MANUAL is the kind of book that pays for itself many times over. If you own a foreign car, it will show you how to perform repairs and adjustments yourself—and save labor costs. If you are a professional mechanic, it will help you to work on many cars you were not qualified to handle before . . . and get into the growing, profitable field of foreign-car repair.

**Seven-Day Free Trial—at
 Special Introductory Price**

This manual is published and guaranteed by Chilton—America's largest automotive publisher. We are so sure you'll find it a gold mine of information that we will gladly let you examine it FREE for seven days. Then you may either return the book and owe nothing, or pay the \$15.95 introductory price in easy installments. (After March 29, 1963, price goes up to \$17.50!) Write to Chilton Books, Dept. PS-23, 525 Locust Street, Philadelphia 6, Pa. Wherever books are sold, or use convenient coupon.

THESE IMPORTANT FEATURES:

- Engine design differences
- Complete servicing of all European carburetors: S. U., Solex, Zenith, Weber, Bosch Diesel and Fuel Injectors
- Lucas, Bosch, and Marelli electrical equipment
- Complete tables of specifications, all models
- Wiring diagrams of all models
- Exploded views, all vital parts
- Detailed troubleshooting charts
- Flat-rate time schedules in hours and tenths of an hour
- All specifications in meters and inches . . . PLUS MANY MORE!

Illustrated, step-by-step repair instructions on all these models

Alfa Romeo	Datsun	Metropolitan	Sabra
Austin Healy	Fiat	M.G.	Simca
BMW	Ford	Morris	Singer
Borgward	(Foreign)	Magnette	Sunbeam
Citroen	Hillman	NSU Prinz	Triumph
DAF	Humber	Opel	Toyopet
Daimler	Jaguar	Peugeot	Vauxhall
DKW	Lancia	Porsche	Volkswagen
	Lloyd	Renault	Volvo
	Mercedes Benz	Rover	
		Saab	

SEND NO MONEY

CHILTON BOOKS, Dept. PS-23
 525 Locust St., Philadelphia 6, Pa.

Please send GLENN'S FOREIGN CAR REPAIR MANUAL for 7-day FREE examination. I will then remit \$5.00 in 7 days, pay \$5.00 a month later, and a final payment of \$5.95 (plus 45¢ postage) a month after that. Otherwise, I will return Manual postpaid and owe nothing.

Name.....

Address.....

City.....Zone.....State.....

SAVE. Enclose \$15.95 now and publisher pays postage. Same return guarantee.

FREE! AIRMAILS!



Fabulous collection of all-different genuine Airmail Stamps from remote corners of the world — Africa, Europe, Exotic Orient, everywhere! World's Largest Airmail, Flying Doctor, Bomber, \$2.00 Helicopter, many others. PLUS Collection of thrilling Space-Age stamps . . . Sputniks, Jets, fantastic Moon Rocket stamps. Both of these remarkable collections — containing stamps worth up to 25c each! — for only 10c to cover mailing costs. Extra: Other sensational stamps for your free examination, plus Big Bargain Catalog. Rush 10c today to:

Jamestown Stamp Co. Dept. F23PS, Jamestown, New York
RUSH my Free Airmail Collection and other offers.
 I enclose 10c for mailing costs.
PLEASE PRINT

Name

Address

City & State

SAMURAI SUICIDE WARRIORS KARATE!

JUDO BOXING! MUSCLEBUILDING! YOGA! STRONGMAN STUNTS! STRENGTH & ENDURANCE! HANDBALANCING! ETC.

YOU GET ALL THESE! ● 20 Illustrated KARATE blows ● SAVATE foot fighting ● Secret NERVE CENTER and ANATOMY charts ● 20 vital JUDO throws ● 20 terrific STRONGMAN STUNTS ● Complete MUSCLE-BUILDING program ● Ancient YOGA secrets ● HANDBALANCING stunts ● Complete BOXING program ● Secrets of ENDURANCE ● WRESTLING holds ● WEIGHTLIFTING section ● ALL COURSES cram-packed with illustrations ● Giant Wall Charts

FOR ONLY 35¢

K-MAN Huge KARATE PRACTICE DUMMY Life like! Shows attack points, nerve centers, weak spots. 15c with 35c order only. Total 50c. **15¢** you get the lot! Over 300 Illustrations

OXFORD STUDIO, 44P26 Bromfield St., Boston 8, Mass.

NAME (print) **35c Program**

Address

City State..... **50c with K-man**

FREE EICO® CATALOG

Build your own stereo and mono hi-fi, radios, walkie-talkies, ham gear, test instruments—save 50% with famous EICO kits. No technical knowledge needed. Simple, step-by-step "Beginner-Tested" pictorial instructions guide you all the way. Choose from 108 beautiful kits. Mail coupon now!

EICO Electronic Instrument Co., Inc. PS-2
 3300 Northern Blvd., L.I.C. 1, N. Y.
 Please send free catalog and name of local dealer.

Name

Address

City.....Zone.....State.....

109 STAMPS 10¢

plus 88 FLAGS OF THE WORLD



Monaco U.S. Postage Set: Washington, Lincoln, F. D. R.

What a bargain! You get all the stamps shown here — plus Germany Moon Rocket, Australia Antarctic Explorers, Formosa Ancient Fortress, South Africa Gold Mine. Grand total 109 stamps — all genuine, all different. Also included: 88 Flags of the World in full color; Midget Encyclopedia of Stamp Collecting. All this for only 10¢. At the same time we will send a fine selection of other stamps on approval for free examination, to help you build a fine collection at low cost. Buy only those you wish to keep, return the balance within 10 days. Your satisfaction always guaranteed.

Send 10¢ today — ask for lot EH-41.
ZENITH CO., 81 Willoughby St., Brooklyn 1, N. Y.



Famous **ELECTROTONE** battery chargers at wholesale prices.
AUTO... MARINE... FARM
 Priced from **\$3.75** prepaid.
SAME DAY DELIVERY.
 Write today for free full line catalog.

DORON ENTERPRISES, INC. P. O. Box 7214 • Chicago 80, Ill.

DOLLS!

LEARN WORLD'S MOST FASCINATING BUSINESS
 We teach you to make, repair, and sell dolls and accessories. Study at home. Excellent part or full time money making opportunities. Low monthly payments—many pay for course out of earnings. May we send **FREE** and without obligation our booklet?
NORM and SUE MORRIS • THE DOLL HOSPITAL SCHOOL
 11824 SAN VICENTE BLVD. • STUDIO PS-23 LOS ANGELES 49, CALIF.

PAGE FOR TILLING PLOWING MOWING

A FULL LINE — 2 to 9 HP
 with complete gear drive and reverse
FREE CATALOG • LOW PRICES • EASY TERMS
 Over 40 years experience
OVER 60 ATTACHMENTS AVAILABLE!
PAGE Richfield 16 Wisconsin
DEALERS WANTED

RUPTURE!

An amazing Air-Cushion Invention allows body freedom at work or play. Light, neat, cool, sanitary. Durable, cheap. Day and night protection helps Nature support weakened muscles gently but surely. No risk. **Sent on Trial!** Write NOW for free Booklet and **Proof of Results.** All correspondence confidential.
Brooks Company, 348 State St., Marshall, Mich.

ELECTRIC WELD - BRAZE & CUT

REPAIR MOST EVERYTHING MADE OF METAL
 Home, Car-Factory, Farm-garden equipment. Make and repair lawn chairs, tables, ornamental iron, gates, etc. Solder, heat, bend, with terrific heat from arc torch shown. Cut and weld up to 1/2" steel plate. A million uses for Home, auto, farm, inventors, factories, etc. Works from any 110 volt plug-in. Complete with dark welders facemask, arc goggles, arc torch, supply of carbon welding and brazing rods. Complete beginners
 Welding Instruction Book. 1 year guarantee.
SEND ONLY \$2.00 (cash, ck, mo) and pay postman only \$12.95 plus COD postage on arrival or send \$14.95 and we will send postpaid. Ideal gift for mechanically minded, relatives, friends. Available only from **MIDWAY WELDERS Dept. DPS-2, KEARNEY, NEBR.**

Sworn statement from CHAS. LEMMING reads:

"After starting my own business

Not everyone does as well...
Mr. Lemming owns two machines

I'VE AVERAGED

\$100 A DAY
—most of it clear profit!"

• In city of less than 50,000, Mr. Lemming started his own business after filling in coupon like one below. He averaged \$100 a day during first year, some days \$200. F. E. Doran grossed \$1050 in a single month. Geo. Held grossed \$300 in one week.

How much you earn depends largely on you. You need no special skill, no large investment. Start spare time until full time justified. Hire helpers as needed. **NO SHOP NECESSARY** • You clean upholstered furniture with efficient **PORTABLE ELECTRIC DETERGER** on customers' premises—homes, hotels, motels, etc. Auto upholstery, too. No hauling; operate from your home. Watch business grow as customers tell friends. Supplies cost little; what you take in is mostly profit. If you want to be independent—free from layoffs, bosses—start this profitable year-'round business of your own. We will help you to start and work with you for your success.



OURS IS NOT A LEASE ARRANGEMENT • You are free to operate in an independent manner. You sign no contract. You own the detergent outright and are always your own boss...and every dollar you take in is yours to keep. You pay no fees, or dues, or royalties to anyone. And you take no risk. Your detergent is fully guaranteed and enough supplies come with it to return far more than your investment. Many earn the cost of the detergent in a week or two. It costs nothing to get the details...write TODAY.

MAIL COUPON TODAY FOR FREE BOOK

VON SCHRADER MFG. CO.
211 "D" Pl., Racine, Wis.

Without obligation rush your **FREE** booklet about how I can start my own permanent, profitable electric Upholstery Cleaning business.

Name _____

Address _____

City _____ Zone _____ State _____

INSTALL BURGLAR ALARM SYSTEMS... BIG PROFIT HOME BUSINESS

Typical outright store installation
CHARGE . . . \$90.00
COST \$14.00
PROFIT \$76.00
Plus bell and box profits. Plus \$6,000 to \$12,000 per year by servicing contract installations.

Start spare time. No mechanical experience or costly equipment. Expert shows beginners way to big profits installing in stores, homes. Big demand. Write for **FREE PLAN** now. **NASA, 11071 Massachusetts, Dept. J 242, Los Angeles 25, Calif.**

OPERATE A FIX-IT SHOP

Earn Big Money. Repair household appliances, rewind motors, sharpen mowers, saws, do house wiring, etc. Every neighbor, stranger a prospect. We show you how to make repairs, secure business, what to charge, buy needed parts wholesale, etc. **FREE BOOK.**

CHRISTY TRADES SCHOOL
Dept. A-3101 3214 W. Lawrence Chicago 25

ENGINEERING



Heald's Micro-wave and Radar Laboratory Equipment.

AMERICAN INDUSTRY NEEDS TRAINED ENGINEERS NOW

BACHELOR OF SCIENCE DEGREE, 30 MONTHS

SAVE 2 YEARS' TIME

B.S. Degree Courses:

- Electronic Engineering
- Electrical Engineering
- Mechanical Engineering
- Civil Engineering
- Architecture

Diploma Courses:

- Radio-Television Plus Color Technician
- Electronic Technician
- Architectural Drafting
- Mechanical Drafting
- Structural Drafting

APPROVED FOR VETERANS

Send for **FREE** Information

ENROLL NOW FOR NEW TERM

HEALD Engineering College

Van Ness at Post, Dept. PS-263 San Francisco, California

NAME _____

STREET _____

CITY _____ STATE _____

PROTECT YOURSELF



TEAR GAS

A SAFE, LEGAL WAY TO PROTECT YOURSELF!
No Permits Required

Be **SAFE**, carry a **TEAR GAS** protector in your pocket, car, or purse! A burst of Tear Gas will halt an attacker in his tracks, renders him helpless while you summon aid! Effective immediately yet causes no permanent injury. Also handy to flush animals from holes.



TEAR GAS GUN OUTFIT

This small size auto shoots 6 times as fast as you can pull the trigger. Complete with 6 tear gas shells, cleaning brush and instructions.
Blue Steel \$9.98
Chrome \$11.98

TEAR GAS PEN

It looks like a fountain pen, but simple thumb action trigger releases burst of choking Tear Gas. Fires forward, can't affect user. **BALL POINT PEN** size. Effective to 6 feet. Complete with 3 shells. \$4.98
FOUNTAIN PEN size, will affect 2 or more attackers. Complete with two 38 magnum shells. . . \$9.98



TEAR GAS DEVICES CO., ST. LOUIS 22, MISSOURI

Rush! GUN 9.98
 PEN 9.98
 PEN 4.98
Enclosed .38 shells 75c ea.
is check .22 shells 15c ea.
(No C.O.D.s) Gun Holster 2.00

NAME _____

ADDRESS _____

CITY _____ ZONE _____ STATE _____

DEALERS—AGENTS WANTED

Detroit report

By Devon Francis

Fiber-glass woes

If you have your heart set on an Avanti or a Corvette, you may have a long wait. Neither Studebaker nor Chevrolet can produce fiber-glass bodies fast enough.

At Studebaker, the shortage is so severe that the company has set up a new assembly line in South Bend.

The big problem is assembly. As one factory man said, "You can't stick a two-by-four in a fiber-glass door and spring it into shape." This is done in fabricating sheet-metal bodies. But not with fiber-glass; parts have to fit perfectly the first time.

Chevrolet's problem: The new Stingray Corvette is just too popular. A 300-400-percent increase in sales over last year is building up.

The situation is happier with individual body parts; plastics are still moving into the industry like gangbusters. At least one model of the 1964 Rambler line may have a hood made of a tough plastic already used in instrument panels and consoles.

Ford has announced fiber-glass body parts for the Galaxie—primarily for competition, when such parts are not prohibited. They include front fenders, hood, outside door panels, and deck lid. Saving, with other options: 160 pounds.

Still fighting smog

Anti-air-pollution devices may cost you still more money when you buy your next new car. Buyers of 1963 cars are already paying for positive crankcase ventilation—a device that channels blow-by gases from the crankcase back to the engine. The latest word is that California may require exhaust purifiers on all new cars by the fall of 1964. Several such devices are being tested. They should

be considerably more expensive than crankcase purifiers.

Another step planned in California is to require all used cars put up for sale to have positive crankcase ventilation by 1964.

Flexible glass

Nothing has excited Detroit engineers recently as much as that new type of glass developed by Corning. It looks just like tempered glass, but it's five times stronger. Result: The glass can bend and flex without breaking.

The new glass will simplify installation of curved side windows. The expensive and space-consuming mechanism for rolling down curved windows won't be needed, since the window can be withdrawn into a straight part of the door. Another advantage: Thinner, lighter-weight glass can be used.

Motorists in orbit

The average motorist driving along a crowded freeway is more tense and nervous than an astronaut in orbit. These were the findings of the Hughes Aircraft Co., developers of a device that electronically measures heart beat, respiration, and galvanic skin response—an accurate barometer of tension. Some traffic situations, it was found, are more frightening than blastoff from a launching pad.

The device will be worn by astronauts to record emotional condition in flight.

Better brake fluid

The new government standards for brake fluids, which become effective in March, will be tougher than the SAE standards now generally accepted by the industry.

A fluid that is to be sold in interstate commerce must meet minimum specifications for boiling and flash points, viscosity, acidity, stability at high temperatures, corrosiveness, fluidity at low temperatures, evaporation, water tolerance, compatibility, effect on rubber, and resistance to oxidation.



Cleans itself 2,000 times a minute

What Every Driver Should Know About the Spark Plug That Cleans Itself While You Drive. How does an Autolite Power Tip Spark Plug clean itself while you drive? Simple. The electrode or firing tip of a Power Tip spark plug is longer than usual. This extra length puts the firing tip deeper into your engine's combustion



chamber. The tip soaks up the heat of the exploding gasoline. Enough heat to actually burn away fouling deposits while you drive. That is how Autolite Power Tip Spark Plugs stay cleaner, longer than ordinary plugs to keep your power and mileage at their peak. Try a set and see. Autolite Power Tip, the spark plug that cleans itself while you drive.

PRODUCTS OF  MOTOR COMPANY

SPARK PLUGS • BATTERIES • SERVICE PARTS
 **AUTOLITE**
 THE NAME TO REMEMBER WHEN YOU CARE FOR YOUR CAR

1873 "In his chapter on the special expressions of animals, Mr. Darwin writes,

"The lips of young orangs and chimpanzees are protruded, sometimes to a wonderful degree, under various circumstances. They act thus, not only when slightly angered, sulky, or disappointed, but when alarmed and even when pleased. But

the degree of protrusion is not the same in all cases. The drawing represents a chimpanzee made sulky by an orange having been offered him and then taken away. A similar protrusion or pouting may be seen in sulky children."

"In his evidence before the Royal Commission on the water-supply of London, Dr. Parkes states that where the population of any town shows a considerable amount of diarrhoea, and also of typhoid fever, it would lead him to suspect the water-supply; for the health of the population seems to be very much influenced by the purity or impurity of the water consumed."

1903 "If we take those men who have most attracted the eyes and ears of the world, we have a definite group which we can analyze. We have examined six biographical dictionaries and encyclopedias—two English, two French, one German and one American—and noted the men in each who were allowed the longest articles. Then the men who appeared in at least three dictionaries were selected and, from these, the thousand who were allowed the greatest average space.

"According to this list the 10 most eminent men in order are Napoleon, Shakespeare, Mahommed, Voltaire, Bacon, Aristotle, Goethe, Caesar, Luther, and Plato."

"According to the census report of 1900, there were 111,000 deaths from tuberculosis during the year 1900. This does not,

however, include the deaths in certain states in which the vital statistics are incomplete, and it is probable that there are at least 145,000 victims of the great white plague annually within the limits of the United States.

"The last census return in those states where registration was approximately correct shows that 12 percent of all deaths resulted from pulmonary tuberculosis, 8½ percent from pneumonia, 3 percent from typhoid fever, and 3 percent from diphtheria and croup."

1933 "A blast of dynamite echoed at noon recently through the Colorado River valley near Boulder City, Nev. The blast opened an epic battle between men and nature—the turning of the great river from its channel to clear the way for building Hoover Dam. Five thousand shots of dynamite choked the river channel with debris from the cliffs around the dam site. Dump trucks hurled load after load into the stubborn river to seal the barrier. At three in the morning, the men rested beneath floodlights, exhausted with their fifteen-hour fight—but it was won."

"A vacuum tube was devised by Thomas A. Edison long before wireless sets were dreamed of. Proof of its ability to pick up a modern radio program was given the other day at a New York broadcasting studio. Music was tuned in on a receiving set using a faithful copy of Edison's original tube, with a curved filament of carbonized bamboo and a plate formed of two upright wires."

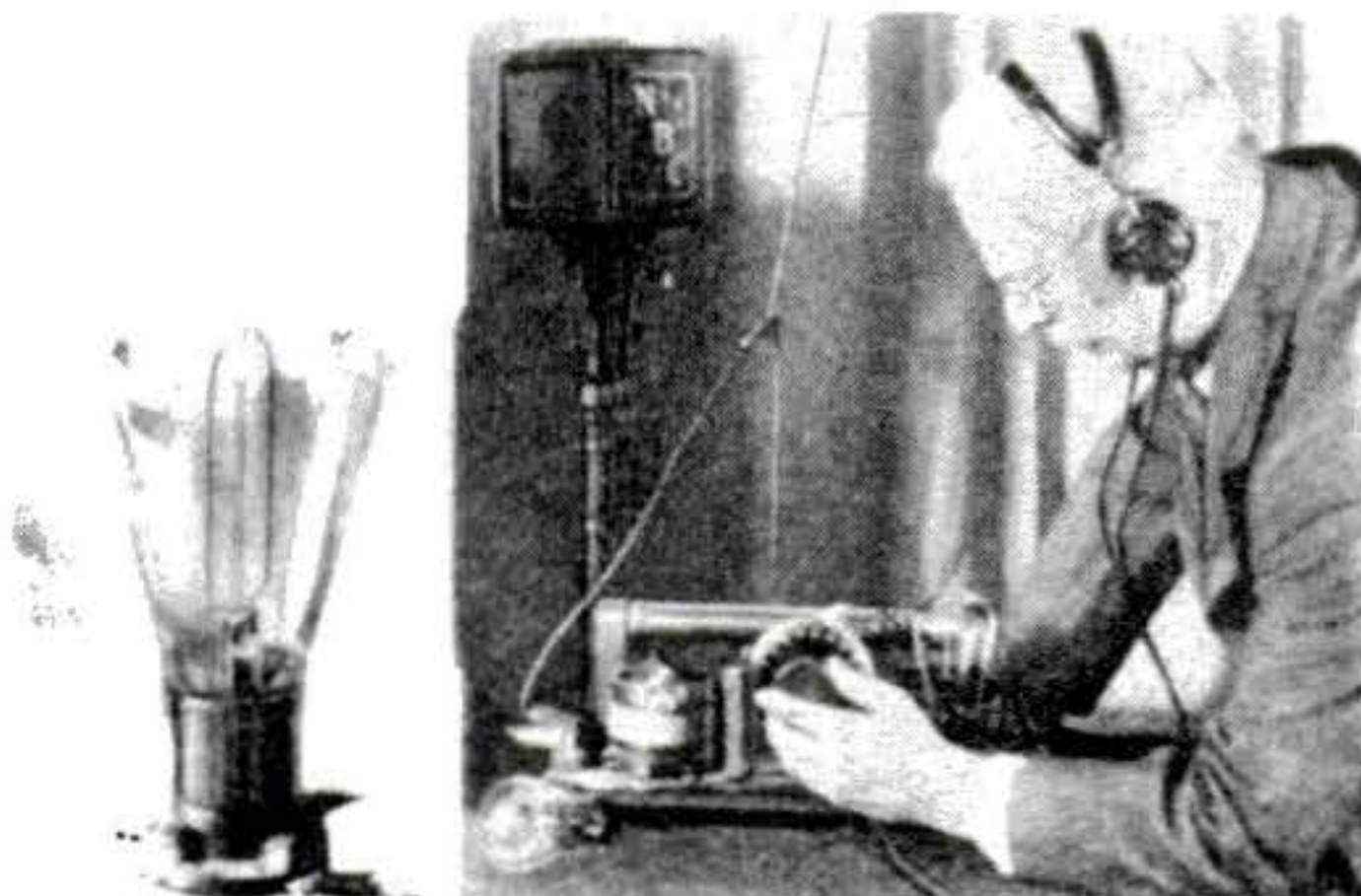



Wherever toughness counts, in axles, frame or springs... count on new

'63 FORD PICKUPS

...BUILT LIKE THE BIG TRUCKS



No "Knee-Knocker." Ford doors open wide with no annoying "dog-leg" to get in your way. Custom Cab offers 23 lbs. of insulation for a quiet, relaxing ride.



Tough I-Beam Axle—the same design as big trucks! Maintains front-end stability... keeps front wheels tracking true for longer tire life!

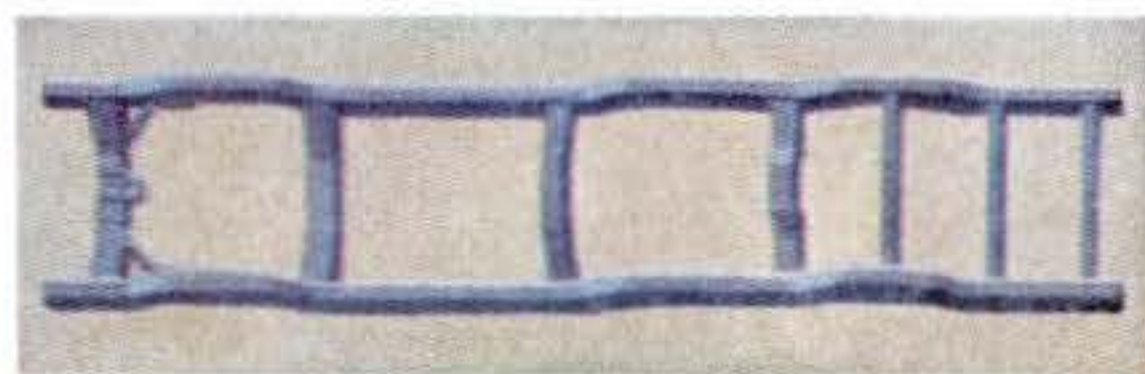

Parallel-Rail Frame gives Ford pickups that same kind of rugged backbone that's used in the biggest trucks! See the '63 Ford pickups today!

A new Ford pickup may ride like a car, but there the likeness ends—everything else is truck-tough...*big-truck-tough!* From axle to axle, Ford builds pickups like big trucks for extra durability and reliability, and for lower operating costs!

FORD TRUCKS

For
**Outstanding
Reliability &
Durability**

New 75 hp Sea-Horse
Electramatic Motor



NEW!
2-Year Warranty
On every '63 Johnson

Meet water skiing's 5-Star Admiral!

Shifts automatically, electrically! Most responsive outboard ever built!

Want blistering pick-up for skiing? Want big dig for big loads? Trust this new 75 hp Super Sea-Horse V-engine. Revolutionary new electric clutch engages automatically in a split-second . . . makes this the most responsive outboard ever built! Other features: 20-ampere alternator-generator; 5-way super-silencing; a healthy 89.5 cu. in. displacement for impressive reserve power and longer engine life. Your Johnson dealer's listed in the Yellow Pages.

See him soon. Other models to check out: the 28 hp "Convertible" and the new Johnson Compacts at 18, 10, 5½ and 3 hp. For free catalog, write: Johnson Motors, 1326 Pershing Rd., Waukegan, Ill., Division of Outboard Marine Corp.

JOHNSON First in Dependability



Exclusive Electramatic Drive

Outboarding's first truly automatic transmission. Unique directional throttle (no extra charge) controls both gas and gears. Makes driving sure, docking easy. Available at 75 and 40 hp.

Color Photos in 60 Seconds

With Polaroid's amazing new film, you can shoot color pix and see finished prints almost immediately

By Bob Hering

IMAGINE peeling off a finished color print just one minute after you snapped the picture. Unbelievable? We agree. Seeing your subject in a full-color print, 60 seconds after you aimed the camera, is nothing short of magic.

Just shoot the picture and pull the tab. There's a stir of migration as a whole school of linked molecules, each molecule consisting of a special dye and developer leashed together by an inactive atomic thread, begin

**TO SEE HOW THE NEW
COLOR PROCESS WORKS, TURN THE PAGE**

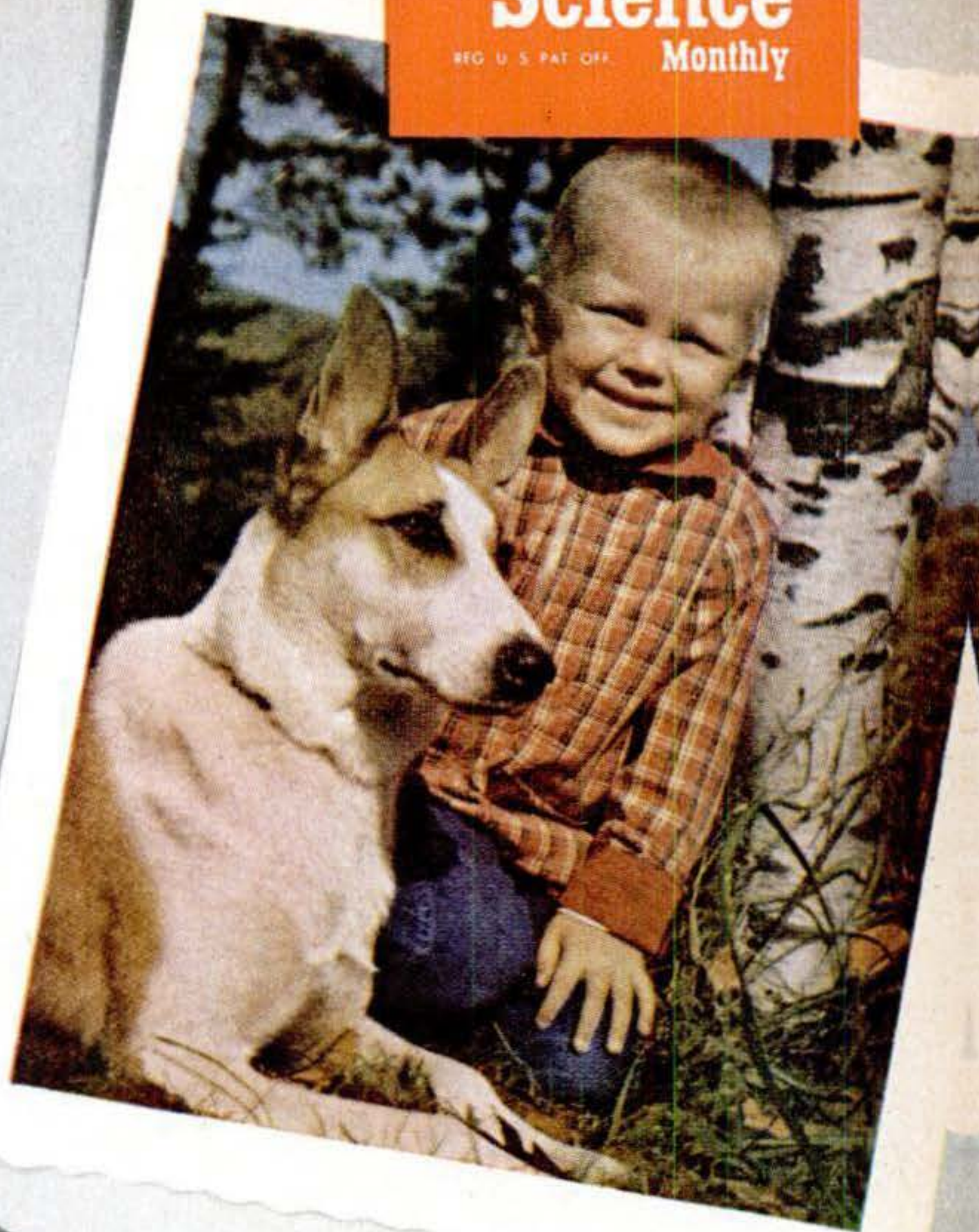

How Polacolor works—from exposure to finished print

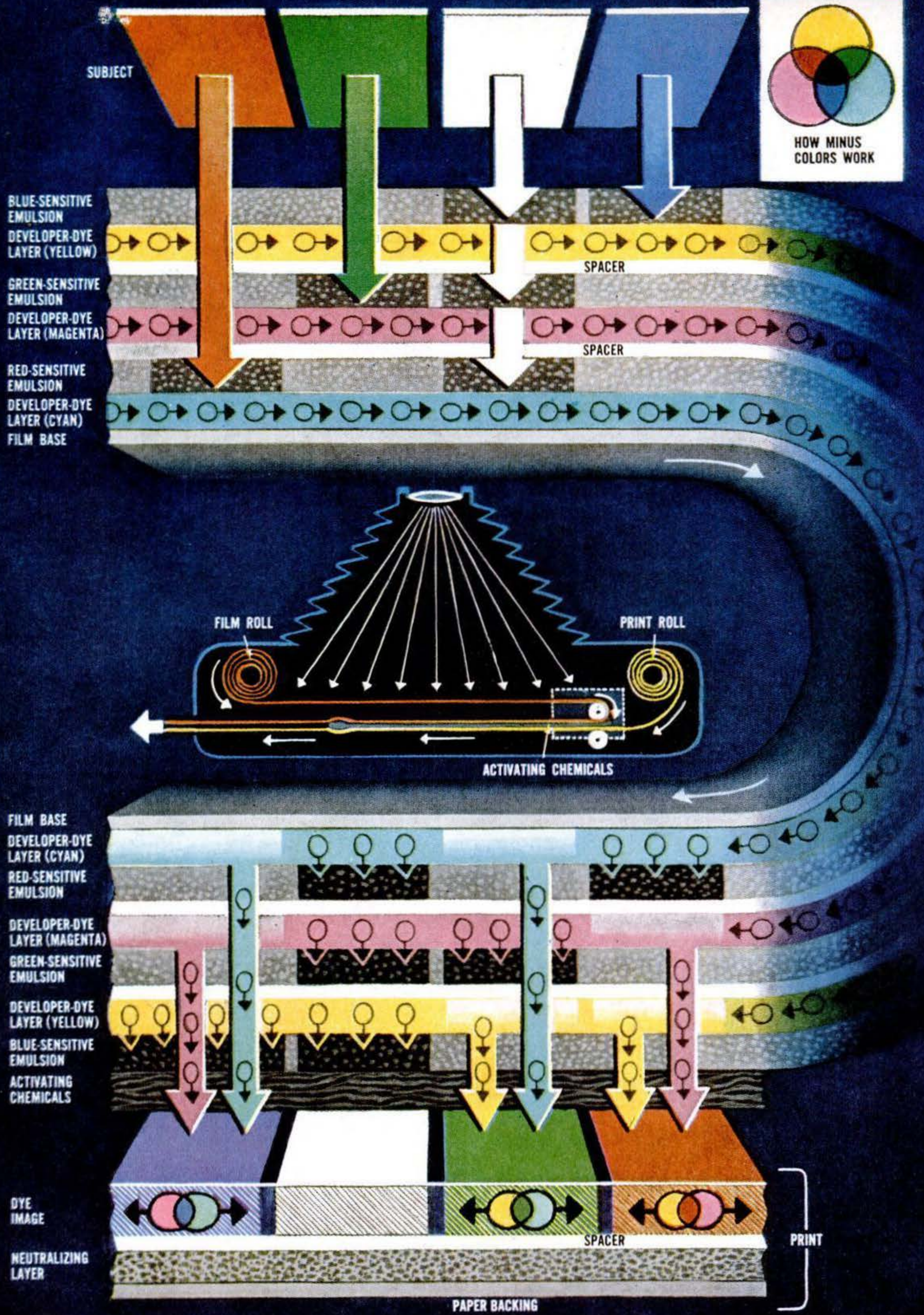
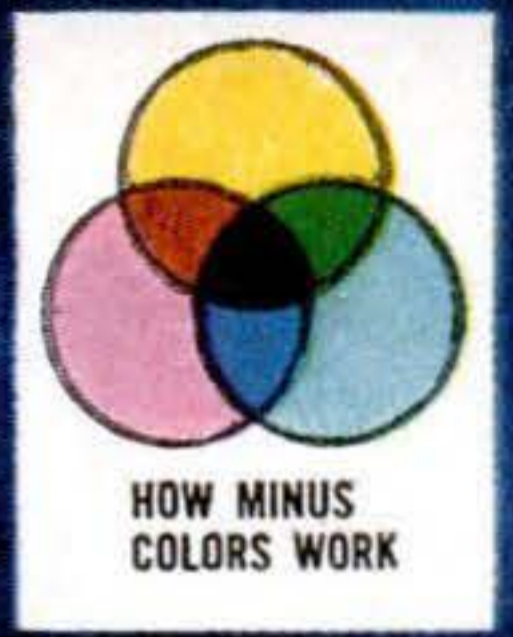

POLACOLOR, like other color films, depends on "minus colors"—yellow, magenta, cyan. Each is the complement of one of the primary colors of white light—blue, green, red; and each *subtracts* its complement from white light. Insert on facing page, at upper right, shows how overlapping minus filters produce the primary colors: Clockwise from top, yellow and cyan subtract blue and red, letting only green light through; cyan and magenta subtract red and green, leaving only blue; magenta and yellow subtract green and blue, leaving red. Black results where three filters overlap. Diagram shows what happens as shutter is clicked. Dotted rectangle over camera is area of full-page diagram.

When you snap the shutter, light from lens is filtered by color-sensitive layers. Green light passes through blue-sensitive emulsion (yellow dye layer) without affecting it, but exposes silver halide grains in green-sensitive emulsion (magenta layer). Red and blue light act similarly in their sensitive layers. White light exposes the grains in all layers.



When you pull the film tab, film, print, and processing pod are pulled between a pair of metal rollers, breaking pod and spreading a thin layer of alkaline reagent between film and print. Reagent reaches all layers of film and sets linked developer-dye molecules into motion. Molecules bump into exposed grains, seeking correct ones to develop and be trapped by.

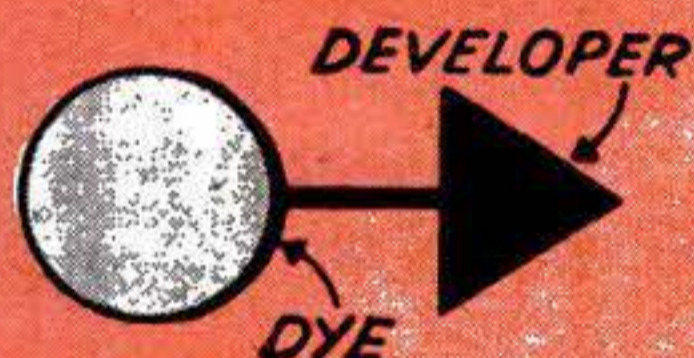

Exposed grains, for instance, in red-sensitive emulsion are developed by, and trap, the cyan developer-dye molecules.

When a developer-dye molecule meets no exposed grains, it keeps moving toward print. It can pass through layers already developed, since silver grains there have trapped as many developer-dye molecules from adjacent layers as they can hold, and will accept no more.

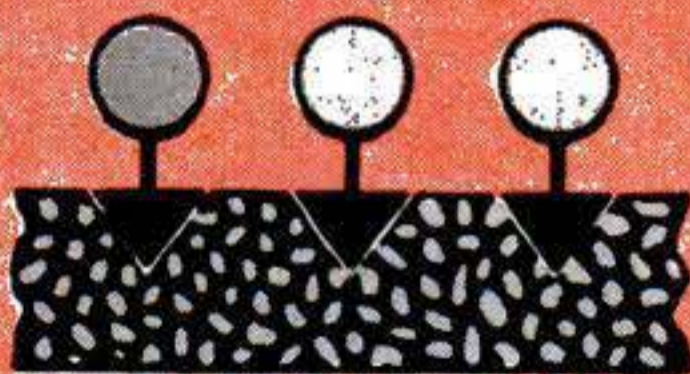

When you look at the picture, you see colors subtracted by the dyes in the print. Dye molecules, having migrated to receiving layer of print, are embedded as layer turns to permanent plastic. But the dyes are minus colors.

The colors you see are formed by white light bouncing off the print's white backing through the dyes' subtractive filtration. Neutralizing layer of acid molecules stops chemical action, stabilizing the colors.

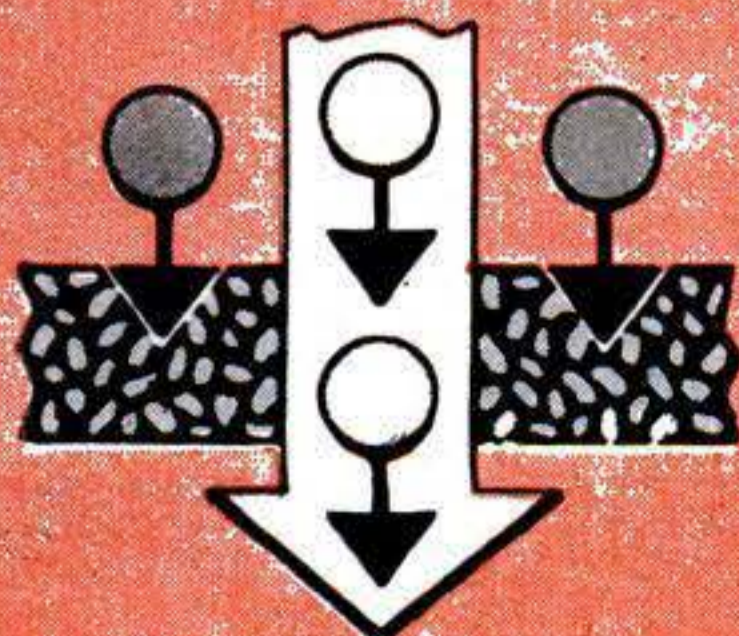

nudging their way down through the negative to the print, making chemical changes as they hurry through the thin layers. Wait 60 seconds, flip open the back, and lift out a full-color print. That's Polacolor, Polaroid's new color film—so new that this report by POPULAR SCIENCE, with pictures actually taken on Polacolor, is the first to appear in any magazine.

The entire process, from exposing the negative to delivering a finished color print, takes place within the camera.

In perfecting this, Polaroid has achieved several extraordinary firsts:

- A finished color print is made outside a darkroom.
- A one-step process replaces the 20-odd steps required in most conventional color-print methods.
- Processing time is cut from 1½ hours to a minute.

Even during the early Forties when Dr. Edwin H. Land, founder of the Polaroid Corporation, was developing the basic process, he dreamed of inventing a one-step process for color. Now, after continuous research and more than 200 patents, the dream is a reality.

To use the new color film in existing Polaroid cameras, the diffusion-transfer technique, employed in the original black-and-white process, was adapted. Polacolor contains everything to make a picture: silver to record the image, a developer to process the film, and dyes to produce a color image.

Two basic requirements were set up early in the program: one, the need in the negative for a dye linked to a developer in a single molecule, so the molecule could control its own diffusion transfer from the negative to the positive; the other, the need for a color-stable positive that needed no coating or washing.

Among the early attempts to invent a one-step color film that would produce finished pictures in the camera, two processes showed promise: a "strip-emulsion" process, and one using "exhaustive color couplers."

The strip-emulsion idea involved laying down microscopic strips of emulsion.

what PS staff thought of Polacolor

“ I tried Polacolor outdoors on a gray, overcast day, with fill-in flash. The results were excellent—even in shadows, under trees, the prints were ‘natural.’ Daylight flash, indoors, mixed with normal room lighting, resulted in prints a little too warm in color, by strict standards—but for family-and-friend use, they were a delight. Processing timing and the other details of use gave no problems.—*John R. Whiting, Executive Vice-President and Publisher (former editor of “Popular Photography”).*

Polacolor is a tremendous milestone in color photography. My picture of the little boy and dog is true in color, although subtle and less exaggerated than we find in some color materials. I found the reds lacking in color saturation and leaning towards the orange side. Skin tones were excellent. Blues were a bit exaggerated. It worked well with electronic flash and flash bulbs.—*Robert D. Borst, Staff Photographer.*

The introduction of Polacolor is about the most exciting news for the amateur since the first days of Kodachrome. Blues and flesh tones are excellent. Reds are less brilliant than I would like them, but I’m sure later emulsions will improve them. Peeling off a color print in just seconds is an exciting experience.—*W. W. Morris, former Chief Photographer.*

The real treat of Polacolor is being able to see it almost immediately. It’s especially good for outdoor use in clear or slightly diffused sunlight—and that’s where most of us will be shooting it. The fact that prints won’t need coating made a big hit with me.—*Robert L. Hering, Photography Editor.*

exposed silver salts in each of the three emulsion layers to metallic silver. After re-exposure during processing, dye-coupler molecules associated with the silver grains in the positive image combine with chemicals in the color developer to form three dye images—cyan, magenta, and yellow. The amount of dye produced is proportional to the amount of silver developed. These cyan, magenta, and yellow dye images act as subtractive filters to control the amounts of red, green, and blue that you see through the transparency. The relative densities of the subtractive colors determine the intermediate colors. With this method, the dyes are created when the film is processed. Time and temperature are critical.

But Polaroid needed a process that did not involve precise time and temperature control. They also had to eliminate that second exposure, so the film could be used in Polaroid cameras. This required a new approach—and out went the exhaustive-color-coupler process.

As the work progressed, researchers developed a completely new concept based on linking—chemically—a preformed or complete dye to a developer in a single molecule. The dyes could be put in the film at manufacture instead of being created during processing, as in conventional film.

This dye-linked-to-a-developer in a single molecule is the key invention that makes Polacolor possible.

The invention was the basis for development of an extremely complex negative: In a total thickness of less than half a human hair, there are more than eight layers.

One big problem in the multilayer process was the interaction between the layers. All action in the molecules had to be completed within their appropriate layer before they reached the next layer. To keep the emulsion layers apart, researchers used gelatine spacers.

Many of the dyes tested destroyed the film’s sensitivity to light, and had to be discarded. Also, the dyes had to be bal-

[Continued on page 208]

But this proved impractical, as distinct lines showed up on the finished prints.

The exhaustive-color-coupler process held out more hope.

In conventional reversal (transparency) processes, the developer reduces the

A LITTLE red car, making big-car noises as it streaked around an oval test track in a Detroit suburb, last month ushered in the second edition of the U.S. auto industry's display of 1963 products.

Fairly bursting with the energy of its first V-8 engine, the little red car, a Falcon, was called a 1963½ model by its parent, the Ford Motor Co. So were three other Falcon models, a brace of Ford Galaxies, a Thunderbird, and a collection of Mercury Comets, Meteors, and Montereys.

With 10 models from the Chrysler Corp., either spanking new or with optional mechanical variations, it all totted up to 20 mid-season additions that have been made to the manufacturers' car lines.

They have new shapes. They wear new spangles. Fresh transmissions turn their propeller shafts. But their outstanding characteristic is the growl from their tailpipes.

The Falcon is a case in point. Introduced

CONTINUED

What's New in the 1963 1/2 Cars

By Devon Francis

Mid-season entries give you a wider choice in the new cars.

Here are highlights of what the auto makers are offering



just 3½ years ago as a car that could get 30 miles from a gallon of gas, it had a little coffee mill of an engine that produced 85 horsepower. Now here it is, with a 260-cu.-in. V-8 putting out a thundering 164 hp.

And don't be surprised if the Falcon is upgraded presently to a considerably higher horsepower—on this same engine.

I drove a 1963½ Falcon on Ford Motor's acceleration strip at the Dearborn test track. Called the Sprint, it was a hardtop with a floor-mounted, four-speed manual transmission, a stiffer body than is usually built for the Falcon, a beefed-up rear axle, heavy-duty springs,

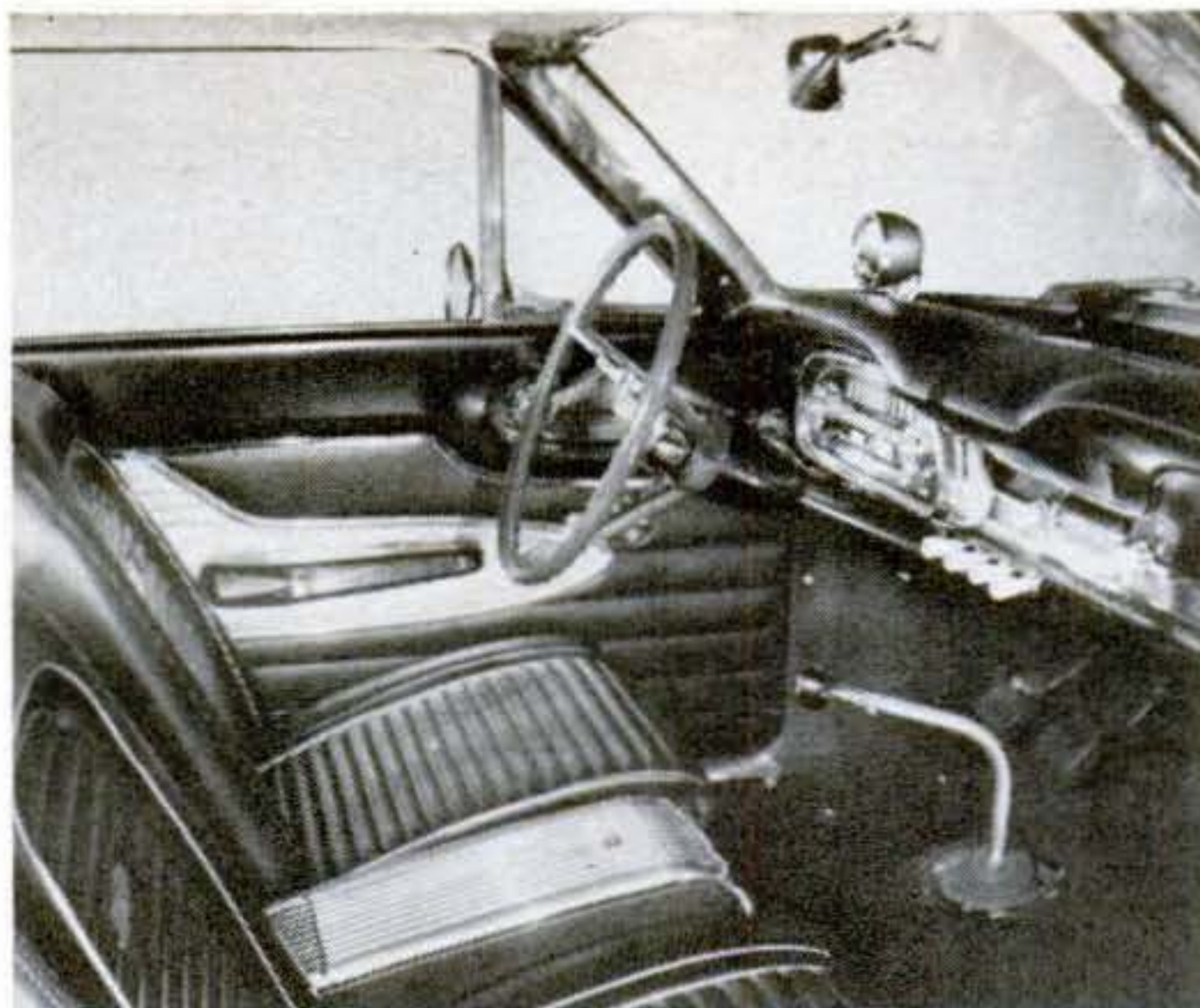

Bucket seats, tachometer above dash, and floor-mounted, four-speed manual transmission are embellishments of new Ford Falcon Sprint.

CONTINUED

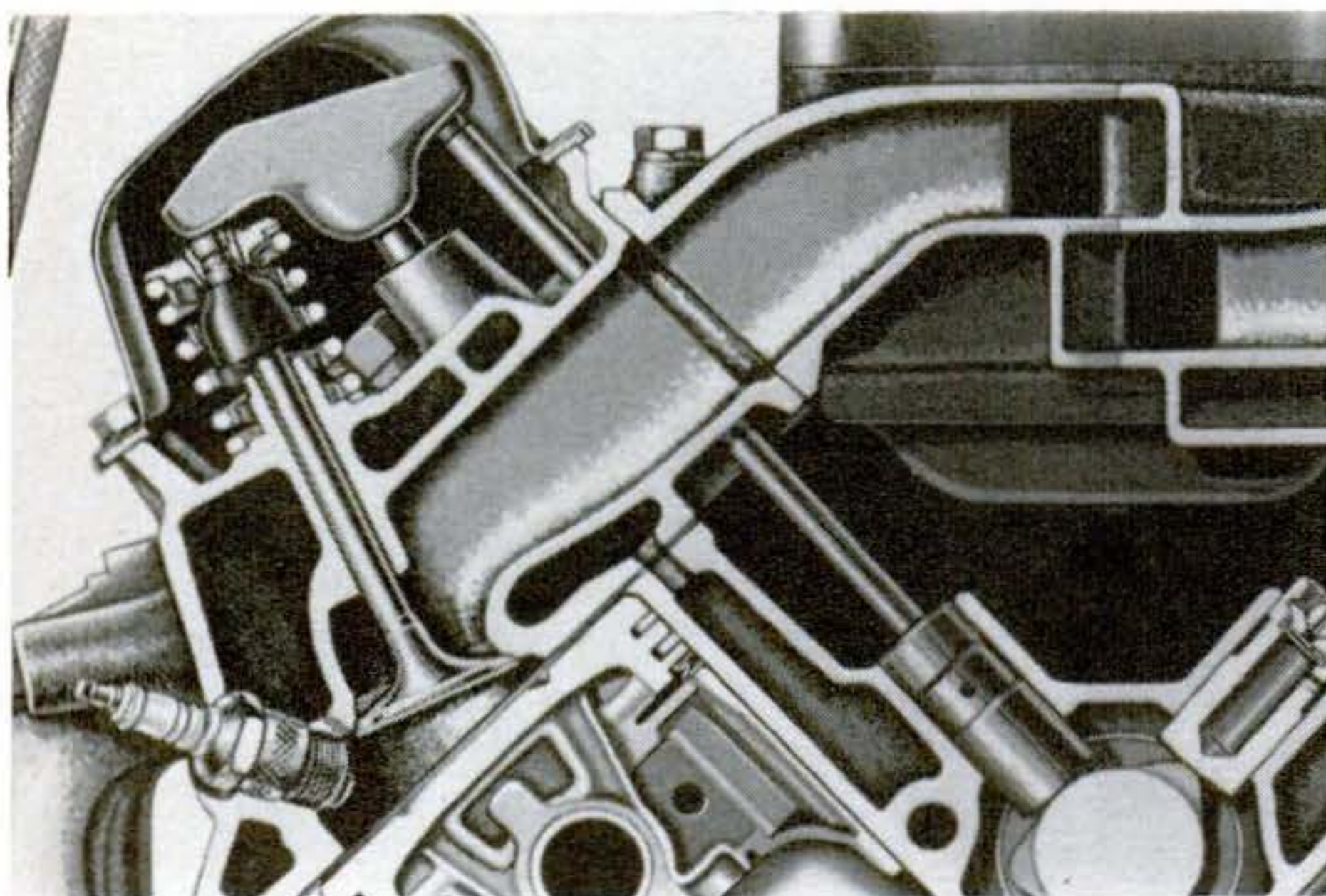

New engine, with solid valve lifters, producing 271 hp. from 289-cubic-inch displacement, is option on high-performance Ford Fairlane and Mercury Meteor. Compression ratio is 11:1.



Dodge and Plymouth offer four-speed manual shift with various engines. Ratios with Dodge's 383-inch engine are 2.2, 1.66, 1.31, 1. Optional axle ratios are 3.23 and 3.55.

Here is what the 1963½ cars have to offer you

By brands, here are the cars and new mechanical options that have appeared on showroom floors since the introduction of the '63 cars last fall:

- Two Dodge Dart convertibles in the 111-inch wheelbase series, known as the 270 and GT.

- Three Dodge 880-series models, priced lower than the Dodge Custom 880, with new grille, hood, front fenders and bumper.

- A manual four-speed, floor-mounted transmission for Dodge's 318- and 383-inch engines in four of its "big car" series,

and for Plymouth's 318-, 361-, and 383-inch engines. This transmission will also be made available on Dodge's (and the Chrysler Corp.'s) huskiest engine, displacing 426 cubic inches.

- A Chrysler New Yorker with a landau roof.

- The Chrysler 300J, with a 413-inch, 390-hp. engine.

- A Chrysler New Yorker salon with headrests, reclining seats, autopilot, humidity control, special tires to reduce road noise, and vacuum door locks as standard equipment.

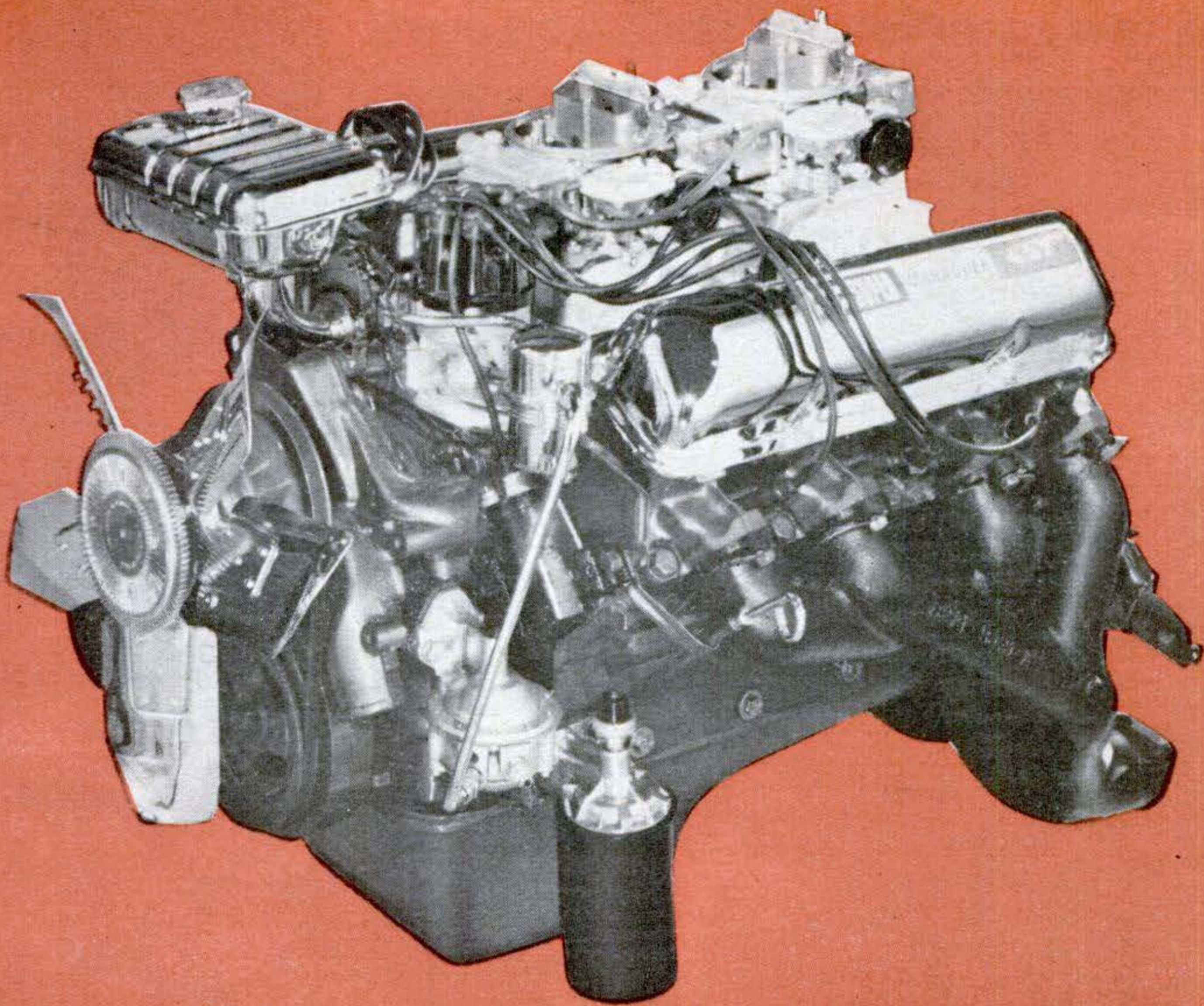

Newest and biggest Ford Motor engine displaces 427 cubic inches, produces up to 425 hp. Available in Galaxie, Merc Monterey and Marauder,

huskiest version has two four-barrel carburetors, burns superpremium fuel. Compression ratio is 11.5:1. The valve lifters are solid.

- Two Mercury Marauder two-door hardtops with "fastback" roof lines, one with bucket seats.

- Two Mercury Comet two-door hardtops with fastback roofs, one with bucket seats.

- A Mercury Monterey four-door hardtop with bucket seats.

- Two Falcon fastback hardtops, one with bucket seats.

- Two Falcon Sprint performance compacts, one a hardtop, one a convertible.

- Two Ford Galaxie fastback hardtops.

- A Thunderbird landau, designated as a limited edition.

- A 289-inch Ford Motor Co. engine,

replacing the 260- and 292-inch engines in the Galaxie. Rated at 195 horsepower, it is boosted to 271 hp. in optional, high-performance versions of the Ford Fairlane and Mercury Meteor.

- A 427-inch, 425-hp. engine for the Galaxie and full-size Mercs. This engine replaces one of 406 inches producing 405 hp. A transistorized ignition system is optional on this engine.

- Other Ford Motor cars are upgraded on power, mostly as an option, with existing engines—the Fairlane and Meteor get a six-cylinder, 200-inch, 116-hp. engine; the Falcon and Mercury Comet a 260-inch, 164-hp. V-8.

Mid-season's new cars have new shapes, wear new spangles, and growl with power



DODGE 880 HARDTOP



VALIANT CONVERTIBLE



COMET HARDTOP FASTBACK



MERCURY MARAUDER HARDTOP



PLYMOUTH FURY 4-SPEED



THUNDERBIRD LANDAU

and brakes and tires of increased size.

The speedometer correction showed a speed of 56.3 m.p.h. at an indicated 60, and 77.7 at an indicated 80.

With the accelerator on the floor, the speedometer indicated a trifle over 100 m.p.h. While the dial was marked only to 100, the car was running out of steam at 4,500 engine revolutions per minute when the needle nudged past the last graduation. What I had encountered was tappet pump-up on the hydraulic lifters—the valves refused to seat. With solid lifters—which will produce a lot of added power at 5,800 to 6,000 r.p.m.—the car no doubt will clock well beyond a true 100 m.p.h.

Here were some of the accelerations on corrected speedometer readings:

0-60 m.p.h., without getting out of third gear: 10.9 seconds.

0-80: 22.1.

30-60 with no downshift: 9.7.

30-60 with downshift to third: 7.3.

40-60: 6.9.

40-70 with no downshift: 11.1.

40-70 with downshift to third: 11.2.

40-80: 16.5.

60-80: 10.2.

The 40-70 and 60-80 accelerations in high gear showed that the engine—with a 3.5:1 axle—had ample spunk in the higher speed ranges.

Let it be remembered that the original Falcon ate up almost 23 seconds in reaching 60 m.p.h. from a standing start, and had a top speed of around 78 m.p.h.

Despite the Sprint's stiffer springing,

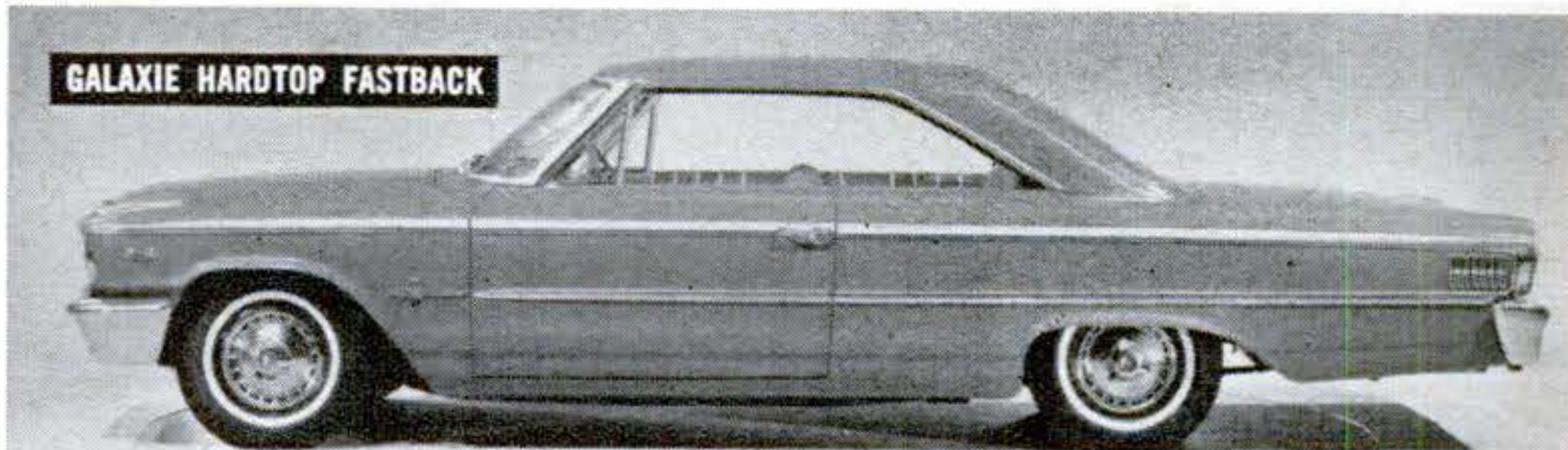
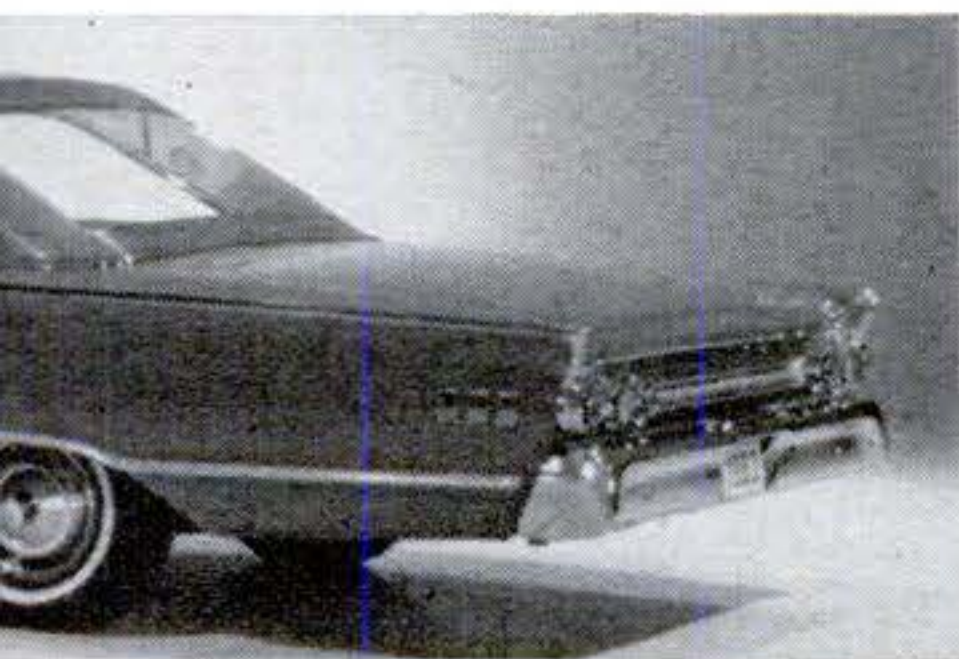

its ride was not harsh. I found it quite comfortable.

Another 1963½ car with explosive horsepowers under its hood is Plymouth's four-speed Sport Fury.

Wesley S. Griswold, POPULAR SCIENCE's West Coast Editor, drove one of the first of these 330-horsepower jobs just off the production line.

"My convertible had a 383-inch engine and a 3.23 axle," he reported. "If my calculations on the speedometer correction are on the button, this car won't quit until it reaches a true 120 m.p.h.

"Here are some of my accelerations:

"0-30 m.p.h.: 3 seconds.

"0-60: 7.

"40-70, starting in second gear and going up only through third gear: 5.3.

"40-70, in fourth gear: 6.6.

"50-80, starting in second gear and going up only through third gear: 6.2.

"50-80, in fourth gear: 6.8.

"The car cornered snugly at any speed. On straightaways, in passing, it almost tugged the seat out from under me.

"I didn't care for the rough idle caused by the high-lift cam, but that's the penalty you pay for performance."

Finally, as a case in point with the 1963½ cars, there is that Ford Motor 427-incher. Editor Robert P. Crossley witnessed this engine drive both a Ford Galaxie and a Mercury Monterey to 160 miles an hour at Bill France's Daytona speedway.

For other news of the mid-season cars, see the accompanying pictures. ■ ■

Today's tranquilizers, energizers, and similar drugs help the sick mind. Soon they may improve the healthy

The

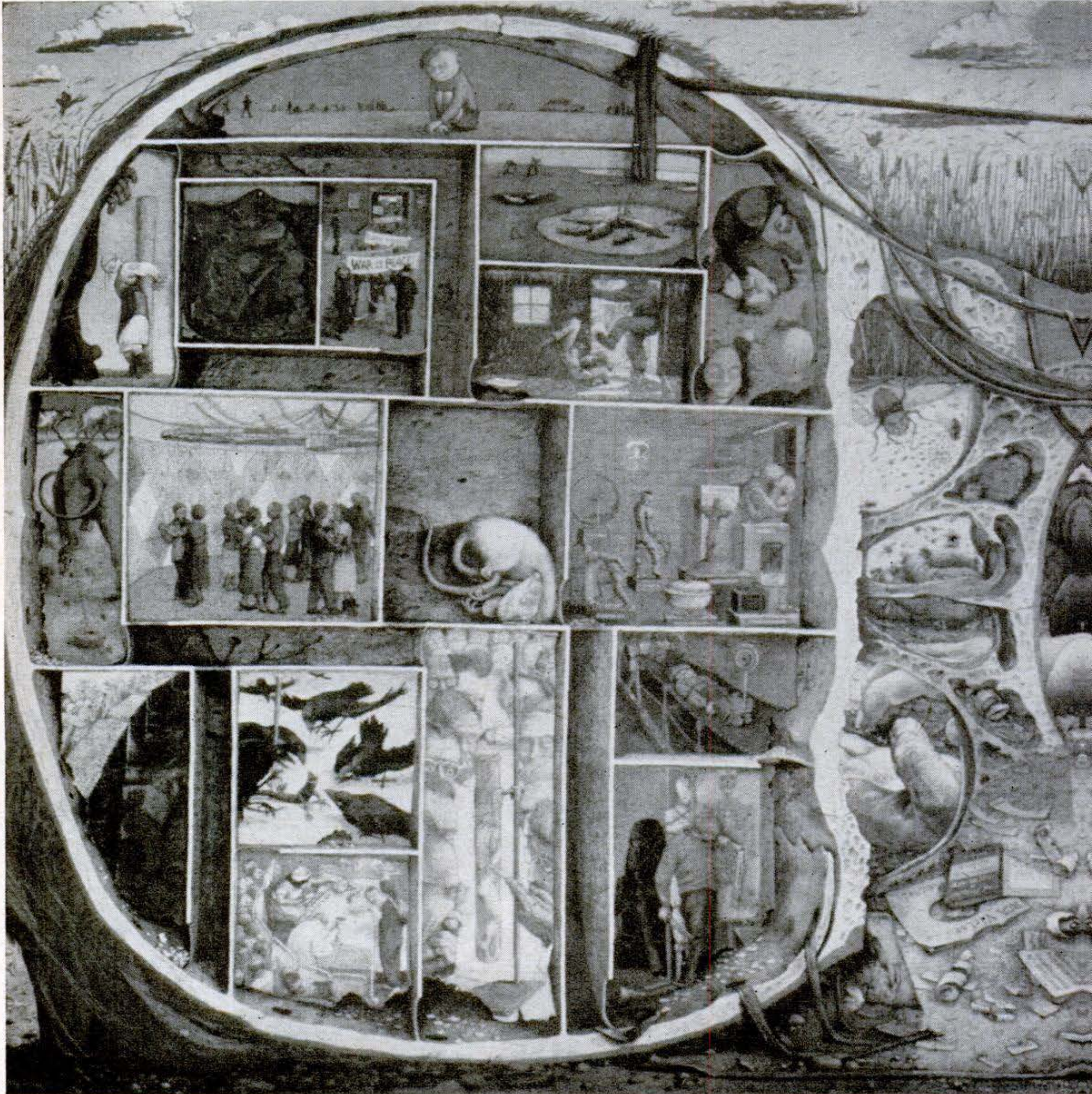

A schizophrenic artist paints the torment of his tortured soul

Creative people often retain their talents when mentally ill. This psychotic painter saw himself lying on his side on stony ground, his skull split open to reveal a life story in compartments that are chambers of horror. Pictured, from the

top down, are scenes of childhood cruelties, war, frustrations in love and work, and torments by his doctors. The rat in the center is the artist who, having nibbled at the bitter fragments of his life, now curls up to die.

Truth About Brain Drugs

By Joan Steen

TRANQUILIZERS work. So well, that in a decade they've become the third most frequently prescribed drug in America.

Phenobarbital, an older drug, works too for many a sleepless patient. So does Benzedrine—as the long-haul truck driver or others hard-pressed at times to stay awake can report.

But what makes such drugs work? Why do some drugs calm you down or knock you out, while others stimulate you or waft you to a painfree state of bliss?

Up to eight or nine years ago it was anybody's guess. Then came the tranquilizers. So impressed were doctors at the profound improvements—even apparent cures—of mental patients who took these drugs that they began to take a new look at all drugs that affect behavior.

Now the research is paying off. Scientists are on the verge of unraveling the strange biochemical mechanisms that underscore our behavior.

New “psychoactive” drugs have come to light with startling new effects. Some may improve your memory; others may step up your creative output; still others may stimulate a “seat of pleasure” in the brain to produce that glow of well-being called joy.

To fit these ideas in place, first consider some facts about the mind:

If you ask a physicist how he visualizes an atom he may tell you he sees a central very dense mass (the nucleus), enveloped in a cloud of energy-charged particles (electrons).

A “*bowl of jelly.*” Ask a biologist how he sees the central nervous system and you may get a remarkably similar picture. For the dense nuclear core read “brain,” that “modest bowl of pink jelly”—according to biochemist Robert S. DeRopp—which packs over 10 billion energy-charged particles in its soft, warm mass. These particles, the nerve cells, are the most extraordinary cells in the body. While the “head” of each cell is a microscopic bit of protoplasm, its

CONTINUED

71

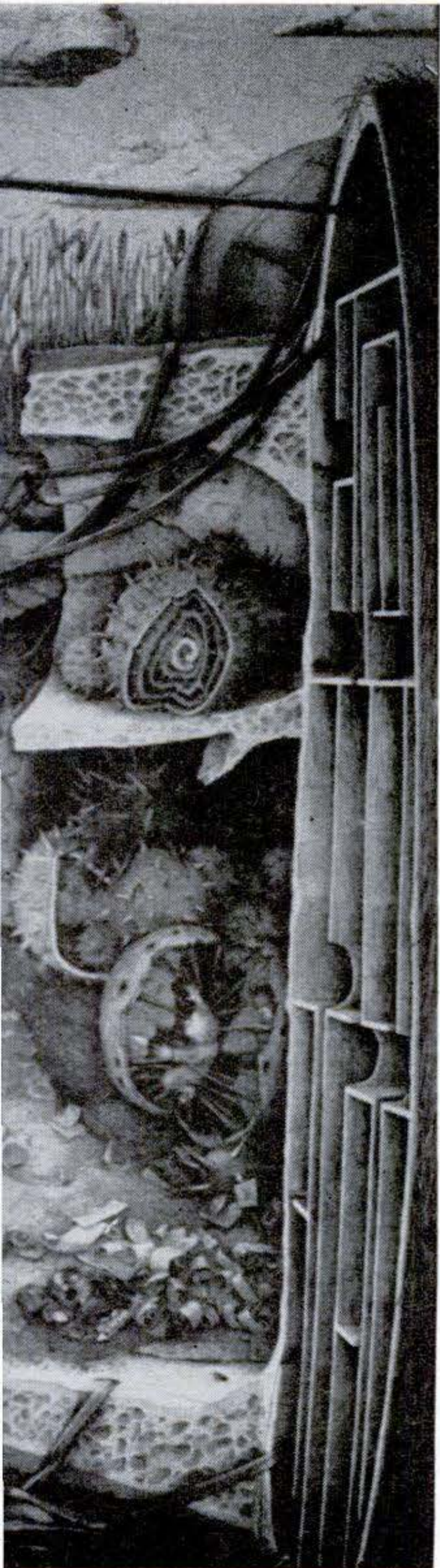

Nightmare world of the disturbed

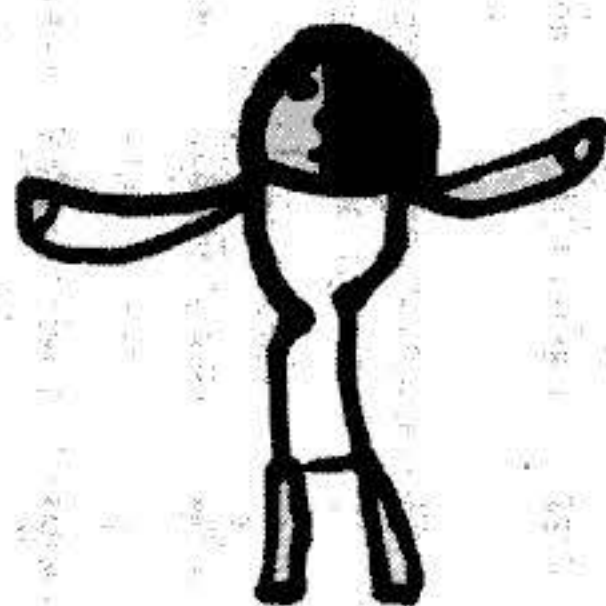
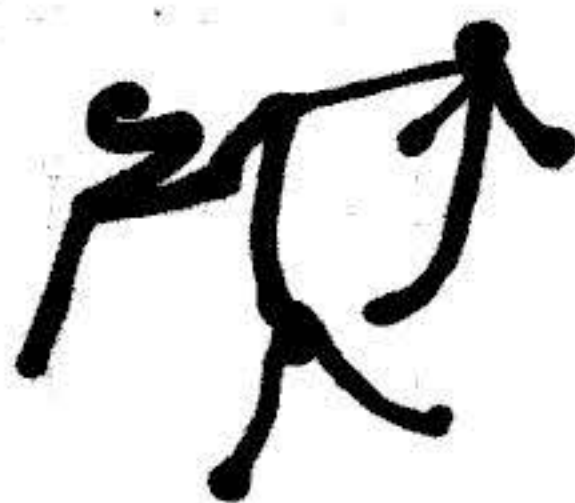
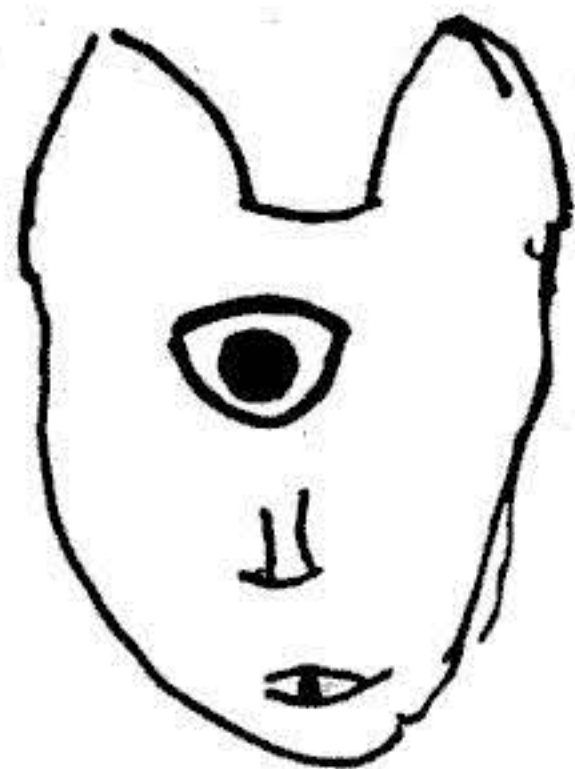

hairlike "tail" may trail out several feet to reach your eyes, your ears, your fingertips.

When stimulated sharply enough, the tail "fires"—clicks out an electrical impulse. But the transmission is not the same as a telephone wire carrying current at 20,000-mile-a-second rates. Nerves fire their charges more slowly, like explosive fuses. The fastest pulses travel about 300 feet a second.

If an impulse reaches the head of the nerve and has enough energy, it jumps across the tiny gap that separates it from a neighboring cell to fire it, and spark a path to the brain. There it joins forces with other impulses to light up your mind in a unique pattern that determines your behavior.

Suppose you turn the corner of a street and find yourself facing a thug coming at you with a knife. What happens? In a flash your heart starts pounding; your breath deepens; you stop digesting food. Blood leaves your body center and rushes to your muscles. The liver releases sugar and the spleen gives up blood corpuscles. Now you are equipped to get away fast—this is a "flight" reaction.

But suppose you take a stand? Anger wells up within you; your face gets red; your fists bulge; you lunge forward, prepared to put the man in his place. That's a "fight" reaction. Either way, you're experiencing fast chemical changes.

When the nerve impulses carrying the threat reached the brain they set off chain reactions. Back streamed messages to muscles and glands. There the impulses triggered the release of chemicals—hormones—to do the work.

If the major hormone released was adrenaline, you were prepared for flight; if it was noradrenaline—a close relative—you were prepared to fight. Most people react consistently one way or the other.

The adrenal hormones are just two of half a dozen major hormones stored throughout the body. It is these chemicals plus the electrical impulses that tease them into life (and later destroy them) that drugs affect.

The tranquilizers. The first "new" behavioral drug scientists studied was old outside the western world. It was Rauwolfia—derived from the roots of a plant. In India its use dates back at least 2,500 years. It was popular as a child pacifier, a reducer of blood pressure, and a drug of "rare merit" for treating nervous disorders.

All these claims were justified, the doctors discovered. They extracted and purified the roots of the plant to make reserpine—still one of the most powerful in today's sprawling collection of tranquilizers.

Generally the collection is divided into three groups:

Hallucinatory monsters are depicted in four of six drawings at left done by patients in acute mental states. The female figure was drawn by a woman in an attempt to describe her divided self. The wiggly lines below it are sketches by an anxious depressed patient.

reserpine (trade names "Serpasil," "Rau-Sed," etc.) along with other Rauwolfia derivatives; chlorpromazine ("Thorazine," "Compazine," etc.), one of a group called phenothiazines; and meprobamate ("Miltown," "Equanil") with its relatives.

The three share one property: They can reduce hallucinations, delusions, and other forms of abnormal thinking in the mentally ill, but they don't otherwise effect the cortex—the "thinking" part of the brain. They don't make you forget your troubles.

What they do seem to affect are the layers under the cortex, the older structures of man's "primitive brain." These parts are the heart of man's emotional life. Depress them and you may be able to quiet the raving maniac, soothe the anxious or the angry, take the sense of pain from the cancer patient. Stimulate them and you can rescue the suicidally depressed, excite the passive into passion, intensify the vision of the poet or the painter. The strange truth is that most drugs do both.

One way to see why this is so is to study how the brain is hooked up electrically. This is what Dr. Harold E. Himwich of the Galesburg (Ill.) State Research Hospital has done, watching the effects of drugs on two great system loops in the brain.

The brain's alarm clock. One is the reticular activating system—the RAS. When stimulated, it makes you alert. When depressed, it relaxes you, makes you drowsy.

Suppose you light a cigarette and the matchbook flames up in your hands. You get scorched slightly and drop the book. What happened? One route of incoming messages had beelined directly to the cortex and reported: *cigarette-match-flame-fire*. Another had sidetracked through the

[Continued on page 190]

From an evil eye to a country cottage



Two contrasting scenes were sketched by a woman among first to take reserpine. Drug, she said, "cut the rot" from her mind.

Sinister spider no longer threatens

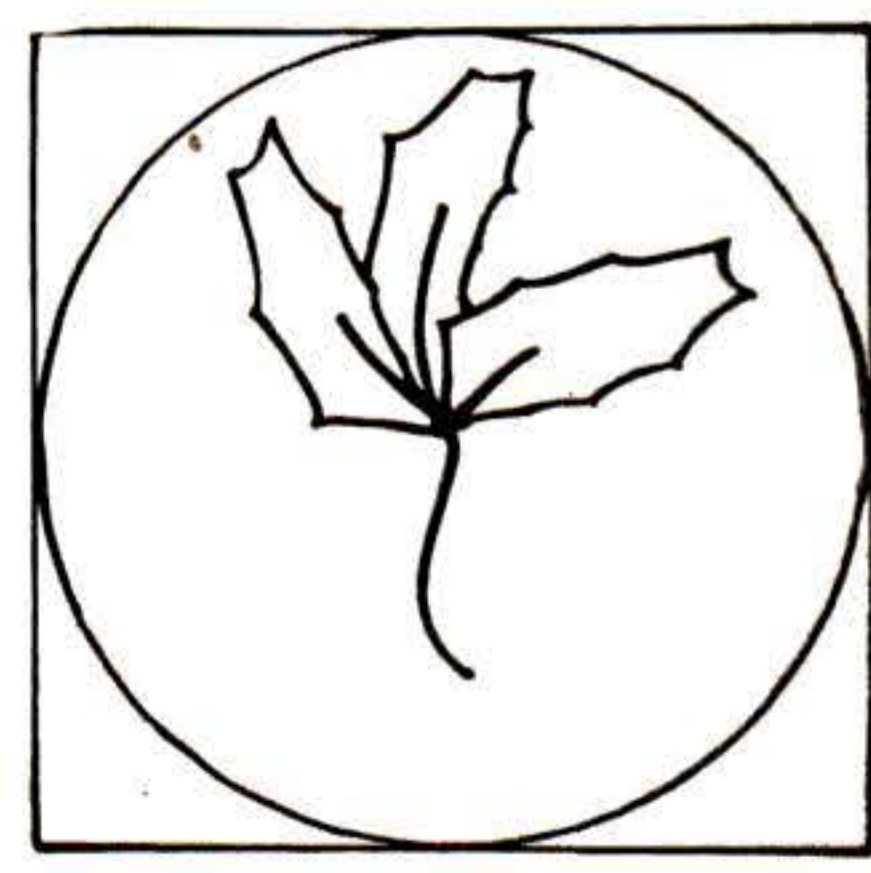
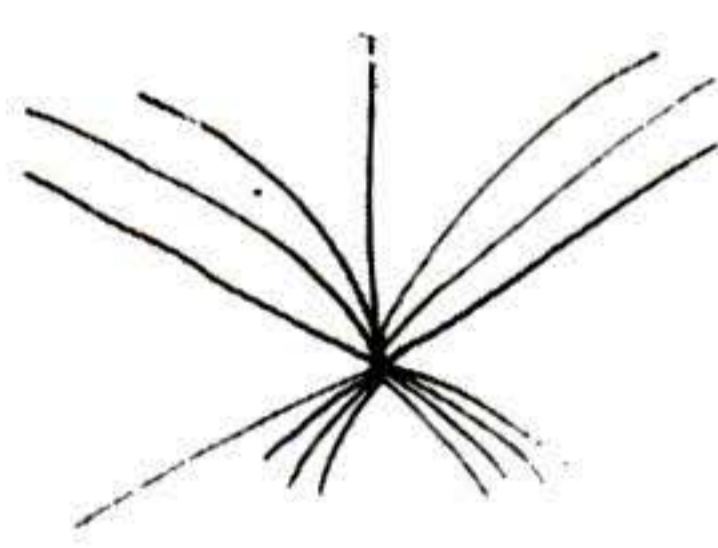

Frightened, depressed woman who sketched insect at top was treated with energizers, later pictured herself as healthy branch of holly.

From chaos to an ordered world

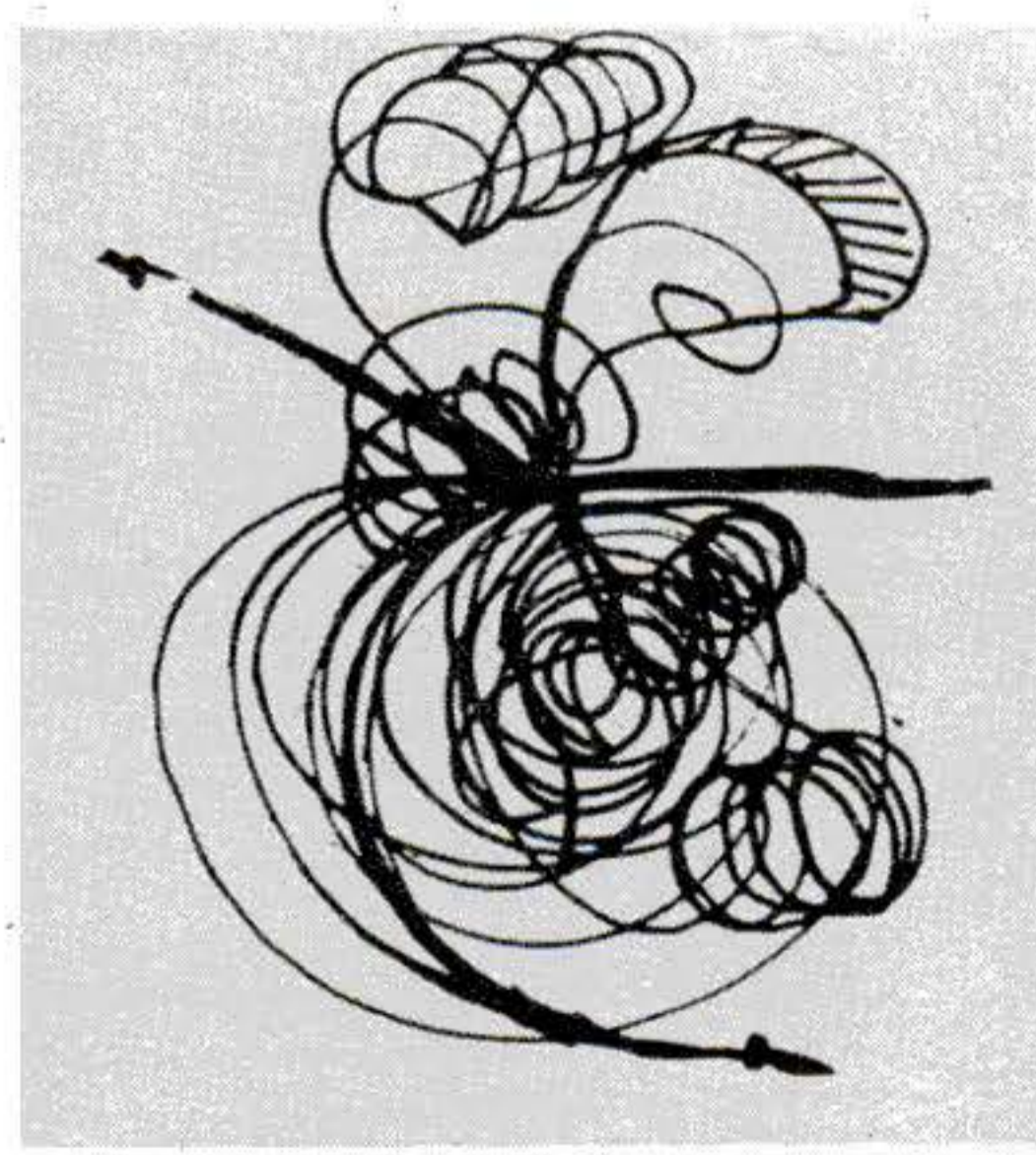

"That's me—a broken mainspring," a schizophrenic man said on completing the drawing above, at left. He worked with Walter Brown, art therapist at Rockland State Hospital, New York. Later, after therapy and tranquilizers, he produced the happy, gentle self-portrait at right.

This month at Daytona, site of the U.S. stock-car classic, sedans will average higher speeds than those in the Indianapolis 500

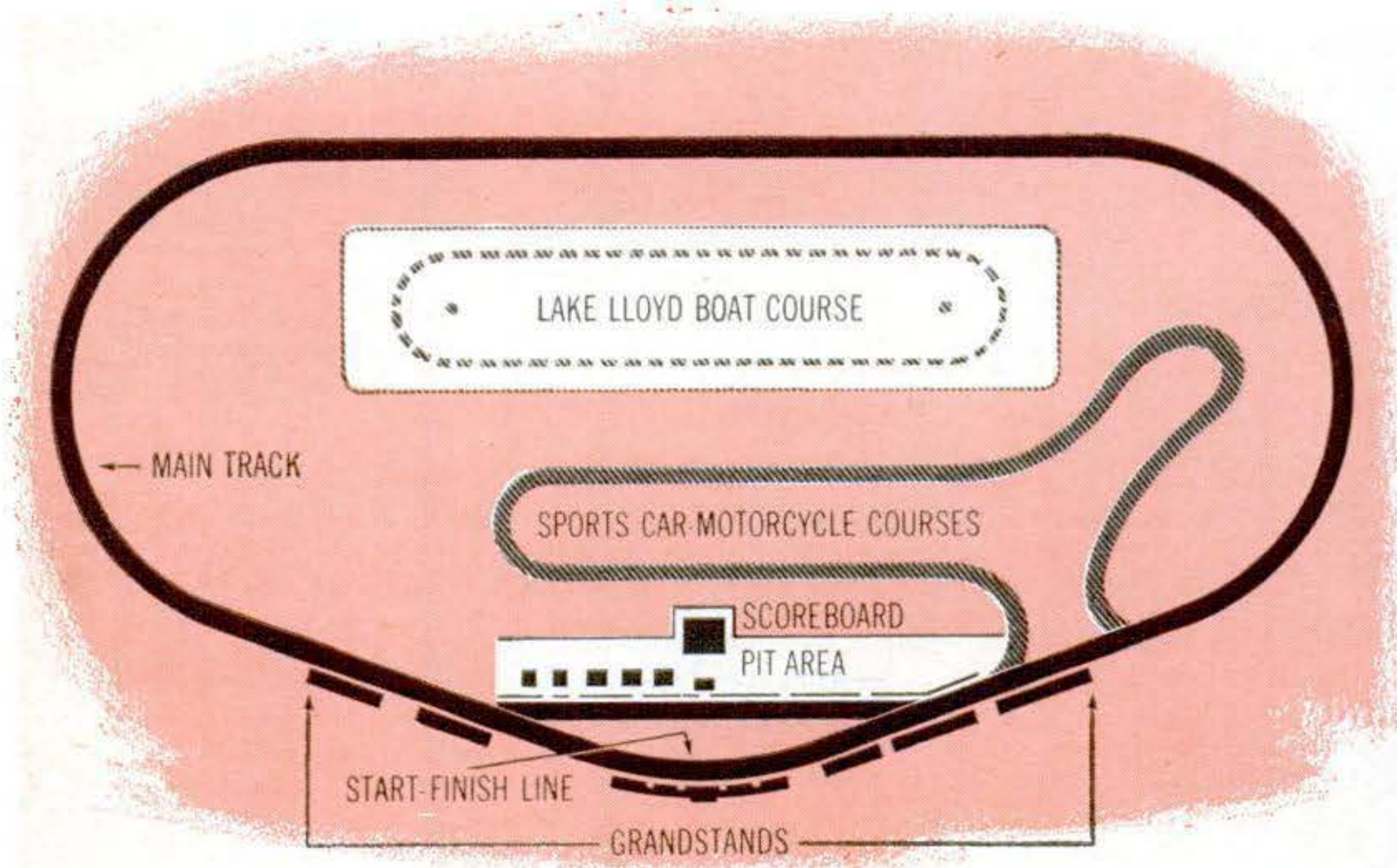

Daytona Speedway is world's newest, fastest, safest track. It's 2½ miles long and has turns mathematically banked. Infield is used for sports-car and motorcycle racing, the lake for boat racing.

In 200 circuits of track, drivers make four pit stops (right) for gas —cars get only five miles per gallon. Tires are changed once or twice. Picture was taken before rule limiting number of pitmen.

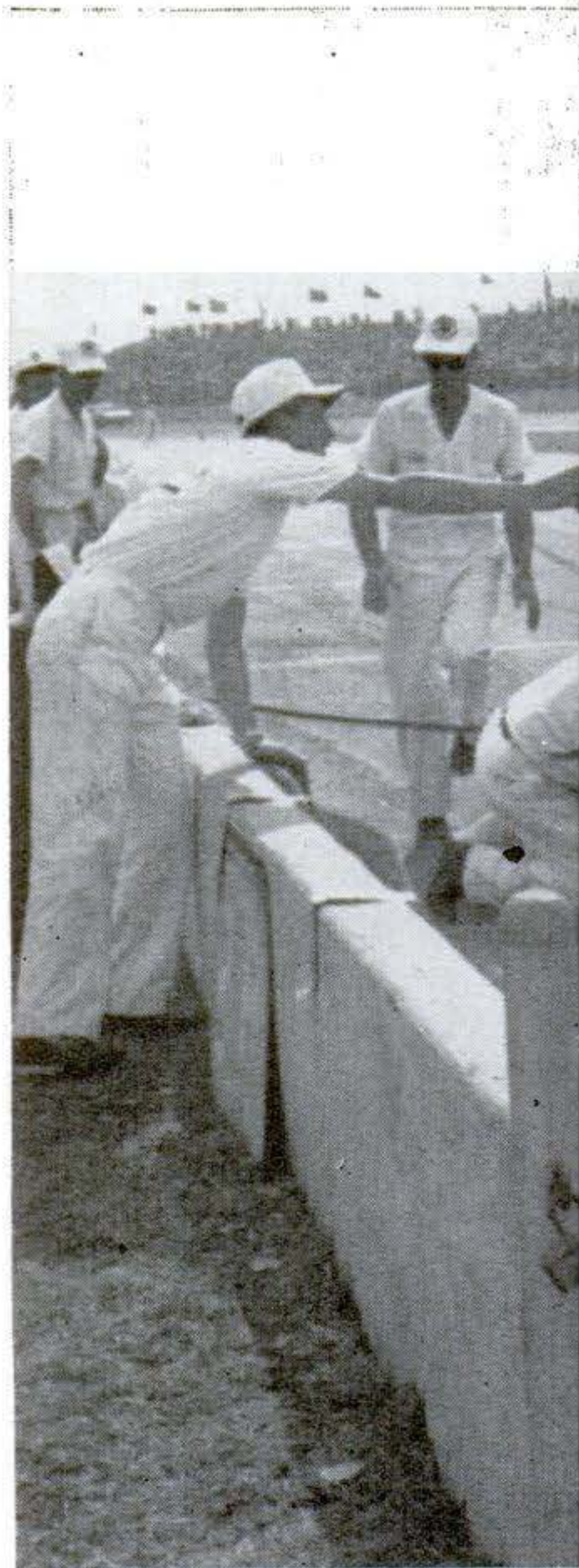

Detroit Goes Back



A start-of-the-race parade? No. The two cars in the rear are easing up to get a "draft" for more speed. Cars maintain an almost constant pace, slacking off only slightly on the turns.



to the Races

By Keith Vining

ON THE 24th day of this month—February—a man of considerable skill and a fair spate of nerve is going to slide behind the wheel of an automobile and, in the next 3½ hours, proceed to earn himself \$7,500 an hour. When he finishes he will be the winner of what is becoming the classic of U. S. stock-car racing—the “Daytona 500.”

That’s only part of it. He and the several dozen drivers who will race against him will split a total kitty of about \$115,000. True, it’s not much compared with the \$425,000 annually distributed among the drivers at the Indianapolis 500, but it ain’t hay.

The winner of the Daytona 500 will

earn his loot. On what is billed as the world’s fastest and safest auto-racing track, the Daytona International Speedway, the victorious driver will *average* better than 150 miles an hour. That’s 10 miles an hour faster than cars especially built for racing can do on the daddy of all American tracks, the Indianapolis Speedway.

And, mind you, that 150-plus m.p.h. will be in a stock automobile. How it differs from your family jalopy is explained later.

The track record for the Daytona 500, 152.5 m.p.h.—set by Glenn “Fireball” Roberts in a Pontiac—will be in jeopardy, as will records in several other racing

CONTINUED

75

events during Daytona's Speed Week starting February 16. Behind that is a reason. Detroit—meaning the companies that make the automobiles—has returned to the racing pits.

It has been a long time since Detroit got its hands grimy at a race track—officially, that is. In 1957 the auto manufacturers formally eschewed stock-car racing. Racing drew a bad image of the family automobile in the public mind. Detroit would not even supply an innocent pace car for the Indianapolis 500.

That's all changed now. Detroit is back, and the intimate association between racing victories and the sale of automobiles bearing the winners' brand names possibly has something to do with it.

Detroit's support of stock-car racing, boosting the liveliness of the competition, is for the most part covert (as, indeed, it has been ever since the industry's pious announcement of divorce from racing in 1957). But it is real. To name names, General Motors, the Ford Motor Co., and the Chrysler Corp. all turn out parts on their production lines to boost the performance of their stock cars on the race track.

As this issue of POPULAR SCIENCE goes to press, here are the cars and the quantity thereof scheduled to compete in the Daytona 500 qualifying trials preceding the big race: five Pontiacs, nine Fords, four Chevrolets, eight Mercurys, four Dodges, and five Plymouths. There will be a lot more.

[\[Continued on page 205\]](#)

Steep banks on turns forced special techniques during track construction. Rollers were suspended on cables from "cats" above in laying pavement on curves banked up to 31 degrees.

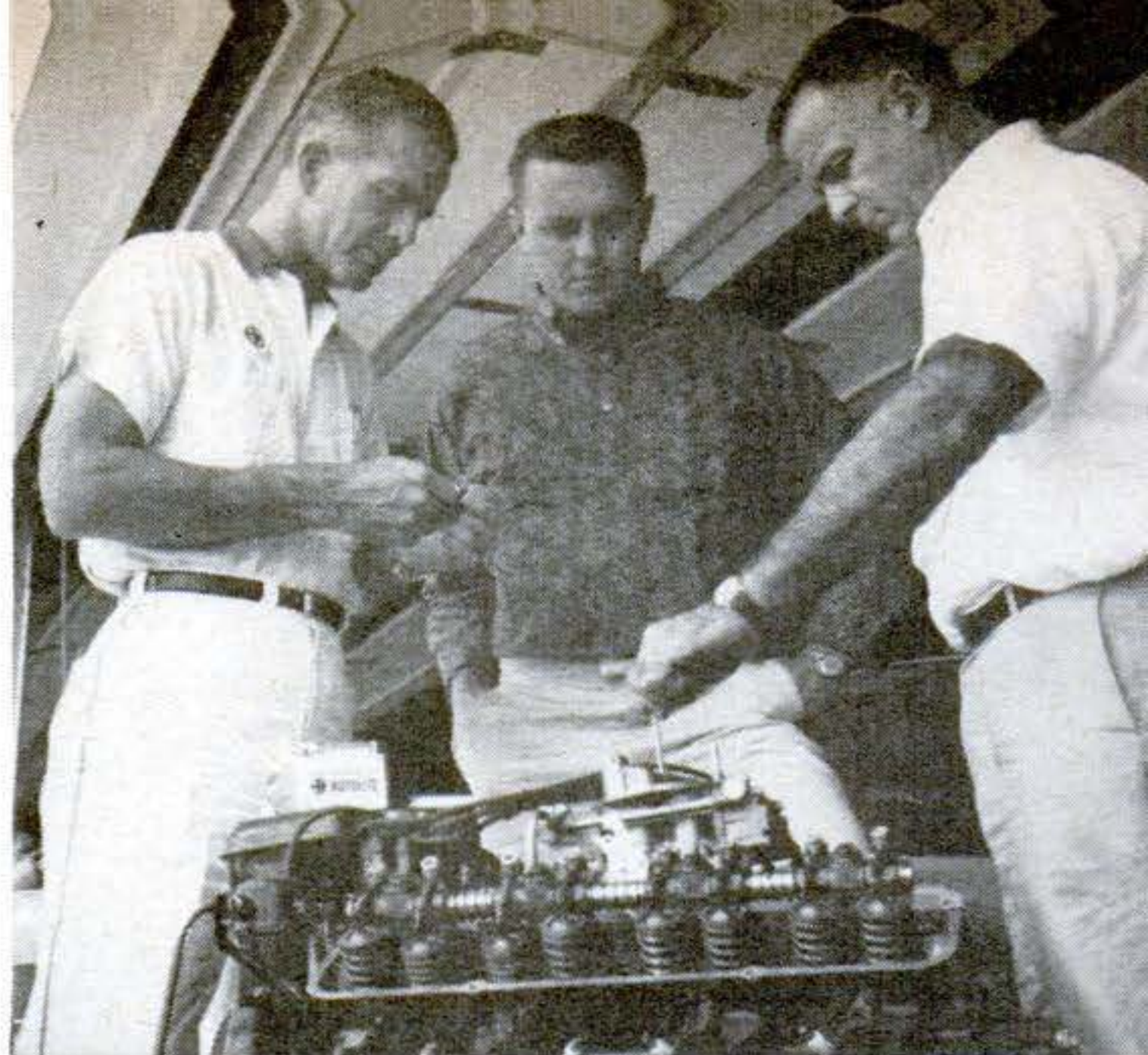
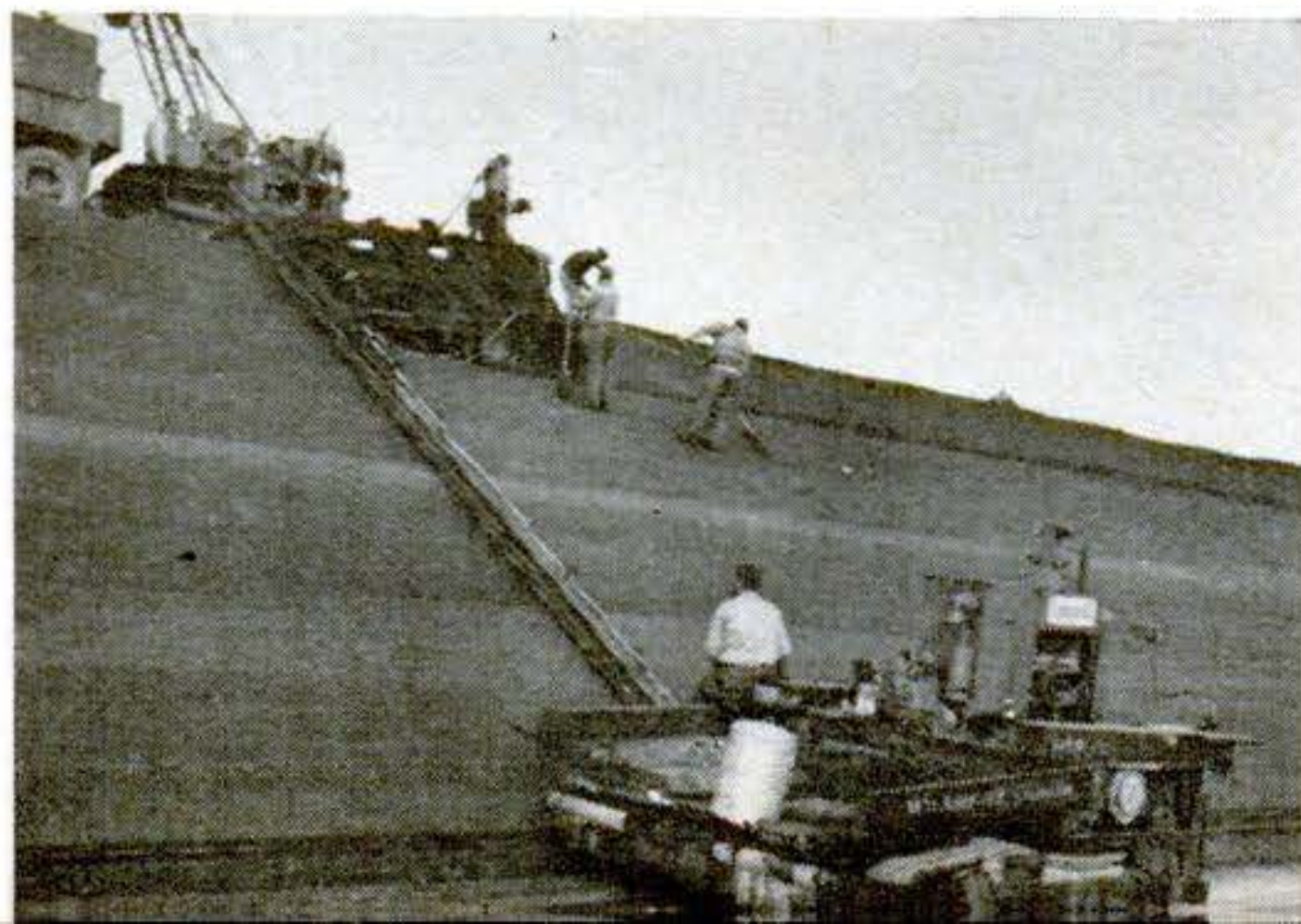

Skull session: Dan Eames of Autolite, Driver Troy Ruttman, and Bill Stroppe study a carb.

How they get a 'stock car' ready for Daytona

PREPARING a stock car for the rugged 500-mile race at Daytona this month is something like preparing a house to stand up to a hurricane.

An expert recently showed me how it's done. Bill Stroppe, long known nationally for his success in setting up racing cars and managing race crews, let me see how he and his "boys" prepared six 1963 Mercury Marauders for the supreme test in Florida. He is 43, a square-faced, tanned ex-football player with blue eyes, a crew cut, and undented amiability.

The car he showed me was a two-door Merc with a 427-cu.-in. Marauder V-8 engine, rated at 410 hp. His six identical Mercurys had all come off a production line—with heavy-duty radiators, batteries, springs, shock absorbers, axles, brakes, and stabilizer (sway) bars.

To prepare the Merc, it was stripped right down to its frame, and rebuilt. The frame itself was especially notched over the rear axle, so that it could be lowered as much as the rules allow.

Every weld was rewelded, for ruggedness. All shock towers and brackets were welded on. Bolts of aircraft quality and sturdiness were put on the shackles. Nuts

[\[Continued on page 204\]](#)

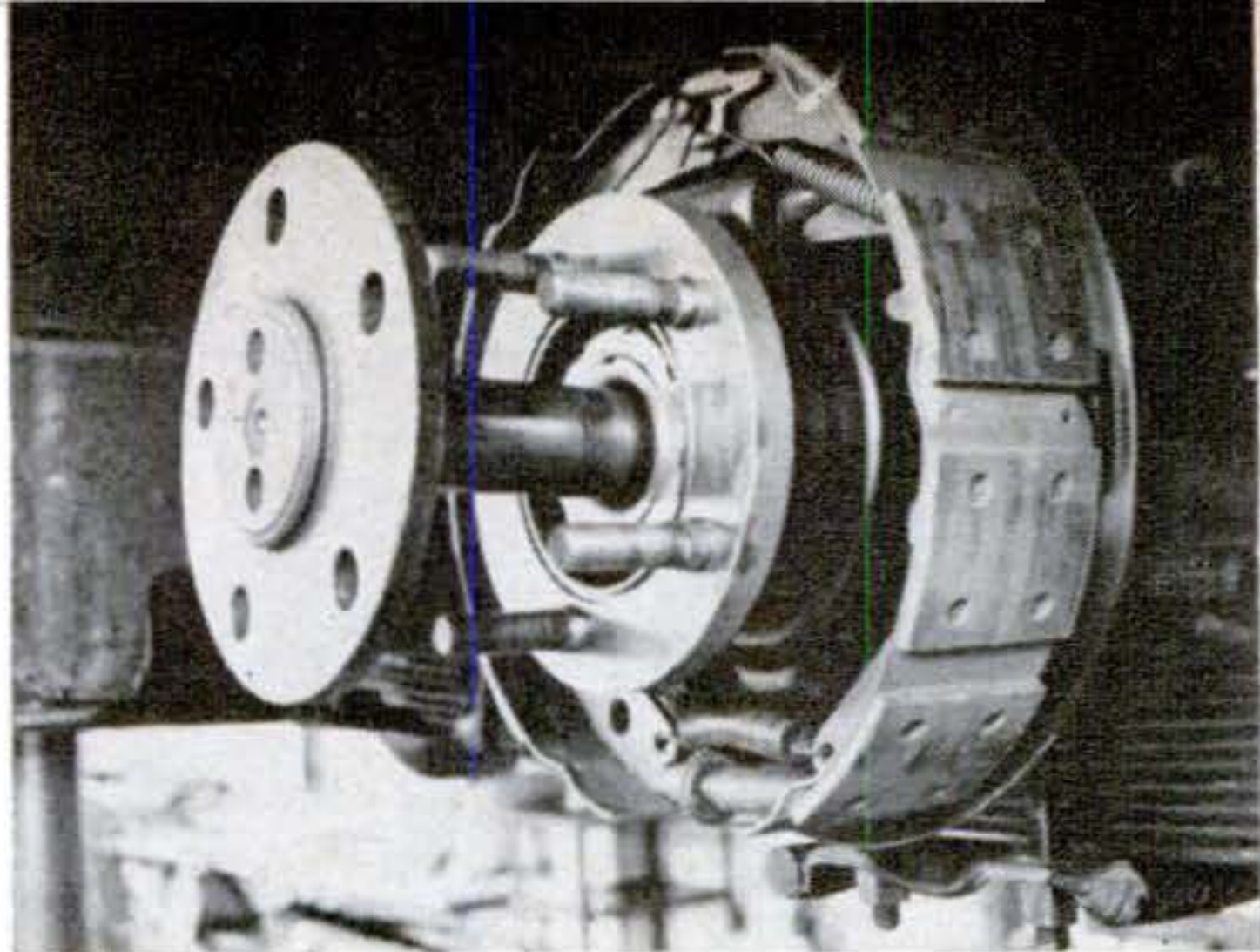

A racer's rear axle is full-floating type. For safety, the drums have special hubs to carry the bolts for beefed-up wheel spiders.



Dash has tachometer, gauges for water temperature, fuel supply and pressure, oil temperature and pressure. Toggles are for ignition.

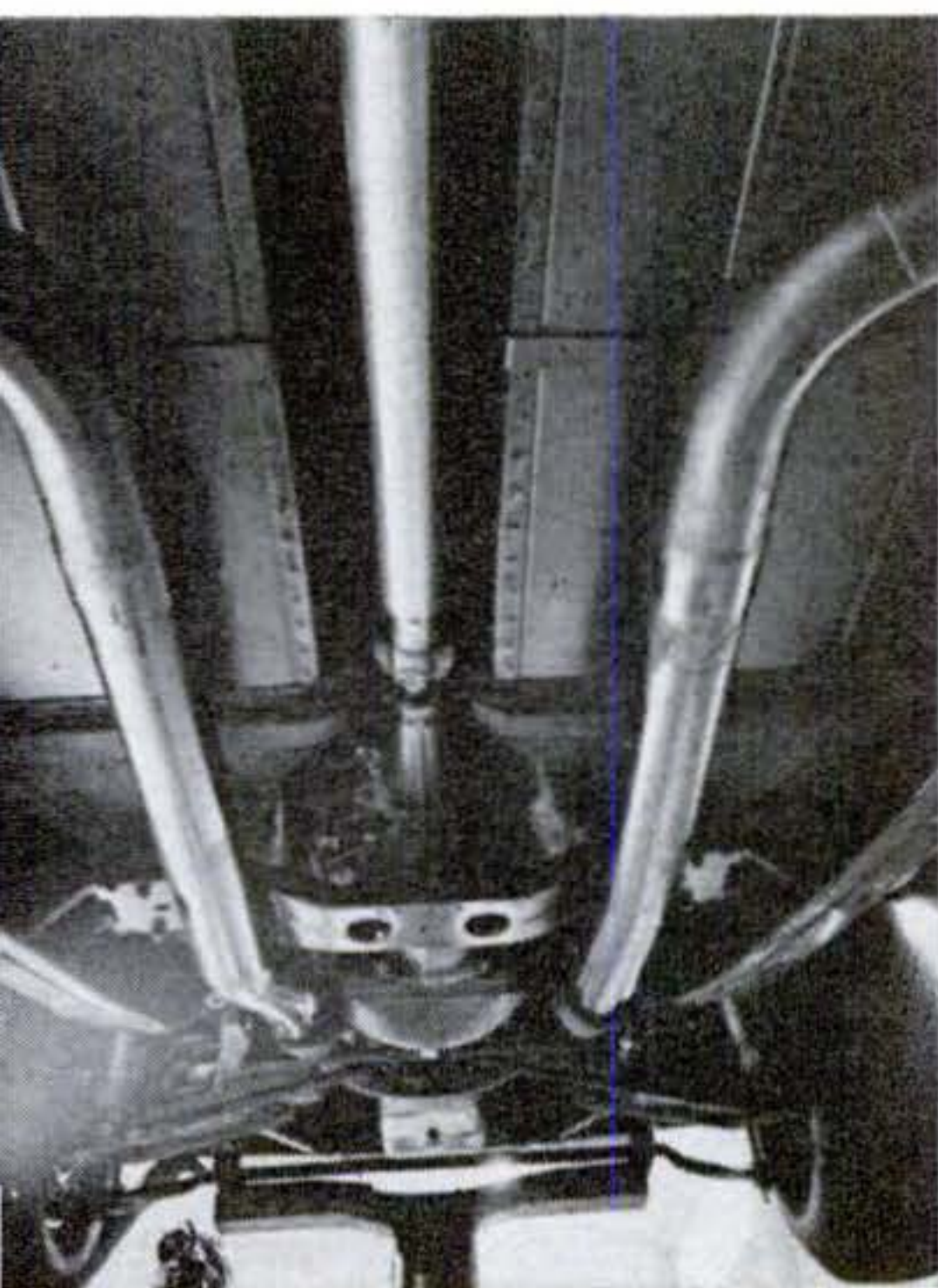

Unmuffled twin exhaust pipes are routed out sides of car, to exit behind doors. This is done to cut down on the fire hazard at fueling stops.

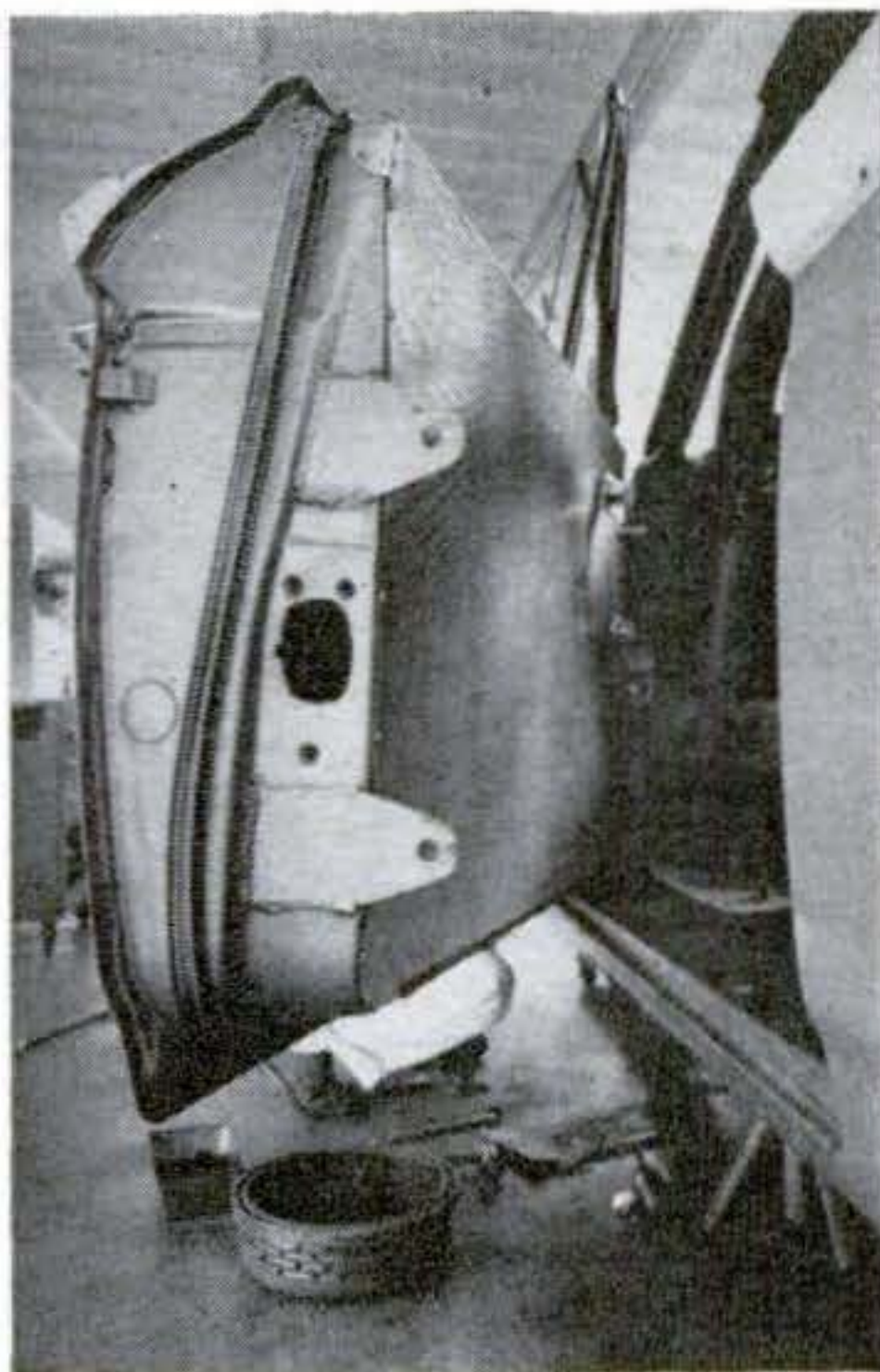

Car doors are lined with aluminum as a fire barrier, and bolted shut, then fastened to roll-bar framework. The driver crawls in through window.

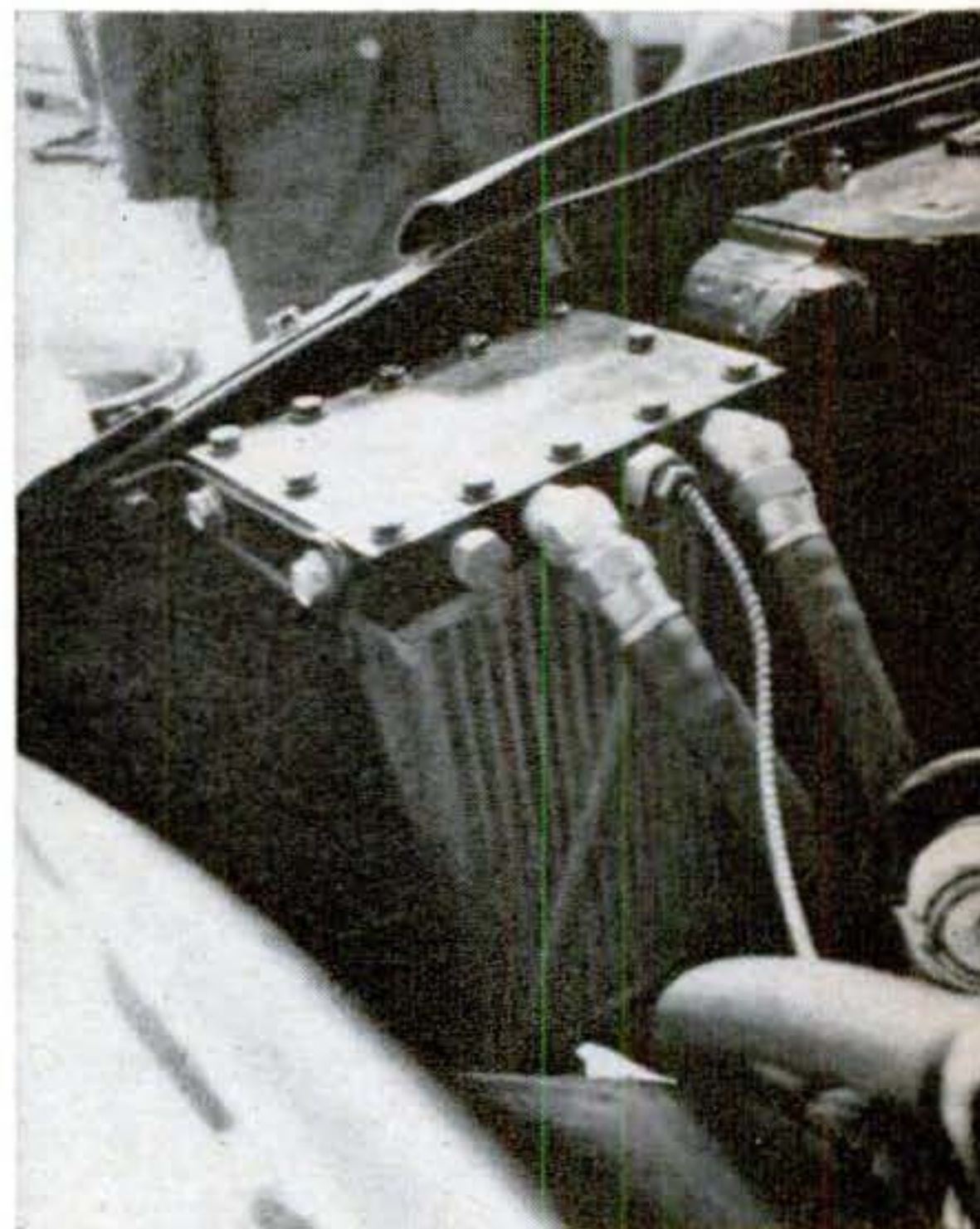

Cooler is installed in left front of engine compartment to keep oil down to 190 degrees. When cars bunch up, fresh air for engine cooling is scarce.

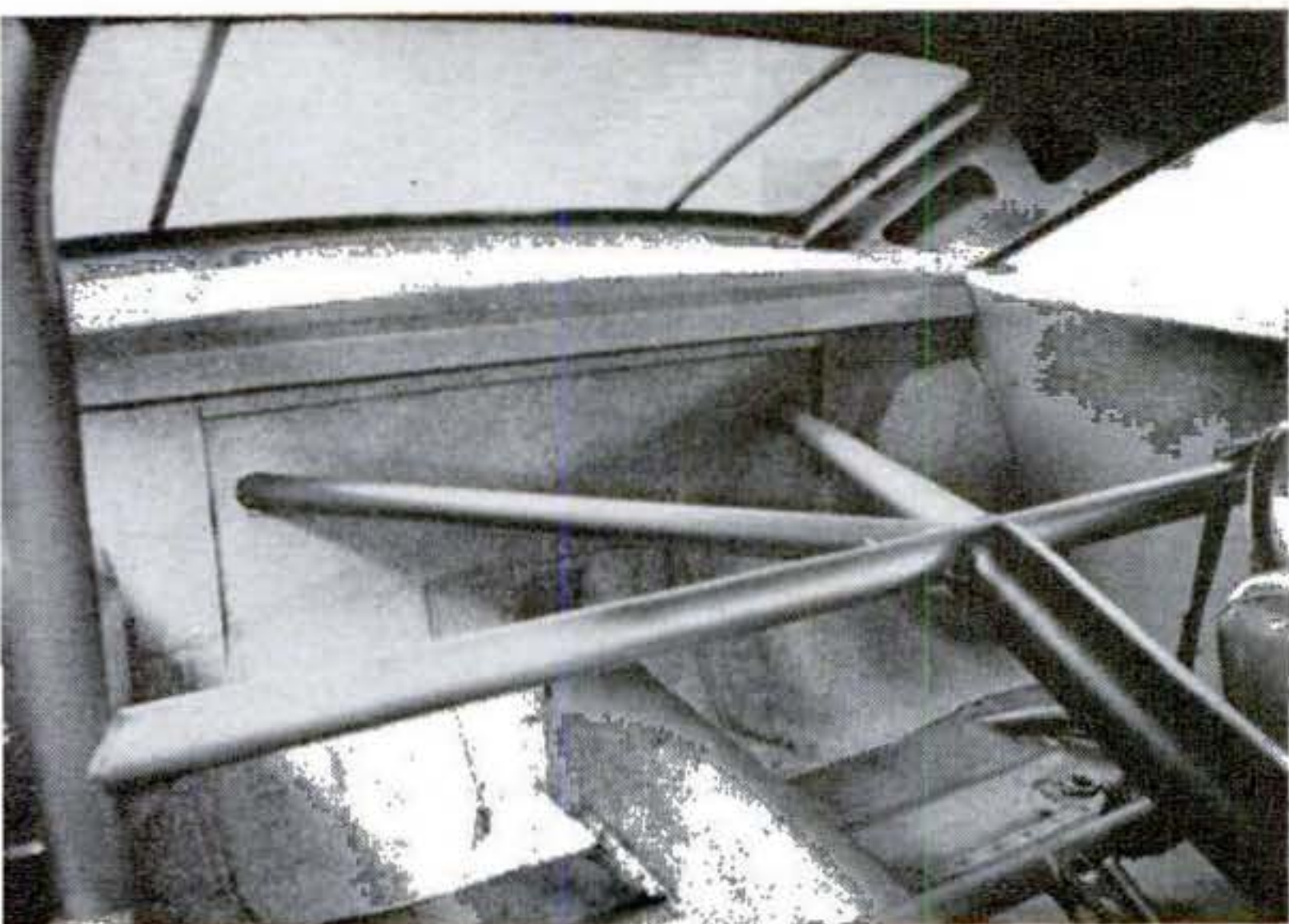

Steel firewall stiffened with steel bars, is substituted for the usual cardboard partition between the passenger compartment and the trunk.

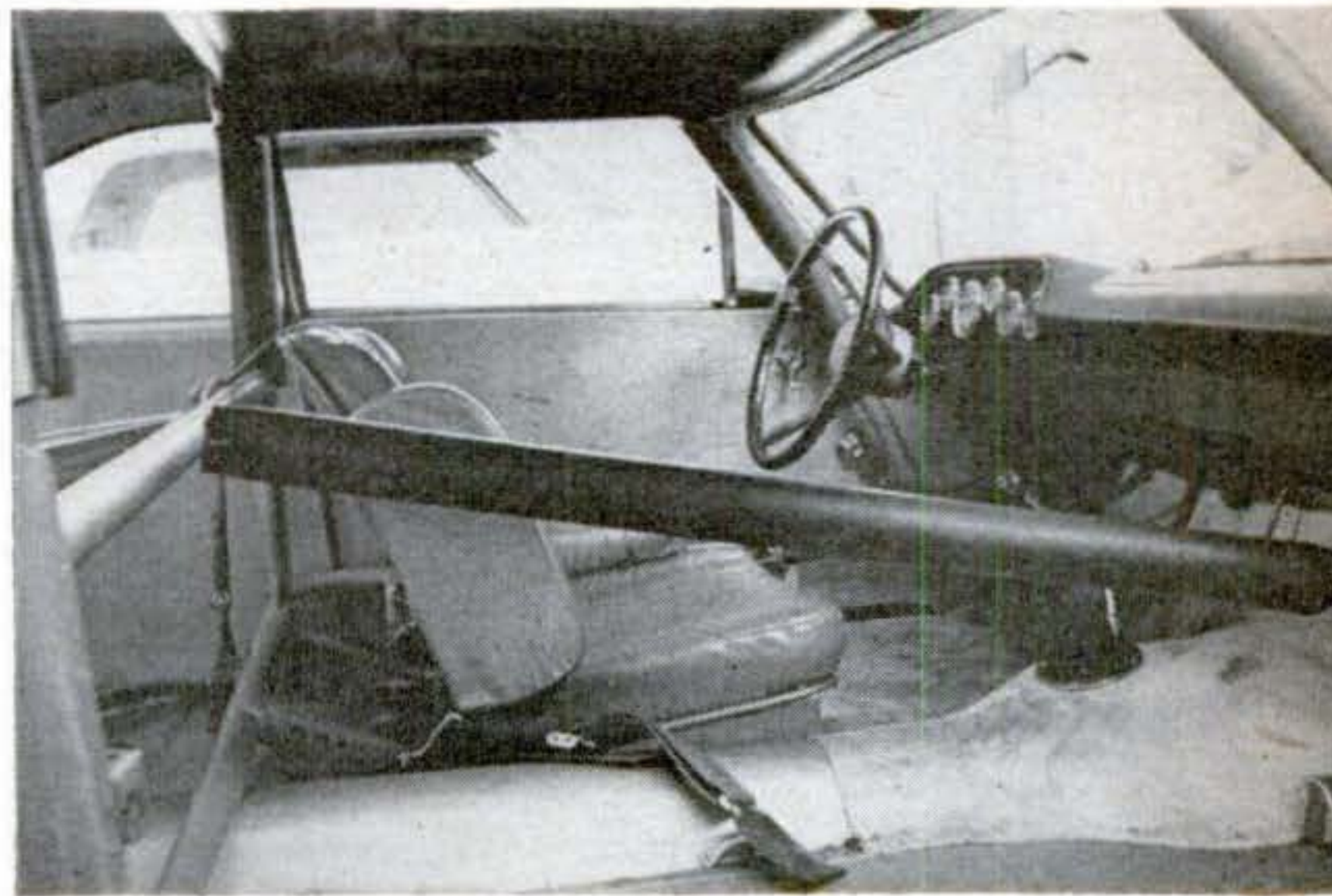

Same steel bars help form support for roll-bar framework, anchored to car frame. Driver's bucket seat is bolted to this framework.

Fastest, Highest, Hottest

The Incredible

By Wesley S. Griswold

STARTING a flight in the X-15 is like starting your car while falling off a cliff. The little black research plane with the ball-tipped nose and inadequate-looking wings drops like a bomb from its B-52 launch plane.

After a plunge of 500-1,500 feet, the craft—if its tremendously powerful rocket engine “gets a light”—climbs as though shot out of a cannon. It is hurled upward by nearly 600,000 hp. at full throttle—the all-out thrust of 2,000 robust automobile engines. That terrific power flashes into being with the sound of an explosion; in just a few seconds the plane is supersonic. The pilot hears no more noise from the engine, feels only the subdued vibration of its effort.

The craft barrels aloft until burnout—two minutes at most. The pilot, weightless, then crests an invisible summit in the near-vacuum of space, and the X-15 starts falling earthward, belly foremost.

In space, the plane’s “attitude” is controlled by steam jets in nose and wings (like a spaceship) but this has no effect on its ballistic trajectory. As the craft re-enters the atmosphere, its “angle of attack” becomes critical. Spearheading into the atmosphere at top speed would burn too much skin off the X-15. For frictional braking, the pilot must point the nose at an angle above his trajectory. The angle must be precise, since too much re-entry stress would tear the plane apart.

Descending from the awesome heights to which the black bird soars is a sensation the dizziest roller coaster couldn’t begin to match. During re-entry, de-



X-15

Writing history with a ball-point rocket plane, a band of test pilots is compiling know-how for the day when we'll really fly in space!



Moment of release is shown in this NASA photo as X-15 aerospace research plane falls away from wing pylon of B-52 mother plane over the Nevada desert, at 45,000 feet. Rocket's first-stage igniter is on at drop, but pilot has no engine power—he must “get a light” before heading for space. F-104 chase plane is in the distance.

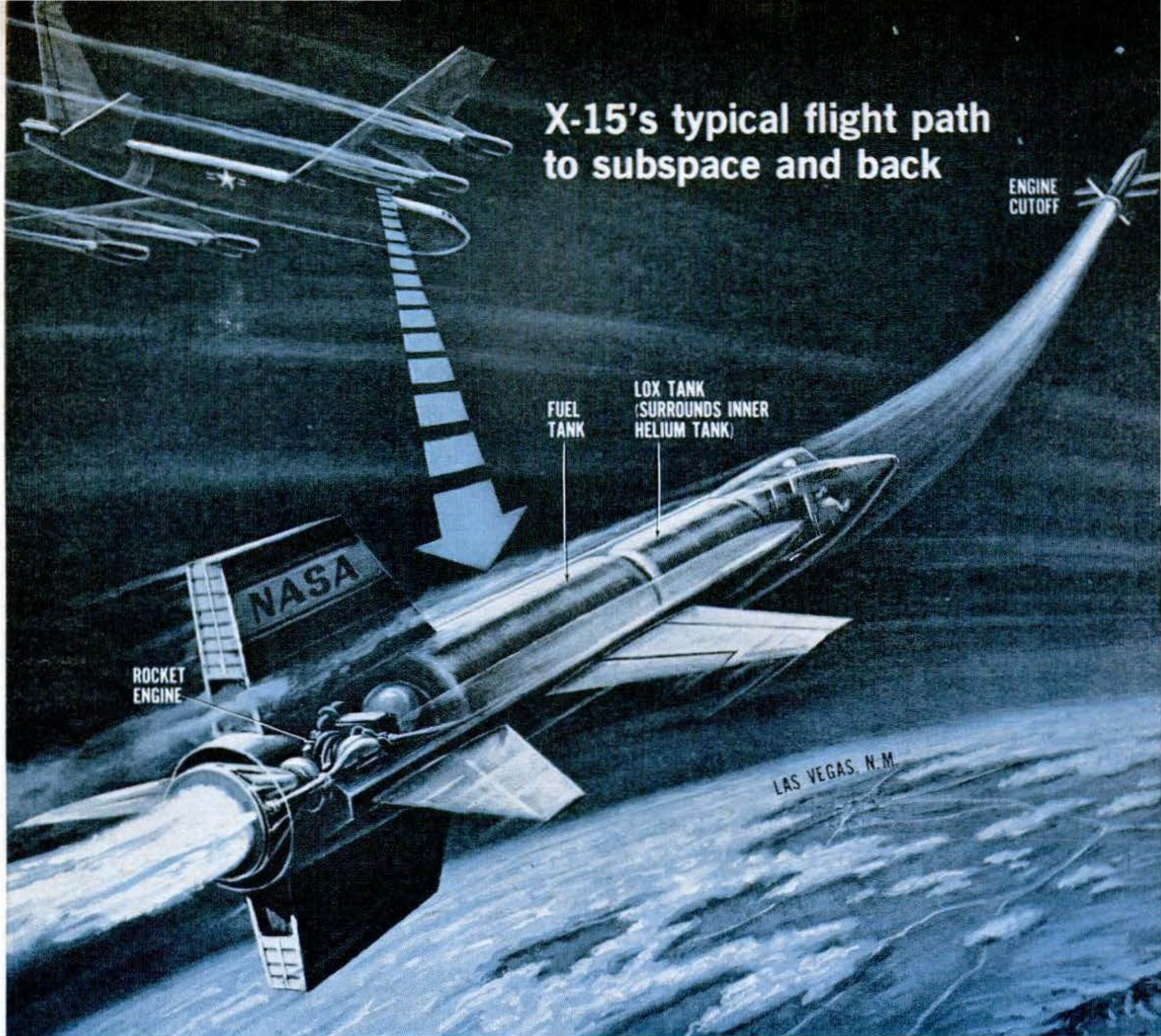

X-15's typical flight path to subspace and back

ENGINE CUTOFF

ROCKET ENGINE

FUEL TANK

LOX TANK (SURROUNDS INNER HELIUM TANK)

LAS VEGAS, N.M.

After the drop of 500-1,500 feet from its B-52 launch plane, X-15's rocket engine starts, if pilot is lucky. The 600,000-hp. engine is fed 4.2 tons of fuel (liquefied ammonia gas) and 5.2 tons of LOX (liquid oxygen) from outer wraparound tanks by pressure from helium in central tank. Pilot cuts engine, after less than two-minute powered flight, at 125,000 to 140,000 feet and continues, weightless, in ballistic trajectory over

the hump at border of space. Looking across 420-mile flight range, view here is easterly toward Las Vegas, with Sierra Nevada Mountains in lower right foreground. As X-15 falls toward earth and re-enters atmosphere, ship's undersurfaces must be presented at correct angle for frictional braking. Farther down, pilot regains aerodynamic control and lands at Edwards Air Force Base in California.

celeration G-forces shove the pilot against his harness with fierce energy. He might black out or come apart inside if it weren't for the body-gripping, blood-damming air bladders that automatically inflate his pressure suit.

Terrific come-down. Landing the 50-foot plane-missile is like driving a car at racing speed on the bare rims of its rear wheels. The X-15's landing field is a hard-baked dry lake. It sets down on two three-foot steel skids and a pair of small nose wheels at 180-225 m.p.h., and

slides for a mile or more before it stops.

It was during such a landing that one of the three X-15s, ship No. 2, was wrecked last November 9. After dropping from the mother plane, pilot Jack McKay discovered that his engine was unable to reach full power. He shut down the engine and made an emergency landing on Mud Lake, 195 miles from home base. The nose-wheel support collapsed at the end of his landing slide, and the ship flipped over. McKay had anticipated trouble and had blown

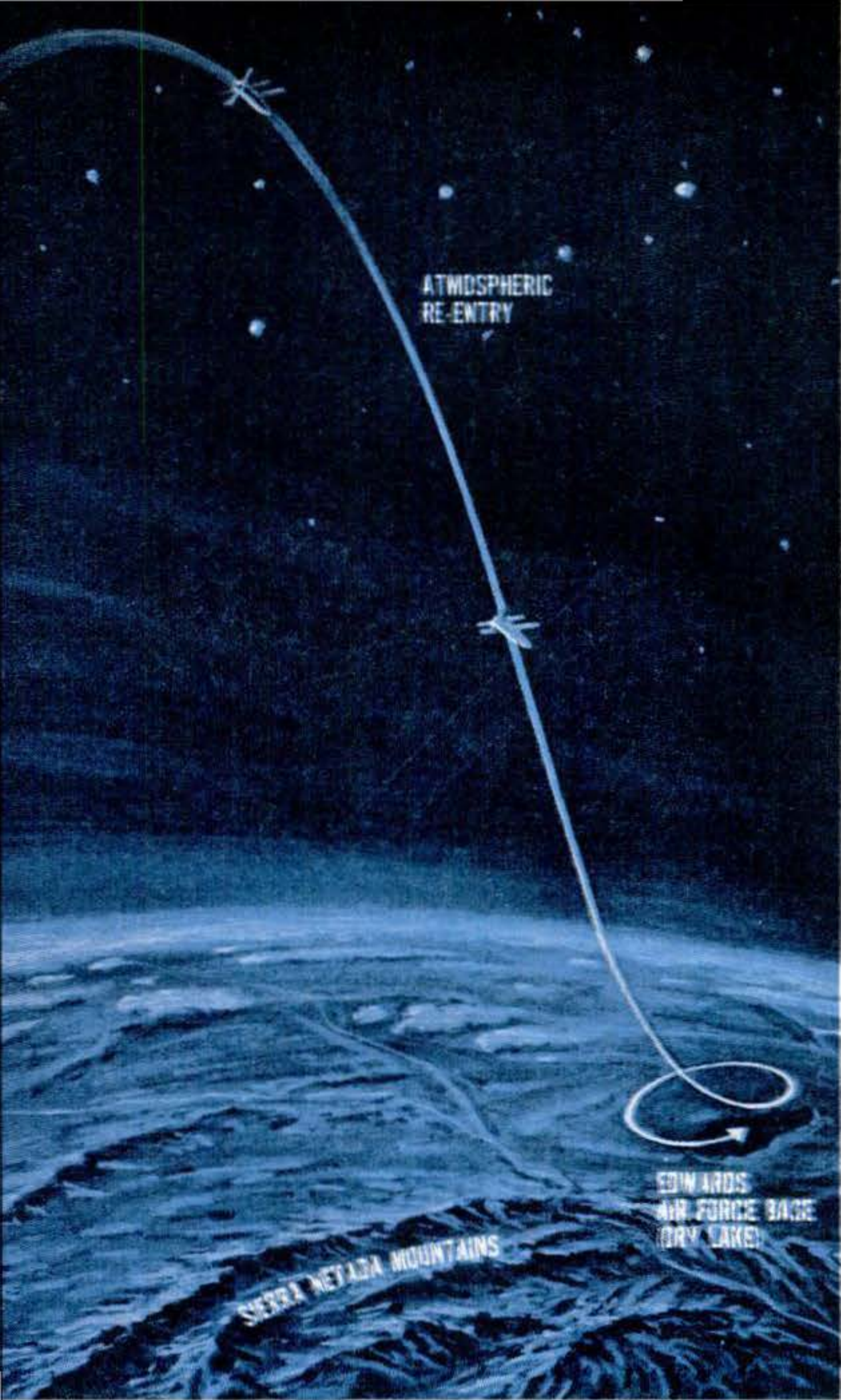

Inside Q-ball: Hollow nickel-chrome ball, cooled by liquid nitrogen, can take 4,000 degrees F. and pressures up to 2,500 lb. per sq. ft. It's made by Northrop's Nortronics division.

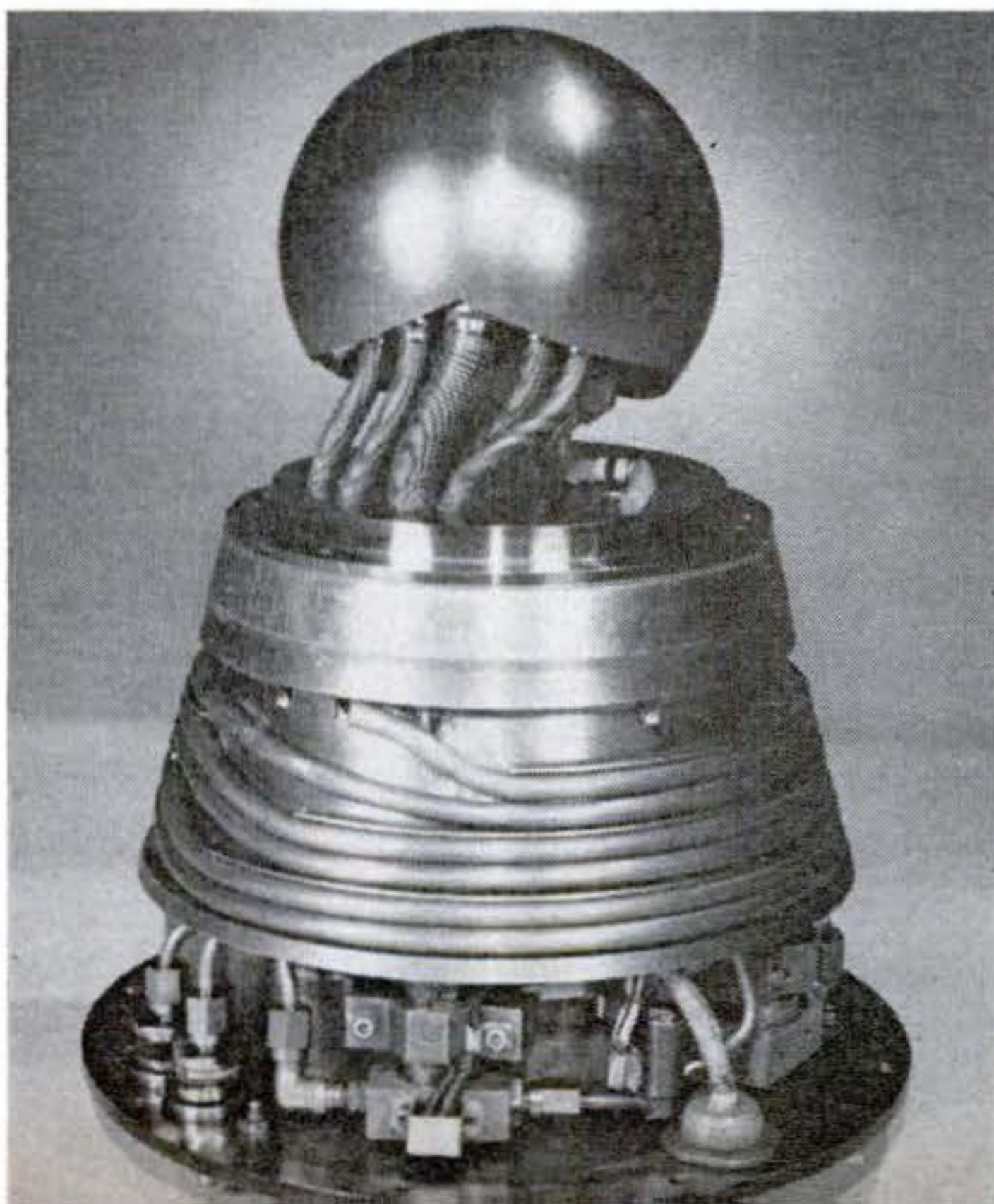

How X-15 is aimed for re-entry

1 Q-ball, at tip of X-15's nose, and jets of steam (generated by hydrogen peroxide) from miniature rocket motors, also shown, are both needed for ship's return to earth. Q-ball senses X-15's critical "angle of attack."

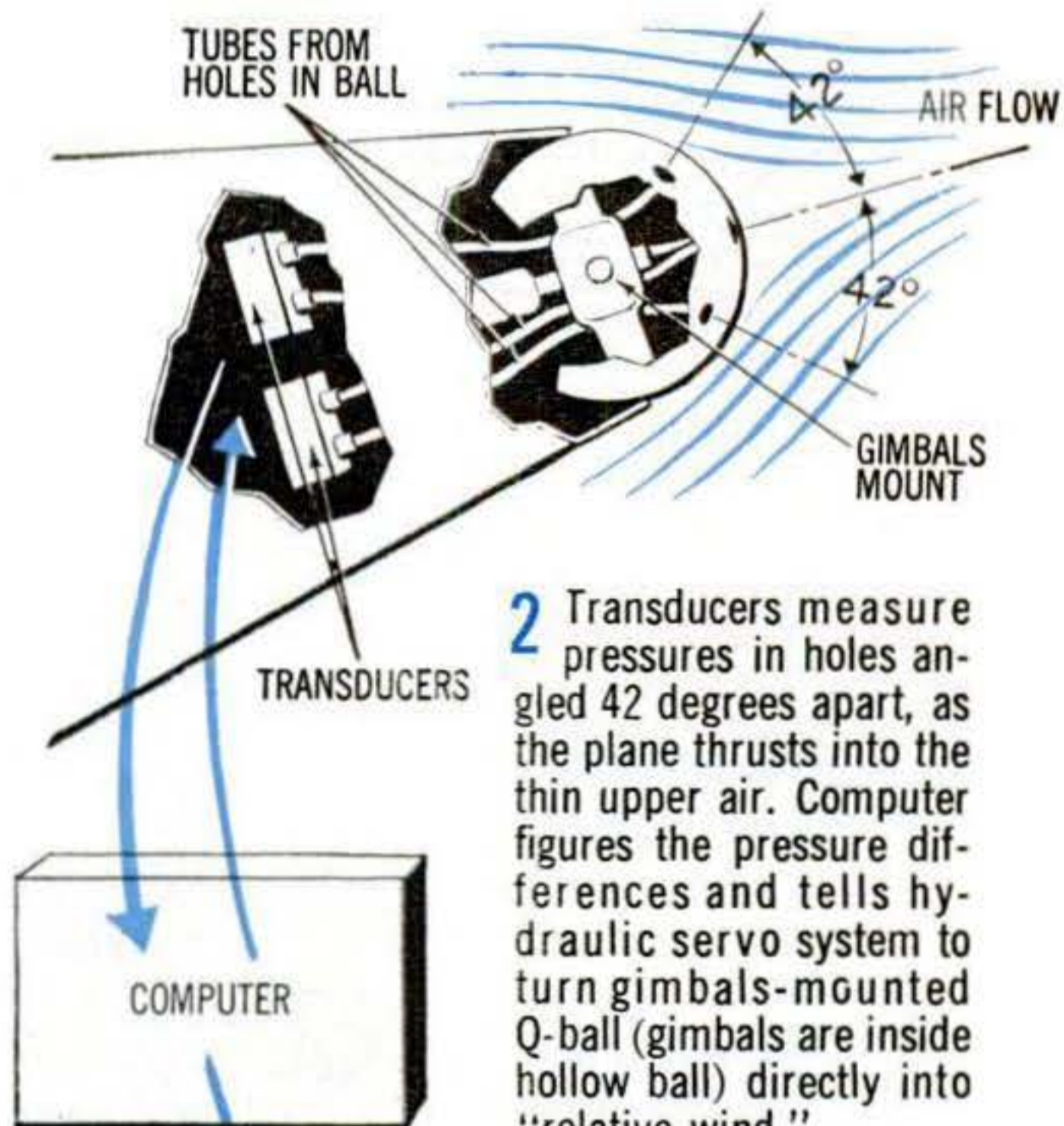

2 Transducers measure pressures in holes angled 42 degrees apart, as the plane thrusts into the thin upper air. Computer figures the pressure differences and tells hydraulic servo system to turn gimbals-mounted Q-ball (gimbals are inside hollow ball) directly into "relative wind."



3 The same computer directs a cockpit indicator that copies movements of Q-ball. Pilot can correct angle of attack relative to plane's trajectory.

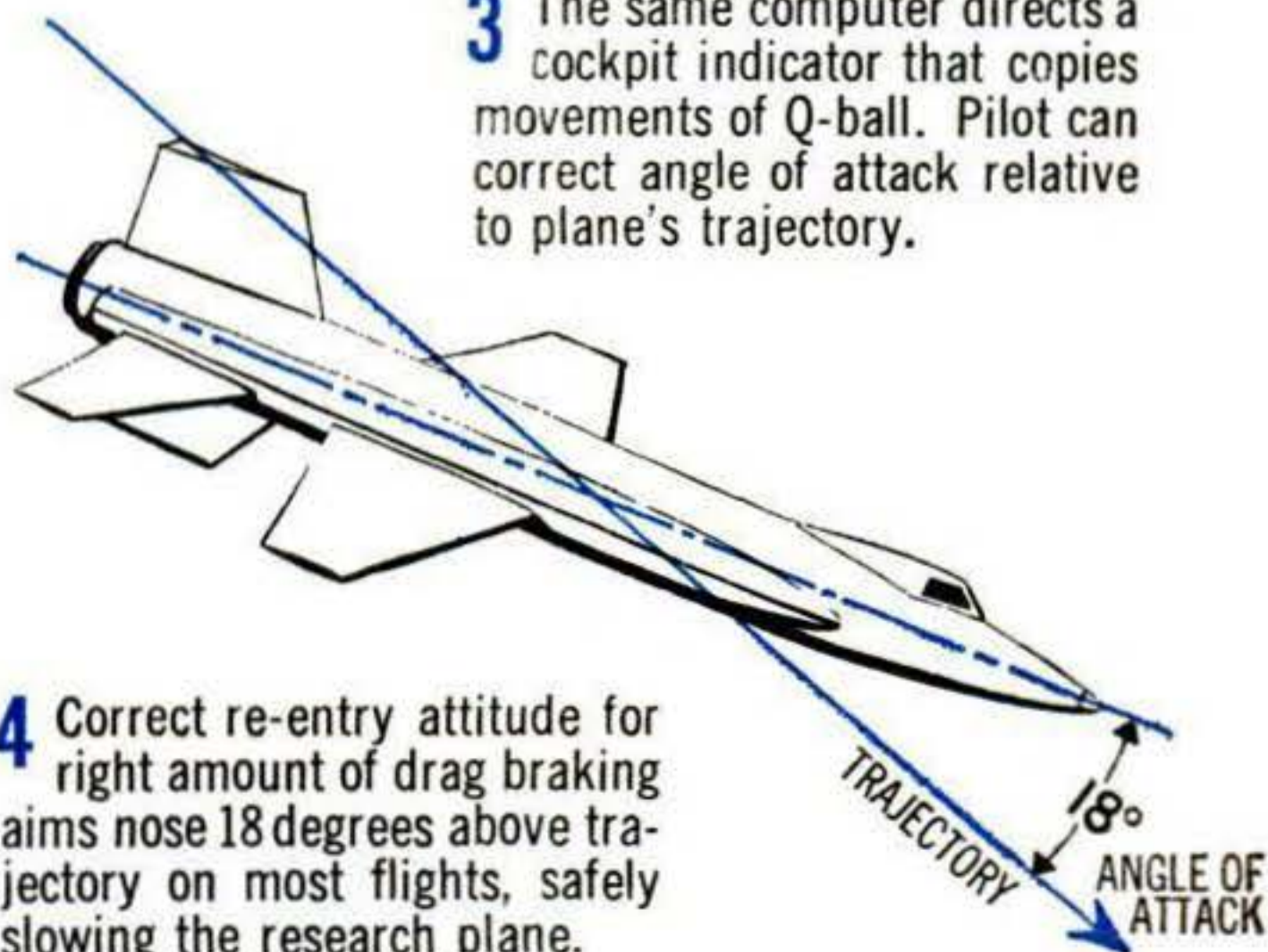

4 Correct re-entry attitude for right amount of drag braking aims nose 18 degrees above trajectory on most flights, safely slowing the research plane.



Pilot gets a choice of conventional center stick or one at his right in atmospheric flight. Both wiggle tail and wing surfaces. Side stick is used when G-forces won't let him reach center stick.



In the thin air of subspace, where aerodynamic control is lost, pilot uses steam jets, controlled by stick at his left (top center of photo). Striped handle is for emergency ejection seat.

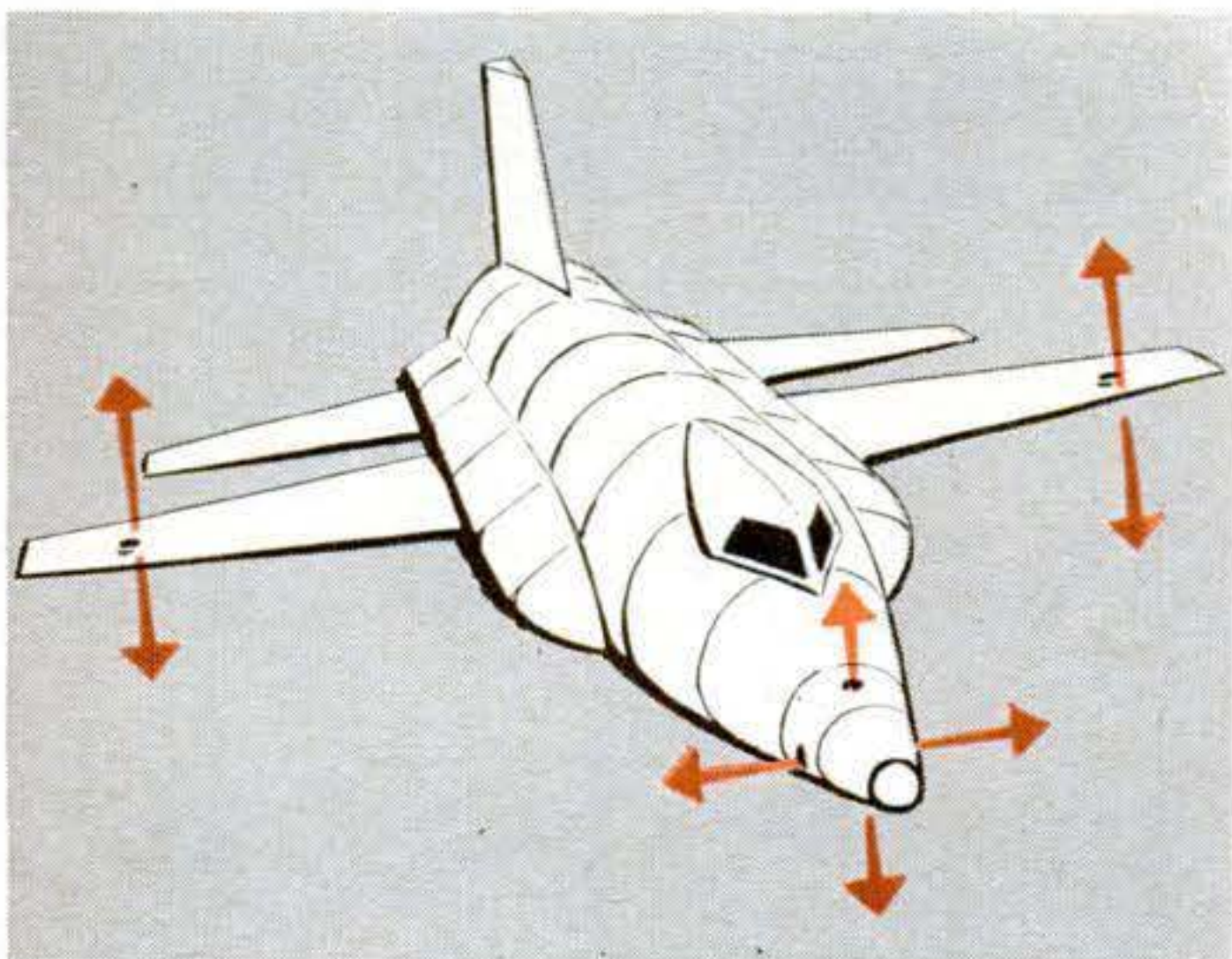

Steam jets are used in various combinations to change plane's attitude when outside the atmosphere. Nose jets control vertical pitch and sideways yaw; wing jets control roll.

off his cockpit canopy. Rescuers eased him out in five minutes, only bruised.

When POPULAR SCIENCE first took a look at the X-15 [June, '58], we needed a crystal ball and a lot of luck to make out even its outlines. The plane wasn't finished. It was under tight security wraps. Only extravagant predictions about it were easy to come by. "This will be a steppingstone to space," said North American, its builder.

In the 4½ years since, flying out of Edwards AF Base, Calif., under a joint Air Force, Navy, and NASA program, the X-15 has repeatedly proved itself the most incredible aircraft ever built. It has set altitude and speed records far beyond the capabilities of any other known plane.

Miles-high adventures. The X-15 has already found answers to important questions about subspace that couldn't have been answered satisfactorily in any other way—answers to problems about leaving and entering the earth's atmosphere, aerodynamic heating, and the operation and control of hypersonic aircraft. The X-15 has also provided vital biomedical information for pilots of future aerospace craft, who will fly both in space and in the atmosphere.

The X-15 pioneered the use of steam jets to control a vehicle's attitude in space, and has firmly established that it is practical and preferable to have men, rather than robots, pilot spacecraft.

The X-15 has blazed a path from outer space to earth for the forthcoming X-20 (better known as Dyna-Soar) and other globe-girdling ships to come. The Dyna-Soar will be launched on the tip of a Titan III, go into orbit like a Mercury capsule, and then fly back to the ground like a plane—like, in fact, the X-15.

Furthermore, the X-15 has tested out special instruments and systems that are almost sure to be used on such craft.

For instance, the "Q-ball." This odd and crucial sensor is a 5½-inch hollow sphere of nickel-chromium alloy, mounted in the pointed nose. By determining "relative wind" at the plane's

[\[Continued on page 211\]](#)

Dressing up a manikin in upholstery (right), survival instructors Don Conroy and Leo Morin give demonstration to Air Force personnel. Conroy fits face mask while Morin makes warm clothing from seat upholstery.

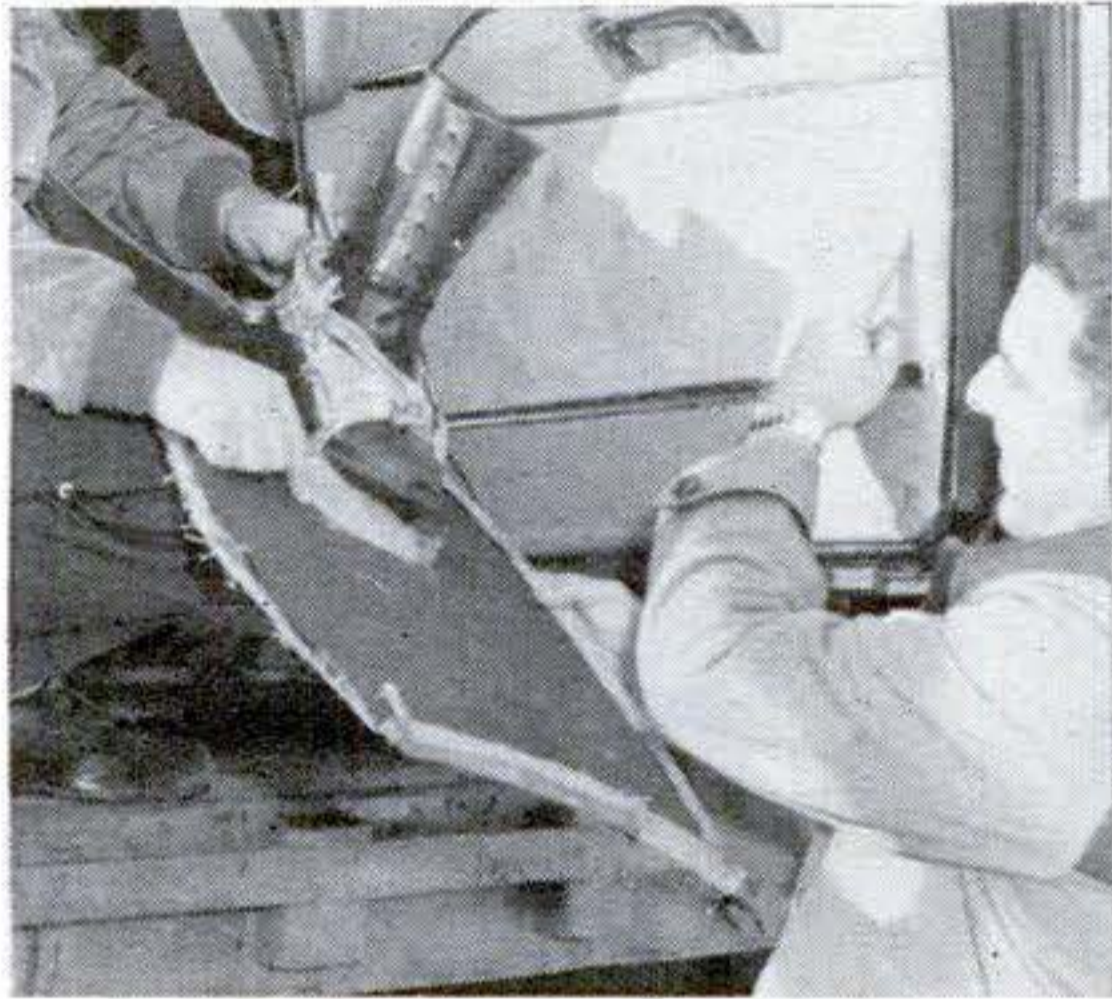

Serviceable snowshoe is improvised from fiberboard panel cut from inside the car door. It's tied to a boot with strips ripped from the seat covers.



How to survive a blizzard using your car and your head

Stranded in a snowstorm in your car, how would you survive? Don Conroy, Air Force survival specialist at Hanscom Field, Mass., suggests you tear the car apart.

Snowshoes can be improvised from fiberboard cut from inside the doors, face masks and mukluks shaped from the ceiling lining. Seat covers can be ripped into strips for

leg and foot wrappings; upholstery padding can be made into warm boots.

Conroy has one more tip: Remove the spare to a safe distance. Fill a hubcap with gas by disconnecting the fuel line at the carburetor and pressing the starter. Dump the gas on the tire to start a long-lasting and bright signal fire.



1902 antique-car race re-enacted

A 1900 Winton with Alexander Winton Jr. at the wheel spurts ahead of a 1902 Oldsmobile driven by Keith Oderkirk in a re-enactment here of the first speed race on Florida's hard-packed sand beaches. It was part of the 60th anniversary of beach racing during Ormond Beach's annual Birth-

place of Speed Celebration. In the re-enactment the Olds won two of three half-mile sprints, but in the original race in 1902 the senior Winton's Bullet tied R. E. Olds' Pirate—at 57 m.p.h.

The following year Winton pushed the speed mark to 68 m.p.h. In 1935 at Daytona Beach, Sir Malcolm Campbell set a record of 276 m.p.h. that still stands.



Special trailer makes 4,000-pound Cubmarine easy to tow on land. Flappers on each side of bow are

Portholes all around provide clear view in every direction above or under surface. Square plate behind pilot standing in main hatch is emergency escape hatch for use when submerged.

Newest underwater craft: two-man Cubmarine

Unlike most of the tiny submarines used for skin diving, this Cubmarine will take you and a pal down without bathing trunks or skin diving equipment. It's a self-contained dry sub that descends to a depth of 225 feet. Air is supplied to the cockpit by two separate systems feeding from four

pressure cylinders. Recirculators remove carbon dioxide and add oxygen for up to eight hours. Mouthpieces are available for emergency, and there are outside fittings that can be hooked up with an escort vessel or a skindiver's air bottle.

Powered by a four-hp. motor drawing



Sporty new walk-through Scout

Two-tone bucket seats and matching two-seat rear bench mark the latest version of International Harvester's all-purpose Scout.

A partition dividing the front and rear sections has been removed and the right front seat is hinged to lean forward and provide easy access.

Removing the back seat turns the Scout into a pickup. For more space, the tailgate (with attached spare tire) lowers. Three tops are available.



diving planes. Propeller at stern is shrouded in rudder to protect it against underwater obstructions.

Instrument panel resembles a small plane's. It has compass, depth finder, pressure gauges, inclinometer, voltmeter, ammeter, and clock. Switch at left is for forward or reverse. Levers at right flood or vent Cubmarine's two sets of trim tanks.



juice from ten 12-volt marine batteries, the 18-foot boat cruises on the surface at six knots, submerged at five, and has a range of about 20 miles. It has a three-foot beam and is five feet, nine inches high from hatch to keel.

Diving planes at the bow and the rudder are maneuvered by airplane-type controls. Other equipment includes a blow-and-flood system for the main ballast tanks and trim

tanks forward and aft. Water may be interchanged in these or pumped out to sea.

The Cubmarine, built by Perry Submarine Builders, West Palm Beach, Fla., was born of an idea that came to John H. Perry Jr. during an encounter with sharks while spear-fishing. Because of that experience, the prow of its aluminum hull has two spear-gun tubes for hunting in the depths. The little boat costs \$29,600.

Three jets in tail

America's first triple-jet airliner, designed for short to medium range, is rolled out by Boeing at Renton, Wash. The 727 is powered by Pratt & Whitney JT8D turbofan engines. It will carry 70 to 114 passengers from 150 to 2,000 miles at cruising speeds of 600 m.p.h. Five airlines have ordered 87 of the new jet planes.





STRATOSCOPE II:

Sky-High and Starry-Eyed

Inflation begins as helium flows through tubes into the side of Strato II launch balloon.

Photographic assignment for a bizarre balloon-telescope: Go up 15 miles, get best shots ever of planets and stars

By Robert Gannon

ONE evening late this month or early in March, a 90-foot balloon will rise through the dusk over Texas, dangling a 340-foot plastic sausage, two parachutes, and a three-ton telescope. The whole string is as tall as a 66-story office building.

As the balloon gains altitude, the sausage casing will rip and a giant plastic bag inside it will begin to inflate, becoming a second, and even bigger, balloon. The double balloon will carry the telescope to 80,000 feet. Then astronomers on the ground will order it to get our first really good look at Mars.

Photos of the planets and stars by Stratoscope II (as the balloon-telescope combination is called) will be the sharpest and clearest ever taken. They'll even be better than those shot through the massive 200-inch scope on California's Mount Palomar, though Strato II's magnifying mirror is only 36 inches across. The reason: The balloon telescope drifts above 96 percent of the turbulent, dusty atmosphere that limits "seeing" conditions from the ground.

A series of flights this year will answer many long-standing questions about the canals of Mars, the cloud patterns of Venus, the red spot of Jupiter, the craters of tiny Mercury.

To make best use of the good seeing up there, Strato II's telescope has the most perfect large astronomical mirror ever polished and an aiming mechanism so precise that its camera can take time exposures lasting all night.

The wasp-waisted double-balloon configuration is the product of an ingenious launching technique designed to keep the balloon from wrecking its payload by dragging it along the ground. (The scope cost \$2,500,000, and is supposed to be re-usable.) Total cost of the project to date: around \$5,000,000.

All that money came from the National Science Foundation, the Office of Naval Research, and the National Aeronautics and Space Administration. The man who talked them into putting it up, and who directs the project, is Dr. Martin Schwarzschild, internationally noted Princeton University astronomer.

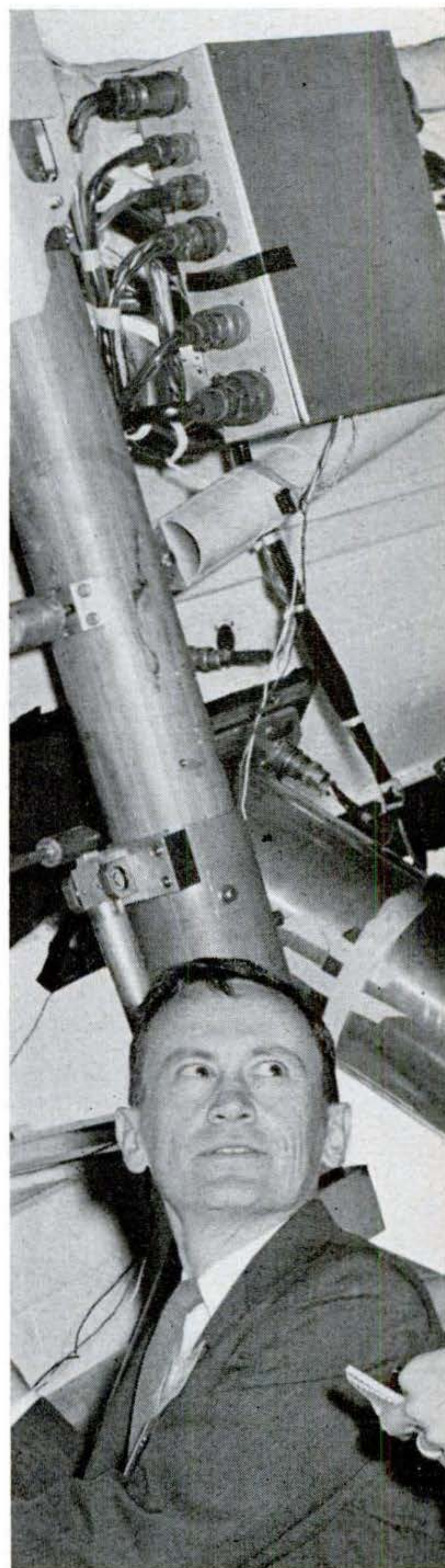

Dr. Martin Schwarzschild, originator of balloon astronomy, supervises the Strato II flights. The big telescope, his brainchild, towers over him.

CONTINUED

87

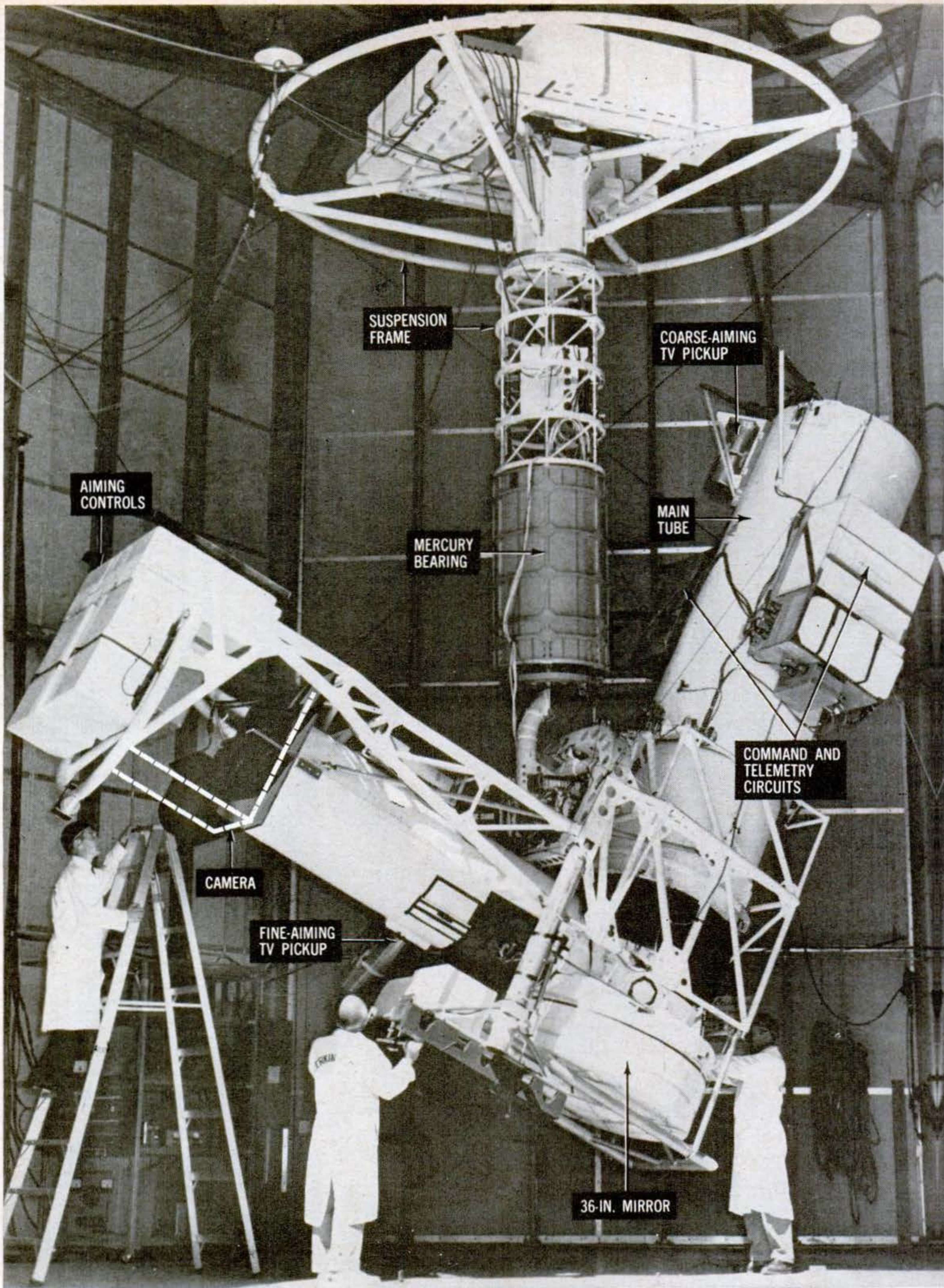

Payload of Stratoscope II is this three-ton telescope, built by Perkin-Elmer. Right arm is scope's 18-foot main tube, with 36-inch mirror

at bottom. Eleven-foot left arm carries controls and camera. The whole works turns gently on a huge mercury bearing in the center frame.

Simplified diagram of scope and camera. Wide-field TV pickup, upper right, is for coarse aiming. Light entering main tube, right, hits magnifying mirror, is directed by mirrors through lens system of camera, left. Camera sees center of image. Field mirror sends wider image to TV pickup, lower left, for fine aiming. Beam-splitters send images of guide stars to photomultiplier tubes that control servo motors, moving correction lens to keep image centered on the film.

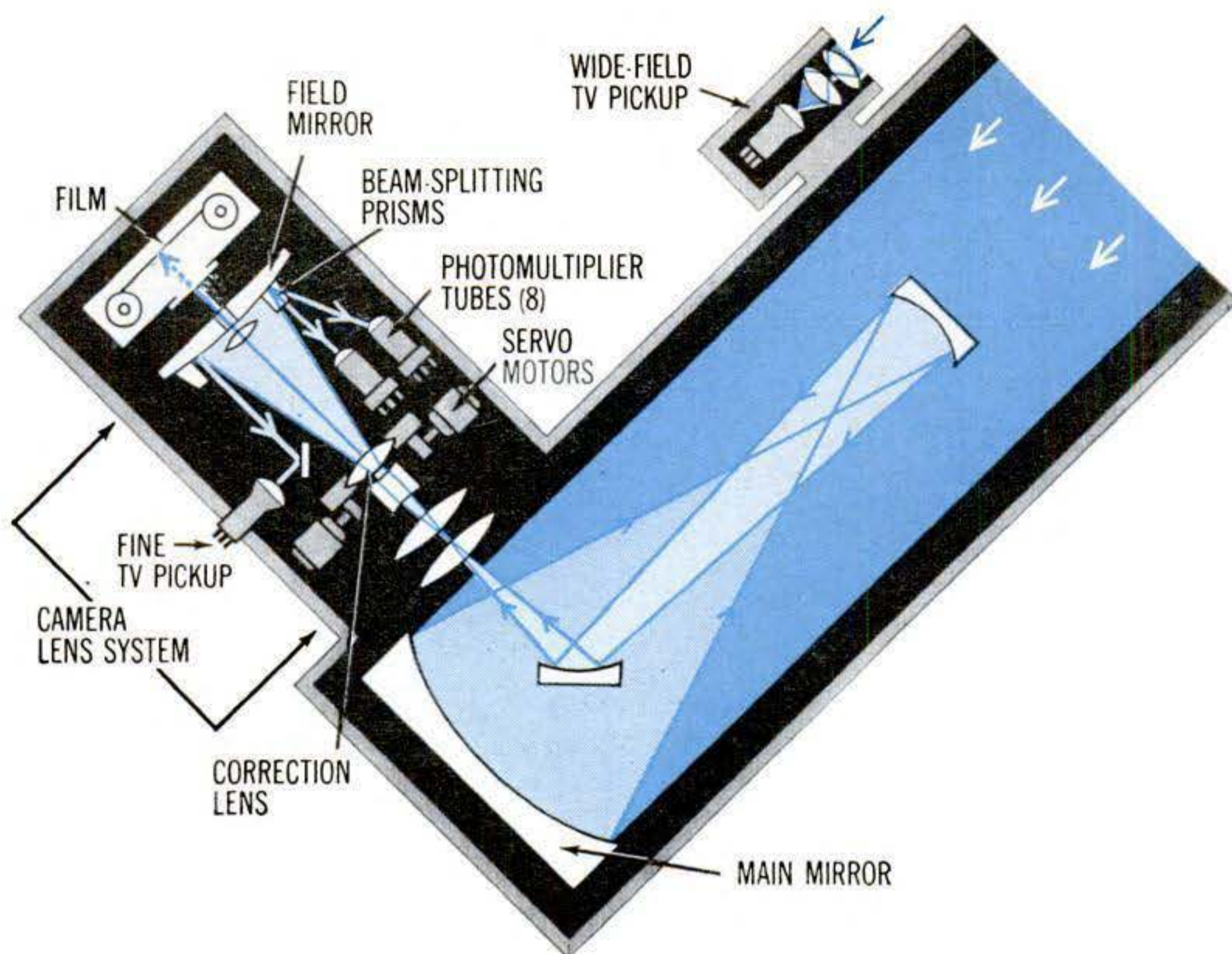

The concept of hanging a telescope from a balloon had its genesis at Princeton in 1955. Dr. Schwarzschild had just returned from a six-month sun-study project at Mt. Wilson Observatory. "I wasn't very happy with the results," he told me recently. "There was too much blockage from the atmosphere. We just couldn't see the sun clearly enough—and I couldn't figure out how to solve the problem."

The key idea was provided by James A. Van Allen, now of radiation-belt fame. On a visit to Princeton, Van Allen had lunch with Schwarzschild, listened to his complaints, and gently took him to task. "You astronomers are a conservative lot," he said. "We physicists aren't. For example, for years we've been using balloons to hoist scientific instruments into the stratosphere."

Schwarzschild latched onto the suggestion, developed it, and convinced the government of the value of a balloon-borne observatory. Sponsored by three U.S. agencies, Stratoscope I, a 12-inch ground-controlled balloon-telescope designed to take pictures of the sun, was launched in 1957. It worked spectacularly, taking the sharpest photos of sun-

spots and the sun's boiling surface ever obtained. From this unqualified success, Stratoscope II evolved.

The telescope itself looks like a giant "L" with arms 18 feet and 11 feet long. It hangs from a vertical frame, floating on a washtub-size mercury bearing. So perfectly balanced is it that when I leaned against the structure in a test lab at the Norwalk, Conn., plant of Perkin-Elmer Corp. (designer and builder), the three-ton scope swung slowly, as easily as a barn door.

The 36-inch mirror is a masterpiece of craftsmanship. Cast by Corning Glass Works and fine-ground by Perkin-Elmer, the 400-pound quartz mirror is polished to a tolerance of one 2½-millionth of an inch, and will give an optical resolution of 1/10 second of arc. That's equivalent to an ability to distinguish between two toadstools a yard apart 1,000 miles away. Best photos ever taken by a telescope up to now have had a resolution of ⅓ second of arc—about a third as sharp as those Strato II will provide.

Heavyweight lift. The telescope, ballast system, and other paraphernalia weigh about five tons, an immense weight to be lifted by balloon. The dou-

Ascent of Stratoscope II

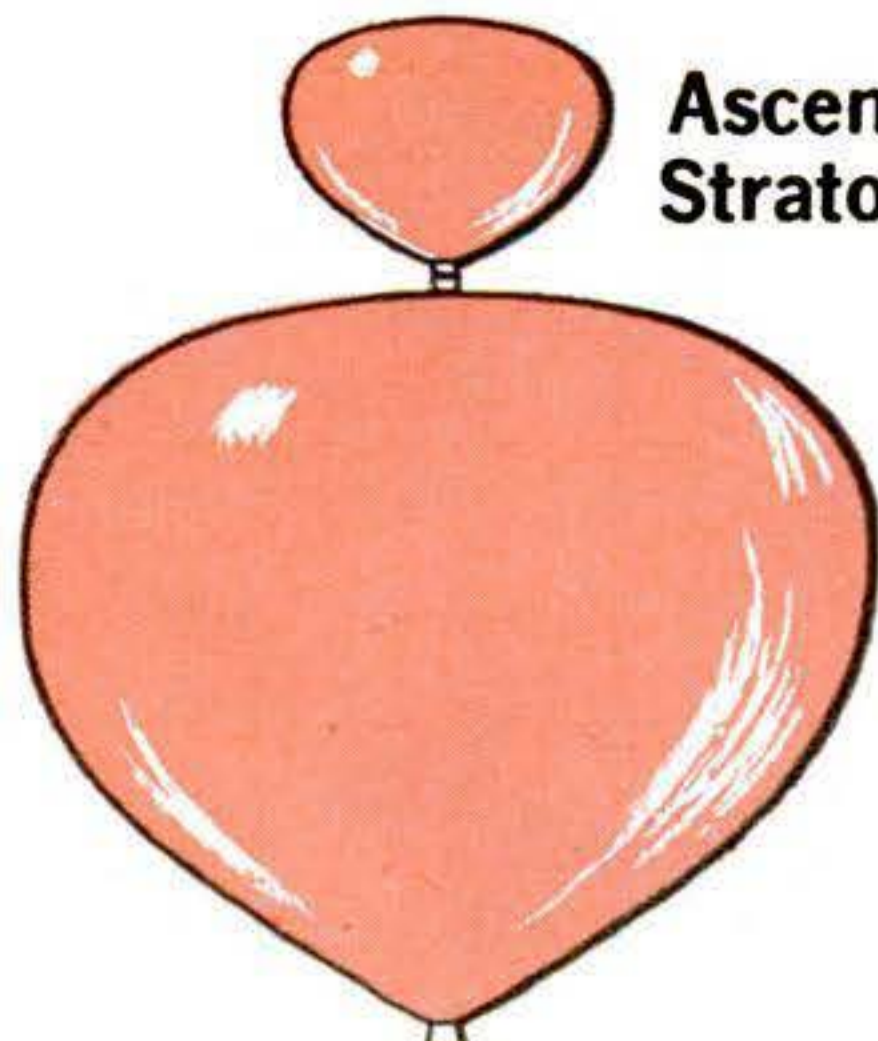

4 At 80,000 feet, both balloons are fully inflated. Telescope swings to sighting position. Strato II drifts till dawn, is valved down

SCOPE IN SIGHTING POSITION

3 As balloon rises, helium expands into main balloon, ripping sheath

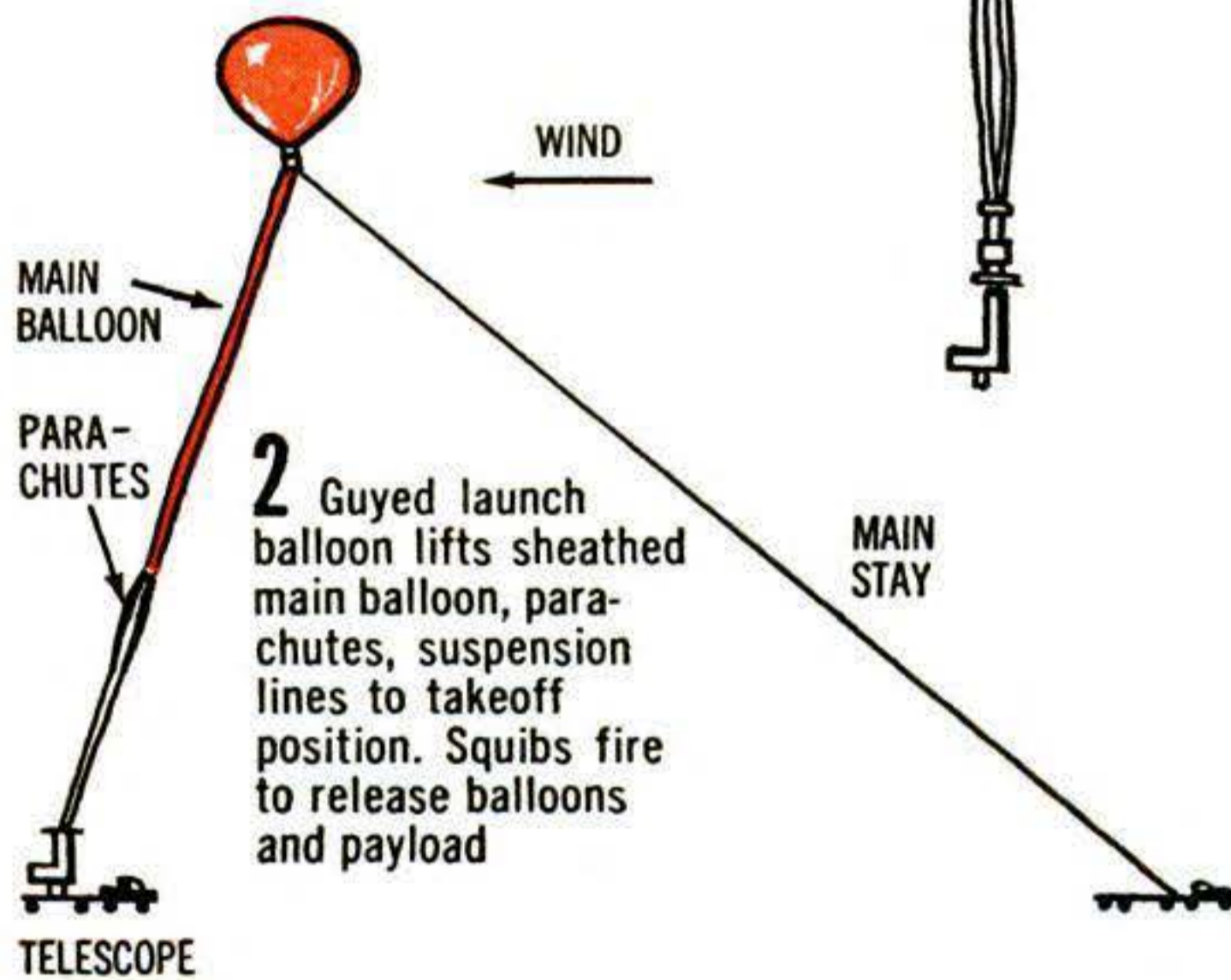

2 Guyed launch balloon lifts sheathed main balloon, parachutes, suspension lines to takeoff position. Squibs fire to release balloons and payload

MAIN BALLOON

PARACHUTES

WIND

MAIN STAY

TELESCOPE

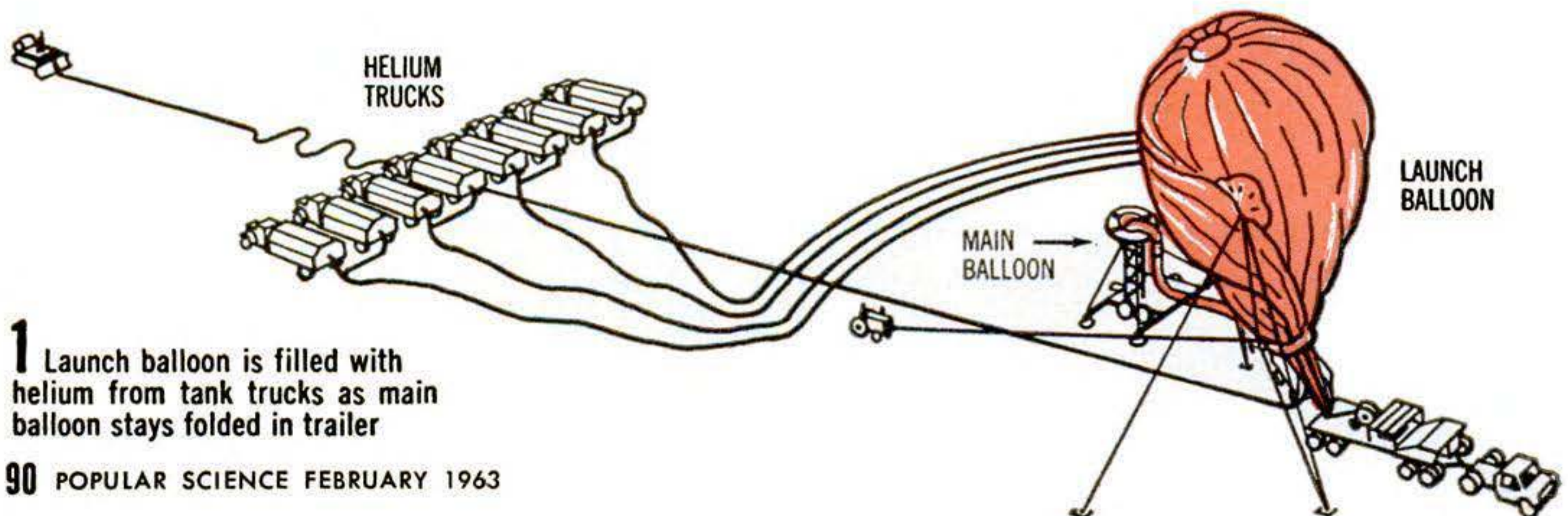

1 Launch balloon is filled with helium from tank trucks as main balloon stays folded in trailer

HELIUM TRUCKS

MAIN BALLOON

LAUNCH BALLOON

ble balloon alone weighs a ton and a half.

A few years ago the project would have been impossible; no balloon material was strong enough. But in 1959, the G. T. Schjeldahl Co., balloon makers of Northfield, Minn., tried mylar, a plastic some 10 times stronger than the most commonly used gas-bag material, polyethylene. To the thin mylar, Schjeldahl laminated a net of dacron threads that double the strength of the mylar. As of today, the combination can't be beat for strength and lightness.

Launching of Stratoscope II will take place at a newly completed airfield near Palestine, Tex. Called the NCAR (National Center for Atmospheric Research) Scientific Balloon Flight Station, it's the first year-round facility devoted exclusively to scientific ballooning. Vitro Laboratories of Silver Spring, Md., is responsible for Strato II flight operations.

From the air the facility looks like a giant water splash on the Texas plains, with launch aprons radiating like fingers from a short, fat silo called the Stratoport—a hangar for Strato II's scope.

Trial launch. On December 12 the apparatus made a full-scale test flight, the first from Palestine. The operation was complete in detail except that a dummy payload was used.

After a weather okay (the day was sparkling), operations began about noon. Vitro engineers wheeled the trailers carrying the two balloons out on the apron.

Though it looks like a Rube Goldberg contraption, the double-balloon system is an ingenious solution to the problem of getting Stratoscope II off the ground. Enough helium to lift the five-ton pay-

[Continued on page 194]

Uphill skiing comes easy on escalator

A rubber conveyor belt on Mount La Crosse, Wisc., serves as an escalator to carry skiers back up a steep slope after they have reached the end of the run. Builders of the Ski-A-Later call it the world's first.

Skiers just slide on, one ski slightly advanced. In just over a minute, the 300-foot rubber belt takes them up a slope with a vertical drop of 43 feet. The lift has a capacity estimated at 1,200 to 1,400 skiers an hour.



Economy car comes at high price

For only \$12,000 plus change, you can be the proud owner of a 1963 Lost Cause.

A customized Corvair, you say? You're right. All trim is removed, the top upholstered, and a tiny rear window put in. Paint is hand-rubbed British racing green. Interior is trimmed in black leather and walnut. Other specials: six chromed wire wheels (rear tires are larger, meaning two spares), tachometer, AM-FM radio, trunk straps, picnic hamper, and lap robes.

The line forms at Lost Cause Motors, Louisville, Ky. Delivery takes eight to ten months.



Car-shuttling train

An experimental platform train to shuttle cars through the proposed tunnel under the English Channel is demonstrated above by the French tube promoters. The 12-car train carried 40 cars 35 miles from Paris to Fontainebleau, about the length of the tunnel. The autos were not lashed down for the ride. They were unloaded at one end in two minutes, driving off over steel plates closing the gaps between cars.

More Answers to Your Questions About Space by Dr. Wernher von Braun

Q Why has the Mercury capsule a blunt nose?

A For an orbiting spacecraft to return to the earth's surface, its initial velocity must be reduced to zero. To provide the entire retardation energy with retro-rockets is unattractive; it would call for a rocket-propulsion system of about the same power and propellant consumption as the one used to carry the spacecraft into orbit in the first place. For this reason, retrorockets are employed only for the limited task of pushing the spacecraft's orbital path back into the atmosphere. The bulk of the braking action

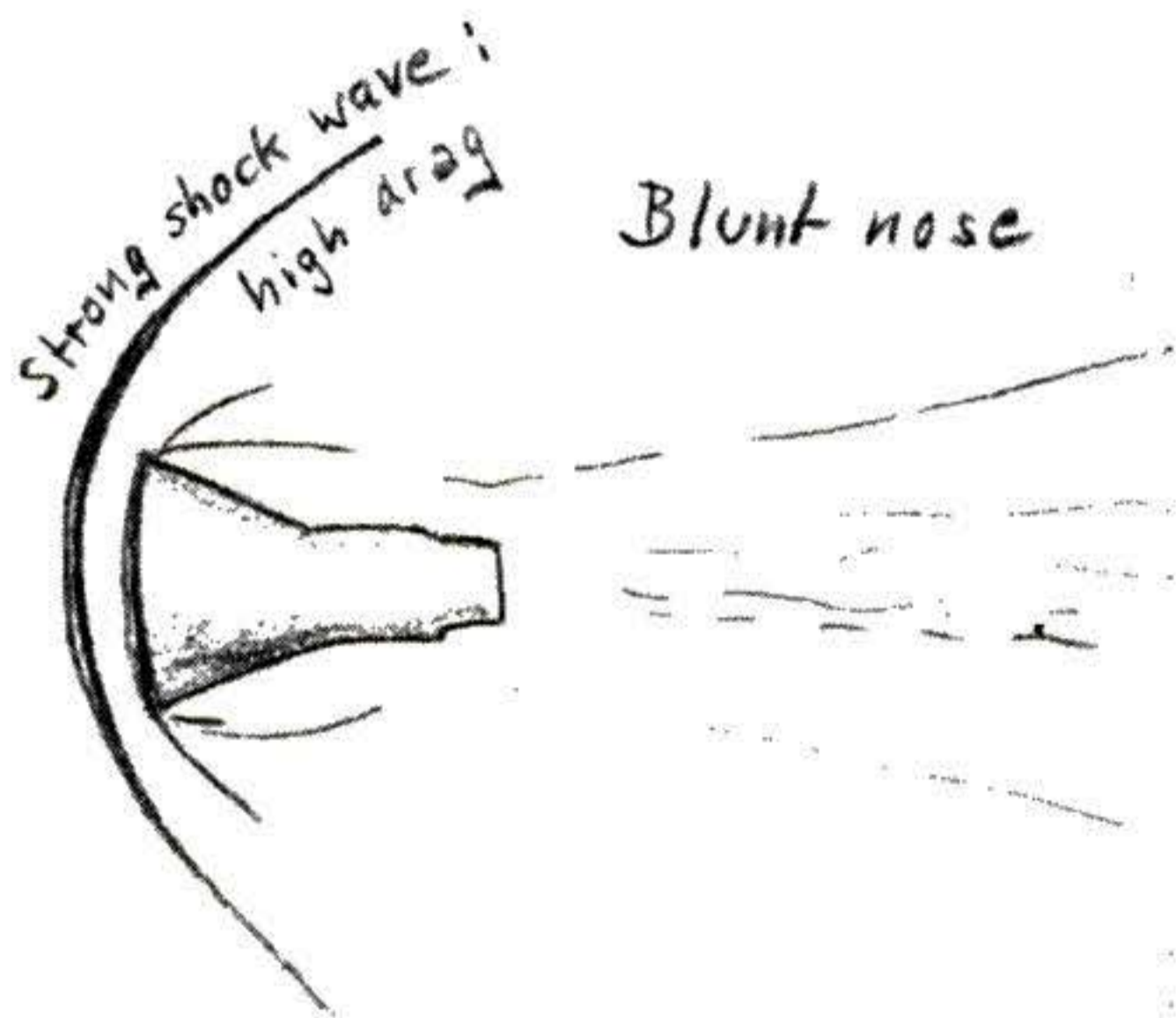

is provided by the ensuing aerodynamic drag.

The drag is produced by air compres-

sion and air friction. Both generate heat. Suppose the kinetic energy of an iron ball, entering the atmosphere at an orbital speed of 25,600 feet per second, was completely converted into heat and all that heat was transferred back into the ball. It would never reach the ground, because there would be enough heat to melt 35 iron balls!

For successful re-entry it is therefore essential that only a small fraction of the total heat generated during aerodynamic deceleration be absorbed by the spacecraft. The most effective mechanism to carry energy away from the spacecraft and into the surrounding air is a shock wave. You may have witnessed the havoc caused to adjacent moorings by a large boat moving through a narrow channel at excessive speed. It demonstrates vividly that a very substantial portion of the boat's horsepower is carried away by the bow wave.

The blunter the bow, the stronger the wave. This is just as true for a spacecraft returning at hypersonic speeds.

We see, therefore, that the Mercury capsule has a blunt nose in order to *minimize* the heat absorbed by the spacecraft's structure, and to *maximize* the heat carried away by the shock wave.

What about supersonic aircraft?

Supersonic airplanes are needle-nosed to keep down aerodynamic drag. This is necessary when the designer has the

Co-chairman of a \$100-a-plate "Night of Exploration" dinner in New York, November 2, Dr. Wernher von Braun presents a scroll on behalf of the Explorers Club to Astronaut Walter M. Schirra Jr. Sharing the head table with Dr. von Braun, Director of the George C. Marshall Space Flight Center, were such notables as Sir Edmund Hillary, conqueror of Mt. Everest; General James A. Doolittle; Lowell Thomas; James E. Webb, Director of the National Aeronautics and Space Administration; and Colonel Bernt Balchen, first man to pilot a plane across both poles.



task of reaching ever-increasing speeds with the limited engine power at his disposal.

Aerodynamic heating, on the other hand, is not yet a very serious problem at the speeds of present-day supersonic aircraft, operating at Mach 2 or 3.

An orbiting spacecraft such as the Mercury capsule is boosted into space by a powerful rocket that rises vertically. Its flight path begins to level off only after it has cleared the denser layers of

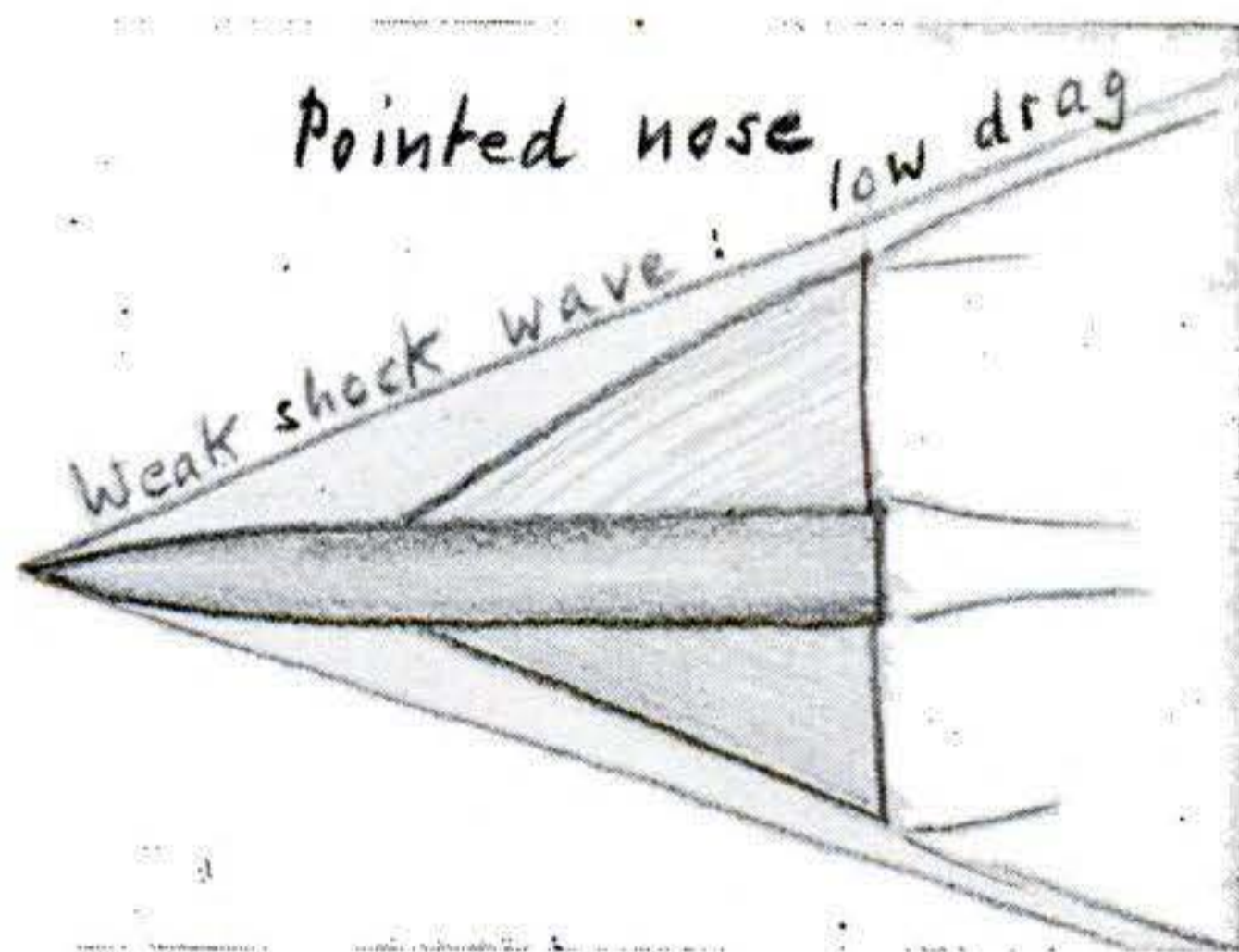

the atmosphere. Here, drag reduction during the ascent becomes a minor consideration. Re-entry from orbit, however, is commenced at Mach 25! During the blazing retardation maneuver that follows, the job of keeping the heat away from the capsule, and of dissipating as much of it as possible into the surrounding atmosphere, must be our first concern.

Q *How dense is the Martian atmosphere?*

A It's pretty thin, and its physical makeup is quite different from that of the atmospheric shell that surrounds the earth.

Before we discuss it further, let us see on what observations those conclusions are based.

All of the light coming from Mars is reflected sunlight. Part of that light, before reaching our eyes, has been reflected by the Martian surface and has thus penetrated the Martian atmosphere twice—on the way down and on the way back up. The rest has been reflected by Mars' atmosphere itself and thus has never reached the ground.

Figuring pressure at surface

A careful analysis of the sunlight reflected by Mars has led astronomers to conclude that the *mass* of a column of Martian atmosphere resting upon a square inch of the planet's surface amounts to about 22 percent of that of a comparable column of air on earth. Due to the much smaller size of the Red Planet, the gravitational pull at Mars' surface is only 38 percent of one "G" (the gravity to which we are accustomed on earth). Consequently, the surface *weight* of that column of Martian air is only $.38 \times .22 = .084$ of the weight of its terrestrial counterpart.

Mars' atmosphere . . . and tying down a rocket

The atmospheric pressure at Mars' surface is the weight of that column of air. Since, on earth, sea-level pressure averages 29.92 inches of mercury, it follows that on Mars we may expect a surface atmospheric pressure of about $29.92 \times .084 = 2.5$ inches of mercury (or 85 millibars).

This is one-twelfth of the sea-level pressure on earth and about the same pressure that prevails 11 miles up in our stratosphere.

Atmosphere, though thin, goes high

However, as we rise from the Martian surface into this tenuous atmosphere, we find its pressure stratification quite different from that of the earth's air. This, again, is a direct result of Mars' feeble gravity, which simply fails to compress its atmosphere into as tight and compact a layer of gas as ours. In the earth's atmosphere we have to climb to an altitude of about 10 miles to experience a reduction of atmospheric pressure by a factor of 10—that is, from 29.92 inches to 2.992. (It is down to .299 inches at 20 miles, to .0299 at 30 miles, and so on.) In Mars' atmosphere, we would have to climb to an altitude of about 25 miles to experience a pressure drop to a tenth of the Martian surface pressure—from 2.5 inches to .25. We would have to ascend to 50 miles to get it down to .025 inches, and to 75 miles to reduce it to .0025.

This leads to an interesting conclusion: Although the surface pressure on Mars is only one-twelfth of our sea-level pressure, at altitudes above 19 miles the Martian atmosphere is actually *denser* than our own.

What astronauts can expect

This is of considerable practical importance for future voyages to Mars. Many important phenomena (aurora effects, airglow, ionization, meteorites) take place in the upper layers of a planetary atmosphere. Altitudes of clouds are directly related to the pressure stratification of the atmosphere. Generally speak-

ing, we can say that in the Martian atmosphere, atmospheric phenomena can be expected to extend to much higher altitudes.

The first astronauts to enter the Martian atmosphere for a landing will feel its decelerating effect at altitudes where back on earth they orbited with no noticeable atmospheric drag.

Q *How are large rockets prevented from taking off with inadequate thrust?*

A The rocket is tied to the launch platform by a multiple clamp-down mechanism, which is released only after there is clear evidence of adequate rocket-engine performance.

The technique of holding rockets down during thrust build-up was tried, off and on, during the early years of guided-missile development. It became standard procedure with the advent of multiengine rockets, because of the obvious hazards involved in a takeoff with one faulty or inoperative rocket engine.

In launching large multiengine rockets such as Atlas or Saturn, at least one characteristic indication of adequate engine performance (such as combustion-chamber pressure) is piped into the control room for all engines involved in the takeoff. The decision to release the clamp-down mechanism (commonly called the "tail grab") is made by the launch director on evidence that all engines are "in the green." In modern launch facilities the procedure is often automated; that is, the tail-grab signal is activated automatically when all engine read-outs are within pre-specified limits. All engines are shut off if this condition is not met within a few seconds. ■ ■

.....

Dr. von Braun will consider answering questions from readers of POPULAR SCIENCE in the magazine, but he cannot undertake to answer each one by mail. Letters to him should be addressed in care of POPULAR SCIENCE, 355 Lexington Ave., New York 17, N. Y.



Air-terminal restaurant with a high-up view

Rising 135 feet above the \$70 million extension to Los Angeles International Airport is the parabolic Central Theme Building. At its base is a bank, a barber

shop, and a cafeteria. Seventy feet up beneath the arches is a gourmet restaurant. Sixty 11-foot-high windows give diners an unobstructed 360-degree view.



Power egg is hinged to ride up and down with wheel. Trailing link and coil spring carry the front wheel.

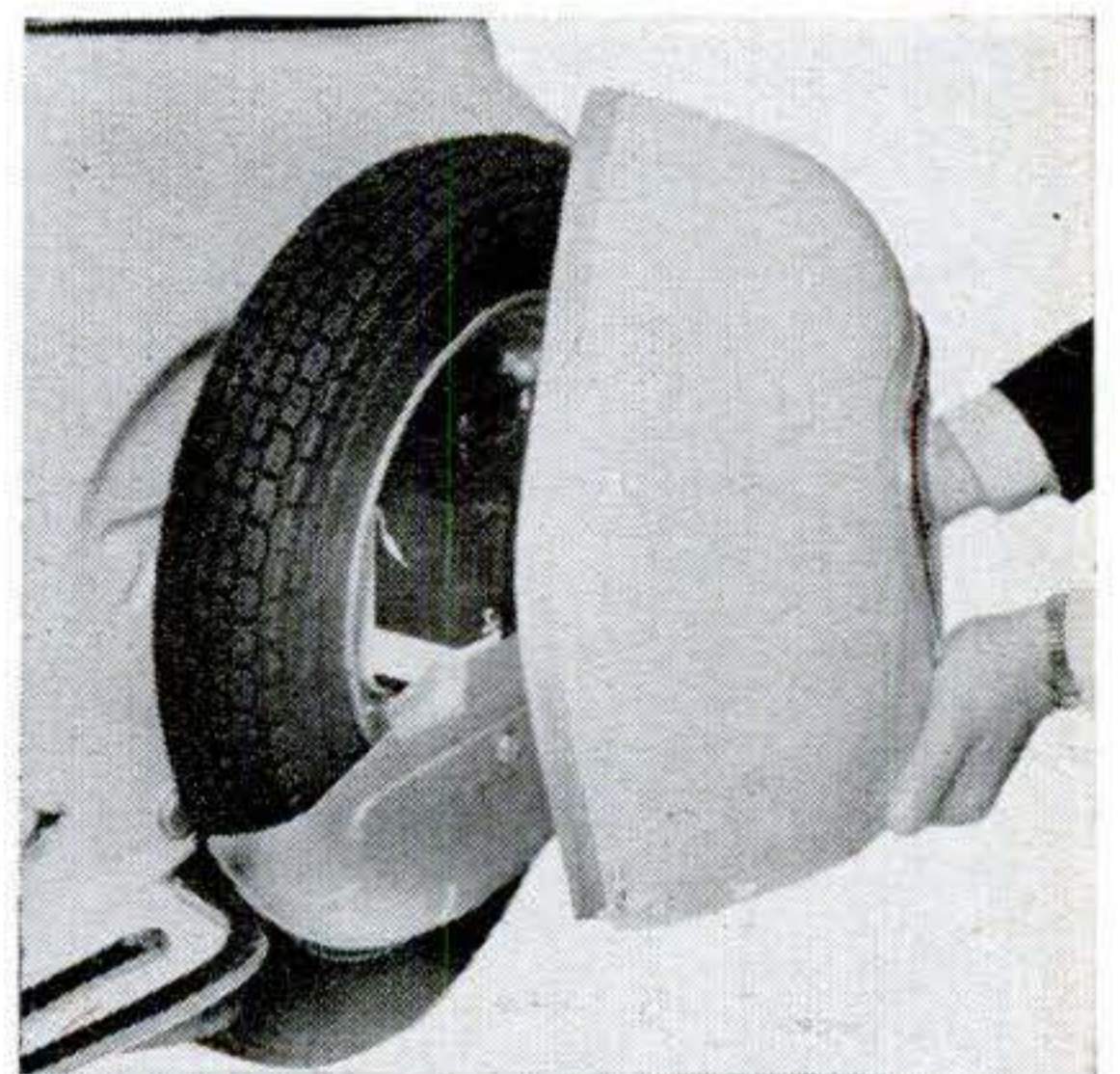

Removing cover gives access to spare, and to battery mounted snugly inside.

New Vespa hides its spare

The spare wheel on the latest Vespa scooter is housed neatly behind a detachable cowling that balances the cover for the off-

set engine on the opposite side. A lockable toolbox fits into waste space beneath the double seat and provides room for odds and ends. The new model is powered by a 9.8-cu.-in. engine giving 60-m.p.h. performance.

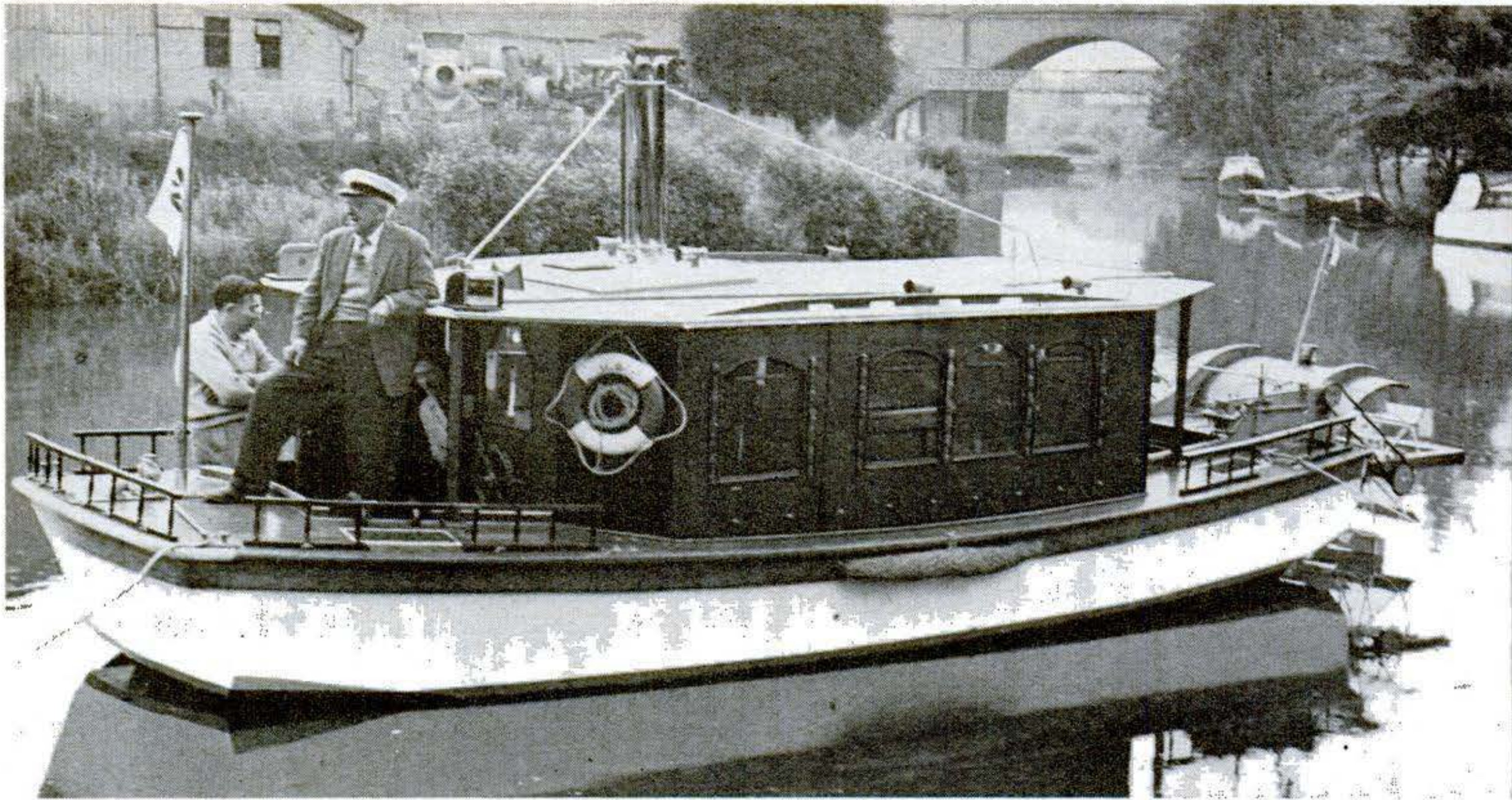

Cabin of Guildford Belle is topped by 30-inch copper-bronze stack rising from boiler room.

The little sternwheeler cruises at four knots while burning 11 pounds of coal an hour.

Mississippi steamboat now at home on the Thames

Scaled down to 30 feet, this British-built sternwheeler is copied from an old Mississippi river boat. Spurred by a childhood fascination, 44-year-old Fred C. Mitchell, who has a hi-fi shop in Dorking, Surrey, spent five years on the model, even visited America to study details. He did the work

himself, making the engine and hardware in his shop, leaving only the bare oak hull to a small nearby shipyard.

The main cabin behind an open cockpit in the squared-off bow houses the boiler room and living quarters. Twin steam engines in the aft cockpit are double-acting

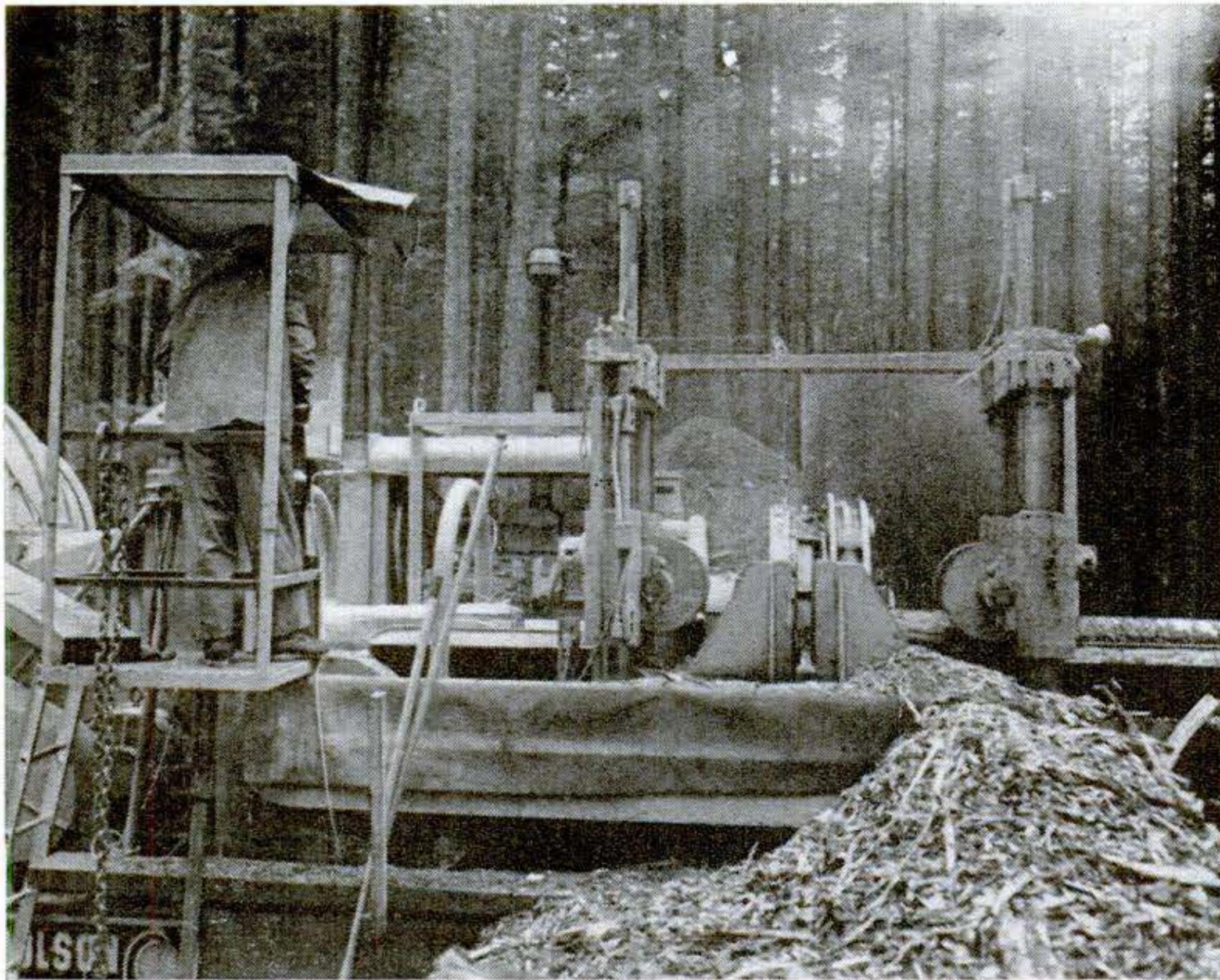

Wood chopper moves in on logs

A \$130,000, 72-foot machine that barks and chips logs right in the forest is making it practical to harvest small-diameter hemlock. The experimental Utilizer is now undergoing tests by Crown Zellerbach in Oregon.

It pulls trees along a conveyor through blades that bark them and chop them into small chips for easy transportation. Power is supplied by two Cummins diesels rated at 280 and 700 hp.

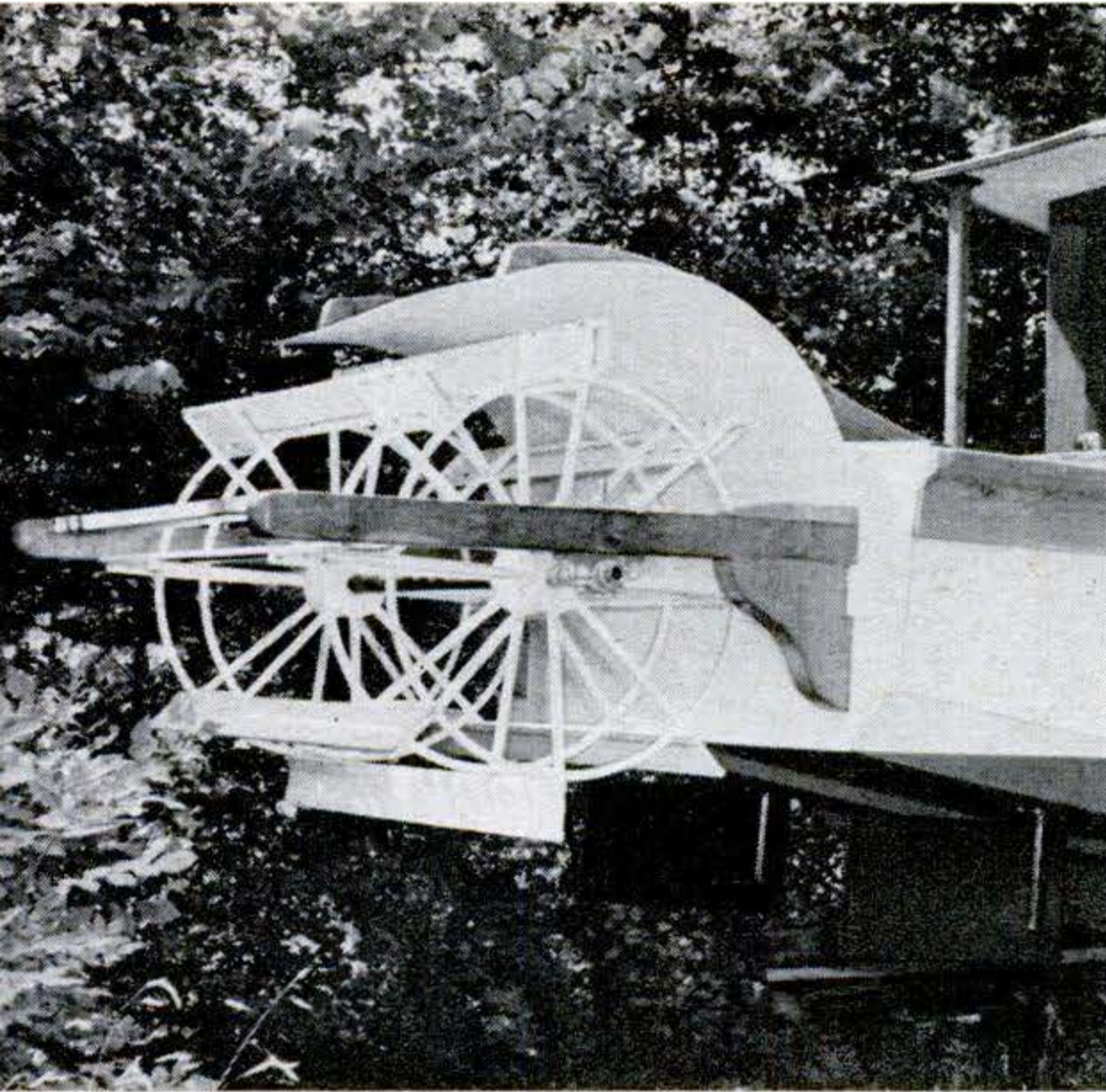

Chain-driven paddle wheel is 51 inches wide. Dual rudders under the stern steer the boat.

slide-valve units with a combined output of nine hp. and a top speed of seven knots. Steam is fed from a coal-fired multitube boiler that develops a working pressure of 120 pounds, but is capable of 250.

Mitchell, in true Mississippi River tradition, has christened the 5½-ton craft the Guildford Belle. He realizes his life's ambition with weekend cruises with his family on the close-by Wey and Thames.

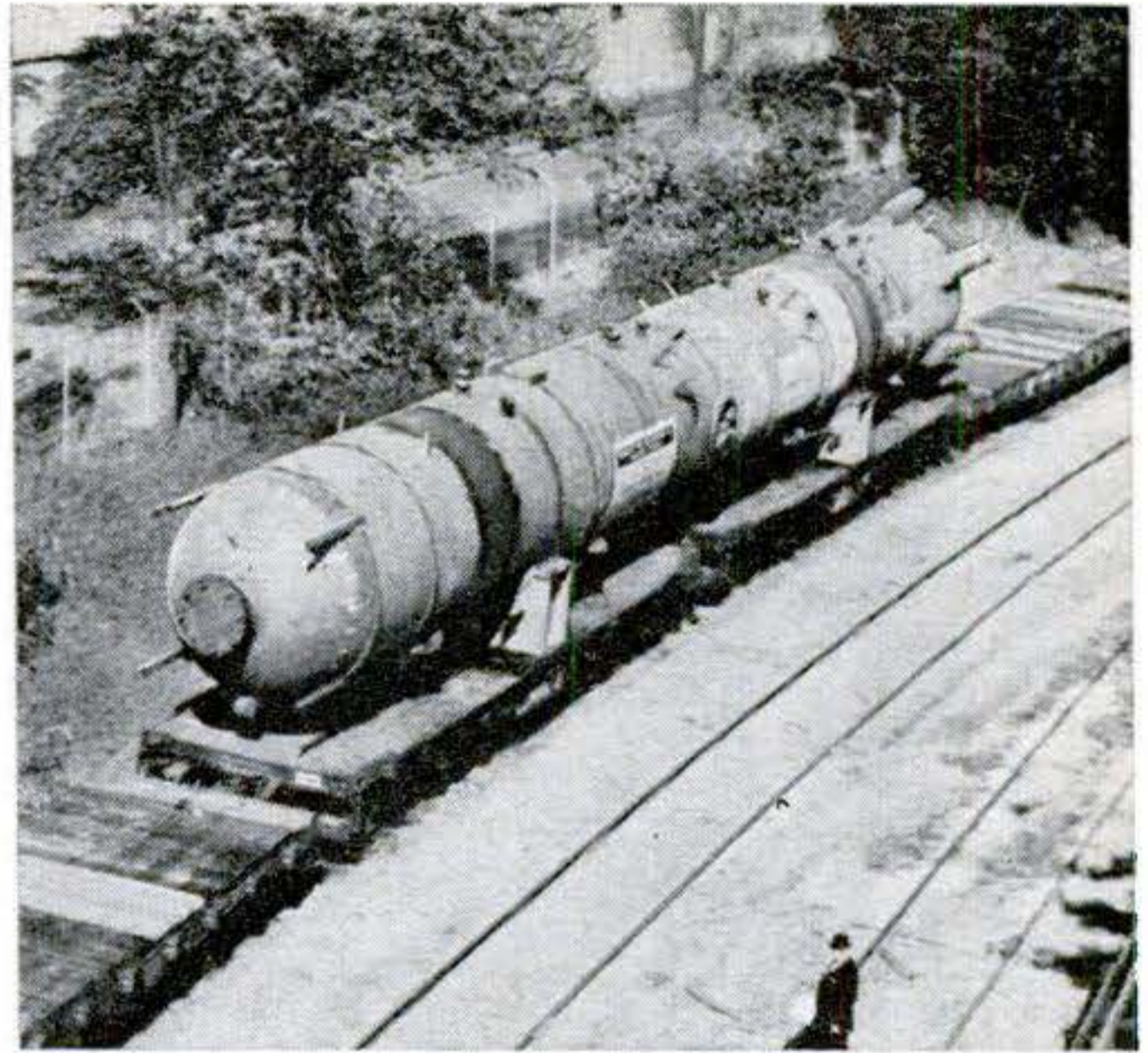

Railroad carries record load

Heaviest single piece ever shipped by rail, a 500-ton pressure vessel journeyed two-thirds across the country—2,200 miles from Milwaukee, Wis., to Avon, Calif. The 98-foot vessel, one of six built by A. O. Smith Corp. for a Tidewater Oil Refinery, was carried on two flatcars designed with four trucks each, instead of the customary two, in order to even out the load.

Combined weight of the vessel, blocking, and flatcars was 1,079,200 pounds, 13,600 more than the previous record. The trip was made on the Milwaukee, Santa Fe, and Southern Pacific in three weeks, with speed held to 30 m.p.h., no passing on curves, and frequent overnight stops.

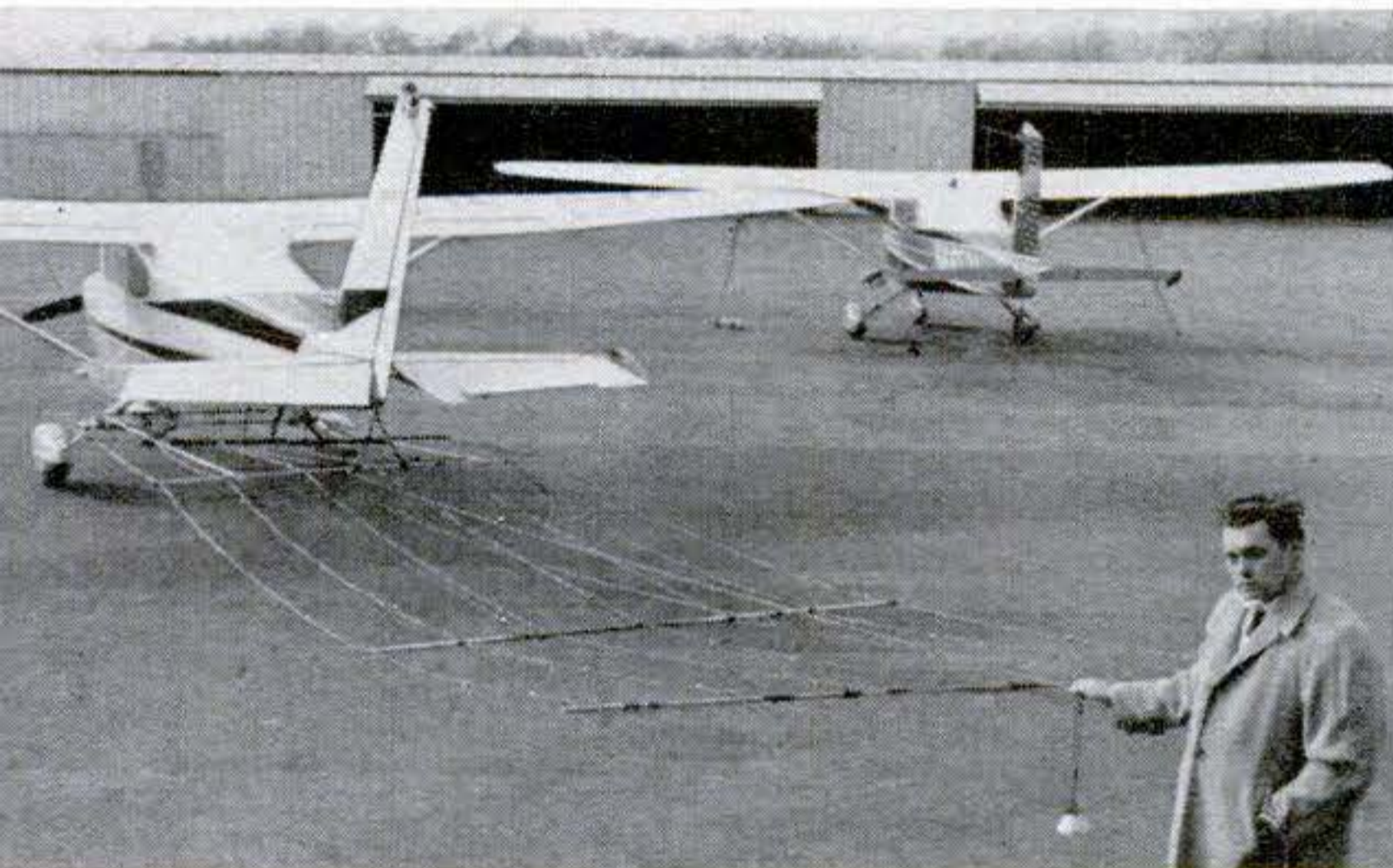

Skywriting on electric billboard

Look up after dark in the area of Kingston, Pa., and chances are you'll see a plane skywriting with electric bulbs. Like daytime skywriters, the plane shoots out messages from its tail a letter at a time—but they are in electric lights instead of smoke.

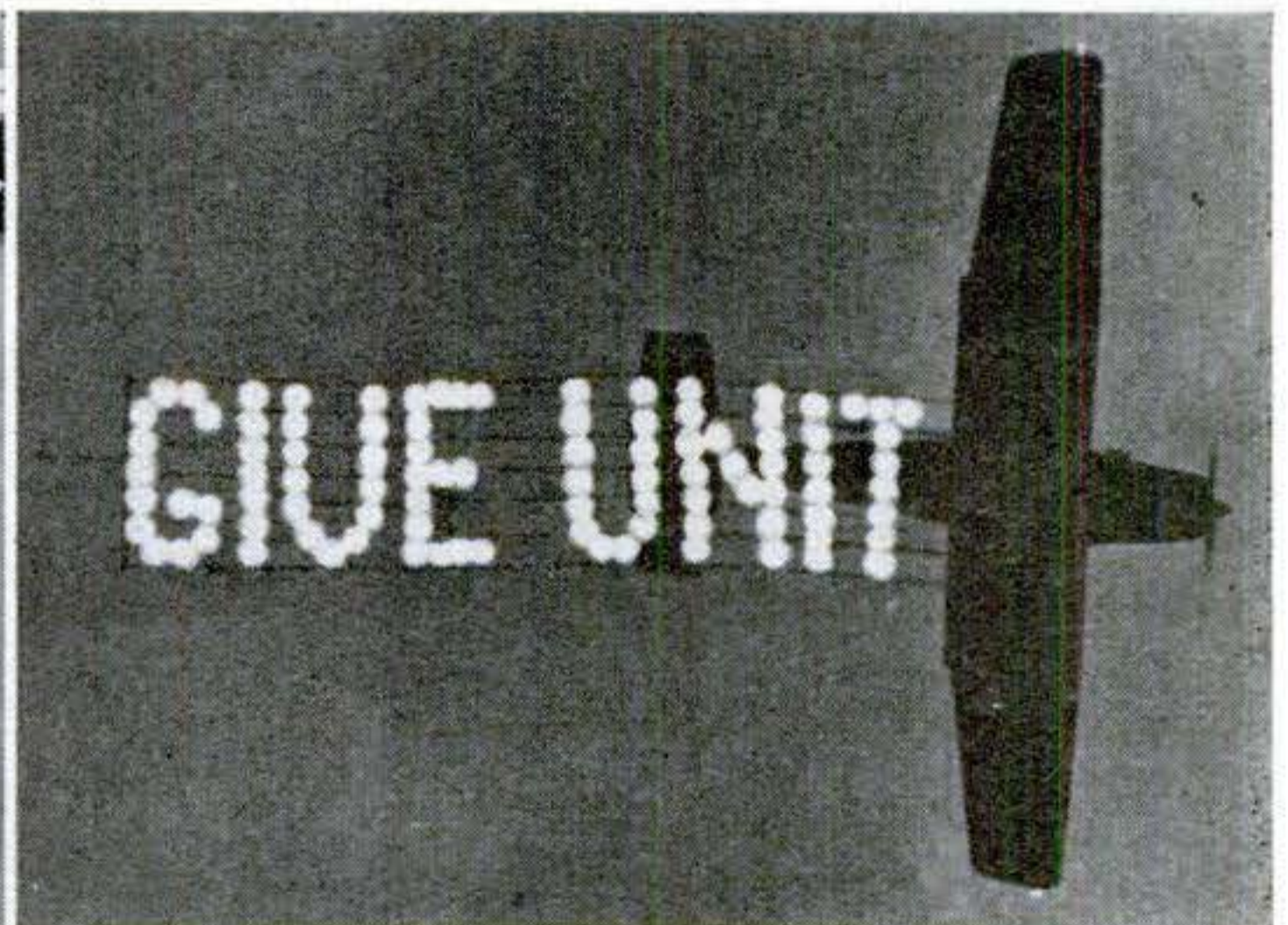

Re-View Agency's equipment consists of a trailing frame of electric wires fitted with on-off bulbs fed by the plane's 35-amp generator and working like electric billboards that spell out news bulletins or other messages letter by letter. The message being flown above is an appeal for Kingston's United Fund.

Snowplow, Go Home!



New tunnel and covered highway to keep Alpine route open all winter

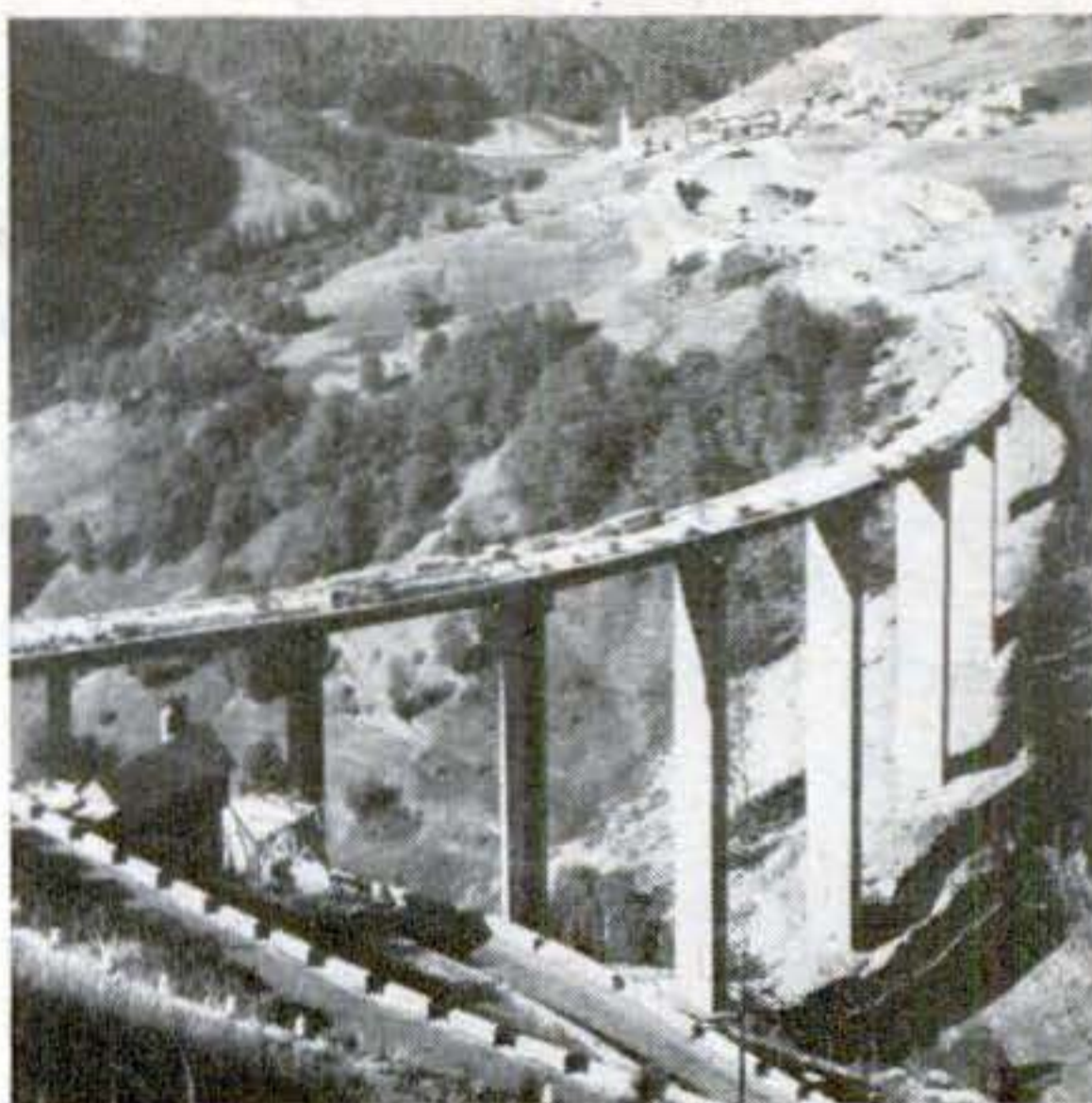

Viaducts like this one span mountain valleys north of Turin. No grade on route is steeper than five percent.

OPENING late this year, an all-weather highway that bores 2,000 feet under the St. Bernard Pass will let European motorists drive from northern Europe to the Mediterranean—year 'round—without skirting the Alps. Up to now, the pass has been closed eight months of the year.

A joint Swiss-Italian project, the highway has nine miles of approach roads, kept snow-free by concrete roofing, and a 3½-mile tunnel. This is a 31-foot tube, cut through solid rock, with a two-lane roadway. Huge ducts suck in fresh air, blow out exhaust fumes.

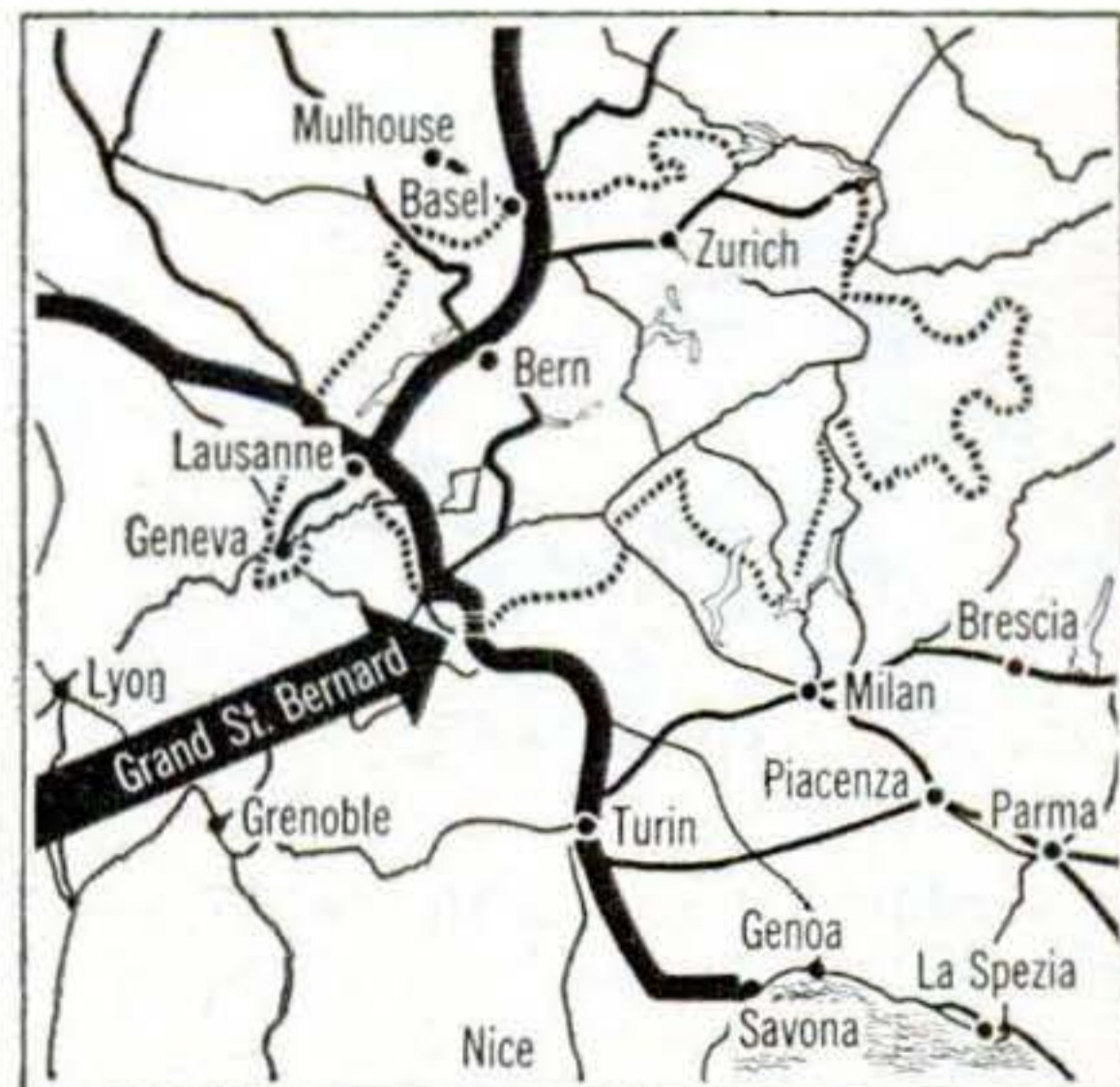

Customs and toll gates are at both ends. Drivers will pay \$1.35 to \$3.30 for cars, 40 cents for each passenger.

"I'd like to see them make..."

An oil-fired flame thrower for clearing ice from sidewalks and driveways. A flame close to the ground would melt thin ice and loosen thick ice.—*Ralph Monroe, Pontiac, Mich.*

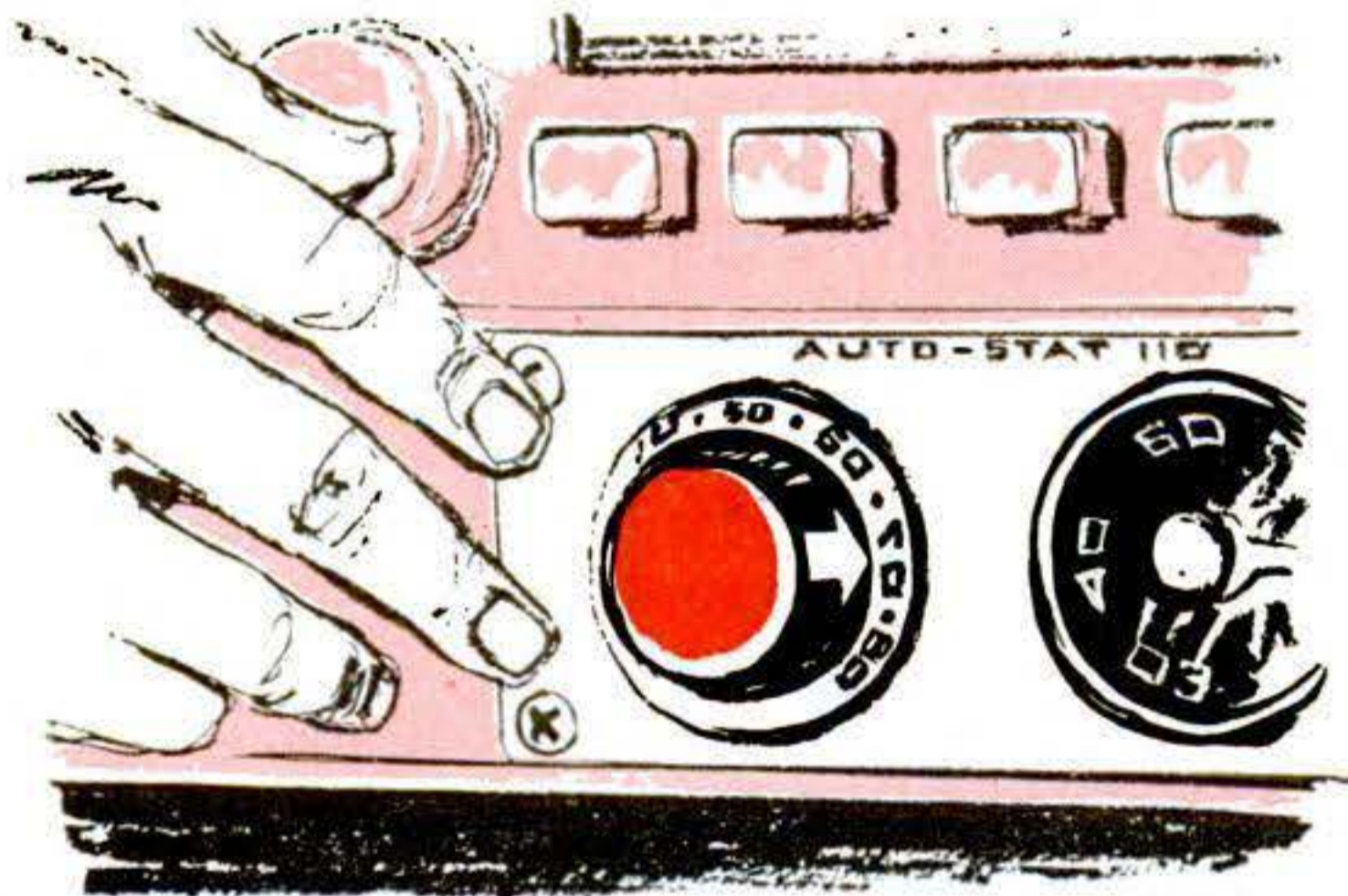
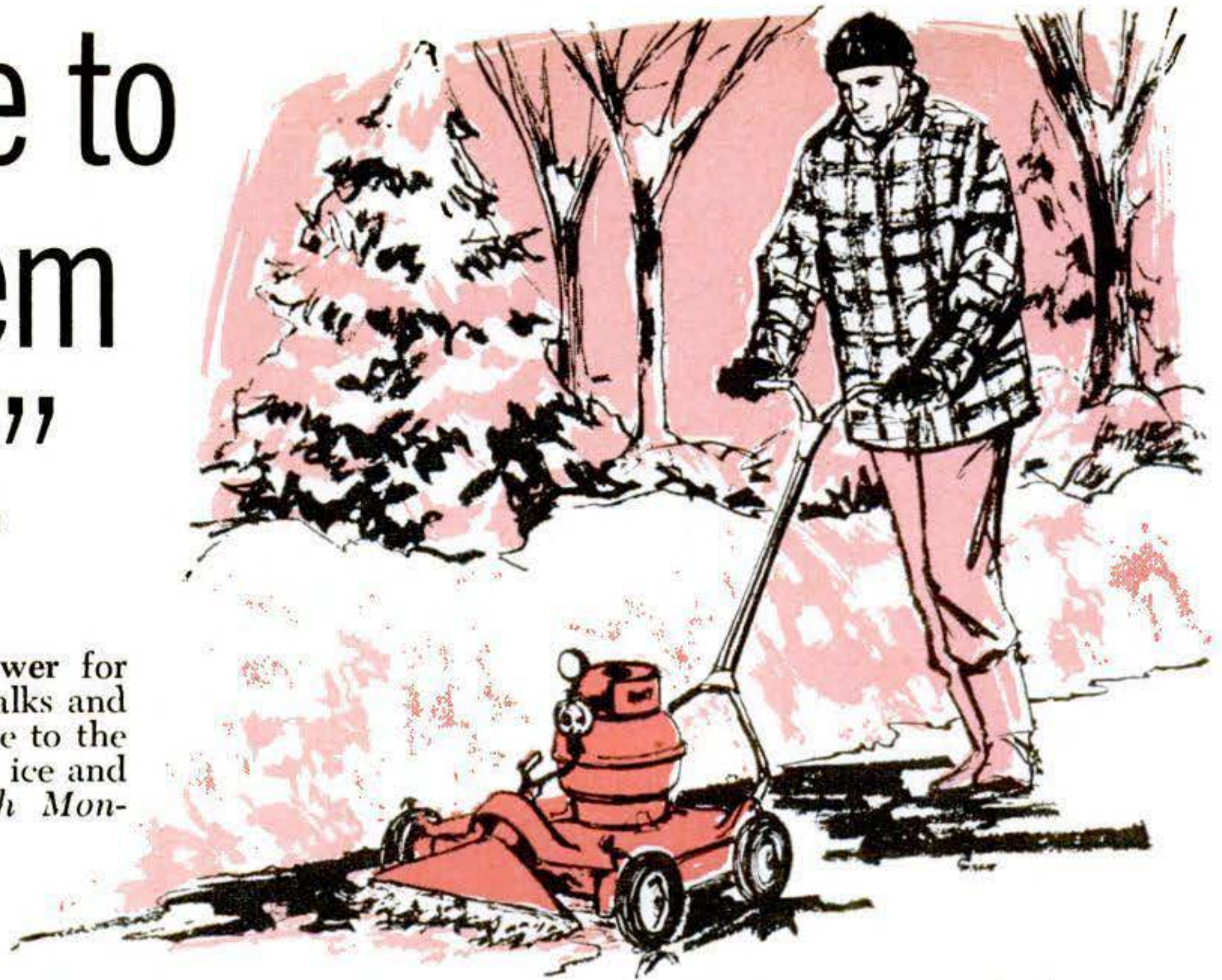

A car-heater thermostat that you could set for desired temperature. This would eliminate being baked, as well as constant need for adjustment.—*Mrs. Barbara Davis, Rome, Ga.*

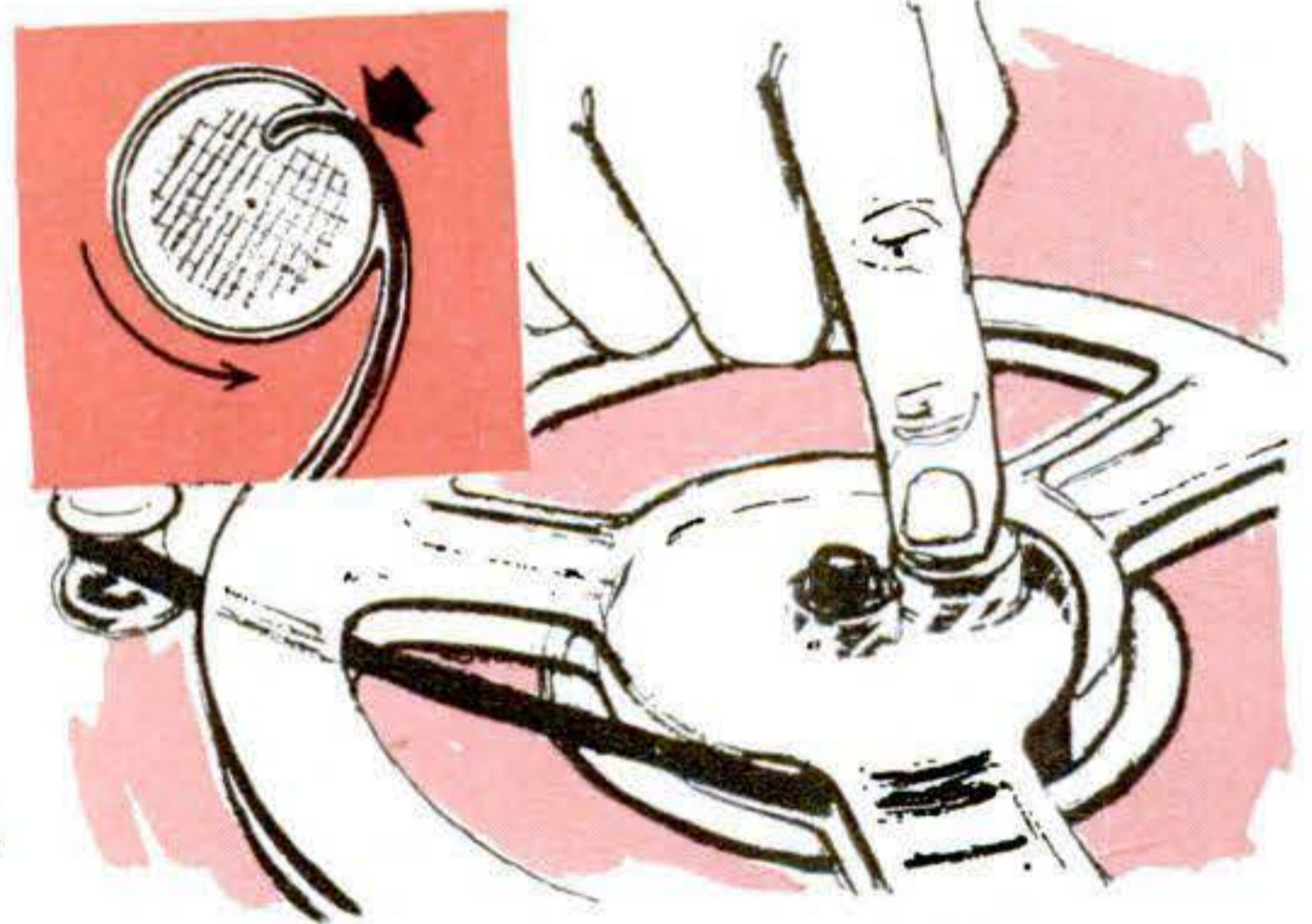

Easy-to-load tape-recorder reels. They'd have a slotted plug, set in flush, that you could turn with a finger to lock in the starter end of the tape.—*David A. Odom, Puyallup, Wash.*



Snow-shedding shovels with blades coated with Teflon—the plastic used on greaseless frying pans—and a built-in hand warmer in the handle.—*H. F. Stephens, Pleasantville, N.J.*

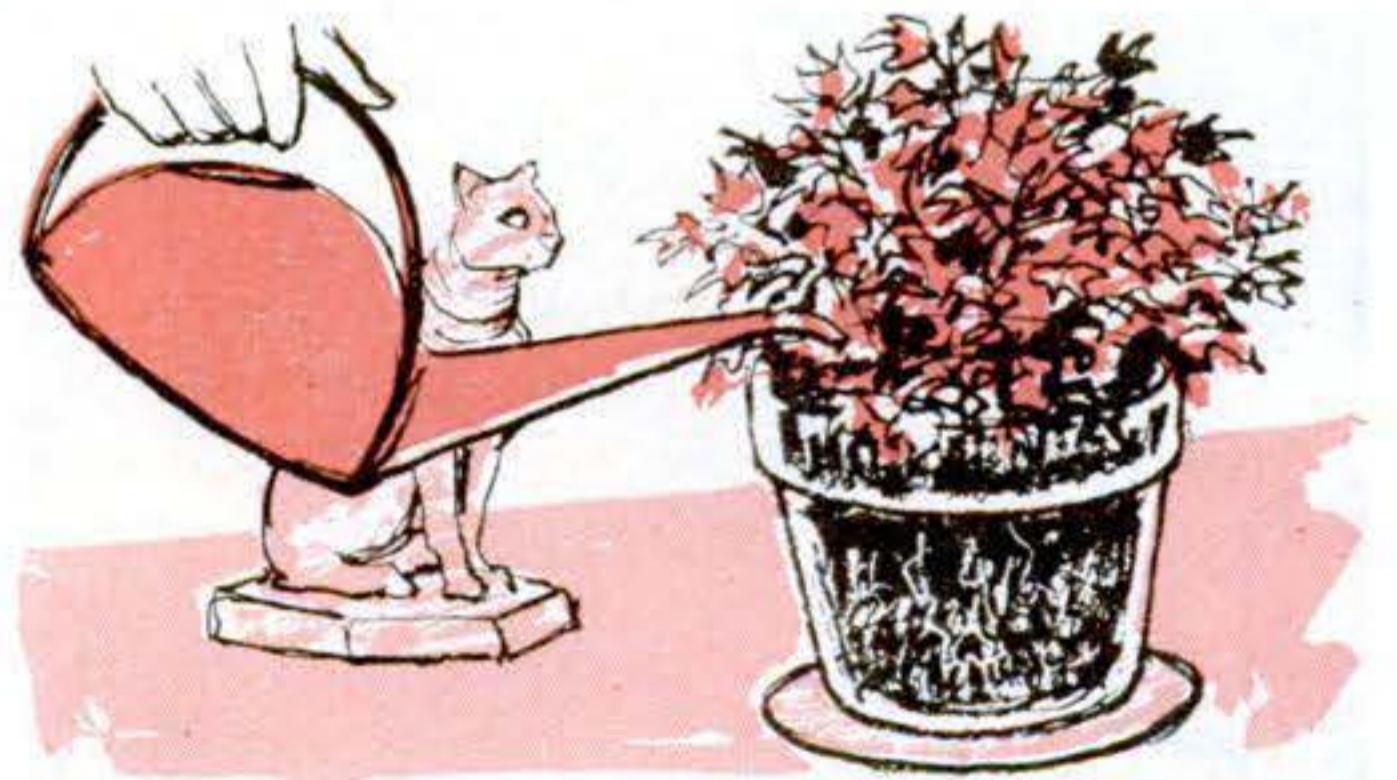

Transparent flowerpots for house plants so you could check depth penetration when watering and even determine when roots were outgrowing the pot.—*Roger Rachow, Omaha.*

Everyone has his own pet idea of a gadget that he would like to see in general use. What's yours? We will pay \$5 for each one published. Please use Government postcards

only. Send to ILTS Editor, Popular Science, 355 Lexington Ave., NYC 17. Write your name and address clearly. Contributions cannot be acknowledged or returned.

GIs will get firepower plus when . . .

The Sergeant Shoots Off

By Herbert O. Johansen

THE white-painted missile was only a little fellow, standing less than 35 feet in its bare fins—but it blasted off with a boom like that of its big brothers that can hurl astronauts into orbit or atomic warheads across oceans.

Sergeant is its name—a new Army nuclear-nosed artillery missile. Recently I watched A Battery of the 3rd Missile Battalion, 38th Artillery (from Fort Sill, Okla.), fire it from the desert floor of New Mexico's White Sands Missile Range—the first launching by tactical troops.

CONTINUED

Blastoff: Actual photo of first firing of Army's new artillery missile by troops.

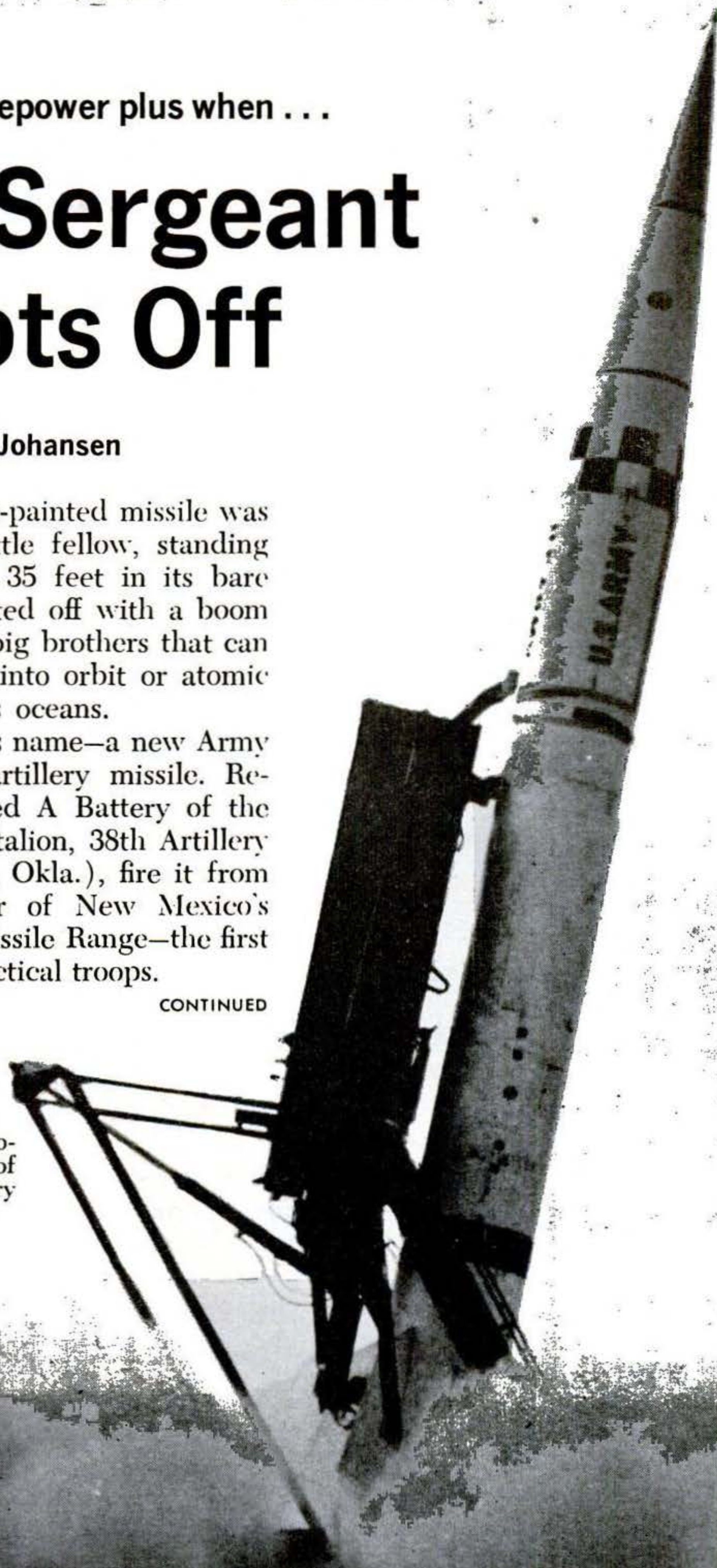

"The Sergeant missile embodies the traditional traits of the tough and battle-hardened Army sergeants for whom it was named"

GIs put Sergeant together on the double-quick. Here's how six



1 Assembly begins: Launcher boom is swung out as truck carrying rocket-engine and guidance-section containers pulls alongside.



2 Rocket section is lifted out of its container by an electrohydraulic hoist, hung and locked to boom's underside by three hooks.



4 Warhead—which can be nuclear, biological, or chemical—is mated. Detonation circuit will obey preset electronic-brain signals.



5 Control fins are attached to rear of the rocket. They provide aerodynamic stability, attitude control, and some maneuverability.

A limited-war, solid-propellant battlefield weapon, the Sergeant will replace the now outdated, liquid-fueled Corporal. In the Army's missile arsenal it will take its place between the shorter-range Honest John and Lacrosse and the much-longer-range Redstone and Pershing.

At zero countdown, poised on its launcher, the Sergeant's rocket ignited with the roar of a thousand angry bulls, kicking up a huge, enveloping cloud of desert dust. Then it came into view, streaking aloft with bright-orange flame spewing from its tail. Even after rocket

burnout seconds later, the missile could be followed by wind-whipped, squiggly vapor trails. Speeding at 2,000 miles an hour, it climbed to 28 miles—then nosed down toward a desolate tumbleweed and bunch-grass target 85 miles uprange.

There was an anxious wait for reports from an outer-range observation post. Then: "Shot good—within target area."

More complete data (some 70 optical and radar ground stations tracked the missile flight) followed on over-target impact: "In the pickle barrel," said a mis-

[Continued on page 202]

missilemen do the job in seven minutes—then “shoot and scoot”

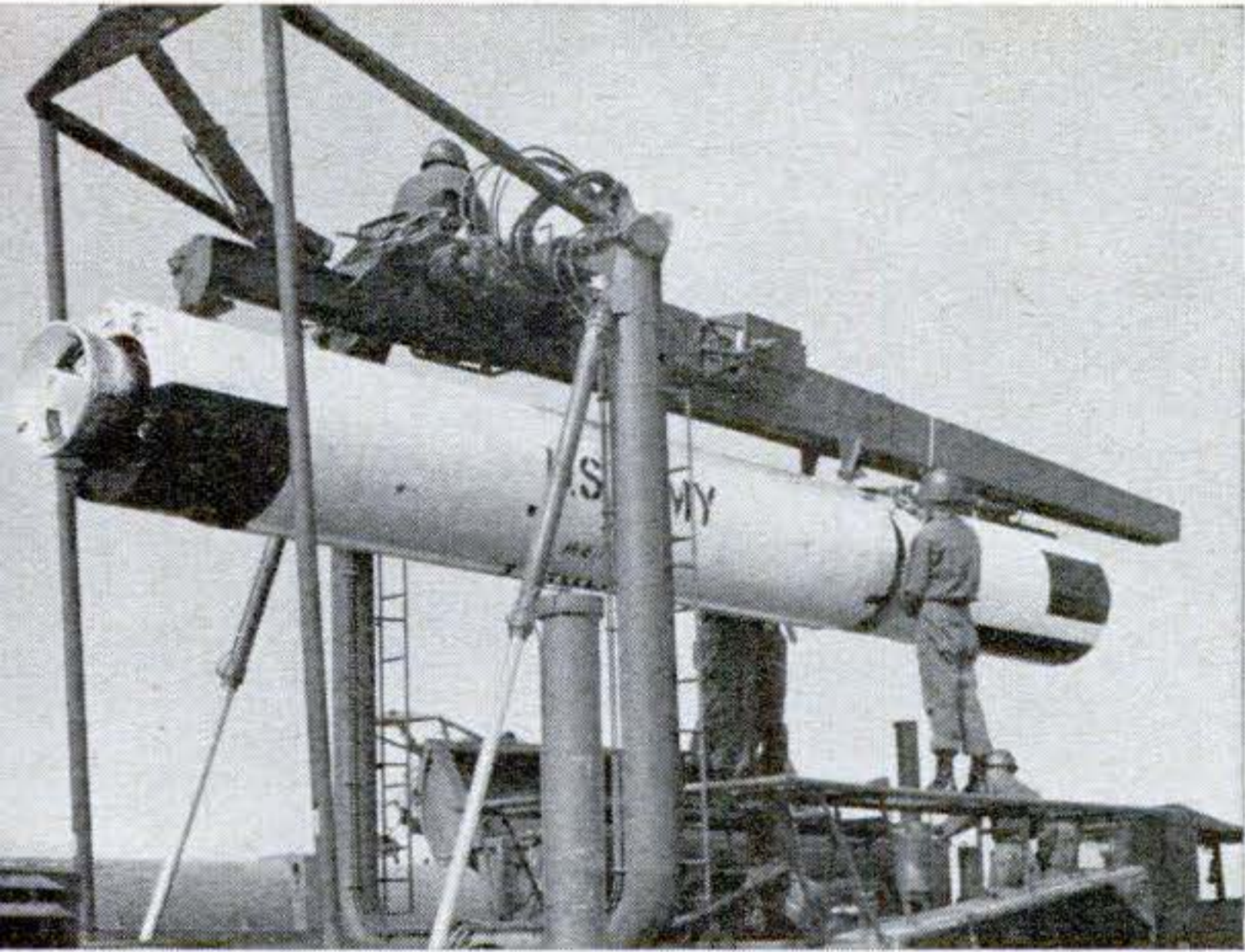

3 Inertial-guidance unit comes next. It goes ahead of the rocket engine, and is joined to it by four quick-connect, swing-type bolts.

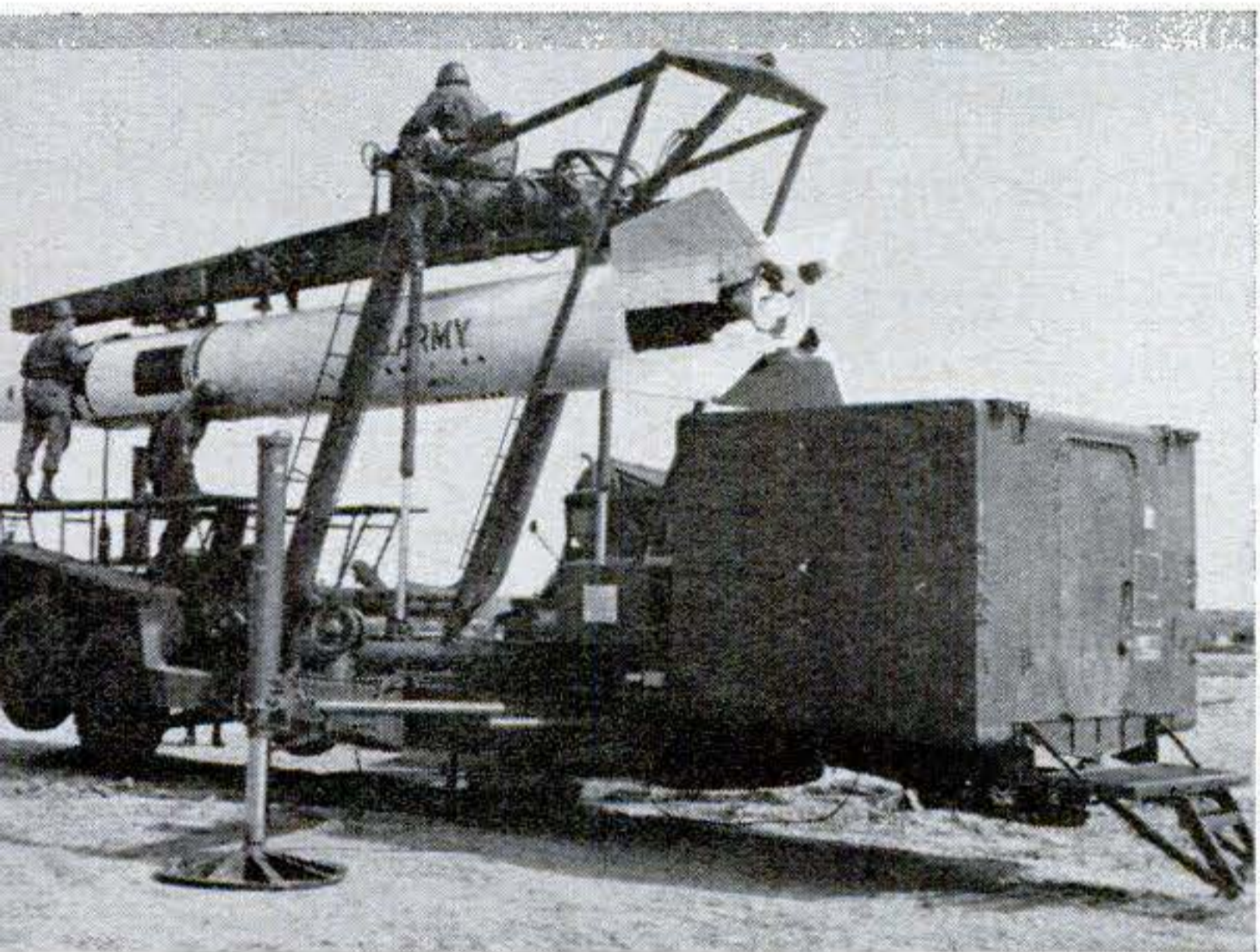

6 Missile assembly is rechecked. Because of generator noise, crew chief (on boom) uses hand signals to direct all operations.

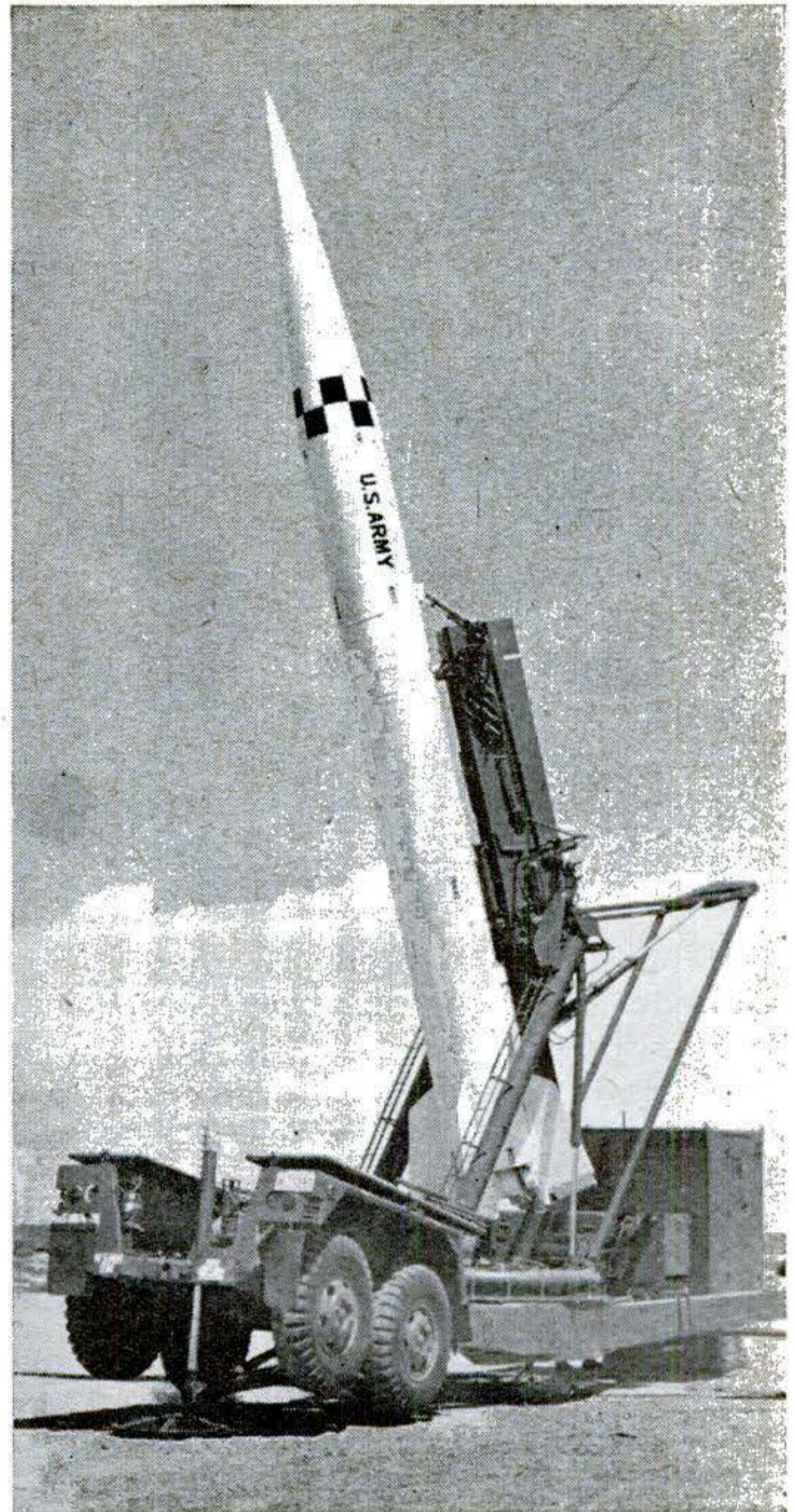

7 Launching angle is always 75 degrees. Large cabinet at rear houses computers and circuits to program the missile's flight mission.

8 Last few minutes of Sergeant countdown is monitored from a remote-control firing pit about 250 yards away from the launcher. Manual override can stop countdown up to the last split second if the missile self-testing circuits indicate a malfunction, or on radiophone orders from a higher command.



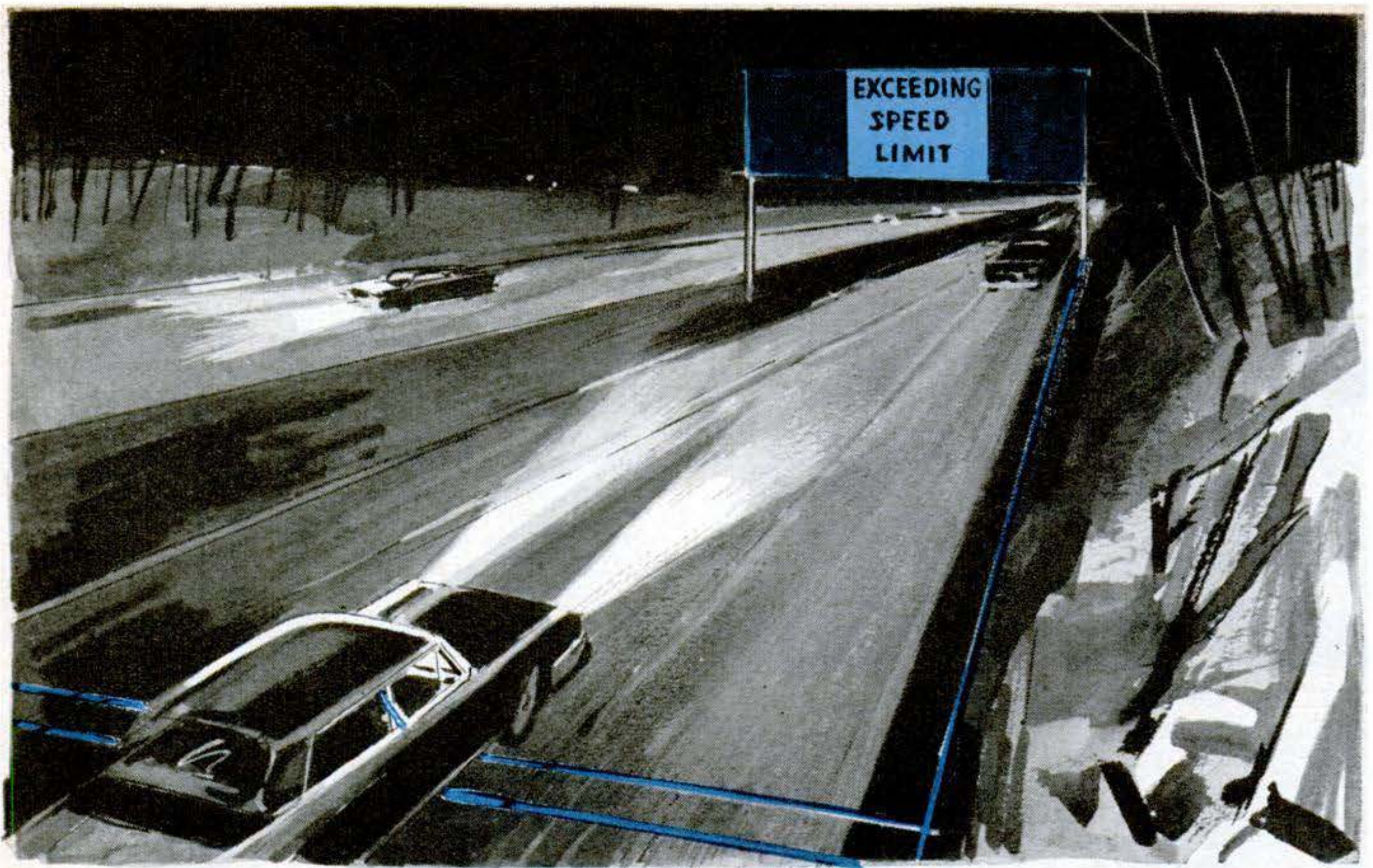

Sign lights if you speed. To alert drivers to unintentional speeding—and cops to the other kind—this recently patented sign would flash a warning ahead of a car that

was exceeding the local limit. Wheel pressure on hoses laid across the road would trigger switches in a speed calculator that would turn on the sign.

New ideas from the inventors

Bubble levels drill. Bracketed to the housing of your electric drill, the multiposition bubble level below would let you aim your drill horizontally or adjust it to several other angles. You'd hold the drill bit on a true line by keeping the bubble centered in the selected window.

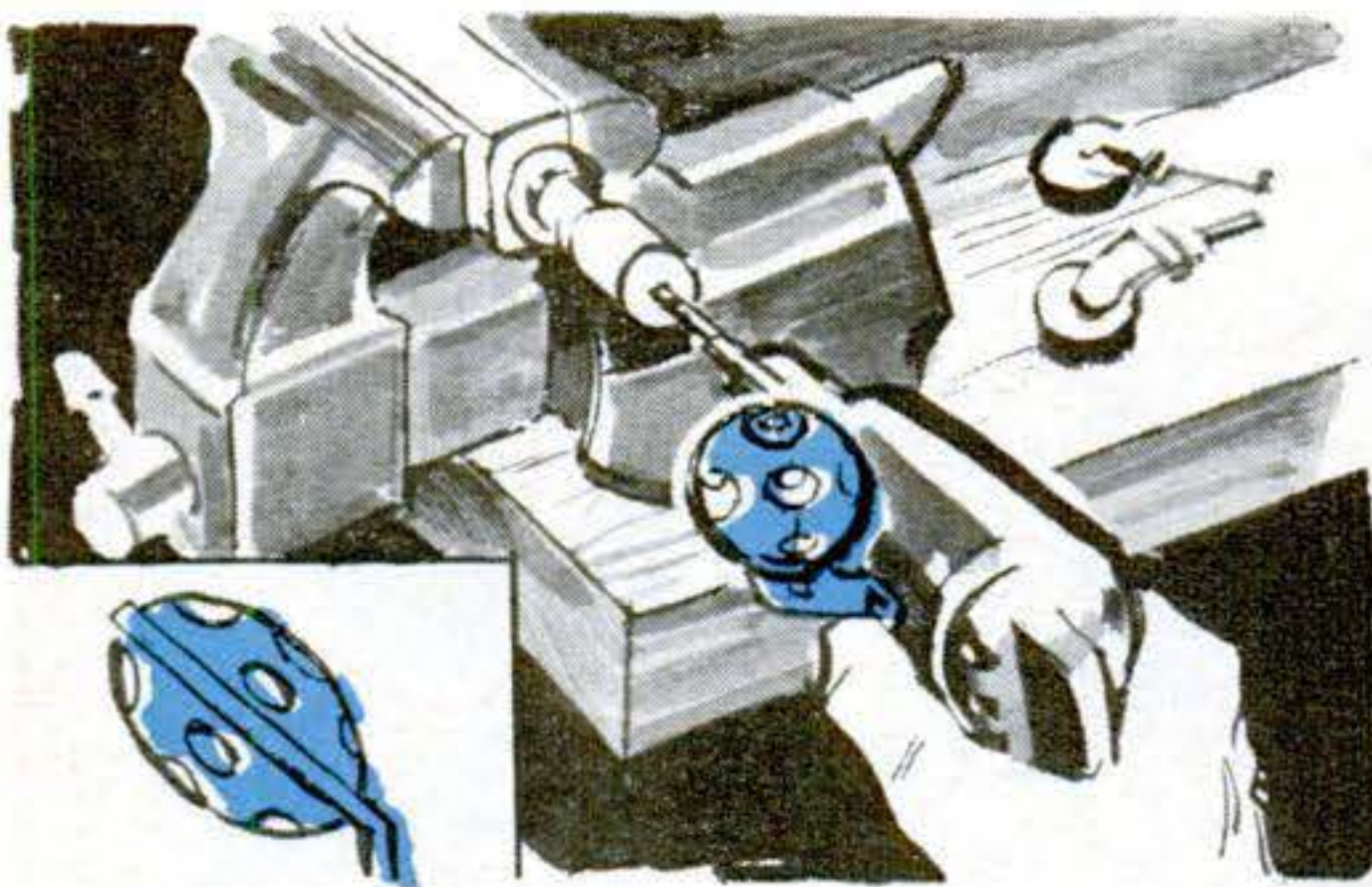

The following patents have been issued on these inventions: **Speed sign**—No. 3,054,087 to Rue L. Clegg, Salt Lake City; **Drill level**—No. 3,052,036 to Raymond J. Oliver, San Jose, Calif.; **Carriage rocker**—No. 3,048,419 to Martha Fredman, Milwaukee; **Amplifier**—No. 3,042,749 to Jarl A. Johnson, Pasadena, Tex.; **Mat Light**—No. 3,017,497, to Jack L. Albright, Racine, Wis.; **Swivel**

Carriage rocker calms baby. Clamped to the arms of a carriage or crib, this vibrator might help soothe baby while mother attended to other duties. A cam driven by a spring—or electric—motor would produce vibration by shuttling a spring-loaded weight from side to side.

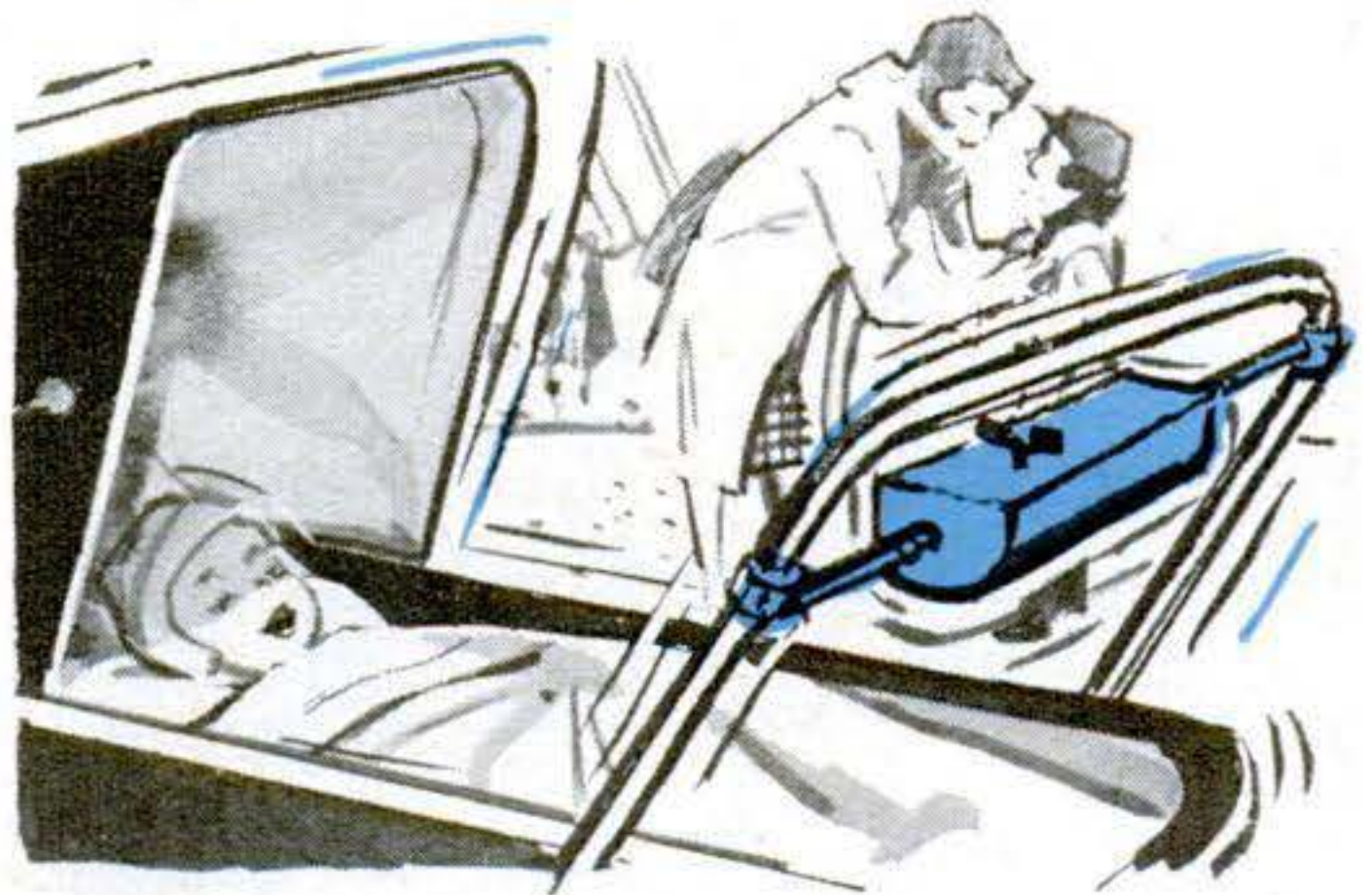

truck—No. 3,041,111 to Joseph W. Wyrick Jr., Little Rock, Ark.

Copies of patents may be ordered, by number, from the Commissioner of Patents, Washington 25, D.C., at 25 cents each. To write to an inventor, if the address given above is insufficient, address him (by name and patent number) in care of the Commissioner of Patents.



Amplifier moves with you. With this transistorized, portable, public-address amplifier hung around his neck, a coach, referee, tour guide, or even an after-dinner speaker could make himself heard while moving about freely. To free his hands, as well, he could use a strapped-in-place throat microphone connected by a standard jack.



Mat turns on night light. You wouldn't stumble in and out of bed in the dark if you had a mat like this at your bedside. You'd switch on the shaded light by stepping on the treadle as you got out of bed. When you next put your weight on the mat—getting back into bed—the treadle-operated switch would turn the light off.

Swivel truck levels load. A dump-truck operator could unload on target if his truck bed leveled the load even on tilted ground. And by holding loaded dirt or similar

loose cargo upright, this swivel-based truck body would let him carry a fuller load faster over rough ground and with less risk of spillage.

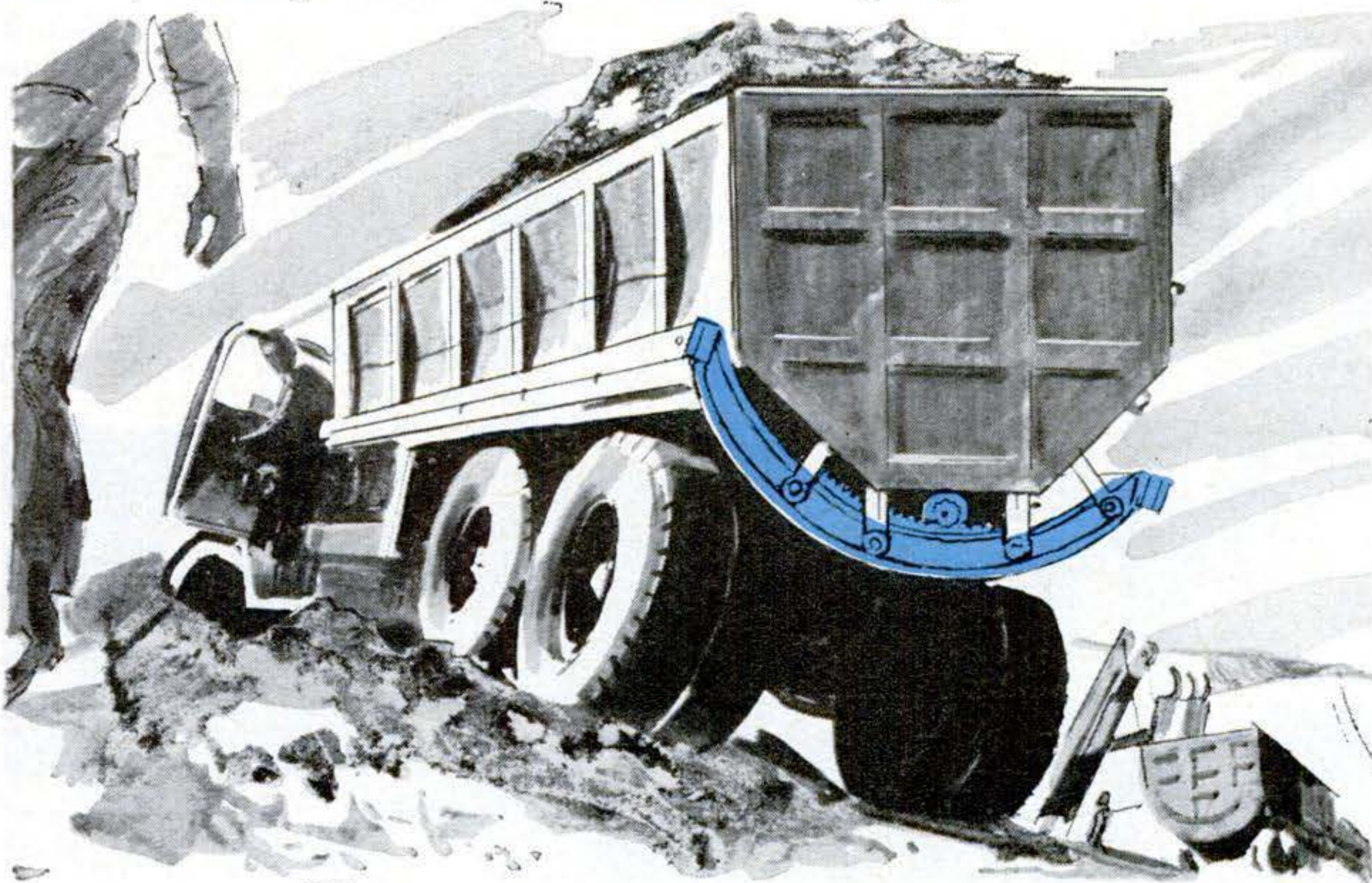



We ate a hearty breakfast and had a last sentimental dip in the Atlantic before setting

“American Kids Can Take It!”

They proved it in a hike across a Florida wilderness, living on snakes and swamp water in hundred-degree heat



We made a driftwood raft to ferry our packs across the mile-wide Halifax River. If the raft collapsed, our packs would float—buoyed by air in the plastic bags.

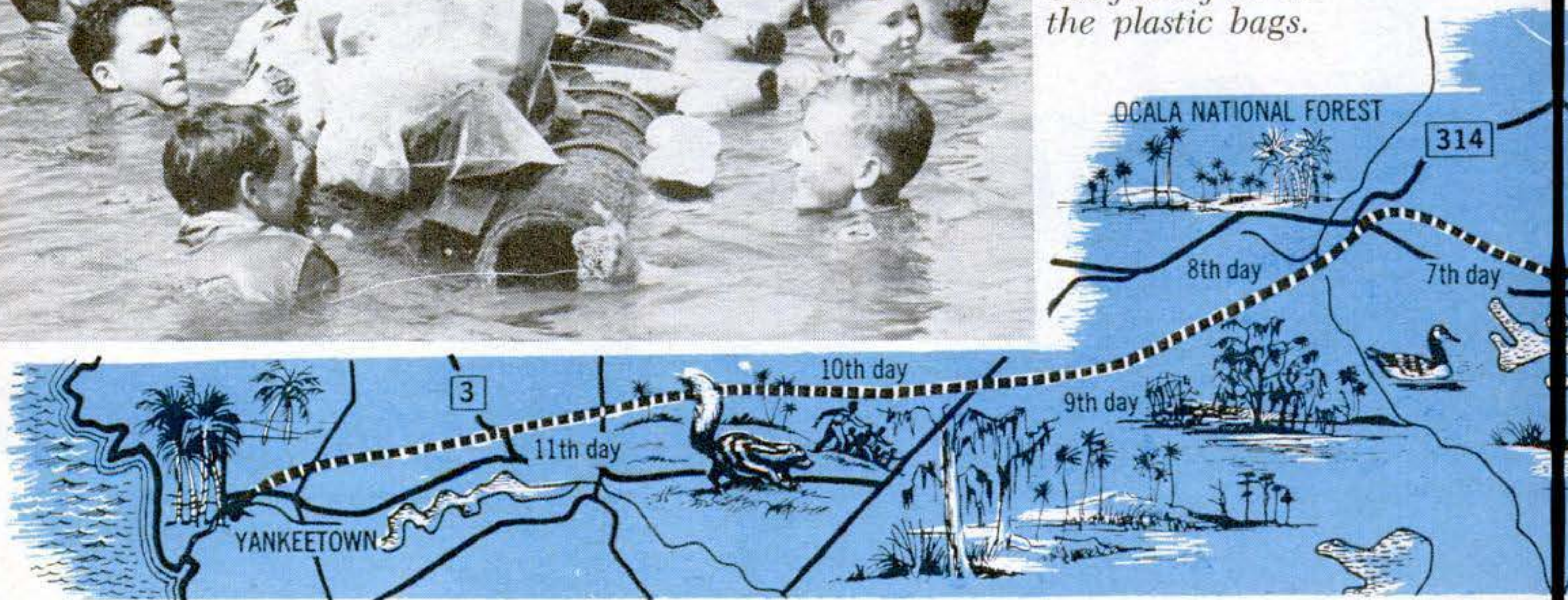



out across the sand dunes south of Daytona Beach. The time: 8:45 a.m., Monday, June 18.

By Ross Allen as told to Keith Vining

I'VE wrestled alligators and milked venom from more deadly snakes than I can count. I've explored the Everglades and tramped through Central and South American jungles. Yet not until last June, when I led eight boys across Florida from Daytona Beach on the Atlantic to Yankeetown on the Gulf, did I experience my toughest battle with Nature.

We were bogged down in uncharted swamps, maddened by insect bites, weakened from lack of food, nauseated by

swamp water. We were up to our waists in clinging, stinking mud, hacking a path through impenetrable brambles, making less than a quarter-of-a-mile-an-hour progress in 100-degree heat.

This was a survival hike. Our knapsacks contained no food—we would have to forage for that—and only a quart of water each.

We had vowed to cross the state in two weeks or less. The map distance was a little over 120 miles. But detours would add another 30.

I had dreamed of the trip for years,

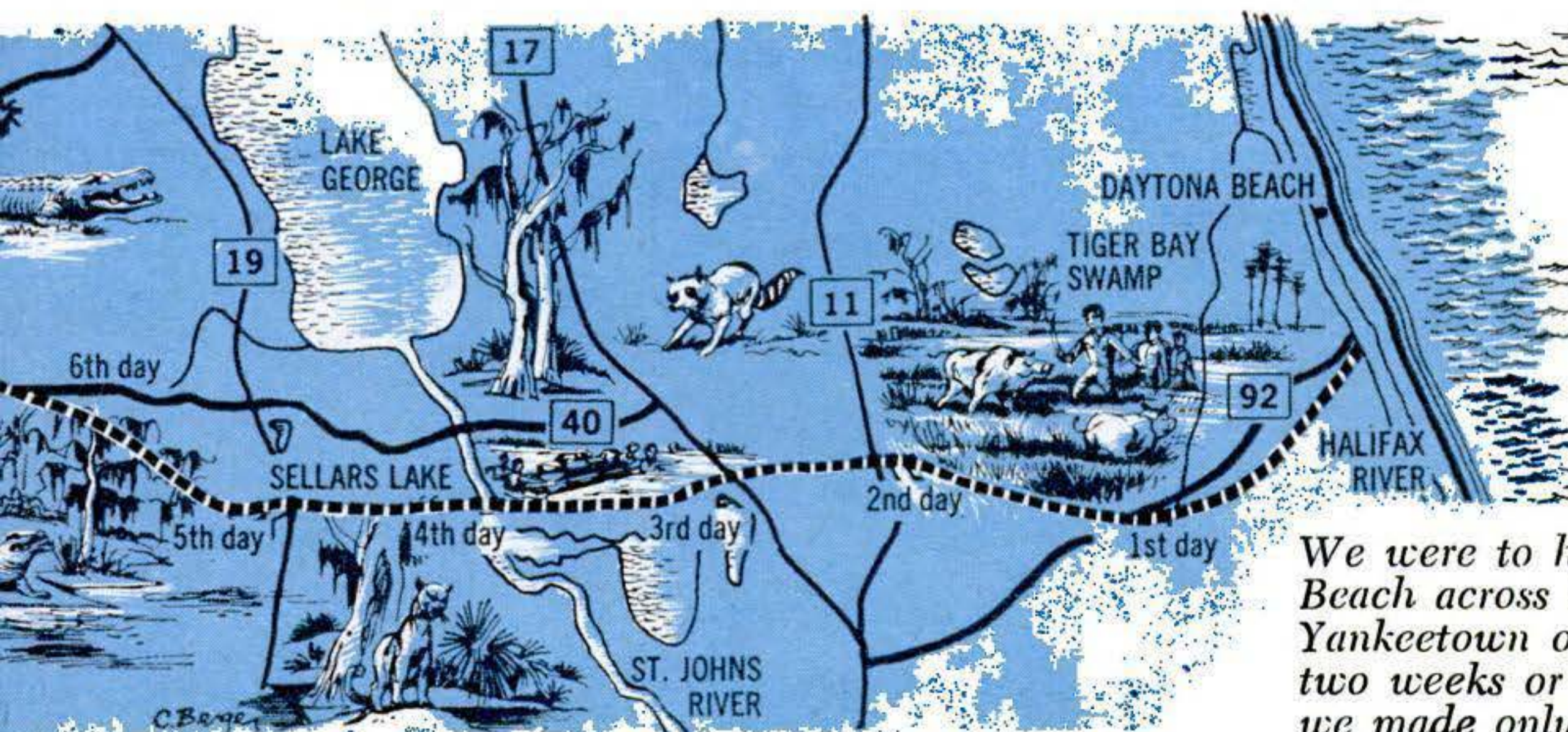

There were no detailed maps, no easy trails, in the 12-day, 150-mile hike

We were to hike from Daytona Beach across Florida to Yankeetown on the Gulf—in two weeks or less. Some days we made only five miles.



The shore of the St. Johns River was all marshland, so instead of fishing or camping there we had to lash a raft together and swim the deep quarter-mile river before dark.

We were lucky in killing two young wild pigs on the second day out. Robert Rile and Bob MacKichan skinned one of them.

We often hiked and hunted at night when it was cooler. We used our miner's headlamps to capture and kill this armadillo.

SILVER SPRINGS STUDIOS



planning to train boy scouts for it. I chose eagle and explorer scouts, and the eight who finally set out with me were the elite of scores who had volunteered.

We were to live off the land, to simulate what a group might find if they were forced into the wilds. But we had an added handicap: We would have to obey all wilds-preservation and hunting laws. In addition, we would have no weapons except our hunting knives and one machete for the group.

We would be dependent on wild fruits, berries, or other plants we could find in the wilderness. For meat we would have to catch fish, frogs, reptiles, skunk, wild hog, opossum, raccoon, armadillo, and even grasshoppers. We could take only the barest essentials to sustain life in the jungle:

Salt, matches, hunting knife, spoon, pocket knife, mosquito bar, plastic bags, insect repellent, aluminum foil, antivenin kit, water-purification tablets, compass, whistle, miner's headlamp, soap, small towel, socks, underwear, handkerchiefs.

These items, plus a canteen and the haversack itself, were to weigh less than 10 pounds.

Here, from my log, are highlights of what turned out to be a nightmare journey that lasted 12 days.

First day, Monday, June 18. We waded in the Atlantic Ocean as a last sentimental gesture, and set out across the sand dunes heading due west. The time was 8:45 a.m. It took an hour to cross the land and reach the Halifax River at a point where we could find driftwood to make a raft. We lashed old logs and boards together with some garden hose we'd found, and soon had a fairly substantial raft.

We put our haversacks in plastic bags and tied them up, trapping a little air inside. If the raft broke up, the packs would float.

Wading ashore on the other side, near Port Orange, at 11:00, we wrung out our clothes, got our packs on, and at 11:45 headed for our first check point. The temperature was 91.

A couple of miles inland we ate a hasty

[\[Continued on page 198\]](#)



SILVER SPRINGS STUDIOS

Allen cuts a seed pod from a wild sunflower. The seeds were good eating.

A mild-mannered Tarzan of the Florida jungles

Ross Allen has pitted himself against nature for most of his 54 years. Now head of the Reptile Institute at Silver Springs, Fla., he has probably had more experience with snakes than anyone else in the world.

A stocky, smiling-eyed, soft-spoken man, who looks more like a small-town banker, Allen's job is raising snakes for venom. He personally milked each of the 73,960 snakes required to provide 90 percent of the antivenin used by the armed forces in World War II.

Allen's enthusiasm for nature began early. At six he was skipping classes and wandering the fields and forests. He grew up to wrestle alligators with the Seminole Indians. Somehow he also found time to gain a college degree and raise a family.

Asked his plans for the next Cross-State Survival Hike, Ross replied, "I'm planning some shorter ones—for girl scouts."

Meanwhile you can find him dressed in a white shirt, khaki pants, and moccasins—wandering through the Seminole Indian Village, the Reptile Institute, or the Anti-Venom Laboratory at Silver Springs.

Scoring: Game is 7 points; set, 3 games in 5

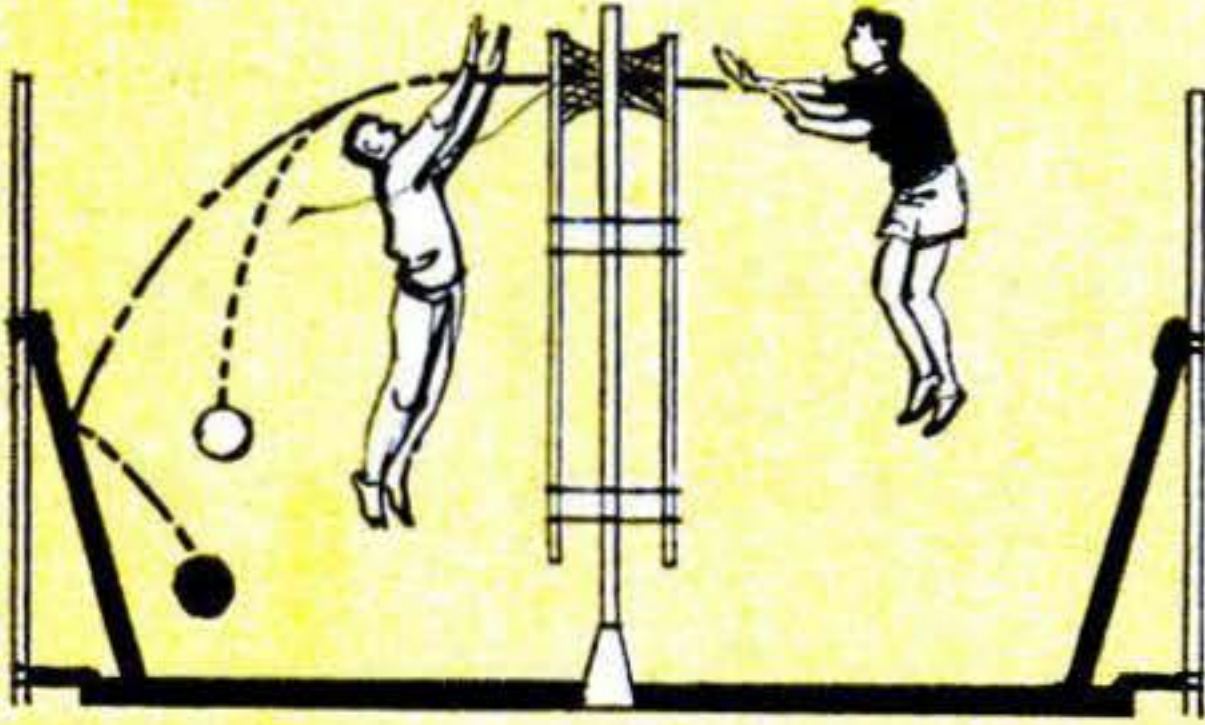

Server scores one point when he passes ball through gantry and beyond receiver, striking scoring zone on backstop or trampoline bed.

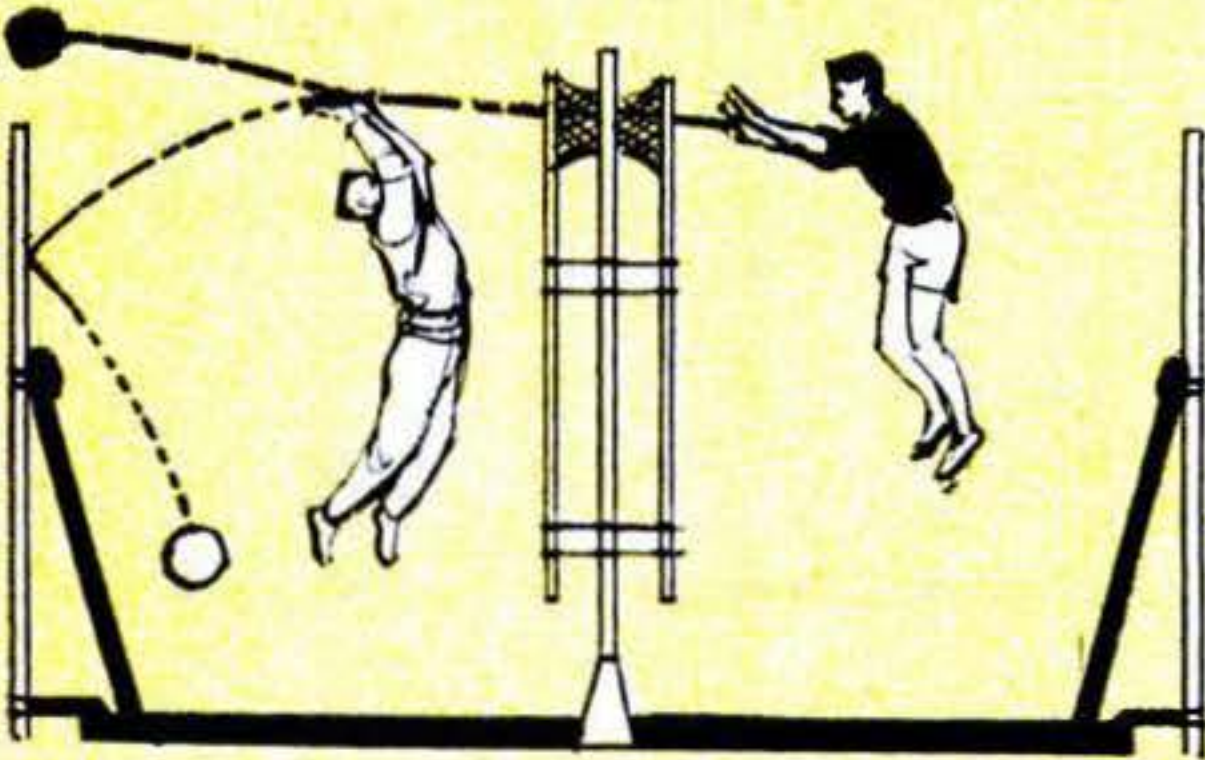

Server also scores when "butter-fingered" receiver fails to catch ball, merely deflecting it, even if it doesn't strike scoring zone.

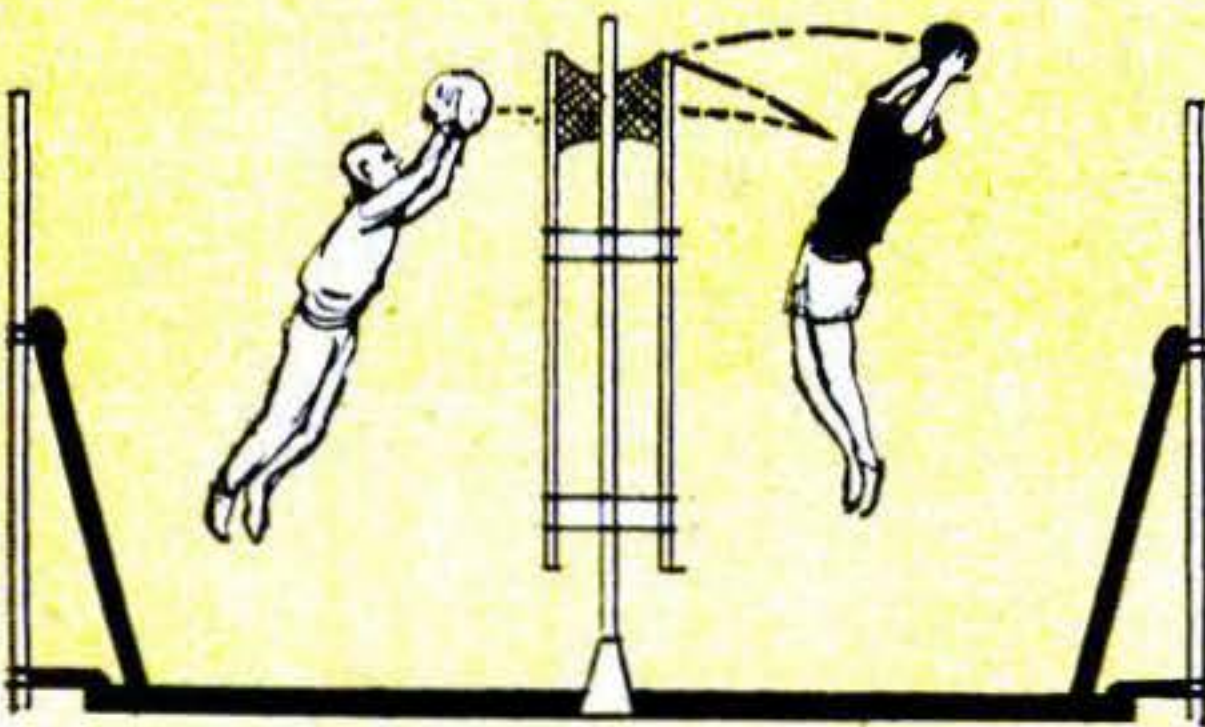

Neither player scores if ball hits gantry, bounces back, and is caught by server, or if thrown through basket and caught by receiver.

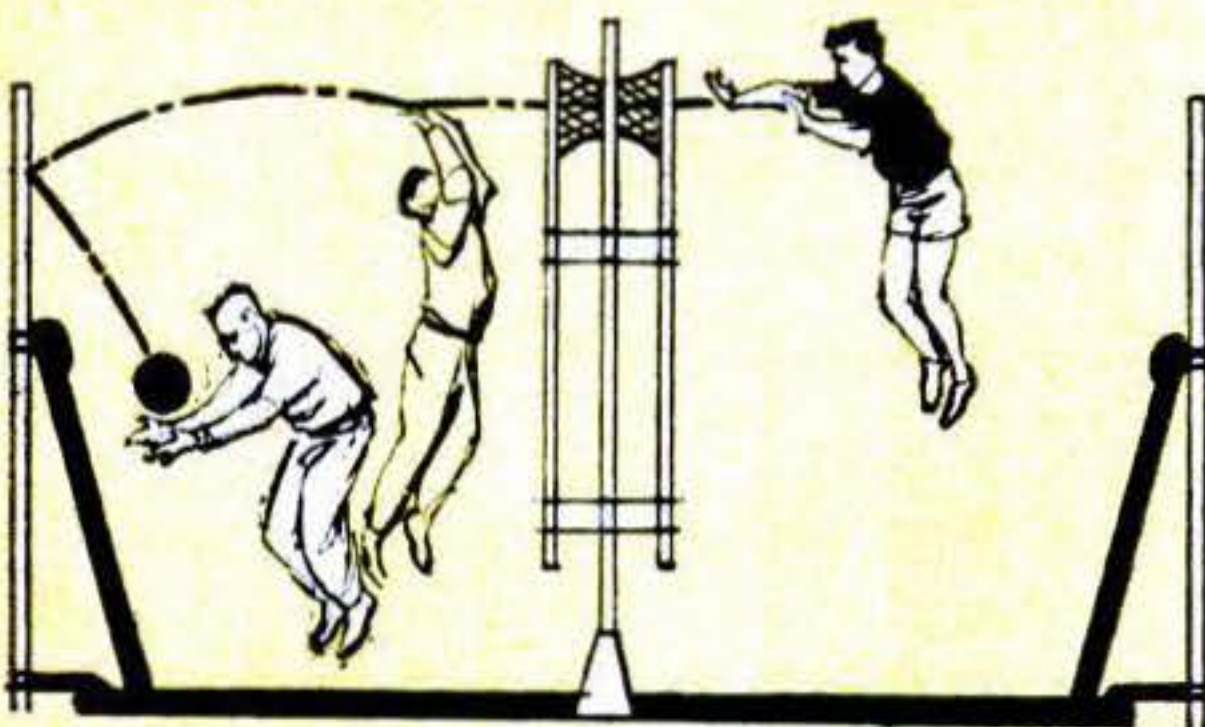

There is no score if defense tips ball but catches it before it hits bed. Touching gantry or stepping over center line is point penalty.



Space Ball

Nearest thing to weightlessness is this new three-dimensional game

Receiver scores point if server throws ball through gantry basket and sends it completely out of playing area, provided receiver doesn't touch it as it passes.

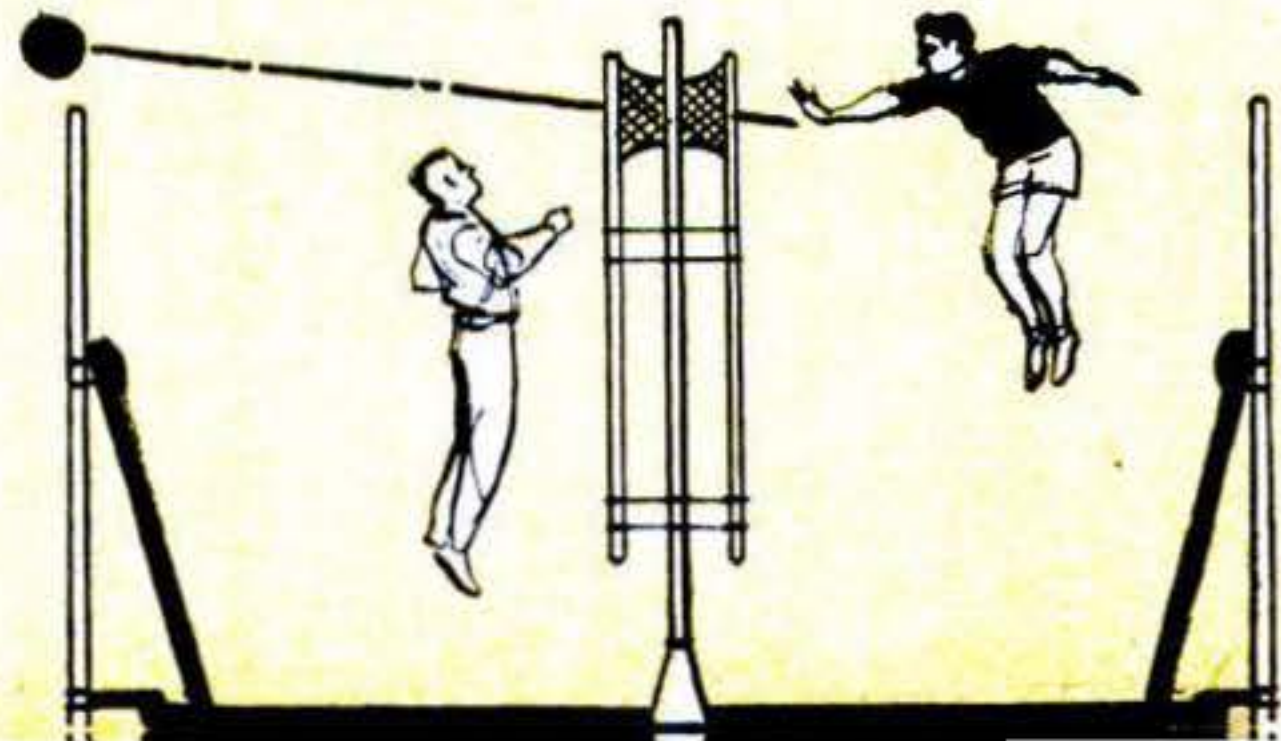

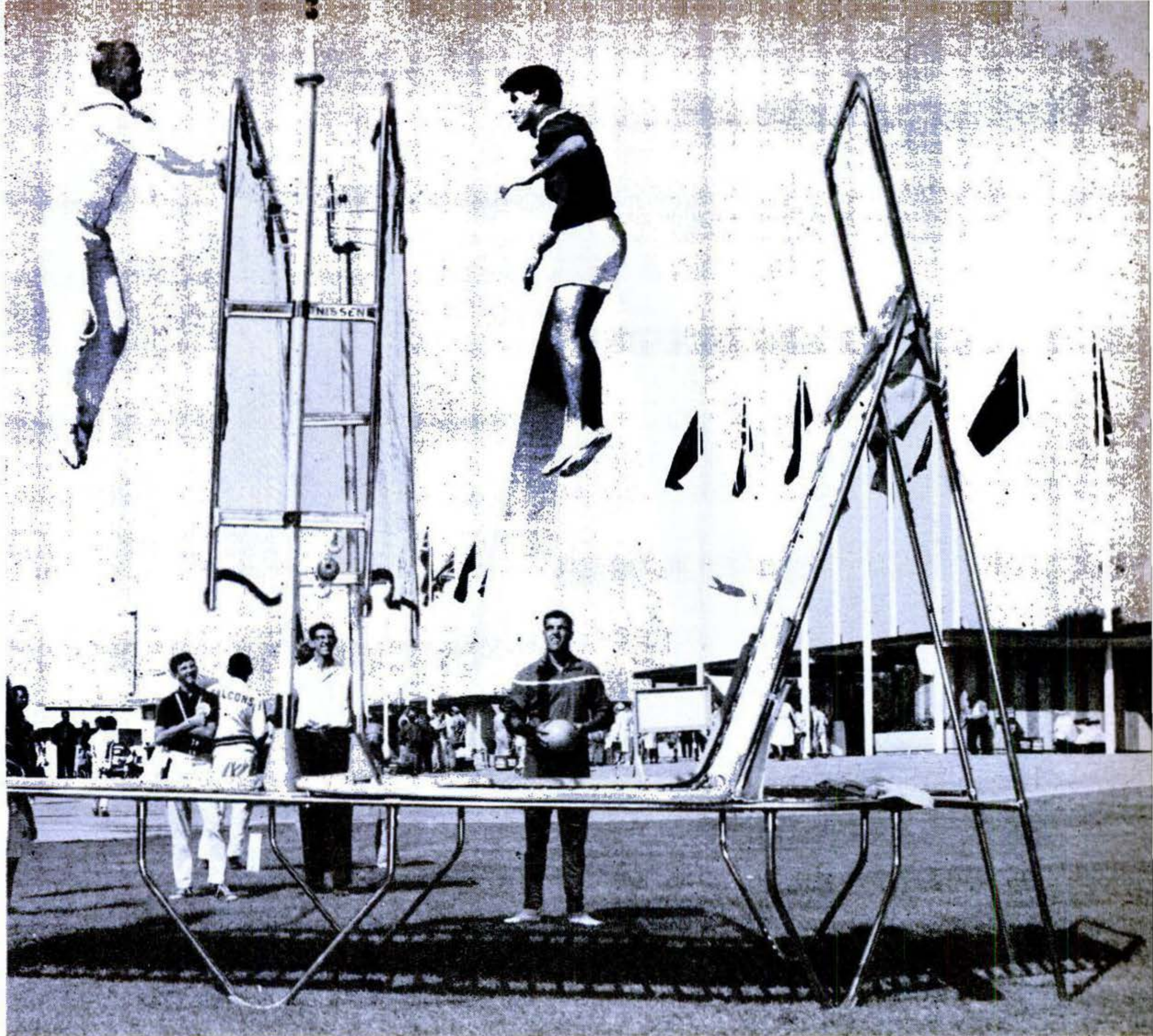

CATCHING on all over the country is this exciting gymnastic game played while contestants are weightless, or nearly weightless, while bouncing on a trampoline. It resembles volleyball but adds a third dimension of space to the length and width of the court. The ball is served through a basketlike hole

in a net-hung upright called a gantry. The skill, says the inventor, George Nissen of Cedar Rapids, Iowa, is in judging when the ball is coming through, for once a player starts his bounce he can't stop. Extra equipment needed are the gantry and two backstop nets.—*Henry and Vera Bradshaw.*

Receiver also scores if server misses basket or hits rim and ball falls to bed. If receiver reaches into basket, however, it's a foul, and server scores.

Simplest way for receiver to score is merely to catch ball on rebound when it's thrown by server outside scoring zone and bounced back into playing area.

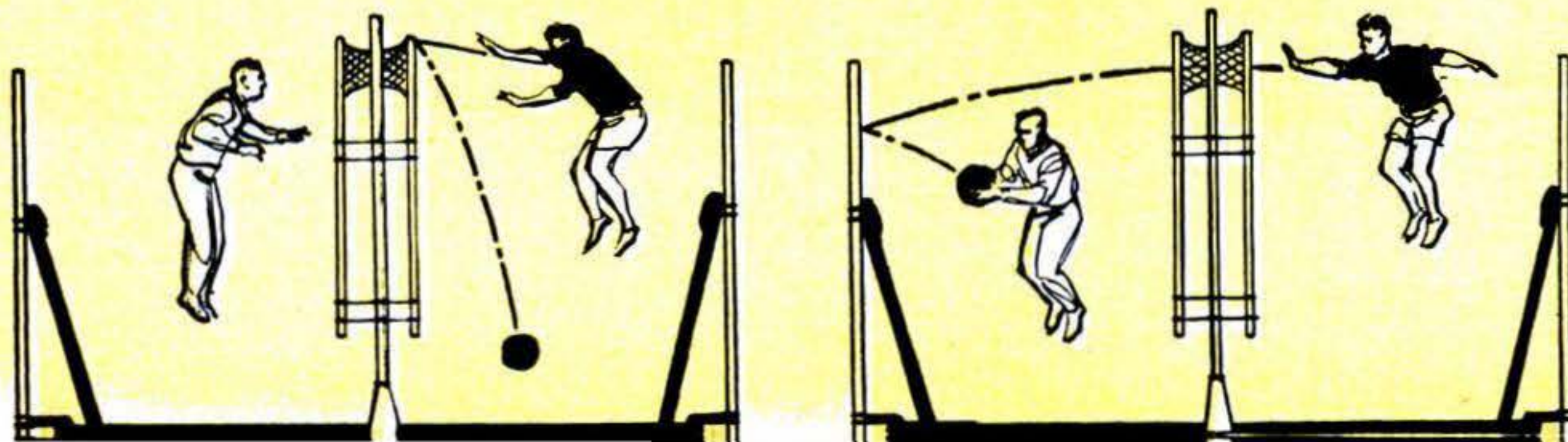



IN CALIFORNIA one day a truck throbbed up a mountain road. As it rounded a turn, the driver saw a curious ripple of snow on the pavement. Then the snow rose like water in a flash flood and hurled the truck off the road.

The driver leaped for life and escaped. He was lucky. Not many people caught in an avalanche live to tell about it.

Near Seattle two climbers saw a white wave running down a mountain at incredible speed. A killing wind hit them. They tried to run but were swept to death in an avalanche. So was a dentist snowshoeing in Wyoming. So was a trucker eastbound from California on U.S. 160.

In Colorado recently a highway maintenance man on U.S. 550 felt himself

whirled over, 20 times, by a vicious wind.

"It was like a tornado lying down," he told me. Then snow buried him. "I tried to swim in it," he said. "People always do. I've found them frozen in swimming positions." He, too, was lucky. Hours later he was dug out alive, and today an avalanche is named for him: the Henry Brown.

Although there are hundreds of avalanches each winter in our high mountain states—from California to Maine—you haven't heard much about them until lately. The reason is simple: Mountain people have always avoided them like rattlesnakes. They strike over and over again in the same valleys, and their haunts, or chutes, are well known. Some have been given grim or even hateful

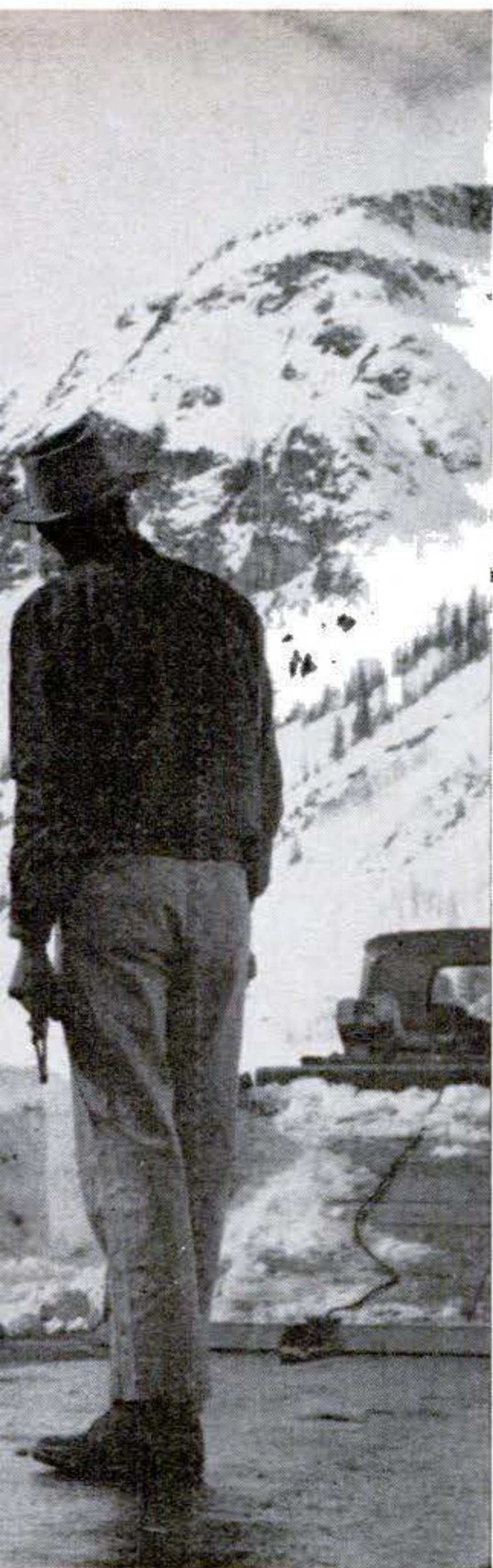

On U.S. 550 in the Rockies a cannon barks and a shell screams skyward as the world's most unusual highway crew goes into action

I Rode with the Avalanche Patrol

By E. D. Fales Jr.

Through field glasses, the patrol engineers watched the shell climb. After five seconds a flash lit the peak and all hell broke loose.

names, like Black Widow, Slippery Jim, and Sudden Death. The alert Colorado Highway Department now maps them. One is listed eloquently on official maps merely as the "S.O.B."

But lately millions of tourists, salesmen, and skiers have been venturing into avalanche country on growing networks of good roads. Lodges, resorts, houses, and whole towns have been built near big slides. Many people don't know their danger—as was the case in a hamlet on State Highway 82 near Twin Lakes, Colo., which was hit by an avalanche last winter.

The busiest avalanche state. As a result, all high mountain states and even the U.S. Bureau of Roads now have avalanche warning—and control—projects.

The remarkable thing is that there haven't been *more* tragedies, and in Colorado, "busiest" avalanche state of all, credit for that goes to the State Highway Department's lifesaving Avalanche Patrol.

Besides planning defensive earthworks to dam or deflect slides, the patrol keeps an eye on several hundred known chutes in every storm. It warns and guards motorists, and sometimes attacks the poised snow fields with cannons—to kill the killer slides before they can strike.

Just after the tragic Twin Lakes slide last winter, this reporter rode with the patrol in the soaring San Juan mountains of southwestern Colorado. We went gunning for an avalanche. We took along an ugly bulldog of a cannon, and in an awe-inspiring moment we got us one.

CONTINUED

113

When I met the patrol I learned first that the study of avalanches has become a real science. Often they build on slippery ice formed by early winter storms. They grip the mountain at the edges—but may lie in brittle slabs unsupported in the center. Snow engineers check them visually and test them by thrusting sampling poles deep into them. By studying the sample cores in laboratories, the engineers can tell when a slide is getting ready to fall.

Many don't need such analysis. Snow blowing over mountain tops gets trapped on the lee side and comes down by the ton. Thus many lee-side avalanches load up heavily and "run" in almost every big storm—after a foot or so of fresh snow is measured on the level.

In avalanche country, keep going. Roads in many mountain states now are marked with signs that warn: DON'T STOP NEXT MILE. The word "avalanche" isn't used, for fear of frightening people unnecessarily. But I learned this from the patrol: *If you ever see such a sign in winter, don't dream of disobeying it.*

Not long ago, in one Western state, a man did. He left his wife parked in his car while he went skiing. Moments later an avalanche roared across the road. It missed the car but took him with it. He was dug out hours later, dead.

If you should ever be trapped in an avalanche while driving in a mountain state, what should you do? Patrol members say only: "It has happened to us once or twice. As a result we now always keep our windows tightly closed. If our trucks get buried, this holds a small reserve of air that may help until assistance comes."

Above all, I learned, no motorist should ever trifle with a snow slide. It may look "purty," as they say up here, but it's deadly. Once buried, in a car or out of one, a man may never dig out; the snow closes in like cement. Men have been found dead after tunneling as much as 30 feet the wrong way—*because they didn't know which way was up.*

[Continued on page 214]

Terror

ON STATE HIGHWAY 82, near Twin Lakes, I learned how cruel an avalanche can be. I got the story, standing on the mulchlike wreckage of what had been, until a few days before, a hamlet of pleasant homes. I heard it from survivors who still talked in frightened tones. Toward dark on the evening before tragedy, a well digger named General Shelton, who lived near Route 82, had paused to look up the snowy slope of Mt. Elbert, 14,431 feet high.

It had been blowing a gale, and there was talk of avalanches. But the Sheltons weren't worried—first because no slide had ever come this way, and next, because of a great boulder that towered over their house.

"If one *does* come," Shelton had told the postmaster, "that rock will split it around my house."

The mountain lay many feet deep in snow "slabs." Avalanches are often made up of slabs—some heavy as rock, overlying each other like shingles on a roof. Strange things have triggered these slabs—auto horns, shouting, thunder, sonic booms.

No one knows what triggered the slide. Trouble began toward 5:28 a.m. Far up, in the darkness before dawn, snow came down two chutes, joined, and in seconds the whole mountain seemed falling.

Directly in the path lay the Gordon mine, an abandoned gold digging with heavy-timbered buildings, a power plant, and a locomotive-size steam boiler. As the snow came down, the wind ahead of it pushed these off the cliff. Trees began going, and soon thousands of tons were pouring down toward the homes on Route 82, two miles below the mine. Riding the crest came the grotesque steam boiler.

Down below the avalanche, General Shelton, his wife, and three children slept secure in knowledge of that sheltering rock. Next door was his brother's house, but as fate had it, his brother and family were away. Across the road, rancher Bill Adamich and his wife were in bed. Their twin sons slept in the next room. Some distance away, Adamich's cattle dozed in his 100-foot barn.

Perhaps 150 feet from the Shelton house,

at Twin Lakes



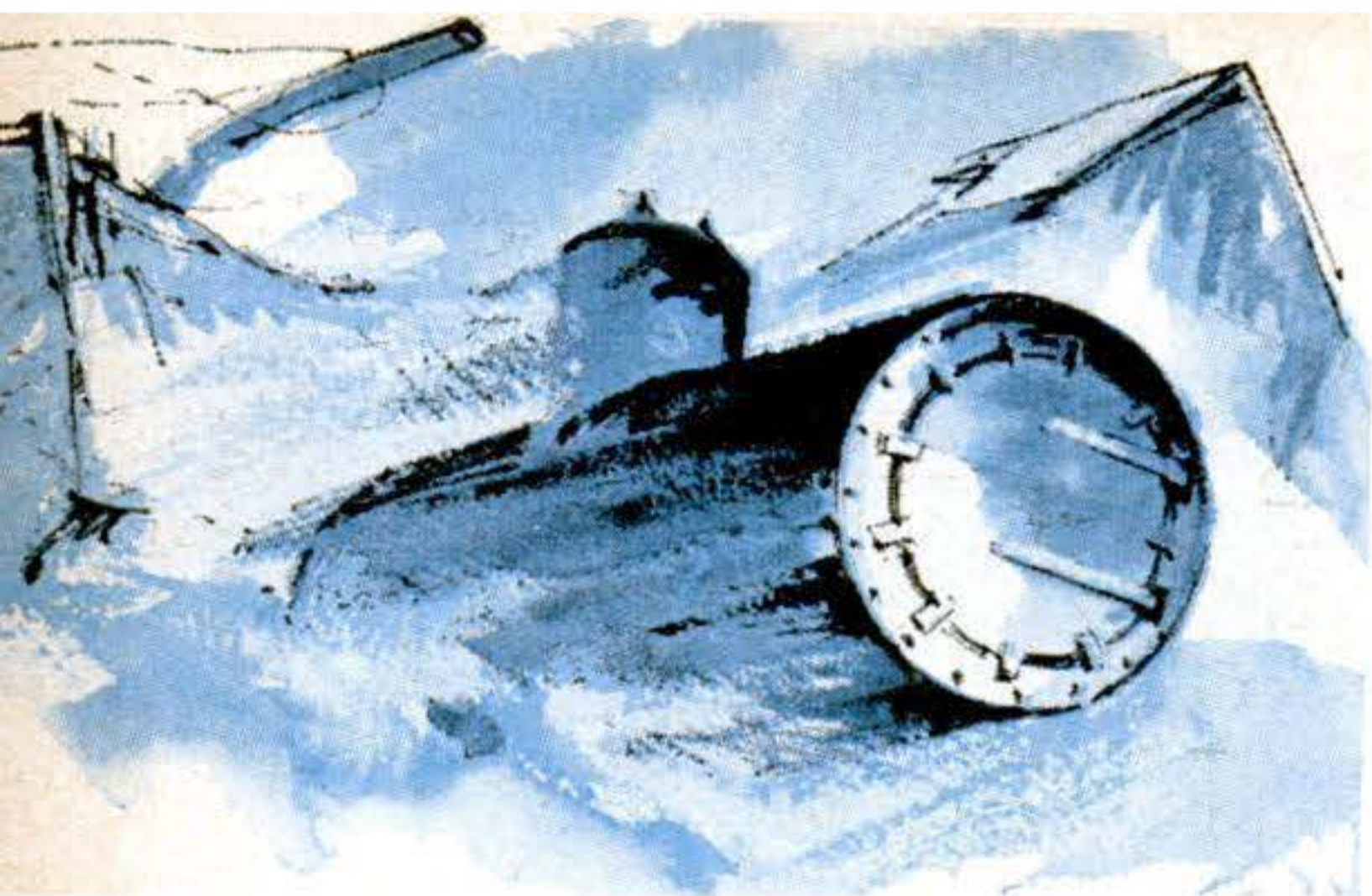

Flung toward the town at 130 m.p.h., the mine boiler traveled two miles on the snow wave.

Nels Lindstone, 66, a builder, slept in a trailer in his back yard. He had rented his house to a family named Rowe, and they were asleep, too.

Lights were on in at least two houses. Toward 5:25 a.m., Adamich's dog, Pepe, had whined, waking his master. Deciding Pepe wanted to get out, Adamich had opened the door. It was still snowing. The dog went out into the snow and Adamich went back to bed and dozed off.

But a quarter-mile away another neighbor, Bud Davis, and his wife were wide awake. Bud was smoking and noted that the electric clock said 5:30. Suddenly the lights went off and Davis heard a roar, but only for an instant.

"It sounds like snow just fell off our roof and broke the wires," he told his wife. "I'll fix them when it's daylight." They went back to sleep.

Another neighbor, Frank Cerise, awoke at 5:30 to find his wife standing nervously at a window.

"What's the matter?" he asked.

"Oh, that awful wind started to blow again," she replied. Cerise recalled having heard, for a second or two, a hollow roar like a rising gale. Mrs. Cerise moved her collection of 40 African violets away from the window, and the Cerises went back to sleep.

Into the ravine. The avalanche, a few seconds before 5:30, entered a deep ravine a quarter-mile above Route 82. By rights it should have ended right there, for the ravine lay back of a wall of rock as high as a 30-story skyscraper.

But such was its fury that it never stopped. It fell 300 feet into the ravine on one side, crushing trees, then *climbed* 300

feet up the opposite rock wall and poured over the top. All this happened in a flash.

The slide now had attained its maximum width of nearly a quarter-mile. It was moving like a snake. Ahead raced that terrific avalanche wind; behind was a powerful vacuum. As it sloped up over the last ridge and started down, another vacuum may have been created above it.

At exactly 5:30 by the electric clocks that stopped, it hit Route 82.

Rancher Bill Adamich, just dozing off (after letting the dog out), heard an explosion, thought his furnace had blown up, and tried to jump out of bed. He never made it. His house was lifted and blown away. The acceleration was such that he slid part way out of bed.

The wind hurled the house 400 feet due south. Snow piled over it. Two closet doors and a dresser fell on Adamich and probably saved his life.

He kept calling his wife and sons. He had no way of knowing that his wife was buried eight feet beneath him, still alive but pinned as if in concrete. Nor did he know that his sons had been sucked out through the windows by the vacuum, and were dead.

The avalanche whirled within 100 feet of Nels Lindstone's trailer but left it unharmed. Lindstone and his neighbors slept on.

When day broke, about 7:30, it was still snowing. In his trailer, Lindstone woke up, and as usual got his own breakfast. Toward 8:30 a.m. he heard someone at the door. His tenant, John Rowe, stood there, horror written on his face.

"Funny thing," says Lindstone, "he was there but he wasn't looking at me. He was staring over his shoulder. I said, 'What are you looking at, John?' He said, 'Come see for yourself.'"

Lindstone, a slow-moving man, came out into the zero morning, drawing on mackinaw and gloves. He stood with Rowe for

Lindstone and Rowe started out, not believing their eyes.

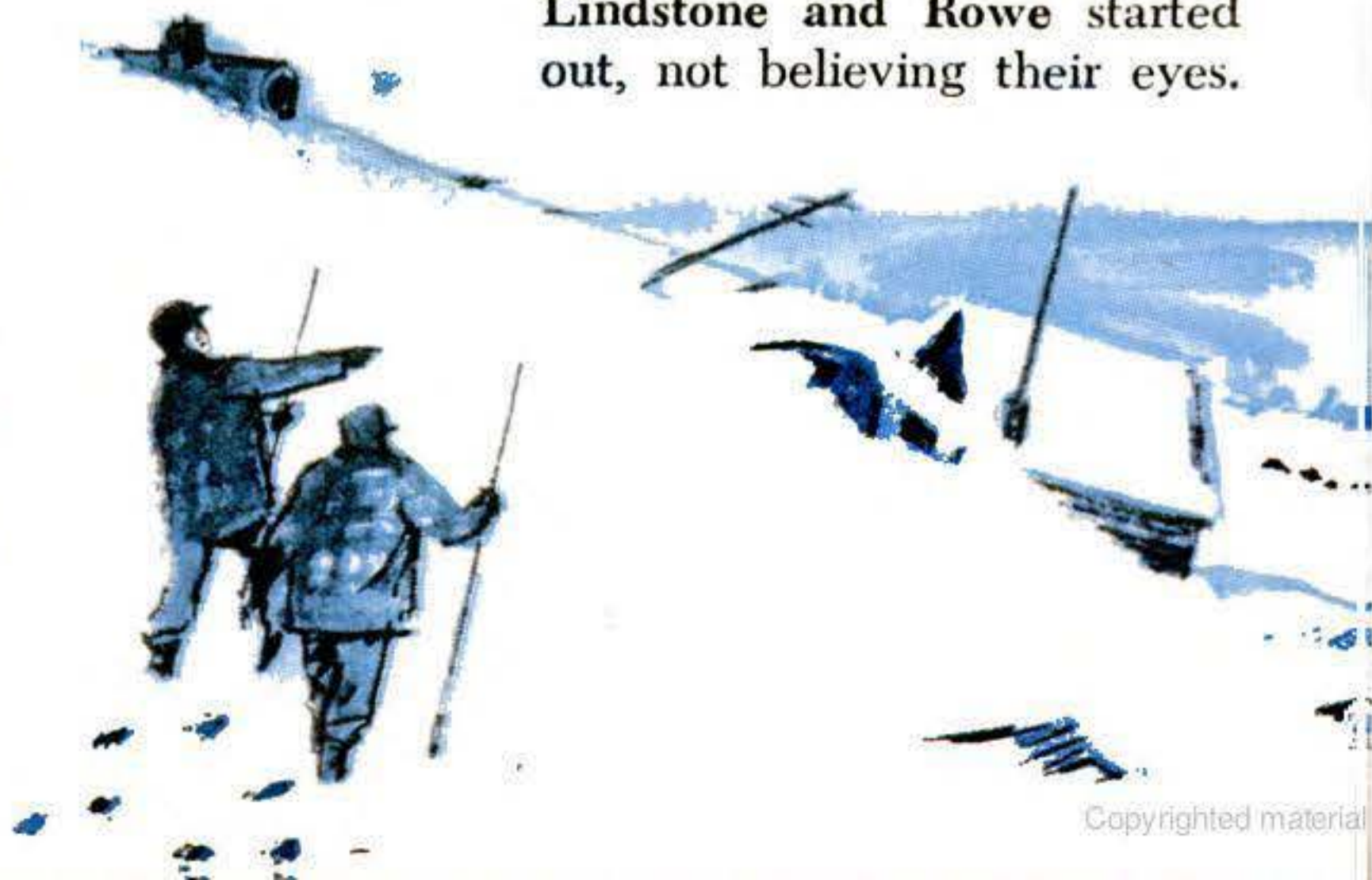

"Move!" The search patrol advanced one step in unison. Then: "Probe!" The poles were thrust deep in snow. If one hit something hard, that was wreckage; something soft would be a person, alive or dead.



long minutes, trying to believe the nightmare he saw.

A house trailer lay on top of a tilted house next door. Adamich's barn was gone, along with a garage and other buildings. There was no trace of Adamich's house or the Sheltons'. Where there had been a forest, the mountain was bare. The fallen avalanche lay like a glacier, 25 feet deep over Route 82. It had pushed far down into a meadow below.

Lindstone said to himself: "*Everything's gone—even the forest.*"

"It didn't occur to me at first that anyone could still be alive" he said. "But then we started out in the slide to look."

The alarm spreads. Some time after this, Bud Davis and his wife heard someone pounding on the door. It was Lindstone. He could hardly get the words out: "There's been an avalanche and the Sheltons and Adamiches are all gone."

Mrs. Davis raised a window shade. "Bud," she said, "for God's sake, come look."

Davis joined her. "Get some warm clothes on quick," he said. "We've got to go with them and get help."

At this time Bill Adamich, lying in snow, dressed only in sweatshirt and shorts, was waiting to freeze to death. As the snow settled, he knew he was near the top but he couldn't move. Toward 9:30 he heard a throbbing sound. "That's a plow," he thought, "but it's a long way off." He didn't know that 500 searchers already were hurrying to the scene from many miles around.

When National Ski Patrol searchers dig for bodies in avalanches they use the blunt end of long steel poles that come in four-foot sections.

They move over the surface a step at a time, elbows touching. The search leader says, "Move!" Each man advances a step. "Probe!" Each thrusts his pole deep. Again, "Move!" and "Probe!" When a pole hits something hard, that's a rock, or wreckage.

"If it hits something soft," a patrol member says, "that's a body."

Methods like this were used to seek the victims at Twin Lakes, and some searchers also hunted with long compressed-air hoses, thrusting air jets into the debris. They eventually found the Sheltons, all dead. And by 10 a.m. they located Mr. and Mrs. Adamich, both alive. It was more than an hour, however, before they were dug out, destined by some miracle to live. The pup, Pepe, lived, too.

Just how great a fury ran in that slide was revealed when the snow began to melt. Walking over the fallen avalanche above and below Route 82, I was surprised to find it matted with millions of green spruce needles torn from twigs and branches. The smell of these needles was still in the air. Hurricane winds can smash trees, but only incredible tornadic fury could have stripped an evergreen forest of needles.

A great silence. The noise must have been very great. Why, then, did no one hear it? I remembered the slide I had seen shot down on U.S. 550. The movement was so brief. The explosive edge of the Route 82 avalanche had probably shot through town in two seconds.—All sound must have been muffled by that same wall of silence we saw rise near U.S. 550—the dreaded snow fog.

One object rode out the storm—that indomitable steam boiler. I found it lying 200 feet above the highway, at a cockeyed angle, still grotesquely on top of the heap. U. S. Forestry Service experts now compute the speed of the Twin Lakes slide at 130 miles an hour—which means that the boiler had probably ridden down two miles in less than a minute.

I asked a neighbor what had happened to the great boulder above General Shelton's house.

"That's a mystery we're still trying to solve," he told me, shaking his head. "It's just gone." ■ ■

Plane Hurls Bomb from Tail

Launching a big bomb from a plane racing twice as fast as sound is quite a trick. Hit by the terrific air wash, a missile loosed from a bomb bay in the belly might flip tail-up, and collide with the plane. So the Navy's A3J Vigilante bomber, based on the nuclear carrier Enterprise, catapults its bomb from its tail. Details of how the North American Aviation-designed craft does it have just been officially cleared:

Ignition of a powder cartridge drives a piston along the barrel of a launching gun, as in plane-launching "powder catapults" of World War II. Acting as a ram, an extension of the piston propels the bomb rearward on a roller carriage, along tracks in a tunnel in the fuselage, and ejects it from a port in the tail. A tail cone, covering the port, is automatically unlatched and jettisoned as the bomb emerges.

The few uncensored details about the bomb itself, which can pack a nuclear warhead, indicate a remarkable dual-purpose design. A pair of tanks from

which the plane draws fuel, on the way to its objective, form the body of the bomb. At the moment of launching, fuel-line connections part, and the tanks—usually empty by then—become the air frame supporting the stabilizing fins of the bomb.

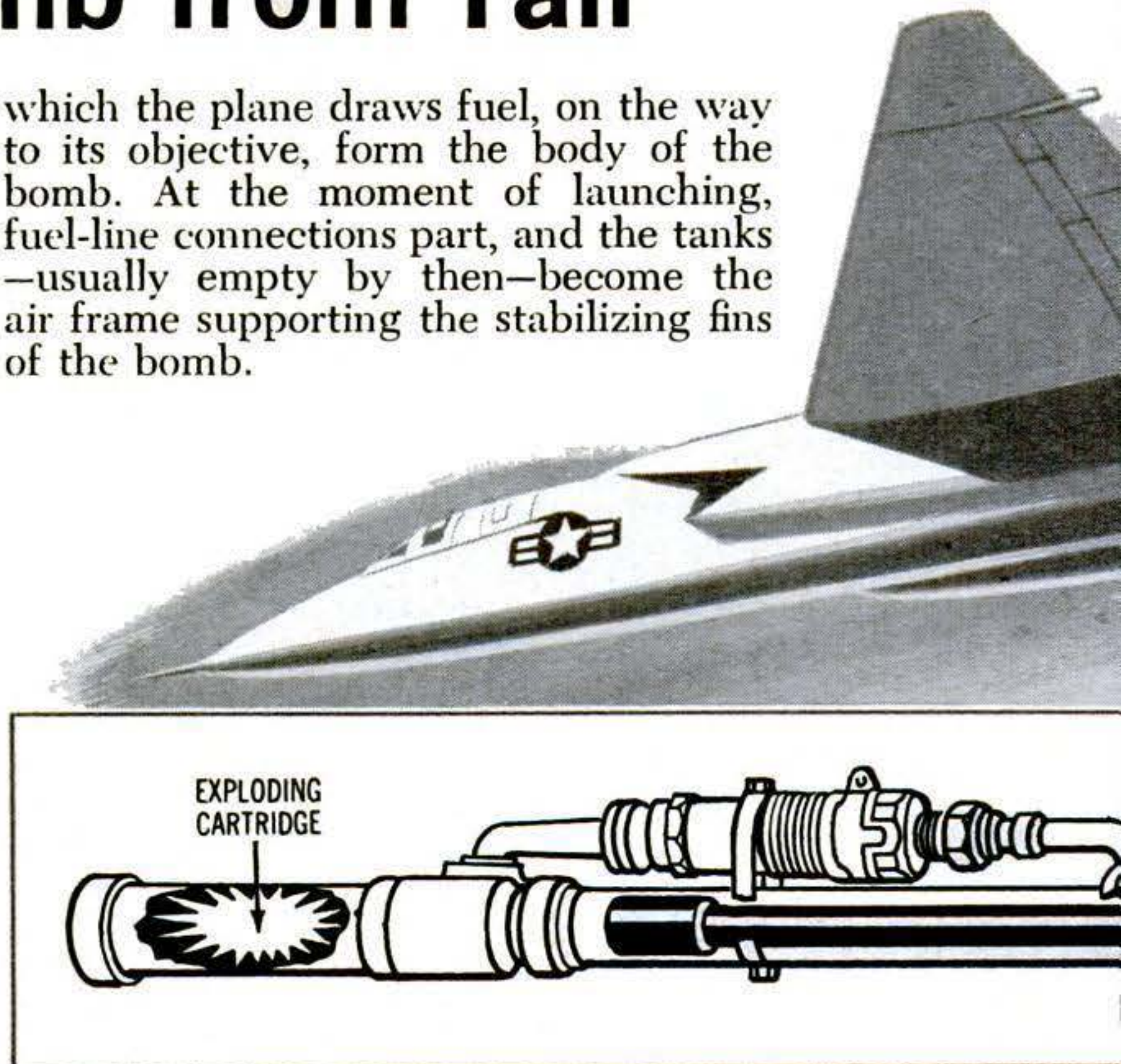

Supersonic plane ejects bomb from tail (top view) with launching gun shown just above. Explosion of powder cartridge drives piston along barrel of gun

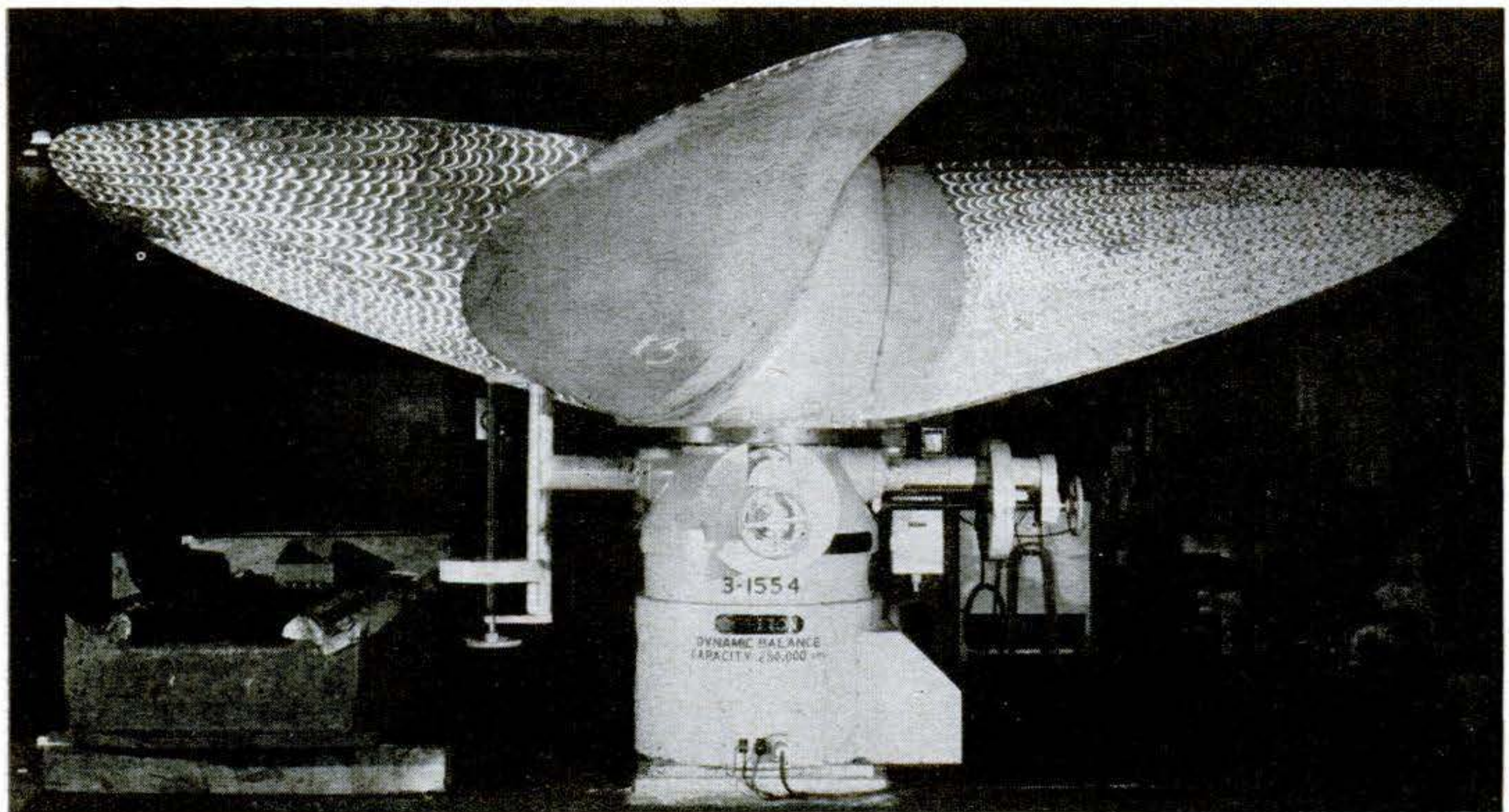

Machine balances 125-ton prop

With propellers growing in size to drive the huge new tankers, Bethlehem Steel's propeller plant at Staten Island, N.Y., has installed a dynamic balance with a capacity of 250,000 pounds. The big wheel shown

on it here is a four-blade manganese-bronze propeller for a Mariner-class ship. It's 22 feet in diameter and weighs 61,000 pounds. Mounted on a vertical-axis universal joint, it's measured by strain gauges and other instruments for both static and dynamic unbalanced forces.

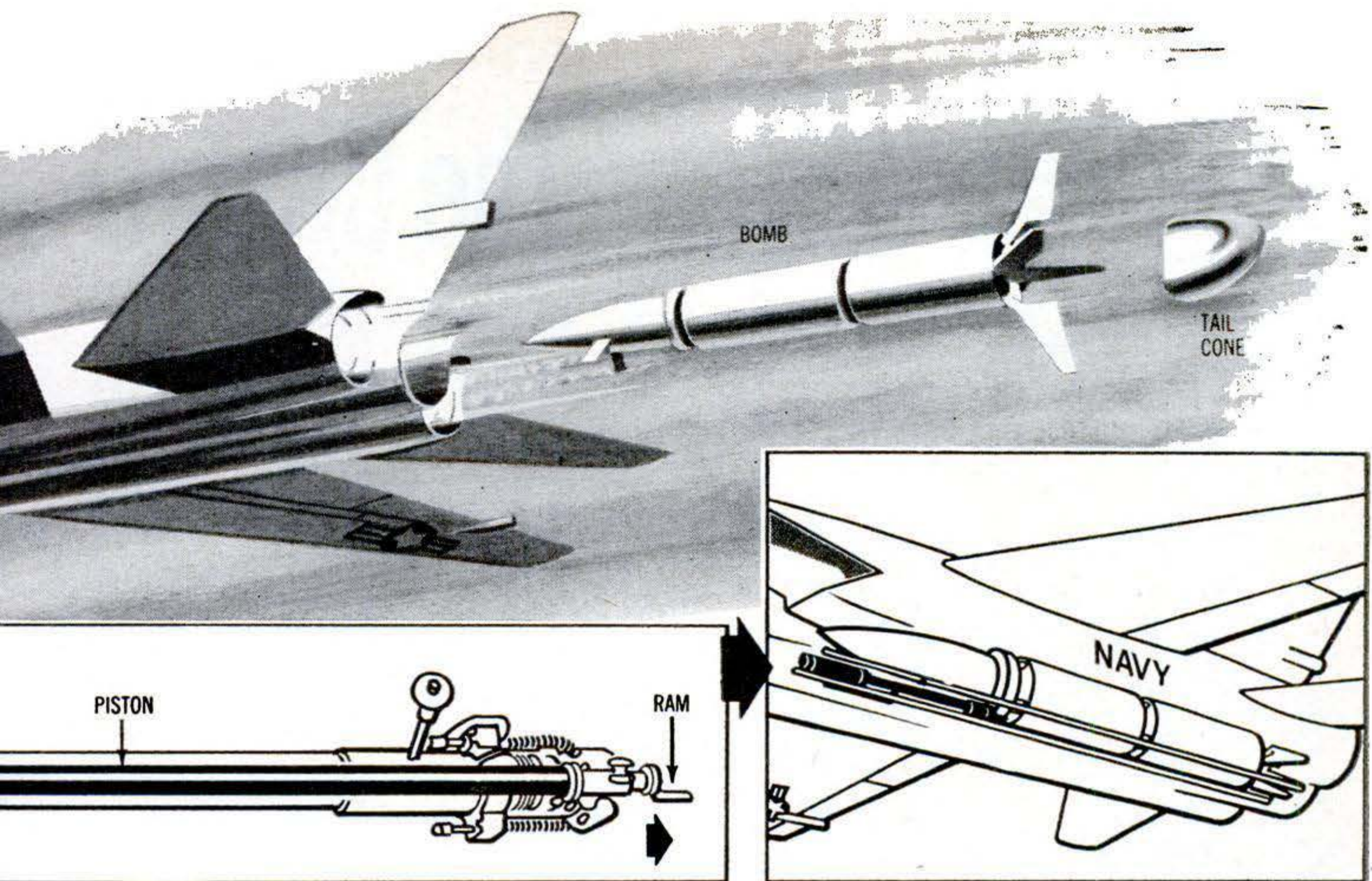

(toward right, in diagram). Extension of piston acts as a ram to propel bomb aft in tunnel in fuselage, where view at right shows it, and

out through port in tail. Bomb is stabilized in flight by nose and tail fins, the ones on the tail unfolding as the bomb emerges.

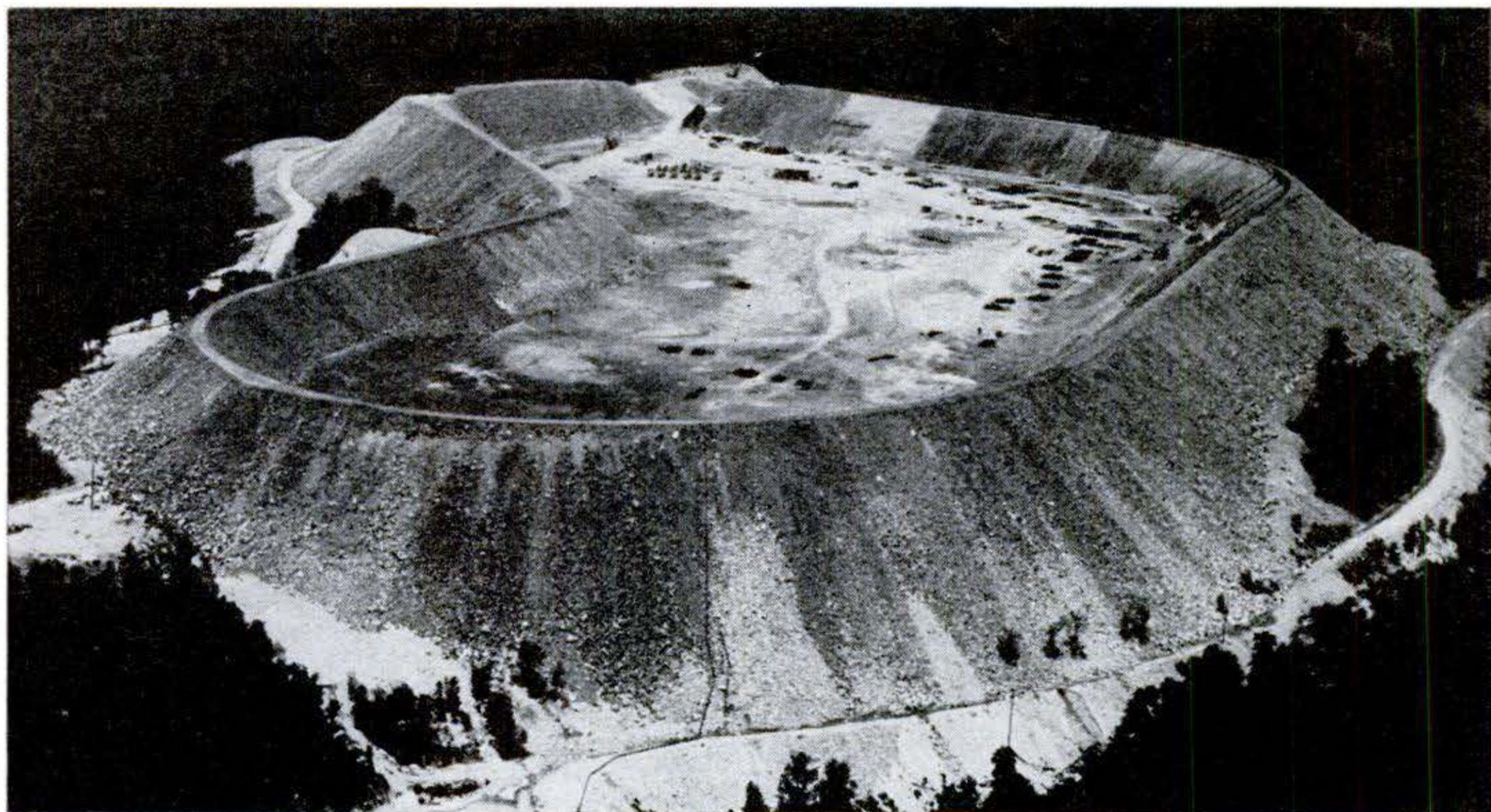

Mountain-top lake to generate power

This 55-acre bowl is the upper reservoir under construction at Taum Sauk, high in the Missouri Ozarks. When completed this year, it will draw water pumped from the Black River 800 feet below to provide St.

Louis with an additional 350,000 kilowatts of power. By night and on weekends, with industry shut down and electric consumption low, water will be pumped by a big reversible pump-turbine through shafts 18½ to 27 feet in diameter; in daytime it will flow back down to turn the generators.

crosspiece at the other for making the break. The wheel is available at shops dealing in ceramic tile. It's a replacement for a rental cutter. Price: about \$3.

The base is $\frac{3}{4}$ " plywood covered with $\frac{1}{32}$ " steel. A flathead bolt at each corner holds steel, plywood, and supporting angle iron in a firm sandwich.

Strips of $\frac{1}{8}$ "-by-1" steel surround three edges of the base, joined by the stop bar as you see in the drawing. A hard-aluminum center blade placed square down the middle of this enclosure creates two equal recesses for the $\frac{1}{2}$ "-thick sponge rubber on which tiles rest for cutting. The rubber rises $\frac{1}{16}$ " above the center blade and edge strips. A step cut in the end of the center blade locks into a slot in the stop bar.

The handle and crosspiece are best cut with a metal-cutting bandsaw—or you can have them cut by a local machine shop. A slot in the handle provides for up-and-down adjustment of the cutter wheel for best scoring of the tile.

The slider assembly must be accurately fitted to the slider arm to move easily—but without play. Locate the two sliding-bar end supports just far enough off center so that the cutter wheel rides true on the centerline of the center blade.

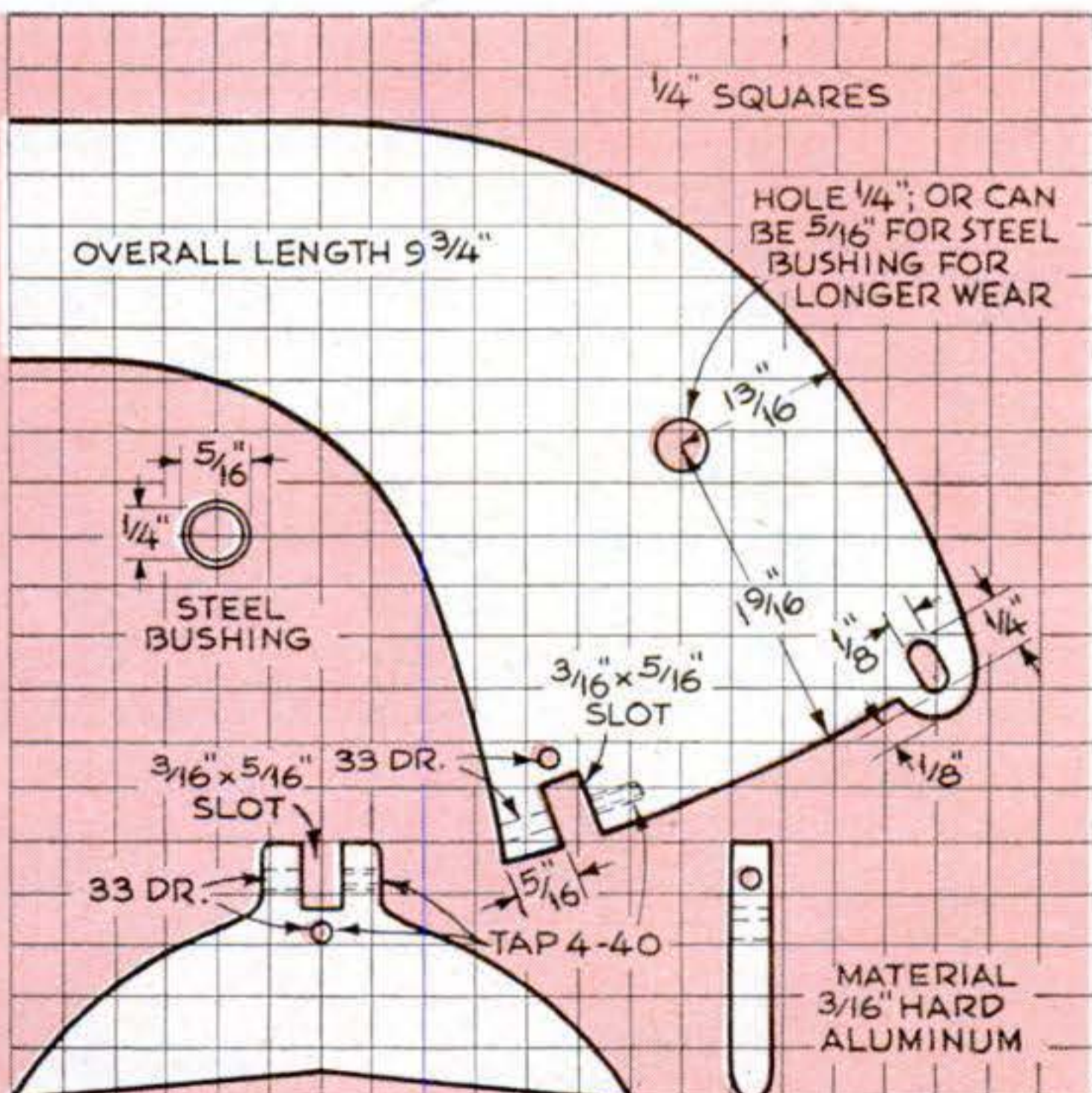
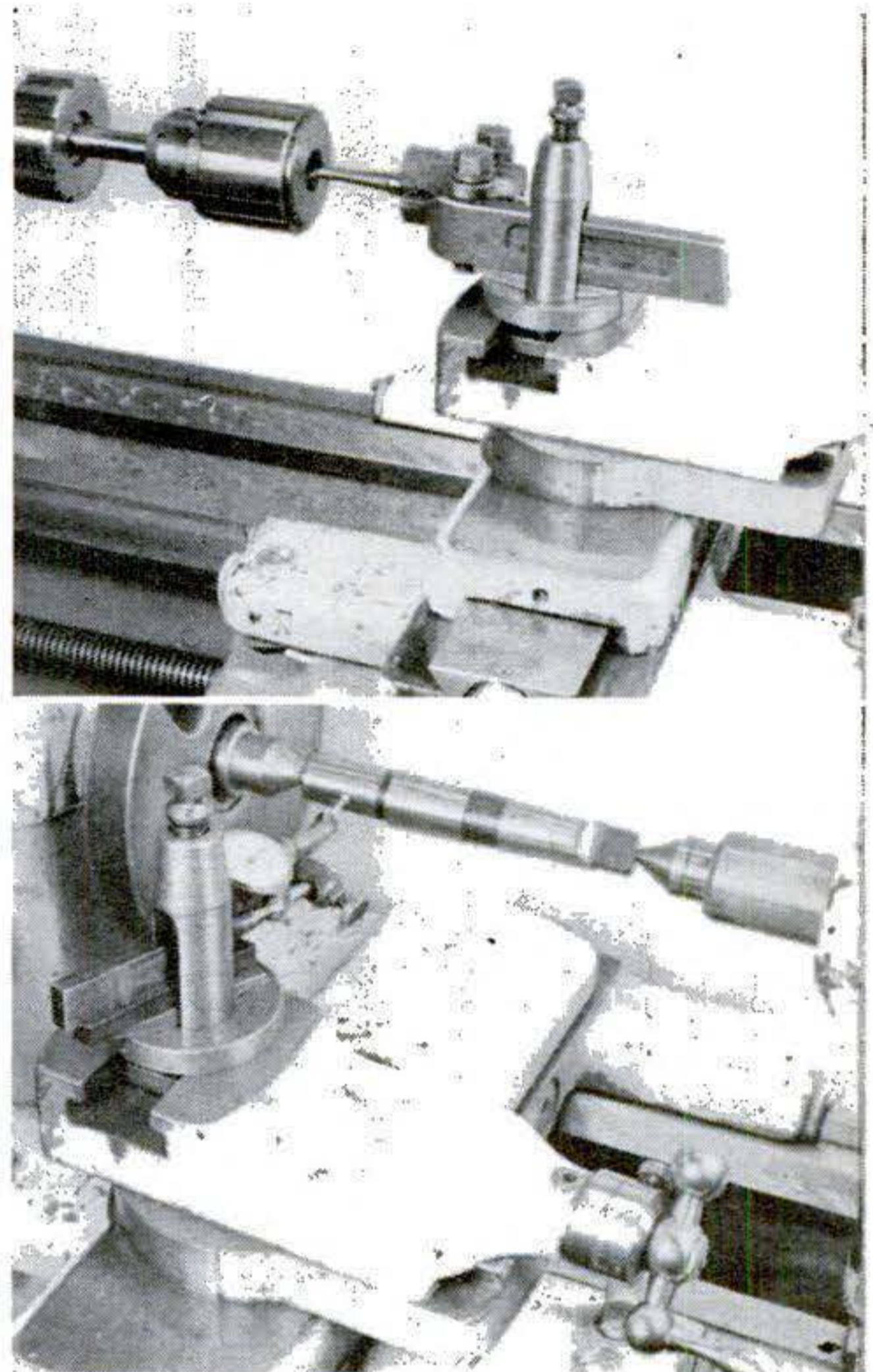

DETAILS OF HANDLE AND CROSSPIECE

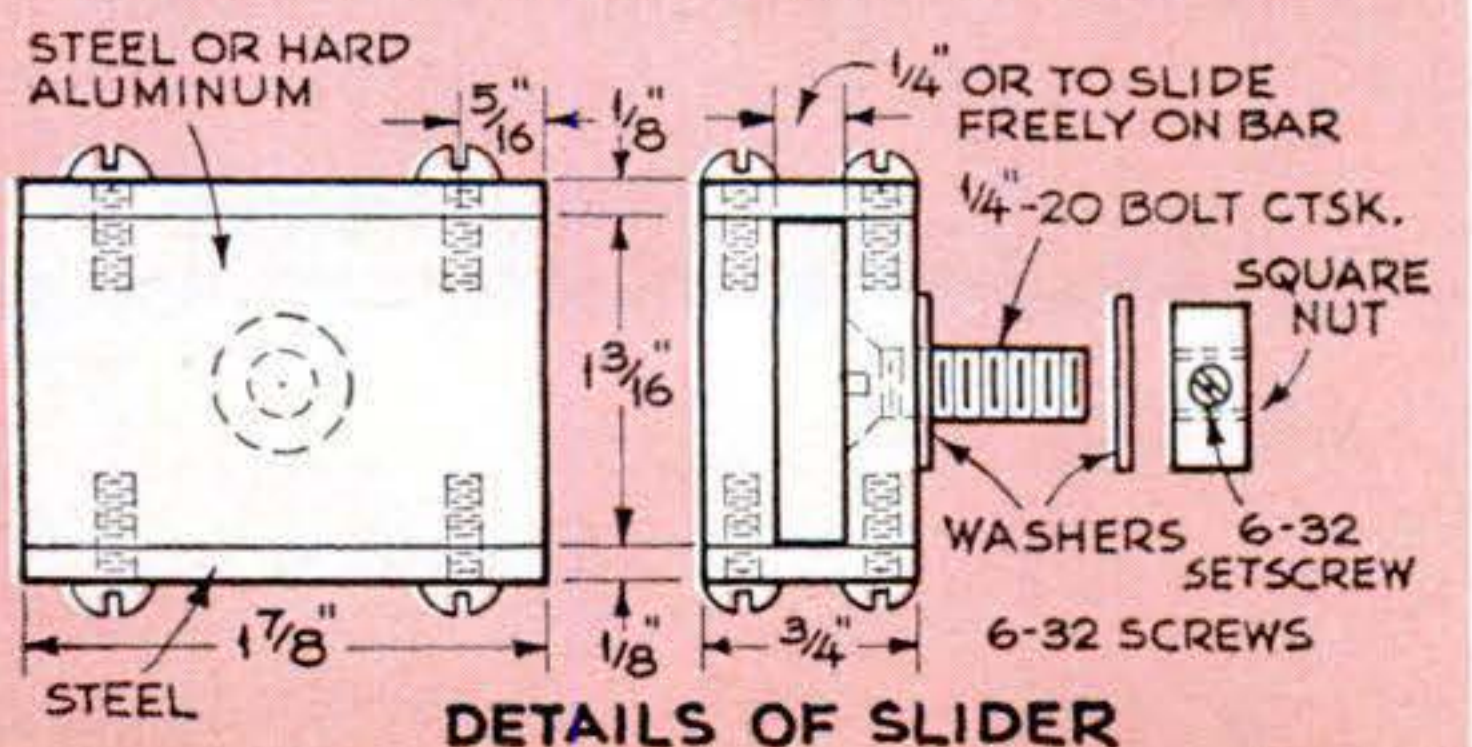

DETAILS OF SLIDER

Easy way to retrue a drill chuck

Out-of-true drill chucks of the taper-socket type can be retrue, but not the way you might think. Truing the jaws themselves is difficult and requires an internal grinder. The trick, instead, is to rebores the taper socket so it compensates for the jaws and runs true even though both it and the jaws are out-of-true. The two photos above illustrate how it's done.

Mount the chuck in the lathe on a short length of drill rod. The lathe compound is then used to feed a boring tool into the chuck socket at correct taper angle. To find this angle, set up a taper-shank chuck arbor between lathe centers. With a dial indicator mounted in the compound, feed the compound along the short taper that fits in the chuck. Adjust compound on its base until indicator registers zero run-out. Indicator contact and cutting lip of the boring tool must be on exact center height. Bore out only enough so your regular arbor will still fit the new hole. —H. J. Gerber, Menomonie, Wis.

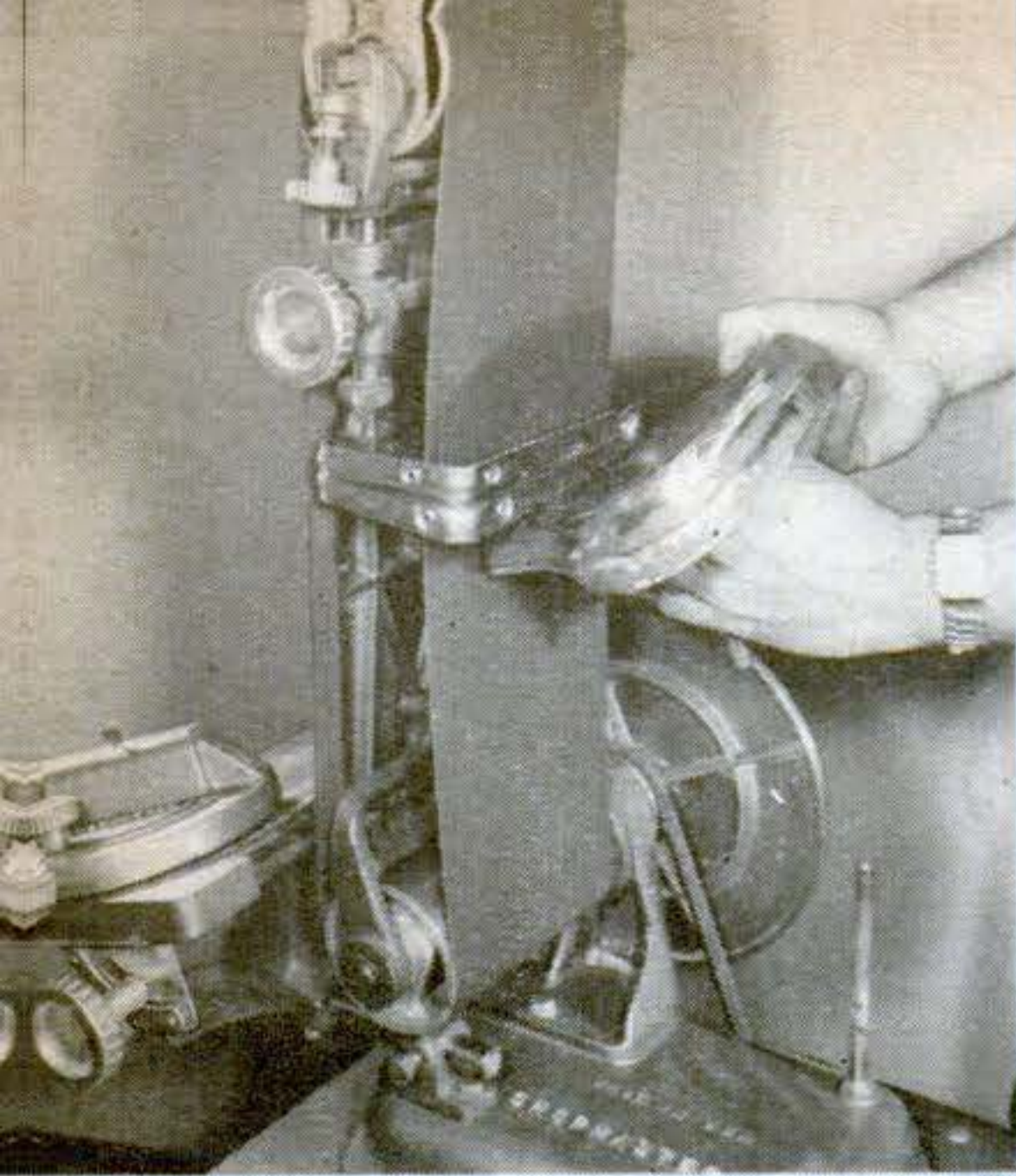

Tilt the belt up to its vertical position and you can use its slack underside for freehand shaping of curves and contours. A stop to pivot the work against can be fashioned from a strip of bent metal or a shelf bracket like the one above.

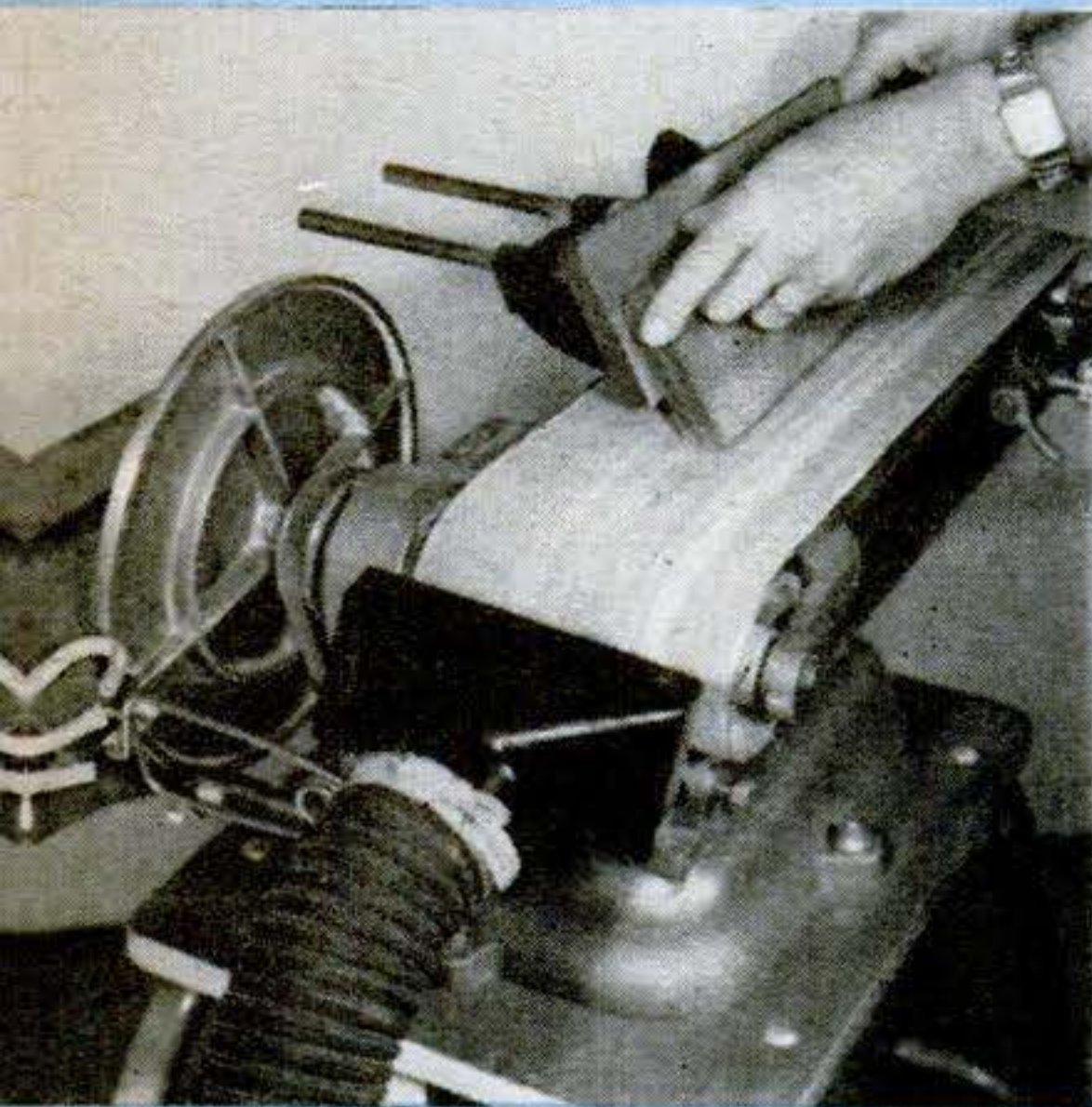

Dust problem is solved with a shop vacuum placed close to the belt or disk where it will suck up almost all sanding dust before it becomes airborne. The nozzle is held by a spring-type photo light clamp clipped to the sander's table.

For sparkling polishes, try this setup. Cement a circle of heavy felt to the disk and charge it with polishing compound. You'll be amazed at the results. Protect the highly polished faces by taping strips of felt to the table.



Belt-Disk Sander: a tool to own

This versatile machine will do many more jobs than you might suspect. Here's how one expert gets it to perform a whole shopful of tricks

By Phil McCafferty

A BELT-DISK sander, combined with a few tricks and some homemade jigs, can become *the* most all-around useful tool in your shop. There's an important reason why: The belts and disks you use are *not* ordinary sandpaper. Except for a few designed solely for wood, they're made by coating heavy cloth with the same abrasives that form grinding wheels.

Between the belt and the disk, what you have, in effect, are a flexible grinder of tremendous area capable of producing all sorts of shapes in metals as well as wood, together with a rigid grinder capable of producing dead-flat surfaces on precise machining jobs. The very disks and belts used in these machines—in fact, many of the same machines themselves—are the heavy-duty work horses used in industry for such rugged jobs as sharpening carbide cutting tools and hogging large amounts of metal off rough castings.

Because of their large, flat surfaces, belt-disk sanders remain true without much need for dressing. On most machines, you can single-pass grind a metal surface a foot by a foot-and-a-half. Belt-disk sanders are also safer—there's no solid wheel to shatter. And they cut much cooler because of their large exposed area. A 6"-by-48" belt, for instance, is equal to a 6"-thick grinding wheel more than 15" in diameter.

CONTINUED

Sparks fly as a power-mower blade is sharpened in a single pass at right—one of the many bonus jobs you can do on a belt-disk sander.

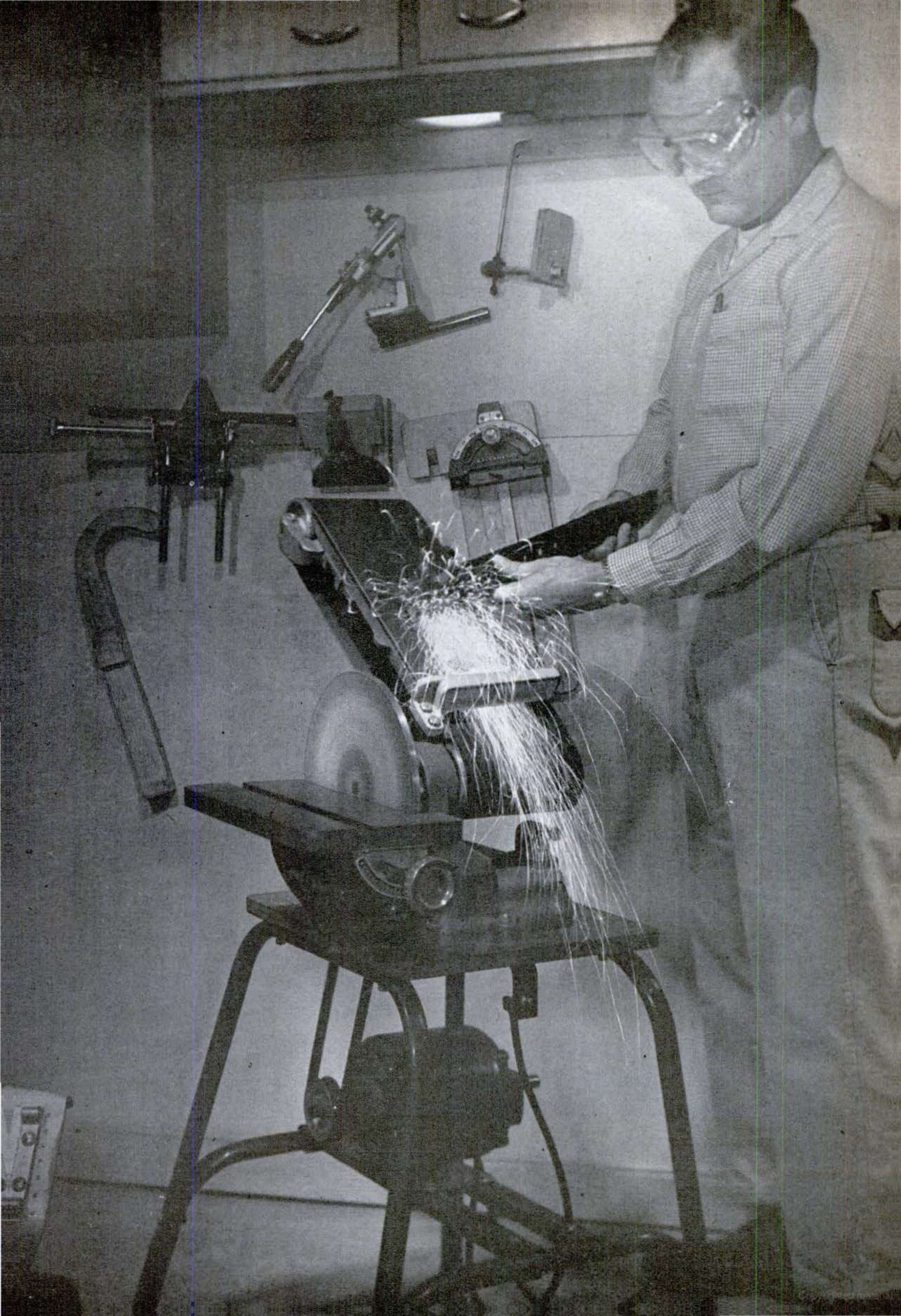

You can centerless-grind round shapes quickly and accurately with this

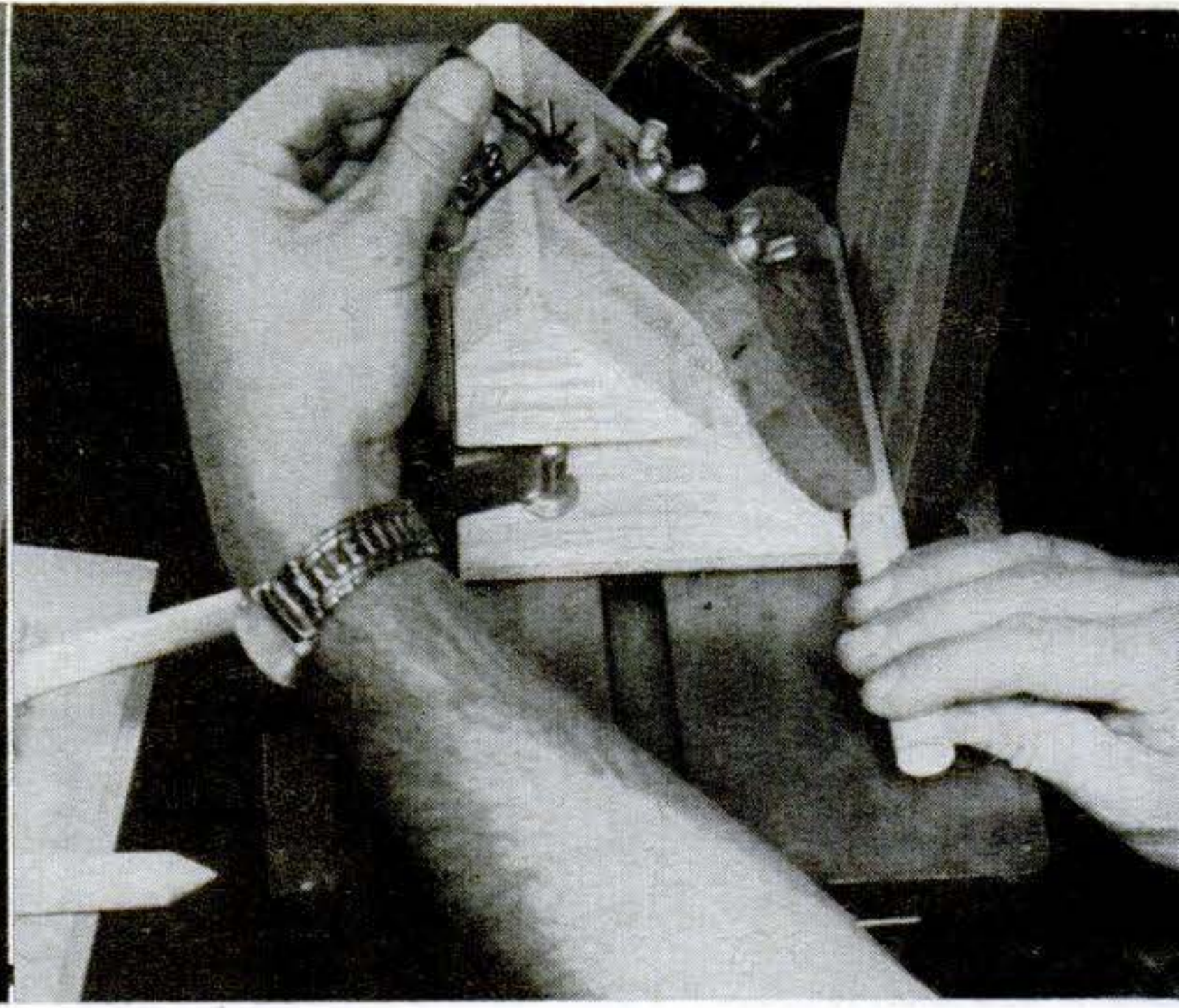
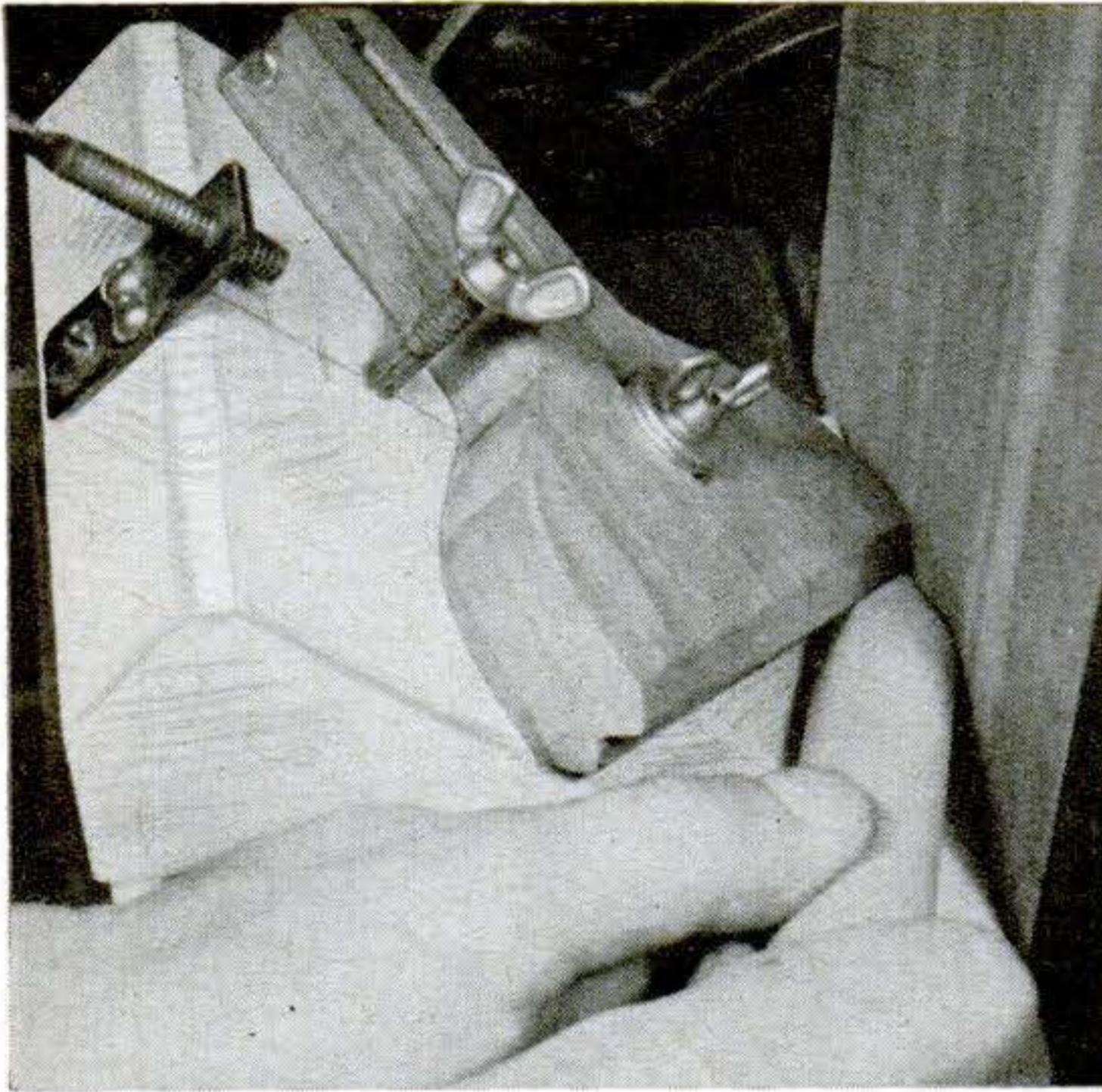

Want to taper dowels or neck down pins for a precise assembly fit? They're a cinch in this centerless grinding jig. For tapering, the V-grooved feed block can be locked at an angle (left). For straight grinding, it can be squared

to the belt and precision-fed with the thumb-screw (right). The jig base is made from glued-up two-by-six stock, notched as shown at far right for C clamps. The feed block should be hardwood, waxed for easy turning of the work.

An auxiliary table turns the disk into an automatic tool sharpener

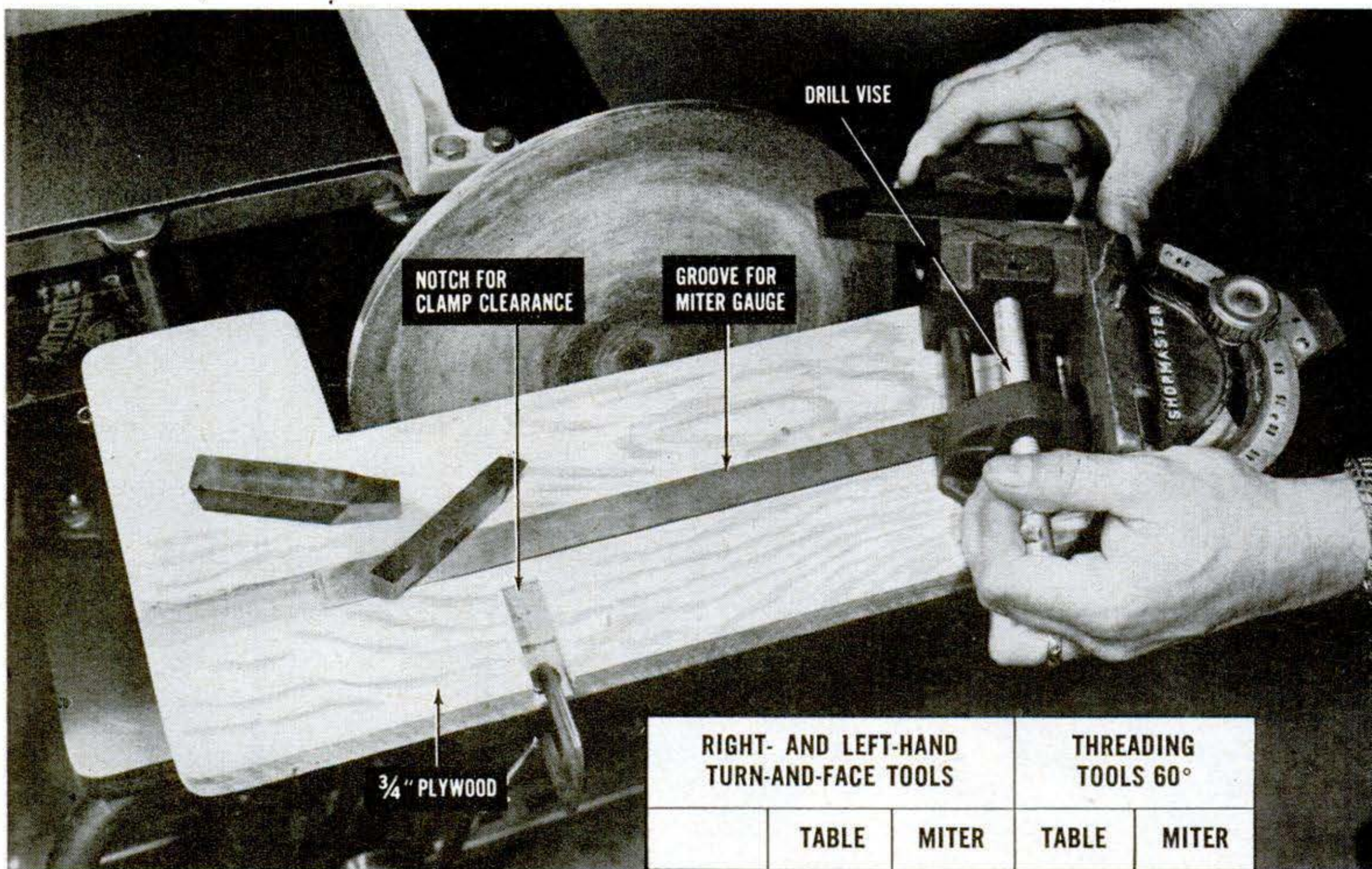

Lathe tool bits are precision-ground by setting table and miter gauge to the proper angles. Auxiliary wood table, clamped to regular table, allows miter gauge to extend beyond the disk's edge. Chart shows table and miter-gauge settings for commonly used tool bits.

	RIGHT- AND LEFT-HAND TURN-AND-FACE TOOLS		THREADING TOOLS 60°	
	TABLE	MITER	TABLE	MITER
SIDE	11°	18°	10°	30°
FRONT	11°	22°	—	—
TOP	15°	5°	5°	0°(90°)

simple jig for the belt sander

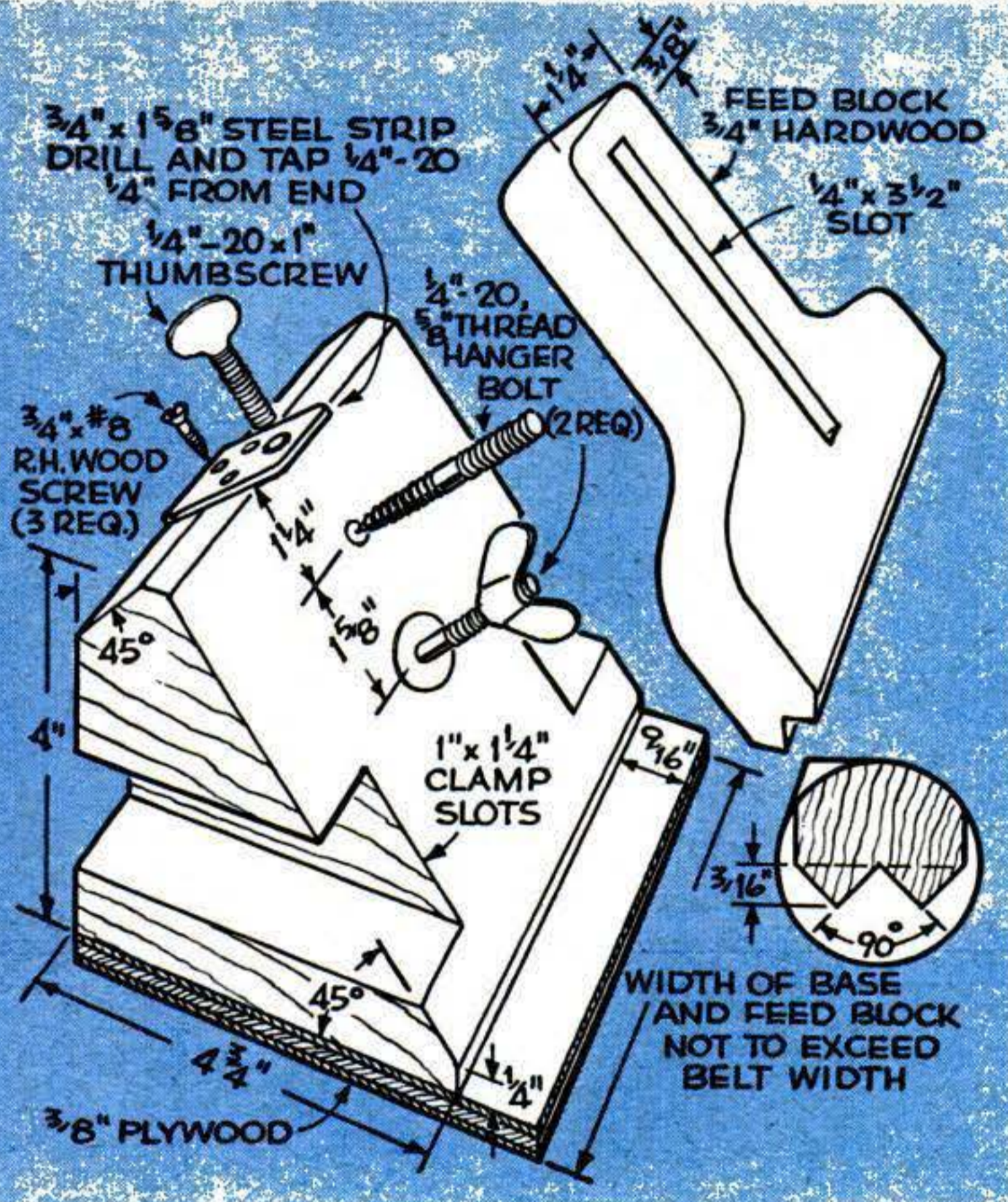

How to choose belts and disks

MATERIAL	GRIT SIZE TO USE		TYPE OF ABRASIVE
	ROUGH CUTS	FINISH CUTS	
SOFTWOOD	40-60	80-100	Garnet
HARDWOOD	50-80	120-180	Aluminum oxide
STEEL	50-80	100-180	Aluminum oxide
CAST IRON	40-60	80-150	Aluminum oxide
STEEL CUTTING TOOLS	60	150-180	Aluminum oxide
CARBIDE CUTTING TOOLS	60*	150-180	Aluminum oxide
STAINLESS STEEL	80	100-220	Aluminum oxide
ZINC, ALUMINUM, BRASS, BRONZE	36-80	120-220	Aluminum oxide or silicon carbide
GLASS, PLASTICS, MARBLE, STONE, CERAMICS, BONE	80-150	180-400	Silicon carbide

*Silicon carbide preferred for roughing.

For hollow grinding, use the belt's drum with a jig like this

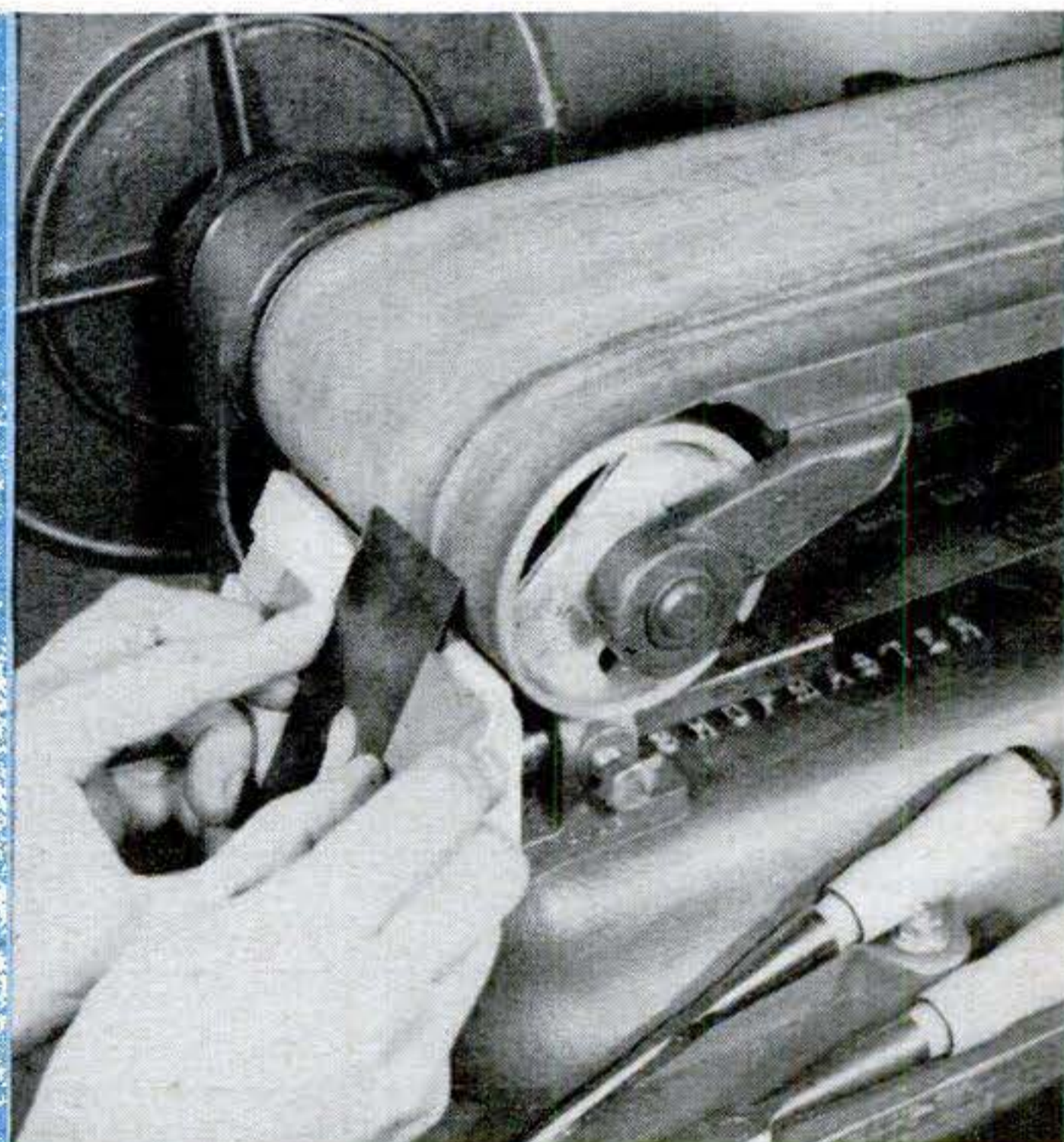
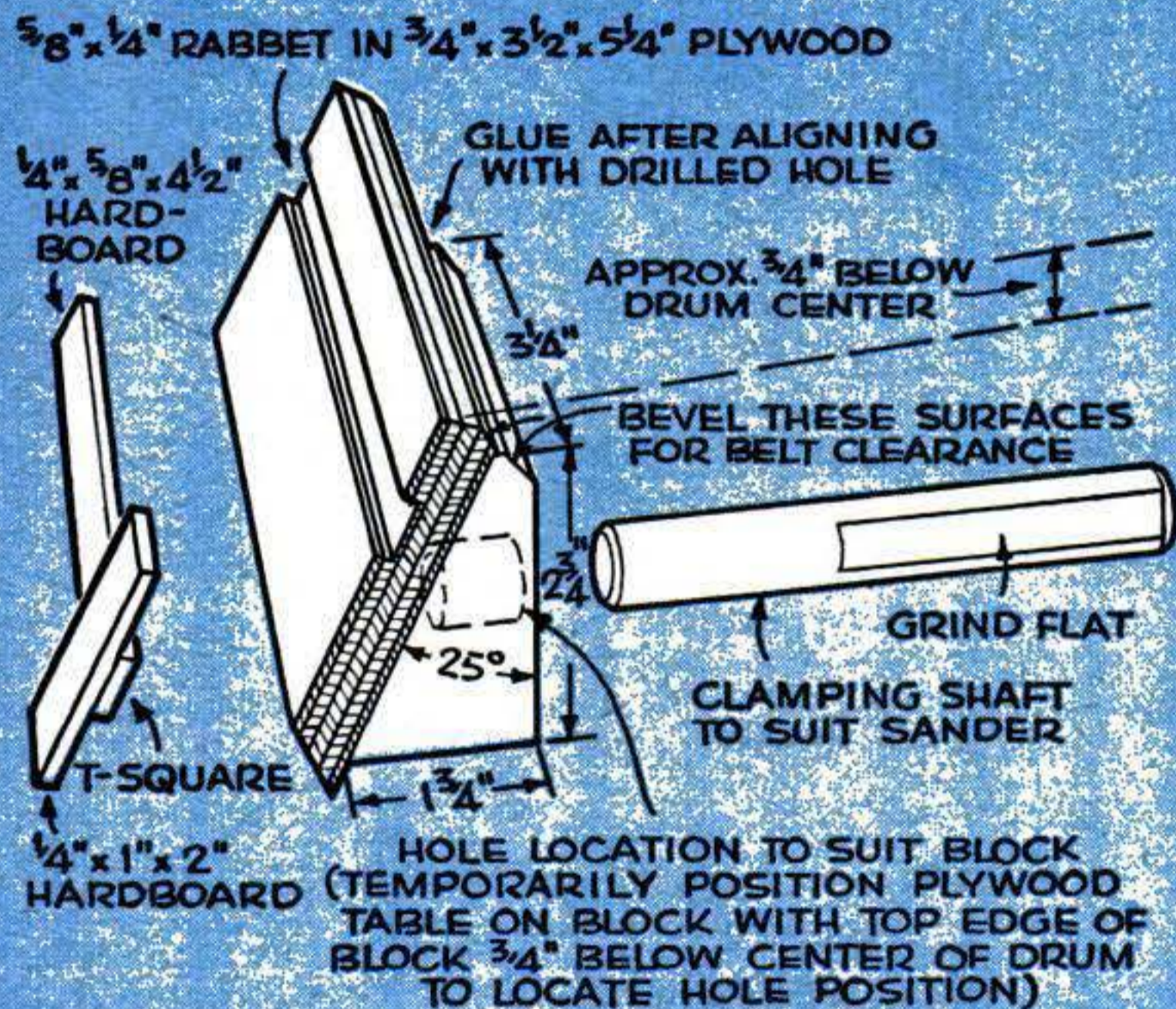

Curved belt drum is ideal for hollow-grinding plane blades and chisels. The small T square lets you slide a tool accurately across the belt for a uniform grind. The jig is held by a rod

that fits in the sander's table-mounting socket. Drill the base a snug fit for the rod, then glue the rod in with epoxy, carefully propping the jig square to the belt drum during setting.

Switching jobs is faster, too. You can maintain a whole stable of different belts and disks and change from one to another in only a minute or two. Using the right abrasive for the job is the secret of both better working efficiency and longer life for your belts and disks.

When you remove a disk, transfer it immediately to a square of painted hardboard or other slick surface to keep the tacky back side dustfree and ready for quick replacement. Mark the grit size and abrasive type on the board for easy reference. Belts should be stored on large "pegs," such

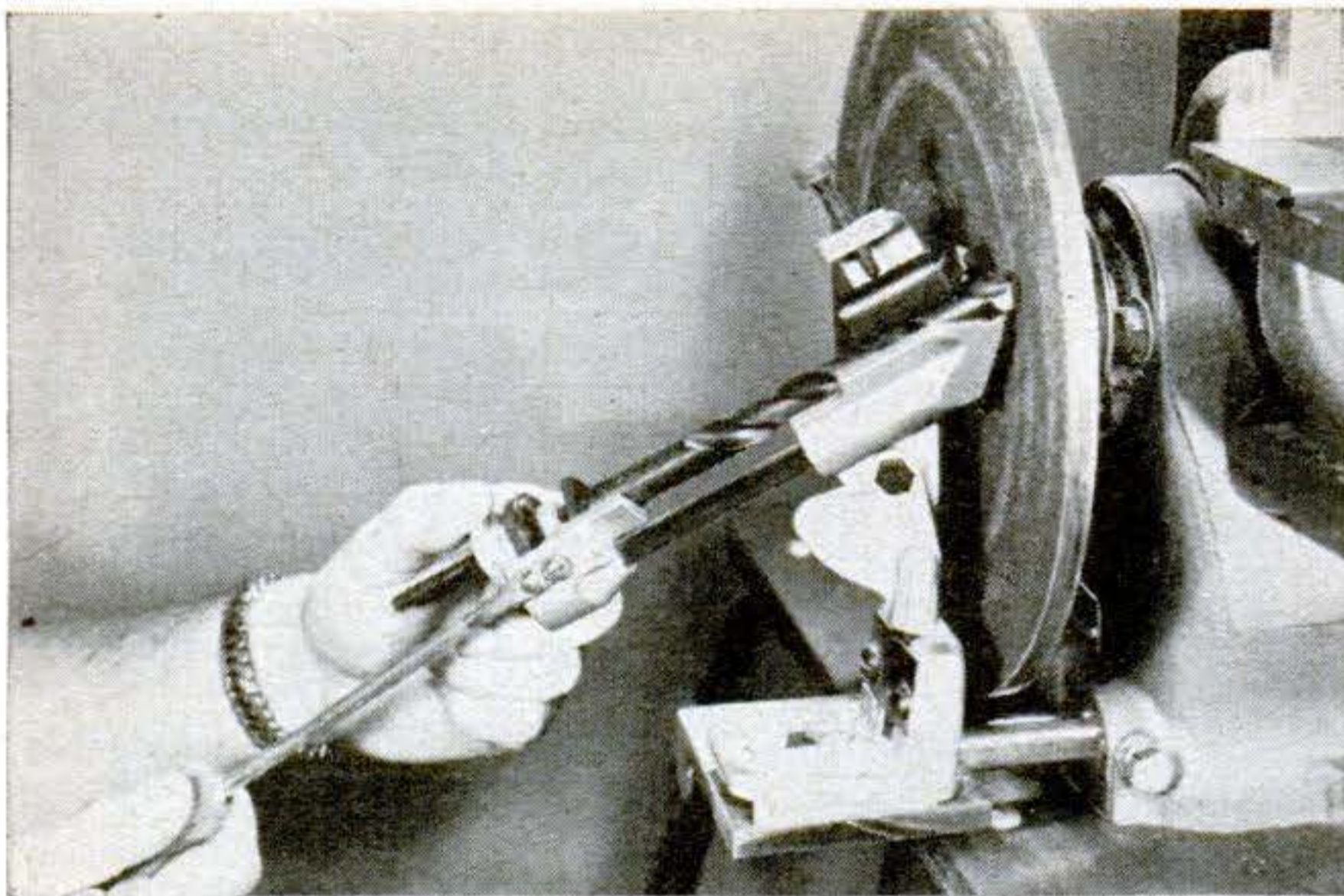

Drill-sharpening jigs work better on a disk than a grinding wheel because you get a truly flat grind. Fasten the jig to a rod that fits the table-mounting socket. An old screwdriver bolted to the jig makes a handy control arm.

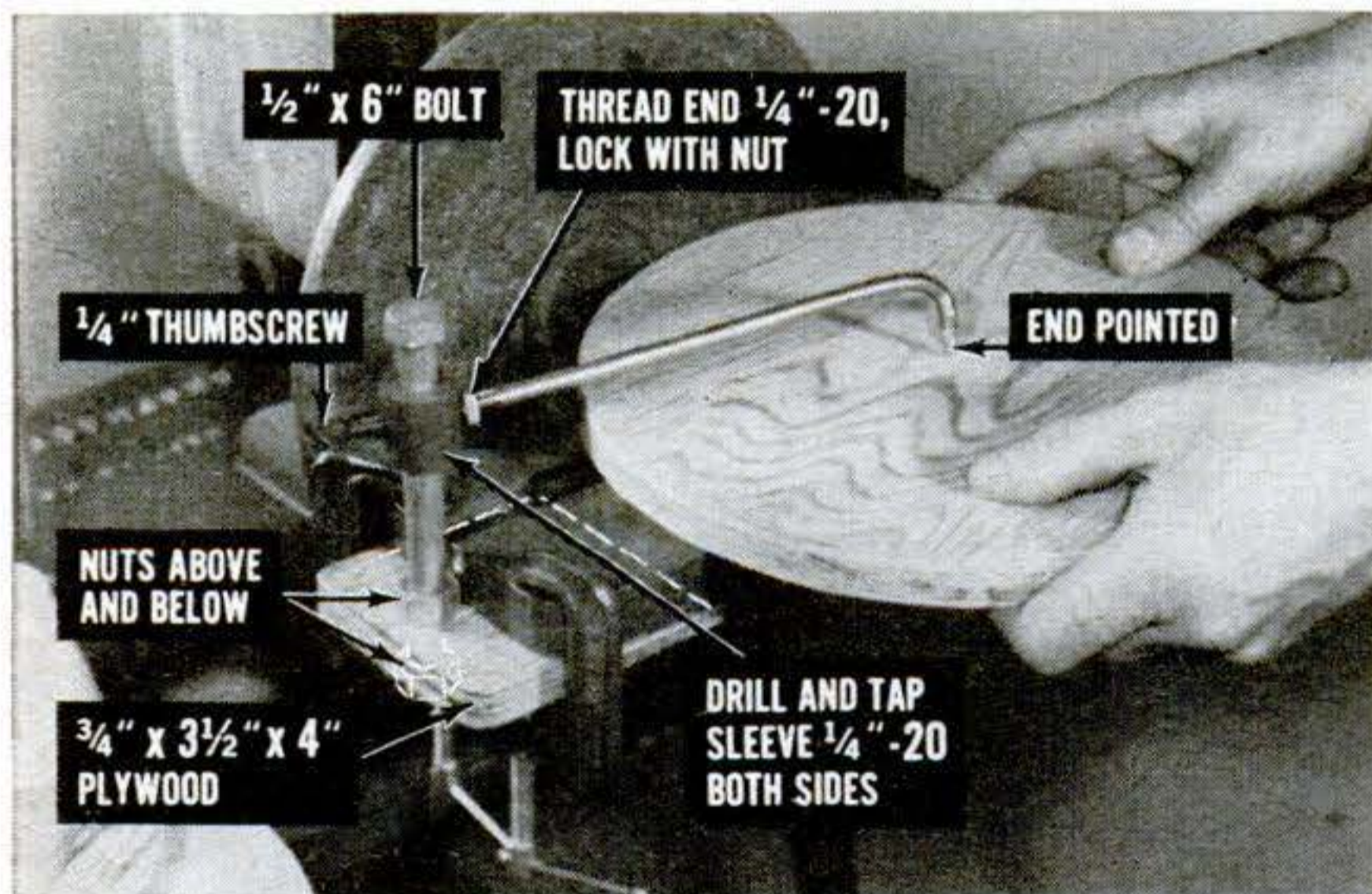

as sections of mailing tube. Cloth-backed abrasives come in two grades—"industrial cloth" and "industrial belt cloth." The latter is costlier but more durable.

Use these ideas:

- Try different materials on the disk. One photo here shows felt for polishing. Glue heavy canvas on the disk and charge it with lapping compound for lapping truly flat metal surfaces. Canvas without charging will burnish surfaces, too.

- When belts are ready to be thrown out, don't. Rip them into strips. They are still good for sanding intricate shapes.

- If a disk or belt becomes gummed from hardwood, salvage it by passing a discarded drill bit or high-speed tool over it to dislodge the particles.

- And, as in any grinding, wear goggles. ■ ■

Sand circular parts really round with this jig. The work pivots under sharpened point of over-arm clamped to the table. Table's tilt adjustment makes possible neat edge beveling and conical sanding.

Buyers' guide to belt-disk sanders

Make	Model	Approx. List Price (less stand and motor)	Disk Size (inches)	Belt Size (inches)	Belt Support Plate Area (sq. in.)	Tilting Table Size (inches)	Belt Drum Dia. (inches)	Bearings	Minimum Motor (hp. req.)
CRAFTSMAN (Sears, Roebuck)	99H2254L	\$57	9	6x48	105	6¼x12	3	Prelubed ball	½
DeWALT (formerly Atlas)	630	\$115	10	4x37½	47	8x15	3	Ball	½
DURO	AD3066	\$90	9	6x48	96	6½x11	3	Needle	½
	PD3066	\$140	10	6x48	99	7¼x13½	3	Sealed ball	½
POWERMATIC	30	\$133	12	6x48	87	10x16½	4½	Ball	½
POWR-KRAFT (Montgomery Ward)	84A2710	\$59	9	6x48	98	7x12	3	Oilite bronze & ball	½
SHOPMASTER	SR-1000	\$100	10	6x48	102	6x12	3	Oilite bronze	½
TOOLKRAFT	335	\$70	9	6x48	105	6¼x12	3	Oilite bronze	½
WALKER-TURNER	31-600	\$135	12	4x52½	48	9¾x16¼	5	Ball	1

A fabric called Dynel, just announced, offers a fast way of applying a tough hide to a beat-up old hull

THE boat was a battered, leaking hulk just one step from the junk heap when we took her over. As she was trailered up our drive in a heavy rain, water poured from her seams as fast as it went into the cockpits.

But in one day's working time (not including periods for resin curing) she was transformed into a dream boat, as watertight as a sealed bottle. Her new, ivory-smooth hide is one of the toughest ever developed. It never needs painting (though it takes paint beautifully) and it never needs caulking. The resale value now is at least five times the \$50 we paid for the boat.

The basis of her jiffy rejuvenation is Dynel #815 marine fabric. It's made from a fiber developed by Union Carbide Corp. from natural gas, salt, ammonia, and water.

CONTINUED



New Way to Save an Old Boat

By George Daniels





What Dynel looks like —and where to get it

Why a smooth boat-covering job is easy with Dynel is illustrated by this photo—a piece of #815 marine fabric pulled over a salad bowl. Note that it takes the curves without the slightest wrinkle.

If local boat dealers don't stock Dynel, write to Textile Fabrics Dept., Union Carbide, 270 Park Ave., NYC 17.

Half the weight of fiber-glass, it sells for about the same price. Its tensile strength of 57,000 pounds per square inch almost matches steel, yet it's so soft that artificial fur coats are made from it.

In marine form, the fabric fits every contour of a hull like a tight sweater, with plenty of give in all directions—until the resin hits it. Then it forms a tough armored hide. You use the same resins as in fiber-glassing but you use them with a new trick. You don't coat the hull with resin and lay the fabric in it. Instead, you smooth the fabric on first, staple it tight, and then roll and brush the resin through it. This way there's no rush to work the wrinkles out before the resin sets. The fabric is already taut and smooth before you even mix the resin. And the soak-through bond is so

solid you can't get the fabric off without ripping a layer of wood with it.

The material you need. Measure the length of the gunwales and the distance from gunwale to gunwale under the hull at the beamiest point. Then allow an extra half-yard or so for trimming and lapping.

The width in #815 marine fabric is usually 4', which lets you cover small hulls with a single strip to a side. If you have to seam it, allow a 2" overlap. Figure on a quart of resin per square yard for the first soak-through coat, half as much for each of the two successive coats.

You'll also need a mohair paint roller with a couple of extra sleeves, a pair of cheap new 2" brushes, and a painter's squeegee. Unless you know you're not allergic to resin, add rubber gloves.

Applying a Dynel covering to a small boat is a job

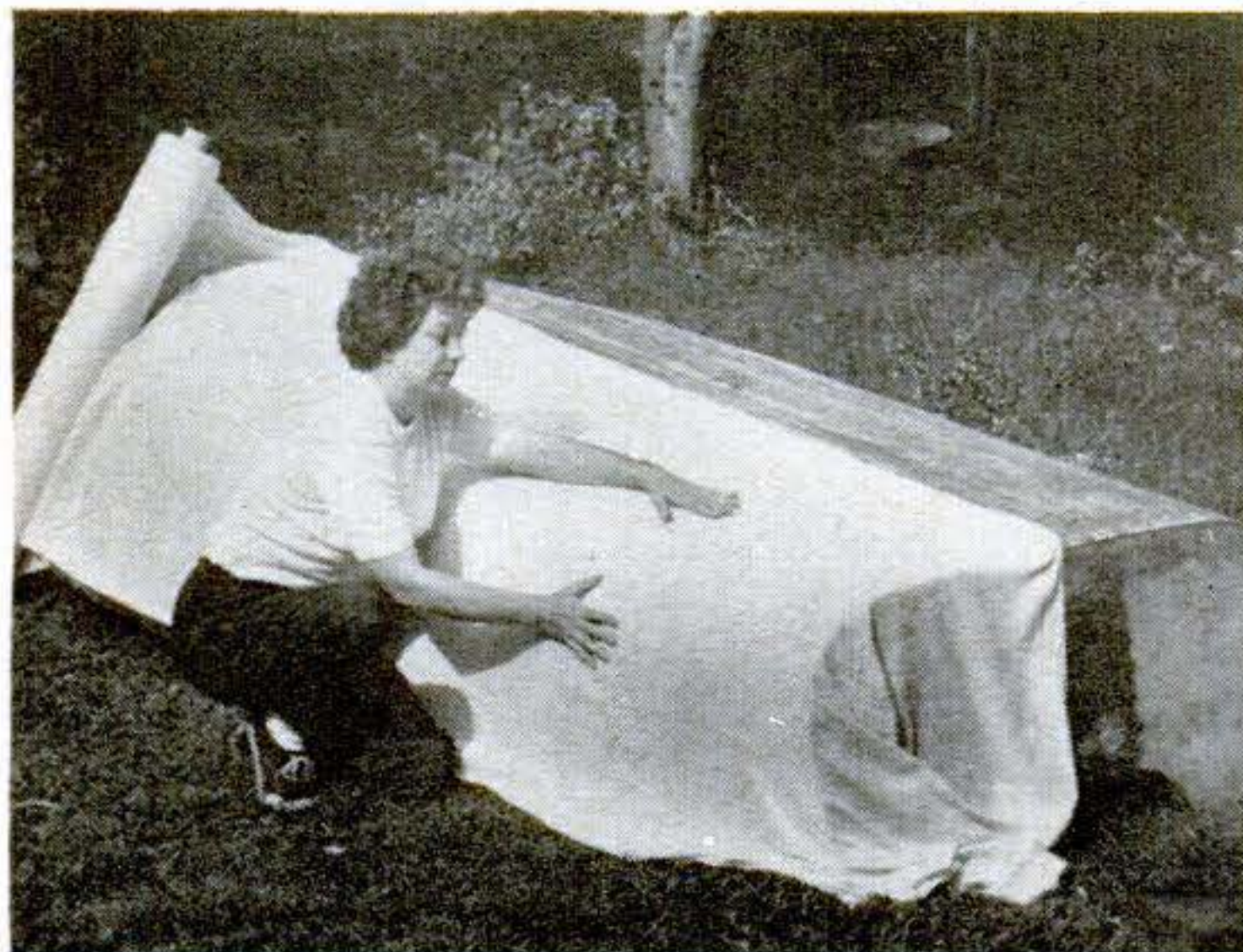

Fabric is smoothed out over one side of the hull after spray rails, skids, all fittings—and the paint—have been removed. The fabric is then stapled in place and the excess scissored off along edges

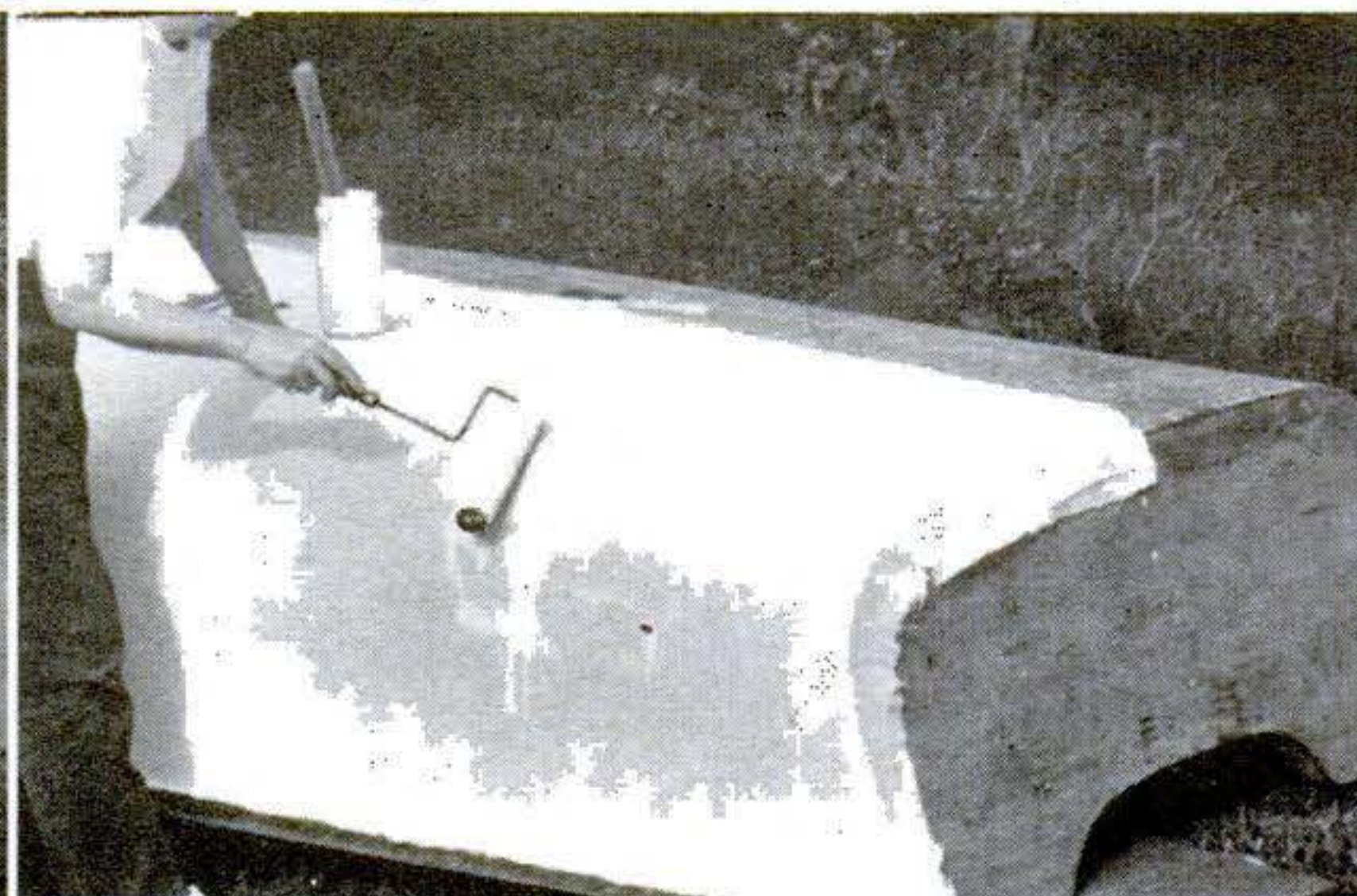

and at ends. A soak-through resin coat is then applied, as above. This bonds the fabric to the planking. Applying this coat to the fabric surface took the author only 30 minutes.



Weathered and leaking, the boat looked hopeless when George Daniels began the restoring job.

Sand down to the bare wood with coarse, open-coat floor paper (about 3½ grit on a disk sander). This works fast and leaves the surface just rough enough for good adhesion. You can use a wax-free paint remover on outer layers of paint.

Leave the calking alone if it's hard and firm. Rake out any loose sections and replace with wood dough or a Thiokol type. Neither is affected by the resin.

Use ink to X-mark spray-rail screwholes. You can see the marks through the material after it's snug. Push finishing nails through to keep track of the holes after the resin goes on. Otherwise you'll have trouble replacing the rails.

Applying the resin. This is best done out of doors. The vapor irritates some people and can be an indoor fire hazard.

You can do an entire side at a time, rolling it on generously and spreading it with brush and squeegee into corners. There's no rush. On the boat shown, the soak-through coat took only 30 minutes to a side, the following coats 25 minutes. This left plenty of margin, as the resin I used has a 45-minute (and better) working time.

Sand between coats, but take it easy on the first coat so you don't sand through the weave. The second coat fills it in and the third one gives it a cue-ball finish. Use medium-grade paper on the sander to skim off the stiffened protruding fibers of the first coat. Sand the second coat with fine paper.

If the sanding turns up any sags in the second coat, sand them smooth. If you spot any dents that didn't show up in the

you needn't be afraid to tackle yourself

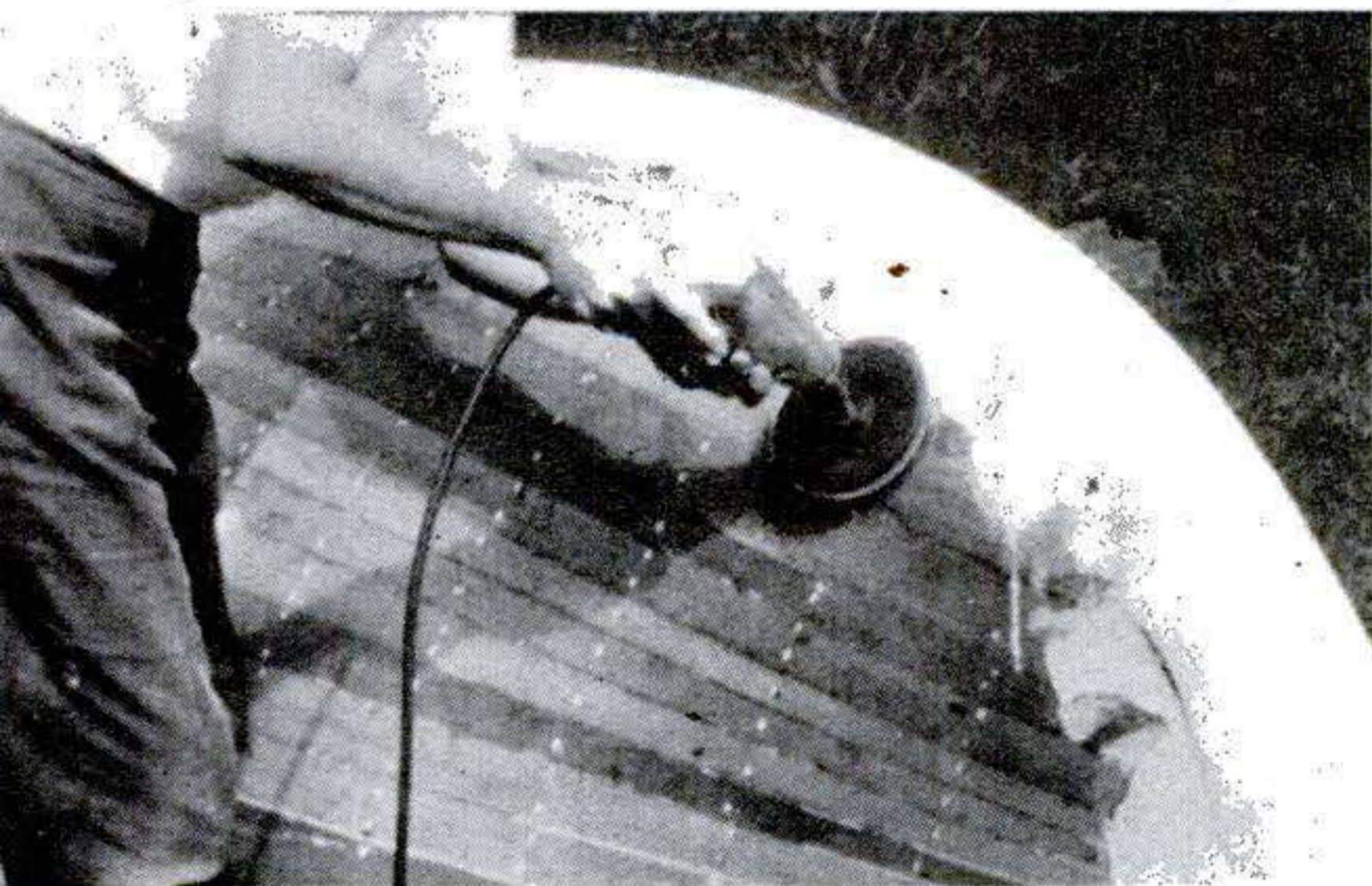

Feathering out the laps at stem and transom is required so fabric will smooth out on the second side. Latter was later lapped over the first side and also feathered out. Series of sketches above

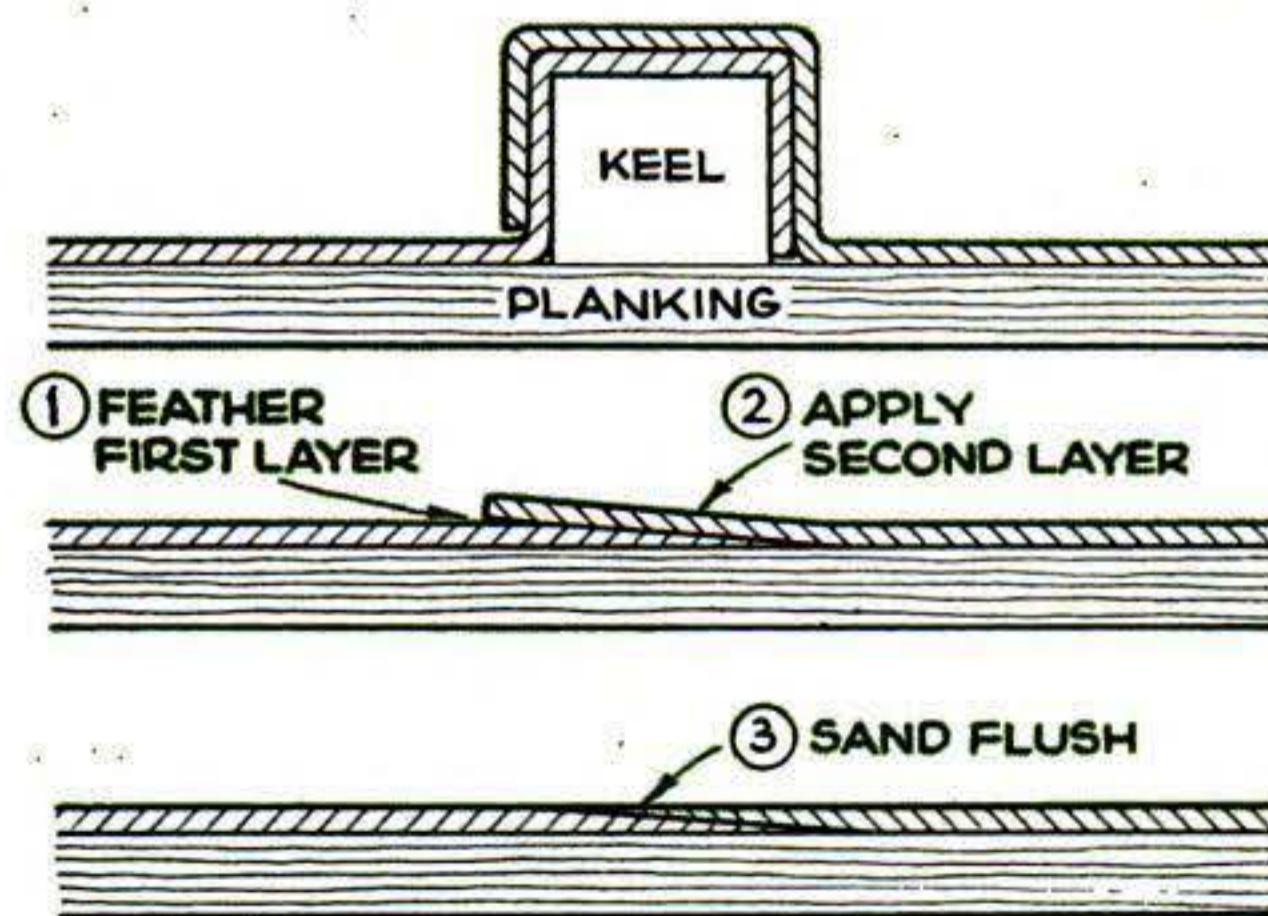

shows other lapping details. A Dynel skin often increases a boat's speed a bit because the slick surface has less surface friction. There's little gain in the final weight of the boat.

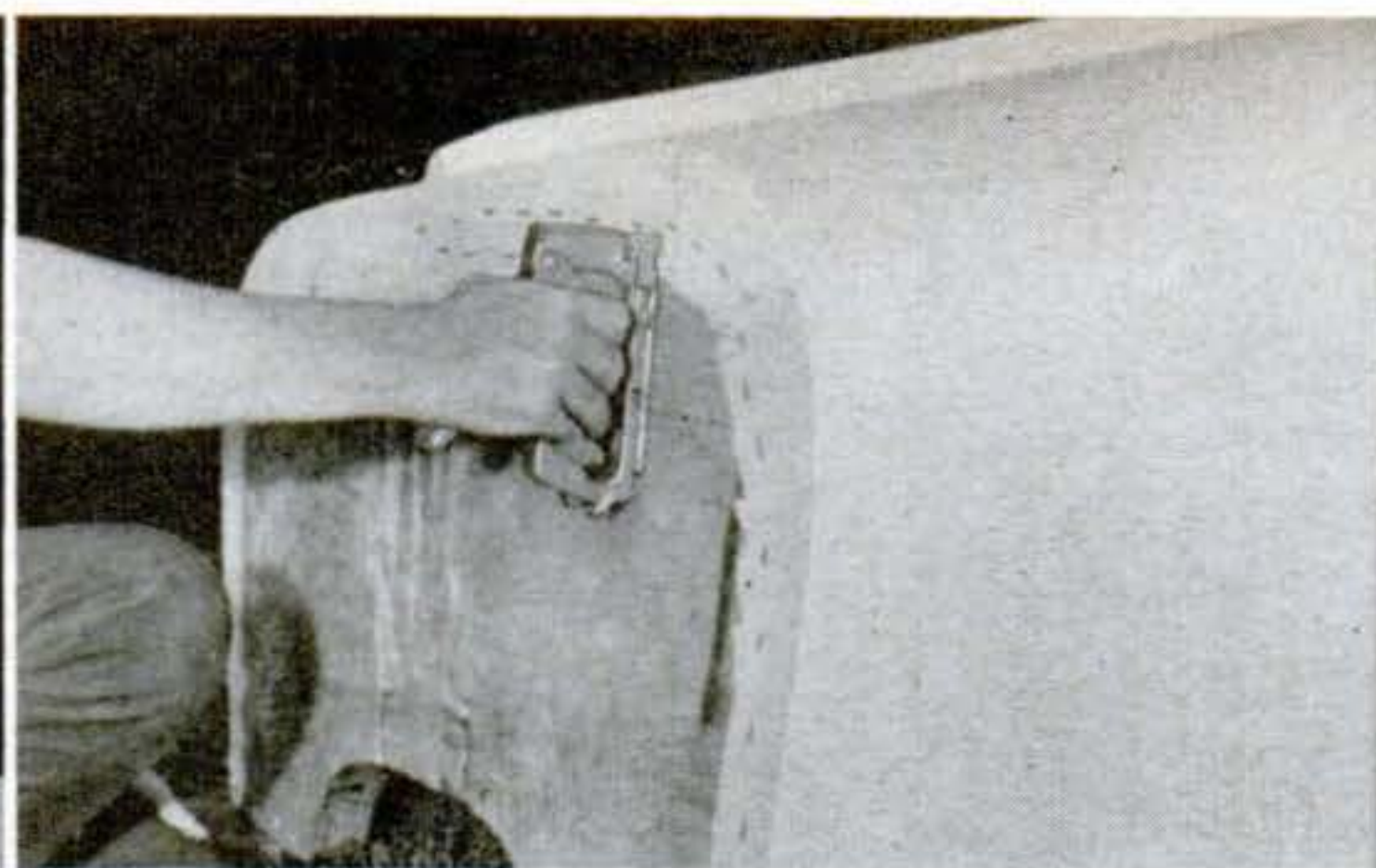

Staples hold the fabric in place until first resin coat has bonded it to the wood. They should be set closely at the stem and extra ones added if puckers appear. Use short staples and tap

them flat if they don't drive fully into hardwood. Transom staples are set in from edge slightly so edges can be feathered. Separate piece of fabric goes on the transom of the boat.

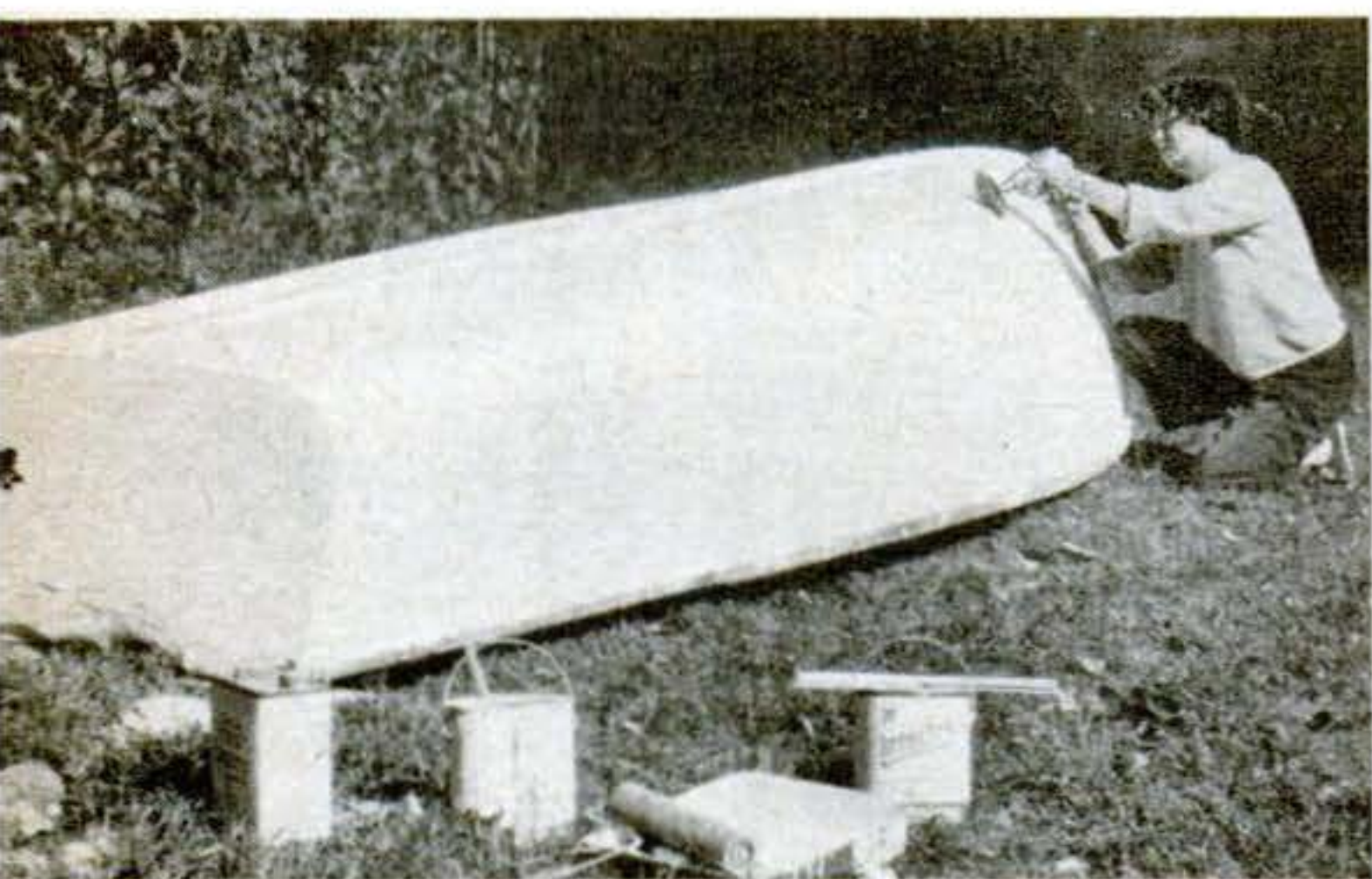

Between-coat sanding is done with a medium-grip disk after first resin coat, medium-fine after the second. Dynel fabric was applied to the decks, too, and also to the steering wheel.

wood, putty them with a little resin mixed with dry talc or portland cement. The mix sets rock-hard and never lets go.

Choose your color. Resin pigment will give you just about any built-in color you want. You can paint over it later on if you want a new color. (You fine-sand the glossy surface to give the paint a grip.)

The cost for 12 yards of Dynel to do hull and decks came to just under \$29, the resin and pigment to about \$55. Grand total: \$84. This, plus a day's work, boosted the value of the boat by at least \$200, made her stronger than she had ever been, trouble-free, and leakproof. ■ ■

Ready to go: Boat now looks modern with paint over fabric; wheel and windshield moved forward.





Winter job for a barbecue —start plants in it

Don't let your portable barbecue gather dust until spring. Use it, as I do, as a portable greenhouse.

It lends itself well to this. You can keep it inside near a sunny window or under a light bulb on cool days, wheel it outside on favorable days. If it has a hood, leave it on for a windbreak. A translucent plastic cover draped over the hood protects seedlings.—*John Allen De Frees, Durhamville, N.Y.*

Adjustable support for a young tree

Here's a solid support that keeps the trunk of a new tree from swaying in any direction. It's made from a two-by-four cut lengthwise. A stove bolt clamps the support to a 1" conduit post in the ground.

Foam-type hair curlers are split and used as padding around the trunk. Available at drug stores, these allow air circulation, dry out quickly when wet, and are chemically inert. The support is easily adjusted as the tree or branches grow.—*H. G. Frommer, Mequon, Wis.*

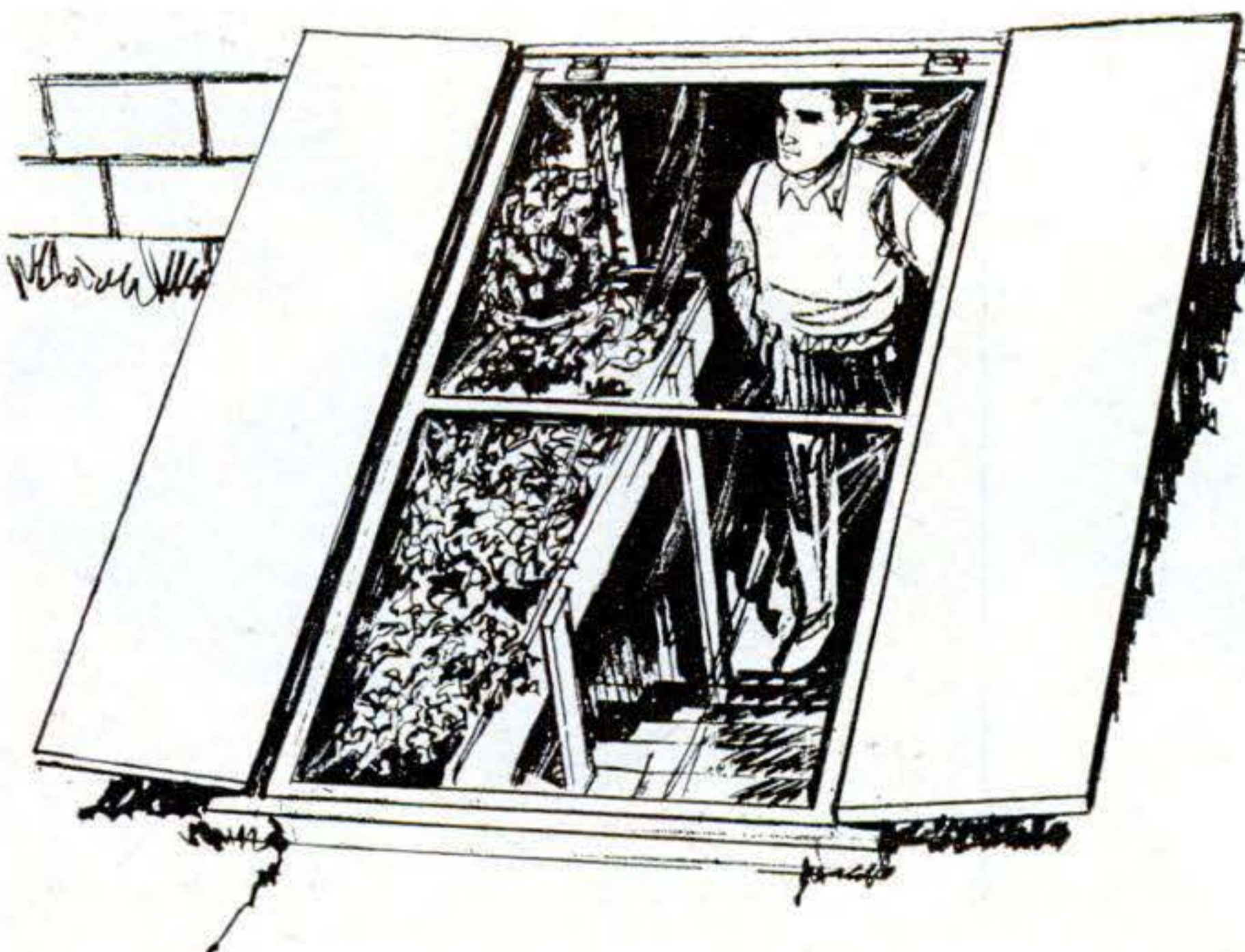
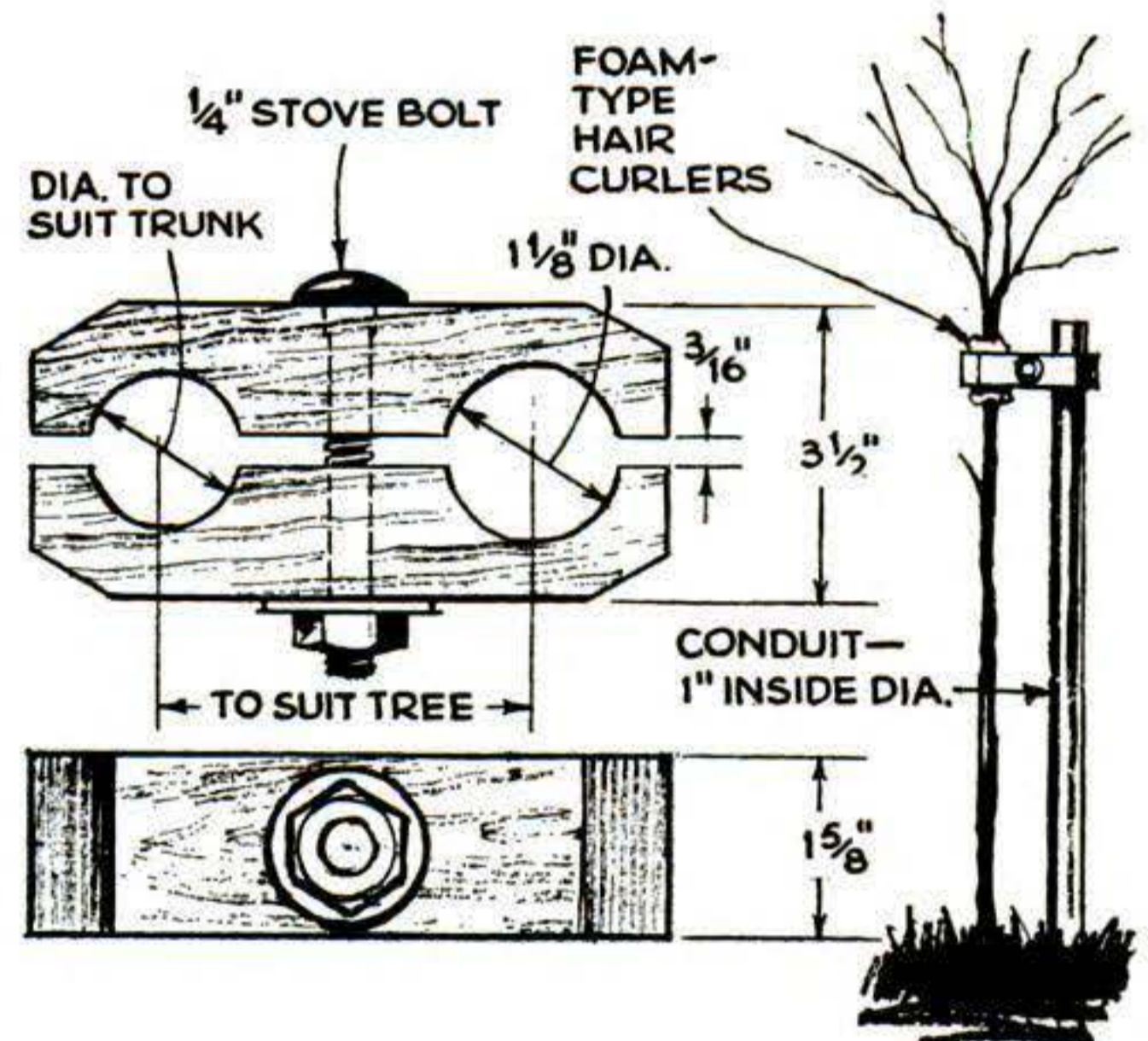

You can have a hothouse in a cellarway

We use the cellarway as a hothouse for early plants. A simple frame holds pots and flats at the wall that gets the most sun. A sash of furring strips and heavy plastic sheeting over the opening is attached with storm-window brackets so that it can be raised a bit on very warm days. The cellar furnace provides heat, and the sash is inset to permit closing the doors at night.—*Mrs. Margaret Butts, Norton, Mass.*

Wordless Workshop

By Roy Doty
and Harald Solaas

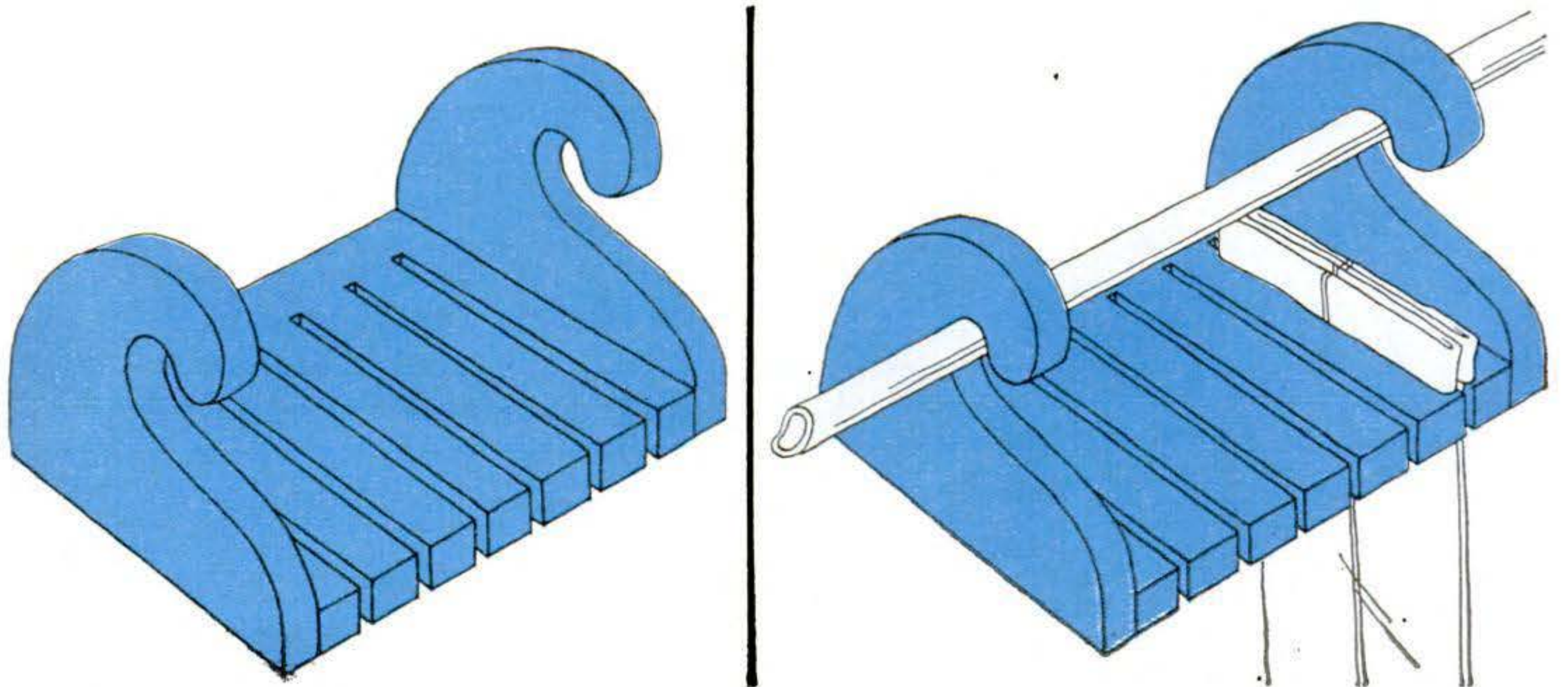
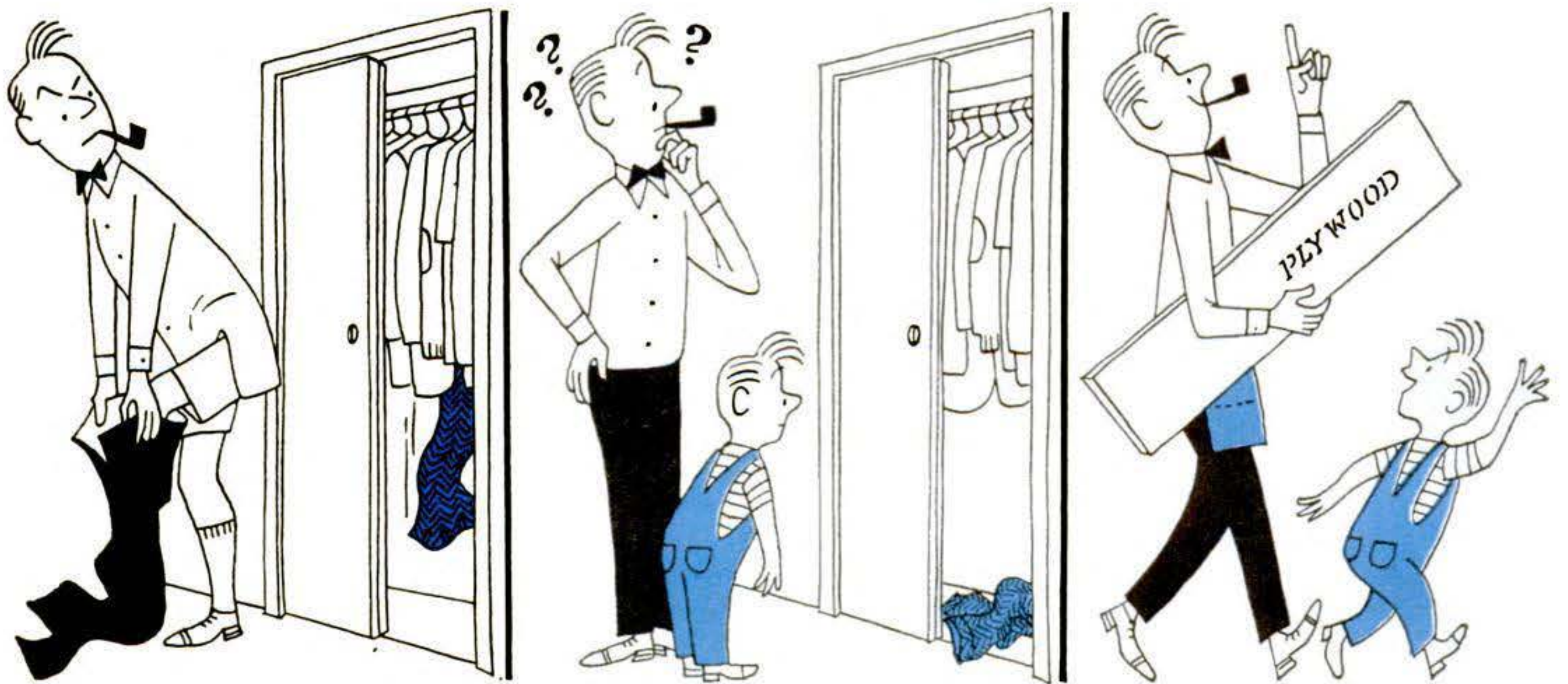

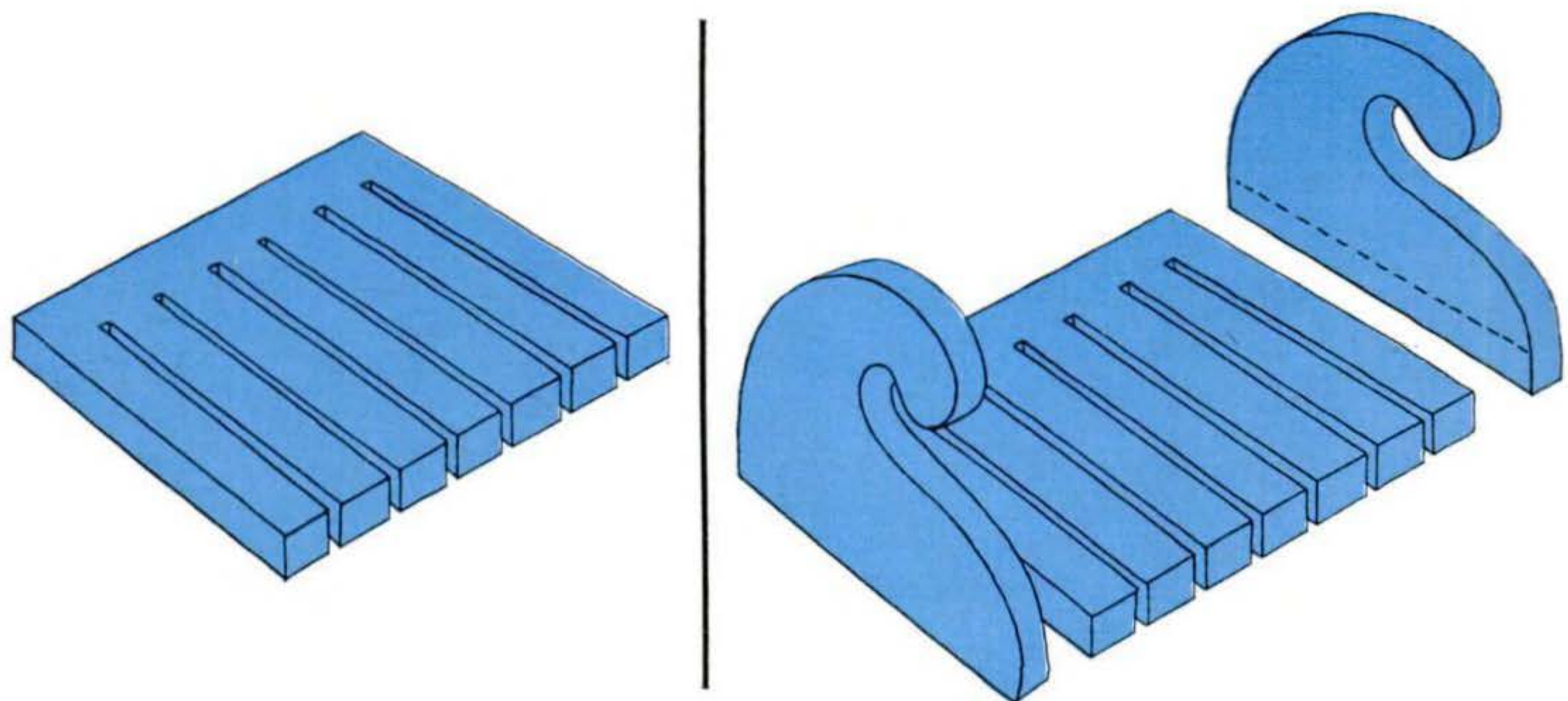

My Trailer Does More Than Haul a Boat

Looking for hot ideas in a load hauler? Toting a runabout is just one of many jobs for this rig

By Bonner I. Buller

MOST trailers are built to tote one thing. Here's a job that's a self-loading boat trailer, a general-purpose yard hoist, a mobile camper, and a heavy-duty hauler all rolled into one. I designed it originally to pull our boat up the steep banks of a nearby lake, then discovered I had a versatile rig that would pay its keep all year 'round. Consider its features:

- A retractable boom at the rear, operated by a hand winch, plucks a boat or other heavy load right off the ground and sets

CONTINUED



With the boom upright, winch pulls the boat's bow high in the air, as at right. As bow nears top of boom, the boom brace is detached, as shown above, allowing boom to pivot freely.

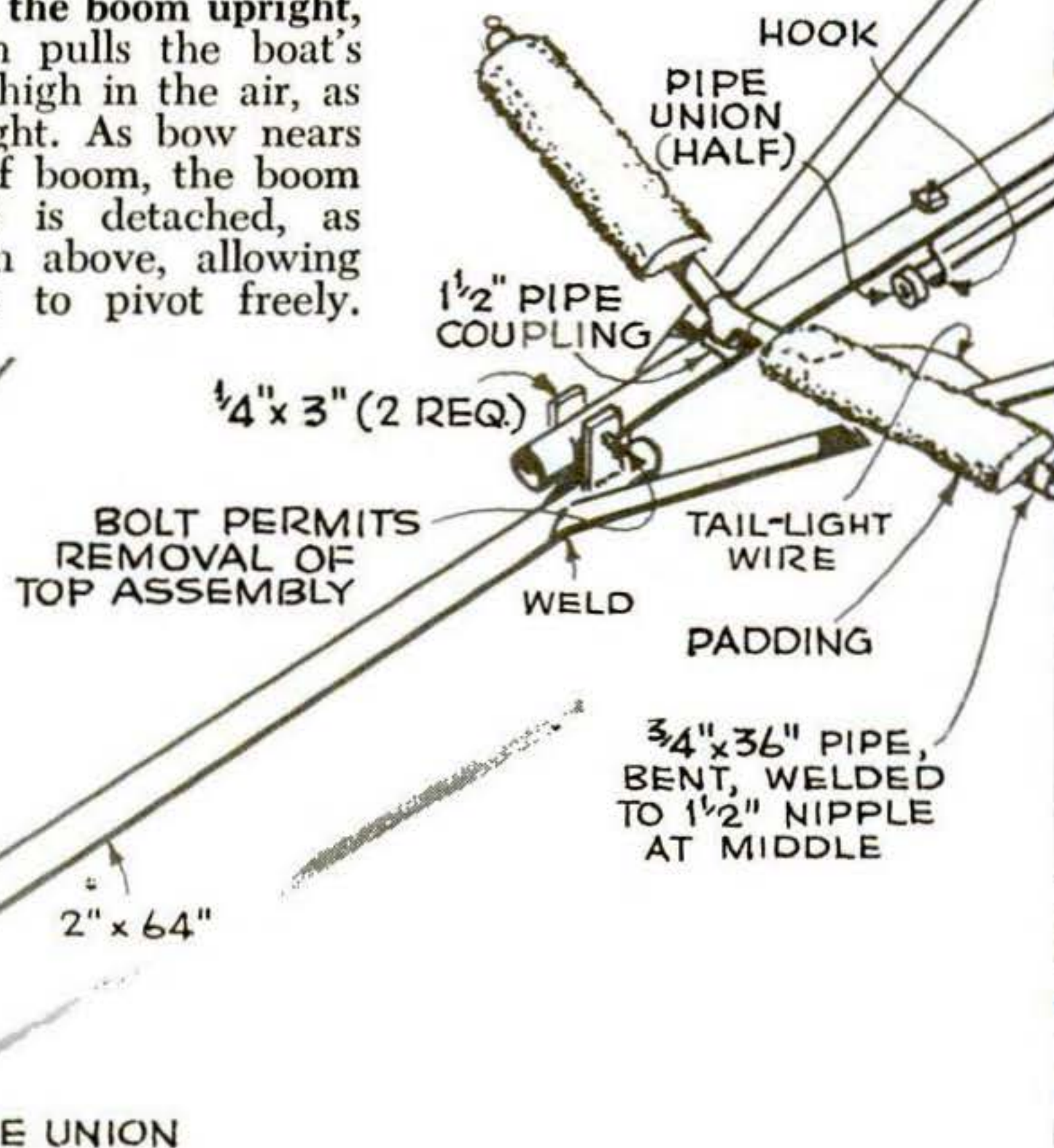

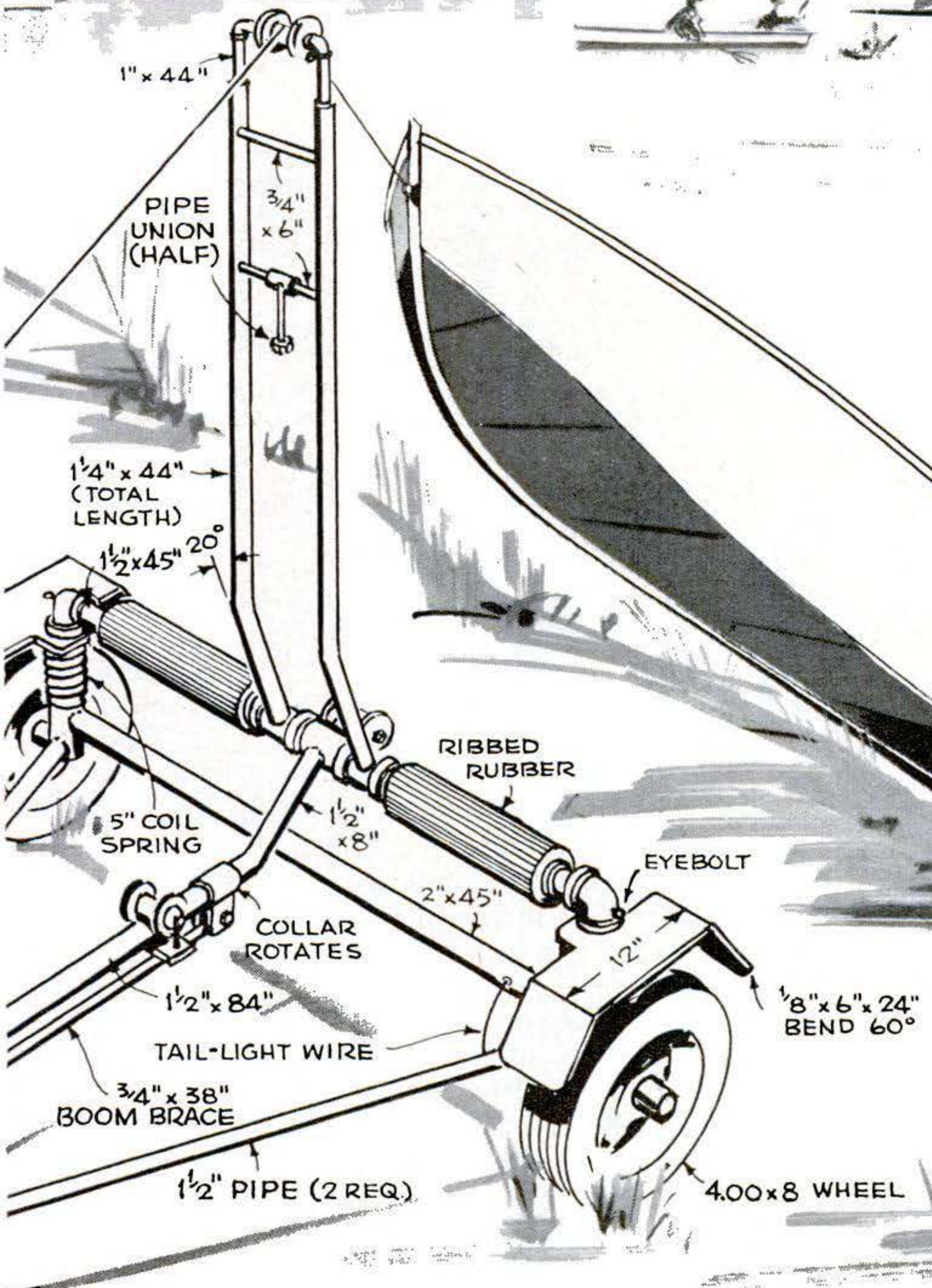

As the bow slides up and onto the boom, its weight tilts the boom downward, and the boat is plopped neatly onto the trailer bed. A few more turns of the winch draw the boat fully forward onto the front cradle, ready for a quick trailer ride home.

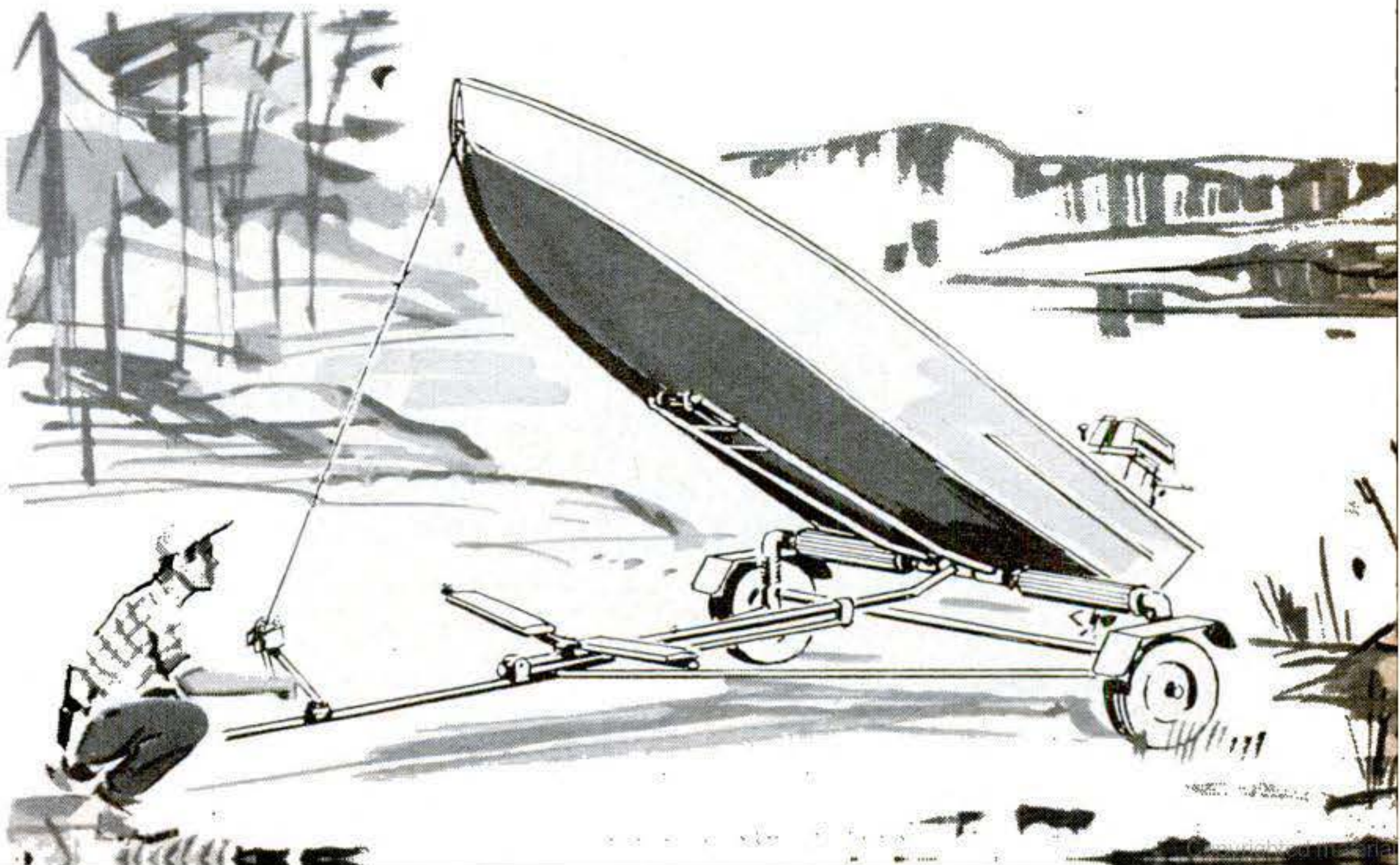

With or without a boat, this jack-of-all-jobs works the year 'round



Side-winchng solves problem where you can't back trailer toward water.

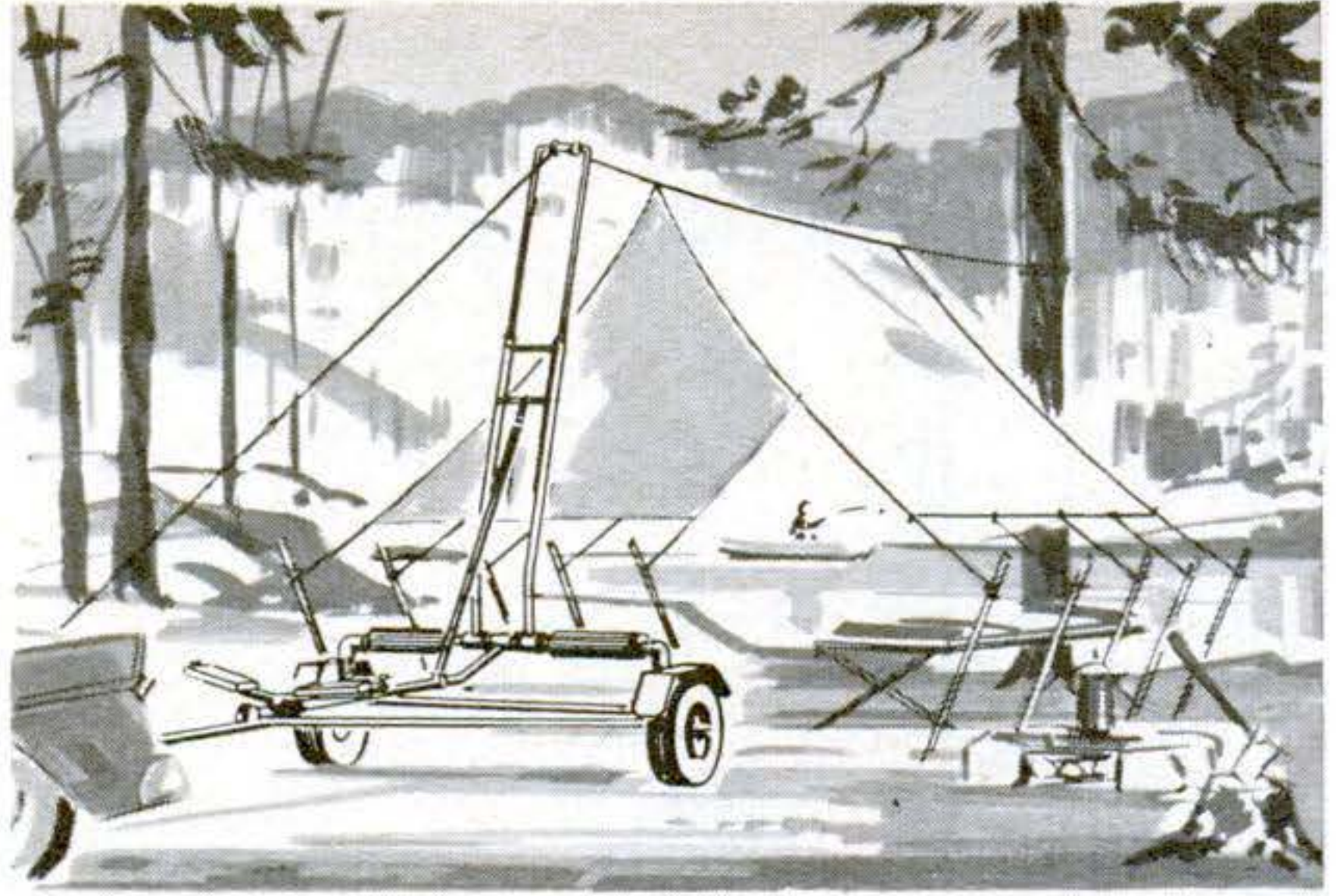

Want a quick support for a tent? Just extend the boom, tie the line to a tree, and winch the tent up taut.

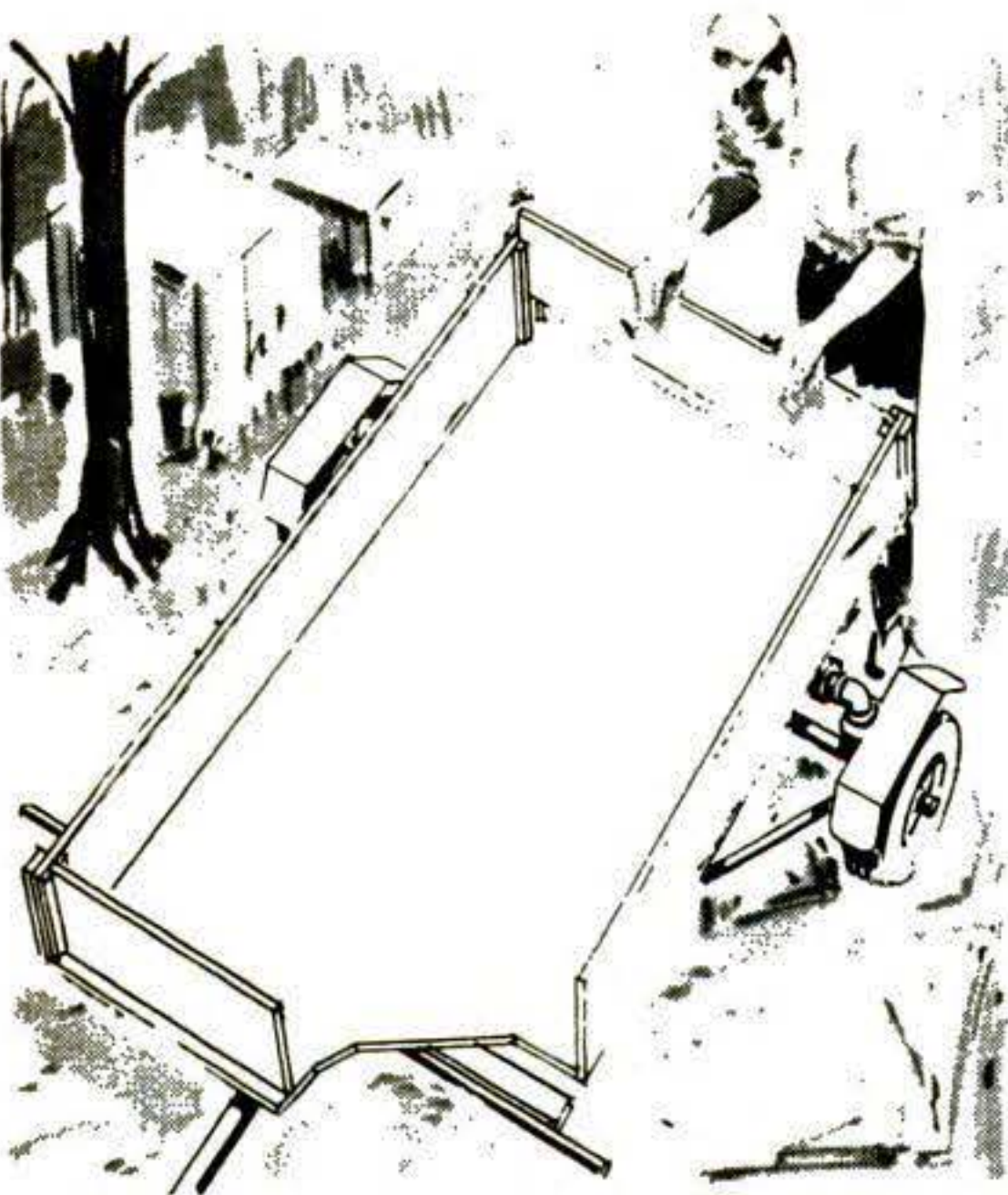

Lift-off box has cleats that simply fit between front and rear supports.

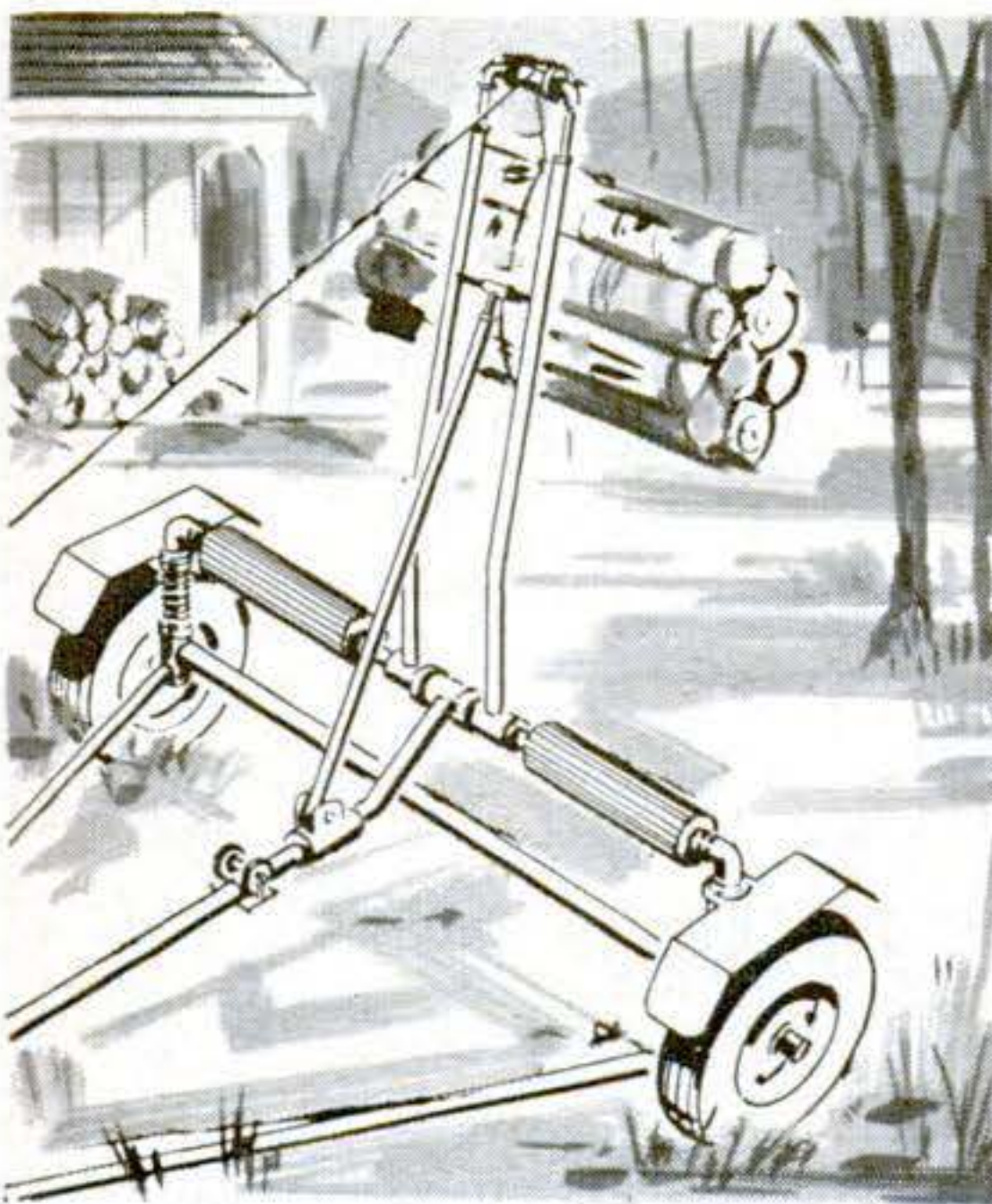

As a mobile hoist, trailer handles heavy lifting jobs around the yard.

it smartly on the trailer with no lifting on your part.

- Lock the boom upright and you have a fixed hoist for stacking firewood, pulling stumps, or lifting heavy machinery. You can winch a load off the ground, then just wheel it to wherever you want.

- Retract the boom and you have an unobstructed frame that can be converted to a box trailer, flat-bed hauler, or mobile camper. The front bow cradle, used when you're toting a boat, can be unscrewed and replaced with other types of supports to take almost any kind of trailer body.

- The winch mount, normally fixed, is free to swivel so it can pull in any direction. This enables you to hoist a load even where you can't park the trailer in line with it.

The cost is low because nearly all parts are common black-iron pipe, usually available secondhand for about half price. Welding is required at the joints—even those that thread together—for maximum strength. This can be done easily by a local welding shop.

All of the sliding and pivoting joints are simply two sizes of pipe chosen to slip together as closely as possible. The boom, made of two telescoping sections of pipe, can be extended up to 8' to give you a tall derrick or pole support. The roller at the top of the boom serves a double purpose. Made of two rubber rings on a rotating pipe collar, it acts as a pulley for the winch line when the boom is raised and as an additional support for a boat hull when the boom is lowered.

The brace that holds the boom upright is connected with a standard pipe union, allowing you to attach and remove it quickly. Another pipe union is the swivel for the winch mount. One half is welded to the trailer's drawbar and the other half to the winch support. By loosening the union's collar, you

[\[Continued on page 222\]](#)

Tips for the Home Shop

By R. J. De Cristoforo

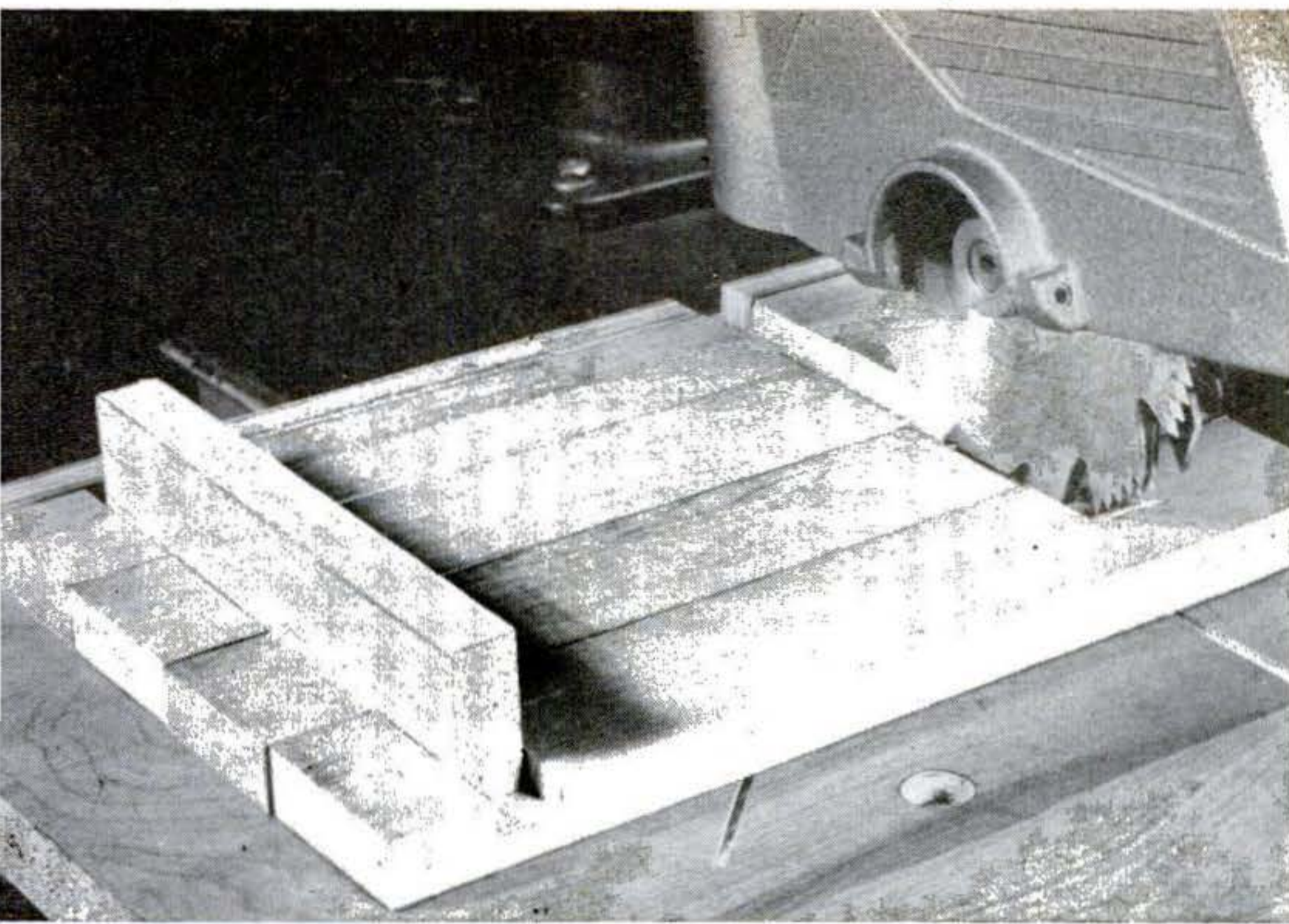

Duplicating dados on similar pieces of wood is a cinch with a radial-arm saw. Insert a snug-fitting piece of wood in the first dados. This holds the pieces together, aligning them for the following cuts, and spaces the dados equally in each piece.

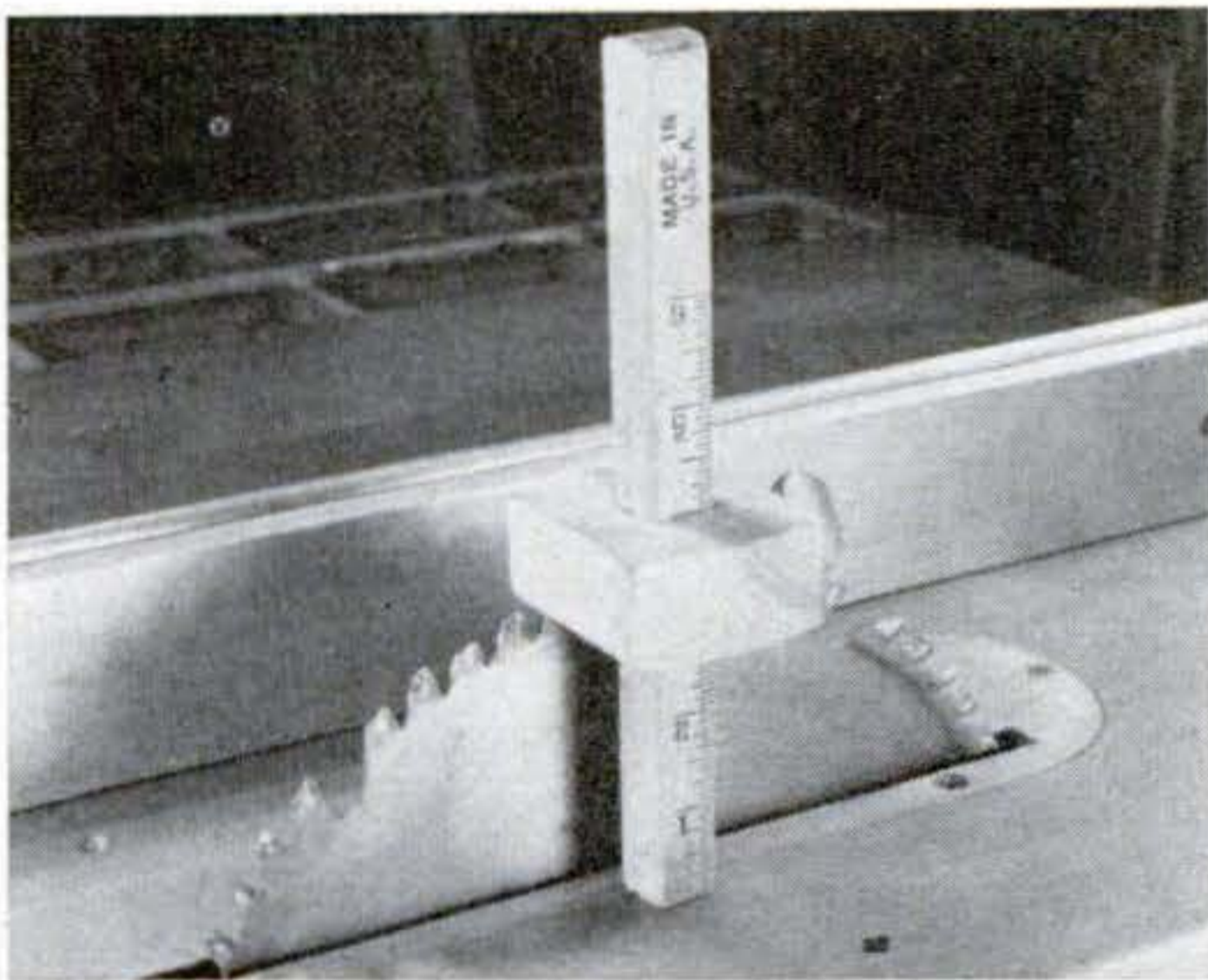

Blade projection can be measured accurately with a marking gauge modified like this one. Just remove the point and cut off the end square at the start of calibrations. The gauge also gives precise settings for a dado or molding head.

Here's a setup for sharpening drills—although you won't get a true conical grind. Turn the grinding wheel slowly as you touch the bit to it by extending the quill. A smooth stone is best. Restrict such sharpening to larger drills. Those under $\frac{1}{8}$ " tend to be too flexible.

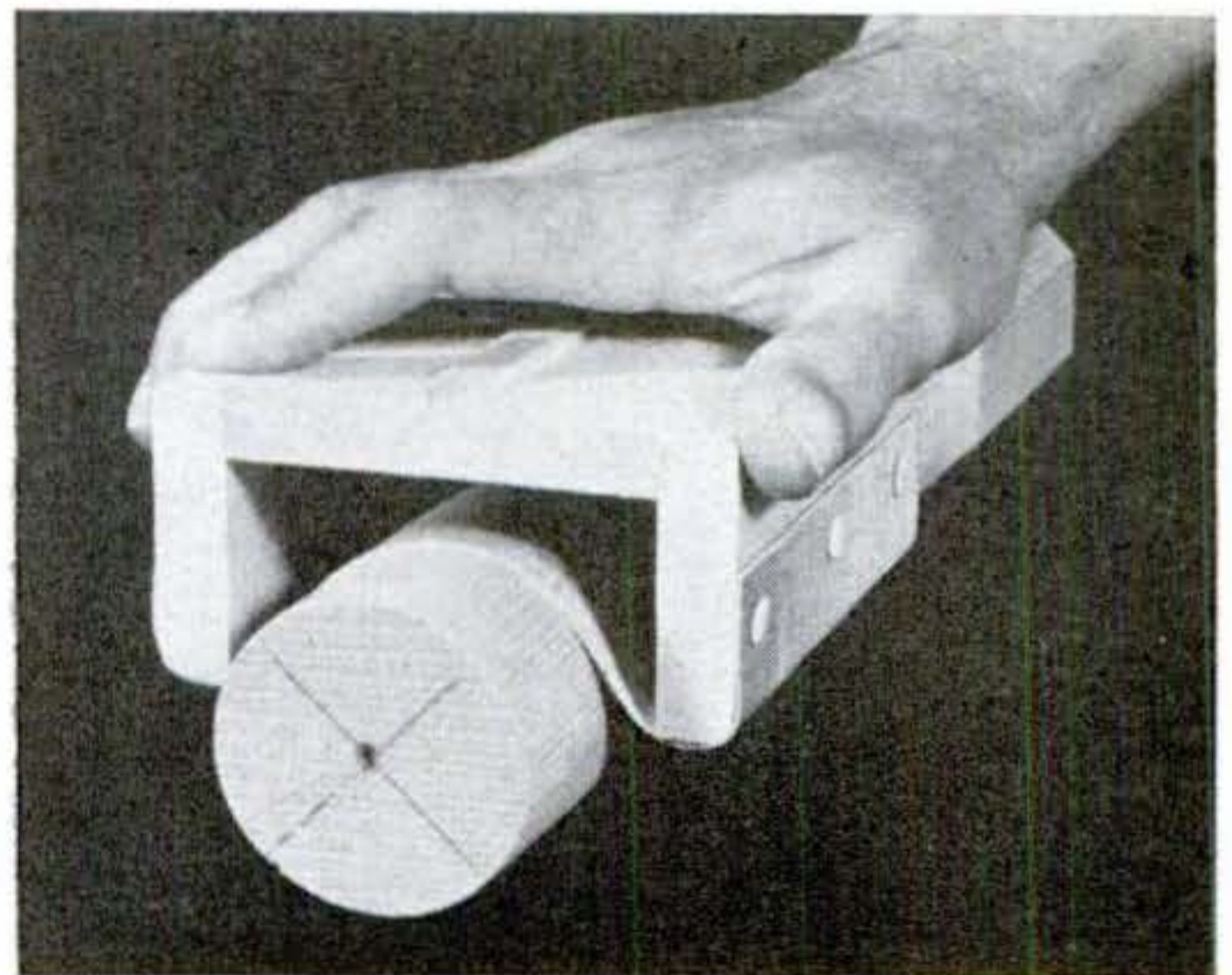
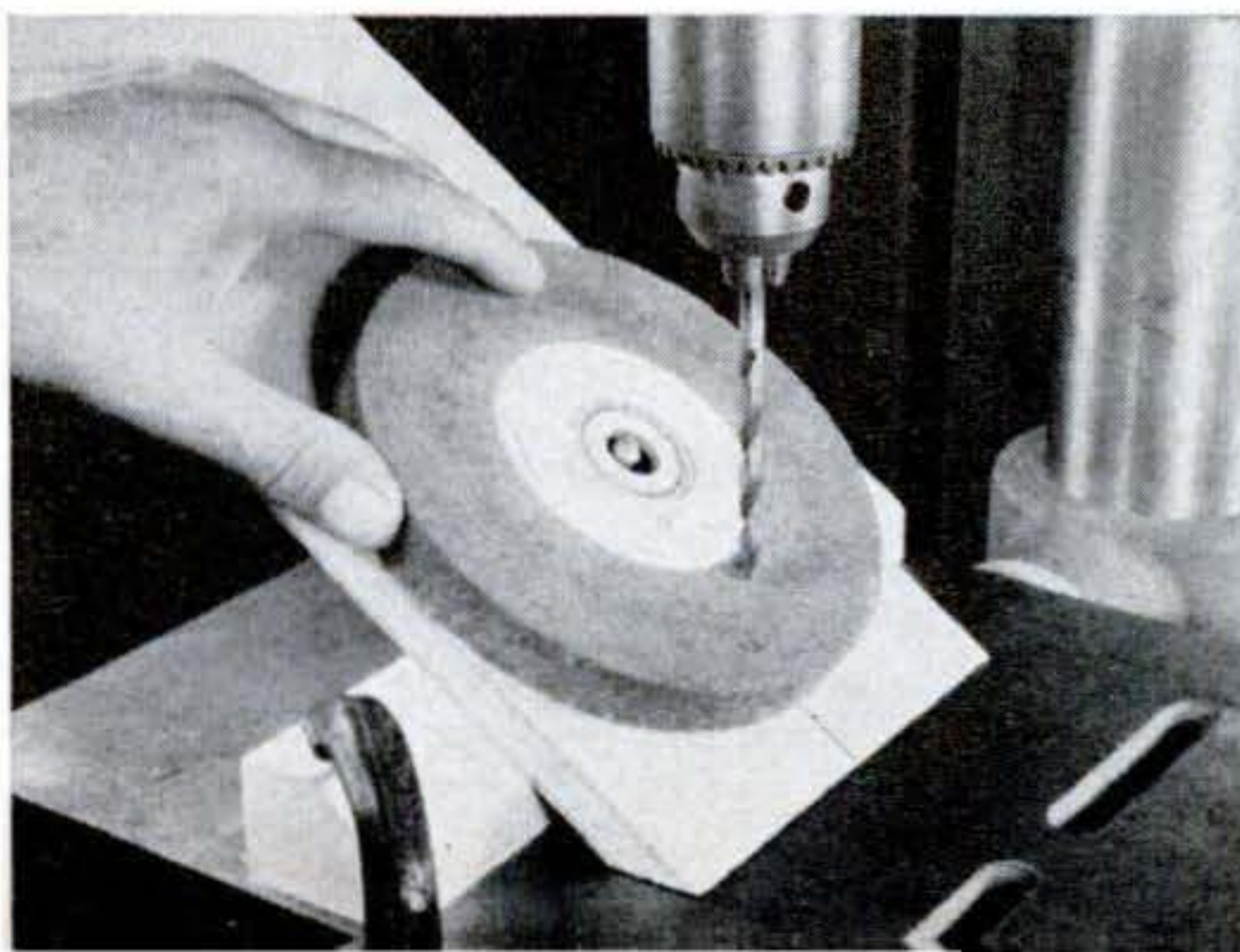

A U-shaped sanding block is ideal for smoothing cylinders and many irregular shapes since you can fit it to the work by adjusting the tautness or looseness of the paper across the block. Screw a handle on if you wish.

A V slot, a chamfer, or a bevel can be cut on the edge of a wood disk with this setup. Pivot the disk on a scrap of wood screwed to a strip that fits the table slot. Clamp the strip and rotate the disk against the angled blade. Raise blade about $\frac{1}{16}$ " after each pass.

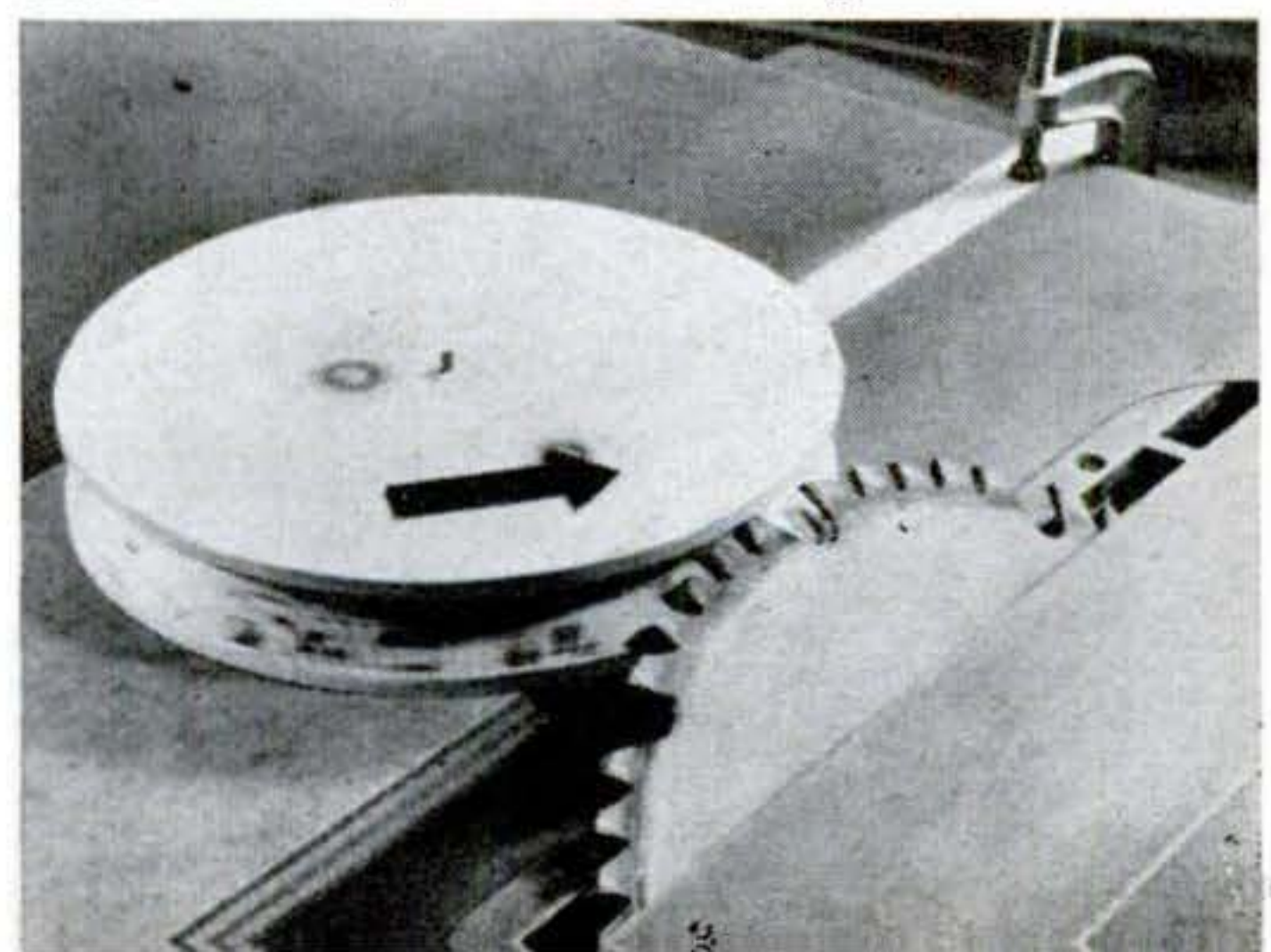

PS TOOLS

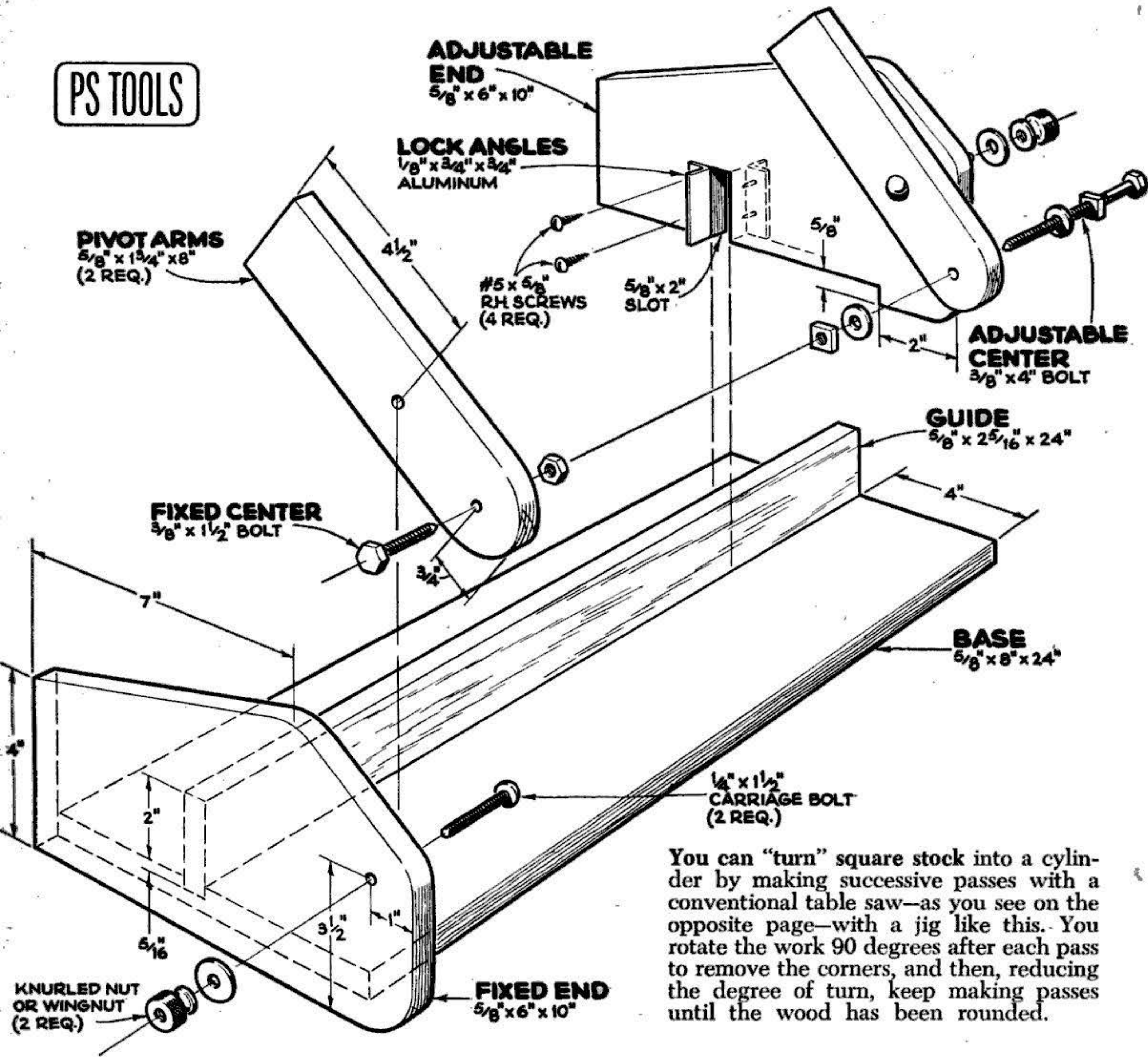

You can "turn" square stock into a cylinder by making successive passes with a conventional table saw—as you see on the opposite page—with a jig like this. You rotate the work 90 degrees after each pass to remove the corners, and then, reducing the degree of turn, keep making passes until the wood has been rounded.

How to Do Lathework on Your Table Saw

Combine an easily made wooden jig with a little know-how and you have, in effect, added a new tool to your shop at little cost

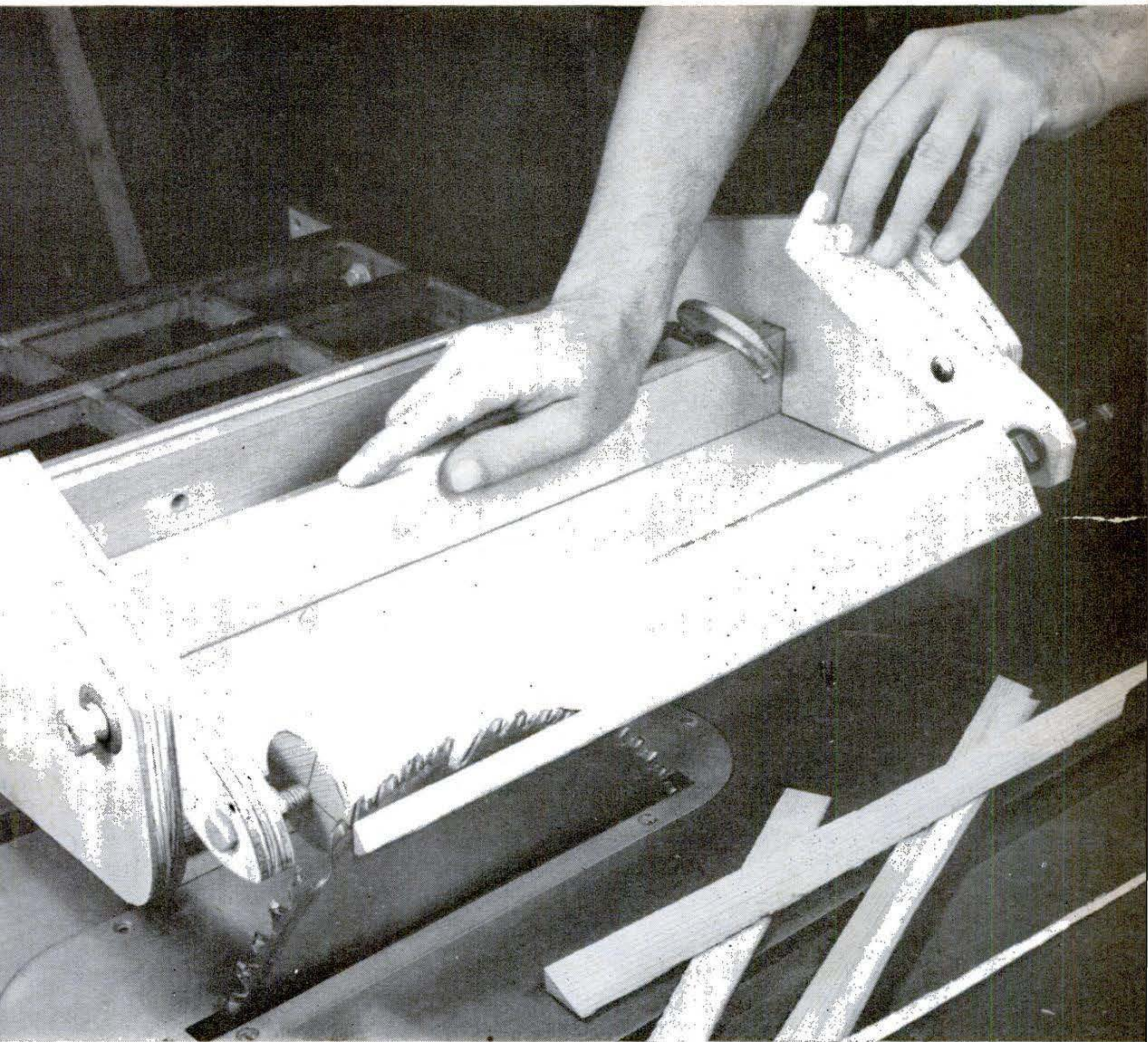

By R. J. De Cristoforo

STRANGELY enough, many intriguing lathe effects can't be accomplished on the lathe itself or by using conventional turning tools. Most longitudinal details—cuts such as reeding and fluting—require a specially mounted and powered cutter, with the lathe—if it is used at all—merely a holding device for the work.

If another tool is used, most often a jig is improvised for use on a drill press—one permitting longitudinal passes under a cutter gripped in the chuck. This is fine for fluting, not so good for reeding.

Switching the application to a table saw

is a logical alternative. You have a built-in guide (the rip fence), a convenient depth-of-cut adjustment (raising or lowering of the arbor), and you can work with a molding head and its vast assortment of knives, or a dado, or even a saw blade.

Combine these assets with a special jig and you have a complete tool—one you can't buy. It's adjustable for work length and diameter, and has mounting centers that can operate independently.

What the tool does. With the jig you can reed or flute or make any similar cut on spindles that have been shaped in the lathe, or on ready-made cylinders such as a large dowel or closet pole. In addition, using a

CONTINUED

139

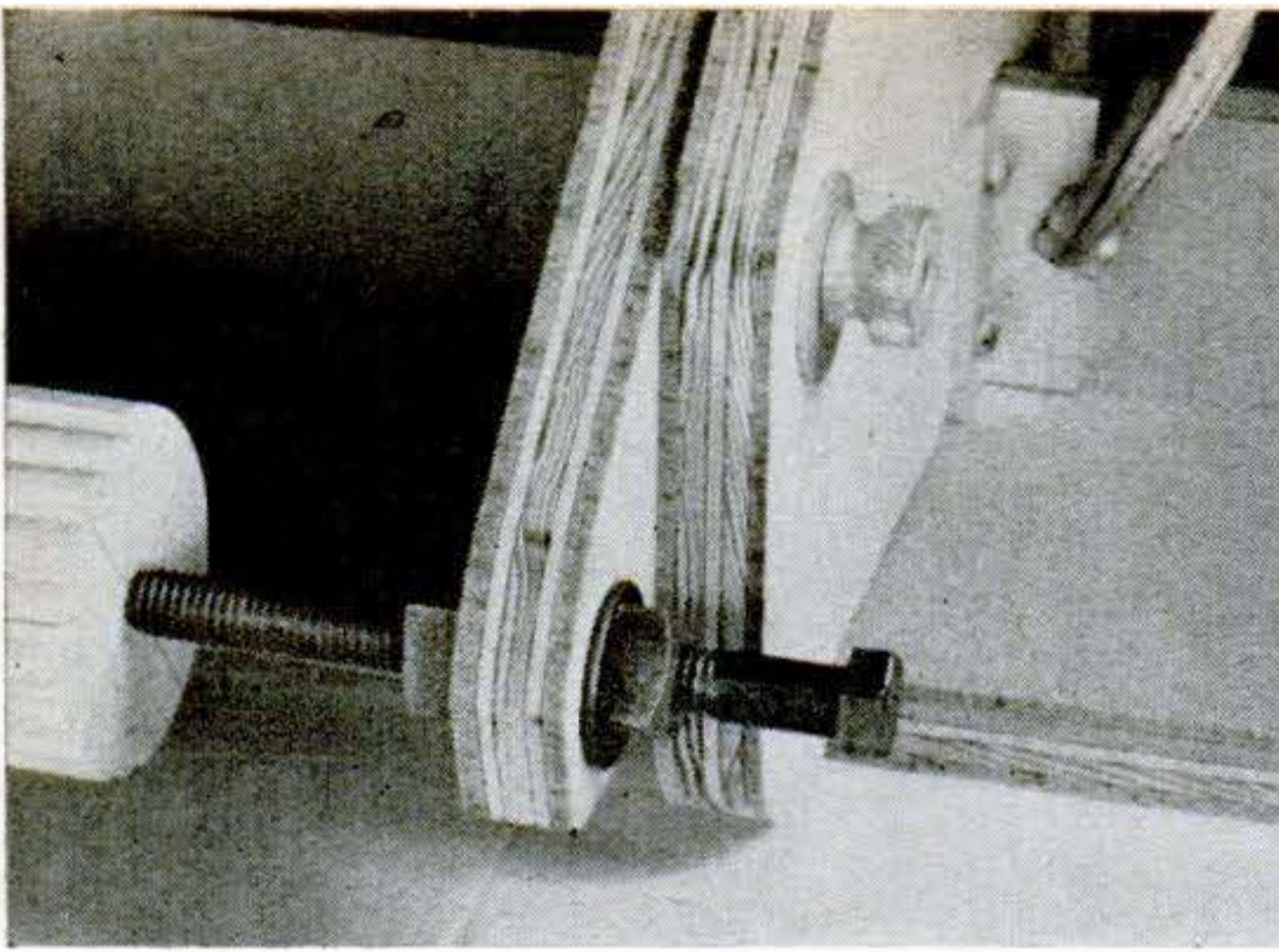

Adjustable center is a $\frac{3}{8}$ "-by-4" bolt pointed with grinder or file. Double nuts lock the center after it has been set to hold cylinder. The pivot arms are locked with a knurled nut or wingnut.

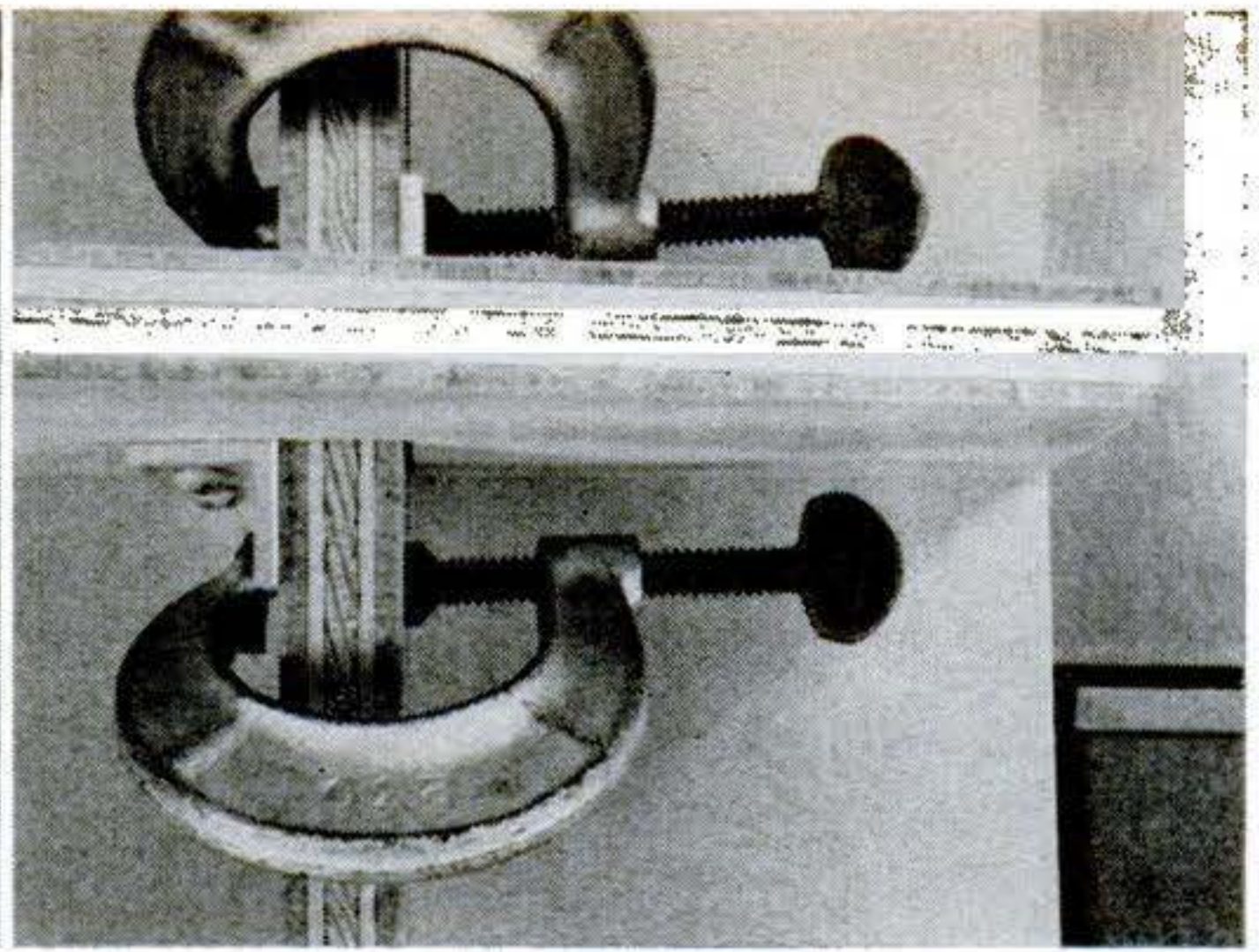

Lock angles are screwed to the adjustable end to bear on the guide. C clamps lock the adjustable end in approximate position and the adjustable center is used for final setting.

conventional saw blade, you can "turn" square stock into round and, by working with offset centers, form a tapered leg from a square blank or a round one.

You can easily slice off a section to create a "flat" on a cylinder (a good way to make shaped, half-round moldings) and you can use the jig to do coving operations on round

stock or on squares. Using the jig after some preliminary lathework has been done, you can create faceted effects on turnings that will impress even the most experienced power-tool woodworkers.

Making the jig. First cut the base and guide to size. Run a snug $\frac{5}{16}$ "-by- $\frac{5}{8}$ " dado the length of the base and 4" in from one

Here's how you use the jig for reeding or fluting a cylinder

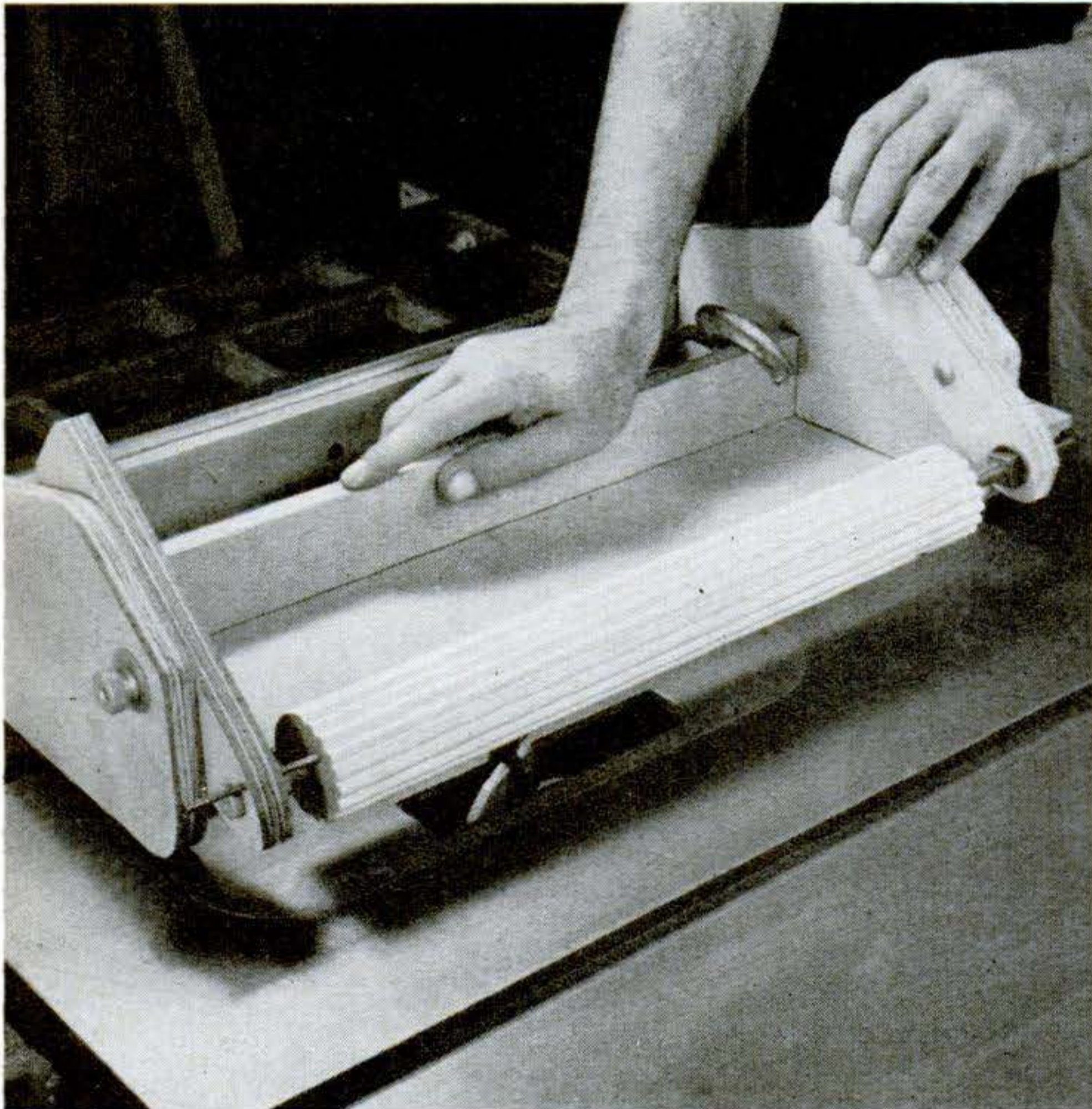

Reeding and fluting, the more common "after jobs" in lathework, are a cinch with the table-saw jig. After the cylinder has been turned on a lathe, or cut on the saw as shown on previous page, you mount it as above and make passes with the saw blade.

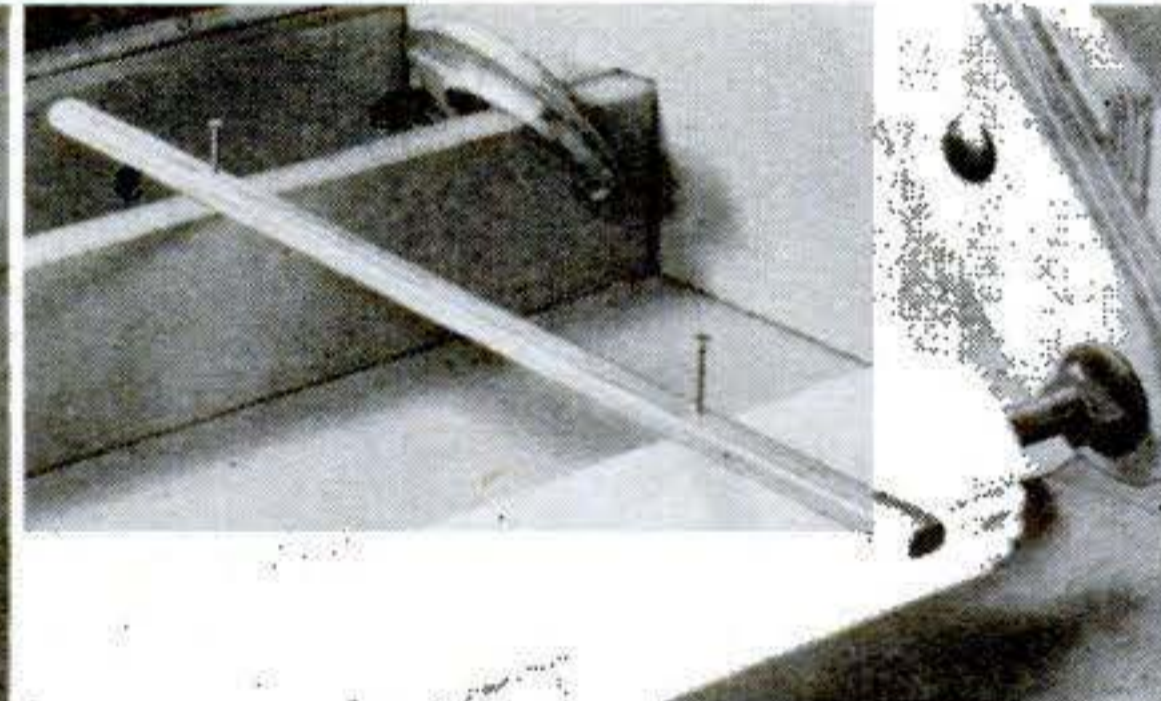

One way of indexing the cylinder is to tack a strip of wood across the guide and the work after positioning the work.

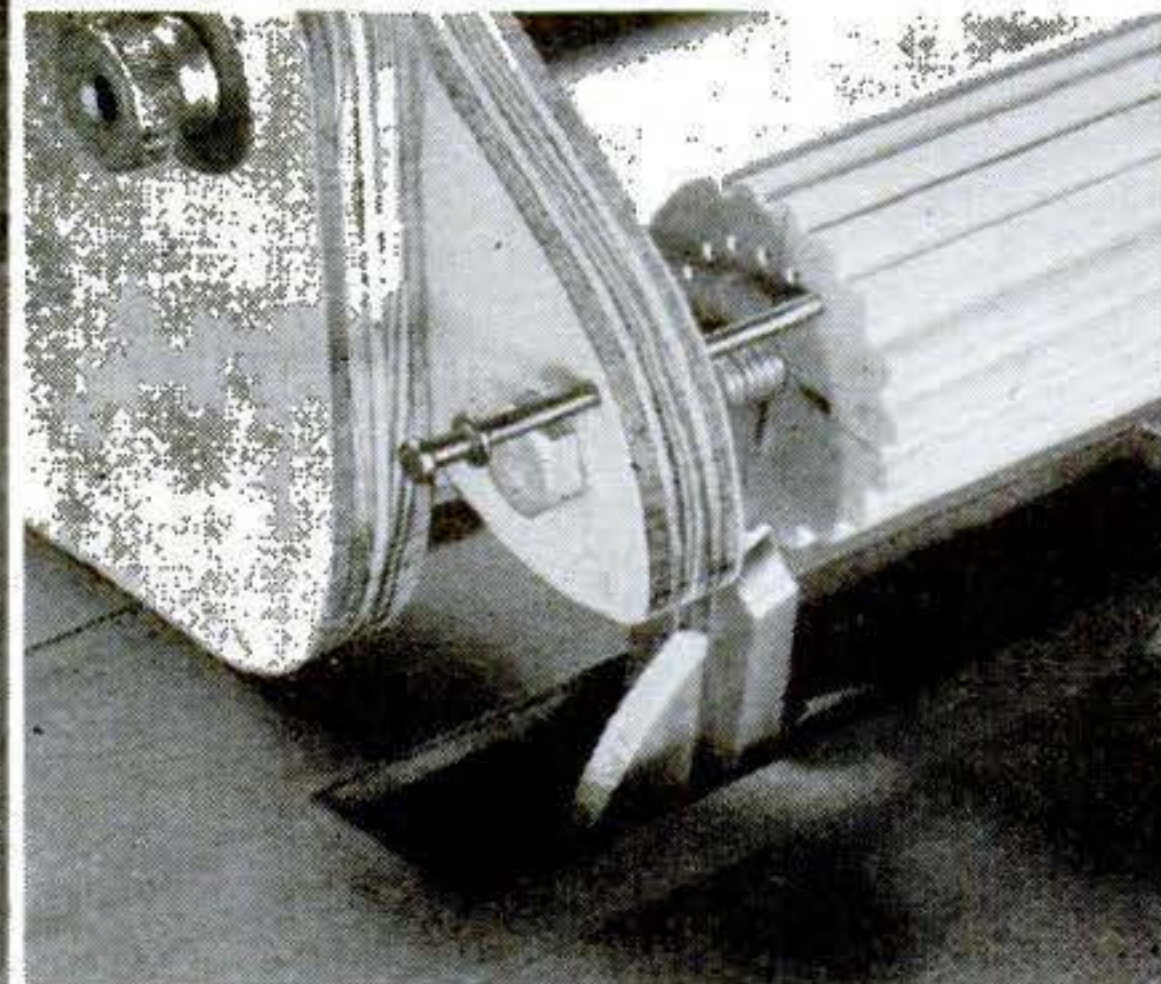

Second indexing method is shown here—a nail through a hole in one pivot arm. A light hammer tap locks the work.

edge. Glue and nail the guide in place. Next make the ends. These are duplicates except that the adjustable one is recessed at the bottom to accommodate the base and notched to fit snugly over the guide.

It's best to nail two pieces of wood together until you have the basic shape and have drilled the hole. Then do the recessing and notching on the adjustable end. Attach the fixed end to the base and guide with glue and nails. Cut to length the lock angles for the adjustable end and screw them to the end so that they bear on opposite sides of the guide.

The pivot arms are duplicates and must be drilled accurately. The centers are made from the bolts called for in the drawing and are pointed on a grinding wheel or by hand with a file. Be sure to use carriage bolts when attaching the pivot arms to the ends.

Use a good grade of hardwood or some hardboard-surfaced plywood to make the jig. Sand all parts carefully before assembly. Apply several coats of sealer—sanding between coats—and a heavy coating of paste wax to the underside of the base.

Adjusting the jig. When adjusting for work length, first set the adjustable end in an approximate position and lock it in place with small C clamps; then use the adjustable center for the final setting. Take up on the screw enough so the work will be held securely between centers.

Adjust the pivot arms for work height and lock in place, and set the rip fence so the work centerline will be directly over the cutter. Further depth-of-cut adjustment can be made by using the saw arbor. ■ ■

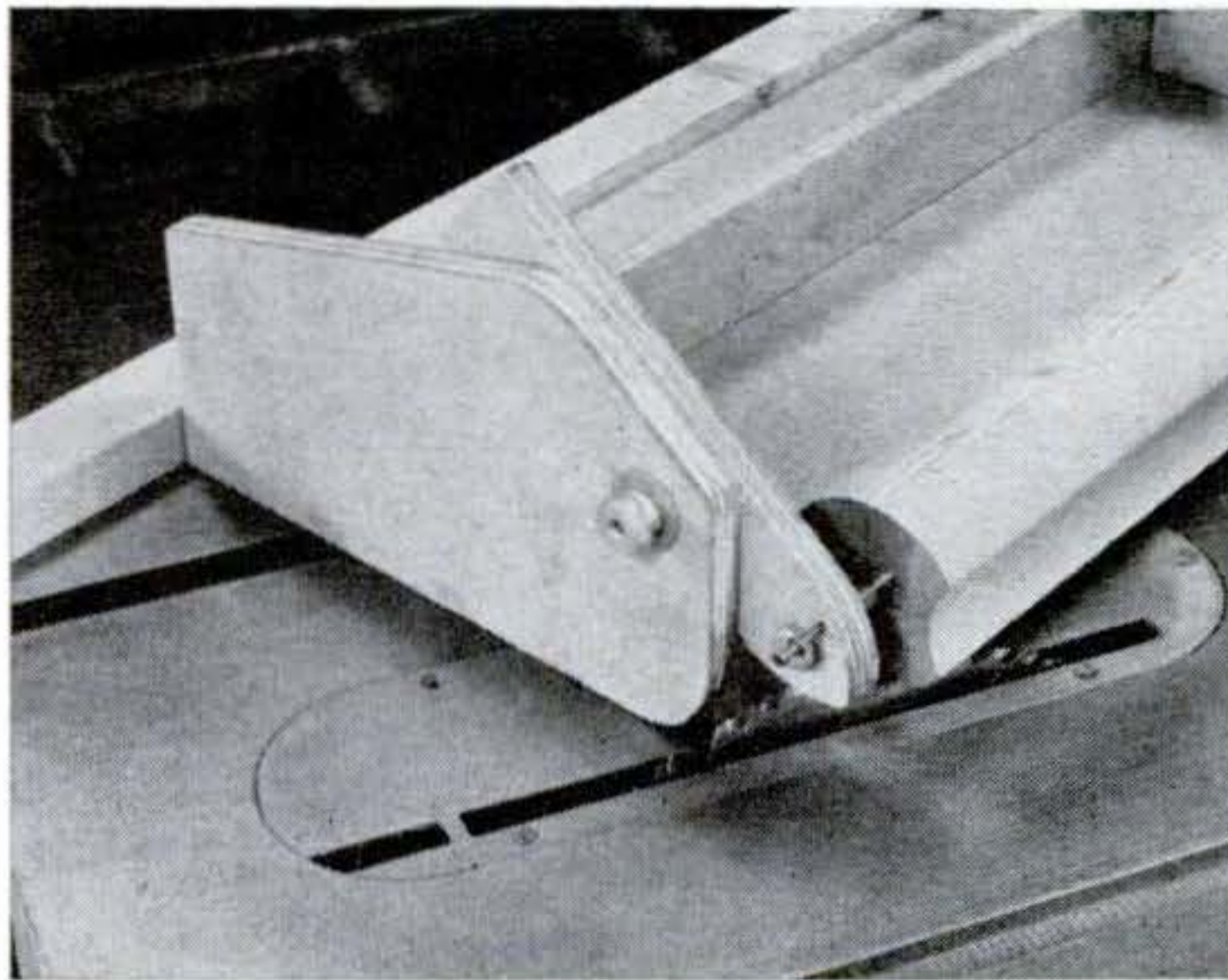

You can cove cylinders by clamping a guide strip to the table so that the work can be passed obliquely across blade. Make successive passes with blade projection increased $1/16"$.

And just look at the other jobs you can do with the jig!

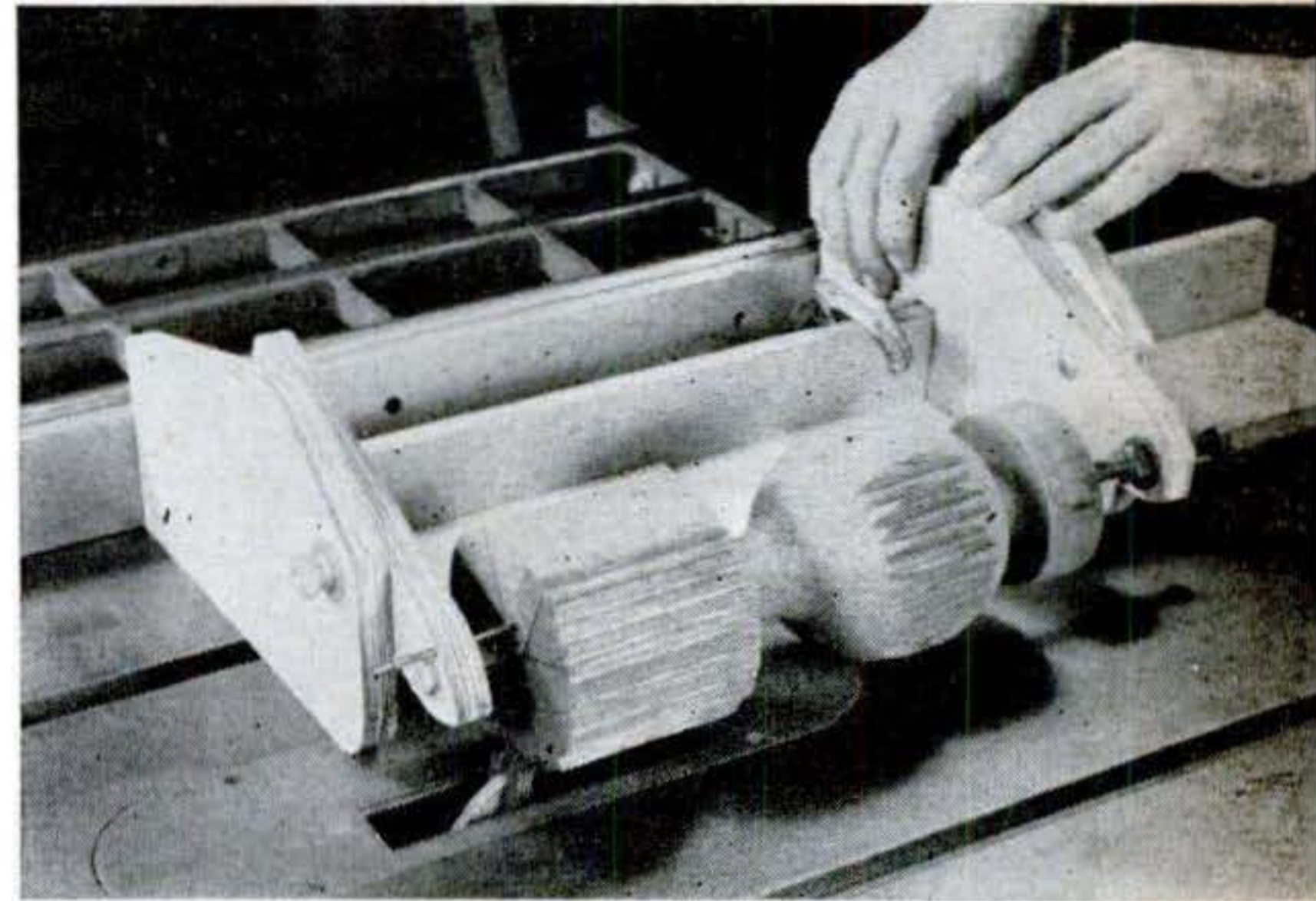

Even shaped lathework can be handled: Depth of cut is controlled by cutter projection and position of pivot arms. If your lathe has an indexing head, mark the stock before removing it.

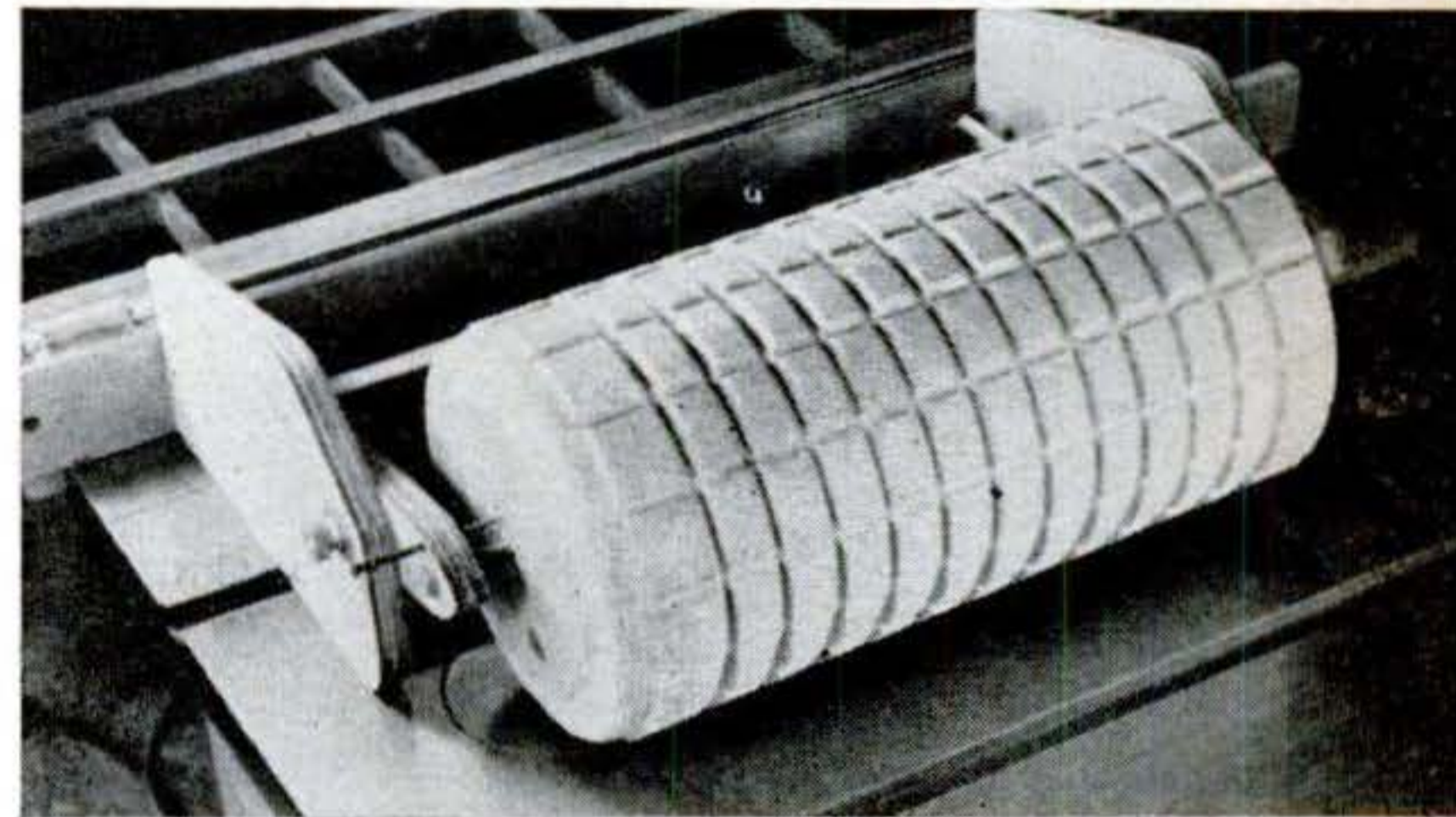

Large diameters fit in the jig, as you see here. Faceted effect is result of small coving cuts made on the lathe followed by longitudinal cuts with the work mounted in the jig.

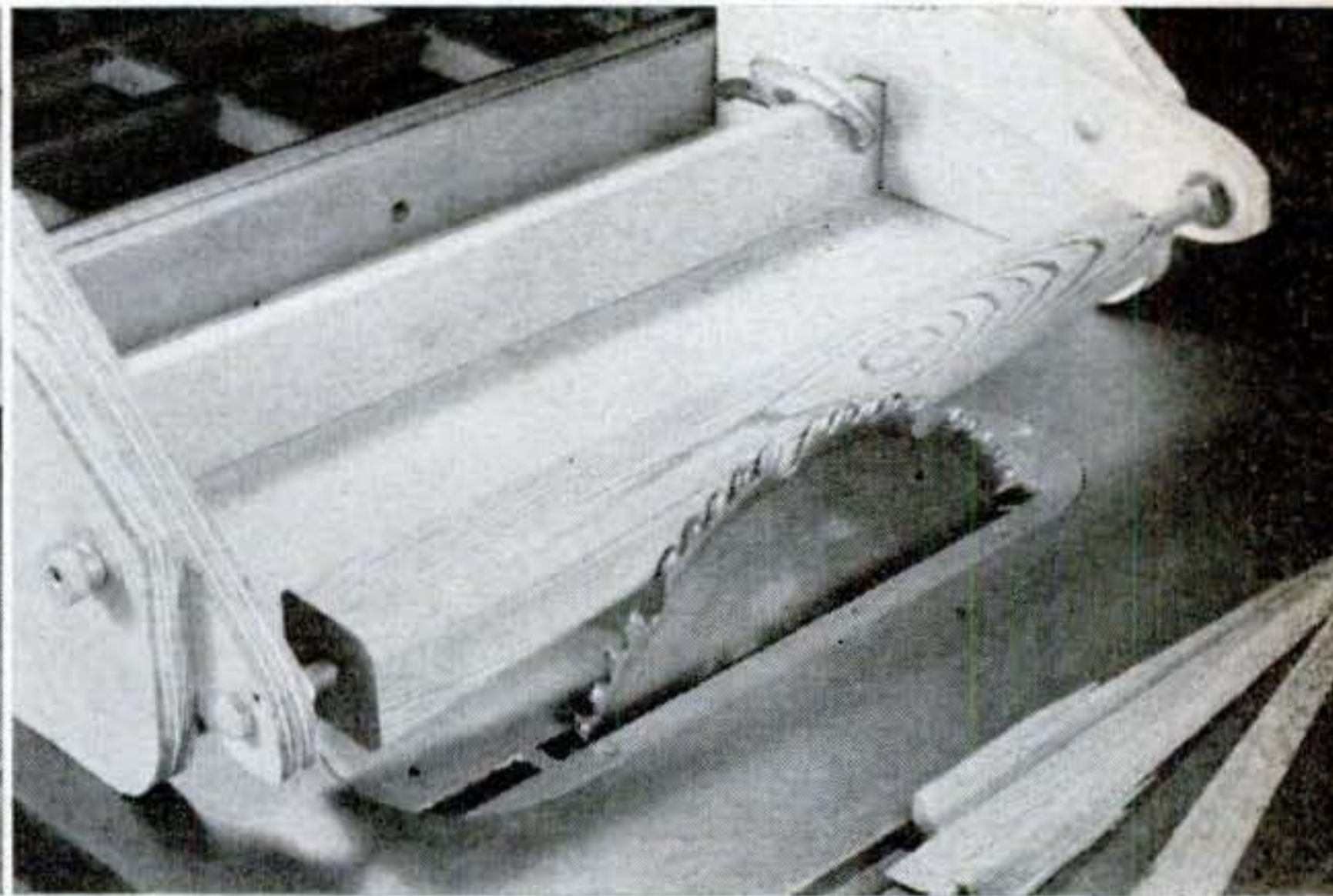

Offset the centers and you can "turn" a taper by making repeat passes with a regular saw blade. This is an ideal way to make multiple pieces for modern chair or table legs.

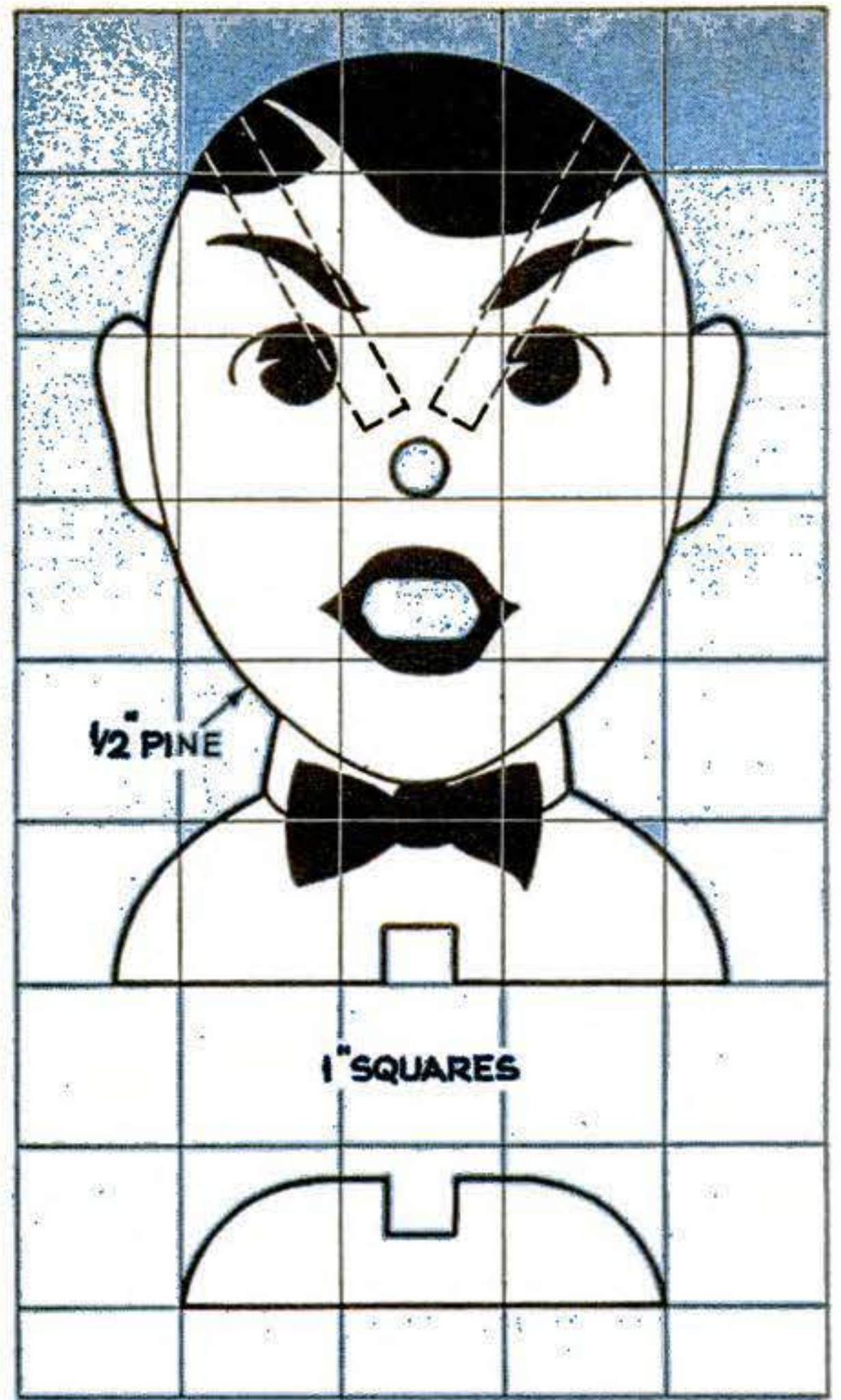
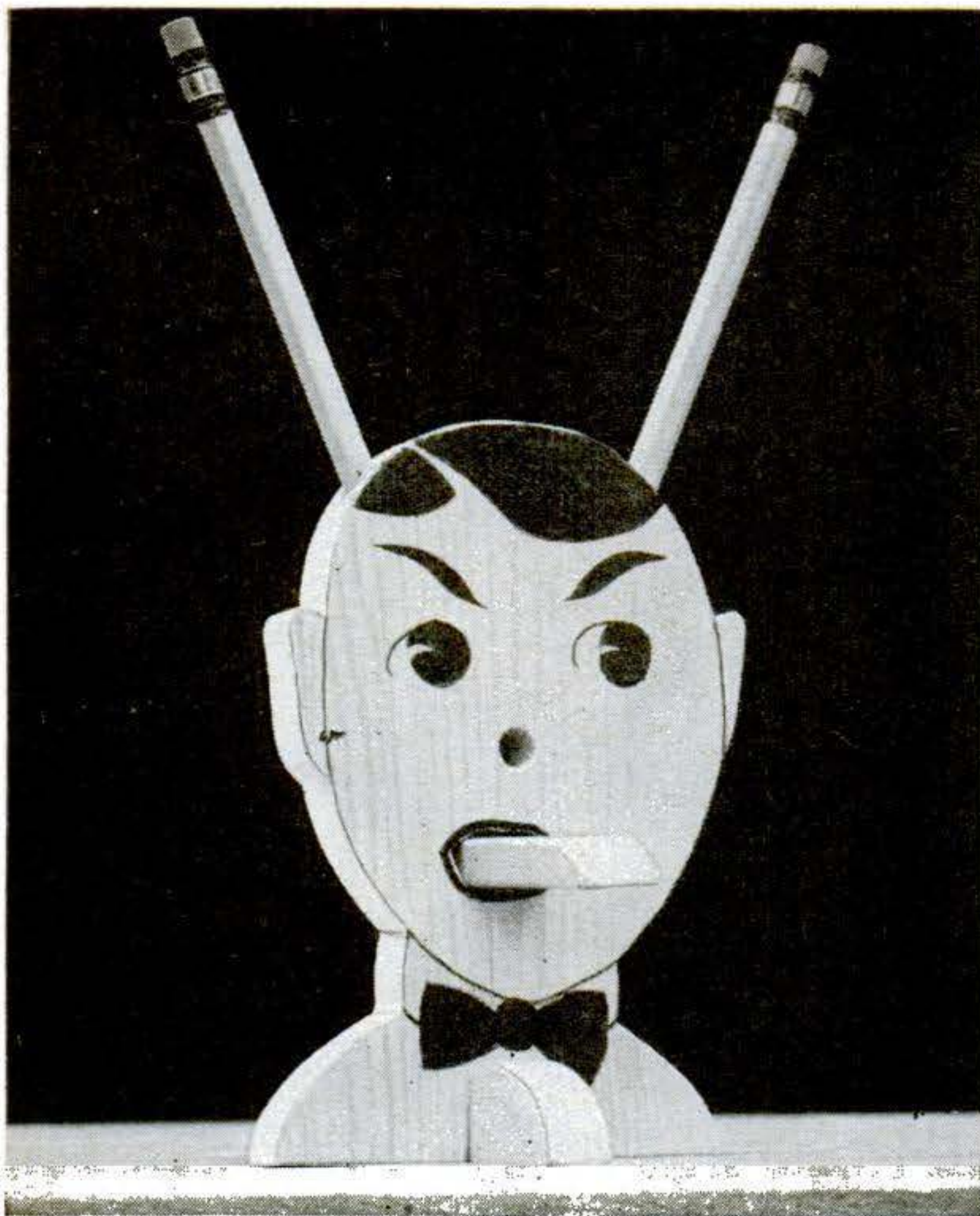

Desk set for a youngster

The devilish look of this homemade desk set ought to delight any child. It holds an eraser and two pencils or ballpoints; the nose is a pencil sharpener. Transfer the outline to a piece of pine or plywood. Before cutting the interlocking notches, make a trial cut on a piece of scrap to get width right. Screw a dime-store sharpener to the rear of the nose.—C. Sinapi, Flushing, N. Y.

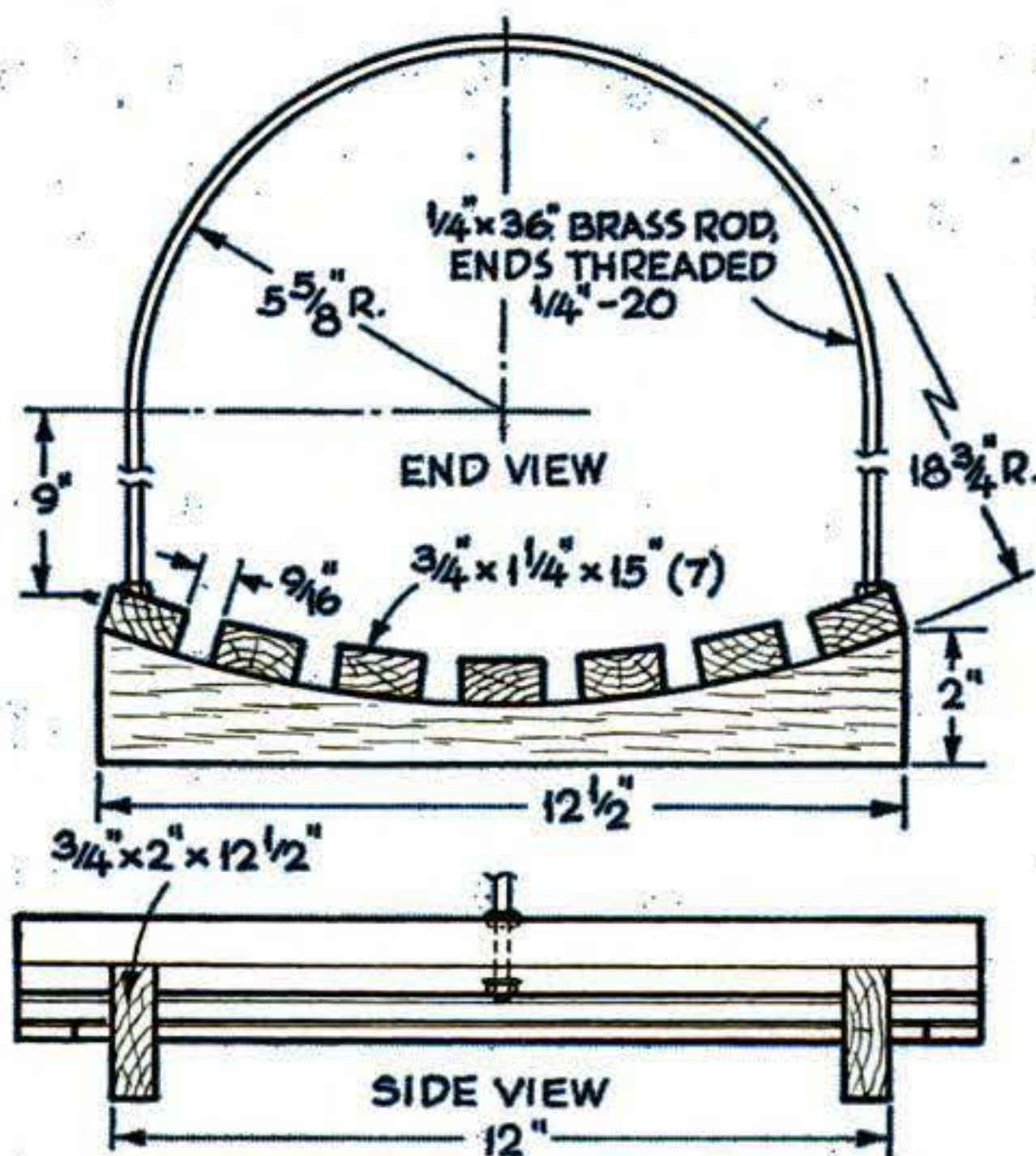
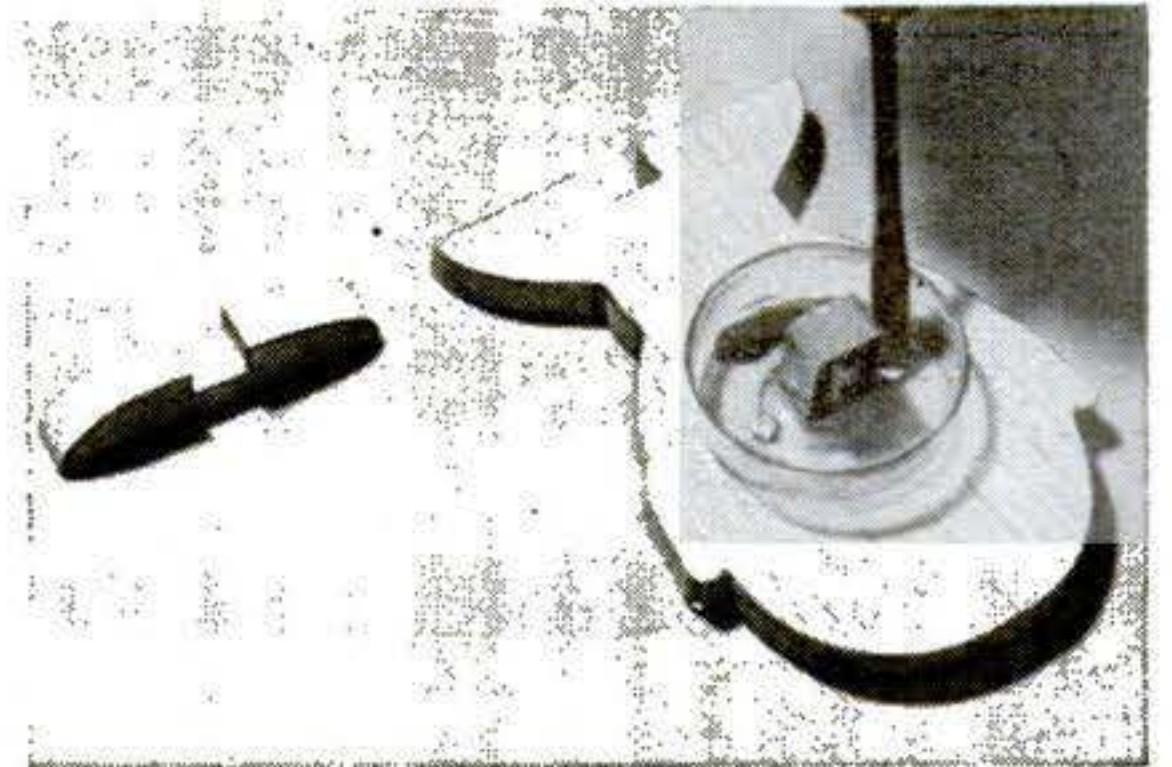

Low-cost magazine rack for your home

Nominal cost and easy construction are the talking points for this magazine rack. I used pine to make mine, but anything in your scrap bin will do. The only cost may be the dollar or so for the $\frac{1}{4}$ \" brass rod with $\frac{1}{4}$ \"-20 threads cut on each end. For the sake of appearance, I preferred to cut the center slat 13\" instead of the 15\" indicated for all the others. Drill $\frac{17}{64}$ \" through the slat for the handle. Attach the slats with both glue and nails. Finish with a natural stain.—Ray Ayers, Oxnard, Calif.

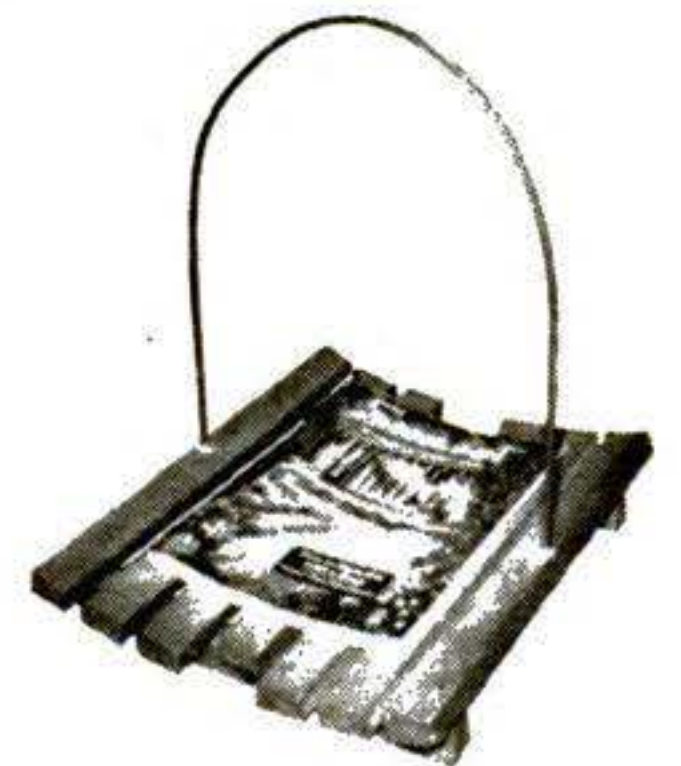

Secrets of a snug press-fit

It's the little things you do that make a successful press-fit. One common mistake is to leave the end of the male piece squared off. The sharp edge is difficult to start and will shear out the hole as it's driven through, making a loose fit.

A simple chamfer, as at A, provides little guidance for starting and may still shear the hole, especially if the piece is hardened. A radius, as at B, will usually prevent shearing, but also offers little help in alignment. A taper, as at C, is best. It gives you a good guide with no sharp edge. A length of $3/32''$ to $1/8''$ is sufficient for small stock, but increase this on larger work. Use a taper angle of 6 to 10 degrees.

On long stems, it's best to step the mating pieces, as shown at E. This way, the stem's travel is only half as far, and there is less chance of metal pickup, or galling, that often causes extreme binding before the stem is seated. A final caution: Always follow the force-fit tables in a machinist's handbook when planning the amount of oversize or interference.

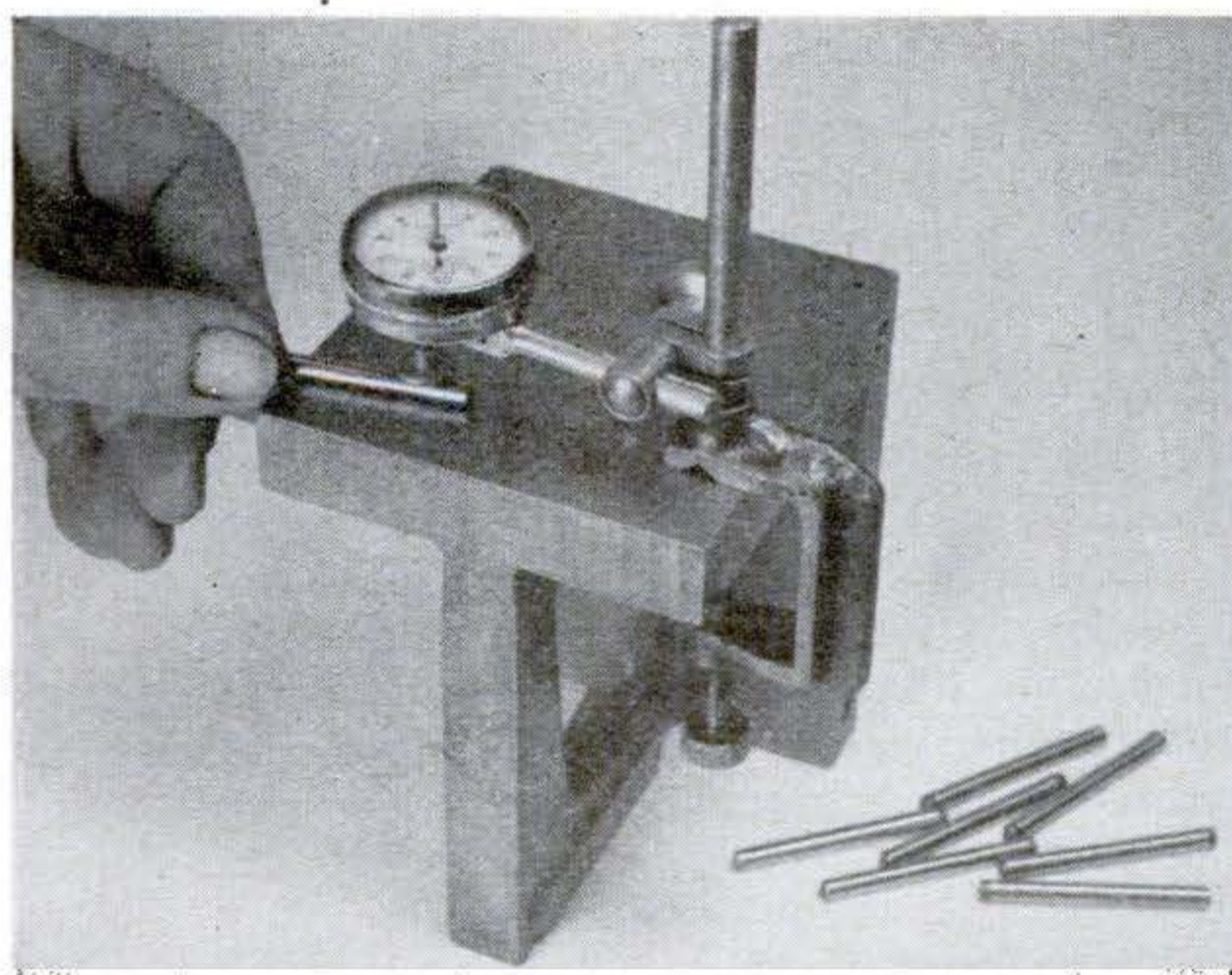
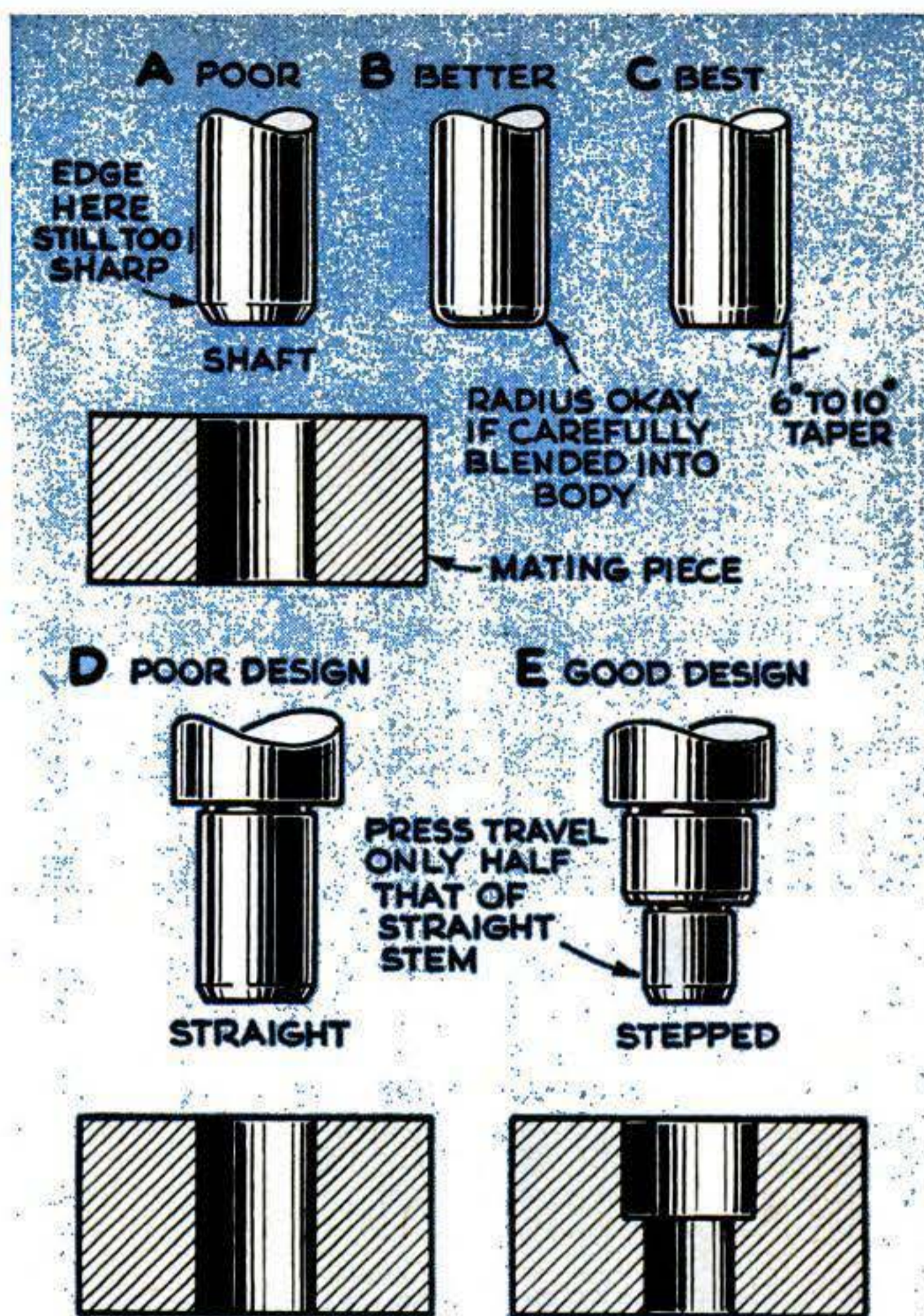

Dial indicator makes a quick inspection gauge

A dial indicator clamped to a small inspection angle plate makes a first-rate bench comparator for fast checking of small diameters. The indicator's height can be preset to provide the exact desired dimension. All you have to do is slide the work between its contact button and the plate to get an immediate reading of oversize or undersize in thousandths of an inch. The desired gap can be set with a precision gauge block or a piece of work of the correct size.

Metalworking Tips

By H. J. Gerber

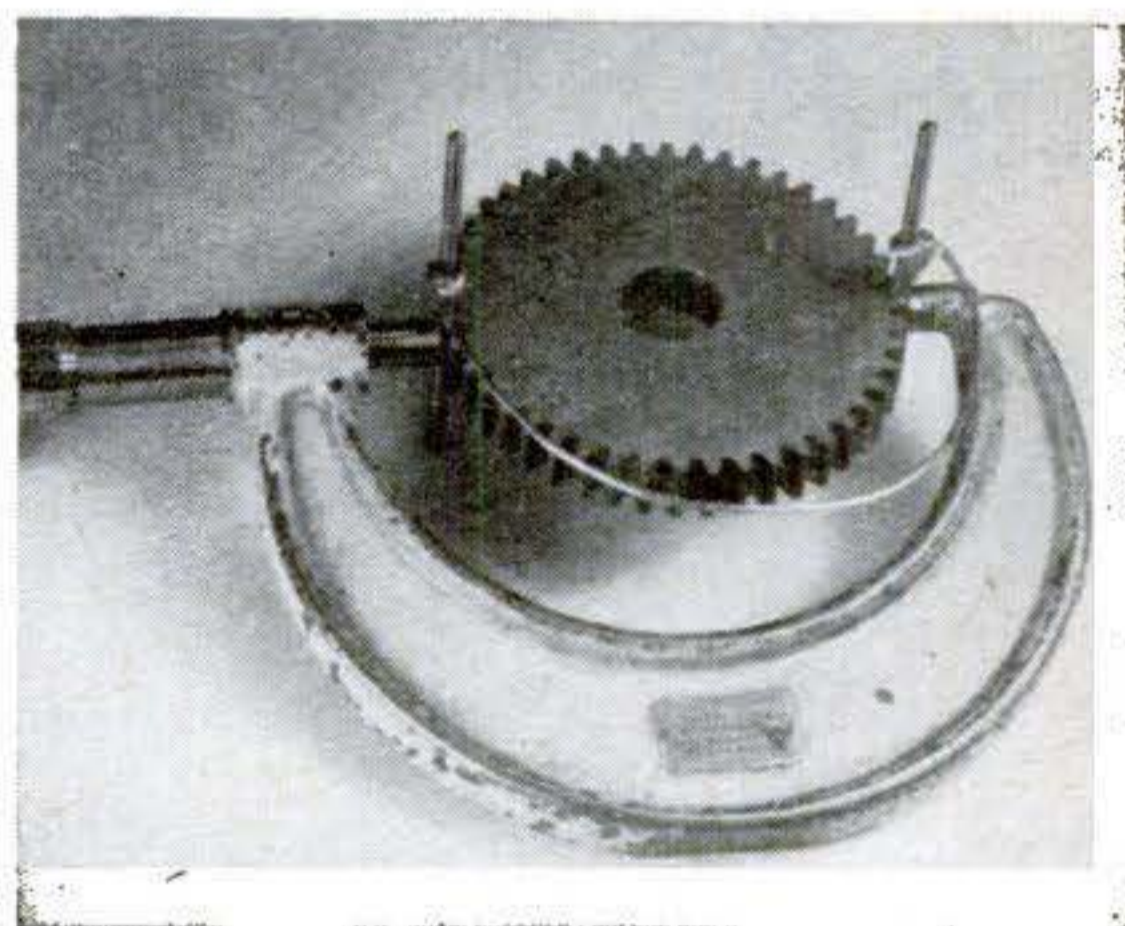

Harness holds measuring wires

Measuring gear teeth with standard wire gauges is much easier if you connect the two wires on opposite sides of the gear with a simple harness of half-hard brass wire to help hold them in place. For repeated use, I usually solder the harness on, but tight loops around the wires will hold for temporary work.

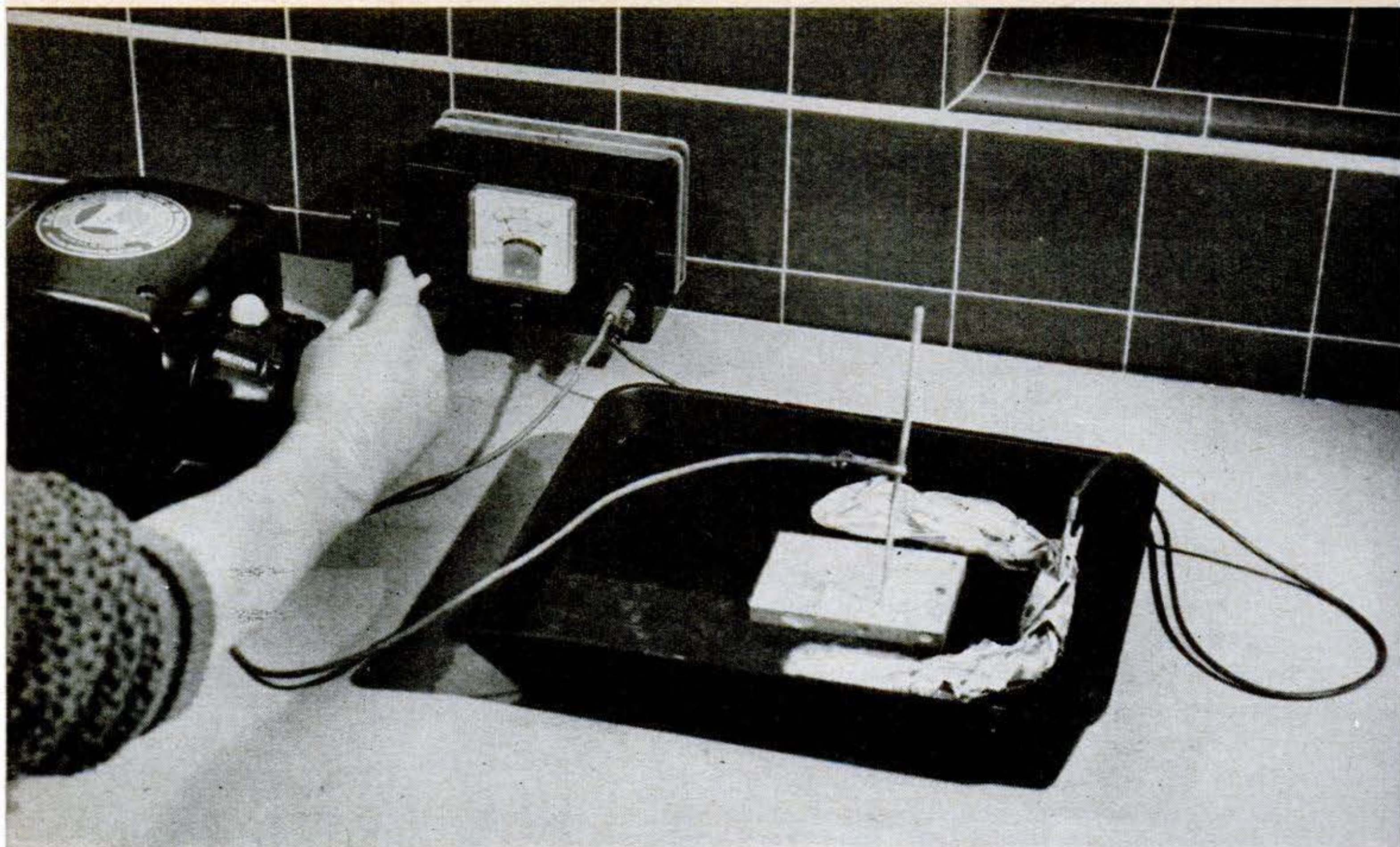

PS METALWORKING

How to Anodize Aluminum

With this simple kitchen-table setup, you can reproduce those sparkling store-bought metallic finishes

By Hank Stockert

THE deep, rich luster you've admired on manufactured aluminum articles can be duplicated right in your own basement or kitchen. The process, known as anodizing, requires only a few chemicals and a source of low-voltage direct current. You can use it to add spectacular finishes to your aluminum projects or to anodize existing articles that have no such finish. The anodized finish is attractive by itself on plain aluminum or can be made even more dazzling with colored dyes. The colors, chemically sealed into the metallic finish, can't chip or wear off as paint does.

What anodizing does is convert the surface of aluminum into a form of aluminum oxide—a substance so tough that it's used in abrasive sanding papers. The aluminum is placed in an acid solution and an electric current passed through the acid. The electrolytic action releases oxygen that combines with the aluminum to form the aluminum oxide coating.

The process is similar to electroplating except that the object is connected to the anode, or *positive* post, of your power supply rather than the negative cathode as in electroplating. This is because you're modifying an existing metal instead of depositing a new metal on it.

Because the aluminum oxide coating is thin, you can't expect it to hide surface defects. You'll have to remove tool marks and other imperfections before anodizing or they'll show up afterward. The coating's thinness does, however, have an advantage: It won't mask out fine detail.

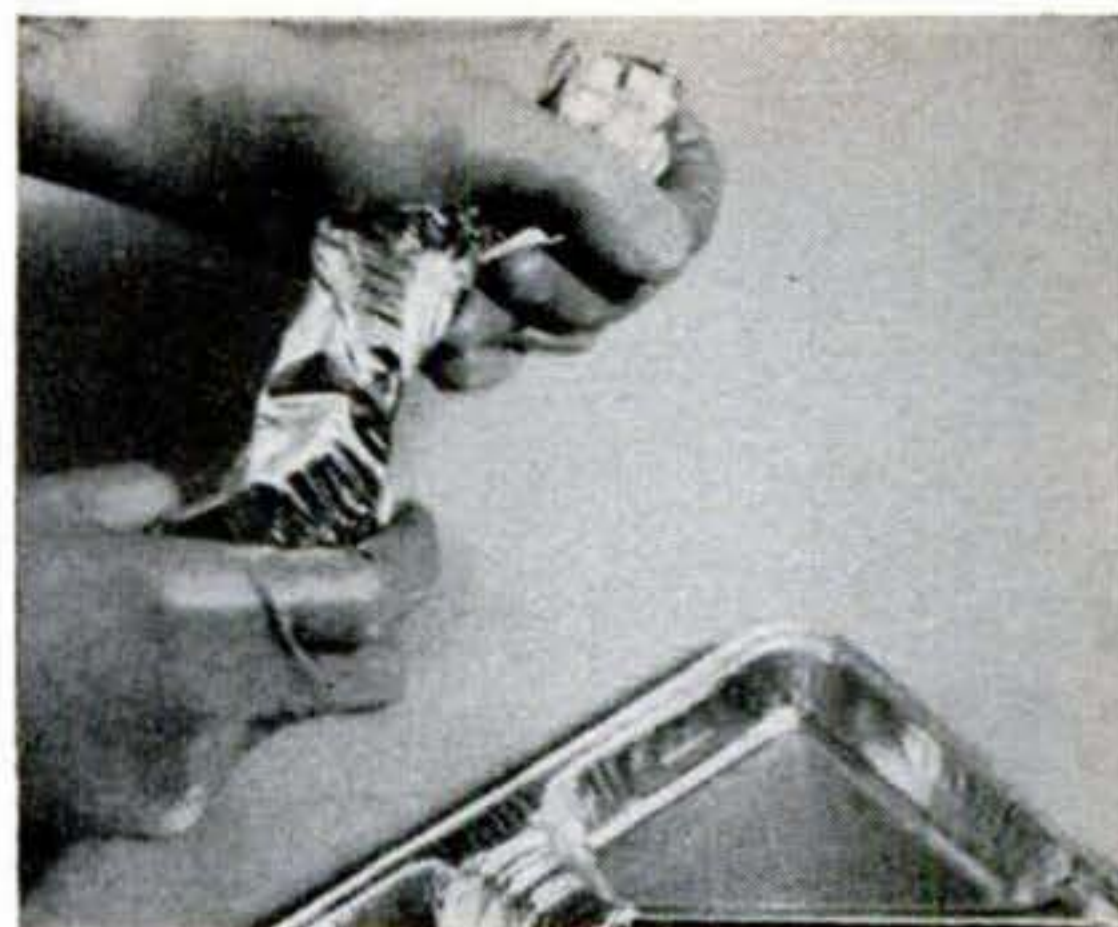
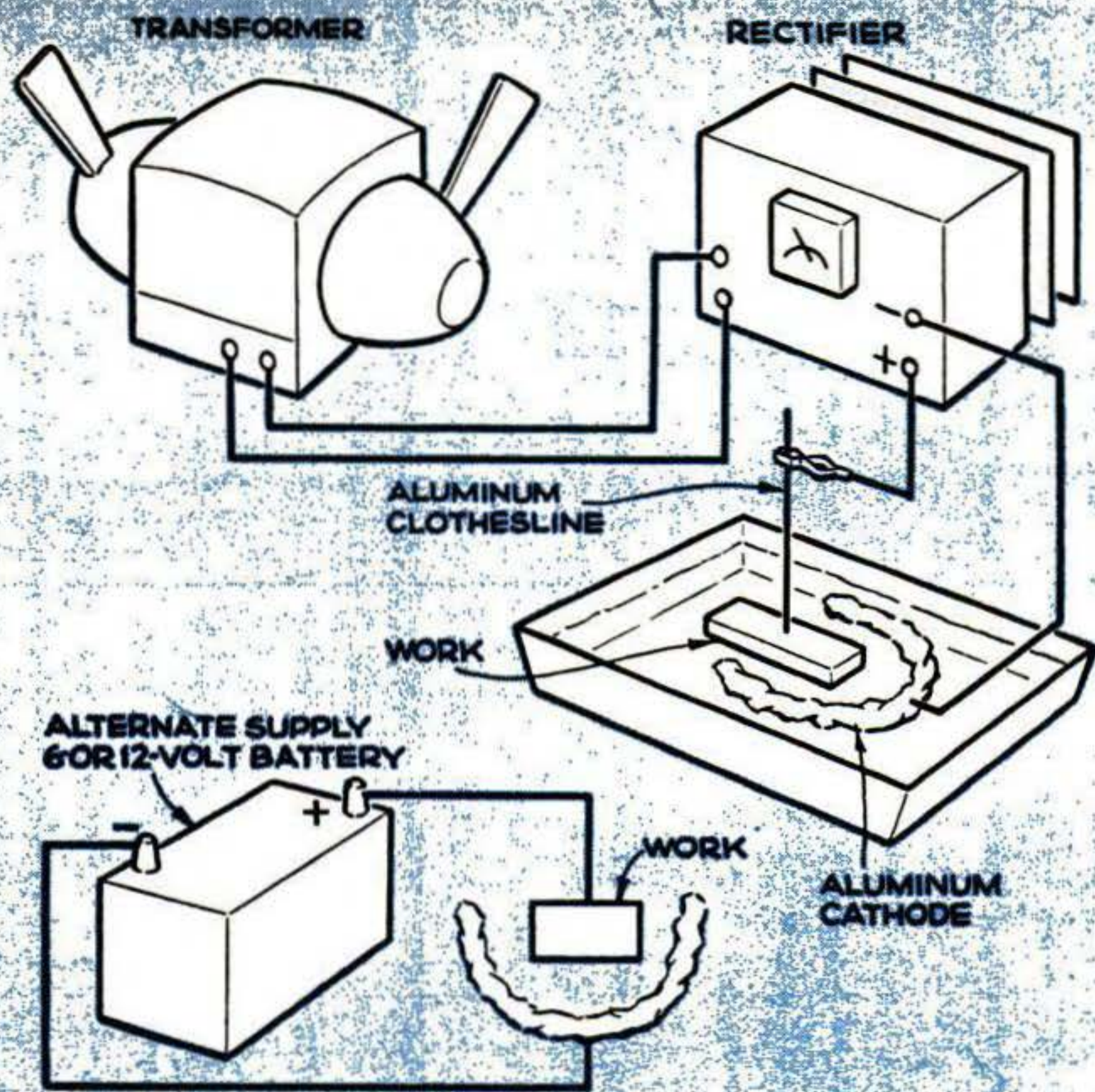

Aluminum trays from frozen dinners make an excellent cathode. Twist them into curved "sausages" and pierce holes in them to let gas escape.

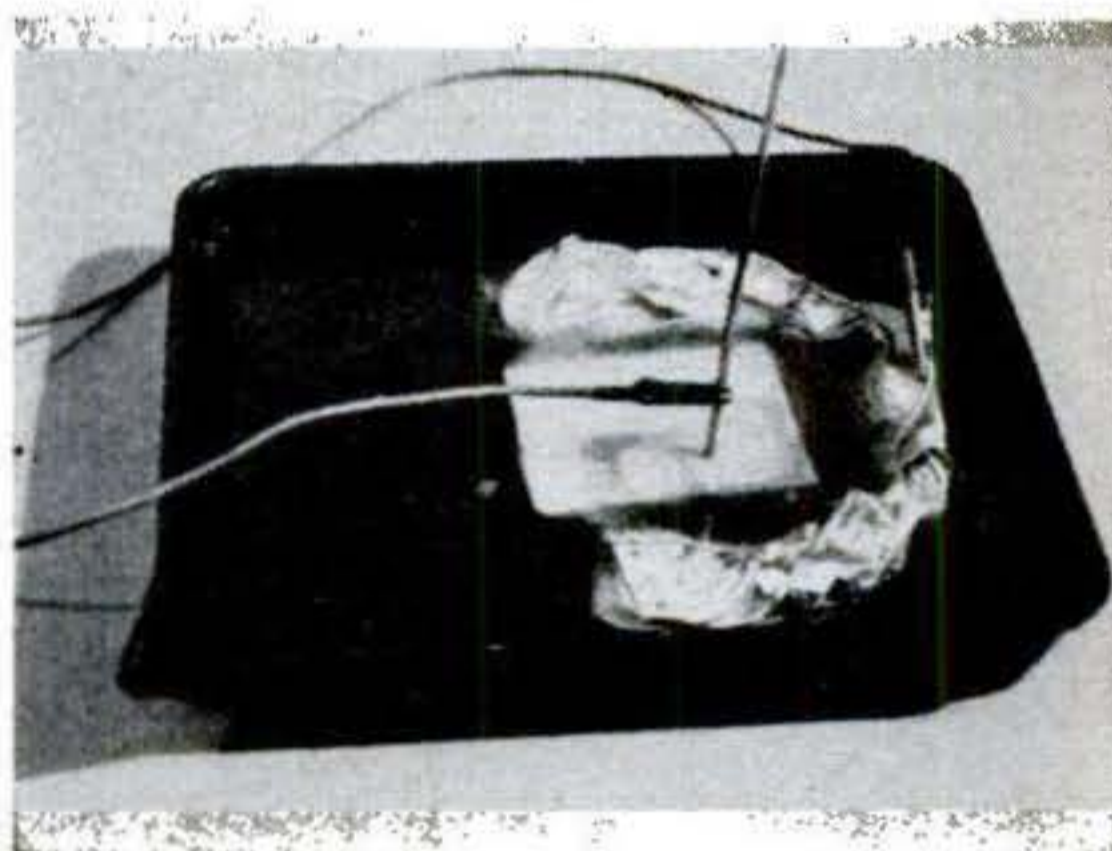

Negative lead can clip directly to the cathode where it protrudes above the solution. Positive lead goes to short length of aluminum clothesline.

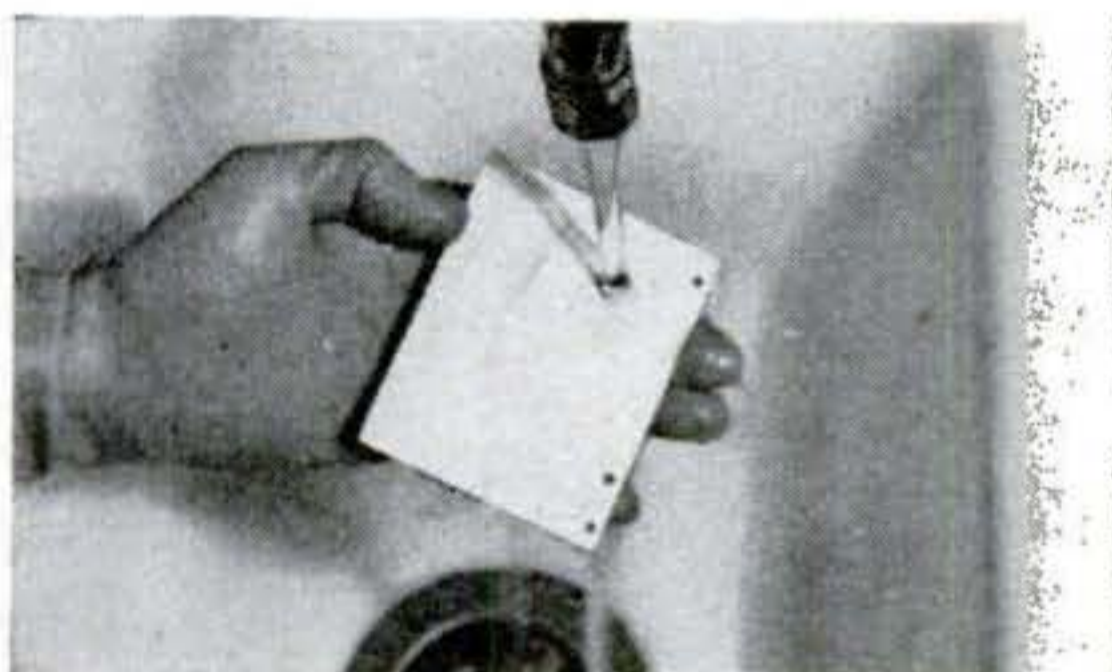

Rinse your work thoroughly under running water between the steps. Wearing rubber gloves is important to keep fingerprints from marring the finish.

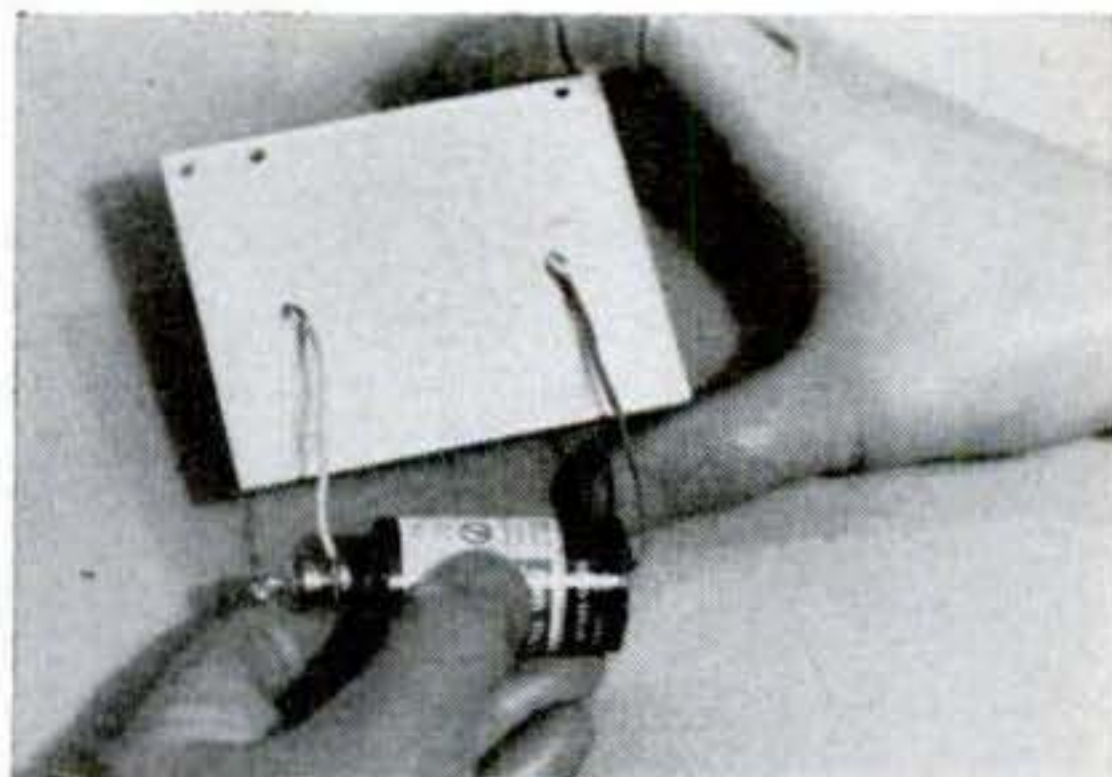

Quick test for anodizing: Bulb soldered to a flashlight battery, with leads touching the coating, will not light if the anodizing is complete.

What you need. While the pros use many types of acid baths, all you really need is a sulfuric-acid solution of about 15 percent acid by weight. If you use commercial-grade acid, you can measure the volume of water needed to cover the work and divide this by eight to determine the volume of acid to pour in.

Always pour the acid slowly into water—never the other way around. (Water poured into acid boils at an explosive rate.) The resulting bath should be treated with the same respect as your car's battery acid. Many old hands recommend goggles.

You'll need a container large enough to let the acid completely cover the work. It must be nonmetallic and not affected by sulfuric acid. A plastic dishpan or photo tray are useful. For large objects, a glass fish tank is a good bet.

Your power supply can be anything that delivers low-voltage DC. Voltage and current requirements aren't critical. A battery charger such as the one shown in *POPULAR SCIENCE* in May, 1962 (page 160), is easy to use. A DC power pack for model trains or an AC train transformer combined with a rectifier will also work fine. You can even use a car battery.

The terminals of most power supplies are clearly marked positive and negative so you can be sure of connecting your work to the positive side. If you should use one that isn't marked, try it with the wires hooked up one way; if no anodizing results, reverse the connections.

Setting up the rig. Everything that enters the anodizing bath must be aluminum: the work with a

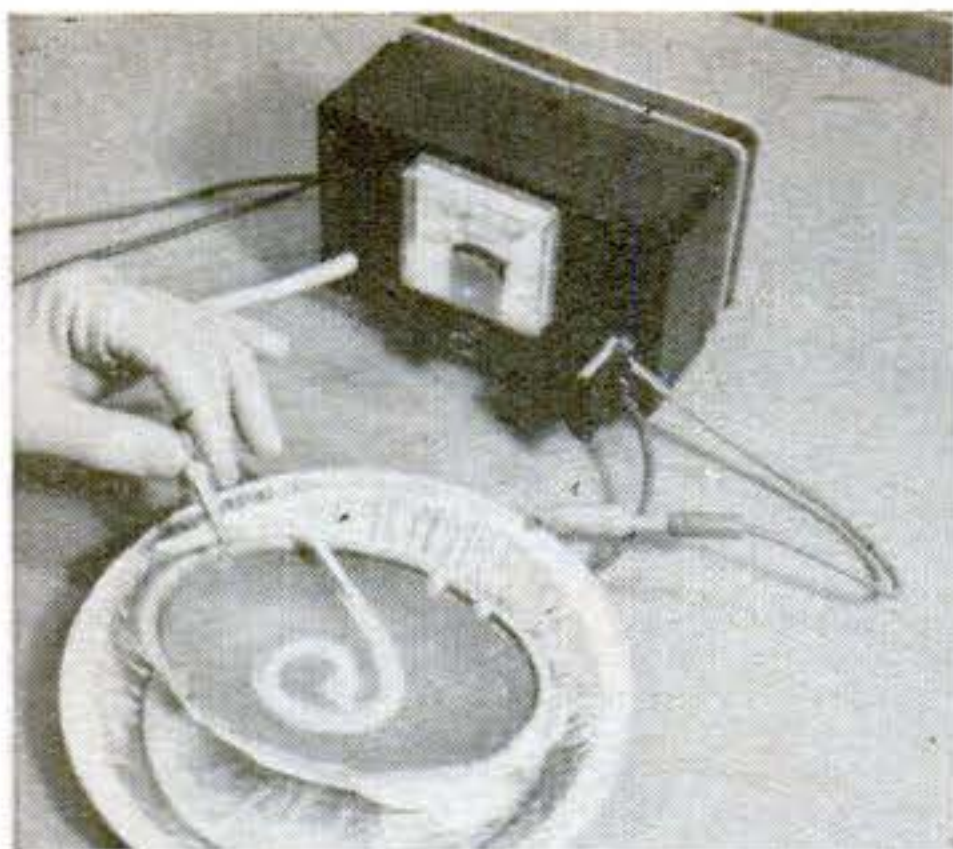

"Inside-out" setup lets you coat only inside of bowls like this ash tray. Fill bowl with acid and drop cathode into it.



Black shoe dye, unlike other dyes, can be swabbed on cold. Let dry overnight, suspend over boiling water for an hour.



Finished ash tray, dyed black on the inside, provides a striking contrast with plain aluminum outside.

wire leading to it and the cathode and its wire. Aluminum clothesline is an excellent conductor. Hook the work on the line and change its position a few times during anodizing to insure an even coat.

The aluminum cathode should have a surface area greater than the work. Crumple up one or two aluminum TV-dinner trays and form them, if possible, into a U shape to fit around the work. (Anodizing goes a little faster if the cathode surrounds the work.) If the cathode projects above the solution, you can clip the negative power-supply lead directly to it at that point. If it doesn't, twist the crumpled trays around a length of aluminum clothesline. A rubber band will keep the trays touching the line as they are eaten away.

Before immersing the object in the bath, clean it thoroughly with acetone or lacquer thinner. Use rubber gloves whenever handling it. When you turn on the current, you'll notice that there are more bubbles coming from the aluminum foil than from your project. This is normal. Let the process work for about 30 minutes. The acid solution will heat up but should not reach boiling, or you're overloading your power supply.

How to tell if it's good. You can use one of the properties of an anodized film to tell you when the process is complete. A sound film acts as an electrical insulator.

Use a low-resistance ohmmeter or a flashlight battery and bulb in series with a pair of rounded-tip test probes. Remove the work, rinse it in warm water, and allow it to dry. Sample the surface in several spots with your test probes to see if any current flows across the film. Try corners and areas that were farthest from the cathode. A high resistance reading (or an

unlit bulb) means your job is done. Otherwise, continue anodizing for a while.

Adding the color. After the work has been carefully rinsed in cool water, it may be dropped into a boiling dye solution. Boil until you get the tint you desire. Maximum color will probably be reached in about one hour.

Time was when you could use household dyes, but manufacturers have been adding various fabric and water conditioners that make them risky for anodizing. The pros use coal-tar dyes. These can be obtained at chemical-supply houses and can generally be ordered through drug stores. You can also try common household materials such as black liquid shoe dye (which gives a beautifully deep black), colored inks, and food colorings. Where possible, it's best to color a few anodized test scraps first to see what you're going to get.

Sealing in the color. When you boiled your aluminum in the dye, you filled the pores of the aluminum oxide with dye. To keep the dye inside permanently, you need to seal the pores.

Take the freshly dyed and rinsed work and dunk it for about 15 minutes in a boiling solution of two ounces of nickel acetate to a quart of water. Follow this with a rinse and then transfer the project into boiling water for about 45 minutes to seal the surface. A final buffing will bring the coating to a deep luster. You can finish off with a light waxing.

If you're after a prominent matte finish, you can etch the aluminum before anodizing. Immerse it in a solution of six to eight ounces of household lye to a gallon of water. Check it now and then and remove and rinse it when it reaches the desired surface texture. ■ ■

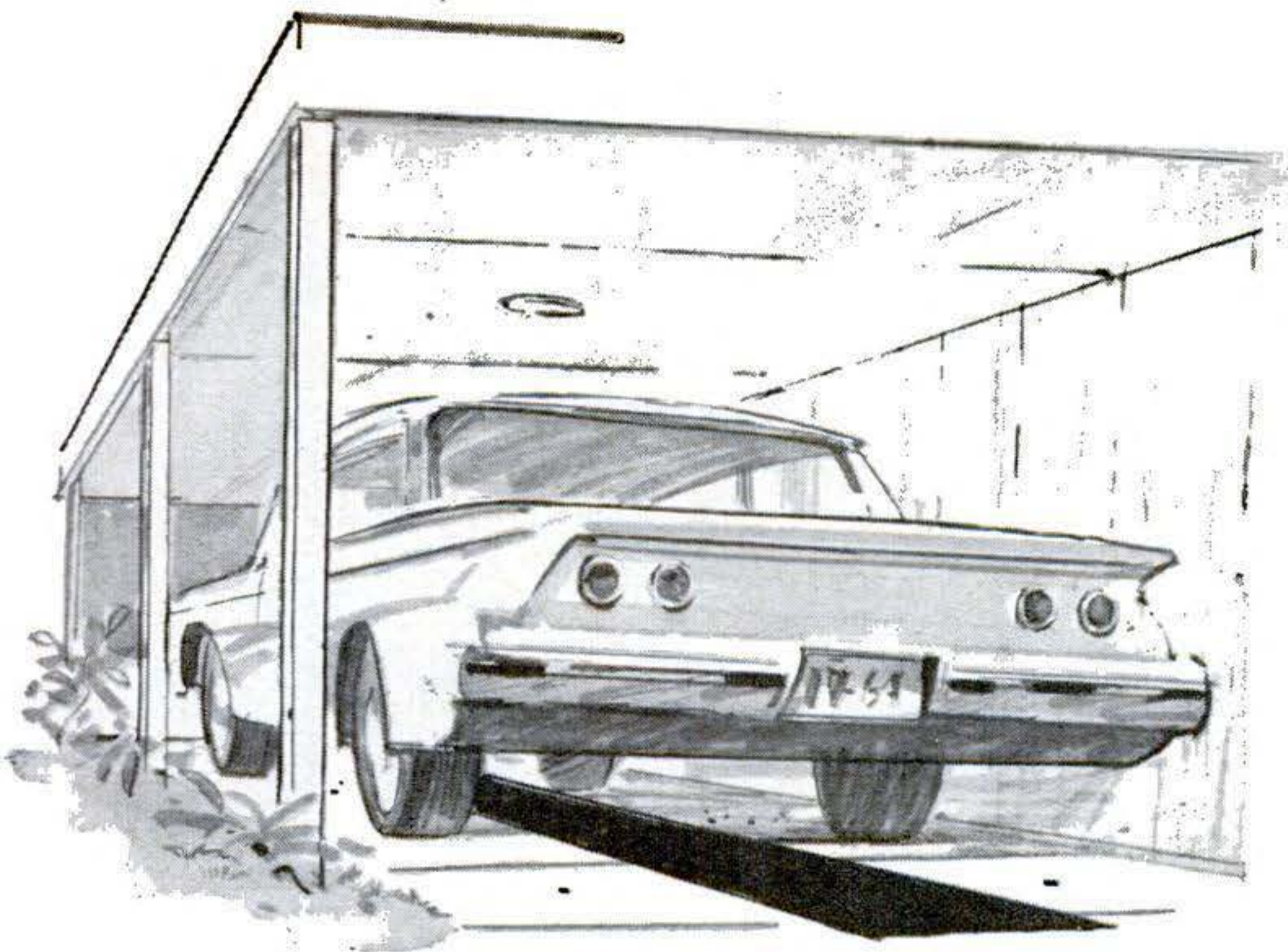

Camouflage trick hides oil drips from his car

The pans and mats used to catch dripping car oil are just as ugly as the oil itself, especially in an open car port. I solved the problem by painting a 2'-wide black stripe down the center of the floor. It hides the drips, looks trim, even helps me park accurately.—*Stephen N. Stresnic, Ft. Lauderdale, Fla.*

Quick repair for a leaky water tank

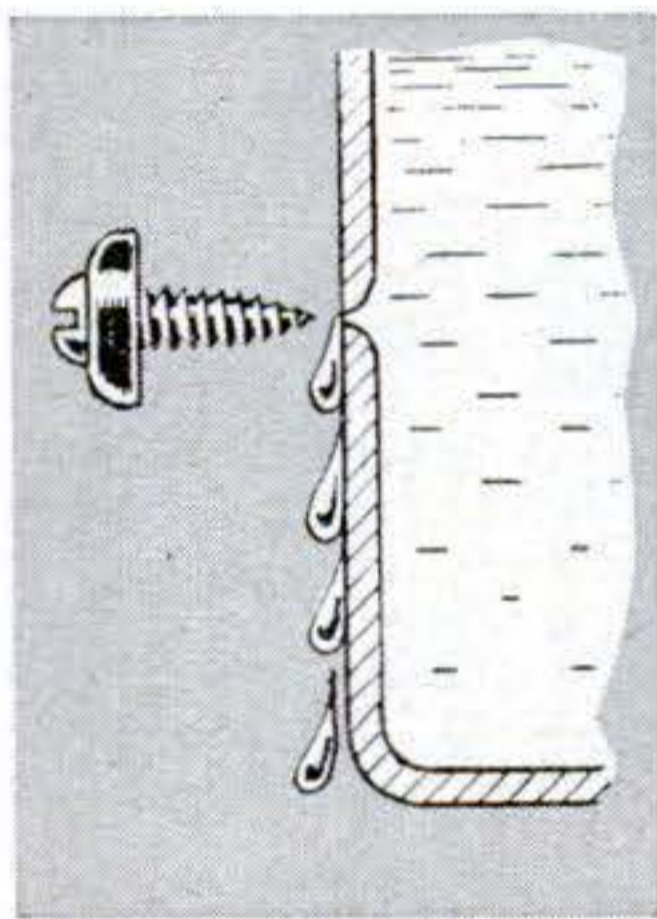

A faucet washer and a self-tapping screw make a handy plug for small corrosion leaks that develop in hot-water tanks. And catching the holes while they're small saves installing regular plugs later.—*A. Weber, Edmonton, Alberta.*

Spray shield for a power paint mixer

A paint mixer used in an electric drill sometimes slings paint all over the place if you aren't careful. A hood made from a plastic food bag will catch spatters. Tie the bag around the paint can and the drill.—*Ernest Guerra Jr., San Antonio.*

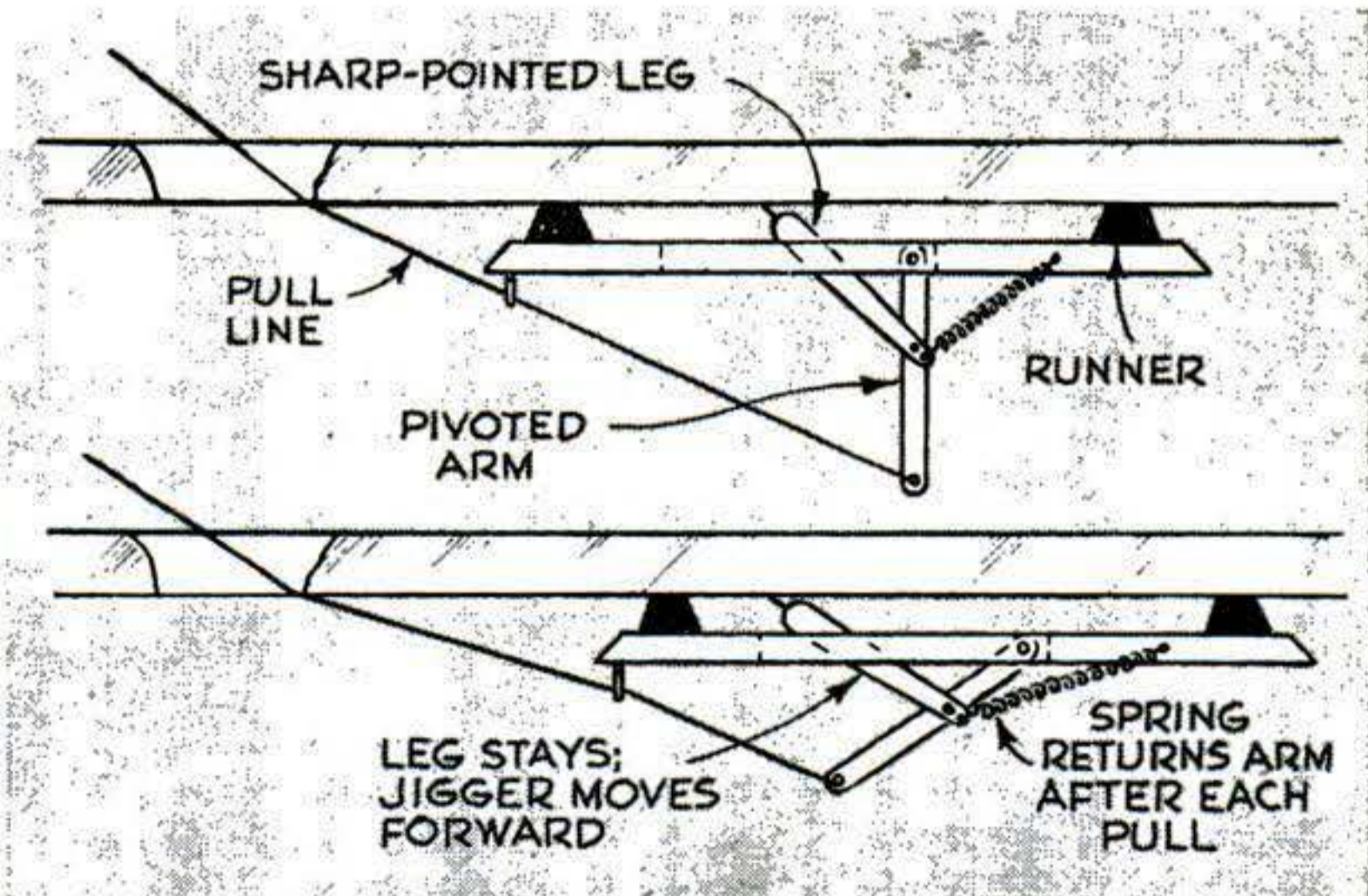
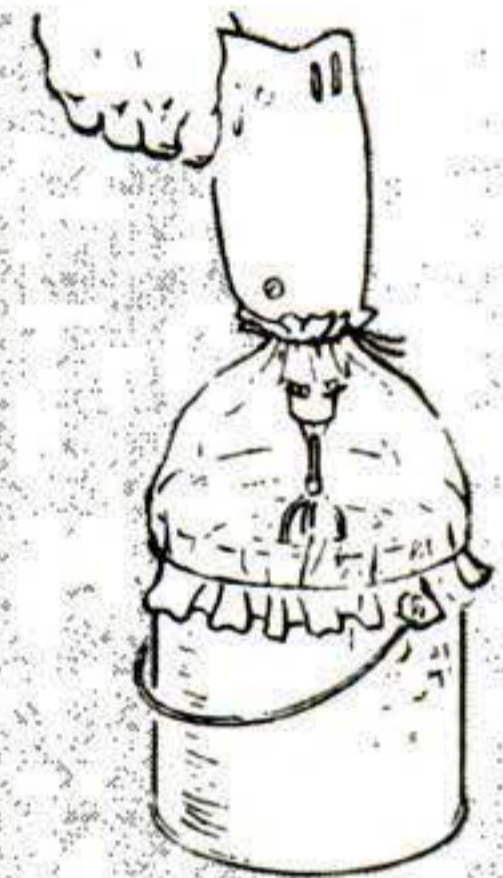

How to net fish under the ice

Ice fishermen everywhere could use an ingenious device developed in Canada for stretching a fish net under ice. Called a prairie jigger, it's a slotted plank 7½' long with metal tabs for runners and a lever-

actuated leg that jabs into the ice as shown at left. The jigger is inserted through a hole with a line tied to the lever. Each tug on the lever causes the leg to push the plank ahead, pulling the net behind it. The jigger can scoot along at a rate of 100' a minute—and that's no fish story.

Four Special Jobs for a Saber Saw

Attachments give you extra value from this useful tool

By Walter E. Burton



2 peening metal

A HAMMERLIKE tool made from $1/16$ " steel produces a "hammered" finish on soft aluminum, zinc, etc. The photos at right show how it was used topeen a design on a square of 0.007" sheet brass, softened by heating to dull redness and cooling in water.

A shallow recess was drilled in the tang to receive the end of one of the two opposed setscrews in the chuck. The round head of a $3/8$ " iron rivet in the projecting part of the hammer acts as a peen. For prolonged service, this head could be case-hardened.

The slipper-plate opening of the saw

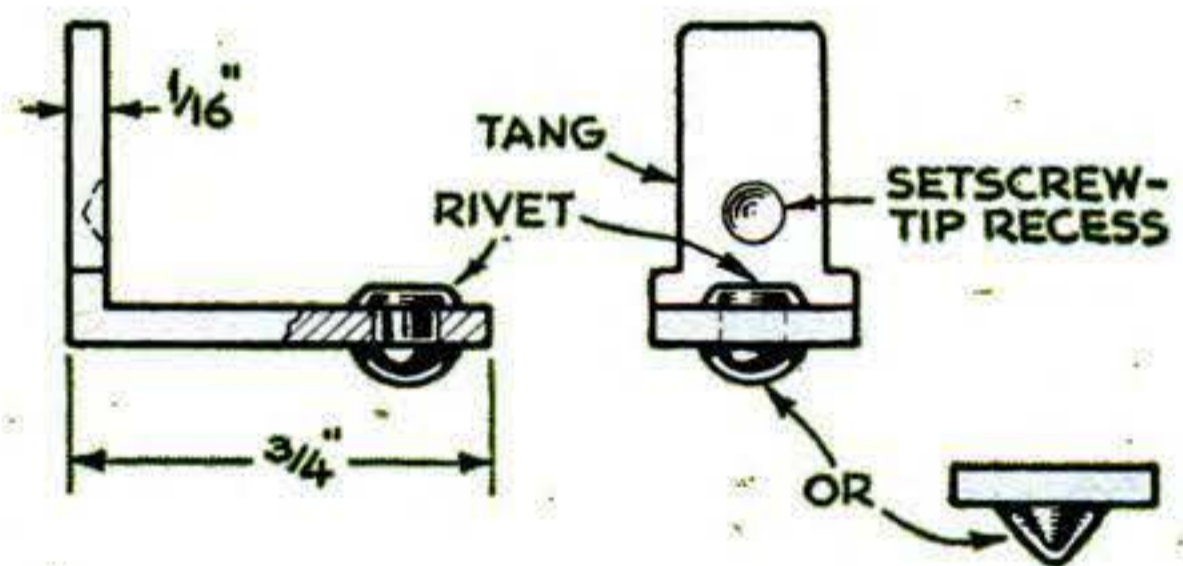

used lets the hammer extend about $3/4$ " to one side of the chuck. This gives some resiliency. Because the rivet head projects a bit beyond the plate in the down position, the plate is held slightly above the work.

In the photos, the saber-saw hammer was used to force metal into a groove routed in hardboard backing. The metal later was stiffened by applying Plastic Steel to the back.

1 sanding and polishing

A VERY useful attachment for special sanding jobs was made by wrapping abrasive cloth around a piece of $1/16''$ steel shaped as shown. The tang is off center to clear the slipper plate. Notches and the hole near the tang accommodate soft iron or copper wire that laces the abrasive to the blade. A strip of abrasive is cut to the width of the sanding blade and twice its length, exclusive of the tang.

In using the sander to smooth the slots of a wood grille, as shown in the photo at left, it's best to insert the bar before starting the saw—or its end may mar the wood. Work with little or no pressure, the abrasive surface just touching the wood.

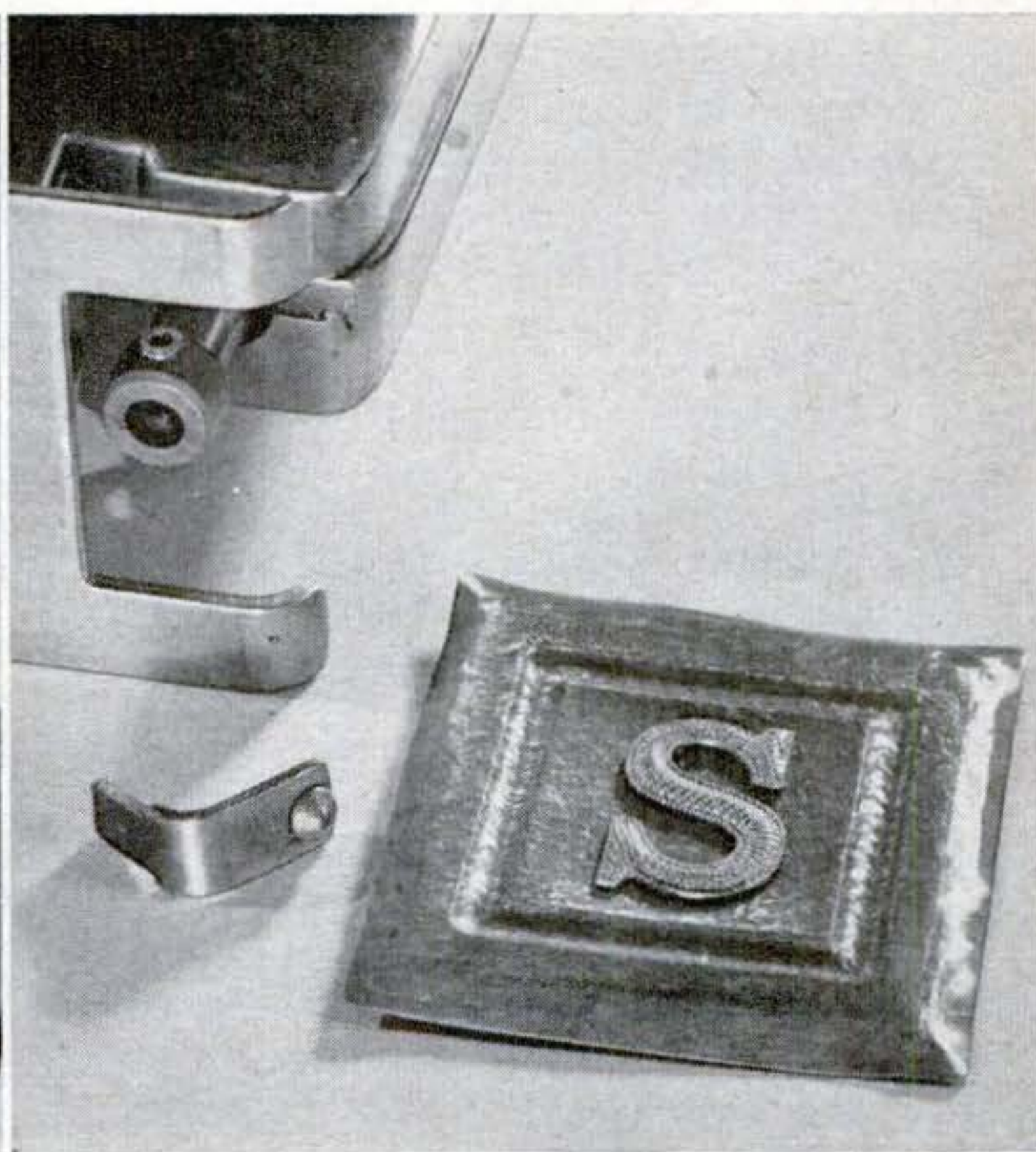
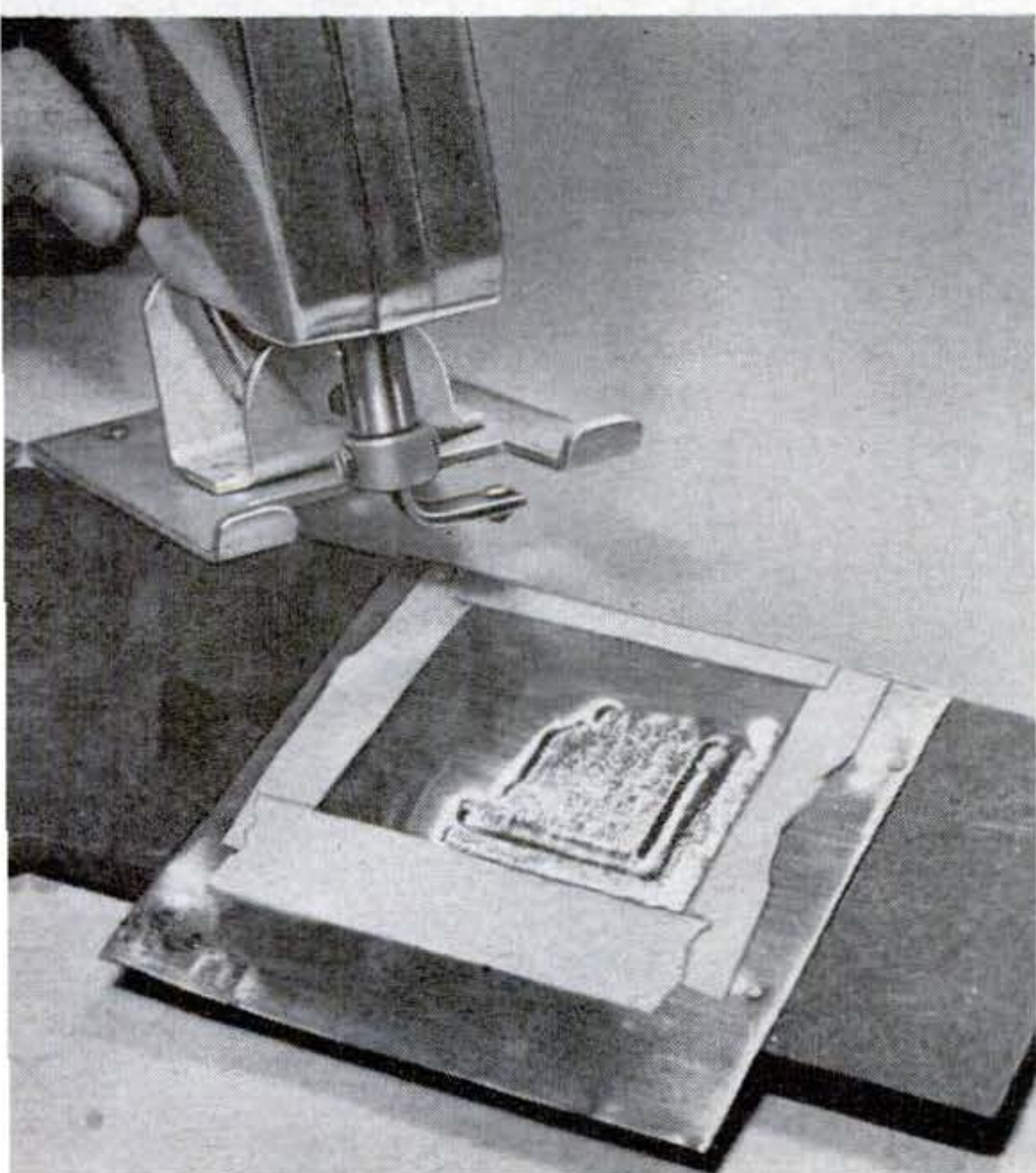
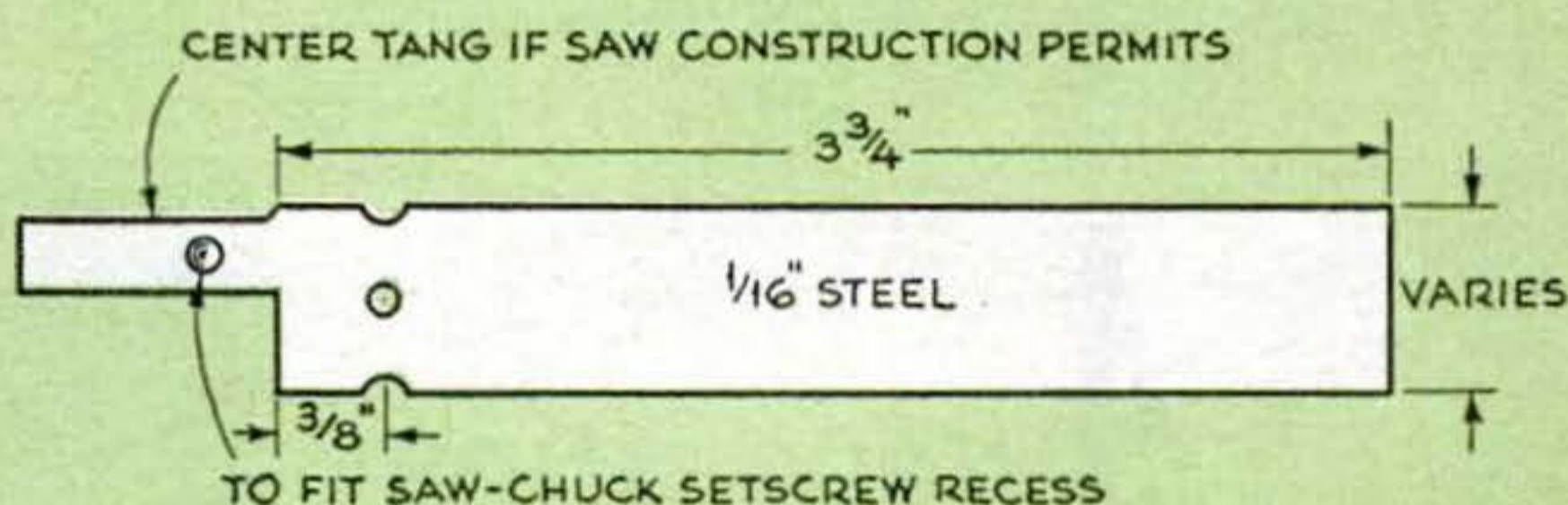
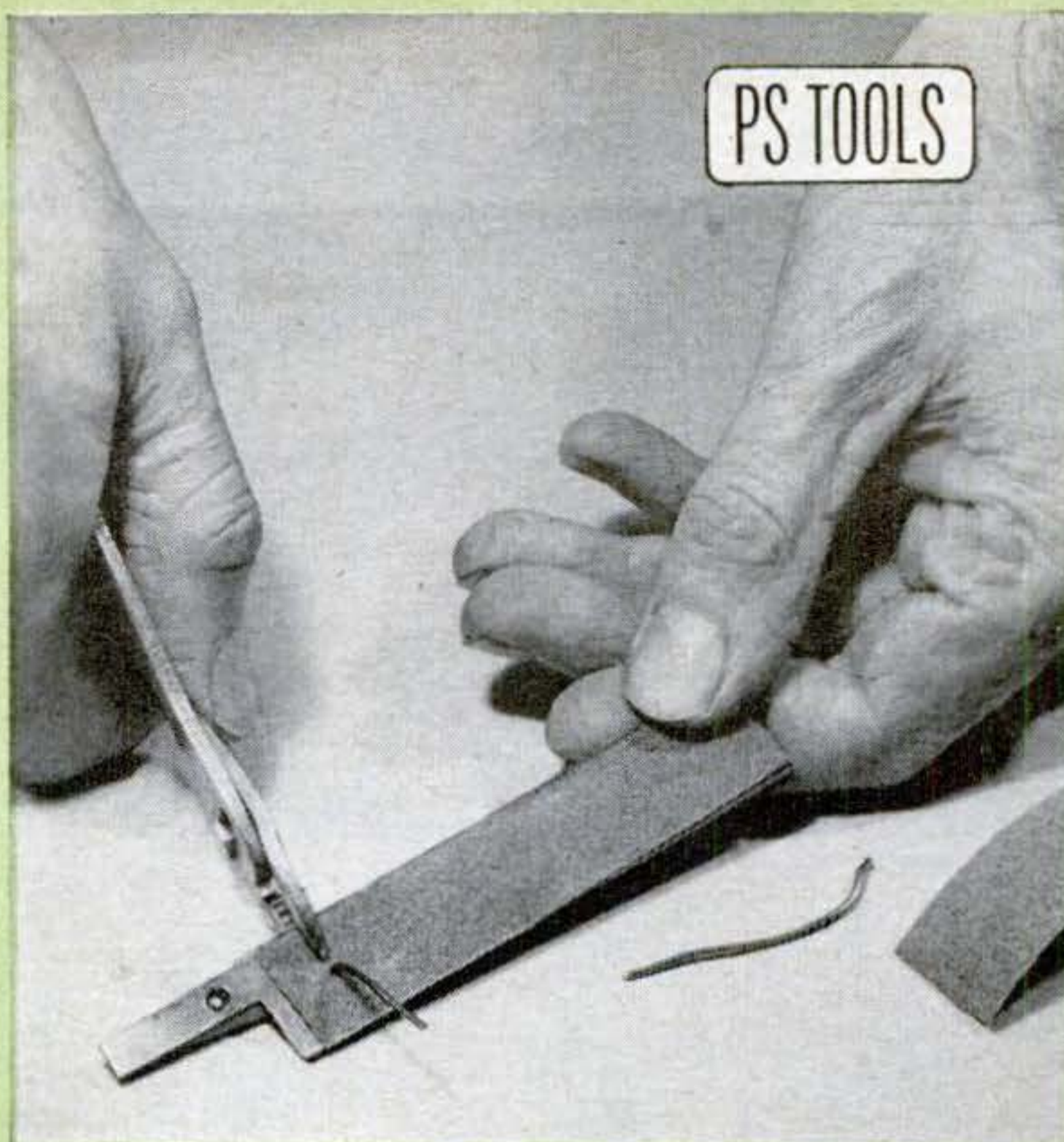

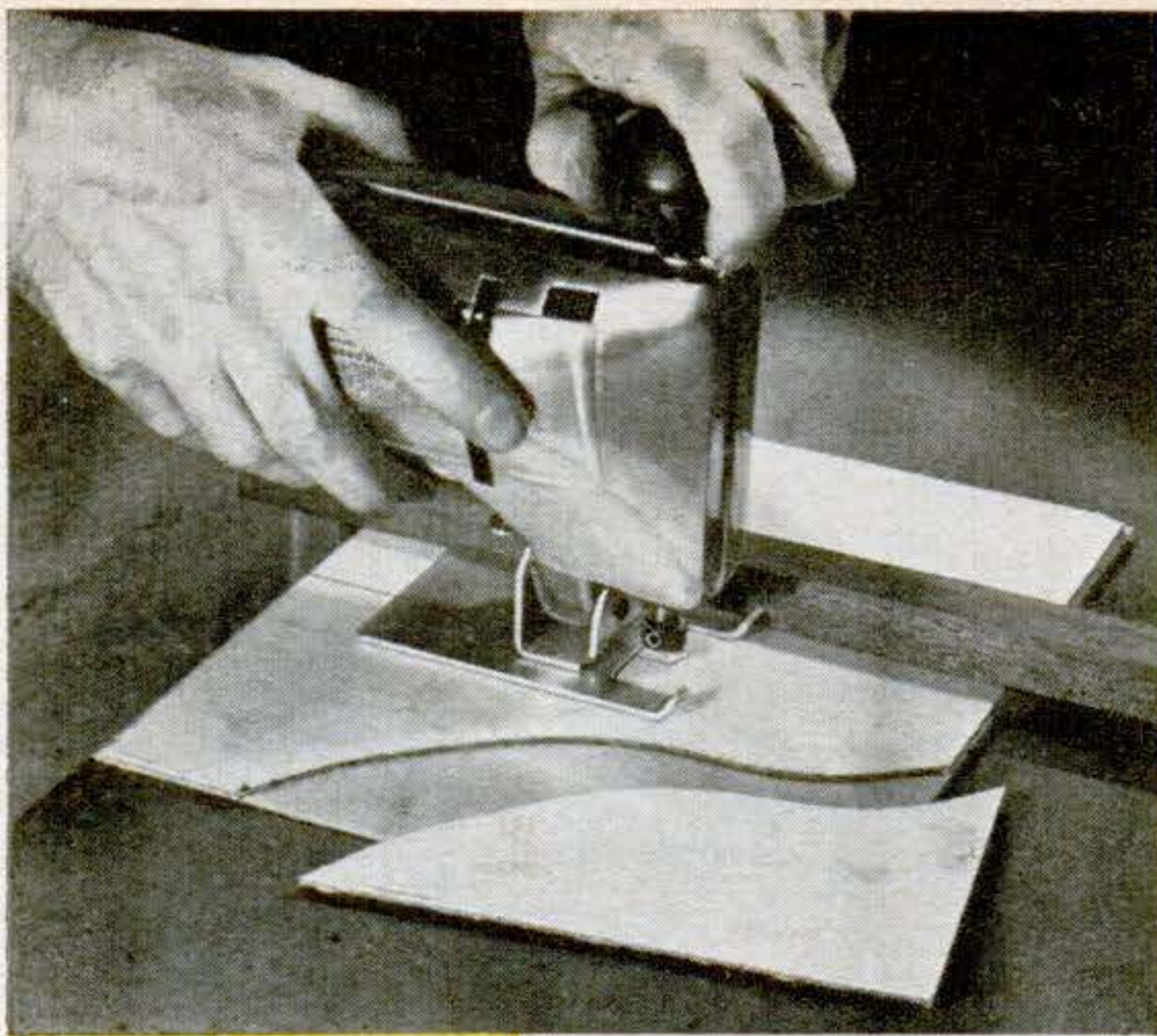

3 cutting linoleum and cardboard

A SPEAR-POINT chisel ground from a worn saw blade makes clean cuts in linoleum, cardboard, and other thin, soft materials. The cutting point was positioned so its maximum projection below the slipper plate is about $1/16''$. The cutter edges at the point were beveled equally on both sides.

Material to be cut is placed on a soft surface such as cardboard. The saw is guided by sight for making irregular cuts (top photo at left), by a clamped board for straight ones. Angle cuts can be made by tilting the slipper plate, and circular cuts are a cinch to handle if your saber saw is equipped with a circle-cutting attachment.

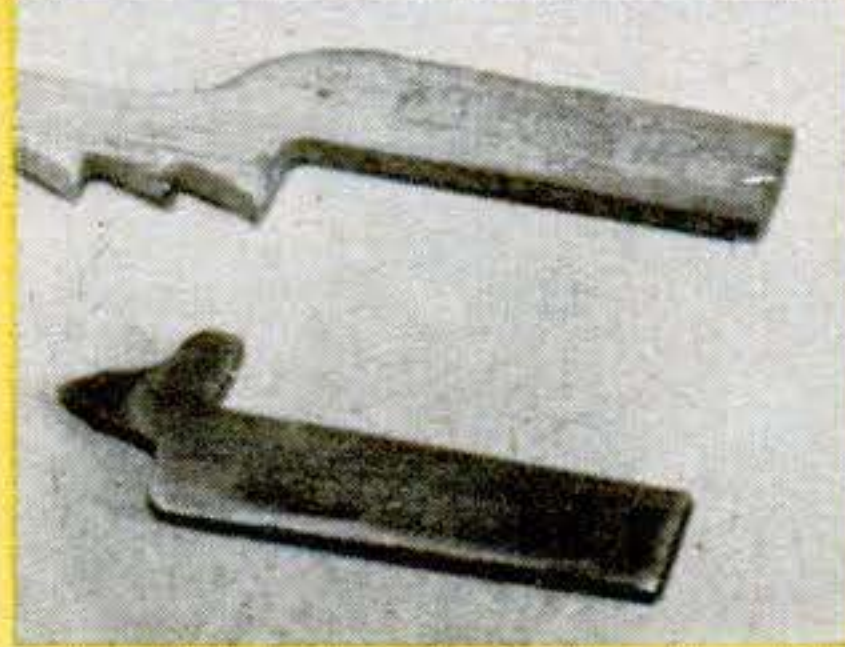
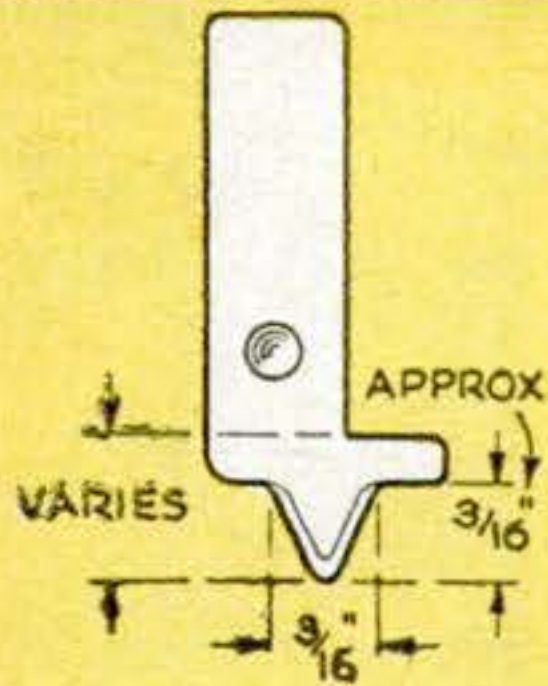

4 decorating metal

A ROUND pencil eraser held in a special chuck is the thing for this. An ink eraser has the greatest abrasive action. The saw is held so that the eraser tip strikes the work at about 45 degrees. The tip ultimately wears to a bevel.

The photo (upper right) shows the tool being used to develop a polished design on an aluminum camera lens-board. Spots were abraded at various angles so light is reflected from different directions, creating a changeable pattern.

The tool is also handy for polishing rounded contours, such as rivet heads, or removing tarnish from a hammered brass bowl. Another use—as an eraser: removing pencil marks from wood surfaces. ■ ■

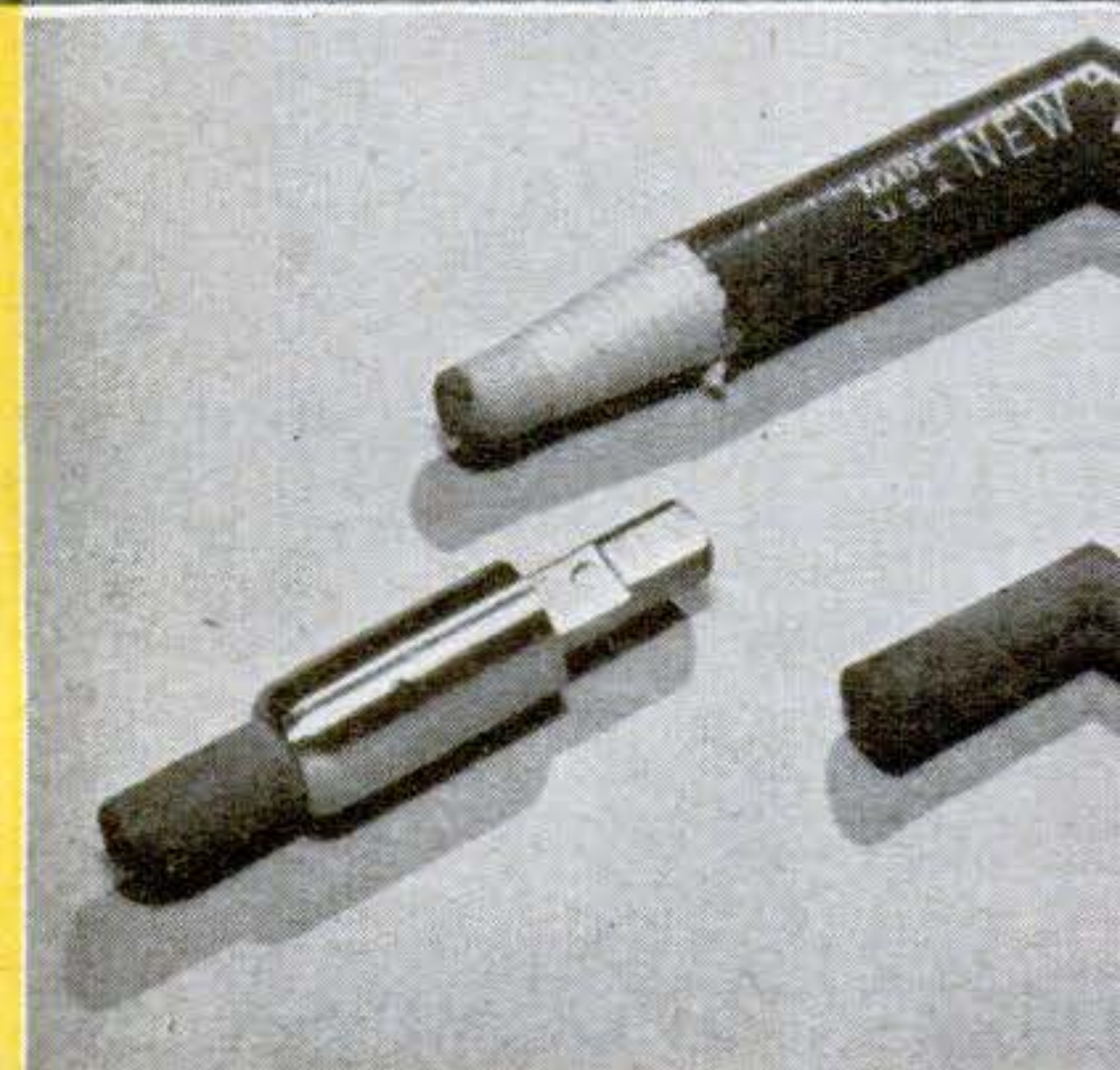
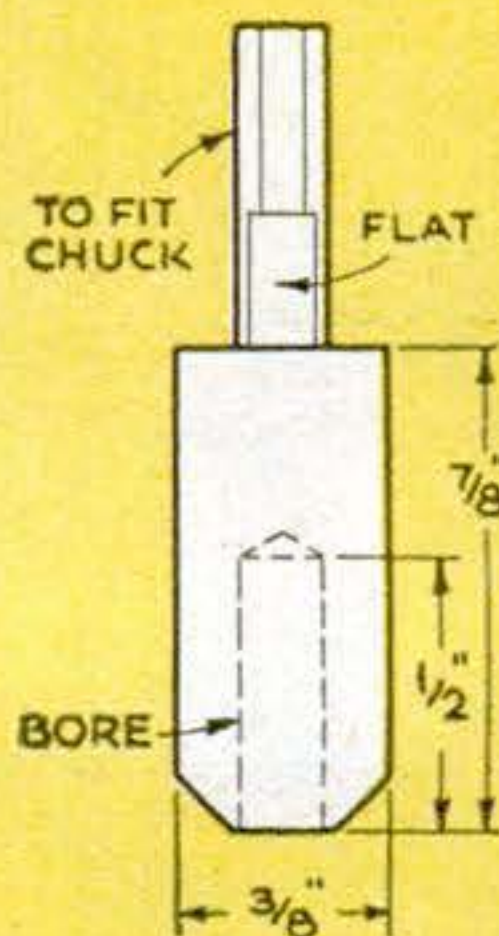
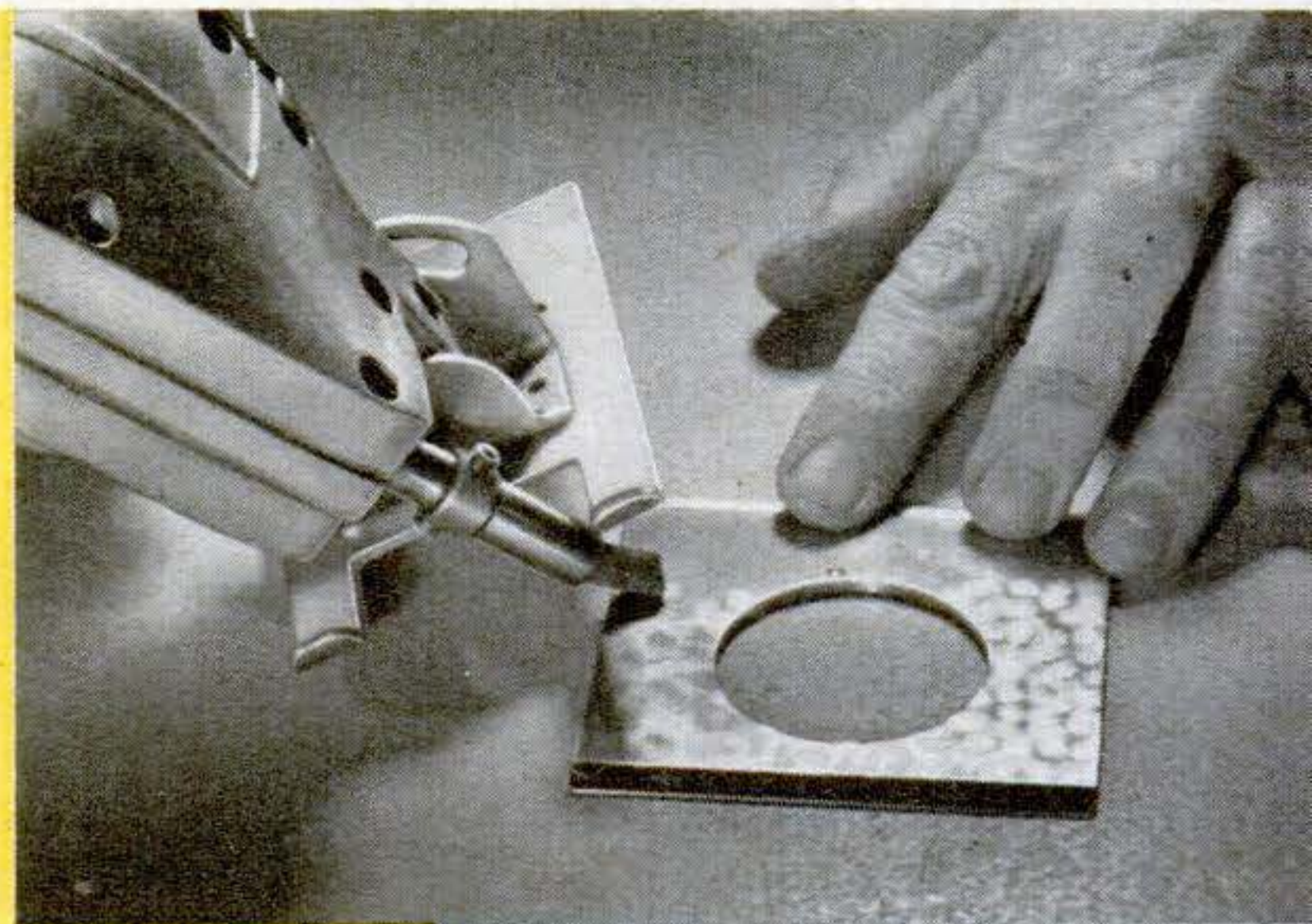

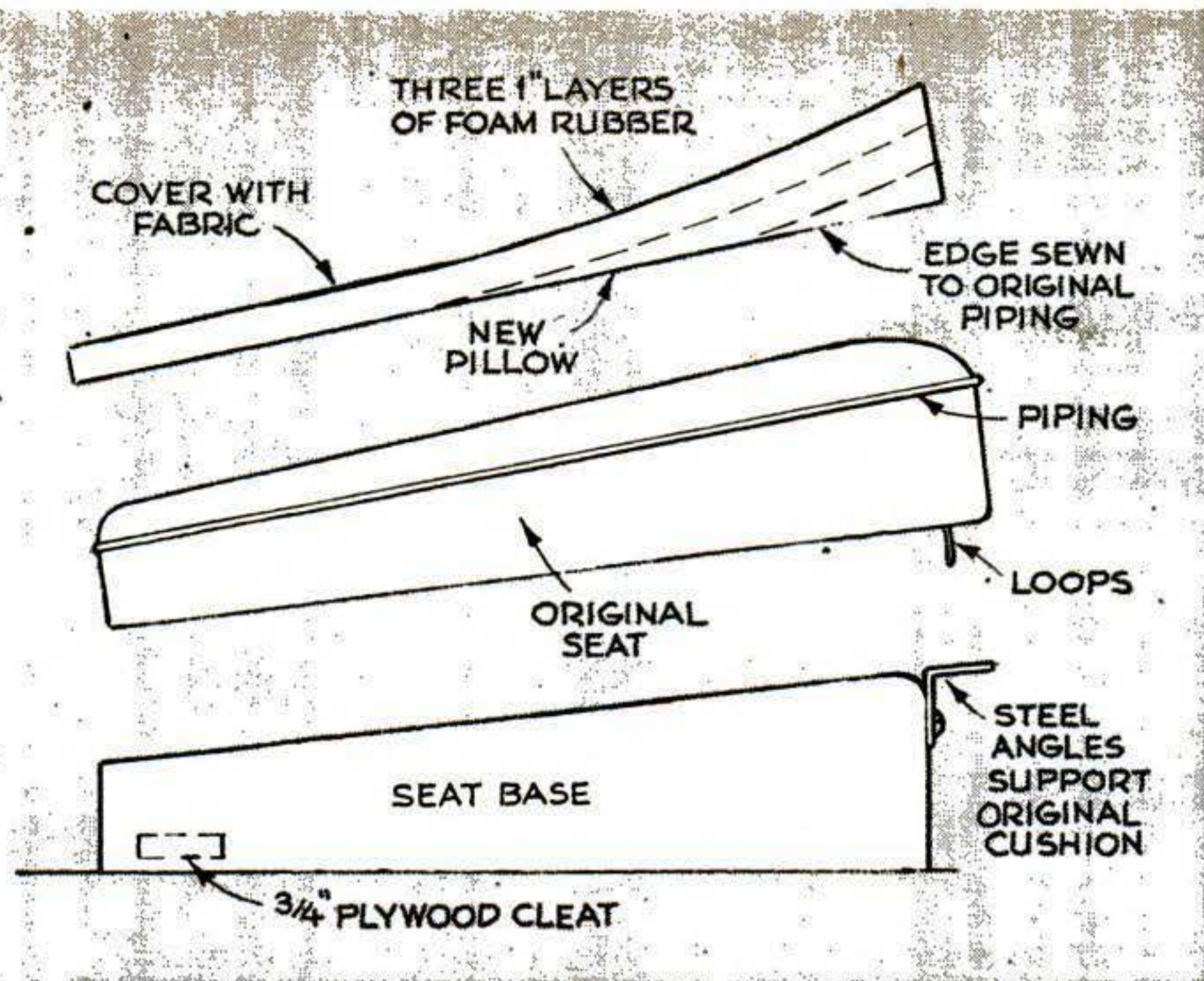

Adding comfort to a car's rear seat

You can increase rear-seat comfort in many cars by moving the seat forward and making it higher to give you more leg support. Two angle brackets bolted to the front of the seat base will let you move

the original cushion 2" forward. A new cushion made of foam rubber and upholstery fabric can then be placed on top. It should be thick in front and taper toward the rear. Sew its lower edge to the piping on the original cushion for a trim appearance. —Edward N. Horr, Hickory, N.C.

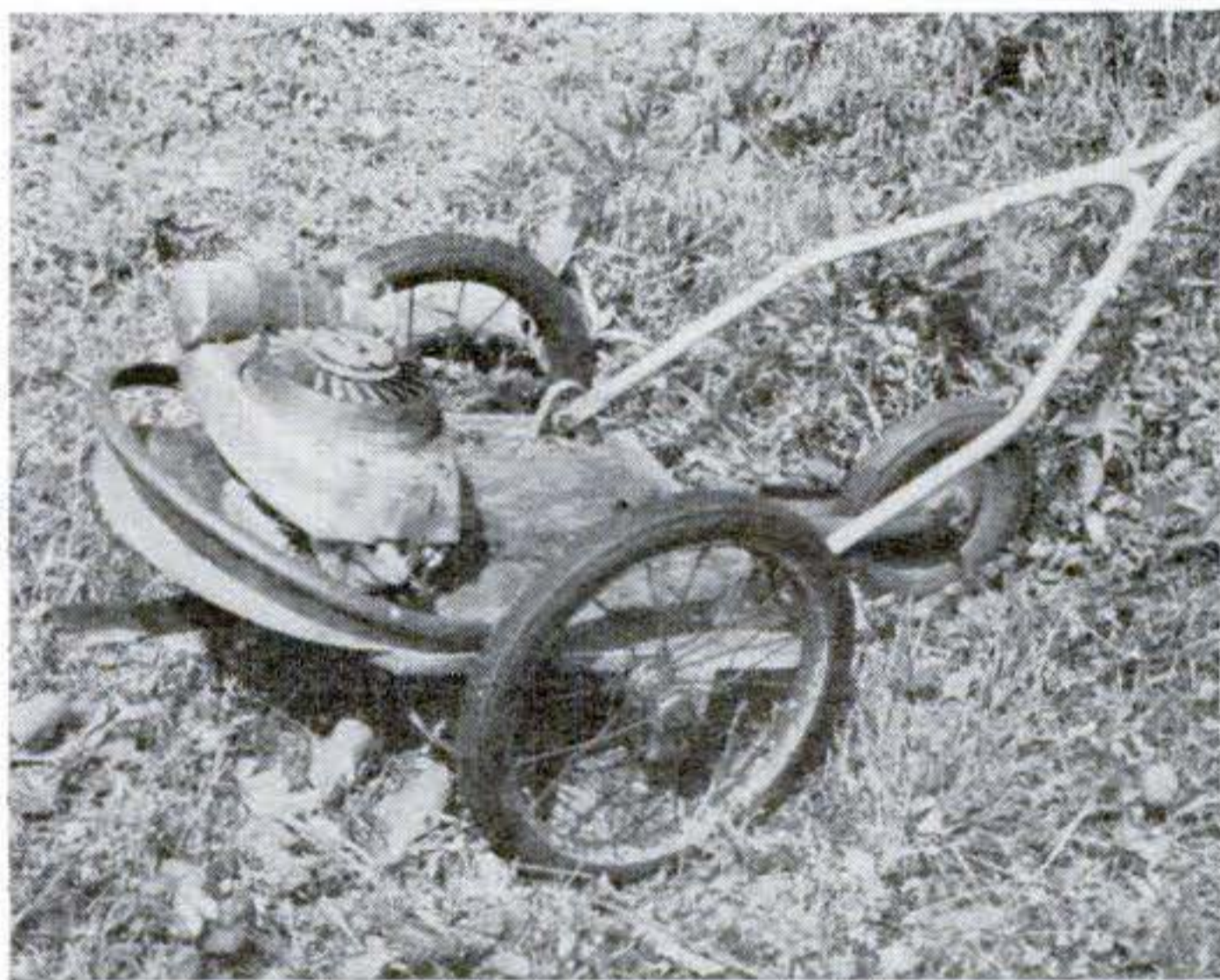

Old mowers never die—they cut weeds

When the housing on my 10-year-old power mower finally fell apart, I was left with a still-good engine and handle. So I mounted them on a plywood base, added bike wheels, and the result is a rugged weed and brush cutter that slices saplings up to 3/4". Because the blade is exposed in front, I use the rig only when no one else is around. A two-by-four shields the blade in back. The big wheels roll easily over rough ground and hold the blade high to clear rocks. A small third wheel is held at the rear in an old tricycle fork. —Thomas M. Martin, Bedford, Va.

School bell now announces callers

We needed an especially loud doorbell, so I worked up this rig for an old school bell I found. I hung the bell on a spring held by a wall bracket near the door. Then I ran a line loosely from the bracket to the bell's handle and from there through an eye on the wall and out a small hole in the door casing, with a knob tied on the end.

The slightest tug on the knob jounces the bell enough to be heard anywhere in the house. A loose line between bell and bracket lets the bell move, but keeps it from being pulled too far down on the spring. —John Calder, Laurel, Md.

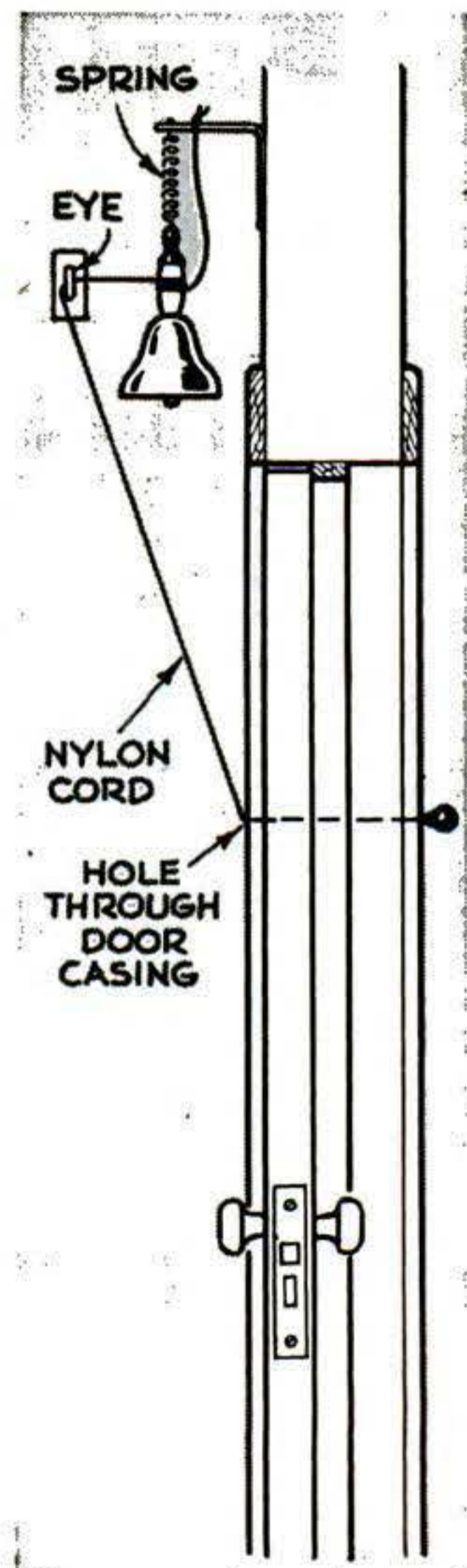

How to Choose the Right Mike

Five basically different types of construction are used to convert sound waves into electrical signals

By Lewis A. Harlow

THE quickest way to improve your home-grown tape recordings is to invest in a better microphone. Most home tape recorders are capable of better performance than the mikes that come with them. But shopping for a mike can be an expensive, as well as a frustrating, experience if you're hazy about the difference in types and the meaning of the specs.

The carbon mike is the oldest of microphones. The one in your telephone is the most

sensitive of all designs. The frequency response of the carbon mike is narrow, 400 to 4,000 cycles—excellent for speech intelligibility but hopelessly inadequate for the 30-15,000-cycle music spectrum. Carbon mikes are used in noisy communications sites by the military, by taxicabs, in plane cockpits, and occasionally by sports announcers. The newest models are in palm-fitting cases acoustically designed to accept speech from an inch or less away and to reject noise from greater distances.

The crystal mike holds second place for

Five different kinds of microphones—how they work

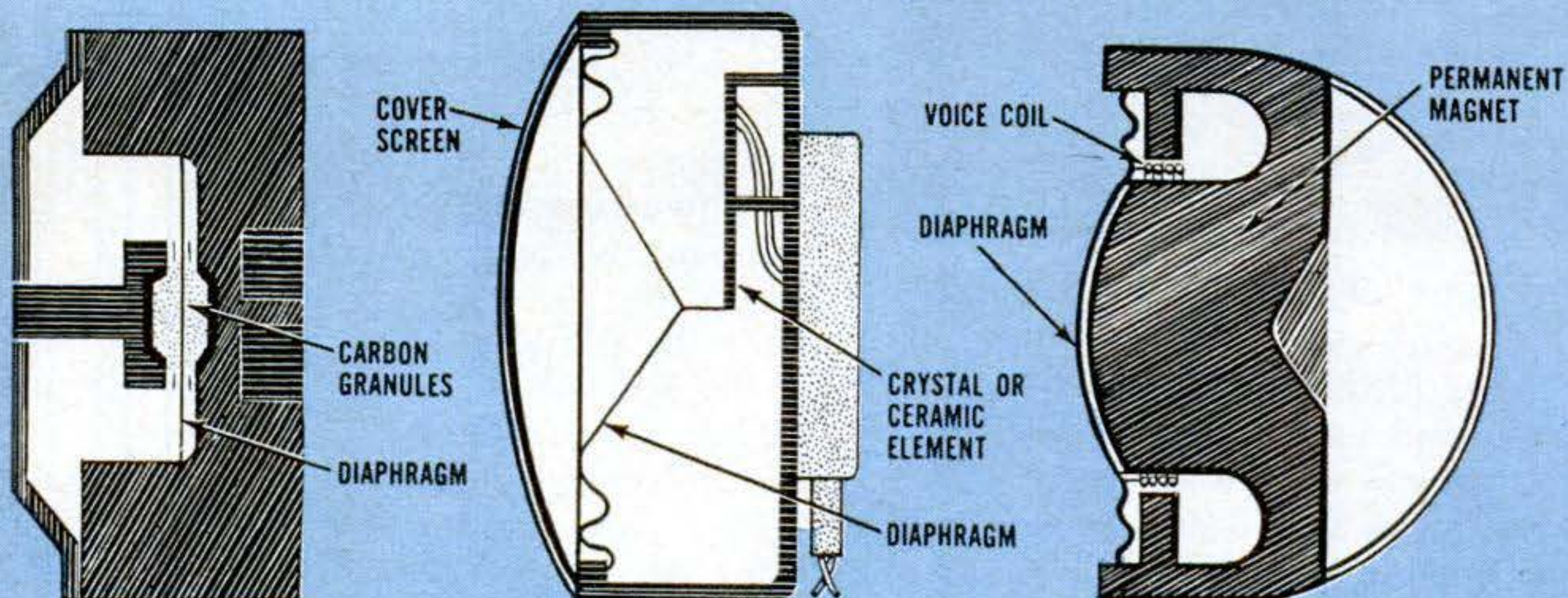

Carbon mike varies current (usually from a battery) through it when sound vibrates diaphragm, putting alternating pressure on carbon granules.

Crystal mike generates an electrical signal when piezoelectric crystal is flexed by diaphragm. Ceramic mike is similar, but uses man-made element.

Dynamic mike generates an electrical signal when a coil attached to the diaphragm moves in the field of a permanent magnet. Principle: Current flows in a conductor when it cuts across magnetic lines of force.

wide usage. In a simple plastic "box" (for protection and not for acoustic improvement), you can buy a crystal mike for \$5 or less. Or you can pay \$25 or more, and get (1) cardioidism, (2) acoustic design of the case to minimize the crystal's limitations of frequency response, and (3) an adequately long cable of good quality.

In its approach to the highs of hi-fi, a crystal quits at about 10,000 cycles—5,000 short of ideal. The bottom limit is about 50 cycles, lower than most home speakers will reproduce cleanly. Between these limits you get peaks and valleys, louds and softs.

There is another crystal weakness, too. Its twisting sandwich of Rochelle salt is damaged by both high temperatures and high humidity—130 degrees F. is absolutely fatal. Crystal mikes have a sensitivity of about minus 55 to minus 50 decibels (db.).

The ceramic mike is like the crystal electrically, but the oscillating sandwich is a ceramic, not a natural crystal, and this avoids the temperature problem. A ceramic averages about two db. less sensitivity than a crystal, and its frequency response is almost as wide—and about as ragged. Ceramics compete only with lower-priced crystals. You don't find "better" ceramics.

The dynamic mike bridges the price gap between the better crystals and the present "ultimates," the capacitor and the ribbon types. The mechanical principle of the

CONTINUED

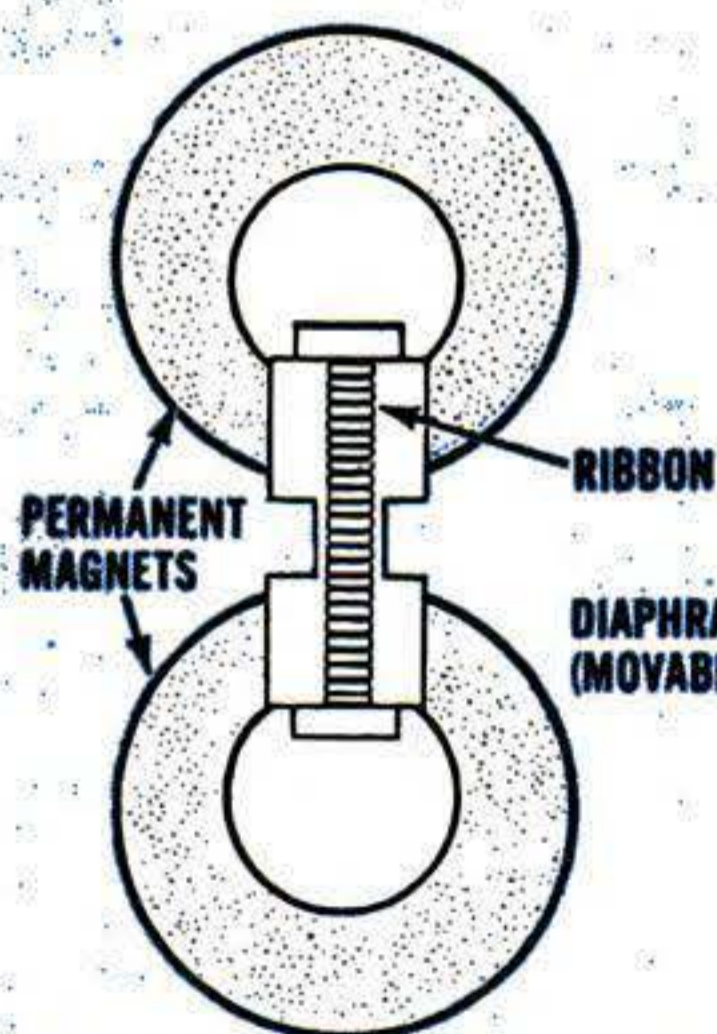
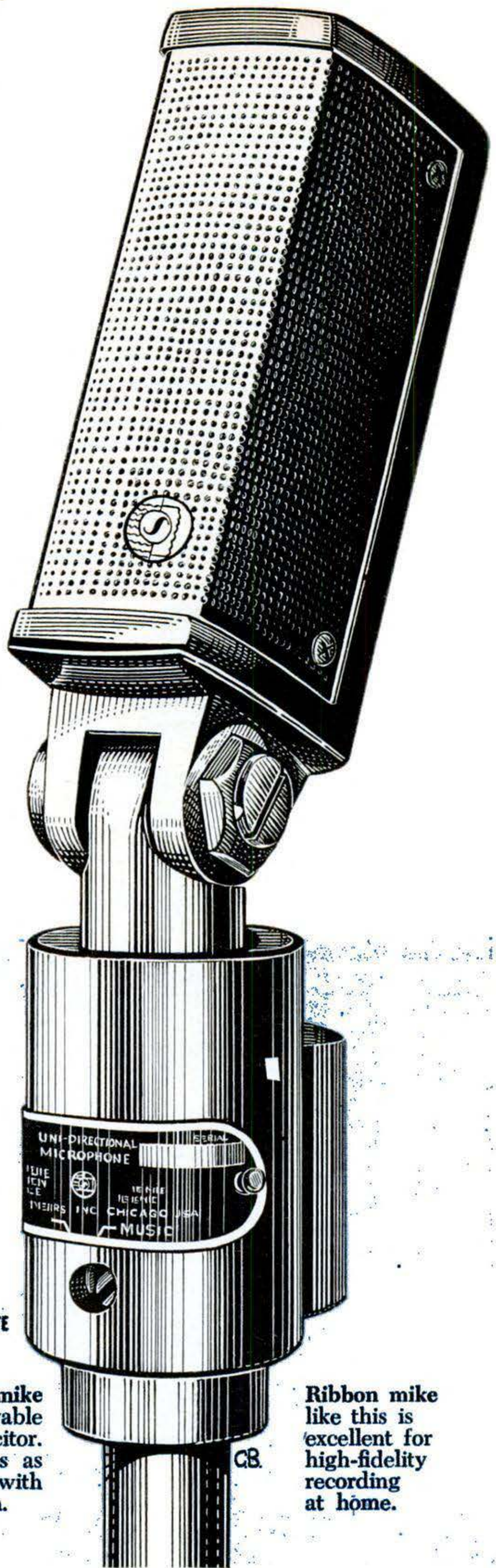

Ribbon mike works on same basic principle as dynamic, but uses a thin metal ribbon, moving in field of magnet, as diaphragm and conductor.

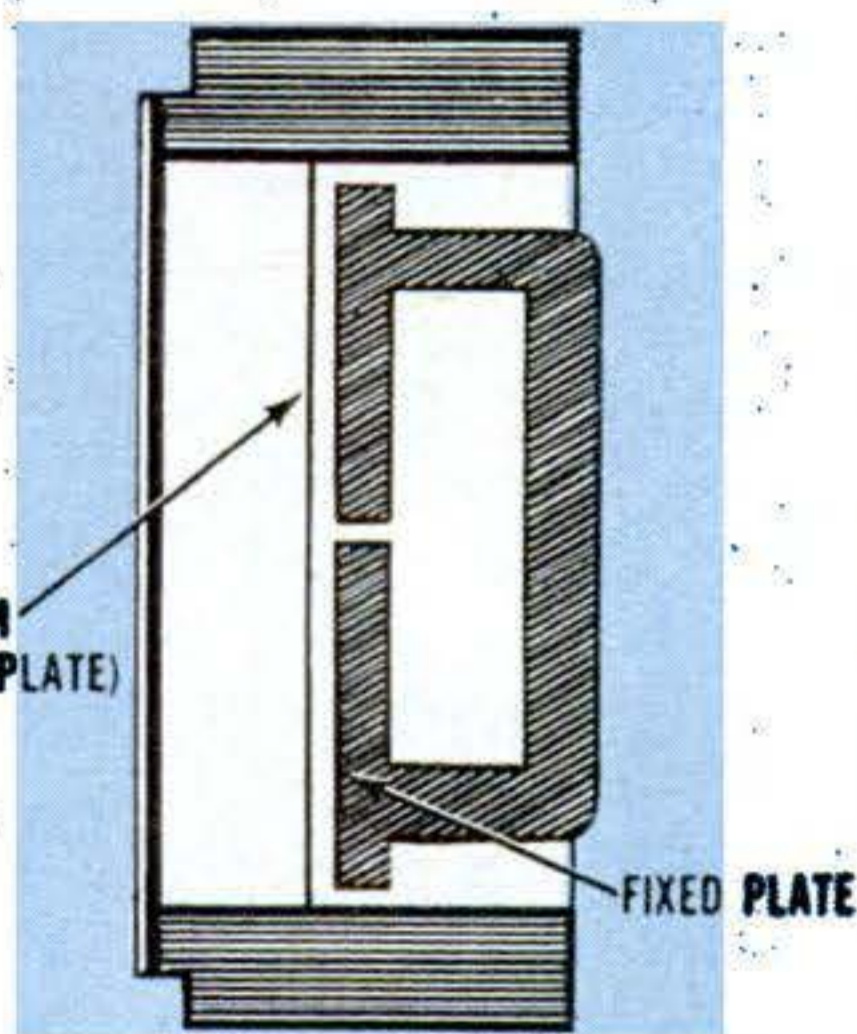

Capacitor (condenser) mike uses diaphragm as movable plate of variable capacitor. Voltage to plates varies as capacitance changes with movement of diaphragm.

Ribbon mike like this is excellent for high-fidelity recording at home.

CB.

Microphone terms— what they mean

Cardioidism. A characteristic of certain microphones indicating a heart-shaped, directional pickup pattern.

Diaphragm. The flexible membrane in a microphone, which vibrates under the physical impact of sound waves.

Frequency response. The range of sound vibrations—lowest to highest—to which a microphone responds with approximately uniform electrical output.

Impedance. The total opposition a circuit offers to the flow of alternating current. It is measured in ohms.

Omni-directionalism. A characteristic of a microphone indicating sensitivity to sounds coming from all directions.

Pressure type. A microphone in which electrical output corresponds to the instantaneous sound pressure. The back of the diaphragm is enclosed.

Velocity type. Unlike the pressure type, this mike is open all around. Electrical output corresponds to instantaneous particle velocity of the sound wave.

Sensitivity. Electrical output for a specified sound pressure. Usually given in minus decibels (db.). The larger the number, the lower the output.

dynamic permits a frequency response all the way up to the hi-fi top of 15,000 c.p.s. This response is quite uniform, and it can be further smoothed by acoustic design of the case. You can pay \$200 for a dynamic mike, or you can buy one of the recent imports for \$10. The most popular dynamics sell for about \$50, and this is the range to consider if you want an improvement over one of the better crystals.

The magnetic mike is a mechanical switch on the dynamic. Originally developed for heavy-duty military applications, this design competes with the carbon rather than the dynamic. Magnetic prices are modest, and cases are minimal. Frequency response is fair, and sensitivity is average.

The ribbon mike has a frequency response almost ideally uniform over the entire hi-fi spectrum. It is a velocity mike. The inherent freedom of ribbon movement makes it quite susceptible to wind pressure. It is not for outdoor use.

The capacitor (or condenser), all things considered, is today's best microphone. It is the laboratory choice for precise sound measurements, and its flat frequency response rates it with the ribbon for best music reproduction. It is better than the ribbon outdoors, and it will stand rougher handling. Shortcomings? A few. It is expensive to build. It is an "active" mike, requiring an external power supply. It is extremely insensitive, requiring an extra amplifier of its own (often located in the base of the microphone itself).

In addition to type names, here is what you'll need to know to make sense out of the fine print in catalogue descriptions:

- **Impedance.** There will be a choice of "high" or "low," and you want high, because your recorder has a high impedance input. This impedance match is important.

- **Accessories.** You do *not* want to pay for on-off switching at the mike—or dual-impedance switching—or any other kind of switching. You *do* want your mike to come equipped with good cable 15-20 feet long, and you *do* want it to have a mounting socket with the standard $\frac{1}{8}$ -by-27 thread for the great convenience of mounting the mike on a standard table stand or an adjustable floor stand.

- **Cardioidism.** For home use, you are not interested; but the generous size of the cardioid provides room for other desirable acoustic features. Choose it rather than the fashionable pencil mike for this reason.

- **Sensitivity.** Not important. Your volume control is far more than adequate to handle any rating between -55 db. and -48 db., the range listed in the catalogues.

- **Frequency response.** If yours is a super tape recorder with a "highs" rating of 15,000 c.p.s., you need a microphone to match. If your recorder cuts off at 10,000 or below, as many do, a mike investment in higher frequencies is wasted.

- **Type and price.** The best buy under \$30 is a good crystal, a big old-fashioned cardioid if you can find one, with standard mounting thread and 15 to 20 feet of good cable. If your budget will stand \$50, there are several excellent cardioid dynamics to choose among. ■ ■

This \$39.95 intercom kit lets your voice ride the AC wires to any outlet in the house

PS ELECTRONICS

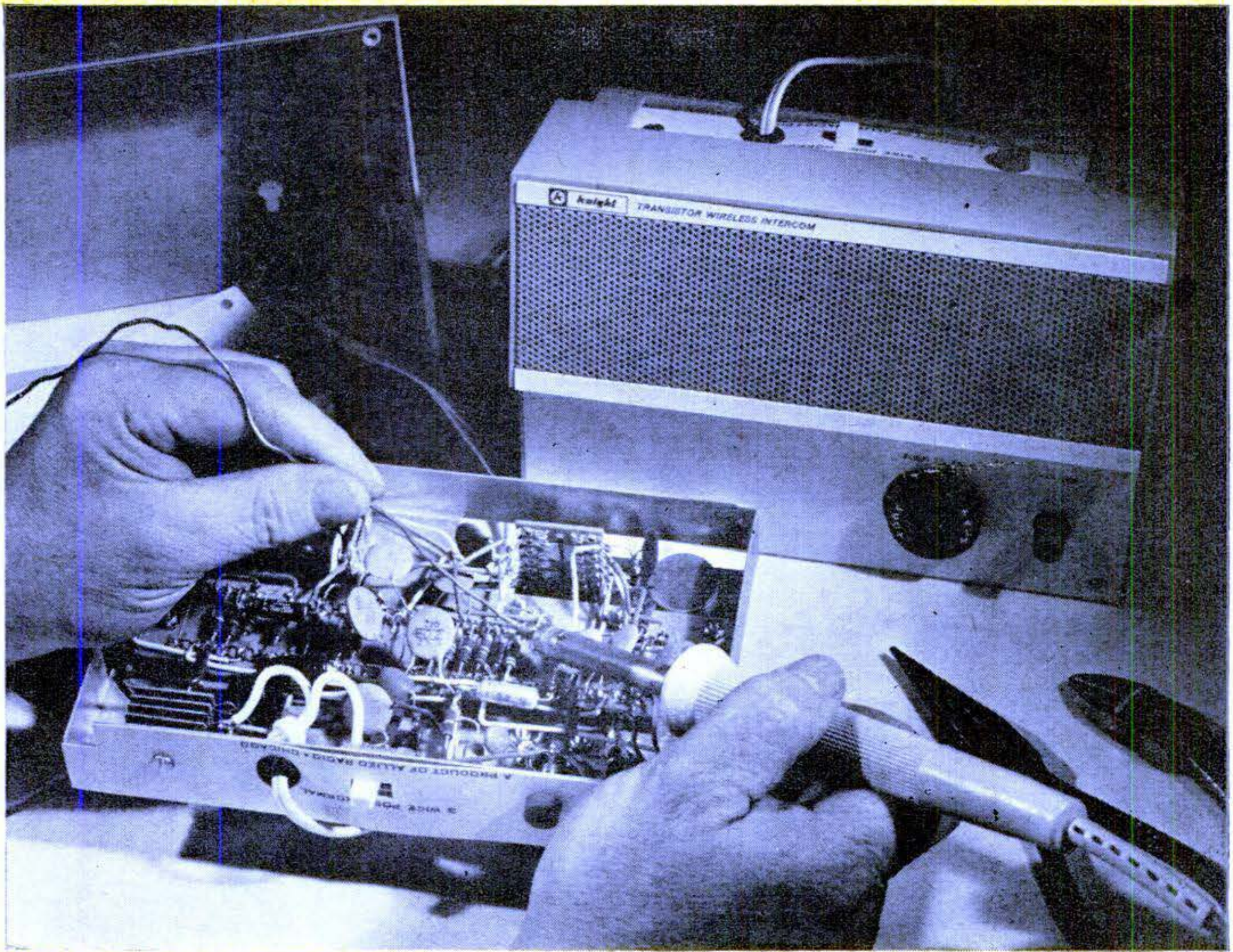

Back Talk from Your House Wiring

By Charles Tepfer

THERE'S a new kind of intercom that uses no special wiring, can be left on indefinitely, and may be moved any time to any place (where there's an electric outlet) for instant two-way talk. The first week I had it, I used it:

- To keep in touch with my wife in the house while I worked outside.
- As an outdoor telephone ringer.
- As a baby sitter while I visited with the next-door neighbors.
- As a sickroom attendant for my youngster in his upstairs room.
- For temporary use at my front door while I was in the darkroom.

CONTINUED

155

All this I did with only two all-transistor, wireless intercom units that I bought from Allied Radio Corp. in Chicago. These are Knight kits which I assembled in 13½ hours. Total cost: \$39.95.

The system is called "wired wireless" because it needs no wiring of its own—you plug it into the *house* wiring, which carries the message and supplies operating current.

Conventional intercoms need separate wires to carry the message from one unit to the other. Once installed, the wires and the intercoms stay put. They can't be picked up and used elsewhere unless the wires are moved or a set of new wires installed. Scattering many remotes all over the house might be the answer, but this would call for lots of wire stringing and lots of money.

In a wireless intercom system, all units are masters—each can originate calls to and talk with any other unit. Each can be anywhere it is needed at any time. All-transistorized units draw so little current that they are left on continuously—you never miss a call.

The only real limitation of these intercoms is that they must all be connected to the power line on the same side of the pole transformer. This is no problem when they are used within the house or from a house to its outbuildings. Between houses, however, there may be a power-line transformer. The number of houses served by a single transformer varies from neighborhood to neighborhood. To use the intercoms between houses, check first to make sure there is no pole transformer between.

How it works. All four transistors in the intercom are used for both receiving and transmitting. A push-to-talk switch, with a spring return, rearranges the circuits for each function.

With the switch down, talking into the microphone-speaker produces an audio signal that goes through the preamplifier and amplifier. The boosted signal then enters the line-coupling coil where it mixes with and changes the wave shape of a 200,000-cycle carrier signal generated by the radio-frequency oscillator. This mixed, or modulated, signal travels through the house power line to the other intercom unit where the switch is in the up position.

When the signal enters the receiving unit via the power plug, it goes first to the r.f. amplifier where it is boosted, and then to the diode crystal demodulator where the audio is peeled off the r.f. carrier. The

How to use "wired wireless" intercoms to save time, temper, and money

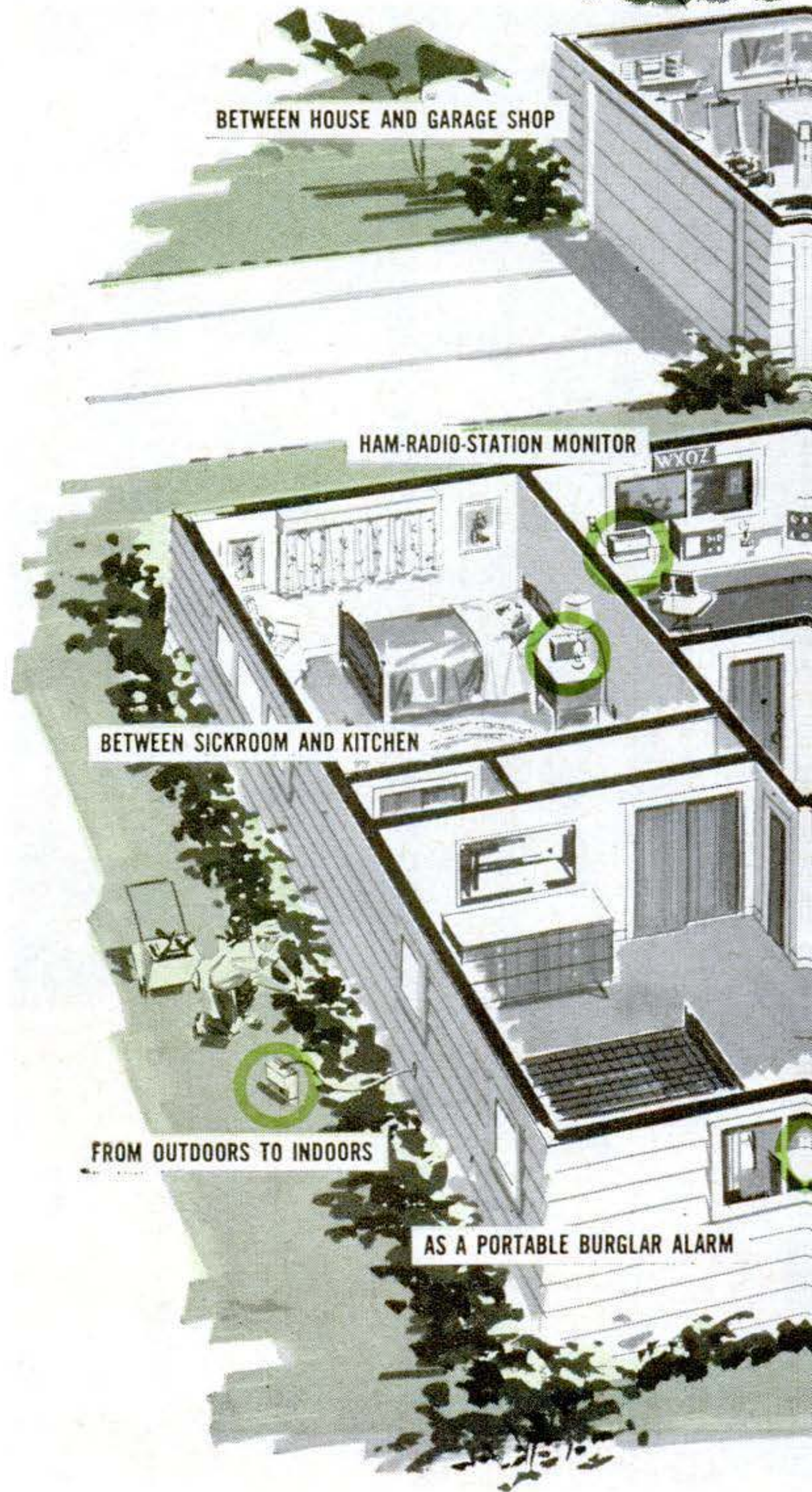

audio signal is then fed to the transistor amplifiers and into the speaker.

The AC is blocked off from the signal circuits by two capacitors. (The r.f. signal has so little current that it doesn't bother the power line at all.) Any interference that might get through to the signal circuits from the line is suppressed by the

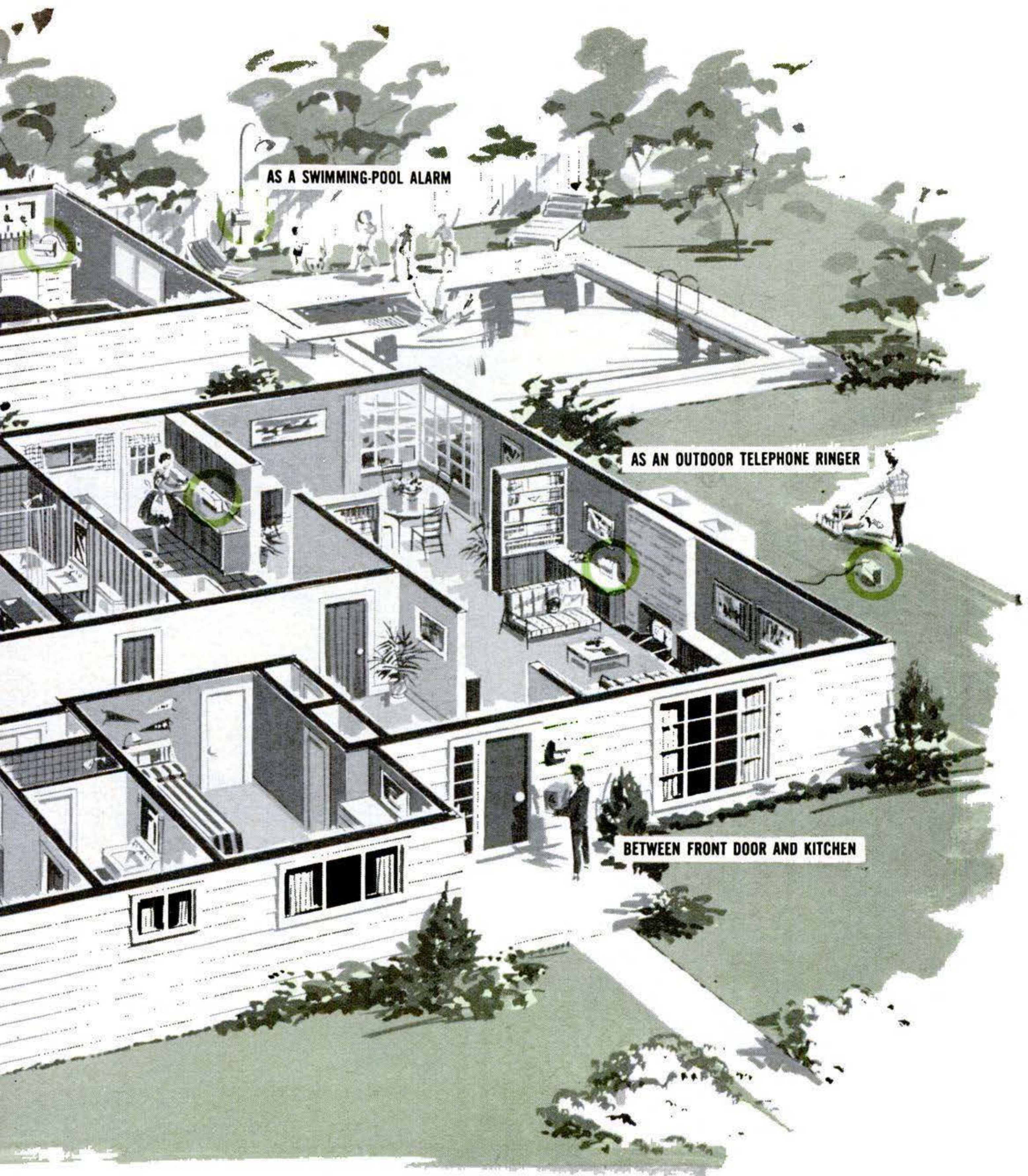

AS A SWIMMING-POOL ALARM

AS AN OUTDOOR TELEPHONE RINGER

BETWEEN FRONT DOOR AND KITCHEN

intercom's "squench." The squench transistor (on transmit it serves as a microphone preamplifier) acts as a gate, turning the audio amplifiers on for audio signals and off for interference.

When a signal with audio information enters the intercom, a portion of the detected audio is fed to the squench transistor,

making it a conductor. The voltage it conducts goes to the audio amplifier, setting it up to pass and amplify the audio coming through. Interference signals that contain no audio cannot trip the squench into conduction. The squench circuit is adjusted initially to ignore any relatively constant interference signals that may contain audio. ■ ■

Pull saw cuts right up to an obstruction

Repairs and remodeling may call for sawing a piece where another piece stops the blade at the end of the cut (as in cutting away rotted porch trim shown in the photo). A pull saw does a cleaner, quicker job than an ordinary one because it can cut up to the corner, removing sawdust from the kerf.

I made my saw from an interchangeable keyhole-saw blade. I placed the small end of the blade in a piece of slotted wood, squeezed in a vise to sink the teeth in the wood, wrapped the handle with tape. — *Harry Walton, White Plains, N.Y.*

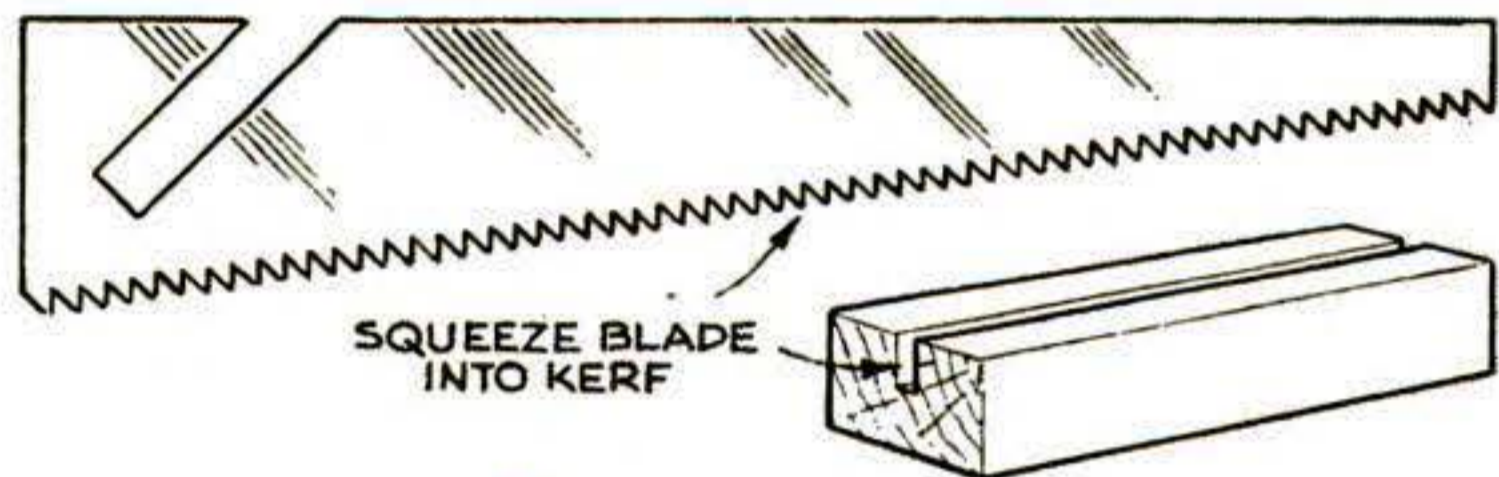
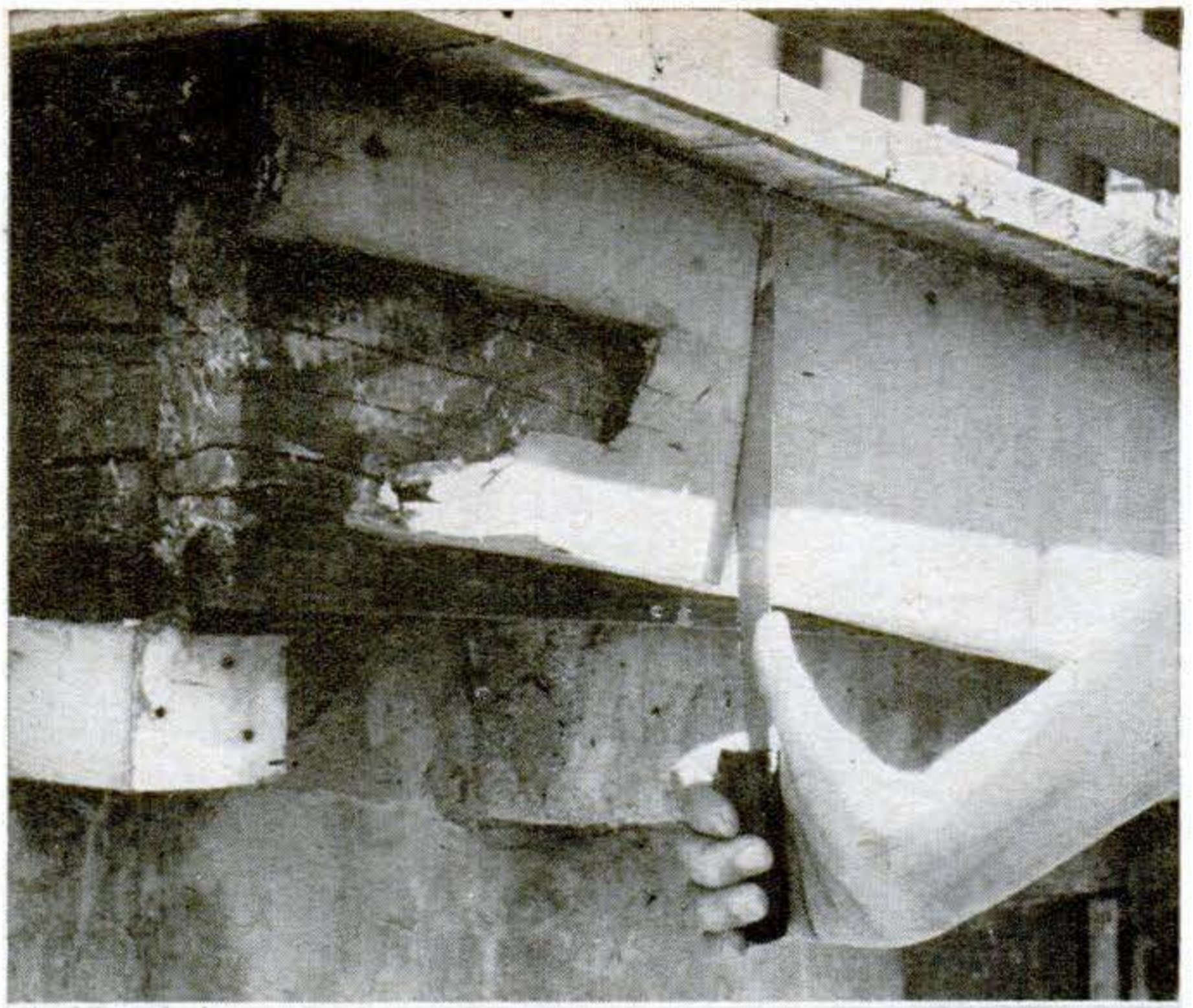

▶▶▶ Why worry about keeping a variety of clamps on hand? I make my own to suit the job, large or small, using two bolts through two strips of wood for each one.— *George L. Broomhall, Utica, N.Y.*

▶▶▶ To locate interior wall studs behind plasterboard, I place a flashlight against the wall and shine it parallel to the wall face. This shows up the fill over nailheads.— *D. E. Young, Somerville, N.J.*

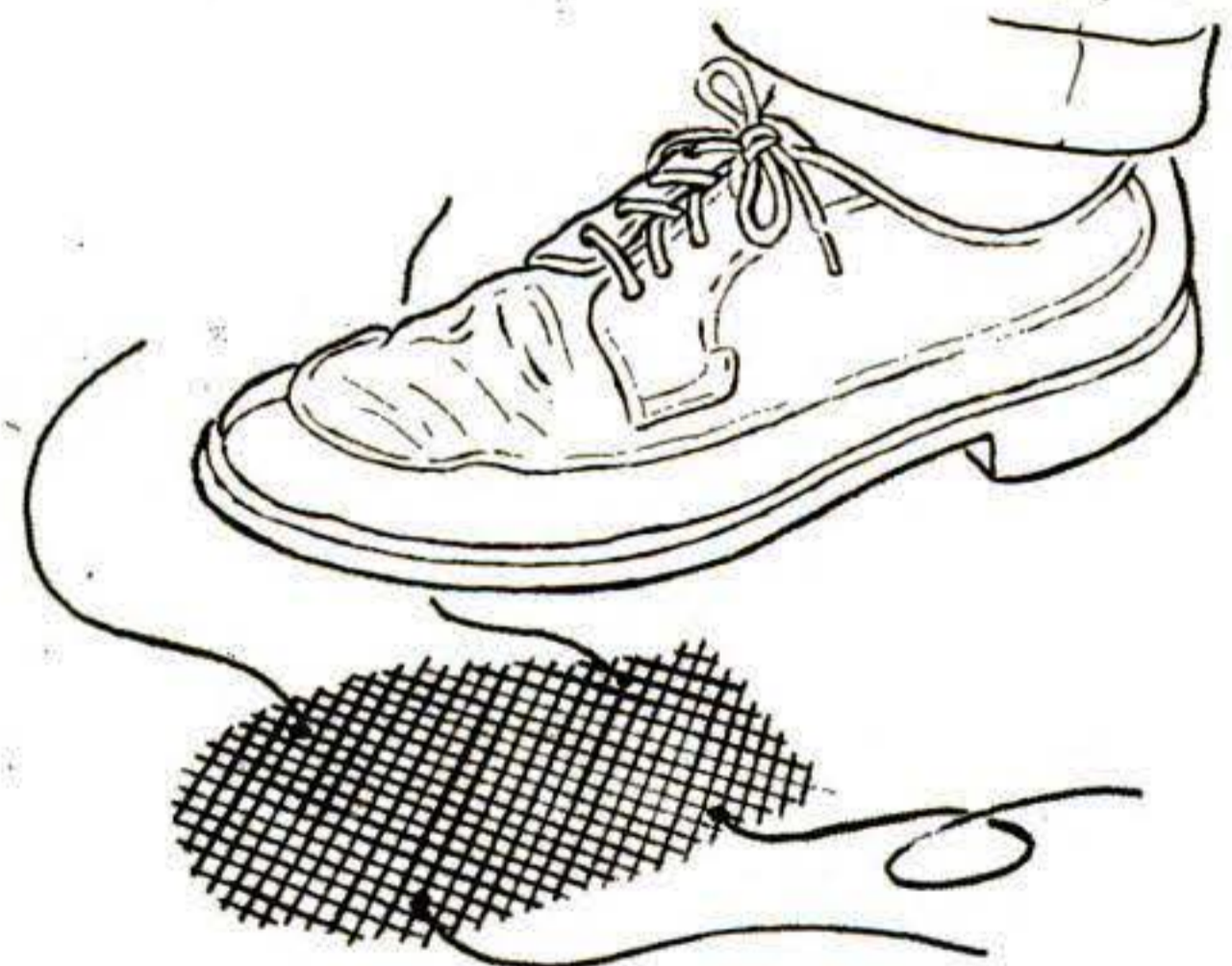
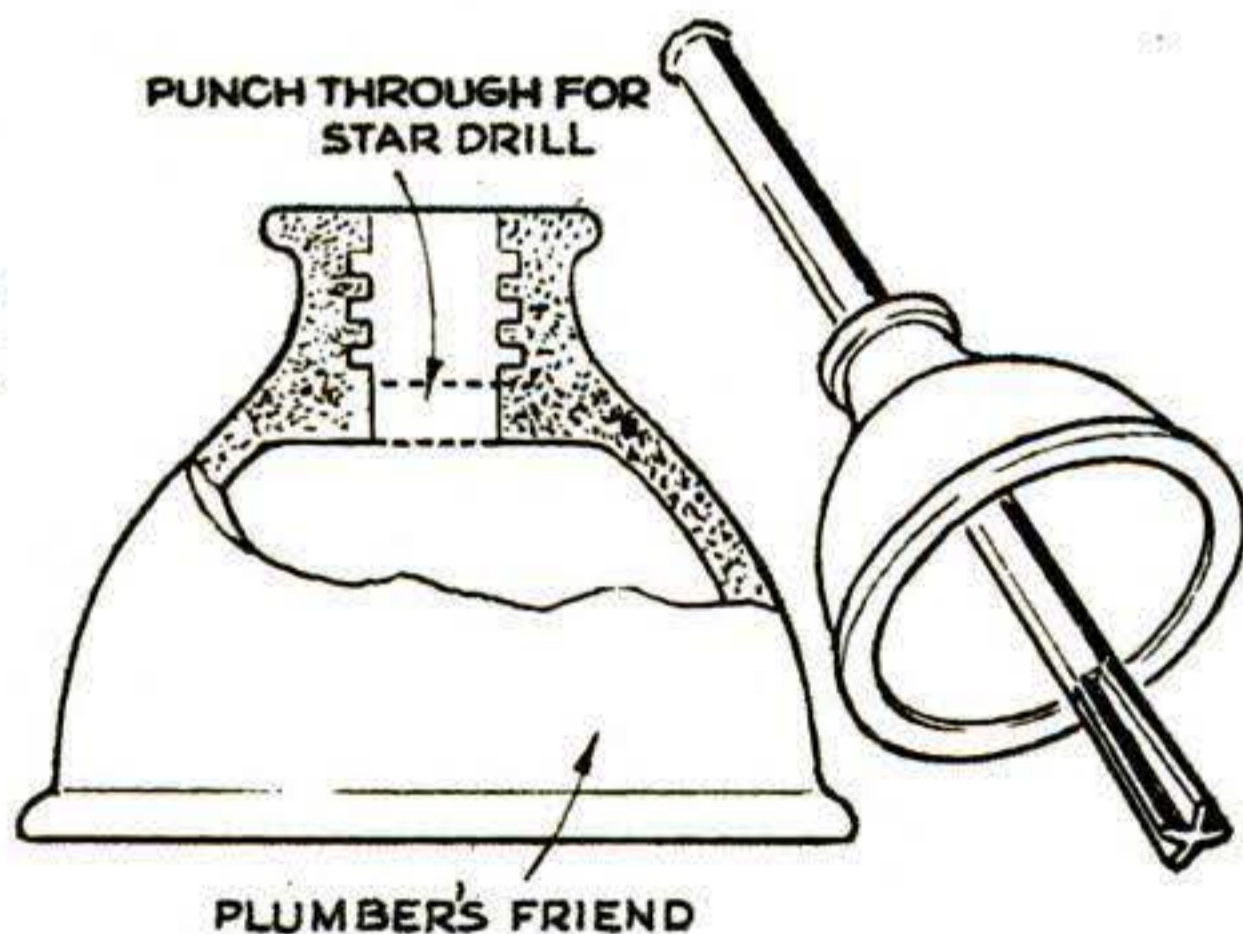

Toilet plunger shields star drill

A rubber plunger from a "plumber's helper" serves nicely as a shield to guard eyes from flying chips when you use a star drill. I heat a metal rod red and burn a hole through the rubber for the drill.— *F. P. Faltersack, San Jose, Calif.*

Snow soles prevent winter falls

For secure footing on ice or snow, you can make yourself a pair of tie-ons. Step down on a scrap of expanded-steel lathing and trace around your shoe from toe to instep. Cut out and tie on with leather thongs.— *J. H. Matthews, St. Louis.*



COPYRIGHT © 1963, THE BORDEN COMPANY

WORKING WITH ELMER'S EPOXY GLUE AND COMPOUND

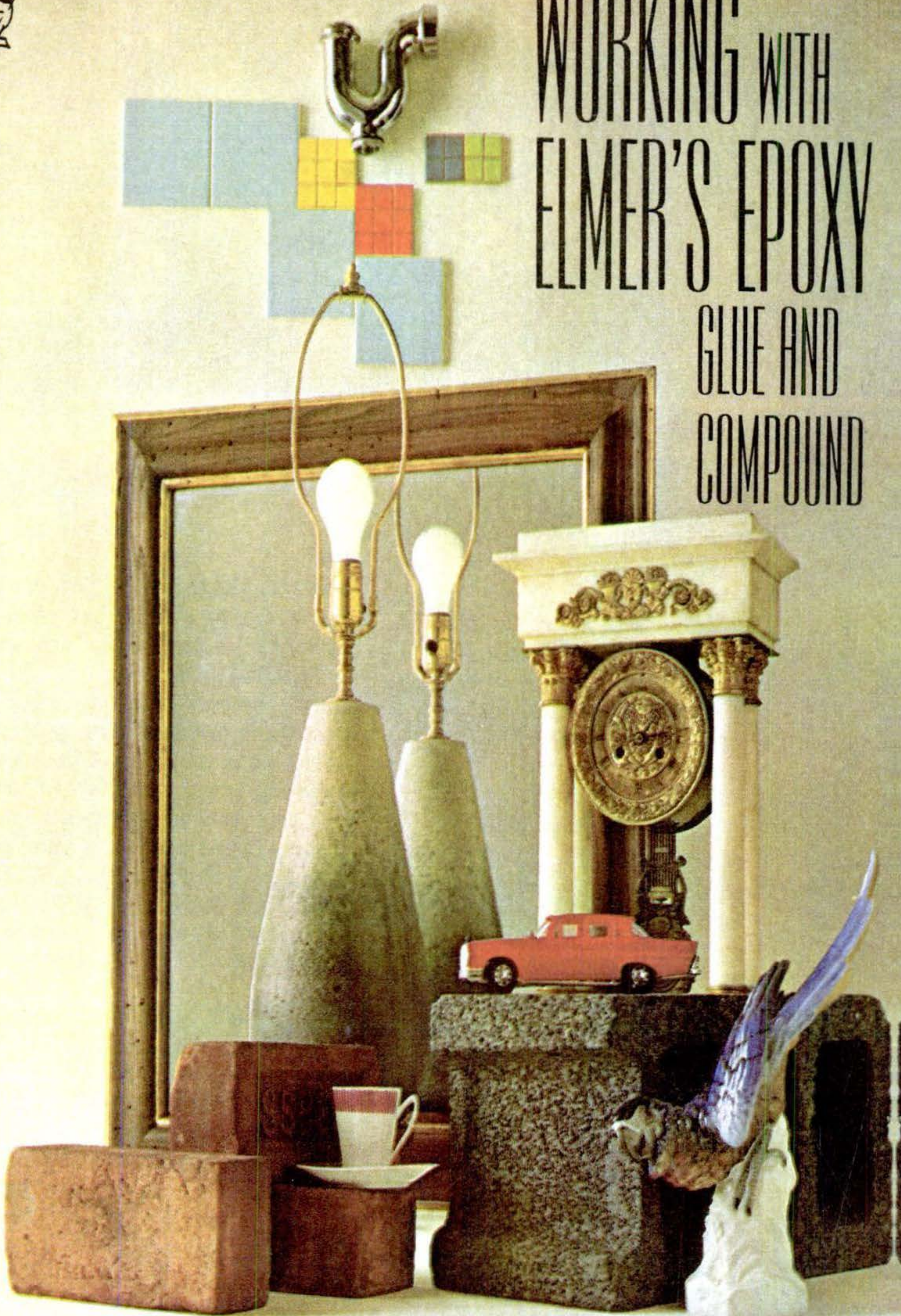

ELMER'S twin teams make "impossible" jobs easy

WHETHER you're a home handyman, mechanic, or craftsman, both ELMER'S Epoxy Glue and ELMER'S Epoxy Metal Compound belong in your workshop. Here's why:

ELMER'S EPOXY GLUE is the wonder adhesive that sticks practically anything to anything. The joints this waterproof and nearly transparent glue produce are so strong that stresses of up to a ton per square inch won't part them.

ELMER'S EPOXY METAL COMPOUND is a blend of the same adhesive and minute particles of aluminum. The result is a full-bodied formulation ideal for bonding irregular surfaces, and for filling, sealing, patching, and filleting. When ELMER'S Epoxy Metal Compound hardens, it's so dense you can machine, file, sand, drill, and tap it.

WHY TWO CONTAINERS? Ordinary glues and metallic fillers contain an evaporative solvent. ELMER'S Epoxies do not. Just before use, you mix equal parts of two components—one a chemical hardener. With nonevaporative curing, ELMER'S Epoxies offer three dividends—superstrength joints without clamping, a metallic compound free from any shrinkage, and no storage waste.

THERE you have them—two remarkable ELMER'S products, each an easy-does-it answer to formerly tough and impossible construction and repair jobs.

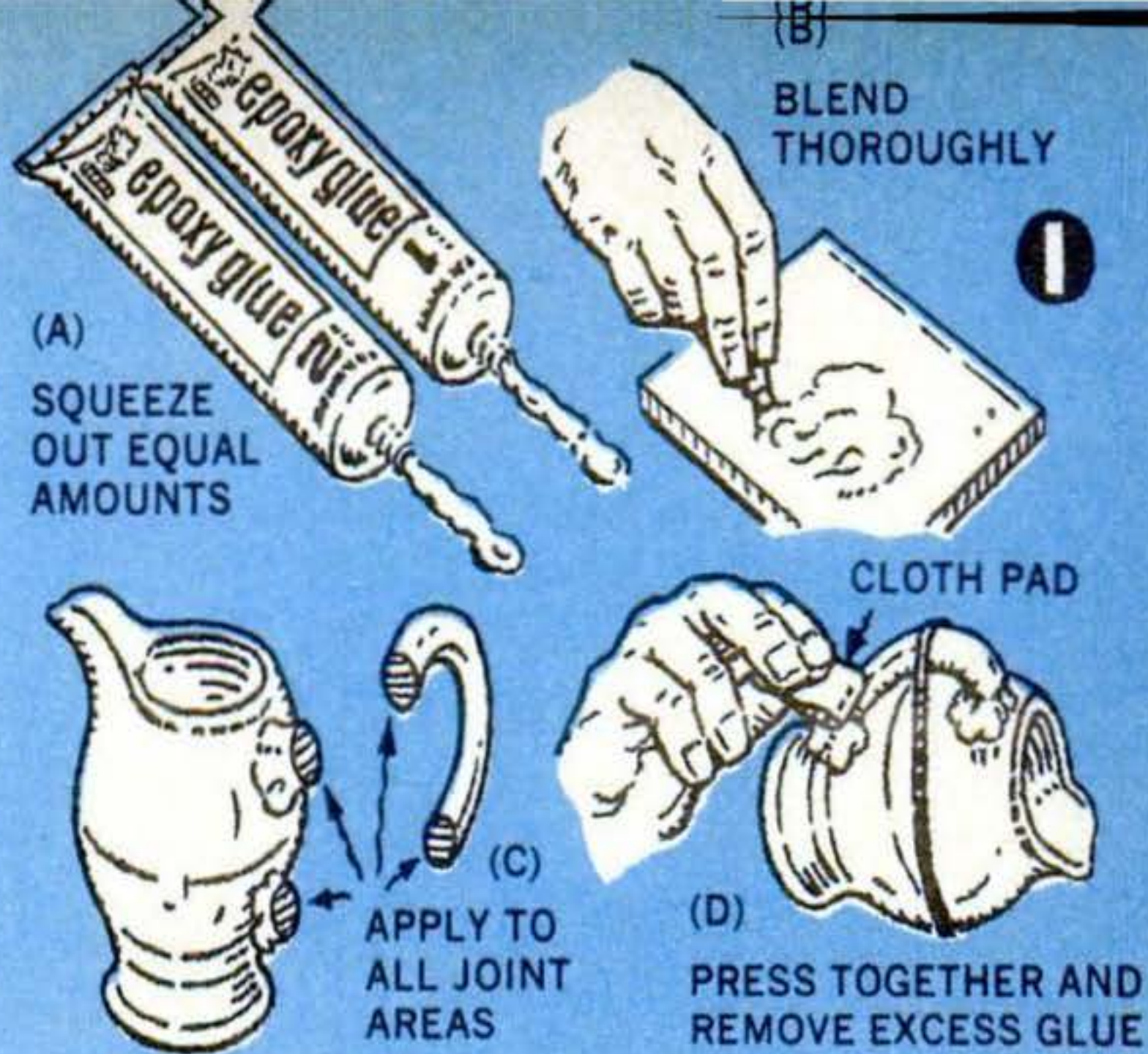

Bonding with

WHEN TO USE IT. While ELMER'S Epoxy Glue is the most versatile adhesive ever developed, it is not offered as a replacement for ELMER'S six other top-grade glues and cements (see back cover). Use Epoxy glue, primarily, to join heretofore ungluable and difficult materials. That goes for steel, iron, aluminum, bronze and brass—for concrete, brick, and tile—glass, porcelain, china, and crockery—leather and most hard plastics (phenolic and polystyrene). ELMER'S Epoxy Glue is the right choice, too, for superstrength wood joints involving small contact areas—like broken furniture legs.

HOW TO MIX AND APPLY. ELMER'S Epoxy Glue comes in two tubes, both numbered and color-coded, along with their caps, for easy identification. Tube 1 (orange) contains the resin, tube 2 (blue) the hardener. Squeeze equally long ribbons of the components side by side on a scrap of glass or other disposable palette. Then blend thoroughly, either with one of the tube-cap

WIRE JOINTS



WEAK STRONG STRONGER



RUBBER SUCTION CUP

RUBBER BAND

REFILED EMPTY ICE DUCK
WATER-FILLED ICE PACK
OR SHOT BAG

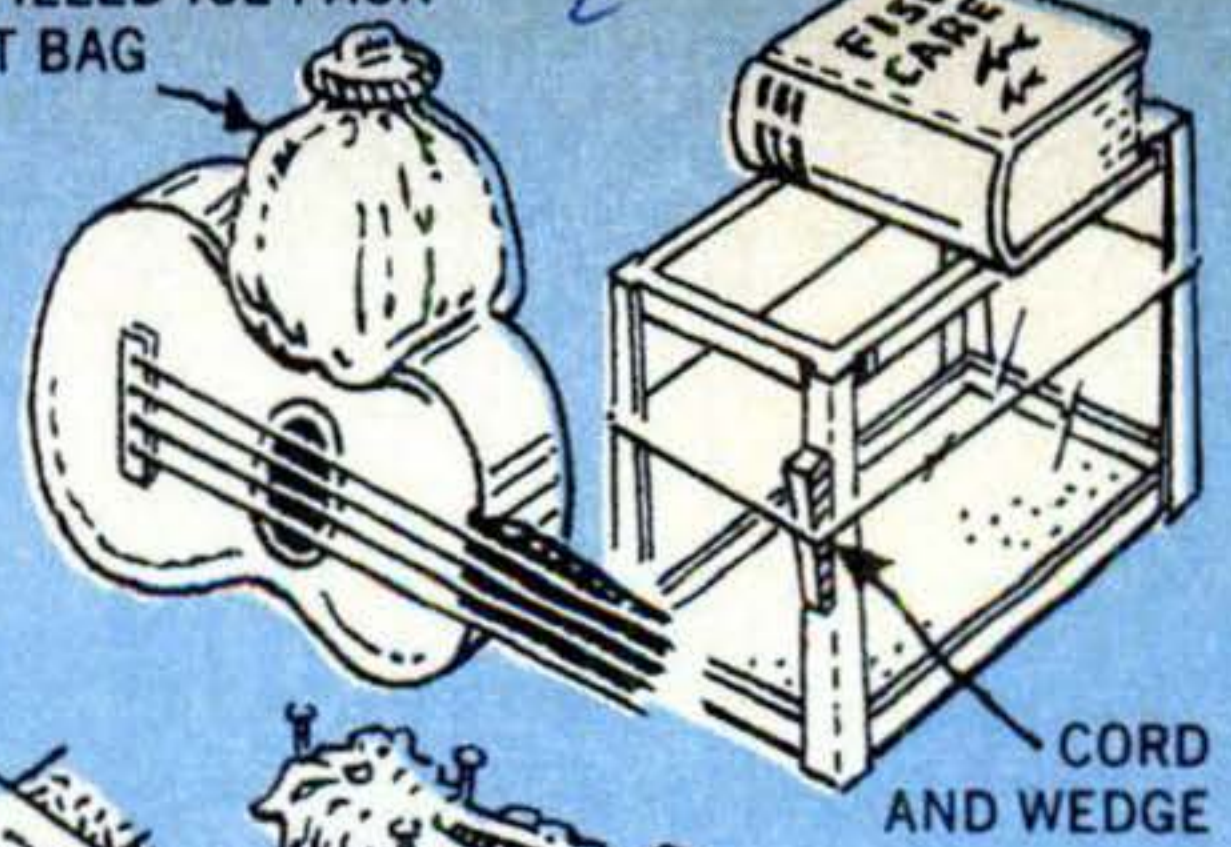

CORD AND WEDGE

SHEET METAL JOINTS

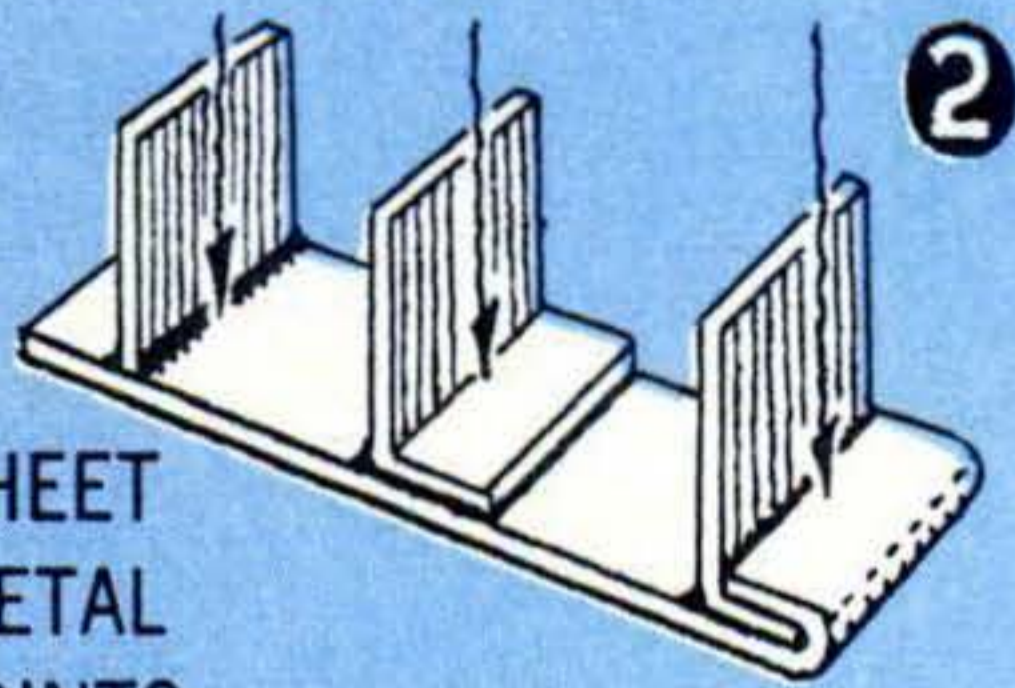

2

3

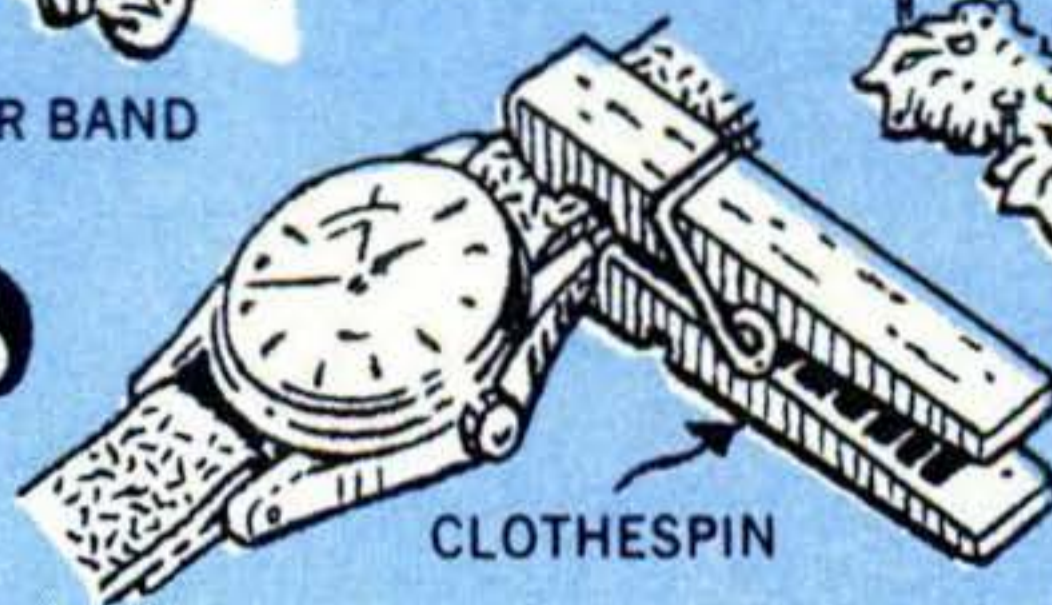

CLOTHESPIN

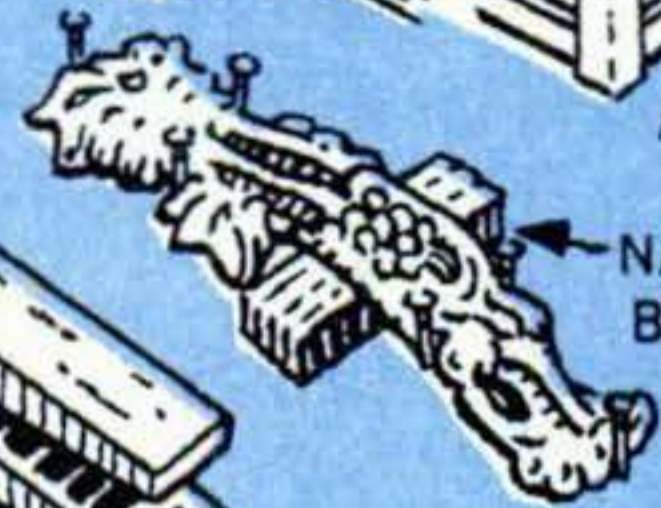

NAILS AND BLOCKING

HOLD-DOWNS

ELMER'S Epoxy Glue

applicators or an old knife. Apply to both faces of the joint immediately after mixing. Work areas should be clean and, in the case of nonporous materials, roughened with a file or sandpaper. Press the parts together and wipe off squeeze-out (drawing 1). With new projects, remember that the greater the gluing area, the stronger the bond (drawing 2). Where possible, provide a mechanical interlock.

HOLD-DOWNS. While there's no need for pressure clamping, parts must not be allowed to shift while the adhesive is setting. Suggested hold-downs are shown in drawing 3. Don't let excess glue run onto them. Where required, shield hold-downs from the work with wax paper to prevent unwanted bonding.

THERMAL SETTING. At room temperatures (60° to 72°), ELMER'S Epoxy Glue sets in about two hours and cures overnight. To reduce setting time to as little as 20 min-

utes, and curing time proportionately, subject joints to moderate heat. Use an infrared lamp placed approximately 16 inches from the work. Or where project size permits, preheat a well-insulated kitchen oven to 150 degrees and place the work inside. Heat-cured bonds will be ready for use in 90 minutes.

DURABILITY. Properly prepared and cured, joints made with ELMER'S Epoxy Glue last practically forever. These tough-as-nails bonds have excellent freeze-thaw stability, withstand boiling water, and are resistant to most dilute acids and alkalis. Thermal curing of this revolutionary adhesive produces somewhat stronger bonds than those made at normal room temperatures. Where maximum resistance to heat is more important than top strength and flexibility (as in the case of chinaware, crockery, and glass exposed to scalding water and steam), use a blend of two parts resin to one part hardener.

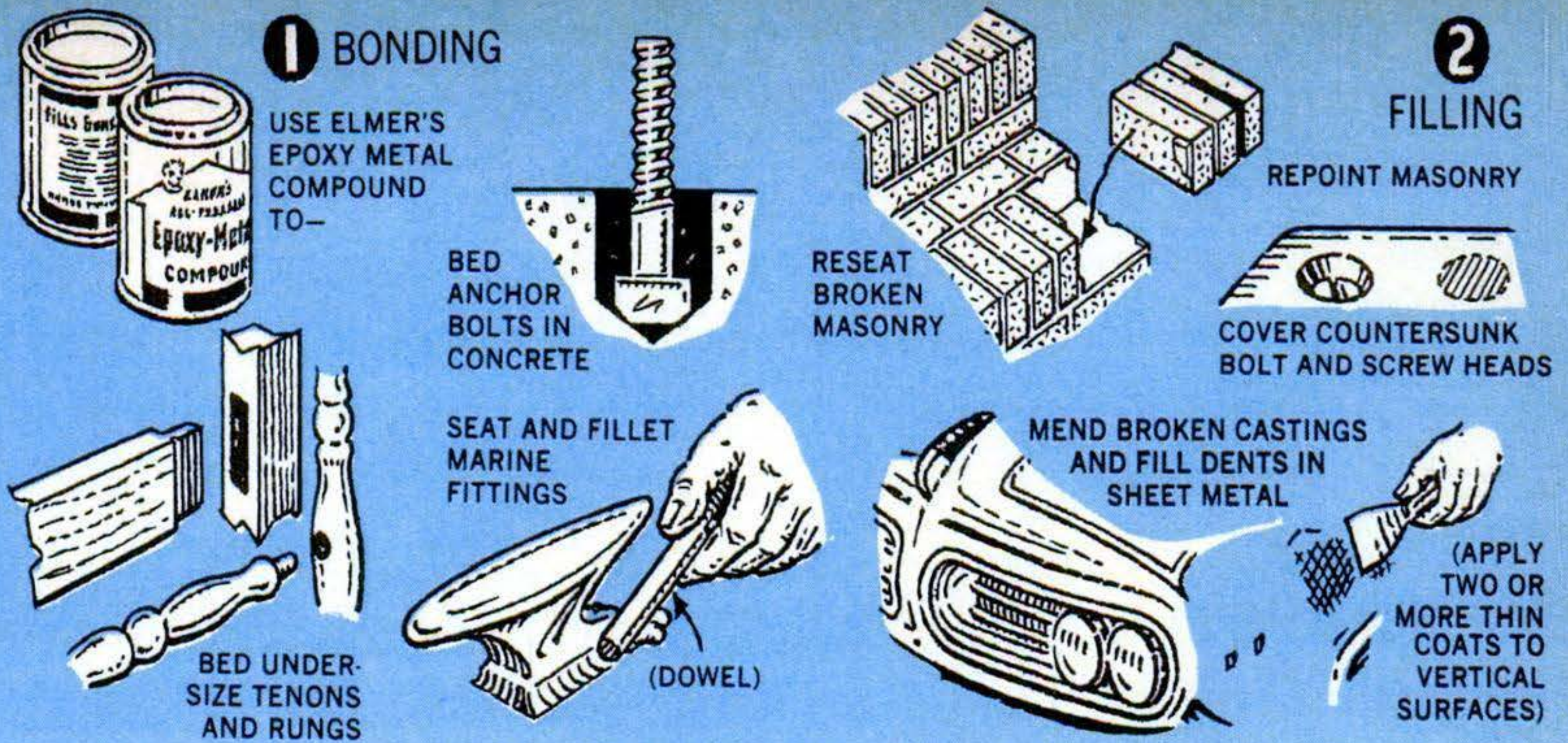

The many uses of ELMER'S Epoxy

LOOKING for a heavy, superstrength adhesive to bed anchor bolts in concrete? A superior "cold solder" to fill a dent in an automobile fender? Or a rugged sealer to plug a hole in a car radiator or a gutter? For these and scores of other uses around the home and garage, ELMER'S Epoxy Metal Compound is tops.

MIXING. Observe the same general rules recommended for ELMER'S Epoxy Glue. However, you're now dealing with two putty-like components packed in twin cans. *Product 1* is the metal-filled resin—gray in color. Ivory-colored *Product 2* is the hardener. Blend equal amounts in an old china bowl or other disposable container, and apply at once with a putty knife or similar spreading tool. Clean the applying tools immediately after use with denatured alcohol, lacquer thinner, or acetone.

BONDING. Trowel enough compound on both joint surfaces to prevent voids when parts are pressed together. Wipe off squeeze-out, unless you wish to run a fillet around the edges of a bond for additional strength. In that case, apply a bead of ELMER'S Epoxy Metal Compound, and press it to final form with a dowel or other shaping tool (drawing 1).

CAULKING. Use ELMER'S Epoxy Metal Compound for permanent, waterproof seals between metal windows and door frames and masonry walls. Apply and shape the way just described for filleting. Epoxy Metal Compound is *not* recommended for exterior wood-to-wood, wood-to-metal, or wood-to-masonry caulking. There you need an elastic sealer to compensate for unequal expansion and contraction.

3 SEALING

STOP LEAKS IN RADIATORS AND PLUMBING

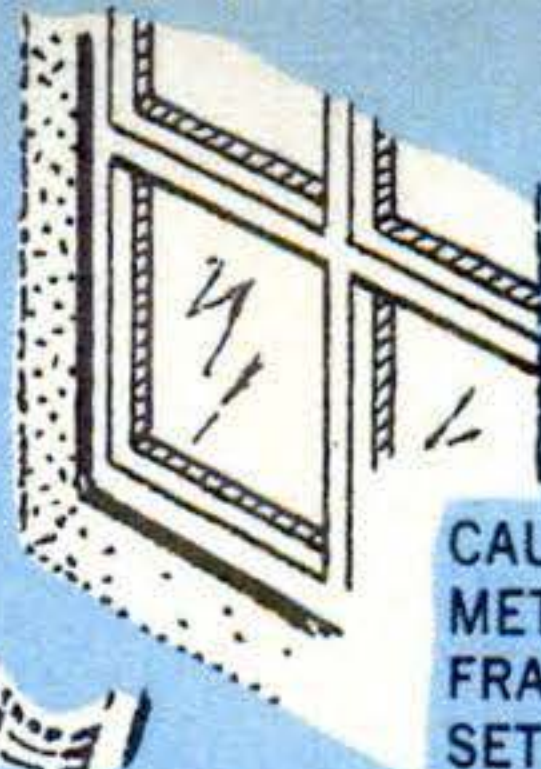
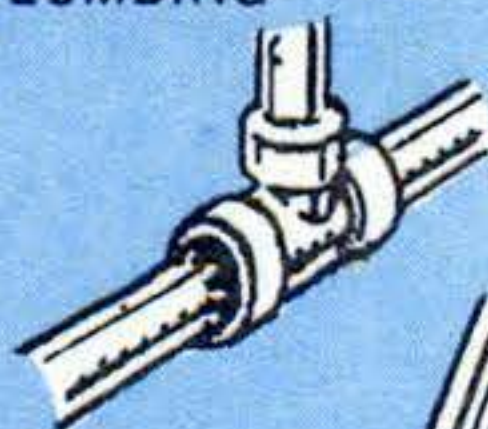

CAULK METAL FRAMES SET IN MASONRY

REPAIR GUTTERING



(METAL-TO-METAL PATCHES)

(FILLET DOWNSPOUTS)

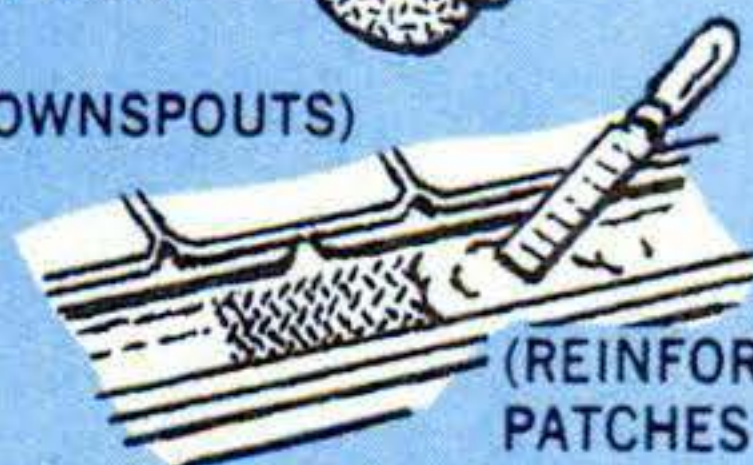
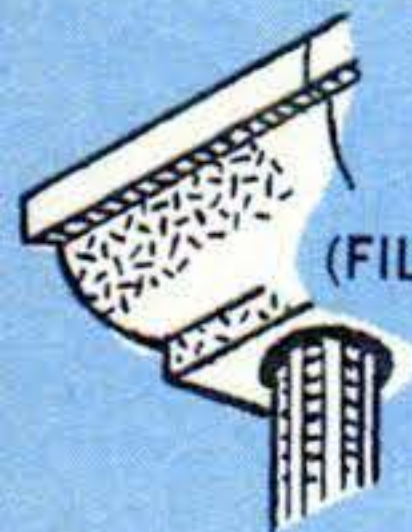

(REINFORCE PATCHES IN WOOD WITH SCREENING)

4 SURFACING

FILE ELMER'S EPOXY METAL COMPOUND



SAND IT

EVEN GRIND IT

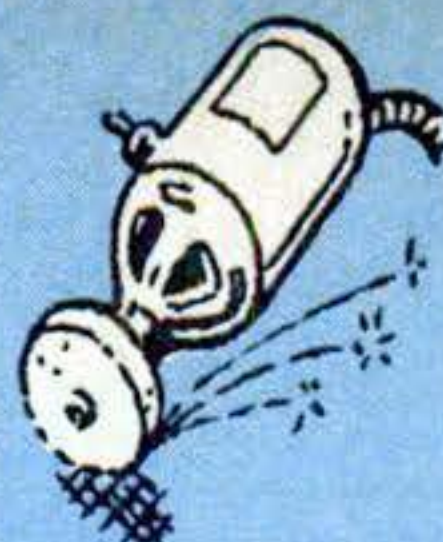

5 TAPPING

(A) ROUT OUT STRIPPED THREADS WITH OVER-SIZE BIT



(B) PLUG HOLE WITH COMPOUND AND REDRILL FOR TAPPING



(C) CUT STRONG, SHARP NEW THREADS IN COMPOUND

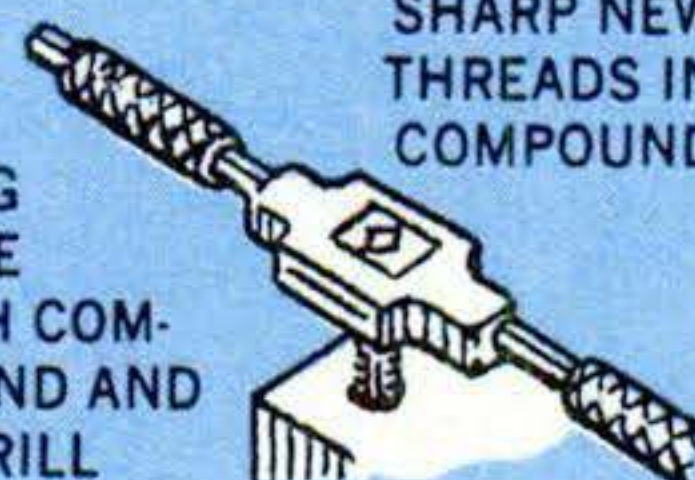

Metal Compound

FILLING. To build out a dent in sheet metal work, apply only enough compound to bring the surface slightly higher than surrounding areas for dress-up filing or sanding after the material cures. That's one of the advantages of ELMER'S Epoxy Metal Compound—there's no appreciable shrinkage to allow for with guesswork overfilling. On vertical surfaces, unusual nonslumping characteristics let you apply heavy filler coats. But don't expect the impossible. If dents are deep, lay on several coats, letting one harden before adding another (drawing 2).

SEALING. A small hole in a car radiator or leak in a pipe joint needs only a dab of ELMER'S Epoxy Metal Compound for a permanent seal (drain out water first, to insure a dry and pressure-free work area). Where you're dealing with rust-outs in metal gutters, apply patches of the same metal,

bedding them in compound and feathering edges smooth. With wood gutters, cut back to solid stock, bridge the gap with wire mesh screening and cover with ELMER'S Epoxy Metal Compound (drawing 3).

SURFACING. After ELMER'S Epoxy Metal Compound hardens, bring it to surface—contour with either woodworking or metal-shaping tools and abrasives (drawing 4). Painting is no problem. Enamels, lacquers, and water-soluble paints can be applied without special priming.

MACHINING. Where stripped threads in a bolt-hole no longer offer a grip for bolts and studs, bore the hole to larger diameter and fill with ELMER'S Epoxy Metal Compound. After curing, drill an undersized hole through the center of the plug, tap—and you're back in business (drawing 5). Machining characteristics like this make ELMER'S Epoxy Metal Compound a favorite of professional mechanics and pattern-makers. They work it just like conventional metals—even with latheing and milling.

TOYS FROM PLASTIC DISCARDS

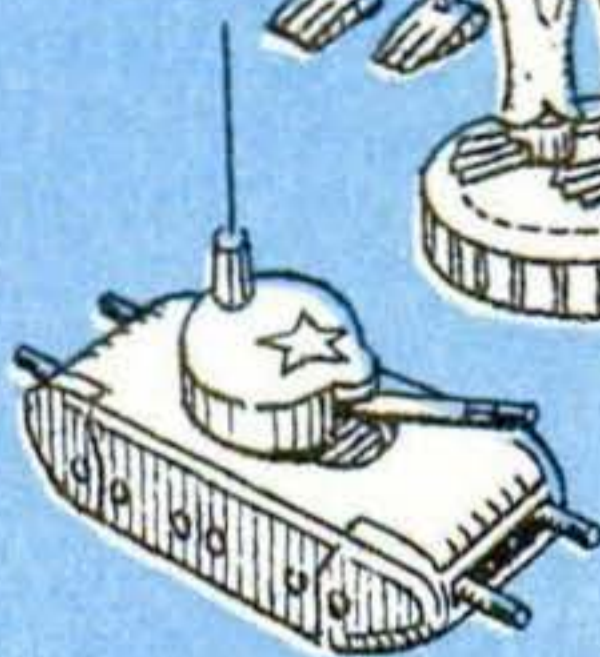
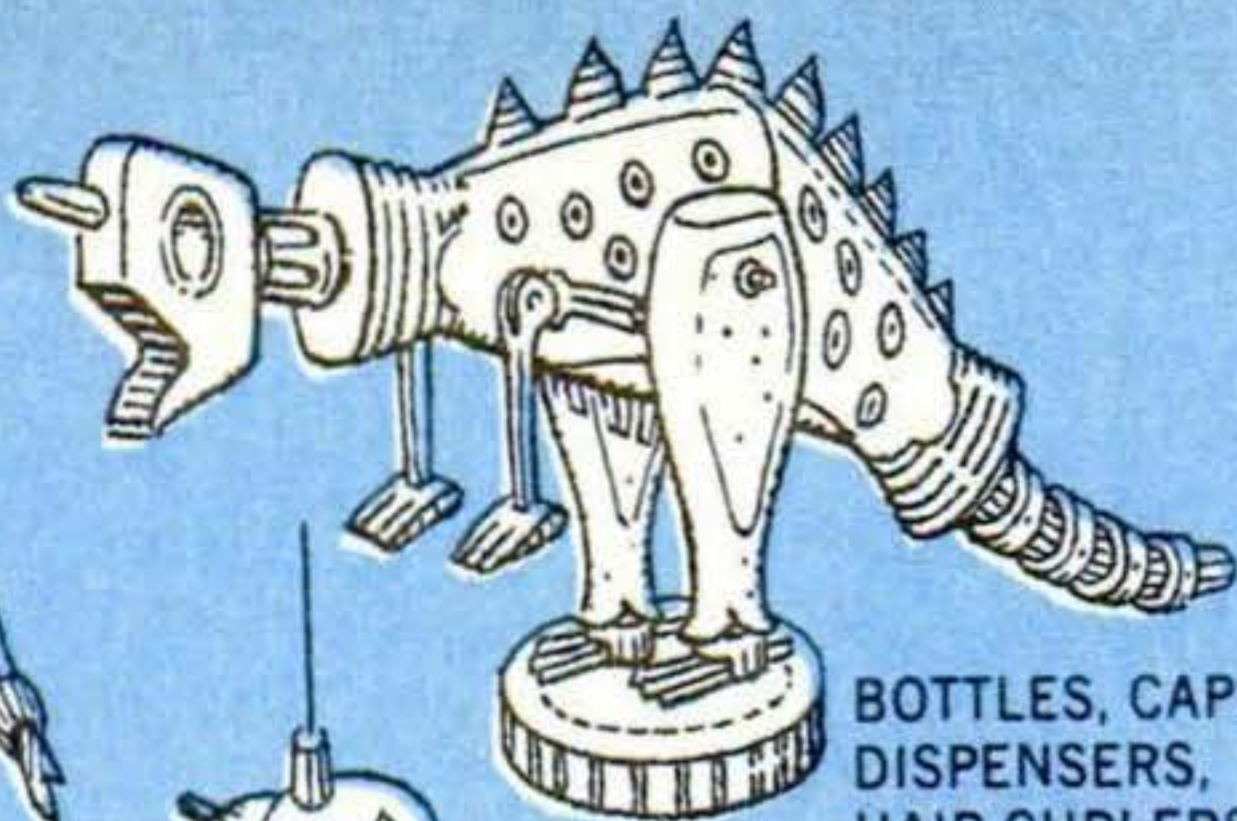

BOTTLES, CAPS,
DISPENSERS,
HAIR-CURLERS,
COMBS, PENS, ETC.

PLAQUES



LETTER HOLDERS AND BOOK ENDS

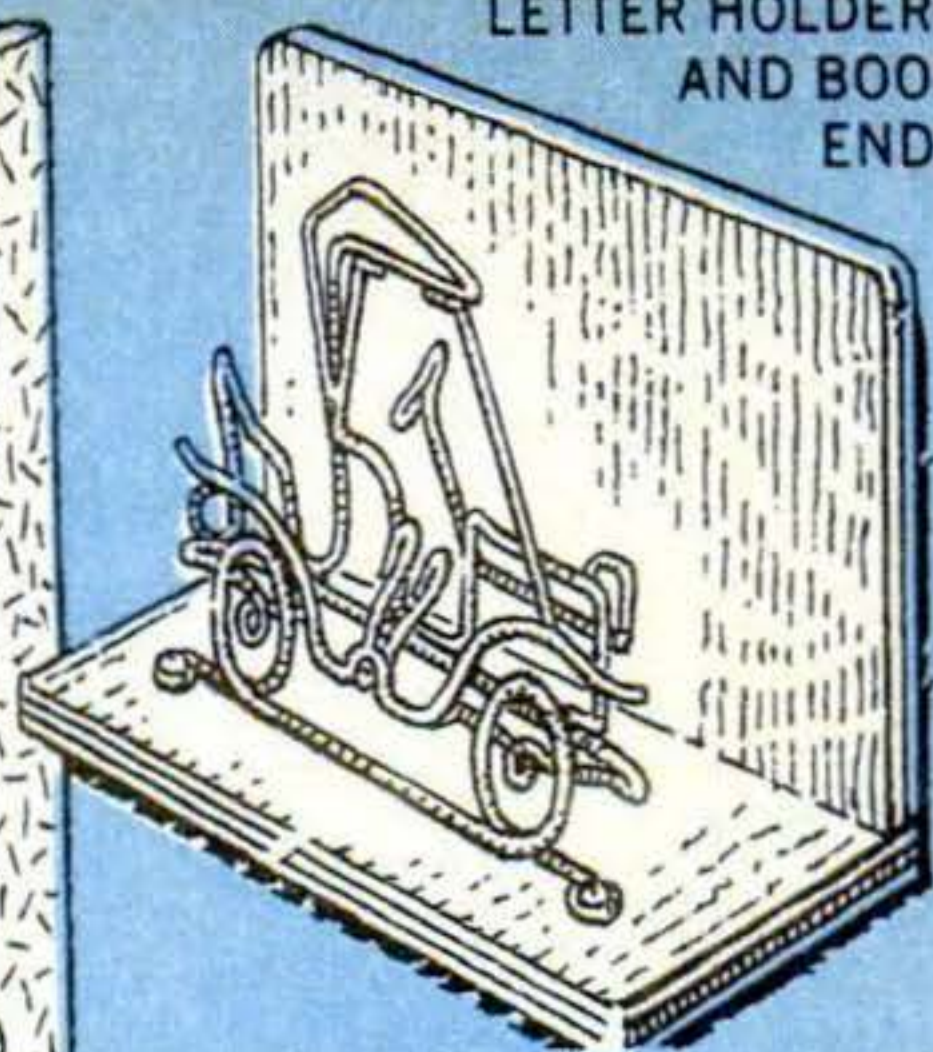

WIRE SCULPTURE

MODELING



(A)
COAT
PATTERN
WITH
LIQUID
LATEX

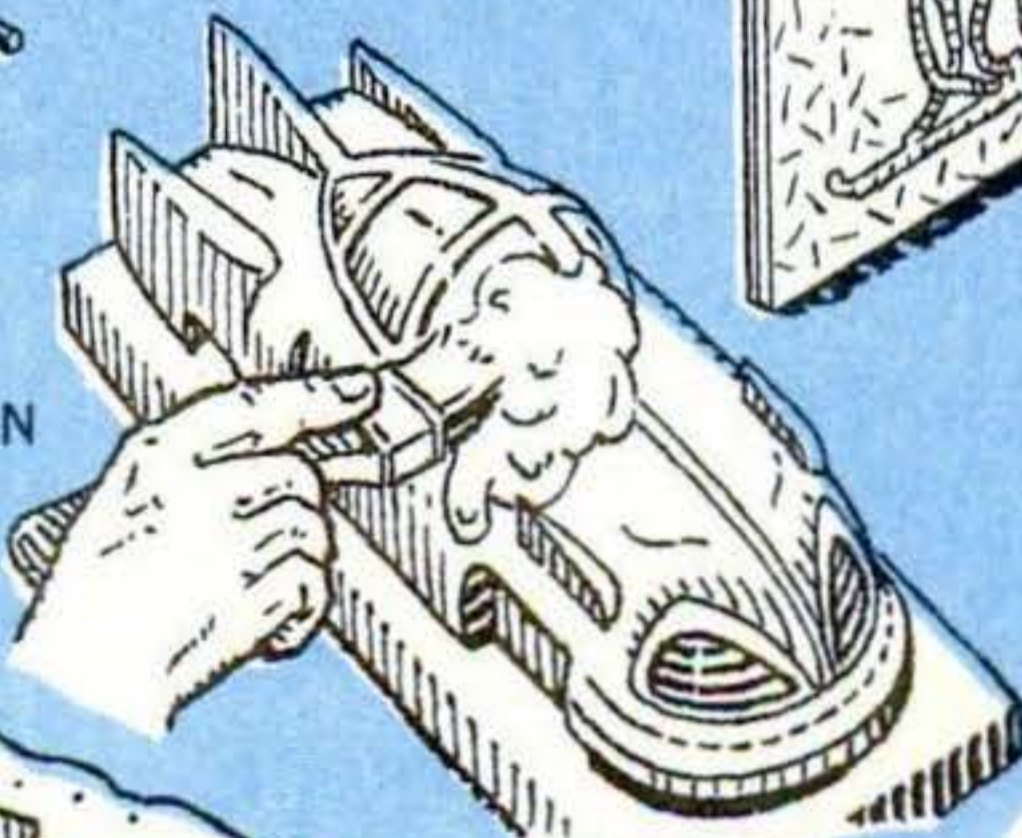

CASTING



(B) TROWEL
COMPOUND
INTO LATEX
MOLD

METALIZED CARDBOARD CUTOUTS

FIGURINES
AND
MOBILES



(C)
PEEL
MOLD FROM
HARDENED
CASTING



Arts and crafts

TOYS AND MODELS. Here, ELMER'S Epoxy Glue is the answer to metal-to-metal, and metal-to-wood bonds. Use it, too, to assemble plastic construction kits. The additional time you'll spend rewards you with far stronger joints than those made with conventional model cements, and eliminates the possibility of distorting or dissolving finely molded details. Another tip: By teaming ELMER'S Epoxy Glue with old plastic

utensils, and containers and caps of the kind everyone throws away by the hundreds each year, you can create distinctive toys and models that will delight any youngster and be real conversation pieces.

WIRE SCULPTURE. This fast-growing hobby no longer calls for skill with a soldering iron, gun, or torch. All you need to turn out novel wall plaques, letter holders, and trivets, are a few lengths of coathanger wire, softened by heating cherry-red on a stove burner, a pair of pliers, and easy-to-use ELMER'S Epoxy Glue.

MODELING. Top-flight sculptors have already recognized in ELMER'S Epoxy Metal Compound a new and exciting art medium. Applied over wire and mosquito-netting forms or "armatures," the non-slumping material can be molded into busts and figurines by building up successive layers and forming them with clay-working tools as they begin to set. After final hardening, the metal compound lends itself to further shaping with a hand grinder, and may be brought to a smooth finish with sanding and buffing.

CASTING. Medallions and small metal-like parts for costume jewelry and models are easily cast in large numbers using ELMER'S Epoxy Metal Compound poured into latex molds. Art stores carry liquid latex, a heavy-bodied fluid that is brushed over patterns in successive layers. These harden and build up into thick elastic molds. After prying out the pattern, give the cavity a light coating of oil or cold cream. Then fill it with ELMER'S Epoxy Metal Compound. If necessary to release trapped air, joggle the mold and puncture the compound from the back with a straightened paper clip or toothpick. After it hardens you'll have a faithful reproduction of the pattern.

METALLIC "PLATING." Figurines, mobiles and ornaments, cut from cardboard and assembled with ELMER'S Glue-ALL, may be given the effect of antique bronze castings by coating them with ELMER'S Epoxy Metal Compound and adding shallow relief with a stylus or other pointed tool. Dimple with a wire brush to simulate pitting left by sand molds. When the compound cures, paint with spatter coats of green, flat-black, and bronze enamel.

ELMER'S 7 rules for epoxies

1. CLEAN AND ROUGHEN WORK SURFACES. Remove dirt, oil, paint, metal plating, rust, or other foreign or loose matter from areas to be joined or covered. In addition, roughen nonporous surfaces.

2. IMMOBILIZE PARTS TO BE BONDED. Use hold-downs, where necessary, to keep parts aligned while epoxies set.

3. MIX SMALL BATCHES. Because epoxies start to harden quickly, mix no more than you can use in from 20 to 30 minutes. For big jobs mix successive batches. With ELMER'S Epoxy Metal Compound, usable time can be increased by blending components in a container placed in ice water.

4. WATCH THE THERMOMETER. Use epoxies at temperatures no lower than 60°. If you apply heat to speed hardening, temperatures should not exceed 150°.

5. KEEP UNUSED EPOXY COMPOUNDS APART. Avoid interchanging caps and, when dipping components of epoxy metal compound from their cans, use a separate utensil for each. Otherwise a portion of one component transferred to the other will cause hardening in the container.

6. REMOVE EPOXIES FROM HANDS AT ONCE; they can be irritating. Wipe off with nail polish remover or denatured alcohol. Then wash with soap and water.

7. KEEP OUT OF CHILDREN'S REACH. Store on a high shelf or in a cabinet.

WORKING WITH ELMER'S EPOXIES
 THE BORDEN CHEMICAL COMPANY, A DIVISION OF THE BORDEN COMPANY, NEW YORK 17, N. Y.



Printed in U.S.A. CPD-24

PRODUCT  **ELMER'S**
Epoxy
 GLUE

HOW YOU CAN GLUE METAL, GLASS, PLASTIC AND OTHER NON-POROUS MATERIALS

BONDS METALS	GLASS
CERAMICS	MARBLE
CHINA	ALUMINUM
BRICK	PORCELAIN
MOST PLASTICS	

Borden

ELMER'S
 ALL-PURPOSE
Epoxy-Metal
 COMPOUND

fills - bonds - repairs

METAL, MOST HARD
 PLASTICS, TILE,
 CONCRETE, BRICK,
 MARBLE, CERAMICS,
 WOOD, GLASS

BONDS STRONGER THAN NER

what's new

.....BOATING



Three-Point Hull in New Models

These slick 17-footers are two of the newest models in the OMC 17 line of out-drive three-point hulls introduced a year ago. Outboard Marine's Seasport (left) is powered by an 88-hp. V-488, a new light-weight, compact, two-cycle engine, and is

designed for fishing, camping, skiing, or skindiving. The 176-hp. twin-engined job at right is a Dual Deluxe capable of speeds of more than 40 m.p.h. The Seasport is listed at \$2,995, the Dual Deluxe at \$4,250, both f.o.b. Waukegan, Ill.



Laminated sails need no stitching

Latest in sailmaking is laminated seams with no stitching. Ratsey & Laphorn, City Island, NYC, does it by butt-jointing the edges of dacron panels, fastening with colored synthetic tape on both sides, then impregnating with a bonding agent. Seams reduce friction, make for smoother air flow.

Install-it-yourself marine radiophone

The 12-volt radiophone below has a 25-watt transmitter and an eight-transistor receiver with three-microvolt sensitivity on marine bands, 20 on broadcast. At Heath Co., Benton Harbor, Mich., \$189.95.



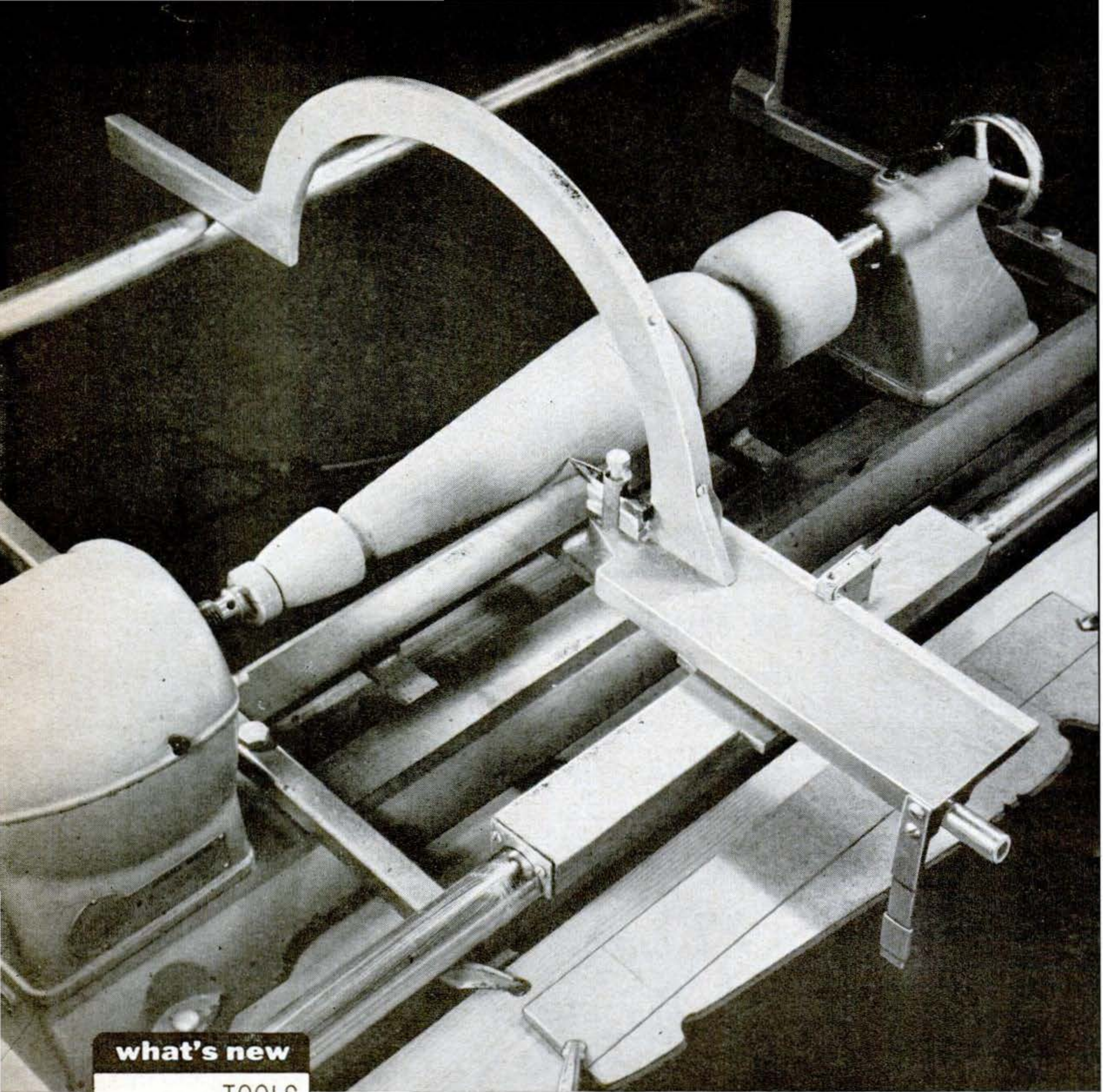

what's new

.....TOOLS

Now... Automatic Turning for Your Lathe

By R. J. De Cristoforo

THERE'S only one thing better than being able to turn out beautiful shapes on a lathe—and that's being able to do it automatically. This new lathe duplicator, called the Giz, allows you to do just that. Insert a profile template of the shape you want turned at the front of the lathe, and a cutter bit mounted on a sliding car-

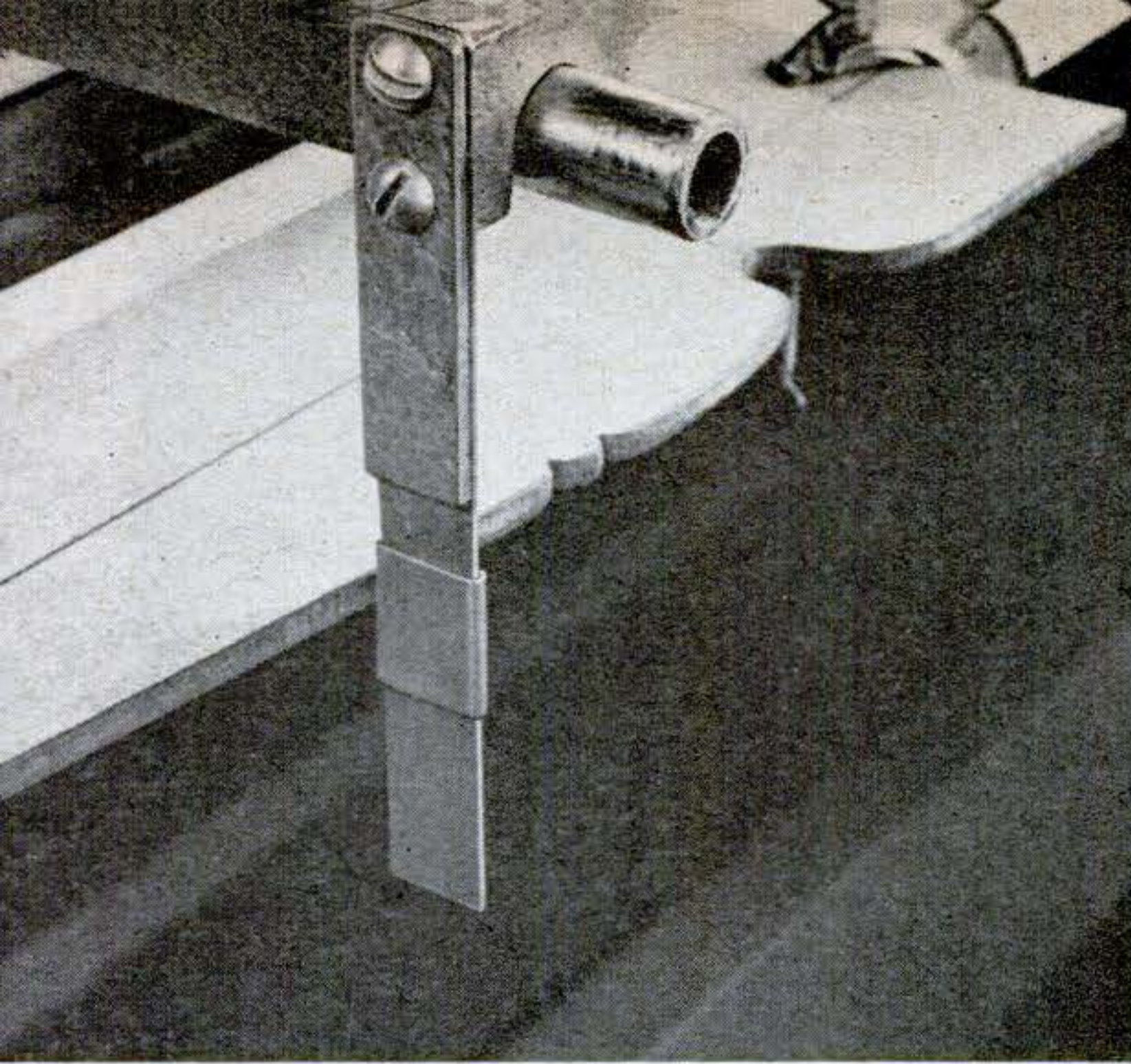

How it works: A steel feeler guide rides along edge of the pattern, moving the carriage in and out. The cutting bit, mounted on the carriage, duplicates the pattern in the spinning work.

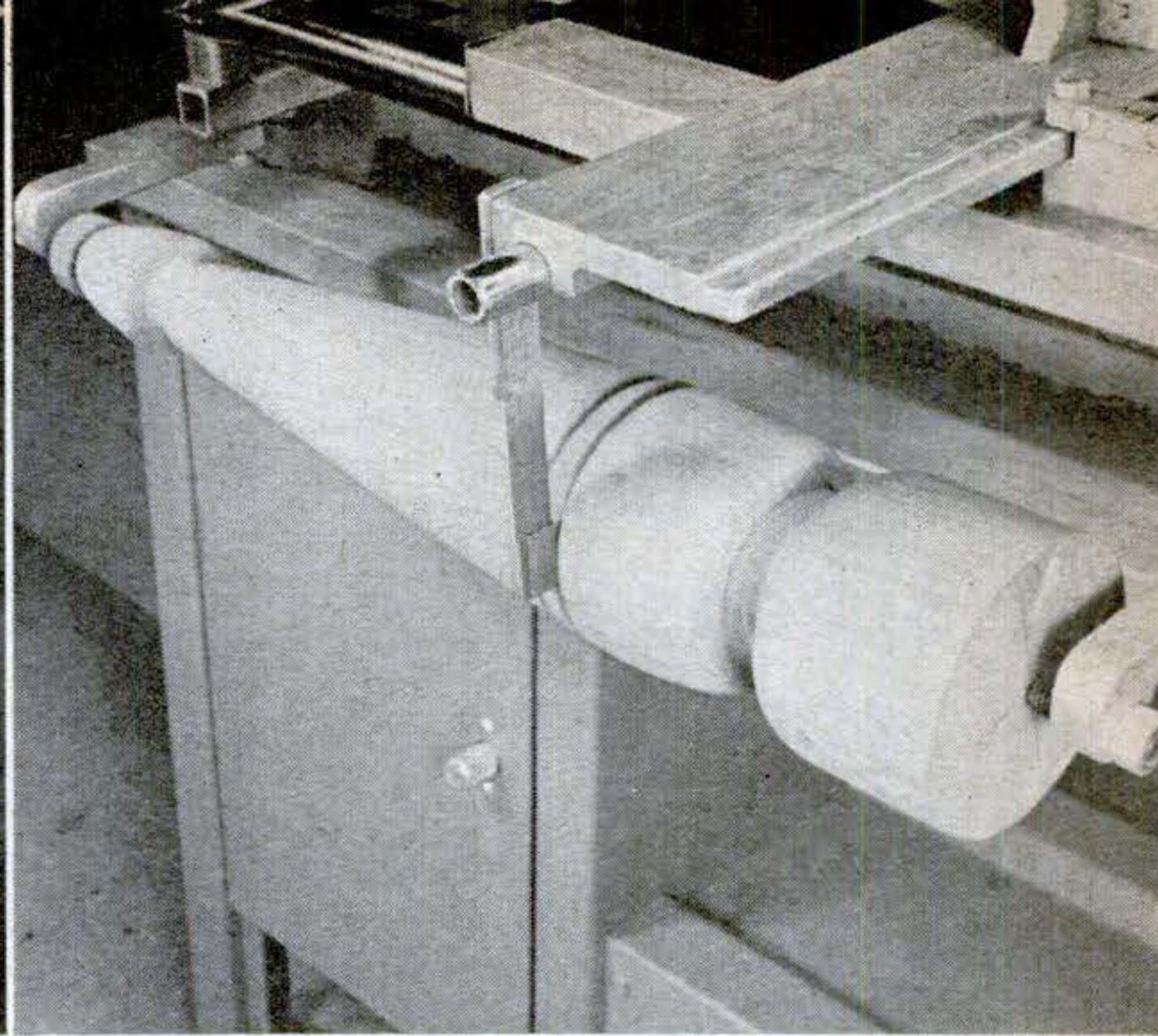

Turned shapes can be copied in the same way as a flat template. A sleeve on the feeler lets you rough-cut the work slightly oversize. For final trimming, the sleeve is slid out of the way.

riage faithfully follows the shape, producing an exact three-dimensional copy in the lathe.

The duplicator, designed especially for home shops, is one of the slickest we've seen short of the big, costly types used in industry. It automatically reproduces any shape that can be turned by conventional methods and takes the sweat out of trying to follow a template freehand with trial-and-error cuts.

The truth is, we found the Giz so versatile that, once you've mounted one on your lathe, you can throw away the conventional toolrest and chisels—you just don't need them. When you're not duplicating a pattern, the attachment can be used just as easily and accurately for freehand turning.

The carriage that holds the cutter moves

in two directions—sideways along two tubular rails fastened to the lathe, and in and out to vary the depth of cut. A feeler guide attached to the carriage rides along your template, forcing the cutter to move in an identical path.

The standard cutter, which looks like a sharply pointed machine bit, is slim enough to reproduce even highly detailed patterns. For straight cuts and faceplate turning, other cutters are available.

The two-way motion of the carriage seems a little strange at first, we found, but is not at all difficult to control once you get used to it. The Giz is not a cheap accessory—it sells for about \$125—but you'll find that its remarkable abilities are well worth the investment. The Model 201 shown is made by Gizco, Whittier, Calif.

Perfect ball shapes, normally a tricky lathe job, are easy with this half-round template cut from hardboard. Work is rough-shaped first without the feeler touching the template.

Molding knives make handy templates for intricate detail work. Here, a fluting cutter is used to produce symmetrical rings. Note how the feeler follows even fine contours.

For faceplate turning, tool holder is turned 90 degrees in the carriage. A special right-angle feeler guide is sold as an accessory, as are extra-long cutting bits like this one.

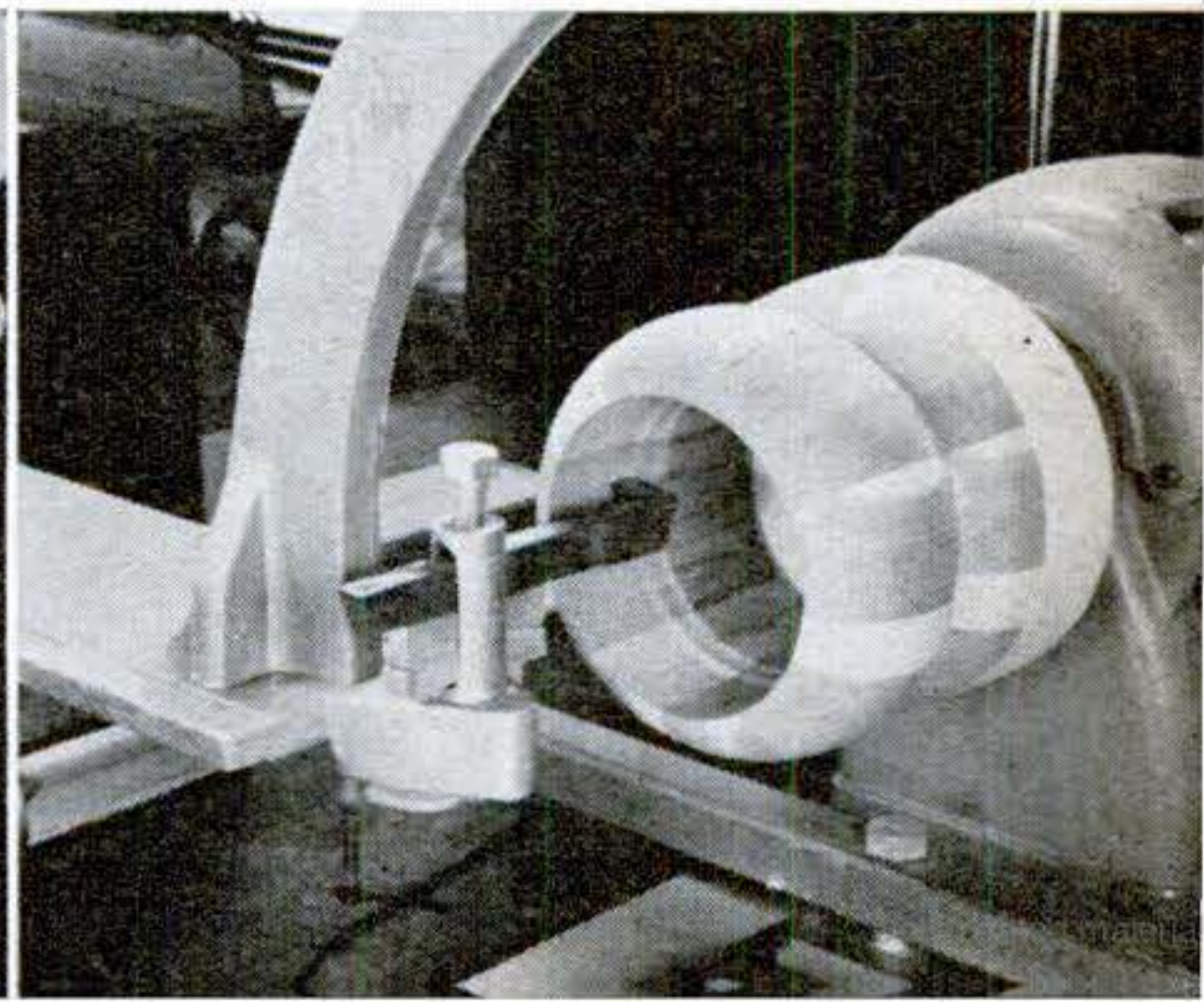
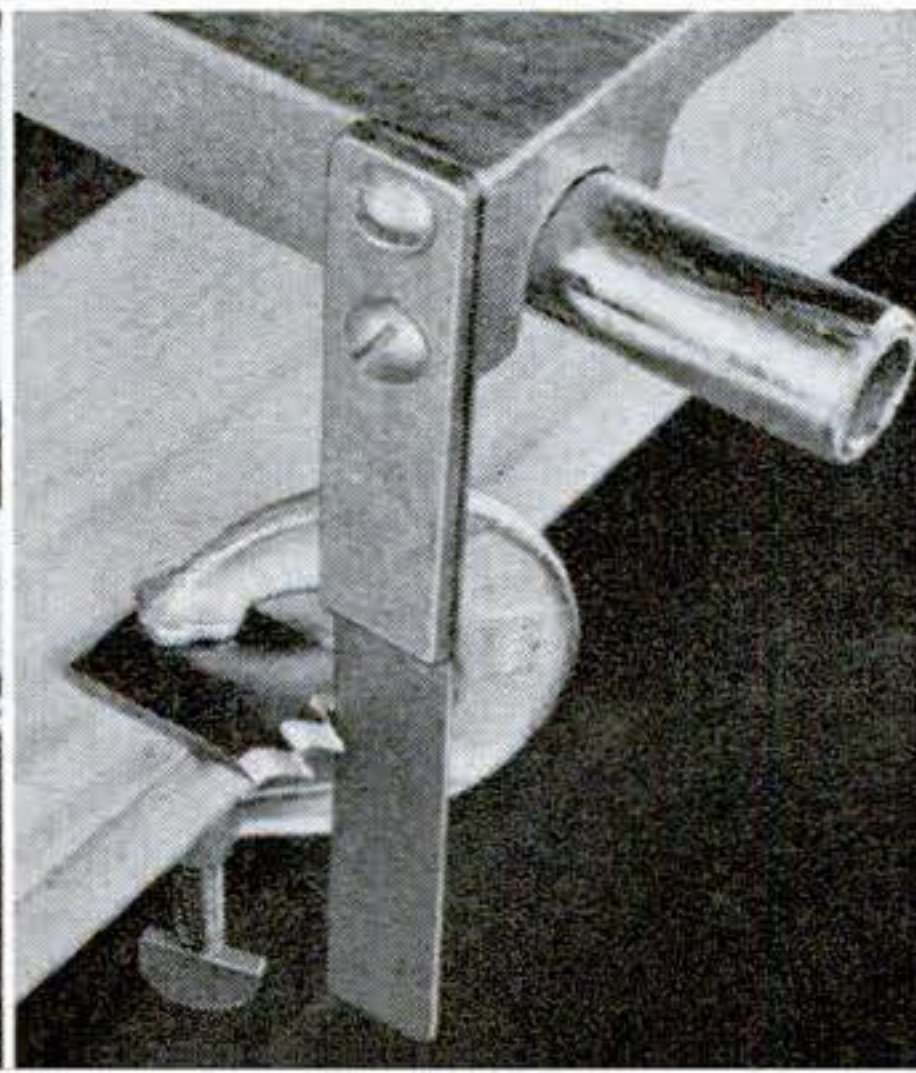
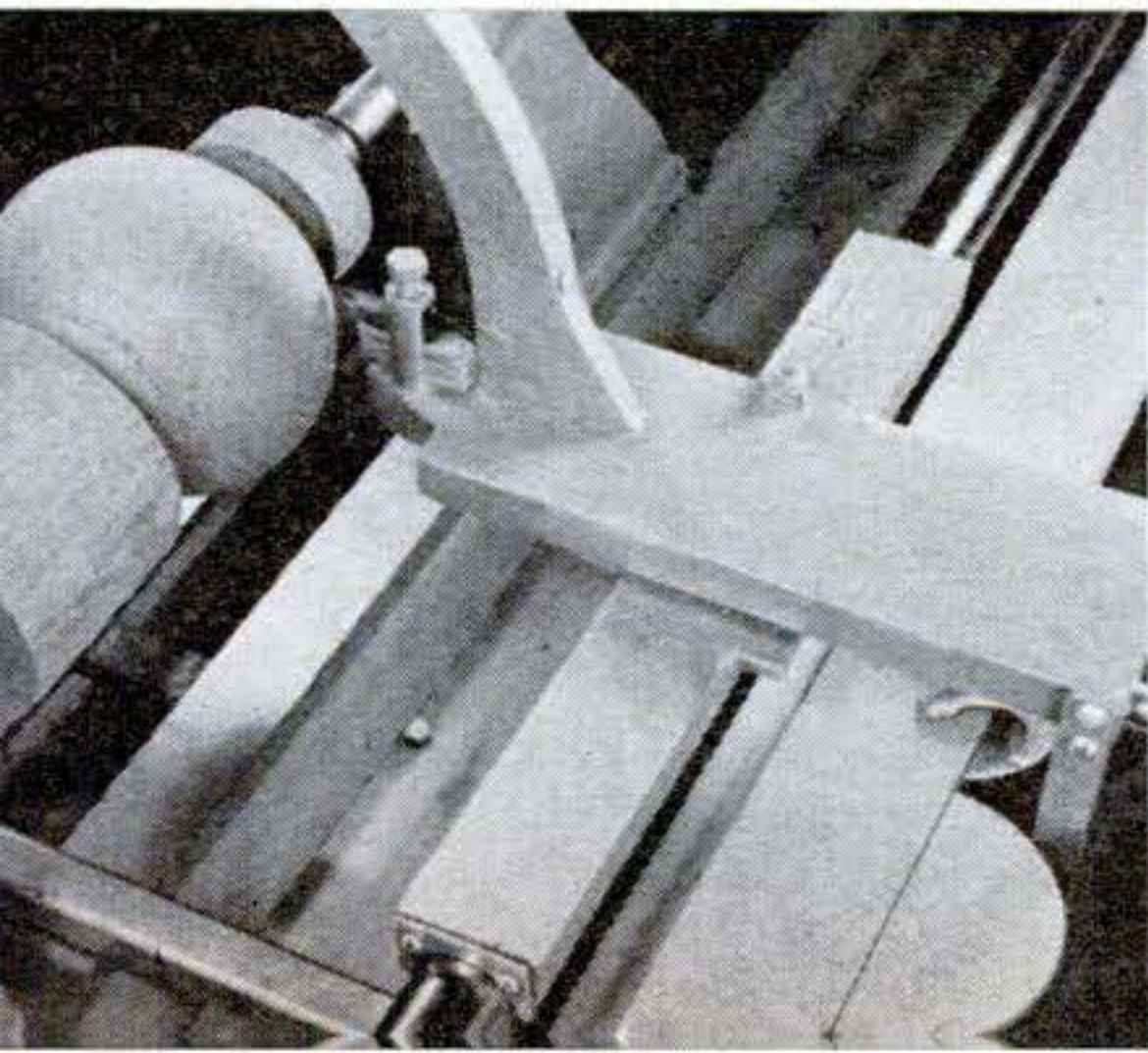

what's new

.....TOOLS

Trick Drive Speeds Up Saber Saw

How do you make a saber saw cut faster without increasing blade speed beyond the efficient point? This Shopmate turns the trick by speeding up its noncutting downstroke, then *slowing down* its cutting upstroke to normal speed.

This is done by an offset pivot on the blade holder that forces the crank pin to move farther on the cutting stroke than on the return stroke. Result: Total cut-and-return time is shortened several milliseconds, enabling the saw to make nearly 20 percent more cutting strokes a minute without traveling any faster than normal. The saw also has a removable blade guide (shown in photo) that keeps thin, delicate blades from twisting on scroll cuts. About \$25, Portable Electric Tools, 1200 E. State St., Geneva, Ill.

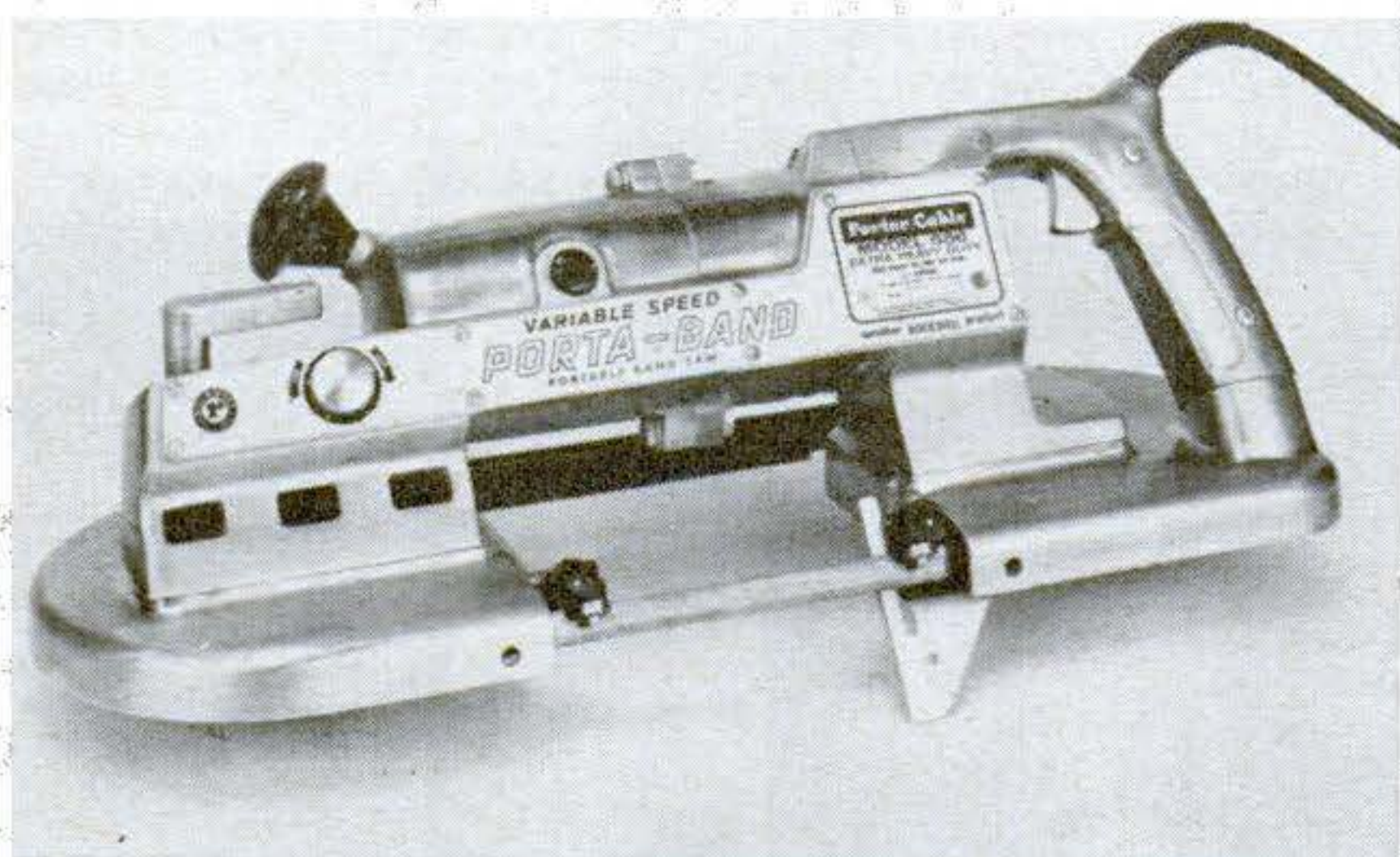
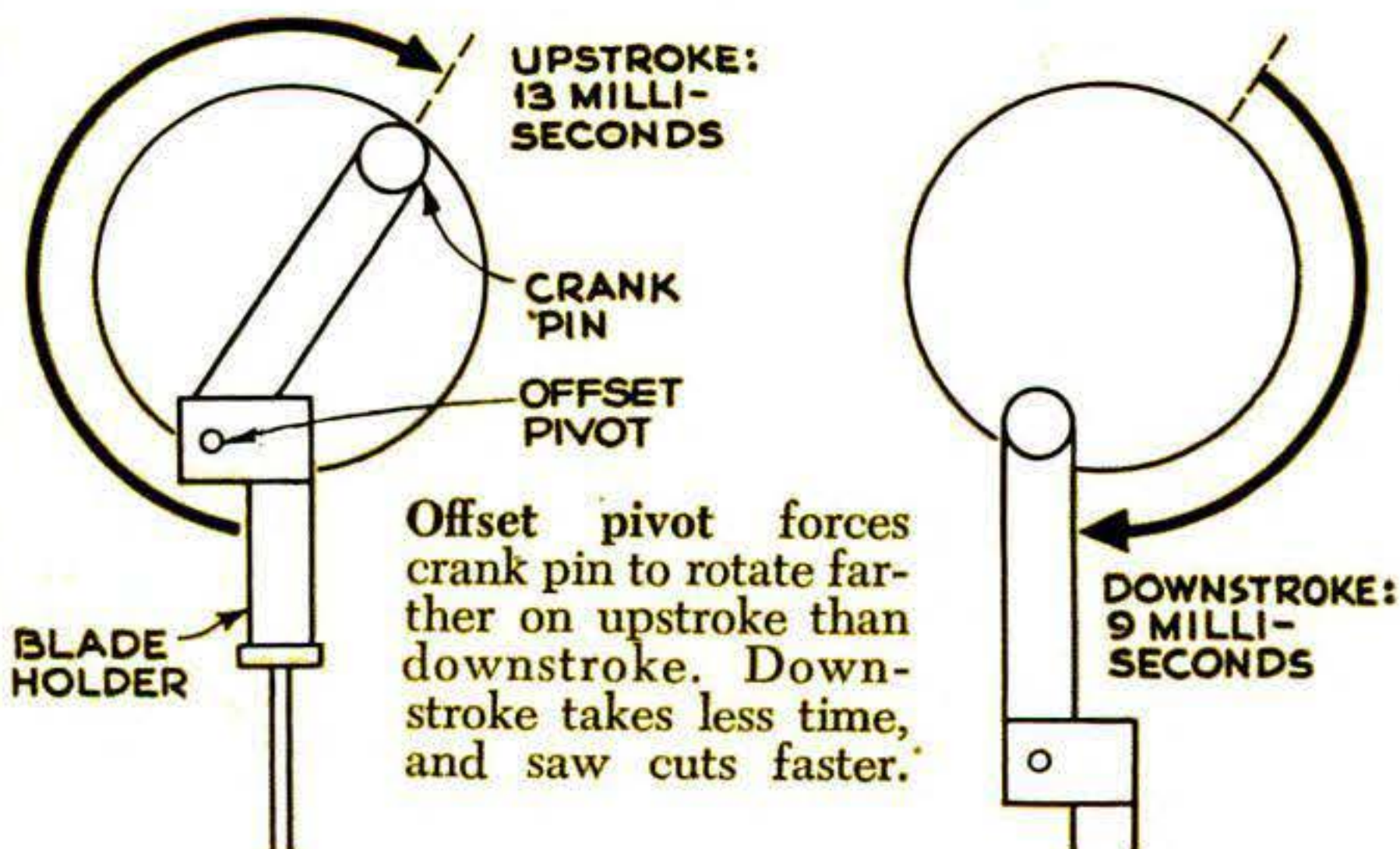
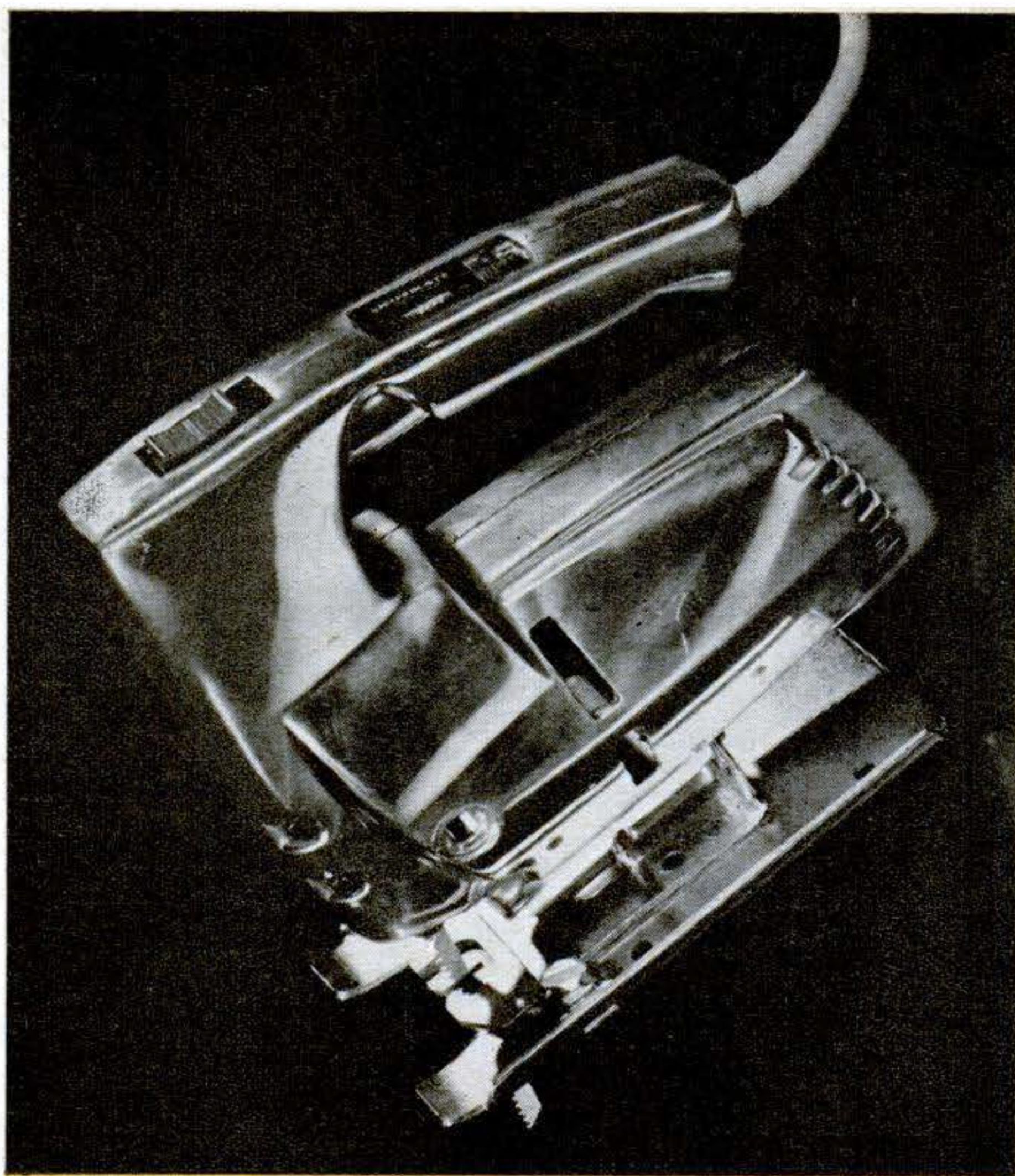

New dial-your-speed bandsaw

Twirl a knob on this Porter-Cable portable bandsaw and you can dial any blade speed from 80 to 250 surface feet per minute to handle wood or metal. The variable-speed drive uses a new silicon-controlled rectifier [PS, Dec. '62] that gives full power at any speed. The Porta-Band saw weighs only 16½ pounds. About \$298, Rockwell Mfg. Co., 400 N. Lexington Ave., Pittsburgh.

what's new

.....for your CAR

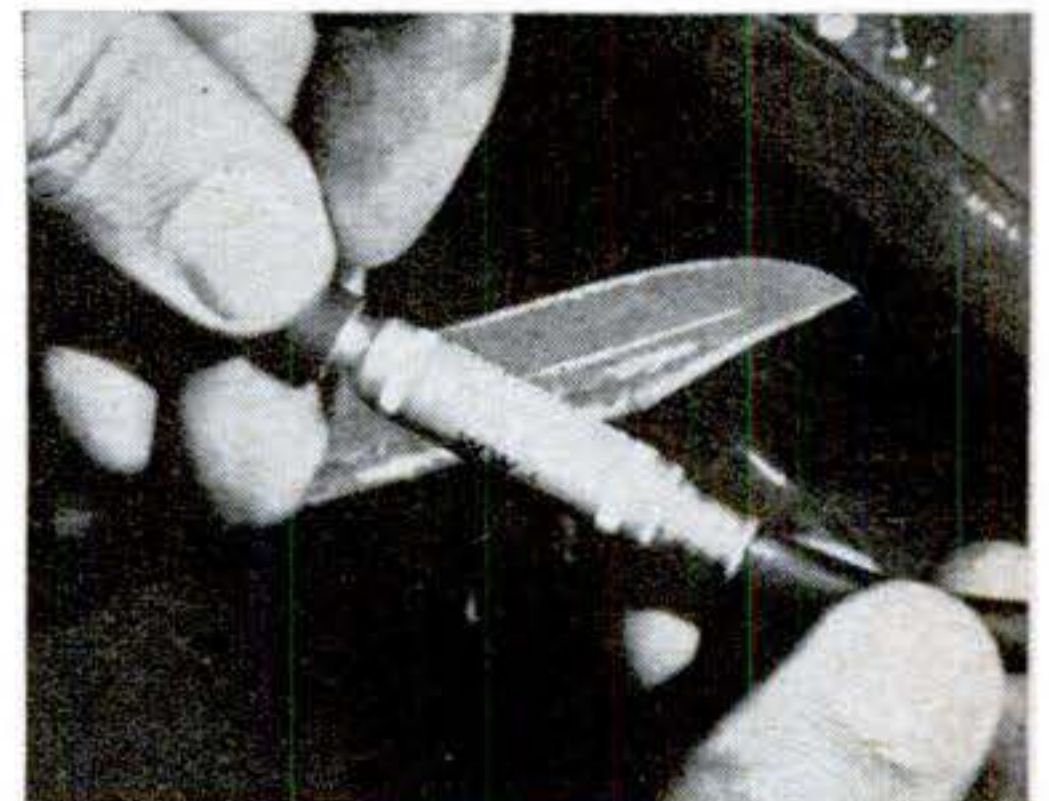

Filter Keeps Windshield Washers Squirting

Windshield washers won't clog if you install this 75-cent filter. The device is connected to the water hose, where it is said to trap dirt and sediment before they reach

the tiny washer spray jets. The filters, made by Fram, Providence, R.I., are available at service stations, can be installed in a few minutes without special tools.

Gun melts ice and snow on windshield

Instant defrosting of windshield and windows is claimed with this \$7.95 Safco Quickee defroster gun. It plugs into the cigarette-lighter socket. A blast of hot air from the nozzle melts snow and ice within 30 seconds, says A.G. Busch & Co., 6138 Northwest Highway, Chicago.

▶▶▶A booster heater for foreign cars is available from Sears, Roebuck and Co. The 6,000-BTU unit supplements existing heaters that are inadequate for U.S. winters. In very small imported cars it can even serve as the only heater. It fits the Dauphine, MGA, Simca, Volvo, Triumph, and others. About \$25, with all fittings and directions.



Kiddy harness holds tots in place

This nylon harness protects children when you have to stop suddenly, yet allows them to sit, stand, or sleep. The Kiddie

Keeper is made from seat-belt webbing and steel hardware. Waist-belt buckle, says the maker, is hard for a child to open; adults can unlatch it easily. \$6.95. Munro Mfg. Co., P.O. Box 5295, Pasadena, Calif.

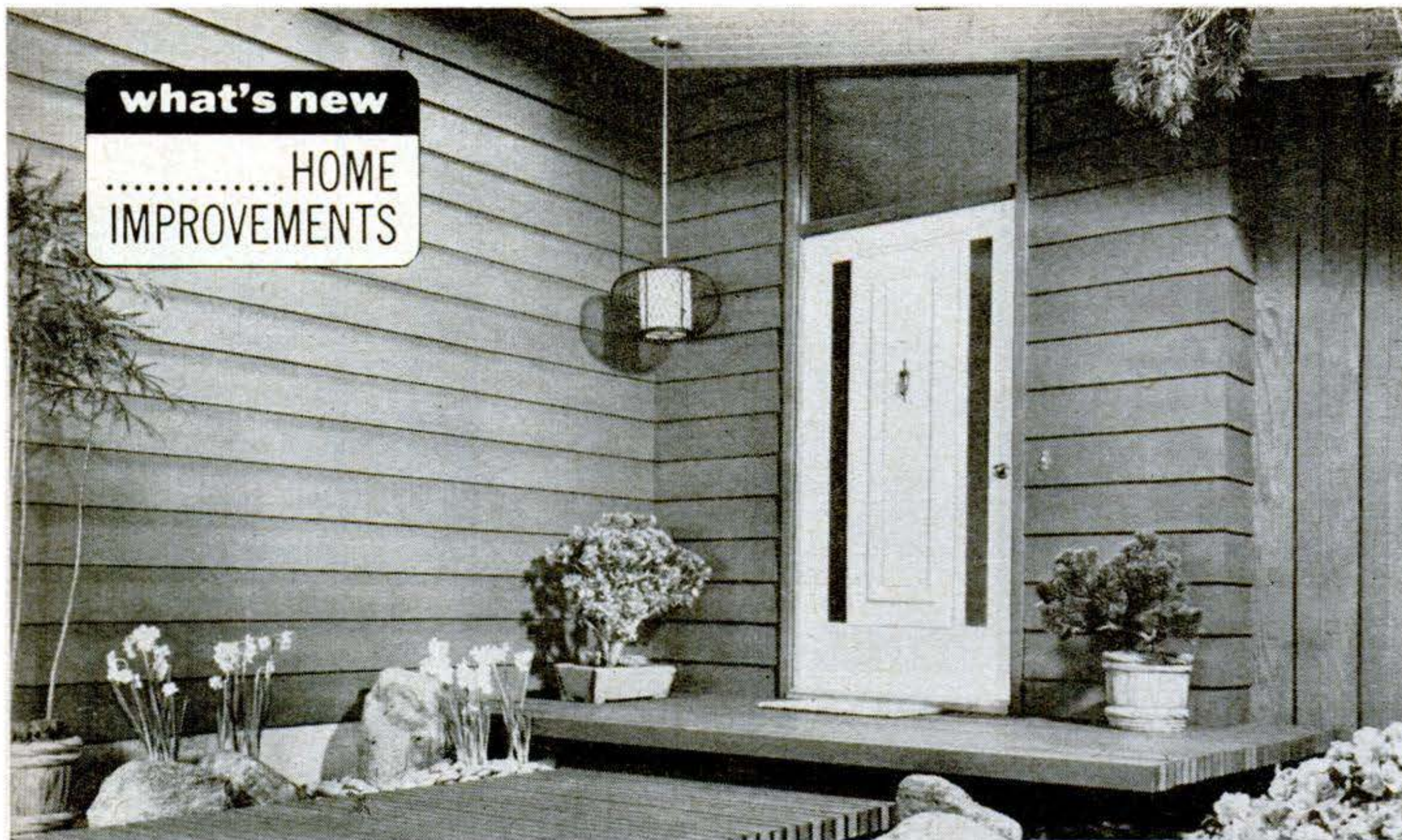

Distinctive Entrance Door at Budget Price

This paneled door is designed to give the entrance of your home an expensive custom look at moderate cost. You get a choice of four styles of panels that go with any kind of architecture, and they may be changed

at any time without having to buy an entirely new door. Walter Dorwin Teague designed the door for the Simpson Timber Co., Seattle. It's made in four widths, is 1½ inches thick, and sells for around \$34.

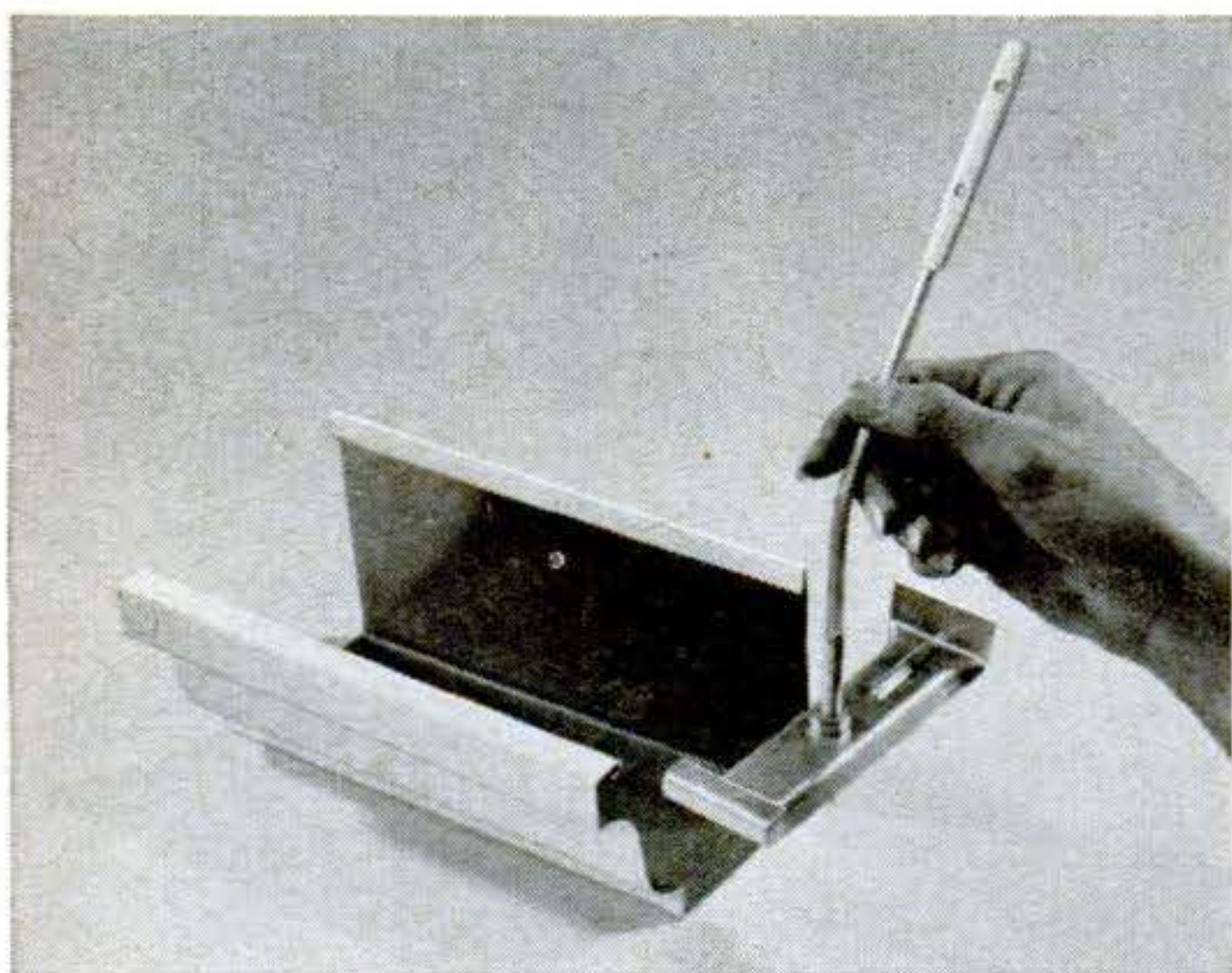

Gutter hanger has center suspension

A new type of hanger that gets around obstructions at the edge of a roof has been developed by Alcoa for use with its aluminum gutters. An aluminum plate that locks under the crimped edges is suspended from the center (instead of one end) by a rod you can bend to fit the roof's slope. Plate and rod are held together by two nuts. Hangers are available at Alcoa gutter dealers at less than 50 cents each.

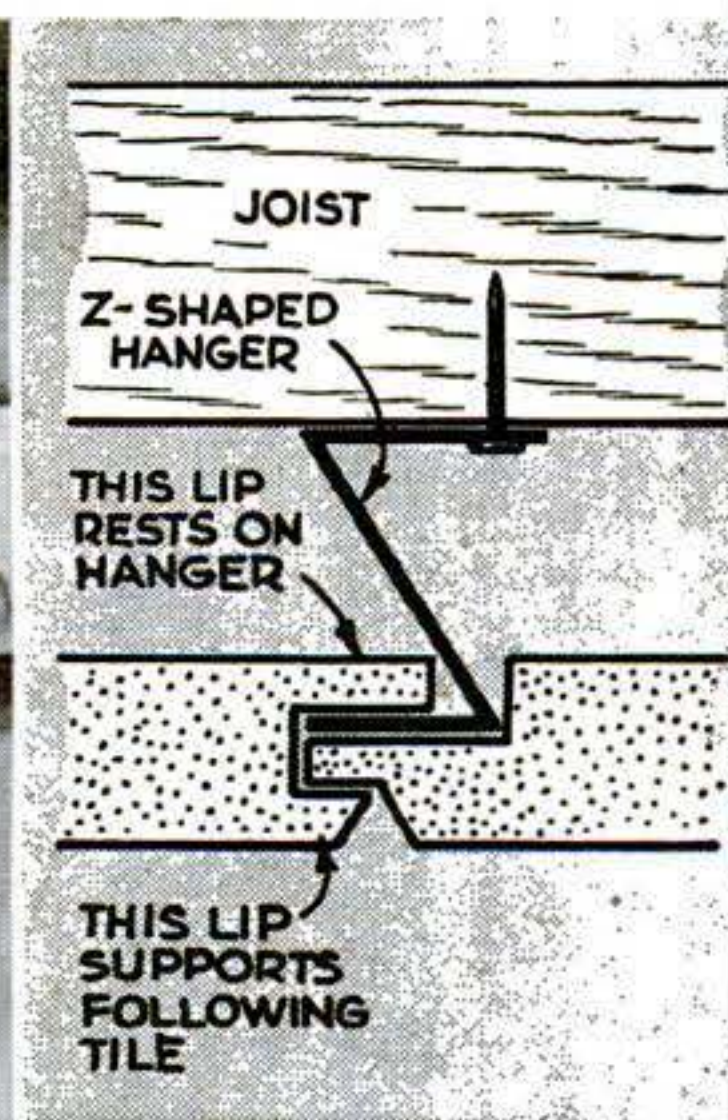
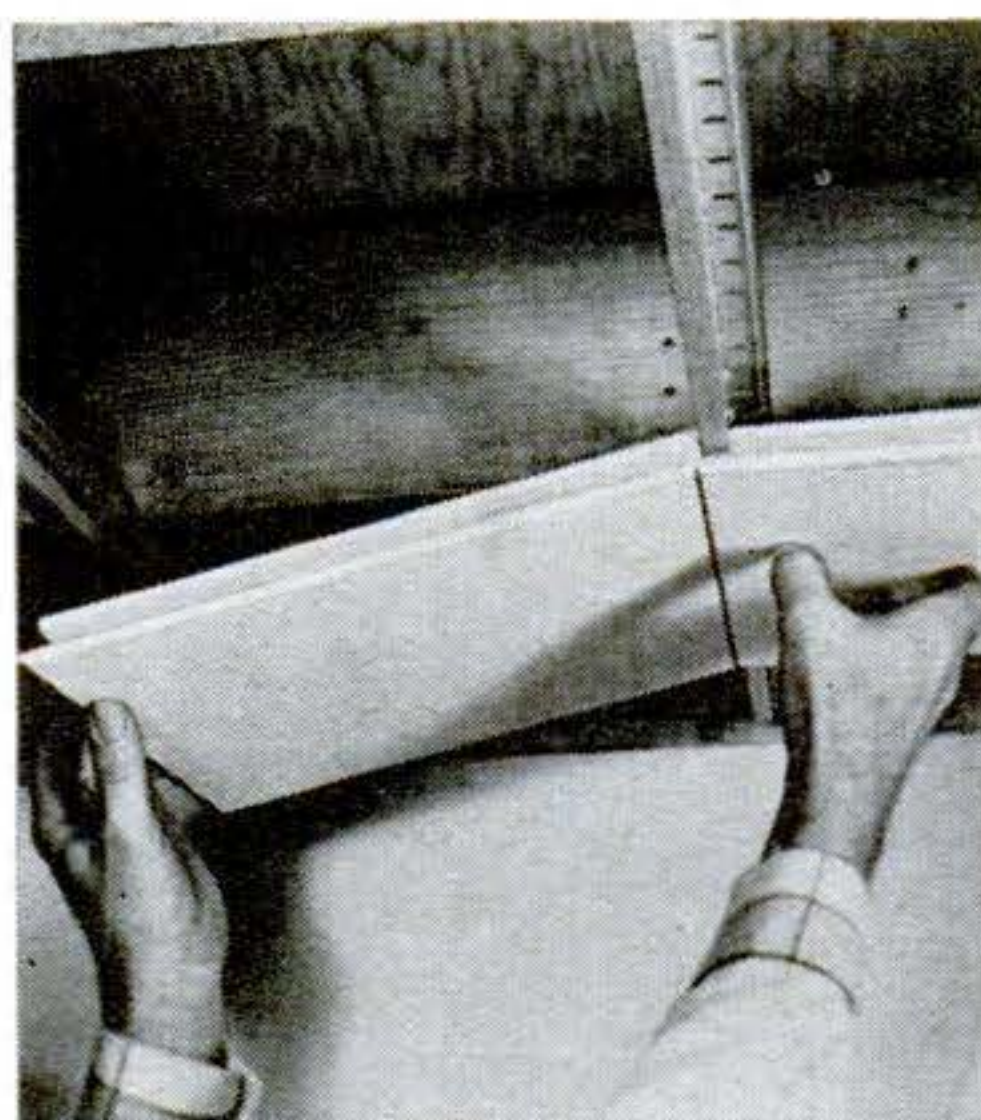

Z-shaped furring supports ceiling tiles

Once you nail this metal furring to the joists, it's a simple matter to lock tongue-and-groove tile boards into place. The easiest way to achieve professional alignment is to hang the tiles row by row, nailing on the next furring strip after each row is hung. Insulite Fastile furring is 5 cents per foot. The company also makes molding edge strips for 10½ cents a foot and plastic cove molding for 6½ cents.



Crack cement has vinyl finish

Six chemicals in a concrete-repair mix, including vinyl compounds, give it extra bonding strength and make it go farther. Used in cracks in basement walls, driveways, patios, and the like, it dries to a hard vinyl finish. Aqua-Dri comes in 10- and 40-pound bags at \$2.25 and \$7.70 from Silcoa Products, 51 E. 42nd St., NYC.

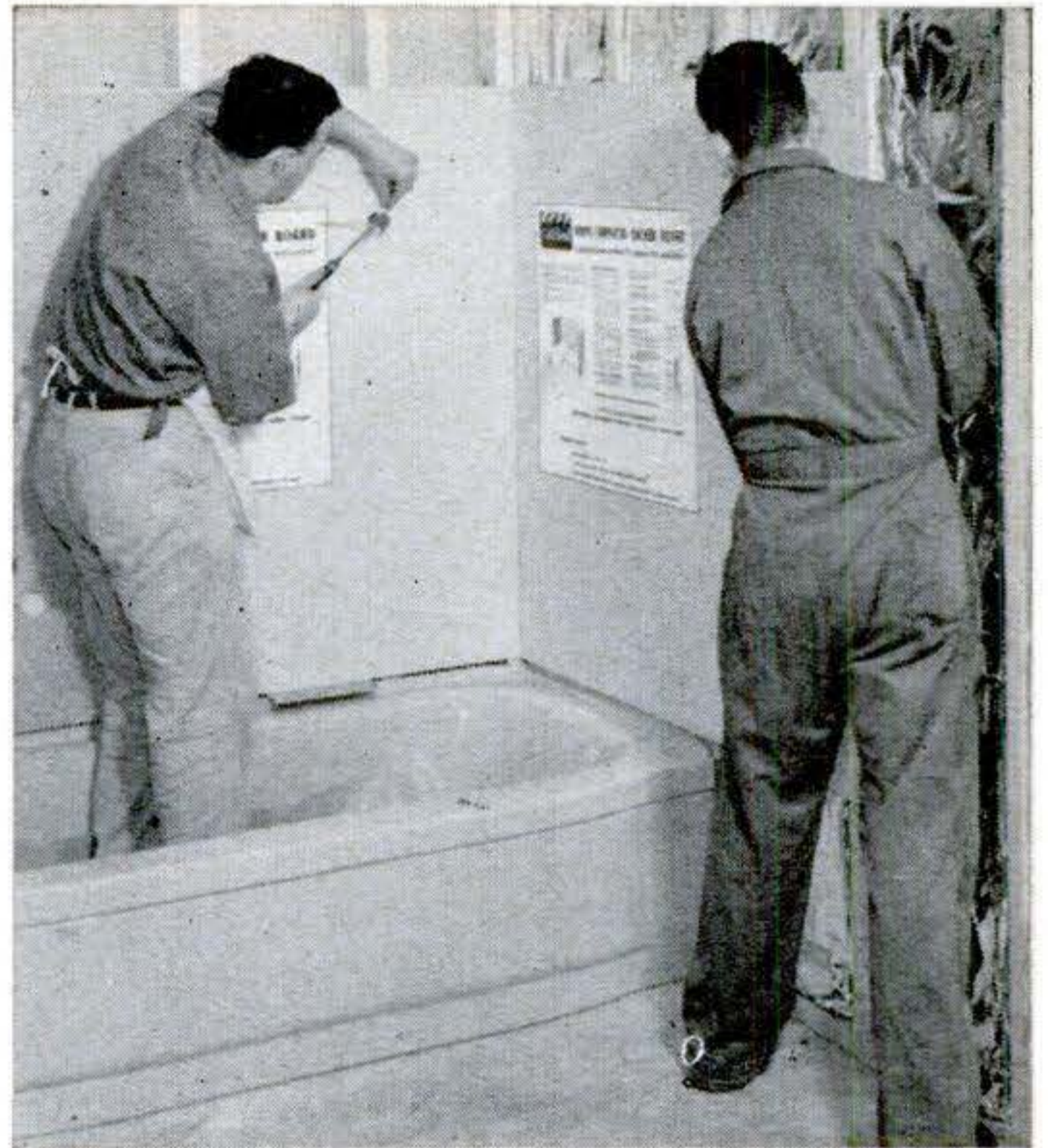

Vinyl-surfaced gypsum board

Waterproofing for the shower area around a tub is built into this backer board for wall tiles. It's National Gypsum's vinyl-surfaced Gold Bond. You install it in the same way as the rest of the drywall and do no other waterproofing. It costs \$7.50 to \$8.50 for a 4'-by-8' panel, enough to take care of a tub enclosure.

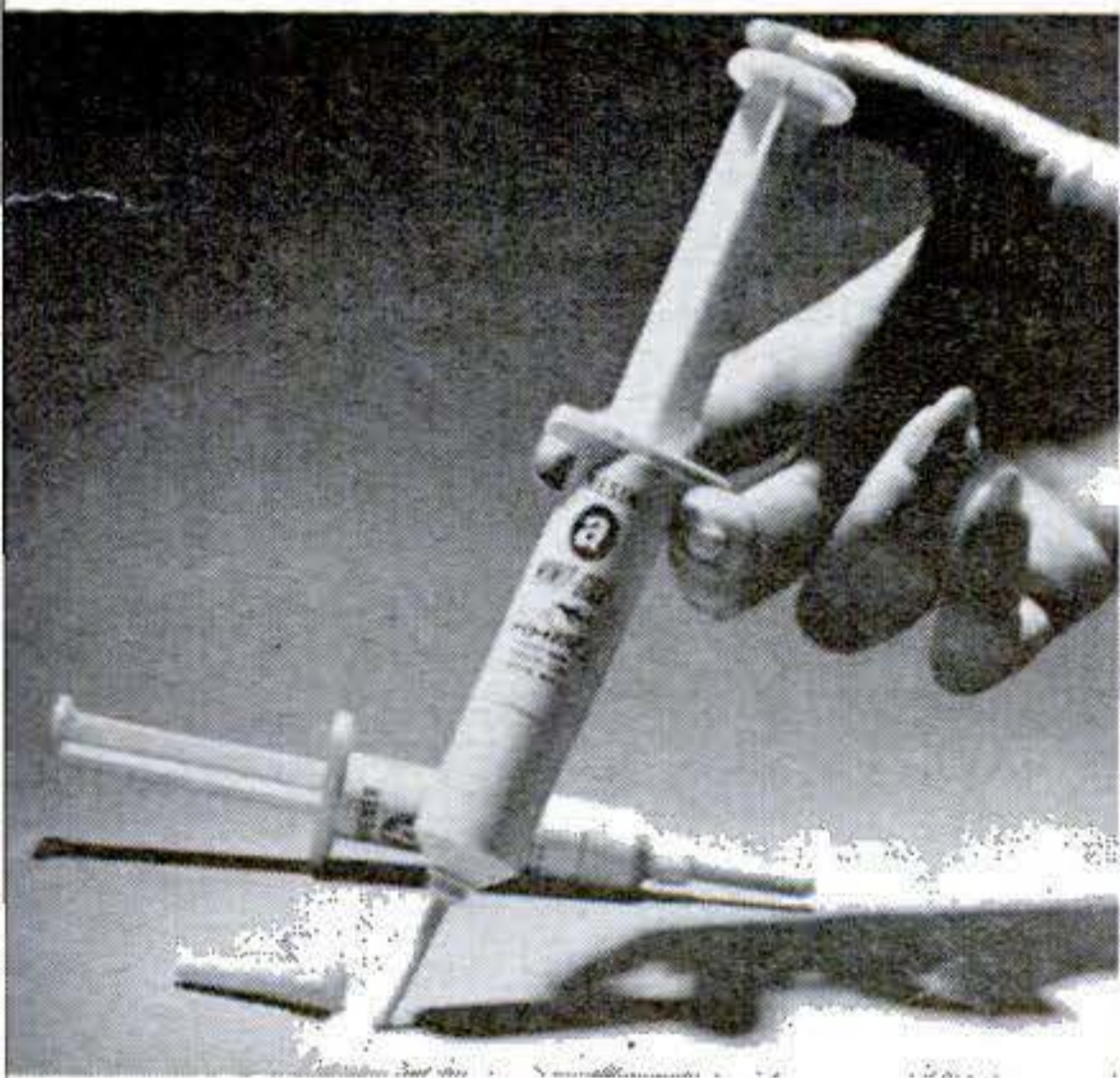

Hypos measure shots of epoxy and hardener

Separate syringes measure out epoxy and hardener in correct ratio. A special hardener formula cures the mix in one minute, says Harvey Home Products Corp., 549-A Tremont St., Boston. With plastic syringes, Minit-Grip costs 98 cents.

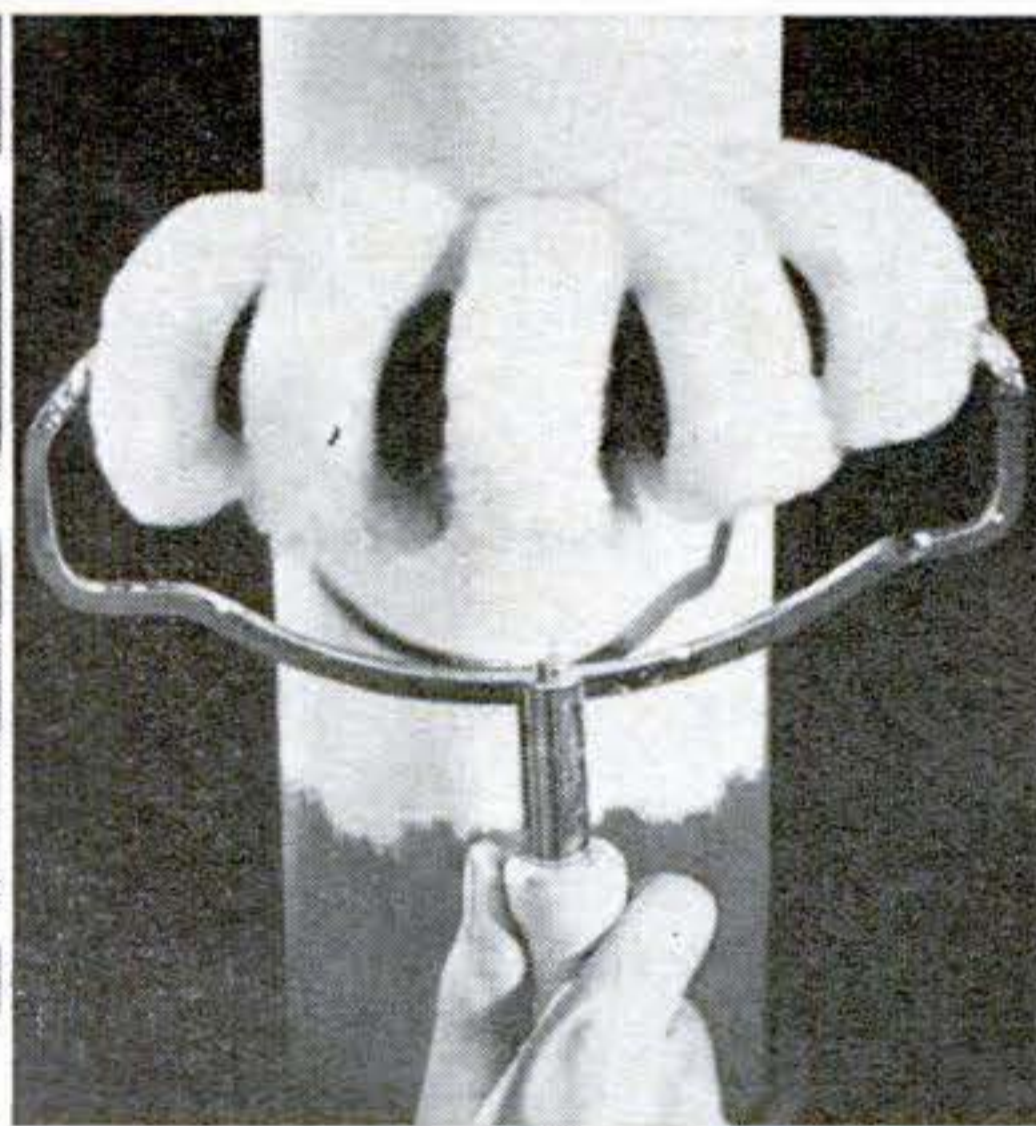

Jointed paint roller wraps around pipes

This flexible paint roller made of five separate wheels will fit almost any contour you need to paint, line up flat for reloading. The sleeves of Dynel fiber are washable. EZ Paint Corp., Milwaukee, lists the five-wheeler at \$8.30, handles extra.

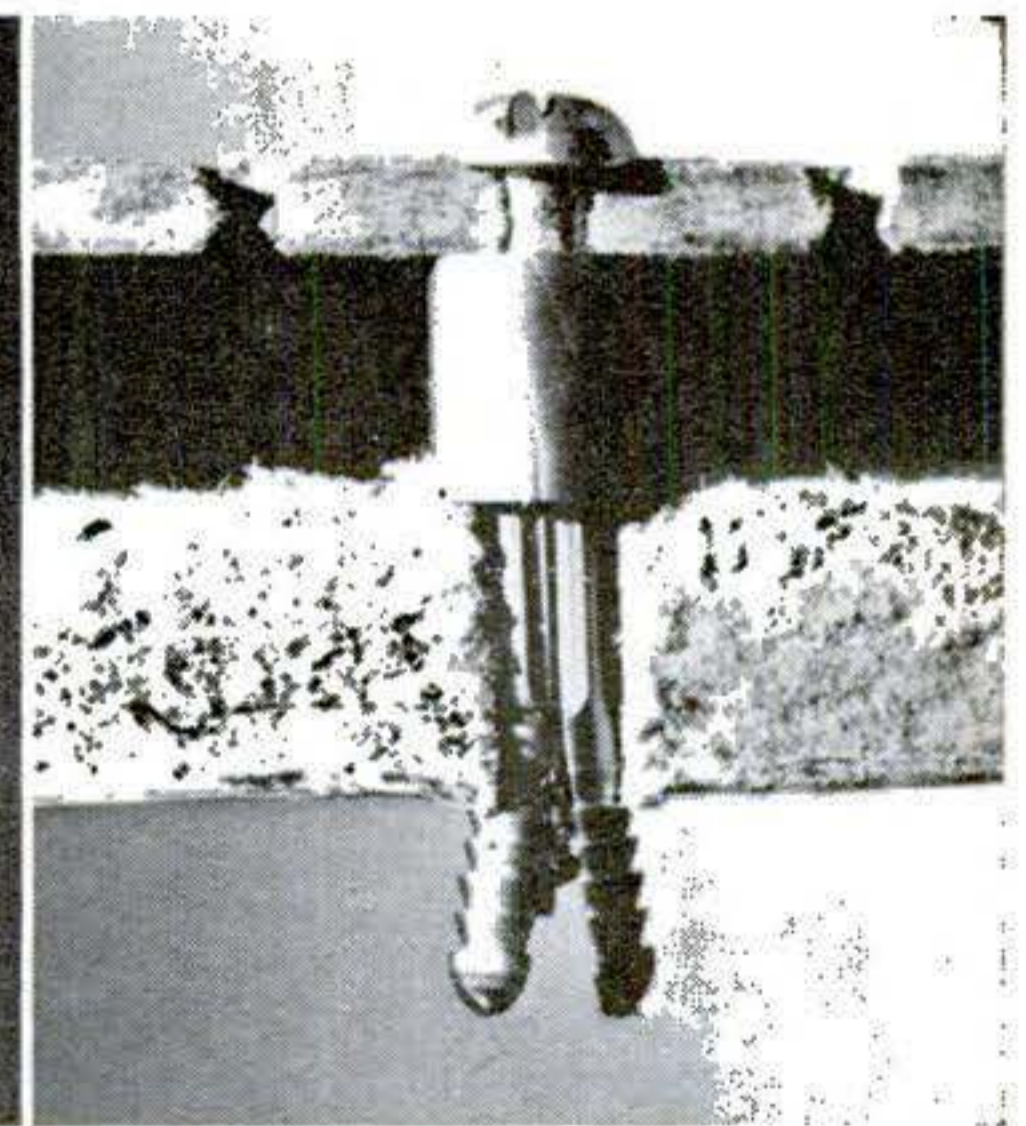

Spacers on wall anchors mount perforated board

An expandable anchor for plaster or plasterboard walls has a $\frac{3}{8}$ " bushing already in place to space perforated hardboard so you can insert hangers. It's molded in one piece of Tenite plastic by Jordan Industries, Miami. Four, with screws: 25 cents.



what's new

...ELECTRONICS



Hinged cover on 70-watt transistorized stereo amplifier drops to expose secondary controls—tape monitor, loudness, phase, and input-level adjustments. This gives maximum flexibility yet simplifies panel for casual operation.

to music in less than three seconds.

Do transistor amplifiers actually sound better? Some might argue, but I'm convinced. The Heath AA-21 I put together is an exceptionally clean amplifier. It's hard to put your finger on just what the difference is, but there *is* a different sound. The music has greater transparency—it sounds less like hi-fi, more like music.

It's a good thing the AA-21 has a sound worth working for, because as a kit it had two drawbacks: It's a big construction job, and it's relatively expensive (\$134.95; factory-assembled, \$219.95).

Most stereo-amplifier kits in the same power range can be built in 15 hours or so. The AA-21 took 26. Four printed-circuit boards, which went together quickly, and six modules helped speed construction. The most tedious job was preparing the shielded cables. Almost 30 shielded leads are used. At each end of each cable, the outer insulation must be stripped, the shielding braid carefully peeled back and formed into a pigtail, and the inner conductor stripped.

This might not be the best kit for a novice but, if you're determined, you can complete the AA-21 successfully even if your previous electrical experience has been limited to, say, changing light bulbs.
—C. P. Gilmore.

New transistor stereo amp kit

TRANSISTORS are the hottest thing in electronics because equipment built with them can be small and light. It's surprising, then, that Heath's entry in the transistorized stereo hi-fi amplifier sweepstakes—the new AA-21, a deluxe 35-watt-per-channel unit—is about the same size as conventional tube units of similar ratings, and weighs only slightly less.

Why use transistors at all, then? The answer seems to be that most high-fidelity manufacturers believe that transistors promise better sound than the best vacuum-tube circuits. And transistors don't wear out as tubes do. A transistor amplifier should sound as good in five years as it does new.

Another bonus: No warmup is needed. Flip on the switch and you're listening

How to pick the right glue for every job

WELDWOOD ADHESIVES	APPLICATION																
	HOUSEHOLD REPAIRS china, glass, metals, plastics, porcelain		INTERIOR WOOD CABINETS, BUILT- INS, FURNITURE		INSTALLING PLYWOOD WALL PANELS		PLASTIC LAMINATES TO PLYWOOD OR PARTICLE BOARD	CONCRETE TO CONCRETE, WOOD, MASONRY	PAPER TO PAPER, FABRIC, CARDBOARD	CANVAS OR FELT TO WOOD	CORK TO WOOD	HARD- BOARD TO WOOD	BOATS (WOOD)	LEATHER TO LEATHER, WOOD	METAL TO METAL, WOOD, MASONRY	CHINA TO CHINA, GLASS	EXTERIOR WOOD OUTDOOR FURNITURE, SPORTS EQUIPMENT, WOOD TO WOOD, CORK, CANVAS
	LIGHT DUTY	HEAVY DUTY	LIGHT ASSEMBLY	HEAVY ASSEMBLY	WITH NAILS	WITH OUT NAILS											
Weldwood® EPOXY GLUE		✓					✓							✓	✓		
Weldwood® CONTACT CEMENT	✓				✓	✓								✓			
Weldwood® PRESTO-SET GLUE			✓						✓	✓	✓						
Weldwood® PLASTIC-RESIN GLUE				✓	✓						✓						
Weldwood® WATERPROOF RESORCINOL GLUE												✓					✓

...all you need are these 5 Weldwood adhesives



**Weldwood®
Epoxy Glue**

Resin and hardener, easily mixed. Clamping not required. Hardens overnight. Waterproof.

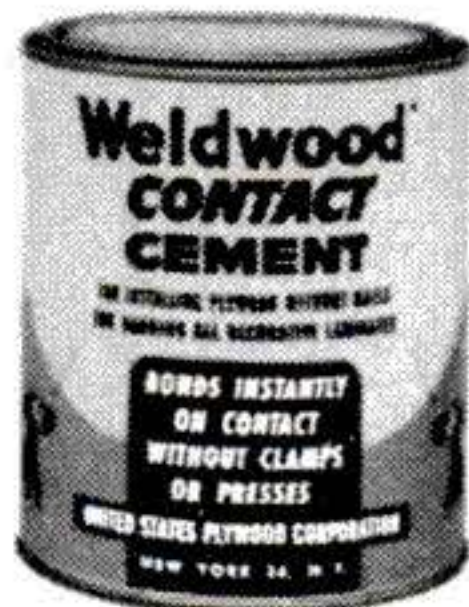

**Weldwood
Contact Cement**

Liquid, ready for use. No clamping. Bonds on contact when dry. High water resistance.



**Weldwood
Presto-Set® Glue**

Liquid, ready to use. Use moderate pressure. Sets 20-30 min. Moderate water resistance.



**Weldwood
Plastic Resin Glue**

Powder, mixes easily with water. Clamp. Sets 5-6 hours. Very high water resistance.

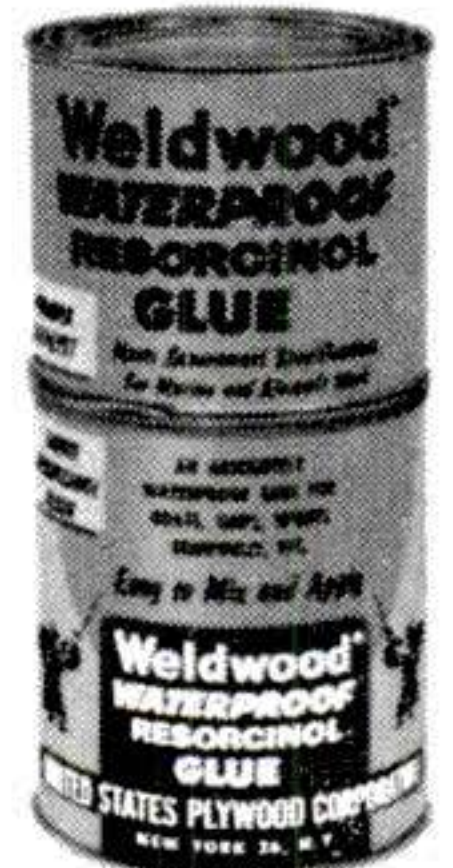

**Weldwood
Waterproof Resorcinol Glue**

Liquid and powder, easily mixed. Clamp. Sets 8-10 hours. 100% waterproof.

FREE. Get the Weldwood Glue Guide—printed in full color on heavy stock—full size, 12" x 18", easy to read. Put it up on your workshop wall for easy reference.



Products of United States Plywood

United States Plywood, Dept. PSM 2-63
55 West 44th Street, New York 36, N. Y.

Please send me the Weldwood Glue Guide free.

Name

Address

City

Zone State



NEW FROM OUTBOARD MARINE...

**THE BEST THING THAT'S
HAPPENED TO WATER IN YEARS!**

Until OMC Boats came along, nobody ever made such a concerted effort to engineer out all the exasperations of boat ownership; to engineer in all the travel comfort, dependable performance, uncomplicated operation and ease of maintenance of the family car!

It's a new idea in boating, starting with a unique hull that resists tipping no matter how tight the turn, how lopsided the load... with the speed characteristics of a 3-point hydro plus twin sponson displacement smoothing the ride... with stability and handling ease even a novice can appreciate.

Tucked in the stern is the 88 hp OMC 488 stern drive — a V-4 with 4-barrel carburetor. You'll like its low-keyed, authoritative voice... its

eagerness to get up and claw water when you lean on the throttle. (The fabulous OMC 17 Dual Deluxe has TWO of these sweethearts — each with its own running system — for a sizzling 176 horsepower!)

And boating was never easier! No extras to buy, no complex get-ready, no toilsome maintenance. Your big difficulty will be deciding which of OMC's 5 brilliant models suits you best — and prices are much lower than rumor (or the boats themselves) would lead you to expect. See your OMC dealer!

Opposite: OMC 17 Dual Deluxe. A. OMC 17 Deluxe. B. OMC 17 Seasport. C. OMC 17 Custom.



OMC BOATS

see your OMC dealer now... or write for free brochure!

©1963, OMC BOATS, Dept. PS-2, A Division of Outboard Marine Corporation
Waukegan, Illinois. In Canada: Peterborough, Ontario. Patents pending!



OMC 17 Deluxe, First Award Winner, Marine Interior Design Competition, Sponsored by American Institute of Interior Designers and Popular Boating.

Chevrolet has all kinds of horsepower for '63!

140

Power plant number one: A new 230-cubic-inch six-cylinder with seven main bearings for smoothness and power that'll make you think you're driving a V8. It's approximately 23% lighter, nearly three inches lower in overall height, two inches less in length.

HP

195

Power plant number two: Our old friend and yours, the 283-cubic-inch Chevrolet V8, with new cylinder heads and a higher compression ratio for better traffic performance, better highway performance, and better fuel economy in the bargain.

HP

340

Power plant number three:* A brand-new version of the Chevrolet 409. It has a moderate cam, hydraulic lifters, a compression ratio of 10 to 1, a four-barrel carburetor, and can be ordered with Powerglide.* It tailors the 409 to the pace of everyday commuting.

HP

400

Power plant number four:* Basically the same as the 409-cubic-inch V8 that delivered 380 horsepower last year, but now with a new higher lift special camshaft and free-flow manifolding that boosts volumetric efficiency and brings the horsepower up to 400.

HP

425

Power plant number five:* The King! The most powerful engine in the Chevrolet lineup. It's like the 400-horsepower 409, but it has *two* four-barrels and bags of torque. It comes with either the three- or the four-speed* stick. It could be described as stimulating.

HP



The optional 327 V8s with 250 and 300 hp, respectively, are also available, but are unchanged from 1962. . . . Chevrolet Division of General Motors, Detroit 2, Mich.

**Optional at extra cost.*



Hints from the Model Garage

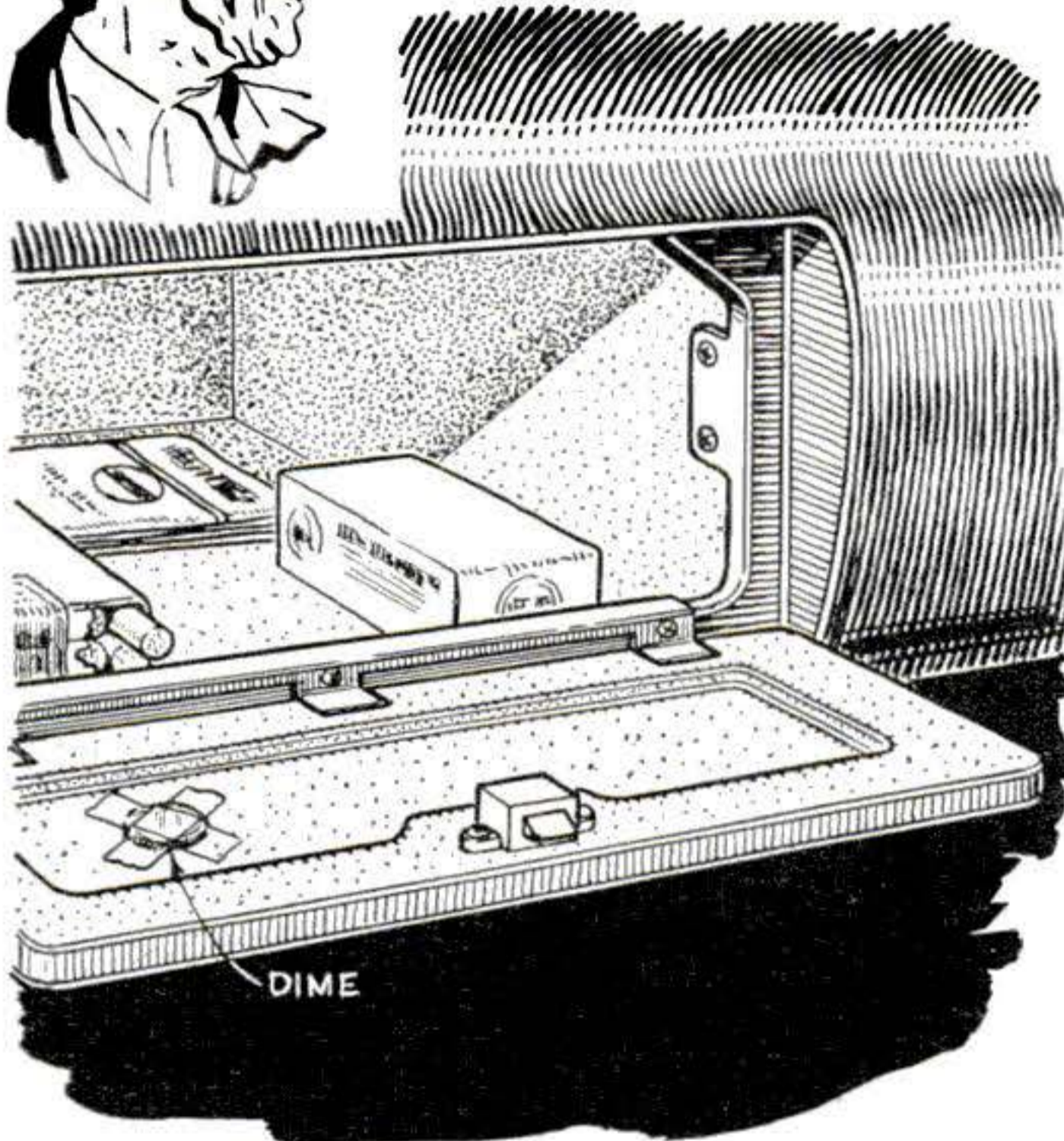

A dime taped to the glove-compartment lid could be the most important piece of emergency equipment you have. A phone call from a roadside booth can quickly summon an ambulance for an accident victim or a mechanic if your car should break down.

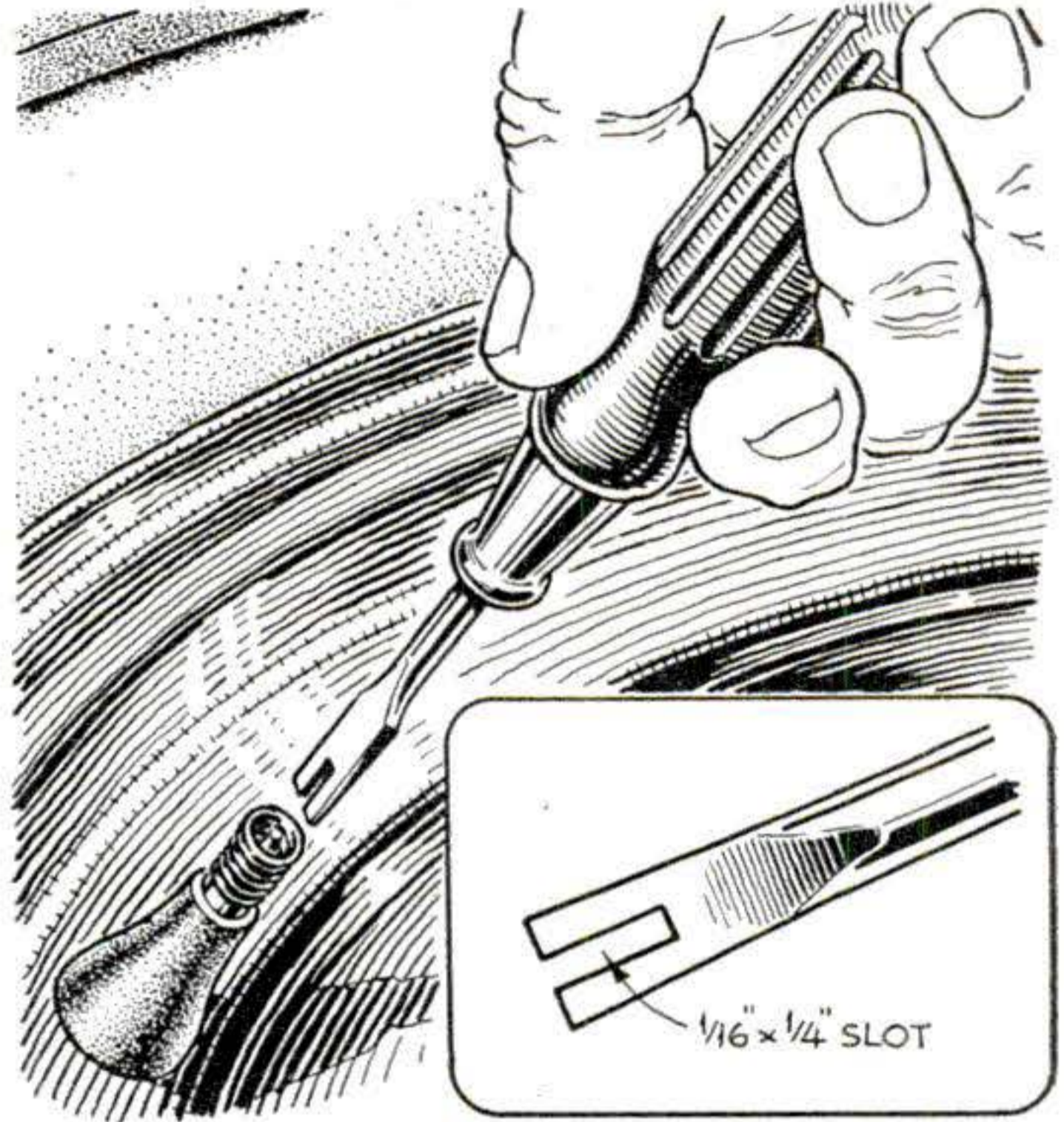

Removing the valve stem from a tire is an easy job with this homemade valve tool. Cut a $\frac{1}{16}$ " slot in the tip of a thin-bladed screwdriver with a hacksaw and file. You may have to grind down the edges of the blade so it will fit inside the valve.

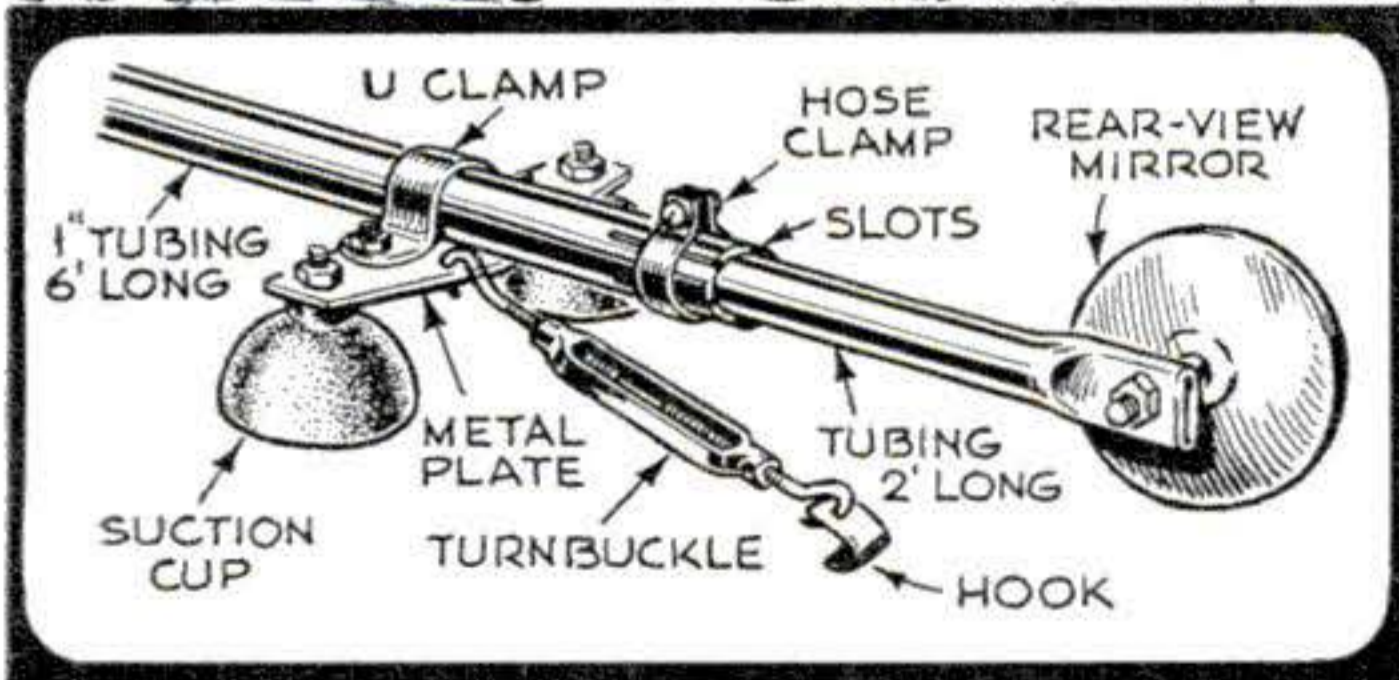

Extend these mirrors when towing a trailer and push them in when the trailer is unhitched. Accessory mirrors are attached to 2' aluminum tubes that telescope into a 6'-long, 1"-diameter tube with slotted ends. Clamps hold the extensions tight.

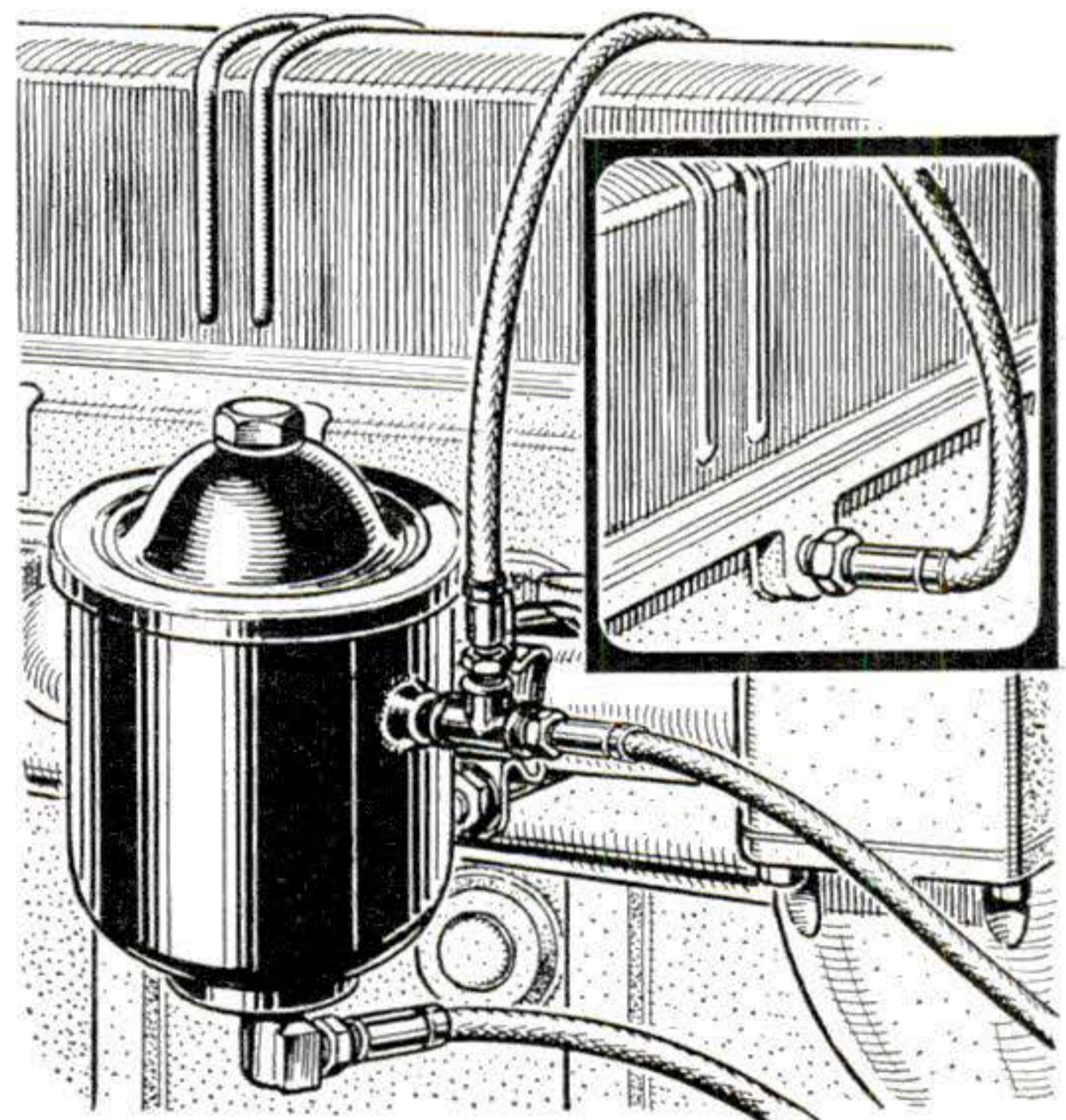

Fouled rocker-arm oil lines are common on certain sixes. Easy fix: Install a tee fitting on the oil-filter outlet. Then run a flex line from the tee to the clean-out hole on the right side of the block to feed oil directly from the filter to the rocker arms.

More Hints from the Model Garage

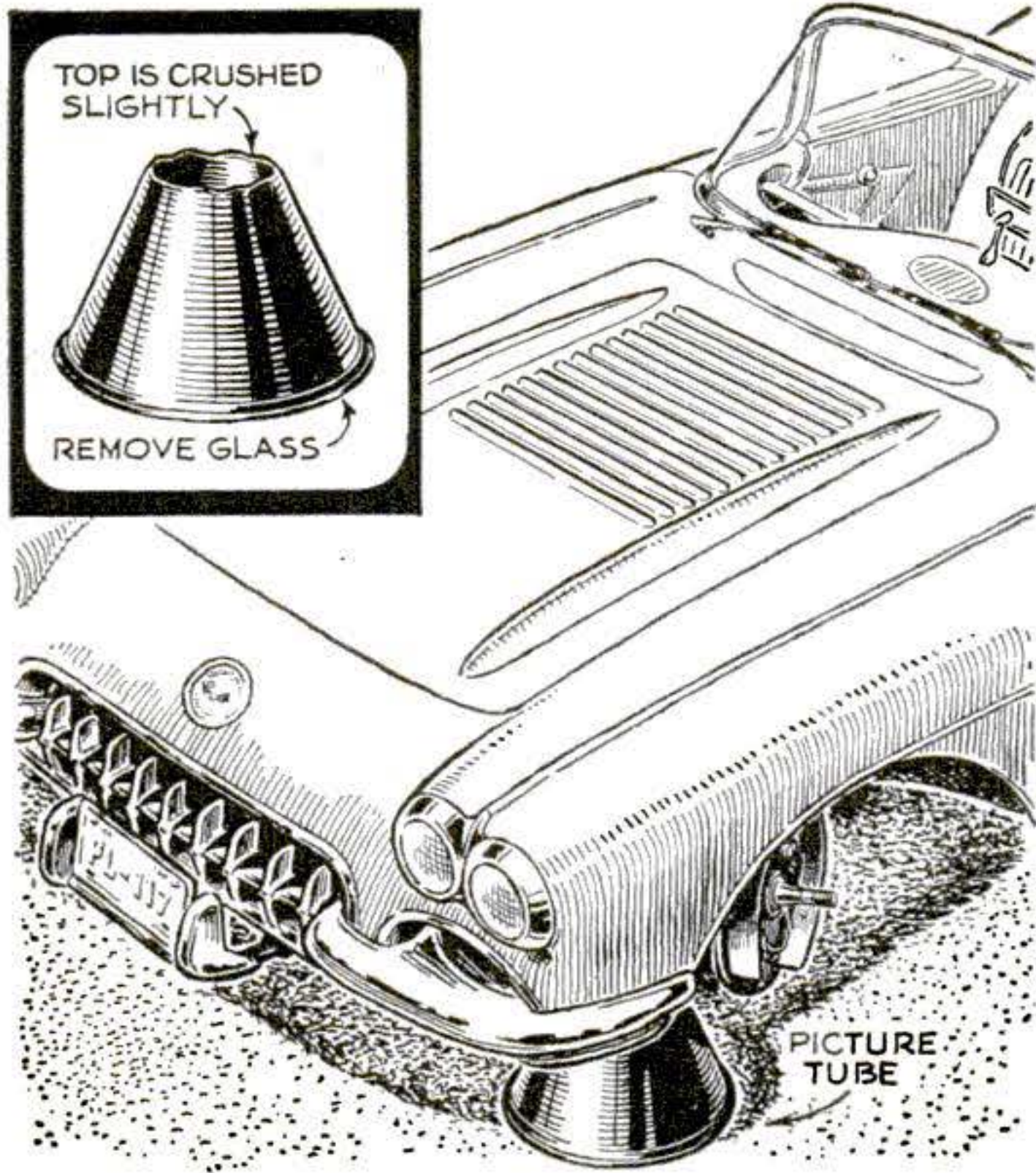

An inexpensive axle and frame stand can be had from your TV repairman; just ask him for a burned-out picture tube. Have the glass removed (let him do this). The top of the metal cone will crush slightly in use; this keeps the car from slipping off.

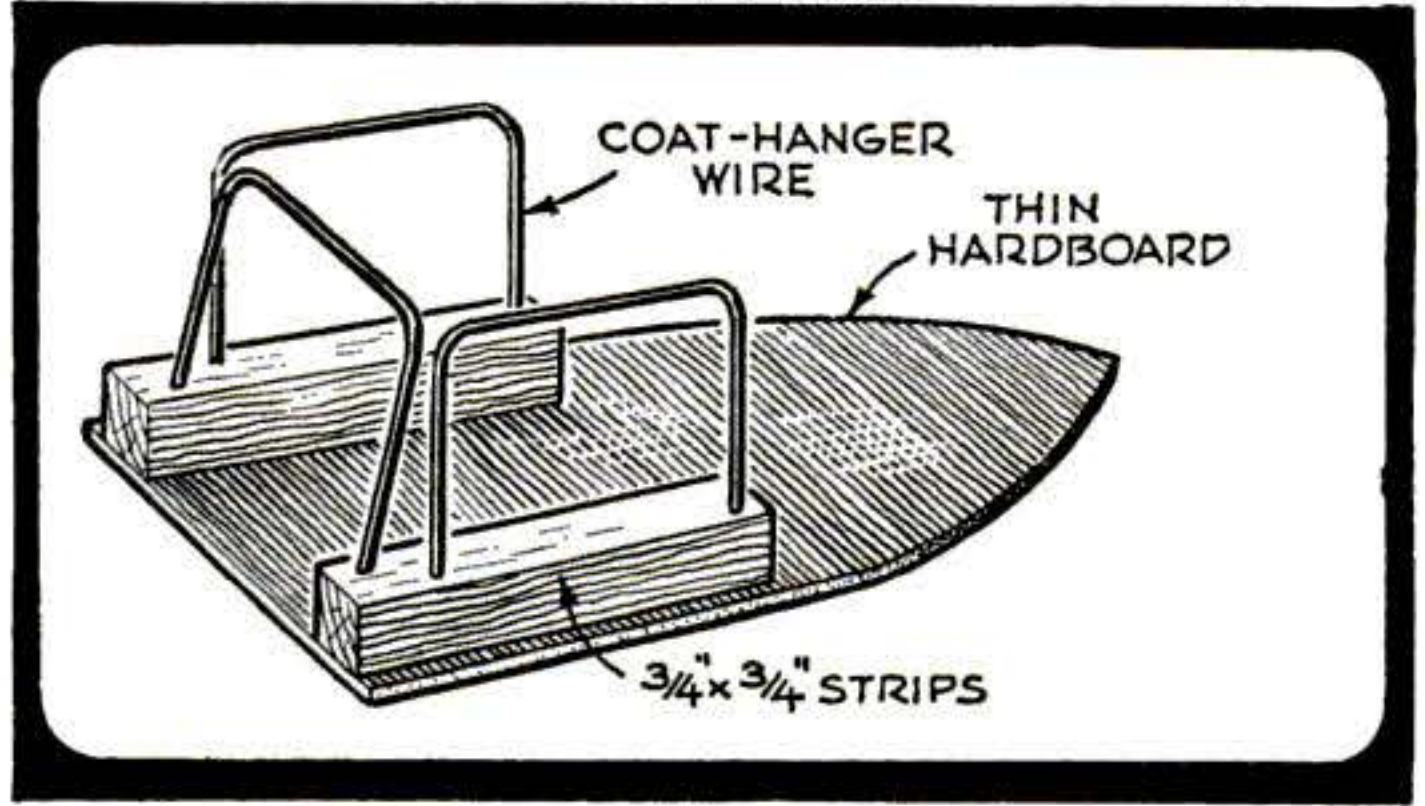
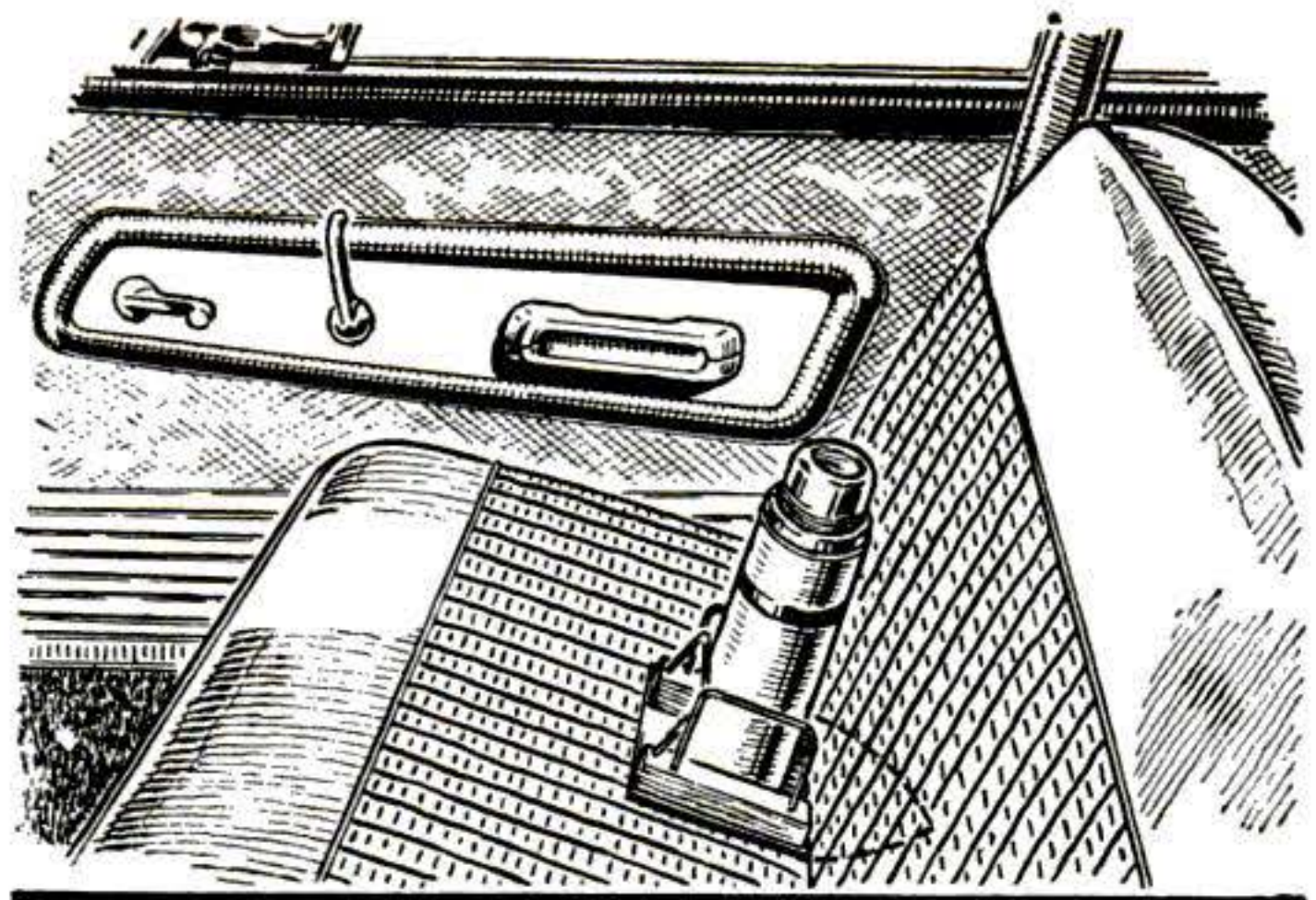

A wire holder for your thermos bottle will keep it from tipping when you turn or stop quickly. Cut the flatiron-shaped base from hardboard. Tack and glue wood strips to it and drill them to accept coat-hanger wire. The base slips under the front seat back.

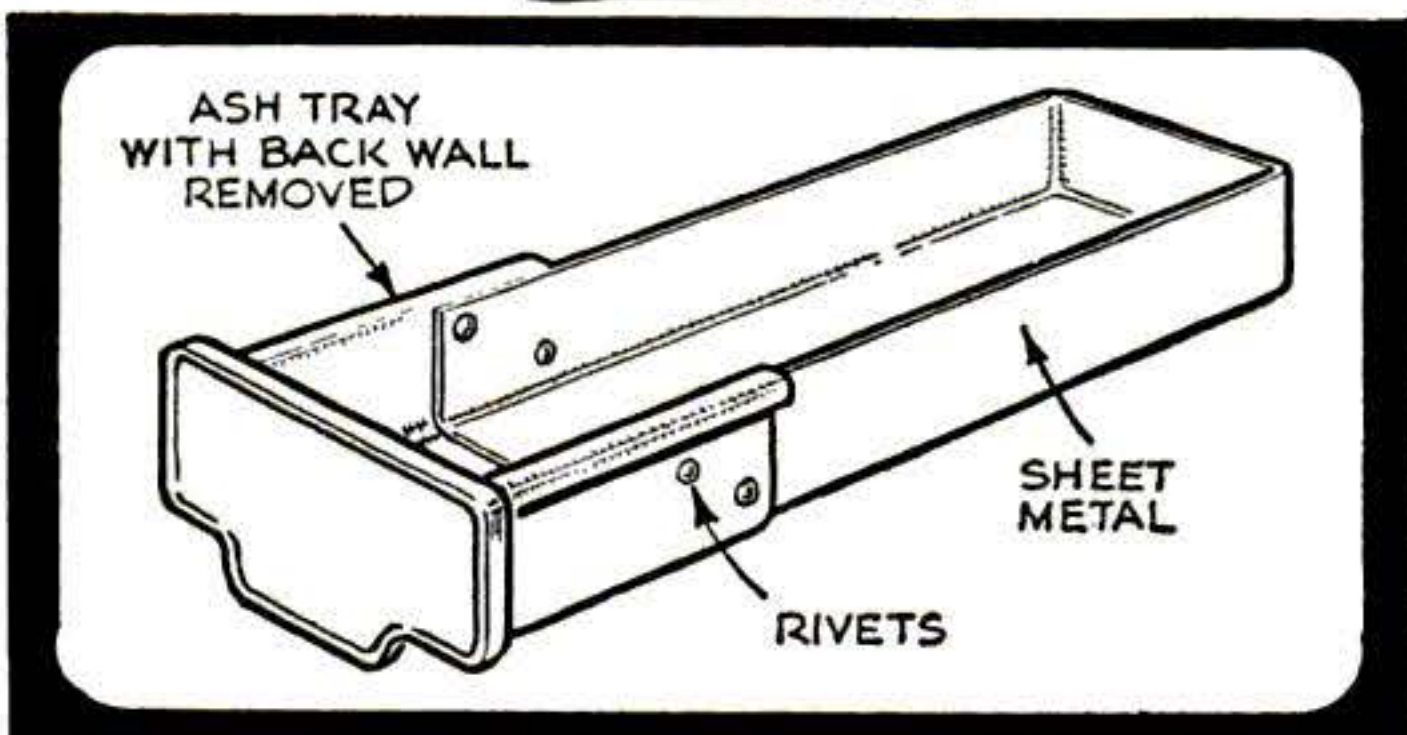
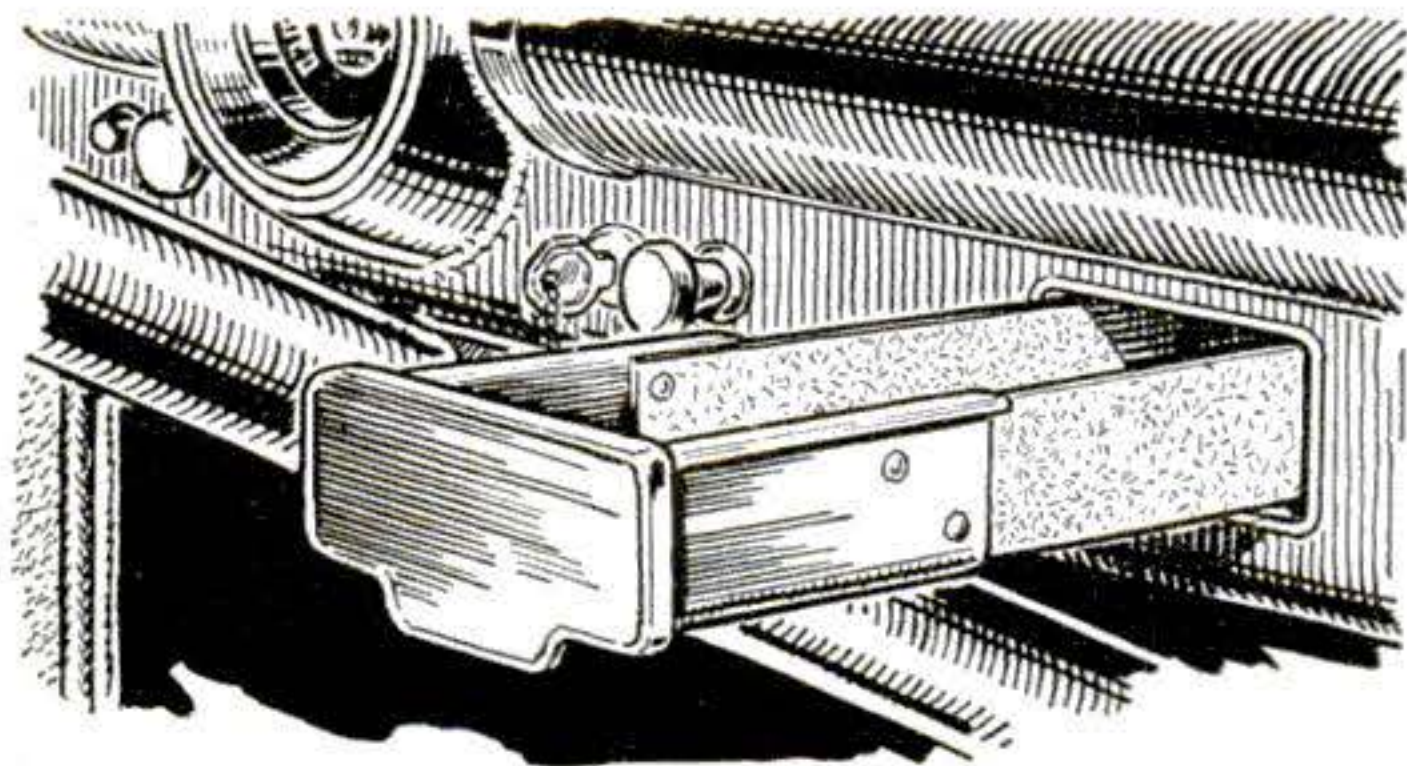

Use your pull-out ash tray as a storage box if you're a nonsmoker. Remove the back wall and extend the length of the tray with sheet metal. You will then have a handy storage compartment for a pencil, pen, comb, tire gauge, and other small items.

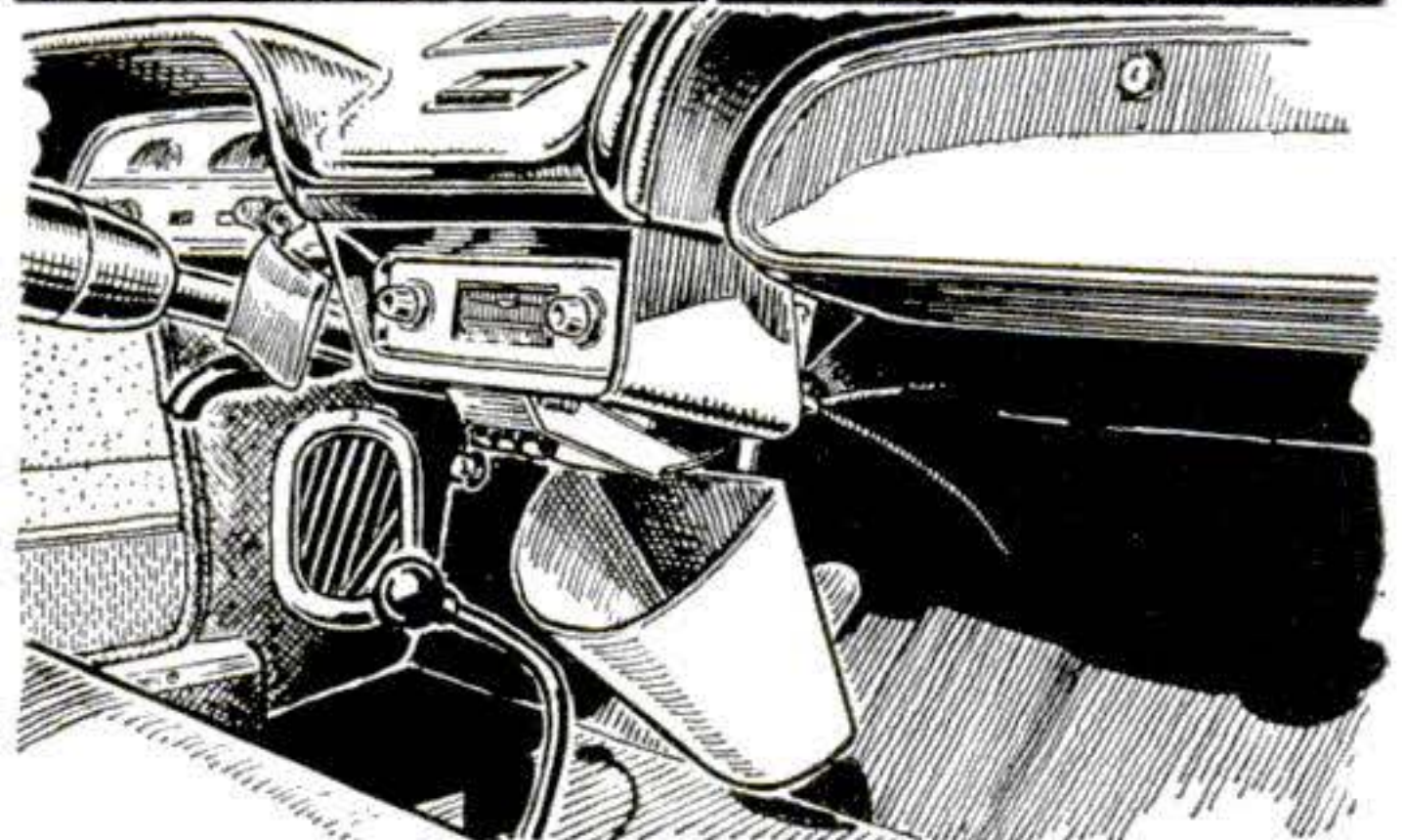
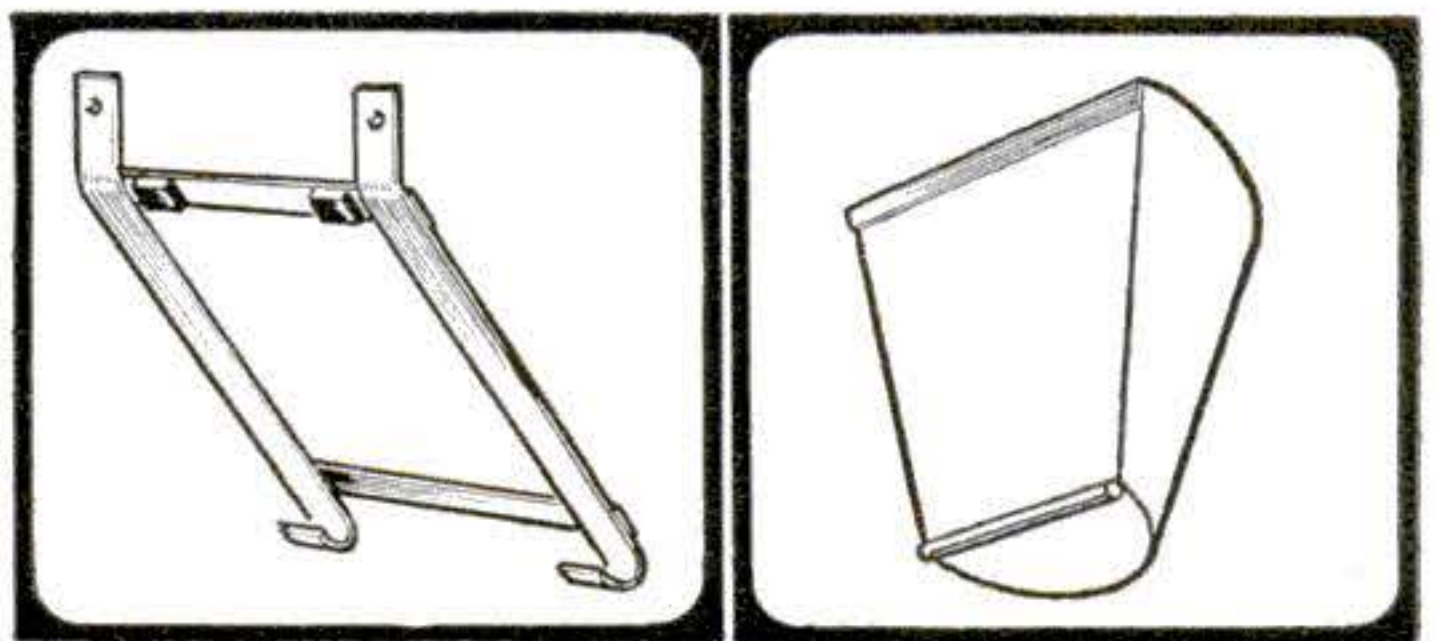

Install a litter basket in your Corvair under the radio. A cross-braced bracket hangs on screws in back of the radio. A 1/4" dowel glued to the bottom of the basket fits curved bracket ends. Two magnets on the bracket hold a metal strip at top.

Monroe **FRONT** and **REAR** Load-Leveler®

stabilizing units

END THESE HIDDEN DRIVING DANGERS

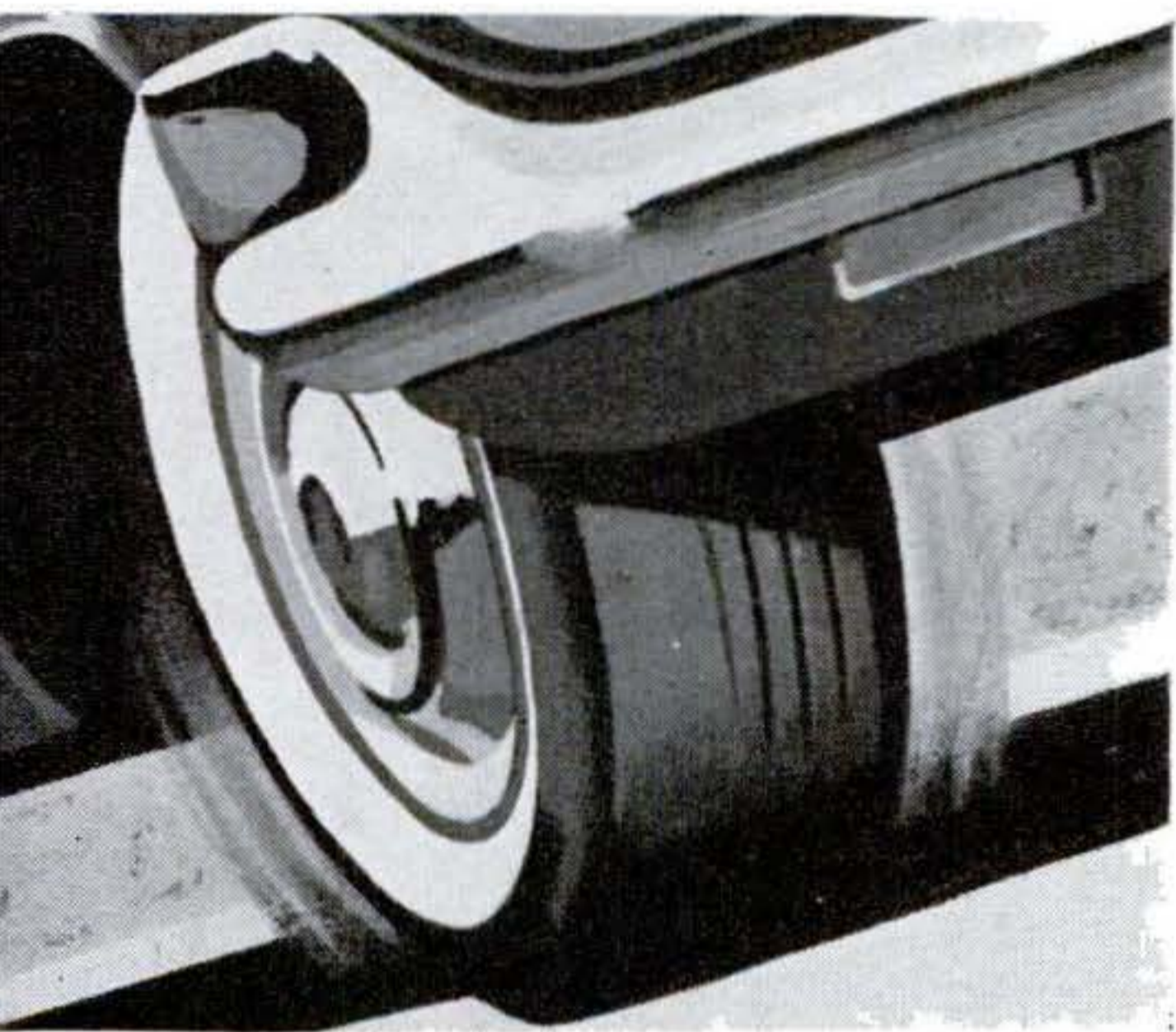

FRONT-END SAG? Sagging springs throw wheels out of line, cause shimmy, fast tire wear, loss of car control. Front Load-Leveler stabilizing units end these hidden dangers and make your car ride like new.



TAIL DRAG? Even with loaded trunk and rear seat passengers, car remains on safe, stable keel with rear Load-Leveler stabilizing units. Swaying on curves and bottoming on bumps is ended.



Your car's suspension system is an often unsuspected source of danger when shock absorbers wear out or are put to heavier use than they're designed for. Eliminate this danger—and enjoy a more comfortable ride—with Monroe rear Load-Levelers and the New Monroe front Load-Leveler stabilizing units.

Have Monroe Load-Levelers installed today where you have your car serviced. Look for the yellow and blue Monroe demonstrator barrel.



World's largest maker of ride control products including Monro-Matic® shock absorbers

MONROE AUTO EQUIPMENT COMPANY • Monroe, Michigan
In Canada, MONROE-ACME, LTD., Toronto, Ontario • In Mexico, MEX-PAR, Box 28154, Mexico City

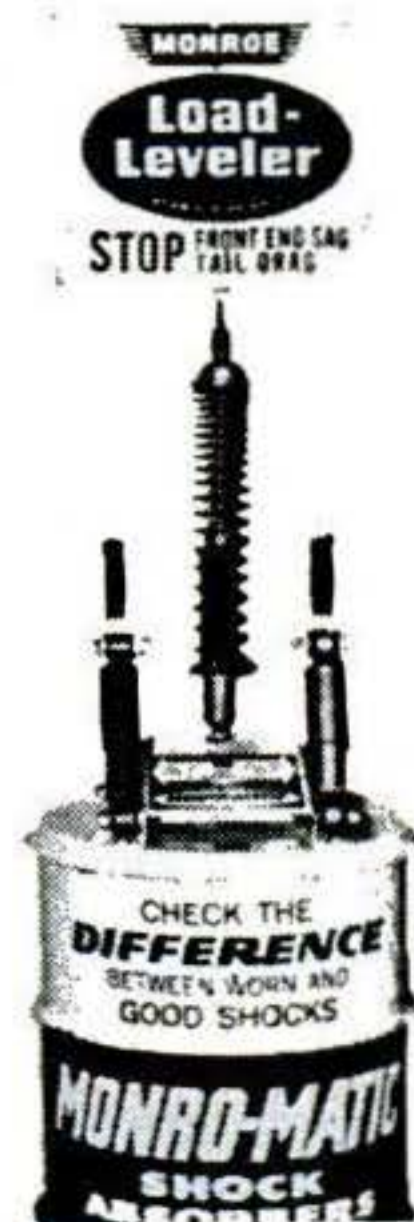

Gus Tackles a Wee Bit o' Scotch

By Martin Bunn

A FOOTSTEP brought Stan out from under the Model Garage's lube rack.

"Might I see your-rr boss, laddie?"

The speaker was a stubby man in a checked jacket; he had knobby features underlined by a large reddish mustache.

"He's out," said Stan. "Can I help?"

"Might be. My car's outside. It runs, but it does have a wee ailment. What d'ye charge for a small job?"

"Can't tell until I check," said Stan. "Just what's wrong with it?"

"If I knew that, I wouldnae be askin'," returned the other. "The motor is sweet as butter, but it don't have the gumption it did. I thought ye could tell me what to do, for a wee fee."

"Well, drive it in, Mr. . . ."

"I'm Bruce Duncan, laddie."

"Drive it in, Mr. Duncan. No charge for checking, and I'll give you a price if it looks like much work."

Surprisingly, the car that rolled in a minute later was a late model, which must have set its owner back a fair sum even if bought used. It idled silkily as Duncan got out. Stan opened the hood and gunned the engine briefly.

His practiced ears caught a reluctance and a hint of roughness that suggested the spark was retarded. He made sure that the vacuum-advance line was intact. Then he shut off the engine, got out the shop's timing light, and loosened the distributor-cap clips.

"Wait, mon! It cannae be there."

"I want to check ignition timing," explained Stan. "It's routine to make sure the points are set right."

"And rr-right they are, ye may be sure, for I set them myself."

Stan shrugged. "Okay." He replaced the clips, pulled off the vacuum-advance

tubing, and hooked the timing light to plug number one. "Start it up."

Duncan did so. In the flash of the light Stan watched the timing mark on the harmonic balancer.

"See that?" asked Stan as Duncan came around. "The spark is about two degrees late at idling speed."

"Cannae ye make a small adjustment?"

Stan killed the engine. "I could reset the distributor, but that might be starting at the wrong end. I should check the point gap first. You say you set the points?"

"Aye, and right on the button. I'm a machinist. When the blueprint says half a thousandth, I can split it to a hair. My car book says the gap should be from 19 to 22 thousandths, so of cour-rrse I set it at 19."

Stan grinned inwardly as he lifted the distributor cap. He nudged the engine around to stop the breaker arm on a high point of the cam, then inspected the points. They were serviceable.

"Want to check the gap again?" he asked. "If it's still 19 thousandths, I won't charge you a thing."

The reddish mustache seemed to bristle as Duncan produced a thickness gauge from his pocket. He leaned over and checked the point gap, grunted in disbelief and checked it again.

"You're right, lad, it's down to 17," he confessed, straightening up. "Who'd have thought I could go so far off?"

"You didn't," said Stan. "The only mistake was setting them at 19 thou."

"But the book says so, lad."

"That's minimum for points that have bedded down. But when you install new ones, you want to set them on the high side of the tolerance range. Then, after this fiber rubbing block wears itself in against the cam, you'll still be inside the tolerance range. If you set the gap at the minimum, cam wear can leave the gap too small."



"Weel, now, if ye could fix them, I might be money ahead," mused Duncan.

Duncan's forehead became a corduroy of wrinkles. "Makes sense. I'll know better next time. Now what'll you charge to re-time the ignition?"

"Just resetting the point gap may do it," said Stan. He increased it by three thousandths. "When the gap is too small, this contact I'm adjusting holds the breaker arm a hair too far off the cam. So the lobe has to swing a little farther before it breaks the points. By then the piston has moved along, too—and your spark is late. A gap four thousandths too small shifts ignition timing four or five degrees."

He buttoned up the distributor and re-started the engine. In the flash of the timing light, the mark appeared about two degrees ahead of its previous position. Stan hooked up the vacuum-advance line and gunned the engine. The timing mark advanced obediently. Duncan pursed his lips as he dug deep to bring out his wallet.

"I think that does it." Stan disconnected the light and closed the hood. "That thickness gauge you used, by the way, is okay only if the points are clean and flat. If they're pitted, it can give you a wrong gap, because it hits only the high spots." He

made out a small bill, which Duncan promptly paid.

"A rr-reasonable price. I've a mind to give you some more business. What'll it cost me for three sets of points?"

"Three sets?" asked Stan in amazement. "But your own are still okay."

"For the noo," said Duncan glumly. "But I'm sure to be needing new ones soon."

"We'd have to order three sets," said Stan. "Maybe Mr. Wilson will give you a discount on them. Come back in an hour, if you can."

"I'll do that, and thank ye."

Gus Wilson was in no amiable mood when he returned some time later. He lugged a small, heavy package from his car and set it with a thud on the workbench.

"That the new motor for our valve refacer, Gus?" asked Stan.

"Yes, but they've changed the motor base," growled Gus. "Won't fit our old model until I tap four new holes. While I do that, you can take the valves out of the Anderson car."

Gus detached the burnt-out motor, set the new one in place, and punch-marked

the hole locations. Electric drill in hand, he hunted around the bench.

"Seen that hand-soap can I keep around here, Stan?" he called.

Stan emerged briefly from under the hood of Bill Anderson's car. "Think so, but I can't remember exactly." The sound of an entering car made him turn about. "There's a Mr. Duncan to see you."

Gus grunted and set the drill on one of the marks. Pausing occasionally to squirt cutting oil on the bit, he allowed it to bite through. Then he laid the drill aside and turned to the chunky little Scotsman.

"I'm Gus Wilson. You want to see me?"

"As I told your-rr young man, I want to buy three sets of ignition points for you car."

"Going on a trip?" asked Gus.

"No, but my car burns them fast."

"How fast?" asked Gus.

Duncan scratched his mustache. "In a few weeks. I put in this set two weeks ago. I suppose it's that power-rrful engine does it."

Gus shook his head. "It shouldn't. I can think of a couple of things that might, though." He got out a specifications list.

"Weel, now, if ye could fix them, I might

CONTINUED

The dodge that saved the day



"Put that special order on tonight's express plane," the boss said as he left, "and you'll get not only overtime, but a bonus. It's urgent."

Sam and I finished wiring the complex electronic unit; then he nailed a crate together while I ran the final checks. I disconnected the soldering iron, read him the serial number to fill in on the invoice, and put the thing in its box.

"Ten fifty-two," he said with relief, laying aside the carbon copy and sealing the invoice into an envelope. "Nail it up, paint on the name and address, and we're off."

"Eighteen minutes left, and 12 miles to

the airport," I said. "It's going to be close. Where's the paint?"

Then I remembered that the old can had been thrown out. We hadn't a drop of paint in the lab, nor any time to hunt elsewhere, let alone buy any at this hour. There went our bonus money.

"We have no crayon, chalk, or even grease," I said. "And this hard drafting pencil barely writes on the wood."

"And ever since one of our labels came off a box," Sam said, "that agent has been a stickler for having big, fat letters painted right on the wood. Pencil won't do. He'd keep us arguing while the plane took off. Plug the soldering iron in again."

I did, but shook my head. "It'll take all night to burn that name and address in with this pen-size iron."

"I'm not going to," Sam retorted. "It'll be marked in nice, thick, dark-blue letters in just a minute."

Turn page upside down for the answer.

Answer: Sam laid the carbon paper from the invoice sheets face down on the wood. Then he drew the letters on the back of the carbon with the flat face of the warm iron. Wax and carbon color were melted into the wood fibers, making broad, indelible letters that stood out boldly enough to satisfy the most pernickety freight agent.

WILDCAT!



Anatomy of a WILDCAT! External characteristics . . . sleek, sure-footed, muscular—325-hp strong. Three distinct types—convertible, 2-dr. sport coupe, 4-dr. hardtop. Internal structure . . . V-8, 401 cu. in. Wildcat engine. 10.25:1 compression ratio. 4-bbl. downdraft carburetor. Automatic Turbine Drive transmission. 12" brakes—finned aluminum up front. Temperament . . . terribly impatient in captivity. Thrives best on the open road (tracks arrow-straight, and corners like a cat). Habitat . . . wherever you see a Buick dealer's sign.

Buick Motor Division also presents: Buick Special Skylark/LeSabre Electra 225/Riviera

WILDCAT BY BUICK!

be money ahead even after I pay for your wor-rrk," mused Duncan.

"And save yourself some trouble besides," agreed Gus. "Let's just take a quick look-see."

List in hand, he went to the car and opened the distributor. The condenser was of the listed capacity. A clip on the resistance wire leading to the coil identified it as the proper one for the car.

Gus got out a voltmeter and connected its leads across the coil's battery terminal and ground. Then he propped the meter up so that he could see it from the driver's side of the car.

Carefully he turned the ignition key past "on" toward "start," but just short of actuating the starter. The meter needle surged to 12 volts. He let the key snap back to "on." The needle twitched, then held at 12 volts.

Gus repeated the test as Duncan leaned close, watching.

"There's your trouble," said Gus.

"I dinnae understand."

"Modern 12-volt ignition systems use full battery voltage at starting, to insure a hot spark while the starter is drawing current," explained Gus. "But when the engine fires and you let go of the key, a different contact routes current to the coil through a ballast resistor or a resistance wire. That drops the voltage to half. Half the voltage gives enough spark and saves the points and your budget.

"Your switch is hanging up on the start side, putting 12 volts on the primary circuit all the time the engine is running. That overloads the points, so they burn fast. The meter proves it. That needle in my meter should drop back from 12 volts to 6."

"Can ye nae fix the switch?"

"They're tough to take apart and almost impossible to put together again. It'll cost you less to put in a new one."

"Aweel," said Duncan. "If it's an economy, let's do it."

"Soon as Stan can go get one," promised Gus. "It's just down the street."

Having dispatched Stan on the errand, Gus returned to the workbench. Oilcan in hand, he went on drilling the holes in the refacing machine.

"Ye've helped me with a good tip or two," said Duncan. "Mind if I return the favor?"

"'Course not," said Gus, mystified. "Always glad to learn something new."

"It's unhandy and time-wasting to squirt oil by hand for drilling and tapping. I've long made a habit of keeping a can of grease drippin's on hand—bacon fat or the like. You dip the tap or drill in it and go on with the wor-rrk. The heat o' friction melts the fat slow, givin' the tool lubrication as good as a third hand. Best of all, it dinnae cost you a cent. The drippin's are free."

"A mighty good idea. Sure wish I had some now," said Gus sincerely.

When Stan returned with the switch, Gus installed it himself, then repeated the meter test. The indicated voltage dropped as soon as the ignition key was released to running position.

"*Say, Gus,*" said Stan as the Scotsman drove out. "Now I remember. I put that hand-soap can in the washroom. Isn't that where you want it?"

"Won't do us any good there," grunted Gus. He went to the lavatory and got the can back. Whistling, he placed it on the bench and began to fit a tap in the tap wrench.

Stan brought a set of valves over to be refaced. "That the can you been wanting? Why do you keep it around? What's in it, anyway?"

Gus took off the lid and plunged the tap into the white stuff inside.

"Bacon fat," he said. "Beats anything for drilling and tapping steel. Best of all, it dinnae cost you a cent." ■ ■

Gus is in a book now. Twenty-five of the best Model Garage stories from the pages of POPULAR SCIENCE are collected in a new paperback. You may find old favorites you'd like to reread, or even some you missed. The book is a fine gift for friends not acquainted with Gus, or youngsters

eager to learn more about automobiles. You can get *Gus Wilson's Model Garage* (40 cents) at local paperback bookshops or from Berkley Publishing Corp., 15 East 26 St., N.Y.C. (Add 10 cents for wrapping and shipping.) Please do not send orders for the book to POPULAR SCIENCE.

Here's a

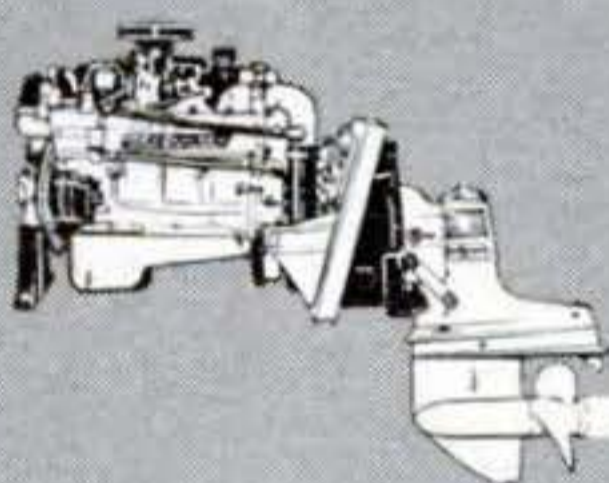

success story:

In less than one year of actual production, over 110 boat manufacturers have switched to MerCruiser Stern Drive Power Packages as original equipment.

What more can we say?

*110, 140, 190, 225, and 310 hp gasoline
39 and 100 hp diesel*



MERC[CRUISER]
STERN DRIVE POWER PACKAGES

© 1963, KIEKHAEFER CORPORATION, Fond du Lac, Wisconsin, Subsidiary of Brunswick Corporation

SHOP TALK

By Sheldon M. Gallager



Now it's car advice from the South Pole, yet

Just received word from one of our deep-south readers, Lt. Dave Flanagan, who's aboard the Coast Guard icebreaker Eastwind busily breaking up ice in—guess where?—warm and sunny McMurdo Sound, Antarctica. Although he has no use for a car jack where he is, he passes along this reminder to motorists back home: "Old-timers complain about bumper jacks, but they sure can be versatile in an emergency. If a mashed fender jams against a tire, just brace the jack against the wheel hub or a lug nut and jack the fender away. You'll save a towing charge. The jack will even reseal a dislocated engine."

If you're looking for it, they've got it

Constantine's, a long-time favorite of craftsmen, has just announced its biggest catalogue to date, a beauty: 132 pages of rare woods, patterns, tools, and woodworking tips. You can get a copy by sending 25 cents to the company at 2050 Eastchester Rd., New York 61, N. Y. . . The Cabot people now have a glare-reducing green paint designed especially for Ping-pong tables . . . So many readers asked about a more attractive enclosure for the Gough hi-fi speaker [PS, Nov. '61] that the company has decided to offer restyled plans for \$2, or a new cabinet itself assembled or in kit form. More information can be obtained from Gough & Co., Box 254, San Carlos, Calif.

BENT
COAT-HANGER
WIRE



More solutions to an often-solved problem

The paint that stubbornly collects in a paint-can rim is one of the most common household nuisances. To prove it, our mailbag always contains at least one or two solutions to this exasperating problem. Here's our pick of some of the most interesting: William Surridge of Philadelphia suggests bending coat-hanger wire into a U shape and suspending it in the can, as at upper left. Scraping your brush against this instead of the can edge keeps paint out of the rim . . . Arthur Tanner of Poughkeepsie, N. Y., saves old lids and cuts semicircular openings in them, as at lower left, to seal the rim and provide a scraper for the brush . . . Other favorites: "Make nailholes in the groove and they'll let the paint drip back into the can" . . . "Cover the rim with foil or plastic food wrap and when you're finished, just peel it off—along with the drips" . . . "Force twine into the groove. It will keep the paint out and can be removed to replace the lid." Any other pet ideas?

Assignment: make our cars more rust-resistant



**Result: '63 Ford-built cars are
better protected against rust
than ever before**

To tackle this assignment, Ford Motor Company engineers turned to zinc. Galvanized, or zinc-clad, steel is noted for its resistance to corrosion. It presented special problems, however, in automotive applications. It was hard to weld, difficult to paint.

Our engineers solved the welding problem. They found a process which eliminates the crystalline pattern on galvanized steel and produces a surface that will accept a high-quality paint job.

Now zinc is married to steel and used for vital underbody parts and rocker panels of Ford-built cars. The zinc coating forms a tough barrier to corrosive moisture—and if corrosion attacks, the zinc sacrifices itself through galvanic action, saving the steel.

Other avenues explored in the fight against rust also brought results: special zinc-rich primers to protect critical lower body areas, aluminized and stainless steels to extend muffler life, quality baked-enamel finishes that are more durable (and look better).

Added rust protection marks another step forward in Ford Motor Company's quest for total quality—and brings you cars that last longer, need less care and keep their value better.

*Salt-water bath is one of tests
used to check rust protection
built into Ford-built cars.*

**FORD • MERCURY • THUNDERBIRD
LINCOLN CONTINENTAL**



MOTOR COMPANY

**WHERE ENGINEERING LEADERSHIP
BRINGS YOU BETTER-BUILT CARS**

The Truth About Brain Drugs

[Continued from page 73]

parts of the RAS and said *fire-burn-hurt*. You tensed your muscles, said "Ouch," and dropped the book.

In other words, one pathway gave you the news; the other let you feel it.

Now suppose a drug depresses the RAS but not the cortex. The facts still get through, but the feelings—the emotional pain and suffering—are diminished. This is one of the ways chlorpromazine acts.

But neither reserpine nor meprobamate do this. Reserpine in fact *stimulates* part of the RAS. How do they work, then?

That's where the second great system loop comes in—the Papez circuit. Here the link of emotion and thought starts in a set of odd-shaped parts at the forward base of the brain called the rhinencephalon—literally man's "smell brain."

Impulses travel from the rhinencephalon to the cortex by way of a part called the thalamus and, under it, the hypothalamus.

The hypothalamus—the size of a Ping-pong ball—at the base of the brain may be the key piece in the whole jigsaw puzzle of behavior. It coordinates all the breath-blood-muscular responses to flight or fight emergencies. It regulates hunger and sex needs (animals will forego mating for the delights of direct stimulation of the hypothalamus). And it also programs the output of the pituitary gland—the pump that primes the flow of many hormones.

The strong tranquilizers, reserpine and chlorpromazine, depress the hypothalamus. Meprobamate, much milder, leaves the hypothalamus alone, but checks the thalamus and rhinencephalon instead. The result is that you calm down.

Now you would assume that the strong tranquilizers would also perform this fine muscle-relaxing trick. They don't. In fact they stimulate the rhinencephalon—so that the strong doses used in treating mental patients sometimes produce muscular tremors.

Ups and downs. Such perversity is not all built into the drug and comes as no surprise to specialists. The truth is, the brain starts out as a split personality. Half of it wants to soup you up; half wants to put on the brakes. All motor activity results from a balancing of these opposing forces. And both opposing kinds of nerves or hormones may be mixed up in the same substructure. So to say that a drug "depresses the hypothalamus" may mean that it takes pres-



Lifelike water color at top was painted by a normal artist. After taking LSD she couldn't paint solid objects but managed the flowers—pretty but vague in weightless, unreal world.

sure off the gas pedal only—like chlorpromazine. Or it may mean that it does that but also steps on the brakes—like reserpine. (It stimulates nerves that want to dilate blood vessels, lower heart rate.) Or it may mean that the drug takes the load off both systems—which is how the barbiturates act:

Phenobarbital, Nembutal, and their like generally depress the brain's activity, spreading their effect to the cortex so that finally you knock off conscious thinking altogether and sleep.

But suppose you don't want to sleep? At the opposite pole from tranquilizers and sedatives are the "psychic energizers."

Dr. Nathan S. Kline, Director of Research at New York's Rockland State Hospital, describes the work of these drugs as "fill-

6 REASONS WHY SKILSAW POWER SAWS OUTSELL EVERY OTHER MAKE!

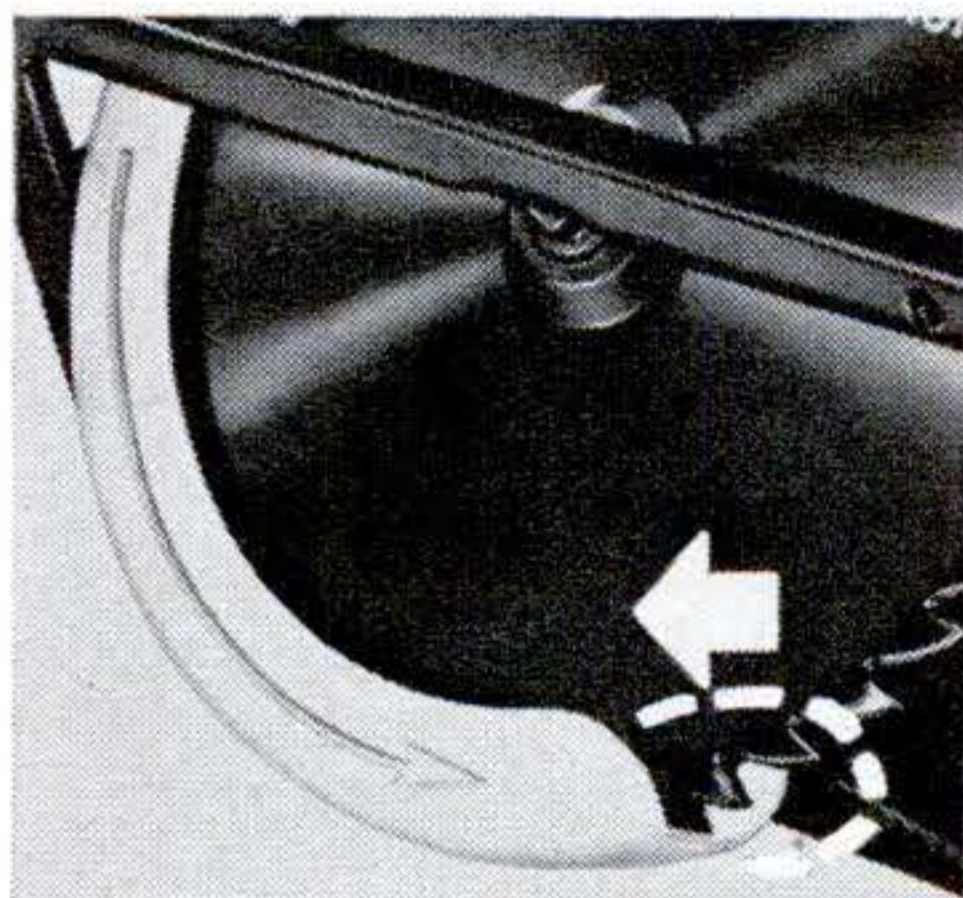

Bind-free lower guard—Retracts automatically when saw base is tilted, thus allowing bind-free starts—even on compound miter cuts.

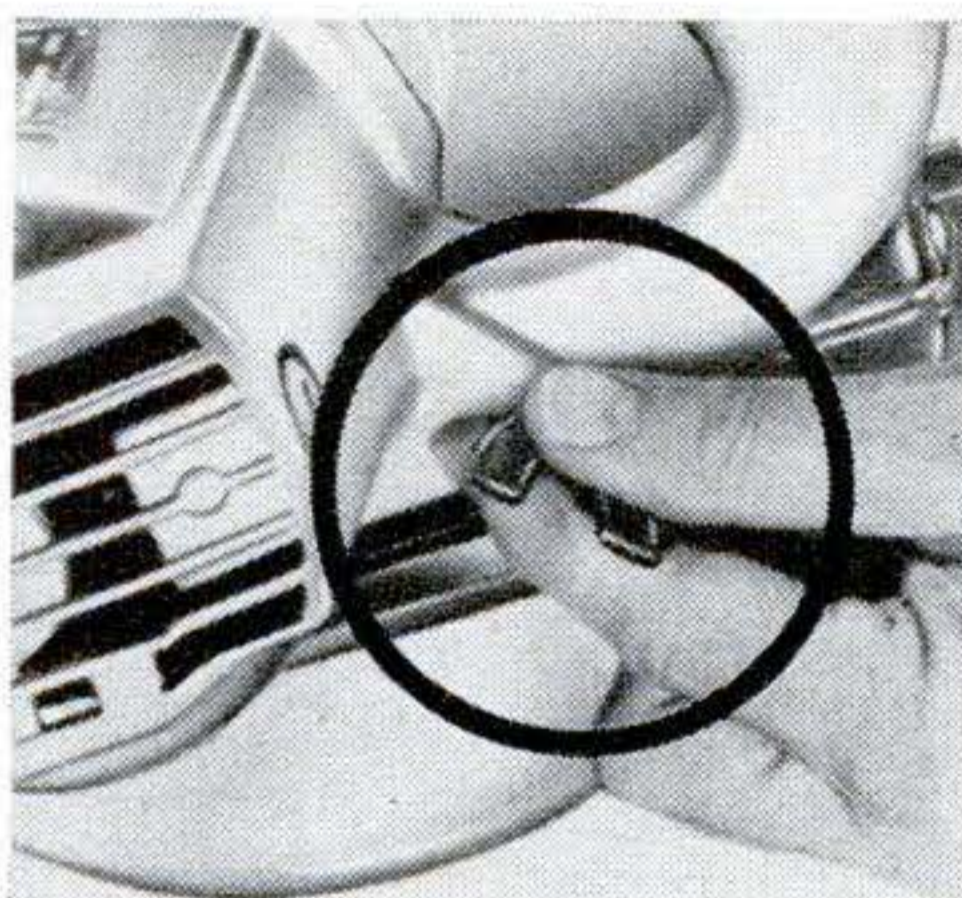

Easy-to-set depth control—Conveniently located for easy one hand adjustment. Control locks the saw firmly and quickly at any desired cutting depth.

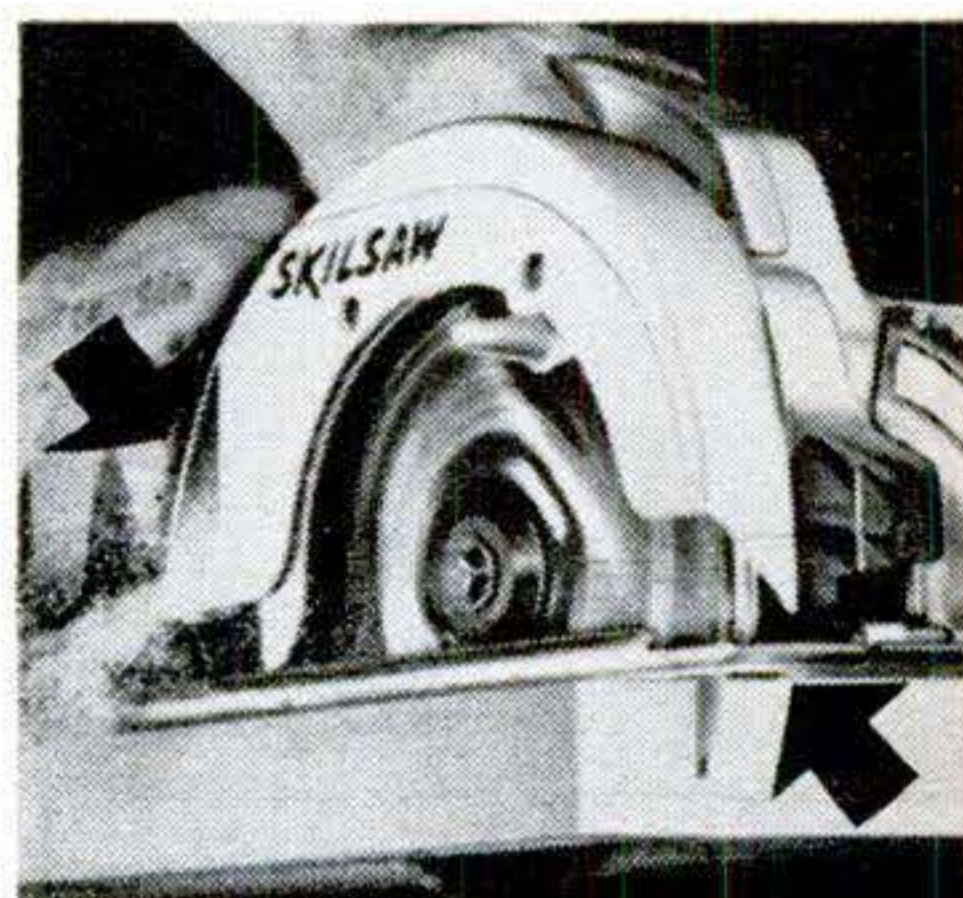

Exclusive sawdust ejection—Special air stream ejection system directs sawdust down to floor, away from the operator; blows it off the line of cut.

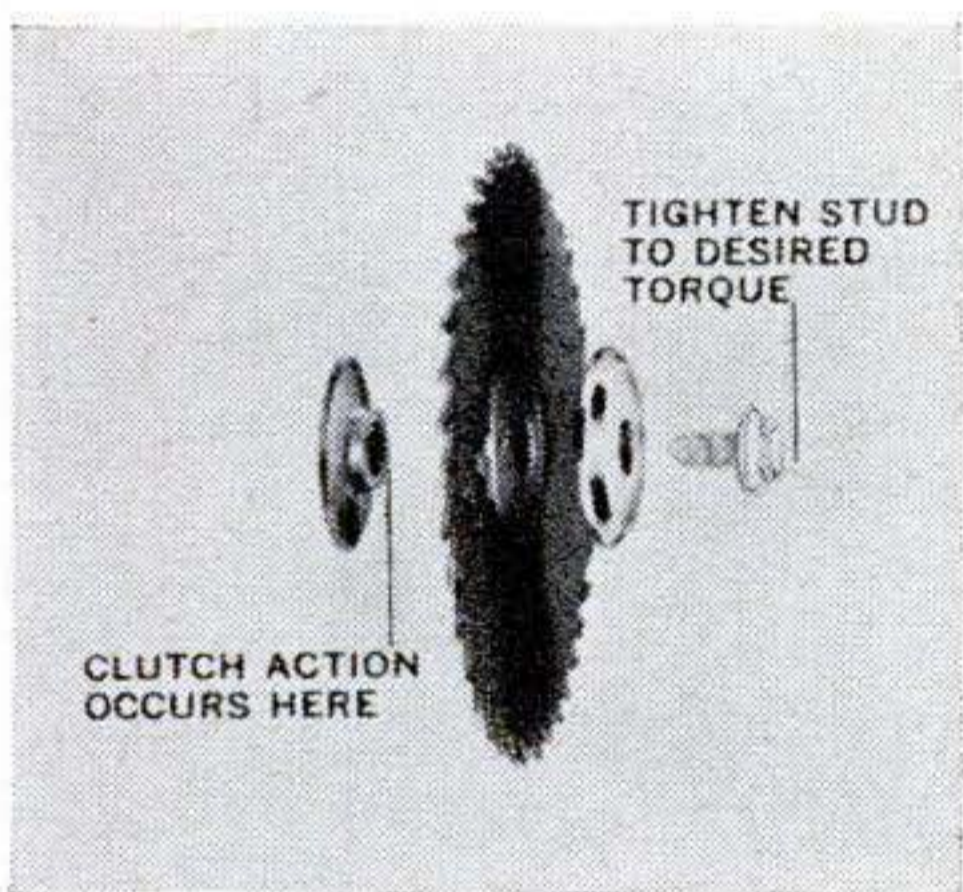

Vari-Torque safety clutch—Disengages blade if it binds or jams. Protects gears and other parts from damage, prevents saw kick-back.

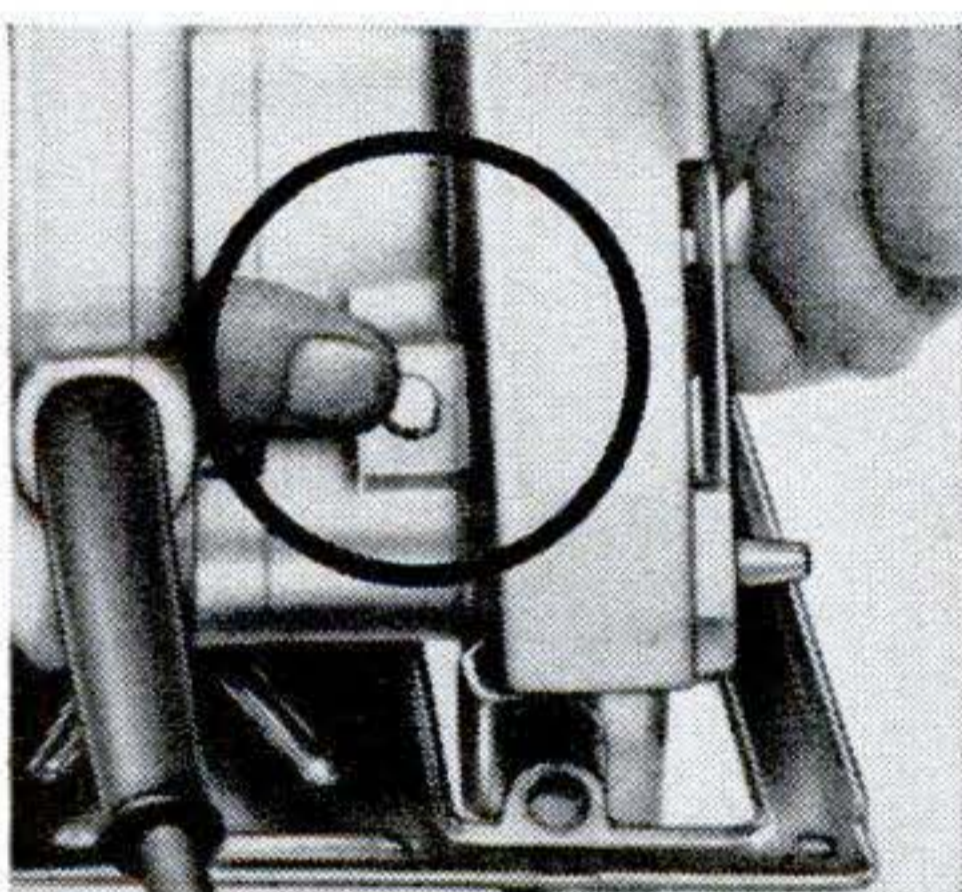

Exclusive Blade Lock* (Patented Feature) For fast, easy blade changes. Push-button engages and locks blade shaft for greater user safety.

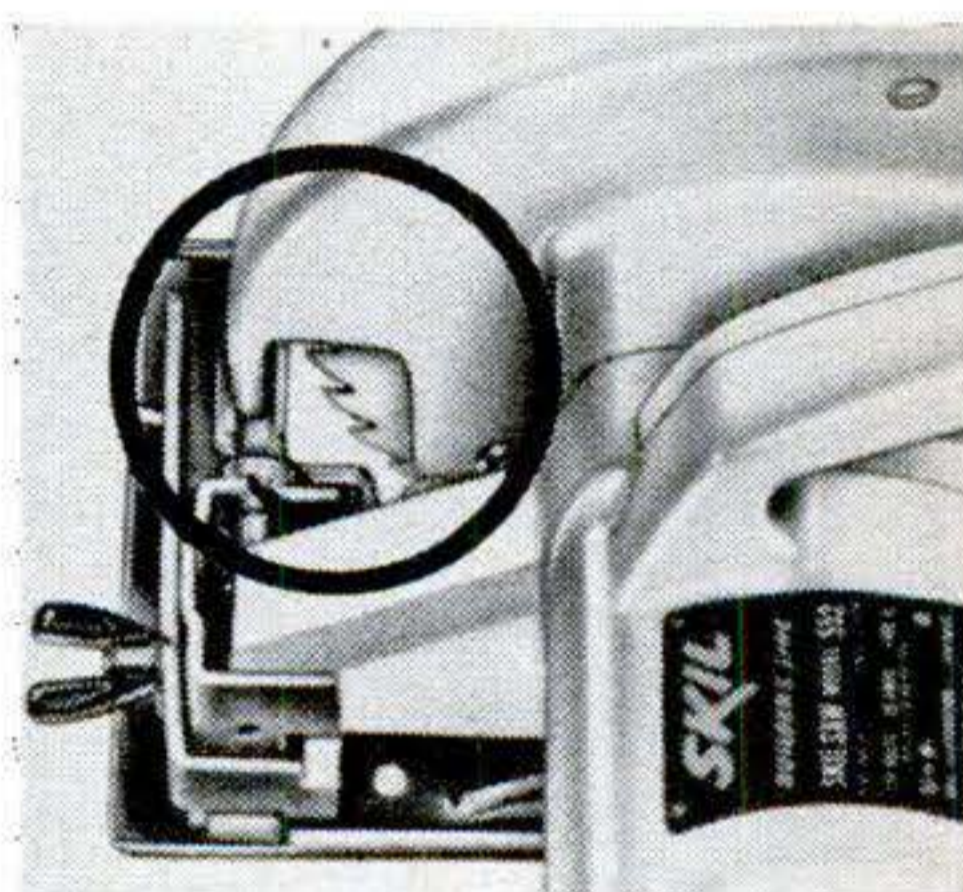

Full-View Blade—Upper blade guard designed to allow clear view of blade all through the cut for absolute precision and accuracy.



Skilsaw Model 536—World's largest-selling 6½" saw. Makes 45° bevels in 2" lumber, has super burnout protected motor. Other models up to 8¼".

There are many more features, too! Like super burnout protected motors on *all* models, and full ball-bearing construction on heavy-duty models.

Because Skil never compromises on quality, no other saw offers all these features to make every cutting job easier and faster.

Skilsaw Power Saws are made in both deluxe and heavy-duty models with full range of blade sizes from 5½" to 8¼". See them at your nearby lumber and hardware store.

Prices start under \$30—slightly higher in Canada.

SKIL
POWER TOOLS

* available on heavy-duty models only

The Truth About Brain Drugs

ing the pump"—giving you what it takes to make you sharp and fast-working without fatigue setting in. This is very different from the amphetamine (Benzedrine) school of "psychic stimulants" where the effect is one-shot: You're supercharged for a few hours but then you hit bottom. The pump operating at peak performance has poured out all the juices—the adrenal hormones—and now it's empty.

Block that kick. The energizers ("Nardil," "Niamid," "Marplan," "Parnate," etc.), in contrast to the stimulants, seem to work by blocking the action of a chemical the body sends out to destroy these hormones after they have been released. Hence they can continue their alerting work.

When energizers are used on patients suffering acute melancholia, the results are astonishingly good.

When used on "normal" people, they are harder to predict, but they may be a clue to "mind-improving" drugs. Dr. Kline took energizers for a brief period and found he could work harder, longer, and with greater imagination. He slept less but was not tired. (His dreams, he added, distinctly improved.)

Others found their moods deepened, so that if they started out feeling low the drugs plunged them into deeper gloom.

This could be because the chemical balance in the normal person's brain is more nearly in line. A potent drug could throw it out. But in the abnormal person this is not so. Studies of violent patients in mental hospitals show suspiciously large amounts of adrenal hormones and several others.

Proteins, too, may figure in the picture. A number of research groups have extracted certain ones from the blood of disturbed patients. These, when injected in normal adults or in animals, seem to produce schizophrenic symptoms.

Other specialists prefer to look for differences between the normal and the abnormal inside the brain itself. Dr. William Sacks of Rockland State Hospital has experimented with glucose injections. His results suggest that less glucose—the blood sugar that is the brain's major fuel—is burned in the brains of ill patients. This could mean that some of the atoms are being used elsewhere in the brain, or that, in their unused state, they may sour into poisons that cause insanity.

Such a "stale" form of adrenaline can

do this. So can the most impressive of the newer man-made drugs: lysergic acid diethylamide 25. Impressive because in infinitesimal amounts (1/700,000,000 of a man's body weight) it can make normal people mad—temporarily.

A true derangement takes place under LSD. The walls of the room may seem to melt and move in and the person may feel disembodied and floating. Sights and sounds are intensified so that dazzling patterns are seen and the sound of a typewriter becomes an infernal machine.

Yet when LSD has been given to neurotic patients—especially ones driven by obsessions or compulsions—it has helped in a remarkable way: It has restored memory. The long-lost childhood incident that may be the crucial clue to illness suddenly springs to mind.

Apparently LSD and other potent "hallucinogens" strike the brain universally, but hit especially hard the cortex area with its memory-storing temporal lobes.

If scientists could figure out precisely how all the mind-affecting drugs act, if they could determine whether the drugs behave strictly chemically or also electrically (either by dampening the energy level throughout the nervous system or by acting as "circuit breakers" in parts of it), they would have a weapon infinitely more powerful than any produced in space-age labs. At stake is the possibility of man, at last, controlling himself. ■ ■

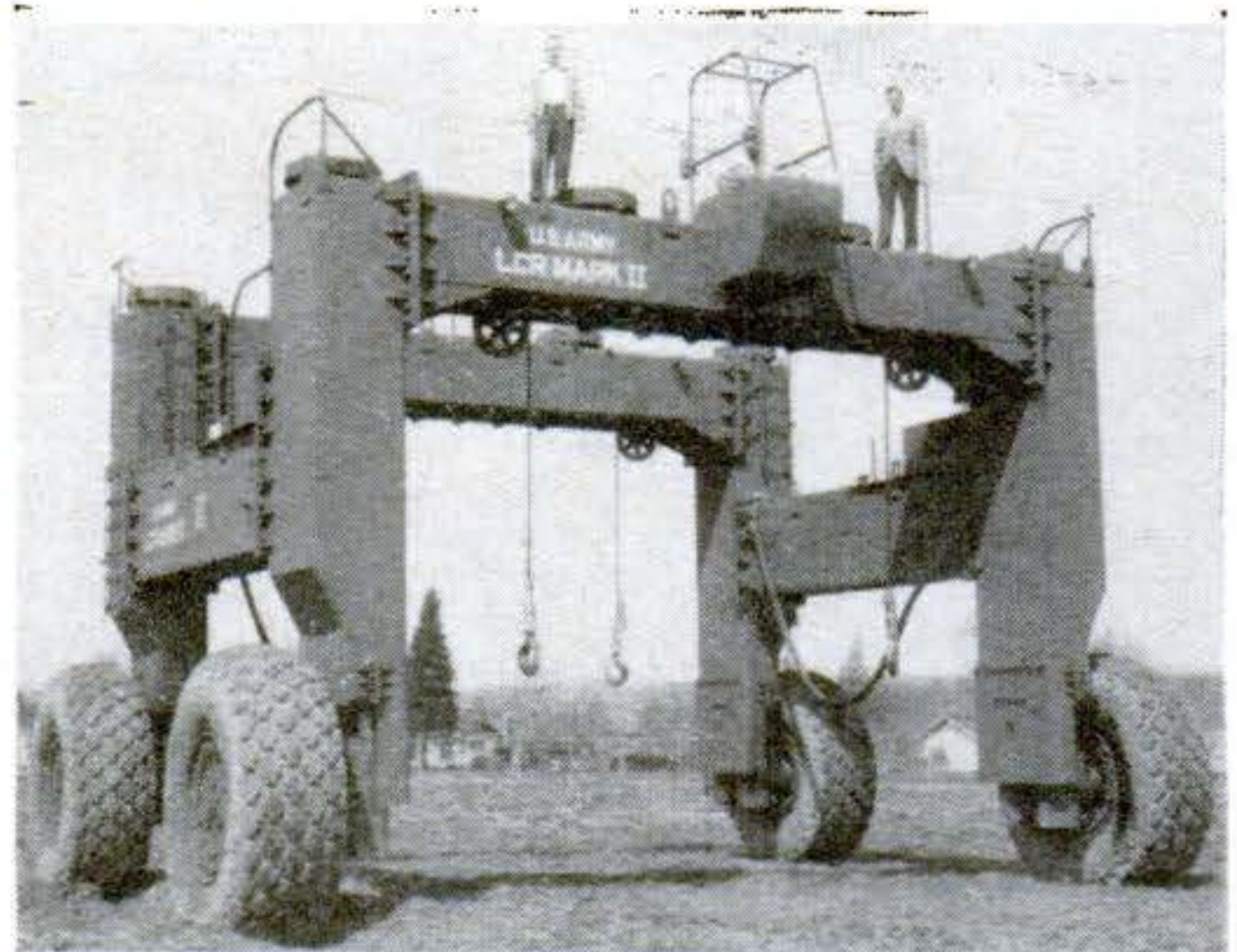

BOAT SAVER. The Army's Mark II Landing-Craft Retriever lifts its own weight, 70 tons. Its job is to rescue beached and disabled landing craft from the surf. Maker: Skagit Steel and Iron Works, specialists in logging machinery.



Cheer Up! Gear Up with

GRAVELY



NEW Tools For Even More VERSATILITY!



NEW Looks To Match *GRAVELY'S* Unmatched **POWER-PERFORMANCE!**

Cheer up! Gear up with Gravelly—say good-bye to drudgery, disappointments, half-done jobs!

And watch the neighbors' eyes pop when they see you riding your stylish new Gravelly—they'll turn as green as that velvety lawn you have when Gravelly does the mowing.

Ride or guide for complete versatility. Power your choice from 31 tools. Including NEW 50" Rotary Mower, NEW 20-gallon Sprayer. You choose from FIVE mowing tools, complete lawn and garden attachments . . . the unique Rotary Plow that gives you a perfect seedbed in one operation . . . the power Cultivator. Name the tool you need, Gravelly's got it!

ALL-GEAR DRIVE TO, THROUGH TOOLS

All GEAR-POWERED by the one Gravelly Tractor. No belts or chains . . . INSTANT forward and reverse, plus your choice of high or low speeds . . . easy-handling with gear power to and

through the tool to get your tough jobs done fast!

Cheer up! Gear up to make your place a show-place with less drudgery, more satisfaction in a job well done—easily!

FREE 'POWER VS. DRUDGERY' BOOKLET

See all about the new Gravelly—in color! Check the Yellow Pages for your authorized Gravelly Sales and Service representative. Or send for your free, BRAND NEW "Power vs. Drudgery" booklet . . . Write Now!



TRACTOR DIVISION

Studebaker

C O R P O R A T I O N

5902 GRAVELLY LANE
DUNBAR, WEST VIRGINIA

Sky-High and Starry-Eyed

[Continued from page 90]

load to altitude fills a balloon 90 feet tall and 75 feet in diameter at ground level. But as the balloon rises and atmospheric pressure lessens, the expanding helium would need a much larger gas bag. Such a big balloon would be mostly empty at launch and would billow like a spinnaker—and might bump the telescope along the ground at takeoff. By using two balloons, the bigger one encased in a plastic sleeve at first, the area exposed to the wind is reduced.

It was no secret when inflation began—you could hear it for a mile around. Helium from high-pressure tanks screeched through four waist-thick tubes into the side of the launch balloon. Each tube was held steady by two men wearing insulated gloves to guard against frostbite (helium being no exception to the rule that there's a sharp temperature drop when any compressed gas expands to atmospheric pressure). As the gas squealed in, the balloon stirred, bulged, and crackled as folds in the plastic snapped open.

Fully inflated, the launch balloon was allowed to rise slowly as guy wires were winched out. Beneath it, the sheathed main balloon, parachutes, and suspension lines were pulled up. The payload was still anchored to the ground.

Cutting it loose. Held down by cables, the apparatus stretched higher than the Washington Monument. Then, sounding like light pistol shots high in the evening air, small explosive squibs were fired electrically. One cut the main stay, allowing it to float down 500 feet by means of a tiny parachute. Another one started a seam ripping in the main balloon's sleeve. A third squib released the payload hold-down cables.

As twilight neared, the giant mobile slowly rose into the night. A truck, hauling a helicopter, began to follow below.

As the gas bag rose into thinner air, the helium inside it expanded. At about 6,000 feet, the launch balloon was filled to its limit, and slowly the gas squeezed through a three-foot collar into the main balloon. The 340-foot sheath split open, letting the main balloon inflate.

Ideal speed for the balloon's rise is 800 feet per minute. To insure that it ascended at the right speed, a radio plane circling below it monitored altitude signals tele-

metered from the scope. If it rose too slowly, the plane sent a signal for ballast to drop. Too fast, and a signal opened a valve in the top, letting out gas.

All night the balloon and its dummy payload floated eastward over the southern U.S. It was a successful test, but things went wrong at the end of the flight.

At dawn, a signal was sent to valve the apparatus down, but the balloon didn't respond. A little later, an automatic timer carried on board triggered the exhaust valve, and the balloon came to earth near Krotz Springs, La. Now the ballast—steel powder held in an electromagnetic hopper—spilled accidentally and the balloon rose again, but only to 14,000 feet, since much of its gas had been valved off.

The balloon drifted across the Gulf of Mexico and Florida, then out over the Atlantic. Approaching heavily traveled air lanes, it became a navigational hazard. Navy jets finally shot it down about 100 miles off the coast.

An embarrassment to the Strato II team, to be sure—but other test flights have landed successfully. The malfunction was not considered a serious one.

That flight was the last of five telescopeless trials, preludes to the main event scheduled for this month or next.

Let's see what that will be like—when Strato II carries real instruments and its 36-inch telescope instead of a dummy payload. Launch, tracking, and balloon control will be identical. The big difference, this time, will be an antenna-circled trailer some 200 miles from Palestine—at the flight's expected halfway point.

In the trailer will be two astronomers, a telemetry engineer, an RCA TV engineer, and a navigator—all anxiously waiting for the scope to reach altitude. Project director Schwarzschild won't be there yet. He'll be driving furiously from Palestine after supervising the takeoff.

As Strato II nears its ultimate altitude of 80,000 feet, technicians in the trailer will begin to monitor the radio equipment. Transmitters in the telescope can report data over 64 different channels. From the ground, 40 channels will be open for sending more than 100 kinds of instructions, controlling everything from focus to fine aiming.



By this time Schwarzschild will have

Once you own a Hallicrafters...

You gain a deeply satisfying new perspective on world events as you hear them reported in English direct from Moscow . . .  Berlin . . . London . . . New Delhi—and with as many

different viewpoints. You listen with quiet pride, and renewed hope, as the Voice of America and radio amateurs alike  (perhaps a neighbor) melt the Iron Curtain with words of warm

friendship and cold fact. Mysteriously, your children begin to pronounce the difficult foreign names like natives, and attack their language study  with new vigor. Frequently you

pause in your dial-roaming to eavesdrop on military and civilian aviation  or marine communications  and, on rare occasions, a barn-burner of an emergency. Enough

excitement? Switch instantly to superb local reception—clean, clear and from more stations than you thought existed. For this is a Hallicrafters you own. A unique and

incomparable new Information Center for a thoughtful man's home.



World-Range Radio by *hallicrafters*



For well under \$100 you can own one of these remarkable Hallicrafters precision communications instruments. No other type of short wave receiver can bring you satisfactory, understandable world-wide reception. This model is the WR-1000, in exquisite mahogany veneer cabinetry. Three short wave bands plus local broadcast. Professional-type electrical bandspread for razor-sharp tuning of close-together stations. Outlet for earphones. Telescope antenna. Model S-120 available in gray steel cabinet. We've printed a beautiful miniature book entitled, "Guide to Short Wave Listening" that might interest you. 64 pages, illustrated. It tells the whole story of short wave radio. If you'd like a copy, please send 35c to:



hallicrafters

Dept. 17-B, Chicago 11, Ill.

Sky-High and Starry-Eyed

arrived at the control trailer. As soon as the scope reaches height, a signal will be sent to it, and motors will tilt it from an upright L to a V position, with the long arm pointing upward through only three percent of the carbon dioxide and 1/10 of one percent of the water vapor that are present in the earth's atmosphere.

The men will crowd around the TV set; on the screen the stars will appear, as seen through a small telescope strapped to the side of the big one.

What will they see? The sighting scope takes in a field about 10 degrees wide—roughly the area blocked by a coffee can held at arm's length. The answer will come when telemetered attitude and compass readings are coordinated against a star map. Then the telescope will be swiveled to point at a preselected spot in the night sky.

Once the image is centered in the coarse scope, the TV view will be switched to the camera inside the big scope, a pickup so sensitive it can focus on stars of the twelfth magnitude (the naked eye does well to see sixth-magnitude stars).

Now comes locking in. Gadgets for this operation were devilishly tough to design, because the telescope's aim must not shift more than six millionths of a degree per hour, even though the scope is swaying.

Instead of locking on the object to be photographed, the aiming system is set to fasten its attention on two guidepost stars, one on each side of the subject. Reason: Most of the bodies to be examined, particularly planets and nebulae, are just too big; objects for fixation must be points, not disks.

Two sets of servo motors will keep the telescope pointed. One set will move the whole scope. For the delicate movements needed for fine aiming, small motors inside the tube will gently wobble one of the lenses in the telescope's folded light path.

Through the night, as the observations take place, the truck driver will be jockeying around the countryside on back roads with the helicopter in tow, trying to second-guess wind directions so as to be underneath the balloon when dawn arrives.

At daybreak, the telescope will be valved down to about 5,000 feet and held there until the copter can lift off and catch up with it. Now the copter will take over

control and valve the balloon down to 200 feet or so, where it will drift until it's over a good landing site. Releasing more gas, then, will lower the load to the ground (the parachutes are for emergency use only). Hopefully, the scope will bump softly enough to be used many times over, perhaps for years. Data from one night's work will be enough to keep the researchers busy for months interpreting it.

The first flight of Stratoscope II will be for infrared studies of Mars. Measurements by sensitive equipment may detect water and organic molecules on the planet—clues to the existence of life there. It must come soon, for Mars, due to its proximity to Earth, will be in a "window" only until the end of March.

The following flight—and the first to take photos—is slated for August, with flights planned every four months thereafter. What do the scientists hope to find? Here are a few questions to which Strato II may supply answers:

- Venus, our sister planet, is continually veiled in clouds. Are these composed of water droplets, ice crystals, dust? Or what? Perhaps Strato II will be able to tell. It may even reveal the surface through gaps in the cloud cover.

- Jupiter, largest of the planets, may or may not be made up largely of gases. Nobody knows. And what is the 30,000-mile-long "red spot" hovering over its surface?

- Saturn's rings are probably composed of billions of particles. What are they? How close together are they? How large are the pieces?

- "Dark companions" of stars may not actually be dark—it's just that nobody's been able to see them yet. We know *something* is there, shown by the gravitational effect (a wobble) on their visible companions.

- Many nebulae, including the Great Nebula in Orion, are startlingly similar to our own Milky Way. The cores of nebulae are particularly interesting to astronomers, for here is where new stars probably are being formed. Strato II may resolve them into something more than blobs of light.

Most exciting of all is the possibility—when light amplifiers are later added—of seeing planetary systems of other stars.

It used to be said that good astronomers go to the moon when they die. The seeing there is excellent. Stratoscope II makes *that* trip unnecessary. ■ ■

1/4" 3/8" 1/2" AND UP!

**CHUCK SIZE? YOU NAME IT!
PERFORMANCE? NO CONTEST!
VALUE? BLACK & DECKER'S REALLY GOT IT!**



If you're a price man, get a load of this new **U-100 1/4" Utility Drill**. Check the tag. Impossible? No. Go ahead and buy—it's for real! Handles all B&D attachments. Full year free service warranty (except commercial applications).

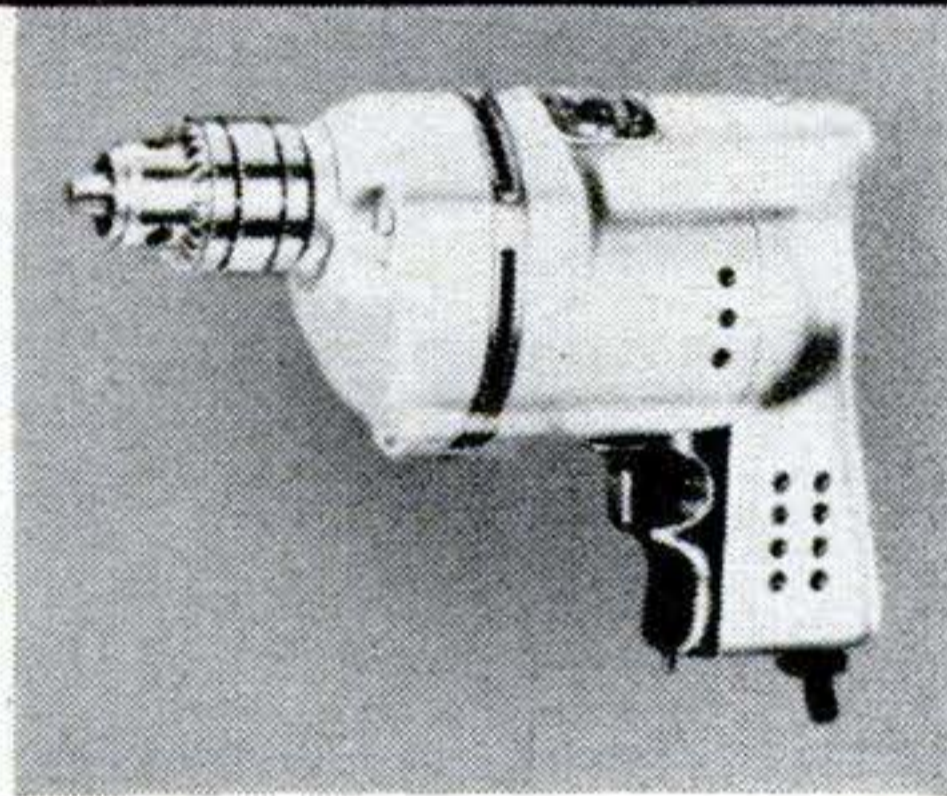

This is no "warmed over" 1/4" drill. It's a 3/8" drill that's 3/8" through and through. The **U-120 3/8" Utility Drill** has double reduction gears for extra power—a totally superior tool for the price. Up to 3/8" holes in steel; 3/4" in wood; 1/2" in masonry.

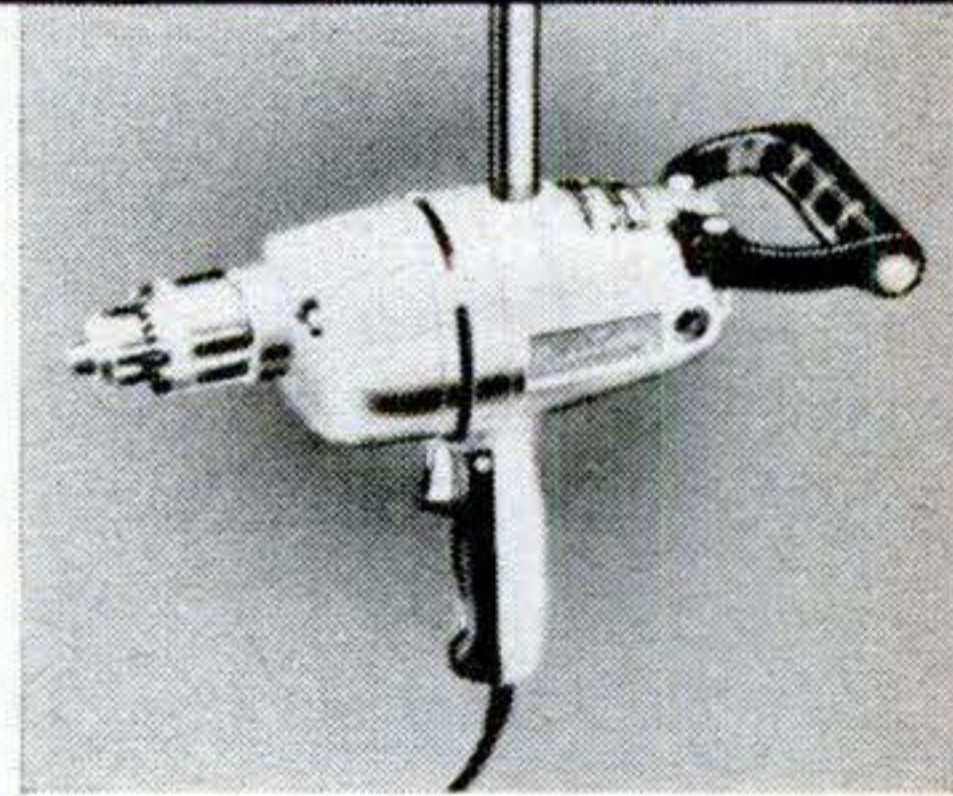

Bigger jobs? Heavier construction, maintenance, repairs? Get next to this **U-226 1/2" Deluxe Drill**—and get something that's tough enough to take the punishment and dish it out. Greatest 1/2" drill buy—for economy, capacity.

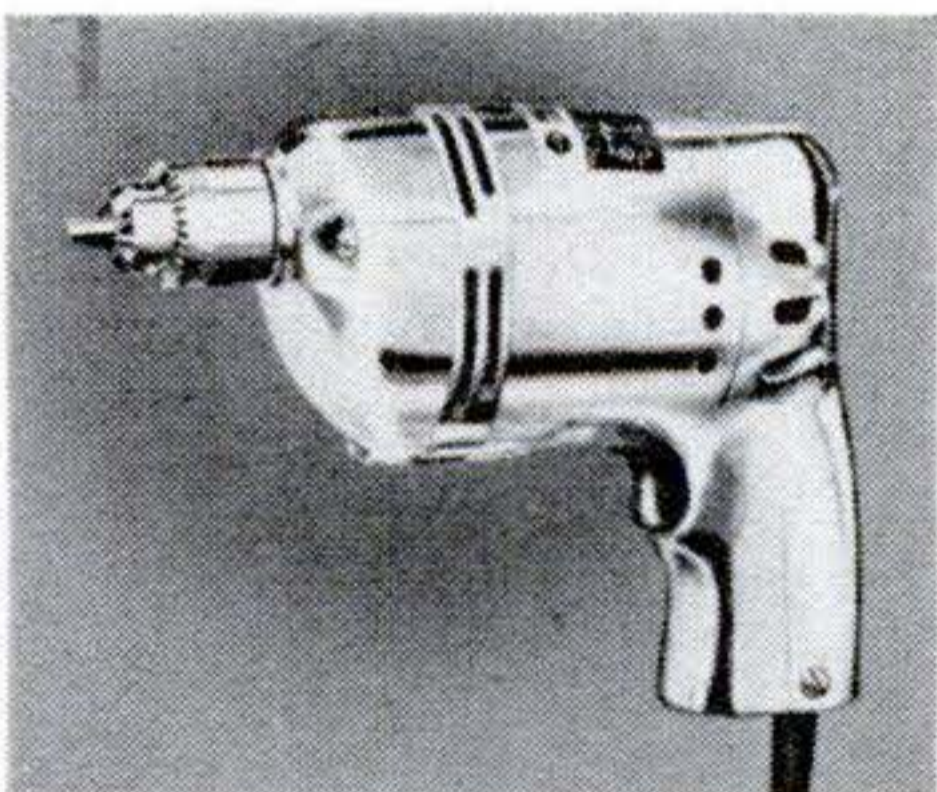

Like to own the best 1/4" drill made? Admire *real* quality? Want maximum power and performance? This is yours! This **U-300 1/4" Professional Roller Bearing Drill** defies comparison. All roller bearings. Top efficiency. More torque—20% more power.

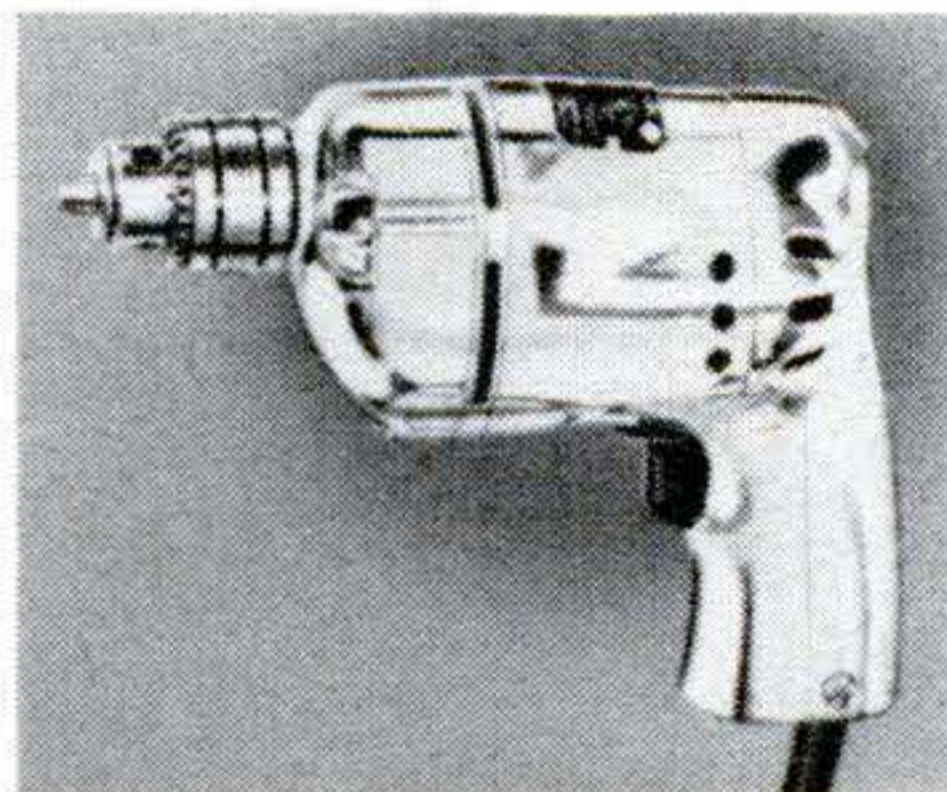

Take this **U-220 3/8" Deluxe Drill**—and drill circles around anything in its class. True double reduction gearing. Terrific capacity for wood, steel, masonry, plastic. 1,000 holes from now you'll say: "Man—I got my money's worth on you!"

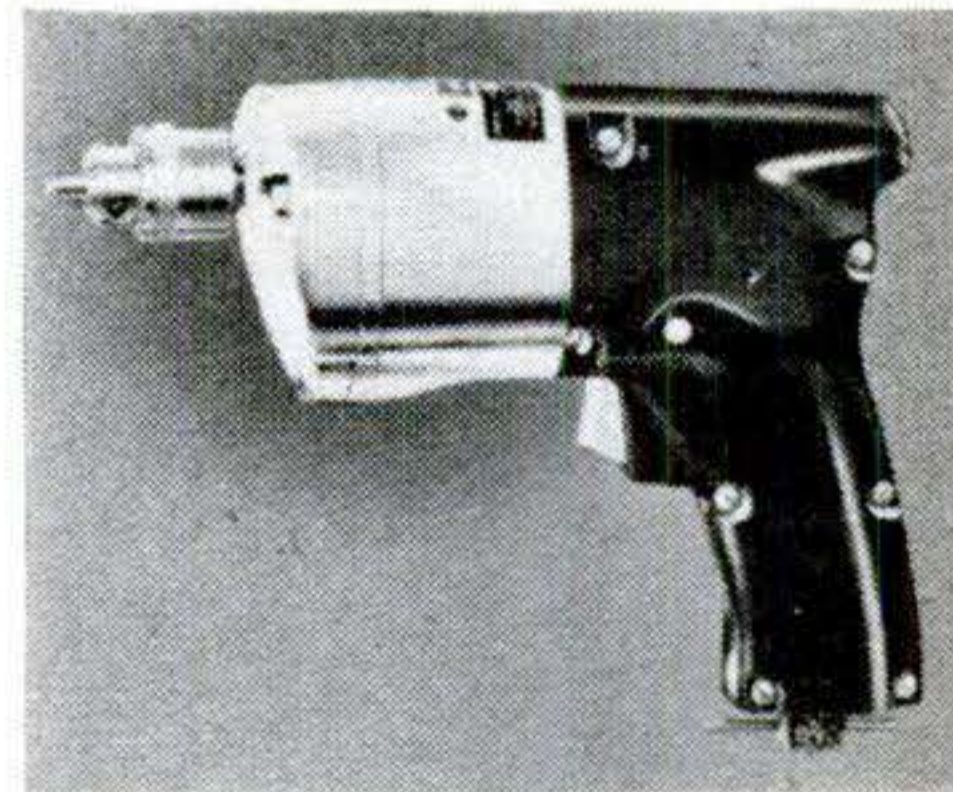

No cord. No plug. No outlet. And no dangling batteries! For the man who repairs, fixes, builds beyond a power source, the **C-601 1/4" Cordless Electric Drill** is a must. Amazing capacity. Rugged. Shockproof. Complete with Power Pack Charger.



Black & Decker

MAKER OF THE WORLD'S FIRST CORDLESS POWER TOOLS

Master Power
AIR TOOLS



DeWALT
POWER TOOLS



"How to Choose and Use Power Tools." 180-page booklet only 25c. Write: The Black & Decker Mfg. Co., Dept. P-023, Towson 4, Md.

South Bend[®]

10" LATHES

*with new
welded steel
floor legs*

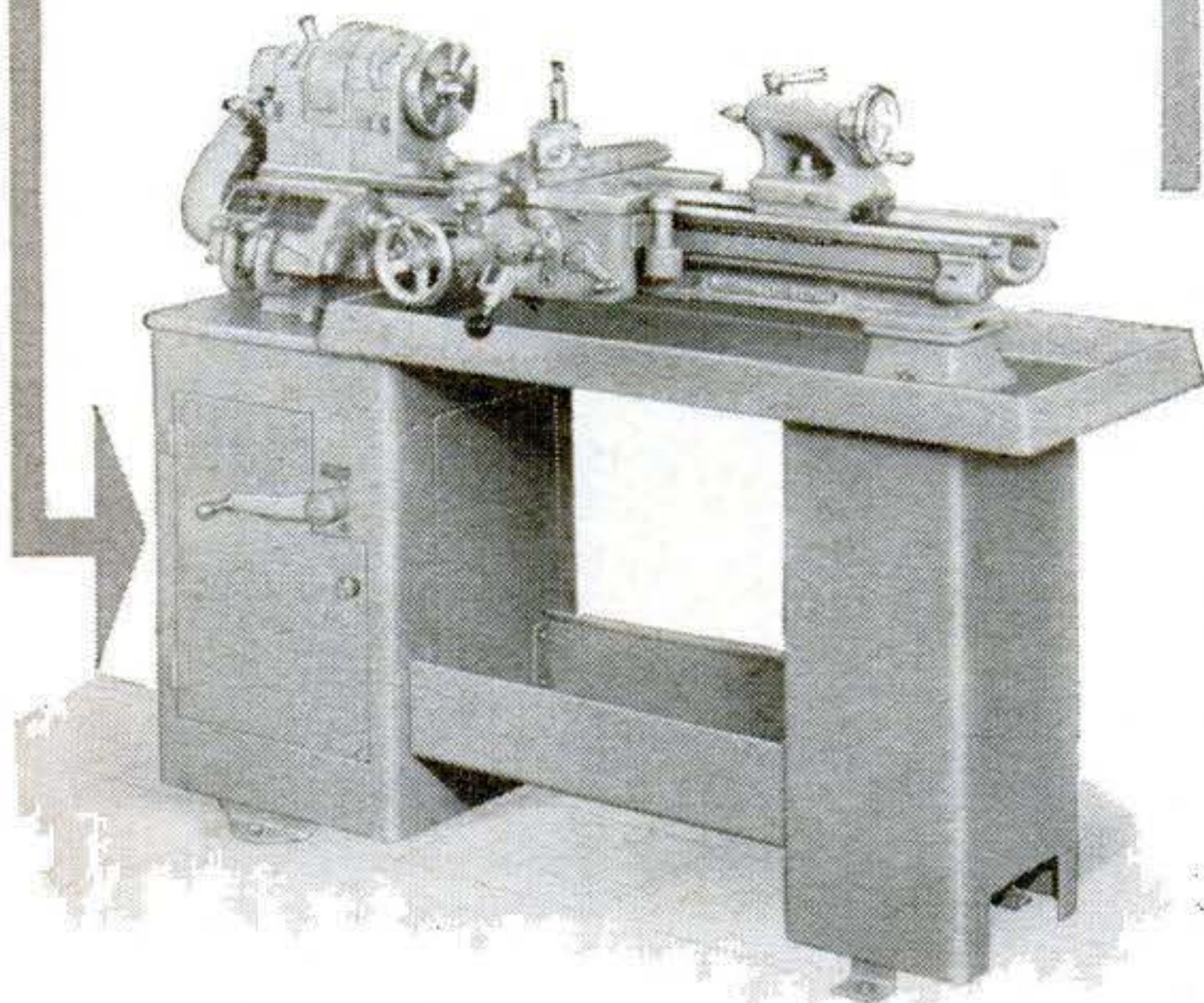

- New, trim floor legs . . . reinforced construction of welded, heavy gauge steel . . . maximum rigidity with minimum weight . . . no increase in price!
- Famous South Bend dependability.
- Superfinished spindles and bearings for uniform accuracy and fine finishes.
- 70 screw threads (4 to 480 per in.) . . . 70 longitudinal feeds . . . 70 cross feeds.
- Tool room and Engine Lathe models . . . prices start at \$1346 f.o.b. factory.

WRITE FOR CATALOG

*of South Bend Lathes, Milling Machines,
Shapers, Drill Presses*

SOUTH BEND LATHE, INC.

South Bend 22, Indiana

Building Better Tools Since 1906

up to 36 months to pay



"American Kids Can Take It!"

[Continued from page 109]

lunch of cattails, saw grass, wild cherries, roasted yucca pods and stems, and drank pine-needle tea.

When we reached our check point, near U.S. 92 and Interstate 4, it was 6:30. We had traveled 11½ miles—but only 9 on the map. We had had to bypass a large swamp. On the way we had caught a small banded water snake. Divided nine ways, it was all we had to eat as we were too tired to hunt. We slept on beds of Spanish moss.

Second day, June 19. We got up at 5:15. Since there was nothing to eat in this barren country, we set out at once.

Water got alarmingly scarce. What we found was bitter-tasting, coming from brownish pools in an occasional cypress swamp. We skirted one huge swamp just before noon. We looked for gopher tortoise, ripe berries—anything—but food just wasn't there.

At two in the afternoon we stumbled out on the banks of a drainage canal. We were way off course and weak from lack of food and good water. The canal water was no help. The heat was unbearable. The temperature must have topped 100.

"Let's rest until it gets a little cooler," I said, and led the way to some small trees along the bank. I had just dozed off when somebody shook my arm.

"Ross, what's that?"

Awake at once, I could hear heavy bodies crashing through the low scrub. Then the grunting. "Wild hogs!" I said.

Just then two razorback sows with half-grown litters came out on the opposite bank.

"Cut off the little ones!" I yelled. We all jumped in the water. The sows squealed and tried to lead the small pigs back. I threw the machete and struck one. Buddy Nye threw himself on it.

"I've got it, I've got it!" he called, stabbing the squirming animal.

As I ran toward him, grabbing the machete again, I saw the mother about to charge Buddy from the back. Men have been killed by enraged wild sows. I yelled and ran faster.

"American Kids Can Take It!"

But Buddy calls

ear the sow or my
t have been a yard
re and slammed her
e turned, confused,
egan belaboring her
while the young pig
ddy scrambled off.
d to see how the others
and spotted Dick Fowl-
n in the canal. From his
ally cutting the water, I
another pig.

We were so grateful for the meat—our first solid food in two days—that we skinned both pigs on the spot and cooked them on spits over an open fire.

We set out again, following a small fire trail west for a mile or so until it branched south and disappeared into a "bayhead" swamp. Bayheads are branches of larger swamps—nasty sinks of deep, gooey mud, lined with sweet-bay trees and cypresses draped with sphagnum moss. Heavily thorned smilax and blackberry vines weave through them. As the vines were

too thick to be pushed aside, we plunged in, Buddy and I taking turns hacking a path with the machete.

Instead of tapering off, the bayhead became thicker. The mosquitoes were fierce. We sweated the repellent off as fast as we applied it. Several of the boys were ill, probably from bad water.

It was nearly dark when we found a dirt road leading north; it dead-ended into a swamp. We backtracked and found a small trail that took us west to another north-south road. This took us to an old timber trail leading west.

We finally came out on a dirt road that led us to our check point on Highway 11 at 2:30 in the morning. We quenched our thirst with some dried-out oranges we'd found. Then we crawled under our mosquito nets and slept on the ground, having walked, waded, and crawled 17 miles.

Third day, June 20. We ate the rest of our oranges and pork for breakfast, then bathed in a small lake. To avoid the heat, we waited until late afternoon to resume



**Prove it yourself—
RISLONE babys your
car's engine as
nothing else can!**

Want better gas mileage? Lower oil consumption? New car pep? Add RISLONE® every oil change, or when you're down a quart. Cleans out power-robbing gum and sludge . . . restores quiet, efficient engine operation. Nothing like it to maintain lubricating efficiency of all motor oils, including the new long-life types. Now, with longer intervals between oil changes, it becomes more important than ever to use RISLONE regularly. Your money back if RISLONE doesn't improve engine performance. At your service station or garage. \$1.50 per quart. Slightly higher in Canada,

Free Proof of Performance Booklet: Record your RISLONE performance statistics . . . get valuable driving and money-saving tips. Write to: The Shaler Company, Dept. PS2, Waupun, Wisconsin.

"American Kids Can Take It!"

our hike. Hunting would be better at night, too. We could use our headlamps to hunt armadillo.

We made 9½ map miles that day, though we walked 15. The country was desolate. Our only food: one pygmy rattlesnake and a cottonmouth; our only drink: the juice of a few dried-up oranges until we made camp by a creek.

Fourth day, June 21. We came to the St. Johns River in midafternoon, but since the approaches were all swamps we had no chance to fish or camp. So, plowing our way through hyacinths, we collected a few fence rails trapped among them, and swam the river, our packs riding a makeshift raft.

Only five miles that day; we were starved and exhausted. Many of us were ill. Some of the boys found a few old lines and rusty hooks along the shore and went fishing while the rest of us made camp. They caught 16 small fish which we cooked on a piece of aluminum foil along with a snake. The night was miserable. Mosquitoes and midges were so bad that if you brushed against the net you'd be bitten a dozen times before you could draw away.

Fifth day, June 22. Our hike doctor came by to check on us this morning. He found several of the boys sick from the tannic acid in the water we'd drunk. He gave them anti-acid pills. We caught and ate about 40 small fish.

By midafternoon we were strong enough to continue our hike. On the way to Sellars Lake in Marion County we found a bountiful supply of huckleberries. We camped at the lake, though we'd made only 6½ miles. After dark we caught a few frogs, some fish, and a coral snake. What with food and clear water, we had a good night.

Sixth to tenth days, June 23-27. The next few days were good. The land was higher and cooler, the woods more open. Food was plentiful. We plotted our course so we were always within hiking distance of a lake.

On the sixth day we came to Ocala National Forest and hiked 12 miles through

it, heading for Half Moon Lake. We kept 100 or 200 yards apart, on our own food. After 1½ or 2 hours we were on our feet in the air for 15 minutes, in part by the chirps of cricket. We reached the lake at midnight. But being good, we pressed on to the edge of Highway 314 and made camp at two in the morning. We had killed two armadillos on the way.

And so it went. The next few days we feasted on huckleberries, blackberries, morning-glory root (it tastes like potatoes when roasted), and cabbage-palm heart; wild pig, armadillo, gopher tortoise, frog, fish, and even roasted grasshoppers. We were lean and fit. But I knew things couldn't stay that way.

On the morning of the tenth day we decided to start out early, rest at noon, and then do our usual evening stint. About seven a.m. Bobby Rile spotted a skunk and we ran to surround it.

"This is the way to catch a skunk so he won't spray musk on you," I said, hauling him up by the tail. I had heard that if you hold a skunk that way he can't use the musk gland which lies at the base of the tail.

Apparently the skunk hadn't heard this. He climbed his own body, grabbed his hind legs with his front paws, and let me have it right in the eyes. He caught Dick Fowler, too, and generously sprayed everyone's clothes.

The boys reacted at once—some dumped their canteens of water into Dick's eyes and mine; others killed the skunk. A lotion wash fixed up our eyes.

When the skunk was skinned, we went upwind to cook it; the meat was delicious. But we washed our clothes and bathed repeatedly for the rest of the trip.

In two more days we came into Yankeetown, end of the trail.

We had learned a lot—that man can survive in the worst kind of country with teamwork and planning. I had learned, too, that American kids can take it! They are rugged and knowledgeable. An enemy would have a hard time stamping out their fine spirit. ■ ■

VOYAGER



look what Lone Star has done

with aluminum!



MEDALLION

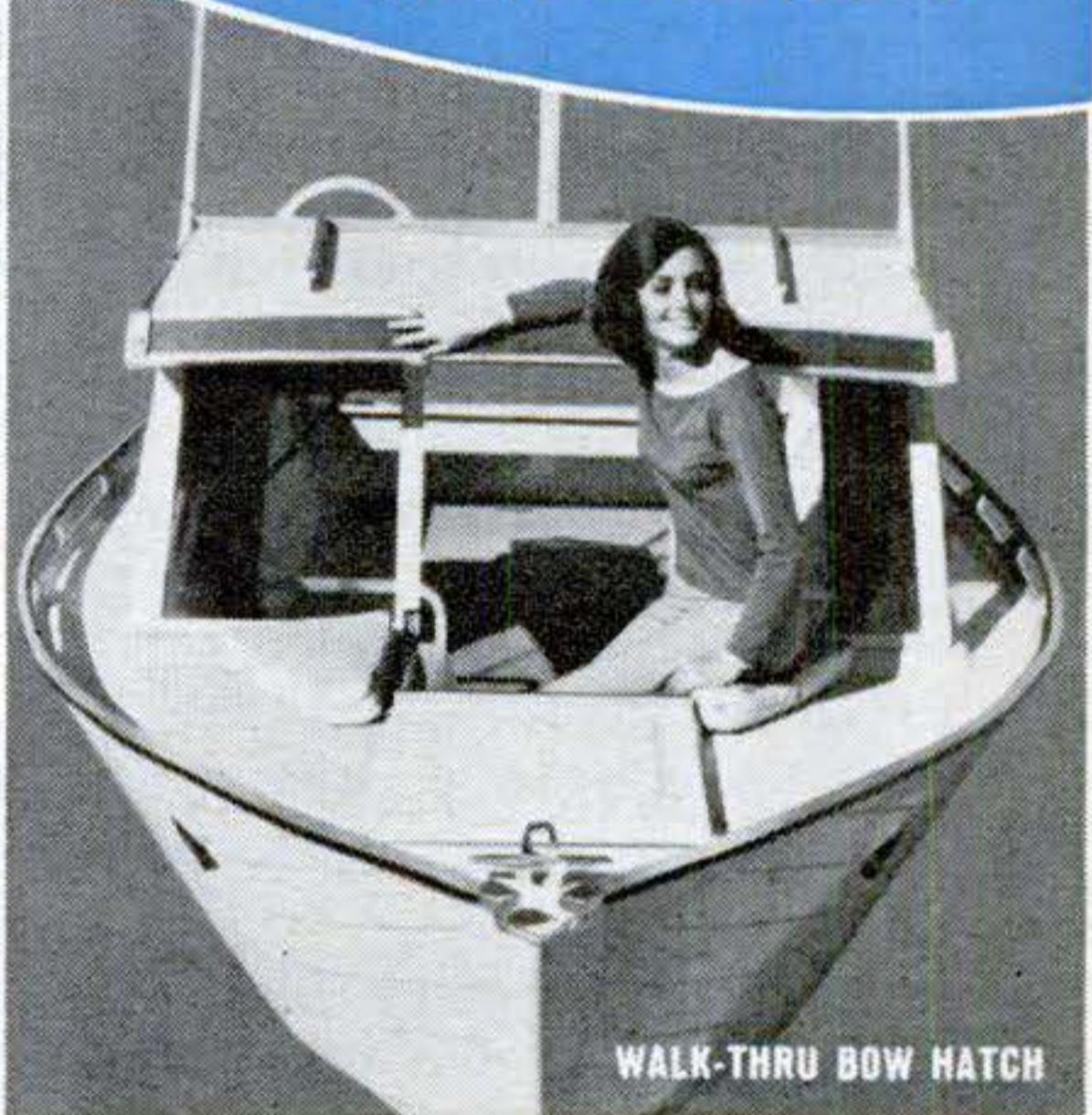

WALK-THRU BOW HATCH

Lone Star — who always gives you more boat for your money — has achieved a new breakthrough in aluminum boat design . . . a breakthrough that makes your Lone Star aluminum cruiser or runabout more usable, more practical, more enjoyable.

Note, for example, the addition of a remarkable new Walk-Thru Bow Hatch (pat. appl. for). Once you slide the center windshield panel and hatch cover forward, the cockpit or cabin becomes four feet longer for even greater passenger roominess and better load distribution. And you have much easier access to bow deck for fishing, docking, boarding or anchoring.

Other developments are less obvious but just as important. The artful marriage of strength and beauty through precision lapstraking and hydropress metal forming. The marine-archi-

tect designed hulls, with extra "lift" for smoother planing from Lone Star engineered lift rails.

Take it from us, these are the best boats ever built — otherwise we couldn't guarantee them for a lifetime.* Or challenge the entire marine industry by standing pat on a policy of no year-to-year changes just for the sake of change.

Your Lone Star Dealer is so excited about the new models that he is now offering a 4 band (AM, Marine, 2 Short Wave) 9-transistor marine radio free with purchase or down payment of the new 16 ft. Medallion or 18 ft. Voyager (above). Details at any Lone Star Dealer displaying transistor radio offer. Visit your Dealer now . . . offer ends Feb. 28, 1963.

**"Lone Star aluminum boats in non-commercial usage are warranted for the LIFE-TIME of the original owner against skin punctures and popped rivets." (Excerpt from Lone Star Warranty.)*

**FREE MARINE TRANSISTOR RADIO (WORTH \$69.95)
WITH PURCHASE • OFFER ENDS FEB. 28, 1963**





6303

Remodel with Marlite paneling for wash-and-wear walls

Soilproof finish of beautiful Marlite takes wear and tear that would harm most other finishes. Tough and dent-resistant, Marlite resists heat, moisture, stains . . . stays like new with an occasional damp cloth wiping.

For any decor you'll find a Marlite paneling: authentic Trendwood reproductions, exciting solid colors, distinctive marble and decorator patterns.

Easy installation makes Marlite a wise choice for building and remodeling. It is quickly applied over old walls or new framing with ordinary hand tools. And it never needs painting or further protection.

Send for new "Professional Guide to Room Planning & Interior Decoration." It provides dozens of helpful suggestions for making your home more attractive. See your building materials dealer, or mail coupon.

Marlite®

plastic-finished paneling

Marlite Division of Masonite Corporation
Dept. 226, Dover, Ohio

Please send full-color "Professional Guide to Home Planning." 25c enclosed.

Name _____

Address _____

City _____ State _____

ANOTHER QUALITY PRODUCT OF MASONITE® RESEARCH

202 POPULAR SCIENCE FEBRUARY 1963

The Sergeant Shoots Off

[Continued from page 102]

sile-artillery officer on reading the report.

The Sergeant had made its debut as an operational Army weapon that will be combat-ready with U.S. troops in Europe this year. Designed for atomic attack, the missile also can carry a biological or chemical warhead—but not conventional high explosives.

The Sergeant and the Corporal (which has been with troops since 1955) are both nuclear-delivery weapons and both have about the same range—30 to 85 miles. What, then, makes the second-generation Sergeant so much better? Let's look.

Solid-propellant rocket. This high-energy, quick-reacting fuel is easy to handle and gets the missile off in a hurry; transportation over even the most rugged terrain doesn't bother it; and inherent stability makes possible long-term storage of fueled rockets without deterioration—ready to fire. That is not the case with the liquid fuels used in the Corporal.

Mobility. All components and vehicles of the Sergeant Missile System can be hauled in Air Force C-130 Hercules cargo planes. Overland travel, even across rough, off-road areas, requires no special vehicles. The Corporal, more cumbersome and complex, does not have this flexibility of movement—or the fast, self-contained launch ability.

Ready, aim, fire. The erector-launcher gets its own power from two gas-turbine generators. It mounts a swinging boom for assembling the missile sections on the launcher—rocket, guidance unit, warhead. Attached to the rear is an electronics-packed, computer-brained firing station. Once a Sergeant's mission data has been programmed into its circuits, the countdown to blastoff is automatic, and self-testing for malfunctions.

At X minus 3 minutes, the launching team scrambles out of the blast area; two men take cover in a sandbagged firing pit 250 yards away.

At X minus 85 seconds, the missile is raised five degrees. Five seconds later, the launcher slews around to target-aiming azimuth and elevates to 75 degrees. The countdown continues automatically to "fire." Unless it receives a manual override from the pit, the five-ton Sergeant, boosted by 45,000 pounds of thrust, is on its way—sure, swift, self-guided.

The Sergeant Shoots Off

The Sergeant is not choosy about a launching site; any fairly level clearing about 60 feet across will do.

Assembly time: seven minutes for a crew of six. A "rocket safe" plug is pulled and replaced with a firing plug. Then comes the countdown. With the bird launched, the missile battery and its vehicles can be off the site and on the road in less than the 90 seconds it takes the Sergeant to reach its target. "Shoot and scoot," they call it.

Inertial guidance. Gyros, a computer, and a battery-power source are the heart, brains, and muscle of the Sergeant's guidance system. In flight the missile needs no commands from outside to take it unerringly to target. It carries its own orders, and in flight continuously compares what it is doing with what it was told to do. If trajectory or attitude varies from the preset pattern, the gyros sense it and initiate course corrections. (The three tiny gyros are so sensitive that if it took the second hand on a watch four years instead of 60 seconds to make a sweep, they could detect that incredibly slow motion.)

Range is pinpointed during flight by automatic aerodynamic drag brakes, rods that are periodically extended and retracted from the body of the guidance section to vary speed.

Foolproof in flight. We know of nothing that the enemy can do to disable the Sergeant's guidance system in flight or divert the missile from its course, except by a direct hit from ground fire. And that would take some doing, what with the bird's supersonic speed and the surprise it is capable of.

The Sergeant, like most Army sergeants, didn't make it the easy way. It took seven years and half a billion dollars for the weapon to make the grade from laboratory to launching. Research was begun in 1955 by the California Institute of Technology's Jet Propulsion Laboratory. In 1959, the Sperry Gyroscope Co. took over as prime contractor. A special company was formed—Sperry Utah—to build the missile and its operational system.

In the Sergeant, the Army has the second-generation artillery missile it wanted—a powerful atomic weapon ready to back up the GI on the battlefields of the limited and brush-fire wars that may well threaten us for many years to come. ■ ■

Owners Report on DELTA COMPACTOOL

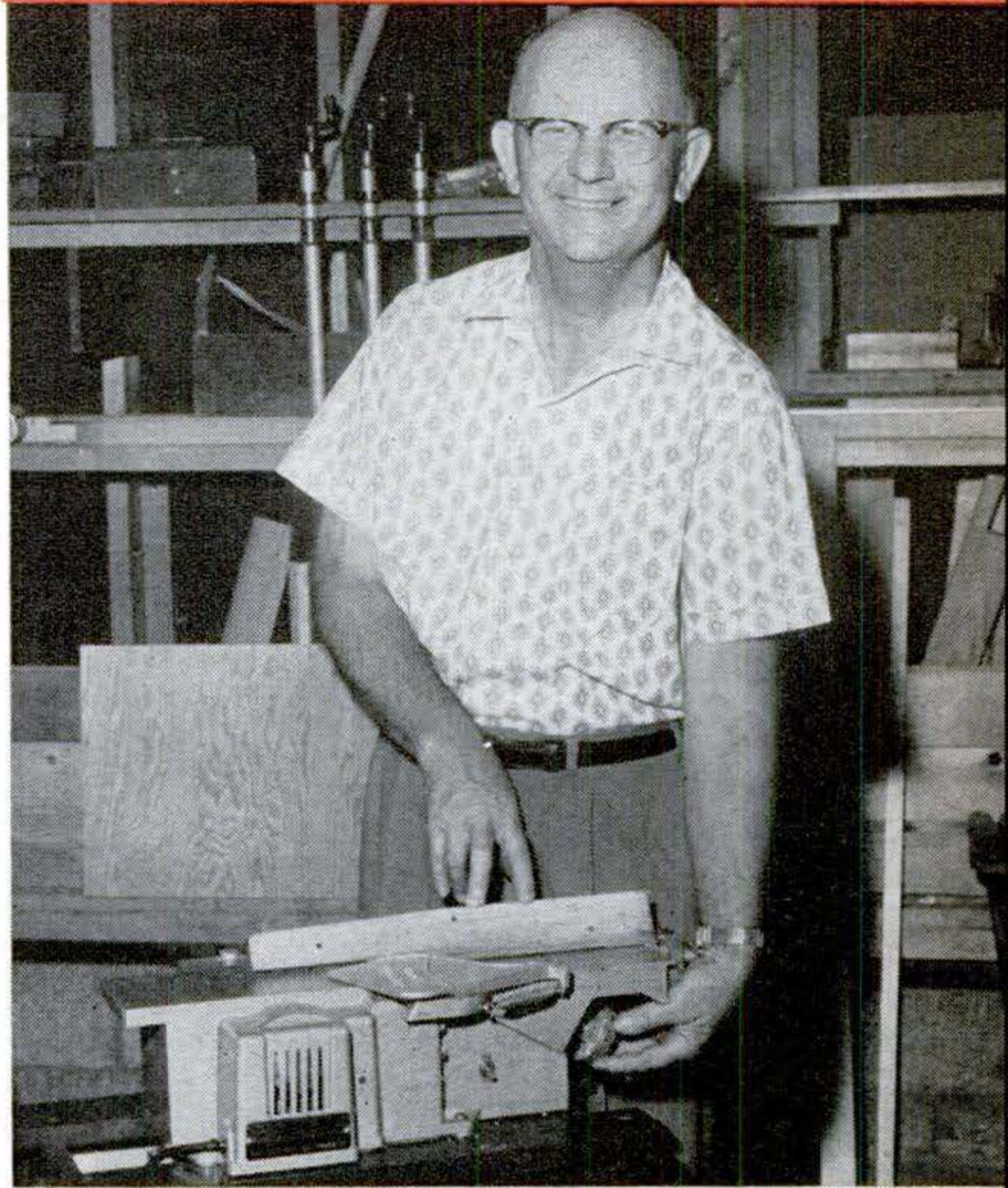

"Big tool" power—
built-in motor

RALPH ADDY,
West Lafayette, Ohio

"I've had access to other, much bigger jointers in Industrial Arts shops, lumber yards and pattern shops, but this is undoubtedly the most complete and powerful small Jointer I've used. It's really accurate—gives a smooth finish that couldn't be improved on with *any* size jointer. But the best surprise of all is that I got my COMPACTOOL Jointer as a gift—from my wife!"

DELTA COMPACTOOL



Drill Press



Circular Saw



Jointer

Write for **FREE** Brochure

Rockwell
MANUFACTURING COMPANY
504B N. Lexington Avenue
Pittsburgh 8, Pennsylvania



If You're Handy, I Can Help You Start A Business Of Your Own!

Operate unique profitable business during spare time in your basement or garage



Walter M. Ringer Jr.

Do you envy the man who has his own business; who can pick up and go fishing whenever he desires; who can say to himself, "I'm my own boss"? I want to tell you about a profitable business you can start right now in your spare time. You don't need a big office or store. You can operate this service business in a corner of your basement or garage. And you don't

need a large investment. But the profits are exceptional.

Keep 90c Out of Every \$1.00

No inventory necessary! No expensive operation! And yet every job nets you 90% profit. You can make up to \$6.00 an hour in your spare or full time. And you can live in a town of 150 or a million. Since 1932 we've helped hundreds of men (from 21 to 71) start successful saw sharpening businesses with one simple-to-operate machine—The Foley Saw Filer. Equally important, we can almost guarantee success because we'll reveal to you the simple rules on how to be successful in our fact-filled booklet.

Foley Saws Build Repeat Business

One satisfied customer tells another. Recently Dick and Jo Ann Koester wrote to us after starting a Foley sharpening business just 10 months earlier. "We have acquired another Foley Saw Filer and for the past two months we have been in full-time operation. Business for the future looks even better as good machine filing is our best advertising."

FREE BOOKLET Explains How

The story of this wonderful business opportunity and actual true story results of others is all contained in easy-to-understand booklet called "Money Making Facts." Send for it; read it thoroughly. Then, you can consider the business opportunity from every angle. You make your own decision. No salesman will call. You're under no obligation. But act today if you're really interested in "A Business of Your Own." Return coupon or a post card and I'll rush this booklet to you!

Walter M. Ringer Jr., President
FOLEY MANUFACTURING CO.

Walter M. Ringer Jr., President, Foley Mfg. Co.
219-3 Foley Building, Minneapolis 18, Minn.

Please send me free booklet with complete information about this profitable home business.

Name _____

Address _____

City _____ Zone _____ State _____

Getting a "Stock Car" Ready for Daytona

[Continued from page 76]

and bolts were safety-wired when possible.

The car's front suspension and springs were beefed up. Upper and lower suspension arms were boxed and gusseted for reinforcement.

Because the right side of the car takes the severest loads on the turns (the race is run counterclockwise), the right front spring was given almost three times the spring rate that it has in your car. The heavy-duty shocks were set more firmly on the right side of the car. Front shocks were remounted outside the coil springs, rather than inside as usual.

The rear-axle housing was reinforced by strap steel welded to the bottom of it.

The heavy-duty brakes were given sintered-metal linings instead of the standard kind. The hotter these brakes get, the better they hold. Brake drums and back plates were peppered with drilled holes to let in as much cooling air as possible.

The deep-dish steering wheel, with horn ring removed, was wrapped with several layers of rubberized tape. A two-inch-thick circular pad of sponge rubber covered the center.

The car's windshield was reinforced with three steel clamps to keep it from popping out. Two-inch-wide vertical strips of stainless steel were fastened over the rear window for the same purpose.

Hood and trunk lid were specially clamped down to keep them from flying open or being wrenched off.

To minimize the risk of driving over broken glass or having windows shattered by hurtling fragments of metal, all car lights, hubcaps, and body trim were removed.

The car's front-wheel wells were enlarged to make room for the big tires—8.00-8.20-by-15s.

The engine was "blueprinted": taken apart, and every part checked to make sure it exactly met all Mercury specifications. Gear ratios are each team's secret.

"How does it feel to drive one of these Mercs after you're through rebuilding it?" I inquired.

Stroppe gestured at Troy Ruttman, the 1952 winner of the Indianapolis 500.

"This baby," said Ruttman, slapping the tail of the Mercury we had been inspecting, "handles at 160 like a sedan going along a city street."—Wesley S. Griswold.

Detroit Goes Back to the Races

[Continued from page 76]

A qualifying speed of more than 160 m.p.h.—160!—for two laps, totaling five miles, no doubt will be necessary.

It's no mystery why auto racing has become the second biggest spectator sport in the U.S. (the first: horse racing), and why Daytona (where, and at adjacent Ormond Beach, speed records were set and smashed on the beach sands for a half-century) has become the Mecca of its stock-car phase. The man in the grandstand can imagine himself behind the wheel of one of the machines streaking around the track. After all, it's only a souped-up stock car.

Everybody becomes a buff. The happily unredeemed fan in the stands can tell you second by second what each crewman will do as a car rolls into the pits for service.

The pit crews' performance is as stylized as that of a ballet company. Waste movement is a crime. Fuel is in individual cans, and only one can is permitted at a time over the protective wall intervening between the storage area and the pit proper. That cuts down the fire hazard.

A car coasts in. The crew chief leaps the wall with a can of gas in one hand and a wrench in the other. As he passes the right rear wheel he starts a wheel nut. On his heels is his number two man who goes at the wheel while the chief pours gas. Man number three attacks a front wheel as other crewmen pass over replacement tires.

After the tires comes the windshield and rear glass wipe, with swabs on long handles thrust at the car from behind the wall. That's necessary because only six men besides the driver are allowed in the pit proper at one time. A cooling drink—on a handle—is thrust at the driver.

The tank's full. The wheels are changed. The engine comes to life like a machine gun.

Time in the pit: less than a minute, despite the lack of a conventional racer's knock-off hubs.

The buff knows all the driver's tricks on the track. Ever hear of "drafting"? That's getting a free ride. Snuggle up close behind a car in front of you, and the vacuum in his wake helps you. Oddly enough, both cars pick up speed. The one in front seems to shed some of its wind drag.

Know how to make a turn? Most drivers "feather" their engines—ease off on the accelerator—to "breathe" them.

CONTINUED



PAT. PENDING

**BE SAFE . . .
 . . . BRING YOUR
 CAR UP-TO-DATE NOW!**

- AMBER COLOR TURN SIGNALS HAVE BEEN RECOMMENDED BY THE SOCIETY OF AUTOMOTIVE ENGINEERS (S.A.E.) AND ARE STANDARD ON ALL 1963 MODELS.
- AMAZING LOW PRICE FOR COMPLETE **AMBER** LENS CONVERSION KIT FOR THE TURN SIGNALS ON YOUR CAR!

only \$1.00 per set

- CONVERT YOUR OLD FASHIONED WHITE DIRECTIONAL SIGNALS NOW TO NEW, **SAFER**, AMBER COLOR.
- **AMBER-LITE** CONVERSION IS NOW AVAILABLE FOR YOUR CAR — 1950 THROUGH 1962 (Foreign Cars Too!)
- EASY TO INSTALL IN A FEW MINUTES!
- FULL MONEY-BACK GUARANTEE!

FREE! **AMBER-LITE** will ship 4 CONVERSION SETS to you for the price of 3. You get a set for one car absolutely FREE!

AMBER-LITE P.O. BOX 62
 BOSTON 32, MASS.

GENTLEMEN: I enclose \$..... for.....sets for the following car(s):

MAKE YEAR

MAKE YEAR

MAKE YEAR

MAKE YEAR

PLEASE RUSH MY ORDER TO:

NAME

STREET

CITY STATE

AMBER-LITE Pays Postage and Handling.

Detroit Goes Back to the Races

Know about superstitions? You'd better if you're going to race. Green is a bad-luck color. Nobody knows why. Peanuts are taboo. That notion originated in the days when the pits were under the grandstand and spectators let shells dribble down to get into the intake pipes. Getting your picture taken before a race is bad luck, too.

Stock-car racing rules are rigid. Some samples:

No engine can be of more than 428 cubic inches of piston displacement. A car can have only one carburetor, and that of no more than four barrels. (More carburetion will literally run a car out of track—it will go too fast.) A gas tank can hold no more than 22 gallons.

Body panels of anything but steel are ruled out as unsafe. Each car must weigh no less than its showroom counterpart. Actually, it weighs from 200 to 300 pounds more because so many of the components are beefed up. All door latches and hinges must be fixed to prevent their flying open in accidents.

Body clearances must be 12 inches on the right, 9 inches on the left. (The cars are all lopsided because centrifugal force slams down that right side on the turns.) Exhaust pipes must clear the pavement by four inches, oil pans by five.

I asked Norris Friel, technical director of the National Association for Stock Car Auto Racing (NASCAR), the supreme governing body for the sport, about that.

"Supposing," he explained, "a car blows a tire. It goes into a long skid. The oil pan drags and breaks. Whoosh! the guy behind skids."

"What about the hoods?" I asked. "Why the extra latch-downs?"

"Hoods used to buckle in the middle, where there wasn't a catch, from high speed and minor sideswipes," he said. "So now we require a center catch."

Occasionally a car owner—shush, must we admit dishonesty?—will try to put something over, winking at the rules. So Friel has 10 men inspecting the cars, two of them unidentified gumshoes.

"Aren't you afraid to admit that these spies circulate among the pits?" I asked.

"No," he said. "We want the drivers and crews to know that we've got an eye on them. Keeps 'em honest."

It all makes sense. One result has been that the Daytona International Speedway is

pretty safe. In four seasons there has not been a fatality. Injuries have been few.

This was a dream of the track's founder, Bill France, high priest of U.S. stock-car racing.

For racing, the beaches had had their day. The encroachment of hotels and motels had made driving on them hazardous. Moreover, the wind had to be just right to smooth the sand, and races had to be run when the tide was out.

In the planning stage the track was a mathematician's dream—or nightmare, depending on how much trigonometry you've had. Classified as a tri-oval, the 2½-mile asphalt roadway includes a 3,400-foot back straightaway, two end turns (each 2,700 feet around), and a straightaway in front of the grandstands dented by two shallow turns in the center.

The turns are beautifully banked. They should be—it took 18,000 separate calculations to shape their slopes for various speeds. If you're in the proper lane at the proper speed, you can take your hands off the wheel at up to 110 miles an hour. The car will track by itself.

The big names in stock-car racing will be back this month at Daytona. To the true buff, they are as familiar as the famous bangtail pilots. The Daytona counterparts of the Bill Hartacks and Manuel Ycazas are Banjo Matthews, Glenn Roberts, Dave Pearson, Dick Petty, and Junior Johnson.

Big names in the standard race-car field, including those who compete at Indianapolis, compete at Daytona, too: Rodger Ward (he won the Indianapolis 500 last year), Troy Ruttman, Parnelli Jones, Paul Goldsmith, Len Sutton, and A. J. Foyt.

Yes, Detroit has gone back to the races. In Daytona the inspectors, looking over a rig, only ask, "Is this part in the manufacturer's catalogue?"

If it is, it's "stock." And Detroit makes sure that anything that will give a car more speed is in the catalogue. ■ ■

.....

Other Daytona Speed Week Events

Feb. 16—American Challenge Cup race for grand touring and sports cars.

17—Daytona Continental three-hour grand-touring and sports-car race.

22—Two 100-mile NASCAR Grand National Circuit races.

23—National Championship NASCAR 250-mile Modified Sportsman race; 25-mile consolation.



WORLD'S LARGEST SELECTION OF QUALITY HOMES!



ALADDIN'S NEW 1963 book of homes

Designed To Save You Up To \$5000

**PRICED FROM \$3000
FREIGHT PAID**

NEW CONSTRUCTION SYSTEM

Aladdin . . . world's oldest and largest manufacturer of Read-Cut homes . . . shows you how to save up to \$5000 . . . how to save material, time, labor and middleman profit . . . Aladdin Homes are sold on money-back guarantee — your complete assurance of a quality home.

Aladdin's new B-I-Y System combines the basic principles of their famed Read-Cut Home with the most advantageous techniques of custom-built, component and pre-assembled construction methods that now makes it easier than ever to build your own home . . . gives you the best possible home for the least possible money.

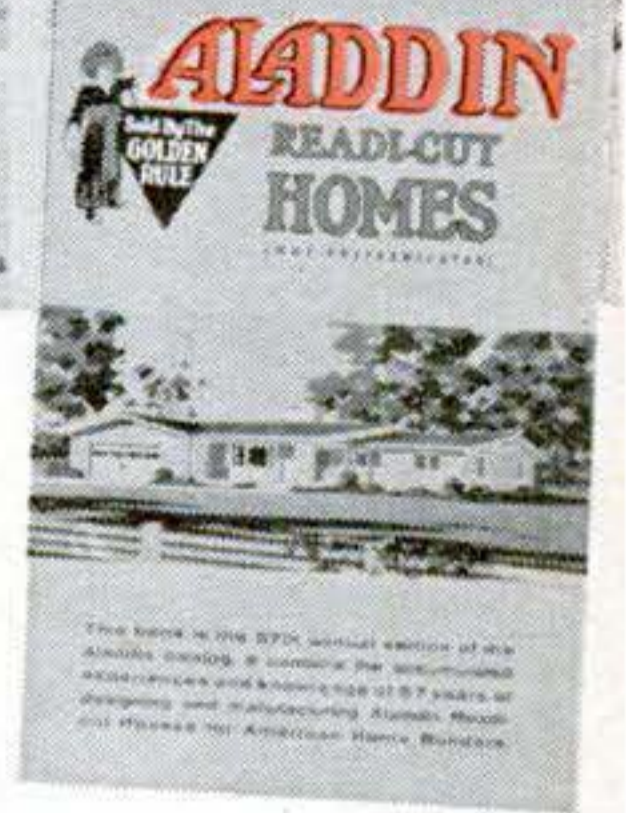

THE ALADDIN COMPANY, 63-29 BAY CITY, MICHIGAN.

Please send 1963 "BOOK OF HOMES" in beautiful color with complete information about the new Aladdin B-I-Y Home-Building System. Enclosed is 25¢.

NAME

ADDRESS

CITY

ZONE STATE

(Please Print Carefully)

NOW

**Increase Machine Life
Cut Vibration
and Noise**

Famous UNISORB Mounts

- Packaged, ready to install • No tools needed • Pre-cemented • Ideal for Household appliances, Workshop machines • Cut noise • Reduce vibration • Prolong life of machine • Improve performance.

Send check or money order and get your complete set postpaid - Send today, offer limited.

Complete set COSTS ONLY **\$125** Postpaid

MONEY BACK GUARANTEE

FELTERS COMPANY, Jackson, Michigan

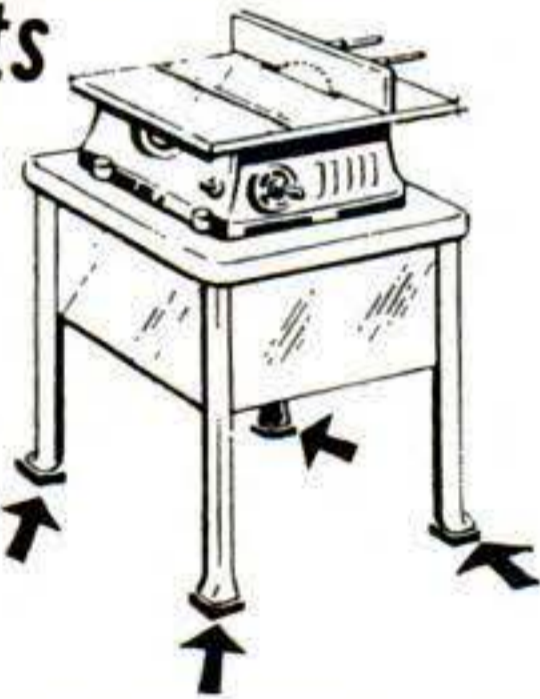

Best Remover FOR Refinishing Furniture

Low-viscosity Klean-Strip is a free-flowing remover that peels off all furniture finishes without making a gummy mess.

Old finish stays wet and workable, can be wiped off easily. Leaves surface dry, clean, ready for new finish. Non-flammable, safe.

KLEAN-STRIP PAINT REMOVER

THE KLEAN-STRIP CO., INC.

MEMPHIS 6, TENN. — WINNIPEG, MAN.



Home Craftsmen! Here's Your NEW MONEY SAVING CATALOG



FINE DOMESTIC AND RARE IMPORTED WOOD

Veneers, Plywoods, Mouldings, Kits, Ornaments, Lamp Parts, Mosaic Tile, Upholstery Materials, Hardware. Over 1,500 Essential Items ... 132 Pages ... Full Color

Send for this complete new wood buying guide and project book. Your complete source of finest kiln-dried domestic and rare imported woods, beautiful wood inlays, colorful bandings, furniture legs, matched plywoods, glue injector, embossed mouldings, carved ornaments, newest woodworking tools, "hard-to-find" cabinet hardware and fittings . . . more than 1,500 items! New project ideas. Send 25c for postage, handling.

Big Discounts on Famous Stanley Power Tools, Drills, Router, Many Others

CRAFTSMAN WOOD SERVICE CO.
2729 South Mary Street
Dept. B-2, Chicago 8, Illinois

MAIL COUPON NOW!

Craftsman Wood Service Co., Dept. B-2, 2729 South Mary Street, Chicago 8, Illinois
Rush new Craftsman Wood Catalog. 25c enclosed.

NAME

ADDRESS

CITY ZONE STATE

5 WAYS TO GET A BETTER GRIP ON YOUR JOB

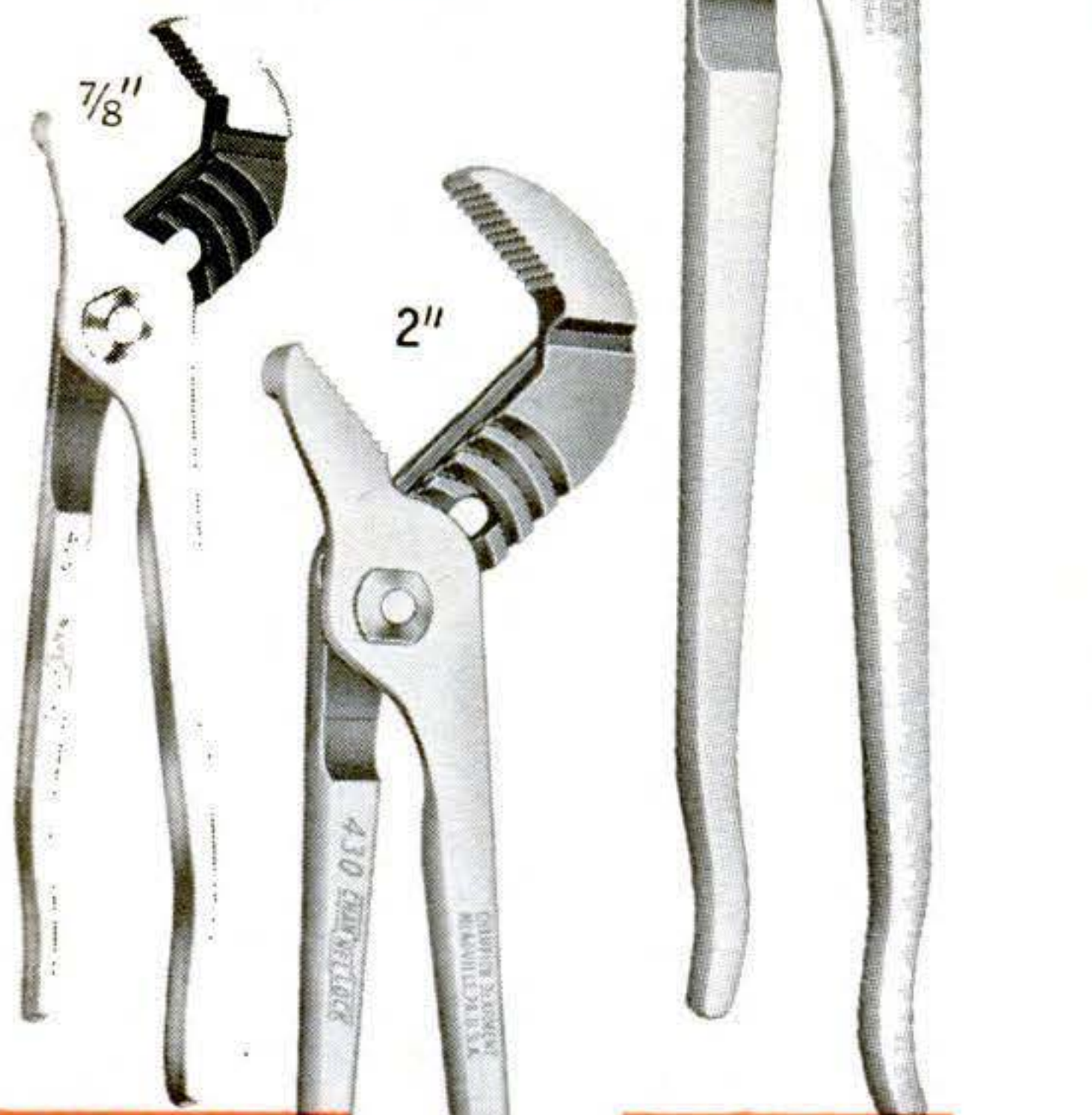

CHAN NEL LOCK®

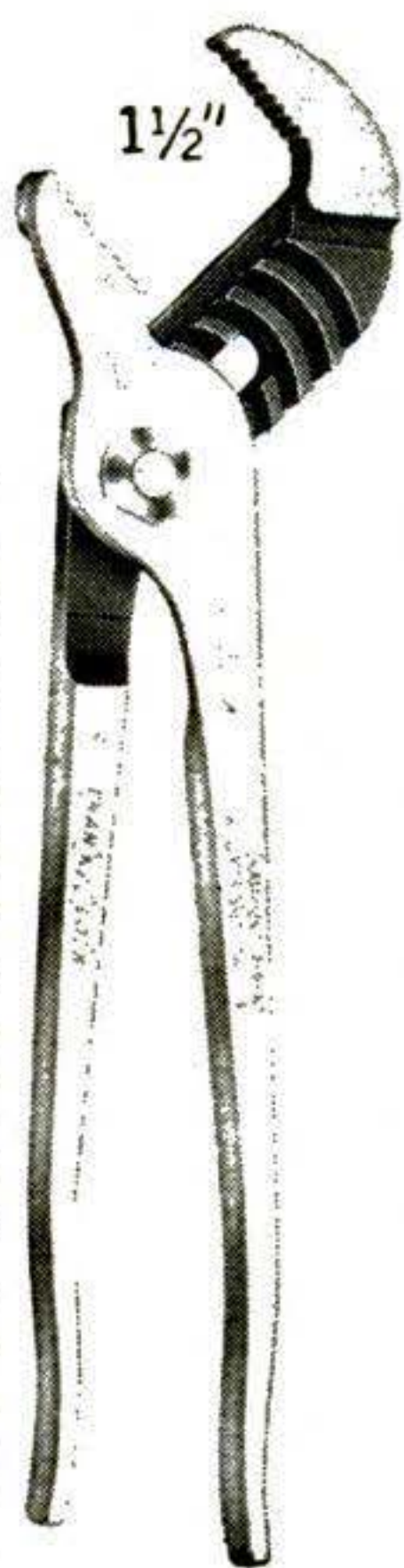

Whatever your gripping job, there's a Channellock that will subdue it. Powerful parallel jaw grip . . . tremendous leverage . . . patented, smooth-

working, can't-slip adjustments. Your choice of five jaw capacities: 1/2, 7/8, 1 1/2, 2 and 2 1/4 inches. *Be sure it's a genuine Channellock. Look for the trademark on the handle. Write for catalog showing complete line of pliers. Made Only By Champion DeArment Tool Company, Meadville, Penna.*

Color Photos in 60 Seconds

[Continued from page 64]

anced to reach full development simultaneously. Chemists would create a molecule linking a developer and a dye only to discover, say, that its solubility characteristics failed to match that of the dye molecules in the other emulsion layers.

Stability of the dyes, of course, is important. The linked molecule makes it possible for Polaroid to place the dyes in the film at manufacture, insuring stability in the negative and permanency in the finished print. The linked molecule also increases the number of dyes that can be used. As part of that linked molecule, the developer controls how much dye stays in the negative and how much reaches the positive.

Who will make the film? After Polaroid had developed the process, they approached the Eastman Kodak Co. and asked them to adapt the process to Eastman's established manufacturing methods. Eastman now manufactures the color-negative material, while Polaroid manufactures the print material and the processing pods.

The first prints from the new color film required coating within seconds after developing. Reason: The developer portion oxidized in the air and affected the dyes. Polaroid beat this by putting a new receiving layer on the print. Now your print has a brilliant, permanent plastic surface.

How true are the colors? A certain amount of color distortion appears in all processes. This is true of Polacolor, too. It produces good color prints—but no miracles.

When you compare it with other color processes, keep in mind what it accomplishes: permanent, finished prints that are ready to be viewed almost immediately. It fills the same place in color that Polaroid's other films do in black and white.

The real test comes when you peel off the print and start comparing it with the scene before you. No other film has to meet such a rigid test. For the first time, you can compare the colors in the scene directly with the colors in the print—and do it immediately after taking the picture.

Do all the colors reproduce exactly? Of course not. Nor will you see a print made on any present color material that looks exactly like the subject. But move back, so to speak, and look at the print.

The skin tones. Usually these are warm and flattering when taken in full sunlight—sometimes even warmer than you may like.

Color Photos in 60 Seconds

Taken under diffused light with the proper filter, the skin tones appear normal. Indoors, using blue flash for illumination, skin tones seem rather yellowish, though these probably are rendered with greater accuracy than the skin tones recorded outdoors.

Warm, saturated colors, such as fire-truck reds, appear somewhat subdued (diluted with white) in the prints.

The blacks and grays? Compare these with the subject and you find them rich and true, with little color contamination.

The colder, saturated colors—blues and greens—reproduce darker than those you see in the subject. Pictures made on sunny days, of course, show better color saturation than those made on overcast days by diffused light. But even in clear, bright sunlight, Polacolor prints have a pleasing subdued appearance—there's no exaggeration in the strong colors.

What particularly impressed us was the excellent rendition of delicate pastels and fine details, which hold up well even in the shadow areas.

We did notice that colors tended to shift more from print to print than they would under precise laboratory time-and-temperature controls. Most of our tests, however, were made on films that still required coating. Any loss of time before coating affected the print quality. Now that coating has been eliminated, print quality should be more consistent.

Development will usually vary from one to 1½ minutes, depending on temperature. Just keep in mind that it is the temperature of the camera, not the temperature of the atmosphere, that counts. When we pulled one picture in a quarter-minute under normal developing time, our test chart, instead of photographing neutral gray, showed pink overtones. Overdeveloped, the picture showed blue overtones.

Temperature tips. If camera temperature is 45 to 60 degrees, for instance, you let the film process for 1½ minutes. Warmer camera temperatures shorten the time. At 80 and above you give it less than a minute. It is possible to use Polacolor below 45 degrees, but results will be more consistent if the camera temperature is kept above freezing.

If you were to use the film at zero, for instance, processing time would be about 10 minutes or more, and results would be undependable.

CONTINUED

WHEN THE ROAD ENDS...

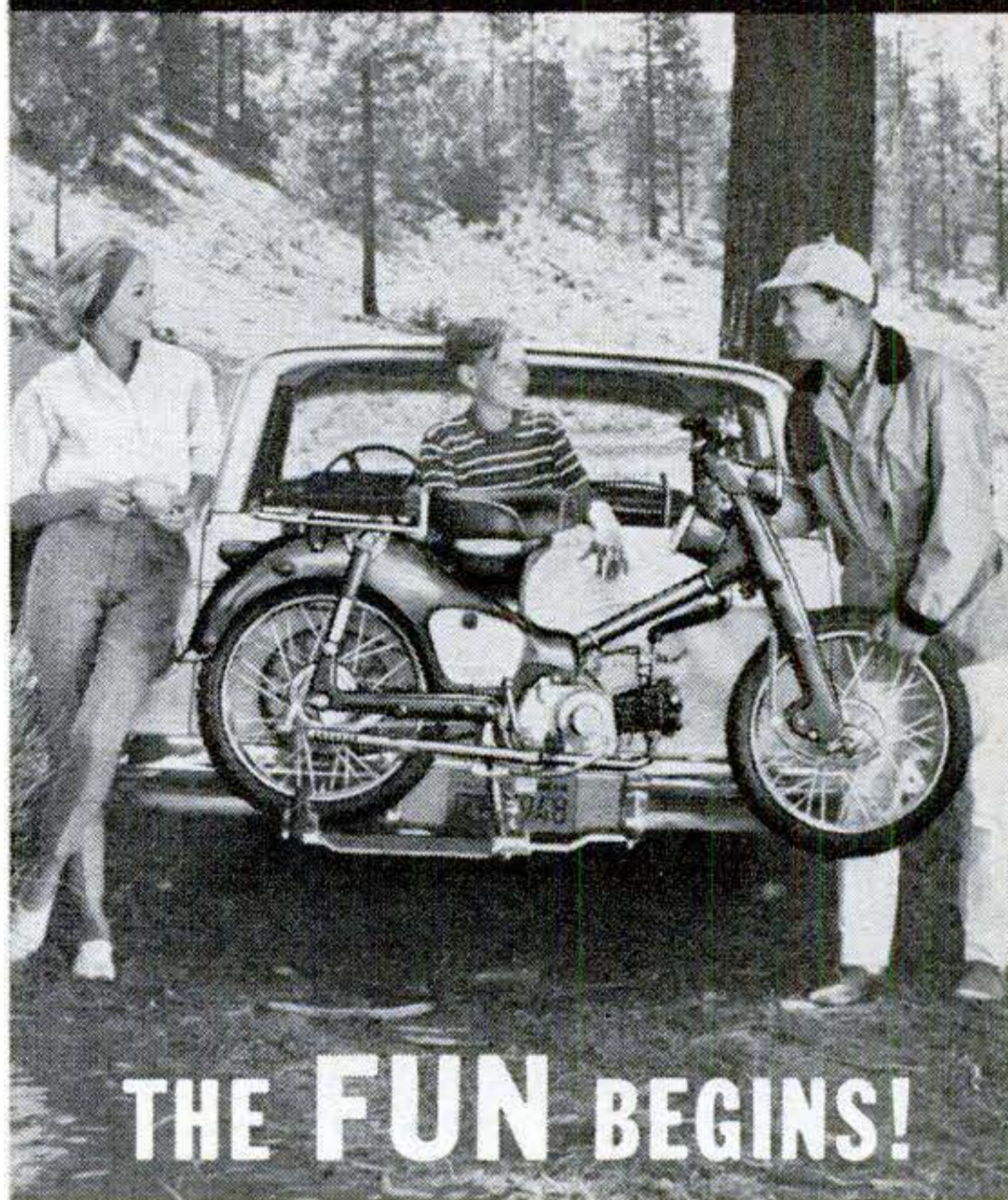

All nature is yours to explore when you take along the all new HONDA Trail "55"—the trail machine that needs no trail!

The Trail "55" is virtually indestructible and maintenance-free, yet so compact and light (121 lbs.) it'll fit on a car bumper with a simple attachment—or in a station wagon, camper, trailer or small boat. Super-powerful low gear ratio of 70 to 1! Speeds to 30 m.p.h., with quick-change sprocket for 45 m.p.h. touring! Powered by Honda's famous 55 cc 4-cycle O. H. V. engine!

For name of nearest dealer, phone Western Union and ask for OPERATOR 25.



HONDA
TRAIL "55"

only
\$275

plus destination and setup charge

HONDA

World's Largest Motorcycle Manufacturer

Write on letterhead for dealer franchise information. American Honda Motor Co., Inc., 4077 W. Pico Blvd., Los Angeles 19.

AMERICAN HONDA MOTOR CO., INC. Dept. PS-63-2

P.O. Box 20918, Pico Heights Station, Los Angeles 6, Calif.

Please send free literature on HONDA TRAIL "55" to:

NAME _____

STREET _____

CITY _____

STATE _____

PHONE _____

Include information on the complete Honda "50" line.

Include information on Honda motorcycle line (9 models, 125 to 305 cc).

THE POCKET SIZE MACHINE SHOP Dremel MOTO-TOOL

Handiest tool you'll ever own. Moto-Tool's high speed (27,000 rpm) is ideal for precision grinding, drilling, polishing, carving, engraving, deburring, sharpening. Does fine detail work with pin-point accuracy. Eliminates time consuming hand work, gives the finished job a professional look. Weighs only 13 oz. — handles easily as a pencil. Fastest, most powerful tool of its kind. Widely used by tool and die makers, model builders, gunsmiths, repair men, schools



No. 2 Moto-Tool only.....\$19.95
No. 2 Moto-Tool Kit..... 29.95
(Incl. No. 2 Moto-Tool & 23 assorted accessories in steel case)

NEW HEAVY DUTY NO. 3 MOTO-TOOL

New high torque motor designed for industrial use. Same features as No. 2 plus 50% increase in power. Weighs only 18 oz. Complete with 1/8" and 3/32" collets and finger grip in steel case...\$29.95

SEE YOUR DEALER OR WRITE FOR CATALOG
DREMEL MFG. CO. DEPT. 123-B, RACINE, WIS.
QUALITY POWER TOOLS SINCE 1934

STANDARD DIAL PHONES WITH BELL

Western Electric late model dial phones same as used by all telephone companies. Ideal as extensions on any system. Easy to connect. Several may be connected on one line. Easily modified for private inter-com system. Cost \$40.00 new—guaranteed excellent condition.



ITEM 855 NC, Wt. 8 lbs.\$6.95

Heats quickly anything from a cup of water to a washtub full . . . much faster than any stove or costly heater. Indispensable for laundry, dishes, baths, etc. Ideal for dishes, heats right in the sink. Made of unbreakable shock proof "Nyalite." Simple and cheap to operate . . . just plug it in. Follow directions for safe use. 1200 watts, 115 v. A.C. Money back guarantee. Item 856. Prepaid, only \$3.95



Send 10c for 100 page Catalog FREE with order. Prices f.o.b. factory—send check or M.O.

MASTER MECHANIC MFG. CO., Dept. B263, Burlington, Wis.

Southern Customers write Dept. B263, Box 65, Sarasota, Florida



LOW COST WELDER

WELD - BRAZE - SOLDER - CUT

NO OTHER WELDER AT THIS PRICE INCLUDES THIS COMPLETE EQUIPMENT—FULL FACE SHIELD, HEAVY CABINET, GROUND CLAMP, HEAVY WELDING CABLES PLUS twin carbon arc torch, welding rod holder, carbons, welding and brazing rods, flux,

solder, instruction book. Make and repair auto bodies, parts, fenders, trailers, boats, metal furniture, fixtures, ornamental iron, farm equipment, garden tools, bicycles, toys, etc. Operates on any properly wired 115 V. line. **TEN-DAY FREE TRIAL. FULL ONE-YEAR GUARANTEE.** More than 250,000 in use in homes, garages, farms, shops, factories. Now ANYONE can weld, braze, solder, cut, heat metal without experience. Does 1001 jobs on all metals. Save and earn money.

SEND ONLY \$2.00

Pay postman \$12.95 plus C.O.D. charges. Practical lifetime gift for hobbyist, mechanic, auto restyler, hot rodder, homeowner. Order today on 10 DAY MONEY-BACK GUARANTEE.

FOUR WAY WELDER CO. 1810 S. FEDERAL ST. DEPT. W3-B CHICAGO 16, ILL.

Color Photos in 60 Seconds

Exposure meters should be set at ASA 50, except when the temperature is 80 or above. Then set the meter at ASA 100, thus reducing exposure by one stop.

While you may only occasionally shoot extremely short or long exposures, Polacolor, like other films, works efficiently only within a specific range of shutter speeds. Polacolor's working exposure range is from 1/1,000 to 1/10 of a second. Over 1/10, there is a loss of speed and an increase in yellow densities (due to reciprocity failure). To compensate for the color shift, a blue filter is recommended.

What about color balance? Polacolor is balanced for daylight only. Use blue flash bulbs or electronic flash for fill light and as sole sources of illumination. When using photofloods as a light source, correction filters are necessary.

Exposure latitude? Typical of the reversal processes, Polacolor film has a relatively short scale. For satisfactory results, you can go only about a half-stop over or under the recommended exposure and still obtain an acceptable print.

Can you use the new film in your present Polaroid camera? It's a qualified yes. Certain modifications are needed on a few models. But only models 80, 80A, and 80B require factory conversions to use the new film.

The Polacolor negative base is much tougher than the Polaroid black-and-white film base. Unless you own a camera with notched teeth, you'll find it difficult to tear off the negative tabs. But an inexpensive accessory cutter bar is available that does the job easily.

Polaroid will offer a copy and enlargement service similar to that for black and white.

Price of the new film? Following a Polaroid policy, dealers set their own prices. At present we can only give you a rough idea: It should sell between \$4 and \$5 for a six-exposure roll. It will be available in Type 48 (3 1/4" by 4 1/4") and Type 38 (2 1/2" by 3 1/4") roll film in daylight type only.

At present, you may not find the film in your local stores, since it's being introduced gradually, starting with seven or eight of the southern states. But by summer it will be available throughout the country.

Polacolor will make a big hit with anyone interested in seeing his color shots immediately. And who isn't? ■ ■

nose, it helps the pilot find and hold the critical angle of attack for re-entry, which determines whether the X-15 will come home safely or burn up and tear apart on the way down.

An adaptation of the Q-ball is thought certain to be mounted in the nose of the Dyna-Soar glider, which will depart and return through the earth's atmosphere much faster than the X-15 does.

Dyna-Soar seems certain, too, to use the marvelous "adaptive control system" that the X-15 has flight-tested. The ACS has been installed in the No. 3 ship alone. Its electronic brain senses rapid changes in flight conditions that the pilot's own brain can't grasp fast enough. It then decides whether the craft should be steered and angled by steam jets, aerodynamic controls, or a mixture of both.

The system, in effect, ties the X-15's three control sticks together, and the plane responds to whichever one the pilot can most easily reach.

Pilots of the X-15 have discovered a lot of important and useful facts about how to get out into space and back into our atmosphere. And they've done it with a surprisingly small number of bruises.

The few mishaps of the X-15's highly dramatic career have all ended without catastrophe. Several times the artificial atmospheric pressure of the cockpit has leaked away and pilots have been saved from death by their automatically inflating pressure suits. Twice, extremes of temperature cracked one side of the craft's windshield. Maj. Bob White, the pilot on both occasions, had to land "blind in one eye" (figuratively speaking), but he made it.

There have been several emergency landings on Mud Lake—where X-15 No. 2 cracked up. Standard procedure in such emergencies is to jettison fuel before landing. The No. 2 ship also blew up during an early engine test on the ground, with no one in it at the time, and had to be rebuilt.

Through the window in space. Beginning in April, X-15 No. 1 is expected to start taking ultraviolet pictures of stars. Special cameras have been installed in a bay behind the cockpit. When the plane reaches the top on one of its dazzling arcs of flight, high above the ozone that obscures ultraviolet light for earthbound cameras and telescopes, metal eyelids flush with the X-15's

CONTINUED

Clip and save . . . more to come

FIX-UP / Product Tips from / **DAP**®

HOW TO MAKE OLD FURNITURE LOOK NEW



Use **DURATITE WHITE GLUE** to repair before you refinish. Squeeze a quick coat on contacting surfaces to reset loose rungs,

braces, legs, arms, trim, veneer. Dries fast, clear. Makes joints strong as wood itself.

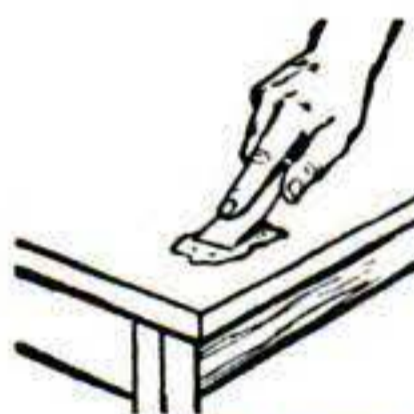

Use **DURATITE WOOD DOUGH** for fast, matching, one-time fills in deep holes, joints, cracks. Won't shrink—sands smooth

—takes any stain or finish. A professional plastic wood filler. Nine popular wood-finish colors.



Use **DURATITE SURFACING PUTTY** to restore marred wood surfaces. Sands to a feather edge for almost invisible table

top repairs. Hides nicks, dents, burns, scratches. Takes paint, stains or any finish.

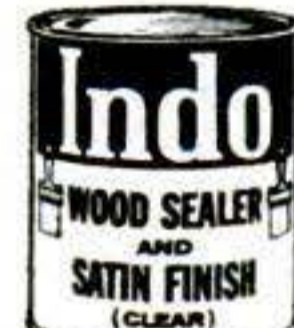
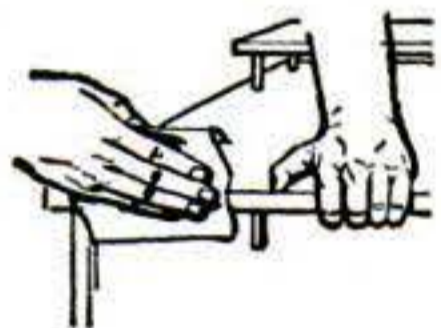

Use **INDO WOOD SEALER AND SATIN FINISH** for a rich, low-lustre finish on antiques, cabinets, doors, woodwork,

Dries for rubbing and recoating in two hours. Rich-looking lustre deepens with each coat.

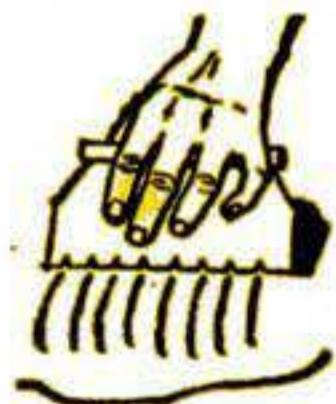

Use **DURATITE CONTACT CEMENT** for "new look" plastic laminate tops on tables, counters, lavatories. Spread on

facing surfaces—let dry 20 minutes—install pre-cut sheet. Fast, long-lasting, waterproof.

If your dealer doesn't carry these products, please send us his name and address.

DAP INC., Dept. 40, DAYTON 31, OHIO • SUBSIDIARY PLOUGH, INC.

DAP / DURATITE / Indo

The Incredible X-15

skin will slide open. The pilot will aim his craft to accommodate the cameras, and unique astronomical photography should result.

Studies of the light spectrum of the earth's horizon as seen from the edge of outer space are scheduled. The horizon looks flat from normal airplane height. When one is homeward bound from space, however, the full roundness of our globe, with its bright halo of refracted sunlight, is all too apparent: Finding the horizon then is too difficult for human eyes. In-bound spacecraft must have special instruments to do the job. Securing data for their development will be one of the X-15's new missions.

The X-15 has been called "the basic trainer of the Space Age," and for good reason. Rockets have taught us a little about the territory between the top limit of conventional aircraft flight and the bottom limit of satellite travel, but rocket launchings are like dipping a toe in the ocean of space. X-15 flights are like going in for a swim.

We're not alone in our admiration for the X-15. Top U. S. space officials have expressed equal enthusiasm. For example, Dr. Hugh Dryden, Deputy Administrator of NASA, has said: "Some of us have been a little regretful that the exploits of the X-15 have not received . . . widespread recognition. . . . From a technological point of view, the X-15 development may be a lot more significant in the long run than the Mercury capsule."

The Men Who Set X-15's Flight Records

Seven quiet, dedicated men calling themselves research pilots—actually, they're college-bred engineers who fly for a living—have put the X-15 through the most spectacular paces in the history of flight.

The first to experience X-15 flight was Scott Crossfield, North American test pilot. He made sure the bird met basic expectations before it was turned over to the Air Force-Navy-NASA joint research program.

After him came three military officers and three civilians. The Navy's Comdr. Forrest Petersen has since been called away to squadron duties. NASA's Neil Armstrong has become an astronaut. Only four pilots are now active in the X-15 program.

One of them, amiable Joe Walker, 42, drove the X-15 on its *fastest flight*, on

June 27, 1962. He hit 4,105 m.p.h. (68.4 miles per minute) in ship No. 1.

Another—cool, precise Maj. Bob White, 38—piloted the space plane on its *highest flight*, July 17, 1962. He flew X-15 No. 3 to 314,750 feet (59.6 miles), setting the world's altitude record for aircraft. Going over 50 miles high put him officially in the astronaut class. (Actually, the X-15 could climb to 142 miles if allowed to, but its pilot would never be able to glide back to a safe landing from there.)

Soft-spoken Jack McKay, 40, made the craft's *hottest flight* on June 29, 1962, using X-15 No. 2, now disabled. He set the ship at such an angle as it belly-flopped home from the border of space that its leading edges heated to 1,250 degrees F. and glowed like embers. As the plane's nickel-chromium skin expanded and contracted from extremes of heat and cold, "it sounded as if sledge hammers were pounding the sides," McKay reported. (The skin has joints that permit up to an inch of expansion.)

The fourth X-15 pilot, Maj. Bob Rushworth, 38, and McKay have deliberately risked serious control problems by flying without the bottom fin of the ship's unique vertical stabilizer. (The plane seemed better off without it.) And they have flicked off the automatic roll-and-yaw damping system to see if the craft could be controlled manually in its most perilous passages. (It could.)

These men have done such things with as little flourish as they would exhibit in making supermarket runs for their comparably calm wives. There is not the faintest aura of hot-shot pilot about any of them. They are family men to a rather extravagant degree, the four being the fathers of a total of 15 children. Their hobbies are simple and homely—golf, hiking, camping, mountain-climbing, fishing, hunting.

Despite the ever-present danger of their work, they've never had a serious accident.

Yet, in flying far higher and faster and hotter than men have ever traveled in aircraft before, they haven't merely been proving that it could be done.

"We're not in the business of setting records," declares Paul Bikle, head of NASA's X-15 research program and a champion glider pilot. "We just happen to be doing experiments in the speed and altitude ranges where the records are." ■ ■

SURPLUS SALE

GOVT. SURPLUS
EXCESS INVENTORY
BANKRUPT STOCK



TELEPHONE SWITCHBOARD

● Item #701. Install your own private system. Fine for motels, factories, stores, apartment, etc. Connect any 2 lines together by pressing key. Capacity 12 lines. Connect to local system. Beautiful walnut cabinet. Brand new. Govt. cost \$450. SALE



\$79.50

HIGH SPEED 3 3/4 H.P. MOTOR

● Item #1023. Many uses, boats, cars, etc. New hi-speed powerful compact motor. Operates on DC 12 to 24 volts. 6000 RPM at 12 volts, 18 amps no load. Rotation CCW. Shaft 5/8" dia. Size 8 1/2" x 7 3/8" x 4". Wt. 17 lbs. Govt. cost \$100. SALE



\$12.97

REMOTE THROTTLE or VALVE CONTROL

● Item #533. Marvelous low speed geared-down ball bearing motor which can be run either direction from remote control.
● Built-in limit switches will stop rotation any point. Use to control gas throttles, open doors, many other servo uses. Rotates 3 RPM on 12-v DC. Takes only 1 amp or less. Size 5"x4 1/2"x3". Wt. 2 lbs. Govt. cost \$45. SALE



\$4.99

HEAVY DUTY 12-V GENERATOR

● Item #630. New expensive Govt. 12-volt DC generator. Hi-current (35 amps output.) Rotation CW. Shaft 5/8" diam. Easily mounted. Size 10 1/4"x5 1/2". Wt. 38 lbs. Govt. cost \$79.50. SALE



\$9.25

A-C POWER PLANTS

● Real buys in Govt. and commercial plants and generators. Save to 70%.
● 1000-w 115-v 60-c... \$172.50
● 2500-w 115-v 60-c... 269.50
● 3500-w 115/230-v 60-c... 329.50
● 5000-w 115/230-v 60-c... 447.50
● 3000-w AC generator 60-c... 139.50
● 3000-w DC generator... 54.75

AIR COMPRESSOR BARGAINS

For painting, cleaning, tires, control terminals. Assemble your own outfit.
● DeLuxe Kit. Compressor, tank gauge, regulator, paint gun, fittings. How to build instructions. List \$67.50. SALE



\$49.50

G.E. TELECHRON CLOCK SWITCH



● Turns appliances, radios, TVs, electric signs on and off at pre-set time.
● Can be set to skip any day or days of week.
● 110-V. 60-c. Contacts will handle 15-amps. Cost \$13.50. SALE

\$5.97

SELF PRIMING WATER PUMP



● Item #204. New Govt. Fine for boats, sump, etc. Timken bearings. 1 1/2" intake and discharge ports. 3/4" shaft. Size 12"x10"x18". Wt. 32 lbs. Cost Govt. \$97.50. SALE

\$19.49

BATTERY REMOTE CONTROL WINCH

● ITEM #322. Govt. DC hoist with push-button switch, 20' control cable.
● 35' 4000-lb. cable. High strength rating 1000-lbs. on 12-v. Fine for boats, docks, trucks, jeeps, farms, etc. Electric brake. Wt. 90 lbs. Size 12"x14"x8". Govt. cost \$395. SALE



\$68.25

DIAL TELEPHONE

● Item #716. Std. phone, same used on all phone systems. Use as extension to main phone and on private systems. Directions furnished. Wt. 8 lbs. Govt. Cost \$25.00. SALE



\$7.95

SPECIAL OF THE MONTH!

LABORATORY AC to DC RECTIFIER

● Item #2253. Compact Army Rectifier that is excellent commercial or home laboratory unit. Converts 115-v 60-c AC 25-190-v DC or AC at 250 m.a.
● Finest filters and components. Standard 19" rack mtg. size. Designed for Army phone and code systems. Size 19"x12"x3". Wt. 40 lbs. Govt. cost over \$100. SALE



\$6.91

HI-STRENGTH SET OF CABLES

● Item #329. Govt. surplus. New 6-piece hi-strength galvanized flexible tow and lift cables. Fine item for farmers, contractors, etc.
● Consists of 5', 10', 20', 30', 60' and 100' 5/16" stranded cable with thimble eye and clevis. Wt. packed 55 lbs. Govt. cost over \$50. SALE



\$19.95

TACHOMETER SYSTEM

● Item #2146. Expensive mechanical-drive electric output system. Consists of G.E. precision AC generator driven by engine, motor, etc.
● Generator connects to RPM meter with two wires, may be any distance away. Reads 0 to 6000 RPM. Fine for hot rodder, laboratory, shop, etc. Govt. cost \$50. SALE



\$19.63

FUEL TRANSFER PUMP

● Designed for use in planes for transferring fuel from one tank to another. Makes excellent pump for contractor, farmer, etc. for refueling tractors, dozers, etc.
● Complete with filter which takes out dirt and rust. Capacity 300 gal. per hr. Ports 1" iron pipe. Size 15"x5"x7". Wt. 10 lbs. Govt. cost over \$30. SALE



\$11.95

MISC. ELECTRONIC BARGAINS

● \$35 Astronomical Time Switch 110-v... \$ 5.98
● \$99 Auto Step-by-step Tel. Switch... 12.91
● \$95 Telephone Line Amplifier... 7.95
● \$5 Radio Telegraph Key... 1.39
● \$150 Servo Experimental Amplifier... 4.95
● \$9 Powerful 110-v Solenoid... 2.98
● \$14 Hi-Voltage (10,000-v) Spark Coll... 3.91
● \$20 Navy Geiger Tubes... .69

ALL ITEMS THIS AD FOB LINCOLN
Send for big new Free 1963 Catalog

SURPLUS CENTER

Dept. 836, LINCOLN, NEBR.

SUCCESSOR TO VARNISH

Mirror Gloss

You'll marvel at FABULOY, super-tough, super-gloss, clear protective coating. Highlights the beauty of all interior wood surfaces, bare or finished. Magic resin formula applies smoothly... dries fast. Insures maximum resistance to dirt, grime, stains. At Paint, Hardware, Lumber Stores. Send 50¢ for complete wood finishing manual, Pierce & Stevens Chemical Corp., Box 466, Buffalo 5, N.Y.

NATURAL
WOOD
FINISH

Made by the makers of famous FABULON

FABULOY

SUPER-GLOSS NATURAL WOOD FINISH

Works
in
Seconds!



Loosens Rusted Bolts
nuts, screws, "frozen" parts!

LIQUID WRENCH

SUPER-PENETRANT

BONUS USE: Add to crankcase to quiet noisy valve lifters... remove gum, sludge deposits!

THEN ADD ...

MOTOR-MEDIC
EXTRA LUBRICATION...
SMOOTHER PERFORMANCE



Both at leading dealers everywhere!



Backyard Blues?



Good News!

Here's the way to add amazing new beauty and convenience to your home. Replace that troublesome wood door with a modern Bilco. All steel, permanent, watertight, opens and closes at a touch. A new Bilco Door will do wonders for your home... and for you!

The Bilco Co., Dept. R-72, New Haven 5, Conn.
Please send me your free illustrated folder and name of local dealer.

Name _____
Address _____
City _____ Zone _____ State _____



AMERICA'S FINEST
BASEMENT DOOR

Garage
Basement
Shed, Shop
Barn

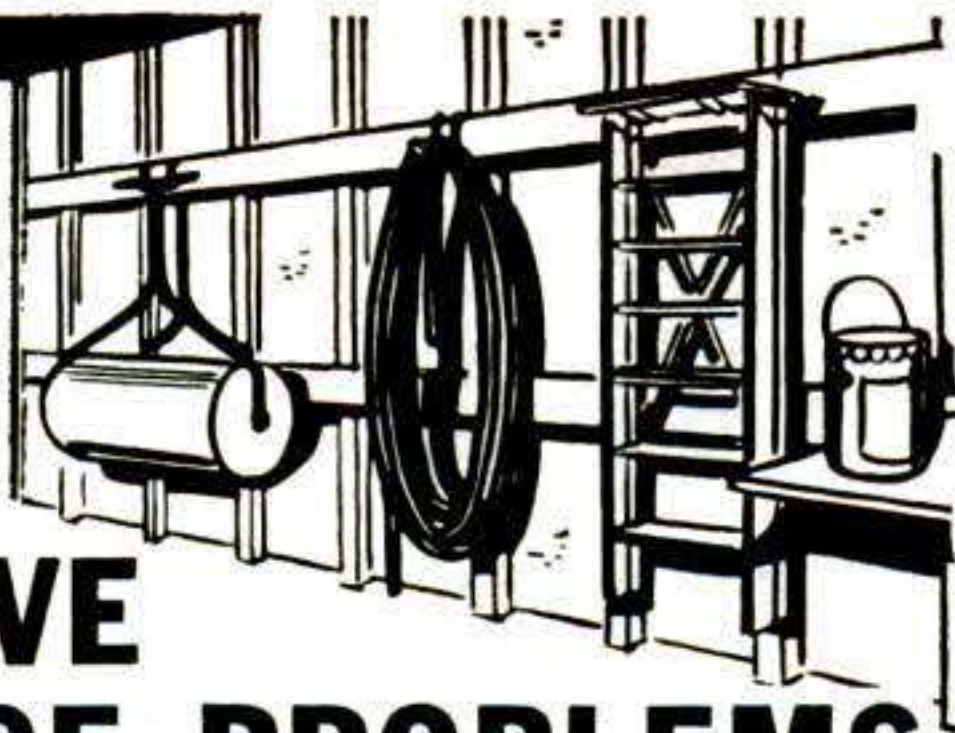

SOLVE STORAGE PROBLEMS

WITH HERCULES HOOKS

Patent applied for
obsoletes every other method of
HEAVY DUTY WALL STORAGE

These giant steel hooks are approx. 1/4" thick. They fit over the common 1" x 4" wood board. Simple to put up. NO perforated wallboard is used.

Hold the heaviest tools, equipment, shelves, etc. **HOLDS EVERYTHING.** Ask for them by name at your dealer. **HERCULES HOOKS!**

Sample hook sent direct to you. Enclose 10¢ for mailing. Literature **FREE!**

8 DIFFERENT STYLES

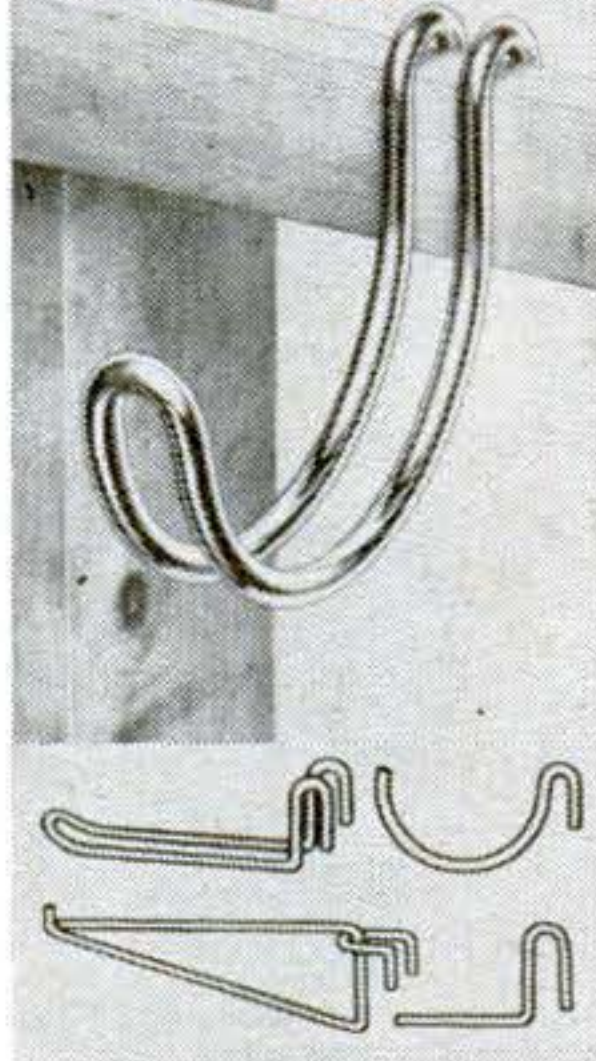

K THE KERR WIRE PRODUCTS CO.
935 N. Cicero Avenue • Chicago 51, Illinois

16" size
0" to 4 1/4"
parallel jaws.

BIGGEST PLIER MADE

DIAMALLOY

Ask for
HL 116P
Diamalloy
Groove-
Joint
Pliers

Sizes down to 4 in. Handiest tools in your kit. Chrome finished. "There is nothing finer than a DIAMOND". Made only by makers of famous Diamond Wrenches and Pliers.

Write for free tool catalog
DIAMOND TOOL
and Horseshoe Co.

DULUTH, MINNESOTA EST 1908 TORONTO, ONTARIO

I Rode with the Avalanche Patrol

[Continued from page 114]

Henry Brown, when buried by the avalanche named after him, couldn't tell which way to dig. "Luckily, I'd raised my arms over my face," he told me. "I could move them just enough to dig a trifle. But first I made small snowballs and tried to drop them on my face. When they went the other way—up—I knew I was lying about 30 degrees from upside down, so I began digging toward my feet." Few people are ever able to dig however, for their arms are pinned hard.

A man caught in an avalanche may never know he is moving at all. "The snow just opened up and began drawing me down in," said a National Ski Patrol member I talked to. "Nothing was moving—until I looked across to the forest on the other side which was silently going uphill." Luckily this slide was a short one and other Ski Patrol members soon located their man by following a bright yellow nylon cord tied to his waist.

There had been days of storm when I reached Silverton. Over 30 avalanches had fallen or been shot down without loss of life, thanks to the patrol.

Then one sunny morning at breakfast word came that high winds were again loading snow into several slides above U.S. 550.

We didn't wait, for the highway is used by school buses. We set up our cannon right in Silverton, butting it hard against the wheel of a highway truck. One of the menacing slides was the Jennie Parker, which once knocked a busload of tourists over a cliff.

Major Willard Croonenberghs, a highway engineer and reserve artillery officer, yanked the lanyard. The gun barked, a high-explosive shell screamed, and we saw a bright orange burst on a peak 12,000 feet above sea level. The Jennie shivered, but didn't come down.

"That will settle her—compact her—for a few days, however," said Major Sid Foster, another engineer, also a reserve artilleryman. "Now let's shoot the old S.O.B."

We began climbing lonely Red Mountain—a convoy of two plow-equipped trucks and two state cars with the cannon on a trailer behind a third truck. The patrol closed the road to traffic and, from a high switchback, began lobbing shells at the

I Rode with the Avalanche Patrol

S.O.B. This ornery slide was stubborn and refused to budge—yet. Then we hurled shells across a great valley to the monster Horseshoe slide on Red Mountain, and “settled” this one for a while. When a slide settles, it moves like a man in his sleep, choosing a more comfortable spot. The snow packs down and takes a tighter grip on the mountain.

Toward noon, we looked high up to the north and saw the Mineral Bridge slide. We could see snow blowing over the mountain and falling on the slope.

“That one,” said Orville Francis, district engineer, “looks ready for trouble.”

All this time the patrol had two trucks guarding the road. One, two miles down, had stopped traffic. The other was a half-mile above us on a switchback.

Another shot. Maj. Foster, hatless, practically standing on his head, bore-sighted the cannon—a 75mm mountain howitzer of the sort used by the U.S. Army in Italy in World War II. I looked up the bore and saw only blue sky.

“We shoot high,” Foster said. “Shooting an avalanche is like shooting a tiger. To kill, you must hit just right. We shoot for something called the fracture line. That’s like shooting for the shoulder.”

The Mineral Bridge is a big slide and it was poised above us. It is named for a bridge it likes to bury without warning. We could see its usual track toward the bridge because there were no trees left—just snow. A patrol man searched the area with binoculars for ski or snowshoe tracks to be sure no one was in the mountains.

“Now,” said Foster, “gimme that ammo.”

A handler passed the two-foot-long shell. The crew stood with mouths open and ears covered. We took a last look for cars. Then Foster yanked the lanyard. The howitzer roared and jumped.

The recoil hissed, the concussion blasted snow against our legs. From behind the gun you could see the shell disappearing like a big black baseball headed out of the ball park. The shell’s scream melted in a growing roar as each mountain threw back the blast.

Four seconds . . . then the snowy peak was lighted by an orange flash. The shell had arched and come down below the top. More seconds . . . and the boom of our high explosive came down to us. The snow field shook, moved, and stopped.

CONTINUED

WAR SURPLUS AND OTHER BARGAINS SAVE UP TO 90%



50-1 GEAR HEAD MOTOR Terrific for pulling or lifting. Makes excellent small winch. Also can be used for electric steering of boats. Output speed 180 RPM. Reversible. Contains chain sprocket & pulley on 1/2" shaft. Runs on 24 V. AC or DC. Wt. 9 lbs. Approx. GOVT. COST \$97. NEW. \$10.95.



"BIG 12" ARC WELDING AND BATTERY CHARGING KIT

With Deluxe accessories consisting of one R1 300 amp generator, 30 feet welding cable, welder's adjustable helmet, electrode holder, 300 amp ammeter, 300 amp shunt, rheostat, toggle switch, 300 amp reactor coil arc stabilizer, voltage regulator, battery charging relay, one pair heavy duty welder's gloves. All units guaranteed pre-tested. Approx. Govt. cost \$750. Most items new — all perfect. Wt. 82 lbs. \$49.50

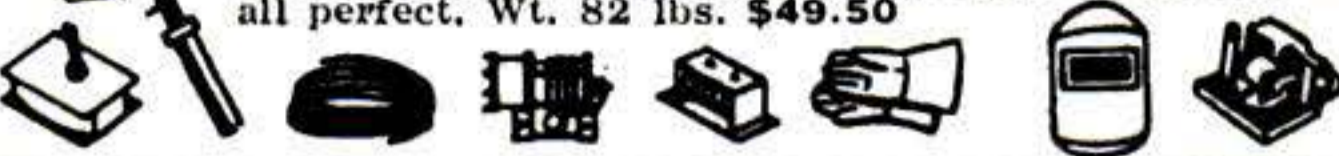

FAMOUS P2 GENERATOR—200 AMP,

continuous duty rating at 24 to 32 V.D.C. 4000 RPM. Self-contained cooling fan. One of the finest DC Gen. in use today for all welding or battery charging purposes. All units pre-tested prior to shipment. Shpg. Wt. 50 lbs. Approx. GOVT. COST \$375. Terrific value \$29.50.

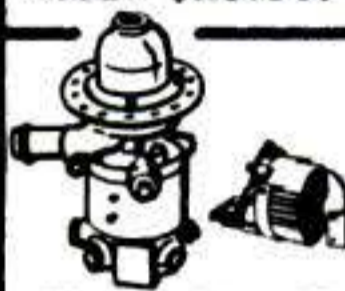

ELECTRIC PUMP WITH CONTROL UNIT

For boats, campers & trailers. Output 10 to 200 gal. an hr. Variable rheostat contains on & off switch and controls output of pump. 1/2" pipe thread into bronze impeller housing. 12 V.D.C. Radio noise filter. Explosion-proof const. Shpg. Wt. 9 lbs. Complete with mounting instructions & wiring diagram. Approx. GOVT. COST, \$200. NEW. \$10.95.

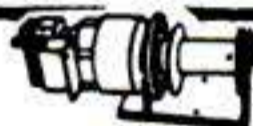

DELUXE ELECTRIC STORAGE BATTERY WINCH

Handles 250' of 1/4" cable. Operates on 6 and 12 V. battery. 160-1 gear reduction. Lift cap. 2500 lbs. Heavy-duty mounting base with out-rigger bearing and spool support. Rugged construction. Heavy-duty. Dim. 22" L x 9" W x 8" H. For jeeps, trailers, boats, trucks, campers. Shpg. wt. 80 lbs. Approx. GOVT. COST \$490. New. Model E-D. \$72.50

MODEL E. Same as above less outrigger support and extra heavy base. Spool cap. 70' of 1/4" cable. Cap. 2000 lbs., \$52.50



BIG NEW 1963 CATALOG!

Send 25c in coin for amazing new catalog with 1000's of surplus bargains in hydraulics, electrical, precision tools, marine items, automotive, etc. for hobbyists or industrial. Or order from this ad and receive a free copy. All prices F.O.B. Culver City, Calif. 50% dep. for C.O.D. Send check, cash or money order. Order today!

AIRBORNE SALES CO., INC. DEPT. PS263
8501 Stellar Drive • Culver City, California

Constantine's
New 130-Page



WOOD CATALOG & MANUAL

Since 1812, World Headquarters for Wood Craftsmen
Largest, most complete selection of rare imported and finest domestic woods in veneers, lumber, plywood . . . plus inlays, bandings and carvings. Also hand and power tools, veneering, finishing, upholstery supplies, hard-to-find hardware. Hundreds of new items—fabulous dyed woods, veneers, new tools, pre-cut inlaid wood picture kits—over 2,000 items in all! More than a catalog—a manual too! Dozens of "how to" articles on veneering, finishing, cabinetry, etc. Wood Identification Chart in NATURAL COLOR. Send 25c to help pay postage and handling.

ALBERT CONSTANTINE AND SON, INC., Dept. B-6
2050 Eastchester Road, New York 61, N. Y.



ALBERT CONSTANTINE AND SON, INC., Dept. B-6
2050 Eastchester Rd., New York 61, N. Y.
Enclosed 25c for new Constantine Catalog and Manual.

NAME _____
ADDRESS _____
CITY _____ ZONE _____ STATE _____

TABLE TIPSY?
fix it quick with



PLASTIC WOOD
Handles like putty-hardens like wood!



"MADE \$1200 ON ONE JOB"

Some make more, some less...

We help you start Your Own All-Year Business

Make BIG Money! • With our easily operated, highly efficient Wall Washer, G. H. Jones made \$1200 on one school job. E. L. Goss took in more than \$10,000 in one year. E. C. Taber wrote, "I made \$400 gross in two weeks." And no wonder... this machine washes walls 6 times faster and better than by hand—with no mess...no drop cloths.

Your Money-Making Opportunity • We want more men to go into this profitable business for themselves and enjoy independence...freedom from layoffs and bosses. Customers everywhere—homes, offices, schools, churches, hotels, etc. How much you earn depends largely on you, but we help you to start and work with you for your success. What you take in is mostly profit. No need to rent shop or office; operate from home. Start spare time until full time is justified.

Ours is NOT a Lease Arrangement • You are free to operate in an independent manner. You sign no contract. You own the detergent outright and are always *your own boss*...and every dollar you take in is *yours* to keep. You pay no fees, or dues, or royalties to anyone. And you take no risk. Your detergent is fully guaranteed and enough supplies come with it to return far more than your investment. Many earn the cost of the detergent in a week or two. It costs nothing to get the details...write **TODAY**.

MAIL COUPON TODAY FOR FREE BOOK

VON SCHRADER MFG. CO.

211 "W" Pl., Racine, Wisconsin

Please rush your **FREE** booklet about your **WALL WASHING MACHINE** and how I can start *my own* permanent, profitable business.

Name _____

Address _____

City _____ Zone _____ State _____

Loss No Time!—Send Coupon Today for All the Facts!

EVERLITE* World's THRIFTIEST Light Plants

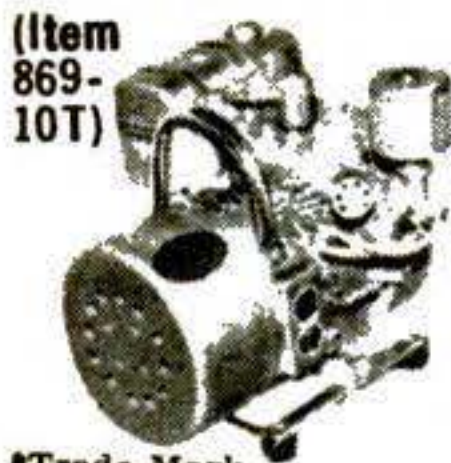

NEW TRANSISTOR ALTERNATOR REPLACES GENERATOR

Now a Service Free Light Plant built with a transistorized alternator. Offers 30% greater efficiency—more power for less fuel. Terrific service life—no brushes to arc and burn. No more commutator to wear, no collector ring trouble. And best of all it costs no more to "go modern with Everlite." Thrifty 1000 watt, 115v. AC plant powered by a rugged easy starting 4 cycle engine—leader priced Model 869-10T. Wt. 65 lbs. as illustrated **179.50**

*Trade-Mark Registered Special models for public utilities—Approved for Civil Defense. Write f.o.b. factory

All sizes available—can finance. Write for catalog.

MASTER MECHANIC MFG. CO., Dept. B-263, Burlington, Wis.

Southern Customers write Dept. B263, Box 65, Sarasota, Florida

A Complete Miniature Machine-Shop!

Metal - Plastics - Wood

- Turns • Threads • Bores
- Drills • Mills • Grinds
- Polishes • Buffs • 900-7200 rpm • 16" of bench space

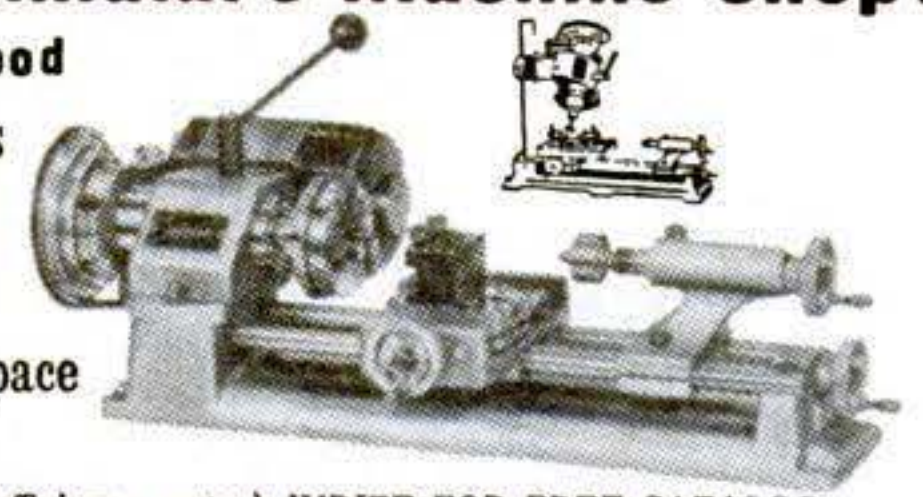

BASIC UNIMAT:

\$139.50 (includes high-efficiency motor). WRITE FOR FREE CATALOG.

AMERICAN EDELSTAAL, INC., DEPT. HB, 350 BROADWAY, N.Y. 13, N.Y.

TOOLS WHOLESALE

SELL TOOLS to your friends and neighbors, or buy tools for your own use and **SAVE MONEY \$\$\$**. Send **\$1.00** for your **WHOLESALE CATALOG TODAY!!**

A MILLION DOLLAR INVENTORY AT YOUR FINGERTIPS. NO STOCK TO CARRY. ORDER AS YOU NEED IT.

BUY AT WHOLESALE PRICES. Extra \$25.00 profit on your accumulated purchases. \$1.00 refund on first purchase or refunded if you are not 100% satisfied.

THOUSANDS!! of Nationally Advertised items of Hand Tools, Power Tools, Machinist Tools, Tool Chests, Paint Sprayers, Light Fixtures, Appliances, Guns, Gifts, Toys and other items too numerous to mention.

WE SHIP COAST TO COAST Whise. Disc. up to 50% off

SILVO HARDWARE CO., Dept. PS-2 107 Walnut St., Phila. 6, Pa.

DO MORE PLANING JOBS WITH LOW COST BELSAW



Exclusive **MONEY-MAKING** Features: Full 12 1/4" x 6" capacity • Power feeds at 14' to 34' a minute • Provides for Grinding Knives in the Cutter-head • Attachments for Jointing, Rabbeting, Tongue, Matching, Groove. Convert low cost rough lumber into high priced stock. Easy to make flooring and popular patterns. Send Today for **FREE** Literature and Prices.

LOW DOWN PAYMENT EASY TERMS

Belsaw Machinery Co, 2063 Field Bldg., K.C. 11, Mo.

Fill Flaws In Plywood

Handles like putty. Hardens like wood.

PLASTIC WOOD®

The *Genuine*—Accept No Substitute.

AUTOMATIC RETOOTHER

MAKES NEW PROFITS

for HAND SAWS

Cuts new teeth in 50 seconds—any size 4 to 16 points. Old teeth fall off as chips. Easy to operate. A perfect job.

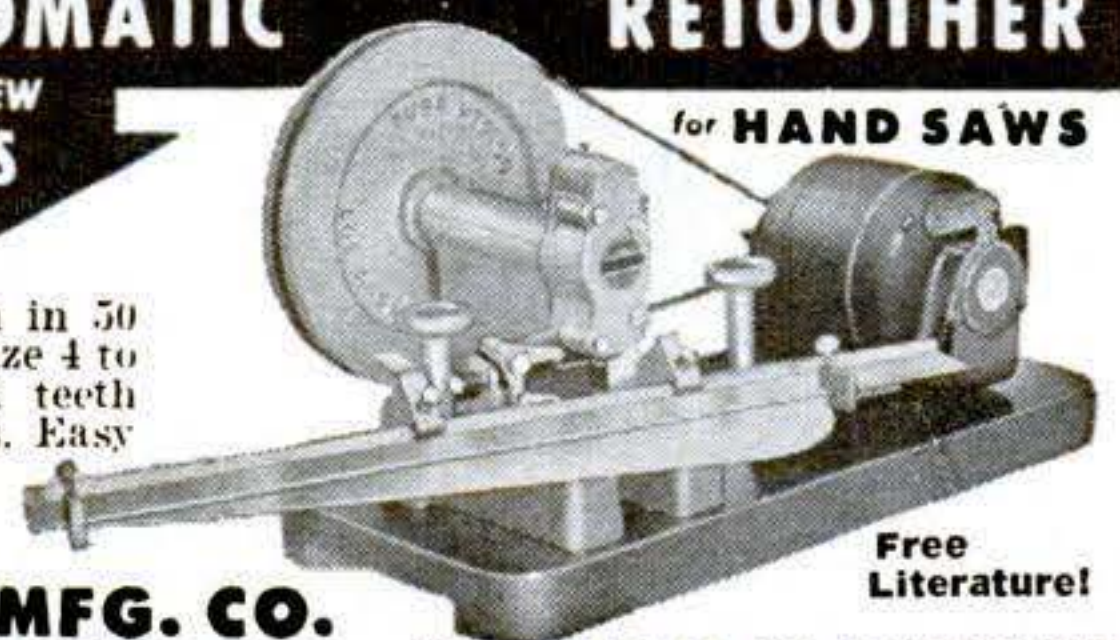

Free Literature!

BURR MFG. CO.

8943-F VENICE BLVD

LOS ANGELES 34, CALIFORNIA

I Rode with the Avalanche Patrol

"Too low," said Foster. "I'm going up five degrees. We've got to get this fellow down."

Wrong-way slide. The second shell hit just below a dark ridge. Again the mountains roared. We waited, tense, as blue smoke drifted from the gun. Then someone called:

"She's starting!"

Cracks like angry black lightning flickered through the snow—the fatal wound. The snow stirred heavily. A vast white shiver ran down, and in a wink the whole great slope was unlatched.

Foster said, blowing on his hands: "That gun was damn cold." He was interrupted by a shout:

"She's coming, but she's coming the wrong way!"

For some reason, the slide had jumped its usual track. It was coming toward us and would dump into a valley a half-mile below. It was heading not for the bridge but for an area farther west of the bridge and much closer to us.

An avalanche wind of great force, pushed by snow, raced ahead, breaking trees before the snow swallowed them. We saw bending trunks and thrashing branches. Then there was a sharp explosion, as if someone had fired a rifle. Down in a forest below, the first giant spruce tree had snapped like a matchstick.

After this there was complete and sudden silence. In the strange quiet, the avalanche came galloping on in bounding waves. Leaping high, it swallowed the forest. Dozens of trees must have snapped, but we heard no sound, for the avalanche now was moving behind a towering wall of silence. We could see that wall: a cottony snow fog that rose swiftly several hundred feet and hung, muffling all sound. Snow fogs are made of millions of crushed snowflakes. Men have suffocated in them, just as they have been killed by concussion, without ever being touched by an avalanche.

Within seconds, it was all over, although a bounding, wavelike motion continued to run through the snow fog. The patrol reopened U.S. 550 and we went on hunting more slides.

It would be days before the Mineral Bridge avalanche could again threaten U.S. 550. And it had been a rare and beautiful sight. ■ ■

RAM PRESENTS TWO HOMESHOP FAVORITES

A TRUE TWO-WAY SANDER

Perfect combination of orbital and straight line sanding action. Plenty of power for a better sanding job. Industrially rated.



A REAL WORKHORSE 3/8" DRILL

This workhorse by Ram solves your problems of drilling in steel, wood or masonry. Has Jacobs Chuck, 3/8" cap. in steel. Industrially rated.

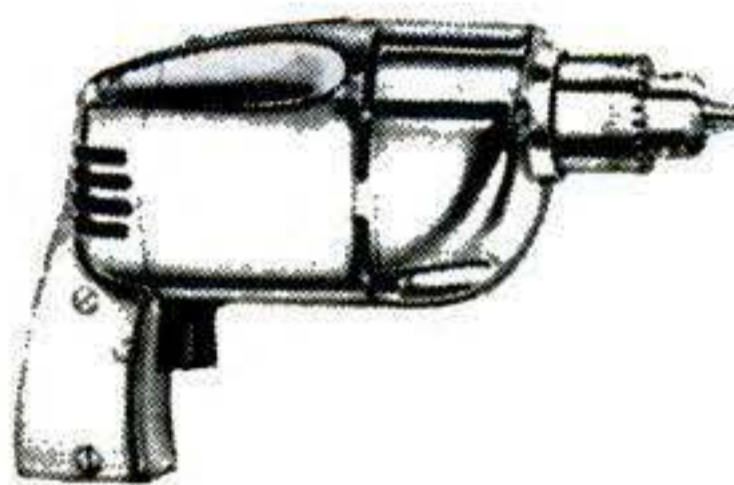

Write for catalog of other Ram Tools.

RAM TOOL CORP., Dept. PS2

411 NORTH CLAREMONT AVENUE • CHICAGO 12, ILLINOIS

SHOOT A STAPLE WHEREVER YOU'D DRIVE A NAIL!

Same Machine
uses 6
Staple
Sizes . . .



"ONE
SQUEEZE
AND YOU'VE
NAILED IT!"

WITH
AN

ARROW

Brooklyn 12, N. Y.

No. T-50 All-Purpose STAPLE GUN

Available at Hardware, Building, Lumber and Stationery Dealers Everywhere.
ARROW FASTENER CO., INC. 1 Junius St., Brooklyn, N. Y.

A great new
**POPULAR
SCIENCE
BOOK CLUB!**

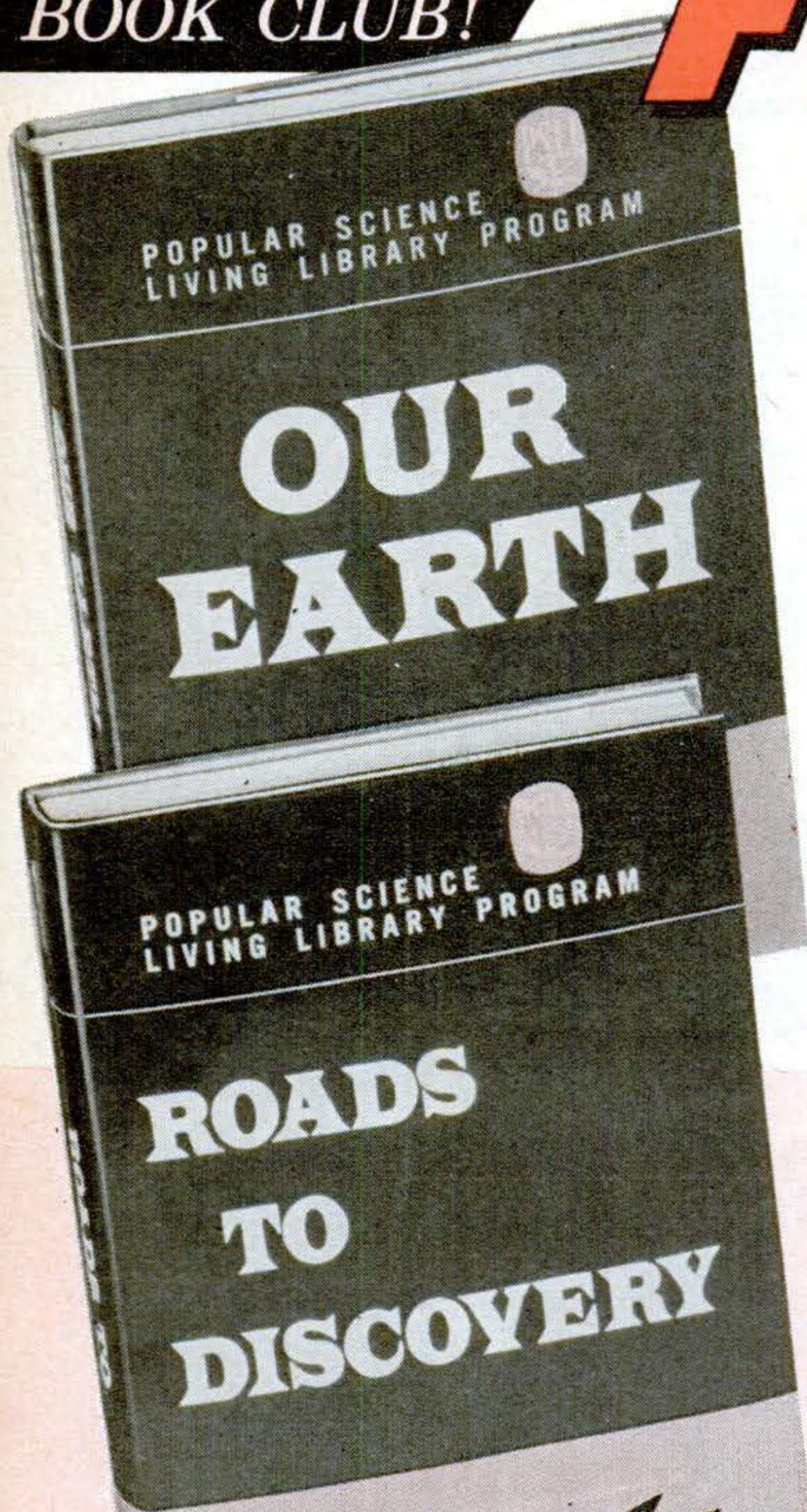

You Get **\$12.90** Worth
of Books in Your First
Shipment for **ONLY \$1.95!**

Get These **TWO**
FREE with

as a Joining Member
POPULAR SCIENCE

Here is a completely new kind of book club, created especially for POPULAR SCIENCE readers! This exciting book program makes it simple for you to build an ever-growing library of fact-filled, easy-to-understand science books at tremendous savings. In these exciting books you'll explore every aspect of modern science—from the invisible atom to the complex human machine to the vast solar system.

By joining the POPULAR SCIENCE LIVING LIBRARY PROGRAM now, you immediately get two free selections: OUR EARTH and ROADS TO DISCOVERY. With these two free books comes your first regular selection, SPLENDOR IN THE SKY. Your bill for all three books (\$12.90 in bookstores!) will be a mere \$1.95! After this first shipment, you receive a new, exciting LIVING LIBRARY selection every three months—at a guaranteed low price of only \$1.95. That comes to barely 2¢ a day! Yes, for mere pennies you get superb science books that are handsomely printed and illustrated, clothbound in a variety of attractive colors, all in matching format. This amazingly low

**You're off to an exciting start
with your fascinating FREE books!**

Each is a gem of popularized science writing — exciting, colorful, authoritative, well illustrated and packed with facts!

OUR EARTH by Dr. Arthur Beiser. Come travel the frontiers of knowledge about our planet from its deepest interior to the outer reaches of its atmosphere! Here is fascinating information on the earth, its unique properties, its strange and violent history. Here are the latest scientific facts on the size of the earth, its composition from core to crust, its place in the solar system, effects of tides and magnetism. Here are the latest conclusions on the earth's origins, its age, its fantastic future in the face of a constantly swelling sun, and much more. Illustrated with photos and drawings.

ROADS TO DISCOVERY by Dr. Ralph E. Lapp. A world-famous physicist, Dr. Lapp illuminates the fascinating world of the atom and describes the great discoveries that have progressively led scientists to the heart of its mystery. You'll eyewitness the birth of the atomic age when Roentgen discovers X-rays. See Becquerel prove that uranium is radioactive. Watch the Curies isolate radium. You'll see Rutherford become the first to crack the atom, Fermi the first to achieve a chain reaction and much more leading up to the H-bomb and nuclear power plants. There's also plenty on the past, present and future of atomic energy in medicine, industry, farming, etc. Illustrated.

POPULAR SCIENCE LIVING LIBRARY PROGRAM

355 Lexington Ave., New York 17, New York

GREAT SCIENCE BOOKS

First Selection at only **\$1.95**

total value
\$12.90

of the New and Exciting **LIVING LIBRARY PROGRAM!**

price for cloth books (less than the present-day cost of many paper-bound books) is made possible by the great economies in enormous printings.

You'll be delighted to find, as your LIVING LIBRARY grows, that your enjoyment and knowledge of modern science have deepened, that you have at your fingertips a ready grasp of many subjects which may have baffled you before, that you can easily answer so many questions your friends and family ask.

POPULAR SCIENCE LIVING LIBRARY books are never priced higher than \$1.95 (plus postage) even though bookstore prices are much higher. You never pay in advance. We bill you later. All selections are fully returnable within 10 days. And, of course, you may quit the PROGRAM at any time by simply dropping us a line.

So, get on the road to the best science reading at the lowest possible prices, without risk! Mail the attached post-free card TODAY!

Your future books will cover other thrilling science subjects!

New books in the POPULAR SCIENCE LIVING LIBRARY PROGRAM will cover such fascinating subjects as the living drama of medicine . . . the amazing world of animals and nature . . . the development of power from windmill to nuclear reactor . . . the conquest of space . . . the fantastic workings of the human body . . . the teeming life in the soil beneath our feet and much, much more! Drawing upon the riches of chemistry, biology, botany, archeology, atomic science, zoology, physics, meteorology, and all the other fascinating branches of science, the LIVING LIBRARY PROGRAM will bring you books that are masterpieces of simplicity and readability! Each one will be a valuable addition to your growing, comprehensive home science library!

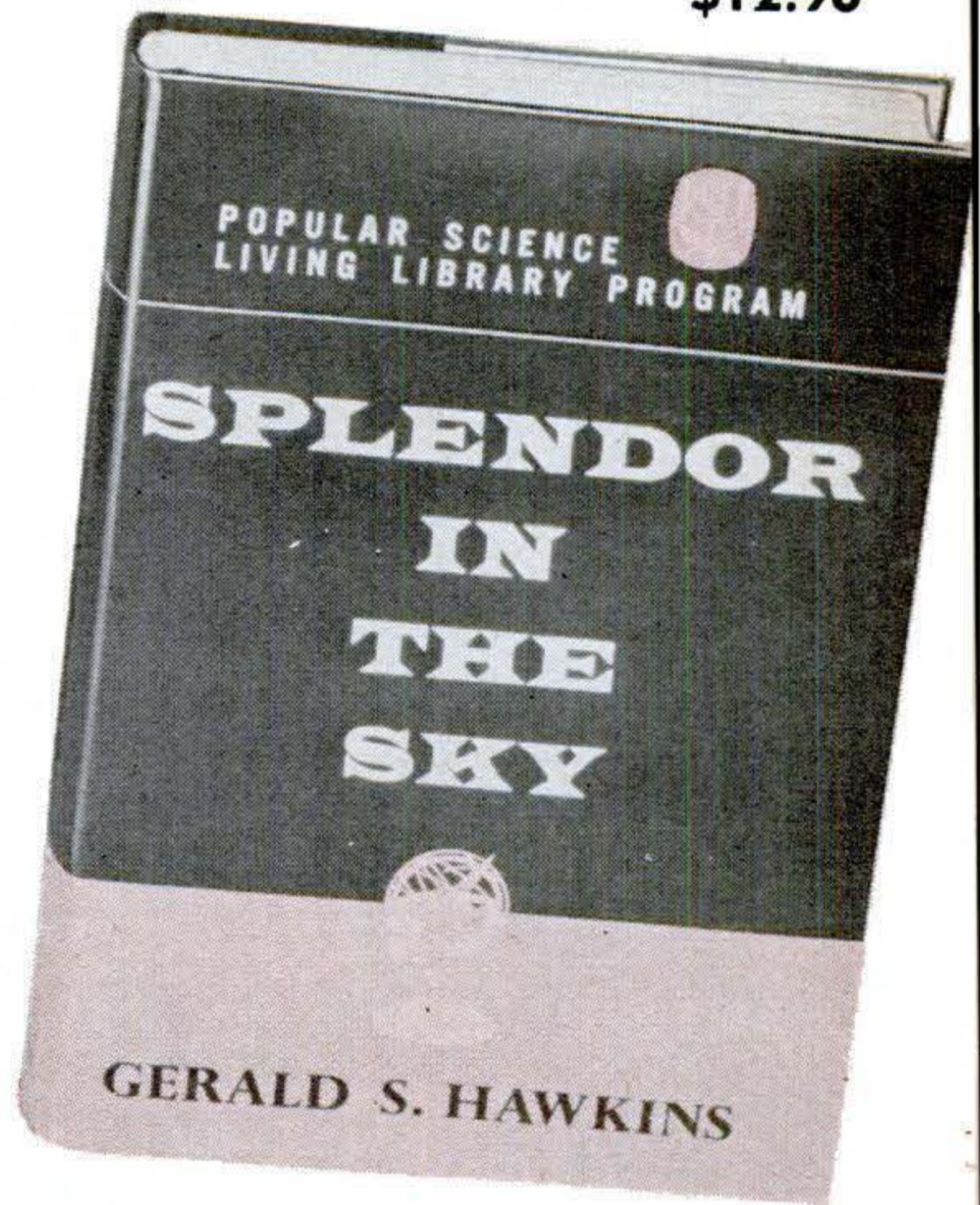

SPLENDOR IN THE SKY by Dr. Gerald S. Hawkins. An exciting and beautifully illustrated view of astronomy ranging from the planets to the stars to the galaxies beyond. Starting with the ancients, you are swept through the thrilling and turbulent days of great astronomical discoveries. You get a deeper understanding of the contributions of Copernicus, Brahe, Kepler, Newton. Rapidly unfolding before you are the secrets of our universe—our galaxy, stars, radio stars, clusters and superclusters, meteors, comets, plus all the modern theories of the creation of our universe. Dozens of pages of illustrations, scores of drawings.

CHECK THE MANY MEMBERSHIP ADVANTAGES IN THIS EXCITING NEW PROGRAM!

- ✓ GET TWO FREE BOOKS IMMEDIATELY. *Our Earth* and *Roads To Discovery* are yours free along with your first selection, *Splendor In The Sky*.
- ✓ FIXED LOW PRICE TO MEMBERS FOR EVERY BOOK. All LIVING LIBRARY books are priced at only \$1.95, regardless of higher bookstore prices.
- ✓ FREE 10-DAY EXAMINATION OF EVERY SELECTION. You *alone* decide whether you want the book or not. Books are always returnable, with no obligation.
- ✓ YOU NEVER PAY FOR A BOOK UNTIL AFTER YOU'VE READ IT. You must first be convinced that it is an outstanding bargain.
- ✓ CHOOSE AS MANY OR AS FEW BOOKS AS YOU WISH. No minimum number of books required. Take only what you like.
- ✓ AUTOMATIC QUARTERLY SHIPMENT OF SELECTIONS. Books are automatically sent every three months (four new books a year)—no forms to fill out, nothing to forget.

MAIL CARD TODAY—Build a valuable science library for only 2¢ a day!

Planer-Molder-Saw!

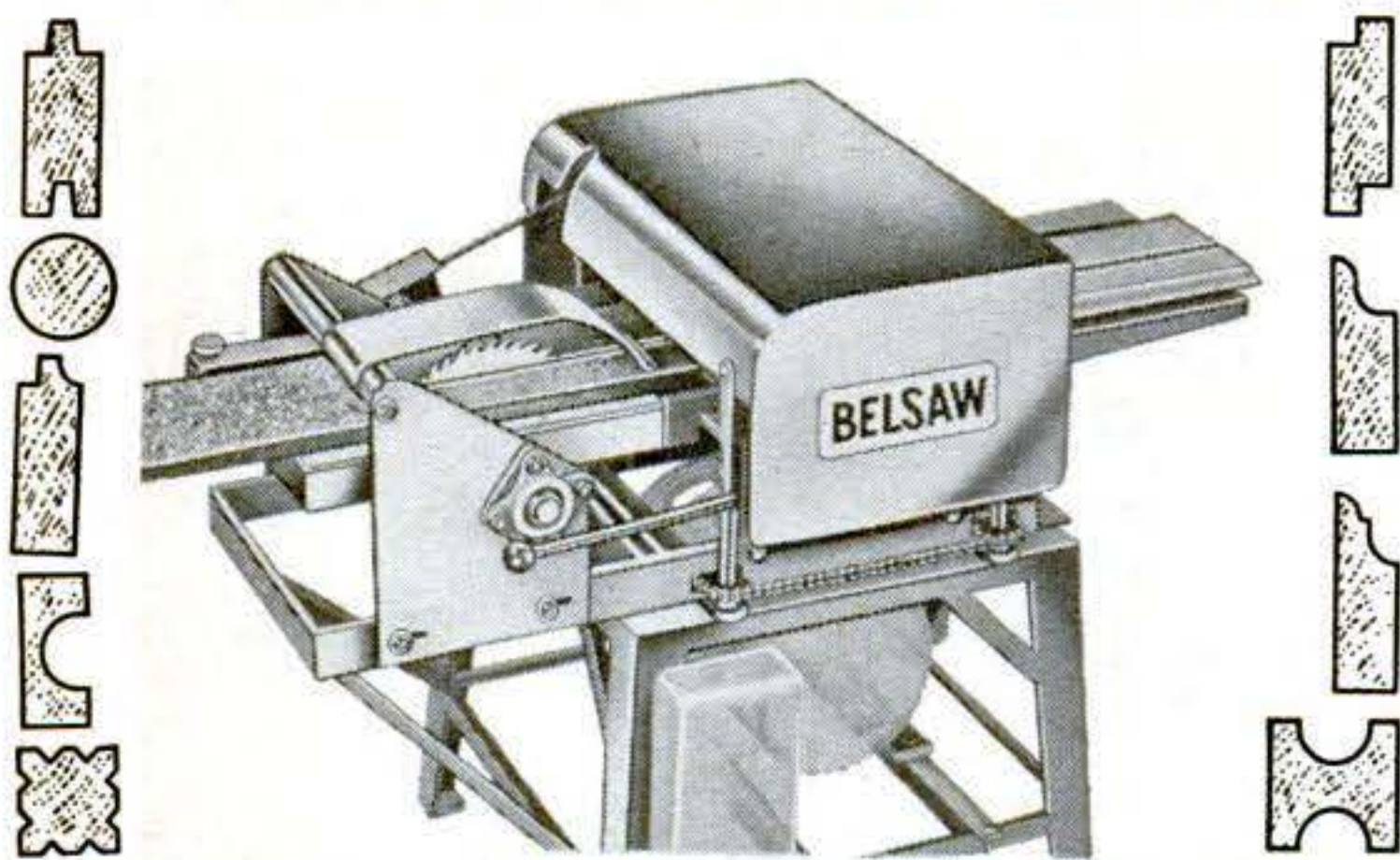

Now you can use this ONE power feed shop to turn rough lumber into high-value moldings, trim, flooring, furniture... ALL popular patterns.

RIP...PLANE...MOLD...separately or all at once by power feed...with a one horsepower motor. Use 3 to 5 HP for high speed commercial output.

LOW COST... You can own this MONEY MAKING POWER TOOL for only \$3000 down payment

Send coupon today

BELSAW POWER TOOLS 923 Field Bldg., Kansas City 11, Mo.
 Send me complete facts on the MULTI-DUTY Power Tool.
 No obligation.

Name _____
 Address _____
 City _____ State _____



POWER GUN OPENS SEWER INSTANTLY

**SAVES PLUMBING
REPAIR BILLS**

FREE BOOK
 ★ Tells How
 To Clean
 All Drains

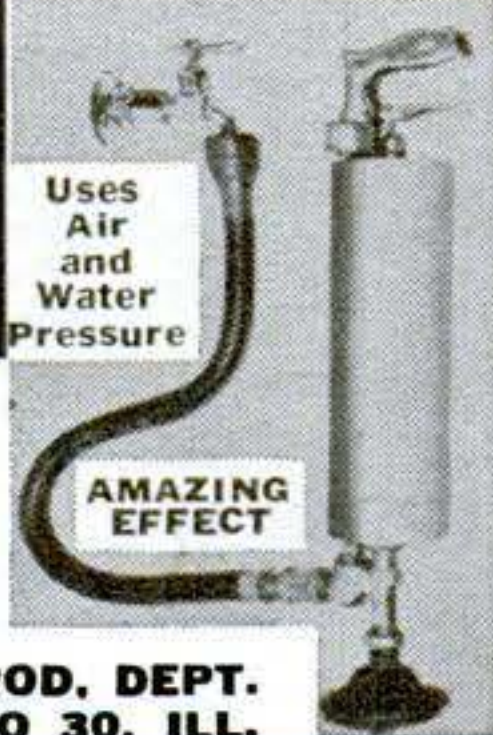

One INSTANT SHOT of this new **POWER GUN** removes Grease, Detergent, Roots in **SINKS, URINALS, TOILETS, SHOWERS, HOT & COLD WATER PIPES, HOUSE-TO-STREET SEWERS, 1/2" to 6" pipe 200 Ft.** Powerful reaction. Write for **FREE BOOK.** No Agent will call (Chicago Phone Kildare 5-1702). **MILLER SEWER ROD, DEPT. PSF, 4642 N. CENTRAL AVE., CHICAGO 30, ILL.**



GENUINE ALNICO MAGNETS

AMAZING, PERMANENT, NON-ELECTRIC, HIGHLY PRACTICAL. Conduct interesting experiments; Hundreds of uses. Retrieve valuable steel items such as guns, tackle from fresh or salt water; tools from tanks & drains. **GUARANTEED.** Try any magnet one week. Money back if you are not well-pleased.

S- 90 (Wt. 5 oz.) Has pull of 15 lbs. on steel block	\$ 3.50
S-500 (Wt. 13 oz.) Has pull of 50 lbs. on steel block	\$ 5.00
S-575 (Wt. 18 oz.) Has pull of 75 lbs. on steel block	\$ 7.00
S-625 (Wt. 70 oz.) Has pull of 125 lbs. on steel block	\$10.00
S-710 (Wt. 53 oz.) Has pull of 225 lbs. on steel block	\$18.00
S- 44 Rod Magnets for Electric Guitars 1/4" Dia. x 1 1/4" 12 for	\$ 4.00
S- 47 Hot Pad Magnets. 10 for \$1.00. 50 for	\$ 4.87
S- 35 Science Experimenter Kit of 8 magnets	\$ 2.00

Send M.O. or check. We pay postage. Sorry no C.O.D.'s.
MIAMI MAGNET COMPANY, 3240 N. W. 27th Ave., Miami 42, Fla.

My Trailer Does More Than Haul a Boat

[Continued from page 136]

can swing the winch to any position and then lock it tight. An ordinary threaded joint would loosen up as you swiveled the winch.

The removable bow cradle just screws into a regular pipe coupling welded to the drawbar since it doesn't have to swivel. Thread a flat support into the same coupling and you have the basis for a box or flatbed trailer. The body needn't even be bolted on. Just arrange cleats on the underside so they wedge between the front and rear trailer supports.

Coil-spring suspension, too. The rear-load-supporting crossbar floats. Its ends form sockets that simply slip over smaller diameter pipes projecting upward from the wheel mounts. In fact, the entire assembly—crossbar, boom, and bow cradle—can be lifted off if you want to mount a platform directly on the lower frame for low-to-the-ground loading.

Small coil springs inserted between the crossbar's floating joints give the trailer a soft ride. The coils are two 5" lengths cut from a standard automobile overload spring about 2 1/2" in diameter.

The secret of the small wheels lies in the trailer's design—it throws a good share of the load forward onto the hitch. Because the wheels don't have to support the full weight, you can use the less expensive 4.00-by-8 type made for motor scooters. They should have ball bearings and at least a 1" bore.

The only tricky part is aligning the wheels when mounting the axles. It's easiest to remove the tires and work with a square and straightedge against the rims. They should toe in slightly for proper tracking. Since the wheels turn on their own bearings, the axles are simply short lengths of 1" solid steel rod welded rigidly into the lower pipe frame.

The mudguards are welded to the upper telescoping cross member so they float right along with it. The rollers used to slide a load onto the trailer are sections of free-turning pipe wrapped with strips of rubber for padding. Two short sections of similar pipe are also slipped over the rear cross member and are welded to the ends of the boom. These serve as collars to let the boom pivot. The boom brace, when not in use, folds down and under the trailer's frame so it's out of the way. Its free end is held in a hook.

KING MIDGET 1963

"WORLD'S MOST EXCITING LOWEST PRICED CAR"

Drive it for 75c a week. Rider Agents Wanted. Send 25c for 32 page book. full details, dealer price. Or send \$1 (Refunded first order) for this plus Service and Repair Manual and 16 5x7 photos of car and factory.



MIDGET MOTORS CORP. Athens 2, Ohio

ADJUSTABLE MITER BOX & CORNER CLAMP

2 TOOLS IN ONE

Holds the wood and holds your saw. No. 44 Uses any handsaw for accurate cuts from 0° to 180°. Full 3" capacity. Sides of joints exposed for nailing, gluing. PPD \$2.75

No. 33 Works the same as No. 44, but without saw guide attachment. \$1.75 ppd.

DRILL GRINDER

Sharpens round shank drills like new with hand or power grinders. \$2.95 ppd.

Adjusts to any angle!

send for **FREE CATALOG**

A. D. McBURNEY, 5908 Hollywood Blvd., Hollywood 28, Cal., Dept. 5-23

DURHAM'S Rock Hard WATER PUTTY

Solves Repair Problems

Durham's fills cracks and holes in plaster, wood and tile. Won't shrink or fall out. Economical, easy to use. Big 4-lb. can, only \$1.40 at lumber, paint and hardware dealers, or shipped direct postpaid in U. S. for \$1.75. Money-back guarantee. Order now. Donald Durham Co., Box 804-U, Des Moines, Iowa.



make your own Gems 36.50 FOB

The Gem Maker comes complete with all necessary equipment, including a super-charged diamond blade for sawing, and all the wheels for grinding, shaping and polishing; also complete instructions. The complete equipment as shown, less motor and belt for only \$36.50, f.o.b., Burlington, Wisconsin. Write today for information and literature.

B&I MANUFACTURING CO.
Dept. S Burlington, Wis.



DRAINS cellars, cisterns, wash tubs; **\$7.95**

IRRIGATES - CIRCULATES - SPRAYS

1,001 uses. Stainless shaft. Won't rust or clog! Use 1/8 HP motor or larger . . . 3/4 HP for up to 2,400 GPH; 450 GPH 80' high; or 1800 GPH from 25' well. 1" inlet; 3/4" outlet. Coupling included free. \$7.95. **HEAVY DUTY BALL-BEARING PUMP.** Up to 5,200 GPH; or 3,000 GPH from 25' well. 1 1/4" inlet; 1" outlet. \$12.95 Postpaid if cash with order. **MONEY BACK GUARANTEE**

Centrifugal and Gear Pumps in All Sizes

LABAWCO PUMPS, Belle Mead 3, New Jersey



NEW FAST DU-OL Synthetic -- NOT AN OIL PENETRANT

FREES FROZEN RUSTED - Bolts - Nuts - Parts

- Will Not Burn
- Harmless to Skin
- Stainless
- Odorless
- Works Fast - Saves Money

BENEFICIAL TO RUBBER

UNIVAL CORP. UNIVAL Dept. PS 2, Derby, Conn.



WELD FOR PLEASURE OR PROFIT TRINDL INDUSTRIAL ARC WELDER

Own a Trindl 125 Amp Industrial Welder at less than smaller machines. Welds metals to 1/2" thick. Operates off properly wired 110 or 220 volt line. 16 heat stages from 20 to 125 amps. Make, repair anything of metal in the home, garage, farm or shop. No experience or training needed. Full "do-it-yourself" instructions. Guaranteed 12 months in continuous operation. Complete only \$98.50 FOB or write for details on 125A and other Heavy Duty Trindl Welders. Dealer Inquiries Invited.

Trindl Products, Ltd., Dept. T3-B, 1807 S. Clark St., Chicago 16, Ill.



palley's BARGAIN CORNER

CENTRIFUGAL ELECT. WATER PUMP

A unique Gov't Surplus Bargain! Use on Boats, Campers, Trailers, in Cabins, etc. Delivers 12 to 300 gallons per hour through use of a variable rheostat. Heavy duty, explosion proof motor operates on 12 to 24 V., DC power from either battery or generator. Has 1/2" internal pipe intake and 1" hose outlet port. Comes complete with Rheostat control. **995**
Cost Gov't Approx. \$190 -



HYDRAULIC REMOTE CONTROL MASTER & SLAVE

Ideal to operate the controls on boats, hydraulics, engines, machinery and any equipment controlled from a remote position. Eliminates complicated linkage, cables, pulleys, etc. Simply connect the Master to the Slave with 1/4" tubing. When line is filled with oil the two act as precision, remote power transmission units. Moving handle of Master causes Slave arm to respond in exact motion.

HARD-TO-FIND UNITS

COST GOV'T APPROX 200.00

4750 PR.

No. H-EX-1
Stock Limited!



M4 U.S. ARMY KNIFE-BAYONET

Excellent skin divers knife, hunting knife or for the collector. Made of finest steel by Canillus. Has 6-1/2" blade, double-edged for 3" from the point. Handle is laminated leather. Overall lgth. is 11-5/8". A spectacular Value!

NOW Only 2.98



WORLD'S MOST FANTASTIC CATALOG

260 PAGES of AMAZING BARGAINS

GOVT SURPLUS. Factory Closeouts and Hard-to-find items! You'll find bargains in U.S. Army, Navy, Airforce and Industrial Surplus . . . PLUS the World's largest on-the-shelf stocks of New and Used Hydraulic Cylinders, Pumps, Valves, Motors, etc. Send for your copy NOW and SAVE! **Only 50c** Your 50c will be refunded with your first order of \$1.00 or more

TO COVER HANDLING & MAILING

TO ORDER - Send your Check or Money Order. Enclose 50% deposit with all C.O.D.'s. All items sent freight or postage collect.

2263 E. VERNON AVE., Dept. PS-23 LOS ANGELES 58, CALIFORNIA



palley's

Outlasts Varnish 2 to 1

New miracle clear plastic finish dries dust-free in minutes, needs no sealer, goes on any kind of wood—inside or outside. Gives tougher, longer-lasting protection for patio furniture, siding, doors, cabinets, floors, paneling, tables, boats. Glass-like finish resists alcohol, boiling water, food acids. Won't darken, crack or peel. Odorless. Non-toxic. Gloss or Satin finish. For free brochure and nearest FLECTO VARATHANE dealer, contact:

Flecto Company Inc., Box 84-P, Sta. A, Berkeley 2, Calif.



World's greatest classified opportunities

POPULAR SCIENCE MONTHLY
355 LEXINGTON AVE.
NEW YORK 17, N. Y.

Classified Ads only \$1.20 per word insertion, payable in advance. Minimum ad 10 words. To be included in April issue, copy should be in our office by February 20. No cancellations accepted after February 15. All advertisers using post office box number in ad must furnish complete name and street address for our records. Address orders to O. K. Kelly.

1 AUTOMOBILES & MIDGET CARS

CROSLY or Foreign car parts catalogue. Parts discount club. Box 7, Elmont, New York.

HANDCOLORED Automobile Prints. Sample \$1.00. Corre, Box 841, G.P.O., New York City 1.

AUTOMOBILE literature, antique, modern. Catalogs, photos, manuals. Monthly Bulletin. Non-profit organization. Free information. Enthusiasts, Box 451A, Mount Clemens, Mich.

2 AUTO SUPPLIES & EQUIPMENT

BATTERY chargers . . . home type. Electro-tone's famous line. Wholesale prices. Same day delivery. Free catalog. Write Dept. D, Doron Enterprises, Inc., Box 7214, Chicago 80, Ill.

JEEP Parts! For Military and Civilian. At great savings. Largest inventory. Catalog for owners and dealers. Inquiries invited. American Auto Parts Co., 1830-PS Locust, Kansas City, Mo.

1909-1934 **FORD** Parts Illustrated catalogs 75c. Mark Auto, Layton, New Jersey.

IMMEDIATE Delivery on Foreign Car Parts. For complete catalog send Name, Address, and 25c to Tibur Imports, Dept. PS, P.O. Box 6194, Chicago 80, Ill.

PARTS and Accessories Catalog For Ford Model "A". Everything to renew, rebuild, and renovate your '28-'31 Model "A" Ford. Send 10c. J. C. Whitney, 1919 QS-2 Archer, Chicago 16, Ill.

FREE! "Ring-Valve Motor Job." Improved performance unconditionally Guaranteed. Send 50c For handling, presenting. Refunded if not satisfied. Motor, La Verne, Calif.

RING-Valve Job While Driving, \$6.00 Postpaid. Guaranteed. Nothing Like It. Used By Mechanics; A Spencer, Mokena, Ill.

TRANSISTOR Ignition. 260/1 Coil, Manual, Special—\$8.50. Anderson Engineering, Wrentham, Massachusetts.

AUTO shop welding repair training in world's largest non-profit welding school. Low tuition. Free booklet. Hobart Welders, Box P-23, Troy, Ohio.

SAVE Up To 50% on Auto Parts. Accessories! Get new 356-page Illustrated Catalog, just out. Over 100,000 items to renew, rebuild, renovate all makes, models, domestic, foreign cars, trucks, sports cars, from 1920 to 1963's; '28 to '31 Model A! Latest Hollywood accessories, custom and hi-speed equipment. Rush 25c for postage, handling—refundable on first order. Whitney, 1919-PS2, Archer, Chicago 16.

PARTS Model "A." List 25c (Refundable) Matco, Box 135, San Pedro, Calif.

RING-Valve Job While Driving, \$6.00 postpaid. Guaranteed! Nothing like it! Many mechanics recommend! Motaloy, Grantham 27, Penna.

AMAZING device saves money, tires. Free gift. S & L's, Highland, N.Y.

USE THIS HANDY INDEX TO FIND WHAT YOU WANT

Advertising, Agencies for Advertisers . . .	53
Agents Wanted . . .	43
Antiques, Relics & Indian Goods . . .	29
Art Instruction, Cartooning, Sign Painting . . .	54
Authors Service . . .	52
Auto Supplies & Equipment . . .	2
Auto Trailers . . .	3
Automobiles & Midget Cars . . .	1
Aviation . . .	5
Batteries, Generators, Etc. . .	6
Boats, Outboard Motors . . .	11
Body-Building Courses, Jiu Jitsu, Etc. . .	12
Books & Magazines . . .	23
Business Opportunities . . .	37
Business Service, Information, Name Lists . . .	50
Buy It Wholesale . . .	38A
Cameras, Photo Supplies . . .	34
Camping Equipment & Tents . . .	16
Coins & Currency . . .	26
Detectives . . .	47
Do-It-Yourself . . .	66
Dogs, Birds, Hamsters & Pets . . .	17
Earthworms, Crickets, Frogs . . .	18
Educational & Instruction . . .	45
Electric Trains . . .	64B
Electrical Supplies & Equipment . . .	7
Employment Information . . .	42
Engineering Services . . .	60A
Engineering Supplies & Equipment . . .	9D
Engines, Motors, Etc. . .	10
Farms, Other Real Estate . . .	19
Field Glasses, Telescopes . . .	14
For Inventors . . .	60
For Sale Miscellaneous . . .	71
Formulas, Plans, Etc. . .	39
Government Surplus . . .	11A
High-Grade Salesmen . . .	44
Hobbies, Collections . . .	31
Home Craftsman . . .	65
Hypnotism . . .	24
Inventions Wanted . . .	61
IQ Tests . . .	51A
Jokes, Games, Novelties, Etc. . .	24A
Language Outfits . . .	48
Loans By Mail . . .	80B
Machinery, Tool Supplies, Etc. . .	9
Magic Tricks, Puzzles, Etc. . .	25
Mathematics . . .	41A
Minerals & Precious Stones . . .	30
Miscellaneous . . .	79
Models, Model Supplies . . .	64
Moneymaking Opportunities . . .	38
Motion Pictures & Color Slides . . .	33
Motorcycles, Bicycles & Supplies . . .	4
Musical Instruments and Song Writers . . .	35
Of Interest To Women . . .	70
Old Gold, Jewelry, Watches . . .	67
Old Stamps Wanted . . .	27
Personal . . .	80
Phonograph Records . . .	35A
Photo Finishing, Photocopies, Etc. . .	32
Plastics . . .	40
Printing, Multigraphing, Etc. . .	57
Printing Outfits, Supplies . . .	58
Profitable Occupations . . .	22
Radio, TV, Electronics, Hi-Fi . . .	36
Remailing Service . . .	80A
Rubber Stamps & Office Supplies . . .	56
Science & Chemistry . . .	41
Special Services . . .	51
Sporting Goods, Guns, Fishing Tackle, Etc. . .	15
Stamp Collecting . . .	28
Treasure Finders & Geiger Counters . . .	77
Trees, Shrubs, Roots & Herbs . . .	20
Typewriters & Office Machines . . .	55
Wanted to Buy . . .	72
Watch Repairing . . .	78
Welding, Soldering . . .	8

GIVE Your Car "That 1963 Look"! Spray Your Turn Signals With Tempo Amber Lite. You'll be amazed! This spray will give your older model car a brand new look. Tempo Amber Lite makes driving safer. Gives turn signals greater visibility, Day Or Night. Coats your turn signal lenses with a clear, brilliant, translucent spray of Amber. For Tempo Amber Lite (2 oz. can) send \$1.25 postpaid to Time Tested Products Co., 2062 East 70th St., Cleveland 3, Ohio. By the makers of Tempo Instant Spray Automotive Touch-Up Paint.

TRANSISTOR Ignition. Save gas, tune-ups. Points, plugs last longer. Improved cold starting, high-speed performance. Complete systems from \$34.50. Free Literature. Dealers invited. Palmer Electronics, Dept. P, Carlisle, Massachusetts.

JEEP Owners—V8 conversions. Read Jeep Owners ad. page 50.

3 AUTO TRAILERS

PICKUP Campers. Pre-cut Kits. Blueprints. Supplies. Literature 10c. Comstock Trailers, Parsons, Kansas.

BUILD Expanding Eight Foot Trailer. Accommodates Five. Literature 10c. Framar Company, Wilmington, Mass.

4 MOTORCYCLES, BICYCLES AND SUPPLIES

RECONDITIONED Motorcycle Motors. Large Stock Indian, Cushman, Vespa, Mustang, NSU Parts. Indian Motorcycle Sales, Kansas City 27, Missouri.

DOODLEBUG motorscooter \$10. Go Cart \$25. Crosley Station Wagon \$35, less engines. Engines \$3.50 up. Send 25c, (35c for First Class Mailing), for 32-page Directory-Catalogue Number 111, listing these and hundreds of other bargains in midget cars, motorscooters, homebuilders plans, parts, etc. Midget Motors Directory, Athens, Ohio.

BUILD motor scooter from old bicycle frame. Detail Plans \$1.50, refundable. Free Catalog. Gilliom Manufacturing, St. Charles 12, Missouri.

BICYCLE Motor-izing Plans . . . \$1.00: Free literature. Go-Byk Industries, Fergus Falls, Minnesota.

ACCESSORY Lamps: Blue, White, Red. \$3.50 Pair. T.J.'s, 19420 Conant, Detroit 34, Mich.

"**NIMPOW**" \$19.95 Kit converts bicycle to motorbike. Rear engine, low center of gravity. Literature 50c. (Refundable). Roycraft, 222J West 39th Street, Kansas City 11, Missouri.

5 AVIATION

PROPELLERS for Airboats, Snowplanes, Icesleds. Beautiful Colors. Boat Kits, Mounts, World's Best. 25c for Catalog. Aerial Propeller Company, Box 692, Greenville, Texas.

PROPELLERS, Plans, supplies for airboats, snowplanes. 125 h.p. Lycomings—\$115.00, 150 h.p. Continentals—\$125.00. Parts, gauges, throttles, spark plugs, hose, coolers, etc. Catalog 25c. Banks-Maxwell, Box 3301G, Ft. Worth 5, Texas.

6 BATTERIES, GENERATORS, ETC.

REBUILD Batteries! Complete Manual \$3.00. Hydraulic Jack Repair Manual \$3.00. Chrysler Corp. Alternator Guide \$3.00. C.O.D. Accepted. Bayer Publications, 938 Betty Avenue, Neenah, Wisconsin.

7 ELECTRICAL SUPPLIES & EQUIPMENT

ELECTROPLATING Equipment And Supplies. Send \$1 For Formulas, Equipment Guide, Operating Data And Catalog. Hollywood Bronze Supply, Dept. N7, 3445 Union Pacific Ave., Los Angeles 33, Calif.

ELECTRO-Scribe! Engraves all Metals. \$2.00. Beyer Mfg., 10511-C Springfield, Chicago 55.

ELECTRICIANS! Bend conduit Easily, Correctly. Latest! Simplified Manual, \$2.00. William Goforth, 949 W. Fessler, Santa Maria, Calif.

FIRE in your house, basement, garage sounds alarm. Complete alarm system \$6.95 Postpaid. Just plug in light socket. Satisfaction Guaranteed. Tom's Electric, 174 Willow, East Brunswick, New Jersey.

8 WELDING, SOLDERING

FREE Catalog. Welders, Kits. Build 350-ampere welder using aircraft generator, plans 25c. Dunbar, Minneapolis 8, Minn.

FREE Welder Catalog. Kits, Build 350-Ampere Welder Using Aircraft Generator, Plans, 25c. LeJay, Minneapolis 31, Minnesota.

WELDERS. 110-220. Welds 1/2". \$39.50. Morris, 1070 Inner Drive, Schenectady, New York.

9 MACHINERY, TOOL SUPPLIES, ETC.

NEW Surplus—Choice of 12 different Tools, only \$3.50. Send order today. Free List. Salme Enterprises, 50 Uxbridge Street, Worcester 5, Massachusetts.

STAINLESS Steel Tubing Pipe. Write For Price List. Box 192, Mamaroneck, N.Y.

9D ENGINEERING SUPPLIES & EQUIPMENT

GUARANTEED America's Finest and most Complete line of Slide Rules. Wholesale Prices. You Save 30 to 50%. Post card brings our catalog. Lewis S. Crawford & Sons, Joanna, South Carolina.

DRAFTSMANS movable arm protractor—better than adjustable triangles. Guaranteed \$2.00. M. Van Meter, Lavallette, N. J.

10 ENGINES, MOTORS, ETC.

DIESEL Injector Parts and Fuel Pumps Wanted GM51-53-71-110. Mayer, 2093 East 19 Street, Cleveland 15, Ohio.

REWIND Motors yourself. Complete instructions \$1.00. Lewis Manufacturing, Howell 11, Michigan.

SCOOTERS. Go-Karts. Parts. Electric Tools. Discount Catalog 10c. Loren Products. Danville, Illinois.

11 BOATS, OUTBOARD MOTORS

NEW, used, rebuilt marine motors. Marine conversions, fittings. Free Catalog. Stokes Marine Supply, Dept. 23, Coldwater, Mich.

FULL size, cut-to-shape boat patterns, blueprints, 7 1/2-38 feet. Big new illustrated "Build a Boat" catalog of 64 designs, including Catamarans, Cruisers, Runabouts, Skiffs, Outboard Boats, Sailing, Racing, Houseboats, 50c. "How to Build a Boat" booklet, \$2.50. Cleveland Boat Blueprint Co., Box 1651, Cleveland, Ohio.

BOAT Kits! Factory molded fiberglass or pre-assembled plywood. 50 models. 12' to 22'. Free catalog. Luger, Dept. AC-63, 9200 Access Road, Minneapolis 31, Minnesota.

BOAT Plans, Frame Kits, Full-Size Patterns! 80-page catalog illustrating over 40 Build-it-Yourself boats 50c. Glen Marine, 9152 Rosecrans, Bellflower, Calif.

PLYWOOD Waterbikes. Plan, Parts Set. Details \$1.00. Selleck, Boca Raton, Florida.

1962 SCOTT Outboard Motors Closeout: 3 1/2 H.P.—\$99.50, 7 1/2 H.P.—\$195, 14 H.P.—\$258, 28 H.P.—\$318, 44 H.P.—\$378. 1961, 75 H.P. Electric Generator \$558, 1962, 75 H.P.—\$638. We Ship Anywhere Or Hold On Our Layaway Plan. Factory Warranty. Electra Marine, (Dept. S), 1427 Broadway, Brooklyn, N.Y. Tel.-212-GL5-0122.

SEA Boats For The World—Low cost power Dorries, sailing Dorries, Catalog 44 pages. Action photos, Speed tables, \$1.00. Texas Dory Boat Plans, P.O. Box 720, Galveston, Texas.

WHY dream of owning a boat? Build one now! Custom Craft, originator of marine engineering marvels, offers prams to cruisers, sailing dinghies to dragsters in the 20th Anniversary Catalog. Prepaid Freight. Financing can be arranged. Send 50c to cover handling to Custom Craft, 1700 Niagara Street, Buffalo 7P, New York.

FIRST Plan and Pattern Catalog in two years to offer every conceivable type craft, including class sail boats for any size budget—"A Book Worth Keeping." Send \$1.50 to Custom Craft Plan Division, 1700 Niagara Street, Buffalo 7P, New York.

11A GOVERNMENT SURPLUS

JEEPS \$278, Airplanes \$159, Boats \$7.88, Generators \$2.68, Typewriters \$8.79 are typical government surplus sale prices. Buy 10,001 items wholesale, direct. Full details, 627 locations and procedure only \$1.00. Surplus, Box 177-C31, Abbottstown, Penna.

U.S. GOVERNMENT Surplus—Jeeps, \$264.00, Radios, \$2.53, Guns, Typewriters, Cameras, Tools, Thousands of Items. Fabulously Low Surplus Prices. Complete information sent immediately. Send \$1.00 to: Surplus, P.O. Box 50512, Dept. F, New Orleans 50, Louisiana.

FREE, Valuable War Surplus Bargain Information. Box 8PS, Thomasville, Penna.

JEEPS—\$223.83, Typewriters—\$4.15, Radios—\$2.65, Boats—\$6.18, Televisions, Guns, Cameras, Recorders, Watches. Typical Surplus Prices. Exciting Details Free. N. Y. Enterprises, Box 402-S5, Jamaica 30, New York.

FREE! You can get hundreds of big illustrated Government Surplus catalogues absolutely Free! For full information send dime today to Honour, Box 187-PS, Abbottstown, Penna.

SURPLUS Bargains! Typewriters \$4.10, Airplanes \$76.50, Radios \$2.55. Typical surplus prices. For complete information send \$1.00. Surplus Service, Box 820, Holland 2, Mich.

JEEPS \$111.68, Airplanes \$75.20, Boats \$6.18. Many others direct from U.S. Government. For complete "Directory" send \$1.00 to Quality Surplus, Box 22163-P2, Indianapolis 22, Indiana.

GOVERNMENT Surplus How and Where To Buy In Your Area. Send \$1.00. PS Surplus Information, Headquarters Building, Washington 6, D. C.

GOVERNMENT Surplus. Any Item—Farm, Home, Office. No Agents. Deal Direct. Most Complete Details \$1.00. Abbey Company, Box 127, Cliffside Park, N. J.

GOVERNMENT Surplus: Boats, Power Tools, Diving Equipment, Sporting Goods. Everything imaginable. You buy direct. "Locations and Procedures" plus "Buying for Profits." \$1.00. Satisfaction Guaranteed. Southwestern Surplus, Box 18571-A2, Dallas 18, Texas.

JEEPS \$111.26, Boats \$6.38, Typewriters \$7.17. Thousands of items direct from Government, in your area. Complete directory \$1.00, to Surplus Information, 1402-PSS, Englewood, Colorado.

12 BODY-BUILDING COURSES, JIU JITSU & ATHLETIC EQUIPMENT

"GIANT Arms." Dr. Young's, D. C. Revolutionary discovery. \$2. Satisfaction or refund. Gaucho, Box 9309-S6, Chicago 90.

BUILD powerful arms, chest, shoulders! 22 exercises, \$1. Fonsad, Box 601-C, 1100 Market, Wilmington 99, Delaware.

BIG Muscles Fast—Gain up to 4" on arms, 10" on chest in just 7 weeks. Free details. Sinkram Body Builders, Dept. SC-10, Box 11, Brooklyn 36, N. Y.

BAR-BELL Course, illustrated \$1.00. Catalogue 10c. Good Barbell, B-1495, Hendersonville, N. Car.

HEALTH! Reducing, Gaining, Muscles, Longevity. Mail 25c for all 4 Courses. Buy Now. Health Course \$1.00. Agents Kit \$2.00. Big Deal \$3.00. Guaranteed! Sid's System, (PS-E63), 8421-C Evergreen, Southgate, California.

BEST Results—Shortest Time! Amazing New Scientific Discovery uses only a Rope! Strength, Health, Muscles, Gain—Reduce. Complete Course, not mere "chart." 10,000 satisfied pupils, ages 11-87, prove this exclusive principle. obsoletes ordinary methods. Money-back Guarantee. Only \$2.00. Ropercise, 4834 Art, San Diego 15, California.

DEADLY Kungfu Karate "Iron, Poison Hand Fighting." Break Bricks Within 100 Days, \$5.00. Free Literature. Oriental Book Sales, Box 1183, Oakland 4, Calif.

KARATE, Jiu-Jitsu Books: Karate by Pictures, \$3.95. Karate, Nishiyama, \$7.50. Greatest study to date! Jiu-Jitsu Complete, Nakae \$5.00. Send 25c coin for descriptive lists on many self-defense books to: Aradparke Books, Box 395-PS, Tarzana, Calif.

STEAM cabinet—Build your own for less than \$25.00—Complete plans \$2.00. Thermo-Craft, 1853 West Ave., Miami Beach 39, Fla.

14 FIELD GLASSES, TELESCOPES

FREE Catalogue! Thousands war surplus optical bargains. Lenses, Prisms, Telescopes, Binoculars, etc. Send \$1.00 for 10 Lens Hobbyist Set and Project booklet. G. Jaegers, 691 West Merrick Road, Lynbrook, New York.

SCIENCE Bargains! Lenses, Telescopes, binoculars, microscopes, kits, parts, war surplus. Send \$1.00 for beginner's 10-lens kit with instruction booklet. Order Stock 2-CN. Request Free 144-page Catalog CN. Edmund Scientific Co., Barrington, New Jersey.

DYNASCOPE—Amazing world famous reflector telescope. Request free brochure. Criterion, Dept. DS-6, Hartford 1, Conn.

CUSTOM Telescopes, Lenses, Tripods, Equatorial And Accessories, Magnifiers: UPCO, Sunbury, Penna.

BUILD your own Reflector Telescopes. Complete kits; Mirrors, Eyepieces, Tripods, all other accessories. Request free illustrated literature. Criterion Manufacturing, Dept. KP-98, Hartford 1, Conn.

ASTRONOMICAL books, star-atlases, free list. Herbert Luft, 69-11 229th St., Flushing 64, N. Y.

15 SPORTING GOODS, GUNS, FISHING TACKLE, ARCHERY, TRAPPING

10,000 GUN Bargains!!! Modern—Antique Guns—Accessories . . . Giant 128 Page Bargain Catalog \$1.00. Agramonte's, Yonkers, N. Y.

MASTER craftsmanship for discriminating fisherman. Famous Clarkspoon lure for fresh and salt water trolling and casting. Record catches. Mail \$1.00. Tomlin Sales, Box 2512-PS, Lakeland, Florida.

TREMENDOUS Wholesale Catalog . . . Amazing Selections, Merchandise. Taylor Distributors, Newton 18, New Jersey.

FREE . . . Wholesale Catalog. Beads, Spinners, Lure parts, Sinkers, Jigs, Reels, Finny sports, (PE), Toledo 14, Ohio.

5000 GUNS, Swords, War Relics. Catalog 50c. Smith Museum, Runnemede, N. J.

MOLDS for Fisherman's Sinkers, Jigs, Squids, Casting and Spinning Lures. Free Catalogue. Sweet's Molds, Tonawanda 3, New York.

EXTRA Strong Woven Felt for Soles for Fishing Boots and Waders. Enough for Two Pairs of Soles 1/2" Thick, \$10.00; 3/8" Thick, \$8.00. Henry M. Nagel, P.O. Box 125, Boulder, Colorado.

JAP rifles altering American shells \$6.00. Jap shells \$3.95, catalog 10c. TP Shop, West Branch 10, Michigan.

PLASTIC Lure Bodies, Worlds famous Spinning Reels, Factory Prices. Free Circular. Quaker, 3514-24 N. Lawrence, Philadelphia 40, Pa.

B.B. SHOT, fascinating pocket size invention. See ad on page 40.

16 CAMPING EQUIPMENT & TENTS

TENTS, 300 styles (most erected on display). Camping Trailers, Sleeping Bags, Tarpaulins, Flies, Canvas Yard Goods, Aluminum Tent Poles, Stakes, Cots, Tables, Refrigerators, Stoves, Lanterns, Heaters, Cook Sets, Canteens, Mess Kits, Water Bags, Packs, Rucksacks, Dehydrated Foods, Camping Books. Send 25c for new giant catalogue, (includes camp sites and complete handbook). Morsan Tents, 810-G Route 17, Paramus, New Jersey.

17 DOGS, BIRDS, HAMSTERS, RABBITS & PETS

RAISE Rabbits on \$500 month plan. Free details. White's Rabbitry, Mt. Vernon, Ohio.

18 EARTHWORMS, CRICKETS, FROGS

EARN Money raising fishworms for us! Exciting details free! Oakhaven-121, Cedar Hill, Texas.

FREE Literature—We teach you how to raise, sell fishworms, crickets. Hybrid red-worms 3000—\$5.95, 5000—\$8.95, 10,000—\$16.95, Postpaid. Carter Farm-12, Plains, Georgia.

MEN!—WOMEN! Make Money Raising Bait for Us at Home. Free Details. Red Wigglers, Warsaw 3, Indiana.

19 FARMS, OTHER REAL ESTATE

CANADIAN Vacation Lands: Full price \$385.00. 40 acres, \$10 month. Suitable cottage sites, hunting, fishing, investment. Free information. Land Corporation, 3768-D Bathurst, Downsview, Ontario, Canada.

CANADIAN Lands, seized and sold for taxes. Our 46th annual series of lists, just begun, describe many choice properties, situated from coast to coast, acquired by us through Tax Sale. Priced as low as five dollars per acre, guaranteed perfect title, small monthly payments, no mortgage. Beautifully situated hunting and fishing camps, where there is real sport; summer cottage sites, heavily wooded acreages. Now is the time to invest in Canada's minerals, forests and farms. Write to-day for free twenty-four page booklet with full explanation. Tax Sale Service, Room 411-H, 1173 Bay St., Toronto 5, Canada.

FLORIDA Campsites—deep in the heart of the great Ocala National Forest. Abundance of game, best fishing. Warranty deed. Unrestricted—pitch tent, park trailer, build lodge. Free maps and photos. Winfree Vernor, DeLand, Florida. AD-60088(Q-O)

NEW Strout Spring Catalog Just Out! Free! Farms, Homes, Businesses; Coast-to-Coast; established 63 years. World's Largest! Strout Realty, 251-ZB Park Ave. So., New York 10, N. Y.

NEW Homes From \$35 per month. Nothing Down, Custom Constructed on your lot. Over 88,000 Built. Free information and illustrated brochure. Jim Walter Corporation, Box 9128, Dept. PS-2, Tampa, Florida. 212 branch offices to serve you.

FLORIDA'S Greatest homesite value. High, dry 1/4 acre site—\$495. No money down, \$10 monthly. Free photos. Write Dept. 619-E, Rainbow Park, Box 521, Ocala, Florida. (AD 62070-K-O)

CENTRAL Florida homesites. Lakefront, Hillside, Highway, or Acreage Tracts. Tell Me Which You Want. Priced From \$395.00. Terms \$10.00 Monthly. Victor Roepke, DeLand, Florida.

ONTARIO Border—lakefront cottage lots, islands, \$2.50 foot. Sparkling lakes, good roads! Postcard brings maps, photographs. Beaver Lumber, 1731 Weston, Toronto, Canada.

LICENSED Salesman! Home Course \$49.50. Nationwide Real Estate School, Route 1, Jackson, Kentucky.

\$1 ACRE—Canadian border—Hundreds campsites, islands, farmlands directly from Tax Authorities (non-profit). Lists mailed: Bureau, 282 Davunport, Toronto 5, Canada.

20 TREES, SHRUBS, ROOTS, HERBS

10 DIFFERENT Cactus plants, \$2.00; 15 different, \$3.00. Phillips, 1290-PS Cottonwood, Banning, Calif.

GROW Large, 8 Year Old, Bearing Size Trees and Shrubs in 8 Weeks. Easy, Illustrated Instruction Book, \$3.00. Literature Free. Robbins-6, 57 Scott, San Francisco 17, Calif.

EVERGREEN Seedlings and Transplants in Leading Varieties for Christmas Tree Production. Assorted Ornamentals. Free Price List and Planting Guide. Flickingers' Nursery, Sagamore, Pa.

22 PROFITABLE OCCUPATIONS

INVESTIGATE Accidents. Earn \$750 to \$1,000 monthly. Men urgently needed. Car furnished; business expenses paid. No selling. No college education necessary. Pick own job location. Investigate full time. Or earn \$6.44 hour spare time. Write for Free Book. No obligation. Universal, CPS-2, 6801 Hillcrest, Dallas 5, Texas.

VENDING Machines—No Selling, Operate A Route of Coin Machines and Earn Amazing Profits. 32-Page Catalog Free. Parkway Machine Corporation, 715PSP Ensor Street, Baltimore 2, Maryland.

EARN Money raising fishworms for us! Write: Oakhaven-7, Cedar Hill, Texas.

BECOME independent with your own franchise business. Thousands earning handsome incomes. Request interesting facts today. National Franchise Reports, Y-528, 333 North Michigan, Chicago 1.

CHROME Plating. Instructions, Equipment and Supplies. Platers' Supply, P. O. Box 565, Lugo Station, Los Angeles, Calif.

INVESTIGATE Auto Accidents—Earn up to \$8 an hour, part-time or full-time. Investigators needed everywhere. No selling. Car furnished; expenses paid. Or start business of your own. Meet interesting people. We train you in spare time at home. Hold present job until ready to switch. Free information. No obligation. Liberty School, Dept. C-21, 1139 West Park, Libertyville, Illinois.

FREE Literature—Make Big Money Raising Fishworms and Crickets. Carter Farm-10, Plains, Ga.

FREE Book: "609 Unusual Businesses." Box 1001-K, Evanston, Illinois.

LEARN LP-Gas Carburetion. Big new field! Servicemen needed for tractors, trucks, forklifts. Work spare-time, full-time, rural or city. Free information: J&S Carburetor Co., P.O. Box 10391-T, Dallas 7, Texas.

SHARPEN—Scissors, pinkers, clippers. Inexpensive, capable machines. . . . Blackhawk, Sheldahl, Iowa.

EARN Money Tattooing. Complete Hand Outfits \$5.00. Malonson, 5020 Aldama Street, Los Angeles, Calif.

FREE Report: "Mailorder Profits And Pitfalls." Box 63-T, Bellwood, Illinois.

AUCTIONEERING—Resident and Home Study Courses. Diploma granted. Auction School, Ft. Smith, Ark.

BAKE New Greaseless Doughnuts in kitchen. Half profit. Sell stores. Free recipes. Stephen, 3605 15th, Minneapolis 7, Minnesota.

23 BOOKS & MAGAZINES

"PROPHET Elijah Coming Before Christ" Wonderful Book Free. 58 Megiddo Mission, Rochester 19, New York.

BRITISH Book Bargains. Any subjects. Catalogue free. Transanbooks, Wantagh, New York.

ATHEIST Books. Catalogue free. Truth Seeker Co., 38 Park Row, New York 8.

BOOKHUNTERS: All Subjects. Send Wants! Jaher Book Service, 183 Hazelwood Drive, Westbury, New York.

NATIONAL Geographic Magazines, Any issue. 1888-1960. Periodical Service, Box 465-PS, Wilmington, Delaware.

BOOK hunting? Thousands on hand—others obtainable upon request. Inquire, please. No obligation. Books-On-File, Dept. POP-3, Union City, New Jersey.

SAVE To 84% on Books, Records. Free Catalogue. Discount Reader's Service, SCB-5435 Upland Way, Philadelphia 31.

BOOKFINDING Our Specialty. Try Us. Babcock, 412 Lulu, Wichita 11, Kansas.

MAGAZINES—Pocket Novels! Catalogue 10c. Ajay Sales, Box 5796, Pikesville 8, Md.

BOOKHUNTERS! Scarce, Miscellaneous Books Supplied! Atlantic Book Service, 10 Cedar, Charlestown 29, Mass.

24 HYPNOTISM

FREE Hypnotism, Self-Hypnosis, Sleep-learning Catalog! Records, Tapes, Books, Courses, Equipment! Drawer PS400, Ruidoso, New Mexico.

HYPNOTIZE Self, Others while asleep with amazing hypnotic phonograph records, tapes. Catalog free. Research Association, Box 24-G, Olympia, Washington.

FREE Illustrated Hypnotism. Selfhypnosis Catalogue. Write: Hypnotist, 8721 Sunset, Hollywood 69P, California.

"HYPNOTIZE . . . One word . . . One fingersnap." on stage. Satisfaction—or refund. \$2. Hypnomaster, Box 9309-S6, Chicago 90.

HYPNOTIZE quickly, efficiently. Learn everything about Hypnotism. Immense power. All methods fully disclosed. Satisfaction guaranteed. Sent immediately. Only \$1.00 to: Force-F, Box 512, New Orleans 1, Louisiana.

HYPNOTIZE Unnoticed, quickly, effortlessly, or refund! Thousands delighted! \$2. Intern, Box 244, Cedarburg, Wisconsin.

"LATEST Hypnotism Methods!" Hypnotize Immediately! Modern Instruction Manual Includes "Self-Hypnosis!" \$2.00, postpaid. Brugenheimer Company, Box 201-7, Lexington, Massachusetts.

HYPNOTISM—Little known method. Free information. Dr. Azadian, Fowler, California.

PATENTED new hand device enables you to hypnotize unnoticed, silently, swiftly, or refund! Device with complete hypnosis, self-hypnosis instructions, \$2. Hypnosis Foundation, Box 487, La Mesa 2, California.

SELF-hypnosis may help you many ways. Dynamic new concept of learning quickly, easily! Book! Tape! Record! Free literature. McKinley Publishers, Audio Dept., Box 3038, San Bernardino, California.

HYPNOTISM. Selfhypnosis. Guaranteed home study courses. Diploma awarded. Free particulars. School Hypnology, East Meadow 1, New York.

BECOME A Hypnotist. Free Information. No Obligation. Hypnotism Center Training Academy, 339 Masonic Building, Meadville, Penna.

HYPNOTIZE Successfully! "One Word," "Instantaneous," "Against Will," methods exposed! Complete Illustrated course—including "Secret Nerve Pressure Technique" \$1.00. Free Sleep-learning Information included. Arthur Fowler, Box 4391, Woodbury, New Jersey.

CAN'T Quit Smoking? Quit without conscious thought or effort with mind power record. \$4.95. Results Guaranteed. Free Hypnosis-sleep learning catalog. Fletcher, 2407-P.S. Catherine, Dallas 11, Texas.

"ORIENTAL Hypnotism," \$1.20. Most Powerful. Control Others. Hypnotize Instantly! Eaton, Box 1242-N, Santa Rosa, California.

NEW Hypnotism Book, "Amateur To Professional." \$2.00. 339 Masonic Building, Meadville, Pa.

HYPNOTIZE Others—Unnoticed. Quietly, Quickly, Safely. Sure-Easy Instructions \$1.00. Rorick's, Cincinnati 26, Ohio.

HYPNOTIC Aids. World's Largest Illustrated Catalog 10c. Stowell's Woodstock, New York.

DISGUISED Hypnosis. Fascinating, revealing methods, unconditionally guaranteed. See ad on page 45.

24A JOKES, GAMES, NOVELTIES, ETC.

MAGIC number squares—all columns totalling same—vertically, horizontally, diagonally. Solutions to squares containing 9, 16, 25, 36, 49, 81, 121, 169 & 225 numbers. On wallet-sized cards. Your choice, any 3 for 25c. Guaranteed Specialties, 2803 Pacific, Wildwood, N.J.

POPULAR SCIENCE OPPORTUNITIES

25 MAGIC TRICKS, PUZZLES, ETC.

VENTRILOQUISM! Information Free! Dummy Catalog 25c. State age. Maher, Box 36-B, Kensington Station, Detroit 24, Michigan.

84 PAGES, Completely Illustrated Catalogs, 25c. Manhattan Magic, Box 334-S, N.Y.C. 11.

BE Popular! Entertain with magic. Send 10c for Douglas Famous Catalog, 500 Tricks, describing best in magic for pocket, parlor, club, stage, with balls, cards, silks, coins, ropes, apparatus, books. For 40 years Douglas has supplied magicians everywhere with fastest same-day service. Join in the fun! Douglas Magicland, Dept. 52, Dallas, Texas.

BE A Magician! Introductory Catalog with Free Trick, only 35c. Ireland, 109-T North Dearborn, Chicago 2.

GREATEST Collection of Tricks, Jokes, Professional Magic Ever Assembled! Big Exciting Catalog 10c. House of 1000 Mysteries, Dept. PS2C-63, Monroe, Conn.

WORLD'S Finest Magic Catalog, \$2.50, (\$2.00 magic included free). 3000 Tricks, Pocket, Stage, (408 pages). Kanter's, S-200 South 13th, Philadelphia 7.

FORCING Deck, Trick, And Catalog, \$1.00. Poules' Magic, 437 Brittain, Akron 5, Ohio.

MAGICIAN'S Famous Tricks! Special \$1—! Box 107, Old Village Sta., Great Neck, N.Y.

WORLD'S finest professional magic Joker novelties. Giant illustrated catalog 10c. Top Hat, Evanston 13, Illinois.

26 COINS & CURRENCY

GIANT Illustrated Catalog listing hundreds of Bargains in Coins and Supplies, only 25c. Ben's Coin Shop, 31-A North Clark, Chicago 2.

INTRODUCTORY: Pinetree Shilling, Confederate cent (replicas) and foreign coin; all \$1.00; Coin, medal catalog, 25c. Collectors, Box 71-D, Rockaway 94, New York.

SELLING Your Coins Profitably? 35c. American Box 663-PS, Kansas City 4, Missouri.

UNCIRCULATED 1935 Silver Pony Express Commemorative Medal \$1.00. Coin Lists Free. Sayers, 1000 Unaka, Johnson City, Tennessee.

100 FOREIGN Coins \$2.95. 2 Mexican Silver Dollars \$1.00. Blackstone, Box 6350S, Phoenix 5, Arizona.

25 DIFFERENT coins from 25 foreign countries. \$1.00 bargain. Hindley, Box 708, Aurora, Illinois.

BARGAIN List! U.C. Coins, Accessories. Stamp please. Hugh's, Hickory, N.C.

LARGE English Pennies—Five different dates for 25c with coin approvals. Edmund Molzan, Box 275, Alameda, California.

TOPS! Fascinating coin collection from Camerouns, Formosa, Vatican, etc. and foreign banknote. Catalog Price Over \$1.50! Only 10c with exciting coin approvals! Littleton Coin Company, Littleton T2, New Hampshire.

SAVE Your slick nickels where date is worn off. Order a bottle of Coin Date. It will bring the date out on Buffalo, V Shield nickels. It's easy to use. Satisfaction guaranteed. \$1.00 postpaid. Box 276-P, Mooresville, North Carolina.

8 DIFFERENT small German Notgelt bills—25c. Jolie, Roslyn Heights, N. Y.

ANY Four Mercury dimes except 1916-D, \$1.00. Dombecky, 14232 Bentler, Detroit, Mich.

COIN Bargains Galore! Illustrated Lists, 10c (Refundable). Hutchinson's, Box 6256, Philadelphia, Penna.

COIN Magazine, 200 pages. Sample 50c. Numismatic, 7320 Milwaukee, Chicago 31.

1878 CARSON City Dollar Uncirculated \$5.00. Coin Catalogue 50c. Shultz, Salt Lake City 10, Utah.

12 DIFFERENT Lincolns before 1921 \$1.00. 24 Before 1931 \$1.50. Gene Carlton, Box 88-PS, Chandler, Okla.

FREE Coin Supplies. Giant Coin list 10c (refundable). Economy Sales, Mansfield, Massachusetts.

BARGAINS—Rare 1898-O, 1904-O, Dollars. Brilliant Uncirculated, each \$9.00. \$20.00 Gold—About Uncirculated \$57.50; Brilliant Uncirculated \$64.50. Liberia's New Dollar \$2.50. Bargain Lists 15c. Retail Guidebooks — "Redbook" \$1.75; "World's Coinage" \$4.25; Canadian \$1.25. Bebee's, 4514 North 30th, Omaha 11, Nebraska.

SILVER Dollar Bargains! All Brilliant Uncirculated. 1898-O, \$9.00; 1902-O, \$6.00; 1903-O, \$100.00; 1904-O, \$8.00. Wayne Pratali, 202 Avon Road, Haddonfield, New Jersey.

LINCOLN Mints, 10 Different Before 1931. \$1.95. Reighard's, R. D. 1, Steubenville, Ohio.

CHARLTON'S Illustrated Coin Guide With Dealer's buying prices for Canadian and U.S. Coins and bills 50c. Canada Coin Exchange, 80 Richmond East, Toronto 1, Canada.

LINCOLNS: 40 Different 1909-41 plus 1960D small date \$1.95. 24 different "S" (including rare 1955S) \$1.50. Harris, 9011J Presidio, San Francisco 29, California.

ANY Four Roosevelt Dimes \$1.10. Tracy, 25 Quinlan, Staten Island 14, New York.

LINCOLN Cents: 23-S, 24-S, 21-S & P, 16-S & D, 17-S & D, 18-S & D, 19-S & D, 20-S & D, 25-S & D, 29-S & D, 30-S & D, 28-S & D, 27-S & D, 55-S, 54-S & P, 32-D, 33-P, 39-S & D, 49-S. Good to Fine—Complete Lot—\$8.50—Rolls 55-S \$12.50 Fine to X. Fine—49-S \$3.50 Roll. Berry, Box 306, Westminster, Calif.

40 PAGE illustrated United States and Canadian coin list 10c. Stony, 260 Washington, Boston 8, Mass.

BARBER Halves! 3 different dates, \$3.00. Prepaid. Nice Coins. List Included. Stroud's Coins, Kinston, N.C.

TWENTY-four page 1963 retail price list of U.S.A. and Canadian coins, 10c. Our selling prices on thousands of coins and coin collectors supplies. Bryson Incorporated, 612B White, Toledo 5, Ohio.

\$18,000.00 FOR 1913 Liberty Head Nickel. Uncirculated Dollars 1804-1839. 1893-S, 1895-P. 1858 pay \$200.00—\$15,000.00. Certain Dates—Lincoln Cents before 1932—\$250.00; Flying Eagle Cents—\$950.00; Indian Cents—\$1,750.00; Dimes before 1943—\$5,250.00; Quarters before 1924—\$5,250.00; Half Dollars before 1929—\$7,500.00; 2c Pieces—\$200.00; 3c Pieces—\$200.00; Halfdimes—\$3,250.00. Hundreds of others worth \$10.00—\$10,000.00. Canadian Coins — 1921 — 5c Silver — \$300.00. 1875 Quarter — \$500.00. 1921 — 50c — \$2,000.00. Wanted 20c Pieces, Gold Coins, Paper Money, etc. Our Large Illustrated Guaranteed Buying-Selling Catalogue. Giving Complete Allcoin Information—send \$1.00. Purchase catalogue before sending coins. Worthycoin Corporation (K-199-C), Boston 8, Massachusetts.

COIN Collectors. Largest Newspaper. Twice. Monthly. 10 issues \$1.00, \$2.00 yearly. Numismatic News, Washington St., Iola, Wisc.

27 OLD STAMPS WANTED

I WILL Pay \$100.00 each for 1924 1¢ green Franklin stamps rotarypress perforated eleven (up to \$1000.00 each unused). Send 20¢ for Large Illustrated folders showing Amazing prices paid for old stamps and coins. Cataldi-Stamps, Box 85, PS-23, Bronx 58, New York.

28 STAMP COLLECTING

300 DIFFERENT Given Free with approvals. Particulars. Windsor Stamps, P.O. Box 735, Santa Clara, California.

FREE! Giant Bargain Catalog — New Edition listing thousands of bargains including U.S. and B.N.A. Stamps, packets, mixtures, albums, accessories and supplies; sent with beautiful approvals. Jamestown Stamps, Dept. E23PS, Jamestown, N. Y.

EXCEPTIONAL 125 different, cataloging \$3.00. Includes triangles, commemoratives, 10c approvals. Reeves, Box 37597P, Miami 37, Florida.

TWO \$5.00 United States Stamps, twenty others 10c with United States approvals. Irwin, Box 1109, Brooklyn 30.

225 STAMPS For only 10c! This mammoth value includes Airmails, Pictorials; stamps from strange Countries cataloguing up to 25c each! Also Approvals. Mystic Stamp Company, Camden 55, N. Y.

UNITED Nations, 15th Anniversary Sheet. With first day cancel, as commemorated by Russia. Free! While they last, with approvals. Philatelics, P-J, New Paltz, N. Y.

80 DIFF. U.S. Stamps. Includes 19th Century Commemorative. High values. Plus 1943 Flag Stamp of Occupied Nations. All for only 25c. Approvals included. Willett Co., Box 338-Y, Yorktown Heights, N. Y.

25 DIFFERENT Commemoratives 1893 up 10c. U. S. Approvals. K & B, Box 70, Brooklyn 23, N. Y.

U.S. Mint Specials! Flag Set Complete, \$1.00; 1c, 2c, 3c Famous Americans (21 different), \$1.00. Free list. Brooks, 2323 Avenue X, Brooklyn 35, New York.

WORLDWIDE, 50 all different, absolutely free, just to introduce our incomparable approvals. Kent Stamp Company, G.P.O. Box 87, Brooklyn, N. Y.

UNITED States commemorating collection containing 33 different—10c. Approvals. White, 516-W Avenue L, Brooklyn 30, New York.

AMAZING Offer! 200 U.S. stamps—including commemoratives, airmails, high denominations to \$1.00—only 10c to Approval Applicants!! Illustrated Bargain Lists free. Mystic Stamp Co., Dept. 55, Camden, New York.

WOW! 110 All Different Germany 10c Zeppelins, Semi-Postals, Airmails, High values, etc. Giant Catalog, bargain lists included with beautiful approvals. Jamestown Stamp, Dept. A23PS, Jamestown, N. Y.

NUDES set (4)—Unusual Approvals 10c. Atlas, Plainfield, Racine, Wisconsin.

STAMP Collecting Outfit, includes packet Worldwide stamps, package hinges, watermark detector, millimeter gauge. Everything 10c with approvals. Lorraine Brown, Marion, Michigan.

702 U.S.A.—25c (plenty commemoratives. Request Approvals. Horace Gatewood, Winston-Salem, N. C.

WONDERFUL Lincoln Diamond, Giant Roosevelt, 100 Others Different, 10c. Approvals. B & G Stamp Service, 114 West Washington, Sigourney, Iowa.

DIAMOND Roosevelt, Pope, Triangle, Greenland, Angola, 51 others 5c. Approvals. Longhorn, Box 3068P, Lubbock, Tex.

21,000 ALL Different, only pennies a day using our systematic payment plan. Details Free. Sjoquist, 1435-A Cherrydale, San Jose 25, California.

ISRAELI New Year 5718. Issued for the Hebrew New Year 5718 (our 1957), a complete, multicolored stamp set with commemorative tabs. Free! While they last, with approvals. Philatelics, P-O, New Paltz, N. Y.

PENNY Approvals jammed with Bargains. For better values, try Putnam Stamp Company, Mahopac, New York.

TOPICALS, 25 different, only 10c to approval applicants. Stamac, 108 Park Place East, North Charleston, South Carolina.

200 DIFFERENT Stamps, 25c with approvals. Smith, 508U Brooks, College Station, Texas.

117 DIFFERENT: Monaco "Chevy," Fairy Tales, African Triangles, British Colonies, 10c. Approvals. Catalinas Stamps, Orange, California.

FREE! 222 Worldwide, 10c handling. Penny Approvals. Jung, Box 46277, Los Angeles 46.

90,000 STAMPS Sale! Bargain Lot: Sets, Packets, Rare Stamps \$1. Giant Assortment Extra Special \$5. High Value Packet \$3. Literature, Samples 10 cts. Persile, 436 N. Y. Ave., Brooklyn 25, N. Y.

AMERICAN Historical Collection!! Enormous George Washington beauty, F.D. Roosevelt Diamond, Giant Abe Lincoln U.S.A. Flag Commemorative, plus Midget soldier, Latin Orchid issue, Old St. Pierre Fisherman, etc. 10c with approvals. Roseland Stamps, Spring Lake 10A, Mich.

TERRIFIC Stamp Bargain! Israel—Iceland—San Marino—plus triangle set—Plus Antigua — Borneo — Virgin — Scouts — Congo—Russia—Plus large stamp book— all four offers free—Send 10c for mailing cost. Empire Stamp Corporation, Dept. PR, Toronto, Canada.

POPULAR SCIENCE OPPORTUNITIES

FREE—Mint British Colonials from Maldives, Solomon Islands, Pahang, St. Christopher, Nevis, Sarawak, Cayman Islands, Gilbert Ellice. Free with approvals. Viking. Great Neck 5, N. Y.

25 **LARGE** American Commemoratives 10c. Accompanying approvals. Free perforation gauge. Linstamps, St. Catherines 102, Ontario.

NO gimmicks—No Gadgets—No give aways. Just attractive approvals at attractive prices. Sunny Stamps, Apopka 10B, Florida.

103 **DIVERSIFIED** British Commonwealth 10c. Approvals included. Crown Stamps, Virgil 602, Ontario.

OLD scarce U.S. seconds on approval. Slightly defective, bargain prices. Hearnfeld, Clinton Station, Newark 8, N. J.

U.S. STAMPS. Giant Discount Catalog—25c. Raymax, 37-VX Maiden Lane, N.Y.C. 38.

327 **WORLDWIDE** Different 25c. Bargain approvals. Niagara Stamps, St. Catherines 202, Ontario.

FREE—Mammoth Collection, including \$10,000 Airmail, World's smallest Stamp, gorgeous multi-color pictorials plus Scott's Internationals, Master Global Albums, Scott's 1963 Catalogues, all Free when you buy Foreign approvals. Bargain Stamps, Box 1112B, Miami Beach 39, Florida.

GIANT Stamp Collection including: Astronauts, Satellites, Moonrockets, Boy Scout Issue, Complete UN Set, Many Olympic and Sport Issues, etc; Plus Big Stamp Dictionary and Approvals. Everything 10c! Stampex, Box 47-LP, White Plains, N. Y.

HOLY Stamp depicting Christ and cross! Plus triangle discus thrower, enormous multi-colored Balkans diamond issue, wonderful map collection from Timor, Macao and Angola. Extra! Brilliant flag set, etc. Only 10c with approvals. Capital Stamp Co., Ferrysburg 10C, Michigan.

OVER \$20.00 value for \$1.00. 1,000 Different Worldwide. Approvals included. Adults Only. Universal, Box 6, Kenosha 6, Wisconsin.

DEALERS Wholesale Catalog. Postage 4c. Franksco, 5031 Queensbury, Baltimore 15, Maryland.

FREE Macao Mint Set, Approvals. Corvett. GPO Box 1546, N.Y. 1.

SPECIAL collection 75 different Denmark (Catalog \$2.50), 10c with unique worldwide approvals 1/2c up. Stamp Studio, Box 171S, New York 24, N. Y.

THREE Hundred Different Stamps 25c. Tremendous Value. Norge. Hohokus, N. J.

TWO Antique Auto sets, 25c, No approvals. Stamps, Box 874, Los Alamos, New Mexico.

50 YEARS Old—15 different United States Stamps at least 50 years old—10c with low priced United States approvals. Jaxon, 510 Avenue L, Brooklyn 30, N. Y.

5 DIFFERENT Mint Sets, including British Colonial, New African, Triangles, 10c. Approvals. Cambridge, Box 411, Cambridge, Ohio.

U.N. FLAG set, Pope Triangle, Butterfly diamond, 50 others, 10c; approvals. C&R Stamps, Box 522, Hicksville, New York.

FREE—100 Different Foreign, Including Colorful Mint Sets, Flowers, Butterflies With Fine Approvals. R. M. Roberts, 345 Rivera Street, San Francisco 16, Calif.

NO Approvals, 200 France, \$2.00. Silver, Box 58, Auburn, N. H.

99 DIFFERENT Latin American, Just 10c, With Approvals. Fred Pittsley, South Montgomery, Napa, California.

FREE, 100 Different Foreign Approvals 10c Handling. Bell, Box 279, Manchester, N. Y.

10 DIFFERENT Civil War United States and Representative Confederate States Stamps Plus Pricelist 10c. Minute-man, 127 Lincoln, Lexington 73, Mass.

FIVE Complete Sets. Beautiful Finland, Bulgaria, and others, with approvals 10c. Lodge Co., 6231 Surfside, Miami Beach 54, Fla.

80,000 DIFFERENT! Amazing new plan builds your collection systematically, country by country. Only 50c weekly. Free details. Ware, Monroe 70, Conn.

GIANT Approvals Thousands Different 1c and 2c each. Wahl's Stamp Exchange, 7008K Farragut, Chicago 31, Ill.

ENORMOUS variety old U.S. flags, famous Americans, Commemoratives with approvals, surprise packet, 10c handling. Metropolitan Stamps, Box 312 PS, Jackson Heights 72, N. Y.

FREE Sample! Interesting, Informative, Illustrated. National Stamp News, Anderson, South Carolina.

EXCHANGE. Send 100-200 different foreign with 20c. Receive different. Patterson, Lancaster 12, New York.

VATICAN Mercies Airmails 10c, Approvals. Snedco, Box 68A, Waldwick, N. J.

60 DIFFERENT U.S. (30 Commemoratives) 25c. No approvals. Seidenberg, Appleton, Wis.

100 OLD U.S. Stamps between 1861 and 1935 \$1.00. Rousch Stamps, 51 Chestnut, Mansfield, Ohio.

CANADA Capex: Trains, Stagecoach, Beaver, only 10c. Attractive approvals. Rheume, 6591-11th Ave., Montreal, Canada.

FREE Mint Set! Approvals accompany. Mintco, Box 737, Memphis 1, Tenn.

1500 STAMPS \$1.00 On and off paper. Good variety. World wide. Many pictorials. No approvals follow. Satisfaction guaranteed. Whalen, 1435 First Ave., Oakland 6, Calif.

START Approval Business—Details 25c. Steele, Box 553-SC, Pacific Grove, Calif.

TOPS! Mystery lot of over 500 different world-wide only 35c. Catalogs over \$15.00! Approvals included. Offer to adults only. Littleton Stamp Co., Littleton Q2, N. H.

1000 DIFFERENT \$1.00 with approvals. Goldens, 6721 Eastwood, Philadelphia 49, Penna.

30,000 DIFFERENT 1c-3c Each. Howard Division, Suncook 5, New Hampshire.

EXTRA cash! Sell stamps by mail. Century, 1065, Homestead, Florida.

POSITIVELY Free! Scott's \$15.00 International Albums, 1963 Catalogues to Approval Buyers. Claire's Stamps, 2015 Shore Parkway, Brooklyn 14, New York.

REGULAR \$2.75 value, all yours for only 25c! Amazing U.S. Stamp Offer—you get 29 different large-size Commemoratives, 10 obsolete Air-Mails, Hi-Value \$1 and \$5 postage dues, plus all 14 Confederate States facsimiles in authentic colors. You also get—full-size illustrated album pages for U.S. Airs and Commems. from 1893, plus Midget Encyclopedia of Stamp Collecting and 250 hinges. A Fine Selection of Low-Priced U.S. Zenith approvals also accompanies. Buy what you want, return balance within 10 days. Send 25c today. Ask for lot EH-42. Zenith Co., 81 Wiloughby St., Brooklyn 1, N.Y. Supplies Limited.

LOOK! Six Queen Elizabeth Mint Sets from Antigua, Caymans, Malta, Montserrat, Mauritius, St. Kitts! 21 Brilliant Pictorials 25c. Attractive Approvals! Gannon Stamps, Box 931, Canton 1, Ohio.

UNITED States approvals. Select copies, used-mint. Kingsbury, Groton 1, Vt.

50 DIFFERENT Israel \$1.50 Value, Only 25c to Approval Applicants. Kuehne, 6917 Timberline, Dayton 32, Ohio.

YOUR Own Personalized Stamped Cover. A Treasure, One To Each, For \$1.00. Mar Chas. P.O. Box 735, So. Norwalk, Conn.

FREE!!! Beautiful stamps Gold, Silver, others. Approvals. Delor, 20226 Westphalia, Detroit 5, Michigan.

FREE! Surprise "Mystery" packet. Premiums. Approvals. Dancer, B75-T39, Mansfield, Ohio.

168 DIFFERENT U.S. commemoratives \$1.00. Carstamps, 739 Ordway, Freeport, Illinois.

FREE! 50 Portugal, 10c handling. Approvals. Berchtold Stamps, Troy, Ohio.

PORTUGUESE! 25 Different free. Approvals. Elkhart, Box 33, Elkhart, Indiana.

NUDES . . . 25 Exotic Russia! 10c—approvals. Illustrated Nudes, Rocket Lists. Paul, 24-JR Lime Street, Boston 8, Massachusetts.

NEW ZEALAND, 20 different including giant Christmas and centennials. 10c. Approvals. Reinhardt's, Box 93SJ, Troy, Michigan.

SENSATIONAL Penny Approvals! Pictorials, Topicals, Etc. Write Today! Schmidt, Box 5426, Reno, Nevada.

GIGANTIC Collection! 100 U.S.A. Commemoratives, 500 Foreign, \$1.00. Approvals. Sadler Stamps, 2306 Evergreen, Phoenix 6, Arizona.

240 DIFFERENT World Wide Only 10c To Approval Applicants. Winchester Stamps, 45 Winchester Rd., Mansfield, Ohio.

R.S. CANADA price list, 130 pages, 700 illustrations, stamp identification, 20c. Thom, 4808-15th Avenue, Minneapolis 17, Minnesota.

COLORFUL Pictorials from 25 different countries, includes triangles, etc. 10c with approvals, West Coast Stamp Emporium, P.O. Box 3042, North Hollywood, Calif.

FREE! 25 Egypt, 10c handling, Approvals. Bellet Stamps, Hazel Park, Michigan.

FREE! 29 thrilling jet, astronaut rocket, space, airmails. Send 10c handling. 2c approvals included. ABC World, Box 6000-WK, San Francisco, California.

TRADE Your Duplicates. (Toward Approvals). Complete Information, 10c. VSS, Box 98-S, Newton Highlands 61, Mass.

MILLION Foreign Stamps! 2c each! Send for thrilling, giant approvals! ABC, Box 6000-ML, San Francisco 1, California.

50 DIFFERENT, topicals, diamond, triangle, timor, 10c with approvals. Carpenter, Box 310, Claremont, Calif.

COMPLETE Used Set Washington Bicentennial plus 12 different Famous Americans, \$1.00. H. Edgar Stamps, Box 194, Defiance, Ohio.

BARGAIN US 51 Different 10c, with beautiful worldwide approvals. Stamps, Kennebunk, Maine.

PENNY Approvals! Regardless Catalogue! Kloster, 4164-52nd Ct., San Diego 5, California.

PRICE List Foreign Older Issues. Thomas, 5000 Miami, St. Louis 9, Missouri.

29 ANTIQUES, RELICS & INDIAN GOODS

12 AUTHENTIC Indian Arrows Only \$3.50. 100 for \$25.00. 1000, \$225.00. Raymond Johnson, 3115 San Edwardo, Laredo, Texas.

SELLING 20,000 Indian Relics, Arrowheads, Spearheads, Etc. List Free. Lear's, Glenwood, Arkansas.

LARGE Photo-Illustrated Indian Relic Catalog, Plus Free Book Offer 10c. Al's Relics, Box 393, Bellmore 5, New York.

30 MINERALS & PRECIOUS STONES

GET Free Catalog no serious rockhound, gem cutter, jewelry maker, hobbyist or Craftsman can be without. Full of bargains, exclusive items, low prices from largest suppliers and authorities in the field. Free . . . new catalog just off the press—yours for the asking! Write Grieger's, Dept. C-14, 1633 E. Walnut, Pasadena, Calif.

PROSPECTORS! Learn from experienced geologists how to locate and identify precious rocks and minerals. A Comprehensive Home Study Course designed for anyone interested in exploring for valuable ore deposits. Write Today for free literature. Pacific School of Mines, Box 2538, Palm Springs, California.

20 DIFFERENT worldwide mineral stones with history of origin and uses, \$2.00. Phillips, 1290-PS Cottonwood, Banning, Calif.

EARTH Science—Rockhounds National Magazine. Subscription \$2.50. Sample 35c. Box 1357-PS, Chicago (90), Ill.

OPALS: Precious, Fiery! 10 Ready To Set \$4.50. Free pricelists. Apartado 80, Sanmiguel, d'Allende, Gto, Mexico.

U. S. and Foreign Mineral Specimens. Lists 10c. Hartson, Winston 5, New Mexico.

THIRTY Individually Wrapped Mineral Specimens—\$5.00: Fifty—\$10.00. Green's, 6552 Vrain, Arvada, Colorado.

GOLD. Silver, Titanium Ore With Catalog 50c. Gemco, Eisner Ave., Sheboygan, Wisc.

31 HOBBIES, COLLECTIONS

COLLECT Medals—Introductory: 5 French \$4.00, 4 British \$3.00, 3 Belgium, \$2.00. Catalog 25c. Insignias, Box 71-S, Rockaway 94, N. Y.

INVENTING can be an interesting and profitable hobby. Write for complete particulars. Institute of American Inventors, Dept. 30-E, 635-F St., N.W., Washington 4, D. C.

JEWELS of the Sea: Fascinating shells from Continents and Islands of the World. Send 25c for colorful brochure. Davy Jones' Locker, 3 Ellen Drive, Farmington, Conn.

LEAD Soldiers—All the world's armies. Unpainted 12c to 30c each. Catalogue 50c. Jack Scruby, 2044 South Linwood, Visalia, California.

HOBBY Magazine With Interesting Mail 25c. Hobby Mail Trade, Box 134, Clifton-8, N. J.

SOLDIERS—Over 1,000 painted sets. All periods. Catalog #2 50c, Bussler, Box 107-E, Wollaston 70, Mass.

AMERICAN Newspaper, Before 1860, Original, Complete, \$1.50. P.T. Cook, Box 8731, Memphis 28, Tenn.

32 PHOTO FINISHING, PHOTOCOPIES, ETC.

COLOR Movie Fans! Low Cost—High Quality processing our specialty, 8mm just \$1 (or \$3 with fresh film). Mailed back next day. Craftsmanship guaranteed. Send exposed reel or request free mailers and price list of complete photo-finishing services. Direct Mail Photo, Box 8352-PS, Pittsburgh 18, Pa.

FAST, Hi-quality Finishing—Kodacolor Rolls: Eight Jumbo Prints \$1.98—Twelve \$2.49—Twenty \$3.49—Reprints 15c. Also low B&W Prices. Custom Quality Studio, Box 4838A, Chicago 80.

OIL Coloring Photographs—A fascinating hobby or profitable sideline for those with artistic talent. Learn at home. Easy simplified method. Free booklet. National Photo Coloring School, 835 Diversey Parkway, Dept. 1722, Chicago 14.

33 MOTION PICTURES & COLOR SLIDES

SEE the World in Color. 8mm—16mm. Kodachrome movies. Alaska, Hawaii, America, Europe, Africa, South Seas, U.S. National Parks. Also War and Rocket Test films. 185 subjects. Low prices. Write World in Color, Box 392-PS, Elmira, N. Y.

USED 16MM Sound Projectors, also sound films, rental, sale, exchange. Stereo tapes, rental and sale. Write for free catalog. National Cinema, 71 Dey Street, New York City.

8MM, 16MM MOVIE Subjects—silent, sound—new, used—2"x2" color slides—biggest selection anywhere! Free, each month, big 24-page newspaper-size catalog. Blackhawk Films, Davenport 15, Iowa.

FREE Catalogues. 5,000 8-16MM Films. International-S Films, Greenvale, New York.

MOVIE Film! Free catalog! Eso-H, 47th Holly, Kansas City 12, Mo.

SAVE! Process your own movies at home. Free Catalog. Superior, 442-448 N. Wells, Chicago 10.

8MM SILENT Films. 16MM Sound Films. Bedner, 5300 So. Talman, Chicago.

LADY Wrestling. Movies, Photos. Free List. Peerless, Box 171-P, New York 13, N. Y.

34 CAMERAS, PHOTO SUPPLIES

PHOTOGRAPHY for pleasure or profit. Learn at home. Practical basic training Long established school. Free booklet. American School of Photography, 835 Diversey Parkway, Dept. 1722, Chicago 14.

FREE! Send now for photographic bargain catalog. Dept. 4-K-2, Central Camera Company, 230 So. Wabash Ave., Chicago, Illinois.

35 MUSICAL INSTRUMENTS AND SONG WRITERS

POEMS Wanted for musical setting and recording. Send poems. Free examination. Crown Music Company, 49-P West 32 Street, New York 1.

ACCORDIONS, Guitars, Chord Organs! Save 1/2. Famous makes. Free home trial. Easy terms. Trades. Free catalogs. Mention instrument. International Music Mart, Dept. P, 2003 Chicago Avenue, Chicago 22.

SONGWRITERS! Protect your ideas! Hold all poems, songs! Write for safe, correct procedure! Song Service, Dept. PS, 333 W. 56th, New York 19, N. Y.

ACCORDION-O-RAMA, 874 Broadway, New York 3, N. Y. Tremendous Discounts. Top Brands. Free Brochure.

SONGPOEMS and songs wanted! Mail to: Tin Pan Alley, Inc., Box 405, Radio City Station, New York 19, N. Y.

ACCORDION-Organs! Buy Direct! Big Savings! Free Catalog. Terms. Accordion Import Center, 7120 Galli Dr., San Jose 29, Calif.

SONGS Into \$\$\$\$\$\$—Share \$33 million dollars yearly for New Songwriters, Song-poets. Any subject, songs composed, published, promoted by largest firm. Information, appraisals Free. Send Nordyke Music Publishers, 6000 Sunset, Hollywood 28PS, California.

GUITAR Making, books, plans, imported woods, tools. List 10c. Wildwood, 510 East 11th Street, New York 9, N. Y.

SONGS Placed with Legitimate Publishers. Contract. Guarantee. Stamps for details. Mosick Agency, 56 South Second, Elizabeth, New Jersey.

SONGWRITERS, with publisher contacts, want song ideas. Share royalties. Send poems, free examination: Songwriters' Associates, 1650 Broadway, N. Y. 19-G.

SONGPOEMS Wanted! Collaborate with professional Songwriters equally. Share royalties. Songwriters Contact, 1619-N Broadway, New York 19.

USED Professional Guitars, Amplifiers, Drums. Write: Music, 1215 War Memorial, Peoria, Illinois.

ELECTRIC Guitars, amplifiers, wholesale. Free catalog. Carvin, PSM, Covina, California.

35A PHONOGRAPH RECORDS

RECORDS—Stereo, Monaural. Big Discounts. Noelsson, Box 211, New York 5, N. Y.

36 RADIO, TELEVISION, ELECTRONICS, HI-FI

FIX Your Own TV, Save 80%! Send for Free Illustrated Chart showing how! We'll include Giant Electronics Catalog. Zalytron, 461 Jericho Tpke., Mineola, N. Y.

ELECTRONICS Course only \$14.95. Includes all tubes, parts, tools, instructions. Write for full information. Progressive "Edu-Kits," Inc., Dept. 578A, Hewlett, N. Y.

SAVE 30% Up! Blank-Stereo Recorded Tape—Recorders—Norelco Speakers. Saxitone, 1776 Columbia Road, Washington 9, D. C.

TAPE recorders, Hi-Fi components. Sleep Learning Equipment, tapes. Unusual values. Free Catalog. Dressner, 1523 Jericho Tpke., New Hyde Park 1, New York.

SAVE dollars on radio, TV-tubes, parts at less than manufacturer's cost. 100% guaranteed! No rebrands, pulls. Request Bargain Bulletin. United Radio, 1000-S, Newark, N. J.

TAPES: 1200'—\$1.00; 1800'—\$1.25; 2400'—\$2.00. Towers, Lafayette Hill, Penna.

BEGINNER'S Crystal-transistor Giant catalog. Laboratories, 1131-T Valota, Redwood City, California.

TRANSISTOR Radios Repaired. \$5.00 covers parts, labor, return postage. Mail radio and \$5.00 to: Mannington TV Co., 23 Pyles Ave., Mannington, West Va. Guaranteed.

ASTOUNDING Government surplus illustrated catalog 10c. Meshna, Malden 48, Mass.

37 BUSINESS OPPORTUNITIES

MURAL Artists Needed! No experience required, earn \$10-\$15 per hour! Amazing "Project-A-Mural" Method. Project pattern slides, trace-off, paint per color guide. Professional results guaranteed! Huge demand from homes, bars, restaurants, offices, etc. Sell \$100 murals for "pennies" in paint. Free Success Plan. Associated Muralists, Dept. F2C, 500 Plumas, Reno, Nevada.

SELL Champion, AC, Autolite spark plugs. Reconditioned, electroplated, guaranteed 10,000 miles. 100% profit. Free sample. Lee Plugs, 1608-K Roberts, Houston 3, Texas.

MANAGE Motel or Resort. Men, women, couples can make \$400.00 to \$1,000.00 monthly plus apartment. Pick own location with our employment assistance. Learn at home. Free Booklet. Motel Managers Training School, Dept. PSC-23, 612 So. Serrano, Los Angeles 5, Calif.

PACKAGE at Home for Profit! We supply everything. No selling. Free Home business details. HPC, 807AF Sunset Blvd., Los Angeles 12.

IMPORT-Export opportunity, profitable world-wide, mail-order business from home, without capital or travel abroad. Established world trader ships instruction for no-risk examination. Experience unnecessary. Free details. Mellinger, J692, Los Angeles 25.

EARN Money raising fishworms for us! Write: Oakhaven-42, Cedar Hill, Texas.

\$100.00 WEEKLY spare room. Raise redworms odorless, soilless way. Charlie Morgan, Box 116-C, Bushnell, Florida.

OPERATE profitable mail order business. Write Walter Service, 4159-B East 112th, Cleveland 5, Ohio.

MAKE extra money. Big steady earnings, repeat business. Sell advertising Book Matches, full or part time. New 1962 line. Show Glamour Girls, Colorama, Tenorama; dozens more. All sizes. Free Master Outfit, sales helps, leads, no experience necessary, no investment. Write today. Superior Match, Dept. PX 263, 7530 Greenwood, Chicago 19.

BRONZE Baby Shoes. Genuine Electroplating process. Equipment, Mountings, Instructions. Send \$1.00 for Valuable Book "Your Guide To Success" Bronzing Baby Shoes, plus complete catalog. Hollywood Bronze Supply, Dept. B70, 3445 Union Pacific Avenue, Los Angeles 23, California.

BUY Direct From Factories—Appliances, Cameras, Watches! Free details! Cam Company, 436PS Bloomfield Ave., Verona, N. J.

WANT Your name with 1000 mailers? 25c lists your name with out mailings every month. Dixie Mailers, King, N. C.

FREE "Franchise Profit Letter" tells how unique NFR service is helping thousands seeking profitable businesses. Write today. National Franchise Reports, PS-528, 333 North Michigan, Chicago 1.

IMMEDIATE Profits with no capital or experience. Take orders for all magazine subscriptions. Friends and neighbors are your prospects. Write now for complete free kit. McGregor Magazine Agency, Dept. DB2, Mount Morris, Illinois.

STOP Throwing Away Bortops! They're worth money! Some. 25c! Inquire: "Box-tops-DG". Cedar Hill, Texas.

MAILORDER Catalogs—No inventory required. Full profits. Operate from home. Send 25c for 32-page sample catalog featuring 150 unusual fast-moving products and complete details. Satisfaction guaranteed. Gaylords, North Adams 7, Mass.

VENDING Machines—No Selling. Operate A Route of Coin Machines And Earn Amazing Profits. 32-Page Catalog Free. Parkway Machine Corporation, 715 PSB Ensor Street, Baltimore 2, Maryland.

SIMPLE, pleasant mailorder can net \$12,000 year. Rutward, 2016 Bryant, Columbia Station, Ohio.

\$15.00 AN Hour possible in new Home Manufacturing Business. Spare or full time. Amazing velvet-spray transforms hundreds of old items into \$\$\$\$ products. Write for samples free "50 Business Opportunities Booklet." Craft Industries, Dept. JP2, Los Angeles 61.

\$250.00 WEEK Spare time profit possible. Earn at home with new fascinating printing method. \$5 starts you—send no money now. Free confidential Facts and Valuable Sample. Screen Print, Dept. JP2, Los Angeles 61.

POPULAR SCIENCE OPPORTUNITIES

LEARN Professional TV Servicing in one week! Fabulous new simplified system. No big expense. No studying. No tools or equipment. Spare, full time. Own your own big profit business! Save! Amazing but true! Free! Write: TV Systems, Dept. P2, 1038 So. La Brea, Los Angeles 19.

WANT To Make Big Money At Home? \$10.00 profit in an hour possible with Invisible Mending. Make tears, holes disappear from clothing, fabrics. Steady year-round demand from cleaners, laundries, homes. Details Free. Fabricon, 1535 Howard, Chicago 26, Illinois.

INSTALL Burglar Alarm Systems. Big profit home business. Beginners start spare time, without mechanical experience or costly equipment. Free starter plan. Nasco, Dept. J692, 11071 Massachusetts, Los Angeles 25.

FREE Literature — Make Big Money Raising Fishworms and Crickets. Carter Farm, Plains, Georgia.

DOLLS! Dolls! Dolls! We teach you to repair, make, sell all kinds of dolls and accessories including clothing. Study at home. Earn while you learn. Free booklet. Lifetime Career Schools, Studio PSC-23, 11824 San Vicente Blvd., Los Angeles 49, California.

IMPORT-Export Opportunities. Start your own big-money business part-time. Learn from an expert. Sample instructions \$1.00. World Trade Register, Box 921, New Braunfels, Texas.

LEARN Landscaping and plant growing. Start a profitable business part or full time. Free information without obligation. Lifetime Career Schools, Dept. PSC-23, 11826 San Vicente Blvd., Los Angeles 49, Calif.

WORK at home packaging merchandise. Very profitable. No selling. Everything supplied. Details free. HBE, 1148-S West Grand, Chicago 22.

PLASTERCRAFT molds, liquid rubber, plasters, flocks, candle supplies. Catalog and manual free. Jayhawk Plasters, Blue Rapids, Kansas

MAKE \$25-\$65 weekly typing at home. Details \$1. Bonco, 130 Cumberland, Manton 2, Pa.

FREE: "How To Win Contests." International, Box 63-A, Bellwood, Illinois.

HOME Producers needed desperately in exploding new Plastics Business. Sell us your spare time. No selling—most territories still open! Hurry! NPC, Box 23321-LD, Los Angeles 23.

MAKE \$25-\$50 week clipping newspaper items for publishers. Some clippings worth \$5.00 each. Particulars free. National, 81, Knickerbocker Station, New York.

MAIL-Order home business. Get Free Copy. "Make Money in Mail Order." Mailco, 1554 S. Sepulveda, Dept. J692, Los Angeles 25.

\$200 WEEKLY Selling Books By Mail. Box 51-R, Des Plaines, Illinois.

BE Sharp—Do Sharpening—make money sharpening knives, scissors, saws, tools. Big profits. Treyco hollow grinding outfit \$34.95. Write for free book. Treyco Products, N. Tonawanda 4, N. Y.

TELEPHONE For \$\$\$\$ Spare Time! Home-Business Information; revealing details about joining Nationwide Organization. Write: Telephone Contactors, Dept. P2, 1038 So. La Brea, Los Angeles 19.

BUSINESS Guidance Service. 20 different setup services for selection. Hermes Company, 152 West 42, New York City 36.

"CO-PUBLISH" Home Business Digest! Sample, Complete instructions, \$1.00. Free Details! Stratford, Box 38-306, Miami 38, Fla.

HELP Others Get Started in Mail-order. Big Business. Details 25c. Mail-Order Distributors, P.O. Box 17175, San Diego 17, Calif.

HAVE \$12,000 to \$30,000 a year in profits from your own fund-raising business. We can help you. Group Funds, 3010 West Belmont, Chicago 18.

NEW in mail order! No competitive book. Market in millions. Dealer Goldmine! 25c full information. Ancrow, 128 Hawthorne, Haddonfield, New Jersey.

MAILORDER To Motels, Churches, institutions. Individual setup, not just instructions. Hermes Advertising, 152 West 42, New York City 36.

OPERATE profitable mail order business. Write Wayne's Service, 3016-B Channing, Washington 18, D. C.

MAKE \$46 From Square Foot Plywood; Jigsaw necessary. Free Details. Woodarts, Bridgewater, Mass.

MAKE Money Mending at Home. New Simple Method for Burn, Moth or Snag Holes. \$3.95 Post Paid. Free Samples. Mend Master, 4408 Sillman Place, Dayton 40, Ohio.

TURN Spare Time Into Cash. Plans. Ideas. Egyptian, Box 168A, Anna, Illinois.

PROFITS in Mail Order. Priceless Information! Send 5c Stamp. MoneyMaker, 722-S2 East Silver Spring, Milwaukee 17, Wisconsin.

EARN \$3.00 Hour Home, Sparetime, Assembling Pump Lamps. Novelty Lamps, Cabot 1, Arkansas.

SELL Books by Mail. 400% Profit. Royal, Box 450-M, Cleveland 27, Ohio.

I MAKE Money Every Week By Mail-order! Helped Others. Will Guide You. Webster, 2038-45 Mockingbird, Columbia 4, S. C.

PROFITS With or Without Tape Recorder. Rapid, 2449-S Lavender, New Orleans, 22.

PROFITABLE Catalog Mailorder Business. Vikari's 468-PS Third Avenue, Salt Lake City 3, Utah.

PIANO Tuning learned quickly at home. Tremendous field! Musical knowledge unnecessary. Information free. Empire School of Piano Tuning, Champaign, Illinois. (Founded 1935.)

PEST Control. Start own part, full time business. Charge \$10.00 hour! Elston, 4035 Lake-Cook, Northbrook 2, Illinois.

FREE wholesale directory list—350,000 items. Dean's Box 40-PS, Elberton, Ga.

MAKE Durable building plastic easily. Waterproof, fireproof, economical. Bays Laboratory, Cedaredge 2, Colorado.

ASSEMBLE Artificial Lures at home for stores. Materials supplied Free. Profitable! Write: Lures, Fort Walton Beach 8, Florida.

MAKE \$25-\$50 week clipping newspaper items for publishers. Some clippings worth \$5.00 each. Particulars free. National, 81, Knickerbocker Station, New York.

I Made \$40,000.00 Year by Mailorder! Helped others make money! Start with \$10.00—Free Proof. Torrey, Box 3566-F, Oklahoma City 6, Oklahoma.

WORLD'S Largest wholesale supply. Buy from 679 American, European, Japanese wholesalers. Tailormade suits from Hong Kong. 123 dropship catalogs. Rockbottom prices. Free details. International Buyers, 216-PS2 Jackson, Chicago 6, Illinois.

"HOW and Where to Obtain Capital." Reliable Service, Rome City, Indiana.

HOME Business Confidential—Best opportunities not widely publicized—Never Overworked! Send postcard for free "Inner Circle" listing. S-M Research, Box 432-PA, Detroit 31, Michigan.

OPERATE Paying Mail Order Business From Home Or Office. Easy, Pleasant Work. Eye Opening Literature Supplied. Details. Write Ashe Co., 45-A Calumet Road, Holyoke, Mass.

"HOW-TO of Mailorder"—Techniques, Secrets, Laws, Regulations. Complete Manual—\$1.00 Dean's, Box 40-POP, Elberton, Georgia.

MAKE Money At Home—Full or spare time. Your own business. Steady substantial income. Financial security. No investment. Details Free. Rex Dye, Marketing Counsel, 1442 Griswold Street, Detroit 26, Michigan.

\$200.00 MONTHLY. Spare Time. With Tablesaw, Bandsaw or Jigsaw. Write. Holiday House, B3800 Harney, Vancouver, Washington.

SAWDUST. Tin-Cans, Newspapers. Over 200 uses. Instructions \$1.00. Charles Company, 42-DPE, Norwood, Ohio.

"POSTAGE Saving Guide." Reduces mailing costs despite increased postage rates. \$1.00 postpaid. Wonderful dealers proposition. Everybody buys. Neil H. Tasker, Shamokin, Pennsylvania.

"EVERYBODY Likes Candy"—Make professionally home . . . (Our 50th Year). Ragsdale Candies, D 107, East Orange, New Jersey.

\$70 WEEKLY—Home, spare time. Simplified mail bookkeeping. Immediate income—easy! Auditax, 34741D, Los Angeles 34.

BIG Money! Learn Television Repair! Easy! TV, 2300 S. Jefferson, St. Louis 4, Missouri.

BIG Profits Mailing Wholesale Catalogs. Matteson, 1341P Stoneylane, No. Kingstown, Rhode Island.

SELL Champion, AC, Autolite spark plugs. Precision reconditioned, electroplated, guaranteed 10,000 miles. Up to 308% profit. Free samples. Indy 500 Spark Plug Co., Plant 2, 4620 N. Braeswood, Houston 35, Texas.

TREMENDOUS Money-making Opportunities. Handcrafted Jewelry Business. Free Details. LPS, Dept. 223, 1706 Argon, Mesa, Arizona.

BAKE New Greaseless Doughnuts In Kitchen. Sell stores. Free recipes. Summers, 3605 South 15th, Minneapolis 7, Minnesota.

HOMEWORK. \$1 brings list of companies offering homework. Eagle, Box 135, Bronx 60, N. Y.

MAKE Figurines. Rubber for Molds. Extra Thick. Free sample. W. Wooley, 1915-B North, Peoria, Ill.

OPERATE Home mailorder business. Vosacek Printing, 4444-PS Ute, San Diego 17, Calif.

COLORGLAZED Concrete pottery made without molds. Patented method. Cemetery products, novelties, tiles. Basement leak-sealing. Money-making projects. Booklet, details free. Men only. National Potteries, Grand Rapids, "Minnesota."

PEARL/Bronze Baby Shoes. Exclusive Home Business. Supplies on Credit. Free Booklet. Box 5036C, Inglewood, California.

MOLD Statuary, Pottery, Tiles, Novelties—5c materials makes dollar sellers! Particulars free. Marbleizing Service, Edwardsville, Illinois.

1963 DIRECTORIES: International Imports, Wholesale Books, Wholesales. Mail Opportunities 25c. Mail-Order Headquarters, Box 412-ACB, Lawndale, California.

HUNDREDS of small businesses for sale in Sunny Florida. Monthly reports. Write Business Opportunities, 1435 Falcon Drive, Orlando, Fla.

BUILD, sell Electronic Fire and Burglar Alarms, photoelectric controls. Details, sample part, \$2.00. El-Tec, 52 Longview Ave., Lake Hiawatha, New Jersey.

38 MONEYMAKING OPPORTUNITIES

MAKE Plastic novelties for extra income. Low cost home training now available. Write for free booklet. Interstate Training Service, Dept. D-2, Portland 12, Oregon.

VENDING Machine—No Selling. Operate A Route of Coin Machines And Earn Amazing Profits. 32-Page Catalog Free. Parkway Machine Corporation, 715 PSM Ensor Street, Baltimore 2, Maryland.

TO \$100.00 Weekly, Mailing Catalogs. Sample, instructions, 25c. Costar, GPO Box 972-PS, New York 1.

AMAZING successes through franchises! Become exclusive franchise holder your territory. Information rushed. National Franchise Reports, SP-528, 333 North Michigan, Chicago 1.

HOME Mailorder "manufacturing." Everything supplied. Clenso Products, 184 Oakview, Winnipeg 15, Manitoba.

TREE-Mushroom Pioneers! Spawn. Instructions, \$1.00. Ohga, PSTR-421, Sigakokusatu, Japan.

WE Love our mailman. Leaves \$1,000.00 monthly in our rural mailbox. My college professor husband's scientific mailorder pays. We bought a Texas ranch, live as we always wanted. Free folder on "Ranch Mailorder." Eveningshade Ranch, Boerne, Texas.

RAISE Rabbits and Fishworms on \$500 month plan. Free details. White's Rabbitry, Mt. Vernon 59, Ohio.

SELL Diamonite Gems: More Brilliant than Diamonds. Catalog 10c. Diamonite, 2420-S 77th, Oakland 5, California.

FREE Literature — Make Big Money Raising Fishworms and Crickets. Carter Farm-11, Plains, Ga.

MINK Raising information free. Complete. Lake Superior Mink Farm, Superior EE, Wisconsin.

MEN — Women! Start Money-Making Plastic Laminating Business at home in spare time. Material that costs 11c brings back \$2.58. No canvassing or selling but mail orders bring in \$20 a day. Write for full particulars free. Rush name on postcard to Warner, Room CL-3-A, 1512 Jarvis, Chicago 26, Ill.

DETECTIVES—Work home—Travel. Experience unnecessary. Detective Particulars free. Write Wagoner, P-125 West 86th, New York 24.

IMMEDIATE buyer will pay premium prices for oil and gas leases which you obtain for 50c per acre. Complete free information. Central Southwest Oil, Box 13611-H, Dallas 24, Texas.

SELL Three New Sport Items—No Competition, Easy Sales, Big Money! Write Dept. A. Kayenvee Enterprises, Oskaloosa, Iowa.

WE purchase items you make at home for us. Enclose stamp for details. Wolfe Specialties, Box 171-A, Center Line, Michigan.

MEN, Women: Turn spare time into cash! B. Taylor Enterprises, Export, Pennsylvania.

INCOME From Oil Can End Your Toil! Free Book, Maps! National Petroleum, Miami Beach Federal, Miami Beach 39, Florida.

BELOW Wholesale Cost. Merchandise, Housewares, Jewelry, Toys, Gifts. Bargains, P.H.A.-14, Farr Road, Columbus 4, Georgia.

EASY to start rubber stamp business at home in spare time. Make up to \$9.80 an hour without experience. Facts free. Write to Roberts, 1512 Jarvis, Room CR-3-A, Chicago 26.

PIANO Tuning Learned at Home Quickly. Tremendous Field! Be Independent! Information Free. Empire School, Dept. S, Champaign, Ill. (Founded 1935).

BIG Money, Part, Full Time, Six Complete Proven Ways. One Dollar. No Other Obligation. Wilco, Box 152, Antwerp, N.Y.

MAKE \$25-\$50 week, clipping newspaper items for publishers. Some Clippings worth \$5.00 each. Particulars free. National, 81, Knickerbocker Station, New York.

\$100 WEEKLY possible. Compile Mailing lists and address envelopes for advertisers. Home-spare time. Particulars free. National Service, 81, Knickerbocker Station, New York City.

\$10,000 YEARLY, drawing simple cartoons. Over 200 markets. Information free. Maler-5-23, 11620 Lansdowne, Detroit 24, Michigan.

SPLIT Leather Wallets. 1 Doz. \$5.95, Sample \$1.00. Edward Silverman, 148 Osborne Terrace, Newark, N. J.

LEARN the secrets of repairing junk batteries, generators, starters, profitable, easy, at home. Free particulars. Batteryman, Prunedale Station, Salinas, California.

TRUE—You can make money in mail order with us. Join Free. Co-Ops, 694 Kerr, Columbus, Ohio.

PROFITABLE hobby adds to income. Operate Home Mail Order Business. Write Publicity, Box 727B, Kalamazoo, Michigan.

CIGARETTES—Make 20 plain or filter-tips for 9c. Facts free. Moberly, Box 4013, Owensboro, Kentucky.

FREE Advertising For Mailorder Items. Branvolt, 5718 Troost, North Hollywood, California.

START good pay business at home in spare time. No experience needed to operate little table-top machine for bronzing baby shoes. Make \$6.00 profit on every pair. Full particulars free. Send postcard to Warner, 1512 Jarvis, Room CM-3-A, Chicago 26, Illinois.

38A BUY IT WHOLESALE

BUY Direct From Factories! Appliances, Cameras, Watches. Free Details! Cam Company, 436PB Bloomfield Avenue, Verona, New Jersey.

BARGAINS! Buy Wholesale! Save Money! Free Catalog! Norris, 273-L Merrick Road, Lynbrook, N. Y.

FREE! Name Brands Catalog! Your own high profit business. Sell Name Brands, full or part time. No inventory—no investment. More than 2000 Name Brand items; lowest wholesale prices. Watches, jewelry, cameras, hi-fi, stereo radios-phonos, appliances, housewares, hardware, power tools, luggage, musical instruments, garden equipment, sporting goods, toys, many others. 8 Floors of Name Brands. Million dollar inventory. Orders shipped complete within 24 hours. Send for Free beautifully illustrated catalog. Now! Separate wholesale price list. H. B. Davis Corp., Dept. PS, 145 West 15 St., New York 11, N. Y.

NEW Deluxe below wholesale catalog. Automobile catalog and others. Furniture, clothing, housewares, appliances, refrigerators, freezers, washers, dryers, television, radios, luggage, binoculars, hi-fi, stereo, phonographs, recorders, cameras, projectors, musical instruments, sporting goods, toys, tools, typewriters, watches, jewelry. Huge discounts on thousands of name brand items. For free specimen list of actual factory prices—postcard: Selbyco, Decatur 16, Illinois.

SAVE, Hundreds Of Bargains. Name Brands. Catalog Free. Box 205, Washington, New Jersey.

WORLD'S Largest wholesale supply. Buy from 679 American, European, Japanese wholesalers. Tailormade suits from Hong Kong. 123 dropship catalogs. Rock-bottom prices. Free details. International Buyers, 216-PS Jackson, Chicago 6, Illinois.

DRUG Sundries. Complete Line Of Rubber Goods. Nationally Advertised Brands. Vitamins, Etc. Write For Free Catalog. Federal Pharmacal Supply, Inc., Dept. PS, 6652 North Western Avenue, Chicago 45, Illinois.

ELECTRIC Guitars, amplifiers, wholesale. Free Catalog. Carvin, PSW, Covina, California.

BELOW Wholesale! Thousands Famous Products! Major Appliances, TV, Housewares, Jewelry, Cameras, Recorders, etc. Factory Guarantees. Free Details! United, 718 Myrtle, Albany 8, New York.

AMAZING Wholesale Guide Available. Details Free. Enterprise, 434-A Temple, Fredonia, New York.

100,000 PRODUCTS Wholesale! Terrific Bargains! Wholesalers, 1265 Broadway, New York 1, N. Y.

39 FORMULAS, PLANS, ETC.

FORMULAS—All Kinds. Amazing Big Catalog 10c. Kemisco, Park Ridge 15, Illinois.

MONEY-making Cosmetic Formulas! Catalog 25c, (Refunded first order). Conner, 3530 S. Atlanta Road, Smyrna, Georgia.

10,000 MODERN Moneymaking Formulas. Details Free. Harvey's, 1402-PSC, Englewood, Colorado.

LATE Modern Manufacturing Formulas List Free. Chemical Service, Martville, New York.

40 PLASTICS

NEW Liquid casting plastic, clear, colors. Embed real flowers, butterflies, photos, coins. Send 25c for two handbooks "How to Cast Liquid Plastics" and "How to Make Extra Money at Home." Castolite, Dept. B-102, Woodstock, Illinois.

LEARN plastics at home. Send 10c for sample plastic, 3 experiments, full details. Plastic Projects, Box 5171, Detroit 36, Michigan.

EMBEDDING, casting secrets free. Sample, 25c. Crystal, 4350-H N. Whipple, Chicago 18.

PLEXIGLAS — Any thickness — Clear — Colors — Cut to size — Clear Rods — Tubing. McClarin Plastics, P.O. Box 168B, Hanover, Pennsylvania.

"CHEMIGLAS" clear casting resin. Complete experimental outfit, \$1.00. Technicraft, 3 Brackett, Boston 35, Mass.

NEW! Plastic Vacuum Forming Machines. Hobby. Easy, Profitable. Details: Burr, 7645 Oakland, Kalamazoo, Mich.

CELLULOID scrap, assortment gauges, attractive colors. Box 333, Kearney, New Jersey.

41 SCIENCE & CHEMISTRY

ROCKETS: New Illustrated Catalog 25c. Single And Multistage Kits, Cones, Engines, Launchers, Trackers, Technical Information, Etc. Fast Service. Estes Industries, Penrose 6, Colorado.

AMAZING New Book Of Science Experiments, formulas and Catalogue of Laboratory Supplies. Only 35c. National Scientific Co., Dept. PS-2, 13 S. Park Avenue, Lombard, Illinois.

MICROSCOPES, accessories, prepared slides, supplies, etc. Free brochure. New England Science Service, PS-2, P.O. Box 315, Peterborough, New Hampshire.

NEW Concepts in physics and astronomy comprising a unique structural explanation for the subatomic particles and their forces. Nuclear theory challenged. 25 cents postpaid. C. F. Krafft, 4809 Columbia Road, Annandale, Virginia.

UNUSUAL Chemistry books, courses, kits! Rare chemicals, cheap! Catalog 25c. National, Box 133-A, Palo Alto, Calif.

SEARCHING For Economically Priced Chemicals and Apparatus? Catalog and Gift 25c. Starr Scientific, Manitowoc, Wisconsin.

BUDGET Priced Chemicals, Apparatus, Biology. Catalogue 25c. Dept. PS-2, Mid-States Scientific, 7053 N. Clark, Chicago, Ill.

CALCULATING Aids. Catalog 10c. Dyna-Slide Inc., 600 S. Michigan Ave., Chicago 5, Illinois.

EXPERIMENTER'S Handbook Free With Bigger Catalog 25c. Hagenow Laboratories, Manitowoc, Wisconsin.

ILLUSTRATED Catalog; Chemistry, mineralogy, biology 25c. Tracey Laboratories, Evanston, Illinois.

CHEMICALS and apparatus for industrial, analytical and private laboratories. Catalog 35c. Dept. M-26, Biological Supply Co., 1176 Mt. Hope Ave., Rochester 20, N. Y.

ROCKETS! New illustrated catalog of rocket kits, supplies, engines, chemicals, 25c. Central Rocket Company, Div. 189, Waupaca, Wisconsin.

CHEMICAL Assortment, VCM Chemical Co., 8154 Orion, Van Nuys, Calif. Catalog 25c.

PROFESSIONAL, Student Microscopes, prepared slides, stains, biological apparatus. Brochure 25c. John Winn, 124 West 23, New York 11, N.Y.

SMALL quantity chemicals, biology supplies. Catalog 35c. Winn Chemicals, 124 West 23rd, New York 11, N. Y.

ROCKETRY Supplies: Kits, Engines, Cones, Tubes, Launchers, Firing Panels. Latest illustrated catalog 25c. Centuri Engineering Co., 340 W. Wilshire, Phoenix 3, Arizona.

WUMCO Chemical Co., Chemicals and Chemical Apparatus. Catalog—25c. Booklet of Experiments—50c. Box 681, Reading, Penna.

FREE—Pair of Chemical Resistant Polyethylene Gloves with catalog. Low priced Chemicals, Biologicals, and Apparatus. New Illustrated Catalog only 35c. Dover Scientific, 35-24 31st St., Astoria 6, New York. Open All Day Saturday.

CHEMICALS, biologicals, apparatus and plastics catalogue 25 cents. Free periodic chart of elements. Unichem Products, Box 3626, Grand Central Station, New York 17.

41A MATHEMATICS

ARITHMETIC, your most important asset in any field! Now a brand new system, 10 times better, is obtainable only through this ad! Regains interest, precision with half the writing! Complete, easy to learn—send \$1.00 today to cover costs. Rithematics, 2900—9th Street, Rock Island, Illinois.

POPULAR SCIENCE OPPORTUNITIES

42 EMPLOYMENT INFORMATION

DIRECTORY Reports. Construction, aviation, shipping, oilfields, government, manufacturing, trucking, etc. Foreign-Stateside. Helpful information plus job-getting tips on preparing application letters. Unconditional money-back guarantee of satisfaction. Act Today. Only \$3.00. (\$3.25 Airmail) (C.O.D.'s Accepted) Research Services, Meramec Building, St. Louis 5-PS, Missouri.

FOREIGN Employment. Construction, other work projects. Good paying overseas jobs with extras, travel expenses. Write Only: Foreign Service Bureau, Dept PS, Bradenton Beach, Florida.

FOREIGN Employment information. Europe, Africa, Asia, South America. Free Transportation. Up to \$1600.00 monthly. Sensational opportunities. Construction workers, clerks, truck drivers—every occupation. Complete information, application form, sent immediately by return mail. Satisfaction guaranteed. Only \$2.00 (\$2.25 airmail) (C.O.D.'s accepted) to: Jobs, P.O. Box 50512, Dept. F, New Orleans 50, Louisiana.

JAPAN! Korea! Okinawa! Many hi-paying jobs available. Complete, detailed reports \$2.00. Japan Reports, Box 2202-E, Newport Beach, California.

PLUMBERS, Electricians, Maintenance. Florida Opportunities Awaiting. One Dollar. Jobs, Box 367, Melrose, Florida.

43 AGENTS WANTED

NEW "Magic Knife" slices frozen foods, even bone—pays up to 100% profit! Rush postcard for free double-your-money details, special Starting Assortment discount offers. Dalo, Dept. K-608, 4333 N. Pulaski, Chicago 41, Ill.

EVERY Man A Prospect. Refundable sales kit offer showing line belt buckles, tie clasps, money clips, cuff links, lapels, identification badges, individualized with customer's name and emblems. Cap badges for trucking, bus, taxi, police, firemen, also heavy construction emblems. Choice 3000 emblems. Hook-Fast, Box 1088PS, Providence, R. I.

MAKE Big Money taking orders for Stark Dwarf Fruit Trees. Everybody can now grow Giant Size Apples, Peaches, Pears in their yards. Also Shade Trees, Shrubs, Vines, Roses, etc. Outfit Free. Stark Bro's, Desk 30123, Louisiana, Missouri.

YOUR Own business—Suits \$1.50; Overcoats 65c; Mackinaws 35c; Shoes 12¹/₂c; Ladies' Coats 30c; Dresses 15c. Enormous profits. Catalog Free. Nathan Portnoy Associates, 2109-J Roosevelt Road, Chicago 8, Ill.

MAKE Most Extra Cash with world's biggest line everyday greeting card assortments, gifts. Introduce friends, neighbors, to over 150 assortments. 500 big money-makers. Pocket up to 100% profit plus big cash bonus. Free giant color catalog; samples on approval. Write Arrow Greetings, 513 Fourth Ave., S., Dept. 84-A, Minneapolis, Minn.

START Your Own Business On Credit, U.S. Only. Your own boss. 1199 Dealers sold \$5,000 to \$25,500 in 1961. We supply stocks, equipment on credit. 200 home necessities. Sales experience unnecessary. Pleasant, profitable business backed by world-wide industry. Write Rawleigh, Dept. B-U-PSC, Freeport, Ill.

FREE Sample, Beautiful Curios! Sell on Sight! Apartado 9036, Mexico City.

EXOTIC Earrings! Details free. Pair \$1.00. Ohga, Pser-422, Sigakenkusatu, Japan.

EXTRA Cash Aplenty! Show 'em and you'll sell 'em—sensationally beautiful, handpainted plastic photo enlargements, personalized compacts, costume jewelry. Take orders—collect 40% commission. Self-selling sales kit free. Novelko, 3343 North Avenue, Chicago 47.

AGENTS—300% profit selling genuine gold window letters; stores and offices. Free samples. Metallic Sign Letter Co., 1217-E West Newport, Chicago.

232 POPULAR SCIENCE FEBRUARY 1963

MAKE Up To \$25 In Day introducing sensational Flora-Scent. Graceful apothecary jar with exquisite flower enhances any room. Actually is effective room air freshener, deodorizer. Sells on first sight and scent. Every home buys 1, 2 or more. Sell stores for resale. Free money-making kit. Merlite, 114 East 32nd, Dept. W-74D, New York 16.

REVISTA Mundo, Spanish News Magazine Seeks Distributors All Over U.S.A. Write: Revista Mundo, San Salvador, El Salvador.

STRANGE "Dry" Window Cleaner. Replaces messy rags, liquids. Simply glide over glass. Samples sent on trial. Kristee-130, Akron, Ohio.

EARN \$50 Weekly In Sparetime. New Unusual way to earn extra money in your spare-time—no investment necessary! No sales experience needed. Get merchandise on credit. Work your own hours! If you'd like complete details on how to earn money this interesting way, write Greetings Unlimited, Park Square, Room 3-699, St. Paul, Minnesota.

EARN Big Money introducing amazing Color-V. Makes ordinary TV show in beautiful colors. Low \$2.98 price—sells like hotcakes. Free details. Excellent Buys, (Dept. PS-3), 34 E. 12th, N.Y.C.

DEALERS Wanted . . . Men, Women Write: Wilknet, Adv. C2032, Greenfield, Ohio.

BUSINESS Kit Free! Postcard puts you in business! Complete line 230 shoe styles, jackets! New Discoveries pay Big Commissions. No investment. Send for Free Kit. Mason, Chippewa Falls K-455, Wisconsin.

BRITE-View Silicone Eyeglass Cleaner. Lasting Clarity, Luster. No Mess. Built In Applicator. Guaranteed. Polishes, Coats. Helps Prevent Fogging. Agents Wanted. 49c, three \$1.00. Catalog Free. Chemist Distributor, Box 1287-PS, Chicago 90, U.S.A.

DIAMOND—Faceted, Bluewhite, Fiery Gems! Cadienco, 187 Miraloma, Miraloma, California.

44 HIGH-GRADE SALESMEN

MAKE extra money. Big steady earnings-repeat business. Sell advertising Book Matches, full or part time. New 1962 line. Show Glamour Girls, Colorama, Tenorama; dozens more. All sizes. Free Master Outfit, sales helps, leads, no experience necessary, no investment. Write today. Superior Match, Dept. P 263, 7530 Greenwood, Chicago 19.

SENSATIONAL new longer-burning Light Bulb. Amazing Free Replacement Guarantee—never again buy light bulbs. No competition. Multi-million dollar market yours alone. Make small fortune even spare time. Incredibly quick sales. Free sales kit. Merlite (Bulb Div.), 114 E. 32nd, Dept. C-74-D, New York 16.

YOUR free copy of World's biggest sales magazine tells you how and where to make more money on your own in selling. Write Specialty Salesman Magazine, Desk 6B, 307 North Michigan, Chicago 1.

Make Extra Money Selling advertising matchbooks. Free catalog and sales outfit. Matchcorp, Dept. PS-23, Chicago 32.

EARN Big Commissions Full Or Part Time. Show America's largest line low priced business printing and advertising specialties. Big Free Sales Kit samples hundreds items used daily by business people. Build profitable repeat business. Start right now. National Press, Dept. 9, North Chicago, Illinois.

MAKE Up to \$50.00 Daily, listing delinquent accounts from business, professional men. Free Sales Kit. General Finance, Dept. AR-2, Pickwick Bldg., Kansas City 6, Mo.

I'LL send you Free stocking sample! Newest advancement in hosiery since nylon. Patented, full-length. Stays up over-the-knee without supporters, without girdle! Nationally advertised price \$1.95. Make money introducing to friends at \$1.00 pair. American Mills, Dept. 734, Indianapolis, Indiana.

LONG Needed Invention. Men to contact service stations. Huge profits. Cyclo Mfg., 3816 Dahlia, Dept. 117, Denver 1, Colorado.

CALENDARS, Novelties—Full or Part Time. Liberal Commissions. Fleming, 6535-B, Cottage Grove, Chicago 37.

IF you're interested in making money in selling, see the hundreds of exceptional opportunities in Salesman's Opportunity Magazine. Send name for your copy, absolutely free. Tell us what you're selling now. Opportunity, 848 N. Dearborn, Dept. 18, Chicago 10, Illinois.

EARNINGS Up To \$78.00 In Day possible, even spare time, calling on firms, taking easy orders for Work Uniforms That Advertise, embroidered with company name, emblem. No investment, no inventory. Big-quantity orders. Rush name, address for big Style Display, everything needed to make money first day—Free. Topps, Dept. 107-B, Rochester, Indiana.

WILL You test new items in your home? Surprisingly big pay. Latest conveniences for home, car. Send no money. Just your name. Kristee-153, Akron, Ohio.

\$3.00 UP Hourly for Route Work. Permanent. Write McNess, Freeport 43, Ill.

NEW Car Thief Signal, Lightning Seller. Samples Sent on Trial. Northwest Electric, Ave. 26, Mitchell, S. Dak.

\$1,000.00 A month for making dramatic 3-second demonstration of amazing lightweight Presto Fire Extinguisher. New chemical used by Airforce snuffs out fires instantly. Only \$4.95. Terrific commissions. Millions want it. Free Kit. Merlite, 114 E. 32nd, Dept. 66-D, New York 16.

\$50 WEEKLY Extra part time selling Beaver Shoes to friends, relatives. Made of Everon; looks, feels like leather, wears far longer. Sample free. Beaver Shoes, Dept. PS 263, Beaver Meadows, Pa.

45 EDUCATIONAL & INSTRUCTION

BE A Real Estate Broker, Insure Security for yourself and your family. Study at home. Prepare for state examination. GI approved. Write for Free Book Today. Weaver School of Real Estate, 3519R Broadway, Kansas City, Missouri.

WOODWORKING and Cabinetmaking course for beginning and advanced home craftsmen. Only complete low-cost home training program available. Write for free booklet. Interstate Training Service, Dept. G-2, Portland 12, Oregon.

USED Correspondence Courses and Books sold and rented. Money back guarantee. Catalog free. (Courses Bought.) Lee Mountain, Pisgah, Alabama.

LEARN Civil and criminal investigation at home. Earn steady, good pay. State age. Institute Applied Science, 1920 Sunnyside, Dept. 332, Chicago 40, Illinois.

MASTER Watchmaking at home. Free sample lesson. Chicago School, 2328-WO Milwaukee, Chicago 47.

HIGH School Diploma at home. Licensed teachers. Approved materials. Southern States Academy, Station E-12, Atlanta, Ga.

MEN wanted. Learn Auto-Diesel Mechanics in our shops. Learn with tools on real equipment. Earn While You Learn. Many of our graduates earn \$125 a week and up. Write for free bulletin. Auto-Diesel College, Dept. 262, Nashville 3, Tenn.

LEARN While Asleep with your recorder, phonograph or amazing new "Electronic Educator" endless tape recorded. Details free. Research Association, Box 24-NN, Olympia, Washington.

BECOME Tax Consultant. Graduates earn \$1,000-\$3,000 every tax season preparing returns evenings. State approved. Union Institute, Lakewood W-1, N. J.

WANT a Diesel Job? Higher Pay? Advancement? We can help you qualify! Complete Diesel Tractor and Heavy Equipment and Cummins Diesel Engine Shop-method home-training courses available. Write today. Interstate Training Service, Dept. B-2, Portland 12, Ore.

BOOKKEEPERS — Operate Your Own "Dollar-A-Week" System. Ellis, Box 203, Cedar Grove, North Carolina.

COMPLETE Your High School at home in spare time with 65-year-old school. Texts furnished. No classes. Diploma. Information booklet free. American School, Dept. X246, Drexel at 58th, Chicago 37, Illinois.

PIANO Tuning Pays. Big money in spare time. Learn at home. No musical knowledge necessary. Phonograph, records, tools and instructions furnished. Electronic tuning also taught. Free catalog. Capital Tuning School, 3160 S.W. 16th Court, Ft. Lauderdale, Fla.

GOOD paying jobs open! Operate, repair heavy earth moving equipment! Learn "on the job" operating latest cranes, bulldozers, earth carriers! V. A. Approved Free Catalog. Write B. P. Hutch Greer Technical Institute, Braidwood, Illinois.

FCC LICENSE in 6 weeks, First Class Radio telephone. Results Guaranteed. Elkins Radio School, 2603A Inwood, Dallas, Texas.

GAME Warden, Government hunter, Forestry, Park and Wildlife Services Announce job openings regularly. Enjoy outdoor work, good pay, real security. Complete information Free! Write North American School of Conservation, Dept. 182, 810 Dodsworth, Covina, Calif.

LEARN Auctioneering, Term Soon, Free Catalog. Reisch Auction College, Mason City 3, Iowa.

WRITERS Wanted for Magazines, Television, Newspapers, Motion Pictures. Easy to learn Home-Study Course. Shows you how to write and sell stories. Free!—Revealing Book, Lesson, Writers Magazine, and Aptitude Test. Write: Palmer Institute, 6087-P2 Sunset, Hollywood 28, Calif.

FINGERPRINTING and Identification easily learned at home. Diploma awarded. Alabama School of Fingerprinting, Fairfield, Alabama.

FINISH High School at home. No classes. Texts furnished. Diploma awarded. If 17 or over and have left school, write for Free information and catalog. Wayne School, Dept. 14-510, 417 S. Dearborn, Chicago 5, Ill.

PIANO Tuning quickly learned with home study course. Diploma granted. American Tuning School, Gilroy, California.

USED Courses! Books! List 10c. Smith's, 124 Marlborough, Salem, Mass.

DYNAMIC speaking, singing. Self-training records. Amazing!! Canfield, 2018-C Fifth Avenue South, Minneapolis 4, Minnesota.

GRAPHOANALYSIS — Learn scientific handwriting analysis for profit, pleasure. Free sample lesson, catalog reveals plan. Write IGAS, Inc., 325 Jackson, Dept. 2CY-1, Chicago 6.

MISSOURI Auction School. Free catalogue. 1330 Linwood, Kansas City 9-x5, Missouri.

LEARN Scientific Swedish Massage in few months at home. Skilled operators earn \$4.00 to \$5.00 an hour. Open your own office or earn good income at health and recreational centers. Wonderful part-time profession. Free Anatomy Charts and catalog. Anderson School Of Scientific Massage, Dept. XB2, Princeton, Illinois.

DENTAL Technician's Home Study Student's Kits. Instruments, plastic, etc. Illustrated instructions. Write for Free lesson. Grant Laboratory, Haas Bldg., Los Angeles 14, Calif.

CHILDREN'S Education. Courses Cost Twenty Dollars. Divino Salvador School, San Salvador, El Salvador.

MATHEMATICS, Electronics. No Contract. Pay as you learn. Free brochure. Indiana Home Study, 64 Hemenway Road, Framingham, Mass.

STOP working for pennies! Start competing for big money now! Get our amazing techniques: Guide, Box 362-SE2, Yorktown Heights, New York.

REAL Estate Course. Economical home-study. Literature free. Howard Schools, Box 8394-B, Kansas City 5, Missouri.

ENGINEERING And Art Degrees earned through home study. Electronics, Mechanical, Liberal Arts. Major Accounting. When writing specify course desired. Pacific International College of Arts & Sciences, primarily a correspondence school. Resident classes also available. 5719-A Santa Monica Blvd., Hollywood 38, California.

FREE General Catalog—100 Pages Text vocational, educational, instructional subjects. Millions of volumes, new and used Bargain prices. Books bought. Est. 1902 Long's College Book Co., Dept. PS, Columbus 1, Ohio.

OWN local collection office. Pays big. Franklin Credit, Roanoke, Virginia.

LEARN Electricity, Appliance Repair, and Slide-Rule Calculations in 32 Compact Lessons. World-Wide School, 2555 Shelley Drive, Indiana, Penna.

PENMANSHIP Corrector: Improve poor penmanship quickly. Details free. Ozment, Box 665 35, St. Louis 88, Mo.

EARN as you learn, camera repair. National Camera Repair School offers accredited Home Study Course—instructions, texts, tools and practice equipment. Free information. Write Box 174PE2, Englewood, Colorado, today!

STOP SHAVING! I did 18 years ago! My secret is yours for \$2.00 or send for details. Leonard Champagne, Box 201, Sta. F., Buffalo 12, N.Y.

COLLEGE Home study courses from leading universities. Full credit toward Bachelor's or Master's degree. 5,000-course directory \$2.00. College Research, North Highlands 2, Calif.

ARITHMETIC Made Easy. Check Answers Lightning Fast. Complete, Simple Course \$1.95. Hazelwood Research, Box 96, Hazelwood, Missouri.

GET A British Degree. Divinity, Philosophy, Healing, Metaphysics. 35 courses. Prospectus Free. Brantridge Forest School, "Lodge" Brantridge, Balcombe, Sussex, England.

47 DETECTIVES

DETECTIVES—Work home—Travel, Experience unnecessary. Detective Particulars free. Write Wagoner, P-125 West 86th, New York 24.

DETECTIVE Profession. Home Study Lapel pin, Certificate, Future. Box 41197-G, Los Angeles 41, California.

DETECTIVE Course. Credentials. Diploma. Free Information. Southwestern Institute Criminology, Box 202, Geronimo, Oklahoma.

INVESTIGATORS, free brochure, latest subminiature electronic listening devices. Ace Electronics, 11500-F NW 7th Ave., Miami 50, Florida.

DETECTIVE training. Career for young and old, men and women. For free information write to 1917-C North Kenneth Avenue, Chicago 39, Illinois.

48 LANGUAGE OUTFITS

ESPERANTO, UNESCO's interlanguage. Text, Pronunciation record \$1. Esperanto, Dept. P.S., Middleton, Wis.

50 BUSINESS SERVICE, INFORMATION, NAME LISTS

MAILING Lists most all kinds 1000 \$5.00. FREE folder. Your circulars mailed \$4.00 1000. Dixie Mailers, King, N. C.

51 SPECIAL SERVICES

PROPERTY Mapping our specialty. Free estimates. Write Deed-Ettes, Mt. Pocono, Pennsylvania.

51A I Q TESTS

I.Q. TESTS. Accurate, inexpensive. Home-administered, professionally interpreted. Research data needed. University Testing Institute, R-14, Box 6744, Stanford, California.

52 AUTHORS SERVICE

WANT Your Book Published? Learn how we publish, advertise, promote, distribute. Many successes. Free booklet PS, Vantage, 120 West 31, New York.

WRITERS! N. Y. publisher wants "how-to" book manuscripts and other subjects (fiction, nonfiction). Two free brochures reveal tips on writing; how to become published author. Write Paula Scottsdale, Exposition Press, 386 Park Avenue South, New York 16, New York.

PUBLISH your book! Join our successful authors; All subjects invited. Send for free appraisal and detailed booklet. Carlton Press, Dept. PSB, 84 Fifth Avenue, N.Y.C. 11.

53 ADVERTISING, AGENCIES, ETC., FOR ADVERTISERS

ADVERTISE: 24 words, 50 Canadian Newspapers. \$5.50. Lists Free. Advertising Bureau, 10511-P Springfield, Chicago 55.

FREE expert assistance for mailorder advertisers. Ratebook leading newspapers, magazines 10c. Chicago Advertising Agency, 28 E. Jackson, Chicago 4.

ARE you just getting started in mail order? Or are you an "old timer?" Whichever you are, you'll benefit by reading, "How to Make Money Through Classified Advertising." It tells you what, where, when and how to advertise, points out what to do, and what to avoid. Thousands of copies of this booklet have already helped mail order men all over the world. To get your copy, just send 10¢ to cover postage and handling to O.K. Kelly, Dept. 263, Popular Science Classified, 355 Lexington Avenue, New York 17, N.Y.

54 ART INSTRUCTION, CARTOONING, SIGN PAINTING

"HOW to Make Money With Simple Cartoons"—A book everyone who likes to draw should have. It is free; no obligation. Simply address Cartoonists' Exchange, Dept. 192, Pleasant Hill, Ohio.

"KEY to a Cartoon Career." Send 50¢ for booklet. Cartooning, Box 3176, Colorado Springs, Colorado.

PAINT Signs! Using Patterns! Trial Alphabet \$1.00. Harwell, PS-263, Byrdstown, Tennessee.

LEARN Profitable Magazine Cartooning! Free Details. Cartoonists, Box 3097, Lincoln 10, Nebr.

PAINT Signs! Easy With Our Letter Patterns. Also "Popular Raised Letters." Paulo Signs, Crystal Falls, Michigan.

LEARN Sign Painting. Fascinating System. Straley, 410-P South Western, Springfield, Ohio.

YOU can Entertain with Chalk Talks. Catalog 10c. Cartoonist Balda, Oshkosh, Wisconsin.

55 TYPEWRITERS & OFFICE MACHINES

RECONDITIONED Typewriters, Mimeograph, printing presses \$25.00 up. Write Dixiegraph, King, N. C.

FACTORY Cost Plus 5%! Smith-Corona! Cole Steel! Desks—Files—Typewriters—Adders—Registers—Duplicators—Dictators Don Moore, 1832 North 5th, North Las Vegas, Nevada.

56 RUBBER STAMPS & OFFICE SUPPLIES

MIMEO Stencils—\$2.85 quire shipped Postpaid. Quantity discounts. Cole-Tee Products, Box 444, Scranton, Penna.

FREE Catalog. Rubber Stamps As Low As 25c Each. Leon's Quality Products, Box 1103, Portsmouth 1, Virginia.

3 LINES (with ink pad) \$1.00. Guaranteed. Printers, Lake Placid 1, New York.

FREE 32 Page Rubber Stamp Catalog. Signature Stamps \$3.50. Youngers Stamp Shop, Princeton, Iowa.

POCKET Or Office Type Stamp \$1.00. Vargo's, 4119A Buechner Ave., Cleveland 9, Ohio.

POROUS Rubber Stamps. Require no ink pad. Free Catalog. Melco, Box 53331-PS, New Orleans 50, La.

57 PRINTING, MULTIGRAPHING, ETC.

FREE Catalogs. Postpaid printing, Rubber stamps. D M Press, Sebastopol, Calif.

1,000 8 1/2 x 11 \$5.95 plus postage. Free Catalog. Musselman, Box 2766P, Kalamazoo, Mich.

SAVE On Printing. Catalog Free. Allen, 216-P West Jackson, Chicago 6.

OFFSET printing. Some shipped day received. Mimeo Press, Rocky Mount, N. C.

AMAZING Business Printing values. Samples. Print Shop, Box 576P, Greenville, R. I.

DISTINCTIVE Business Printing Samples. McDonald, 545 North Oakland, Pasadena, California.

1000 GUMMED Name & Address Labels \$1.00. Perk's, Essex, Mass.

1000 NAME, Address Labels \$1.00. Rubber Pocket Stamp \$1.00. 1000 Business Cards \$3.95. Printing, Personalized Items. Free Literature. Jordan's 552 West O'Connor, Lima, Ohio.

2000 GUMMED Name-Address Labels \$1.00. Jantzen, 514 St. Lawrence, New York 72.

DISTINCTIVE Mimeographing. Lowest prices. Samples sent. Perkins Printing Service, Fremont 5, Nebraska.

FREE Catalog! Quality low cost printing. Steinbergen, Box 2354F, NYC 8.

1500 NAME, Address Labels \$1.00. Sturdevant, 207 Cambridge, Cincinnati 30, Ohio.

1000 BUSINESS Cards, "Raised Letters" \$3.75 postpaid. Samples. Routh PS-2, 3910 Kipling, Greensboro, N. C.

58 PRINTING OUTFITS, SUPPLIES

PRINTING Outfits, type, supplies. Send dime for illustrated supply book and samples. Kelsey, Inc., H-8, Meriden, Conn.

RUBBER Stamp Presses, Hydraulic Operated. Electrically heated. Sizes 5"x8", 8"x12", 10"x15", starting outfits, supplies, Printing Presses. Custom Manufacturing, 1464 East Commercial, Springfield 2, Missouri.

PRINTING Presses, Type, Supplies, Lists, 5c. Turnbaugh Service, Mechanicsburg, Pa.

MAKE Your Own self-molding rubber stamps and printing cuts. Plexirubber, Argyle 2, Wisconsin.

TYPE and supplies for rubber stamp makers. Send for free brochures. Star Stamp Supply, 633 Plymouth Ct., Chicago 5, Ill.

TYPE case catalog. Manufacturer. King McKay Company, 23179 Telegraph, Southfield, Michigan.

RUBBER Stamp Presses, Supplies. Kiewiet, 2025 Barney Road, Kalamazoo, Michigan.

60 FOR INVENTORS

INVENTORS. If you have an invention for sale, patented or unpatented, write Institute of American Inventors, Dept. 30A, 635-F St., N.W., Washington 4, D. C.

INVENTORS: Prepare your own patent application. Our "Patent Kit" includes detailed instructions and all necessary material. \$12.95. Money back guarantee. National Inventors Company, Box 88, Ben Franklin, Washington, D. C.

INVENTIONS needed immediately for manufacturers. For additional information write Kessler Corporation, C-72-FI, Fremont, Ohio.

SAVE High Fees! Get Patent Protection For Less Than 50c. Write: "Protection," 4105-B Metropolitan, Dallas 10, Texas.

PATENT Searches, including copies of related U.S. Patents, \$6.00. Inventors, attorneys, manufacturers use my "Worldwide" Airmail service! "Invention Record" form and "Information Every Inventor Needs", sent free! Miss Hayward, 1029 Vermont Ave. NW, Washington 5, D.C.

URGENT Inventions Only. Contact for the Big Income. I.C.E., Box 451, Rock Island, Ill.

U.S. Patent Office Searches—\$5.00. Free Invention Record. Patents Engineered. Patent Office Searchers, 233 Broadway, Room 3615, New York.

PATENTS Skillfully Prepared for maximum commercial value with useful product development. High record of success in proving and claiming patentability. Valuable market service. Patents prepared and filed for service fee as low as \$200.00. Send for self protecting invention record forms free. Patent search with valuable engineering report \$10.00. Foreign patents filed at lower cost. Thirty Years established. Joseph O'Brien, Patent & Development Engineer, 132 Nassau Street, New York 38, N. Y.

PATENT Searches, professional patent development of inventions by Licensed Professional Patent Engineer and U.S. Patent Office Former Examiner with staff of engineering specialists in all fields of inventions. Expert searches performed in the U.S. Patent Office. Your inventions and ideas engineered for maximum patent protection and greatest commercial value. Inventions developed by us negotiated for cash or royalties with our nationwide contacts. Send for free Protection "Invention Certificates" and further interesting, valuable Patent Information. George Spector, Licensed Professional Patent Engineer, U.S. Patent Office Former Examiner, Woolworth Building, New York.

SAVE High fees! Prepare your patent application yourself! New "Do-It-Yourself" Patent Kit now makes it easy. Free "Registration Form." Miss Blaine, 306 Carry Building, Washington 5, D.C.

PROFESSIONAL Patent searches, \$6.00, including official copies of related U.S. Patents! Prompt, dependable Airmail service! For free "Invention Record Folio" and "Information Every Inventor Should Have", write: Congress Invention Institute, 210 McKim Building, Washington 5, D.C.

PATENT Searches, \$6.00, including official Patent Office copies of related U.S. Patents. Certified, Airmailed! For free "Invention Record" and "Patent Information", write: United States Inventors Service Company, 1311 "G" Street, NW, Washington 5, D. C.

FREE—"Vital Information Every Inventor Needs Before Selling Invention." Adams, 15 Park Row, New York City.

PATENT Searches including full airmail report and closest patent copies, \$6.00. Quality searches, expertly administered. Free protection forms and "Patent Information." Write Professional Patent Office Search Bureau, 709 Albee Building, Washington 5 D. C.

PATENTS professionally prepared for maximum commercial value. Patent searches including report \$6. Valuable market service. Cash or royalty sales. 10 years dependable service. For Free Self-protective Record of Invention forms write: H. Lawrence Blasius, 19 Park Row, New York 38, N. Y.

PATENT Searches, complete and thorough, Related copies Air Mailed with maximum speed \$6.00. Free Protection Forms, and "Patent Information." Write Mercury Patent Office Searchers, Washington Bldg., Suite 422, Washington 5, D. C.

PROFESSIONAL Searches of the Patent Office. Dependable—Reliable \$6.00 including airmail report and related patents. For Free protection forms and "Patent Information" write—Trans-World Patent Service, 500 Walker Building, Washington 5, D. C.

INVENTORS! Searches of the Patent Office \$6.00 including air mail report, related copies. Free Protection Forms, "Patent Information." Washington Patent Office Search Bureau, 1426 G Street, N.W., Washington 5, D. C.

60A ENGINEERING SERVICES

MACHINERY, Electronics, Chemistry, Equipment Development. Industrial research. Inquiries held confidential. Todd Consulting Engineers, 424 West 119th, New York 27.

61 INVENTIONS WANTED

INVENTIONS wanted. Patented; unpatented. Tremendous Manufacturers lists. Global Marketing Service, 2420 77th, Oakland 5, Calif.

INVENTORS: Hundreds of manufacturers have requested our assistance in locating marketable new products. Complete information free. Institute of American Inventors, Dept. 30C, 635-F Street, N.W., Washington 4, D. C.

WANT to sell your invention. Patented, Unpatented. Write for information =2302W. Cash, Royalty. Riddle Engineering, 2661 Northwood, Toledo 6, Ohio.

INVENTORS: If you have an invention for sale, patented or unpatented, write for free brochure outlining manufacturers requirements, royalty rates. Kessler Corporation, C-72-IW, Fremont, Ohio.

INVENTIONS Promoted — For Cash-Royalty Sales with Manufacturer Contacts. George Spector, Licensed Invention Engineer, Woolworth Building, New York.

INVENTORS! Sell your invention for cash or Royalties! Our client manufacturers constantly seeking new items. Patented. Unpatented. For free information write Gilbert Adams, Patent Broker, 80 Wall St., Financial District, New York, N. Y.

INVENTORS! Let us help develop, sell your idea or invention to our client-manufacturers seeking new items for outright sale or royalties. Financial assistance if needed. Write Wall Street Invention Brokerage, 79 Wall Street, Financial District, New York 5, N. Y.

INVENTORS Needing Help with any problem, financial, development, securing manufacturer, obtaining patent. Write the organization that delivers action and results—not promises. Pioneer Invention Service, 150 Broadway, New York 38, N. Y.

INVENTORS! Don't sell or license your invention for cash or royalties until you receive our offer. Write International Invention Institute, 17 Park Row, New York 38, N. Y.

INVENTORS! Outright cash sale or royalties for your inventions. Patented. Unpatented. Constant demand from our client manufacturers. Write United States Invention Brokerage, 78 Wall Street, New York 5, N. Y.

INVENTIONS Sold, Licensed. Cash-royalty basis. Inventions International, Box 560 Wall Street, New York 5, N. Y.

CASH or royalties for inventions! Consider our offer first before licensing or selling your patented or unpatented invention. Write—Aladdin Industries, 80 Wall Street, New York 5, N. Y.

INDUSTRY needs inventions immediately. Inventions for Industry was organized to discover and assist new inventors. Write Invention for Industry, 150 Broadway, New York 38, N. Y.

64 MODELS, MODEL SUPPLIES

SHIP and yacht model fittings; blueprints. Send 50c for Illustrated catalog listing hundreds of items. A. J. Fisher, Inc., 1002-2 Etowah Ave., Royal Oak, Michigan.

SHIP Models, Kits, fittings, plans, books, tools, engines, motors. Big illustrated catalog 50c. James Bliss & Co., Dept. PS, 342 Atlantic Avenue, Boston 10, Massachusetts.

ROCKETS: New Illustrated Catalog 25c. Single And Multistage Kits, Cones, Engines, Launchers, Trackers, Technical Information, Etc. Fast Service. Estes Industries, Penrose 3, Colorado.

HARD To Get Metal Rods, Tubes, Sheet, By Foot. Largest Selection U.S.A. Complete Line Steam, Gasoline Engines. Illustrated. 100 Page Catalog, \$1.00. Cole's Power Models, Ventura, Calif.

SHIP Model Kits and fittings: clippers, frigates, etc. Catalog, paint-tool list, book list, 35c. Model Shipways, Box 85, Bogota, New Jersey.

FREE Plan for Miniature Steam Engine included in New illustrated comprehensive Model Engineering Supplies Catalog; largest selection model gasoline, steam-engine casting kits; 1962 catalog 35c. Octura Models, 8148 Milwaukee Ave., Niles 48, Ill. Dept. FPS.

SHIP Model Kits, Clippers, Galleons, Liners; Operating Power Boats for Radio Control; Send 25c for Catalog. Ideal, 17 West 18 Street, New York 11, N. Y.

BUILD Miniature Buildings With Professional Materials. 50c For Instructions And Samples. Architectural Model Materials, PS23, 2008 No. Keystone, Chicago, 39.

COLLECTORS, Replica Builders! Selling out 500 world's most highly regarded antique plans, kits, parts. Rush 25c for catalog before taken off market. Cleveland-Peerless Antiques, 4506S2 Lorain, Cleveland 2, Ohio.

ELECTROPLATING Kits For Model Makers. \$2.95 Postpaid. Write: Miniplating, Box 161, Middlesboro, Mass.

LIVE Steam Engine Castings Catalog 25c. Ship Models Ltd., Andover, Mass.

64B ELECTRIC TRAINS

LIONEL Trains Big Discounts Bulletin 10c. Catalog 25c. Mack Bros., 2041 Chicago Avenue, Chicago 22.

65 HOME CRAFTSMAN

SKIL-CRAFTS New '62-'63 Catalog. Largest and Finest selection of Leathercraft, Artist, Hobbycraft supplies in the world. Free Gift with first order. Send 50c. Refundable with first order. Skil-Crafts, Box 167-PS, Joplin, Mo.

PICTURE Frame Moldings, Tools and Instruction book. Free Catalog. Chesapeake Frames, 414-PS E. Baltimore St., Baltimore 2, Md.

GRANDFATHER clock movements, case plans, kits. Catalog 25c. Mason-Sullivan, Osterville 2, Mass.

WOODWORKERS — Home Workshop — catalog 132 pages. Save on fine woods, hardware, power tools, 25c. Craftsman, 2719 S. Mary, Chicago 8, Ill.

FREE "Do-It-Yourself" Leathercraft Catalog. Tandy Leather Company, Box 791-E47, Fort Worth, Tex.

FREE. New Catalog. 2447 Plans, Patterns. World's greatest selection things to do, make. Fun. Profit. Craftplans, 18250-B, Harwood, Homewood, Ill.

SAVE: Raw picture frame moulding, all species, all styles. We will miter corners. Bauerle Cabinet Works, Inc., Hammond, Louisiana.

SQUAREKNOTTERS: Make belts, handbags, lanyards, dog leashes, etc. Special offer! Beginner's book, catalog and quality cord samples 25c. P. C. Herwig Co., Dept. 71-P7, 39 Henry St., Brooklyn 1, New York.

101 PATTERNS of smart Gifts, Novelties, Shelves, Action windmills plus "Make Money Jig Sawing." \$1.00. Mastercraft, 25S. 7041 Olcott, Chicago 31.

66 DO IT YOURSELF

BUILD your own Tractor plans. Free information. Eltraco, Dept. B, Camptonville, Calif.

EASILY build heavy duty twin or economy single shop vacuum cleaner. Many parts from your shop. \$1.00 cash, check or money order brings complete, fully illustrated plans for 3 different units. H. Dodge, 1308 S.W. McKinney, College Place, Washington.

GRAVITY Defying Novelty—complete plans \$1.00. Dot Products, Box 127, Oakland, N.J.

"**STEAM** power your car with Boiler, Whistle, Hand Throttle, Turbine Generator." Preliminary plans \$5.00. Hartman's, Fruitland 1, Idaho.

67 OLD GOLD, JEWELRY, WATCHES, ETC.

WANTED, gold, silver, platinum, scrap (any form), coins. Information free. Wilmot's, 1067 Bridge St., Grand Rapids 4, Michigan.

USED and new watches \$2 up. Free Catalogue, Southern Watches, 5-PS So. Wabash, Chicago 3.

HIGHEST Cash for Gold, Teeth, Jewelry, Rings, Diamonds, Watches, Silver, Platinum. Mail Articles Today. Free gift with information. Chicago Gold & Precious Metals, 6 E. Monroe, Dept. 4657, Chicago 3.

CASH Immediately For Old Gold, Jewelry, Gold Teeth, Watches, Diamonds, Silverware, Spectacles, Platinum, Mercury. Free information. Rose Industries, Heyworth Bldg., Chicago 2.

DIAMONDS, Jewelry. Save 1/2. Factory. Compare Anywhere. Hedges, Amityville 187, N. Y.

70 OF INTEREST TO WOMEN

LEARN Expert Cake Decoration, Candy Making. Free Details on Home Instruction Method. Candy & Cake, Dept. D-644, Fallbrook, Calif.

MAKE \$25-\$65 weekly typing at home. Details \$1. Bonco, 130 Cumberland, Mason-town 1, Pa.

HOME Typing for Business Firms! Instructions \$1. Ballingero, 500 So. Hampton, Orlando, Florida.

71 FOR SALE MISCELLANEOUS

POLYETHYLENE disposable gloves, 100 for \$2.95 postpaid. Specify size. Nbars, 9325-R Menard, Oak Lawn, Ill.

72 WANTED TO BUY

QUICKSILVER, platinum, silver, gold. Ores analyzed. Mercury Terminal, Norwood, Massachusetts.

MONEY For Dixie Evans' Burlesque Movies. Novelty, 832, Fontana, California.

OLD Copies of Popular Science wanted —any issue from 1890 to 1915. Condition not too important provided books are complete with no pages removed. Write to Room 521, 355 Lexington Avenue, New York 17, N. Y.

77 TREASURE FINDERS & GEIGER COUNTERS

TRANSISTOR Treasure Detectors, underwater detectors. Many models. Free catalog. Gardiner Electronics Co., Dept. 1, 2545 East Indian School, Phoenix, Arizona.

EXPLORE Underground, years ahead transistor locators detect Gold, Silver, Coins, Relics. Information Free. Curt Fisher, Dept. D, Box 793, Menlo Park, California.

TRANSISTORIZED Treasure Finder! Hi-sensitivity, low oper. cost. Details: Sierra Scientific, 2023E Burbank Blvd., Burbank, California.

TREASURE, Gold, Silver, Relics. Find them with new 1963 models. Free information. Raytron, Box 715, North Hollywood, California.

FUN & Profit finding buried treasure, relics with Transistor M-Scope. Booklet, interesting customer comments Free! Terms. Fisher Research, Dept. DX, Palo Alto, California.

GOLD, Silver, Indicators. Pamphlet Free. Geo. Simpson, 18788 Cajon Blvd., San Bernardino, Calif.

NEW Coin Locator! Free literature. Howe, 811-A Kansas, Atchison, Kansas.

TREASURE Finders—Easy to make electronic kits or assembled models. Underwater models available. Free literature. Electronic Applications, Inc., Dept. S, Box 6095, Alexandria, Virginia.

TREASURE. Find gold, silver, relics with super powerful, Detectron locators. Free information. Detectron, Dept. PS-2, San Gabriel, California.

78 WATCH REPAIRING

WATCH and clock repairing books. Free catalog. North American, 2320-BB Milwaukee, Chicago 47, Illinois.

FREE Watchmaking Course! Details, Wholesale Catalogue 25c. Bengal's, Culver City, California.

WATCHMAKERS' Tools, Materials, Supplies, Watches, Catalog. Gales, Box 1000, Chicago 90, Illinois.

WATCHES Repaired, Cleaned, Guaranteed. Electronically Timed \$3.95. H. White Jewelers, Concord, Tennessee.

79 MISCELLANEOUS

FREE Wholesale Catalog! 100,000 Products . . . Tremendous Discounts! Taylor Distributors, Newton 3, New Jersey.

OVER 100 Lost Treasures and Mines of the United States. Accurately as possible. \$1.00 Claude Mills, Route 3, Jackson, Tennessee.

"**HOME BREWING**" . . . Beers, Wines, Scotches, Champagnes, Liquors, etc. Complete instructions. \$1.00. Harvey's, 1402-PSB, Englewood, Colorado.

LIGHTER Flints! 100 for \$1.00. Flints, Box 701, Harlingen, Texas.

KEEP Your Mail Box Loaded. Get Listed 25c. Frankland Enterprises, P.O. Box 112, Chicago 17, Ill.

SPEAK Instant Spanish. New, streamlined method really works. Free details. Trader May, Box 3488-W, Ridgecrest, Calif.

RECEIVE Mails—Offers. From Wholesalers. Manufacturers, Publishers, Everywhere. Get Listed, 25c. Rorick's, Cincinnati 26, Ohio.

MAKE Wines—Cordials—Syrups. Delicious Beverages. Full Instructions, Trade Secrets, \$1.00. Rorick's, Cincinnati 26, Ohio.

HOLLAND Imports. Illustrated list, 25c. Melco, Box 69, Edwardsville, Ill.

DISGUISED Hypnosis. Fascinating, revealing methods, unconditionally guaranteed. See ad on page 45.

RECEIVE worldwide mails. Lifetime 25c. Beacon, Box 71-A, Astoria, Oregon.

BEERS, Wines. Best, Most Powerful. Easy instructions \$1. Krause, 930 Rogers, Bucyrus, Ohio.

B.B. SHOT, fascinating pocket size invention. See ad on page 40.

80 PERSONAL

LOANS by mail, \$100-\$600. Anywhere. Confidential. Write Union Finance, Dept. PS, 323 E. Camelback, Phoenix, Arizona.

"**RULE** Others with your Thoughts." Telepathy. (Adults.) Write: Clarion, Box 9309-S6, Chicago 90.

INDEPENDENT Thinkers — investigate Humanism, the scientific, personal philosophy! Free literature. American Humanist Association, Dept. PSM2, Yellow Springs, Ohio.

FOUR "Will" Forms and "Instruction Booklet by Lawyer." \$1.00. National, Box 48313-PS, Los Angeles 48, California.

"**STAMMER**—Stutter—No More." (Dr. Young.) Write: Gaucho, Box 9309-S6, Chicago 90.

RUPTURED. Relief and Comfort. No Understraps, Elastic or Steel. Write Hand Lock Products, Preston 2, Ontario, Canada.

FREE—one handwriting analysis, revealing positive qualities, faults impeding progress, when paying for detailed analysis \$10.00; general report \$5.00 or brief \$1.00. Write Norma Buser, 211 Park Street, Roselle, New Jersey.

SUPER memory overnight! Success guaranteed! Bijou, Box 1727-V, Hollywood 28, Calif.

"**WHO, ME?**" Yes, You! "How To Wake Up Life-Changing Winning Ability" sent you free. Write: President, Box 1924-O, Louisville 1, Ky.

MEXICAN Law Practice. 1203 Arizona Ave., El Paso, Texas.

80A REMAILING SERVICE

HAWAII Secret Address. Receiving-Forwarding 25c, \$3.00 Monthly. Postcards. Coe, 44-143A Bayview Haven, Kaneohe, Hawaii.

MIAMI Beach remails 25c; 5 for \$1.00. Monthly \$3.00. National, P.O. Box 266-B, Miami Beach 39, Florida.

CONFIDENTIAL Mail Address, 25c remails, West, 2617-SC Armacost, Los Angeles 64, California.

BRANCH office. Mail forwarded, re-mailed. Details. Allen, 216-S West Jackson, Chicago 6.

SECRET Mail Receiving-Forwarding System. Hedgpeh, Box 830, Alhambra 24, Calif.

ARIZONA Remails. Single 25c. Monthly \$3.00. Dick. P.O. Box 8104, Phoenix, Ariz.

MAKE Miami Your Address. Box 3053, Norland Br., Miami 69, Florida.

MEXICO Remails: Three For Dollar. Suarez, Box 2104, Mexico City, Mexico.

SECRET—Address—Personal—Business—Write: De Graff, Box 14-156S, San Diego, California.

80B LOANS BY MAIL

LOANS By Air Mail, \$100 to \$600. Anywhere. Confidential. Write Security Finance Co., 898 Van Ness Avenue, Dept. PS, San Francisco 9, California.

BORROW \$100 to \$1000 by Mail. Quick, Easy, Private. No Co-signers. Repay in 24 small monthly payments. For the amount you want write today to Dial Finance Co., 410 Kilpatrick Bldg., Dept. 2-215, Omaha 2, Nebraska.

NEED Money? Borrow \$100—\$1000 by mail. Confidential. repay in 24 months. Free loan application. Budget Finance Co., Dept. BB-313, 114 S. 17th, Omaha 2, Nebraska.

BORROW \$1,000 AIRMAIL! Repay \$44.82 for twenty-nine months. State licensed. Postal Finance, Dept. 11-E, Kansas City 1, Kansas.

ARTHUR GODFREY SAYS: "I.C.S. MADE THE IMPOSSIBLE-EASY!"



You've probably heard Arthur Godfrey on his coast-to-coast TV and radio programs. But have you ever heard what this famous personality has to say on the subject of International Correspondence Schools?

"I had to quit high school before the end of my second year. Later in life, at the U. S. Naval Materiel School at Bellevue, D. C., I had to master a working knowledge of math, all the way from simple decimals and fractions through trigonometry, in the first six weeks or be dropped from the course. So I took an I.C.S. course and finished at the head of the class! I.C.S. made the impossible - easy!"

As usual, Arthur Godfrey knows what he's talking about. And as an I.C.S. graduate, Mr. Godfrey is in the best of all positions to tell you about the educational system for men and women that's served so long as talent scout for American business and industry.

Read what he has to say carefully. Then mark your interest on the coupon and mail it today for full information on what I.C.S. can do for you!

Clip coupon here—and take your first big step to real success!

I.C.S., Scranton 15, Penna.

Fully Accredited Member
National Home Study Council

INTERNATIONAL CORRESPONDENCE SCHOOLS **I C S**

Box F4751B, Scranton 15, Penna.

(In Hawaii: P. O. Box 418, Honolulu. In Canada: I. C. S. Canadian, Ltd., Montreal.)

Without cost or obligation, rush me FREE Success Kit, with 3 valuable booklets: (1) How to Succeed; (2) opportunity booklet about the field I've checked below; (3) Sample I. C. S. Lesson.

ARCHITECTURE and BUILDING TRADES

- Air Conditioning
- Architecture
- Arch. Drawing
- Building Contracting and Estimating
- Carpentry & Millwork
- Heating
- House Planning
- Painting
- Plumbing

ART and DESIGN

- Commercial Art
- Fashion Illustrating
- Interior Decorating
- Magazine Illustrating
- Show Card & Sign Painting
- Sketching and Painting

AUTOMOTIVE

- Auto Body Rebuilding
- Auto Electric Technician
- Automobile Mechanic
- Engine (Gas & Diesel)
- Engine Tune-Up

- Transmission Specialist

AVIATION

- Aero Engineering
- Aircraft Drafting
- Aircraft Mechanic

BUSINESS

- Accounting
- Cost Accounting
- Public Accounting
- Bus. Administration
- Executive Training
- Marketing
- Personnel-Labor Relations

CHEMICAL

- Programming for Digital Computers
- Purchasing Agent
- Real Estate
- Salesmanship
- Sales Mgmt.
- Small Business Mgmt.
- Traffic Mgmt.
- Analytical Chemistry
- Chem. Engineering
- General Chemistry

- Lab. Technician
- Nuclear Energy
- Plastics
- Pulp. Paper

CIVIL ENGINEERING

- Civil Engineering
- Construction Engrg.
- Highway Engineering
- Reading Structural Blueprints
- Sanitary Engineering
- Structural Engineering
- Surveying & Mapping

DRAFTING

- Architectural
- Electrical and Electronic
- Mechanical
- Sheet Metal

ELECTRICAL

- Elec. Appliance Servicing
- Electrical Engineering
- Elec. Eng. Technician
- Elec. Motor Repairman
- Industrial Electronic Technician

- Industrial Telemetering
- Instrument Technician
- Practical Electrician
- Practical Lineman

ELECTRONICS

- Automation
- Basic Electronics
- Electronic Computers
- Electronics Technician
- Hi-Fi Stereo and Sound Systems
- Industrial Electronics
- Ultrasonics

ENGINEERING (Professional)

- Chemical
- Civil
- Electrical
- Mechanical

ENGLISH and WRITING

- Better Business Writing
- Introductory Technical Writing
- Short Story Writing

Practical English

HIGH SCHOOL (Diploma)

- High School General
- High School Math
- High School Secretarial
- High School Vocational
- College Preparatory

MECHANICAL and SHOP

- Gas and Electric Welding
- Industrial Engineering
- Industrial Instrumentation
- Machine Design
- Machine Shop Practice
- Mechanical Engineering
- Reading Shop Blueprints
- Tool Design
- Toolmaking
- Safety Engineering

SECRETARIAL

- Clerk-Typist
- Professional Secretary

- Shorthand
- Stenographic
- Typist

STEAM and DIESEL POWER

- Boiler Inspector
- Power Plant Engineering
- Stationary Diesel Engineering
- Steam Engineering

SUPERVISION

- Foremanship—Suprv'n
- Personnel—Lab. Rel'n's

TV-RADIO

- Radio and TV Servicing
- Radio-Telephone License
- TV Technician
- Practical Radio-TV Engineering

MISCELLANEOUS

- Railroad
- Textile
- Other (please specify)

Name _____ Age _____ Sex _____

Home Address _____

City _____ Zone _____ State _____

Occupation _____

Employed by _____ Working Hours _____

Special low rates to members of U. S. Armed Forces!

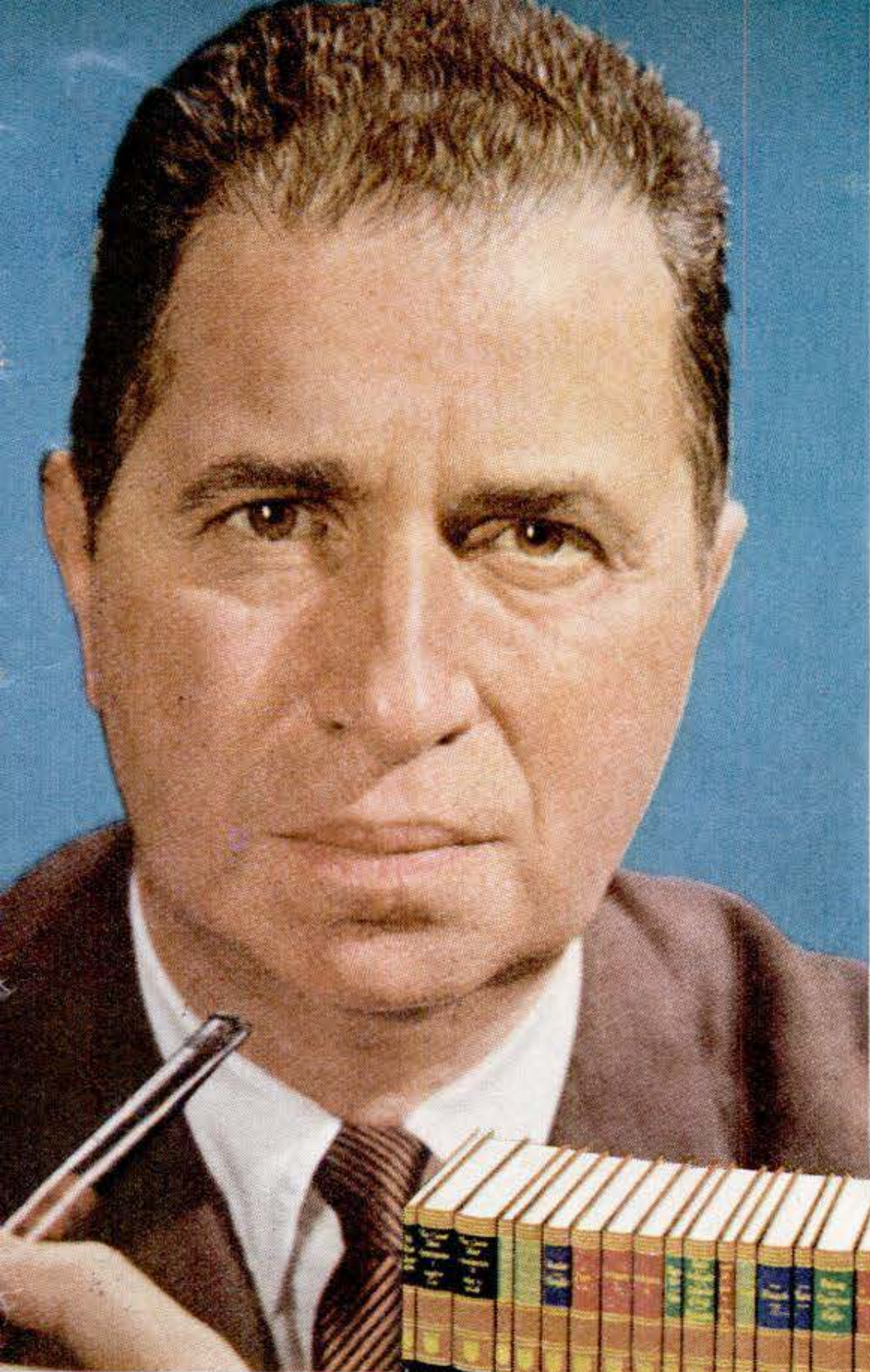

A college education does not make an educated man

A message from **Dr. Mortimer J. Adler**
Director of the Institute for Philosophical Research
Editor of the SYNTOPICON

"The ultimate end of education is not just to learn to be an engineer, a lawyer, a doctor, or a scientist. Those are skills—like any others—which help you earn a living and render a useful service to society. But knowledge of any one particular subject is not necessarily evidence of an educated man.

"Education is the sum total of one's experience, and the purpose of higher education is to widen our experience beyond the circumscribed existence of our own daily lives. Most people have only begun their education when they finish school, and after school the steady pressure of a job narrows rather than expands their experience.

"That is why the Private Library Edition of the GREAT BOOKS described below was published—to give every thinking person, no matter what his degree of formal education, the opportunity to become a really educated man. Through this Private Library Edition of the GREAT BOOKS you can acquire for yourself the total experience of the whole human race. With that experience, you will then be far better equipped to face life and love it—to meet its challenges and problems with courage, confidence, and intelligence."

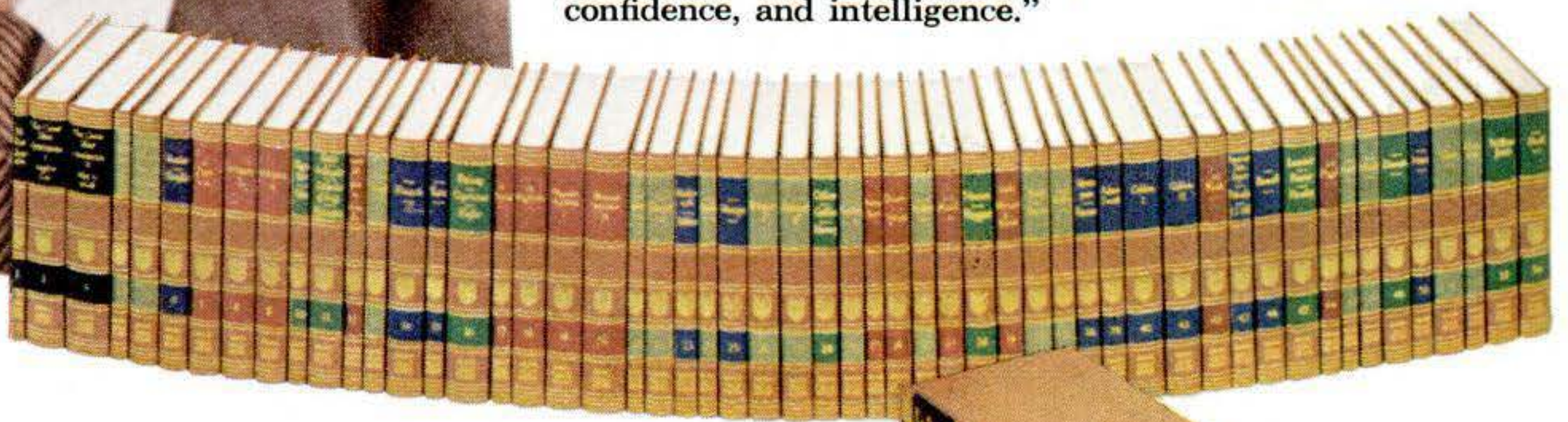

Essential in the library of every thinking person

GREAT BOOKS OF THE WESTERN WORLD

Published by the
Encyclopaedia
Britannica in
collaboration with the
University of Chicago

Now available direct from the publisher with great new **SYNTOPICON**

VERY few people have either the time or money to return to school, and to embark on a program of self-education without a "teacher" is both unrewarding and unproductive. Guidance, interpretation, discussion are necessary to help you relate the total experience of the whole human race to the problems of today. That is why this Private Library Edition of the GREAT BOOKS OF THE WESTERN WORLD was published.

The key to its enormous educational value is the "teacher" it provides—the amazing SYNTOPICON pictured above. The SYNTOPICON is a new concept in self-education. It is the product of 400,000 man-hours of research by 100 scholars over a period of eight years. It is quite literally a great "teacher" living in your home... always at your

disposal to interpret the GREAT BOOKS to you.

As you begin to absorb and understand the great ideas by which man has survived and progressed, you will begin to reflect their greatness in your own ability to think, speak, and act with a new and impressive maturity. You will have sounder judgment on political and economic issues, as the great minds who conceived and contributed law and justice make the whole idea of government clear to you. You will develop a sounder philosophy of life as the accumulated experience of the race becomes your experience through the great minds of the ages.

You will not be limited in your business progress by your own narrow specialty, but will be prepared to handle the daily problems of top

level management which call for broad general thinking rather than limited technical knowledge.

Even in your own personal life, the experience of mankind through century on century can guide you to the decisions and actions which have eternally resulted in the greatest success and contentment.

Don't miss this opportunity to learn all the details of this handsome Private Library Edition of the GREAT BOOKS. Please fill in and mail the postage-free reply card for a free descriptive booklet. It will explain how you can find new understanding of yourself and the world through the great ideas which have engrossed men since the written record of man began. It is in this way that one acquires an education. It is in this way that one acquires wisdom.

Tastes Great

because
the
tobaccos
are!

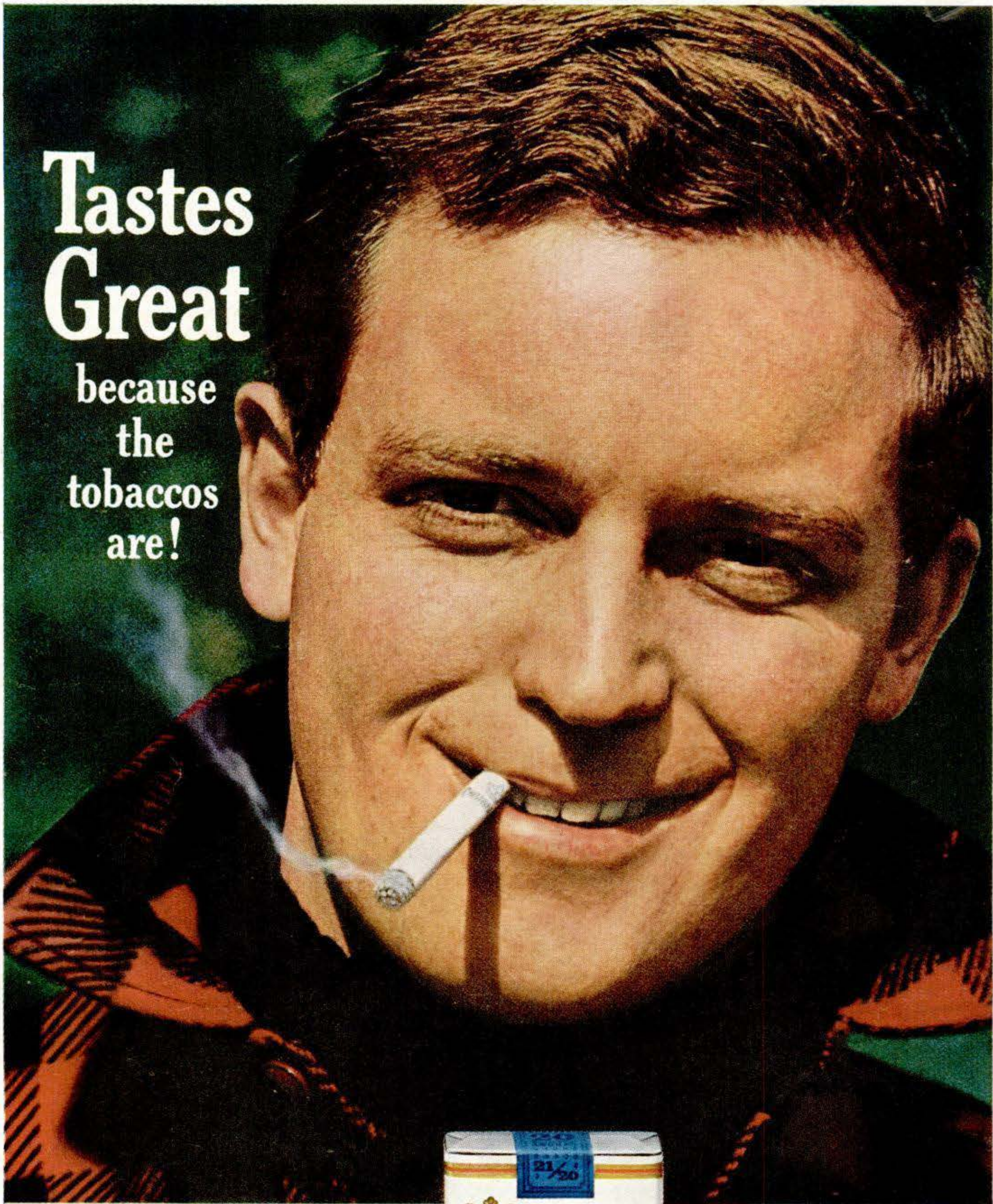

**21 Great Tobaccos make
20 Wonderful Smokes!**

CHESTERFIELD KING tastes great, smokes mild. You get 21 vintage tobaccos grown mild, aged mild and blended mild, and made to taste even milder through its longer length.

CHESTERFIELD KING

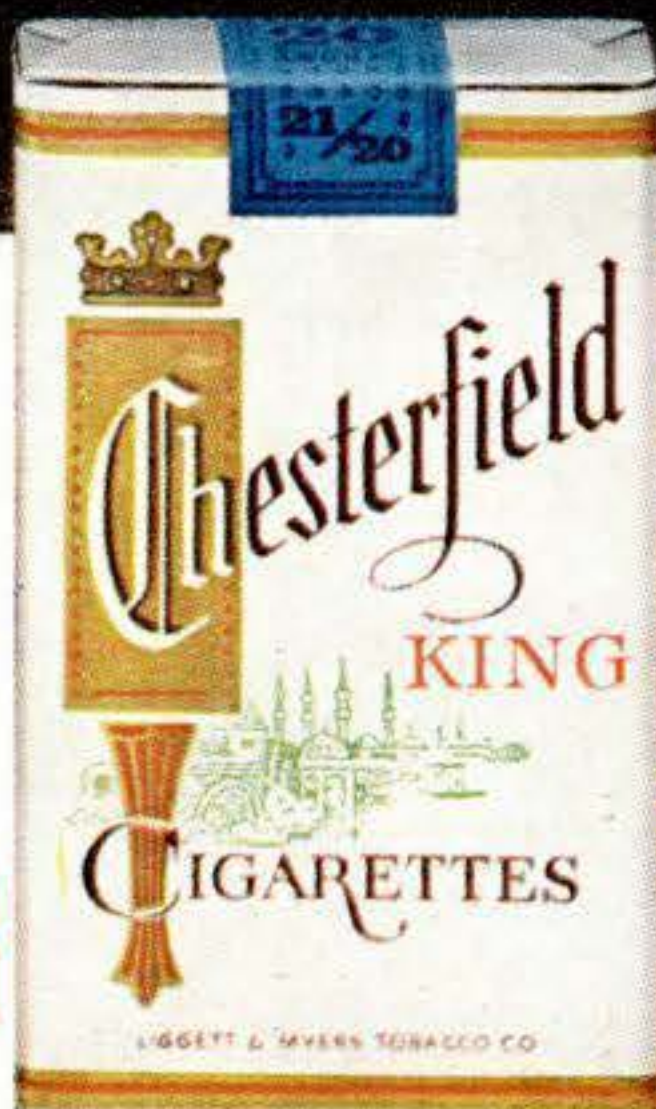

LONGER LENGTH means milder taste

The smoke of a Chesterfield King mellows and softens as it flows through longer length.