

APRIL 1963 35 CENTS

# Popular Science

Short-Cut Math  
on a Carpenter's  
Square

TV in Bed?  
How to build a receiver  
only you can hear

Monthly

## Slow Drivers Can Kill You!

A startling new  
report by  
Columbia University

## New Sideways Jets for Easy-Does-It Docking



**ECONOMY  
ACCELERATION  
BRAKES**

**How '63 Cars Scored in  
World's Best-Policed Auto Tests**

**Wernher von Braun  
Answers Your Questions  
About Inertial Guidance**





# POWER TOOLS

help you breeze through the toughest jobs



Building a bookcase . . . refinishing a table . . . adding a room . . . whatever the job or material, it goes faster, easier and ends up neater when the right Ram Power Tool is nearby and ready to help.

Ram Tools are built to keep up with the heavy demands of the professional. And, the home handyman finds them as easy to use as they are to own. (So does the guy who doesn't think he can do a job till he sees the estimate).

Now's a good time to buy your first Ram Tool — or pick out your second. You'll be surprised what you can do with it.

- A** SABRE SAW Does 8 different jobs
- B** 1/4" DRILL Most popular power tool
- C** 3/8" DRILL A real workhorse
- D** 1/2" DRILL For those BIG drilling jobs
- E** 7" POWER SAW Handles the toughest jobs
- F** POLISHER Sands, buffs and polishes
- G** HEDGE TRIMMER Lightweight, perfect balance
- H** SANDER 2-way; straight or orbital
- J** BENCH GRINDER Powerful, dependable, safe



LOOK FOR RAM wherever power tools are sold. Or write for catalog and dealer's name.

## TOOL CORP.

411 N. Claremont Avenue  
Chicago 12, Illinois



From the "heart" (motor) out, Ram makes every part for every tool. Full 1 year factory guarantee.





## Yes, outwears...Yes, any other!

Super Hi-Miler keeps rolling, when other truck tires are pushing up daisies!

The new Super Hi-Miler by Goodyear outwears any other all-wheel, any-position, standard-level truck tire made. And here's why:

Its extra-broad tread reduces rate-of-wear by spreading out the wear. There are no small segments to squirm and scuff away mileage. And, it's "dual-compounded"—an outer tread for maximum wear, a resilient inner tread to reduce heat buildup!

Best of all, the Super Hi-Miler is built with TUF SYN . . . toughest, longest-wearing rubber in our history!

But let this revolutionary tire prove itself to *you*. See your Goodyear Dealer or Goodyear Service Store; specify the Super Hi-Miler on your next equipment order. Goodyear, Akron 16, Ohio.

**Another reason why: more tons are hauled on Goodyear truck tires than on any other kind.**

**GOODYEAR**

Hi-Miler, Tufsyn—T. M.'s The Goodyear Tire & Rubber Company, Akron, Ohio



# Next Month in Popular Science

- **Vacationing on Wheels.** Big special section tells you how to beat the problems of camping with a car, gives details on camping rigs you can buy, build, or rent.
- **Testing the Hot Compacts.** PS turns its auto experts loose on the hottest compacts to see how they compare.
- **Inventing Is Easier Than Ever.** How new materials and devices can help you turn ideas into money.
- **Jim Roe Tests the Lone Star Cruise Liner II.** PS's fast-traveling boating editor tries out a new outboard on Mobile Bay.

.....

E. S. DUFFIELD, President

JOHN R. WHITING, Executive Vice-President and Publisher

EUGENE WATSON, Vice-President, Circulation

CHARLES S. THORN, Vice-President, Advertising

EDITORIAL OFFICES: 355 Lexington Ave., New York 17, N. Y.

PUBLISHED MONTHLY by Popular Science Publishing Co., Inc., 355 Lexington Ave., New York 17, N. Y.

**SUBSCRIPTION SERVICE.** *New or renewal orders:* Send to Popular Science Subscription Department, Boulder, Colo. One year \$4, 2 years \$7, 3 years \$9 in U.S., its possessions, and Canada. Elsewhere, 1 year \$6.50, 2 years \$12, 3 years \$17. Single copy 35¢. *Subscription orders processed electronically.* ● *All subscription adjustments:* Write to Robert Harlan, Popular Science, P.O. Box 1083, Boulder, Colo. For change of address allow four weeks; please give both old and new addresses. Notices of undelivered copies (Form 3579) to Mr. Harlan. ● Second class postage paid at New York, N.Y., and at additional mailing offices. Entered as second class matter at the Post Office Department, Canada. Printed in U.S.A. ● **ADVERTISING OFFICES.** NEW YORK: 355 Lexington Ave.; CHICAGO: 360 N. Michigan Ave.; DETROIT: 2810 Book Bldg.; SAN FRANCISCO: 703 Market St.; CLEVELAND: 1220 Huron Road; LOS ANGELES: 1709 W. Eighth St.; PORTLAND, ORE.: 520 S.W. Sixth Ave.; DENVER: 333 W. Colfax Ave.; SEATTLE: 101 Jones Bldg.

Copyright © 1963 by Popular Science Publishing Co., Inc. All rights reserved

GM CARS  
AND GENUINE  
GM PARTS  
ARE MADE  
FOR EACH  
OTHER!

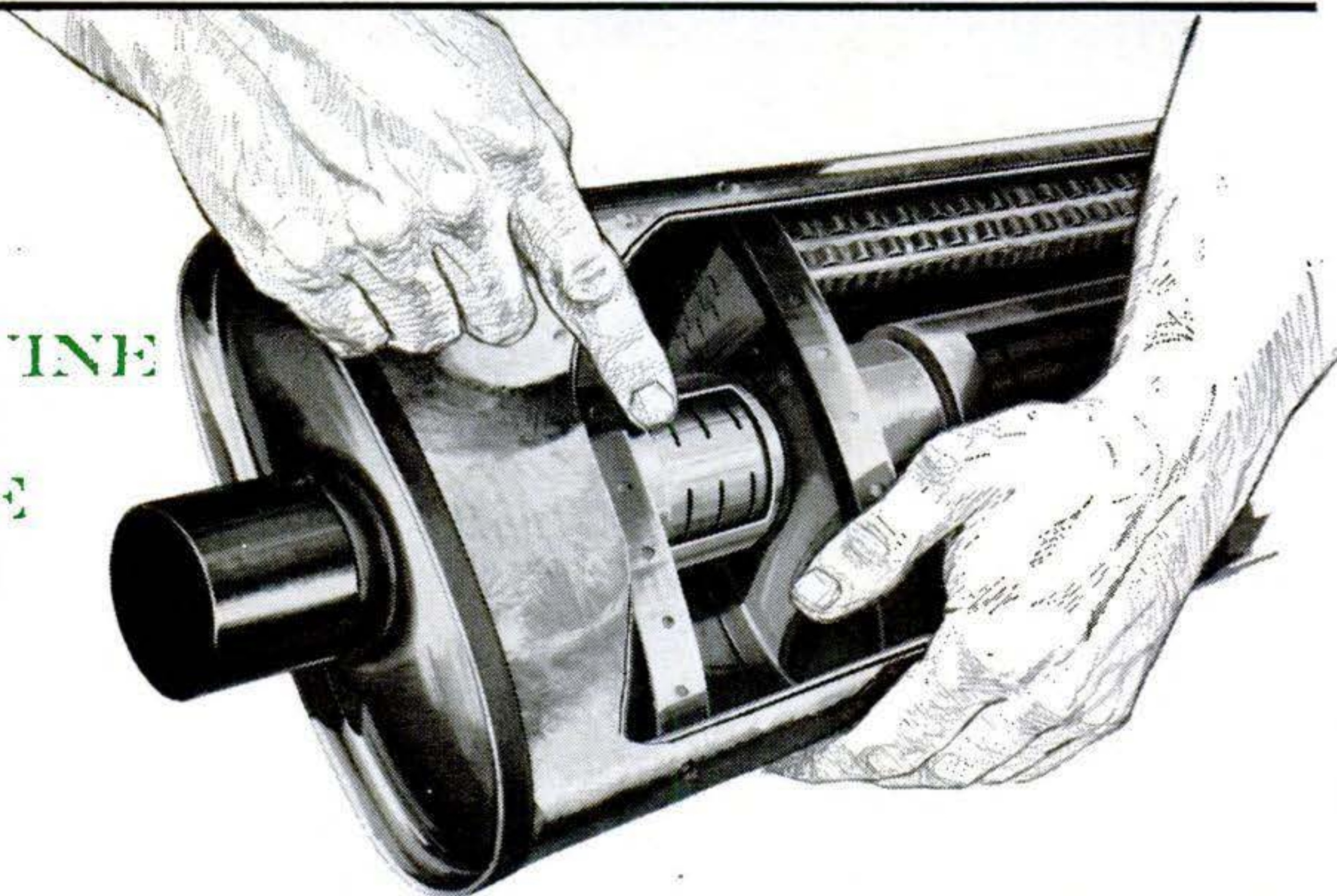

This all-welded GM muffler contains specially engineered, separately tuned resonance chambers to suppress vibrations, minimize back pressure, give your car maximum engine efficiency. See your GM dealer for genuine GM parts—built and installed to save you money.

SEE YOUR **GM** QUALITY  
DEALER FOR THE BEST  
KIND OF SERVICE



**GUARDIAN  
MAINTENANCE**

CHEVROLET • PONTIAC • OLDSMOBILE • BUICK • CADILLAC • GMC TRUCK



# How to **CRACK** the education barrier



Is there an "education barrier" between you and promotion? Are young college graduates being brought in to fill positions above you?

You can break down that barrier . . . gain real security, responsibility, prestige . . . *surprise fellow employees and win their respect.* You can match yourself against the smartest of the college boys and come out a WINNER. Here's how!

## AN HOUR A DAY THE I.C.S. WAY!

If you can spare an hour a day, if you have the determination to make good, if you're willing to invest pennies now for dollars later on—then I.C.S. can help you. You can be a man or woman, young or old, skilled or unskilled. So long as you

can understand simple language and illustrated training manuals, you need have no doubts. The I.C.S. hour-a-day plan is SUCCESS-PROVED. You learn while you earn—anywhere, any time.

### Just pick the subject you want!

Only I.C.S. offers you such a wide range of subjects to choose from. Drafting. Engineering. Television. Aeronautics. Business. High School. 249 courses in all. *I.C.S. is the oldest, largest home-study school. It is also the best known in business and industry.*

### Free catalog plus free booklets!

When you mail the coupon below, you get a complete booklet on the subject you check with information about employment opportunities, training requirements, etc. And you get "How to Succeed"—36 pages of valuable tips on winning recognition, pay raises, success. Also, a free sample lesson in basic mathematics.

Clip coupon here—and take your first big step to real success! I.C.S., Scranton 15, Penna.

Accredited Member  
National Home Study Council

## INTERNATIONAL CORRESPONDENCE SCHOOLS **I C S**

Box F2751D, Scranton 15, Penna.

(In Hawaii: P. O. Box 418, Honolulu. In Canada: I.C.S. Canadian, Ltd., Montreal.)

Without cost or obligation, rush me FREE Success Kit, with 3 valuable booklets: (1) How to Succeed; (2) opportunity booklet about the field I've checked below; (3) Sample I.C.S. Lesson.

### ARCHITECTURE and BUILDING TRADES

- Air Conditioning
- Architecture
- Arch. Drawing
- Building Contracting and Estimating
- Carpentry & Millwork
- Heating
- House Planning
- Painting
- Plumbing

### ART and DESIGN

- Commercial Art
- Fashion Illustrating
- Interior Decorating
- Magazine Illustrating
- Show Card & Sign Painting
- Sketching and Painting

### AUTOMOTIVE

- Auto Body Rebuilding
- Auto Electric Technician
- Automobile Mechanic
- Engine (Gas & Diesel)
- Engine Tune-Up

- Transmission Specialist

### AVIATION

- Aero Engineering
- Aircraft Drafting
- Aircraft Mechanic

### BUSINESS

- Accounting
- Cost Accounting
- Public Accounting
- Bus. Administration
- Executive Training
- Marketing
- Personnel-Labor Relations
- Programming for Digital Computers
- Purchasing Agent
- Real Estate
- Salesmanship
- Sales Mgmt.
- Small Business Mgmt.
- Traffic Mgmt.

### CHEMICAL

- Analytical Chemistry
- Chem. Engineering
- General Chemistry

- Lab. Technician
- Nuclear Energy
- Plastics
- Pulp, Paper

### CIVIL ENGINEERING

- Civil Engineering
- Construction Engrg.
- Highway Engineering
- Reading Structural Blueprints
- Sanitary Engineering
- Structural Engineering
- Surveying & Mapping

### DRAFTING

- Architectural
- Electrical and Electronic
- Mechanical
- Sheet Metal

### ELECTRICAL

- Elec. Appliance Servicing
- Electrical Engineering
- Elec. Eng. Technician
- Elec. Motor Repairman
- Industrial Electronic Technician

- Industrial Telemetering
- Instrument Technician
- Practical Electrician
- Practical Lineman

### ELECTRONICS

- Automation
- Basic Electronics
- Electronic Computers
- Electronics Technician
- Hi-Fi Stereo and Sound Systems
- Industrial Electronics
- Ultrasonics

### ENGINEERING (Professional)

- Chemical
- Civil
- Electrical
- Mechanical

### ENGLISH and WRITING

- Better Business Writing
- Introductory Technical Writing
- Short Story Writing

- Practical English

### HIGH SCHOOL (Diploma)

- High School General
- High School Math
- High School Secretarial
- High School Vocational
- College Preparatory

### MECHANICAL and SHOP

- Gas and Electric Welding
- Industrial Engineering
- Industrial Instrumentation
- Machine Design
- Machine Shop Practice
- Mechanical Engineering
- Reading Shop Blueprints
- Tool Design
- Toolmaking
- Safety Engineering

### SECRETARIAL

- Clerk-Typist
- Professional Secretary

- Shorthand
- Stenographic
- Typist

### STEAM and DIESEL POWER

- Boiler Inspector
- Power Plant Engineering
- Stationary Diesel Engineering
- Steam Engineering

### SUPERVISION

- Foremanship—Suprv'n
- Personnel—Lab. Rel'n's

### TV-RADIO

- Radio and TV Servicing
- Radio-Telephone License
- TV Technician
- Practical Radio-TV Engineering

### MISCELLANEOUS

- Railroad
- Textile
- Other (please specify)

Name \_\_\_\_\_ Age \_\_\_\_\_ Sex \_\_\_\_\_

Home Address \_\_\_\_\_

City \_\_\_\_\_ Zone \_\_\_\_\_ State \_\_\_\_\_

Occupation \_\_\_\_\_

Employed by \_\_\_\_\_ Working Hours \_\_\_\_\_

Special low rates to members of U. S. Armed Forces!



Robert P. Crossley  
Editor

JAMES M. LISTON  
Executive Editor

KENDALL W. GOODWYN  
Managing Editor

ROBERT P. STEVENSON  
Director, Products and Projects

HOWARD JENSEN  
Art Director

**Senior Editors**

Alden P. Armagnac, Wallace Cloud  
Everett H. Ortner, Joan Steen

**Automobile Editor**  
Devon Francis

**Electronics and Technical Editor**  
Hubert Luckett

**Home Workshop Editor**  
Sheldon M. Gallager

**Photography Editor**  
Robert L. Hering

**Boating Editor**  
Jim Roe

**West Coast Editor**  
Wesley S. Griswold

**European Editor**  
David Scott

**Associate Editors**  
Frank Dorr, Herbert O. Johansen  
Alex Markovich  
Ruth Westphal

**Editorial Assistants**  
Eleanor Crapullo (Chief)  
Jeanne Cox, Anna Dallas  
Barbara Weisheit

**Art Editors**

Herbert Anthony  
Harry Samuels

**Associate Art Editor**  
Richard J. Meyer

**Art Associates**  
Robert Martin, Kenneth Buddington

**Art Production Manager**  
Henry W. Kazmirowski

**Photography**  
Robert D. Borst

JOHN R. WHITING, Executive Vice-President and Publisher

April 1963

Cover painting by John McDermott

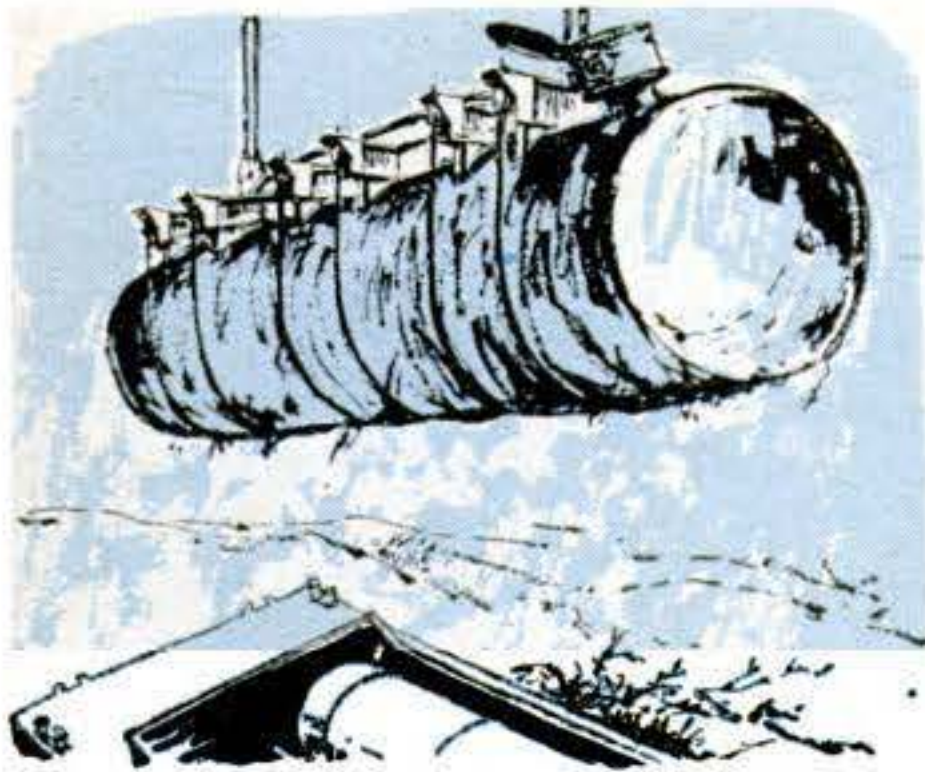

On the river bottom, divers raced against death. Page 124.



How does an astronaut tighten a nut out in space? Page 112.

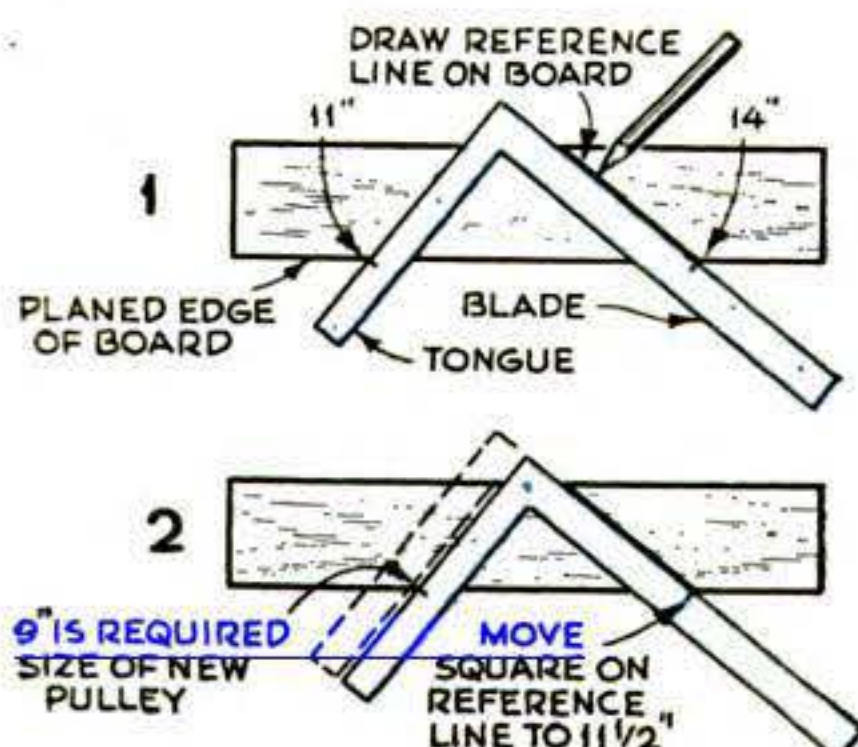

Shop math with a carpenter's square? Easy as  $\pi$ . Page 132.

## SPACE AND AVIATION

[Wernher von Braun: Inertial Guidance • 18](#)

[Van Allen Tells What Space Is Like • 73](#)

[Flying Without a Navigator • 86](#)

[Wing "Breathes" to Boost Range • 96](#)

[Lunar Housing for Early Arrivals • 108](#)

[A Spin in a Weightless Workshop • 112](#)

[Learning to Rendezvous in Orbit • 117](#)

## CARS AND DRIVING

[The Most Revealing Car Tests Yet • 67](#)

[Slow Drivers Can Kill You! • 77](#)

[The '63 Cars: Better in 36 Ways • 90](#)

[Way-Out Rods and Customs • 102](#)

[Bluebird Bids Again for Record • 118](#)

## SCIENCE AND INVENTIONS

[Amazing Marina City • 82](#)

[Lightweight Liner—the Canberra • 94](#)

[Can Your Writing Give You Away? • 104](#)

[Tell It to Sceptron! • 120](#)

## SPECIAL REPORTS

[Frogmen Fight Fires Under Water • 80](#)

[How Metal Detectors Spot Treasure • 99](#)

[Should You Try for a Better Job? • 110](#)

[Time Bombs in the Mississippi • 124](#)

Contents *continued on page 6*





## ***now the 1963 Tempest has Wide-Track!!***

***(when you're through cheering, go see your dealer)***

***What calms jumpy roads like Wide-Track? What makes for stability like Wide-Track? Nothing. That's why we widened Tempest's track this year, to go along with its front engine-rear transmission setup. That gives us a car with road-soothing balance all 'round. The dealer to see is your Pontiac dealer. Feel free to finish cheering, if you can wait.***

***Wide-Track Tempest***  
Pontiac Motor Division • General Motors Corporation



## HOME IMPROVEMENT: SPECIAL SECTION

- Instant Paving: Lay It and Use It • 165
- A Bolt-Together Steel Pool • 166
- Infrared—for Cracked Asphalt • 168
- Patio Room Has Roll-Up Windows • 171
- Instant-Setting Cement • 172
- A Garden House You Can Build • 173
- What's New for Your Garden • 174

## THE HOME WORKSHOP

- Workshop Math with a Square • 132
- Shop Talk • 139
- Disston's Dial-A-Power Drill • 153
- Between Us Machinists • 156

## BOATS AND BOATING

- A Jet Boat That Goes Sideways! • 114
- Building Gas Tanks Into Your Boat • 136

## ELECTRONICS

- All's Quiet on the TV Front • 140

## PHOTOGRAPHY

- Move In Close • 146
- Photographically Speaking • 177
- What's New in Photography • 179

## AUTO REPAIRS

- Spring Car Care • 158
- Hints from the Model Garage • 180
- Gus Matches Wits with a Miser • 184

## PICTURE NEWS

- Plug-in Vest Heats from Dashboard • 89
- Reds Ride on Air Cushions, Too • 98
- Wankel Engine Pushes New Boats • 109
- Minicar Takes On an Extra Engine • 117

## SHORT CUTS AND TIPS

- How to Cut Without Scribing • 131
- Fan in Helmet Keeps Welder Cool • 138
- Fast Way to Burn Out Stumps • 145
- Strips and Disks Make Airy Lamp • 151
- Compressor or Welder Carriage • 152

## EVERY MONTH

- PS Readers Talk Back • 6
- Science Newsfront • 29
- Getting Ahead • 36
- Detroit Report • 62
- 90, 60, and 30 Years Ago in PS • 64
- I'd Like to See Them Make • 93
- New Ideas from the Inventors • 122

# PS readers talk back

## He's Way Out There—in Space

Congratulations on Dr. Wernher von Braun's column. I bought the January issue on the strength of the cover announcement and found his article extremely interesting and most lucid. I look forward to more.

JAMES MARLIN, Nashville, Tenn.

## Of Spies and Saviors

I thought "Should You Tell on the Other Driver?" [Jan.] was excellent. About a year ago while driving over a toll bridge, the car ahead of us started weaving. The car hit the right side of the bridge so hard that sparks came from the hubcaps. Ours was the only other car on the bridge. When we arrived at the toll station we were quite shaken, and I told the guard on duty. The driver of the weaving car pulled up only two lanes away, but the guard insisted that unless I made charges he could not or would not stop him. Nor did he contact a State Police car to be on the alert.

With four small children in our car, we felt we could not risk being detained. But I have since decided that it is better to stop and press charges against a driver obviously unfit to drive. Who knows whose life will be saved?

MRS. F. MEYER, Southington, Conn.

... I was surprised to find PS promoting a police state in this country. Are we not har-



assed enough by highway stormtroopers at every turn of the wheel? Let's not turn our citizens into spies.

C. O. PRESCOTT, LaGrange, Ill.

... I was the author of the plan for highway observers in Connecticut. Unfortunately, the mention of police gave many people the impression of a highway Gestapo. Actually, the card notification could have been handled other than by the police. The plan was never designed to deal with "highway criminals," but to edu-



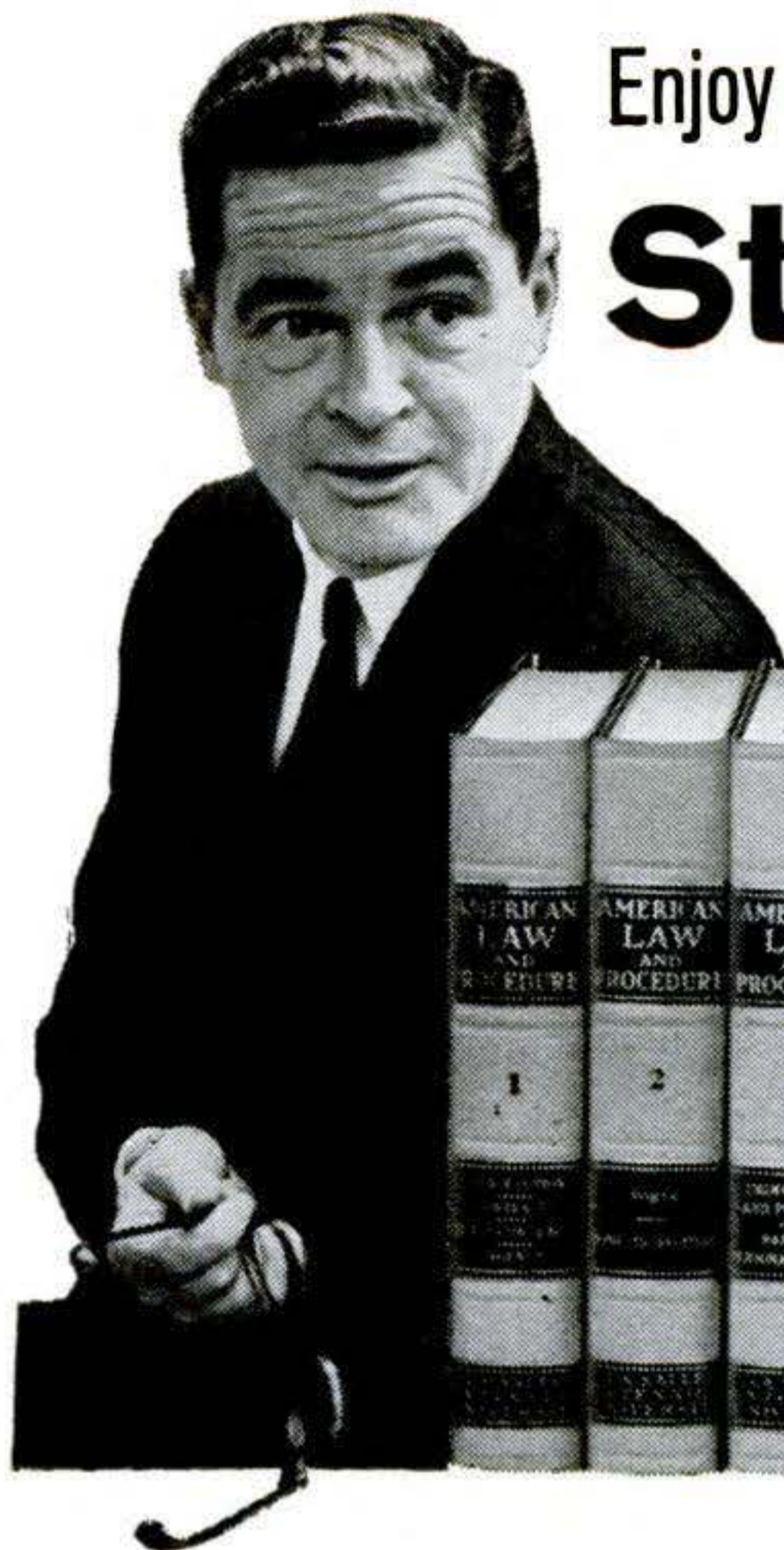

# Enjoy the rewards offered Law-trained men in business

# Study LAW at home

EARN AN LL.B. DEGREE FROM LA SALLE

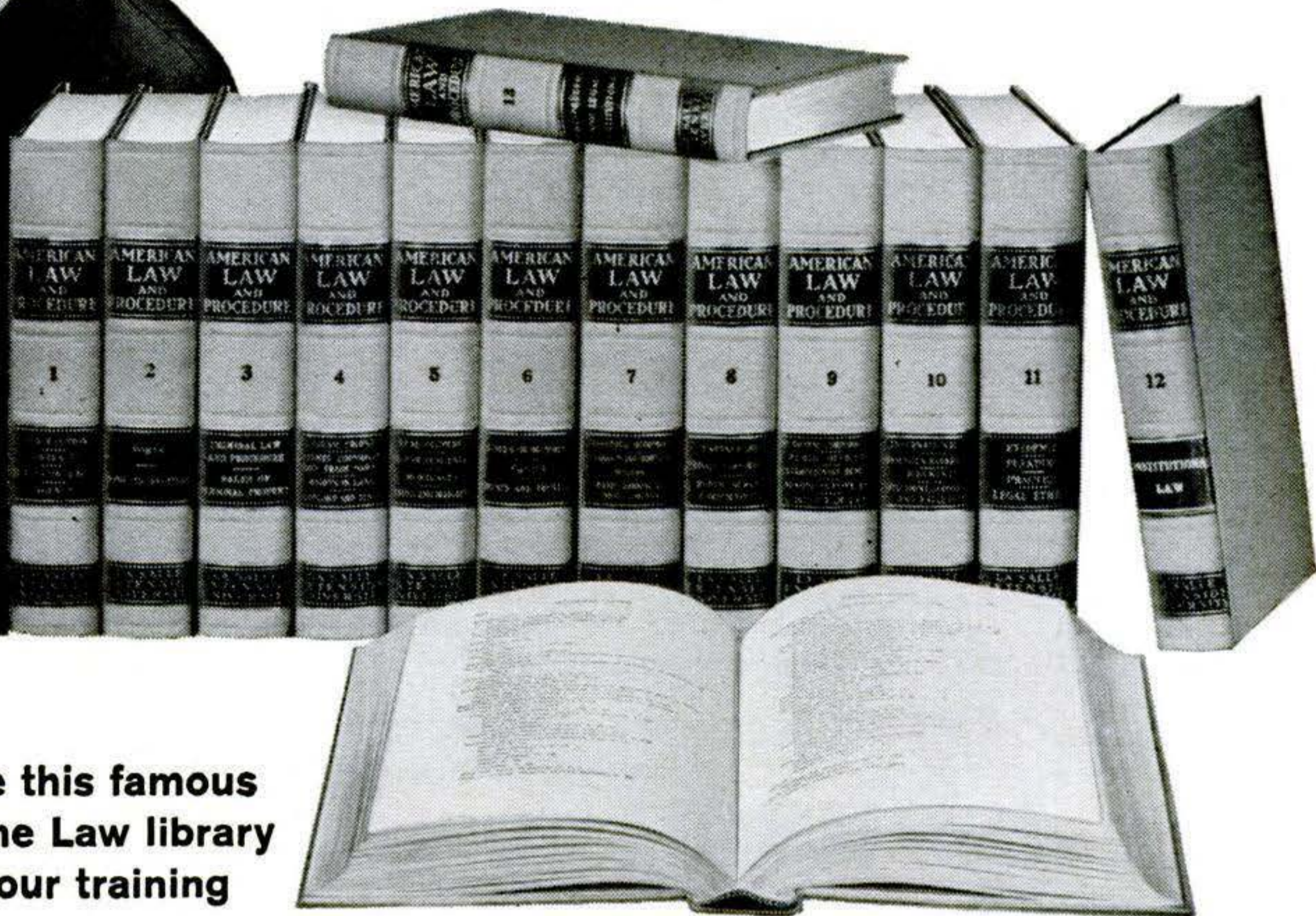

Receive this famous  
14-volume Law library  
with your training

**W**HATEVER your present position, whatever your previous schooling, you can multiply your opportunities for rapid promotion, big income and prestige through LaSalle Law Training at home.

A knowledge of Law is regarded today as indispensable in every business activity. The greatly increased role of government in business, the many new problems of Law involving taxes, insurance, contracts, liability, employment—and much more—all require the legally-trained executive who can make day-to-day decisions effectively. That is why leading corporations seek out such men for key positions and reward them with top salaries.

### Study in your spare time

Men and women in accounting, banking, sales, credit, real estate, traffic, insurance, government and the armed services have profited from LaSalle law training.

You can master Law easily and enjoyably in your own home under the supervision of LaSalle's distinguished faculty of lawyer-instructors. You work with actual legal cases, acquiring real experience. Upon completion of your training, you are awarded a Bachelor of Laws degree if qualified. *The famed LaSalle law library of 14 volumes is given to you as part of your course.*

### The cost is remarkably low

For 54 years LaSalle has been an acknowledged leader in business training, with more than 1,000,000 students. Why be stalled in a dead-end job when a knowledge of Law will make you worth so much more money? Send for the free booklet "Law Training for Leadership" and see how LaSalle can help you move up rapidly in your career. You will be surprised by the low cost. Mail coupon to LaSalle, 417 So. Dearborn Street, Chicago 5, Ill.

This valuable booklet

LAW

TRAINING FOR LEADERSHIP



Free

to men who want to get ahead

It describes in detail today's opportunities for the Law-trained man and contains the full story of the La Salle home study program. For free copy, send the coupon today.

LA SALLE EXTENSION UNIVERSITY

A Correspondence Institution

417 South Dearborn St., Dept. 16-049, Chicago 5, Ill.

Please mail me, free of cost or obligation, your illustrated booklet "Law Training for Leadership."

Name ..... Age .....

Address ..... County .....

City & Zone ..... State .....

215



cate generally good drivers regarding their individual unsafe driving habits.

It seems impossible for authorities and laymen to conceive of highway safety as an educational as well as a law-enforcement problem. In other fields of danger, only special attention to specific unsafe acts of the individual has had dramatic results.

R. C. MERRITT, Ridgefield, Conn.

### That Chrysler Turbine Car

Your Detroit Report [Dec.] states that our upcoming turbine cars were designed by Ghia. Actually, the car body was designed in our styling studios, right here at Highland Park. Ghia is doing the construction work for us.

JOHN C. GUENTHER  
Chrysler Corp., Highland Park, Mich.

### Puzzle of the Month

Counting gears in that hybrid car ["PS Readers Talk Back," Jan.] was an interesting problem. According to my figures, both you and the owner are incorrect. With the Chevy's three forward gears and one reverse and the truck's four forward and one reverse, I say he has a total of 36 forward speeds and seven reverse.

J. E. LAWRENCE SR., Killeen, Tex.

No. We still count only 13 forward speeds.

As we understand Mr. Baker's setup, the first transmission has to drive through the second. The engine cannot drive the second transmission directly, nor can the first transmission drive

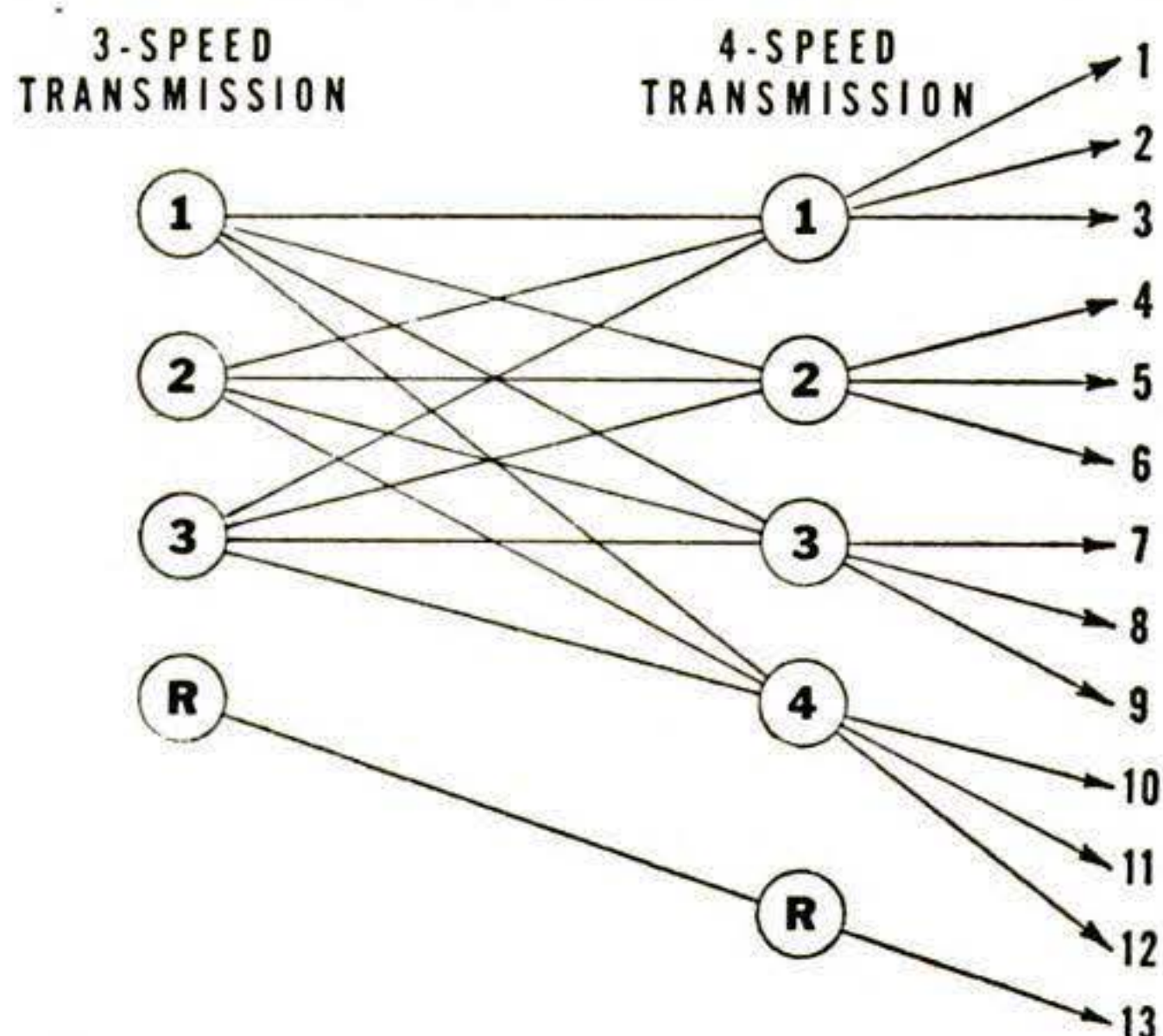

the rear end directly. In the diagram, each arrow represents a possible gear combination.

### Explorers Did Them Proud

Our post would like to congratulate Ross Allen and the Eagle Scouts and Explorers for successfully completing their survival hike

CONTINUED

# Why Johnson built 2 new reels in one

"Build a reel that offers the best of BOTH spinning and bait-casting." That's what anglers asked for, and Johnson did it . . . built the Johnson "710". Here's the reel that gives you spinning ease on the cast, bait-casting power on the retrieve. THEN, when a big one runs and you want game-taming drag, simply SHIFT the handle back a fraction of a turn. Drag takes over automatically. Run's over, you resume normal retrieve. Keep the fun of catching fish . . . and keep your catch, too.

Ask your dealer to show you the Johnson "710".



**BIGGER SABRA® LANDS THE LUNKERS.** Want "710" action in a reel with super power? See the Johnson SABRA. Comes with 15-lb. monofilament on the reel, 20-lb. mono on extra spool.

**WRITE for FREE 20-page, full-color booklet** crammed with fishing tips, latest Johnson tackle.

**JUST OFF THE PRESS . . .** New 18" x 28" guide to look-alike fish, full color, shipped in tube. Send 50¢ to cover handling and postage.

## Johnson REELS/RODS

Johnson Park, Mankato 4-N, Minnesota  
Manufactured by Denison-Johnson Inc.  
Distributed in U.S.A. by Johnson Reels, Inc.



'710'

Shifts from spin-casting to bait-casting reel in 1/10 second.

**CAST: IT'S A SPINNING REEL!** Long, clean casts. No backlashes. Easier to use because Johnson knows spin-casting.

**RETRIEVE: IT'S A CASTING REEL!** Good anglers want that "fish-on" feel, the control and power of direct-to-fish retrieve.

**SHIFT: IT'S A SPINNING REEL!** Back the handle a fraction of a turn and drag takes over automatically.



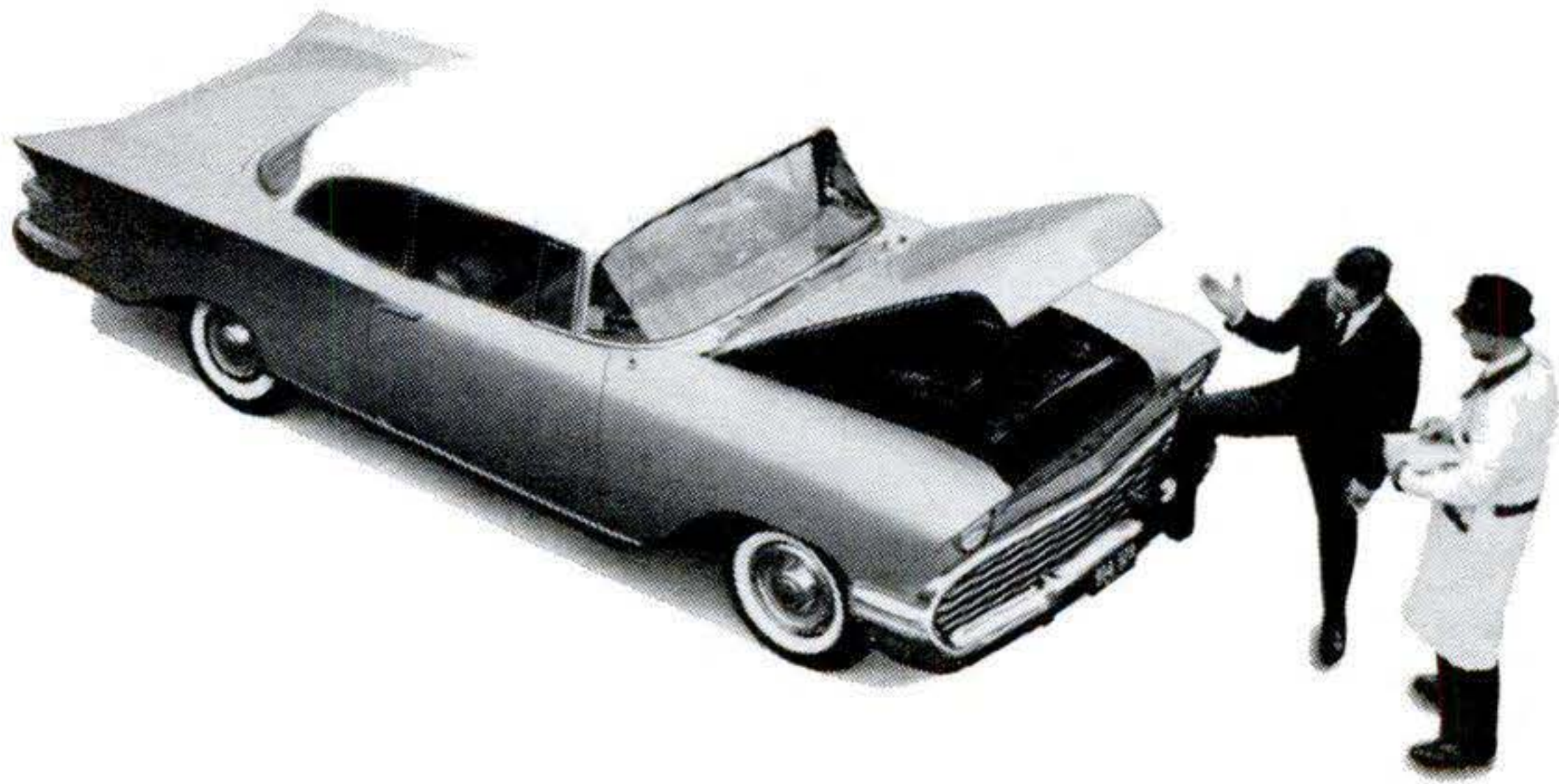

## **"It makes sort of a tic-tic-tic peep baa-room"**

Imagine trying to diagnose an engine's ills from a description like that. And yet, good mechanics do it all the time. That's because most mechanics today are better trained than ever before. And part of that training comes from the makers of Perfect Circle piston rings.

Many years ago we set up our Doctor of Motors clinics to provide mechanics with specialized training in engine maintenance. Over 800,000 men have attended so far!

When you want to be sure of top piston ring performance, ask any mechanic about

the power you get with Perfect Circles.

Or ask a race driver — 28 of the last 35 Indianapolis winning cars have been Perfect Circle-equipped.

Ask a NASCAR or USAC winner. Year after year more of the major competitions are won with PC-equipped entries than by cars using any other brand of rings.

When you want an engine that really delivers in pick-up, power, and oil economy, always be sure to re-ring with Perfect Circles — the piston rings preferred by the engine "pros" throughout the world.



# **PERFECT CIRCLE**

**PISTON RINGS • CYLINDER LINERS • PRECISION CASTINGS  
TURBINE BLADES AND WHEELS • ELECTRONIC PROGRAMING EQUIPMENT  
SPEED CONTROLS • HAGERSTOWN, INDIANA**

Plants and Subsidiaries: HAGERSTOWN, RICHMOND, NEW CASTLE, TIPTON AND RUSHVILLE, INDIANA  
THE PERFECT CIRCLE COMPANY, LTD., DON MILLS, ONTARIO, CANADA • SCHELLEN'S TRUE CORPORATION,  
IVORYTON, CONNECTICUT • PERFECT CIRCLE INTERNATIONAL, FT. WAYNE, INDIANA • PERFECT  
CIRCLE HOLLAND N.V., THE HAGUE, NETHERLANDS • Factories, Affiliates and Licensees in MEXICO,  
ARGENTINA, AUSTRALIA, BRAZIL AND FRANCE



# Test your automotive I.Q.

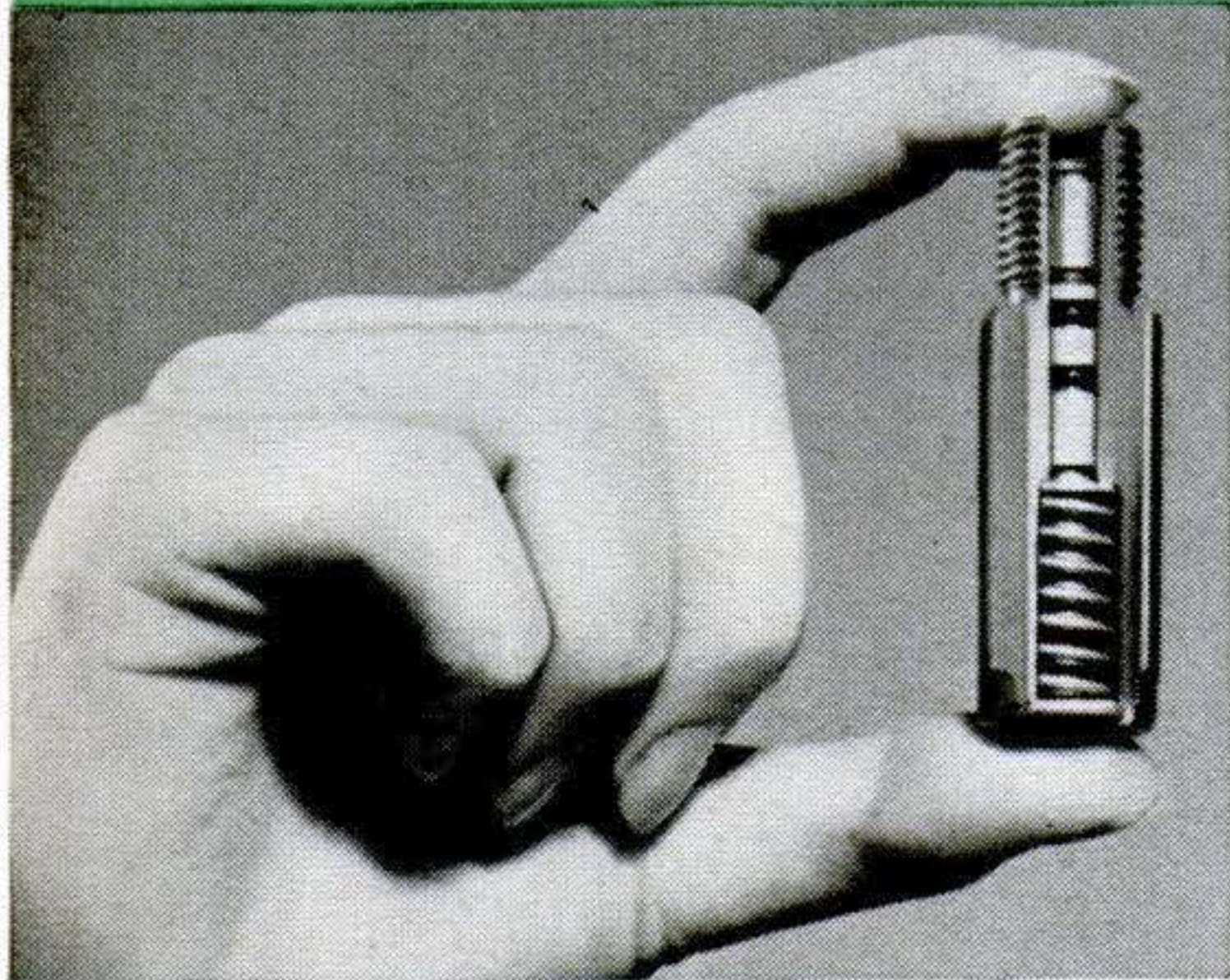

*What is this device? What is its purpose?*



*What does this symbol stand for?*

A "Throttlekicker" (top) prevents engine stall while parking cars with power steering. The life preserver is the symbol of Quaker State Motor Oil—the best engine life preserver. Made from 100% pure Pennsylvania Grade Crude Oil, Quaker State gives every car longer-lasting lubrication, top protection. Insist on Quaker State—your best engine life preserver.



QUAKER STATE OIL REFINING CORP., OIL CITY, PA.

across Florida ["American Kids Can Take It," Feb.]. Incidentally, Exploring is a program of the Boy Scouts; there are no "Explorer Scouts." You are either a Boy Scout or an Explorer.

JERRY ANCONA, V.P.

Explorer Post 30, Montgomery, N. Y.

## Dogs on the Force

In "Canine Cops Put Teeth in the Law" [Jan.], you quote Police Chief William M. Lombard "of Buffalo." Happily for us, Chief Lombard directs the police at Rochester, N. Y.

HAROLD CHECHTER, Rochester, N. Y.

*Apologies to Chief Lombard of Rochester; and to Buffalo's Police Chief Howard E. Finney, whose force has a 17-dog unit of its own.*

. . . You say seven years ago no U. S. city had dogs on its police force. What about Berkeley, Calif., where Dobermans were on duty in the late Thirties?

ELMO JONES, Mountain Lakes, N. J.

## That Antique Valveless Engine

The curious gas engine owned by Mr. Bundy ["PS Readers Talk Back," Jan.] was patented by my uncle, Henry R. Sieverkropp, in 1910. Its unique cylinder design eliminated precompression of the fuel, or charge, in the crankcase.

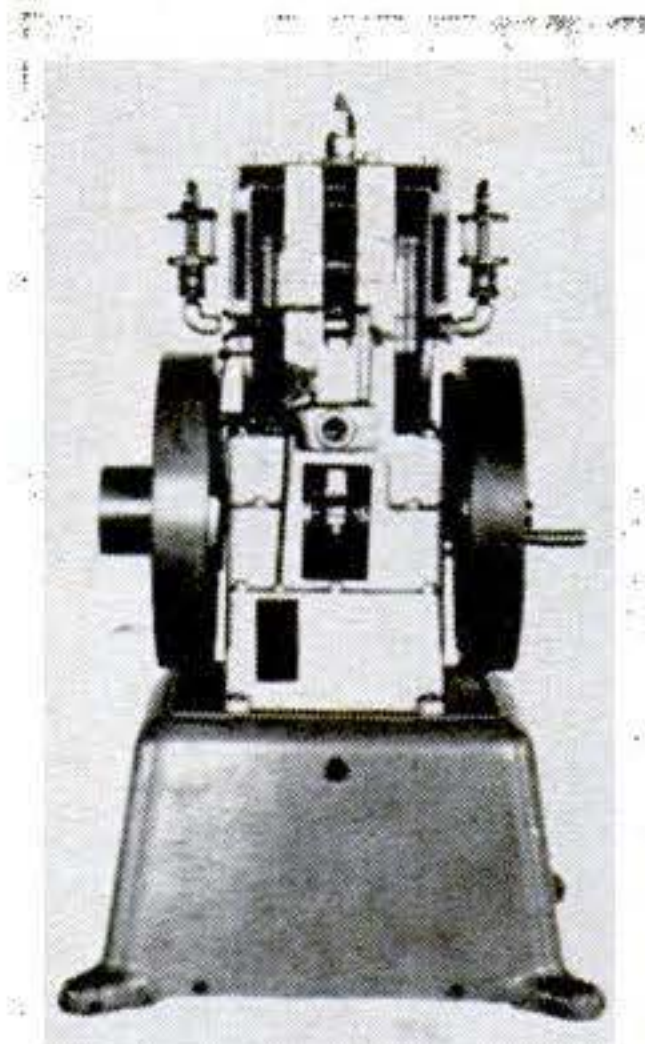

The cylinders lie on either side of a compartment, cast in the same block. Two pistons work in unison, connected by one wrist pin, with a single connecting rod in the compartment. Only the compartment's lower end is open to the crankcase; the cylinders' lower ends are sealed off, but connected together by the precompression chamber.

A fuel-mixer, poppet-valve carb of suction type on the lower end of the chamber is connected to a cast-iron gasoline tank (and engine mount). A centrifugal governor in one flywheel controls speed. The engine turns out its three hp. as follows:

On the down stroke, the charge below the pistons is compressed in the lower end of the cylinders and in the precompression chamber. Near the end of the stroke, the pistons uncover exhaust ports in the cylinders, discharging the spent charge. Immediately, the pistons uncover intake ports connected to the lower precompression chamber. The trapped charge escapes into the upper ends of the cylinders.

On the up stroke, the intake ports are covered by the pistons and, immediately after, the exhaust ports are covered. As the pistons



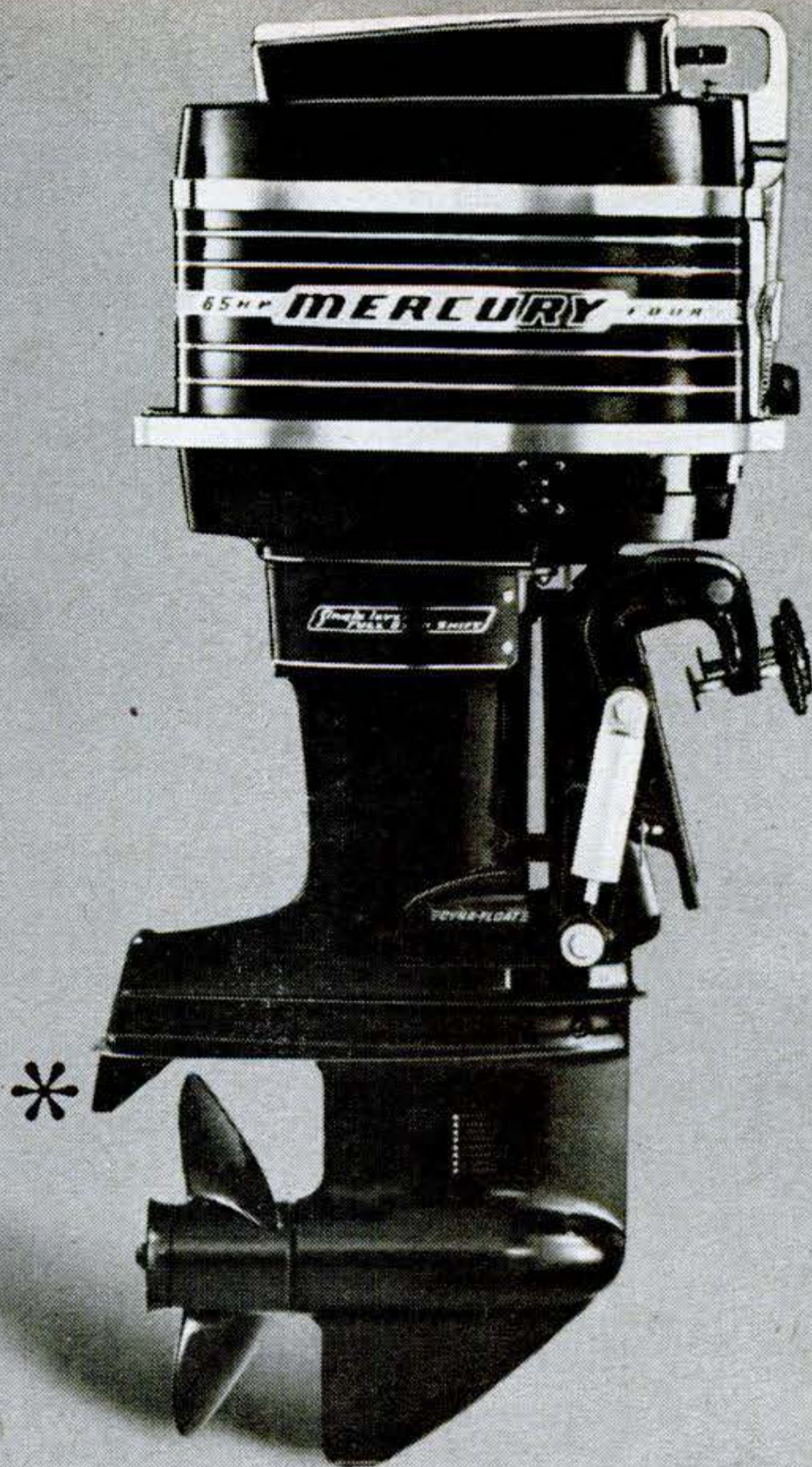

New Merc 650/65 hp/4 cylinders

## *One part on a Merc is designed to wear out*

\* This is a trim tab. It may be adjusted with a simple hand tool to offset engine torque for easy steering. This year, it has been designed to wear out. Here's why:

Up to now, outboarders using bronze propellers in salt water had a corrosion problem. When two unlike metals, such as bronze and aluminum, are submersed in salt water, an action is set up called galvanic corrosion. It is the reverse of plating one metal with another, causing one of the metals to be eaten away.

Mercury's new trim tab is cast from a special self-sacrificing alloy. In salt water, it allows itself to be slowly "eaten away"... thereby protecting the other metal parts of your motor. When your motor begins to steer hard, it's time to replace the trim tab. And,

a new one costs only a buck. In fresh water, it lasts like aluminum.

A small thing, perhaps... but another example of the tender, loving care in design, proving, and production to give you more RUN for your money with Mercury.

# **MERCURY**

100, 85, 65, 50, 35, 20, 9.8 and 6 hp outboards



**MerCruiser Stern Drive  
Power Packages • 310, 225,  
190, 140, and 110 hp gasoline  
100 and 39 hp diesel**

© 1963, KIEKHAEFER CORPORATION, Fond du Lac, Wisconsin  
Subsidiary of Brunswick Corp.



# New, improved Chevrolet Corvan...toughest,



Corvan on Powell St. hill in busy San Francisco.

***Checked out 40,000 miles in city, mountain, desert driving. A king-sized delivery run demonstrated the toughness of this quality-built Corvair 95 Corvan.***

*We just kept rolling along—and rolling and rolling and rolling!* In a grueling performance test that criss-crossed the country from Detroit to San Francisco, a 1963 Corvan ran up 40,000 miles of trouble-free performance under all conditions—highways, desert heat, driving rain (with nearly 7,000 miles of stop-and-go running through the busy city streets of hilly San Francisco!).

You'll like the extra durability of the new Corvan. There's added toughness from new features such as heavy-duty engine

valves, self-adjusting brakes and improved clutch and transmission controls.

You'll also like the Corvan's handy utility . . . big easy-to-get-at cargo space resulting from space-saving rear-engine design.

Big double doors on the right side open up to a load floor only 16" off the ground so that you can load a 4-foot crate with ease. There are wide-opening double doors at the rear and optional\* double doors on the left side just as big as those on the



# handiest delivery truck you can buy!



*Chevrolet Greenbrier and Rampside Pickup accompany Corvan on 25,000-mile leg of endurance run in Death Valley desert country. Here, day-and-night high-speed operation showed durability of improved new air-cooled engine.*

right. All 191 cubic feet of cargo space is there to be *used*—easily and quickly.

Rear-engine Corvan design also gives you other important benefits. Extra weight on the rear wheels gives surefooted traction on slippery roads. And with the main cargo space cradled near the center of the truck, you get balanced handling whether the truck is empty or carrying a full 1,700-lb. payload.

We'll say it again—the new, improved Chevrolet Corvan is the toughest, handiest

delivery truck you can buy! Test-drive it yourself at your Chevrolet dealer's—and be sure to ask him about the *new low price!* . . . Chevrolet Division of General Motors, Detroit 2, Michigan. \*Extra Cost



**QUALITY TRUCKS COST LESS!**



W 9316  
16-FOOT  
SUPER  
MEZURALL



**NEW**

## LUFKIN 16-FOOTER

### works fast on 4-foot modules

The 16-foot White Clad® blade is  $\frac{3}{4}$  inch wide and accurately graduated. Marked in consecutive inches to 16ths inch on lower edge; first 12 inches to 32nds inch. Marked in feet and inches to 16ths inch on upper edge, with preceding foot number indicated each inch.

Its self-adjusting end hook compensates for its width on butt-end measurements. And its blade can be replaced in seconds without tools.

It's amazingly lightweight . . . only 7½ ounces with die-cast, chrome-plated aluminum case. Easy to handle. Convenient to use.

Ask your hardware or building-supply dealer to show you this great Lufkin 16-foot Super Mezurall. Retail for approximately \$3.95, including handy vinyl belt pouch.

*Measure for measure, the finest made...*

# LUFKIN

SAGINAW, MICHIGAN

continue upward, trapped gas in the cylinders' upper ends is compressed and a fresh charge is drawn into the lower end of the cylinders and into the chamber.

A standard spark plug fires the compressed charge in the firing chamber and the explosion drives the pistons downward. There's a power stroke on every revolution of the crankshaft.

MACK SIEVERKROPP, Racine, Wis.

The inventor's daughter, Mrs. Milo Sorenson, supplies this further information from her father, now 85: Two drip oilers on the cylinders lubricate pistons and wrist-pin bearings. Connecting-rod and crankshaft bearings are lubed by the crankcase oil. No oil is mixed with the fuel. The engines were used primarily on farms and to run washing machines.

### The Gentle Touch

The fellow townsmen who gave Reverend Few prescriptions for discouraging auto thieves ["PS Readers Talk Back," Dec.] sure have a sense of humor. Hooking up a gun to fire buckshot at the driver's seat may have been suggested for laughs, but it *could* be worked at that! Take the buckshot from the shells and fill 'em with rice or—more unkind—with hard rock salt which will give a more lasting sting. This will leave the car thief in one piece so the law can take its course.



BILL CORON, Chester, N.J.

### Advice for the Car-Lorn

Tell that Dodge Lancer owner troubled with hard starting ["PS Readers Talk Back," Feb.] to have his dealer take another look. I'm sure he'll find an in-line fuel filter sitting warm and cozy over the rocker-arm cover. This little innovation has caused no end of problems. The solution is simply to get the filter away from the engine heat by moving or insulating it.

RICHARD OESTREICH, Canandaigua, N. Y.

. . . The fuel-pump pressure of that Lancer is too high. When the motor is shut off the high pressure on the fuel forces it past the float valve and floods the manifolds. Then, when trying to start, the engine is flooded. A fuel-pressure regulator placed between the pump and carburetor solves the problem.

RICHARD KING, Salem, Ore.

. . . Jakabcin's trouble is a faulty spark coil that is shorted by heat. Perhaps moving the (new) coil would prevent this.

R. E. PALMER, Kansas City.

. . . I'd say Jakabcin has a leaky check valve in his Lancer's carb. He should clean and re-



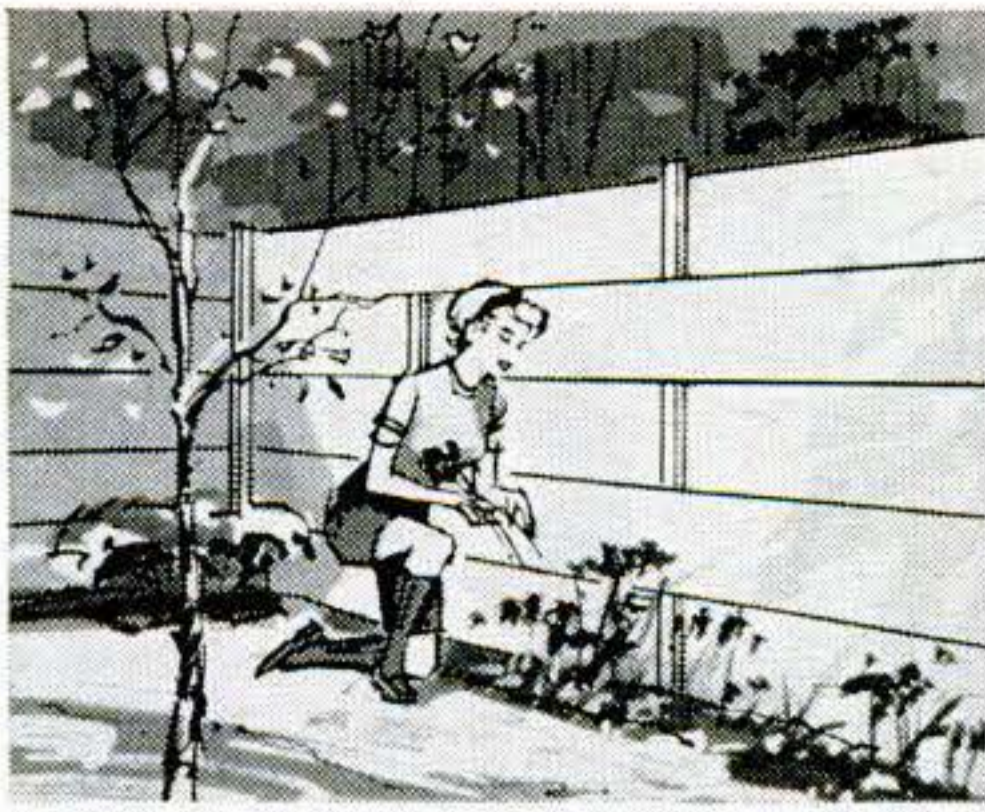

1. Fences of distinctive design

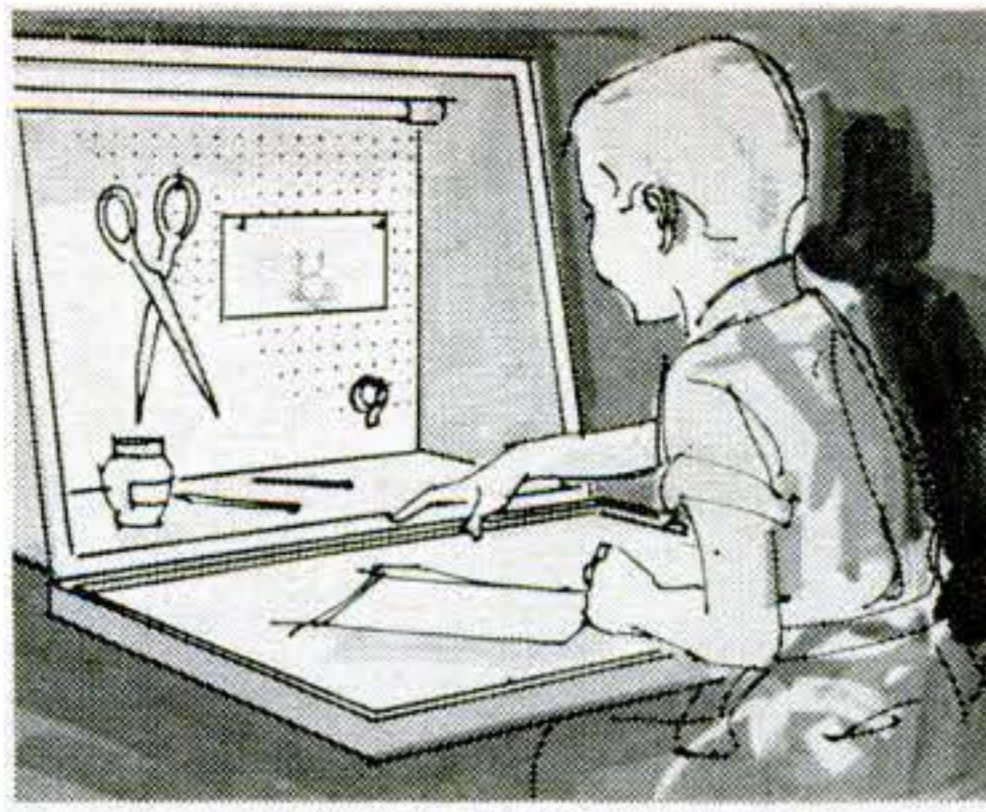

2. Wall desk with optional chalkboard front

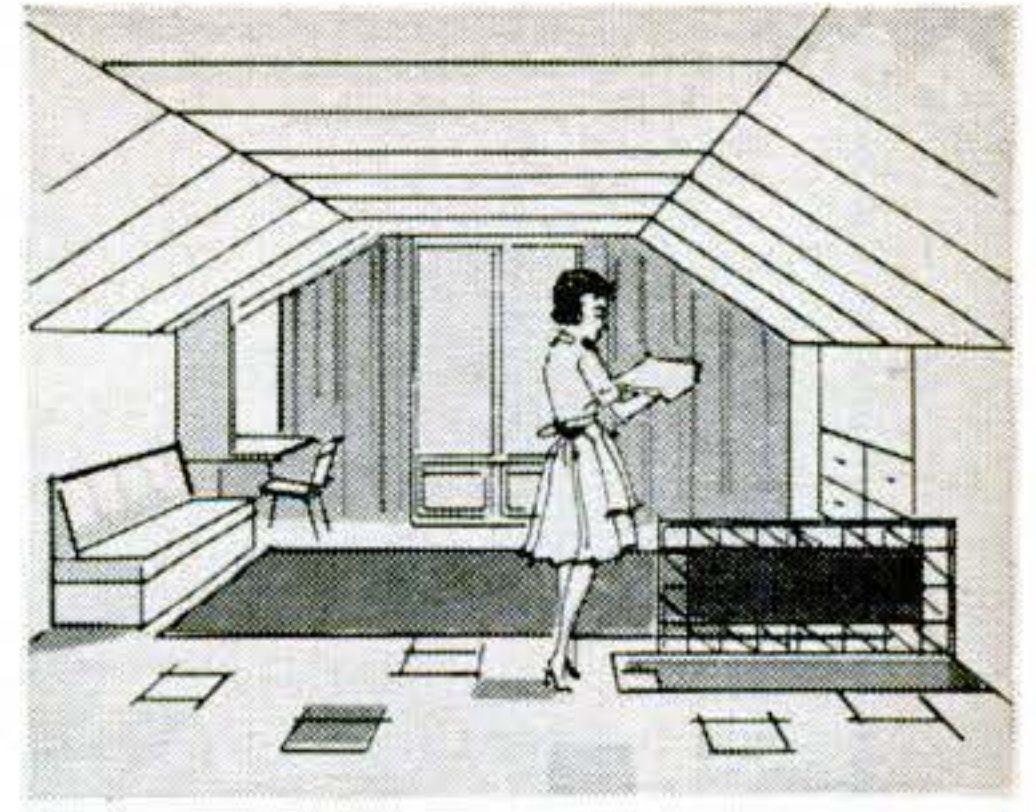

3. Remodeled attic

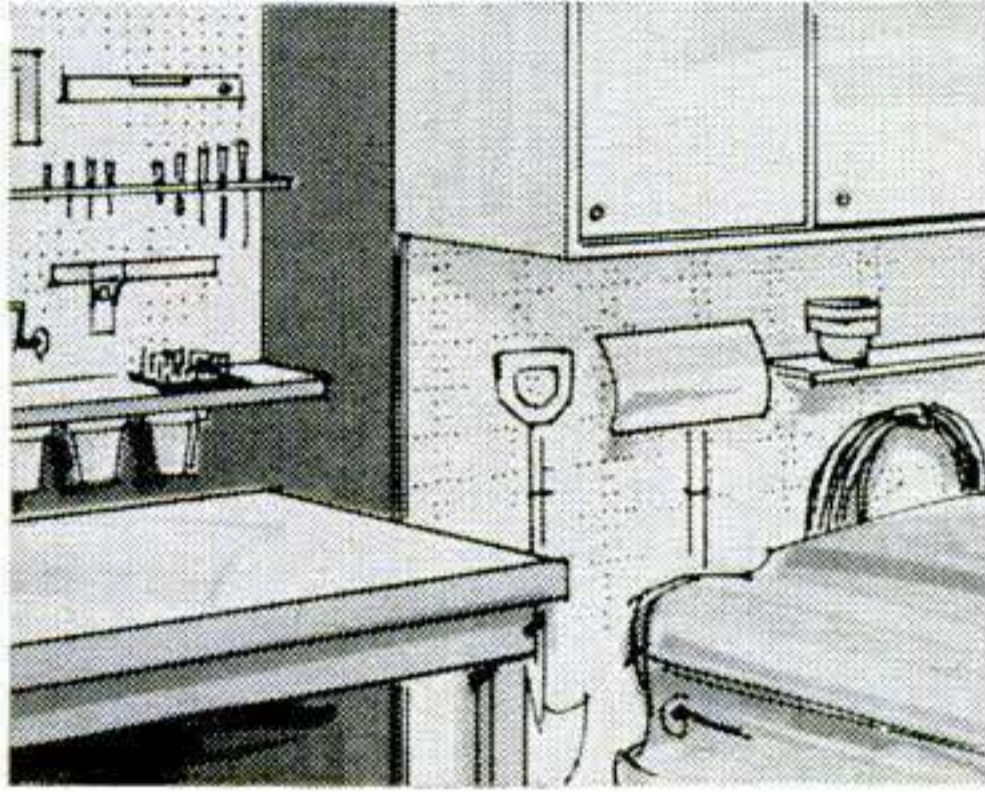

4. Garage interior remodeling

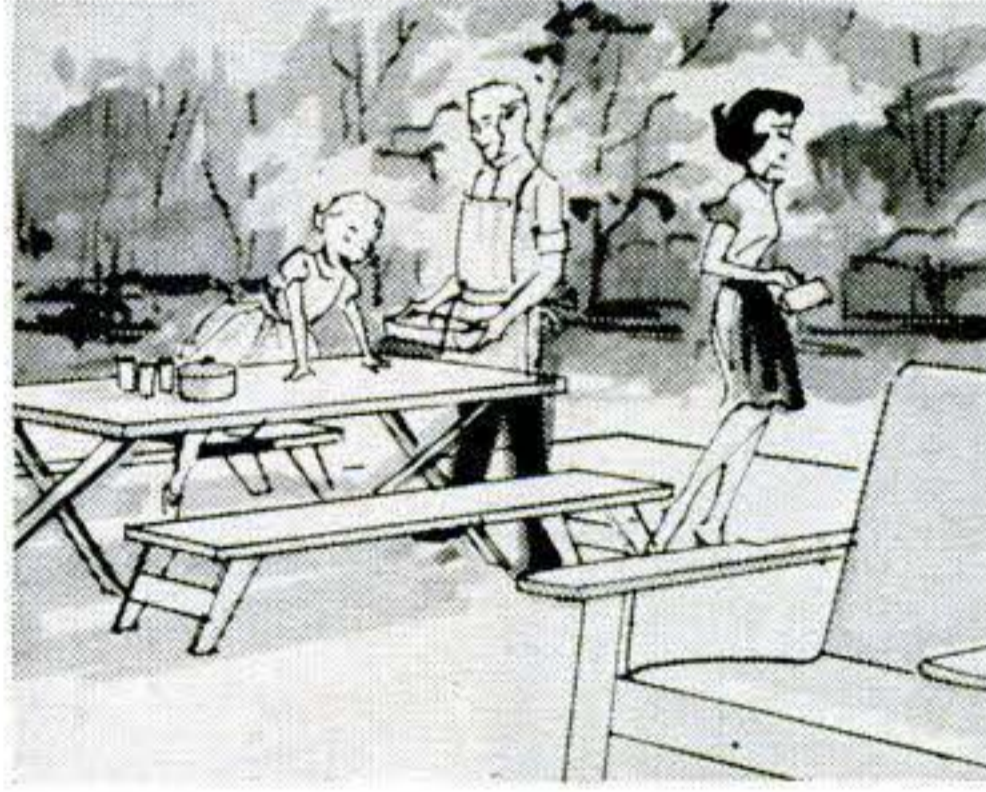

5. Picnic table and benches, lawn chair

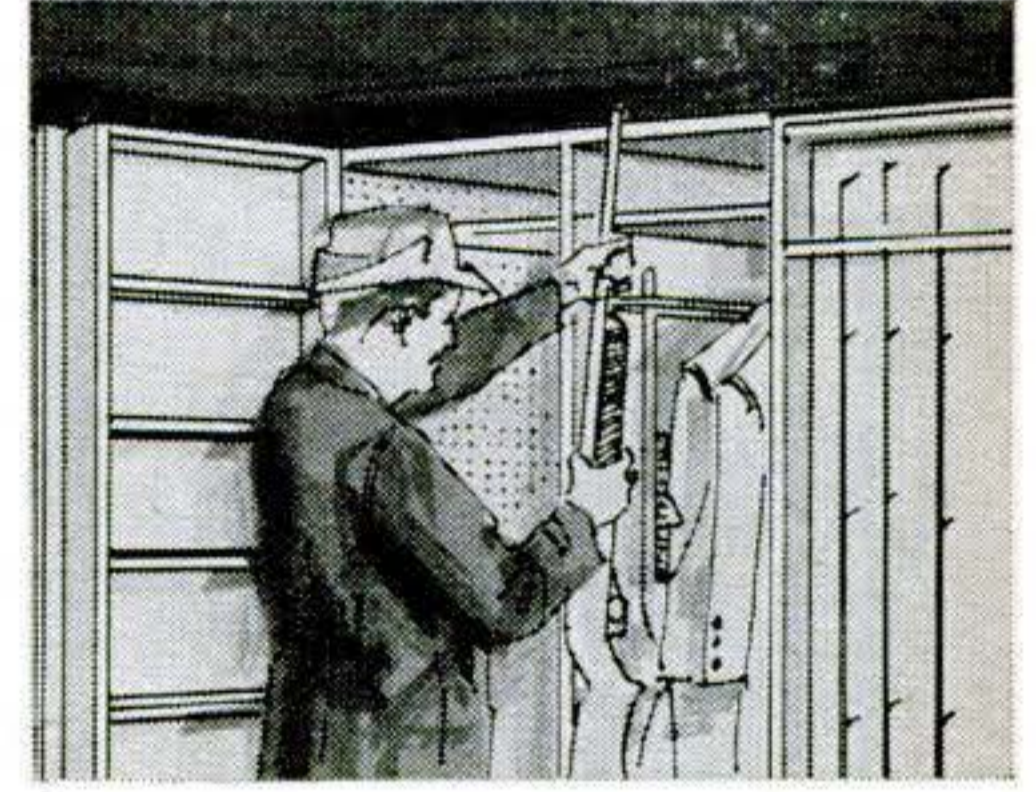

6. The sportsrobe

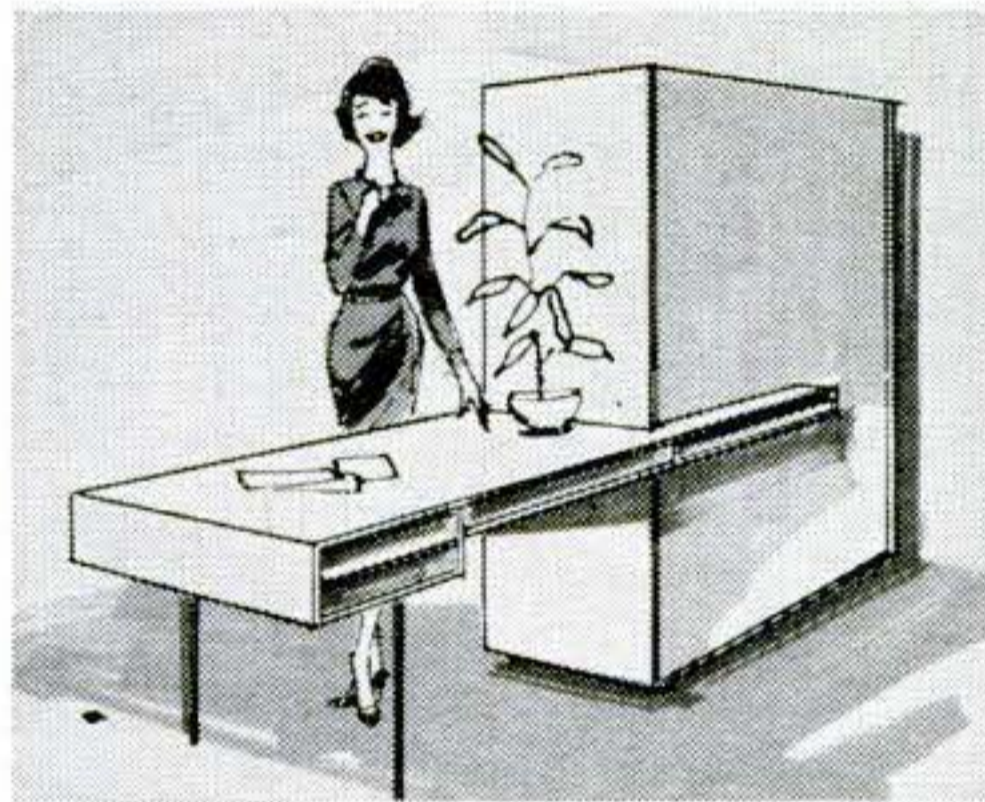

7. Room divider with desk and wardrobe

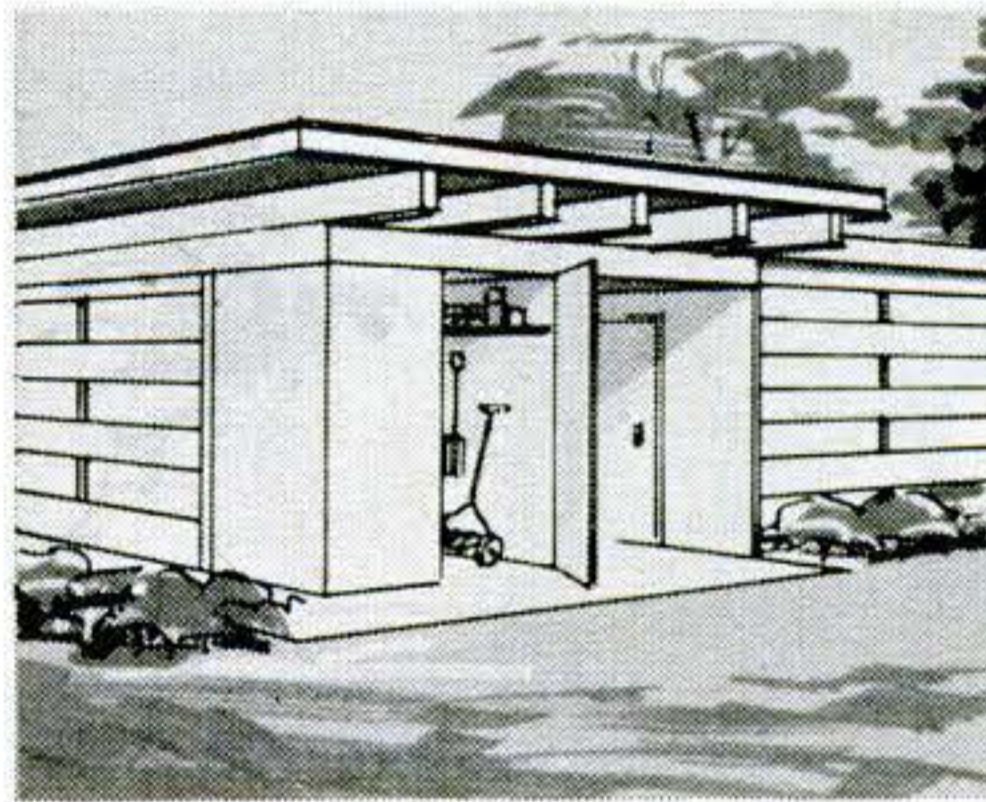

8. Woven carport wall with tool room

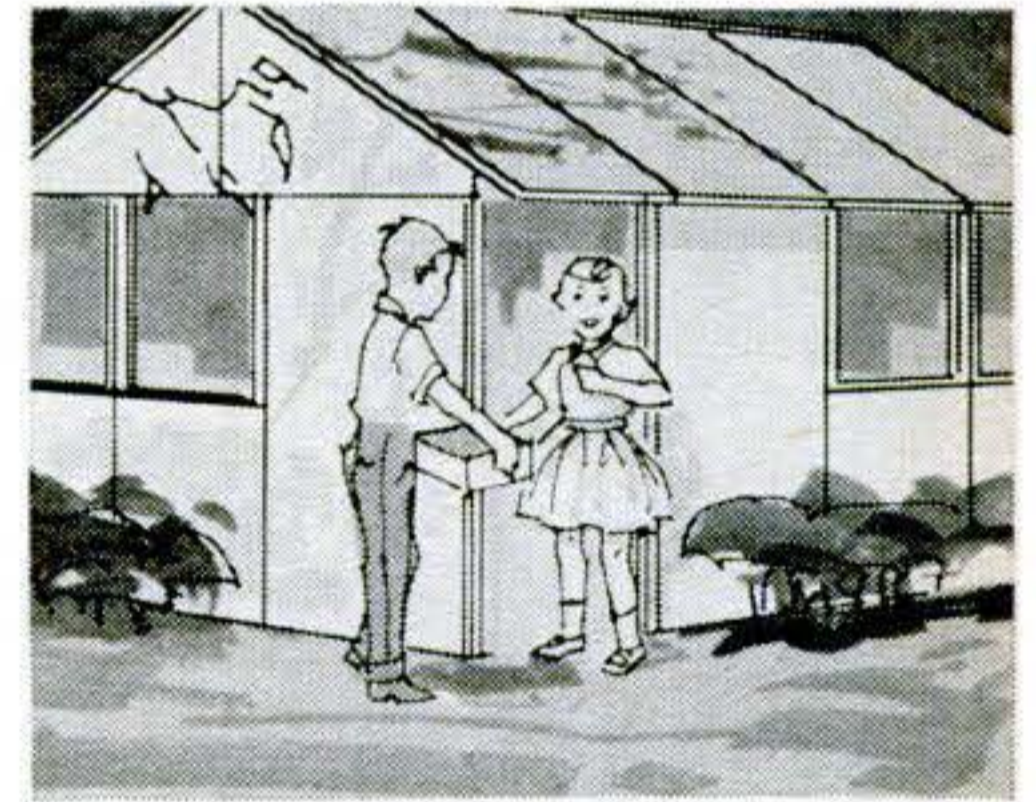

9. Playhouse plan for children



10. Home entertainment center  
Family leisure hi-fi center

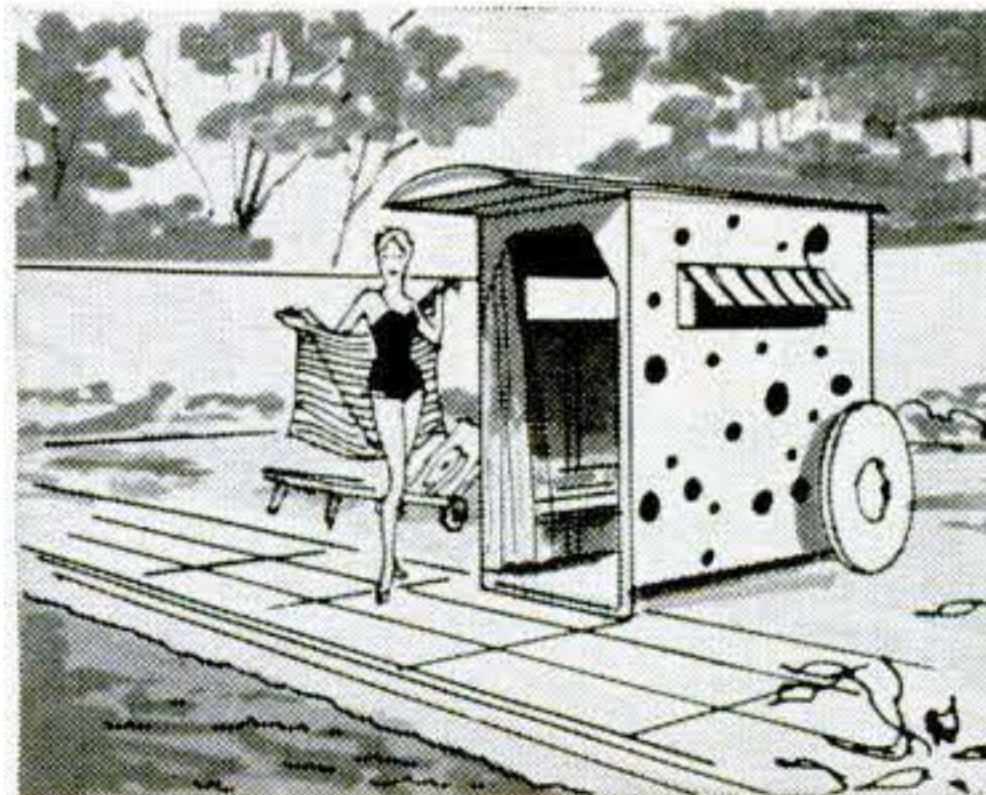

11. Roll-away cabana

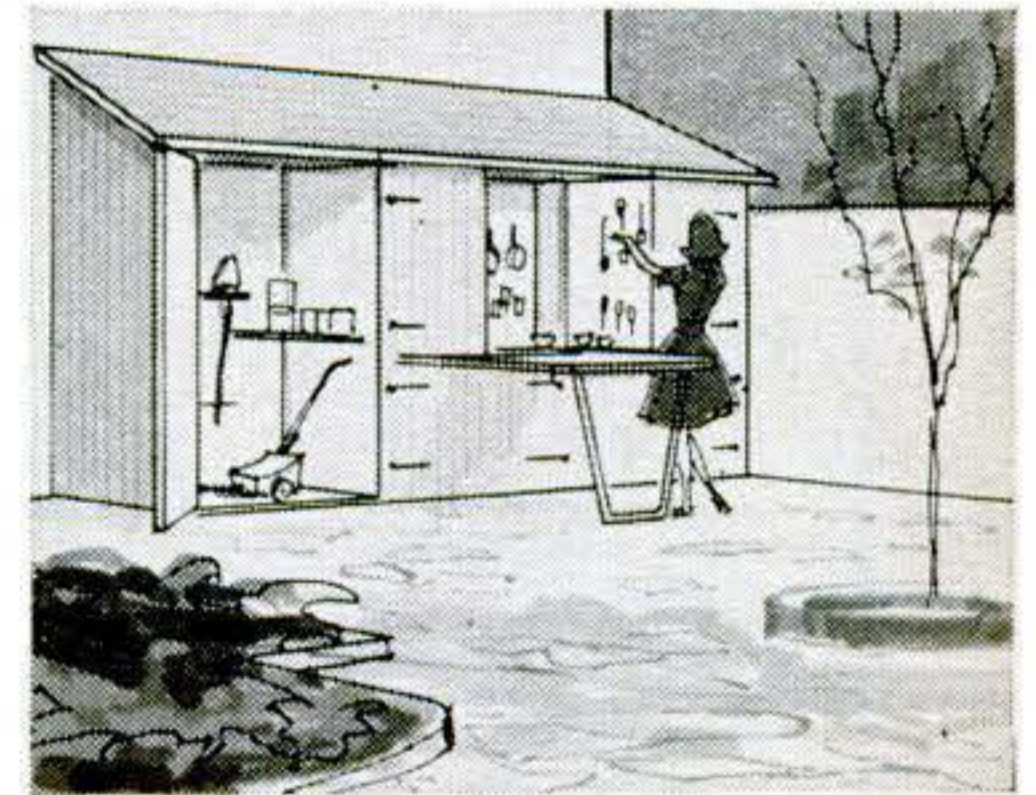

12. Outdoor living room

**FREE from Masonite:**

**66 "IDEA PLANS"**

*to add to your family enjoyment*

**MASONITE shows the way!**

Masonite is a registered trademark of Masonite Corporation



Masonite Corporation, Dept. PS-4, Box 777,  
Chicago 90, Illinois

Please send me free "Idea Plans" booklet and  
Plan No. \_\_\_ (one only).

NAME \_\_\_\_\_

ADDRESS \_\_\_\_\_

CITY \_\_\_\_\_

COUNTY \_\_\_\_\_ STATE \_\_\_\_\_



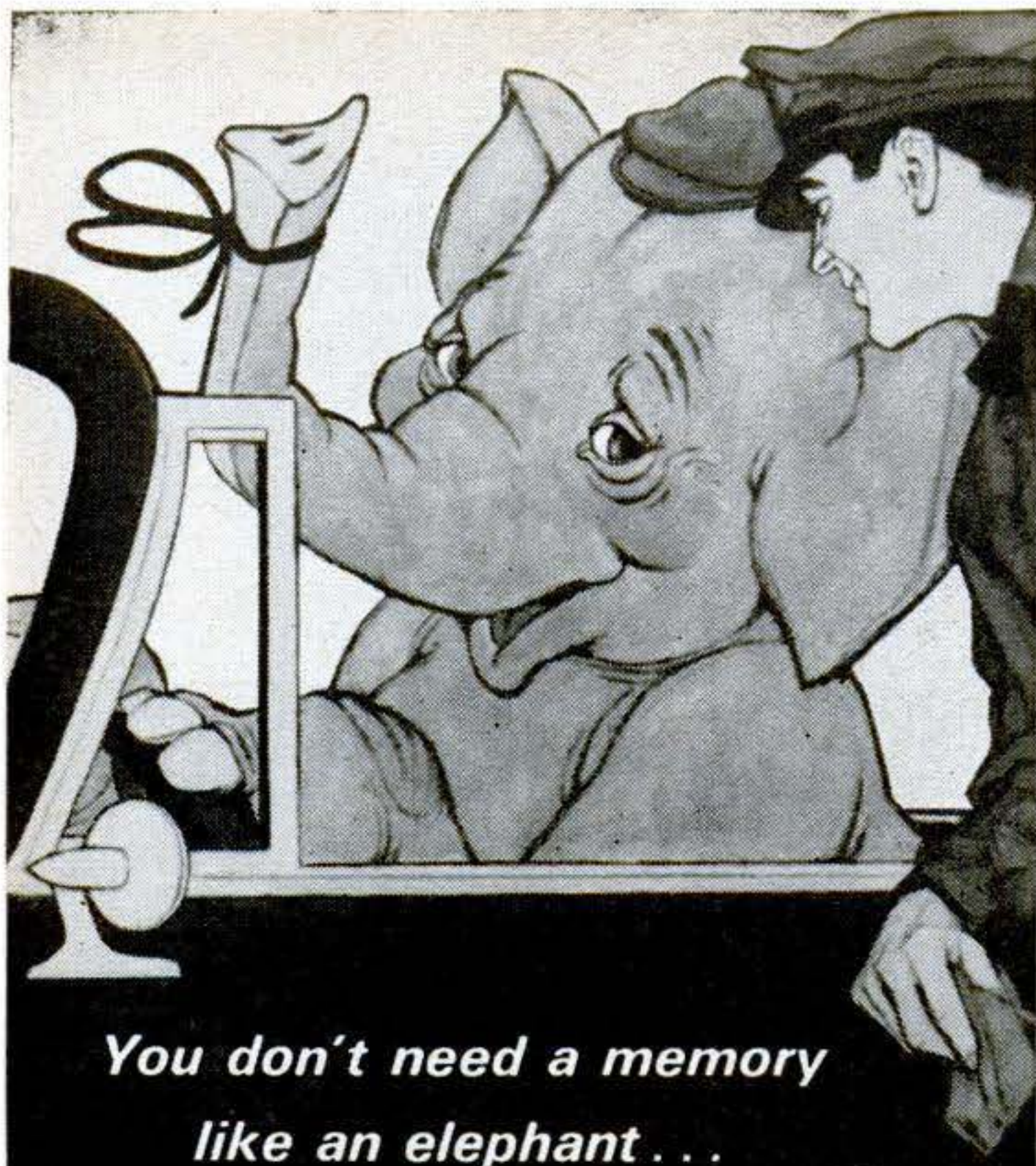

*You don't need a memory  
like an elephant...*

**If you forget to  
change oil  
PENNZOIL  
STILL PROTECTS**

©Pennzoil 1963

**Not being elephants,** people are apt to forget. That's why we build *protection reserve* into Pennzoil Z-7, so it will go on protecting even if you forget to change oil when you should. Use Pennzoil Z-7 always, and ask for it even if you don't see it displayed. Pennzoil, Oil City, Pa.

**Best time to change oil:** Every 60 days, normally. Every 30 days under severe stop-and-go or cold-weather driving conditions.



Hear "Chet Huntley's Perspective on the News" Monday through Friday, NBC Radio Network

seat it. When the engine stops with pressure on the fuel line, gas seeps through the valve, raises the gas level, and loads up the manifold. He can check this by removing the air cleaner a few times and peering down the barrel, right after stopping the motor. A couple of tries should catch the culprit in the act of soaking the manifold.

H. E. SHELLMER, Madison, N. J.

### Woman at Work!

Let's have *more* of Jackson Hand ["How to Change a Faucet Washer When There Isn't One," Jan.]. I now have about two inches of water on my bathroom floor, and I find it exceedingly difficult to become pals with the several packages of rubber washers I have had to purchase to carry on. Certainly Mr. Hand was correct to a point:

(1) Those little handles *were* canopies to hide working parts. (2) It *was* necessary to remove the handles before going inside. (3) There *was not even* a packing nut. (4) All working parts *were* removable.

But now that I have the dern thing apart, using a Phillips screwdriver as told, *how* do I get the faucet back together again? Mr. Hand does not say what to do when one wears away the screw threads by using pliers instead of a wrench.

May I suggest—as a public service to those of us confined to the bathroom with a thumb in the spigot—a follow-up article: "How to Make Friends with a Wretched Wrench."

BETTE J. SOLDWEDEL, Piermont, N.Y.

(1) *Get someone to turn off the water.* (2) *Buy a new faucet.* (3) *Use the right tool from the toolbox to install it.*

### More Trade for the Junkies?

That extended-lubrication stuff ["30,000 Miles Between Grease Jobs," Jan] is a sales gimmick to move a few more slow-selling cars. Only the junkyards will benefit.

HORACE A. GILTNER, Peoria, Ill.

### Synchronized-Transmission Debate

Let me straighten out Gary Gernert ["PS Readers Talk Back," Jan.]. Packard did *not* have a transmission synchronized on all three gears from 1936 to 1954. What they *did* have was a constant-mesh low gear engaged by a dog clutch—similar to all modern second and high engaging clutches, but without any brass synchronizing ring on low gear. Only the column-shift versions from 1940 on had the constant-mesh low gear.

The Packard transmission was an engineering masterpiece with the widest, strongest gears in the automotive industry: all forward gears constant-mesh, and all gears supported on double ball bearings, roller, or needle bearings.

R. L. RAVENSBORG, St. Paul, Minn.



# WILDCAT!



*The name fits. WILDCAT! Sleek, sure-footed, muscles of steel . . . and terrible tempered. Only full-size luxury sports job with Advanced Thrust engineering, WILDCAT tracks arrow-straight, corners tight, handles with caliper precision. Front buckets and center console with tach and Turbine Drive selector stick are standard in the eye-popping WILDCAT convertible and 2-dr. sport coupe. Like to try your hand at taming one? There's a willing WILDCAT waiting at your Buick dealer's now.*

Buick Motor Division also presents: Buick Special/Skylark/LeSabre/Electra 225/Riviera

**'63 BUICK  
WILDCAT**

**ANATOMY OF A WILDCAT!** Engine: 90° V-8 valve in head. Displacement: 401 cu. in. Maximum hp: 325 @ 4400 rpm. Compression: 10.25:1. Bore and stroke: 4.1875 x 3.64. Carburetor: one 4-bbl. downdraft. Valves: hydraulic lifter type. Rear axle: hypoid semi-floating. Gear ratio: 3.42. Transmission: automatic torque converter type. Brakes 12" Duo-Servo, finned aluminum up front. Advanced Thrust engineering for straight tracking, flat cornering.





Dr. von Braun watches a Juno II launching from Cape Canaveral blockhouse. In background is Dr. Kurt Debus, Launch Director at the Cape.

# Dr. Wernher von Braun Answers Your Questions on Inertial Guidance

**Q** *Why does a rocket need a guidance system?*

**A** To keep a rocket on its prescribed flight path despite disturbances by wind, or by slight deviations from the rocket's standard weight or performance, we must continuously generate and apply commands that correct its motion. We can take our choice of two guidance systems: remote control or inertial guidance.

Guidance commands may be generated by tracking the rocket with optical instruments, radar, or radio, and comparing the *actual* track with the *prescribed* flight path. A remote-control command passed on by radio instructs the speeding rocket to reduce any difference between "is" and "should be" to zero.

Such guidance systems, based on remote control by radio, have several basic drawbacks. For one, they are subject to intentional as well as unintended interference, which makes them particularly vulnerable in military operations. For space-flight operations, an even more serious drawback lies in the fact that it is impossible to maintain radio contact between ground station and rocket except along a line of sight between them. For economy in consumption of propellant, an orbital rocket must ascend to its orbit along a very shallow trajectory—and so the burn-out point of the last rocket stage is frequently well below the horizon of the launching site.

In deep-space missions, the rocket may

stay in one or several "parking orbits," and must restart its engine at a very precise instant for the ensuing power maneuver that leads to injection into a trajectory to the moon or the target planet. The orbital restart point may be over Australia or the Pacific Ocean, while the launching was from Cape Canaveral, Fla. Radio-guidance schemes for such operations would involve a complicated globe-circling network.

An *inertial*-guidance system does away with all these communication difficulties by generating the guidance commands *on board the rocket*. Such a system is entirely self-contained.

**Q** *What is the principle of inertial guidance?*

**A** The basic idea behind an inertial-guidance system for a rocket is to measure its accelerations in three "orthogonal" (mutually perpendicular) directions, such as up-and-down, right-and-left, fore-and-aft. The three accelerations then are "integrated," an operation that a following paragraph will make clear, to obtain the velocity in each direction. In turn, the three velocities are integrated to get the *displacement*, or distance traveled, in each direction. This answers the rocket's ever-repeated query, "Where am I?"

Knowing from an electronic memory where the rocket *ought* to be at any moment, and noting any deviation, the



You're always in good company when you

# Choose the Leader!

When you select *any* Harley-Davidson, you get the world's widest *choice* of models, colors, styles, accessories, clothing, and servicing products . . . all tailor-made to suit your particular riding pleasure. This exclusive combination is why Harley-Davidson continues its long-standing leadership. See your Harley-Davidson dealer. You'll be in the best of company.

Seven basic motorcycle models and the world's snappiest scooter  
Largest combination of models for your choice of performance, style, color  
Hundreds of special accessories from saddle-bags to side-mirrors  
Rider-tailored clothing, smartly-styled, sharpest quality, makes cycling more fun  
Many mechanical options . . . Customize for your own riding pleasure  
Friendly service . . . Wherever you ride, Harley-Davidson dealers help you feel at home



**HARLEY-DAVIDSON**  
MOTOR CO., MILWAUKEE 1, WISCONSIN



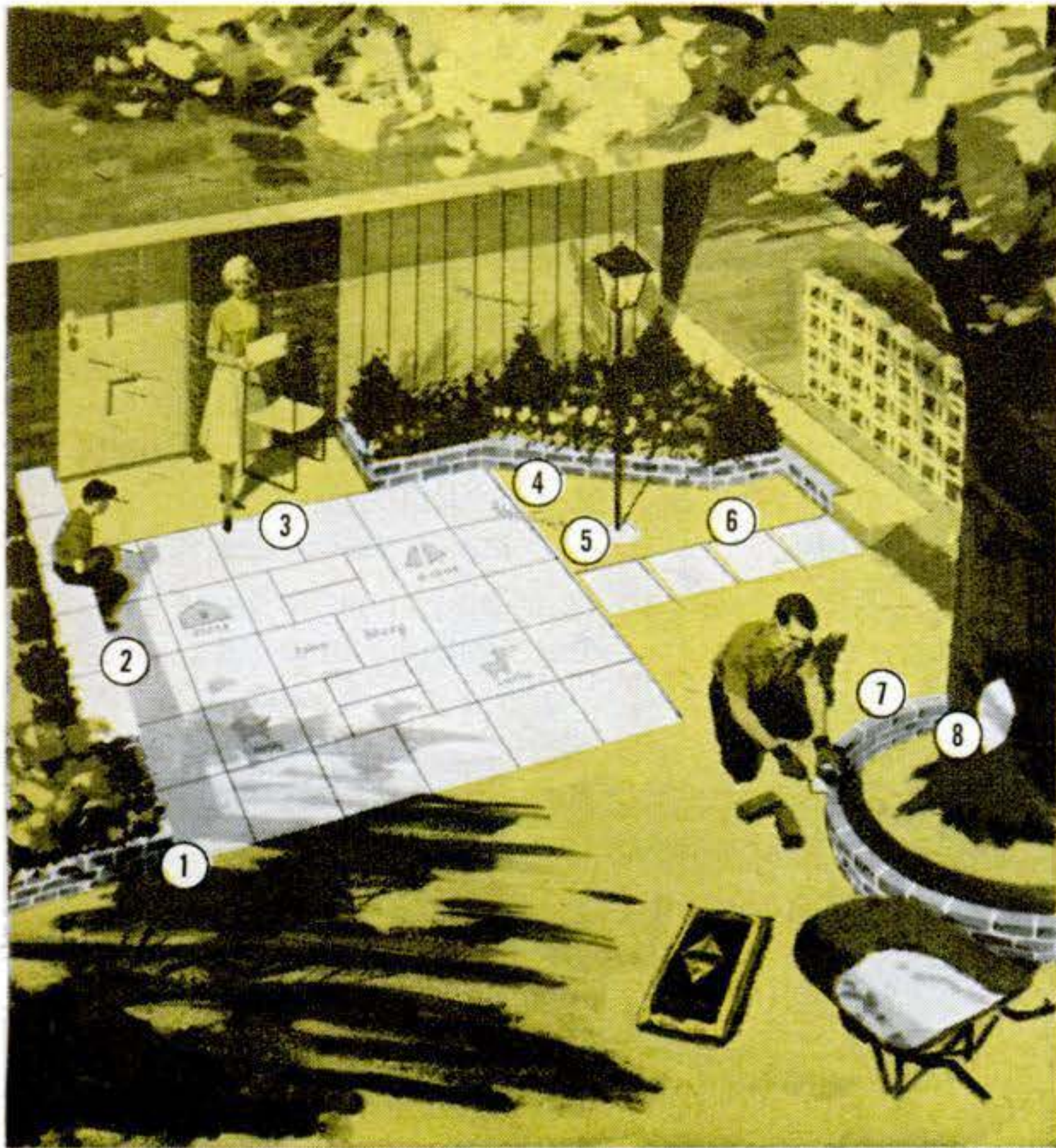

Build these **8** patio projects  
yourself with **SAKRETE**<sup>®</sup>  
... for less than **\$99\***

For hours of fun and relaxation all summer long . . . there's nothing like a patio. You can build your own for less than \$99—with SAKRETE Concrete and Mortar Mixes. You'll have fun making your own patio blocks, planter boxes and flower bed edging with pre-mixed SAKRETE. Do a little at a time . . . start and stop any time . . . for SAKRETE stores indefinitely until you add water. High strength, easy to use, economical, no waste. Get SAKRETE today at your lumber, building material or hardware dealer.

\*Approximate cost of materials in most areas for this 10' x 12' patio project.



**FREE** booklet of cement building and repair projects. See your dealer or write SAKRETE, Inc., Dept. PS, Box I, Cincinnati 17, Ohio.

**SAKRETE**<sup>®</sup>  
concrete and  
mortar mixes



SAKRETE IS A REGISTERED TRADE MARK OF SAKRETE INC. © 1963

guidance system produces the needed commands to correct the flight path.

The heart of any inertial-guidance system is thus a set of three orthogonal accelerometers, to measure the three components of the rocket's acceleration.

**Q** How can you measure acceleration?

**A** Acceleration is what sports-car drivers call "getaway." It manifests itself as a force that presses the driver against his seat back when he steps on the accelerator. This force is the result of his body's inertia, which resists the sudden change of pace—whether the car is accelerating from a standstill, or from 40 to 60 m.p.h. to pass a lumbering truck.

There are many types of accelerometers, but they all measure that "force against the seat back" due to the inher-

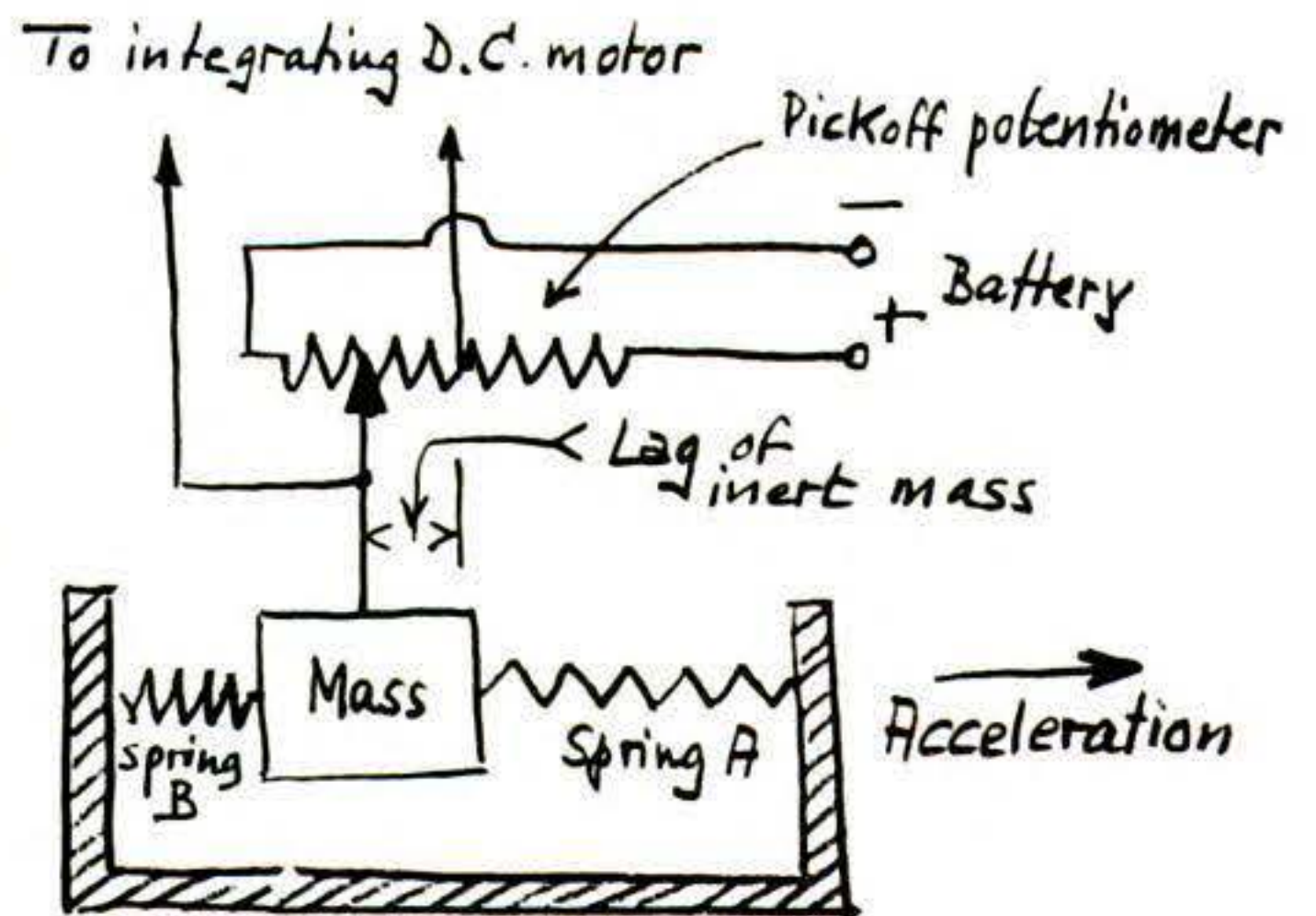

ent inertia of mass. The simplest is the spring-mass accelerometer in my sketch.

As the rocket accelerates in the direction shown by the arrow, the inertia of the mass causes it to lag behind, stretching spring A and compressing spring B. A sliding-contact variable resistor, labeled "pickoff potentiometer," produces a voltage that corresponds to the acceleration at any instant.

**Q** How are accelerations integrated?

**A** The speedometer in our sports car clearly indicates that the velocity is increasing, second by second, as long as we feel that pressure against the seat



**Assignment:  
build a brake  
that will make  
its own  
adjustments**

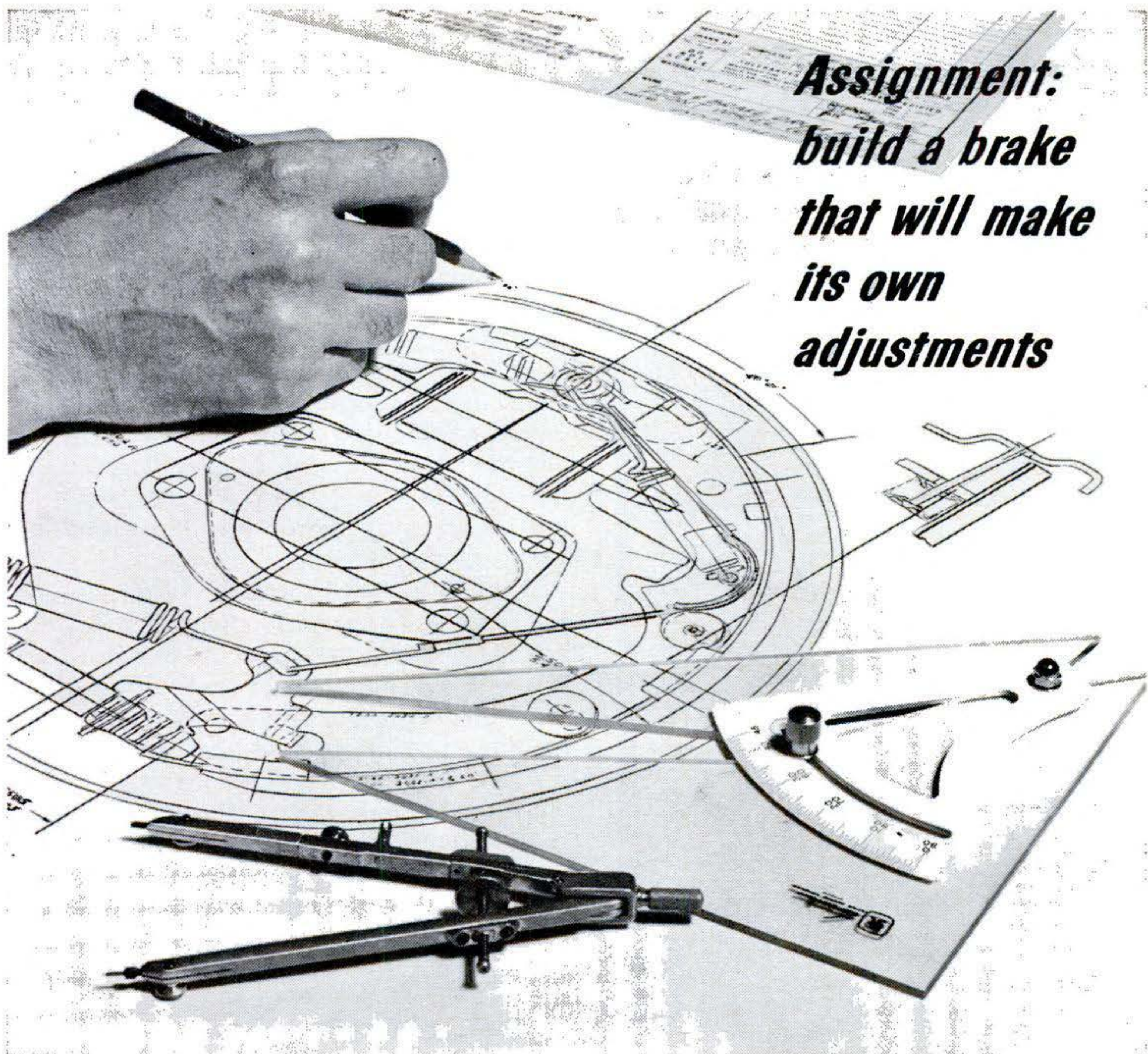

**Result: Every Ford-built car in '63 has self-adjusting brakes**

"Give us a brake," Ford Motor Company engineers were told, "that will automatically compensate for lining wear whenever an adjustment is needed—and make it work for the entire life of the lining."

Today, not only does every Ford-built car (Falcon extra-duty bus-type wagons excluded) have self-adjusting brakes, but the design is so excellent that adjustments can be made more precisely than by hand.

This Ford-pioneered concept is not complex. Key to it is a simple mechanism which automatically maintains proper clearance between brake drum and

lining. Self-adjustment—which normally occurs but once in several hundred miles of driving—takes place when brakes are applied while backing up.

The quest for total quality in Ford-built cars has produced other extra-value features like extended major chassis lubrication intervals, use of rust-resistant galvanized steel for vital underbody parts and new, longer-life electrical systems.

Such achievements through engineering excellence are reasons for Ford Motor Company's success in bringing you quality cars that last longer, need less care and keep their value better.

**FORD • MERCURY • THUNDERBIRD  
LINCOLN CONTINENTAL**



**MOTOR COMPANY**

**WHERE ENGINEERING LEADERSHIP  
BRINGS YOU BETTER-BUILT CARS**





# HIGH WAGES

for operators of heavy construction equipment

**. . . here's your opportunity to be a part of the biggest booming industry in the U. S. A. . . . National's actual field training teaches you how!**

NOW is the time for you to learn to be an Operating Engineer for big diesel-engined bulldozers, draglines, cranes, back-hoes, scrapers and motorgraders!

Cash in on the training you'll get at National for years to come. The construction field is going up, up, up . . . heavy equipment operators today are making as much as \$10,000 a year and more! You can make a career out of it . . . and the best part of all is that you need no experience to start. National School trains you right from the beginning.

National is NOT a correspondence school . . . qualified job-experienced instructors teach you in person on over 3/4 million dollars worth of School-owned modern diesel-engined machines of the same type now in use by the industry. Full 220-hr. and 440-hr. courses. VA approved. Ages 17-56. Payment plans available. Full-time Job Advisory and Counselling Director for the exclusive benefit of graduates.



### GRADUATES REPORT . . .

*New Yorker, on a project in South, says:*

" . . . job will take at least a year to complete . . . my accomplishments changed me from a \$60-a-week man to a \$150 to \$350-a-week man."

Jon E. Oppenheim  
Great Neck, N. Y.



*California graduate reports:*

" . . . a new contract gives 83¢ an hr. raise over the next three years; now getting \$4.53 1/2 an hr. . . . also paid holidays."

Paul Van Wattering  
Van Nuys, Calif.

Eight years ago, I founded National School of Heavy Equipment Operation, the first school of its kind in the world. Since then, students from all 50 states and 28 foreign countries have been enrolled at National, and now hundreds of graduates are working in the construction field for higher wages than they ever made before!

Gilbert S. Shaw  
President and Founder



Decide NOW to train for high wages and job security as a Heavy Equipment Operator. Mail coupon TODAY for FREE illustrated School Catalog. No obligation. (Even if you are taking a course in heavy equipment operation — write for our catalog and compare your training with ours.)

**NATIONAL SCHOOL OF HEAVY EQUIPMENT OPERATION**  
Dept. A-36 P. O. Drawer 1686, Charlotte, N. C.  
Please send me FREE illustrated school catalog and complete information without obligation about how I can become an operator.

Name \_\_\_\_\_ Age \_\_\_\_\_

Address \_\_\_\_\_

City \_\_\_\_\_ Zone \_\_\_\_\_ State \_\_\_\_\_

back. Of course, the speedometer is rigged to the wheels and really tells how fast they're spinning. But we could build another speedometer around our spring-mass accelerometer:

Suppose we drive a little DC electric motor with the voltage from the accelerometer's pickoff potentiometer. The motor will spin as long as there is an acceleration, stop as soon as it ends.

The speed at which the motor's armature revolves corresponds to the voltage supplied by the pickoff potentiometer, which in turn corresponds to the acceleration. But the total number of turns that the armature makes, over a given period of time, corresponds to the velocity built up as a result of the acceleration during that same period.

Thus, all we have to do to get our accelerometer-driven speedometer is to attach an indicator needle to the armature of the little motor—over a high gear ratio, of course. Our new speedometer is the prototype of what guidance people call an "integrating accelerometer."

We could stick a second potentiometer on the needle axis of our new instrument, and drive a second electric motor with the voltage output. Since the picked-off voltage corresponds to the car's velocity, the second electric motor will spin at a rate corresponding to that velocity, and the total number of revolutions made by its armature will correspond to the distance traveled by the car. A needle attached to the second motor, again over a high gear ratio, will show the mileage covered—giving the same reading as the car's standard odometer. (The latter counts the total number of turns made by the wheels.) With the second electric motor we've performed the "second integration"—we have integrated velocity over time elapsed and found the distance traveled.

**Q** *Is there more to designing a practical rocket guidance system?*

**A** Yes. The designer is confronted with two principal kinds of difficulties:  
1. The rocket changes its attitude





# Cheer Up! Gear Up with

# GRAVELLY



## NEW Tools For Even More VERSATILITY!



## NEW Looks To Match *GRAVELLY'S* Unmatched **POWER-PERFORMANCE!**

Cheer up! Gear up with Gravely—say good-bye to drudgery, disappointments, half-done jobs!

And watch the neighbors' eyes pop when they see you riding your stylish new Gravely—they'll turn as green as that velvety lawn you have when Gravely does the mowing.

Ride or guide for complete versatility. Power your choice from 31 tools. Including NEW 50" Rotary Mower, NEW 20-gallon Sprayer. You choose from FIVE mowing tools, complete lawn and garden attachments . . . the unique Rotary Plow that gives you a perfect seedbed in one operation . . . the power Cultivator. Name the tool you need, Gravely's got it!

### ALL-GEAR DRIVE TO, THROUGH TOOLS

All GEAR-POWERED by the one Gravely Tractor. No belts or chains . . . INSTANT forward and reverse, plus your choice of high or low speeds . . . easy-handling with gear power to and

through the tool to get your tough jobs done fast!

Cheer up! Gear up to make your place a show-place with less drudgery, more satisfaction in a job well done—easily!

### FREE 'POWER VS. DRUDGERY' BOOKLET

See all about the new Gravely—in color! Check the Yellow Pages for your authorized Gravely Sales and Service representative. Or send for your free, BRAND NEW "Power vs. Drudgery" booklet . . . Write Now!



TRACTOR DIVISION

# Studebaker

C O R P O R A T I O N

5904 GRAVELLY LANE  
DUNBAR, WEST VIRGINIA



throughout the flight. At takeoff it stands upright. At injection into orbit it speeds along horizontally. Moreover, as it passes through the atmosphere, it is tossed around by turbulence and shifting wind, changing its attitude temporarily.

Our three orthogonal accelerometers must therefore be placed on a gyroscopically stabilized platform. However the rocket may turn and waver, the three accelerometers will now have and retain a fixed orientation in space. To meet the stringent accuracy requirements of inertial-guidance systems for space rockets, the stabilized platform must maintain its angular position within a fraction of a degree, for several hours.

2. Any mass permitted to make constrained movements is subject to friction. In our spring-mass accelerometer, for instance, the inert mass is constrained by springs, whose stretching or squeezing involves some friction. (Just bend a piece of wire a few times, rapidly, and feel the heat produced by the friction!) Also, unless the accelerometer

operates in a vacuum, there will be air friction. The potentiometer pickoff is another source of friction.

All this friction reduces the accuracy of the whole system. It is no overstatement to say that the success of modern inertial-guidance systems is the direct result of a relentless fight against friction. Many methods have been tested in this fight:

There are "flotation bearings" where the suspended mass floats in a fluid of equal density. There are "gas bearings" in which the suspended mass rides upon a cushion of air or nitrogen. There are electrostatic supports, and even magnetic supports, which utilize the strange effects of electrical superconductivity at extremely low temperatures.

Accuracy of the system is improved, too, by increasing the forces created by acceleration. Gyro accelerometers, utilizing the phenomenon of gyroscopic "precession," have proved superior to simple mass-spring accelerometers.

Further gains in accuracy have come

CONTINUED

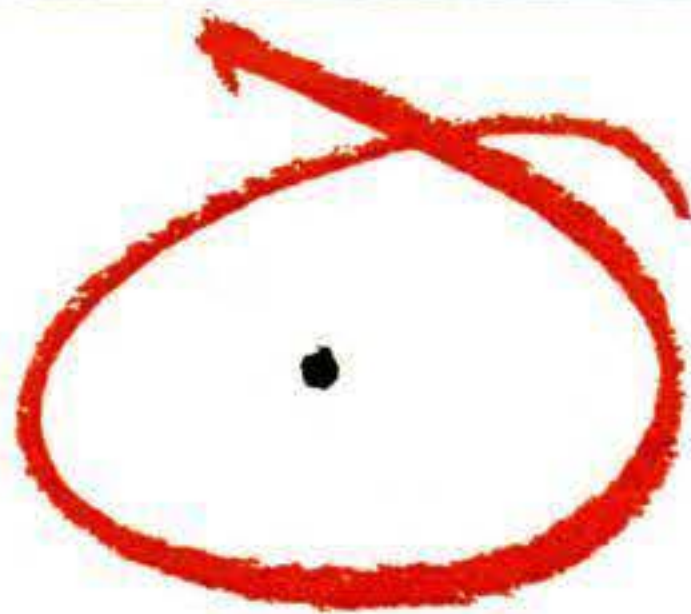

## SMALL SPECK... BIG TROUBLE... EASY CURE

It takes only a tiny speck of dirt or gum to foul up your car's carburetor. Small speck but big trouble . . . hard starting, loss of power, poor performance, wasted gasoline. Just add GUMOUT to your gas tank...it cleans your carburetor quickly and completely as you drive. Get GUMOUT today. Available from your service station or wherever automotive products are sold.

**GUMOUT DIVISION, Pennsylvania Refining Co., Cleveland 4, Ohio**





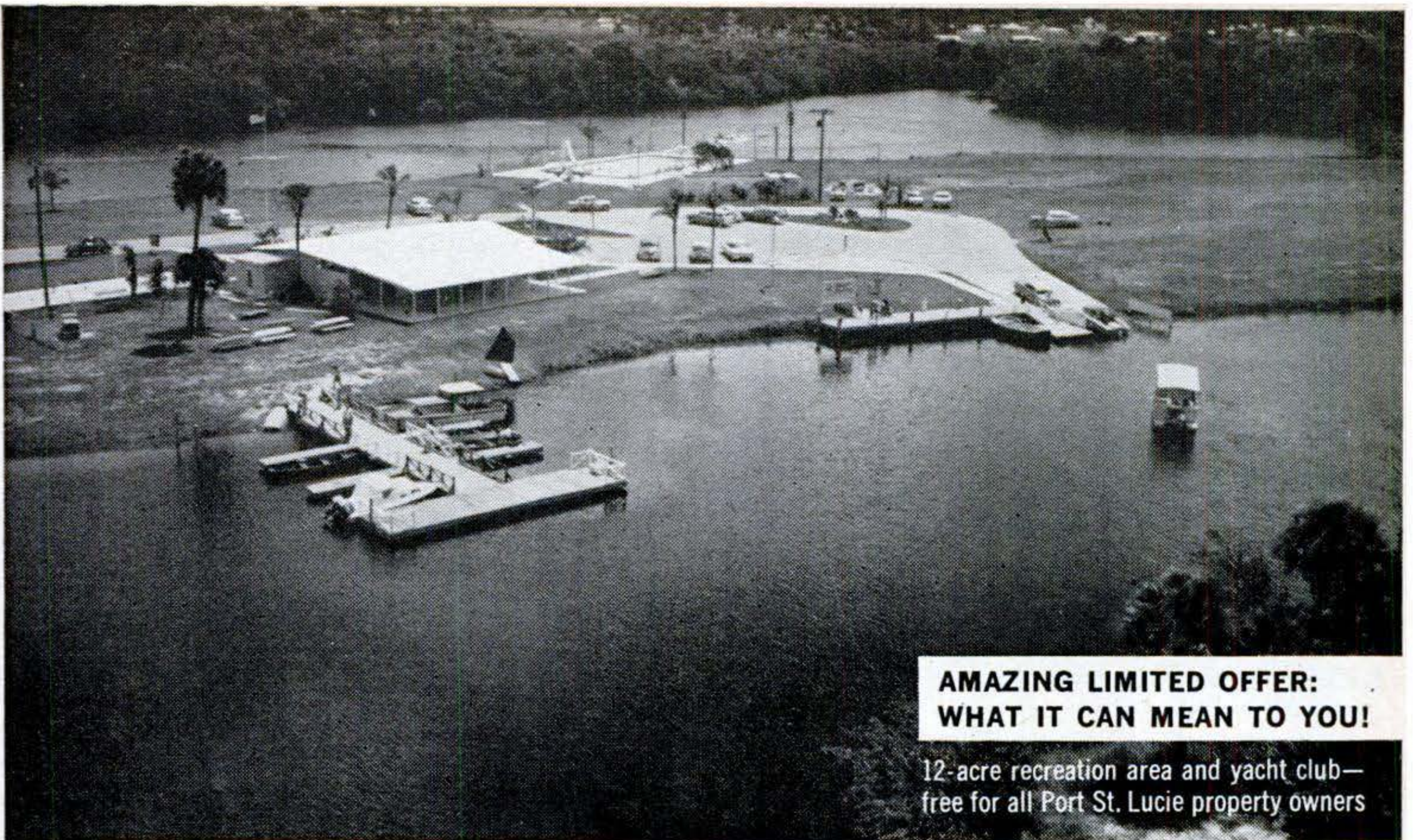

**AMAZING LIMITED OFFER:  
WHAT IT CAN MEAN TO YOU!**

12-acre recreation area and yacht club—  
free for all Port St. Lucie property owners

**FOR RETIREMENT... INVESTMENT... EMPLOYMENT**

**NOW YOU CAN RESERVE PRIME  
FLORIDA LAND FREE! NO OBLIGATION!**



*If you are seriously interested in Florida, for any purpose, for any time in the future, you owe it to yourself to learn the exciting facts about Port St. Lucie and Florida's*

**GIANT  
"PINCER OF  
PROGRESS"**

If you request it **at this time**, highly-respected General Development will tentatively reserve for you—and guarantee today's low price on it—most desirable land in superb, fully-equipped, economical Port St. Lucie... the community that dominates the area where both arms of Florida's huge "Pincer of Progress" are destined to meet! Up from the south come fabulous recreational facilities and opportunities... down from the north come the fruits of billions poured into the U.S. Space Exploration Program, including employment potential. Full facts and figures are yours, along with Property Ownership Plan which answers questions you have about Florida. **NO CHARGE! NO OBLIGATION!**



**COUPON ENTITLES YOU TO FREE RESERVATION PRIVILEGE**

GENERAL DEVELOPMENT CORPORATION K3-39  
P.O. Box 1308, Miami 34, Florida

Entirely **without cost or obligation**, tentatively reserve for me  one,  two or  three 80' x 125' homesites at beautiful Port St. Lucie, and rush me complete facts and figures which show what ownership (at today's low cost and modest \$15 monthly payment terms) can mean to my future.

MR.  
MRS.  
MISS.....

ST. & NO.....

CITY..... ZONE.....

COUNTY..... STATE.....

I'm primarily interested in:  Retirement  Investment  Employment. If retirement, check:  Plan to retire in less than 6 months.  More than 6 months, less than 3 years  Later than 3 years from now.

AD 58194(F-21)



# Do it all easily, quickly with a SWINGLINE STAPLE GUN

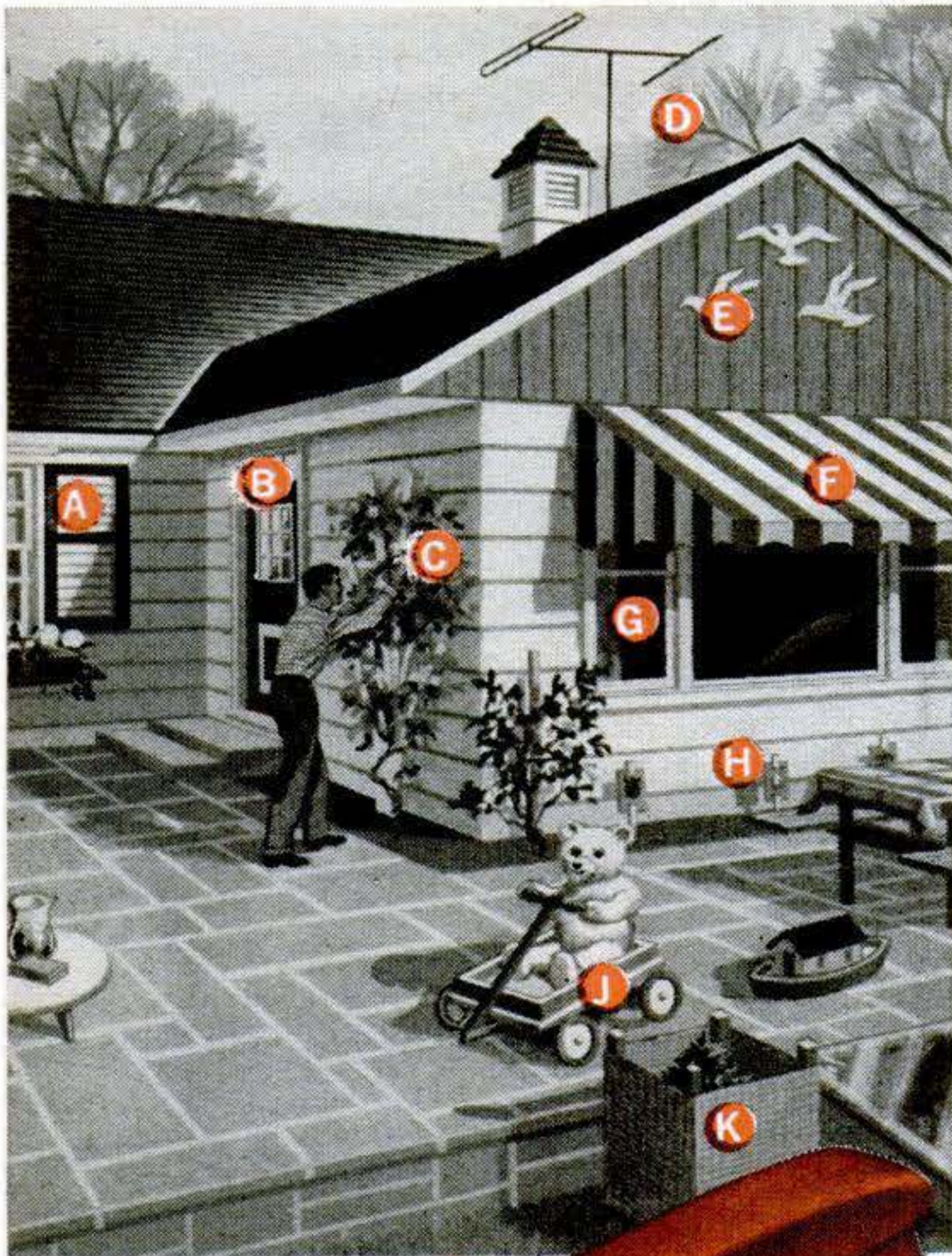

ONLY  
\$4<sup>95</sup>



- Push-button loading
- Built-in extractor
- Handle lock
- Rugged, heavy-duty steel construction
- Load indicator
- Open channel takes 2 staple sizes: 1/4" and 5/16"
- At better hardware, department, stationery stores

A Swingline Staple Gun makes immediately possible—and easy—all those time-consuming, hard-to-do chores both inside and outside your home.

- (A) Repairing shutter slats (B) Weatherstripping (C) Fastening plants, vines to trellis (D) Television antenna wire (E) Outdoor decorations (F) Awnings (G) Screening (H) Markers for seeding (J) Repairing toys (K) Burlap covers

**FREE!** Send for booklet on how to do many stapling jobs.

**Swingline**® INC.  
Long Island City 1, N.Y.

World's Largest Manufacturer of Staplers for Home and Office

26 POPULAR SCIENCE APRIL 1963

from performing integration operations, not with friction-plagued electric motors, but with friction-free electronic digital computers.

Present-day inertial-guidance systems can place a satellite in orbit with an injection accuracy of a few feet per second in velocity, and a fraction of a mile in altitude.

**Q** What is a solar battery?

**A** It is a source of electrical power for spacecraft. A solar battery is made up of a bank of solar cells. These are small shingles of pure silicon, whose outer surfaces have been contaminated by exposure to boron vapor. Sunlight striking these cells is converted directly into current. Here is how this works:

The smallest unit to which electricity can be reduced is the *electron*. Similarly, light energy cannot be subdivided beyond a unit called a *photon*.

A light photon impinging on the boron-contaminated surface of a silicon shingle is absorbed within a layer not exceeding 1/100,000 of an inch in depth. Its absorption invariably leads to the displacement of an electron. While free electrons are few and far between within the boron-containing layer, they are in ample supply in the pure silicon beneath. As a result, when enough energy has been imparted to a displaced electron to propel it from the boron-doped layer into the pure-silicon region, it is free to move into an external circuit where it helps to deliver power.

Solar batteries produce only a few watts of electrical power per square foot of panel surface. In order to drive high-powered transmitters for deep-space communication, they usually feed their weak but round-the-clock power into a chemical storage battery capable of high-power, short-time discharge. ■ ■

.....  
Dr. von Braun will consider answering questions from readers of POPULAR SCIENCE in the magazine, but he cannot undertake to answer each one by mail. Letters to him should be addressed in care of POPULAR SCIENCE, 355 Lexington Ave., New York 17, N. Y.





1963 Rambler Classic V-8 "770" 4-Door Sedan

Floor-shift option is one of four transmissions offered.

## ANNOUNCING RAMBLER CLASSIC WITH A BRAND-NEW V-8

"Car of the Year" now offers high-economy V-8 running mate to famous Classic 6

Here's America's newest V-8 —tested, proved and ready to bring you new V-8 performance and economy.

It's a maximum-efficiency performer with a new V-8 power train engineered for its new capabilities. And that's backed by a new and huskier suspension, new brakes, new

tire size . . . even an exclusive all-electronic alternator.

Result: you get the balanced performance of this V-8 with remarkable V-8 economy. And this easy-working 198-hp engine is yours for only \$105 more than a Classic 6.

See the new Classic V-8—now at your Rambler dealer!

**FREE!**  
**1963 CAR**  
**X-RAY**  
**BOOKS**



may save you hundreds of dollars. See comparisons of all popular '63 cars. Get yours —at your Rambler dealer!

# RAMBLER '63

Winner of Motor Trend Magazine Award: "CAR OF THE YEAR"



GET READY FOR THE SPACE and SCIENCE ERA! SEE SATELLITES, MOON ROCKETS CLOSE-UP



# AMAZING SCIENCE BUYS

for FUN, STUDY or PROFIT



See the Stars, Moon, Planets Close Up!

## 3" ASTRONOMICAL REFLECTING TELESCOPE

60 to 180 Power—Famous Mt. Palomar Type! An Unusual Buy!



Assembled—Ready to use! You'll see the Rings of Saturn, the fascinating planet, Mars, huge craters on the Moon, Phases of Venus, Star Clusters, Moons of Jupiter in detail, Galaxies! Equatorial mount with lock on both axes. Aluminized and overcoated 3" diameter high-speed f/10 mirror. Telescope comes equipped with a 60X eyepiece and a mounted Barlow Lens, giving you 60 to 180 power. Low-cost accessory eyepiece available for higher powers. An Optical Finder Telescope, always so essential, is also included. Sturdy, hardwood, portable tripod. FREE with Scope:

—Valuable *STAR CHART* plus 272 page "*HANDBOOK OF HEAVENS*" plus "*HOW TO USE YOUR TELESCOPE*" BOOK.  
Stock No. 85,050-N .....\$29.95 Postpaid

## 4 1/4" Astronomical Reflector Telescope!

255 Power. New Vibration-Free Metal Pedestal Mount.

Stock No. 85,105-N .....\$79.50 F.O.B.



## WAR SURPLUS! American-Made! 7x50 BINOCULARS

Big saving! Brand new! Crystal clear viewing—7 power. Every optical element is coated. An excellent night glass—the size recommended for satellite viewing. Individual eye focus. Exit pupil 7 mm. Approx. field at 1,000 yds. is 376 ft. Carrying case included. American 7 x 50's normally cost \$274.50. Our war surplus price saves you real money.

Stock No. 1544-N .....only \$74.80 pstd. (tax included)

## 'FISH' WITH WAR SURPLUS MAGNET

Go Treasure Hunting On The Bottom

Great idea! Fascinating fun and sometimes tremendously profitable! Tie a line to our 5-lb. Magnet—drop it overboard in bay, river, lake or ocean. Troll it along the bottom—your "treasure" haul can be outboard motors, anchors, fishing tackle, all kinds of metal valuables. 5-lb. Magnet is war surplus—Alnico V Type—Gov't. Cost, \$50. Lifts over 125 lbs. on land—much greater weights under water. Order now and try this new sport.



Stock No. 70,571-N 5 lb. Magnet .....\$12.50 Postpaid  
Stock No. 70,570-N 3 1/2 lb. size .....\$8.75 Postpaid  
Stock No. 85,152-N 15 lb. size, lifts 250 lbs. ....\$33.60 FOB

## MYSTERIES OF SPACE BROUGHT TO EARTH



Fascinating assortment of materials introduces you to space science—the mysteries of the universe. Includes full-color pictures of Mars, Saturn, Jupiter, sun spots, solar prominence; 3 giant star and space maps; completely illustrated "Story of Space;" "How to Use Your Telescope;" "Astronomy and You;" plus Diffraction Grating Replica that breaks up white light into all the glorious hues of the rainbow.  
Stock No. 9341-N.....\$2.50 Postpaid

## LARGE SIZE OPAQUE PROJECTOR

Ideal for photographers, this low-cost unit projects 3 1/2 ft. sq. image at 6 ft.—7 1/4 ft. sq. image at 12 ft. Projects photos, drawings, sketches, clippings, any opaque copy up to 6" x 6"—larger pieces in sections. Lenses are 2 plano-convex, 3 1/2" dia. mounted in 5 1/4" barrel. Projector is 11 1/2" high, 13 1/4" wide, 9" front to back, pressed steel in black wrinkle finish, bakelite handle. Uses two 200 watt bulbs—not included. Complete with side platform to hold illustrations, 6 ft. elec. cord, heat resist. plate glass mirror.  
Stock No. 80,066-N .....\$42.00 Postpaid



## MAIL COUPON for FREE CATALOG "N"

NEW! 1000's of Bargains—164 Pages

EDMUND SCIENTIFIC CO., Barrington, N.J.

Please rush Free Giant Catalog-N.

Name.....

Address.....

City.....Zone.....State.....

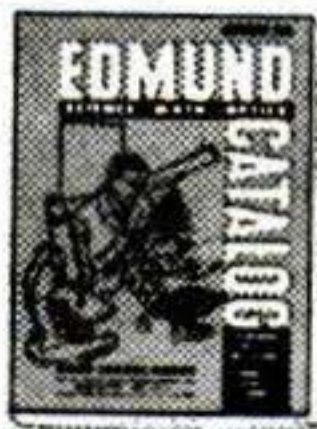

## Exciting New Color Experiments . . . FABULOUS DIFFRACTION GRATING REPLICA KIT

See Nov. "Popular Science" Article Featuring This Wonder Material in Christmas Lighting Projects.



This amazing material breaks up white light into deep, rich hues. Sparkles with all the color of the spectrum. Comes alive with the flashing brilliance of rainbow magic. Now you can create spectacular color-coordinated effects and decorations—inside & out—convert old, unwanted earrings, cufflinks, pendants, etc., into beautiful, iridescent pieces of jewelry. Real conversation piece, too. Kit contains 8 1/2" x 5 1/2" sheets of see-through (transmission) and reflecting type grating, mounted circular grating, unmounted transmission and reflecting types, round pieces of mounting, double-faced mounting tape, stereo viewer, and Edmund Diff. Grating Idea Book.

Stock No. 70,563-N .....\$5.00 Postpaid

TRANSMISSION TYPE (you see through it)

Stock No. 40,267-N 8" x 11" sheet .....\$1.50 Pstd.

Stock No. 50,180-N 8" x 6 ft. sheet ..... 5.95 Pstd.

REFLECTING TYPE (reflects spectrum)

Stock No. 50,201-N 8" x 11" sheet .....\$ 2.50 Pstd.

Stock No. 50,203-N 8" x 6 ft. sheet ..... 10.95 Pstd.

## WOODEN SOLID PUZZLES



12 Different puzzles that will stimulate your ability to think and reason. Here is a fascinating assortment of wood puzzles that will provide hours of pleasure. Twelve different puzzles, animals and geometric forms to take apart and reassemble, give a chance for all the family, young or old, to test skill, patience, and, best of all to stimulate ability to think and reason while having lots of fun. Order yours now.

Stock No. 70,205-N.....\$3.00 Postpaid



## MINIATURE WATER PUMP

Wonderful for experiments, miniature waterfalls, fountains, HO gage railroad backdrops, etc. Tiny (2 3/8" x 1 3/8") electric motor and pump ideal for hobbyists, labs, schools. Pumps continuous flow of water at rate of one pint per minute at a 12" head. With 2 D Batteries in series will pump to 24" high. Runs 48 hrs. on battery. Works in either

direction. Self-priming. Stock No. 50,345-N .....\$2.25 Postpaid



## OPAQUE PROJECTOR

Projects illustrations up to 3" x 3 1/2" and enlarges them to 35" x 30" if screen is 6 1/2 ft. from projector; larger pictures if screen is further away. No film or negatives needed. Projects charts, diagrams, pictures, photos, lettering in full color or black-and-white. Operates on 115 volt, A.C. current, 6-ft. extension cord and plug included. Operates on 60 watt bulb, not included. Size 12" x 8" x 4 1/2" wide. Weight 1 lb., 2 oz. Plastic case with built-in handle.  
Stock No. 70,199-N .....\$7.95 Postpaid



## BUILD A SOLAR ENERGY FURNACE

A fascinating new field. Build your own Solar Furnace for experimentation—many practical uses. Easy! Inexpensive! Use scrapwood! We furnish instructions. This sun powered furnace will generate terrific heat—2000° to 3000°. Fuses enamel to metal. Sets paper aflame in seconds. Use our Fresnel Lens—14" diameter . . .f.l. 14".  
Stock No. 70,130-N.....Fresnel Lens.....\$6.00 Postpaid

## 11" SQ. FRESNEL LENS F.L. 19"

Stock No. 70,533-N .....\$4.75 Ppd.



## HIGHLY VERSATILE, AUTOMATIC TIME SWITCH ASTRONOMIC TYPE

Sauter type. Originally used to turn lights "on" at dusk and "off" at dawn. Many other uses today. Automatic adjustment of "on-off" cycles for varying lengths of daylight and darkness. Trippers have 1 1/2 hour adjustment of "on" and "off" times. Swiss-made timing mechanism driven by Hayden synchronous motor (120W, 60C, 2.7W) Switches can be dismantled for parts mentioned above, plus 15 amp single pole, single throw switch, misc. gears. Housed in clear plastic cover. Hubbell 3-wire "Twist-Lok" male plug on base. Ht. 5 7/8"—in case 6 3/4" x 3 3/4" dp.

Stock No. 60328-N .....\$11.00 Postpaid



## INTRIGUING LOW-COST MOON MODEL

Exciting outer space display and conversation piece. Exact replica, 30,000 formations—peaks, craters, Ocean of Storms, etc.—all in relief. Scaled to size. Accurate distance relationships. Proper lighting shows moon phases; "black light" produces startling effects. Tough, washable plastic. Three colors. Far side blank—can be used for space data. Excellent gift item. 12" dia., wt. 3/4 lb.

Stock No. 70,515-N .....\$12.50 Postpaid

ORDER BY STOCK NUMBER . SEND CHECK OR MONEY ORDER . SATISFACTION GUARANTEED  
EDMUND SCIENTIFIC CO., BARRINGTON, N. J.



A monthly report: What's going on in science and why it's important to you

## PHYSIOLOGY

### Revolution in breathing

If mice, rats, and dogs can become water-breathing creatures, so can men. This is the conclusion of a scientist who kept mice alive for up to 18 hours under water and helped dogs to successfully re-adapt to normal respiration after breathing water.

These fantastic events took place in the laboratory of Dr. Johannes A. Kylstra at the University of Leiden, Netherlands. In this country, Dr. John W. Severinghaus of the University of California Medical Center is doing similar work with rats, but four hours is the longest they have survived under water.

Physiologists started wondering if it could be done after research indicated that unborn babies "breathe" in the womb, although their lungs are filled with fluid. It began to seem logical that lungs could serve as gills.

To give the animals a better chance to survive, Dr. Kylstra made special water by mixing up a balanced salt solution matching the salinity of body fluids that normally bathe the lung sacs (about a third as salty as the sea). The solution was buffered with a chemical that reacts with exhaled carbon dioxide. Then the concentration of dissolved oxygen was increased by shaking the fluid with pure oxygen under pressure. Animals enter the compression chamber through an air lock. A pressure of about eight atmospheres provides an animal with the amount of oxygen it would get from air, but Dr. Kylstra reports increased survival times at pressures up to 160 atmospheres (equivalent to the pressure a mile deep in the ocean).

Dogs removed from the chamber had their lungs pumped out with oxygen and have survived with no aftereffects. Mice are too small to make resuscitation practical, but the California researchers drained the lungs of their rats and even forced oxygen into their lungs. The rats lived for only half an hour in air, survived up to 21 hours

with positive-pressure oxygen breathing.

We asked Dr. Kylstra if his experiments lend credence to predictions made by Commandant Jacques-Yves Cousteau, inventor of the aqualung, that man will eventually be able to live beneath the sea without air-breathing apparatus. He replied, "If Cousteau could change the water in the oceans, he might be able to live as a true *homo aquaticus* . . . However, it might be possible to use an appropriate fluid instead of a gas mixture in a Scuba."

## SPACE

### Bones and Mercury 9

Will astronauts of the future come back from long voyages at zero gravity with rubbery bones? The ninth Mercury space flight may help answer that question.

Air Force Major Leroy Gordon Cooper Jr., whose flight was originally scheduled for April 2, will probably be the last man to orbit the earth in a Mercury capsule. But his trip will be the longest U.S. space voyage to date. Official plans are for at

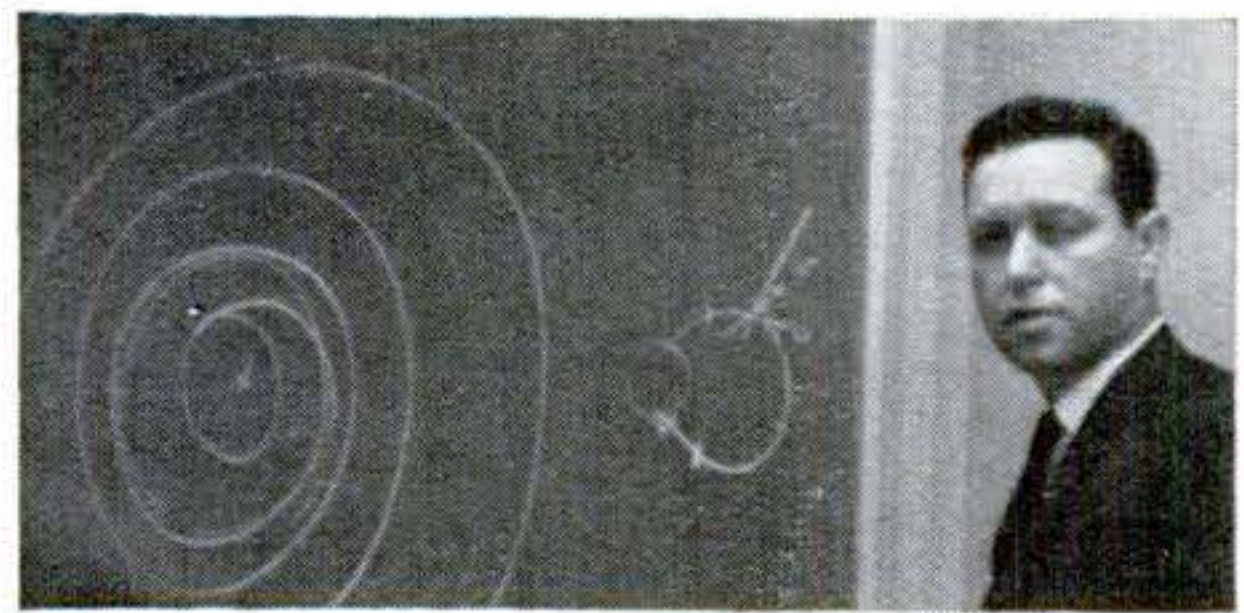

**Space broom.** To clean up the Van Allen belts [see "Van Allen Tells What Space Is Really Like," page 73], physicist Alan Rosen of Space Technology Laboratories suggests a large flat satellite that would spiral out from earth, knocking radiation particles harmlessly out of the belts. A satellite with an area of 250 acres would take 35 days to sweep all high-energy particles from the zone of the artificial radiation belt created by last summer's high-altitude bomb test. That's beyond the state of the art, he says, but smaller, slower space brooms may be feasible.



# FREE

## 1963 VACATION GUIDE TO NEW YORK STATE

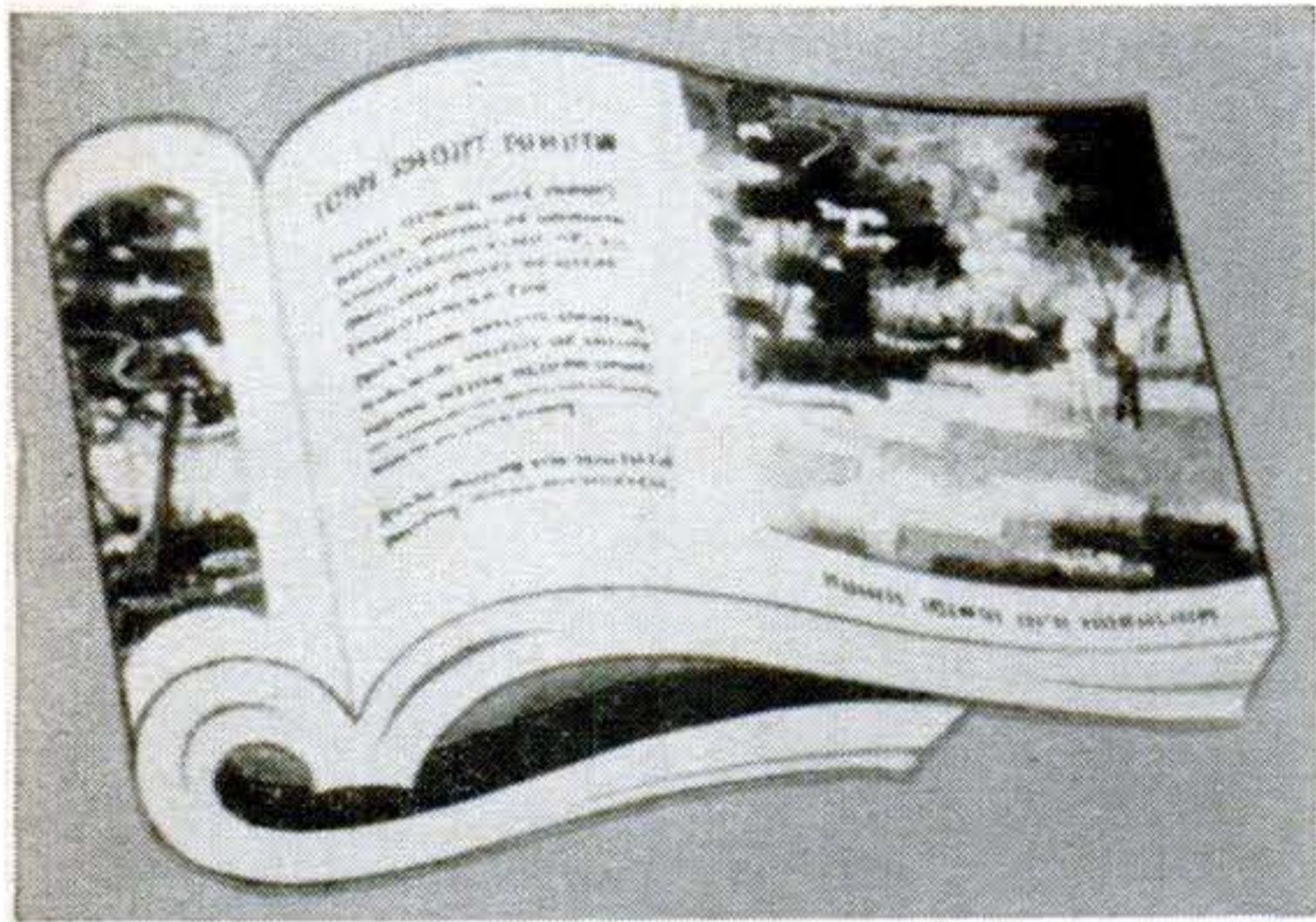

- 196 pages of vacation information . . . 140 full-color photos
- Describes hundreds of exciting vacation attractions and communities
- Tells how to get to each by car, train, plane and bus
- Lists 150 public golf courses
- New sections on boating, camping, state parks and touring
- Locates forts, battlefields and other historical sites
- Lists attractions for children

### A WORLD OF FUN AWAITS YOU THIS SUMMER AND AT THE WORLD'S FAIR, 1964-65

New York State Department of Commerce  
Dept. SC-11, P.O. Box 1350, Albany 1, N. Y.

Please send me the free 1963 "New York State Vacationlands" guide.

Name \_\_\_\_\_

Address \_\_\_\_\_

City \_\_\_\_\_

Zone \_\_\_\_\_ State \_\_\_\_\_

## Science newsfront continued

least 18 orbits (26 hours), maybe 22 orbits (34 hours). Cooper said in a press conference that he will go for more than 22 if his oxygen and fuel hold out. The launch was postponed for installation of an improved autopilot in the Atlas rocket.

There is some worry among space-medicine men that long periods of weightlessness may cause loss of calcium from the bones. At zero gravity, the usual bumps and stresses on the bones are eliminated, reducing the stimulus for normal replacement of bone material. Dr. Stanley C. White of the National Aeronautics and Space Administration says Russian space scientists have confided that they found increased calcium in the urine of their cosmonauts after the twin-orbit flight last August. During his Mercury flight, Cooper will collect urine samples periodically in a set of plastic bottles. Analysis of the urine may shed light on bone softening.

Other experiments are also aimed at collection of data on the physiological effects of weightlessness. Major Cooper is expected to sleep in orbit, perhaps alternating eight hours on duty with four hours of sack time. He will try out the new freeze-dried concentrated space food, which has to be reconstituted in flight by adding water; NASA officials say it's delicious. He will also let the air out of the Mercury capsule to test the emergency value of his space suit in case of sudden decompression.

---

**Extra-terrestrial news.** Two far-off stars recently exploded, producing a nova and a supernova. The brighter supernova, found by an Italian astronomer, is too far away to see without a large telescope (it's to the north in Coma Berenices). The nova can be seen with the naked eye in the early-morning sky (located to the northwest in Lyra, close to the bright star Vega). It was sighted almost simultaneously by a Swedish astronomer and an American amateur, Leslie C. Peltier of Delphos, Ohio.

---

### ELECTRONICS

#### More profound gyro

For years we've been getting along with gyropilots not much more complicated than their prototype, the toy top. The gyro it-



Cast your ballot for a successful future!

# 249 I.C.S. COURSES



I.C.S. is the oldest and largest correspondence school. 249 courses. Business, industrial, engineering, academic, high school. One for you. Direct, job-related. Bedrock facts and theory plus practical

application. Complete lesson and answer service. No skimping. Diploma to graduates.

Send for the 3 free booklets offered below and find out how I.C.S. can be your road to success.

## ACCOUNTING

Accounting  
Auditing  
Cost Accounting  
General Accounting  
Junior Accounting  
Practical Accounting  
Public Accounting

## ADVERTISING

Advertising  
Magazine & Newspaper  
Advertising

## ARCHITECTURE AND BUILDING CONSTRUCTION

Architectural Drawing & Designing  
Architectural Interiors  
Architecture  
Building Contractor  
Building Contractor with Drawing  
Building Estimator  
Building Maintenance  
Carpenter-Builder  
Carpentry & Millwork  
House Planning  
Lumber Dealer  
Mason  
Painting Contractor  
Reading Arch. Blueprints  
Reading Struct. Blueprints

## ART

Advertising Layout & Illustration  
Amateur Artist  
Commercial Art  
Commercial Cartooning  
Fashion Illustrating  
Figure Drawing & Painting  
Magazine Illustrating  
Show Card & Sign Prod'n  
Show Card Writing  
Sign Painting & Designing  
Sketching & Painting

## AUTOMOTIVE

Auto Engine Tune-up  
Automobile  
Automobile Body Rebuilding and Refinishing  
Automobile Electrical Technician  
Automobile Technician  
Diesel Engines

Diesel-Gas Motor Vehicle Engines  
Gas Engines  
Internal Combustion Engines

## AVIATION

Aero-Engineering Technology  
Aircraft & Engine Mechanic  
Aircraft Mechanic  
Aviation Engine Mechanic

## BUSINESS

Business Administration  
Business Correspondence  
Business Law  
Business Management  
Business Management & Marketing  
Business Management & Production  
Business Psychology  
Canadian Business Management  
Clerk-Typist  
Commercial  
Condensed Business Practice  
Federal Tax Course  
Managing a Small Business  
Marketing  
Office Administrative Engineering  
Office Management  
Professional Secretary  
Programming for Digital Computers  
Purchasing Agent  
Retail Business Management  
Shorthand  
Stenographic  
Typewriting

## CHEMICAL

Analytical Chemistry  
Chemical Engineering  
Chemical Engineering Unit Operation  
Chemical Laboratory Technician  
Elements of Nuclear Energy  
General Chemistry  
Industrial Analytical Chemistry  
Industrial Chemistry  
Professional Engineer—Chemical

## PULP AND PAPER

Paper Making  
Pulp & Paper Engineering

Pulp & Paper Making  
Pulp Making

## CIVIL ENGINEERING

Bridge & Building Foreman  
Civil Engineering  
Construction Engineering  
Highway Engineering  
Mine Surveying & Mapping  
Principles of Mapping  
Principles of Surveying  
Professional Engineer—Civil  
Railroad Engineering  
Roadmaster  
Sanitary Engineering  
Section Foreman  
Sewage Plant Operator  
Structural Engineering  
Surveying and Mapping  
Water Works Operator

## DRAFTING

Aircraft Drafting  
Architectural Drafting  
Drafting & Machine Design  
Electrical Drafting  
Electrical Engineer Drafting  
Electronic Drafting  
Industrial Piping Drafting  
Junior Mechanical Drafting  
Mechanical Drafting  
Sheet Metal Drafting  
Structural Drafting

## ELECTRICAL

Elec. Appliance Servicing  
Electrical Contractor  
Electrical Eng'r'g (Power Plant option—Electronic option)  
Electrical Engineering Tech.  
Electrical Instrument Tech.  
Electric Motor Repairman  
Illumination Eng'r'g Tech.  
Industrial Electrical Techn.  
Power-House Engineering  
Power Line Design and Construction  
Practical Electrician  
Practical Lineman  
Professional Engineer—Electrical  
Reading Electrical Blueprints

## HIGH SCHOOL

Good English  
High School Business  
High School College Prep (Arts)

High School College Prep (Engineering & Science)  
High School General  
High School Mathematics  
High School Secretarial  
Modern Letter Writing  
Short Story Writing

## LEADERSHIP

Industrial Foremanship  
Industrial Supervision  
Personnel-Labor Relations  
Supervision

## MATHEMATICS

Mathematics and Mechanics for Engineers  
Mathematics and Physics for Engineers  
Mathematics and Physics for Technicians

## MECHANICAL

Industrial Engineering  
Industrial Instrumentation  
Junior Mechanical Engineering  
Mechanical Engineering  
Professional Engineer—Mechanical  
Quality Control  
Introductory Technical Writing

## PETROLEUM

Natural Gas Production & Transmission  
Oil Field Technology  
Petroleum Production  
Petroleum Prod'n Eng'r'g  
Petroleum Refinery Operator  
Petroleum Refining  
Petroleum Technology

## PLASTICS

Plastics Technician

## PLUMBING, HEATING, AIR CONDITIONING

Air Conditioning  
Air Conditioning with Draw'g  
Air Conditioning Maintenance  
Domestic Heating with Oil & Gas  
Domestic Refrigeration  
Heating  
Heating & Air Conditioning with Drawing

Heating, Drawing & Estimat'g  
Plumbing  
Plumbing, Drawing & Estimating  
Plumbing & Heating  
Practical Plumbing  
Refrigeration  
Refrigeration & Air Conditioning  
Steamfitting

## RAILROAD

Air Brake Equipment  
Car Inspector & Air Brake  
Diesel Electrician  
Diesel Engineer & Fireman  
Diesel Locomotive  
Diesel Machinist  
Railroad Administration  
Railroad Car Repairer

## SALESMANSHIP

Creative Salesmanship  
Real Estate Salesmanship  
Retail Merchandising  
Retail Selling  
Sales Management  
Salesmanship  
Salesmanship & Sales Management

## SHOP PRACTICE

Boilermaking  
Electric Welding  
Foundry Practice  
Gas and Electric Welding  
Gas Welding  
Heat Treatment of Metals  
Industrial Metallurgy  
Machine Shop Inspection  
Machine Shop Practice  
Machine Shop Practice & Toolmaking  
Metallurgical Engineering Technology  
Physical Quality Control of Metals  
Practical Millwrighting  
Reading Shop Blueprints  
Resistance Welding Technology  
Rigging  
Safety Engin'r'g Technology  
Sheet Metal Worker  
Tool Design  
Tool Engineering Technology

Toolmaking  
Welding Engineering Technology

## STEAM AND DIESEL POWER

Combustion Engineering  
Power Plant Engineering  
Stationary Building Eng'r'g  
Stationary Diesel Eng'r'g  
Stationary Diesel-Electric Engineering  
Stationary Fireman  
Stationary Steam Eng'r'g  
Steam Engine Operation

## TEXTILES

Carding and Spinning  
Carding  
Cotton Manufacturing  
Cotton Warping & Weaving  
Dyeing & Finishing  
Hosiery and Circular Knitting  
Loom Fixing  
Spinning  
Synthetic Fabric Manufacturing  
Synthetic Throwing, Warping & Weaving  
Textile Designing  
Textile Engineering  
Textile Mill Supervisor  
Woolen Manufacturing  
Worsted Manufacturing

## TRAFFIC

Motor Traffic Management  
Railroad Rate Clerk  
Traffic Management

## TV-RADIO-ELECTRONICS

Gen'l Electronics Technician  
Industrial Electronics  
Practical Radio-TV Eng'r'g  
Radio Operating  
Radio Servicing  
Radio Servicing with Practical Training  
Radio & TV Servicing  
Radio & TV Servicing with Practical Training  
Servicing Electr'n'c Devices  
Servicing Sound Equi'p't  
Practical Telephony  
Telephony and Radio Communications  
TV Receiver Servicing  
TV Technician

For Real Job Security—Get an I. C. S. Diploma! I. C. S., Scranton 15, Penna.

Accredited Member,  
National Home Study Council

## INTERNATIONAL CORRESPONDENCE SCHOOLS



BOX H1751D, SCRANTON 15, PENNA.

In Hawaii reply P.O. Box 418, Honolulu

Without cost or obligation, send me "HOW to SUCCEED," the opportunity booklet about the field I have indicated below, and a sample lesson:

Name of the course in which you are interested \_\_\_\_\_

Your Name \_\_\_\_\_ Age \_\_\_\_\_ Home Address \_\_\_\_\_

City \_\_\_\_\_ Zone \_\_\_\_\_ State \_\_\_\_\_ Working Hours \_\_\_\_\_ A.M. to \_\_\_\_\_ P.M.

Occupation \_\_\_\_\_

Canadian residents send coupon to International Correspondence Schools, Canadian, Ltd., Montreal, Canada. . . . Special low monthly tuition rates to members of the U. S. Armed Forces.





# Compact Cost... Big Tractor Tough

**This one's no toy!** The International Cub Cadet is priced with other 7-hp lawn and garden tractors, but it's built like the big ones by the world's most experienced tractor maker. Clean-mow an acre an hour... mulch leaves... clean snow from walks and drives... handle every season's chores with speed and economy! For nearby dealer's name and Cadet catalog, write: International Harvester Co., Dept. PS-4, P. O. Box 7333, Chicago 80, Illinois.

INTERNATIONAL®  
**CUB CADET**® 

## Science newsfront continued

self is just a spinning flywheel; the rest of the mechanism is a sensing system to pick off the wheel's resistance to changes in direction.

But we're flying blind more and more these days—in airplanes, spacecraft, and submarines—so there's a need for more sensitive "inertial-guidance systems," as the sophisticated gyropilots have come to be called. Designers are looking more deeply into the nature of matter and energy to find things that point more steadily.

The experimental system shown in the photo is a "closed-circuit laser" figured out



by Sperry Rand. Instead of relying on the inertia of matter, it takes advantage of the constancy of the speed of light and exploits the "coherence" of the light produced by lasers—which means that the light waves put out by a laser are *in step*.

The four helium-neon gas lasers are stimulated by a radio frequency and synchronously emit coherent light in the infrared range (the visible light is an accompanying spurious emission). The coherent beams shoot out of both ends of each tube. Mirrors at the corners of the square bounce the light so that two counter-rotating beams are kept whirling around the sides of the square. The mirror at the far corner is half-silvered, allowing some of the light to pass through to a photocell in the camera-like box.

If the table stands still, the light waves reaching the detector are exactly in step, and the photocell notices no difference between them. But if the table rotates—even as slowly as a fraction of a degree per minute—the light waves traveling around the circuit in one direction are compressed, while those traveling in the other direction are stretched: There's a shift in the frequencies of the light waves (the Doppler



**JUST  
ADD  
A GALLON  
OF GAS  
AND YOU'RE  
READY TO GO  
225 MILES**



**FROM  
\$245**  
plus destination  
and setup charge

Up to 225 miles per gallon is no trick at all for the thrifty HONDA "50". But its amazing economy and low price tag are only the beginning. Thousands of Americans each month are discovering how much fun two-wheel travel can be... to work, to school, to outdoor recreation spots... on the HONDA "50". Traffic's a breeze. You can park the "50" anywhere. And HONDA's superb 4-stroke, 50 cc OHV power plant—the envy of engine manufacturers the world over—purrs like a kitten at 45 mph cruising speed. With its automatic clutch, 3-speed transmission and advanced, dual cam-type brakes front and rear, even a youngster can ride the HONDA "50" safely and easily the first time out! ■ Get acquainted with America's new riding habit (there are 4 beautiful models, including the all-new Trail "55") at one of the more than 800 HONDA dealers across the country. For the dealer nearest you, call Western Union by number and ask for OPERATOR 25. Or check your Yellow Pages.

**HONDA**

*World's Largest Motorcycle Manufacturer*

AMERICAN HONDA MOTOR CO., INC., P.O. BOX 19-488, LOS ANGELES, CALIF.

AMERICAN HONDA MOTOR CO., INC. Dept. PS-63-4  
P.O. Box 20918, Pico Heights Station, Los Angeles 6, Calif.

Please send literature on the HONDA "50" line to:

NAME \_\_\_\_\_

STREET \_\_\_\_\_

CITY \_\_\_\_\_ ZONE \_\_\_\_\_

STATE \_\_\_\_\_ PHONE \_\_\_\_\_

I am especially interested  
in HONDA TRAIL "55".

Include literature on  
complete HONDA motorcycle line  
(9 models from 125 to 305cc).



shift). [For a navigational system based on the Doppler effect, see "Flying the Atlantic Without a Navigator," page 86.] Now the two beams are no longer in step, and their wave trains interfere with each other. The difference between the two emerges as a frequency that is sensed by the photocell.

**PSYCHOLOGY**

**Two weeks in a blank world**

A "don't-give-a-darn attitude" that lasted up to eight days was the way three men felt after spending 14 days alone and in virtual isolation from their own senses. The experiment was made at the University of Manitoba, Canada, under the supervision of Dr. John P. Zubek.

Individually, two college seniors and a professor spent two weeks in a dome-shaped chamber with toilet facilities and an air conditioner, but with no furniture except an air mattress. Their contact with even this limited environment was muffled by heavy pajamas, fluffy gloves, translucent goggles, and ear muffs wired for "white noise"—a hiss like that of a radio tuned to no station. Food was handed in through a trapdoor in the floor. Singing or talking was not allowed, and the subject was monitored by intercom and closed-circuit TV. The students were each paid \$300 for participating.

Brain waves were recorded at intervals; they slowed down considerably below normal. In contrast to some experiments of a similar nature, the men reported only mild visual hallucinations, such as flickering points of light. But they thought they heard birds singing and waves splashing. When they came back to the world, colors seemed unusually vivid.

Most sensory-deprivation experiments last only a few days. Loss of motivation resulting from long stays in solitary may help us understand the experiences of prisoners of war better, Dr. Zubek said. ■ ■

**Ancient hipsters.** Word from the tomb is that Egyptians used opium the way we use aspirin. They thought it had health-giving properties, used it as a cure-all, painkiller, and pacifier for crying children, according to R. S. Merrillees of University College, London.

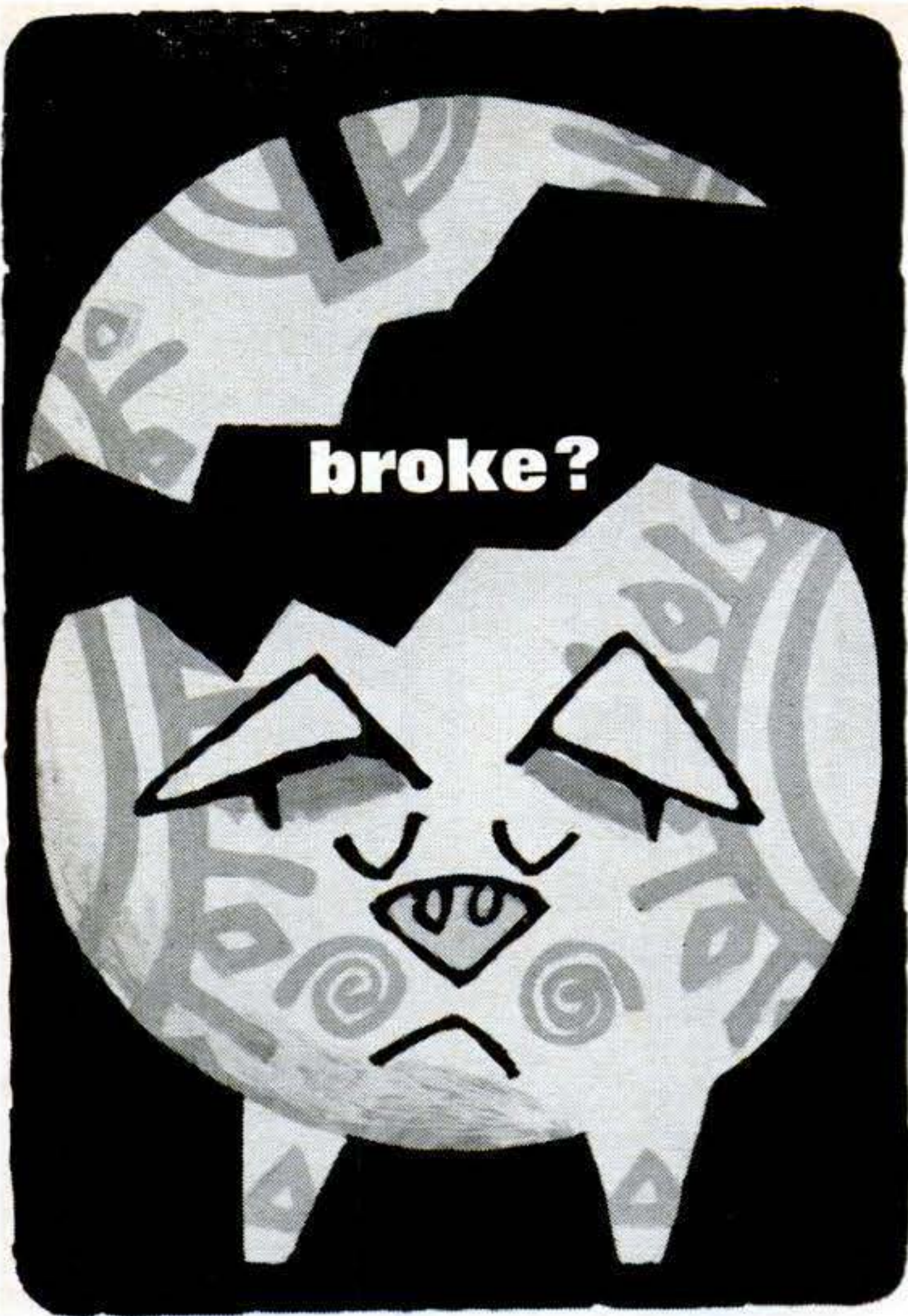

**FIX IT FOR KEEPS WITH "DUCO" CEMENT**

**Faster, neater. Mends china, glass, leather, wood, paper, metal. Clear, waterproof, quick-setting.**

[P.S. For plastics, use new Du Pont Plastic Cement.]



BETTER THINGS FOR BETTER LIVING . . . THROUGH CHEMISTRY



**SAMURAI SUICIDE WARRIORS KARATE!**  
**JUDO BOXING! MUSCLEBUILDING! YOGA!**  
**STRONGMAN STUNTS! STRENGTH & ENDURANCE! HANDBALANCING! ETC.**

YOU GET ALL THESE! ●20 illustrated KARATE blows ●SAVATE foot fighting ●Secret NERVE CENTER and ANATOMY charts ●20 lethal JUDO throws ●20 terrific STRONGMAN STUNTS ●Complete MUSCLE-BUILDING program ●Ancient YOGA secrets ●HANDBALANCING stunts ●Complete BOXING program ●Secrets of ENDURANCE ●WRESTLING holds ●WEIGHTLIFTING section ●ALL COURSES cram-packed with illustrations ●Giant Wall Charts No C.O.D. Two sets only \$1.00 with extras.

**FOR ONLY 35¢**

**K-MAN** Huge KARATE PRACTICE DUMMY Life like! Shows attack points, nerve centers, weak spots. 15¢ with 35¢ order only. Total 50¢.

OXFORD STUDIO, 44F28 Bromfield St., Boston 8, Mass.

NAME (print) .....  35c Program  
 Address .....  
 City ..... State.....  50c with K-man



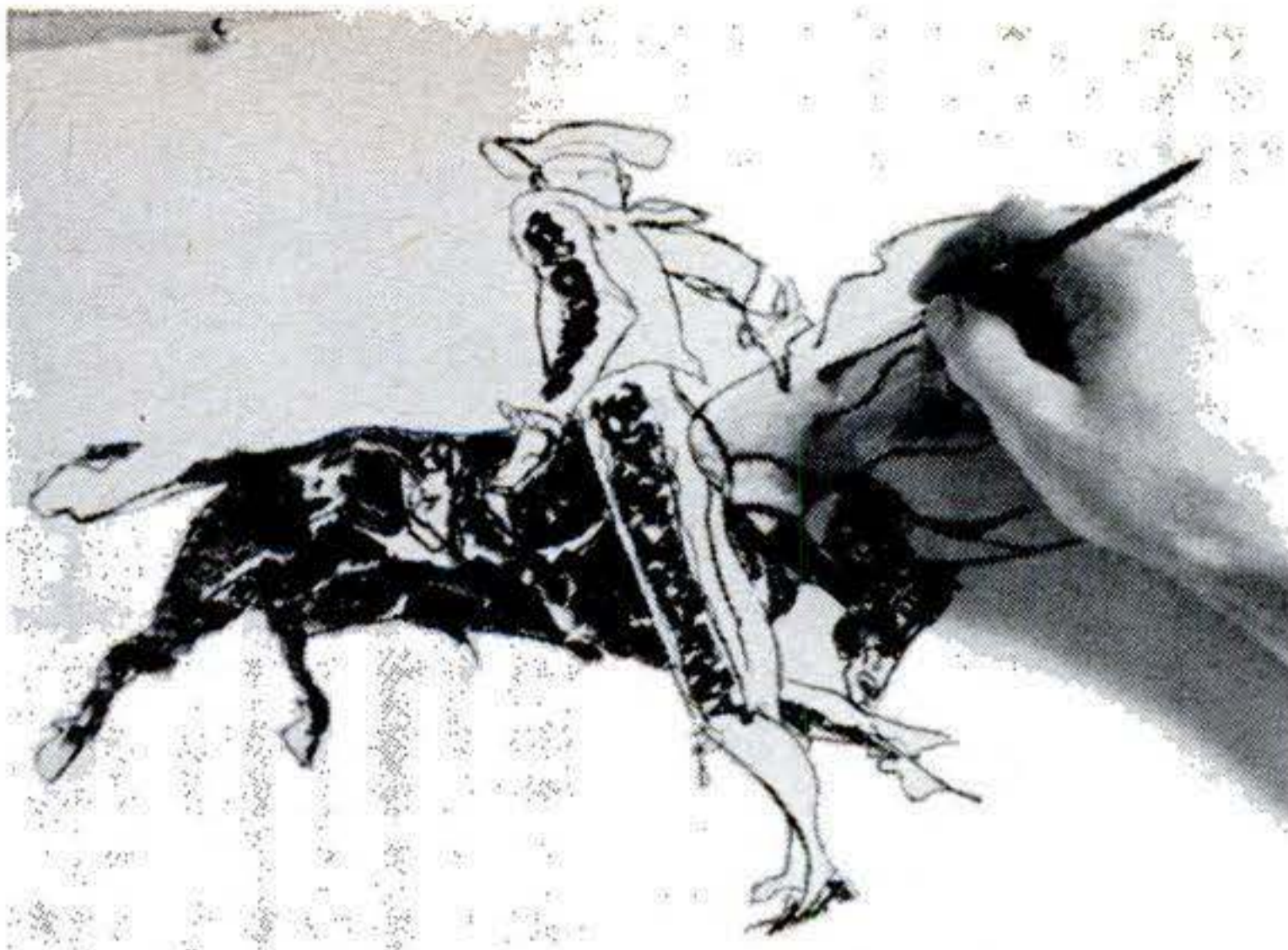

**Magazine illustrating** is a fascinating field—highly paid, too. Fresh new art talent being sought for designing covers and illustrating the stories.



**Fashion artists** now in demand all across the country. Opportunities for both men and women artists. A field rapidly expanding, glamorous.



**Posters, Signs.** You see them outdoors, in stores, theatres, everywhere. For many different products and purposes. Each designed by an artist.



**Advertising artists** are needed by the thousands. By stores, firms, advertising agencies, commercial art studios, publishers. Even beginners welcomed.

## Commercial Art Talent Hunt Open to You

In every branch of commercial art today—advertising, magazine illustrating, cartooning, greeting card design and many others—there is opportunity for both men and women.

An appraisal of your talent is given without charge by Art Instruction Schools, and without obligating you in any way.

All you need do is take the art talent test the school uses to screen prospective students for its home study course in commercial art. You take the test at home, then return it to the school. Experienced commercial artists review your test and tell you, frankly, whether

your talent could be developed for an art career.

More artists practicing today were trained by Art Instruction Schools than by any other art school. Step-by-step lesson assignments are furnished. Also illustrated art textbooks. These demonstrate the techniques of some of America's best known artists including John Clymer, Post cover illustrator, and Charles M. Schulz, creator of the cartoon strip "Peanuts".

How talented are you? Find out now by taking this school's art talent test. No cost, no obligation. Mail the coupon today.

-----

**ART INSTRUCTION SCHOOLS**  
 Studio 4143  
 500 So. 4th St. • Minneapolis 15, Minnesota

*Please send me your Talent Test without cost or obligation. (PLEASE PRINT)*

Name \_\_\_\_\_

Occupation \_\_\_\_\_ Age \_\_\_\_\_

Address \_\_\_\_\_

City \_\_\_\_\_ Zone \_\_\_\_\_

County \_\_\_\_\_ State \_\_\_\_\_

Accredited by the Accrediting Commission of the National Home Study Council





# Getting Ahead By Dr. Lewis R. Fibel

A monthly column to help you prepare yourself for a better job

**The U.S. Patent Office** in Washington, as most inventors know, is *the* place to search for information relating to their ideas and, eventually, the authority that must approve their patent applications. It takes time and highly competent patent examiners to do this work.

Now David L. Ladd, Commissioner of the Patent Office, has announced a plan to train high-school graduates as aides to patent examiners. The program will include formal and on-the-job training in Washington. Starting salary is \$3,820 a year, with increases up to \$8,400. And there'll be opportunities for promotion.

Applicants must have a good background in high-school science and mathematics and qualify in a nationwide Civil Service examination to be given this year.

**A graduate program in space science** financed by the National Aeronautics and Space Administration will begin next September at the University of Texas (Austin). NASA wants to encourage Ph.D. candidates in the fields of space and space-related subjects.

Some of the general research projects planned are spectroscopic analysis of planetary radiation, studies of extreme-temperature effects on structural materials, air purification in spacecraft, solar-energy power plants, and the crystal structures of rare-earth compounds.

Some specific Project Apollo-related activities will be temperature mapping and radar studies of the moon, design of temporary housing for use on the moon, and satellite motion in the vicinity of the earth and the moon.

**"I am connected with the engineering and service divisions of a large corporation. I travel extensively so can't**

**attend night-school classes, but I'd like to work for a degree in mechanical engineering. Are there correspondence schools that offer college-accredited courses in mechanical engineering?"**  
—G.C.L., San Francisco.

Generally you can't get a degree through correspondence courses alone. A number of colleges and universities in the country will allow one or two years of home study toward a degree, but no more. You should check this carefully with the dean of the college for any correspondence work.

The following colleges, accredited by the National Extension Association, do offer correspondence work in mechanical-engineering subjects.

University of Arkansas, Fayetteville.

Brigham Young University, Provo, Utah.

University of Colorado, Boulder.

University of Tennessee, Knoxville 16.

**"I would like to work on research-and-development programs being carried out on advanced manned, lunar, and earth-orbital space projects. What kind of an education would I need? Where can I get it?"**—C.W., Kansas City, Mo.

American space programs are so varied and so complex that they require large numbers of scientists, engineers, technicians, and craftsmen of all kinds.

In general, top research men require specialized education through the doctorate (Ph.D.), but they are assisted by large numbers of scientists and engineers with master's and bachelor's degrees, technicians who are graduates of technical institutes and similar programs, and countless others with a variety of practical and theoretical training. You can get



**NOW!**



**YOU CAN CASH IN ON A VIRTUALLY  
UNTAPPED MARKET...WITH THESE  
ALMOST UNIVERSALLY NEEDED**

**"LIFETIME" CONCRETE INCINERATORS**

**NO PREVIOUS  
EXPERIENCE  
NECESSARY**

**MAKE IT YOURSELF WITH 88¢ WORTH  
OF SAND AND CEMENT**

**SELL IT FOR  
\$20<sup>00</sup>**



**FILL IN AND MAIL  
COUPON AT ONCE  
...NO OBLIGATION!**

**SPARE OR FULL TIME MONEY-MAKING**

Start small in your spare time to supplement your present income . . . build it up into a full time business that can earn you greater financial security than you ever dared hope for.

**ACT NOW FOR EXCLUSIVE  
PROTECTED FRANCHISE**

No competition . . . many choice exclusive territories still available. Write immediately for full details. Help yourself to a greater measure of financial independence.

**A VAST EVER-GROWING MARKET**

Nearly 80% of all homes have inadequate, unsatisfactory or unsafe incineration facilities. Experience shows that even steel incinerators are prone to rusting out and burning out. This is your market . . . a huge one that keeps growing year after year as the population explodes . . . and more and more new homes continue to mushroom in all directions.

**A SUPERIOR "LIFETIME"  
INCINERATOR—VOLUME PRICED**

Imagine . . . for only 88¢ worth of sand and cement, you can manufacture "LIFETIME" CONCRETE INCINERATORS that are rust-proof, fireproof, weatherproof, frost-resistant . . . almost indestructible . . . AND SELL THEM FOR \$20.00 each . . . and more . . . by far the best value of its kind.

**SELL THRU RETAIL STORES, TOO**

TOR franchisees are manufacturing "LIFETIME" concrete incinerators in large quantities for large department stores, hardware stores, mail order houses and garden supply stores, with tremendous success.

**NO SPECIAL EXPERIENCE OR PLANT**

Just follow the simple instructions . . . all needed equipment, welded steel, heavy duty lifetime molds, literature and other selling aids supplied. Set up shop in your own basement, backyard or garage.

**FULL INFORMATION WILL BE RUSHED TO YOU.**

Dept. PS-43  
T. C. TOR  
318 Rancocas Avenue  
Delanco, New Jersey

Gentlemen:

Please rush full information about your Concrete Incinerator Protected Franchise Offer . . .

Name \_\_\_\_\_

Address \_\_\_\_\_

City \_\_\_\_\_ Zone \_\_\_\_\_ State \_\_\_\_\_



# EARN MORE-LEARN AUTO DIESEL MECHANICS

## OR TRAIN WITH OTHER GREER DIPLOMA COURSES

- |   |   |
|---|---|
| <input type="checkbox"/> AUTO MECHANICS       | <input type="checkbox"/> REFRIGERATION        |
| <input type="checkbox"/> DIESEL MECHANICS     | <input type="checkbox"/> AIR CONDITIONING     |
| <input type="checkbox"/> BODY & FENDER REPAIR | <input type="checkbox"/> MACHINIST-TOOL & DIE |
| <input type="checkbox"/> GAS, ARC WELDING     | <input type="checkbox"/> AUTOMATIC            |
| <input type="checkbox"/> HELIARC WELDING      | <input type="checkbox"/> TRANSMISSIONS        |
| <input type="checkbox"/> DRAFTING             | <input type="checkbox"/> MOTOR TUNE-UP        |
- Civ. or  G.I.

Skilled men are needed in every part of the country. Earn top pay in established shops or start your own business. Greer's expert instruction and actual shop training teaches you how. You learn by doing—quick, easy courses using the latest tools and equipment. Day, evening and part time instructions available.

Job placement aid and convenient living accommodations are yours while training. Contact GREER'S FREE JOB PLACEMENT SERVICE when you enroll if you wish part time or full time employment assistance.

### TECHNICIAN COURSES

- DIESEL AUTOMOTIVE TECHNICIAN—21 MONTHS
- REFRIGERATION & AIR COND. TECHNICIAN—17 MONTHS
- WELDING TECHNICIAN—14 MONTHS

Please rush me free literature on the trade indicated at no obligation.

NAME \_\_\_\_\_ AGE \_\_\_\_\_

STREET \_\_\_\_\_

TOWN \_\_\_\_\_ ZONE \_\_\_\_\_ STATE \_\_\_\_\_

Established 1902

# GREER SHOP TRAINING

Box P, 2238 S. Michigan Ave. Chicago 16, Ill.

*Nothing fits  
your CB needs  
like hallicrafters'  
new transistorized CB-5!*

- Weighs less than 7 lbs. • Size only 10¼" x 8¼" x 3¼"
- 18 transistors, 3 instant-heat tubes
- Battery drain only .225 amps. on receive standby
- Instant warm-up • 6 crystal-controlled channels
- 100% modulation, 5 watts input • Sensitivity less than 1 µv for 10 db. S+N/N



Accessories for maximum versatility  
AC Pedestal Power Supply  
Portable Battery Pak  
Tone-Coded Squelch

**\$199.95** accessories optional extra

For complete literature write to



## hallicrafters

5th and Kostner Aves.,  
Chicago 24, Illinois  
Dept. 4C



a more complete picture from the following booklets:

*Science and Your Career* (Bureau of Labor Statistics, U.S. Department of Labor, Washington 25, D.C.).

*How to Get into Science and Engineering* (Science Service, 1719 N Street, N.W., Washington 6, D.C.).

*Should You be a Scientist?* (New York Life Insurance Co., Box 51, Madison Square Station, NYC 16.).

**"I am a high-school sophomore and hope to become an executive pilot. How do I go about it?"—S.R., Santa Rosa, Calif.**

Airline pilots with a flair for administrative work can move into supervisory and executive jobs, but the opportunities are limited. In any case, you first must become a pilot. Most scheduled airlines start their men as copilots, or sometimes flight engineers. "Beginners" usually are expected to have had between 500 to 1,000 flying hours and must meet rigid physical tests. Some airlines require at least two years of college, and prefer college graduates.

A young man may obtain the necessary knowledge, skills, and flight experience through military service or from a private flying school. He must then pass a physical and a written examination given by the Federal Aviation Agency.

**"How or where can I get the complete picture on electronic engineering?"—E.D., Los Angeles.**

I recommend the following publications:

*Electronics—Career for the Future* (Institute of Radio Engineers, Inc., 1 E. 79th St., NYC 21).

*The Indispensable Man—The Electrical Engineer* (American Institute of Electrical Engineers, 33 W. 39th St., NYC 18, 20 cents).

.....  
Send your questions on careers and technical training to:

Getting Ahead Editor, POPULAR SCIENCE  
355 Lexington Ave., New York 17, N.Y.  
Not every question may be used. Questions cannot be answered by individual letters.



LOOKING FOR EXTRA COMFORT AND LONGER WEAR?

# Herman SERVICE SHOES

with **NEOPRENE SOLES!**



Style No. 5690



Better Things for Better Living . . . through Chemistry

Herman service shoes are big on comfort . . . long on wear. It's the way they're made. Fully cushioned insoles combined with soft, flexible uppers bring day-long comfort to active men on the job. Soles and heels of tough DuPont Neoprene give extra-long wear . . . more miles to the pair. Neoprene resists oil, grease, chemicals and cold-weather cracking . . . helps reduce fatigue because of its lasting resilience. Write Du Pont, Dept. PS-4-NS, Wilmington 98, Del.

Look for Neoprene soles when you buy Herman service shoes

## TREAT YOURSELF TO THE FUN OF LANDSCAPING

WITH A

# BOLENS HUSKY

*For tilling, grading, seeding and mowing*

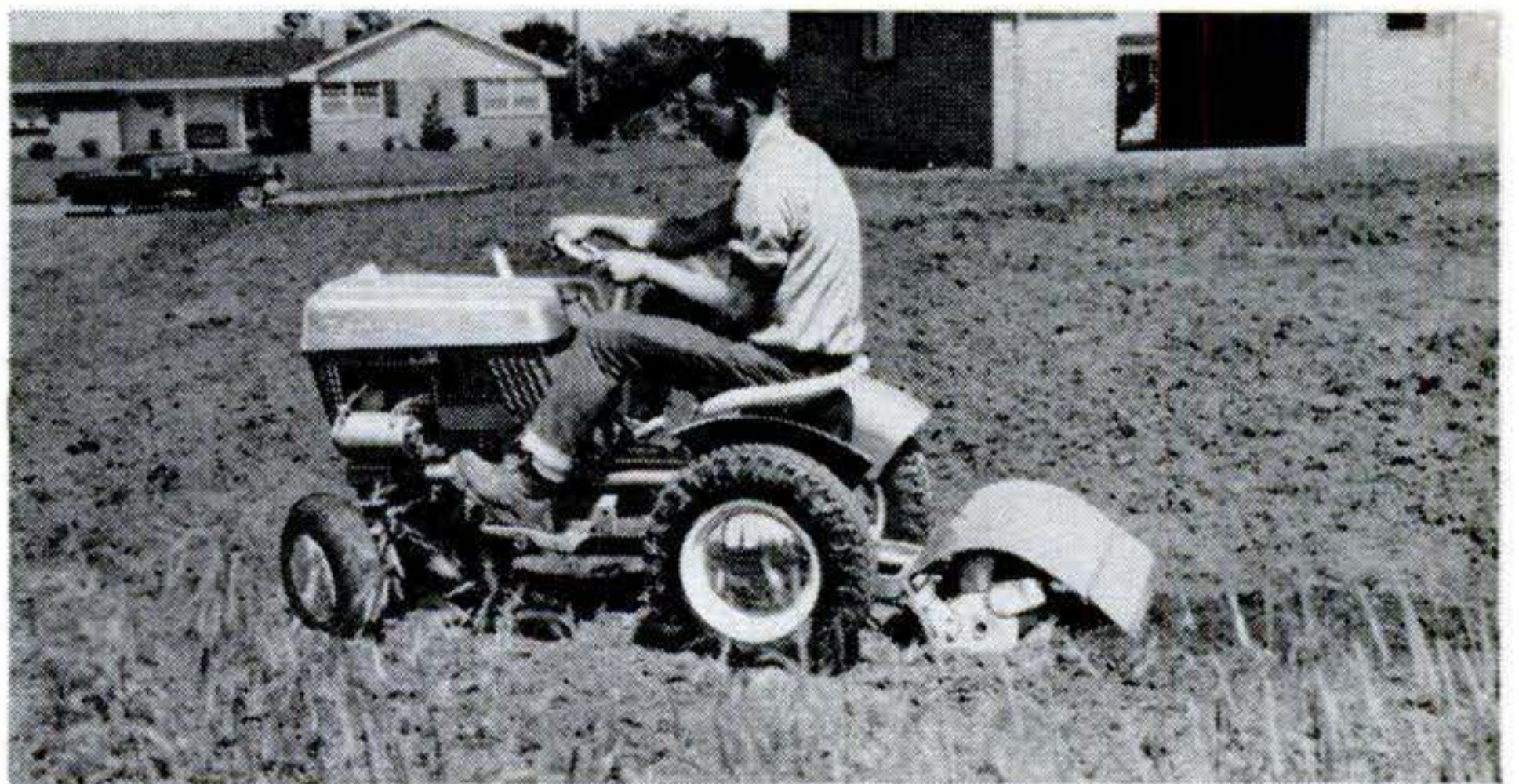

Landscaping is an easy job with a Bolens HUSKY . . . it's fun to maneuver. This rugged performer, with Fast-Switch attachments will grade, till, seed, mow and fertilize your lawn (in winter it's a plow or snow caster) • Best part is the Fast-Switch Attachment System — lets you change powered attachments in less than a minute • PTO drive-shaft powers attachments . . . no belts to align or break • Geared transmission and two speed ranges give you 6 speeds forward, 2 reverse from less than 3/4 mph to 6 mph. See your Bolens dealer today. He'll be happy to demonstrate a Bolens HUSKY. Available in 2 models: 7 1/4-hp HUSKY 800 and 6-hp HUSKY 600.

**BOLENS DIVISION, FMC CORPORATION**  
Dept. HD-32-8, Port Washington, Wisconsin

Send me more information about HUSKY tractors.

NAME .....

ADDRESS .....

CITY ..... ZONE ... STATE .....

**fmc** **BOLENS** DIVISION  
PORT WASHINGTON, WISCONSIN  
*America's Finest Outdoor Power Equipment*

8-63



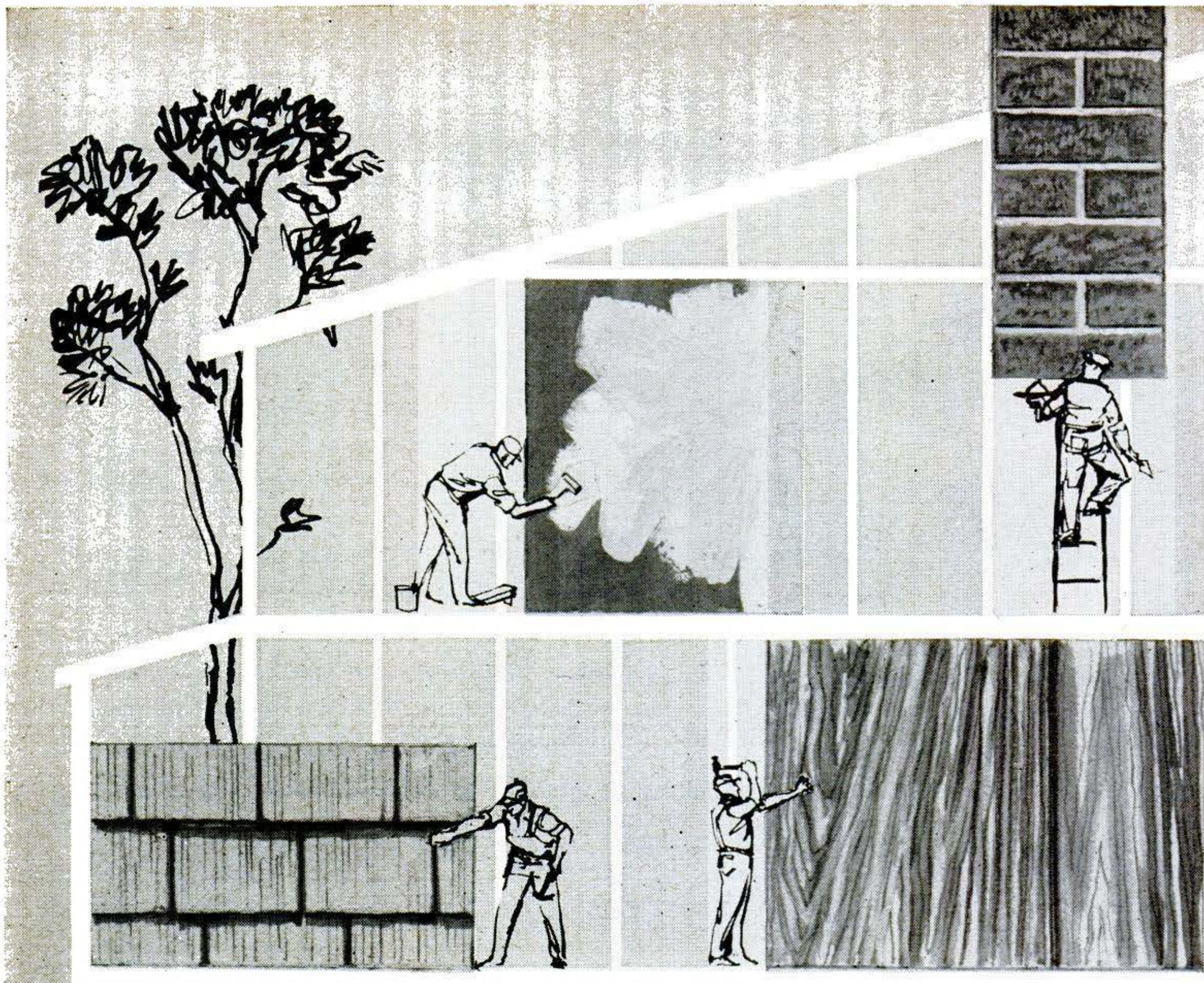

## YOUR BUILDING MATERIAL DEALER

Take advantage of the know-how, equipment and years of experience your neighborhood Lumber & Building Materials Dealer offers you!

That dream home or super remodeling idea you've seen in **POPULAR SCIENCE** can be a reality with the help of this friendly dealer. As a member of the NLBMDA, your local dealer is pledged to serve you honestly, efficiently and economically. He is pledged to provide you with the best of materials and keep you posted on the latest methods and products to save you money.

Make Your Lumber & Building Materials Dealer Your One Stop Shopping Center For Home Improvement.

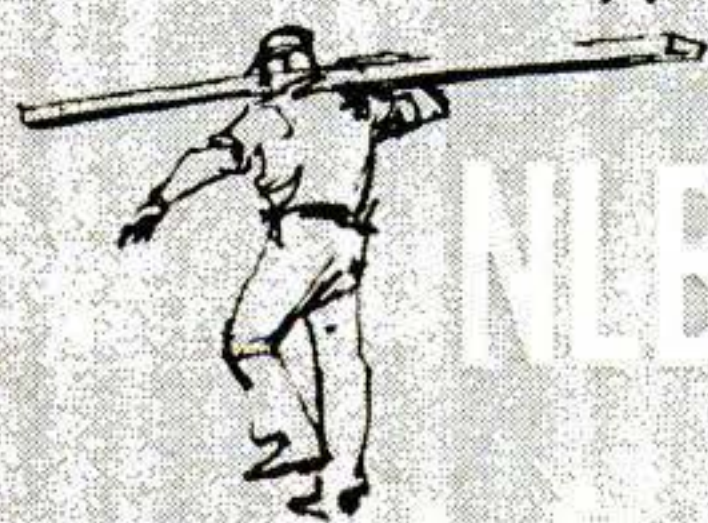

NLBMDA

NATIONAL LUMBER &  
BUILDING MATERIAL DEALERS ASSOCIATION  
18 & M STREETS, N.W., WASHINGTON 6, D.C.



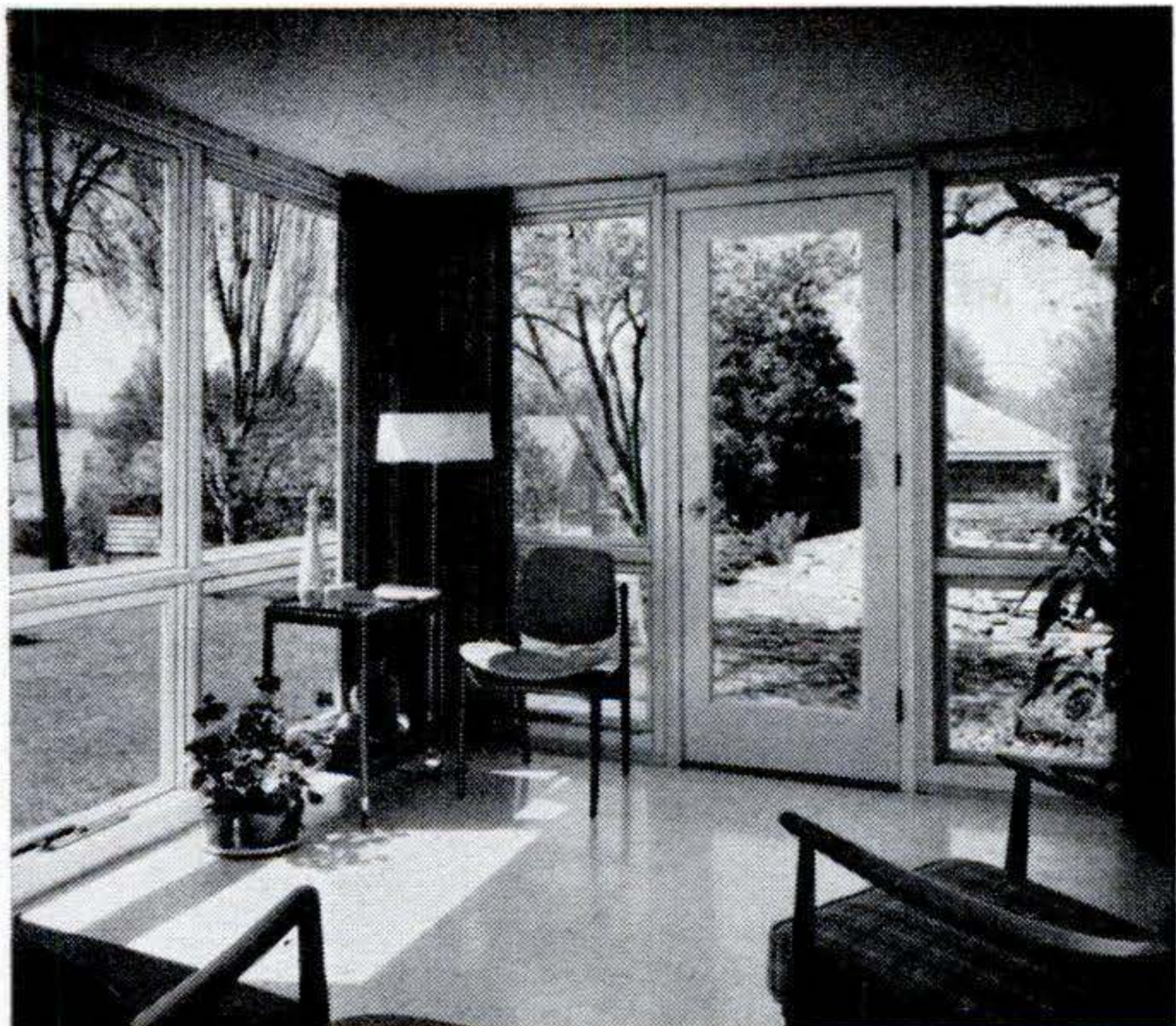

**Want an easier way to enclose your porch?** Andersen Windows are the perfect way to turn your drafty porch into a spacious, year-around family room. And you can get the care-free convenience of welded insulating glass that will eliminate the need for storm windows . . . give you two fewer glass surfaces to clean.

CLIP AND MAIL TODAY!

# FREE!

## WINDOW PLANNING IDEAS FOLDER

to help you make your porch a comfortable, year-around family room. Send today for new, full-color folder packed with illustrated ideas and a complete description of the Andersen Window line.

- I plan to build.  
 I plan to remodel a \_\_\_\_\_

Mr. \_\_\_\_\_  
 Mrs. \_\_\_\_\_

Address \_\_\_\_\_

City \_\_\_\_\_ State \_\_\_\_\_

PS-43

**AW Andersen Windowalls**

Andersen Corporation • Bayport, Minn.

Works in Seconds!



**Loosens Rusted Bolts**  
nuts, screws, "frozen" parts!

**LIQUID WRENCH**  
SUPER-PENETRANT

BONUS USE: Add to crankcase to quiet noisy valve lifters . . . remove gum, sludge deposits!

THEN ADD . . .

**MOTOR-MEDIC**  
EXTRA LUBRICATION . . .  
SMOOTHER PERFORMANCE



Both at leading dealers everywhere!

## FREE EICO CATALOG



Build your own stereo and mono hi-fi, radios, walkie-talkies, ham gear, test instruments—save 50% with famous EICO kits. No technical knowledge needed. Simple, step-by-step "Beginner-Tested" pictorial instructions guide you all the way. Choose from 108 beautiful kits. Mail coupon now!

EICO Electronic Instrument Co., Inc.  
3300 Northern Blvd., L.I.C. 1, N. Y.

PS-4

Please send free catalog and name of local dealer.

Name .....

Address .....

City.....Zone.....State.....

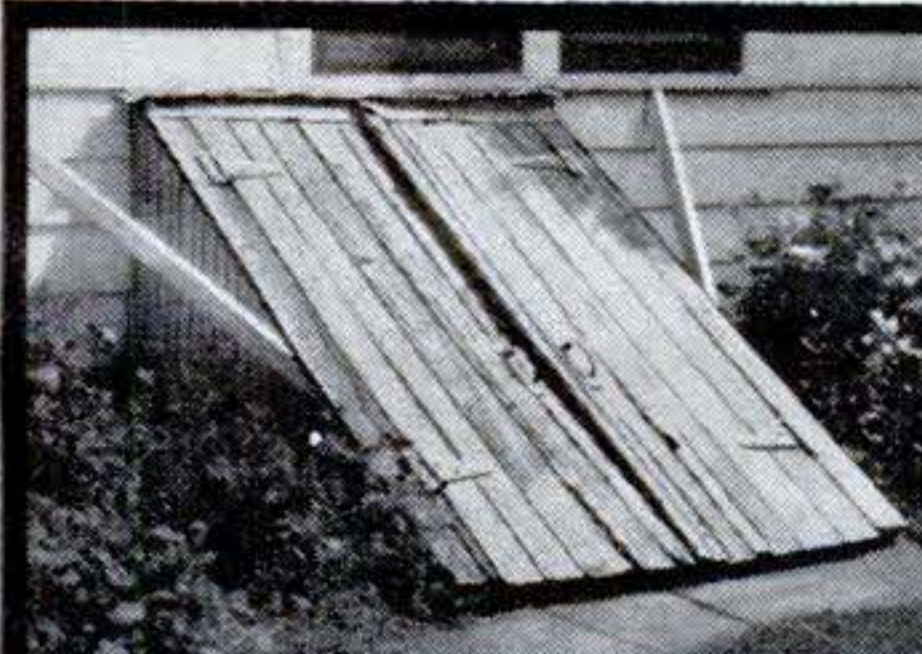

**EASY TO REPLACE**

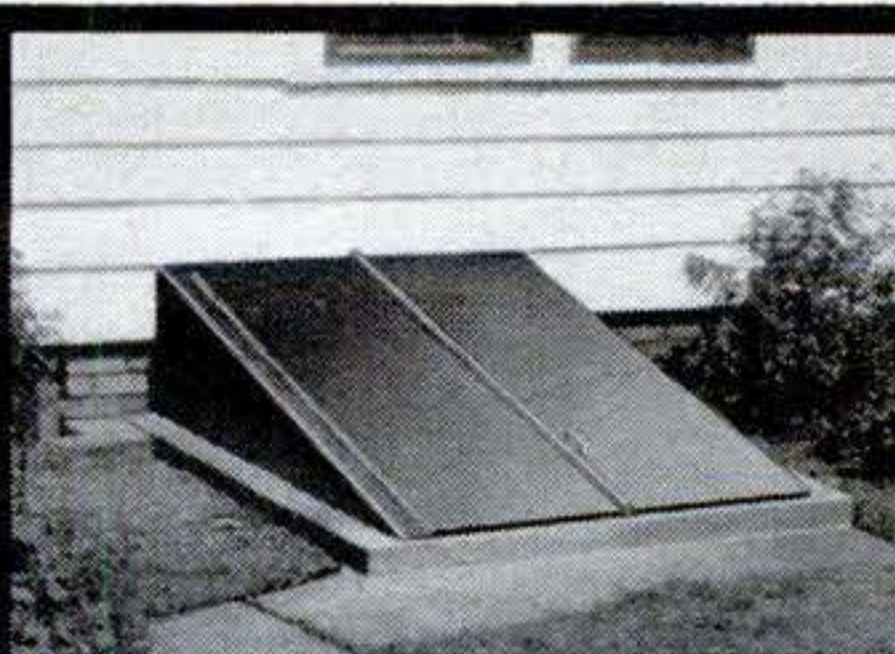

**THIS MODERN WAY**

**Bilco**

AMERICA'S FINEST BASEMENT DOOR

Here's the way to add amazing new beauty and convenience to your home. Replace that troublesome wood door with a modern Bilco. All steel, permanent, watertight, opens and closes at a touch. A new Bilco Door will do wonders for your home . . . and for you!

The Bilco Co., Dept. R-74, New Haven 5, Conn.  
Please send me your free illustrated folder and name of local dealer.

Name .....

Address .....

City.....Zone.....State.....



# MEN PAST 40

## Afflicted With Getting Up Nights, Pains in Back, Legs, Nervousness, Tiredness

If you are a victim of these symptoms, your trouble may be due to Glandular Inflammation—a constitutional Disease that requires special types of medical treatment. Neglect of such Inflammation may cause men to grow old prematurely and often leads to Incurable conditions.

Most men, if treatment is taken in time, can be successfully NON-SURGICALLY treated for Glandular Inflammation. If the condition is aggravated by lack of treatment, surgery may be the only chance.

## NON-SURGICAL TREATMENTS

The NON-SURGICAL treatments used at the Excelsior Medical Clinic are the result of discoveries in recent years of new techniques and drugs, plus over 20 years research by scientific technologists and doctors.

Men from all walks of life and from over 1,000 communities have been successfully treated here at Excelsior Springs. They found soothing and comforting relief and better health.

### EXAMINATION AT LOW COST

When you arrive, our Doctors, who have years of experience in this field, make a complete examination. You then decide if you will take the treatments needed, which are so mild, hospitalization is not needed.

**REDUCIBLE HERNIA**  
Is also amenable to a mild Non-Surgical Treatment available here.

**RECTAL-COLON DISORDERS**  
are often associated with Glandular Inflammation.

Either or both of these disorders may be treated at the same time you are receiving Glandular Inflammation Treatments.

### Write For FREE BOOK

The Excelsior Medical Clinic has published a New FREE Book that deals with diseases peculiar to men. It could prove of utmost importance to you. Write today. No obligation.



**EXCELSIOR MEDICAL CLINIC**  
Dept. B6251  
Excelsior Springs, Mo.

Gentlemen: Kindly send me at once, your New FREE Book. I am interested in full information. (Please Check Box)

- Glandular Inflammation       Hernia  
 Rectal-Colon

Name.....

Address.....

City..... State.....

### LEARN TO EARN



## HIGH WAGES AS A HEAVY EQUIPMENT OPERATOR OR MECHANIC

- WORLD'S ONLY CONTRACTOR OWNED AND OPERATED SCHOOL
- MODERN EQUIPMENT, HIGHLY QUALIFIED INSTRUCTORS
- V.A. APPROVED FOR GI TRAINING

Learn to operate bulldozers, draglines, cranes, back hoes, scrapers and motor graders **ON ACTUAL CONSTRUCTION PROJECTS!**

Learn by doing . . . no impractical correspondence courses.

WRITE TODAY FOR FREE SCHOOL CATALOG

## WESTERN SCHOOL OF HEAVY EQUIPMENT OPERATION

Dept. S-2, Box 510  
Weiser, Idaho  
Phone 549-1112



Member American Road Builders Association  
Associate Member Associated General Contractors

## PLAY RIGHT AWAY!

Even If You Don't Know a Note of Music Now

Now it's EASY to learn any instrument. No boring exercises. Start playing real pieces by note right away. Amazing progress at home, in spare time. No teacher. Few cents per lesson. 1,000,000 students! Write for FREE BOOK. U. S. School of Music, Studio A154, Port Washington, L. I., N. Y. Licensed by N. Y. State Educa. Dept.



## GUARD YOUR EYES like you guard your power tools

get these new Sellstrom professional type safety glasses.



### SELL-FIT SAFETY GLASSES

with **Sellstrom's** Exclusive New ADJUSTABLE TEMPLES that you fit to your own face.

Don't take chances with your eyes . . . wear these lightweight, comfortable plastic frame Sellstrom Safety Glasses that fit everybody. Same glasses now being used by leading plant safety engineers. Hardened lenses. Send check or money order for \$3.98. Satisfaction guaranteed or return glasses post-paid within 30 days for full refund.

### BARRINGTON OPTICAL CO.

P.O. Box 105-A • Barrington, Illinois  
Please send pair of Sellstrom Safety Glasses. I enclose \$3.98 (check or money order).

NAME.....

ADDRESS.....

CITY..... ZONE..... STATE.....



# BE THE MAN IN DEMAND

Train for a high-paying job in one of these 4 major fields



Highly trained technicians are higher paid... better skilled... confident of success.

## ELECTRONICS

TELEVISION AND RADIO

Course covers TV-radio servicing, communications, automation circuitry, microwaves, ind. electronics. One Master Course; low cost. Includes TV set, radio, multimeter.

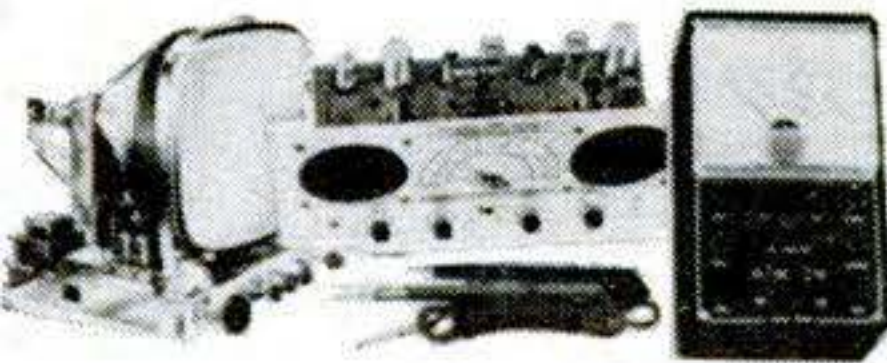

## AUTO MECHANICS

AND DIESEL

All-around mechanic training. Covers tune-up, automatic transmissions, trucks and busses, stationary gas and diesel engines. Includes socket set, analyzer, tools.



## AIR CONDITIONING

REFRIGERATION ELECTRICAL APPLIANCES

50 million air conditioners, refrigerators, appliances need fixing every year. Start own business or work with dealer-distributor. Includes tester, gauges, tools.



## HOME APPLIANCE

TECHNICIAN'S COURSE

Full-time or "spare-time" career. Fix toasters, mixers, irons, washing machines; all appliances. Costs less than \$1.50 a wk. Includes tester, soldering set, tools.



Each of these fields offers big opportunities to N.T.S. trained men. You get everything you need — lessons, manuals, professional kits with tools and instruments for service, repair, all-around use. Study at your own pace; earn money as you learn. You enroll by mail; no salesman means lower cost for us, lower tuition for you.

## NATIONAL TECHNICAL SCHOOLS

WORLD-WIDE TRAINING SINCE 1905

## NATIONAL TECHNICAL SCHOOLS

WORLD-WIDE TRAINING SINCE 1905

4000 So. Figueroa St., Los Angeles 37, Calif.

Accredited Member  
National Home Study Council

### RESIDENT TRAINING AT LOS ANGELES

If you wish to take your training in our famous Resident School in Los Angeles — the oldest and largest school of its kind in the world — check special box in coupon.

SEND FOR  
**FREE BOOK  
AND ACTUAL  
LESSON IN  
FIELD OF YOUR CHOICE**

NO OBLIGATION  
NO SALESMAN  
WILL CALL

ACTUAL LESSON



CHECK ONE

National Technical Schools, Dept. C-43  
4000 S. Figueroa St., Los Angeles 37, Calif.

Please rush FREE Book and Actual Lesson checked below. No obligation. No salesman will call.

- Electronics — TV — Radio  
 Auto-Mechanics & Diesel  
 Air Conditioning, Refrigeration & Electrical Appliances  
 Home Appliance Technicians Course

Name \_\_\_\_\_ Age \_\_\_\_\_

Address \_\_\_\_\_

City \_\_\_\_\_ Zone \_\_\_\_\_ State \_\_\_\_\_

Check here if interested ONLY in Resident Training at L.A. High school home study courses also offered. Check for free catalog.

## FREE INTERNATIONAL CATALOG

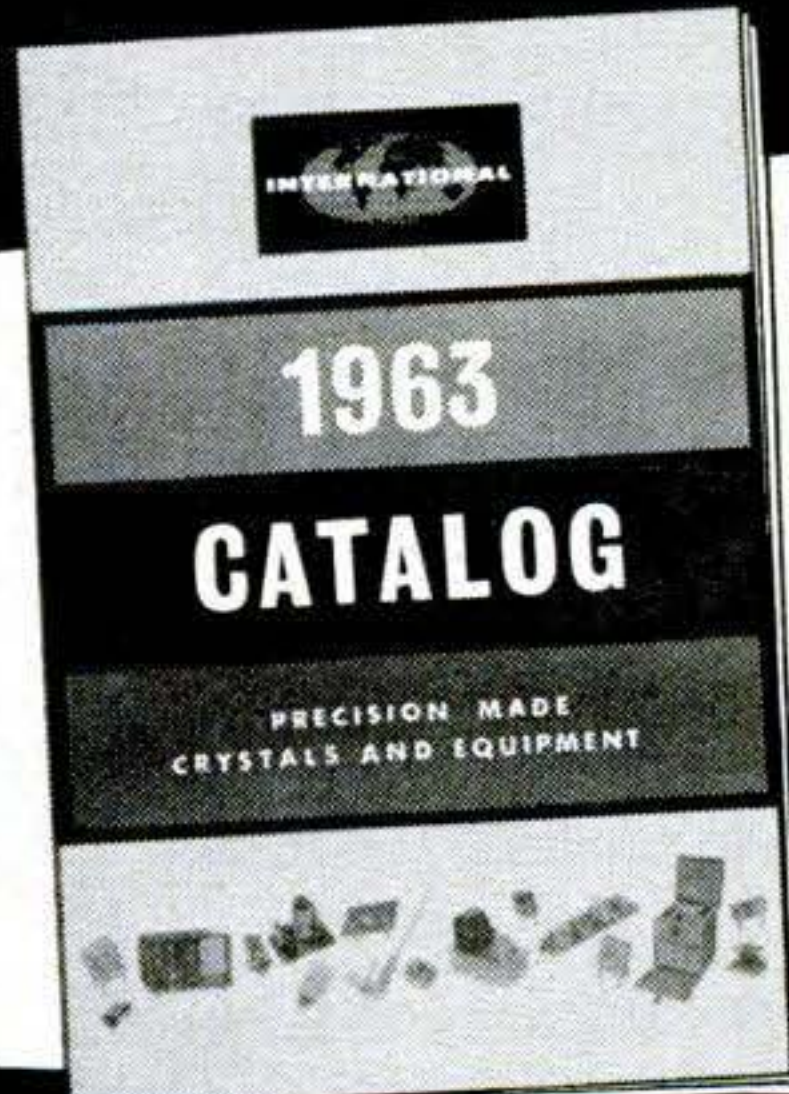

- Citizens Band Transceivers
- Citizens Band Antennas and Accessories
- Amateur and Citizens Band Crystals
- Commercial Crystals
- Transmitters/Modulators
- Frequency Alignment Equipment
- Power Supplies

Your 1963 Buying Guide for Precision Made Radio Crystals and Electronic Equipment.

International Crystal Mfg. Co. 563  
18 North Lee, Oklahoma City, Okla.  
Rush 1963 FREE Catalog.

Name \_\_\_\_\_ Please Print

Address \_\_\_\_\_

City \_\_\_\_\_ Zone \_\_\_\_\_ State \_\_\_\_\_

## Free! SCARCE "TRIANGLE" COLLECTION



Start TODAY to enjoy an exciting new hobby! Get this big, valuable collection of gorgeous, multi-colored triangle shaped postage stamps... brought to you from strange and mysterious lands in the wilds of Africa, enchanting Europe, exotic Latin America, etc. All genuine, all-different—picturing man-eating reptiles, jungle birds, action-packed sports, ancient clipper ships; PLUS scarce airmails, fabulous commemoratives, giant and midget-sized stamps. EXTRA! Bargain Catalog, "Collector's Manual" plus other exciting offers for your inspection. Enclose 10c for mailing costs. Supplies limited. ACT NOW!

JAMESTOWN STAMP CO. Dept. H43PS JAMESTOWN, N. Y.

RUSH my Free "Triangle" Collection and other offers. I enclose 10c for mailing costs.

Name \_\_\_\_\_

Address \_\_\_\_\_

City & State \_\_\_\_\_



# NEW DELTA Fast-Flo

**HIGH-VOLUME  
BILGE PUMP  
SUBMERSIBLE**

MODEL A1100 **\$1995**



- Pumps 10 gallons a minute against 3' head.
- Easily handles salty, sandy and other contaminated water. No screens to clean.
- Dependable 12-volt D.C. Leece-Neville motor... heavily chromed solid brass housing... seals resistant to oils, gasoline.
- Impeller and impeller housing of molded Delrin®.
- Compact 5 3/4" high, 4 5/8" dia., weighs only 3 1/2 lbs.
- Fully guaranteed.

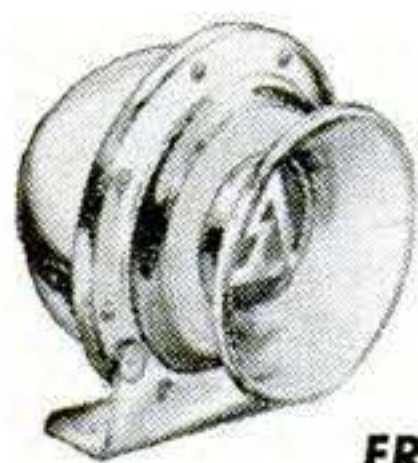

**POWERhorn** Far-reaching resonant tone. Solid brass with heavy chrome finish. Motor is permanently sealed. Tone unaffected by vibration. 12-V. Model A-2998, **\$14.95**

**FREE**—Marine catalog. Write today.

## Delta LIGHTS THE WAY

Delta Electric Co. 325 W. 33rd Street, Marion, Indiana

# MOWER TIRES SMOOTH?

Restore full traction with

# Replace-a-Treads

With Replace-a-Treads you can restore original traction power to worn-out, slipping power mower tires... at less than half the cost of new tires or wheels. Installed quickly, simply, without removing mower wheels. Complete instructions on package. Fits all standard tires from 8 1/2" to 11" dia... treads up to 1 7/8" wide... reel type power and hand mowers.

**Tough tread gives long wear!**

Made of same tough tread rubber used in passenger tires. Outlasts original mower tires by far. Won't leave black marks on walks or drives. Only \$3.95 a pair at your favorite hardware store, garden center, mower repair shop or service station.

TPA-2003

only **\$3.95** a pair 

**The Gates Rubber Company** 999 South Broadway Denver 17, Colorado

# WATER SKI KITS! ASSEMBLE AND SAVE 50% OR MORE ON REGULAR PRICE

Assemble your own professional quality skis. Just decorate and install binders. Kit includes select White Ash ski blanks with Guaranteed permanently bent tips. Sanded, sealed and ready for varnish or paint. Also foam-cushioned E-Z adjustable high tab binders and aluminum fins. Made by world's top manufacturer of water skis.

Prices include postage. Send check or Money Order to: Dept. B

ALL-PURPOSE SKIS **\$12.95** Pr. SPECIAL SLALOM SKIS **\$8.95** Ea.

6 3/4" x 69" size

**THOMPSON SKIS, INC., CRIVITZ, WIS.**

## ECONOMY TRACTOR

**DOES MORE  
KINDS OF  
JOBS**

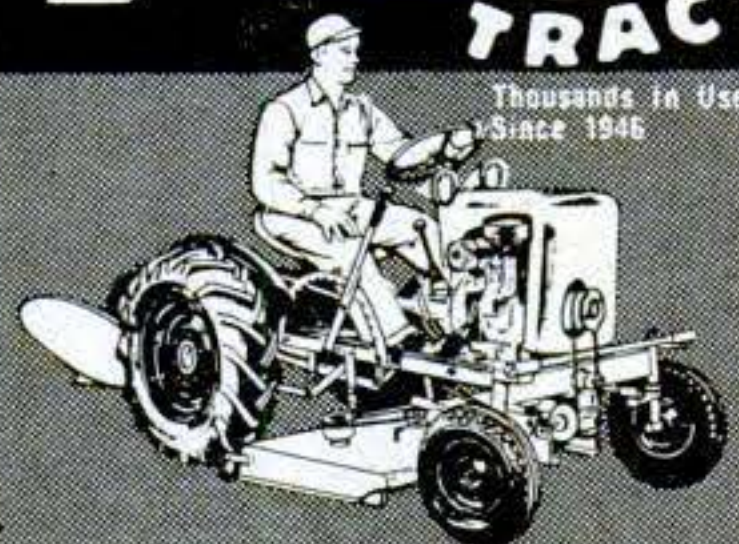

Powerful! America's big tractor value. Low price. Rugged, built-in quality. Easy to operate. 9 hp. ALL GEAR DRIVE incl. clutch, 3-spd. trans., diff., 176 to 1 reduction. Wt. 790 lb. 21 low-cost, quick-change tools for farm, lawn, snow, woodland. Write for FREE CATALOG

Engineering Products Co.  
1005 A-4 Anoka Ave., Waukesha, Wis.

### HELP WANTED - SPARE TIME

SENSATIONAL NEW LONGER-BURNING LIGHT BULB. Amazing Free Replacement Guarantee—never again buy light bulbs. No competition. Multi-million dollar market yours alone. Make small fortune even spare time. Incredibly quick sales. Free sales kit. MERLITE (Bulb Div.), 114 E. 32nd, Dept. C-16F, New York 16, N.Y.

## LAW FREE BOOK THE LAW TRAINED MAN

Write today for a FREE copy of illustrated law book. "THE LAW-TRAINED MAN," which shows how to earn the professional Bachelor of Laws (LL.B.) degree through home study of the famous Blackstone Law Course. All necessary books and lessons provided. Moderate cost; convenient monthly terms. Write for FREE law training book today.

**Blackstone School of Law, 307 N. Michigan Ave.**  
Founded 1890 Dept. 124, Chicago 1, Illinois

## Fantastic Savings on NEW ACCORDIONS 1/2 OFF



SAVE UP TO 1/2 OFF RETAIL PRICES OF COMPARABLE ACCORDIONS Just arrived! More than 40 exciting new models! Many new electronic accordions-amplifiers! Packed with new ideas, new styling, new features! Buy direct from world's largest exclusive accordion dealer! Importer-To-You Prices! Most famous Italian makes. Easy Terms; LOW Down Payment. 5-DAY Free Home Trial; Positive Money Back Guarantee. Free Bonus Gifts! Trade-ins welcomed - BIG allowances! Rush coupon below today for FREE Color Catalogs!

LIFETIME GUARANTEE

**FREE**  
New Color  
Catalogs—  
Discount  
Prices

Accordion Corporation of America, Dept. P-43,  
2003 W. Chicago Ave., Chicago 22, Ill.  
Send Free Catalogs—Special Discount Price List.

NAME \_\_\_\_\_  
ADDRESS \_\_\_\_\_  
CITY \_\_\_\_\_ ZONE \_\_\_\_\_ STATE \_\_\_\_\_





# FOR A BETTER JOB WITH BETTER PAY

## LEARN ELECTRONICS AT HOME

Choose from these complete up-to-date courses

- Radio and Electronic Fundamentals
- TV Servicing • Color TV
- Communications Electronics

- FCC License Preparation
- Mobile Communications
- Electronic Drafting
- Automation Electronics
- Computer Programming • Transistors

Each lesson a complete training package! Practical application begins with your first lesson — you get prime quality equipment as required to keep and use on the job. Courses for beginners and advanced students.

**Voluntary Tuition Plan** — pay for each lesson only when you order it! You never have to pay for the whole course if you don't complete it; courses can be interrupted at any time you wish — resumed later!

Approved for veterans.

**SEND FOR THIS FREE BOOK NOW!**

**64-PAGES OF CAREER IDEAS IN ELECTRONICS!**



**RCA INSTITUTES, INC.**

A Service of Radio Corporation of America  
The Most Trusted Name in Electronics

Resident School Courses in New York City and Los Angeles offer comprehensive training in Television and Electronics. Day and Evening classes start four times each year. Detailed information on request.

RCA INSTITUTES, INC. Home Study School, Dept. PS-43A  
350 West Fourth Street, New York 14, N. Y.

Rush me the FREE 64-page illustrated booklet "Your Career in Electronics" describing your electronic home study training program. No salesmen will call.

Name ..... Age.....

Address.....

City..... Zone..... State.....

**CANADIANS** — Take advantage of these same RCA courses at no additional cost. No postage, no customs, no delay. Send coupon to: RCA Victor Co., Ltd., 5581 Royalmount Ave., Montreal 9, Quebec.

# THREE TO SEE

# '63

# for

Aluma Craft Boats  
Alpex Fiberglass Boats  
Aluma Craft Trailers



The perfect water control line in fiberglass: ALPEX runabouts, sisters to the Aluma Craft fleet!

Only Aluma Craft and Alpex Boats have Stable-matic® hulls!

**AT YOUR ALUMA CRAFT DEALER NOW!** Your Aluma Craft dealer is ready with the greatest early-season fun packages ever . . . the world's finest aluminum and fiberglass boats . . . Aluma Craft's NEW "Great 8" Trailers!

Write for Free Catalog!

SEE! The new Aluma Craft Trailers — for boats from 12 to 20 feet — maximum convenience, safety, and performance.



No. 1 in aluminum . . . Aluma Craft — for fishing, cruising, skiing, fun for one . . . or the whole family . . . America's best boat value!



**BOAT DIVISION**  
ALPEX CORPORATION  
1521 Central Ave. N.E.  
Minneapolis 13, Minnesota

## NEW AEC 77 TRANSISTORIZED Electronic Ignition System

FOR YOUR CAR



Increases engine power 10% . . . Hotter spark under load . . . Eliminates 3 out of 4 tune-ups . . . doubles and triples spark plug life . . . prevents fouled plugs . . . 75,000 mile point life . . . instant starting in sub-zero weather . . . 20% more mpg . . . simple 30-minute installation.

With conventional ignition, high voltage at the spark plugs drops from 28KV to 13KV as engine speed increases — results in weak spark causing incomplete combustion, fouled plugs, loss of power and poor gas mileage. AEC 77 transistor ignition increases high voltage to 30KV and keeps it there with no voltage fall-off at any rpm. AEC 77's guaranteed "hot spark" releases full engine power with up to 20% more mpg.

**FREE TRANSISTOR TUNE UP METER** with every order.

**\$39.95**  
AEC, 387 Park Ave. So., N.Y. 16, N.Y.



**GUARANTEED FOR 3 FULL YEARS**

**WORLD CHAMPION PHIL HILL:**

"AEC 77's strong spark can make up for worn points and spark plugs. It will make your car run smoother, and improve its performance and economy."



**PROVEN IN OVER 2,000,000 MILES OF TESTING**

**AUTOMOTIVE ELECTRONICS COMPANY** PS-4  
387 Park Ave. South, N.Y. 16, N.Y.

I enclose check or money order for.....AEC 77's NAME.....

ADDRESS.....

Make, Year, Car Model.....

..... Please send me further information on AEC 77



# 1963 BSA SUPER ROCKET

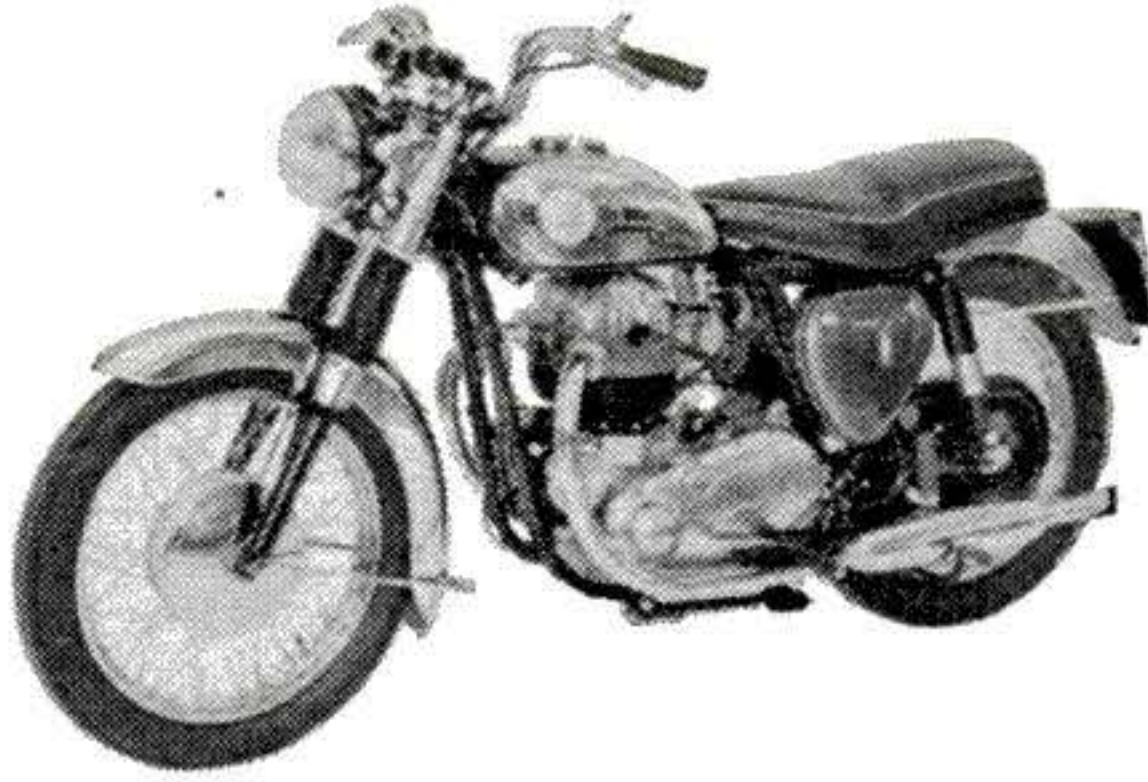

**delivers high performance!  
reflects brilliant beauty!**

A famous and superbly designed twin cylinder sports motorcycle now improved for even better performance. Beautifully finished in blazing red enamel, with fully chromed fenders, and many other parts in chrome and highly polished alloy.



Write to the nearest address for illustrated free color catalog of the new 1963 models.

Catalog offer limited to U. S. residents only.

West:  
**HAP ALZINA**  
Dept. S43  
3074 Broadway  
Oakland, California

East:  
**BSA INCORPORATED**  
Dept. S43  
639 Passaic Ave.  
Nutley, New Jersey

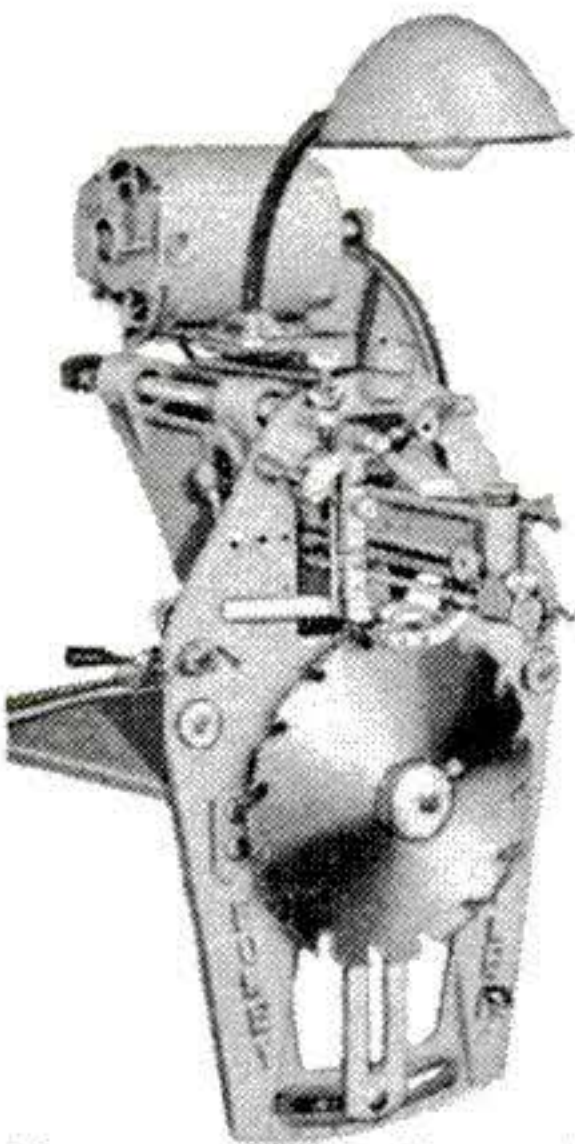

## MAKE \$20 to \$30 A WEEK EXTRA MONEY

Need extra cash to keep up with the bills? Turn your spare time into dollars this fast, easy, sure way. Make \$3 to \$6 an hour sharpening saws with a Foley Automatic Saw Filer.

START IN YOUR BASEMENT OR GARAGE. Build your own business without special training or experience. "The first saw I sharpened with my Foley Filer came out 100%", writes Clarence E. Parsons. Small down payment puts a Foley Automatic Saw Filer in your hands. Pays for itself with profits. No canvassing.

Every saw you sharpen brings you more customers. Hundreds are making big money the Foley way right now. You can too.

### FREE BOOK Shows You How to Start

It explains how you can get business immediately from home owners, farmers, carpenters, schools, factories, etc., and keep on getting it every week. Don't wait. Mail coupon now for "Money Making Facts" and easy pay plan details. No salesman will call.



**Mail Coupon for FREE BOOK Now!**

FOLEY MANUFACTURING CO.  
419-3 Foley Bldg., Minneapolis 18, Minnesota  
Rush free book, "MONEY MAKING FACTS", and Easy Payment Plan details.

Name \_\_\_\_\_  
Address \_\_\_\_\_  
City \_\_\_\_\_ State \_\_\_\_\_

**Take Up Slack Time — Make Extra Money  
Repair Small Engines on Go Karts, Power  
Mowers, Cycles, Scooters and Chain Saws**



Fix Chain Saws



Repair  
Power  
Mowers

More than  
1,250 Models  
42  
Manufacturer's  
Makes

**Big New edition of SMALL ENGINES  
SERVICE MANUAL just off-the-press**

Big New edition with over 45,000 maintenance and repair facts. Gives complete information on servicing, maintenance and repair of small engines under 45 cu. in. displacement. Covers all Power Mower engines. Edited by skilled mechanics and engineers. Information on more than 1,250 models. 42 major manufacturer's makes, including McCulloch, West Bend, Power Products, Briggs & Stratton, Clinton, Homelite, Lauson, Continental, Wisconsin, and others. Practical, down-to-earth information on 2 and 4-cycle engines. Authoritative section on servicing ignition and carburetor equipment. Section on trouble shooting for beginners. \$4.95. Send checks or M.O. and we will send post-paid. Satisfaction guaranteed or your money back. Clip this ad to order.

Small Engines Service Manual, Dept. 263  
1014 Wyandotte, Kansas City 5, Mo.

## NO JOB WORRIES

PLASTEX INDUSTRY needs manufacturers on small scale for big production of Lamps, Clock Stands, Art Goods, Novelties in Plastic Marble imitation. No Experience necessary. 1/2c material makes regular 10c store sellers. Moulds furnished for fast production. Small investment brings good profit. Big wholesale orders now being placed. Ambitious men have chance for real prosperity and job security. Our NEW FREE booklet will interest and benefit you.

PLASTEX INDUSTRIES, Dept. 2, 3400 Third Ave., New York 56, N. Y.

## Make Rubber Stamps for BIG PAY



Need more money? Earn \$30-\$50 a week, spare time, at home making rubber stamps for offices, factories, individuals. Hundreds of uses. Hundreds of prospects—everywhere. Right in your own community. Turn out special stamps for names, addresses, notices, prices, etc., in minutes with table-top machine. We furnish everything and help finance you. Write for free facts. No salesman calls.

Rubber Stamp Div., 1512 Jarvis Ave., Dept. R-3-D, Chicago 26

## LEARN IBM

AT LAST! With THOUSANDS of prestige positions waiting for new data processing technicians and PAY scales at a RECORD HIGH. A.T.C.'s exclusive methods are available to you in a SPECIAL HOME STUDY PROGRAM GEARED TO YOUR TIME AND BUDGET. No contracts to sign . . . you pay for each lesson only when you order it! Send for your Giant 'IBM CAREER CATALOG' TODAY! Enclose \$1.00 to cover cost of postage and handling. No obligation of course.

**AUTOMATION TRAINING CORPORATION**

7023 E. Kirby, Dept. PS43, Detroit 11, Mich.

**POWERFUL NEW INVENTION, ONLY 2" LONG  
SHOOTS THRU 100  
PAGES-THIS BOOK!  
'B-B SHOT'**



MAKE THIS TEST... Load your 'BB Shot' and fire against this magazine. Notice that it drives BB's through more than 100 pages. Though only 2" long x 1" in diameter, this pocket-size device has amazing power and accuracy. Use it for targets, pests and hunting. Scientifically designed for high power, operating ease and safety.

**FREE!** Get the 'BB Shot' now—we'll include an extra Velocity Cone and FREE Target, BB's and Automatic BB Dispenser—all for only \$1.98 ppd. or 3 for \$5.00 ppd. Money Back Guarantee. Not sold to N.Y.C. residents or minors. **GRAYSON CO. • Dept. E-43, 210 Fifth Ave., N. Y. C. 10**

**MONEY-BACK  
GUARANTEE**

Name.....  
Address.....  
City..... State.....

**\$1.98**  
ppd.



Sworn statement from CHAS. LEMMING reads:

"After starting my own business

I'VE AVERAGED

\$100 A DAY

—most of it clear profit!"

Not everyone does as well...  
Mr. Lemming owns two machines



• In city of less than 50,000, Mr. Lemming started his own business after filling in coupon like one below. He averaged \$100 a day during first year, some days \$200. F. E. Doran grossed \$1050 in a single month. Geo. Held grossed \$300 in one week.

How much you earn depends largely on you. You need no special skill, no large investment. Start spare time until full time justified. Hire helpers as needed.

**NO SHOP NECESSARY** • You clean upholstered furniture with efficient **PORTABLE ELECTRIC DETERGER** on customers' premises—homes, hotels, motels, etc. Auto upholstery, too. No hauling; operate from your home. Watch business grow as customers tell friends. Supplies cost little; what you take in is mostly profit. If you want to be independent—free from layoffs, bosses—start this profitable year-'round business of your own. We will help you to start and work with you for your success.

**OURS IS NOT A LEASE ARRANGEMENT** • You are free to operate in an independent manner. You sign no contract. You own the detergent outright and are always your own boss... and every dollar you take in is yours to keep. You pay no fees, or dues, or royalties to anyone. And you take no risk. Your detergent is fully guaranteed and enough supplies come with it to return far more than your investment. Many earn the cost of the detergent in a week or two. It costs nothing to get the details... write TODAY.

MAIL COUPON TODAY FOR FREE BOOK

VON SCHRADER MFG. CO.  
411 "D" Pl., Racine, Wis.

Without obligation rush your FREE booklet about how I can start my own permanent, profitable electric Upholstery Cleaning business.

Name \_\_\_\_\_

Address \_\_\_\_\_

City \_\_\_\_\_ Zone \_\_\_\_\_ State \_\_\_\_\_

## ELECTRIC APPLIANCE SERVICE NEWS

### A "MUST" FOR APPLIANCE REPAIRMEN

**EASN**—now in its 13th year—is the Only Publication Serving the ENTIRE Appliance Repair Field.

**EASN LISTS** sources of supply for parts on all types of household electric appliances, such as washing machines, dryers, ironers, vacuum cleaners, ranges, sewing machines, toasters, irons, mixers, coffeemakers, and so forth.

**EASN OFFERS** a "Buyers' Guide," listed alphabetically by product name, to help you get the parts you need.

**EASN ADVERTISERS** send free mailings of catalogs and other pertinent market data to readers from time to time.

**EASN BRINGS NEWS** of appliance repair schools and clinics in your area.

**EASN OFFERS** editorial material covering industry news with articles on techniques used by service firms, technical information, and industry trends.

#### TRIAL OFFER

**ELECTRIC APPLIANCE SERVICE NEWS** (Published Monthly)  
505 N. La Salle St., Chicago 10, Ill.

GENTLEMEN: Enclosed find  Check  Money Order  Stamps  
 Cash to cover my subscription as I have indicated below:  
 \$1.00 for 4 months trial subscription, or  
 \$2.00 for 1 year  \$3.00 for 2 years  \$4.00 for 3 years

By (Individual) .....

Firm Name .....

Street .....

City..... Zone..... State.....

(Please enclose your business card or letterhead stationery) PSM

### "I Upped My Earnings \$200 A Month"



Says **TEDDY RYAN**, Norfolk, Va.  
"I have always liked working with my hands, and locksmithing seems to be what I've been looking for. I've increased my monthly earnings by \$200 just during my training period."

## Be a LOCKSMITH



306

pieces of equipment  
—locks, picks,  
tools & parts  
Supplied  
for use with  
course.

Add 50% - 100% to YOUR INCOME with easy spare time earnings. Cash in on nationwide shortage...in good times and bad. Quickly step into a big-pay opportunity job—high profit shop of your own.

**Earn Extra Money RIGHT AWAY! All Special Tools, Supplies Furnished.**

Age, education, minor physical handicaps don't matter in this growing trade. You can quickly qualify as a skilled locksmith. Study at home as little as one hour a week. Gain practical experience through well-illustrated lessons. Do real jobs on car locks, house locks, padlocks and safe locks, under guidance of experts.

#### FREE Illustrated Book

For a future as your own boss or in a high-pay job, send for FREE book and sample lesson pages. Only school of its kind. Lic. State of N.J. Acc'd Member NHSC. Vet. App'd. Locksmithing Institute (Div. of Tech. Home Study Schools). Dept. 204-3, Little Falls, N.J.

#### MAIL COUPON NOW!

Please send, without obligation, FREE Book, "Big Money in Locksmithing," and Sample Lesson Pages. No Salesman will call.

LOCKSMITHING INSTITUTE, Dept. 204-3  
Little Falls, New Jersey

Name \_\_\_\_\_  
(Print here)

Address \_\_\_\_\_

City \_\_\_\_\_ Zone \_\_\_\_\_ State \_\_\_\_\_

Check if Veteran



# HOW MANY RIDING MOWERS WILL DO THIS?

## Ride King

The Ride King pulls by a single, steerable front wheel which pivots 360° for sharp turns or reverse. One complete turn of the steering wheel gives you reverse without changing gears or belts. This eliminates complicated transmissions, differentials, etc. Therefore less maintenance and initial cost. Ride King trims within 3/8" from either side, turns square corners, makes a clean cut around trees, and poles with one pass as illustrated.

**OTHER OUTSTANDING FEATURES:**

- Twin blades (smoother cut)
- Belt drive blades (means no sprung crankshaft)
- All steel construction
- Ball bearings throughout
- Clutch for engaging blades
- Automatic brake prevents coasting
- 6 HP 4 cycle Lauson engine
- 32" cut
- Priced from \$299 to \$309

FOB factory  
Write for free folder and nearest dealer.  
**SWISHER MOWER & MACHINE CO. INC.**  
333 East Gay Street  
Warrensburg, Missouri

**BRAND-NEW!**

## NOW-You Can Fix Cars Faster

With **MOTOR'S 2-in-1 Auto Repair Manual!**

Fix just about any part of 2,519 models, 1955 through 1963. NEW edition. Troubleshooter spots what's wrong—Manual pages show exactly how to fix it! Over 1,300 pages, 2,850 pictures. MUCH MORE! FREE 10-DAY TRIAL. Then, pay \$2 in 10 days, \$3 a month for 2 months, then \$1.95 (plus 45¢ delivery charge and sales tax), or return book. Send no money now! **MOTOR, BOOK DEPT., Desk 324, 250 West 55th St., New York 19, N. Y.**

**TRY GIANT ILLUSTRATED "HOW-TO" BOOK FREE FOR 10 DAYS**

## Repair any watch

... SWISS OR AMERICAN

Unique, modern Sweazey System starts you making repairs right away. Develops skill step by step at home in spare time. Tuition \$5 monthly. Diploma awarded. Free sample lesson. No obligation.

**CHICAGO SCHOOL OF WATCHMAKING**  
2330 Milwaukee, Dept. 443, Chicago 47, Ill.

## FREE MUSCLE BUILDING INFORMATION

Sensational New Methods  
Less Time—Less Effort—Better results

**BODY-TONE, Box 638-E, North Miami 61, Fla.**

## GET MAXIMUM FIRE POWER PLUS A LIFETIME TUNE-UP WITH

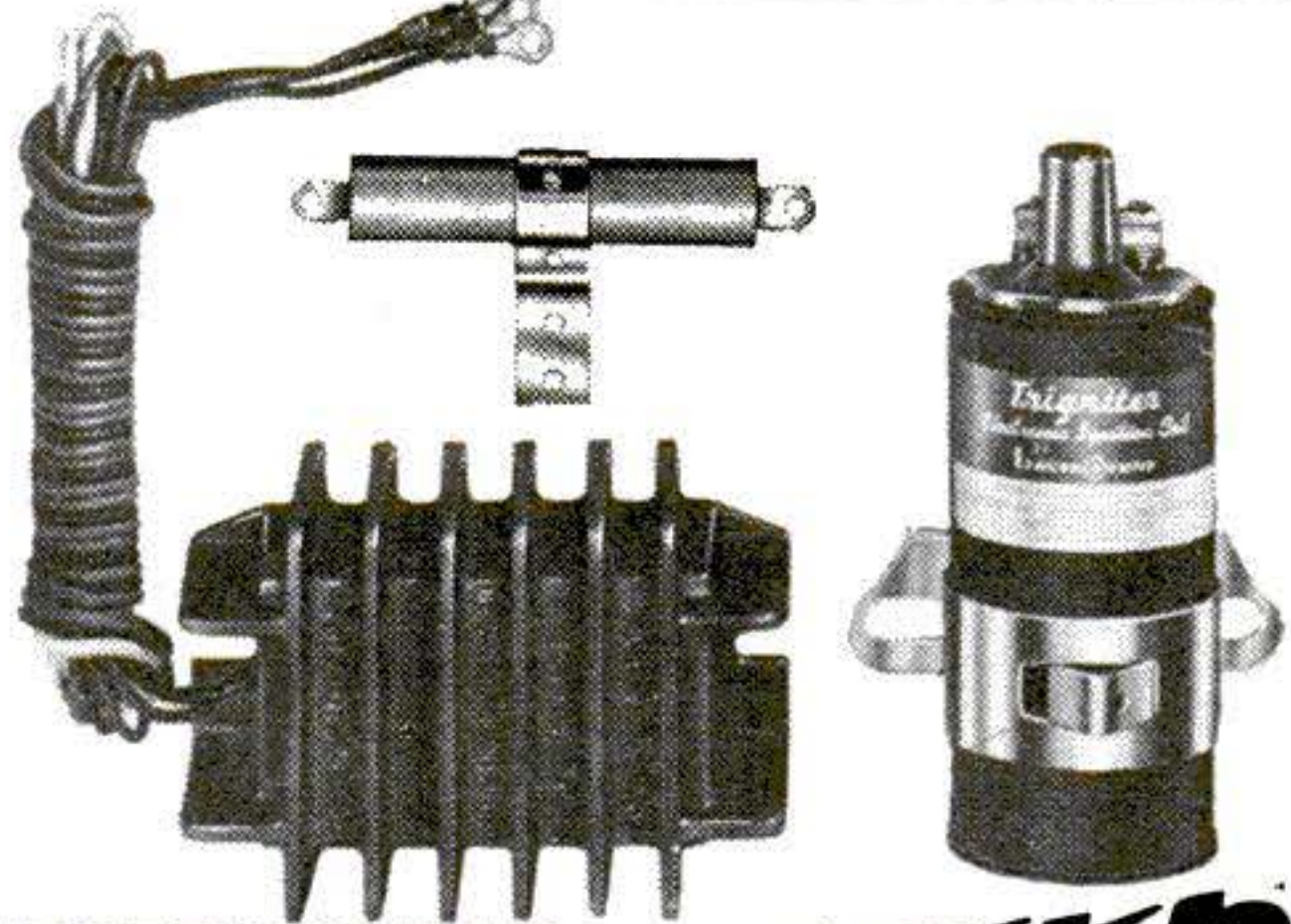

## ELECTROTONE'S SS-1 TRIGNITER

THE MOST ADVANCED TRANSISTORIZED ELECTRONIC IGNITION SYSTEM

- Eliminates spark plug, points and condenser replacement
- Special heavy duty 400:1 coil
- High voltage Bendix transistor—zener diode protected
- Improves gas mileage, assures better acceleration
- Instant cold weather starting
- Professional, patented die-cast heat-sink

Available NOW at leading auto stores and jobbers at low introductory prices. Write for new catalog sheet and name of nearest dealer...

**ELECTROTONE LABORATORIES, INC.**  
1713 N. Ashland Ave. • Chicago 22, Illinois

## BLUE BOOK OF CRIME FREE!

Given to men who want to get into **CRIME DETECTION FINGER PRINT IDENTIFICATION**

Train at home, spare time. Join hundreds of I. A. S. graduates now employed by police and identification bureaus in every state. Learn fingerprint identification, crime investigation, firearms identification, police photography, other subjects vital to qualifying for good paying, secure, interesting jobs. "Blue Book of Crime" and details Free. Must state age.

**Institute of Applied Science, Dept. 1364**  
A Correspondence School Founded in 1916  
1920 Sunnyside Ave., Chicago 40, Ill.

# RUPTURED

## BE FREE FROM TRUSS SLAVERY

Surely you want to **THROW AWAY TRUSSES FOREVER**, be rid of Rupture Worries. Then Why Do you put up with wearing a griping, chafing and unsanitary truss the balance of your life? If you do, it will NOT be through necessity but through choice on your part.

Now there is a modern Non-Surgical treatment that is designed to correct rupture. These Non-Surgical treatments are so dependable that a Lifetime Certificate of Assurance is given. Write today for our new **FREE BOOK** that gives facts that may save you painful, expensive surgery. Tells **HOW** and explains **WHY NON-SURGICAL** Methods of Treating Rupture are so successful today. No obligation.

**EXCELSIOR MEDICAL CLINIC**  
Dept. H6238, Excelsior Springs, Mo.



# special delivery!

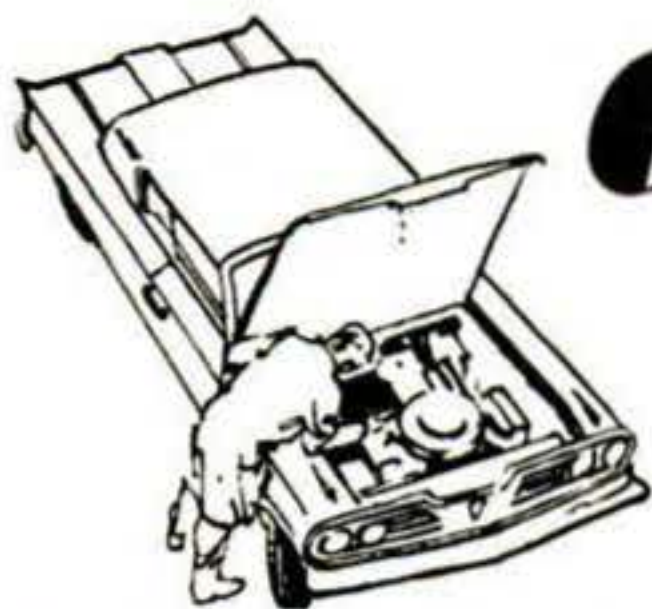

## The Stewart-Warner "240" Electric Fuel Pump

offers distinct advantages for anyone wanting to perfect his car's performance. Reliable and efficient under all conditions. Has adjustable automatic pressure regulator (exclusive with Stewart-Warner) that keeps fuel flowing smoothly to the carburetor...prevents flooding, starving, "vapor lock"...helps you get instant starts in the coldest weather. You can easily install it yourself. Available for 6 or 12 volt electrical systems at leading service stations, garages and parts stores. See the difference in the Stewart-Warner "240" Electric Fuel Pump. (Also ask about the "220" series.)



**INSTRUMENT DIVISION**  
**STEWART-WARNER**  
CORPORATION

Dept. C-43, 1840 Diversey Pkwy., Chicago 14

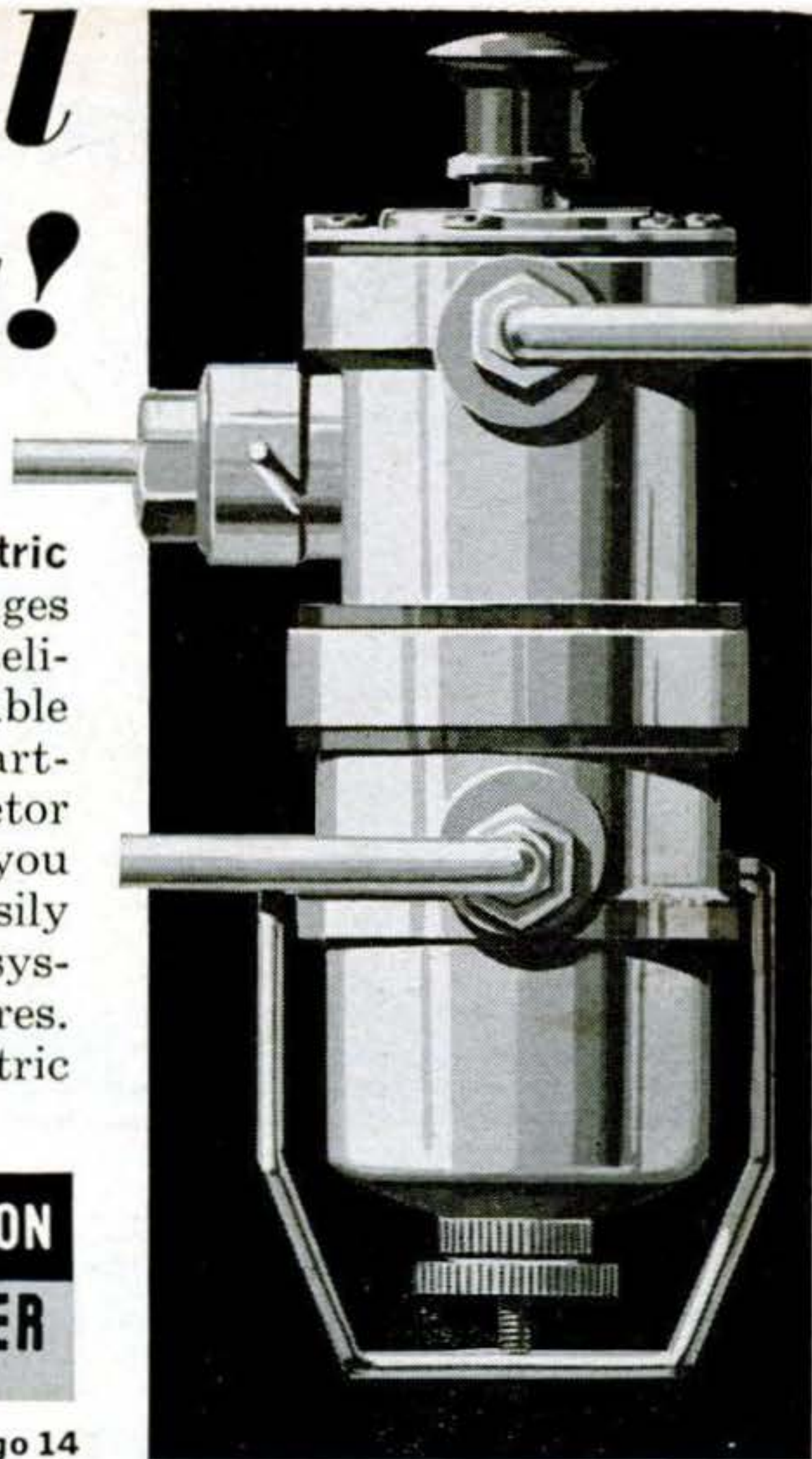

## "Messenger" CB Transceivers...rated BEST in Nation by Electronic Distributor Salesmen\*



\*New impartial survey by leading electronic magazine shows Johnson "Messenger" Transceivers rated "BEST"—BEST BY NEARLY 50% OVER SECOND CHOICE BRAND.

### 4 feature-packed "Messengers" ... and Selective Call System outperform everything!

**Compact, Hand-Held**—100 milliwatt or 1 watt "Personal Messengers". Rugged and reliable—11 transistors, 4 diodes! Twice the sensitivity and 40% more range than similar units with conventional circuitry—more output than similar units with same rated inputs!

**Mobile or Base Stations**—performance proved Viking "Messenger" and new "Messenger Two". Punches your signal across the miles—high efficiency design makes full use of maximum legal power. Excellent receiver sensitivity and selectivity. Automatic "squench" control—5 or 10 channel coverage—easy to install anywhere!

**Tone Alert**—37 tone selective call system mutes speakers until one unit calls another—then automatically your stations receive audio note and indicator light flashes "On".



**NEW! 4-color BROCHURE—write for your free copy!**



**E. F. JOHNSON CO**

2003 10th Ave. S.W., Waseca, Minnesota

Please rush "Messenger" details to:

NAME \_\_\_\_\_  
ADDRESS \_\_\_\_\_  
CITY \_\_\_\_\_ STATE \_\_\_\_\_



## EARN \$10,000 A YEAR

- DIESEL
- ELECTRONICS
- AUTO
- AUTOMATION

The average starting salary of students, completing our FCC License, Electronics Technician Course, and those completing our Diesel Automotive Training, is \$4,300 per year.

After becoming familiar with the industry, their salary usually increases to \$6,000 or \$7,000 per year.

After they become senior technicians, or master mechanics, they can earn \$8,000 to \$10,000 per year.

When they become specialists, or a part of management... or start their own business... they can earn considerably more.

**RESIDENT SHOP TRAINING** is easier and costs less than you may think! We provide you with housing and part-time jobs while in school, plus free nation-wide placement service for graduates.

Check subject above in which you are interested and mail for



**FREE BOOKLET**  
**BAILEY**  
**Technical Schools**



Veteran Approved  
1626 S. Grand, Rm. 50, St. Louis 4, Mo.

Name \_\_\_\_\_ Age \_\_\_\_\_  
Street \_\_\_\_\_  
Town \_\_\_\_\_ Zone \_\_\_\_\_ State \_\_\_\_\_





# LAFAYETTE RADIO ELECTRONICS

**FREE FOR '63**

**1963 CATALOG 630 388 GIANT SIZE PAGES**

**The Largest Catalog in our 42-Year History**

It's New—It's Big— It's Better Than Ever

It's from the "World's Hi-Fi & Electronic Shopping Center"

Here it is—the exciting, all-new 1963 Lafayette Catalog. 388 giant sized pages—everything in hi-fi and electronics for the audiophile, technician, hobbyist, student, engineer and serviceman. Thousands of items at lowest prices.

Now—buy the Easy Way with Easy-Pay. No money down . . . up to 24 months to pay.

### Lafayette Locations

Syosset • Jamaica • New York City • Bronx • Scarsdale  
Newark • Plainfield • Paramus • Boston • Natick

MAIL THE COUPON FOR YOUR FREE CATALOG

Lafayette Radio, Dept. KD-3  
P.O. Box 10, Syosset, L. I., N. Y.  
Rush My FREE 388-Page 1963 Lafayette Catalog

Name \_\_\_\_\_  
Address \_\_\_\_\_  
City \_\_\_\_\_ Zone \_\_\_\_\_ State \_\_\_\_\_



Best \$ you can spend on your car

**HASTINGS**

**PISTON RINGS  
OIL FILTERS  
CASITE ADDITIVES**

# NEW MIRACLE GLUE



for metals, glass, china, tile, most plastics, other non-porous materials. It's Elmer's new Epoxy glue—the new wonder-glue—the "stickiest" glue made especially for non-porous surfaces. The molecules of the Epoxy bond with those of the surface to be repaired. Dries clear, strong, and waterproof. Send stamped, self-addressed envelope for your FREE copy of "WORKING WITH ELMER'S EPOXY." Elmer, The Borden Company, Dept. PS-43, 350 Madison Ave., New York 17, New York. (Available in Canada.)

# IDEAL LAWNMOWER SHARPENER 900

"Two-Way" Grinding Option means bigger profits for you!

The Ideal sharpens any reel-type mower by either "Hook" or "Straight-Line" methods. No limitations, every job perfect with no hand filing. Ruggedly built, screw adjustments can't slip, 1/2 hp. motor.

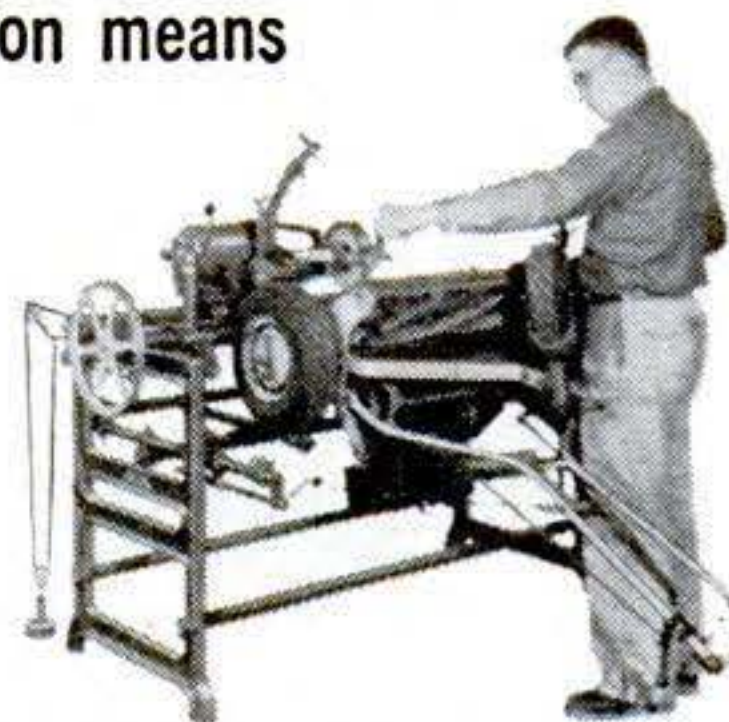

Write for Full Details

The-Fate-Root-Heath Co., Dept. PS-4, Plymouth, Ohio

# POLYSEAMSEAL®

TUB CAULK • TILE ADHESIVE

Pure White • Elastic Permanent

Sticks like glue! 101 Household Uses!



# EARN MONEY FAST!

## REPAIR HYDRAULIC JACKS

Earn while you learn at home. Millions of jacks in gas and auto-service stations, truckers, body-shops, riggers, factories, farms need servicing. We show you HOW — easy step by step directions and what tools to use. EARN UP TO \$5 an hour, in spare time, in your basement or garage. Start your own business NOW!

Write for folder PS-4 and free bonus offer



**INSTITUTE OF HYDRAULIC JACK REPAIR**  
P. O. BOX 50 • BLOOMFIELD, N. J.  
A Correspondence School Licensed by N.J. Bd. of Ed.

## NOW! EARN BIG MONEY IN CARTOONING AND COMMERCIAL ART

Now you can enter this highly-paid field quickly and easily. Learn in your own home, in spare time. No previous training or art ability required. Own your own business — urgent demand for artists everywhere! Earn 100% profit on all drawings — we show you how!

Send for your FREE Catalog today!



Continental Schools, Inc. Dept. E-23 4201 S. BROADWAY, LOS ANGELES 37, CALIF.



DAN LURIE  
World's Most Famous Body-Builder, TV Strongman

## A BODY LIKE MINE IN SHORT TIME with famous DAN LURIE BARBELLS!

SEND FOR FREE GIANT CATALOG

Factory Prices	Cast Iron	Semi-Steel	<b>\$9.48</b>
50 lb. Set.	\$9.48	\$10.48	
100 lb. Set.	15.98	18.98	
150 lb. Set.	23.48	27.48	

Plus Free Extra Wts. 16c lb. 18c lb. \$10 Course MONEY BACK GUARANTEE—Send 50% in check or money order F.O.B. Plant Brooklyn, New York. Balance C.O.D.

DAN LURIE BARBELL CO. 1661, S-4 Utica Ave., Dept. 370D, Brooklyn 34, N.Y.

## BE A REAL ESTATE BROKER



PAYS BIG! SEND FOR FREE, BIG, ILLUSTRATED CATALOG NOW! Graduates report making substantial incomes. Start and run your own business quickly. Men, women of all ages, learn easily. Course covers Sales, Property Management, Appraising, Loans, Mortgages, and related subjects. **STUDY AT HOME** or in classrooms in leading cities. Diploma awarded. Write TODAY for free book! No obligation.

Approved for World War II and Korean Veterans  
**WEAVER SCHOOL OF REAL ESTATE** (Est. 1936)  
3523 G Broadway, Kansas City 11, Mo.

FREE BOOK TELLS HOW





**Prove it yourself—  
RISLONE babys your  
car's engine as  
nothing else can!**

Want better gas mileage? Lower oil consumption? New car pep? Add RISLONE® every oil change, or when you're down a quart. Cleans out power-robbing gum and sludge . . . restores quiet, efficient engine operation. Nothing like it to maintain lubricating efficiency of all motor oils, including the new long-life types. Now, with longer intervals between oil changes, it becomes more important than ever to use RISLONE regularly. Your money back if RISLONE doesn't improve engine performance. At your service station or garage. \$1.50 per quart. Slightly higher in Canada.



**Free Proof of Performance Booklet:** Record your RISLONE performance statistics . . . get valuable driving and money-saving tips. Write to: The Shaler Company, Dept. PS4, Waupun, Wisconsin.

**"\$7,108.50 First Year  
SERVICING RADIATORS!"**

— Hank Konter, Newcastle, Wyo.

Make good money servicing auto-truck-tractor radiators with new Inland 1-Piece Radiator Shop. Easy to test-clean-repair radiators. Inland, world's largest radiator equip. mfr., trains you free. Small down payment starts you. Easy-pay plan lets you pay from profits. Proved merchandising assures volume. Profitable dept. for garage or service station. **WRITE for Free Book.**

**INLAND MFG. CO., Dept. PS-4, 1108 Jackson St., Omaha 2, Nebr.**

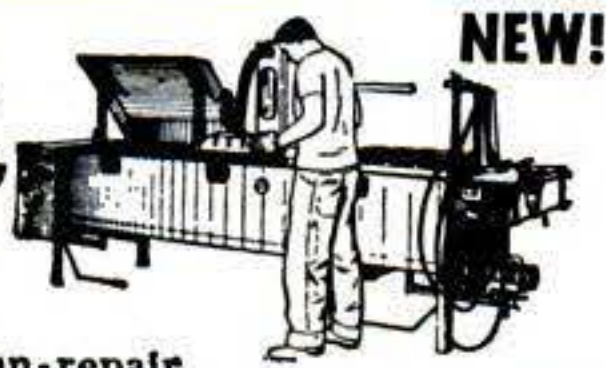

**NEW!**

**BE YOUR OWN BOSS!  
A CERTIFIED MASTER REFINISHER**

**EARN UP TO \$25.00 PER HOUR.**

**REPAIR, REFINISH, TOUCH-UP PORCELAIN, APPLIANCES, FURNITURE. LEARN IN SPARE TIME, AT HOME!**

Master Refinishers are badly needed everywhere. Practically no competition. Touch-up & refinish bathtubs, refrigerators, sinks, furniture for \$10, \$25 or more per hour. Contractors, landlords, hotels, hospitals hire you. Full or part time. Year 'round, no layoffs. Be an E.N.A. Refinisher in months. Easy lessons by mail, by skilled craftsmen. **ARK OFFERS ONLY COURSE OF ITS KIND!** **BONUS! 2 WEEKS IN CHICAGO FOR ON-JOB TRAINING. NO ADDED COST. SEND NAME, ADDRESS FOR FREE FACTS!**

**ARK INSTITUTE**  
1858 E. 75TH ST. — CHICAGO 49, ILLINOIS

**CUPRINOL®**

**WOOD PRESERVATIVE  
PRESERVES WOOD FOR GOOD!**

**Stops Rot! Kills Termites!**



**ENGINEERING**

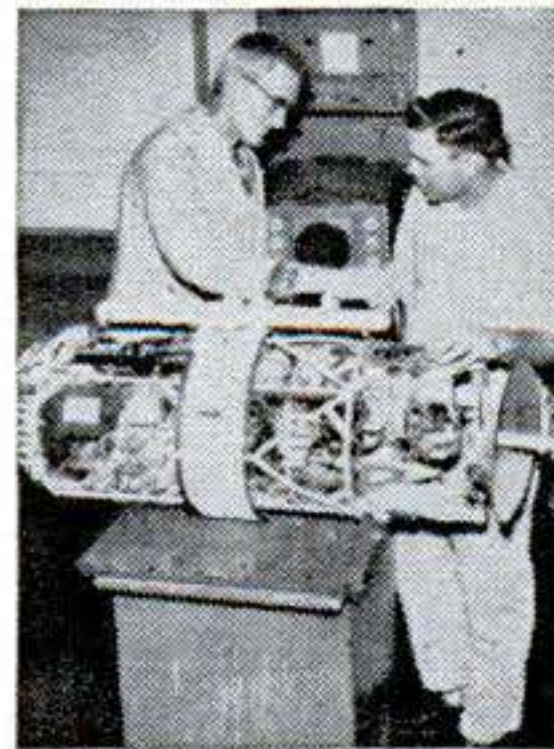

Heald's Micro-wave and Radar Laboratory Equipment.

**ENROLL NOW FOR NEW TERM**

**AMERICAN INDUSTRY NEEDS TRAINED ENGINEERS NOW**

**BACHELOR OF SCIENCE DEGREE, 30 MONTHS**

**SAVE 2 YEARS' TIME**

**B.S. Degree Courses:**

- Electronic Engineering
- Electrical Engineering
- Mechanical Engineering
- Civil Engineering
- Architecture

**Diploma Courses:**

- Radio-Television Plus Color Technician
- Electronic Technician
- Architectural Drafting
- Mechanical Drafting
- Structural Drafting

**APPROVED FOR VETERANS**

**Send for FREE Information**

**HEALD Engineering College**

Van Ness at Post, Dept. PS-463 San Francisco, California

NAME \_\_\_\_\_  
STREET \_\_\_\_\_  
CITY \_\_\_\_\_ STATE \_\_\_\_\_



# CASH IN ON HIDDEN PROFITS

## In Broken Electrical Appliances EARN \$3 TO \$5 AN HOUR

Spare time, full time — Learn at home

FREE BOOK, offered below, shows how YOU can now have a good-paying business of your own, right in your own home. No experience needed, just simple tools. Learn to repair Electrical Appliances. Pays \$3 to \$5 an hour!

400 million appliances are in American homes right now. 76 million more bought each year. People need them fixed, good times or bad. YOU make good money doing it. In your basement, garage, even on your kitchen table.

### QUICK WAY TO GET STARTED

For less than 20 cents a day our easy, well-illustrated instruction — backed by 45 years of success in home training — prepares you for top earnings in this booming field. Earl Reid of Thompson, Ohio says: "Made \$510 in one month spare time. NRI course is priceless." At no extra charge you get your own Appliance Tester Kit, too. Finds trouble-spots, speeds and checks your work. Get your FREE Book and FREE Sample Lesson! Mail coupon below, letter or postcard, now.

FREE BOOK SHOWS HOW FREE LESSON STARTS YOU

NATIONAL RADIO INSTITUTE, Appliance Division  
Dept. BD3, Washington 16, D.C.

Send Free Book, Free Appliance Repair Course Lesson. Am interested in:

- Spare Time Earnings     My Own Business  
 Better Job

Name.....

Address.....

City.....Zone...State.....

Accredited Member National Home Study Council

FREE BOOK

FREE LESSON

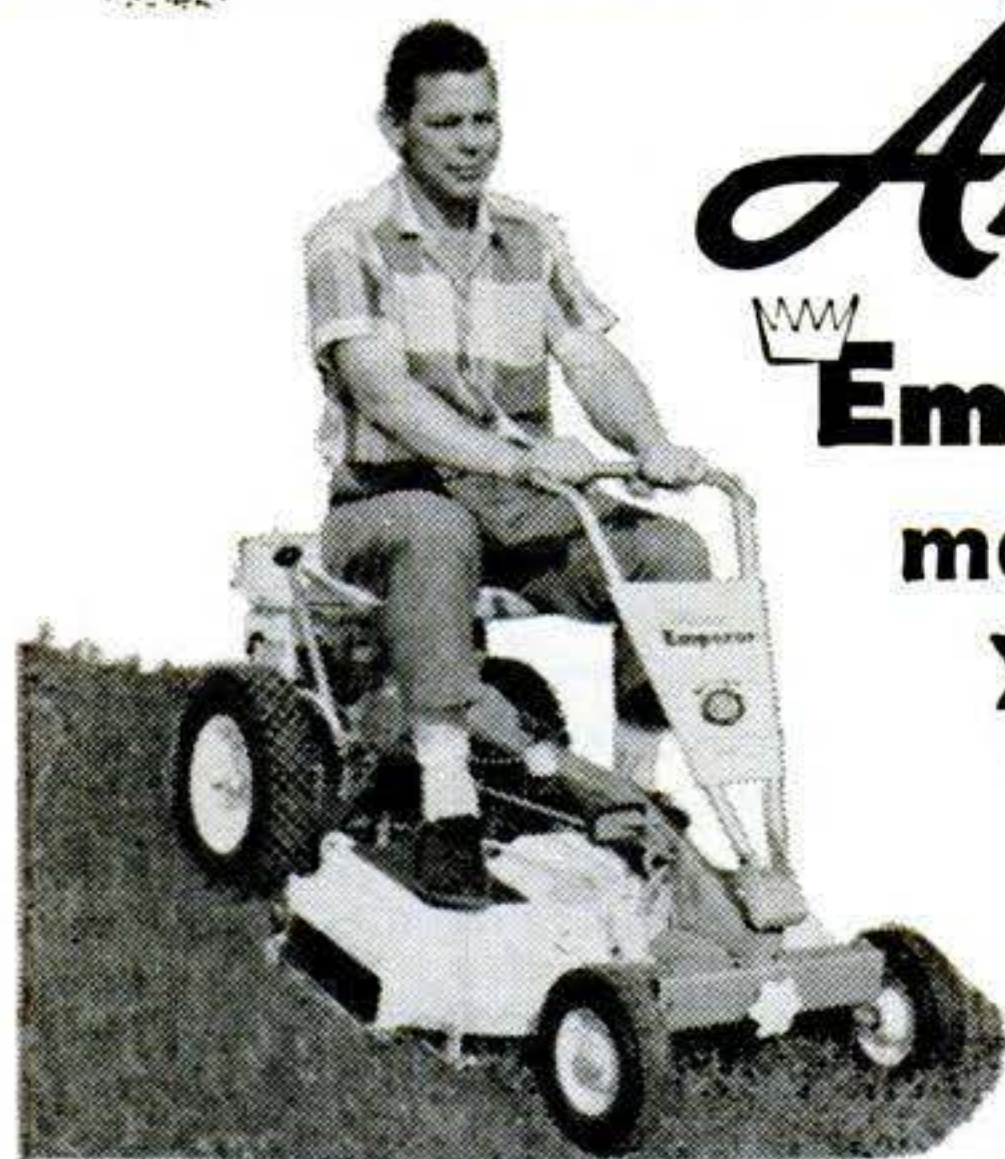

# Ariens Emperor

makes yard care

*fun!  
easy!*

This powerful 6 h.p. riding mower saves time and work on many tough, year 'round Gard-N-Yard jobs! Ariens EMPEROR mows, aerates, rakes, rolls, fertilizes lawns; hauls carts . . . plows snow. Choice 32" or 26" rotary mower. Has rear-mounted 6 h.p. engine for extra traction, stability . . . 4 speeds forward; reverse—fingertip controls. Built for long service—priced to save money!

For free Emperor literature send name and address to

**ARIENS COMPANY**

159 Calumet St., Brillion, Wis.



# CAR-MAC®

== Snap-Apart ==  
**KEY CHAIN**

PUSH RING TO SEPARATE

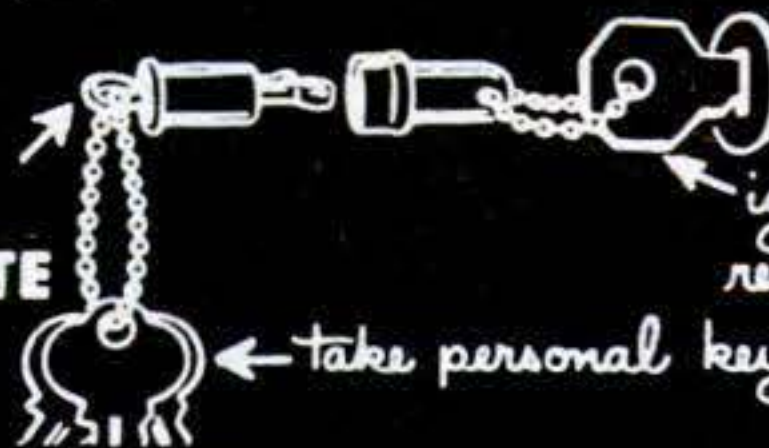

ignition key remains in car

← take personal keys with you

LIVCO, INC., 261 Wolcott St. NEW HAVEN, CONN.

## PAINT LIKE PROFESSIONALS DO This EASY-HOOK Way!

Scientifically engineered, this portable gallon paint bucket support hook fits all extension ladders firmly. Easily moved and used on top or any desired ladder rung. Gives brush clear entrance to bucket. Recommended by professional painters. Saves time, gives you maximum ease and safety. Will last a lifetime—only \$1.00—we pay postage. Money back guarantee. Dealer inquiries invited.

O. F. HOELZEL

106 Parkview Avenue, Portsmouth, Va.

# FREE BOAT KIT CATALOG

New 70 page catalog including cruisers, runabouts, hydroplanes, prams, sail boats, catamarans, air boats, hydrofoils, flying boats, and accessories.

## TAFT MARINE WOODCRAFT

Dept. PS-463 • 636—39th Avenue N.E. • Minneapolis 21, Minn.

## PROFIT IN YOUR SPARE TIME

**SMALL ENGINE REPAIR PAYS BIG!**

Outboard • Powermower • Chain Saw • Tractor

**MAKE EXTRA MONEY** — or fix your own engines and SAVE! Illustrated, easy-to-learn Home Study Course qualifies you as expert. Free information. Write today!

Free information. Write today!

**LINCOLN TECHNICAL INSTITUTE**

Suite 4-G, 472 Market Street, Newark 5, N. J.

# RUPTURED?

TEST THIS TRUSS FREE FOR 30 DAYS



Wear a Web for strong support and lasting relief of reducible inguinal rupture. If not satisfied after 30-day trial, purchase price refunded in full. Write now for free book on rupture care.

**WEB TRUSS Co. Dept. PS-4, Hagerstown, Md.**

## EYE GLASSES by MAIL As low as \$1.95

WRITE for FREE CATALOG with 14 LENS SAMPLE CARD

Thousands of Customers Est. 1939



QUALITY READING — or BIFOCAL GLASSES for FAR and NEAR Recommended for folks approximately 40 years or older who do not have astigmatism or disease of the eye, and who have difficulty reading or seeing far.

**ADVANCE SPECTACLE CO. Inc., Dept. PS-4**  
537 So. DEARBORN ST. CHICAGO 5, ILLINOIS



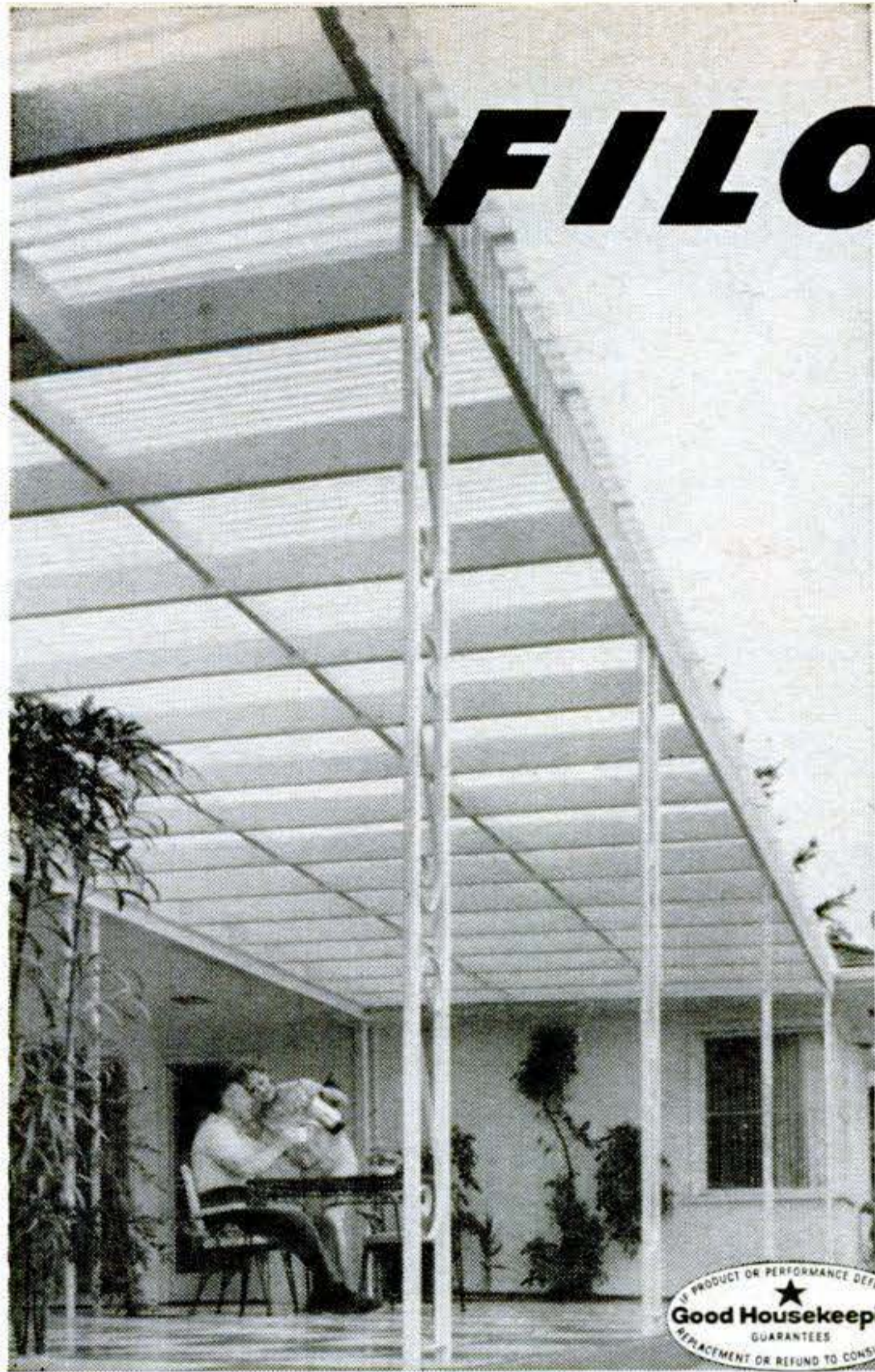

# FILON<sup>®</sup> *translucent fiberglass building panels*

## BRIGHTENS YOUR BUILDING IDEAS WITH *color and light*

Transform ordinary building ideas with the color and light transmitting beauty of FILON. For patio roofs, carports, fences... dividers, shoji screens, luminous ceilings... outdoors and in... applications unlimited! Easy to work with: saw, nail, drill with ordinary tools. Weather-resistant, shatter-resistant, durable. Only FILON has unique parallel nylon-strand reinforcement for extra strength, your hallmark of quality in fiberglass panels. Available in corrugated and flat panels in sheets and rolls. Ask for FILON at your lumber or building materials dealer.

**NEW! FILON "IDEA-PLANS" KIT**  
Colorful, 12-page idea folder; individual building plans for patio roofs and carports, fences, awnings, shoji screens, home greenhouse-utility shelter. Send only 10¢ to help cover handling, postage.



**FILON CORPORATION**  
333 N. Van Ness Avenue, Dept. 3-18, Hawthorne, California  
Sales Offices in Principal U. S. Cities.

## 125 LB. PULL MAGNET \$7.95

New rugged design retriever assembly. Strong handle. Alnico V permanent magnet. Pulls 125 Lb. on steel block. More in water. No. R125 (5"x3 1/2"/wt. 5 lbs.)... **\$7.95 ppd.**  
**MW35** Pulls 35 lbs. (2 1/2"x2x2 in./wt. 32 oz.)... **\$3.75**  
**R75** Pulls 75 lbs. (3x3x1 5/8 in./wt. 42 oz.)... **\$4.95**  
**M30** Alnico small bar (1x3/16x1/8 in.)... **20 for \$1.75**  
**SAMPLE PAIR M30 & CATALOG OF MAGNET BARGAINS 25c**  
**MONEY BACK GUARANTEE/WE PAY POSTAGE**  
**MAGNA MAGNETICS, 7777 Sunset, Los Angeles 46, Calif. Dept. P**



**ENGINEERING  
SCIENCE  
MATH**      **B.S. DEGREE  
IN 36 MOS.**

**U.S. NEEDS 50,000 NEW ENGINEERS EVERY YEAR**

**EARN ACCREDITED B.S. DEGREE** in Science or Engineering in 36 months—year-round program optional. 27-month engineering diploma also available. *Classes start June, September, January, March.* **QUALITY EDUCATION.** Graduates employed throughout U.S. and foreign countries. Government approved for veteran training. Students from 50 states, 40 countries. 20 buildings; dorms, gym. Campus. New library and laboratories. Employment help provided. **SAVE TIME AND MONEY.**

Write for catalog and complete information.



**Indiana Institute of Technology**  
formerly Indiana Technical College

**1618 E. Washington Boulevard, Fort Wayne 2, Indiana**

Please send free information on accredited B.S. Degree programs in Engineering and Science as checked:

- |   |  |
|---|--|
| <input type="checkbox"/> Aerospace Engineering  | <input type="checkbox"/> Mechanical Engineering    |
| <input type="checkbox"/> Chemical Engineering   | <input type="checkbox"/> Metallurgical Engineering |
| <input type="checkbox"/> Civil Engineering      | <input type="checkbox"/> Physics                   |
| <input type="checkbox"/> Electrical Engineering | <input type="checkbox"/> Chemistry                 |
| <input type="checkbox"/> Electronic Engineering | <input type="checkbox"/> Mathematics               |

Name \_\_\_\_\_  
 Address \_\_\_\_\_  
 City \_\_\_\_\_ State \_\_\_\_\_

## Can YOU qualify for a Duraclean dealership?

- Start full or part time, \$9 hourly
- No shop, no experience needed
- We'll help finance you

We are looking for a reliable, honest and able man or woman to own a service dealership in open locations.

We'll help finance the right person who has a few hundred dollars of his own and zeal to work for success.

This business grows from **recommendations** and **repeat orders**. Dealers often gross \$6 hourly profit on EACH serviceman... \$9 on own service. Only one small job a day brings a good starting income.

Our dealers provide 6 urgently needed services to homes, hotels, theaters, clubs, motels, car dealers and institutions. They operate from office, shop or home.

Jobs come from ads, mailings, phone calls, decorators, upholsterers, car dealers, stores and magazine ads.

We prefer you have no experience... no old methods to "unlearn." We and an experienced dealer will train and assist you... reveal the proven ways to build customers. It's easy to learn... quickly established.

Our staff and dealers work together. We hold regional dealer meetings, training schools, conventions. You are backed by national ads, Parents' Magazine Seal, McCall's "Use-Tested," furniture & carpet maker endorsements.

Dealers often stay at present job while customer list grows... then go full time, lining up jobs for servicemen. Many add equipment and men as volume grows.

Besides a **growing income**, your dealership **grows in value**. Dealerships resell at up to 10 times their cost. We help dealers sell if they wish to.

Government figures show service businesses growing much faster than stores or industries... \$750 million yearly potential in just one of your 6 services.

If you believe you have the qualifications to start small and grow big in a growing business, we'll send you a 36 page booklet and all facts you need to decide whether this is the business for you... **no obligation.**

But don't delay. Your location may be open NOW... but will not be later. A postcard will bring a prompt reply.

**Duraclean Co., 3-184 Duraclean Bldg., Deerfield, Ill.**



# AUDELS GUIDES

- No. 1 AUTOMOBILE MECHANICS GUIDE. 1132 Pages.....\$ 6.00
- No. 2 HOME APPLIANCE SERVICE GUIDE. 864 Pages..... 6.00
- No. 3 TV & RADIO SERVICE LIBRARY. 2 Book Set..... 8.00
- No. 4 HANDY BOOK OF ELECTRICITY. 1052 Pages..... 5.00
- No. 6 PLUMBERS & STEAMFITTERS GUIDES. 4 Book Set..... 9.00
- No. 7 PAINTING & DECORATING MANUAL. 585 Pages..... 4.00
- No. 8 CARPENTERS & BUILDERS GUIDES. 4 Book Set..... 9.00
- No. 10 WELDERS GUIDE. 608 Pages..... 4.00
- No. 11 MATHEMATICS MADE EASY. 672 Pages..... 4.00
- No. 12 MACHINISTS & TOOLMAKERS HANDBOOK. 1250 Pages 6.00
- No. 14 REFRIGERATION & AIR CONDITIONING. 1360 Pages... 6.00
- No. 15 ELECTRIC LIBRARY. 10 Volume Set..... 22.50
- No. 26 MASONS & BUILDERS GUIDES. 4 Book Set..... 9.00
- No. 27 ELECTRIC MOTOR GUIDE. 1056 Pages..... 5.00
- No. 29 SHEET METAL PATTERN LAYOUTS. 1152 Pages..... 7.50
- No. 43 DO-IT-YOURSELF ENCYCLOPEDIA. 2 Book Set..... 8.95
- No. 44 NEW MECHANICAL DICTIONARY. 712 Pages..... 6.95
- No. 46 WATER SUPPLY AND SEWAGE. 436 Pages..... 4.00
- No. 47 PRACTICAL CREATIVE PHOTOGRAPHY. 416 Pages... 3.95
- No. 48 GAS ENGINE MANUAL. 480 Pages..... 4.00
- No. 49 OUTBOARD MOTORS & BOATING GUIDE. 400 Pages... 4.00

### 7-DAY FREE EXAMINATION

SEND NO MONEY—Pay the postman nothing! We'll send you any of the Audel Guides for FREE examination. If you decide to keep the books you pay for them under our easy-pay plan of only \$2 a month.

### HERE IS ALL YOU DO

IT'S EASY TO ORDER: In the No-Risk Mail Order Coupon below draw a circle around the number of Guides you want. We will send them to you at once. If you are not completely satisfied, return the books to us.

## MAIL THIS COUPON TODAY!

THEO. AUDEL & CO. — Self Improvement Publishers Since 1879  
49 W. 23rd Street, New York 10, N. Y.

S-4

Please mail me for 7 days' FREE EXAMINATION the books I have circled below. I agree to mail \$2 in 7 days on each book or set ordered, and to further mail \$2 a month on each book or set ordered until I have paid the purchase price, plus shipping costs. If I am not completely satisfied with my Audel Guides I may return them.

NAME \_\_\_\_\_

ADDRESS \_\_\_\_\_

EMPLOYED BY \_\_\_\_\_

1	2	3	4	6	7	8	10	11	12	14	<input type="checkbox"/>	Check Here for Free Complete Catalog
15	25	26	27	29	43	44	46	47	48	49		

**SAVE SHIPPING COSTS!** Check here if you enclose complete payment with order. We pay postage charges. You have same return privilege.

## FREE CAREER BOOKLET

to guide you to a successful future in Engineering and Engineering Technology

Write for your copy!



### MILWAUKEE SCHOOL OF ENGINEERING

Dept. PS-463,  
1025 N. Milwaukee St., Milwaukee, Wis.

Tell me about an engineering career through residence study in:

Electrical       Mechanical

Name.....Age.....

Address.....

City.....State.....

MS-204

# Would YOU Like to Make \$1,000 A MONTH?



That's What Stanley Hyman Made Selling **PRESTO Amazing Midget Fire Extinguisher**



Stanley Hyman

Sensational! Presto does job of bulky extinguishers costing 4 times as much. Ends fires fast as 2 seconds; fits palm of hand. Never corrodes; guaranteed 20 years! Sells for only \$4.95. Show it to owners of homes, cars, boats, farms, etc., and to stores for re-sale—make good income. Write for FREE Sales Kit.

**MERLITE INDUSTRIES, Presto Div.**

114 East 32nd St. • Dept. P-16F • New York 16, N. Y.  
In Canada: Mopa Co., Ltd., 371 Dowd St., Montreal 1, P. Q.

## Train Now For BIG Pay Jobs!

**EARTHMOVING EQUIPMENT OPERATOR**

**HEAVY EQUIPMENT REPAIR-REBUILDING**

*Greer*

**TECHNICAL INSTITUTE**

Atten. S. D. Hutch, Box 358, Braidwood, Ill.



Get ready for a man's job in the booming road and construction industry. Operate cranes, "dozers," earth-movers, etc. Train "on the job" in 5 to 13½ weeks. Classes start weekly; reserve space now. Approved for vets. Complete catalog and reservation facts FREE. Write today!



## LEARN MEAT CUTTING

Train quickly in 8 short weeks at Toledo for a bright future with security in the vital meat business. Big pay, full time jobs—HAVE A PROFITABLE MARKET OF YOUR OWN! Pay after graduation. Diploma given. Job help. Thousands of successful graduates. Our 40th year! Send NOW for FREE catalog. No obligation. G. I. Approved. **NATIONAL SCHOOL OF MEATCUTTING, Dept. 51-S, Toledo 4, O.**

## BE A MAGICIAN!

Get started today! Become a popular man of mystery. Earn and learn in spare time. Magic is fun and profitable too. Be the Life of the Party Astonish your friends!

**RUSH 10¢ now for PROFESSIONAL MAGIC CATALOG**  
160 pages thick • 800 Illus. • 1000 Mysteries  
Also Jokes, Puzzles, Secrets, Illusions.  
**FREE Magic Trick included**  
**HOUSE OF 1000 MYSTERIES • Dept. PS4-63, MONROE, CONN.**



## Fires 75 Rounds NEW Automatic

75-Shot Rapid Fire Repeater

Exciting new 1963 model of automatic. Holds and fires 75 rounds automatically from oversize chamber. Peak accuracy firing power to distances of 30 feet and more. Superbly balanced, smooth, jam-proof action guaranteed. No recoil. Non-lethal. No permit needed. Police use for target practice. Safe, great shooting fun for father and son. Send \$1.98 cash, check or money order plus 27¢ shipping charges and we include 50 silver shot-shells. Satisfaction guaranteed or money back. **Bargain Gun Co., Dept. P-4, 101 East 32nd Street, New York 16, N. Y.**



**\$198**

(100 shot-shells \$1) (250 shot-shells \$2)

## LICKITY LOG SPLITTER

Ends Wood Splitting Drudgery

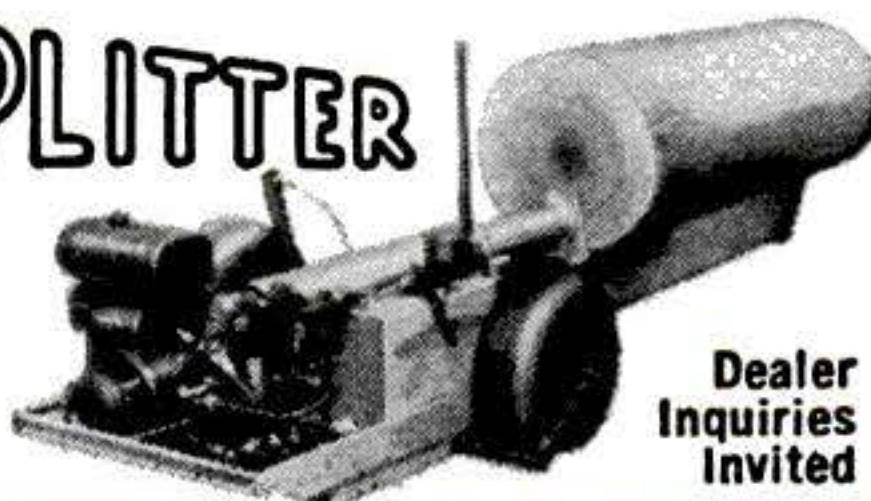

Dealer Inquiries Invited

Smooth 18 ton hydraulic power splits big profits for you from the toughest woods, including American Elm. 7 HP trailer unit squats under own power to receive large logs without "dead" lift. Has 2 speeds, auto-shift and auto-stroke. 26" ram travel splits up to 34" lengths, any diameter—or, with extended frame and adjustable wedge, splits up to 52" lengths, any diameter. Write for details. **THE WACO AIRCRAFT CO., Dept. K, Troy, Ohio**



# BE A BUILDING BEAUTIFIER

C-13



## A LOW-INVESTMENT, HIGH-INCOME OPPORTUNITY

Turning dirty drabness into clean, gleaming newness is the purpose of Colorcrete. When stucco, concrete, or other masonry becomes shabby and time-worn — whether it's a home or almost any kind of commercial or public building — there's a job awaiting the local Colorcretor. In the briefest of time, old surfaces are transformed into walls of colorful beauty that outlasts the years — at small cost to the owner and good profit to the Colorcretor. Write for the Colorcrete Opportunity Book.



W. E. DUNN MFG. CO. INC.  
572 Ottawa Avenue, Holland, Mich.

## MAKE UP TO \$5.00 AN HOUR AT HOME

Let Me Prove It To You FREE!

I'll show you how Plastic Sealing and Laminating at home, spare time, can give you as much as \$5.00 each hour you operate. Table-top machine sets up anywhere. Easy. Fun. No experience needed. We furnish everything. We'll even help finance you. No house-to-house selling. Orders come by mail. Write for facts FREE. No salesman will call.



WARNER ELECTRIC, 1512 Jarvis, Dept. L-3-D Chicago 26, Ill.



## Print Your Own

Cards, Stationery, Advertising, Circulars, labels, photo and movie titles, church work, tags, etc. Save money. Sold direct from factory only. Raised printing like engraving, too.

### Own a Printing Business

Print for Others, Good Profit. Have home shop. Junior press \$15; Senior \$35 up. We supply everything. Easy rules. Pays for self in short time. Write now for free details.

KELSEY PRESSES, Z-33 Meriden, Conn.

## NOW... AMAZING METHODS REVEAL DISGUISED HYPNOSIS

LEARN THESE SENSATIONAL TECHNIQUES AND TRICKS TO CAUSE THE "INDIRECT" HYPNOTIC TRANCE... WITHOUT THE SUBJECTS KNOWLEDGE!

Here, in a clear, easy to follow manuscript, you'll learn jealously guarded secrets and techniques used by expert hypnotists to cause the "Indirect Trance". Read how subjects are hypnotized without their knowledge or cooperation. Discover tricks and shortcuts used to hypnotize quickly and easily. Learn amazing techniques like the "fake nerve pressure" method used to hypnotize a subject in minutes without his knowledge — yet it is quite harmless. See how to convert the simple "falling back" test into a hypnotic trance in seconds. Read, for the first time anywhere, how the author uses a common household cooking ingredient to hypnotize one or a roomful of people without their knowledge. This secret method is so dramatic and effective, it's worth the low price of this book alone. You'll learn many other exciting techniques too. Order now, take advantage of our special "Make Friends Introductory Offer" — get these two unusual items FREE: (1) The fascinating folio "Entertain and Amaze Your Friends with Hypnotic Demonstrations" and (2) The clever Hypnotic "Trance-Fet" Chart. Place this chart on a table or desk — have your subject unfold it and watch how it helps you put him into a "disguised" trance. Order Now — the complete Hypnotic package is only \$1.98 ppd. Read it — use it for 10 full days. If you don't agree that this is the best "Hypnotic buy ever" return it for a prompt refund. Sent to you in a plain wrapper.



**10 DAY UNCONDITIONAL MONEY BACK GUARANTEE!**

**\$1.98** ppd.

**ALLIED-AIDS**  
Dept. D-71 1133 Broadway, New York 10, N.Y.

I am enclosing \$1.98, send the GUARANTEED "Disguised Hypnosis" package—you pay postage.

Name \_\_\_\_\_  
Address \_\_\_\_\_  
City \_\_\_\_\_ State \_\_\_\_\_

# EARN MORE WITH UTAH SAVINGS



## 5 REASONS WHY

- ASSETS OVER \$24 MILLION
- ACCOUNTS INSURED TO \$20,000 BY AMERICAN SAVINGS INSURANCE CO. HOME OFFICE JACKSON, MISS.
- 44 YEARS OF CONTINUOUS SERVICE
- STATE GOVERNMENT SUPERVISION
- SAVERS-BY-MAIL IN 50 STATES AND 45 FOREIGN COUNTRIES

## PLUS FREE GIFTS

- \$ 100 TO \$ 249 — Six-Piece Manicure Set
- \$ 250 TO \$ 499 — Shaeffer Pen & Pencil Set
- \$ 500 TO \$ 999 — Leatherette Travel Clock or Rechargeable Flash Light
- \$1,000 TO \$1,499 — Dormeyer Hair Dryer or Dormeyer Hand Mixer
- \$1,500 TO \$2,499 — G E Table Radio or 52-Piece Stainless Steel Set
- \$2,500 TO \$4,999 — \$59.95 Benrus Wrist Watch 17-Jewel, Men's or Lady's
- \$5,000 TO \$9,999 — G. E. Transistor Radio, Electric Blanket or \$71.50 Men's or Lady's Gruen Wrist Watch
- \$10,000 AND UP — Polaroid Land Camera

(Gift Offer Void in States Where Prohibited)

Savings Postmarked by the 20th  
Earn from the 1st of the Month

## UTAH SAVINGS and Loan Association

65 North University Avenue, Provo, Utah

- Please Send Further Details PS
- Enclosed is remittance of
- \$..... To open my account
- Name .....
- Address .....
- City ..... State .....
- Gift Choice: .....



## PROCESSING OF

# KODACHROME

(Licensed by Eastman Kodak)

also: EKTACHROME  
ANSCOCHROME  
KODACOLOR

KODACHROME I & II  
8mm Roll or 35mm 20 Exp. Mtd.

**\$1.00**

8mm MAGAZINE ..... .75  
35mm 36 EXP. MTD. .... 1.75

SEND FOR FREE MAILERS and our big FREE 25th Anniversary CATALOG of Film and Processing, Splicers, Titlers, Screens, Viewers, Cameras, Projectors at low discount prices.

**SOLAR** CINE PRODUCTS, Inc.

4247 S. Kedzie • Chicago 32, Ill. • DEPT. PS

SOLAR  
26th  
Anniversary

## BARBELLS

140-Pound, CHROME DELUXE Barbell-Dumbbell set only \$19.80. This is our feature set and is the finest ever manufactured. Training with adjustable weights is the BEST way to keep fit; the ONLY way to develop great strength and a perfect body. As the oldest and best equipped barbell company, BUR gives great value and prices no one can equal. Buy from manufacturer.

**SEND FOR FREE CATALOG**  
**BUR BARBELL CO.**  
Lyndhurst 5, New Jersey

**100 POUND SET \$12.80**  
Extra Plates Only 12c Pound



## EXCLUSIVE DOUBLE-BEARING HEAVY DUTY PUMPS

IRRIGATE • DRAIN • CIRCULATE • SPRAY  
Use 1/4 HP motor or larger . . . 1 HP for up to 5,200 GPH; 1,000 GPH 60" high; or 3,000 GPH from 25' well. 1 1/4" inlet; 1" outlet. Stainless shaft. TYPE X—2 oil-less bronze bearings. Won't rust. . . . . **\$10.95**  
TYPE XB—Ball bearing model. Best for belt drives. . . . . **\$12.95**

Postpaid if cash with order.  
Don't delay—send for yours today!  
**MONEY BACK GUARANTEE**  
Centrifugal and Gear Pumps in All Sizes  
LABAWCO PUMPS, Belle Mead 4, N. J.



## BUILD FINE GRANDFATHER CLOCK NOW

The simple sensible SPEEDE Red-i-Kut way as thousands have—FOR YOURSELF OR SELL AT A GOOD PROFIT. SAVE HUNDREDS OF DOLLARS. SHOP TESTED PLANS "SPIRIT OF THE CENTURY". Narrow waist 83" tall or stately straight side "SPIRIT OF AMERICA". EASY-TO-FOLLOW photopack PLANS & LIFE SIZE PATTERNS tell all—plus MOVEMENT BROCHURE \$42 up, heavy brass weight (Kuempel original) Westminster, tube Bell chime, movements, gorgeous bronze-silver MOVING MOON dials, LYRE pendulums, 3/4" solid-mahogany Jiffy Joint-Kwik-Bilt case kits. Send \$1.00 today—Both plans. Rush \$1.50 as folks have done for over forty years.

Kuempel Chime Clock Works, # 18 Kuempel Bldg., Minneapolis 16, Minn.



## Graphoanalysis

LEARN TO ANALYZE HANDWRITING—THE PROVED, SCIENTIFIC WAY!

YOU can learn to analyze character from handwriting. Clinically proved principles of Graphoanalysis help you understand people—including yourself. Fascinating home-study training. Many career opportunities for both men and women, full or spare time. Send for FREE catalog and sample lesson. No salesman will call. (State age.)

**INTERNATIONAL GRAPHOANALYSIS SOCIETY, INC.**  
325 West Jackson Blvd. Dept. DY-1 Chicago 6, Illinois

**Free! TRIAL LESSON**

## ELECTRIFY PLAYER PIANOS PUMP ORGANS

YOU CAN QUICKLY END TIRESOME FOOT-PUMPING With a Compact Low-Cost Lee Silent Suction Unit

EASY TO INSTALL  
FULLY GUARANTEED  
1000'S IN USE

write to  
**LEE MUSIC MFG. CO.**  
Box 595, Tujunga, Calif.



# FREE GIANT NEW 1963 CATALOG



**HI-FI & STEREO COMPONENTS AND SYSTEMS**

**SAVE UP TO 50% ON B-A SELECTED KITS**

**TOP VALUES IN POWER & HAND TOOLS**

**30 PAGES OF BARGAINS NOT IN ANY OTHER CATALOG**

**BURSTEIN-APPLEBEE CO.**

Dept. P5, 1012 McGee St., Kansas City 6, Mo.

Rush me FREE 1963 B-A Catalog.

Name .....

Address .....

City..... State.....

SEND FOR IT TODAY

FREE

MY SPARE TIME HOBBY  
MAKES ME  
**\$5<sup>00</sup> an hour**  
**CASH PROFIT**

— Grover Squires

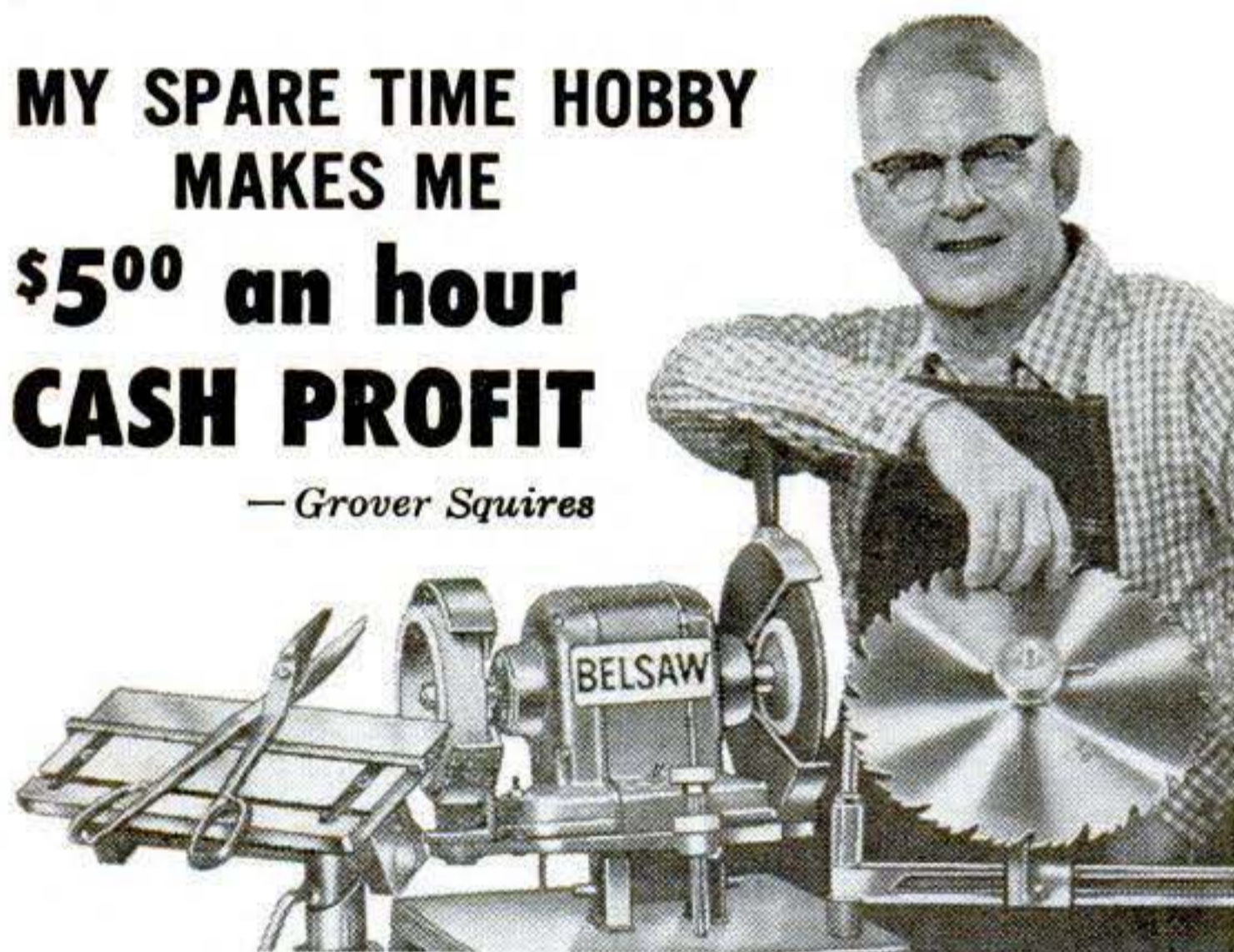

**START YOUR OWN SPARE TIME BUSINESS**  
You can turn your spare time into Big Cash Profits with your own COMPLETE SHARPENING SHOP . . . Grind saws, knives, scissors, skates, lawn mower blades . . . all cutting edges. Your Own Cash Business with no inventory . . . right at home . . . no experience needed.

**FREE BOOK** tells how you can start your own spare time business while you are still working at your regular job. Low Cost — time payments only \$15.00 a month. Send coupon today.

**BELSAW SHARP-ALL CO.**, 703 Field Bldg., Kansas City 11, Mo.

Send Free Book "LIFETIME SECURITY". No obligation.

Name .....

Address .....

City..... State.....

FREE BOOK



Not everyone does as well, but T. N. CODY, who started a business of his own, reports...

For 12 months  
I've averaged

**\$800**

**PER  
MONTH  
INCOME**



**—most of it clear profit for me!**

Many men have discovered how to be independent, to be free of layoffs and bosses. C. G. Naples grossed more than \$200 his first week. A father-son combination grossed \$44,000 their second year. H. Lemon says, "I netted \$133 in one 8-hour day."

How much you earn depends largely on you, but we help you to start and work with you for your success. You need no special skill, no large investment. Start part time if you wish. Hire helpers as needed.

**NO SHOP NECESSARY** • Our **PORTABLE ELECTRIC DETERGER** shampoos rugs, carpets right on customer's floor. Wonderful results bring you repeat business, large fees. So efficient and safe, it is used by largest hotels and railroads.

**OURS IS NOT A LEASE ARRANGEMENT** • You are free to operate in an independent manner. You sign no contract. You own the detergent outright and are always *your own boss* ...and every dollar you take in is *yours* to keep. You pay no fees, or dues, or royalties to anyone. And you take no risk. Your detergent is fully guaranteed and enough supplies come with it to return far more than your investment. Many earn the cost of the detergent in a week or two. It costs nothing to get the details...write **TODAY**.

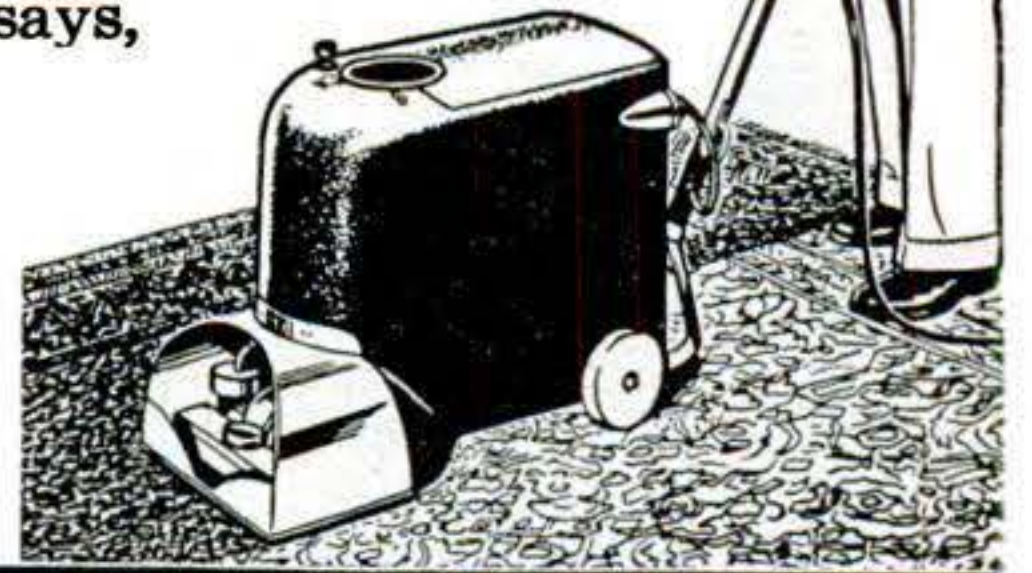

**MAIL COUPON TODAY FOR FREE BOOK**

**VON SCHRADER MFG. CO.**  
411 "R" Pl., Racine, Wis.

Without obligation send me **FREE** booklet about your **RUG DETERGER** and tell me how I can start *my own* permanent, profitable business.

Name \_\_\_\_\_

Address \_\_\_\_\_

City \_\_\_\_\_ Zone \_\_\_\_\_ State \_\_\_\_\_

**NEW MFG CAR TOP-FISHERMAN**



**NEW TRIHEDRAL HULL**—Provides greater stability, maximum maneuverability. Takes you through rough water comfortably.

**ONE-PIECE FIBER GLASS CONSTRUCTION**—No rivets to pop, no screws to replace, no sealing, no caulking, freedom from rot, corrosion. No metallic noise.

**EASILY TRANSPORTABLE**

WEIGHT APPROX. 110 LBS.

For further information write

**MFG MOLDED FIBER GLASS BOAT COMPANY**  
83 Fourth Avenue, Union City, Pennsylvania

LOW, LOW PRICE

**\$197<sup>00</sup>**

F.O.B. Union City



**LEARN ELECTRONICS AT HOME**

**FOR A BETTER JOB WITH BETTER PAY**

Choose from these courses: 1. Radio and Electronic Fundamentals 2. TV Servicing 3. Color TV 4. Communications Electronics 5. Automation Electronics 6. Computer Programming 7. Transistors 8. Electronic Drafting 9. FCC License Preparation 10. Mobile Communications.

RCA Institutes offers you the finest training-at-home program in electronics. Practical application begins with your first lesson. All equipment furnished is of prime quality...to keep and use on the job. Pay only as you learn. Courses for beginners and advanced students. Approved for Veterans.

**RCA INSTITUTES, INC.**

A Service of Radio Corporation of America

The Most Trusted Name in Electronics

**CANADIANS**—Take advantage of these same RCA courses at no additional cost. No postage, no customs, no delay. Send coupon to: RCA Victor Company, Ltd., 5581 Royalmount Ave., Montreal 9, Quebec.

**CUT OUT AND MAIL FOR FREE BOOK!**

**RCA INSTITUTES, INC.** Home Study School,  
Dept. PS-43 350 West Fourth Street, N. Y. 14, N. Y.

Rush me the **FREE** 64-page illustrated booklet "Your Career in Electronics" describing your electronic home study training program. No salesman will call.

Name..... Age.....

Address .....

City..... Zone..... State.....





WEAR THE SHOE THAT'S  
**JOB-FITTED**  
FOR YOU

**Thorogood®**

Designed and built for comfort and service . . . 50 different Thorogood Job-Fitted Work Shoe styles to meet the requirements of 30 basic occupations. Look for dealers displaying the Thorogood sign; or write to us for the name of the one nearest you.

*Weinbrenner®*  
A **textron** DIVISION  
MILWAUKEE 1, WISCONSIN

**Luger Fiberglass or Plywood BOAT KITS Save You Money!**

**FREE 64 PAGE Full Color Boat Kit Catalog**



Save \$1000 to \$2500 on 18'-20'-22' LUGER LUXURY CRUISERS . . .

Save to \$500 on speedy 14' or 16' Molded Fiberglass Runabouts! *Over 50 Models!* Easily assembled by anyone with ordinary tools. Every part and every section comes pre-cut, pre-assembled or precision molded from factory. Just put sections together! Many models take only one or two evenings to complete. Easy Terms! 3 Years to Pay! *Money Back Guarantee!* Rush name, address for big full color catalog—64 pages—FREE! Write

**LUGER BOAT KITS, Dept. A-43 9200 Access Road, Minneapolis 31, Minn.**



**NEW HI-FI PERFORMANCE**

The Exciting NEW **MODEL 422 BENJAMIN CO<sub>2</sub> 10-SHOT SEMI-AUTOMATIC**

**.22 PELLET PISTOL**

**\$24.00**

Ask Dealer for Demonstration.

**EFFICIENT—SAFE—DEPENDABLE—CONVENIENT Famous BENJAMIN Quality**

AT LAST—an Amazing New Handgun that Incorporates the Characteristics Wanted for Serious Training, Plinking and Match Competition—Indoors and Outdoors—at **LOWEST SHOOTING COSTS!** Handsome, Dynamic, Mechanically Reliable, MODEL 422 combines Traditional BENJAMIN PEAK POWER and ACCURACY with Incredible Firing Speed—Smooth JAM-PROOF ACTION (no ramrod for cleaning pistol bore required)

WITH **EXTRA MARGIN**

**BENJAMIN'S Unique DOUBLE SAFETIES**

Press Trigger Safety "OFF"

Release Hammer Safety as Illustrated.



**KEEPS SHOOTING & SHOOTING & SHOOTING & SHOOTING AS FAST AS YOU CAN SQUEEZE THE TRIGGER!**

**FREE** Write today! Complete Catalog Benjamin Rifles & Pistols—Single Shot & Repeaters—BB or 177 or 22. Also, Special Offer on Hunting Knives.

Use Benjamin H-C Pellets in Model 422 for Accurate, Jam-Free Shooting.

**BENJAMIN AIR RIFLE CO. 852 MARION ST., ST. LOUIS 4, MO.**

**engineering degree in 27 months**

Industry demands graduates. Enjoy higher income . . . advancement. Major corporations regularly interview and employ seniors. **BACHELOR OF SCIENCE DEGREE IN 27 MONTHS** in Electrical, Mechanical, Aeronautical, Chemical, Civil Engineering. **IN 36 MONTHS** a B.S. Degree in Business Administration (General Business, Accounting, Motor Transport Administration majors). One-year Drafting-Design Certificate Program. Small classes. More professional class hours. Well-equipped labs. Campus. Dorms. New library. *Moderate costs. Founded 1884. Enter June, September, January, March. Write J. F. McCarthy for Catalog and "Your Career" Book. Learn more and you'll earn more.*



**TRI-STATE COLLEGE**

543 College Avenue • Angola, Indiana

**75 POWER TELESCOPE \$3.98**

**NEW** 3 in one telescopes, 3 variable 25X 45X-75X magnification. Brass bound, 25 power for ultra bright images 45 & 75 power for long range. Guaranteed to bring distant stars, moons, objects, sports 75 times closer.



**Most powerful scope sold anywhere near this amazing low price.** American made, 5 sections. Opens 36", closes 1 ft.; contains 4 ground & polished lenses. Can also be used as powerful compound microscope. Mass production enables us to offer telescope complete at \$3.98 postpaid. Money back guarantee. **CRITERION CO., Dept. PSB-12; 331 Church St., Hartford, Conn.**

**Hotels, Motels Call for Trained Men**

Record-breaking travel means nation-wide opportunities and a sound substantial future for trained men in the hotel, motel and hospitality field. Fascinating work; fine living; quick advancement. You can qualify at home or through resident classes in Washington. Previous experience proved unnecessary. Placement Service without extra cost. Write for **FREE Book, "Your Golden Opportunity."** Accredited member National Home Study Council. Course Approved for ALL Veteran Training. 47th Year. **LEWIS HOTEL TRAINING SCHOOL, Rm. JD-9712, Wash. 7, D.C.**

**JEEP OWNERS**

**Re-Power NOW with a V-8 or 6 Cyl engine—Use Ford - Chev - Mercury - GMC - Pont - Stude - Dodge or Plymouth in Jeeps, Jeeps, Trucks, Sta-Wgn, Trucks, Kaiser & H. J. cars. Conversion kits \$43.35 to \$56.90. Want fast action? Give us full information, send \$15.00 Dep. and we will ship correct kit. Bal. COD. Send full amount for prepaid shipment. Wire, phone or write today. Details FREE.**

**HOOSIER MACHINE PRODUCTS CO.**

314 S.E. 6th St. Phone CR6-3442 Pendleton, Oregon



Transistor Radio with Battery \$1.96

17-Jewel Watch \$2.87



Derringer Pistol \$5.74

**HOME-IMPORT BUSINESS—Make Big Profits**

New Drop Ship Plan offers you first day profits! Deal direct with overseas sources at prices shown. Dazzling bargains with no investment. Full or spare time. Write for **FREE BOOK** today to . . .

**MELLINGER, 1554 S. Sepulveda, Dept. K244, Los Angeles 25**

**You Can Have a HE-MAN Voice**



**STRENGTHEN** your voice this tested, scientific way. Yes—you may now be able to improve the **POWER** of your speaking and singing voice . . . in the privacy of your room! Self-training lessons, mostly silent. No music required.

**FREE BOOKLET**

Write today for Eugene Feuchtinger's great booklet "How to Develop a Successful Voice." It's absolutely **FREE!** You must state your age. Booklet mailed postpaid in plain sealed envelope. No salesman will bother you. Send your name and age **RIGHT NOW!** **PREFECT VOICE INSTITUTE, 325 W. Jackson Blvd., Studio DY-1, Chicago 6, Ill.**



# HUNTING WITH GAS

A GROWING SPORT

**Rattlers run, gophers go and fox fume . . . when you hunt with TEAR GAS . . .**

It's been a long hard winter cooped up in the living room looking at TV. The spring woods beckon! Your trigger finger is itching, and your hound dog instincts are at fever pitch.

If you've got some experimenting blood in those hunter's veins of yours, you might want to try the fast-growing sport of hunting with TEAR GAS . . . the equipment is cheap and simple. You can use a special .22 caliber automatic or a single-shot .38 caliber, fountain-pen-type, TEAR GAS discharger; neither of which will run you more than a sawbuck.

Your quarry is everywhere . . . in holes, caves, tree stumps, hollow logs, burrows and mounds. It doesn't matter if your region is woody, swampy or prairie . . . it will still hold game galore for this sport.

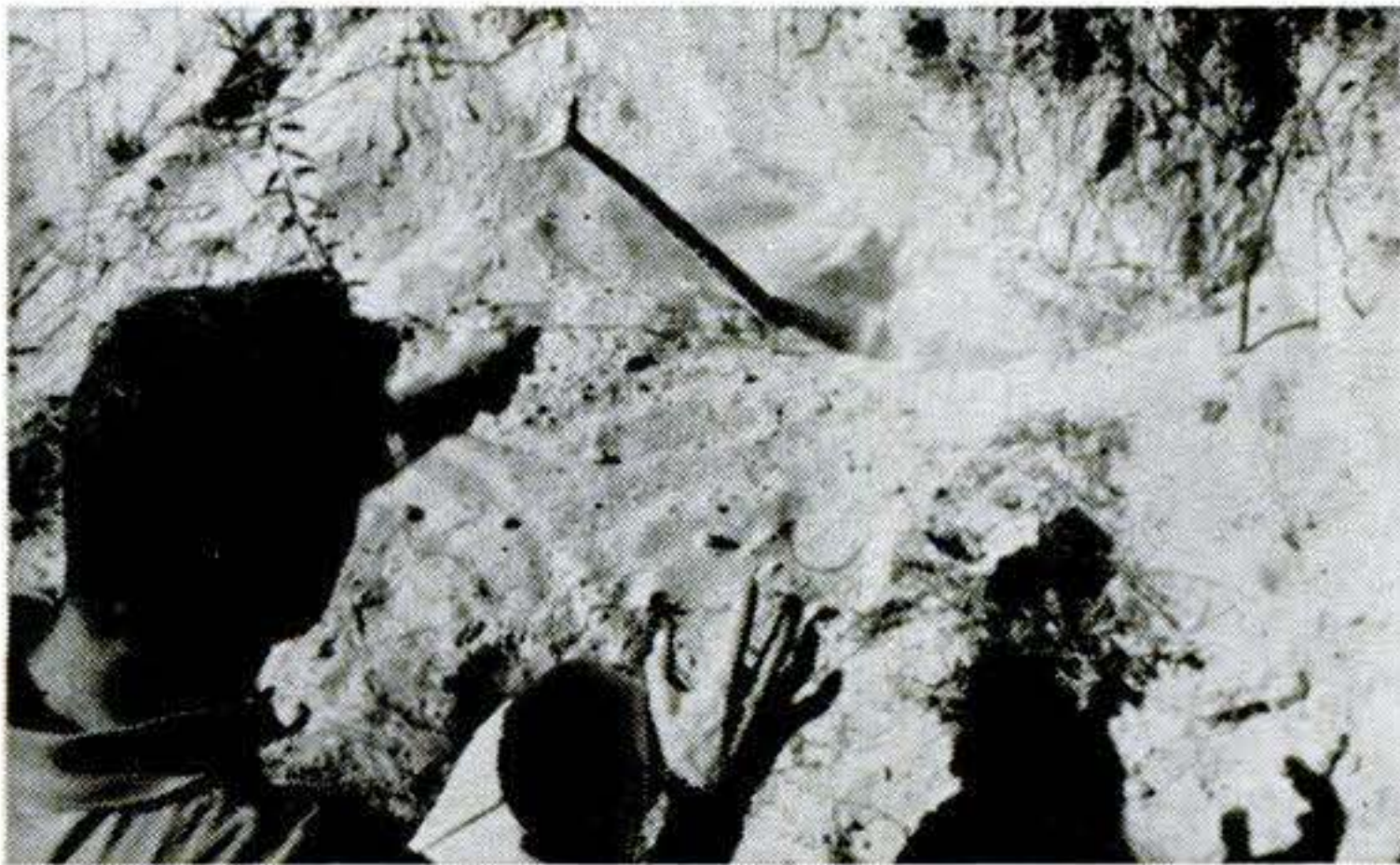

Rattler with fangs bared lunges from hole as hunter pumps another shot home from a .22 gun.

Your quarry is so varied, you never know what you're going to come up with next. Poke your pistol in a hollow log and you may flush out anything from a valuable mink to a snarling bobcat. That harmless-looking hole in the ground may harbor a spitting rattler or a frightened gopher. Just use a little caution and common sense—watch that the wind doesn't blow gas in your direction.

You don't have to be a deadeye, either, for in this sport you just about can't miss. The .22 gun shoots a cloud of gas about 6 feet and will fire 6 times without reloading. The .38 magnum shell that shoots in the pen goes 12 to 15 feet with a wide area exposed to the gas. So, use the gun on small animals . . . the pen on big ones, point your weapon at the target and fire away. If there's anything in there, it

will be out and running in short order! This makes them ideal for farm or ranch pests.

Hunting with gas is free from a lot of cumbersome regulations. The Federal Firearms Act exempts these items, since they cannot possibly be used to fire live ammo of any kind. Since Uncle Sam allows no small arms ammo (even blanks) to be mailed, the whole works are shipped by bus, express or U.P.S. So, it is best to order additional ammo with the projector.



Here a fox races from his lair with tear-filled eyes, after the powerful .38 Magnum Pen did its work.

Many of the boys on the local game commissions are encouraging sportsmen to get rid of game- and bird-killing pests by flushing them out with TEAR GAS. They'll generally give you the green light to try for anything which isn't protected. In Florida, for example, our hunters went after—and got—bobcat, fox, snake, skunk, opossum, coon, squirrel, gopher, armadillo, rattler, tortoises and mixed reptiles. In other regions you can add all variety of varmints, such as nutria, rats, moles, shrews, woodchucks and prairie dogs.

Even the animal-protection people do not object too strongly to this sport, since all it does is give the critters a good cry and some exercise.

If you're not going hunting, these devices are excellent for personal protection in your home, car or your wife's purse.



HUNT YEAR 'ROUND



**WITH**

**TEAR GAS**



TEAR GAS GUN OUTFIT	"GAME FLUSHER" PENS
 <p>This all-steel, .22 cal. TEAR GAS gun shoots 6 times as fast as you can pull the trigger. Also fires blanks for alarm or dog training. Complete with 6 tear gas shells and instructions.</p> <p>BLUE STEEL . . . . . \$ 9.98</p> <p>CHROME . . . . . \$ 11.98</p>	 <p>This handy size chrome pen shoots the new powerful .38 spec. MAGNUM cartridge. Will flush game out of the deepest holes. Powerful enough to even stop a Bear!</p> <p>Complete with 2 shells . . . \$9.98</p> <p>Same as above in .22 caliber with 3 shells . . . \$4.98</p>
<p><input type="checkbox"/> Gun \$9.98    <input type="checkbox"/> Pen \$9.98    <input type="checkbox"/> .38 Shells .75 ea. 20 for \$13.50</p> <p><input type="checkbox"/> Gun \$11.98    <input type="checkbox"/> Pen .38 Cal. 2 shot \$11.98    <input type="checkbox"/> .22 Shells .15 ea. 100 for \$13.50</p> <p><input type="checkbox"/> Pen \$4.98    <input type="checkbox"/> Gun Holster \$2.00    <input type="checkbox"/> .22 Blanks 100 for \$1.25</p> <p style="text-align: center; font-size: small;">Minimum order \$3.00</p>	
<p>TEAR GAS DEVICES CO., ST. LOUIS 22, MISSOURI</p>	
<p><b>Rush!</b> Enclosed is check. (No. C.O.D.'s)</p>	<p>NAME _____</p> <p>ADDRESS _____</p> <p>CITY _____ ZONE _____ STATE _____</p>



# MANUFACTURE THIS BEAUTIFUL CONCRETE OUTDOOR FIREPLACE

Right In Your Own Backyard

**\$4.00 Worth of Sand & Cement produces this Attractive Fireplace.**

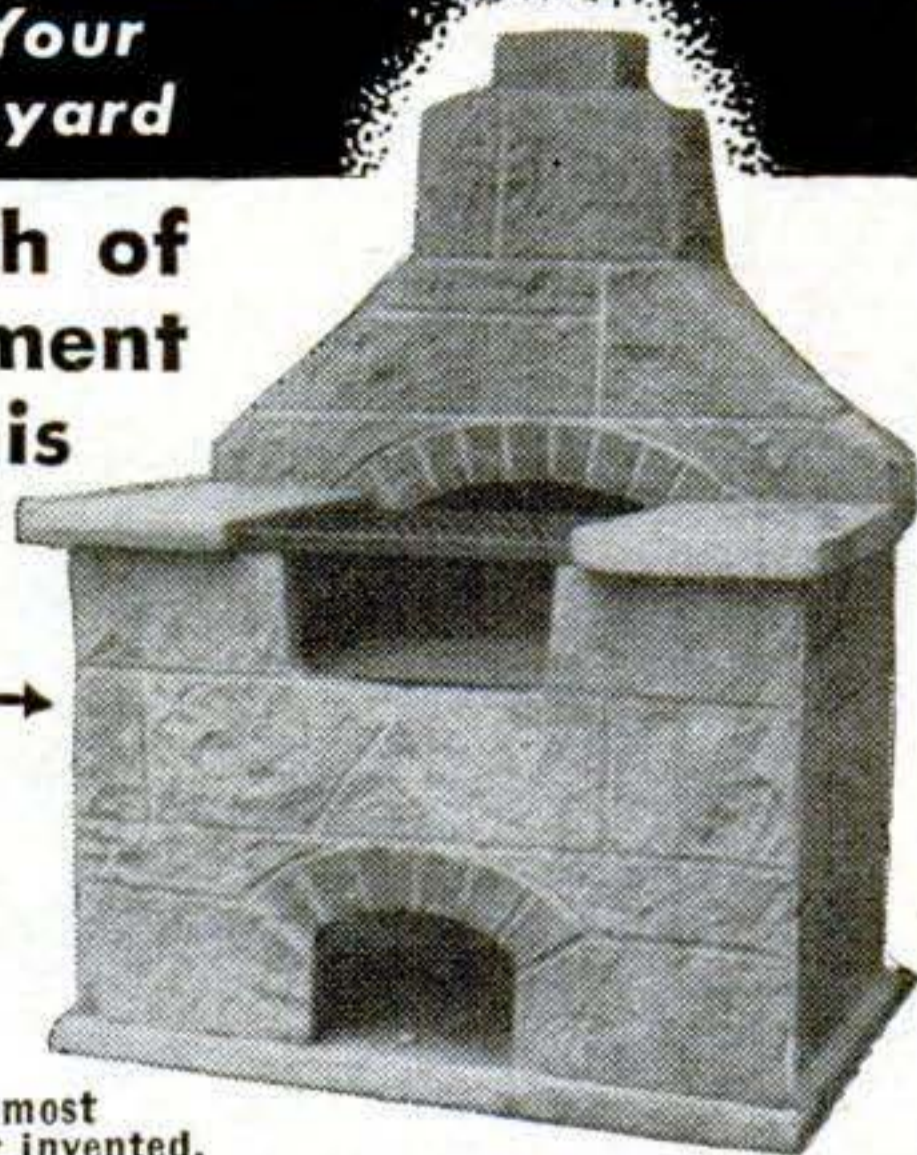

**Sells on Sight from \$60. to \$80. Easy to start your own Profitable Business.**

The General Fireplace Molds and Process are the most amazing and foolproof ever invented. Simple to operate. Two men can produce five fireplaces a day.

### BIG DEMAND!!

Sell all you produce to Department Stores, Homeowners, Parks, Nurseries and Picnic Groves. Fireplaces sell on sight. No experience necessary. We supply full operating instructions and equipment plus the know-how that spells **BIG PROFITS**. This is an outstanding opportunity for men of vision and small capital to get into a busy rich paying field. Don't delay, be the only exclusive manufacturer in your own home town. Mail coupon at once for full details as to how you can reserve your territory. Molds sold only on exclusive franchise

**GENERAL ENGINES CO., Inc., Dept. SF-43**  
ROUTE 130, THOROFARE, NEW JERSEY

Mr. Tor of Philadelphia writes: Sold 250 in first 4 months. Selling to Sears Roebuck, John Wanamaker, and Gimbel Bros. in Philadelphia area.

Name .....  
Address .....  
City .....Zone.....  
State .....

## FREE MUSCLE COURSE!

Trade in that skinny scrawny, milk toast or overweight body of yours for a new Weider Jet-Charged body, rippling with mountains of muscles loaded with energy, drive and virility, the envy of every man and admiration of every women, now! In 15 minutes I'll prove you can slap on 4 inches of muscles to your chest,—3 inches to each arm—give you life-guard shoulders, trim your waist to athletic size—give you speedy athletic legs. I don't care if you're short or tall, (skinny or fat) young or not so young, expect a muscle building miracle when you send for my FREE course. Send only 25 cents to cover postage and handling and write to the Trainer of "Mr. Universe", "Mr. America", "Mr. Europe".

**JOE WEIDER, Dept. 100-43,**  
803 Palisade Ave., Union City, N. J.



## BE A CLAIM INVESTIGATOR

### INVESTIGATE ACCIDENTS!

Many earning \$750 to \$1000 a month. Thousands of insurance companies, steamship lines and Government Offices need Claim Investigators. Also big opportunities for your own spare time business. We train you at home. National Placement Service FREE of extra charge. Bill King writes: "Your course has paid off for me with large earnings. You can quote me — your Adjuster Training Course is worth many times the cost." Write TODAY for FREE book.

### UNIVERSAL SCHOOLS

University Park, Dept. PS-4, Box 8202, Dallas 5, Texas



# Shrinks Hemorrhoids New Way Without Surgery Stops Itch - Relieves Pain

For the first time science has found a new healing substance with the astonishing ability to shrink hemorrhoids and to relieve pain — without surgery.

In case after case, while gently relieving pain, actual reduction (shrinkage) took place.

Most amazing of all — results were so thorough that sufferers made astonishing statements like "Piles have ceased to be a problem!"

The secret is a new healing substance (Bio-Dyne®)—discovery of a world-famous research institute.

This substance is now available in suppository or ointment form under the name Preparation H®. Ask for it at all drug counters.

## GET INTO ELECTRONICS

V.T.I. training leads to success as technicians, field engineers, specialists in communications, guided missiles, computers, radar, automation. Basic & advanced courses. Electronic Engineering Technology, an ECPD accredited Technical Institute curriculum. Assoc. degree in 29 mos. B.S. obtainable. G.I. approved. Start Sept., Feb. Dorms, campus. H.S. graduate or equivalent. Catalog.

**VALPARAISO TECHNICAL INSTITUTE**  
DEPARTMENT 5, VALPARAISO, INDIANA

## RUPTURE!

An amazing Air-Cushion Invention allows body freedom at work or play. Light, neat, cool, sanitary.

Durable, cheap. Day and night protection helps Nature support weakened muscles gently but surely. No risk. Sent on Trial! Write NOW for free Booklet and Proof of Results. All correspondence confidential.

**Brooks Company, 348 State St., Marshall, Mich.**



**Close Out! Clinton Engines**  
65% discount 5 1/2 hp E65 Clinton Clockwise rotation only. (facing end of power shaft). Go-Cart mfg. gone out of business — offering engines at ridiculous prices. Complete with exhaust stack, recoil starter. Motor mount, air cleaner. \$34.00 ea. Retail \$97.50. Send check, cash, or money order (no C.O.D.). Add \$3.00 ea. for parcel post, insurance and handling in the U.S.  
Box 337 Warrensburg, Mo.



**FOR CARTS  
SCOOTERS  
AIR BOATS  
GRAIN AUGERS  
CHAIN SAWS**

## TALK THRU ANY RADIO WITH THIS WALKIE TALKIE!

### YOUR OWN POCKET SIZE RADIO STATION

Sends your voice to any car or house radio. Works up to 1-2 miles from car to car or 1-5 or more blocks house to house depending on local conditions. Just Push Button to Talk—No Complicated Hookups or Wires—Anyone can use it.

Transistor powered by flashlight batteries. No License or Permits Needed. Guaranteed to Work. 1 yr. Service Guarantee. Should Last for Years!

**SEND ONLY \$3.00** (cash, ck, mo) and pay postman \$9.99 C.O.D. postage or send \$12.99 for postpaid delivery. Ready to operate, with clear instructions. Order your Radio-Talkie today—NOW! Made in U.S.A. Available only from:  
**WESTERN RADIO, Dept. TPS-4, Kearney, Nebr.**



## G E A R S

In Stock—Immediate Delivery

Gears, speed reducers, sprockets, thrust bearings, flexible couplings, pulleys, etc. A complete line is carried in our Chicago stock. Can also quote on special gears of any kind. Send us your blueprints and inquiries.

Send for Complete Catalog No. 220  
**CHICAGO GEARWORKS**  
440-450 N. Oakley Blvd. Chicago 12, Ill.



This brand-new book shows you  
**HOW TO FIX EVERY  
 FOREIGN CAR**  
 sold in America.  
 Covers every model  
 right up to 1963!

1024  
 giant  
 pages



**M**OST foreign cars are easy to fix — IF you know exactly what you're doing! Engines, carburetors, transmissions, and other vital parts are often very different from American makes. With the brand-new GLENN'S FOREIGN CAR REPAIR MANUAL, you will never have to work in the dark... never risk the costly damage a wrong guess can lead to. You will know exactly what to look for and what to do.

**Thousands of Pictures . . .  
 Every Step Simplified**

This big, 1024 page book is filled with thousands of pictures . . . detailed drawings, diagrams, photos, and exploded views of all mechanical parts.

Everything you read in this book is illustrated with clear, how-to-do-it photographs—so that you can follow along step by step. It's as simple as 1-2-3 whether you are a skilled mechanic or just a beginner!

Here is what this book shows you:

- The design, workings, and specifications of every component of every foreign car.

- How to take each mechanism apart, inspect, clean, and repair it. Every part of the car—engine, fuel and electrical systems, power train, running gear—gets this same thorough going-over.

**SPECIAL FEATURE:** Complete factory-approved racing modifications for many sports-car models.



**Watch This Book Pay For Itself!**

GLENN'S FOREIGN CAR REPAIR MANUAL is the kind of book that pays for itself many times over. If you own a foreign car, it will show you how to perform repairs and adjustments yourself — and save labor costs. If you are a professional mechanic, it will help you to work on many cars you were not qualified to handle before . . . and get into the growing, profitable field of foreign-car repair.

**Seven-Day Free Trial**

We are so sure you'll find this book a gold mine of information that we will gladly let you examine it FREE for seven days. At the end of that time, you may either return the book to us and owe nothing, or pay the \$17.50 price in easy installments.

GLENN'S FOREIGN CAR REPAIR MANUAL is published by Chilton Books, publisher of the famous GLENN'S NEW AUTO REPAIR MANUAL. Write to Chilton Books, Dept. PS-43, 525 Locust Street, Philadelphia 6, Pa. Wherever books are sold, or use convenient coupon.

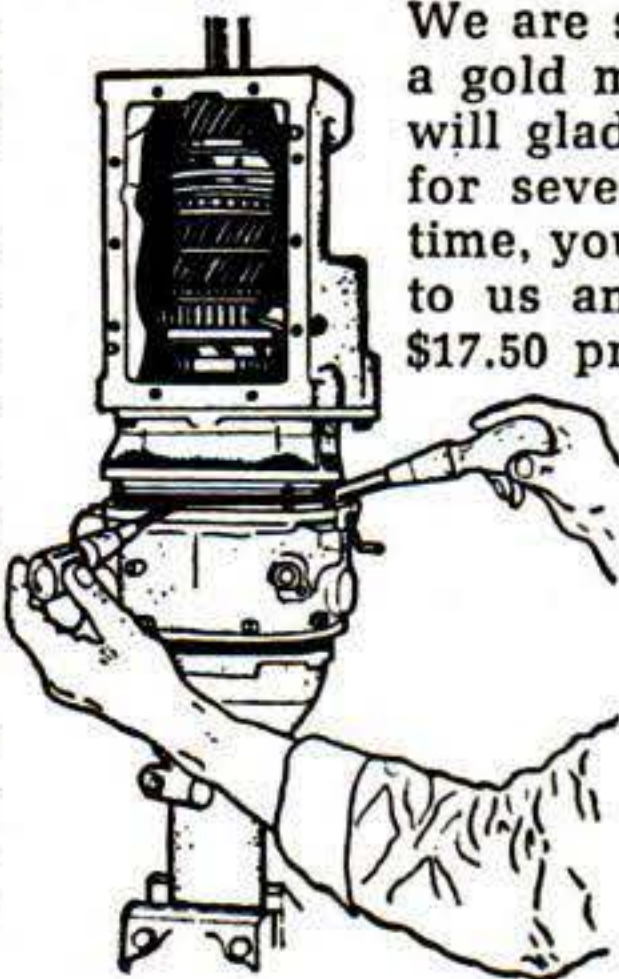

**THESE IMPORTANT FEATURES:**

- Engine design differences
- Complete servicing of all European carburetors: S. U., Solex, Zenith, Weber, Bosch Diesel and Fuel Injectors
- Lucas, Bosch, and Marelli electrical equipment
- Complete tables of specifications, all models
- Wiring diagrams of all models
- Exploded views, all vital parts
- Detailed troubleshooting charts
- Flat-rate time schedules in hours and tenths of an hour
- All specifications in meters and inches . . . PLUS MANY MORE!

**Illustrated, step-by-step repair instructions on all these models**

Alfa	Datsun	Metropolitan	Sabra
Romeo	Fiat	M.G.	Simca
Austin	Ford	Morris	Singer
Austin-Healy	(Foreign)	Magnette	Sunbeam
BMW	Hillman	NSU Prinz	Triumph
Borgward	Humber	Opel	Toyopet
Citroen	Jaguar	Peugeot	Vauxhall
DAF	Lancia	Porsche	Volkswagen
Daimler	Lloyd	Renault	Volvo
DKW	Mercedes Benz	Rover	
		Saab	

**SEND NO MONEY**

CHILTON BOOKS, Dept. PS-43  
 525 Locust St., Philadelphia 6, Pa.

Please send GLENN'S FOREIGN CAR REPAIR MANUAL for 7-day FREE examination. I will then remit \$6.00 in 7 days, pay \$6.00 a month later, and a final payment of \$5.50 (plus 45¢ postage) a month after that. Otherwise, I will return Manual postpaid and owe nothing.

Name.....

Address.....

City.....Zone....State.....

SAVE. Enclose \$17.50 now and publisher pays postage. Same return guarantee.



# Detroit report

By Devon Francis

## Off to the races

Unless the signals are switched, three Ford-engined racing cars will be entered next month in the Indianapolis "500"—granddaddy of all U.S. auto races. The cars are being built by Lotus Cars, Ltd., in England, but Ford is being coy about who's sponsoring the entries. The engines are the V-8s that power the Falcon Sprint, sleeved-down from 260 cubic inches to the Indianapolis limitation of 256.2. With beefed-up crankshafts, the reported horsepower is a whopping 400 at 7,000 r.p.m.

Chevrolet engines will also compete at Indianapolis. Mickey Thompson, who built three cars powered by aluminum 256-inch V-8s (Buick's 215-incher bored out) for last year's Indy race, intends to enter four cars this year. These will have smaller-displacement aluminum versions of the Corvette 327-inch V-8.

Last year's Thompson entries looked impressive against the Offenhouser-engined cars until they were eliminated by mechanical trouble in the qualifying trials and the race proper. This year's cars, says Thompson, will weigh 100

Aluminum-lightened hot Dodge.



pounds less (about 1,100 pounds). The new engines are expected to be sturdier and more powerful.

Chrysler Corp. isn't planning to enter the Indianapolis race, but stock-car racing is something else again. To give

their RamCharger-powered Dodges and Plymouths an even bigger weight advantage over competition, they have introduced aluminum body parts that pare off 150 pounds. The limited-production factory-installed kit consists of front fenders, hood with an air scoop, stone and splash shields, and front bumper and supports. Price: \$550 complete.

Also, the battery in all RamCharger-equipped cars will be moved from the engine compartment to the right side of the trunk for improved traction.

## More disk brakes are coming

At least five auto manufacturers are testing new disk brakes made especially for American cars by the Budd Co. One of the most interested is General Motors.

The new Budd brake is revolutionary in design: four lining pads instead of the customary two; a vented area in the center of the disk that reduces heat build-up. These features help eliminate some of the objections to disks that car manufacturers previously had. Eleven-inch versions of these disks can stop a 5,000-pound car, it's said.

## On the way for '64

The coming model year should see major retooling throughout the industry. Several cars, including the Buick Special, Olds F-85, and Pontiac Tempest, will definitely give up unitized construction. Chrysler Corp. may be returning to frame-body construction for several of their cars, too, although possibly not until 1965. Noise and vibration are said to be the main reasons for the switch.

Ignore any rumors that Chrysler may abandon its torsion-bar front suspension in favor of front coil springs, for its 1964 models, but look for a reappraisal of it by the company for 1965.

The entire Ford line should see big changes, too. The 1964 Lincoln will be lengthened four inches to increase interior room. It also will have unusual new tires that reportedly provide softer ride, longer life, and less rolling resistance. The 9.75-by-15 tires will have an extremely low profile.



"YOU'RE NOTHING  
BUT AN  
ECONOMY NUT"



"I CAN'T HELP IT.  
AUTOLITE  
MADE ME THAT WAY"



**OBVIOUSLY, CLEAN SPARK PLUGS SAVE GAS. THE PROBLEM IS TO KEEP THEM CLEAN.** Spark plugs seldom wear out. They foul out. Slow speed city driving loads them up with unburned fuel and other deposits. The plugs short out. Your gas goes out the exhaust pipe. To solve this problem, Autolite engineers developed a new kind of spark plug. The Autolite Power Tip. The spark plug that actually cleans itself

while you drive. The spark plug with the longer firing tip that uses the heat of engine combustion to burn fouling deposits away. Drive in the city? Notice that a gallon of gas doesn't go as far as it used to? Guess what. You've got 'em. Deposits. If you're in no hurry to meet 'em again, just drive in and ask your dealer for Autolite Power Tip, the thrifty, long-lasting spark plug that actually cleans itself while you drive.

SPARK PLUGS • BATTERIES • SERVICE PARTS



**AUTOLITE**

THE NAME TO REMEMBER WHEN YOU CARE FOR YOUR CAR

PRODUCTS OF  MOTOR COMPANY



**1873** "An improved version of 'Honsen's Writing-Ball'—a writing machine introduced in the past season in the Copenhagen Exhibition and in London is now adapted to the purposes of copying as well.

"By interposing carbonized paper between the sheets and making all move together, several copies may be written or printed off at a single operation. It will thus perform the duty of several copying-clerks, and has also been found admirably suited to the work of writing out telegraphic dispatches."

"One of the newest uses for paper is to employ it as skins for sausages. This is of course a German notion, and Würtem-



burg is its birthplace. Unlike the *skins* commonly used, the paper envelope is not subject to fermentation, and is cleanliness itself."

**1903** "Russian newspapers are of two classes: censored and uncensored. The former must show everything that is printed to a local censor beforehand. The latter are subject to the minister of the interior who suppresses them as he sees fit.

"Among the large number of forbidden subjects are news concerning disorders in the higher educational establishments or in factories and industrial works; information concerning the appearance of epidemic diseases or the spread of plague; and historical and critical articles in scientific journals which by reason of their content and distribution among a wide circle of readers might lead to *undesirable* results.

"A recent article in POPULAR SCIENCE MONTHLY concerning the heredity of the Romanof family was cut out of the issue

and the title on the table of contents inked out.

"We shall look forward with interest to learn whether the censor discovers this note and cuts it out of copies of the MONTHLY going to subscribers in Russia this month."

**1933** "Radio fans witnessed a twentieth century marvel the other night when they listened to a radio program transmitted over a ray of light.

"An orchestra played before a microphone and a 50,000 candle-power searchlight sped the music to a studio window where a big lens caught the beam and concentrated it on a photoelectric cell so that the music could be picked up and broadcast.

"The main problem in talking over a light beam is in finding a source sufficiently sensitive to go on and off 10,000 times a second. A remarkable wireless lamp perfected by Elman B. Meyers is the answer. The lamp is an oddly shaped quartz tube eight inches long. When the tube is placed inside a high-frequency electric coil, a thimbleful of mercury within it turns to vapor and emits a dazzling blue light that may be flashed on and off 400,000 times a second!"

"Since the Versailles treaty forbids military aviation in Germany, potential war flyers get their gunnery training on the ground through ingenious expedients. One device employs an airplane wing mounted on a turntable controlled by a distant operator. It executes a dive while the gunner peppers it with bullets."





SCOUT is the registered trademark for a vehicle manufactured exclusively by International Harvester Company, Chicago, Illinois.



**Room for all this in the SCOUT?...A family, too!**

All this modern camping equipment stows away snugly inside the handsome fiberglass Deluxe Model SCOUT Camper.

Look at it: fully-equipped galley, sink with running water, 3-burner stove and oven, a refrigerator that makes ice cubes, flush toilet and septic tank, two fold-down beds and thick foam mattresses. There's also a folding table, side seats and even storage area.

If you already have a lot of camping gear you can get a Standard SCOUT Camper. This one has foldout beds enclosed by canvas roof and walls with

screened windows. There's enough room left over for all your equipment.

Either SCOUT Camper with optional folding bunk takes a family of four to where the fun is, roads or no roads. Snappy 4-cylinder 93 hp. COMANCHE® engine has the power. Rear-wheel or all-wheel-drive provides the traction. Heavy frame shrugs off jolts. And ample clearance ignores obstructions.

See the specialized SCOUT Camper or one of the many other exciting SCOUT models at your INTERNATIONAL Dealer or Branch.

**THE**  
*Scout*®  
**BY INTERNATIONAL®**



International Harvester Company  
Department PS, P. O. Box 7333  
Chicago 80, Illinois

Please send me free literature on the SCOUT Camper.

NAME \_\_\_\_\_

ADDRESS \_\_\_\_\_

CITY \_\_\_\_\_ STATE \_\_\_\_\_





**Pall Mall's  
natural mildness  
is so good  
to your taste!**



*You can light  
either end!*

**So smooth, so satisfying,  
so downright smokeable!**

*For flavor and enjoyment you just can't beat  
Pall Mall's natural mildness. It's so good  
to your taste. Never too strong. Never too  
weak. Always just right! Enjoy satisfying  
flavor... so friendly to your taste.*

**Outstanding... and they are Mild!**

**COMPARE ALL THREE!**

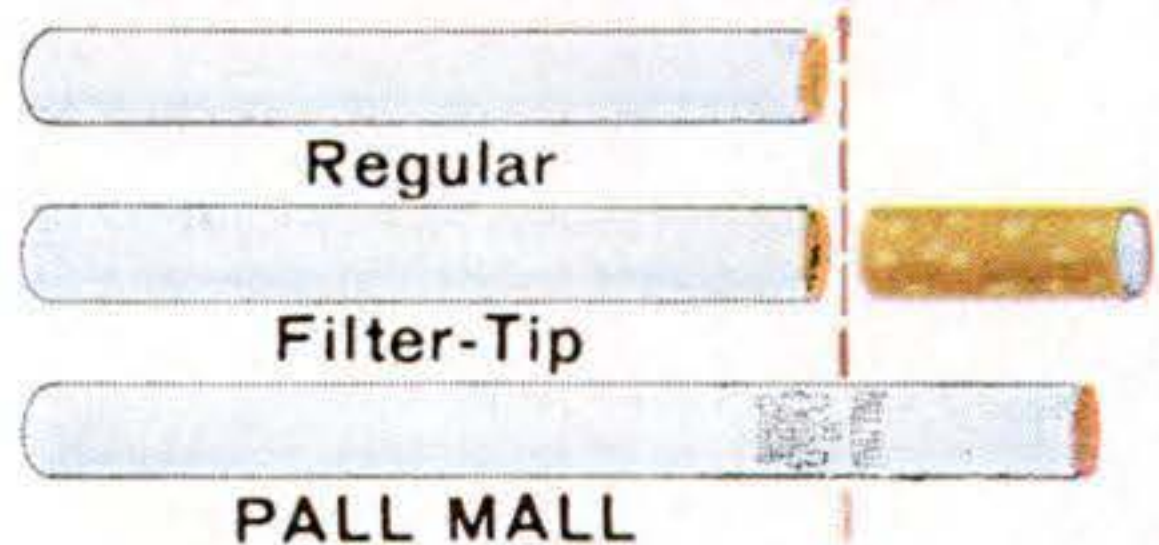

**Smoke "traveled" through fine tobacco tastes best.**  
Pall Mall's famous length travels the smoke naturally  
... over, under, around and through the finest tobaccos  
money can buy. Makes it mild... but does not filter  
out that satisfying flavor!





Exact distance an entry goes on a gallon of gas is measured by fifth wheel on official car.

# 'Keep-'Em-Honest' Car Tests

By Hubert Lockett

How '63 models compared in

- **ECONOMY**
- **ACCELERATION**
- **BRAKING**

**C**AR tests have become a national rite rivaling bathing-beauty contests in their claim on public attention. "Stock" car races, cross-country runs, and a welter of other tests all produce results that makers of winning cars believe invaluable in persuading you to buy *their* latest model.

As often as not, however, these rituals are as much a test of men as of machines. A skillful driver or an



Premeasured gallons of gas, stored in chipped ice until each contestant is ready to start, insure identical quantities.

CONTINUED

67



ingenious mechanic can make a difference in the outcome. And the preferences, prejudices, and limitations of the tester may color the results.

At the Daytona International Speedway in January, I witnessed a series of tests that are different. I believe the 1963 Pure Oil Performance Trials come closer to being an authentic comparison of the machinery you can buy from your car dealer than any public competition so far. Here's why:

- Inspection of the entries is merciless—unbelievably detailed, knowledgeable, and complete.

- Each of the trials—economy, ac-

celeration, braking—is designed to minimize the effect of driver skill.

- Timing and measurement, almost entirely automated, leave little room for human error.

- All trials take place on a closed circuit, with every move rigidly supervised by an army of NASCAR officials.

*No stacked decks.* I poked around behind the scenes for a week trying to find loopholes or soft spots that would allow a clever mechanic or a driving genius to win with a car unlike any you could buy. I found none. The factory reps, mechanics, and drivers I talked to, in general, agreed there weren't any.

CONTINUED

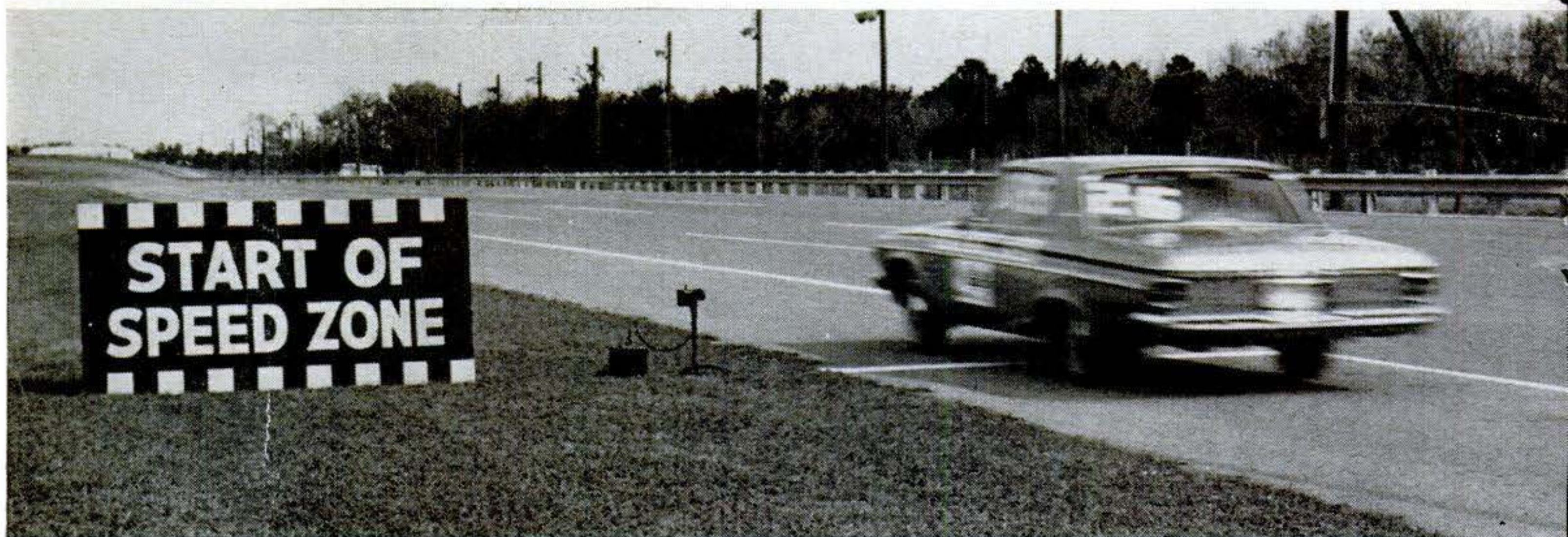

On the backstretch of each lap of the economy run, cars had to run at a true speed of 65

m.p.h. Speed zone was included to simulate average, everyday driving conditions.

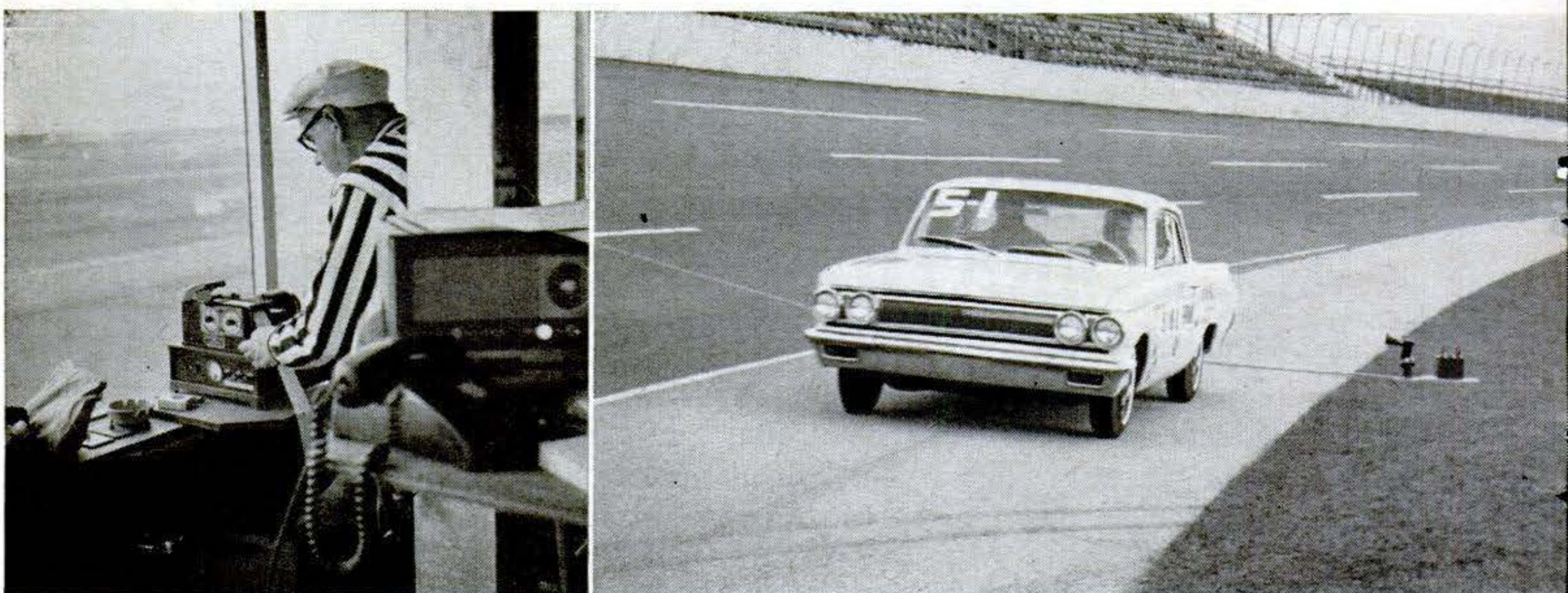

Automatic timer, actuated by a photocell set up beside the track, prints on a paper tape the exact time a car interrupts the light beam on each lap. The official timekeeper writes the

number of the car alongside each imprint. An overall average speed of 40 m.p.h. is required by test rules from the time the car takes off at the starting line until it rolls to a stop.



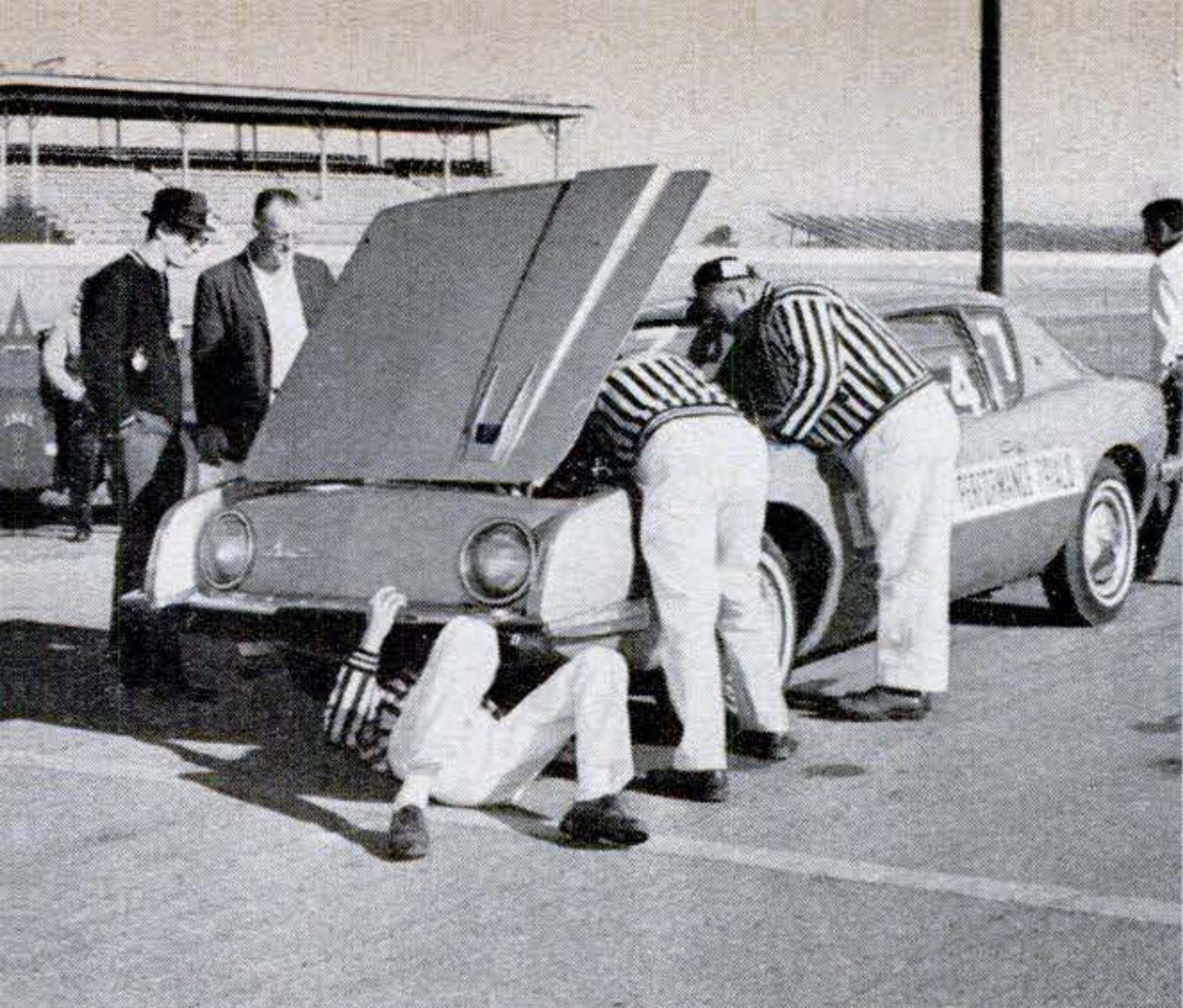

At the starting line, the car's regular fuel tank is disconnected and the remaining gas exhausted from the carburetor and fuel lines.



Special one-gallon tank on front door is connected by tubing to fuel pump, and premeasured fuel is poured in immediately before start.

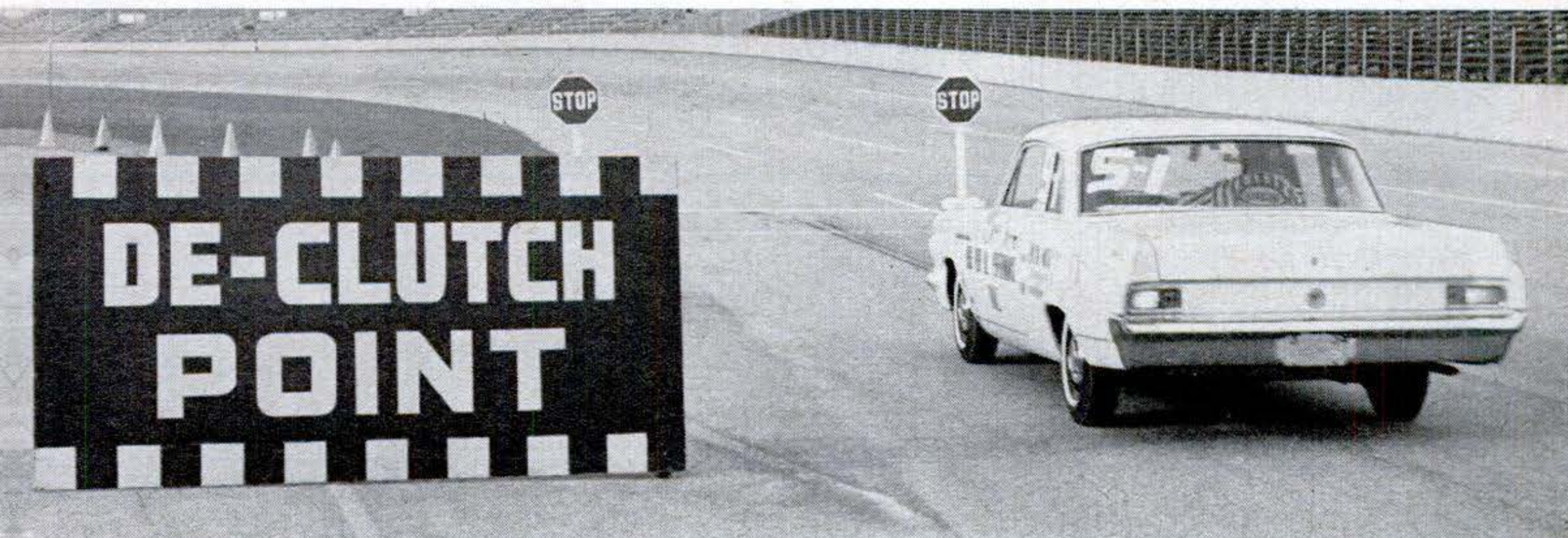

Complete stop on every full lap is required. Cars with standard synchromesh transmissions

may not de-clutch before reaching this sign placed 75 feet from the stop line.



Riding observer marks paving to show position of the front wheel when car rolls to a stop after exhausting its one gallon of fuel. Car is then pushed off the track by hand.

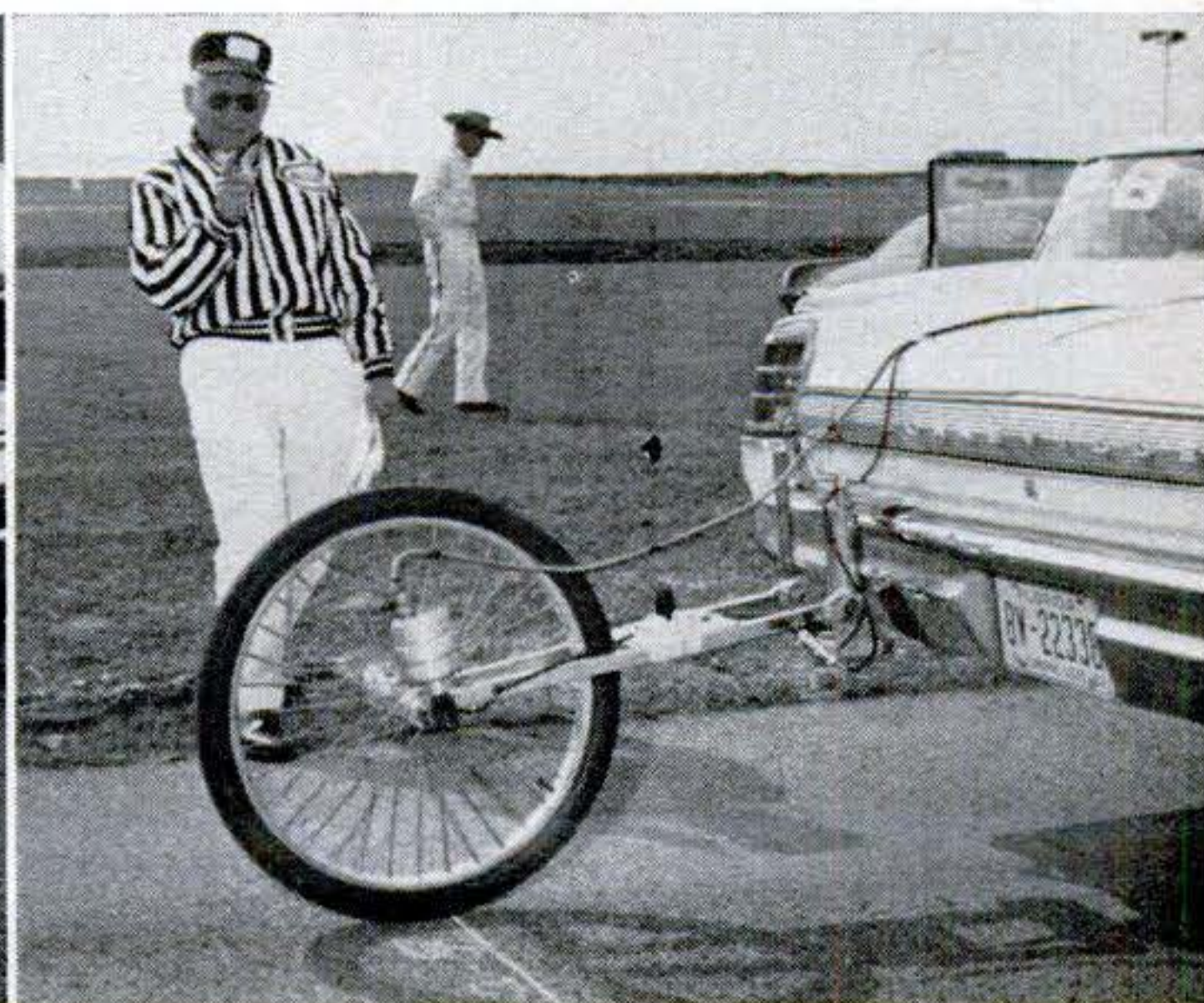

Fifth wheel measures the distance from the last surveyed marker on the track to the observer's chalk mark, to tell the exact distance the car covered on its single gallon of gas.



# How They Ran

CLASS	CAR NO.	TOTAL POINTS EARNED	ENGINE TYPE	DISPLACEMENT (cu. in.)	CARBURETOR	HORSEPOWER	TRANSMISSION	ECONOMY			ACCELERATION		BRAKING		TOTAL POINTS		
								M.P.G.	POINTS	PENALTY (m.p.g.)	TIME (sec.)	POINTS	PENALTY (sec.)	STOPPING DISTANCE (feet)		POINTS	PENALTY (feet)
CLASS I 401 to 450 cu. in.; luxury V-8 engines	FORD GALAXIE 300	1-8	20	V-8	427	2 4-bbl.	425	3-spd. o.d.	14.27	5		5.296	7	184.1	8	38	
	FORD GALAXIE 300	1-7	18	V-8	406	3 2-bbl.	405	3-spd. o.d.	14.08	4		5.858	5	178.3	9		
	PLYMOUTH BELVEDERE	1-9	15	V-8	426	2 4-bbl.	415	4-spd.	14.34	6		5.308	6	249.7	3	36	
	PLYMOUTH BELVEDERE	1-10	21	V-8	426	2 4-bbl.	415	4-spd.	16.13	8		5.005	8	217.3	5		
	PONTIAC CATALINA	1-11	17	V-8	421	1 4-bbl.	405	4-spd.	8.53	0		4.879	10	189.4	7	36	
	PONTIAC CATALINA	1-12	19	V-8	421	1 4-bbl.	405	4-spd.	9.39	0		4.950	9	174.2	10		
	CHEVROLET IMPALA	1-3	12	V-8	409	1 4-bbl.	400	4-spd.	13.36	2		5.890	4	191.3	6	21	
	CHEVROLET IMPALA	1-4	9	V-8	409	1 4-bbl.	340	4-spd.	16.49	9		8.328	0	*	0		
	BUICK LE SABRE	1-1	7	V-8	401	1 4-bbl.	325	auto.	13.92	3	3	8.455	0	222.6	4	17	
	BUICK WILDCAT	1-2	10	V-8	425	1 4-bbl.	340	4-spd.	15.08	7		7.488	1	255.6	2		
CHRYSLER 300	1-5	12	V-8	413	1 4-bbl.	360	3-spd.	17.38	10		7.296	2	299.1	0	17		
CHRYSLER 300	1-6	5	V-8	413	1 4-bbl.	360	3-spd.	11.10	1	6	7.203	3	258.1	1			
CLASS II 362 to 400 cu. in.; large V-8 engines	FORD GALAXIE 300	2-1	21	V-8	390	1 4-bbl.	330	3-spd. o.d.	16.02	6		7.402	6	183.6	9	42	
	FORD GALAXIE 300	2-2	21	V-8	390	1 4-bbl.	330	3-spd. o.d.	16.07	7		7.963	4	169.5	10		
	PLYMOUTH BELVEDERE	2-6	20	V-8	383	1 4-bbl.	330	4-spd.	15.24	5		6.298	9	209.9	6	41	
	PLYMOUTH BELVEDERE	2-7	21	V-8	383	1 4-bbl.	330	4-spd.	17.17	8		6.667	8	216.2	5		20
	PONTIAC CATALINA	2-8	27	V-8	389	3 2-bbl.	313	4-spd.	18.12	9		6.200	10	190.5	8	20	37
	PONTIAC CATALINA	2-9	10	V-8	389	3 2-bbl.	313	4-spd.	18.55	10		*	0	*	0		
	OLDSMOBILE STARFIRE	2-4	14	V-8	394	1 4-bbl.	345	auto.	14.97	3		7.345	7	277.4	4	20	30
	OLDSMOBILE STARFIRE	2-5	16	V-8	394	1 4-bbl.	330	auto.	15.11	4		7.445	5	206.6	7		
MERCURY MONTEREY	2-3	5	V-8	390	1 4-bbl.	250	auto.	12.49	2		12.470	3	**	0	5		
CLASS III 321 to 361 cu. in.; medium V-8 engines	CHEVROLET BEL AIR	3-1	24	V-8	327	1 4-bbl.	300	4-spd.	18.04	9		7.885	8	180.5	7	49	
	CHEVROLET BEL AIR	3-2	25	V-8	327	1 4-bbl.	250	4-spd.	20.08	10		8.941	7	176.6	8		
	PONTIAC TEMPEST	3-4	19	V-8	326	1 4-bbl.	280	3-spd.	16.28	5		7.032	9	196.3	5	20	44
	PONTIAC TEMPEST	3-5	25	V-8	326	1 4-bbl.	280	3-spd.	16.67	6	0.3	6.585	10	174.9	9		
	RAMBLER AMBASSADOR	3-6	18	V-8	327	1 4-bbl.	270	3-spd. o.d.	17.60	7	3.0	10.743	5	180.7	6	42	
	RAMBLER AMBASSADOR	3-7	24	V-8	327	1 4-bbl.	270	3-spd. o.d.	17.97	8		9.886	6	167.5	10		
	DODGE 880	3-3	12	V-8	361	1 2-bbl.	265	auto.	15.24	4		11.244	4	224.0	4	12	
CLASS IV 259 to 320 cu. in.; small V-8 engines	PLYMOUTH BELVEDERE	4-5	26	V-8	318	1 2-bbl.	230	3-spd.	23.37	10		9.966	10	201.5	6	51	
	PLYMOUTH BELVEDERE	4-6	25	V-8	318	1 2-bbl.	230	3-spd.	23.08	9		10.325	9	189.8	7		
	CHEVROLET BEL AIR	4-1	25	V-8	283	1 2-bbl.	195	3-spd. o.d.	22.23	8		11.045	8	182.1	9	47	
	CHEVROLET BEL AIR	4-2	22	V-8	283	1 2-bbl.	195	3-spd.	21.03	7		11.259	7	186.4	8		
	FORD FAIRLANE	4-3	15	V-8	260	1 2-bbl.	164	3-spd. o.d.	20.20	6		13.318	4	208.4	5	35	
	FORD FAIRLANE	4-4	20	V-8	260	1 2-bbl.	164	3-spd. o.d.	20.19	5		13.223	5	176.7	10		
	STUDEBAKER AVANTI	4-7	10	V-8	289	1 4-bbl.	280	auto.	16.12	4		11.270	6		0	10	
CLASS V 201 to 258 cu. in.; large 6-cylinder and compact V-8 engines	PLYMOUTH VALIANT	5-10	15	S-6	225	1 2-bbl.	145	3-spd.	24.56	8		13.715	5	208.0	2	36	
	PLYMOUTH VALIANT	5-11	21	S-6	225	1 2-bbl.	145	3-spd.	25.40	10		12.373	6	184.5	5		
	BUICK SPECIAL	5-1	16	V-8	215	1 4-bbl.	200	4-spd.	22.32	4		9.623	9	206.2	3	20	33
	BUICK SPECIAL	5-2	17	V-8	215	1 4-bbl.	200	auto.	22.56	6		10.971	7	185.1	4		
	OLDSMOBILE F-85	5-8	20	V-8	215	1 4-bbl.	185	4-spd.	22.35	5		9.345	8	178.0	7	20	32
	OLDSMOBILE JETFIRE	5-9	12	V-8	215	1 1-bbl.-S	215	4-spd.	20.26	1		8.828	10	211.3	1	20	
	FORD FAIRLANE	5-6	16	V-8	221	1 2-bbl.	145	3-spd. o.d.	20.44	3		16.375	3	158.2	10	30	
	FORD FAIRLANE	5-7	14	V-8	221	1 2-bbl.	145	3-spd. o.d.	20.42	2		15.589	4	169.2	8		
	CHEVROLET BISCAYNE	5-3	8	6	230	1 1-bbl.	140	3-spd. o.d.	24.02	7		17.008	1	252.4	0	28	
	CHEVROLET BISCAYNE	5-4	20	6	230	1 1-bbl.	140	3-spd. o.d.	24.71	9		16.613	2	162.9	9		
DODGE DART	5-5	6	S-6	225	1 1-bbl.	145	auto.	15.24	0	5.7	19.083	0	181.0	6	6		
CLASS VI 131 to 200 cu. in.; compact 4- and small 6-cylinder engines	PONTIAC TEMPEST	6-8	21	4	195	1 4-bbl.	166	4-spd.	23.54	4		10.465	10	165.4	7	34	
	PONTIAC TEMPEST	6-9	13	4	195	1 4-bbl.	166	4-spd.	22.54	0		10.857	9	175.8	4		
	RAMBLER AMERICAN	6-10	10	6	195	1 2-bbl.	138	3-spd. o.d.	23.83	5		15.400	5	193.2	0	20	33
	RAMBLER AMERICAN	6-11	23	6	195	1 1-bbl.	125	3-spd. o.d.	29.18	10		17.410	4	163.4	9		
	BUICK SPECIAL	6-1	12	V-6	198	1 2-bbl.	135	auto.	22.94	3		15.120	6	179.0	3	30	
	BUICK SPECIAL	6-2	18	V-6	198	1 2-bbl.	135	4-spd.	23.92	6		13.277	7	169.9	5		
	CHEV. CORVAIR SPYDER	6-3	17	H-6	145	1 1-bbl.-S	150	4-spd.	22.60	1		12.974	8	164.0	8	30	
	CHEVY II 100	6-4	13	4	153	1 1-bbl.	90	3-spd.	28.43	9	0.3	21.080	3	191.4	1		
	FORD FALCON	6-5	11	6	144	1 1-bbl.	85	4-spd.	27.25	8		23.810	1	190.7	2	20	26
	FORD FALCON	6-6	15	6	144	1 1-bbl.	85	4-spd.	25.07	7		23.580	2	168.3	6		
MERCURY COMET	6-7	12	6	170	1 1-bbl.	85	3-spd.	22.93	2		32.325	0	160.4	10	12		

\*Did not start. \*\*Did not qualify.



# ACCELERATION

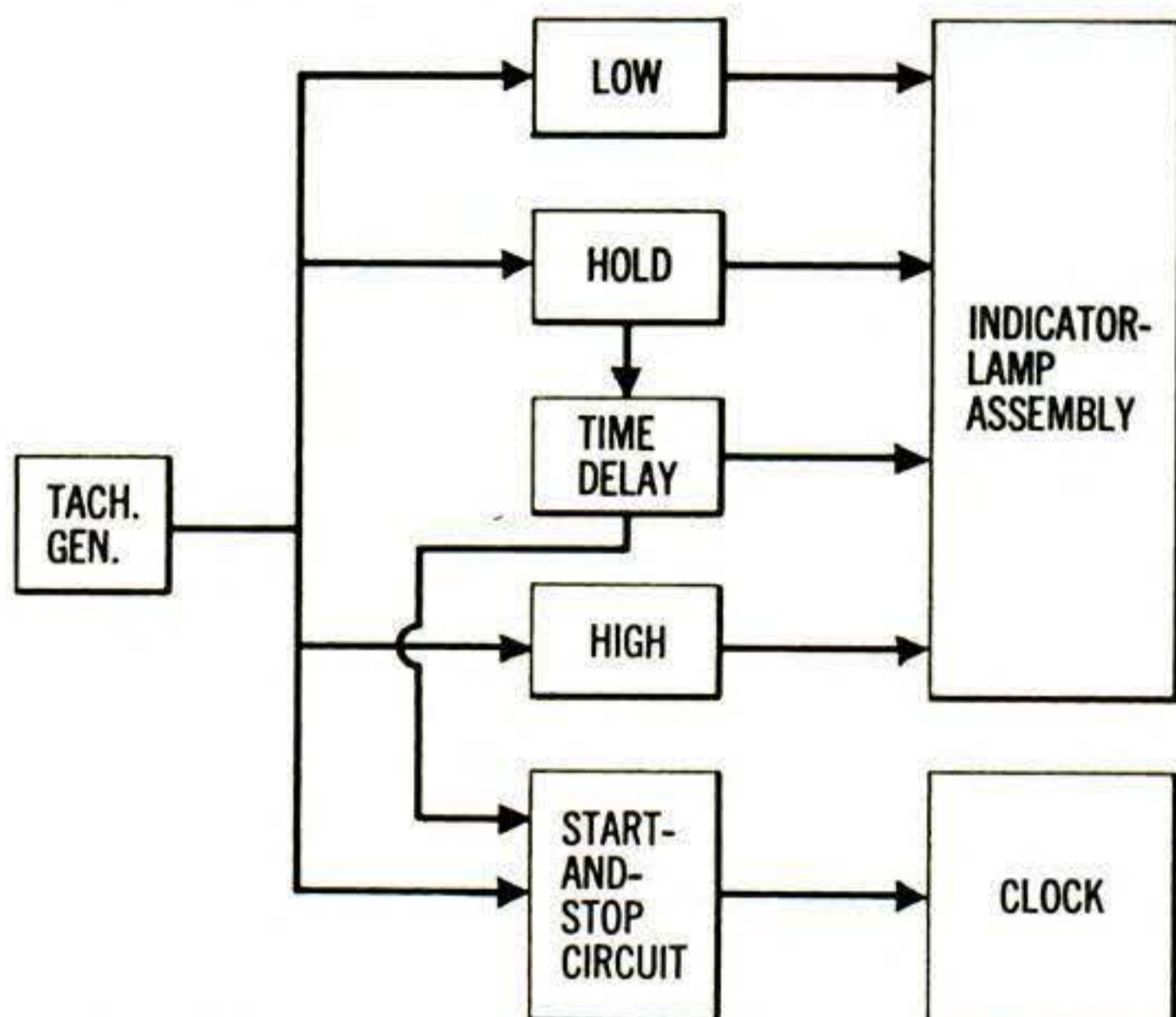

Electronic brain-box is shown here in a block diagram. One group of circuits controls signal lights in front of driver; another controls the clock. It's programmed with five dials.



Voltage output of the generator on fifth wheel is accurately proportional to speed, within one percent, from 0-100 m.p.h. Final fine calibration is done by varying air pressure in tire.



Colored lights in a box in front of driver tell him when he has leveled off and is driving at the proper speed (22-24 m.p.h.) to start acceleration run. When the green light is holding steady he steps on accelerator. When speed passes 25 m.p.h., timer clock starts automatically and runs until speed reaches a true 70. Official riding observer records elapsed time.



Some of them had to be convinced the hard way: Four entries were ordered to install completely new engines; several had to replace entire rear-end assemblies; about half had to replace all their valve springs. Cylinder heads, carburetors and carb jets were among other items challenged by the inspectors for not conforming to manufacturers' published AMA specifications. Five non-stock camshafts were discovered, and only one out of 10 carburetors was found

to have the factory-specified float setting.

A fantastic 16,600 man-hours went into the precompetition inspection. The engines of all 57 cars entered were disassembled and each part measured, weighed, flow-tested, or otherwise checked to make sure it corresponded precisely to specifications. One carburetor jet that appeared stock and measured correctly was found to give an incorrect flow rate when tested on a flow

CONTINUED 71



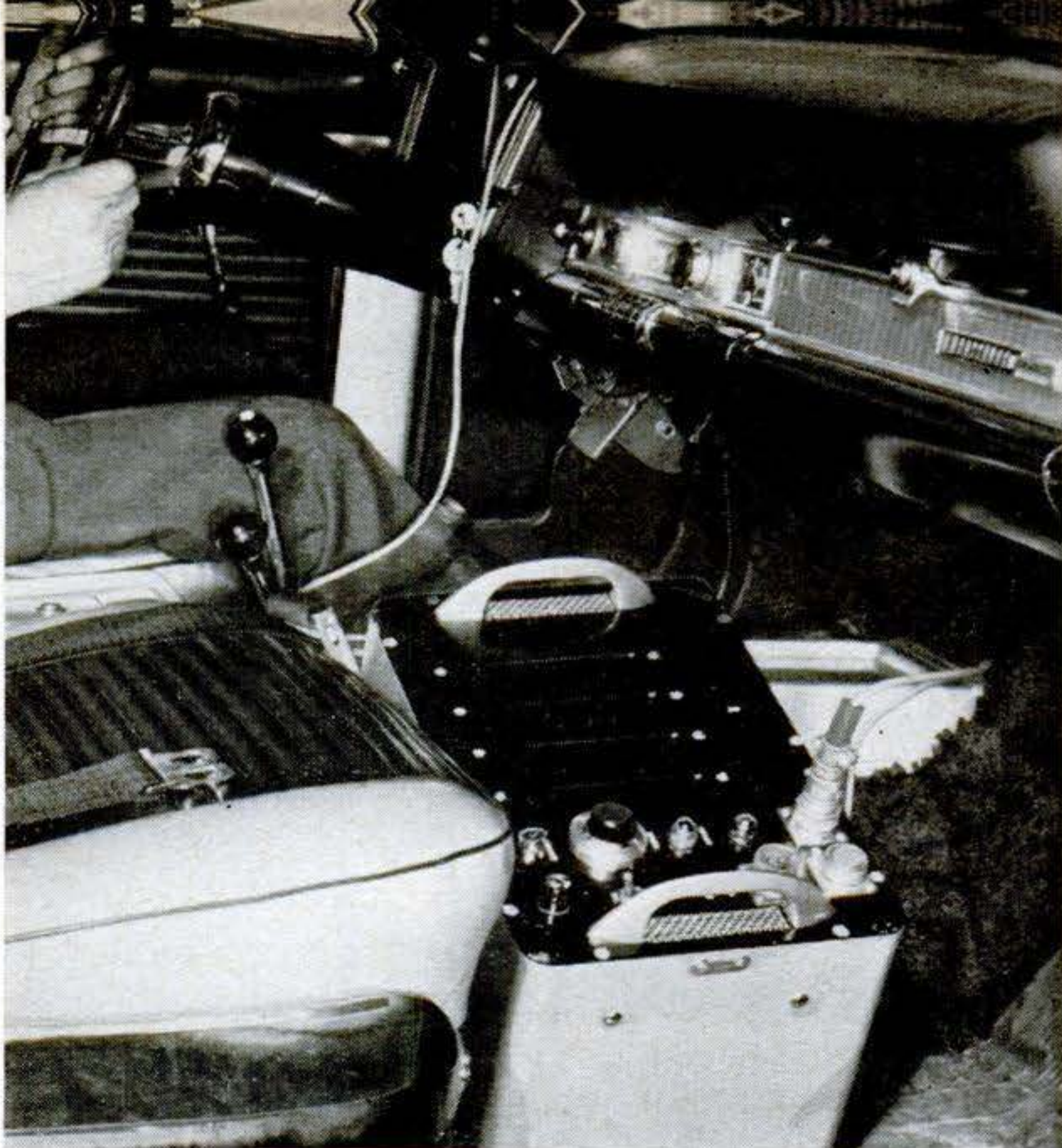

Brain-box for braking test turns on ready light at 60 m.p.h. When brake is applied, stoplight switch on brake starts electronic counter, which runs until car stops.

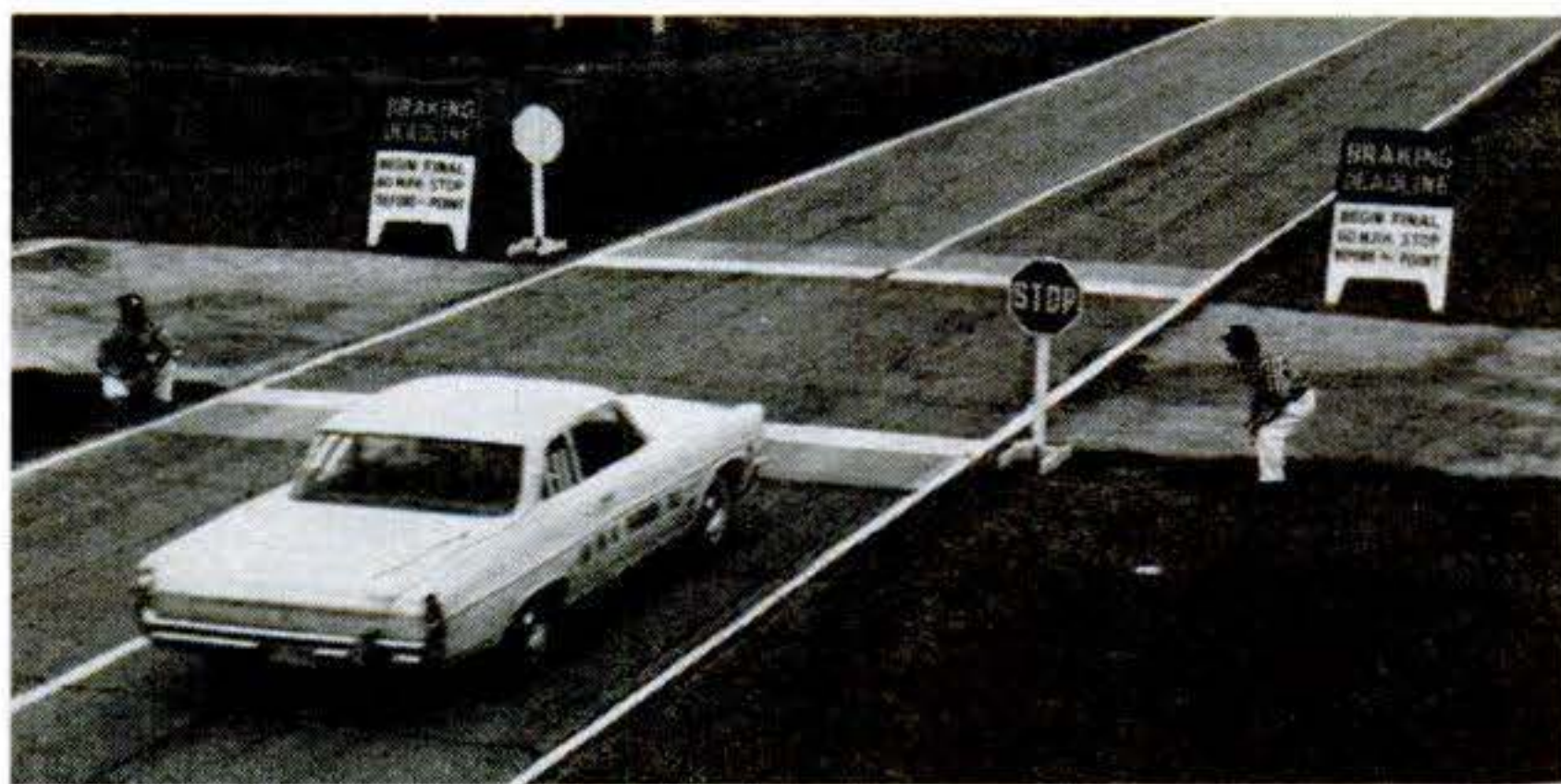

Before final panic stop from 60 m.p.h. (the one that's measured), each car makes 21 stops in rapid succession.

bench. Inspection with a magnifying glass revealed that the tip had been peened slightly to restrict the flow.

The official attitude is that variations from specs are the result of production-line variations or accidents. And, indeed, many of the off-standard items would have handicapped a car's performance. But, accidental or intentional, there seem to be no loopholes NASCAR's inspectors haven't plugged.

*Eyeing the cars.* They check the voltage regulator to be sure it hasn't been backed off to lessen the generator load; measure cooling-water flow—a water pump can be gimmicked to pump less

and therefore sap less engine power. Thermostat-opening temperature is measured—an engine burns less gas at higher temperatures. Fan-belt tension is checked—if the belt slips, it's not pulling the full generator and water-pump load. They guard against the ancient slashed—or thrown—fan-belt trick by sealing the hood for each run. Any car without a fan belt at the end of a run is disqualified.

The cars are weighed to catch concealed use of aluminum or fiberglass to replace standard steel parts. Tires are carefully inspected (some premium-

*[Continued on page 210]*

## BRAKING

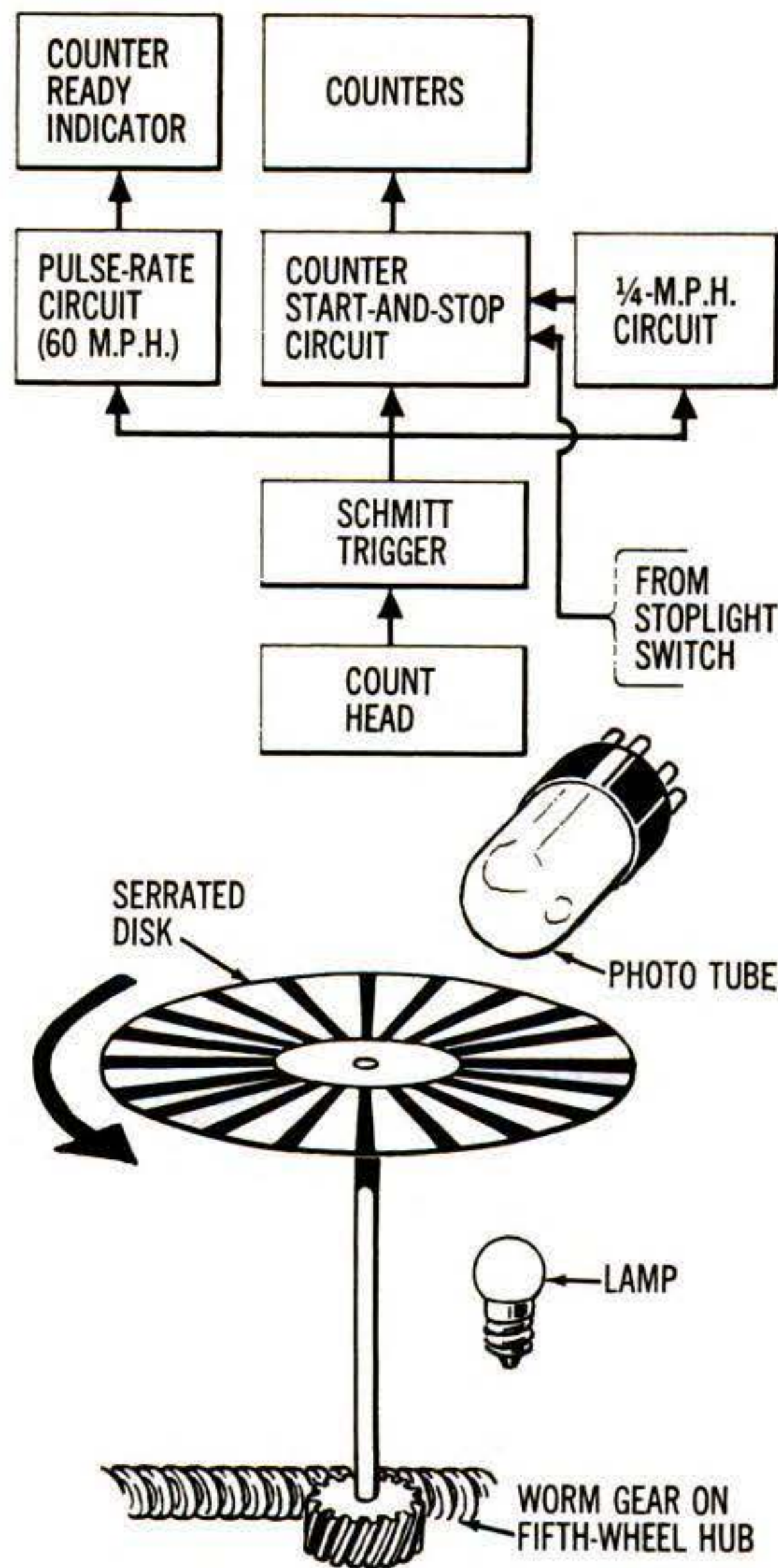

Count head on fifth wheel uses striped disk (actually a photo negative) to interrupt beam of light shining on photocell a fixed number of times for each revolution of the wheel. Electronic counter counts resulting electrical pulses and displays numerical read-out of braking distance.



**N**OW that man has taken his first step into space through orbital flight, the stage is set for an even greater adventure. That will be the conquest of "cislunar" space—the space this side of the moon.

What's it like out there? Is space really "empty"? What is the solar wind? What new risks will astronauts encounter in the radiation fields that encircle the earth?

To learn the answers to such questions, POPULAR SCIENCE sought out a top authority — Dr.

James A. Van Allen, head of the physics department at the State University of Iowa. He is the discoverer of the earth's invisible radiation belts—and also their proprietor, according to President Kennedy. (Last year, during scientific controversy preceding the high-altitude hydrogen-bomb blast set off July 9, Kennedy quipped: "I know there's been a disturbance about the Van Allen belt, but Van Allen says it's not going to affect the belt, and it's his.")

I found Dr. Van Allen in Boston, at Massachusetts Institute of Technology, where he was conferring with other space scientists. That evening, over dinner, I asked him about newly discovered phenomena of "empty" space. "Most people still think of space as a cold, black vacuum," I said. "Is it true that scientists shared this misconception until very recently?"

"Most scientists did think of space as a barren waste," he said. "When we started getting real information, it was quite a revelation.



# JAMES VAN ALLEN TELLS WHAT SPACE IS REALLY LIKE

An exclusive interview  
with the discoverer of the  
earth's radiation belts,  
by Popular Science Senior  
Editor Wallace Cloud



## How Van Allen sees the invisible contents of far-from-empty space

A sea of energy, space is aptly shown colored, instead of usual black void. Black lines radiating from the sun stand for steaming plasma of the solar wind, which compresses the earth's magnetic field; a shock wave and tur-

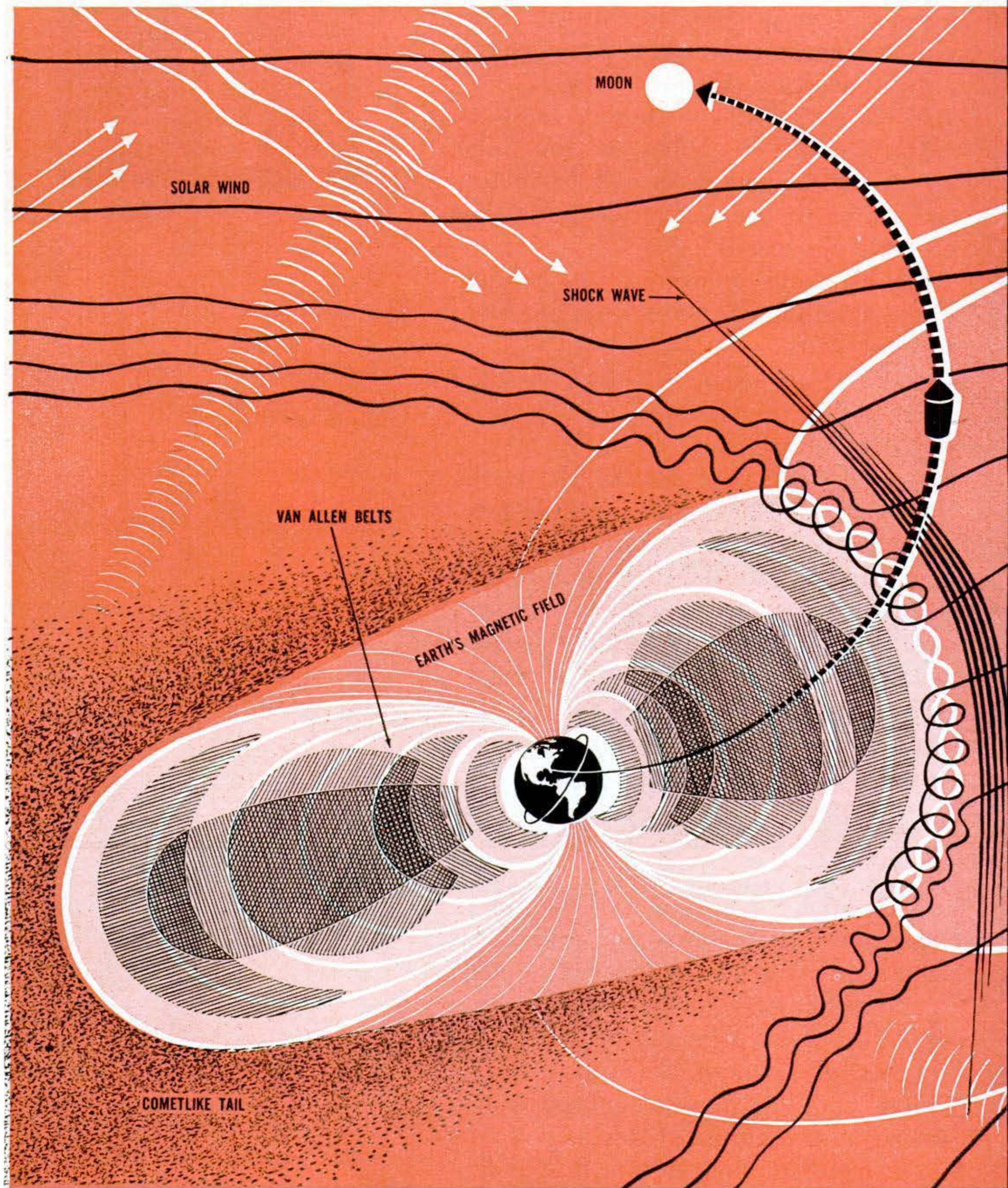

“Perhaps I can give you an idea of how we felt when we discovered the radiation belts. In 1958, when Explorer III was in orbit, we had a counter aboard to register cosmic-ray particles. The data

we got back was puzzling. Radiation increased up to 500 or 600 miles out, then dropped sharply to zero. When we realized that the counter was too sensitive—that it simply got overloaded and jammed



bulence occur where they meet, and wind gives earth a cometlike tail of dust and gas. So far, manned space flights have been safe inside Van Allen belts, but moon ships must traverse radiation zone, may encounter dangerous solar

flares. Flare hurls high-energy plasma, moving so fast it carries along loops of sun's magnetic field, which can deflect cosmic rays. Space also contains interstellar radiation of many kinds from sources outside solar system.

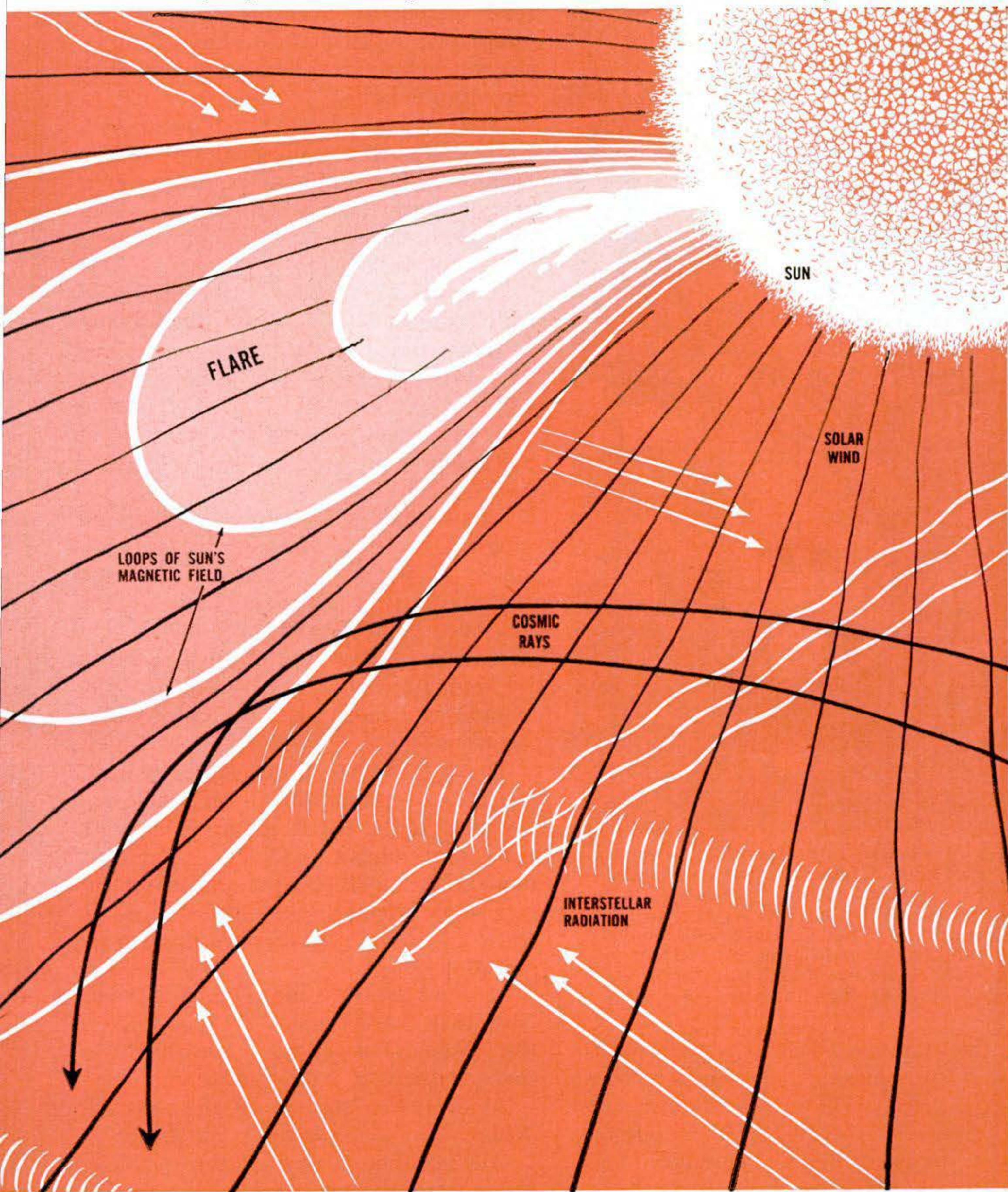

—one of the boys, Ernest Ray, exclaimed: 'Space is radioactive!'

This brought up the radiation hazards of space flight. So far, men have orbited safely inside the Van Allen belts, but

getting to the moon involves going straight through them.

The artificial belt created by last summer's bomb test is no problem, Dr. Van Allen said, since it will have disappeared



## "Space" was invented on earth before we knew what was out there

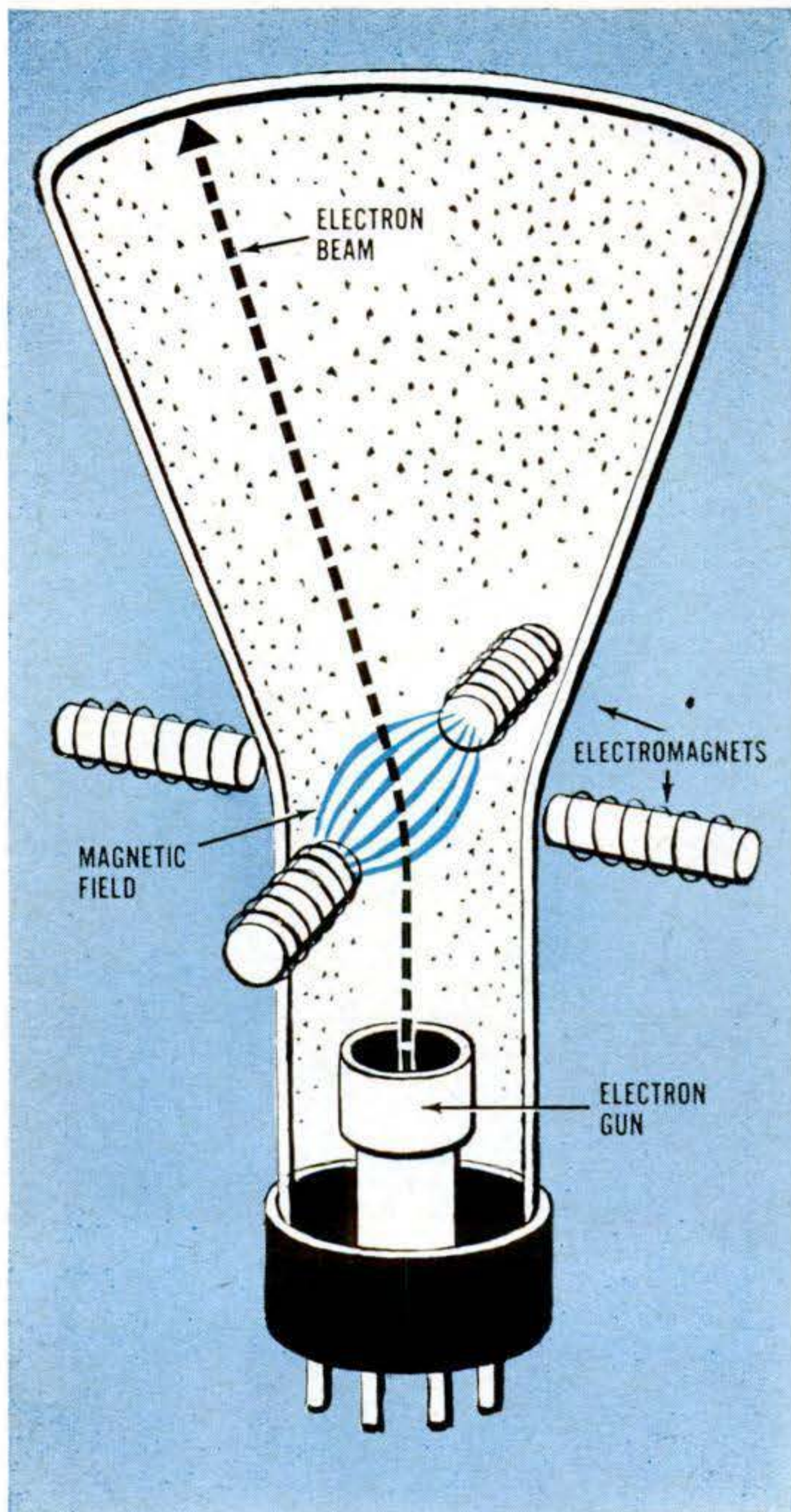

**Space in a bottle:** In ordinary TV picture tube, electron beam is aimed by electromagnets to make it scan face of tube, simulating the way magnetic fields deflect particles in space. Conditions of outer space (plasmas, radiation, magnetic effects) occur in many electronic devices. But energies are much higher in space, plasma is much thinner than in man's inventions.

by this summer. Even so, a one-way trip through the natural belts "on a hot-dash escape basis" will expose an astronaut to about 10 roentgens of radiation—a lot in terms of normal radiation tolerances on earth.

"But in a high-risk mission like space flight, that much radiation isn't taken too seriously," he said. About 400 roentgens would be a dangerous exposure.

Making one or more round trips doesn't increase the risk, he explained,

since radiation sickness isn't cumulative. "Certain effects do build up, of course—such as genetic effects. It would be advisable for an astronaut to have a family already before traveling back and forth through the belts."

"How many belts are really out there?" I asked. "Some people speak of one Van Allen belt, but originally you discovered two of them. And recently some scientists have been talking about a single 'magnetosphere.'"

"The magnetosphere is the region in which the earth's magnetic field dominates space," Dr. Van Allen said. "The two original belts are quite distinct within this zone. But the fact is that you can map almost any number of belts, depending on what kind of particle you're interested in."

I had read in a news story that the artificial belt was created by approximately a pound of electrons, injected into the earth's magnetic field by the hydrogen-bomb explosion. I asked Dr. Van Allen if that estimate was correct.

"Actually, that's high," he said. "The amount was more like one milligram of electrons."

That's 1/28,000 of an ounce of matter. It had caused an international controversy and created a new belt with very real physical effects (including damage to satellites, perhaps even the failure of Telstar). "Well, then," I asked, "how much matter is there in the natural radiation belts?"

"A few grams," said Dr. Van Allen. "But that doesn't give you any idea of the tremendous energies involved. In space, energy is really in command."

"What's the source of the energy? Where do the particles come from?"

"We're almost certain the particles come from the solar wind," he said.

He explained that the solar wind consists of matter being ejected from the sun by the force of repeated thermonuclear explosions. This material is mostly hydrogen, plus some helium and a

[Continued on page 206]



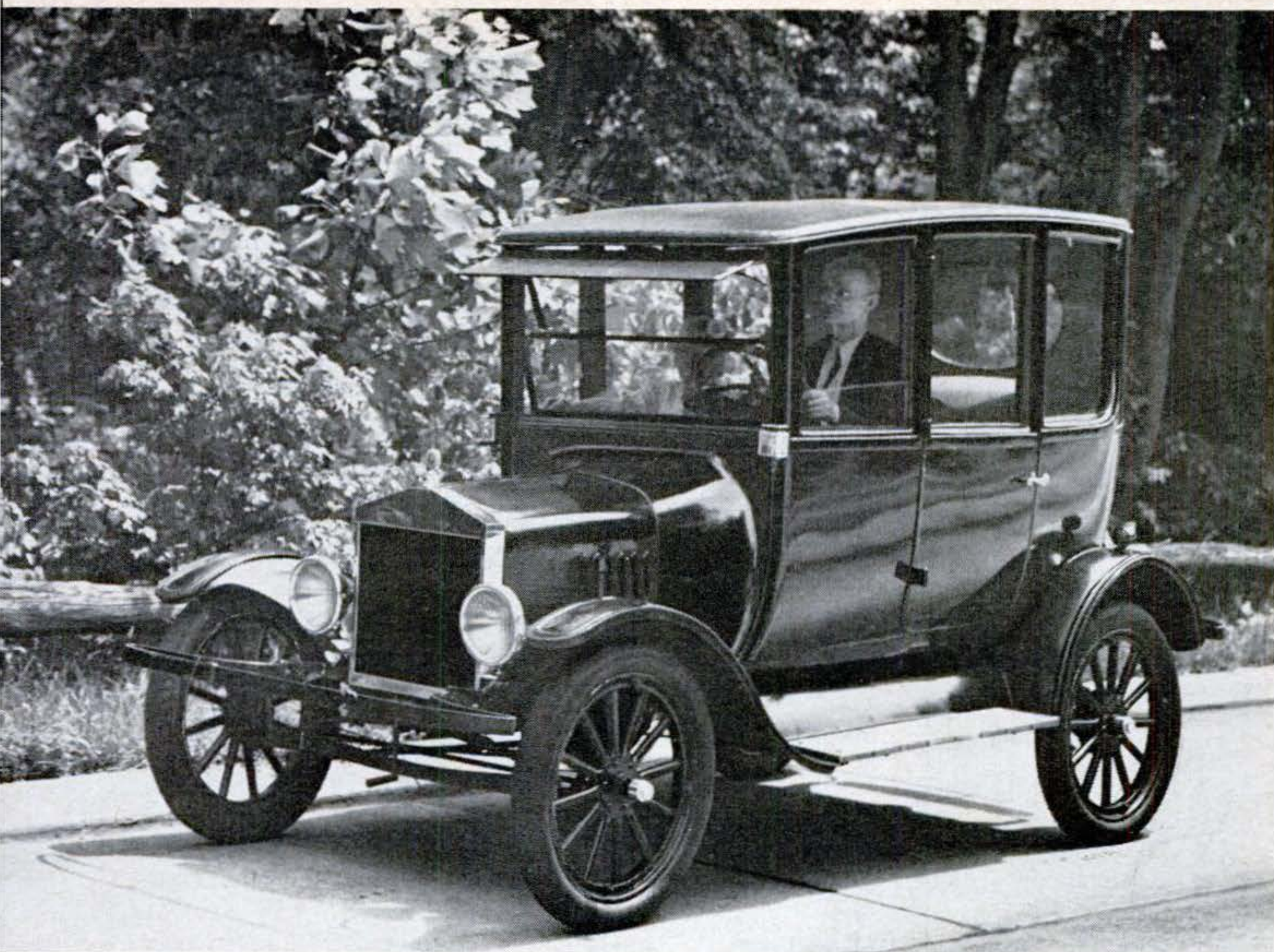

CULVER PICTURES

Columbia University  
researchers take  
a look at your  
driving habits—and  
come up with some  
startling findings

# Slow Drivers Can Kill You

By Martin Mann

**T**HE cops may be handing out tickets to the wrong guys. *Slow* drivers could be the bad drivers. In fact, they might even kill you.

That is just one revolutionary conclu-

sion that Columbia University researchers have drawn from a two-year study. If their report, just released, stands up, the entire art of driving is due for a shake-up. The findings also suggest how you can be a better driver yourself in ways you probably never thought of.

CONTINUED

77



# How Good a Driver Are You?

Your answers to the questions below and on the facing page reveal your driving habits, say Columbia psychologists. These are samples from a long test designed to separate good drivers from bad. (Correct answers are given below, at right.)

## The situation:

You are in Car A passing Car B. When you are only a few feet behind B, he starts into left lane.

## You should:

- 1 Sound your horn and keep going.
- 2 Move left and accelerate to pass B.
- 3 Slow down to let B enter passing lane.
- 4 Move quickly to right-hand lane.

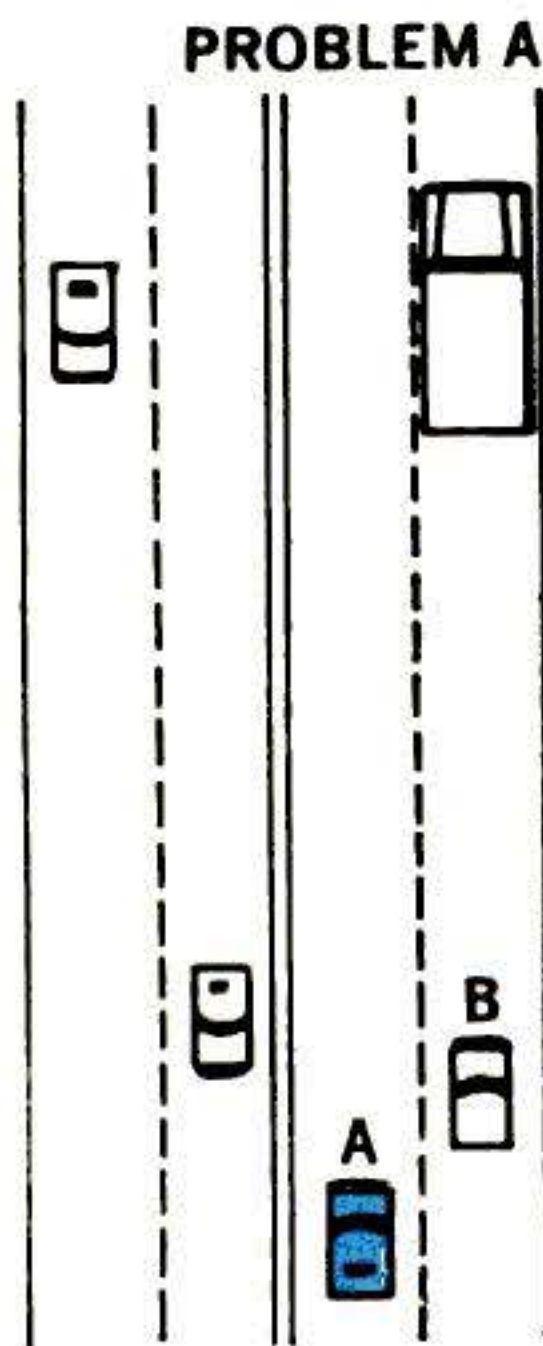

## PROBLEM B

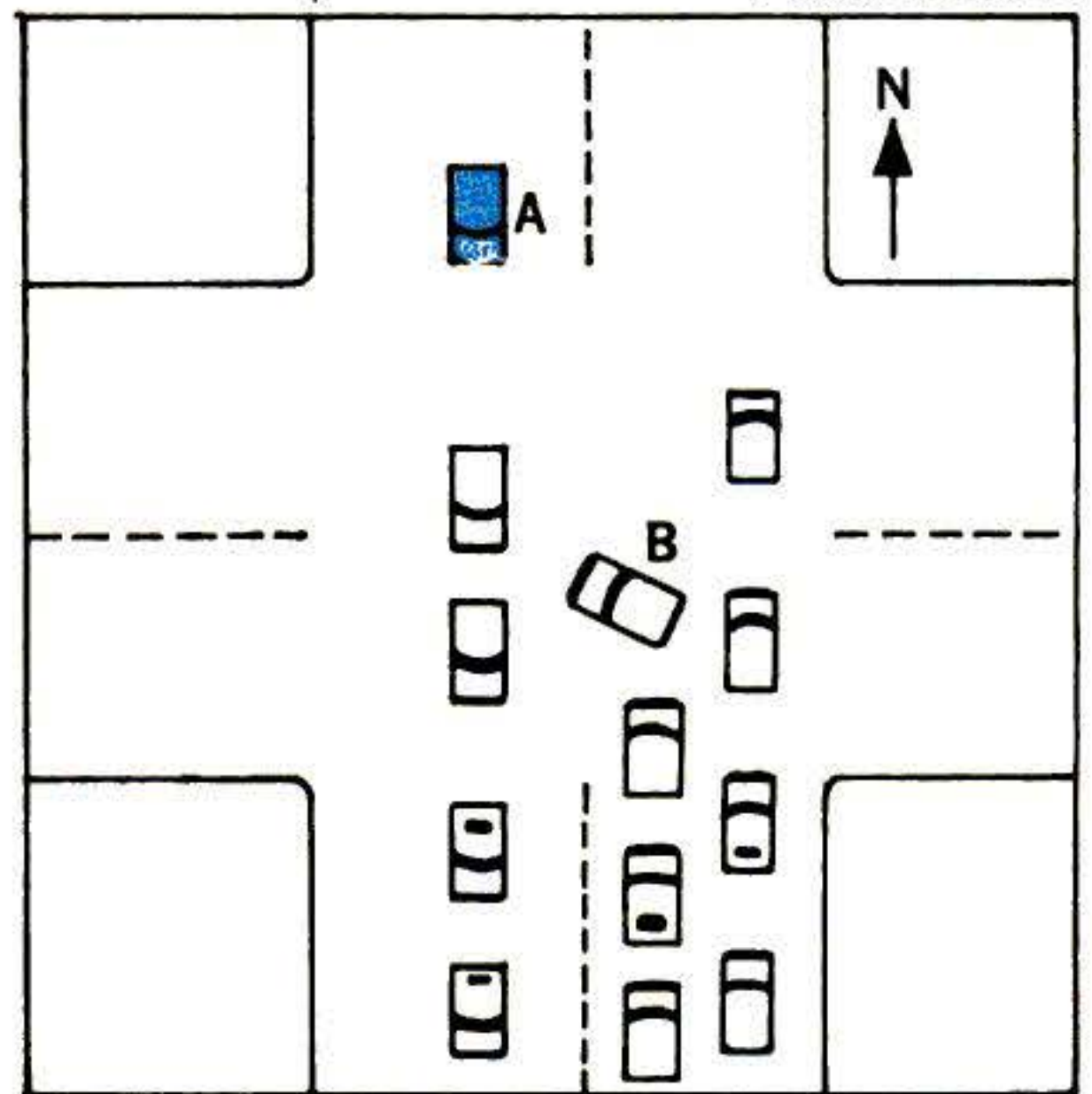

## The situation:

You are heading south in Car A, approaching an intersection. Car B on the northbound side is waiting to make a left turn. Southbound traffic apparently has prevented him from completing his turn. Several cars are now immobilized behind him.

## You should:

- 1 Accelerate to get across the intersection as fast as possible.
- 2 Proceed at your same speed.
- 3 Slow down slightly just in case the driver trying to make the left turn decides to cut in front of you.
- 4 Stop short of the intersection and let the other driver turn left.

The Columbia report contradicts some of the most hallowed beliefs about driving. For example, the researchers maintain that:

- Fast drivers, even reckless drivers, are not as dangerous as some other kinds.
- Breaking the rules is a good idea—sometimes.
- Bulling ahead, taking advantage of every opening without hesitation, may be safer—for some drivers in some vehicles.
- Defensive driving—trying to anticipate the other guy's mistakes—may not be the best way to drive.

These ideas grew out of a search for characteristics of good and bad drivers by the Safety Research and Education

Project at Columbia's Teachers College. The study was financed by the American Automobile Association Foundation for Traffic Safety and the U.S. Public Health Service. Here's how the project's director, Dr. James L. Malfetti, describes the characteristics of the genuinely good driver:

"We found that the good driver always keeps the cars around him in mind. He helps traffic flow smoothly, and never gets in the way. More, he does what other drivers expect him to do.

"The bad driver acts as if he has the only car on the road. He pokes along too slow for the traffic or clogs a fast lane. He hesitates at turns and intersections, so that you can't tell whether he means to go first or let you go first. He's either



**PROBLEM C**

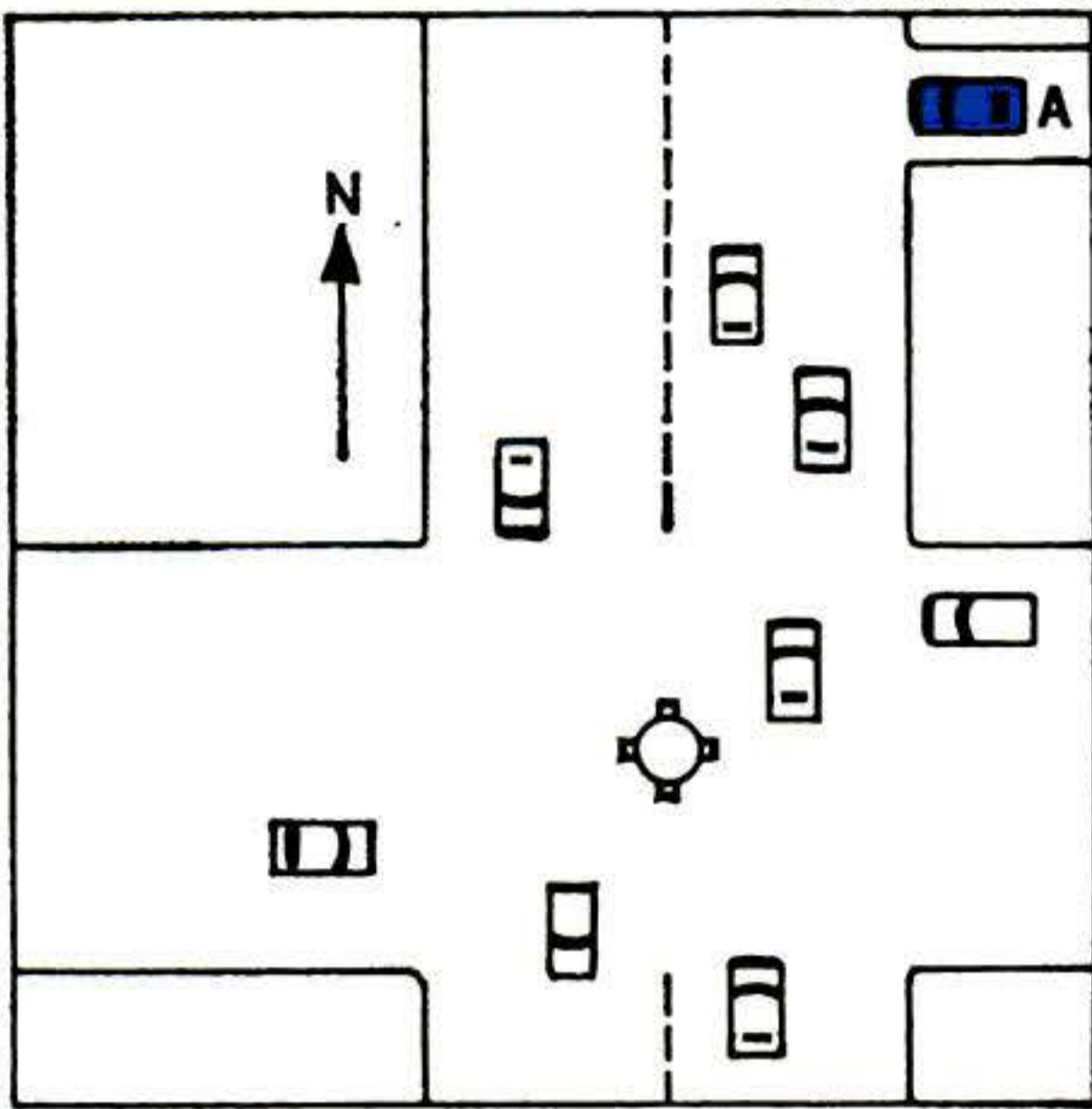

**The situation:**

You are in Car A in a driveway, pointed toward the road. The intersection, left, has a traffic light. You wish to go south. Northbound traffic is moderate, southbound light.

**You should:**

- 1 Wait until north-south traffic is stopped for a red light; then proceed carefully to cross the northbound lanes and turn left.
- 2 Make a right turn, drive north for a short distance, and when convenient make a U-turn to head south.
- 3 Slowly inch out until the northbound cars are forced to stop for you.
- 4 Signal for a left turn and cross quickly into the southbound lane.

**PROBLEM D**

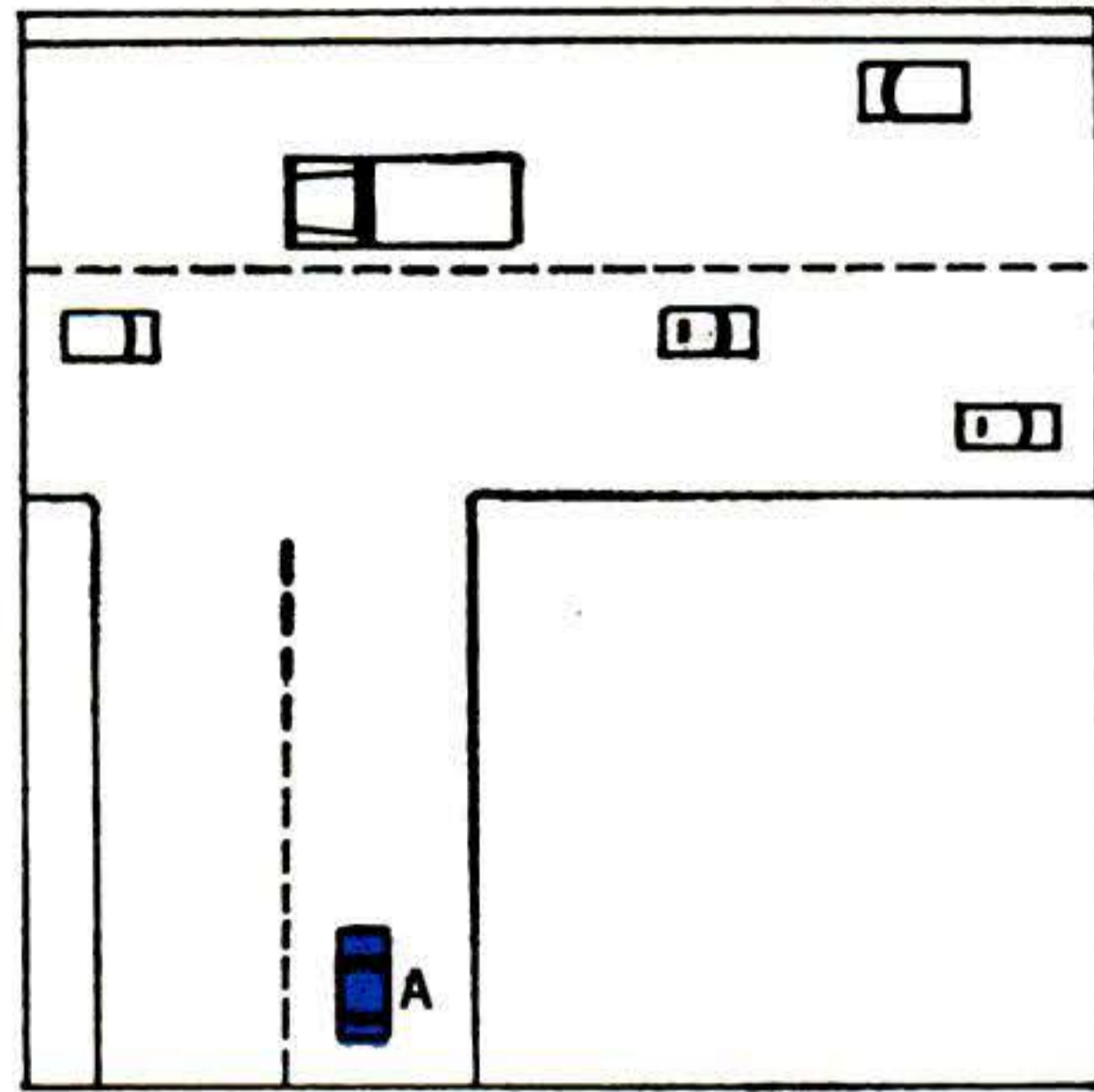

**The situation:**

You are in Car A driving down a side road toward a highway. You are slowing down and signaling for a left turn. Directly ahead of you, you see truck B stopped on the highway and signaling for a left turn.

**You should:**

- 1 Attract the truck driver's attention to see if he will allow you to make the turn before he does.
- 2 Keep in your present lane and come as far forward as possible before stopping at the intersection.
- 3 Concentrate on your turn; the truck driver should courteously wait.
- 4 Stop one or two car lengths short of the intersection.

unaware of cars around him, or he just doesn't care. He gets in the way and sets up accidents."

What's bad about the defensive driver?

Dr. Malfetti says: "He expects the other fellow to act stupidly or belligerently, and tries to outsmart him. Driving a car is complex enough without trying to outsmart other drivers."

Breaking rules is one mark of the good driver, Dr. Malfetti claims—when it's done at the right time in the right place. He cites this example:

A car straddles the white line right in the middle of the road and slows down. Stupid? No. Smart. He sees a road-block ahead that the cars following him cannot see. If he slowed in his lane, the others would pass him and pile into

trouble. By straddling lanes, the motorist *compels* everybody to slow for a stop.

Dr. Malfetti will not say that fast, hard driving is good. He does believe it is nowhere near as deadly as preachers of the "Go Slow, Be Careful, Speed Kills" doctrine make out. Here's why:

**The leadfoot.** The fast driver makes himself obvious. Everybody recognizes him and keeps out of his way. Because his actions are clear and expected, he is not so likely to cause trouble.

[Continued on page 209]

**Answers to Driving Problems**

lem D-4.  
A-3; Problem B-4; Problem C-1; Prob-  
"Good" drivers choose these options: Problem





"Into the water" is signal for firemen to dive in with equipment. Buoyant balsa blocks are strapped on hose, form collar behind nozzle.

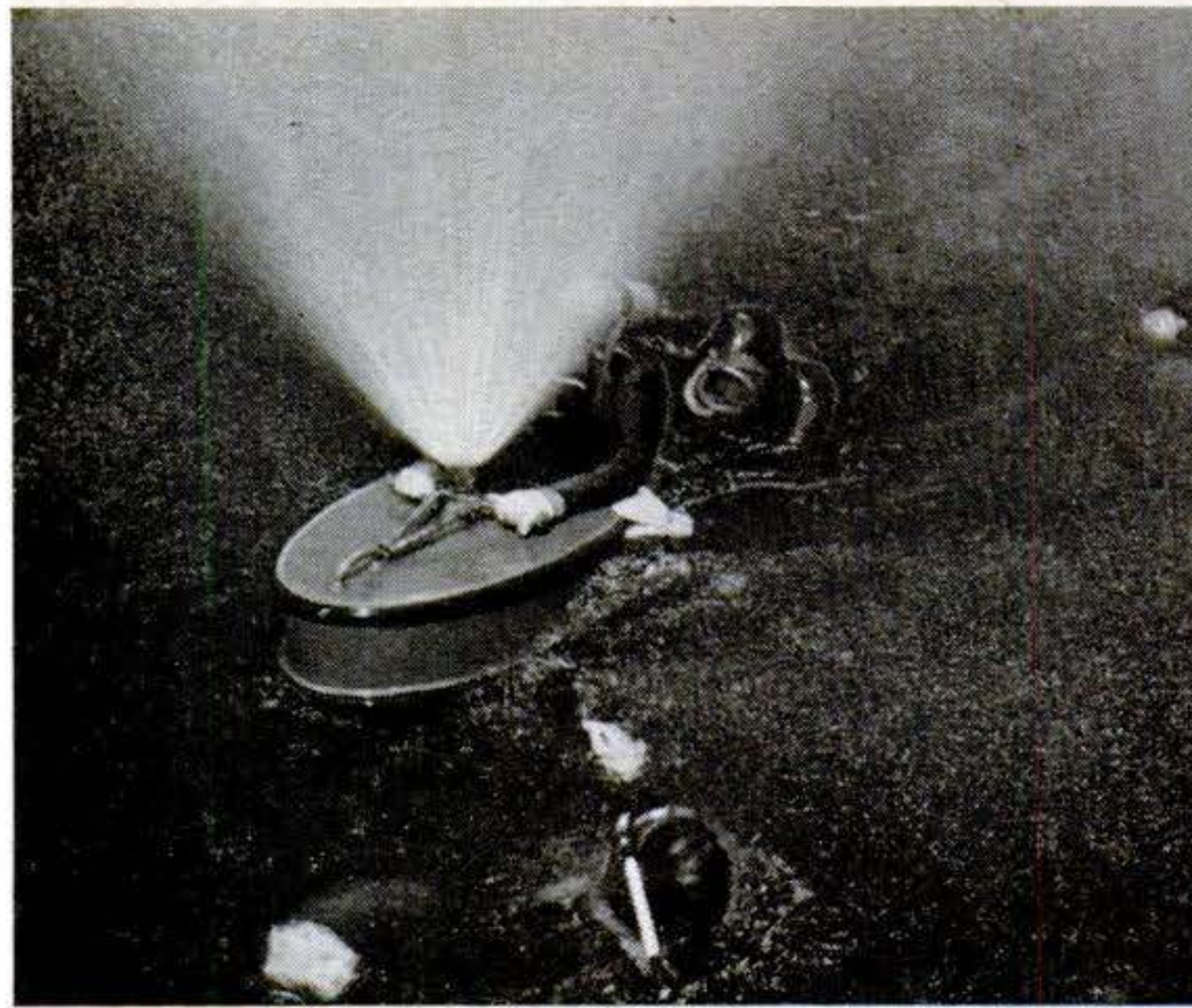

Jet-propelled doodlebug spraying tons of water upward is guided into midst of blaze. Scuba firemen dive underwater in case of danger.

## Frogmen fight dock fires under water

The Los Angeles Fire Department now has a skindiver division—the first in this country. Responsible for 19 miles of harbor docks, it's an important adjunct to the fireboat brigade. Tangled mazes of tar-and creosote-soaked timbers, pilings, and docks burn fiercely giving off an acrid smoke that hides the fire from hosemen, and deflect water directed from above.

The Scuba firemen hit them from below. Rubber-suited and equipped with underwater breathing apparatus, they are pro-

tected from both heat and choking smoke. Standard 1½- and 2½-inch hose is still the firemen's favorite weapon, but the frogmen have added some new wrinkles. Blocks of balsa wood are lashed to the hose for buoyancy and the nozzles are thrust through balsa collars to keep them afloat.

Another aid is a three-foot floating sprayer they call a doodlebug. It's jet-propelled and guided by swimmers underwater into the heart of a blaze where it shoots torrents up into the timbers.



### Different kind of bike: tiny wheels, rubber springs

British makers of the bicycle at left boast they've made the first basic design change in 70 years. It has 16-inch wheels, ultra-rigid frame of oval tubing, substantial luggage space, and an adjustable saddle that fits one size to an entire family.

Small wheels, which lower the center of gravity, and a long wheelbase give stability. Tires are inflated to a rock-hard 60 pounds to reduce resistance to roll, but rubber springs smooth the bumps. Moulton Bicycles, Ltd., Bradford-on-Avon, makes five road and racing versions.





Streams of water poured in from under dock penetrate complex of tar-soaked and creosoted timbers.

### Trailer-truck feeler previews big haul

To check highway width before transporting preassembled 40-ton RIFT (Reactor-In-Flight-Test) vehicles with nuclear engines, Lockheed sent ahead a truck and trailer equipped with a pipe framework. Rounded arms measured for the 35-foot diameter of the rocket stage; a 40-foot mast checked overhead clearance. The trial run helped prepare a special road map of the 435-mile route from Port Hueneme, Calif., to Jackass Flats, Nev. RIFT vehicles will be shipped next year for static tests by the National Aeronautics and Space Administration.





Like to live in a 60th-story apartment overlooking Lake Michigan, park your car 18 stories high, ride an elevator to your boat? Then move into—

# MARINA CITY

By James M. Liston Illustrated by Ray Ploch

**T**HE most spectacular new building in America looks like two stacks of giant poker chips piled on the north bank of the Chicago River.

The twin towers of Marina City represent a cool \$36 million bet that a big idea boldly executed will pay off. The big idea:

- A downtown skyscraper apartment building so close to everything that a man can walk to work.
- A five-building "city within a city" with an exciting atmosphere that gives prestige to the address. In the "basement," or first plaza level, a 700-boat marina (hence Marina City),

CONTINUED

TO BE TOPPED  
BY 437-FT.  
TV ANTENNA





LAUNDRY AND STORAGE;  
CAR SERVICING BELOW

YEAR-ROUND  
SKATING RINK

1,200-SEAT  
THEATER

16-STORY  
OFFICE  
BUILDING

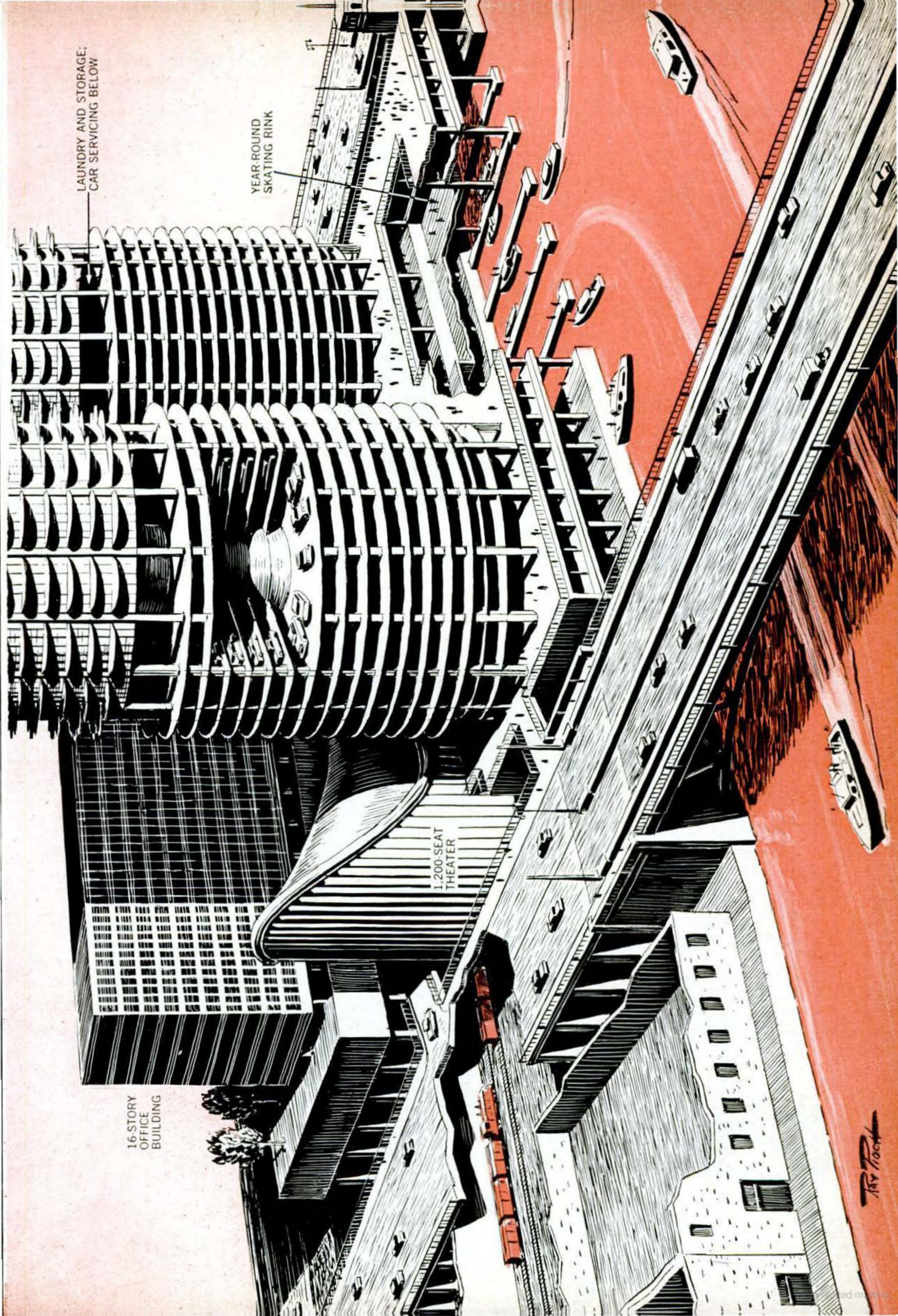

Ray Focht



# Success hinged on getting materials and equipment up

several acres of restaurant and shopping space, a gym, a swimming pool, and an exhibition hall. On the first 19 floors of each tower, spiraling parking ramps for 500 cars; on the 20th, storage and laundry facilities; and above the noise and dirt of the city, 40 floors of apartments. In the "back yard," a year-round skating rink, a 34-lane bowling alley, a 1,200-seat theater, and a 16-story office building on stilts for those who want to limit

their commuting to a 28-second elevator ride.

● A building that takes city dwellers out of boxes and offers them wedge-shaped rooms expanding toward the horizon, with cantilevered balconies to let them peer down right into the heart of Chicago.

The man who thought he could make it come off is architect Bertrand Goldberg. The investors who bet he could

## Center core provided a platform for all hoisting

Climbing crane, which sat on decks of core, with shores down four floors, was raised 8½ feet each day by four hydraulic jacks. Typical apartment floor surrounds core.

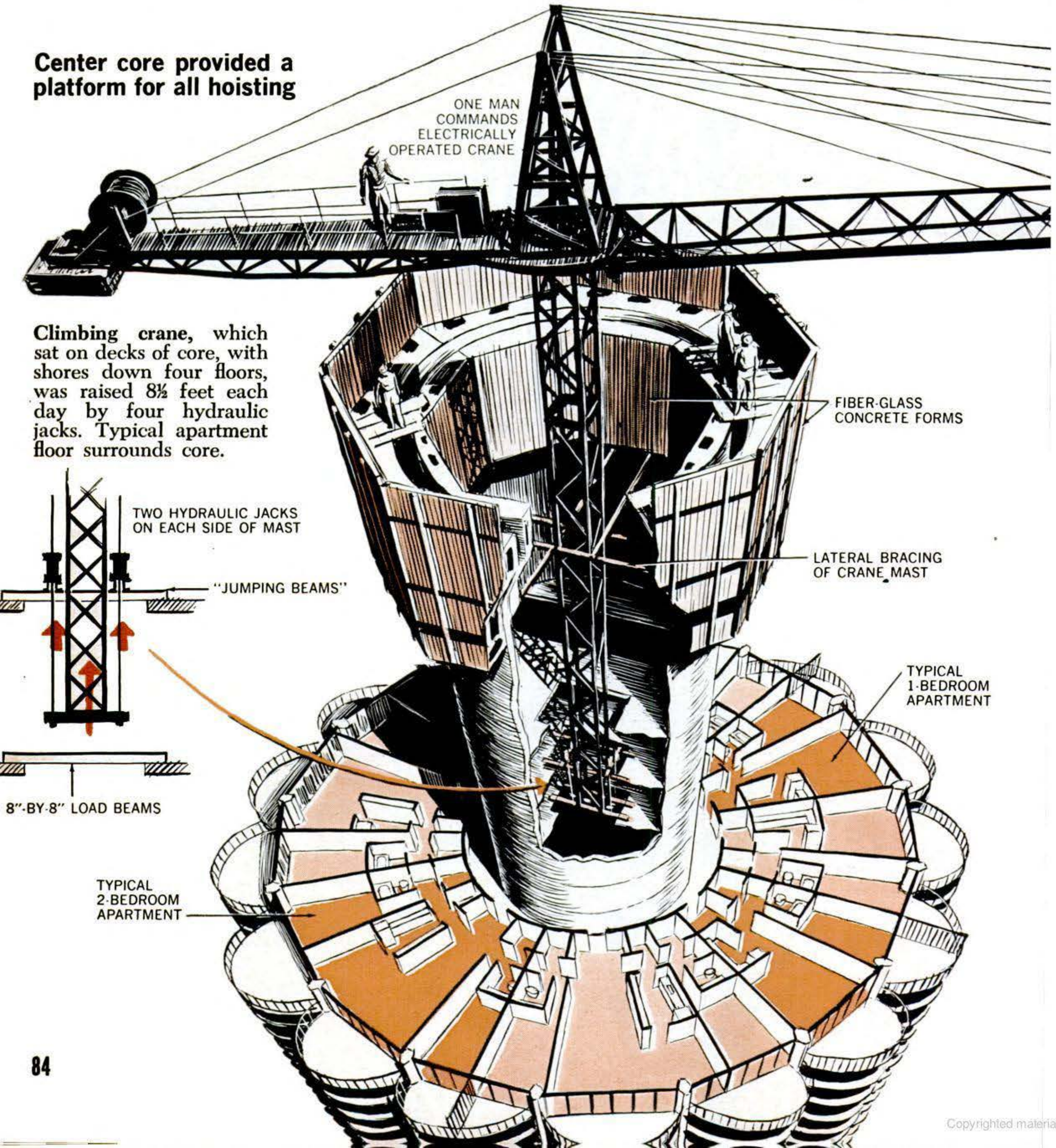



## into the air as the job rose. Solution: the Linden crane

are the Building Service Employees International (the janitors' union), a string of banks, and the FHA. Wags call it "the house the janitors built." Few janitors can afford to live in it (rents range from \$115 for an efficiency apartment to \$350 for two bedrooms), but the project benefits the union funds.

**Why round?** Goldberg used a circular form for the high-rise towers of the five-building complex because: 1) It gave the

highest ratio of usable floor space to exterior skin. 2) It reduces actual wind loads and the wind stresses that the building code requires be taken into account. 3) The circular shape reduces the length of supply and return runs for utilities. Since all utilities—heat, air conditioning, cooking, and hot water—are serviced by electricity, only electricity, cold water, and telephone had to be supplied to each tenant. With individual

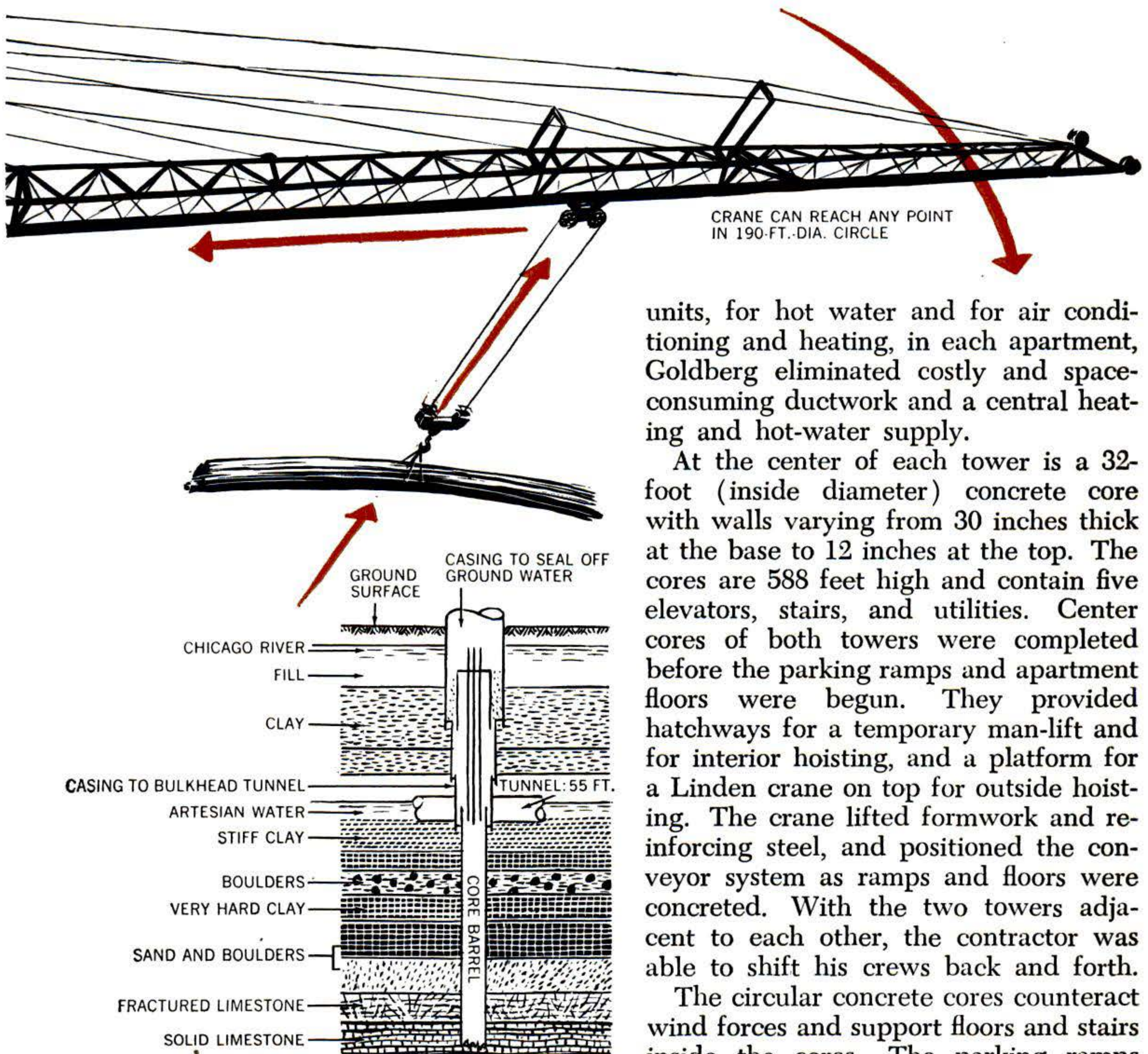

**Steel-core barrel caissons** (158 were installed) penetrated fill to limestone. Water-filled tunnel was sealed with steel-shell bulkhead.

units, for hot water and for air conditioning and heating, in each apartment, Goldberg eliminated costly and space-consuming ductwork and a central heating and hot-water supply.

At the center of each tower is a 32-foot (inside diameter) concrete core with walls varying from 30 inches thick at the base to 12 inches at the top. The cores are 588 feet high and contain five elevators, stairs, and utilities. Center cores of both towers were completed before the parking ramps and apartment floors were begun. They provided hatchways for a temporary man-lift and for interior hoisting, and a platform for a Linden crane on top for outside hoisting. The crane lifted formwork and reinforcing steel, and positioned the conveyor system as ramps and floors were concreted. With the two towers adjacent to each other, the contractor was able to shift his crews back and forth.

The circular concrete cores counteract wind forces and support floors and stairs inside the cores. The parking ramps and apartment floors are supported by

[Continued on page 194]



# Flying the Atlantic Without a Navigator



Ocean vessels, navigating by stars and sun, still use time-honored sextant—as on the S.S. United States, above.

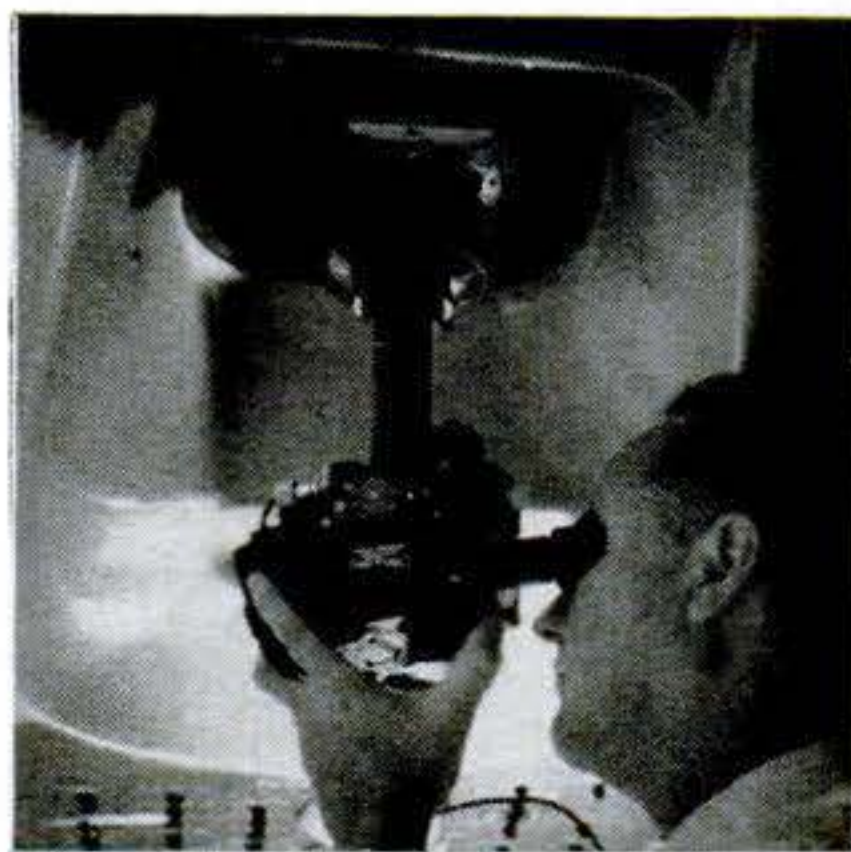

Transocean planes have used this aerial version of sextant to get star "fix"—but task is too slow for jets.

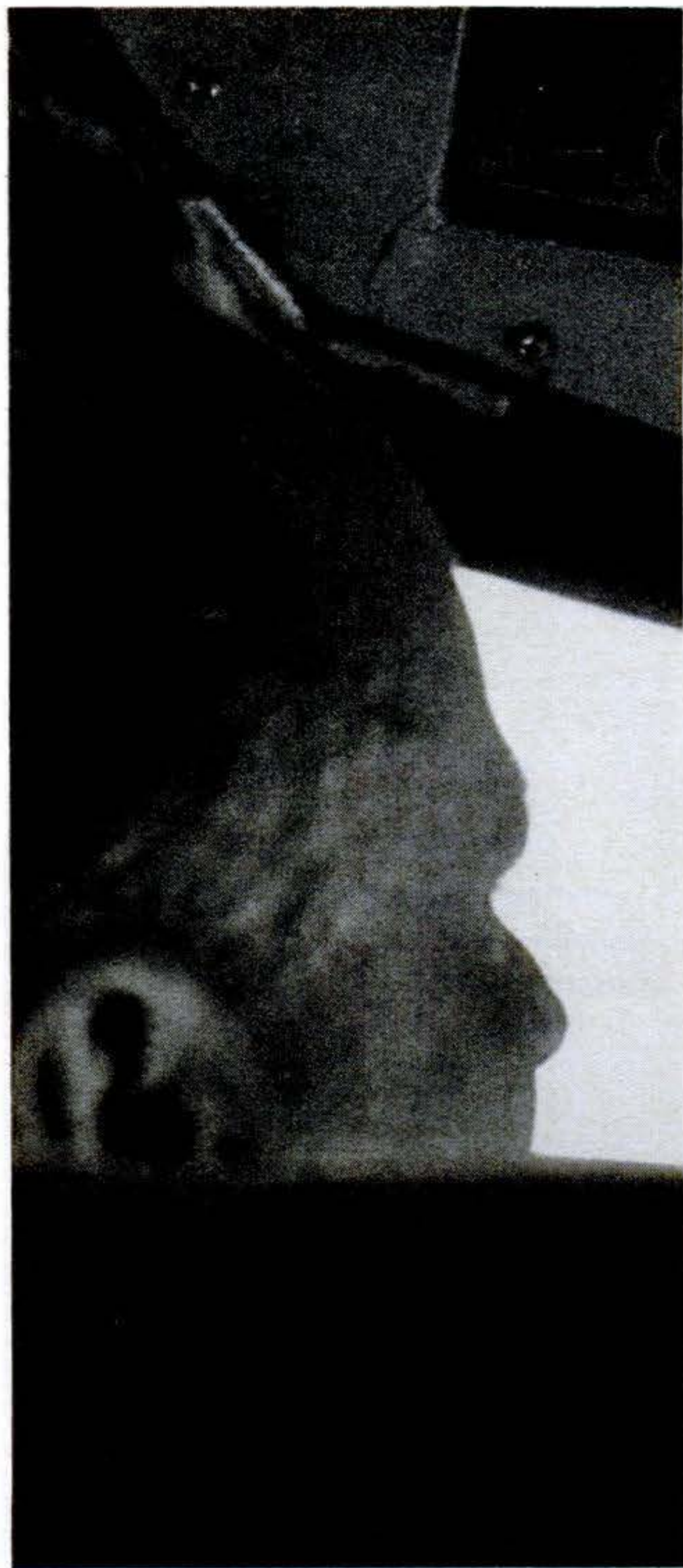

New Doppler system, dispensing with navigator and celestial observations, is TWA's answer to guiding fast jets. The pilot (right) simply dials intended course into overhead panel. Radar beams detect straying, and guide him back to course.

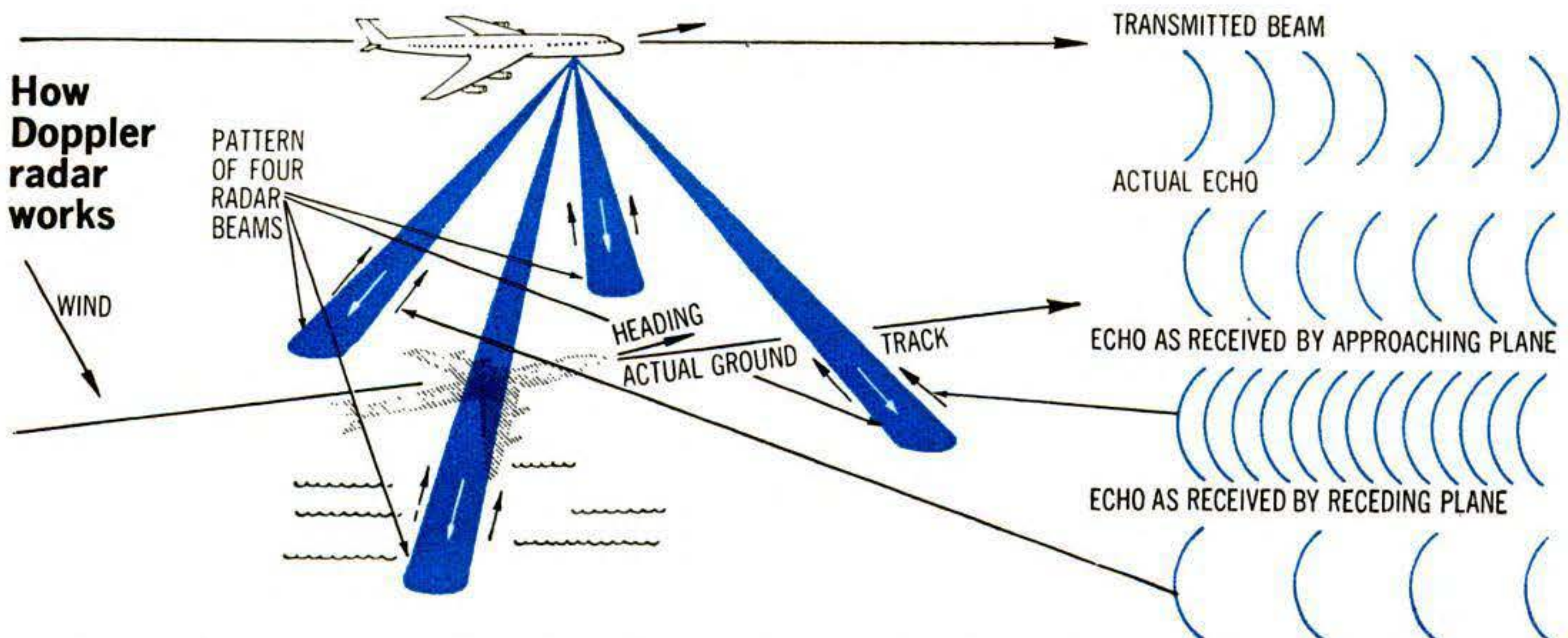

Four radar beams are aimed seaward by antenna. Echoes tell jet's speed in each beam's direction, by "Doppler effect" shown at right.

Jet's motion alters echoes' apparent frequency.



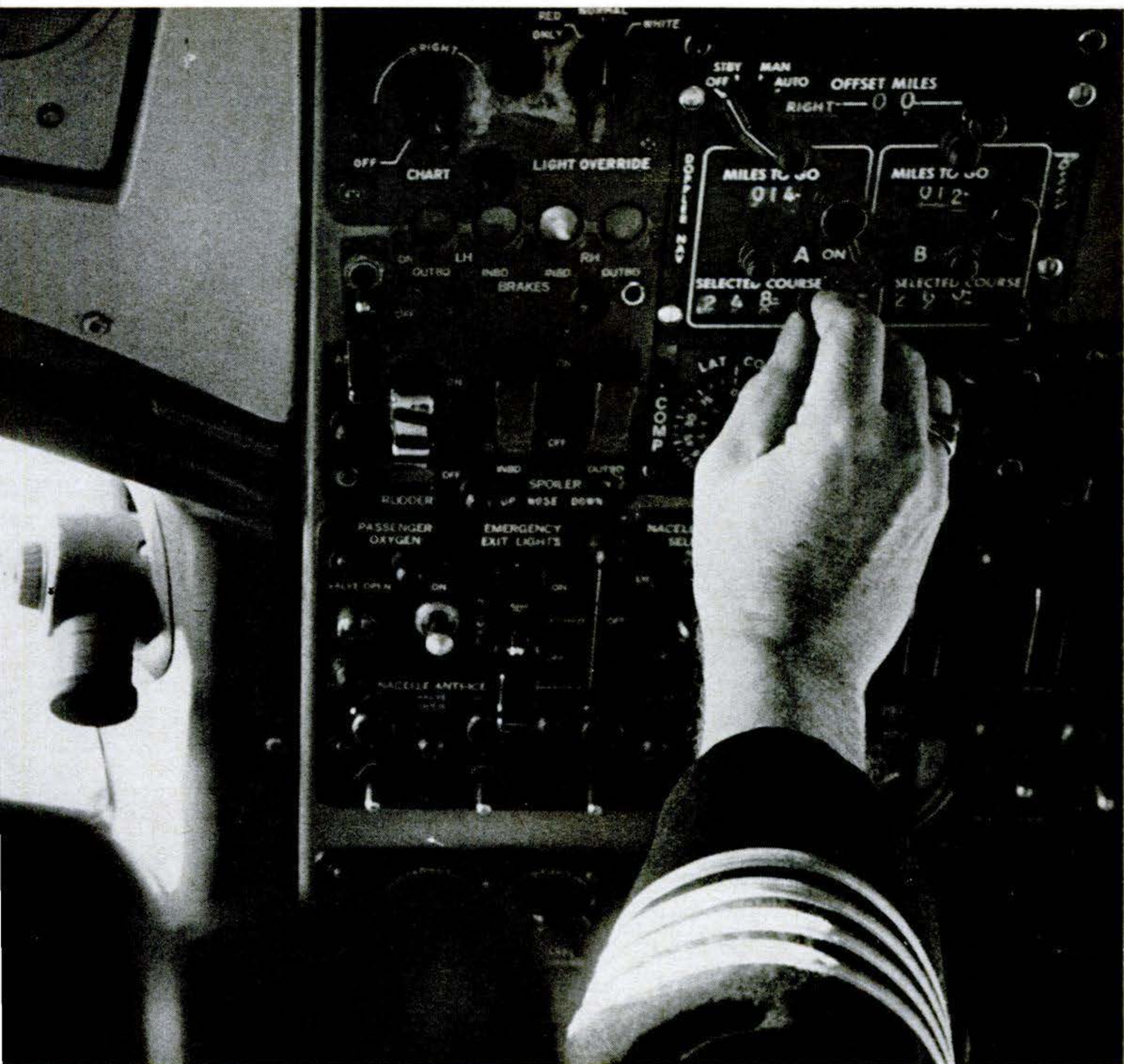

## High-speed jets have forced a break with classical navigation by stars and sun, in favor of radical new Doppler system

By Robert E. Smallman

**T**HERE'S an empty seat up front these days on TWA's overseas jet flights. Although his swivel chair remains bolted to the flight deck, the navigator is as extinct as the dodo bird.

An electronic system called Dual Doppler Radar has taken over his job. Constantly it fingers the sea beneath the speeding plane with four diverging radar beams. Apparent changes in frequency

of the beams' echoes, due to the plane's motion in any direction, show its ground speed and track. If the plane is straying from its intended course, as unpredictable winds may make it do, a computer comes up with the direction and distance to fly to get back on course.

Thus, it's estimated, a pilot can keep a jet within an average of 10 miles to left or right of a planned course. That compares with a margin of safety of 60 miles, to each side of an aircraft, that

CONTINUED

87



## Pilot uses these knobs and indicators—and Doppler system does the rest

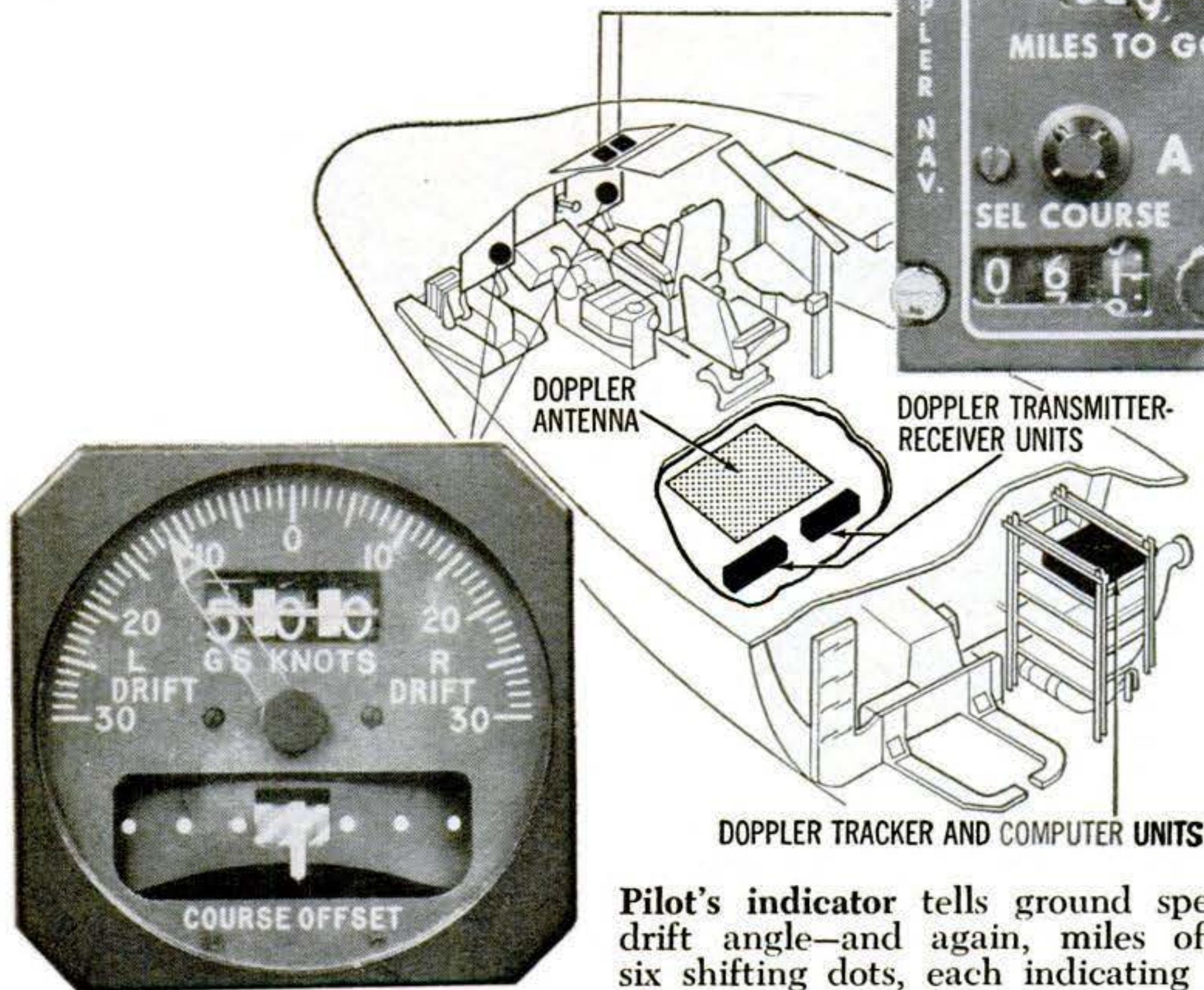

Computer controller is fed by pilot with selected course and distance for two legs of flight. Numbers tell miles left to go, and miles off course to left or right ("Offset Miles"). Center drawing shows location of pictured instruments.

DOPPLER TRACKER AND COMPUTER UNITS

Pilot's indicator tells ground speed in knots, drift angle—and again, miles off course, by six shifting dots, each indicating two miles.

present Atlantic "air corridors" provide.

Jet liners flying the ocean nearly as fast as sound, at altitudes where winds normally range from 100 to 200 knots, have forced a break with the traditional procedure of navigating by the stars and sun. A three-star "fix" to find a plane's position takes 20 minutes to plot. By that time a jet has sped 200 miles farther. And it isn't good enough to know where you were, 200 miles back—conditions aloft change too fast.

For the safety of the 2,000,000 passengers who fly the North Atlantic in about 40,000 planes of all lines yearly, pilots need to know where they are right now. And that's what the new Bendix-developed Doppler system, which TWA has brought to an operational version with the approval and cooperation of the Federal Aviation Agency, tells the pilots of its jets.

To see how simple the system is to operate, let's join TWA's Chief Pilot C. W. Horstman on a typical Atlantic cross-

ing. In Flight Operations, he plots a great-circle course, dividing the 2,600-mile flight into seven legs; they average 375 miles in length, each following a slightly different compass heading. After personally checking the big 707's exterior, he goes aboard and, with his copilot, runs a minute cockpit check. Behind him in the radio compartment are 80 pounds of electronic equipment—the Doppler's radar transmitter and receiver and its computer.

Just before takeoff he programs flight information into the Doppler. Side by side on the ceiling instrument panel are computer controllers marked "A" and "B." Into the "A" side he dials his first heading and the distance of his first leg. These appear as numbers in little windows marked "Selected Course" and "Miles to Go." Into the "B" side goes the same information for the second leg.

After takeoff, Horstman circles, and flies over a radio-marker beacon—his

*[Continued on page 213]*



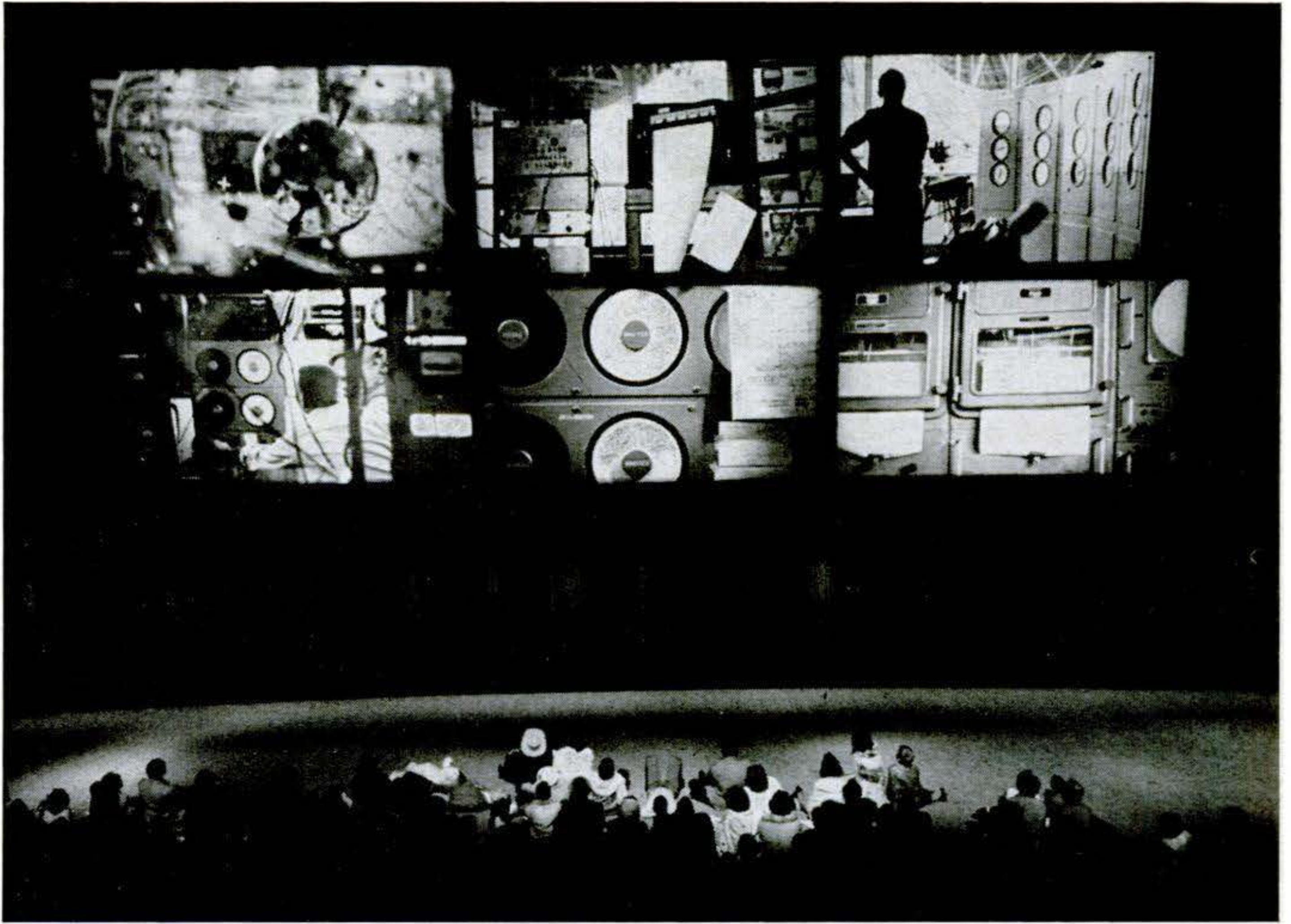

Synchronous projectors show only film of its kind. It tells of growth and unity of science.

## Permanent science exhibit follows record fair run

So popular did the U.S. Science Exhibit prove last summer at Seattle's World's Fair that it is reopening this spring on a full-time basis. The \$10,000,000 center attracted more than 6,500,000 persons in the six months the fair was open. Turned over to the Pacific Science Center, it was kept open on weekends during the winter, with three new exhibits added in December: a planetarium, optical light maser, and satellite-tracking display. Admission is \$1 for adults, 50 cents for students.



Pigeons match intricate patterns learned in method that led to building teaching machines.

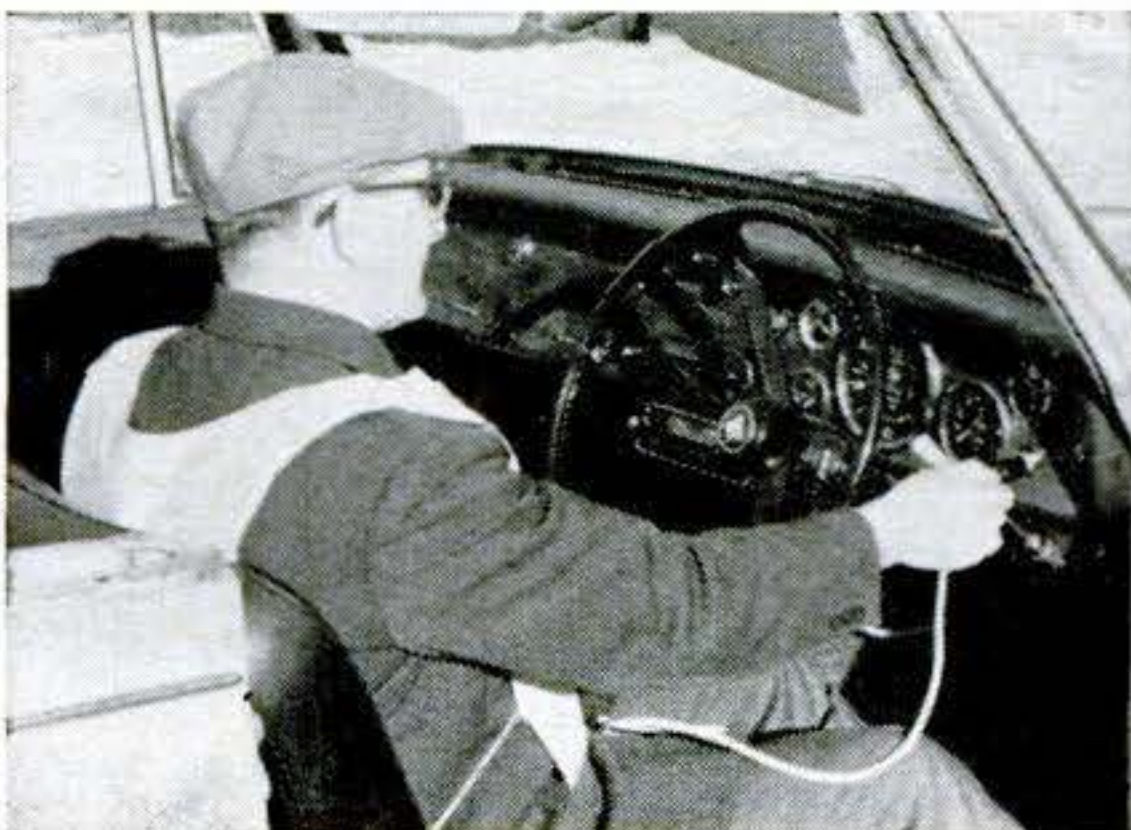

## Plug-in vest heats from dashboard

Riders in open cars, boats, tractors, or on motorcycles can now keep warm on cold days, says the inventor of this plug-in vest. It has flexible heating elements enclosed in plastic front and back panels, plugs into a cigarette-lighter receptacle connected to a 6-, 12-, or 24-volt battery.

Normally worn inside the jacket, the French device is demonstrated here by a Delaney Electronics, Ltd., employee on a cold day in London. When not in use, the plug can be tucked in a pocket.



## THE '63 CARS:

# How They're Better in

**E**VERY autumn U.S. automobile manufacturers take the wraps off their spanking-new products in thousands of showrooms from Bangor to San Diego. They advertise the big

changes—new engines, new transmissions, new body shells.

But there are hundreds of other changes built into the new cars for performance, convenience, or looks that the



- Chevy has a fresh answer to rocker-panel rusting (above). Rain water flows from inlets in front of the windshield down through the panels to wash out dirt. Drying air follows the same course. Windshield pillars are straighter.

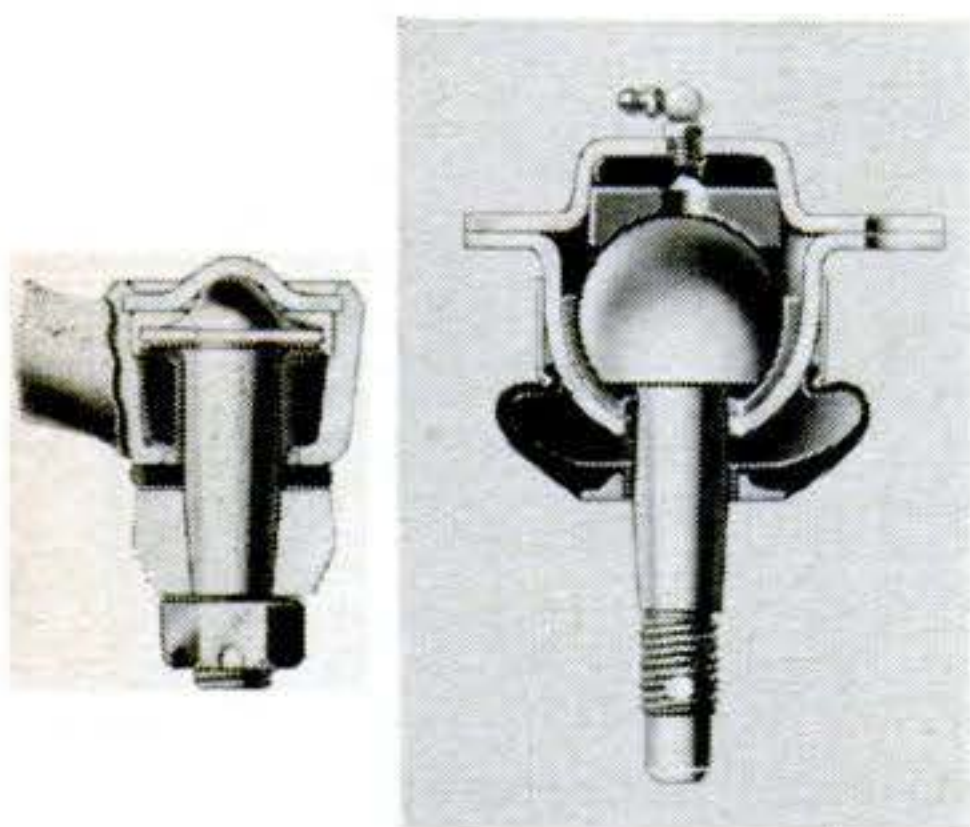

- Ever hear of polytetrafluoroethylene? Well, that's a fluorocarbon resin that is being used in the upper-control-arm spherical joint of Chevy's front suspension (above, right). This low-friction material is one reason for Chevy's extended-lube periods. The pitman-arm ball joint (left) is designed to be maintenance-free.

- Rambler's Ambassador sports a double universal joint in the drive shaft for "constant velocity" as it turns. Most joints set up a vibration. Rambler's is smooth as silk.

- You can't trip over seat belt anchorages when you climb into Cadillac's rear seat—they're now in the floor-pan side walls.

- To save weight, Oldsmobile Rocket, Skyrocket, and Starfire engines use an aluminum front cover and water-pump housing.

- Ford now has rubber window seals. One immediate result is less internal rust from dripping.

- A "heat stove" (below, arrow) on Ford Motor's 260-inch engine, powering the Fairlane, Falcon, and Meteor, hastens cold-weather warm-ups and prevents carburetor icing. Heat comes from the exhaust manifold. A thermostatic valve shuts it off.

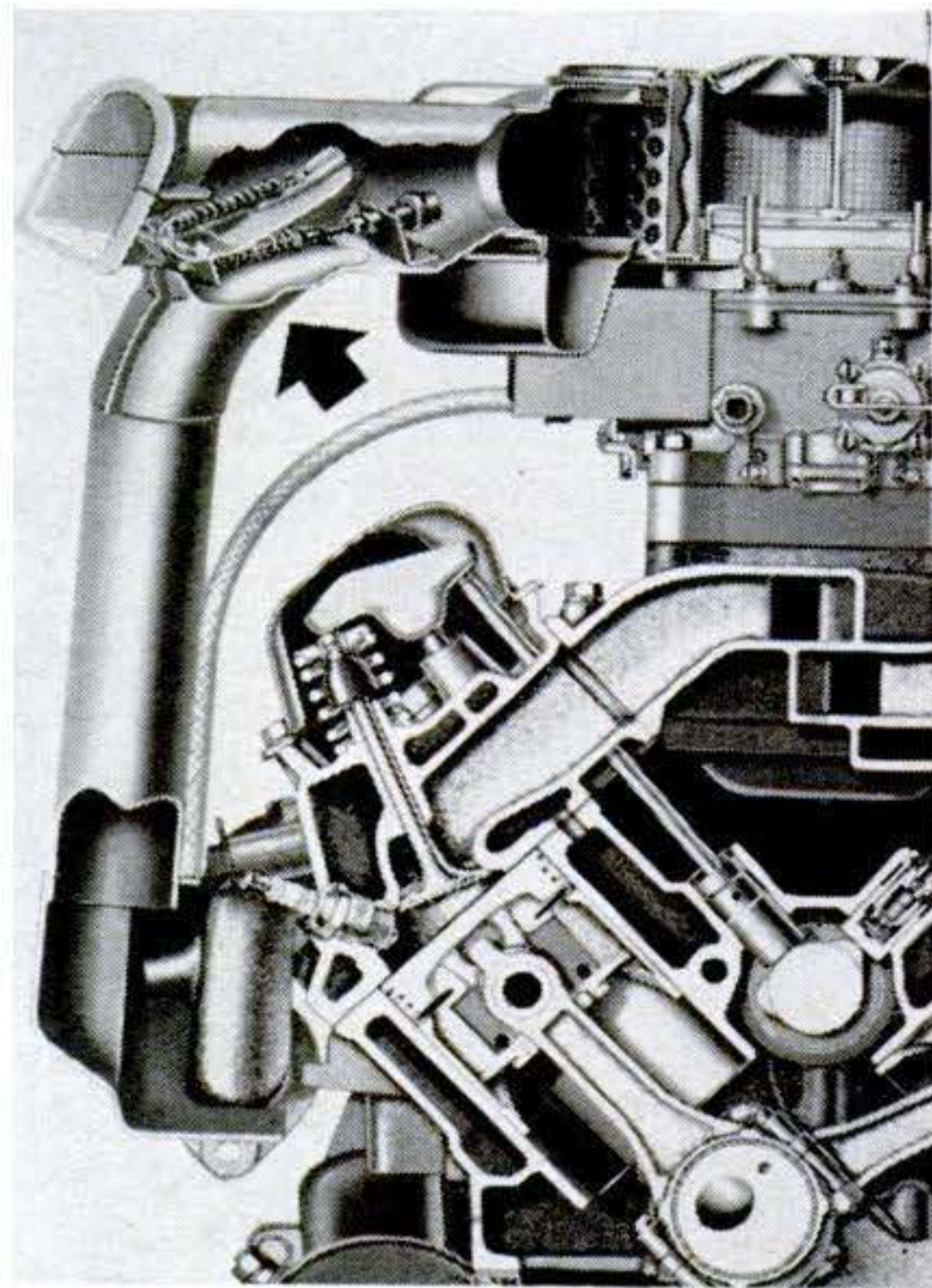

- Parallel-action windshield wipers on Rambler's Classic and Ambassador sweep two-thirds of the glass area.

- Studebaker has direct-reading oil and amp gauges on all models. Studey, too, has parallel-sweep wipers, plus a fail-safe split brake system like Cadillac and Rambler.



# 36 Little Ways

By Devon Francis

motor makers seldom emphasize. The 1963 cars are from an especially fine vintage year for innumerable little refinements. On these pages you will find some of the "tremendous trifles" that

improve the current cars—most of them hidden from view behind the sheet metal. They range from devices to keep convertible tops from flapping to heat stoves for faster warmups in cold weather.

- A can-type, throwaway fuel filter has been adopted by Buick for its V-8s with four-barrel carbs. It does a better job, lasts twice as long. It's more easily removed and replaced, too.



- Three hard-chrome buttons keep Ford brake shoes (above) from sticking to the backing plate when released.

- Both Pontiac and Chevrolet have solved the problem of side-flap and "ballooning" in their convertible tops—a bother on all "rag-roof" cars. The fabric is snugged down with adjustable steel retaining cables.

- An airfoil (winglike) shape in Chrysler Corp. wiper-blade brackets keeps the blades from separating from the glass at high speeds.

- Also from Chrysler: anti-corrosion, aluminized mufflers.

- Lincoln Continental sedans have aluminum brake drums in front for slower fade.

- Distributors on Mercury engines require less adjustment—breaker points are of pure tungsten, silver-brazed.

- Buick air conditioners and heaters are in one housing, with a consequent weight reduction. And the entire unit is mounted in the center of the instrument panel, for easier operation and servicing.

- A "nesting" exhaust pipe—it is enclosed in another pipe—reduces noise from resonance in the Thunderbird.

- A check valve in the oil-filter drain-back line on Dodge Darts reduces oil-pressure build-up time in starting the engine.

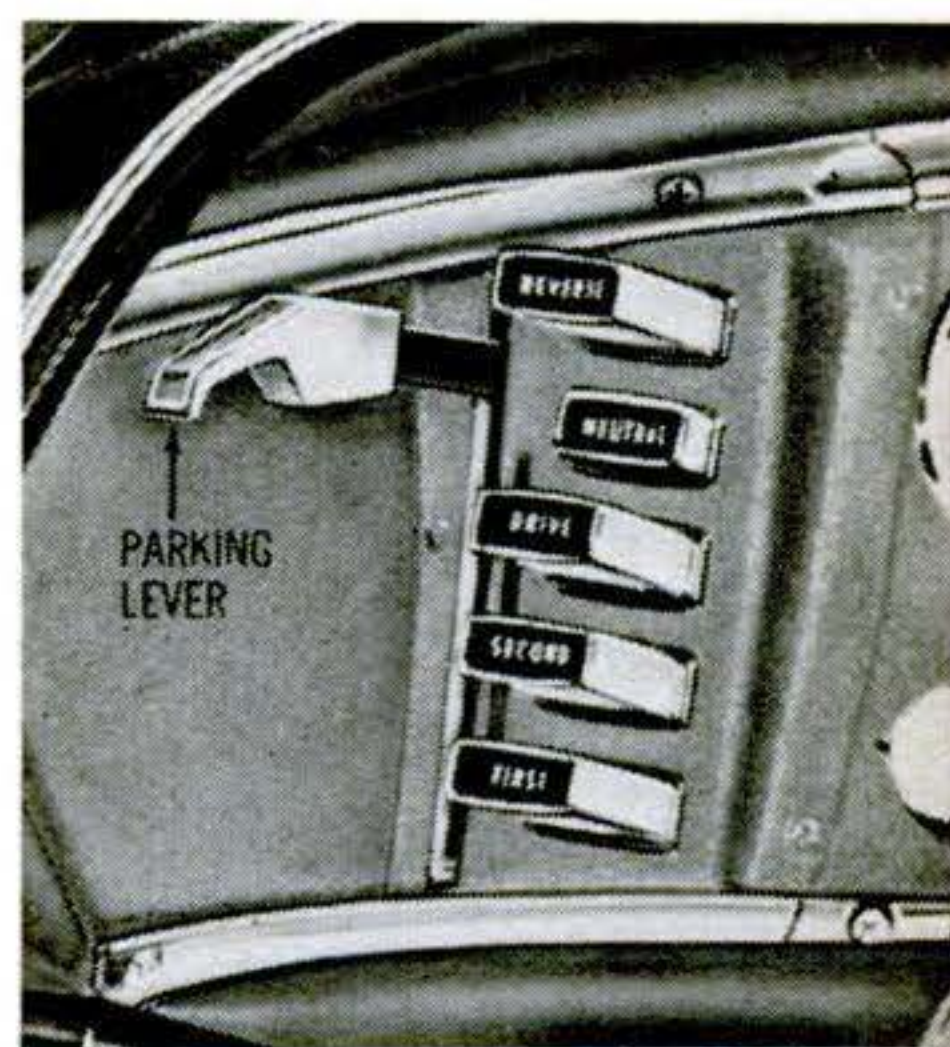

- A parking lever is added to the Chrysler's pushbutton control console (above). It's actually a rod that locks the output shaft to its housing, similar to the "Park" position on other cars with torque-converter transmissions.

- Supercharged Studebaker engines have a viscous fan drive to save power. It slows the fan at high engine speeds.

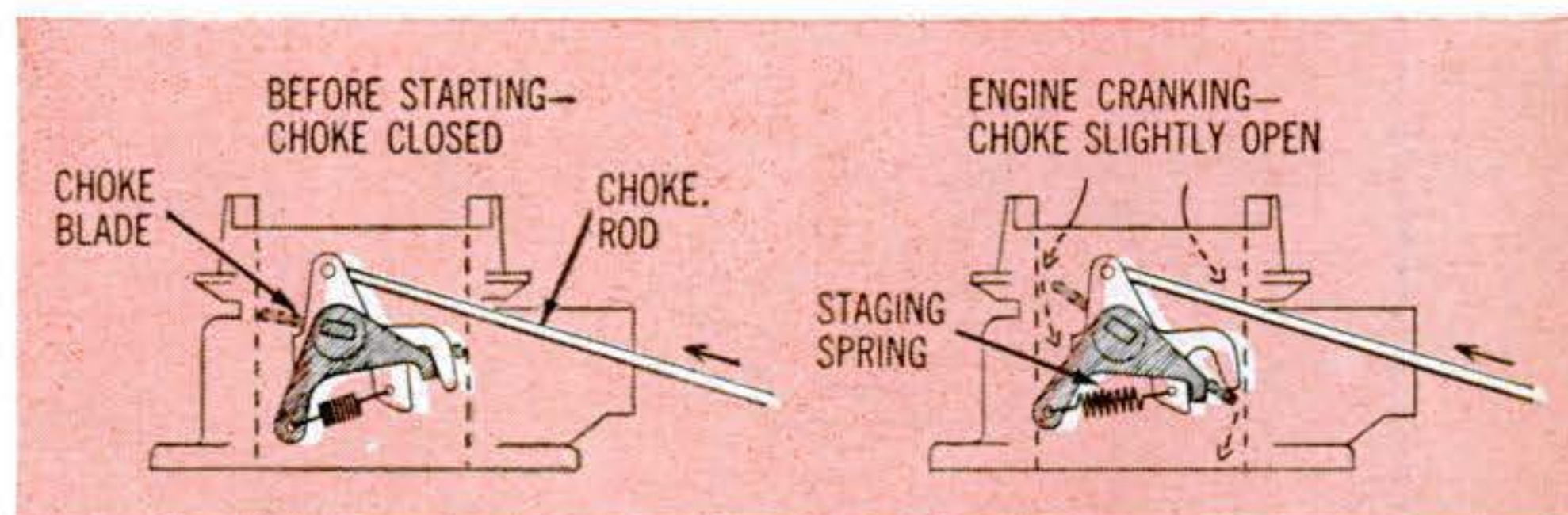

- A coil spring and bell crank in the carburetor choke mechanism (above) of the Plymouth Valiant reduces choke-blade closing torque when firing up at temperatures below zero. This meters a proper starting mixture, gives a faster ignition "catch," helps prevent flooding by heavy-footed drivers.

CONTINUED





- A thiefproof storage compartment (above) is concealed beneath the cargo floor of Rambler Classic and Ambassador station wagons. The glove-box key locks it.

- The Mercury Comet hood is counterbalanced with coil springs to take the toil out of lifting it.

- Standard on all deluxe models and optional on other Olds F-85s is a full safety-padded instrument panel made of thicker material.

- Like other Chrysler Corp. cars, the big Dodge abounds with molding-attachment clips made of nylon. This eliminates the electrolytic corrosion that metal clips cause.

Caddy's optional Cruise Control (which maintains any selected speed) has an on-off switch. This allows the system to be used as a speed indicator, through back pressure on the accelerator, even when not locked in.

- The Tempest's rear suspension (below) has a new lower control arm to improve handling. "Low-rate" rubber mountings cut road noise.

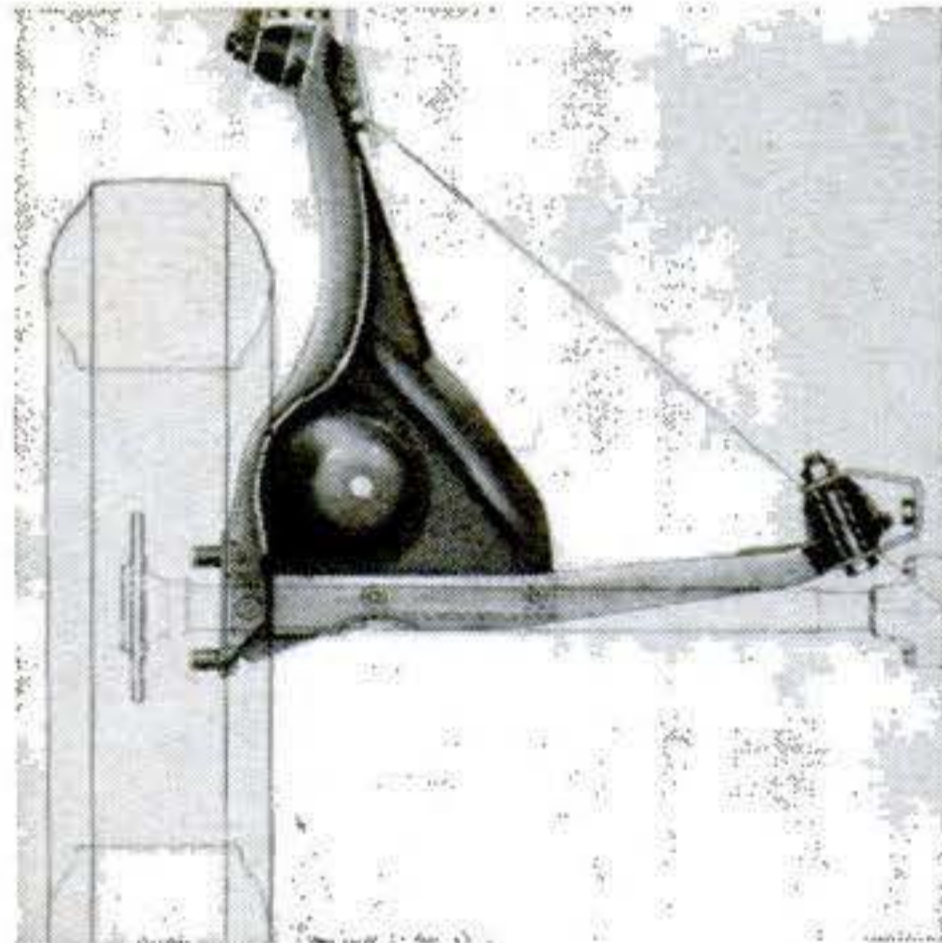

- The Plymouth's bumper sections are beefed up to provide better collision protection, and height is adjusted for better alignment with bumpers on other cars.

- The constant jounce of a car's springs and shocks strains exhaust-pipe joints. Ford has solved this with a self-aligning joint to insure a seal against gas seepage.



- All Olds engines have an oil-filler cap (above)—a washable and replaceable polyurethane element—that does a better job. In normal use, the element need be cleaned only each 12,000 miles.

- And again Plymouth: A stronger return spring on the throttle control gives a crisper accelerator feel. On cars with automatic transmissions, splash shields keep snow, slush, and water from collecting in the control linkage.

- Electric single-speed windshield wipers are standard on all Ford Falcons. Two-speed electrics are optional.

- The Chrysler New Yorker Salon has reading lamps for rear-seat passengers.



- The Cadillac's gas-tank cap (above), when placed in indentations made for it, becomes a brace to hold the little spring-hinged metal door open. Silly? No. Such doors, pushing against the gas nozzle, often get scuffed.

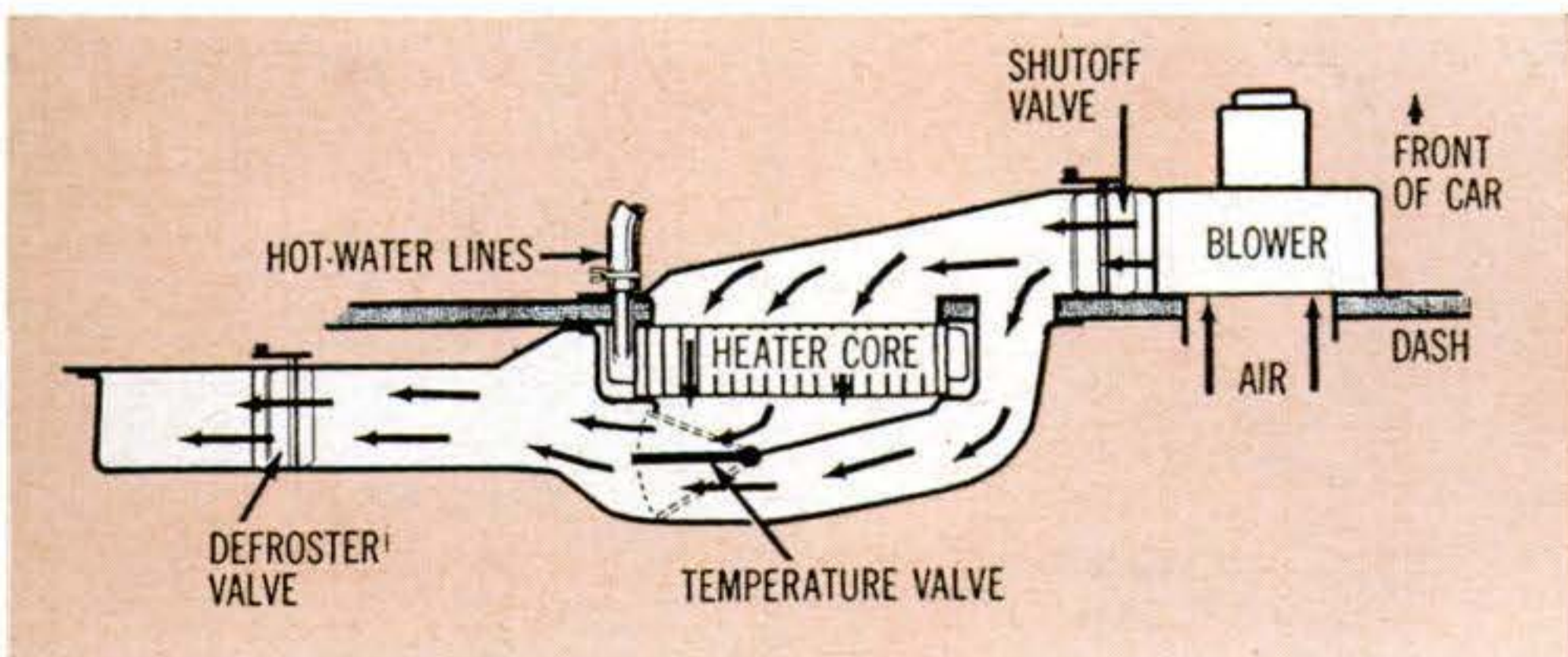

- Buick's heater is less sensitive to speed. Formerly, the temperature of the air from the heater was controlled by a valve that regulated the amount of water through the core. The new heater mixes hot and cold air. Part of the incoming air bypasses the core, to be mixed later.



# "I'd like to see them make..."

**Headlight - dimmer switches** on the gearshift levers of trucks. They'd make it easier to lower lights on hills and curves where there's lots of shifting.—*Clifford R. Kreiling, Palmdale, Calif.*

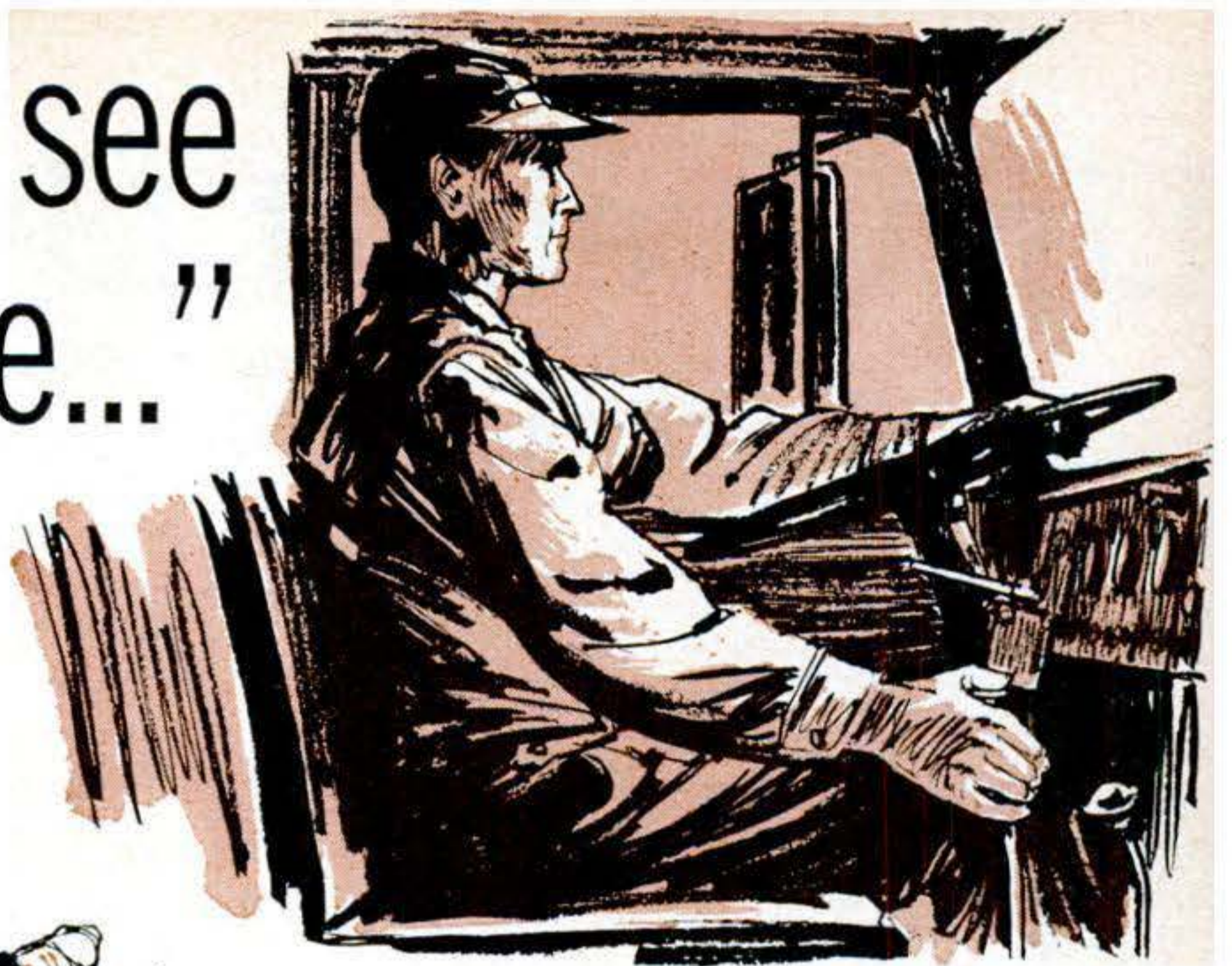

**A curved push-broom** for sweeping large areas, as in schools or factories. Flared ends would keep sweepings from escaping and save overlapping.—*Ernest Levy, New Orleans.*



**Transparent aerosol cans** for products used daily—shaving cream, toothpaste, insect sprays—so you could tell when they're about empty.—*Mrs. R. J. Carpenter, Glenshaw, Pa.*

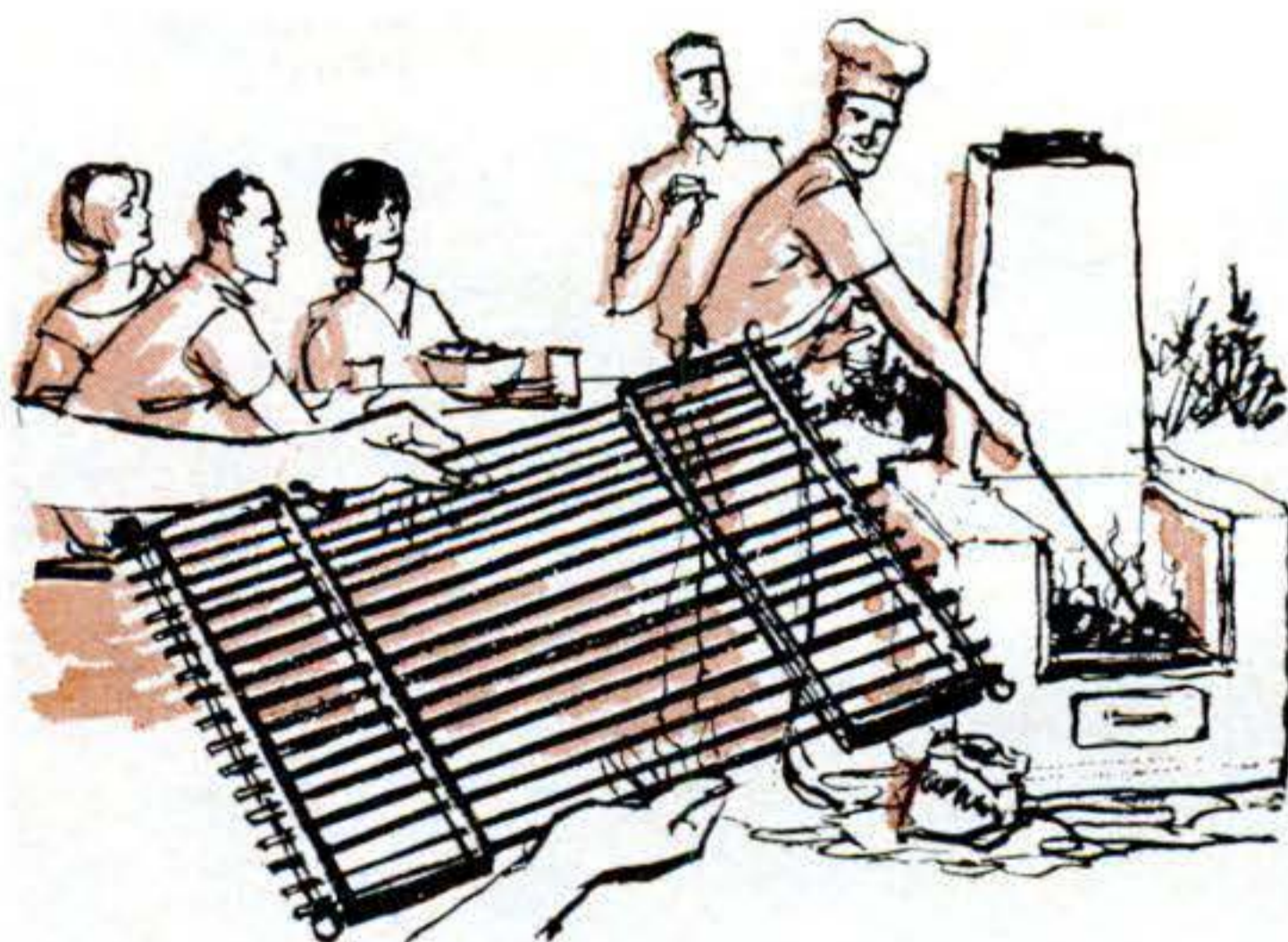

**Come-apart barbecue grilles** with fewer cross-pieces. The rods would lock at the ends for use, but could be slipped out for easy (and thorough) washing.—*J. D. West, Newark, N.J.*

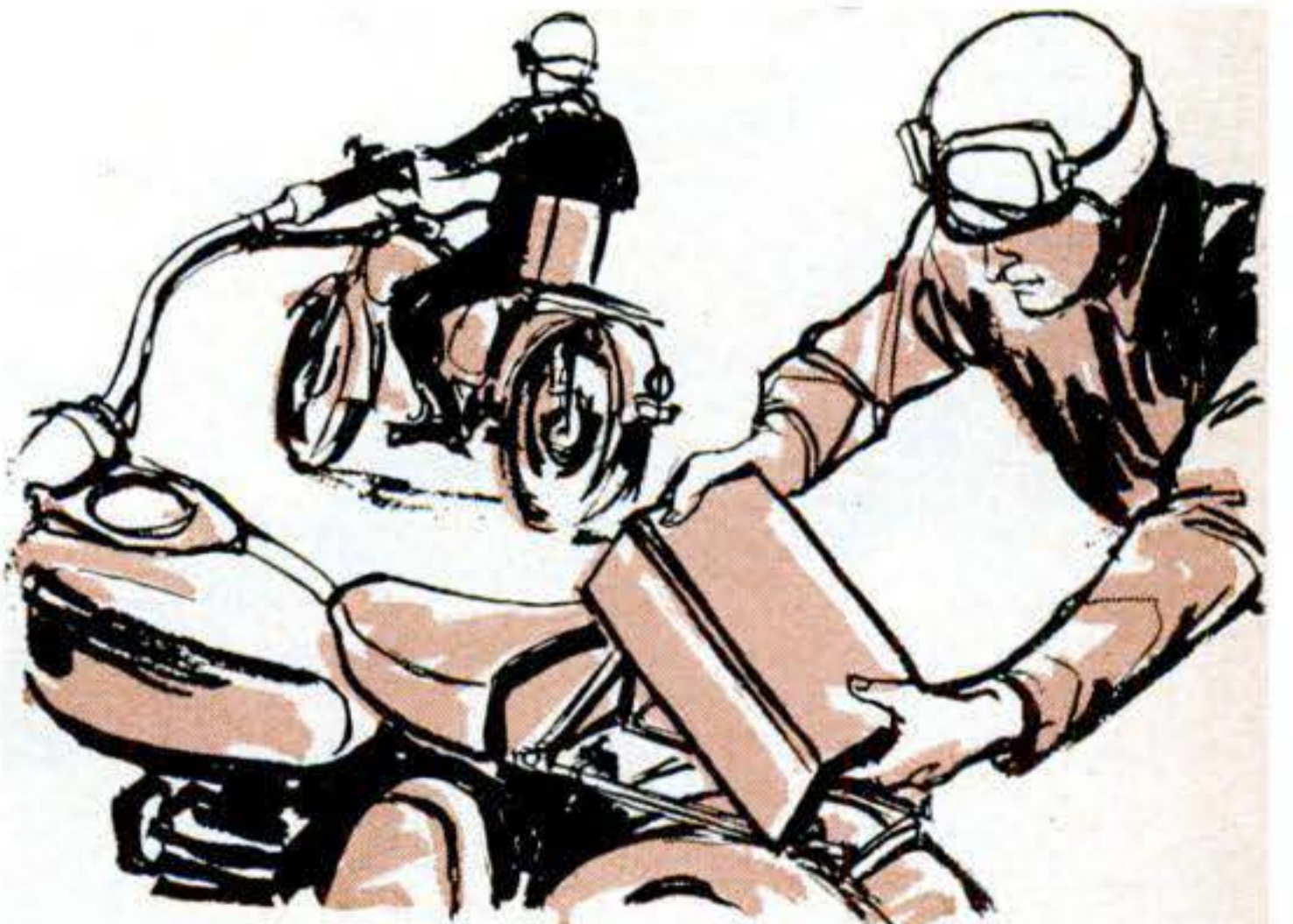

**A padded motorcycle backrest**, curved to fit the back. To provide a flat seat for a second rider, you'd move it back and swing the curved side down.—*B. D. Galligher, Headrick, Okla.*

Everyone has his own pet idea of a gadget that he would like to see in general use. What's yours? We will pay \$5 for each one published. Please use Government postcards

only. Send to ILTS Editor, Popular Science, 355 Lexington Ave., NYC 17. Write your name and address clearly. Contributions cannot be acknowledged or returned.



# Lightweight Liner...

## She carries more passengers than the

**O**NLY 820 feet long, the Canberra is not the biggest luxury liner afloat. Yet the new British ship holds more passengers than any other ocean-going vessel.

She's one of the most revolutionary passenger ships of our time. Her entire superstructure, including masts and funnels, is aluminum. This makes her so light that she displaces only 45,000 tons and gains an extra deck—she has 15 in all. The Canberra accommodates 2,338 passengers. The Queen Elizabeth carries 2,314.

Last August the Canberra made her first Atlantic crossing, from Southampton to New York, in less than five days. Old stuff? Yes. The Queen Mary, Queen Elizabeth, United States, and France do it regularly

in less time. But they all require four propellers to maintain such speed. The Canberra uses only two. Her twin turbo-electric engines, totaling 85,000 hp., push her along at 27½ knots.

She makes good time in harbor, too. A bow propeller driven by an 800-hp., 10-ton-thrust electric motor turns her quickly to either side. It saves up to an hour in docking, especially in small Oriental ports, where there may be as few as two tugs. The Canberra was built primarily for the Pacific trade.

At the pier, baggage and cars are speedily loaded. An elevator rolls out on a track on either side to hoist the cargo. Conveyor belts whisk trunks and suitcases—there may

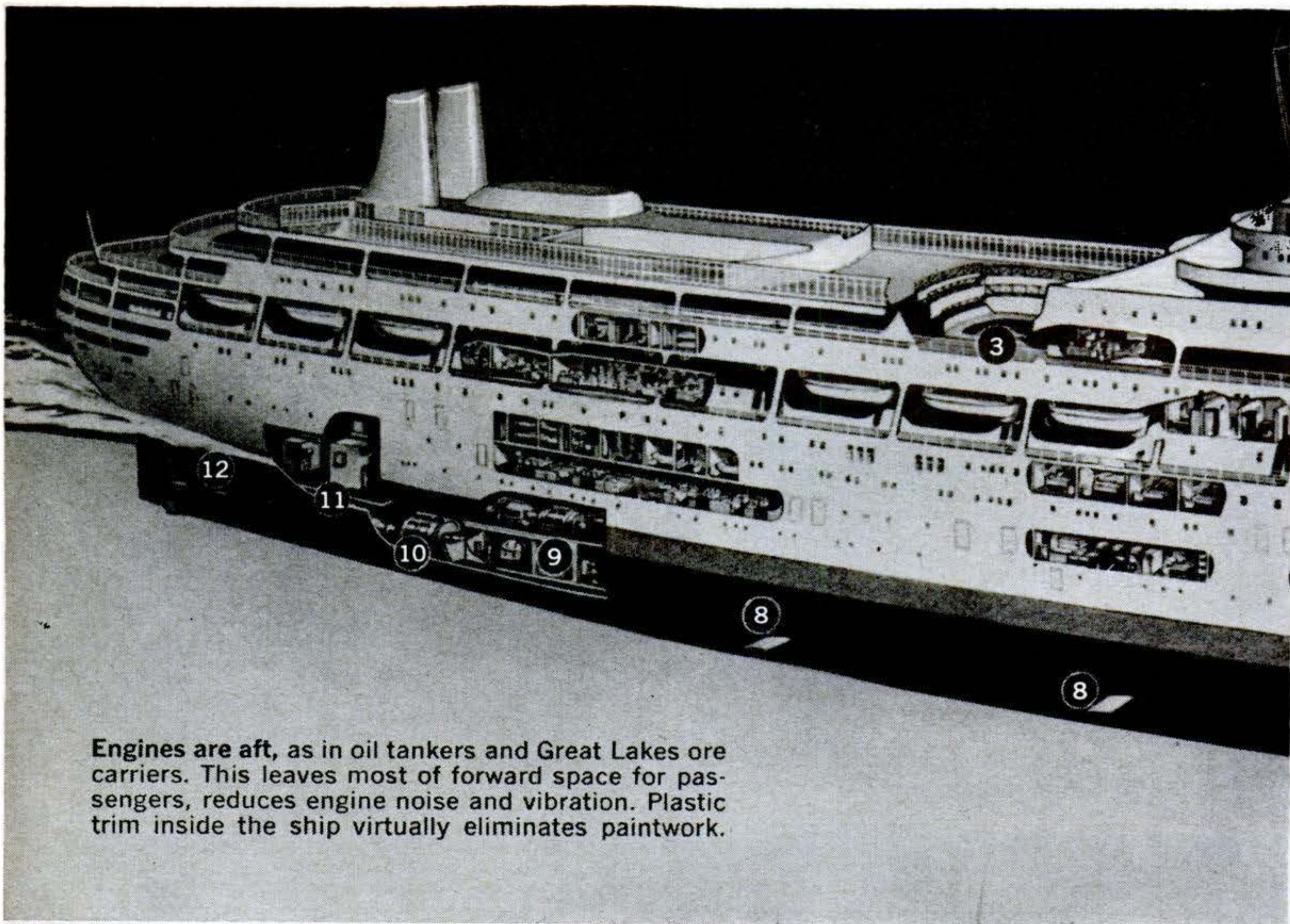

Engines are aft, as in oil tankers and Great Lakes ore carriers. This leaves most of forward space for passengers, reduces engine noise and vibration. Plastic trim inside the ship virtually eliminates paintwork.



On first visit to New York, Canberra received a rousing welcome. The ship stands unusually high in the water, but her streamlined shape cuts wind resistance as twin props spin.



## Queen Elizabeth

be as many as 9,000—to the proper decks, where they're pushed off automatically.

Passengers aren't annoyed by engine vibration. The two 30-ton propellers, 20 feet, 6 inches across, run in "broken step."

The two stacks are side by side near the stern to keep smoke away from decks and cabins. The top deck, where passengers play games or lounge in deck chairs, is completely screened from the wind.

Pitching and rolling—and subsequent seasickness—are practically eliminated. The ship has a bulbous bow similar to those on some World War II battleships and carriers. It rounds out like a globe below the waterline. In ordinary seas it greatly reduces pitching. But should the weather become

bad enough to lift the bow out of the water (it's happened in a Pacific monsoon), the captain admits it's worse than a knife-edge bow. That big, round surface must be forced back into the water.

To cope with side-to-side motion—rolling—two pairs of gyroscopic stabilizers, resembling stubby airplane wings, are extended below the waterline. In rough seas they reduce roll to as little as 1½ degrees—which is barely noticeable. Recently, during a full Atlantic gale with a heavy following sea, passengers enjoyed a fancy-dress ball.

But luxury doesn't come cheap. The ship cost \$1,000 a ton—a tidy \$45 million in all.—*Gardner Soule.*

- |  |                    |
|--|--------------------|
| 1 GAMES AREA                             | 7 FRESH-WATER TANK |
| 2 OBSERVATION LOUNGE                     | 8 STABILIZER FINS  |
| 3 FIRST-CLASS SWIMMING POOL              | 9 ENGINE ROOM      |
| 4 CARGO TRANSPORTERS                     | 10 ENGINE          |
| 5 CREW SWIMMING POOL BELOW               | 11 BOILER ROOM     |
| 6 OPENING FOR TRANSVERSE-PROPULSION UNIT | 12 PROP SHAFT      |

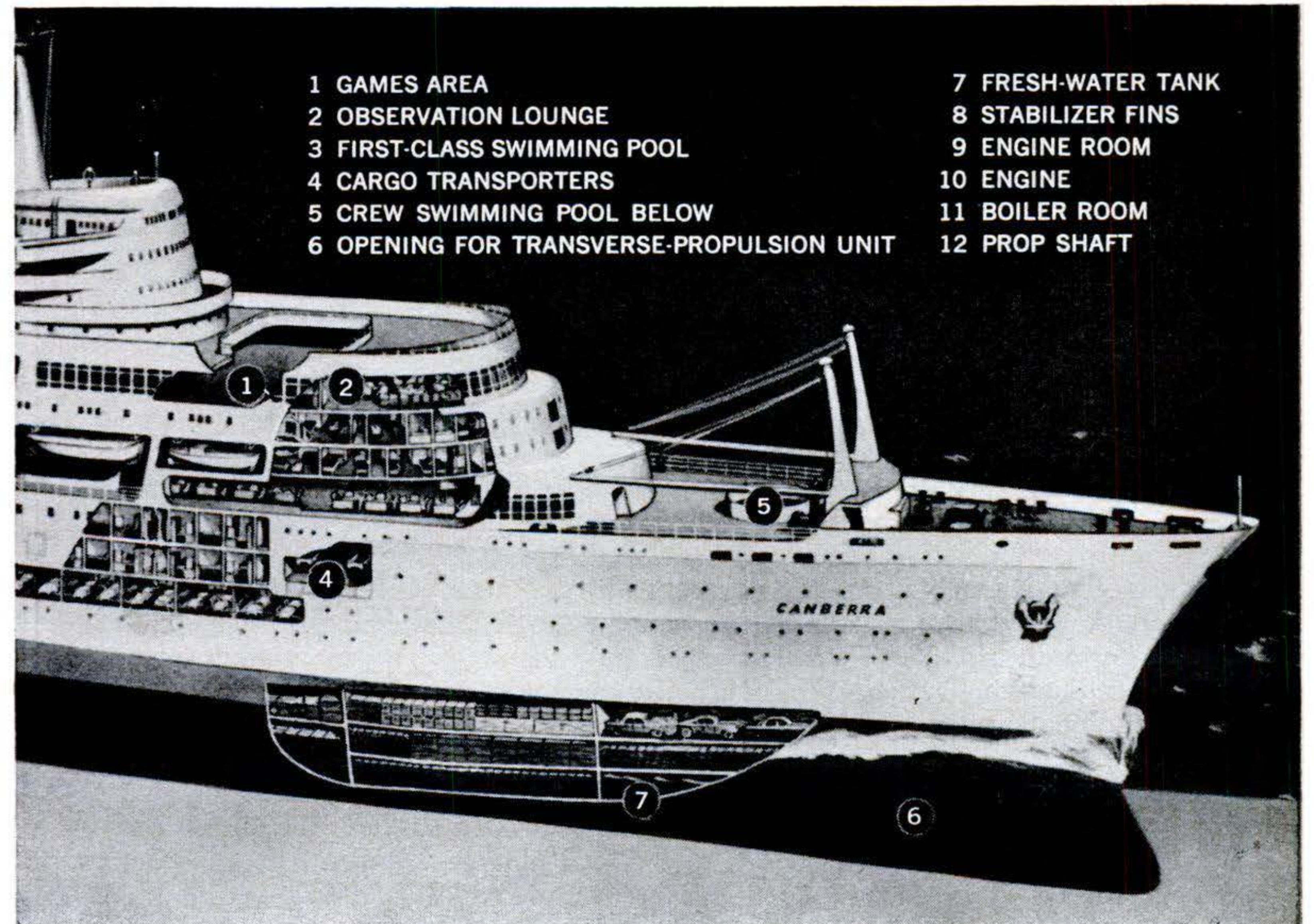



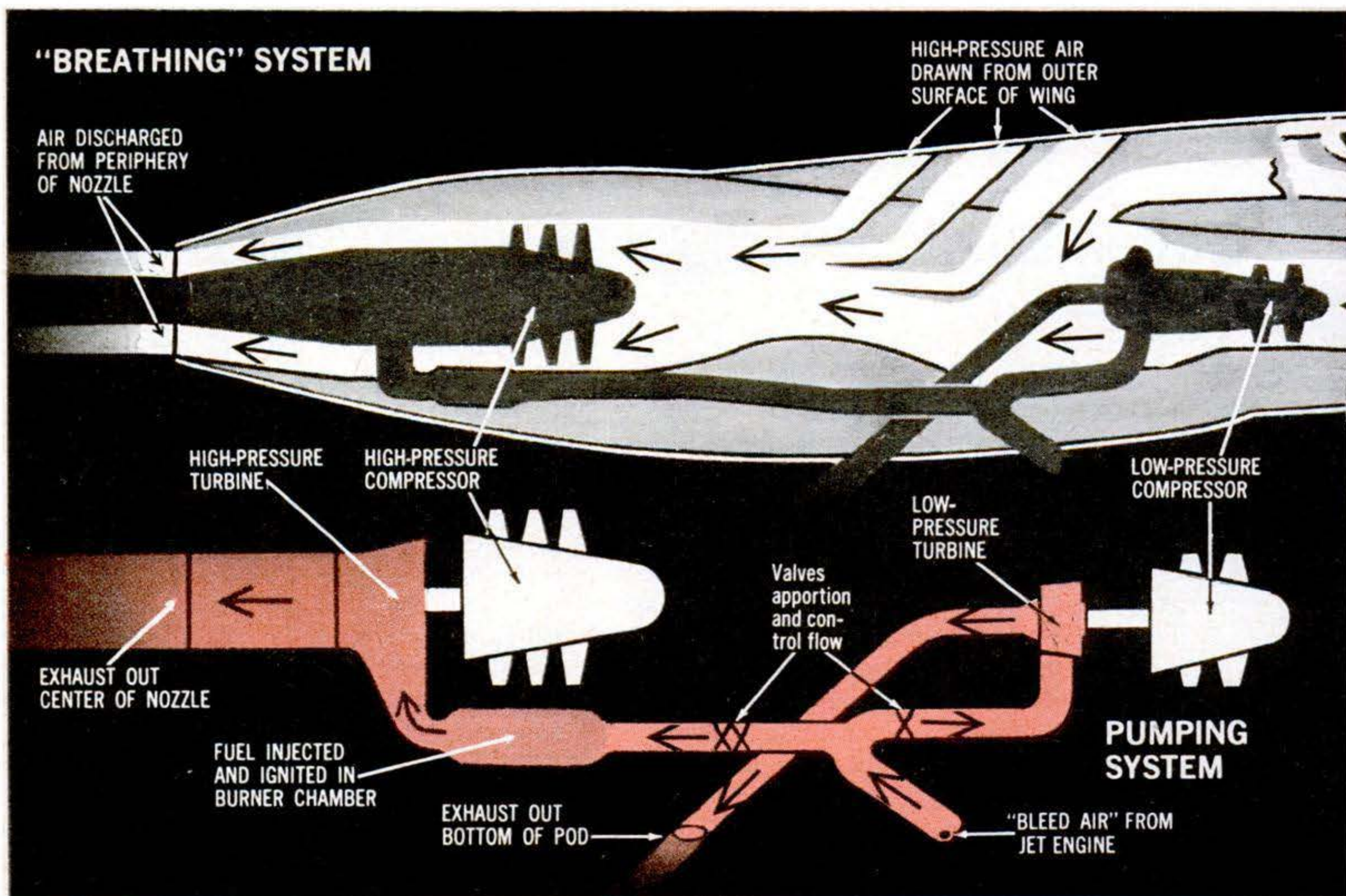

# Plane's Wing 'Breathes' to Boost

By Wesley S. Griswold

**A** PLANE with wings that breathe, made over by Northrop from an Air Force WB-66 bomber and renamed the X-21, may soon make aviation history.

In demonstration flights out of Edwards Air Force Base, it's expected to prove that the braking drag of air friction on a plane can be virtually eliminated—simply by sucking in air from the wing surface and expelling it aft.

Further, the experimental X-21 and a coming sister craft are intended to show that its breathing-wing system is feasible for an operational airplane. The resulting boost in range, payload, or endurance, Northrop says, would be dramatic.

Take a transcontinental jet airliner that now flies 3,700 miles on 25,000 gallons of kerosene. With wings like the

X-21's, and the same amount of fuel, it could fly 6,000 miles. Alternatively, it could carry 15,000 pounds of extra payload to its present range. Or it could stay in the air—for military surveillance, say—hours longer.

The secret lies in getting rid of turbulence in the "boundary layer," the air nearest the skin of a plane in flight.

One way is to pump air outward through holes in the wing—literally blowing away the "bubbling" layer. Since this gives control surfaces a better grasp on the air, it's now being developed for landings and takeoffs in limited space. Another way to remove the turbulent layer is just the reverse—to suck air *into* the wing. This, the X-21's method, is preferred for reducing drag in flight.

Fine slots run along the outside of the X-21's big new wings, at top, bottom, and leading edge. They form air intakes.



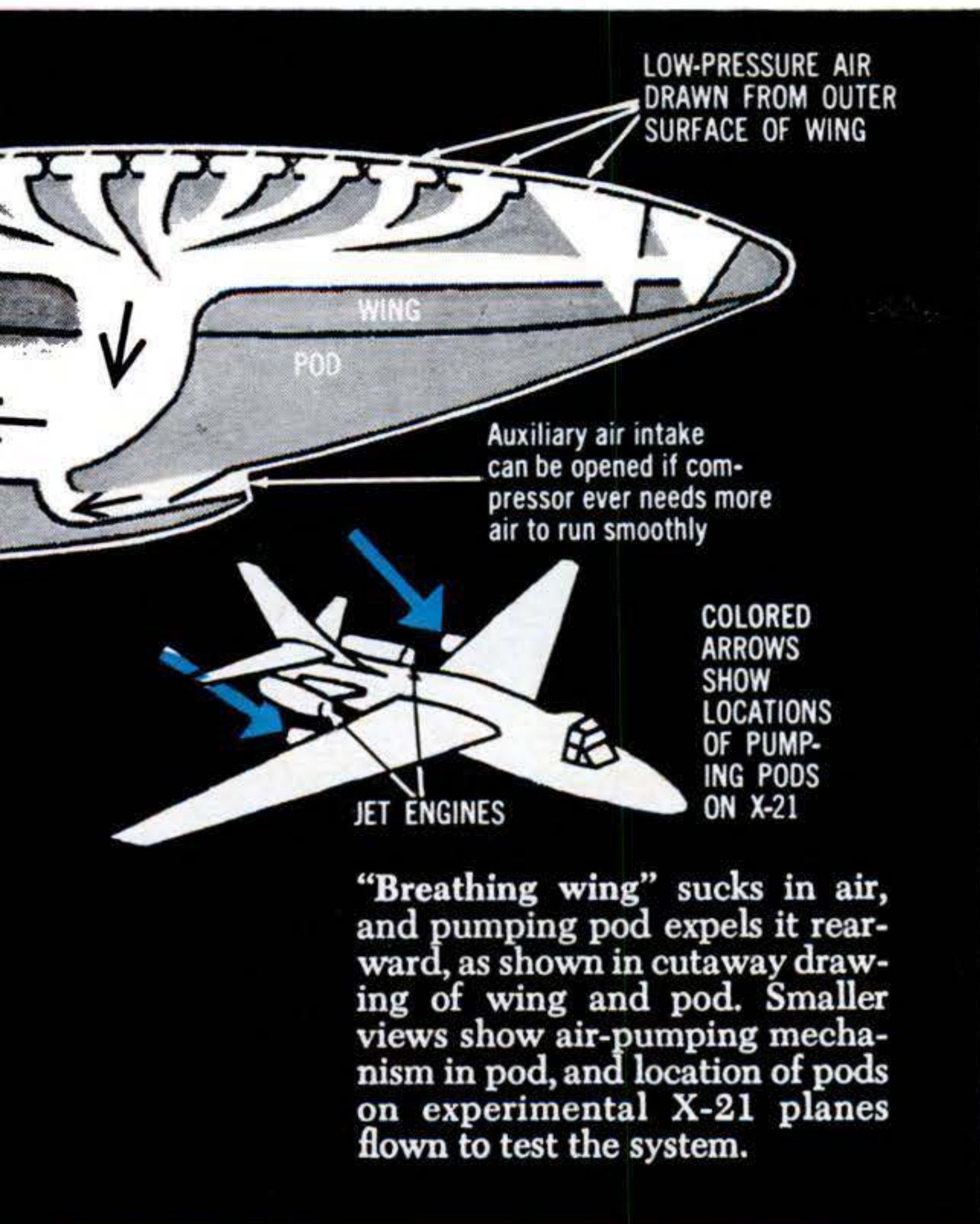

“Breathing wing” sucks in air, and pumping pod expels it rearward, as shown in cutaway drawing of wing and pod. Smaller views show air-pumping mechanism in pod, and location of pods on experimental X-21 planes flown to test the system.

# Its Range

Inside a wing, the inhaled air passes through ducts to a pumping pod slung below each wing at mid-span.

Two compressors in the pod provide the suction. A low-pressure compressor draws air from the forward, upper wing surface. A high-pressure compressor sucks air from the remainder and discharges all the inhaled air rearward.

To drive each pod’s compressors, a stainless-steel pipe brings “bleed air” from the nearer of the plane’s two aft-mounted jet engines. This is air that has been compressed and heated in the engine, but diverted before reaching the engine’s combustion chamber. At the pod, part of this pressurized-air stream whirls the low-pressure compressor. The rest goes to a burner chamber where fuel is squirted into it, and ignited by a spark plug. Given this added kick, it spins the high-pressure compressor.

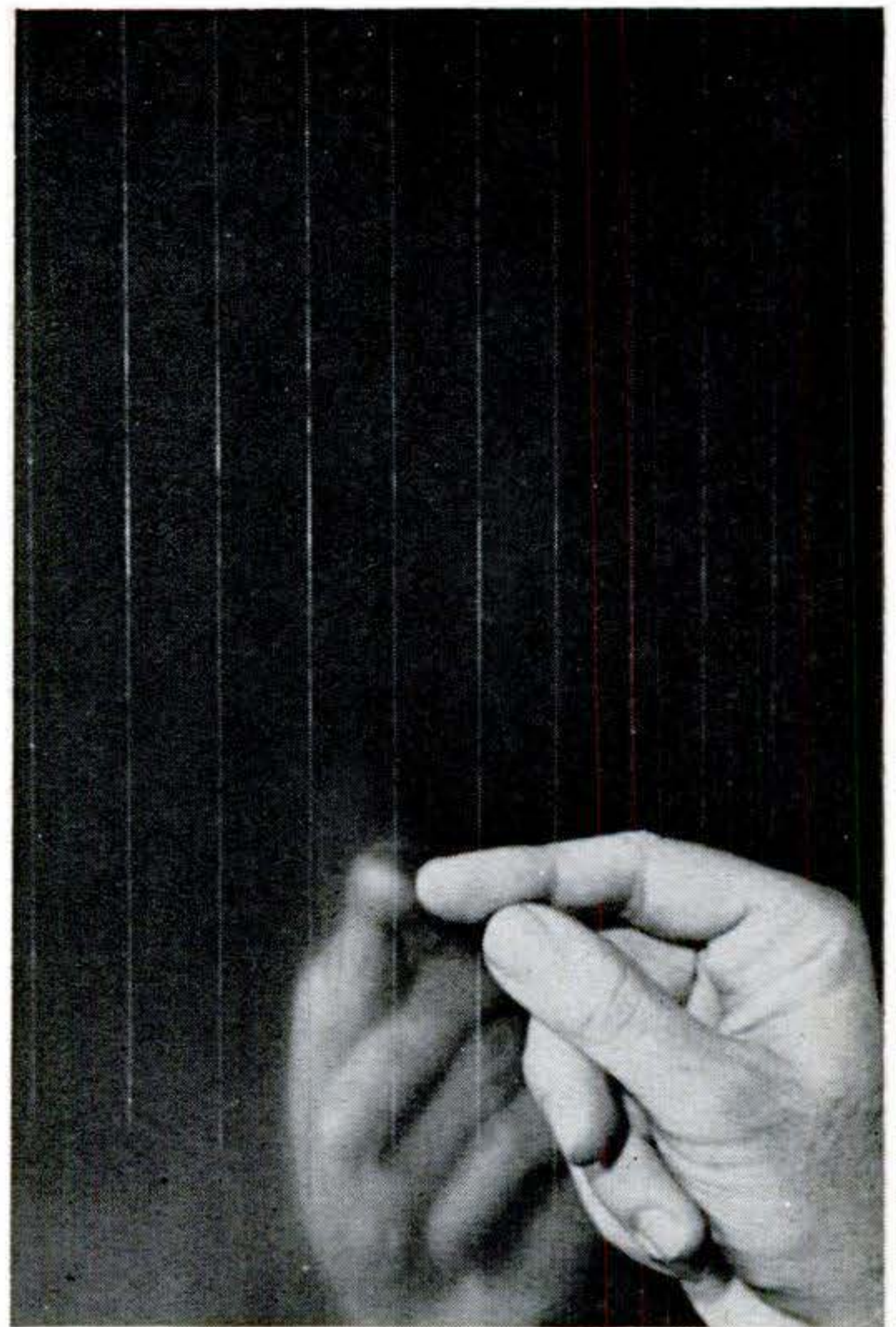

Outside of breathing wing is pin-striped by these tiny slots through which air is drawn from surface to interior. Slots, nearly parallel, are spaced from a half-inch to three inches apart.



Inside a wing, tributary ducts—whose yellow-green plastic sections resemble a parade of caterpillars—lead the air from wing slots toward bigger ducts and air-pumping compressors.



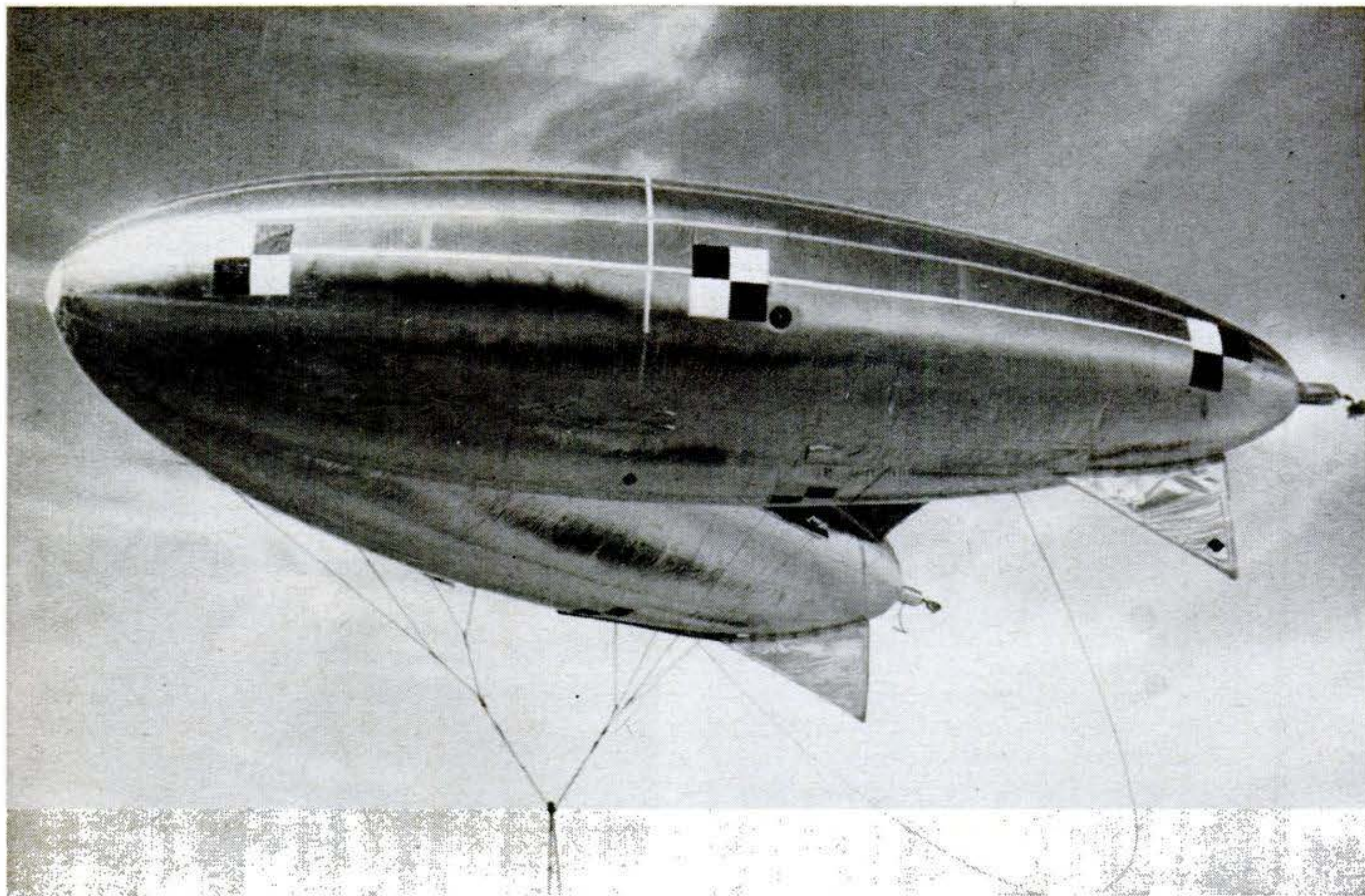

### V shape stabilizes instrument-carrying balloon

Joined like two blimps cheek-to-cheek, this tethered airship will keep GE scientific instruments aloft for long periods in almost any weather. The V shape, designed by Goodyear, enables the craft to ride at stable,

nose-high angles. Each ship is 110 feet long and 27 feet in diameter. Automatic devices maintain the pressure of the helium inside the gas bags at varying altitudes and temperatures.



### Reds ride on air cushions, too

The Soviet hovercraft Neva is shown here during a trial run at Leningrad along the river for which it was named. The 38-passenger air boat is said to have a maximum speed of 40 m.p.h., riding on a cushion of air created by fans driven by two aircraft

engines and trapped between rounded hull ends and floats on the sides. Forward speed is obtained from a third engine, mounted at the stern and powering a propeller. Neva's relatively simple plenum arrangement is probably less efficient than similar machines developed in the U.S. and England, say experts on ground-effect machines.



# Metal Detectors

...can they really spot buried treasure?

By V. Lee Oertle

IT'S both wild-goose chase and fine art—will-o'-the-wisp and golden promise. But there's just enough truth in those lost-treasure stories you've heard to make metal detectors the hottest hobby in years.

I dogged the tracks of experts, tested nearly all the major brands, unearthed heaps of tin cans and a tantalizing handful of relics, and I'm convinced. The new breed of metal detector is exciting.

Advertising claims often sound too good to be true. Typical example: "Retired man finds for-

CONTINUED



Face value of old coins often is dwarfed by prices collectors are willing to pay. This is part of a huge cache unearthed in a New Mexico ruin.

You work each area in a pattern, covering every inch. Most of your finds will be junk, but there's always the chance the next will be a bonanza







Abandoned mines are happy hunting grounds for relics, coins, and other valuable items. So are deserted buildings, seashores, old battlefields, and other historic spots.



Scanning walls and ceilings is done the same way as floors: Detector head is held parallel, a few inches away.

tune hidden in back yard." What really happened was that an eccentric man buried his life's savings in a tin can—and forgot where. Police used a metal detector to find the container.

Another example: "Explorer reaps thousands in old Spanish gold coins." This lucky fellow actually did find a valuable hoard. But he spent 2½ years in Old Mexico before he hit paydirt. Still, you *can* find valuables; all it takes



Detectors are handy at home, too. They help locate pipes, storm drains, or buried steel tanks, saving you many hours of digging. Contractors and surveyors also use detectors.

is a reliable detector, a little experience—and plenty of luck.

**What is a metal detector?** As the name implies, it's an instrument that detects buried metal and conductive minerals. No black magic is involved. It's simply a transmitter and receiver of electrical impulses. By inducing a short-range electromagnetic field, the instrument detects changes in the electrical conductivity of the area it passes over. The detector "reads" gold, silver, copper, iron, and other metals.

The detectors used by weekend treasure hunters are usually compact, short-ranged, and ultrasensitive. Don't expect them to locate paper money, priceless gemstones, or anything else nonmetallic. Nor can they tell the difference between gold bullion and bottle caps. The detector *can* find ore deposits—but it can't tell you whether the ore is gold or iron.

**Using the detector.** The average detector has a round head about an inch thick and the size of a large meat platter. An attached carrying handle helps you keep the head parallel to the ground. A transmitter-and-receiver box is attached on top of the carrying handle.



Detection is both visual and auditory. When the head passes over metal, the register needle (mounted on the control box) crashes hard right, fluttering wildly. Earphones worn by the user go from a low, steady hum to a loud one. By stepping back and forth and sideways, you can pinpoint the exact location of the buried object. The detector will read through ice, concrete, wood, and earth.

It has limitations, however. It can't tell you what the object is, how deep it's buried, or whether it's valuable. There's one way to find out: with a spade.

**Depth range.** Detectors are made to find either large ore deposits deep down—as much as 30 feet—or small items such as guns, rings, and coins near the surface. You can't get maximum depth range and ultimate sensitivity in the same instrument.

The following factors influence depth range:

- The surface area of the deposit. Large, bulky, metallic objects lying flat are easy to detect down to about 30 feet. The same object edge up might be detectable no farther than two feet.

- The moisture content of the ground.

- The length of time an object has been buried. After a couple of years, the immediate area around a metallic object provides three or four times the area of conductivity, and readings are easier to spot.

- The type of instrument being used.

Representative of the new breed of detectors are the Metrotech, Fisher, Detectron, Raytron, Goldak, Geo-Finder, and others. All use the same principle. But operation, depth range, balance, and sensitivity vary tremendously. The differences are readily apparent. For example, you can get many kinds of carry-



Most detectors have about the same depth range, but sensitivity varies greatly from brand to brand. Shown from left to right are Metrotech, Geo-Finder, Detectron, and Goldak.

ing handles. But what really matters is balance. A unit that's hard to hold parallel to the surface will cramp your arms. Bulk is another consideration. The new transistorized detectors, such as Metrotech, weigh only 3½ pounds. Prices range from about \$75 up to \$250.

**The basic types.** Almost all weekend treasure hunting is done with transistorized, tube-type, or surplus military detectors.

Transistorized detectors can take rough treatment. Most use standard lantern batteries, which are good for 150 to 250 hours of continuous duty. Cost of operation: ¼ to 2 cents an hour. Depth range isn't as great as that of tube-type units, but sensitivity near the surface is amazingly good. Goldak claims its detector can locate a silver or gold ring buried at three inches; medium-sized gold or silver coins at eight inches; and an iron kettle filled with coins or other metal objects at four feet.

Until a few years ago, the tube-type

[\[Continued on page 202\]](#)



# Back-yard engineers build way-out rods and customs

No matter where Detroit puts that strip of chrome, or how much horsepower they pack under the hood, there are always people who aren't satisfied. A few—the hot-rodgers and customizers—do something about it.

When some of their weird and wonderful creations converged on New York City recently for a national show, PS was there. Entries included cars designed for every-

day transportation and for drag-strip competition. Some are so valuable that they are never driven; they're towed to and from shows.

Many are so extensively modified that their origin is unrecognizable. A few, including the dragster shown here (far right, center of page) were built literally from the ground up.



The hood is the only hint that this is a 1940 Ford. A strip was cut from the body at the center line and the two halves welded back together for sleeker appearance. The top was cut down. Right front wheel is off to show chromed brake drum. Quad lights and custom grille are new. An Oldsmobile engine powers the car.



Latest of bubble tops is this dream car with hand-formed metal body over Buick chassis. Engine is modified and fuel-injected Buick V-8. Canopy can



## Seaplane skims on hydrofoil

The Navy is now trying hydrofoils on seaplanes, as part of a test program to improve operation in rough water.

The single high-speed hydrofoil, mounted between two ventilating struts, is located below the center of gravity of this JRF-5 Grumman Goose (borrowed from the Coast Guard). Two bow skis stabilize the plane during landing and takeoff, and prevent diving in case of damage to the hydrofoil.



1955 Buick V-8 engine takes place of weary 4 in this Model T roadster. An overbore increases its displacement to 352 inches for greater power. Highly chromed engine has six carburetors. The car was shortened and narrowed, and the body channeled (lowered) over the frame rails.

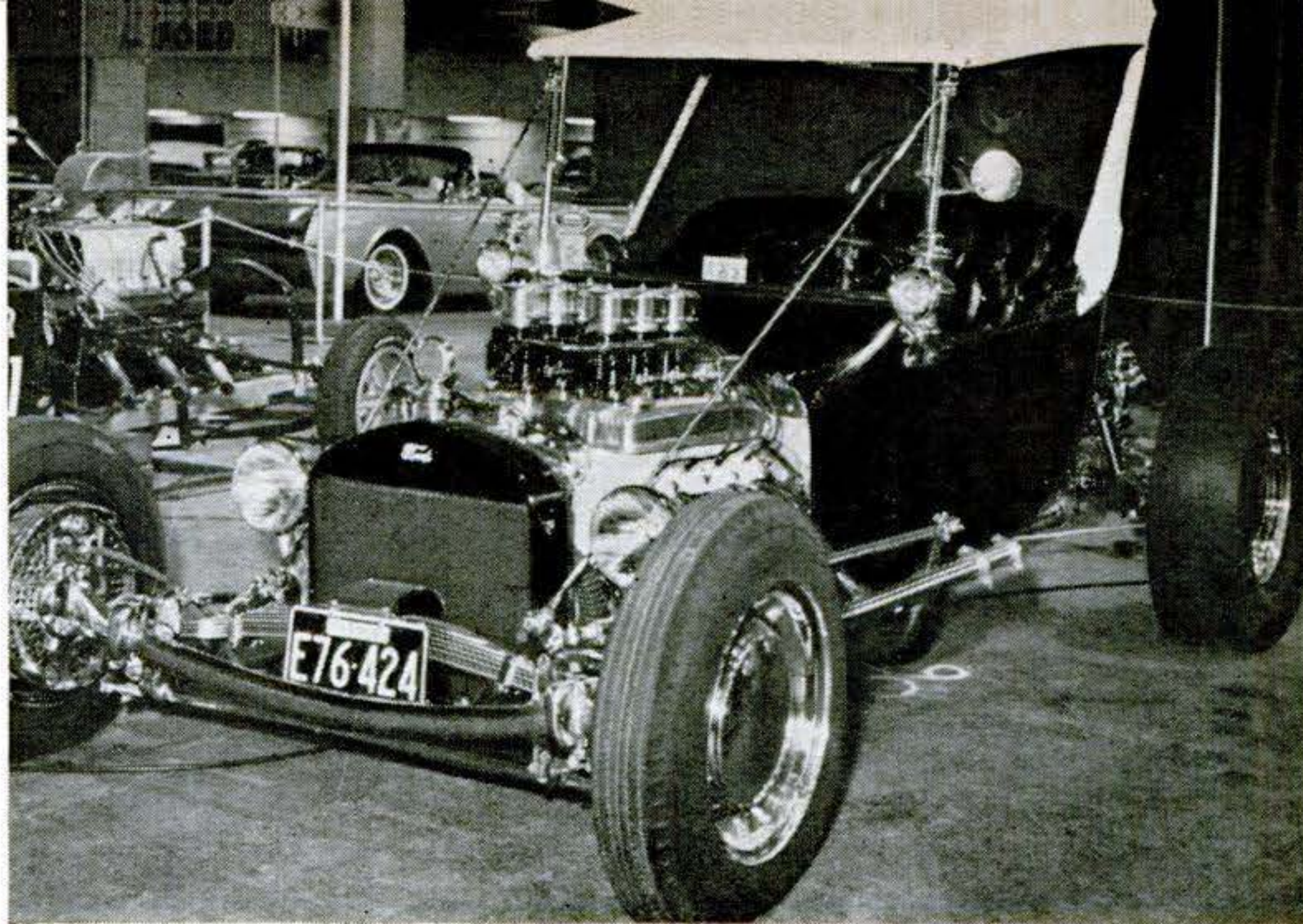

be opened and all instruments operated from outside. Cable at lower right leads to remote-control box. Finish is multicoat maroon lacquer.

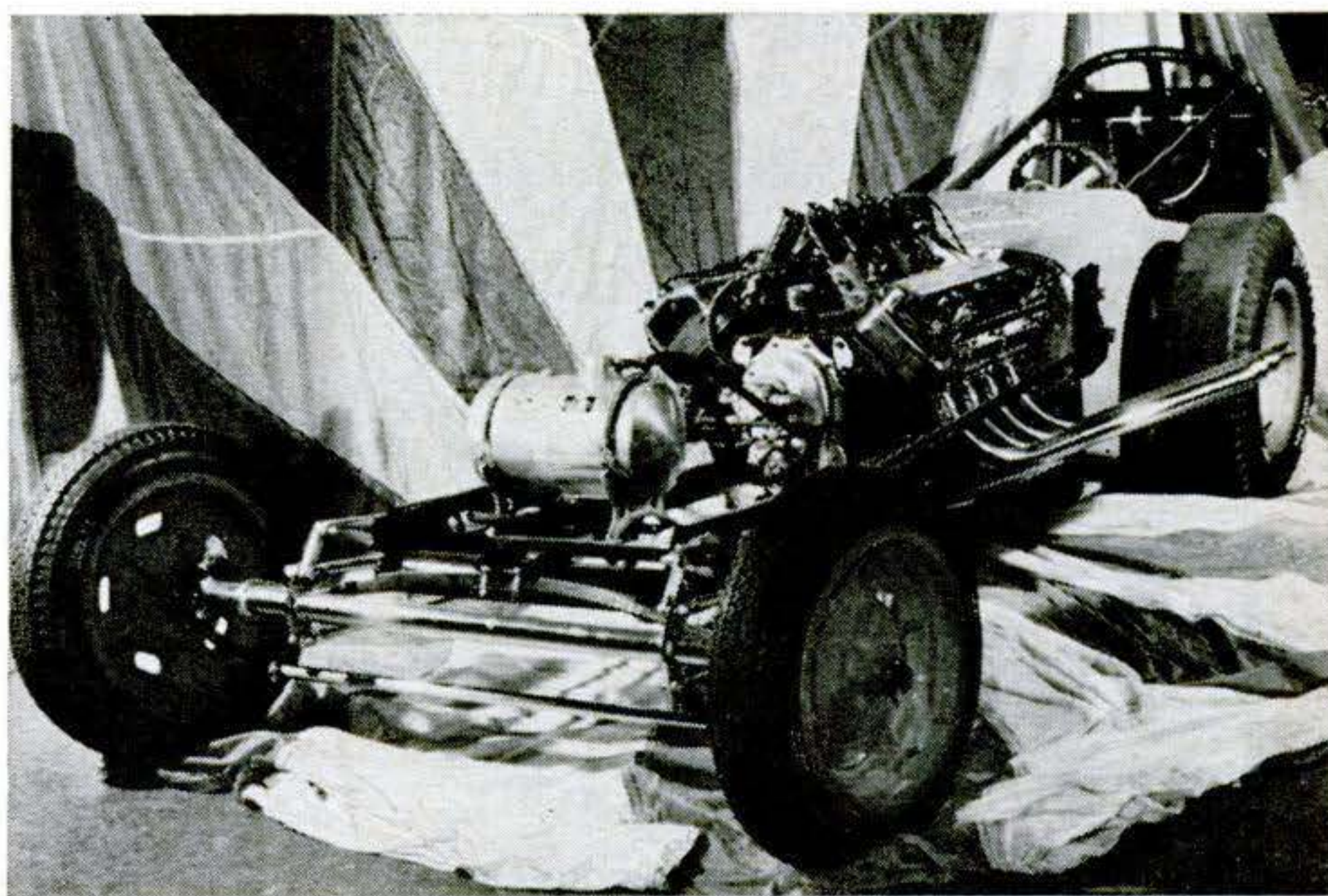

For better rear-wheel traction, engine of hot rod above is set back and driver sits behind rear axle. So car would qualify for its class, displacement of fuel-injected Chrysler V-8 was reduced to 299 inches by inserting sleeves in cylinder bore. Dragster does a standing-start quarter-mile in a hot 10.8 seconds.

## Landlocked sternwheeler

Retired after years on the Mississippi, the Algiers (right) has become a palatial residence on the Florida beach at Sanibel Island. Its site: a 1,000-foot stretch of beach beside a little inland pond.

To get the boat to the site, a quarter-mile channel was cut from the Gulf of Mexico, and she was inched in with the aid of bulldozers. Then tons of sand and crushed shell were dumped in for a foundation.

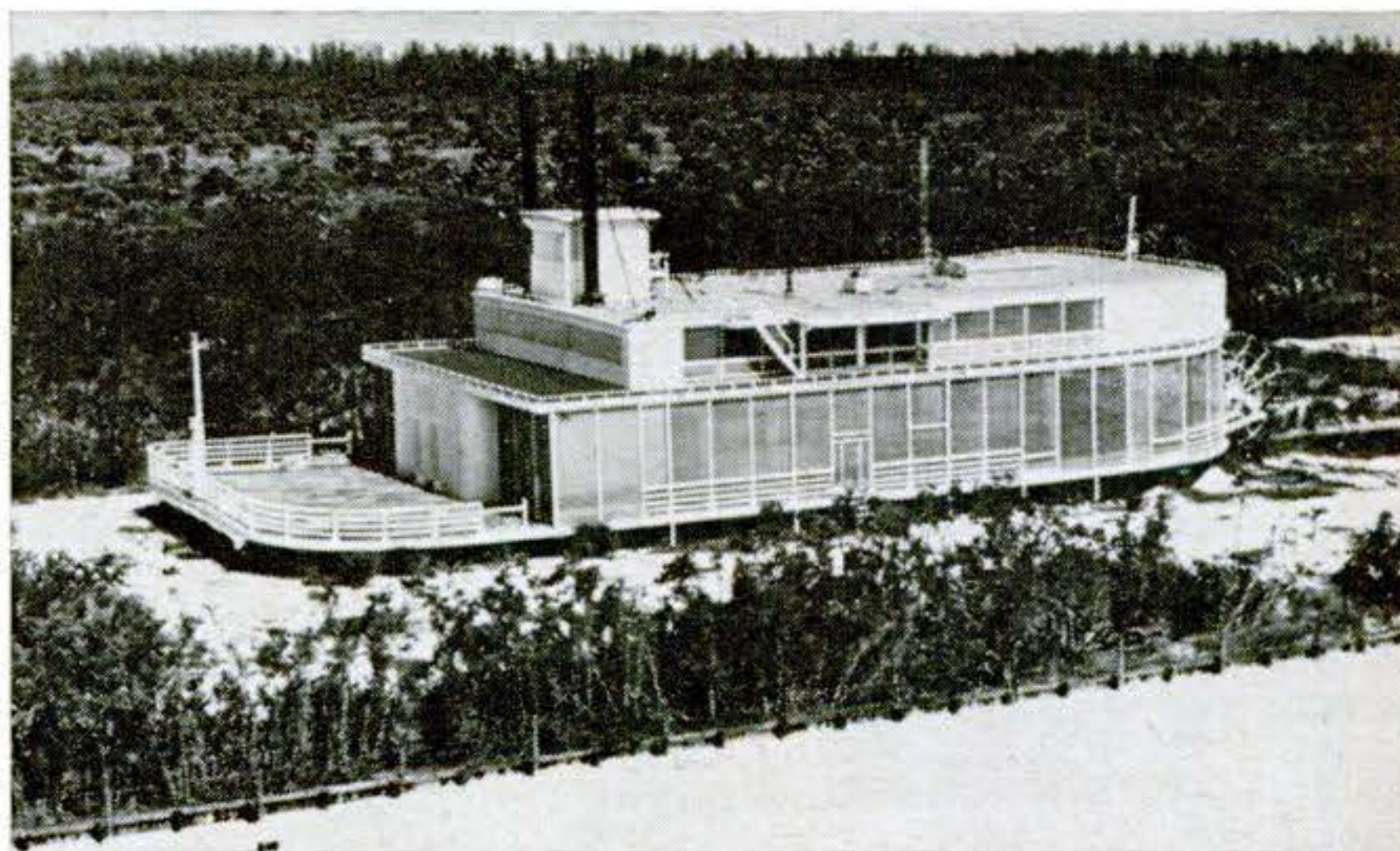



# Does Your Handwriting Give You Away?

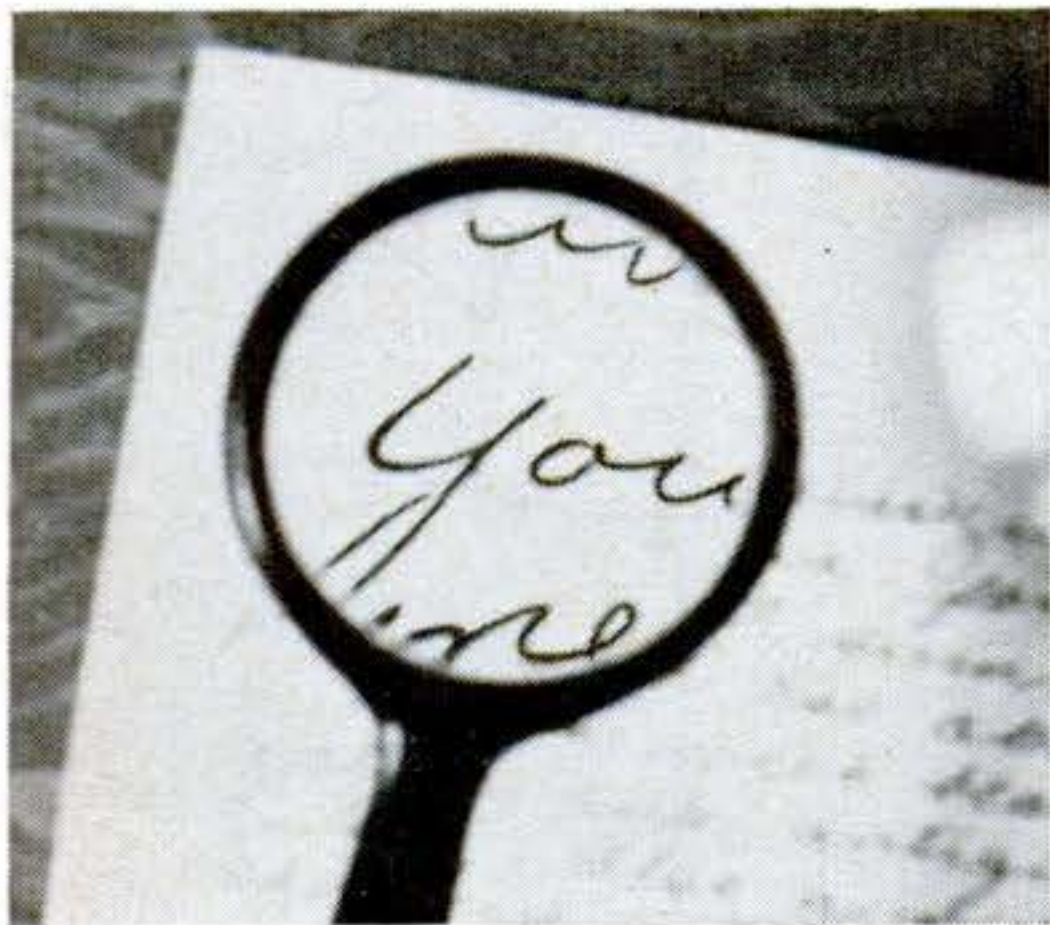

Science? Quackery?  
Here are today's  
facts about the art  
—over a hundred  
years old—of  
reading personality  
from handwriting

By James R. Berry

**D**OES your handwriting tell anything about your personality? For decades most educated people have scoffed at the very notion, lumped graphology—analyzing personality from writing—with astrology, palm reading, and other forms of hocus-pocus. Today, though, the tide may be turning. Take these cases for example:

- Last May, 13 Bangor, Me., bankers finished a course in handwriting analysis. Now they're using it to judge a borrower's honesty, to hire tellers who are good at details, even to estimate a client's business sense.

- A trucking firm hired a graphologist to spot accident-prone drivers, claims it's cut crashes and reduced insurance rates.

- A St. Louis diamond dealer recently had an outbreak of thefts. Suspecting an inside job, he sent writing samples of

his 15 employees to a graphologist. A day later the analyst had singled out the most likely suspect. A week of watching this employee's every transaction proved the expert right.

- The director and chief probation officer of an Illinois family court, Charles F. Martin, claims handwriting analysis is less trouble and as good as psychological tests in marital counseling and understanding adolescents.

Have these people been duped by clever quacks, or been so enticed by the prospect of interpreting handwriting that they have lost perspective? Or is graphology actually an underestimated science?

Unlike palmists, astrologists, and other occultists, handwriting analysts don't say they can, or want to, tell fortunes, read thoughts, or predict the future. They do claim, however, that your writing reveals:

- Intelligence, emotional stability,

Giveaways? How you write your name shows how you want the world to see you, say graphologists. Here are some famous signatures. First column: Franklin D. Roosevelt, Harry Truman, Walt Disney, John F. Kennedy. Top of second column: Napoleon (note heavy-pressure underscoring). Below Dwight D. Eisenhower's signature are three samples indicating Benito Mussolini's self-inflation: First one was written when he was a little-known journalist; then, coming to power, he spread himself and dropped his first name (swelling ego); finally, he joined Hitler against the world, and his self-importance shows up in a huge signature with tremendous pen pressure.



*Franklin Roosevelt*  
*Dwight D. Eisenhower*  
*Harry Truman*  
*Benito Mussolini*  
*Walt Disney*  
*John F. Kennedy*  
*Murderer*

imagination, ability to work with others.

- Capabilities and unsuspected talents.
- Personality strengths and weaknesses.
- Many kinds of mental and physical illnesses.

Just what are the bases for their claims?

Writing, declare the graphologists, is more complicated than we think. The impulse to form a letter begins in the brain's writing center—in the cortex. This center, akin to the brain areas that control vision, hearing, talking, and walking, guides the muscles as they weave through the complex movements that make words. Since writing begins in the mind, emotions and attitudes, both part of the mind, influence how we write, just as they influence how we walk and talk.

Take signatures. The way you sign your name unconsciously shows how you

want the world to see you. The body of a letter reveals what you're really like. A large, ornate signature following tiny script very likely means the writer is outwardly an extrovert, but feels in-

CONTINUED



Six lines of writing enabled expert Norris J. Starkey of the Indianapolis police department to identify a criminal. Your handwriting, experts claim, is as individual as your fingerprints.



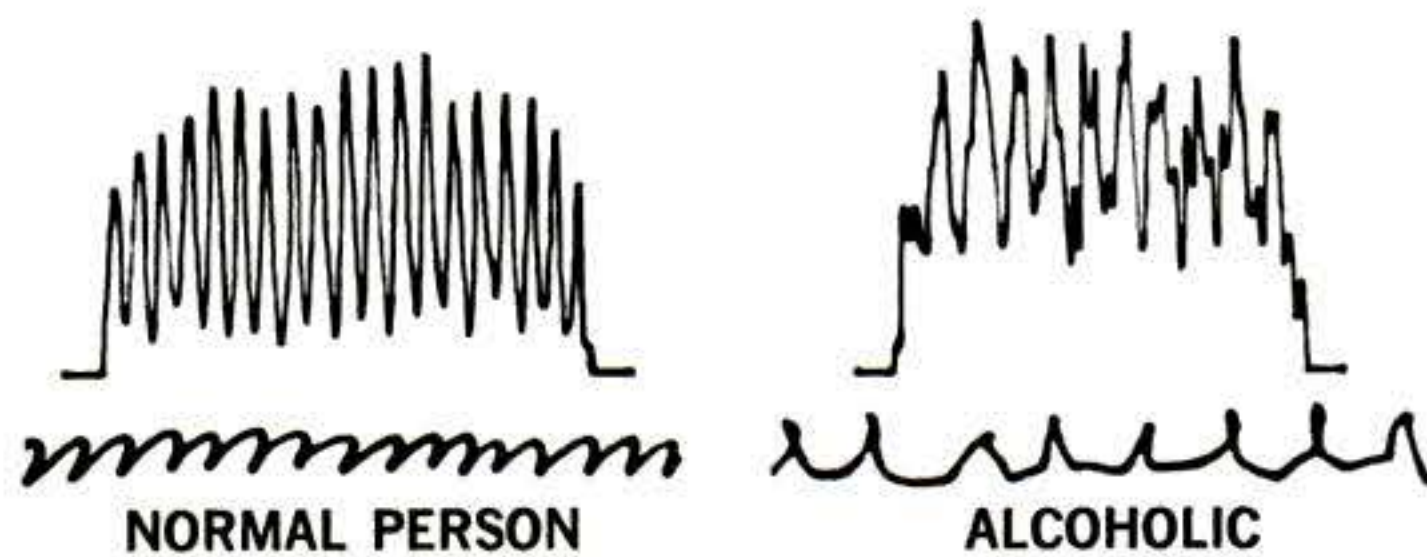
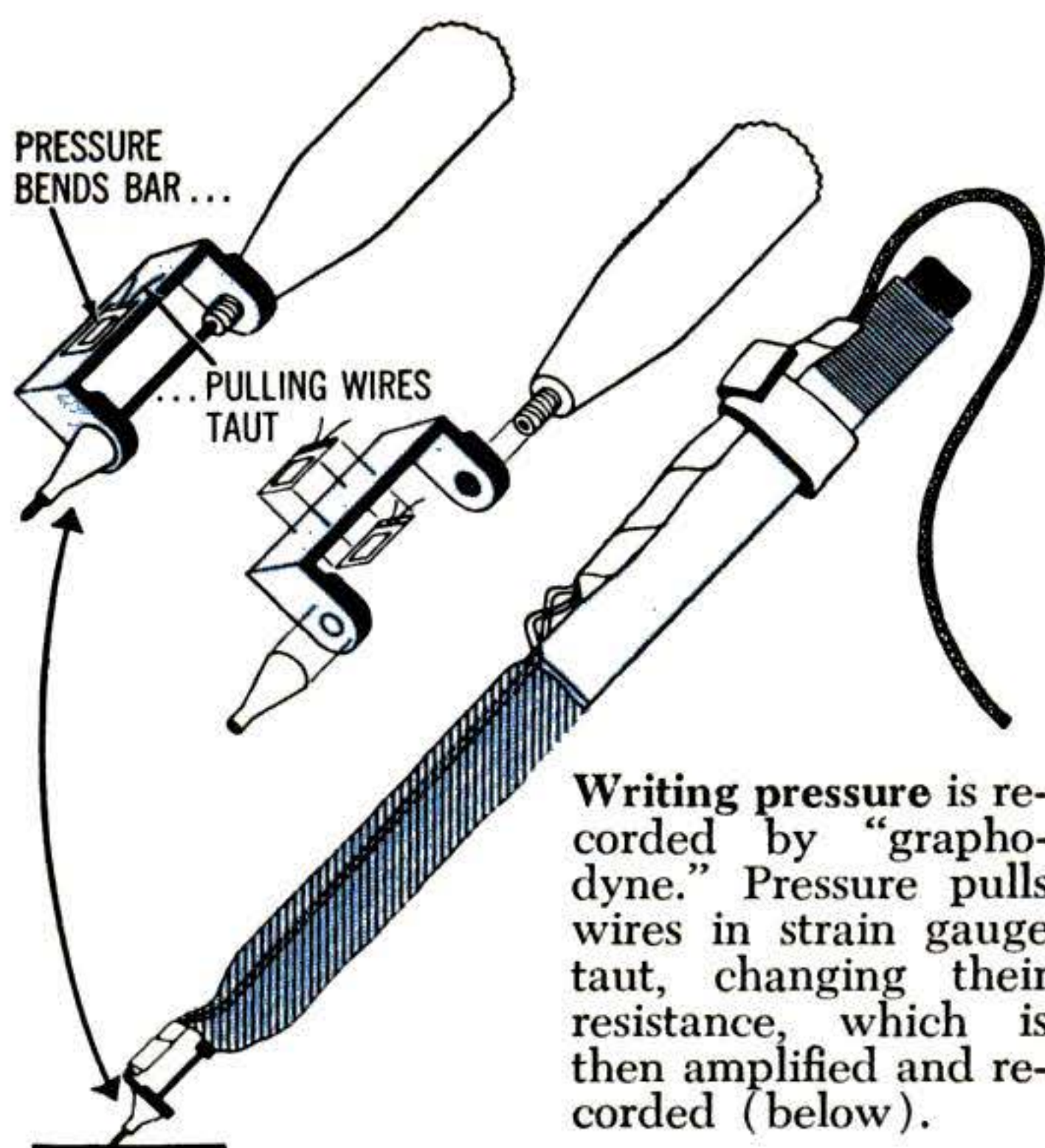

wardly insecure. A tiny autograph after large letters indicates the writer is modest, has more to him than a first meeting indicates.

By combining the meanings from dozens of writing traits such as signatures, slant, speed, and word spacing, the analysts assemble a personality portrait. But, they add, no one sign or group of signs is conclusive by itself. Often, one writing trait changes the entire meaning of another.

**Illegible writing.** Writing that's hard to read generally points to indifference, laziness. But add extreme writing speed, and the picture changes. If the writer whizzes along, his mind is miles ahead of his hand. His script tries to keep up, becomes illegible.

Graphologists say they need a page or two of writing and a signature to give a thorough analysis. But even scraps of writing tell a lot.

Not long ago an Indianapolis businessman was swindled out of several thousand dollars by a confidence man. Police got a tip that the gyp artist lived in a

nearby hotel. When they arrived he had already skipped. Their only clue: a hotel registration card with a few lines of writing.

The detectives turned the card over to Norris Starkey, member of the force and a handwriting analyst. Starkey studied the writing. The crook, he declared, was well educated, intelligent, and had extraordinary planning ability. He was a smooth talker, dressed well, and remained calm in emergencies.

The police soon hauled in a felon who tallied with this description. Warned by Starkey that he probably had a well-prepared alibi, they weren't fooled by his answers, kept shooting questions until he finally broke down and confessed.

**Hiring by handwriting.** Many industries think enough of graphologists' claims to use handwriting analysis in hiring personnel. Albert Nickerson, a vice-president of Socony Vacuum Oil Company, found in a survey of 76 corporations that 90 percent of discharged employees were fired because of personality problems. Today, scores of companies throughout the country say they avoid this trouble by using handwriting analysts to weed out applicants who won't get along with fellow workers.

Firms using graphology don't broadcast it. But when an ad states: "Answer in your own writing," the chances are fairly good that your script will get a careful scrutiny.

"Often we have to hire overseas help sight unseen," reports an executive of a giant industrial corporation. "A mistake can be costly. By using graphologists to check applications, we avoided hiring several persons who we now know would have been bad choices."

Emotional troubles and mental diseases turn up in handwriting, too, say graphologists.

Not long ago, the *American Journal of Psychiatry* had an article by psychologist William R. Perl stating: "... there is an intricate and interpretable relationship between a person's emotions and his

[Continued on page 196]



## What the experts watch for in analyzing handwriting

According to graphologists, chances of two identical handwritings are several billion to one. Dozens of different traits go into each person's script, but four traits, common to all writing—stand out. Here's what handwriting analysts say about them:

### PRESSURE

Writing pressure has nothing to do with physical strength. Men who can crack walnuts in their fingers often write very lightly; some 90-pound women write as if wielding a pile driver.

Heavy, uniform pressure indicates mental "get-up-and-go" power, drive, and zest—an ability to handle five projects at once and start another.

Minuscule writing would smear if pen pressure was heavy. In this case mental energy is indicated by uniform light pressure in combination with speed and regular spacing.

### SLANT

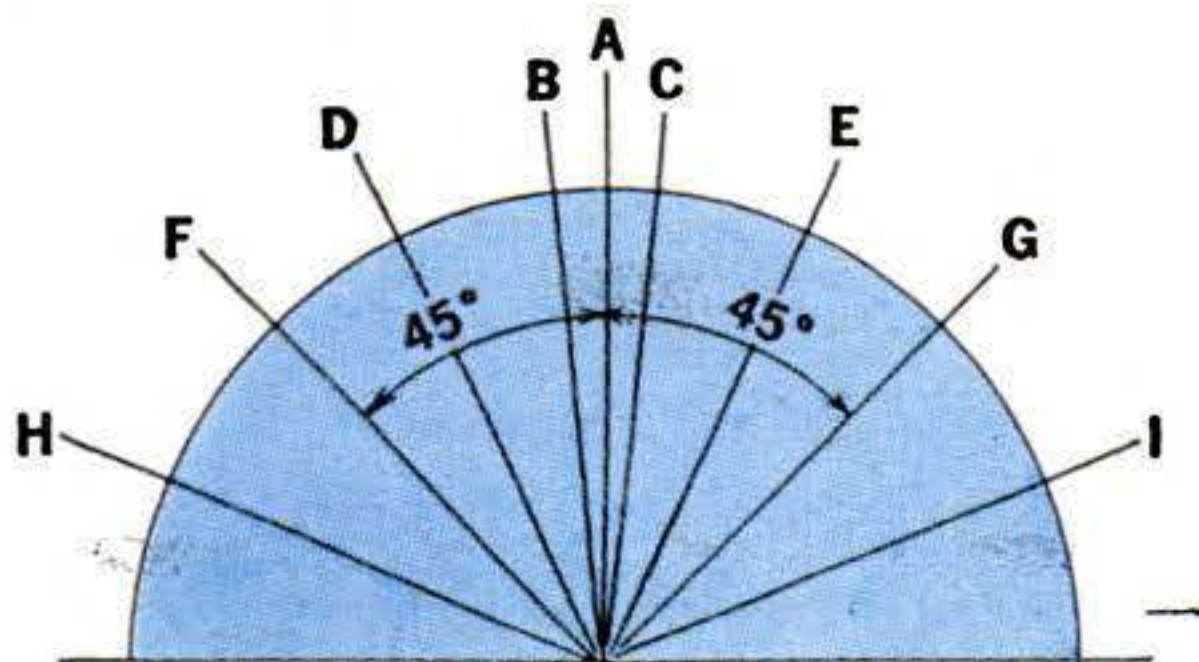

Vertical writers (A on the scale) resist the natural inclination to slant to the right, reveal they can hold emotions in check and use logic in making decisions. A pronounced backhand writing (F or H on the scale) points to bottled-

up emotions, secretiveness, and stubbornness. The other extreme (I) is the mark of extreme emotional instability.

### WRITING SPEED

Fast writing marks a quick (but not necessarily accurate) thinker and talker. If letters have original shapes yet are simplified to cut down writing time (these qualities taken together make what graphologists call the "form level") the writer is intelligent. Form level and writing speed provide clues to how fast and how accurately a person thinks.

### ZONES

Even parts of single letters disclose inner attitudes. The upper zone reflects imagination, idealism, intellectuality. Artists, writers, and people with strong convictions make original

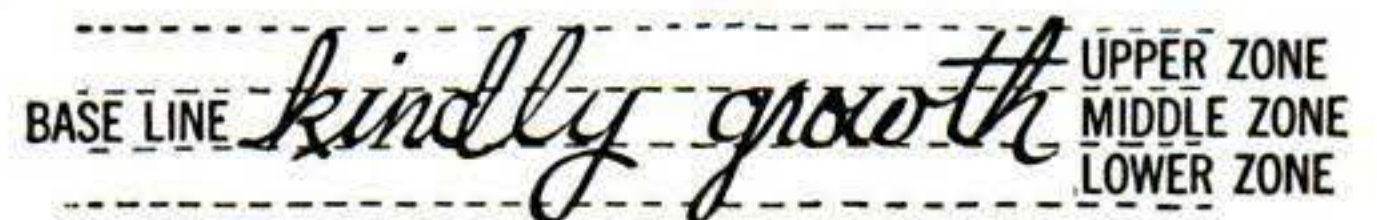

shapes here. The middle zone reveals your attitudes towards others and how you face everyday problems.

The lower zone divulges your sexual and material drives. People who like high living and money will make well-formed and lusty shapes in this area.

One more common characteristic: margins. A thrifty person—one who'll squeeze an empty toothpaste tube for days—instinctively uses up all his writing paper. His margins start near the paper's left edge and run close to the right one; the lines of script are close together.

If the left margin becomes wider farther down the page, a native sense of generosity is winning the battle over economizing. If the margin starts wide and narrows toward the edges later, he's just the opposite.

## What "T" formations mean to graphologists

 Inflated loop means a person is sensitive, quick to feel hurt.

 Tied stroke at end shows persistence, stick-to-it spirit.

 Short, thin, and weak crossing indicates a lack of will power.

 Heavy, long, strong crossing goes with strong will power.

 Cross stroke fading beyond stem means a fading will power.

 Bow-shaped crossing is associated with a person's self-control.

 Slanted, arrow-shape crossing shows a dominating person.

 Above-stem crossing goes along with a person of vision.

 No crossing at all reveals a person is careless about details.

 Hook-at-end of crossing is sign of hang-on ability, tenacity.

 Hook at beginning of crossing shows writer is acquisitive.

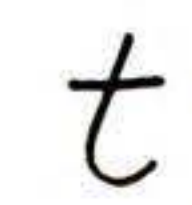
 No initial stroke indicates straight-talk, direct approach.

 Tent-shaped stem is interpreted as an indication of stubbornness.

 Basin-shaped crossing means a person has a shallow nature.

 Separated stem shows the writer as one of deliberate action.

 Stem-stopping crossing means put-it-off procrastination.

 To-the-right-of-stem crossing is a sign of temper in a writer.

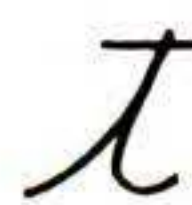
 High-on-stem crossing means a high or distant goal in life.

 Halfway-on-stem crossing shows person has a practical goal.

 Low-on-stem crossing reveals that no goal has been established.



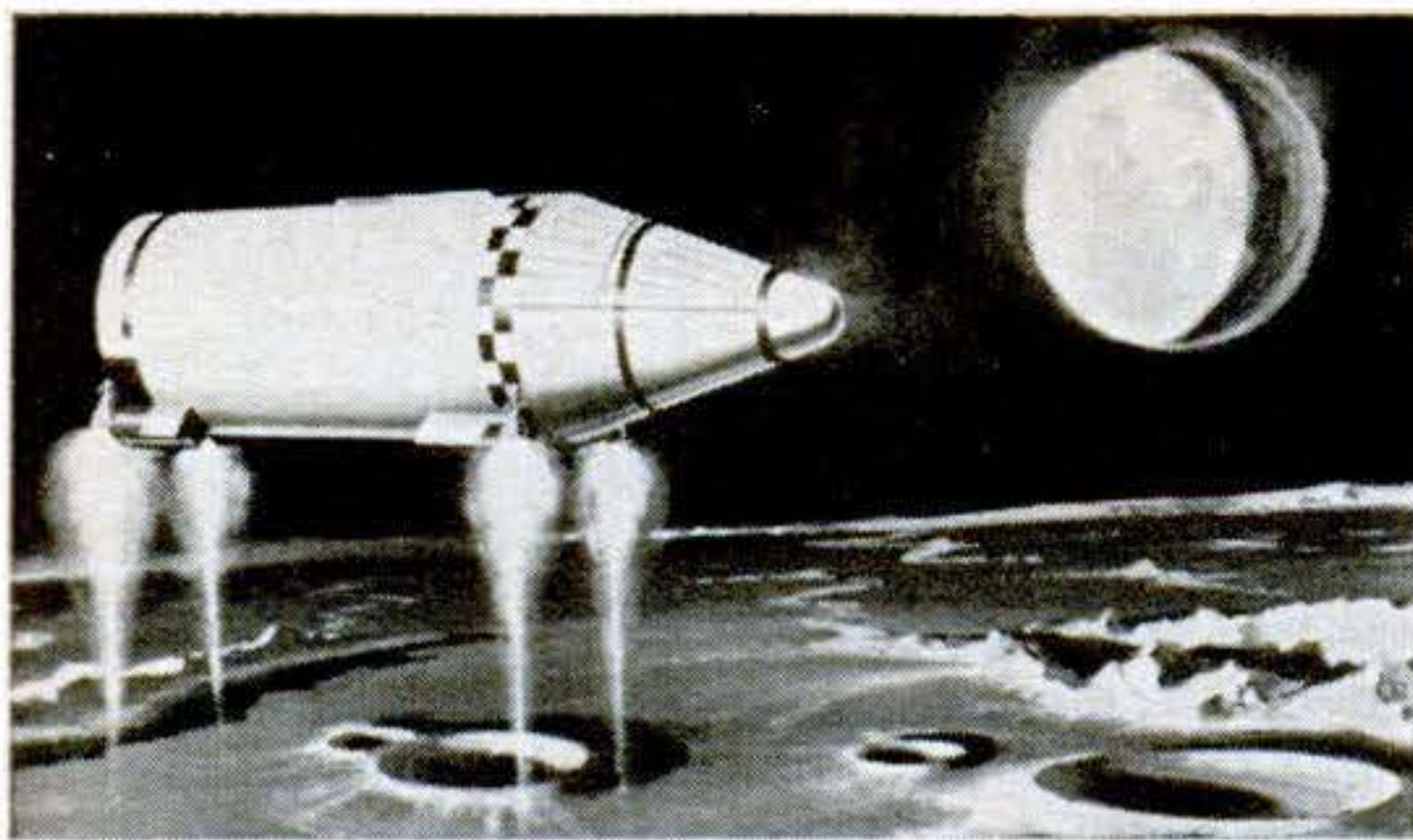

Soft landing on the moon with aid of hover and landing retrorockets is depicted by artist.

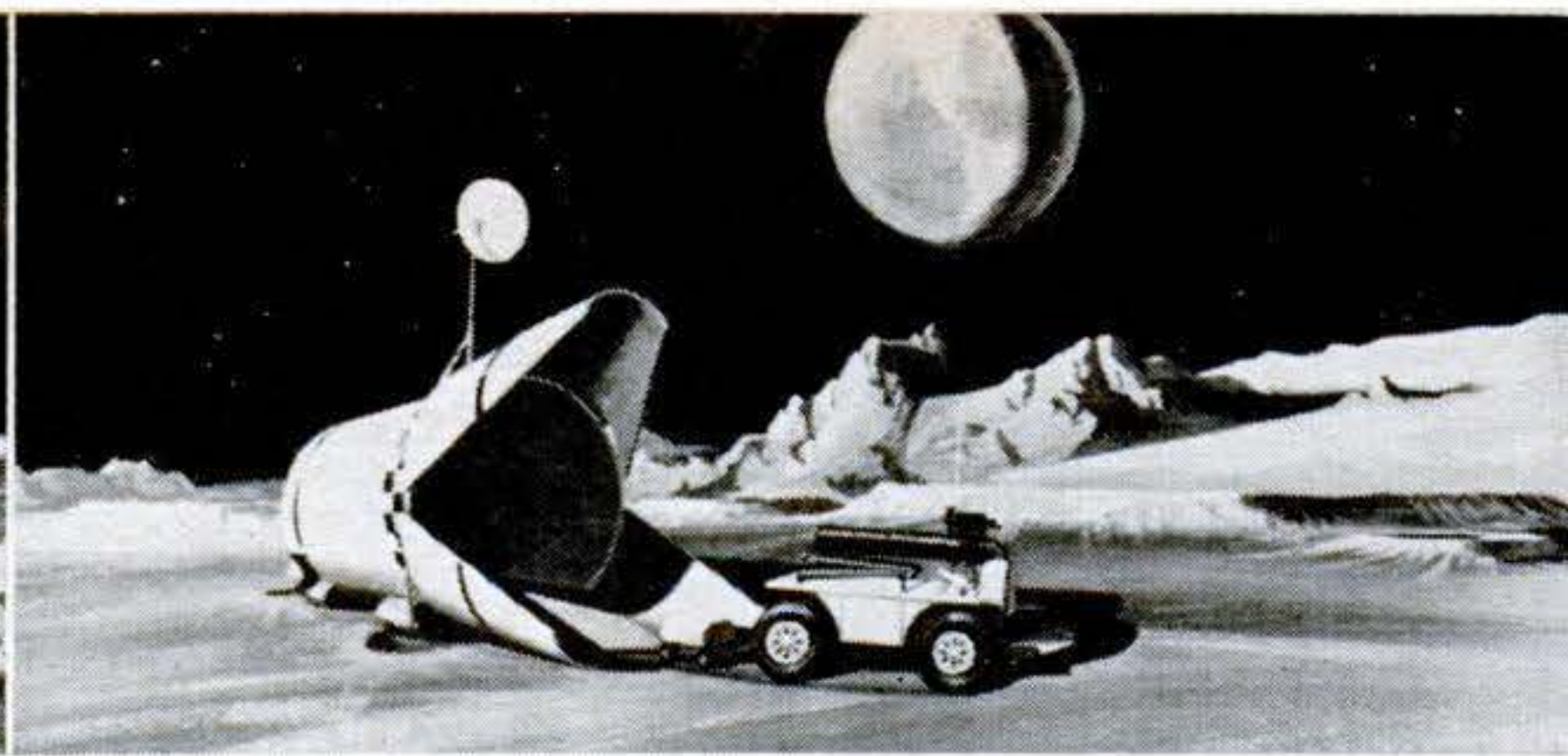

Nose cone opens wide, and robot rolls out, towing nuclear reactor that provides power.

## Lunar housing for early arrivals

When man makes it to the moon, he'll need a place to live—and quick. Douglas Missile and Space Division proposes to send a robot on ahead to prepare a shelter for protection against meteoroids, radiation, and temperature extremes. The robot would be an all-purpose vehicle controlled by telemetry and monitored by television. It would land in a rocket nose that would

serve as the astronauts' earliest shelter. Its first job would be to set up a portable nuclear reactor for power and communications. Then, acting like an earthbound snow blower, it would scoot around the shelter, scooping up lunar soil and spraying it on the nose to bury it.

For later lunar explorers, North American Aviation's Space Systems Division



Wheel spokes in model above are empty booster tanks that serve as quarters for astronauts. Rim

of underground shelter contains enclosed oxygen converters and gardens to grow food.



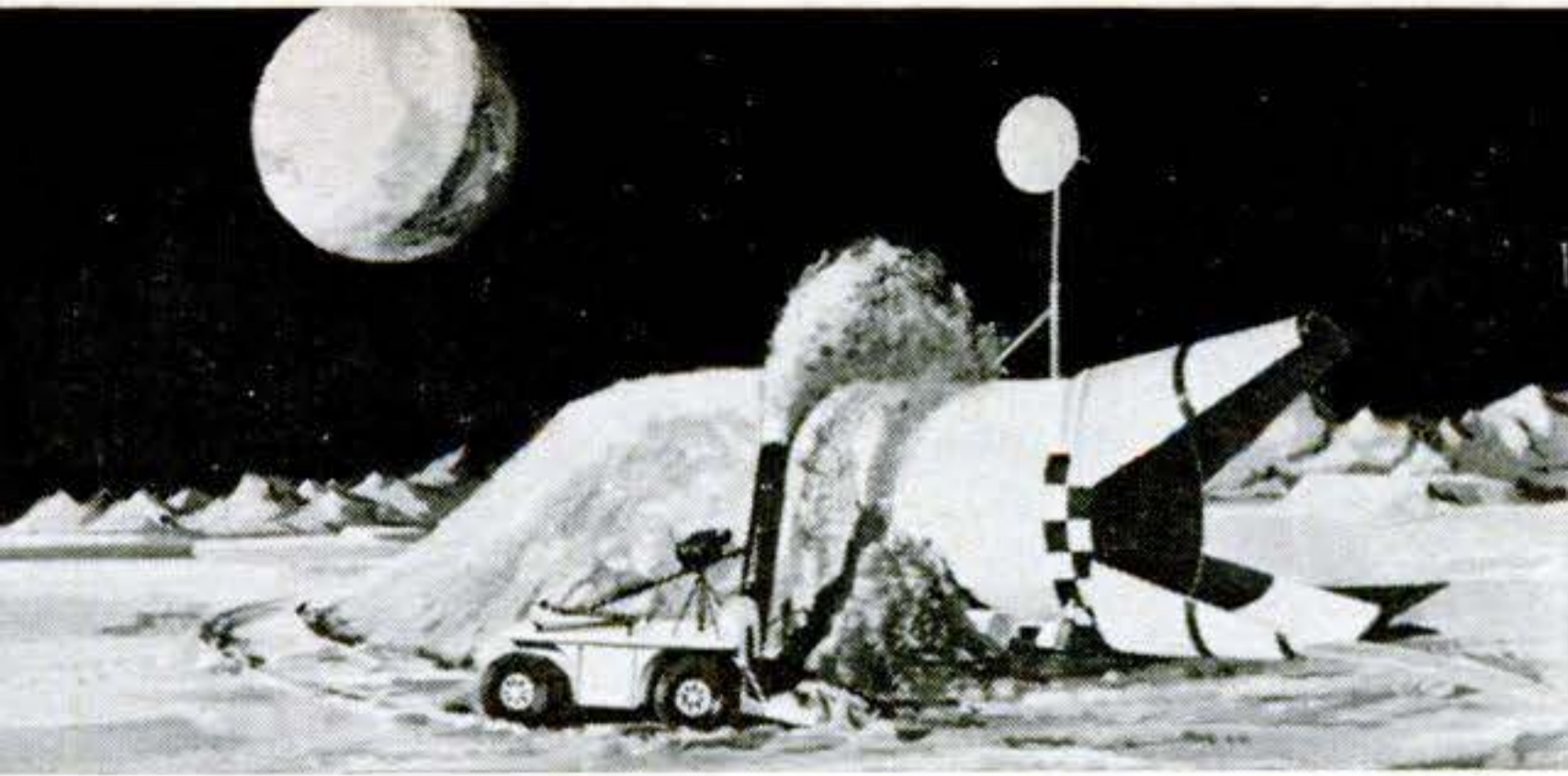

Lunar soil is scooped up, blown over shelter. TV camera on tripod near spout monitors work.

visualizes a self-sufficient colony (below). It would be built from rocket-booster tanks radiating like the spokes of a wheel from a communications hub. They would contain living quarters, medical center, recreation areas, and shop facilities. Ringed around them would be enclosed gardens to provide food and to convert carbon dioxide into oxygen. A water-conversion plant would be set over a fissure from which volcanic rock would be mined through a vertical shaft, crushed, and heated to extract up to a gallon of water per cubic foot.

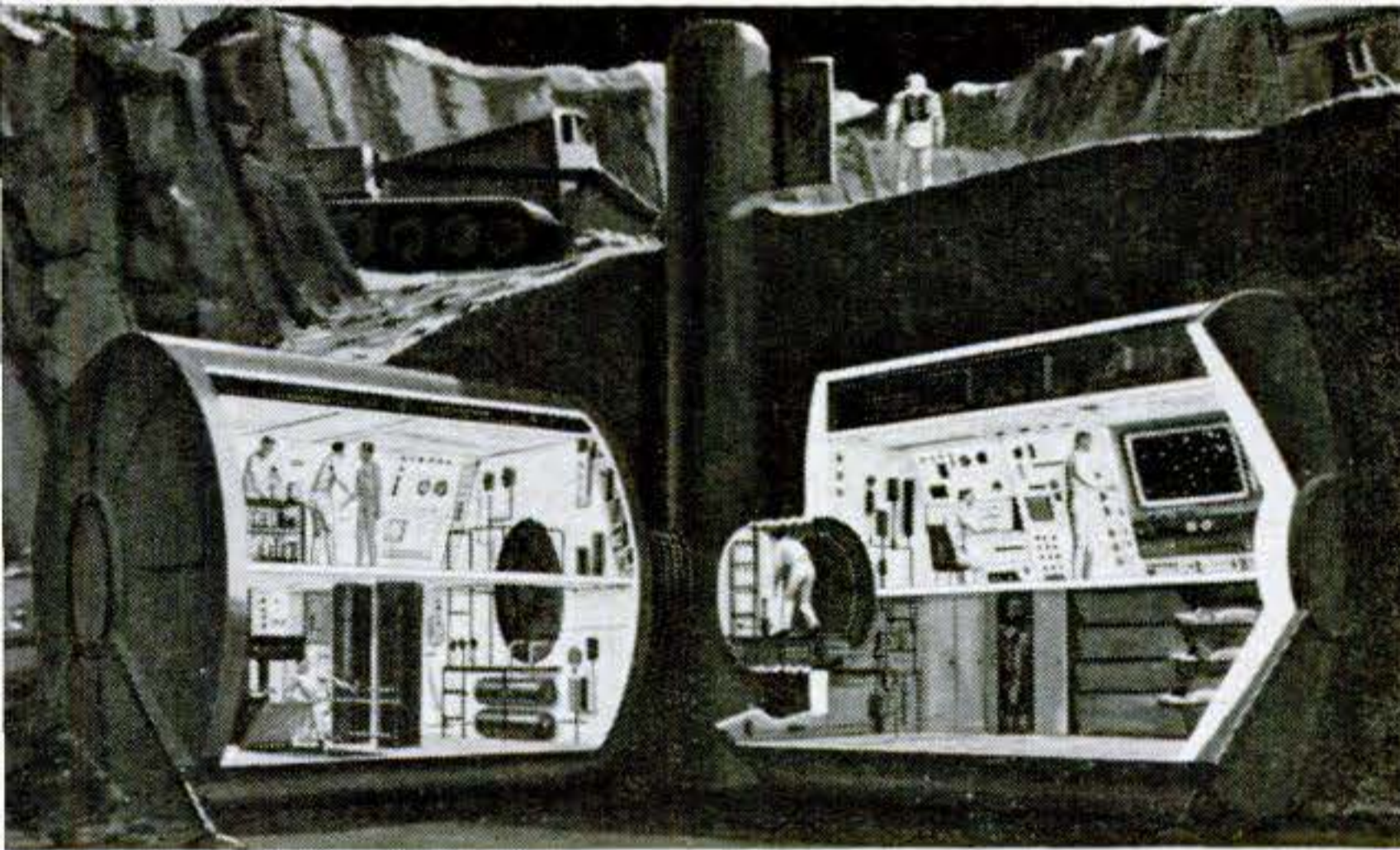

Cutaway of buried booster tanks shows how they may be arranged to care for explorers' needs.

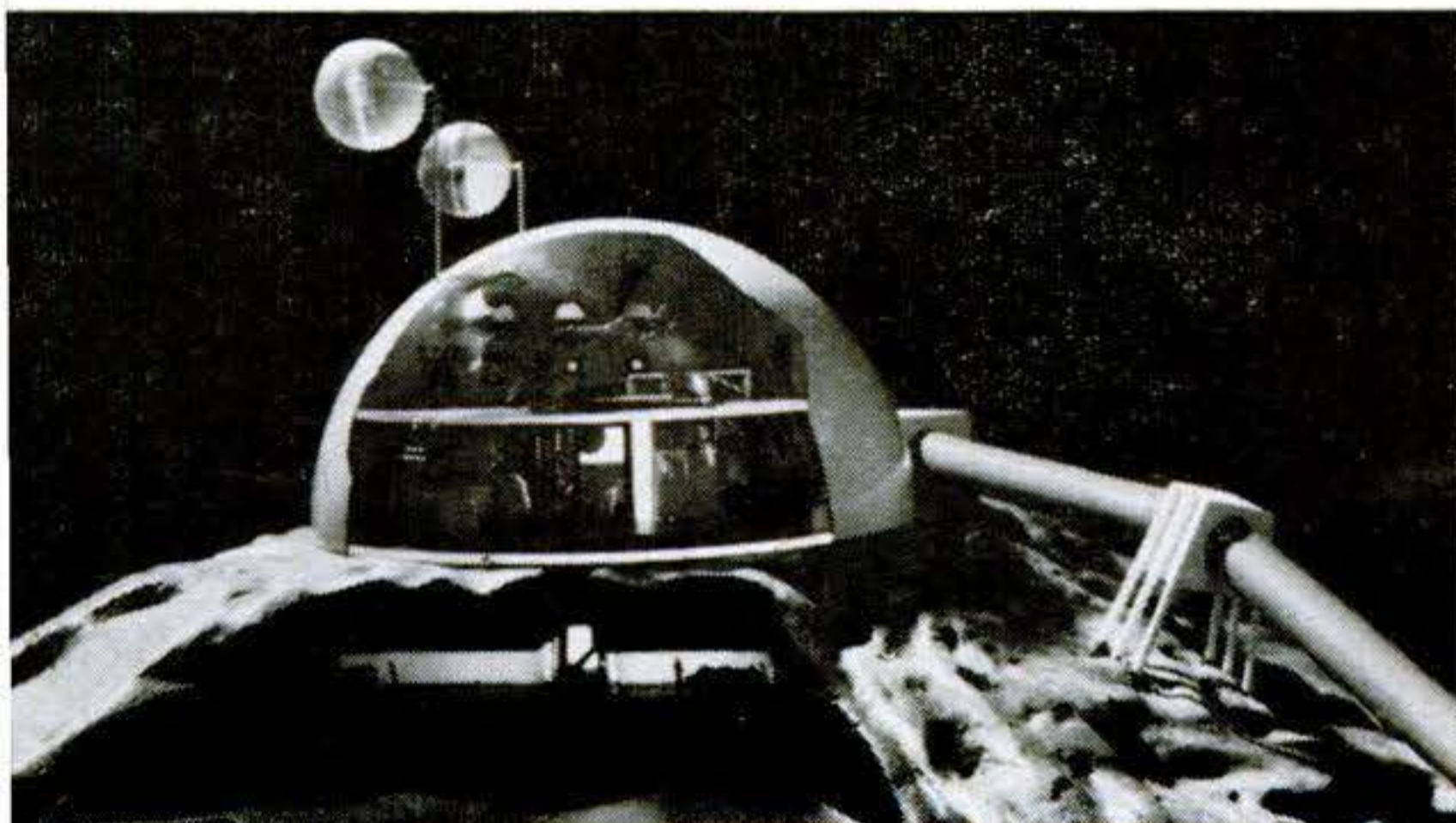

Water-conversion plant covers a fissure from which volcanic rock may be processed for water.



Water jet swivels to steer no-prop, no-rudder, shallow-draft experimental boat.

## Wankel rotary engine pushes these new boats

The Wankel rotary engine [PS, Mar. '60] has finally found practical use—but not in a car. A 43-hp. version powers the Swiss experimental jet boat above. Pumps suck up water from the underside, exhaust it under pressure.

A smaller 21-hp. Wankel engine pushes the Ski-Craft below, a German water-skiing device, at up to 27 m.p.h. The Ski-Craft will be sold by Transcontinental Motors in New York for over \$1,000. A larger Wankel will appear this fall in a German NSU car.



Ski-Craft has grab handles attached to control box. A gallon of fuel lasts an hour.



Millions of exciting chances are opening up for bright young men as fast-growing new industries holler for help

# Should You Try for a Better Job?

By Herbert Yahraes

*"I'm eager to get ahead. I read about the scientific and technical revolution—space, atoms, electronics. What opportunities does it open up for me? How can I find out which jobs I might do best in? How can I get training for work like that and keep on supporting my family?"*

**T**HIS plea, from a young shipping clerk in Michigan, is typical of hundreds of letters received by POPULAR SCIENCE. The editors asked me to find the answers. I talked to personnel directors at big corporations, training experts, the heads of schools, business executives, and government officials. What they told me will open your eyes. They pointed out the big, new chances, and explained how recently developed training programs—in technical institutes, adult-education groups, correspondence schools, corporation study plans—help ambitious young men latch onto those chances.

## Now is the time

While automatic machinery takes over farming, old-fashioned factory production, and office routine, the new fast-growing industries are cry-

ing for help. Here are some hot areas:

- Space research—the boom industry of the Sixties—employs well over 1,000,000 people *but was short 40,000 or so this year* and will need more and more for years to come.

- Construction, of homes (more than 1,000,000 a year) and of everything else from supermarkets to launching pads, requires 3,000,000 men. By 1970 the number will be 4,000,000 to 5,000,000.

- Service work keeps multiplying—automotive, TV, home, commercial, government. Today there are 33,000,000 jobs in this field; by 1970 there will be 7,000,000 to 10,000,000 *more*.

Don't worry if these fields seem strange to you. A Washington acquaintance of mine, Chuck Billings, had been a Navy machinist for 18 years when the plant closed down. He could have transferred to another



government shop. But he had a secret hankering to get into sales. He lined up a job selling power tools to hardware stores. His wife says, "He's become a nice guy again."

Chuck is no exception. Official statistics show that 8,000,000 workers change their jobs in a typical year. Two-thirds of them go to different industries. And half switch to completely different occupations.

### **Advanced jobs take advanced training**

Space-age industries eat up all kinds of skills, from cooks and bakers to machinists and tool checkers. But they're hungry for specialists:

- Pipe fitters (qualified on lox and hydrazine lines).
- Electricians (for exotic power systems).
- Cameramen (on telescopic tracking cameras).
- Chemical-plant operators (to cast solid fuels).
- Radarmen (to set orbits).

The best-paying, fastest-promotion spots are open for men expert in the newest techniques. In a government-sponsored training program for computer specialists, 600 students had jobs sewn up *before graduation*.

Construction-machine operators are in heavy demand. Today even ditch-digging, once a synonym for the most menial of work, is a highly skilled occupation; the modern ditch-digger commands a complex, expensive machine and averages around \$4 an hour.

You get the idea just by skimming the help-wanted ads. Here's a sampling from one paper:

- Auto mechanic (alignment)—\$150 a week.
- Construction estimator.
- Die-casting diemakers—\$3.50 per hour.

- Sheet-metal draftsmen—\$150-\$175 a week.

- Computer technician—\$150 a week.

- Engineering aides—\$120 a week.

- Metal spinner.

- Plumbing estimator.

- Heli-arc welder (stainless steel).

- X-ray technician.

- Wiremen—\$3 an hour plus heavy overtime.

One study, by International Correspondence Schools, shows that 500,000 skilled jobs will open up this year alone.

And the prospects for technicians—men with one or two years of basic engineering training after high school—are fantastic. Technicians handle most of the detailed design and construction of complex equipment. Every graduate engineer should have two technicians working with him—a potential of more than 1,500,000 jobs. Yet today there are less than a third that number of technicians in the U.S., and only 16,000 new ones are being turned out each year.

### **Training waits for you**

You can't just fall into jobs like those. But never before have there been so many opportunities to prepare yourself to win them. Here is a quick rundown:

If you like the company you work for now, ask about training for a better job right there. Some corporations, like Martin in Baltimore and IBM in Poughkeepsie, N.Y., have set up courses close to the plant. At Ford, more than 20,000 employees take studies ranging from apprentice training to full-time university schedules.

Home-study courses are the most convenient training. They bring the school to you, and let you train in

[Continued on page 204]





*Hesitantly, I accept a space suit from GE's Carl R. Cording. Outfit formerly belonged to ex-GE test pilot Elliott See, one of the new astronauts.*



*America's first chicken astronaut (me) starts to sweat—combination of an airtight suit and nervousness. (After test, I decided to remain a terranaut.)*

I went for a spin in a

# Weightless Workshop

By Robert Gannon

**W**RENCH gripped tightly, I yanked down, trying to loosen the nut. It didn't budge—but I did, swinging evenly, flipping head over heels in my space suit. I lunged at the side of the craft, missed, and slowly floated away, helplessly.

I wasn't in zero-gravity space, of course, but on a device that comes darn close to giving that sensation. It's called the Spaceworker, or, more formally, Five-Degree-of-Freedom Simulator. General Electric's Missile and Space Division put it together to see how well a man in orbit can work outside his ship.

Spaceworker is a simple contraption—a basketlike stretcher balanced in gimbals, a yolk attached with ball bearings to a three-footed post. The whole thing is kept floating just off the floor by three frictionless air bearings, disks with holes through which air flows to hold them up like flapjack-size hovercraft.

Strapped in the simulator, you pitch, yaw, roll—even spin, if you want to. In fact, Gene Day, the lab supervisor, once got himself revolving at 27 r.p.m. (On the 44th revolution he got sick.) Gravity isn't absent, of course, but that doesn't seem to make much difference.

Before I got aboard, Carl R. Cording, manager of GE's Valley Forge (Pa.) Manned Spacecraft Laboratory, helped me squirm into a space suit.

I didn't feel like an astronaut, but my walk to the lab took me through the lobby,

*[Continued on page 218]*



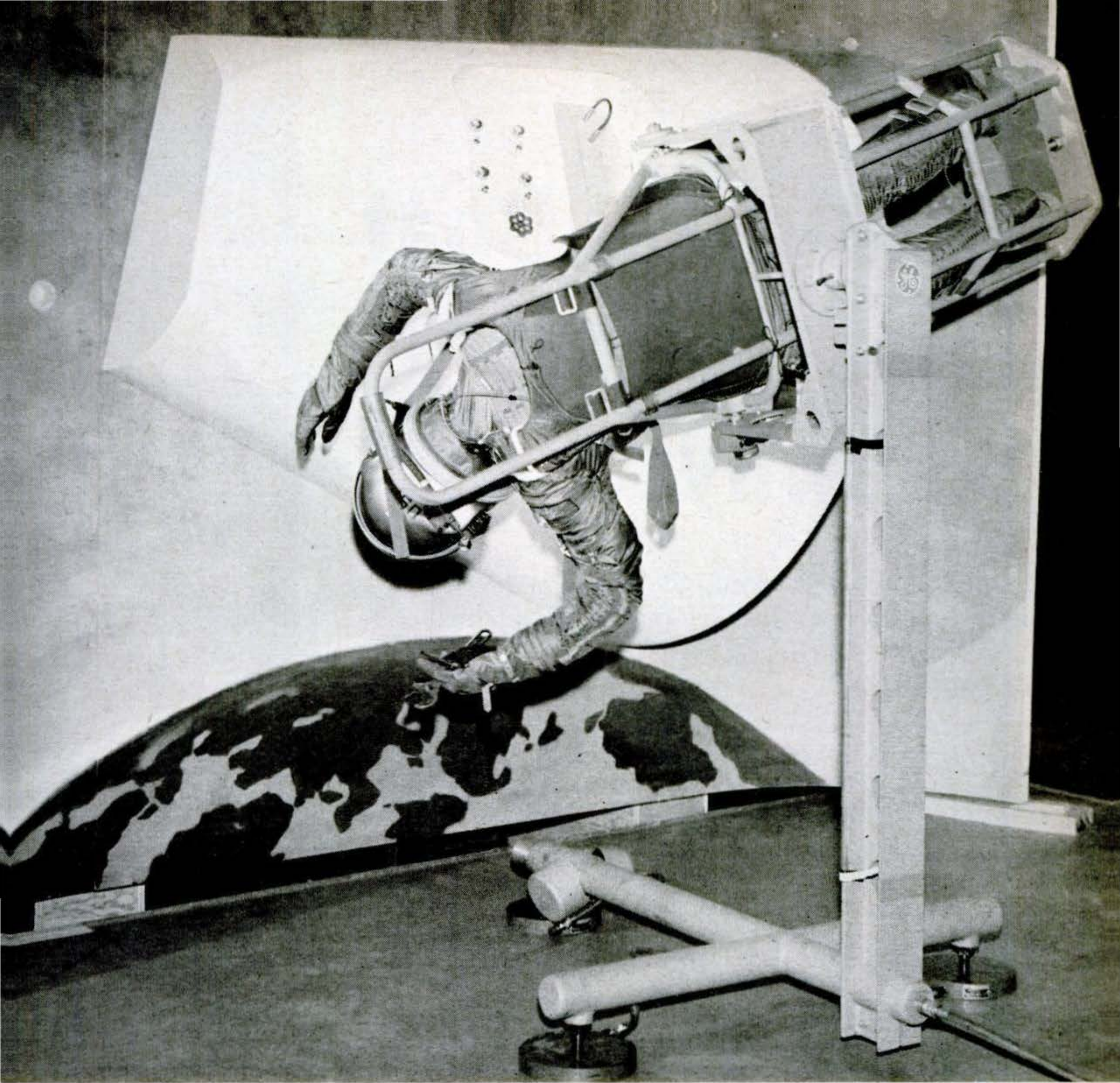

*Top-heavy, I flip head-downward. Adjusting for exact center of gravity can be tedious.*

*With nothing to push against, I couldn't "jump" or jerk myself along—could only turn on my axes. Here I wait to be pushed to mock-up capsule.*

*Simulated problem—removing nut—is easy if you get hang of using body mass for leverage.*

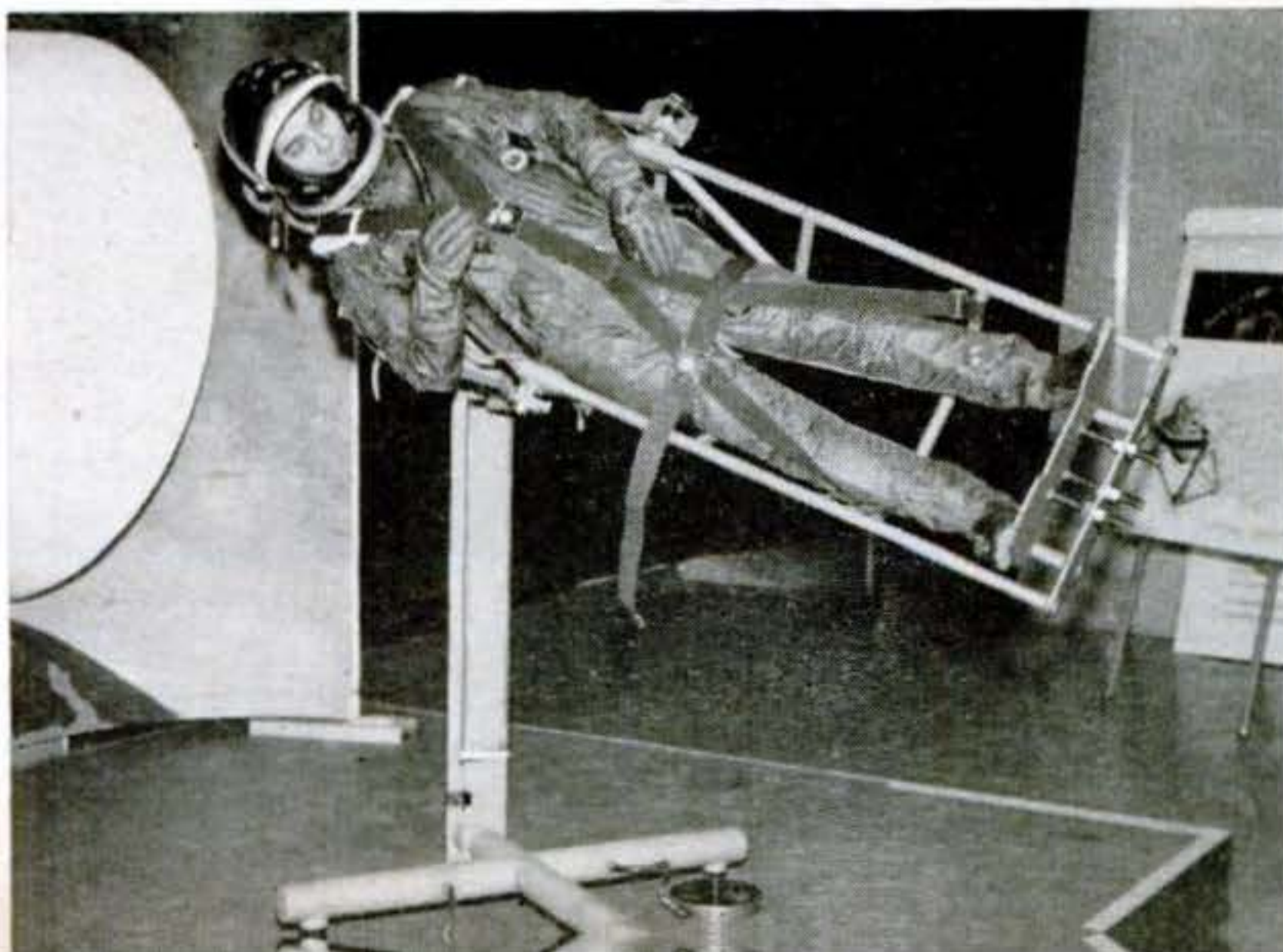



# Now—a Jet Boat That Goes Sideways!

Thrust from two jet ports, one at the bow and one at the stern, eases this new craft into the dock

By Hubert Lockett

**T**HERE'S now another trick to add to the impressive list of things you can do with a jet-drive boat that you can't do in any other: move sideways.

A new jet by Upson Marine has *bow* steering. With it, you can forget the aim-and-pray routine when docking in heavy wind or current. Instead, you just take your time and sidle into a crowded berth as casually as a woman shopper inching in ahead of a man at a checkout counter.

The basic propulsion unit is a single-stage, axial-flow pump. It is available in six different models to match engine sizes ranging from 40 to 275 horsepower.

CONTINUED



Powered sideslip is accomplished by turning reverse jet to one side and opening the valve to the bow jet on the same side. You can control bow and stern independently.

Pinwheel maneuver lets you spin boat in its own length. Reverse jet is turned to one side with wheel, and bow jet on opposite side is activated. Other bow jet stops the spin.





Shift lever controls bow jets when moved sideways; and forward, neutral, and reverse position of control gate when moved fore and aft.

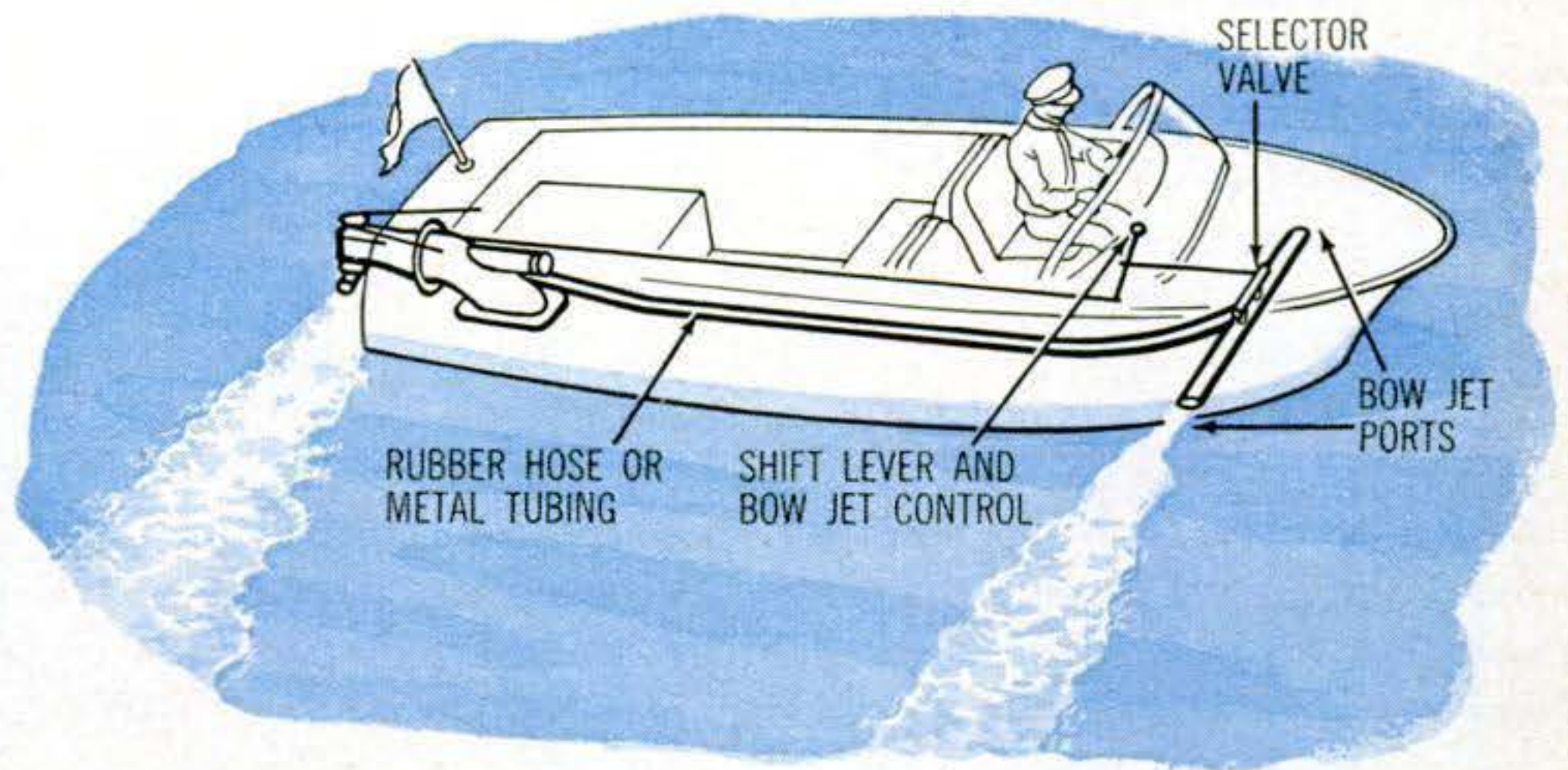

Bow steering system for low-speed maneuvering uses auxiliary jets on either side of the bow. Water under pressure is supplied through a rubber hose or metal tubing from an outlet on the side of the jet pump. Operating pressure is applied to this line when the control gate is in the reverse or neutral position.

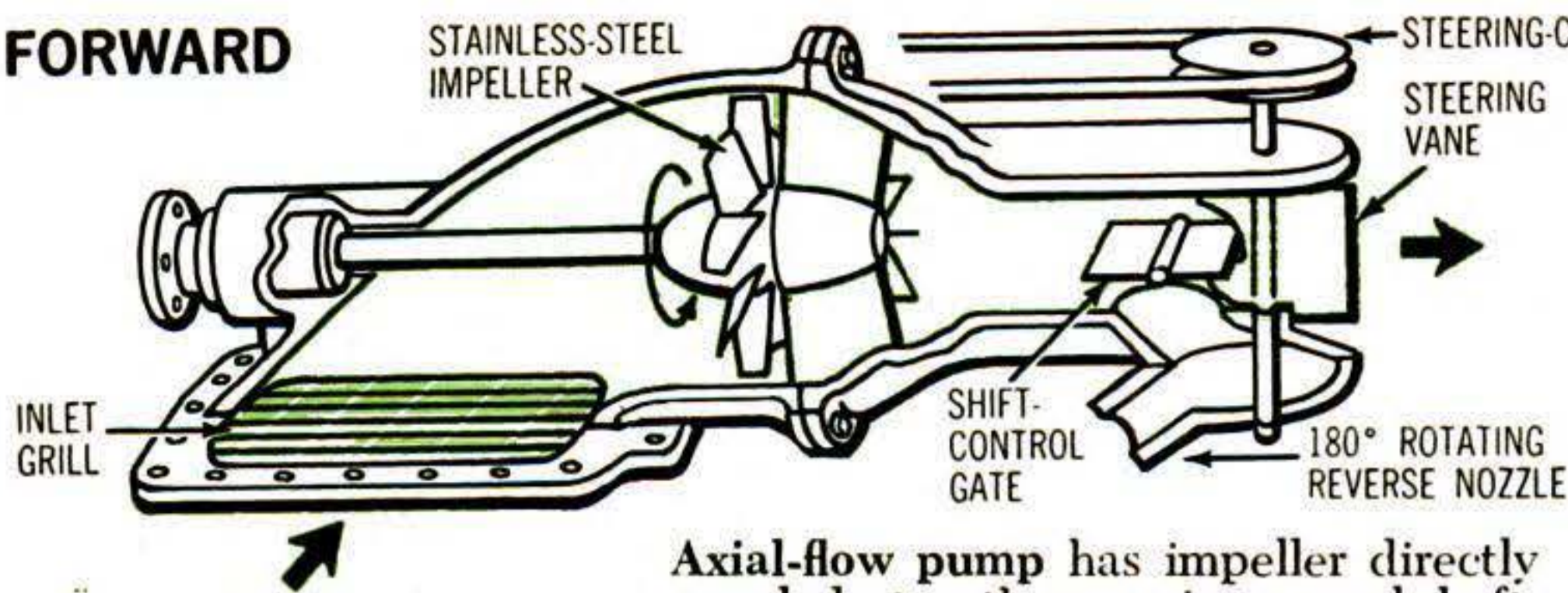
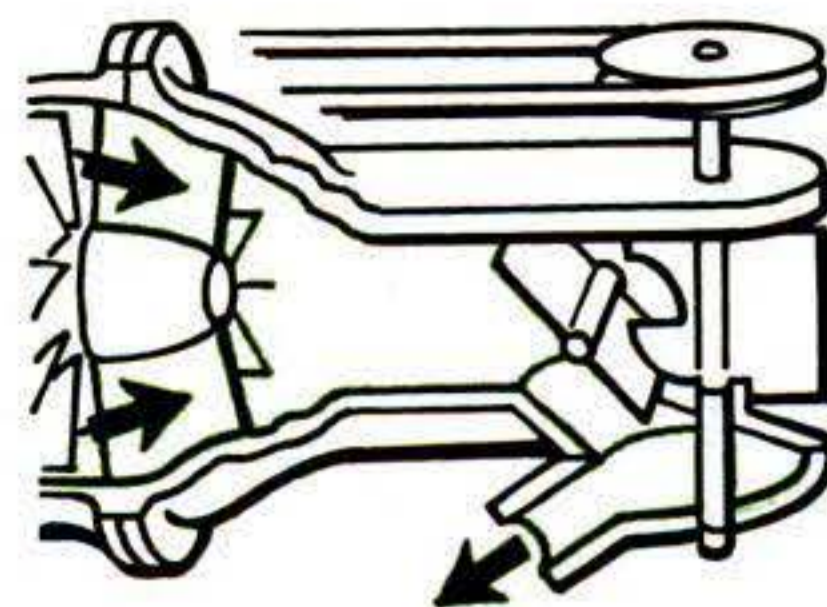
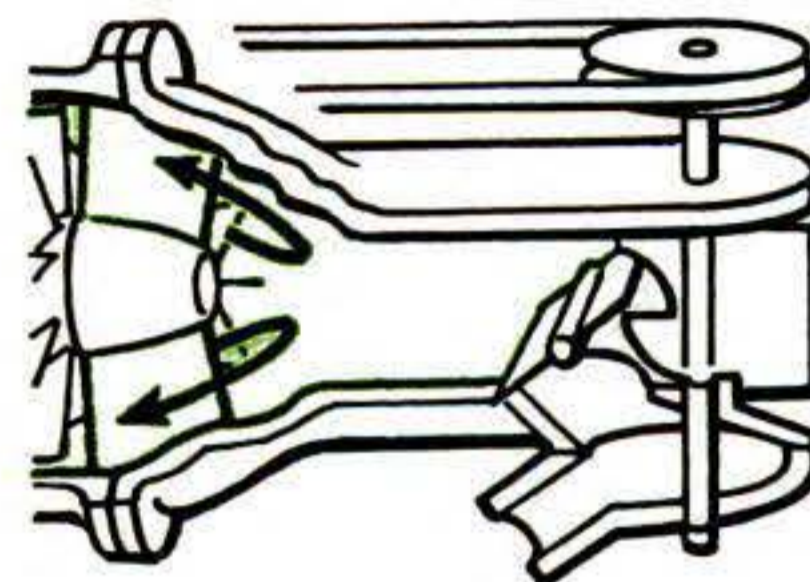

**FORWARD****REVERSE****NEUTRAL**

### Taking a look inside the jet-drive system

Axial-flow pump has impeller directly coupled to the engine crankshaft. Shift control gate is operated by lever at driver's seat. Above, control gate is shown in forward position. At top right, gate is in reverse position with water diverted into reverse nozzle, which rotates with the rudder.

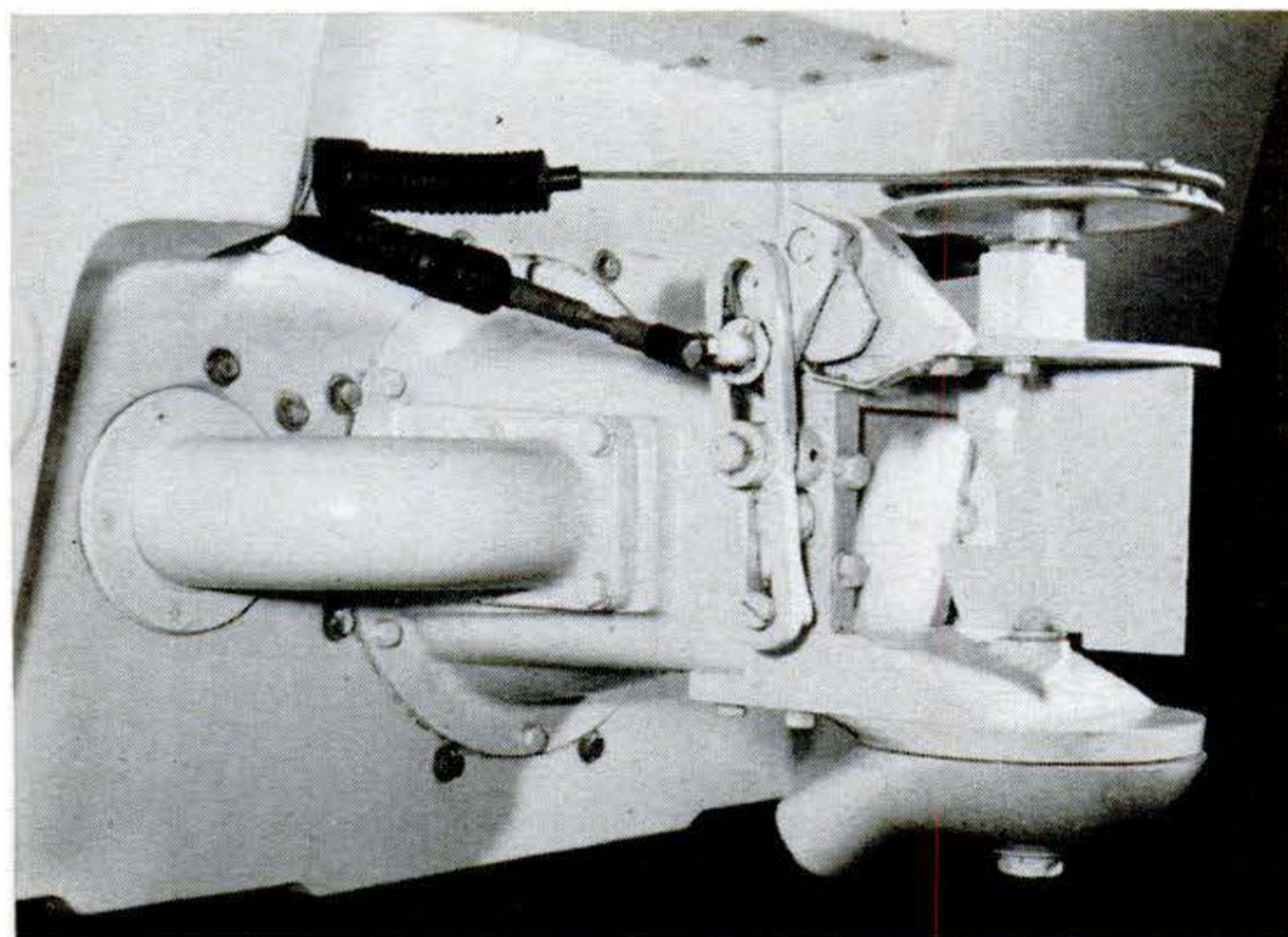

◀ Nozzle housing can be removed if necessary without taking boat out of the water. Rudder and control gate of balanced design require little force to operate—any cable-and-pulley, single-cable push-pull, or drag-link system will tie them to wheel and shift lever. Elbow at side of housing is for bow jet supply.

In a jet boat, thrust (the force that drives the boat) is created by accelerating a large volume of water. One model of the Upson jet will deliver 4,000 gallons of water per minute at 4,000 r.p.m. The manufacturer claims acceleration from 0 to 30 m.p.h. in six seconds and top speeds of over 50 m.p.h.

**The bow steering.** This trick is handled by two ports, one on either side of the bow at the water line; a selector valve that directs water flow to one or the other of these ports; and a hose that delivers water under pressure from the jet unit. Bow steering is used only for docking or maneuvering in tight places. When the boat is under way, a vane in the main jet stream gives steering control. For reverse, the stream is diverted to a swiveling nozzle on the lower end of the rudder post.

The Upson Marine jet unit can be installed in almost any existing hull fitted with

an engine of the specified horsepower. Special mounts and transom angle-adjustment wedges simplify its adaptation to the hull, regardless of design and construction, so long as a smooth flow of solid water can be maintained to the unit's inlet. No special tools or skills are required to install the jet system. Only two openings are needed: one through the bottom for water intake and one through the transom to take the jet nozzle.

The unit weighs only 136 pounds, so the dead weight your boat must carry will be reduced over most standard prop drives. The jet drive saves space inside the boat, too. The 8" models need only 18", and the 10" sizes only 21½". A special intake grille keeps weeds and debris out of the pump. And, of course, jet boats have no props, struts, or rudder projecting under the hull to create drag or get fouled on rocks or snags. ■ ■



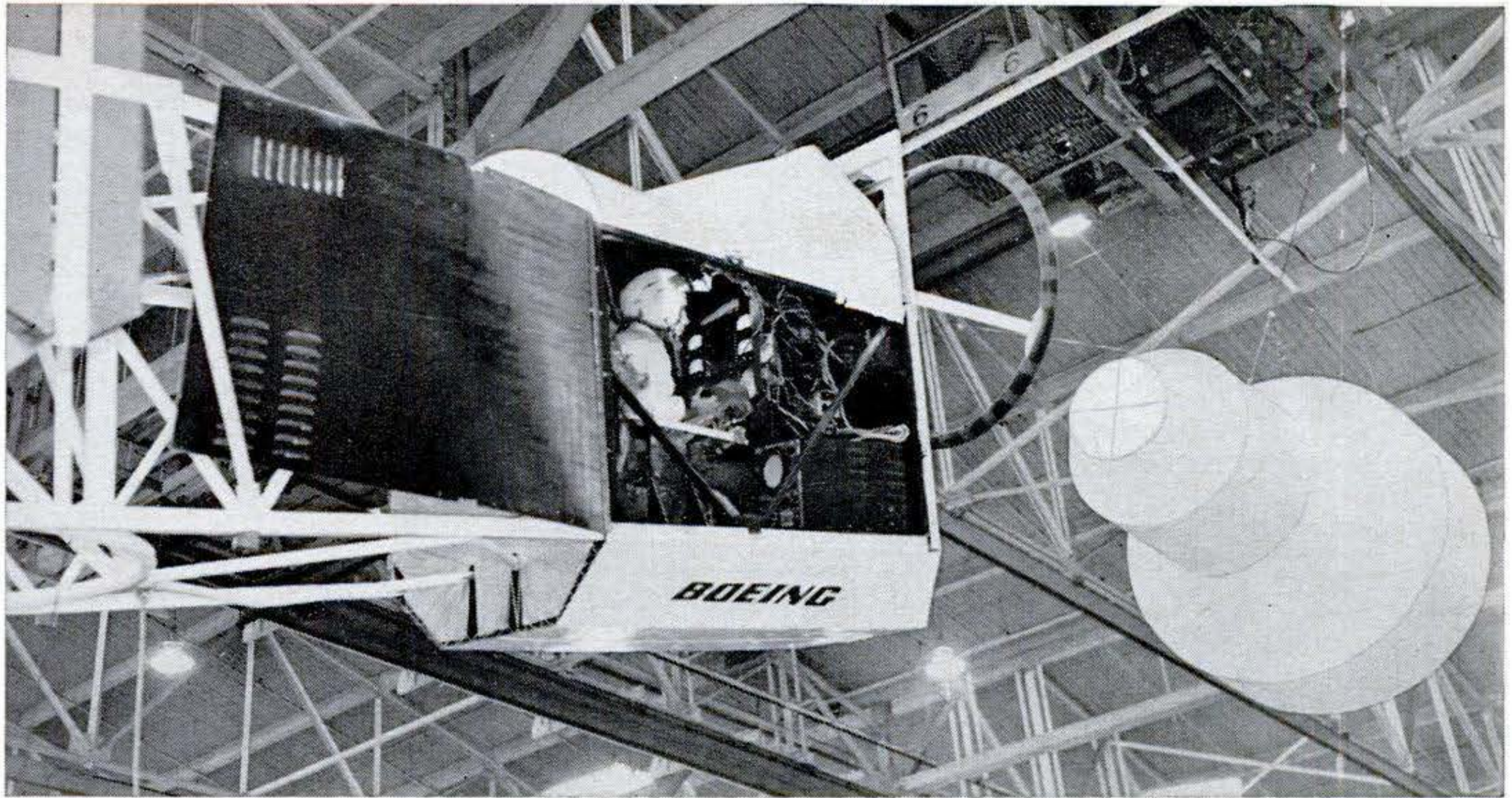

## Learning how to rendezvous in orbit

Future astro pilots are now getting realistic practice in the tricky technique of coupling two spaceships in orbit—while remaining safely earthbound. In a Boeing-developed simulator, one “rocket ship” is a cabin mounted on a frictionless bearing that permits the pilot to produce the motions

of pitch, roll, and yaw while positioning for rendezvous with another “ship” suspended from a crane. He controls *this* one through a computer to simulate the effect of rocket reaction. His goal is to maneuver the nose of the forward “space capsule” into a rubber ring in front of his cabin.



## New midget scooter: transportation or fun

This tiny scooter squeezes 125 miles from a gallon of gas and makes 35 m.p.h. while doing it. The Wren has a 38-inch wheelbase, weighs 62 pounds, costs \$100. An automatic centrifugal clutch is standard. Bird Engineering, Omaha, Neb., builds it for hunting, errands, or just fun.



## Minicar takes on extra engine to become off-road cross-country vehicle

Individual 52-cu.-in. engines power the front and rear wheels of the Moke, a rough-terrain version of British Motor Corp.'s front-wheel-drive minicars. Each engine is transversely mounted directly over the wheels for added traction. Combined output is 72 hp. The throttle and clutch controls are linked, but separate gear levers permit disengaging the rear drive when it is not needed.

At a demonstration in snowbound England last winter, the Moke showed exceptional climbing ability and versatility as a load carrier, snowplow, and prime mover. Price in England is \$1,330.



Engine drives all four wheels. It's modified with rear power take-off from turbine shaft.

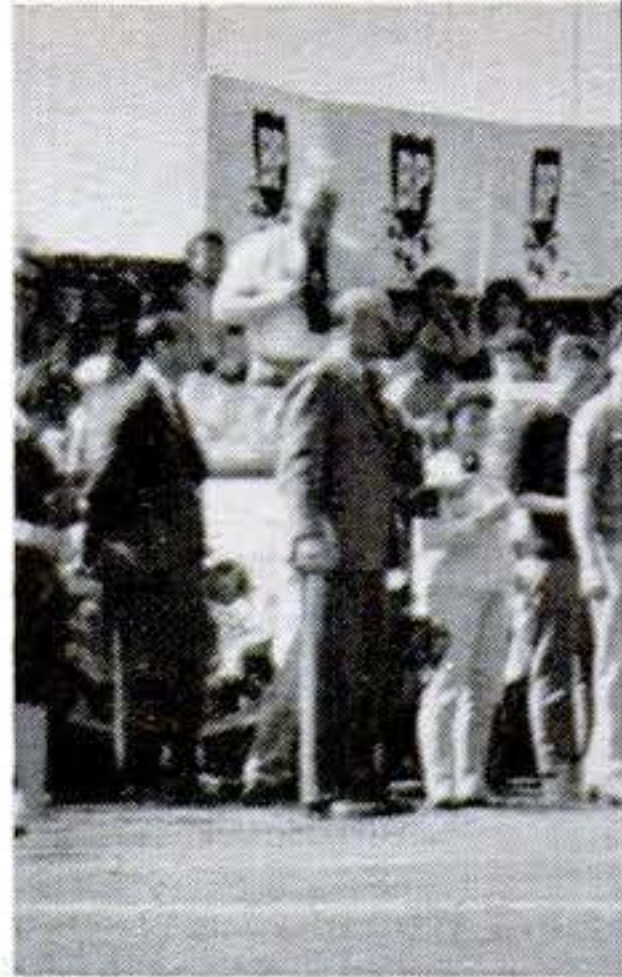
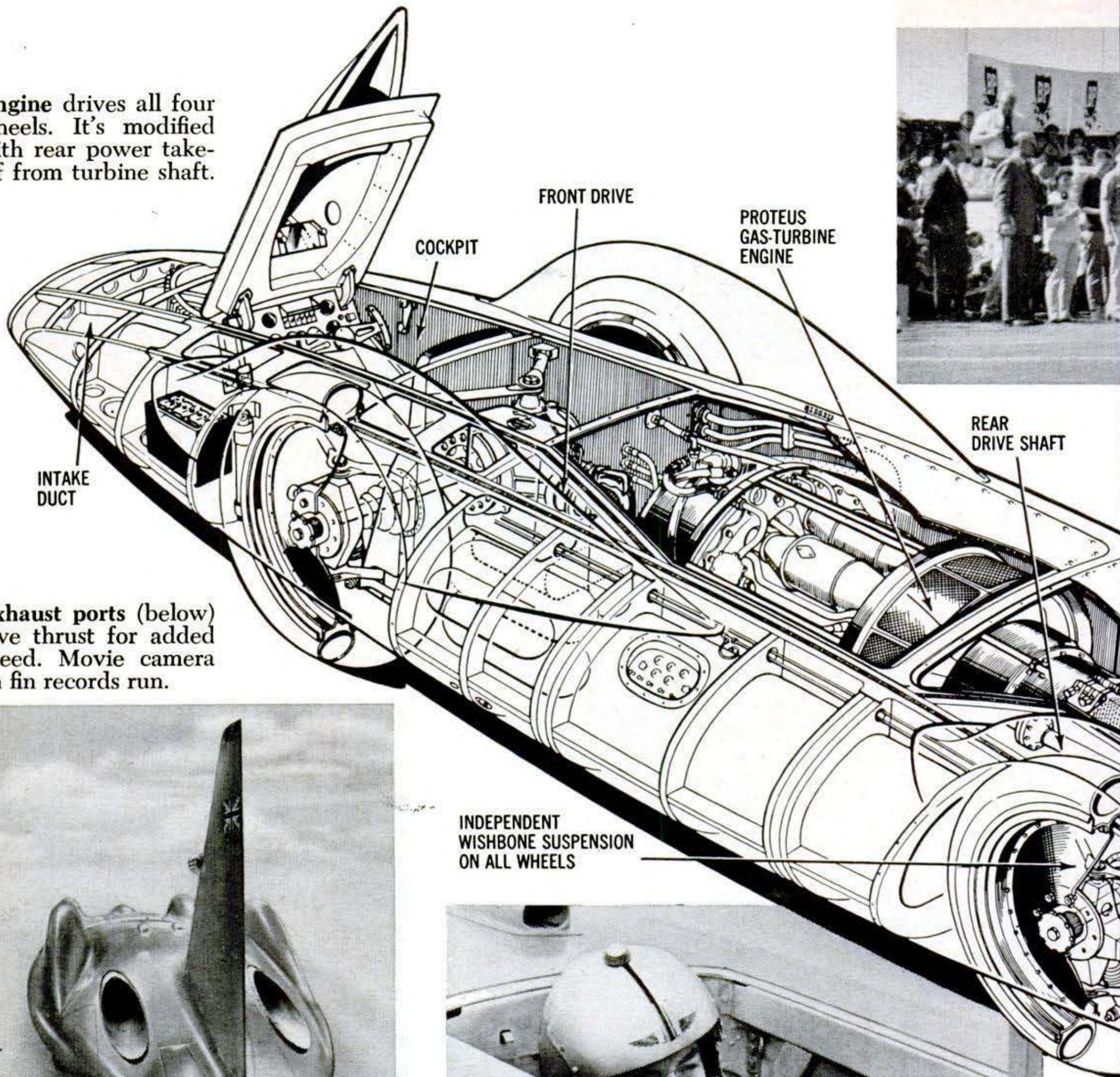

Exhaust ports (below) give thrust for added speed. Movie camera on fin records run.



Campbell sits low in cramped cockpit at right. Throttle, brake, and wheel are only controls.



INDEPENDENT WISHBONE SUSPENSION ON ALL WHEELS

## Bluebird makes another bid for

The attack on John Cobb's long-standing 394.196-m.p.h. land-speed record (still official despite Mickey Thompson's one-way run of 406.6 m.p.h. in 1960) will be renewed this month at Lake Eyre, Australia, by Donald Campbell. The Britisher will pilot a Bluebird rebuilt according to lessons of his crash in 1960 on the Bonneville Salt Flats in Utah.

Added this year is a tail fin to improve

stability at high speeds. The fin stands 7 feet 8½ inches above the ground, but is designed to be shrunk section by section, after initial tests, for a compromise between stability and drag. Lockable front and rear differentials also help the Bluebird hold course.

The Bristol Siddeley Proteus turboprop aircraft engine delivers 4,100 hp. at 11,100 r.p.m.—enough, it is hoped, to push the car



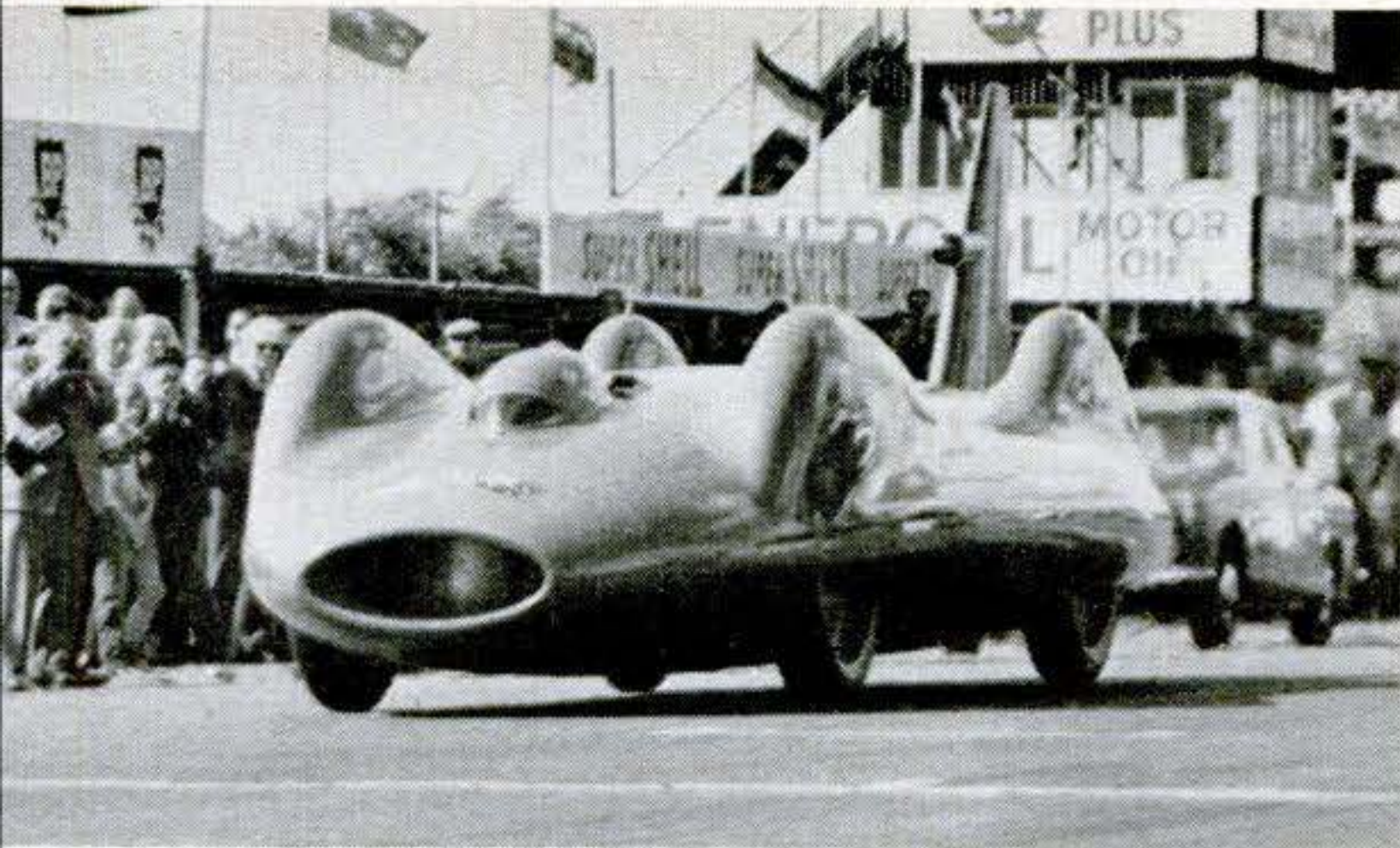

Rebuilt Bluebird begins demonstration run at Goodwood race track in England. Shatterproof bubble is fiber-glass and clear plastic.

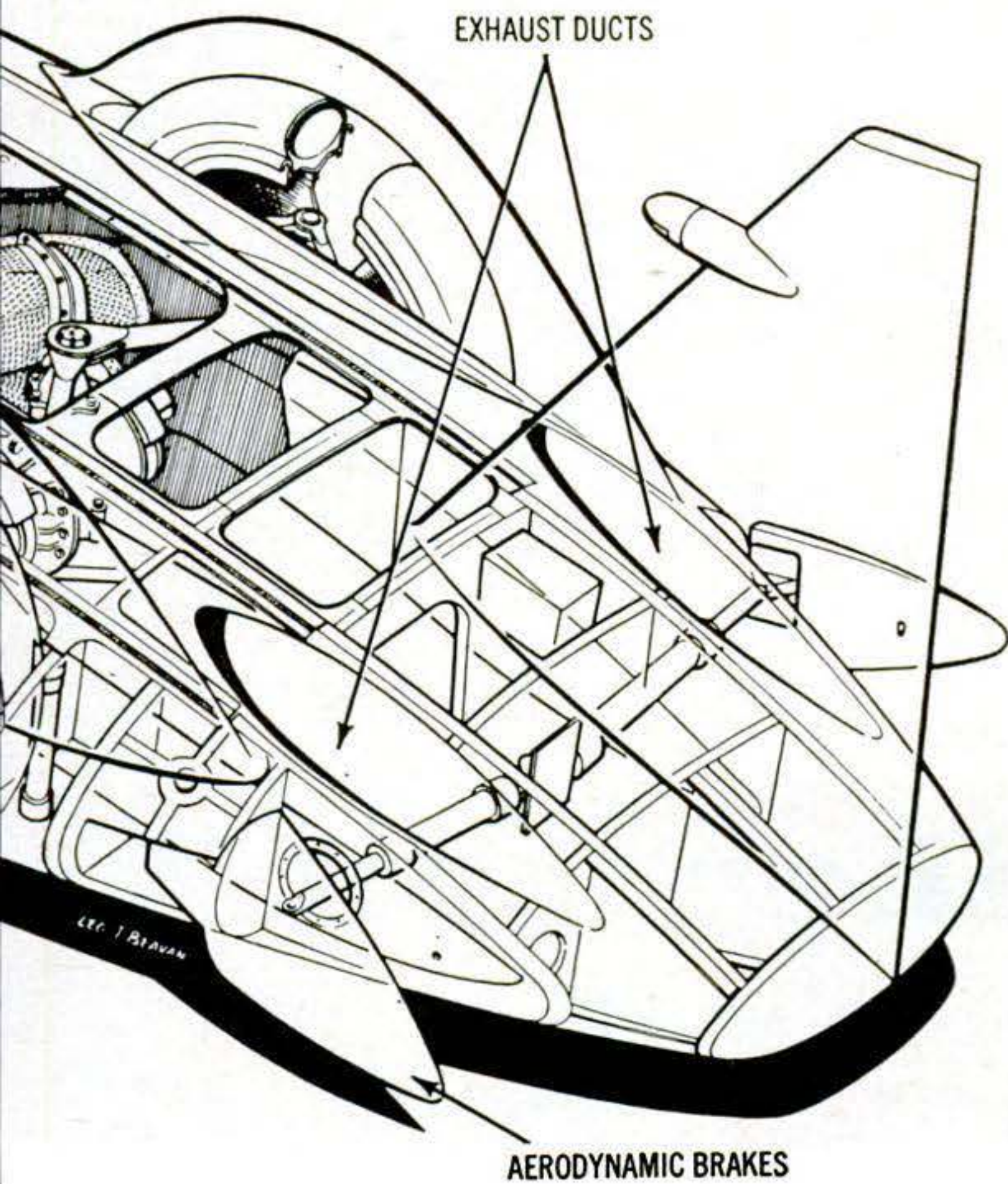

## speed record

to 450 m.p.h. No power-robbing transmission is necessary.

Wheels with 52-inch-diameter tires are sprung on nitrogen in oleopneumatic suspension-shock-absorber units designed for maximum traction. Brakes are twin-caliper disks operated by air and capable of a 60-second stop from 400 m.p.h. Supplementing the disks are flap-type air-resistance brakes on both sides of the tail.



## Solid Army punch on the move

Mauler, shown here in an engineering mockup, is the Army's answer to front-line bombing and strafing by enemy jets and harassment by short-range missiles. While on the run, the mobile, self-propelled launcher can fire a dozen radar-guided solid-fuel rockets at a time. The guided-missile carrier was developed by General Dynamics at Pomona, Calif., for the Army Missile Command at Redstone Arsenal.



## Concrete-and-glass football

With two curved sides coming to a point at the ends, the Phoenix Mutual Life Insurance Building brings something new in architecture to Constitution Plaza in Hartford, Conn. Incorporated in the design are a two-level underground garage for 300 cars and an enclosed street-level park. The building will open in September.





Table-top Sceptron hookup, listening to talk by its demonstrator, lights up indicator (right of center) whenever he says "five"—and ignores every other word. Assembling enough Sceptron units to obey many verbal commands might yield voice-operated phone dials and cash registers, and typewriters that take dictation by directly transcribing spoken words.

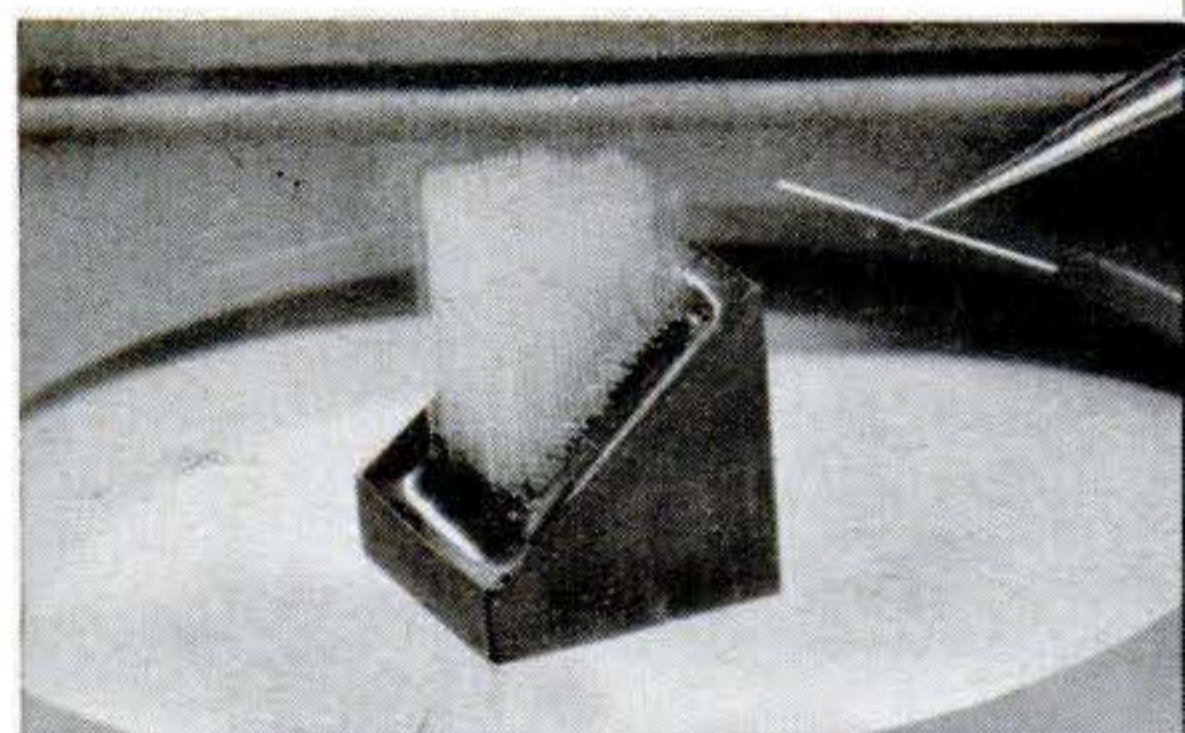

Heart of Sceptron is tuft of quartz fibers, like one held in forceps. Fibers vary in length, and different frequencies, blended in an incoming signal, make different ones vibrate.

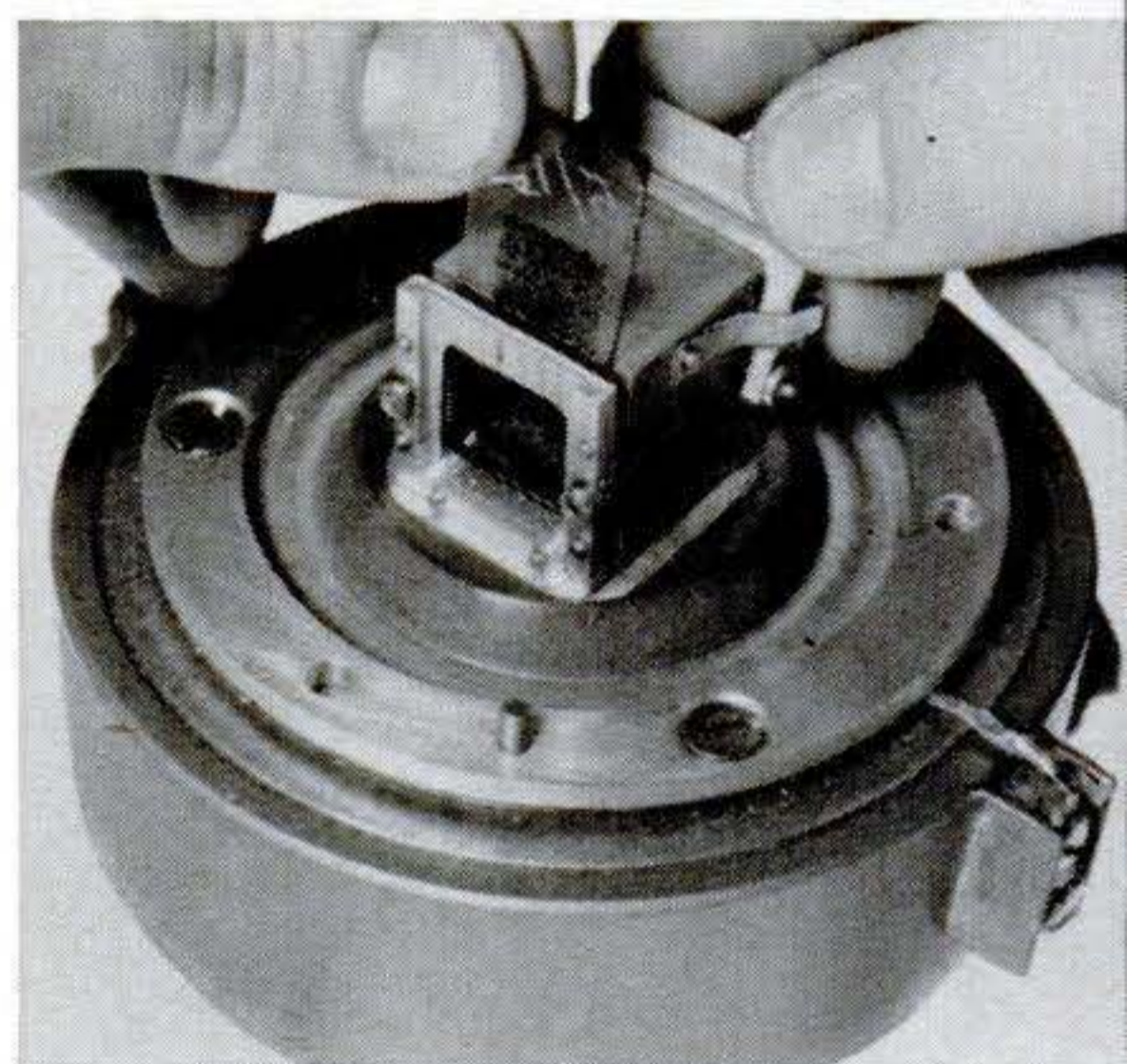

Photo-plate mask, being inserted, is "memory" that recognizes a certain word. Interchangeable masks, each with a different pattern, make Sceptron responsive to various cues.

# "Tell It to Sceptron!"

Newest electronic brain recognizes spoken words,  
and will carry out your verbal commands

By Alden P. Armagnac

PHONES that dial a spoken number, typewriters that print out whatever you say to them, underwater ears that identify a hostile submarine—these are just a few of the uses foreseen for a new signal-recognizing "brain."

In a recent demonstration of its talents, an engineer talked into a microphone connected to a table-top version of the device. The instrument had been set up to respond to the word "five." Whenever he

uttered this word, the brain instantly flashed a telltale light. It ignored every other word he said.

As easily, the device can be adapted to recognize any word whatever—or any signal, audible or visible, that can be translated into electrical pulses. A composite "brain," made up of a number of the units, could recognize many spoken commands and respond in appropriately different ways to each one.

Called the Sceptron (for "Spectral comparative pattern recognizer), the device is



## HOW SCEPTRON WORKS

These are key parts of "brain":

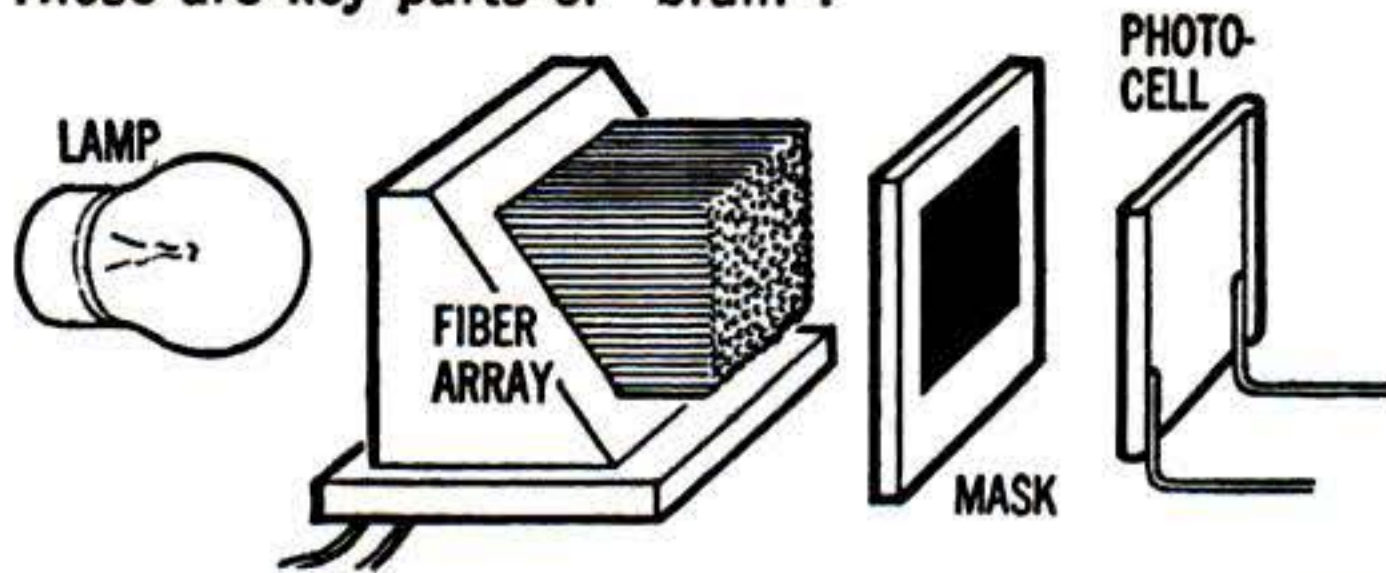

Sceptron consists essentially, left to right, of a lamp; a cluster of quartz fibers, through which lamp's rays travel lengthwise, vibrated by an incoming electrical signal; a mask, whose pattern transmits the light emerging from some fibers' tips but not from others'; and a photocell, which responds to light by actuating a signal such as a buzzer or indicator lamp.

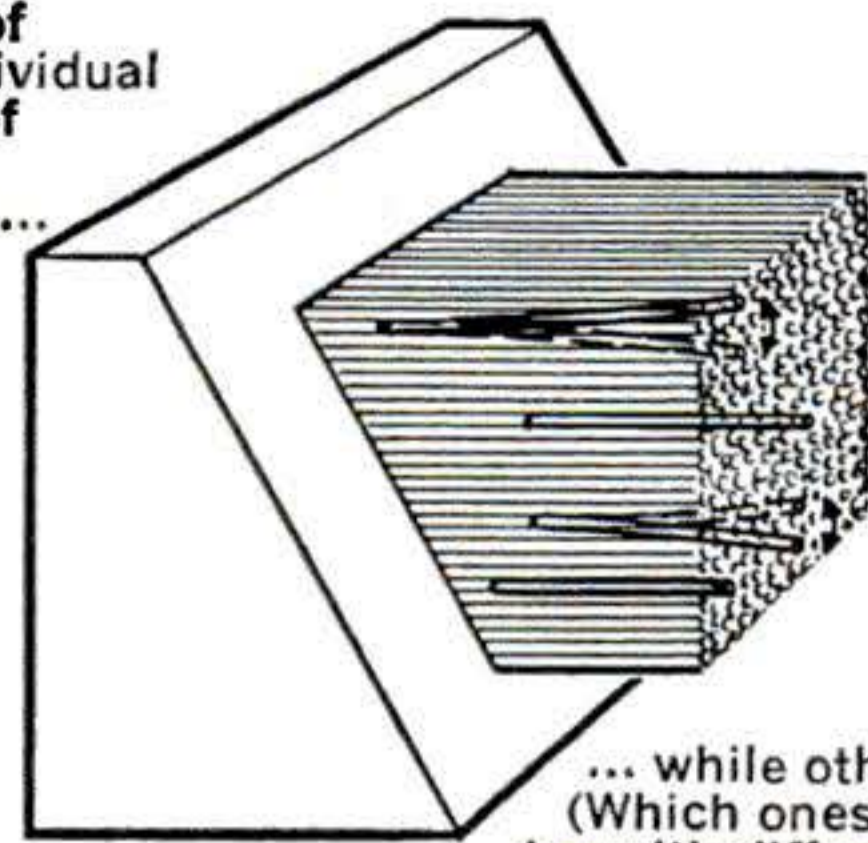

In response to signal like word "five":

Some of the individual fibers of quartz vibrate...

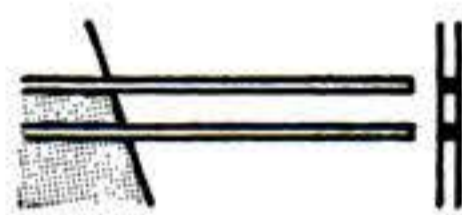

... while others do not. (Which ones dance varies with different words.)

A mask, to transmit the particular signal of interest and reject others, is made by these steps:

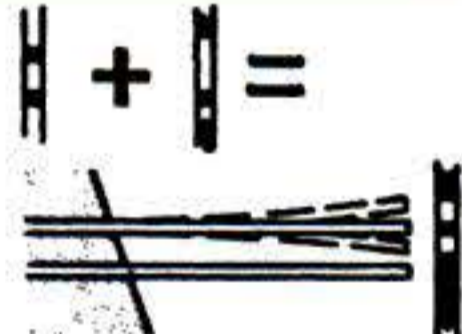
- 1 Photo plate is exposed to light from tips of fibers at rest. Resulting negative forms "rejection mask" that blocks light from zero (no) signal. 
- 2 While fibers are vibrated by signal to be recognized, second plate is exposed to tips. This negative provides a "rejection mask" that blocks light from wanted (to-be-recognized) signal, and also from a zero signal. 
- 3 Making photo positive from second negative gives "acceptance mask" that transmits light from wanted signal or zero signal. 
- 4 Combining this positive and first negative gives "acceptance mask" passing light of wanted signal—and of no other one. 

A Sceptron in action

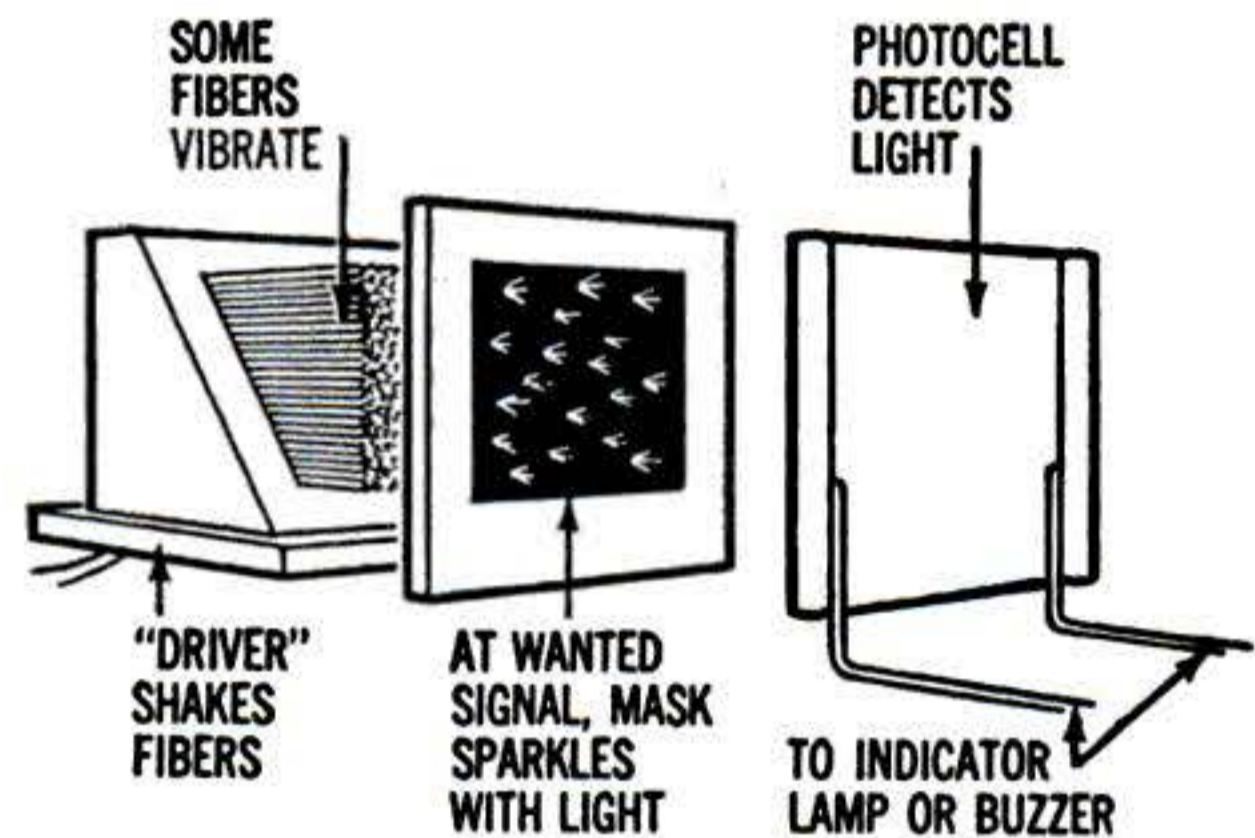

When the right signal comes along, such as the spoken word "five," Sceptron's mask sparkles with twinkling pinpoints of transmitted light—and its photocell responds by turning on an indicator lamp or buzzer. To all other incoming signals, Sceptron is oblivious; its mask remains dark and its indicator inactive. Singly or grouped, Sceptron units can be adapted to recognize any spoken word, a particular person's voice, the sound of an enemy submarine—or anything else, including pictures as well as sounds, that can be converted into an electrical signal.

being readied for both civilian and military uses by the Sperry Gyroscope Co., which considers its novel principle an advance as fundamental and versatile as the transistor. Invented by Robert Hawkins, Sceptron combines vibrating optical fibers that analyze sounds or other signals, and a photographic memory cell to recognize them.

Within a Sceptron is a tuft of 700 or more transparent quartz fibers, of varying length, supported at one end like bristles in a shaving brush. An incoming signal jiggles the fibers' mounting, by means of a driver unit such as a loudspeaker coil or a piezoelectric transducer. Some fibers vibrate, others don't, depending on their individual responses to the various frequencies blended in a signal.

Meanwhile, light from a lamp bulb travels lengthwise through the fibers—and emerges

from their quivering or motionless tips.

All that need be added to put Sceptron in business is a "memory" mask, which transmits the emerging light only when the fibers are vibrating in a particular pattern—and, beyond the mask, a light-detecting photocell. Accompanying drawings show how the complete device works, and how the mask is made—by the very signal that it's to recognize. Variations in mask-making technique give a mask that recognizes a certain word, whoever speaks it; or a certain person's voice, whatever he says.

In the demonstration model, Sceptron's quartz-fiber array takes up a cubic inch of space, but Sperry has already made a miniaturized version as small as 1/300 of a cubic inch. Thus, it says, it's approaching the point where a composite "brain" as complex as the human brain could be put in a desk-size console.



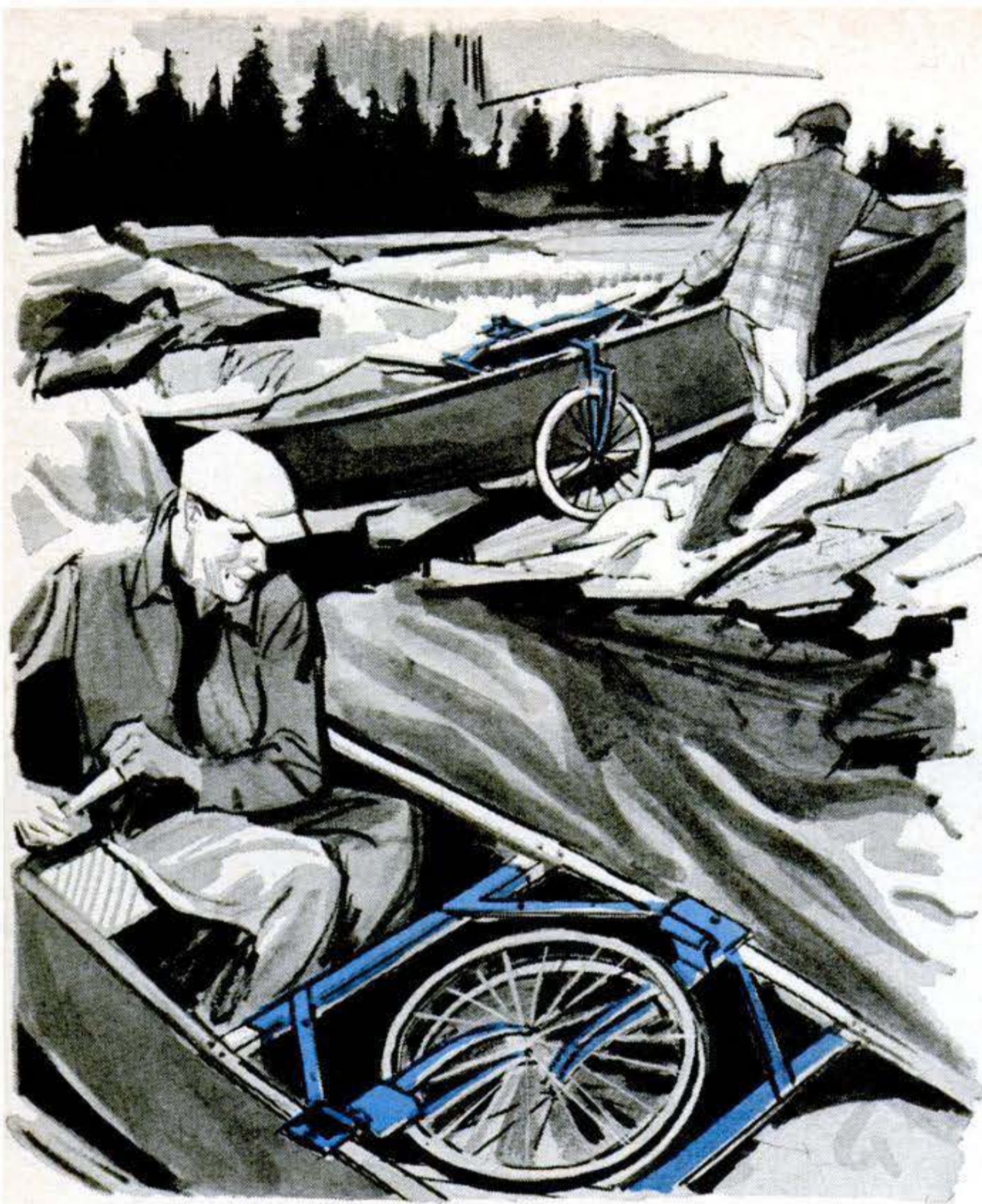

# New ideas from the inventors

**Fold-in wheels carry boat.** Lightweight wheels that could be carried in a small boat or canoe might ease lake-to-cabin hauling or lake-to-lake portaging. These recently patented wheels would be hinged to a frame clamped to the gunwales. Thumbscrews would lock them in riding position, release them to swing inboard one on top of the other.



**Cap measures powdered coffee.** Your instant coffee might be even more instant—as well as more uniform—if you replaced the jar cap with this screw-on dispenser. Pulling a slide would release a fixed amount of coffee into the dispenser through one aperture; pushing the slide would drop it into the cup through an exit aperture.

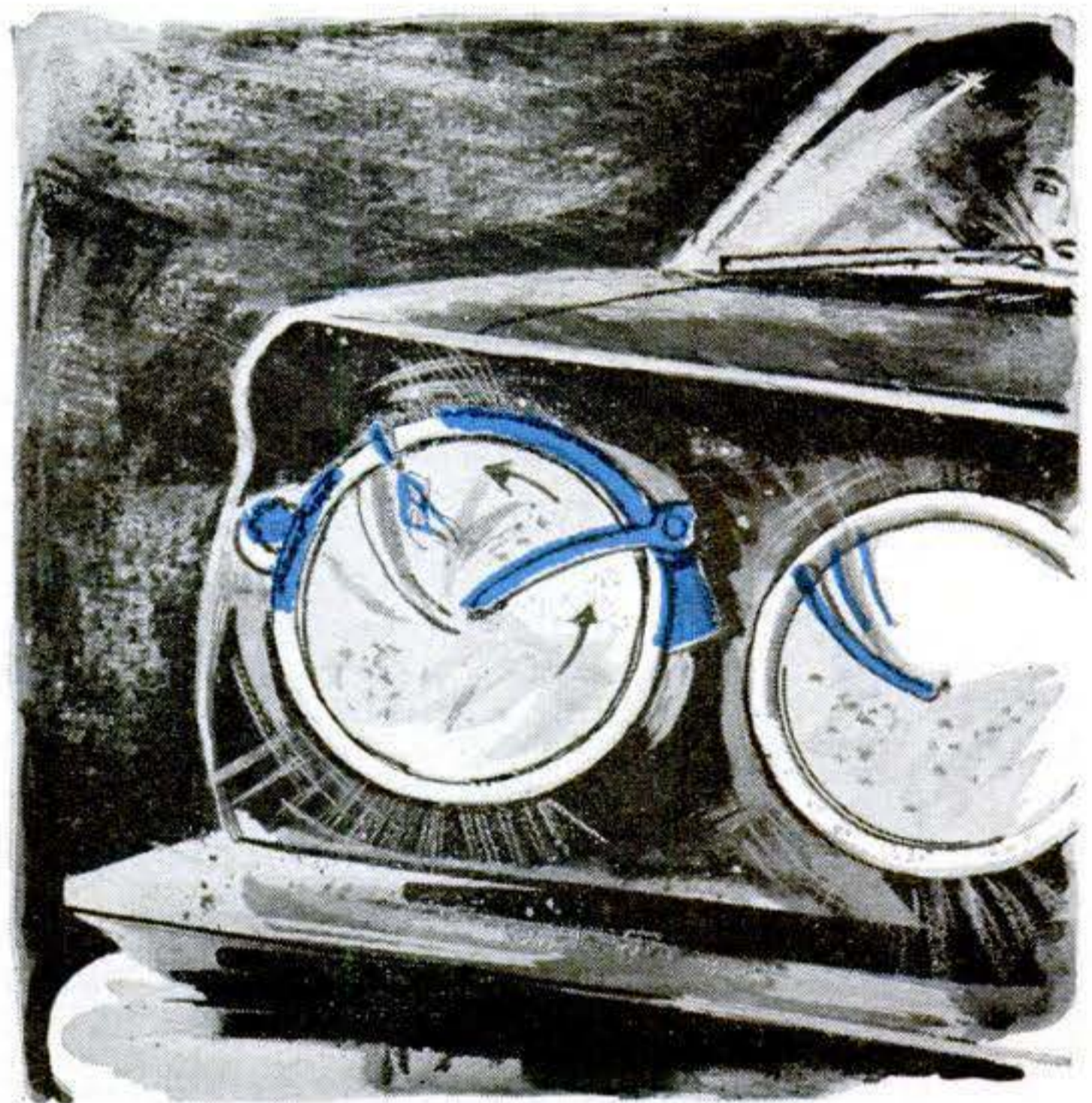

**Wiper keeps lights clean.** You might see—and be seen—better in bad weather with a system that kept headlights clean. This GM invention would divert a jet from the windshield washer to spray the lenses, and wipe them with a blade whose pivot point would be ratcheted around the lights. The blade would then snap up out of the way.



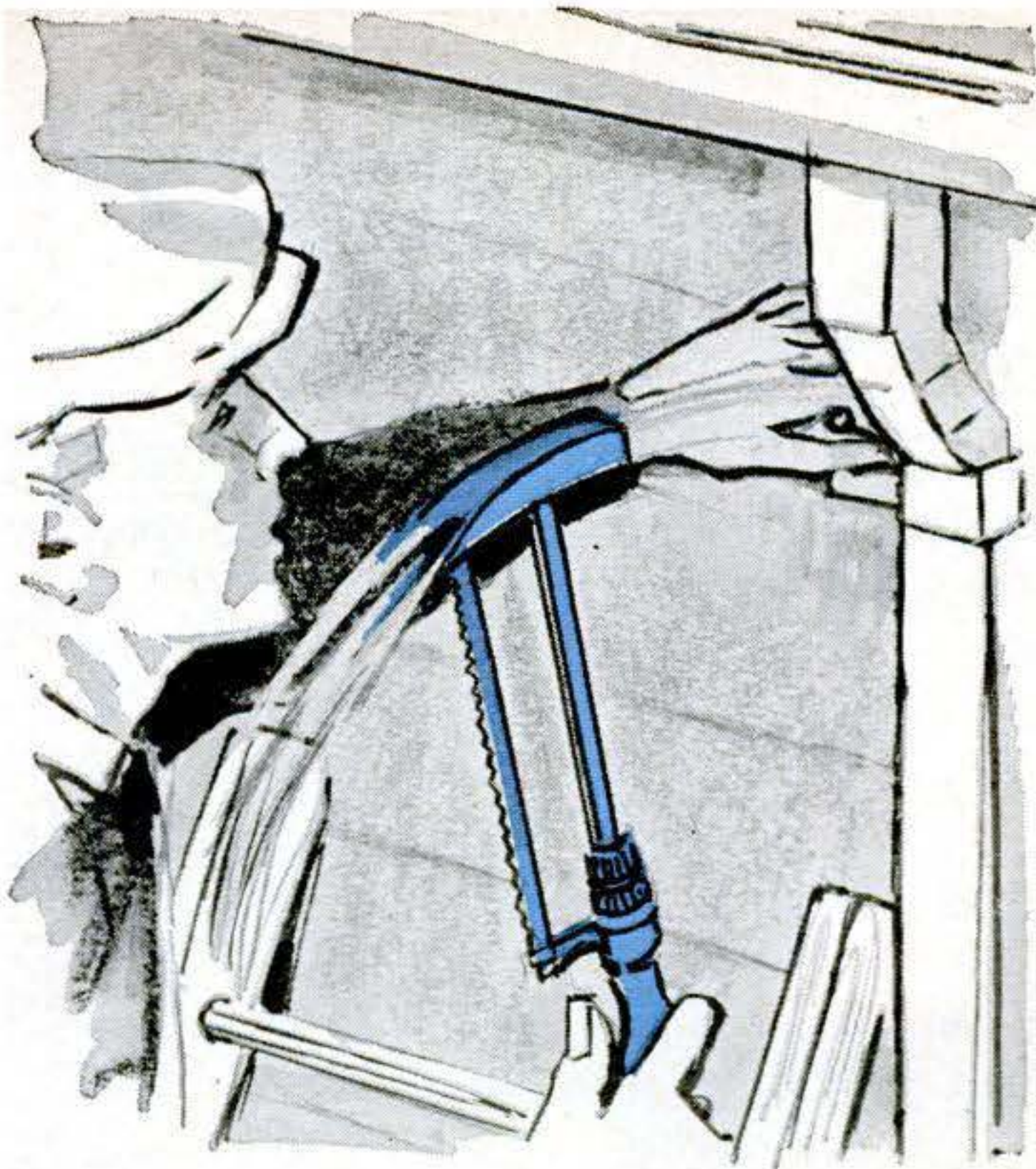

**Kit fits saw to hammer.** You might do less interchanging of tools if you had this knockdown, multipurpose kit for handyman jobs. Saw, claw, and hammer would support each other, and any one could be used without changing the setup. Reversing the tool, you could chuck matched drills and screwdrivers in the handle.



**Handle inflates umbrella.** You'd be prepared for doubtful weather with this collapsible umbrella in your pocket. To use it, you'd pull the pleated, plastic canopy out of its case, slip the case onto a plunger, and work the plunger to pump air between the canopy's seams. Telescoping joints would extend the handle.

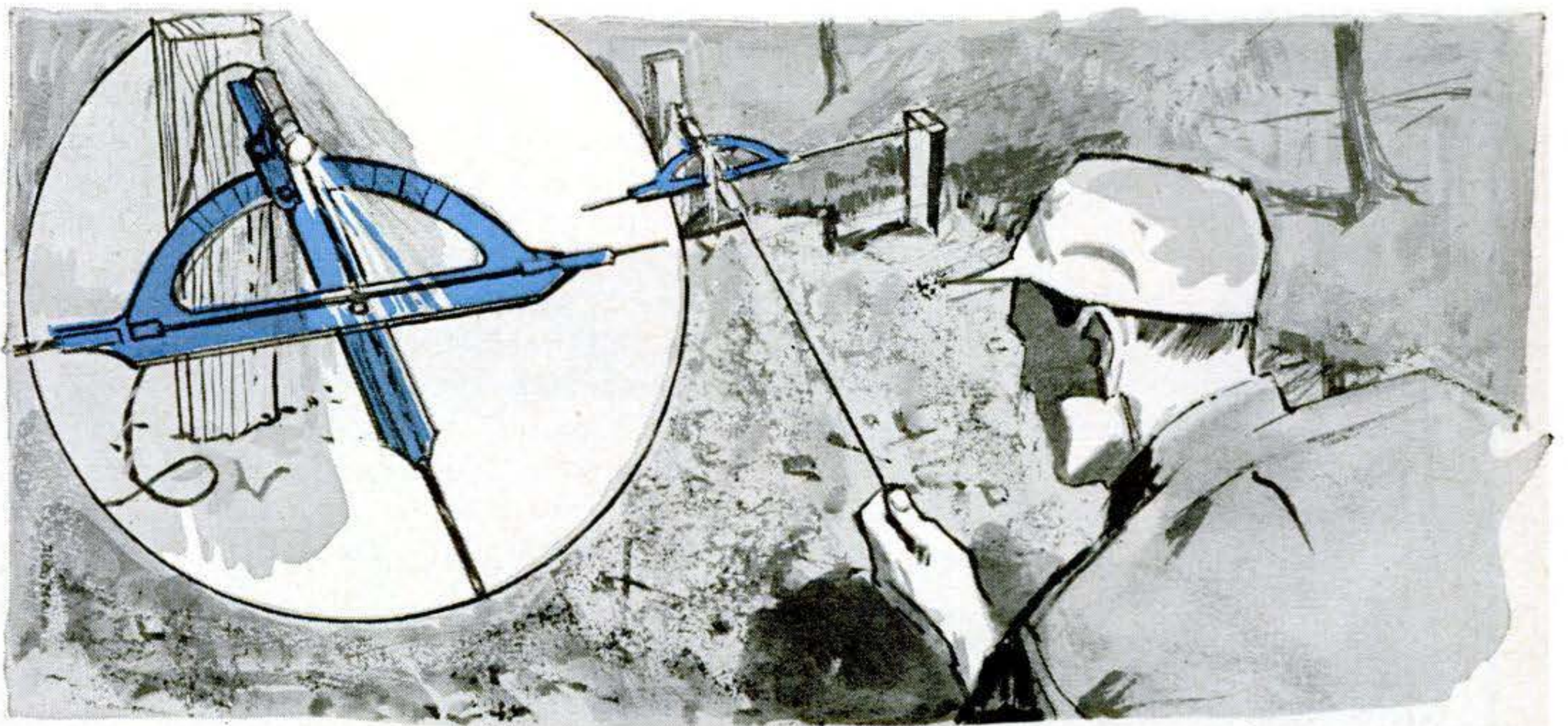

**Protractor light guides line.** One man could sight a construction line easily and accurately with this light-up protractor. He'd set an adjustable contact to any de-

sired angle, then draw out the line attached to a pivoting contact. When the contacts closed, a flashlight would signal that the line angle was just right.

*The following patents have been issued on these inventions: Boat wheels—No. 3,035,282 to Herbert A. Bemis, Carlsbad, N. Mex.; Coffee dispenser—No. 3,056,532 to Charles E. Germano, Poughkeepsie, N.Y.; Wiper—No. 3,058,142 to Samuel C. Pollock, Rochester, Mich.; Tool—No. 3,038,177 to Fritz Mächtle, Korntal, Germany; Umbrella—No. 3,053,266 to Thomas H. Burns, Seattle,*

*Wash.; Protractor—No. 3,061,931 to Benny J. DiStefano, Detroit.*

*Copies of patents may be ordered, by number, from the Commissioner of Patents, Washington 25, D.C., at 25 cents each. To write to an inventor, if the address given above is insufficient, address him (by name and patent number) in care of the Commissioner of Patents.*



# Time Bombs in the Mississippi

Four tanks of liquid death—chlorine—lay at the river bottom, ready to spew a lethal gas over two states

By E. D. Fales Jr.

**T**WO states braced for disaster. All ships on the Mississippi had been warned. Six thousand residents had fled Vidalia, La., and Natchez, Miss., where a 15-car escape train waited to gather up hundreds more. At least 40,000 gas masks had been given out, for at any moment a choking yellow cloud might spread like a horrible ghost into the night over Louisiana and nearby Mississippi.

The U.S. Weather Bureau had set up

Circle of danger encompassed dozens of towns.

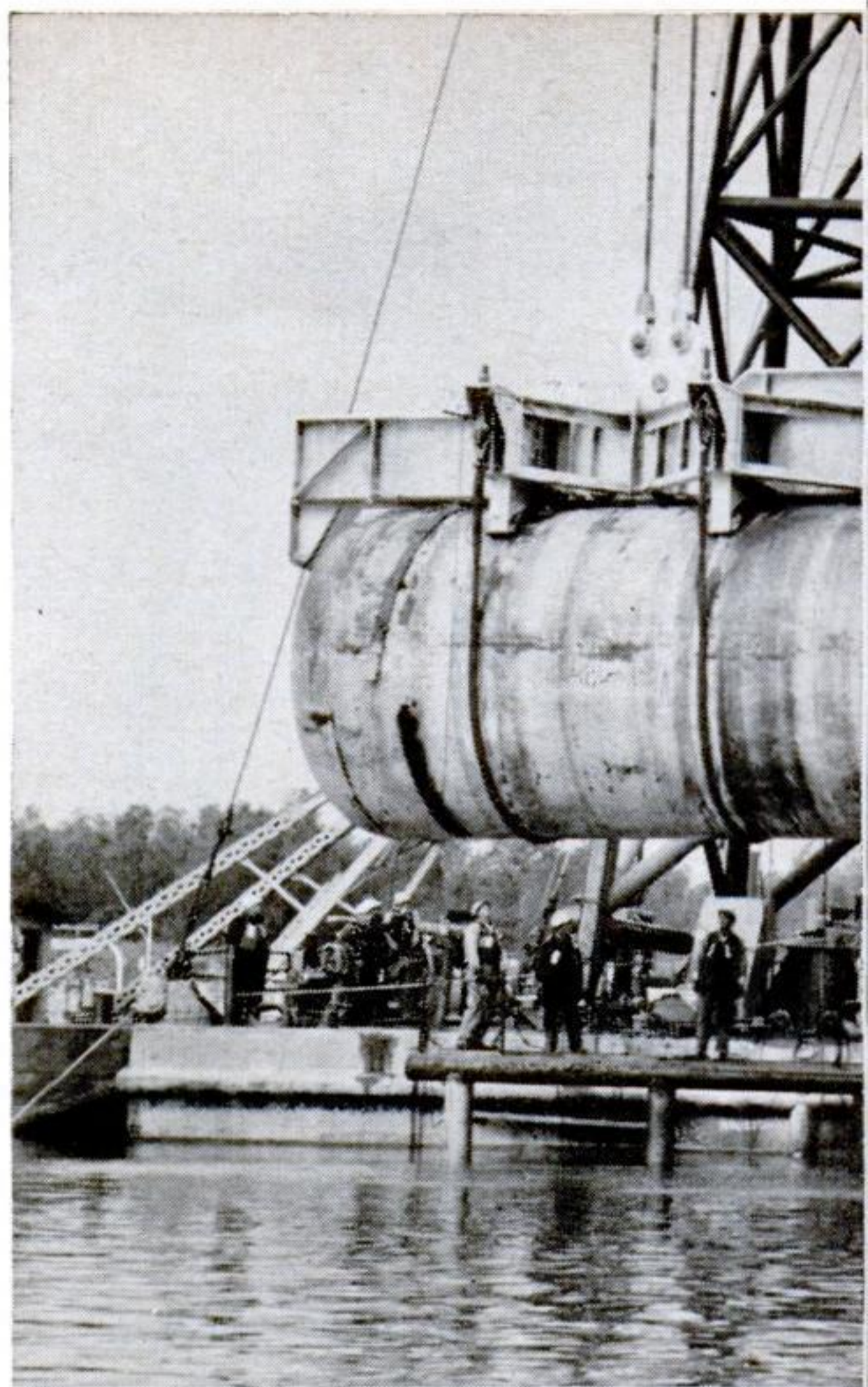
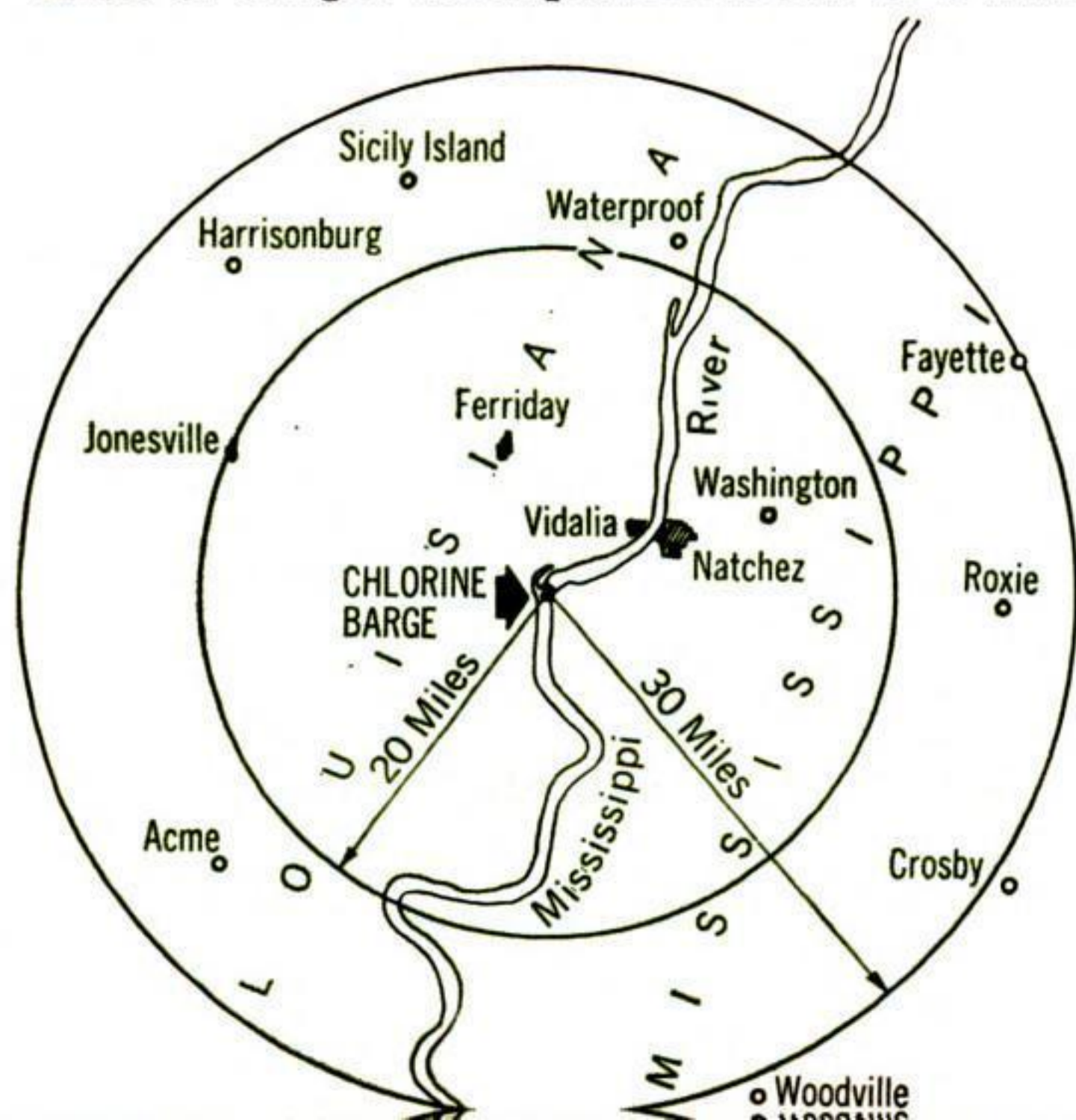

First of the huge tanks is lifted

six emergency stations to test the slightest shift in wind, on which the safety of 70,000 now might hang.

Armed troops waited along Mississippi roads to snatch wrecked cars away and keep traffic moving if the gas came. Disaster workers flew in. The Red Cross evacuated the sick. Over Louisiana highways came a parade of vans—the disaster fleet of the Louisiana State Police.

In 20 towns, meetings were called. If the gas comes, citizens were told, *move fast and keep moving.*

A circle 60 miles across was declared the danger zone. It reached from Fayette, Miss., west to Acme, La., taking in long stretches of U.S. Highways 61 and 84. On the Mississippi River, ships and barges heading toward Natchez were stopped and gas masks given crews and passengers.

Somewhere at the bottom of the river lay four weird time bombs that together contained more poison gas than was used in any major battle of World War I.

The nightmare had begun at dawn on March 23, 1961. The 3,500-hp. diesel towboat Eastern had been battling upriver behind 16 barges, hugging the eastern



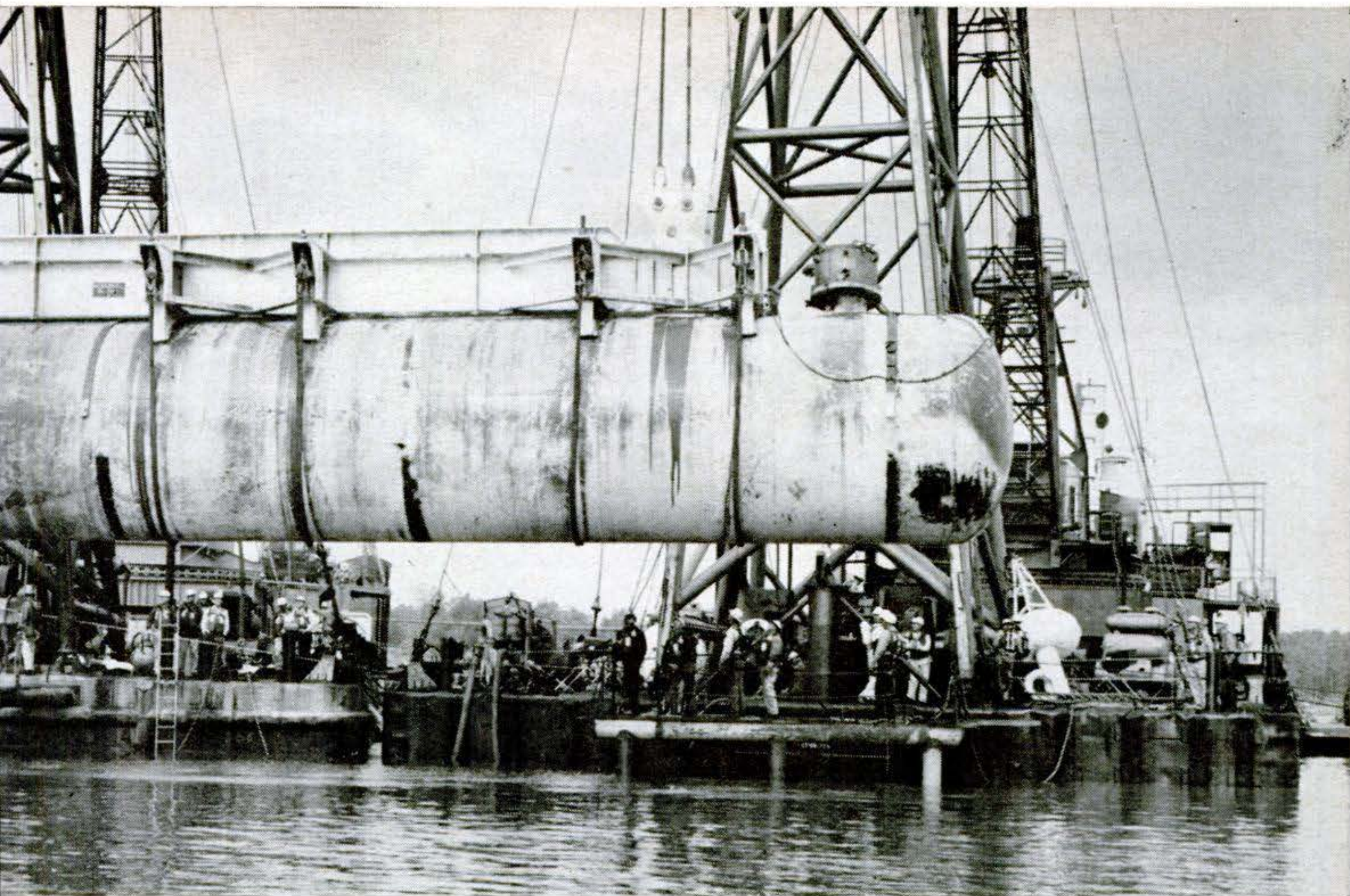

by Bolin and Herman B. A 30-ton strongback rides astride the tank. Valve dome is at right.

shore, working north in quiet backwaters.

Its barges rode four abreast. The left-front one, called Wychem 112, was making a 1,200-mile voyage from Baton Rouge to Charleston, W.Va. It carried a cargo for a large chemical company—four monster green-and-white steel tanks. Each, if stood on end, would tower over a six-story building. Rising from each was a steel dome that protected sensitive safety valves. The domes carried the ominous lettering, CHLORINE.

Seven miles south of Natchez, all north-bound ships make the Natchez Island crossing. At 4:47 a.m., in hazy light, the Eastern came to the crossing and headed for the western shore. And at this moment the four front barges smashed headlong into a vicious spring-flood current.

*A bow wave built up.* Three of the four leading barges rode it out. But from Wychem 112 came staccato sounds like gunfire as the giant wave raced across her deck and crashed into her hold.

The sounds were Wychem's cables parting. Swamped by the wave, the barge poked her bow under the surface, shot down like a submarine—and vanished mysteriously.

The river here, in flood, was 100 feet deep. The Army Engineers patrol boat that sped to the scene, fathometer going, should have had no trouble picking up strong echo signals from such a huge wreck. But no signals came back. And, later, when divers went down, they found no trace of a wreck at all.

No one worried—yet. A newspaper quoted an official as saying that a shipment of

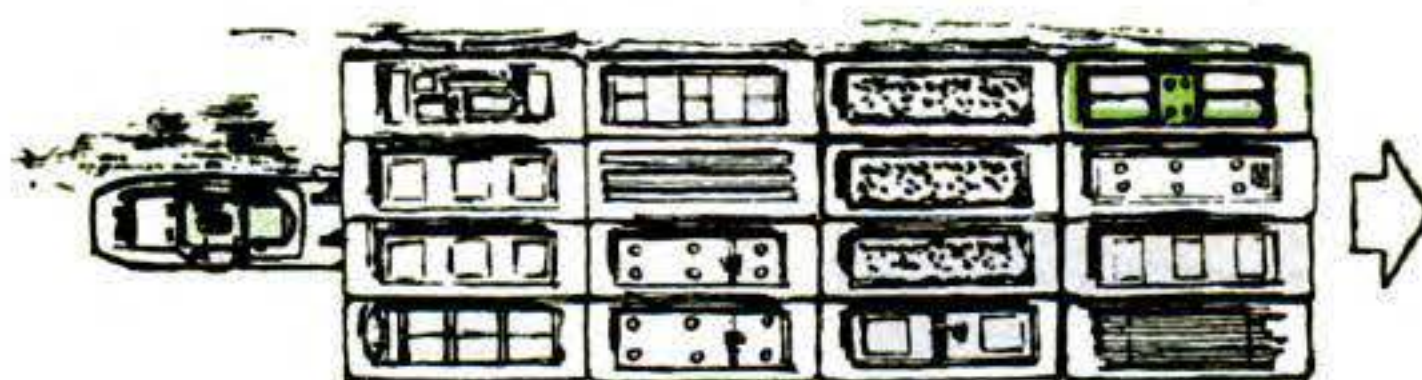

chlorine had sunk, but if any escaped it would merely "purify the muddy Mississippi." This was a remarkable statement in the light of later events.

Liquid chlorine is a pale-yellow fluid. Released from tank pressure, it turns into green-yellow chlorine gas. By coincidence, not many days earlier, a railroad tank car of chlorine had burst in a train wreck near New Roads, La. A green-yellow cloud had scourged the countryside for six miles. Over



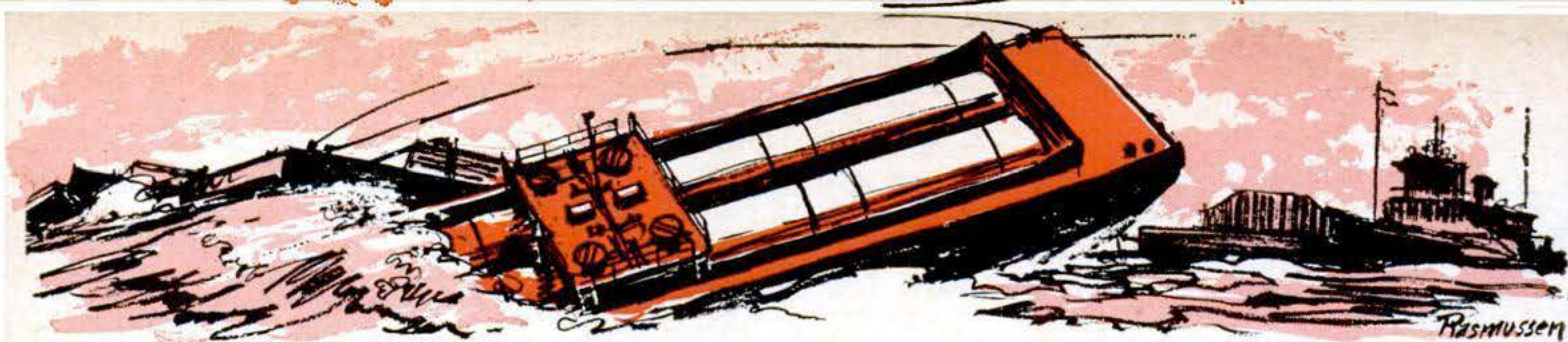

Stern bucked high in the air, the Wychem 112 snapped its cables and nose-dived like a sub.

100 people were taken, choking, to hospitals. A child died. Hundreds of animals were killed. Yet this had been a relatively small shipment, a mere 20,000 pounds. By contrast, there was 2,200,000 pounds of liquid chlorine in the four submerged tanks.

But more than a year passed during which the prosperous Valley towns lived in blissful ignorance. Then last summer someone told the U.S. Public Health Service: Somewhere at the bottom of the river was enough chlorine to fill a whole train of tank cars. Since all wrecks rust, it was only a matter of time before it would escape. There was also the danger that a ship might ram the wreck, for the river was dropping 60 feet to a 40-foot summer depth. Or a falling anchor might smash the tanks. Or weakened safety valves might blow.

Quickly, the nation's "disaster central"—the office of Emergency Planning in Washington—swung into action. On September 7, a decision was made. Since the Army Corps of Engineers keeps rivers navigable, it would be their job. Orders went to the Vicksburg district: "Find those tanks. Use any means to get them out—fast." The district chief in Vicksburg, Col. Warren S. Everett, read his orders and whistled. If rust had set in, even minutes might count. But where were the tanks?

**A remarkable search began.** Three days later, a Navy submarine-hunter plane, cruising low near Natchez Island, began getting strikes on its electronic sub-hunting gear. Yet this was an area that had been carefully searched before. The answer lay in the shifting sands of the river bottom. The barge had become a restless ghost, moving with the sands.

A crew was sent to drill the river bottom. Water-jet probes, which would not burst the tanks, were used. The next afternoon, 65 feet below the surface and 14 feet deep in sand, a probe hit a hard object. The Wychem, after a year and a half, had been found.

Col. Everett moved fast. On September 30, his salvage contracts were let. At 4 a.m.

the next day a \$10 million commando salvage fleet was highballing toward the scene from a Gulf Coast port 600 miles away. It included two towering hammerhead derrick-barges, an ocean tug, two floating crew-hotels, and 20 other craft. At the same time, rolling east from California came trucks bringing 16 "wind machines"—gasoline-powered fans used in fighting Western forest fires. Should the gas escape, engineers would try to roll it back behind a wall of wind to give the 130 crewmen a chance to get off their ships.

**A call went out for divers.** Courage and skill were needed: Underwater cutting torches, burning at 5,000-degrees F., would have to be held steadily within an inch and a half of the steel tanks. This would be like holding a lighted match beneath a fuse, for steel, in chlorine, lights up and burns at 400 degrees.

The salvage contracts went to two Gulf Coast engineering outfits: Triple-C Boats, Inc., and Brown & Root, marine operators.

In all the excitement, few citizens had noticed three dusty pickup trucks from Texas that plowed along the levee near Natchez and discharged their load: a pile of diving suits, some underwater cutting torches, and eight solemn-faced men—divers.

They came from an outfit called J & J,

**Waiting to make a new descent,** chief diver Joe Carroll (right) chats with author on deck of the Bolin. Hard hats and life jackets were compulsory throughout the operation.





of Pasadena, Tex. The two Js stand for Joe and John: Joe Carroll, president and chief diver, and John Galletti, vice-president.

Lights glittered all over the salvage fleet when Carroll, Galletti, and six hand-picked divers saw it. A curtain of sound hung in the night: the whine of compressors, the roar of wind-machines tuning up, the clatter of hammers.

For days before they dared enter the river, Carroll and his team pored over blueprints of the Wychem, memorizing every rivet. Meanwhile, a diving station was set up on the Bolin, one of the two derrick barges.

When Carroll dived on October 14, he was appalled by the blackness of the river. It was like diving into strong coffee. He couldn't see his hand before his helmet, or even the little round window itself. He dropped cautiously, letting himself down a hand line. He wore no diving shoes, only soft galoshes. He didn't want to kick holes in rusty metal.

A diver lives by his lifeline—and his tender. Carroll's tender, a little man in a red steel hat, happened to be another Joe Carroll: his father. As Joe Jr. descended, his father cautiously fed out lifeline—air pipe, steel safety wire, and phone line all wrapped in one.

Underwater, Joe Jr. let himself drop slowly. He was 20 feet down when he heard the propellers of a big barge train, similar to the one to which the Wychem had belonged, fighting its way up the other side of the river. Then a surge of water swept past him, swinging him away from the hand rope. Though the barges were a quarter-mile away, the underwater currents they set up were trying to tear him away from his hand line.

*Carroll hung on hard*, waiting for the currents to subside, then continued on down. He was to have this experience many times, whenever a large ship or barge train passed. Now, letting himself down, he was suddenly stopped at 40 feet. His feet had hit something soft.

He groped cautiously and felt a small mound of sand. Wishing desperately that he could see, he thought of calling for floodlights but decided they'd be useless.

In the darkness, he had three fears: He might kick a hole in a rusted tank; he might dislodge heavy wreckage that could smash a tank; or he might disturb the sensitive

spring-loaded safety valves on top of each tank, set to blow off under certain emergencies. The valves were shielded inside the protective steel domes. But if they were damaged or had become seriously rusted, they might now be frail as paper. He lay prone to spread his weight and began digging carefully.

Minutes later Carroll's voice reached those on deck. "I'm on the dome of a tank and the damned safety hatch is wide open!" He was right over the naked valves. If they popped off now, he'd be instantly caught in a geyser of yellow chlorine.

Carroll backed away cautiously, coming to rest on a sand drift that he knew must cover a tank. Clammy forces began pulling at his feet. He moved to escape and a moment later his helmet rang against a hard object. He'd floated into a grotesquely-twisted steel handrail reaching up as though the Wychem were trying to climb out of its sandy grave.

The bottom of the Mississippi River is never still. It flows slowly, like a moving sidewalk—toward the sea. The curious force clutching at Carroll's feet was the effect of shifting sands. It was these that had buried the Wychem so quickly. If he made a misstep they might bury him, too.

For days, two Army dredges had been doing their best to uncover the wreck, sucking away mountains of loose sand. But since they had not dared drop their clumsy "suction snouts" near the tanks, they had dug a vast crater around it. This crater now was 800 feet wide, and the Wychem rose at its center.

Carroll phoned his discoveries to the deck. Still blind, he now found that by shutting his eyes he could get a better sense of feel and direction. After that, he always worked with his eyes shut.

For two hours he explored, and what his fingers "saw" appalled him. It had been



**He wouldn't quit** in spite of danger: "Wee Willie" Brown comes up after a dive.



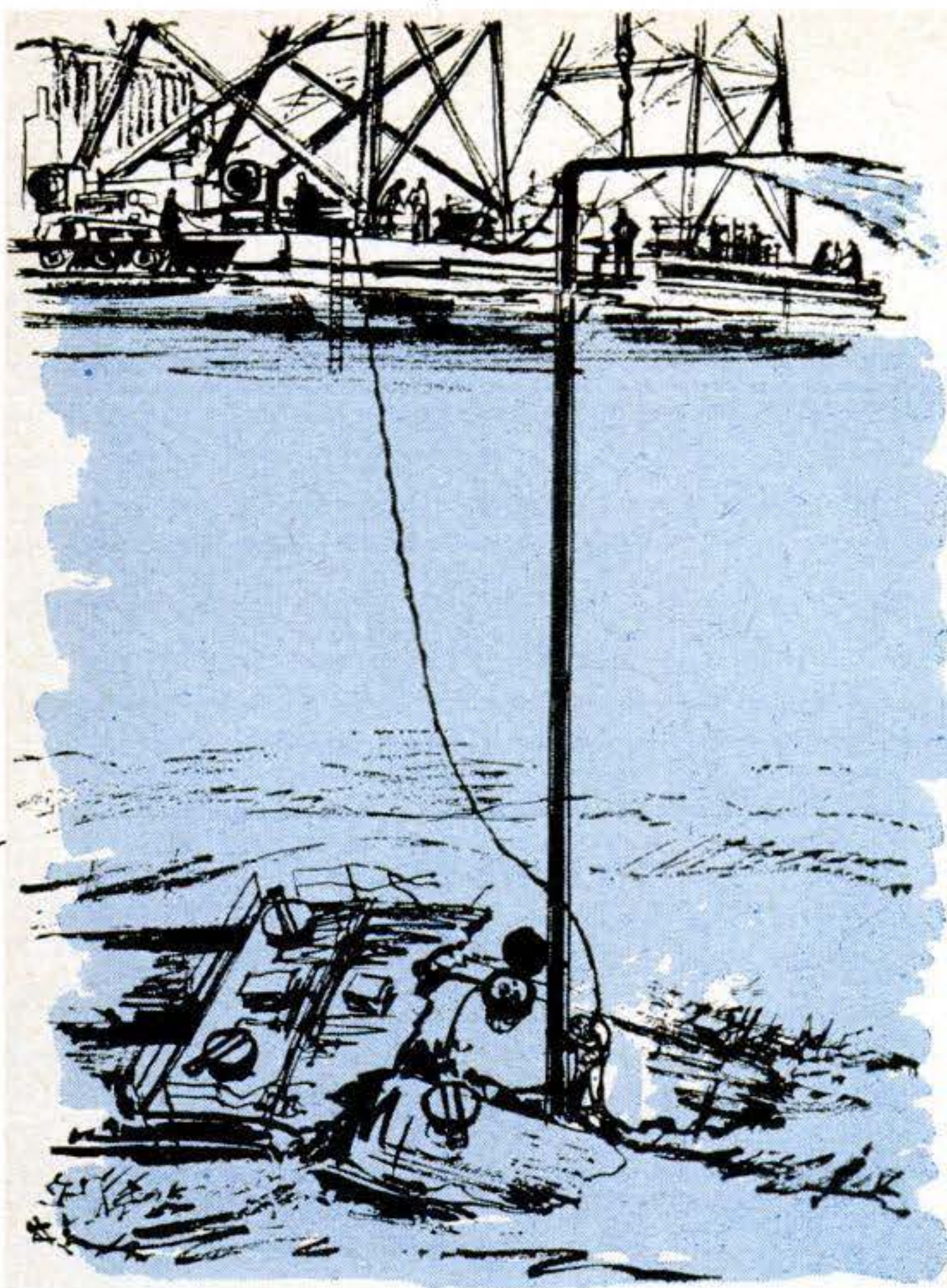

Bracing a shoulder against the airlift pipe, John Galletti grabbed it with both hands and began to siphon sand and rocks. Little by little, the four huge tanks were unearthed.

an impact wreck. The Wychem had rammed the bottom with enough force to bend itself in half and hurl its 100-foot stern half, along with two tanks, upward until they had tried to fold over the forward half. Then the stern had fallen back.

Toward noon Carroll went topside. "It's one hellish mess," he told his team. "Before we can go for the tanks, we've got to airlift."

An airlift is an angry pipe with the kick of a mule. Get between it and a wall and it will smash your ribs. This one was a 10-inch-diameter, 85-foot-long steel suction pipe.

Night had fallen when the airlift was ready, and John Galletti went down into the river to receive it. He grabbed it in a bear hug and guided it down between the tanks. He drove his shoulder against it and called for power.

*The mule began to kick.* With a roar, the airlift went to work. On one side of the pipe a high-pressure water jet blasted the sand between his feet, loosening it. On the other, a screaming air jet, turned upward into the bottom of the airlift, created a

mighty siphon. Galletti heard sand and stones booming up in the big pipe; the airlift was beginning its work.

Other divers relieved him: Herb Atwood, Norman Knudsen, Jim Bush, Don Hackin. Then Galletti took over again. Toward midnight, those on deck heard a cry: "Cut!" Galletti's left foot had been pulled into the suction pipe. Someone cut the power. He withdrew his foot and went on dredging. More and more, the tanks were being exposed. Yet the shifting sand kept trying to cover them up. Once diver Tom Hynson used the water jet to hose off the tank tops. It was like using a garden hose under water.

For three days and nights the airlifting went on. On the 19th, Carroll went down to size up the situation.

The No. 1 tank on the port forward side, to be tackled first, was tipped, and slowly creeping toward a sharp steel edge of the barge. The No. 2 tank hung ominously above No. 1. The after tanks, 3 and 4, were in better shape. But all had snapped some of their steel tie-downs, the powerful five-inch straps that anchored them to the barge. And if enough tie-downs snapped unexpectedly the tanks might roll.

*Falling wreckage was a hazard.* The tank walls were only 1½ inches thick, and tests had shown that even a small hole would grow by chemical action. Liquid chlorine, spurting out, would become a gas, bubble to the surface, and hang low over the river. Even a mild seven-mile-an-hour breeze could blow it into Natchez in an hour.

But the great danger was the electric torches. They can cut through steel as though it were butter. The flick of a flame against a tank could mean disaster.

Carroll's best torch man was a big Texan named Will Brown. "Wee Willie" had one weakness: The greater the danger, the more he hated to quit.

This was the man Carroll chose to start the surgery. His assignment was to burn away tangled railings and pipes, then cut the loading deck—a large steel platform—into sections for lifting.

On October 19, Brown went down with his pistol-like torch. Eyes shut, standing on the No. 1 tank, he found a torn railing, pushed the torch against it and called: "Make it hot!"

On the Bolin, someone closed a switch, throwing 400 amperes into the torch. Brown pulled the trigger and waited for the daz-



zling flame that, he expected, would help him see.

He heard a sizzling sound. But no light came. His fingers grew hot; the torch was blazing not two feet from his eyes, and he couldn't see it. He thought: "Now I do need eyeballs in my fingers."

Almost immediately he made another discovery: The flame refused to bite the steel. Barge and tanks had been painted with tough epoxy-resin paint. After 18 months it was still protecting the metal: He had to burn it for a full 15 seconds before the flame would touch steel. Even so, he often had to chisel or file the paint away.

To cut the supporting beams, it was necessary to crawl under the deck. Brown had just begun a cut there when the explosion came.

They heard it up on the Bolin. The loudspeaker squawked wildly and thunder shook the deck. Task Force Chief Ira Boswell and Salvage Chief W. B. Nelson heard it in disbelief. Men reached for gas masks. Then there was silence, and from the depths, a dark, bubbling swirl appeared.

The silence was broken by the urgent chatter of an outboard motor. Coming fast was a 21-foot surveillance boat, Corky, with engineer Curtis Love at the helm. Love yanked the throttle open and raced the Corky directly into the swirl, his free hand spraying the air with gas-detecting fluid from an atomizer.

*If gas were spewing from the river*, the fluid—ammonium hydroxide—would turn white, and Love would push the panic button. If he sounded a siren, all hands would abandon. The task force command would broadcast: "MAYDAY MAYDAY MAYDAY FLASH MAJOR ESCAPE OF GAS. ABANDONING." A headlong rush for shore would begin. And as the news spread, 70,000 civilians would rush to cars, buses, and evacuation trains.

As Love reached the swirl, many eyes watched. Three times he squeezed the atomizer. Each time the spray hung briefly and remained clear. No chlorine—yet.

But what had happened below?

Wee Willie Brown's cutting torch was a type fed by oxygen and hydrogen, and at times both gases escape unburned. When Brown went under Wychem's deck, the gases were trapped in an explosive mixture. Working blind, he could not see the gathering bubble, or red-hot bits of metal from his torch.

The blast came with no warning. There



Chalking out a diagram of the wreck is easier over a cup of hot coffee. Carroll and the other divers often worked 12-hour shifts and stayed down as long as two hours at a time.

was a sudden roar. Brown's head rang, the live torch was torn from his hands, and he felt himself hurled through the water. Then he went numb all over.

He came to and heard Joe Carroll on the phone. Carroll was coming down. Suddenly Brown remembered his torch, humming with 400 amperes. He shouted topside: "Make it cold. *Make it cold!*" Someone cut the power. Then Brown, angry at being tossed around, found his torch and roared, "Hell, I'm all right. Make it hot!" He went to work again.

Diver Don Hackin got it next: A smashing explosion like a hand grenade sent him up, bleeding from the nose. After that Carroll went down again.

Hydrogen explosions do happen, but why were these repeating? Fingering his way, Carroll found the trouble: Beams under the deck had trapped gases in several pockets. There was only one thing to do: drain them all.

He called for a torch, crawled out on deck, and began burning holes. Minutes later an explosion hurled him away and stunned him. He'd found the first pocket. He rested, waited for his numb arms to come alive, and then cut again, only to be hit by another blast.

"He worked for an hour," says engineer Ed Kyle. "He was half dead when we brought him up, but he'd bored more holes than a woodpecker." There were no explosions after that.

From October 20 to 22 there were many minor problems, each calmly met and solved. Col. Everett stayed close by in his



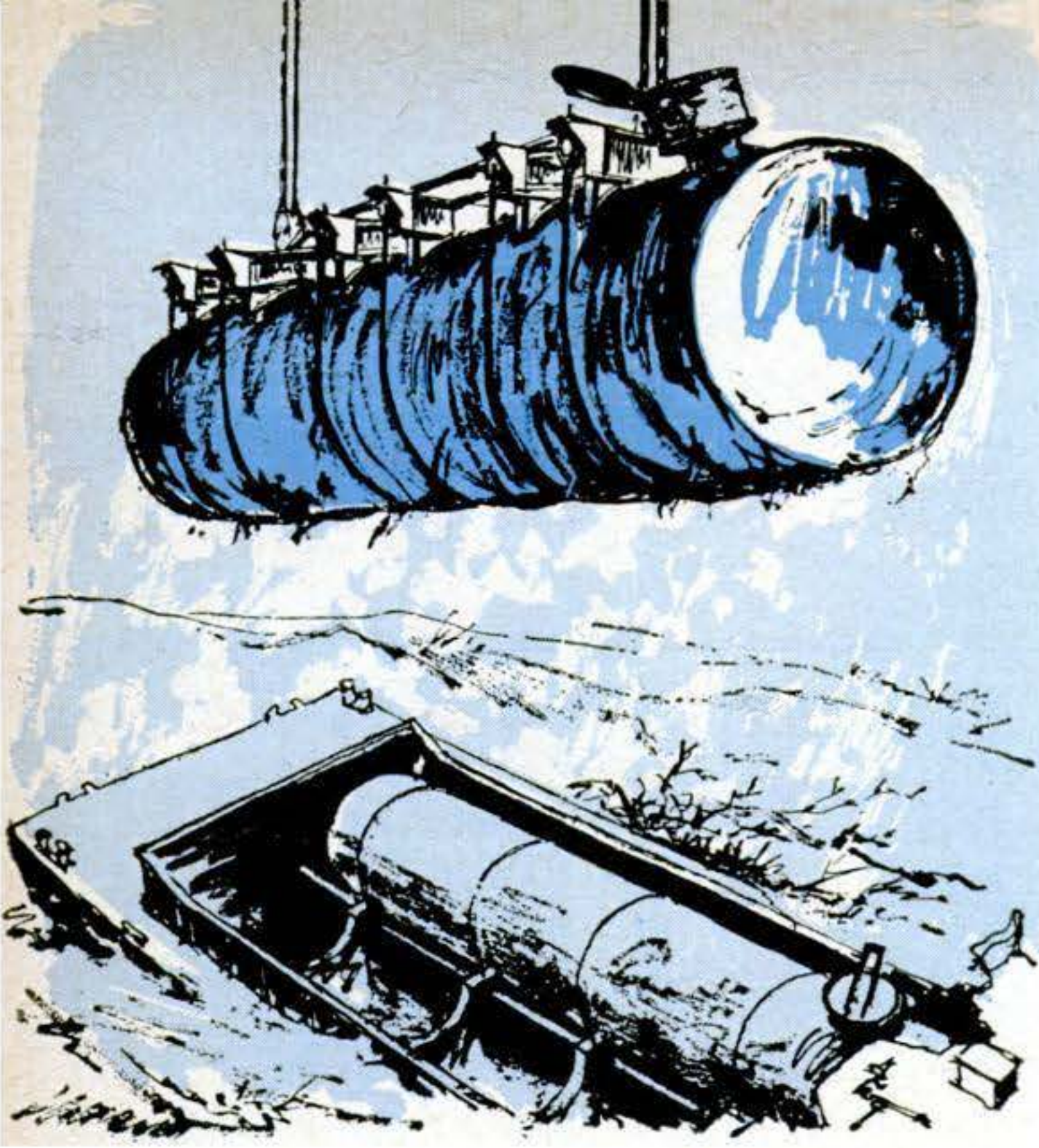

**Strongback**, a 30-ton strait jacket lashed to the tank, was lifted gingerly. Critical moment came when tank "readjusted" itself in its cables from slanting position to horizontal.

patrol boat. But he never interfered, and thereby won the gratitude of engineers and divers. Once, diver Hackin got blown to the surface feet first by a blast of air. Another time, Wee Willie's diving dress ripped and filled. He was hauled up and dumped upside down to drain. His worried mates then saw him grinning at them, upside down, through his window.

Repeatedly the divers crept along the big chlorine tanks, feeling the clammy sides until they found the five-inch-wide tie-down straps. They burned these, a mere inch or two from the tank walls, until they twanged



**Massive 20-part lower block** of the Herman B derrick is brought down slowly to pick up one of the special 2½-inch hoisting cables before the strongback is lowered. The Bolin's block can be seen at far right in picture.

apart. Sometimes they shoved small asbestos sheets between straps and the tank for safety.

*All the loose wreckage was lifted* by the night of the 22nd, and the No. 1 tank was ready for its "strait jacket"—a monster steel claw called a strongback. This was 60 feet long and weighed 30 tons. On October 23 it was gingerly lowered astride the tank and the divers lashed the big chlorine-bearing egg to it with 12 sling cables. The derricks wouldn't chance lifting the tank, lest it break in the middle. Instead, they would lift the strongback. This, in turn, would lift the tank, which now lay shakily in its clutches.

At midnight the strongback was ready. Early on the 24th a big impact wrench was lowered to give the sling-cable turnbuckles a last tightening. Then the divers came up. It was now up to the derricks. The lift would have to be silky smooth, so—in this diesel age—the job was given to steam.

Lift day, the 24th, had dawned clear and fearful. To avoid confusion, firemen and police ashore were ordered not to sound sirens for *any* emergency—but gas. Children in 40 schools went through drills.

At the emergency weather station on the levee, one small problem arose. A screech owl from a nearby wood had developed an interest in the whirling wind cups. It kept flying out to sit on the weather vane, and upset the readings. Weathermen kept running out to chase the owl so they could flash the correct readings by radio. At sun-up, the breeze was from the north, good for Natchez but ominous for scattered communities southward. During the day it might shift.

The great danger now was that the No. 1 tank would be dropped. It could be lashed to the strongback only in the tilted position it had assumed in the wreck. During the lift, it would have to be leveled; and this readjustment would throw tremendous strain on the sling cables.

There was also a weight hazard. Under

[\[Continued on page 214\]](#)

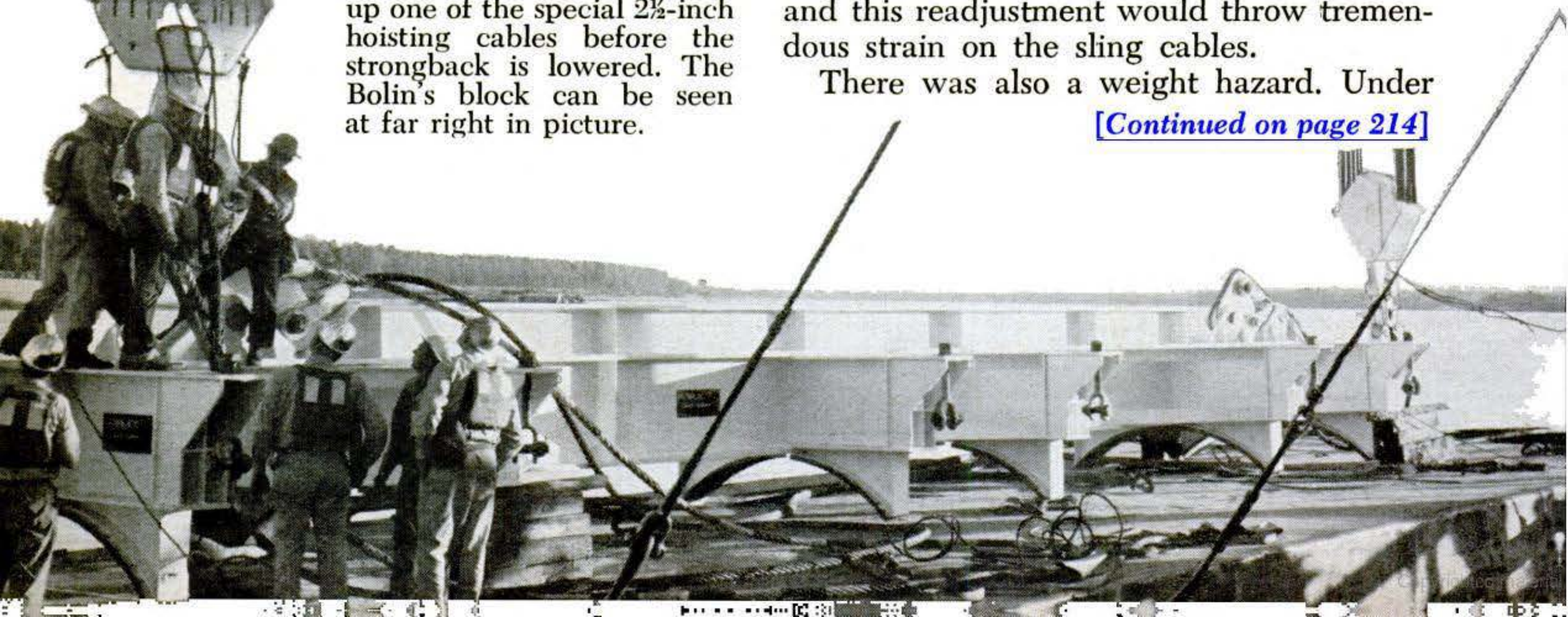



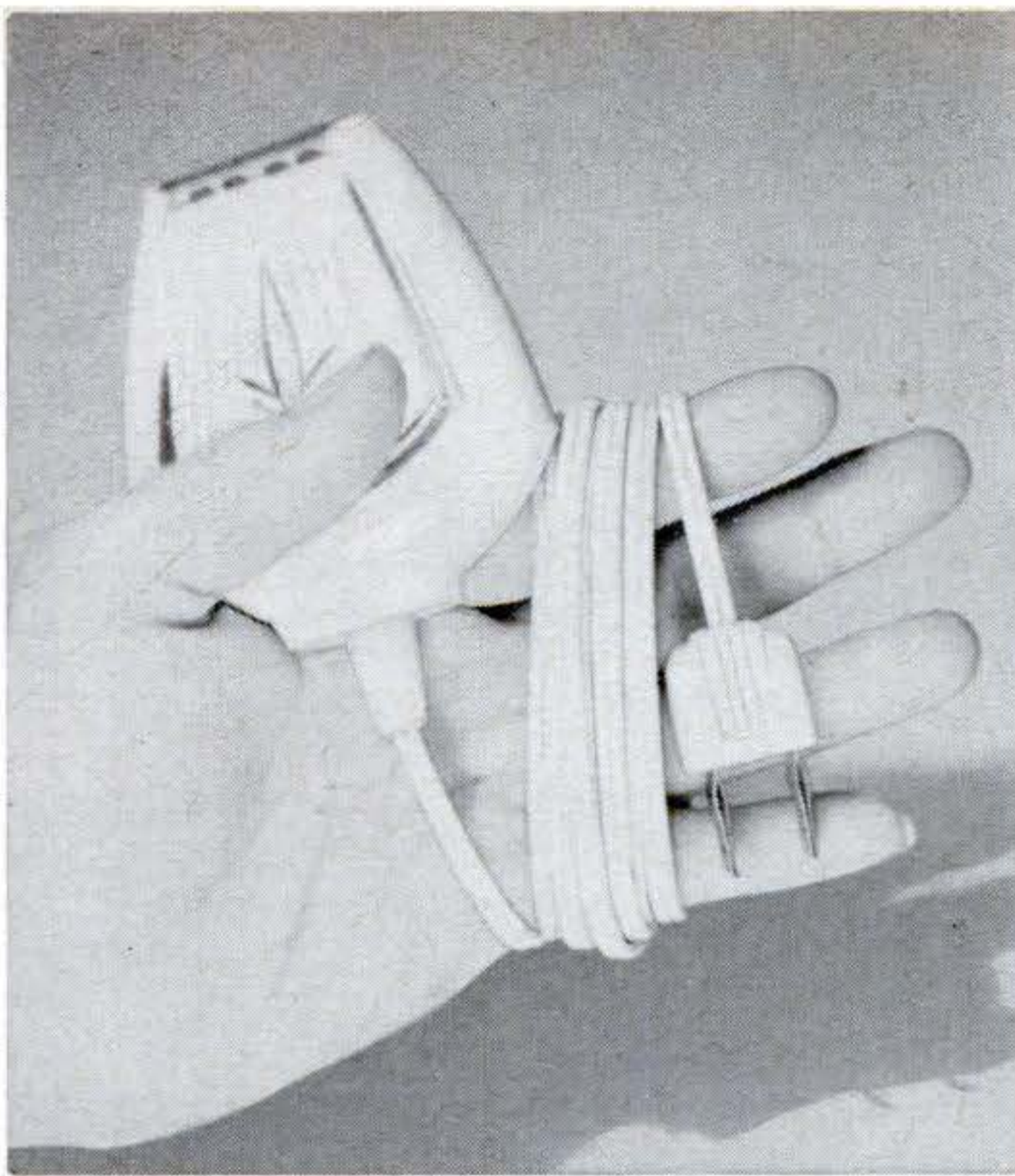

### Cord coiling for small appliances

Here's an easy way to coil a cord from a shaver or other small appliance without fuss or fumbling. Hold the shaver in the crook of the thumb (as shown above) while your extended fingers act as hooks on which to wind the cord tightly. As you withdraw your fingers, pull the plug through. Easy as pie—and fine for appliances that can't be left permanently plugged into an outlet.—*Jack Kenison, Tacoma, Wash.*

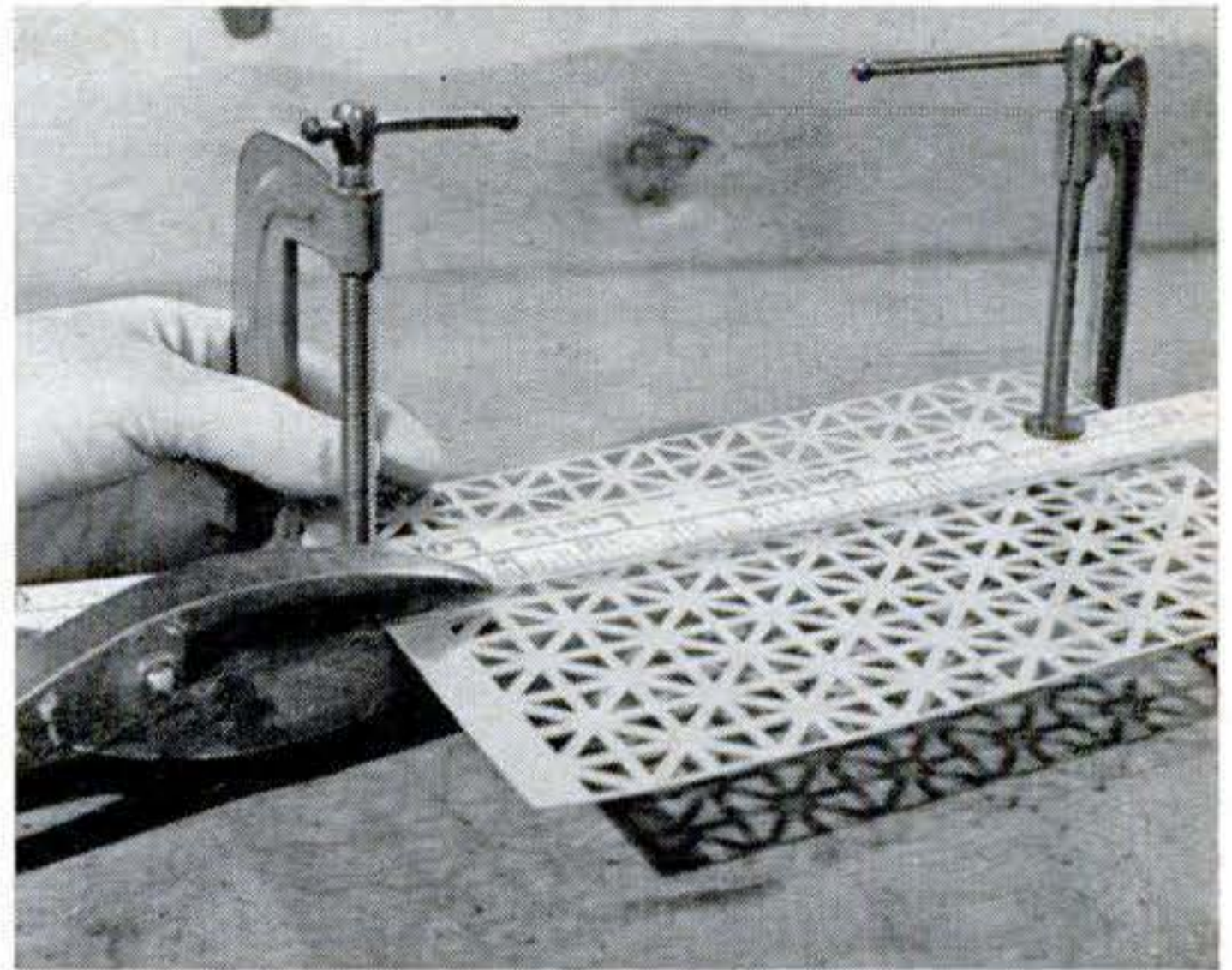

### Smooth way to cut without scribing

A pencil or scribed line on workshop sheet aluminum is not easily seen when cutting. To lick the problem, I clamp each end of a yardstick to the metal and use it as a guide for my cutting snips. By looking at the inch marks, I can tell where to stop cutting. A small piece of work is shown, but of course the yardstick is long enough for use with a large sheet of aluminum.—*Ken Murray, Colon, Mich.*

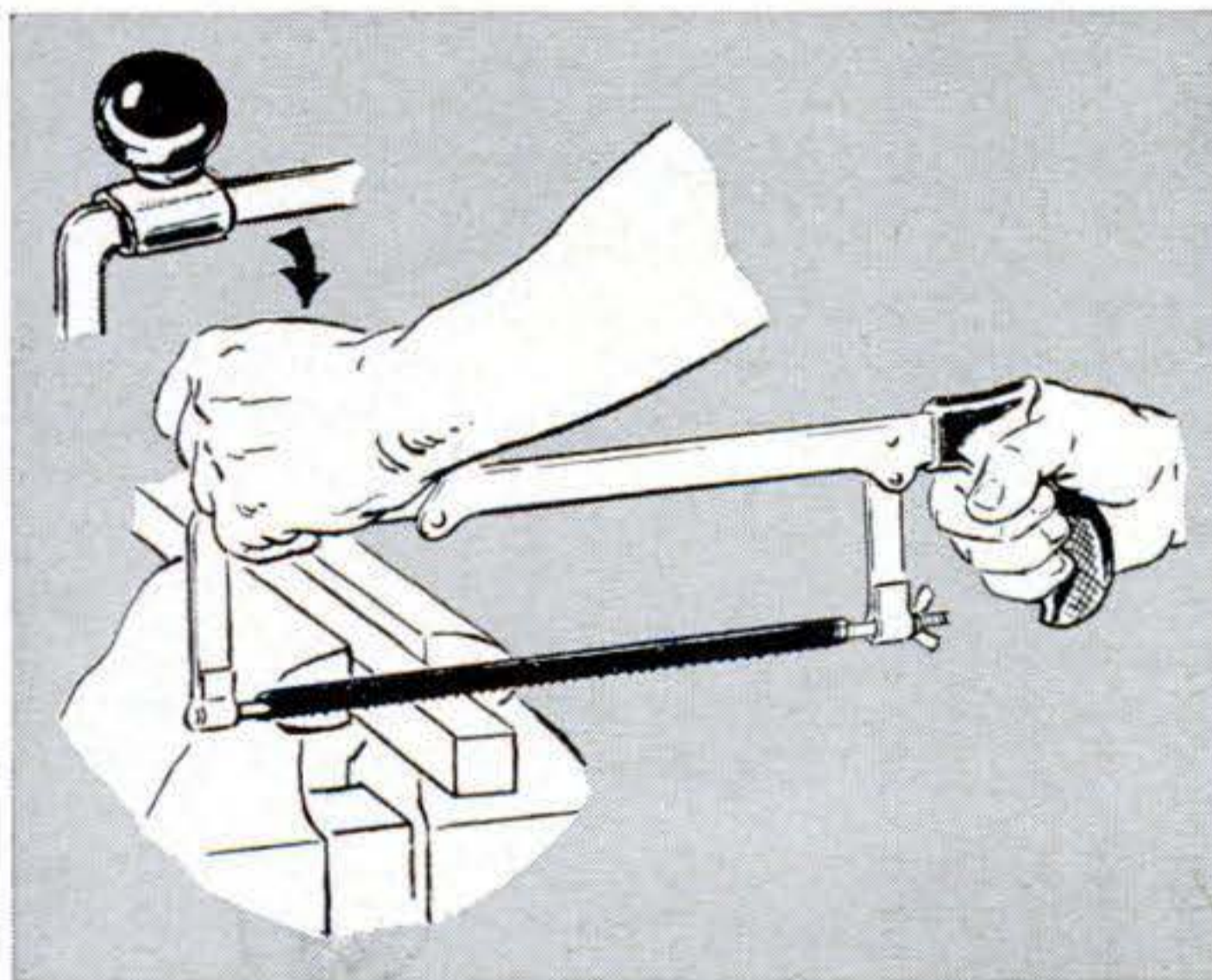

### Adding a knob to a hacksaw

Mounting an auto steering-wheel control on a hacksaw provides a better grip when two hands are needed for quick or difficult cuts. The knob also prevents slipping on the backstroke—and injury to your other hand—which can happen when you hold only one end of the saw frame.—*M. Peacock, King of Prussia, Pa.*

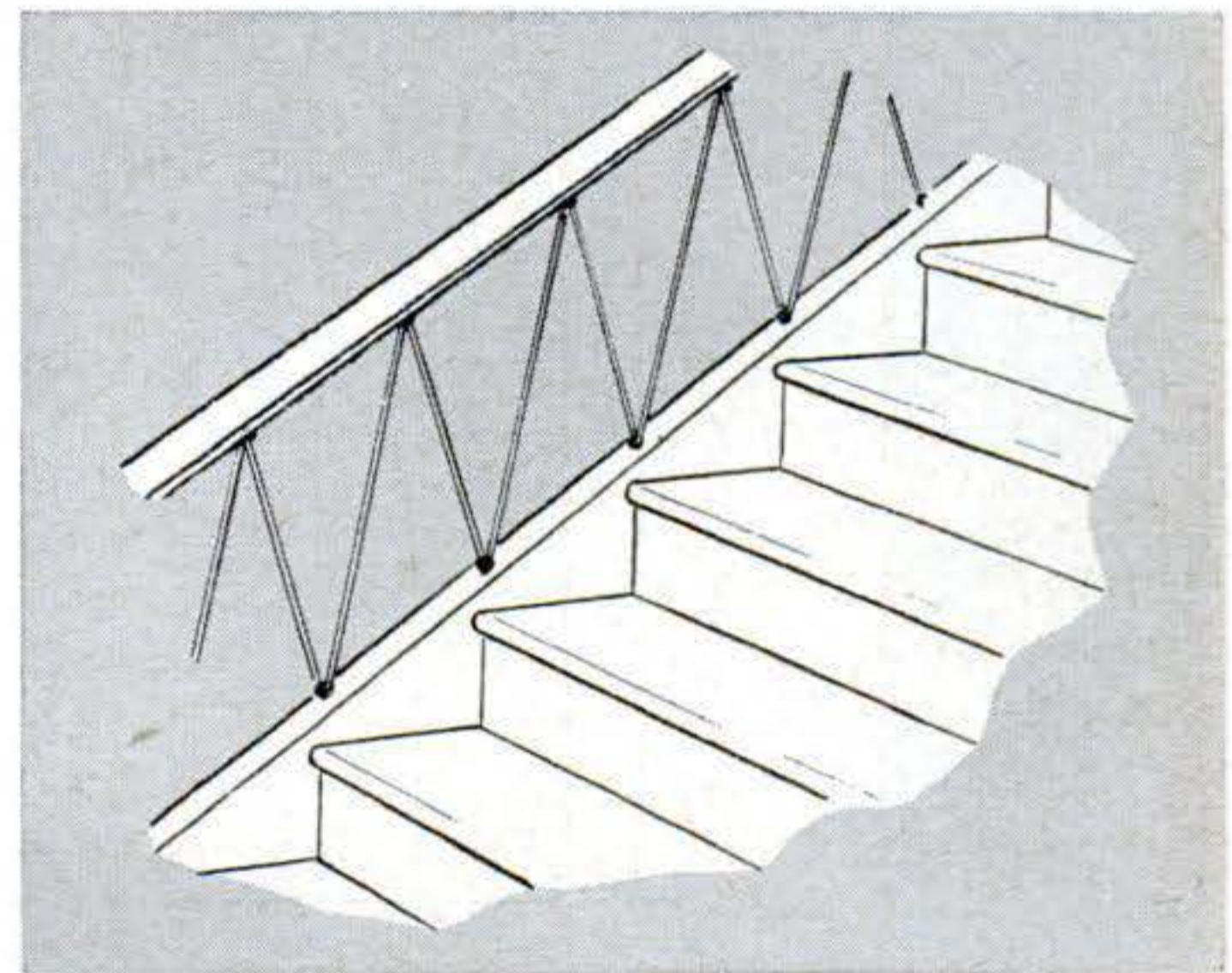

### Clothesline makes stairway safer

A little work and some inexpensive materials made my open stairway safe. After securing the handrail at a convenient height, I installed screw-eyes along its underside and on the edge of the stairs. Then I zigzagged a plastic clothesline through the screw-eyes and anchored it with a knot.—*Mrs. M. Krucker, Davenport, Iowa.*



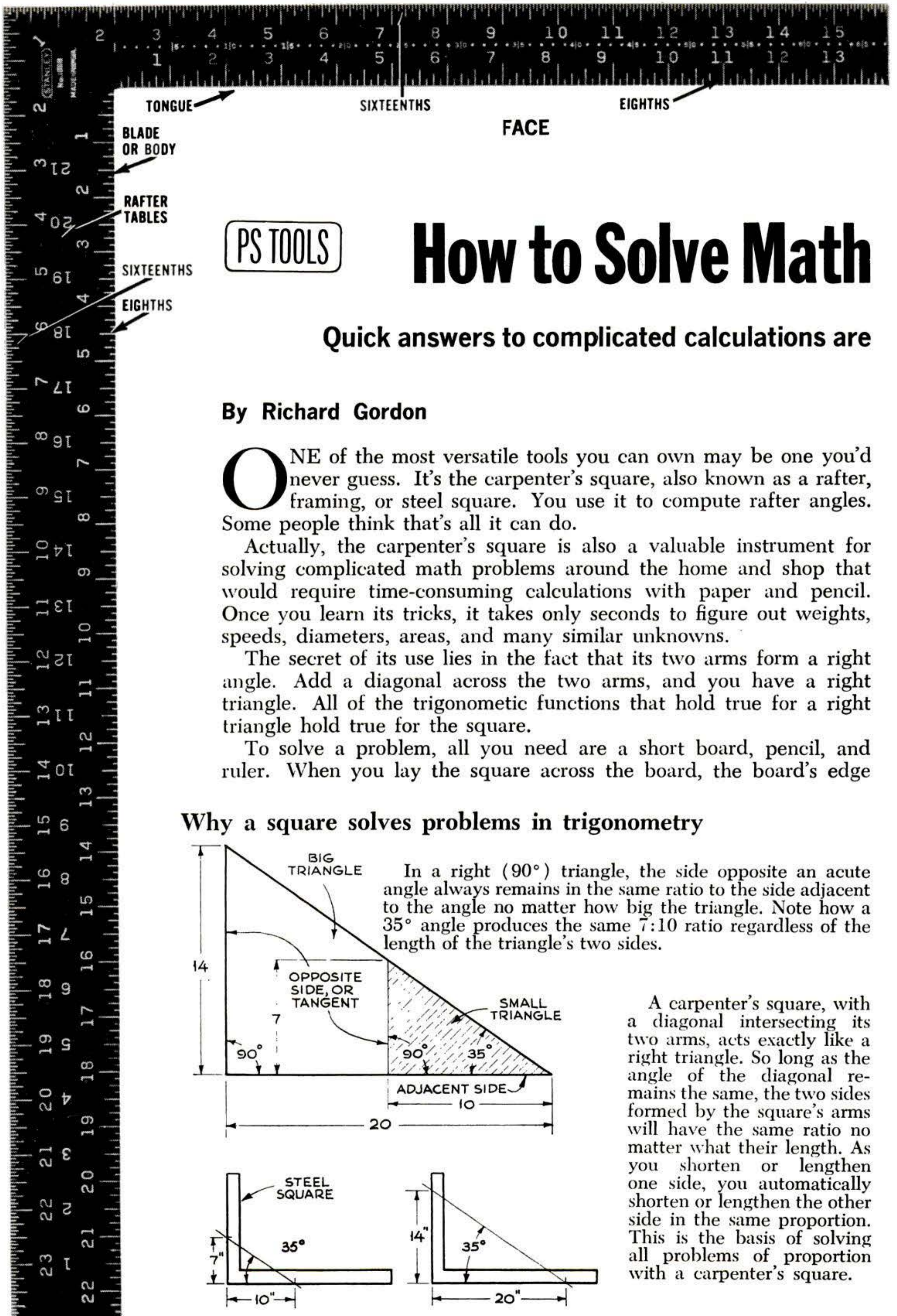

PS TOOLS

# How to Solve Math

Quick answers to complicated calculations are

By Richard Gordon

ONE of the most versatile tools you can own may be one you'd never guess. It's the carpenter's square, also known as a rafter, framing, or steel square. You use it to compute rafter angles. Some people think that's all it can do.

Actually, the carpenter's square is also a valuable instrument for solving complicated math problems around the home and shop that would require time-consuming calculations with paper and pencil. Once you learn its tricks, it takes only seconds to figure out weights, speeds, diameters, areas, and many similar unknowns.

The secret of its use lies in the fact that its two arms form a right angle. Add a diagonal across the two arms, and you have a right triangle. All of the trigonometric functions that hold true for a right triangle hold true for the square.

To solve a problem, all you need are a short board, pencil, and ruler. When you lay the square across the board, the board's edge

## Why a square solves problems in trigonometry

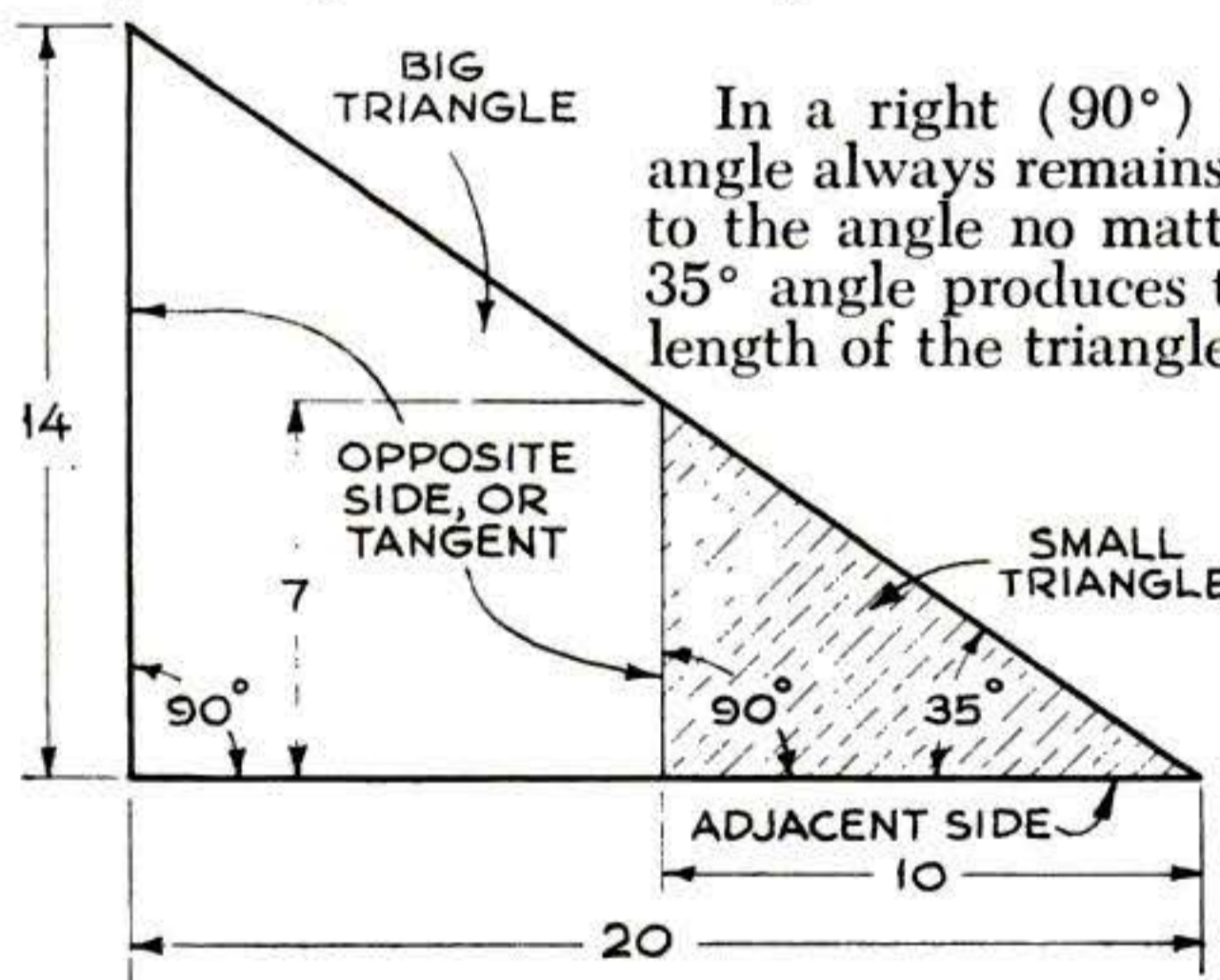

In a right ( $90^\circ$ ) triangle, the side opposite an acute angle always remains in the same ratio to the side adjacent to the angle no matter how big the triangle. Note how a  $35^\circ$  angle produces the same 7:10 ratio regardless of the length of the triangle's two sides.

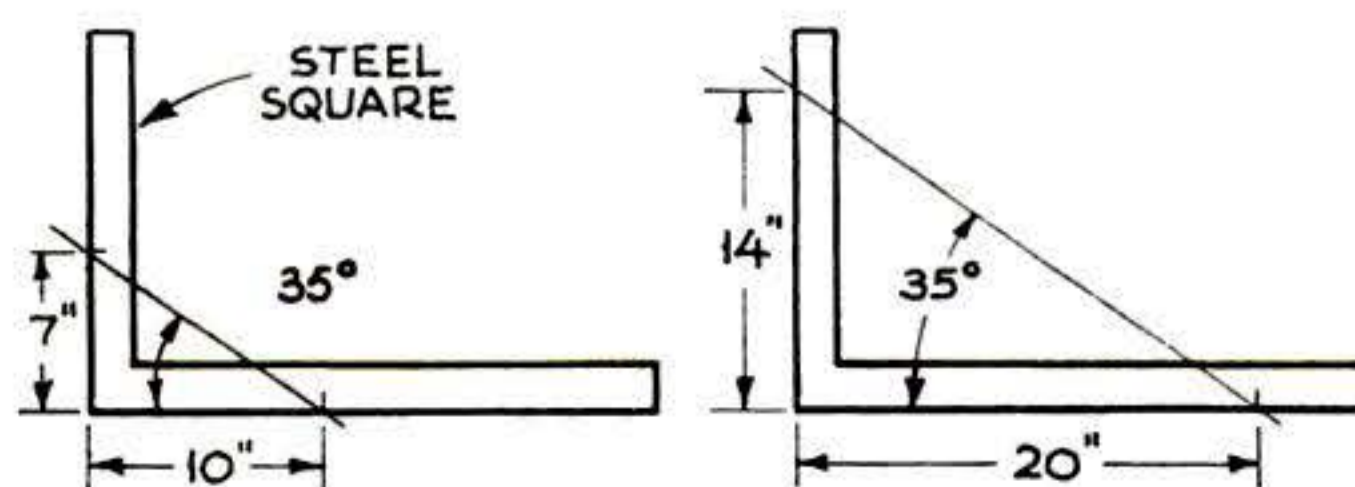

A carpenter's square, with a diagonal intersecting its two arms, acts exactly like a right triangle. So long as the angle of the diagonal remains the same, the two sides formed by the square's arms will have the same ratio no matter what their length. As you shorten or lengthen one side, you automatically shorten or lengthen the other side in the same proportion. This is the basis of solving all problems of proportion with a carpenter's square.



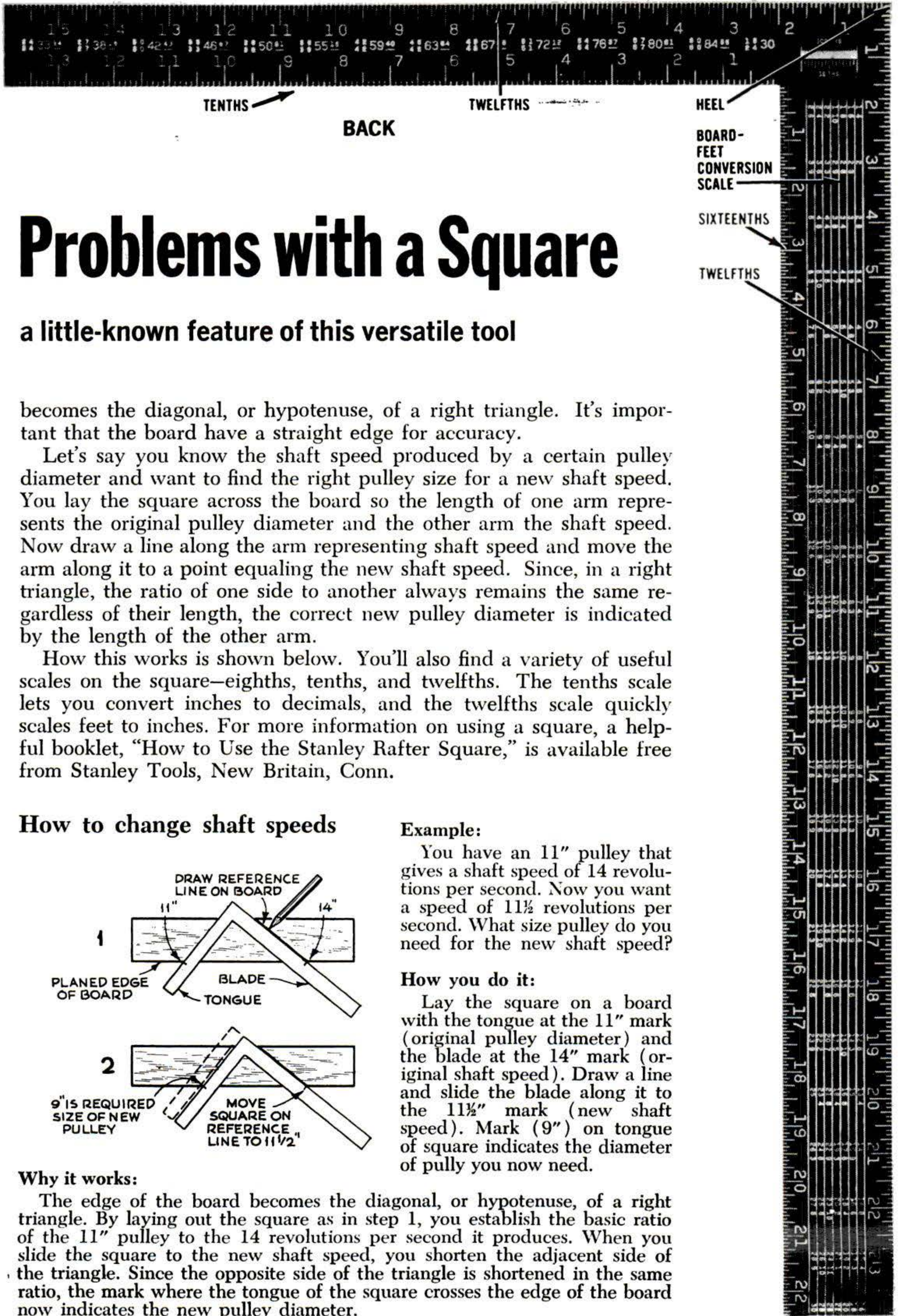

# Problems with a Square

a little-known feature of this versatile tool

becomes the diagonal, or hypotenuse, of a right triangle. It's important that the board have a straight edge for accuracy.

Let's say you know the shaft speed produced by a certain pulley diameter and want to find the right pulley size for a new shaft speed. You lay the square across the board so the length of one arm represents the original pulley diameter and the other arm the shaft speed. Now draw a line along the arm representing shaft speed and move the arm along it to a point equaling the new shaft speed. Since, in a right triangle, the ratio of one side to another always remains the same regardless of their length, the correct new pulley diameter is indicated by the length of the other arm.

How this works is shown below. You'll also find a variety of useful scales on the square—eighths, tenths, and twelfths. The tenths scale lets you convert inches to decimals, and the twelfths scale quickly scales feet to inches. For more information on using a square, a helpful booklet, "How to Use the Stanley Rafter Square," is available free from Stanley Tools, New Britain, Conn.

## How to change shaft speeds

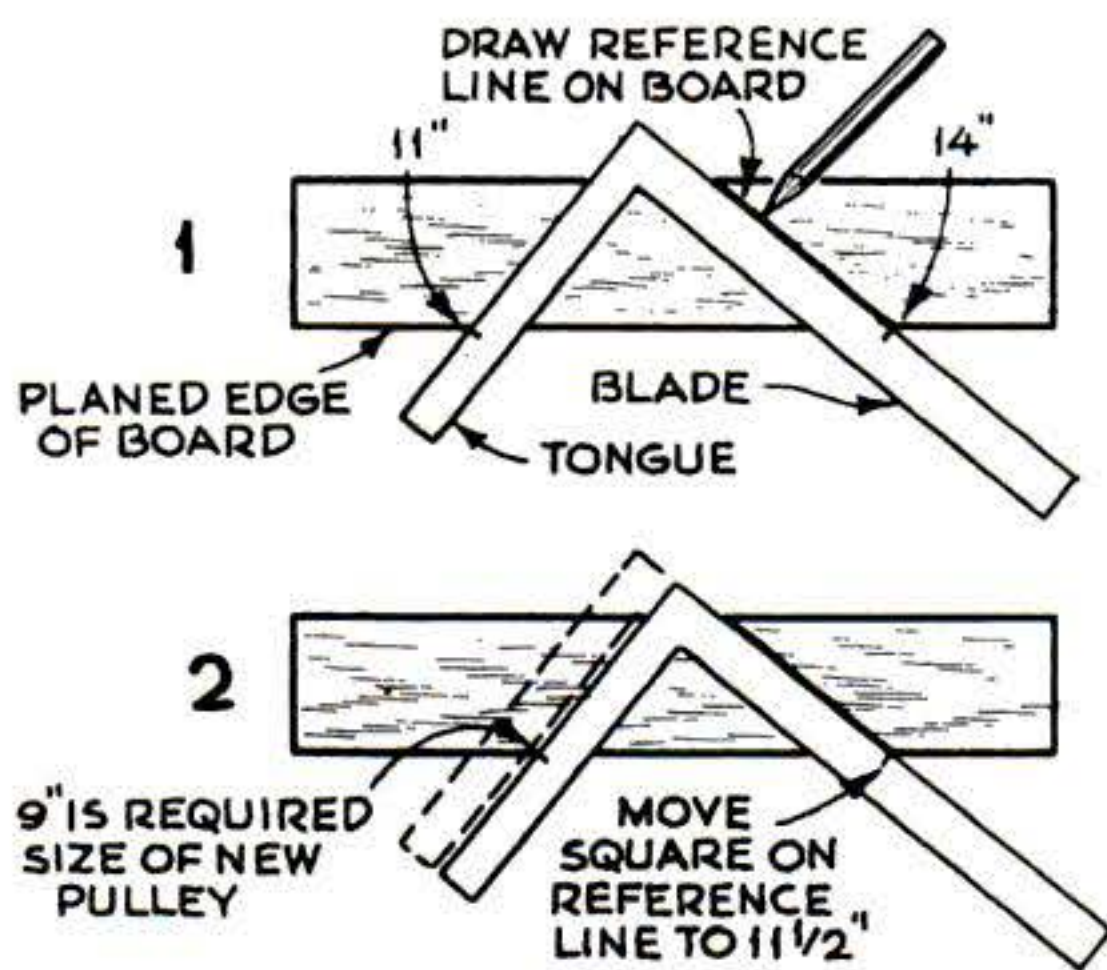

### Example:

You have an 11" pulley that gives a shaft speed of 14 revolutions per second. Now you want a speed of 11½ revolutions per second. What size pulley do you need for the new shaft speed?

### How you do it:

Lay the square on a board with the tongue at the 11" mark (original pulley diameter) and the blade at the 14" mark (original shaft speed). Draw a line and slide the blade along it to the 11½" mark (new shaft speed). Mark (9") on tongue of square indicates the diameter of pulley you now need.

### Why it works:

The edge of the board becomes the diagonal, or hypotenuse, of a right triangle. By laying out the square as in step 1, you establish the basic ratio of the 11" pulley to the 14 revolutions per second it produces. When you slide the square to the new shaft speed, you shorten the adjacent side of the triangle. Since the opposite side of the triangle is shortened in the same ratio, the mark where the tongue of the square crosses the edge of the board now indicates the new pulley diameter.



## How to balance a lever

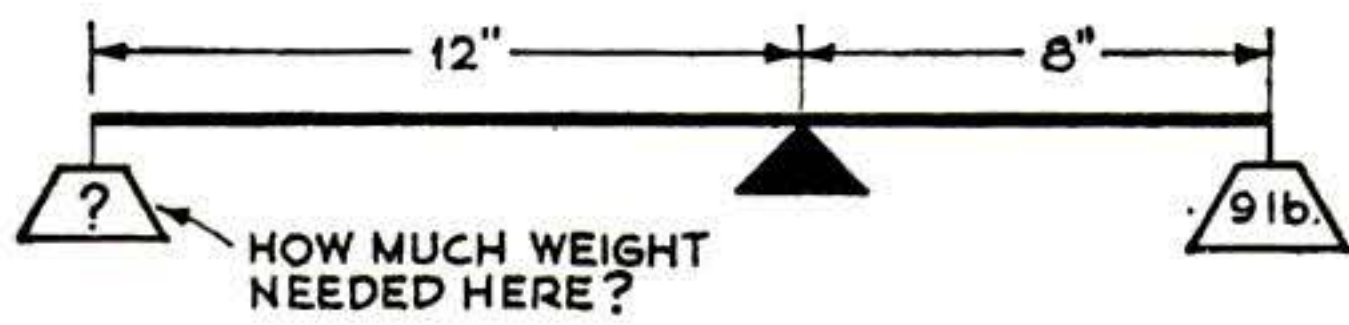

- 1 SET SQUARE TO REPRESENT 8:12 RATIO
- 2 MOVE SQUARE TO REPRESENT KNOWN WEIGHT. DIMENSION SHOWN ON TONGUE OF SQUARE THEN INDICATES WEIGHT NEEDED TO BALANCE THE LEVER IS 6 LB.

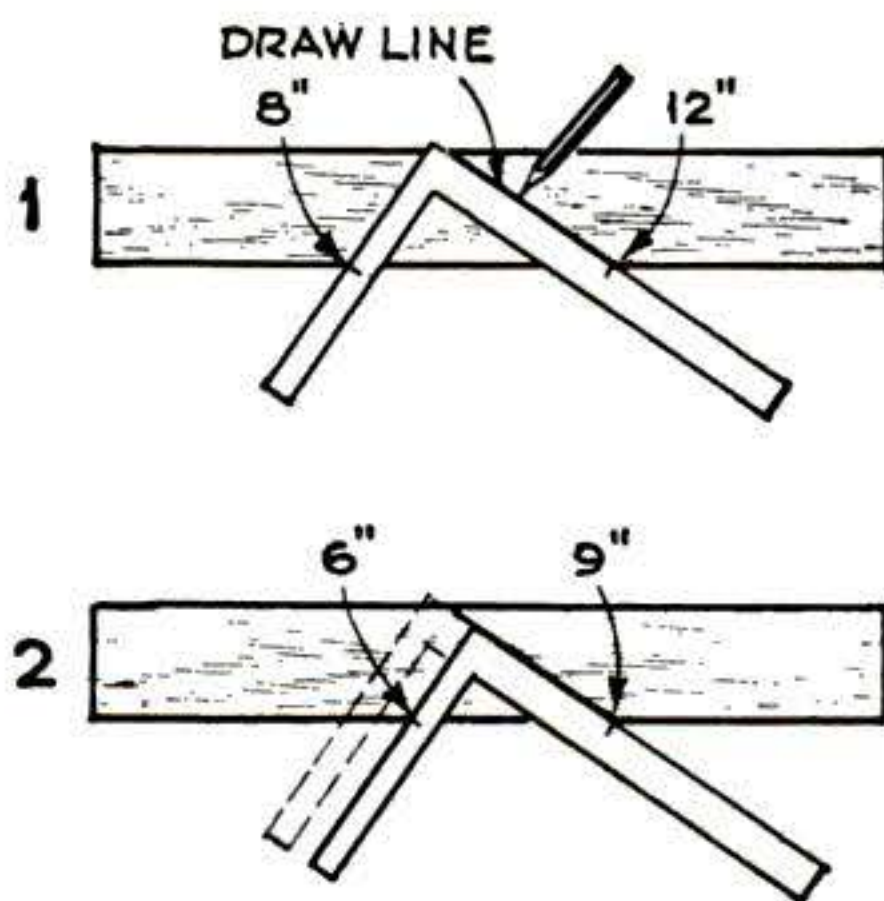

## How to convert centimeters or millimeters to inches

TO SET UP A SCALE, FIRST DRAW LINE TO REPRESENT A RATIO OF 10 TO  $3\frac{15}{16}$ .

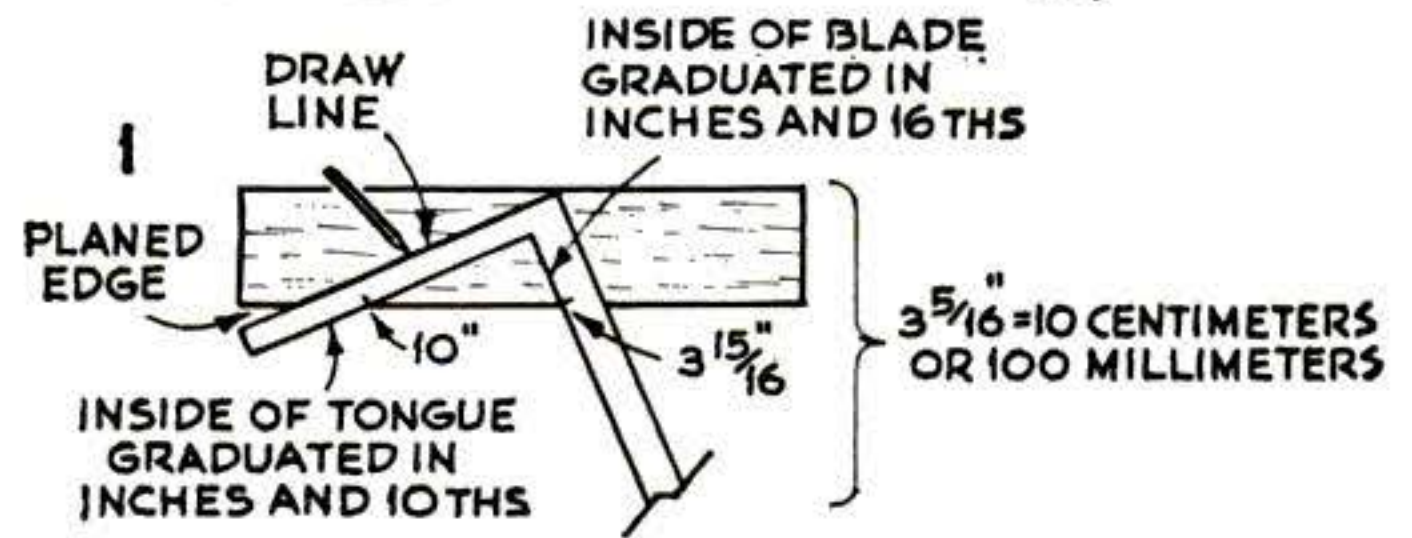

EXAMPLE: 6 CENTIMETERS OR 60 MILLIMETERS EQUAL HOW MANY INCHES?

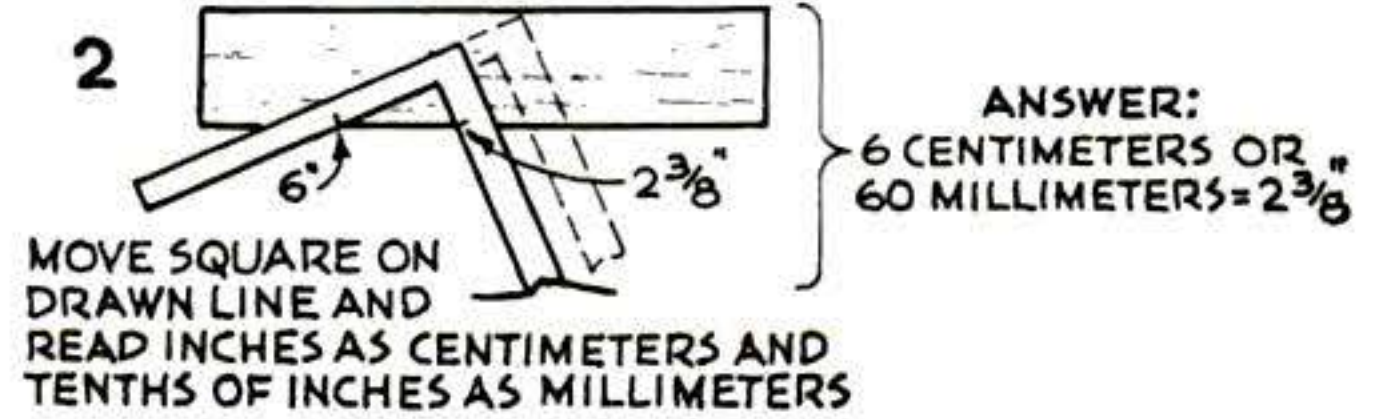

(IF A NUMBER OF CONVERSIONS ARE TO BE MADE, CLAMP A STRAIGHTEDGE ON THE DRAWN LINE)

## How to divide a line into equal parts

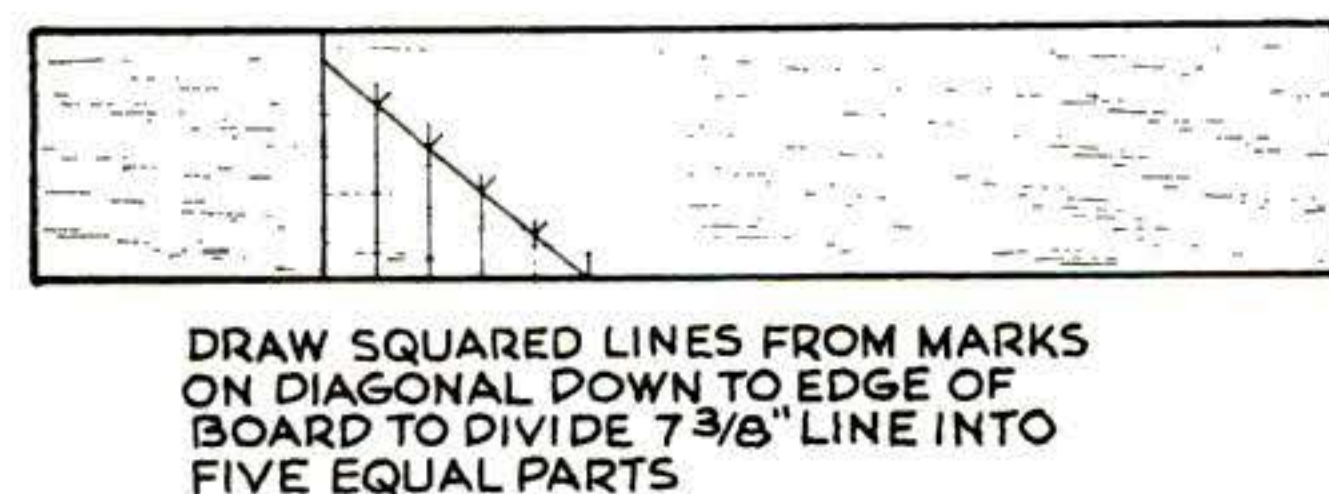
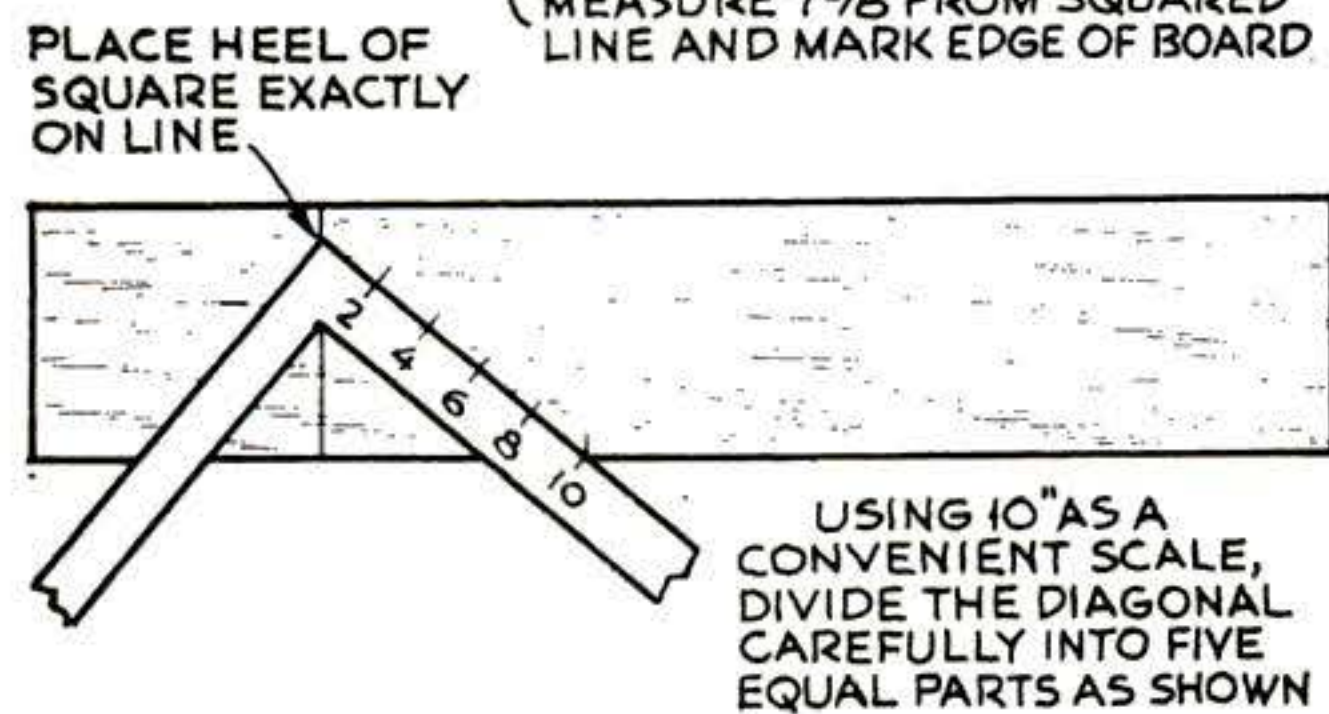
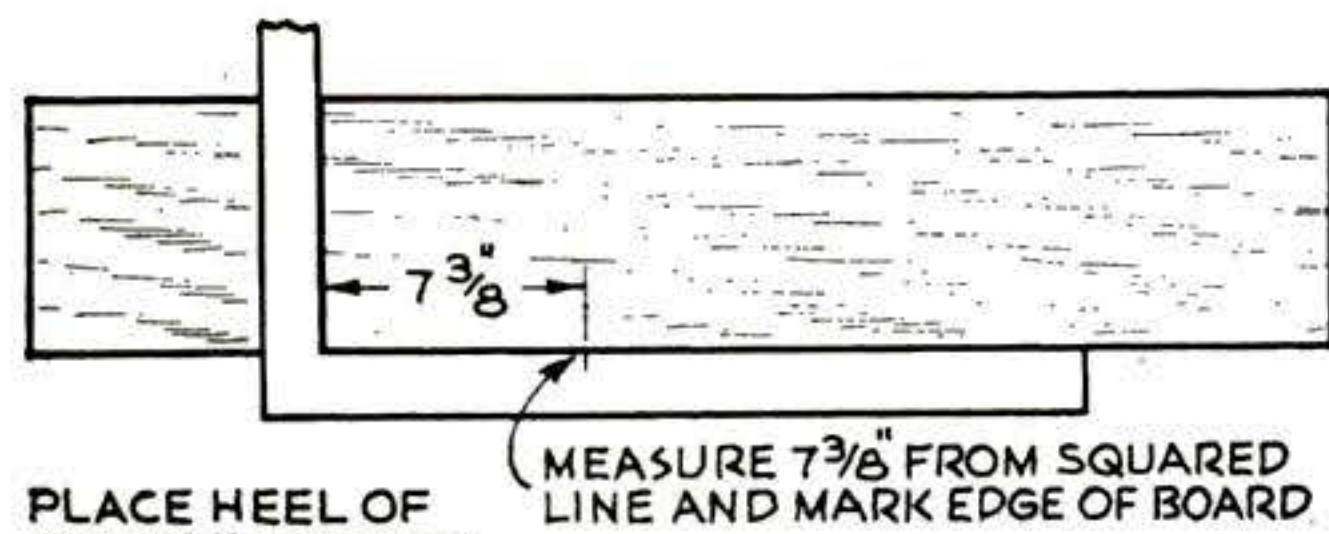
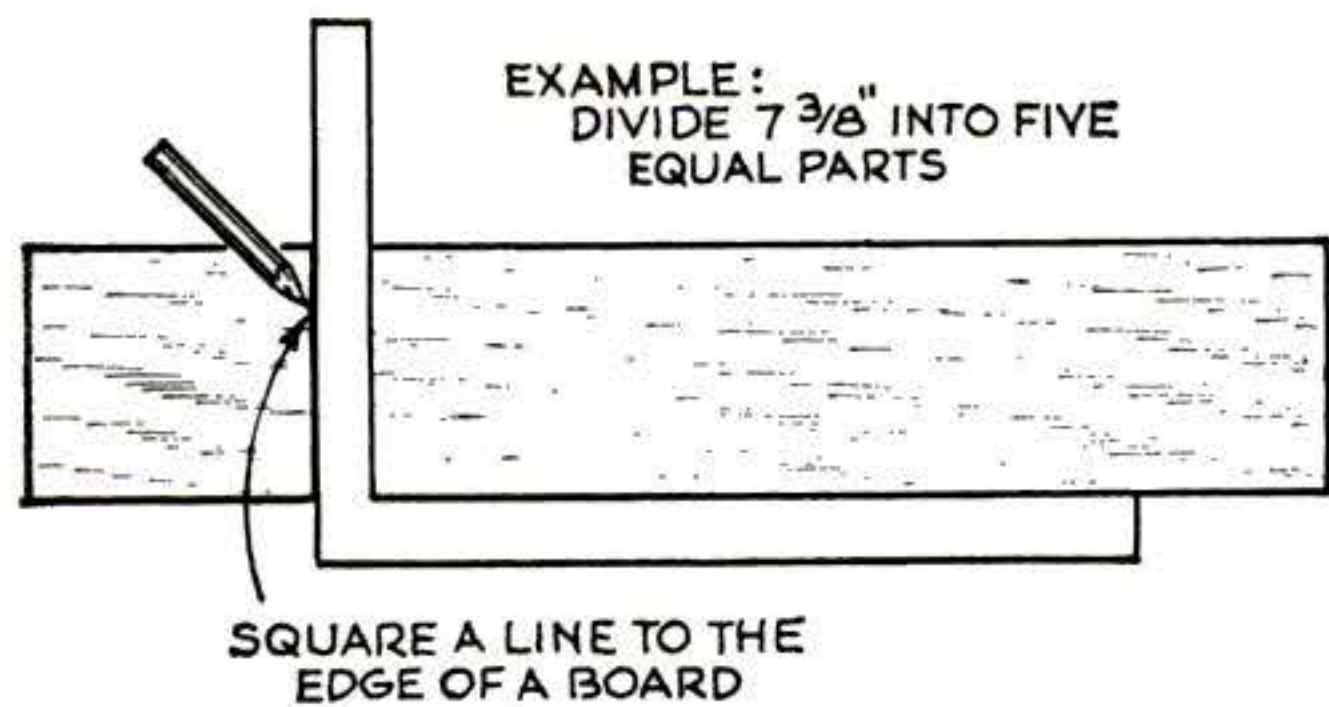

## How to find the center of a circle

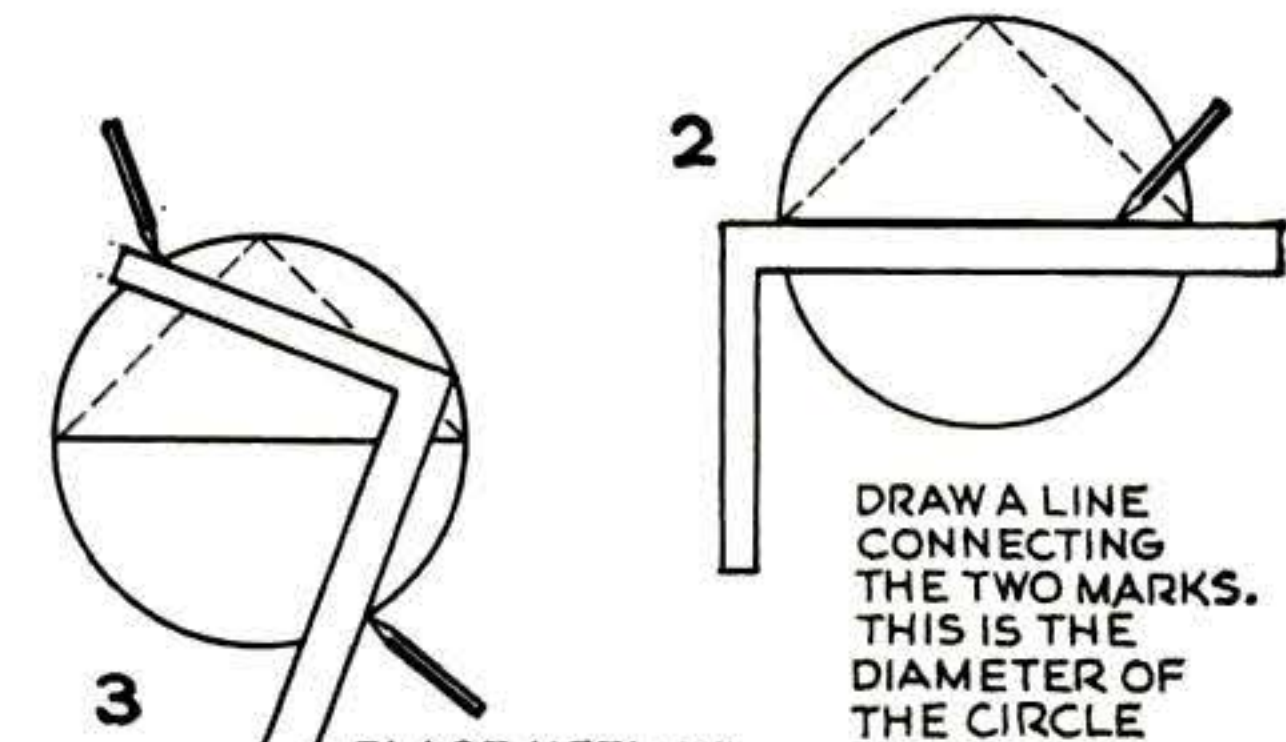
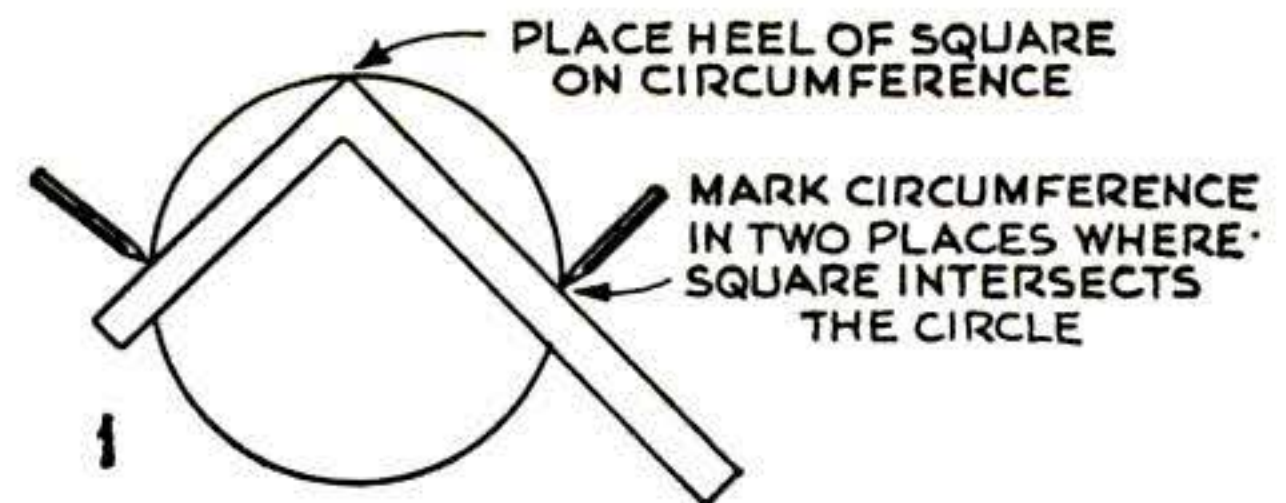

THE INTERSECTION OF THE TWO DIAMETERS IS THE CENTER OF THE CIRCLE



## How to inscribe three small circles inside a large circle

### How you do it:

Set the square at the  $6\frac{1}{2}$ " and 14" marks as shown (right). Draw a line and slide blade to the diameter of the large circle that you want to use. The diameter of the small circles is then indicated on the tongue of the square.

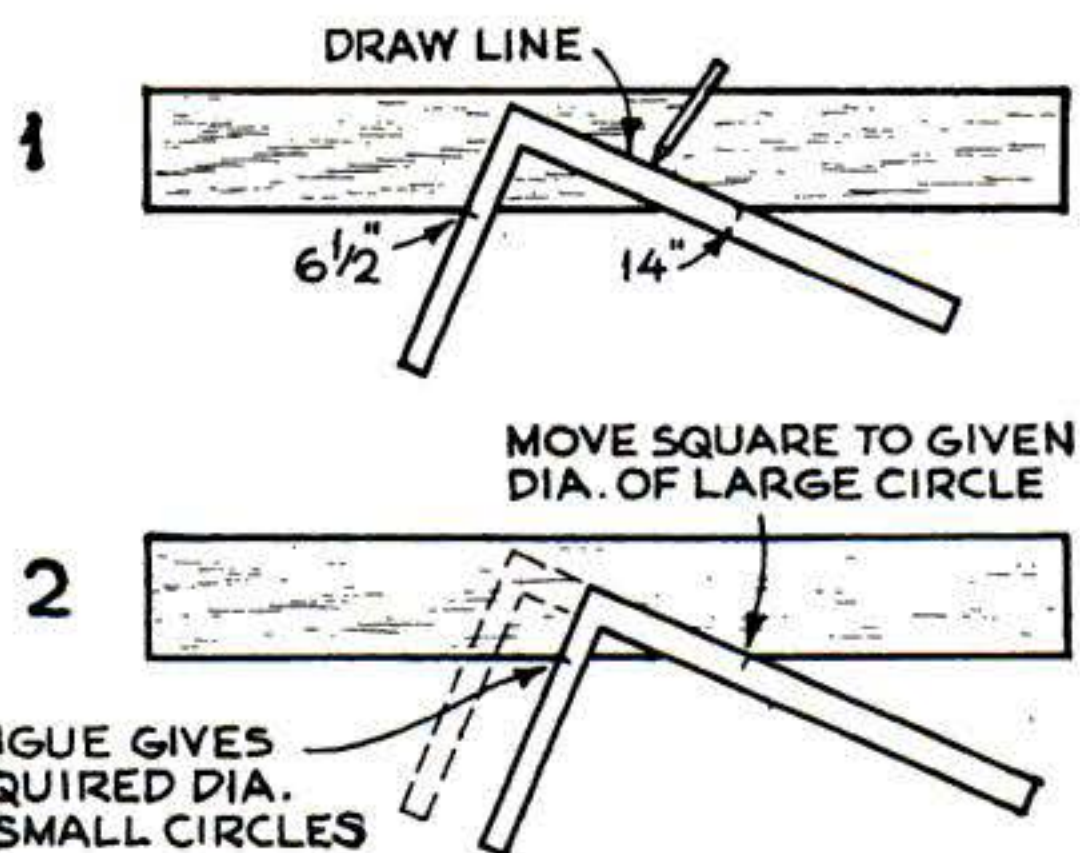
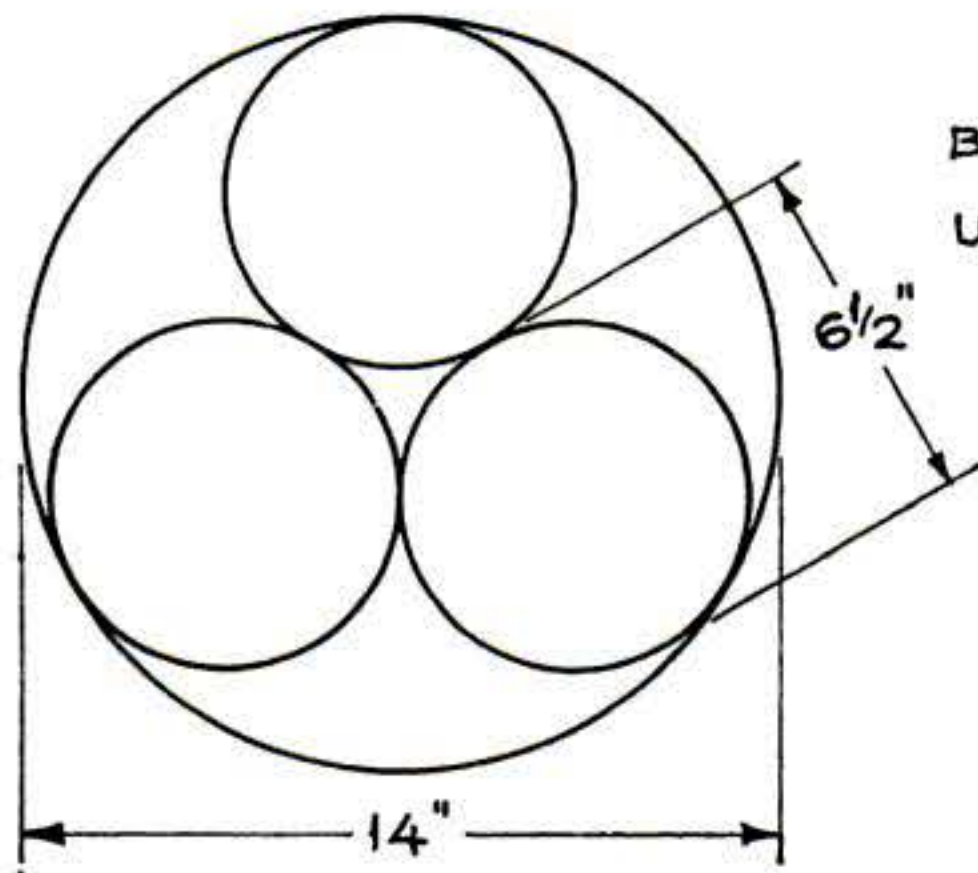

### Why it works:

The ratio of  $6\frac{1}{2}$ :14 that you set up in step 1 holds true for any three small circles enclosed in a larger one, no matter what their size. Sliding the blade of the square to any desired large diameter automatically causes the correct small diameter, always in the same ratio, to show up on the tongue.

## How to find one pipe that equals two

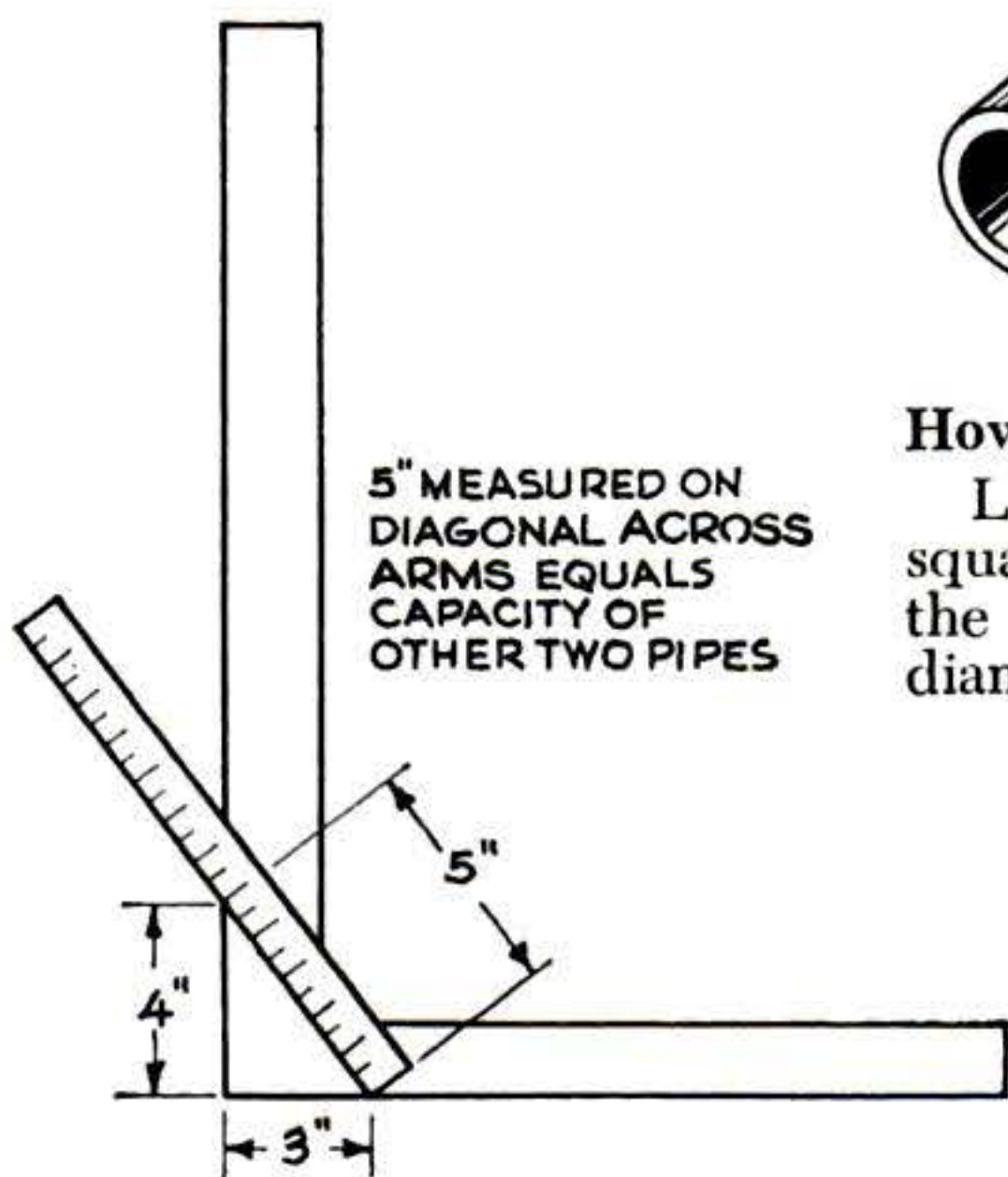

### How you do it:

Locate the inside diameter of one pipe on the blade of the square and the i.d. of the other pipe on the tongue; then measure the diagonal between the two points. The result—here 5"—is the diameter of a pipe equal in capacity to the other two.

### Why it works:

This trick is based on the ancient Pythagorean theorem: In a right triangle, the square of the hypotenuse equals the sum of the squares of the other two sides. The diagonal across the square is the hypotenuse of a right triangle. Its square—25—equals the sum of the squares of the two small pipe diameters. The square root of the diagonal—5—is thus the geometric equivalent of a pipe diameter totaling the other two pipes. This is proved arithmetically at right. ■ ■

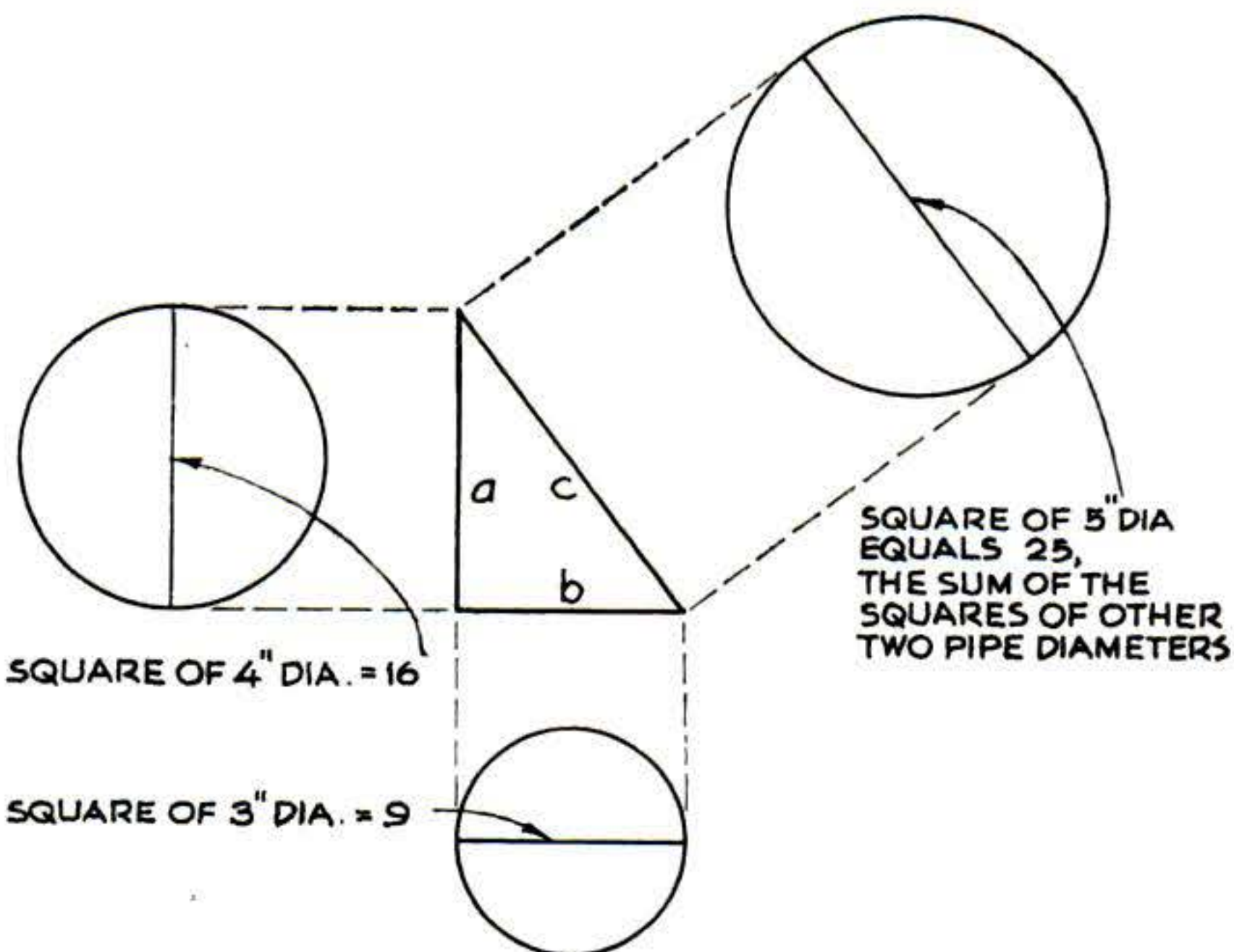

### Proof by area of circles (area = $\pi r^2$ ):

Area of 3"-dia. pipe:	$1.5 \times 1.5 \times 3.1416 = 7.069$
Area of 4"-dia. pipe:	$2 \times 2 \times 3.1416 = 12.566$
	Total area: 19.635
Area of 5"-dia. pipe:	$2.5 \times 2.5 \times 3.1416 = 19.635$



# How to Build Gas Tanks

By Jim Roe

HERE'S one of the easiest things you can do to increase the pleasure and use you get from your outboard: Install built-in gas tanks. They give you two big benefits:

- They increase your cruising range. It's disappointing to break off your boating

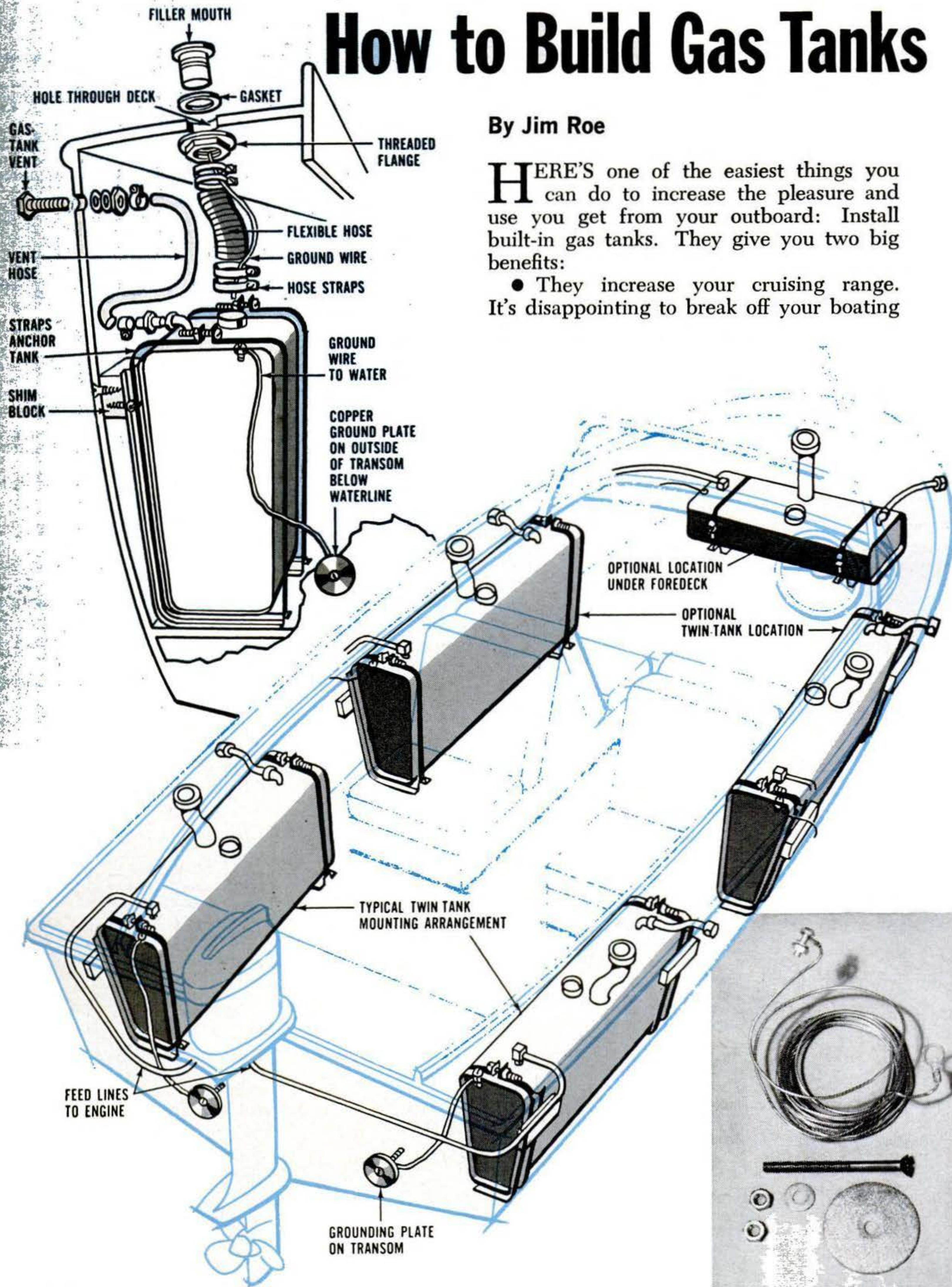



# into Your Boat

in the middle of the fun to go back for more gas. Built-in tanks give you enough range for all-day skiing or extended cruises not possible with only the normal six or 12 gallons of fuel.

- They increase your safety. Extended range in itself makes your boat safer since it lessens your chances of running out of gas at a critical moment. And built-in tanks, properly installed, eliminate fueling hazards. They assure outside-the-cockpit fueling where spilled gas and fumes go over the side, not down into the bilge.

The rules say you are to take portable tanks *out* of the boat to fill them, but all too few boatmen do this. Since the average gas attendant will overflow or spill gas on every two out of three tanks he fills, you have a constant threat of gas fumes in the bilge. This is just as dangerous in an outboard as in an inboard.

Built-in tanks are relatively easy to install, but the job takes care. Electrical grounding is a must, and it's important that the filler pipe be located where spilled gas will drain overboard, not into the boat. Even at that, the job can easily be done in a spare afternoon, and will pay off for many years to come.

U-shaped brackets are fastened to side of hull first to anchor the tank securely. Kits include filler hose, deck fittings, all necessary hardware. Separate grounding kit (below, left) provides wire and special metal plate that bolts to the outside of the hull below the waterline.

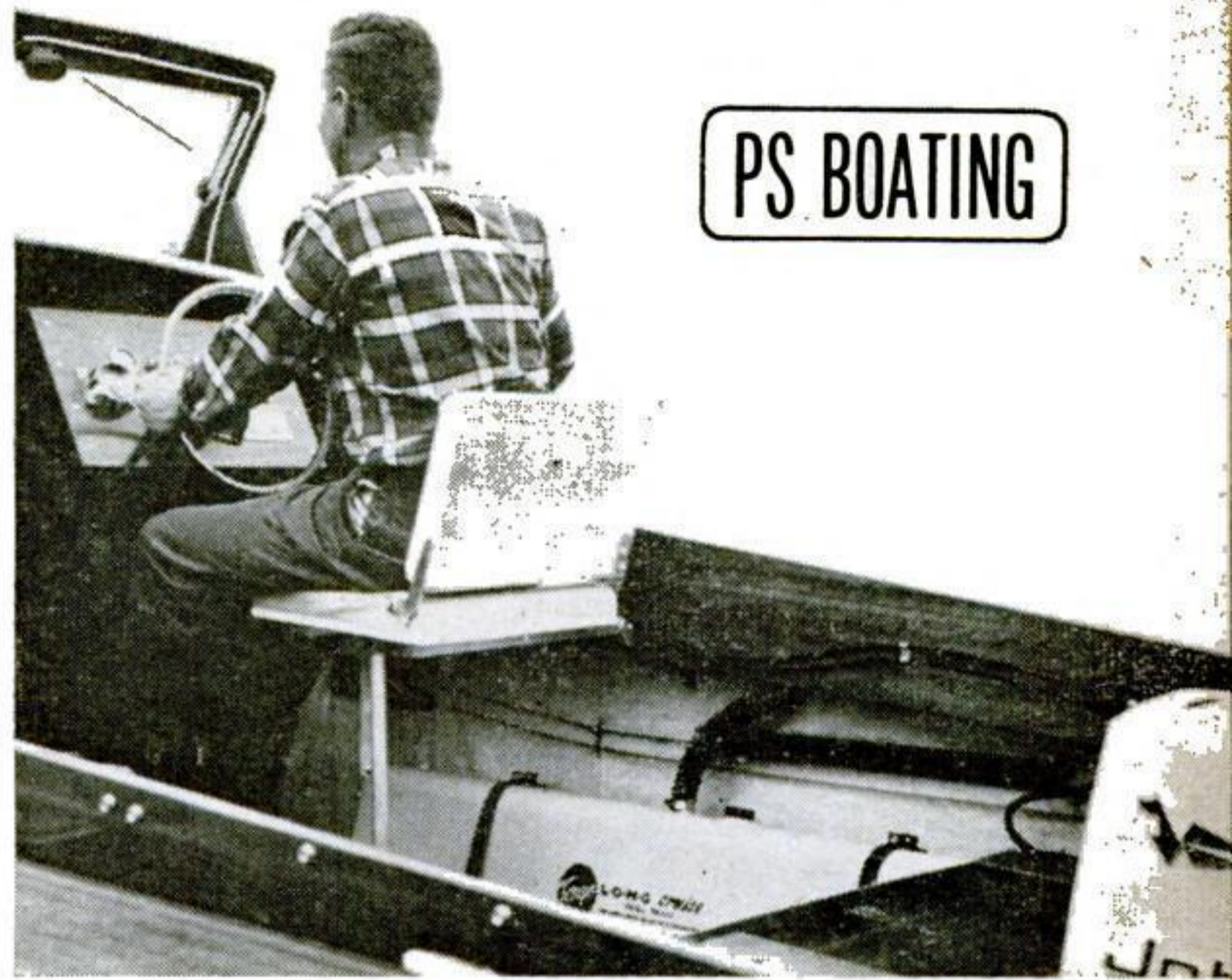
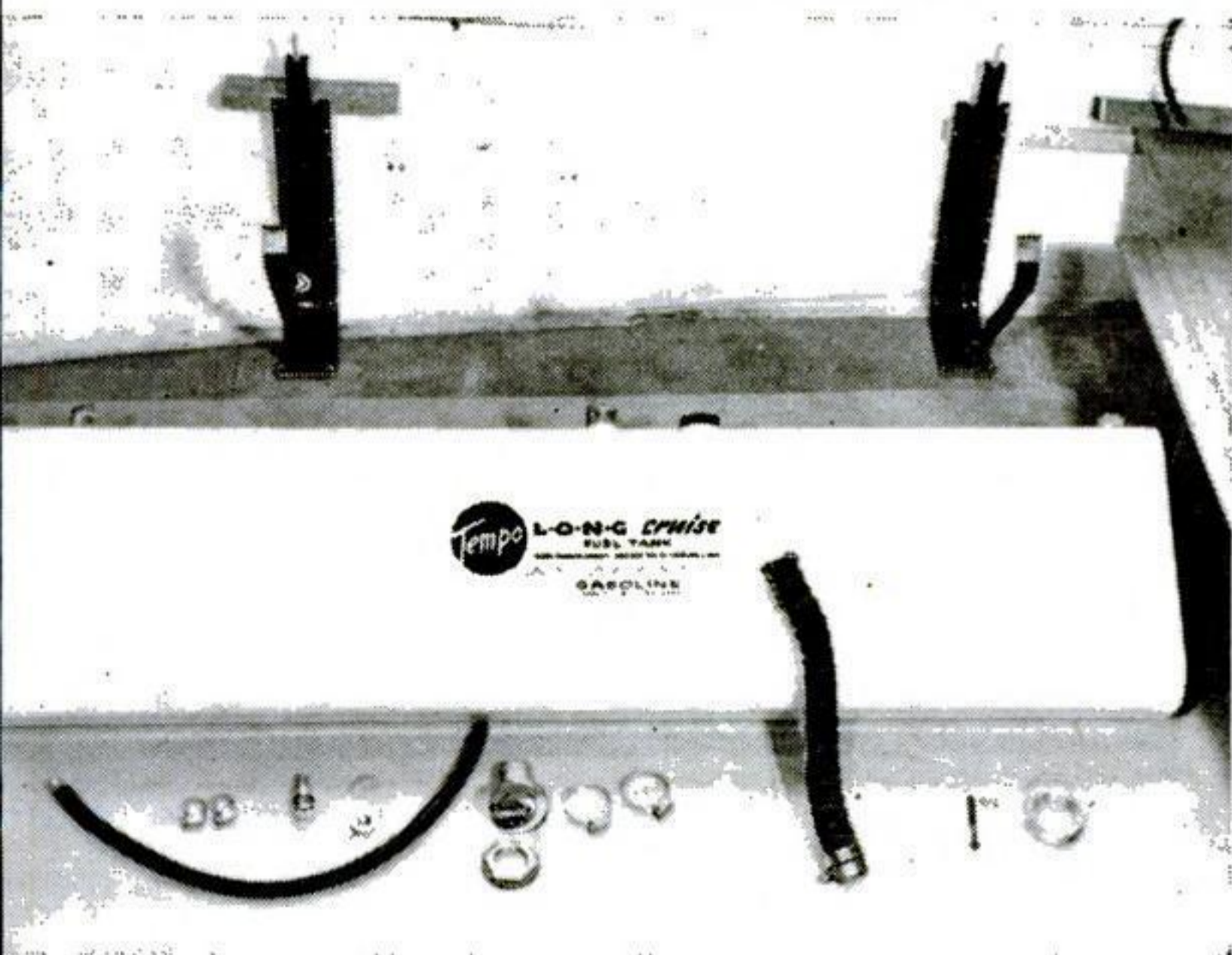

PS BOATING

Long, slim tanks like this Tempo hug side of boat, take up little space. Some possible locations are shown in drawing on facing page.



Space for built-in tanks, like these hollow seat backs, is provided in many boats. Be sure, though, that enclosed tanks are ventilated.

Locate the filler pipe where no gas can spill into the boat. This raised coaming around the cockpit is an ideal spot for the filler mouth.





### Roll-on stencil patterns speed decorating job

A midget paint roller—the kind sold for finishing small areas around trim—makes quick work of stenciling. It also demands less skill than dabbing with a stubby brush.

Use the roller fairly dry, rolling excess paint off on a newspaper. It's wise to clean the back edges of the cutout after

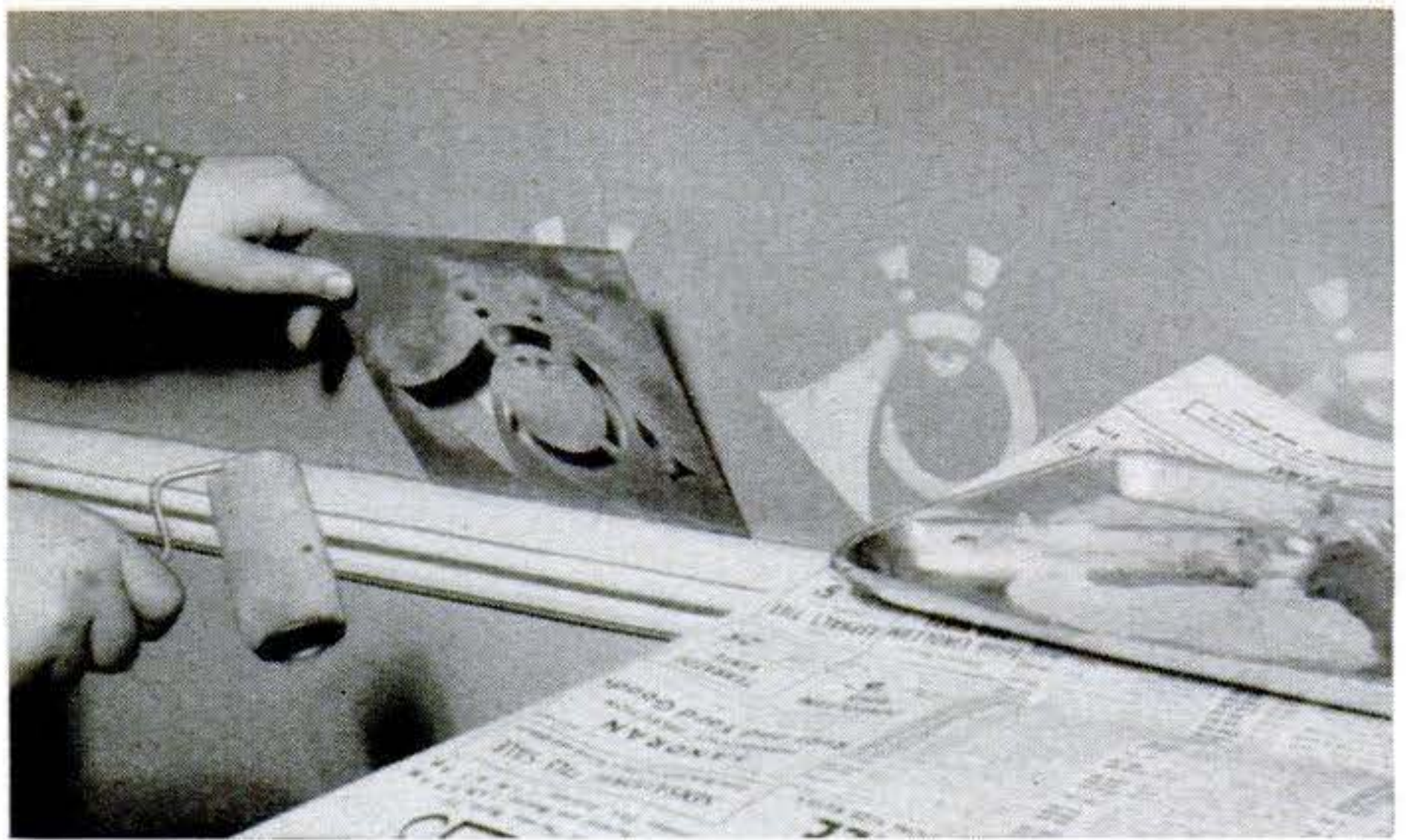

each transfer to prevent overrun. An aluminum TV dinner plate makes a handy paint tray.—Harry Walton, White Plains, N.Y.

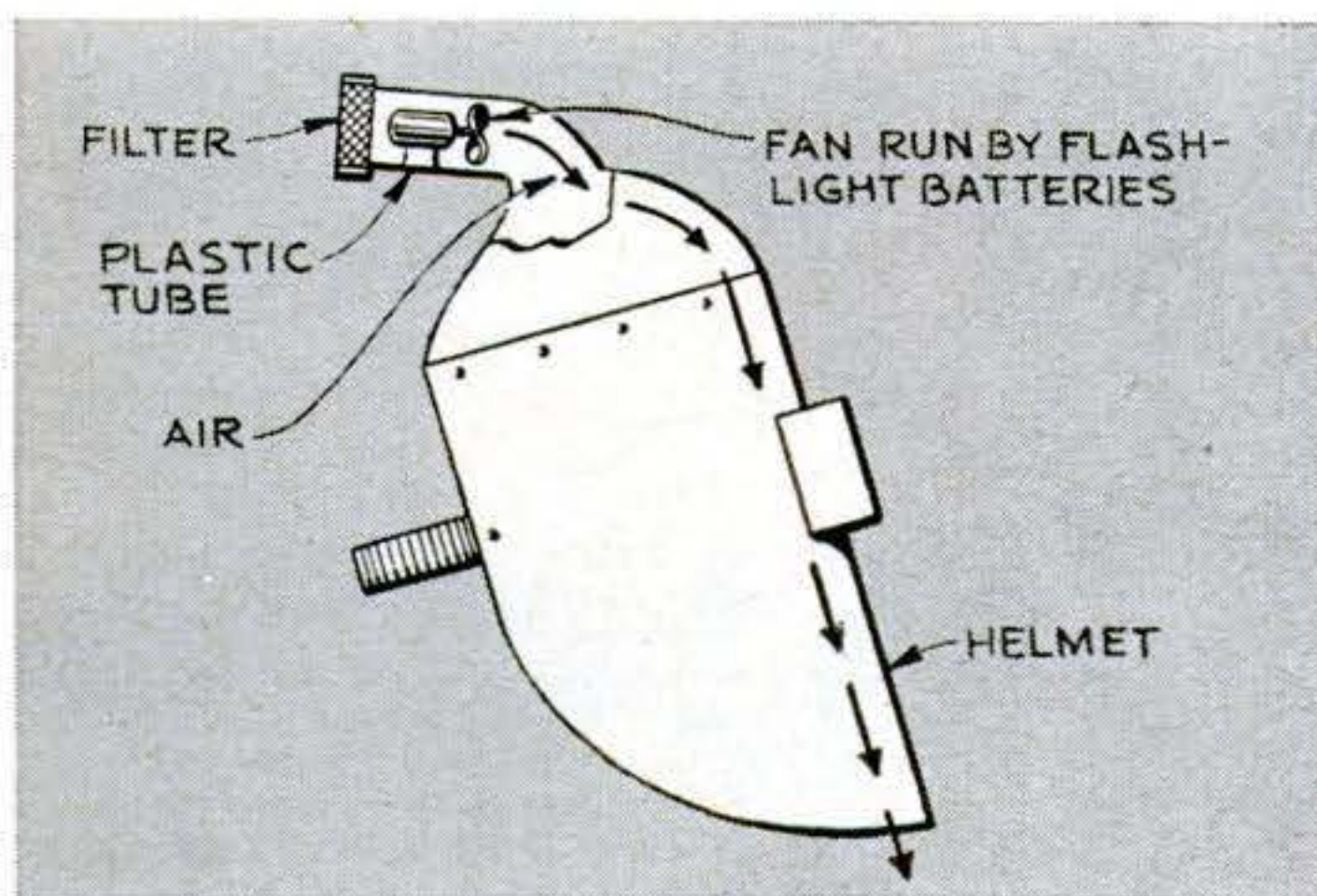

### Fan in helmet keeps welder cool

A welding helmet can become mighty stuffy and uncomfortable in some working conditions—and quite a few makers offer helmets with a system of supplied air. But Edward A. Wilson of Courtenay, British Columbia, has solved the problem himself—as shown in the sketch above from a recent issue of the *Welding Engineer*. Two flashlight batteries run a small fan in a plastic tube at the top of the helmet.

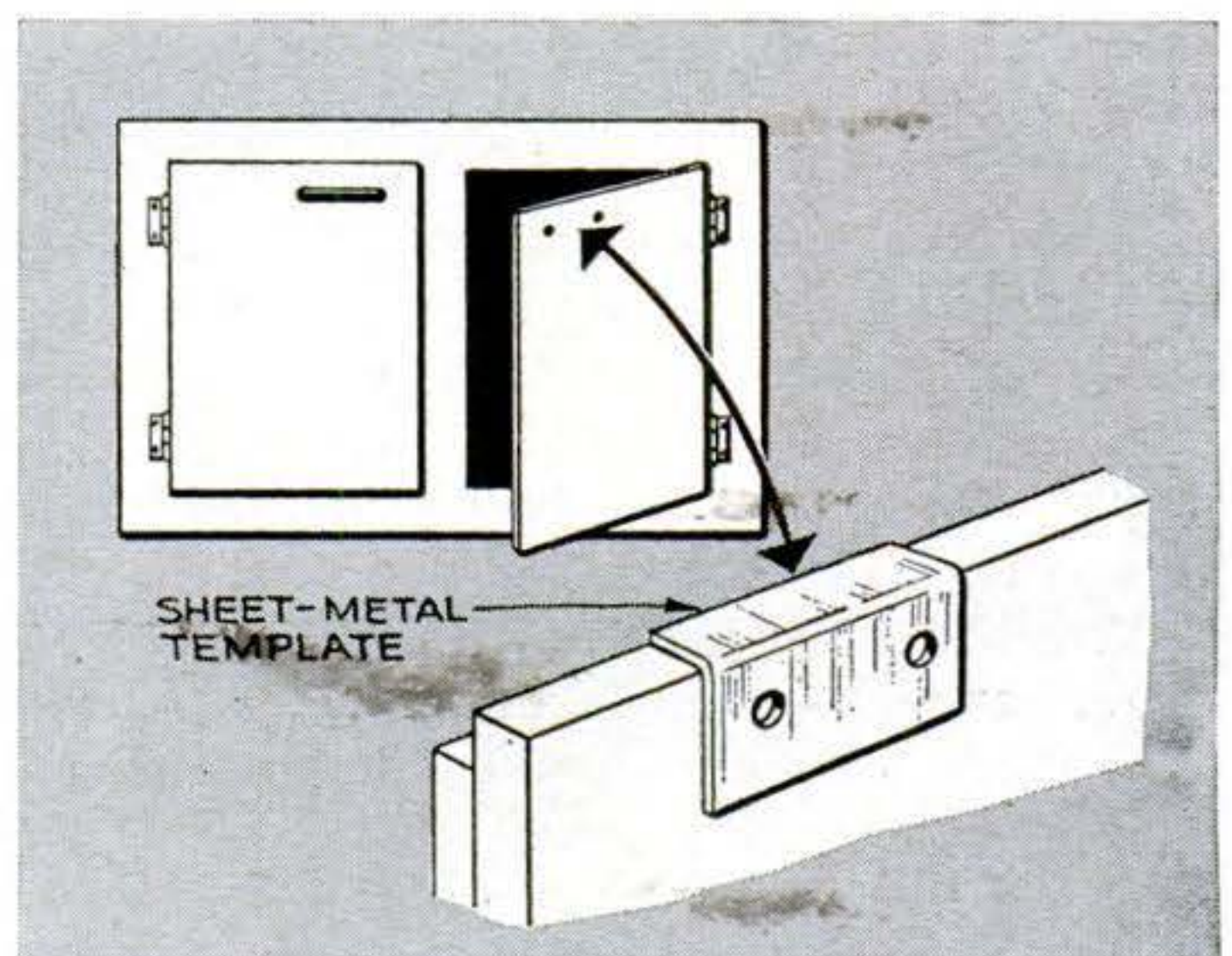

### Template keeps hardware uniform

To insure uniformity in attaching hardware, such as handles on cabinet doors, I use this method. First I make a sheet-metal template for drilling the holes. Then I fold the edge of the metal to insure that the template will be precisely the same distance, from holes to door edge, for each handle.—Hugh Lineback, Tulsa, Okla.

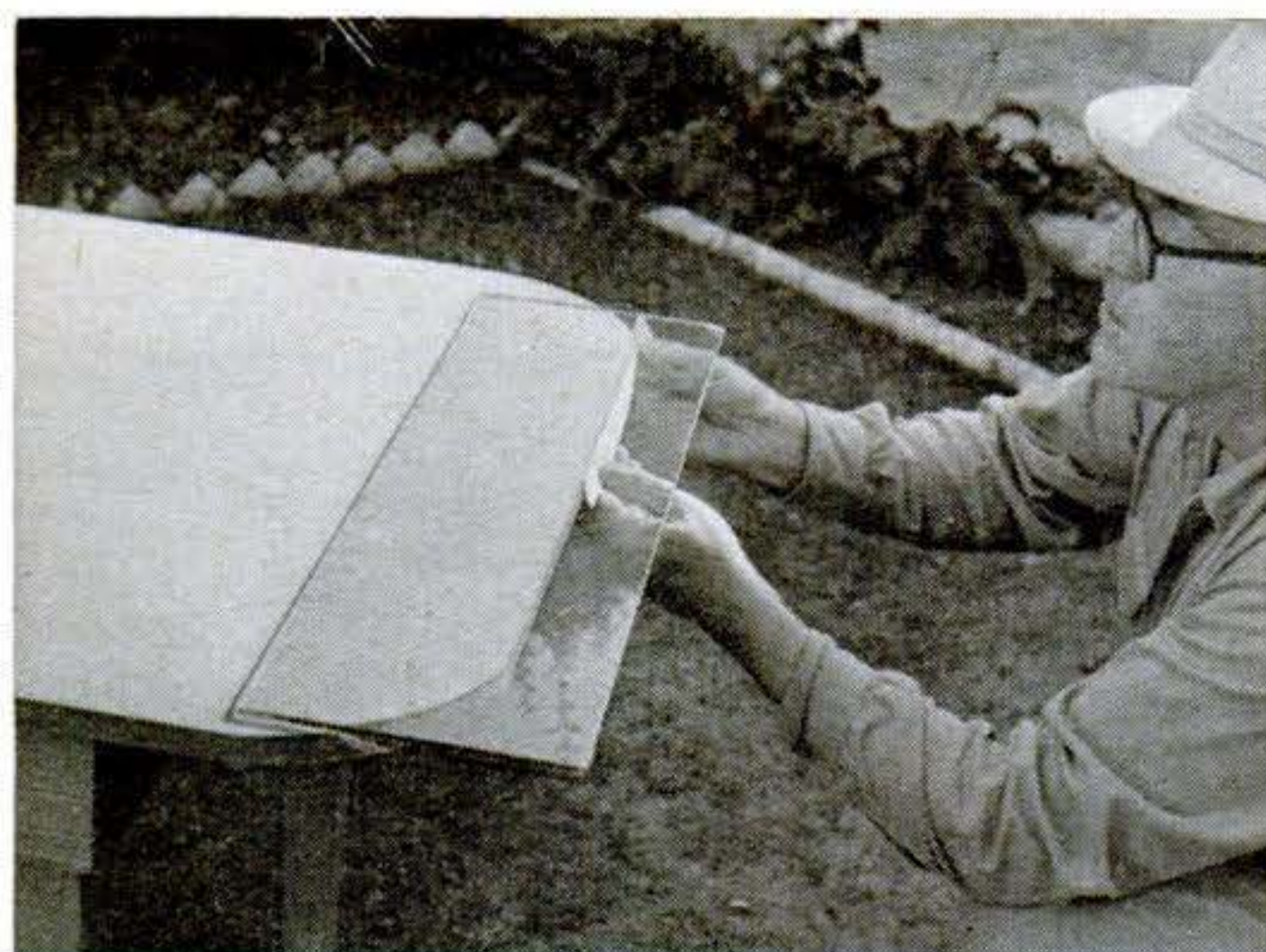

### Glass guides edging into place

When you're applying edge stripping, such as wood-veneer tape, to a table or counter top, it's a big help to have a piece of window glass projecting beyond the edge as shown at left.

The underside of the glass serves as a guide to bring the upper edge of the tape into perfect alignment with the upper table surface. It also lets you see what you're doing. The glass is moved around the table as taping progresses.—W. G. Wagoner, Sacramento, Calif.



# SHOP TALK

By Sheldon M. Gallager



## New way to lubricate shop machinery: paste-on "grease"



Here's one of the slickest ideas we've seen in a long time. It's a solid-form lubricant that you just peel off a backing strip and wrap around a shaft, as at left. It works like a pressure-sensitive tape, holding lubrication in bearings or along sliding ways. Test strips are still going strong after a year with no overheating or wear. The big promise: fast, semipermanent lubrication of tools and machinery. The Ore-A-Tape was developed by Ore-Lube Corp., 126-06 18th Ave., College Point, N. Y.

## Painting a concrete floor? Try this no-fuss etch

Picked up an interesting fact about etching concrete on a recent visit to Du Pont's research center at Wilmington, Del. The Du Pont people have developed a special chemical, called sulfamic acid, that does the same job as conventional etching acids but without the corrosive fumes or harmful effects to skin and clothing. The reason: It needs a much lower concentration to do its work and is thus safe and easy to use. Etching is important in preparing concrete for paint or tile mastic (to make sure the paint or tiles stick). The sulfamic acid can be bought at paint and hardware stores.

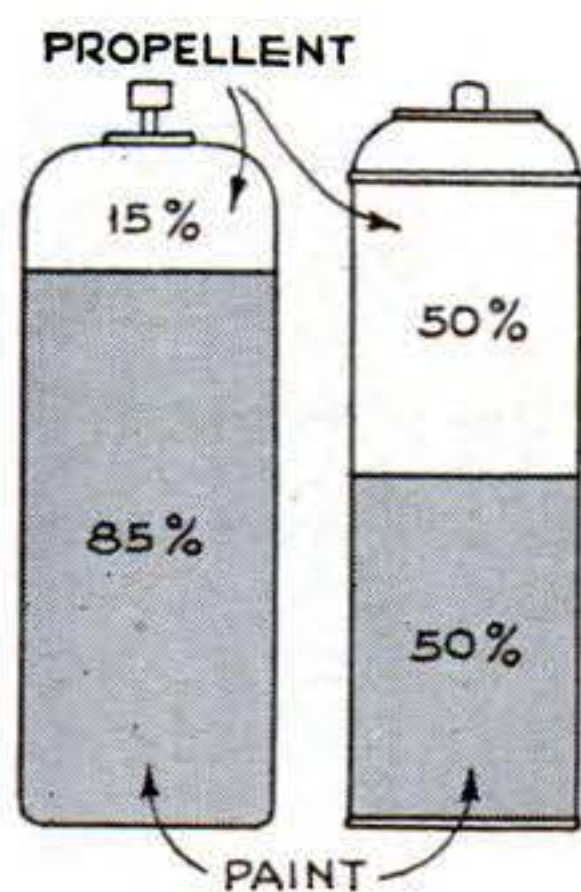

## How they get more paint into the same size spray can

The BernzOmatic folks, famous for their handy propane torches, have come up with a new line of pushbutton spray enamels propelled by—what else?—propane. Because the gas is three times as powerful as conventional propellents, much less is needed in each can—only 15 percent compared with the normal 50 percent. Result: More space for paint, as at left. How come you can spray with an explosive gas? No problem, says BernzOmatic. The gas floats on top of the paint and does not come out of the can until the paint is gone. A nonflammable chemical is also mixed with the gas to keep it from burning. To prove it, there's even a propane fire extinguisher on the way. The new enamels come in 15 colors and in two sizes: 8 and 16 ounces, priced at \$1.79 and \$2.95.



## For cleaning muddy garden tools, make a dunk box

Now that the gardening season is almost upon us, the Stanley Tool people pass along this tip for keeping wet and dirty digging tools in good shape. Make a box about 18" square and fill it with a mixture of sand and old crankcase oil. After each use, plunge the tools into the sand a few times. The sand scrapes off mud, while the oil coats the metal to prevent rust . . . Two Stanley products good to know about are antirust oil and tree-pruning paint, both in handy spray cans. The pruning paint, out just this month, makes it easy to seal pruning cuts—and speed healing. It also serves as a wood preservative for posts and yard furniture.



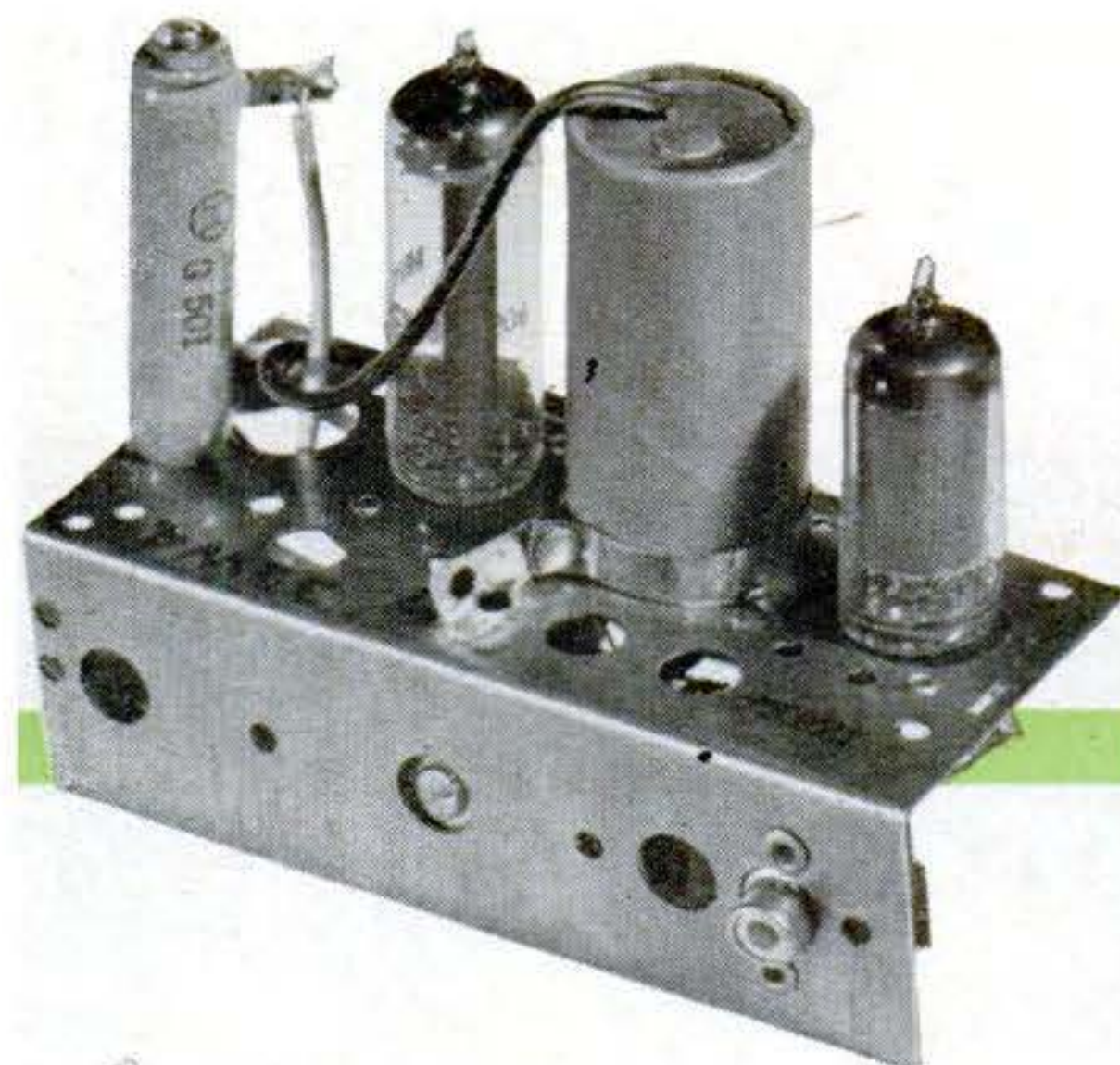
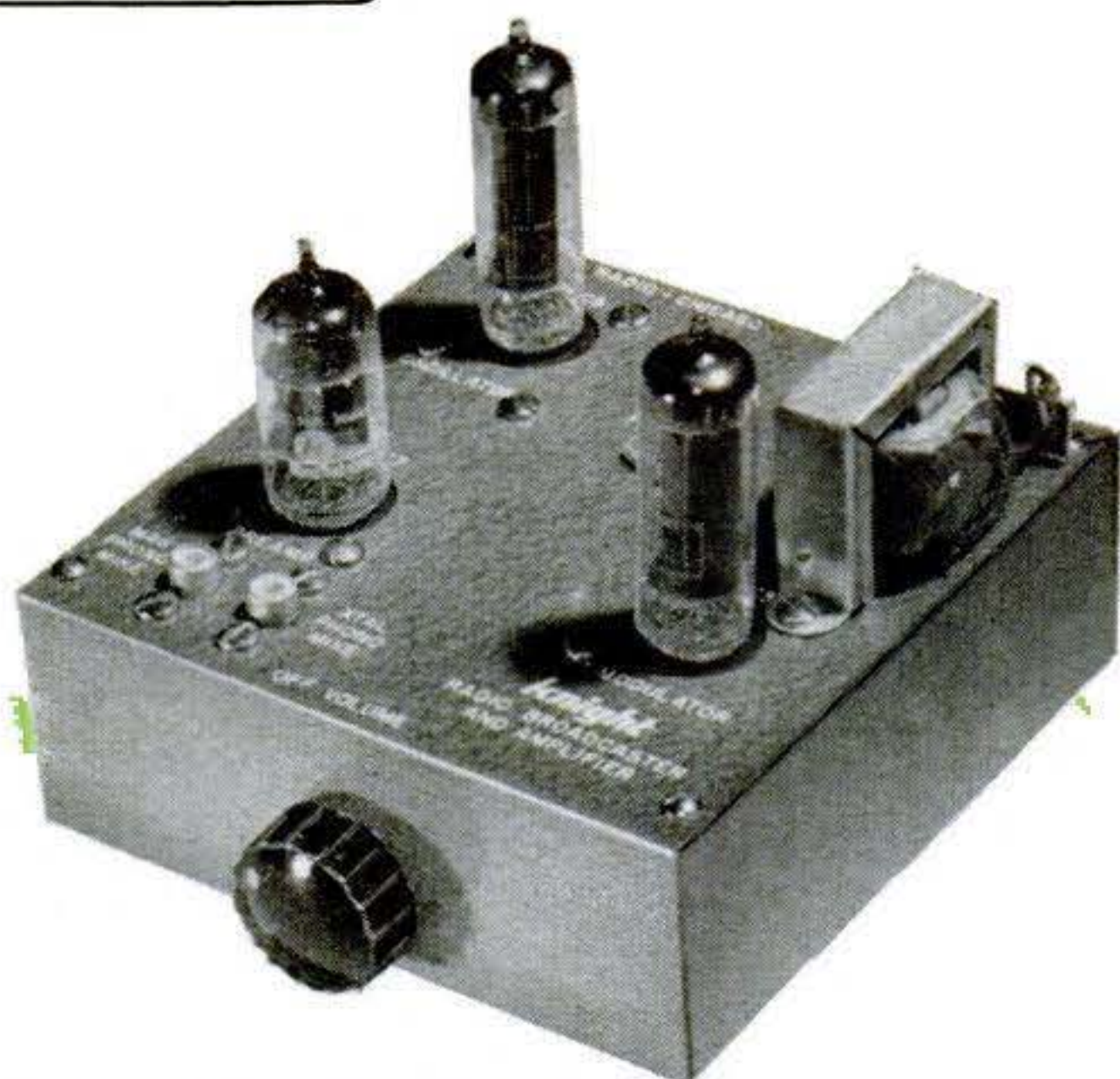

Two tiny broadcast transmitters suitable for private listening system are shown above. The Knight-Kit (left), a deluxe unit, can also be used as an amplifier. It has two inputs—use the one marked “Xtal.” Lafayette unit (right) is a phono oscillator only.

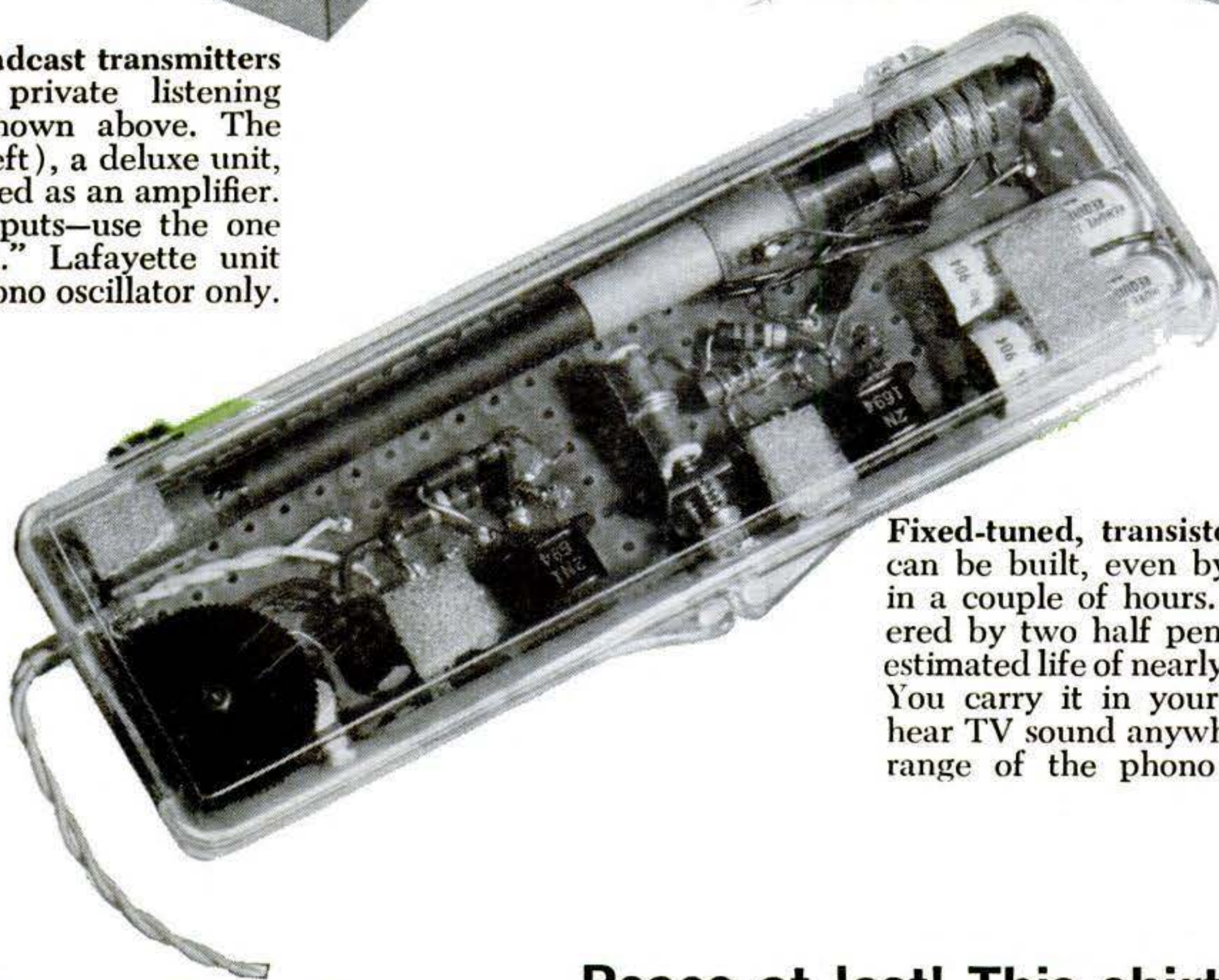

Fixed-tuned, transistor receiver can be built, even by a novice, in a couple of hours. It is powered by two half pen cells with estimated life of nearly 500 hours. You carry it in your pocket to hear TV sound anywhere within range of the phono oscillator.

# All's Quiet on the TV Front

Peace at last! This shirt-pocket

By Howard G. McEntee

**D**O the blasting of gunshots and the whoop of Indians disturb your quiet when you want to read the evening paper—and the kids are deeply involved in a TV western? Or, with the shoe on the other foot, do you have to give up your favorite private-eye thriller while they do their homework?

Here's a happy solution to this typical family dilemma: With a new listening system, you can watch TV and hear the sound



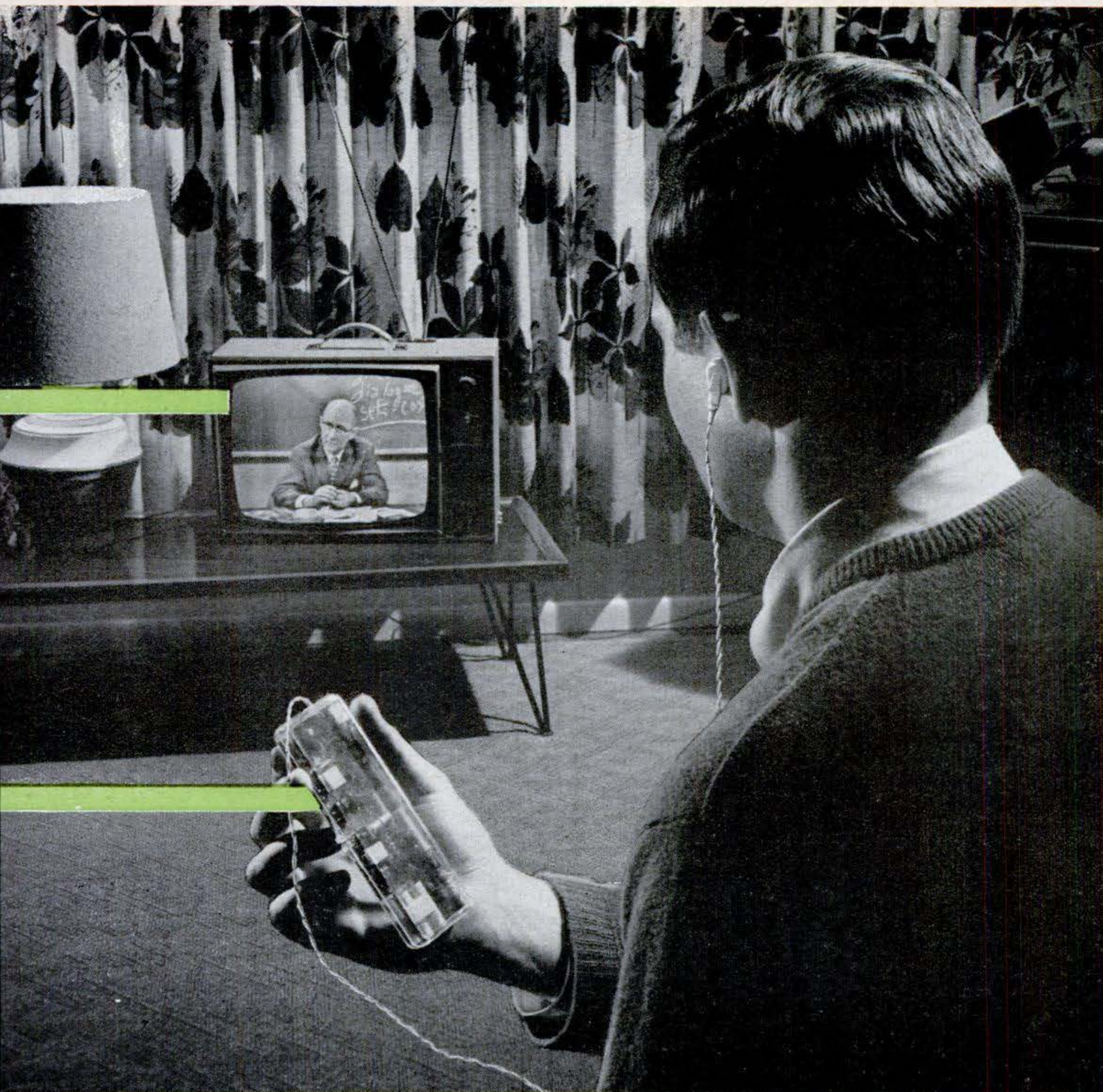

## transistor receiver delivers TV sound only to the viewer

loud and clear—while no one else in the room can hear it unless he wants to.

Private listening with earphones is, of course, not new. But the old way requires wires strung across the room that you can trip over. And when you leave the room, you have to disengage yourself from the gadget, perhaps missing an important bit of the sound.

Now, your earphone can go with you, and in most homes you'll be able to hear the sound anywhere in the house—a boon for mama if she wants to hear a cooking

class while she's busily doing the dishes.

The secret is a tiny radio transmitter that broadcasts the TV sound to a small transistor receiver in your pocket. The transmitter, known as a "phono oscillator," is available from radio-parts supply houses and is inexpensive. You can build the receiver from instructions given in this article.

To use this silent-listening system, you simply plug the input of the phono oscillator into a jack you mount in the side of your TV set. This silences the TV speaker and at the same time feeds the audio into



the transmitter. Switch on your personal receiver and you're ready to listen. You can have as many receivers as you wish; they won't interfere with each other.

No license is needed for these little transmitters, but still they must satisfy FCC requirements. The simplest and safest way is to buy a commercially made unit that has been checked out by the manufacturer and certified to comply. We list a couple that we bought and tried out.

The receiver you build uses a tuned RF (radio frequency) stage to amplify the weak signal picked up by the "energized loopstick" antenna. A transistor detector is followed by a single transistor AF (audio frequency) stage, which puts a potent signal into a hearing-aid-style phone (ordinary double headphones may be used, too, if you prefer). The only external control is R3—a volume adjustment that also has a built-in power switch. Properly tuned up, the receiver will give good volume many feet from the phono oscillator—how many is hard to say, as the signal seems, to some extent, to follow water pipes, power lines, and other metallic paths through the house. Anyhow, it will certainly work throughout the largest living room.

**The receiver.** We chose a long, slim shape for the receiver so it could be slipped into a shirt pocket and also allow a fairly long loopstick core to increase pickup. All parts are mounted on a perforated board. The plastic outer case originally housed a pen-and-pencil set.

Tiny eyelets are used as soldering points on the base plate. Fasten R3 with two flat-head, 2-56 screws. Make a circular cutout under it to clear the switch parts. Also cut away the base plate to make room for the two half pen cells.

Solder all parts except the loopstick before you solder the transistors into place. Solder the transistor leads directly to the eyelets, holding the wires tightly with long-nose pliers to prevent overheating the transistors.

C3 is the regeneration control. As you get it, this capacitor is intended for vertical mounting on a metal chassis, and some changes are needed (see sketches, right). Mount the capacitor body horizontally on the base, using an angle bracket to hold the adjustment screw. A 6-32 tapped hole carries this screw, and a slot through the bracket allows the sides to be squeezed together enough to put tension on the

screw. This assures good electrical contact and holds it at the desired setting.

**The antenna.** Considerable modification is needed on the loopstick. You can't buy such a unit with a core near 5" in length, so the next best bet is to get one with a 7" core, and cut it to size. The drawings show the changes needed.

The loopstick assembly goes on last. Be sure to leave the leads long enough so the assembly can be slid all the way from one end to the center of the core. The transformer, TR, must also be modified. Carefully bend back the tabs on the bottom and pull out the entire coil assembly. Under a thin strip of phenolic you will see a sub-miniature capacitor. This must be removed from the circuit. Easiest way is simply to crush it, making sure the ends of the capacitor are completely isolated. Reassemble and mount TR on the base with a dab of glue. *Don't* try to bend the connecting pins—they'll break off.

**The transmitter.** When you have completed the wiring, you're ready to tune up. For this you'll need your little transmitter operating. We tried two different commercially available units (Lafayette #PK-25, \$4.50 ready to use; and Allied Radio's Knight-Kit #83 Y 706-J, \$12.95). Both were satisfactory, but we had to add a 50mmf. capacitor across the tuning element of the Lafayette job to get it to tune to the lower end of the broadcast band. The Knight-Kit is the most deluxe phono oscillator we could find, but, of course, you have to put it together. It has a some-

CONTINUED

## Fixed-tuned transistor

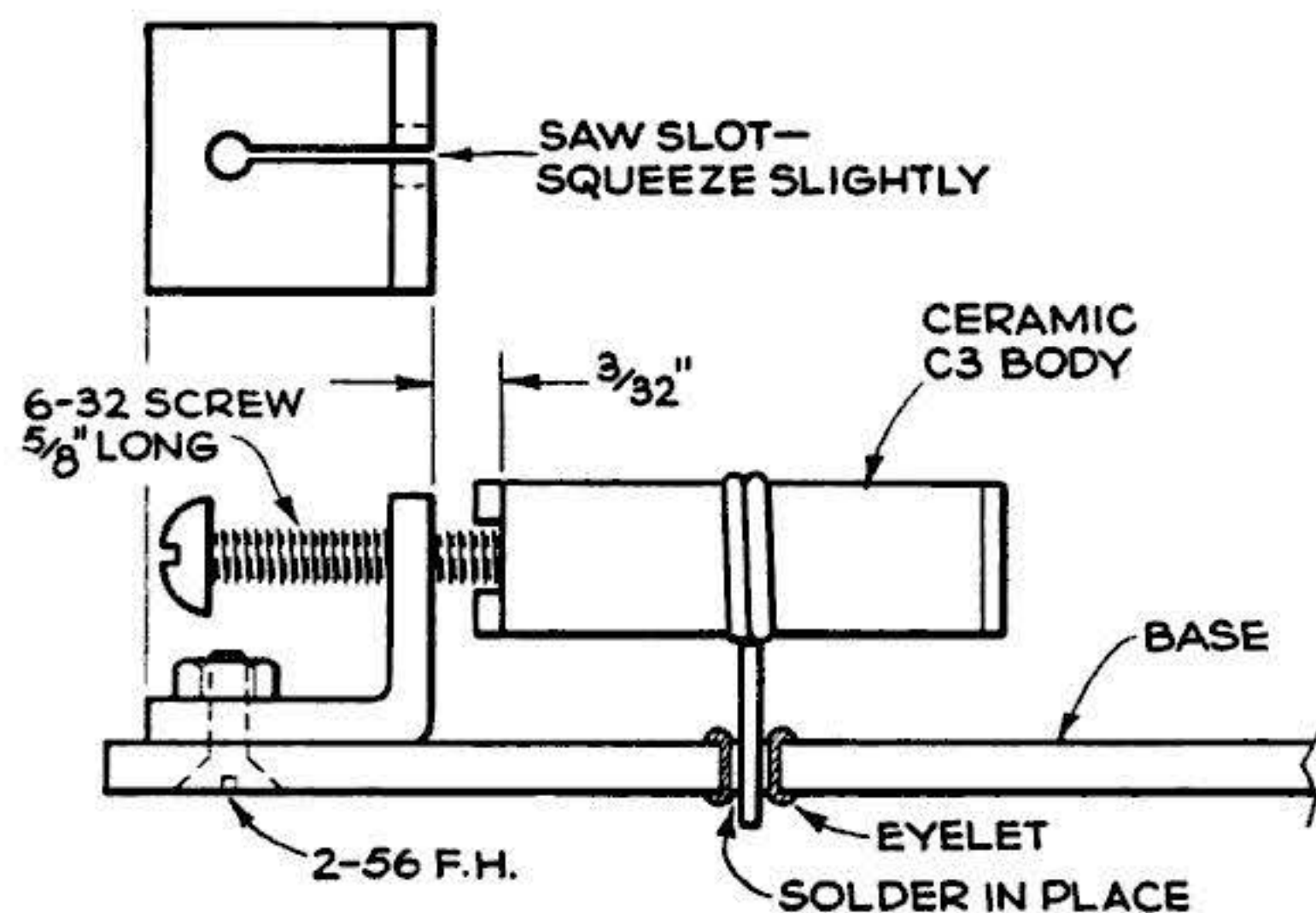

Tubular trimmer capacitor controls regeneration. Turn the screw to vary capacity. Use a small angle bracket tapped for a 6-32 screw, saw slot, and squeeze to put tension on screw.



## PARTS LIST

X1, X2—Transistors, GE 2N1694 NPN  
 X3—Transistor, GE 2N1305 PNP  
 L1—7" loopstick (Lafayette MS-44)

TR—Subminiature IF transformer (Lafayette MS-776)  
 R1—330,000-ohm resistor, 1/4 w.  
 R2—2-megohm resistor, 1/4 w.  
 R3—5,000-ohm variable resistor with switch (Lafayette VC-62)  
 R4—560,000-ohm resistor, 1/4 w.  
 C1—68-mmfd. mica capacitor  
 C2, C5—.01-mfd. ceramic capacitor, 75 v.

C3—.5-to-3-mmfd. ceramic trimmer capacitor  
 C4—18-mmfd. mica capacitor  
 C6—.05-mfd. ceramic capacitor, 75 v.  
 C7—2-mfd. electrolytic capacitor, 6 v.  
 Earphone—Dynamic type, 1,500 ohms (Lafayette MS-260)  
 Perforated phenolic board, 1/16" thick (Lafayette MS-305)  
 Package 1/16"-diameter eyelets (Lafayette MS-733)  
 Two N-size flashlight cells  
 TV output load resistor—10-ohm, 10-w. adjustable wire-wound resistor (Mallory type 1 AV or equal)  
 Small audio output transformer to hook TV set to oscillator (Stancor A3328 or almost any small audio transformer)  
 Miniature closed-circuit jack and plug  
 Shielded audio cable with RCA-type pin plug  
 Phono oscillator—see text

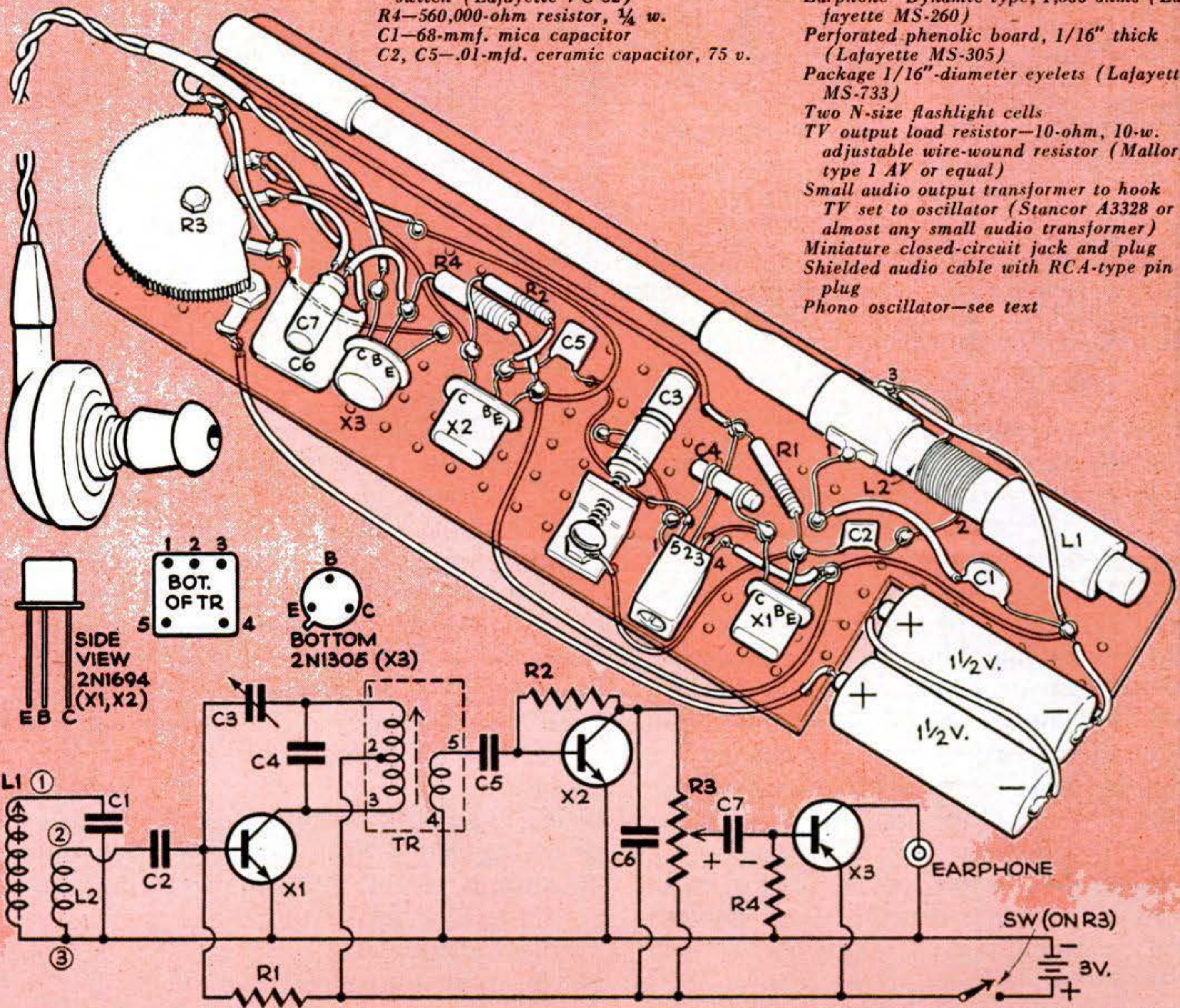

TOTAL CURRENT DRAIN—ABOUT .6 MA.

## receiver is simple enough for anyone to build

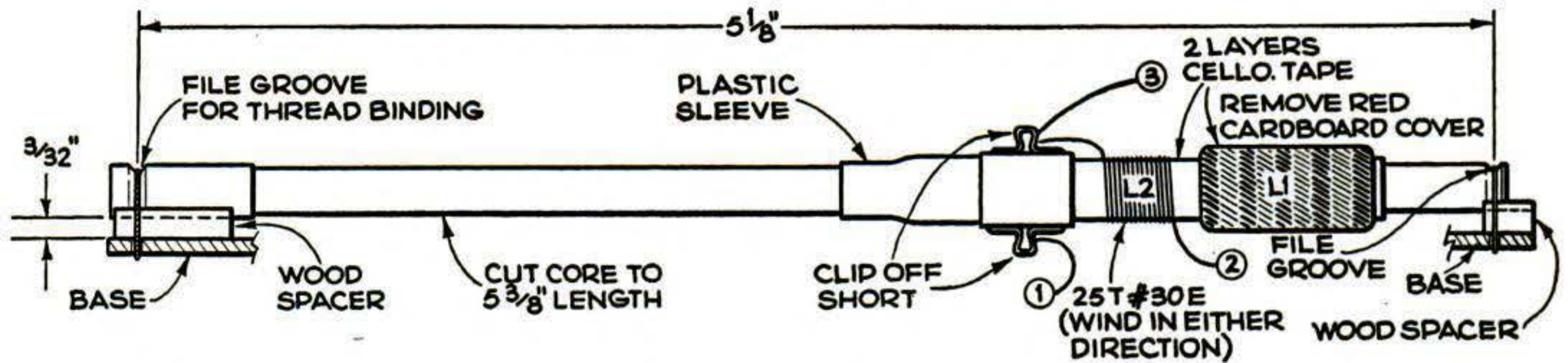

Loopstick size and adjustment greatly influence sensitivity of receiver. By using a 7" loopstick, cutting it exactly to fit your case, and modifying it so it can be accurately tuned to one frequency, you get much better sensitivity than with a smaller one used "as is". The core material is quite hard. To cut it, file a groove all the way around the rod and break it with a sharp rap. Tune by sliding the entire winding assembly along the core. To get a reasonable tuning range,

L1 must be movable as close as possible to one end of the core. Mount rod with wooden spacers so that the core is about 3/32" from base. File grooves at each end to receive thread binding that holds rod. Before binding, smear model cement on the parts to hold assembly firm. Remove the red cardboard cover from L1 and wrap it with two layers of cellophane tape. Wind L2 as indicated and wrap it with tape, too. Connect the ends of L2 as shown here.



## How to connect the transmitter to your TV set

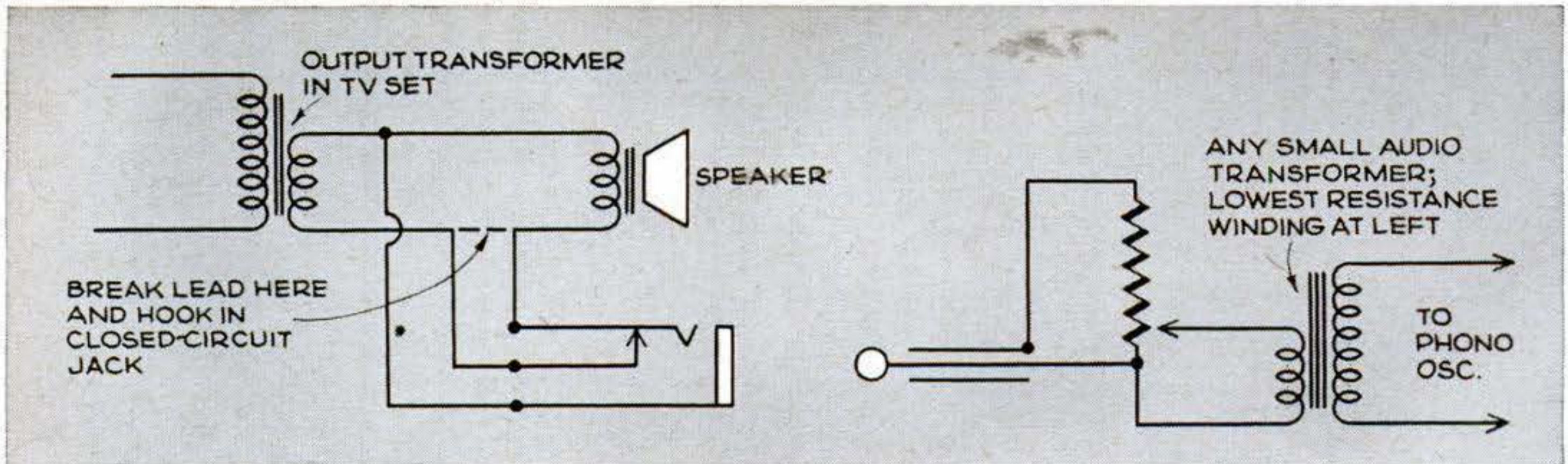

Connect to TV set with a closed-circuit jack and plug. Wire jack across lead to speaker voice coil as shown. If TV cabinet is metal, be sure to insulate jack with insulating washers. Output load

resistor and transformer can be mounted in a separate box or you can place it inside the cabinet you make to house the oscillator. Use only shielded cable for the audio leads.

what stronger output than the \$4.50 unit.

The diagram directly above shows you how to hook up the oscillator to your TV set. Both of these phono oscillators use transformerless circuits (like table-model radios) so their metal chassis should be treated as though they were one conductor of the power line. For safety, you should enclose them in a wooden box or cabinet. Avoid touching any metal object that might be grounded when there is any chance you might be in contact with the oscillator chassis. Mount the unit so it can't be reached by children.

**Tuning the system.** With the oscillator on, set TV volume control about midway and the variable resistor across the TV output near the bottom of its range. With your receiver on and held near the oscillator antenna, move L1-L2 near the center on the core and set the adjustment screw of TR at midpoint. The screw of C3 should be just at the point of entering the tubular capacitor. Turn the tuning adjustment of the oscillator through its range and you should pick up the TV sound at some point. When you do, adjust L1 and TR for maximum volume. Move across the room and repeat the adjustment of L1 and TR. Finally, move as far as possible from the antenna while still getting a signal and adjust C3 for maximum volume. If you hear a squeal, back off slightly on the adjustment.

If you get interference from a local broadcasting station at the frequency you have chosen, try another frequency. You may have to work back and forth several times, between the oscillator and the receiver, before you get a clear, clean signal.

You should get a definite peak in volume when you adjust the tuning of your receiver. That is, for a given setting of the oscillator tuning control, you should find a position for L1 and TR such that a movement in either direction will result in a loss of volume. If you don't get a definite peak, the oscillator frequency is beyond the range of the receiver. Move the tuning control on the oscillator and try again.

The sound you hear in your earphone should be clear. If it seems muddy or distorted, you are probably overloading the phono oscillator. Try various combinations of settings of the TV volume control, the output-level control, and the input control on the oscillator, if it has one.

The oscillator antenna should be placed as near as possible to the center of the desired pickup area. Under the floor or above the ceiling are usually desirable locations, although we found there was signal strength to spare in most installations with the transmitting antenna simply strung along a wall. The receiver antenna is quite directional, so you'll find a considerable difference in range depending on how you hold the receiver.

**Keeping within the law.** The FCC regulations require that the power radiated by unlicensed transmitters, such as these, be strictly limited. The manufacturers of phono oscillators must certify that their units will not exceed these limits when used as directed. The directions are mainly concerned with the length of antenna used. If you use a longer antenna than specified, you may interfere with your neighbor's radio, and that could get you into trouble with the FCC. ■ ■





### Vacuum-cleaner blast burns out stumps

Where blasting is not possible or permissible in removing tree stumps, I burn them out—using the blower side of a household vacuum cleaner to keep the flames going. After digging out around the stump, and under it if possible, I build the fire at the bottom of the hole and start up the vacuum. I have eight feet of hose on the cleaner, plus a steel pipe 10 feet long on the hose itself.—*E. F. Stoner, Edmonds, Wash.*

### A setup for cutting disks fast

The job of cutting a lot of 4" wooden toy wheels went fast with this jigsaw setup. The wood blocks were pivoted on a pin placed in an aluminum plate 2" from the blade. (The distance of the pin from the blade determines the radius of the disk.) The aluminum plate has a slot so that it can be slid into place. A freehand cut is made to the edge of the circle.—*R. A. Pollock, Staten Island, N. Y.*

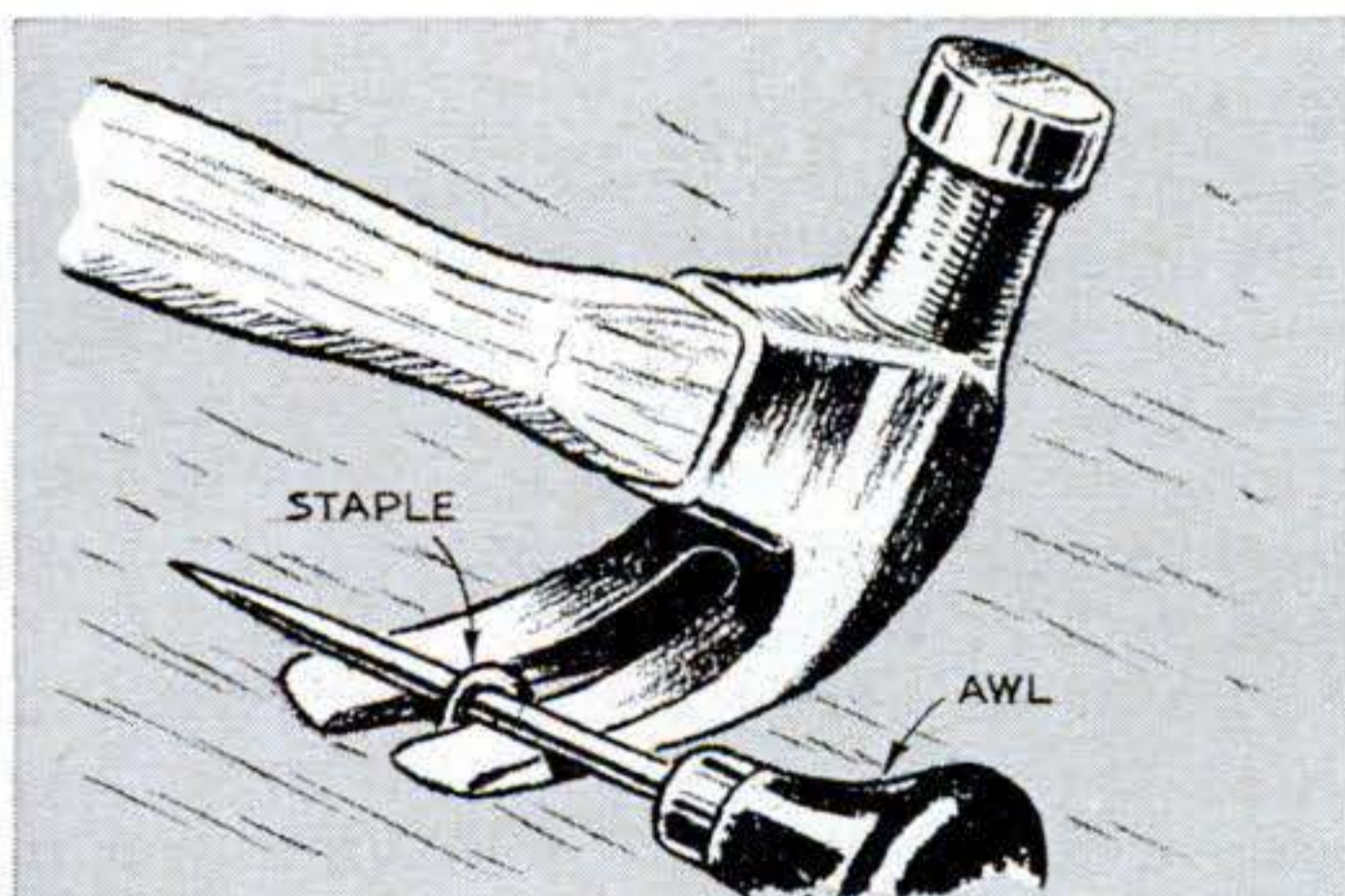
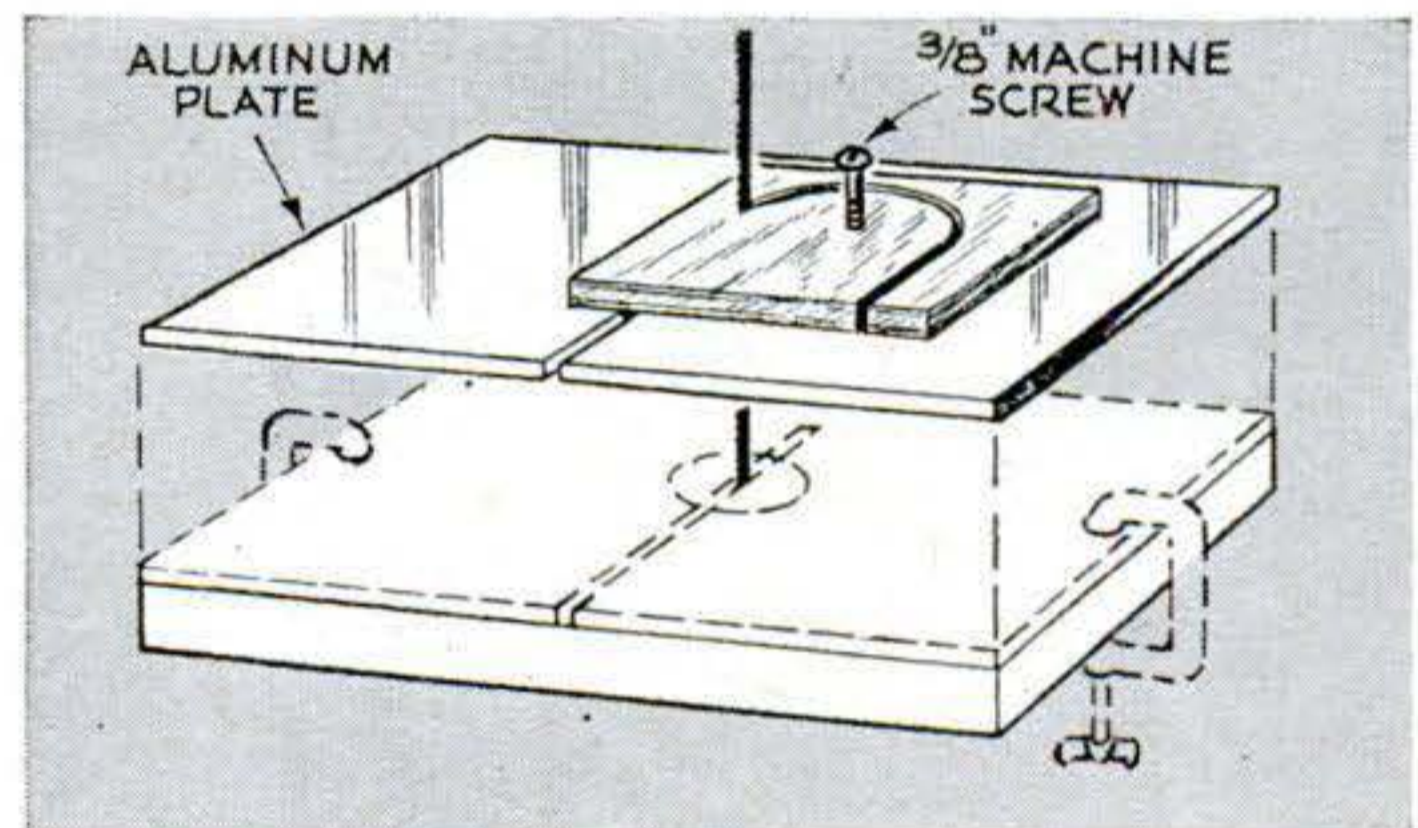

### A good trick for pulling staples

Here's a way to avoid damage to wood surfaces when pulling out staples. Insert the tip of an awl through the staple, place the hammer claws under the awl, and exert leverage on the hammer handle.—*Daniel Bousha, Jackson, Mich.*

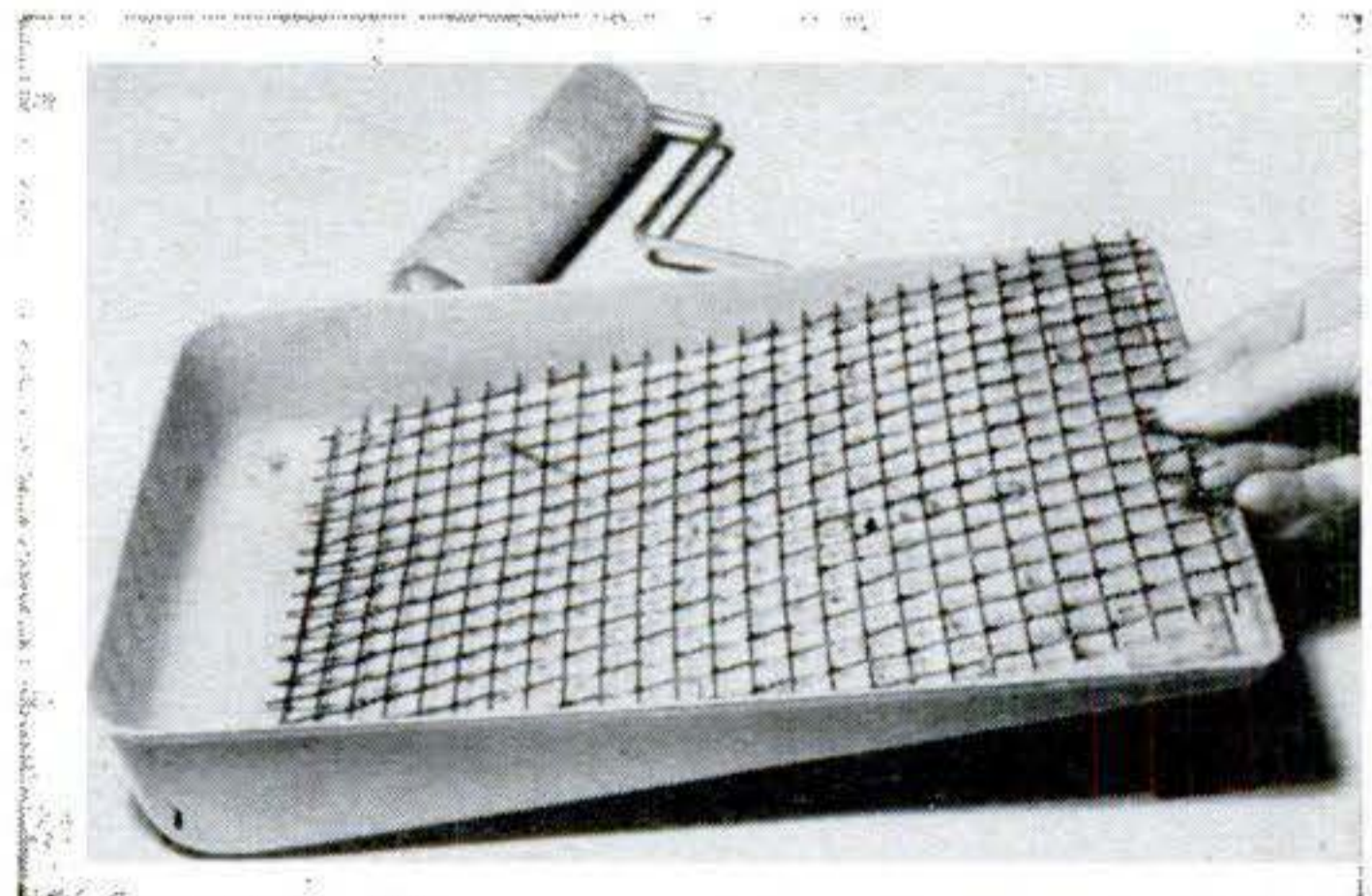

### Nonskid surface for a paint roller

A paint roller won't skid in the tray if you line the bottom with a piece of  $\frac{1}{2}$ "-mesh hardware cloth before you start. The hardware cloth also helps to distribute the paint more evenly on the roller for a better job.—*William Swallow, Brooklyn, N. Y.*





# Move In Close

there's  
a wealth  
of detail  
within  
the  
3-foot  
range

By Bob Hering

**Y**OU'VE missed a lot of fun in photography if you've never moved in close to a subject. There's dramatic impact in a frame-filling photograph. Try it. It's surprising what you see from this vantage point.

What is a close-up? Basically, it's recording on film a more detailed image than you can see with the naked eye. Except when using extreme telephoto lenses, you work close—three feet or less—to the sub-

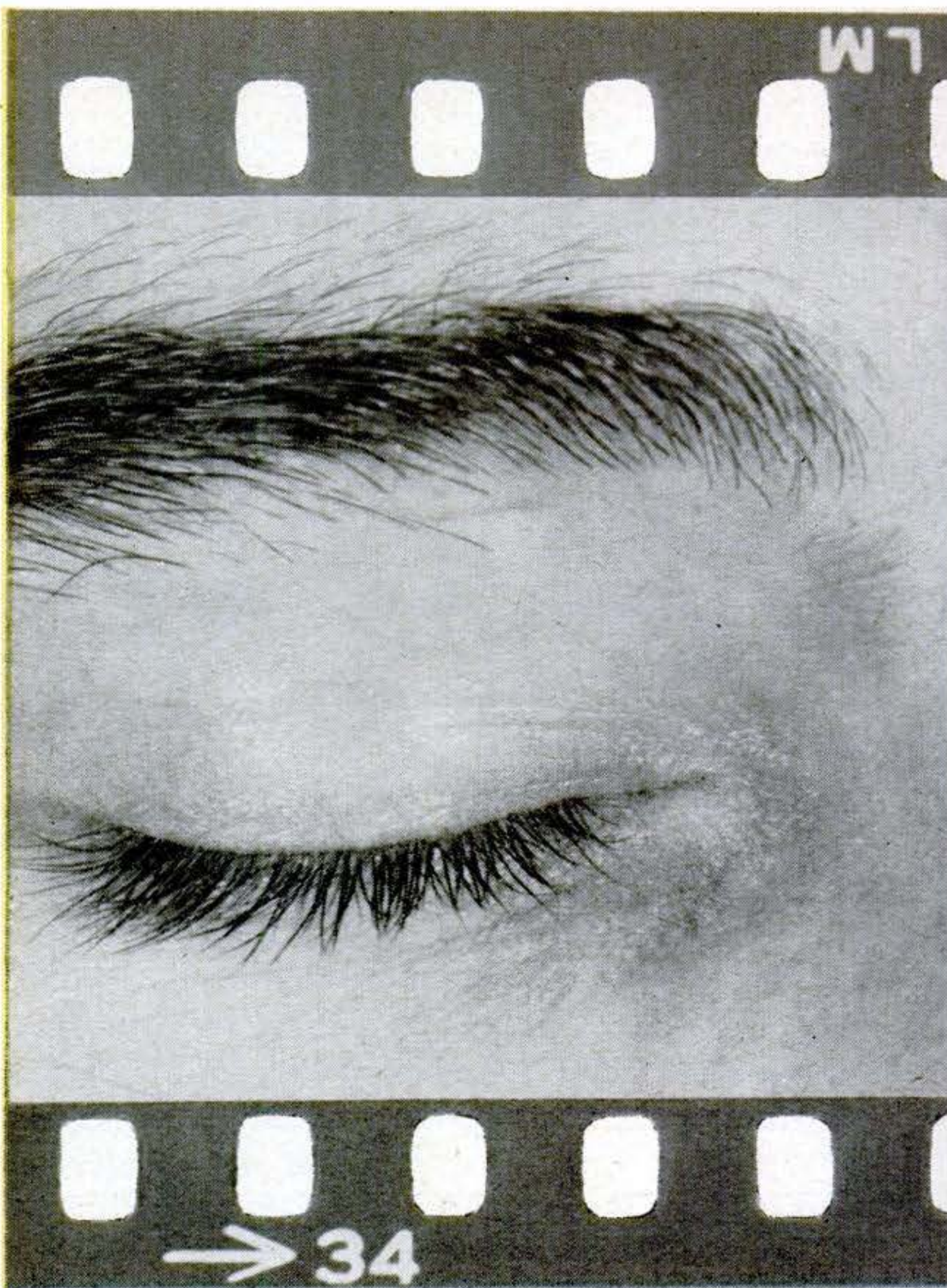

ject. The closer you get, the smaller the area included.

Whether you're interested in copying for record, producing artistic compositions, or shooting close-ups just for the fun of creating an image bigger than life, there are certain basics to know.

You can start with simple equipment—even an inexpensive fixed-focus camera and close-up lens. If shooting close-ups arouses your interest, you can then buy more elaborate gear. Only a small area is needed for photographing. Usually a setup can be left standing until you're satisfied—it's there to work with at your leisure.

This tiny world of the close-up demands attention to details—focus, lighting, composition, and exposure. By the time you're shooting consistently good close-ups, you'll have the technical side licked. You can then concentrate on subject matter and composition, confident of making sharp, clear pictures.

Entering the nearsighted realm of the close-up requires reorienting your thinking. You'll need to look close at everything,



PS PHOTOGRAPHY

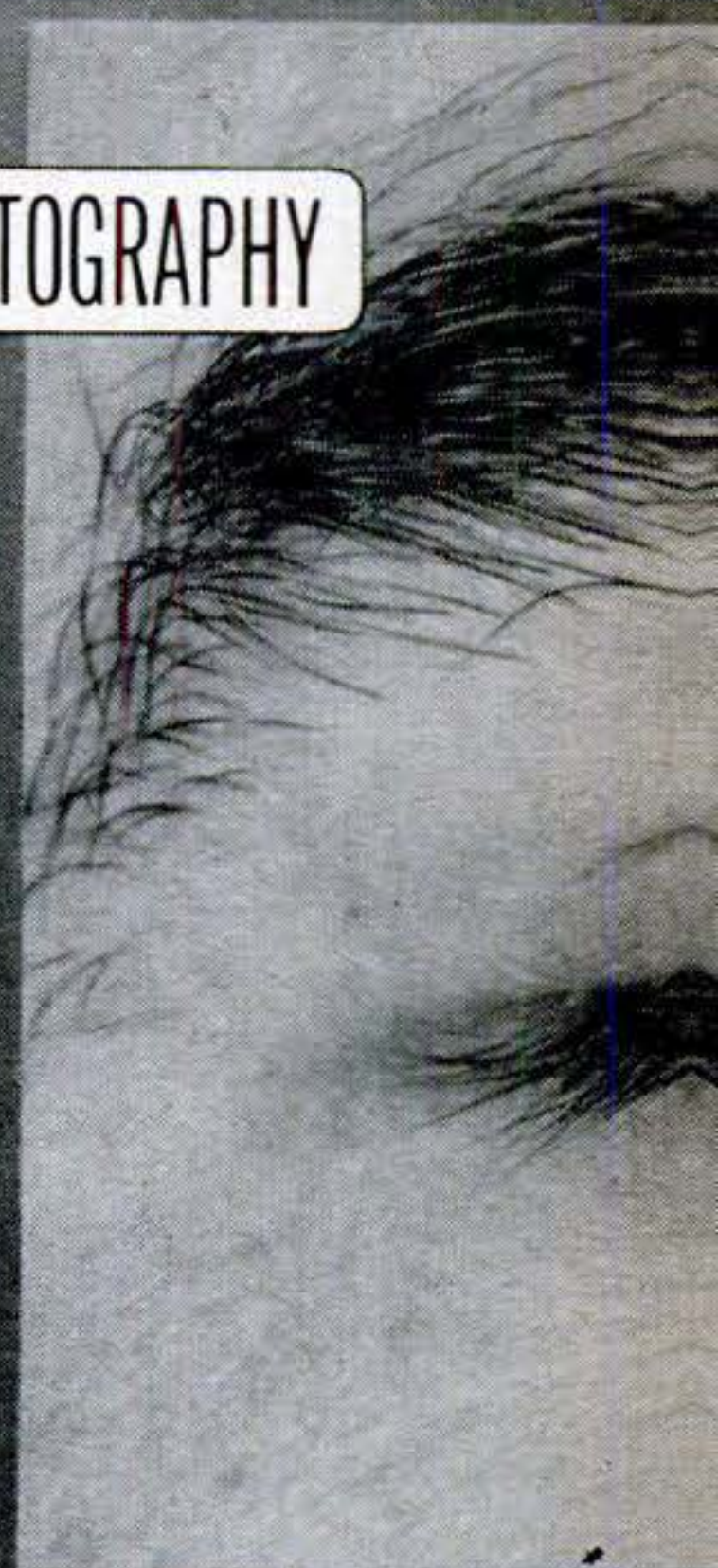
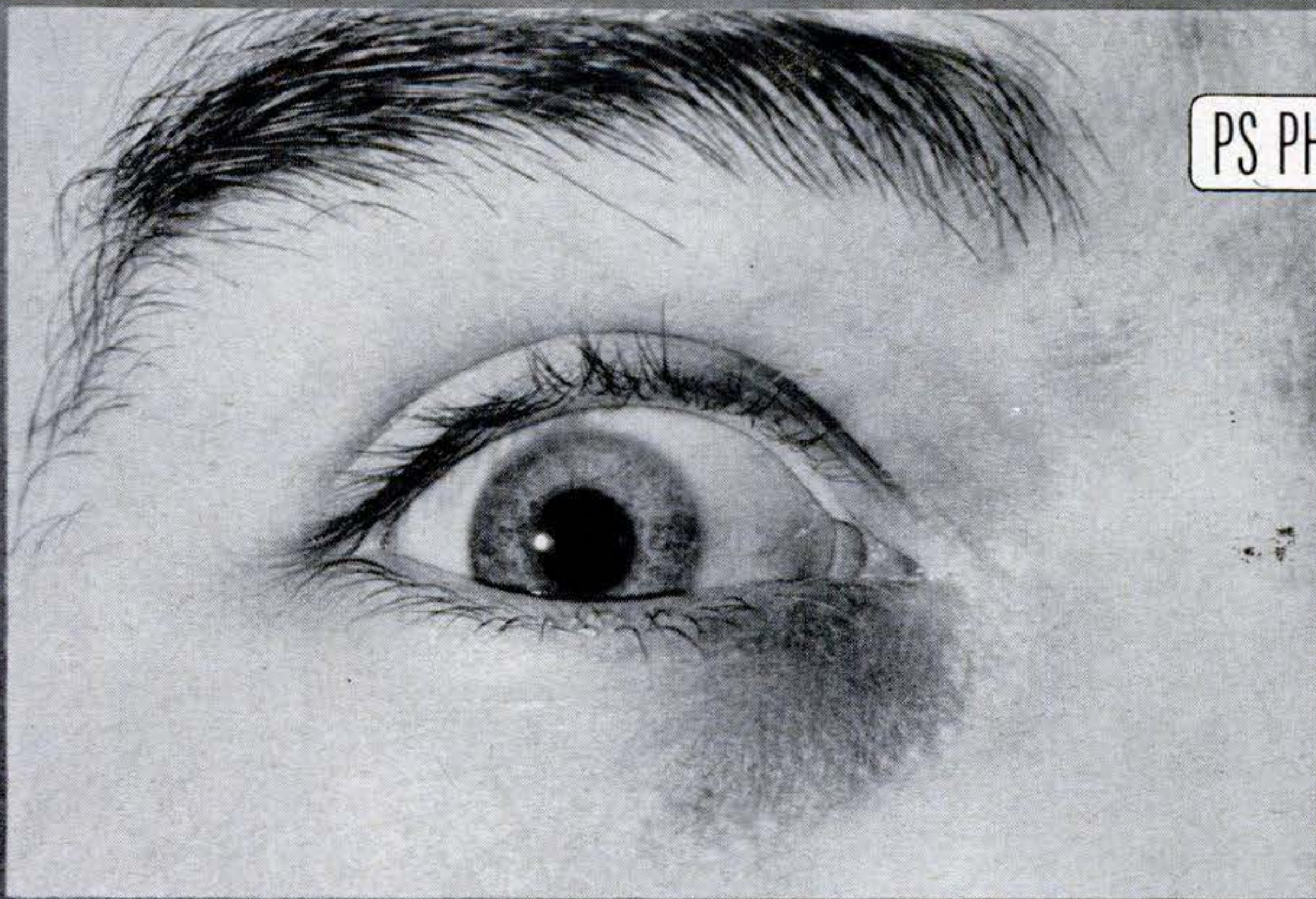

→ 35

develop an awareness of the detail in the world about you. Subjects are everywhere: in the home, the garden, the woods. Tiny subjects can become giants on photographic paper. Typical are those too small to see

clearly when viewed from a normal distance—small plants and animals, flowers, leaves, and insects, to name a few. Include a finger or some other common object to indicate scale when photographing extra-

CONTINUED

### Focal frame measures off working distance and locates picture area

A simple wood or metal frame, laid out according to the lens-to-subject distance and the picture-area dimensions (usually supplied with supplementary lens), makes a practical range-

and view-finder. Everything inside the frame will appear in the picture. Use dowels or nails to extend the uprights to top of picture area. Push far end of frame close to the subject.

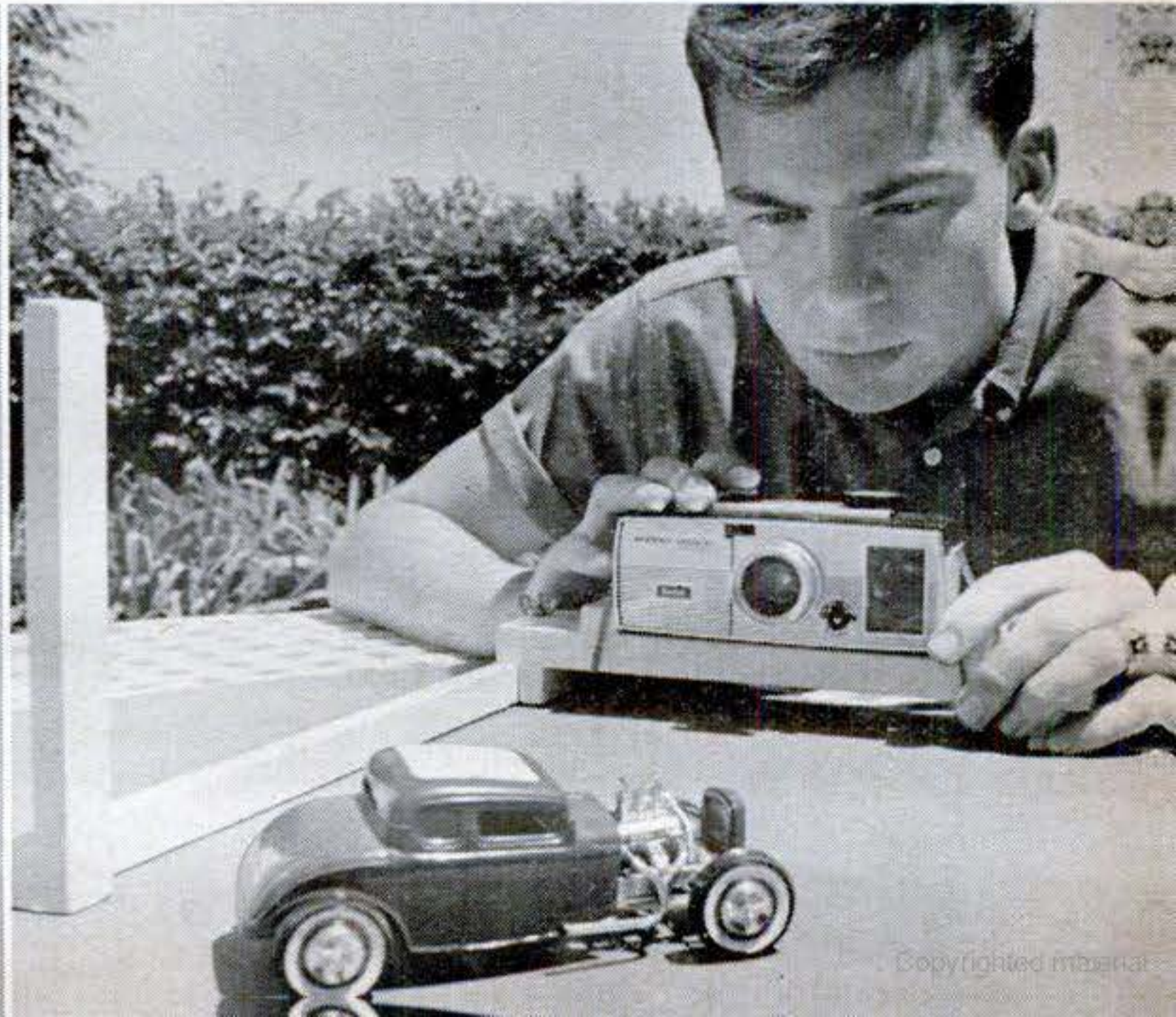
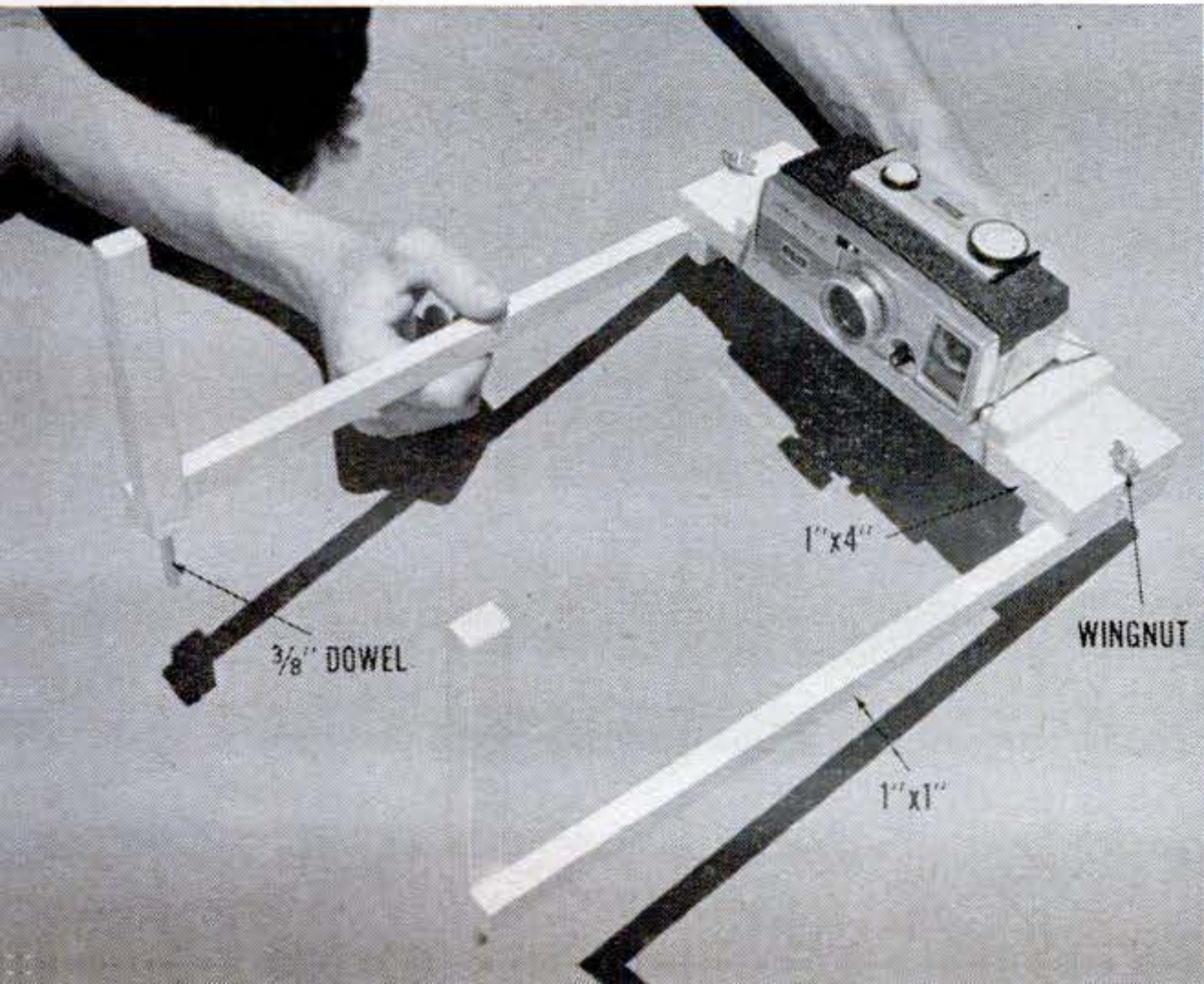



small objects. Try an extreme close-up of one of your favorite pets napping. People's faces—or even just their eyes—make good studies. There's subject matter aplenty once you train your eyes to look for it.

**Which camera?** Most cameras are adaptable to close-up work, but, for best results, two features are important: a ground glass for viewing and focusing, plus some means of extending the lens, by bellows or extension tubes.

A ground glass shows the exact area the film records. Focus is so shallow at 1:1, for example, that only ground-glass focusing assures sharpness. Providing a way to physically extend the lens, as in a view camera, cuts out the need for supplementary lenses.

**Single-lens reflex.** Of the roll-film cameras, the most versatile for close-ups and copying is the single-lens reflex. Whatever you see through the lens is recorded on the film—you can focus precisely on the ground glass, or on a prism viewfinder.

The SLRs that accept interchangeable lenses can use bellows, tubes, or tele lenses for close-ups. But on the leaf-shutter SLRs, which do not accept interchangeable lenses, supplementary or front-element convertibles are used. For hand-holding on a field trip, no camera compares with the single-lens reflex.

**Rangefinder.** Next in convenience for close-up work is the rangefinder camera

## These attachments outfit



**Bellows attachment,** combined with the ground-glass focusing of the SLR, provides the most flexible way at close range of physically extending the lens and composing the image.

that accepts interchangeable lenses. But here for through-the-lens viewing and focusing you need an auxiliary reflex housing—at close distances without through-the-lens viewing the camera viewfinder sees a slightly different picture than the camera lens. This is known as parallax error.

The reflex housing is bulky and fairly expensive. You may decide that it's more feasible to pick up a moderately priced single-lens reflex instead of adding a housing.

When a reflex housing is not used, some

## To adapt rangefinder cameras for close-up work, add these



Rangefinder cameras with removable lenses accept reflex housings and either bellows extensions or extension tubes. The setup gives you all the advantages of a single-lens reflex camera.



For hand-holding rangefinder cameras in close, there are several devices. The one above has parallax adjustment that allows you to work directly through the camera's own optical system.



## single-lens reflex cameras for close-up work

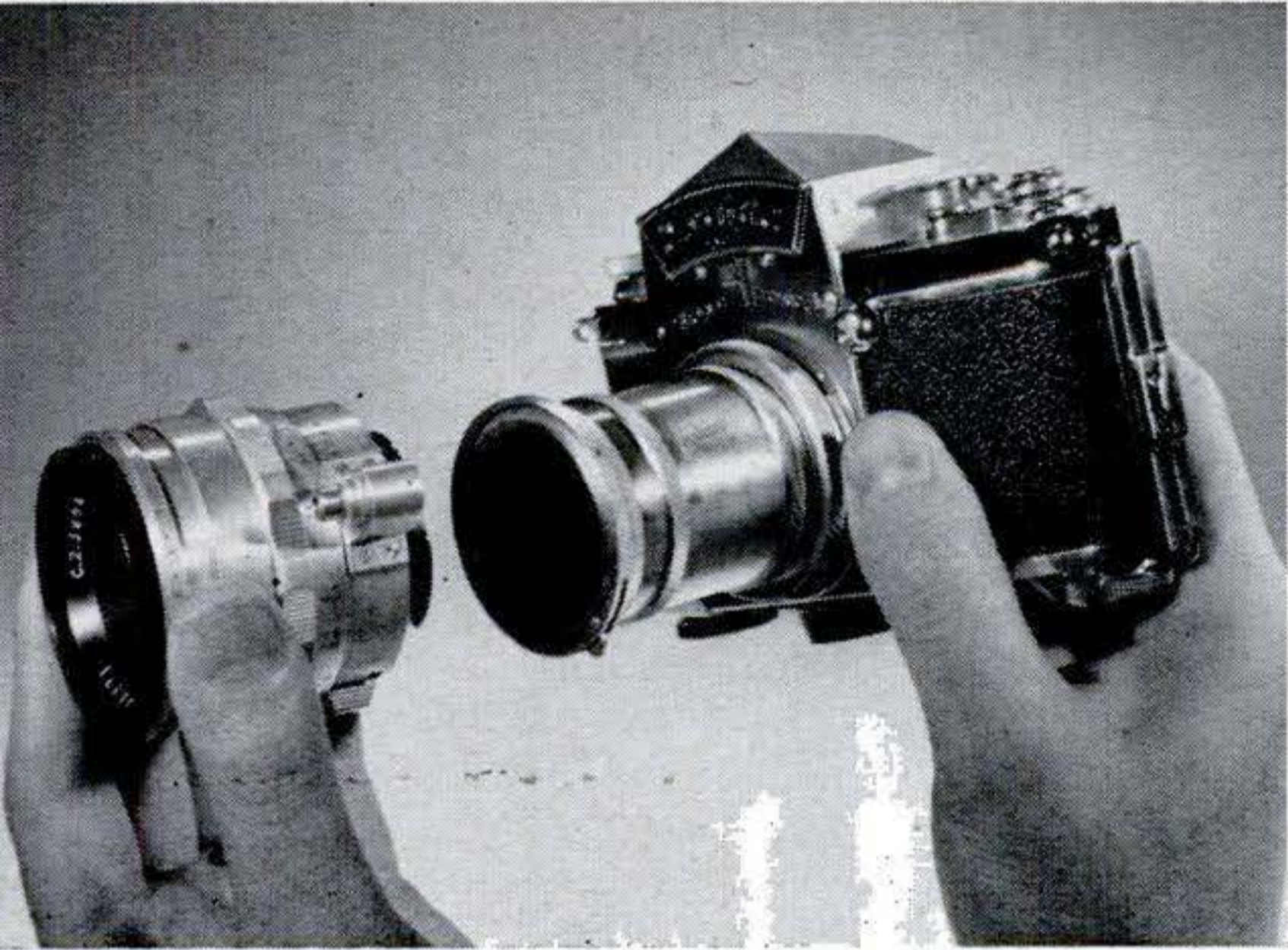

Extension tubes, used in combinations, offer a variety of lens-to-film ratios. They are inexpensive, but their fixed lengths limit their focusing range compared with bellows.



Most leaf-shutter reflexes require supplementary lenses, but Contaflex Super B (above) uses lenses with removable front elements. This lens can take a big 1:1 image (actual size).

sort of supplementary viewfinder is needed for the rangefinder camera. It can be a simple wood or metal frame, or one of the more precise optical supplements.

**Twin-lens reflex.** For general photography, the twin-lens reflex is a favorite, but it presents problems for close-up photography. Usually there's sufficient parallax correction for distances from three feet to infinity. But for closer work, a twin-lens reflex lacks the advantage of interchangeable lenses (except the Mamiyaflex),

and the parallax error increases as you move in.

For moderate close-ups, you can add matched supplementary lenses to both the viewing and camera lenses. For extremely close work, the twin-lens camera is impractical. It requires a special optical or mechanical accessory to correct parallax.

**Fixed-focus and others.** Fixed-focus and other inexpensive eye-level cameras without interchangeable lenses are the least adaptable to close-up photography. To use them,

CONTINUED

## Twin-lens reflexes require parallax correction

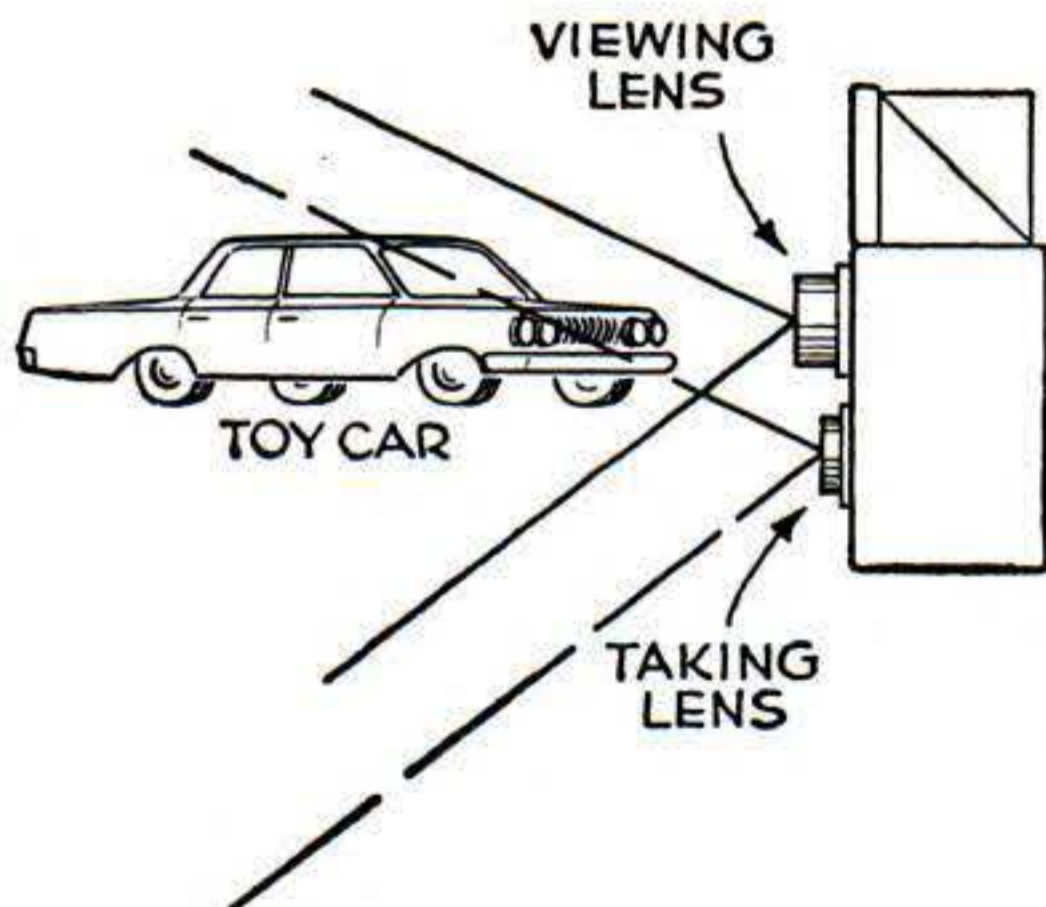

Parallax error with twin-lens reflex is illustrated above—at close range, lenses see different pictures. Supplementary lens over viewing lens, at right, has prism that refracts rays so you see what taking lens, with its supplementary, will catch.







.....

## Flowers are favorites for color slides

One of the most popular subjects among camera fans who shoot color slides is flowers. And the most dramatic way to portray them is by moving in close until a single bloom—or a few at most—practically fills the frame. Jackson and Perkins, rose specialists, suggest photographing blooms  $\frac{3}{4}$  open, from a camera angle partially looking into the center of the flower. An overhead light gives best basic illumination, with other lights as needed. John Staby shot prize-winning Tropicana rose (left), using this lighting method to emphasize texture.

.....

you must add a supplementary lens and some device to solve the parallax problem. For this purpose, a simple focal frame can be rigged up from metal rods, wire, or wood strips. Such equipment, however, should be confined to shooting moderate close-ups.

**What about focus?** Whenever you focus a camera, you alter both lens-to-film and lens-to-subject distances. At normal shooting distances, these changes are easy to handle. But as you move closer than 3', it becomes more difficult to focus accurately—and depth of field decreases sharply. Sharpness may extend only a fraction of an inch from the plane of sharpest focus. With a 2" lens on a 35mm camera, for example, the depth of field at a distance of 18", with the diaphragm stopped down to f/8, is slightly less than 1". In extreme close-ups, there's practically no depth of field. No wonder focusing is so critical.

**The big image.** To get a larger-than-normal image on film, you need a way of extending the focusing range of your camera. This requires certain accessories to increase the distance from lens to film.

You have several choices: You can physically extend the lens with bellows or extension tubes; you can optically shorten the normal focal length with positive supplementary lenses; or you can use a telephoto lens.

**Supplementary lenses.** Looking much like a filter, a supplementary lens is the least expensive and simplest close-up accessory.

When placed over a camera lens, a positive supplementary lens reduces the focal length. These lenses come in strengths of 1+ to 10+ and in a variety of sizes and mounts, usually fitted to specific cameras. A supplementary lens decreases definition slightly, especially if it is one of the stronger plus lenses (6+ to 10+). It's desirable, for this reason, to work with the main lens system stopped down two or three openings to increase depth of field and sharpness.

A big advantage of supplementary lenses, in addition to low cost, is that [\[Continued on page 224\]](#)



**Metal copy stand** functions like a focal frame, holding the camera at a predetermined distance from the subject to be copied. The legs indicate the corners of the picture area.



# Strips and Disks

## Make an Airy Lamp

THIS lamp was designed for use where there is need for an airy fixture blending well with modern furniture. It's built of contrasting woods—eight  $\frac{1}{8}$ "-by- $\frac{1}{4}$ "-by- $15\frac{1}{2}$ " mahogany strips and three birch disks. A rear strip hides the wire.

Locate notch positions on the disks by drawing four diameter lines across each one, spacing the lines 45 degrees apart. Space the notches in the base on a  $1\frac{3}{4}$ " radius from the center. On the center and top disks cut notches on the edges, those

on the top one only part way through. Glue the strips to the middle disk first, clamp, and let the glue set before curving out the strips to suit the other disks.

Mount the bulb socket on a piece of

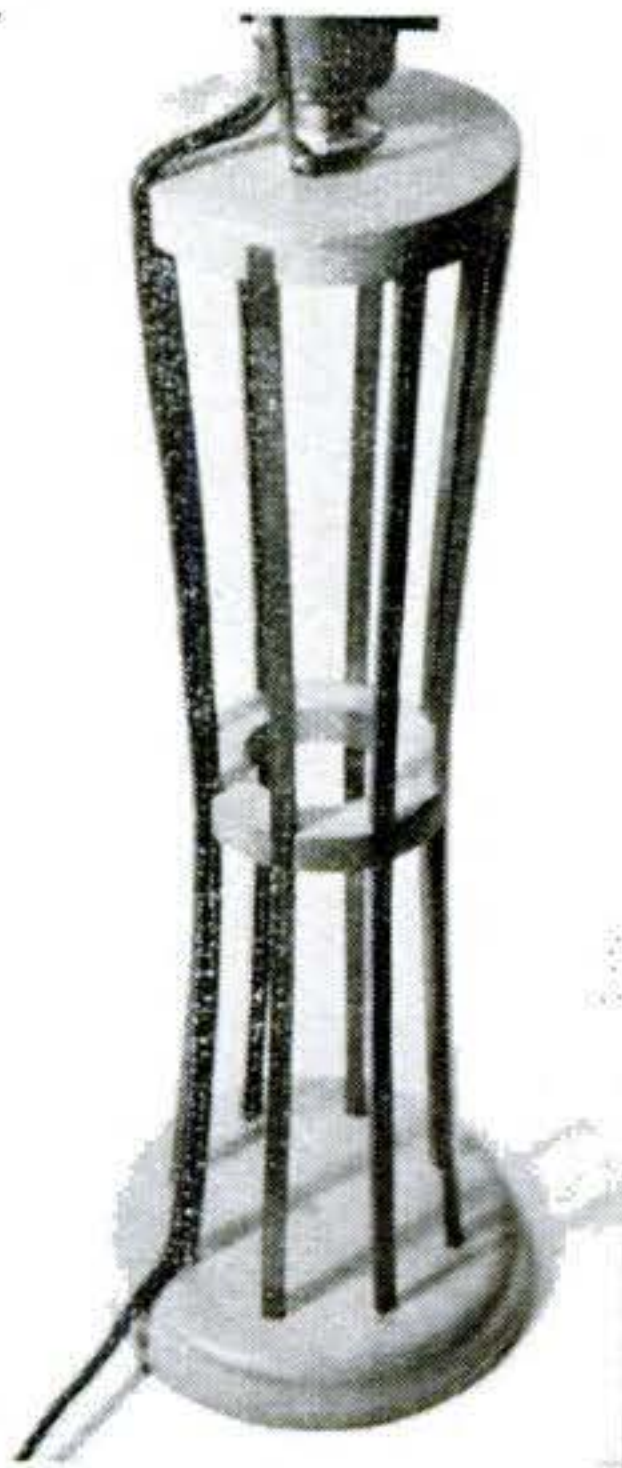

threaded fixture tubing run through a  $\frac{3}{8}$ " hole in the top disk and held with a hex nut.—*Jorma Hyypia, Greenwich, Conn.*

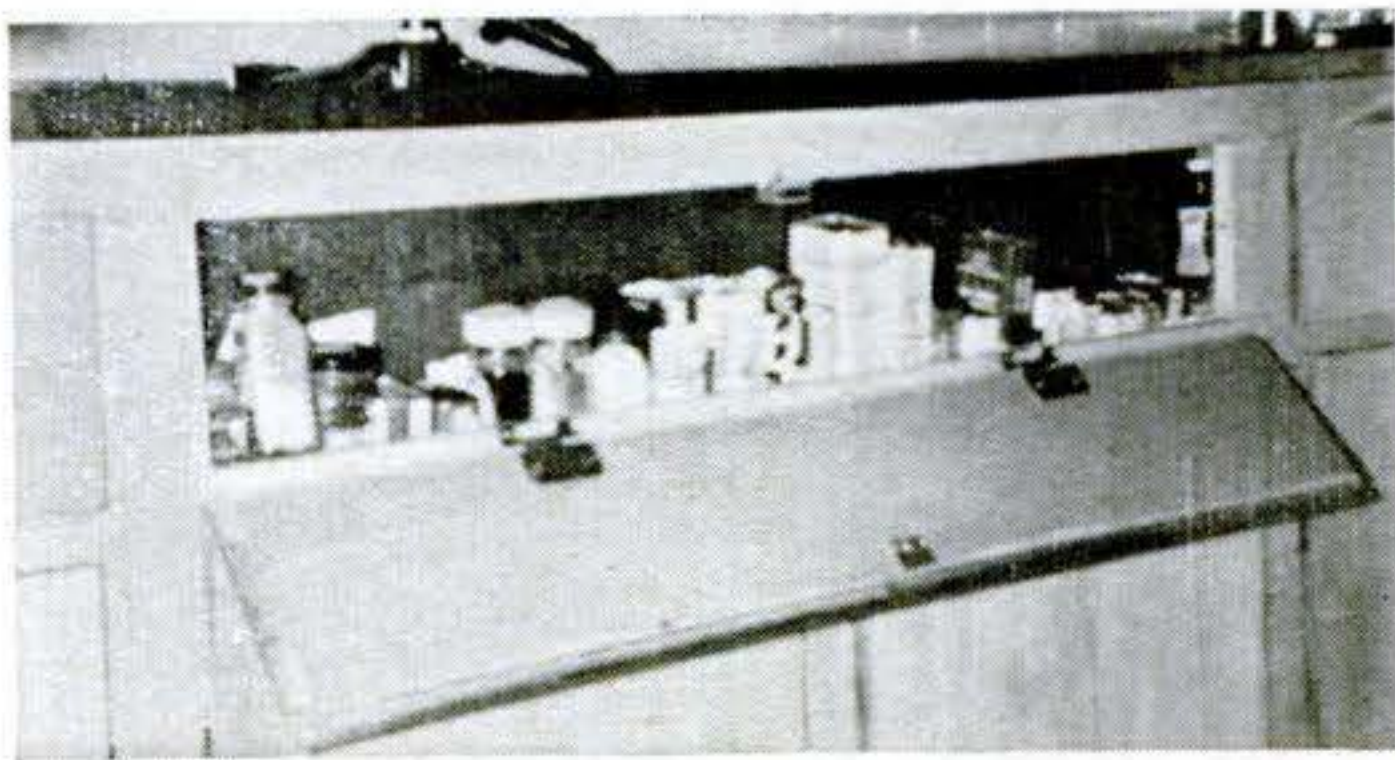
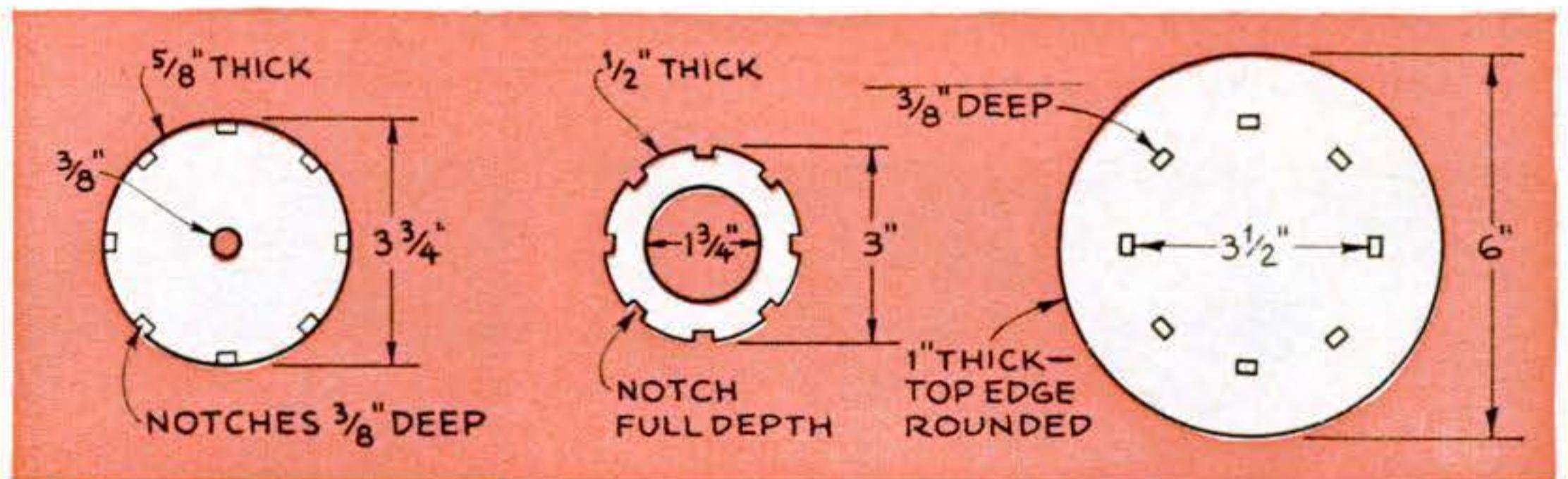

### Using all the kitchen space

The spice cupboard above was created from the most-often-wasted space in any kitchen—the area behind the panel concealing the sink. A magnetic catch holds the door shut. The recess has a hardboard back.—*Leonard Kameron, Tallmadge, Ohio.*

### A key caddy for your wallet

Keeping four or five keys in a wallet may seem impossible. However, a caddy made from flexible leather is thin enough to slip into a wallet without bulking.

Use leather at least  $\frac{1}{16}$ " thick. Fasten each key with a brass eyelet. Compress the eyelet just enough to let the key move freely on it.—*Robert Micals, Freehold, N.J.*

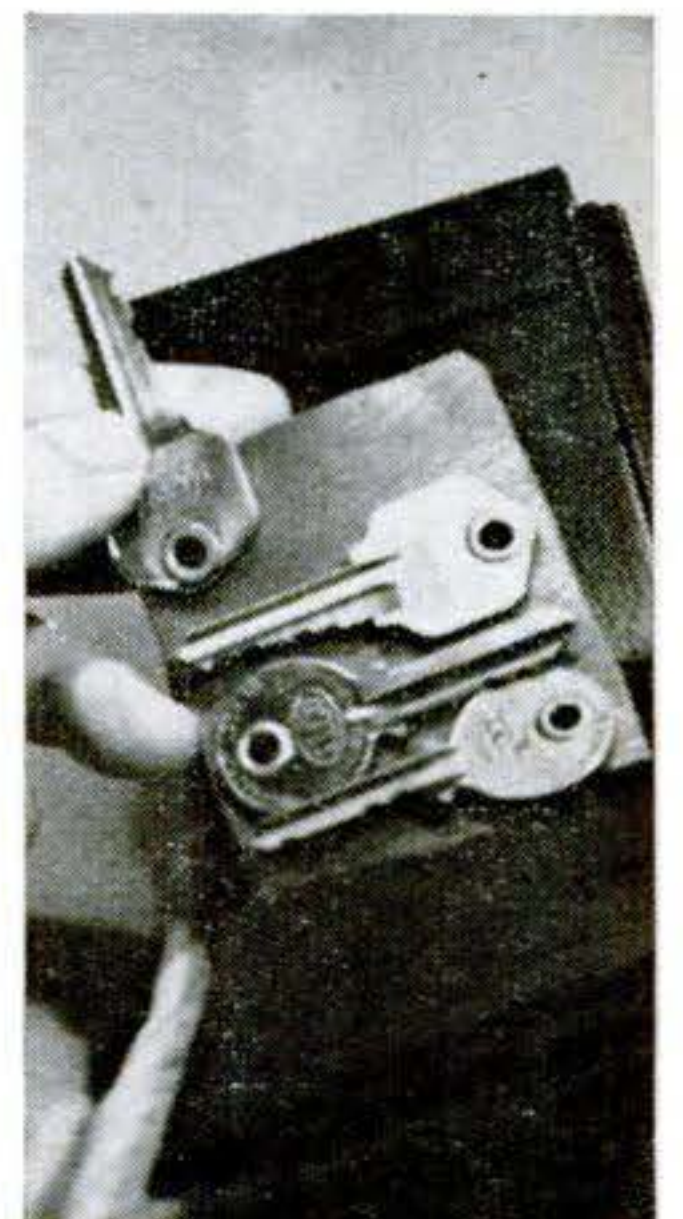



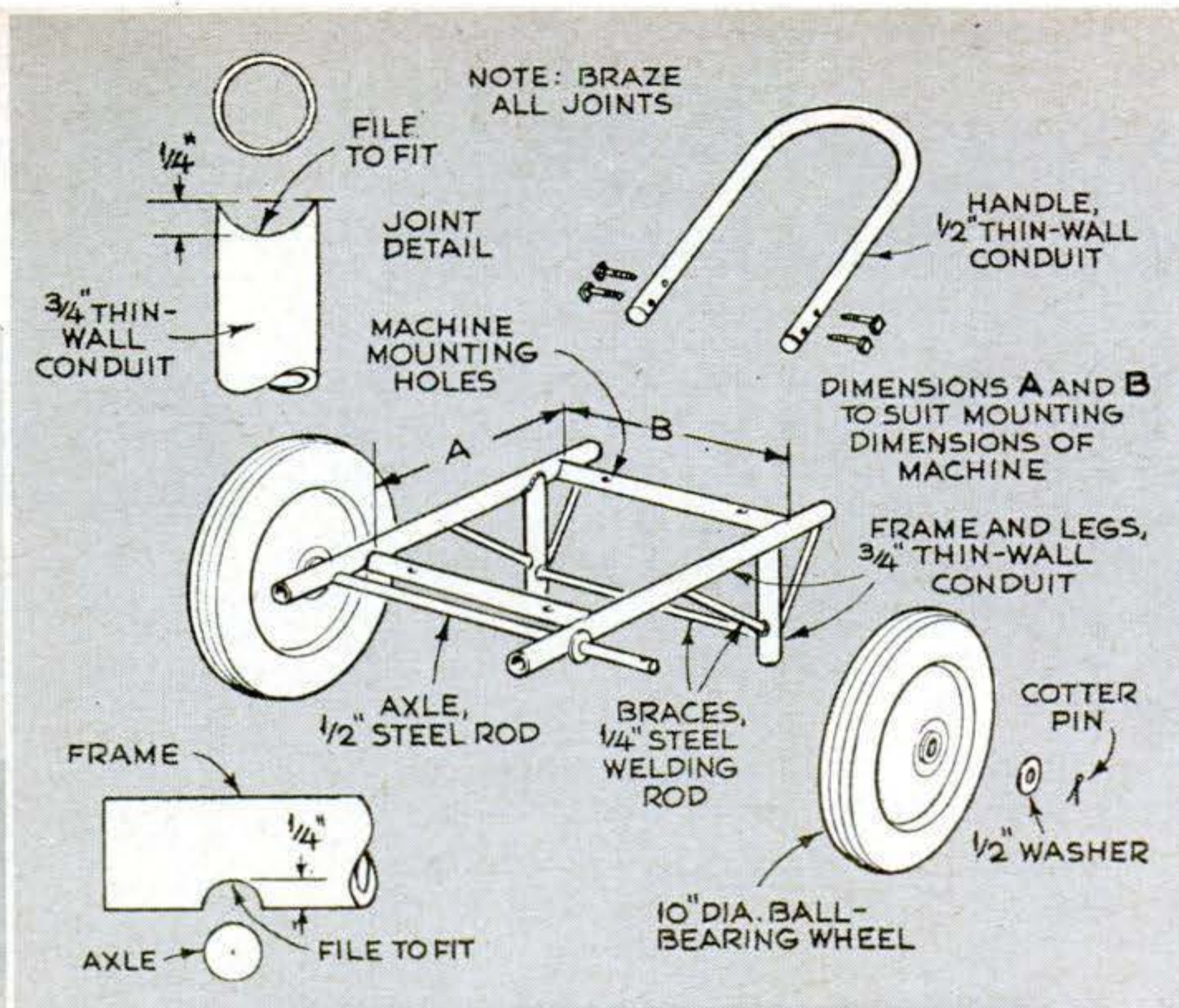

### A carriage for compressor or welder

Small air compressors, welding outfits, and other machines are often too heavy to be handily portable. This homemade carriage, adapted to a particular machine, will put it on wheels for maneuvering wherever you want it.

The carriage makes use of standard utility wheels (10" by 1.75) and 1/2" and 3/4" thin-wall conduit and steel rod—all avail-

able at hardware stores. Dimensions of the carriage you'll want depend on the size of your machine.

Use a 3/4" round file to bring the frame joints to a close fit with the joining member, a 1/2" file to fit the axle. Braze all the joints if you're equipped for that, or have them welded professionally. Use 1/2" washers on each side of each wheel, and drill the ends of the axle to take cotter pins.—*Manly Banister, Portland, Ore.*

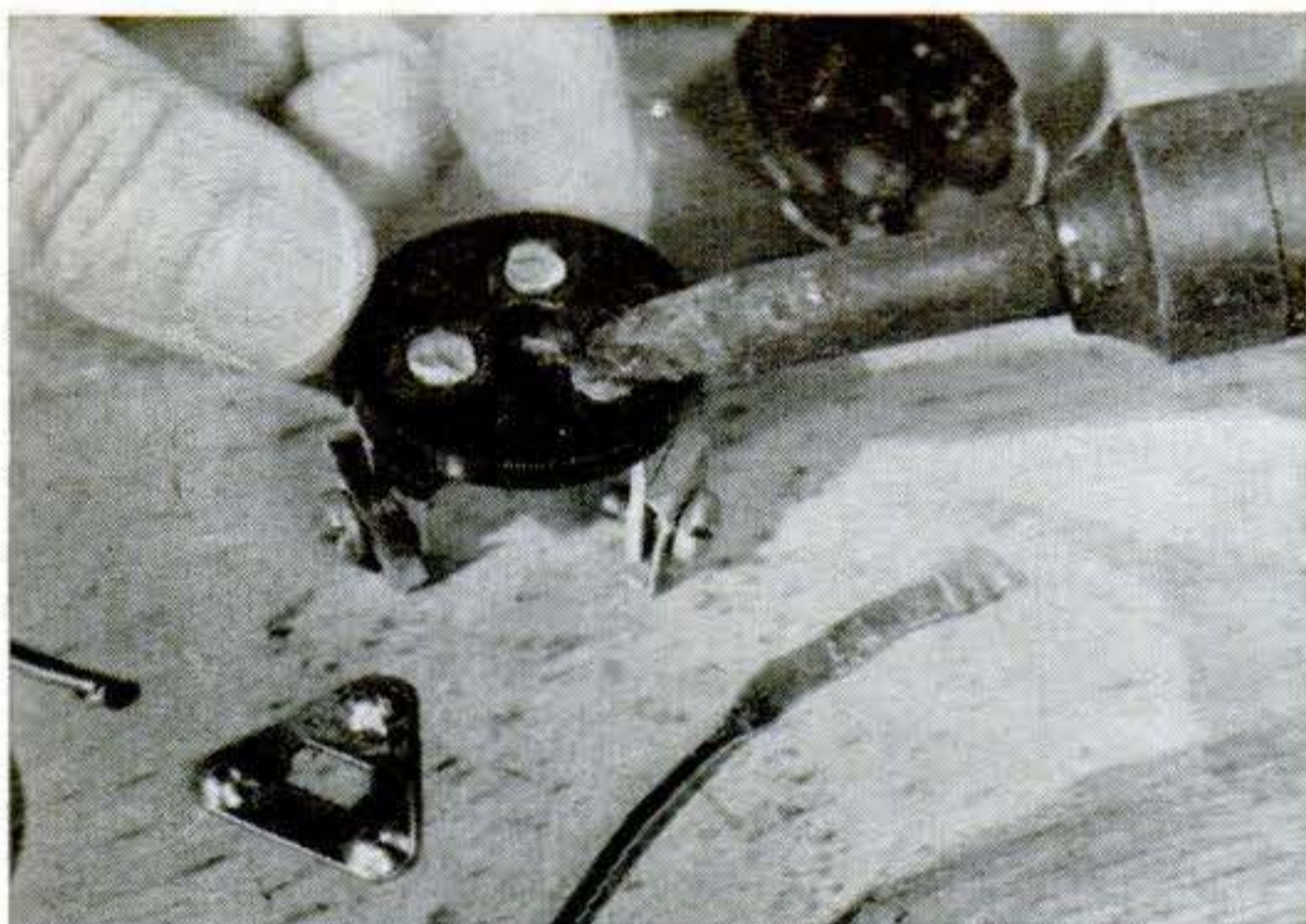

### How to repair an ignition switch

Ignition trouble may result from worn or grooved contact surfaces in the ignition switch. If you can't get a new switch, or if you'd simply like to make the old one serve longer, fill the worn areas in the contact points with solder. For longer service, hammer a piece of copper wire flat, solder a tiny sheet of it over each one of the stationary contacts, and dress down the edges.—*Ken Murray, Colon, Mich.*

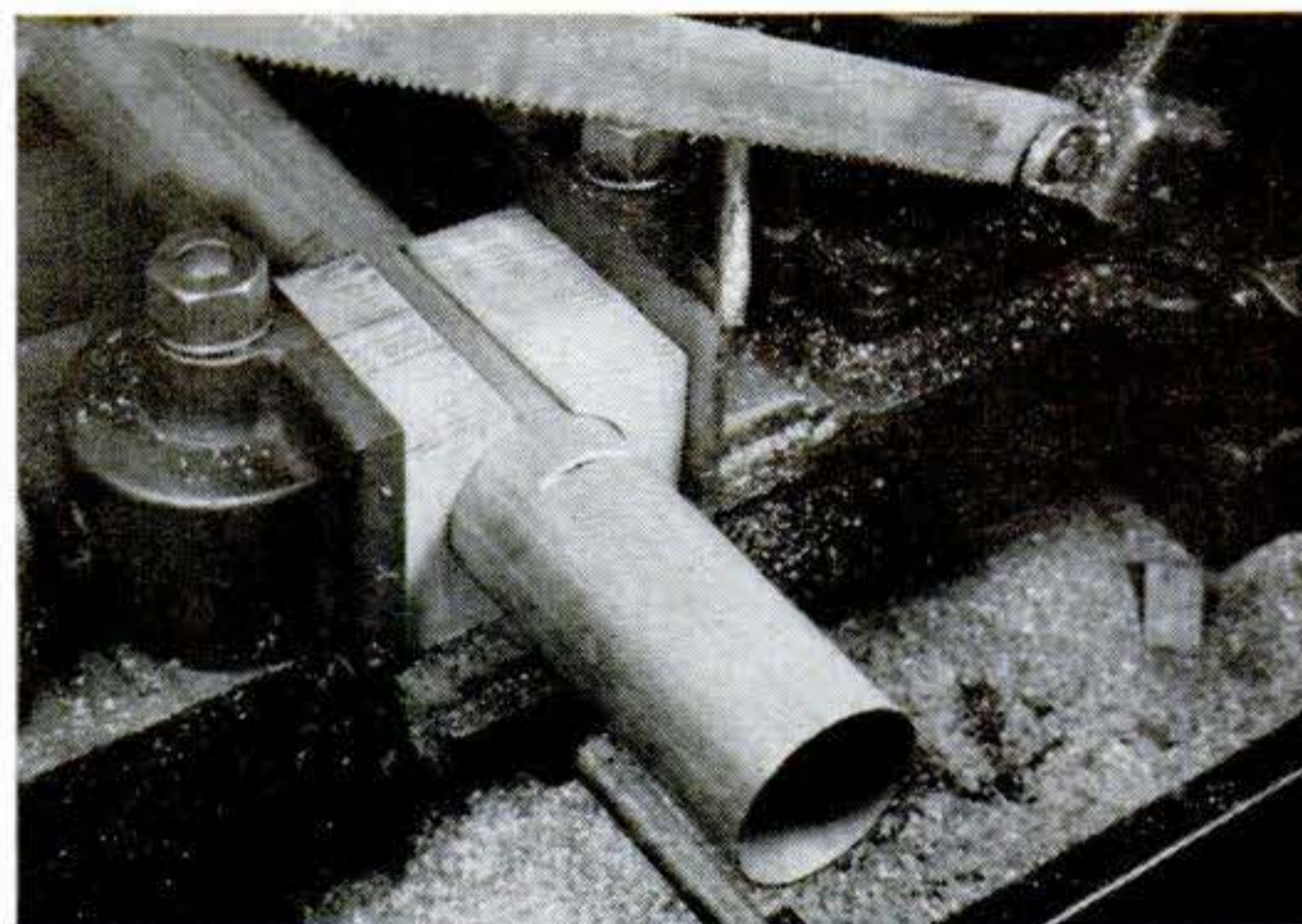

### Wood blocks hold tubing for hacksaw

Production hacksawing of thin-wall tubing is easy if you use form-fitting hardwood grip blocks like these to prevent marring and crushing the stock in the vise or clamp jaws.

The blocks shown were cut out of hard maple. The circular gripping inner faces were sawed into the blocks with a narrow blade on a metal-cutting bandsaw.—*H. J. Gerber, Menomonie, Wis.*



DRILL SIZE	DRILL MAT'L.	BRASS ALUM	C. I. SOFT	C. I. HARD	MILD STEEL	MALL IRON	WOOD PLSTC
1/16	H.S.S.	1	1	1	1	—	1
	C.S.	1	1	1	2	1	1
1/4	H.S.S.	1	1	6	2	4	1
	C.S.	1	6	8	8	8	1
3/8	H.S.S.	1	3	7	3	6	2
	C.S.	3	7	8	8	8	3
1/2	H.S.S.	1	5	8	7	8	3
	C.S.	5	8	8	8	8	4

SETTING	APPROX. R.P.M
1	2,000
2	1,800
3	1,600
4	1,400
5	1,200
6	1,000
7	800

SETTING

**DIAL-A-POWER SETTINGS**

PS TOOLS

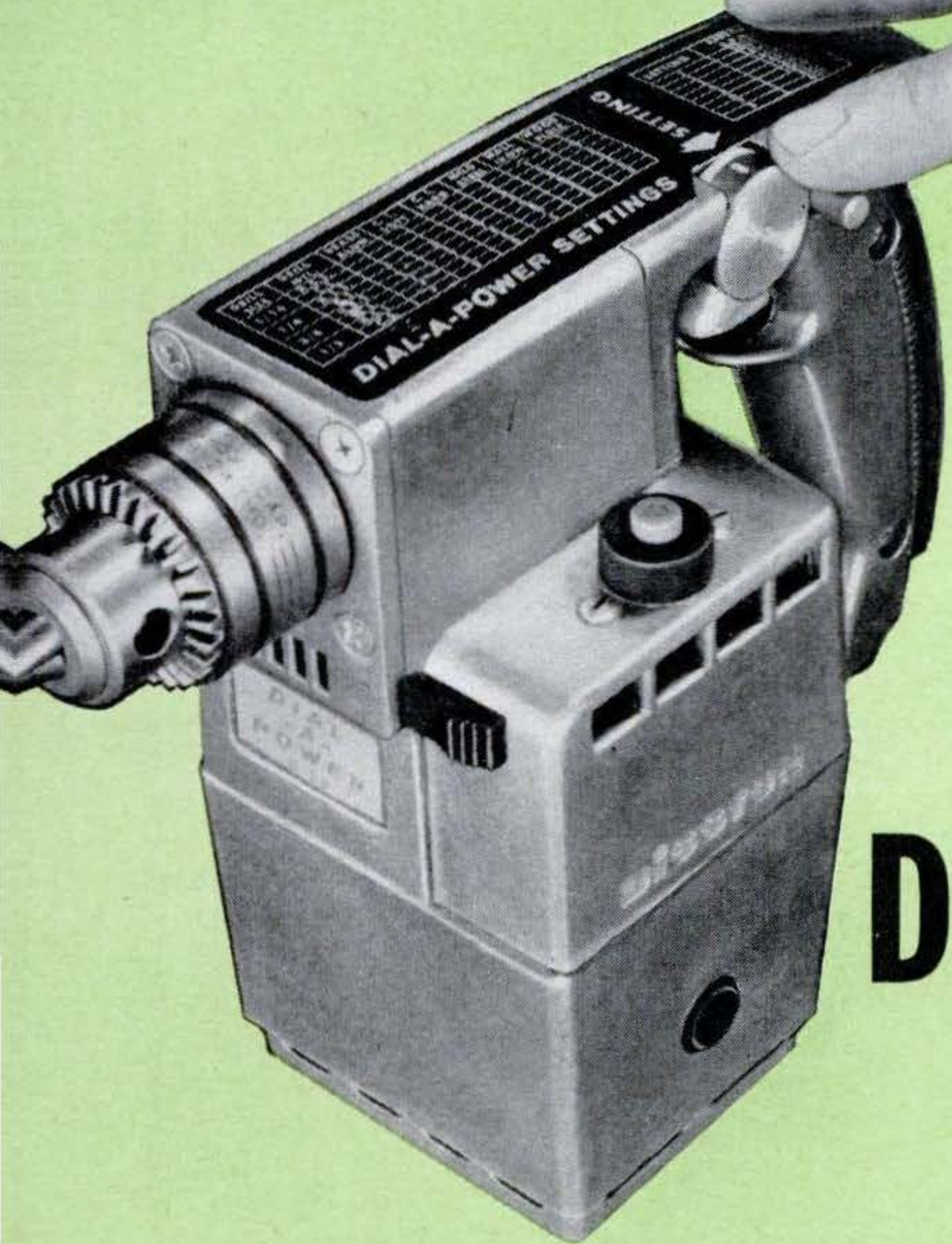

A personal-use report on —

# Disston's Dial-a-Power Drill

By R. J. De Cristoforo

**C**AN a single electric drill really be gutsy enough to bore 1/2" holes in steel and yet delicate enough to make 1/16" holes in plastic? This is just one of the many claims made for Disston's new 1/3-hp. drill with an electronic variable-speed drive. POPULAR SCIENCE reported briefly on the tool in the December issue when it was first announced, then passed on to me the job of testing it in the shop. The results are impressive.

Think of a dozen or so typical jobs—things like putting a 1/4" hole in maple, a 3/8" hole in aluminum or brass, a 1/2" hole in brick or concrete using a

CONTINUED

Munching through steel is easy—you shift into low speed and still get full power. Chart on top of drill shows proper speed for each material and bit size.

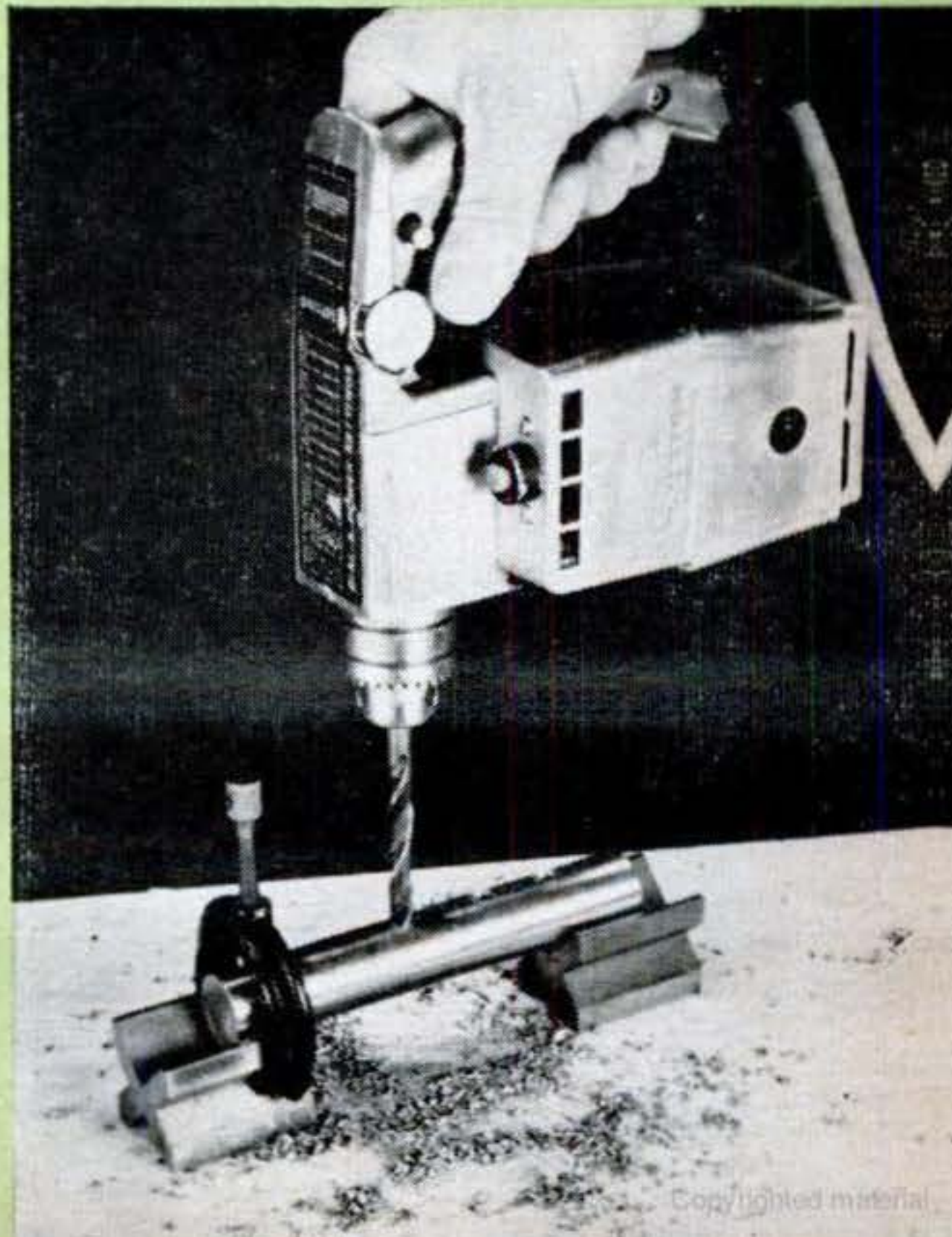



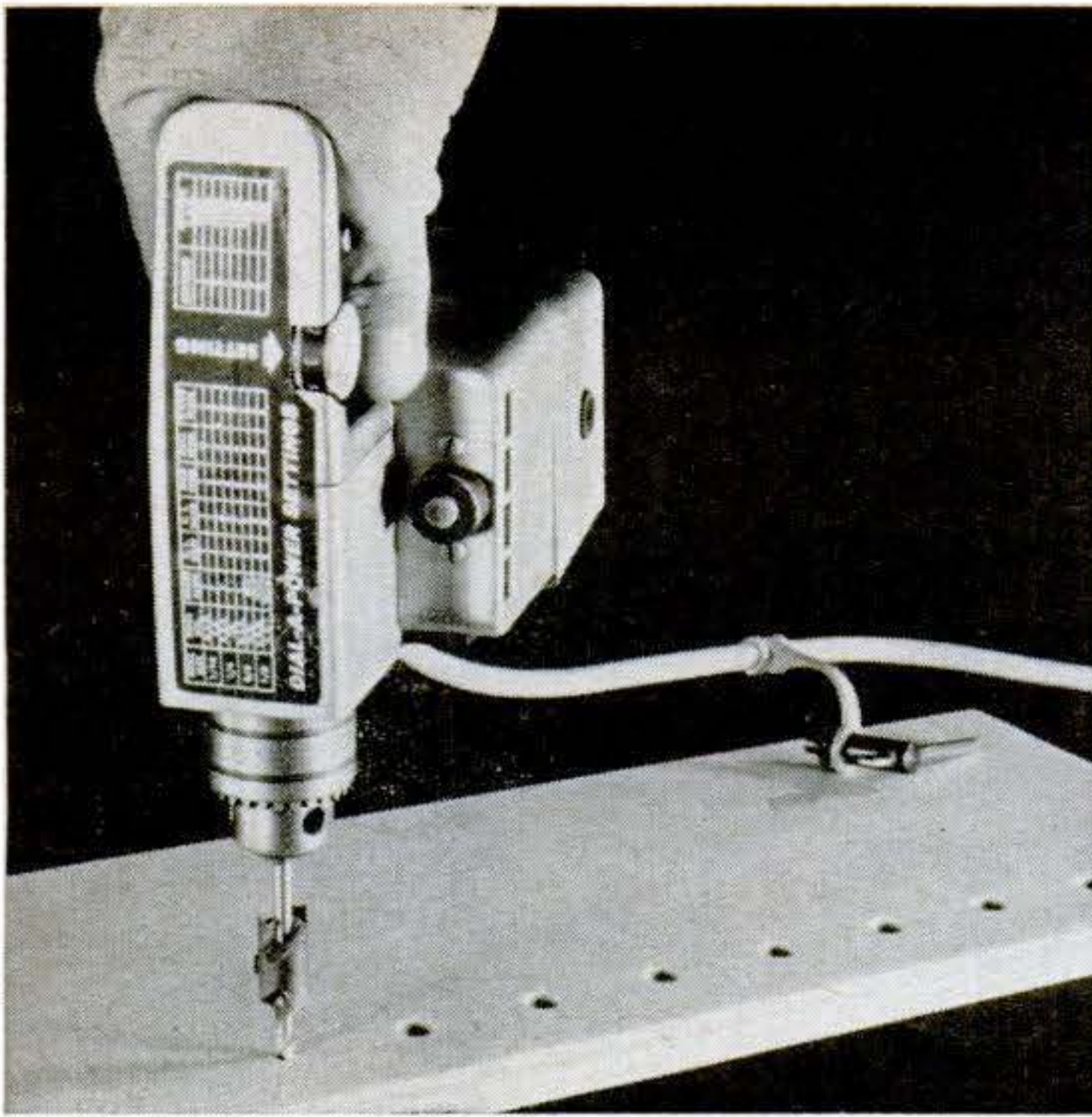

For fast drilling in light materials, you run the motor up to full speed. If you hit a knot, you can throttle down by simply flicking the knob with your thumb—with the drill running.

carbide-tipped bit, mixing paint so it doesn't whip out of the can. The new Disston Dial-A-Power drill did all these jobs and others—including making 3" holes in  $\frac{3}{4}$ " hardboard-surfaced plywood with a hole saw.

The range of work would normally have required two or three different drills, and even then any particular speed would have been a compromise.

**Dialing the speed.** Setting the speed is a cinch. Glance at the chart on the top of the drill to find your correct speed, and turn the small, numbered knob at the side. You can choose any speed between 600 and 2,000 r.p.m.—and at any setting you select you get the full power of the  $\frac{1}{2}$ -hp. motor.

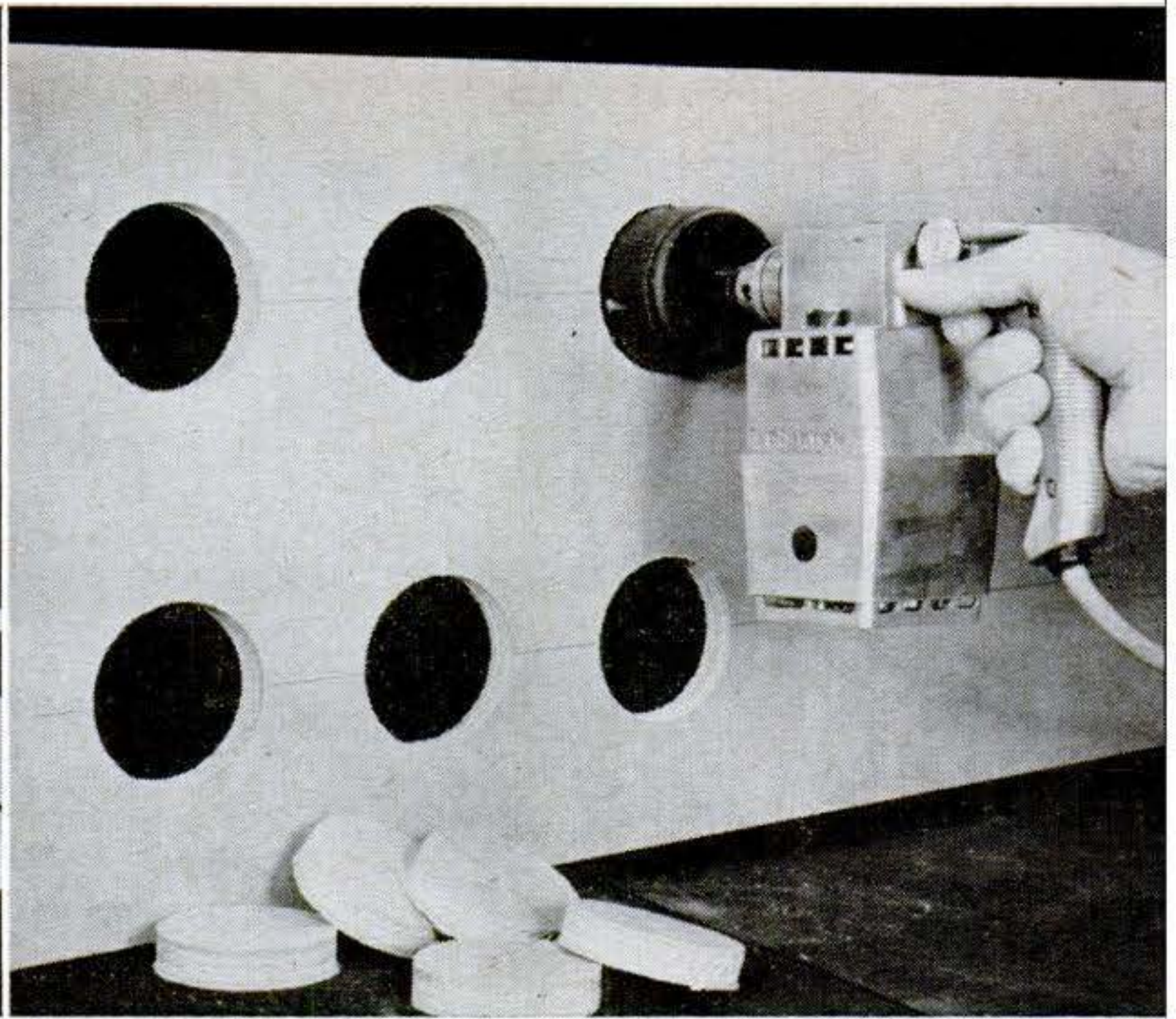

Large holes like these three-inchers are a tough job for any drill, but proved to be no problem for the Dial-A-Power. Even deliberately forcing the feed failed to stall the drill.

You can change speeds regardless of whether the drill is shut off, running free, or under load. That last possibility proved especially impressive when I had to get through a particularly knotty area in a piece of wood. It was like shifting a car into low gear halfway up a steep hill.

But this drill doesn't use gears. Gears couldn't give you those infinitely variable speeds; and besides, it's doubtful if you could squeeze them into the case, which is the size of a standard  $\frac{1}{4}$ " drill.

The secret behind the Disston drill's variable speeds is a silicon-controlled rectifier—the miracle device that will surely end up revolutionizing the workshop by adapting the speed of many machines to the work.

## How electronic speed control works

The concept is based on the use of solid-state electronic circuitry with what is known as "feedback." The principle is not new in electronics, but using it in a portable electric tool is an imaginative and highly successful application.

The feedback circuit is like an electronic brain that manipulates drill power according to the load at the cutting end. Its heart is a silicon-controlled rectifier. Turning the small control knob to select a speed adjusts a variable resistor that decides the value of the bias voltage on the

controlled rectifier. In turn, this controls the amount of current that can pass through the motor's armature.

Drill power is produced by rectifying the AC house current in a solid-state rectifier bridge network to provide a pulsating DC voltage. When this pulsating voltage is at zero, which occurs at the end of every half-cycle, the armature's motion generates a small voltage of its own—feedback. This is returned through a transistor to the controlled rectifier.

When the drill speed is constant (a no-load condition), the feedback voltage remains constant. When the drill slows down



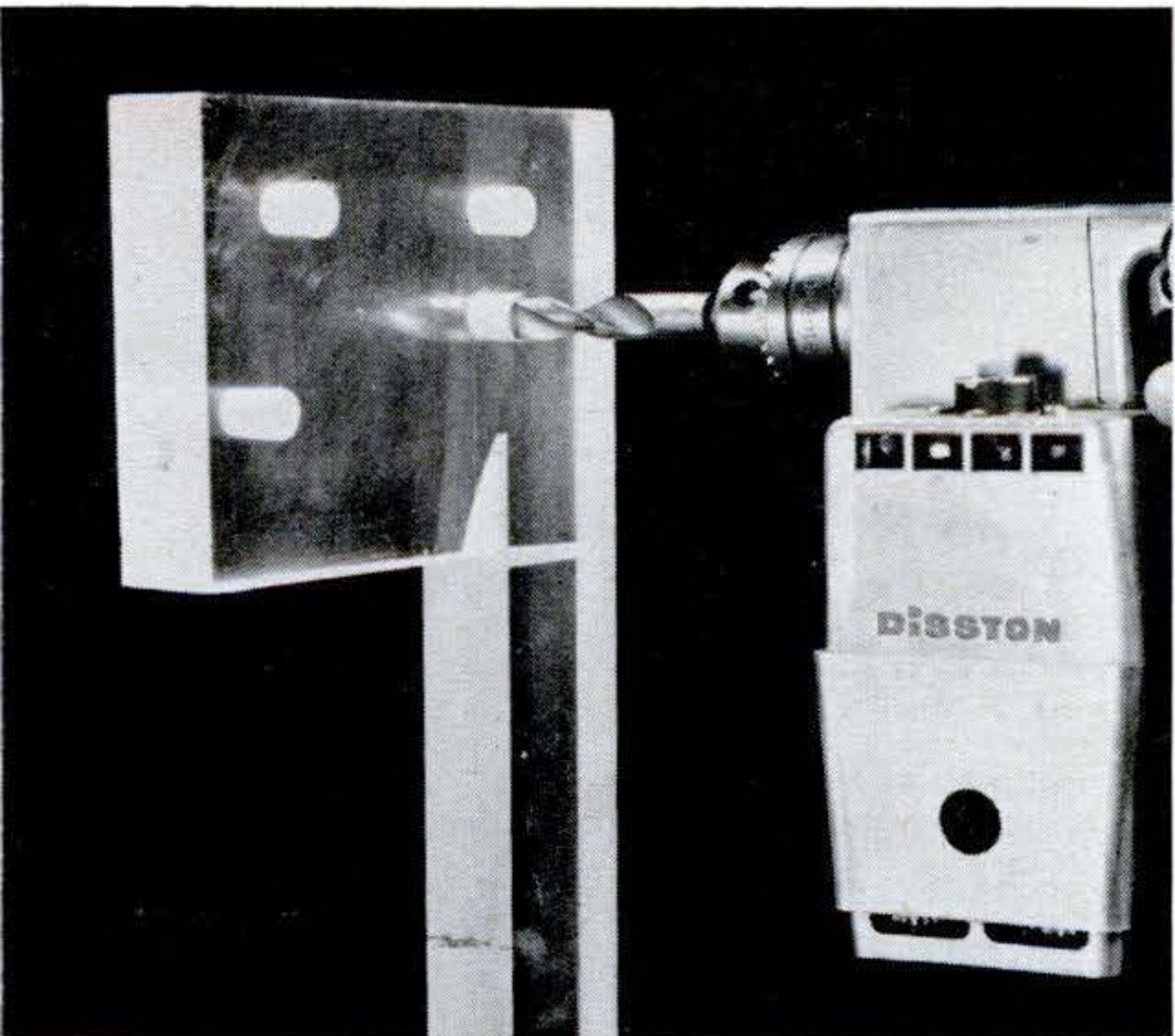

**Clean holes in plastic**, difficult with a fixed-speed drill, are made possible by slowing down the Disston. This eliminates overheating that melts the plastic, gums up drill bits.

**Protection from burn-out.** Another fine feature is a thermostat that provides over-heat protection by shutting off power if the drill gets too hot. When it cools off, it's ready to go to work again. This is one drill you can't burn out.

In shape and size, the new drill almost duplicates the  $\frac{1}{4}$ " drill with which Disston made its debut in the portable-drill field a year ago. There are the same stand-up base, offset motor, on-or-off blower, slim profile, and short overall length that lets you get between studs and into other tight places.

Made by the Disston Division of H. K. Porter Co., Pittsburgh, the  $\frac{3}{8}$ " Dial-A-Power drill sells for \$69.96. The electronic circuit is guaranteed for a year. ■ ■

(a load condition), the feedback becomes smaller and changes the value of the bias on the controlled rectifier. This increases the amount of current fed to the motor, speeding up the drill. The action is practically instantaneous so that drill speed remains constant no matter what the load.

Actually, this is somewhat similar to a household thermostat that, sensing a drop in temperature, automatically decides more heat is needed. By varying the bias voltage with the control knob, you can set the drill to run at any desired speed—just as you would set a thermostat to provide a desired temperature. Thereafter, the auto-

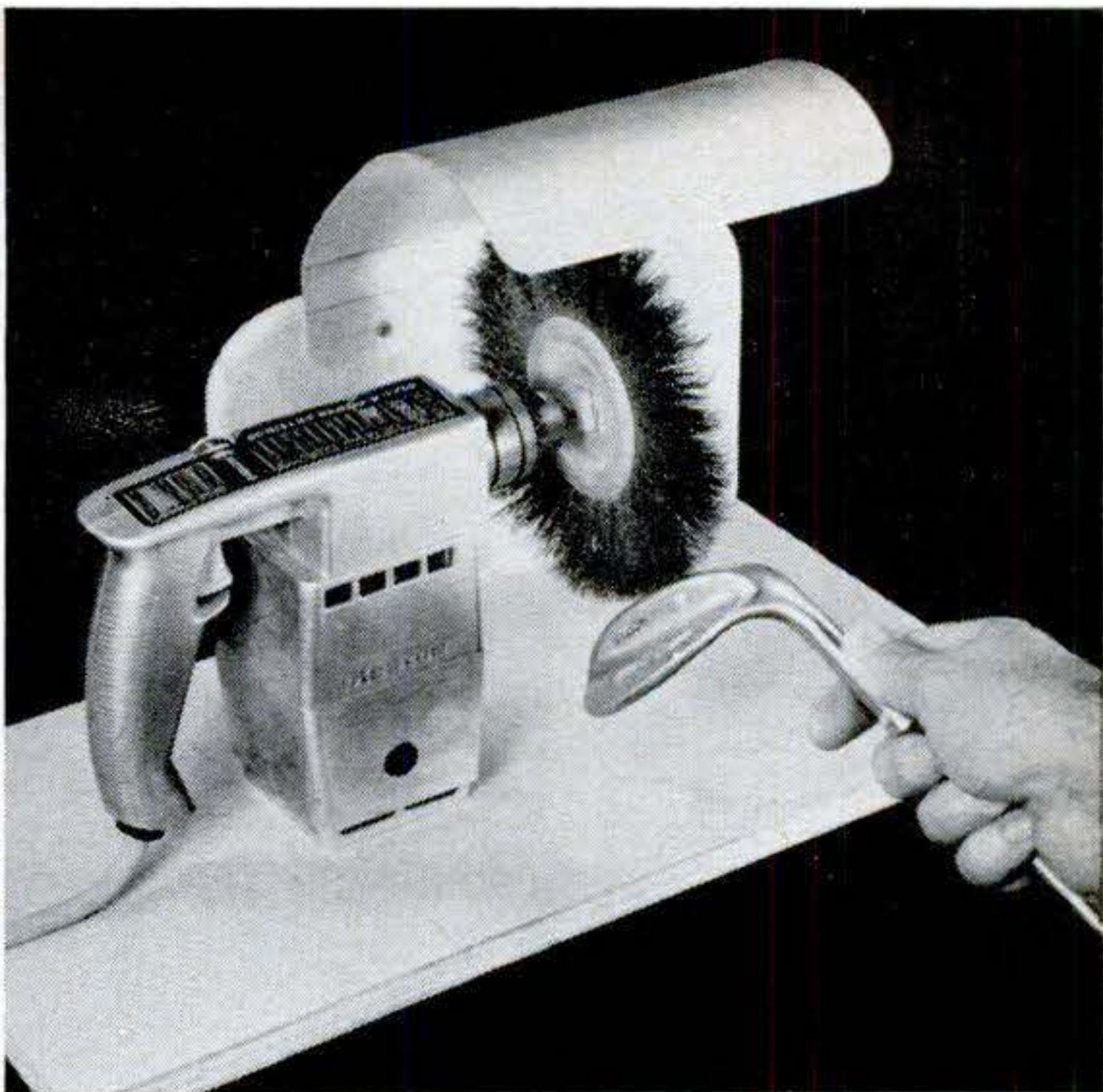

**Stand-up base** makes the drill ideal for use with accessories. It can be bolted to a wood stand by replacing short screws in the base plate with long ones that go through the wood.

## The new DISSTON DRILL at a glance

Speed: 600-2,000 r.p.m.

Chuck capacity:  $\frac{3}{8}$ "

Amps: 4.1

Power:  $\frac{1}{2}$  hp.

Weight: 4 pounds

Overall length: 7 $\frac{1}{2}$ "

Price: \$69.65

matic action of the feedback voltage keeps the drill running at that preset speed regardless of load.

The components are strategically located to get maximum benefit from the forced-draft cooling system and have their own cooling fins. A thermostat will break off contact under particularly harsh drilling conditions, thus guarding against burn-out. To make the drill operative again, you merely press a reset button.

The circuit was developed in conjunction with Texas Instruments, Inc., whose products can be found in items ranging from vest-pocket radios to satellites.



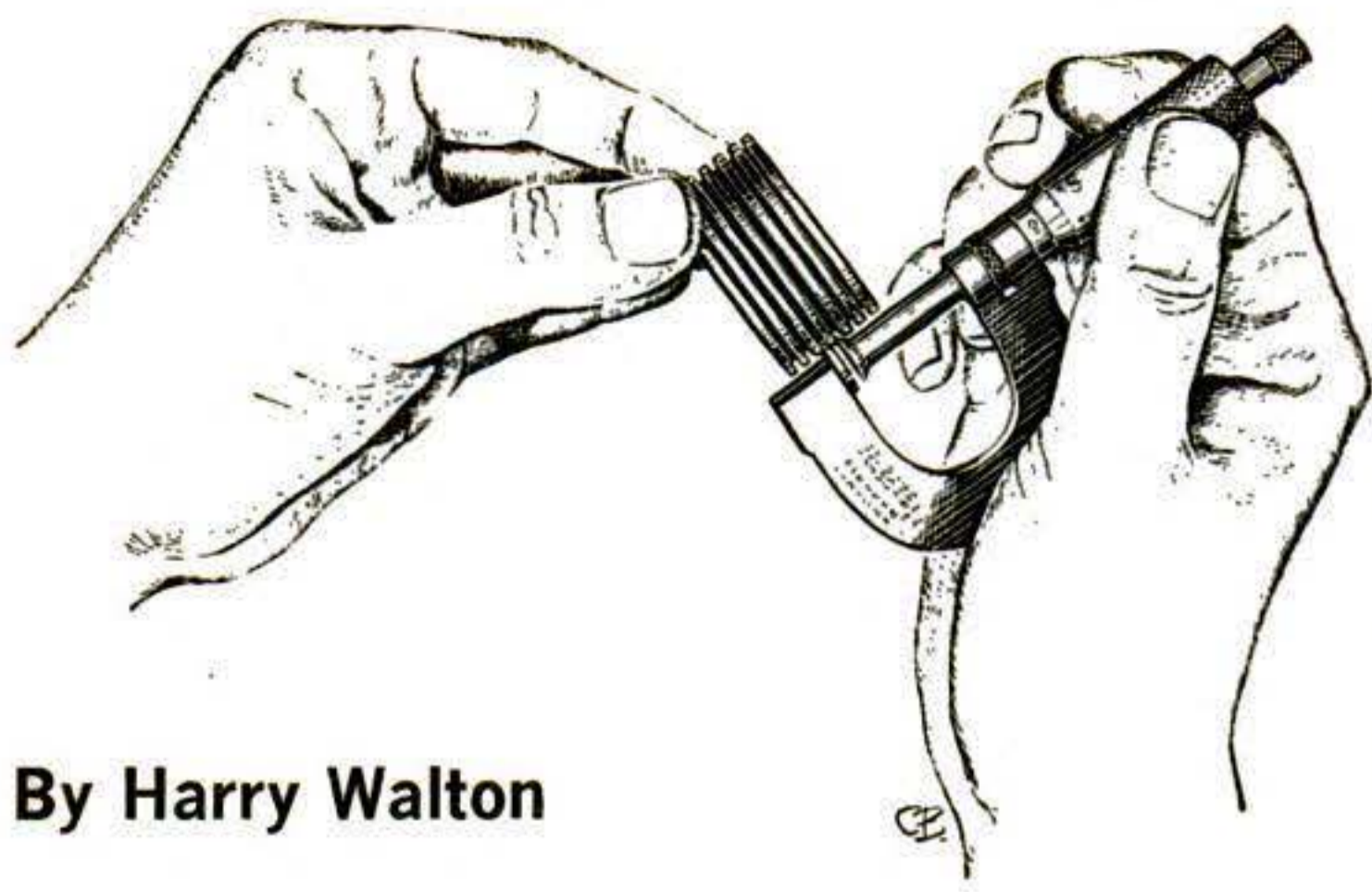

By Harry Walton

# Between Us Machinists

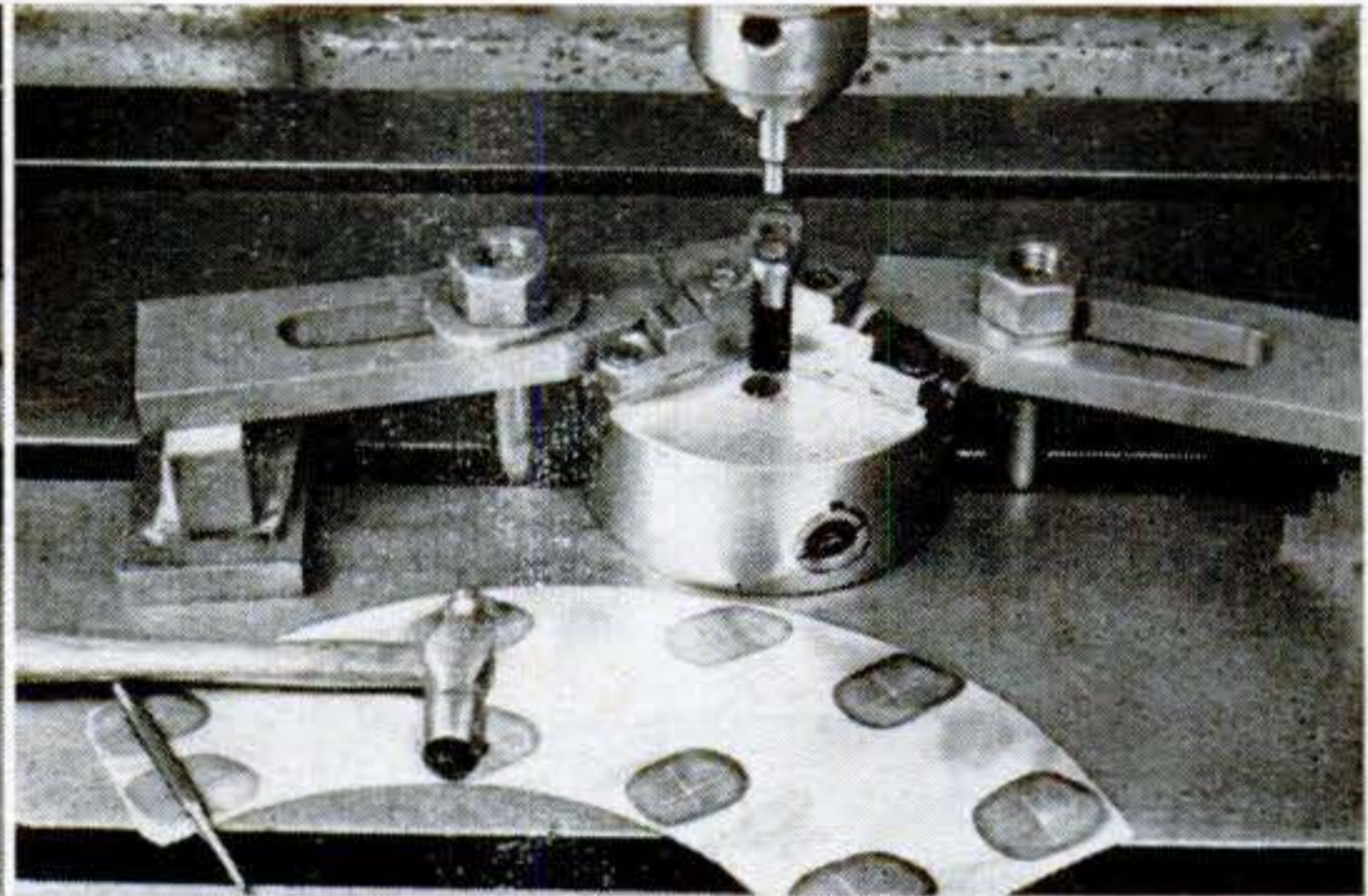
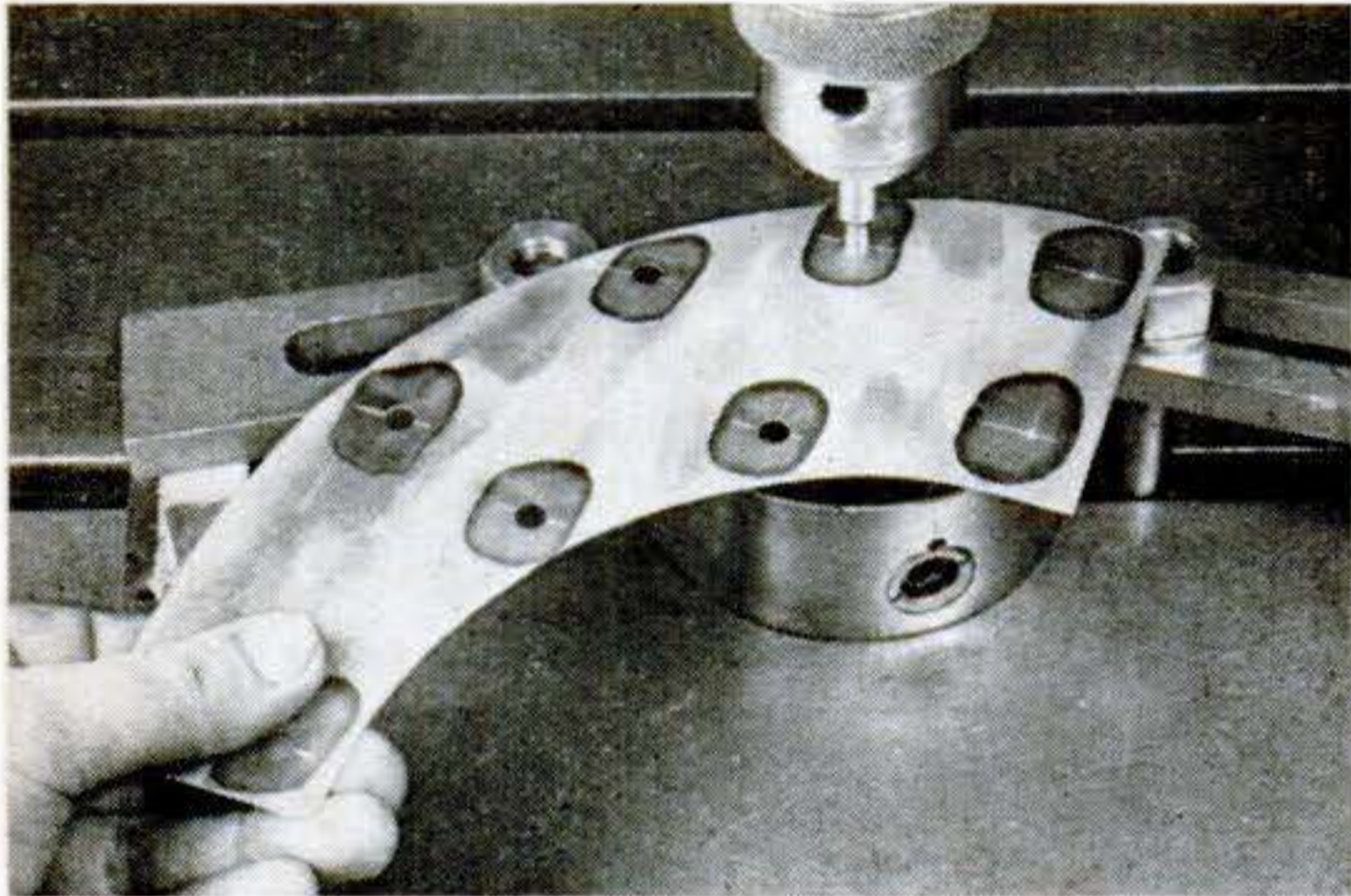

For cleaner holes in sheet metal, says H. J. Gerber of Menomonie, Wis., use your drill press to punch them out instead of drilling. It's not only cleaner but also faster than drilling, especially on repeat work. Make punches of drill rod, long enough to bottom in the drill chuck. Face the end square, leaving a small center nib to engage cen-

ter-punched layout dimples on the work. Drill the dies to a close sliding fit. Harden both parts. The dies can be held in a lathe chuck clamped to the drill-press table as above, or in a plain steel block. A shoulder turned on the dies to take working thrust will make it unnecessary for you to tighten the chuck excessively.

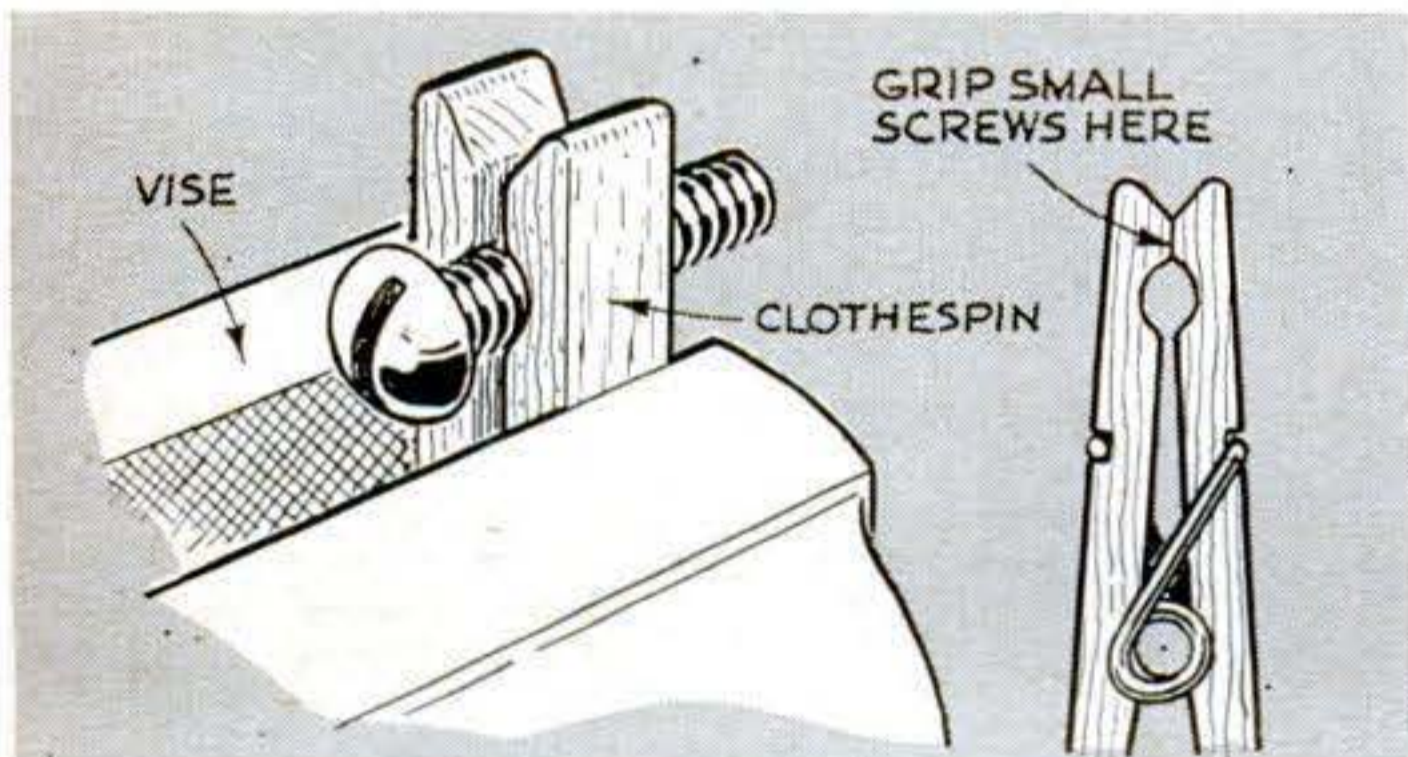

Spare the threads and you save the bolt. That's why I keep a wooden spring clothespin around for use if I have to saw a bolt shorter. I pinch the bolt shank in the clothespin and clamp the pin in a vise. The wooden jaws don't harm even brass screws. Little ones such as 2-56s are less likely to be fumbled and lost this way than if you put them directly in a large vise. If too small to grip in the notch of the clothespin jaws, they can be held between the flats above the notch.

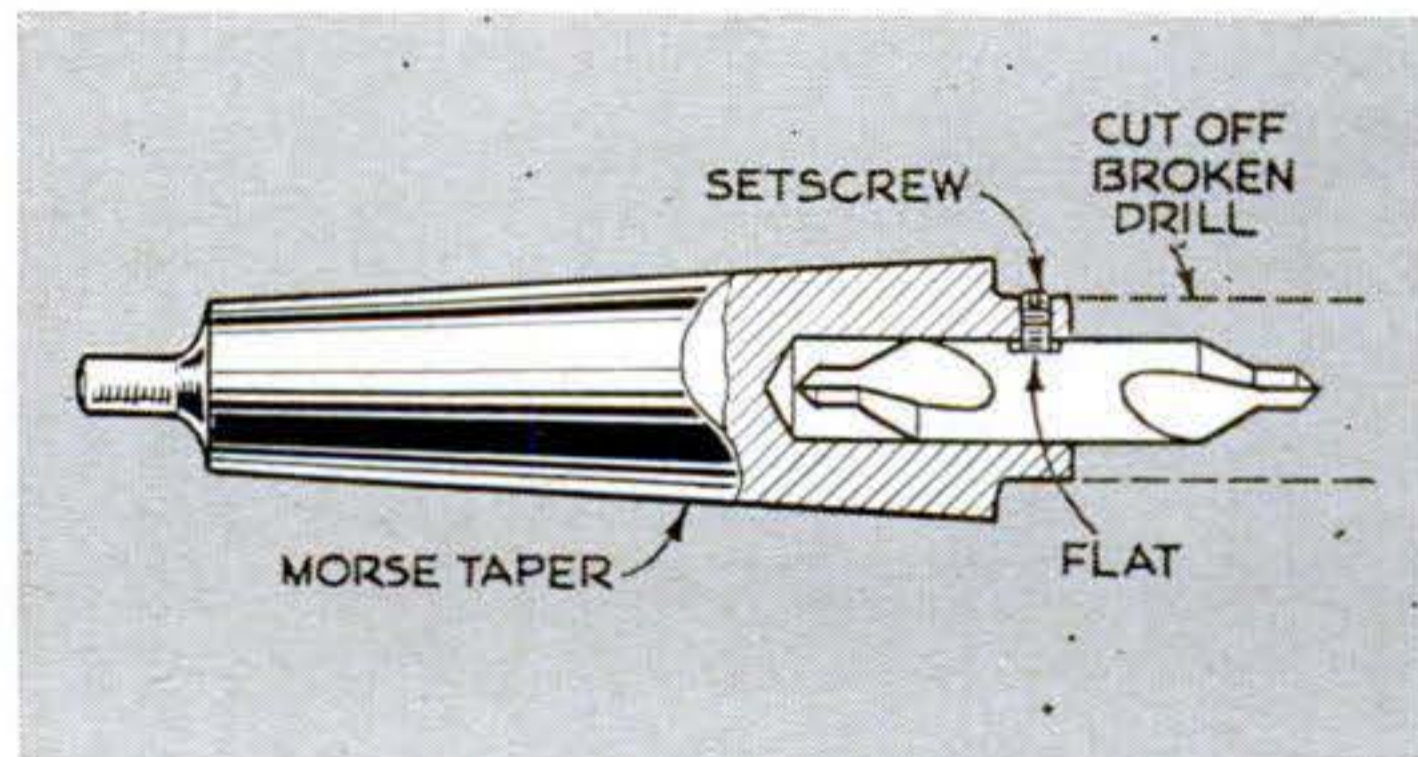

Centerdrills in taper shanks save much time in the shop where he is a trainee, reports James W. Hauser of Racine, Wis. Lathe operators find it's much quicker to pick up one of these and slip it into the tailstock than to first mount a chuck and then lock a centerdrill in it. Shanks are salvaged from broken taper-shank drills. Cut off the stub, leaving enough shoulder to tap for a setscrew. Face the end, drill to suit, and grind a little flat on the centerdrill for the setscrew.



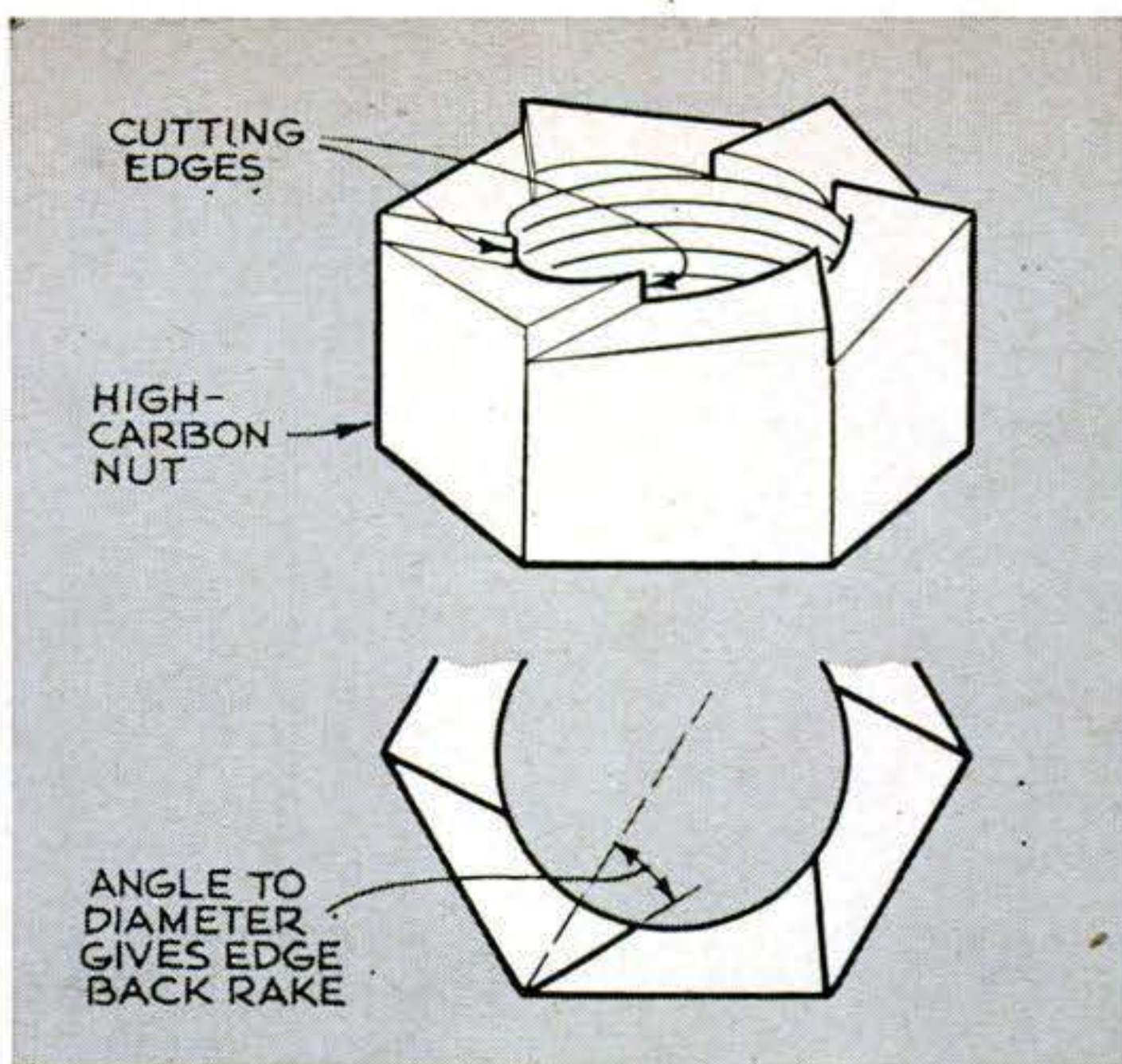

When a stud was damaged on his car, Fred F. Davis of Vancouver, British Columbia, restored the marred threads with a chaser made of a high-carbon nut of the same size. On one face of this he ground and filed a slope adjacent to each wrench flat, so forming six edges like those of a die. Their rake angle made them effective. The chaser is turned on edged face first.

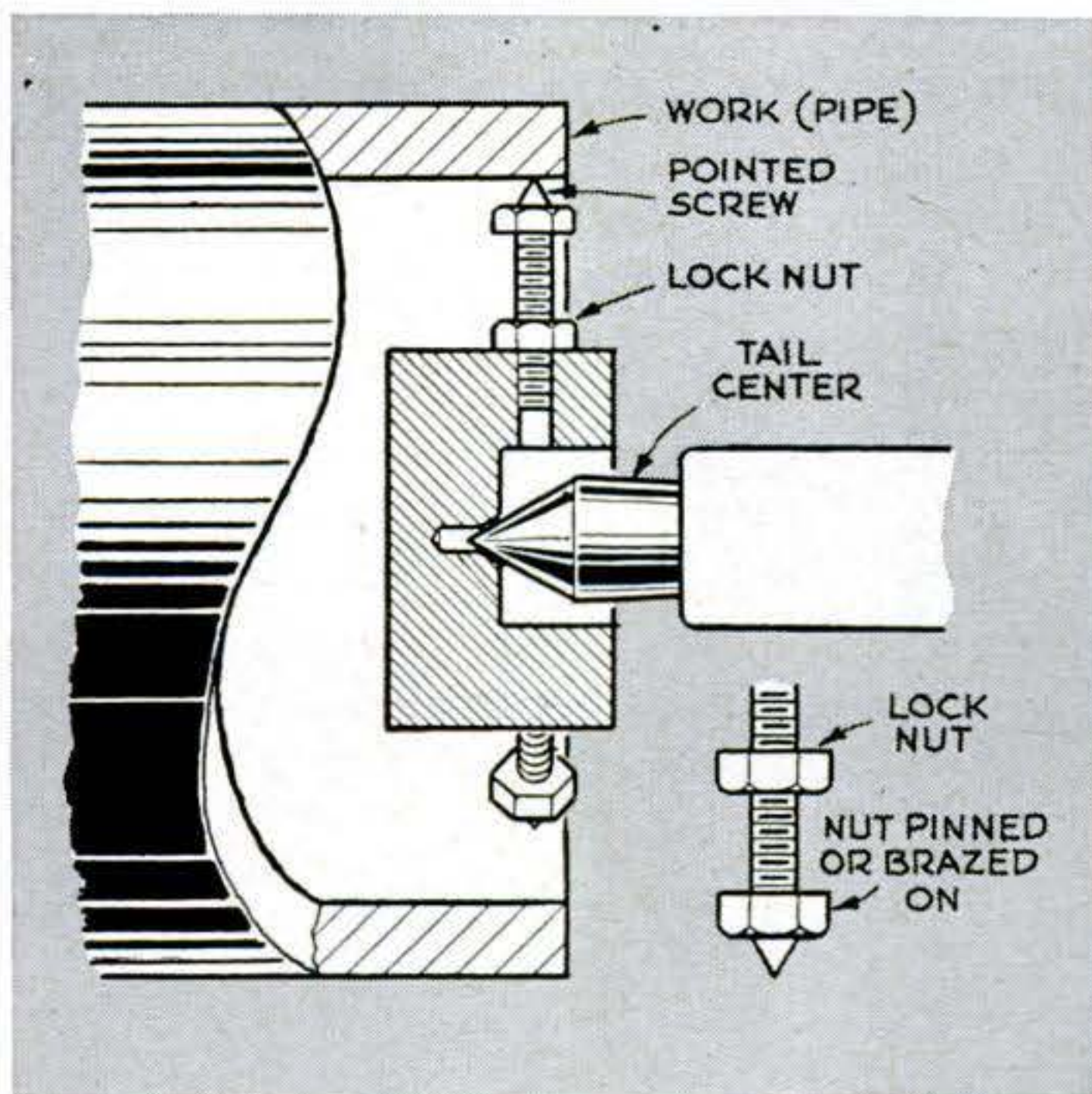

A big adjustable center for mounting pipe in a lathe can be made from a small scrap of round stock. In a  $1\frac{1}{4}$ " length of 2" bar, suggests Federico Strasser of Santiago, Chile, bore a  $\frac{3}{4}$ " hole  $\frac{3}{4}$ " deep. Centerdrill the inner face. Drill and tap three radial holes 120 degrees apart in the edge. Turn points on three screws, and pin or braze nuts near the points. Mount pipe to run true by adjusting the screws inside it, turning them by the brazed nuts. Tighten lock nuts to hold them.



### Motorless mower is a handy dolly

Removal of the motor from an old power lawn mower converted it into a convenient dolly for moving heavy loads around my home and shop. The top of the blade guard is ideal for such items as the barrel being carried above. The four rubber tires make the dolly easy to roll on any surface.—Wayne Floyd, Fayetteville, Tenn.

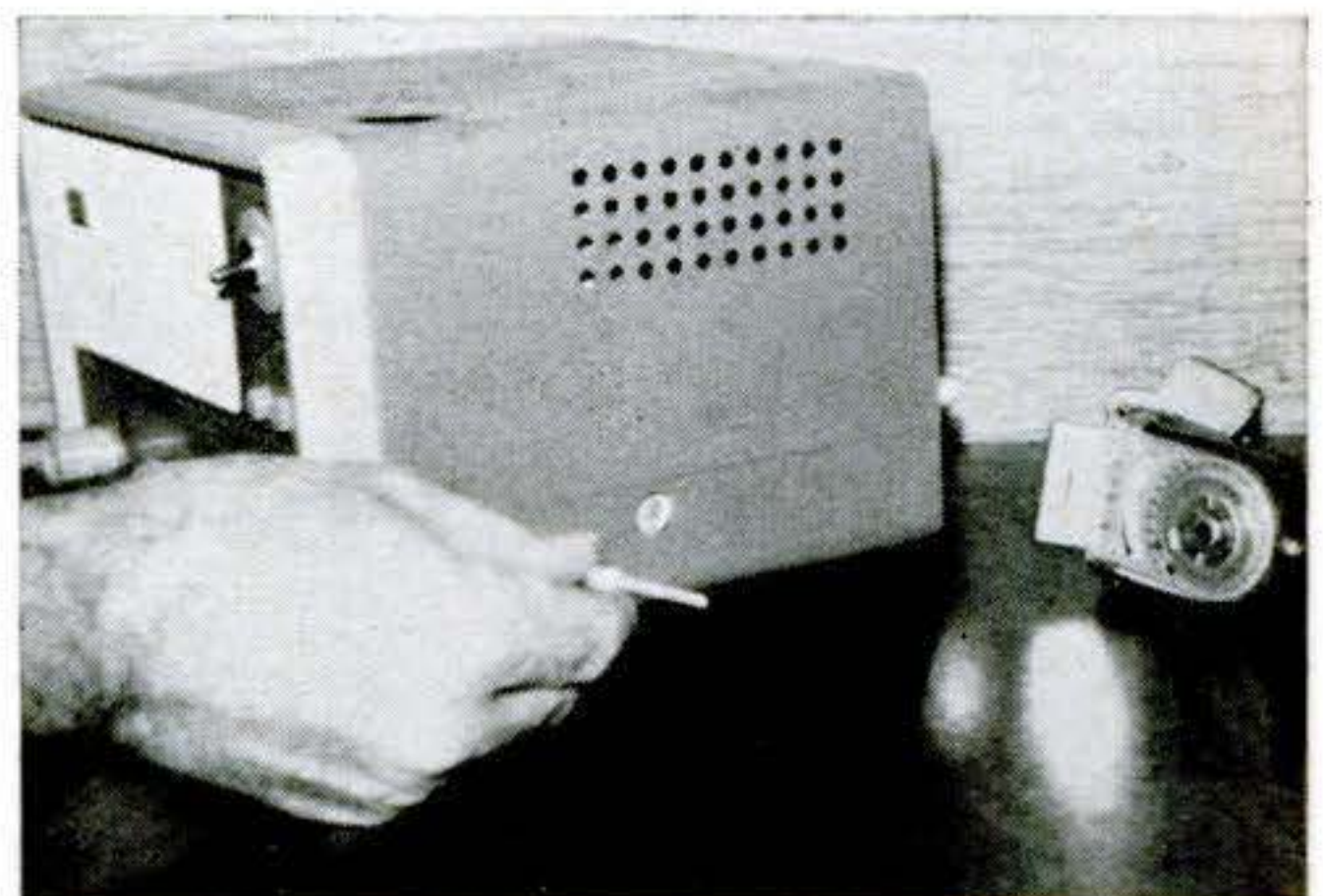

### Use light meter for radio tuning

When tuning the transmitter of a citizen's-band or ham radio to a dummy-load light bulb, use a light meter instead of looking at the light itself.

You won't be blinded by the light since it can be behind the set. The degree of brilliance can be noted on the meter and comparisons made. You can use any light meter; adjust the distance from the bulb until the meter shows about a half-scale reading. Distance from bulb to meter is not important, but the distance and the angle of the meter should be kept uniform when comparing sets or components.—R. A. Brown, Shelbyville, Tenn.



# SPRING CAR CARE

## Do it now—don't wait till summer

By Herbert R.  
Pfister

**T**HE best insurance against having your car conk out on some sun-scorched day this summer is to go over it carefully this spring. You'll be surprised at how much you can do in your own driveway or garage on a Saturday morning. What do you need? Not much more than a screwdriver, a few wrenches, a bit of confidence, and these tips from Popular Science.

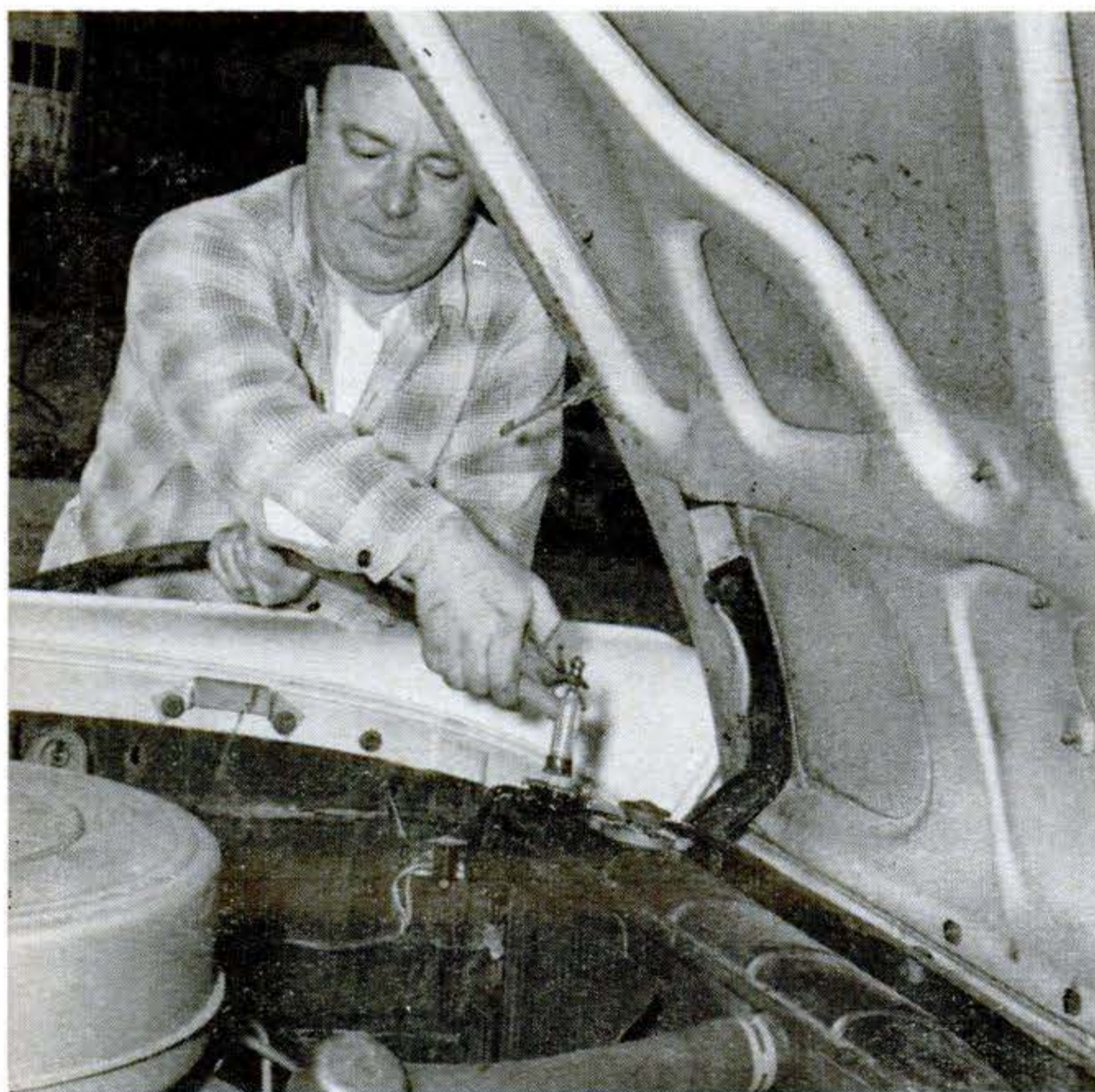

Draining and refilling the cooling system is a spring requirement unless you use an all-season coolant. It's simple to do this at home. Look for drain cocks on one side of a four- or six-cylinder engine block, on both sides of an eight. Turn them counterclockwise to drain the system.

## COOLING SYSTEM

**M**ANY things can cause engine overheating—underinflated tires, for example—but a neglected cooling system is the most common villain. Unless you use an all-year coolant, drain the cooling system completely. Refill with clean water and rust inhibitor.

If hose connections are cracked or feel limp when you squeeze them, replace them now before they rupture.

Adjust the fan belt so that it gives about  $\frac{1}{2}$ " when you apply thumb pressure halfway between fan and generator pulleys. Adjust by loosening the generator and pivoting it outwards. Be sure to tighten the pivot bolts securely. Replace the belt if it's frayed or cracked; a worn belt racing around pulleys can set up vibrations that travel through the car.



# FUEL SYSTEM

**Y**OUR fuel system's worst enemy is dirt: dust, sediment, gum. Begin by cleaning the air filter on top of the carburetor. Tap the filter sharply to dislodge dirt, and wipe the housing clean with a dry cloth.

Wash the oil-filler cap and fuel-pump bowl with kerosene or lacquer thinner.

Follow the fuel line back from the pump and bend it away from the engine or exhaust manifold; close proximity to any hot spot can cause fuel in the line to boil. The resulting vapor lock will stall the car. Although vapor lock can happen anywhere, it is most frequent in mountain driving.

Clean the carburetor by adding a solvent (such as Wynn, Carbmater, Marvel, Siloo, Gumout) to a tankful of gas, or by connecting a carburetor cleanout kit to the inlet fitting and running solvent through the unit by gravity flow.

No amount of carburetor tinkering will make your car run better—jets and metering rods are set at the factory—but you can make the engine idle smoothly and prevent embarrassing stalling by adjusting the idle speed and mixture, as shown in photos on this page. After adjusting the carb on a car equipped with an automatic transmission, make a final check by pulling up hard on the parking brake and shifting to Drive. If the idle speed slows to the point of stalling, give the hot-idle adjusting screw a half-turn or so to increase r.p.m.

CONTINUED

**Manifold heat-control valve**, which hastens warmup by diverting exhaust around intake manifold, can cause engine to run hot if stuck closed. Open, it encourages condensation by delaying warmup. To free it, squirt rust solvent or penetrating oil on shaft and jiggle arm up and down until it swings easily.

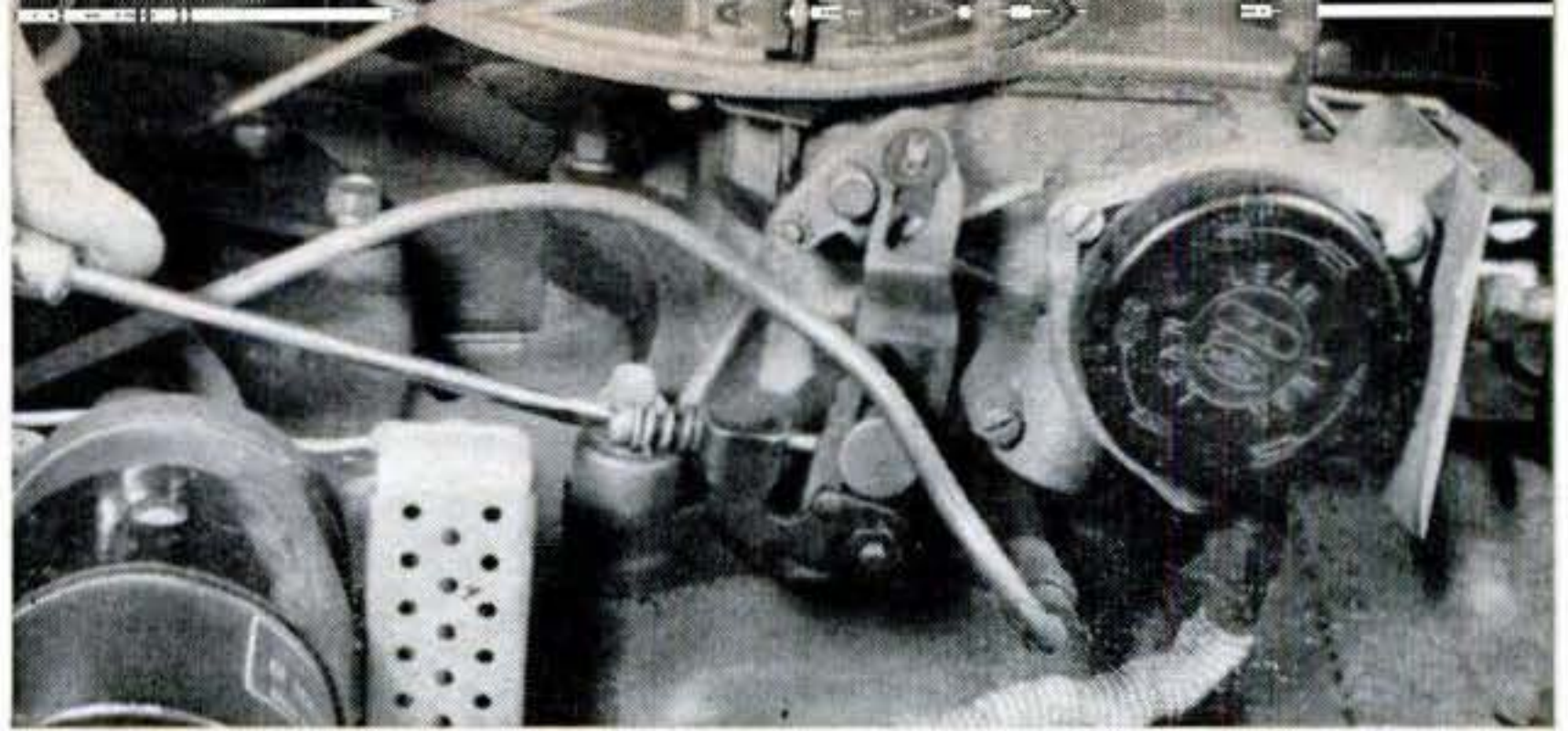

**Begin carburetor adjustment** with fast-idle adjustment—while the engine is cold and the choke closed. Adjusting screw bears against high point of stepped cam linked to the choke control. Note the position of the butterfly valve and linkage while the engine is cold.

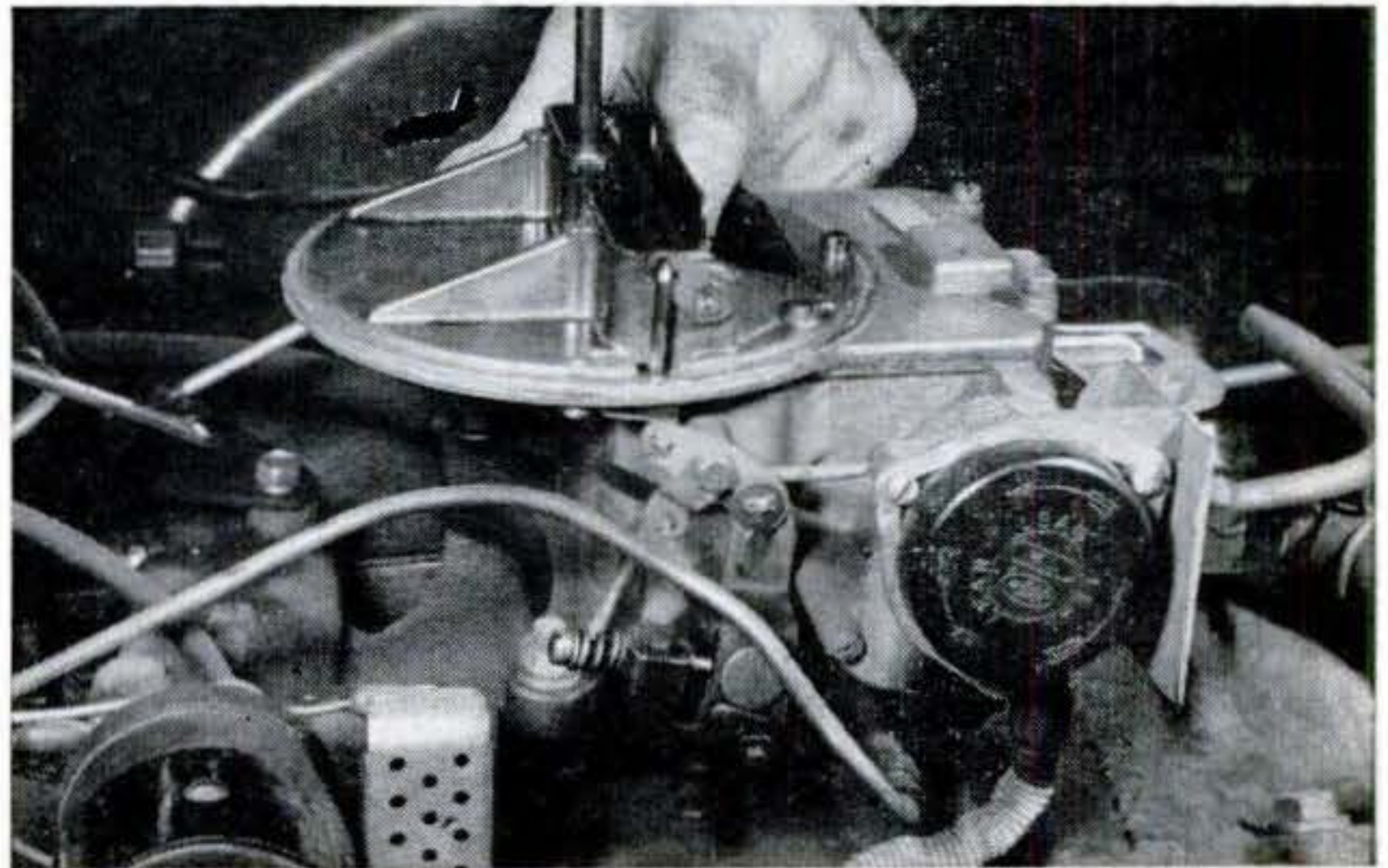

**Choke and linkage** look like this after engine warms. The butterfly valve has opened and the fast idle cam has moved, no longer holding throttle partly open.

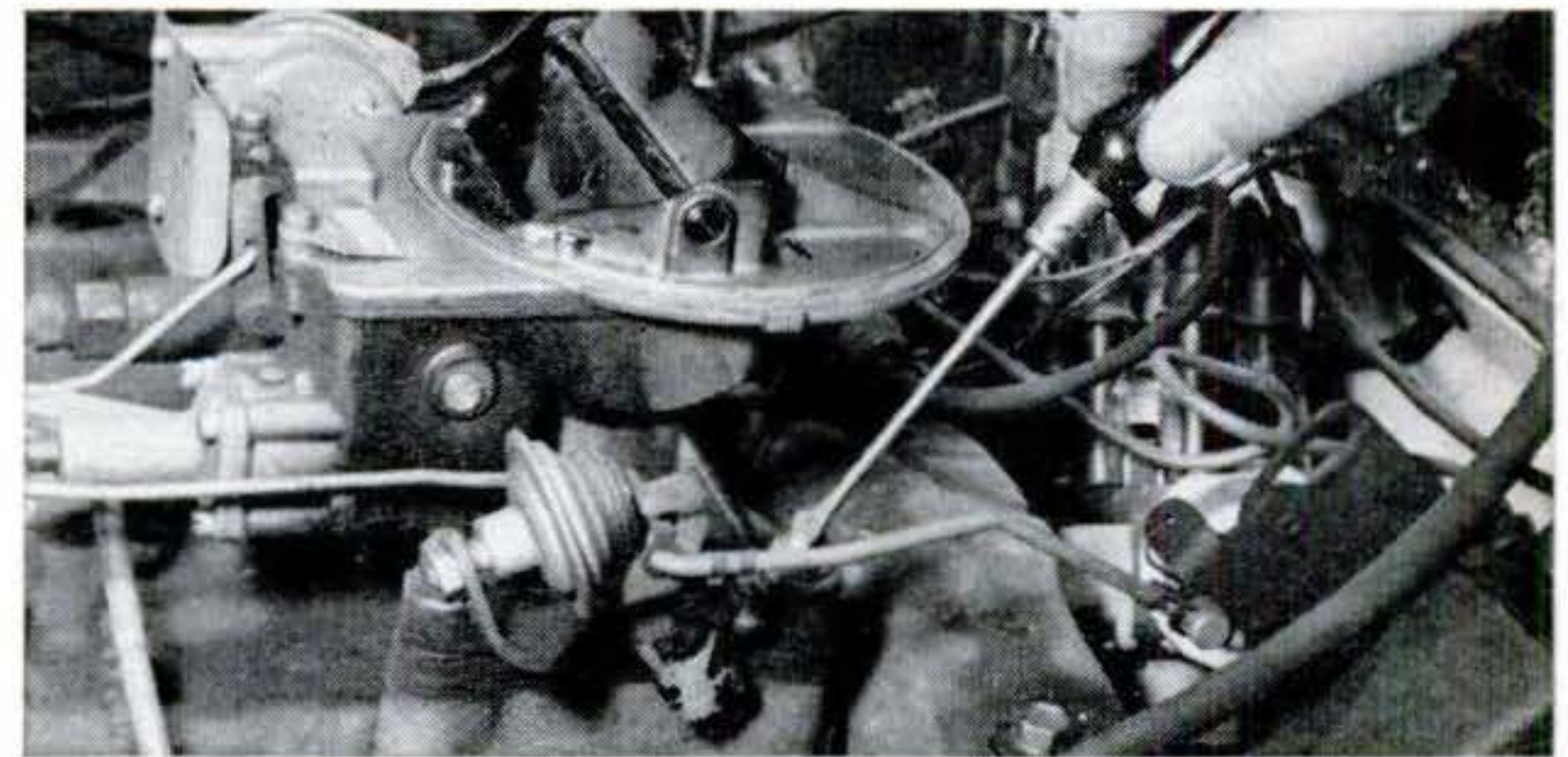

**Hot-idle adjustment**, or normal setting, is made after engine warms. Adjusting screw, usually on opposite side of carb, is set for slowest reliable idle speed.

**Mixture** is made richer or leaner by turning adjusting screw (or screws) in until engine skips. Then back screw out until engine purrs smoothly. If you have trouble doing this, it often helps to remove the adjusting screws and wash their pointed ends with lacquer thinner.

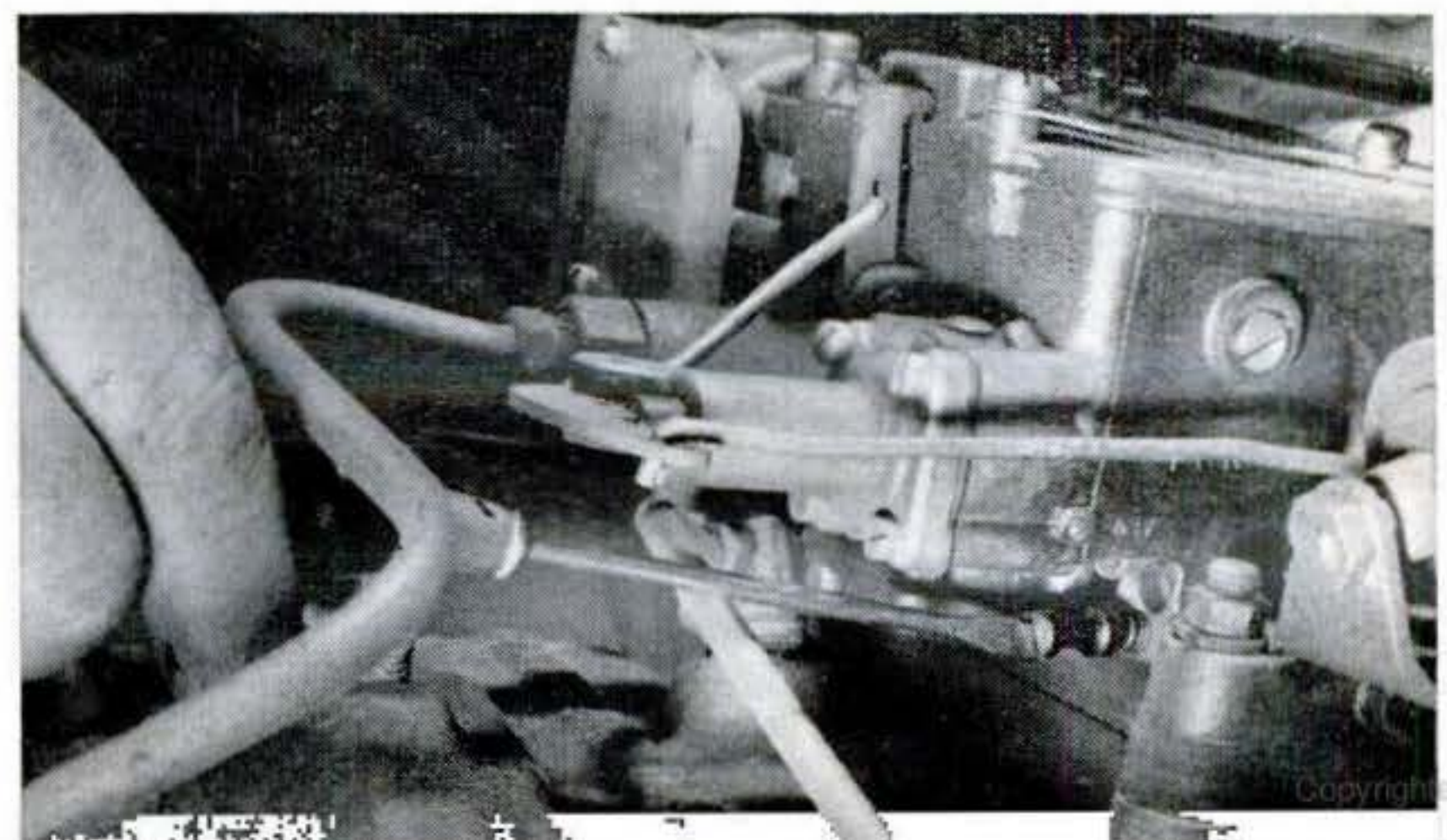



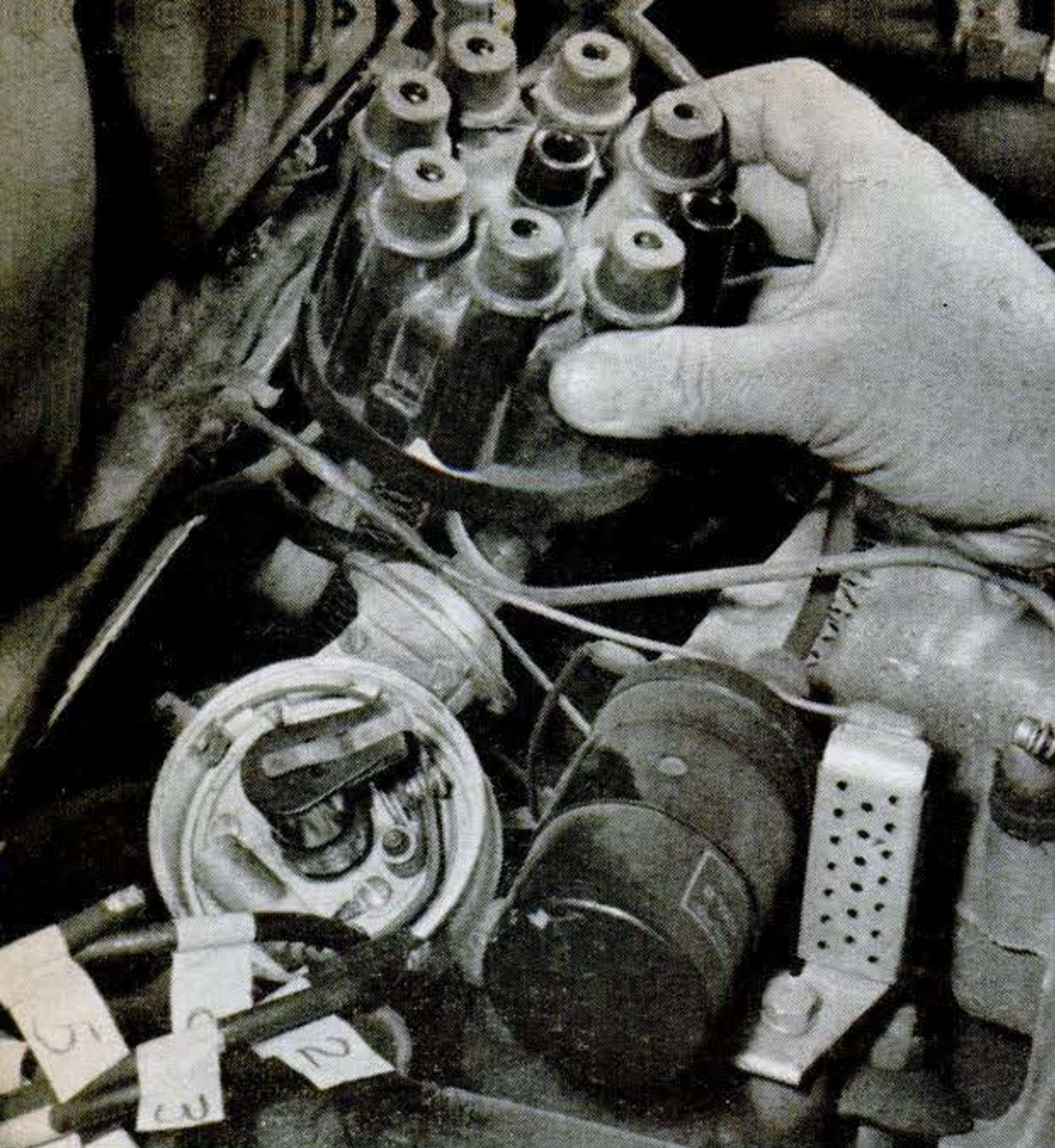

**Distributor cap** must be removed if you'd put new pep in the engine. No need to be timid about it; just snap off the clips on each side and lift the cap upward. Play safe by numbering wires before you remove them from cap.



**Rotor works hard**, rotating rev for rev with engine to fire all plugs each time around. Likely trouble spot is spring contact. Sand clean and bend it up slightly for better contact. Install a new rotor if you find severe pitting.

## IGNITION SYSTEM

**T**HE ignition system must produce a hot, fat spark at just the right time to ignite the fuel to push down on the pistons that turn the crankshaft to make your car go. As with any electrical equipment, simply keeping all contacts clean and bright goes a long way toward maintaining peak performance.

Start where the spark occurs by removing the spark plugs. If they're only dirty and the electrodes aren't burned thin, soak them in a pan of lacquer thinner—not benzine, kerosene, or alcohol—while you check the high-tension wires from the distributor and use a kit to replace them if they're cracked or oil-softened. After soaking the plugs about 10 minutes, scrape around the insulators with a large needle to flake off the softened carbon. Set the plug gap by bending the outer electrode up or down until its lower edge is separated from the center electrode by the proper gap, using a feeler gauge. If you've no manual, your gas dealer can tell you the correct settings for plugs, points, and ignition timing. Write these specs on a small card and tape them to the firewall for permanent reference.

Write numbers on masking tape and stick them on the plug wires before you yank them out of the distributor cap. This way, you'll be certain to reinsert them in the proper terminal sockets. As you pull each wire, inspect the metal contact on its end. If it's dirty or green with corrosion, sand it bright and check the matching socket in the distributor cap. Black powder in the socket indicates an arcing condition, and a new cap is recommended. A sound cap can be cleaned with lacquer thinner and wiped dry. Twist a thin wad of steel wool in the sockets to brighten terminals.

Pull straight up on the rotor to remove it from the distributor shaft. Brighten the spring contact and the tip of the rotor with fine sandpaper and wipe the part clean with a dry cloth.

On most GM cars, the points can be adjusted from outside the distributor while the engine is running. Insert an Allen wrench in a hole in the side of the cap and turn it slowly until the engine skips. Then back off a half-turn for a basic setting.

Adjusting the point gap changes the ignition timing very slightly—usually not enough to require retiming. But for top performance, check the timing as shown on facing page.



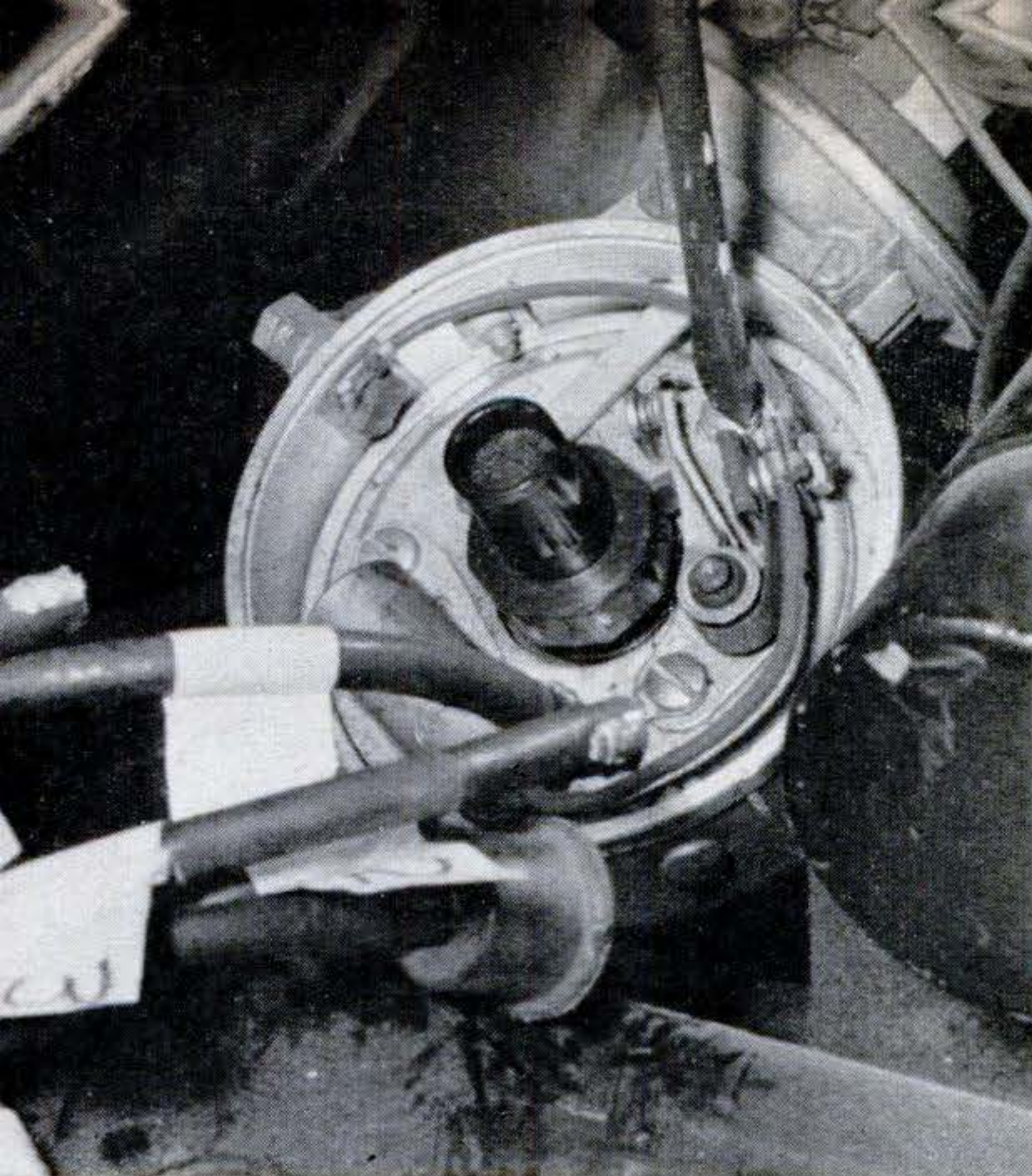

Ignition points close and open just before each spark is generated. Press the movable arm outward to inspect contact faces. If they're pitted or sooty, put in new points. Otherwise, check and set the point gap. Crank the engine until the little fiber block rests on one of the high spots of the cam. Loosen the adjusting screw and move the stationary arm against a feeler gauge placed between the points. Tighten the screw and recheck the point gap.

**T**HE automatic transmission must be checked with the engine idling. Set the parking brake, shift the transmission through all ranges, then slip the selector to Park. Add only enough type A transmission fluid to bring the fluid level to the Full mark on the dipstick; too much fluid causes foaming and subsequent overheating. If the shift has been sluggish, pouring in a can of transmission cleaner can work wonders by dissolving the tacky varnish that builds up on moving parts. Auto stores stock several brands of cleaner.

**C**HANGE the engine oil to get rid of sludge and condensation. Do it right after a short, hard run (to stir up sediment).

Even if you didn't run up the recommended mileage, changing the oil filter at winter's end is a good investment. On most cars, oil bypasses a clogged filter, leaving the engine completely unprotected.

## How to make a 59-cent timing light—and use it

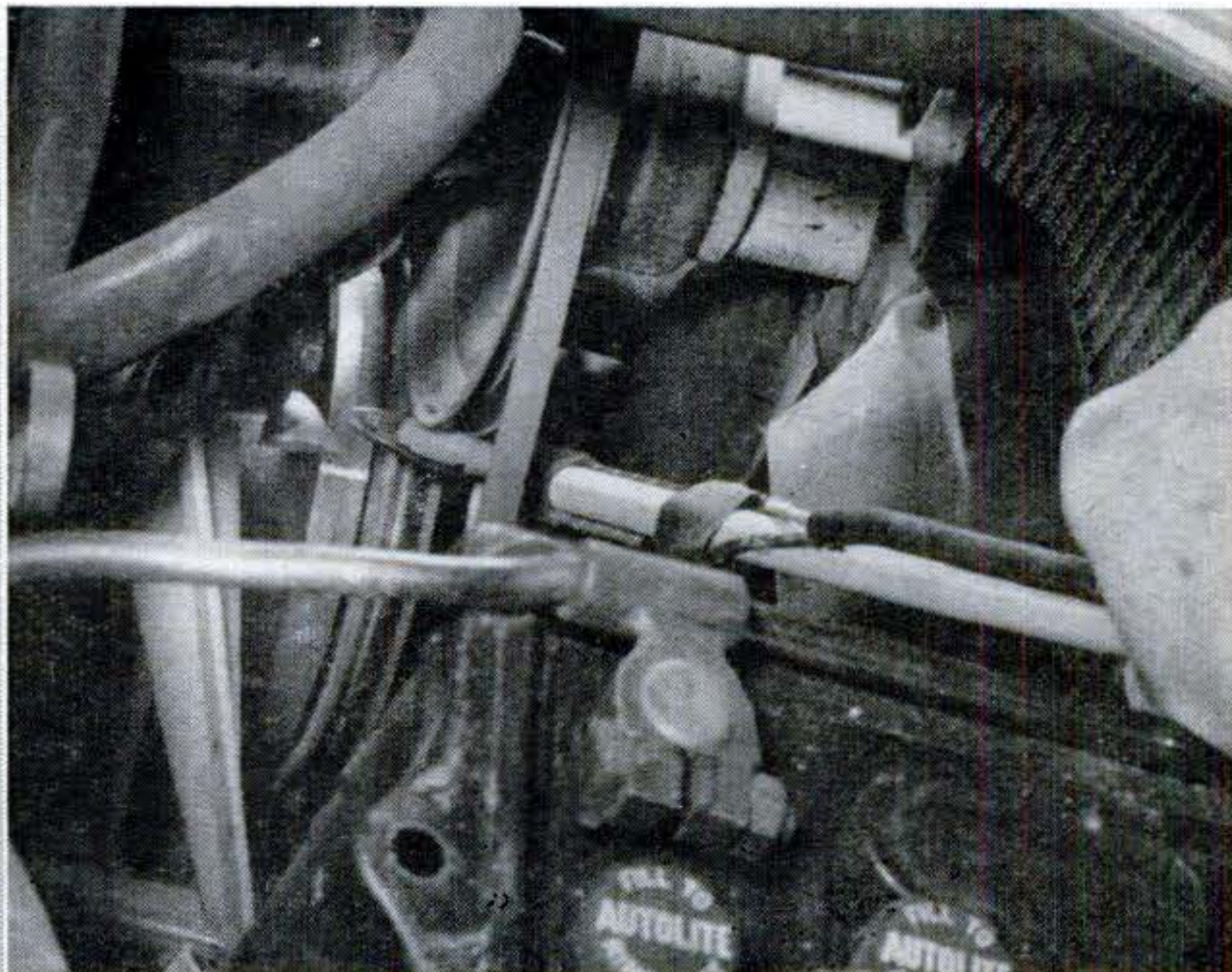
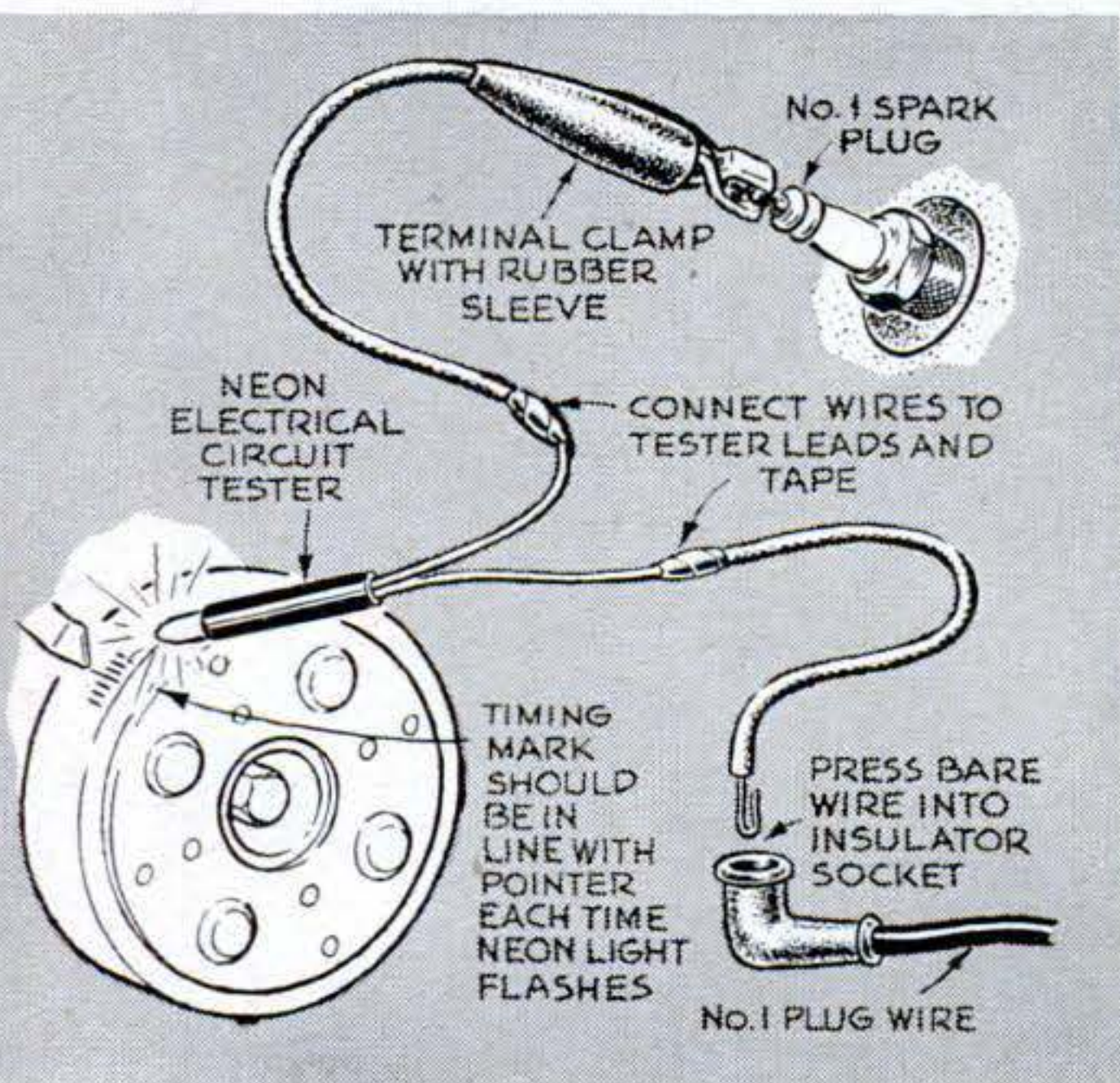

Timing light can be made from a neon circuit tester costing 59 cents in any hardware store. Tape tester to a dowel so you can place it close to the timing mark on the flywheel. Work in the shade so dim light of neon tube will illuminate the chalk-brightened timing mark. Leads are connected to No. 1 spark plug and wire. Disconnect the vacuum line at the distributor

and hold the timing light close to the pointer while the engine idles. If timing mark doesn't line up with pointer as shown, loosen lock nut beneath distributor and rotate the unit very slightly to advance or retard the timing until strobe effect of neon tube shows mark at correct setting. Tighten the nut under the distributor and reconnect vacuum line when job is done.



## BRAKES

**I**F THE pedal feels low, or if you must pump it to build up braking effort, it's probably time for some brake work. It's a good idea to pull the front brake drums (or have it done) and clean the wheel bearings in kerosene. Wipe them dry with a *clean* cloth and repack by pressing fibrous wheel-bearing grease between the rollers. While the drums are off, check the brake lining. If it's worn flush with the rivets, or if there are coarse grooves on the lining and drums, it's high time to reline the shoes on all four wheels.

When putting drums back, tighten the castellated nut until the drum binds when rotated. Then back off the nut until the slots line up with the cotter-pin hole in the spindle. Use new cotter pins, and insert them from above. Bend the legs around the nut.



Check brake fluid in the master cylinder. It should be about  $\frac{1}{4}$ " from the top.

## BODY CARE

**Hose off the underbody** to get rid of corrosive salts thrown up from winter highways. You can do this by taping the hose and shower head to a rake or other long-handled tool and pushing the head under the car. If possible, connect the hose to the hot-water faucet in the basement utility sink. The hot water will do a better cleaning job than cold.

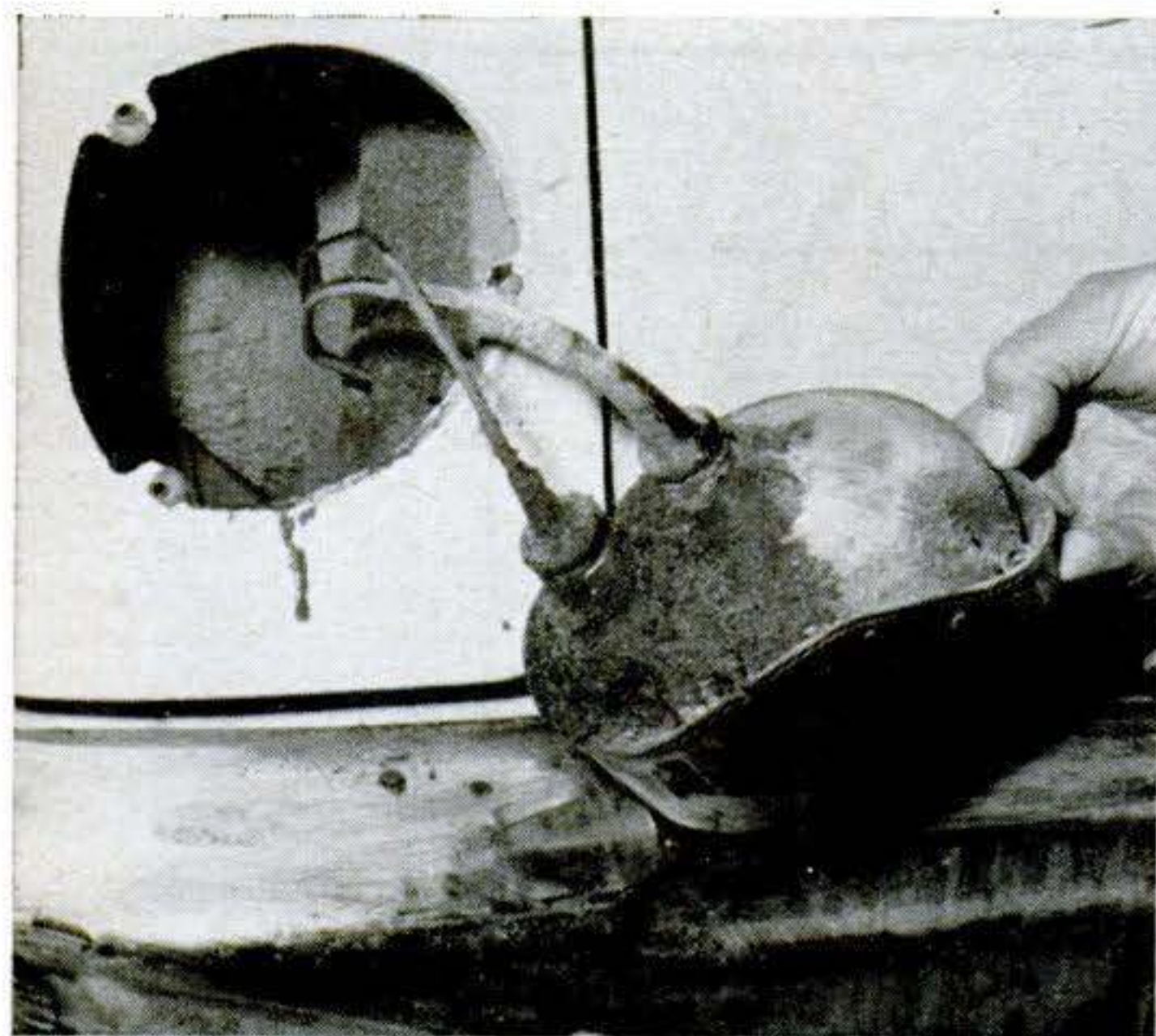

**Tail lights rust out fast** when highway salts pack into and around them, as you see in this photo. So it'll pay you to remove yours and check their condition while there's time.



**Paint touchup** takes only a few minutes. Matching colors for all cars are available in spray cans. Complete job by cleaning and waxing finish to protect it from the hot summer sun. ■ ■



Super sea-worthy! New 40 hp  
Sea-Horse Electramatic motor



**NEW!**  
2-year warranty  
on every '63 Johnson

## Built to boss big water!

**Most responsive outboard ever built! Touch one lever—everything's "go"!**

Move the directional throttle forward. Your clutch engages automatically, electrically—in a split-second. Simultaneously your engine accelerates. Johnson's exclusive Electramatic Drive gives you the fastest gears-and-gas control, the quickest response in all outboarding. And the king-sized cubic inch displacement ensures both effortless power and a long, happy engine life. See all ten new Sea-Horse classics—from 3 to 75 hp—at your Johnson dealer's now. He's listed in the Yellow Pages. For free catalog, write: Johnson Motors, 1348 Pershing Rd., Waukegan, Ill., Div. of Outboard Marine Corp.



### Exclusive Electramatic Drive

Outboarding's first truly automatic transmission. Unique directional throttle (comes with motor at no extra charge) controls both gas and gears. Makes driving sure, docking easy. At 40 and 75 hp.

**JOHNSON** First in Dependability





FUN FIRST CLASS—a roomy camper body on a rugged Ford pickup! Ask your Ford Dealer!

# Solid comfort—solid truck!

Slip into Ford's new Custom Cab and you'll find evidence of solid comfort everywhere. Doors open wide with no knee-knocking "dog-leg." A handy step helps you up and in. New foam seat cushioning is five inches deep; visibility is unmatched; over 23 pounds of insulation give you a quiet, relaxing ride.

But beneath this easy comfort lies solid truck . . . with big-truck toughness from axle to axle. See your Ford Dealer and see how painless buying a Ford can be . . . and how pleasant one is to drive!



**BUILT LIKE THE BIG ONES.** Wherever toughness counts—in axles, frame, springs—'63 Ford pickups give you extra freedom from costly breakdowns; the same kind of durable design as big trucks. Result: pickups that stay on the job and keep costs down over their long, long life!

PRODUCTS OF



MOTOR COMPANY

## FORD TRUCKS

For  
Outstanding  
Reliability &  
Durability





## INSTANT PAVING: use it the day you lay it

**A** RESIN you mix with sand only and trowel on like concrete dries to a hard, tough surface in hours. Unlike cement, you need no gravel foundation; just tamp the dry soil firmly and lay on a  $\frac{1}{2}$ " coating. The makers say it will be as strong as concrete five times as thick.

Armor-Cote Instant Patio Builder is a composition of polyethylene and urethane for driveways, walks, and the like. Five gallons will build a 10'-by-10' patio. Delka Research Corp., Hawthorne, N. J., sells it for \$9.95 a gallon.

CONTINUED

**Just tamp soil firmly to provide dry, level surface after removing sod. Apply mix of Patio Builder and sand, one part to five, and trowel to  $\frac{1}{2}$ " thickness.**

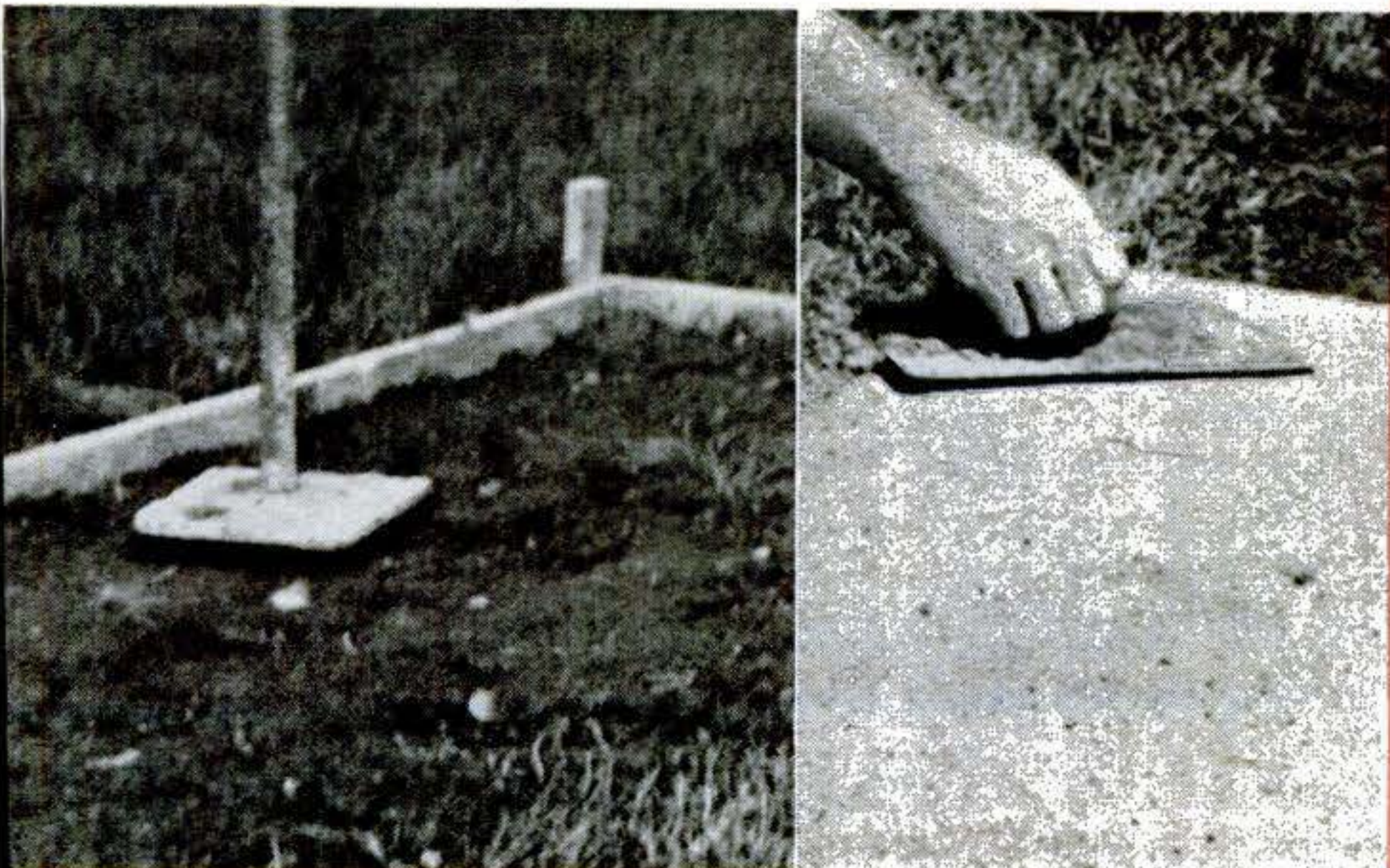

# 12 pages of the latest ideas

# for your home and yard



**what's new**  
for the HOME

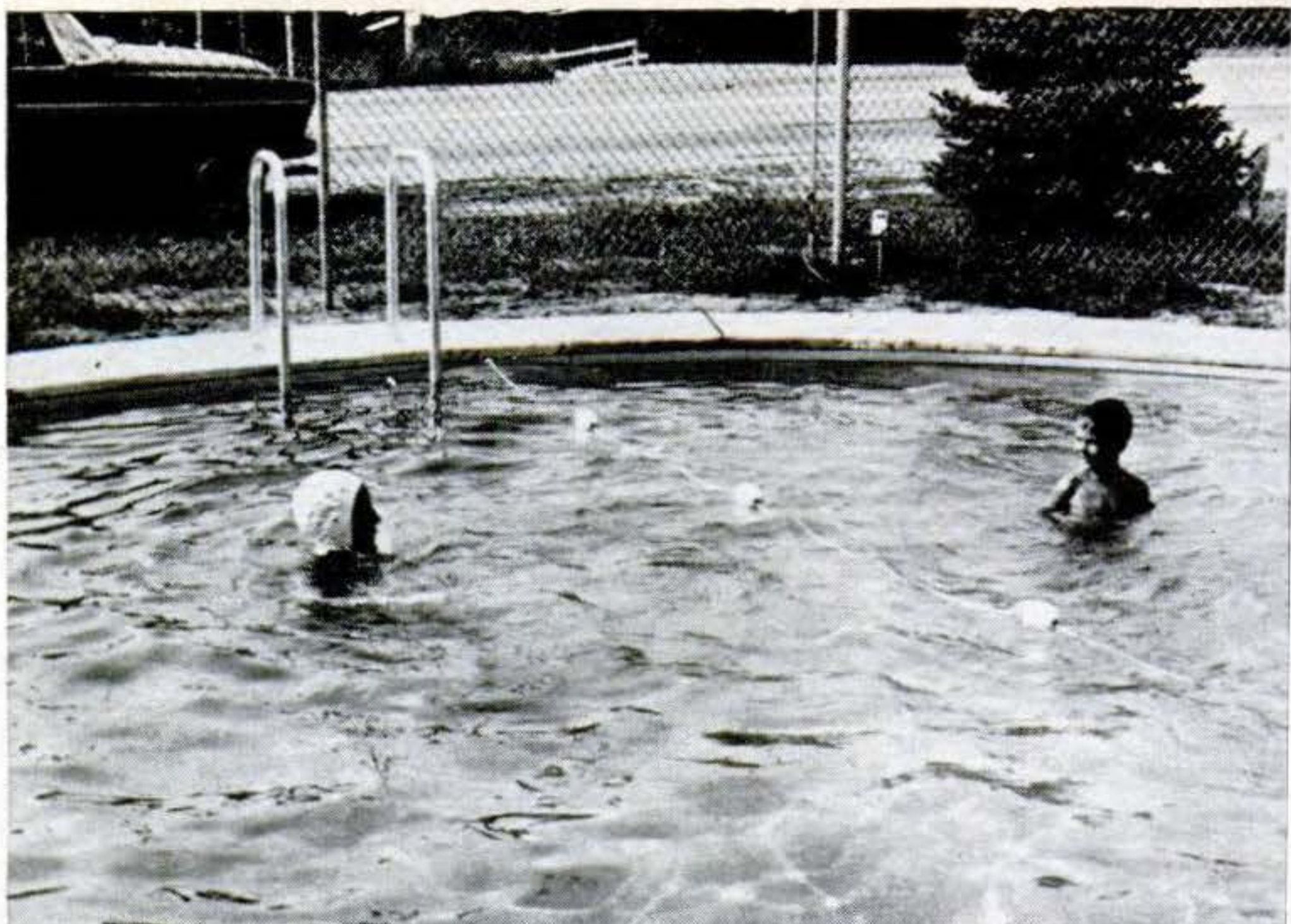
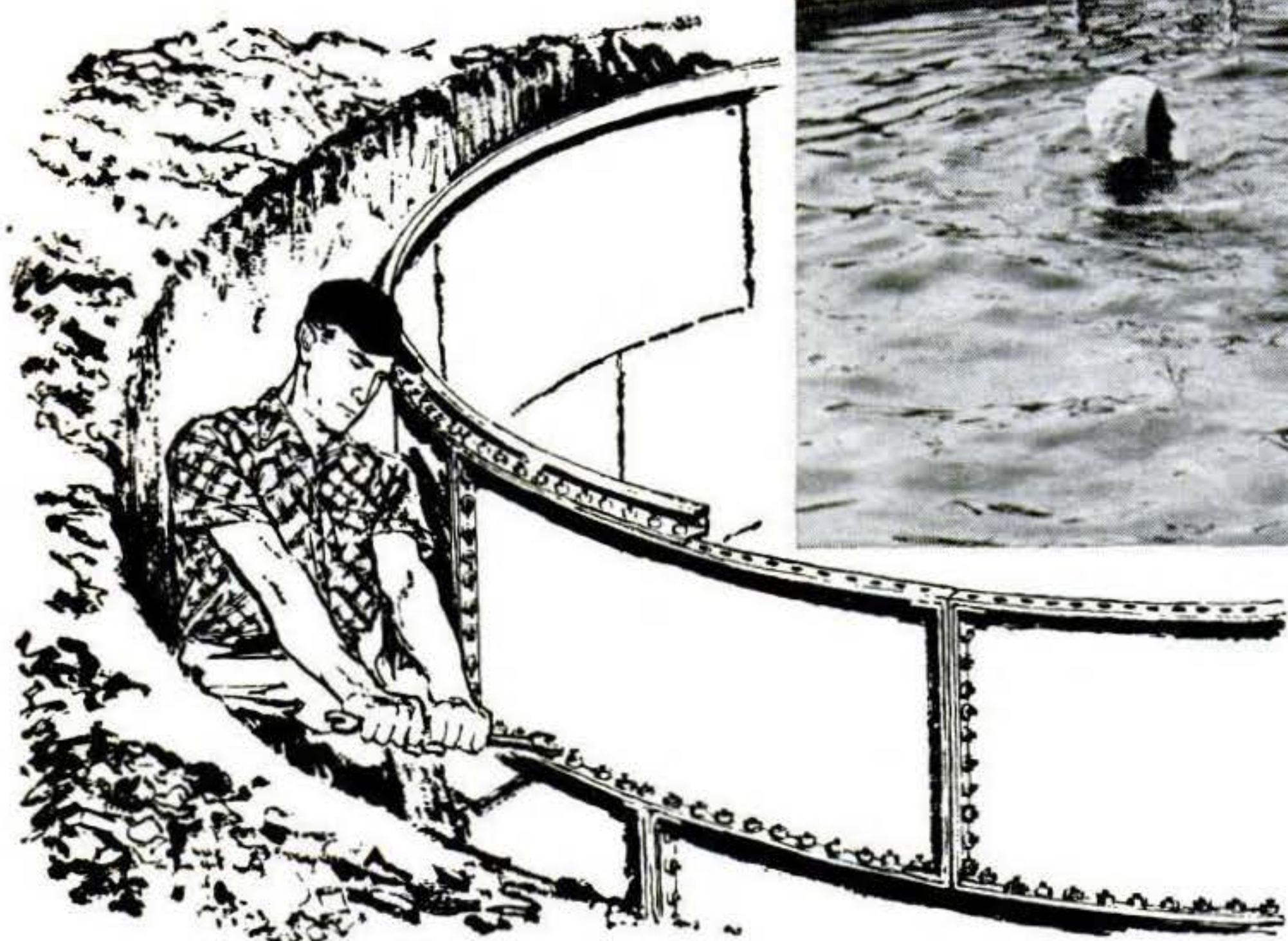

To keep pool watertight, panels are calked at seams; a steel footer channel and rubber water stop join walls to concrete floor. Backs of steel panels are covered with bituminous coating.

## A Bolt-Together Steel Pool That Anyone Can Build

**Y**OU buy only the walls of this pool—the part that's hardest to build. The floor and deck edging are conventional poured concrete. The walls are panels of porcelain-covered steel that simply bolt together and need no painting. Combining

straight and curved panels makes possible many shapes and sizes. A 15'-by-33' pool, completely installed with filter, sells for about \$3,000. But you can put the same pool in yourself for about \$1,800, says its maker, Clayton & Lambert, Buckner, Ky.

### Steel foundation goes up in half a day

Tomorrow's homes may rest on steel stilts. A power auger digs a dozen holes, and steel-legged frames are simply dropped in—in as little as half a day. The method, devised by U. S. Steel, eliminates all concrete work except small footings below the frost line. Result: Builders aren't idled by bad weather.

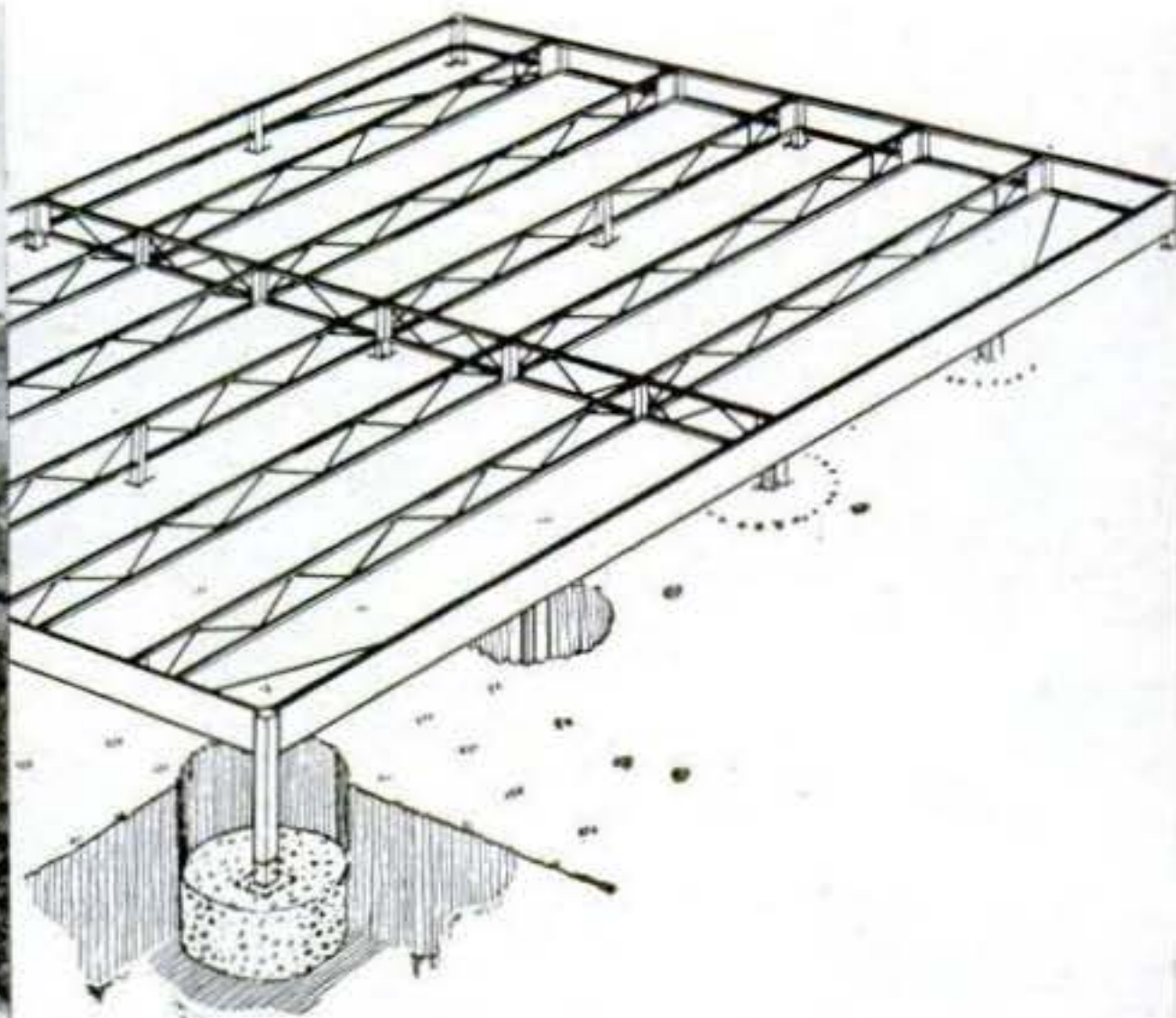



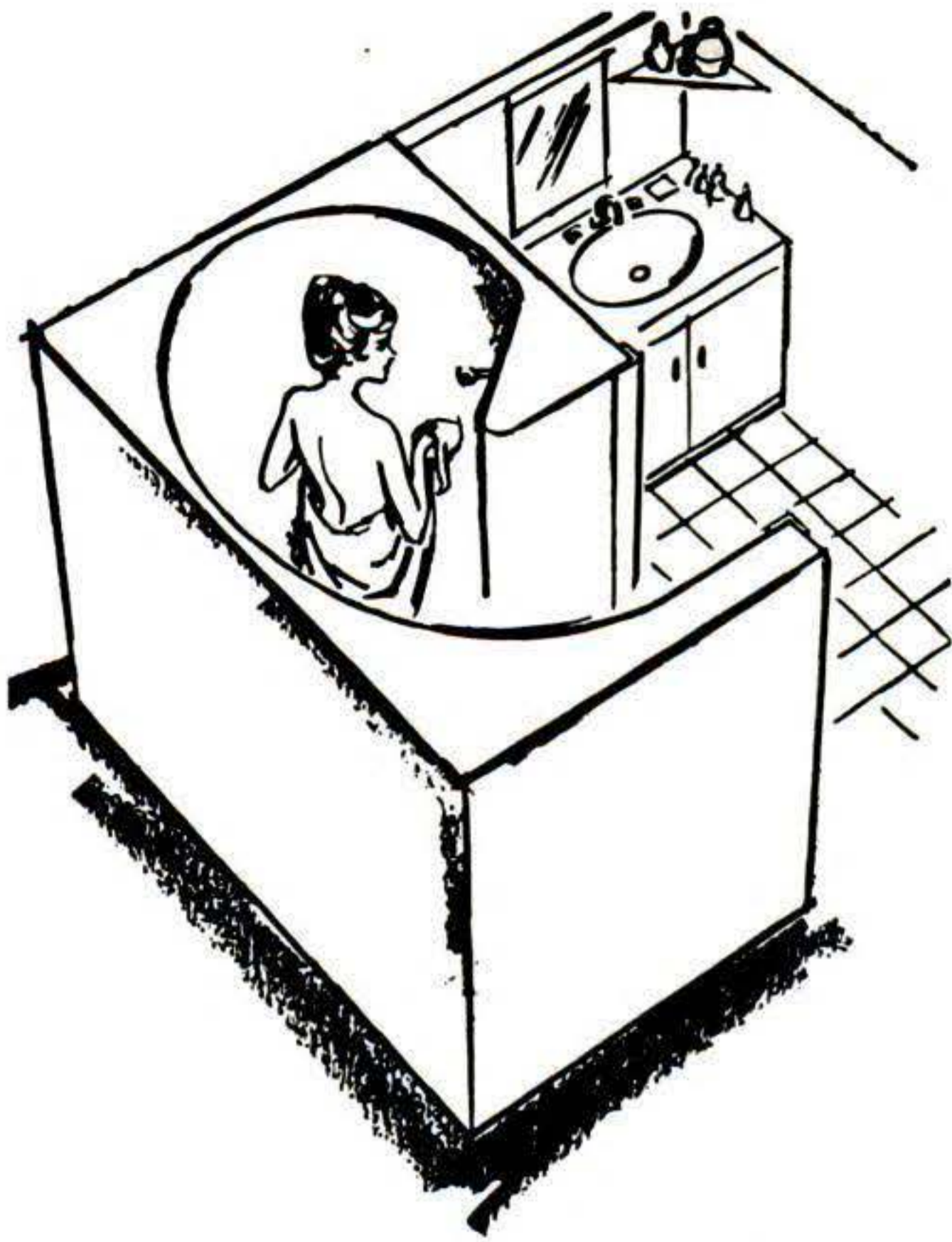

### Doorless shower: peekproof, splashproof

Walk into this spiral shower and you're completely enclosed yet need no door or curtain. The idea: no messy curtain to fuss with, no water splashed on the bathroom floor. The curved walls are molded in one piece of fiber-glass and can't rust or rot. Price is about \$250. Swan Enterprises, Inc., 44 Railroad Ave., Greenwich, Conn.



### Gas-burning candles last forever

These candles never burn down, never drip. They burn butane fuel—like a cigarette lighter—and last four hours on each filling. Adjustable jets vary flame size and light output. Inside is a transparent reservoir (right) that shows when refilling is needed. About \$24 a pair, Ronson Corp., 1 Ronson Rd., Woodbridge, N. J.



### Cook-anywhere solar grill needs no fuel

You don't need fuel or a fireplace to cook a picnic steak with this portable solar grill. The sun does the work. Reflectors funnel its rays through glass plates where their heat is trapped behind an air space. Temperatures reach 400 degrees, cooking meats in 20 to 30 minutes. Folded, the grill looks like a small suitcase. \$29.95, Carmer Industries, Parsippany, N. J.





Intense heat fuses cracks in 60 seconds. Grid under burner converts flames to infrared rays.

# **INFRARED— Quick, New Home Cure for Cracked Asphalt**

Machines you can rent for a Saturday afternoon let you mend blacktop driveways, walks, and patios so they look like new



## How you heat-seal a crack in three easy steps

By James Joseph

**K**EEPING the cracks and potholes out of an asphalt driveway, walk, or patio is one of the toughest yard chores. Makeshift patches rarely hold. Weeds and expanding ice constantly force breaks to open up no matter how often or carefully you fill them.

Now comes a fast new home cure for ailing asphalt—"quick-patchers." These asphalt-patching machines look something like a power mower and contain a high-temperature gas burner that produces intense infrared heat rays. Roll a machine over a small crack, and in seconds it melts the asphalt under it. The softened asphalt then fuses together into a solid seal, and the crack disappears. Large cracks and holes are treated in the same way except that you add a dry-packaged asphalt mix to fill the breaks. The infrared heat softens both old and new asphalt, and fuses them into a single, permanent surface.

The best part about these quick-patchers, normally expensive, is that you don't have to buy one. You can rent a machine for a day's work from a local distributor or tool-rental agency. More and more rental agencies across the country, seeing a booming market for quick-patchers, are adding them to their stock of available tools. The charge is usually about \$10 a day.

**How quick-patchers work.** The new home-size patchers are actually small versions of the machines used to repair asphalt highways. Their burners are fed from a small tank of butane or propane gas and reach temperatures of 1,600 to 1,700 degrees. The secret of their quick penetration lies in a special nickel or ceramic grid in the burner that converts 50 to 70 percent of the flame's heat into infrared rays. The rays are almost instantly absorbed by the black asphalt and penetrate up to 2" deep. In 60 seconds, the asphalt is soft enough to fuse. At the same time, the intense heat burns out weeds and closes up water-trapping pockets that form ice.

There are several types of patchers, differing mainly in the area of asphalt that they cover. Some are designed especially for small cracks; others handle



**1** Narrow cracks are first opened up wide enough to insert a dry-mix patching asphalt. Use an old chisel or screwdriver and enlarge the crack to about twice its original width.



**2** Work the dry-mix asphalt into the crack, tamping it firmly down as you go. Feather the edges out slightly on each side of the crack—the way you'd patch a crack in plaster.

**3** Gas-heated patcher is moved back and forth along crack until old and new asphalt are permanently fused. Patcher shown has metal shoe behind burner that "irons" patch smooth.





## Choose a patcher to do the job you need—there are several types

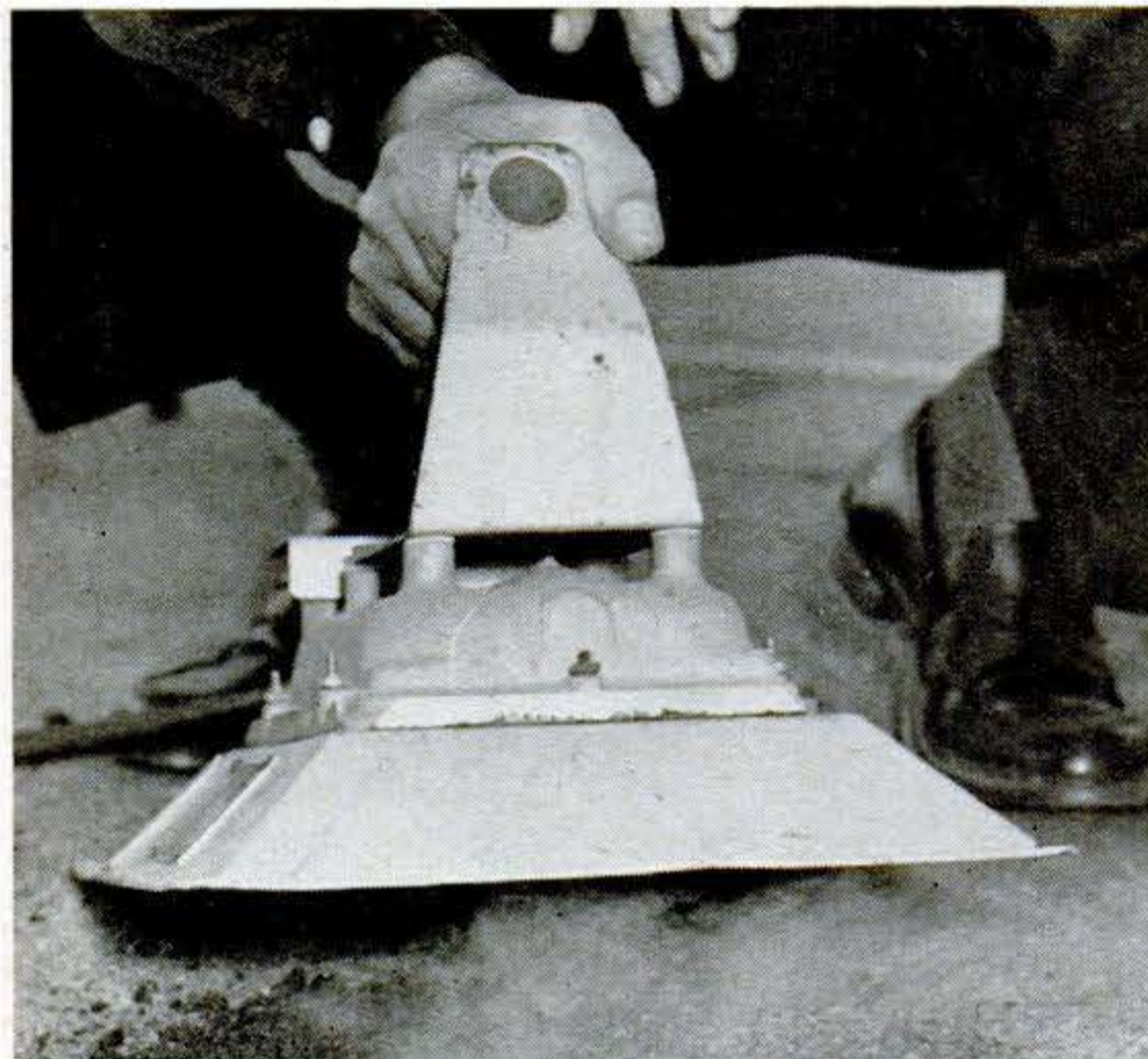

Small, portable patcher is hand-held a few inches above the asphalt, puts out 16,000 BTU of heat. It's easy to use on small cracks, but is not designed for patching large areas.



All-purpose patcher handles both cracks and holes, carries five-gallon propane tank on a two-wheeled cart. Here, igniter hose is lighted first, then used in turn to light the burner.

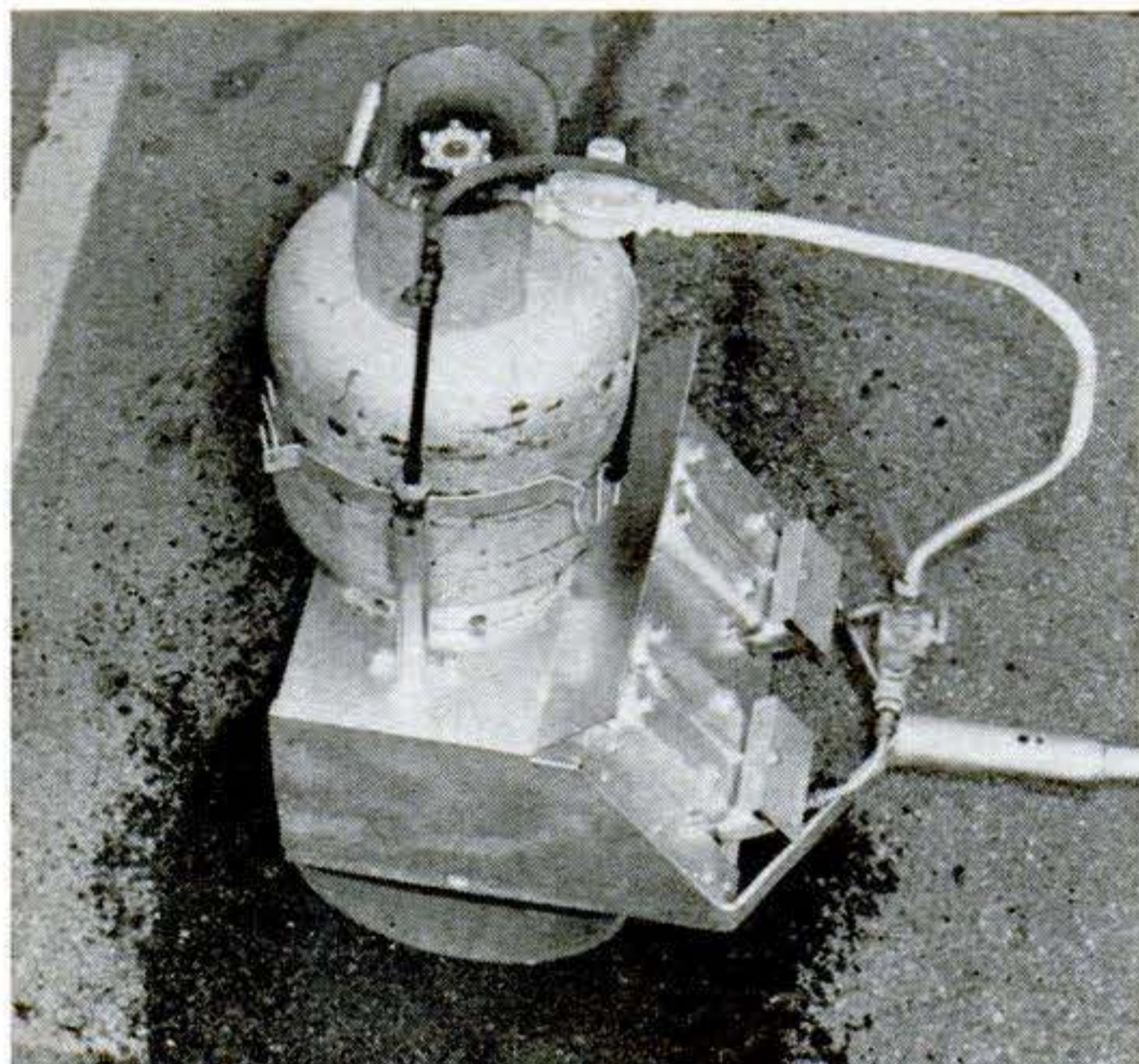

Hot roller (above) is a specialized form of patcher that combines an 18"-wide drum with an infrared burner. It's especially good for big repair areas that must be rolled smooth.

large holes. Here's how they compare:

**Crack-sealer.** This has a narrow burner, about 6" wide, that rides ahead of a metal shoe. The burner softens the asphalt on either side of a crack, and the shoe smooths the joint. You use it just like an iron, moving it back and forth until the crack is sealed.

**Area patchers.** These are designed to cover a large area, as much as 2' by 5' or more, and generally have several burner units. You need one of these if you're going to tackle a large pothole or a hump that you want to soften and then level.

**Multipurpose patchers.** These have a long but narrow burner, typically 8" by 24", that can handle both large and small repairs. Used lengthwise along a narrow break, it's a crack sealer. Turned side-

[\[Continued on page 192\]](#)

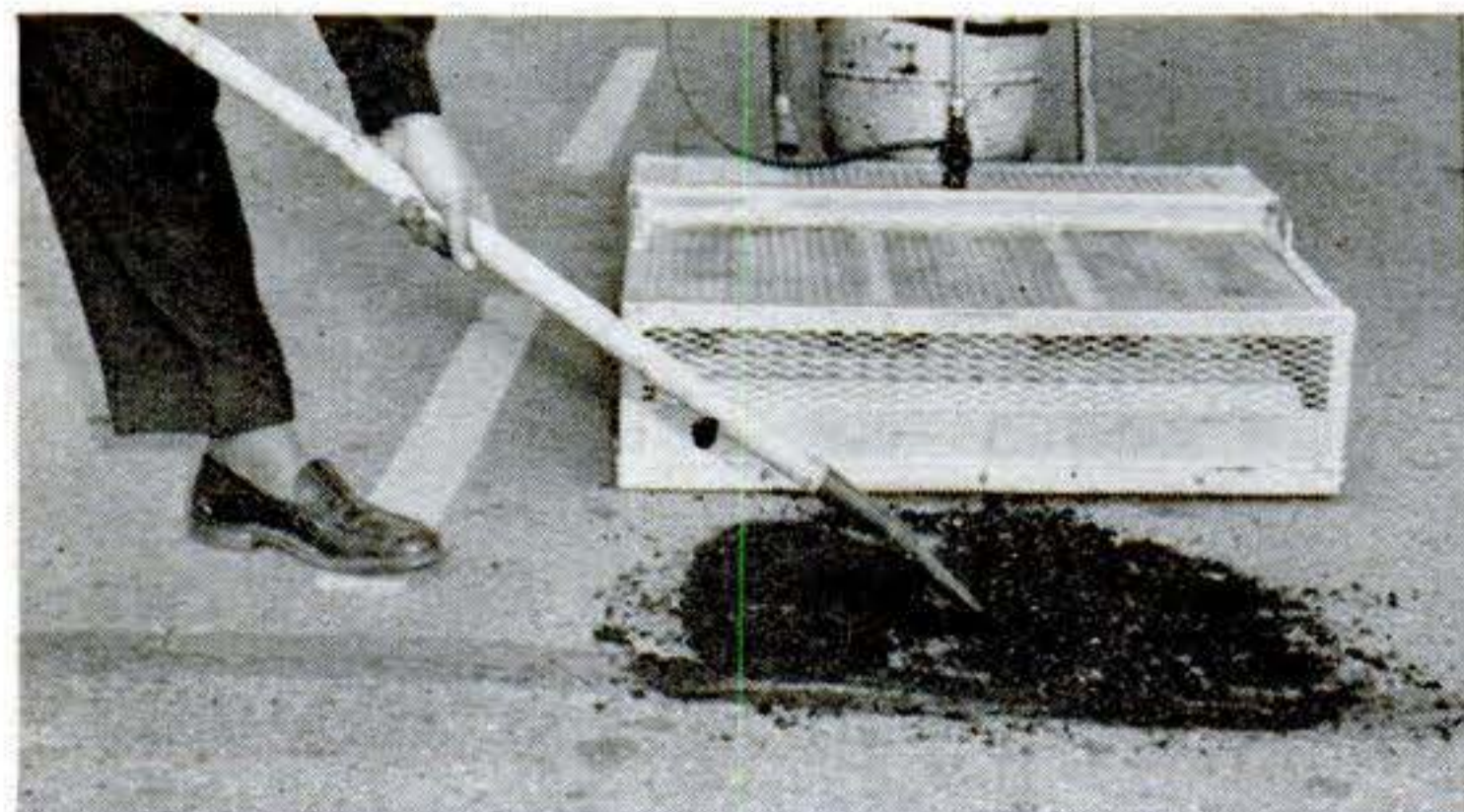

Large-area patcher is ideal for leveling high spots as well as filling in big potholes. At left, a hump is first softened and the top scraped off. At



right, loose asphalt is screeded level with a board, then heated again to fuse the flattened area into a smooth, inconspicuous patch.



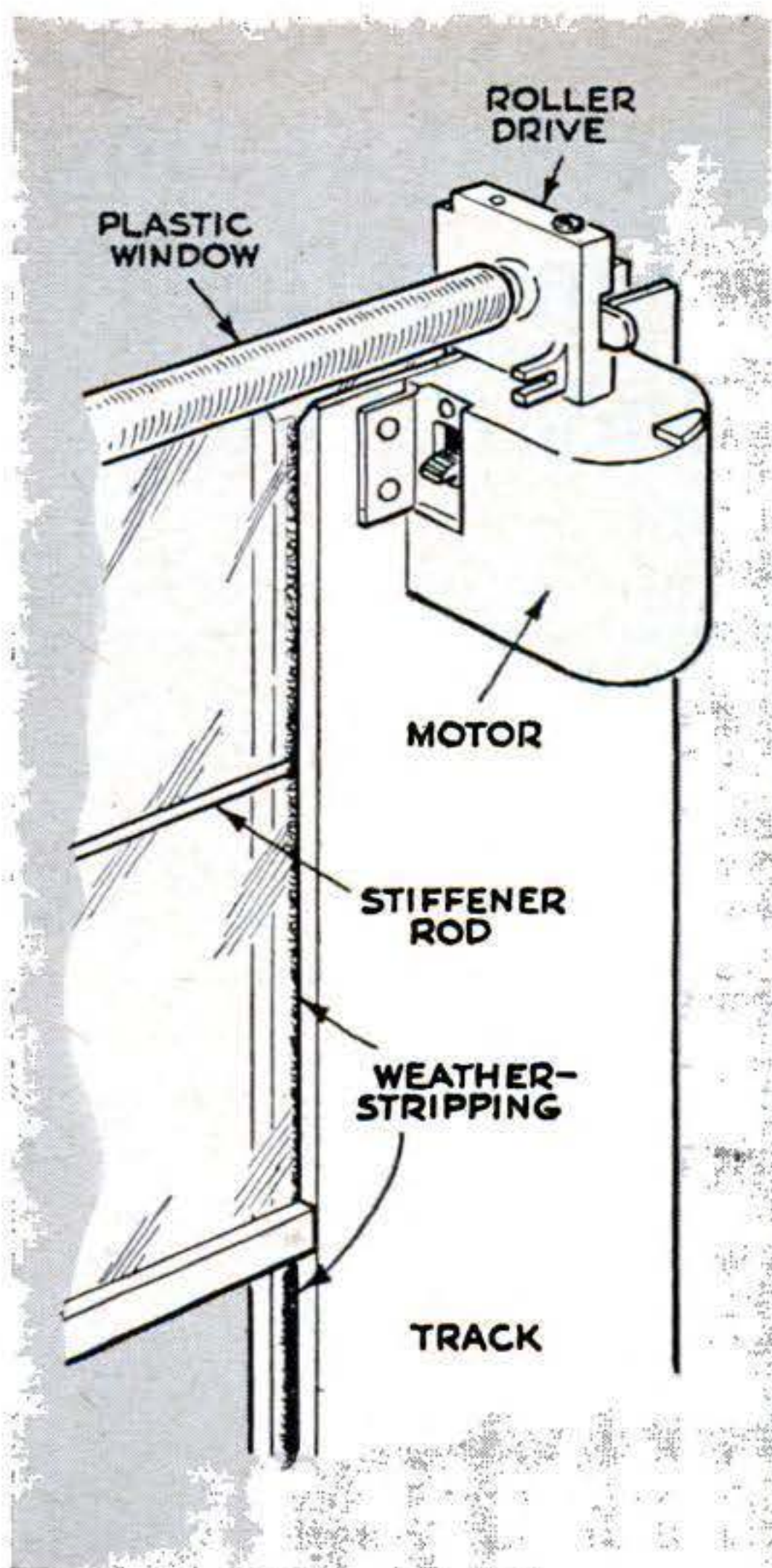

## Patio Room Has Roll-Up Windows

Want to turn an open patio into an enclosed sun room? You can with these pre-fab walls and roof of heavy-gauge flexible plastic in an aluminum frame. The plastic, called Plastok, comes clear, translucent, or opaqued, fits in weather-stripped runners. Each window is controlled by a motor so

it rolls up or down like a window shade. With two or three good helpers, you can add the room in a day. Guaranteed Weather, Inc., Bradenton, Fla., makes sizes of 10' by 16' to 13.5' by 16' for \$1,422 to \$1,646, uninstalled. Wall sun lamp and gas fireplace grill (not shown) are extra.

### Floor-tile adhesive goes on with roller

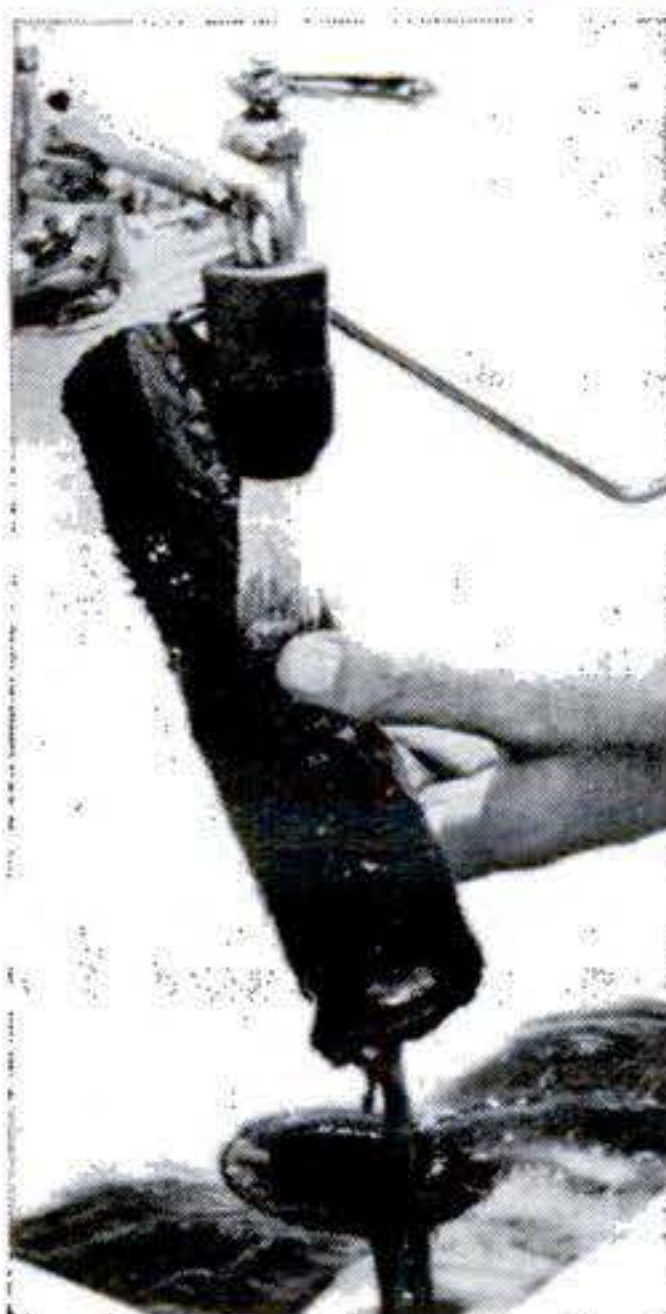

Here's a floor-tile mastic you can spread with an ordinary paint roller. You wash off the roller with soap and water for other use. The adhesive remains tacky for 24 hours so you don't have to lay the tile right away. Grip-Tite Roll-On Type 10 is put up by Curtis Products, 3233 W. 36th St., Chicago, in quart and gallon cans for about \$1 and \$2.

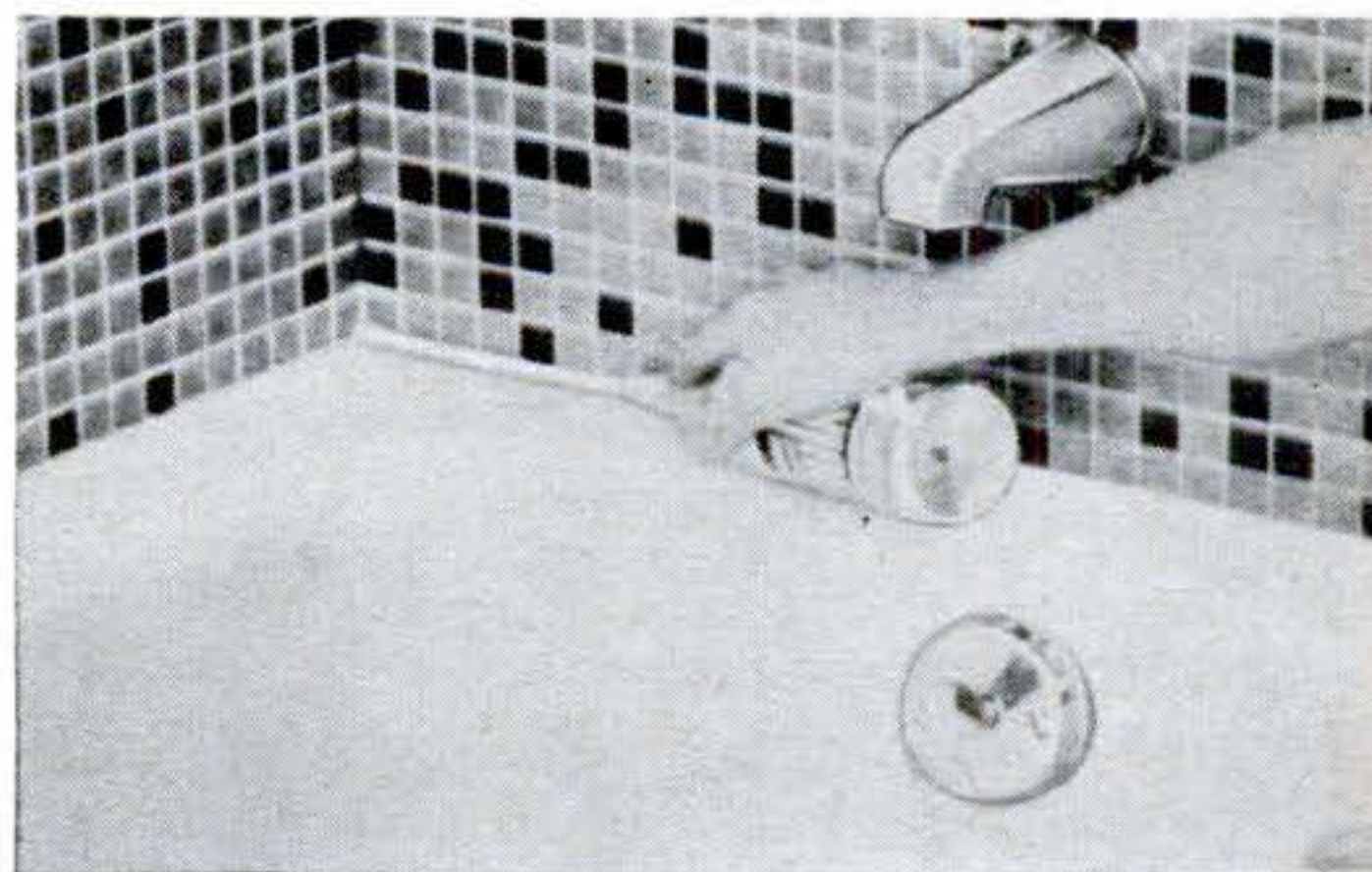

### Calking compound in aerosol cans

With a press of a finger you can lay a bead of calk quickly around a bathtub or sink, patch cracks, or recondition a boat. White Instant Caulk will take paint. It's \$1.39 a can at Curtis Products, Chicago.



**what's new**  
for the HOME

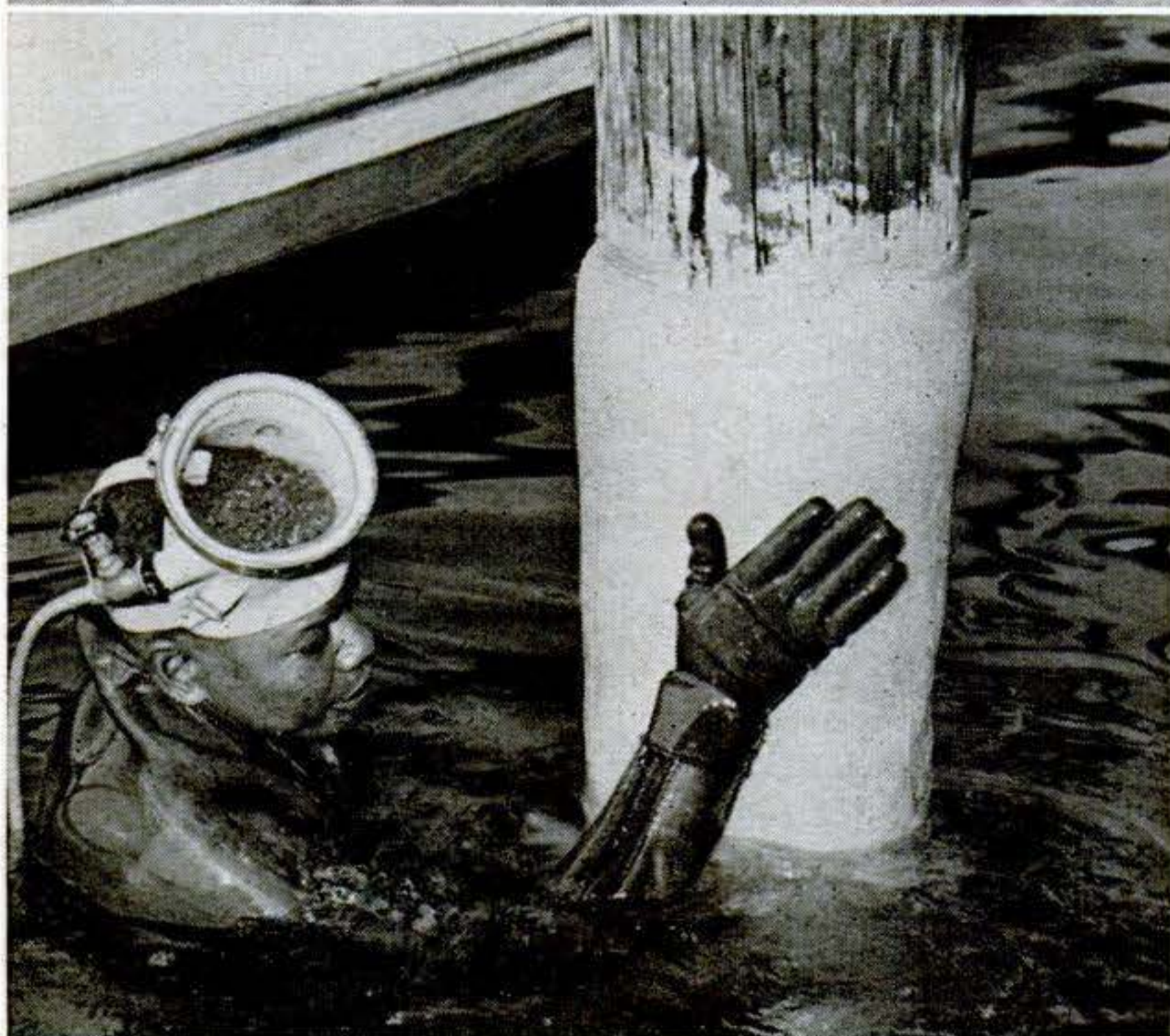
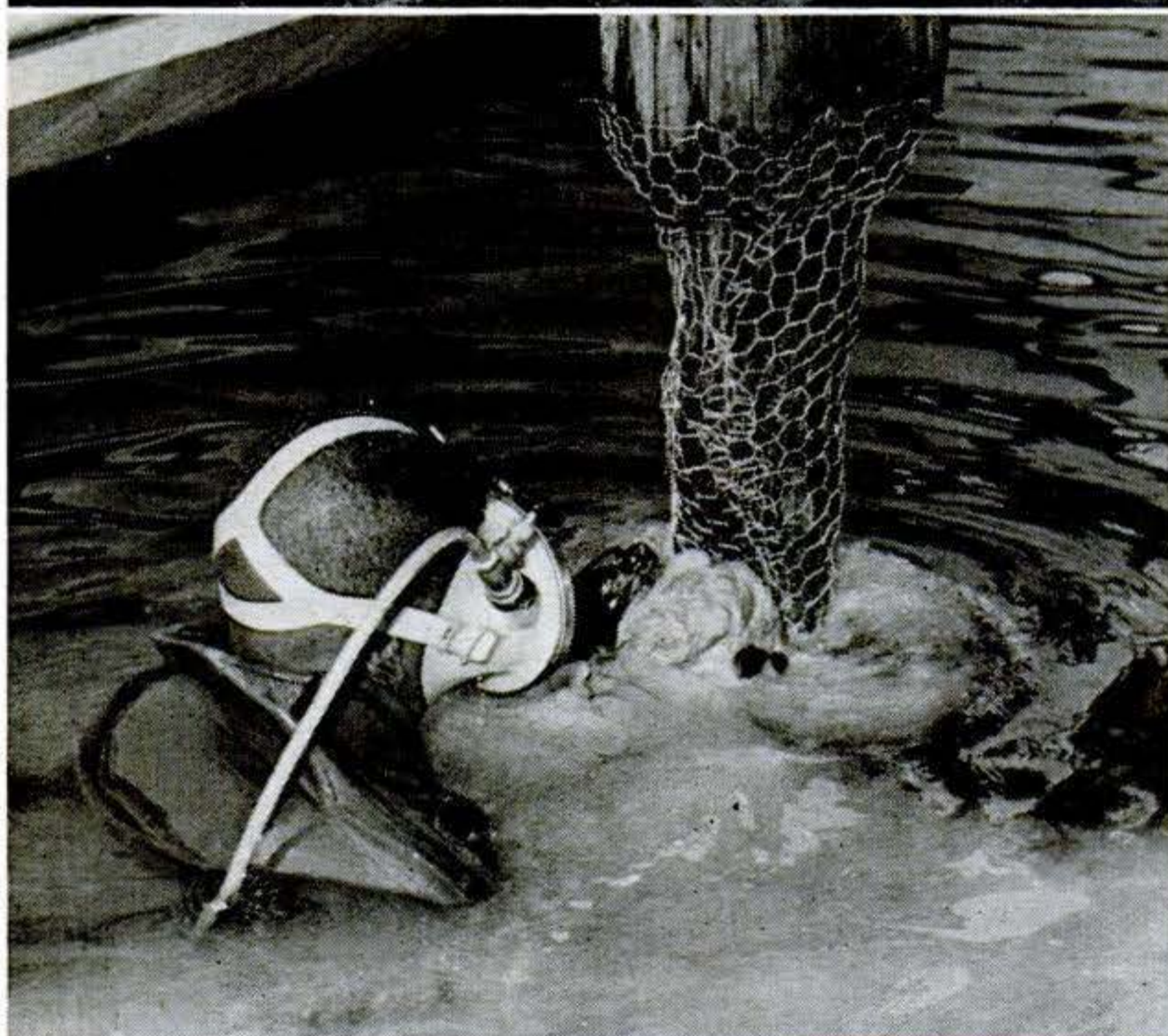

## Instant-Setting Cement Goes On Under Water

Masonry repairs can be made either above or below water to pilings, sea walls, driveways, and other surfaces with a new cement that bonds into a cohesive mass in minutes. Chip the work down to a solid base; apply wire mesh, if needed, to hold the new cement; and press on the cement by hand, trowel, or with a cement gun. Perma-Cement will adhere to old masonry, wood, or metal. It's made by L. F. Popell Co., 2501 N.W. 75th St., Miami. A 10-pound can costs \$4.98, a 50-pound bag around \$10.



### Flip-out ironing board

This self-storing ironing board comes in a cabinet as above or as a counter built-in. Both contain a 33"-high metal board, non-scorch rest plate, electric plug, cord holder, and storage space for an iron. Swanson Mfg. Co., 607 S. Washington St., Owosso, Mich., lists the cabinet at \$85.75, the built-in at \$69.95.



# A Handy Garden House You Can Build



**H**ERE'S a garden house packed with extras that make it a center of yard activities. There's a built-in greenhouse at the back and an attractive covered porch in front with a potting bench that doubles as an outdoor shop bench. Under the roof are a 2'-deep walk-in closet for tools and supplies, and a storage shed big enough to park a power mower and other yard equipment.

The best part: Complete plans for building the 8'-by-15' house are available free from Masonite. There's no tricky foundation to install. The entire frame rests on three long skids, simply blocked up on flat stones. The walls and roof are covered with large panels of weather-proof tempered hardboard. Tools hang up neatly on perforated hardboard in the walk-in closet. All frame parts are two-by-fours.

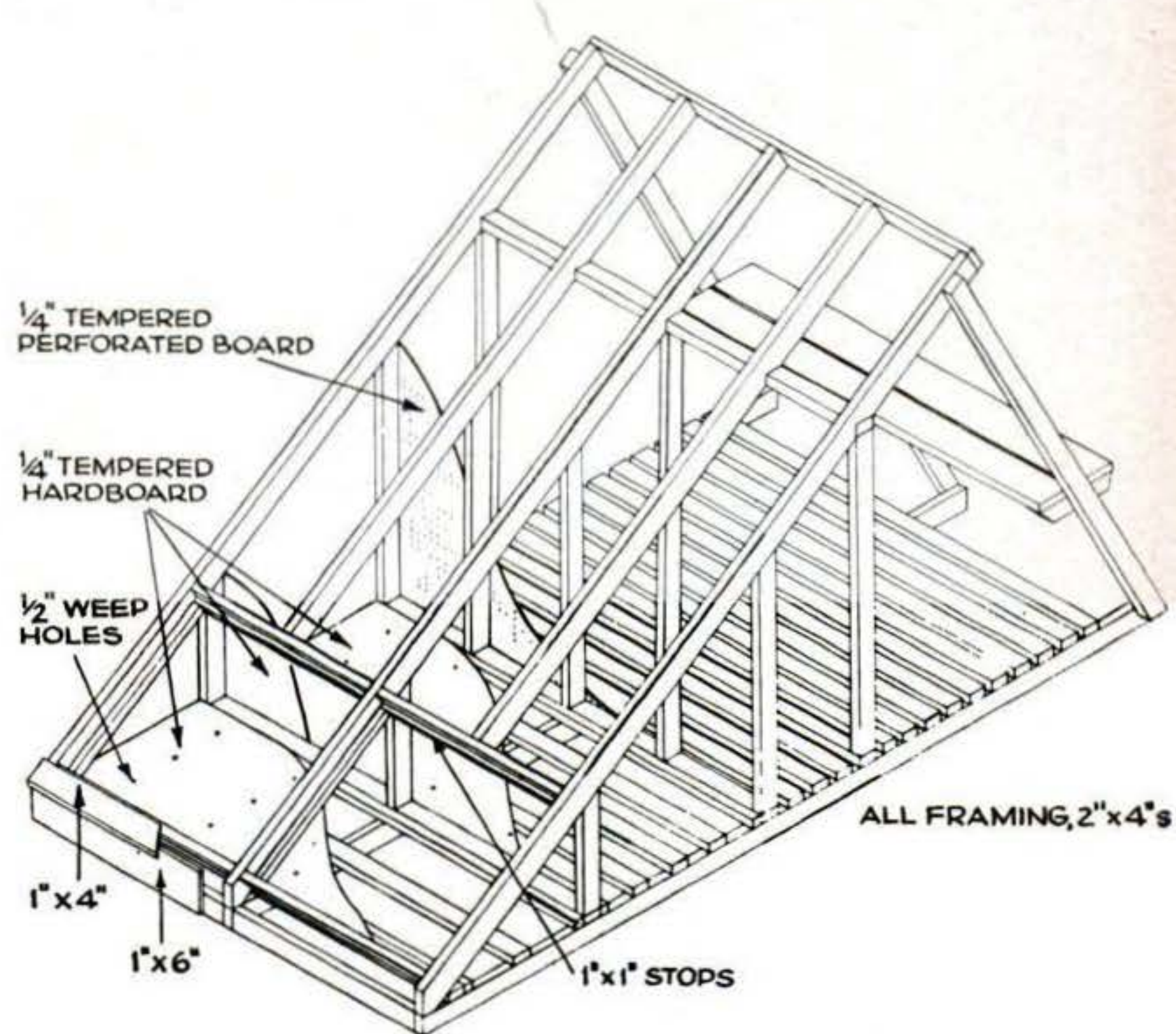

Two-by-four frame has slat floor to let mud and water drain through. Sketch above is one of several you get free from Masonite Home Service Bureau, 29 N. Wacker Dr., Chicago. Ask for plan No. AE-384.

**Lift-out windows** make it easy to reach potted plants in the greenhouse section at the rear.

**Big storage section** has room for wheelbarrow, power mower, and other bulky yard equipment.







**what's new**  
for your GARDEN

## Work-Saver Loading Attachment

**I**DEAL for moving heavy loads about the yard is the Danco all-purpose loader designed for the Jacobsen Chief garden tractor. Features include: twin-cylinder lift with full hydraulic control that can raise a 300-pound payload to a height of four feet, all-welded construction, and bucket lock. Loader, without tractor, \$348. Jacobsen Mfg. Co., Racine, Wis.



### All-purpose power tool does many garden chores

The new Lawn-Boy Hobby Gardener, equipped with interchangeable attachments, weeds, hoes, tills, and edges. Attachments screw on and off quickly. Its extended arm lets it work around plants without damaging foliage, and go where heavier equipment is impractical. A two-horse aluminum engine powers the unit. Price is \$99.50, complete with the four attachments. Lawn-Boy, Lamar, Mo.



### Power trimmer adds neat lawn touch

The new Jacobsen Trim-O power tool, designed to trim lawns quickly and cleanly with a minimum of effort, includes a three-hp. engine, automatic rewind starter, and replaceable side-trim guards. Price is \$97.45. Jacobsen Mfg. Co., Racine, Wis.



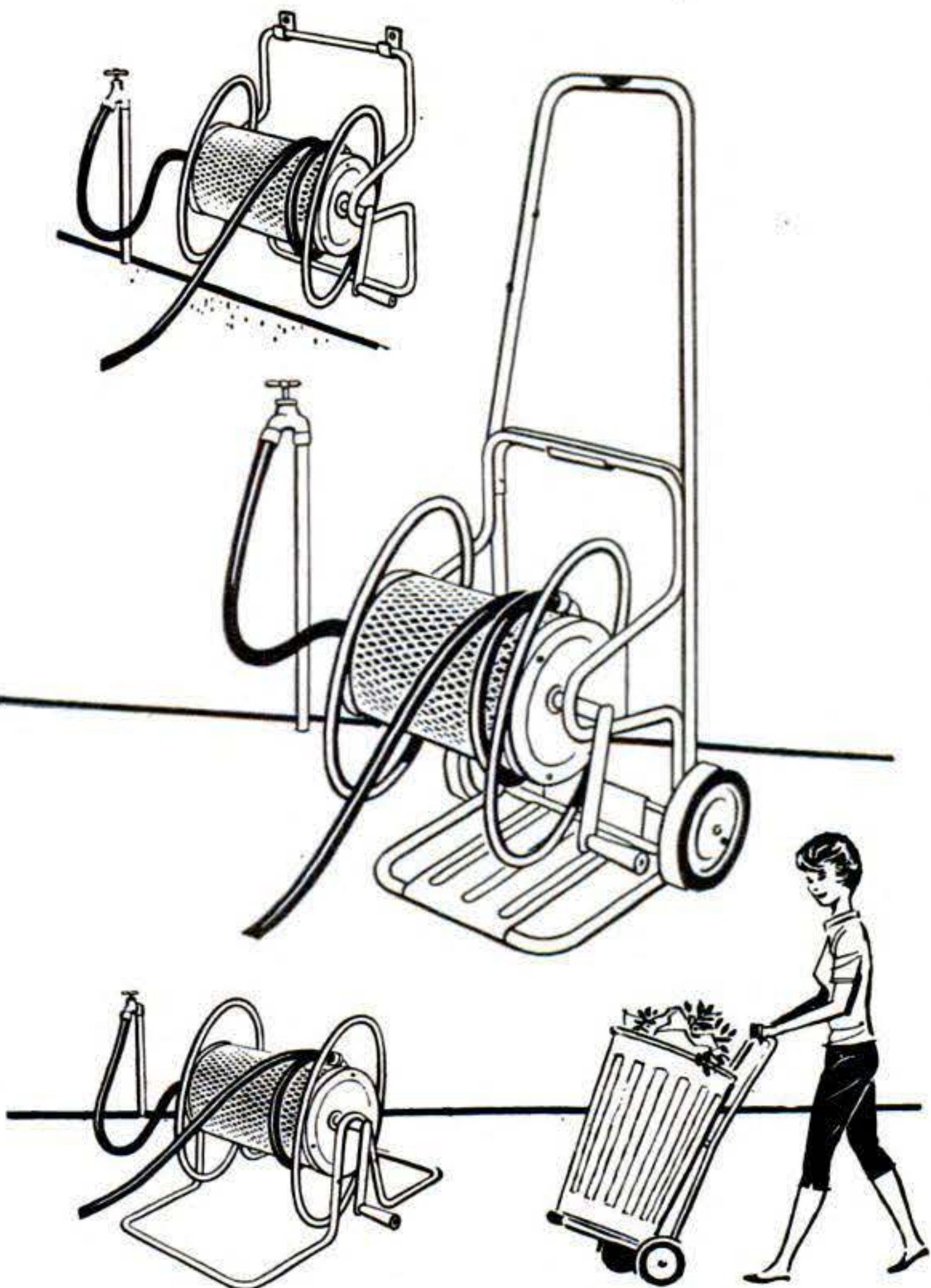

### Combination hose reel and garden cart

This Cal-Dak hose reel unwinds when you pull the hose forward, rewinds with a crank. The reel detaches from the caddy for hanging on a wall or use on the ground—or if you wish to use the caddy as a handcart. Price: \$16.95. Cal-Dak, Little Rock, Ark.

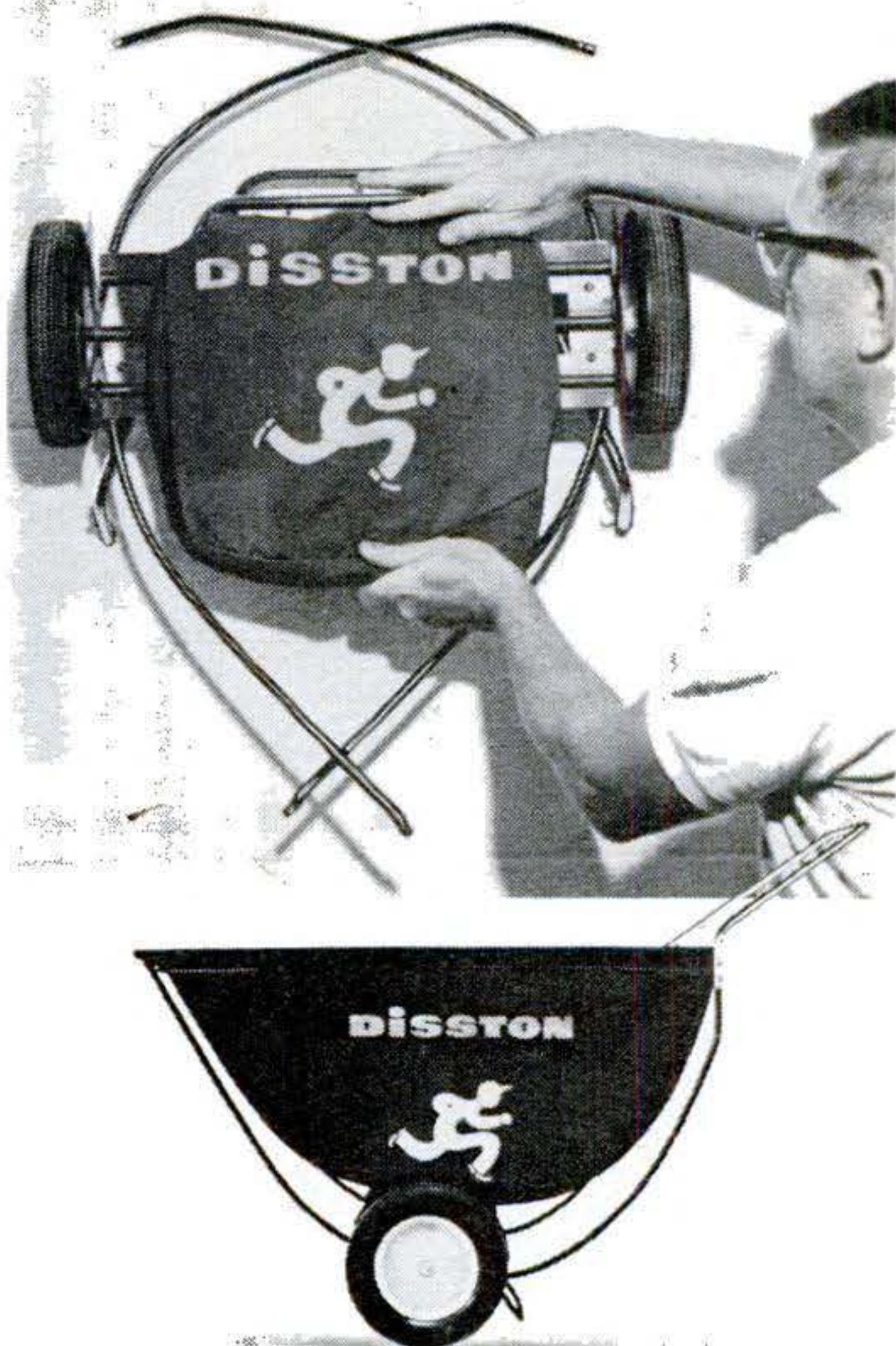

### Collapsible cart folds to handy size

You can speed the job of handling leaves, grass, and other garden debris with this lightweight canvas cart. It folds compactly for storage on a garage or basement wall. Capacity: 3½ cubic feet. \$10.95. Disston Division, H. K. Porter Co., Pittsburgh.

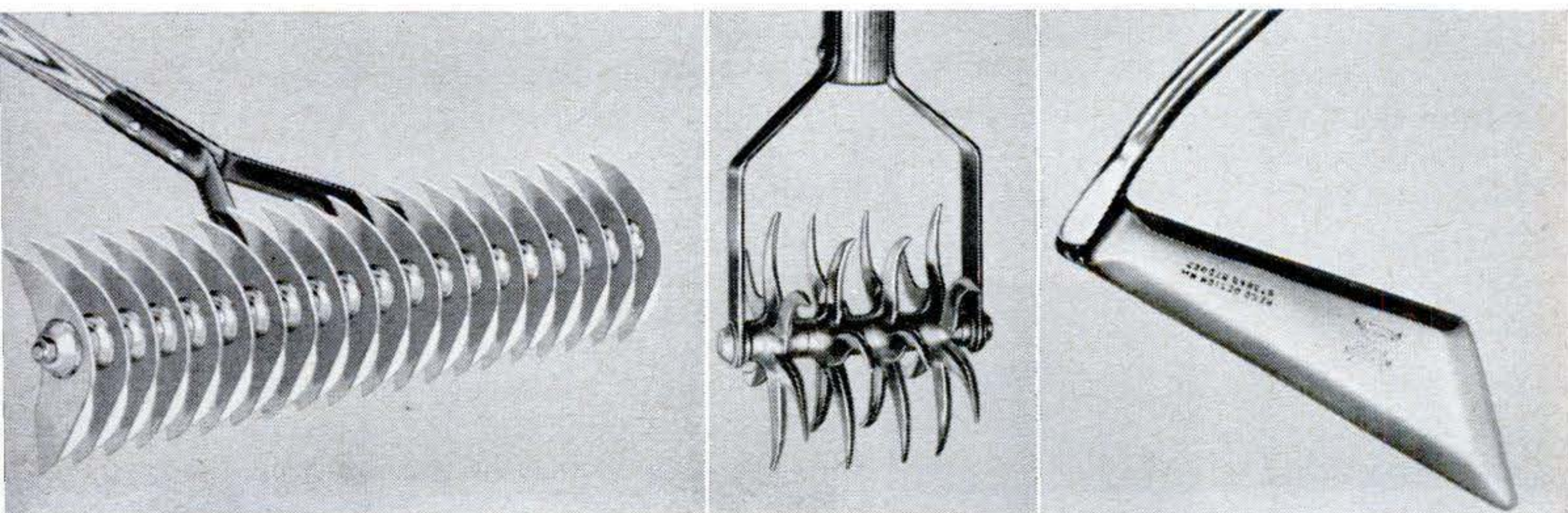

### Tools for grooming the garden

These specialized cultivating tools can make light work of many tedious garden jobs. The lawn-grooming rake (left) is self-cleaning. You don't even have to lift it from the ground. \$4. (O. Ames Co., Parkersburg, W.Va.) The soil cultivator

(center) has four polished six-tine spurs to break up all types of soil with a simple push-pull action. \$4.95. (True Temper Corp., 1623 Euclid Ave., Cleveland.) The Swoe (right) has three edges for weeding, cultivating, grass cutting. \$10.95. (Wilkinson Sword, Ltd., London, England.)



## Easy way to haul stones—try an old auto trunk lid

Using an auto trunk lid that cost me less than a buck at a junk yard, I moved several hundred pounds of rock easily and with little lifting. I removed the lock, passed a chain through the hole and wrapped it around a piece of 1½" pipe placed across the front of the lid for strength.

One afternoon of hauling the lid behind a truck dented it considerably, but it still remained usable.—*Thomas M. Martin, Bedford, Va.*

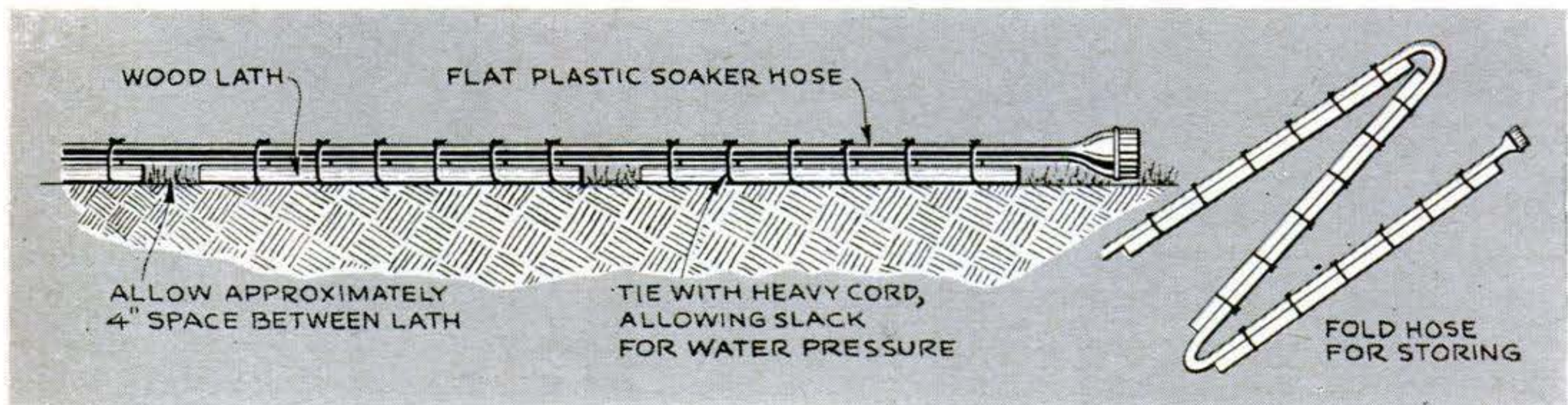

## Wood strips keep soaker hose flat

It's a nuisance to have to straighten out a soaker hose each time you use it. Here's how I got rid of the problem—at absolutely

no cost. I used some pieces of wood lath because I happened to have them on hand. You could use any other strips. The hose stays put—with the water holes up.—*O. M. Hamilton, Tujunga, Calif.*

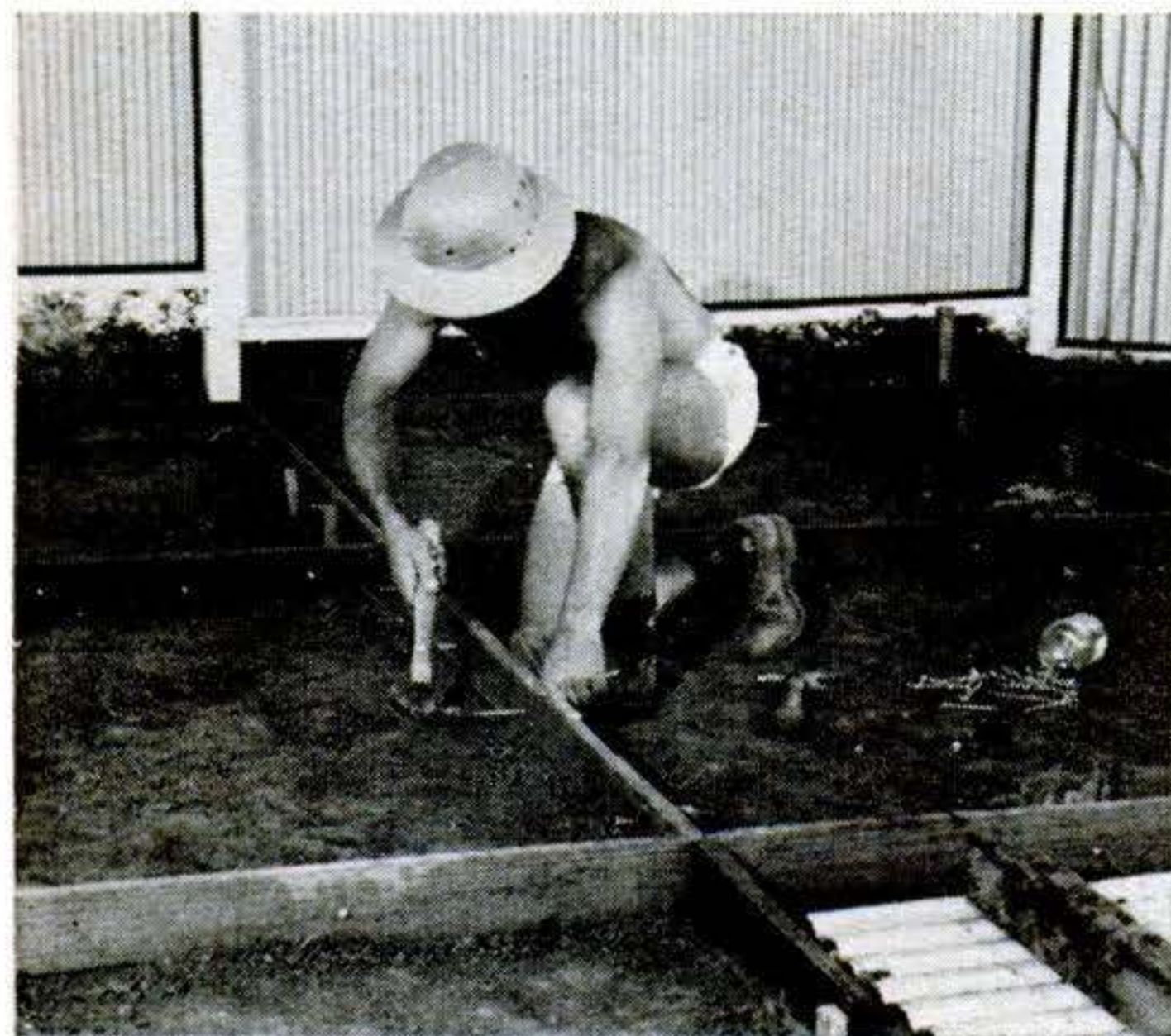

## Nails help keep concrete patio level

A grid-patterned patio can eventually become uneven due to movement in the concrete or wood. You can minimize the chances of this by studding the redwood headers with 16-penny galvanized nails before pouring the concrete. Keep the nails at least 1½" beneath the surface.—*R. J. De Cristoforo, Los Altos Hills, Calif.*

▶▶▶I make window screens ¾" smaller than the opening and glue ½" plastic foam around all sides. When this compresses, it forms an insectproof screen, and I don't have to spend time planing edges.—*Ted Hinton, Vancouver, B.C.*



# PHOTOGRAPHICALLY SPEAKING

By Bob Hering PS PHOTO EDITOR



## Lamps for 8mm movie fans: One signals, one stays cool

Seems projection lamps always choose the most inconvenient time to die. To prevent such abrupt interruptions, Sylvania has developed a dual-filament projection lamp that gives advance warning. It dims for a short time before it burns out. A light-giving coil and a ballast coil are connected in series. The ballast coil acts as a buffer for excessive voltage, lessening the chance of premature failure in the lamp, and keeping it going—though dimmer—for a while.

Another projection lamp—from Westinghouse—has a dichroic reflector: a glass mirror that reflects visible light but transmits infrared (heat) rays out the rear of the bulb. Advantages: cooler film projection and higher light intensity on screen while burning at just half the usual operating temperature.

## First SLR still camera with built-in zoom lens

One of the better new camera buys to arrive so far this year is the Nikkorex 35 Zoom. I've been using one for about a month and find that it has a lot to offer. Most important: It brings zoom-lens photography within reach of quite a few more pocketbooks. At \$219.50, the camera isn't cheap, but look what you get:

By merely turning the zoom ring on the lens barrel you vary the focal length from 43mm wide-angle to 86mm telephoto—all within one lens. This gives you the advantage of interchangeable lenses without bothering to lug along extra ones. It's a neat vacation package.

The camera is semiautomatic—a built-in exposure meter couples to both shutter and diaphragm. You need only line up the needle with the index mark.

Four rings on the lens barrel make it easy to adjust the camera. One controls aperture opening and includes the ASA scale; another controls shutter speeds; a third changes focal length of lens; and a wide fourth ring adjusts the focus. Without moving your eye from the viewfinder, you can focus, select the focal length for best framing, and adjust the meter needle for the correct exposure.

The meter needle is visible in two locations: through a little window above the exposure cell on top of the camera and through the viewfinder. Despite its "long nose," the camera is comfortable to hold. You're working the rings and supporting the lens barrel at the same time.

## Automation in space

An aerial-reconnaissance system that will take exposed film from an aerial camera, automatically develop it, and elec-





# PHOTOGRAPHICALLY SPEAKING

tronically scan the 4½-by-4½ frames for transmission to a ground recording station is being developed by CBS Laboratories for the Navy. The photographic quality of the system, the company says, will permit immediate analysis of the picture.

## Adding sound to a silent projector

Would you like to add sound to your 8mm films without discarding your present silent projector? You can do it now at a reasonable price. Sears sells an adaptor that fits most of the present 8mm projectors that have drive sprockets. Previous adaptors fit only one or two models, or, if adaptable to several projectors, were expensive.

Basically, Sears' adaptor is a tape recorder synched with your projector, and depends on sound striping on the film. It is not designed for use with commercially produced 8mm sound films, but is meant primarily for adding comment to your own films—those you intend to play back on the same machine.

Sound-striping service is available through photo dealers, or you can add your own, using one of the new strippers.

In operation, the film runs past the recording head of the adaptor unit and then through the projector. It not only records and plays back, but permits automatic erasing and re-recording.

Yes, it *can* record music, but you may be disappointed in the quality.

Price of the adaptor: \$99.95. I'd suggest you try one on your projector before buying—just to make sure the noise level is low enough for acceptable sound.

## New multipurpose flash bulb

To take the guesswork out of selecting the right flash bulb, Westinghouse is introducing a single bulb that should handle most of the flash situations that come up for the amateur or professional. The M3 will take the place of No. 6, M5, and M25 bulbs. A shredded-zirconium filling in the new bulb comes to a high intensity level (twice the light output of shredded aluminum) quickly and maintains it for a long time. It can be used with most focal-plane shutters, all leaf-type shutters.



## Strobonar flash increases output

Designed primarily for use with rechargeable nickel-cadmium batteries, the Strobonar 65C electronic flash has a built-in battery charger, fast cycling, and 81 percent more light intensity than the Futuramic II. The charger plugs into a household circuit. Batteries are also recharged when the flash is operated on AC power. Price: \$64.95. Honeywell Photo Products, 4800 E. Dry Creek Rd., Denver 10.



## Electric-drive 8mm movie camera

Pushbutton zoom control on this Keystone K-14 lets you change smoothly from wide-angle to tele range (9mm to 27mm). A built-in coupled exposure meter responds instantly to light changes. Other features include reflex viewing and an indicator in the viewfinder to show lens setting and warn when light is too weak. Penlight batteries provide power. \$249.50. Keystone Camera Co., Boston 24.



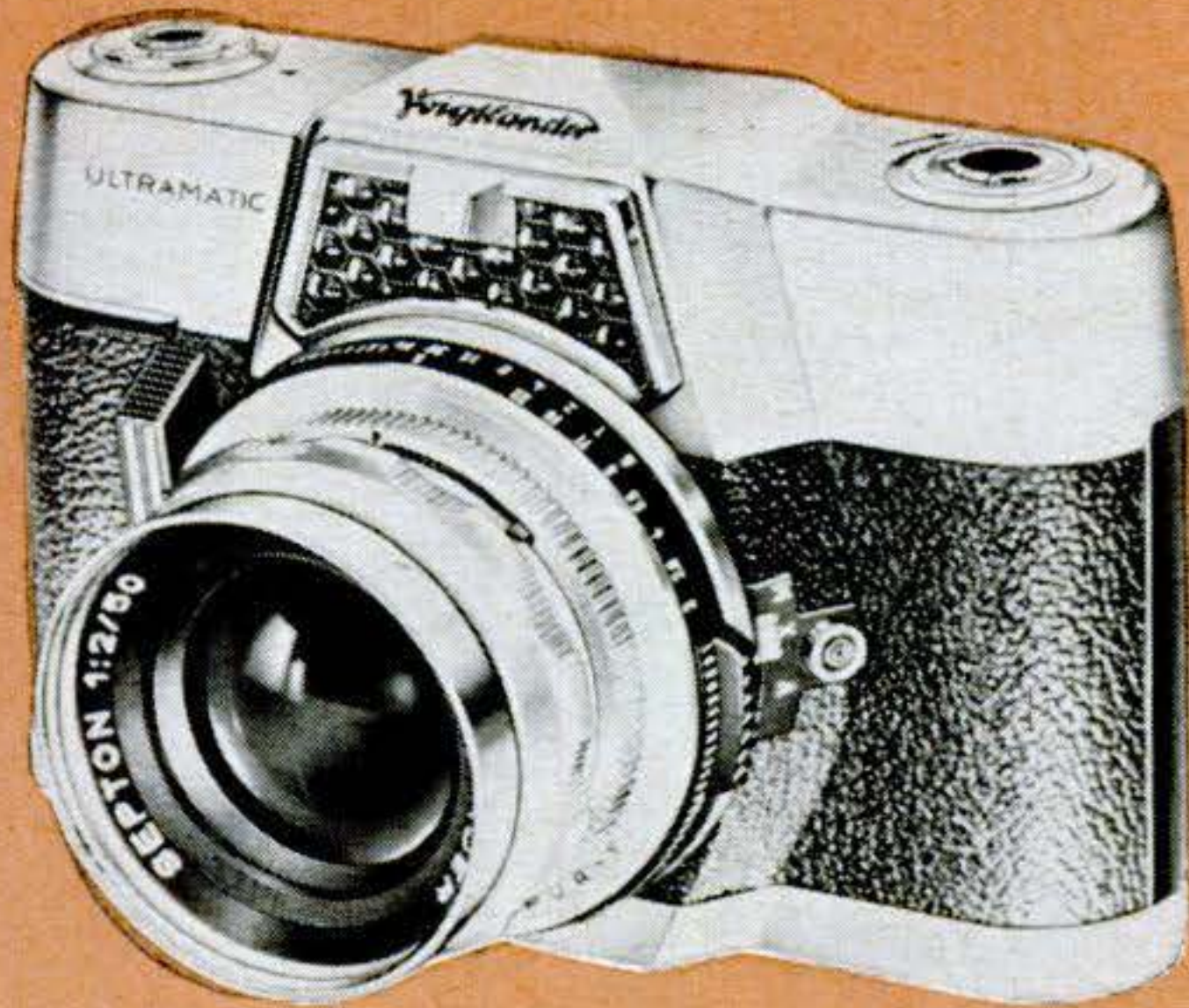

**what's new**  
**PHOTOGRAPHY**

## SLRs Go Automatic

Two 35mm single-lens reflex cameras, new from Voigtlander, follow the trend toward automation. The Ultramatic gives you fully automatic exposure control plus semiautomatic and manual control. Look through the viewfinder and you see, along the outer edge, a number that shows the shutter speed, a scale and pointer to indicate the aperture setting, and a small ring

to tell when compensation is being made for filter factor or backlighting. A signal indicates when the light is too high or too low for satisfactory exposure.

The new Bessamatic Deluxe is similar to the standard Bessamatic, except that the aperture and shutter settings show in the finder. It is \$229; the Ultramatic, \$295. H. A. Bohm & Co., Chicago 45.



## Now it's "talking" slide projectors

There's a completely new audio-slide system: a projector using sound-slide mounts surfaced with the material used on tape—a coating of magnetic oxide. After your slides come back from the processor, you slip them into the mounts, and a special record-

ing head that revolves in a spiral path over the mount adds sound. Each mount holds 20 seconds of recording. You can re-record as you do on tape. You can also run soundless slides with live commentary, using the mike and amplifier as a P.A. system. Revere 435 projector lists at \$250. Revere Camera Co., Chicago 16.



# Hints from the Model Garage



To blow dirt from around spark plugs before you remove them, use an empty snip-off-cap plastic detergent bottle. A few good squeezes will whisk the dust away. The same method can be used to blow lint out of heaters without damaging them.

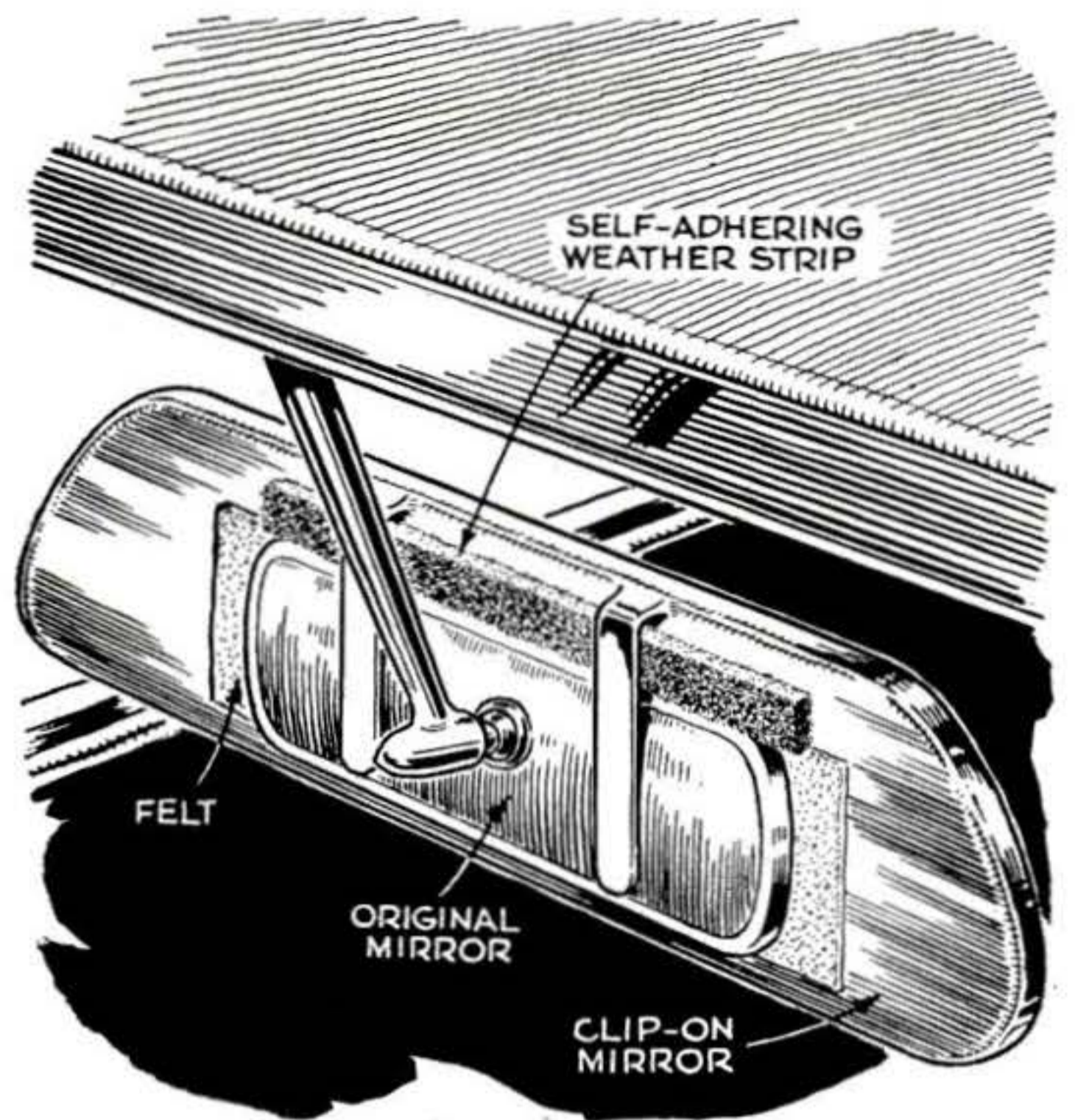

That oversize clip-on mirror won't loosen and rattle if mounted this way. Place a length of weather stripping just above the stock mirror to carry the weight of the clip-on. Cement a piece of felt to the back of the clip-on to absorb vibration.



Hold cans upright in a truck bed with inexpensive, readily available magnetic cup hooks. Bend each hook closed to form an eye. When slipped over the neck of the can, the eye keeps the can from overturning and perhaps spilling its contents.

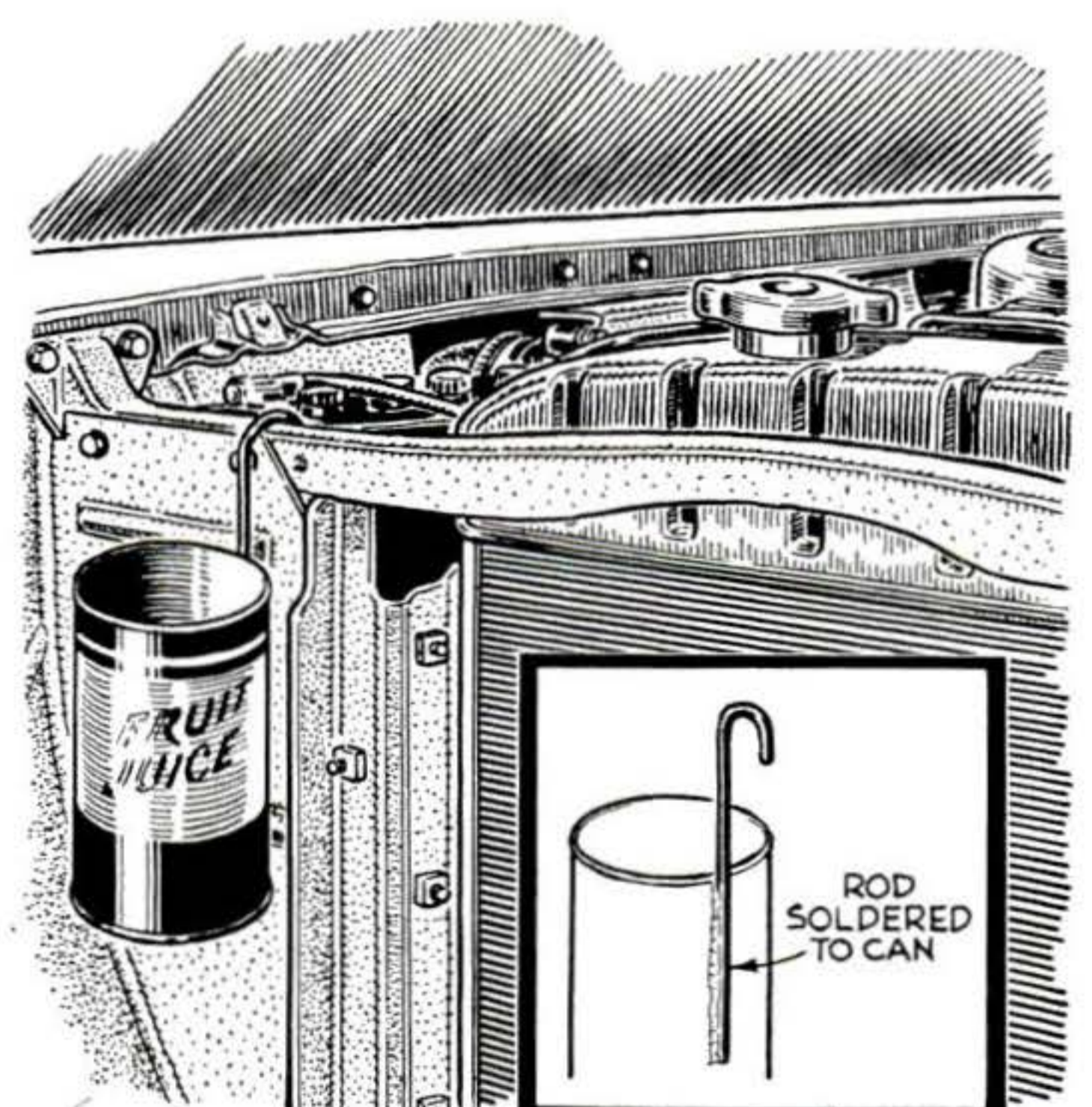

A container for holding small parts can be a big help when you're working under the hood. Use a small tin can and a foot-long piece of rod bent into the shape of a cane. Solder the rod to the can and form the hook to fit the top of the radiator guard.



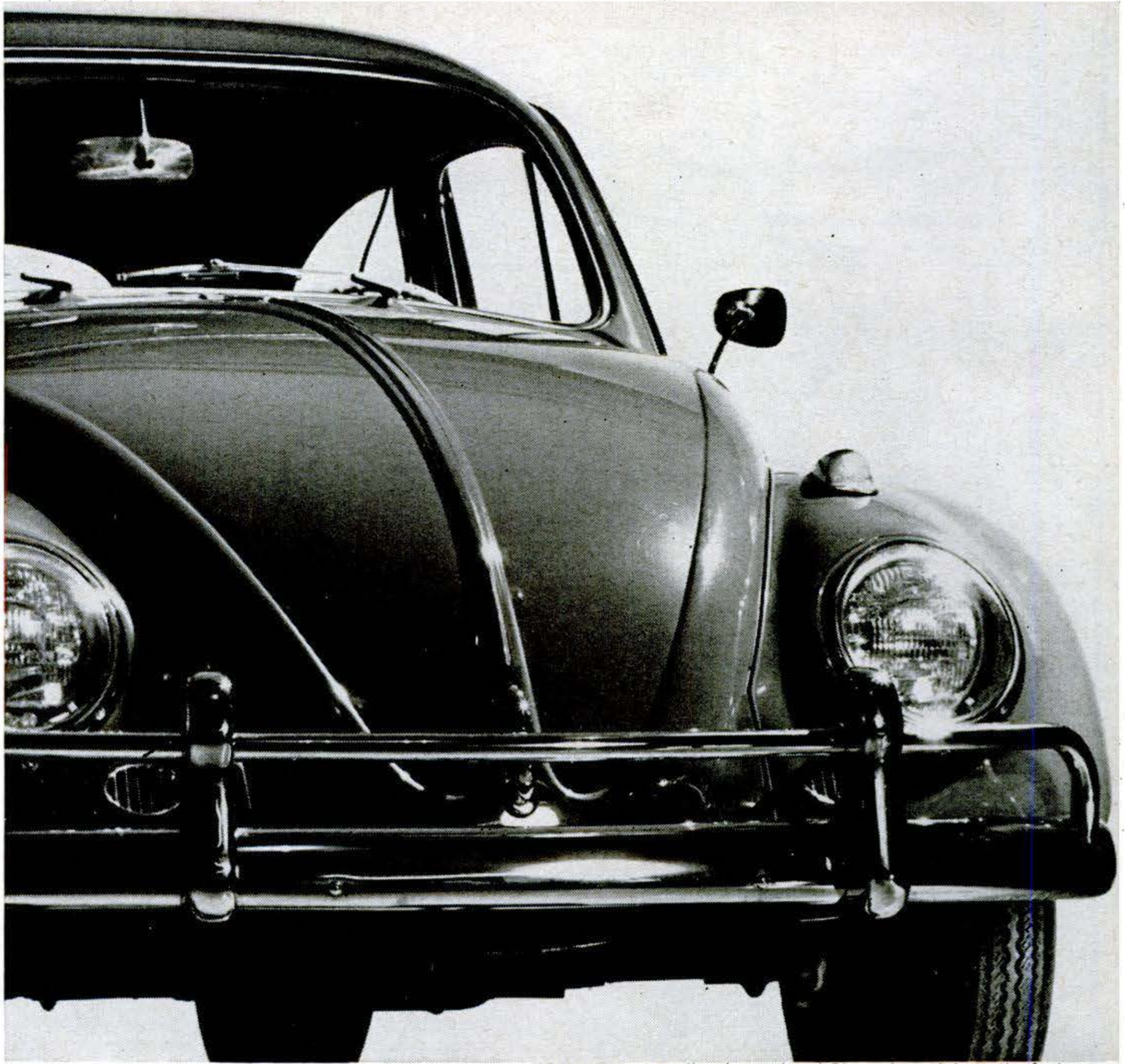

Volkswagen installs silvery-plated Champions right at the factory

Volkswagen uses Champion spark plugs because they give the utmost in dependability and efficiency. Actually, more than twice as many car makers the world over specify Champions. Why settle for less in your car?



**CHAMPION**

For maximum engine efficiency in your own car... install new Champions every 10,000 miles



## More Hints from the Model Garage

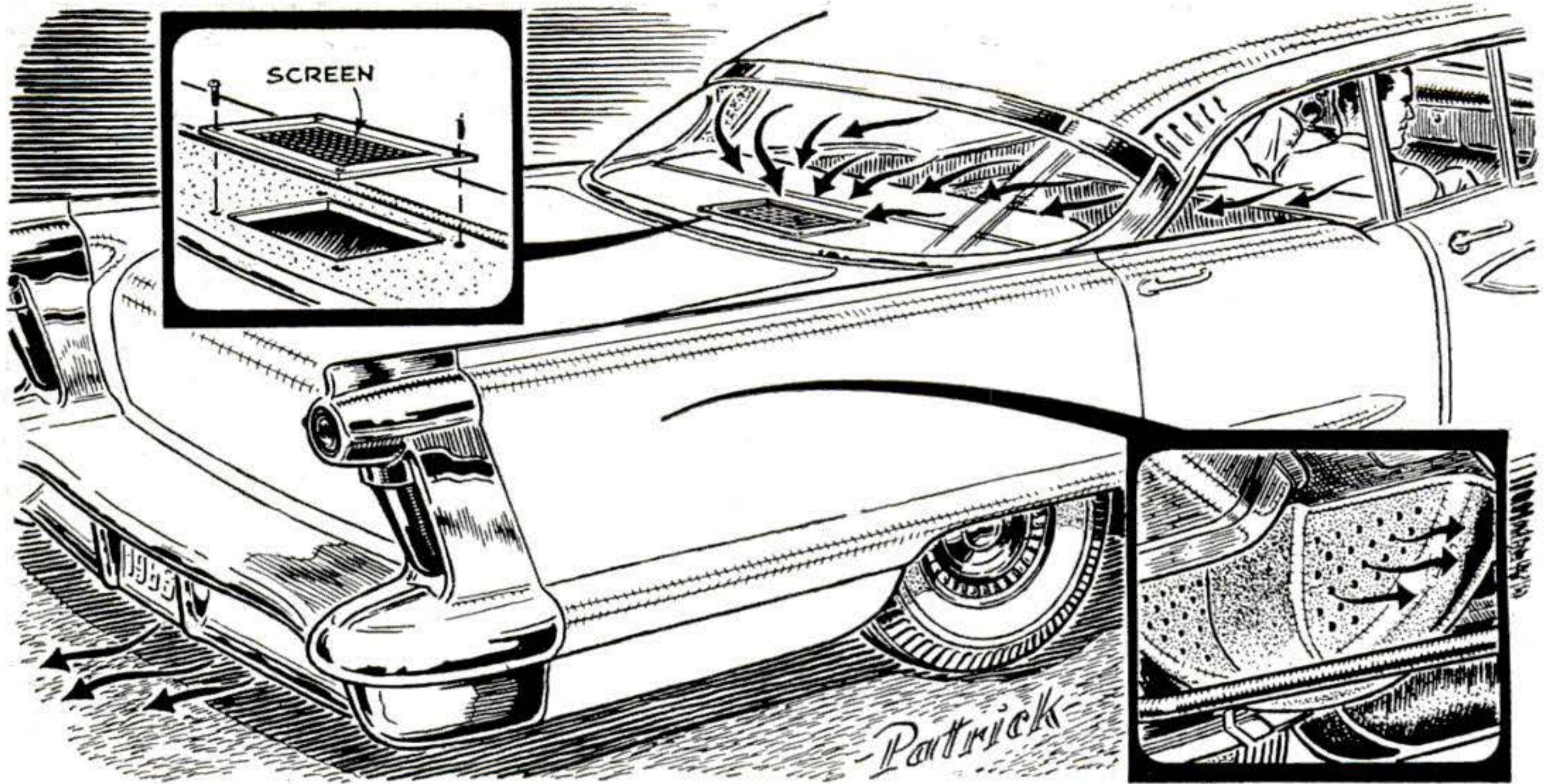

A rear-window air-exhaust duct provides ventilation without need for open rear windows. Cut an opening in the rear-window shelf (most late-model cars come with a cutout for a rear speaker in the metal bracing under the cardboard) and install a

metal screen. Then drill the sides of the spare-tire well full of holes to allow the air to flow out of the trunk. Locate the holes where water can't splash in. Vents under the dashboard will give adequate air flow. Closed windows eliminate draft.

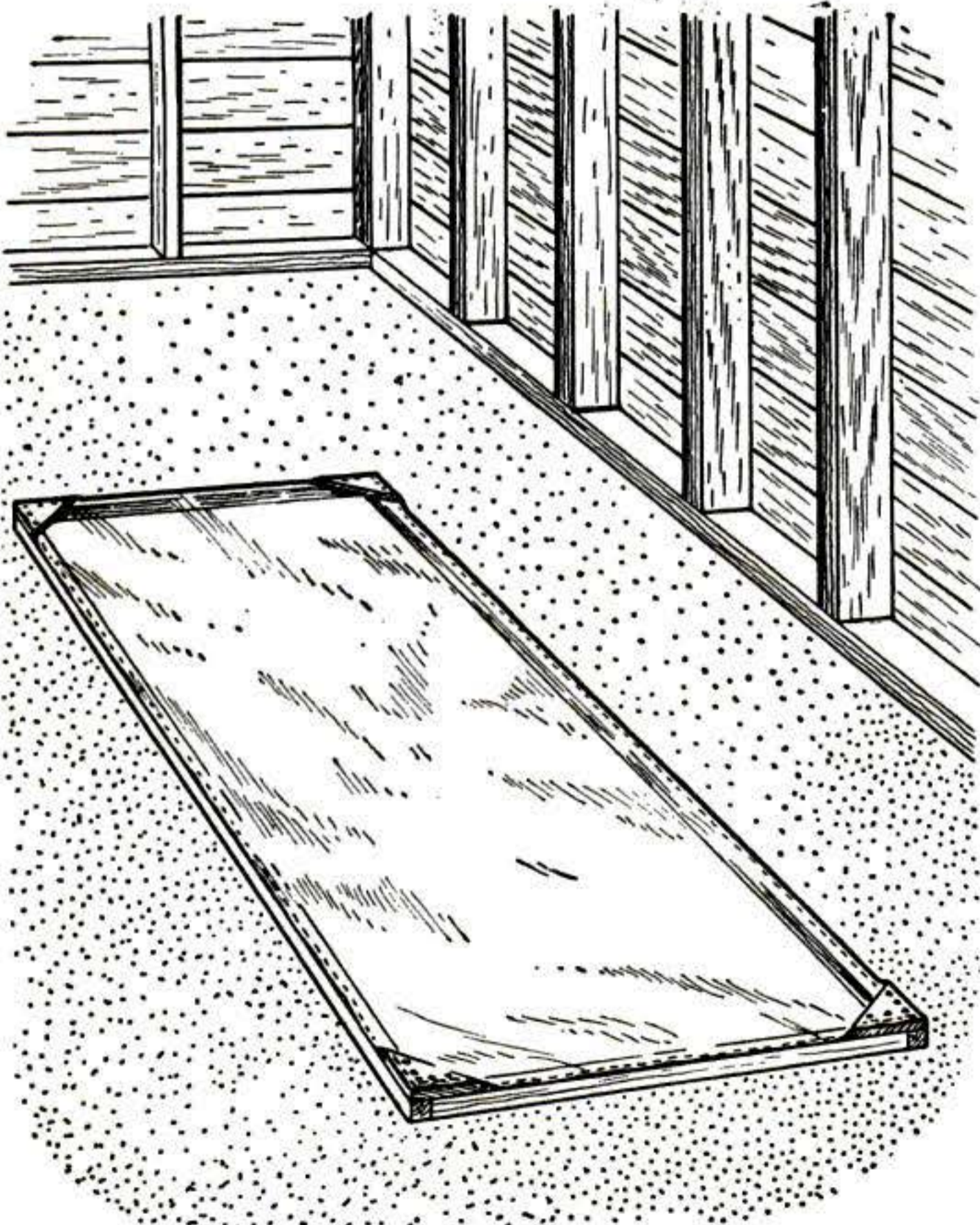

To keep your garage floor clean, build this simple pan for catching grease drippings. From one-by-one stock, cut two 7' and two 2' lengths. Form a frame, brace the corners with plywood, and staple on an inexpensive plastic dropcloth.

## Do You Have An Auto Hint? Send It in and Win a Prize

**H**AVE you discovered or developed a money-saving short cut for making your own auto repairs? Have you found an easier way to do a difficult job? Got a tip that will make driving safer or easier? Or do you know someone who has an original tip, one not previously published.

POPULAR SCIENCE will pay a cash prize of \$15 for every auto-repair hint accepted for publication each month in "Hints from the Model Garage."

Describe your idea as completely as you can in words. Add a pencil drawing, or shoot a photo, if you feel that this will make it more easily understood. Address your entry to Model Garage Editor, POPULAR SCIENCE, 355 Lexington Ave., New York 17, N.Y.



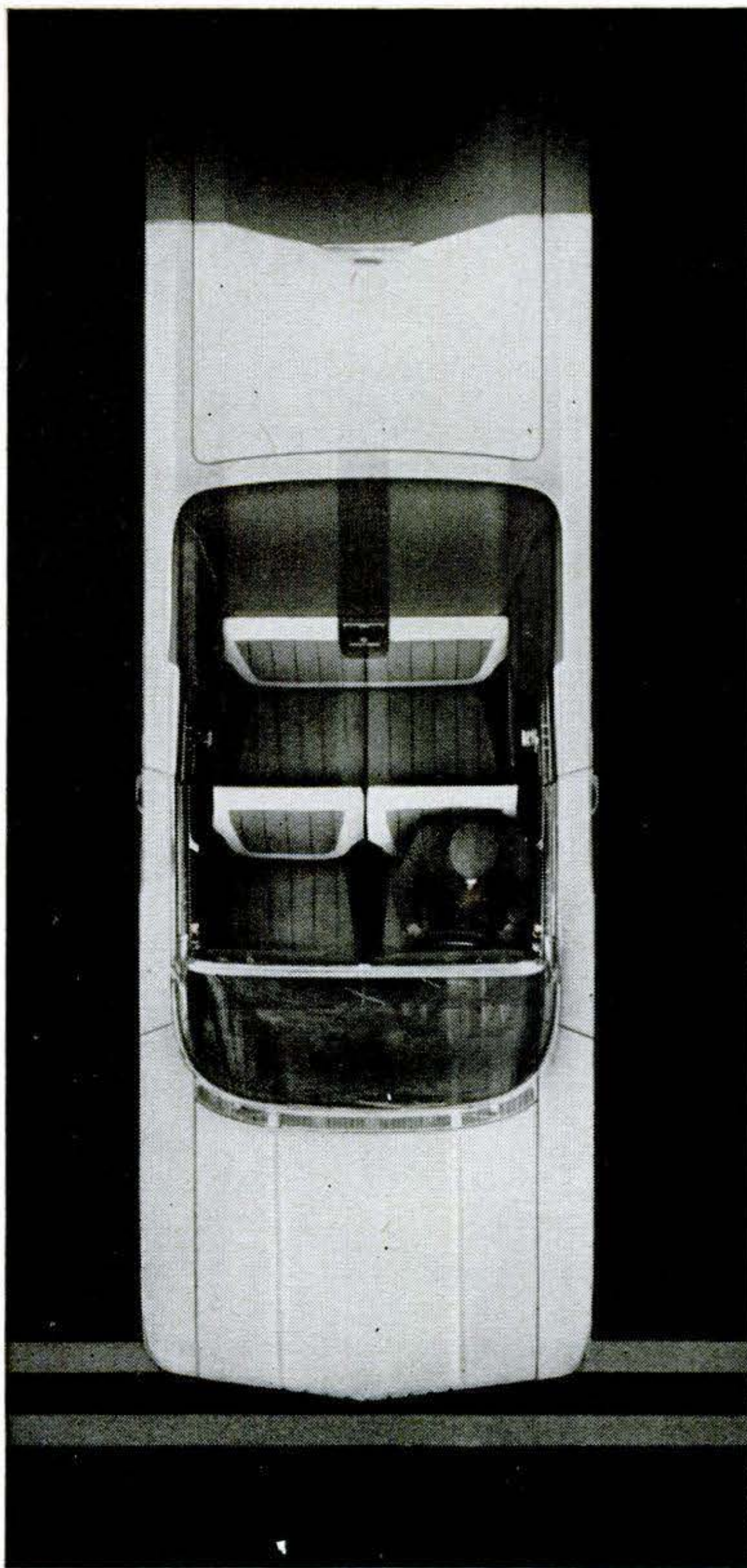

**stop**

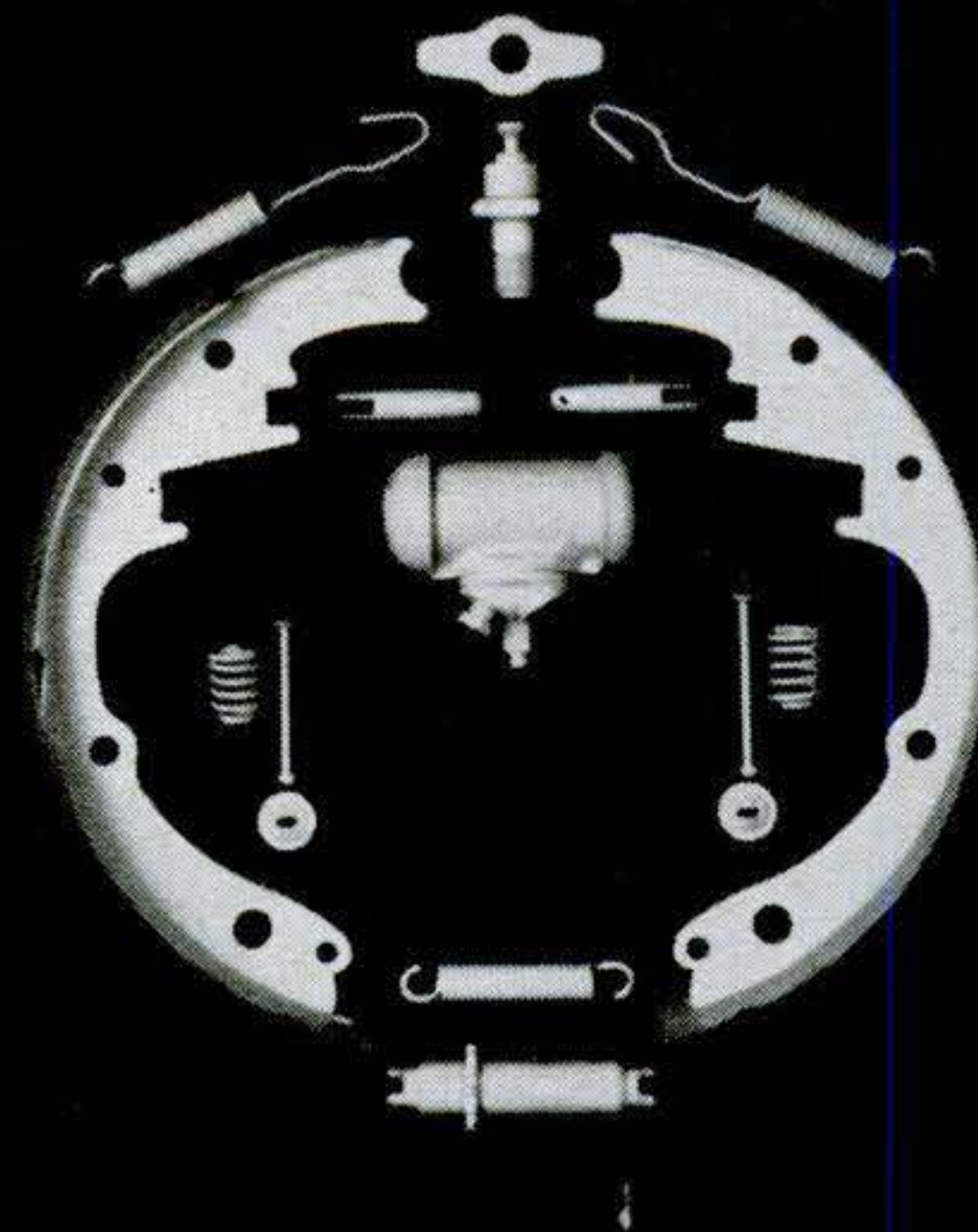
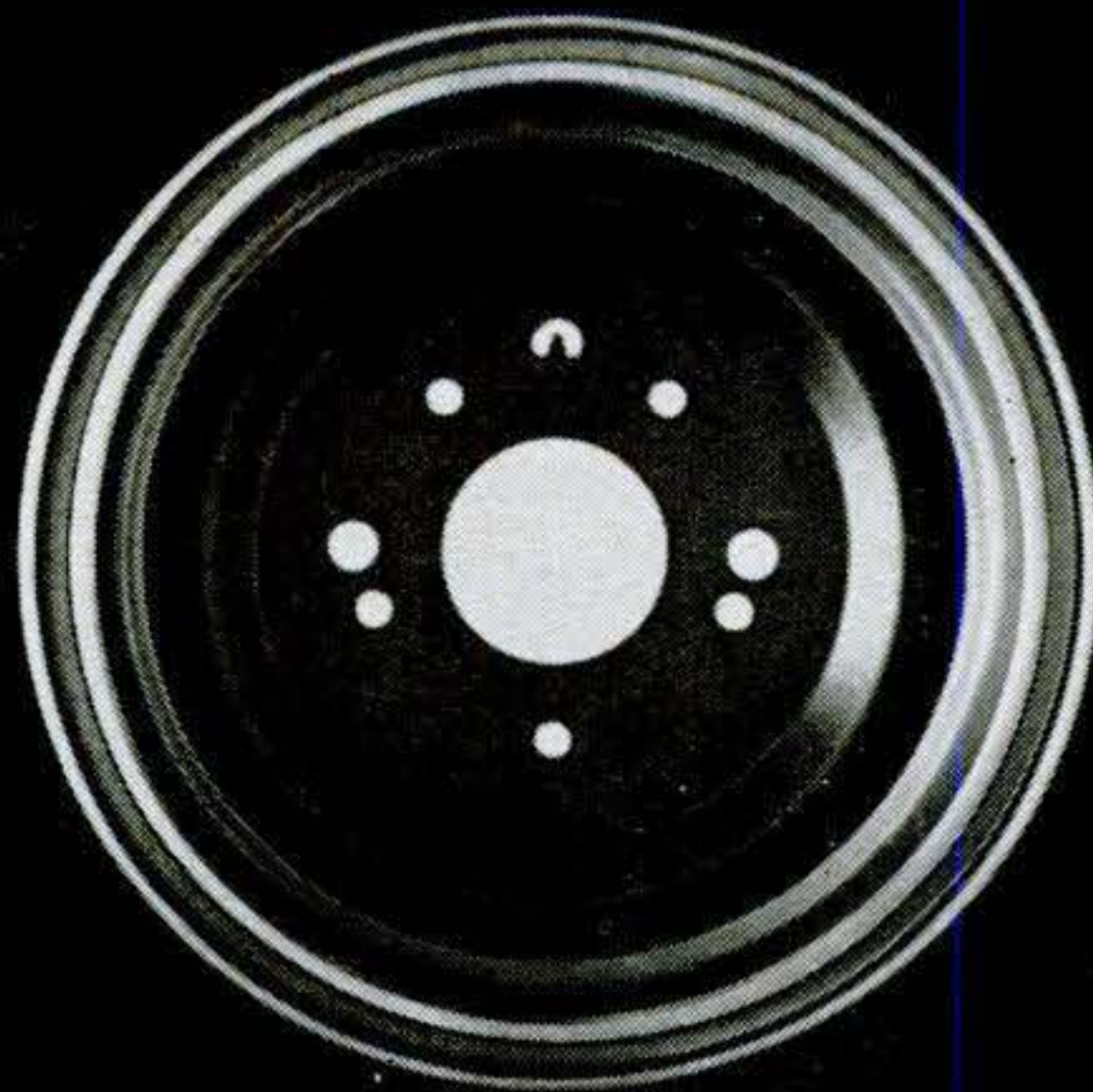

**better**

**When you want your Chevrolet to stop like new again,  
ask for GENUINE CHEVROLET REPLACEMENT PARTS**

When you need new brake linings for your Chevrolet, doesn't it make sense to get the kind that were on your car when it was new? That means genuine Chevrolet replacement linings, built especially to restore your Chevy's original reserve of safe, straight-line stopping power. And because they're formulated to Chevrolet's high quality specifications, you know they'll give you long, dependable service. (Chevrolet linings are *bonded* to the shoes; there are no rivets that can possibly damage the drums.) Like all genuine Chevrolet parts, they're readily available at your Chevrolet dealer's and at leading independent garages and service stations. . . . Chevrolet Division of General Motors, Detroit 2, Michigan.

LOOK FOR THIS SIGN



**IT PAYS TO KEEP  
YOUR CHEVY THE  
CHEVY-EST**



# Gus Matches Wits with

By Martin Bunn

"GUS WILSON," Silas Barnstable called as he walked through the doorway of the Model Garage. "I want to ask you a question."

Gus tightened the last of the plugs he was installing and turned to greet the town's most notorious skinflint.

"Good morning, Silas," he called cheerfully. "Be with you as soon as I wipe my hands."

"Won't do you no good to clean those slippery fingers of yours," Barnstable snapped. "You'll not dip them into my pocketbook."

"Wouldn't risk getting them caught in that mousetrap you keep in there," Gus countered good-naturedly. "What's on your mind?"

"I read in a book about how some feller stopped a leak in his radiator by putting in oatmeal. Now, you give me a straight answer. Will it work?"

"As a matter of fact, it has worked," Gus replied. "But just as often, the oatmeal clogged the whole system. You ought to let me take a look at the radiator now. It'll cost you five times as much to get the radiator cleared after you feed it mush."

"Didn't say I was going to feed it mush," said Barnstable, glaring. "I just wanted to hear what you had to say about oatmeal before I spent good money to get the leak fixed over at the Discount Repair Shop. The prices they advertise are half what you charge, Wilson. Besides, I don't need a fancy mechanic to fix a little leak." He turned to leave and bumped into Gus's assistant, Stan Hicks, almost knocking two containers of coffee out of Stan's hands.

"Hmmp!" Barnstable sniffed. "No wonder your prices are so high. The customers have to pay for your coffee breaks." He walked to his car and drove off, leaving a trail of water on the road.

"What's the old miser been trying to get for nothing?" Stan asked.

Gus told him, and Stan laughed heartily.

"Wait till those sharpshooters at the Discount Shop finish with him. He'll be back begging us to take his money."

"I wouldn't say that," said Gus. "But I'll bet we haven't seen the last of him. Let's have our coffee and get to work on this brake job."

*Several days passed* before Gus's prediction came true. The sound of a horn honking impatiently outside the shop announced Silas' return. Great clouds of steam billowed from beneath his car.

Stan was alone in the shop. "So, you did it anyway," he called as Silas drove in. "You went ahead and put oatmeal in your radiator after Gus warned you not to."

"Didn't do any such thing," Silas shouted over the hissing steam. "She started boiling on the way over here and there wasn't any place I could stop to get water."

"Thought you were going to get it fixed at the Discount Shop," Stan shouted back.

"No sirree!" Silas exclaimed. "Those robbers over there wanted to put in a new radiator for \$59. Told me there wasn't much sense in trying to fix up a sieve like this."

"So now you've brought your troubles back here."

"No such thing!" Silas answered. "I went home and did a little detective work myself and"—he beamed proudly—"I've found the trouble. Bring a light and I'll show you what to do." He raised the hood. The steam had subsided, leaving a pool of water beneath the car.

Stan hung a trouble light on the upraised hood and Silas pointed to a thin line of rust originating at a point about halfway up the radiator. "There she is. Now, you you fix that and nothing else," he ordered.

Stan inspected the area. "Looks like a leak, all right, Silas," he said. "But I don't see how you could lose so much water from a pinhole like that."

"Stop trying to make a big job out of a little one," Silas grumbled. "What's the cheapest way to fix it?"



# a Miser



*"Good thing I didn't pay you," roared Silas. "Can't a man find an honest mechanic any more?"*



# Springtime Tips for

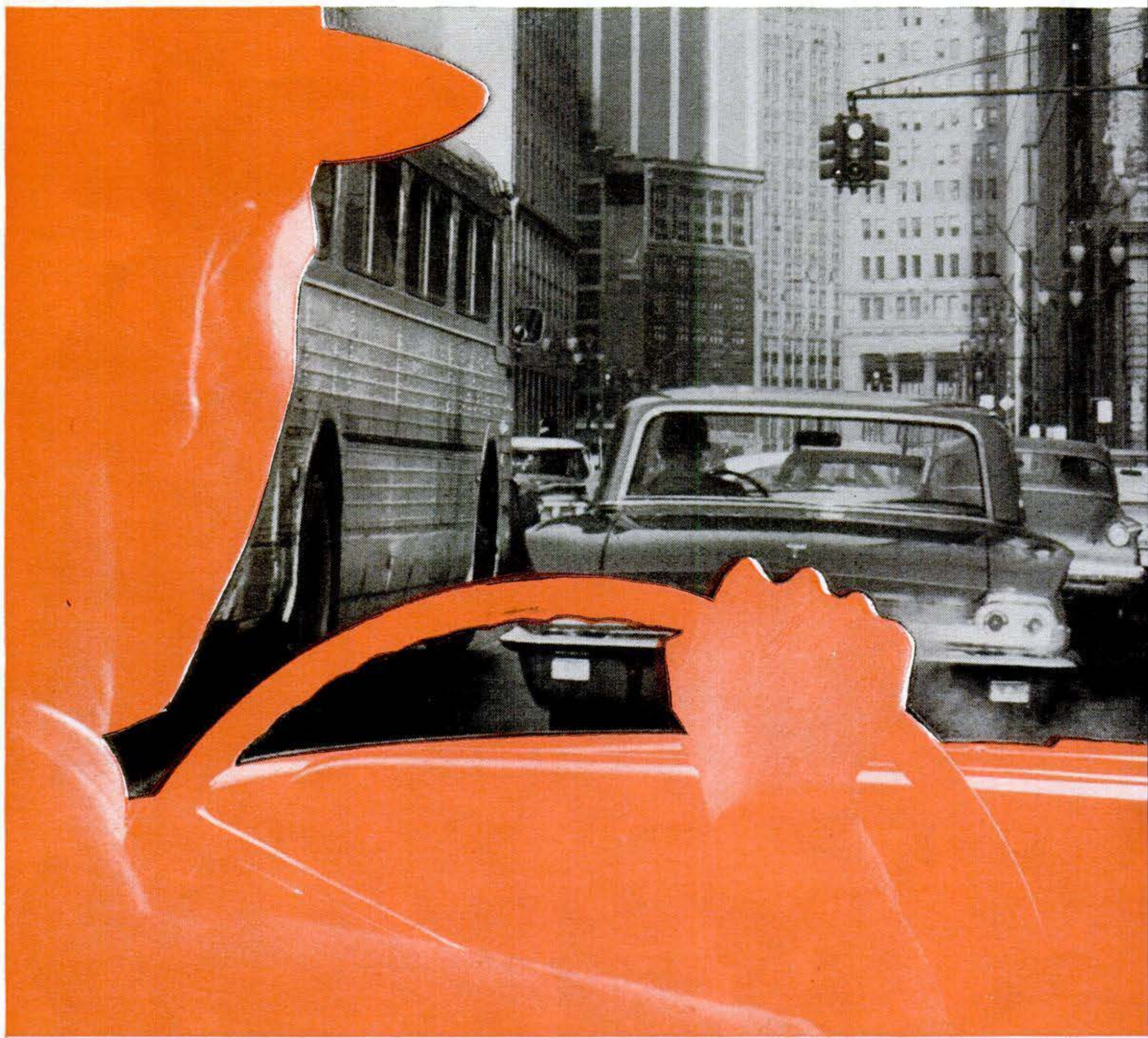

## for round-the-block spins



**FIRE-RING  
SPARK PLUGS**

**TUNE UP WITH AC SPARK PLUGS FOR FULL POWER AND ECONOMY** — Winter weather likely has taken its toll of engine vitality, especially ignition parts. That's why a spring tune-up alone is not enough. Your car needs new AC Fire-Ring Spark Plugs, too, if you are to get smoother pickup, greater economy, and peak performance this summer. Only ACs have the self-cleaning *Hot Tip* to help give more mileage and increased power by keeping power-robbing deposits from forming. For superior performance, insist on AC Fire-Ring Spark Plugs. They're best for all cars.



# Carefree Summer Trips

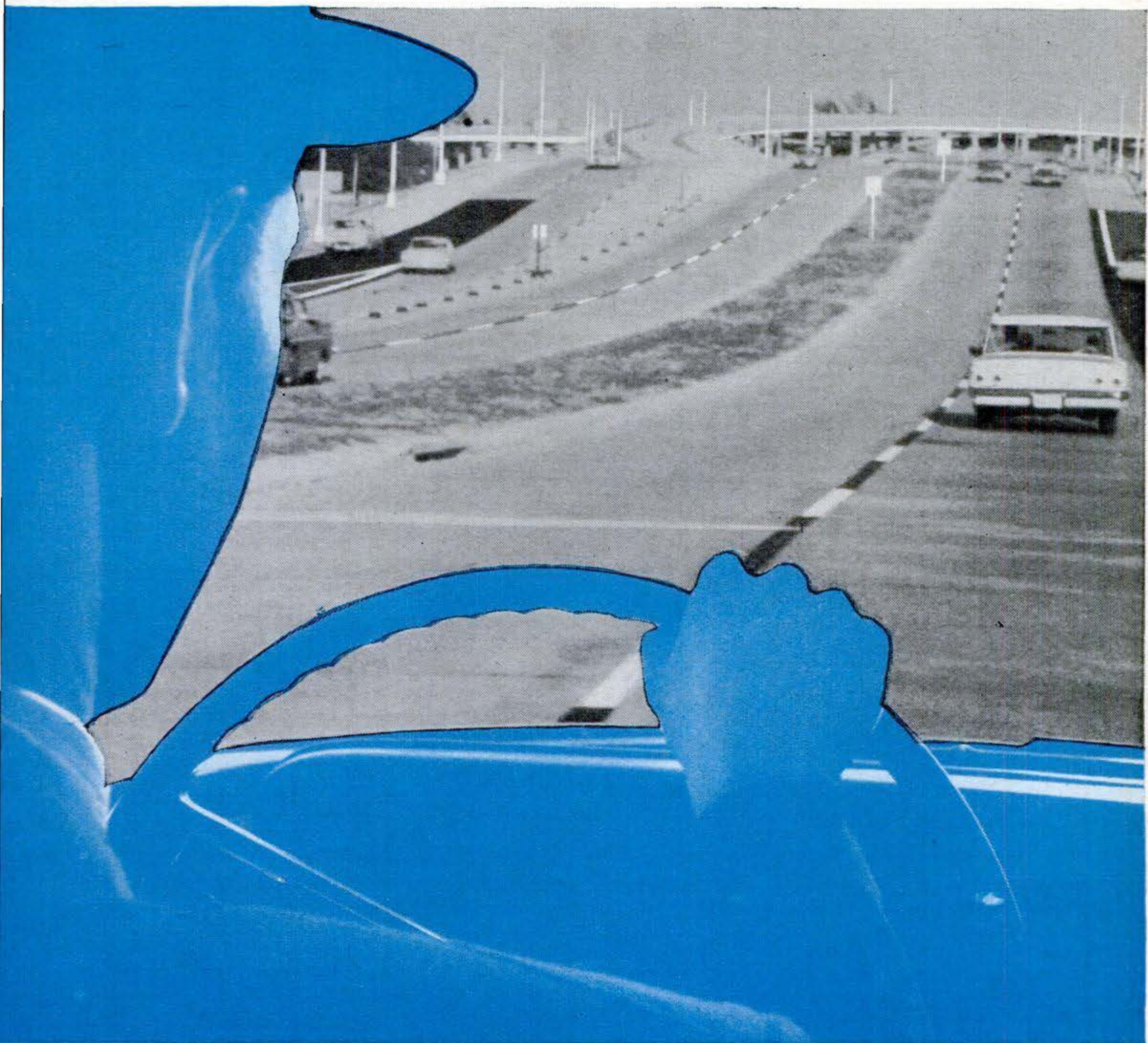

AC SPARK PLUG  THE ELECTRONICS DIVISION OF GENERAL MOTORS

## ...and turnpike travel

**INSTALL A NEW AC OIL FILTER FOR SMOOTHER ENGINE PERFORMANCE** — Flush winter-worn, dirt-laden oil from your crankcase and fill with your favorite brand of fresh, clean oil. Then keep it clean with a new AC Oil Filter — the oil filter that's standard equipment on all GM cars. When you buy AC, you get the oil filter that's specifically designed for your car, whatever its make and model. You get the best in continuous engine protection with AC's positive filtering action because it removes harmful grit and abrasives. Remember, the cleaner your oil, the smoother your car's performance.



**OIL FILTERS**

187



"Well," Stan said thoughtfully, "the right way would be to remove the radiator and solder it, but maybe I can save you some money with an old boilermaker's trick." He went to the bench and, after a few minutes, returned with a long, slender bolt, a nut, several washers, and two pieces of rubber cut from an inner tube. He slipped a washer and a rubber disk on the bolt, passed the bolt through the radiator core where the leak appeared to originate, and put the second rubber disk and washer on the end of the bolt protruding through the opposite side of the radiator. Then he tightened the nut, squeezing the rubber firmly against both surfaces of the radiator.

"There, that ought to do it." Stan straightened. "The pinhole's still there, but the rubber has sealed both ends of the core so the water can't escape." He dragged a hose to the car and filled the cooling system.

Silas inspected the repair carefully. "See, I told you," he cried jubilantly. "There's no leak now."

Stan wrote out a bill. "That'll cost you just 75 cents," he said.

"Seventy-five cents for 10 minutes' work!" Silas complained. "Bet you could've done it in five if you'd wanted to. Anyway, I'm not paying till I'm sure you've done a good job." He started the engine and drove out.

When Gus returned a short time later, Stan was still outraged. He blurted out a full report, waving the bill.

Gus cautioned his assistant, "Careful, Stan, or you'll boil over. I thought you knew Silas well enough not to let yourself get all worked up."

"Can't help it, Gus. I hope his hood blows off next time." He had hardly finished the sentence when a loud hissing and clouds of steam filled the garage entrance. Silas drove into the shop, killed the engine, and stepped out of the car, shaking a knobby fist at Stan.

"Good thing I didn't pay you," he roared. He turned to Gus. "Can't a man find an honest mechanic any more? Don't know

what this town's coming to, what with thieves charging 75 cents for a 10-cent bolt that didn't even do the job."

Stan jumped forward, jaw thrust out. "Isn't my time, the tools, and this shop worth anything?"

"Here, hold on, you two," Gus intervened. "There's a misunderstanding here or my name isn't Gus Wilson."

"Your name'll be mud if you don't tear up the bill this amateur mechanic made out for me," Barnstable bawled. "Him and his boilermaker's tricks!"

"I fixed his radiator just like he asked me to—the cheapest way possible." Stan glared at Silas. "Can't blame me if he wouldn't let me check the entire cooling system."

### What's this a photo of?



ANSWER: The face of an ogre? No, just a two-headed sprinkler half-buried among some bushes.

Gus raised the hood and inspected the repair Stan had made. "Silas," he said, "you still owe 75 cents. Stan did a fine job on that repair. There's no wetness around it and the radiator seems perfectly sound otherwise. Let's call a truce while we try to find the real cause of your trouble." He turned to his assistant. "Start the engine while I fill the radiator."

Gus twisted the pressure cap on tightly after bringing the water level even with the filler neck. He called to Stan, "Keep her idling until she reaches normal operating temperature."

Making conversation while the engine warmed up, Gus said to Silas, "I hear they wanted to replace your radiator for \$59 over at the Discount Repair Shop, instead of repairing it."

Silas didn't reply, and the next five minutes were spent in silence until Stan called out, "Okay, she's warm."

Except for a few random drops of condensed steam still dripping from the radiator frame and front-end linkage, there was no sign of a leak from under the front of the car.

Gus walked around to one side, and then suddenly turned to Silas. "Are you still saving your antifreeze in gallon jugs from year to year?"

Silas smiled disdainfully. "Yes, but that



# ONLY ARMSTRONG TIRES CAN SAVE YOUR LIFE

with "Ounce of Prevention" Safety Discs!



Plus New  
Wide-Track Tread  
gives you up to  
10,000 more safe miles  
than ordinary tires!

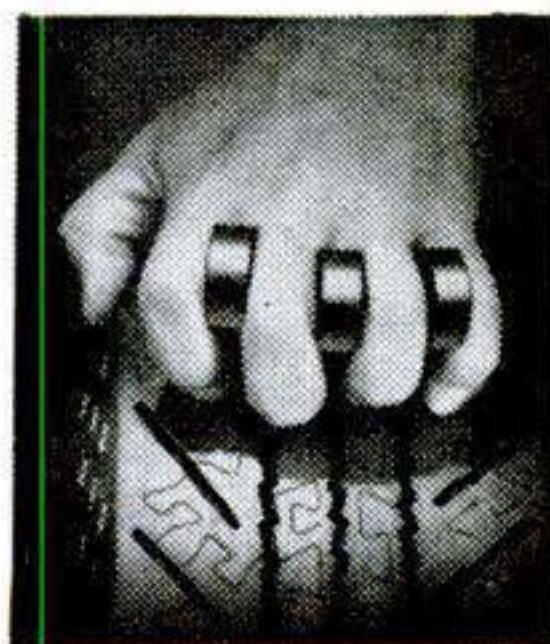

**PATENTED ARMSTRONG SAFETY DISCS  
KEEP TREAD RIBS OPEN . . . READY TO  
GRIP THE ROAD TO SAVE YOUR LIFE!**

Only Armstrong Tires have Safety Discs between the tread ribs. These discs keep tread open — always ready to grip — no matter how hard you brake! But ordinary tires, without Safety Discs, can squeeze shut, go smooth, and suddenly — you skid! So get Armstrong Tires — they grip the road to save your life!



**NEW WIDE-TRACK TREAD . . . DOUBLES THE  
RUBBER WHERE TIRES WEAR MOST . . . GIVES  
YOU UP TO 10,000 MORE SAFE MILES!**

Ordinary tires have narrow outer ribs — where tires wear most. But new Wide-Track doubles the width of the outer ribs—adds as much as 10,000 more SAFE miles to the life of your tires. Get this extra mileage, at no extra cost, only with Armstrong Tires. See the Yellow Pages for your nearest Armstrong dealer.

*You can't buy a better tire . . . to save your life . . . than ARMSTRONG!*



has nothing to do with it. Charlie Grimm down at the gas station tests it free after I pour it in each fall. It always checks out for about 10 below zero. Been using the same stuff for four years."

"Still saving the pennies to spread the dollars," Gus remarked dryly.

"Me?" Silas snorted. "Keeps its strength because I drain it back into the jugs at first sign of spring. Good thing I drained it a couple of weeks ago, or I would've lost it all with this leak."

"I thought so," Gus said as he rolled beneath the car on a creeper. "Here's the trouble, Silas, and you've caused it yourself." He called to Stan, "Cut the engine and toss me a hammer, a punch, and a freeze plug to fit this model."

Stan handed Gus the tools and a thin metal disk about the size of a silver dollar as Silas leaped to protest.

"Goldang it, Gus Wilson, are you trying to tell me I let my engine freeze? I told you before that it was definitely protected all winter."

Gus ignored him. The sound of light hammer blows against metal came from beneath the car, followed immediately by the gurgle of water running onto the shop floor.

*Gus appeared*, holding a metal disk impaled on the punch. The disk was rusted through; it was obvious that the punch had pierced it with little effort.

Silas looked at the water rushing across the floor to the storm drain, then scrutinized the rusted disk. "What have you done to my car?" he demanded. "And what in tarnation is that thing?"

Gus handed the disk to Silas. "It's a freeze plug," he explained. "There are six of them pressed into core holes cast in the lower part of the engine block. For your sake, I hope the other five are in better shape than this one. Some of them are hard to reach and, believe me, they can take hours to replace."

"But I told you," Silas argued. "The engine never froze."

"Didn't say it did." Gus held up the new disk. "See how thin this metal is—about a sixteenth of an inch. Your foolish economy protected the engine against freezing, but stopped there. You tell him Stan," said Gus, grinning. "I haven't got the heart."

"That old antifreeze gave no protection

against rust. After the first winter's use, the rust inhibitor in the antifreeze exhausted itself." Stan spread his hands wide.

"From then on, corrosion ran wild with nothing to check it. It's fortunate that these disks rust through before the block is badly damaged. They give a word of warning to the wise," finished Gus.

"But why did you call them freeze plugs?" Silas persisted.

"Because they've been called freeze plugs for years," Gus answered. "When those early thick-walled engines froze solid in winter, mechanics noticed that the ice often pushed these plugs right out of their seats the same way frozen milk sometimes pushes the cap an inch or two above the bottle. As a result, they were misnamed freeze plugs and the name stayed with them. Technically, they're called core-hole plugs, since they're used to close the holes that result from casting the water passages inside the block. In today's light engines, they have little if any value as protection against damage caused by freezing."

Gus got back on the creeper. "I'll drive this new plug in place; then we can refill the cooling system. But this time I suggest you add a can of rust inhibitor to the water. It'll arrest corrosion in the other disks before they develop leaks."

"I think I'll take a little walk," Stan whispered to Gus. "I don't want to be around here when you hand Silas the bill for this little job."

"Just for that, *you* can give him the bill. Add \$3.50 for installing the freeze plug and a dollar for the inhibitor to the 75 cents he owes for the radiator repair." Gus hastily retreated to safety under the car.

Stan hadn't finished tallying the tab when Silas handed him a five-dollar bill and a shiny new quarter. The old gent was smiling.

"Wha—what's got into you?" Stan asked. "You almost look happy."

Gus finished installing the freeze plug and reappeared just as Barnstable, a picture of gracious dignity, replied, "Of course I'm happy. The other day I nearly had to buy a radiator for \$59. Today, I had my car expertly repaired for less than one-tenth that amount, and got an education to boot. Any day that I can save better than 90 percent is a very good day."

Gus and Stan exchanged glances, sighed, and threw up their hands.

Barnstable had scored again. ■ ■





Mercury's new sizzler the...

*Marauder*

## A new breed of scat!

Note the sleek, racy design of Mercury's newest hardtop: the 1963½ Marauder. Aerodynamic styling cuts air resistance, takes full advantage of Mercury's brilliant new V-8's.

No matter which Mercury V-8 engine you choose, you get brilliant performance! A big 390V-8 is standard on the Marauder hardtop

model. On S-55 bucket-seaters, the standard engine is a 4-barrel Super Marauder 390V-8. Optional engines range up to a 427 V-8.

Marauder transmission choices include multi-drive Merc-O-Matic and 3- and 4-speed fully synchronized manual shifts. Looking for a top performer? See your Mercury dealer.

**FACTS ON SUPER MARAUDER 427 V-8:** Displacement: 427 cu. in. • 4.23 bore x 3.78 stroke • 425 hp @ 6000 rpm • 480 lb-ft torque @ 3700 rpm • dual 4-barrel carburetors • compression ratio 11.5:1 • mechanical valve lifters • fully synchronized 4-speed stick shift transmission.

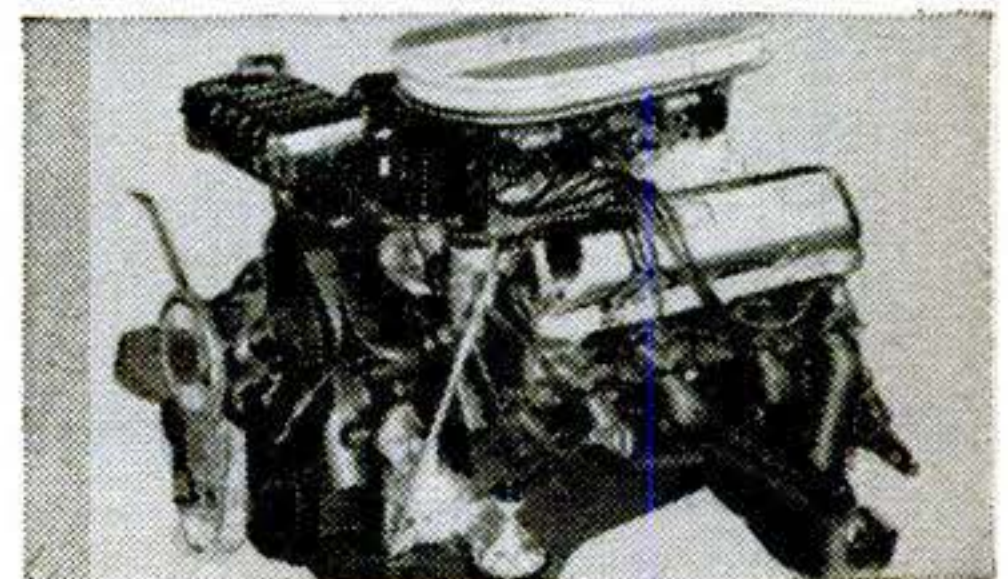

COMET • METEOR • MERCURY; PRODUCTS OF  MOTOR COMPANY • LINCOLN-MERCURY DIVISION  
FOR 60 YEARS THE SYMBOL OF DEPENDABLE PRODUCTS



## Infrared—Quick, New Home Cure for Cracked Asphalt

[Continued from page 170]

ways, it becomes an area patcher for holes up to 2' across.

**Hot roller.** This is a more specialized type of patcher. It combines an 18"-wide roller with an infrared burner. The burner heats the roller, which in turn heats the asphalt. The roller is ideal where repair areas are large—a big driveway, tennis court, or patio floor. But since the roller's burner warms the asphalt indirectly, it doesn't work a cure quite as fast as patchers that apply heat directly.

Once fused, cracks should stay sealed for the lifetime of your asphalt. Old sub-surface problems may cause new cracks, but seldom do they reopen a crack that's sealed by infrared. Moreover, neither rainy nor freezing weather will stop you from using a patcher, as it often does with other asphalt-repair methods. Infrared rays dry out potholes, thaw ice-filled cracks, and are fully as effective in wet weather as in dry, winter or summer.

**Repairing cracks.** Short-run, hairline cracks ( $\frac{1}{8}$ " or narrower) need be heated only a  $\frac{1}{2}$ " or so deep. The cure is quick and easy: Simply set a narrow-width crack-fuser over the crack and hold the burner a few inches above it. When the asphalt begins to fume and appears to be crawling, the patcher is removed. The softened asphalt is then screeded level with a board and rolled or tamped smooth. And that's that.

Wider cracks should be opened up with a chisel or screwdriver and new dry-mix asphalt (the kind that comes bagged and ready to use) worked into the opening. First, enlarge the crack to about twice its original width. Then rake and tamp in the dry mix. Screed the new mix even with the surrounding asphalt. Tamp it once more. Finally, administer the infrared treatment.

The rays bond the old asphalt with the new and make a smooth, permanent repair. Usually one to two minutes' heat over a filled crack is enough. The repaired crack may at first appear blacker than the surrounding, weathered surface, but it will gradually blend with the rest in three to six months. There's no need to uproot weeds and grass first since the patcher will burn them out for you.

**Repairing potholes.** These take a bit more doing because the area is larger and

you'll need to do more careful filling. Select a patcher whose burner area (actual burner dimensions) is large enough to cover the pothole completely. You can repair a pothole with a smaller patcher by making several passes over it, but you'll find that heating it in sections makes screeding and leveling more difficult. It's a lot easier to use a machine that will cover the whole damaged area at one time.

Potholes vary considerably in depth. Some are merely surface depressions, while others, long neglected, may reach clear to subsoil. Shallow holes—less than 2" deep—are no problem. Simply fill them level with new dry-mix asphalt, tamp, and apply the patcher. Be sure that the filled spot is level with the surrounding surface after the fusing and final tamping. You may find that the softened asphalt has settled somewhat under the tamping. In this case, spread on some additional dry-mix asphalt and repeat the fusing.

Holes deeper than 2" take more care because the patcher's heat penetration is limited to about 2". Here, the filling must be done in stages, a layer at a time. Each layer should be no thicker than 2" and should be thoroughly tamped and fused before you add the next layer. If you do all the filling at one time, you'll merely fuse the top 2" and the material underneath may settle later and cause a new break. For the same reason, whenever a hole goes all the way down to the ground, the soil or rock base should first be firmly compacted.

**Leveling humps.** High spots in an asphalt drive, while not as objectionable as holes, cause rain water to pool and disrupt the driveway's built-in drainage pattern.

To knock down high places, heat them with a large area-type patcher until the asphalt is soft, then trowel or screed off the melted asphalt level with the surrounding surface. Compact the area and reheat it to fuse the repair permanently. On very high humps, you may have to be careful not to thin the asphalt surface too much or go all the way through it by scooping off the top. In this case, it may be necessary to remove all the asphalt first and level off the hump under it before putting down a new asphalt surface. As in patching potholes, it's best not to attempt a surfacing job that's bigger than the patcher can handle at one time. ■ ■



**TRIMS TRIMMING TIME!** In corded products, two B&D Hedge Trimmers, each cuts a 13" swath in a sweep of your arm. Light, easy one-hand control to reach the tough spots. Right or left hand auxiliary handles. Powerful, air-cooled motors.

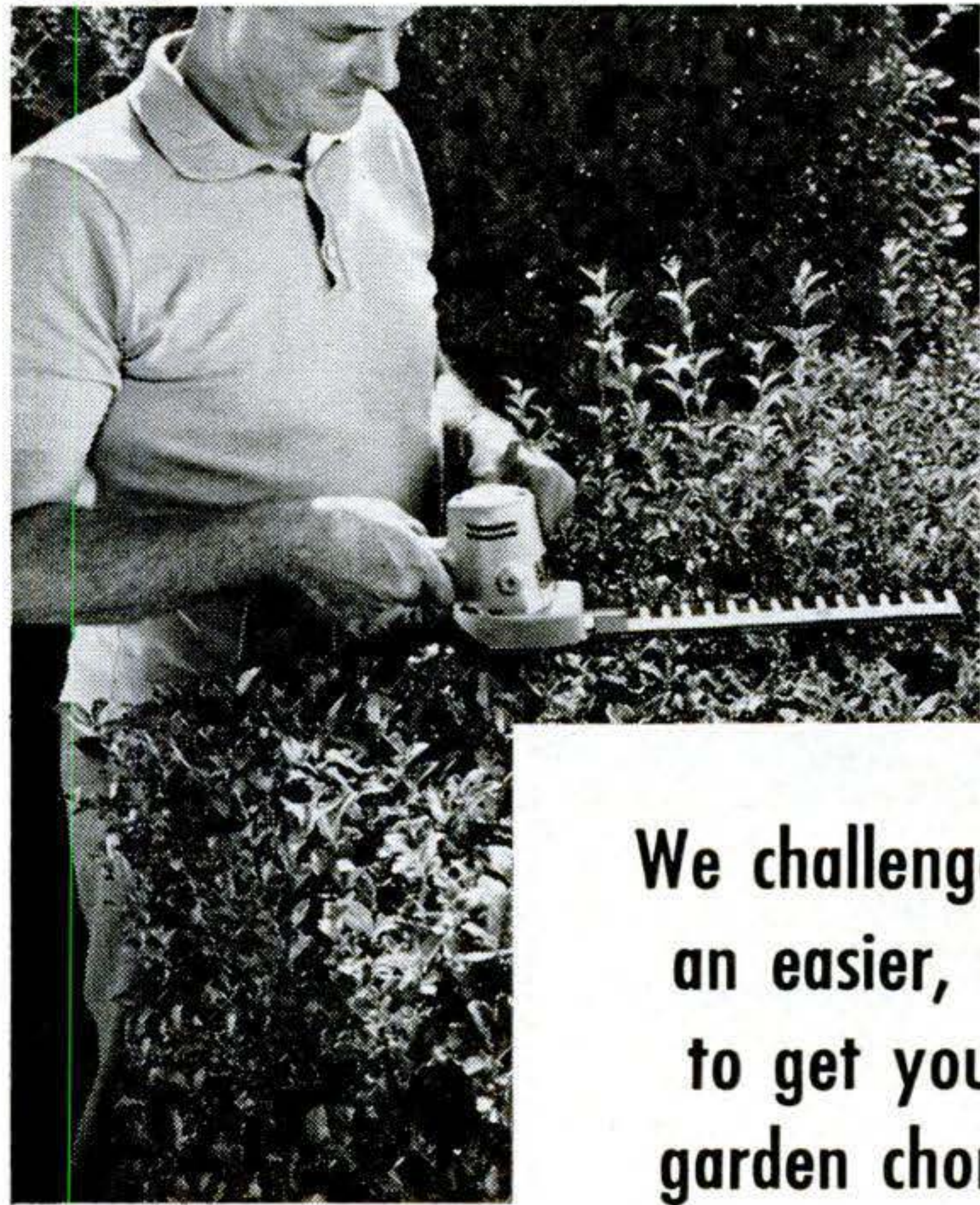

**CORDLESS, OF COURSE!** World's first, B&D's Cordless Hedge Trimmer has nickel cadmium Power Pack in handle that delivers enough power to trim an average hedge 3 feet high and 200 feet long! No cords, generators! Recharge overnight.

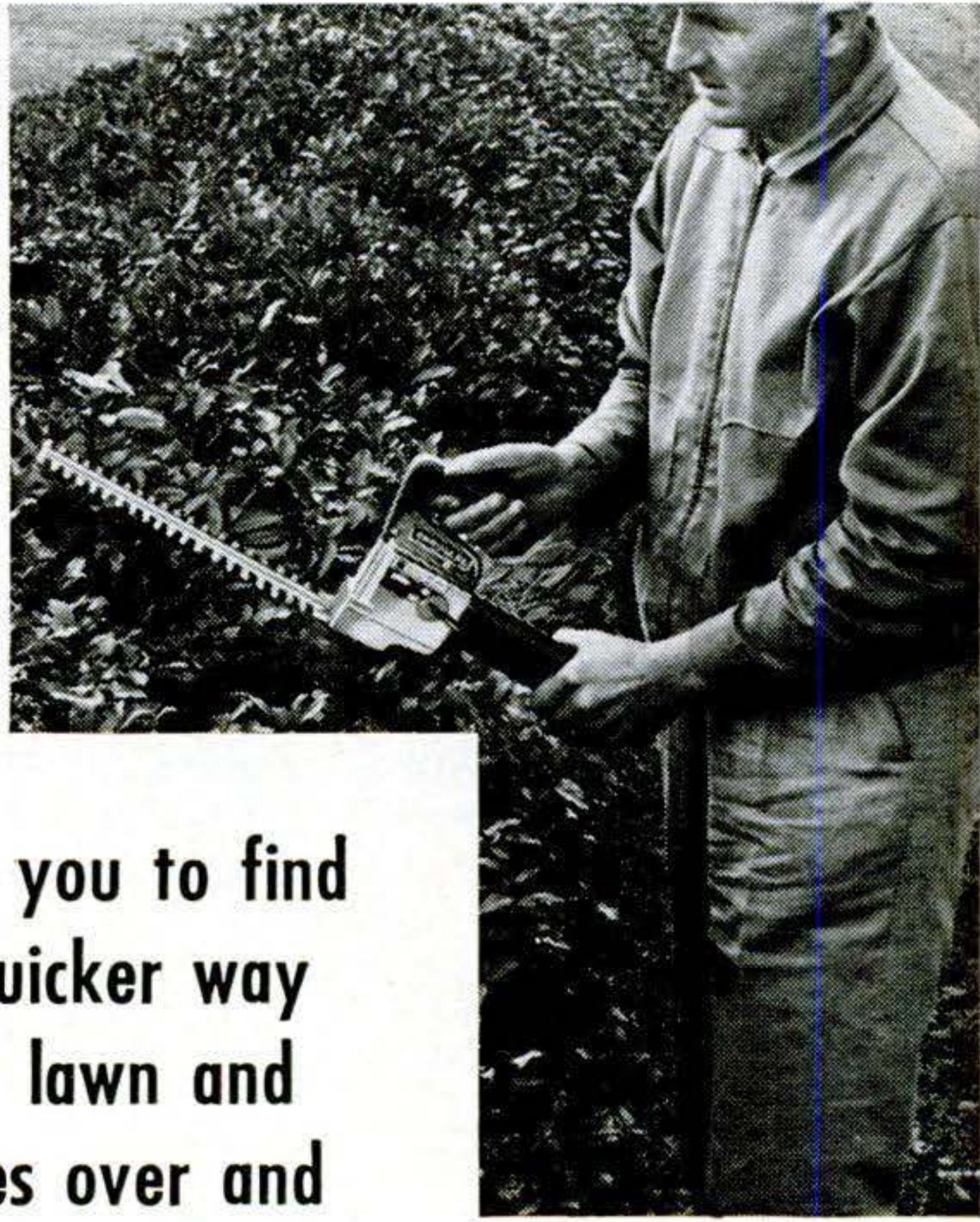

**We challenge you to find an easier, quicker way to get your lawn and garden chores over and done with this weekend.**



**Black & Decker®**

MAKER OF THE WORLD'S FIRST CORDLESS POWER TOOLS

**Master Power** **DEWALT**

AIR TOOLS

POWER TOOLS

CHECK YELLOW PAGES "Tools-Electric" for the nearest B&D dealer. Send 25c for 180-page book, "How to Choose and Use Power Tools" to: The Black & Decker Mfg. Co., Dept. P043, Towson 4, Md.

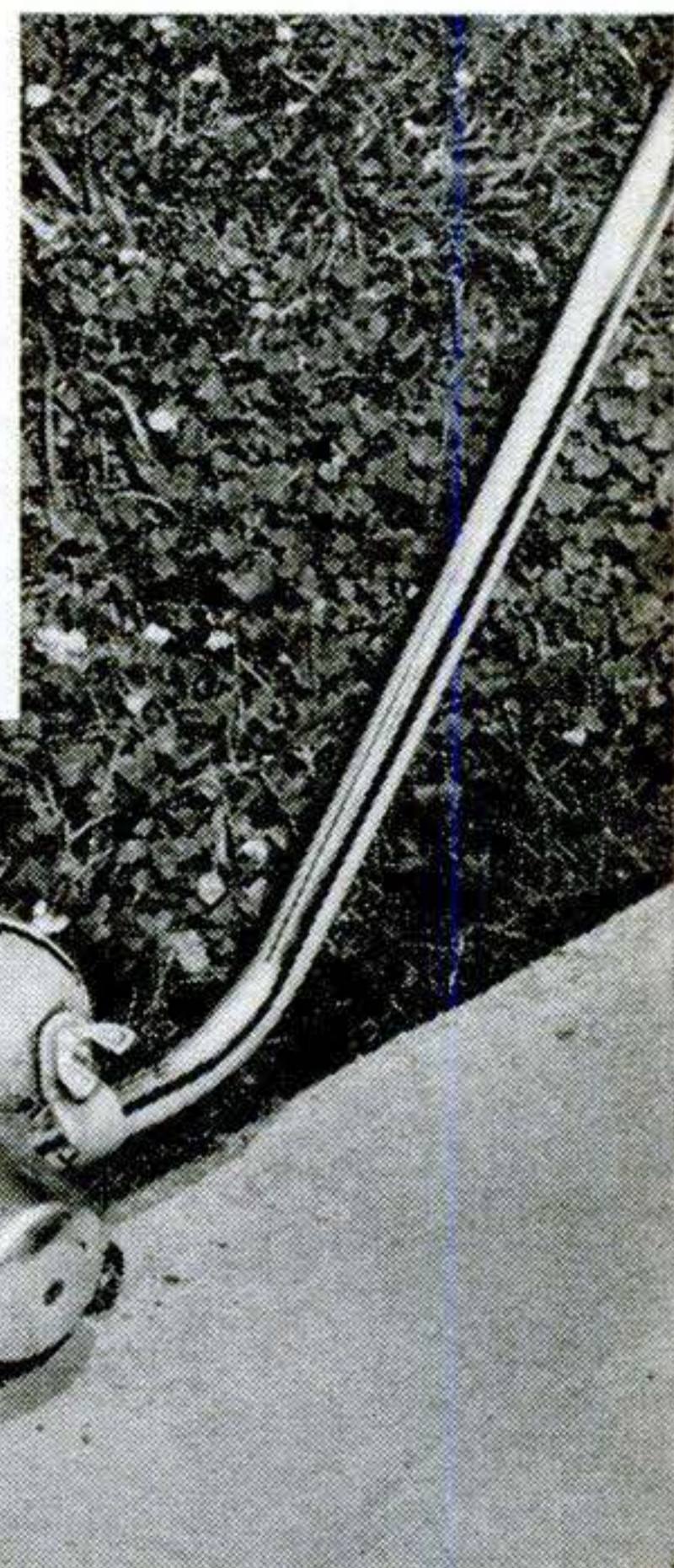

**GOODBYE BACKACHE!** Say so-long to tedious hand clipping with a B&D Lawn Trimmer. Perfect for cutting around flower beds, fences, trees, walks, hard-to-reach spots. Scythes down troublesome weeds. Light (only 5½ lbs.), yet powerful.

**TWO FOR YOUR MONEY!** B&D's combination Lawn Trimmer & Edger takes the groans out of gardening. You walk erect as you TRIM grass or weeds. Turn two wing nuts and the head, and you're EDGING around walks, patios, driveways.



two 16-column rings: an inner ring 47 feet in diameter, and an outer ring, of diamond-shaped columns, 109 feet in diameter. Sixteen reinforced-concrete beams span from the inner core across the inner ring of columns to the outer ring. Ramps and balconies extend 10 feet beyond the other columns to give each tower a total outside diameter of 128 feet.

**Climbing cranes.** The Linden crane used atop the core of each tower was invented eight years ago by Ellis Linden of Vasteras, Sweden, and first used in this country in 1960. The model used at Marina City weighed 18 tons, had a radius of 95 feet, a capacity of 8,000 pounds, and cost \$35,000. The base of the crane rested on an interior floor of the core, usually two or three floors below actual construction, with shores down an additional four floors. According to Bertold Weinberg, resident engineer, the crane made possible a concrete-construction cycle, in each tower, of a floor a day on the core walls, half a floor every day on the parking ramps, and a full floor every other day for apartment floors.

On the Marina City project the interest on money invested in real estate and development was said to amount to \$500 a day. Time was costly, and the contractor, James McHugh Construction Co., worked out a carefully detailed 48-hour construction cycle that resulted in substantial savings.

With the schedule calling for one apartment floor every day in one tower, construction crews performed the same tasks every day at the same time—one day at one tower, the next day at the other.

Concreting started at six a.m. By noon, surveyors laid out the next floor on the new concrete. At two p.m., ironworkers began erecting reinforcing steel. Concreting was done by four. At five, carpenters came on, followed during the night by electrical-layout crews and ironworkers. At six a.m., another electrical crew did piping work and ironworkers reinforced the slab, and concreting of columns and slabs for the next floor would begin. It took time to work all the crews into the cycle, but once achieved, the schedule was maintained regularly for more than three months with only occasional delays caused by weather.

**Saving time and money.** The use of fiber-glass forms for walls, columns, beams, and slabs proved to be economical in mate-

rial cost—\$4 to \$5 per square foot for core forms, \$1 per square foot for slab forms (because they were re-used many times). Core forms 9 feet high (for floor-to-ceiling heights of 8½ feet) were re-used 67 times—until the cores were topped out. Fiber-glass also cut labor costs. The forms could be handled easily in large, lightweight sections and required simplified shoring. They impart such a smooth, flawless surface that much of the concrete in Marina City is left exposed.

Crushed-stone concrete was used in all the vertical members, columns, and walls. Lightweight concrete was used for all horizontal framing, beams, and five-inch-thick floors of ramps and apartments. With standard concrete, thicker slabs and beams would have been necessary, and the added dead weight would have required bigger beams, columns, and caissons. Conventional steel framing, with suspended ceilings, might have called for as much as 18 inches more in floor-to-floor heights. With 60 floors, that would have added 90 feet to the overall height of each tower, and would have involved the added cost of 60 feet more of window wall, 90 feet of plumbing lines and elevator travel, plus larger caissons and bigger pumps to raise water to the top floors. Lightweight concrete and the elimination of ductwork made possible 60 stories with a height that usually yields 40 stories when steel framing is used.

Marina City set a record as the world's tallest reinforced-concrete structure (588 feet, not including its 437-foot TV broadcasting antenna), and it has also set some precedents. New residential building projects have followed its lead to the long-neglected downtown area of Chicago, and both Detroit and Denver want Goldberg to design a similar round city-within-a-city as a step in restoring their downtown areas.

When Goldberg described to his mother-in-law the central-city planning he envisioned in Marina City, he went through a lengthy explanation. She listened, then summed it up brightly. "Oh, that's what we used to call 'living above the store.'"

The first eager tenants moved into Marina City last October before floors above and below them were finished. The entire project will be completed late this summer and all apartments occupied, confirming Goldberg's belief that people want to "live above the store"—if they can do it in style. ■ ■





Saber Saw



Radial Power Saw

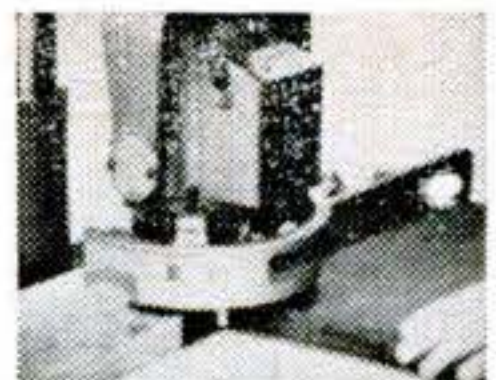

Jointer



Drum Sander



Shaper



Surfacer



Tilt Arbor Saw

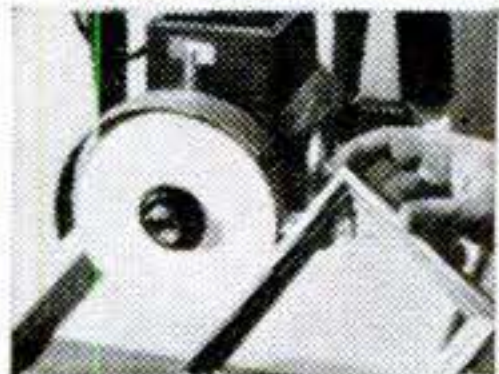

Buffer-Polisher



Metal Cutter



Grinder



Dado Saw



12" Lathe



Horizontal Drill



Router



Disc Sander

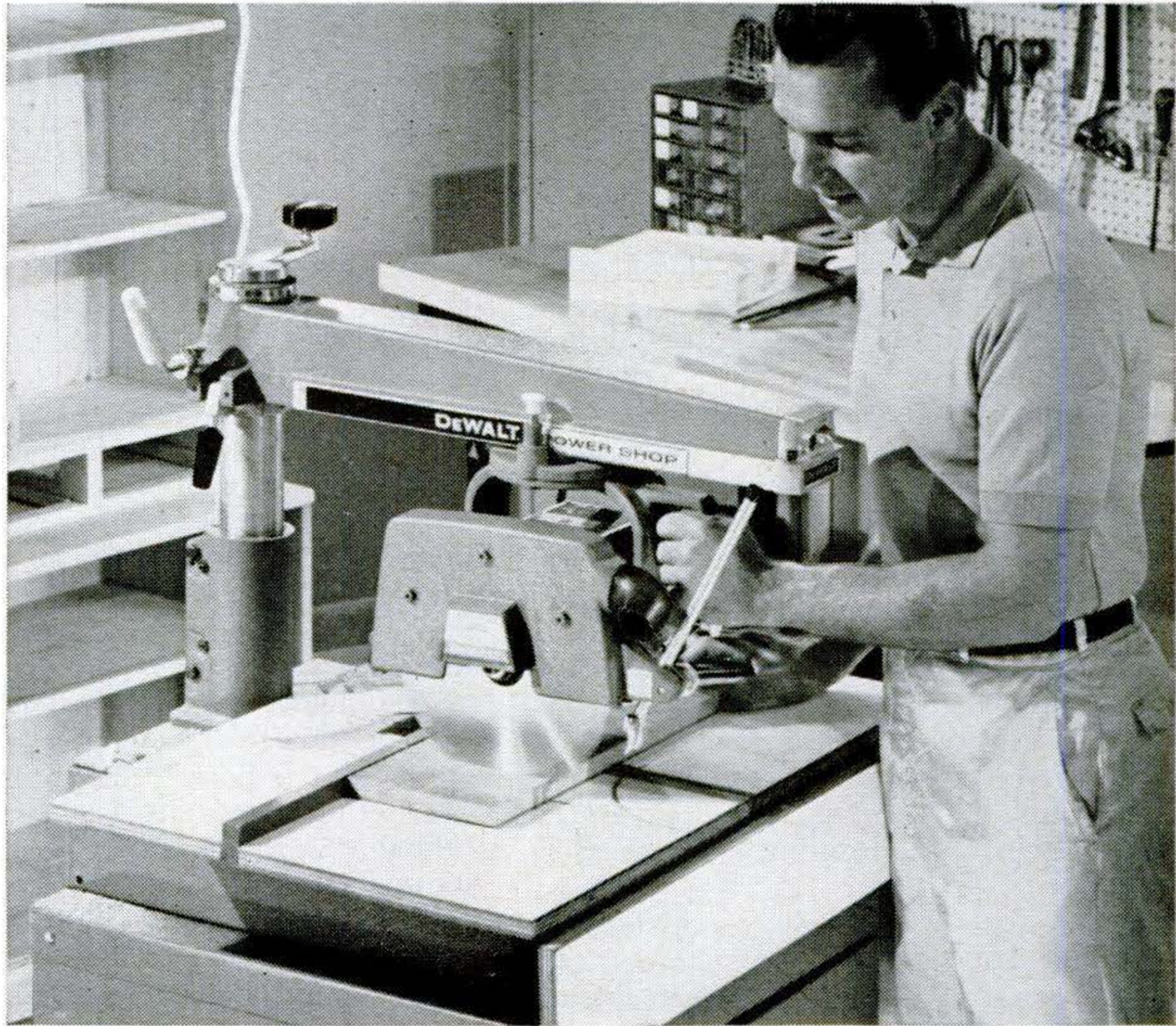

## NEW DEWALT POWER SHOP\* SAVES YOU HUNDREDS OF DOLLARS IN POWER TOOLS

With Minute-Magic Changeovers, this handsome DeWalt Power Shop becomes 15 power tools in one—gives you professional results *faster* and *easier*. DeWalt's power, capacity and flexibility make it a never-ending pleasure for you to build things for the family from a hutch cabinet to a complete house. Compact, it fits into a workbench. Your dealer has the free plans. Ask him for a demonstration and find out why experts and beginners have been saying "There's nothing like DeWalt!" since 1922. And don't forget to ask for low budget terms.

\*T.M. DeWalt



**DEWALT, INC.** 34004 Fountain Ave.  
Lancaster, Pa.  
**POWER TOOLS**  
A **Black & Decker** Subsidiary

Send free 16 page catalog  I enclose \$3.95 for illustrated book "Newest Ways to Expert Woodworking." (Check or M.O.)

Name.....

Address.....

City.....Zone.....State.....





## Does Your Handwriting Give You Away?

[Continued from page 106]

(writing) motions. . . . The manic-depressive has an exaggerated size and direction, moves slowly and rhythmically. The schizophrenic shows a severe conflict between the contracting and releasing writing strokes . . . resulting in a deteriorated rhythm."

Perl, former chief clinical psychologist at the Army's Fort Leavenworth disciplinary barracks, also maintains that handwriting is valuable in judging emotional stability, impulsiveness, and aggression.

Psychologist Thea Stein Lewinson, former researcher at New York's Psychiatric Institute and now graphological consultant to St. Elizabeth's Hospital in Washington, D.C., affirms that paranoia, schizophrenia, and other mental ills show up in handwriting months, even years, before obvious clinical signs.

**Physical ills.** Sickness leaves its mark on handwriting, too, according to a recent article by psychiatrist and neurologist W. G. Eliasberg in the medical magazine *Geriatrics*. Herry O. Teltscher, handwriting consultant to the War Department's Military Intelligence Division during World War II, agrees.

"Brain tissue is especially sensitive to any lowering of oxygen," states Teltscher, now a practicing psychologist. "Heart disease, circulatory ailments, tumors—any physiological condition which changes the amount of oxygen the brain gets—will influence handwriting in a special way and give an early record of pathological dangers."

The most astounding claim of diagnostic graphology is that it detects cancer. After three decades of research, graphologist Alfred Kanfer says he has proved that cancer changes writing. Kanfer, now a research assistant at New York's Handwriting Institute, Inc., a foundation studying graphology, explains his extraordinary findings this way:

"For some reason—no one knows if it's a toxin, a chemical, or something called host reactions—cancer distorts microscopically fine portions of the writing in a special pattern. Find this pattern and you've spotted cancer."

Though Kanfer has had no formal medical training, the New York Hospital for Joint Diseases, private benefactors, and several insurance companies were impressed enough with his work to finance his research and

supply writing samples of tens of thousands of cancer patients. Statistics published in 1958 indicated the test had an 80-90-percent accuracy, and was even more effective when the patient was under 60.

**False hypotheses?** Kanfer has his critics, too. Many cancer researchers say his studies aren't conclusive, that he's working under false hypotheses and that his methods aren't scientific. The question may be settled once and for all when New York's Memorial Hospital for Cancer and Allied Diseases publishes a near-finished report dealing with the latest findings on the Kanfer test.

Though the Memorial Hospital report may soon decide Kanfer's claims, other handwriting analysts have plenty of objections to answer before they've proved their point. Albert Osborn, one of the country's leading handwriting-*identification* experts and examiner of forged documents, raises this criticism.

"Handwriting analysts assert that vertical writing indicates something about personality," says Osborn. "Yet, for 15 years vertical writing was taught in our schools and probably over 150 million people learned to write that way. Vertical writing and other traits indicate school training, not character."

Dr. James H. Ricks of The Psychological Corporation in New York City comments: "Handwriting is a form of behavior and as such may reveal general characteristics of a person. Usually, however, these are obvious characteristics that can be easily observed other ways. Graphologists' claims to assess subtle qualities like honesty or determination have not been supported by the kind of critical test customarily given to other psychological measurement methods."

Other foes of graphology hold that analysts try to meet the subject and get insights into his personality from his movements, way of dressing, and manner of speaking, and that the wording of a "character analysis" is usually so vague that it would fit anybody.

**For the defense.** Handwriting analysts have reasonable-sounding answers to most objections. But there's one criticism they admit they're hard pressed to answer: Where is the *scientific proof* that graphology really works?

"Sure, handwriting tells *something*," says Dr. James Farr, psychological consultant to





## You have a big investment in wood Protect it!

### Beautify while you protect—with P.A.R.™

This penetrating water-repellent lets natural beauty of wood show. In 4 colors and clear. Costs less than paint, both as first coat and in maintenance. Keeps wood dry, prevents staining. Cannot blister, peel or craze.

*Shingles • Sidings • Fences • Trim • Indoor paneling*

**Satin redwood sheen—plus protection from water—with Patiolife™.** This beautiful penetrating finish guards against warping, swelling, cracking, discoloration. Color won't rub off. Can't blister or peel.

*Garden furniture • Flower boxes • Fences • Any outdoor woodwork*

**Basic water-repellent preservatives for wood—indoors and out—Woodlife™.** Retards shrinking and swelling. Reduces warping. Guards against checking and splitting. Minimizes grain raising and surface checking. Prevents decay. Controls fungus stain. Protects against termite and insect attack. Improves paintability and paint holding.

**101 different uses around the house.** *Garden stakes • Trellises • Hot beds • Window sills, sash, and frames • Doors and door frames • Storm sash • Furniture, particularly doors and drawers to prevent sticking • Sports equipment • Beach chairs • Musical instruments • Tool handles • All wooden things kept in the basement • Garage doors • Furring strips and subflooring before they're covered • Anything of wood you want to protect. Brush Woodlife on raw or sanded wood before you do anything else.*

Get the facts on how to get more life out of wood. Send the coupon for these three booklets.

**United States Plywood, Dept. PSM 4-63  
Protection Products Div.  
Box 747, Kalamazoo, Mich.**

Send me booklets on the following products

- "101 Tips on Better Living with Wood"—Woodlife  
 Water-repellent finish P.A.R.  
 Water-repellent finish Patiolife

Name.....

Address.....

City.....Zone....State.....



**Does Your Handwriting Give You Away?** management and industry. "A person who's excited will write more illegibly than when he's calm. But there's no proof that someone's writing expresses his complete personality."

Graphologists have long verified their claims by empirical evidence—i.e., proof by case history. In 1860 a French priest, Abbé Michon, became interested in handwriting and personality. He collected hundreds of writing samples from people who were known to have such character traits as courage, honesty, deceit, etc., in common. After studying these samples, Michon found that each group made a similar writing sign or combination of signs such as wide letters, large loops, or high T bars. He concluded that these writing signs in his control groups were caused by their common personality characteristic, assumed that they indicated this personality trait for everybody, catalogued hundreds of such writing signs—and launched handwriting analysis.

Since then, Michon's followers have collected enough evidence in support of his theory to make graphology a respected science in Europe. Many universities, including the Sorbonne, the University of Hamburg, and the University of Zurich, teach graphology. Often, it's admitted as evidence in court cases.

But most American psychologists aren't satisfied. They want proof that handwriting analysis is a science, not just educated guesswork.

**A license for graphologists?** Graphologists admit that graphology teems with frauds. They are trying to clean house, establish licensing systems such as European countries have. A handwriting analyst, they say, must have years of training in psychology or psychiatry, and they become livid when confronted with a book purporting to teach handwriting analysis in 10 easy lessons. "Practicing graphology after reading one of these books," a handwriting expert told me, "is like attempting surgery after skimming through a first-aid pamphlet."

What does graphology's future look like? Right now, more young psychologists than ever are studying and doing research in it. For many older psychologists, cautious curiosity has replaced scorn. But it will probably be some years before we know whether graphology will prove itself, or go down as another dud that fell by the scientific wayside. ■ ■

## 1963 SAAB... built so well

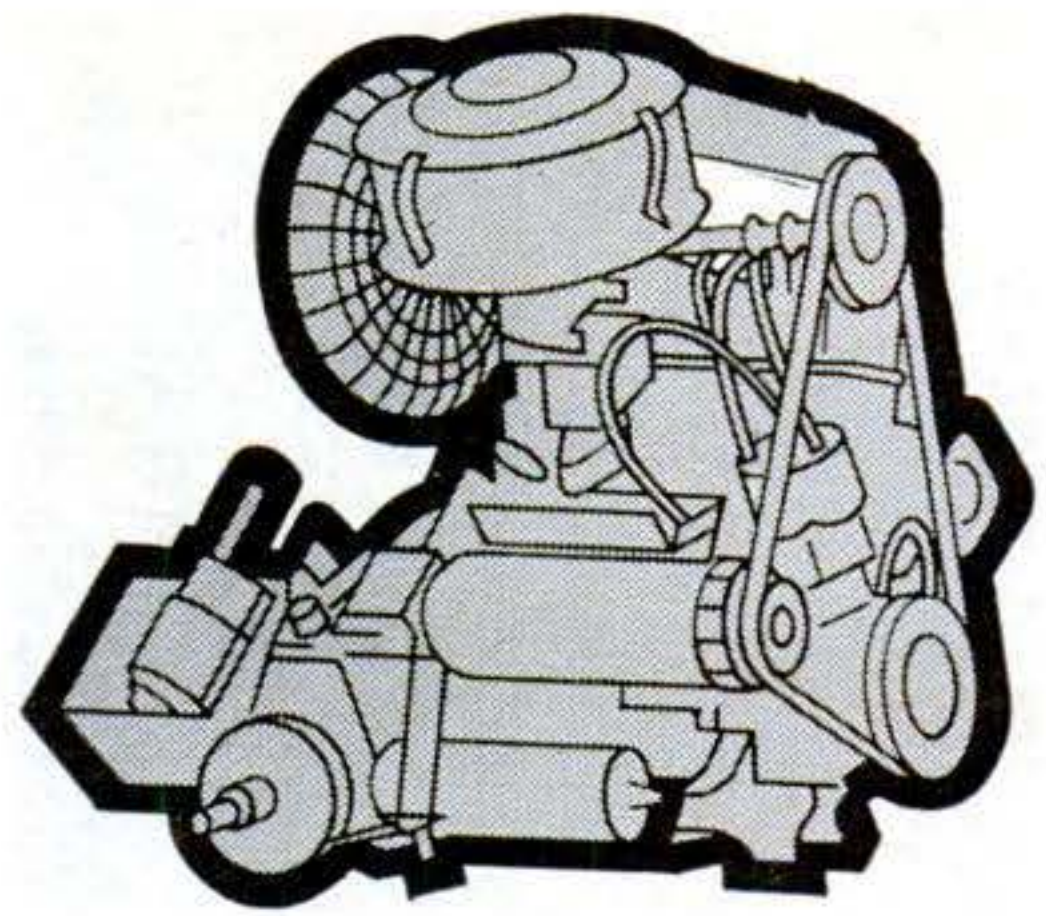

**SAAB ENGINE**, an economical, quiet three-cylinder, two-stroke valveless unit, employs Schnürle principle of charging through the crankcase. Simple, efficient design produces all the power of 6 cylinders with only 7 basic moving parts, eliminates 103 points of friction, wear, potential trouble. Engine proved in world-wide competition driving victories, and by the many SAABs which have delivered low maintenance performance past the 100,000-mile mark.

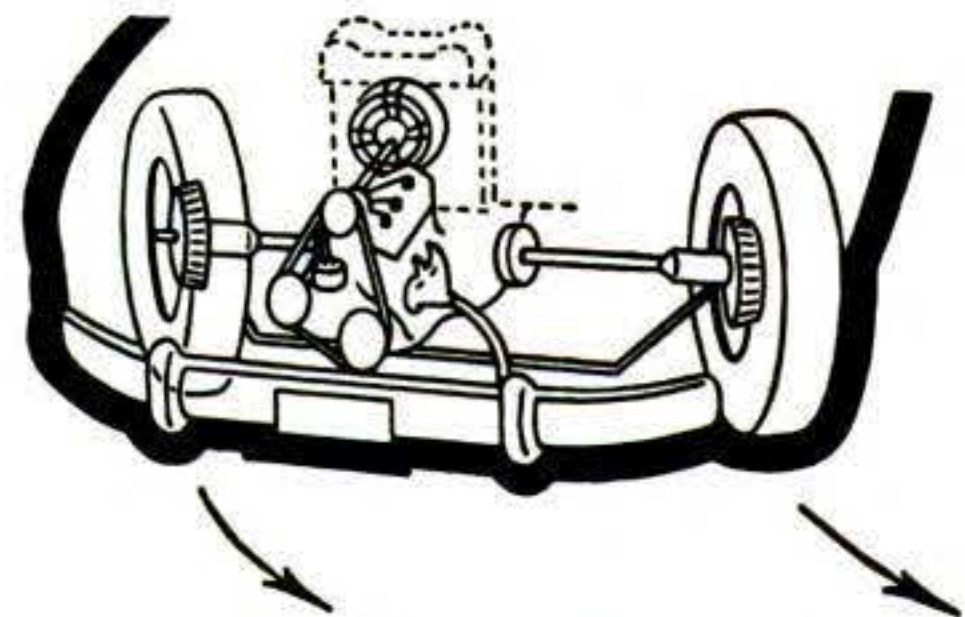

**SAAB FRONT WHEEL DRIVE** transmits engine torque directly to front wheels. The result is extraordinary directional stability and handling ease under all road conditions, plus outstanding traction around corners, over icy, wet, or muddy patches, and snow. Front wheel drive and carefully calculated understeering provide best possible high speed roadability and safety. Other advantages: more comfort (because there is no driveshaft hump) and more trunk and interior space.

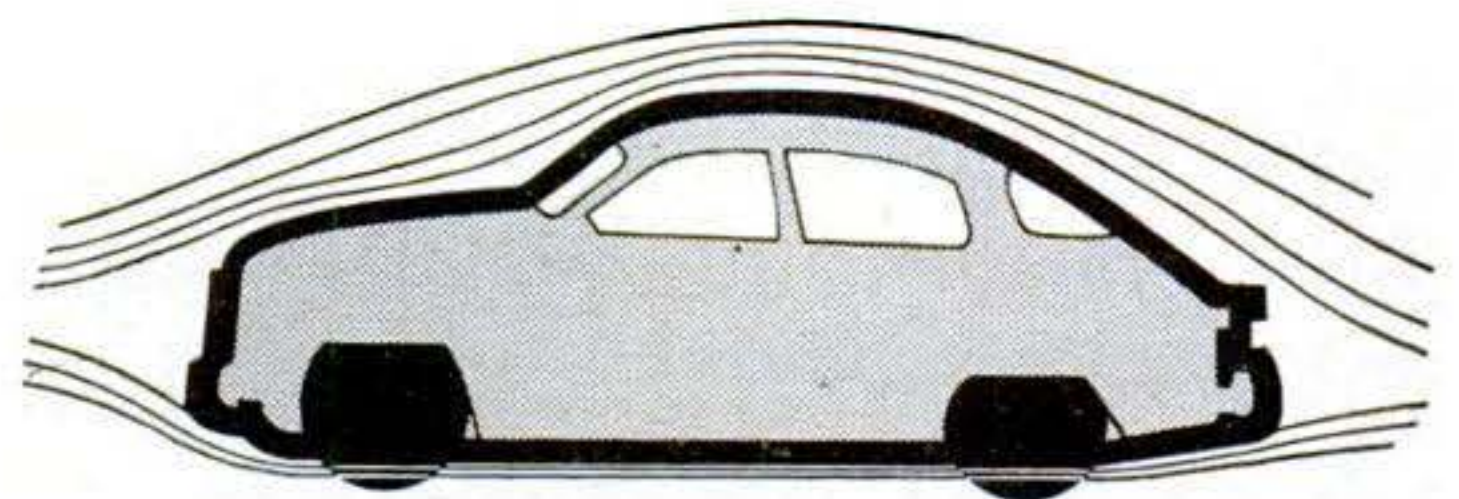

**SAAB BODY SHELL** is designed and wind tunnel tested for best possible aerodynamic efficiency. Full belly pan further reduces wind resistance and subdues road noise. Result: increased economy, better performance, excellent stability—even in cross-winds of gale force. Moreover, body shell is virtually uncrushable, combining 18- to 20-gauge steel (thicker than most American cars) and rigid unitized construction for optimum safety.



that it has a 24,000-mile/24-month written warranty\*

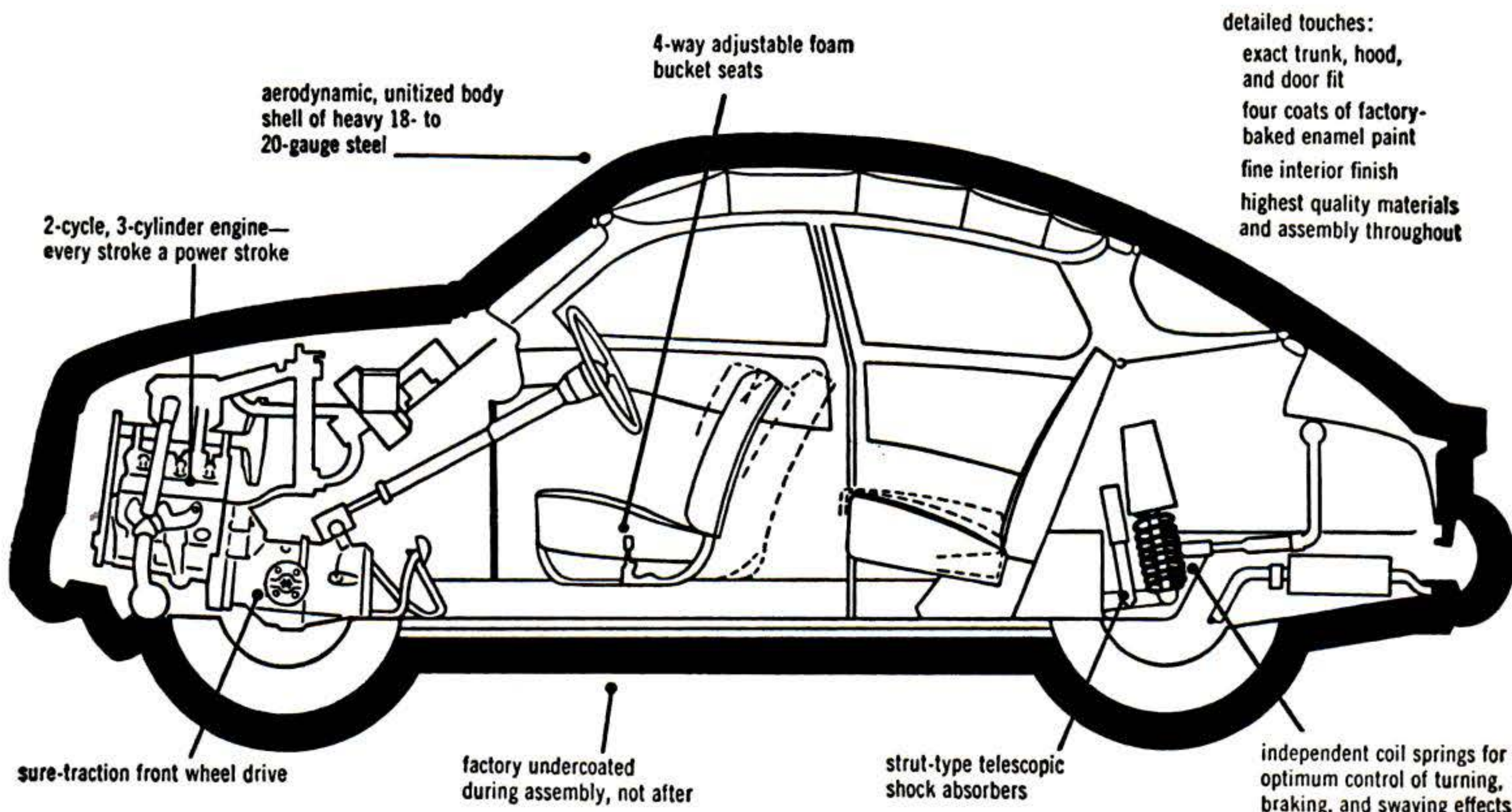

## Take a critical look at SAAB engineering

Aircraft reliability and performance standards are blended with an entirely new approach to over-all automotive design in the Swedish SAAB 96. This car was built to be better, not different... built by one of Europe's leading aircraft manufacturers... built for those who

enjoy mechanical excellence, technical uniqueness, and extraordinary craftsmanship.

A critical look at all the facts and specifications will prove that the new SAAB 96 is unquestionably one of the world's best engineered cars.

\*Engine, transmission (3- or 4-speed gear box available), and differential have a written warranty for 2 years or 24,000 miles.

1ST OVERALL WINNER—MONTE CARLO RALLY, 1962-1963



**\$1895** P.O.E. (little enough for one of the world's best engineered cars)

Arrange a test drive at your nearest SAAB dealer. Or write for more information—and the SAAB North American Road Atlas, a 64-page comprehensive travel guide valued at \$1.00, but yours for only 25¢ to cover postage and handling. SAAB Motors, Inc., Dept. 604, 405 Park Avenue, New York, New York.



SAAB MOTORS, INC. — NEW YORK • NEW HAVEN • JACKSONVILLE • ST. LOUIS



**LUCK INTO YOUR  
FAVORITE LONE STAR BOAT  
WITH ONE LUCKY PUNCH!**

## Grand Prize

### *Lone Star* TRITON

A new concept in hull design! Unique Quad-Chine Hull (pat. appl. pend.) utilizes molded-in auxiliary planing surfaces for exceptional stability and fast, glass-smooth ride in turns or straightaway. Double hull construction: Fiberglass inner and outer hulls bonded by Foam-Pac® 15'4" centerline.

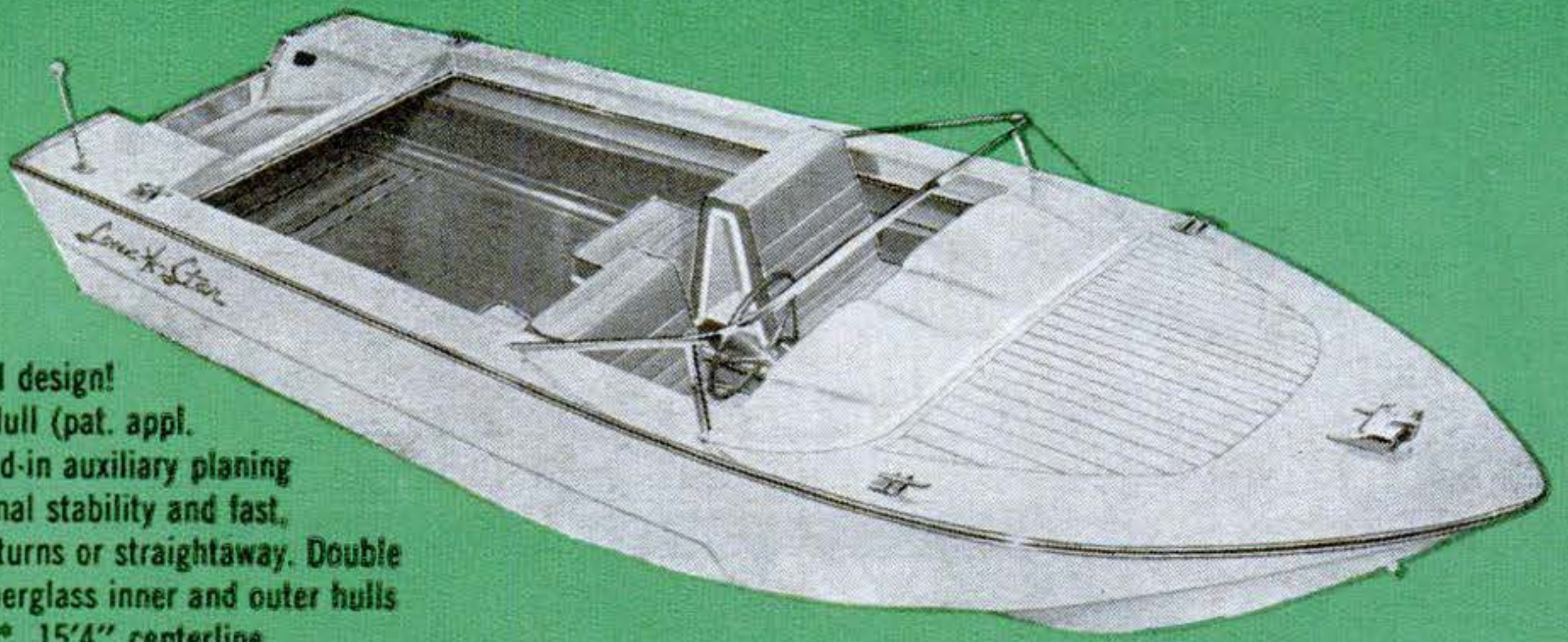

## Grand Prize

### *Lone Star* BISCAYNE

Deep-hulled fiberglass runabout with high performance bottom and popular lapstrake styling. Back-to-back seats convert quickly to 6 ft. bunks with storage beneath; 6 ft. side storage shelves. 15'11" centerline.



## Grand Prize

### *Lone Star* SALEM

Full lapstrake fiberglass hull for smooth ride and stable maneuvering. Side storage shelves and space under motor well provided storage for skis and gear. Back-to-back seats ideal for ski watching! New Foam-Pac® bottom construction. 13'9" centerline.

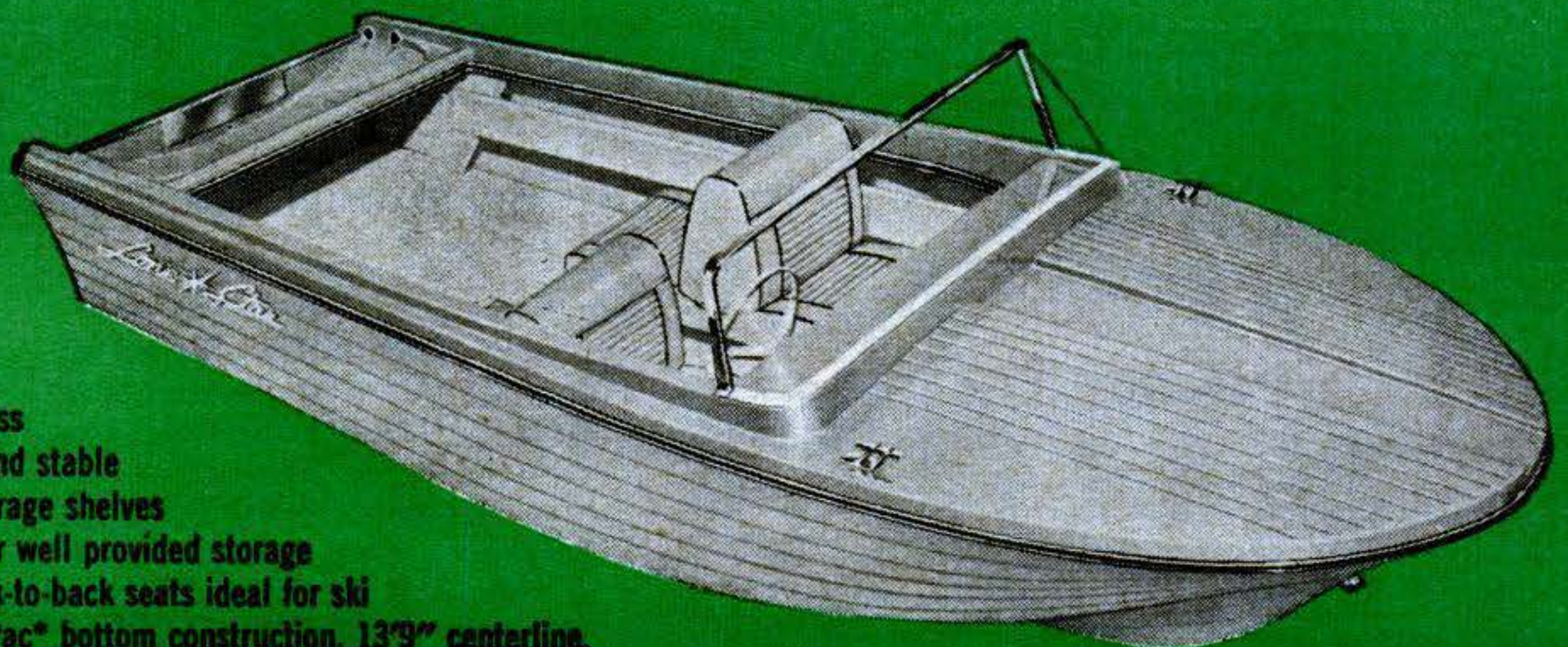

\* Foam-Pac — an exclusive process developed at a cost of over \$100,000, fills bottom of hull with high density foam seven times stronger than ordinary foam. Absorbs bottom flexing for more speed, better performance, and permanent flotation.



# 22 other valuable prizes to be given away at each of these Lone Star dealers!



**SPINNING REEL**  
Zebco Model 33  
\$19.50 value



**TWO VACUUM BOTTLES**  
American Thermos  
each a \$3.69 value



**CAMP STOVE**  
American Thermos  
\$18.45 value



**TWO SUN-BRELLAS**  
with clamp for  
attaching anywhere  
each a \$7.95 value



**SPINNING REEL**  
Zebco Model 66  
\$12.95 value



**TWO PONCHOS**  
handy all-weather  
protection  
each a \$3.00 value



**PICNIC JUG**  
American Thermos  
\$5.95 value



**TWELVE DE-LIARS**  
by Zebco  
weighs fish up  
to 8 lbs.  
each a \$2.00 value

It's FUNTIME at your Lone Star dealer's. Come by and see his beautiful new Lone Star boats and find out how lucky you are. You have a better than 1-in-14 chance to win. Look for his "Lucky Punch" prize board . . . where you may win one of these handsome new Lone Stars (three given away nationally) or one of 22 other sport prizes at each dealership.

There's absolutely no purchase required to play the "Lucky Punch" game. Entries limited to the first 294 adults (one per family) at each dealership. Simply leave your name and select a punch on the board under the Lone Star model you like best. First come, first served.

Winners will be determined after close of "Lucky Punch" contest, May 31, 1963, by each dealer with his master seal's winning number list. Winners will be notified by dealer by mail to each winner's listed address; and prizes will be awarded immediately. Contest open to adults only but not to employees (or members of their families) of any Lone Star dealer, the Company, or its advertising agency, Norsworthy-Mercer, Inc. This offer not valid in any jurisdiction where a contest of this nature is prohibited, restricted, regulated or subject to license. At all dealerships in such jurisdiction the 22 prizes referred to above (but not the three national grand prizes) will be distributed on an alternative basis. See your local Lone Star Dealer for information.

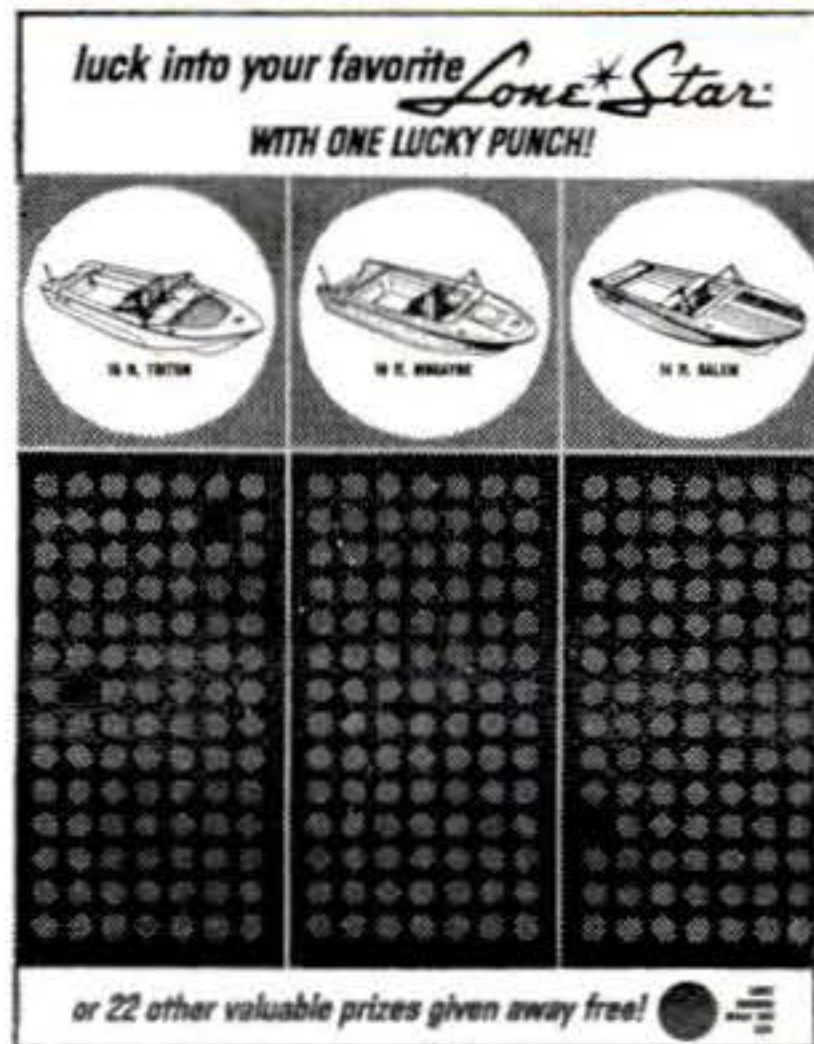

## ALABAMA

Birmingham—Keith's Marine Supply  
Decatur—John D. Wyker & Son  
Gadsden—Bucks Boats  
Guntersville—Lee Matthews Boat & Motor Co.  
Mobile—A. H. McLeod Marine Co.  
Northport—Bennett's Marina  
Orange Beach—Safe Harbor Marina  
Sheffield—Martin Marine Co.  
Tallassee—Robertson & Son Marine Supply  
York—York Saw Co.

## ARKANSAS

Ft. Smith—Hill's Mobil Home Marine Sales  
Little Rock—Cook Auto Company  
Springdale—Bryant Motor Co.

## FLORIDA

Cocoa—Brevard Marine Co.  
Eau Gallie—Hammond Marine  
Ft. Pierce—Sportsman Center  
Gainesville—Baird Hardware  
Homestead—Layson Marine, Inc.  
Jacksonville—Albritton Marine Sales  
Lake City—McDuffie's Sporting Goods  
Lakeland—Lakeland Evinrude, Inc.  
Milton—Phil White's Marina  
North Miami—Bob Hewes Boat & Ski Shop  
Orlando—Ransom Downes Outboard Service  
Pensacola—Runyan's  
Pinellas Park—Cliff S. Hadley & Son  
Sarasota—The Outboarder  
St. Augustine—St. Augustine Marina  
Tallahassee—Bellflower Marine  
Tampa—Barney's Outboard Marine, Inc.  
West Hollywood—The Boat Mart  
West Palm Beach—Kramer Marine  
Winter Haven—Charles Orr's Marine, Inc.

## GEORGIA

Athens—Russell Daniel, Inc.  
Atlanta—Dee Spring Walco Marine  
Calhoun—Nation's Trim & Marine  
Columbus—Dolphin Marine  
Griffin—McGee Hardware & Machinery, Inc.  
Hartwell—Anderson Auto Parts Co.  
Jackson—L. H. May Marine Supply  
Savannah—Savannah Marine, Inc.  
West Point—A. M. Ennis & Co.  
Winder—Larry's Easy Pay

## KENTUCKY

Ashland—Black's Marineland  
Bowling Green—Bettsworth Motor Company, Inc.  
Campbellsville—Campbellsville Cleaners  
Elizabethtown—E. L. Anderson & Son  
Erlanger—Herb Rolsen Boats & Motors  
Lexington—Perry Lumber Co.  
Louisville—Arnold's Boats & Motors  
Owensboro—Owensboro Boat & Motor Co.

## LOUISIANA

Abbeville—The Sportsman  
Alexandria—Brister's Marine Sales Co.  
Baton Rouge—Bonfanti, Inc.  
Franklin—Scelfo's Sporting Goods  
Hammond—C-W Marine Sales  
Metairie—Soroe's Boat Exchange  
Morgan City—M. C. Sporting Center  
Monroe—Howard Griffin, Inc.  
New Iberia—Dauterive's Marine  
Raceland—Laforce Sporting Center  
Shreveport—Reeves Marine Center

## MISSISSIPPI

Biloxi—Bel Brou Marine Mart  
Greenwood—Ralph Campbell Sporting Goods  
Jackson—Tatum's Sporting Goods, Inc.  
Moss Point—Baker Sporting Goods  
Vicksburg—Martins, Inc.

## NEW MEXICO

Clovis—Pierce Marine  
Hobbs—Western Boat Sales  
Las Cruces—Witt's Tackle Marine Supply  
Truth or Consequences—Morgan Mast Marine Service

## NORTH CAROLINA

Asheville—Curtiss Motor & Boat Co.  
Charlotte—Boat & Motor Center of Charlotte  
Elizabeth City—Causeway Marine  
Wilmington—Pickard's Sporting Goods

## OKLAHOMA

Ada—Jerry Whittle Marine  
Ardmore—Gordon Leaman Marine Service  
Durant—Quick Tire & Battery  
Enid—Zaloudek Implement Co.  
Muskogee—Ramsey's Sport Shop  
Oklahoma City—Fay Horaney Marine  
Okmulgee—Youngblood Sport Shop  
Sapulpa—Moore's Sporting Goods  
Tulsa—Thoroughbred Boats

## SOUTH CAROLINA

Charleston Heights—Marine Center  
Columbia—Eau Claire Marine Sales  
Easley—Owens Dillard Sporting Goods  
Lexington—Pine Crest Marine Center

## TENNESSEE

Chattanooga—Bill Penny Tire & Marine Co.  
Knoxville—Athletic House  
Nashville—Modern Marine, Inc.

## TEXAS

Abilene—The Fishing Village Marina  
Amarillo—Beer's Marine Supply, Inc.  
Austin—The Boat Shop  
Baytown—Baytown Marine Sales  
Beaumont—Frank's Outboard & Sporting Goods  
Borger—Western Auto  
Breckenridge—R. V. Carey Marine  
Brownwood—Gaines Boat Co., Inc.  
Dallas—Valentine's Marine Supply  
Phil Dill Marine  
Johnny Williams Marine  
Denison—Dusek & Miller  
El Paso—El Paso Boats & Motors  
Ft. Worth—G & W Marine Sales  
Texas Marine Distributors  
Gilchrist—Claud's Outboard Service  
Gladewater—Shipp's Marine Service  
Houston—C. B. Delhomme, Inc.  
Freeway Boat Yard  
Houston Chris Craft Sales Co., Inc.  
Oak Forest Outboard  
Irving—Irving Marine Supply  
Killeen—Killeen Boats & Motors  
Kingsland—Bill's Boats & Motors  
Lufkin—Jennings Auto Supply  
Lubbock—Farmers Exchange  
McKinney—Joe Ledbetters Sporting Goods  
Odessa—Roberts Hardware  
Orange—Hodge's Sporting Goods  
Pampa—Ogden & Son  
Pasadena—Sportscraft Distributors, Inc.  
Pharr—Moore Equipment Co.  
Rockport—Marineland  
San Angelo—Wilson Distributing Co.  
San Antonio—Norton Hargis Marine  
Ray Russell Marine Equipment Inc.  
Seymour—Carl Hash Motors  
Sherman—Taylor Boat Company  
Terrell—Holton Marine  
Texas City—Dub's Boats & Motors  
Tyler—Williams Marine Co.  
Waco—Yowell's Boat Yard  
West Columbia—Parrack Marine  
Wichita Falls—Jim Miley Boat & Motors





## Metal Detectors . . . Can They Spot Treasure?

[Continued from page 101]

unit was the only model available. Some users still prefer them. But operating costs are higher; average battery life is from 75 to 100 hours. A word of caution: Don't buy a model that requires nonstandard batteries. You'll spend too much time chasing down replacements.

Military surplus detectors? My advice is: Don't buy them. Batteries are often of special size and construction; to adapt the detectors to standard batteries, modification is necessary. Also, the military units—designed for mine detection—were made to locate large masses of metal. Those who've used them consistently say they aren't worth a hoot on small objects near the surface. Perhaps the biggest drawback is sheer size and weight.

The single advantage seems to be price. I've seen them advertised as low as \$30 to \$40. But this kind of economy can be expensive.

**Business or hobby?** Don't buy a detector expecting quick, rich rewards. View it as recreation. If you do find a buried bonanza, it's a bonus.

The first question is where to look. This depends on where you live. But wherever you are, there's good hunting close by. The difference among areas is chiefly in the types of objects you can find. For example, in the West (where I live) there's always a clutch of abandoned ghost towns within three or four hours' drive; also, old mining camps, crumbling stone houses, adobe ruins, and historically interesting sites.

What have I found? Not counting tin cans, foil wrappers, and bottle caps, I've unearthed a fair collection of blacksmith tools, iron pots, and assorted objects too old to identify.

An enthusiast I know, who lives at Huntington Beach, Calif., travels the dawn tidelines every morning crouched over his detector. He carries a long-handled scoop-screen. When he gets a reading, he scoops up sand in the screen and lets it sift through. The object remains. He's got boxes full of old pennies—most of them worth at least a quarter. He finds an occasional watch, jewelry, rings. He's found diamond rings appraised as high as \$2,500. Often he's hired to find a lost family heirloom.

In the East, Civil War battlefields get a lot of attention from detector users. One fellow reports he's been so successful in

finding old belt buckles, gun parts, and regimental insignia that other hunters follow him on the sly. He has to backtrack, and turn down alleys, over hills, and through ravines to reach his favorite hunting ground alone. It's standard procedure for him to camouflage his car with brush while he hunts.

The most successful hunters—those who find really valuable objects—study their areas. They pore over old maps, town records, tax assessments, old newspaper accounts, and historical books. Pinpointing the precise location of an old hotel, a stage-line office, or Wells Fargo stop is a big advantage.

Years ago, travelers took along their valuables. They often stashed the stuff under the floorboards of their hotel rooms or buried it in open country.

Abandoned homesites are good hunting. Many a recluse has died alone, leaving thousands of dollars hidden in walls, attic, or basement. Many used metal containers.

But remember to stay out of state and national parks with your detector. A stiff fine may be imposed for digging in these locations, and your detector may be confiscated. On private lands, come to an agreement with the owner *before* hunting. The average split is 50-50, but negotiate any reasonable deal. If you make a find before asking permission, he'll descend on you with the law and likely take it all!

**The hunt begins.** The proper way to work a detector is with the head held a few inches from the ground. Work the area thoroughly in a definite pattern. Hold the detector head the same distance from the surface at all times. This avoids false readings caused by lifting and lowering the head as you walk. Walk slowly, since very small objects such as rings and single coins barely flutter the needle.

At peak sensitivity, the detector has the shortest range. When it's adjusted for maximum depth, small objects are hard to locate, but large objects down deep show up well. On the theory that most valuable items are buried a foot or less, most users adjust for maximum sensitivity.

There is no way to tell what you've spotted with the scope without digging. But the electronic wizardry of the detector will give you a big edge in any treasure hunt. ■ ■





When  
you ask for  
a **CRESCENT** Wrench



make sure  
it says so  
on the handle

One adjustable wrench looks a lot like another. But not everybody takes 76 steps to make one adjustable wrench. The Crescent Tool Company does. It shows up in the longer useful life of the wrench. Make sure the name **CRESCENT** appears on the handle. Then you own the **CRESCENT** adjustable wrench, made only by Crescent Tool Company. Available at your hardware store.

**CRESCENT** 

**CRESCENT TOOL COMPANY, JAMESTOWN, NEW YORK** A Division of Crescent Niagara Corporation



## Should You Change Your Job?

[Continued on page 111]

spare time, at your own pace. More than 300 subjects are offered: aeronautics, air conditioning, automation, computers, construction, electronics, foremanship, gas engines, instrumentation, mathematics, radar, surveying and mapping, tool design and toolmaking, welding, wiring, woodworking, and so on. You can get a list of accredited schools from the National Home Study Council, 2000 K St. N. W., Washington 6, D.C. (Some reputable schools, however, have not requested accreditation.)

Studying at home demands sustained will power, but if you stick with it, you do get ahead. POPULAR SCIENCE'S OWN survey [see "Plain Facts about Correspondence Schools," Feb. and March, 1958] showed that almost everyone who finished his course got raises or promotions or both. In my own town, a man who had been working in a nearby factory studied drafting in his spare time; he doubled his pay. In Texas a toolmaker completed his course and was made foreman. In Maine a loom fixer studied to be a supervisor and won the promotion. An Illinois printer, fearing the results of technological change, studied business management; instead of moving out, he moved up—to become assistant to the vice-president.

Don't overlook technical institutes. They offer classroom and laboratory instruction—often at night—for engineering aides, lab assistants, draftsmen, electronic technicians, auto mechanics, and many others. Similar courses are given by junior colleges and universities in many cities. You can get a list of accredited technical-institute programs from the Engineers' Council for Professional Development, 345 E. 47th St., New York 17, N.Y. (It costs 25 cents.)

Vocational high schools often offer adult training at night. Your county superintendent of schools can refer you to one near you. At the Bergen County Vocational and Technical High School, Hackensack, N.J., eight jobs are available to every graduate, says the principal.

You may even be able to get free training (plus a living allowance) through such government plans as the New Manpower Development and Training Act. On this, check with your local state employment office; it decides what skills are needed in your area and selects the men to be schooled in them. You do not have to be out of work to qualify. This program alone is set to up-

grade several hundred thousand people during the next three years.

And unions—faced with more calls for skilled workers than they can fill—are pushing apprentice programs. The International Brotherhood of Boilermakers (150,000 members) just this year called on International Correspondence Schools to help. Apprentices must now complete a 600-hour, four-year home-study course before they advance to journeyman.

### Count your talents

Before diving into any course, no matter how glorious its promised future, make sure you are fitted for the work. You'll get some counsel from the schools. Many check on aptitude before accepting trainees. You can probably tell even better by examining yourself critically:

- What did you do best—and like best—in school? Math ability is basic to the computer field. If shop was your favorite, there are auto repair, welding, toolmaking. If you were good in English and science, technical editing is a booming profession.

- How about jobs you worked at? Your past experience is a solid clue to what you should try for—or stay away from.

- And hobbies? This country is full of auto mechanics, TV servicemen, and craftsmen who transformed home workbenches into profitable careers.

But a surprising number of people possess talents that lie hidden. Take Ralph Hanlon in Kansas City. He had been unhappy in a whole string of clerical jobs. No wonder. His natural bent, aptitude tests revealed, was for carpentry or cabinetmaking.

To find out if you are hiding your light under a bushel, get expert guidance. Call on the counselors in the local office of your state employment service. Ask the principal of your high school—he can tell you the results of formal aptitude tests given you when you were a student. Or he may suggest a professional agency that (for a fee) will run you through a battery of talent-analyzing psychological examinations.

A lot of work? It is. And it's worth it.

In every section of the country, exciting, high-paying jobs are going begging right now. In the coming years, millions of brand-new jobs will open up. They will go to the men who know where to look for them—and are prepared to fill them. ■ ■



# FOUR FINE STANLEY TOOLS

that deserve space on your workbench

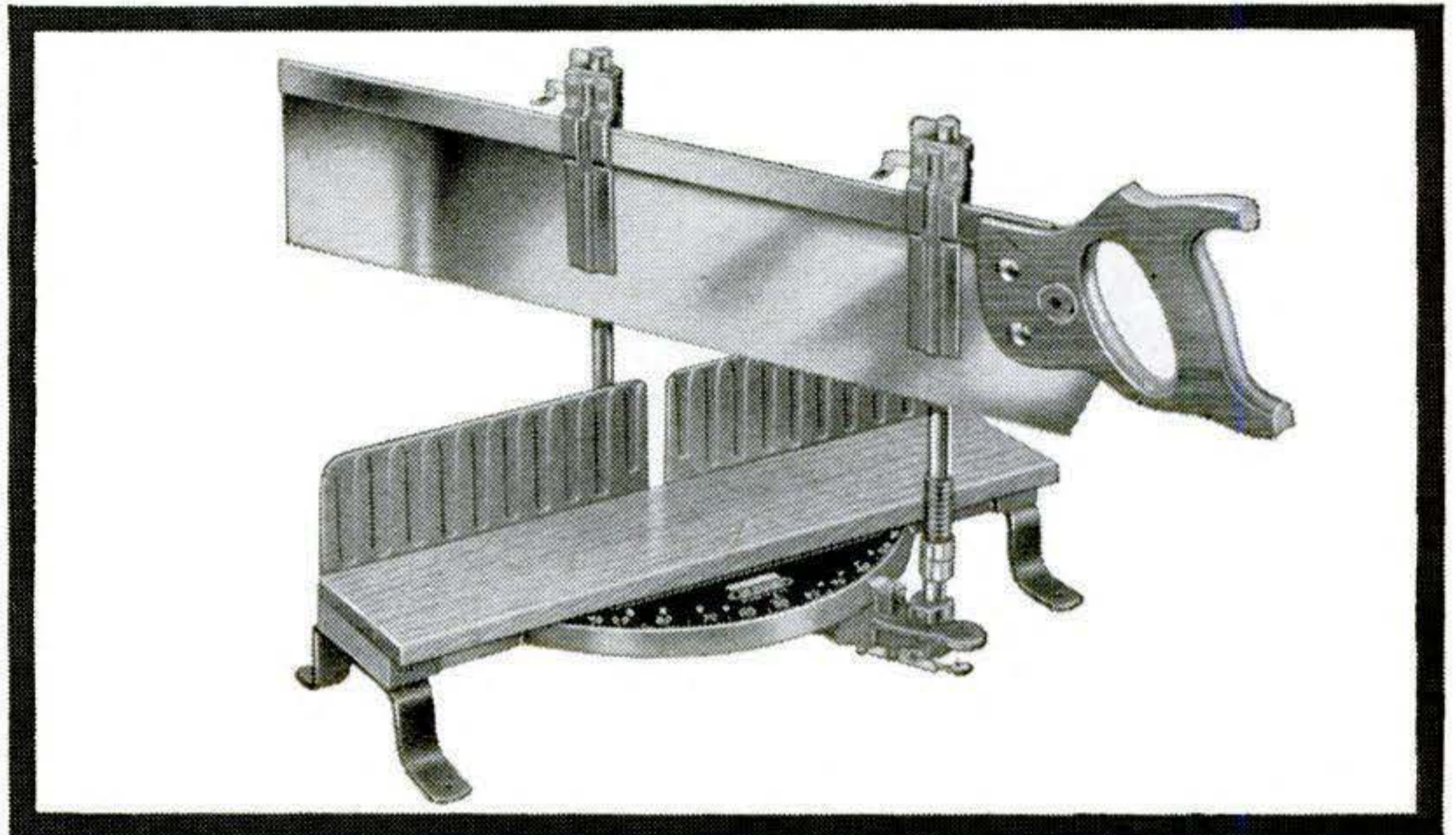

**MITRE BOX with SAW** — Cuts every angle from 45° to 90°. Accurate enough for the most demanding joining and cabinet work. 24" x 4" back saw. No. 60MB.

**COMBINATION SQUARE** — Handiest measuring tool of them all; combines the functions of square, plumb, level, bevel, rule, try-square, depth gauge and marking gauge. No. 122.

**4-WAY EXTENSION RULE** — Who said a folding rule couldn't be improved? Among the many extras: brass slide graduated on both sides, extends from both ends — permits inside measurement readings centered at one point. You'll have to try the versatility of this rule to believe it. No. X226.

**24" MAGNESIUM LEVEL** — How perfect can a level get? Practically unbreakable. One-piece I-beam construction, and so light — it weighs less than wood or aluminum levels. Elongated hand holes for comfortable grip. No. 255A.

See these and other Stanley Tools at better stores everywhere, or write for complete tool catalog to:

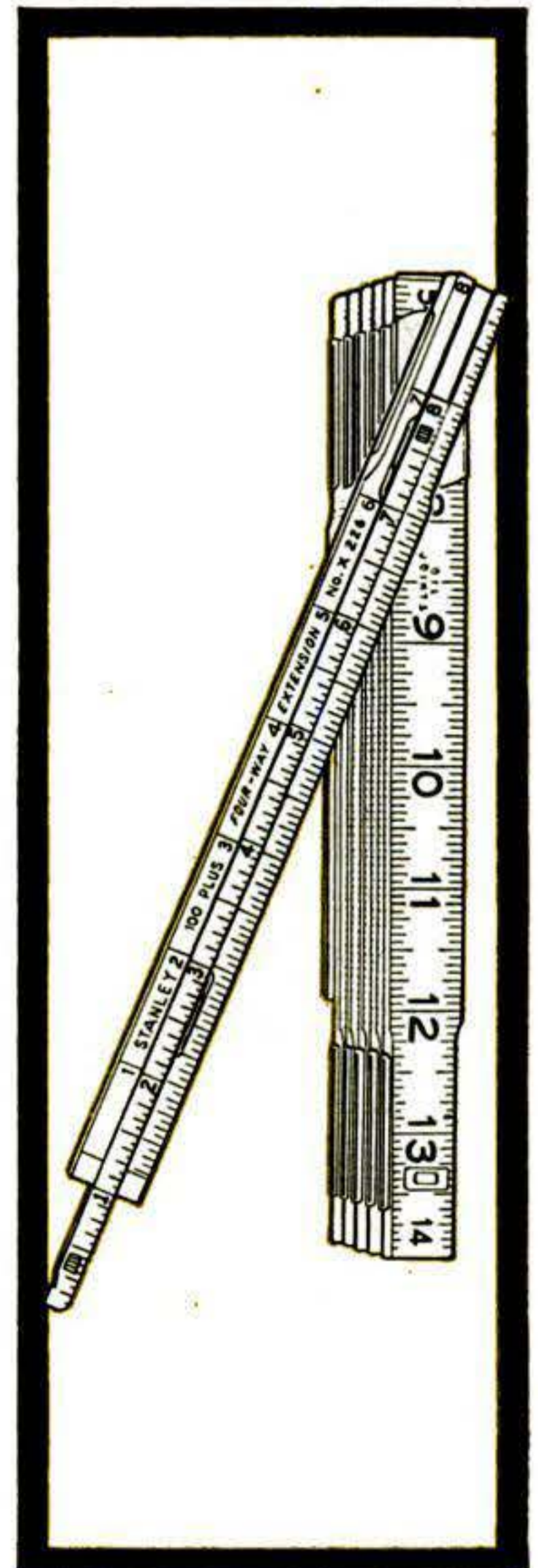
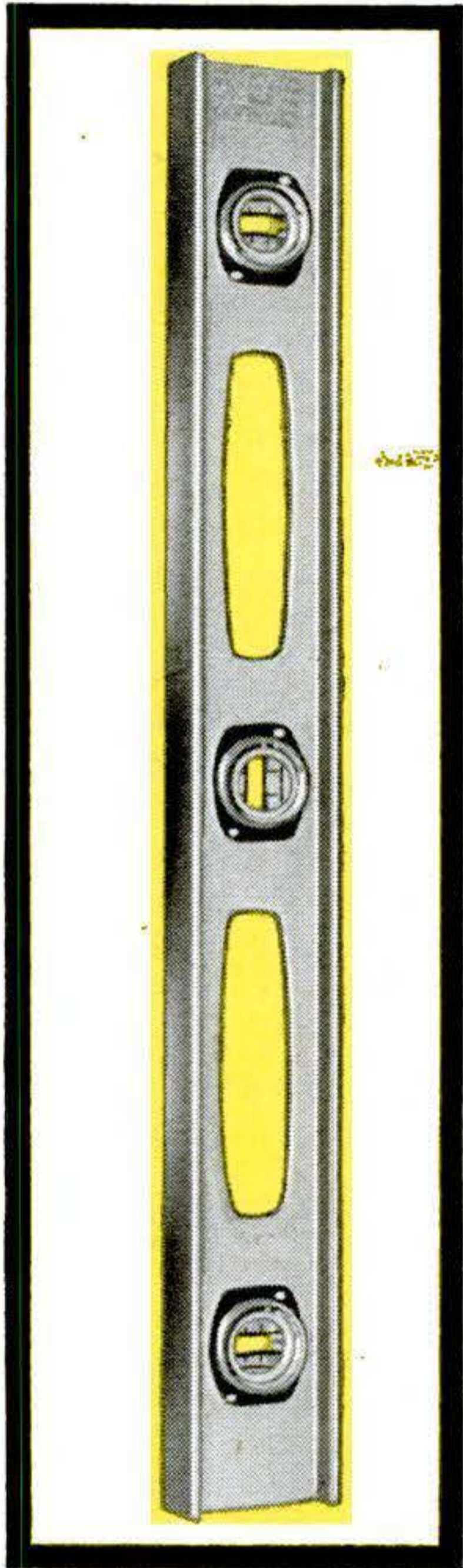
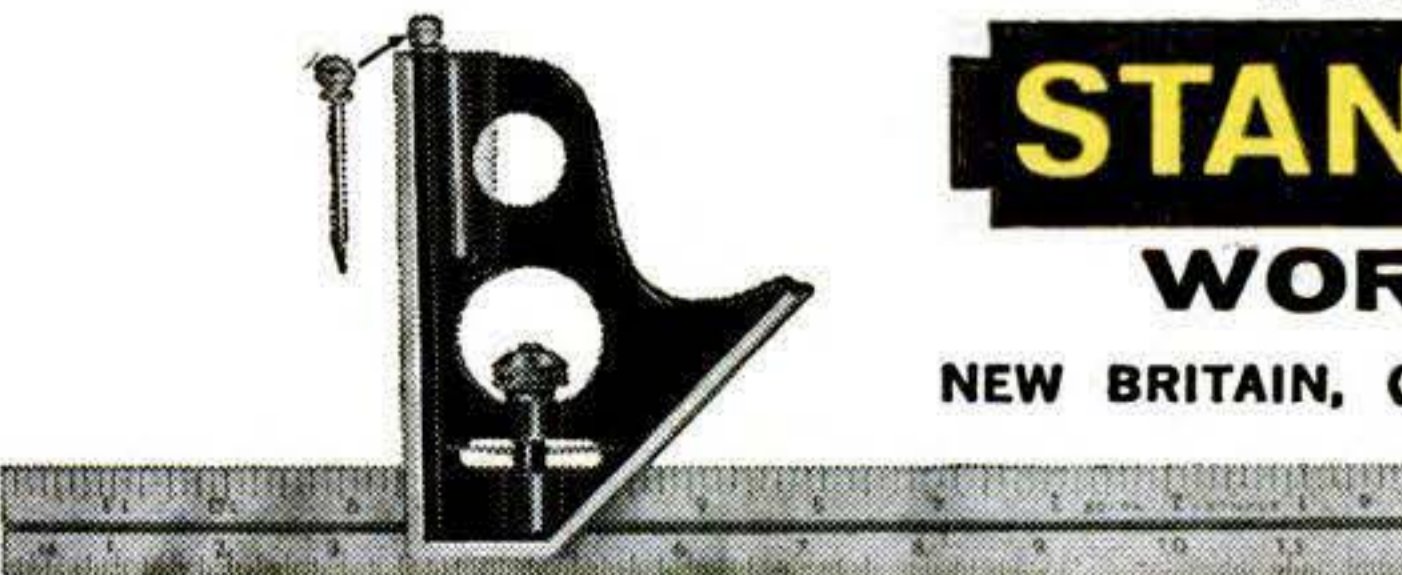
**THE**  
**STANLEY**  
**WORKS**®  
NEW BRITAIN, CONNECTICUT



smidgen of other elements—a representative sample of the solar material.

The sun's powerful ultraviolet radiation ionizes the atoms of this matter, stripping the electron shells from their nuclei. So the wind is an outward streaming of subatomic particles—electrons, protons (the nuclei of hydrogen atoms), and the nuclei of other elements.

These electrically charged particles spiral around the lines of force of the sun's radial magnetic field, which may extend as far as the orbit of Jupiter. But the particles are traveling at "supersonic" velocities—faster than kinks or compressions of a magnetic field, which are the outer-space equivalent of sound waves. So the solar gusts actually carry loops of the sun's magnetic field along with them, and pile up shock waves in space.

"How much matter is actually being thrown out by the sun?" I asked.

Dr. Van Allen did a few calculations. "Hmm, that's quite a bit," he said. "I never really thought about it before. Roughly 400,000 tons a second. That's being cast out in all directions, of course."

"And how fast is the wind blowing?"

"About three million miles per hour," he said. "But that may be its top speed. We don't really know how it varies yet."

"Then the earth is really moving through the sun's atmosphere?" I said.

"Yes, but that's torturing the word 'atmosphere' a bit. The earth's atmosphere is captive gas. The solar wind is material being thrown out so fast that it's escaping from the sun's gravitational field."

"Is the material of the solar wind and the radiation belts the same thing as plasma?"

"Yes, it is plasma, the fourth state of matter—gas in which the atoms have been broken into charged particles."

"Now that we know that space is not empty, is it fair to say that plasma is what space is full of?"

"It's not full in the sense that it couldn't hold some more," said Dr. Van Allen. "But plasma is what largely occupies solar space. Of course there are other things out there—dust, gas that's not ionized (in interstellar space), cosmic rays and other specialized particles, electromagnetic radiation such as radio waves and light waves, electric currents, and other energy manifestations, like gravitational and magnetic fields."

"What about heat?" I said. "Is space really cold?"

"Well, there are several ways of thinking about temperature," he said. "The Mariner spacecraft, as it approached Venus, had an equilibrium temperature close to the boiling point of water; it absorbed heat from the sun and reradiated much of it again. But in terms of the average kinetic velocity of the particles, the temperature of the plasma near the earth is about a million degrees. You wouldn't feel it if you were out there in a space suit, because relatively few particles would bump into you. The matter is very sparse—100 to 1,000 particles per cubic inch, compared with about 330 billion billion molecules per cubic inch in the air at sea level."

It's a strange wind that blows hot and cold at the same time, I thought. "Can the conditions of space be compared to anything we're more familiar with on earth?"

"Yes, I think so," said Dr. Van Allen. "You see, in inventing electron tubes and other devices involving vacuums and plasmas, in exploring ionization and various magnetic effects in the laboratory, we've accidentally stumbled on many of the conditions that exist naturally in space."

"Then what would be the best model of space conditions?"

"To me, the closest thing would be the beam of accelerated particles in a cyclotron. However, the material is not as thinly distributed as in space."

"An atom smasher may be familiar to you, as a physicist," I said. "But it's not to the average person. How about the environment in a TV picture tube? There's an electron beam there, and it's aimed by magnetic fields."

"Yes, but again the plasma is thinner in space, and the energies are much higher. A cyclotron is the best example, because it gives you an analogy with what happens near the earth, as the solar wind interacts with the earth's magnetosphere."

"I meant to ask you about that," I said. "How do the particles get into the Van Allen belts?"

Dr. Van Allen laughed; apparently there's a controversy on that subject right now. "We wish we knew," he said. "There are various explanations, but they're what I call hand-waving arguments. You have to talk very fast and wave your hands around,



# FREE! \$495 DIAL SAW

for drilling holes 1 1/8" to 2 1/2"...

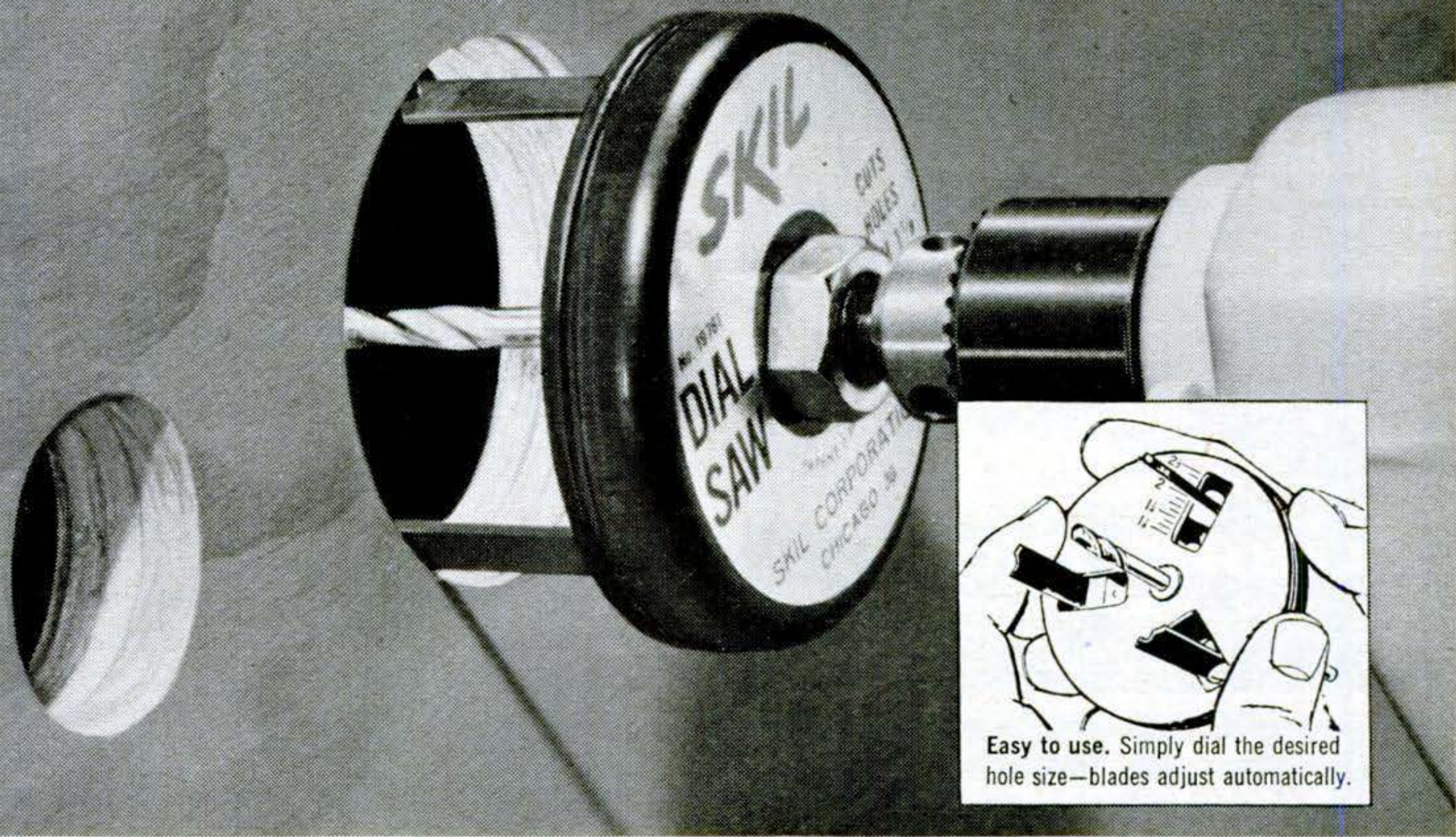

Easy to use. Simply dial the desired hole size—blades adjust automatically.

## with any of these powerful Skil drills!

**Model 503D 1/4" Drill** has a full 2.5 amp. motor that provides power to spare for drilling in concrete, metal, brickwork, plaster, wood or wallboard. Lightweight—only 3 lbs. Priced under \$20.



**Model 560D 3/8" Drill** has double reduction gears, powerful motor for greater drilling torque. Side handle gives extra control, removable when drilling in tight spots. Priced under \$35.



**Model 541D 1/2" Drill** — Most compact, low-cost 1/2 inch available. Gives big drill performance with small drill handling ease. Powerful 3 amp. motor, multi-ball thrust bearing for heavy-duty work. Removable side handle. Priced under \$37.



**SKIL**  
POWER TOOLS

Prices slightly higher in Canada.

You'd need a dozen or more attachments to cut the range of hole sizes made by this remarkable Skil Dial Saw.

Dial any size from 1 1/8" to 2 1/2". Cut through wood, wallboard, plastics and compositions.

The Dial Saw is yours *Free* with any of the three Skil drills illustrated. But don't wait. This is a limited time offer available at most hardware and lumber dealers.



### WRITE FOR FREE SKIL POWER TOOL CATALOG

Send to Skil Corp., 5033 Elston Ave., Chicago 30, Illinois.

Name \_\_\_\_\_

Address \_\_\_\_\_

City \_\_\_\_\_ Zone \_\_\_\_\_ State \_\_\_\_\_

Dept. 514-D



NOW **6** SIZES



HL 14  
HL 16  
HL 18  
HL110  
HL112  
HL116

## GROOVE-JOINT PLIERS

With the new 8-inch size added, you can get any size of this useful every purpose tool . . . from the handy little 4-inch ignition plier, to the giant 16-inch—the largest plier made—with jaws that open parallel up to 4 $\frac{1}{4}$  inches . . . All fully nickel-chrome plated.

*"There is nothing finer than a DIAMOND"*

Be sure and ask your dealer for  
Diamalloy Groove Joint Pliers.

**DIAMOND TOOL**



*and Horseshoe Co.*

EST. 1908

DULUTH, MINNESOTA TORONTO, ONTARIO

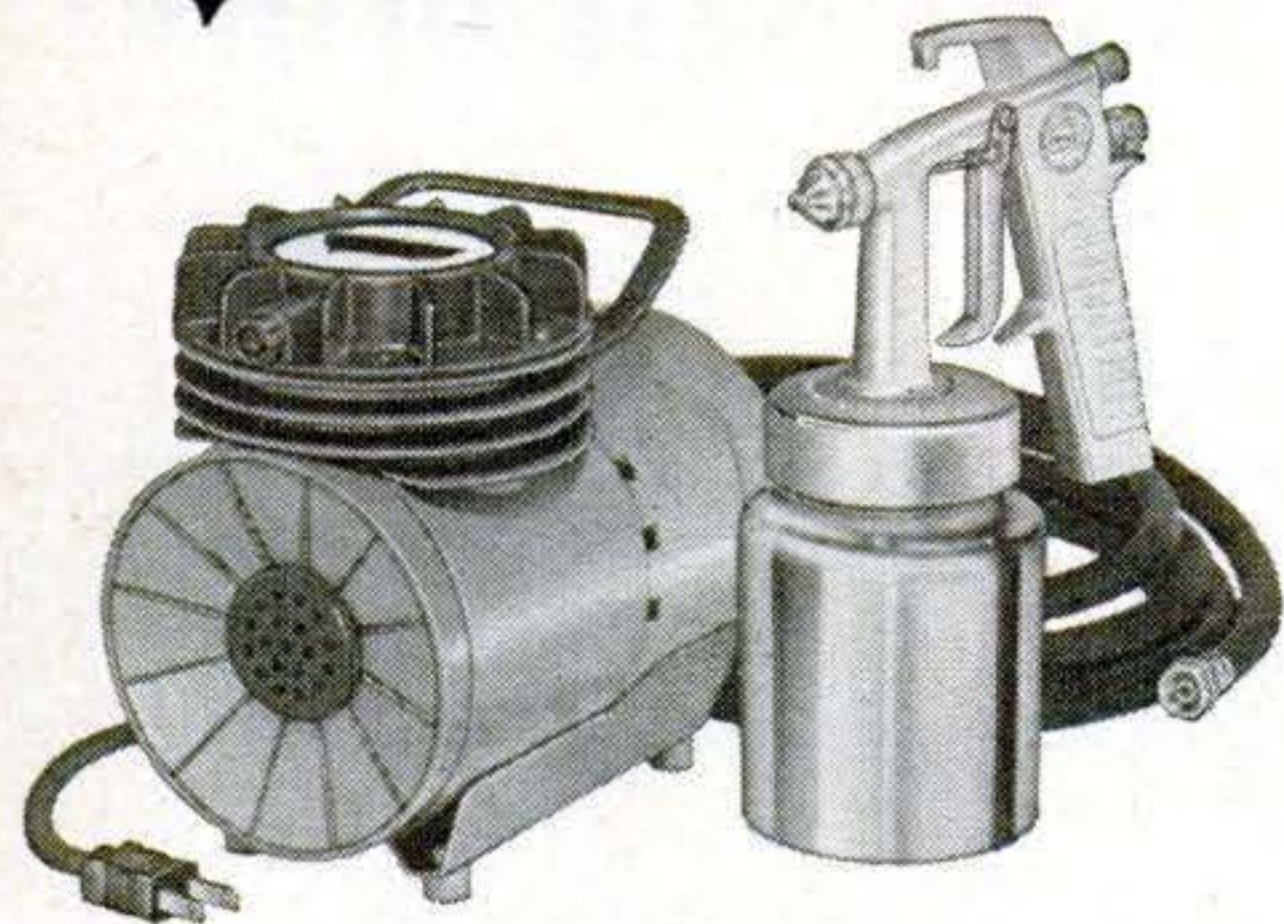

### Tool of a dozen uses!

Motorized! Ready to plug in and spray! Use it to paint anything, from a toy to a house. Does an hour's painting in just minutes. Pays for itself on the first big job. Also use it to spray insecticides, weed killers, liquid fertilizer; vacuum, tire inflator, etc. A real professional tool needed in every work-shop. Ask for Speedy Sprayer "Compact" No. 404. **\$39<sup>95</sup>**

Slightly higher Denver West.

Write for "How to Spray" booklet and catalog.

**W. R. BROWN CORP.**

*Specialists in Portable Sprayers Since 1921*

**2637 N. NORMANDY AVE., CHICAGO 35, ILL.**

208 POPULAR SCIENCE APRIL 1963

### Van Allen Tells What Space Is Like

or somebody might ask a question and demolish your argument.

"We know that the particles coming from the sun don't have as much energy as the particles in the radiation belts, so the earth's magnetic field must act as an accelerator. But a static magnetic field won't do that. The source of power has to be the solar wind.

"This 'supersonic' wind creates a shock wave where it encounters the earth's magnetosphere, and the earth's field is compressed as the solar gas flows around it. At the same time, the earth's magnetic field repels the solar field, and electric currents are induced in the plasma. So the solar wind wiggles the magnetosphere, and as particles leak into the radiation belts they get pumped up to high energies."

"Then this mechanism is what makes the particles in the Van Allen belts a hazard to space travel?" I said.

"That's right," he said. "The particles in solar wind itself won't even go through a piece of tissue paper."

"Where do solar flares fit into the picture?" I asked. "I understand *they are* dangerous."

"Flares are the storms of solar space. They're tongues of plasma that occasionally shoot out from the sun, with energies much higher than the normal wind. For example, the biggest flare yet recorded, in September, 1960, would have delivered about 700 roentgens to an unprotected man in space, over two or three days. That's easily enough to kill a man."

"Then astronauts will have to be shielded against these flares?" I said.

"Yes, that's one possibility. But shielding costs weight, and we may not be able to afford it. The other possibility is to schedule flights at times when it's unlikely that an astronaut would receive too much radiation from flares."

"We can't predict the weather very well here on earth," I said. "How good are we at predicting it on the sun?"

"Well, we're learning," he said. "Bubbly, active regions on the surface of the sun seem to show up a few days before flares occur. So it's possible to make some general, prudential predictions. We can forecast for a period of one to two days. That's not good enough, but we hope to improve our accuracy by the time we're ready to send astronauts to the moon." ■ ■



## Slow Drivers Can Kill You

[Continued from page 79]

The Columbia researchers apply the same reasoning to some classes of aggressive drivers. One check of the research results was a study of city taxi drivers who had had no major accidents—despite the roughest kind of exposure. The outcome was surprising. For the study suggested that they were lacking in the attribute that ordinarily distinguishes good drivers: consideration for others.

Aggressive driving may be safer for only specific categories of drivers, however. The reason: Everybody expects them to drive that way and allows for it.

Two years ago the Safety Project set out to work up a test that could separate the good drivers from the bad. With such a test the worst drivers could be kept off the road—before they killed somebody.

But how do you tell a good driver from a bad one? The Project launched a massive mail survey. Thousands of people who in one way or another count as experts (police, judges, teachers of driver education, motor-vehicle administrators) were polled. Each man was asked to send in two "incidents" from his experience: one an example of good driving, one of bad driving.

The Columbia researchers collected more than 4,000 of these incidents. Mining useful information—facts and lessons—from this mountain of crude data was the job of Dr. Malfetti's associate, Jerome L. Fine.

"Good" and "bad." With the information coded into numbers, the sliced-up bits of data were fed to an electronic computer. The computer gave back lists of specific driving actions that had most often been labeled by the experts "good" or "bad."

These lists create pictures of good driving and bad driving. (Slow driving turned out to be the clearest part of the bad-driving image.) They have already been used to design tests to predict drivers' behavior.

Does the system work? Yes, insists Dr. Malfetti. He has tried preliminary tests on several groups of drivers: skillful, safe truckers who piled on hundreds of thousands of accident-free miles, and ticket-collecting types who chalked up so many demerit "points" that state authorities ordered them to attend special retraining classes. The tests checked out, ranking the truckers as the good drivers they were and the persistent violators as the bad drivers they were. ■ ■

# NOW!

## no spindle deflection

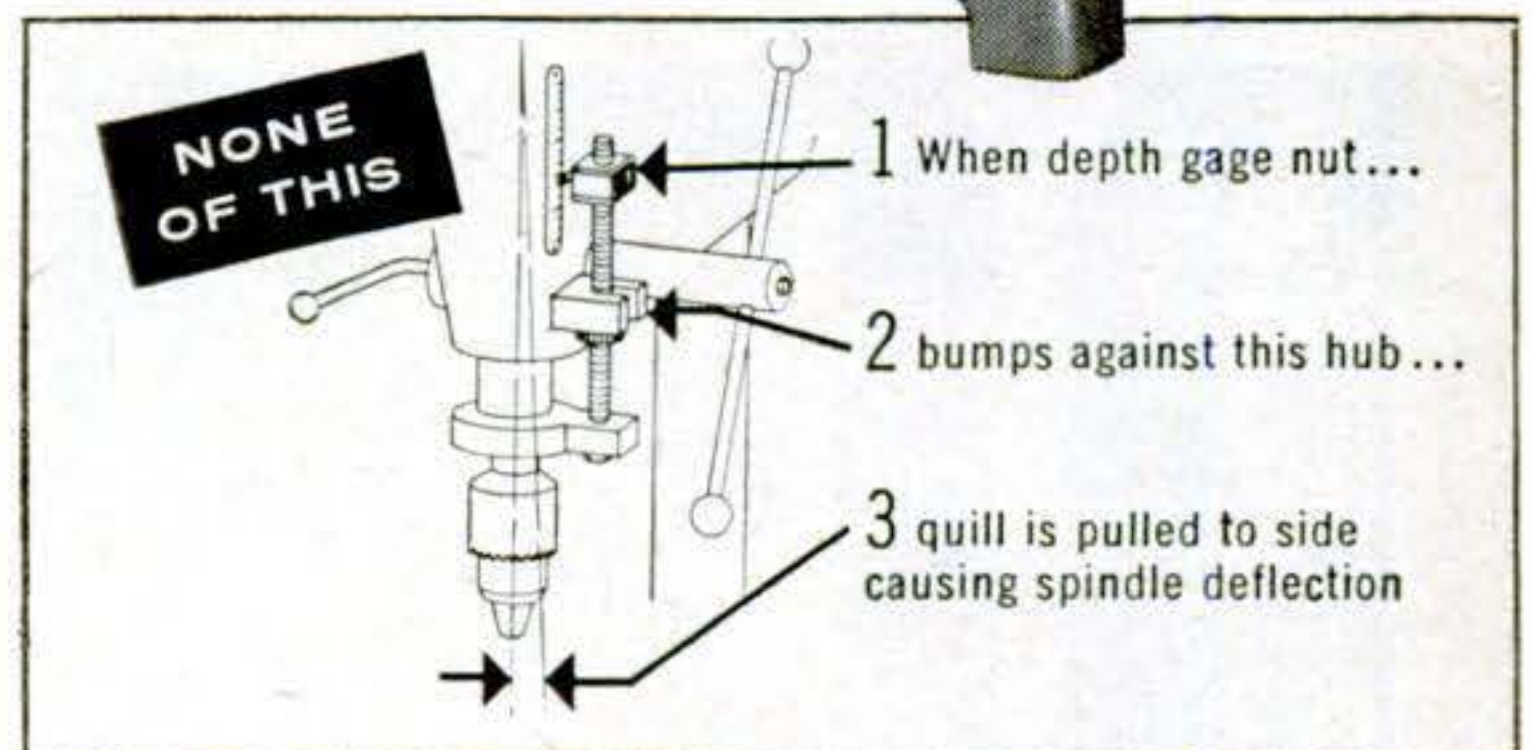

South Bend's design eliminates the major cause of inaccuracies common to all drill presses—spindle deflection resulting from depth gage pressure. *There is no depth gage collar on the quill.* Travel of the quill is controlled by an exclusive Rack Type Depth Gage that limits the rotation of the quill feed shaft. Write for more details about South Bend's exclusive features.

Prices of South Bend® 14" Precision Drill Presses start at \$134 f.o.b. factory

# SOUTH BEND

## LATHE

South Bend Lathe, Inc., South Bend 22, Indiana

Builders of Lathes, Milling Machines,  
Shapers, Drill Presses.

Up to 36 months to pay







# WANT TOPS IN QUALITY?

STAINS  
and  
VARNISHES

DON'T STICK YOUR NECK OUT with just any wood finish, rely on REZ natural wood stains and varnishes for the ultimate in beauty and protection of all interior and exterior wood in your home. REZ is nationally acclaimed by leading architects and homebuilders as "the best thing that's happening to wood!"

**REZ WOOD-TONES, INC.**  
Dept. 134, P. O. Box 142, Springdale, Pa.

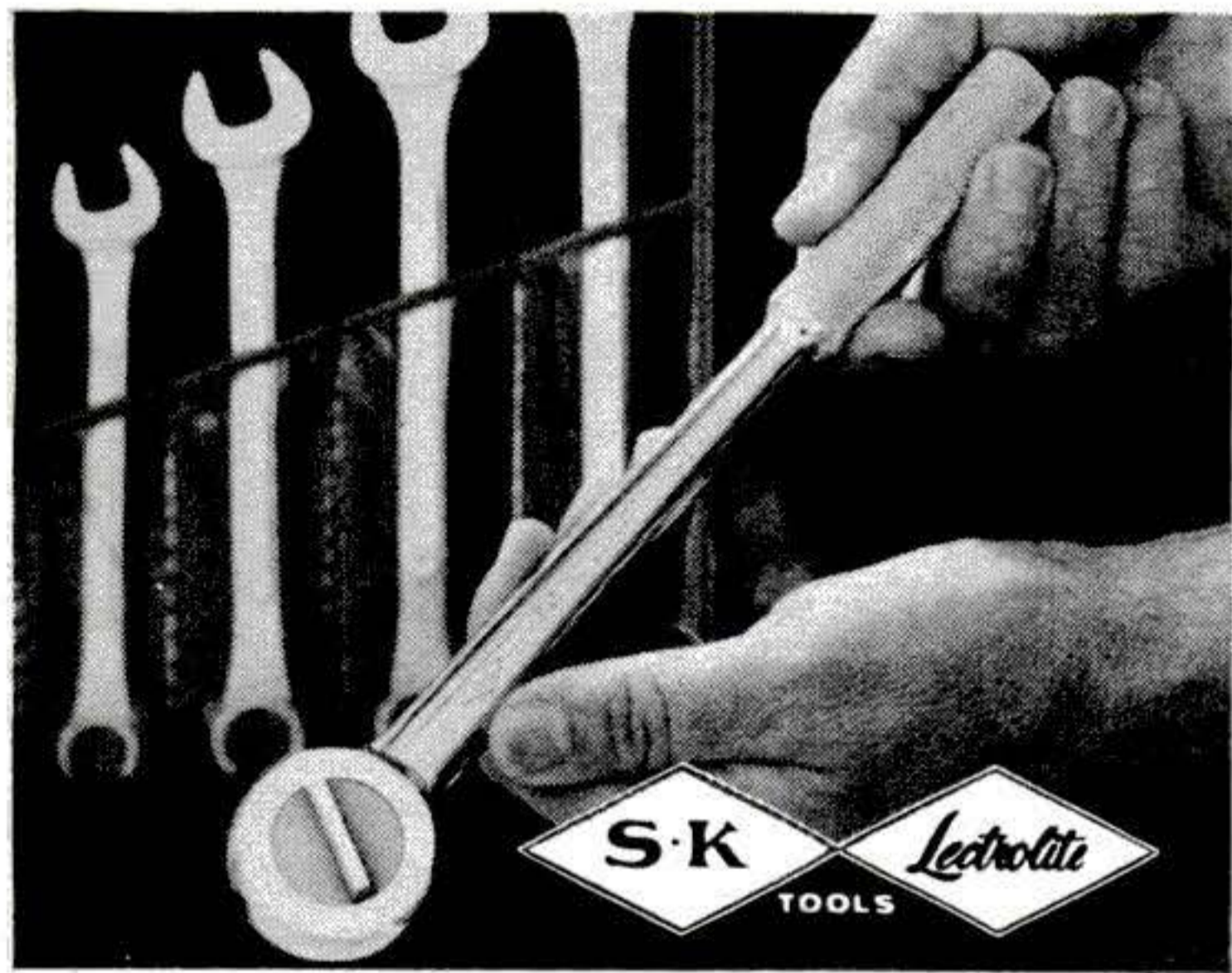

**Preferred by mechanics  
the world over**

Send today for free pocket catalog of S-K/Lectrolite quality hand tools, including ratchets, sockets and handles . . . adjustable, combination and open end wrenches . . . pliers and special automotive tools. Use the coupon.

**S-K/LECTROLITE TOOLS**

Defiance, Ohio

Name \_\_\_\_\_

Address \_\_\_\_\_

City \_\_\_\_\_ State \_\_\_\_\_

## 'Keep-'Em-Honest' Car Tests

[Continued from page 72]

tread rubbers have less rolling resistance than do original-equipment tires) and inflated to a maximum of 28 pounds. Wheel bearings are repacked. Engine oil, and transmission and differential lubricant are replaced.

After inspection, all cars were parked in an impound area guarded day and night for the duration of the trials by NASCAR officials. No one was allowed near a car without an inspector present. Cars were taken out when their turn came and returned after making their run.

*The economy test* run is carefully laid out to give a fair sampling of ordinary, everyday driving. In each 3¼-mile lap there's a stretch of winding road with flat hairpin turns, a high-speed strip where the car must do 65 m.p.h., and a full stop. An average of 40 m.p.h. must be maintained for the entire run.

Each car starts out with a precisely measured one gallon of gas in a special tank hung in the right front window and is driven until it runs out of gas. The distance covered is measured to an accuracy of 1/10 of a foot. A NASCAR observer rides in each car, and the only instrument allowed the driver (other than standard equipment) is a stopwatch.

*The acceleration test* measures the time it takes a car to go from 25 to 70 m.p.h. The timing is completely automatic. On gear-shift models, the driver may not use the clutch before or during acceleration unless he actually shifts. Nor may he ride the brake to help hold constant speed just before the measured acceleration period.

*The brake test* measures the distance it takes to stop from 60 m.p.h. But there is more to it than just making a single panic stop. Brakes have to make 21 hard stops in rapid succession immediately before the test stop. The drums get hot enough to show the brakes' resistance to fade.

Some of the professional drivers I talked to were not too happy about all this rigmarole. Said one: "They might as well run these cars around the track with robots. If the factory doesn't give you a winning car, you don't have a ghost of a chance of taking home prize money." (Winning drivers got \$500.)

Other drivers took a broader view. Les Viland, an American Motors engineer and one of the top economy drivers in the coun-



### 'Keep-'Em-Honest' Car Tests

try, told me: "This economy test is tougher than the Mobil Run. You can't make as good a showing here, but everyone is in the same boat, and the results are more realistic."

Viland added to his reputation as an economy driver by going farther in his Rambler American on a gallon of gas than any other car in the trials. He bettered his teammate, also driving an American, by more than five miles. But lest you think there is some magic in his accelerator foot—the other American had overdrive troubles. Because of some malfunction, the overdrive failed to cut in and the entire run was made without benefit of the overdrive gear ratio.

According to Viland, an overdrive will usually account for about four more miles per gallon. The rest of the difference was mainly due to the slightly hotter engine in the other American.

**Jockeying for points.** With the car makers staking their reputations on the test results, automatic transmissions were not too plentiful. Most elected to use a four-speed box or a three-speed with overdrive. Permitted two entries in each class, manufacturers in some cases set up one entry for economy and the other for performance. Your clue here is rated horsepower. The idea was to garner the maximum total points for the team. In some instances, such as for Chevy in Class III, the plan worked as expected; but not always—the higher-powered Ford in Class I topped its teammate in *both* economy and acceleration.

Plymouth made an enviable record for getting both economy and acceleration out of the same engine. In Class IV, one Plymouth copped first place in both tests and its teammate took second in both. In three other classes, they turned in consistently high scores for both tests. At the end of the economy and accelerations tests, Plymouth was ahead in every class in which it had an entry.

At a roundtable discussion with the Chrysler-products team after completion of the first two events—economy and acceleration—I asked what they thought were the most important reasons for their success. They were unanimous in crediting two design factors:

1) Less dead weight—their cars are from 200 to 500 pounds lighter than competitors with the same equipment.

CONTINUED

211

# Owners Report on DELTA COMPACTOOL

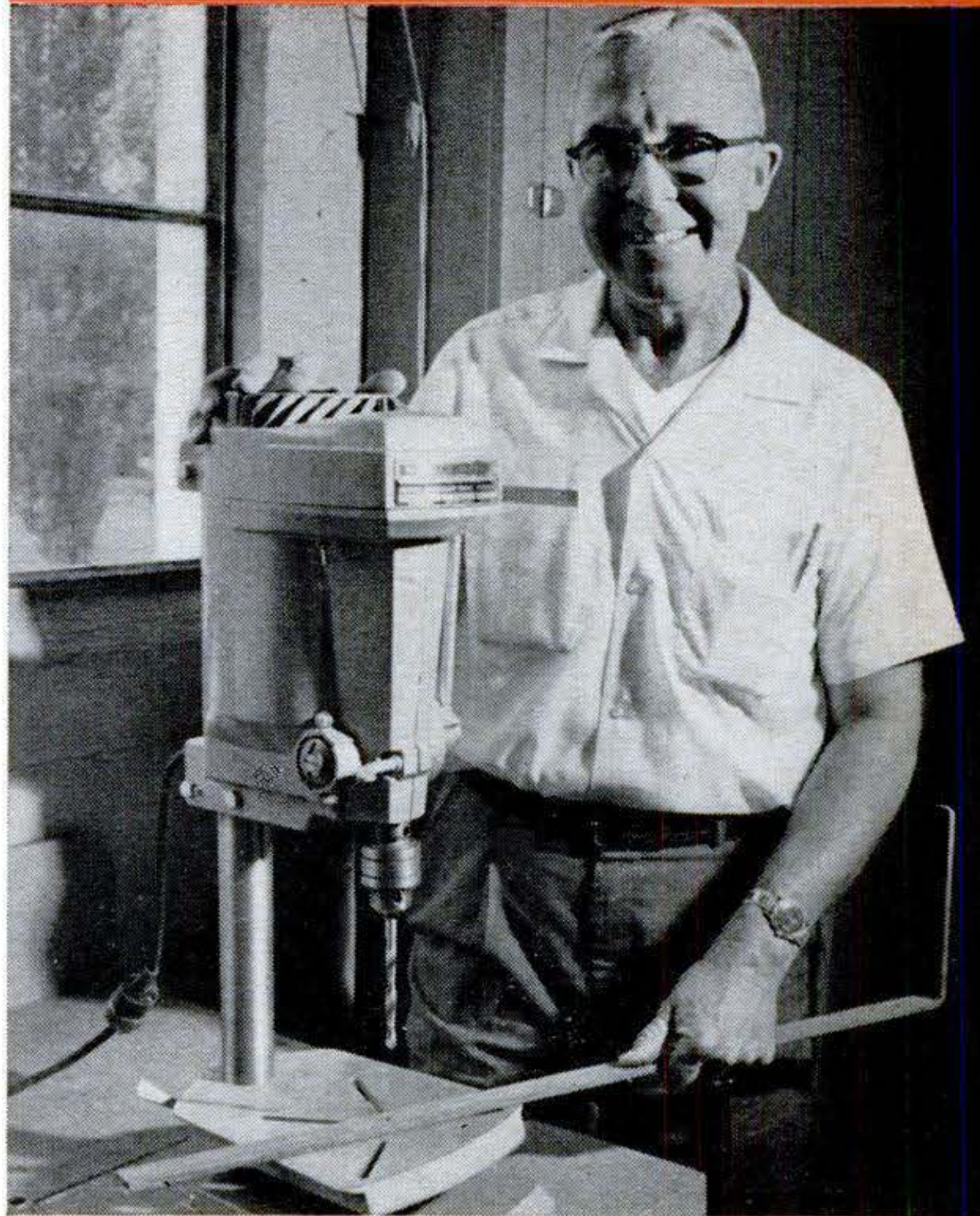

Does "big tool" jobs—  
in or out of shop

**JOHN W. HALLAM,  
Washington, Pa.**

"I bought this COMPACTOOL Drill Press for work in my sign shop. We use it mostly for drilling angle iron,  $\frac{1}{4}$ " strap iron and pipe for sign hangers. When we do a store front, I take it along in my truck. We give power tools an awful beating—but this Drill Press does as well as anything three times its size—and holds up just as long."

## DELTA COMPACTOOL

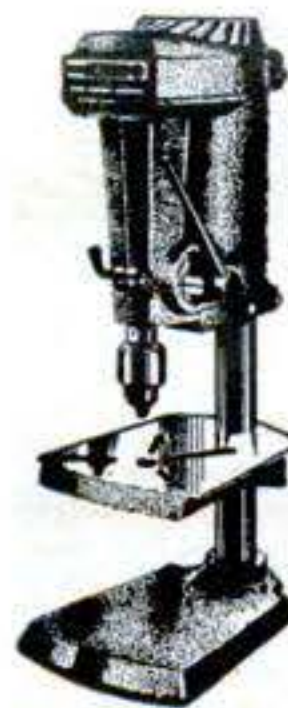

Drill Press



Circular Saw

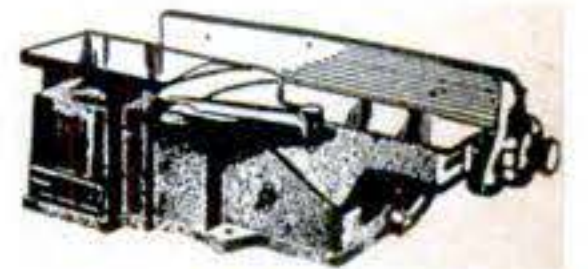

Jointer

Write for **FREE Brochure**

**Rockwell**

MANUFACTURING COMPANY

504D N. Lexington Avenue

Pittsburgh 8, Pennsylvania





More Profit per Tune-Up with Proto

# 'HAND HELD'

## Tune-Up Equipment

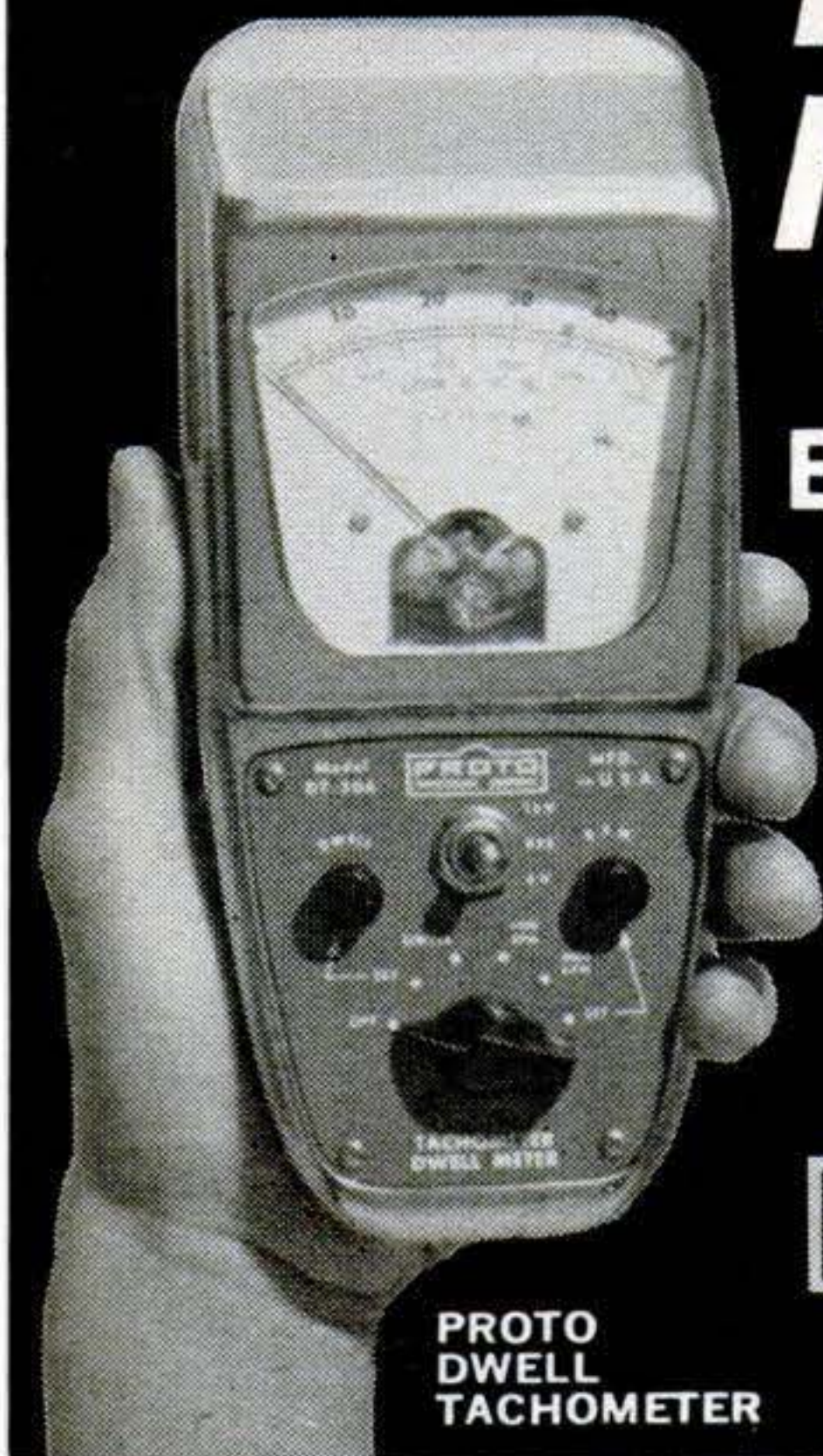

- Over 17 professional models for precise analysis of engine troubles
- Accurate
- Rugged
- Warranted



PROTO DWELL TACHOMETER

Proto Division, Pendleton Tool Industries, Inc.

2203 Santa Fe Avenue, Los Angeles 54, California

503 Allen Street, Jamestown, New York / 1703 Oxford East, London, Ontario, Canada



Garage  
Basement  
Shed, Shop  
Barn

## SOLVE STORAGE PROBLEMS

### WITH HERCULES HOOKS

Patent applied for

obsoletes every other method of HEAVY DUTY WALL STORAGE

These giant steel hooks are approx. 1/4" thick. They fit over the common 1" x 4" wood board. Simple to put up. NO perforated wallboard is used.

Hold the heaviest tools, equipment, shelves, etc. HOLDS EVERYTHING. Ask for them by name at your dealer. HERCULES HOOKS!

Sample hook sent direct to you. Enclose 10¢ for mailing. Literature FREE!

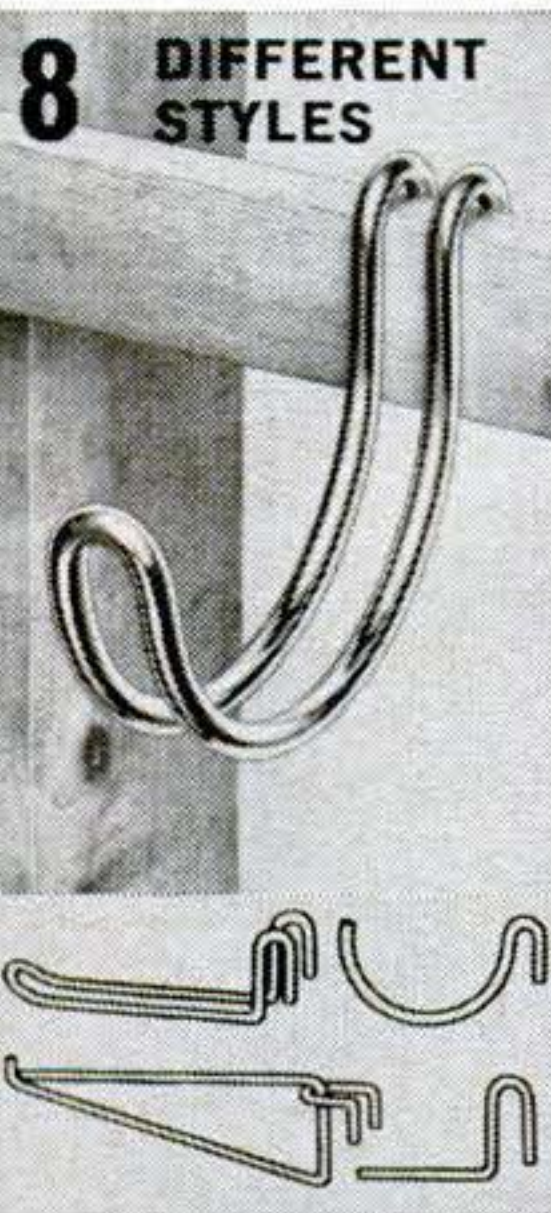

8 DIFFERENT STYLES

**K THE KERR WIRE PRODUCTS CO.**  
935 N. Cicero Avenue • Chicago 51, Illinois

### 'Keep-'Em-Honest' Car Tests

2) Better handling—Plymouth drivers felt they were getting around the sharp bends in the economy run without losing as much speed as their competitors, and with less energy-wasting swerve and slide.

Doug Patterson, a spokesman for the group, said, "Reducing car weight is the only engineering approach I know of that will improve both economy and acceleration at the same time."

The Chevys in Class III and IV and one Pontiac in Class II also turned in high scores for both economy and acceleration. But most cars performed as you would expect—if they did well on acceleration, they didn't do so well on economy.

*What's in it for you?* Probably the braking test will have more impact on the design of future cars than any public car trials ever held. To a large degree, the final outcome turned on the scores in this test.

Relatively low braking scores knocked Plymouths out of first place in two of the four classes they had been leading. Their braking scores were low even in the classes they won. Plymouth wasn't alone: 17 out of the 57 models entered took more than 200 feet (some a lot more) to stop from 60 m.p.h. It was proven at the trials that this *could* be done in 158 feet.

There seems little excuse for such large variations in brake performance. Everyone in Detroit uses the same basic brake mechanism and has access to the same know-how. And, unlike the economy-vs.-acceleration dilemma, there is no engineering reason for compromising on brakes. Nor were better brakes associated with higher price tags. If anything, the reverse was true—some of the poorest results came from the higher-priced models.

The Ford Motor Company chalked up a laudable record on braking with four first places, two seconds, and two thirds. They squeaked into their two overall class victories largely on the strength of the fine braking scores turned in by all four of their cars in Classes I and II.

This annual exposure to public view of comparative brake performance could become the best break yet for car buyers. If the competition for better brakes becomes as fierce as rivalry for acceleration and economy has been, it would be the healthiest influence on Detroit engineering since the threatened mass invasion of the small foreign cars. ■ ■



## Flying the Atlantic Without a Navigator

[Continued from page 88]

starting point. At that moment he flips the controller's switch to "On," and the "A" side starts registering.

A three-inch dial on his flight-instrument panel, the Doppler indicator, shows ground speed in knots; drift angle, left or right, in degrees; and miles off course. If there's no wind, or a direct head or tail wind, the drift needle reads zero. As the radar beams sense any side winds, the dial shows the drift in degrees—and Horstman changes his compass heading accordingly.

The plane's air speed is a constant 600 knots—but air around us, sweeping forward at 120 knots itself, gives us a ground speed of 720 knots. The Doppler computer, told this by its sensors, continuously figures the distance actually traveled. The miles left to go are clicking off in their window—like your car's mileage meter, running in reverse.

Ten miles before the end of the first leg, a red warning light alerts Horstman to watch the controller closely. When "Miles to Go" reach zero, he switches to the "B" side, for the second leg.

Into the now-inactive "A" side, he dials heading and distance for the third leg. Later, when "A" is working again, he'll put fourth-leg data into "B."

To confirm the readings of Horstman's Doppler, his copilot has a duplicate set. Both sets get a checkup by taking a precision Loran fix before the jet passes beyond range of shore-based Loran stations—and another, as it comes into range of those on the other side.

*The innovation has its critics.* Understandably not Doppler enthusiasts, the displaced navigators dispute the high TWA-FAA estimate of the system's accuracy. But in its actual use on 2,600-nautical-mile transatlantic flights, reports Chief Pilot Horstman, his Boeing 707s do even better—actually averaging only 2½ miles off course. They clip seven to nine minutes from flight time, save 300 gallons of fuel, by avoiding zigzagging from the shortest route.

Navigating without a navigator looks good to PanAm, too—a different system of its own, using inertial guidance, is on the way. And TWA's Doppler may take over part of the pilot's job as well. Already, in several of TWA's jets, the computer has been linked to an autopilot—which it automatically switches to a new heading at each leg's end. ■ ■

Clip and save . . . more to come

**FIX-UP** / Product Tips from **DAP**®

## HOW TO FILL STUBBORN CRACKS AND JOINTS

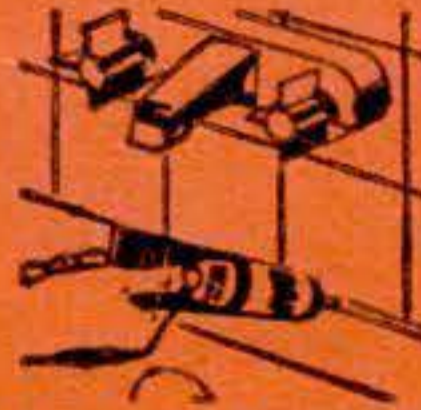

**USE KWIK-SEAL** for watertight seals around tubs, sinks, lavatories and showers. Stays flexible for long-lasting results.

Keeps its neat, attractive satin-white finish to dress-up tile areas in kitchens and bathrooms.



**USE DURATITE WOOD DOUGH** when hinges or drawer knobs come loose. Fill screw holes with Wood Dough, let dry and reseal screws

for tight, sturdy fit. Ideal for covering holes and other blemishes in woodwork, paneling, furniture.



**USE DAP SPACKLING** to patch hairline cracks and large breaks in plaster . . . fill seams in drywall. Ready-mixed, creamy-

smooth. Easy to use. Sticks tight. Sands to an invisible edge. Paint covers without priming.



**USE KWIK-SEAL** for easy and perfect repairs of cracks around interior window and door frames. Apply direct from plastic

squeeze tube. Takes minutes to apply, makes a long-lasting seal. One coat of paint covers.



**USE "33" GLAZING COMPOUND** to replace old, cracked putty that leaks air, moisture and causes heat loss. Stops rattles caused by loose

panes of glass. Easily applied, sets to a smooth surface. Holds fast to wood or metal sash.

*If your dealer doesn't carry these products, please send us his name and address.*

DAP INC., DEPT. 43, DAYTON 31, OHIO • SUBSIDIARY PLOUGH, INC.

**DAP / DURATITE / Indo**



**new development in NYLON  
by DUPONT as shown on TV**

now available nationally  
for the first time . . .

**2-SPEED ANGLE DRIVE**

DOUBLES or HALVES

the speed of your power drill . . .

This unique angle drive fits ANY power drill . . . mounts directly on drill spindle or into chuck. Exclusive white DUPONT nylon body eliminates heat transfer, keeps unit cool. Ideal for high or slow speed drilling, sanding, polishing or wire brushing •

- Extra lightweight • Double or halve drill speed
- Bronze oilite bearings • LIFETIME Lubricated
- Complete with handle and 3 chuck adapters.

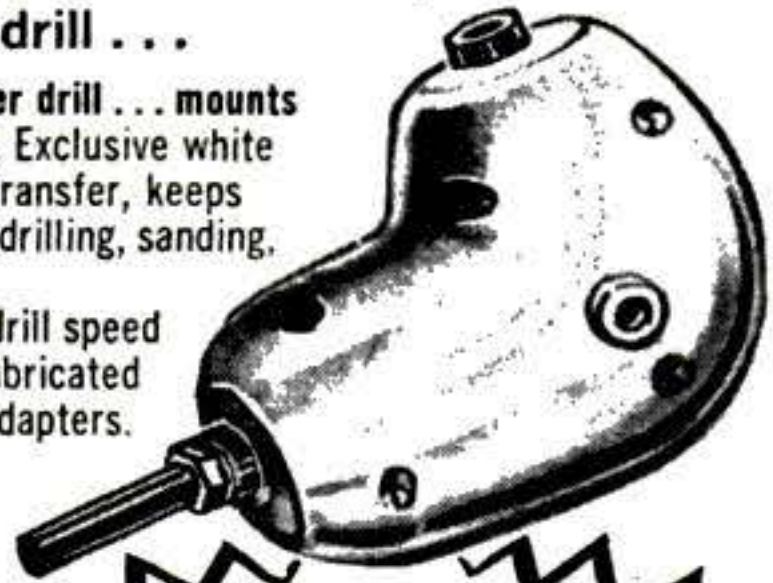

introductory price  
**Only 3.88 ea.**

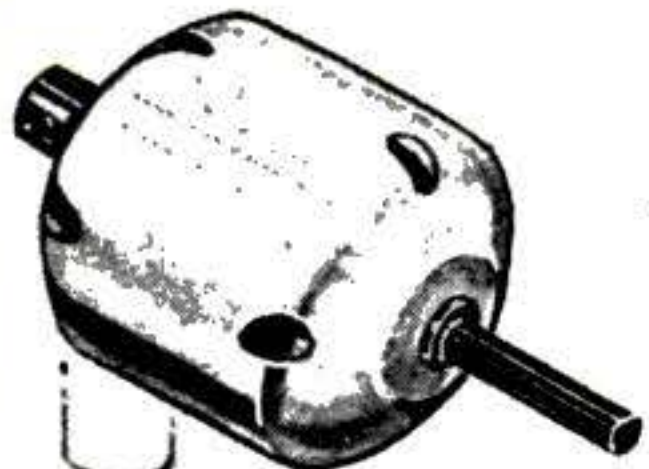

**NEW! POWER SCREWDRIVER**  
with automatic disengage clutch

Nylon body eliminates heat . . . lightweight minimizes load on drill. Special non-slip clutch drives large screws without over-load on drill . . . clutch automatically disengages when screw is set. Fits any power drill. Comes w Phillips #1 blade and 1/4" blade for slotted screw from #6 to #14. Nylon screw finder prevents blade from slipping off screw and marring work.

Above OFFER EXPIRES May 15, 1963  
after that will be priced at \$5.00 ea.

**WORLD'S MOST AMAZING CATALOG**

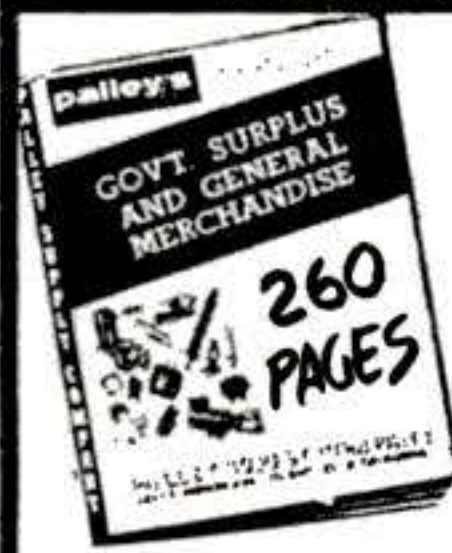

**260 PAGES of SPECTACULAR BARGAINS!** Government Surplus, Factory Closeouts and hard-to-find items of all kinds. You'll find special bargains in U.S. Army, Navy, Air Force and Industrial surplus — including Sports & Outdoor Equip., Hand & Power Tools, etc. **ORDER TODAY!**

**Only 50c** Your 50c will be refunded with your first order of \$1.00 or more  
TO COVER HANDLING & MAILING

**TO ORDER:** Send check or M.O. 1/2 dep. with C.O.D.'s. All items sent freight or postage collect.

**palley's**

2263 E. VERNON AVE., Dept. PS-43  
LOS ANGELES 58, CALIFORNIA

**KRYLON** **SPRAY PAINT**

You have a use for

**SPRAY PAINT**

In Ready-to-Use Aerosol

**IF YOU PRIZE IT...KRYLON-IZE IT!**

**GUNK**® removes grease  
-- scourfully!  
cleans -- degreases -- freshens



- power mowers • engines
- cement floors • kitchen walls • ovens • exhaust ducts
- paint brushes • furnace filters • barbecue grills
- implements • machinery

**AT AUTO SUPPLY, FARM & HARDWARE STORES!**

GUNK CHICAGO CO., River Forest, Illinois  
serving the Midwest and Southwest  
RADIATOR SPECIALTY CO., Charlotte, N.C.  
serving the East, Southeast and far West

**Time Bombs in the Mississippi**

[Continued from page 130]

water, the tank weighed 130 tons. But as it came up, its weight would soar to 350 tons. To this the strongback added its 30 tons. Never before had the hammerheads on the Bolin and the Herman B had to lift 380 tons of death. On the derricks, a half mile of slender cable would be moving on 40 sheaves, and every strand would have to hold.

Joe worried about those tank valves. Pressure in the tank was 85 p.s.i. The valves were set to pop at 160. But suppose they had weakened? What would happen when river pressure, now helping to hold them shut, was taken away?

There was a piece of bad news. On final inspection, a diver reported that the No. 1 tank, again tipping slowly, had raised eight inches off its cradle and had moved dangerously closer to the sharp steel edge. Haste became urgent.

At 2:25, a final briefing was held on the Bolin. It was as solemn as a prayer meeting. Then at 2:30 all hands scrambled, and the Bolin's derrickman, Don Harbolt, climbed to his pulpit.

In his seat at the controls, Harbolt laid his rebreather mouthpiece handy over his shoulder. He looked down over his two great hoisting drums, wound with shiny new steel cable, and glanced across a gap of water toward the other barge, the Herman B. Over there, derrickman K. E. Anderson was climbing to his own cab.

At 2:48, Task Force Chief Boswell on the Bolin radioed Col. Everett, watching from the wheelhouse of the Lipscomb a few yards away: "We are ready to lift, Colonel."

Everett replied quietly: "Proceed, Mr. Boswell."

Simultaneously, a voice said in both Anderson's and Harbolt's earphones: "Lift on both derricks, half speed."

Harbolt flipped two levers, knowing that Anderson, on the other barge, would do the same. There was a rumble. The big drums shifted sideways, to contact the diving disks, and began to turn.

The steam engine on the Bolin is a 50,000-pound-pull, lift-and-draw-works engine, a modern version of an old classic. When Harbolt opened the throttle, steam hissed, a piston slid, and a driving wheel began turning—slowly, then in a fast blur. Harbolt saw his towering derrick shake. The cable,



### Time Bombs in the Mississippi

moving in 20 shining strands, drew taut as a violin string. Slowly the drums began to turn.

Then he felt the strain come. Backstays tightened. The steam engine settled down to a brittle puffing, and the whole barge, half as long as a football field, tipped forward slightly under the weight. In its underwater cradle, the tank stirred.

At 2:50 p.m. the Bolin radioed: "The lift has begun." The word flashed to Natchez, Washington, New Orleans. It was heard in homes, stores, cars, by 70,000 anxious people. Miles away, ships heard and stopped. In his wheelhouse, Col. Everett spoke quietly into his microphone: "All communication channels please stay clear for emergency."

Far down in the wreck, the tank settled slightly and a quiver ran up the cables—a kind of nervous burp. Then Harbolt fed more steam. At three p.m. the tank was coming up 18 inches a minute.

Joe Carroll, ready to dive if needed, was worried. He knew that a major adjustment was now at hand.

Then Harbolt got a signal to stop while the Herman B brought up its end to put the tank on an even keel. Still 15 feet under water, the tipsy tank began to level off. Harbolt fed steam again and the derricks on the two barges once more lifted together.

At 3:17 someone standing near Carroll whispered, "Great God!" A clammy white shadow grew in the water, just under the surface, growing imperceptibly brighter and flickering with ripples. At 3:19, the No. 1 tank shouldered its way out of the river, slow as a rising moon.

All hands had known it would be big, but none expected anything like this. The clammy thing kept growing, a monster coated with slime, sand, and dirty water. Gas-suited chemists waited like Lilliputians to board it and plug any leaks. Men with detectors were everywhere, spraying the air.

The daring little motorboat Corky now shot out and sprayed the rising valve-dome. But there was no sign of gas: The tank still was holding.

The major adjustment came moments later. With no warning, one sling cable lost its grip and slipped.

It happened in a wink. A new ripple raced up the hoist cables. Harbolt felt it

CONTINUED

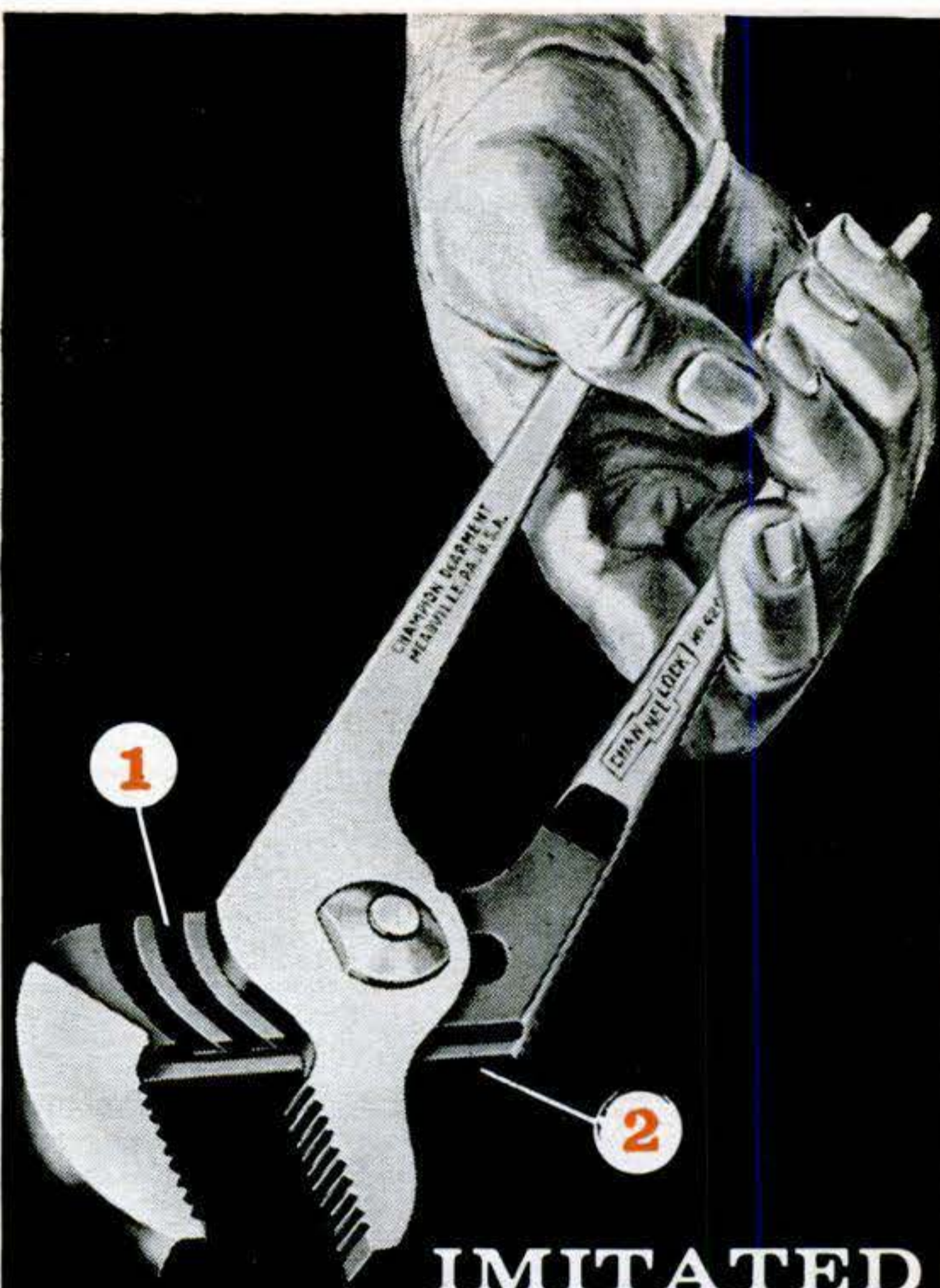

IMITATED  
...BUT  
**NEVER**  
EQUALLED

**CHAN NEL LOCK**

When you buy a Channellock, you get two exclusive patented features you can't get in any other adjustable plier:

- 1 Smooth-working, machined, undercut channels. The tighter you grip, the tighter they lock.
- 2 Reinforcing rib for added strength when you put the muscle to a job.

Only Channellock—the original tongue and groove plier—has these features. *Be sure you're getting the genuine Channellock . . . look for the trademark on the handle.* Your choice of five jaw capacities:  $\frac{1}{2}$ ,  $\frac{7}{8}$ ,  $1\frac{1}{2}$ , 2 and  $2\frac{1}{4}$  inches. Write for catalog showing our complete line of pliers. Champion De-Arment Tool Company, Meadville, Pennsylvania.



# EVERLITE\* World's THRIFTIEST Light Plants

(Item 869-10T)

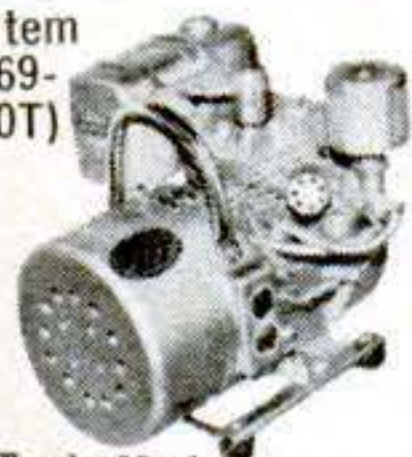

\*Trade-Mark Registered

## NEW TRANSISTOR ALTERNATOR REPLACES GENERATOR

Now a Service Free Light Plant built with a transistorized alternator. Offers 30% greater efficiency—more power for less fuel. Terrific service life—no brushes to arc and burn. No more commutator to wear, no collector ring trouble. And best of all it costs no more to "go modern with Everlite." Thrifty 1000 watt, 115v. AC plant powered by a rugged easy starting 4 cycle engine—leader priced Model 869-10T. Wt. 65 lbs. as illustrated . . . . . **179.50** f.o.b. factory

All sizes available—can finance. Write for catalog.

## MASTER AIR COMPRESSOR

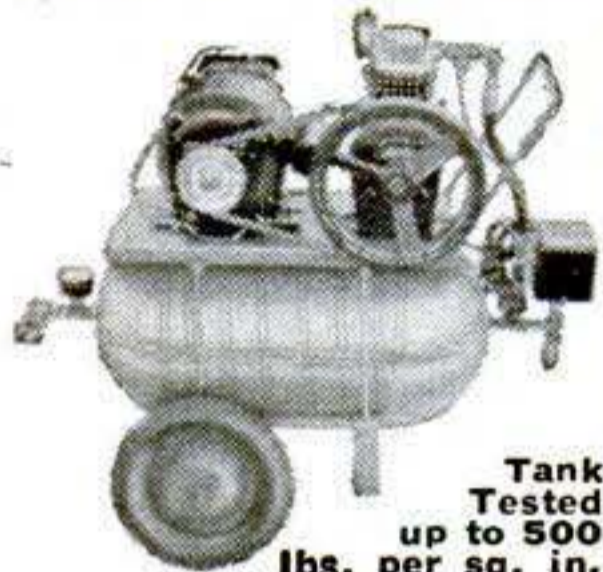

Tank Tested up to 500 lbs. per sq. in.

**COMPARE!** This is the only compressor built with a **NO RUST** stainless steel tank. Safe up to 500 lbs. (Item 209) High pressure type (4 c.f.m.) Large volume of air for heavy duty spraying, inflating truck & auto tires, greasing, and blasting, etc. Piston type 2" bore compressor with built-in air filter. Master built with high strength alloys and precision bearings. Tank, 12"x24", 2100 cu. in. cap. Equipped with automatic switch that starts and stops motor to maintain desired pressure (up to 150 lbs.) and check valve, safety valve, gauge, shut-off valve, 20 ft. air hose and tire chuck. Beautifully balanced on ball bearing

wheels and rubber tires. Don't take chances with used or surplus equipment. Our compressors are factory new and are guaranteed safe. Low factory prices, 1/3 hp. model 209, 85 psi. Regularly \$175.00 etc. (Item 209) . . . . . **\$109.50**

1/2 HP, heavy duty model, big pump, 3.8 cfm, heavy motor with unloader switch. (Item 209a) . . . . . **\$129.50**

Compressor only, same as on Item 209, 2.8 cfm Item 209co, 2x1 3/4 . . . . . **\$19.25**

Item 209aco, (2x2) same as on 209a . . . . . **\$25.50**

Item 209hco, (2 1/2 x 2 twin cyl.), 8 cfm . . . . . **\$47.75**

Send 10c for big catalog: All prices fob factory Special models for public utilities—Approved for Civil Defense. Write

**MASTER MECHANIC MFG. CO., Dept. B-463, Burlington, Wis.**

Southern Customers write Dept. B463, Box 65, Sarasota, Florida

# Planer • Molder • Saw!

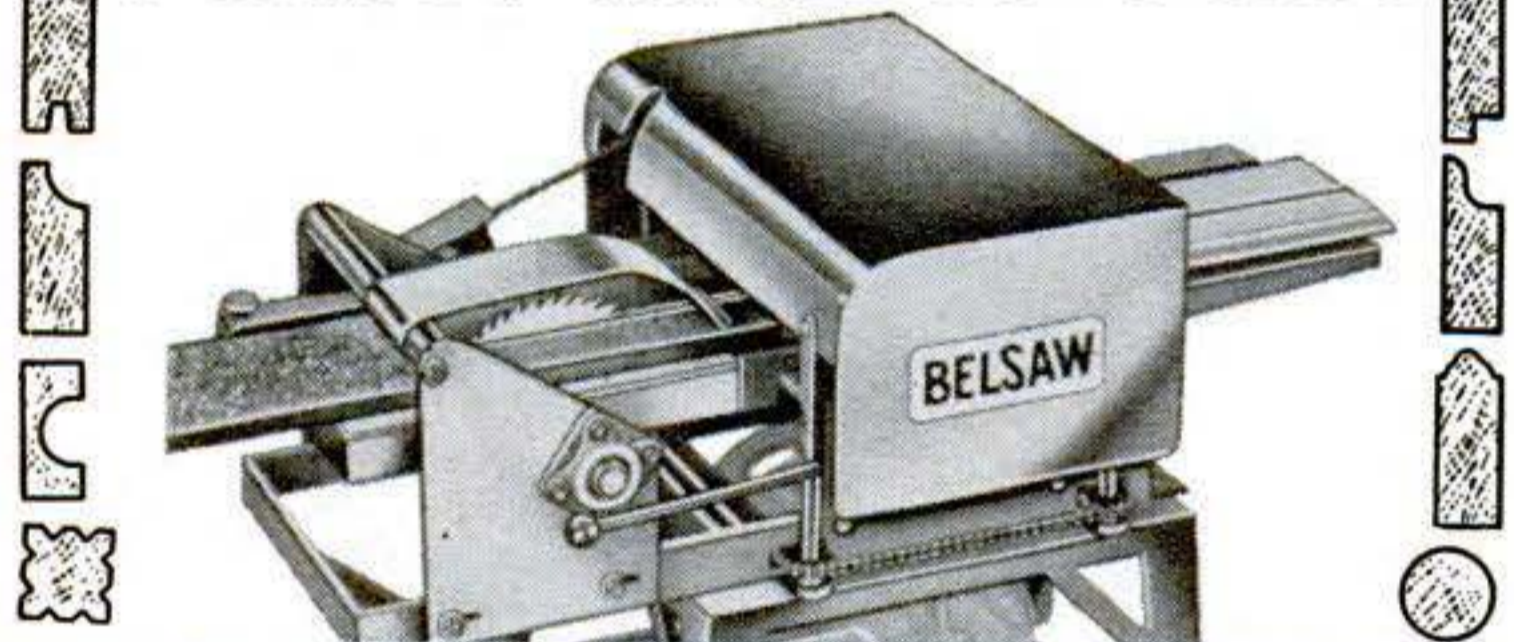

Now you can use this ONE power-feed shop to turn rough lumber into moldings, trim, flooring, furniture . . . ALL popular patterns. RIP . . . PLANE . . . MOLD . . . separately or all at once with a one HP motor. Use 3 to 5 HP for high speed output. Low Cost . . . You can own this power tool for only **\$30.00** down payment.

Send postcard today for complete facts. **BELSAW POWER TOOLS, 293 Field Bldg., Kansas City 11, Missouri**

# A Complete Miniature Machine-Shop!

**Metal - Plastics - Wood**  
 • Turns • Threads • Bores  
 • Drills • Mills • Grinds  
 • Polishes • Buffs • 900-7200 rpm • 16" of bench space

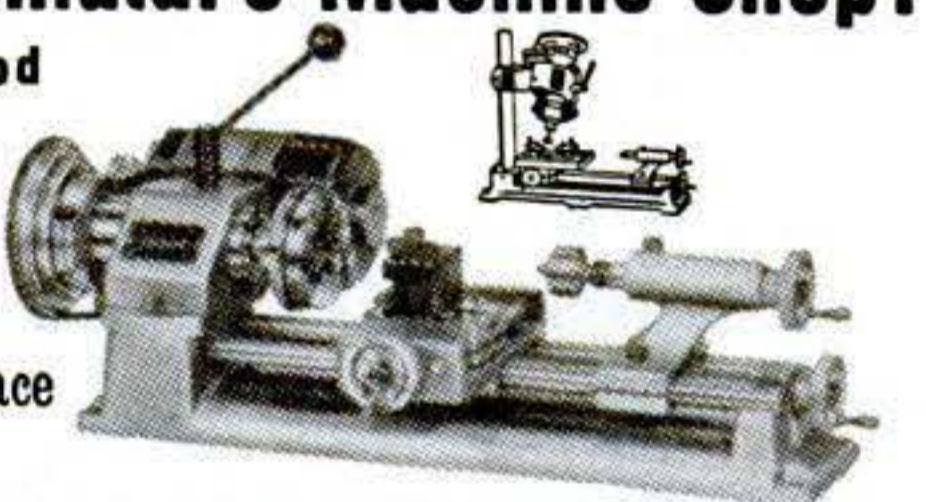

BASIC UNIMAT: \$139.50 (includes high-efficiency motor). WRITE FOR FREE CATALOG.

**AMERICAN EDELSTAAL, INC., DEPT. HD, 350 BROADWAY, N.Y. 13, N.Y.**

# CASTER LOOSE? fix it quick with

# PLASTIC WOOD®

Handles like putty-hardens like wood!

# Time Bombs in the Mississippi

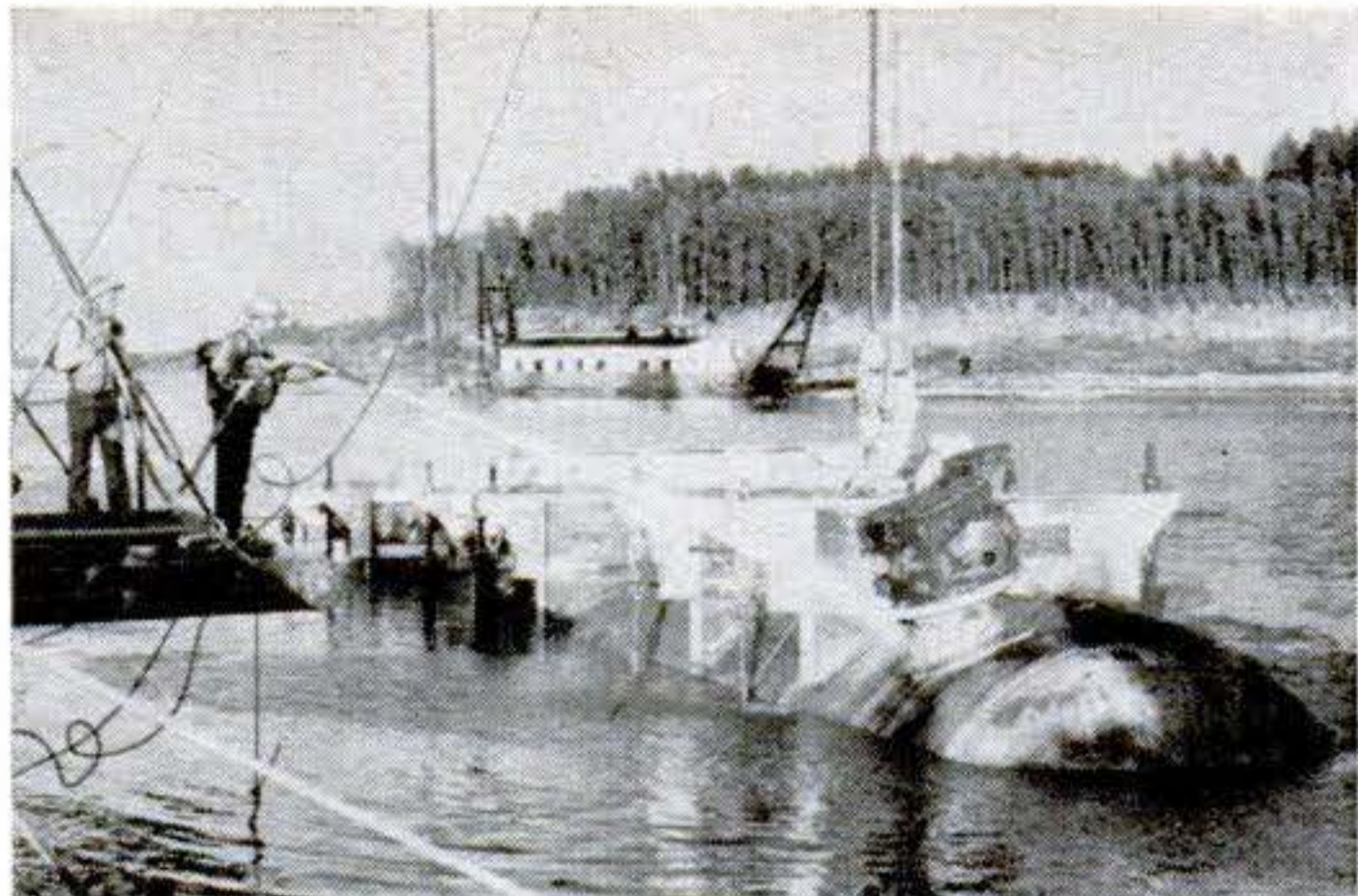

Tip of tank emerges. Chemists with water jets hose off slime in case they must board.

in his derrick. Then, all together, the sling cables slipped.

An ugly clang sounded from the tank. The 30-ton strongback lost its grip and began to slide. Then—with an enormous shock—it caught a new grip. The shift was over almost before it began. The steam engines kept their steady, silky pull as if nothing had happened.

By 3:21, the No. 1 tank was up. Water jets were turned on the slimy metal so men could go aboard, without slipping, to ram caps over the valve. A barge took the horrible thing away. As the tank sailed down the river, its tough white paint glistened.

"That," said a watching diver, "is what held the whole damned thing together." The epoxy resin that had so brutally fought the torches had with equal stubbornness fought off the rust that could have brought disaster.

It had been an incredible 10 days of frightening work, without pause day or night. And there was more to come. But by November 5, the other tanks were recovered and eight tired divers threw their badly battered helmets into trucks and headed back to Texas. ■ ■



Glistening tank is hauled away at last. It's bound for a chemical plant near Baton Rouge.



# NEW Wonder-Paste

**speeds paint removing  
NO WASH-UP NEEDED**

Apply with a paint brush. It's heavy-bodied—won't run on uprights. Retains its consistency regardless of temperature. When paint is softened, slide it off with a putty knife. No wash-up with solvent needed. Effective on paint, enamel, varnish and other finishes.

At paint and hardware stores.

● Send 25¢ for illustrated Refinishing Manual  
Free literature on request.

Wilson-Imperial Co., 121 Chestnut St., Newark 5, N. J.



## GENUINE ALNICO MAGNETS

**AMAZING, PERMANENT, NON-ELECTRIC. HIGHLY PRACTICAL.** Conduct interesting experiments. Hundreds of uses. Retrieve valuable steel items such as guns, tackle from fresh or salt water; tools from tanks & drains. **GUARANTEED.** Try any magnet one week. Money back if you are not well-pleased.

- S-90 (Wt. 5 oz.) Has pull of 15 lbs. on steel block . . . \$ 3.50
- S-500 (Wt. 13 oz.) Has pull of 50 lbs. on steel block . . . \$ 5.00
- S-575 (Wt. 18 oz.) Has pull of 75 lbs. on steel block . . . \$ 7.00
- S-625 (Wt. 70 oz.) Has pull of 125 lbs. on steel block . . . \$10.00
- S-710 (Wt. 53 oz.) Has pull of 225 lbs. on steel block . . . \$18.00
- S-44 Rod Magnets for Electric Guitars 1/4" Dia. x 1 1/4" 12 for \$ 4.00
- S-47 Hot Pad Magnets. 10 for \$1.00 . . . . . 50 for \$ 4.87
- S-35 Science Experimenter Kit of 8 magnets . . . . . \$ 2.00

Send M.O. or check. We pay postage. Sorry no C.O.D.'s.  
MIAMI MAGNET COMPANY, 3240 N. W. 27th Ave., Miami 42, Fla.

## ADJUSTABLE MITER BOX & CORNER CLAMP



Holds the wood and holds your saw. No. 44 Uses any handsaw for accurate cuts from 0° to 180°. Full 3" capacity. Sides of joints exposed for nailing, gluing. PPD

No. 33 Works the same as No. 44, but without saw guide attachment. \$1.75 ppd.

### DRILL GRINDER

Sharpens round shank drills like new with hand or power grinders. \$2.95 ppd.



Adjusts to any angle!  
send for **FREE CATALOG**

A. D. McBURNEY, 5908 Hollywood Blvd., Hollywood 28, Cal., Dept. 5-43

## make your own Gems 36<sup>50</sup>

The Gem Maker comes complete with all necessary equipment, including a super-charged diamond blade for sawing, and all the wheels for grinding, shaping and polishing; also complete instructions. The complete equipment as shown, less motor and belt for only \$36.50, f.o.b., Burlington, Wisconsin. Write today for information and literature.

**B&I MANUFACTURING CO.**  
Dept. 5 Burlington, Wis.

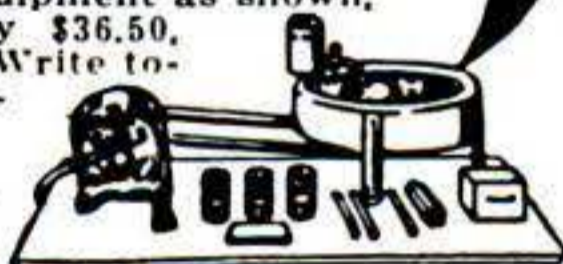

## DYNAMIC INDUSTRIAL TYPE TRANSFORMER WELDER

**WELD-CUT-BRAZE-SOLDER-HEAT  
IRON-STEEL-BRONZE-BRASS  
ALUMINUM AND OTHER METALS**



Professional Electric Arc Welder. Ideal for Home, Shop, Farm or Industrial use. The handiest tool in your workshop. Weld, Braze, Solder, Cut, Bend all metals. Do expert work on your first job. Build or repair Boats, Trailers, Auto Bodies, parts, fenders, metal and ornamental iron furniture, fixtures, farm equipment, garden tools, bicycles, toys, etc. Operates on any properly wired 110 V. A.C. line. Complete with helmet, arc torch, electrode holders, flux, rods, cables, instruction book. **FULL YEAR GUARANTEE.** 10 day money back trial. **ONLY \$38.50 f.o.b.**

**Only \$38.50 f.o.b.** Send only \$6.00 check or m.o. Pay postman balance plus charges. **EASY PAY PLAN.** Low down payment. Pay as you weld.

**DYNAMIC WELDER CO.** 1808 SOUTH FEDERAL STREET  
Dept. D3-D, CHICAGO 16, ILL.

# Shoot a staple wherever you'd drive a nail!

Uses 6 Staple  
Sizes . . .  
1/4" to 9/16".

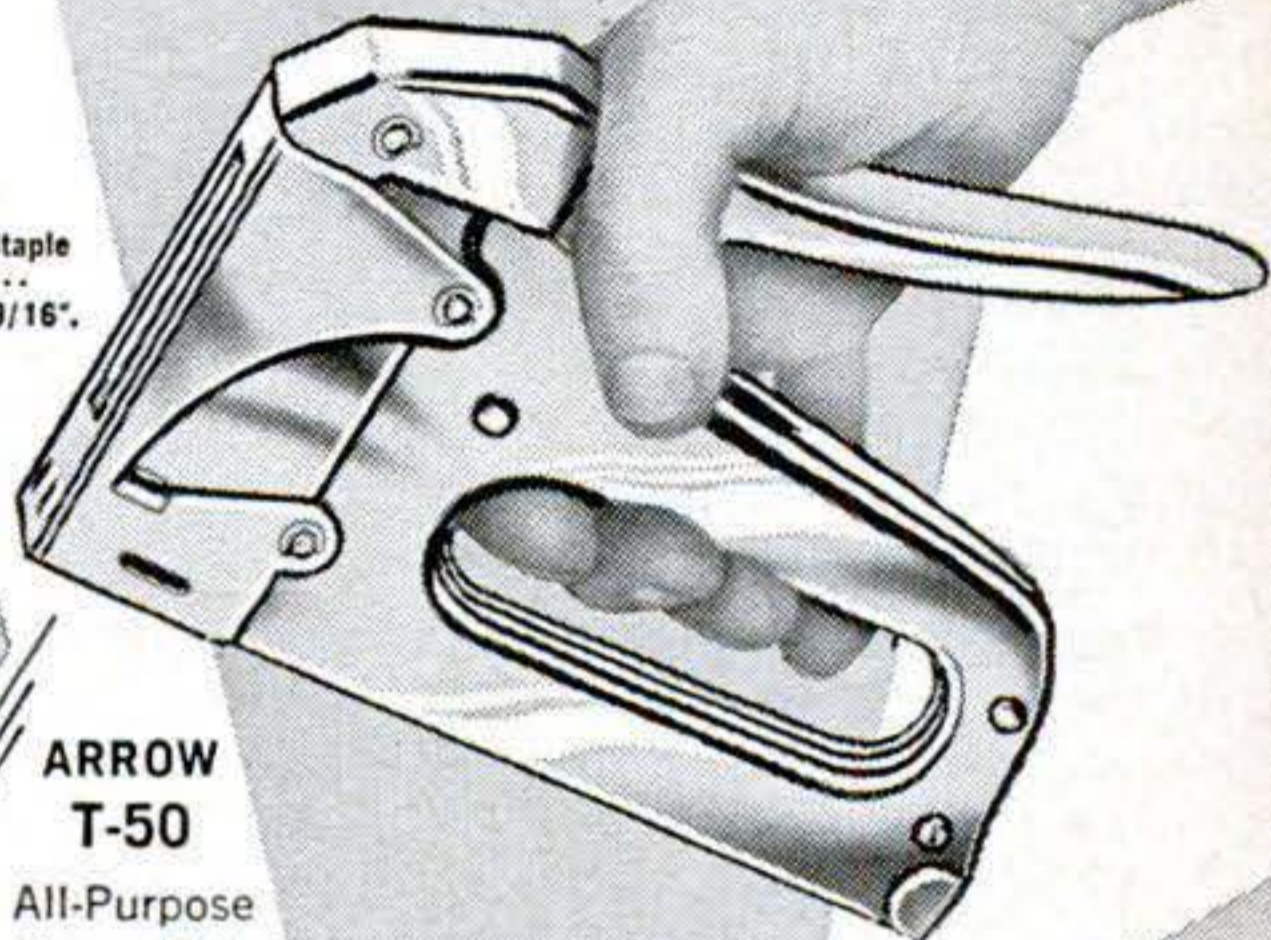

**ARROW  
T-50**

All-Purpose  
Heavy Duty  
STAPLE GUN



**ARROW  
JT-21**

Household  
Light Duty  
STAPLE GUN

**FEATURED SPECIALS  
for 1963 HARDWARE WEEK  
at 22,000 hardware stores!  
(April 18-27)**

**T-50 SPECIAL:**  
\$14.28 VALUE—only \$12.50

- T-50 Staple Gun . . . . . \$12.50
- Staple Lifter . . . . . 1.00
- Bonus Certificate\* . . . . . .78

**TOTAL VALUE \$14.28  
SPECIAL PRICE \$12.50  
CONSUMER SAVES \$ 1.78**

**JT-21 SPECIAL:**  
\$6.48 VALUE—only \$4.95

- JT-21 Staple Gun . . . . . \$4.95
- Wire/Screen Attachment .75
- Bonus Certificate\* . . . . . .78

**TOTAL VALUE \$6.48  
SPECIAL PRICE \$4.95  
CONSUMER SAVES \$1.53**

**YOU RECEIVE WITH PURCHASE OF EITHER GUN:  
\*EXTRA BONUS CERTIFICATE!**  
Worth 78c towards additional purchase of Arrows P-66 hand stapler and 1,000 staples. Reg. \$1.78 value!

**ARROW**  
ARROW FASTENER COMPANY, Inc.  
One Junius Street • Brooklyn 12, N. Y.



**"MADE \$1200  
ON ONE JOB"**

*Some make more, some less...*

**We help you start Your  
Own All-Year Business**

**Make BIG Money!** With our easily operated, highly efficient wall washer, G. H. Jones made \$1200 on one school job. E. L. Goss took in more than \$10,000 in one year. E. C. Taber wrote, "I made \$400 gross in two weeks."

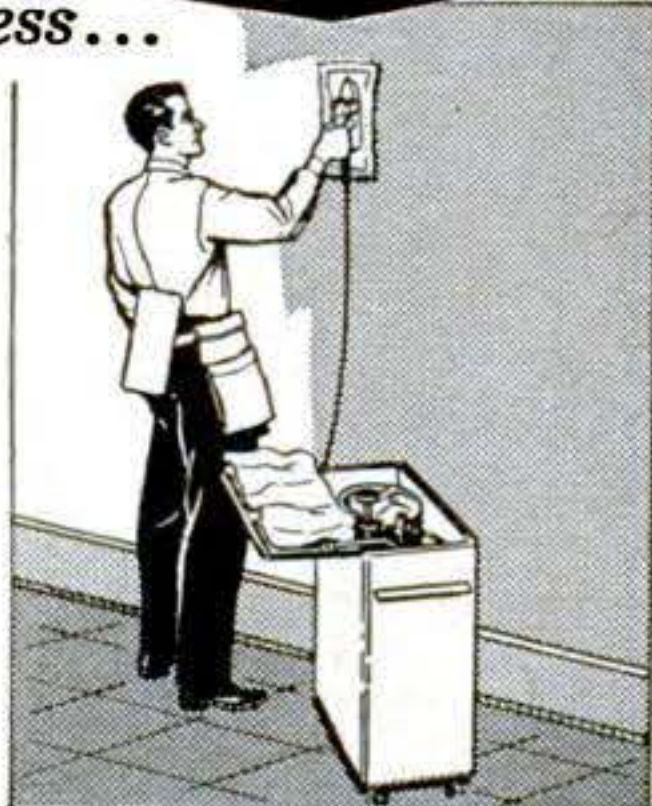

And no wonder... this machine washes walls 6 times faster and better than by hand—with no mess...no drop cloths.

**Your Money-Making Opportunity** • We want more men to go into this profitable business for themselves and enjoy independence—freedom from layoffs and bosses. Customers everywhere—homes, offices, schools, churches, hotels, etc. How much you earn depends largely on you, but we help you to start and work with you for your success. What you take in is mostly profit. No need to rent shop or office; operate from home. Can start spare time until your full time is justified.

**OURS IS NOT A LEASE ARRANGEMENT** • You are free to operate in an independent manner. You sign no contract. You own the detergent outright and are always *your own boss*...and every dollar you take in is *yours* to keep. You pay no fees, or dues, or royalties to anyone. And you take no risk. Your detergent is fully guaranteed and enough supplies come with it to return far more than your investment. Many earn the cost of the detergent in a week or two. It costs nothing to get the details...write **TODAY**.

**Lose No Time — Send Coupon Today for All the Facts**

**FREE BOOK! MAIL COUPON TODAY!**

**VON SCHRADER MFG. CO.**

**411 "W" Pl., Racine, Wisconsin**

Send at once (no obligation) your **FREE** booklet containing information about your **WALL WASHING MACHINE** and how I can start *my own* permanent, profitable business.

Name \_\_\_\_\_

Address \_\_\_\_\_

City \_\_\_\_\_ Zone \_\_\_\_\_ State \_\_\_\_\_

**TABLE TIPSYPY?**

fix it quick with



**PLASTIC WOOD**

Handles like putty-hardens like wood!

**Weightless Workshop**  
[Continued from page 112]

and plant visitors stared. (The first astronaut with glasses.) Cording and several coworkers marched me to the machine and strapped me on. I started sweating.

"Ready?" I wasn't, but I nodded. Cording plugged in the air hose, and I felt the machine rise slightly and start to slither around the floor. Then he pulled loose the bar that held me upright.

The room whirled—and there I was, standing on my head. A couple of technicians hopped over and pulled me upright again. "Sorry," one of them said, "You're top-heavy." More adjustments.

The bar was pulled loose again, and I floated in space. All my fear vanished. The sensation was fascinating: A little jerk of the head and I spun around. A snap of the arm and I stopped. I blew sharply, and in slow motion did a flip on my axis.

"Now let's see you do some work," said Cording. He shoved the machine to where he had set up a repair problem.

Working Phillips-head screws was easy. Though steady pressure can't be used, screws can easily be cracked loose or tightened with a jerk of the arm and hand. The wrench was a little tougher to work. The nuts were on tight, and I had to use body mass as leverage. When I mistimed the yank, the nut wouldn't turn; I would.

By then perspiration was running into my eyes. The crew unstrapped me. My knees were wobbly. I was bone-weary.

Later, I asked Cording why. "You worked harder than if you were on the ground," he explained. "A man under zero-G conditions may use 30 to 40 percent more oxygen than he would doing the same work on earth."

Other things Spaceworker has shown:

- Man can adapt to weightless conditions more easily than had been supposed.
- Special tools—reactionless wrenches, for example—will be needed only for odd jobs, where extra leverage is required, or in hard-to-get at spots.
- A supporting belt will be necessary—perhaps like a window washer's harness—attached to the spaceship's hull.

The next GE research step will be to balance the work panel so it "floats" up and down—the only plane in which Spaceworker can't move. And early this summer, Cording expects to develop a propulsion system—a back pack or gas belt. ■ ■



# EASIEST WAY TO GET THAT HAND-RUBBED LOOK

First non-pigmented semi-gloss finish ever developed. Accentuates all grain patterns, colors and wood tones. No primer needed. The most luxurious "hand-rubbed" finish ever seen! Won't darken or discolor. Easiest to use. For all interior wood surfaces, old work or new. At Paint, Hardware, Lumber stores. Send 50¢ for complete wood finishing manual, P & S Chemical Corp., Box 466, Buffalo 5, N.Y.

## Without Rubbing

Made by the makers of famous FABULON

# WOOD LORE

SEMI-GLOSS NATURAL WOOD FINISH

## ELECTRIC WELD - BRAZE & CUT

REPAIR MOST EVERYTHING MADE OF METAL

Home, Car-Factory, Farm-garden equipment. Make and repair lawn chairs, tables, ornamental iron, gates, etc. Solder, heat, bend, with terrific heat from arc torch shown. Cut and weld up to 1/4" steel plate. A million uses for Home, auto, farm, inventors, factories, etc. Works from any 110 volt plug-in. Complete with dark welders facemask, arc goggles, arc torch, supply of carbon welding and brazing rods. Complete beginners



Welding Instruction Book. 1 year guarantee. SEND ONLY \$2.00 (cash, ck, mo) and pay postman only \$12.95 plus COD postage on arrival or send \$14.95 and we will send postpaid. Ideal gift for mechanically minded, relatives, friends. Available only from MIDWAY WELDERS Dept. DPS-4, KEARNEY, NEBR.

## DRAINS cellars, cisterns, wash tubs; \$7.95 IRRIGATES - CIRCULATES - SPRAYS

1,001 uses. Stainless shaft. Won't rust or clog! Use 1/8 HP motor or larger . . . 3/4 HP for up to 2,400 GPH; 450 GPH 80' high; or 1800 GPH from 25' well. 1" inlet; 3/4" outlet. Coupling included free. \$7.95. HEAVY DUTY BALL-BEARING PUMP. Up to 5,200 GPH; or 3,000 GPH from 25' well. 1 1/4" inlet; 1" outlet. \$12.95 Postpaid if cash with order. MONEY BACK GUARANTEE

Centrifugal and Gear Pumps in All Sizes  
LABAWCO PUMPS, Belle Mead 3, New Jersey

Model B-2  
2 Ton

### ALVA ALLEN Swaine Power Punch Presses 1 to 150 Ton Capacity

Complete line of Punch Presses in hundreds of different style and model combinations. Write for FREE literature on presses and complete line of punch Press accessories as—Feeds, Punch Units, Dies, etc. Alva Allen Industries, Dept PS, Clinton, Mo.

\$107.50  
job  
less  
Motor

fast, lasting repairs

# Magic

## FIXES EVERYTHING!

Magic Plastic Aluminum • Epoxy Glue  
Magic Rubber • Fix-All Porcelain  
Tub 'N Tile Sealer • Magic Wood  
Woodblend Putty Pencils

at all stores

29¢  
to \$1

Magic Iron Cement Co., Inc.  
Cleveland 28, Ohio

MAGIC STEEL  
for all permanent repairs!  
READY TO USE  
...no heat or mixing!

# WAR SURPLUS AND OTHER BARGAINS SAVE UP TO 90%

## HI-PRESSURE PUMP & MOTOR UNIT

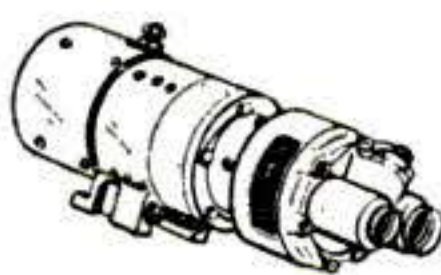

Just received from Air Force stock. Ideal for pumping oil, hydraulic, diesel, insecticides and other fluids. Adjustable relief valve for varying pressure from 1400 PSI down. Also operates well on reduced pressure at 12 V.D.C. Inlet port 3/4" pipe, outlet 1/2" pipe, 15" L. x 4 1/2" W. x 5 1/2" H. Shpg. wt. 23 lbs. Approx. GOVT. COST \$280. NEW. \$17.95

## 50-1 GEAR HEAD MOTOR



Terrific for pulling or lifting. Makes excellent small winch. Also can be used for electric steering of boats. Output speed 180 RPM. Reversible. Contains chain sprocket & pulley on 1/2" shaft. Runs on 24 V. AC or DC. Wt. 9 lbs. Approx. GOVT. COST \$97. NEW. \$10.95.

## "BIG 12" ARC WELDING AND BATTERY CHARGING KIT



With Deluxe accessories consisting of one R1 300 amp generator, 30 feet welding cable, welder's adjustable helmet, electrode holder, 300 amp ammeter, 300 amp shunt, rheostat, toggle switch, 300 amp reactor coil arc stabilizer, voltage regulator, battery charging relay, one pair heavy duty welder's gloves. All units guaranteed pre-tested. Approx. Govt. cost \$750. Most items new — all perfect. Wt. 82 lbs. \$49.50

## FAMOUS P2 GENERATOR — 200 AMP.



continuous duty rating at 24 to 32 V.D.C. 4000 RPM. Self-contained cooling fan. One of the finest DC Gen. in use today for all welding or battery charging purposes. All units pre-tested prior to shipment. Shpg. Wt. 50 lbs. Approx. GOVT. COST \$375. Terrific value \$29.50.

## NEW! ELECTRIC PUMP WITH CONTROL UNIT



For boats, campers & trailers. Output 10 to 200 gal. an hr. Variable rheostat contains on & off switch and controls output of pump. 1/2" pipe thread into bronze impeller housing. 12 V.D.C. Radio noise filter. Explosion-proof const. Shpg. Wt. 9 lbs. Complete with mounting instructions & wiring diagram. Approx. GOVT. COST, \$200. NEW. \$10.95.

## DELUXE ELECTRIC STORAGE BATTERY WINCH



Handles 250' of 1/4" cable. Operates on 12 V. battery. 160-1 gear reduction. Lift cap. 2500 lbs. Heavy-duty mounting base with outrigger bearing and spool support. Rugged construction. Heavy-duty. Dim. 22" L x 9" W x 8" H. For jeeps, trailers, boats, trucks, campers. Shpg. wt. 80 lbs. Approx. GOVT. COST \$490. NEW. Model E-D. \$72.50

MODEL E Same as above but without heavy-duty base and outrigger support. Spool cap. 70', 1/4" cable. NEW. \$52.50

## BIG NEW 1963 CATALOG!



Send 25c in coin for amazing new catalog with 1000's of surplus bargains in hydraulics, electrical, precision tools, marine items, automotive, etc. for hobbyists or industrial. Or order from this ad and receive a free copy. All prices F.O.B. Culver City, Calif. 50% dep. for C.O.D. Send check, cash or money order. Order today!

**AIRBORNE SALES CO., INC. DEPT. PS463**  
8501 Stellar Drive • Culver City, California

## NEW CATALOG

Everything for the Craftsman  
Over 1,500 Items  
Finest Domestic and Imported Woods...  
Kits... Ornaments  
...Tools... Special Hardware... Tile.  
LOW MONEY-  
SAVING PRICES  
Stanley Power Tools  
—Big Discounts!



## Workshop Supplies, Equipment

Send for Craftsman's NEW 132-page catalog . . . get big discount prices on Stanley Power tools! Finest kiln-dried domestic and imported woods, wood and metal legs, ornaments. Over 1,500 items! Big values on tools, craftsman hardware, MosaicTile, upholstery supplies, lamp parts. Glue Injectors. Send 25c to help pay postage and handling. Craftsman Wood Service, Dept. B-4 2729 S. Mary St., Chicago 8, Ill.

MAIL  
COUPON  
NOW!

**CRAFTSMAN WOOD SERVICE CO., Dept. B-4**  
2729 South Mary Street, Chicago 8, Illinois  
Enclose find 25c. Rush new CRAFTSMAN Wood Catalog.

NAME \_\_\_\_\_  
ADDRESS \_\_\_\_\_  
CITY \_\_\_\_\_ ZONE \_\_\_\_\_ STATE \_\_\_\_\_



# THIS HANDSOME, ADAPTABLE BRASS BOOK RACK **YOURS FREE**

## as a joining member of the Popular Science Living Library Program

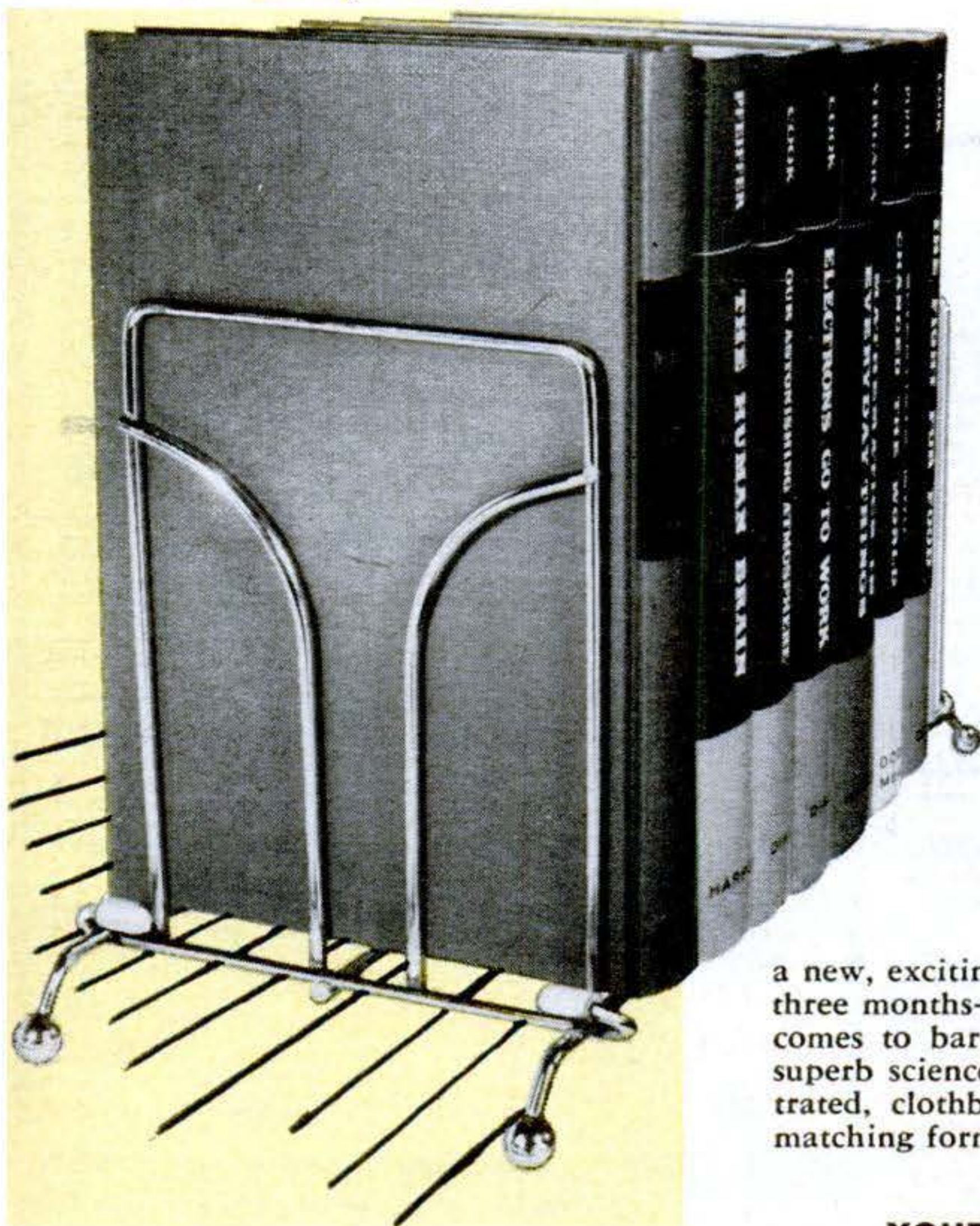

This completely new kind of book club was created especially for Popular Science readers. It is an exciting book program which makes it simple for you to build an ever-growing library of fact-filled, easy-to-understand science books at tremendous savings. In these exciting books, you'll explore every aspect of modern science—from the invisible atom to the complex human machine to the vast solar system.

By joining the **POPULAR SCIENCE LIVING LIBRARY PROGRAM** now, you immediately receive the beautiful brass book rack pictured at left, absolutely free. You also receive your first regular book selection, **MAN AND HIS BODY**, for only \$1.95. Thereafter, you receive a new, exciting Living Library selection approximately every three months—at a guaranteed low price of only \$1.95. That comes to barely 2¢ a day. Yes, for mere pennies, you get superb science books that are handsomely printed and illustrated, clothbound in a variety of attractive colors, all in matching format.

### **YOU'LL BE DELIGHTED WITH YOUR FREE MODERN BRASS BOOK RACK!**

Yes, your stunning, hand-crafted book rack of solid brass will add a decorator's touch to any room. Designed with simple, yet elegant lines, it will fit perfectly with any decor, will serve beautifully to hold reference books on your desk or to display books in your living room. Your free brass book rack will be sent to you individually packaged at the same time your first regular selection, **MAN AND HIS BODY** (at only \$1.95) is shipped.

What's more, even if you should decide *not* to join the **LIVING LIBRARY PROGRAM** after you've examined your first selection, you may *keep* the beautiful book rack with no further obligation!

### **YOUR PRACTICAL BOOK RACK IS COMPACT AND ADJUSTABLE!**

Your book rack will hold as many or as few books as you wish—it is fully adjustable. It folds flat when not in use and is easy to store. Special protective ball feet will not scratch furniture.

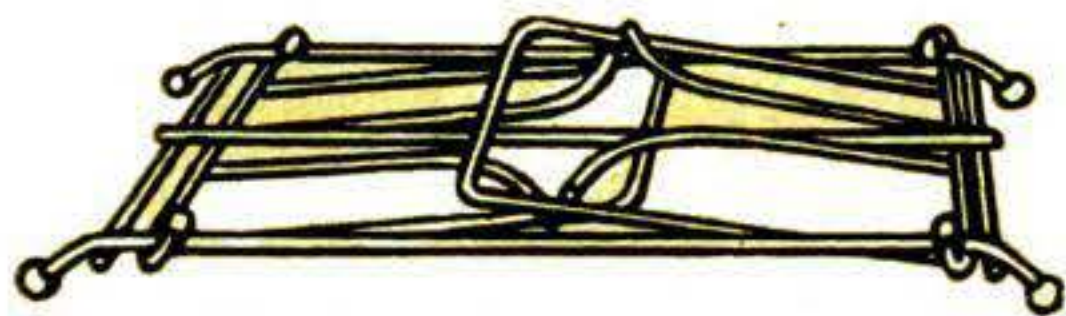

Folds flat when not in use, easy to store. Special protective ball feet will not scratch furniture.

Popular Science Living Library Program, 355 Lexington Ave., N. Y. 17

## **MAIL CARD TODAY - BUILD A VALUABLE**



# YOUR FIRST CLUB SELECTION--AND EVERY OTHER SELECTION--COMES TO YOU FOR ONLY \$1.95

One of the many advantages of membership in the POPULAR SCIENCE LIVING LIBRARY PROGRAM is that books are never priced higher than \$1.95 (plus postage) even though the bookstore prices are much higher. What a wonderful way to build a lifetime library of clothbound science books at very little cost!

You'll be delighted to find, as your LIVING LIBRARY grows, that your enjoyment and knowledge of modern science have deepened, that you have at your fingertips a ready grasp of subjects which may have baffled you before, that you can easily answer so many questions your friends and family ask.

As a member of the POPULAR SCIENCE LIVING LIBRARY PROGRAM, you will receive the cream of today's popularized science books. You never pay for a book in advance. We bill you later. All selections are fully returnable within 10 days. And, of course, you may resign from the PROGRAM at any time by simply dropping us a line.

## YOUR FUTURE BOOKS WILL COVER OTHER THRILLING SCIENCE SUBJECTS!

New books in the POPULAR SCIENCE LIVING LIBRARY PROGRAM will cover such fascinating subjects as the living drama of medicine... the amazing world of animals and nature... the development of power from windmill to nuclear reactor... the conquest of space... the fantastic workings of the human body... the teeming life in the soil beneath our feet and much, much more! Drawing upon the riches of chemistry, biology, botany, archeology, atomic science, zoology, physics, meteorology, and all the other fascinating branches of science, the LIVING LIBRARY PROGRAM will bring you books that are masterpieces of simplicity and readability! Each one will be a valuable addition to your growing, comprehensive home science library! So, get on the road to the best science reading at the lowest possible prices, without risk! Mail the attached post-free card TODAY!

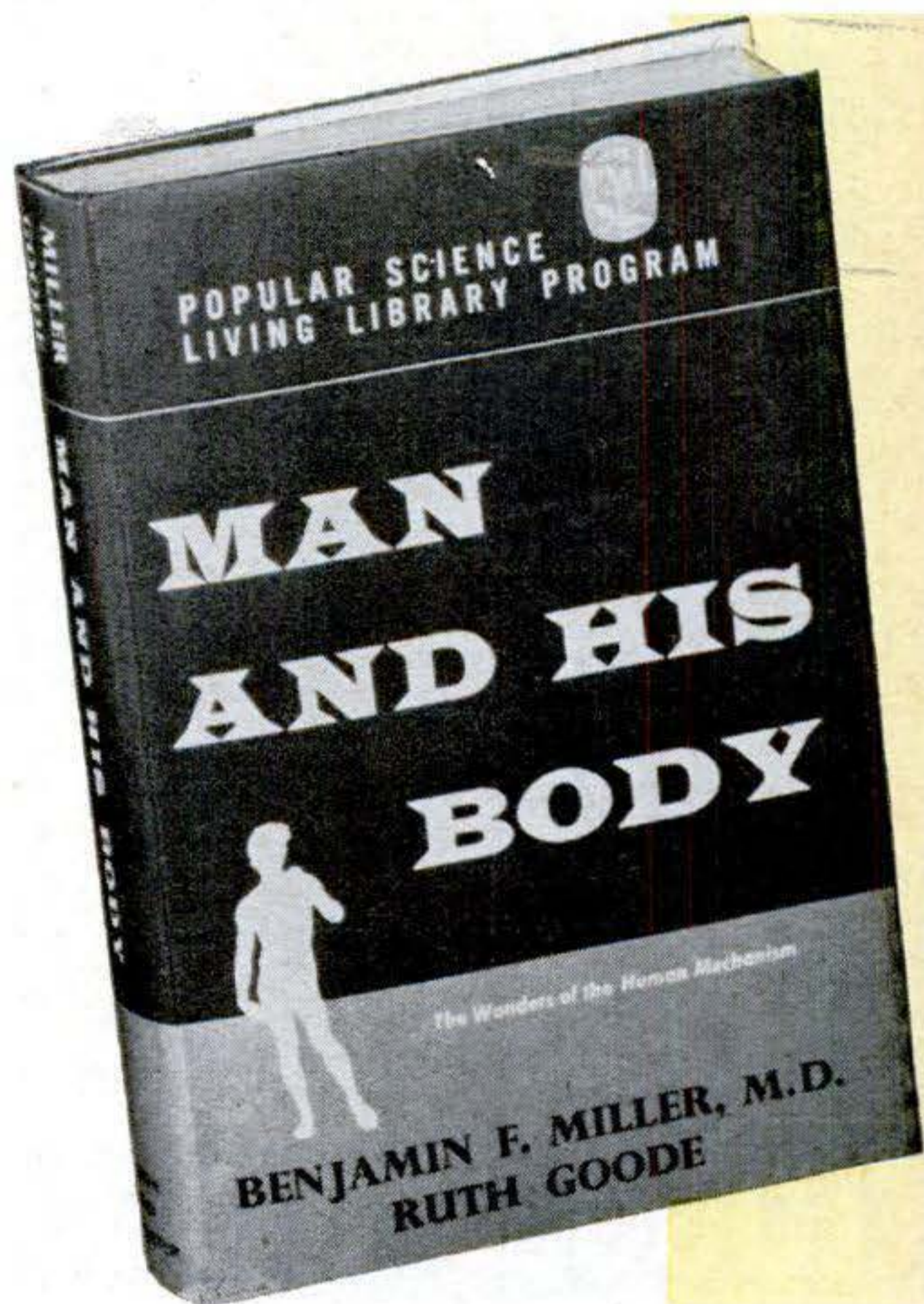

**MAN AND HIS BODY** (Your first selection, only \$1.95). This handsome volume of nearly 400 pages unfolds and explores the wonders of the human mechanism. You will see life begin as a single cell and watch it evolve into the amazing organism of thirty trillion highly specialized cells that constitute man. With ever-growing fascination you will learn of the body's architecture and safety devices, the internal rivers of life, the body's great chemical workshop, the biological love story of reproduction, the man of the future, and so much more. It's all brought to you in a brilliantly clear and readable style, with drama, excitement and inspiration. Illustrated.

## CHECK THE MANY MEMBERSHIP ADVANTAGES IN THIS EXCITING NEW PROGRAM!

**GET YOUR FREE BRASS BOOK RACK IMMEDIATELY** along with your first selection, **MAN AND HIS BODY**.

**FIXED LOW PRICE TO MEMBERS FOR EVERY BOOK.** All LIVING LIBRARY books are priced at only \$1.95, regardless of higher bookstore prices. All books handsomely bound in cloth and jacketed.

**YOU NEVER PAY FOR A BOOK UNTIL AFTER YOU'VE READ IT.** You must first be convinced that it is an outstanding buy.

**FREE 10-DAY EXAMINATION OF EVERY SELECTION.** You *alone* decide whether you want the book or not. Books are always returnable, with no obligation.

**CHOOSE AS MANY OR AS FEW BOOKS AS YOU WISH.** No minimum number of books required. Take only what you like.

**AUTOMATIC SHIPMENT OF SELECTIONS.** Books are sent approximately every three months--no forms to fill out, nothing to forget.

# SCIENCE LIBRARY FOR ONLY 2¢ A DAY!



How would you like a

# SIDE LINE BUSINESS IN YOUR GARAGE?



Ever thought about owning a small business in your home that would net you an extra \$100 to \$200 a month? A business that did not need a large investment and one that you could operate whenever you wanted to work? If you have a small space in your basement or garage, here's an exceptional money-making opportunity. Hundreds of others, just like you, have started such a business in their spare time, found it so profitable

(90c out of every \$1.00 is clear profit) that they have quit their regular job to devote full time to this unique business. Since 1932 we have shown hundreds of men how to build a profitable service business with Foley Saw Filing equipment.

**FREE BOOKLET TELLS HOW**—This fact-filled booklet explains how you can start, how to get business from hardware stores, home owners, carpenters, schools, factories. It tells actual results of others whom I have helped start in business. Send coupon today. No salesman will call.

Walter M. Ringer, Jr., President, Foley Mfg. Co.  
449-3 Foley Building, Minneapolis 18, Minn.

Please send me free booklet with complete information about this profitable home business.

Name \_\_\_\_\_

Address \_\_\_\_\_

City \_\_\_\_\_ Zone \_\_\_\_\_ State \_\_\_\_\_

## CLOGGED SEWERS

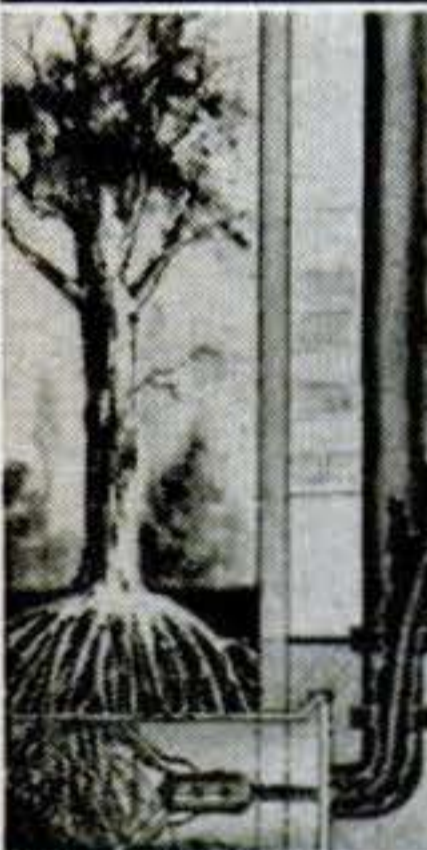

**SAVE COSTLY PLUMBING REPAIR**

PATENTED CUTTERS  
CLEANS  
1" TO 12"  
PIPE  
with Power

★ **FREE BOOK** Tells How To Clean All Drains

Valuable advice on removing Roots, Grease, Detergent, Rags in TOILETS, SINKS, URINALS, BATHTUBS, SHOWERS, HOUSE-TO-STREET SEWERS. Get rid of foul odors. Do your own rodding or start your own Business. Receive **FREE SKETCH** of Plumbing Pipeline in average Building. Save Plumbing Bills. Write for this helpful **FREE BOOK** on Hand and Electric Units. No Agent will Call. (Chicago Phone Kildare 5-1702) **MILLER SEWER ROD, DEPT. PSF, 4642 N. CENTRAL AVE., CHICAGO 30, ILL.**

## AUTOMATIC

MAKES NEW PROFITS

## RETOOTHER

for HAND SAWS

Cuts new teeth in 50 seconds—any size 4 to 16 points. Old teeth fall off as chips. Easy to operate. A perfect job.

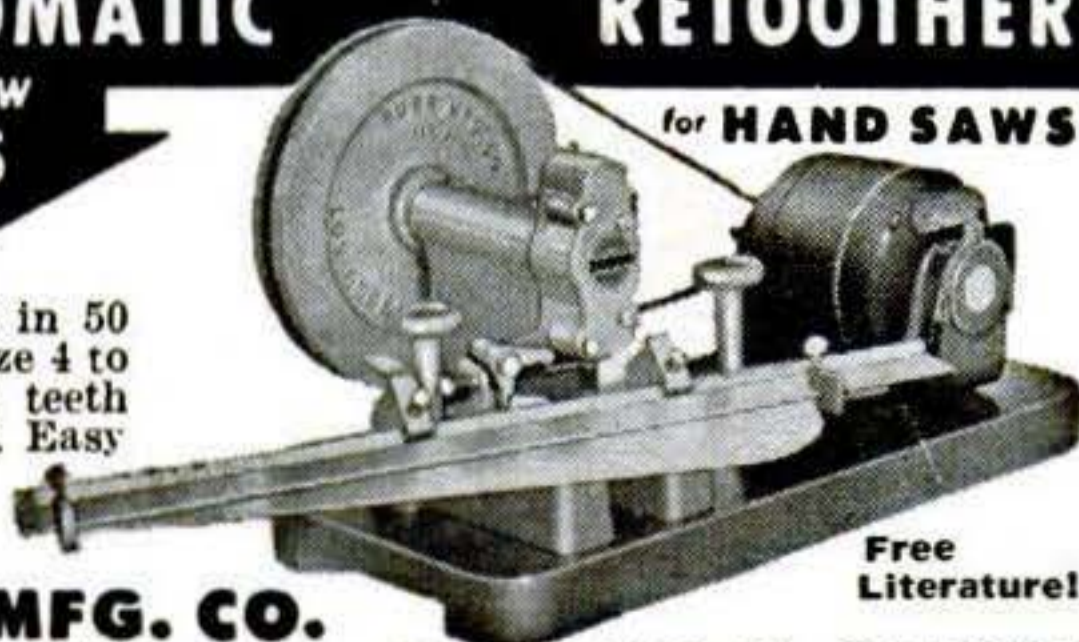

Free Literature!

**BURR MFG. CO.**

8943-A VENICE BLVD.

LOS ANGELES 34, CALIFORNIA

## Move in Close

[Continued from page 150]

they require no exposure increase. The distance between lens and film does not increase, so the same amount of light reaches the film. Supplementary lenses, generally, are used only on cameras lacking removable lenses.

**Bellows and tubes.** Physically moving a lens away from the camera is the simplest way to record a large image on film. But only the more expensive cameras, using interchangeable lenses, accept the focusing devices that do this.

Two types, generally, are available: fixed extension tubes and the more versatile bellows units. Extension tubes of various lengths are marketed by a number of manufacturers, usually for their own cameras. One end of a tube fits the lens mount, the other fits the lens. The fixed length of a tube limits its use somewhat. But in combinations, they provide several reproduction ratios.

Because it provides continuous adjustable focus, an extension bellows is the most versatile. Practically all cut-film cameras have their own bellows, but most 35mm and 120 roll-film cameras require auxiliary bellows attachments to adapt them to this work. While a bellows unit costs considerably more than extension tubes, it is well worth the price.

**Focal frames** come in handy when you add a supplementary lens or an extension tube to a camera that has neither ground-glass focusing nor an auxiliary range- and view-finder. Not only do they measure off the correct lens-to-subject distance, but they show exactly the area included.

**Exposure.** With detail so important in close-ups, it's best to use the minimum exposure required to record the needed tonal details. Overexposure increases graininess, reduces sharpness and tonal separation. It produces negatives difficult to print.

As you rack out the camera bellows or add extension tubes to increase the lens-to-film distance, you must increase the exposure. Focusing at normal distances, exposures are unchanged. But as the lens is moved close, the indicated f-number (stop) is no longer effective. One easy way (without formulas) to figure the new f-number: Measure the lens-to-film distance and use the effective-aperture computer in the Kodak Master Photoguide to read off the modified exposure.



# SURPLUS SALE

GOVT SURPLUS  
EXCESS INVENTORY  
BANKRUPT STOCK

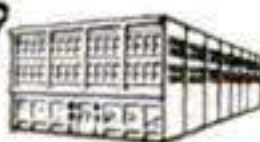

## CONTRACTORS LEVEL-TRANSITS

● Item #823. Leading make brand new latest model level-transit with tripod and case. Used by leading builders, schools, etc. 18-power scope, high accuracy, use as level or transit. Limited time offer. List over \$120. SALE ..... **\$96.06**



## FARMERS-CONTRACTORS PUMPS—PIPE

● Item #204. Self-priming, 1½" size. Use for irrigation, pools, boats, cellar drains, etc. Wt. 32 lbs. Govt. cost \$80.50. SALE ..... **\$19.49**

Many other pump buys.

## PORTABLE GOVT. AIR TANK

● Item #472. New ball bearing, stainless steel 400-lb. pressure unit with hose, chuck, gauge, blow gun. ● Fill tires, spray chemicals, blow dust, etc. Fill any gas station. Size 10"x18". Wt. 12 lbs. Govt. cost \$33.50. SALE ..... **\$16.95**

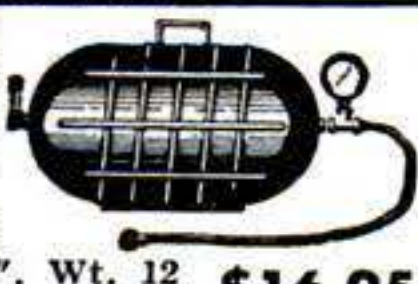

## GENERATOR—3000W—115V

● Item #633. D.C. ball bearing compound-wound Delco unit. 1" dia. shaft. 2800 RPM. Ideal for portable tools, light, etc. Will run any 115-v DC-AC tool. 100 lbs. Govt. cost over \$175. SALE ..... **\$54.75**

Many other Surplus Power Plants and Generators.

## HYDRAULIC SPEED REDUCER

● Hydraulic speed reducer. Any speed from 0 to 750 rpm by throwing a lever. Handle up to 1½ h.p. Use for midget cars, shop saws, etc. Instant reverse. Govt. cost \$400. SPECIAL ..... **\$56.71**



## STORAGE BATTERY WINCHES—HOISTS

● Item #311. 12-v. Govt. reversible, ball bearing 2000-lb. capacity winch. Holds 40' ¼" cable. For trucks, docks, boats, etc. 55 lbs. Cost, over \$250. SALE ..... **\$49.95**

Many other types battery winches—hoists

## SPECIAL OF THE MONTH!

### POLICE SIREN



● Item #117. Genuine siren of type used in New York City police cars. Will work on 6 or 12-v battery. Will also work on 115-v AC thru dropping resistor (99c.) ● Powerful high speed AC-DC motor with efficient siren wheel for maximum sound intensity.

● Use for police and fire cars, private hot rods, as alert warning, for factory quitting time signal, for burglar and fire alarms, etc. Size 7½"x5"x5¾". Wt. 6 lbs. Orig. cost over \$20. SALE ..... **\$9.65**

### EXAMPLE BARGAINS IN 1963 CATALOG

- \$250 Electric Car Motor, 12-v ..... **\$18.95**
- \$38 Portable Govt. Pressure Spray Tank ..... **11.79**
- \$26 Automatic Time Switch ..... **5.94**
- \$11 Fish and Worm Shocker ..... **3.49**
- \$300 AC-DC Aircraft Generator ..... **15.85**
- \$450 3000-w 115-v AC Generator ..... **139.50**
- \$15 AC-115-v water Pump ..... **7.97**
- \$100 Jeep Capstan Winch ..... **33.95**

Write today for large 1963 catalog.

## SURPLUS CENTER

Dept. 538, Lincoln, Nebr.



## Best Remover FOR Refinishing Furniture

Low-viscosity Klean-Strip is a free-flowing remover that peels off all furniture finishes without making a gummy mess.

Old finish stays wet and workable, can be wiped off easily. Leaves surface dry, clean, ready for new finish. Non-flammable, safe.



## KLEAN-STRIP PAINT REMOVER

THE KLEAN-STRIP CO., INC.

MEMPHIS 6, TENN.—WINNIPEG, MAN.

## FIX-IT SPECIAL!

# 2 for 1



**PLASTIC ALUMINUM**  
plus All-Clear  
**Household Cement**  
\$1.49 VALUE - Both tubes  
for only \$1.00!



At your favorite hardware, variety, auto accessory, department or paint stores

THE WOODHILL CHEMICAL CORP. • CLEVELAND 14, OHIO

## TOOLS WHOLESALE

SELL TOOLS to your friends and neighbors, or buy tools for your own use and **SAVE MONEY \$\$\$**. Send **\$1.00 for your WHOLESALE CATALOG TODAY!!**

A MILLION DOLLAR INVENTORY AT YOUR FINGERTIPS. NO STOCK TO CARRY. ORDER AS YOU NEED IT.

**BUY AT WHOLESALE PRICES.** Extra \$25.00 profit on your accumulated purchases. \$1.00 refund on first purchase or refunded if you are not 100% satisfied.

**THOUSANDS!** of Nationally Advertised items of Hand Tools, Power Tools, Machinist Tools, Tool Chests, Paint Sprayers, Light Fixtures, Appliances, Guns, Gifts, Toys and other items too numerous to mention.

**WE SHIP COAST TO COAST** Whise. Disc. up to 50% off

Dept. **SILVO HARDWARE CO., PS-4 107 Walnut St., Phila. 6, Pa.**



## Solves Repair Problems

Durham's fills cracks and holes in plaster, wood and tile. Won't shrink or fall out. Economical, easy to use. Big 4-lb. can, only \$1.40 at lumber, paint and hardware dealers, or shipped direct postpaid in U. S. for \$1.75. Money-back guarantee. Order now. Donald Durham Co., Box 804-U, Des Moines, Iowa.

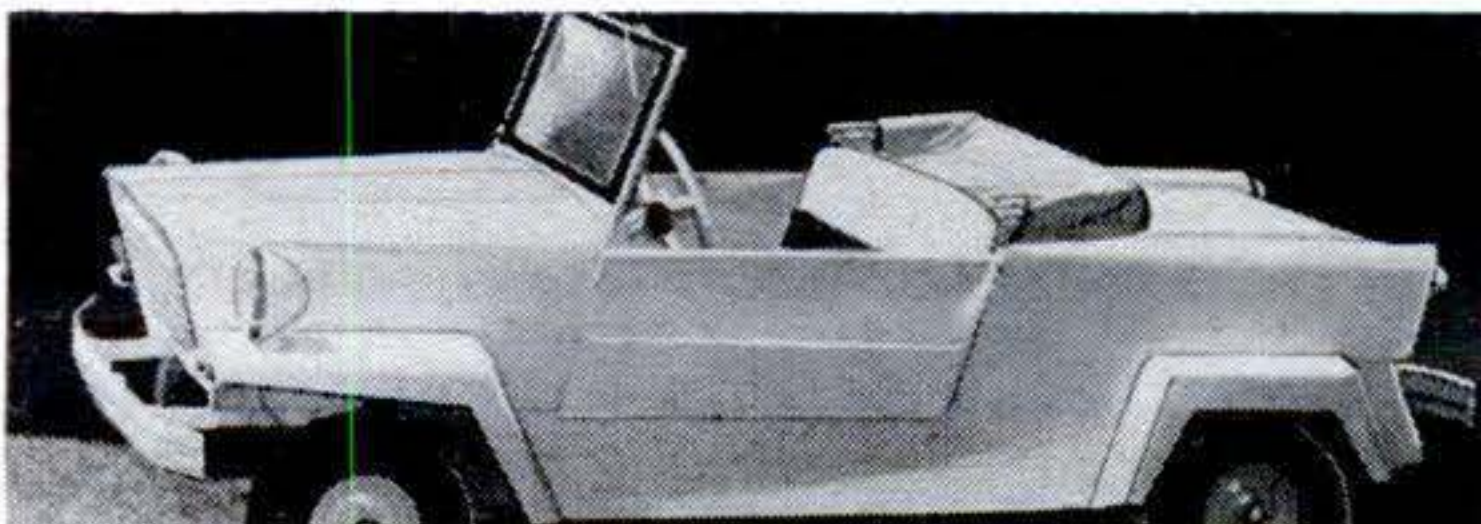

## KING MIDGET "World's Most Exciting Lowest Priced Car"

Drive it for 75c a week. Rider Agents Wanted. Send 25c for 32 page book, full details, dealer price. Or send \$1 (refunded first order) for this plus Service and Repair Manual and 16 5x7 photos of car and factory.

**MIDGET MOTORS CORP.,**

Athens 2, Ohio

## PEG-LOK® HOOKS LOCK INTO SINGLE HOLE



No wobble, sway, mar or scar — Peg-Lok hooks stay where they are. For 1/8" board, they enter and lock into same hole.

- Peg-Lok snaps tight... stays put... repositioning is a snap too.
- In all popular shapes at your hardware dealers.

**FREE SAMPLE:** Send 10¢ to cover mailing cost to:

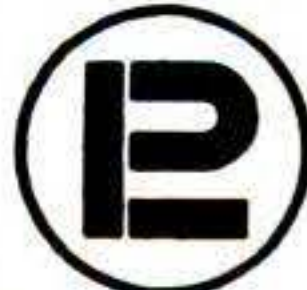

**PEG-LOK, INC.**  
CUMBERLAND, R. I.



World's greatest classified

# opportunities

POPULAR SCIENCE MONTHLY  
355 LEXINGTON AVE.  
NEW YORK 17, N. Y.

Classified Ads only \$1.20 per word insertion, payable in advance. Minimum ad 10 words. To be included in June issue, copy should be in our office by April 20. No cancellations accepted after April 15. All advertisers using post office box number in ad must furnish complete name and street address for our records. Address orders to O. K. Kelly.

## 1 AUTOMOBILES & MIDGET CARS

AUTOMOBILE literature, antique, modern. Catalogs, photos, manuals. Monthly Bulletin. Non-profit organization. Free information. Enthusiasts, Box 451A, Mount Clemens, Mich.

GO-KARTS \$29.95. Full Price less motor. Details 10c. Sportsmobile, 905 N. Broad, Philadelphia 23, Penna.

## 2 AUTO SUPPLIES & EQUIPMENT

1909-1934 FORD Parts Illustrated catalogs 75c. Mark Auto, Layton, New Jersey.

JEEP Owners—V8 conversions. Read Jeep Owners ad, page 58.

SAVE Up To 50% on Auto Parts. Accessories! Get new 324-page Illustrated Catalog, just out. Over 100,000 items to renew, rebuild, renovate all makes, models, domestic, foreign cars, trucks, sports cars, from 1920 to 1963's; '28 to '31 Model A! Latest Hollywood accessories, custom and hi-speed equipment. Rush 25c for postage, handling—refundable on first order. Whitney, 1919-PS4, Archer, Chicago 16.

JEEP Parts! For Military and Civilian. At great savings. Largest inventory. Catalog for owners and dealers. Inquiries invited. American Auto Parts Co., 1830-PS Locust, Kansas City, Mo.

TRANSISTOR Ignition. Save gas, tune-ups. Points, plugs last longer. Improved cold starting, high-speed performance. Complete systems from \$34.50. Free Literature. Dealers invited. Palmer Electronics, Dept. P, Carlisle, Massachusetts.

RING-Valve Job while driving, \$6.00 postpaid. Guaranteed! Nothing like it! Many mechanics recommend! Motaloy, Grantham 27, Penna.

AUTO shop welding repair training in world's largest non-profit welding school. Low tuition. Free booklet. Hobart Welders, Box P-33, Troy, Ohio.

TRANSISTOR Ignition. 260/1 Coil, Manual, Special—\$8.50. Anderson Engineering, Wrentham, Massachusetts.

BATTERY chargers . . . home type. Electro-tone's famous line. Wholesale prices. Same day delivery. Free catalog. Write Dept. D, Doron Enterprises, Inc., Box 7214, Chicago 80, Ill.

AUTO and boat light. Shines under water, waterproof. It floats. Free literature. Edlyn Co., Box 362, Collingdale, Pa.

COURTESY Card: Automobile Owners Safety Association now issues Courtesy Cards to pledged safe drivers. \$1 to P.O. Box 14, Buffalo 23, N. Y.

FREE Trial. \$3.00 Motolife Treatment. Pay If Satisfied. Neher, La Verne, Calif.

PARTS Model "A." List 25c (Refundable) Matco, Box 135, San Pedro, Calif.

IMMEDIATE Delivery on Foreign Car Parts. For complete catalog send Name, Address, and 25c to Tibur Imports, Dept. PS, P.O. Box 6194, Chicago 80, Ill.

## USE THIS HANDY INDEX TO FIND WHAT YOU WANT

Advertising, Agencies for Advertisers . . .	53
Agents Wanted . . .	43
Antiques, Relics & Indian Goods . . .	29
Art Instruction, Cartooning, Sign Painting . . .	54
Astronautics . . .	5A
Authors Service . . .	52
Auto Supplies & Equipment . . .	2
Automobiles & Midget Cars . . .	1
Aviation . . .	5
Auto Trailers . . .	3
Batteries, Generators, Etc. . . . .	6
Boats, Outboard Motors . . . . .	11
Body-Building Courses, Jiu Jitsu, Etc. . .	12
Books & Magazines . . . . .	23
Business Opportunities . . . . .	37
Business Service, Information, Name Lists . . . . .	50
Buy It Wholesale . . . . .	38A
Cameras, Photo Supplies . . . . .	34
Camping Equipment & Tents . . . . .	16
Coins & Currency . . . . .	26
Detectives . . . . .	47
Do-It-Yourself . . . . .	66
Dogs, Birds, Hamsters & Pets . . . . .	17
Earthworms, Crickets, Frogs . . . . .	18
Educational & Instruction . . . . .	45
Electric Trains . . . . .	64B
Electrical Supplies & Equipment . . . . .	7
Employment Information . . . . .	42
Engineering Services . . . . .	60A
Engineering Supplies & Equipment . . . . .	9D
Engines, Motors, Etc. . . . .	10
Farms, Other Real Estate . . . . .	19
Field Glasses, Telescopes . . . . .	14
For Inventors . . . . .	60
For Sale Miscellaneous . . . . .	71
For the Home . . . . .	69
Formulas, Plans, Etc. . . . .	39
Gifts . . . . .	49
Government Surplus . . . . .	11A
High-Grade Salesmen . . . . .	44
Hobbies, Collections . . . . .	31
Home Craftsman . . . . .	65
Hypnotism . . . . .	24
Inventions Wanted . . . . .	61
IQ Tests . . . . .	51A
Jokes, Games, Novelties, Etc. . . . .	24A
Language Outfits . . . . .	48
Loans By Mail . . . . .	80B
Machinery, Tool Supplies, Etc. . . . .	9
Magic Tricks, Puzzles, Etc. . . . .	25
Manufacturing . . . . .	63
Minerals & Precious Stones . . . . .	30
Miscellaneous . . . . .	79
Models, Model Supplies . . . . .	64
Moneymaking Opportunities . . . . .	38
Motion Pictures & Color Slides . . . . .	33
Motorcycles, Bicycles & Supplies . . . . .	4
Musical Instruments and Song Writers . . . . .	35
Of Interest To Women . . . . .	70
Old Gold, Jewelry, Watches . . . . .	67
Patent Attorneys . . . . .	59
Personal . . . . .	80
Phonograph Records . . . . .	35A
Photo Finishing, Photocopies, Etc. . . . .	32
Plastics . . . . .	40
Printing, Multigraphing, Etc. . . . .	57
Printing Outfits, Supplies . . . . .	58
Profitable Occupations . . . . .	22
Radio, TV, Electronics, Hi-Fi . . . . .	36
Razor Blades, Shavers . . . . .	74
Remailing Service . . . . .	80A
Rubber Stamps & Office Supplies . . . . .	56
Science & Chemistry . . . . .	41
Special Services . . . . .	51
Sporting Goods, Guns, Fishing Tackle, Etc. . . . .	15
Stamp Collecting . . . . .	28
Tobacco & Pipes . . . . .	68
Treasure Finders & Geiger Counters . . . . .	77
Trees, Shrubs, Roots & Herbs . . . . .	20
Typewriters & Office Machines . . . . .	55
Watch Repairing . . . . .	78
Welding, Soldering . . . . .	8

## 3 AUTO TRAILERS

PICKUP Campers. Pre-cut Kits. Blueprints. Supplies. Literature 10c. Comstock Trailers, Parsons, Kansas.

## 4 MOTORCYCLES, BICYCLES AND SUPPLIES

GO-CART \$5. Cushman Eagle \$10. Truckster \$10, less engines. Engines \$2 up. Crosley convertible \$95. Whizzer motor-bike \$15. (Mailorder only). Send 25c (35c for First Class Mailing) for Directory-Catalogue Number 112, listing these and hundreds of similar bargains in motorscooters, Karts, Homebuilders Parts, Plans, etc. Midget Motors Directory, Athens, Ohio.

RECONDITIONED Motorcycle Motors. Large Stock Indian, Cushman, Vespa, Mustang, NSU Parts. Indian Motorcycle Sales, Kansas City 27, Missouri.

WHOLESALE Motorcycle Parts, Used Motorcycles Cheap. Bulletins \$1.00. Refundable. Bunico, 146-3G, Covington, Virginia.

SAVE! Build your own Go-Karts, Mini-Bikes, Fun Car. Many closeout parts prices reduced. Huge parts catalog, complete plans \$1.00. Great Lakes Products, Box 6212, Janesville, Wisc.

SPEED cams for Motor Scooters, 3/4 Midgets, \$15.00—Your Core. 50c for Auto Catalog. Weber Speed Equip., 310-C So. Center, Santa Ana, Calif.

## 5 AVIATION

PROPELLERS, Plans, Supplies for Airboats, Snowplanes. 125 H.P. Lycomings, \$115.00. 150 H.P. Continentals \$125.00. Parts, gauges, throttles, spark plugs, wires, hose, oil coolers, gaskets, magnetos. Catalog 25c. Banks-Maxwell, Box 3301G, Ft. Worth 5, Texas.

JETS: New, Valveless, Pulse-Jet Engines. Simple, Positive Starting, No Maintenance. No Auxiliary Starting Equipment Needed. Low-Cost Operation. For Propulsion And Heating Applications: Helicopters, Gyrocopters, Orchard Heaters, Etc. Introductory Price: \$99.00 Each. F.O.B. (Expires April 30, 1963). Brochure, 10c Handling. Jet Products, Jasonville, Indiana.

PROPELLERS for Airboats, Snowplanes, Icesleds. Beautiful Colors. Boat Kits, Mounts, World's Best. 25c for Catalog. Aerial Propeller Company, Box 692, Greenville, Texas.

FOR the most complete listing of like new, used aircraft in the world, send \$2.00 today. Highest trades with best financing available. Graubart Aviation, Valparaiso, Indiana. Twelve issues guaranteed.

## 5A ASTRONAUTICS

ROCKETS: New illustrated catalog 25c. Single and Multistage Kits, Cones, Engines, Launchers, Trackers, Technical information, etc. Fast Service. Estes Industries, Penrose 32, Colorado.



# POPULAR SCIENCE OPPORTUNITIES

## 6 BATTERIES, GENERATORS, ETC.

REBUILD Batteries! Complete Manual \$3.00. Hydraulic Jack Repair Manual \$3.00. Chrysler Corp. Alternator Guide \$3.00. C.O.D. Accepted. Bayer Publications, 938 Betty Avenue, Neenah, Wisconsin.

## 7 ELECTRICAL SUPPLIES & EQUIPMENT

ELECTROPLATING Equipment And Supplies. Send \$1 For Formulas, Equipment Guide, Operating Data And Catalog. Hollywood Bronze Supply, Dept. N7, 3445 Union Pacific Ave., Los Angeles 33, Calif.

ELECTRICIANS! Bend conduit Easily, Correctly. Latest! Simplified Manual, \$2.00. William Goforth, 949 W. Fessler, Santa Maria, Calif.

APPLIANCE — Lamp — Vacuum parts. Wholesale lists free. Complete inventory. SECO, 112 South 20th Street, Birmingham 3, Alabama.

## 8 WELDING, SOLDERING

WELD, solder, cut, braze.  $\frac{1}{8}$ " welder complete \$9.95. Flame-torch \$3.95. Postage 50c. 75 Ampere  $\frac{1}{2}$ " transformer Welder \$29.95 complete. F.O.B. Essay Mfg. Co., Dept. A, Quincy 69, Mass.

FREE Catalog, Welders, Kits. Build 350-ampere welder using aircraft generator, plans 25c. Dunbar, Minneapolis 8, Minn.

PRODUCTION Welders, 110/220 \$69.50, \$39.50. Morris, 1070 Inner, Schenectady 3, New York.

HEAVY Duty 110 Volt ARC Welder. Generates Heat To 6000 Farenheit For Cutting. Complete with Helmet, Gloves, Rods. Instruction Book, Etc., \$19.00. Fully Guaranteed For Five Years. If You Are Not Satisfied Your Money Refunded Within 7 Days. National Electric, P.O. Box 678-B, Miami Beach 39, Florida.

## 9 MACHINERY, TOOL SUPPLIES, ETC.

MACHINIST Tools Factory Direct. Campbell Tools, 1424 Barclay, Springfield, Ohio.

## 9D ENGINEERING SUPPLIES & EQUIPMENT

DESIGNERS, Draftsmen! Send \$1.00 plus the name and address of your local template supplier—receive our new \$1.95 12-inch sweep and spiral curve. Offer ends April 30. Tek Method, 600 S. Michigan Ave., Chicago 5, Ill.

## 10 ENGINES, MOTORS, ETC.

DIESEL Injector Parts and Fuel Pumps Wanted GM51-53-71-110. Mayer, 2093 East 19 Street, Cleveland 15, Ohio.

REWIND Motors yourself. Complete instructions \$1.00. Lewis Manufacturing, Howell 11, Michigan.

GO-CARTS, Scooters, Automatic Clutch. 11T35RC Sprocket, \$8.40. Loren Products, Danville, Illinois.

## 11 BOATS, OUTBOARD MOTORS

WHY dream of owning a boat? Build one now! Custom Craft, originator of marine engineering marvels, offers prams to cruisers, sailing dinghies to dragsters in the 20th Anniversary Catalog. Prepaid Freight. Financing can be arranged. Send 50c to cover handling to Custom Craft, 1700 Niagara Street, Buffalo 7P, New York.

FULL size, cut-to-shape boat patterns, blueprints, 7 $\frac{1}{2}$ -38 feet. Big new illustrated "Build a Boat" catalog of 64 designs, including Catamarans, Cruisers, Runabouts, Skiffs, Outboard Boats, Sailing, Racing, Houseboats, 50c. "How to Build a Boat" booklet, \$2.50. Cleveland Boat Blueprint Co., Box 1651, Cleveland, Ohio.

BOAT Kits! Factory molded fiberglass or pre-assembled plywood, 50 models. 12" to 22". Free catalog. Luger, Dept. AC-63, 9200 Access Road, Minneapolis 31, Minnesota.

BOAT Plans, Frame Kits, Full-Size Patterns! 80-page catalog illustrating over 40 Build-it-Yourself boats 50c. Glen Marine, 9152 Rosecrans, Bellflower, Calif.

FIRST Plan and Pattern Catalog in two years to offer every conceivable type craft, including class sail boats for any size budget—"A Book Worth Keeping." Send \$1.50 to Custom Craft Plan Division, 1700 Niagara Street, Buffalo 7P, New York.

ALUMINUM Boat Kits, \$38.50 up. Assembled in a week-end from factory finished aluminum parts. No riveting, no bending, no guesswork. Save up to 60% of factory built prices. The perfect light car toppers for the sportsman. Models up to 14 feet. Send 25c for new catalog. Alumakit Co., Inc., Dept. PS-43, Salem, Mass.

FIBERGLASS Boat Covering. Wholesale prices. Free literature and sample. Seifert's, Box 1206-X, Green Bay, Wisc.

\$68.50—MOTOR Bargains. Write: Landseair, 4824 North Claremont, Chicago 25, Ill.

NEW, used, rebuilt marine motors. Marine conversions, fittings. Free Catalog. Stokes Marine Supply, Dept. 23, Coldwater, Mich.

## 11A GOVERNMENT SURPLUS

JEEPS \$111.68, Airplanes \$75.20, Boats \$6.18. Many others direct from U.S. Government. For complete "Directory" send \$1.00 to Quality Surplus, Box 22163-P4, Indianapolis 22, Indiana.

GOVERNMENT Surplus Direct From Government. Jeeps \$264.00, Radios \$2.53. Typical Prices. Guns, Typewriters, Cameras, Tools, Thousands More. Amazing Low Prices. How, Where To Purchase, Merchandise Available, Etc., Only \$1.00 To: Surplus, P.O. Box 50512, Dept. F, New Orleans 50, Louisiana.

JEEPS—\$223.83, Typewriters—\$4.15, Radios—\$2.65, Boats—\$6.18, Televisions, Guns, Cameras, Recorders, Watches. Typical Surplus Prices. Exciting Details Free. N. Y. Enterprises, Box 402-S6, Jamaica 30, New York.

JEEPS \$111.68, Airplanes \$75.20, Boats \$6.18. Many others direct from U.S. Government. For complete "Directory" send \$1.00 to Quality Surplus, 1417-46th Ave., Dept. P4, Oakland 1, California.

JEEPS \$111.68, airplanes \$75.20, boats \$6.18. Many others direct from U.S. Government. For complete "Directory" send \$1.00 to Quality Surplus, 512 Interurban Building, Dept. P4, Dallas, Texas.

GOVERNMENT Surplus How and Where To Buy In Your Area. Send \$1.00. PS Surplus Information, Headquarters Building, Washington 6, D. C.

FREE! You can get hundreds of big illustrated Government Surplus catalogues absolutely Free! For full information send dime today to Honour, Box 187-P4, Abbotstown, Penna.

JEEPS \$111.26, Boats \$6.23, Typewriters \$4.17. Thousands of items direct from Government in your area. Complete Guide—\$1.00 to: Surplus Information, 1402-PSS, Englewood, Colorado.

GOVERNMENT Surplus: Boats, Airplanes, Power Tools, Diving Equipment, Sporting Goods. Everything imaginable. You buy direct. "Locations and Procedures" plus "Buying for Profits" \$1.00. Satisfaction Guaranteed. Surplus, Box 6091-B4, Dallas 22, Texas.

NEW Procedure! Get listed free! Buy Single Government Surplus Items thru recently established Government Agency. Satisfaction Assured! Details \$1.00. Hazlett, 2 Bayview Ave., Penns Grove, New Jersey.

## 12 BODY-BUILDING COURSES, JIU JITSU & ATHLETIC EQUIPMENT

"GIANT Arms." Dr. Young's, D. C. Revolutionary discovery. \$2. Satisfaction or refund. Gaucho, Box 9309-S6, Chicago 90.

BUILD powerful arms, chest, shoulders! 22 exercises, \$1. Fonsad, Box 601-C, 1100 Market, Wilmington 99, Delaware.

BIG Muscles Fast—Gain up to 4" on arms. 10" on chest in just 7 weeks. Free details. Sinkram Body Builders, Dept. SC-12, Box 11, Brooklyn 36, N. Y.

HEALTH! Reducing, Gaining, Muscles, Longevity. Mail 25c for all 4 Courses. Buy Now. Health Course \$1.00. Agents Kit \$2.00. Big Deal \$3.00. Guaranteed! Sid's System, (PS-E63), 8421-C Evergreen, Southgate, California.

DEADLY KungFu "Iron, Poison" Hand Fighting. Break Bricks within 100 days—\$5.00. Free Literature. Oriental Book Sales, P.O. Box 1183, Oakland 4, Calif.

OUTSTANDING Physical Development! Any age. New Guaranteed Discovery uses only a Rope! Strength, Health, Muscles. Gain—Reduce. Free information. Roper-cise, 4834-A Art, San Diego 15, California.

KARATE, Judo Books: Send 25c Coin For Descriptive Lists To: Aardparke Books, Box 395PS, Tarzana, Calif.

## 14 FIELD GLASSES, TELESCOPES

BUILD your own Reflector Telescopes. Complete kits; Mirrors, Eyepieces, Tripods, all other accessories. Request free illustrated literature. Criterion Manufacturing, Dept. KP-100, Hartford 1, Conn.

SCIENCE Bargains! Lenses, Telescopes, binoculars, microscopes, kits, parts, war surplus. Send \$1.00 for beginner's 10-lens kit with instruction booklet. Order Stock 2-CN. Request Free 144-page Catalog CN. Edmund Scientific Co., Barrington, New Jersey.

DYNASCOPE—Amazing world famous reflector telescope. Request free brochure. Criterion, Dept. DS-8, Hartford 1, Conn.

FREE Catalogue! Thousands war surplus optical bargains. Lenses, Prisms, Telescopes, Binoculars, etc. Send \$1.00 for 10 Lens Hobbyist Set and Project booklet. G. Jaegers, 691 West Merrick Road, Lynbrook, New York.

ASTRONOMICAL books, star-atlases, free list. Herbert Luft, 69-11 229th St., Flushing 64, N. Y.

## 15 SPORTING GOODS, GUNS, FISHING TACKLE, ARCHERY, TRAPPING

10,000 GUN Bargains!!! Modern—Antique Guns—Accessories . . . Giant 128 Page Bargain Catalog \$1.00. Agramonte's, Yonkers, N. Y.

TREMENDOUS Wholesale Catalog . . . Amazing Selections, Merchandise. Taylor Distributors, Newton 18, New Jersey.

FREE . . . Wholesale Catalog. Beads, Spinners, Lure parts, Sinker molds, Jigs, Reels, Pinnysports, (PE), Toledo 14, Ohio.

PUTTER croquet style "Little Magician." Dead center accuracy. \$6.95 Prepaid. Check or M.O. Home Industries, 336 Athens Street, Jackson, Ohio.

FOCUS on target, split image Hunting Rangefinder instantly shows true range for deadly accuracy every shot. Perfect for varmints. Also Golf and Archery models. \$9.95 up. Free literature. Federal Instrument, 92-60A Queens Blvd., Rego Park 74, N. Y.

5000 GUNS, Swords, War Relics. Catalog 50c. Smith Museum, Runnemed, N. J.

CANNON Fuse 3/32" Diameter, Water-Proof, Burns Under Water: 10 Ft.—\$1.00, 25 Ft.—\$2.00, Postpaid. William Zeller, 10-A, Hudson, Michigan.

SPECIAL Lights and Kits for Fishermen, Boatmen, Skindivers. Literature Free. Headlite Products, Box 569 (PS), Glen Cove, N. Y.

JAP rifles altering American shells \$6.00. Jap shells \$3.95. catalog 10c. TP Shop, West Branch 10, Michigan.

SAVE money, do it yourself Water Ski Kit. Harnesses, Accessories. Free Circular. Write: Water Skis, Box 661, Willerlinie, Minn.

B.B. SHOT, fascinating pocket size invention. See ad on page 46.

## 16 CAMPING EQUIPMENT & TENTS

TENTS, 300 styles (most erected on display). Camping Trailers, Sleeping Bags, Tarpaulins, Flys, Canvas Yard Goods, Aluminum Tent Poles, Stakes, Cots, Tables, Refrigerators, Stoves, Lanterns, Heaters, Cook Sets, Canteens, Mess Kits, Water Bags, Packs, Rucksacks, Dehydrated Foods, Camping Books. Send 25c for new giant catalogue, (includes camp sites and complete handbook). Morsan Tents, 810-G Route 17, Paramus, New Jersey.



# POPULAR SCIENCE OPPORTUNITIES

**WANT** low-cost vacations and weekend outings? Enjoy comfort, convenience and spaciousness in a Holiday Rambler Travel Trailer. Quality constructed to be a home. Write for free brochure. Holiday Rambler, Dept. PS-C, Wakarusa, Indiana.

**GIGANTIC 1963 Catalog**—the "Bible" for every camper—116 pages fantastic savings on tents, sleeping bags, camping gear, clothing and government surplus! Choose from our \$1,000,000.00 inventory and save! Send 25c today for catalog. I. Goldberg, Dept. P.S., 429 Market Street, Philadelphia 6, Pennsylvania.

## 17 DOGS, BIRDS, HAMSTERS, RABBITS & PETS

**RAISE** Rabbits on \$500 month plan. Free details. White's Rabbitry, Mt. Vernon, Ohio.

**EARN** \$10,000 yearly raising Angora Rabbit Wool for us. Information 25c coin. American Angora Company, Malta 1, Montana.

## 18 EARTHWORMS, CRICKETS, FROGS

**EARN** Money raising fishworms for us! Exciting details free! Oakhaven-121, Cedar Hill, Texas.

**FREE** Literature—We teach you how to raise, sell fishworms, crickets. Hybrid red-worms 3000—\$5.95, 5000—\$8.95, 10,000—\$16.95, Postpaid. Carter Farm-12, Plains, Georgia.

**AFRICAN** Worms: One of the largest supplies in South! Ray Thompson, Taylor Bait & Tackle, 119—4th St., Eloise, Florida. CY3-0659.

**MEN!**—Women! Make Money Raising Bait for Us at Home. Free Details. Red Wigglers, Warsaw 3, Indiana.

## 19 FARMS, OTHER REAL ESTATE

**CANADIAN** Lands, seized and sold for taxes. Our 46th annual series of lists describe many choice properties, situated from coast to coast, acquired by us through Tax Sale. Priced as low as five dollars per acre, guaranteed perfect title, small monthly payments, no mortgage. Beautifully situated hunting and fishing camps, where there is real sport; summer cottage sites, heavily wooded acreages. Now is the time to invest in Canada's minerals, forests and farms. Write to-day for free twenty page booklet with full explanation. Tax Sale Service, Room 411-H, 1173 Bay St., Toronto 5, Canada.

**FLORIDA** Campsites—deep in the heart of the great Ocala National Forest. Abundance of game, best fishing. Warranty deed. Unrestricted—pitch tent, park trailer, build lodge. Free maps and photos. Winfree Vernor, DeLand, Florida. AD-60088(Q-O)

**NEW** Homes From \$35 per month. Nothing Down, Custom Constructed on your lot. Over 88,000 Built. Free information and illustrated brochure. Jim Walter Corporation, Box 9128, Dept. PS-4, Tampa, Florida. 212 branch offices to serve you.

**FLORIDA'S** Greatest homesite value. High, dry 1/4 acre site—\$495. No money down, \$10 monthly. Free photos. Write Dept. 619-G, Rainbow Park, Box 521, Ocala, Florida. (AD 62070-K-O)

**CENTRAL** Florida homesites, Lakefront, Hillside, Highway, or Acreage Tracts. Tell Me Which You Want. Priced From \$395.00. Terms \$10.00 Monthly. Victor Roepke, DeLand, Florida.

**ONTARIO** Border—lakefront cottage lots, islands, \$2.50 frontage foot. Sparkling lakes, good roads! Postcard brings maps, photographs. Beaver Lumber, 1731 Weston, Toronto, Canada.

**LANDS**, selling for taxes. Send \$1.00 for list. Box 201PS, Coldwater, Ontario, Canada.

**STROUT** Catalog—Free! Spring edition. Thousands on New properties Coast-to-Coast—Farms, Homes, Recreation, Business, Retirement. World's Largest! Strout Realty, 50-ZB E. 42 St., N. Y. 17, N. Y.

**CANADIAN** Vacation Lands: Full price \$385.00. 40 acres, \$10 month. Suitable cottage sites, hunting, fishing, investment. Free information. Land Corporation, 3768-D Bathurst, Downsview, Ontario, Canada

**FLORIDA** — Big, Beautifully Wooded Tracts on Prominent Highway in Famous Green Hills Pleasure Resort Area 28 miles North Panama City. Also choice 1/4 Acre Lakeside Homesites. \$10 Monthly. Free Maps, Photos. Owen Wood, Fountain—Dept. PS, Florida. AD 62005 (K) (3).

**\$1 ACRE**—Canadian Border—Hundreds campsites, islands, farmlands directly from Tax Authorities (non-profit). Lists. Photographs mailed: Bureau, 282 Davunport, Toronto 5, Canada.

**NEW MEXICO** Land Bargain. Big 1/2 acre ranchettes for only \$199 complete. \$5 down, \$5 a month. Just a short distance from the heart of growing Deming, New Mexico (Pop. 8500). Write today for Free color photos, facts, maps, etc. Deming Ranchettes, Dept. N-5D, 112 W. Pine Street, Deming, New Mexico.

**FLORIDA**—1/4 acre homesites, riverfront subdivision. \$295. No interest! Title Insurance, River Rights, county maintained graded roads. \$5 Down, \$10 Month. Free Pictures—Write Suwannee River Park Estates, Box 87, Dept. 312A, Live Oak, Fla. AD 63004.

## 20 TREES, SHRUBS, ROOTS, HERBS

**GINSENG** bringing \$14 pound. Have seeds, plants. Goldenseal. Full information. G. Collins, Viola, Iowa.

**BEAUTIFUL** White Birch Trees, 4 ft. Planting instructions, Shipped May, Postpaid \$2.95, Canada Only. Douglas Hamilton, Geraldton, Ontario.

**GROW** Large, 8 Year Old, Bearing Size Trees and Shrubs in 8 Weeks. Easy, Illustrated Instruction Book, \$3.00. Literature Free. Robbins-6, 57 Scott, San Francisco 17, Calif.

## 22 PROFITABLE OCCUPATIONS

**INVESTIGATE** Accidents. Earn \$750 to \$1,000 monthly. Men urgently needed. Car furnished; business expenses paid. No selling. No college education necessary. Pick own job location. Investigate full time. Or earn \$8.44 hour spare time. Write for Free Book. No obligation. Universal, CPS-4, 6801 Hillcrest, Dallas 5, Texas.

**VENDING** Machines—No Selling. Operate A Route of Coin Machines and Earn Amazing Profits. 32-Page Catalog Free. Parkway Machine Corporation, 715PSP Ensor Street, Baltimore 2, Maryland.

**EARN** Money raising fishworms for us! Write: Oakhaven-7, Cedar Hill, Texas.

**BECOME** independent with your own franchise business. Thousands earning handsome incomes. Request interesting facts today. National Franchise Reports, Y-528, 333 North Michigan, Chicago 1.

**CHROME** Plating, Instructions, Equipment and Supplies. Platers' Supply, P. O. Box 565, Lugo Station, Los Angeles, Calif.

**FREE** Literature—Make Big Money Raising Fishworms and Crickets. Carter Farm-10, Plains, Ga.

**INVESTIGATE** Auto Accidents—Pays up to \$750-1,000 a month. Investigators needed everywhere, part or full time. Car furnished; expenses paid. No selling. Meet interesting people. We train you spare time at home in weeks. Hold present job until ready to switch, or start own investigating business. Free information. No obligation. Liberty School, Dept. C-21, 1139 West Park, Libertyville, Illinois.

**FREE** Book: "609 Unusual, Successful Businesses." Box 1001-K, Evanston, Illinois.

**FREE** Report: "Mailorder Profits And Pitfalls." Box 63-T, Bellwood, Illinois.

**BARGAINS!** Buy wholesale! Save money! Free catalog! Norris, 273-CQ Merrick Road, Lynbrook, N. Y.

**BIG** Income Servicing Electronic Organs. Knowledge Music Electronics Unnecessary. Details, Box 8351D, Jacksonville 11, Florida.

**SHARPEN**—Scissors, pinkers, clippers. Inexpensive, capable machines. . . . Blackhawk, Sheldahl, Iowa.

**LEARN** LP-Gas Carburetion. Big new field! Servicemen needed for tractors, trucks, forklifts. Work spare-time, full-time, rural or city. Free information: J&S Carburetor Co., P.O. Box 10391-T, Dallas 7, Texas.

**"EVERYBODY** Likes Candy" — Make professionally home . . . (Our 50th Year). Ragsdale Candies, D 107, East Orange, New Jersey.

**BAKE** New Greaseless Doughnuts in kitchen. Half profit. Sell stores. Free recipes. Stephen, 3605 15th, Minneapolis 7, Minnesota.

**AUCTIONEERING**—Resident and Home Study Courses. Diploma granted. Auction School, Ft. Smith, Ark.

**AMAZING** new portable 49c meal! Unbelievable! Needs no refrigeration. Everybody eats! Be first! Write Comidex Corporation, New Canaan 17, Connecticut.

## 23 BOOKS & MAGAZINES

**"PROPHET** Elijah Coming Before Christ" Wonderful Book Free. 58 Meziddo Mission, Rochester 19, New York.

**NATIONAL** Geographic Magazines. Any issue, 1888-1960. Periodical Service, Box 465-PS, Wilmington, Delaware.

**FREE**—Freethought book list and sample Rationalist magazine "The Liberal." Friendship Liberal League, Inc., Thomas Paine Center, Box S, 5233 N. 5th St., Phila. 20, Pa.

**ATHEIST** Books. Catalogue free. Truth Seeker Co., 38 Park Row, New York 8.

**SAVE TO 83%** on Books, Records. Free Catalogue. Discount Reader's Service, SCC-5435 Upland Way, Philadelphia 31.

**ESP** Textbook "Mental Telepathy:" Healing, Radlaesthesia, Witchcraft. Much more; \$4.95. Money-back. Interesting "Literature" free. John Crehore, Walpole, N. H.

**BRITISH** Book Bargains. Any subjects. Catalogue free. Transanbooks, Wantagh, New York.

**"ELECTRICITY** Made Clear." Principals, formulas, illustrations. \$1.75. Pay after receiving. Box 2759, Philadelphia 20, Pa.

**BOOKHUNTERS:** All Subjects. Send Wants! Jaher Book Service, 183 Hazelwood Drive, Westbury, New York.

**BOOKFINDING** Our Specialty. Try Us. Babcock, 412 Lulu, Wichita 11, Kansas.

**MAGAZINES**—Pocket Novels! Catalogue 10c. Ajay Sales, Box 5796, Pikesville 8, Md.

**I CAN** get that book you want. John Friend, Bookfinder, Box 2570PS, Long Beach 1, California.

**"LITTLE** Blue Books." Free catalogs. United Book Service, Box 53, Wilmington, California.

## 24 HYPNOTISM

**FREE** Hypnotism, Self-Hypnosis, Sleep-learning Catalog! Records, Tapes, Books, Courses, Equipment! Drawer PS400, Ruidoso, New Mexico.

**HYPNOTIZE** Self, Others while asleep with amazing hypnotic phonograph records, tapes. Catalog free. Research Association, Box 24-G, Olympia, Washington.

**FREE** Illustrated Hypnotism. Selfhypnosis Catalogue. Write: Hypnotist, 8721 Sunset, Hollywood 69P, California.

**HYPNOTIZE** Unnoticed, quickly, effortlessly, or refund! Thousands delighted! \$2. Intern, Box 244, Cedarburg, Wisconsin.

**WORLD'S** largest catalog free. Merlin Enterprises, P.O. Box 613, Los Catos, Calif.

**HYPNOTIZE** unnoticed! Patented new hand device makes you a Hypnotist first day or refund! Hypnotist's Handbook included! \$2. Hypnosis Foundation, Box 487, La Mesa 2, California.

**HYPNOTIZE** Successfully In Three Hours! "Instantaneous," "One Word," "Against Will," Methods Exposed! Complete Illustrated Course Plus "Secret Nerve Pressure Technique," "Getting Willing, Cooperative Subjects Easily," "Chevreul's Pendulum," "Two Hypnoisks," "Sleep-Learning" Information. \$2.00. Results Guaranteed! Arthur Fowler, Box 4391, Woodbury, New Jersey.



# POPULAR SCIENCE OPPORTUNITIES

SELF-hypnosis may help you many ways. Dynamic new concept of learning quickly, easily! Book! Tape! Record! Free literature. McKinley Publishers. Audio Dept., Box 3038, San Bernardino, California.

"LATEST Hypnotism Methods!" Immediately! Manual includes "Self-Hypnosis!" \$2.00 postpaid. Brugenheimer Company, Box 201-7, Lexington, Massachusetts.

HYPNOTISM. Selfhypnosis. Guaranteed home study courses. Diploma awarded. Free particulars. School Hypnology, East Meadow 1, New York.

FREE Hypnosis—Sleep Learning Catalog. Fletcher, 2407-P.S. Catherine, Dallas 11, Texas.

HYPNOTIZE Others—Unnoticed. Quietly, Quickly, Safely. Sure-Easy Instructions \$1.00. Roric's, Cincinnati 26, Ohio.

IMPROVE Health, Lose Weight, Control Habits With Transitional Sleep Tapes! 92% Effective! Details Free. A.S.R. Foundation, Box 7021Z, Henry Clay Station, Lexington, Kentucky.

HYPNOTIZE Quickly! Certainly! Amazing Power! Mastery! Men. Women Respond Willingly! "Against Will." "Unnoticed." Methods Exposed! Entertain! Self-Help! Aid Others! Complete Course! Illustrated! Send \$1.00. Ducrun, Box 4147-E, Jersey City 4, New Jersey.

HYPNOTISM—Little known method. Free information. Dr. Azadian, Fowler, California.

HYPNOTIC Aids. World's Largest Illustrated Catalogue 10c. Stowell's, Woodstock, New York.

DISGUISED Hypnosis. Fascinating, revealing methods, unconditionally guaranteed. See ad on page 55.

## 24A JOKES, GAMES, NOVELTIES, ETC.

AMAZING "Walking Dog" Novelty. Get Several For Racing. 50c Each. 5 For \$2.00. Prudenco, Box 281, Littleton, Colo.

CHESS. Learn, improve, play by mail. "EL" Cowan, Driggs, Idaho.

## 25 MAGIC TRICKS, PUZZLES, ETC.

BE Popular! Entertain with magic. Send 10c for Douglas Famous Catalog, 500 Tricks, describing best in magic for pocket, parlor, club, stage, with balls, cards, silks, coins, ropes, apparatus, books. For 40 years Douglas has supplied magicians everywhere with fastest same-day service. Join in the fun! Douglas Magicland, Dept. 52, Dallas, Texas.

BE A Magician! Introductory Catalog with Free Trick, only 35c. Ireland, 109-T North Dearborn, Chicago 2.

WORLD'S finest professional magic Joker novelties. Giant illustrated catalog 10c. Top Hat, Evanston 13, Illinois.

VENTRILOQUISM! Information Free! Dummy Catalog 25c. State age. Maher, Box 36-B, Kensington Station, Detroit 24, Michigan.

1000 LATEST Tricks, Jokes, Magic! New 1963 Deluxe Giant Edition Catalog! Hot Off Press! 160 Exciting Pages Thick! Bigger—Better Than Ever! Special—10c. House Of 1000 Mysteries, Dept. PS4C-63, Monroe, Connecticut.

WORLD'S Finest Magic Catalog, \$2.50. (\$2.00 magic included free). 3000 Tricks, Pocket, Stage, (408 pages). Kanter's, S-200 South 13th, Philadelphia 7.

MAGIC Cards, Tricks, Dice! Catalog, Free Trick, 15c. Poules Magic, 437 Brittain, Akron 5, Ohio.

MAGIC Catalogue 50c. Eagle Magic, 419 South 5th Street, Minneapolis 15, Minn.

84 PAGES, Completely Illustrated Catalogs, 25c. Manhattan Magic, Box 334-S, N.Y.C. 11.

## 26 COINS & CURRENCY

25 DIFFERENT coins from 25 foreign countries. \$1.00 bargain. Hindley, Box 708, Aurora, Illinois.

GIANT Illustrated Catalog listing Hundreds of Bargains in Coins and Supplies, only 50c. Rarcoa, 31-A North Clark, Chicago 2.

100 FOREIGN Coins \$2.95. 2 Mexican Silver Dollars \$1.00. Kington, Box 188S, Tolleson, Arizona.

TOPS! Fascinating coin collection from Cameroons, Formosa, Vatican, etc. and foreign banknote. Catalog Price Over \$1.50! Only 10c with exciting coin approvals! Littleton Coin Company, Littleton T2, New Hampshire.

BARGAIN List! U.C. Coins, Accessories. Stamp please. Hugh's, Hickory, N. C.

COIN Magazine, 200 pages. Sample 50c. Numismatic, 7320 Milwaukee, Chicago 31.

SPECIAL! 5 Indian Cents, 5 Liberty Nickels, 10 Lincolns, before 1925. All different. \$3.00. Stroud's Coins, Kinston, N. C.

FREE Coin Supplies. Giant Coin list 10c (refundable). Economy Sales, Mansfield, Massachusetts.

BUYING 1950-D Jefferson Nickels, good or better condition. Paying \$4.50 each. William Styba, 352 East 8th, Winona, Minn.

LINCOLN Cents From San Francisco. Ten different dates (Our Choice), For 25c with coin approvals. Molzan, Box 275, Alameda, California.

NEW Price Lists—108 pages—foreign coins, currency—25c. Jolie, Roslyn Heights, N. Y.

THREE different Indian Cents. Album, Bargain Catalog. \$1.00. Hobby Sales, St. Paul 16, Minn.

COIN collectors! Learn what your coins are really worth. Send 25c for sample or \$3.00 for next 12 big issues. Coins Magazine, Coin Street, Iola, Wisc.

NUMISMATIC News tells today's value of all coins. A Great Newspaper, 26 issues a year full of reliable coin news. Sample 25c. \$3.00 yearly. Dollar Street, Iola, Wisc.

FANTASTIC Coin Bargains. List 10c (Refundable). Bill Comby, Conover, N. C.

UNCIRCULATED 1935 Silver Pony Express Commemorative Medal \$1.00. Coin Lists Free. Sayers, 1000 Unaka, Johnson City, Tennessee.

LINCOLNS: 40 Different 1909-41 plus 1960D small date \$1.95. 24 different "S" (including rare 1955S) \$1.50. Harris, 9011J Presidio, San Francisco 29, California.

12 DIFFERENT Lincolns before 1921 \$1.00. 24 Before 1931 \$1.50. Gene Carlton, Box 88-PS, Chandler, Okla.

COIN Bargains Galore! Illustrated Lists. 10c (Refundable). Hutchinson's, Box 6256, Philadelphia 36, Penna.

1878 CARSON City Dollar Uncirculated \$5.00. Coin Catalogue 50c. Shultz, Salt Lake City 10, Utah.

LINCOLN Cents: 23S, 24S, 21S&P, 16S&D, 17S&D, 18S&D, 19S&D, 20S&D, 25S&D, 29S&D, 30S&D, 28S&D, 27S&D, 55S, 54S&P, 32D, 33P, 39S&D, 49S. Good to Fine Complete Lot \$8.50. Rolls 55-S—\$12.50. Fine to X-Fine 49-S—\$3.50 Roll. Berry, Box 1241, Orange, Calif.

BARGAINS—\$20.00 Gold Uncirculated \$59.50; two different types \$115.00. Brilliant Proof Sets—1957, 1959, 1960 each \$3.95; 1961, 1962, 1963 each \$2.95. Bargain Lists 25c. Bebee's, 4514 North 30th, Omaha 11, Nebraska.

MORGAN Dime With Terrific Bargain List, 50c. Fairway, 121-P, Rye, N. Y.

MORGAN Quarter With Terrific Bargain List 60c. Nelson, 346-S, Rye, N. Y.

BRILLIANT uncirculated Silver Dollars \$1.45 each! 1878S; 1878P thru 1884P; 1922P thru 1925P. Grair Enterprises, 17 Edgewood, Springfield, New Jersey.

TWENTY-four page 1963 retail price list of U.S.A. and Canadian coins, 10c. Our selling prices on thousands of coins and coin collectors supplies. Bryson Incorporated, 612B White, Toledo 5, Ohio.

WOW! "Rare" Silver Dollars! Brilliant! Uncirculated! Low Prices! 1903-O only \$40.00! 1898-O—\$2.50! 1899-O—\$2.00! 1900-O—\$2.00! 1901-O—\$2.00! 1902-O—\$2.00! 1904-O—\$2.00! Thousands of other Coins! Rush your order and get our Free Price List! Silver Center, Box 3293-S, San Francisco 19, California.

ANY Five Jeffersons except 38SD, 39SD, 50D, 51S, 55P, \$1.10. Tracy, 25 Quinlan, Staten Island 14, New York.

## 28 STAMP COLLECTING

EXCEPTIONAL 125 different, cataloging \$3.00. Includes triangles, commemoratives, 10c approvals. Reeves, Box 37597P, Miami 37, Florida.

225 STAMPS For only 10c! This mammoth value includes Airmails, Pictorials; stamps from strange Countries cataloguing up to 25c each! Also Approvals. Mystic Stamp Company, Camden 55, N. Y.

UNITED Nations, 15th Anniversary Sheet. With first day cancel, as commemorated by Russia. Free! While they last, with approvals. Philatelics, P-J, New Paltz, N. Y.

80 DIFF. U.S. Stamps. Includes 19th Century Commemorative. High values. Plus 1943 Flag Stamp of Occupied Nations. All for only 25c. Approvals included. Willett Co., Box 338-Y, Yorktown Heights, N. Y.

25 DIFFERENT Commemoratives 1893 up 10c. U. S. Approvals. K & B, Box 70, Brooklyn 23, N. Y.

U.S. Mint Specials! Flag Set Complete, \$1.00; 1c, 2c, 3c Famous Americans (21 different), \$1.00. Free list. Brooks, 2323 Avenue X, Brooklyn 35, New York.

UNITED States commemorative collection containing 33 different—10c. Approvals. White, 516-W Avenue L, Brooklyn 30, New York.

AMAZING Offer! 200 U.S. stamps—including commemoratives, airmails, high denominations to \$1.00—only 10c to Approval Applicants!! Illustrated Bargain Lists free. Mystic Stamp Co., Dept. 55, Camden, New York.

WOW! 110 All Different Germany 10c Zeppelins, Semi-Postals, Airmails, High values, etc. Giant Catalog, bargain lists included with beautiful approvals. Jamestown Stamp, Dept. A43PS, Jamestown, N. Y.

NUDES set (4)—Unusual Approvals 10c. Atlas, Plainfield, Racine, Wisconsin.

STAMP Collecting Outfit, includes packet Worldwide stamps, package hinges, watermark detector, millimeter gauge. Everything 10c with approvals. Lorraine Brown, Marion, Michigan.

702 U.S.A.—25c (plenty commemoratives. Request Approvals. Horace Gatewood, Winston-Salem, N. C.

WONDERFUL Lincoln Diamond, Giant Roosevelt, 100 Others Different, 10c. Approvals. B & G Stamp Service, 114 West Washington, Sigourney, Iowa.

21,000 ALL Different, only pennies a day using our systematic payment plan. Details Free. Sjoquist, 1435-A Cherrydale, San Jose 25, California.

ISRAELI New Year 5718. Issued for the Hebrew New Year 5718 (our 1957), a complete, multicolored stamp set with commemorative tabs. Free! While they last, with approvals. Philatelics, P-O, New Paltz, N. Y.

TOPICALS, 25 different, only 10c to approval applicants. Stamac, 108 Park Place East, North Charleston, South Carolina.

200 DIFFERENT Stamps, 25c with approvals. Smith, 508U Brooks, College Station, Texas.

90,000 STAMPS Sale! Bargain Lot: Sets, Packets, Rare Stamps \$1. Giant Assortment Extra Special \$5. High Value Packet \$3. Literature, Samples 10 cts. Persile, 436 N. Y. Ave., Brooklyn 25, N. Y.

U.S. STAMPS. Giant Discount Catalog—25c. Raymax, 37-VX Maiden Lane, N.Y.C. 38.

FREE—Mammoth Collection, including \$10,000 Airmail, World's smallest Stamp, gorgeous multi-color pictorials plus Scott's Internationals, Master Global Albums, Scott's 1963 Catalogues, all Free when you buy Foreign approvals. Bargain Stamps, Box 1112B, Miami Beach 39, Florida.

GIANT Stamp Collection Including: Astronauts, Satellites, Moonrocks, Boy Scout Issue, Complete UN Set. Many Olympic and Sport Issues, etc; Plus Big Stamp Dictionary and Approvals. Everything 10c! Stampex, Box 47-LP, White Plains, N. Y.

OVER \$20.00 value for \$1.00. 1,000 Different Worldwide. Approvals included. Adults Only. Universal, Box 6, Kenosha 6, Wisconsin.

50 YEARS Old—15 different United States Stamps at least 50 years old—10c with low priced United States approvals. Jaxon, Box 145 S, Brooklyn 30, N. Y.



# POPULAR SCIENCE OPPORTUNITIES

**FREE!** Get This New Valuable North American Collection, all-different postage stamps of Greenland (North Pole), St. Pierre, Newfoundland, Canada—Eskimos, Indians, scarce 1867 Confederation, 1862 British Columbia & Vancouver Is. Cent., Nova Scotia, Northern Territories, United Nations, U.S. Stamps—19th Century, First Plane, Steam Boat, Pony Express, etc. Also, complete Colonial & Civil War Issues, many others. Plus full color flag stamps of 87 foreign countries. Extra! Bargain Catalog; "How to Recognize Rare Stamps"; other exciting stamp offers for free inspection. Send 10c for mailing. Kenmore, Milford EF-464, New Hamp.

**95,000 DIFFERENT!** Pennies A Day Builds Collection Methodically. Free Particulars. Holtzman, 95-S Terrace, Levittown, Pennsylvania.

**FLAG Stamp Free with U.S. Approvals.** Gorlizz, Box 265, Park Ridge, Ill.

**FIVE Mint Sets 10c with Approvals!** Ross, 1127 Nichols, Stratford, Conn.

**U.S. Canada catalogue only 20c.** New-Way Stamp, Lawrence (3), Mass.

**FREE!** Giant Bargain Catalog — New Edition listing thousands of bargains including U.S. and B.N.A. Stamps, packets, mixtures, albums, accessories and supplies; sent with beautiful approvals. Jamestown Stamps, Dept. E43PS, Jamestown, N. Y.

**TERRIFIC Stamp Bargain!** Israel—Iceland—San Marino—plus triangle set—Plus Antigua — Borneo — Virgin — Scouts — Congo—Russia—Plus large stamp book—all four offers free—Send 10c for mailing cost. Empire Stamp Corporation, Dept. PR, Toronto, Canada.

**FREE 400 genuine postage stamps!** Worth \$10.00 at catalogue prices. Africa—Europe—Asia—British Emp.—a fascinating, valuable mixture from foreign convents, banks, etc. Who knows what you will find. Also free valuable Booklet. Adults only. Approvals enclosed. Frasek Co., PS4, White Plains, N. Y.

**PENNY Approvals jammed with Bargains.** For better values, try Putnam Stamp Company, Mahopac, New York.

**WILL Rogers Air! Helicopter Triangle!** Plus Monte Carlo Dove Triangle! Stamp printed in Solid Gold! New York Empire State Bldg. airmail, lovely Congo Orchids in full colors, etc. 10c with approvals. Sunny Stamps, Apopka 10A, Florida.

**FREE—Mint British Colonials from Maldives, Solomon Islands, Pahang, St. Christopher, Nevis, Sarawak, Cayman Islands, Gilbert Ellice.** Free with approvals. Viking, Great Neck 5, N. Y.

**AMERICAN Historical Collection!!** Enormous George Washington beauty, F.D. Roosevelt Diamond, Giant Abe Lincoln U.S.A. Flag Commemorative, plus Midget soldier, Latin Orchid issue, Old St. Pierre Fisherman, etc. 10c with approvals. Roseland Stamps, Spring Lake 10A, Mich.

**MAYFLOWER Stamp Album 10c.** 407 illustrations, 64 pages. Approvals accompanying. Niagara Stamps, St. Catharines 702, Ontario.

**TOPS! Mystery lot of over 500 different world-wide only 35c.** Catalogs over \$15.00! Approvals included. Offer to adults only. Littleton Stamp Co., Littleton Q2, N. H.

**105 DIVERSIFIED British Empire 10c.** Approvals included. Linstamps, St. Catharines 402, Ontario.

**QUEEN Elizabeth on Stamps—A beautiful collection of 50 different stamps from 22 countries—all bearing the portrait of the Queen of England.** 10c with approvals. Capital Stamp Co., Ferrysburg 10A, Michigan.

**PHILATELIC Jungle 10c.** Fifteen zoological specimens. Approvals included. Free water-mark detector. Crown Stamps, Virgil 302, Ontario.

**FIFTEEN Pleasant Offers Plus Valuable Tips.** Write: Bileski, Station B, Winnipeg, Canada.

**"UNITED States Commemoratives."** All Different. 25—15c; 50—35c; 100—65c; 150—\$1.00. 1000 mixed—\$5.00. 10c Postage on Orders under \$1.00. Cambridge, Box 411, Cambridge, Ohio.

**FREE!** 29 thrilling jet, astronaut rocket, space, airmails. Send 10c handling. 2c approvals included. ABC World, Box 6000-WK, San Francisco, California.

**LOOK!** Six Queen Elizabeth Mint Sets from Antigua, Caymans, Malta, Montserrat, Mauritius, St. Kitts! 21 Brilliant Pictorials 25c. Attractive Approvals! Gannon Stamps, Box 931, Canton 1, Ohio.

**FREE Sample!** Interesting, Informative, Illustrated. National Stamp News, Anderson, South Carolina.

**DAG Hammarskjold "Error" 5c with approvals,** Belmont Stamps, Washington 15, D. C.

**100 OLD U.S. Stamps between 1861 and 1935 \$1.00.** Rousch Stamps, 51 Chestnut, Mansfield, Ohio.

**5 OLYMPIC Sports Sets 10c.** Approvals. Gordon Davison, Henniker 5, N. H.

**GIANT Approvals Thousands Different 1c and 2c each.** Wahl's Stamp Exchange, 7008K Farragut, Chicago 31, Ill.

**MILLION Foreign Stamps! 2c each!** Send for thrilling, giant approvals! ABC, Box 6000-ML, San Francisco 1, California.

**FIRST Day cover approvals!** Included free, valuable airmail cover. Myers, Coopersburg, Penna.

**FREE!! Congo Triangle Set! Boy Scout Beauty! 25 others.** Different. Approvals. Cambridge, Box 411, Cambridge, Ohio.

**GIANT Washington, African Triangle, Diamond, Kennedy Beauty, 25 others, 5c.** Approvals. Van Orden, Box 333, Denville, New Jersey.

**FREE Macao Mint Set, Approvals.** Corvett, GPO Box 1546, N. Y. 1.

**CHEAPIES 1/4c To 2c.** Excellent Foreign 1/3 Catalogue. U.S. Bargains. Tobysco, Gloversville, N. Y.

**U.N. FLAG set, Pope Triangle, Butterfly diamond, 50 others, 10c; Approvals.** C&R Stamps, Box 522, Hicksville, New York.

**DEALERS Wholesale Catalog.** Postage 4c. Franksco, 5031 Queensbury, Baltimore 15, Maryland.

**OLD scarce U.S. seconds on approval.** Slightly defective, bargain prices. Hearnfeld, Clinton Station, Newark 8, N. J.

**PITCAIRN Island, Ten Different 50c.** No Approvals. Norge, Hohokus, N. J.

**240 DIFFERENT World Wide Only 10c To Approval Applicants.** Winchester Stamps, 45 Winchester Rd., Mansfield, Ohio.

**VATICAN Mercies Airmails 10c, Approvals.** Snedco, Box 68A, Waldwick, N. J.

**60 DIFFERENT U.S. (30 Commemoratives) 25c.** No approvals. Seidenberg, Appleton, Wis.

**EXTRAORDINARY! Free; 20 different Finland to those requesting approvals.** Rizenberg, Box 1303, Chicago 90.

**PENNY Approvals! Regardless Catalogue!** Kloster, 4164—52nd Ct., San Diego 5, California.

**100 DIFFERENT Stamps 10c, with approvals.** J. Nutt, Box 357, Penn Yan 1, N. Y.

**300 DIFFERENT Given Free with approvals.** Particulars. Windsor Stamps, P.O. Box 735, Santa Clara, California.

**COLORFUL Pictorials from 25 different countries, includes triangles, etc. 10c with approvals,** West Coast Stamp Emporium, P.O. Box 3042, North Hollywood, Calif.

**80,000 DIFFERENT! Amazing new plan builds your collection systematically, country by country.** Only 50c weekly. Free details. Ware, Monroe 70, Conn.

**ENORMOUS variety old U.S. flags, famous Americans, Commemoratives with approvals, surprise packet, 10c handling.** Metropolitan Stamps, Box 312 PS, Jackson Heights 72, N. Y.

**PORTUGUESE! 25 Different free.** Approvals. Elkhart, Box 33, Elkhart, Indiana.

**FREE! 25 Egypt, 10c handling, Approvals.** Bellet Stamps, Hazel Park, Michigan.

**15 ISRAEL 5c.** Fine Approvals Accompany. Cooper, Box 75053, Los Angeles 5, California.

**FREE! Unusual "Mystery" set.** Approvals. Premiums. Dancer, B75-T41, Mansfield, Ohio.

**TRADE Your Duplicates.** (Toward Foreign Approvals). Write: VST, Box 98-S, Newton Highlands 61, Mass.

**YEMEN Set Free—Approvals.** W-B Stamps, Dept. PS, Wilkes-Barre, Penna.

**SENSATIONAL Penny Approvals! Pictorials, Topicals, Etc.** Write Today! Schmidt, Box 5426, Reno, Nevada.

**THIS Is Different!** Our system brings you hundreds of stamps, each and every week. Gives your duplicates real value. Obtains stamps otherwise hard to find. Complete details and one year's membership, \$1.00. Kinnear, 558 Oakey Blvd., Las Vegas 6, Nevada.

**FREE! 50 Portugal, 10c handling.** Approvals. Berchtold Stamps, Troy, Ohio.

**105 WORLD Collection 10c.** Many Topicals Included. Monjar, Cincinnati 14, Ohio.

**EXCITING Offer! First President Kennedy Stamps, Perforation Gauge, 15c Handling, Approvals.** Bell, Box x279, Manchester, New Hampshire.

**2c—4c APPROVALS! Thousands! World-wide Bargains!** Carling, 463-B, Howard City, Michigan.

**WORLDWIDE Approvals 1/2 to 2/3 Off!** Catalogue. Evington's, Box 22, Melrose 77, Mass.

**FREE!!! Beautiful stamps Gold, Silver, others.** Approvals. Delor, 20226 Westphalia, Detroit 5, Michigan.

**1000 FINE, Mixed United States Stamps, 25c.** Wright's, Box 1122, Hagerstown, Maryland.

**FREE Armenia, Complete Set 17 Beautiful Pictorials, Mt. Ararat, Others.** Value 67c Given Purchasers Of Low Price Approvals. Plymouth, Box 510, Bell, Calif.

**U.S. BARGAIN: 50 different 10c with beautiful world-wide approvals.** Stamps, Kennebunk, Maine.

**FREE! President Kennedy Set! Fifteen others!** Approvals. Reda, 6350 Leonard, Philadelphia 49, Penna.

**TWO \$5.00 United States Stamps, twenty others 10c with United States approvals.** Irwin, Box 1109, Brooklyn 30.

## 29 ANTIQUES, RELICS & INDIAN GOODS

**3 INDIAN War Arrowheads, Scalping Knife; Thunderbird \$4.00.** Catalog. Arrowhead, Glenwood, Arkansas.

**SELLING 20,000 Indian Relics, Arrowheads, Spearheads, Etc.** List Free. Lear's, Glenwood, Arkansas.

## 30 MINERALS & PRECIOUS STONES

**GET Free Catalog no serious rockhound, gem cutter, jewelry maker, hobbyist or Craftsman can be without.** Full of bargains, exclusive items, low prices from largest suppliers and authorities in the field. Free . . . new catalog just off the press—yours for the asking! Write Grieger's, Dept. C-14, 1633 E. Walnut, Pasadena, Calif.

**PROSPECTOR'S! Rockhounds! Outdoorsmen!** Learn from experienced geologists how to locate and identify valuable rocks and minerals. A comprehensive Home Study course designed for anyone interested in exploring for valuable ore deposits. Write Now! For free literature! Dept. B4, Pacific School Of Mines, P.O. Box 2538, Palm Springs, California.

**20 DIFFERENT mineral stones, labeled, \$2.00.** Phillips, 1290-PS Cottonwood, Banning, Calif.

**OPALS: Precious, Fiery! 10 Ready To Set \$4.50.** Free pricelists. Apartado 80, Sanmiguel, d'Allende, Gto, Mexico.

**EARTH Science—Rockhounds National Magazine.** Subscription \$2.50. Sample 35c. Box 1357-PS, Chicago (90), Ill.

**FREE Bargain gem list.** New Lapidary and Silversmith too! Catalog, 50c. O'Brien's, 1116 N. Wilcox, Hollywood 38, Calif.

**GOLD, Silver, Titanium Ore With Catalog 50c.** Gemco, Eisner Ave., Sheboygan, Wisc.

## 31 HOBBIES, COLLECTIONS

**WANTED.** Cigarette, tobacco cards. Write: Charles Bray, East Bangor, Penna.



# POPULAR SCIENCE OPPORTUNITIES

**HOBBY Magazine** With Interesting Mail 25c. Hobby Mail Trade, Box 134, Clifton-8, N. J.

**SOLDIERS**—Over 1,000 models. All periods. Catalog 35c. Bussler, Box 107-E, Wollaston 70, Mass.

**INTRODUCTORY:** 30 Army, Navy, Marine emblems; 150 assorted Service Stripes (\$5.00 value) only 50c, catalog included. Sample foreign medal, 50c. Insignias, Box 71-S, Rockaway 94, N. Y.

**COLLECTORS Matchbook Covers!** 100 Different Unused \$1.00. Catalog 25c. Helene S. Edelman, 1311-P East 84, Cleveland 3, Ohio.

**BEAUTIFUL Shells from Everywhere.** 37 Collection \$1. Foreign Exchanges. Literature Free! Javo Distributors, Box 13288, Tampa 11, Florida.

## 32 PHOTO FINISHING, PHOTOCOPIES, ETC.

**FAST, Hi-quality Finishing—Kodacolor** Rolls: Eight Jumbo Prints \$1.98—Twelve \$2.49—Twenty \$3.49—Reprints 15c. Also low B&W Prices. Custom Quality Studio, Box 4838A, Chicago 80.

**COLOR Movie Fans! Low Cost—High Quality** processing our specialty, 8mm just \$1 (or \$3 with fresh film). Mailed back next day. Craftsmanship guaranteed. Send exposed reel or request free mailers and price list of complete photo-finishing services. Direct Mail Photo, Box 8352-PS, Pittsburgh 18, Pa.

## 33 MOTION PICTURES & COLOR SLIDES

**SEE the World in Color.** 8mm—16mm. Kodachrome movies. Alaska, Hawaii, America, Europe, Africa, South Seas, U.S. National Parks. Also War and Rocket Test films. 185 subjects. Low prices. Write World in Color, Box 392-PS, Elmira, N. Y.

**USED 16MM Sound Projectors,** also sound films, rental, sale, exchange. Stereo tapes, rental and sale. Write for free catalog. National Cinema, 71 Dey Street, New York City.

**8MM, 16MM MOVIE Subjects—silent,** sound—new, used—2"x2" color slides—biggest selection anywhere! Free, each month, big 24-page newspaper-size catalog. Blackhawk Films, Davenport 15, Iowa.

**FREE Catalogues.** 5,000 8-16MM Films. International-S Films, Greenvale, New York.

**MOVIE Film! Free catalog!** Eso-H, 47th Holly, Kansas City 12, Mo.

**SAVE! Process your own movies at home.** Free Catalog. Superior, 442-448 N. Wells, Chicago 10.

**LADY Wrestling, Movies, Photos.** Free List. Peerless, Box 171-P, New York 13, N. Y.

**8MM SILENT Films.** 16MM Sound Films. Bedner, 5300 So. Talman, Chicago.

**USED—New movies.** Free bulletin. Lee Movies, Box 4752, Chicago 80.

**8MM Valentino, Fairbanks, Keaton,** Others. 16MM Sound Features, Shorts, Silent Classics—Large Assortment. Entertainment Films Company, 236 W. 55th, New York City.

## 34 CAMERAS, PHOTO SUPPLIES

**PHOTOGRAPHY for pleasure or profit.** Learn at home. Practical basic training Long established school. Free booklet. American School of Photography, 835 Diversey Parkway, Dept. 1724, Chicago 14.

**FREE! Send now for photographic bargain** catalog. Dept. 4-K-4, Central Camera Company, 230 So. Wabash Ave., Chicago, Illinois.

## 35 MUSICAL INSTRUMENTS AND SONG WRITERS

**ACCORDIONS, Guitars, Chord Organs!** Save 1/2. Famous makes. Free home trial. Easy terms. Trades. Free catalogs. Mention instrument. International Music Mart, Dept. P. 2003 Chicago Avenue, Chicago 22.

**ACCORDION-O-RAMA,** 874 Broadway, New York 3, N. Y. Tremendous Discounts. Top Brands. Free Brochure.

**SONGPOEMS and songs wanted!** Mail to: Tin Pan Alley, Inc., Box 405, Radio City Station, New York 19, N. Y.

**SONGS Into \$\$\$\$\$\$—Share \$33 million** dollars yearly for New Songwriters, Song-poets. Any subject, songs composed, published, promoted by largest firm. Information, appraisals Free. Send Nordyke Music Publishers, 6000 Sunset, Hollywood 28PS, California.

**SONGWRITERS,** with publisher contacts, want song ideas. Share royalties. Send poems, free examination: Songwriters' Associates, 1650 Broadway, N. Y. 19-G.

**POEMS Wanted for musical setting and** recording. Send poems. Free examination. Crown Music Company, 49-P West 32 Street, New York 1.

**GUITAR Making, books, plans, imported** woods, tools. List 10c. Wildwood, 510 East 11th Street, New York 9, N. Y.

**PIANO Accordions—7600-J Cottage** Grove, Chicago 19, Illinois. Chromatics—Hohners—Concertinas—Wholesale.

**SONGPOEMS Wanted!** Collaborate with professional Songwriters equally. Share royalties. Songwriters Contact, 1619-N Broadway, New York 19.

**SONGPOEMS Wanted.** Send Poems for offer. Nashville Music Institute, Box 532-S, Nashville, Tennessee.

**USED Professional Guitars, Amplifiers,** Drums, Catalog 10c. Music, 1215 War Memorial, Peoria, Illinois.

**BANJO Necks, extra long!** Convert your banjo into a "Pete Seeger." Stamm, 823-C Foster, Evanston, Ill.

**BANJOS, Parts, Rings, Necks, Hard-** ware. 263A E. Forhan, Long Beach 5, Calif.

**SONGWRITERS! Protect your ideas!** Hold all poems, songs! Write for safe, correct procedure! Song Service, Dept. PS, 333 W. 56th, New York 19, N. Y.

## 35A PHONOGRAPH RECORDS

**RECORDS—Stereo, Monaural, Big Dis-** counts. Noelsson, Box 211, New York 5, N. Y.

## 36 RADIO, TELEVISION, ELECTRONICS, HI-FI

**ELECTRONICS Course only \$14.95.** Includes all tubes, parts, tools, instructions. Write for full information. Progressive "Edu-Kits," Inc., Dept. 580A, Hewlett, N. Y.

**SAVE 30% Up! Blank-Stereo Recorded** Tape—Recorders—Norelco Speakers. Saxitone, 1776 Columbia Road, Washington 9, D. C.

**SAVE dollars on radio, TV-tubes, parts** at less than manufacturer's cost. 100% guaranteed! No rebrands, pulls. Request Bargain Bulletin. United Radio, 1000-S, Newark, N. J.

**FIX Your Own TV, Save 80%! Send for** Free Illustrated Chart showing how! We'll include Giant Electronics Catalog. Zalytron, 461 Jericho Tpke., Mineola, N. Y.

**TRANSISTOR Radios Repaired.** \$5.00 covers parts, labor, return postage. Mail radio and \$5.00 to: Mannington TV Co., 23 Pyles Ave., Mannington, West Va. Guaranteed. Short-Wave \$10.00.

**CONVERT Any Car Radio To Home Use.** Instructions \$1.00. Custom Design, P.O. Box 63, Roslyn, Pa.

**ASTOUNDING Government surplus il-** lustrated catalog 10c. Meshna, Malden 48, Mass.

**18 DISTANCE Crystal set plans—25c.** Laboratories, 1131-T Valota, Redwood City, California.

**CONDENSOR Checking Kit Only \$4.00.** Nicholson, 307 Glamis, San Antonio 23, Texas.

## 37 BUSINESS OPPORTUNITIES

**MURAL Artists Needed! No experience** required, earn \$10-\$15 per hour! Amazing "Project-A-Mural" Method. Project pattern slides, trace-off, paint per color guide. Professional results guaranteed! Huge demand from homes, bars, restaurants, offices, etc. Sell \$100 murals for "pennies" in paint. Free Success Plan. Associated Muralists, Dept. F4C, 500 Plumas, Reno, Nevada.

**SELL Champion, AC, Autolite spark** plugs. Reconditioned, electroplated, guaranteed 10,000 miles. 100% profit. Free sample. Lee Plugs, 1608-K Roberts, Houston 3, Texas.

**IMPORT-Export opportunity, profitable** world-wide, mail-order business from home, without capital or travel abroad. Established world trader ships instruction for no-risk examination. Experience unnecessary. Free details. Mellinger, K694, Los Angeles 25.

**EARN Money raising fishworms for us!** Write: Oakhaven-42, Cedar Hill, Texas.

**\$100.00 WEEKLY spare room.** Raise redworms odorless, soilless way. Charlie Morgan, Box 116-C, Bushnell, Florida.

**OPERATE profitable mail order busi-** ness. Write Walter Service, 4159-B East 112th, Cleveland 5, Ohio.

**BRONZE Baby Shoes.** Genuine Electroplating process, Equipment, Mountings, Instructions. Send \$1.00 for Valuable Book "Your Guide To Success" Bronzing Baby Shoes, plus complete catalog. Hollywood Bronze Supply, Dept. B70, 3445 Union Pacific Avenue, Los Angeles 23, California.

**BUY Direct From Factories—Appliances,** Cameras, Watches! Free details! Cam Company, 436PS Bloomfield Ave., Verona, N. J.

**WANT Your name with 1000 mailers?** 25c lists your name with out mailings every month. Dixie Mailers, King, N. C.

**FREE "Franchise Profit Letter" tells** how unique NFR service is helping thousands seeking profitable businesses. Write today. National Franchise Reports, PS-528, 333 North Michigan, Chicago 1.

**IMMEDIATE Profits with no capital or** experience. Take orders for all magazine subscriptions. Friends and neighbors are your prospects. Write now for complete free kit. McGregor Magazine Agency, Dept. DB2, Mount Morris, Illinois.

**STOP Throwing Away Boxtops! They're** worth money! Some, 25c! Inquire: "Box-tops-DG", Cedar Hill, Texas.

**VENDING Machines—No Selling.** Operate A Route of Coin Machines And Earn Amazing Profits. 32-Page Catalog Free. Parkway Machine Corporation, 715 PSB Ensor Street, Baltimore 2, Maryland.

**WANT To Make Big Money At Home?** \$10.00 profit in an hour possible with Invisible Mending. Make tears, holes disappear from clothing, fabrics. Steady year-round demand from cleaners, laundries, homes. Details Free. Fabricon, 1535 Howard, Chicago 26, Illinois.

**FREE Literature — Make Big Money** Raising Fishworms and Crickets. Carter Farm, Plains, Georgia.

**DOLLS! Dolls! Dolls! We teach you to** repair, make, sell all kinds of dolls and accessories including clothing. Study at home. Earn while you learn. Free booklet. Lifetime Career Schools, Studio PSC-43, 11824 San Vicente Blvd., Los Angeles 49, California.

**FREE: "How To Win Contests."** International, Box 63-A, Bellwood, Illinois.

**MAKE \$25-\$50 week clipping newspaper** items for publishers. Some clippings worth \$5.00 each. Particulars free. National, 81, Knickerbocker Station, New York.

**"CO-PUBLISH" Home Business Digest!** Sample, Complete instructions, \$1.00. Free Details! Stratford, Box 38-306, Miami 38, Fla.

**MAKE \$25-\$50 week clipping newspaper** items for publishers. Some clippings worth \$5.00 each. Particulars free. National, 81, Knickerbocker Station, New York.

**OPERATE Paying Mail Order Business** From Home Or Office. Easy, Pleasant Work. Eye Opening Literature Supplied. Details. Write Ashe Co., 45-A Calumet Road, Holyoke, Mass.

**MAKE Money In Mail Order.** Free Details. Davenport, Box 132M, Inglewood, California.

**MANAGE Motel or Resort.** Men, women, couples can make \$400.00 to \$1,000.00 monthly plus apartment. Pick own location with our employment assistance. Learn at home. Free Booklet. Motel Managers Training School, Dept. PSC-43, 612 So. Serrano, Los Angeles 5, Calif.

**PLASTERCRAFT molds, liquid rubber,** plasters, flocks, candle supplies. Catalog and manual free. Jayhawk Plasters, Blue Rapids, Kansas.



# POPULAR SCIENCE OPPORTUNITIES

**FREE Report: "Mailorder Profits And Pitfalls."** Box 63-U, Bellwood, Illinois.

**BIG Money—Operate your own fix-it shop.** Service all household appliances: irons, fans, refrigerators, automatic washer-dryers, etc. Do house wiring, commercial wiring. Rewind motors of all sizes. Sharpen mowers, skates, saws. Buy needed spare parts wholesale. Free Book. Christy Trades School, A-2501, 3214 W. Lawrence, Chicago 25.

**MAIL-Order home business.** Get Free Copy. "Make Money in Mail Order." Mailco, 1554 S. Sepulveda, Dept. J694, Los Angeles 25.

**\$200 WEEKLY Selling Books By Mail.** Box 51-R, Des Plaines, Illinois.

**OWN your own Western Auto Store.** Over 3,800 now operating. Minimum investment \$14,000. Free training. No retail experience necessary. For complete details write Chas. Wilson, Room 901, Western Auto, 2107 Grand, Kansas City, Missouri. (Indicate geographical area preferred.)

**EXPORT—Import Business Made Easy.** Complete setup service, not just instructions. Hermes, 152 West 42, New York City 36.

**1961 FORDS \$499.00.** 17 Jewel Watches \$2.90. Men's new Oxfords \$1.85 pair. Details Free. Mann, Box 183-P, Bloomfield, N. J.

**COPUBLISH National Business Builder.** Many Benefits. \$1.00 Brings Copy And Details. P. Kelley, 373 Dept. HL, Carmichaels, Pa.

**"HOW-TO of Mailorder"—Techniques, Secrets, Laws, Regulations.** Complete Manual—\$1.00 Dean's, Box 40-POP, Elberton, Georgia.

**SELL Advertising Book Matches.** Write us today; we put you in business By Return Mail, handling complete line Ad Book Matches in demand by every business right in your town! No investment; everything furnished Free! Top commissions daily! Superior Match. Dept. 463, 7530 S. Greenwood, Chicago 19, Ill.

**INCREASE Your Income! Mail Order Business Gives "Better Odds."** Write: Mize, Box 33014-P, Houston 33, Texas.

**"POSTAGE Saving Guide," \$1.00.** Cuts mailing costs approximately 10%. Dealers Wanted. Neil H. Tasker, Shamokin, Pennsylvania.

**PIANO Tuning learned quickly at home.** Tremendous field! Musical knowledge unnecessary. Information free. Empire School of Piano Tuning, Champaign, Illinois. (Founded 1935.)

**\$20-\$50 DAILY.** At Home. Boys, Girls, 14-90. Easy, Interesting, Fascinating. Details \$1. Stapp Research, 5027 Elm, San Diego 2, Calif.

**WORLD'S Largest wholesale supply.** Buy from 679 American, European, Japanese wholesalers. Tailormade suites from Hong Kong. 123 dropship catalogs. Rockbottom prices. Free details. International Buyers, 216-PS2 Jackson, Chicago 6, Illinois.

**"HOW and Where to Obtain Capital."** Reliable Service, Rome City, Indiana.

**VITAMIN Business.** Complete. \$100.00. Terms. Inventory worth \$330.00. Owner, 2908-V Beverly Boulevard, Los Angeles 57.

**SELL Books by Mail.** 400% Profit. Royal, Box 450-M, Cleveland 27, Ohio.

**PROFITABLE Home Dealer Plan** for men and women everywhere without investment. Write Midwest Chemical Company, Detroit 26.

**MAKE Durable building plastic easily.** Waterproof, fireproof, economical. Bays Laboratory, Cedaredge 2, Colorado.

**\$CASH.** Making Marble Jewelry, Flowers. Catalog 10c. Flocraft, Farrell 37, Penna.

**DISTRIBUTE profitable electric wiring devices.** Dickman's, Box 301, Margaretville, N. Y.

**88—COMMISSION Circular Mailers (Active)** On Gummed Labels, Covering Entire U. S., \$2.00, 50 For \$1.00. P. Kelley, 373 Dept. HB, Carmichaels, Pa.

**FREE wholesale directory list—350,000 items.** Dean's Box 40-PS, Elberton, Ga.

**INCOME from local information.** No selling. Write: American, Forestville, Pa.

**YOUR Own Moneymaking, Home-operated Mailorder business.** Write: Mann, 266-PS, Hillsdale, New Jersey.

**MAILORDER To Motels, Churches, institutions.** Individual setup; not just instructions. Hermes Advertising, 152 West 42, New York City 36.

**WORK at home packaging merchandise.** Very profitable. No selling. Everything supplied. Details free. HBE, 1148-S West Grand, Chicago 22.

**LIQUID Molding Rubber.** Free Information, Chaney's 5415-C San Jose Blvd., Jacksonville 7, Florida.

**\$200.00 MONTHLY.** Spare Time. With Tablesaw, Bandsaw or Jigsaw. Write: Holiday House, B3800 Harney, Vancouver, Washington.

**EARN \$3.00 Hour Home, Sparetime,** Assembling Pump Lamps. Novelty Lamps, Cabot 1, Arkansas.

**IMPORT-Export Opportunities.** Start your own big-money business part-time. Learn from an expert. Sample instructions \$1.00. World Trade Register, Box 921, New Braunfels, Texas.

**OPERATE Home mailorder business.** Vosacek Printing, 4444-PS Ute, San Diego 17, Calif.

**MAKE Figurines.** Rubber for Molds, Extra Thick. Free sample. W. Wooley, 1915-B North, Peoria, Ill.

**INSTALL Burglar Alarm Systems.** Big profit home business. Beginners start spare time, without mechanical experience or costly equipment. Free starter plan. Nasco, Dept. K694, 11071 Massachusetts, Los Angeles 25.

**OPERATE Restaurant Or Diner.** Free Booklet reveals profitable plan. Write Restaurant Business School, Dept. FC-43, 1920 Sunnyside Avenue, Chicago 40, Illinois.

**76 MILLION prospects!** Immediate profits! Sell Champion, AC, Autolite spark plugs. Precision reconditioned, silver-plated, guaranteed 10,000 miles. Up to 308% profit. Free samples—details. Indy 500 Spark Plug Co., 4620 Braeswood, Houston 35, Texas.

**BIG boom in plastic business.** Get in now. Get your share of the money. Learn the easy plans of making all the big selling plastic products of today. Free details. Gary Longmire, Dept. B13, 925 Bluff, Dubuque, Iowa.

**PROFITABLE Mail Order Business Catalogs Imprinted With Your Name.** Free Details. Villanueva, 91 Middleton, Brooklyn 6, N. Y.

**350,000 BARGAINS!** Free Merchandise! Write: Goldmine, 240-PZ, Planetarium Station, New York City 24.

**DYNAMIC Mailorder Beginners Information.** Vikari's, 468-BR Third Avenue, Salt Lake City 3, Utah.

**OPERATE home mailorder business.** Free details. Shaff, 1161 Pacific, Long Beach 13, California.

**REFILL propane torches for dime!** Details free. McCarthy, 2232-A Wisconsin Avenue NW, Washington 7, D. C.

**\$25.00-\$75.00 WEEKLY clipping newspaper items for publishers.** Some worth \$10.00 each. Details free. Harvey's, 1402-PSN, Englewood, Colorado.

**"HOW To Start Your Own Mailorder Business,"** could be best 50c ever spent! Free Buying Guide Offer! Asch, 1608 Nelson, Chicago, Ill.

**ASSEMBLE.** sell inexpensive jewelry. Full, spare time. 100% Profit. Steady repeat business. Experience unnecessary. We supply everything. Details free. Admire Jewelry, Box 461-A, Madison Sq. Sta., New York 10.

**COLORGLAZED Concrete pottery** made without molds. Patented method. Cementery products, novelties, tiles. Basement leak-sealing. Money-making projects. Booklet, details free. Men only. National Potteries, Grand Rapids, "Minnesota."

**BAKE New Greaseless Doughnuts** In Kitchen. Sell stores. Free recipes. Summers, 3605 South 15th, Minneapolis 7, Minnesota.

**I MAKE Money Every Week By Mailorder!** Helped Others. Will Guide You. Webster, 2038-54 Mockingbird, Columbia 4, S. C.

**MAKE \$46 From Square Foot Plywood;** Jigsaw necessary. Free Details. Woodarts, Bridgewater, Mass.

**REWARD: Security!** 10,000 Trade Secrets. Uncle Sam, Box 234-S, Troy, New York.

**TREMENDOUS Moneymaking Opportunities.** Handcrafted Jewelry Business. Free Details. LPS, Dept. 243, 1706 Argon, Mesa, Arizona.

**MAKE \$25-\$65 weekly typing at home.** Details \$1. Bonco, 130 Cumberland, Mason-town 2, Pa.

**MOLD Statuary, Pottery, Tiles, Novelties—5c materials** make dollar sellers! Particulars free. Marbleizing Service, Edwardsville, Illinois.

**"UNITED States Mailorder Laws And Regulations."** Send \$2.00. Details Free. Carmac, 3320 East 44th Avenue, Vancouver, Canada.

**PAWNBROKER.** Be One! I'll teach you. Amazing profits. Pawnbroker Thayer, Bath, Maine.

**LOVE! Pays. Bronze Baby Shoes.** Credit Available. Free Booklet. Box 5036C, Inglewood, California.

**I MADE \$40,000.00 Year by Mailorder!** Helped others make money! Start with \$10.00—Free Proof. Torrey, Box 3566-F, Oklahoma City 6, Oklahoma.

**\$70 WEEKLY—Home, spare time.** Simplified mail bookkeeping. Immediate income—easy! Auditax, 34741D, Los Angeles 34.

**"HOW-To" Make Profits From Movies!** Secret plans reveal how, \$1.00. Elco, Box 1400, Grand Rapids, Michigan.

**HOME Producers needed desperately** in exploding new Plastics Business. Sell us your spare time. No selling—most territories still open! Hurry! NPC, Box 23321-LD, Los Angeles 23.

## 38 MONEYMAKING OPPORTUNITIES

**\$100 WEEKLY possible.** Compile Mailing lists and address envelopes for advertisers. Home-spare time. Particulars free. National Service, 81, Knickerbocker Station, New York City.

**MAKE Plastic novelties for extra income.** Low cost home training now available. Write for free booklet. Interstate Training Service, Dept. D-2, Portland 12, Oregon.

**VENDING Machine—No Selling.** Operate A Route of Coin Machines And Earn Amazing Profits. 32-Page Catalog Free. Parkway Machine Corporation, 715 PSM Ensor Street, Baltimore 2, Maryland.

**TO \$100.00 Weekly, Mailing Catalogs.** Sample, instructions, 25c. Costar, GPO Box 972-PS, New York 1.

**AMAZING successes through franchises!** Become exclusive franchise holder your territory. Information rushed. National Franchise Reports, SP-528, 333 North Michigan, Chicago 1.

**WE Love our mailman.** Leaves \$1,000.00 monthly in our rural mailbox. My college professor husband's scientific mailorder pays. We bought a Texas ranch, live as we always wanted. Free folder on "Ranch Mailorder." Eveningshade Ranch, Boerne, Texas.

**SELL Diamonite Gems: More Brilliant than Diamonds.** Catalog 10c. Diamonite, 2420-S 77th, Oakland 5, California.

**FREE Literature — Make Big Money Raising Fishworms and Crickets.** Carter Farm-11, Plains, Ga.

**MEN — Women! Start Money-Making Plastic Laminating Business** at home in spare time. Material that costs 11c brings back \$2.58. No canvassing or selling but mail orders bring in \$20 a day. Write for full particulars free. Rush name on postcard to Warner, Room CL-3-D, 1512 Jarvis, Chicago 26, Ill.

**DETECTIVES—Work home—Travel.** Experience unnecessary. Detective Particulars free. Write Wagoner, P-125 West 86th, New York 24.

**WE purchase items you make at home for us.** Enclose stamp for details. Wolfe Specialties, Box 171-A, Center Line, Michigan.



# POPULAR SCIENCE OPPORTUNITIES

**INCOME From Oil Can End Your Toil!** Free Book, Maps! National Petroleum, Miami Beach Federal, Miami Beach 39, Florida.

**MAKE \$25-\$50 week**, clipping newspaper items for publishers. Some Clippings worth \$5.00 each. Particulars free. National, 81, Knickerbocker Station, New York.

**PROFITABLE hobby** adds to income. Operate Home Mail Order Business. Write Publicity, Box 727B, Kalamazoo, Michigan.

**\$1000.00 PROFIT Possible** per sale showing our quality aluminum siding on your home. Details free. Aluminum Industries, Dept. PS-4, Kansas City 11, Mo.

**EASY to start rubber stamp business** at home in spare time. Make up to \$9.80 an hour without experience. Facts free. Write to Roberts, 1512 Jarvis, Room CR-3-D, Chicago 26.

**PROFIT with your typewriter.** My folio tells 10 ways you can make money by typing. Send \$1.00 to Hemlock Hill, Box 7198, Pittsburgh 13, Pa.

**MAKE \$50 Per Thousand Addressing Envelopes.** Also names of Magazines that pay for newspaper clippings. Send \$1.00 to J. F. Jereczek, Route 2, Box 61, Arcadia, Wisconsin.

**"SEASHELL Profits At Home."** Write: Thompson's, Sunrise Arcade, Ft. Lauderdale, Florida.

**GET Big Mails—A Stamp Will Do.** Taylor Enterprises, Export, Penna.

**LIST Of 102 Radio Stations** That Sell products on commission basis. \$1.00. 14 Horatio, N.Y.C. 14.

**OPERATE Home Art Studio.** \$5.00-\$10.00 or more hour possible! Advertising agencies, magazines, stores (over 40 Big Fields)—large buyers of Free-lance art and cartoons. We show you how. Sell by mail. Fascinating home study system. Free Book. Write to Continental Schools, Dept. E-152, 4201 So. Broadway, Los Angeles 37, California.

**BECOME A Notary Public.** Win extra income, prestige, business contacts. Details free. Stationers Exchange, Box 166, Hannibal, Missouri.

**MINK Raising information free.** Complete. Lake Superior Mink Farm, Superior EE, Wisconsin.

**BE A Manufacturer! Or Promoter!** License Government Patents Free! Details \$1.00. Dubs Information Service, Box 12525, Houston 17, Texas.

**PAINT Signs for yourself, others.** Easy with our Letter Patterns, Sign Kits. Also "Popular Raised Letters." Paulo Signs, Crystal Falls, Michigan.

**CIGARETTES—Make 20 plain or filter-tips for 9c.** Facts free. Moberly, Box 4013, Owensboro, Kentucky.

**HOMEWORK.** \$1 brings list of companies offering homework. Eagle, Box 135, Bronx 60, N. Y.

**HOME Mailorder "manufacturing."** Everything supplied. Clenso Products, 184 Oakview, Winnipeg 15, Manitoba.

**"GET Rich In Spite Of Yourself."** Title of 62 page booklet that sold 250,000 copies and brought fortunes to many. Author gives astonishingly simple formula for Wealth and Success. Guarantee: If book does not bring at least \$100 extra in six months, return for refund. Send only \$1.00, or book may be sent with bill for \$1.00 plus 25c for bookkeeping charges. Book Of Destiny, 72-C Orchard St., Tarrytown, New York.

**MONEY — Need More? Millionaires Methods, Treasures, Stock Market.** Bibliograph, \$1.00. Sweet, Box 183, Cupertino, California.

**LIST Of Fifty Firms** Needing Home-workers—25c! Farmer, 210-R Fifth Ave., New York 10.

**TRUE—You can make money in mail order with us.** Join Free. Co-Ops, 694 Kerr, Columbus, Ohio.

**DRAW For Profit.** Practical training at home can qualify you to earn additional income. Send your drawings to local publications, advertising agencies or International Syndicates. Huge profits involved. Free Book tells you how. Continental Schools, Dept. E-151, 4201 So. Broadway, Los Angeles 37, California.

**FREE Advertising For Mailorder Items.** Branvolt, 5718 Troost, North Hollywood, California.

**LEARN the secrets of repairing junk batteries, generators, starters, profitable, easy, at home.** Free particulars. Batterymen, Prunedale Station, Salinas, California.

**YOUR Own, Easy-To-Start, Home Mail-order Business, sparetime.** Fascinating; profitable! Information free. Alfano, 19-PS Pine, Closter, New Jersey.

**MAKE up to \$50.00 per day.** Full or Part Time. Men or women; ideal money raising product for clubs and church groups. Send \$1.00 for details and brochure, refundable on first order. Raymar Enterprises, Box 602C, Lynwood, Calif.

## 38A BUY IT WHOLESALE

**BUY Direct From Factories!** Appliances, Cameras, Watches. Free Details! Cam Company, 436PB Bloomfield Avenue, Verona, New Jersey.

**FREE! Name Brands Catalog!** Your own high profit business. Sell Name Brands, full or part time. No inventory—no investment. More than 2000 Name Brand items; lowest wholesale prices. Watches, jewelry, cameras, hi-fi, stereo radios-phonos, appliances, housewares, hardware, power tools, luggage, musical instruments, garden equipment, sporting goods, toys, many others. 8 Floors of Name Brands. Million dollar inventory. Orders shipped complete within 24 hours. Send for Free beautifully illustrated catalog. Now! Separate wholesale price list. H. B. Davis Corp., Dept. PS, 145 West 15 St., New York 11, N. Y.

**BARGAINS! Buy Wholesale! Save Money!** Free Catalog! Norris, 273-L Merrick Road, Lynbrook, N. Y.

**NEW Deluxe below wholesale catalog.** Automobile catalog and others. Furniture, clothing, housewares, appliances, refrigerators, freezers, washers, dryers, television, radios, luggage, binoculars, hi-fi, stereo, phonographs, recorders, cameras, projectors, musical instruments, sporting goods, toys, tools, typewriters, watches, jewelry. Huge discounts on thousands of name brand items. For free specimen list of actual factory prices—postcard: Selbyco, Decatur 16, Illinois.

**WORLD'S Largest wholesale supply.** Buy from: 679 American, European, Japanese wholesalers. Tailormade suits from Hong Kong. 123 dropship catalogs. Rock-bottom prices. Free details. International Buyers, 216-PS Jackson, Chicago 6, Illinois.

**POWER Tools—Belt Sanders—Zipp Saws—Electric Planes.** Write: Carpenter Wholesale, Box 127, Three Forks, Mont.

**DRUG Sundries.** Complete Line Of Rubber Goods. Nationally Advertised Brands. Vitamins, Etc. Write For Free Catalog. Federal Pharmacal Supply, Inc., Dept. PS, 6652 North Western Avenue, Chicago 45, Illinois.

**2,000 PAGES Wholesale Catalogs!** Write Mosaser, Box 47-A, Newark, Ohio.

**350,000 BARGAINS! Free Merchandise!** Write: Goldmine, 240-PT, Planetarium Station, New York City 24.

**FANTASTIC sale!** Gentlemen's 17 jewel gold plated watches with bands, brand new from German Factory. \$9.95 Postpaid. Full lever movement with calendar, \$11.95. Please order one at a time. Order often while supply lasts. Satisfaction Guaranteed. Check or Money Order. Universal Traders, Dept. PS, 1617 Brookline Blvd., Pittsburgh 26, Pa.

**WHOLESALE—Washer, Dryer, Refrigeration, Air Conditioning, Heating, Electric Range, Water Heater, Major Appliance Parts and Supplies.** Free Catalogs! Granger Co., 3rd Avenue and West Maryland Street, Evansville, Indiana.

**100,000 PRODUCTS Wholesale! Terrific Bargains!** Wholesalers, 1265 Broadway, New York 1, N. Y.

**BELOW Wholesale Cost.** Merchandise, Housewares, Jewelry, Toys, Gifts. Bargains, P.H.A.-14, Farr Road, Columbus 4, Georgia.

**FREE Lists—Less Than Cost.** Surplus Electrical, Hardware, Model Train Parts At Sacrifice Prices From Manufacturer. Write: Kusan, Inc., Dept. WPC, Box 9277, Nashville, Tennessee.

## 39 FORMULAS, PLANS, ETC.

**FORMULAS—All Kinds.** Amazing Big Catalog 10c. Kemisco, Park Ridge 15, Illinois.

**LATE Modern Manufacturing Formulas** List Free. Chemical Service, Martville, New York.

## 40 PLASTICS

**NEW Liquid casting plastic, clear, colors.** Embed real flowers, butterflies, photos, coins. Send 25c for two handbooks "How to Cast Liquid Plastics" and "How to Make Extra Money at Home." Castolite, Dept. D-102, Woodstock, Illinois.

**EMBEDDING, casting secrets free.** Sample, 25c. Crystal, 4350-H N. Whipple, Chicago 18.

**PLEXIGLAS — Any thickness — Clear — Colors—Cut to size—Clear Rods—Tubing.** McClarin Plastics, P.O. Box 168B, Hanover, Pennsylvania.

**PLASTIC Embedding for fun and profit, no oven.** Make beautiful jewelry, decorative panels, science specimen castings. Catalog 25c. Natcol Plastics, Box 444, Yucaipa 4, California.

## 41 SCIENCE & CHEMISTRY

**AMAZING New Book Of Science Experiments, formulas and Catalogue of Laboratory Supplies.** Only 35c. National Scientific Co., Dept. PS-4, 13 S. Park Avenue, Lombard, Illinois.

**NEW Concepts in physics and astronomy** comprising a unique structural explanation for the subatomic particles and their forces. Nuclear theory challenged. 25 cents postpaid. C. F. Kraft, 4809 Columbia Road, Annandale, Virginia.

**UNUSUAL Chemistry books, courses, kits!** Rare chemicals, cheap! Catalog 25c. National, Box 133-A, Palo Alto, Calif.

**ROCKETS: New Illustrated Catalog 25c.** Single And Multistage Kits, Cones, Engines, Launchers, Trackers, Technical Information, Etc. Fast Service. Estes Industries, Penrose 6, Colorado.

**FREE 3 Pyrex test tubes with purchase \$3.00.** Catalog 25c. Chemicals, Apparatus, Biology. Mid-States Scientific, 7053 N. Clark, Chicago, Ill.

**POCKET Electroscopes, and radiation indicator.** \$1.00. George Turner, Waterville, Kansas.

**ILLUSTRATED Catalog; Chemistry, mineralogy, biology 25c.** Tracey Laboratories, Evanston, Illinois.

**CHEMICALS and apparatus for industrial, analytical and private laboratories.** Catalog 35c. Dept. M-26, Biological Supply Co., 1176 Mt. Hope Ave., Rochester 20, N. Y.

**LET us furnish your chemical laboratory!** Our low priced chemicals, and apparatus are waiting on line to serve you. Catalog only 25c. United Chemical Products, Box 3626, Grand Central Station, New York 17, New York.

**ROCKETEERS! New 1963 Catalog 25c.** Kits, Engines, Materials, Apparatus, Pyro-fuzer. Central Rocket Company, Waupaca, Wisconsin.

**FREE—Pair of Chemical Resistant Polyethylene Gloves with catalog.** Low priced Chemicals, Biologicals, and Apparatus. New Illustrated Catalog only 35c. Dover Scientific, 35-24 31st St., Astoria 6, New York. Open All Day Saturday.

**WUMCO Chemical Co., Chemicals and Chemical Apparatus.** Catalog—25c. Booklet of Experiments—50c. Box 681, Reading, Penna.

**ROCKETRY Supplies: Kits, Engines, Cones, Tubes, Launchers, Firing Panels.** Latest illustrated catalog 25c. Centuri Engineering Co., 340 W. Wilshire, Phoenix 3, Arizona.

## 42 EMPLOYMENT INFORMATION

**FOREIGN—U.S.A. jobs.** All occupations. Up to \$1600.00 monthly. Free transportation, benefits. Complete "directory." Application form. Send \$1.50 (\$2.00 airmail). Why pay more? C.O.D.'s accepted. Satisfaction guaranteed. International Employment, 152 W. 42nd, Suite 536-C4, New York 36, New York.



# POPULAR SCIENCE OPPORTUNITIES

**FOREIGN Employment.** Construction, other work projects. Good paying overseas jobs with extras, travel expenses. Write Only: Foreign Service Bureau, Dept PS, Bradenton Beach, Florida.

**FOREIGN—U.S.A. jobs.** All occupations. Up to \$1600.00 monthly. Free transportation, benefits. Complete "directory." Application forms. Send \$1.50 (\$2.00 airmail). Why pay more? C.O.D.'s accepted. Satisfaction guaranteed. International Employment, Box 307-C4, Bedford, Indiana.

**FOREIGN Employment Information Job Possibilities** Up To \$1600 Monthly In Europe, Africa, Asia, South America. Free Transportation. Construction Workers, Clerks, Hundreds Of Occupations Men, Women. Complete Information, Proper Application Form Sent Promptly. Satisfaction Guaranteed. Send \$2.00 (\$2.25 Airmail) (C.O.D.'S Accepted) To: Jobs, P.O. Box 50512, Dept. F, New Orleans 50, Louisiana.

**JAPAN! Korea! Okinawa!** Many hi-paying jobs available. Complete, detailed reports \$2.00. Japan Reports, Box 2202-E, Newport Beach, California.

**DIRECTORY Reports.** Construction, aviation, shipping, oilfields, government, manufacturing, trucking, etc. Foreign Stateside. Helpful information plus job-getting tips on preparing application letters. Unconditional money-back guarantee of satisfaction. Act Today. Only \$3.00. (\$3.25 Airmail) (C.O.D.'s Accepted) Research Services, Meramec Building, St. Louis 5-PS, Missouri.

**WORK For the U.S. Government.** Send \$1.00 for next five monthly issues containing announcements of Federal job examinations. Good pay plus fringe benefits. Civil Service Reporter, Dept. P.S., 330 Newbury Street, Boston 15, Massachusetts.

**MERCHANT Marine.** Men—Women. Top wages. Travel. Information. Harvey's, 1402-PSM, Englewood, Colorado.

## 43 AGENTS WANTED

**EXTRA Cash Aplenty!** Show 'em and you'll sell 'em—sensationally beautiful, handpainted plastic photo enlargements, personalized compacts, costume jewelry. Take orders—collect 40% commission. Self-selling sales kit free. Novelko, 3343 North Avenue, Chicago 47.

**YOUR Own business—Suits \$1.50; Overcoats 65c; Mackinaws 35c; Shoes 12½c; Ladies' Coats 30c; Dresses 15c.** Enormous profits. Catalog Free. Nathan Portnoy Associates, 2109-J Roosevelt Road, Chicago 8, Ill.

**EVERY Man A Prospect.** Refundable sales kit offer showing line belt buckles, tie clasps, money clips, cuff links, lapels, identification badges, individualized with customer's name and emblems. Cap badges for trucking, bus, taxi, police, firemen, also heavy construction emblems. Choice 3000 emblems. Hook-Fast, Box 1088PS, Providence, R. I.

**MAKE Most Extra Cash** with world's biggest line everyday greeting card assortments, gifts. Introduce friends, neighbors, to over 150 assortments. 500 big money-makers. Pocket up to 100% profit plus big cash bonus. Free giant color catalog; samples on approval. Write Arrow Greetings, 513 Fourth Ave., S., Dept. 84-C, Minneapolis, Minn.

**START Your Own Business On Credit.** U.S. Only. Your own boss. 1199 Dealers sold \$5,000 to \$25,500 in 1961. We supply stocks, equipment on credit. 200 home necessities. Sales experience unnecessary. Pleasant, profitable business backed by world-wide industry. Write Rawleigh, Dept. D-U-PSC, Freeport, Ill.

**EARN Big Money** introducing amazing Color-V. Makes ordinary TV show in beautiful colors. Low \$2.98 price—sells like hotcakes. Free details. Excellent Buys, (Dept. PS-5), 34 E. 12th, N.Y.C.

**AGENTS—300% profit** selling genuine gold window letters; stores and offices. Free samples. Metallic Sign Letter Co., 1217-E West Newport, Chicago.

**YOUR Own Business—Profit 8 ways** with America's fastest growing shoe company. Part-time or Full-time. Big cash commissions. Free demonstrators. Free insurance, shoes to producers. Write for complete information now. Absolutely no obligation. Ortho-Vent Shoe Co., 434 Brand Road, Salem, Virginia.

**FREE Sample, Beautiful Curios!** Sell on Sight! Apartado 9036, Mexico City.

**DEALERS Wanted . . . Men, Women** Write: Wilknit, Adv. C2034, Greenfield, Ohio.

**REVISTA Mundo, Distributors And Advertisement Promoters; Big Dividends** Wanted In U.S. Inquire: San Salvador, El Salvador.

**WANTED: Agents** for new imported 8MM camera. The Robinson Co., 15468 Hiway 80, El Cajon, Calif.

## 44 HIGH-GRADE SALESMEN

**SENSATIONAL new longer-burning Light Bulb.** Amazing Free Replacement Guarantee—never again buy light bulbs. No competition. Multi-million dollar market yours alone. Make small fortune even spare time. Incredibly quick sales. Free sales kit. Merlite (Bulb Div.), 114 E. 32nd, Dept. C-74-F, New York 16.

**CALENDARS, Novelties—Full or Part Time.** Liberal Commissions. Fleming, 6535-B, Cottage Grove, Chicago 37.

**YOUR free copy of World's biggest sales magazine** tells you how and where to make more money on your own in selling. Write Specialty Salesman Magazine, Desk 6B, 307 North Michigan, Chicago 1.

**Make Extra Money** Selling advertising matchbooks. Free catalog and sales outfit. Matchcorp, Dept. PS-43, Chicago 32.

**EARN Big Commissions Full Or Part Time.** Show America's largest line low priced business printing and advertising specialties. Big Free Sales Kit samples hundreds items used daily by business people. Build profitable repeat business. Start right now. National Press, Dept. 9, North Chicago, Illinois.

**MAKE Up to \$50.00 Daily,** listing delinquent accounts from business, professional men. Free Sales Kit. General Finance, Dept. AR-4, Pickwick Bldg., Kansas City 6, Mo.

**IF you're interested in making money** in selling, see the hundreds of exceptional opportunities in Salesman's Opportunity Magazine. Send name for your copy, absolutely free. Tell us what you're selling now. Opportunity, 848 N. Dearborn, Dept. 18, Chicago 10, Illinois.

**\$3.00 UP Hourly** for Route Work. Permanent. Write McNess, Freeport 43, Ill.

**\$1,000.00 A month** for making dramatic 3-second demonstration of amazing lightweight Presto Fire Extinguisher. New chemical used by Airforce snuffs out fires instantly. Only \$4.95. Terrific commissions. Millions want it. Free Kit. Merlite, 114 E. 32nd, Dept. 66-F, New York 16.

**SELL Advertising Book Matches.** Write us today; we put you in business By Return Mail, handling complete line Ad Book Matches in demand by every business right in your town! No investment; everything furnished Free! Top commissions daily! Superior Match, Dept. 463, 7530 S. Greenwood, Chicago 19, Ill.

**I'LL guarantee your sales!** Sell the Harly Keel, Won't Snag, Won't Twist. (Sample 50c). Harly Co., Wells, Minn.

**EARN Up To \$200 Weekly** full or part time showing fabulous Beaver Shoes made of Everon—looks like leather, wears far longer. Commissions paid daily. Sample free. Beaver Shoes, Dept. PS-463, Beaver Meadows, Pa.

## 45 EDUCATIONAL & INSTRUCTION

**LEARN Scientific Swedish Massage** in few months at home. Skilled operators earn \$4.00 to \$6.00 an hour. Open your own office or earn good income at health and recreational centers. Wonderful part-time profession. Free Anatomy Charts and catalog. Anderson School Of Scientific Massage, Dept. XD2, Princeton, Illinois.

**USED Correspondence Courses** and Books sold and rented. Money back guarantee. Catalog free. (Courses Bought.) Lee Mountain, Pisgah, Alabama.

**LEARN Civil and criminal investigation** at home. Earn steady, good pay. State age. Institute Applied Science, 1920 Sunnyside, Dept. 334, Chicago 40, Illinois.

**MASTER Watchmaking** at home. Free sample lesson. Chicago School, 2328-WQ Milwaukee, Chicago 47.

**HIGH School Diploma** at home. Licensed teachers. Approved materials. Southern States Academy, Station E-12, Atlanta, Ga.

**MEN wanted.** Learn Auto-Diesel Mechanics in our shops. Learn with tools on real equipment. Earn While You Learn. Many of our graduates earn \$125 a week and up. Write for free bulletin. Auto-Diesel College, Dept. 262, Nashville 3, Tenn.

**LEARN While Asleep** with your recorder, phonograph or amazing new "Electronic Educator" endless tape recorded. Details free. Research Association, Box 24-NN, Olympia, Washington.

**BECOME Tax Consultant.** Graduates earn \$1,000-\$3,000 every tax season preparing returns evenings. State approved. Union Institute, Lakewood Y-1, N. J.

**WANT a Diesel Job? Higher Pay? Advancement?** We can help you qualify! Complete Diesel Tractor and Heavy Equipment and Cummins Diesel Engine Shop-method home-training courses available. Write today. Interstate Training Service, Dept. B-2, Portland 12, Ore.

**BOOKKEEPERS — Operate Your Own "Dollar-A-Week" System.** Ellis, Box 203, Cedar Grove, North Carolina.

**PIANO Tuning Pays.** Big money in spare time. Learn at home. No musical knowledge necessary. Phonograph, records, tools and instructions furnished. Electronic tuning also taught. Free catalog. Capital Tuning School, 3160 S.W. 16th Court, Ft. Lauderdale, Fla.

**GOOD paying jobs open!** Operate, repair heavy earth moving equipment! Learn "on the job" operating latest cranes, bulldozers, earth carriers! V. A. Approved Free Catalog. Write D. S. Hutch, Greer Technical Institute, Braidwood, Illinois.

**FCC LICENSE in 6 weeks,** First Class Radio telephone. Results Guaranteed. Elkins Radio School, 2603A Inwood, Dallas, Texas.

**GAME Warden, Government hunter, Forestry, Park and Wildlife Services** Announce job openings regularly. Enjoy outdoor work, good pay, real security. Complete information Free! Write North American School of Conservation, Dept. 184, 810 Dodsworth, Covina, Calif.

**FINGERPRINTING and Identification** easily learned at home. Diploma awarded. Alabama School of Fingerprinting, Fairfield, Alabama.

**PIANO Tuning** quickly learned with home study course. Diploma granted. American Tuning School, Gilroy, California.

**MISSOURI Auction School.** Free catalogue. 1330 Linwood, Kansas City 9-x5, Missouri.

**REAL Estate Course.** Economical home-study. Literature free. Howard Schools, Box 8394-B, Kansas City 5, Missouri.

**BE A Real Estate Broker, Insure Security** for yourself and your family. Study at home. Prepare for state examination. GI approved. Write for Free Book Today. Weaver School of Real Estate, 3519R Broadway, Kansas City, Missouri.

**HIGH School At Home** in spare time with 66-year-old school. No classes. Standard high school texts supplied. Single subjects if desired. Credit for subjects already completed. Progress at own speed. Diploma awarded. Information booklet free . . . write today! American School, Dept. X446, Drexel at 58th, Chicago 37.

**LEARN I.B.M. At Home—A complete** course in punched card data processing—the most progressive opportunity field of the decade! Can easily be completed without job interruption—V.A. approved. Send Today for free course outline. Business Service Associates, Inc., Dept. PS-10, 1814 South Main Street, South Bend, Indiana.

**PENMANSHIP Corrector:** Improve poor penmanship quickly. Details free. Ozment, Box 665 35, St. Louis 88, Mo.

**USED Courses! Books! List 10c.** Smith's, 124 Marlborough, Salem, Mass.

**MATHEMATICS, Electronics.** No Contract. Pay as you learn. Free brochure. Indiana Home Study, 64 Hemenway Road, Framingham, Mass.

**OWN local collection office.** Pays big. Franklin Credit, Roanoke, Virginia.



# POPULAR SCIENCE OPPORTUNITIES

**COLLEGE** Home study courses from leading universities. Full credit toward Bachelor's or Master's degree. 5,000-course directory \$2.00. College Research, North Highlands 2, Calif.

**EARN** as you learn, camera repair. National Camera Repair School offers accredited Home Study Course—instructions, texts, tools and practice equipment. Free information. Write Box 174PE3, Englewood, Colorado, today!

**ENGINEERING** And Art Degrees earned through home study. Electronics, Mechanical, Liberal Arts. Major Accounting. When writing specify course desired. Pacific International College of Arts & Sciences, primarily a correspondence school. Resident classes also available. 5719-A Santa Monica Blvd., Hollywood 38, California.

**FREE** General Catalog—100 Pages Text vocational, educational, instructional subjects. Millions of volumes, new and used Bargain prices. Books bought. Est. 1902 Long's College Book Co., Dept. PS, Columbus 1, Ohio.

**DENTAL** Technician's Home Study Student's Kits. Instruments, plastic, etc. Illustrated instructions. Write for Free lesson. Grant Laboratory, Haas Bldg., Los Angeles 14, Calif.

**DYNAMIC** speaking, singing. Self-training records. Amazing!! Canfield, 2018-C Fifth Avenue South, Minneapolis 4, Minnesota.

**LEARN** Automatic Heating Repairs and Installation at home. Free Sample Lesson, Bonus Offer. ETI, 608-A South Dearborn, Chicago 5.

**ROCKETS:** New illustrated catalog 25c. Single and Multistage Kits, Cones, Engines, Launchers, Trackers. Technical information. Etc. Fast Service. Estes Industries, Penrose 33, Colorado.

**GUIDED** Home-Study — Engineering, Business Administration, Sciences. Unusual Opportunity. Free Details, Auret, Central Valley, New York.

**GET** A British Degree. Divinity, Philosophy, Healing, Metaphysics. 35 courses. Prospectus Free. Brantridge Forest School, "Lodge" Brantridge, Balcombe, Sussex, England.

**GRAPHOANALYSIS** — Learn scientific handwriting analysis for profit, pleasure. Free sample lesson, catalog reveals plan. Write IGAS, Inc., 325 Jackson, Dept. 2CY-1, Chicago 6.

**WOODWORKING** and Cabinetmaking course for beginning and advanced home craftsmen. Only complete low-cost home training program available. Write for free booklet. Interstate Training Service, Dept. G-2, Portland 12, Oregon.

## 47 DETECTIVES

**DETECTIVES**—Work home—Travel, Experience unnecessary. Detective Particulars free. Write Wagoner, P-125 West 86th, New York 24.

**DETECTIVE** Profession. Home Study Lapel pin, Certificate, Future. Box 41197-G, Los Angeles 41, California.

**DETECTIVE** Course. Credentials. Diploma. Free Information. Southwestern Institute Criminology, Box 202, Geronimo, Oklahoma.

**INVESTIGATORS**, free brochure, latest subminiature electronic listening devices. Ace Electronics, 11500-F NW 7th Ave., Miami 50, Florida.

**DETECTIVE** training. Career for young and old, men and women. For free information write to 1917-C North Kenneth Avenue, Chicago 39, Illinois.

## 48 LANGUAGE OUTFITS

**ESPERANTO**, UNESCO's interlanguage. Text, Pronunciation record \$1. Esperanto, Dept. P.S., Middleton, Wis.

## 49 GIFTS

**YOUR** and Her Initials, or one name made into a Lady's sterling silver International Code Flag Bracelet. Each colorful Code Flag represents a letter. \$12.95 Postpaid, tax included. Print letters, nine maximum. Dorith Sterling, Box 167, Syosset, N. Y.

## 50 BUSINESS SERVICE, INFORMATION, NAME LISTS

**MAILING** Lists most all kinds 1000 \$5.00. FREE folder. Your circulars mailed \$4.00 1000. Dixie Mailers, King, N. C.

## 51 SPECIAL SERVICES

**PROPERTY** Mapping our specialty. Free estimates. Write Deed-Ettes, Mt. Pocono, Pennsylvania.

**LOCATING** Service! Any Item or Product. Jake Barraco, 478 Gardner, South Beloit 1, Illinois.

## 51A IQ TESTS

**ACCURATE**, inexpensive. Home-administered, professionally interpreted. Children. Adults. Research data needed. University Testing Institute, R-14, Box 6744, Stanford, California.

## 52 AUTHORS SERVICE

**WRITERS!** N. Y. publisher wants "how-to" book manuscripts and other subjects (fiction, nonfiction). Two free brochures reveal tips on writing; how to become published author. Write Paula Scottsdale, Exposition Press, 386 Park Avenue South, New York 16, New York.

**WANT** Your Book Published? Learn how we publish, advertise, promote, distribute. Many successes. Free booklet PS, Vantage, 120 West 31, New York.

## 53 ADVERTISING, AGENCIES, ETC., FOR ADVERTISERS

**FREE** expert assistance for mailorder advertisers. Ratebook leading newspapers, magazines 10c. Chicago Advertising Agency, 28 E. Jackson, Chicago 4.

**FREELANCE** services! Industrial advertising executive. RGS, Box 886, Rome, N. Y.

## 54 ART INSTRUCTION, CARTOONING, SIGN PAINTING

**"HOW** to Make Money With Simple Cartoons"—A book everyone who likes to draw should have. It is free; no obligation. Simply address Cartoonists' Exchange, Dept. 194, Pleasant Hill, Ohio.

**ART**—Learn At Home. Earn big money. Commercial art, cartooning, lettering, figure drawing, painting, TV. 20c a day. Free 36-page book. Washington School of Art, Studio 154X, Port Washington, N. Y.

**STOP** Dreaming. Start Drawing. New system brings amazing results inexpensively, quickly. See for yourself. Free Book. No obligation. Continental Schools, Dept. E-153, 4201 So. Broadway, Los Angeles 37, California.

**LEARN** Sign Painting. Fascinating System. Straley, 410-P South Western, Springfield, Ohio.

**LEARN** Profitable Magazine Cartooning! Free Details. Cartoonists, Box 3097, Lincoln 10, Nebr.

**"KEY** to a Cartoon Career." Send 50c for booklet. Cartooning, Box 3176, Colorado Springs, Colorado.

**YOU** can Entertain with Chalk Talks. Catalog 10c. Cartoonist Balda, Oshkosh, Wisconsin.

**SIGN** Secrets Revealed. Profitable Course. Free Circular. Barebo Signs, O'Fallon, Mo.

**SIGNS!** Showcards! Learn Speedy "Earn Sooner Method." Send \$3.95. Satisfaction Guaranteed. Information Free. Harris, Box 1567-U, Portland 7, Oregon.

## 55 TYPEWRITERS & OFFICE MACHINES

**RECONDITIONED** Typewriters, Mimeograph, printing presses \$25.00 up. Write Dixiegraph, King, N. C.

## 56 RUBBER STAMPS & OFFICE SUPPLIES

**POCKET** Or Office Type Stamp \$1.00. Vargo's, 4119A Buechner Ave., Cleveland 9, Ohio.

**FREE** 32 Page Rubber Stamp Catalog. Signature Stamps \$3.50. Youngers Stamp Shop, Princeton, Iowa.

**NAMEPLATES** for doors, desk, mailbox, \$1.00. Lehman, 511 Pacific, Pittsburgh 21, Pa.

**3 LINES** (ink-ad) \$1.00. Printers, 2011 Main, Lake Placid, New York.

**THREE** lines. Copy to 3" long. \$1.00. Guaranteed. Bert Morgan, 239 1/2 West Amerige, Fullerton, Calif.

**THREE** line pocket or office stamp \$1.00. Win Atherton, Box 61, Randolph, Massachusetts.

**POROUS** Rubber Stamps. Require no ink pad. Free Catalog. Melco, Box 53331-PS, New Orleans 50, La.

## 57 PRINTING, MULTIGRAPHING, ETC.

**FREE** Catalogs. Postpaid printing, Rubber stamps. D M Press, Sebastopol, Calif.

**1,000** 8 1/2 x 11 \$5.95 plus postage. Free Catalog. Musselman, Box 2766P, Kalamazoo, Mich.

**ATTRACTIVE**—Modern Business Stationery. Color. Cuts, (Samples). OKay-print, Martins Ferry, Ohio.

**AMERICA'S** Finest Economical printing. Catalog Free! Steinbergen, Box 2354K, N.Y.C. 8.

**1000** GUMMED Name & Address Labels \$1.00. Perk's, Essex, Mass.

**OFFSET** printing. Some shipped day received. Mimeo Press, Rocky Mount, N. C.

**1000** NAME, Address Labels \$1.00. Rubber Pocket Stamp \$1.00. 1000 Business Cards \$3.95. Printing, Personalized Items, Free Literature. Jordan's 552 West O'Connor, Lima, Ohio.

**AMAZING** Business Printing values. Samples. Print Shop, Box 576P, Greenville, R. I.

**DISTINCTIVE** Business Printing Samples. McDonald, 545 North Oakland, Pasadena, California.

**POSTCARDS:** 500—\$6.75, 1000—\$8.00, 5000—\$30.00. Information Free. Kardkraft, 7728 Holmes, Kansas City 31, Missouri.

**MIMEOGRAPHING.** Offset Printing. Free samples. Pennsway, Drawer 1340, Scranton, Pa.

**1000** BUSINESS Cards, "Raised Letters" \$3.75 postpaid. Samples. Routh PS-4, 3910 Kipling, Greensboro, N. C.

**24 Hr.** OFFSET, Free Gift. 8 1/2 x 11, 16 lb. white or colored Bond 100—\$3.45; 1000—\$5.95; 5000—\$17.95. Print. 17030 Miles, Cleveland 28, Ohio.

**POSTPAID** Business Printing. Request free samples. Crestview Printing, Owasso, Okla.

**1000** BUSINESS Cards \$2.95 Postpaid. Samples. Jesson Press, Geneva, New York.

## 58 PRINTING OUTFITS, SUPPLIES

**NEW** 1962-63 illustrated printing equipment and supply catalog. This 9 x 12", 336 page book is the most complete catalog of the century. Contains everything used in the graphic arts industry including thousands of offset, letterpress, bindery, rubber plate and stamp, composing room, silk screen, art and engraving supplies and equipment. Includes paper cutters, folding machines, printing & proof presses, padding presses and many more. Send \$2.00 to cover mailing. Refund with first order. Also available is our latest 184 page type catalog—add \$1.00. American Printing Equipment & Supply Co., Dept. PS, 42-25 Ninth Street, Long Island City 1, N. Y.

**PRINTING** Outfits, type, supplies. Send dime for illustrated supply book and samples. Kelsey, Inc., H-8, Meriden, Conn.

**RUBBER** Stamp Presses, Hydraulic Operated. Electrically heated. Sizes 5"x8", 8"x12", 10"x15", starting outfits, supplies, Printing Presses, Custom Manufacturing, 1464 East Commercial, Springfield 2, Missouri.

**PRINTING** Presses, Type, Supplies, Lists, 5c. Turnbaugh Service, Mechanicsburg, Pa.

**MAKE** Your Own self-molding rubber stamps and printing cuts. Plexirubber, Argyle 2, Wisconsin.

**RUBBER** Stamp Presses, Supplies. Kiewiet, 2025 Barney Road, Kalamazoo, Michigan.

**TYPE** case catalog. Manufacturer. King McKay Company, 23179 Telegraph, Southfield, Michigan.



# POPULAR SCIENCE OPPORTUNITIES

## 59 PATENT ATTORNEYS

WASHINGTON Patent attorneys—List free. Patent Information Service, 624 Sheraton Building, Washington 5, D. C.

## 60 FOR INVENTORS

**INVENTORS:** Prepare your own patent application. Our "Patent Kit" includes detailed instructions and all necessary material. \$12.95. Money back guarantee. National Inventors Company, Box 88, Ben Franklin, Washington, D. C.

**IF** your invention is adaptable to promoting we will contract for selling on cash or royalty. Free booklet outlines royalty rates, requirements. Kessler Corporation, C-74-FI, Fremont, Ohio.

**PATENT** Searches—48 hour airmail service, \$6.00, including nearest patent copies. More than 200 registered patent attorneys have used my service. For Free invention protection forms, write Miss Ann Hastings, P.O. Box 176, Washington 4, D. C.

**PATENT** Searches, \$6.00, including official Patent Office copies of related U.S. Patents. Certified, Airmailed! For free "Invention Record" and "Patent Information", write: United States Inventors Service Company, 1311 "G" Street, NW, Washington 5, D. C.

**PROFESSIONAL** Patent searches, \$6.00, including official copies of related U.S. Patents! Prompt, dependable Airmail service! For free "Invention Record Folio" and "Information Every Inventor Should Have", write: Congress Invention Institute, 210 McKim Building, Washington 5, D.C.

**INVENTORS:** We either sell your invention or pay you a cash bonus. Write for complete details. Universal Inventions, Marion, Ohio.

**PATENT** Searches, including copies of related U.S. Patents, \$6.00. Inventors, attorneys, manufacturers use my "Worldwide" Airmail service! "Invention Record" form and "Information Every Inventor Needs", sent free! Miss Hayward, 1029 Vermont Ave. NW, Washington 5, D.C.

**TOY** Inventors: We specialize in selling your ideas to Toy Manufacturers. Product Presentations Associates, 72 Dora Lane, New Rochelle, N. Y.

**SAVE** High fees! Prepare your patent application yourself! New "Do-It-Yourself" Patent Kit now makes it easy. Free "Registration Form." Miss Blaine, 306 Carry Building, Washington 5, D.C.

**PATENTS** Skillfully Prepared for maximum commercial value with useful product development. High record of success in proving and claiming patentability. Valuable market service. Patents prepared and filed for service fee as low as \$200.00. Send for self protecting invention record forms free. Patent search with valuable engineering report \$10.00. Foreign patents filed at lower cost. Thirty Years established. Joseph O'Brien, Patent & Development Engineer, 132 Nassau Street, New York 38, N. Y.

**PATENT** Searches, professional patent development of inventions by Licensed Professional Patent Engineer and U.S. Patent Office Former Examiner with staff of engineering specialists in all fields of inventions. Expert searches performed in the U.S. Patent Office. Your inventions and ideas engineered for maximum patent protection and greatest commercial value. Inventions developed by us negotiated for cash or royalties with our nationwide contacts. Send for free Protection "Invention Certificates" and further interesting, valuable Patent Information. George Spector, Licensed Professional Patent Engineer, U.S. Patent Office Former Examiner, Woolworth Building, New York.

**U.S. Patent Office** Searches—\$5.00. Free Invention Record. Patents Engineered. Patent Office Searchers, 233 Broadway, Room 3615, New York.

**SEND** reply envelope. Don't disclose to me your invention—only its field. Sixteen patents prepared myself. Get the answers—but all! Aberly, 124 Eighth Street N.E., Cedar Rapids, Iowa.

**WASHINGTON** Patent attorneys—List free. Patent Information Service, 624 Sheraton Building, Washington 5, D. C.

**PATENT** searches including report \$6. Valuable market service. Cash or royalty sales. 10 years dependable service. For free self-protective Record of Invention forms write: H. Lawrence Blasius, 19 Park Row, New York 38, N. Y.

**PATENT** Searches, complete and thorough, Related copies Air Mailed with maximum speed \$6.00. Free Protection Forms, and "Patent Information." Write Mercury Patent Office Searchers, 1507 M Street N.W., Suite 103, Washington, D. C.

**PATENT** Searches including Maximum speed, full airmail report and closest patent copies, \$6.00. Quality searches expertly administered. Absolute confidence and secrecy guaranteed. Free Record of Invention forms and "Patent Information." Write Washington Patent Office Search Bureau, 1426 G Street, N.W., Washington, D. C.

**PATENT** Searches, prompt, complete \$6.00. Patent Office copies of related patents airmailed. For free "Protection Forms" and "Patent Information" write to Jane Allen, Suite 1024, Dupont Circle Bldg., Washington 6, D. C.

**OFFICIAL** Patent Drawings, \$35. Satisfaction Guaranteed. Mail Sketch And Remittance. Capital Patents, 4206 Arthur Drive SE, Washington 22, D. C.

**INVENTORS**, if you have an invention for sale, patented or unpatented, write Institute of American Inventors, Dept. 30A, 635-F St., N.W., Washington 4, D. C.

## 60A ENGINEERING SERVICES

**MACHINERY**, Electronics, Chemistry. Equipment Development. Industrial research. Inquiries held confidential. Todd Consulting Engineers, 424 West 119th, New York 27.

## 61 INVENTIONS WANTED

**INVENTIONS** wanted. Patented; unpatented. Tremendous Manufacturers lists. Global Marketing Service, 2420 77th, Oakland 5, Calif.

**INVENTORS:** Hundreds of manufacturers have requested our assistance in locating marketable new products. Complete information free. Institute of American Inventors, Dept. 30C, 635-F Street, N.W., Washington 4, D. C.

**INVENTIONS**—Do you want to sell or license your invention on cash or royalty basis? Write Kessler Corporation, C-74-IW, Fremont, Ohio.

**WE** buy ideas, inventions—back inventors! Details Quarter, C. Johnson, 5717 Estes, Ft. Worth 19, Texas.

**INVENTIONS** Promoted — For Cash-Royalty Sales with Manufacturer Contacts. George Spector, Licensed Invention Engineer, Woolworth Building, New York.

"**TWENTY** Inventions Wanted by U.S. Government." (Information concerning hundreds more). Report, \$1.00. Folborg Research Agency, Box 46, Brooklyn 37, New York.

**INVENTORS!** Sell your invention for cash or Royalties! Our client manufacturers constantly seeking new items. Patented. Unpatented. For free information write Gilbert Adams, Patent Broker, 80 Wall St., Financial District, New York, N. Y.

**INVENTORS!** Outright cash sale or royalties for your inventions. Patented. Unpatented. Constant demand from our client manufacturers. Write United States Invention Brokerage, 78 Wall Street, New York 5, N. Y.

**INDUSTRY** needs inventions immediately. Inventions for Industry was organized to discover and assist new inventors. Write Invention for Industry, 150 Broadway, New York 38, N. Y.

**INVENTORS!** Don't sell or license your invention for cash or royalties until you receive our offer. Write International Invention Institute, 17 Park Row, New York 38, N. Y.

**CASH** or royalties for inventions! Consider our offer first before licensing or selling your patented or unpatented invention. Write—Aladdin Industries, 80 Wall Street, New York 5, N. Y.

**INVENTORS** Needing Help with any problem, financial, development, securing manufacturer, obtaining patent. Write the organization that delivers action and results—not promises. Pioneer Invention Service, 150 Broadway, New York 38, N. Y.

**INVENTORS!** We will develop, sell your idea or invention (patented or unpatented)! Our national manufacturer-clients urgently seeking new items for highest outright cash sale or royalties. Financial assistance if needed. 10 years proven performance. For Free information write: Wall Street Invention Brokerage, 79 Wall Street, Financial District, New York 5, N. Y.

## 63 MANUFACTURING

**TESTED** Formulas! Free List! Gormley Chemicals, 10828 Otsego, N. Hollywood, California.

## 64 MODELS, MODEL SUPPLIES

**FREE** Plan for Miniature Steam Engine included in New illustrated comprehensive Model Engineering Supplies Catalog; largest selection model gasoline, steam-engine casting kits; 1962 catalog 35c. Octura Models, 8148 Milwaukee Ave., Niles 48, Ill. Dept. FPS.

**SHIP** and yacht model fittings; blueprints. Send 50c for Illustrated catalog listing hundreds of items. A. J. Fisher, Inc., 1002-2 Etowah Ave., Royal Oak, Michigan.

**SHIP** Models, Kits, fittings, plans, books, tools, engines, motors. Big illustrated catalog 50c. James Bliss & Co., Dept. PS, 342 Atlantic Avenue, Boston 10, Massachusetts.

**ROCKETS:** New Illustrated Catalog 25c. Single And Multistage Kits, Cones, Engines, Launchers, Trackers, Technical Information, Etc. Fast Service. Estes Industries, Penrose 3, Colorado.

**SHIP** Model Kits, Clippers, Galleons, Liners; Operating Power Boats for Radio Control; Send 25c for Catalog. Ideal, 17 West 18 Street, New York 11, N. Y.

**BUILD** Miniature Buildings With Professional Materials. 50c For Instructions And Samples. Architectural Model Materials, PS43, 2008 No. Keystone, Chicago, 89.

**SHIP** Model Kits and fittings; clippers, frigates, etc. Catalog, paint-tool list, book list, 35c. Model Shipways, Box 85, Bogota, New Jersey.

**CASTINGS** and finished Steam—Gas Engines from simple oscillating to triple expansion. Finest materials and fittings. Catalogue \$1.00. Denison Live Steam Models, PS, 1606 Denison, Cleveland 9, Ohio.

**LIVE** Steam Engine Castings Catalog 25c. Ship Models Ltd., Andover, Mass.

## 64B ELECTRIC TRAINS

**LIONEL** Trains Big Discounts Bulletin 10c. Catalog 25c. Mack Bros., 2041 Chicago Avenue, Chicago 22.

## 65 HOME CRAFTSMAN

**SKIL-CRAFTS** New '62-'63 Catalog. Largest and Finest selection of Leathercraft. Artist, Hobbycraft supplies in the world. Free Gift with first order. Send 50c. Refundable with first order. Skil-Crafts, Box 167-PS, Joplin, Mo.

**PICTURE** Frame Moldings, Tools and Instruction book. Free Catalog. Chesapeake Frames, 414-PS E. Baltimore St., Baltimore 2, Md.

**WOODWORKERS** — Home Workshop — catalog 132 pages. Save on fine woods, hardware, power tools, 25c. Craftsman, 2719 S. Mary, Chicago 8, Ill.

**FREE** "Do-It-Yourself" Leathercraft Catalog. Tandy Leather Company, Box 791-E47, Fort Worth, Tex.

**SAVE:** Raw picture frame moulding, all species, all styles. We will miter corners. Bauerle Cabinet Works, Inc., Hammond, Louisiana.

**2447** PLANS, Patterns. World's greatest selection, things to make for Fun and Profit. Catalog 10c. Craftplans, 18250 Harwood, Dept. B-463, Homewood, Ill.

**SQUAREKNOTTERS:** Make belts, handbags, lanyards, dog leashes, etc. Special offer! Beginner's book, catalog and quality cord samples 25c. P. C. Herwig Co., Dept. 71-P7, 39 Henry St., Brooklyn 1, New York.



# POPULAR SCIENCE OPPORTUNITIES

## 66 DO IT YOURSELF

**CAULKING Kit!** 3 Cartridges, one Gun, only \$2.00. Extra cartridges, three for \$1.00 also Four inch pure bristle brush \$1.00. Daro Sales, P.O. Box 5056, Jersey City 5, New Jersey.

**BUILD Your Own 4'x7' Pool Table.** Complete line of Accessories Available. Plans \$3.00. Mar-Ber Company, Star Route, Massena, New York.

**WELDER.** For Soldering Iron Cost! McWhirter, 317 Lynnwood, Pittsburgh 35, Pa.

**TV Manual!** Tailored To Your Set. Makes TV Repair Easy! Send Brand And Model Of Your TV With \$1.00 For Copy. Television Publications, 1415 West Royal Palm, Phoenix 21, Arizona.

**NOW Trim your hair easily.** Send \$2 for your lifetime Mastertrimmer. Guaranteed. Christensen Patents, 325 South New Hampshire, Los Angeles 5, Calif.

**HOME Hair Cutting Outfit—saves you time and dollars.** 10 pieces. Toastmaster adjustable clipper, UL approved. \$11.95 postpaid. Free catalog of bargains. C. Brooks, 1759 West 39th Place, Los Angeles 62, California.

## 67 OLD GOLD, JEWELRY, WATCHES, ETC.

**WANTED,** gold, silver, platinum, scrap (any form), coins. Information free. Wilmot's, 1067 Bridge St., Grand Rapids 4, Michigan.

**USED and new watches \$2 up.** Free Catalogue. Southern Watches, 5-PS So. Wabash, Chicago 3.

**HIGHEST Cash for Gold, Teeth, Jewelry, Rings, Diamonds, Watches, Silver, Platinum.** Mail Articles Today. Free gift with information. Chicago Gold & Precious Metals, 6 E. Monroe, Dept. 4857, Chicago 3.

**CASH Immediately For Old Gold, Jewelry, Gold Teeth, Watches, Diamonds, Silverware, Spectacles, Platinum, Mercury.** Free information. Rose Industries, 29 East Madison, Chicago 2.

**WATCHES Save!** New Swiss, German, American. Golfers watch with score keeper \$10.50. 17 Jewel thin Swiss \$11.95. Many others, send 15c for Brochure. Rush order Claude Reeds Watch Service, North Adams, Michigan. On Imports, pay post-man small duty (if charged).

## 68 TOBACCO & PIPES

**CIGARS—Wholesale.** Popular Brands. Price List free. Ideal, Box 201, Cicero, Illinois.

**PIPESMOKERS—Put your old pipes in Tip-top shape with Con-Dit-Kit.** Contains polish, sweetener and exclusive new compound for restoring mouthpieces. \$2.00 postpaid. Guaranteed. Write: Con-Dit-Kit, Box 371, Yonkers, N. Y.

## 69 FOR THE HOME

**JAPANESE Oil Portraits Painted In Color On Silk.** Send snapshot, color of hair, eyes, clothes, complexion. 8x10 Just \$7.00. Belle Vernon Wholesale House, 405 Ferncliff, Belle Vernon, Pa.

## 70 OF INTEREST TO WOMEN

**LEARN Expert Cake Decoration, Candy Making.** Free Details on Home Instruction Method. Candy & Cake, Dept. D-644, Fallbrook, Calif.

**MAKE \$25-\$65 weekly typing at home.** Details \$1. Bonco, 130 Cumberland, Mason-town 1, Pa.

## 71 FOR SALE MISCELLANEOUS

**POLYETHYLENE disposable gloves, 100 for \$2.95 postpaid.** Specify size. Nbars, 9325-R Menard, Oak Lawn, Ill.

**HEARING Aid; British Medicare Model \$49.95.** 10-Day Money Back Guarantee. Audium, 89-40 163rd St., Jamaica 32, N. Y.

## 74 RAZOR BLADES, SHAVERS

**SAVE Money! Faster, Smoother Shaves.** 100 Blades—\$3.98. Postpaid. Moneyback Guarantee. Wecco Industries, Columbus, Georgia.

## 77 TREASURE FINDERS & GEIGER COUNTERS

**TRANSISTOR Treasure Detectors,** underwater detectors. Many models. Free catalog. Gardiner Electronics Co., Dept. 1, 2545 East Indian School, Phoenix, Arizona.

**EXPLORE Underground,** years ahead transistor Metrotech locators detect Gold, Silver, Coins, Relics. Information Free. Curt Fisher, Dept. D, Box 793, Menlo Park, California.

**TRANSISTORIZED Treasure Finder!** Hi-sensitivity, low oper. cost. Details: Sierra Scientific, 2023E Burbank Blvd., Burbank, California.

**TREASURE, Gold, Silver, Relics.** Find them with new 1963 models. Free information. Raytron, Box 715, North Hollywood, California.

**TREASURE.** Find gold, silver, relics with super powerful, Detectron locators. Free information. Detectron, Dept. PS-4, San Gabriel, California.

**EXCITING adventure locating hidden loot, treasure, relics, etc.,** with powerful, electronic M-Scope locator. Lightweight. Guaranteed. Very easy terms. Send for Free Booklet, interesting customer reports. Fisher Research, Dept. DY, Palo Alto, Calif.

**SENSITIVE transistor treasure finders.** \$19.95 up. Free catalog. Reilko, Box 10563, Houston 18, Texas.

**TREASURE Finders—Easy to make electronic kits or assembled models.** Underwater models available. Free literature. Electronic Applications, Inc., Dept. S, Box 6095, Alexandria, Virginia.

**TREASURE Handbook 25c! Coin Locators!** Howe, 811-A Kansas, Atchison, Kansas.

## 78 WATCH REPAIRING

**WATCH and clock repairing books.** Free catalog. North American, 2320-BD Milwaukee, Chicago 47, Illinois.

**FREE Watchmaking Course!** Details. Wholesale Catalogue 25c. Bengal's, Culver City, California.

**WATCHMAKERS' Tools, Materials, Supplies, Watches, Catalog.** Gales, Box 1000, Chicago 90, Illinois.

## 79 MISCELLANEOUS

**FREE Wholesale Catalog! 100,000 Products . . . Tremendous Discounts!** Taylor Distributors, Newton 3, New Jersey.

**REMARKABLE Hand Cleaner And Pre-conditioner.** Apply Before Or After To Remove Grease, Grime, Paint, Etc. Non-Toxic. Wholesale. Postpaid, 50c Tube. \$5.00 Dozen. Distro, Inc., Box 6488, Jacksonville 5, Florida.

**SO, CALIFORNIA . . . Save needless worry and expense.** Send \$1.00 for complete information on trip and arrival. Also job and housing situations. Dixon, Box 301, Huntington Park, California.

**POSTPAID From Holland.** Clocks, dolls, lamps, Delftware plates, etc. Illustrated list, 20c. Melco, Box 69, Edwardsville, Illinois.

**INSTANT Spanish.** Free Sample lesson. Trader, Box 3488-D, Ridgecrest, Calif.

**RECEIVE Mails—Offers.** From Wholesalers. Manufacturers, Publishers, Everywhere. Get Listed, 25c. Rorick's, Cincinnati 26, Ohio.

**ROCKETS: New illustrated catalog 25c.** Single and Multistage Kits, Cones, Engines, Launchers, Trackers. Technical information, Etc. Fast Service. Estes Industries, Penrose 34, Colorado.

**LUMIROD Easily Forms To Many Shapes.** Latest In Lighted Displays. Basic Kit \$2.00, Postpaid. Q-Arc Devices, Box 47876, Los Angeles, Calif.

**GET On mailing lists.** Receive bargain offers. 25c. Ouroboros, Box 4953-D, Chicago 80, Ill.

## 80 PERSONAL

**"RULE Others with your Thoughts."** Telepathy. (Adults.) Write: Clarion, Box 9309-S6, Chicago 90.

**INDEPENDENT Thinkers — investigate Humanism, the scientific, personal philosophy!** Free literature. American Humanist Association, Dept. PSM2, Yellow Springs, Ohio.

**LOANS by mail, \$100-\$600.** Anywhere. Confidential. Write Union Finance, Dept. PS, 323 E. Camelback, Phoenix, Arizona.

**HANDWRITING analyzed by certified graphoanalyst.** Character trait one dollar. General analysis three dollars. Lois Reading, 1731 N.H. Ave. N.W., Washington 9, D.C.

**SENSATIONAL new patented product for sore, tired feet.** Descriptive booklet Free. Americana Shops, Reed City, Michigan.

**MEXICAN Law Practice.** 1203 Arizona Ave., El Paso, Texas.

**SUPER memory overnight!** Success guaranteed! Bijou, Box 1727-V, Hollywood 28, Calif.

**FOUR "Will" Forms and "Instruction Booklet by Lawyer,"** \$1.00. National, Box 48313-PS, Los Angeles 48, California.

**HANDWRITING: Scientific analysis reveals aptitudes, character, personality traits: \$5.00.** Send 10 line sample for best results. Frances Chaffee, Box 1774, Fargo, North Dakota.

**PAMPHLET—covering 44 amazing spiritual healings with introduction to show how the spiritual Principle was discovered.** \$1. Pamphleteers, Box 2353-P, Providence 6, R. I.

## 80A REMAILING SERVICE

**MIAMI Beach remails 25c; 5 for \$1.00.** Monthly \$3.00. National, P.O. Box 266-B, Miami Beach 39, Florida.

**CONFIDENTIAL New York City Mail Address.** Remailing, Forwarding, \$3 Month. Details Free. G. Martin, Suite 212B, 136-04 Northern Blvd., Flushing 54, New York.

**HAWAII Secret Address.** Receiving, Forwarding. 25c. \$3.00 Monthly. Postcards. Coe, Box 984-A Kailua, Hawaii.

**SECRET Mail Receiving-Forwarding System.** Hedgpeth, Box 830, Alhambra 24, Calif.

**REMAILS 25c; twelve for dollar.** Champs, 1319 East 26, Kansas City 8, Missouri.

**SECRET — Remailing — Professionals — \$3.00 Monthly.** De Graff, 8765 Innsdale, Spring Valley, California.

**REMAILS.** Single \$.25. Monthly \$3.00. J.L.P., Box 817, Ft. Lauderdale, Florida.

**CONFIDENTIAL Address.** Letters remailed 25c. Foreign remailing. Stamp. West. SE-2617 Armacost, Los Angeles 64, California.

**FLORIDA Confidential Remailing—Forwarding 25c.** \$3.00 monthly. Box 798, Pompano Beach 1, Florida.

**CHICAGO Remails, 25c each, 3 for 50c.** Your secret address, \$3.00 monthly. Ouroboros, Box 4953-D, Chicago 80.

**RECEIVED.** Forwarded—25c. Monthly \$3.00. Jessee, Box 712, Lewiston, Idaho.

## 80B LOANS BY MAIL

**BORROW \$100 to \$1000 by Mail. Quick, Easy, Private.** No Co-signers. Repay in 24 small monthly payments. For the amount you want write today to Dial Finance Co., 410 Kilpatrick Bldg., Dept. 4-215, Omaha 2, Nebraska.

**BORROW \$1,000 AIRMAIL!** Repay \$44.82 for twenty-nine months. State licensed. Postal Finance, Dept. 11-E, Kansas City 1, Kansas.

**MONEY Problems Solved quickly.** It's easier than you think. B.I.C. Cash-By-Mail loans easily arranged, 24-month schedule. \$100.00 to \$600.00. No co-signers or security. Write for application. B.I.C. Loans, 1004 S. Walnut, Hutchinson, Kansas.

**NEED Money? Borrow \$100-\$1000 by mail.** Confidential, repay in 24 months. Free loan application. World Finance Co., Dept. EW-313, 620 Symes Bldg., Denver 2, Colo.



**BUY DIRECT FROM OUR FACTORY**

# Save 80% ON THIS AMAZING *Amco* 8" TILT ARBOR POWER SAW KIT

RUGGED . . . PROFESSIONAL QUALITY . . . HEAVY DUTY . . . LIFETIME ENGINEERED  
UNCONDITIONAL 10 YEAR GUARANTEE

**\$9.95**  
f.o.b. Factory  
wt. 11 lbs.

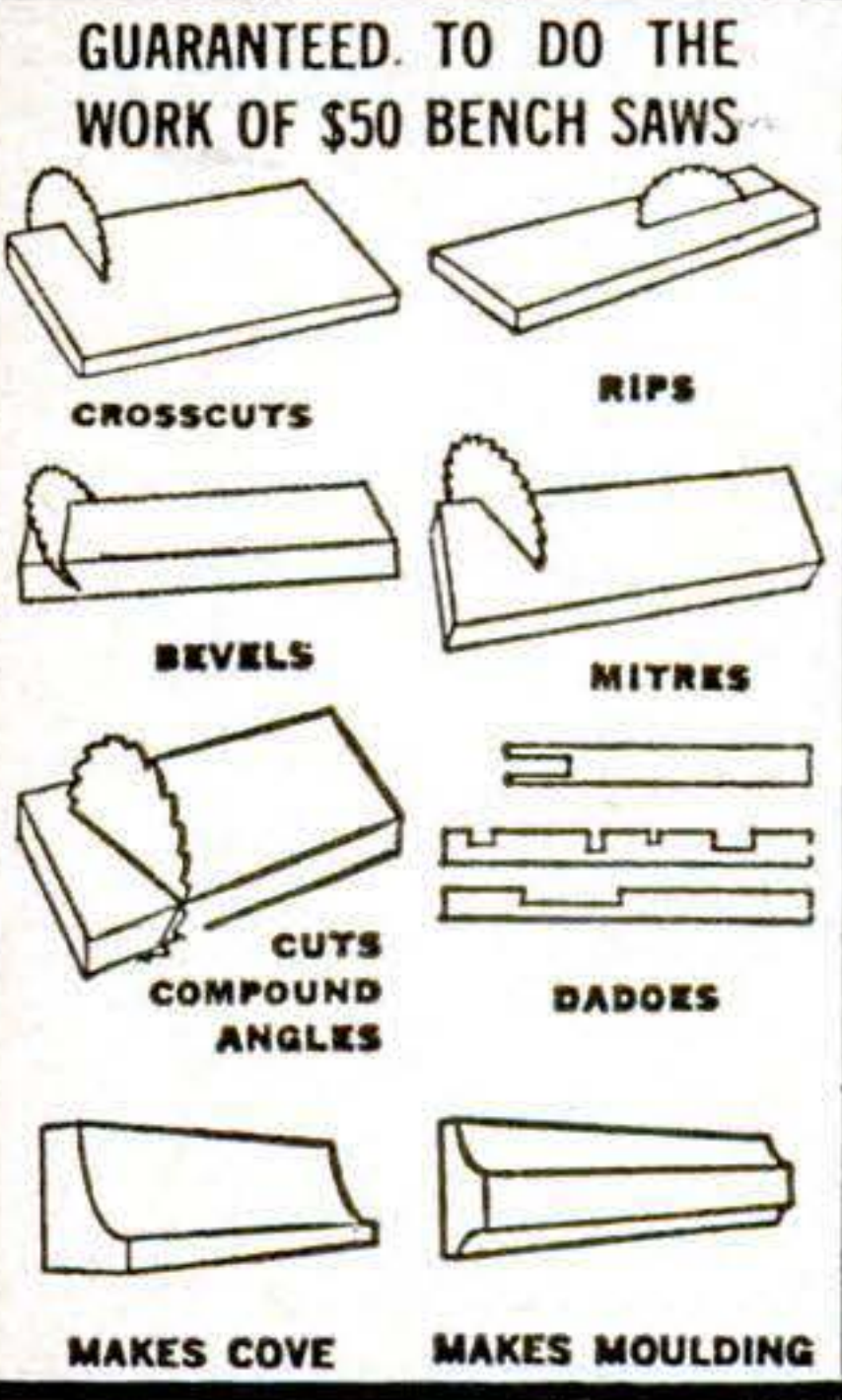

**YOU GET:**

- Complete blade carrying mechanism with depth of cut control
- Ground spindle with saw flanges
- Pre-oiled bearings
- Angle of tilt control
- Etched metal tilt indicator
- Complete mitre gauge
- Complete motor mount assembly
- All needed brackets, screws, nuts and bolts
- ABC assembly plans, plans for sturdy base, and plans for massive 20" x 24" table
- Full operating instructions.

**REVOLUTIONARY NEW PATENTS . . . NEW DESIGN**

A top quality full scale power tool with all the speed and accuracy of similar machines selling for as much as \$100! Even if you've never cut a piece of wood in your life, you can put this saw together in jig time. All you need are common household tools, about 1/2 sheet 3/8" plywood for table and base . . . about 2 hours of spare time. Because of metal saving economy design; because we save expensive assembly labor costs; special patents add to efficiency, accuracy, savings; all metal parts are made, sub-assembled and tested in our own factories . . . and because you buy direct from the maker . . . you enjoy a truly fantastic saving.

**TABLE STAYS LEVEL, BLADE TILTS**

Patented motor mount takes any standard 1/4 h.p. or larger motor . . . keeps belt tight, assures perfect alignment at any angle, transmits full power. Table stays level—blade tilts, locks securely at any angle to 50°, raises, lowers 0"-2 1/4". Patented tilt mechanism has accurate etched scale. Takes standard blade, saw insert removes easily for insertion of any STANDARD dadoe heads, cutters, etc. Accessories, when wanted, at factory prices. Blade not included.

**CLIP AND MAIL THIS MONEY SAVING COUPON TODAY!**      **BUILD ALL THESE**      **INDOOR FURNITURE**      **OUTDOOR FURNITURE**      **SHELVES & CLOSETS**      **CHILDREN'S TOYS**      **ALL HOME IMPROVEMENTS**      **AND SAVE AS YOU SAW**

American Machine & Tool Co. Dept. PS-43B, Royersford, Pa.

Send 8" Tilt Arbor Power Saw Kit at \$9.95.  
 Incl. Rip Fence at \$3.50 (both for 13.45)  
 Payment in full enclosed \$..... or  
 \$3 dep. enclosed, balance C.O.D. I MUST BE FULLY SATISFIED OR WILL RETURN WITHIN 10 DAYS FOR FULL REFUND, no questions asked.  
 Please send free catalog of America's greatest power tool values.

NAME \_\_\_\_\_  
 ADDRESS \_\_\_\_\_  
 CITY \_\_\_\_\_ ZONE \_\_\_\_\_ STATE \_\_\_\_\_

**NO RISK  
10 DAY  
MONEY BACK  
GUARANTEE**

You must be completely satisfied or return 8" power saw kit for full refund. Fair enough?

Also ideal for boy scout troops, clubs and other groups. Share one with your neighbor.

**RUGGED, VERSATILE  
PERFORMANCE PROVED  
BY MORE THAN  
500,000 USERS!!**

**SEND FOR YOURS TODAY!**  
**AMERICAN MACHINE & TOOL COMPANY**  
 DEPT. PS-43B, ROYERSFORD, PA.





## Collector's Item

### (New middleweight wagon that handles a full size load)

Wagon fanciers have made a great discovery: this new Fairlane wagon carries a load like the big wagons, yet is 8 inches trimmer in length, 8 inches slimmer in width (it slips through traffic almost like a compact!)

Other distinguishing features of these trim new middleweights are a remarkably smooth ride, Ford's exclusive twice-a-year (or

6000 miles) maintenance and lively V-8\* (including the extra-eager Challenger 260) or thrifty Six power.

Surprisingly, the Fairlane Station Wagons are priced *below* some wagons with *less* load-space... right down with some *compact* station wagons, in fact! Whether you choose the handsome Squire, illustrated above,

or a beautiful Ranch Wagon, you'll find Fairlane Station Wagons ideal for collecting kids, cargo or compliments! See your Ford Dealer... he's America's Station Wagon Specialist. PRODUCTS OF  
\*Optional



America's longest, liveliest line of wagons

**FORD**  
FALCON • FAIRLANE • FORD

**Talk about wagons...your Ford Dealer has more to talk about**





## ROUND-TRIP INSURANCE —it's an old Evinrude policy

When you're out where sea meets sky, and the way home is only a point on the compass, it's good to know —

That the motor that powers your boat starts with a pull-cord almost as easily as with its built-in electric starter.

That it has a manual choke as well as an automatic choke.

That it has a waterproof ignition system, even though the powerhead is so perfectly sealed against sea and spray that you can douse it with a fire hose without getting a single drop of water inside.

Backing up critical automatic systems with standby manual control didn't originate with the missile program. Here, at Evinrude, we've been

doing it for fifty years, just as we do dozens of other important little things — just for insurance.

We don't have to do any of these things. Most other outboards seem to get along without them. But they're part of what makes an Evinrude the kind of motor it is. And for added insurance, we protect you with a 2-year warranty.

We like to see our customers come back — smiling.

Catalog FREE. Write Evinrude Motors, 4065 N. 27th Street, Milwaukee 16, Wisconsin.

*A Division of Outboard Marine Corporation*



# EVINRUDE

FIRST IN OUTBOARDS

Copyrighted material