

JULY 1963 35 CENTS

What Will the
'64 Cars
Be Like?

Popular Science

Monthly

"Camping Out"
at 100 Fathoms

How Ed Link's
Divers Live
Beneath the Sea

How to
keep cool
in your house
—in your car

When Uncle Sam Played Dirty—
DEADLY GADGETS OF THE OSS

Will we ever go beyond the planets?
Wernher von Braun talks
about travel to the stars



NEWS OF A REMARKABLE HEALTH INSURANCE PLAN

For the 7 out of 8 who need more protection

PAYS MONEY When You're Sick!

When Covered Sickness or Accident Strikes, You Collect Generous Benefits. Today only 1 person in 8 has enough hospitalization insurance. But now there's a wonderful answer... a new kind of plan to give you the CASH PROTECTION you'll need when sick or hurt. Money that's paid direct to you, *over and above* any other protection you have. Generous specified benefits for doctor bills, hospital room, surgeon's fees, drugs—even medicine prescribed when you're out of the hospital. AND if you stay well and don't use all the benefits you get a CASH REFUND at maturity. The amount depends on benefits already received, the principal amount selected, and how long the policy has been in force. Sick or well, this plan pays off!

MONEY BACK

If You Stay Well

When You Stay Well, You Get Cash Back. What could make more sense than health insurance that pays money back if you don't use it? Here's a plan that does! If you need the benefits, the money is there to help you... if you stay well, or use only part of the benefits, you've added to your savings. Think of it! You *don't* have to be sick or hurt to collect! Either way, you *can't* lose! This new kind of common-sense protection, Policy NC-701, is available only from Bankers Life & Casualty Company as part of the famous White Cross Plan. Send today for valuable Free Information about this remarkable health insurance plan.

EITHER WAY YOU MUST COLLECT!

Find out about these six special features never before combined in one policy:

- **Guaranteed Protection to age 75** or until you have been paid the full amount of the principal sum in specified benefits.
- **Your low individual rates can never be raised.**
- **Builds cash values after just 3 years** as long as you pay the premiums.
- **You are guaranteed the full face value of the policy** either in specified benefits or in a contingent cash refund.
- **Generous cash payments** specified for doctor, hospital room, drugs, surgery, miscellaneous bills, etc.
- **Pays cash direct to you—over and above everything you collect on other insurance.**

TEAR OFF POST CARD and mail today for FREE INFORMATION

Policies of
The White Cross Plan / Bankers Life & Casualty Co.
offered by / An Old Line, Legal Reserve Stock Company
HOME OFFICE: Chicago 30, Ill.



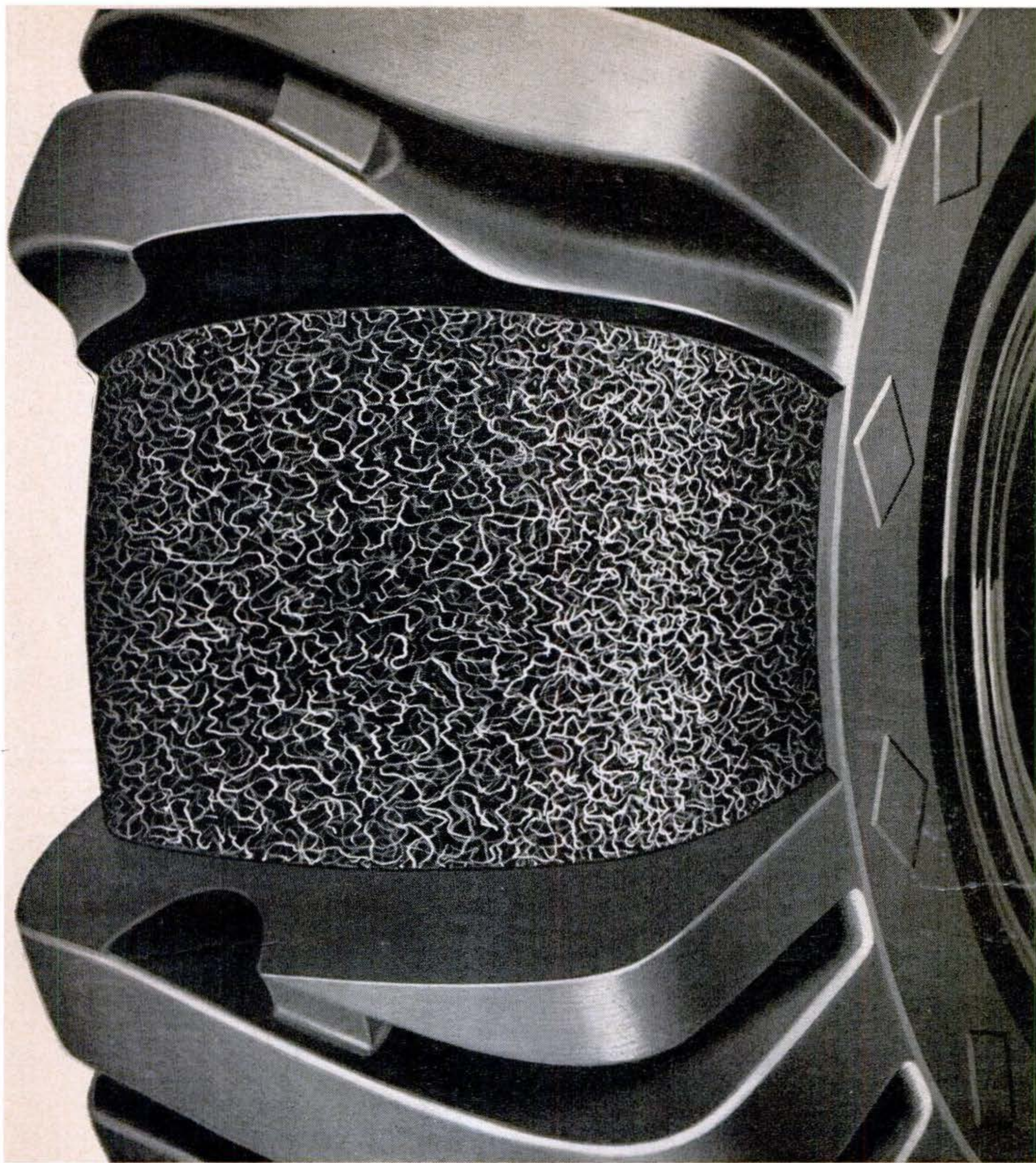

Steel bodyguard stops tire killers cold

6 million short lengths of steel wire are embedded in the undertreads of off-the-road Goodyear tires. They guard the body against cuts and bruise breaks from sharp rocks, stabbing stumps, slashing scrap metal and other tire destroyers.

This steel bodyguard also retards cut growth. And it helps prevent separations too, because it actually "zip-

pers" the tread to the tire body.

This steel bodyguard is a Goodyear *bonus*. Doesn't cost a penny extra in most of the popular sizes. See your Goodyear Dealer or Goodyear Service Store. Goodyear, Truck Tires, Akron 16, Ohio.

Another reason why: more tons are hauled on Goodyear truck tires than on any other kind.

GOODYEAR

Next Month in Popular Science

- **How to Get Towed Without Being Took:** Trouble on the road? Pros tell you how to guard your car and your pocketbook.
- **New Robot Rainmakers for Wall-to-Wall Lawn:** Inside dope on automatic sprinklers for the man who's fed up with playing water boy.
- **How to Make an Electronic Seat-Belt Alarm.** Got a forgetful driver in your home? A flashing light and insistent buzzer will make him buckle down.
- **Getting Started in Scuba Diving.** For a short course in this great new sport, strap on an air tank and explore the bottom of the sea with PS.

Return postage must accompany all manuscripts submitted. We cannot be responsible for the loss of manuscripts or photos.

E. S. DUFFIELD, President

JOHN R. WHITING, Executive Vice-President and Publisher

EUGENE WATSON, Vice-President, Circulation

CHARLES S. THORN, Vice-President, Advertising

EDITORIAL OFFICES: 355 Lexington Ave., New York 17, N. Y.

PUBLISHED MONTHLY by Popular Science Publishing Co., Inc., 355 Lexington Ave., New York 17, N. Y.

SUBSCRIPTION SERVICE. *New or renewal orders:* Send to Popular Science Subscription Department, Boulder, Colo. One year \$4, 2 years \$7, 3 years \$9 in U.S., its possessions, and Canada. Elsewhere, 1 year \$6.50, 2 years \$12, 3 years \$17. Single copy 35¢. *Subscription orders processed electronically.* ● *All subscription adjustments:* Write to Robert Harlan, Popular Science, P.O. Box 1083, Boulder, Colo. For change of address allow four weeks; please give both old and new addresses. Notices of undelivered copies (Form 3579) to Mr. Harlan. ● Second class postage paid at New York, N.Y., and at additional mailing offices. Entered as second class matter at the Post Office Department, Canada. Printed in U.S.A. ● **ADVERTISING OFFICES,** NEW YORK: 355 Lexington Ave.; CHICAGO: 360 N. Michigan Ave.; DETROIT: 2810 Book Bldg.; SAN FRANCISCO: 703 Market St.; CLEVELAND: 1220 Huron Road; LOS ANGELES: 1709 W. Eighth St.; PORTLAND, ORE.: 520 S.W. Sixth Ave.; DENVER: 333 W. Colfax Ave.; SEATTLE: 101 Jones Bldg.

Copyright © 1963 by Popular Science Publishing Co., Inc. All rights reserved



**FINE
SERVICE...**

**FAIR
PRICES**

Regular service at your General Motors dealer's is economical—dependable—convenient! Skilled hands, special tools and genuine GM parts help eliminate the cost of major repairs . . . save you money in the long run.

SEE YOUR **GM** QUALITY
DEALER FOR THE BEST
KIND OF SERVICE

GUARDIAN
MAINTENANCE

CHEVROLET • PONTIAC • OLDSMOBILE • BUICK • CADILLAC • GMC TRUCK

DON'T JUST SIT THERE!

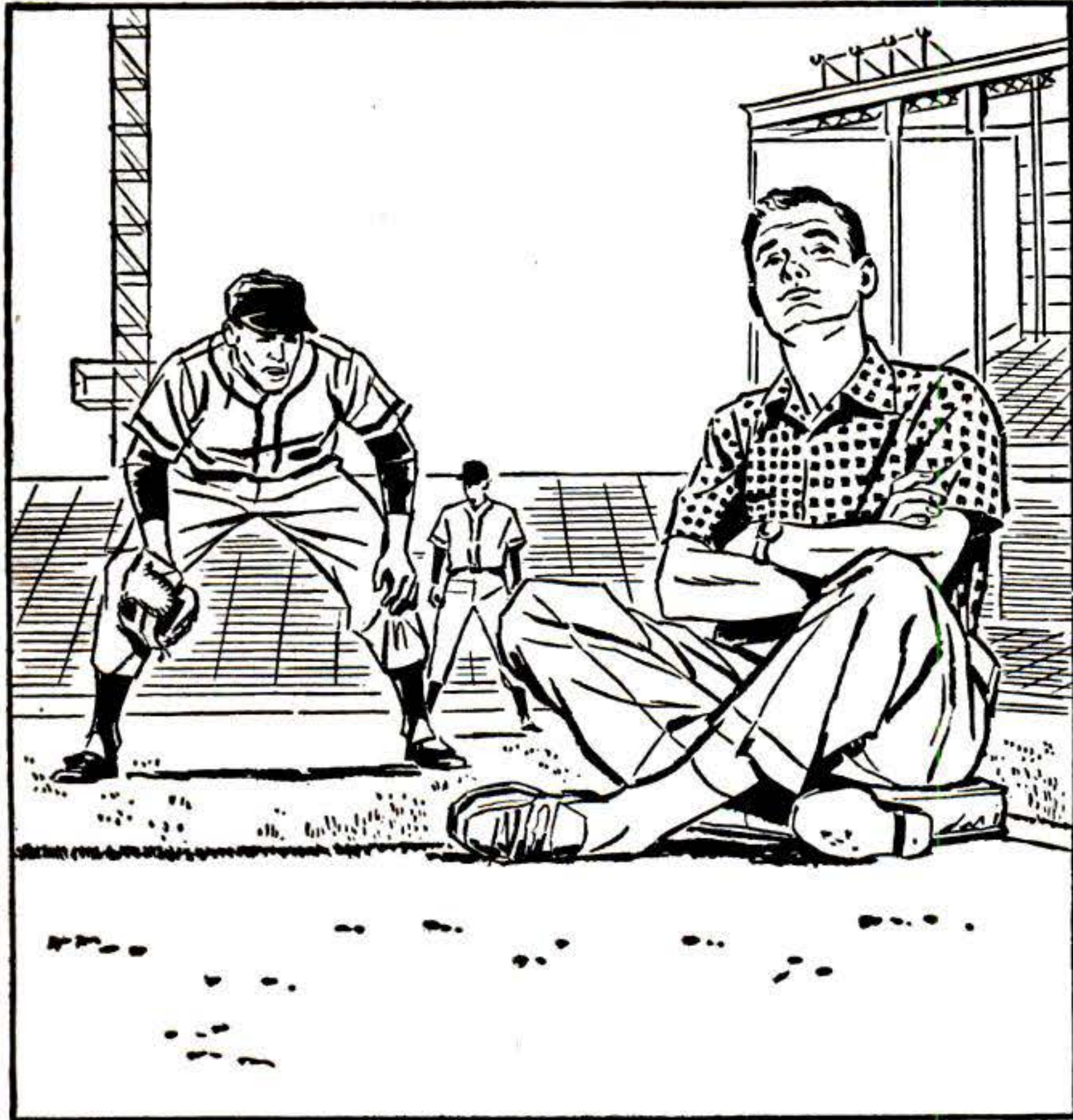

Ever see a man get to first base in his job and then "die"?

He camps there, waiting for something or someone else to advance him. And all too often, he just waits... and waits... and waits.

In the competitive game of business and industry, it's every man for himself. You advance on your own. And the best way to get ahead is to make yourself better qualified than the next guy.

But how? For the man with a family to support, a job to hold down, there's no more sensible method than spare-time training with I.C.S.

It's convenient! It's fast! It's low in cost! *And it works!*

Give us the chance to prove this and we'll send you three helpful and valuable booklets—*free!* We'll demonstrate the I.C.S. method with a sample lesson—we'll show you in an illustrated catalog how quickly and thoroughly you can master any of 250 courses. And you'll get the rewarding career guidebook, "How to Succeed."

Don't just sit there! Mark and mail the coupon!

Clip coupon here—and take your first big step to real success! I.C.S., Scranton 15, Penna. Accredited Member National Home Study Council

INTERNATIONAL CORRESPONDENCE SCHOOLS

Box N8751G, Scranton 15, Penna.

(In Hawaii: P. O. Box 418, Honolulu. In Canada: I.C.S. Canadian, Ltd., Montreal.)

Without cost or obligation, rush me FREE Success Kit, with 3 valuable booklets: (1) How to Succeed; (2) opportunity booklet about the field I've checked below; (3) Sample I.C.S. Lesson.

ARCHITECTURE and BUILDING TRADES

- Air Conditioning
- Architecture
- Arch. Drawing
- Building Contracting and Estimating
- Carpentry & Millwork
- Heating
- House Planning
- Painting
- Plumbing

ART and DESIGN

- Commercial Art
- Fashion Illustrating
- Interior Decorating
- Magazine Illustrating
- Show Card & Sign
- Painting
- Sketching and Painting

AUTOMOTIVE

- Auto Body Rebuilding
- Auto Electric Technician
- Automobile Mechanic
- Engine (Gas & Diesel)
- Engine Tune-Up

Transmission Specialist

AVIATION

- Aero Engineering
- Aircraft Drafting
- Aircraft Mechanic

BUSINESS

- Accounting
- Cost Accounting
- Public Accounting
- Bus. Administration
- Executive Training
- Marketing
- Personnel-Labor Relations
- Programming for Digital Computers
- Purchasing Agent
- Real Estate
- Salesmanship
- Sales Mgmt.
- Small Business Mgmt.
- Traffic Mgmt.

CHEMICAL

- Analytical Chemistry
- Chem. Engineering
- General Chemistry

Lab. Technician

- Nuclear Energy
- Plastics
- Pulp, Paper

CIVIL ENGINEERING

- Civil Engineering
- Construction Engrg.
- Highway Engineering
- Reading Structural Blueprints
- Sanitary Engineering
- Structural Engineering
- Surveying & Mapping

DRAFTING

- Architectural
- Electrical and Electronic
- Mechanical
- Sheet Metal

ELECTRICAL

- Elec. Appliance Servicing
- Electrical Engineering
- Elec. Eng. Technician
- Elec. Motor Repairman
- Industrial Electronic Technician

Industrial Telemetering

- Instrument Technician
- Practical Electrician
- Practical Lineman

ELECTRONICS

- Automation
- Basic Electronics
- Electronic Computers
- Electronics Technician
- Hi-Fi Stereo and Sound Systems
- Industrial Electronics
- Ultrasonics

ENGINEERING (Professional)

- Chemical
- Civil
- Electrical
- Mechanical

ENGLISH and WRITING

- Better Business Writing
- Introductory Technical Writing
- Short Story Writing

Practical English

HIGH SCHOOL (Diploma)

- High School General
- High School Math
- High School Secretarial
- High School Vocational
- College Preparatory

MECHANICAL and SHOP

- Gas and Electric Welding
- Industrial Engineering
- Industrial Instrumentation
- Machine Design
- Machine Shop Practice
- Mechanical Engineering
- Reading Shop Blueprints
- Tool Design
- Toolmaking
- Safety Engineering

SECRETARIAL

- Clerk-Typist
- Professional Secretary

Shorthand

- Stenographic
- Typist

STEAM and DIESEL POWER

- Boiler Inspector
- Power Plant Engineering
- Stationary Diesel Engineering
- Steam Engineering

SUPERVISION

- Foremanship—Suprv'n
- Personnel—Lab. Rel'ns

TV-RADIO

- Radio and TV Servicing
- Radio-Telephone License
- TV Technician
- Practical Radio-TV Engineering

MISCELLANEOUS

- Railroad
- Textile
- Other (please specify)

Name _____ Age _____ Sex _____
 Home Address _____
 City _____ Zone _____ State _____
 Occupation _____
 Employed by _____ Working Hours _____

Special low rates to members of U. S. Armed Forces!

Robert P. Crossley
Editor

JAMES M. LISTON
Executive Editor

KENDALL W. GOODWYN
Managing Editor

ROBERT P. STEVENSON
Director, Products and Projects

HOWARD JENSEN
Art Director

Senior Editors

Alden P. Armagnac, Wallace Cloud
Everett H. Ortnor, Joan Steen

Automobile Editor

Devon Francis

Electronics and Technical Editor

Hubert Luckett

Home Workshop Editor

Sheldon M. Gallager

Photography Editor

Robert L. Hering

Boating Editor

Jim Roe

West Coast Editor

Wesley S. Griswold

European Editor

David Scott

Associate Editors

Frank Dorr, Herbert O. Johansen

Alex Markovich

Ruth Westphal

Editorial Assistants

Eleanor Crapullo (Chief)

Anna Dallas, Claire B. Kelly

Irene Schiff, Barbara Weisheit

Art Editors

Herbert Anthony

Harry Samuels

Associate Art Editor

Richard J. Meyer

Art Associates

Robert Martin, Kenneth Buddington

Art Production Manager

Henry W. Kazmirowski

Photography

Robert D. Borst

JOHN R. WHITING, Executive Vice-President and Publisher

Cover painting by Pierre Mion

July 1963

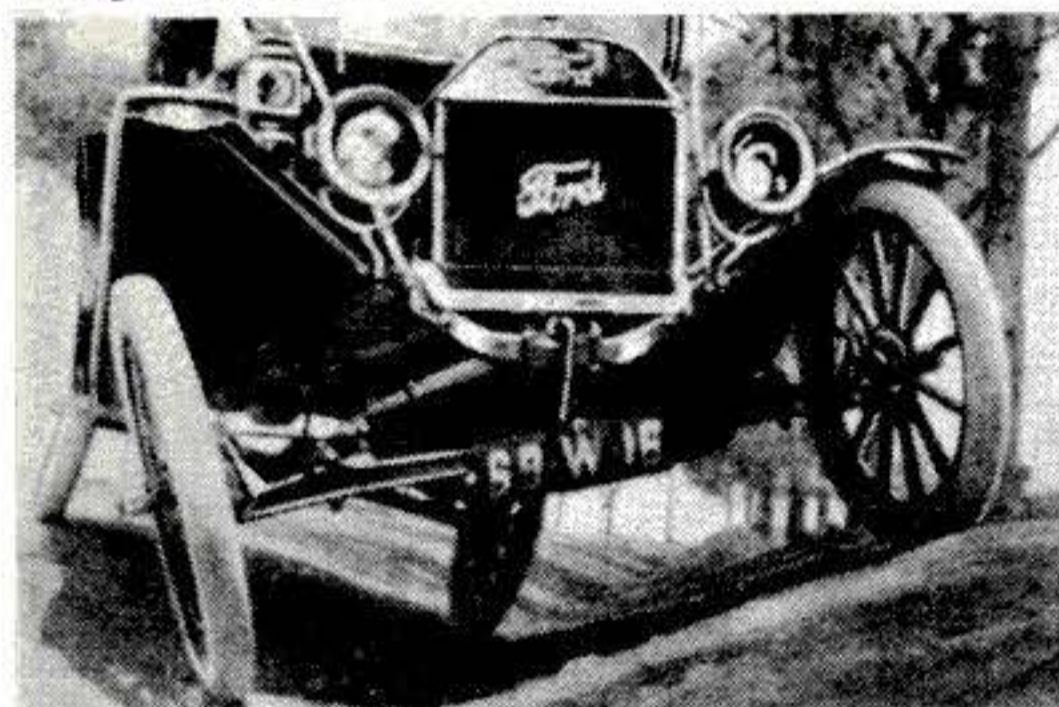

What made the Model T so good?
A Pulitzer Prize historian tells
the inside story. Page 68.

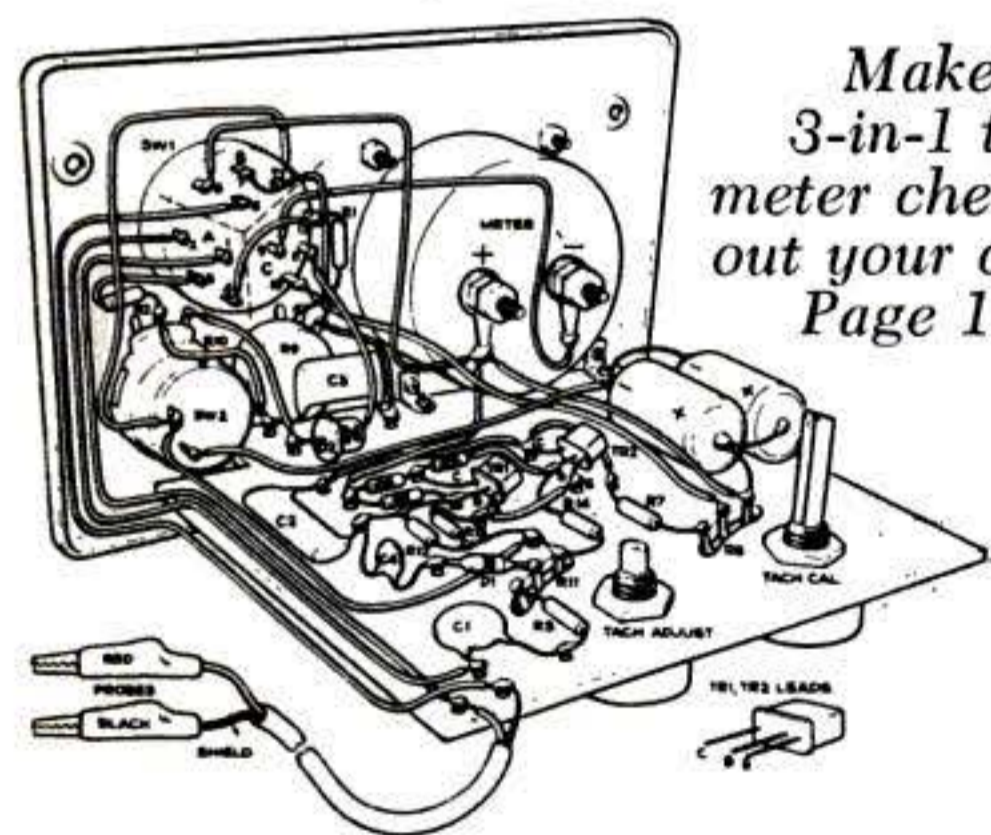

Make it:
3-in-1 test
meter checks
out your car.
Page 124.



Stand on the levee with PS—and
watch 'em tame a river. Page 48.

CARS AND DRIVING

What's Coming in the '64 Cars • 41

The Untold Story of the Model T • 68

"Any Dope Could Drive a Model T" • 73

Is This *Your* Year for Air Conditioning? • 82

Ambassador: Rambler's Hot One • 92

SCIENCE AND INVENTIONS

The Race for the Bottom of the Sea • 35

Buy It, Build It: Ride on Air! • 54

Special \$3.95 Book Digest:

Deadly Gadgets of the OSS • 56

Ship to Shore—Marines Are Still First • 60

Projector Turns Words into Pictures • 66

One-Man Automatic Garage Parks Cars • 90

SPACE AND AVIATION

Dr. von Braun: Travel to the Stars? • 63

How to Bring a Booster Back Alive • 80

SPECIAL REPORT

Ol' Man River Meets His Match • 48

PHOTOGRAPHY

Photographically Speaking • 131

Versatile 'Second' Camera • 132

Put Your Name in Lights • 134

What's New in Photography • 135

Stop wasting time in a dead-end job!
Enjoy the big rewards offered the
Law-trained man in business

STUDY **LAW**

IN YOUR SPARE TIME
as a way to
increased earnings

WHATEVER your present position—whatever your previous schooling—you can multiply your opportunities for rapid promotion, big income and prestige through LaSalle Law Training at home.

A knowledge of Law is regarded today as indispensable equipment in every activity of business. The greatly increased role of government in business, the many new problems of Law involving taxes, insurance, contracts, liability, employment, and much more—all require the legally-trained executive who can make day-to-day decisions effectively. That is why leading corporations seek out such men for key positions and reward them with top salaries.

You can master Law easily and enjoyably at home—at remarkably low cost—under the supervision of LaSalle's distinguished Law faculty. You work with actual legal cases, acquiring real experience. Upon completion of your training, you are awarded a Bachelor of Laws degree if qualified. *The famed LaSalle Law Library of 14 volumes is given to you as part of your course.*

For over half a century LaSalle has been an acknowledged leader in business training, with more than 1,000,000 students. Send for the free booklet "Law Training for Leadership" and see how LaSalle can help you move up rapidly in your career. Address: 417 So. Dearborn St., Chicago 5, Ill.

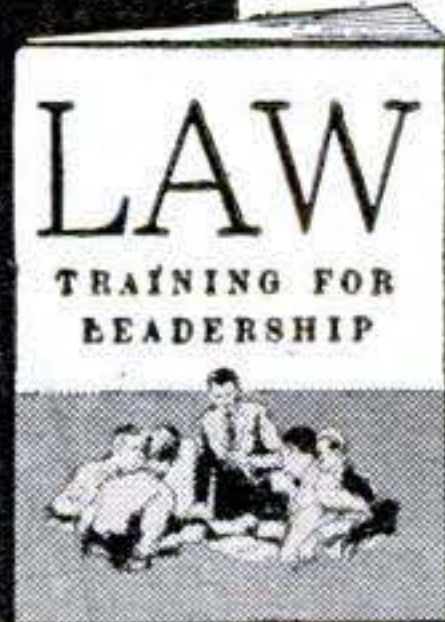

**Send
for
this
Free
Book-
let**

LA SALLE **EXTENSION UNIVERSITY**

A Correspondence Institution

417 South Dearborn St., Dept. 19-105, Chicago 5, Ill.

Please send me, free of cost or obligation, your illustrated booklet "Law Training for Leadership."

Name Age ...

Address County
 City &
 Zone State.....

221

HOME AND SHOP

- A Yard Cart You Can Push or Tow • 94
- Cooling Your House with Free Air • 99
- A Neat Yard the Lazy Way • 102
- New Twists on Rotary Planers • 106
- Shop Talk • 139
- What's New in Tools • 140
- What's New for Your Yard • 141

ELECTRONICS

- What Do They Think of Pay TV? • 75
- Make a Test Meter for Your Car • 124
- What's New in Electronics • 136

BOATS AND BOATING

- What Did They Do Wrong? • 110
- Testing OMC's New Show Boats • 112
- What's New in Boating • 138

CAMPING

- Here's a COOL Way to Camp • 128
- What's New in Camping • 130

AUTO UPKEEP

- Do Pennies Save Your Battery? • 28
- Rattle-Free Case for Car Tools • 120
- Hints from the Model Garage • 146
- Gus Answers a False Alarm • 150
- How to Keep Your Engine Cool • 156

PICTURE NEWS

- Helicopter Gets Lift from Air Pump • 45
- Air Canopy Protects Driver • 79
- Astronauts Study the Stars • 89

SHORT CUTS AND TIPS

- Flip-Flop Jig Helps Cut Wedges • 98
- Making a Handy Photo Light Box • 105
- Give Each Appliance Its Own Fuse • 117
- Wheel Tops Outdoor Fireplace • 142

EVERY MONTH

- PS Readers Talk Back • 6
- Getting Ahead • 12
- Science Newsfront • 19
- 90, 60, and 30 Years Ago in PS • 26
- Detroit Report • 32
- I'd Like to See Them Make • 67
- New Ideas from the Inventors • 86
- Wordless Workshop • 118

PS readers talk back

Drivers: The Hare and the Turtle

Three cheers for Martin Mann ["Slow Drivers Can Kill You," Apr.]. He has said only what is common knowledge to good drivers. It's about time someone had the courage to put this into print.

JOEL M. KAUFFMAN & WARREN SEWALL
M.I.T. Sports Car Club, Cambridge, Mass.

... The article contradicts its title. In the problem situations you set up, the proper driving technique calls for either a slowing down or a stop—not one calls for fast driving or a speed-up.

I sincerely hope that drivers who read your article (particularly the young or poorly informed driver) will do so with an open mind and attention to the true meaning of the sentences: "The cops *may be* handing out tickets to the wrong guys." "Slow drivers *could be* the bad drivers. In fact they *might* even kill you." Nothing very positive here.

The most sensible statement in the article: "Dr. Malfetti will not say that fast, hard driving is good." As for the "leadfoot," your observation is quite correct. The credit for his not having accidents must go to everybody who keeps out of his way.

R. C. MULLIN, Safety Ed. Inst.
Millersville State College, Pa.

Underwater Fire Fighters

The Boston Fire Department has had a skin-diving division for quite a while. ["Frogmen Fight Dock Fires," Apr.]. They came into prominence fighting a dock fire that could not have been put out without their help. At this moment they are giving their time and help in search for the sub Thresher.

LESLIE MATSON, Northborough, Mass.

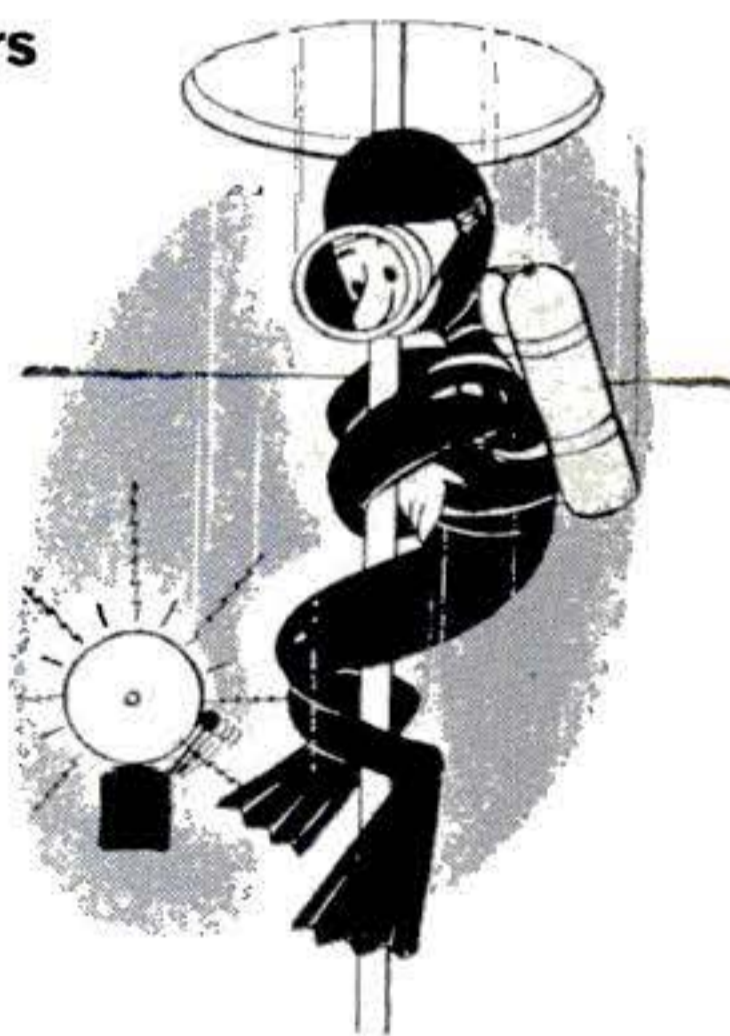

He Says DON'T

Placing an open vent in the rear window shelf ["Hints from the Model Garage," Apr.] and drilling the spare-tire well full of holes could provide an excellent route for carbon monoxide gas and other exhaust fumes to enter

only one
wagon has
"DRIVEPOWER"*

Conventional wagons put horse-
power only at the rear . . . only
2-wheel power . . . only push.

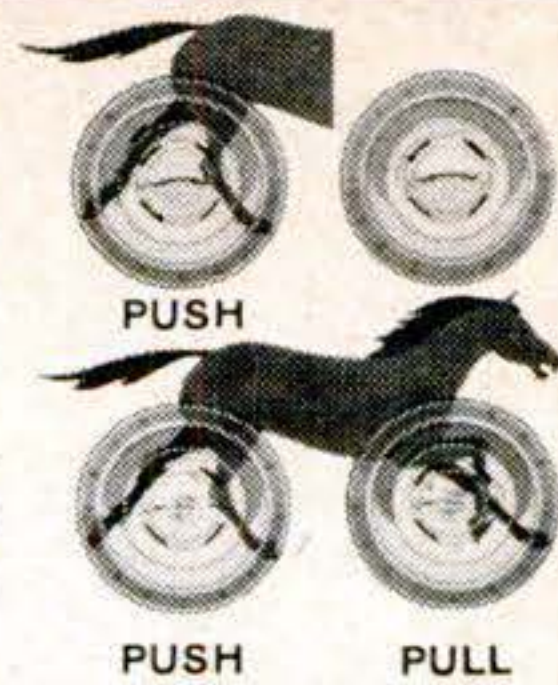

'Jeep' Wagoneer puts horse-
power front and rear . . . 4-wheel
"Drivepower" . . . push and pull.



go the Wagoneer road!

Where there's no road, Wagoneer station wagon makes one. Just hit the "power bolt" . . . the lever that shifts from 2-wheel to 4-wheel drive . . . and pour on the "Drivepower". Go Wagoneer™-ing. Cut out of traffic. Go over hills, through mud, sand or snow. Discover the greater traction, greater driving safety of "Drivepower". Try the new automatic transmission, power options, and quiet highway ride. See your 'Jeep' dealer and shift into greater safety with Wagoneer—the only family wagon with "Drivepower".

KAISER Jeep CORPORATION Toledo 1, Ohio

*"Drivepower" is Wagoneer station wagon's new, improved and exclusive 4-wheel drive system.

ALL NEW 'JEEP' WAGONEER

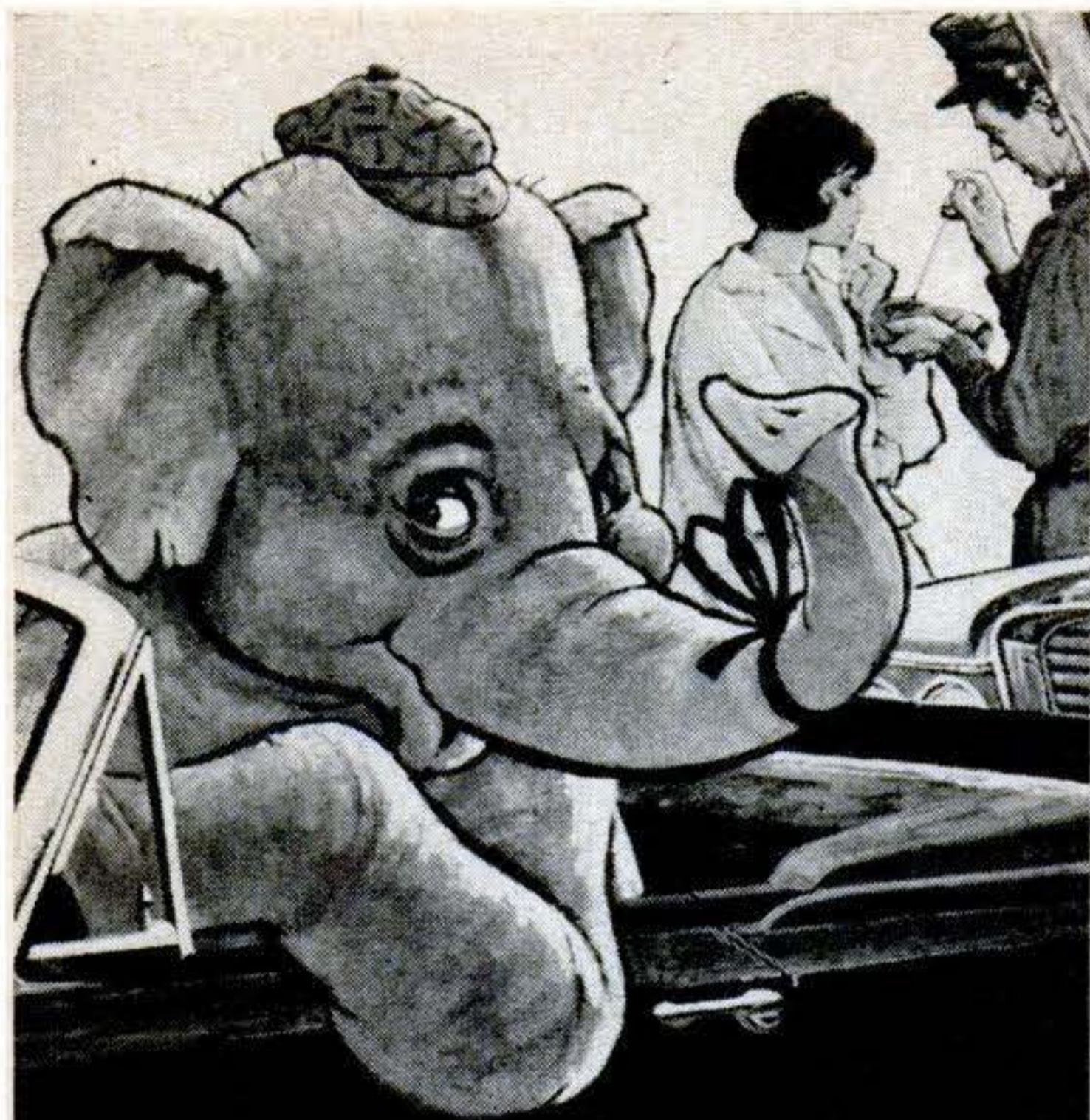

*You don't need a memory
like an elephant . . .*

**If you forget to
change oil
PENNZOIL
STILL PROTECTS**

©Pennzoil 1963

Not being elephants, people are apt to forget. That's why we build *protection reserve* into Pennzoil Z-7, so it will go on protecting even if you forget to change oil when you should. Use Pennzoil Z-7 always, and ask for it even if you don't see it displayed. Pennzoil, Oil City 62, Pa.

Best time to change oil: Every 60 days, normally. Every 30 days under severe stop-and-go or cold-weather driving conditions.



Hear "Chet Huntley's Perspective on the News" Monday through Friday, NBC Radio Network

the car. With all the windows closed to make the best use of your proposed system, a car could become a death trap if there is the slightest leak in the exhaust pipe or muffler.

G. E. EASLEY, Arcadia, Calif.

. . . If the opening could be made on top of the back deck, just below the rear window, it would be safer. I believe the vacuum from wind passage would draw air from inside the car.

F. L. DAVISSON, St. Petersburg, Fla.

Piggyback Camper for a VW

After reading "Vacationing on Wheels" [May], I thought you might like to see the rig I built. It rode with me for over 7,000 miles last summer.

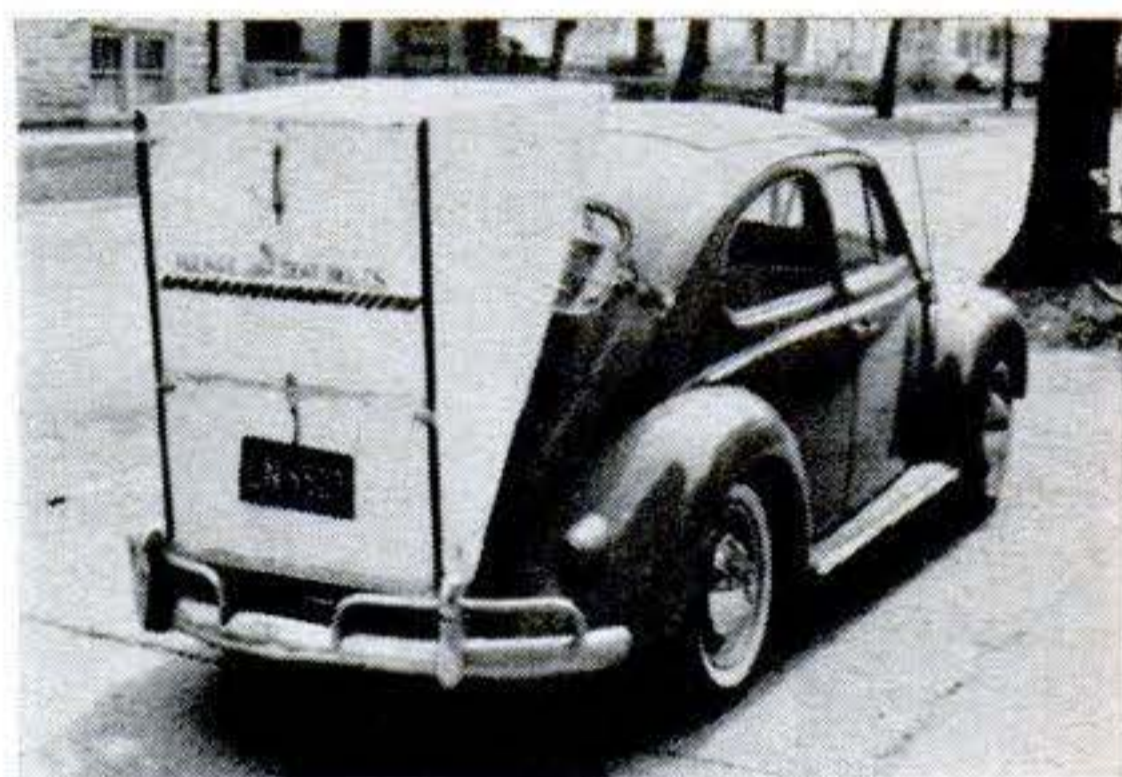

It contains a one-cubic-foot icebox with elastic bands to hold containers in place. There is an eight-gallon water tank. A vent, the door for loading ice, and hooks for hanging packs are on the top surface.

The upper section drops down to form a work surface. The door to the icebox has shelves to hold kitchen utensils. The lower compartment holds a Dutch oven, iron skillet, and other heavy equipment.

The bottom of the plywood unit is supported by short legs that fit into sockets attached to the bumper supports. More support is supplied by a block and suction-cup spacer against the rear window. Hooks to the gutter prevent the window from falling out.

The car's top speed and economy stay about the same, but acceleration above 50 m.p.h. really suffers.

MICHAEL FIRTH, Ames, Iowa.

Rebuttal on Transmission Debate

Neither Ford nor Packard can claim the first synchronized transmission ["PS Readers Talk Back," Apr.]. Do none of your letter writers remember the "traffic transmission"—the only truly synchronized gearbox—built in 1926 by Chandler?

No gear was shifted into mesh with any other gear. They were already in mesh. The drive gear was locked to the shaft by one pair of pawls that slid out with a twisting motion and locked the gear to the shaft as it engaged a cut-out section on the internal area bearing on the



What does it take to feel like a man?

It takes action to feel like a man. Takes pride and courage. But in today's modern world *it also takes training. Technical training.* Ask any mechanic. Ask any missile man.

In today's modern Army all units are fast-moving. Flexible. Men and machines are closely interlocked. And since the machines are complex, men have to be extra skilled to handle them. The Army *makes* men like this—technically skilled, competent, confident.

The training you get can give you a good future. Almost unlimited. You can be expert in areas like engineering, missiles, electronics, motor mechanics—or any of 150 other fields!

And of course you have other choices too. Want *Combat Arms*? Then ask for Infantry, Armor or Artillery. It's as simple as that. If you're qualified, your choice is *guaranteed before you enlist.* Find out how to feel like a man in today's fast-changing world. See your local recruiter today.

A new Winchester 22: son of "The Gun That Won The West."

Only Winchester could have built it. The rifleman's rifle. Winchester's Model 250 22 caliber lever action is the direct descendant of the most famous Winchester of them all...the Model '73, "The Gun That Won The West." Superb balance, dead-in-the-middle accuracy, and rugged construction make this one the gun you'll want along when the going gets tough. Heft it. Work the action. Note how the 250's unique trigger and guard break away with the lever in one smooth motion that prevents pinched fingers during rapid firing. Fires shorts, longs, long rifles interchangeably. Fully adjustable sights. Weight 5 lbs. approximately. Only \$56.95.

WINCHESTER® Western® Olin
WINCHESTER-WESTERN DIVISION



shaft. The pawl was an oval-shaped section that, when in place, made a completely round shaft.

With this transmission, a car moving forward could be *slipped into reverse*. Reverse position had an offset slot to keep this from being done. It probably was a practice that was abused, though the boxes could take it a few times and the rear end was built like a truck.

The second pair of pawls was used for locking another set of gears, depending on whether they were moved forward or backward. In this manner, each pair of pawls worked two sets of gears of a three-speed box.

GEORGE B. HASKIN, Tacoma.

For Budding Astronauts

Here's my version of your teeter-go-round [June '62]. I call it a space centrifuge. Future astronauts can undergo as many Gs as they like



—it's self-propelled with handles on the seats. When they tire of space training, they can go back to the old Wild West and ride a bucking bronco.

It is made of an old car (or truck) wheel with car coil springs just set under it to give it more bounce and hold it level as it goes around. It required little welding; no welding of the springs.

MAX ROBINSON, Bloomington, Neb.

Sports Cars—Family Style?

The Gold Cup Tempest was about as comparable to your test car ["PS Tests the Hot Compacts," May] as a Piper Cub is to an F-100 Super Sabre. Besides being loaded with the 421-cu.-in. super-stock engine that normally makes its home in the big Pontiac and two big 4-barrel carbs, the Gold Cup Tempest had an experimental four-speed transmission. It allowed the car to be shifted without using the clutch.

W. C. JOHNSON, Daytona Beach.

A hot one did sneak in, but who said anything about these compacts being sports cars?

The Peace-Making Transmitter

The other day, I was tuning across my short-wave receiver dial while the TV was on in another room. With the receiver tuned to 4.5 mc., I could hear the TV program with plenty of volume. This system would have more use

and might be cheaper than yours ["All's Quiet on the TV Front," Apr.].

The difference of the audio IF and the video IF (4.5 mc.) acts as a transmitter in the TV, and the receiver changes the signal back to audio. The only equipment needed is a short-wave receiver. Portable receivers and earphones could also be used.

PHILIP M. SHANK, Scottdale, Pa.

. . . Wouldn't it be easier to use a transistor radio instead of going to the expense of building a receiver? I did and it works fine. I drop the radio in my pocket and hook on the earphones.

DEAN HILL, Portland, Ore.

Right on both counts . . . but. A short-wave receiver will sometimes work—but usually not very well. Sure you can use a transistor radio—if you have one.

. . . I've been reading the instructions for connecting the transmitter to your TV set. It seems to me the diagram you show would lose contact completely when the phone oscillator was connected. It should be done as in the diagram [below].

ROBERT DUBUQUE, San Mateo, Calif.

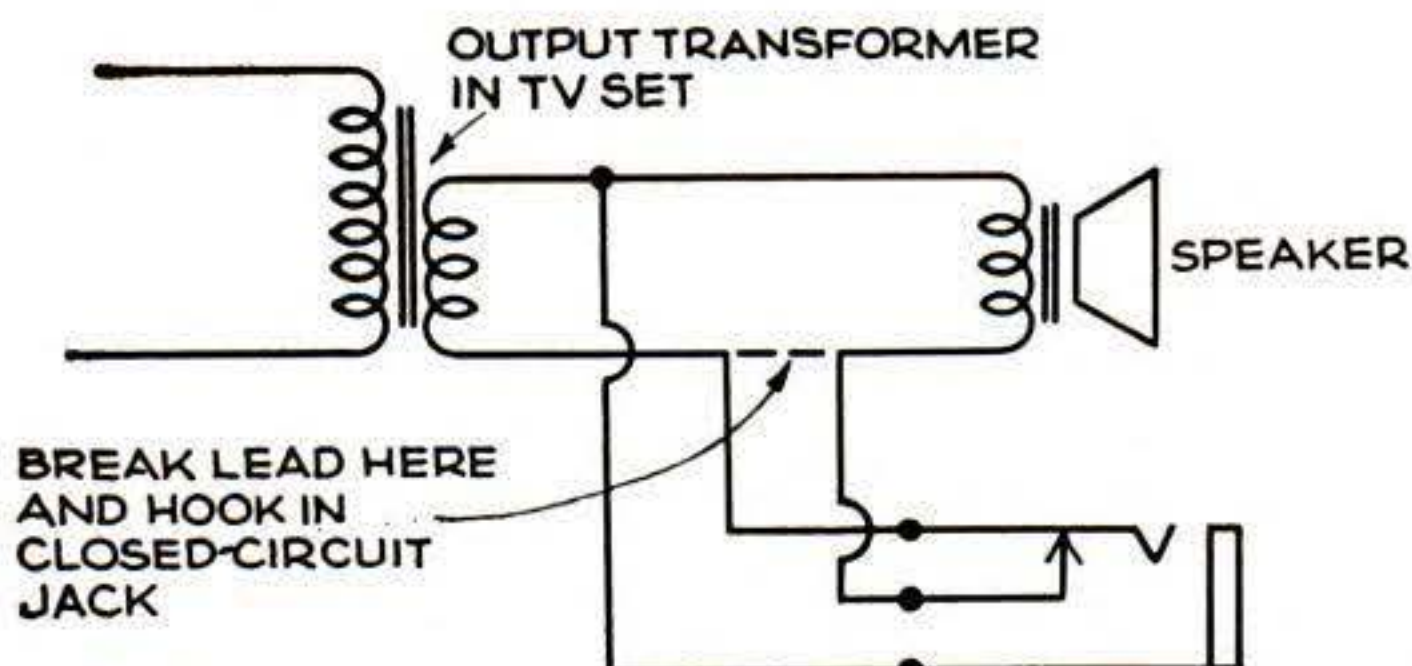

Right.

Always a Better Way

A better way to shorten a bolt ["Between Us Machinists," Apr.] is to put the nut on the bolt beyond the part you are going to saw off, and put the nut between the vise jaws. Then make sure the rough edges are straightened out.

R. R. MEIJER, Little Silver, N. J.

Champ Dragline Operator Speaks Up

Now that a whole year has gone by, I'm about to try digging a pond ["Spot and Dig Your Own Pond," July '62] on my property. One bit of advice has me puzzled. The author says he can dig a 55-foot-wide pond with a 50-foot boom along one side. How come?

A. L. JONES, Boonton, N.J.

You do it like so: 1) turn machine ¼ turn on turntable; pull bucket in. 2) Swing machine to front position; throw bucket out. Boom is lowered to about 30-degree angle during operation. This advice comes from a champ dragline operator. With a 40-foot boom he can control his ¾-yard bucket 65 feet from his machine.

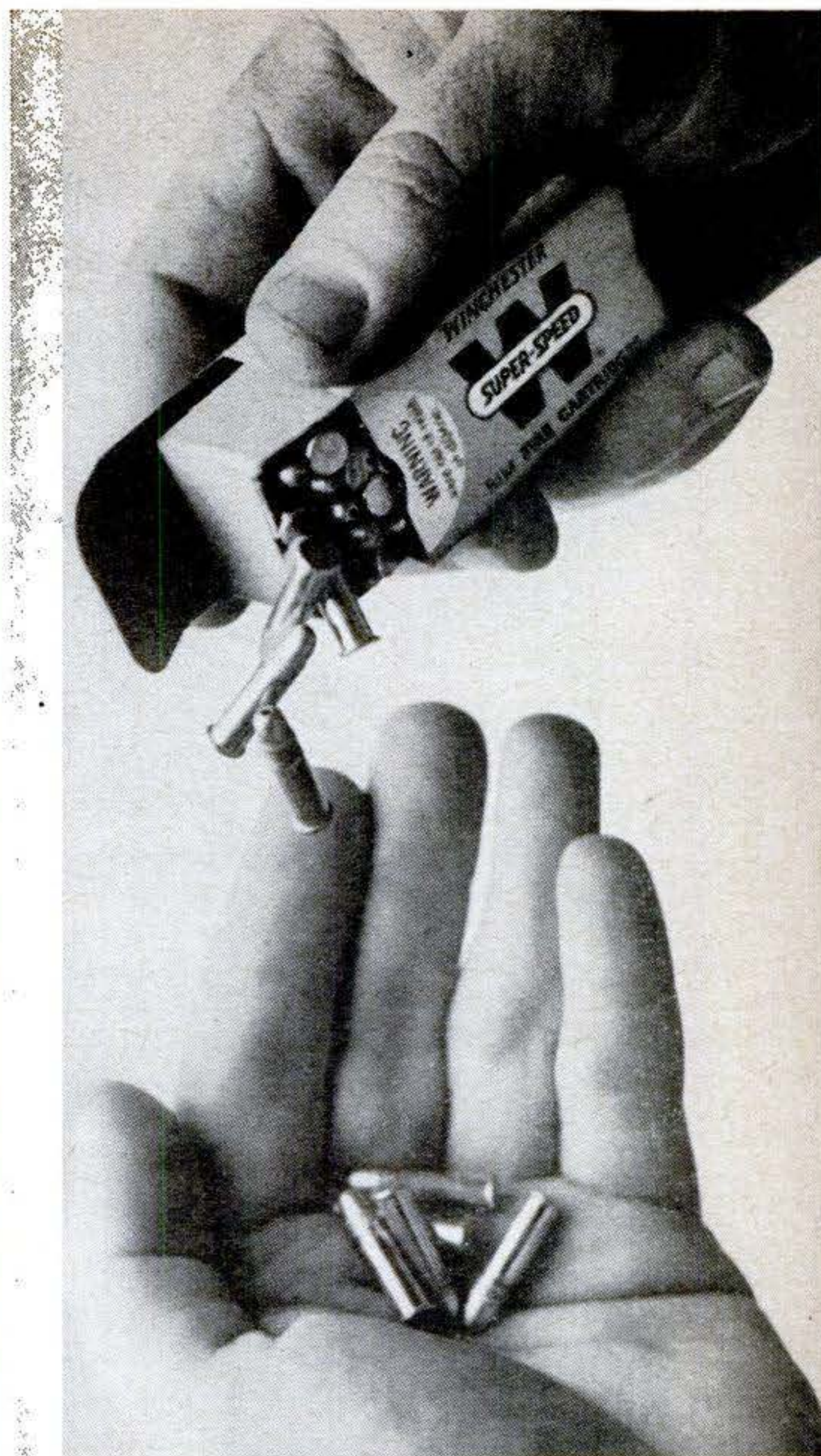

These are what you feed your 22 to give it muscle!

Power? Super-X and Super-Speed Long Rifle 22s are up to 36% more powerful than ordinary 22s!

Whether it's hand inspected Match ammunition or inexpensive 22 shorts for plinking—team winners and woodsmen know it's Winchester or Western for power and performance in a 22.

WINCHESTER®
Western®
WINCHESTER-WESTERN DIVISION **Olin**

Getting Ahead

By Dr. Lewis R. Fibel

A monthly column to help you prepare yourself for a better job

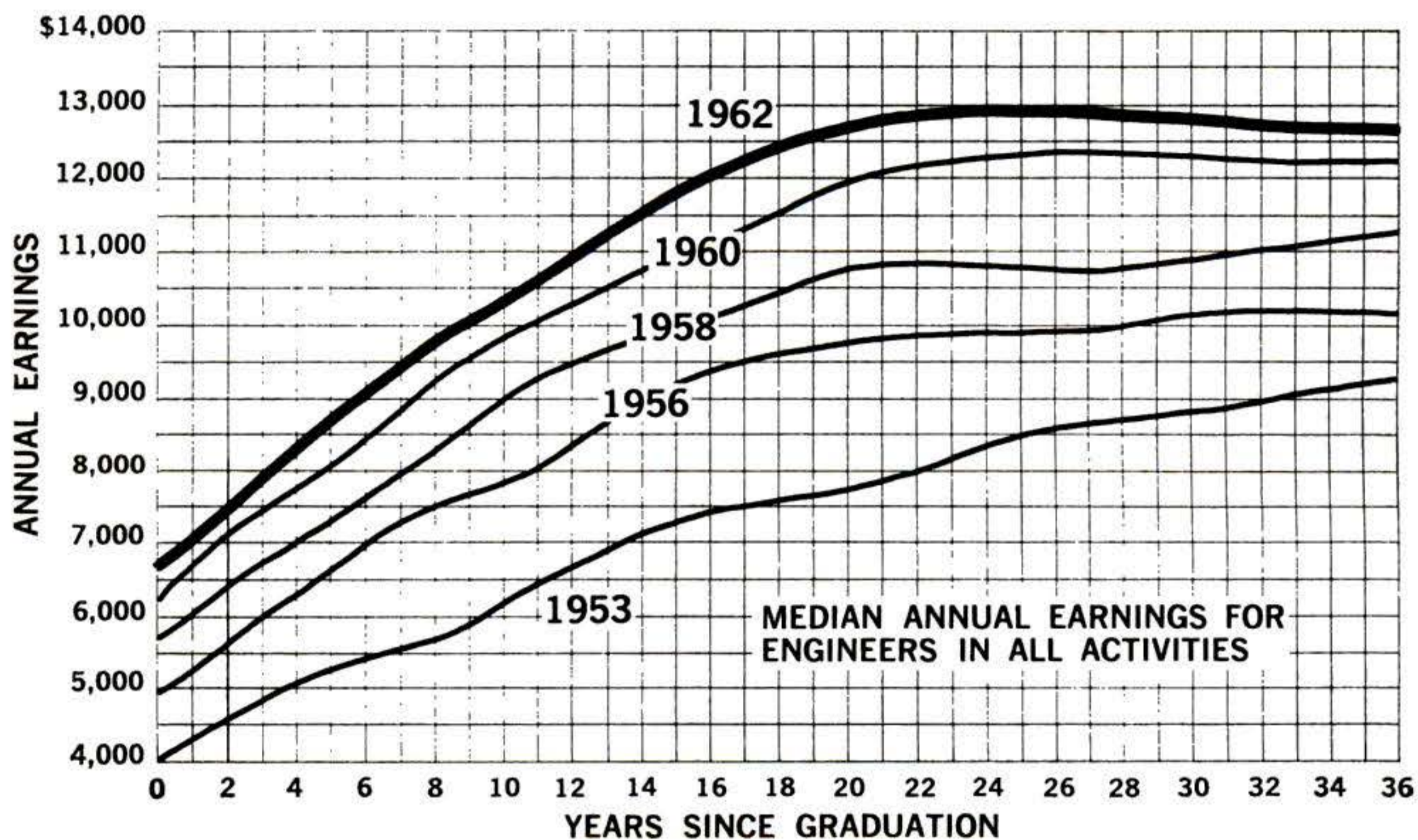

Engineers' average salaries topped \$10,000 in 1962, reports the Engineering Manpower Commission. Half the engineers in the country made less than \$10,375 a year; half equalled or bettered that amount.

Earnings grew at a rate of four percent a year from 1960 to 1962. That's

a shade lower than the five-percent rises from 1958 to 1960 and the 6½ percent increases from 1953 through 1958.

The chart above shows how engineering incomes compare over the years when matched against job experience (years since graduation from college).

Many readers ask if taking correspondence courses is of more value than reading technical books.

Let me answer by saying first that there should be no conflict here: You can't underestimate a continued program of reading—books, magazines, journals, newspapers—in your field of interest. Education should never stop, and the educated man uses every means to keep abreast. To learn a particular skill, however, I believe that

correspondence courses are generally superior to just reading. A correspondence course is a planned activity. It proceeds logically, step by step. Many courses also include practical exercises. And there are tests that, when corrected and returned, provide the student with a check on his progress. Finally, the completion of a correspondence course is an accomplishment that will increase your chances of finding a job in your chosen field.

"I am in the Air Force serving on a Titan missile launch crew as an electric-power-production technician. In the 4½ years I've been in service I've been to

three technical schools for training in power production and distribution. I expect to be discharged later this year, and want to know if I can get a job with

NOW YOU CAN SOLVE "TOUGH" MATH PROBLEMS LIKE THIS!



$$47892 \times 39421 = ?$$

AS EASY AS $1 + 1 = 2$

GET A BETTER JOB WITH HIGHER PAY, SECURITY IN THIS ATOMIC AGE!

This man is multiplying numbers that should ordinarily produce the answer in about 4 minutes. The answer appears on his blackboard in less than 15 seconds flat! Yet he knows little about math! As a matter of fact he failed arithmetic in school. Read on to discover the fantastic new method that even a child can learn easily in just a few short hours—at home . . .

Yes, in just hours you can turn into a "math wizard" even though you know little about arithmetic! Surprise your friends with your "E-Z MATH" ability . . . enjoy job security and advancement . . . a better job . . . Increase your self-confidence and prestige—all through amazing new "E-Z MATH".

The world is moving fast these days. In good times and bad the ability to handle mathematical problems in our age of electronics, automation and nuclear science is becoming more and more necessary for promotion on the job and for higher pay. If you don't think you have what it takes—and if you believe that "math" is beyond your power—then you're in for the biggest surprise of your life!

For now you CAN learn to DIVIDE, MULTIPLY, ADD and SUBTRACT figures not only quickly and easily—but also in a FRACTION of the time the average person requires! You can actually solve such tough problems as multiplying a 5-figure number by a 7-figure number in your head without ever touching pencil to paper . . . or dividing 836791 by 284, for example, in exactly 15 seconds—even if you "flunked" math in school!

The secret of success in "math" is NOT laborious study and wearisome practice—but, on the contrary, knowledge of SPECIAL SHORT CUTS, LITTLE-KNOWN METHODS of calculation and arithmetical "tricks" that take the work and gamble out of figuring. These methods—so new and radical that they have not yet been incorporated in our school systems—take but a few hours to learn. Yet they permit you to OUT-THINK and OUT-FIGURE the average high school and college graduate who hasn't had the benefit of these amazing methods! You can even BEAT AN ELECTRIC CALCULATOR in answering many problems!

Figure with SPEED and ACCURACY!

"E-Z MATH" shows you in plain, easy-to-understand language how to cut figuring time in HALF and even in QUARTERS—and at the same time arrive at the correct answer in every case! The methods and short cuts you learn in "E-Z MATH" are fool-proof . . . require almost NO memorization . . . and are so practical that you'll find yourself using these systems virtually every day. You'll become an expert in no time at all. Before you know it—you're ready to move into that important job you've always wanted . . . to drive ahead and in greater responsibility at higher pay . . . and to amaze, surprise and delight your friends with your new magic powers of mental arithmetic! Yes, "math" will open up new opportunities for you, since the person with "math" know-how can just about "write his own ticket."

Sharpen Your Brain Power— with Short-Cut "E-Z MATH"!

Imagine being asked to divide 38634 by $89\frac{1}{2}$ —and rattling off the answer absolutely correctly in 7 seconds! Or—multiplying 369.34 by 982.7 and coming up with the correct result in 11 seconds! Or adding 29 numbers each with 6 digits—and supplying the right total every time! People will GASP at your fabulous lightning-quick mind. You'll be able to JUGGLE numbers . . . do STUNNING TRICKS . . . amaze your friends and boss—and be a "master mind!"

With a knowledge of "E-Z MATH" you no longer need be puzzled by such every-day figuring as computing interest charges on installment purchases . . . division, multiplication and addition of fractions . . . adding long rows of numbers with 100% accuracy . . . adding and subtracting fractions from whole numbers—plus many, many other practical and valuable pointers you will use daily to your advantage. The few hours you spend with this course will really pay off. Numbers are the basic instrument of all scientific and technical work. The man or woman who can use "math" is rewarded, recognized quickly, moves ahead in his job faster and more surely!

Order Today on No-Risk Free Home Trial!

Send for "E-Z MATH" today on our no-risk money-back guarantee: use the book for 30 days . . . prove to your own satisfaction how far a knowledge of "E-Z MATH" can advance you in business and social life. If you don't agree that this is the best investment you've ever made . . . if your family and friends aren't AMAZED by your new ability—return the book for full and prompt refund.

"My 10-year old had nearly always failed arithmetic with old-method arithmetic. Then he found my copy of 'E-Z MATH'. Now in less time than you can put the numbers on a blackboard, he can multiply 8391726547 by 12. It's amazing and incredibly easy. I use it myself on my job and my wife uses it to check grocery lists."

"You have a unique new teaching approach for which I compliment you. It's the best I have ever seen. Pupils' marks seem to be climbing as a result. Should help in any job. Excellent for home tutoring use."

—SCHOOL PRINCIPAL
"Thank you! Thank you! Thank you! All our children are using your system too, and it is terrific. My husband and I are using it—and it works! My husband has already received a job advancement with tremendous boost in pay. Best investment we have ever made!"

—HOUSEWIFE

CAN YOU SOLVE THESE EVERY-DAY BUSINESS AND SOCIAL ARITHMETIC PROBLEMS IN THE TIME ALLOWED? YOU CAN DO THEM EASILY EVEN WHEN BLINDFOLDED—AFTER YOU'VE READ "E-Z MATH"!



Blindfold yourself and have someone call the following numbers to you as you add them:

- 739
- 463
- 906
- 785
- 642

(Solve in 6 seconds) ?

$$\frac{9864372}{8146} = ? \quad (\text{Solve in 9 seconds})$$

$$\frac{4}{7} \times \frac{9}{4} = ? \quad (\text{Solve in 4 seconds})$$

$1\frac{3}{4}\%$ interest per month amounts to what percentage yearly? (Solve in 4 seconds)

$$367 \times 75 = ? \quad (\text{Solve in 3 seconds})$$

WHAT IS "E-Z MATH"?

"E-Z MATH" is based on an amazing new method of working with numbers—easier to learn and remarkably faster and more accurate than you ever dreamed possible when you took math in school. You'll be shown the newest way of reading numbers—just as though they were words—and of adding and subtracting them almost at a glance—INSTANTLY! You'll be shown a unique new technique for adding hundreds and even thousands of numbers without ever making a mistake . . . yet you'll never add higher than eleven! Yes, from now on you'll whiz through all figuring problems without wasting your valuable time—through income tax, checking grocery lists, homework—as fast as a calculator. You'll never again dislike or avoid numbers—you'll actually ENJOY using them to get ahead in business!

WHAT THEY SAY:

"My employee, Joe Malone, asked for a better job. I recommended he read 'E-Z MATH'. Now that he can do 'tough' problems easily, I've promoted him to head of his department with a \$35. weekly increase in pay. I now suggest all employees read 'E-Z MATH' if they want to get ahead in their jobs."

Business Executive

MAIL NO-RISK FREE HOME-TRIAL COUPON NOW!

E-Z MATH PROGRAM DEPT. R-74
285 Market St., Newark, NEW JERSEY

OK! Prove to me that "E-Z MATH" can bring me higher pay, prestige and social advancement! Rush book to me postpaid in plain wrapper for 30-day free examination and use. If I don't agree with everything you say about "E-Z MATH"—I may return book for prompt refund. I am enclosing \$2.98 as payment in full.

NAME AGE.....
(Please Print)

ADDRESS

CITY ZONE..... STATE.....

E-Z MATH PROGRAM
© Entire contents copyright 1963

DEPT. R-74 285 Market ST.
Newark, NEW JERSEY

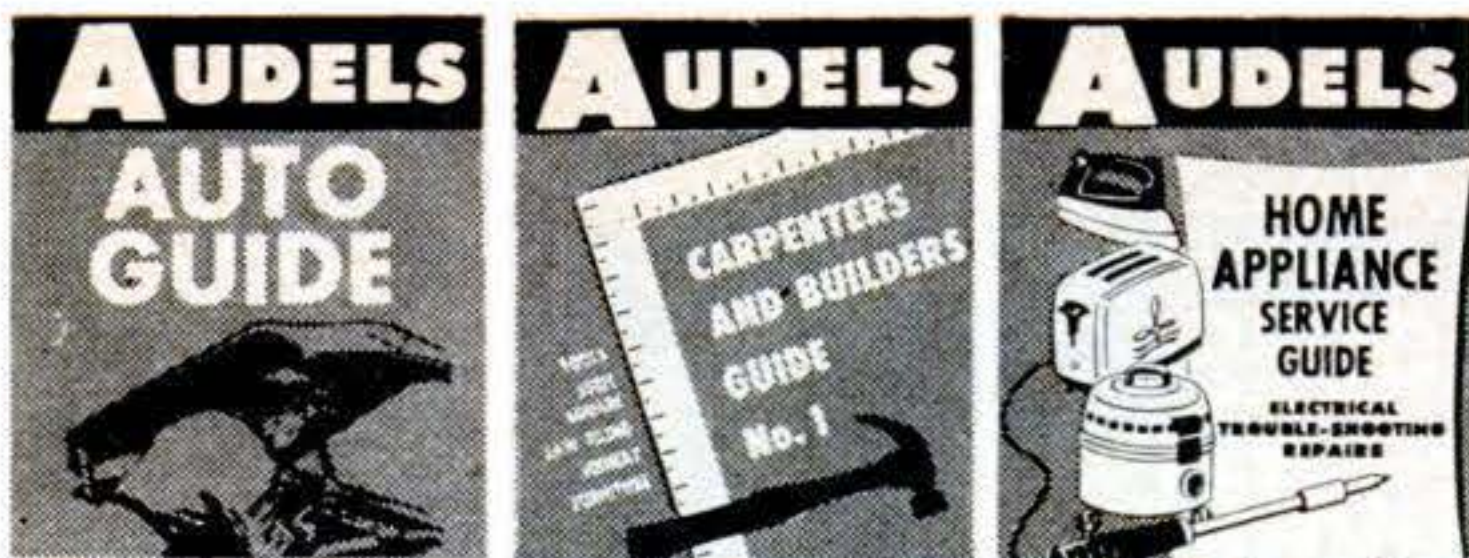

Ready guide for mechanics, stdnts. & car owners. Theory, construction and servicing of modern cars. Illus. 1132 Pgs. \$6.00
Circle No. 1 In COUPON

Four all-inclusive vols. Modern construction for carpenters, builders, and all woodworkers. 3700 Ill. 1600 Pgs. Set \$9
Circle No. 8 In COUPON

How to fix elec. refrigerators, washers, ranges, toasters & all other gas & elec. appliances. 500 Illus. 864 Pgs. \$6.00
Circle No. 2 In COUPON

- | | | |
|--------|--|------|
| No. 11 | MATHEMATICS MADE EASY. 672 Pages | 4.00 |
| No. 14 | REFRIGERATION & AIR CONDITIONING. 1360 Pages | 6.00 |
| No. 26 | MASONS & BUILDERS GUIDES. 4 Book Set | 9.00 |
| No. 43 | DO-IT-YOURSELF ENCYCLOPEDIA. 2 Book Set | 8.95 |
| No. 44 | NEW MECHANICAL DICTIONARY. 712 Pages | 6.95 |
| No. 48 | GAS ENGINE MANUAL. 480 Pages | 4.00 |
| No. 49 | OUTBOARD MOTORS & BOATING GUIDE. 400 Pages | 4.00 |

7-DAY FREE EXAMINATION

SEND NO MONEY—Pay the postman nothing! We'll send you any of the Audel Guides for FREE examination. If you decide to keep the books you pay for them under our easy-pay plan of only \$2 a month.

HERE IS ALL YOU DO

IT'S EASY TO ORDER: In the No-Risk Mail Order Coupon below draw a circle around the number of Guides you want. We will send them to you at once. If you are not completely satisfied, return the books to us.

MAIL THIS COUPON TODAY!

THEO. AUDEL & CO. — Self Improvement Publishers Since 1879
49 W. 23rd Street, New York 10, N.Y.

S7

Please mail me for 7 days' FREE EXAMINATION the books I have circled below. I agree to mail \$2 in 7 days on each book or set ordered, and to further mail \$2 a month on each book or set ordered until I have paid the purchase price, plus shipping costs. If I am not completely satisfied with my Audel Guides I may return them.

NAME _____

ADDRESS _____

EMPLOYED BY _____

1 2 8 11 14
26 43 44 48 49

Check Here for Free Complete Catalog

SAVE SHIPPING COSTS! Check here if you enclose complete payment with order. We pay postage charges. You have same return privilege.

12-TRANSISTOR 2-WAY WALKIE TALKIE

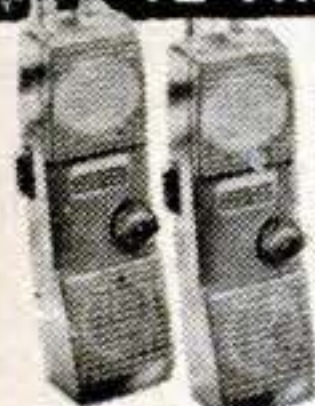

Superb citizens band performance. Lightweight. Model HE-100L features squelch and separate microphone and speaker. No tests or license required. Crystal receive and transmit. With leather case, earphone, telescoping antenna, batteries and crystals. Send \$39.95 for one, or 2 for \$78.88 plus \$1.50 postage. (we refund excess).

Lafayette Radio, Dept. KG-3 P.O. BOX 88, Syosset L.I., N.Y.

B11

WANT TO BE A LOCAL BRIKCRETE* MANUFACTURER?

*Guaranteed to Contain No Clay

High income can be earned operating a Brikcrete plant, because Brikcrete — world's most modern masonry — gives more value for less cost to building owners without sacrifice of profits. Huge savings by local production makes possible low prices and high income potentials.

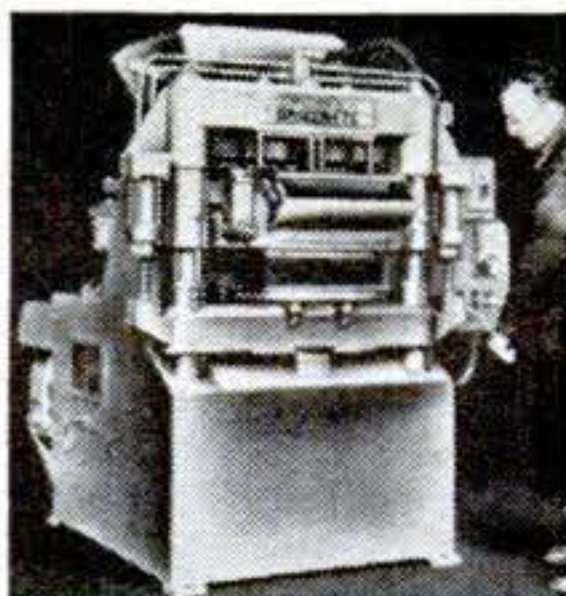

Choice Territories Open

Broad markets are waiting because Brikcrete is popular for every type of residential, commercial and industrial construction. Ultra modern in design, size,

proportion. Cost less than lumber. Wide color range. Combines all the features that make for large consumer acceptance. More local plants are needed. Exclusive privileges in franchise-protected territories. Mark-up averages 100% on basic cost. Machine available on long-term payments. Write for Brikcrete Book No. 2 and tentative reservation of territory.

W. E. Dunn Mfg. Co. 422 W. 25th, Holland, Mich.

a power company doing this kind of work, without a degree in engineering."
—T.J.D., Moses Lake, Wash.

I think your chances are good. Private industry recognizes the value of technical training and experience in the armed forces. Start writing letters of application now. Your unit education officer might help.

But don't overlook the fact that your service training can be the beginning of your education toward an engineering degree, if you want.

"One of our students is interested in gunsmithing. Do you know of any schools that offer courses in this field?"—R.E.N., Gunnallen State Schools, Alaska.

Lassen Junior College (1110 Main St., Susanville, Calif.) and Trinidad State Junior College (600 Prospect St., Trinidad, Colo.), both offer two-year programs.

And there are these possibilities, too:

Colorado School of Trades, Inc., 8797 W. Colfax Ave., Denver.

Pennsylvania Gunsmith School, 1000 Western Ave., Philadelphia.

Oregon Tech. Institute, Klamath Falls.

"I would like to know what corporations offer college chemistry scholarships."—J.H., Fort Worth.

These directories carry listings:

The New American Guide to Scholarships, Fellowships, and Loans, by John Bradley, New American Library of World Literature, NYC (75 cents).

Scholarship Guide, by Clarence E. Lovejoy and Theodore S. Jones, Simon and Schuster, NYC (\$1.95).

For a broad look at the problem, read chapter 20, "How to Pay for Your College Education," in Abraham H. Lass's *How to Prepare for College* (Pocket Books, NYC, 95 cents). Your high-school counselor should also be a good source of information.

"I would like to study auto mechanics by correspondence. How does the pay and demand compare with those for machinists?"—J.A.W., Port Huron, Mich.

Correspondence study in automotive work is available through the following members of the National Home Study Council:

American School, Drexel Avenue at 58 St., Chicago 36.

American Technical Society, 850 E. 58 St., Chicago 37.

\$1,000 DOWN PUTS YOU IN BUSINESS

balance on easy terms

EARN
\$10,000

A YEAR OR MORE

Own a

Tastee-Freez
Drive-in

Year 'round business. Sell Tastee-Freez soft ice cream products, hot dogs, hamburgers, french fries, shakes. No experience needed. We train you. Information FREE.



TASTEE-FREEZ, 4311 W. Belmont, Chicago 41, dept. PS

HYDRAULIC JACK REPAIRS



Earn While You Learn at Home

Millions of jacks in gas and auto-service stations, truckers, body-shops, riggers, factories, farms need servicing. We show you HOW — easy step by step directions — what tools to use. EARN UP TO \$5 an hour, in spare time, in your own basement or garage. Start your own business NOW.

Write for folder No. PS-7 and free bonus offer.

INSTITUTE OF HYDRAULIC JACK REPAIR

P. O. BOX 50 • BLOOMFIELD, N.J.

A Correspondence School Licensed by N. J. Bd of Ed

HELP WANTED — SPARE TIME

SENSATIONAL NEW LONGER-BURNING LIGHT BULB. Amazing Free Replacement Guarantee—never again buy light bulbs. No competition. Multi-million dollar market yours alone. Make small fortune even spare time. Incredibly quick sales. Free sales kit. MERLITE (Bulb Div.), 114 E. 32nd, Dept. C-16j, New York 16, N.Y.

300 POWER.....



Complete
Telescope Lens Kit

only **\$3.98**
postpaid

Conquer Space. Explore the Universe. Planets, Moon craters, New Stars, etc. Complete Lens Kit consists of 80 inch focal length ground and polished objective lens, eyepiece lenses for 50 POWER, 100 POWER, 150 POWER, 200 POWER, 250 POWER, 300 POWER, and all necessary lens fittings. Easy to make from simple step by step instructions. (Tripod and mount not included.) Money back guarantee.

BUSSE SALES CO., Hartford, Conn., Dept. PS-98

MAKE UP TO \$5.00 AN HOUR AT HOME

Let Me Prove It To You FREE!

I'll show you how Plastic Sealing and Laminating at home, spare time, can give you as much as \$5.00 each hour you operate. Table-top machine sets up anywhere. Easy. Fun. No experience needed. We furnish everything. We'll even help finance you. No house-to-house selling. Orders come by mail. Write for facts FREE. No salesman will call.



WARNER ELECTRIC, 1512 Jarvis, Dept. L-3-H Chicago 26, Ill.

Buy and Hold

U. S. Savings Bonds

GET INTO ELECTRONICS

V.T.I. training leads to success as technicians, field engineers, specialists in communications, guided missiles, computers, radar, automation. Basic & advanced courses. Electronic Engineering Technology, an ECPD accredited Technical Institute curriculum. Assoc. degree in 29 mos. B.S. obtainable. G.I. approved. Start Sept., Feb. Dorms, campus. H.S. graduate or equivalent. Catalog.

VALPARAISO TECHNICAL INSTITUTE
DEPARTMENT S. VALPARAISO, INDIANA

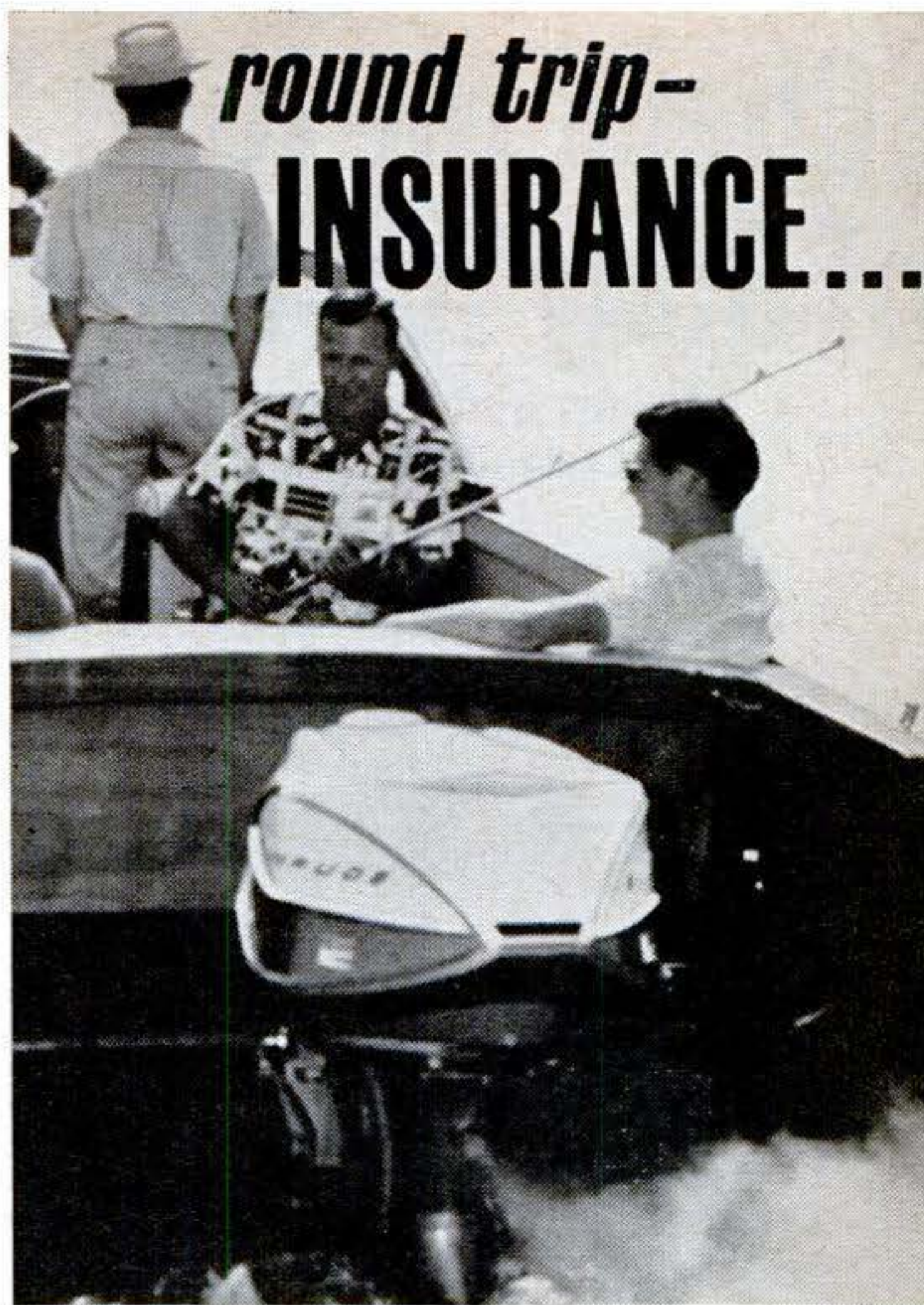

...it's an old EVINRUDE POLICY

When you're out where sea meets sky... it's good to know that the motor that powers your boat:

Starts with a pull cord as well as a battery. Has an automatic choke that's backed up by a manual choke.

Has a waterproof ignition system, even though you couldn't get a drop of water inside with a fire hose.

Just to make doubly sure... we back up our back-up systems with a new 2-year warranty.

We like to see our customers coming back — smiling!



EVINRUDE
FIRST IN OUTBOARDS

EVINRUDE MOTORS, 4070 North 27th Street
Milwaukee 16, Wis., Division of Outboard Marine Corp.
Please send free 24-page catalog.

Name.....

Address.....

City.....Zone....State.....

Check the Kind of Body You Want

Charles Atlas

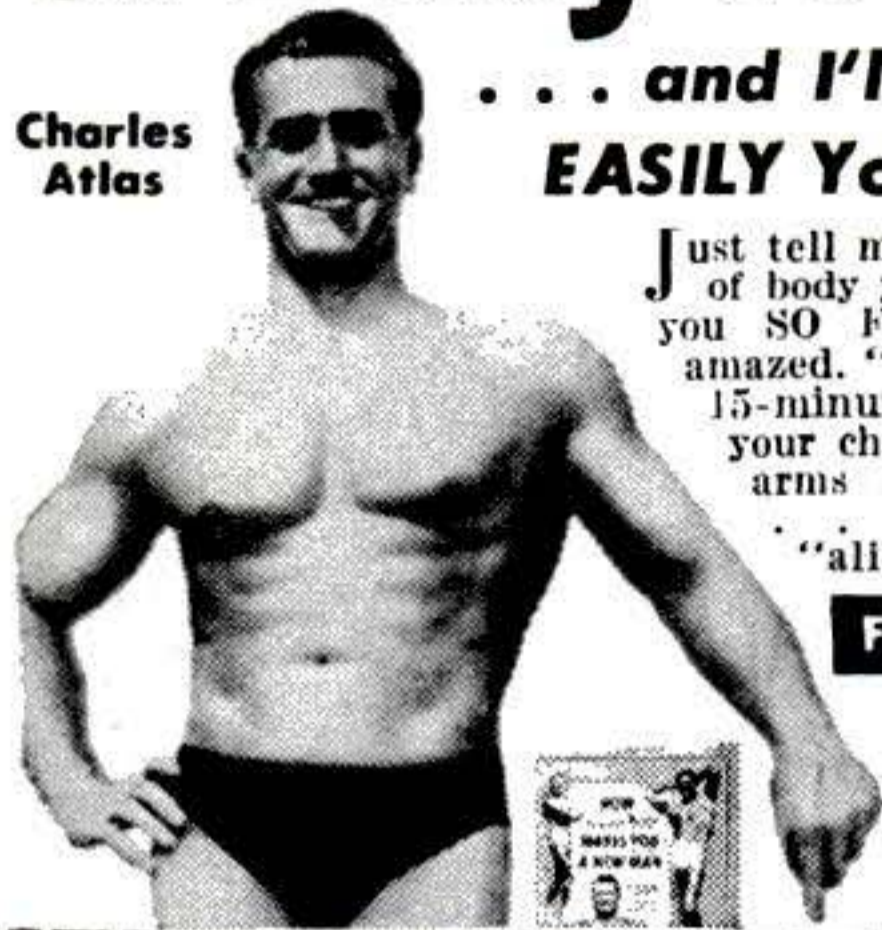

... and I'll Show You How **EASILY You Can Have It!**

Just tell me, in coupon below, the kind of body you want—and I'll give it to you SO FAST your friends will be amazed. "Dynamic Tension," my easy, 15-minutes-a-day method, will make your chest and shoulders bulge... arms and legs surge with power... your whole body feel "alive!"

FREE BOOK Learn how I became "World's Most Perfectly Developed Man" — Mail coupon! CHARLES ATLAS, Dept. 17, 115 East 23rd Street, New York City 10, N. Y.

CHARLES ATLAS, Dept. 17
115 East 23rd St., New York 10, N. Y.

Dear Charles Atlas: Here's the Kind of Body I want:

(Check as many as you like)

- | | |
|--|--|
| <input type="checkbox"/> Broader Chest, Shoulders | <input type="checkbox"/> Powerful Arms, Legs, Grip |
| <input type="checkbox"/> More weight—Solid—
in the Right Places | <input type="checkbox"/> Slimmer Waist, Hips |
| | <input type="checkbox"/> Better Sleep, More Energy |

Send me absolutely FREE a copy of your famous book showing how "Dynamic Tension" can make me a new man—32 pages, crammed with photographs, answers to vital questions, and valuable advice. No obligation.

NAME AGE.....
(Please print or write plainly)

ADDRESS

CITY ZONE..... STATE.....

In England send to: Charles Atlas, Chitty St., London, W.1



Play Right Away!

Piano, Guitar, ANY Instrument

PLAY real tunes on ANY instrument right from the start—even if you don't know a single note now! Amazing course lets you teach yourself at home, in spare time. No boring exercises. You play real notes. Make rapid progress. Easy as A-B-C. Low cost. Over 1,000,000 students.



FREE BOOK describes this famous course. See how easy learning music can be. Write TODAY: **U.S. SCHOOL OF MUSIC, Studio A157, Port Washington, L.I., N.Y. (Est. 1898)** Licensed by N.Y. State Educa. Dept. Tear out as reminder.

Works in Seconds!



Loosens Rusted Bolts
nuts, screws, "frozen" parts!

LIQUID WRENCH
SUPER-PENETRANT

BONUS USE: Add to crankcase to quiet noisy valve lifters... remove gum, sludge deposits!

THEN ADD ...

MOTOR-MEDIC
EXTRA LUBRICATION...
SMOOTHER PERFORMANCE



Both at leading dealers everywhere!

Commercial Trades Institute, 1400 W. Greenleaf Ave., Chicago 26.

International Correspondence Schools, Scranton 15, Pa.

LaSalle Extension University, 417 S. Dearborn St., Chicago 5.

National Technical Schools, 4000 S. Figueroa St., Los Angeles 37.

The average hourly pay of skilled automobile mechanics was more than \$2.60 per hour in 1960, according to the U.S. Bureau of Labor Statistics. Hourly wages of machinists varied from \$1.87 to \$3.17.

"I am interested in becoming a claims adjuster for an insurance company. What would I be doing and where can I get the training?"—F.F.F., Farwell, Tex.

Claims adjusters interpret a customer's insurance policy and decide what payments are to be made—if any—in case of a fire or accident or whatever event the policy covers. When necessary, adjusters conduct investigations.

You can get additional background and training information from:

Institute of Life Insurance, 488 Madison Ave., NYC 22,

Life Office Management Assn., 110 E. 42 St., NYC 38.

Insurance Information Institute, 60 John St., NYC 38.

"Where can I get a list of U.S. colleges that issue bachelor's degrees in radio and TV broadcasting?"—G.D., Hicksville, N.Y.

Write the U.S. Office of Education in Washington, D.C., and ask for the (free) directory of college courses in radio and television by Gertrude G. Broderick.

"I want to learn how to repair electric motors. What schools offer such courses?"—A.F., New Haven, Conn.

Examples of schools in New York City offering such work are:

Berk Trade School, 384 Atlantic Ave., Brooklyn.

New York Technical Institute, 500 Pacific St., Brooklyn.

Mechanics Institute, 20 W. 44 St.

.....
Send your questions on careers and technical training to:

Getting Ahead Editor, POPULAR SCIENCE
355 Lexington Ave., New York 17, N.Y.

Not every question may be used. Questions cannot be answered by individual letters.

BARGAIN FROM LONDON

**102 DIFFERENT BRITISH COLONIALS
+ 23 DIFFERENT GT. BRITAIN - ALL 24¢**

Valuable "Export Parcel" includes Gt. Britain 1841 Queen Victoria *imporforate* (3rd stamp ever issued). Range of G.B. issues of 6 monarchs with high value 2/6, 5/- Queen Elizabeth. PLUS 102 different British Colonials. World War I "Tax"; 60 yr. old Cape Good Hope, many others. Total 125 all different stamps; all G.B. & Colonies. Regularly \$1.54-Export price only 24¢ to introduce overseas approvals.



FREE if you act now-42 stamp-size portraits of Kings & Queens of England since William the Conqueror. **IMPORT DIRECT. SAVE 20-60%.** Buy direct-where dealers buy. Exciting selections, low prices the easy 14-day approval way. Satisfaction guaranteed.

Send 24¢ in unused U.S. Stamps (no coins). Ask for Lot XA-2. **Broadway Approvals Ltd., 50 Denmark Hill, London S.E. 5, England**

REAL ESTATE BE A BROKER

PAY BIG! SEND FOR FREE, BIG, ILLUSTRATED CATALOG NOW! Graduates report making substantial incomes. Start and run your own business quickly. Men, women of all ages, learn easily. Course covers Sales, Property Management, Appraising, Loans, Mortgages, and related subjects. **STUDY AT HOME** or in classrooms in leading cities. Diploma awarded. Write TODAY for free book! No obligation.



Approved for World War II and Korean Veterans
WEAVER SCHOOL OF REAL ESTATE (Est. 1936)
3521S Broadway Kansas City, Mo.

MAKE MORE MONEY Become a Master UPHOLSTERER!!

MEN & WOMEN ALL AGES!



Make Custom Furniture or Reupholster Chairs, Divans, Footstools for **BIG MONEY** in spare or full time. Make Slip Covers, Drapes, Cushions. We give you **EVERYTHING**: 1) Home Training covering **ALL PHASES**, 2) **All TOOLS** to practice **AT ONCE**, 3) Practical Job Projects and **FREE** supplies, materials to build \$300 worth of furniture-yours to keep or sell! Write **TODAY** for Big **FREE** Upholstery Career Kit: 32 pg. Book; Workshop Project; Business Plan Guide. **ALL THREE FREE!** **MODERN UPHOLSTERY INSTITUTE, DEPT. U-11, FALLBROOK, CALIFORNIA.**



LAW FREE BOOK THE LAW TRAINED MAN

Write today for a **FREE** copy of illustrated law book, "THE LAW-TRAINED MAN," which shows how to earn the professional Bachelor of Laws (LL.B.) degree through home study of the famous Blackstone Law Course. All necessary books and lessons provided. Moderate cost; convenient monthly terms. Write for **FREE** law training book today.

Blackstone School of Law, 307 N. Michigan Ave. Founded 1890 Dept. 120-B, Chicago 1, Illinois

NEED MONEY? BORROW \$100 to \$1000 BY MAIL

Always have cash when you need it! Personal **BORROW-BY-MAIL** plan provides cash for any reason... on your signature only. Private, entirely by mail. No endorsers, no personal interviews. Terms to fit your budget. Small payments, 24 months to repay. Fast service everywhere. State supervised. Details sent in plain envelope. No obligation. Inquire now.

\$14.76 MONTHLY REPAYS \$250

Amount of Loan	24 Monthly Payments
\$120	\$ 7.09
\$250	\$14.76
\$450	\$25.91
\$650	\$36.14
\$1000	\$53.17

WORLD FINANCE CO. Dept. LW-143
620 Symes Bldg., Denver 2, Colo.

Name _____
Address _____
City _____
Age _____ Occupation _____



Not for Volkswagens

Or any other car that drinks air. But for a car that drinks water, one can of Mac's No. 13 rust inhibitor will keep its cooling system running clear for a whole year. Don't be inhibited. Ask your service station man for Mac's No. 13 today.

MAC'S SUPER GLOSS CO., INC.
Los Angeles 42, Calif., Cincinnati 26, Ohio

GET READY FOR THE SPACE and SCIENCE ERA! SEE SATELLITES, MOON ROCKETS CLOSE-UP



AMAZING SCIENCE BUYS

for FUN, STUDY or PROFIT



See the Stars, Moon, Planets Close Up! 3" ASTRONOMICAL REFLECTING TELESCOPE

SEE AND PHOTOGRAPH SUN'S ECLIPSE JULY 20TH
Be visually safe and use Edmund's Combination Sun Projection Screen and Camera Holder.
Stock No. 70,162-N.....\$9.95 Postpaid

60 to 180 Power—Famous Mt. Palomar Type! An Unusual Buy!
Assembled—Ready to use! You'll see the Rings of Saturn, the fascinating planet, Mars, huge craters on the Moon, Phases of Venus, Star Clusters, Moons of Jupiter in detail. Galaxies! Equatorial mount with lock on both axes. Aluminized and overcoated 3" diameter high-speed f/10 mirror. Telescope comes equipped with a 60X eyepiece and a mounted Barlow Lens, giving you 60 to 180 power. Low-cost accessory eyepiece available for higher powers. An Optical Finder Telescope, always so essential, is also included. Sturdy, hardwood, portable tripod. FREE with Scope:

—Valuable **STAR CHART** plus 272 page "**HANDBOOK OF HEAVENS**" plus "**HOW TO USE YOUR TELESCOPE**" BOOK.
Stock No. 85,050-N\$29.95 Postpaid

4 1/4" Astronomical Reflector Telescope!
255 Power. New Vibration-Free Metal Pedestal Mount.
Stock No. 85,105-N\$79.50 F.O.B.

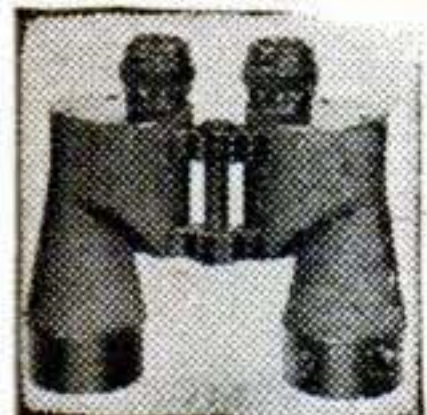

WAR SURPLUS! American-Made! 7x50 BINOCULARS

Big saving! Brand new! Crystal clear viewing—7 power. Every optical element is coated. An excellent night glass—the size recommended for satellite viewing. Individual eye focus. Exit pupil 7 mm. Approx. field at 1,000 yds. is 376 ft. Carrying case included. American 7 x 50's normally cost \$274.50. Our war surplus price saves you real money.

Stock No. 1544-Nonly \$74.80 pstpd. (tax included)
6 x 30 Binoculars—similar to above and a terrific bargain.
Stock No. 963-N\$33.00 pstpd. (tax included)
7 x 35 American Made Binoculars
Stock No. 964-N\$60.50 pstpd. (tax included)

'FISH' WITH A WAR SURPLUS MAGNET Go Treasure Hunting On The Bottom

Great idea! Fascinating fun and sometimes tremendously profitable! Tie a line to our 5-lb. Magnet—drop it overboard in bay, river, lake or ocean. Troll it along the bottom—your "treasure" haul can be outboard motors, anchors, fishing tackle, all kinds of metal valuables. 5-lb. Magnet is war surplus—Alnico V Type—Gov't. Cost, \$50. Lifts over 125 lbs. on land—much greater weights under water. Order now and try this new sport.



Stock No. 70,571-N 5 lb. Magnet\$12.50 Postpaid
Stock No. 70,570-N 3 1/2 lb. Lifts 40 lbs.\$8.75 Postpaid
Stock No. 70,572-N 7 1/2 lb. Lifts 150 lbs.\$18.75 Ppd.
Stock No. 85,152-N 15 lb. size, lifts 250 lbs.\$33.60 FOB

SOLAR CELL SET HARNESSES POWER OF THE SUN

Conduct spell-binding experiments, experience endless fascination in converting sunlight into electricity to power small motors, amplifiers, make light meters, densitometers, burglar alarms, etc. Used experimentally to drive cars, power boats. Low price set includes SILICON SOLAR CELL and SUN BATTERY (produces .2 to .45V 10-16 milliamperes), SELENIUM SOLAR PHOTOCELL (lower power) and 112-page Handbook of Projects, demonstrations, experiments, etc. Also incl. CADMIUM SULPHIDE PHOTO CONDUCTIVE CELL (light sensitive resistor) which generates electricity to turn lights on in the evening, open doors, count traffic, etc., etc.
Stock No. 60,291-N.....\$7.95 Postpaid

MINIATURE WATER PUMP
Wonderful for experiments, miniature waterfalls, fountains, HO gage railroad backdrops, etc. Tiny (2 1/2" x 1 1/4") electric motor and pump ideal for hobbyists, labs, schools. Pumps continuous flow of water at rate of one pint per minute at a 12" head. With 2 D Batteries in series will pump to 24" high. Runs 48 hrs. on battery. Works in either direction. Self-priming. Stock No. 50,345-N\$2.25 Postpaid

MAIL COUPON for FREE CATALOG "N"

NEW! 1000's of Bargains—164 Pages
EDMUND SCIENTIFIC CO., Barrington, N.J.
Please rush Free Giant Catalog-N.

Name.....
Address.....
City.....Zone.....State.....



Exciting New Color Experiments . . . FABULOUS DIFFRACTION GRATING REPLICA KIT

See Nov. "Popular Science" Article Featuring This Wonder Material in Christmas Lighting Projects.



This amazing material breaks up white light into deep, rich hues. Sparkles with all the color of the spectrum. Comes alive with the flashing brilliance of rainbow magic. Now you can create spectacular color-coordinated effects and decorations—inside & out—convert old, unwanted earrings, cufflinks, pendants, etc., into beautiful, iridescent pieces of jewelry. Real conversation piece, too. Kit contains 8 1/2" x 5 1/2" sheets of see-through (transmission) and reflecting type grating, mounted circular grating, unmounted transmission and reflecting types, round pieces of mounting, double-faced mounting tape, stereo viewer, and Edmund Diff. Grating Idea Book.

Stock No. 70,563-N\$5.00 Postpaid
TRANSMISSION TYPE (you see through it)
Stock No. 40,267-N 8" x 11" sheet\$1.50 Pstpd.
Stock No. 50,180-N 8" x 6 ft. sheet 5.95 Pstpd.
REFLECTING TYPE (reflects spectrum)
Stock No. 50,201-N 8" x 11" sheet\$ 2.50 Pstpd.
Stock No. 50,203-N 8" x 6 ft. sheet 10.95 Pstpd.

WOODEN SOLID PUZZLES

12 Different puzzles that will stimulate your ability to think and reason. Here is a fascinating assortment of wood puzzles that will provide hours of pleasure. Twelve different puzzles, animals and geometric forms to take apart and reassemble, give a chance for all the family, young or old, to test skill, patience, and, best of all to stimulate ability to think and reason while having lots of fun. Order yours now.

Stock No. 70,205-N.....\$3.00 Postpaid



OPAQUE PROJECTOR

Projects illustrations up to 3" x 3 1/2" and enlarges them to 35" x 30" if screen is 6 1/2 ft. from projector; larger pictures if screen is further away. No film or negatives needed. Projects charts, diagrams, pictures, photos, lettering in full color or black-and-white. Operates on 115 volt, A.C. current, 6-ft. extension cord and plug included. Operates on 60 watt bulb, not included. Size 12" x 8" x 4 1/2" wide. Weight 1 lb., 2 oz. Plastic case with built-in handle.
Stock No. 70,199-N\$7.95 Postpaid

BUILD A SOLAR ENERGY FURNACE

A fascinating new field. Build your own Solar Furnace for experimentation—many practical uses. Easy! Inexpensive! Use scrapwood! We furnish instructions. This sun powered furnace will generate terrific heat—2000° to 3000°. Fuses enamel to metal. Sets paper aflame in seconds. Use our Fresnel Lens—14" diameter . . . f.l. 14".

Stock No. 70,130-N.....Fresnel Lens.....\$6.00 Postpaid
11" SQ. FRESNEL LENS F.L. 19" SLIGHT SECOND
Stock No. 70,533-N\$4.75 Ppd.

ASTRO-COMPASS AND TRANSIT

War surplus! Astro Compass alone cost Govt. \$75. We have added a Sighting Level to improve versatility. Hundreds of uses in carpentry, brick laying, foundation work, grading, irrigation or drainage. Much below cost of ordinary surveying instruments. Ideal for do-it-yourselfers. 10 1/4" high, 6" long, 4" wide. Adjustable leveling platform—2 spirit levels for aligning—also spirit level in sighting attachment. A tremendous bargain.
Stock No. 70,267-N\$19.95 Postpaid

NOW... AT A FABULOUS SAVING... MAKE A BIG BERTHA WITH WAR-SURPLUS LENSES



Aero Ektars and Tessars at Less than 5% of Original Cost

Sept. '62 feature article in "Popular Science" tells how you can make a fabulous Big Bertha telephoto lens and camera at sensational saving. Originally sold to the Gov't. for over \$1,000, F/6, 24 in. Focal Length Lenses with 23" Lens Cones now sell for \$32.50 new, \$25.00 used. Also for Richest Field Wide-Angle, Low-Power (12X to 48X) Telescopes,

Opaque Projectors, Camera Obscuras, Copying Cameras, or 48-power Table Top Telescopes. These K22 aerial camera units easily removed from cones . . . Focal plane 10" outside of cone. Clear front lens diam.—4", rear 3 5/8". Wt. of cone—25 lbs. Diaphragm F/6 to F/22 (adjustable from 1" to 3 1/2" by flexible shaft). Picture size 9" x 9". Lens elements—4 (2 to brass cell). Carrying case wt. 26 lbs. Shutter not included. Shipping wt.—51 lbs.

Stock No. 85,059-N Used—Was \$39.50 . . . now \$25.00 f.o.b. Utah
Stock No. 85,060-N New—Was \$59.50 . . . now \$32.50 f.o.b. Utah
Above lenses in cells—out of cone and diaphragm
Stock No. 70,190-N\$22.50 Postpaid.

ORDER BY STOCK NUMBER. SEND CHECK OR MONEY ORDER. SATISFACTION GUARANTEED.
EDMUND SCIENTIFIC CO., BARRINGTON, N. J.

Science newsfront

BY WALLACE CLOUD

A monthly report: What's going on in science and why it's important to you

SPACE

Rendezvous in August?

Will the Russians land a TV camera on the moon next month? Or will they top last August's twin-orbit space spectacular by joining two spaceships in orbit? We think the rendezvous is more likely.

The point is that the Russian space program is becoming predictable (see chart). For the past three years, major launches have been staged in April and August.

The chart shows some inconsistencies in the pattern, to be sure, but some of them become more logical with a little interpretation. A useful assumption is that Russian rocketry, in its first years, was not as precise as it is now. Perhaps Sputniks III and IV were scheduled for April launches, but slipped to May; Luniks II and III may have been scheduled for August, 1959, but slipped to September and October.

The increased activity in the months before April, 1961, is easy to explain. It is

known that Sputniks VI, IX, and X were unmanned Vostok test vehicles (as were Sputniks IV and V); the Russians were working hard to meet their target date of April for the first manned launch.

Mars and Venus flights can't be fitted into a schedule—their launch windows must be based on the proximity of the planets. The Cosmos series of "scientific satellites" with launches almost every month since March, 1962, seems to be independent of the pattern. Even so, three Cosmos satellites were launched in April, 1962—more than in any other month.

Why should such a pattern exist? We don't know, but it probably has to do with the logistics of Soviet rocketry. Whatever the reasons, the case for August as Russian Space Month is particularly strong.

SPACE TECHNOLOGY

Edible spacecraft

Pondering the problem of the hungry astronaut, Dr. Sydney Schwarz of Grumman Aircraft had an idea. He went to the

CONTINUED

	1957	1958	1959	1960	1961	1962	1963
JAN			1/2 Lunik I				Cosmos series
FEB					2/4 Sputnik VII 2/12 Sputnik VIII (Venus probe)		⋮
MAR					3/9 Sputnik IX (Vostok test) 3/25 Sputnik X (Vostok test)	Cosmos series starts	⋮
APR		↓		↓	4/12 Vostok I	(3 Cosmos launches)	4/2 Lunik IV
MAY		5/15 Sputnik III		5/15 Sputnik IV (Vostok test)		⋮	
JUNE						⋮	
JULY						⋮	
AUG			↓	8/19 Sputnik V (Vostok test)	8/6 Vostok II	8/11 Vostok III 8/12 Vostok IV	?
SEPT			9/12 Lunik II			⋮	
OCT	10/4 Sputnik I		10/4 Lunik III	(2 Mars failures)		⋮	
NOV	11/3 Sputnik II					11/1 Mars I	
DEC				12/1 Sputnik VI (Vostok test)		↓	



THIS VALUABLE
BOOKLET GIVEN

Free

TO PEOPLE WHO
WANT TO EARN
MONEY IN AN

Accounting Career

LaSalle will train you in your spare time

The demand for trained Accountants far exceeds the supply. Salaries are at an all-time high. Accounting-trained men move up to big positions in business. LaSalle's distinguished faculty prepares you at home, in your spare time—at remarkably low cost. You work with actual Accounting problems, acquire real experience. Thorough, practical, enjoyable—and quick in results. Many students report up to 56% pay increases *even before completing training*. Mail coupon for free booklet and sample lesson.

LA SALLE EXTENSION UNIVERSITY
A Correspondence Institution

417 S. Dearborn, Dept. 19-092, Chicago 5, Ill.

Please send free booklet "Opportunities in Accounting" and interesting sample lesson.

Name..... Age.....
Address.....
City..... Zone.....
County..... State.....

104

TRY NEW
KAYWOODIE
PIPE TOBACCO
YOU'LL LIKE IT
Send for free sample and pipe booklet, Kaywoodie Pipes, N. Y. 22

20 COURSE HOME STUDY PROGRAM
KARATE!
JUDO BOXING! MUSCLEBUILDING! YOGA!
STRONGMAN STUNTS! STRENGTH & ENDURANCE! HANDBALANCING! ETC.

YOU GET ALL THESE! ●20 illustrated KARATE blows ●SAVATE foot fighting ●Secret NERVE CENTER and ANATOMY charts ●20 lethal JUDO throws ●20 terrific STRONGMAN STUNTS ●Complete MUSCLE-BUILDING program ●Ancient YOGA secrets ●HANDBALANCING stunts ●Complete BOXING program ●Secrets of ENDURANCE ●TENSION-FLEX COURSE ●FITNESS EXERCISES ●KEEP FIT PROGRAM ●K MAN DUMMY. No C.O.D.'s. Canadians 75c. You Get The LOT.....

50¢

FREE
K-MAN
KARATE
PRACTICE
DUMMY

HOME GYM & EQUIPMENT PLANS
Build gym equipment: Vault Horse, Rowing Machine, Boxing Ring etc. Convert basement, garage to gym. ONLY 50c with courses. TOTAL \$1.00.
OXFORD STUDIO, 44 P31 Bromfield, Boston, Mass.
NAME (print) | 50c PROGRAM
Address | \$1.00 with Gym
City State.....

Science newsfront continued

supermarket and spent \$4.90 on flour, corn starch, powdered milk, powdered bananas, and hominy grits. He mixed them together and baked the mess for nine minutes in a heated hydraulic press. Out came a material that resembles Masonite.

It can be used, he thinks, for various relatively unimportant parts of spacecraft—partitions, control knobs, lunar landing gear. At some suitable time during a trip, astronauts break off chunks and soak them in water (4½ hours at room temperature). The result tastes like banana-flavored cereal. "With sugar and cream, it's delicious," says Schwarz. "But then, anything is."

Yllarutan. British scientists, investigating the difference between explosions and implosions, have announced that an implosion goes "gnab!"

Side effect. Several women turned from brunette to blonde after taking a muscle relaxant, mephenisin carbamate, for three months, under the direction of Dr. John D. Spillane, a physician of Cardiff, Wales. (However, one who stopped taking the drug turned back to brunette in three months.) The light golden tint was "very pleasing," mused Dr. Spillane.

PUBLIC HEALTH

Law against suds

It will be illegal to use, sell, or possess detergents in Miami after Jan. 1, 1965. The Dade County Board of Commissioners is the first law-making body to take such drastic action on the suds problem that has been foaming up all over the country.

Legislatures of California, Connecticut, Maryland, Nebraska, and Wisconsin are considering such laws, and the Senate Public Works Committee is studying a bill that would set standards of "decomposability" for cleansing products.

The villain is alkyl benzene sulfonate, the active ingredient of most of the detergent powders today. It's too tough to be decomposed by sewage bacteria like old-fashioned soaps. Instead, it keeps on foaming, and has been getting into water supplies all over the country. Some chemists say it's harmless, but the average person hasn't developed a taste for a glass of wa-

BE THE MAN IN DEMAND

Train for a high-paying job in one of these 4 major fields



Trained technicians are higher paid . . . better skilled . . . confident of success.

ELECTRONICS

TELEVISION AND RADIO

Course covers TV-radio servicing, communications, automation circuitry, microwaves, ind. electronics. One Master Course; low cost. Includes TV set, radio, multimeter.



AUTO MECHANICS

AND DIESEL

All-around mechanic training. Covers tune-up, automatic transmissions, trucks and busses, stationary gas and diesel engines. Includes socket set, analyzer, tools.



AIR CONDITIONING

REFRIGERATION ELECTRICAL APPLIANCES

50 million air conditioners, refrigerators, appliances need fixing every year. Start own business or work with dealer-distributor. Includes tester, gauges, tools.

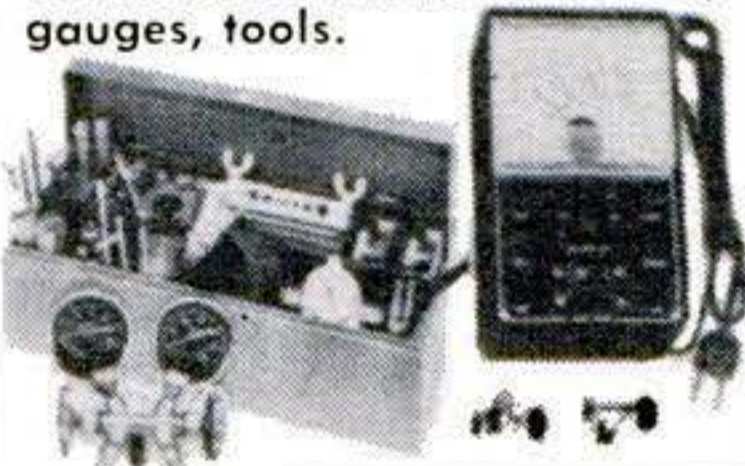

HOME APPLIANCE

TECHNICIAN'S COURSE

Full-time or "spare-time" career. Fix toasters, mixers, irons, washing machines; all appliances. Costs less than \$1.50 a wk. Includes tester, soldering set, tools.



Each of these fields offers big opportunities to N.T.S. trained men. You get everything you need — lessons, manuals, professional kits with tools and instruments for service, repair, all-around use. Study at your own pace; earn money as you learn. You enroll by mail; no salesman means lower cost for you, lower tuition for you.

NATIONAL TECHNICAL SCHOOLS

WORLD-WIDE TRAINING SINCE 1905

4000 So. Figueroa St., Los Angeles 37, Calif.

Accredited Member
National Home Study Council

RESIDENT TRAINING AT LOS ANGELES

If you wish to take your training in our famous Resident School in Los Angeles — the oldest and largest school of its kind in the world — check special box in coupon.

SEND FOR
**FREE BOOK
AND ACTUAL
LESSON IN
FIELD OF YOUR CHOICE**

NO OBLIGATION
NO SALESMAN
WILL CALL

ACTUAL LESSON



CHECK ONE

NATIONAL TECHNICAL SCHOOLS

WORLD-WIDE TRAINING SINCE 1905

National Technical Schools, Dept. C-73
4000 S. Figueroa St., Los Angeles 37, Calif.

Please rush FREE Book and Actual Lesson checked below. No obligation. No salesman will call.

- Electronics — TV — Radio
 Auto-Mechanics & Diesel
 Air Conditioning, Refrigeration & Electrical Appliances
 Home Appliance Technicians Course

Name _____ Age _____

Address _____

City _____ Zone _____ State _____

Check here if interested ONLY in Resident Training at L.A.
High school home study courses also offered. Check for free catalog.

NO JOB WORRIES

PLASTEX INDUSTRY needs manufacturers on small scale for big production of Lamps, Clock Stands, Art Goods, Novelties in Plastic Marble imitation. No Experience necessary. 1/2c material makes regular 10c store sellers. Moulds furnished for fast production. Small investment brings good profit. Big wholesale orders now being placed. Ambitious men have chance for real prosperity and job security. Our NEW FREE booklet will interest and benefit you.

PLASTEX INDUSTRIES, Dept. 2, 3400 Third Ave., New York 56, N. Y.

"Messenger" CB Transceivers...rated BEST in Nation by Electronic Distributor Salesmen*

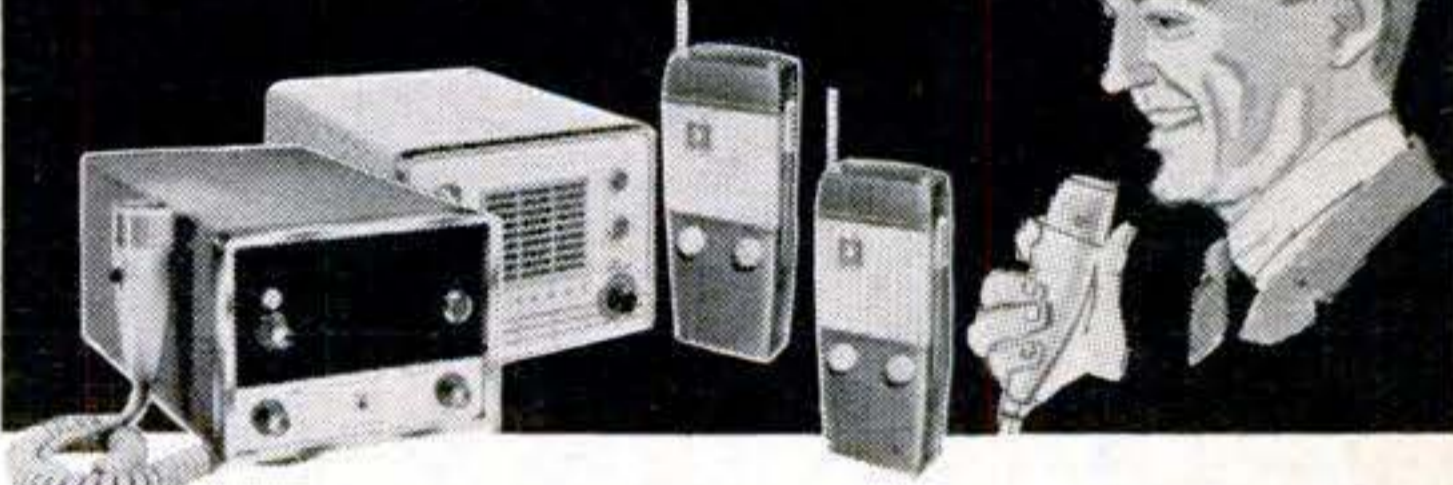

*New impartial survey by leading electronic magazine shows Johnson "Messenger" Transceivers rated "BEST"—BEST BY NEARLY 50% OVER SECOND CHOICE BRAND.

4 feature-packed "Messengers" . . . and Selective Call System outperform everything!

Compact, Hand-Held—100 milliwatt or 1 watt "Personal Messengers". Rugged and reliable—11 transistors, 4 diodes! Twice the sensitivity and 40% more range than similar units with conventional circuitry—more output than similar units with same rated inputs!

Mobile or Base Stations—performance proved Viking "Messenger" and new "Messenger Two". Punches your signal across the miles—high efficiency design makes full use of maximum legal power. Excellent receiver sensitivity and selectivity. Automatic "squench" control—5 or 10 channel coverage—easy to install anywhere!

Tone Alert—37 tone selective call system mutes speakers until one unit calls another—then automatically your stations receive audio note and indicator light flashes "On".



NEW! 4-color BROCHURE—write for your free copy!



E. F. JOHNSON CO

2003 10th Ave. S.W., Waseca, Minnesota

Please rush "Messenger" details to:

NAME _____

ADDRESS _____

CITY _____ STATE _____

Would You Like to Make \$1,000 A MONTH?



That's what Stanley Hyman made selling the amazing new Presto Fire Extinguisher! Many others "cleaning up"—so can you! Amazing tiny new extinguisher ends fires fast as 2 seconds. **Guaranteed for 20 years!** Sells for only \$4.95. Write for Free sales kit.



Merlite Industries, Inc., Presto Div.,
114 E. 32nd St., Dept. P-16J, New York 16, N. Y.

LITTLE PUMP DOES 1000 BIG JOBS



QUICKLY DRAINS CELLARS AND POOLS
FILLS TANKS • IRRIGATES • SPRAYS

Pumps up to 5000 GPH. Up to 60 ft. head. Threaded, 1 1/4" intake. 1" discharge. Rust-free aluminum castings. Superior design. Top quality. Fits any motor. Satisfaction guaranteed or money Standard Model refunded. Send check or M.O. \$1 deposit on C.O.D.'s. Flexible drive coupling \$1 extra. **895** ppd.

Heavy Duty Ball Bearing Model.. \$12.95 ppd.

AMERICAN MACHINE & TOOL CO., INC.

Dept. PS-73, Royersford, Pa.

NEW! TEN POWER TELESCOPE

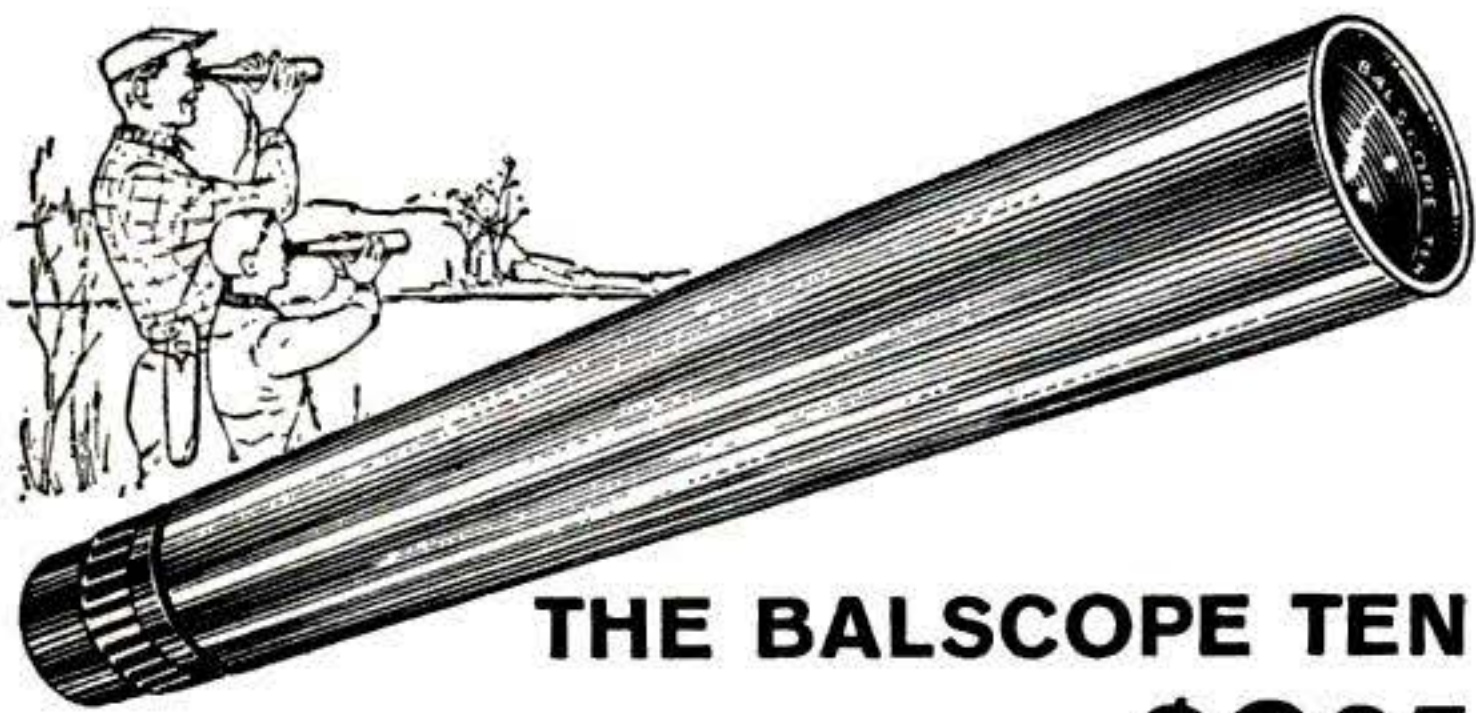

THE BALSCOPE TEN
at only **\$9.95**

■ For the first time, due to a manufacturing breakthrough... a *quality* telescope for only \$9.95! Ideal instrument for all kinds of nature study, for vacations, for all outdoors. No clumsy draw tube—focus with a single turn of the eyepiece. Only 10¼" long, and weighs just 9 ounces. Belt holster accessory at 98¢. See it at optical, photographic and sporting goods dealers. Made to American standards of quality by America's most respected optical craftsmen, Bausch & Lomb Incorporated, Rochester 2, N.Y.

BAUSCH & LOMB



MANUFACTURE this BEAUTIFUL OUTDOOR FIREPLACE in YOUR OWN BACKYARD

\$4.00 worth of sand and cement produces this attractive fireplace. Sells on sight from \$60 to \$80. Easy to start your own profitable business in your backyard. No experience necessary. Big profits. Exclusive manufacturing territories. Write immediately for full details. General machines sold to U.S. Government. Dealer inquiries invited.

GENERAL ENGINES CO., INC. Dept. SF-73 Rt. 130
Thorofare, N. J.

START YOUR OWN MONEY-MAKING BUSINESS

Clean rugs on customers' floors—upholstery in their homes—even painted walls—with highly efficient electric machines which are making big money for others and giving them independence. Write today for complete information. It's FREE!

VON SCHRADER MFG. CO., Dept. 711 "R" PL., Racine, Wis.



Permanent Sealer

Ready to use—no mixing required
Sticks tight on any surface

- metal
- wood
- aluminum
- tile & concrete

49¢, 98¢ tubes & cartridges

W. J. RUSCOE CO.
Akron 1, Ohio

Science newsfront continued

ter with a head on it. Jittery spokesmen for the soap and detergent industry have been claiming that a "soft" detergent would be developed by 1965. Now there's a deadline.

ENGINEERING

Underwater sightseeing

The lack of a mere \$30,000,000 forced abandonment of the Italian scheme to save the Egyptian temples of Rameses II from inundation by the waters of the Aswan Dam [see "Hydraulic Jacks Will Raise Mountain to Save Rameses' Temples," PS, Oct. '61]. The idea was to cut the temples out of the solid rock and lift them above water level.

A British engineering firm now suggests it will do no harm to submerge the temples in clean water, as long as a thin concrete "membrane" holds back the dirty water of the Nile. Tourists would view the temples from underwater chambers—or on the scene, equipped with an aqualung.

Dry acid. Sulfuric acid is now available in powder form. Developed by the Helmer Chemical Company of Canada, the product is made by mixing concentrated sulfuric acid with an absorbent calcium silicate powder, and contains 80 percent acid by weight. Advantages: safer and more convenient handling and shipping.

SCIENTISTS

A man of turbulence

Dr. Theodore von Karman died of a heart attack in Aachen, Germany, on May 6, at 81. His career, spanning the development of aviation and space science, began in Germany in 1906. He became a pioneer American rocket scientist after he emigrated to the United States in 1930. He received the first National Medal of Science from President Kennedy in February.

The chunky, bushy-haired professor, who was born of Jewish parentage in Budapest, began his career with major contributions to the young science of aerodynamics, among the most important an explanation of how eddies form around a wing. This helped to pave the way for supersonic flight. Later he worked out a theory of boundary layers that makes it possible to

BIG Throwing Knife \$1⁰⁰ Special

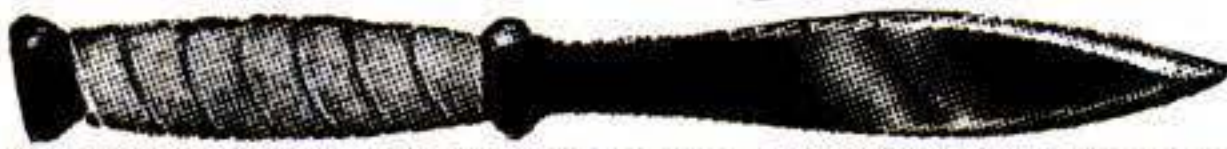

PIERCES METAL

Specially weighted & balanced point zeroes right into bull's eye with a wallop! **Positive accuracy! Deep penetration! Easy throwing! Hard hitting!** Excellent for hunting game, self defense, fun. Cutlery steel, double edge. Big 10" long. Leather handle. You must be delighted or your money back. **Price Postpaid \$1.00. DeLuxe Chrome Finish Model for Exhibition Purposes \$2.50. Leather Sheath 50c. Professional Knife Throwing Book 25c.** **JOHNSON SMITH & CO., Dept. 331, Detroit 7, Mich.**

Imported Stiletto Knife

When Open **LOCKS INTO POSITION**

Prevents blade from snapping shut when in use.



Push button release. Convenient pocket size, yet rugged. Fine quality, polished nickel-steel razor-sharp blade. **PIERCES METAL.** Narrow, tapered stiletto blade with thick rigid backbone for heavy duty use. Fine outdoor knife for sportsmen and emergencies. Comfortable handle. Safety guards. **Postpaid \$2.50** **JOHNSON SMITH & CO., Dept. 331, Detroit 7, Mich.**

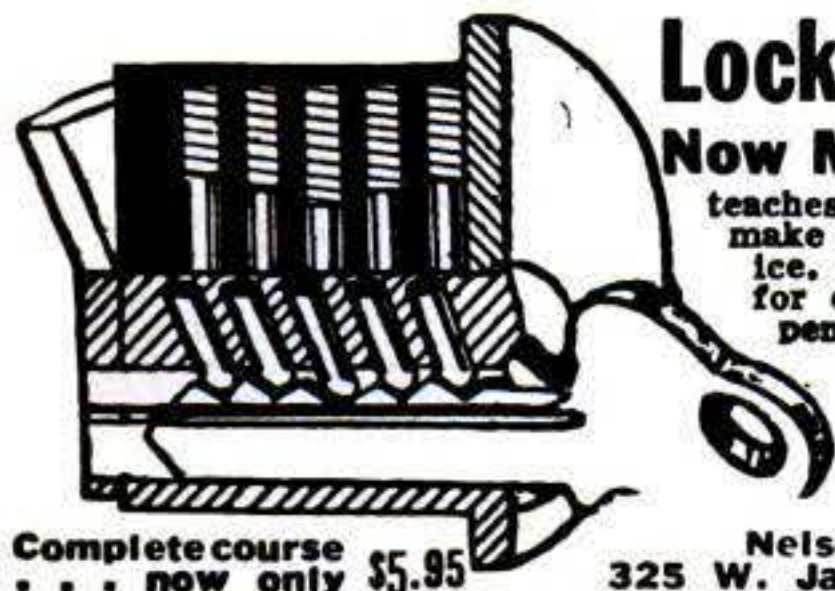

Locksmithing AND KEY MAKING

Now Made Easy! Practical up-to-date course teaches you how to pick locks, de-code, make master keys, repair, install, service, etc. New self-instruction lessons for every handyman, homeowner, carpenter, mechanic, service station operator, fix-it shop, hardware dealer, gunsmith. 53 easy illustrated lessons. Full price only \$5.95, postpaid; or C.O.D. plus postage. Satisfaction or refund guaranteed.

Nelson-Hall Co., Dept. GY-1
325 W. Jackson Blvd., Chicago 6, Ill.

Complete course . . . now only \$5.95



BIG MONEY in BURGLAR ALARMS

Secret for years—now I reveal inside facts! Beginners discover how to start spare time without mechanical experience or costly equipment. My step-by-step plan starts you to prestige career installing burglar alarms. Huge market—factories, homes, stores. Steady income business. Get your \$12,000 profit story. **NASCO, 11071 Massachusetts Dept. K247, Los Angeles 25, Calif.**

Write for **FREE** Plan now!

COMPLETE HEAVY DUTY MOTOR & PUMP

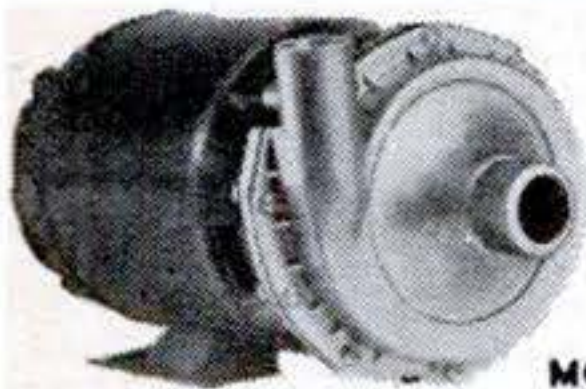

DRAIN • CIRCULATE • SPRAY • IRRIGATE
A terrific value! Includes split phase Westinghouse or Century motor, 1725 rpm, 115v, 60c plus 1200 gph pump with 1" discharge & 1 1/4" suction. Set pump in any of 4 positions. Order Now! Available in

Type FF - w/ 1/4 hp mtr. **\$20.00**
Type GG - w/ 1/3 hp mtr. **\$24.00**

MONEY BACK GUARANTEE Postpaid if cash with order

DAKON CORP., Dep't 2, 1836 Gilford Ave., New Hyde Park, N. Y.



LEARN MEAT CUTTING

Train quickly in 8 short weeks at Toledo for a bright future with security in the vital meat business. Big pay, full time jobs—**HAVE A PROFITABLE MARKET OF YOUR OWN!** Pay after graduation. Diploma given. Job help. Thousands of successful graduates. Our 40th year! Send NOW for **FREE** catalog. No obligation. G. I. Approved. **NATIONAL SCHOOL OF MEATCUTTING, Dept. 51-V, Toledo 4, O.**

BUILD, FLY ONE-MAN COPTER



Fun to build, inexpensive, easy to fly. Factory kits available. Order 3-view drawings, specs, photo of Gyro-Copter \$2 or motorless Gyro-Glider \$1. Send coupon today.

BENSEN AIRCRAFT CORP., Dept. PS-73 Raleigh-Durham Airport, Raleigh, N. C.
NAME _____
ADDRESS _____

RCA introduces a new easy way to learn electronics at home

Learn faster, remember more with this revolutionary new "learning method!" And RCA institutes is first to bring it to you! Forget all your old ideas about learning! The newest method, RCA "Autotext", uses the latest scientific development in the field of home training! RCA "Autotext" is a system of programmed instruction that helps you learn more quickly with less effort.

Complete Home Training Course using new RCA "Autotext" now available! "Introduction to Electronics" gives you the advantages of RCA "Autotext" plus theory lessons, service practice lessons, and all the kits you need! Send for complete information now and **FREE SAMPLE** Home Training lesson!

Wide Choice of Home Training Courses in Electronics! In addition to "Introduction to Electronics" RCA Institutes offers this complete selection of Home Training Courses:

- Electronic Fundamentals
- TV Servicing
- Color TV
- Transistors
- Electronic Drafting
- Communications Electronics
- FCC License Preparation
- Mobile Communications
- Automation Electronics
- Computer Programming

RCA Institutes Liberal Tuition Plan affords you the most economical possible method of home study training! You pay for lessons only as you order them. If you should wish to interrupt your training for any reason, you do not owe one cent!

Classroom Training Available in New York City, Los Angeles, and Cherry Hill (near Camden) New Jersey. Check "Classroom Training" on the coupon and information will be rushed to you.

SEND FOR FREE ILLUSTRATED BOOK TODAY! SPECIFY YOUR CHOICE OF "AUTO TEXT", HOME TRAINING, OR CLASSROOM TRAINING!

RCA INSTITUTES, INC., Dept. PS-73
A Service of Radio Corporation of America
350 West 4th St., New York 14, N. Y.
Pacific Electric Bldg., 610 S. Main St.,
Los Angeles 14, Calif.



THE MOST TRUSTED NAME IN ELECTRONICS

RCA INSTITUTES, INC., Dept. PS-73
350 West 4th St., New York 14, N. Y.

Rush me **FREE** information about "Autotext" _____
Home Training _____, Classroom Training (Choice of City) _____ No salesman will call.

Name _____

Address _____

City _____ Zone _____ State _____

CANADIANS: Take advantage of these RCA Institutes Home Study Courses at no additional cost. No postage, no customs, no delay. Fill out coupon and send in envelope to: RCA Victor Limited, 5581 Royalmount Ave., Montreal 9, Quebec.



Earn HIGH WAGES as a HEAVY EQUIPMENT OPERATOR

... and years of future security in the multi-billion dollar construction industry, in this country and *over-seas!* Learn how at National, the original school of heavy equipment operation. For men ages 17 to 56. Amount of previous *education no barrier.* National is NOT a correspondence school. You train on school-owned diesel-engined machines at National's huge proving ground in North Carolina. Full 220 and 440 hour courses. Full-time Job Advisory and Counselling Director for the exclusive benefit of graduates. VA approved. Payment plans available. Write TODAY for FREE catalog.

Since National School was founded eight years ago, students from all 50 states and 28 foreign countries have been enrolled. Hundreds of graduates are now working in construction for higher wages than they ever made before.

NATIONAL SCHOOL OF HEAVY EQUIPMENT OPERATION Dept. A-39 P. O. Drawer 1686, Charlotte, N. C.

Please send me FREE illustrated school catalog and complete information. I understand there's no obligation.

Name.....Age.....
 Address.....
 City.....Zone.....State.....

Make Rubber Stamps for BIG PAY

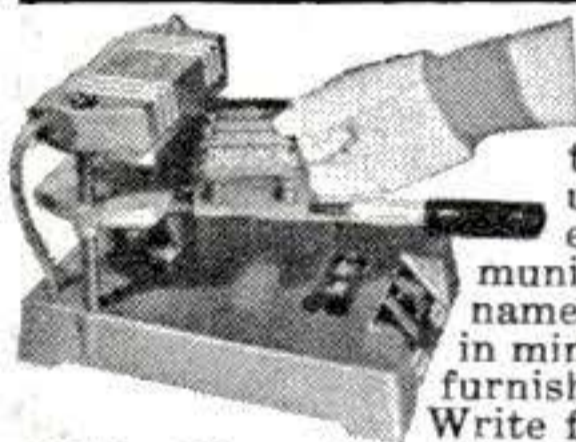

Need more money? Earn \$30-\$50 a week, spare time, at home making rubber stamps for offices, factories, individuals. Hundreds of uses. Hundreds of prospects—everywhere. Right in your own community. Turn out special stamps for names, addresses, notices, prices, etc., in minutes with table-top machine. We furnish everything and help finance you. Write for free facts. No salesman calls.

Rubber Stamp Div., 1512 Jarvis Ave., Dept. R-3-H, Chicago 26

20x50 — \$29.95

High powered, whisper-weight (27 oz.!) color corrected. Achromatic 7" high! Brings objects 20 times closer. Instant finger-tip adjustment. Made in Japan. Hard Coated thru-out. Leather case and straps included.

USE 30 DAYS AT OUR RISK
 If not satisfied return for refund. Add \$1 postage, handling and 10% Fed. tax.
UNITED BINOCULAR CO., 9043 S. Western, H-6216, Chicago 26. DEALERS WANTED



c.o.d.'s require \$2 deposit.

CIGARETTE LIGHTER WITH INSERTED SWISS WATCH

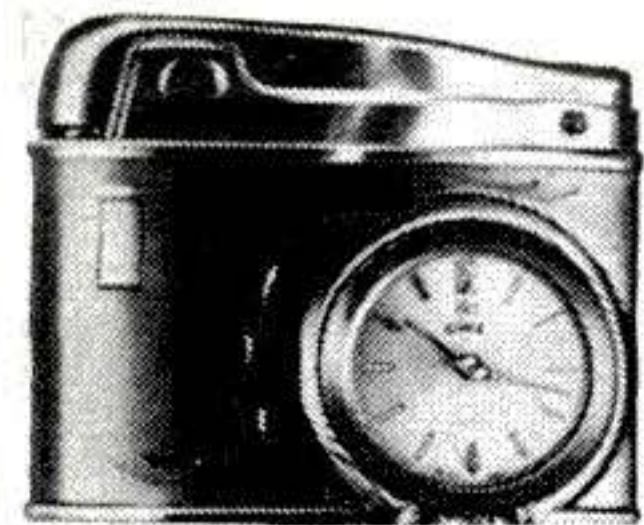

low, low, DIRECT IMPORT. Price prepaid, airmailed registered,

ONLY \$9.00

FREE CATALOG. Send money with order, no personal checks. Address to:

OLLECH & WAJS, Zuerich 39, Switzerland. Dept. PS-1

Science newsfront *continued*

calculate the friction of air on moving bodies, such as nose cones re-entering the atmosphere from space.

At California Institute of Technology he began work on rocket engines, which also involve turbulent gas flow. The experiments did not meet with universal enthusiasm: At one point, his friend, Dr. Robert A. Millikan—who was chairman of Caltech's executive council—threatened to throw von Karman off the campus for tinkering with dangerous rocket fuels. But in 1942, with the support of General Hap Arnold, he transformed his rocket "suicide club" into Jet Propulsion Laboratories, most recently responsible for the Mariner spacecraft. JPL's first notable achievement was the development of JATO (Jet-Assisted Take-Off) capsules used to boost planes from short runways and aircraft carriers. Von Karman was also a founder of Aerojet-General Corporation.

Because of his concern with air turbulence, von Karman became interested in the failure of the Tacoma Narrows Bridge in 1941. The bridge had collapsed under high winds. Hearing a report that the bridge was to be rebuilt to the same design, he wrote the governor of Washington: "If you build the bridge the same way, it will fall in the same way." Invited to join an investigation, he found an impressive group of engineers, each representing some phase of bridge construction. "And I," he said later, "I represented the wind."

Must have been some itch. Keepers at the Philadelphia Zoo have discovered that poisonous snakes are not immune to their own venom. They found their only Gaboon viper dead with his fangs imbedded in his own back. He might have had an itch, they think, and tried to scratch it.

METALLURGY

Hotter potatoes

Black aluminum foil has been introduced by the Smith-Lee Company, a paper products manufacturer of Oneida, N.Y. It's for cooking foods wrapped in foil—baked potatoes, turkeys, and the like. Logically enough, black foil absorbs heat better than shiny foil, and the potatoes get hotter faster, bake quicker. ■ ■



"I EARN TWO INCOMES NOW"

Says John Bennie, Pittsburgh, Pennsylvania
"Thanks to your wonderful training, I have been able to earn \$1300 a year extra doing little locksmith jobs at home. This is the best trade a man can take up."

306 pieces of professional equipment
Supplied for use with course.

Professional Equipment includes
LOCKS—PICKS—PARTS—KEYS
SPECIAL TOOLS & SUPPLIES
all for use with course.

Be a LOCKSMITH

Train at HOME—Earn While You Learn. Add 50%-100% to YOUR INCOME with easy spare time earnings. Cash in on the nation-wide shortage—trained locksmiths in great demand! Quickly step into a big pay opportunity job or start a high-profit shop of your own.

Earn Extra Money RIGHT AWAY! All Master Locksmiths Special Tools, Equipment and Supplies furnished for use with course.

Age, education, minor physical handicaps don't matter in this growing trade. You can quickly qualify as a skilled locksmith. It's like a fascinating hobby. Study at home as little as one hour a week. Gain practical experience through complete well-illustrated lessons. Do real jobs on car locks, house locks, padlocks and safe locks, under the guidance of experts. **FREE Illustrated Book, write now.**

LOCKSMITHING INSTITUTE.

(Division Technical Home Study Schools)

Dept. 207-3 Little Falls, New Jersey

MAIL COUPON for FREE ILLUSTRATED BOOK

For a future as your own boss or in a high-pay job, write now for **FREE Illustrated Book.**

Only school of its kind. Licensed by State of New Jersey. Approved for Veterans.

MAIL COUPON NOW

LOCKSMITHING INSTITUTE, Dept. 207-3 Little Falls, New Jersey

Please send **FREE Illustrated Book**—"Your Big Opportunities in Locksmithing," complete Equipment folder and sample lesson pages—**FREE** of all obligation—(no salesman will call).

Name.....
(Please Print)

Address.....

City.....Zone.....State.....



Mr. "CAR OWNER"—LOOK!



NEW Fuel Pressure Control System GUARANTEED to Give Up to 20% Better Gas Mileage

\$6.98

- Eliminates Vapor Lock
- Eliminates Carburetor Flooding
- Smoother Engine Performance
- Less Pump and Carburetor Wear

An Engineering Achievement that Works Miracles for Autos and Trucks. With amazing **INJECTA-FLO® FUEL PRESSURE CONTROL** you can actually SEE (and feel) the difference—the gas is metered—excess is recirculated thru' the "see thru" tubing for re-entry into the vacuum (tank side) of Mechanical Fuel pump. For continuing fuel economy, **INJECTA-FLO®** is as necessary to the fuel system as is the voltage regulator to the electrical-ignition system.

INSTALLED IN LESS THAN 30 MINUTES

Guaranteed Satisfaction or Money Back

MAGNA ENGINEERING • 1330 N. Rock Hill Road St. Louis 24, Missouri • WO 2-9804

I enclose check or money order for _____ **INJECTA-FLOs®.**
(No C.O.D.s—Postage Paid)

Name _____

Address _____

City _____ Zone _____ State _____

EARN \$10,000 A YEAR

- DIESEL
- ELECTRONICS
- AUTO
- AUTOMATION

The average starting salary of students, completing our FCC License, Electronics Technician Course, and those completing our Diesel Automotive Training, is \$4,300 per year.

After becoming familiar with the industry, their salary usually increases to \$6,000 or \$7,000 per year.

After they become senior technicians, or master mechanics, they can earn \$8,000 to \$10,000 per year.

When they become specialists, or a part of management . . . or start their own business . . . they can earn considerably more.

RESIDENT SHOP TRAINING is easier and costs less than you may think! We provide you with housing and part-time jobs while in school, plus free nation-wide placement service for graduates.

Check subject above in which you are interested and mail for

FREE BOOKLET

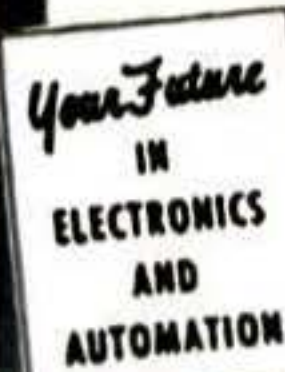

BAILEY Technical Schools

Veteran Approved

1626 S. Grand, Rm. 50, St. Louis 4, Mo.



Name _____ Age _____

Street _____

Town _____ Zone _____ State _____

1873 "The idea of making the several parts of different machines interchangeable is unquestionably of American origin. A mechanic, Thomas Warner, employed in the Springfield Armory, offered the suggestion to the Ordnance Bureau, Washington, but the idea was scouted as impracticable. Mr. Warner persevered, however, and obtained a trial for his system. It is now followed in all armories, as well as in manufactories of sewing-machines, watches, etc."

"The population of the United States (excluding Indians, not taxed, and the inhabitants of the Territories) was 38,115,641 in 1870, a gain of 22 percent in 10 years. The highest gains were in Kansas and Minnesota; the greatest losses were in New Hampshire and Maine. The white population increased by 24 percent as compared with a 9 percent gain for the colored population."

1903 "The majority of pearls found in Ceylon oysters contain the recognizable remains of Platyhelminth parasites. The worms infect oysters, become encased, and die, thus justifying, in a sense, Dubois' statement that 'the most beautiful pearl is, in the final analysis, nothing but the brilliant sarcophagus of a worm.'"

"It is a fact that British physicists are inclined to religious orthodoxy—Faraday and Maxwell, Stokes and Kelvin may be mentioned. Sir Oliver Lodge believes in telepathy, Sir William Crookes in ghosts. Lord Kelvin states that while a fortuitous arrangement of atoms may account for a crystal, some sort of creative power is necessary for the growth of a sprig of moss.

"Biologists disagree. They believe that the processes of animal and plant life are governed by the natural laws which have been established for the inorganic world. Thus Sir William Thistleton-Dyer, director of the Kew Botanical Gardens, calls Lord Kelvin sharply to account, saying that 'for dogmatic utterance on biological questions,

there is no reason to suppose that he is better equipped than any person of average intelligence.'"

1933 "Robots that answer phones are now being rented in Vienna, Austria. When the subscriber leaves home he sets the apparatus to indicate when he will return. All calls are automatically taken by the device, which keeps a record of them, as well as indicating by strokes of a gong when the owner will be back."

"Over the airport at Oakland, Calif., a few days ago a silent plane slanted across the sky trailing a ribbon of white vapor. Spectators saw the pilot flash past at 100 miles an hour, slide to a landing, and roll to a stop in less than 100 feet. They had

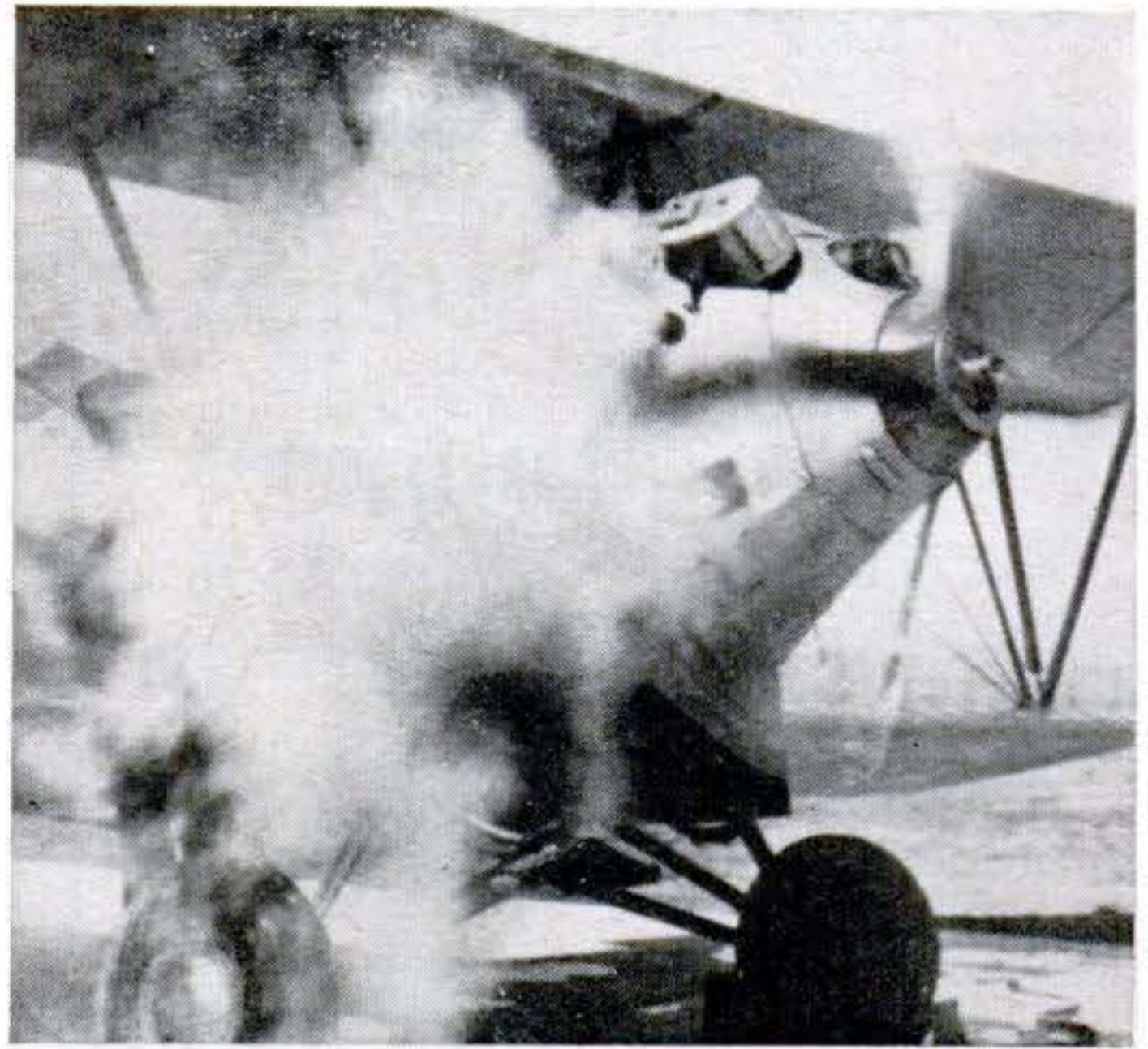

seen, for the first time in history, a plane powered by steam.

"Under the fuselage nose is a condenser like a radiator for a water-cooled motor. At the start of a flight, pilot William Besler (who, with his brother George, invented the system) climbs into the cockpit and flips on the electric blower that drives air mixed with oil spray through the burner. Here a spark ignites the mix, sending a torch of flame down around the coils of pipe. A few minutes later steam pressure is high enough for takeoff."

engineering degree in 27 months

Industry demands graduates. Enjoy higher income... advancement. Major corporations regularly interview and employ seniors. **BACHELOR OF SCIENCE DEGREE IN 27 MONTHS** in Electrical, Mechanical, Aeronautical, Chemical, Civil Engineering. **IN 36 MONTHS** a B.S. Degree in Business Administration (General Business, Accounting, Motor Transport Administration majors). One-year Drafting-Design Certificate Program. Small classes. More professional class hours. Well-equipped labs. Campus. Dorms. New library. *Moderate costs.* Founded 1884. Enter September, January, March, June. Write **J. F. McCarthy** for Catalog and "Your Career" Book. Learn more and you'll earn more.



TRI-STATE COLLEGE

573 College Avenue • Angola, Indiana

FREE "How To Start Your Own MAIL ORDER BUSINESS"

Work from your home. We supply top-notch mail order catalogs imprinted with your name and address. Simply mail out to prospects and all orders come directly to you. We carry all stock and drop-ship for you. Write today for details and free booklet. No obligation. **STATILE CO., MAIL ORDER DIVISION, MONTVALE 14, NEW JERSEY**

EXCLUSIVE DOUBLE-BEARING HEAVY DUTY PUMPS



IRRIGATE • DRAIN • CIRCULATE • SPRAY
Use 1/4 HP motor or larger . . . 1 HP for up to 5,200 GPH; 1,000 GPH 60' high; or 3,000 GPH from 25' well. 1 1/4" inlet; 1" outlet. Stainless shaft. **TYPE X**—2 oil-less bronze bearings. Won't rust. **\$10.95**
TYPE XB—Ball bearing model. **\$12.95**
Best for belt drives. . . .
Postpaid if cash with order.
Don't delay—send for yours today!
MONEY BACK GUARANTEE
Centrifugal and Gear Pumps in All Sizes
LABAWCO PUMPS, Belle Mead 4, N. J.

BUILD FINE GRANDFATHER CLOCK NOW



The simple sensible **SPEEDE Red-i-Kut** way as thousands have—**FOR YOURSELF OR SELL AT A GOOD PROFIT. SAVE HUNDREDS OF DOLLARS. SHOP TESTED PLANS "SPIRIT OF THE CENTURY"**. Narrow waist 83" tall or stately straight side "**SPIRIT OF AMERICA**". **EASY-TO-FOLLOW photopack PLANS & LIFE SIZE PATTERNS** tell all—plus **MOVEMENT BROCHURE \$42 up**, heavy brass weight (Kuempel original) Westminster, tube Bell chime, movements, gorgeous bronze-silver **MOVING MOON** dials. **LYRE pendulums. 3/4" solid-mahogany Jiffy Joint-Kwik-Bilt case kits.** Send \$1.00 today—Both plans. Rush \$1.50 as folks have done for over forty years.

Kuempel Chime Clock Works, # 18 Kuempel Bldg., Minneapolis 16, Minn.

NOW! EARN BIG MONEY IN CARTOONING AND COMMERCIAL ART

Now you can enter this highly-paid field quickly and easily. Learn in your own home, in spare time. No previous training or art ability required. Own your own business—urgent demand for artists everywhere! Earn 100% profit on all drawings—we show you how!



→ illustrated book **FREE!**
Continental Schools, Inc. Dept. E-177 4201 S BROADWAY, LOS ANGELES 37, CALIF.

100 POUND SET \$12.80



BARBELLS

140-Pound, **CHROME DELUXE** Barbell-Dumbbell set only **\$19.80**. This is our feature set and is the finest ever manufactured.
Training with adjustable weights is the **BEST** way to keep fit; the **ONLY** way to develop great strength and a perfect body. As the oldest and best equipped barbell company, **BUR** gives great value and prices no one can equal. Buy from manufacturer.
SEND FOR FREE CATALOG
BUR BARBELL CO.
Lyndhurst 5, New Jersey

FIX CARS FASTER!

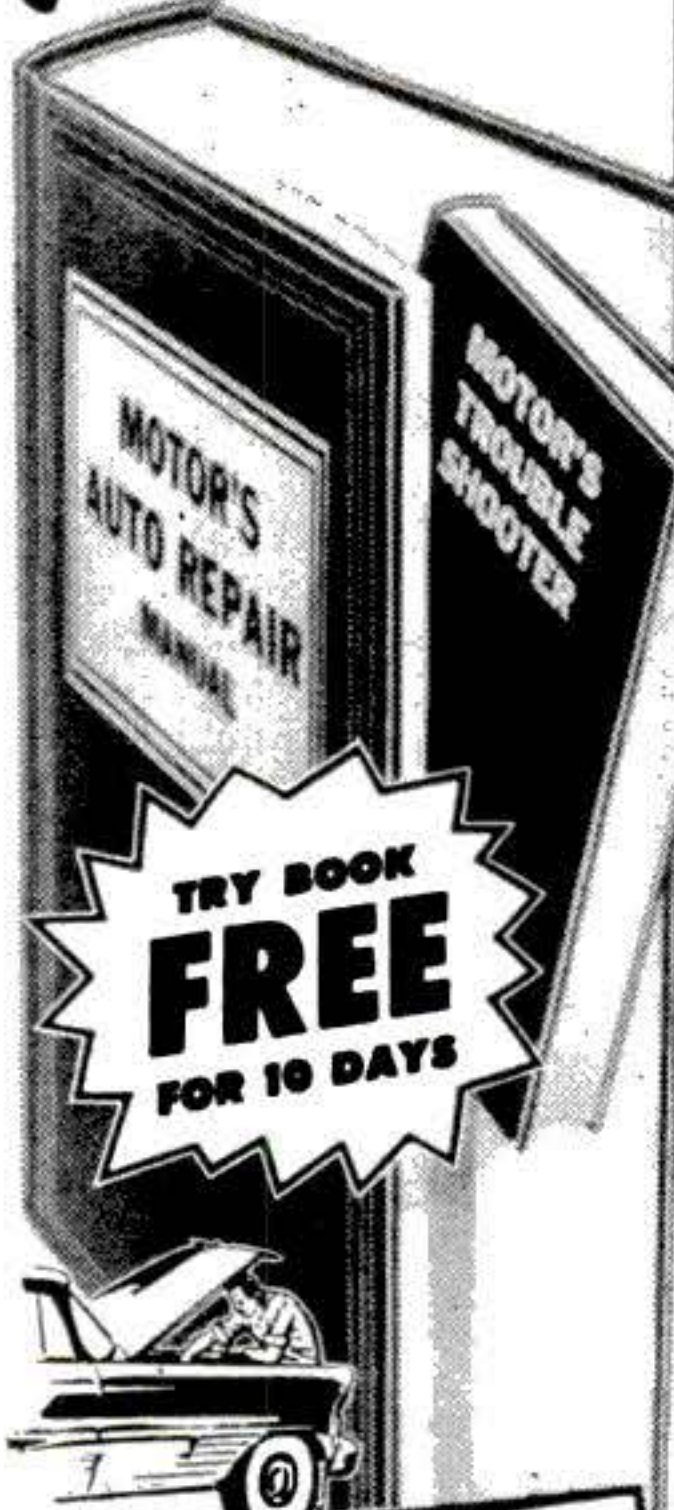

TRY BOOK **FREE** FOR 10 DAYS

with **MOTOR'S** great

2-IN-1 AUTO REPAIR MANUAL

① Famous MANUAL

pages show how you can

FIX 2,519 CAR MODELS

Quick, Easy, Right the first time—Any Car, 1955-1963 including all Compacts

② TROUBLE-SHOOTER

section spots 2300 car troubles for you immediately . . . leads you to exact repair needed

- ### FIX ANY CAR
- | | |
|---------------|-------------|
| American | Galaxie |
| Buick | Imperial |
| Buick Special | Jeep |
| Cadillac | Lancer |
| Chevrolet | Lark |
| Chevy II | Lincoln |
| Chrysler | Mercury |
| Comet | Meteor |
| Continental | Monterey |
| Corvaire | Nash |
| Corvette | Oldsmobile |
| Dart | Olds F-85 |
| DeSoto | Plymouth |
| Dodge | Polara |
| Edsel | Pontiac |
| Fairlane | Rambler |
| Falcon | Studebaker |
| Ford | Tempest |
| | Thunderbird |
| | Valiant |

NOW FIX 2,519 CAR MODELS—fast, easy, right—the first time you try! **MOTOR'S** new 2-in-1 Manual practically does it for you. Makes every job easy as A-B-C. Turns beginners into experts, gives experts time- and money-saving tips.

No guess-work! Crystal-clear directions, big pictures guide your hands thru every job. "Trouble-Shooter" section spots any of 2,300 car troubles fast. Then famous



"This wonderful book has paid for itself time and time again."
—P. Pemper, Wisc.

repair pages show you *where* to begin, *what* tools to use, *how* to use them.

No wonder over **FOUR MILLION** copies of **MOTOR'S** Manual have already been sold! No wonder it is used by schools, the U.S. Army and Navy, thousands of garages and repair shops.

NEW, REVISED, ENLARGED edition covers more than 2,519 popular-make models since 1955, including all the new cars. Over 1,300 pages, 3,200 pictures, 285 easy-to-read charts, 30,000 repair specs, 225,000 service and repair facts. **PLUS** much more!

SEND NO MONEY

Just mail coupon. **USE** it for 10 days. If it doesn't pay for itself in this time, return it and pay nothing.

MAIL COUPON NOW FOR 10-DAY FREE TRIAL

Attach to Postcard for Fast Action

MOTOR Book DEPT., Desk 327, 250 W. 55th St., New York 19, N. Y.

Rush to me at once **MOTOR'S** New **AUTO REPAIR MANUAL**. If O.K., I will remit \$2 in 10 days, \$3 monthly for 2 months and a final payment of \$1.95 (plus 45c delivery charges and sales tax, if any) one month after that. Otherwise I will return the book postpaid in 10 days.

Print Name Age

Address

City Zone State

Also send me for 10 days' Free Trial **MOTOR'S** New **TRUCK REPAIR MANUAL**. If O.K., I will remit \$11, plus delivery charge and sales tax, if any, in 10 days. Otherwise I will return book postpaid in 10 days.

Check box and **SAVE 45c** delivery charge by enclosing **WITH** coupon in envelope entire payment of \$9.95 for Auto Repair Manual (or \$11 for Truck Repair Manual) plus sales tax, if any. Same 10-day return-for-refund privilege.

WEEKEND COTTAGES
 CUSTOM BUILT ON YOUR LOT FOR
 LESS **\$29** PER MONTH
 THAN



NO MONEY DOWN
100% FINANCING
 Get **FREE Brochure**

20 other Models
 to choose from

Completely Paid For
 In Just 12 Years!

Investigate the Nation's most economical way to own a weekend cottage. Not a pre-fab or pre-cut! No giant jig-saw puzzles. Your cottage will be custom-built by master craftsmen for you on your lot or acreage. The monthly payment shown does not include inside finishing . . . save many extra dollars by doing your own inside work, or let Jim Walter do it for you and add the slight additional cost to your monthly payment. Get full details today.

Prices slightly higher in California

212 offices Coast to Coast. Write for nearest office location
 HOME OFFICE P.O. BOX 9128, Dept. PS-7 TAMPA, FLORIDA

Jim Walter Homes
 CORPORATION

AVIATION CAREER

SPECIALIZED EDUCATION / PROFESSIONAL TRAINING . . . only 3 years and 4 months

Top-pay prestige positions, bright future in aviation. Job opportunities waiting for you as soon as you're ready. Air-frame and Powerplant Technician, Aeronautical Engineering Technologist, Business or Executive Pilot. Classes in Miami.

SEND FOR FREE 48-PAGE BOOK

Embry-Riddle Aeronautical Institute
 Miami, Florida (Founded 1926)

Name.....
 Address.....
 City.....Zone.....State.....

3-PS-73

.22 CAL. TRAINING PISTOL

6 SHOT NEW Swing-out Model



Hard to Find A Bargain At only \$6.95

New, exciting feature never before available in a low-priced blank pistol. Swing-out cylinder holds six shots and permits easy loading and shell ejection. Ejection rod fits into handle. Beautifully balanced. Precision-made by master gun craftsmen in Italy. Swift, smooth action. Feels and handles like a real revolver. Perfect for dog training, for sporting and stage events. Guns like this are hard to get—and this is a bargain at only \$6.95. Purchasers must be over 21. Not sold in N. Y. City or Calif.

EMPIRE MDSG. CO. 140 Marbledale Rd., Dept. PS, Tuckahoe, N.Y.

Do Pennies Prevent Battery Corrosion?

Model Garage Editor
 Popular Science
 355 Lexington Ave.
 New York 17, N. Y.

Dear Sir:

Placing a penny in front of each cell in the soft tar of the car battery will help prevent the terminals from corroding. The pennies will take most of the corrosion.

I have enclosed a sketch to clarify what I mean.

Very truly yours,

Michael P. Lawler

Michael P. Lawler

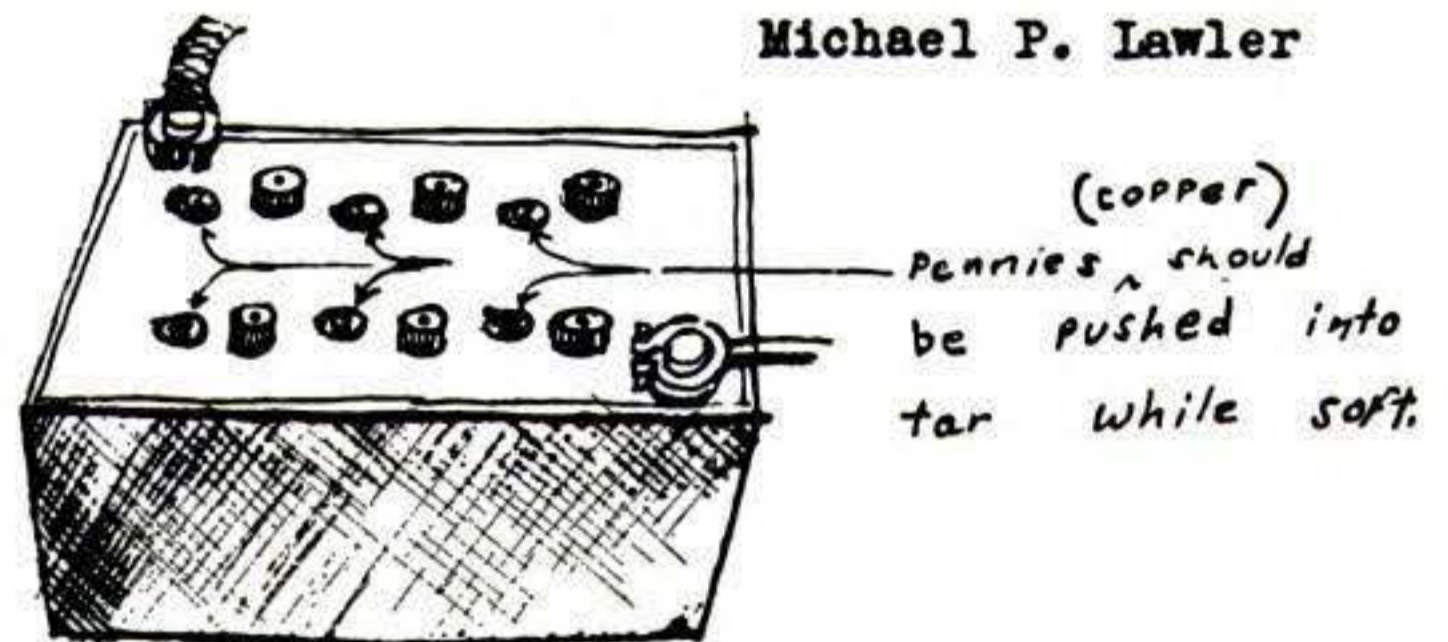

Michael P. Lawler

THIS is an open letter, addressed to a young fellow named Michael P. Lawler of Mt. Vernon, N. Y.

Dear Michael:

One day a few months ago you wrote us stating that copper pennies, pressed into the top of an automobile storage battery,

would prevent corrosion of the terminals.

You also implied a question: Was this true?

Frankly, that's a tough one to answer. We have heard the tale many times. It's a hardy item of garage folklore. At least once a month for a quarter of a century, POPULAR SCIENCE has received just such a letter. We replied to each with a polite but noncommittal thank you.

But after your letter we dispatched a series of inquiries to people who ought to know what there was—if anything—to the penny story. A total of 32 letters went out to battery manufacturers, automobile manufacturers, educational institutions, the Society of Automotive Engineers, the National Bureau of Standards, and the Association of American Battery Manufacturers.

We received 14 replies.

"The use of copper pennies," said the chairman of the storage-battery subcommittee of the S.A.E., "... is of questionable value . . . A penny spent for neutralizing soda will be far more effective."

The general manager of a Massachusetts battery-manufacturing company commented, "... it is a mistaken idea . . . that a penny acts as a catalyst."

From one in Toledo: "... pennies placed on top of a battery will not help prevent the formation of sulphate on the battery terminals."

From one in Milwaukee: "We have done limited testing (on pennies) over the years with results that did not justify further experimental work."

From one in Anderson, Ind.: "The placement of the penny on top of a battery in our opinion has no significant value."

At this point we began to wonder at our temerity in asking the question.

But then some letters began arriving with a different tone. The Chrysler Corp. commented: "Corrosion (sulphate deposits) occurs on battery terminals whenever there is something wrong with the electrical system in the battery-regulator-generator area. Most often the trouble consists of shorted cells in the battery or overcharging by the regulator or generator.

"The only remedy, of course, is to correct whatever is wrong with the electrical system. Nevertheless, the owner *can* eliminate terminal corrosion by pressing one or more pennies into the top of the battery . . . The penny will act as a 'sacrificial anode' to prevent corrosion."

The Ford Motor Co. observed: "The idea . . . has some basis in fact. Due to its position on the electromotive table, copper is more sacrificial than many other metals in an acid atmosphere such as that near the vents of a lead-acid storage battery."

Ford went on to say, however: "While it is true that the penny would corrode considerably more than the lead, the subsequent conclusion that the lead would have

"INVESTIGATING ACCIDENTS Brings Me Up To \$12000 A DAY CASH"

— J. M. Miller
Universal graduate

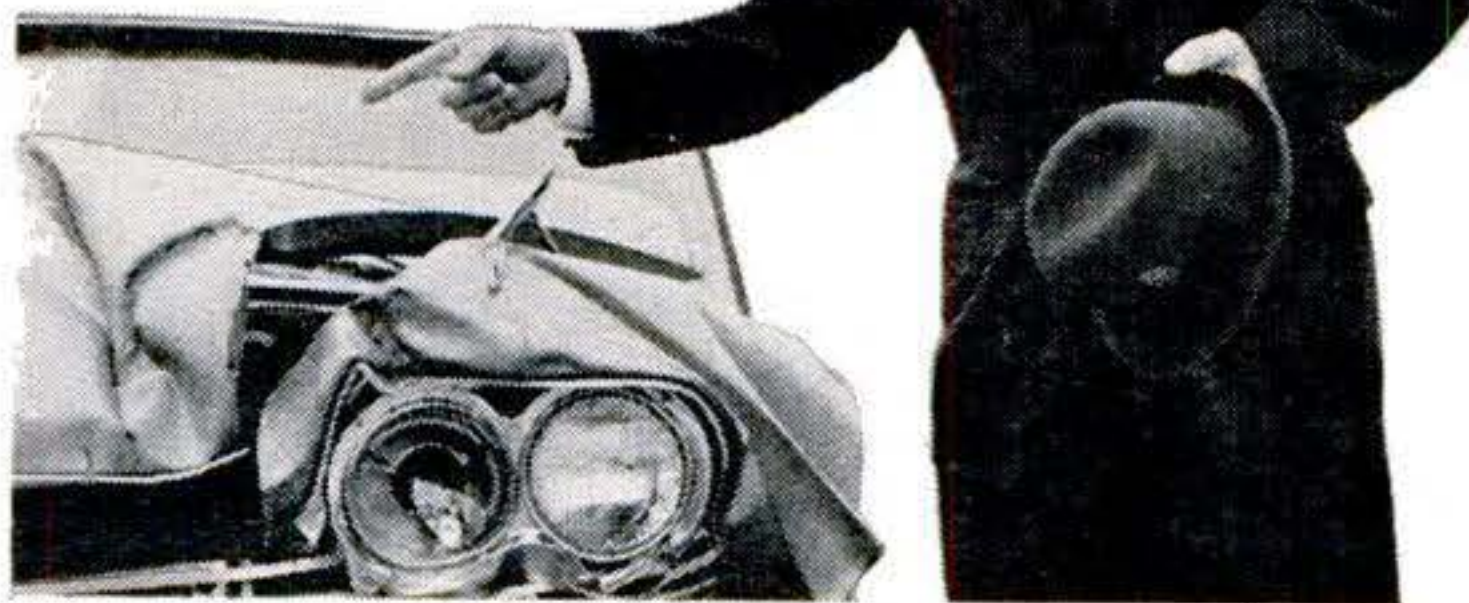

Step Into This Booming \$19 Billion A Year Industry

You can earn up to \$15 an hour... repeat, year-round income... in the exciting, fast-growing Accident Investigation field. Car furnished. Business expenses paid. NO selling. NO higher education necessary. NO equipment needed. And age is NO barrier. You can earn while you learn. Keep present job until ready to switch. Rush coupon for all facts and material.



UNIVERSAL SCHOOLS

PS-7

6801 Hillcrest, Dallas 5, Texas

Send FREE Book on Big Money In The Amazing Accident Investigation Field. No obligation.

Name _____

Address _____

City _____ Zone _____ State _____

ENGINEERING



Heald's Micro-wave and Radar Laboratory Equipment.

ENROLL NOW FOR NEW TERM

AMERICAN INDUSTRY NEEDS TRAINED ENGINEERS NOW

BACHELOR OF SCIENCE DEGREE, 30 MONTHS

SAVE 2 YEARS' TIME

B.S. Degree Courses:

- | | |
|---|---|
| <input type="checkbox"/> Electronic Engineering | <input type="checkbox"/> Mechanical Engineering |
| <input type="checkbox"/> Electrical Engineering | <input type="checkbox"/> Civil Engineering |
| | <input type="checkbox"/> Architecture |

Diploma Courses:

- | | |
|---|---|
| <input type="checkbox"/> Radio-Television Plus Color Technician | <input type="checkbox"/> Architectural Drafting |
| <input type="checkbox"/> Electronic Technician | <input type="checkbox"/> Mechanical Drafting |
| | <input type="checkbox"/> Structural Drafting |

APPROVED FOR VETERANS

Send for FREE Information

HEALD Engineering College

Van Ness at Post, Dept. PS-763 San Francisco, California

NAME _____

STREET _____

CITY _____ STATE _____

**ENGINEERING
SCIENCE
MATH**

**B.S. DEGREE
IN 36 MOS.**



U.S. NEEDS 50,000 NEW ENGINEERS EVERY YEAR
EARN ACCREDITED B.S. DEGREE in Science or Engineering in 36 months—year-round program optional. 27-month engineering diploma also available. *Classes start September, January, March, June.* **QUALITY EDUCATION.** Graduates employed throughout U.S. and foreign countries. Government approved for veteran training. Students from 50 states, 40 countries. 20 buildings; dorms, gym. Campus. New library and laboratories. Employment help provided. **SAVE TIME AND MONEY.**

Write for catalog and complete information.

IT **Indiana Institute of Technology**
formerly Indiana Technical College

1618 E. Washington Boulevard, Fort Wayne 2, Indiana
 Please send free information on accredited B.S. Degree programs in Engineering and Science as checked:

<input type="checkbox"/> Aerospace Engineering	<input type="checkbox"/> Mechanical Engineering
<input type="checkbox"/> Chemical Engineering	<input type="checkbox"/> Metallurgical Engineering
<input type="checkbox"/> Civil Engineering	<input type="checkbox"/> Physics
<input type="checkbox"/> Electrical Engineering	<input type="checkbox"/> Chemistry
<input type="checkbox"/> Electronic Engineering	<input type="checkbox"/> Mathematics

Name _____
 Address _____
 City _____ State _____

75 POWER TELESCOPE \$3.98
25X-45X-75X

NEW 3 in one telescopes, 3 variable 25X 45X-75X magnification. Brass bound. 25 power for ultra bright images 45 & 75 power for long range. Guaranteed to bring distant stars, moons, objects, sports 75 times closer.



Most powerful scope sold anywhere near this amazing low price. American made, 5 sections. Opens 36", closes 1 ft.; contains 4 ground & polished lenses. Can also be used as powerful compound microscope. Mass production enables us to offer telescope complete at \$3.98 postpaid. Money back guarantee.
CRITERION CO., Dept. PSB-13; 331 Church St., Hartford, Conn.

ACCORDIONS UP TO 1/2 OFF

Save up to 1/2 off retail prices of comparable accordions

5-DAY FREE TRIAL
 Buy DIRECT from world's Largest Exclusive Dealer! Compare our Importer-to-You prices! See how you save! Over 80 models—finest genuine Italian makes! New, easier terms! 5-Day Free Home Playing Trial with satisfaction 100% assured. Bonus Gifts Free. Rush name and address for FREE Color Catalogs and direct Importer-to-You prices—FREE. Write TODAY!
Accordions Corporation of America
 2003 W. Chicago Av., Dept. P-73, Chicago 22



Repair any watch

... SWISS OR AMERICAN

Unique, modern Sweazey System starts you making repairs right away. Develops skill step by step at home in spare time. Tuition \$5 monthly. Diploma awarded. Free sample lesson. No obligation.

CHICAGO SCHOOL OF WATCHMAKING
 2330 Milwaukee, Dept. 473, Chicago 47, Ill.



FIRES 200 ROUNDS

Walther Automatic Rapid Fire Repeater

Amazing new 1963 model WALTHER automatic . . . Holds and fires 200 rounds automatically from oversize chamber at incredible firing speed. Peak accuracy firing power to distances of 40 feet and more. Smooth jam-proof action guaranteed. No recoil. Non-lethal. Safe. No permit needed but not sold to minors under 16 years of age. use for target practice indoors and outdoors. Walnut-Color stock is contoured to fit the hand. Send \$3.98 cash, check or money order plus 27c shipping charge. We include free ammo. Satisfaction guaranteed or money back. **Gun Dept. 7-PS, Bon-A-Fide Products, Saugatuck, Conn.**

\$3.98

(200 rounds ammo \$1.00) (400 rounds ammo \$2.00) (1000 rounds ammo \$5.00)



corroded more if the penny had not been present does not necessarily follow. A sufficient surplus of acid ions is present to corrode anything in the vicinity."

But the most studious answer to the penny question was made by Lyle V. Andrews, chairman of the division of science and mathematics at Nebraska State Teachers College, Chadron, Nebr. His comment follows, in part:

" . . . the method (of preventing terminal corrosion) which has been reported most successful, and which appears to have the most logical explanation, involves the placement of one or more pennies on top of a battery in contact with the positive terminal.

" . . . I believe it has definite scientific backing.

" . . . Corrosion, in the case of a lead storage battery, takes place on the connection to the positive terminal. This connection is usually of copper, or a copper alloy. No corrosion begins until a film of sulphuric acid, which has been slopped out of the battery cells, covers all, or a major portion, of the top of the battery.

"This thin layer of acid must come in contact with the cable which is to become corroded. Corrosion takes place because, at the positive terminal, electrons tend to be removed and transferred to the positive lead dioxide plate. The voltage which measures the energy of the change may be two, four, six, or even twelve volts. Any one of the values is great enough to bring about . . . chemical change with copper . . .

"The insoluble lead sulphate forms a protective coating over the lead, and the reaction stops. If a copper cable connected to this positive terminal is in contact with this acid film . . . the copper sulphate does not form a protective coating, and the corrosion continues until a new cable is needed.

"If one or more pennies are placed on top of the battery, making electrical contact with the positive terminal, they will contact the sulphuric acid film before it has reached the cable, and the reaction, as outlined above for copper, will take place.

"In other words, the copper penny corrodes instead of the copper cable, due mainly to its lower position and hence better contact with the acid film."

That's it, Michael. Now you know why we've taken 25 years to answer the question.

Sincerely,
 The Editors



modern KUNG-FU KARATE

BREAK BRICKS in 100 DAYS. Fast, New, Amazing System. **DO IT NOW.**

FREE literature

only \$5.00 cash, check, m.o.
Oriental Book Sales
 P.O. Box 1183, Oakland 4, Calif.

"Secrets of Chinese Karate"
 By Ed Parker—\$5.95

CHINESE GUNG FU
 The philosophical Art of Self Defense by Bruce Lee—\$5.00

Train Now For BIG Pay Jobs!

**EARTHMOVING
 EQUIPMENT
 OPERATOR**

**HEAVY EQUIPMENT
 REPAIR-REBUILDING**

**Greer
 TECHNICAL INSTITUTE**

Atten. S. G. Hutch, Box 368, Braidwood, Ill.

Get ready for a *man's* job in the booming road and construction industry. Operate cranes, "dozers," earth-movers, etc. Train "on the job" in 5 to 13½ weeks. Classes start weekly; reserve space now. Approved for vets. Complete catalog and reservation facts **FREE**. Write today!

Graphoanalysis

**LEARN TO ANALYZE HANDWRITING—
 THE PROVED, SCIENTIFIC WAY!**

YOU can learn to analyze character from handwriting. Clinically proved principles of Graphoanalysis help you understand people—including yourself. Fascinating home-study training. Many career opportunities for both men and women, full or spare time. Send for **FREE** catalog and sample lesson. No salesman will call. (State age.)

INTERNATIONAL GRAPHOANALYSIS SOCIETY, INC.
 325 West Jackson Blvd. Dept. G-Y-1 Chicago 6, Illinois



BE A MAGICIAN!

Get started today! Become a popular man of mystery. Earn and learn in spare time. Magic is fun and profitable too. Be the Life of the Party Astonish your friends!

**EASIER
 THAN
 YOU
 THINK!**



RUSH 10¢ now for
PROFESSIONAL MAGIC CATALOG
 160 pages thick • 800 illus. • 1000 Mysteries
 Also Jokes, Puzzles, Secrets, Illusions.
FREE Magic Trick included
HOUSE OF 1000 MYSTERIES • Dept. PS7-63, MONROE, CONN.

PROFIT IN YOUR SPARE TIME

SMALL ENGINE REPAIR PAYS BIG!

Outboard • Powermower • Chain Saw • Tractor
MAKE EXTRA MONEY — or fix your own engines and **SAVE!** Illustrated, easy-to-learn Home Study Course qualifies you as expert. Free information. Write today!

LINCOLN TECHNICAL INSTITUTE
 Suite 7-G, 472 Market Street, Newark 5, N. J.



**"\$7,108.50 First Year
 SERVICING RADIATORS!"**

— Hank Konter, Newcastle, Wyo.

Make good money servicing auto-truck-tractor radiators with new Inland 1-Piece Radiator Shop. Easy to test-clean-repair radiators. Inland, world's largest radiator equip. mfr., trains you free. Small down payment starts you. Easy-pay plan lets you pay from profits. Proved merchandising assures volume. Profitable dept. for garage or service station. **WRITE for Free Book.**
INLAND MFG. CO., Dept. PS-7, 1108 Jackson St., Omaha 2, Nebr.

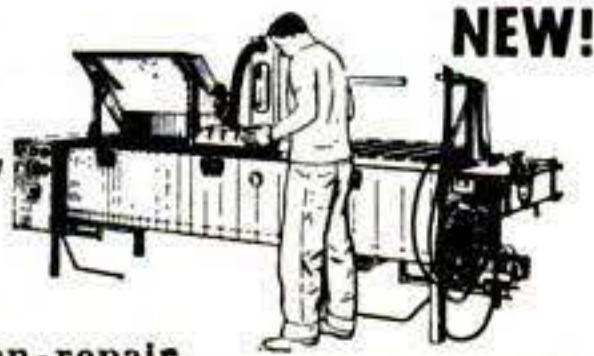

NEW!

CHECKER

**LOWERS THE PRICE OF
 BEING DIFFERENT!**



Don't think you have to buy one of those expensive foreign cars to be different. Checker Motors Corp. has created a totally different kind of family car that's comfortable like a limousine, economical like a compact and built-to-last like a Rolls Royce. Produced in limited quantities in Kalamazoo, Michigan, Checker will appeal to those who appreciate the extra room, extra strength and extra miles that are built into each 4-door sedan and station wagon. A Checker is different, yet costs no more than an ordinary car. Write for brochure.

CHECKER MOTORS CORP.
 Dept. L-2, Kalamazoo, Michigan

Name _____
 Address _____
 City _____ State _____

**NEED
 MONEY?**

\$ \$ \$ \$ \$ \$ \$ \$ \$ \$

IT'S EASY TO BORROW FROM US - BY MAIL!

If you have been on your present job for at least two years

Borrow \$100 to \$600 without collateral or co-signers. Confidential. Repay in small monthly amounts. Tell us how much you need now.

SEND THIS TODAY Send me Application for National Loan By Mail.

Name _____
 Address _____

NATIONAL LOANS

DEPT. 62J, 101 S. Tejon, Colorado Springs, Colo.

\$ \$ \$ \$ \$ \$ \$ \$ \$ \$ \$ \$ \$ \$

Double Your Income

While employed, double your income with YOUR OWN business. Free illustrated booklet tells you how. Then expand full-time. Gross hourly profit: \$9 plus \$6 on each serviceman. Your service is nationally advertised. It's worldwide. Endorsed by McCall's and Parent's Magazine. We'll finance you for all but a moderate down payment. We'll mail details and free book. No obligation. No salesman will call. Write today.
DURACLEAN CO., 3-187 Duraclean Bldg., Deerfield, Ill.

NO.1 for boating fun!

Write for **FREE** Catalog

ALUMA CRAFT BOAT DIVISION • ALPEX CORP.
 1521 Central Ave. N.E., Minneapolis 13, Minnesota



**BOATS, CANOES,
 TRAILERS**



FIBERGLAS BOATS

Detroit report

By Devon Francis

Presto! Chango! The disappearing dent

In the next 12 months, look for something new in automobile bodies—a material that will return to its original shape when dented. The stuff has a “memory” for what it looked like before the dent occurred. Just put a hot-air gun on it for a few minutes, and back it springs.

No, it's no fairy tale. The United States Rubber Co. has been demonstrating the material, called “Expanded Royalite,” for more than a year to automobile manufacturers.

It doesn't fray under impact like resins reinforced with glass fibers. It is lighter than steel. A car door made of it can be turned out in two molds. A steel door requires a dozen and a half separate stampings. At least one of the major auto makers has been testing a body made of it. One trailer manufacturer already is using it for bodies. A company specializing in trailer insurance is considering reduced rates for Expanded Royalite bodies because of their durability.

U. S. Rubber engineers claim that in any quantity over 50,000 it will be cheaper to make auto bodies of the material—a thermoplastic, which takes a permanent form under heat—than of steel. This is a switch on the fiberglass argument—up to now fiberglass has been cheaper only in limited production, as in Chevy's Corvette. Still and all, U. S. Rubber's material no doubt will show up first in low-production cars.

Chrysler's gas turbine

The Chrysler Corp. once again has gone through its almost-annual rite of “presenting” its gas-turbine car. This

time it looked astonishingly like Ford's Thunderbird.

While Chrysler claims an acceleration time of 12 seconds, 0 to 60 m.p.h., a stopwatch caught it 4 seconds slower than that. One of two cars put at the disposal of the working press balked, precipitating a frenzy of repair work by mechanics. A driver's manual cautions against exceeding 44,610 r.p.m. on the turbine, but no provision is made to prevent a forgetful driver from doing it.

Beginning this fall, the first of 50 cars will be lent to 200 specially selected “test drivers” to get an answer to the question: Do Americans want a turbine car? But mass production of it is a long way off—perhaps we'll have it by the time man reaches the moon.

Is your battery “failing”?

The Hester Battery people of Nashville have a word of advice for car owners. A 1962 survey by eight big battery makers, they say, showed that one out of every ten batteries that “failed” only needed recharging.

For good battery care, invest \$1 in a hydrometer. A fully charged battery in good condition should read from 1245 to 1265 specific gravity, with little or no variation between cells at 80 degrees air temperature. (A scale on the hydrometer will let you adjust for temperature variations.) A reading below 1240 means trouble—the battery is failing or needs recharging. A variation between cells of more than 10 to 15 points probably indicates need for replacement.

Finally, run a voltage check on your fully charged battery—if it registers a specific gravity above 1200. Start your car two or three times, turning on the lights. If there's a variation of more than .2 volts, buy a new battery.

When should you replace a battery—before it fails? Hester's recommendations: after 18 months for one that's been used hard; 2 years for one that's been used moderately; 2½ to 3 years for one that's been used lightly. About 40,000 miles is par for any battery.

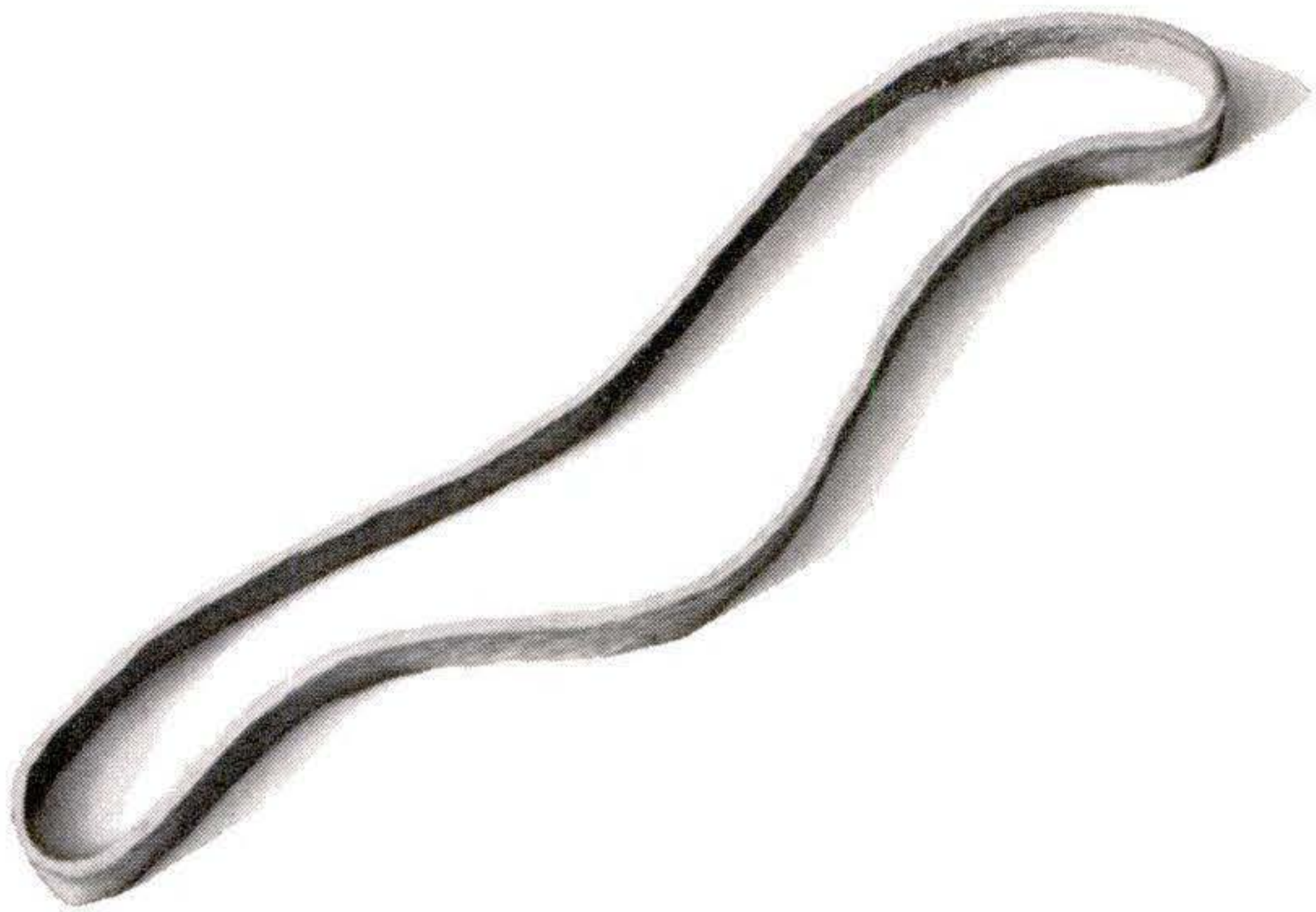

In one respect, it's an ideal piston ring

A rubber band and a piston ring have one characteristic in common that is very important.

That characteristic is conformability — the key to proper compression and oil control in the engine of your automobile.

Simple enough to achieve — in rubber. But, to create metal rings with this perfection of fit . . . rings that will withstand the explosive impact, abrasion, heat and acids in an engine — requires very precise and specialized engineering.

Every year for several decades we have invested heavily in engineering and research. And the result is improved rings

and new designs with that special Perfect Circle quality which produces top performance and extra long life.

That's why virtually every major American manufacturer of passenger cars, trucks, tractors, and construction equipment specifies Perfect Circle rings as original factory equipment.

It's an important reason why the car you drive gives you more *go* to the gallon, more power to pass.

And a *very* important reason, when you *do* re-ring, for insisting on rings made by Perfect Circle — the power-packing piston rings that engine "pros" prefer.



PERFECT CIRCLE

**PISTON RINGS • CYLINDER LINERS • PRECISION CASTINGS
TURBINE BLADES AND WHEELS • ELECTRONIC PROGRAMING EQUIPMENT
SPEED CONTROLS • HAGERSTOWN, INDIANA**

Plants and Subsidiaries: HAGERSTOWN, RICHMOND, NEW CASTLE, TIPTON AND RUSHVILLE, INDIANA
THE PERFECT CIRCLE COMPANY, LTD., DON MILLS, ONTARIO, CANADA • SCHELLENS TRUE CORPORATION,
IVORYTON, CONNECTICUT • PERFECT CIRCLE INTERNATIONAL, FT. WAYNE, INDIANA • PERFECT
CIRCLE HOLLAND N.V., THE HAGUE, NETHERLANDS • Factories, Affiliates and Licensees in MEXICO,
ARGENTINA, AUSTRALIA, BRAZIL AND FRANCE

**Pall Mall's natural mildness
is so good to your taste!**



*You can light
either end!*

So smooth, so satisfying, so downright smokeable! For flavor and enjoyment you just can't beat Pall Mall's natural mildness. It's so good to your taste. Never too strong. Never too weak. Always just right! Enjoy satisfying flavor... so friendly to your taste. **Outstanding... and they are Mild!**

COMPARE ALL THREE!



Smoke "traveled" through fine tobacco tastes best. Pall Mall's famous length travels the smoke naturally ... over, under, around and through the finest tobaccos money can buy. Makes it mild but does not filter out that satisfying flavor!

How Ed Link's divers will camp on the continental shelf . . .

An exclusive report on the next news-making chapter in—

The Race for the Bottom of the Sea

By Wallace Cloud

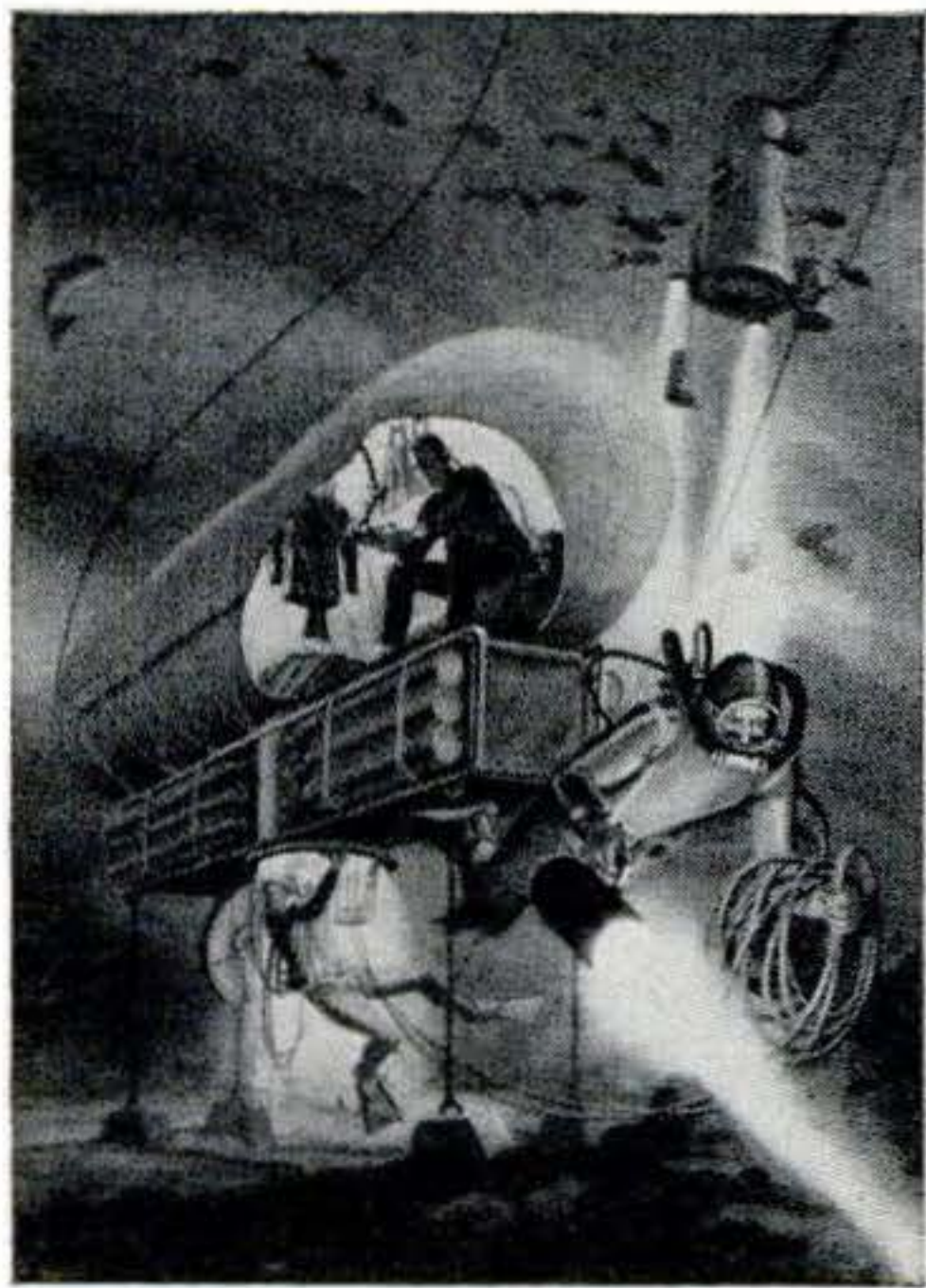

IN UNDERSEA exploration, this is the year of the frogmen.

Small groups of divers are gambling their lives on the hunch that they can live beneath the sea for weeks, and that they can break through the "depth barrier" that now limits skin divers to the upper 200 to 300 feet of the oceans.

For convenience and whatever safety they offer, diving bells and other chambers are used in these experiments. But

they serve only to deliver men to the deep, where they swim with skin-diving equipment. To survive at such depths, the divers breathe trick mixtures of gases instead of air.

The strangest and most important of these undersea adventures is scheduled to begin off Bermuda in September. Edwin A. Link, inventor of the Link Aviation Trainer, will conduct a series of dives in which three-man crews, living underwater for a week at a time, will steadily work their way downward from 200 feet to 400 feet, to 600 feet—perhaps as far as 1,500 feet.

"We don't really know if there is a limit," Link told me.

The men of his "undersea task force" will live beneath the sea in

CONTINUED



Rich engineer Edwin A. Link pilots Sea Diver, \$750,000 laboratory ship he built when he turned from aviation to the sea. The 91-foot ves-

sel is equipped with special diving gear, 6-ton lifting boom, dredges, complete machine shop, radar and sonar. It can cruise 7,000 miles.

a captive bubble of helium and oxygen. A seemingly fragile "underwater tent" of rubberized nylon will contain the bubble. Its bottom hatch will be open to the water, and the men will swim in and out freely.

Link has already conducted deep dives of record duration—last August and September, in the Mediterranean off Villefranche-sur-Mer. One of his divers, a 29-year-old Belgian named Robert Stenuit, spent 26 hours in a one-man diving bell at 200 feet, unprotected from deep-sea pressure except by the special breathing mixture. Normally, skin divers can stay at 200 feet for no more than 10 minutes.

Goats for tests. As part of the same

experiment, Link kept animals at the equivalent of 400 feet for 12 to 13 hours, in a pressure chamber aboard ship. After decompression, they showed no ill effects. Oddly enough goats are the best animals for this sort of test, their body weight being close to that of man.

One strange effect of the helium-oxygen breathing mixture was that as Stenuit descended to test depth, his voice over the intercom rose higher and higher in pitch. At 200 feet it was an unintelligible squeak, and he had to use Morse code to communicate with the surface. If this problem can't be licked, the men living together in their inflated house at 400 feet and lower won't be able to talk to each other.

What else are frogmen doing under water?

An undersea housing project

In April, Commandant Jacques-Yves Cousteau, co-developer of the aqualung, began setting up an "underwater village" in the Red Sea. He proposes to house 24 people at shallow depths, in steel chambers like the one in which two of his divers, Albert Falco and Claude Wesley, lived for a week last October, 33 feet down in the Mediterranean.

The colorful French diver has predicted that within 50 years a new breed of humans

—*homo aquaticus*, the Water Man—will live under water without an air supply. He says NASA scientists are working on an "artificial gill" to be plugged into an astronaut's bloodstream to allow the exchange of oxygen and carbon dioxide without breathing. A PS check with NASA and other sources disclosed no such project.

Death at 1,000 feet

I had been trying to get Peter Small on the phone all day, last Dec. 3. The desk clerk at the hotel on Catalina Island said

Link's designs for undersea living

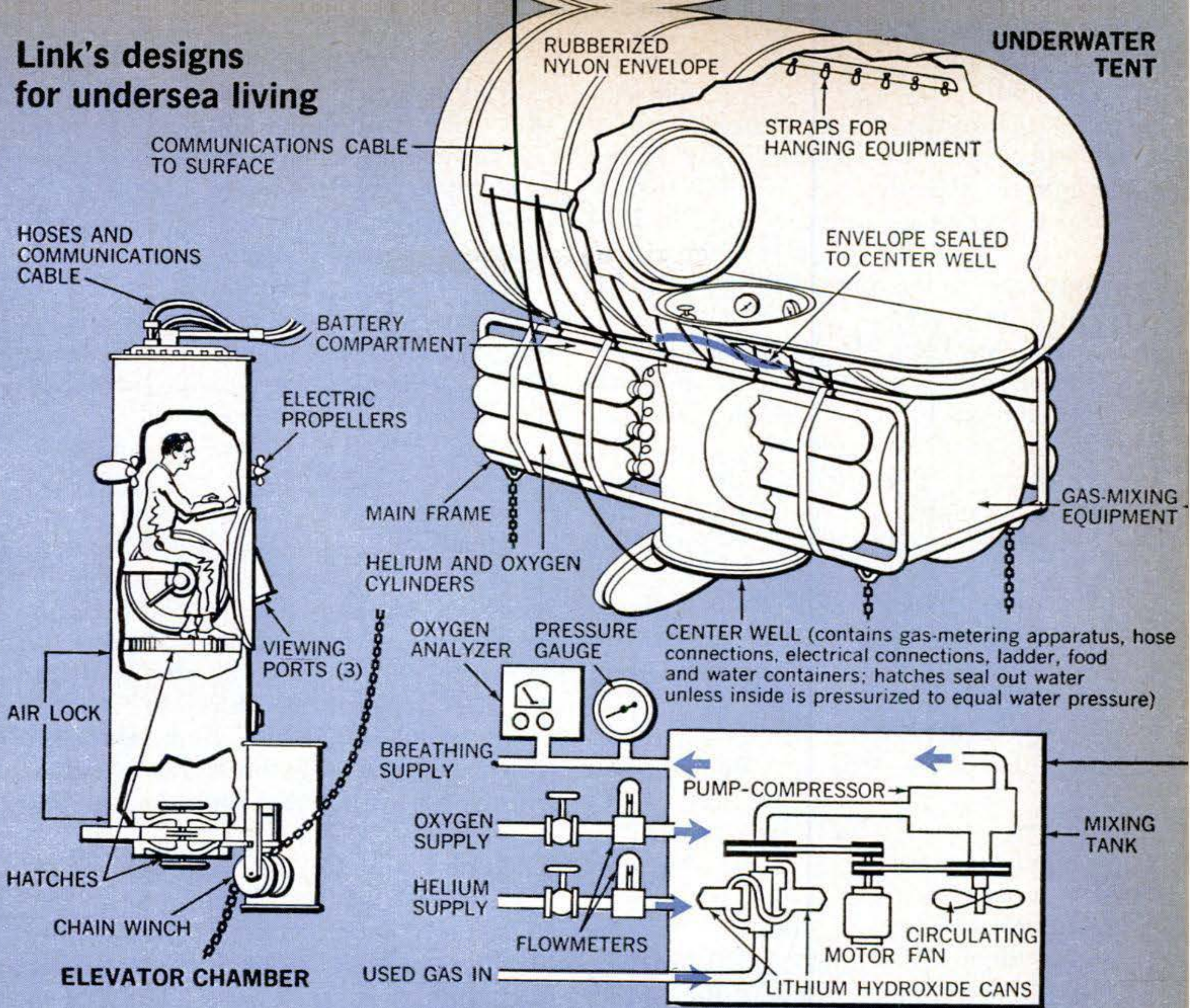

I first met Ed Link last December, a few days after the tragic death of a British diver, Peter Small, in an experimental 1,000-foot dive conducted by Hannes Keller off Santa Catalina Island,

Calif. Some weeks earlier, Commandant Jacques-Yves Cousteau had announced his plans for an underwater village.

Link, who is 59, is a big man with an air of quiet deliberation. He is a multi-

CONTINUED

he was "out diving." That night he said, "He's still in the decompression chamber. They made the thousand-foot dive today."

The next morning I found an item in the *New York Times*: "2 BRITISH SKIN DIVERS LOST IN ATTEMPT TO SET RECORD." Later reports made clear what had happened:

The U.S. Navy had given Hannes Keller, 28-year-old Swiss mathematics teacher, a \$22,000 contract to test his "secret mixture" of breathing gases. Small, 35, a British diver, was to go down with Keller.

It was a "bounce dive," not an attempt to stay on the bottom. After the diving bell reached 1,000 feet, TV cameras showed

the two men struggle to close the bell's hatch (it was to be raised quickly for decompression aboard ship), then pass out.

The hatch wasn't sealed. A young British diver, Chris Whittaker, was lost when he went down to fix it at 200 feet. Rushed to a Navy hospital ship, Peter Small was found dead of the bends. Keller survived.

A few hours after I read the news of the fatal dive, my phone rang. It was Mrs. Small, who had been aboard the diving ship. She called her husband's death "just one of those diving accidents," but she was in tears. Two months later Mary Small committed suicide in London.—W.C.

millionaire, having built the Link Aviation Company from scratch after inventing the Link Trainer as a young engineer. He sold Link Aviation to General Precision Equipment Corp. in 1954.

Why, I asked Link, were men risking their lives to live beneath the sea and to reach 1,000 feet?

"The problem I am interested in," Link said, "is how to stay at great depths long enough to do something useful: repair a telephone cable, do deep-water salvage and submarine rescue work, install a submarine detection station, prospect for oil or mine the continental shelf for manganese and phosphates.

"I don't think of underwater villages, but of underwater task forces—staying at 600 feet, say, which is the average depth of the continental shelf, long enough to do a job. If we can eventually go to 1,500 feet, this will open up the entire continental shelf, an area of 10,000,000 square miles."

Who pays for it? General Precision, with a background in antisubmarine warfare projects, recently began providing some financial support for Link's research. Potential customers for similar work later on are the Navy and oceanographic institutions. Link has spent close to a million dollars of his own money on "Project Man-In-Sea," including \$750,000 to build and outfit the only private oceanographic ship in existence, the Sea Diver.

The most important piece of gear on board, Link says, is the one-man aluminum diving chamber, 11 feet long, 37 inches in diameter. It has two electrically driven propellers that give it limited maneuverability, and an electric winch drive that allows it to run up and down, like an elevator, on a chain anchored to the bottom.

With its air lock open, admitting water to the bottom of the chamber, it can be lowered into the sea as a diving bell. The man inside, breathing air at the same pressure as the surrounding water, can swim in and out. The chamber can be sealed and brought up quickly, so the diver can decompress on deck.

The underwater tent that will be used this fall is still under construction. Back in December, when Link showed me a sketch of this inflatable chamber, he swore me to secrecy. "From an engineering standpoint, it's a simple thing to build," he said. "I wouldn't want someone else to build one and take credit for my idea." Since then, he has given POPULAR SCIENCE permission to publish full details of the project.

Many of the technical details of Cousteau's underwater houses had been worked out by Link and Capt. George F. Bond of the U.S. Navy. But the more Link thought about underwater living quarters, the more he felt that a heavy-walled chamber was unnecessary. "A pressure hull is useful if you want the pressure inside to be different from the water pressure outside," Link said. "But if you're equalizing pressure, you don't need strong walls—no more than a diver needs an iron suit. All you need is a leakproof container to enclose your captive bubble of breathing atmosphere."

It's the same principle that enables the human body to withstand undersea pressure. A diver is saved from being crushed because the pressure of the air in his lungs, adjusted automatically by his aqualung, exactly balances the pressure of the water.

Changing the breath of life. Divers swimming from the underwater tent—their base camp on the continental shelf—will not be able to use conventional aqualung equipment, however. At depths around 100 fathoms, they will breathe a helium-oxygen mixture so compressed that a few breaths would empty their aqualung tanks.

Instead, a closed-circuit breathing system will be used: Two hoses about 25 feet long will lead from each diver's breathing mask to the inflated tent, delivering a fresh helium-oxygen supply and returning the exhaled gas for carbon dioxide removal. This tether is actually no handicap—in the darkness and turbidity of the depths visibility is very limited. A diver without a safety line could easily swim 25 feet from his base

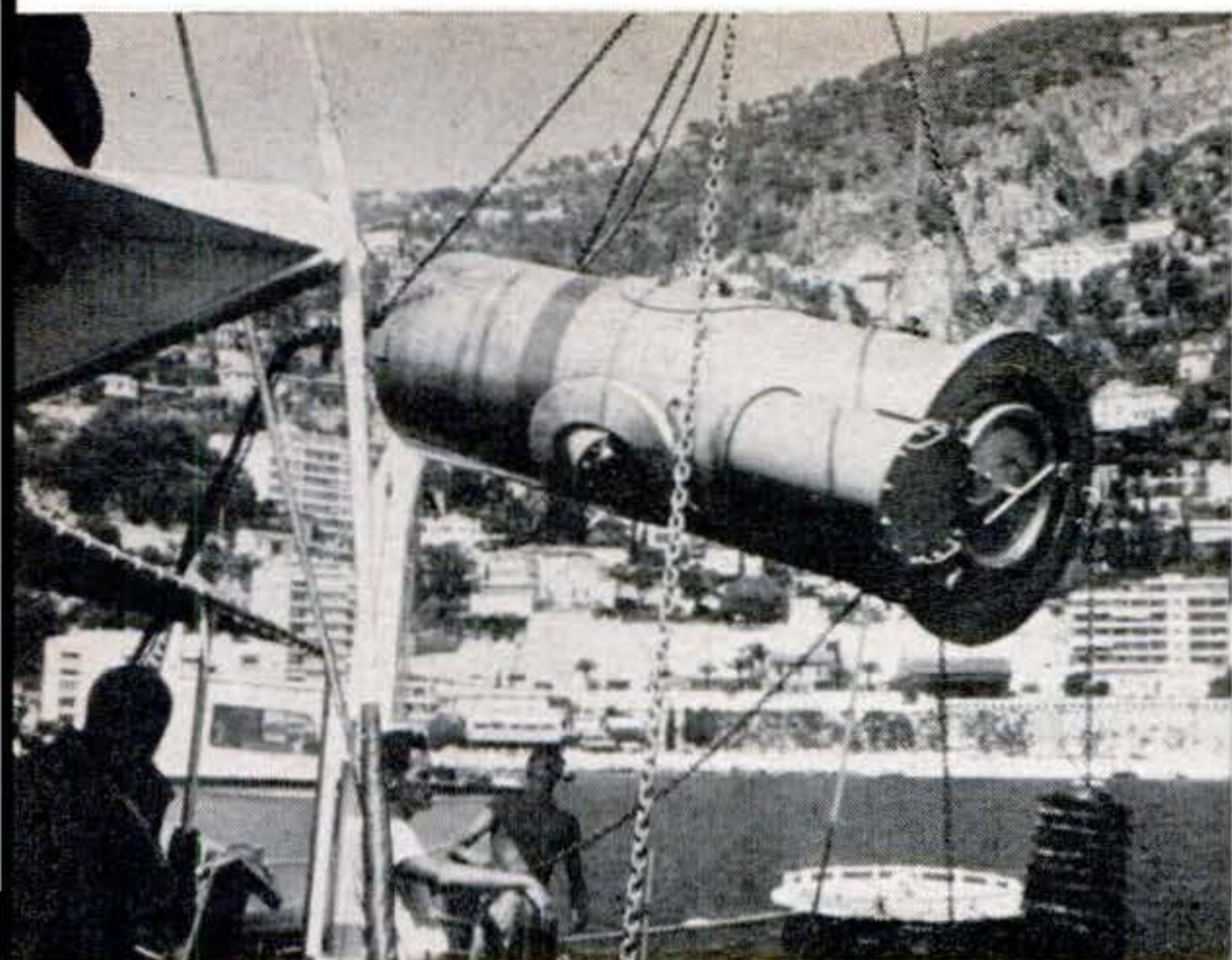

Sealed chamber, still unoccupied, is lowered from the Sea Diver. Air has been evacuated and replaced with helium-oxygen mixture.

How Link's first long, deep dives set records last summer

For the first time last August and September, in the Mediterranean off Villefranche-sur-Mer, divers lived for many hours at deep-sea pressure, breathing helium and oxygen instead of air. In one dive, Ed Link spent eight hours at 60 feet. One of his divers, Robert Stenuit, lived at 200 feet for 26 hours, eating and sleeping in the deep. These photos show how it was done.

Decompressing on deck, Stenuit rests in the chamber, now horizontal. Chamber was sealed to retain pressure before being lifted aboard



Below the surface, Stenuit enters chamber, is then lowered to 200 feet. Hatch remained open and he swam freely in and out during dive.

ship. Decompression took up 67 of the 95 hours—almost four days—Stenuit lived in the chamber. Food was passed in through air lock.



Man Under the Sea

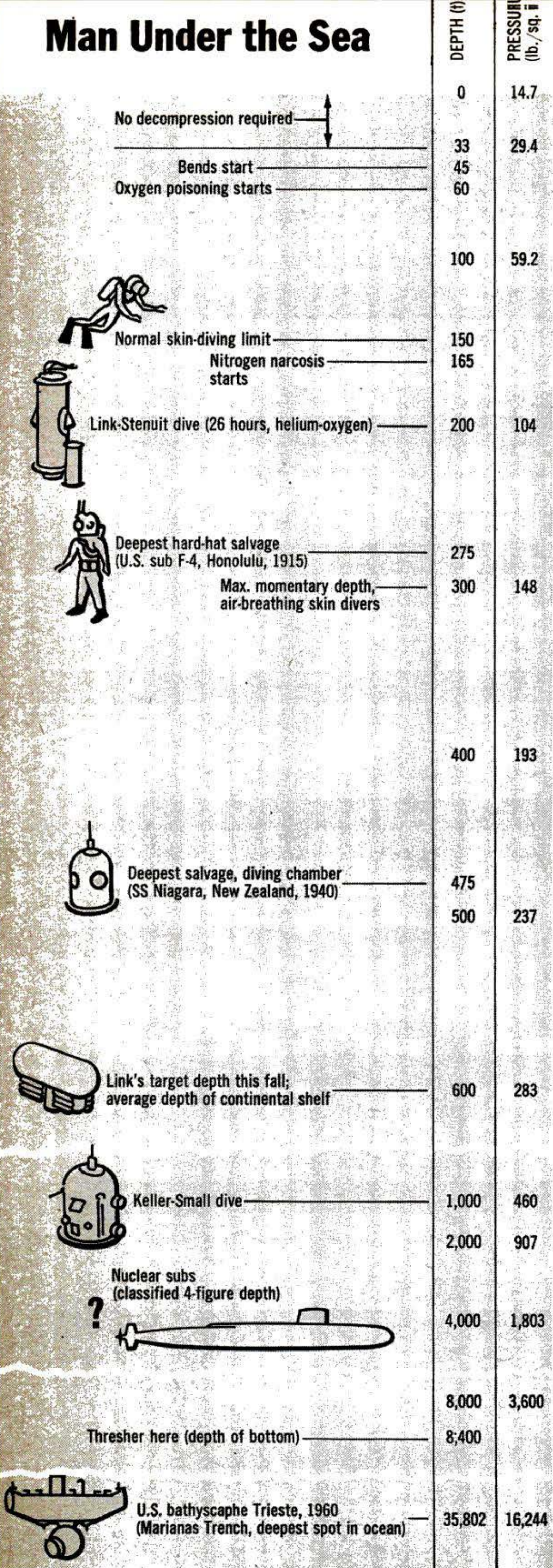

and never find his way back again.

But the divers will be able to transfer from the tent to the small aluminum chamber. Besides serving as an elevator between the base camp and the Sea Diver, the chamber, with its propellers and chain winch, provides mobility. A diver can leave the chamber at any time and swim about, his umbilical breathing hoses connected to the helium-oxygen supply of the chamber. Link calculates that divers living at 400 feet, for example, can travel up to 215 feet or down to 725 feet and return to their inflated house without requiring recompression or decompression periods.

The key to success or failure of the experiment is the helium-oxygen breathing mixture, pioneered by the U.S. Navy. To find out about the effects of breathing gases on the human body, I talked to Dr. Christian Lambertsen of the University of Pennsylvania, an authority on the physiology of diving, and to Lieut. Cmdr. Robert Bornmann, a Navy doctor who was aboard the Sea Diver as an observer last summer, and who is now working with Dr. Lambertsen.

The problems of diving, Dr. Lambertsen said, come from the fact that the human constitution is adapted to the atmosphere at sea level, with its composition of roughly 21 percent oxygen and 78 percent nitrogen, plus small quantities of carbon dioxide and other gases.

As a diver descends, he must breathe air compressed to an additional atmosphere (14.7 pounds per square inch) for every 33 feet of increased depth. So the pressure of the air becomes 59.2 pounds per square inch at 100 feet, 103.7 pounds per square inch at 200 feet, and so on.

The fizzing frogman. The first thing that happens as a result is that the body fluids become charged with gas, like soda water. When the diver heads for the surface, pressure is reduced and the dissolved air starts coming out of solution. If he goes up too fast, it's like opening a soda bottle.

"But, contrary to the popular impression, bubbling of the blood is not the

[Continued on page 164]

The 1964 Cars...

what will they be like?

A spanking-new line, compacts growing out of their britches, lots of restyling, new engines, and even station wagons with "Scenicruiser" roofs await you in the auto showrooms this fall

By Devon Francis

FOR the 1964 model year, the U.S. automobile-manufacturing industry will introduce a number of surprise packages:

- A brand-new line of cars under a new name will appear in Chevrolet showrooms.

- Four of the five lines of General Motors "compacts" will grow in size.

- Ford Motor's Falcon, Comet, Thunderbird, and Mercury Monterey will be completely restyled.

- Ford's Continental will be stretched in length.

- Chrysler's Imperial will not be recognizable as the same automobile, nor will the Dodge.

- Rambler's American will be extensively restyled.

- The new Studebakers will be lower, more powerful.

- Two GM cars will have a sort of extra deck, like Greyhound Scenicruisers, with a second windshield.

- The use of disk brakes will spread.

- A new muffler system will be put into limited use.

- A new automatic transmission is due for introduction.

- Unitized bodies will be phased out on four lines of cars and will be replaced by conventional frames and bolt-on bodies.

- New engines will appear, one of

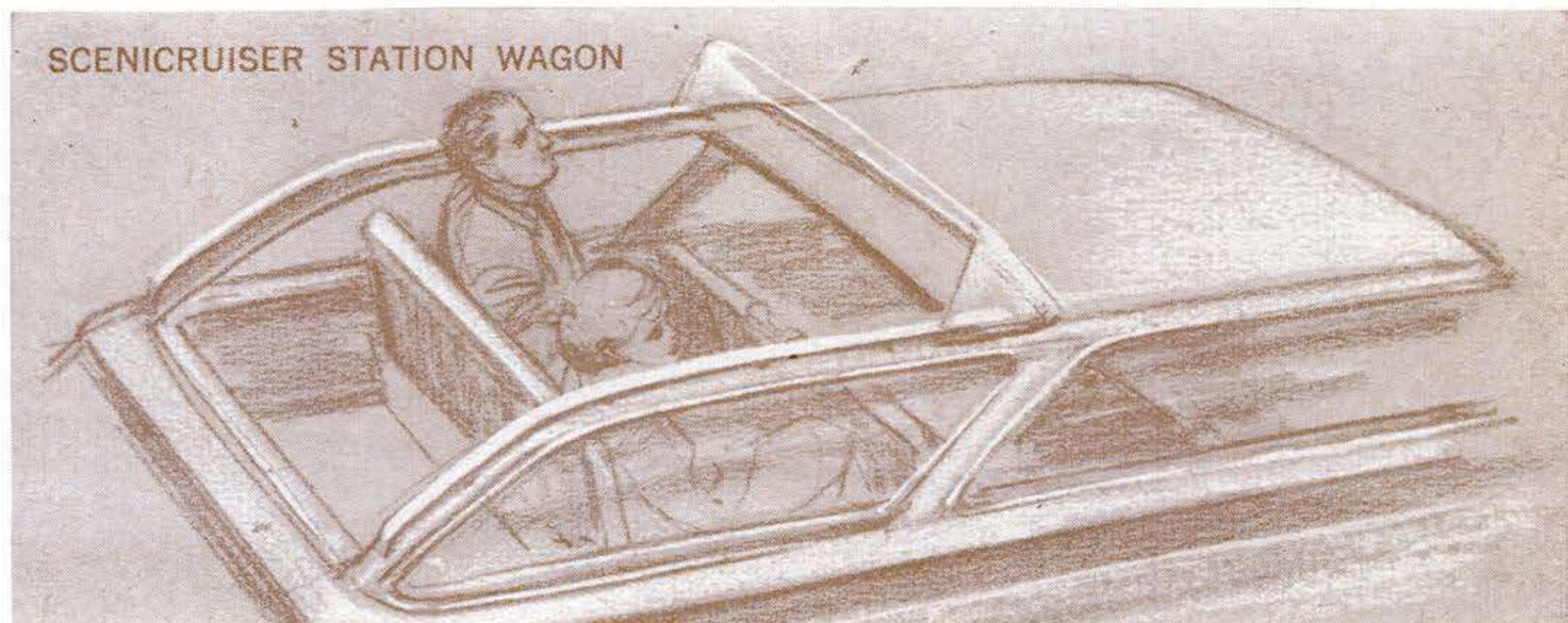

PS's crystal-gazing automobile editor sees a new Chevy, a

them with the only overhead camshaft (aside from that in the Willys) in a U.S. production car. Top horsepower, now at 425 (and higher with some of the exotic options offered), will not go up. They may, in fact, shrink in the course of the model year. The reason: NASCAR, which issues sanctions for stock-car racing, has announced a 396.5 cubic-inch limit for 1964 Grand National events. That's 31.5 inches less than at present. Engines in the 150-300-hp. range, however, will grow in muscle.

- Later in the year, Ford Motor will bring out a genuine sports car, smaller and lighter than the Chevy Corvette.

- Prices will be mixed—some will remain substantially unchanged, while others will reflect last spring's rise in the price of steel.

Now, by companies and divisions:

General Motors

GM, selling twice as many cars as anybody else in the industry, provides the most news.

Chevrolet's fifth line of cars, to be added to the standard Chevy, Chevy II, Corvair, and Corvette, has been given several names by the crystal-gazers—the Chevair, Chevette, Chevrollaire. It will probably wind up with some unimaginative name like Chevy III. An "intermediate" vehicle, midway between the Chevy II's 110 inches and the standard Chevy's 119, it will have a 115-inch wheelbase. Its power train, suspension, chassis, and some of its sheet metal will be interchangeable with those of the Olds F-85, Buick Special, and Pontiac Tempest. It will feature a new, small V-8 engine of 260 inches displacement and about 160 hp.

The same V-8 will be available in the Chevy II. The II will dump its in-line, four-cylinder engine.

Styling changes in the present four lines of Chevrolet cars will be minor.

Discount rumors that Chevy is going to make an orphan of the Corvair. The Corvair will enter its fifth year of pro-

duction wearing the same sheet metal, but with the number of models reduced to two. The Corvair's big appearance change is due for '65.

Corvair's Greenbrier van will be switched to a Chevy II chassis, with a front-mounted, instead of a rear, engine.

Due for lengthening by several inches: the Chevy II, F-85, Special, and Tempest. These cars also will be converted from unitized to body-on-frame construction to reduce fabrication costs. Adjustable steering wheels—like those introduced in several GM cars last fall and in the course of the model year—will be offered in the Corvair, F-85, Special, and Tempest as an option.

The Scenicruiser design will appear in the F-85 and Special station wagons. The stern portion of the roof, raised about four inches, will sport the extra windshield.

Both the F-85 and the Special will drop the aluminum V-8 engine they have featured for three years in favor of a thin-wall iron V-8 of perhaps 160 hp., made by a process pioneered by Ford Motor. Thus these two cars follow in the footsteps of the Tempest.

In addition to the new V-8 in Chevy's intermediate car and the II, GM will bring out an overhead-camshaft, six-cylinder engine of 175 hp. or more for the Tempest. This cam, to be driven by

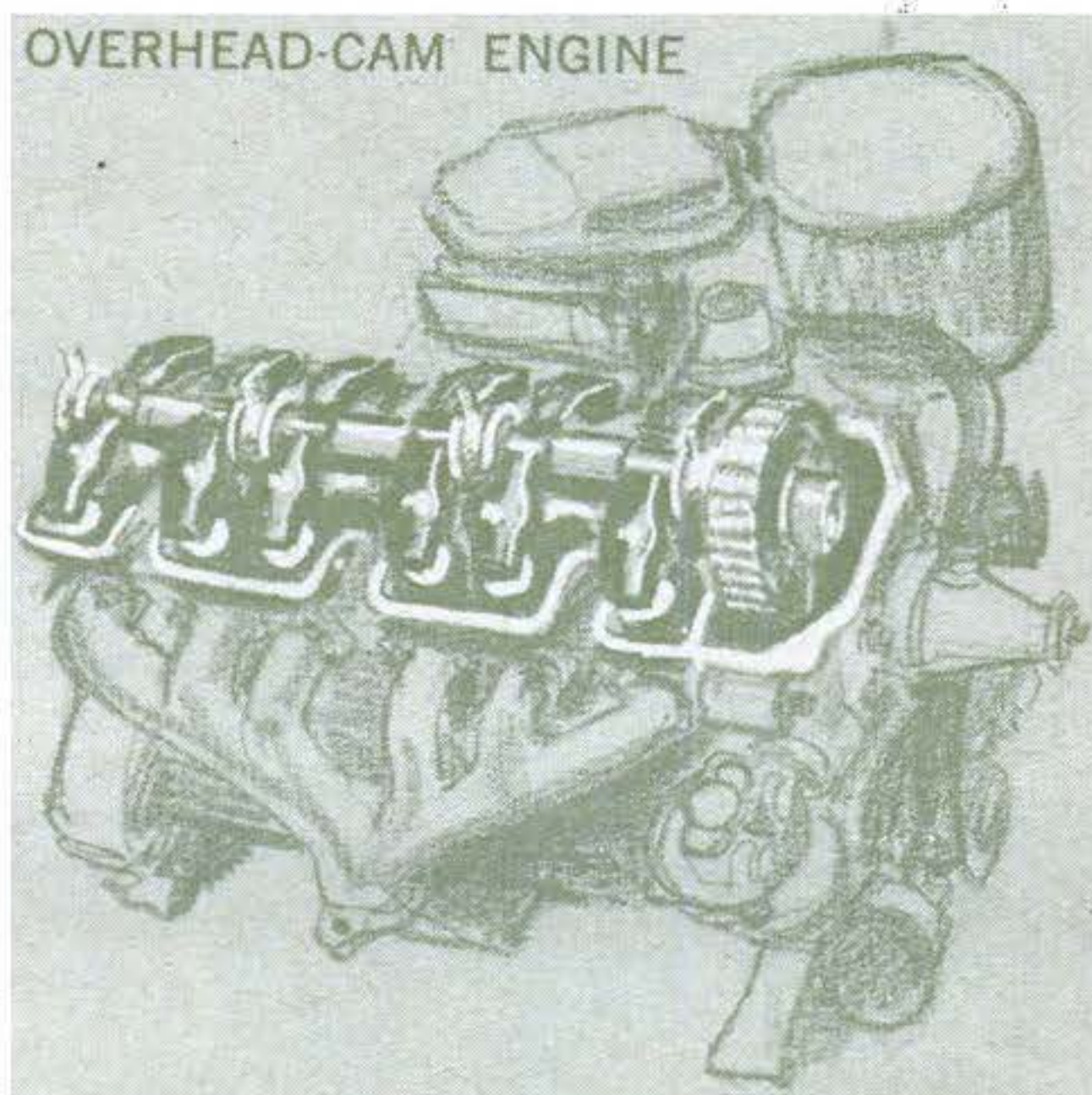

surprise by Studebaker, bigger compacts, a Ford sports car

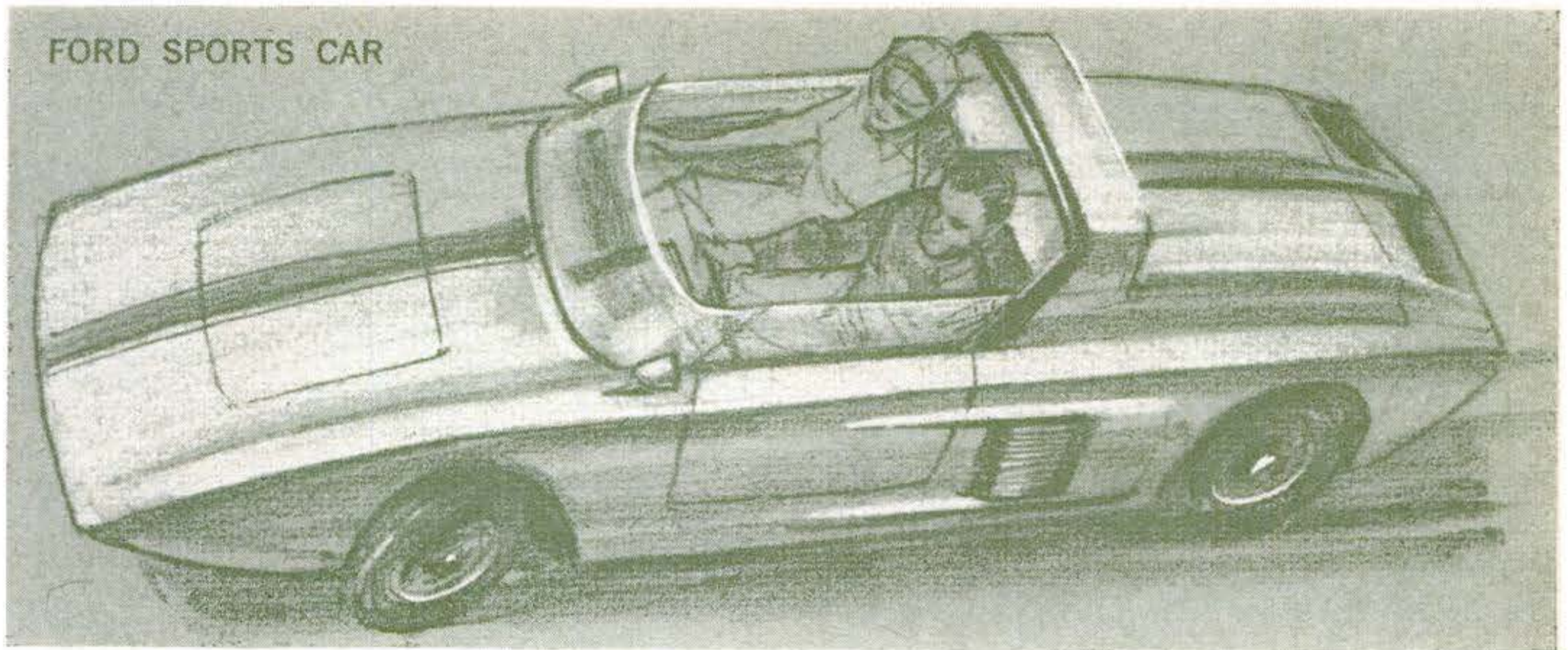

an external cog belt, will develop more power than a push-rod design. The engine will be an adaptation of Chevy's 230-cubic-incher which was new last fall. The novel positioning of the oil and water pumps on the engine front cover, as in the 1963 Cadillac, will be adopted for the Tempest's new power plant.

Abandoned: the Tempest's half-a-V-8 four-cylinder engine, as well as its flexible drive shaft and the transmission nested over the rear axle. This means an end to separately suspended rear wheels.

Buick's Riviera will get disappearing headlamps like the Corvette's.

After 14 years, Buick's famous Dyna-flow automatic drive will be replaced by a new torque converter, currently called the Dyna-Matic. Ultimately it will replace also the oldest automatic in the business—the Hydra-Matic used by Cadillac, Olds, and Pontiac.

Ford Motor Co.

New styling will give the Fairlane less of that look of having been built for Aunt Martha.

The Falcon and Comet will get a new, sporty look somewhat like that of Ford's British-made import, the Cortina, to make them more competitive in appearance with the Corvair. Both will grow four inches in length. Both will get a 289-inch, 195-hp, V-8 optional engine. Except for the Falcon Sprint, and the bucket-seat Comet, these cars will

have to be satisfied with a 170-inch six.

Finally, these two Ford Motor compacts will offer three-speed automatic transmissions in addition to the two-speed drives they have carried as an option.

Ford's Galaxie will be face-lifted. The rounded front-end lines of the Thunderbird will give way to the crisp, sporty styling of 1959 that somehow got lost in the shuffle three years ago. The back seat will be cove-shaped in an interior styling innovation that Ford no doubt will extend to others of its cars later.

The Mercury Monterey will be endowed with sizzling new styling. Not to be discounted are reports that Mercury's Meteor, the division's opposite number to the Ford Division's Fairlane, will be reduced from a complete line of cars to a model name among the higher-priced Comets. Reason: to lesson the confusion in Mercury brands.

The Continental will be four inches longer to provide better seating in the rear, with fat, low-profile tires for a softer ride.

Ford's sports car will not appear until late in the year. Contrary to persistent reports, this vehicle will not be powered by the tiny V-4 engine that drives the German-built Ford, the Taunus Twelve—that's the erstwhile Cardinal [PS, May '62]—as well as the experimental, rear-engine Mustang. It is designed to

SLIMMED-DOWN MUFFLER

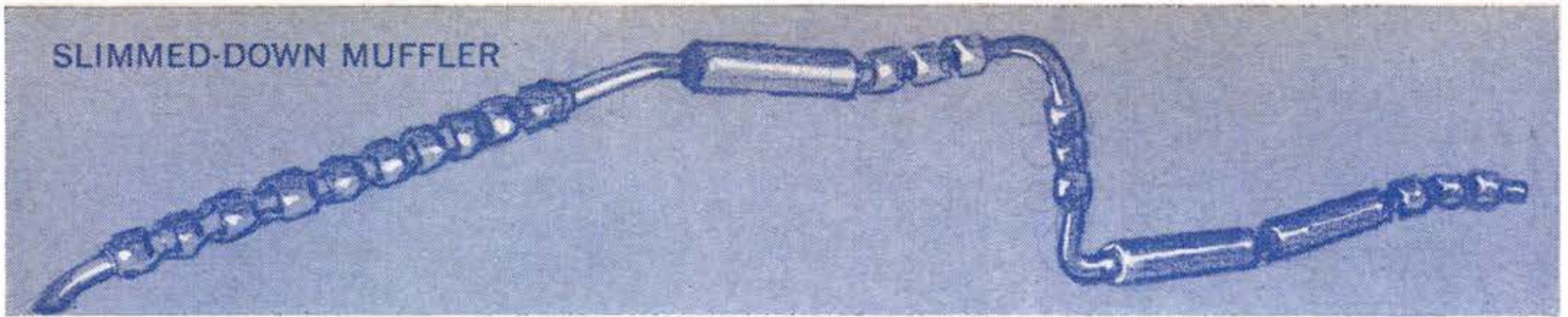

take the 289-inch V-8 that pushed the Falcon Sprint to victory in its class in the Monte Carlo Rally last winter and powered Carroll Shelby's British-built Cobra in the Sebring and Le Mans road races. To be produced in limited numbers, the Ford sports car will, nonetheless, have the Mustang's lines. It will cost considerably less than the Corvette.

The Thunderbird (and Olds F-85) will employ a radical new exhaust system in '64. The muffling components are all contained in a long tube not much larger in diameter than a conventional tailpipe. This frees the stylist to lower the car still further without affecting road clearance. Made by the Walker Manufacturing Co., the system is fabricated of what is known as chambered pipe, with tuned silencing chambers.

Following the lead of Studebaker's sporty Avanti, the T-Bird will adopt disk brakes for the new model year.

American Motors

Biggest news will be an all-new Rambler American, restyled and six inches longer in wheelbase for a better ride, though the overall dimensions will change little.

For the first time, other Rambler lines—the Classic and Ambassador—will feature hardtop models. There'll be more convertibles. Rambler, too, will adopt the Walker exhaust. After one season, American Motors will drop the curved side glass as an economy move. This will be picked up by several GM cars.

Studebaker

Larks will be lowered by five inches. The emphasis will be on power by supercharging. Styling changes will be marked, and Larks will provide one of the sleeper surprises of the year.

The floor-mounted selector quadrant

for the automatic transmission, available now in only the Super Hawk and Super Lark, will be offered as an option in all the company's cars. This is a move toward aiming the Lark's appeal at younger customers who want to hear the tires sing when the light turns green.

Chrysler Corp.

The company's changes for '64 will be few. It will dump its front torsion-bar suspension. Originally scheduled for '64 but now put off until '65 will be abandonment of its pushbutton automatic transmission control, a source of irritation to many drivers.

Biggest styling change will occur in the luxury Imperial. Under the guidance of Elwood P. Engel, who went from Ford to Chrysler in 1961, this car is bound to take on some of the sculptured appearance of Ford's Continental.

Sheet-metal changes in the Dodge will go considerably beyond the face-lifting on Chrysler Corp.'s other cars.

Plymouth will add a model with a 119-inch wheelbase to get on better competition terms with Ford and Chevy. The standard wheelbase: 116. The bigger Plymouth will compete with the Dodge 880.

Biggest change in Chrysler Corp. styling is reserved for the 1965 models. Meantime, the main publicity emphasis will be on its gas-turbine engine, announced in May for incorporation in a few dozen automobiles that will retail at something like \$10,000 a copy [see "Detroit Report," page 32].

Overall, Detroit's prices for '64 will follow this pattern: Low-volume cars will be up in price, while the big-volume vehicles, with the advantage of interchangeability of parts and therefore manufacturing economies, either will hold at today's prices or go up little. ■ ■

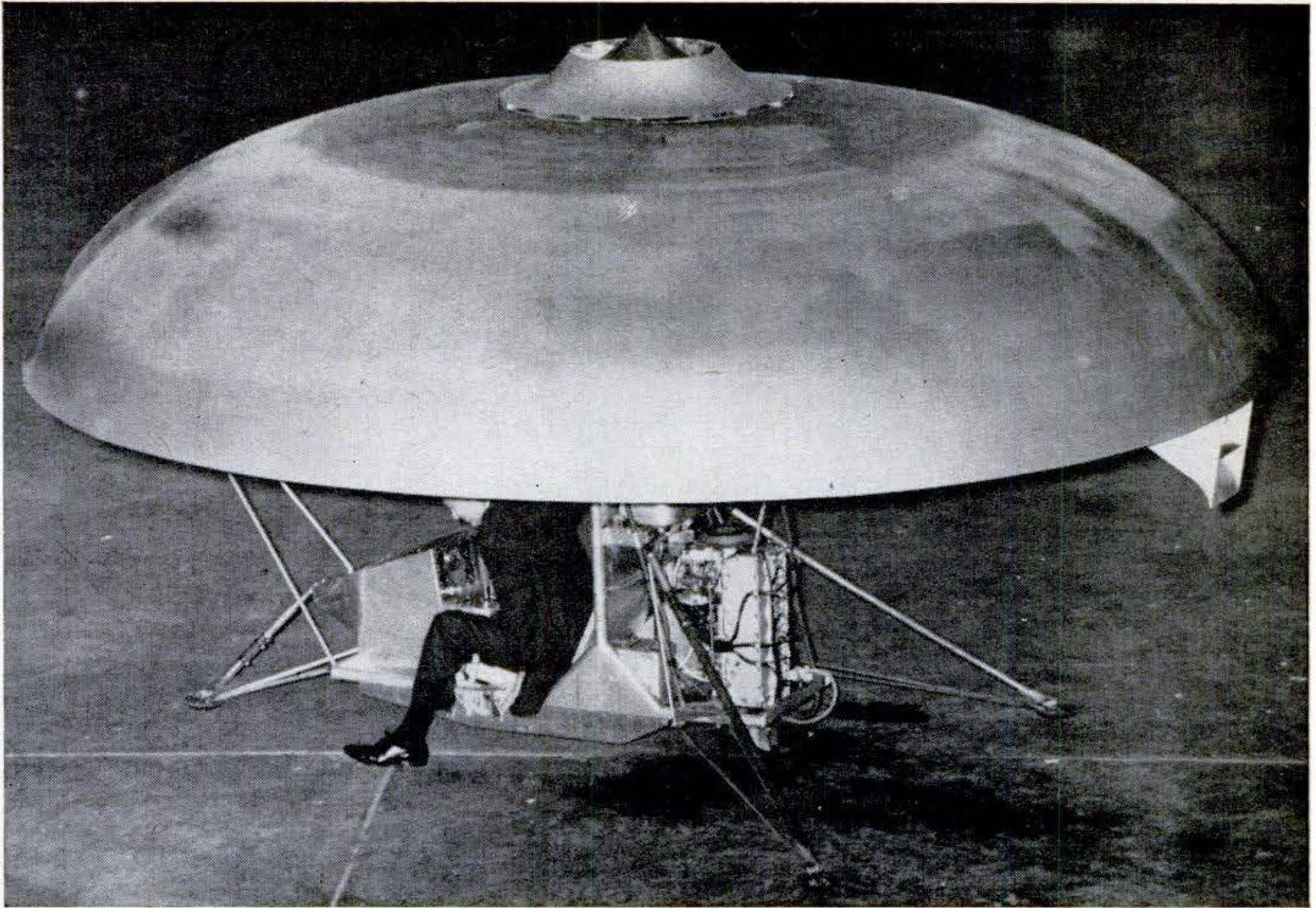

Saucer-shaped helicopter gets lift from air pump

Air pumped from inside this inverted dish by the impeller on top creates an air flow over the upper surface that causes the craft to rise vertically. Reason, says the maker, Astro Kinetics, of Houston: less pres-

sure in this air layer than that of normal air below. This eliminates need for rotor blades, while maneuverability and forward speed are said to be the same as for a helicopter. Motor: a 135-hp. Mercury outboard.

Foam plastic floats basket hoist and raft

The raft on which scuba divers rest at right is one of the Coast Guard's latest rescue devices. Resembling a big mattress, it is stowed folded on shipboard. When needed alongside to get survivors off a ship in a hurry, it is blown up with buoyant urethane foam from a portable generator.

The basket hoist is similar to that used in sea rescues by helicopters. This one has built-in urethane-foam blocks to keep it afloat; on others you had to attach life preservers for buoyancy.

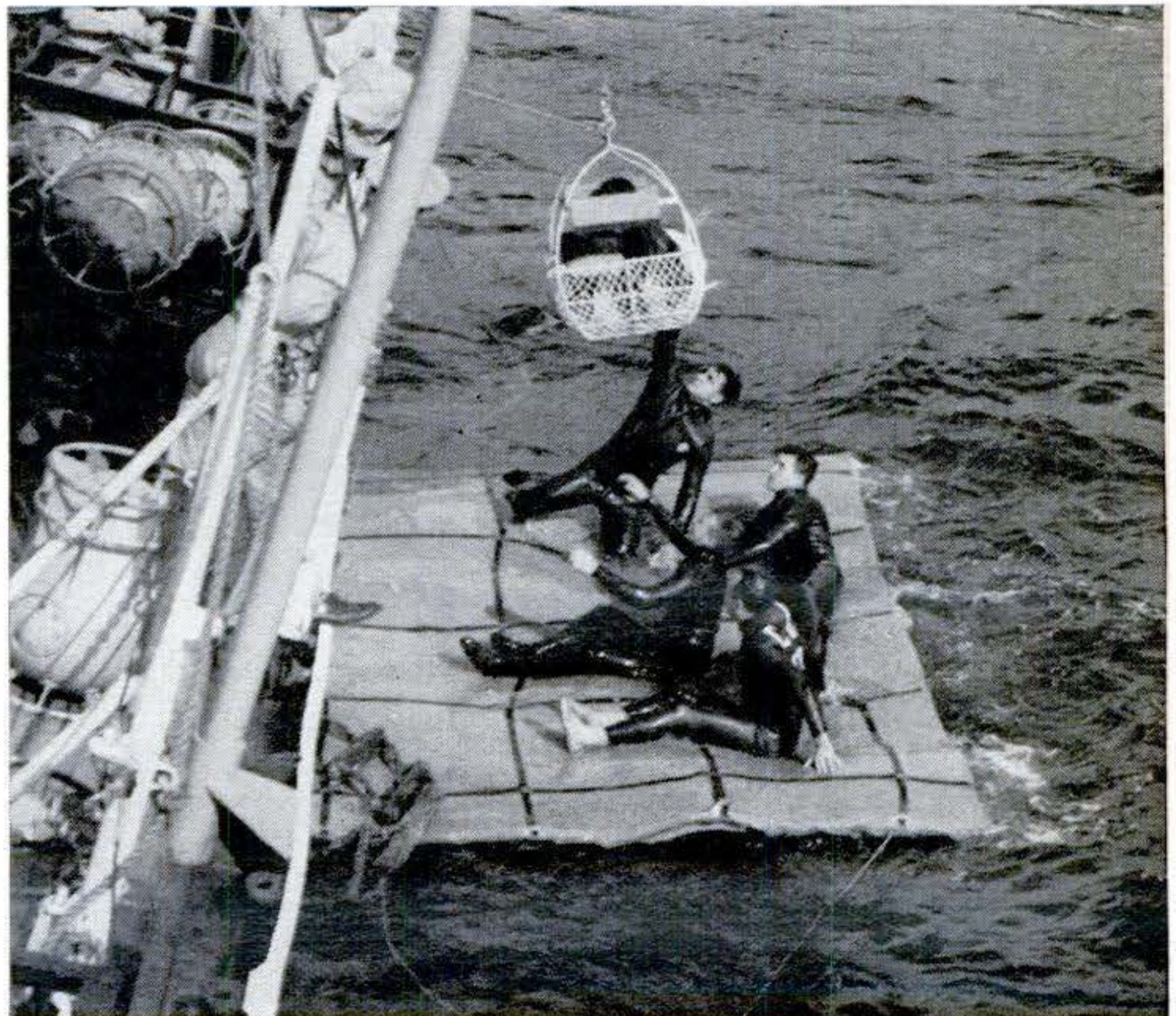

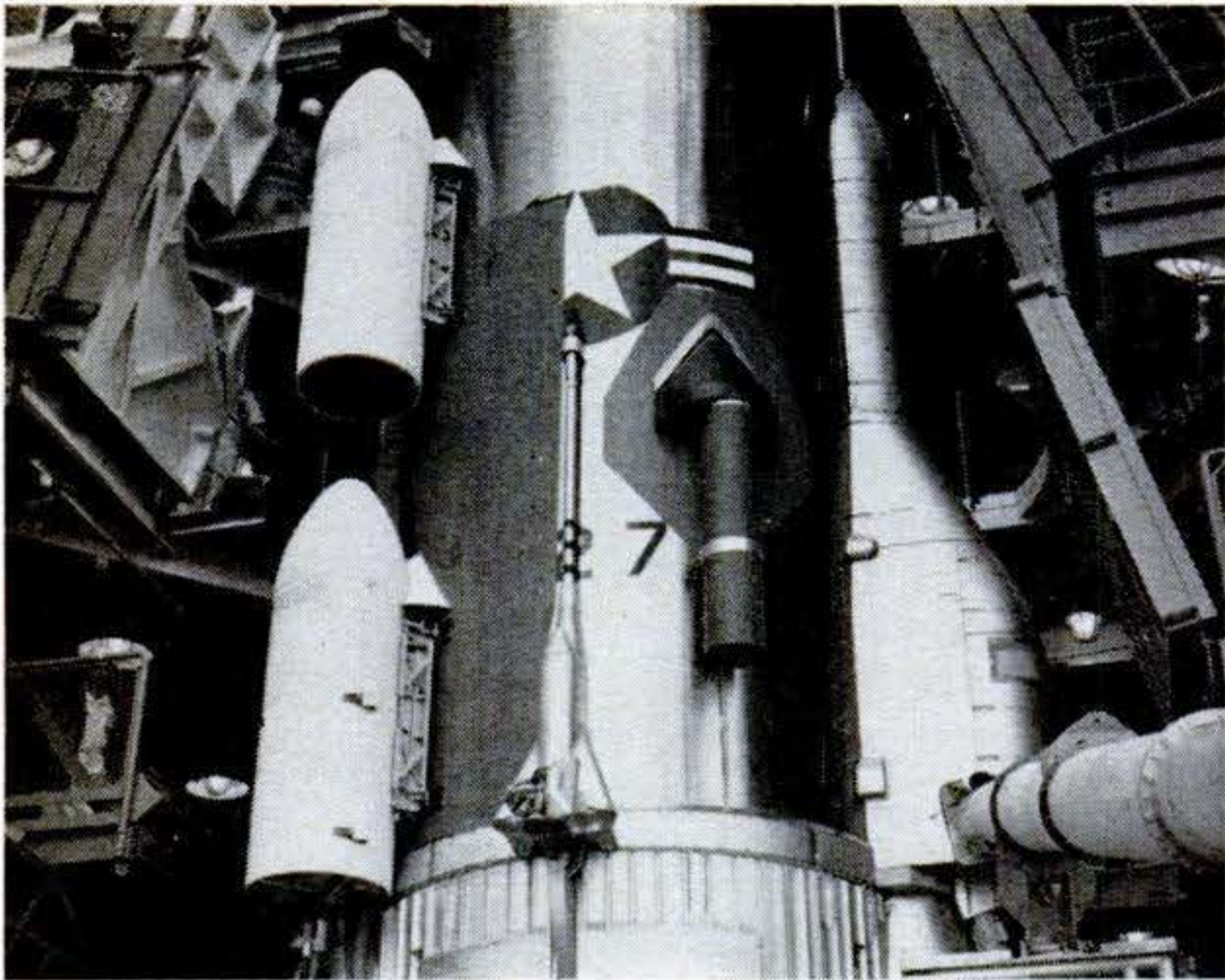

Space hitchhikers ride piggyback on Atlas

Two scientific-instrument pods are mounted in tandem (far left) on an Atlas missile to pick up additional knowledge on a free ride into space.

The small flying laboratories, developed by General Dynamics (which also produces the Atlas), can be adapted to any booster capable of carrying the extra payload. Projections at right are parts of the Atlas booster itself.



London church to cross Atlantic

This war-bombed church in London will be dismantled stone by stone and re-erected at Westminster College in Fulton, Mo., as a tribute to Sir Winston Churchill. Churchill made his famous "Iron Curtain" speech at the college in 1946.

St. Mary Aldermanbury was built by Christopher Wren in 1670-1686 on 15th-century foundations. Cost of transportation alone will be \$200,000.



New face for Times Tower

Landmark of New York's Times Square since 1904, the 23-story Times Tower is being modernized. Only the steel-girder framework will be left when it reopens next year as Allied Chemical's glass-and-marble "showcase for chemistry." It will house offices, sales rooms, and three restaurants. Its famed electric news sign will be there, too.

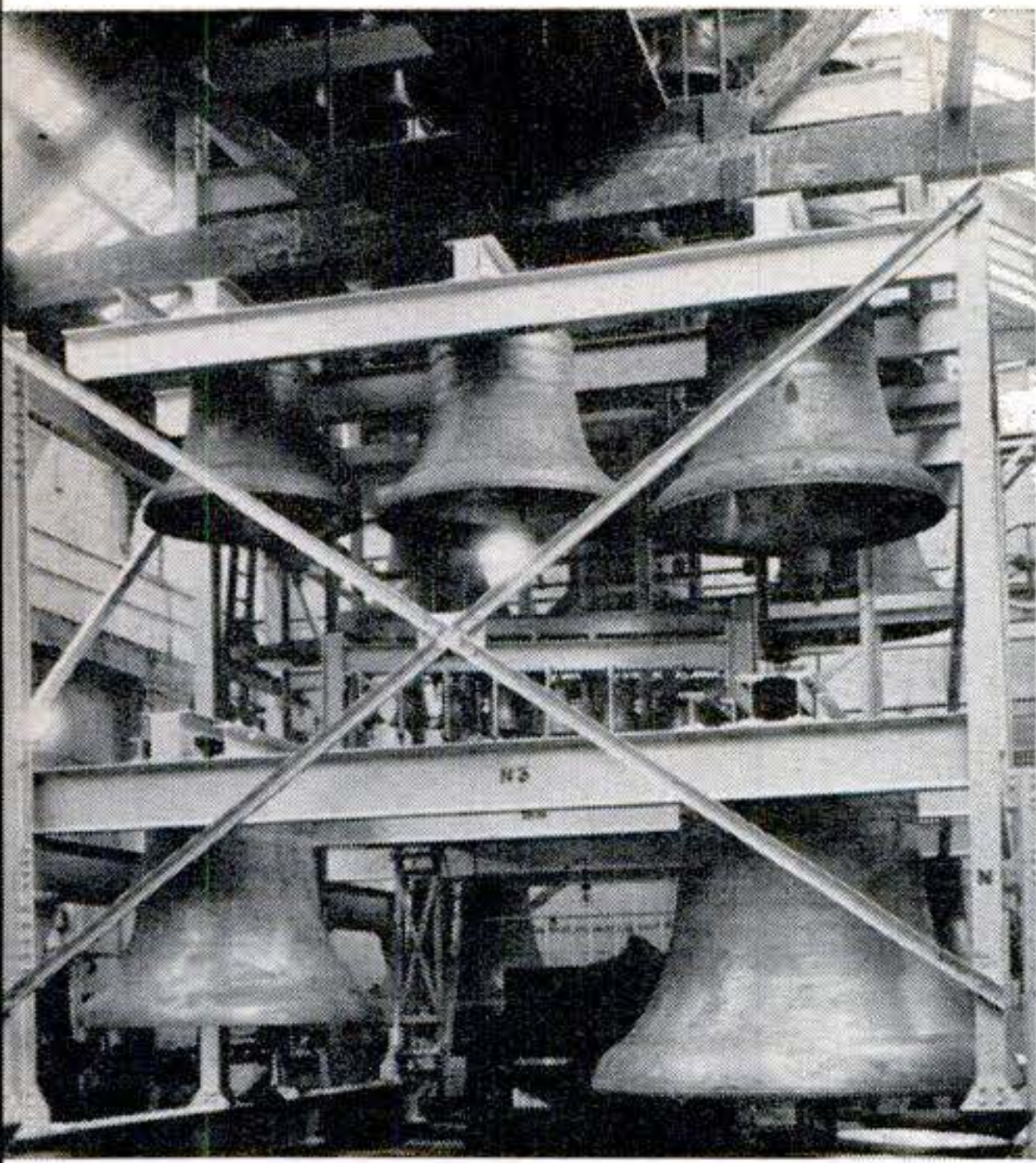

Bells for Washington

The grand carillon for the National Episcopal Cathedral in Washington, D. C., weighs over 100 tons with its 30-foot-high steel frame. Made in England, it has 53 bells covering $4\frac{1}{2}$ octaves. The largest—bass E flat—is an 11-ton bronze casting (lower right) $8\frac{3}{4}$ feet across. It will be installed in the central tower now under construction.



Battery typewriter

Under the keyboard of this portable electric typewriter is a rechargeable nickel cadmium battery that eliminates a cord. Overnight recharging from a household outlet, says SCM Corp., supplies enough power to operate it all day. Black & Decker makes the motor; Gould National Batteries, the power pack. Poweriter costs \$199.50.

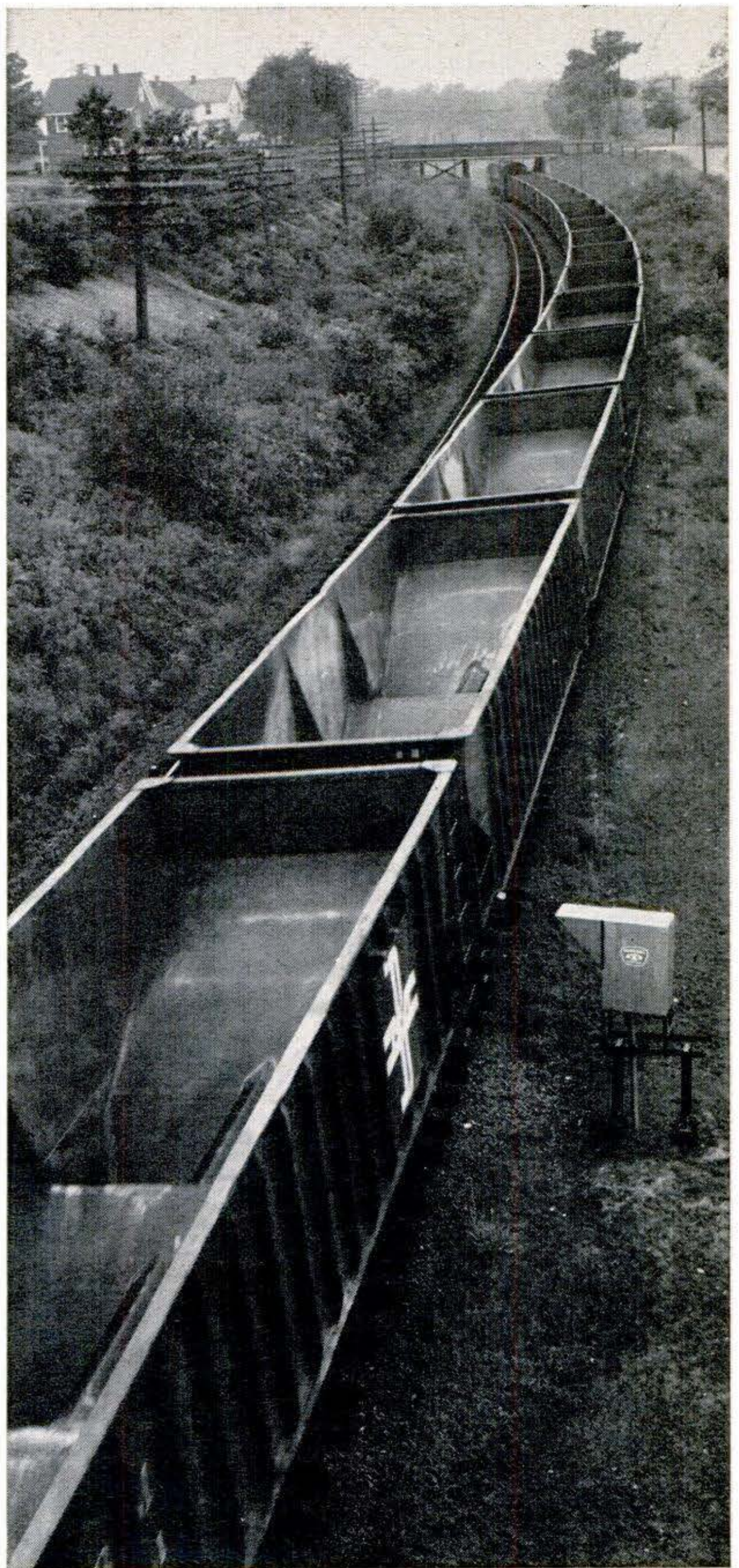

Trackside scanner reads moving labels

Railroad cars on the Boston & Maine are coded with Scotchlite reflective tape for high-speed identification by an electronic scanner. The scanner, developed by Sylvania Electric Products, sends out a beam, receives its reflection in colors, translates the colors to numbers, and prints the numbers on tape. It's reliable at speeds up to 60 m.p.h., day or night, and in snow or rain.

Strange giant machines have begun "paving" the Mississippi—to wipe out threats of superfloods...



Ol' Man River Meets His Match

By E. D. Fales Jr.

BATON ROUGE, LA.

A NIGHTMARE haunts the U. S. Army Engineers whose job it is to control the Mississippi. It's a superflood that might some day top the great 1927 disaster when the river drove

600,000 people away from their homes.

To shore up dikes—the levees—and help valley towns sleep better, the Engineers are using strange, giant machines. One is called the "garmouth," one the "gangster," and one the "rolly-go." These are actually paving the river-

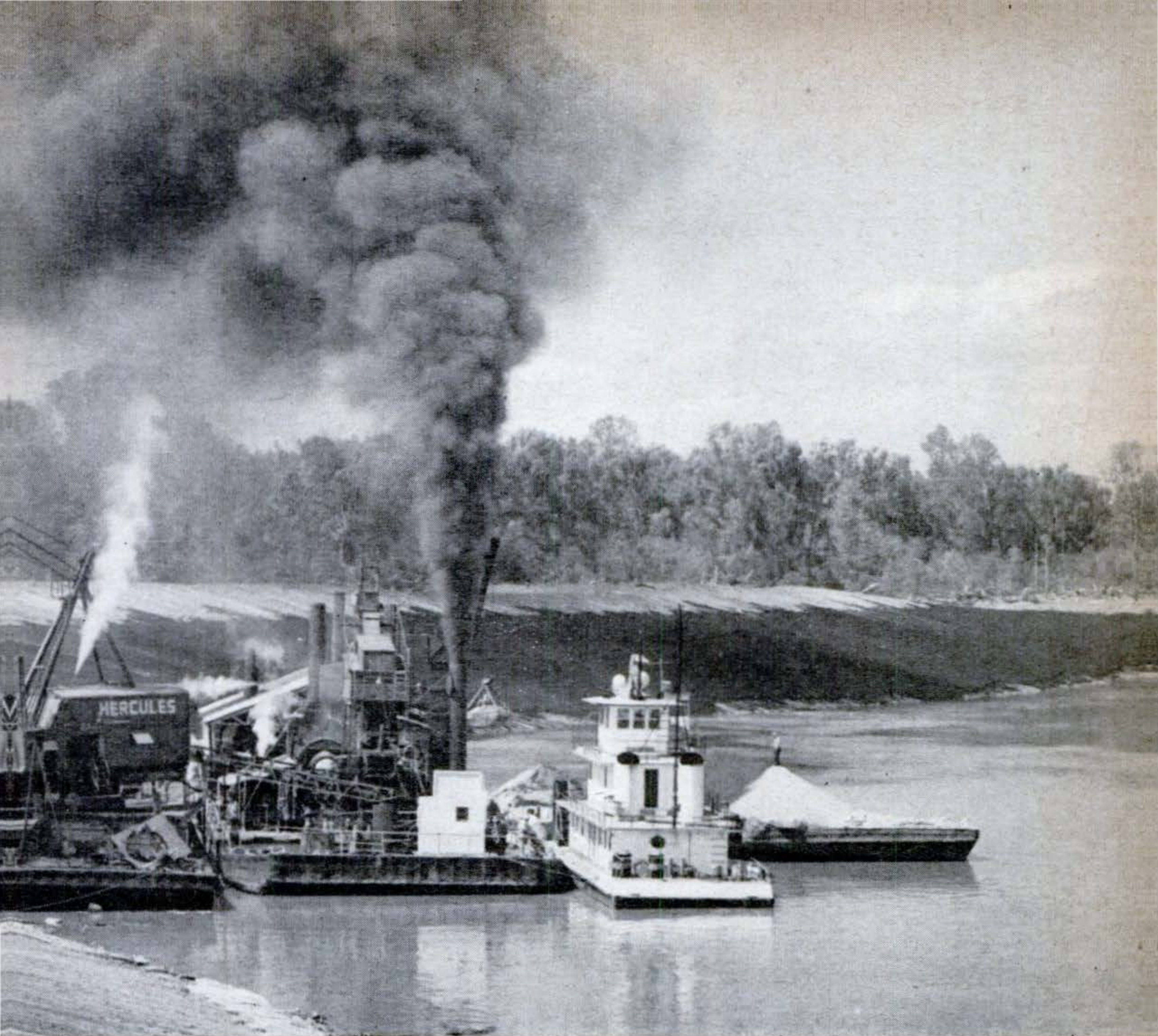

banks—and even the river bottom itself—with a carpet of concrete, in the hope of holding things in place if the big test ever comes. To date nearly 200 miles of such carpeting has been laid.

I'd heard about these big rigs, and with photographer John Turner of the Army Engineers set out to find them. We knew they were being used to beef up dikes near Baton Rouge, and also near Lake Providence, La. At Baton Rouge, the river, writhing like a snake, was trying to bust out and race through a dreary place known as Devil's Swamp. The city's great new harbor lies nearby. If the river came through, it could wreck not only the harbor, but some of the city.

At Lake Providence, pop. 5,000, it was smashing a bluff and a forest, trying to sneak up behind the city.

Into both spots the Engineers had hurled their machines, to heal the torn bluffs by smoothing them down with dirt and paving with concrete carpets.

Turner and I drove for miles along

Danger point: The rising river was trying to take a short cut toward the new Baton Rouge harbor.



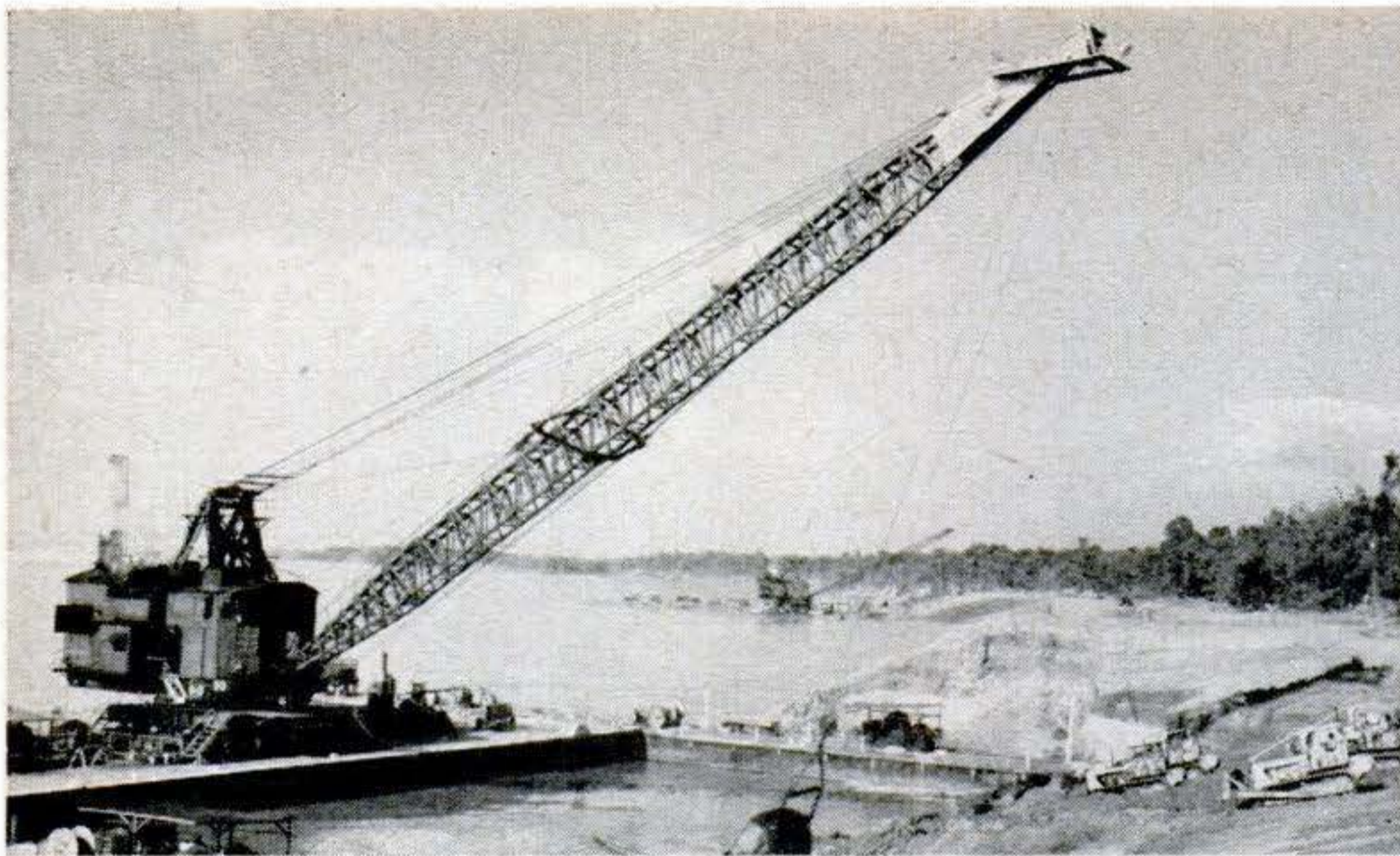

Casting the garmouth: This giant crane boom flings a seven-ton bucket shoreward in its bank-smoothing operation. Note the relative size of the three D-6 Caterpillar bulldozers pushing down dirt on the bank at right to feed the huge bucket. The river bottom is also smoothed out.

the levee. From its crest you look down on rooftops that are below river level. Once we slogged our brand-new Olds through two miles of mud. Then we slogged ahead on foot.

We came at last to a gash in a forest. A whole cliff had fallen. The river was taking hungry bites out of Louisiana.

The garmouth

We were just in time to see three yellow D-6 Caterpillar bulldozers come rattling down the broken bank, pushing up piles of dirt. Out in the swirling river lay a barge with a powerhouse on it as big as a barn. There was a belching smokestack, and a long crane boom, whippy and flexible. Suddenly the boom whipped out and sent a monstrous bucket—big as your garage—flying through the air. It was coming shoreward straight at those yellow dozers—to gobble the dirt piles and drag them into the river. In this way it was smoothing out not

only the bank but the river bottom for 500 feet under water.

Over and over again that bucket was flung at the tractors, then dragged back, pulling mountains of earth. It was hurled with such fine precision that I said: "John, we ought to meet the guy who can bait-cast a seven-ton bucket." A fast boat whipped us out to the barge. I'd seen draglines moving earth, but never anything like this. This drag bucket, the garmouth, named for a vicious, snapping Mississippi River fish, swallows a mammoth dinner of 15 yards—enough to bury your house in two or three casts—then dumps it in the river.

But I was puzzled. I'd expected to find this big machine putting the river-bank back together—not tearing it down. Turner explained: A river chews at any roughness in the bank—as a man keeps scratching an itch. The spot gets worse, eventually breaks through the levee.

And so the garmouth was smoothing

CONTINUED

Here's how the garmouth is healing the river



Rising river has chewed away the forest and a high bluff, trying to attack a levee and town.



D-6 dozers begin smoothing down torn bluff, pushing piles of dirt down for the garmouth.



Mighty garmouth bucket explodes from depths after taking a huge bite of dirt from torn bank

and depositing it in river to smooth off bottom. "Pavers" will come along next.

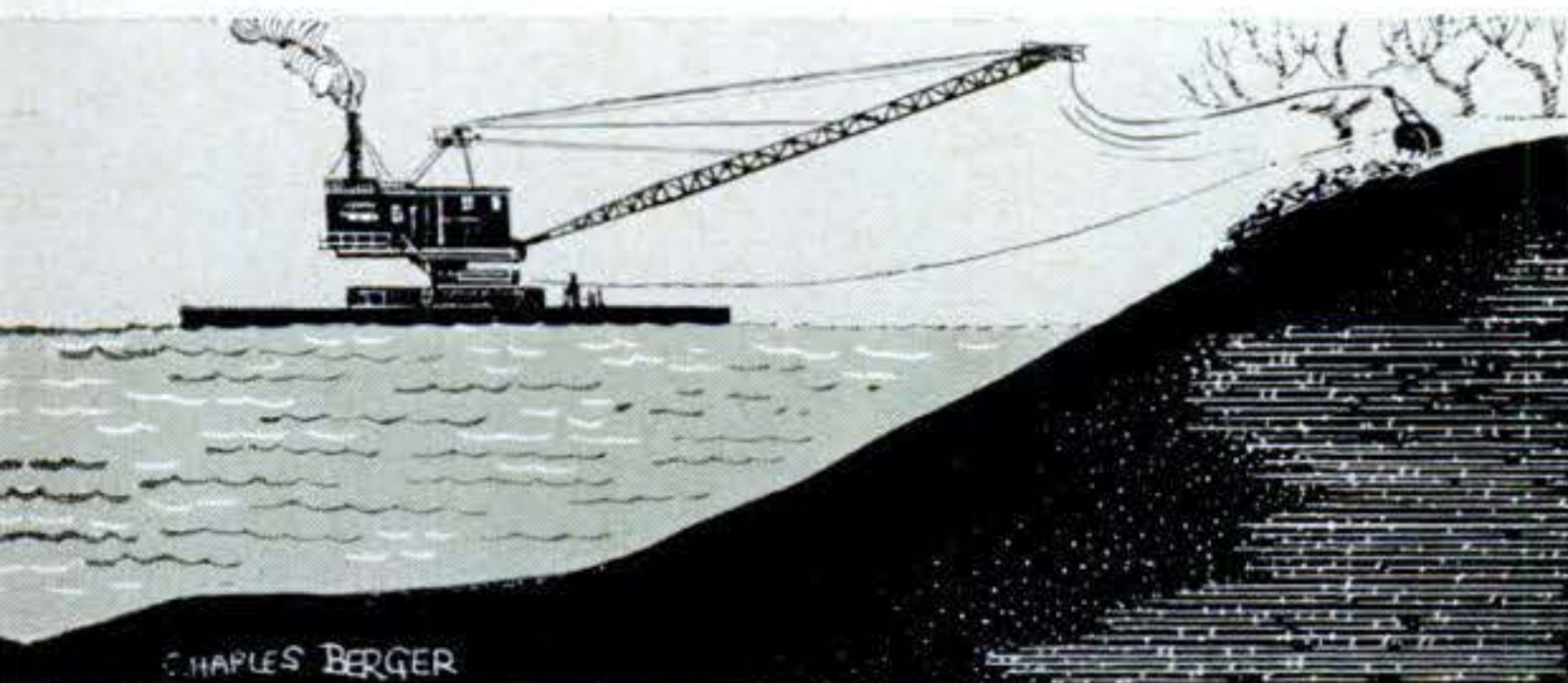

CHARLES BERGER

Big barge arrives and begins flinging bucket ashore, between dozers, to gobble dirt.

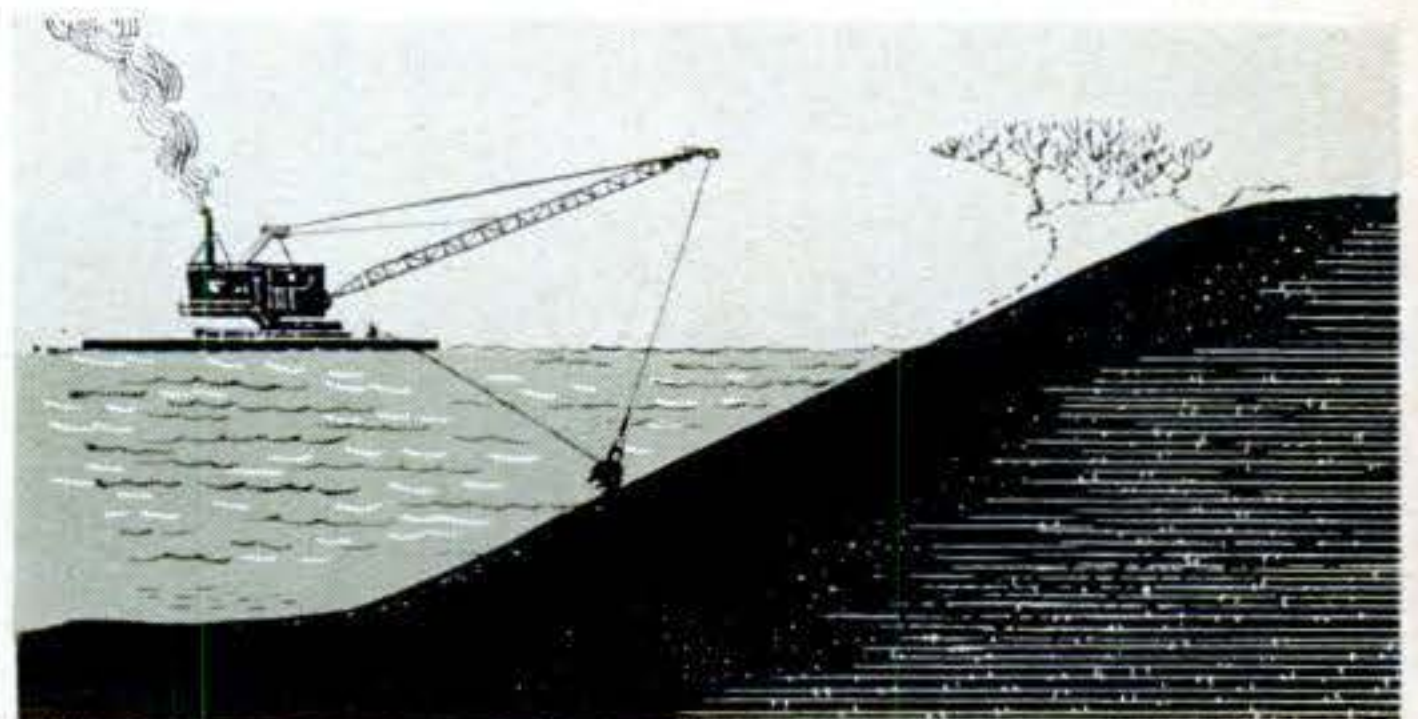

Dirt is hauled down, dropped in river, making bottom for 500 feet as smooth as a highway.

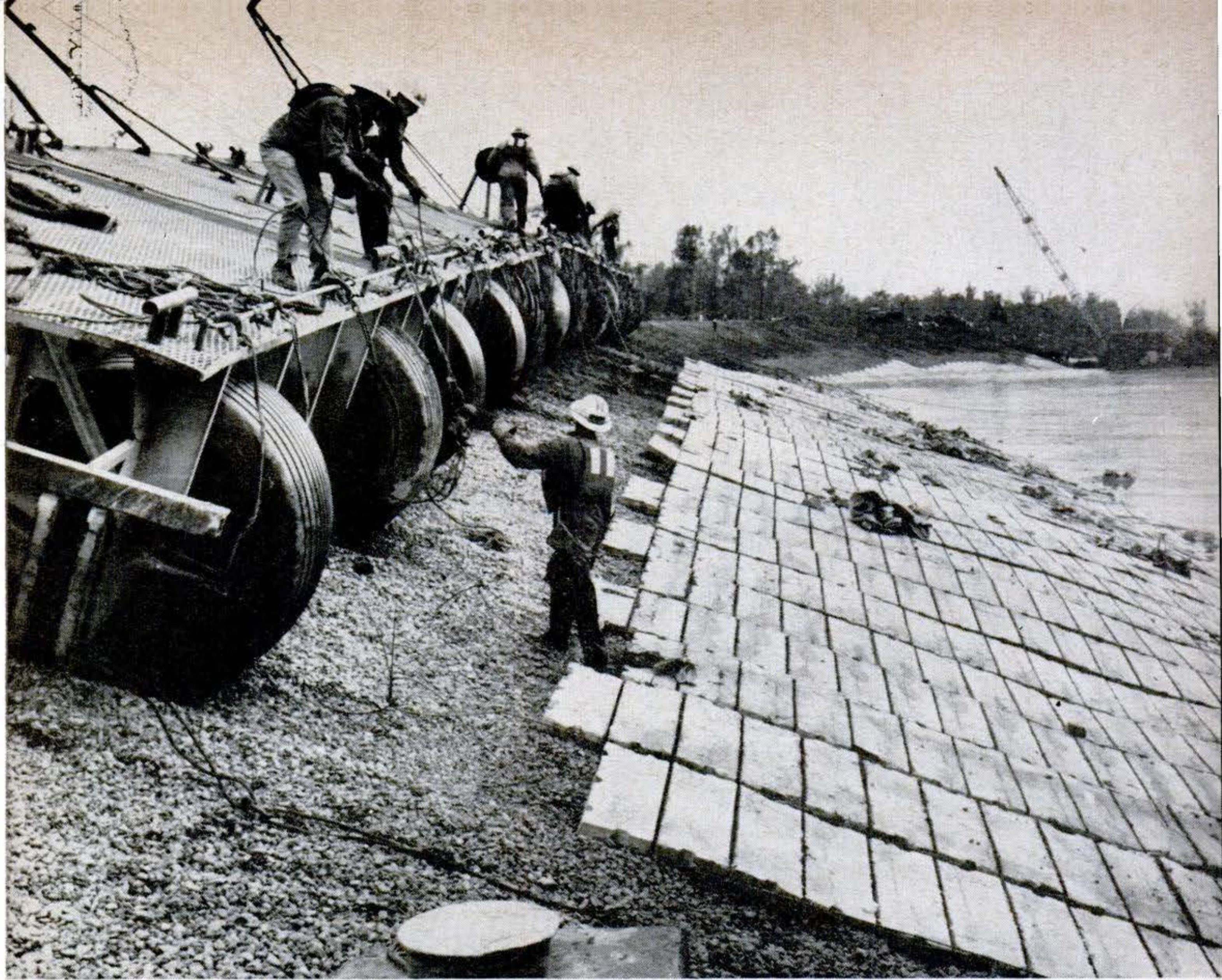

Giant roly-go, hauled by dozers, creaks up the bank dragging shoreward a wire-woven "car-

pet" of concrete slabs. At right, slabs are shown rolling rapidly off the deck of the barge.

pet" of concrete slabs. At right, slabs are shown rolling rapidly off the deck of the barge.

the broken bank. It was doing more, too: preparing it for the gangster barge—the carpet-layer—coming next week.

Out on the dragline barge, we put on tin hats and climbed into the vast dragline power room. It stood up above the deck, a big barn balanced on 80 wheels that could whirl it around on a merry-go-round track. The room roared, shuddered, and shook with each cast of the

bucket, dipping like a ship in a storm. Steam hissed, pipes dripped, Pitman arms flashed, and an eight-foot flywheel sang a shrill *whe-e-e-e*. Holding on tight, we went up another shaking ladder to the control box.

There we met a cheerful, huge-fisted giant named Bob Mathews, who certainly should rate as the world's champ bait-caster.

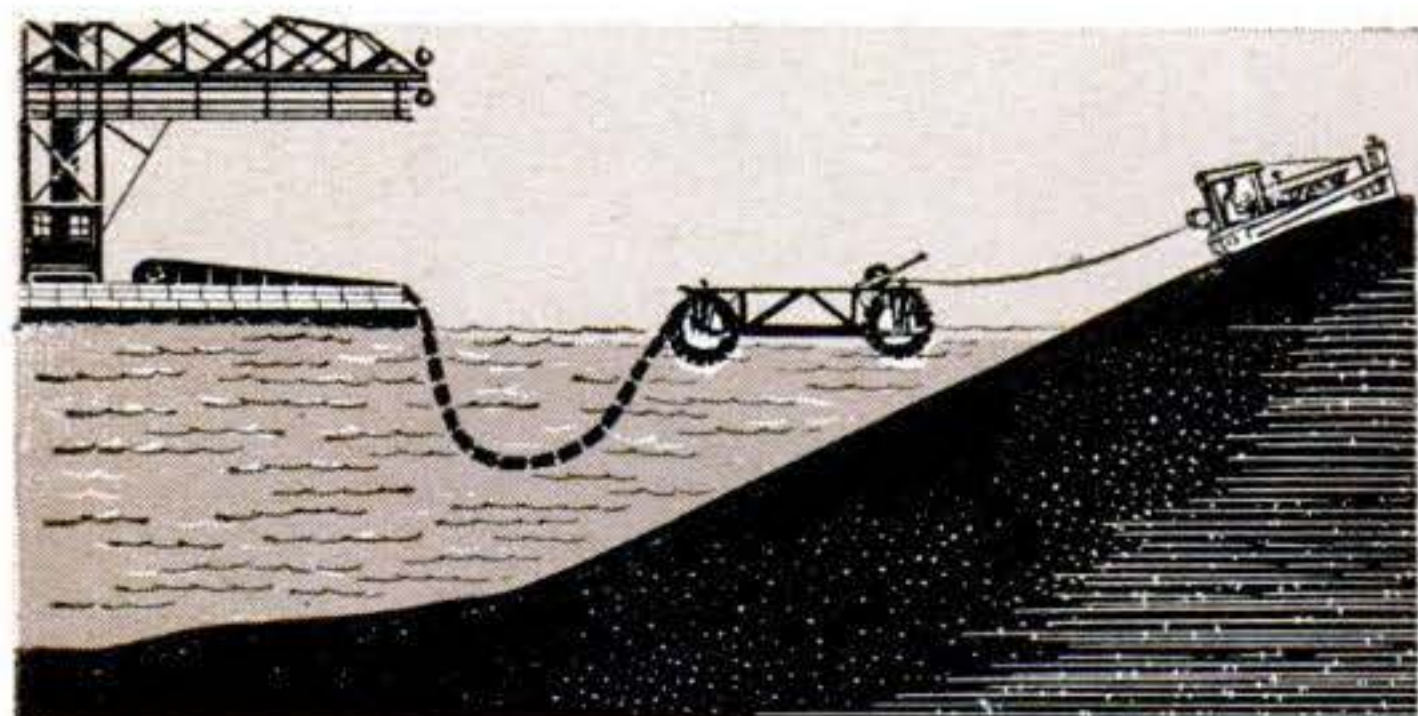

"Water-walking" on its 24 huge tires, the roly-go moves out toward rug-weaving barge.

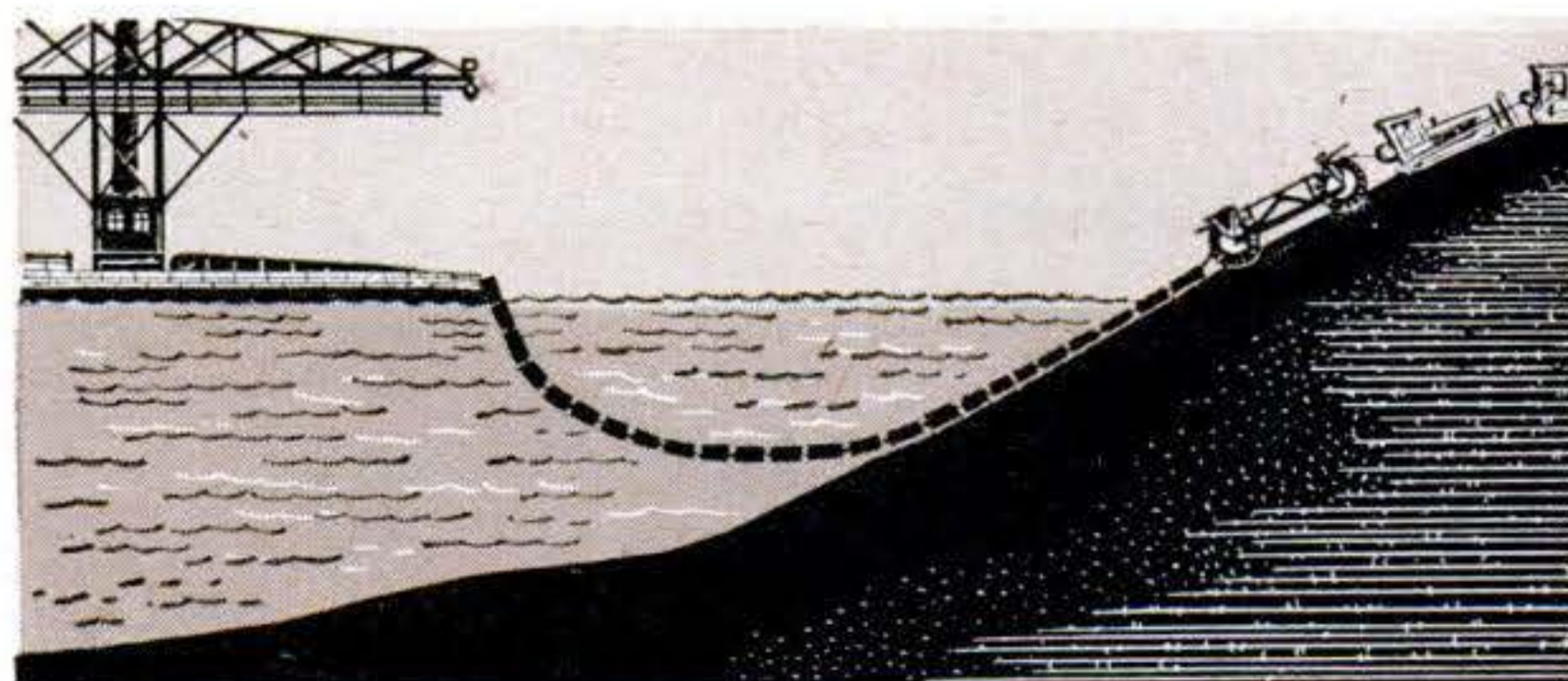

Concrete carpet in tow, it is hauled up riverbank by dozers working on sloping levee.

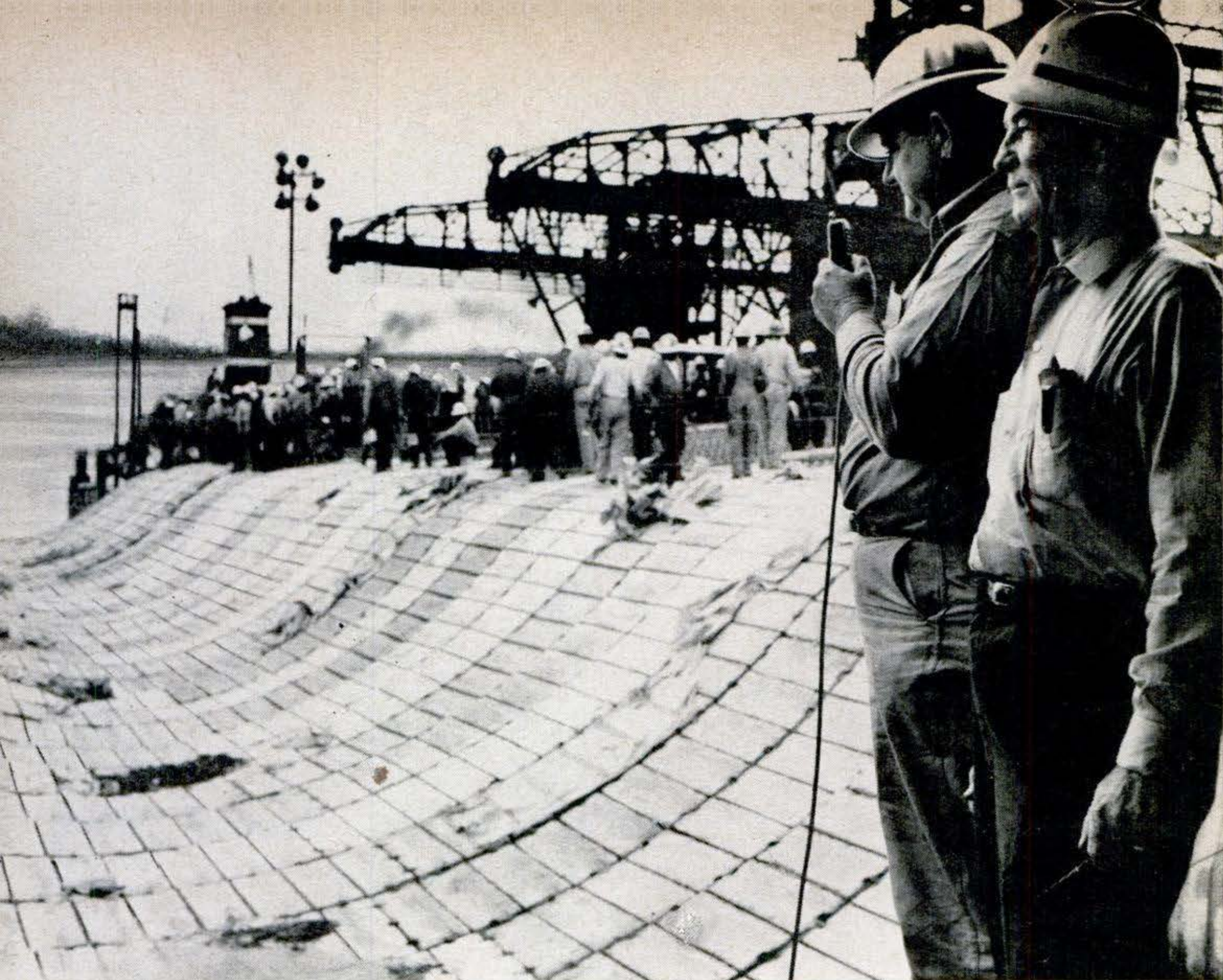

Gangster's barge crew, still weaving rapidly, prepare to move far out into the river, laying

carpet on river bottom as they go. Engineers (right) control the work by radio.

He sat at his levers, punching, pulling, hauling like mad, and in 10 minutes I figured he did a week's hard work. "How long a trick do you work?" I asked, thinking he might manage to hold out an hour or so. "Oh, eight hours," he said with a grin.

We looked down through his window across a gap of water. Beyond, nearly 300 feet away, was the torn bank where

the tractors were shuffling up and down, pushing great piles of earth.

We saw an explosion in the river. Our bucket, drooling dirt, plunged in heavily and dropped its load—for even the river bottom was being smoothed.

Over Mathews' head, like a trapeze, hung a throttle and a curious improvisation. It takes three hands to run the gar-

[Continued on page 162]

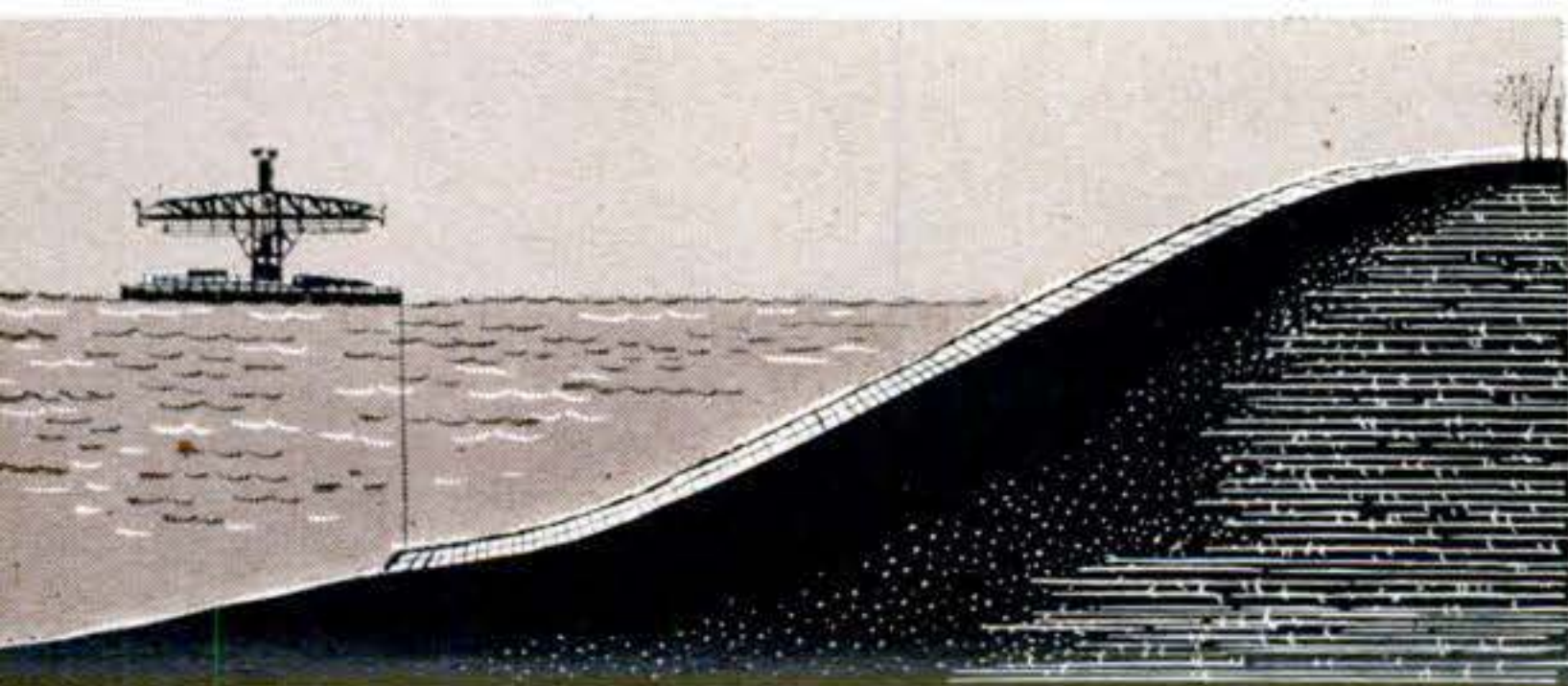

With end of carpet ashore, rug-making barge backs out into the river, weaving as it goes.



Wires holding carpet to barge are cut away, and carpet is left on bottom to control floods.

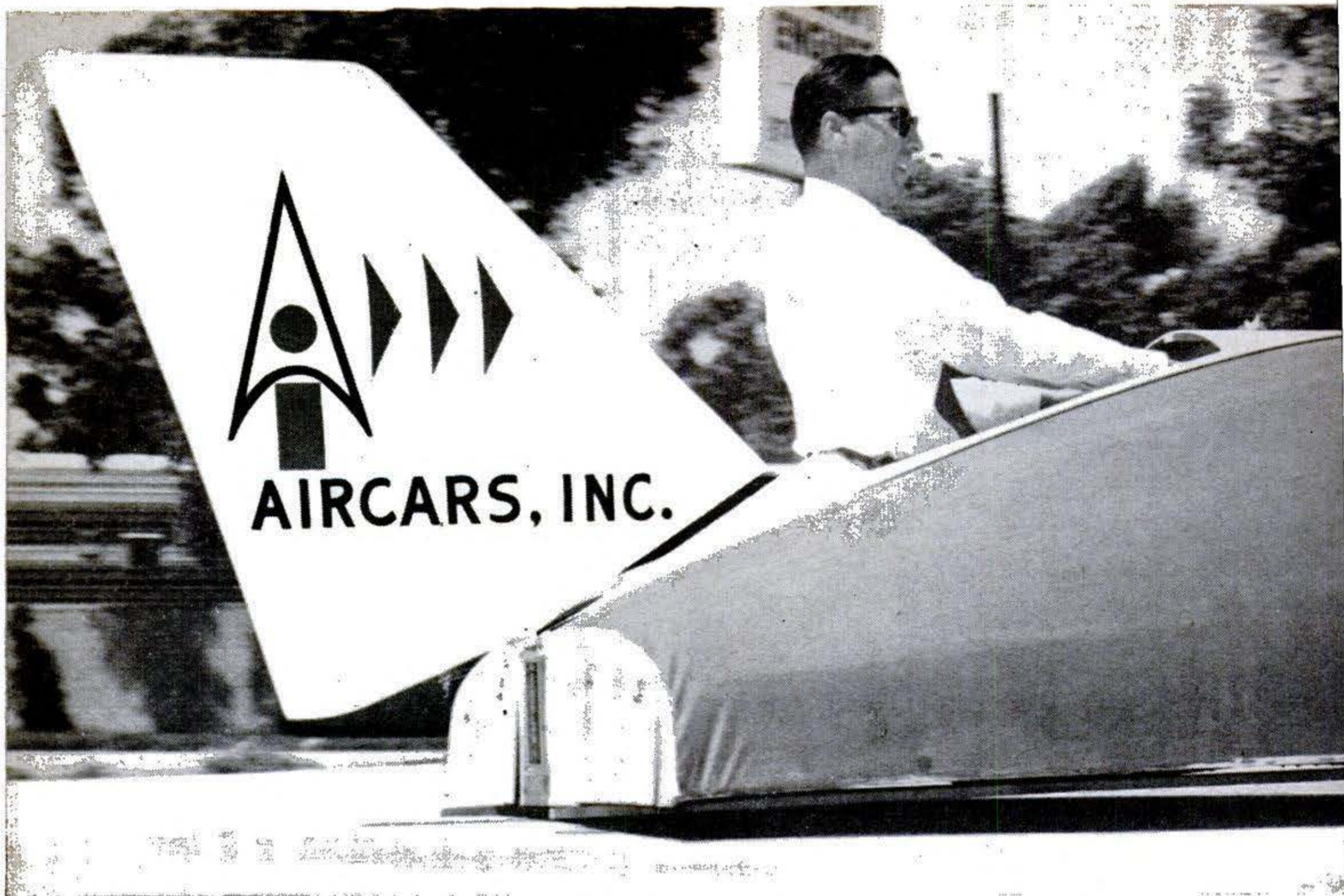

Powered by 10-hp. kart engine turning a 30-inch fan through a sprockets-and-chain reduction

Buy It, Build It:

By V. Lee Oertle

I STOOD there on the sidelines, mouth open, watching the hobby-size air car skitter back and forth like a runaway colt. Dust spiraled away

into the faces of astonished onlookers. Traffic on the nearby road halted, and in 10 minutes we had a good-size crowd.

I kept telling myself—10 horsepower just isn't enough to operate a GEM (ground-effect machine) with the driver



Joy stick controls turning, forward motion, and stopping. Foot pedals control big stabilizer.



Side vents, operated by joy stick, release air jets on sides to provide side thrust for turning.

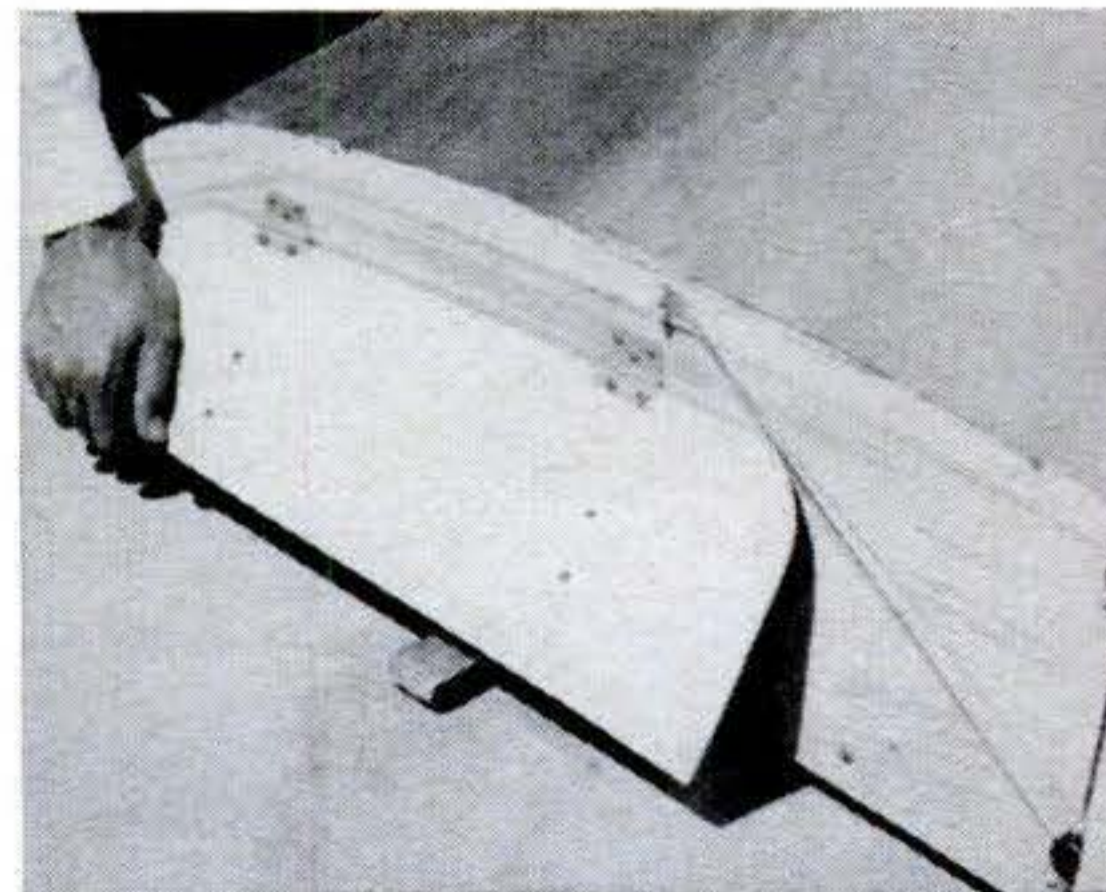

Rear vents, also joy-stick operated, release air jets to the rear, providing forward thrust.



drive, car rides 4 to 5 inches off the ground.

Ride on Air!

aboard. It should be lucky to get off the ground at all. The driver had an ear-to-ear grin as he dashed at half speed about the little parking lot, at least four inches off the ground. There wasn't room to open it up. He'd come tearing



Fan is mounted at a 45-degree angle in front of the car. The stationary vanes behind the fan counteract torque effect.

by, then jerk back on the throttle, just averting a collision with a parked car.

This new air car was invented by Frank Dobson of Newport Beach, Calif. He put the car together, tested it, and readied it for sale in seven months. The Dobson Air Dart will be sold three ways: as a complete unit for \$695; as a knock-down kit at \$495 less engine; or as a complete set of plans for \$2.

The vehicle is low-powered, low-weight, low-priced. But performance is surprisingly brisk. Once the little two-cycle engine warms up, the throttle can be yanked back, and almost without pausing, the Dart is up and hovering. The rear air vents are cracked open, and the Dart goes forward.

The design resembles an upside-down boat hull. The airframe's chromoly tubing is bent to shape, then covered with a plastic cloth. The cockpit is plywood and aluminum, shaped like a rounded diamond.

The most unusual feature is the ducted fan up front. It's set in the frame at a 45-degree angle. Immediately behind the 30-inch, 7-bladed aluminum propeller are several fixed air vanes to disperse airflow. Roughly 350 cubic feet of air per second is sucked through the fan. According to Dobson, it takes 90 percent of this lifting force to maintain the 4-inch hovering height; only 10 percent of the air is discharged to provide thrust. Air exhausted through the rear vent panels provides forward motion. Vents up front, one on each side, control direction.

The Dart is maneuvered with a four-way aircraft stick through a system of cables and pulleys, which operate the two rear vent doors and two side vent doors. A huge air rudder aids directional stability. The vehicle is 8½ feet long, 5 feet wide, and about 4 feet high.

Operation. Starting the Dart is like starting a kart. The two-cycle engine is mounted smack in the middle of the front protector screen. The test unit was fitted with a centrifugal clutch and a rewind starter cord. Power from engine to

[\[Continued on page 169\]](#)



When Uncle Sam Played Dirty in World War II

Deadly Gadgets of the OSS

By Stanley P. Lovell

The author looks like a successful businessman, not a saboteur's accomplice. Today he is a distinguished chemist, president of Lovell Chemical Co., director of Raytheon Co., holder of 70 patents. But during World War II he was the Professor Moriarty—the “mad scientist”—who dreamed up weird and wonderful weapons for that famed cloak-and-dagger outfit, the Office of Strategic Services. Some of their

ideas seemed crazy even then. Like the attempt to emasculate Hitler with doped carrots. Or an incendiary attack on Japan with bomb-carrying bats. Others worked—Aunt Jemima, the exploding flour, Stinger, the job-pocket pistol—and many other devices played critical roles in the defeat of the Axis. Only now, 20 years later, is Dr. Lovell allowed to give the lowdown on his secret operations.—Editor

“I’M COLONEL DONOVAN, Dr. Lovell. You know your Sherlock Holmes, of course. Professor Moriarty is the man I want for the OSS. You’re it.

“I need every device and underhanded trick to use against the Germans and Japanese—by our own people, but especially by the underground in occupied countries. You will have to invent them.”

I had never met a man of such magnetism. I heard myself say, "I will." As soon as I could, I looked up references to the fictional Professor Moriarty. Most of them were discouraging to a chemist called to play the role. "Famous scientific criminal"—well! "The organizer of every devilry." Come! Come!

I moved into a small office down by a brewery. My title: Director of Research and Development, OSS.

Forgeries, Inc.

THE first job was a plant for documentation. Spies or saboteurs would have short shrift unless they had perfect passports, ration books, and money to confirm their assumed status. These are the little things upon which the life of the agent depends. But enemy documents had security built into them, just so no one could imitate them. The paper contained special fibers, invisible inks, and trick watermarks so counterintelligence could expose a forged document.

Philippine money proved the toughest because the fibers were kudzu and mitsumata, to be found only in Japan. No substitute would give the "feel."

I learned that Japanese paper existed in the United States. We could rework it into currency. However, were we to buy it, someone would reason that we wanted it for counterfeit Japanese money. I turned to James Byrnes, then assistant to the President. How he did it I'll never know, but within a week the entire lot of Japanese paper was in a warehouse available to us only.

And in the nick of time. General MacArthur sent word that currency was vital in the Philippines. It was extremely difficult to manufacture the money, even with the proper fibers. The "banana-tree" engraving was most intricate, and there were several color engravings.

Even more baffling, Japanese money in the Philippines was over stamped to identify the district in which, alone, it was valid. This was an ingenious method of controlling travel. If a bill marked Davao were offered in Manila, its possessor was forced to explain what he was doing in Manila. Each Filipino was frozen in his town.

We engraved money sufficient to fill a cargo plane, all over stamped in direct proportion to the population census. The fibers were crisp kudzu and mitsumata, the inks had identical fluorescence under ultraviolet light, and all secret marks were exactly duplicated. These bills would pass everywhere. The Japanese never realized that the OSS utterly destroyed their population currency control in the Islands.



*All secret marks were there
—the bills would pass.*

In Java and Sumatra little resistance could be encouraged with bribes of Japanese occupation currency. The money for which the Indonesians would do anything was the Maria Theresa thaler, a coin about the size of a 25-cent piece.

Accompanying this information was a note saying, "Nothing to be done: the last Maria Theresa thalers were made in 1870."

It ain't necessarily so

WE LOCATED two or three authentic thalers from collectors. We studied the metal on an alloy-analyzing machine. Silver wasn't hard to get.

We made an excellent mold. The molten metal was poured, cooled, the flash trimmed off, and there were as fine thalers as Maria Theresa had ever seen. My group was not enthusiastic. They all felt a counterfeit of cheaper alloy would be more in their line. It was the most honest job we ever did.

I was not able to follow Maria Theresa beyond the shipping door. Did she contribute to the overthrow of the Greater East Asia Co-Prosperity Sphere or was she added to the secret hoard of rascally Sumatrans? I'll never know.

Weapons for subversion

A SPY must never have a weapon. His job is to collect and transmit information. The transmission of information was a whole study itself.

One device originated when a spy told me he was all but trapped in the Adlon Hotel in Berlin. "I would have given anything," he said, "if I could have created a panic in that lobby."

My answer was "Hedy," a firecracker device which simulated the screeching of a falling bomb and then ended in a deafening roar—all completely harmless. By activating Hedy the agent could escape in the turmoil.

One day the Joint Chiefs of Staff asked me to demonstrate our devices. I showed booby traps, our derailing system, incendiaries—and Hedy. As I



Then came the bang. Generals clawed to get out the door.

I spoke I activated one casually in a wastebasket. Hedy interrupted, shrieking. Then came the bang. I saw generals clawing to get out the single door. We were never again invited before the Joint Chiefs.

Unlike the spy, the saboteur is a man of violence. He must harass the enemy. One way is to derail a train. This is easy, we thought: Take out one rail and the train falls over. Unfortunately, it doesn't work.

Perhaps the perfect weapon for derailment was "Casey Jones." It consisted of a permanent magnet on a box. This magnet was to stick the box to the underside of railway cars. From the box an electric eye looked down on the track. Our electric eye was not affected by a gradual diminution of light, such as nightfall, but only by a sudden cutting off of light when a train entered a tunnel. This activated it instantly, and an explosive would blow a wheel off the car.

The resistance put Casey Jones first on repair trains. After that, men, women, and children placed them on any rolling stock.

A long line of cars would wind into a tunnel. Explosion and derailment

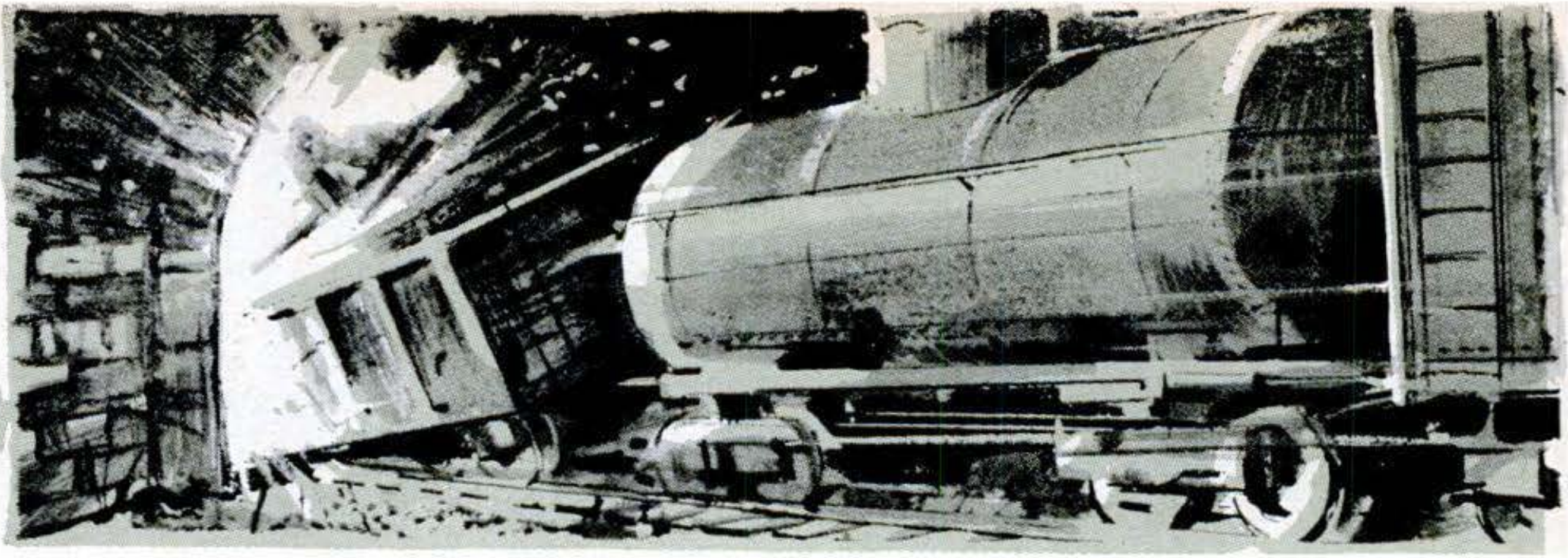

The cars wound into the tunnel; explosion and derailment followed.

followed. When the repair train crawled in, it, too, was derailed in the cramped tunnel. Now both wrecks had to be worked on by hand, and the through line was blocked for a long time.

Every Casey Jones had a decal in German: "This is a Car Movement Control Device. Removal is strictly forbidden by the Third Reich Railroad Consortium. Heil Hitler."

To attack an enemy automobile or tank, one could take two approaches—the fuel tank or the oil system.

The attack on the fuel tank was solved by "Firefly," a small plastic cylinder easily palmed by a filling-station attendant. It contained explosive which fired after the gasoline had swelled a rubber ring. This took hours, so the German vehicle was far away.

Fireflies were rushed to the French underground for the landings at Marseille. Two German divisions, ordered to repulse this attack, proceeded down the highways. All gasoline pumps en route were staffed by the Resistance. As the attendant inserted his hose in the filler pipe, he dropped a little Firefly into it.

The results were dramatic. Along the highways, off in fields, or smack in the roadway were abandoned vehicles. The success of the Marseille landings owed much to little Firefly.

The oil system was harder. All the time-honored tricks failed. Sugar? No result. Sand? Dirt? A little scoring of pistons, but the engine kept running. We tried 50 additives until my respect for the standard six-cylinder engine almost overcame any further work to destroy it.

A Harvard scientist suggested a compound to be put up in a small rubber sack and dropped through the breather pipe. After heat opened the rubber container, his compound became a dispersion. This hit the small mechanical tolerances of the bearings, and all seized simultaneously. The cylinder head burst into shrapnel.

Simple weapons were best. Suppose you knew a French girl who had access to a German officer's room. You'd give her your candle to replace



The gas attendant dropped a "Firefly" into the filler pipe.

[\[Continued on page 178\]](#)

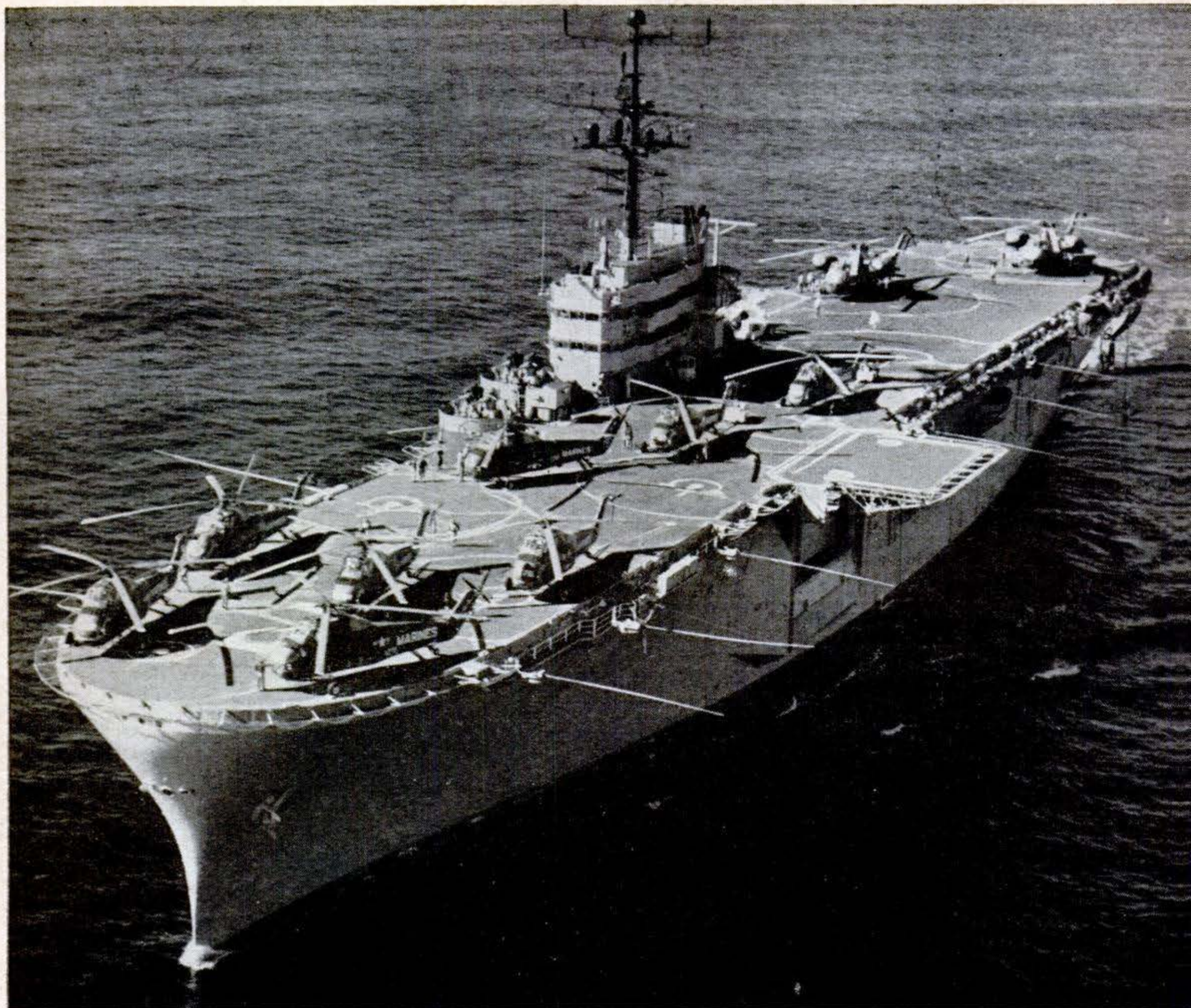

USS Iwo Jima, the first all-helicopter carrier, is built for modern amphibious beach assault.



Double-barrel "gun" shoots light at target

A new laser range finder fires a 186,000-mile-a-second light beam from its long barrel to locate a tank or other target up to seven miles away. The laser-beam echo is "collected" in the short barrel. Round-trip time, automatically computed, gives exact range instantly to artillerymen, says the maker, Hughes Aircraft. The telescopic sight on top is for spotting the target in the first place.



Marines of First Regiment scramble onto flight deck, run to helicopters in training maneuver.

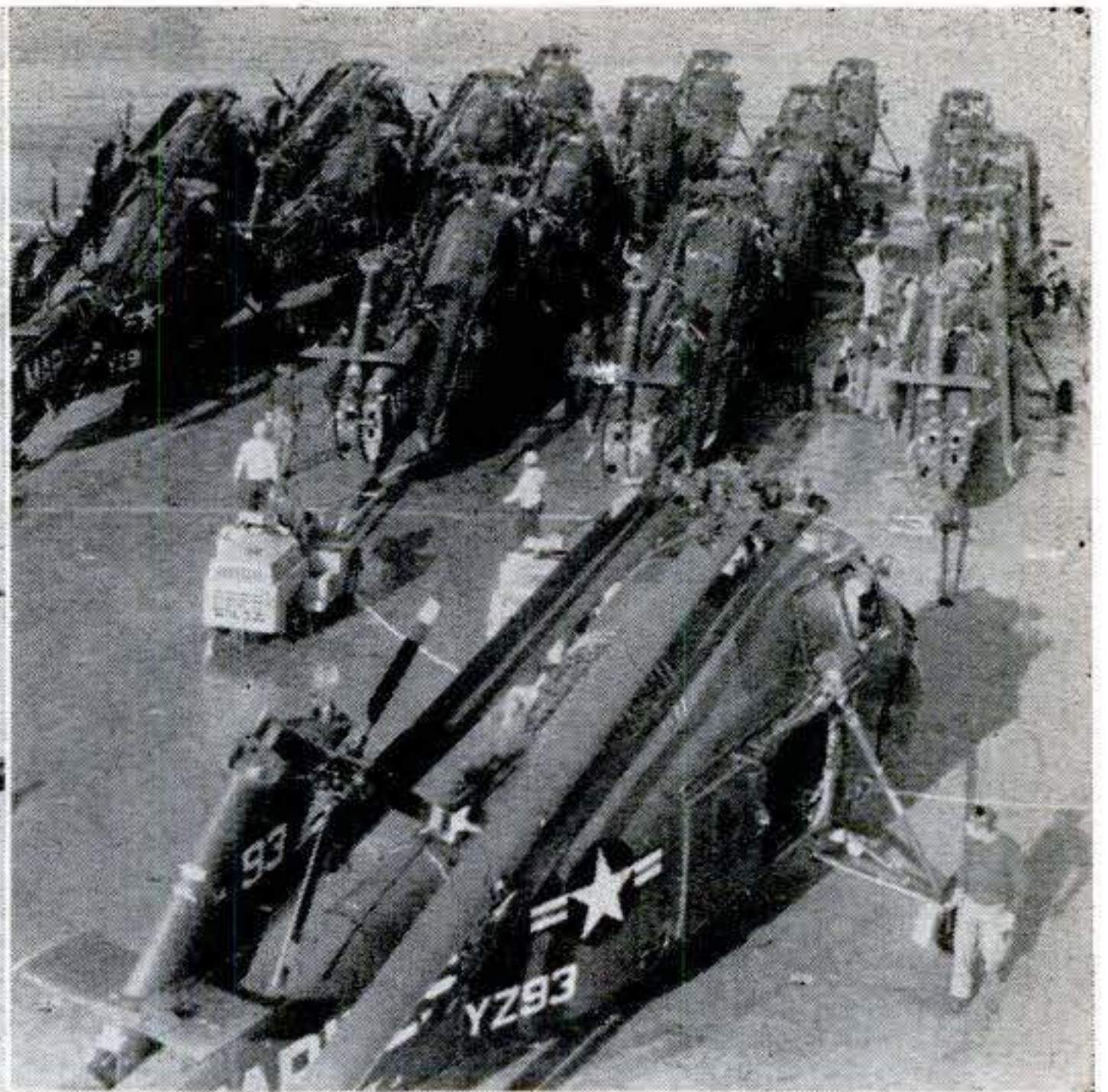

Rotors and pylons folded, HUS-1s are tied down at mission end before going to hangars.

Ship to shore, Marines are still first

The Navy now has a carrier exclusively for the Marines, the first built from the keel up for helicopters. The Iwo Jima carries a battalion of 1,500 tough Leathernecks plus 20 to 45 Sikorsky HR and HUS transport eggbeaters that can land them in a hurry at any trouble spot in the world.

From its 105-by-592-foot flight deck, the Marines can be flown in dispersed formations, and landed behind or on the flanks of an enemy-held beach. The 15,000-ton Iwo joined the fleet last year to begin training exercises like the one shown here conducted

off Oceanside, Calif. A sister LPH (landing platform, helicopter), the Okinawa, has been commissioned. Two more are being built.

The carriers can transport helicopter assault forces, combat supplies, and equipment at a sustained speed of 20 knots. They have the most advanced command facilities and cargo-handling apparatus. Elevators from the hangar deck are at the edge of the flight deck. Horizontal radio antennas jut out from the sides of the ship like long fishing poles.

Walking machine takes giant steps

A manned robot that may let GIs roam the jungles at 35 m.p.h. is being developed for the Army. In a full-size version of GE's model "pedipulator" a man would stand on the platform, and 12-foot legs below would duplicate his every move in multiplied scale. GE expects to build into the machine both arm and leg motion based on locomotion studies by Dr. Karl U. Smith of the University of Wisconsin.

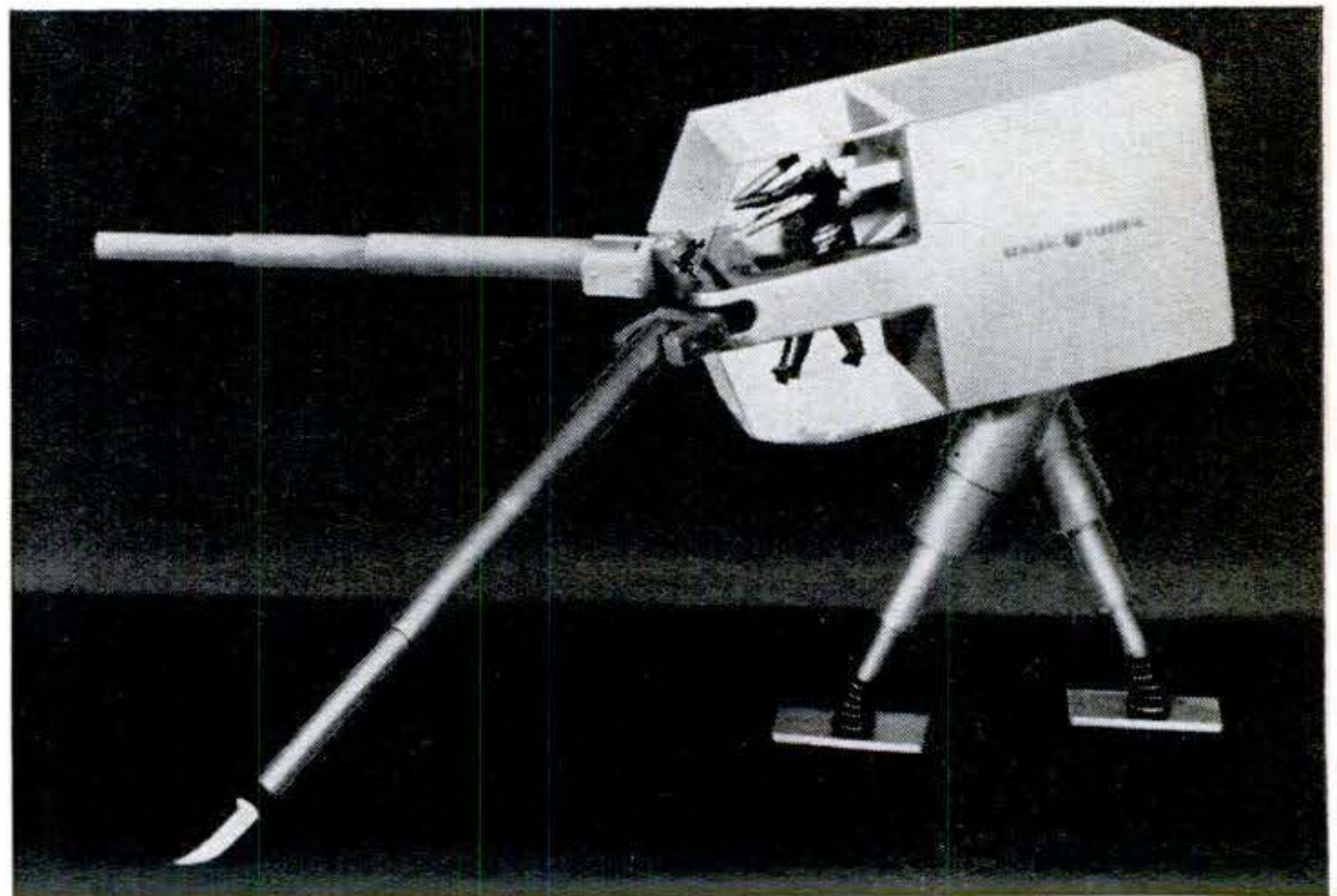

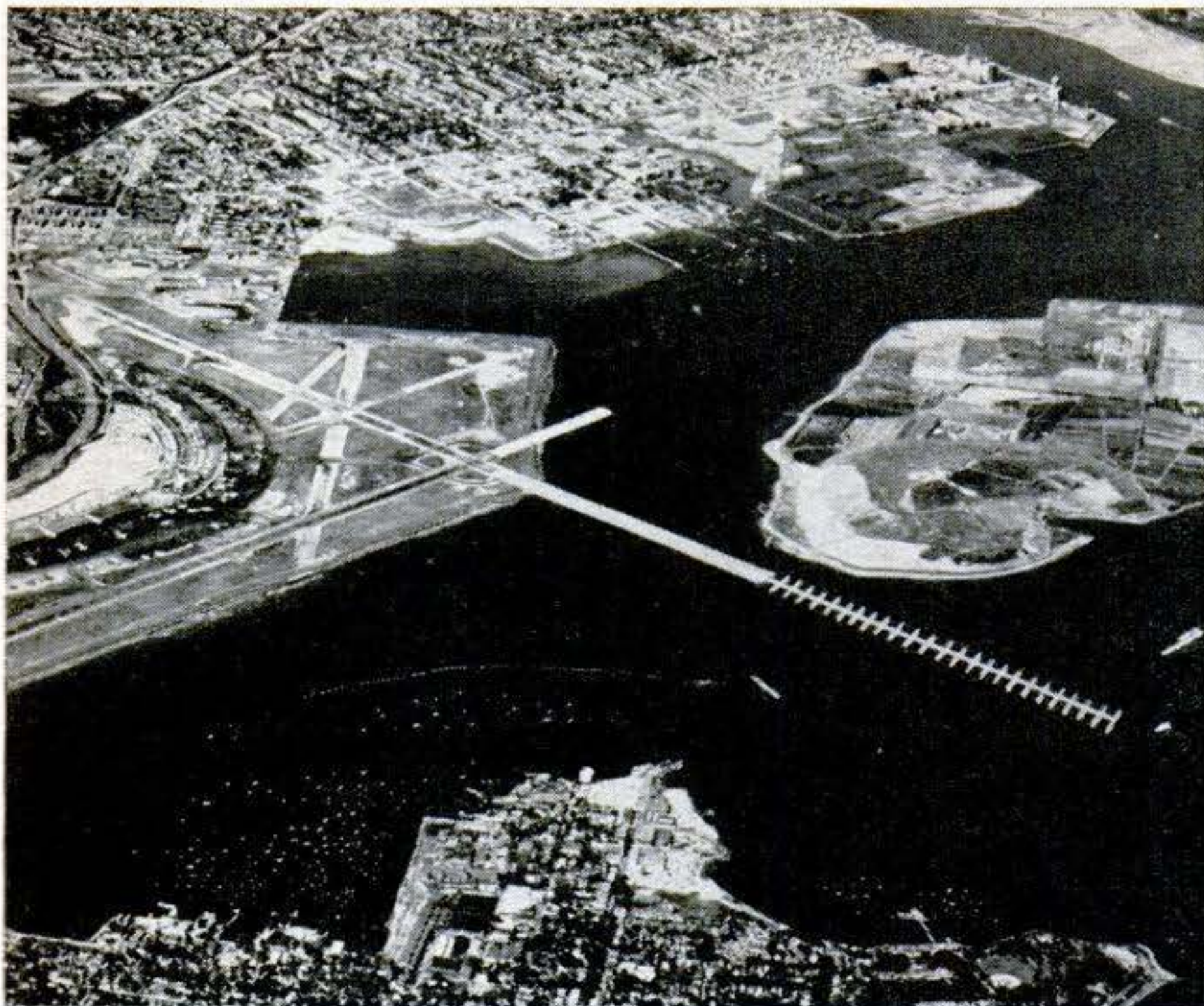

Runways lengthened to open airport to jets

New York's Port Authority is extending the two runways at LaGuardia Airport to 7,000 feet each to make them suitable for use by jets.

Because the longer runways would extend into Rikers Island ship channel (retouched photo at left) a new channel is being dug. The broken line shows approach lights for one runway. The \$36,734,000 project will be ready in 1968.

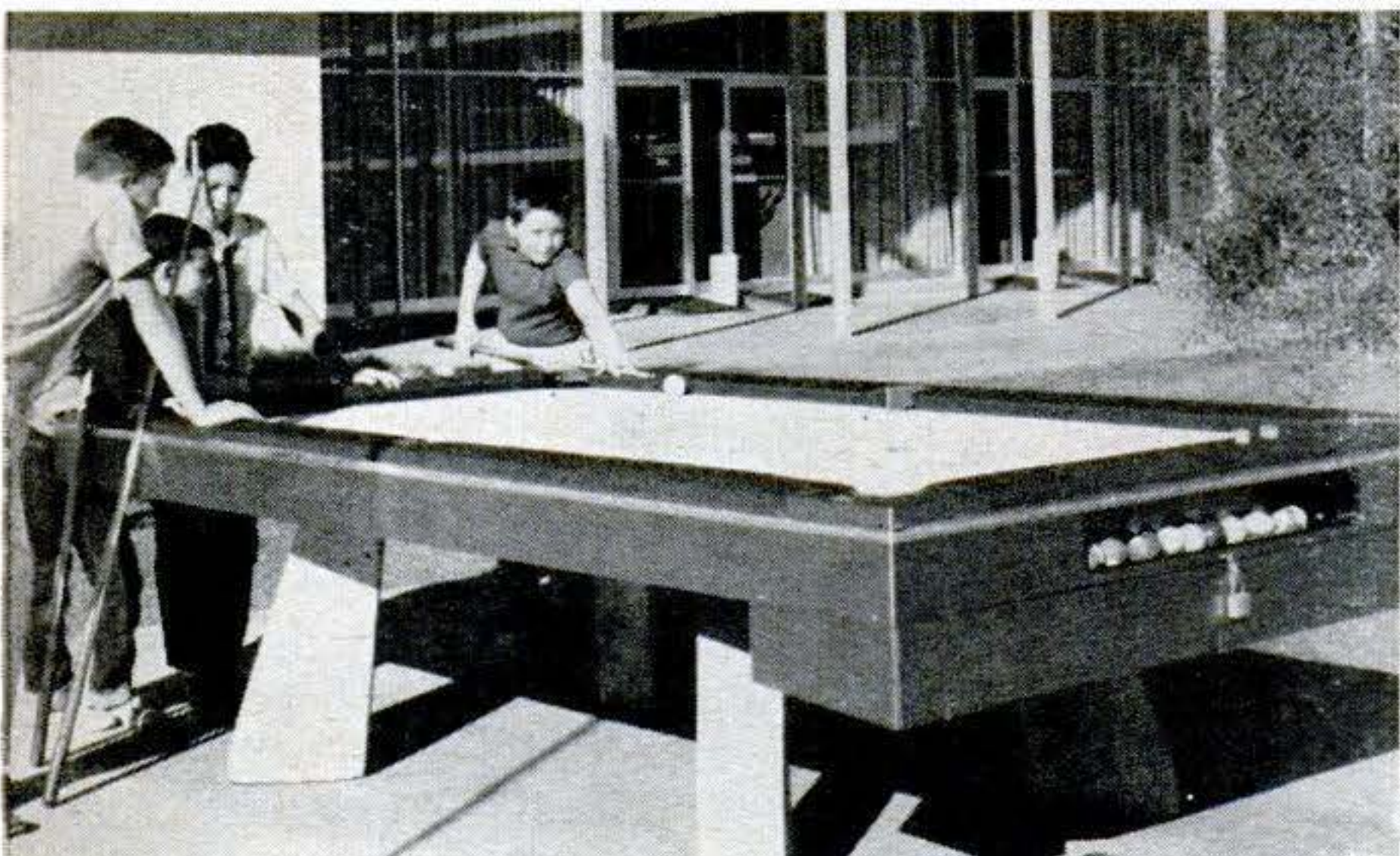

Outdoor pool table made of concrete

The base of this pool table is concrete, and the playing surface is stretched canvas. Side and end rails are steel set in foam plastic. Pockets are lined with rubber.

The table, built by Corwin S. West of Gilbert, Ariz., is an attraction for guests at a plush hotel in Scottsdale. It takes rough use with practically no upkeep.



Hose network keeps greenhouse flourishing

Flower growers near Santa Barbara, Calif., can water as many as 6,000 potted greenhouse plants with a single turn of the faucet. They use a network of $\frac{1}{16}$ -inch laterals working from a three-inch plastic feed hose on the water line.

Wesley Keys, manager of Bodger Seeds, installed the initial system with advice from the University of California at Riverside.



Dr. von Braun (right) with J. R. Dempsey, president of General Dynamics/Astronautics.

Dr. Wernher von Braun lays the cards on the table Can We Ever Go to the Stars?

Will we ever be able to travel to solar systems beyond our own?

The past 20 years should have taught us to use the word "impossible" with utmost caution. Nevertheless, human travel beyond our own solar system is a staggering concept. Even the most reckless optimists do not expect it to come about in our generation—or the next.

Light, traveling at 186,000 miles per second, needs 8.3 minutes to span the 93 million miles between the sun and earth. Light takes 5½ hours to travel from the sun to Pluto, outermost planet of our solar system. But it takes 4.3 years to reach Alpha Centauri, the nearest fixed star (4.3 light-years away); 470 years to Polaris; and 27,000 years to get to the center of our galaxy—a lens-shaped island in space, a little less than 100,000 light-years in diameter, made up of an

estimated total of some 200 billion suns.

Can we build a rocket powerful enough to travel so far?

We have to impart to an object a velocity of slightly more than 25,000 feet per second to place it in a low orbit around the earth. About 36,000 feet per second is needed to hurl it to the moon—which is still within range of the earth's pull—and just a trifle more to kick it completely out of the earth's gravitational field. If we accelerate it up to a terminal speed of 56,000 feet per second (in such a fashion that it leaves the earth in the same direction in which the earth is orbiting at 107,000 feet per second around the sun), it will enter a parabolic flight path and escape from our solar system.

From the point of view of power re-
CONTINUED

Phew . . . and now, back to something easy like designing rockets!

Article and photo were published in them last week and we want them to get the information out to you right away.

x) I'm really proud of it.
It's a stinker, to make
"relativistic" concepts
simple!

Sincerely yours,

Wernher von Braun

Encl
a/s

It's no small feat to make understandable the eerie problems of "relativistic" space flight to stars thousands of light-years away. So PS

echoes this impromptu postscript that Dr. von Braun jotted on his letter forwarding this month's manuscript to Editor Bob Crossley.

By speeding nearly as fast as light, you could go to a star and return

quirements, a needed velocity of 56,000 feet per second (38,000 m.p.h.) may not sound too bad. Just one extra stage on top of the Saturn V, our Apollo moon rocket, could impart that speed to an object of about 8,000 pounds. But as the object coasted, its power spent, on its "uphill" path out of the pull of the sun's gravity, its speed would gradually diminish almost to zero. Millions of years would elapse before it reached one of the nearest fixed stars.

To reduce travel time to figures compatible with the life span of man, travel speeds must approach the speed of light.

Not even nuclear-fission or nuclear-fusion processes are adequate to produce such speeds. For all their dramatic display of power, they convert only a tiny fraction of the mass involved into energy. It would be necessary to devise a rocket mechanism wherein the *entire* mass, M , of the injected "propellant" is converted into radiation energy, E , according to Einstein's famous equation: $E = M \times C^2$. The exhaust of such a "photon rocket" would be a beam of radiation, and the exhaust velocity would of course be equal to the velocity of light, C .

The problem is that nobody knows how to build a photon rocket. Certain subatomic processes are known, such as the joining of an electron (a small negatively charged particle) with a positron (an equally small positively charged particle), that directly transform matter into energy according to Einstein's equation. But so far, physicists have been unable to devise any large-scale processes for this transformation.

There are also tremendous engineering obstacles. By definition, a photon rocket converts its propellant stream into an extremely powerful light beam. To bundle this beam, some sort of mirror is needed. Even if it had a reflectivity of 99 percent, better than our best existing ones, that one percent of absorbed radiation energy would instantly melt the mirror—considering the billions of kilo-

watts converted into the power carried away by the light beam.

Q Is it true that it is impossible to exceed the speed of light?

A Yes. But as we shall see, this is partly a matter of definition. Suppose we had overcome the "minor" problems just described, and we did have a rocket capable of "beaming away" 100 percent

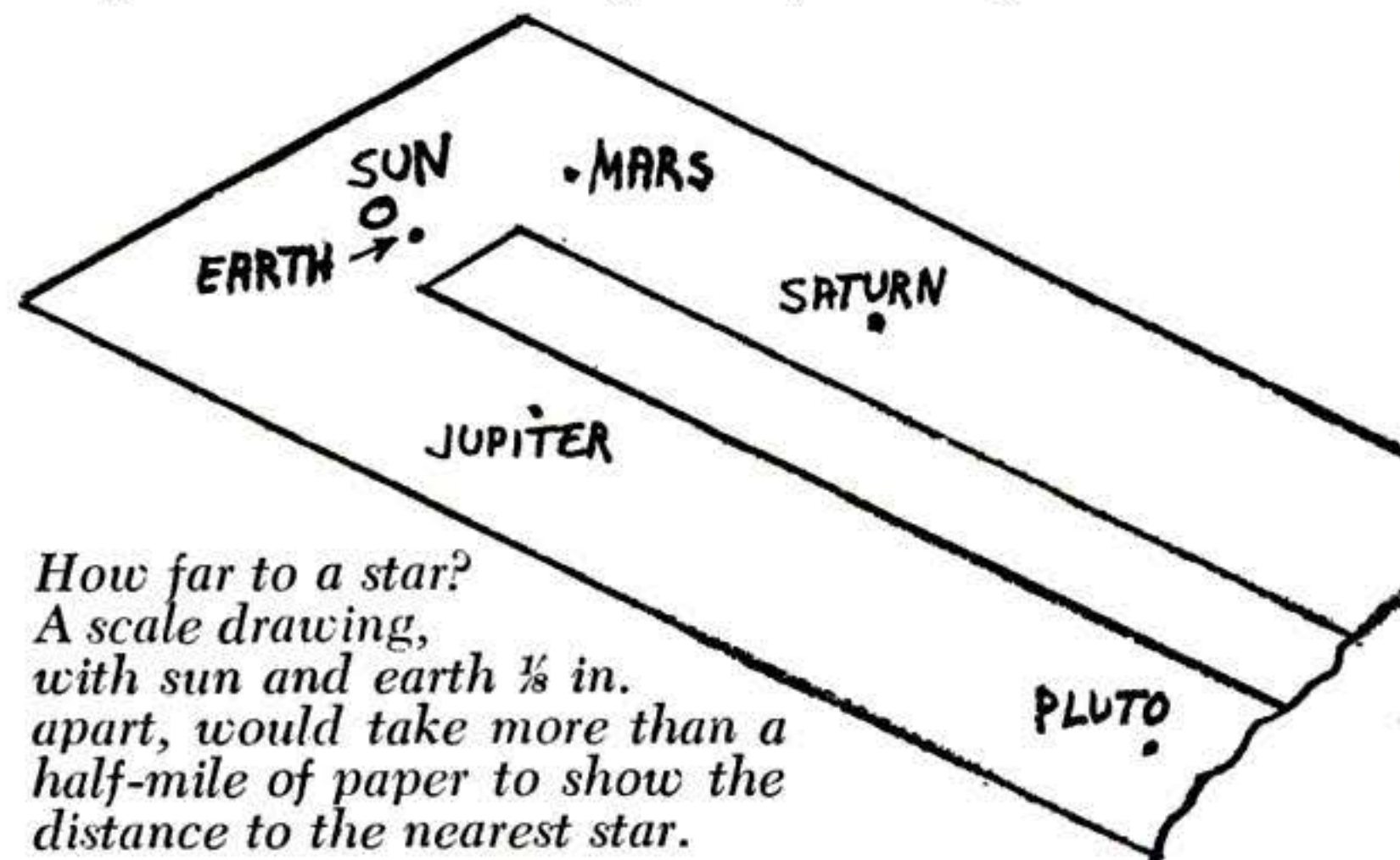

of the mass of its propellant with an exhaust velocity equal to the speed of light. What could we do with it?

If the rocket had a mass ratio (the ratio between its fully fueled and empty weight) of 3, it could reach 80 percent of the speed of light. With a mass ratio of 10, its terminal velocity would be about 98 percent; and with a mass ratio of 1,000 (about what we have today in some of our chemical multistage planetary rockets), we would hit 99.9998 percent of the speed of light.

Again we refer to Dr. Einstein. His Theory of Relativity (which has stood the test of many critical experiments, and has been universally accepted by the scientific community) shows that *the inertia of an object's mass approaches infinity as the object approaches the speed of light*. Hence it would take infinite power to accelerate an object beyond the "light barrier."

But, amazingly enough, the same theory states that a stellar astronaut could still travel to a star 1,000 light-years away and return within his adult life.

in your lifetime—to find centuries had gone by on earth meanwhile

Q *How could an astronaut travel 2,000 light-years in a lifetime?*

A “Time dilation” would help him to stay young. For many people, the strange phenomenon called time dilation is a hard pill to swallow. The flow of time appears to us completely unaffected by physical conditions. Whether we sleep or work, sit at a desk or in a speeding jetliner, our wrist watch seems to tick away at the same pace. So does our heart.

But the fact is that this cherished piece of “everyday experience” is valid only in the realm of relatively low velocities in which we slowpokes live.

A meson (an unstable subatomic particle), when traveling at a velocity close

neither for his watch nor for his heart-beat, which controls his life span.

This strange effect makes it possible for a stellar astronaut to travel from the earth to a fixed star 1,000 light-years away, in what he would think was 13.2 years. For the trip back he would need another 13.2 years. If he didn't spend any additional time at his destination, he would thus have been away from the earth for 26.4 years. The trouble is that, during his absence, more than 2,000 years would have elapsed on earth. Thus, upon return, he might wind up in a zoo.

Q *What would a trip to a star be like?*

A Let us assume we have a photon rocket capable of a continuous acceleration of 1 G. Suppose, too, that our mass ratio is large enough to get us very close to the speed of light; carry us to a star 1,000 light-years away; and slow us down again to normal speeds, so we can visit one of the star's planets. The rocket is also to be capable of flying us back to earth—possibly by “refueling” during the stay at that distant solar system.

As we depart from the earth, the stars of the firmament will first appear in their familiar yellowish hue. As our vehicle builds up speed toward our target star, the Doppler effect will cause a striking change in this star's color. From its original yellow, the light received from it will shift through green, blue, and violet, and toward ultraviolet—in other words, to higher frequencies. Simultaneously the color of the receding sun will slowly change from yellow to orange, red, and toward infrared—that is, to lower frequencies.

This is easy to understand: A boat running *against* the waves is hit by them at a *higher* frequency than a stationary pier is; a boat running *with* the waves, at a *reduced* frequency.

After about 3½ months our stellar photon rocket has reached about 30 percent

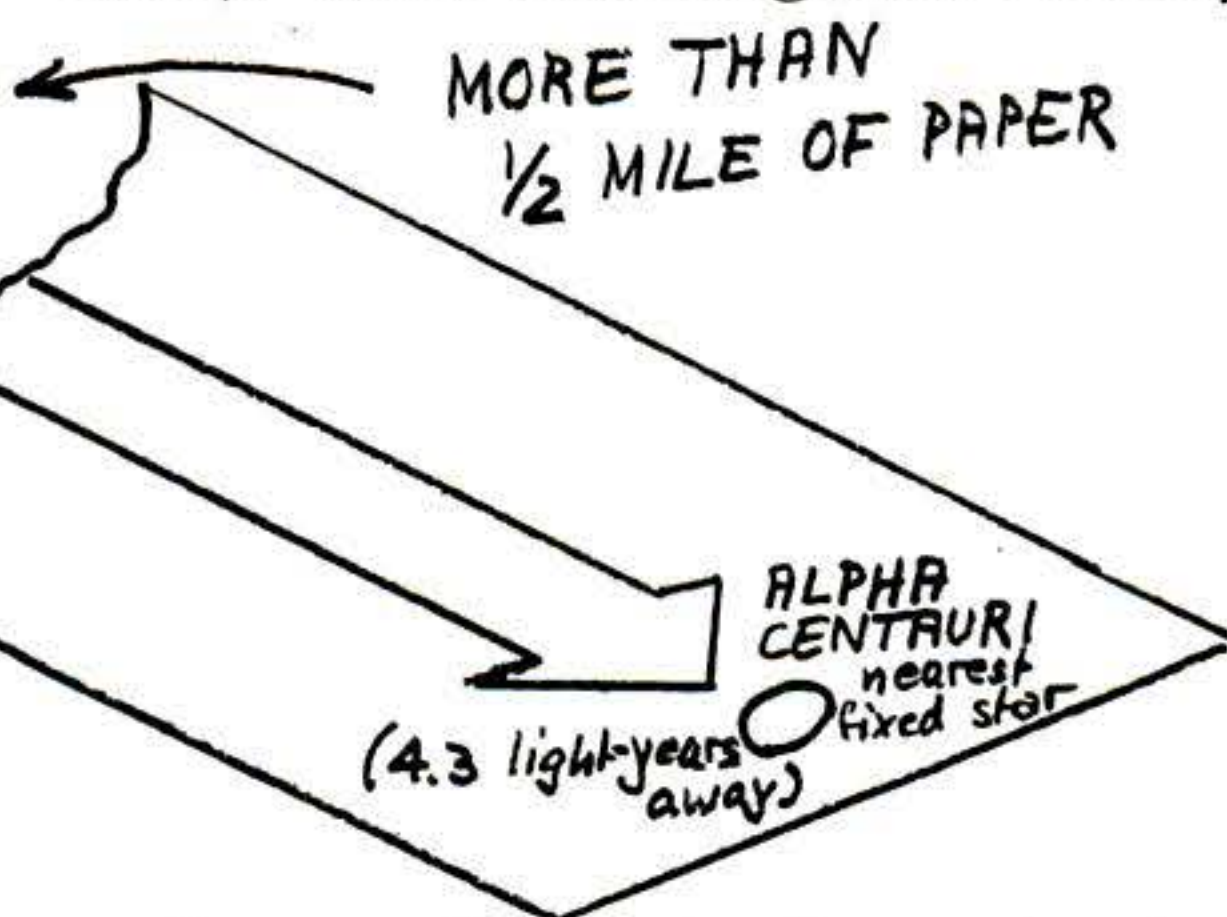

to the speed of light, has a clearly longer decay time than its 2.1-microsecond “half-life” at lower speeds—when an earth-fixed observer does the timing. But if the observer were flying along with the meson, the half-life of 2.1 microseconds would not seem to be affected by the particle's speed, since the observer's watch would be subjected to the same time dilation as the meson itself.

The Theory of Relativity tells us that the pace of time becomes slower and slower for an object approaching the speed of light, compared with time's rate of passage for a stationary observer. At the speed of light itself—an upper limit that no object can ever reach—time would come to a complete standstill. If an object could go so fast, it could cover vast distances while, for a man flying along with it, no time would elapse—

[Continued on page 170]

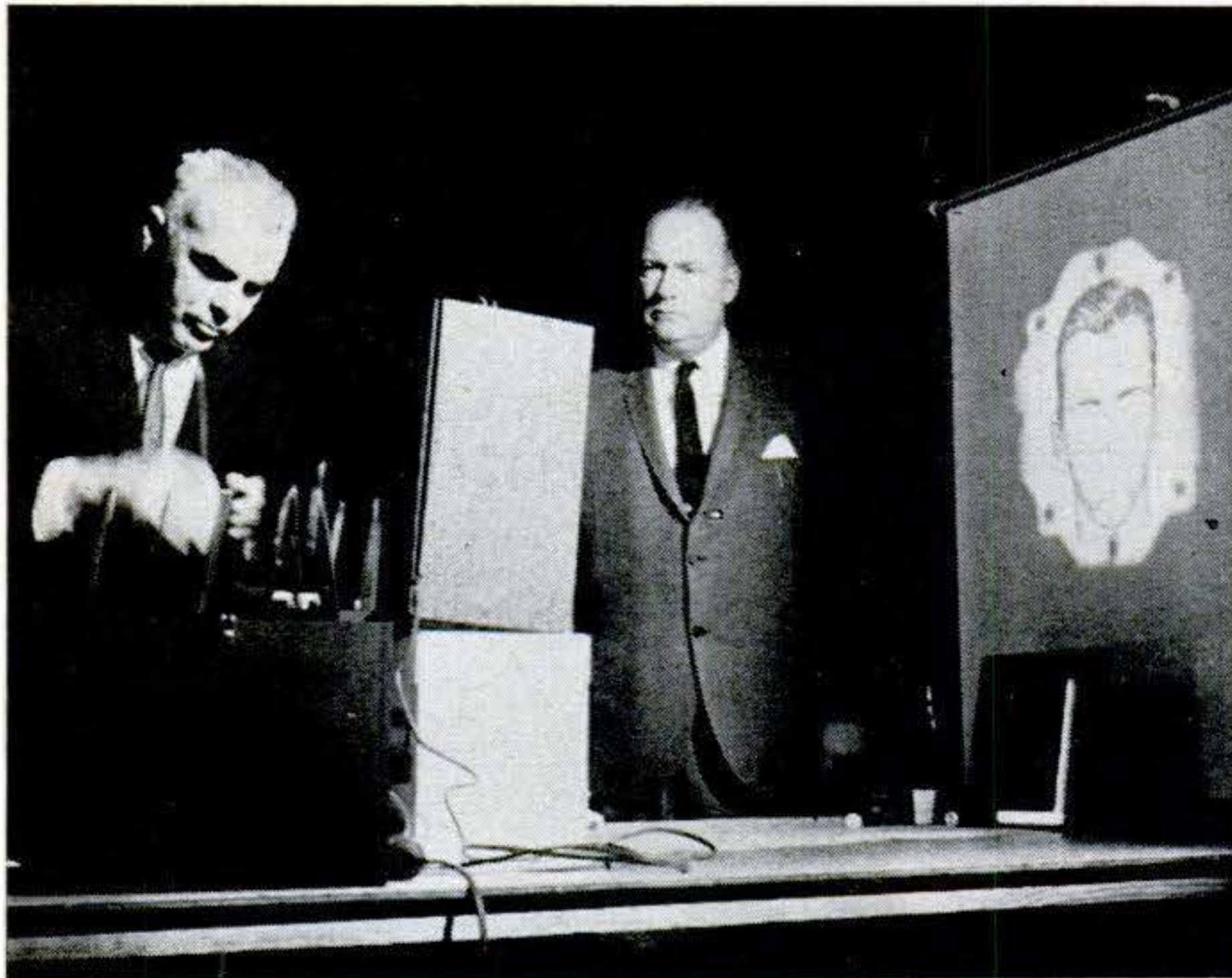

Variable-image projector flashes composite image on a screen.

Projector turns words into picture

The New York police are now using a quick-identification projector invented by one of their own members. It puts together from coded slides a verbal description of a wanted man, and projects his image on a screen where it can be photographed and distributed.

It works from slides offering 600 combinations of facial features, similar to a previous system [PS, Nov. '60], but with important differences. The system, unlike the earlier one, uses a projector, and in addition has built into it a series of wafer-thin mirrors that can distort any of the features at a press of a button. A chin can be lengthened, nose shortened, or eyes widened if a witness desires. The machine cuts the work of hours down to minutes.

Detective Peter Smith, who used to draw identification pictures, developed the machine on his own time and money, turned it over to the department without charge.

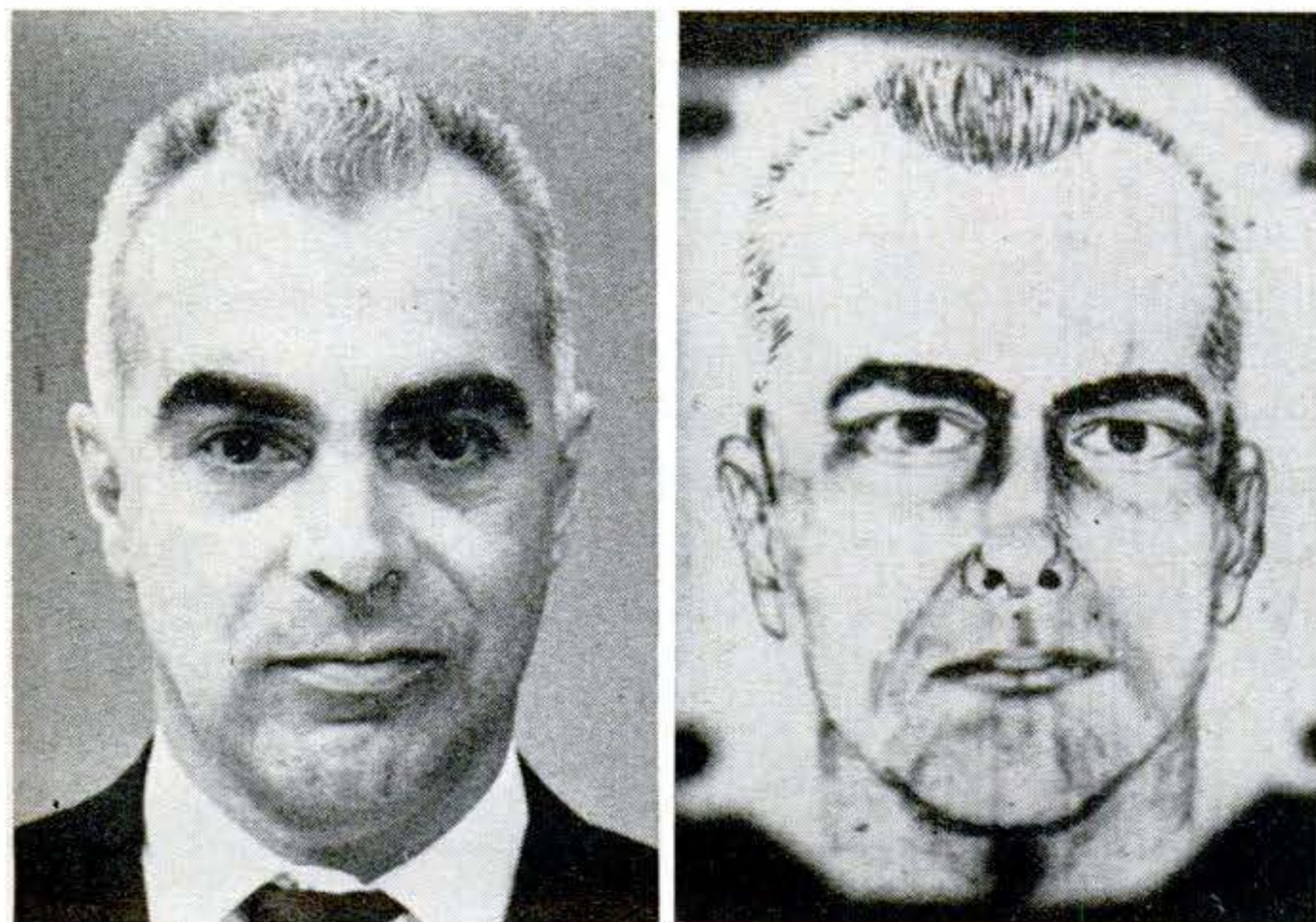

Detective Smith in real life (left) and as shown by projector.

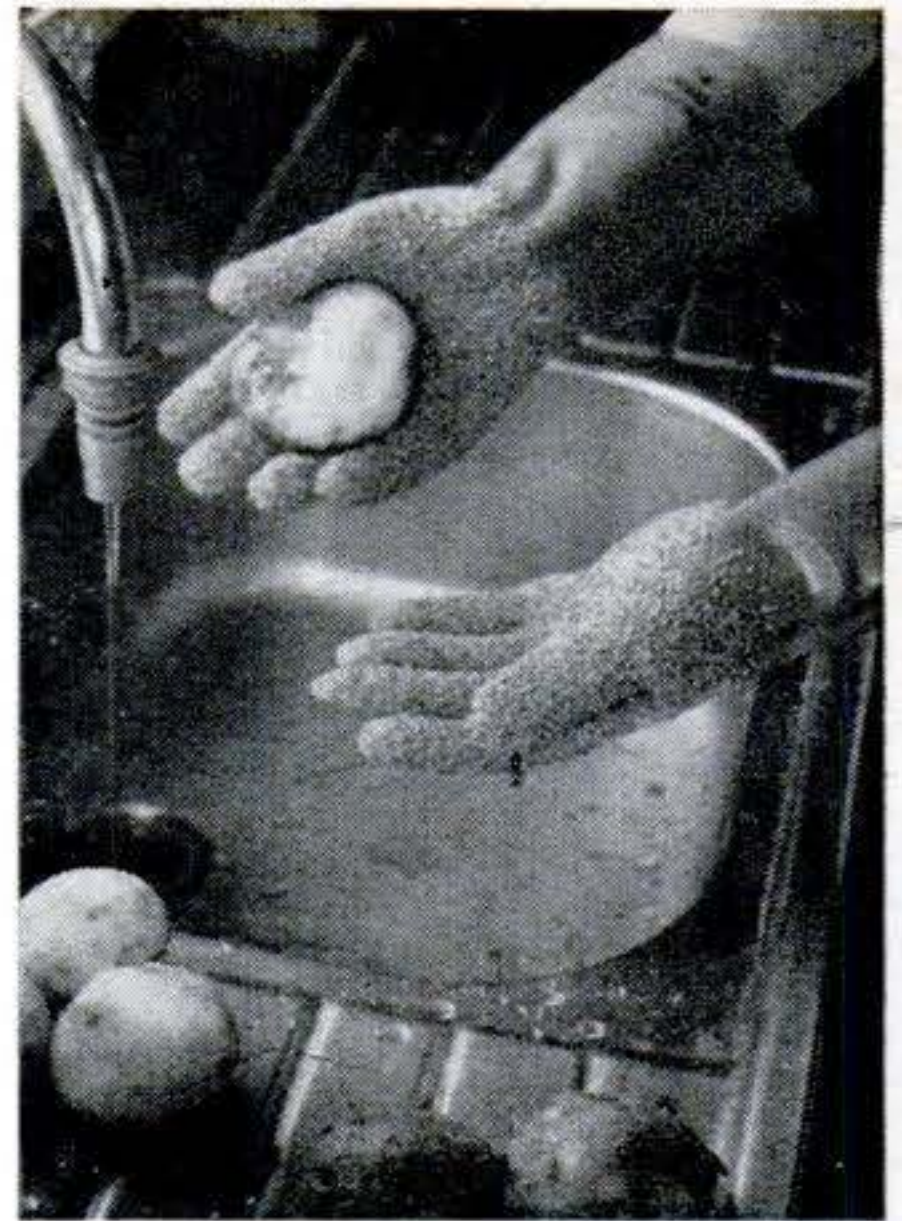

Abrasive gloves rub skin off potatoes

Wash potatoes or root vegetables with these German gloves on, and you can peel them in water running at the kitchen sink.

When the spud is worked under the tap like a cake of soap, emery particles vulcanized in the rubber rub off dirt and skin.



Electroluminescent belt generates own light

Electroluminescent panels replace reflectors on a new Sam Browne traffic-safety belt. They emit flashes from a rechargeable battery at the side. Madigan Electronic Corp., Carle Place, N.Y., is the maker.

"I'd like to see them make..."

Bumpers with built-in hitches for trailer hauling. Add-on hitches are unsightly and make it hard to get a push in an emergency.—*F. M. Maguire, Savannah.*

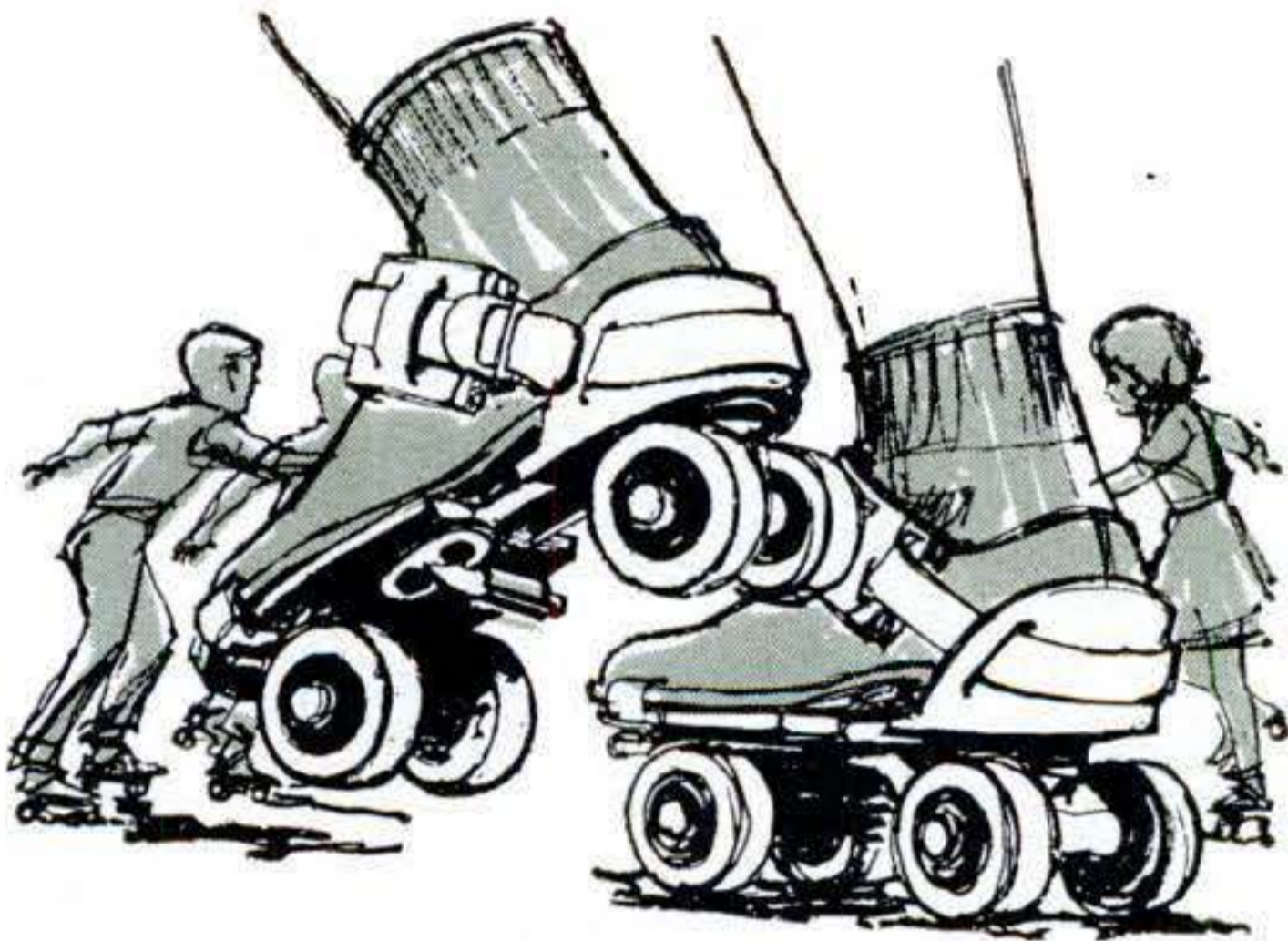

Children's roller skates with a clip or other fastener underneath to hold the clamp key. Loose keys, constantly lost, are just a nuisance.—*Mrs. E. Ross, San Bernardino, Calif.*



Screw-in drain plugs for remote outboard tanks. Sloshing a left-over pint of gas out of that inch hole at top of the can is for the birds.—*H. Anderson, Cassopolis, Mich.*

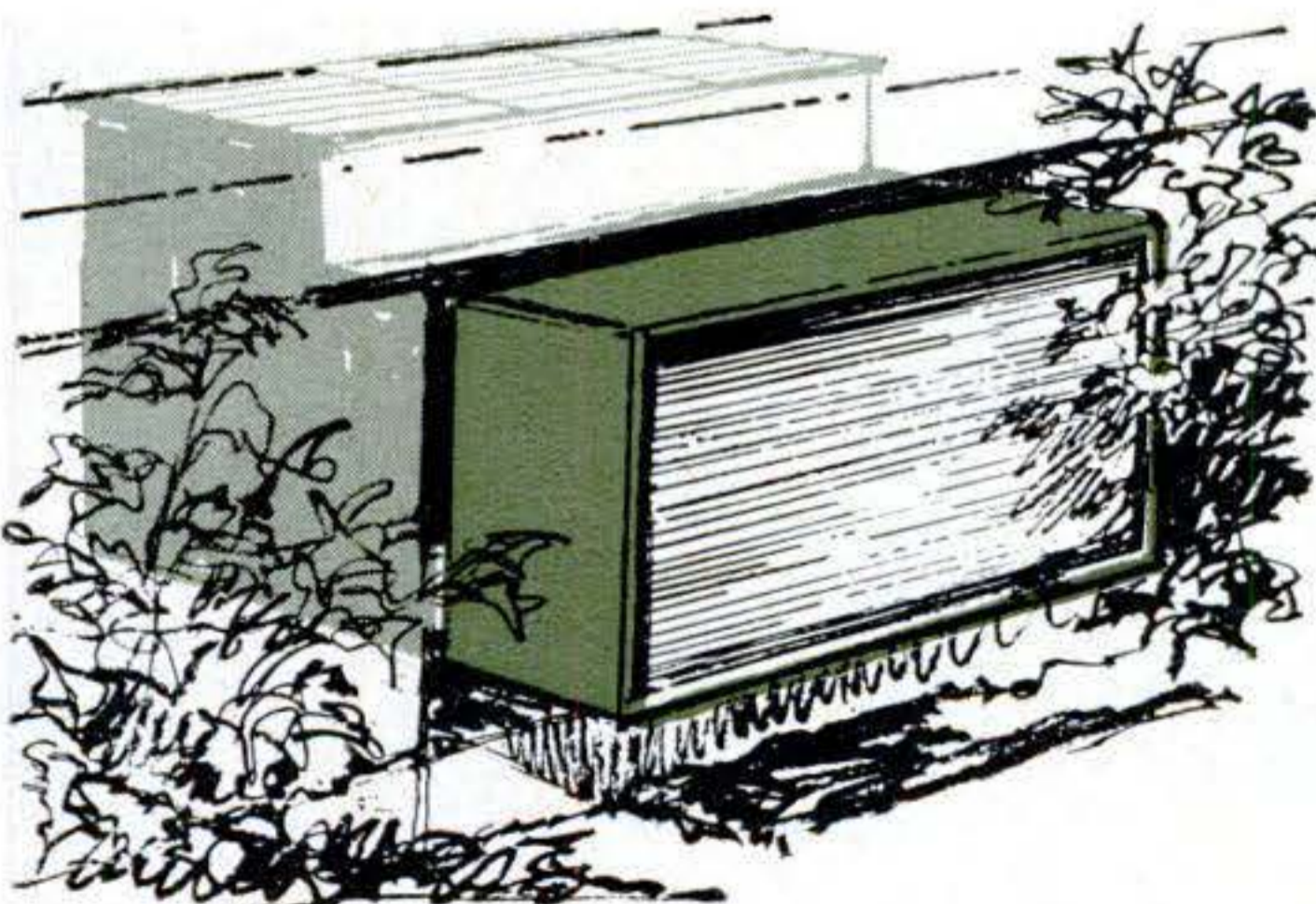

A hide-away air conditioner to fit basement windows screened by shrubs. Cool air from a top vent would be ducted to a floor grille in the room above.—*A. A. Scott, Leonia, N.J.*

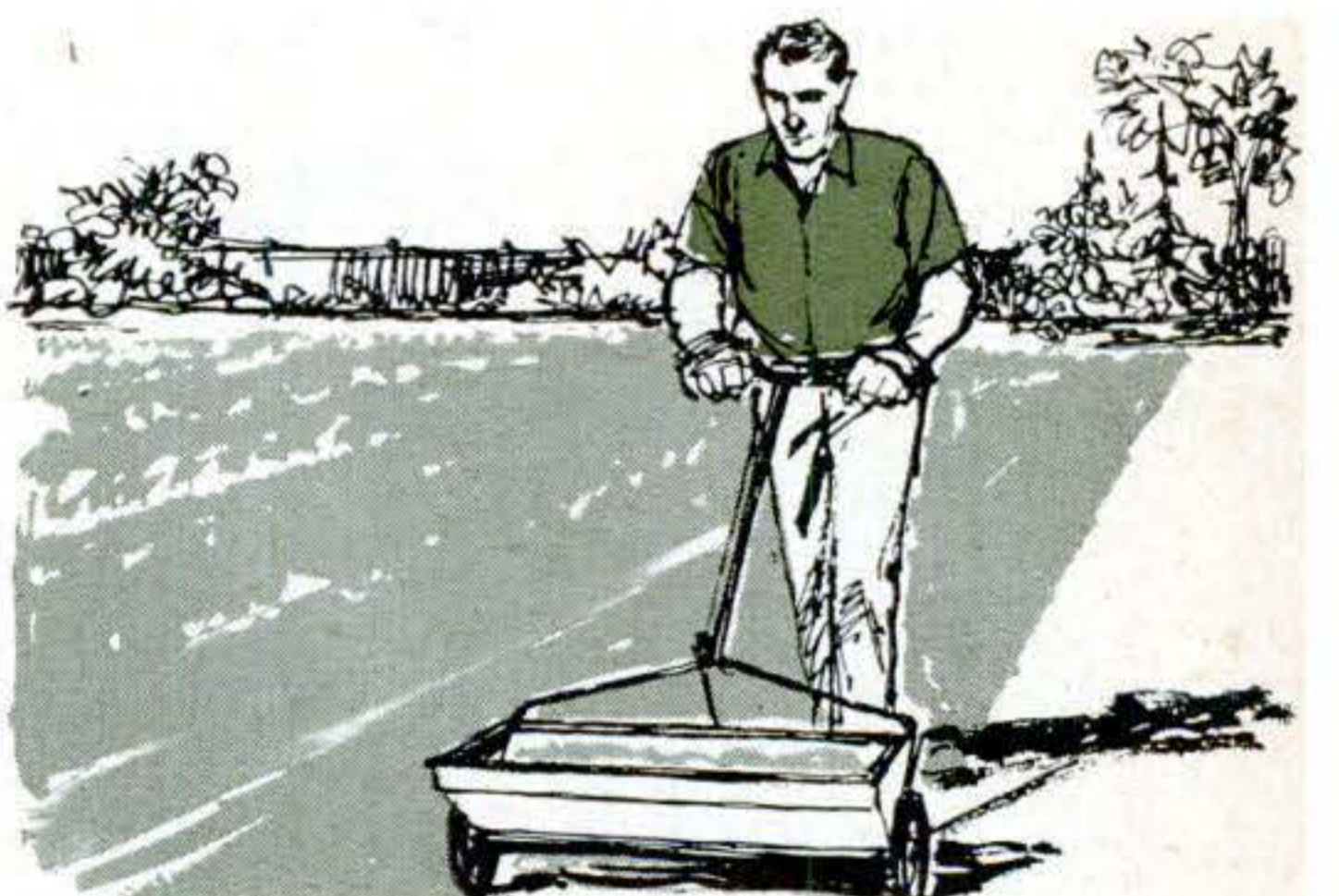

High-visibility fertilizers and weed killers so you could see where you'd been and not overlap on a lawn. Why not dye the pellets a bright color?—*S. Johnson, Wesleyville, Pa.*

Everyone has his own pet idea of a gadget that he would like to see in general use. What's yours? We will pay \$5 for each one published. Please use Government postcards

only. Send to ILTS Editor, Popular Science, 355 Lexington Ave., NYC 17. Write your name and address clearly. Contributions cannot be acknowledged or returned.

The Untold Story of the Model T

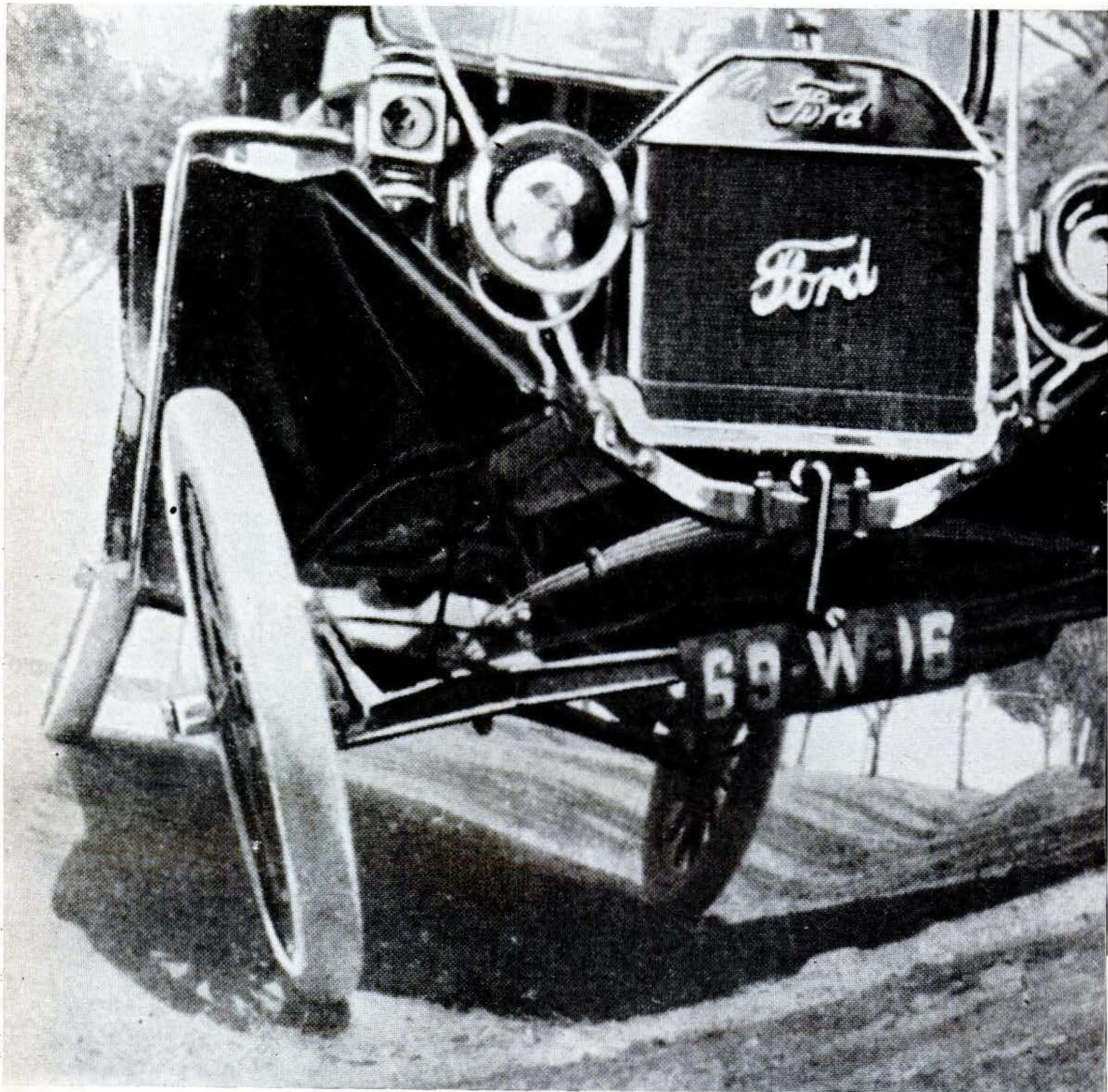

New alloy steels gave "The Universal Car" toughness and durability. A three-point suspension

The Tin Lizzie, a dazzling feat of imagination and technical skill, sold for as little as \$360, and put America on self-propelled wheels



By Allan Nevins

Noted American Historian

ONE hundred years ago this month there was born on a Michigan farm a man who performed one of the most dazzling feats of imagination and skill ever seen in the industrial world. The man was Henry Ford. The feat was the production of his Model T.

Before their manufacture was discontinued in 1927, more than 15,000,000 Tin Lizzies rolled off the assembly line.

Whole books containing nothing but jokes on Henry Ford and the car were published. Its price got down as low as \$360. It was, by far, the most popular motor vehicle in the U.S., the car that put America on self-propelled wheels.

Let me tell you the real story behind the Model T.

As America emerged from the panic of 1907, Henry Ford realized he faced a grim test. The country was hungry for cars. All about him were competitors anxious to seize the market. Ford knew that if he was to meet this test it had to be with new equipment and methods.

The equipment would be an array of revolutionary machines and machine tools. The methods would involve rearrangement of operations to provide more complete mechanization, greater system, and steadier, faster progression.

The success of the four-year-old company had been founded on the Model N, which, with a right-hand drive, a small carriage step instead of a footboard, and a force-feed oiler, sold for \$600. It was the best four-cylinder car for the price. But Ford knew it would never meet the test of the future in which farmers, storekeepers, professional men, and mechanics would demand a durable, low-cost car as reliable as a McCormick mower and as easily supplied with cheap, perfectly fitting spare parts as a sewing machine. The talented mechanical aides and experimenters whom Ford had assembled—Walter E. Flanders, Charles

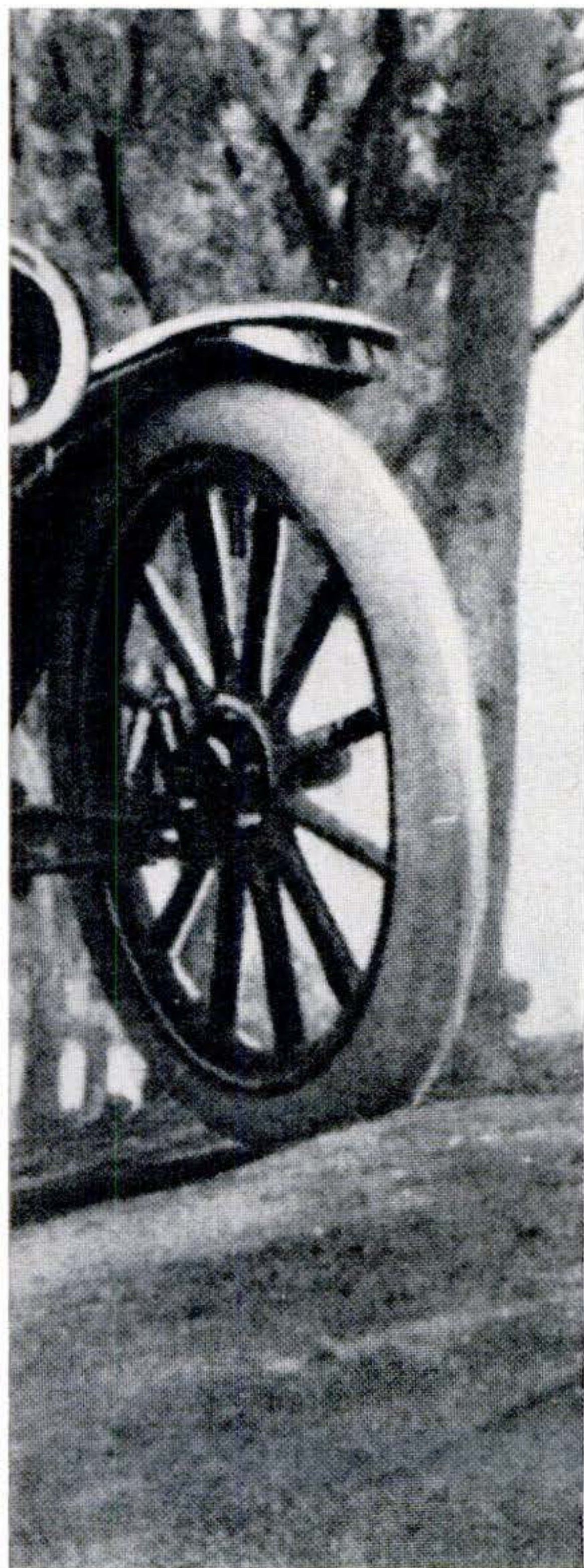

made it agile as a chamois.

CONTINUED

69

Sorensen, Harold Wills, and young C. J. Smith—knew it, too.

Out of this realization came the Model T. But just how did it emerge? The striking story is not how it found its market—how it persuaded doctors, ranchmen, salesmen, schoolteachers, and farmers that a car was a necessity. That story has often been told. The untold story is how the Model T was created and given superior efficiency.

New materials. Ford used special machines and machine tools to supply a mass market more cheaply and efficiently than any competitor. The bicycle boom had helped the machine-tool industry recover from the panic of 1907. Ford believed that American automatic machinery and Yankee methods were superior to those of Europe, but that Europe often had better materials. He especially envied the British their superior alloy steel.

His first important step was to close the gap. Steel alloyed with vanadium,

he discovered, was being effectively used by foreign manufacturers. Tests showed vanadium was more easily machined than nickel steel, that it was lighter and withstood fatigue better.

No American makers were then capable of making vanadium steel, but Ford found an Englishman, J. Kent-Smith, who could advise him in the creation of a metallurgical laboratory. In this laboratory, and in a small factory in Canton, Ohio, Ford and Kent-Smith taught their associates the proper use of manganese-carbon steel for axles, crankshafts, and other parts. They went on to devise new alloys of tungsten steel, nickel steel, chromium steel, and other metals.

Choosing steel. Up to this time, auto makers had failed to perceive that a well-made car required some parts of hard steel, others with tough steel, and still others with elastic steel. Before Ford set to work in 1907, not more than four types of steel had been used in the automotive industry. He was soon using 20.

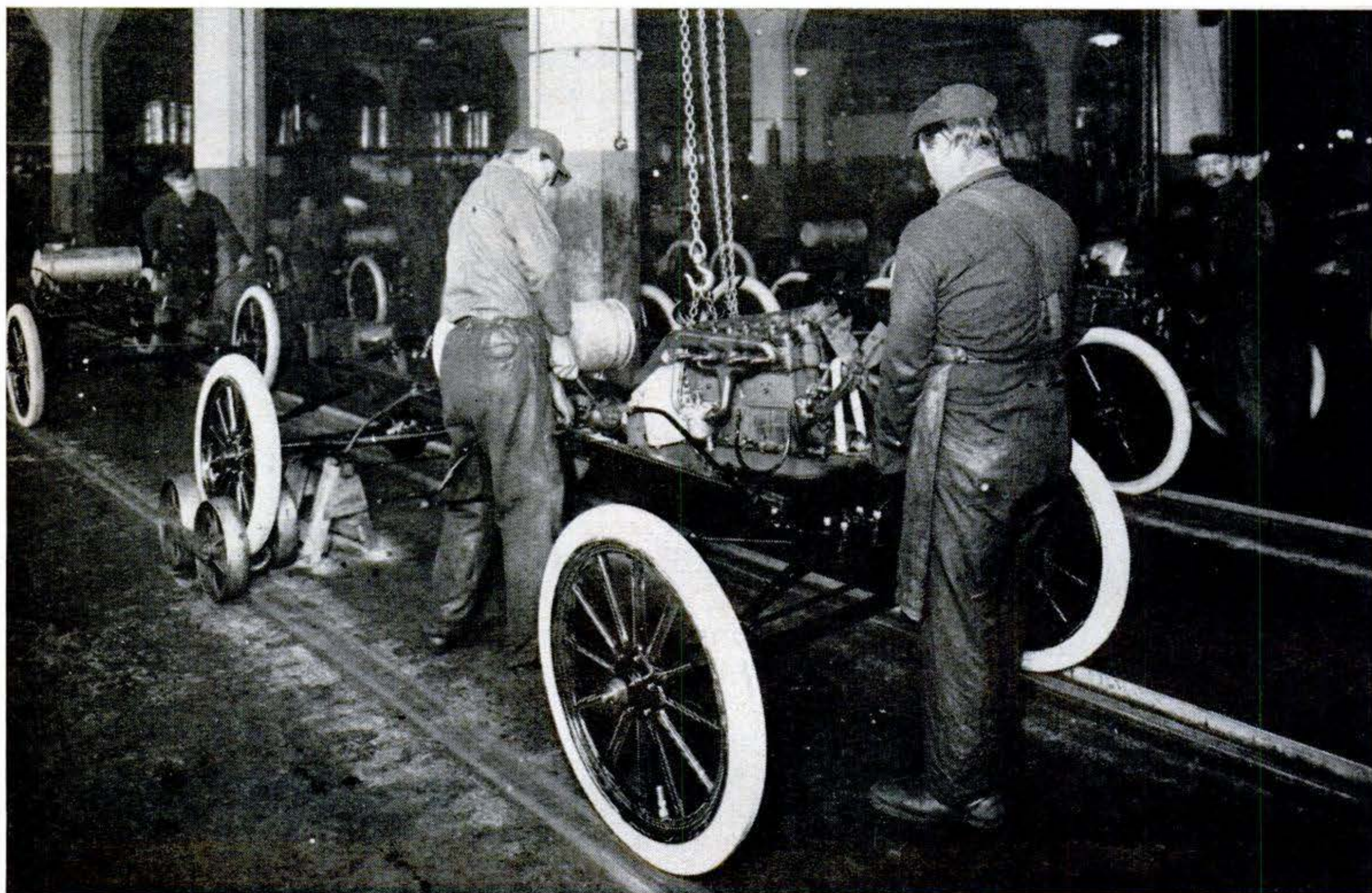

First mass-production line for automobiles was devised by Ford, and in the next 20 years his

metallurgy and manufacturing techniques put 15,000,000 Model Ts on the road.

Pictorial Enumeration of the Advantages of the UNIT POWER PLANT of the Model T Automobile

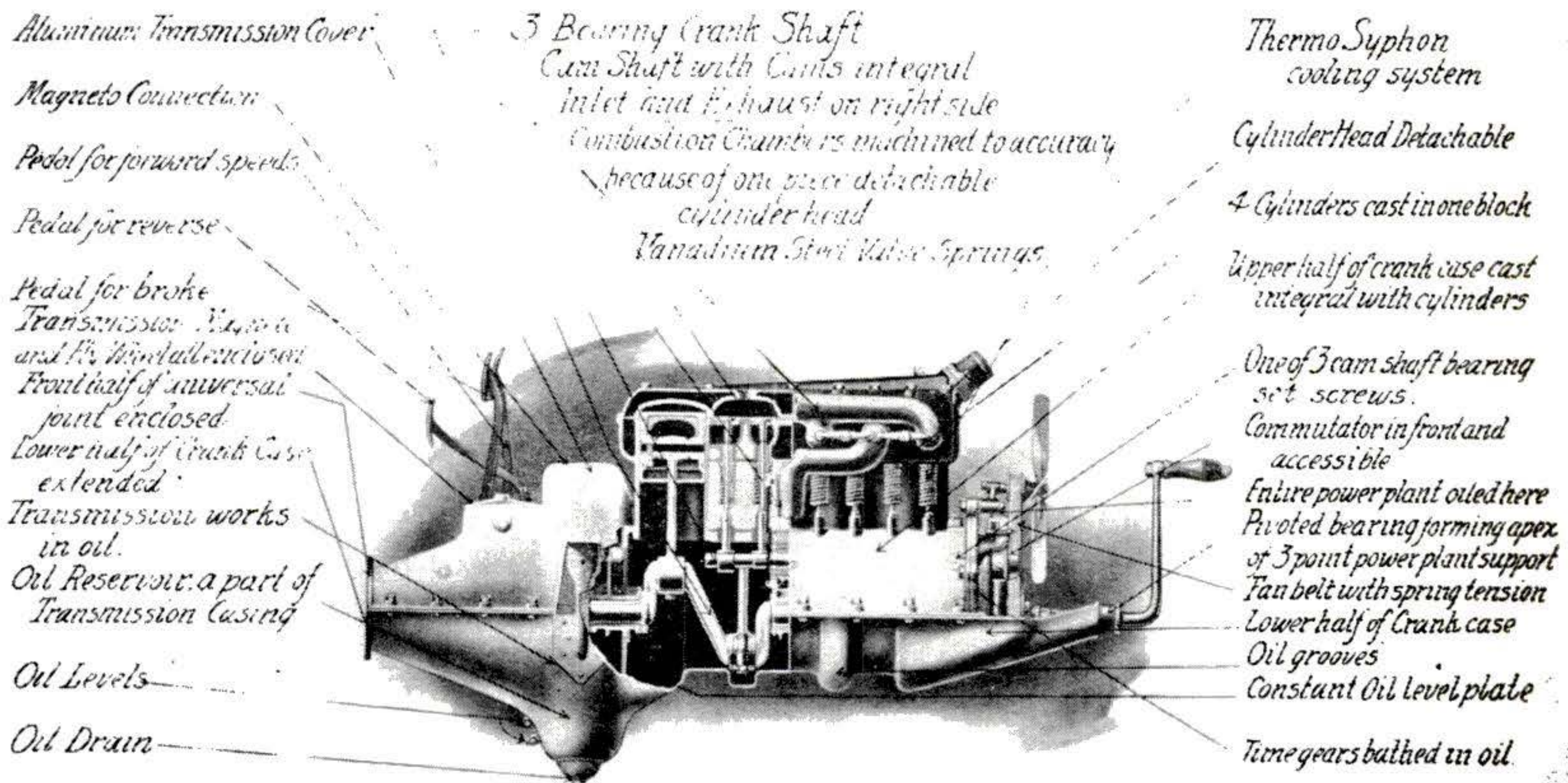

Engine and controls were the essence of simplicity. "Thermo-Syphon" cooling system used

nothing more than the principle that hot water rises. Gravity fed fuel to the carburetor.

Whatever the material, accurate machining was essential. Ford had his own requirements. From the outset, he demanded parts machined for simplicity, accuracy, and durability; he abhorred any resort to rule-of-thumb. "The first Ford ever made is still giving excellent service," he boasted in 1907, referring to a machine of June, 1903.

C. Harold Wills, probably the most creative man in the factory next to Ford, divided his time between machine tools—inventing some of marked originality—and metallurgy. C. J. Smith, only recently a humble machinist who had won Ford's confidence by inventing an improved arbor cutter for simultaneous milling of seven or eight cams, was kept on inventing.

In 1910, it was estimated by Isaac F. Marcossou, a famous newspaperman, that more than 60,000 machine tools were used in making cars. They includ-

ed new vertical millers, improved planers and radial drills, automatic screw machines, and a variety of engine and turret lathes. Marcossou was impressed by the laborsaving machinery. "You find automatics cutting the finest gears by the score, while one man operates a whole battery," he wrote. "You see drills doing from 15 to 20 operations on a piston or flywheel; you see an almost-human machine making 17 holes at one time without observation or care."

Upping production. On June 4, 1908, the Ford plant broke all production records. In one 10-hour day it built 101 complete Model N and Model S cars to fill final orders and clear the way for the Model T. This proved that, with correct tools and alert management, a schedule of 100 cars a day could be maintained. One hundred cars a day was to seem a small figure when the Ford company moved from its old Piquette plant to

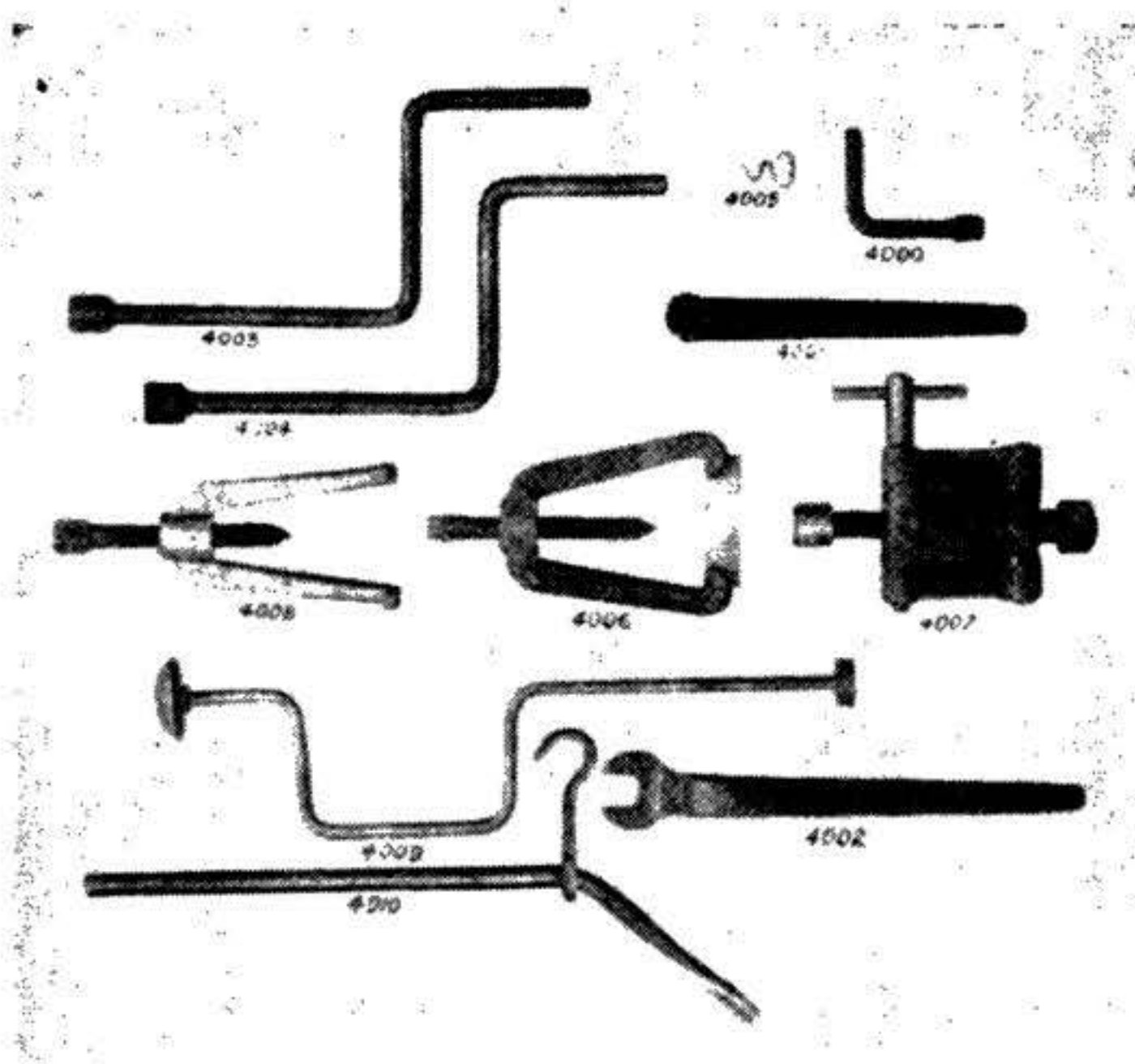

Prices on the 11 tools needed to keep a Model T in working order totted up to \$8.70.

the larger and better-designed Highland Park factory. But in 1908 it was impressive.

Meanwhile, as production increased, the need for planned arrangement of machinery, continuous progression of materials and parts through the factory, and precision in distributing them in the proper order, increased. In making a car, the right pieces of material—gear case, wheels, headlamps, horn, fuel tank—had to arrive at the right spot at the right instant.

Newly painted Ford bodies were hoisted by traveling cranes from the wooden frames which carried them on casters (hands would have marred the paint). It was not until later that overhead conveyors were integrated with a continuously moving assembly line. The motors were at first lifted into place by movable hand chain hoists.

Birth of the Model T. So much for the Ford factory. What of the machine that made Henry Ford immortal?

The first Model T was shown to 15 enthusiastic heads of Ford branches on Sept. 16, 1908. It is important to discard two common illusions. First, it was not the creation of Henry Ford alone; and second, it was no product of sudden inspiration put together in a hurry with untroubled effort. On the contrary, a group of men share important credit with Henry Ford for its creation, and it was brought into being by agonizing, exhausting worry and toil.

Four men in particular helped to give form to the basic ideas and requirements of Henry Ford: Joseph Galamb, a mechanical expert trained in Hungary, Germany, and the Westinghouse plants; Charles Sorensen, endlessly resourceful, experienced, and full of drive; C. J. Smith, already mentioned; and the brilliant Harold Wills, who united talent as a toolmaker with a knowledge of chemistry and metallurgy.

Another aide was Ed Huff, an electrical expert who developed the magneto, that special type of electrical generator, and installed it in the flywheel. Wills's protege, John Wandersee, an eager young mechanic, did a great deal to provide special steels for parts that had to meet grueling stress. Frank Kulick tested models as they were assembled, tore out disappointing parts, and helped suggest replacements. German-born Carl Emden, an engineer, was a fertile contributor of new ideas.

And how hard they all worked! Galamb has told us part of the story. "Mr. Ford," he recalls, "first sketched out on the blackboard his ideas of the design he wanted. He would come in at seven or eight o'clock at night to see how they were getting along. For about two

[\[Continued on page 174\]](#)

About the author

A brilliant historian, winner of the Pulitzer Prize for biography in both 1932 and 1937, former president of the Society of American Historians, Allan Nevins is the outstanding authority on Henry Ford and the Ford Motor Company.

His third volume on the man and his industrial empire (*Ford: Decline and Rebirth*, Charles Scribner's Sons, New York, \$8.95) is being published this month.

Mr. Nevins has been a professor of history at both Cornell and Columbia universities, and is presently senior research scholar at the Huntington Library, San Marino, Calif.



“Any Dope Could Drive a Model T”

By Everett H. Ortner

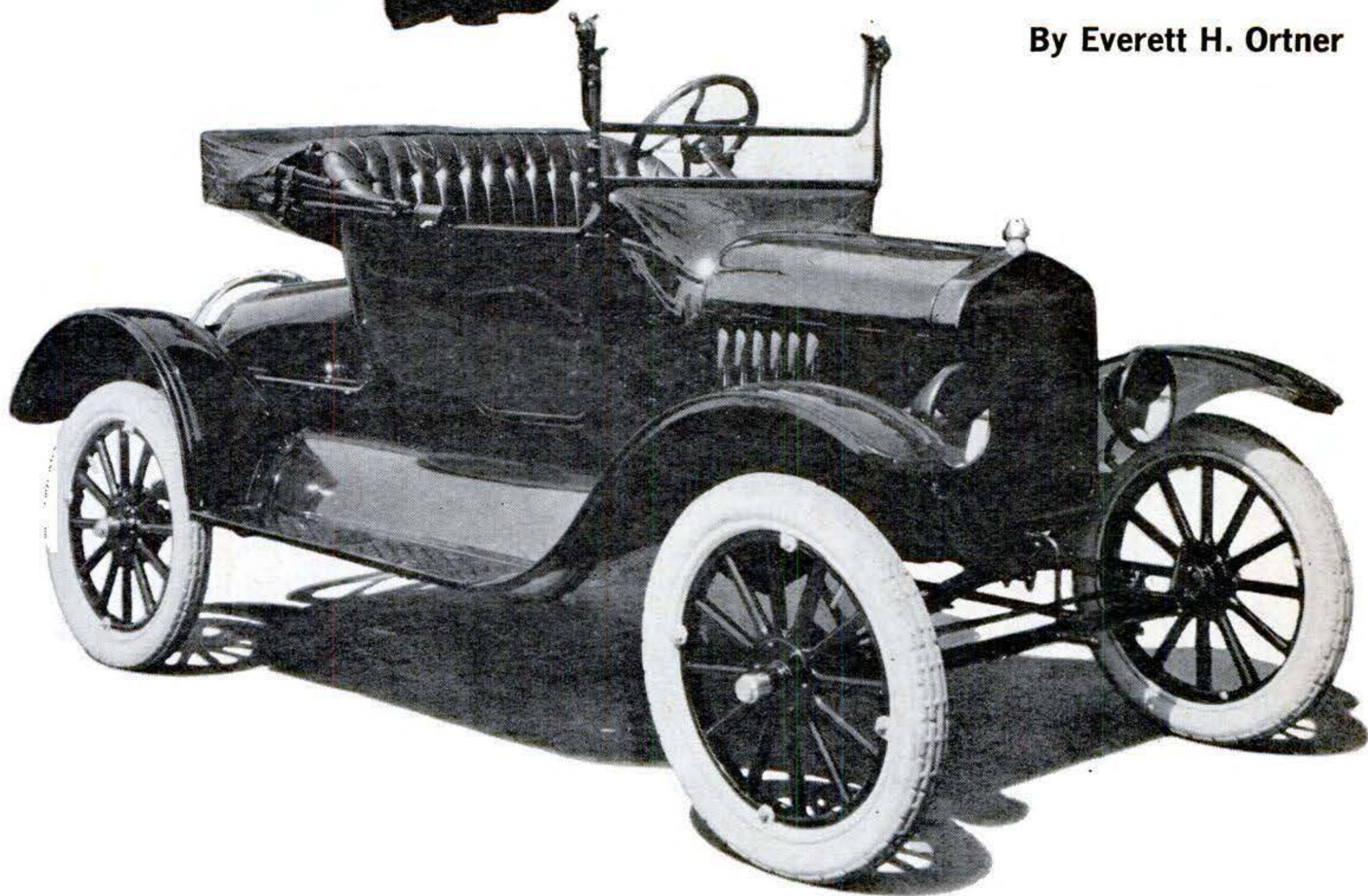

Let PS put you in the driver's seat of the Fabulous Flivver.
Come for a ride with our most nostalgic editor

THEY used to say that any dope could learn to drive a Model T in five minutes. I proved it. My maiden voyage took place on a college campus in a 1926 Flivver. The lack of casualties can be attributed only to the leisurely speed of the elderly car (it was 12 years old), the youthful agility of the pedestrians, and the loud rattle that went

as a warning before it—the only warning, because it had long since lost its horn.

The Model T was simplicity itself—a monument to the directness of mind of the man who designed it. If you or I (if you're a non-engineering type like me) were to conceive a car from scratch, we might well put in a separate pedal for

CONTINUED

73

each function: one for forward, one for reverse, and one to stop.

That was how Henry Ford saw things, too. But he knew that a car would need at least two gear ratios to go forward—one for hills or to overcome starting inertia, one for speed—so he gave that forward pedal a double function. Push it all the way in, and you were in low gear. Let it out, and you were in high, free to speed over the countryside at an exhilarating 35 m.p.h. or so—or anyway as fast as 22½ hp. would take you.

So far, so good. But what about neutral—which you needed when cranking the car or to hold still at an intersection? The forward pedal did that, too. It worked the clutch. Hold it halfway down, and the car stayed in neutral.

If you were lucky or foresighted enough to marry a gal husky enough to turn the crank while you held that pedal down, it might have sufficed. Few men were. So Henry brought another device into play. This was the hand brake, at the driver's left. Pull it back, and it not only held the car still—sort of—but simultaneously, through a cam on the clutch lever, put the car in neutral.

MODEL T owners in those days wore an arm in a sling with the pride that Heidelberg students took in dueling scars in the days of Kaiser Wilhelm. It was a sign of having participated in the great adventure of cranking a Model T.

This was a rite of many parts, and woe to you if you forgot one of them.

There were two quadrants on the steering wheel, each with its own little arm pivoting at the hub of the wheel. Pulling down the one at the right fed gas to the engine. Pulling the arm at the left advanced the spark.

Now you're ready to go. You hop in the car and adjust the quadrant arms: enough gas for a good, fast idle, a retarded spark for easy—and safe!—starting. Pull back the hand brake all the way. Turn the ignition key to "batt" (you'll flip it to "mag"—magneto—later when you're under way).

All set in the cockpit? Now you pop out in front of the car to face the crank. (Late Model Ts came with an electric starter, but mine never worked. And old Henry didn't put any stock in them either; every Model T came with a crank permanently attached.) There's a little ring sticking out of the lower left-hand corner of the radiator; a cable leads from it to the carburetor choke valve. You grab the ring with your left hand and pull it out, brace your legs, wrap your right hand around the crank handle (thumb in, aligned out of the way with your other fingers)—and yank.

Typically, at this point, the engine gave a little *chuff* of annoyance at being waked up, turned on its other side, and went back to sleep. You had to nudge it two or three more times before it started up. That was in mild weather.

WINTER starting called forth all your resolution. In a modern car, the battery drops dead after too much starting work, and you phone the service station to come get you. With a Model T, *you* were the starting motor, and the limits of exhaustion depended squarely on your strength and determination. A truly stubborn man could die right there in front of his Model T, crank in hand.

The second hazard was that broken-arm possibility. The engine was *supposed* to turn in a clockwise fashion (as you faced it from the front). Usually it did. When it didn't—most likely because you'd forgotten to retard the spark—you were in trouble. The engine would back-fire, and the crank would come around the wrong way at an arm-busting 800 r.p.m. or so and—if your arm was in the way—bust it.

A third hazard was the menacing way the Model T—when the clutch-lever screw was worn, which seemed to be all the time—tended to advance on you once the engine started: slowly, threatening to crush you against a house or garage door. Cautious owners liked to keep plenty of escape room behind them when they cranked, and a Model T owner

[Continued on page 176]

In Hartford, with 2,150 families signed up, pay TV has had a real test. Here's the one-year report

What Do They Think of Pay TV?

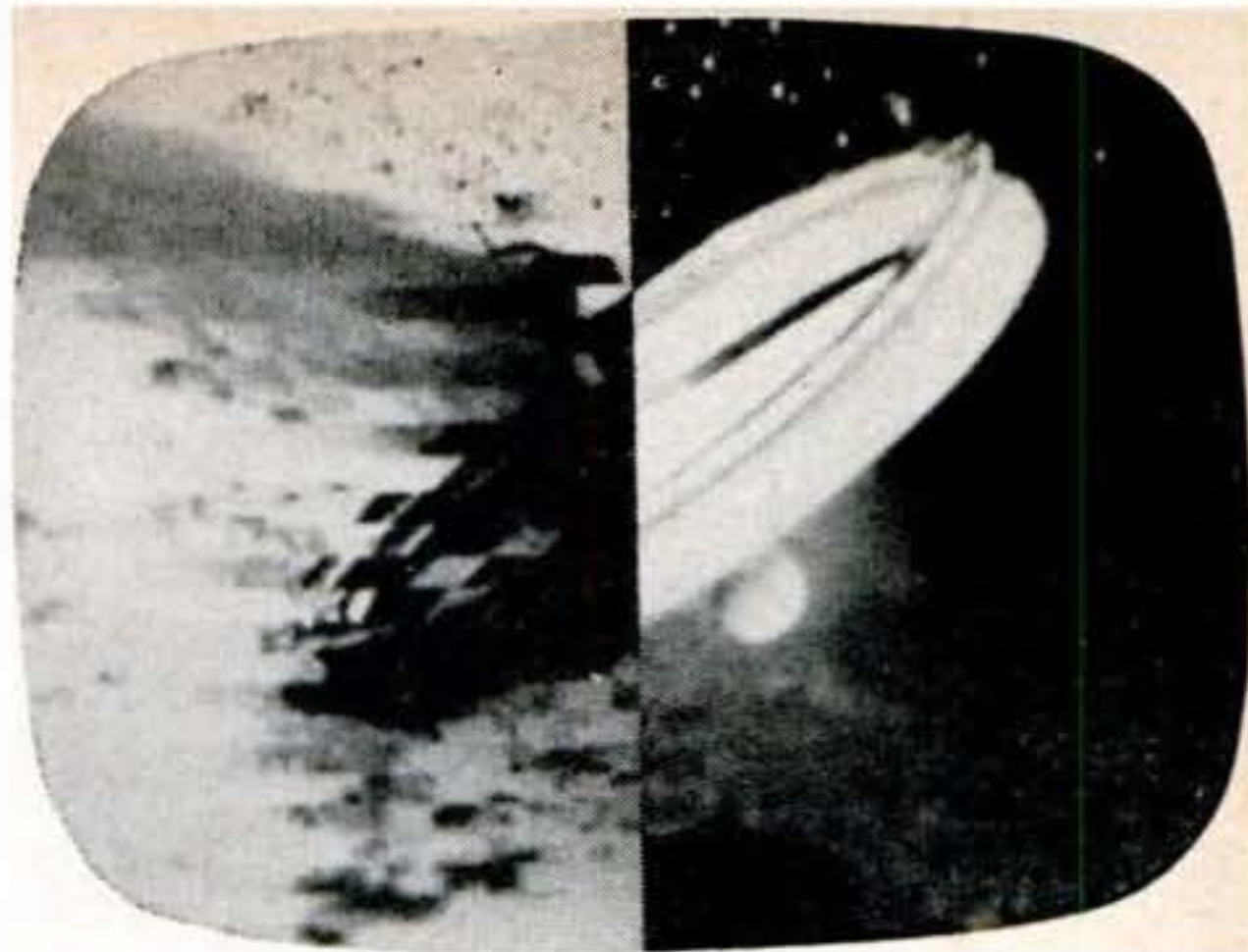

Before and after subscribing to the RKO-Zenith system being tried in Hartford: If you want the clear picture at right, you have to call the man below.

By E. D. Fales Jr.

AFTER a lot of false starts, you may be closer than you think to getting pay TV. It's already been started experimentally in Hartford (by RKO-Zenith) and in Denver (by Teleglobe), and is due to be piped into 25,000 New York City homes next year.

No fewer than five new companies—seeing rich harvests ahead—now are plugging hard to get it started in 25 other cities, and efforts are under way in Santa Monica, Austin, and Little Rock. It's not limited to the U.S. A suburb of Toronto has it, and it's being proposed in Mont-

CONTINUED



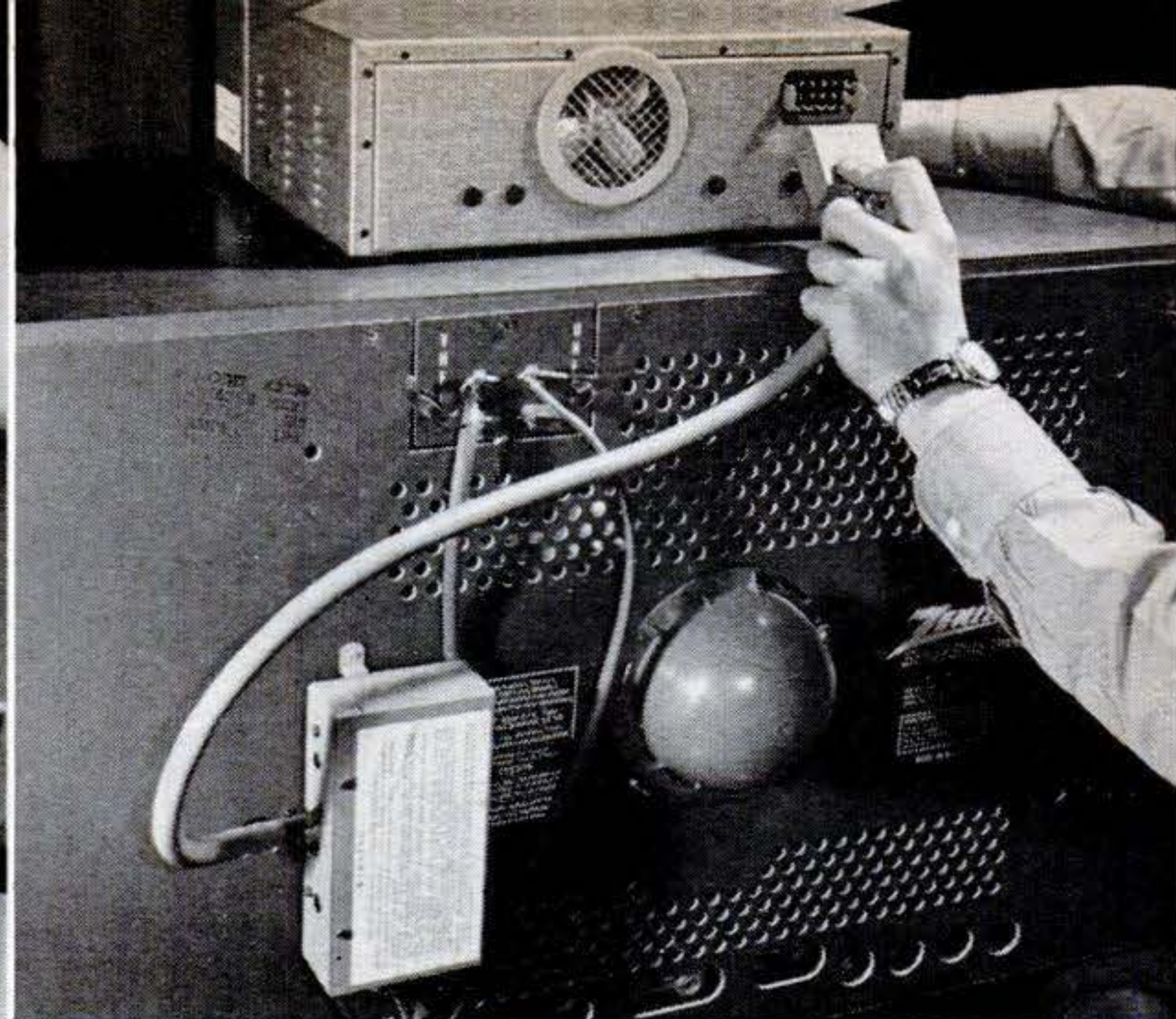
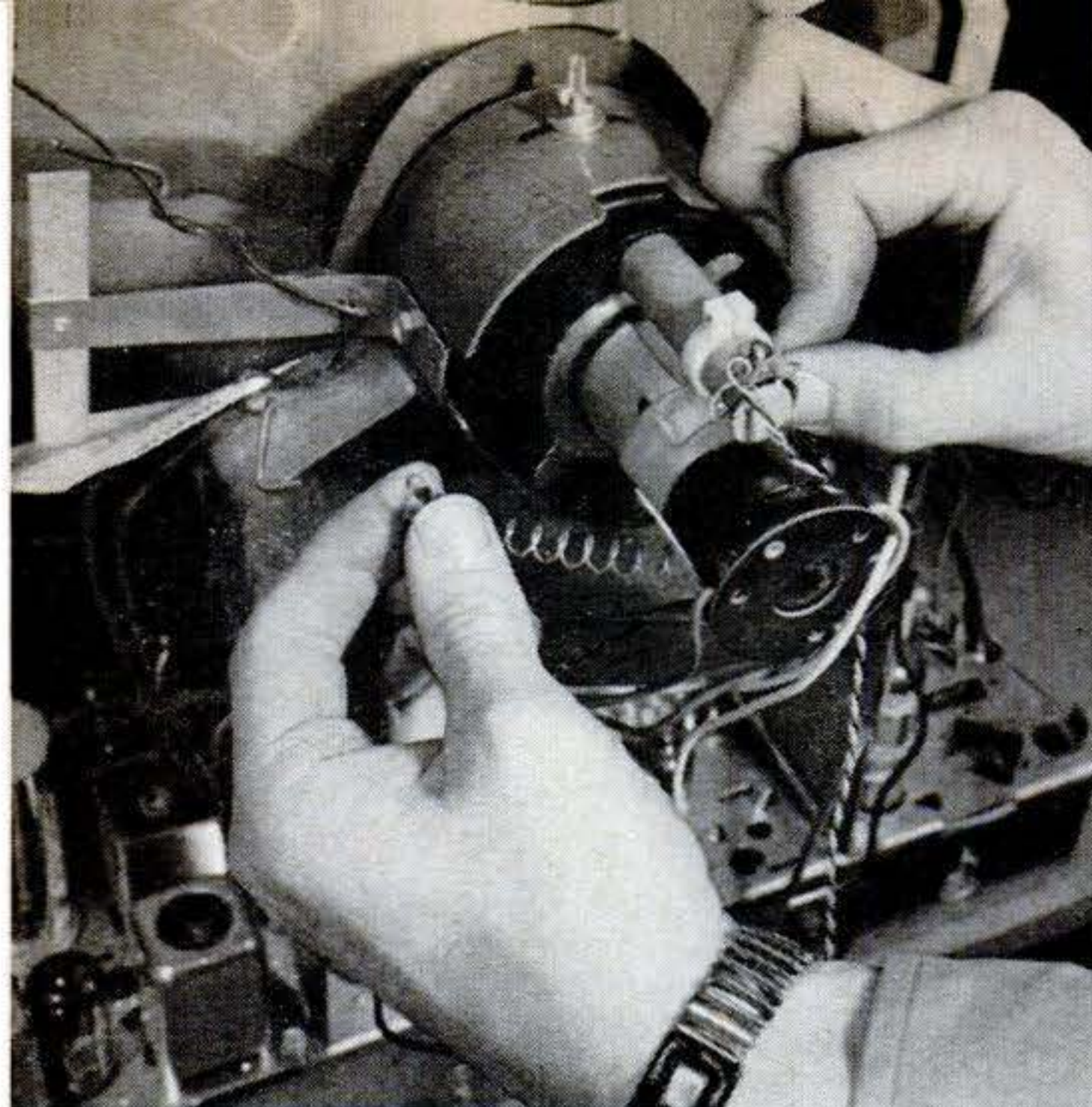

How the Zenith decoder is attached to your television set

1 Signal-pickup coil is attached by a small spring (shown) to the neck of video tube.

2 Signals pass through adapter box (lower left), go by coaxial cable to decoder unit.

real. (In England, engineers are even talking of transmitting pay TV via the gas pipes that serve many homes there.)

Meanwhile, the war waged against it by free TV and Hollywood seems on the wane. More good movies are being made available. Movie producer Otto Preminger admits: "It's as inevitable as automobiles were."

What does this mean to you? Suppose a chance to subscribe came next month? Should you take it? What will you get? Will it kill off your free TV? And what will it cost?

To get answers, POPULAR SCIENCE sent me to Hartford. There, since June 29 last year, hundreds of families have been guinea pigs in the first full-fledged, FCC-approved test of pay TV. They plunked down \$10 each to get it. And they've been spending from \$3.25 to upwards of \$8 a month to see it.

All told, as this is written, 2,150 Hartford set owners, from barbers to bankers, have signed up. They've been seeing movies (including some good new ones), fights, Yale-Dartmouth football, high-school basketball, ballet, orchestras.

On a recent night when other viewers fretted over failure of free TV to show a championship fight, Hartford pay-viewers saw it for \$2.

On another night when free TV was going through the agony of pain-reliever and bathroom commercials, pay-viewers saw an opera, *The Consul*. It ran two hours, spilled over 13 minutes into a third hour.

In those 133 minutes, viewers figured they had escaped nearly 40 commercials. And there was no salesman blasting in to ruin the closing lines.

How do viewers like all this? Here's a clue: Only 23 of those first 2,150 viewers have canceled. And viewers have found that pay TV does not replace their free TV. It's a supplement.

The first man I talked to was the cabby who drove me to Channel 18, RKO's part-time pay-TV station.

"Do you have pay TV?" I asked.

"No, but my neighbor had his decoder installed last night."

"How's it going here?"

"It's a funny thing. Nobody raves about it—it's not *that* good yet. But more keep signing up all the time."

To get pay TV via the RKO-Zenith system used in Hartford, you fill out an application, send \$10, and agree to pay \$3.25 monthly rental for a decoder (worth \$125). Besides that, you'll pay for all shows you watch. These cost from 25 cents to \$3; most are \$1.



3 **Checking it out:** After installing decoder, technician lowers the front door and dials the code number for whatever pay show is playing. (Code numbers show in small odometer

window just above large rectangular white button.) Then he closes door and turns small switch from "TV" to "PV." Once a month you draw your bill from small square door at right.

To be accepted, you must live within 20 miles of Channel 18's transmitter. You use your regular set (even a color set), but it must be in good shape.

There's a waiting list, and several weeks may pass. Then one day a white Volkswagen truck (one of seven) arrives. A blue-uniformed serviceman checks your set for ghosts, snow, or blooms—which would degrade the quality of the broadcast. Then, if everything's okay, he attaches a small adapter behind your set.

This is a gadget that intercepts all scrambled incoming signals and detours them through your decoder, which will unscramble them. The decoder, a trim brown box the size of a portable typewriter, rests on top of your set. It is linked to the adapter by a plug-in coaxial cable.

Channel 18 sends out free TV by day and pay TV by night. On the day I arrived at the studio, pay TV was to begin at 6:01 p.m. At 5:40 p.m., during a free-TV movie, I watched engineer Ray Sigda commit a bit of electronic devilry. Tucking a code sheet under his arm, he opened a glass door in one of the huge studio control panels. Consulting the code for the day, he began twiddling six black plastic knobs, like a

man cautiously dialing to open a safe.

What he was doing was setting up secret amplifier and delaying circuits that would, first, change the broadcast film to a negative. Next, they would lasso some of the outgoing video signals and hold them back. They'd be delayed ever so slightly—just 1.7 thousandth of a second—but enough to create chaos on your screen.

Sigda scrambled the audio signals, too.

At 5:50 p.m., when his skulduggery was done, Sigda closed the glass door and waited for his cue. At 5:55 p.m., the regular free afternoon news show went on the air and ran five minutes.

Suddenly, at 6 p.m., Channel 18 broadcast a blast of trumpets. Channel 18 viewers everywhere recognized it. At the same time a deep voice rang out: "By authority of the Federal Communications Commission!" Then a slide flashed on thousands of screens. It read:

**Subscription TV
First in The Nation**

Pay-viewers hurried to weekly program books (mailed to them) and found:

TUESDAY 6 P.M.

PARAMOUNT'S

"Conquest of Space"

From a satellite 1,000 miles from



Messing up the works: At Channel 18's studio, engineer Ray Sigda takes a clear broadcast sig-

nal (right), codes it, and turns it into the frustrating scramble shown in the center screen.

Earth, scientists take off on the first trip to the planet Mars

(For adults & young people)

Code 247D 85 mins. \$1.00

(To be shown again 6 P.M. tomorrow.)

The trumpets still played, blaring out composer Aaron Copland's *Fanfare for the Common Man*. At 6:01 engineer Sigda got his cue, pushed three buttons. His code circuits went to work. On viewers' screens the printed announcement suddenly fell apart. The letters, no longer legible, looked like a game of dominoes after a player has gotten mad. The fanfare turned to sleigh bells.

Pay TV was on the air. You had one minute to get your decoder in action, or else shift to free TV.

Starting a decoder begins like this: You open the front door, revealing a dial and an odometer like the one in your car. You hear a faint sound of gears advancing a concealed paper strip on

which your bill is printed. You spin the dial (forward or back) until the code given in your program (247D) comes up in the odometer window. That *undelays* the video signals and also returns them from negative to positive.

As you turn the dial you are also ad-

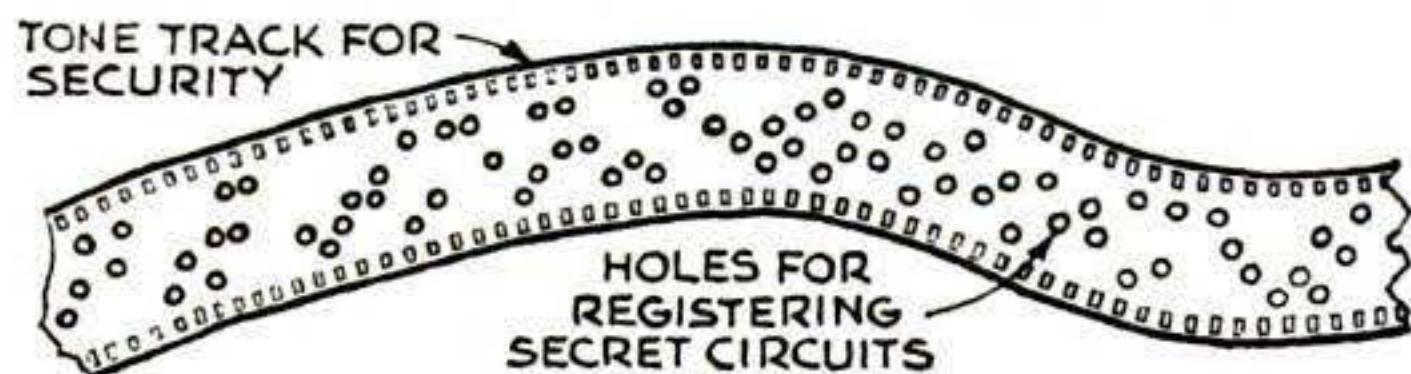

vancing a "security tape"—a strip of 35mm Mylar film punched with a crazy assortment of holes. By dialing 247, certain holes move into position to complete certain circuits. When you dial D, you set a small printer in position to stamp "\$1.00" on your bill.

As you close the decoder door, the secret circuits are completed by gold-

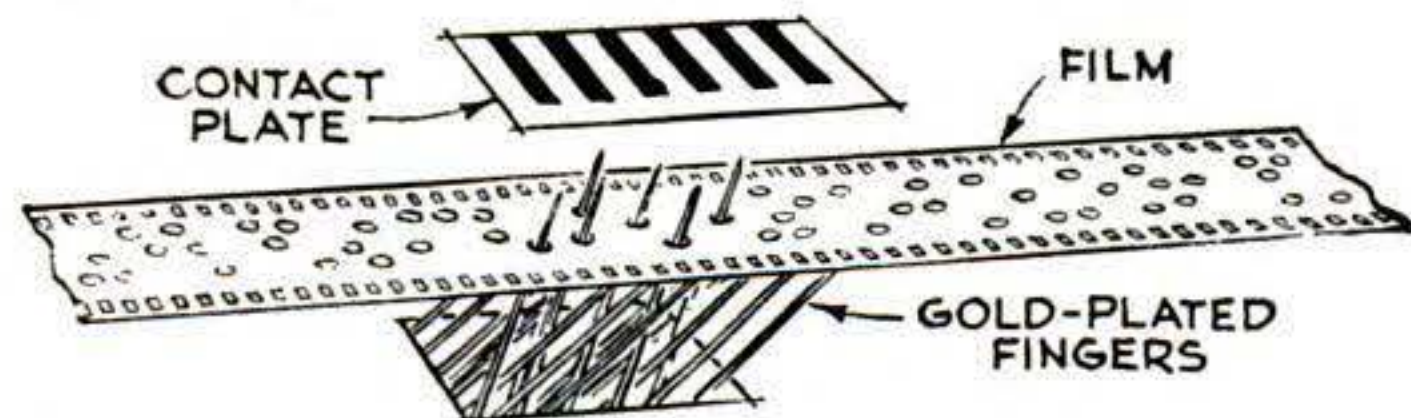

plated fingers. Thirty of these push up against the perforated tape. But only six can get through the holes. These set up the circuits needed to see the show.

[Continued on page 168]

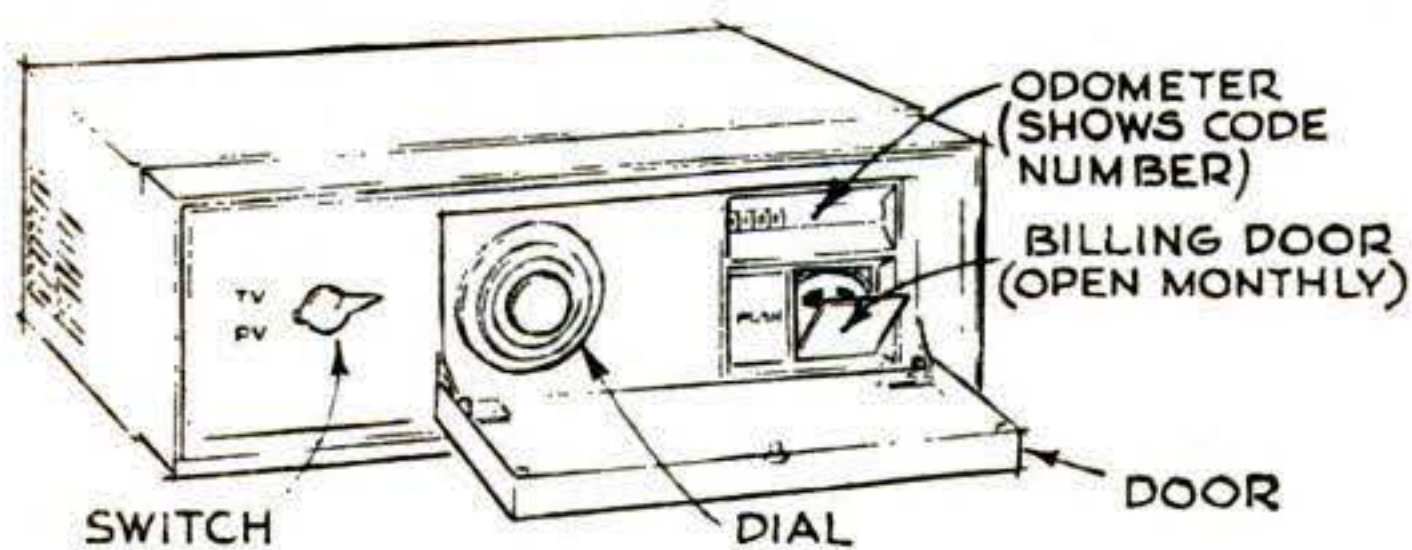

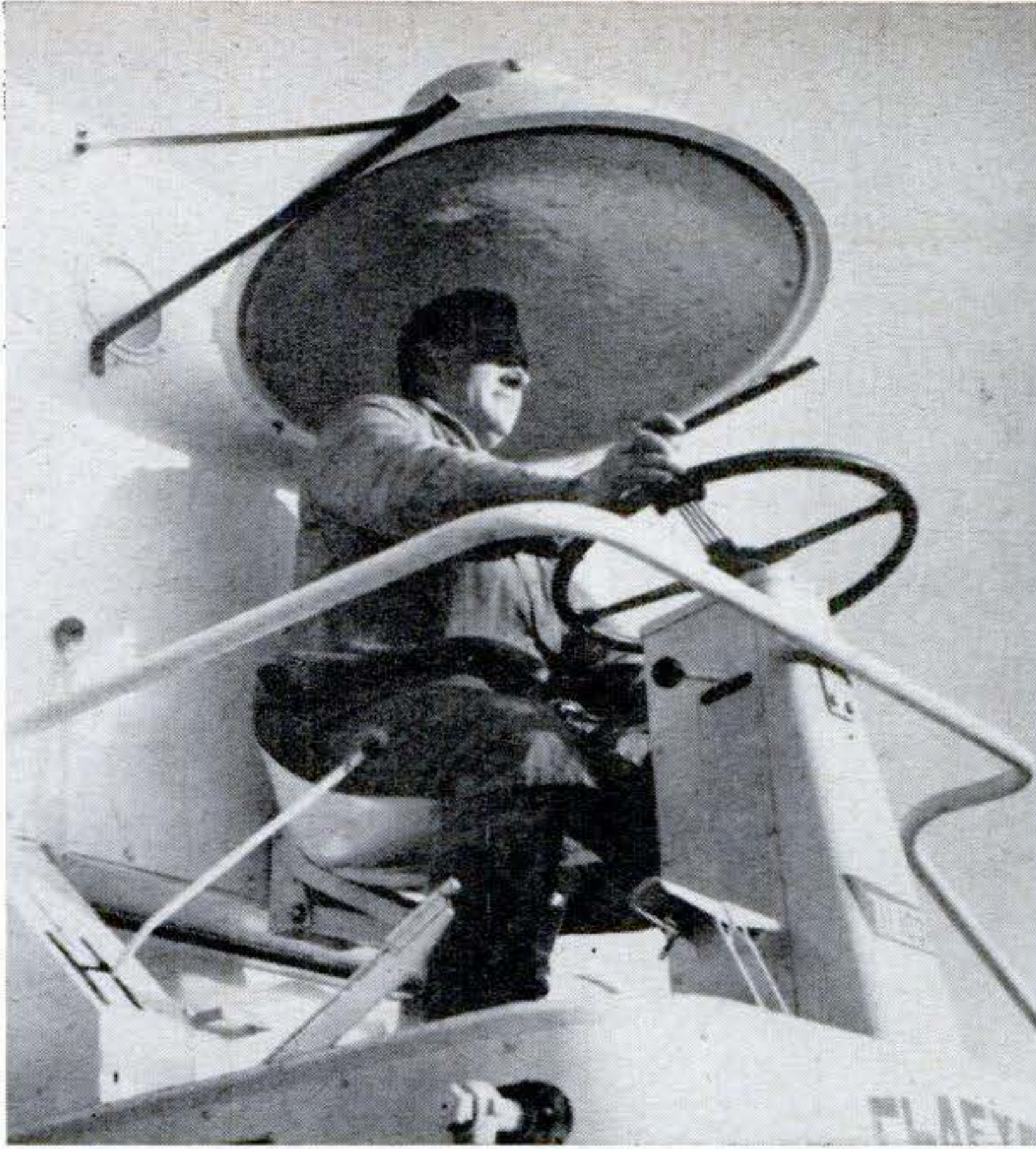

Air canopy protects tractor driver

An air curtain shields British tractor and combine operators from dust, chaff, and insects in the field, making goggles or special clothing unnecessary. A fiberglass dome over the open cab has a built-in fan that blows a sheet of encircling air through a gap at the rim. The canopy also protects the driver from sun and light rain.



Platform rolls like ship's landing deck

An experimental platform that tilts up to 15 degrees is used by the British Navy to test the capability of new helicopters for landing on ships at sea. Shown here is a Westland Wasp, latest antisubcopter. It can be fitted with either wheels or suction cups for landing on small ships.

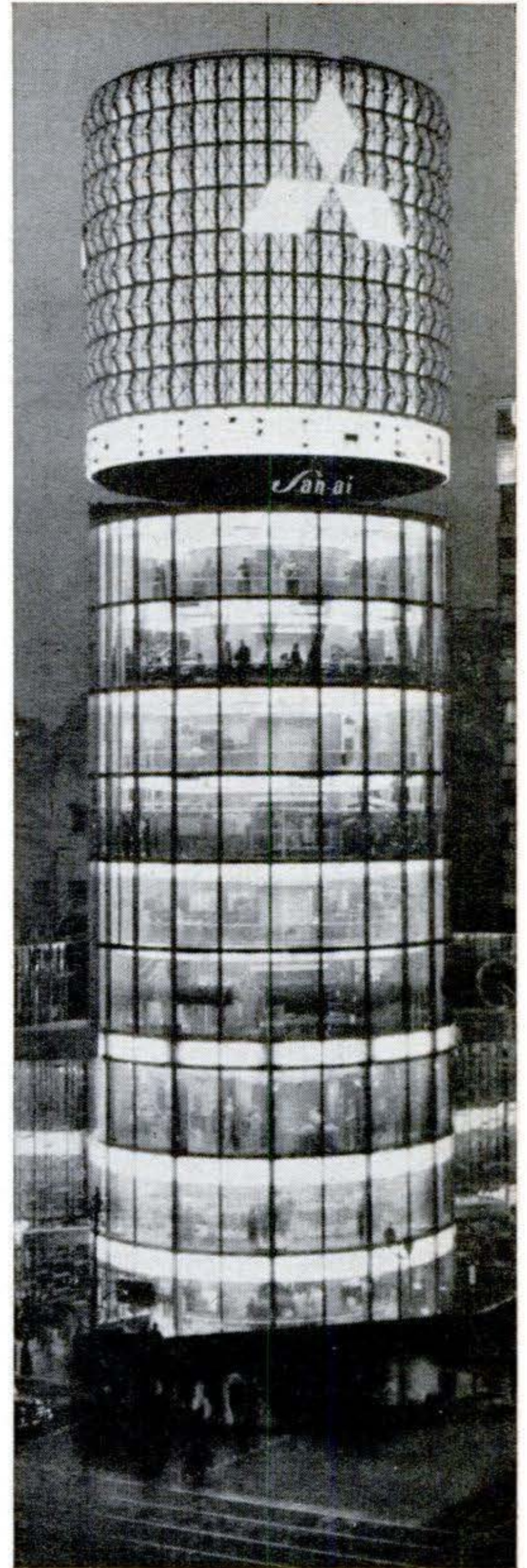

Cylinder of light on Tokyo's skyline

Nine glass-enclosed stories below the neon-lighted tower at top serve as a Tokyo Ginza district showroom for the San-Ai chain of specialty shops.

The circular floors were built one at a time in wedge-shaped sections and assembled around a steel core. The building is designed to withstand severe earthquakes. Cost: \$2,700,000.

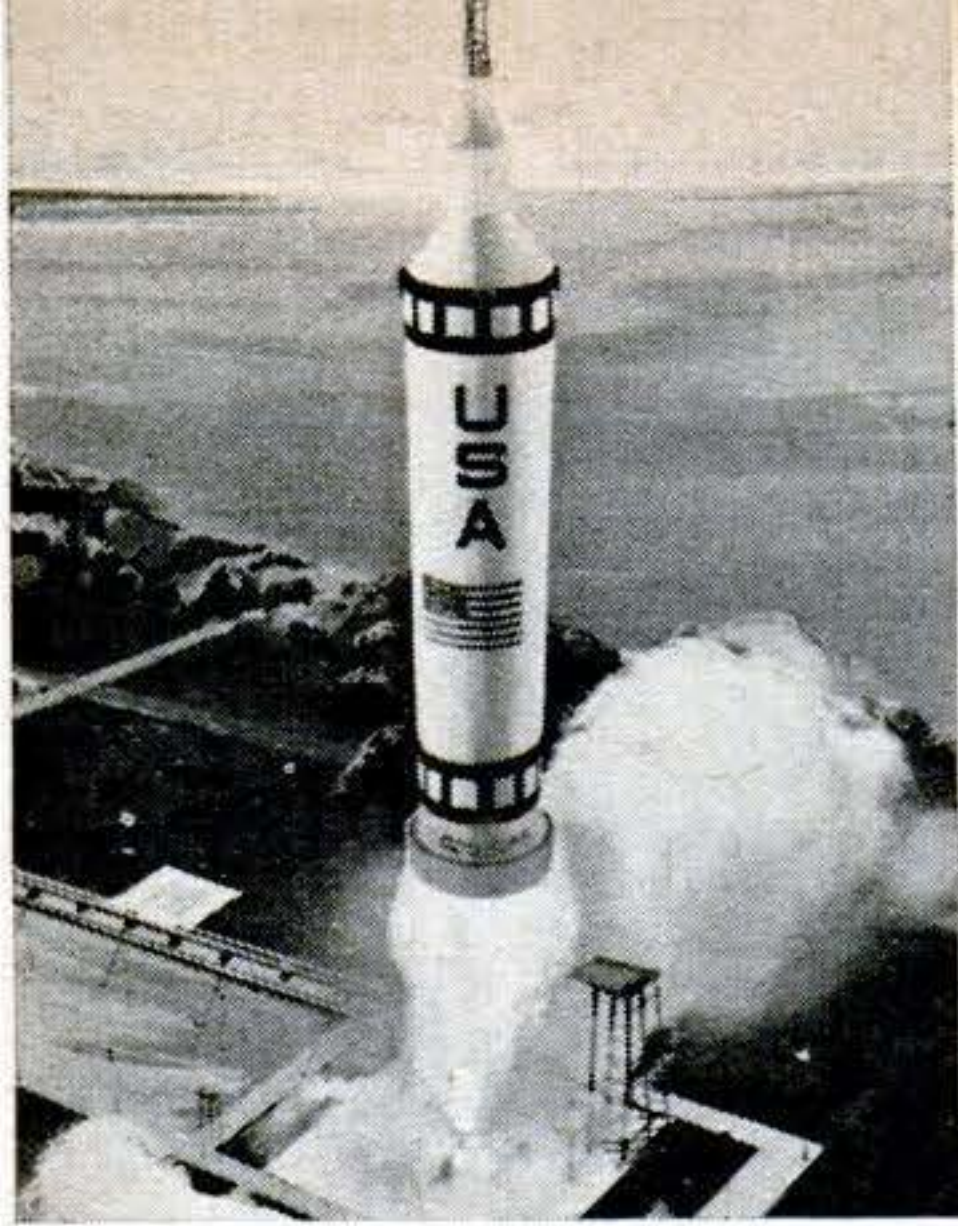

How recovery system would work

1. ROOST was designed for giant single-stage boosters of future like that in drawings here. The boosters, 50 feet in diameter and 173 feet tall, would weigh 10 million pounds loaded and have a cluster of 12 engines generating a mighty thrust of 12 million pounds.

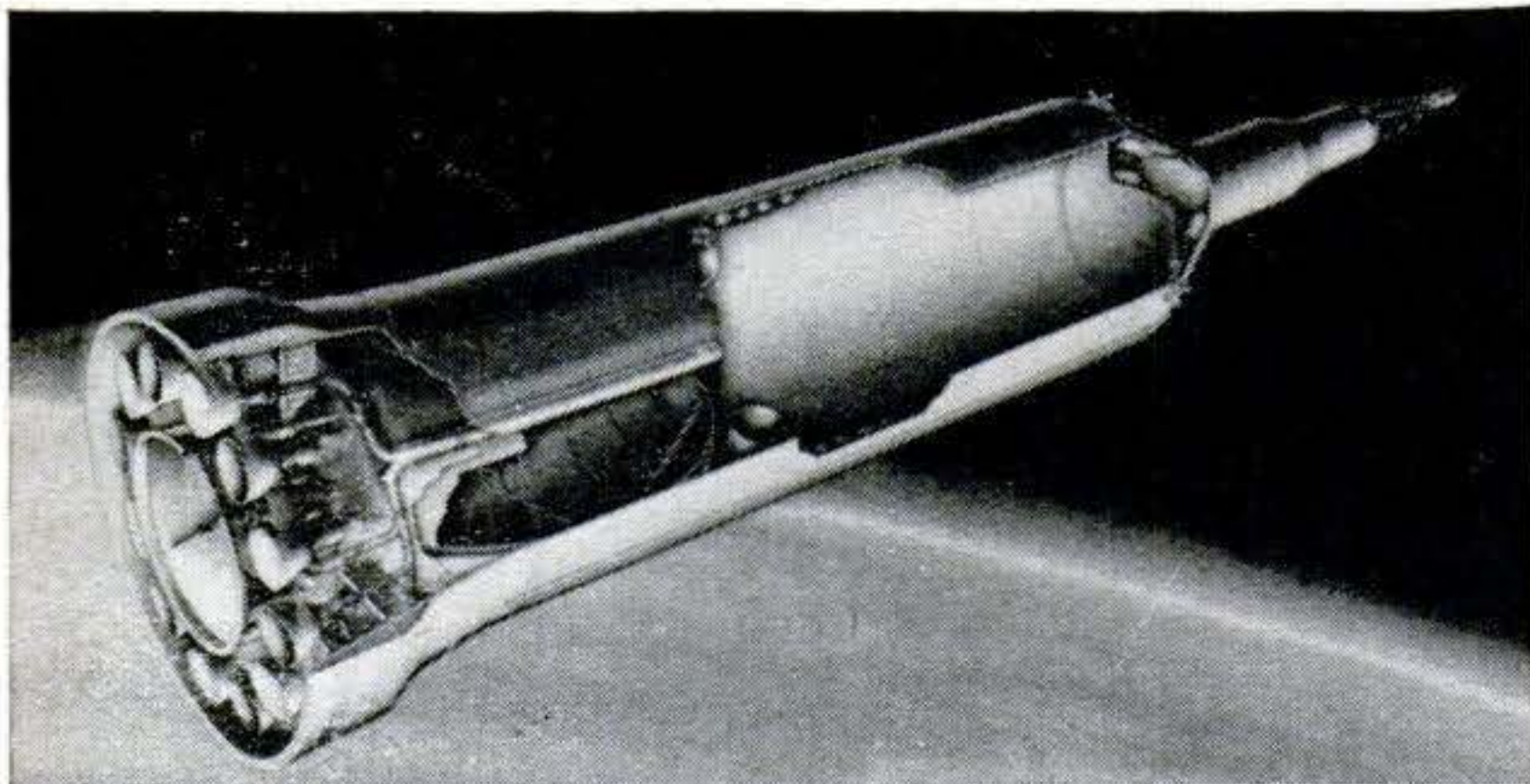

2. Booster speeds toward earth orbit carrying a 160-ton payload that might be a nuclear stage with a manned capsule for moon or outer-space exploration. Cutaway of the booster shows how the deflated recovery bags are stored.

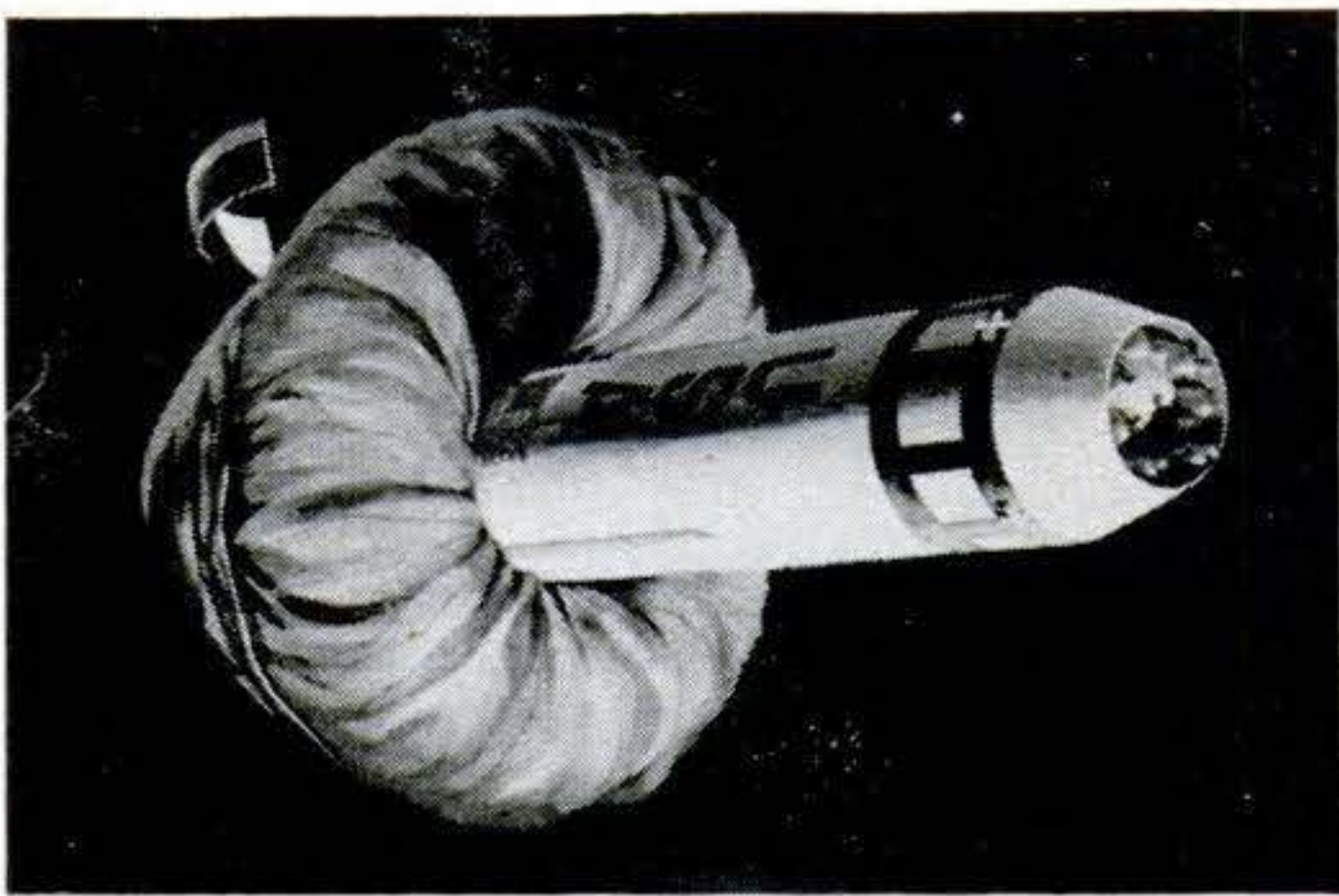

3. In earth orbit, payload has separated, and recovery bags popped out from rear of rocket begin to inflate, throwing off protective plates. Here conical bag begins to take shape.

4. Inflated cone-shaped bag enshrouds rocket while doughnut grips its middle like a choke collar (cutaway, below). Booster can remain in orbit 24 hours until triggered for re-entry.

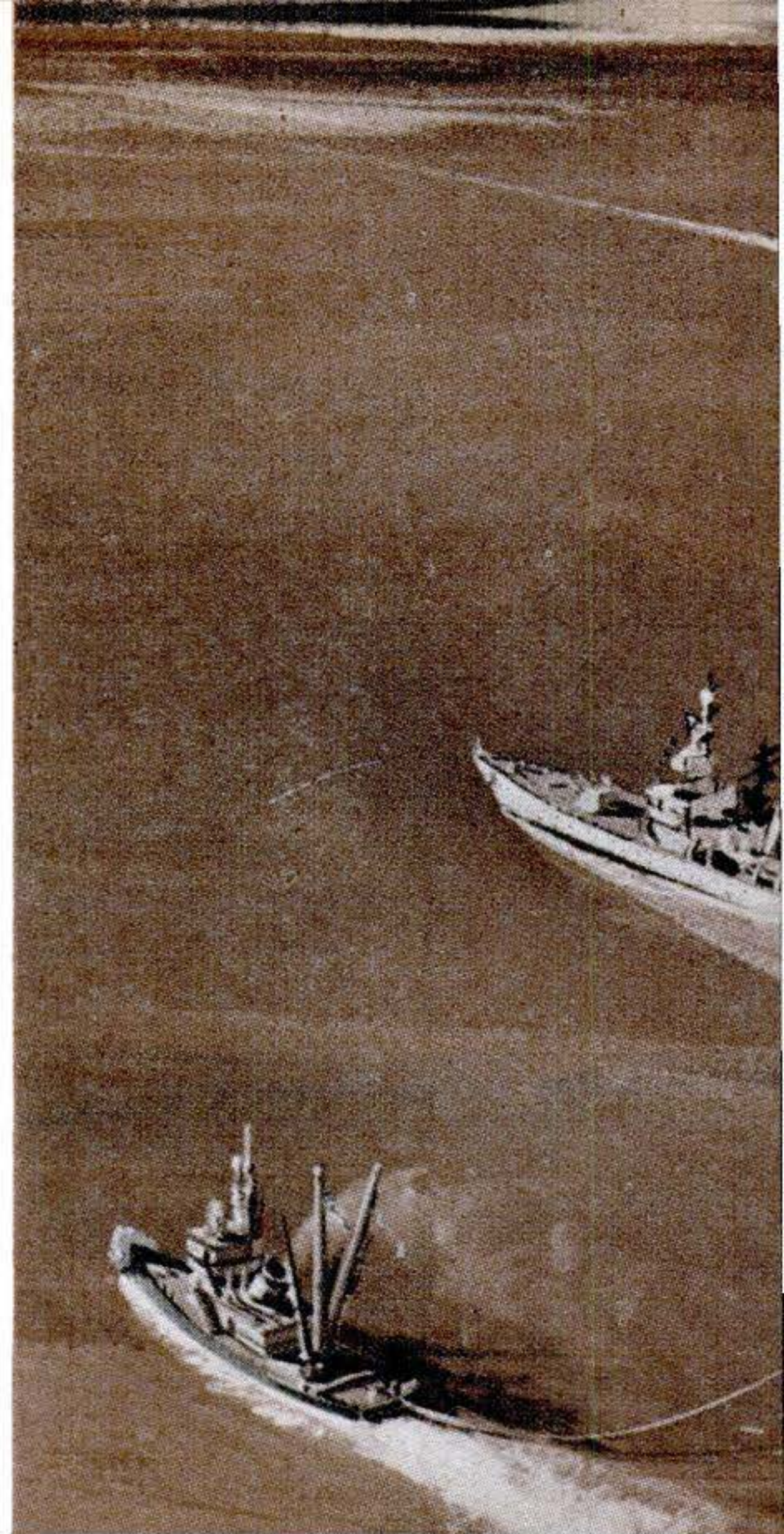
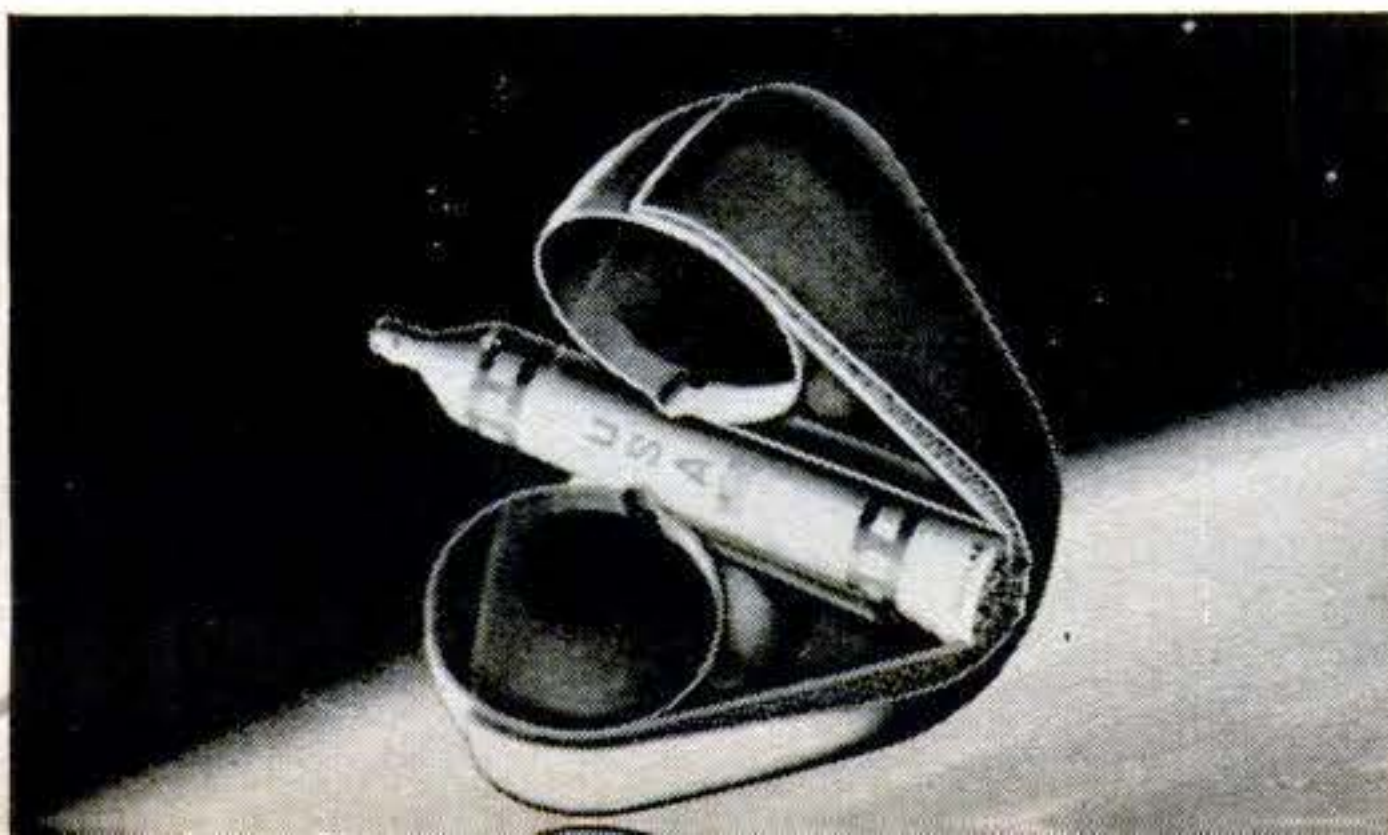

5. As ROOST settles gently in

How to Bring a

THROWING away giant, multimillion-dollar booster rockets in space after one mission makes about as much sense as dumping an airliner after one flight. It may be necessary now, in the early stages of space exploration, but eventually we'll have to start using a booster more than once.

What would it mean if we could "float" big boosters back to earth intact so they could be used again? Peek ahead into the late '60s when single-stage, super-giant boosters will be ready for space exploration—with the price tag of a single boost estimated at \$320 million! That would be the cost with our present prodigal practice of junking the booster in space. But recover the booster (weighing perhaps 500,000 pounds, empty of fuel) and you could bring the cost down to a cool \$16 million. Sev-

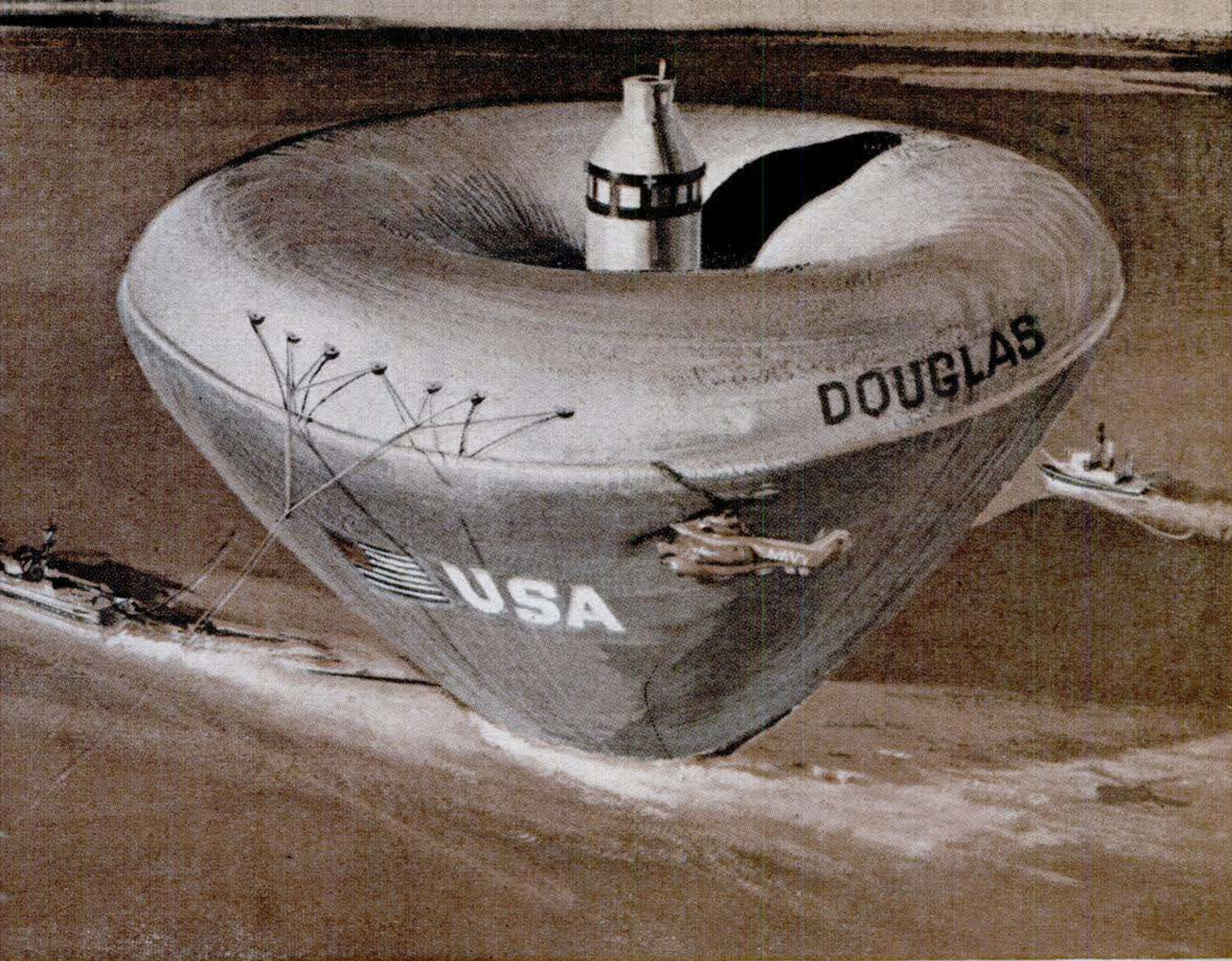

the sea, waiting surface ships pick up the dangling towlines to salvage the costly booster.

Booster Back Alive

By Philip Bono

*Technical Director,
Advanced Launch-Vehicle Studies,
Douglas Aircraft Co.*

eral recovery concepts are now being studied by the National Aeronautics and Space Administration for use in future space boosters. Douglas Aircraft's contribution is ROOST (Reusable One-stage Orbital Space Truck). Naturally we think it is a good system. Here is how it would work:

Essentially ROOST consists of two rubberlike bags carried deflated inside the lower section of the booster. Immediately after earth orbit has been achieved and the payload has separated to continue its space mission, the bags would pop out of the booster's rear to be inflated by gases generated by solar heat on the nearly empty fuel tanks. First a cone-shaped bag would envelope the booster like a shroud (as in artist's conception on facing page); then another bag, doughnut-shaped, would girdle the booster at its midsection.

At the right moment, an electronic signal, triggered from the earth, would fire retro-rockets, breaking the odd-looking "satellite" away from its orbit and starting the recovery descent. At the re-entry-into-atmosphere stage, the conical bag, made of a special wire cloth to withstand 1,800 degrees F, would act as a heat shield against searing temperatures.

The massive cone would approach the earth with the booster projecting from its middle like a huge candle. At an altitude of 2,000 feet, hydrogen gas inside the doughnut bag, heated to 400 degrees, would make the structure lighter than air. As the gas cooled, the entry package would gradually become heavier, coasting down, light as a feather, to land with hardly a splash in the ocean. Waiting surface-recovery ships would then take over.

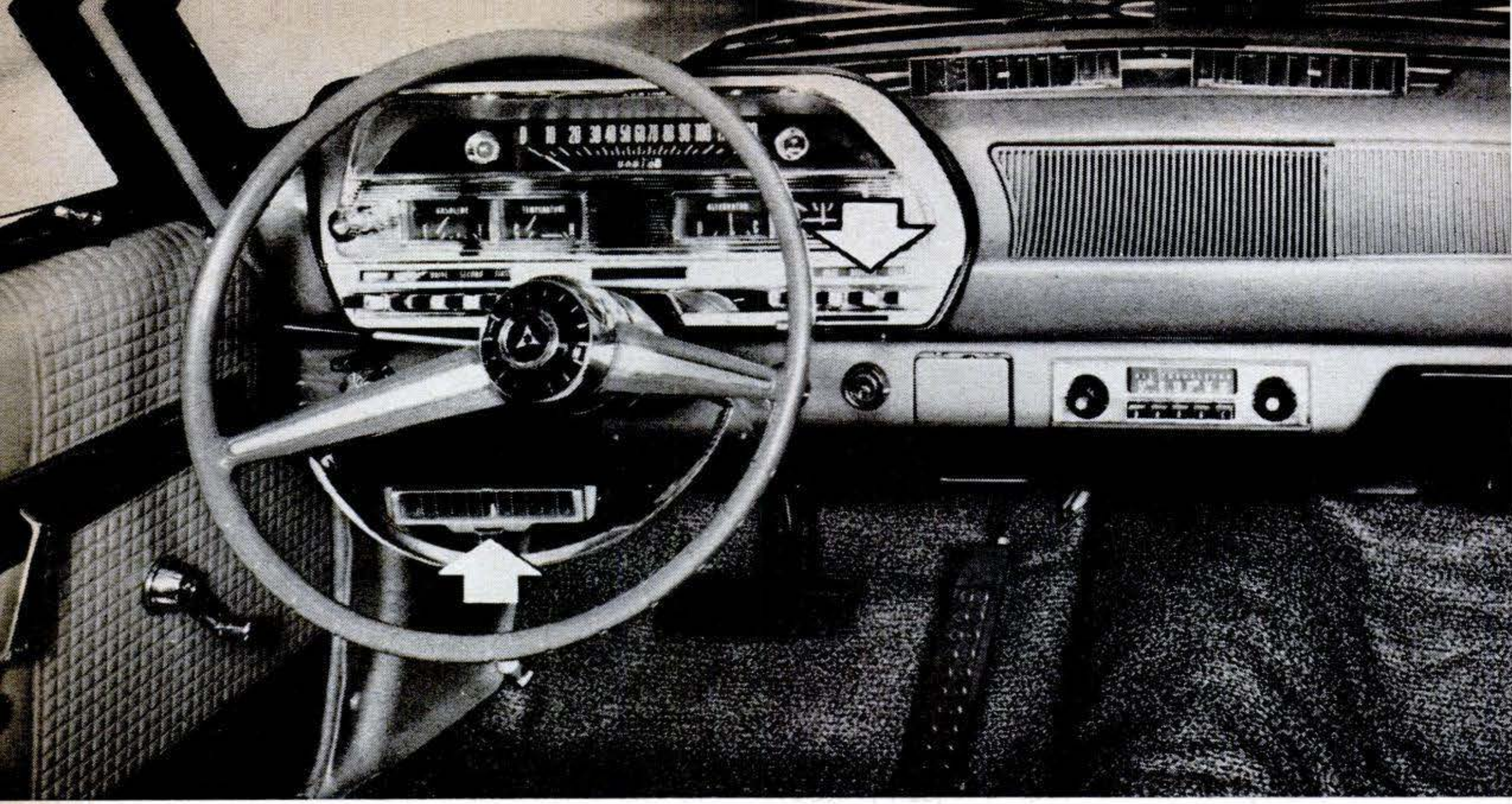

Late-model air conditioners feature a simplified control panel and movable-vane cool-air

Car Air Conditioning: Is This Your Year?

Lower prices, less weight, and better plumbing seals add up to a boom in car coolers

ONE day last winter, with the temperature hovering at a burr-r-r 19 degrees, GM's Cadillac Motor Car division passed a milestone—it turned out its 500,000th air-conditioned car.

A pioneer in weatherproofing automobile interiors, it had taken Cadillac almost 10 years to turn the trick. In 1953 it had sold 8,900 air conditioners. Last year alone it produced 94,150. In 1963 the figure will be well over 100,000, or an air-conditioning unit in every seven Cadillacs in ten coming off the production line.

This is by way of saying that of all the expensive accessories being bought by

U.S. motorists, air conditioning currently is the boomingest. If you're not tempted to order a cooling system for your new car—or, indeed, for your old hack—you're not with it, Buster.

Ah, you say, but Cadillacs come in only coarse currency—Caddy owners can afford cooling systems.

Okay, look at these figures: One out of every 10 Chevrolets sold in 1962, or 200,000 of them, had air conditioning. One out of every four Pontiacs, or 125,000, had it. So did one out of every 14 Ramblers, every 3 standard Oldsmobiles, every 10 Olds F-85s, every 14½ Fords, every 12 Plymouths.

Put it another way: Ten years ago a total of 40,600 automobile air conditioners, including the "hang-on" units made by independent manufacturers and installed by garages, were sold in this country. Last year, according to *Air*



outlets (arrows) as in this Dodge installation.

Conditioning, Heating and Refrigeration News, the total was 1,070,000. This year the estimate is 1,200,000.

Air conditioning is, true, an accessory more commonly found on the more expensive or sporty cars. Six of every 10 Chrysler Imperials coming off the pro-

duction line have it. So do 8 of every 10 Lincoln Continentals and 4 of every 10 Ford Thunderbirds.

The South likes it. Moreover, car air conditioning's popularity varies with the summer sizzle-level, which varies with geography. Again taking Cadillac for an example, 20 representative cities where every Cadillac sold carries air conditioning are below the Mason-Dixon line and its extension westward: Memphis, El Paso, Oklahoma City, San Bernardino, and so on. (Last year, out of 546 Cadillacs sold in Houston, 545 had air conditioners. The company is still trying to find out how that lone maverick got in.)

Of all air-conditioned Chevrolets sold, 43 percent are in Oklahoma and Texas. The Northeast accounts for only two percent of those sales, the Northwest the same. Still and all, as a commentary on the human animal and his sweat glands, 84 percent of all Cadillacs sold in Denver, and 75 percent in Billings, Mont., are air-conditioned.

The growing popularity of air conditioning is due less to a moderate drop in price than to a widening appreciation of its virtues. Packaged with the car heat-

CONTINUED

BUYER'S GUIDE TO CAR AIR CONDITIONING . . . Factory Installations

Manufacturer	Is Unit Integral with Heater?	Factory-Recommended Retail Price*	Blower Capacity (cu. ft. per min.)	Air Recirculated After Cool-Down (percent)	Provision for Engine-Idle Speedup?	Weight of Unit (lb.)	Hang-On Unit Available?	Price of Hang-On Unit	
AMERICAN MOTORS	Ambassador	yes	\$399	200 plus	70	no	50**	no	—
	American	yes	\$360	200 plus	70	no	47**	no	—
	Classic	yes	\$380	200 plus	70	no	50**	no	—
CHRYSLER CORP.	Chrysler	yes	\$510	250	0-100	no	135-225***	yes	\$300*
	Dart	yes	\$364	250	0-100	no	105	yes	\$300*
	Dodge	yes	\$445	250	0-100	no	125-145	yes	\$300*
	Imperial	yes	\$590	250	0-100	no	135-215***	yes	\$300*
	Plymouth	yes	\$445	250	0-100	no	125-145	yes	\$300*
	Valiant	yes	\$364	250	100	no	105	yes	\$300*
FORD MOTOR CO.	Comet****	no	****	230	100	no	98**	yes	\$231
	Continental	yes	\$504	300	70	yes	86-94**	no	—
	Fairlane	yes	\$360	300	100	yes	98**	no	—
	Falcon****	no	****	230	100	no	95**	yes	\$231
	Galaxie	no	\$360	300	100	yes	108**	yes	\$270
	Mercury****	no	****	230	100	no	107**	yes	\$360
	Meteor****	no	****	230	100	no	95**	yes	\$360
	Thunderbird	yes	\$415	300	100	yes	107**	no	—
GENERAL MOTORS CORP.	Buick	yes	\$430	210	0-50	no	99-109	no	—
	Cadillac	yes	\$473	not avail.	0-80	yes	130	no	—
	Chevrolet	yes	\$317	200 plus	10-100	no	117	yes	\$375*
	Chevy II****	no	****	200 plus	100	no	79**	yes	\$317
	Corvair****	no	****	200 plus	100	no	107**	yes	\$349
	Corvette	yes	\$421	200 plus	10-100	no	115	no	—
	F-85	no	\$378	200	90-97	yes	109**	no	—
	Oldsmobile	no	\$430	220	0-97	yes	149**	no	—
	Pontiac	yes	\$430	210	0-80	yes	155	no	—
	Special	no	\$351	150	0-50	no	95-96**	yes	\$331
	Tempest	no	\$318	210	0-75	yes	110**	no	—
STUDEBAKER CORP.	Avanti	no	\$325	235	100	no	80**	no	—
	Hawk****	no	****	250	100	no	80**	yes	\$277-325*
	Lark****	no	****	250	100	no	80**	yes	\$277-325*

NOTES: All data is supplied by manufacturers. Temperature is regulated thermostatically on all units except on F-85 and Oldsmobile. All have freeze protection.

*Price includes installation. **Without heater. ***Optional dual evaporators. ****Hang-on unit only; see last column for price.

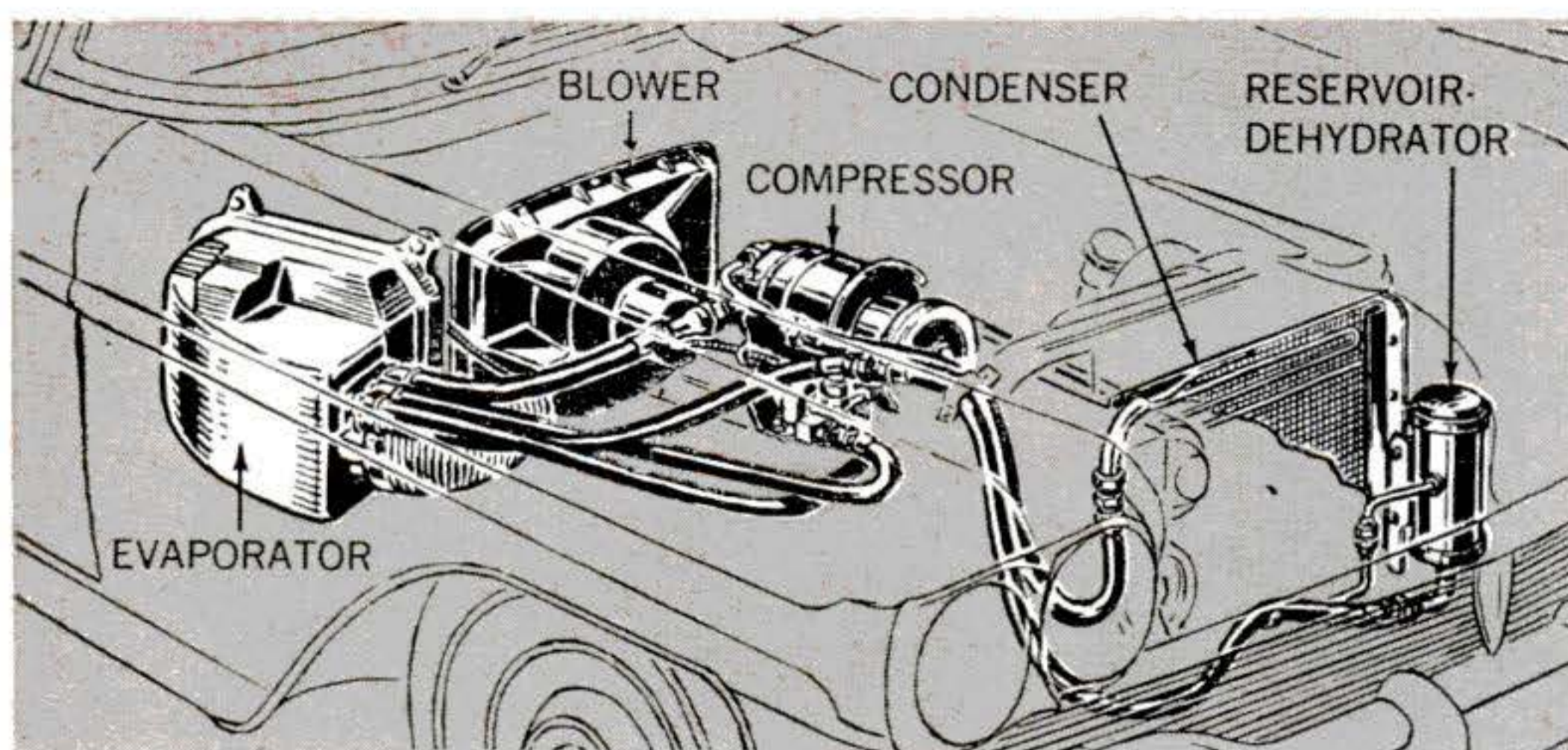

Car air conditioner works like an electric refrigerator except that the compressor is driven by the engine, not an electric motor. Refrigerant gas is compressed, liquefied by condenser, and again gasified in an evaporator, thus absorbing car heat.

er, it lets you drive with the windows closed the year round. You make your own weather.

On warm, rainy days you ride around in a capsule of cool, dry, dustfree air, like an astronaut. If you suffer from hay fever, you filter out the pollen. On days when the devil himself seems to be stoking the furnaces, you begin feeling cooler within three to four minutes after starting your engine. With the windows closed, you are insulated from highway and street noise, and the whine of your own tires. You can drive long distances with little fatigue.

For 1963, air conditioners are better. They weigh less. The system that used to scale 250 pounds is down to little more than half that. It is more compact. The evaporator, where the cool air comes from, has been moved from the hot engine compartment to the passenger side of the firewall.

Other improvements. Plumbing seals for the gas that does the work, Refrigerant 12, are so good these days that it doesn't need replenishing for up to three years. "Cool-down" time has been cut in half.

Some auto makers modulate the coolness with a heat-control lever—the air is routed from evaporator to outlet through the regular heater core. Others do it by turning the compressor on and off.

Most manufacturers continue to recommend the addition of power steering to the air-conditioning package to accommodate the added weight on the front wheels. Radiators must be heftier. Light car colors are favored—they reflect

more of the sun's heat and ease the load on the air-conditioning system.

Station wagons continue to be a problem as, indeed, they were 10 years ago. Their glass area makes them natural hot-houses. Of all the auto manufacturers, only the Chrysler Corp. offers an extra, rear-mounted evaporator to keep wagon temperatures down.

Seven out of 10 air conditioners are factory-installed. One out of 10, a hang-on, is dealer-installed. Two, again hang-ons, are made by independent manufacturers and are garage-installed.

About hang-ons. Many factory-installed units provide 100 percent fresh air after cool-down. Hang-ons, usually costing less, do less of a job. They recirculate the same air. This is not to disparage the hang-on. Crack a window vent, and you've got fresh air.

Factory-installed conditioners are not transferable, car to car, on resale. Hang-ons are—after a fashion. The trouble it takes in acquiring new mounting brackets for different engine-compartment configurations, and disconnecting and reconnecting the plumbing, seldom makes transfer worth the trouble.

The day-to-day cost of running an air conditioner is scarcely noticeable. The unit cuts gas mileage by no more than a mile per gallon, often as little as a half-mile.

But don't count on getting back much more than half your investment in an air conditioner when you trade in your car. Regard the original price as a fully amortized investment in cool comfort.—*Devon Francis.*

BUYER'S GUIDE TO CAR AIR CONDITIONING . . . Hang-On Units

Manufacturer	Brand Name	Factory-Recommended Retail Price	Blower Capacity (cu. ft. per min.)	Weight of Unit (lb.)	Approx. Installation Charge	Approx. Installation Time (man-hours)	Brands and Model Years of Cars for Which Available
A.R.A. Mfg. Co.	Veep, Chairman, Polaris, President	\$239-635	285-365	80	\$40-50	4	All 1955-63 U. S. cars, plus 1950-54 Cad; also some trucks
Arctic-Kar Sales, Inc.	Arctic-Kar	\$259-1,950	480-520	80-110	\$40	3 to 5	All 1959-63 U. S. cars, plus 1951-58 Pont, Ford; 1957-58 Rambler, Plym, Dodge, T-Bird; 1956-58 Stude; 1958 DeSoto; 1955-58 Lincoln, Chev, Corvette; 1954-58 Merc; 1950-58 Buick; 1952-58 Cad; 1954-58 Olds
Clardy Mfg. Co.	Cool Star, Jet Star, Customatic	Not available	225-250	80-85	\$40	4	All 1958-63 U. S. cars, plus 1956-57 Buick, Chrys, Dodge, Plym, Ford, Merc; 1954-57 Cad, Olds; 1955-57 Chev, Pont; 1957 DeSoto
Climatic Air	Selector, Imperial, Royal	\$285-395	350-390	85	\$40	3	All 1956-63 U. S. cars except 1956-57 Lincoln; also 1954-55 Buick; 1952-55 Cad, Chev, DeSoto, Ford, Olds; 1951-55 Chrys, Dodge, Merc, Packard, Plym, Pont; and some foreign cars and trucks
Eaton Mfg. Co.	Eaton	\$312	250	92	\$30-50	2 to 4	All 1957-63 U. S. cars, plus Mercedes-Benz and some trucks
Frigikar Corp.	FrigiKing	\$235 up*	225-417	90	*	3½ to 4	All 1957-63 U. S. cars except 1958-63 T-Bird and 1963 Continental; also 1954-56 Buick; 1952-56 Cad; 1955-56 Chev, Dodge, DeSoto, Chrys, Packard, Plym; 1953-56 Ford, Merc, Olds, Pont; 1956 Stude, T-Bird; and some foreign cars and trucks
Frigiquip Corp.	Cool Queen, Frigette	\$295-369	325	85	\$35-75	4	All 1958-63 U. S. cars except Avanti and Edsel; also 1954-57 Buick, Olds; 1952-57 Cad; 1955-57 Chev, Pont; 1957 DeSoto, Rambler; 1956-57 Dodge, Ford, Merc, Plym, Stude; 1955-57 Pont; and some trucks
John E. Mitchell Co.	Mark IV	\$300-330*	315	80	*	4 to 7	Most late U. S. and some foreign cars
Kauffman Air Conditioning Co.	Kauffman	\$260	390	130	\$40	4	All 1953-63 U. S. and some foreign cars; also some trucks and buses
Kool Engineering Corp.	Kool King	\$225	400	90	\$30	4 to 8	All 1957-63 U. S. cars
National Equipment Co.	National	\$269*	400	100	*	3	All 1954-63 U. S. cars
Nordic International Co.	Nordic	Not available	450	85	Not available	2 to 4	Most late U. S. and some foreign cars

NOTES: All data is supplied by manufacturers. Prices are approximate. Temperature is regulated thermostatically on all units. All have freeze protection.
*Price includes installation



Mirror helps level level. You could make an ordinary bubble level do a transit's work by clipping on this recently patented side mirror. To establish a true horizontal line at a distance, you'd watch the bubble's reflection while sighting along the top of the level, adjusting to center the bubble. With the mirror folded in, you'd use the level as usual.



Socket extends bulb life. Inserted between an ordinary bulb and socket, this adapter would lower circuit voltage (through a resistance wire in the tip) so bulbs would last much longer than they do now. It would also cut illumination slightly, but you'd make up for this by using a bulb of higher wattage rating.



Signal clamps to car door. Slipped into a flange bracketed to a car door, this out-board sign might help clear a right of way for a doctor, a volunteer fireman, or any other driver who is in a legitimate hurry. Besides making emergency trips safer and faster, the sign could be used to summon help on the highway.

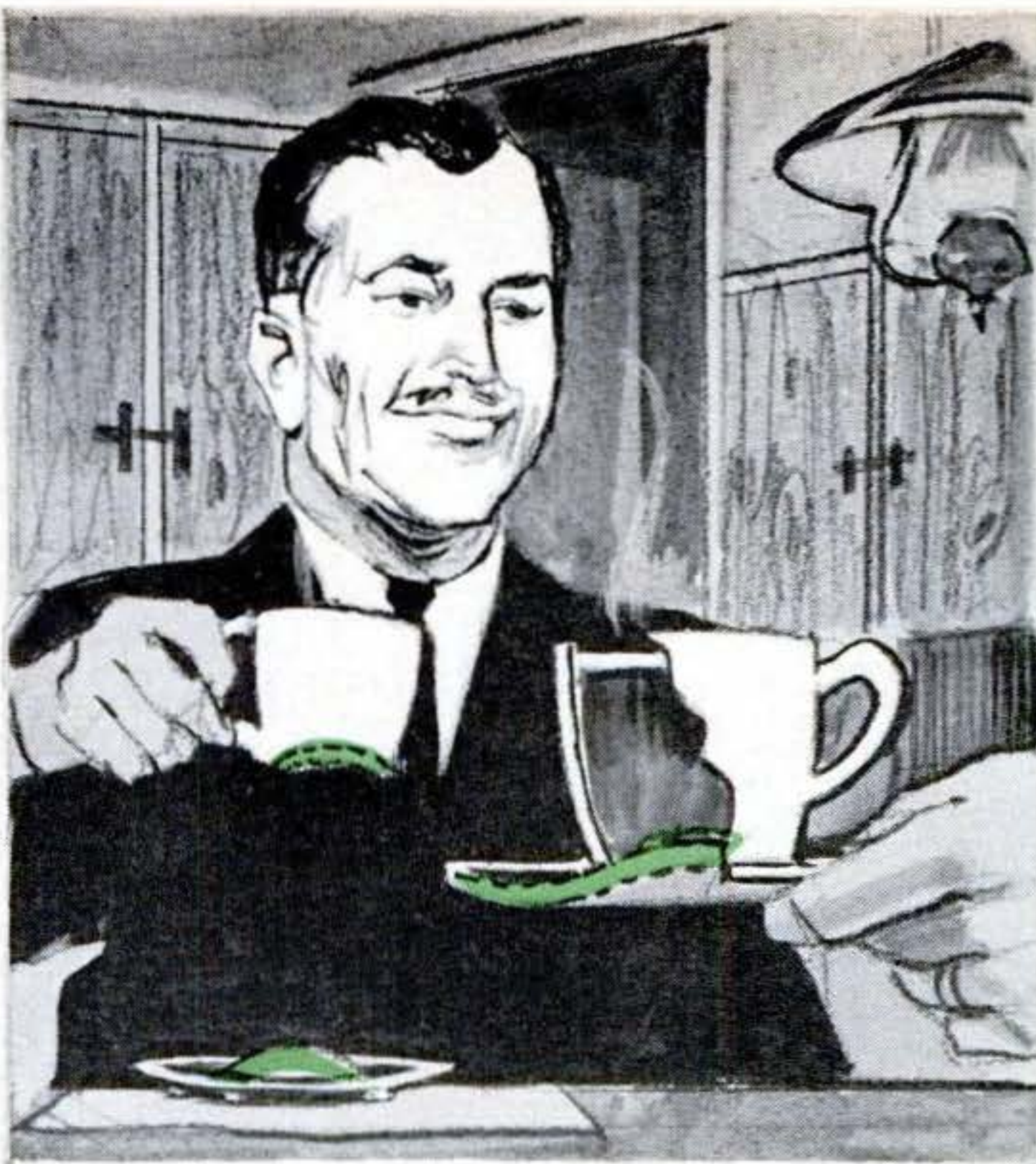

Convex saucer keeps cup dry. A concave seat on the bottom of this cup would rest on a matching convex portion of the saucer, thus holding the cup in place. And if any coffee slopped out of the cup, it would stay in the outer valley of the saucer, leaving the cup high, dry, and dripfree, and your clothing stainless.



One-hand oar lets you fish. An oar designed for one-hand use might let you keep a boat on course—or even propel it a short distance—without limiting the freedom of your fly-fishing hand. This shortened oar would have a handgrip across the widened shaft and would narrow at the top into a forearm brace for stronger paddling.



False bottom makes pool safer. An electric motor, plus a system of pulleys and guide rails, would raise this protective net from its normal position at the bottom of a pool

so that, in an emergency, anyone in the pool could be immediately brought to the surface. When unattended, the pool could be safely closed by leaving the net up.

The following patents have been issued on these inventions: Level mirror—No. 3,064,535 to Roy N. Anderson, Clovis, N. Mex.; Bulb saver—No. 3,070,767 to Jacob Rabinow, Takoma Park, Md.; Signal—No. 3,060,605 to Paul M. Flack, Ogdensburg, N.Y.; Dripless cup—No. 3,067,904 to Malcolm L. Raymond, Johnstown, Pa.; One-hand oar—No. 3,039,120 to Lebern Powell and

Ernest T. Morton, McMinnville, Tenn.; Pool net—No. 3,045,253 to Hollas K. Price, Oak Hill, W. Va. Copies of patents may be ordered, by number, from the Commissioner of Patents, Washington 25, D.C., at 25 cents each. To write to an inventor, if the address given above is insufficient, address him (by name and patent number) in care of the Commissioner of Patents.



Handpiece rests on arms. Ring of bell opens circuit. Pickup is at side. Case contains controls and head-set jacks.

Pushbutton phone answers caller, transcribes message

Without direct connection to the telephone circuit, the black box at left will answer for you, voice a taped personal greeting, and take a message that you can play back when you return.

Plug the machine into a convenient outlet, place the pickup mike at the receiver, and rest the phone's handpiece on adjustable arms that lift it mechanically when a call comes in. Pushbutton controls set the unit for answering, recording a message, playing it back, listening in, taking dictation, or amplifying a message through a loudspeaker. The tape records up to 2½ hours, can be erased for re-use.

Made in England, Phone King is sold here by Phone King Co., Los Angeles.

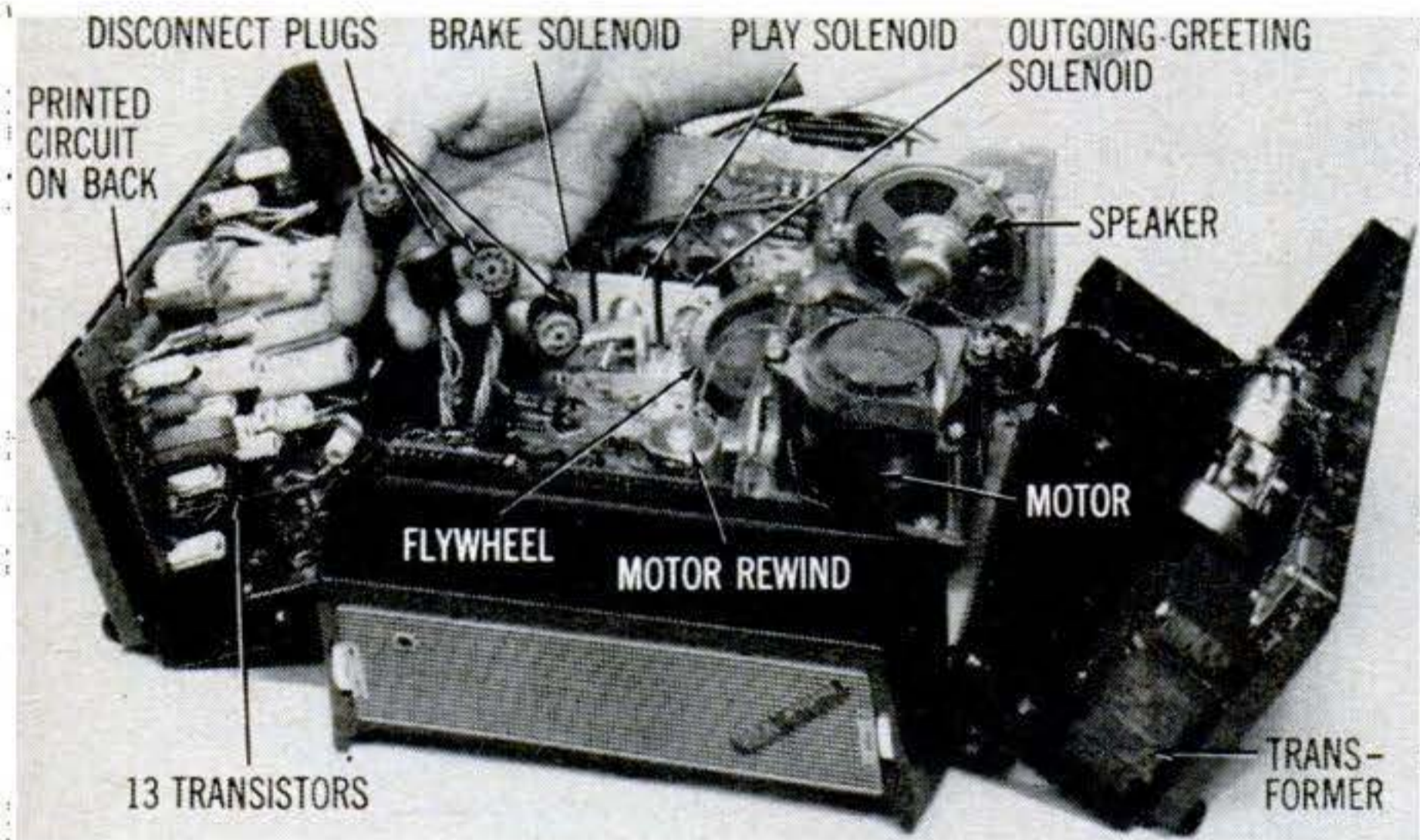

Upside-down view of machine shows location of principal parts. The case swings open on hinges for quick servicing.



Carries both potatoes and fuel oil

To keep oil tankers and trailers from having to run empty in one direction on each trip, Cole Express, of Bangor, Me.,

had GM build a special tandem-drive truck tractor. A tank behind the cab hauls 4,000 gallons of fuel oil to potato growers; a 40-foot trailer at rear returns with 35 tons of produce for market.

Astronauts study stars as guides for moon journey



Training class in celestial navigation includes (above): J. E. Wadsworth, planetarium narrator, and astronauts Lt. Col. John Glenn, Maj. L. Gordon Cooper, Lt. Cmdr. Alan Shephard.



A training program in space navigation for U.S. astronauts has been set up at the University of North Carolina's Morehead Planetarium. Since the stars look the same from any place in the solar system, prac-

tice in celestial recognition is expected to help the astronauts maneuver into position for re-entry into the earth's atmosphere when necessary, and to enable them to make proper astronomical observations.

Short-runway plane can fly very slow

A pair of control fins on the nose, and other aerodynamic devices on a reworked Cessna airframe, cut maneuverable speed of the Wren down to 26 m.p.h.

The plane can take off in 300 feet, land in 200—less than the area of a heliport. Other slow-flight features include wing flaps and a set of spoilers on top of the wings. Despite these additions, top speed is a respectable 160 m.p.h. The plane seats four.





No attendant jockeys your car in this automatic garage.

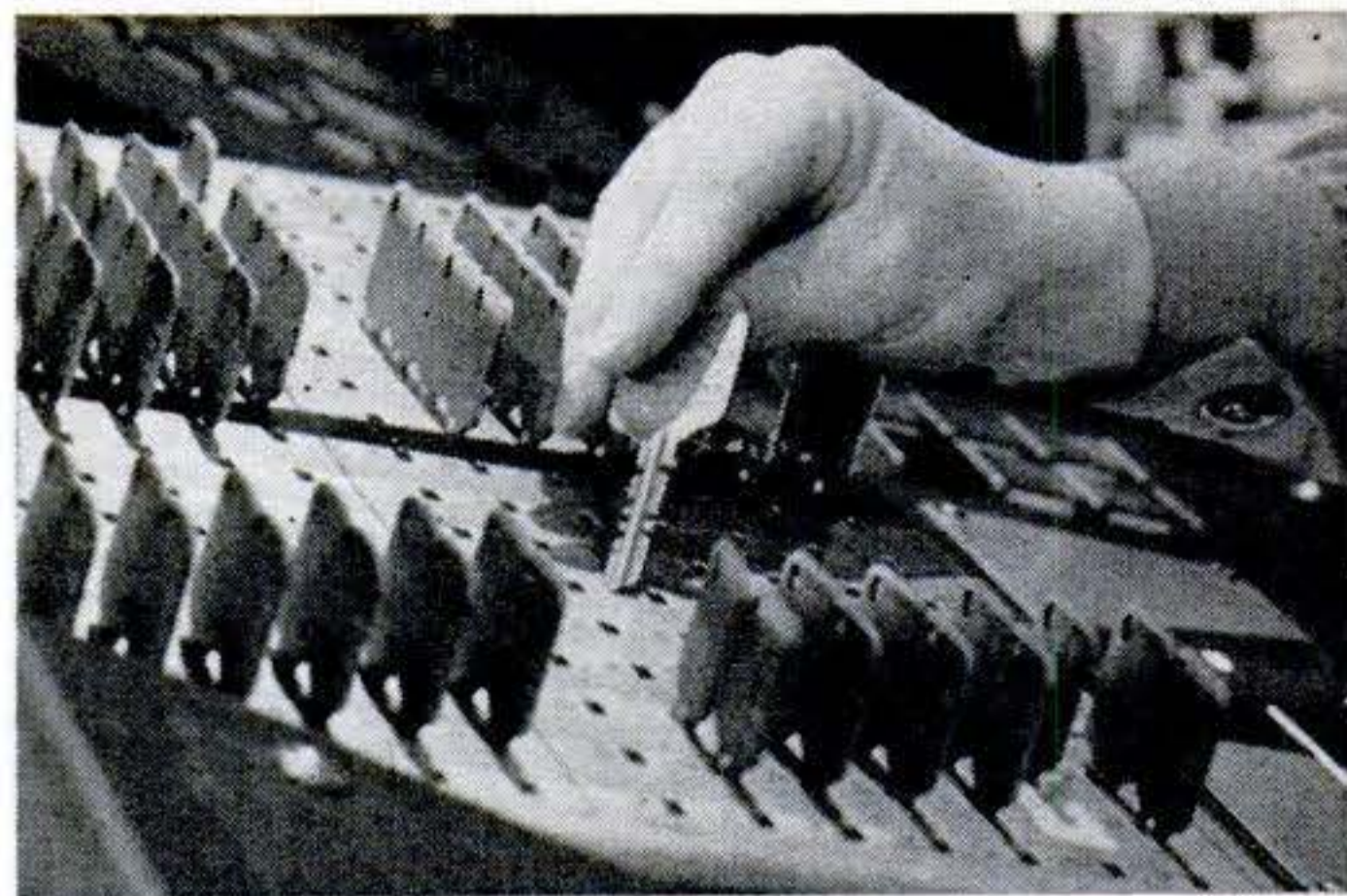

Key is inserted in control panel.

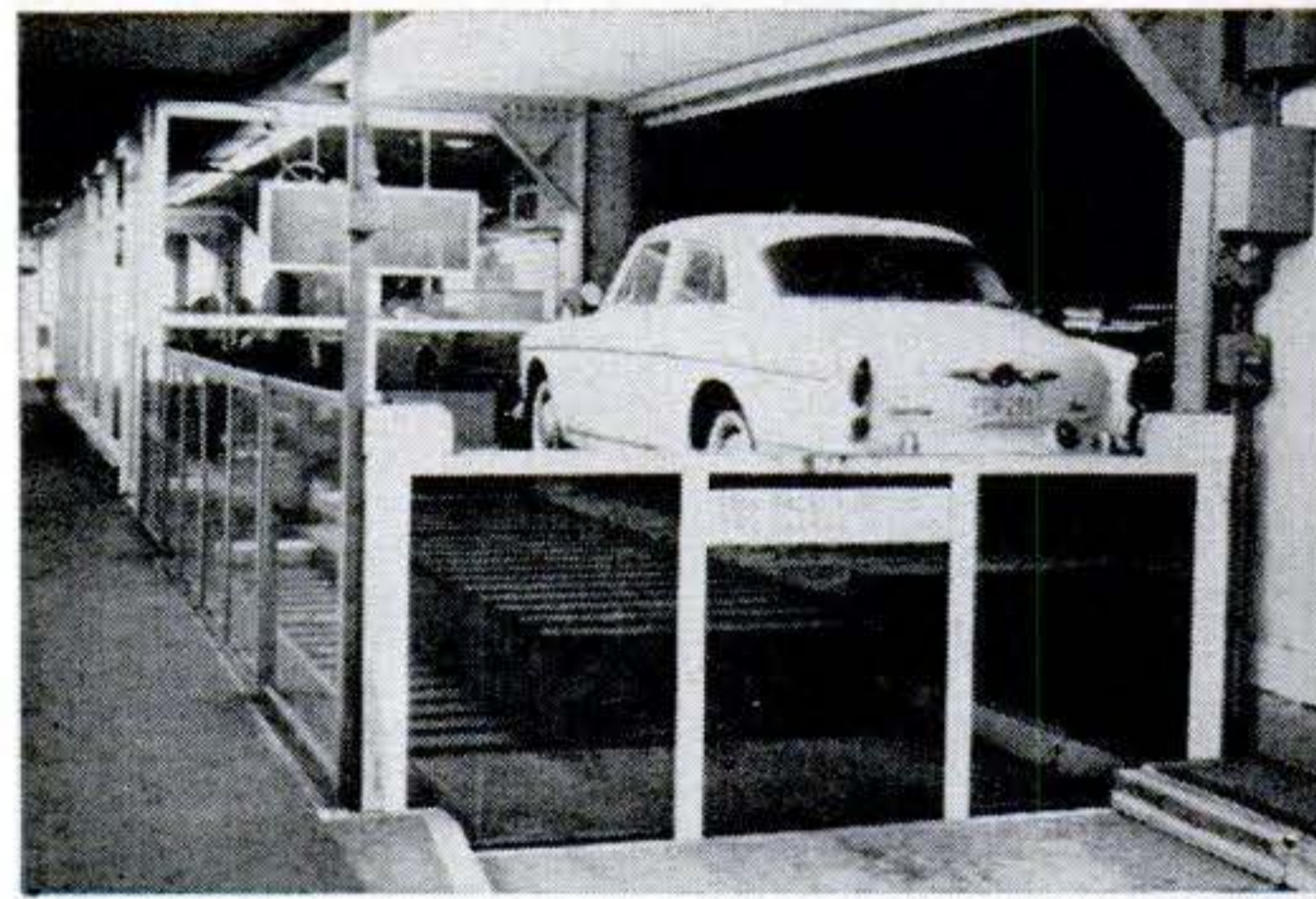

Elevator retrieves car from stall.

One-man electronic garage parks cars by pushbutton

Theatergoers in New York's Times Square area have something new to talk about: a garage that can park or unpark 27 cars in 10 minutes with only one attendant on duty. It's all done by pushbutton and it works this way:

Drive up in your car onto a receiving platform, get out, and you're handed a key. (It's your receipt, keeps anyone else from handling the car.) The lone attendant

then presses a button and automation goes to work. Before you've left the building, long fingers have reached under the car and transferred it to an elevator that deposits it in its designated pigeonhole.

Getting it back is just the reverse. The insertion of your key sends the elevator to your car's stall to bring it down.

Speed-Park garage holds 270 cars. Two special Otis elevators handle the chores.

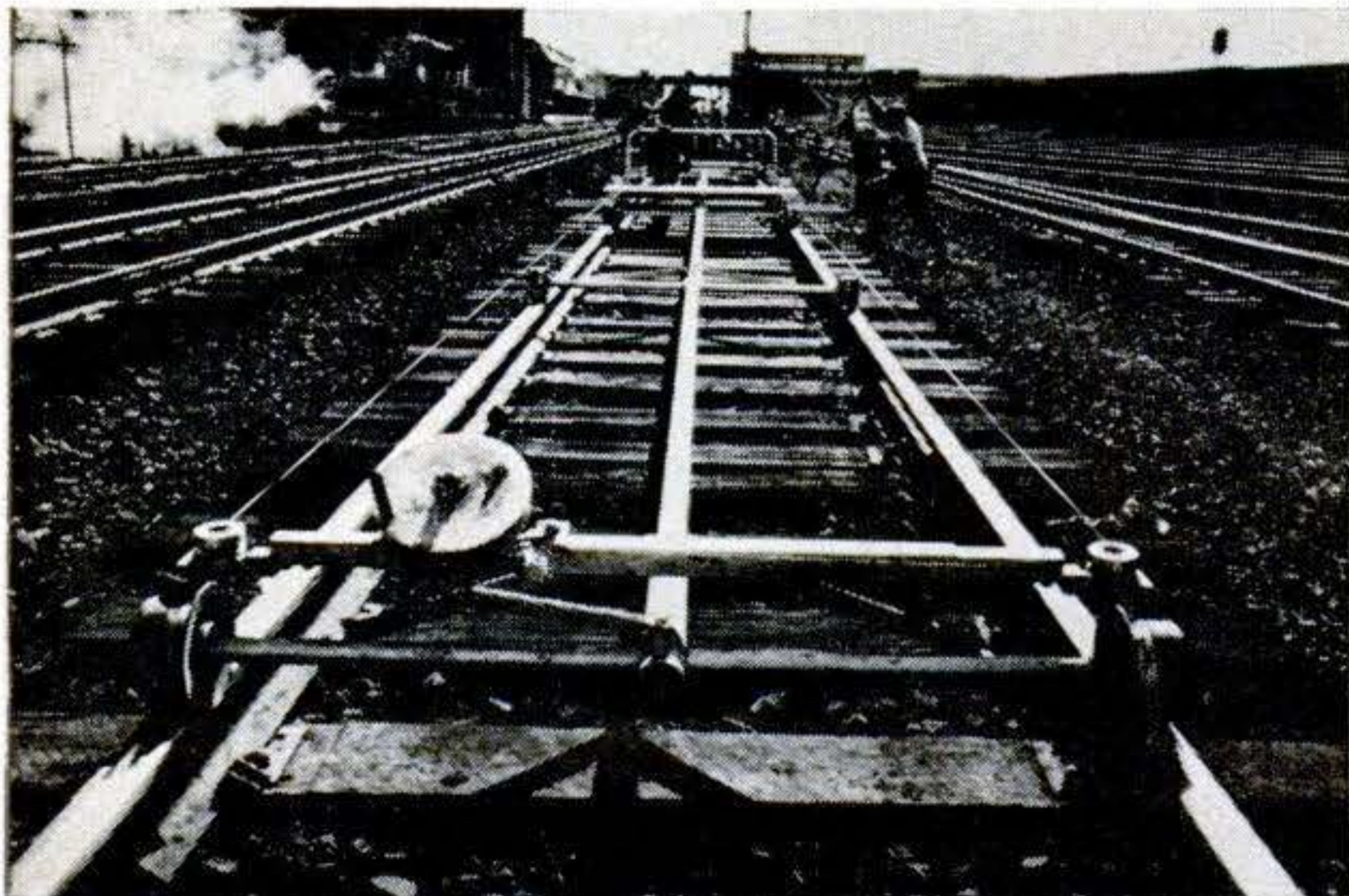

Piano wire locates dips in railroad track

Parallel strands of piano wire strung under tension from end to end on the rig at left help track workers spot low places.

On straight stretches, the small wheels on the crossbar at mid-length of the rig touch the wire; at dips, there's a gap. A spot tamper is moved in at such places to poke ballast around and under the ties to relevel the track and keep your railroad ride smooth.

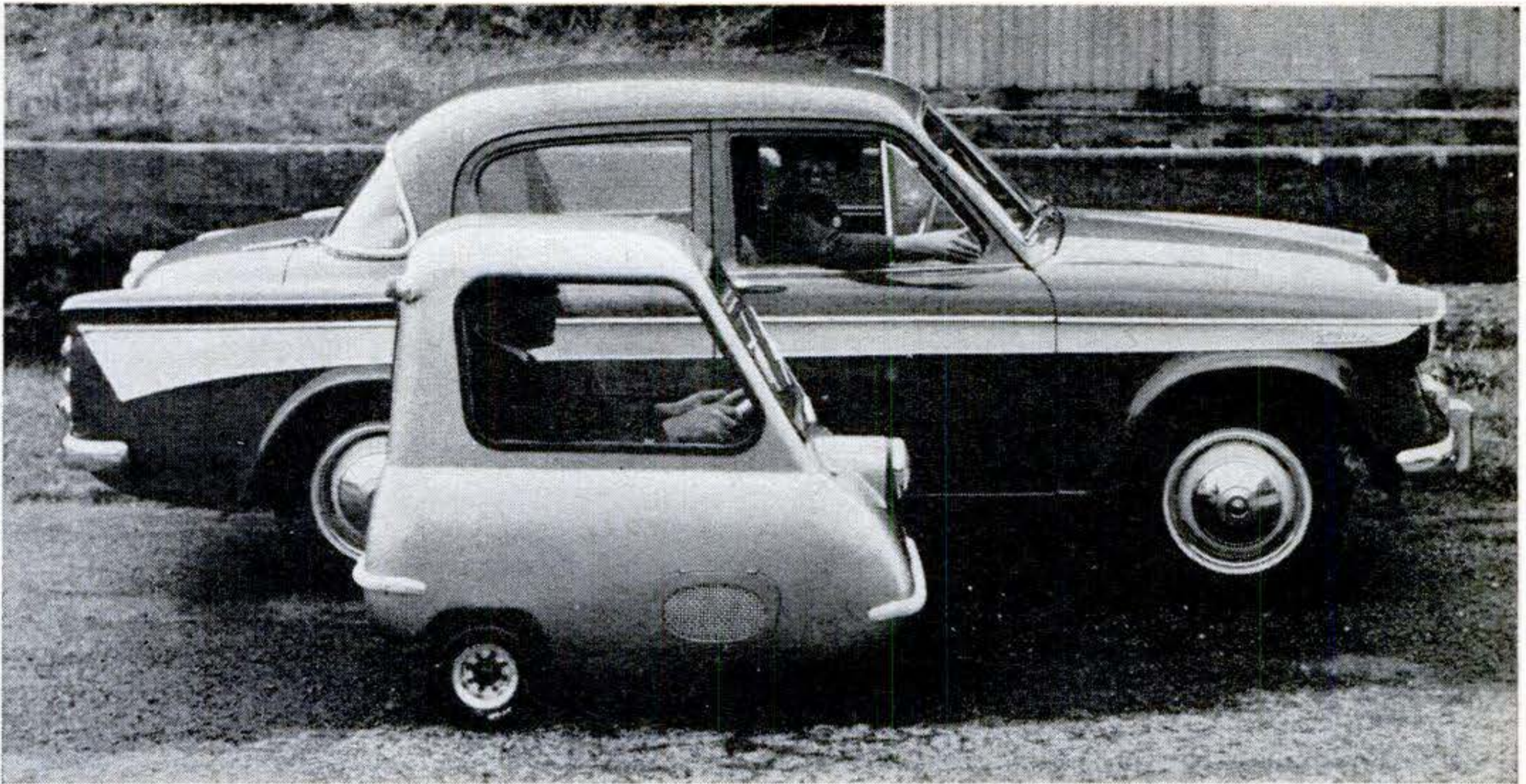

Tiniest car seats a grown man

Barely four feet long, this three-wheel midget weighs only 130 pounds, can be tilted up by the front bumper for parking in tight places. Designed in England for

short-range commuting and shopping, the Peel P-50 houses its three-speed, four-hp. engine in the right side of its plastic body. The driver enters at left through a single door. The one-man Peel makes 40 m.p.h., goes 100 miles on a gallon of gas.

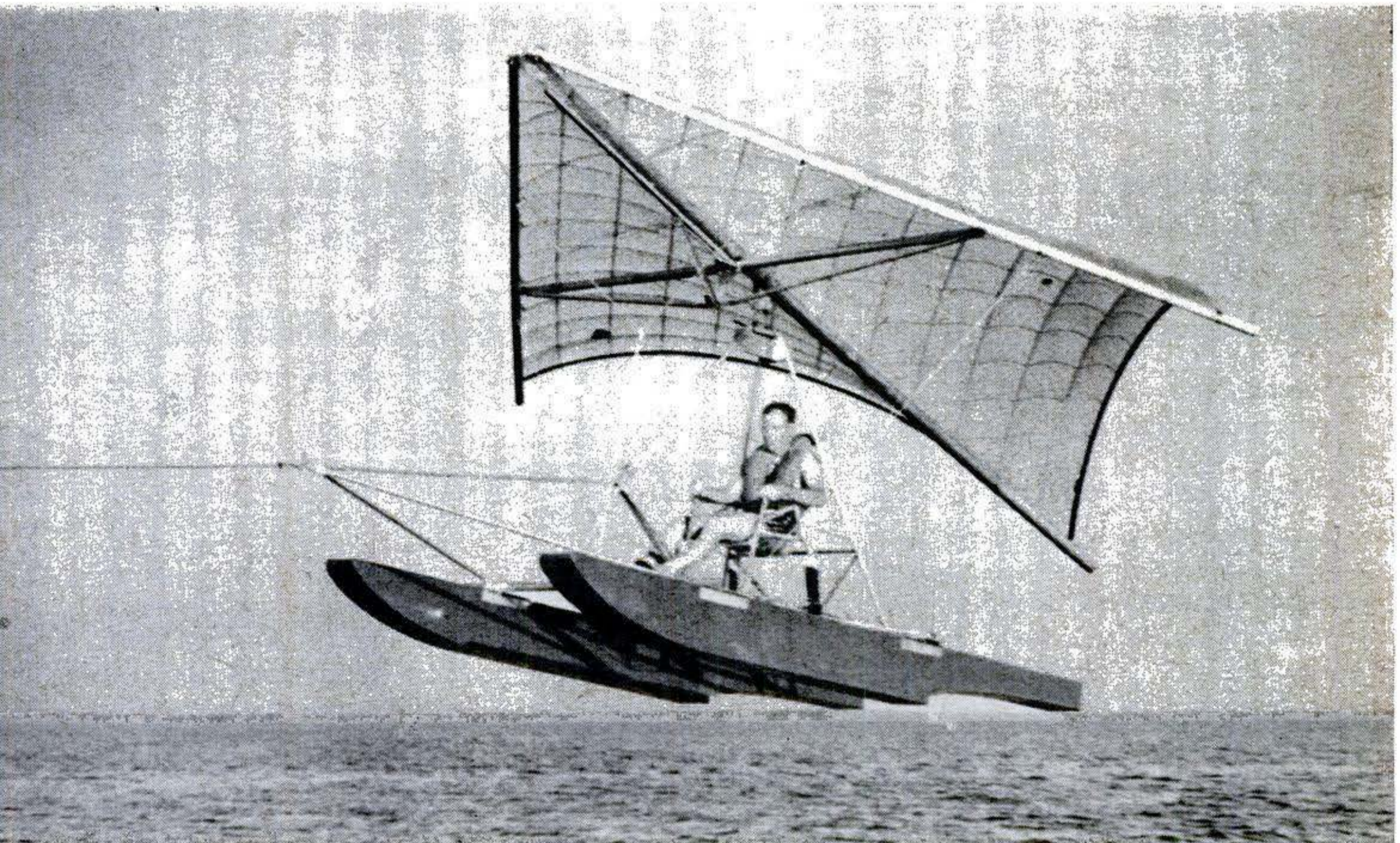

New boat can either fly or sail

Towed by a power boat, this craft takes to the air under its flexwing sail. On its own, wing tilted to catch the breeze, it sails

like a catamaran. A plane-type stick controls the wing in flight; rudder pedals steer the boat on water. Flight Dynamics, Raleigh, N.C., designed it with two skis mounted on an aluminum-pipe frame.



Though basically an understeerer, the Ambassador has enough power on tap to break the rear end loose on a corner if desired.

REPORT FROM THE
DRIVER'S SEAT

AMBASSADOR:

By Alex Markovich

THE rhubarb started last June. The Automobile Manufacturers Association ban on racing had popped like a bubble, and Detroit was scrambling to the race tracks. Only Rambler held back; glamorizing horsepower and speed through promotion of stock-car racing, said American Motors President Roy Abernethy, is "against the public interest."

Bill France, President of the National Association for Stock Car Auto Racing (NASCAR), promptly likened Rambler to a little boy who, having no bat, goes around saying baseball is a terrible game.

But the truth is Rambler does have a bat—a 327-inch, four-carburettored, high-compression Ambassador V-8. And it's really a swinger, as a handful of scattered

hot-rodders are finding out; it's practically unbeatable in its class at the drags.

The car is functional and slightly bulbous in appearance, with a somewhat gaudy interior.

The layout of the controls is excellent. The steering wheel is placed just right, and door handles are well back, away from long-suffering kneecaps. The heating-air-conditioning system is one of the best; hot or cold air billows forth abundantly.

People who believe Rambler owners suffer from tired blood will be surprised when they try the 270-hp. Ambasssador engine. Our test car was loaded with luxury options that consumed power, including automatic transmission, power steering, power brakes, and air conditioning, but performance was good in all speed ranges. A stripped job

[\[Continued on page 167\]](#)

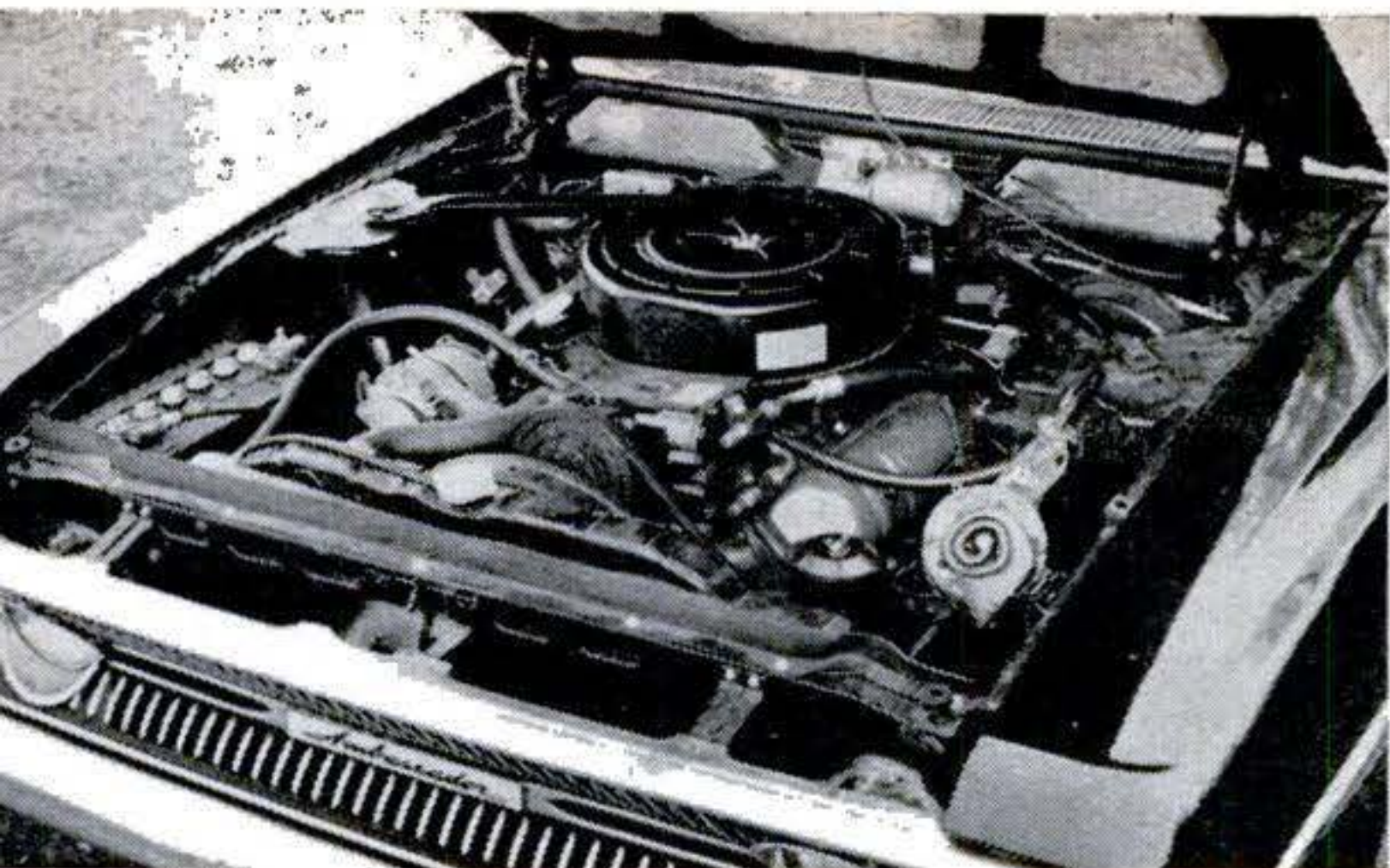

Looking like spaghetti in a bowl, hoses running from luxury options make spark plugs and other components hard to reach.



An auto writer's life is a hard one, and occasional snoozes are called for. Pull handle at side and the seat folds back.

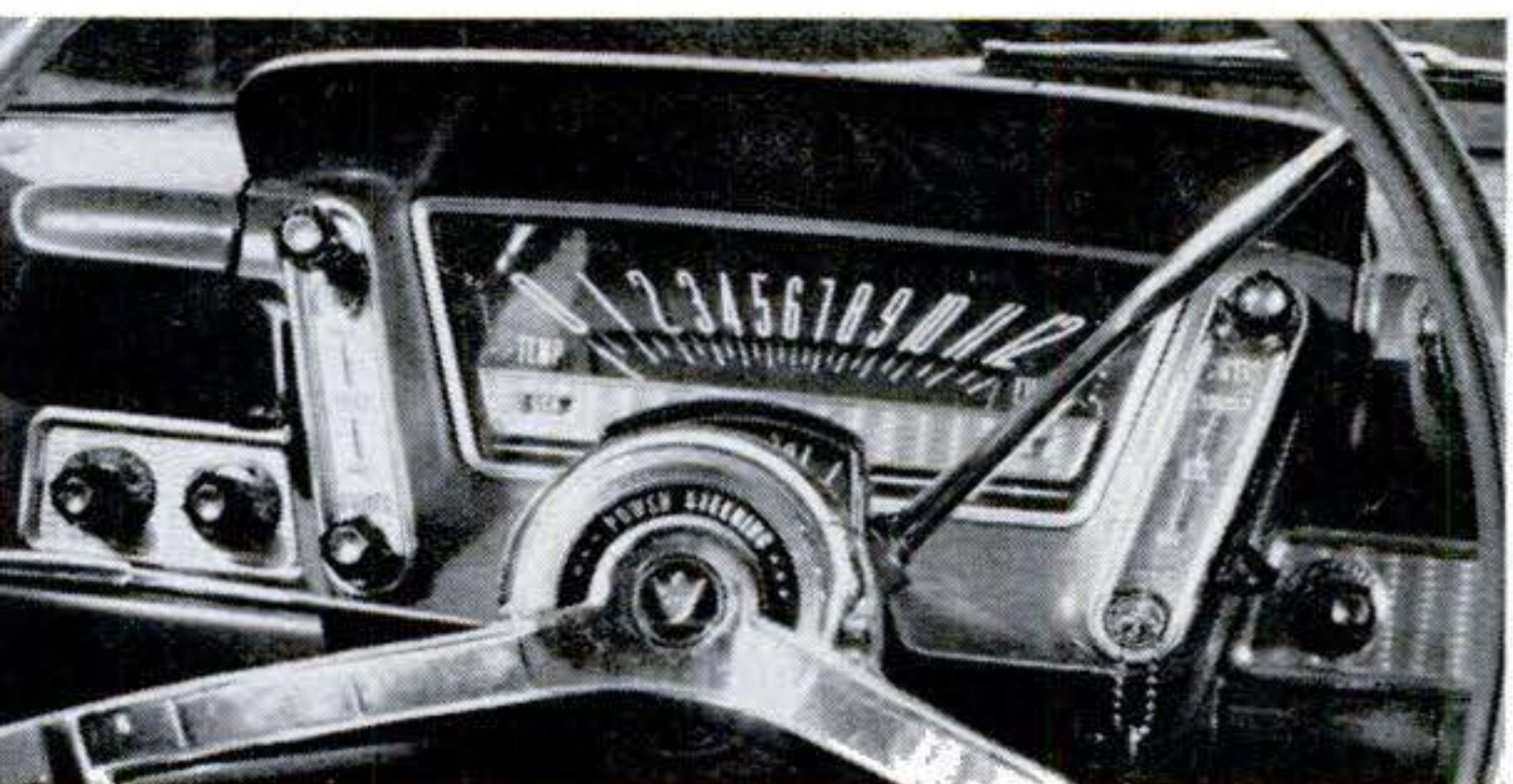

Speedometer, easily seen through steering wheel, would be better round. Idiot lights monitor amps and oil pressure.



Adjustable dashboard vents direct hot or cold air anywhere in the car. Even with a cold engine, you're comfy in three minutes.

Rambler's Hot One

FACTS ON THE AMBASSADOR

Model: 990, four-door sedan

Basic list price: \$2,660*

Price as equipped: \$3,805.75*

Engine: OHV V-8; 270 hp. @ 4,700 r.p.m.; maximum torque, 360 pounds-feet @ 2,600 r.p.m.; bore and stroke, 4.00 by 3.25 in.; displacement, 327 cu. in.; compression ratio, 9.7:1; carburetion, 4-barrel; weight (lb.) per hp., 12.8; engine revs per mile, 2,470; piston travel (ft.) per mile, 1,338; fuel required, premium; crankcase capacity, 4 qt.

Fuel capacity: 19 gal.

Transmission: three-speed auto.; ratios (:1): 2.40, 1.47, 1.00; reverse, 2.00

Axle ratio: 3.15:1. **Steering ratio:** 23.9:1 (power). Turns lock-to-lock, 5. **Brake-swept area:** 267.07 sq. in. **Tire size:** 7.50 by 14

Outside dimensions: wheelbase, 112 in.; track, front, 58.6 in.; track, rear, 57.5 in.; overall length, 188.8 in.; width, 71.3 in.; height, 55.3 in.; ground clearance, 6 in.

Curb weight: 3,449 lb.

Weight distribution: front, 58.8%; rear, 41.2%

Speedometer error:** indicated 60 m.p.h. is true 54.5 m.p.h. **Odometer error**:** -.4%

Gas mileage at constant speeds (gal.):** 30 m.p.h., 25.8; 40 m.p.h., 24; 50 m.p.h., 22; 60 m.p.h., 19

Acceleration (seconds):** 0-60 m.p.h., 10.2; 40-60 m.p.h., 4.9; 50-70 m.p.h., 6.8 (6.3 if transmission held in second gear)

Top speed: 112 m.p.h. (estimated)

* Includes federal excise tax, but no state or local taxes, transportation, or dealer preparation.

** Tests made with Ongaro fifth wheel and fuel-flow meter

PS PROJECTS

How to make A Yard Cart You Can Push or Tow



Dumping on the run is one of many jobs you can do with this versatile yard cart. A spring-loaded barn-door latch holds the cart level during towing (below, left). Pulling the latch chain re-

tracts the bolt, and the cart tips over (right). The latch is mounted on a spacer block and clamped to the drawbar with U bolts. Its bolt engages a socket plate on the push-tow cart.

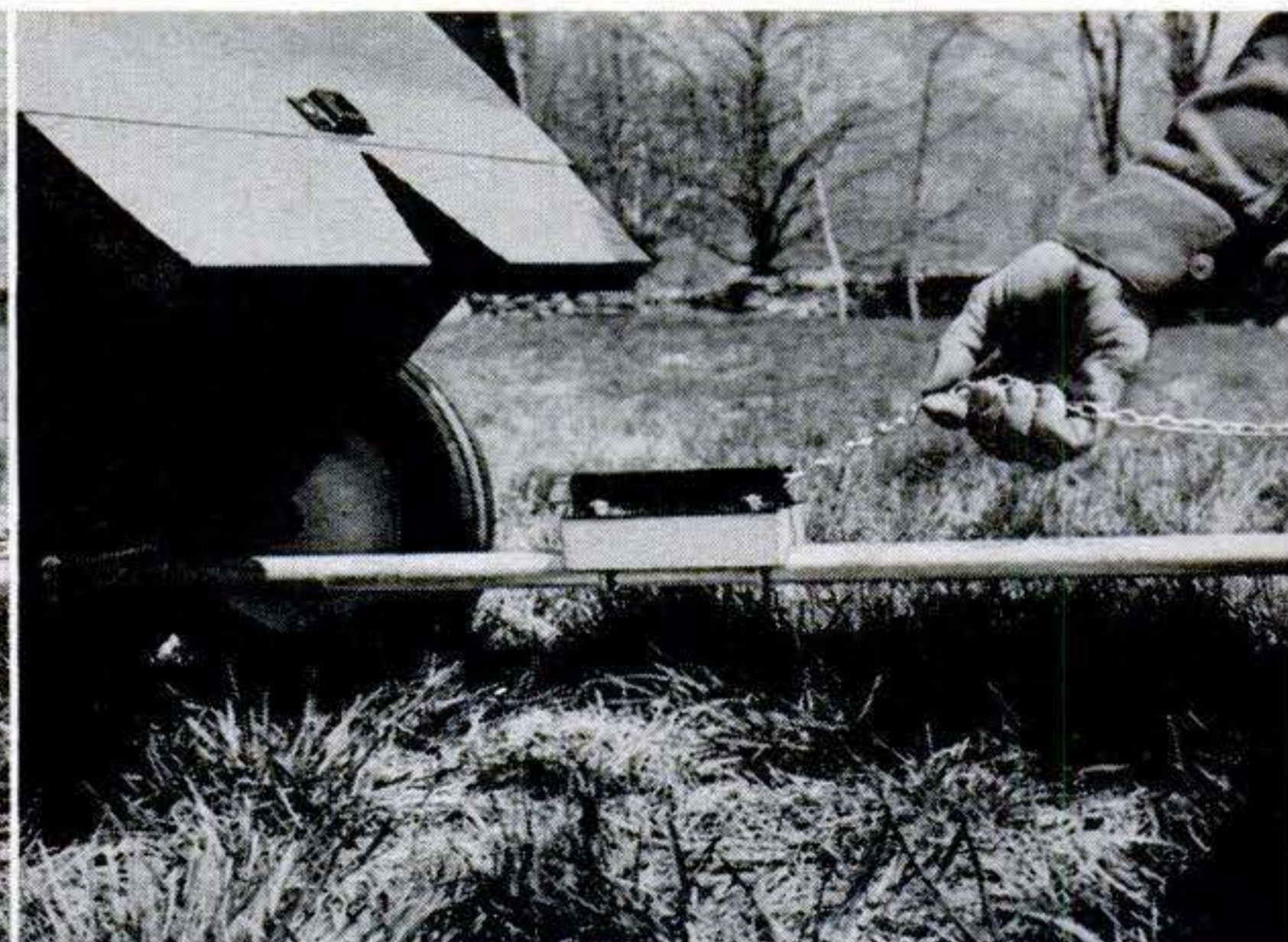
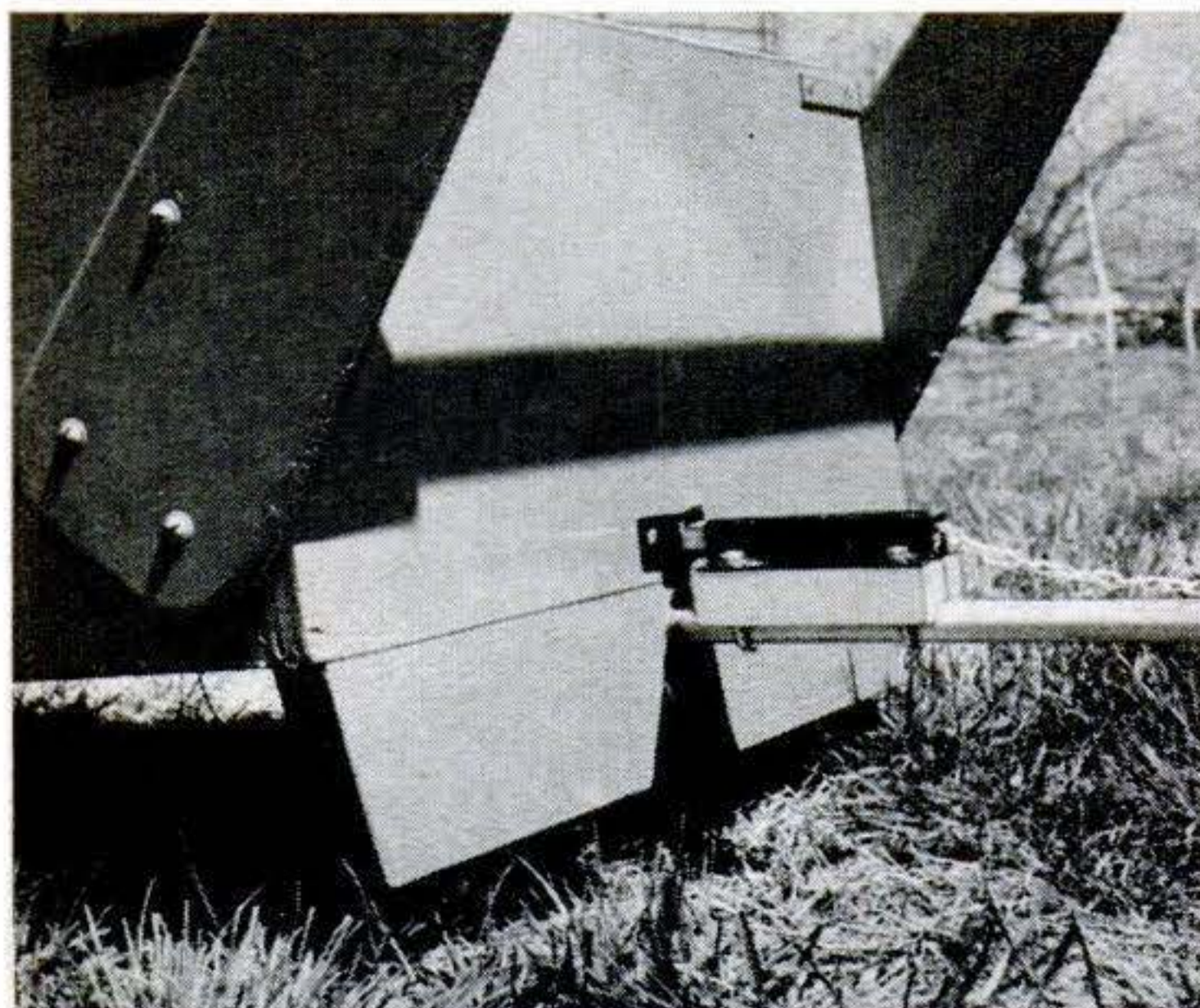

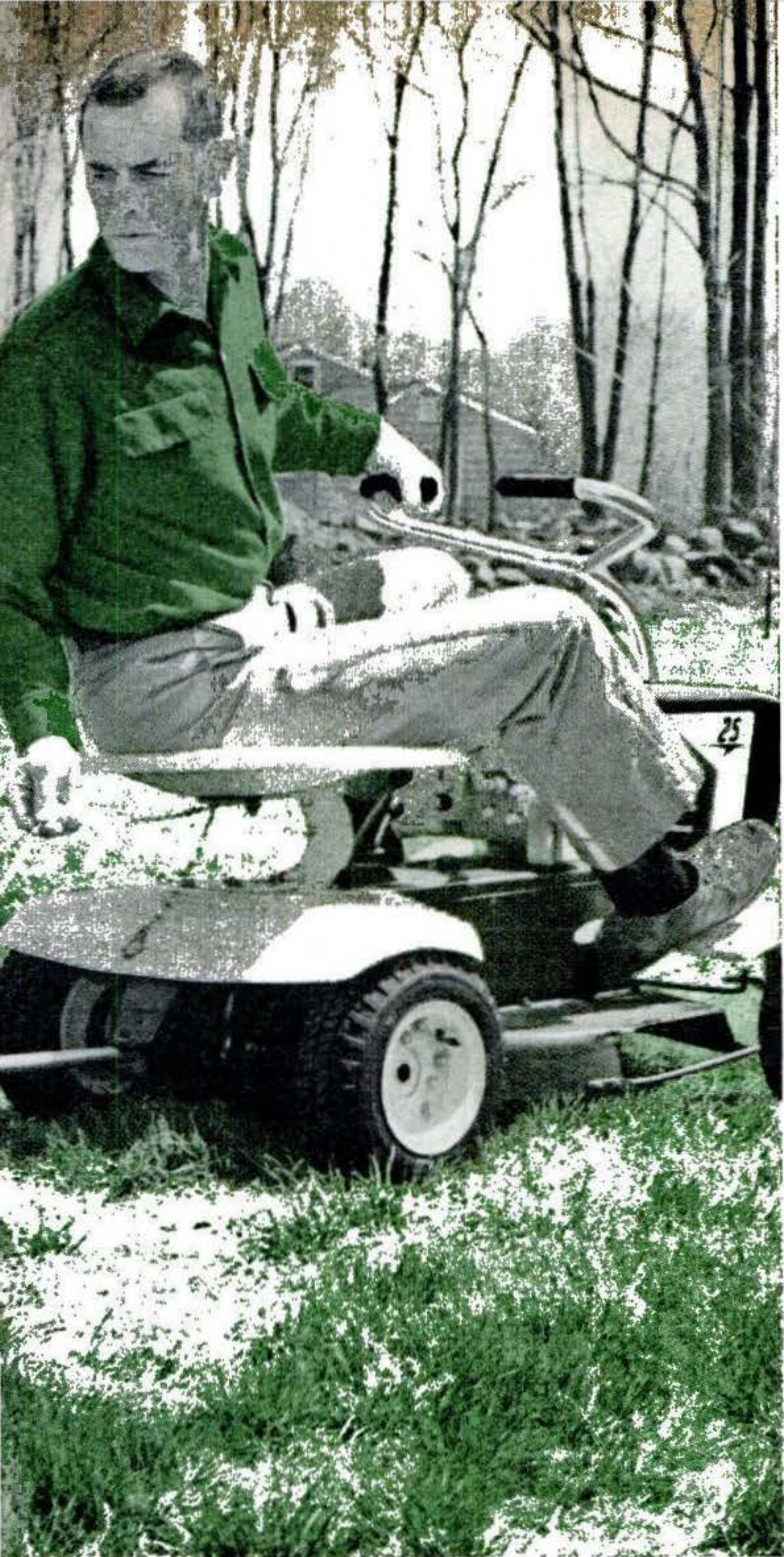

It stoops for loading...



***rolls like a dream...
is a pushover to dump***

It has two-wheel steadiness and can move a mountain—yet costs less than \$25 to build

By Jackson Hand

MOST garden carts are toy-size affairs meant for small tools and plantings. This one's a real earthmover, capable of hauling nearly a quarter-ton of topsoil, sand, gravel, rock, cement sacks—all the backbreakers that take the fun out of yard work. Its two-wheel design, test-proven in rocky, hilly Connecticut, gives it a wide-stance stability you won't find on a conventional wheelbarrow.

CONTINUED



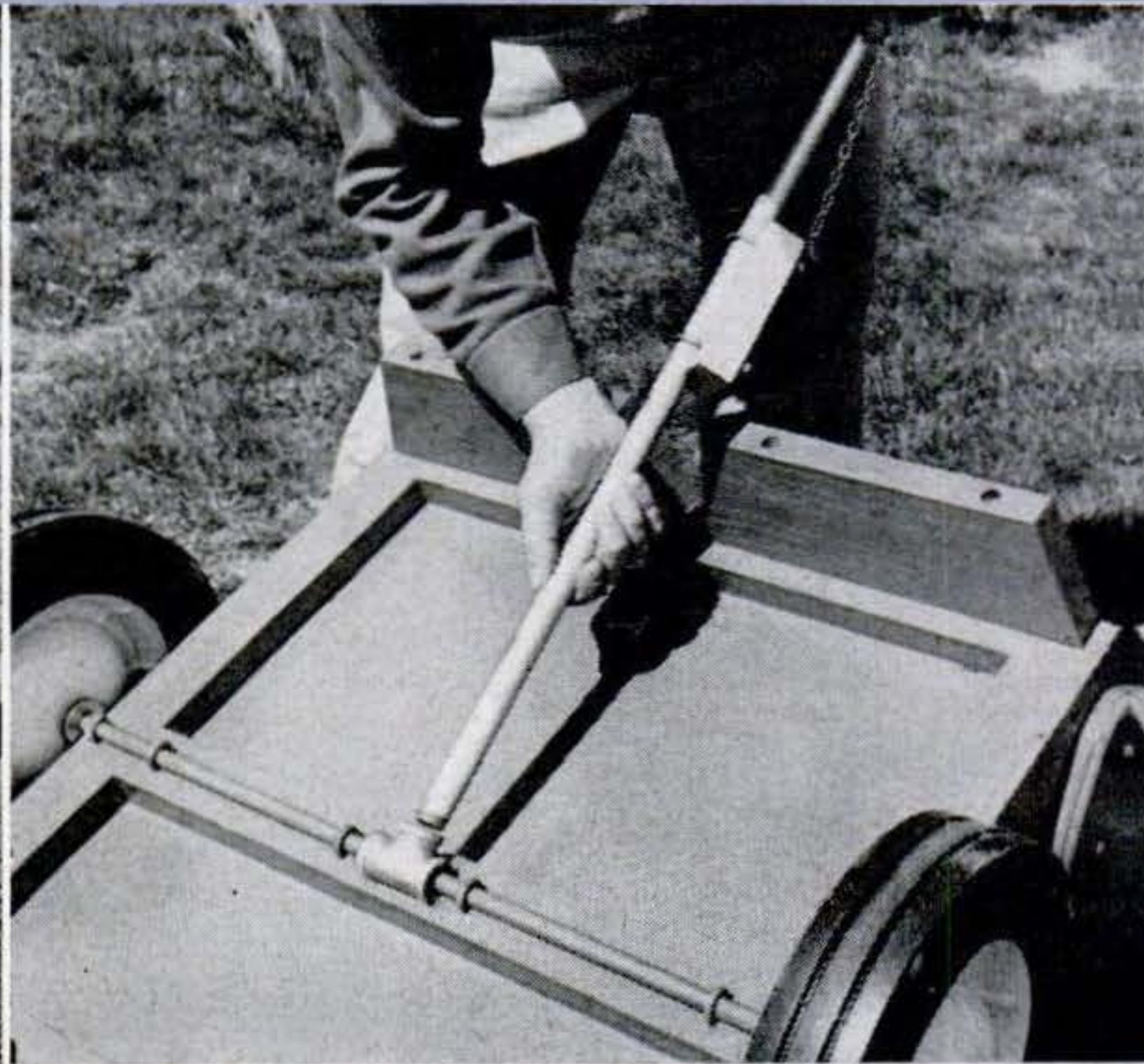
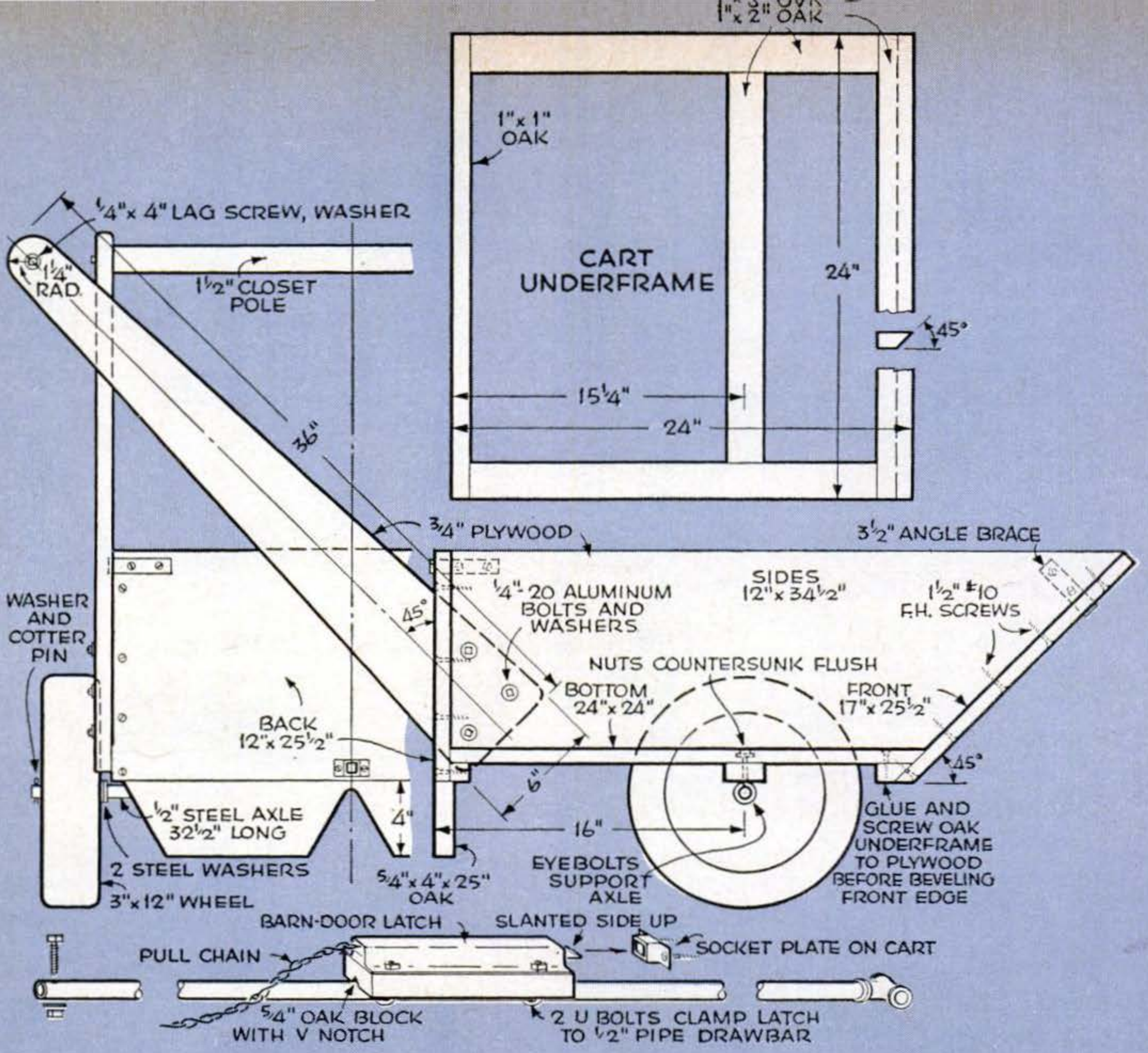

It's a quick switch to either towing or pushing. To trailer the cart, just screw the drawbar into a pipe tee on the underside, hitch the other end to the tractor, and you're off. The pipe tee is

slipped over the axle and rests in a shallow recess chiseled in the oak cross cleat, as at right. Rear leg keeps the cart upright when the drawbar is removed. Long screws hold the leg on.

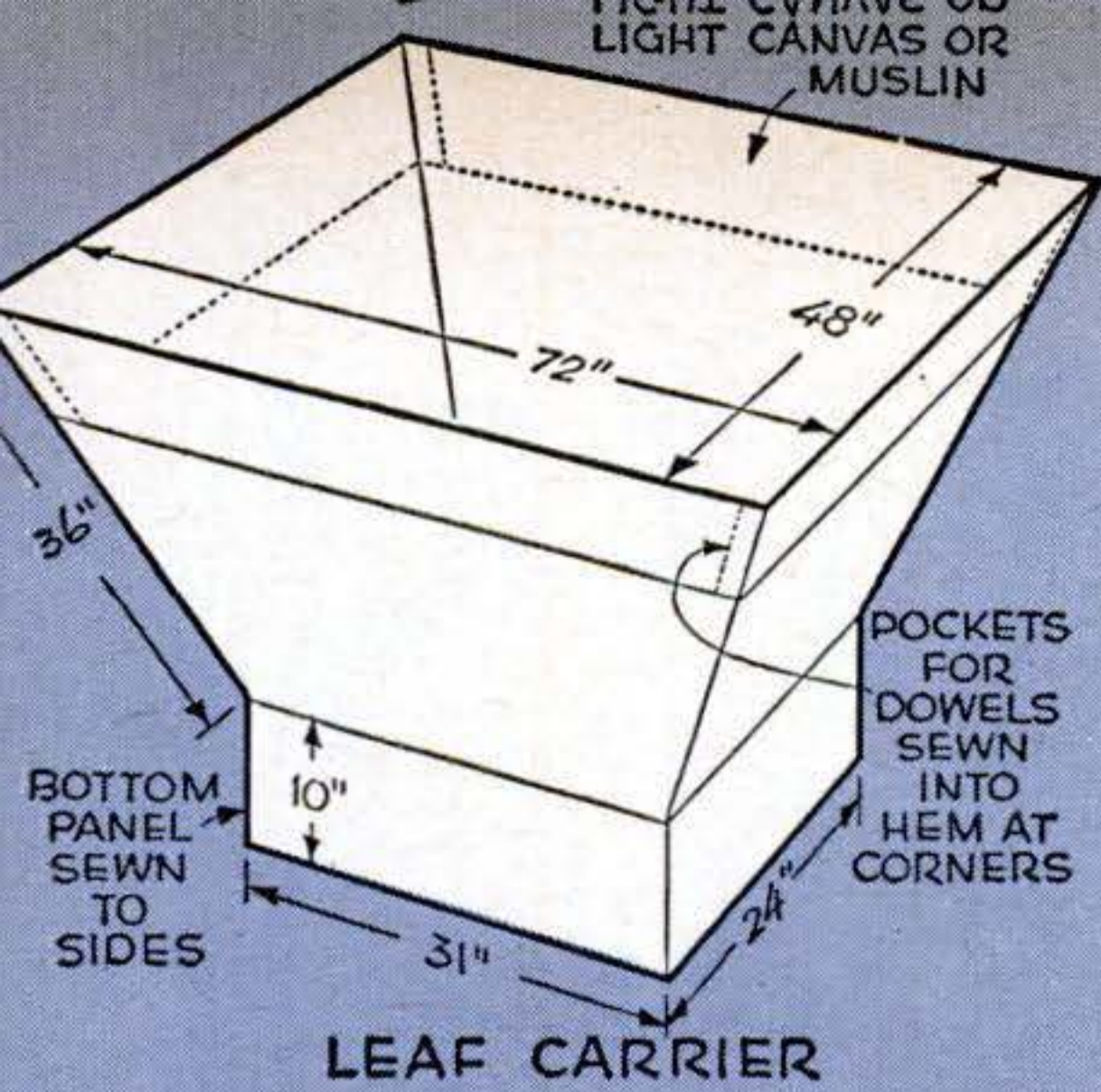

Outsize leaf carrier can be made of any light material, even old bed sheets. The shape of the hopper gives it a large capacity. There's no need to fuss about exact size or fancy stitching. Make the supporting frame first, then fit the material to it. The frame rests on top of the cart with blind holes at the corners for the four outward-angled dowel supports.

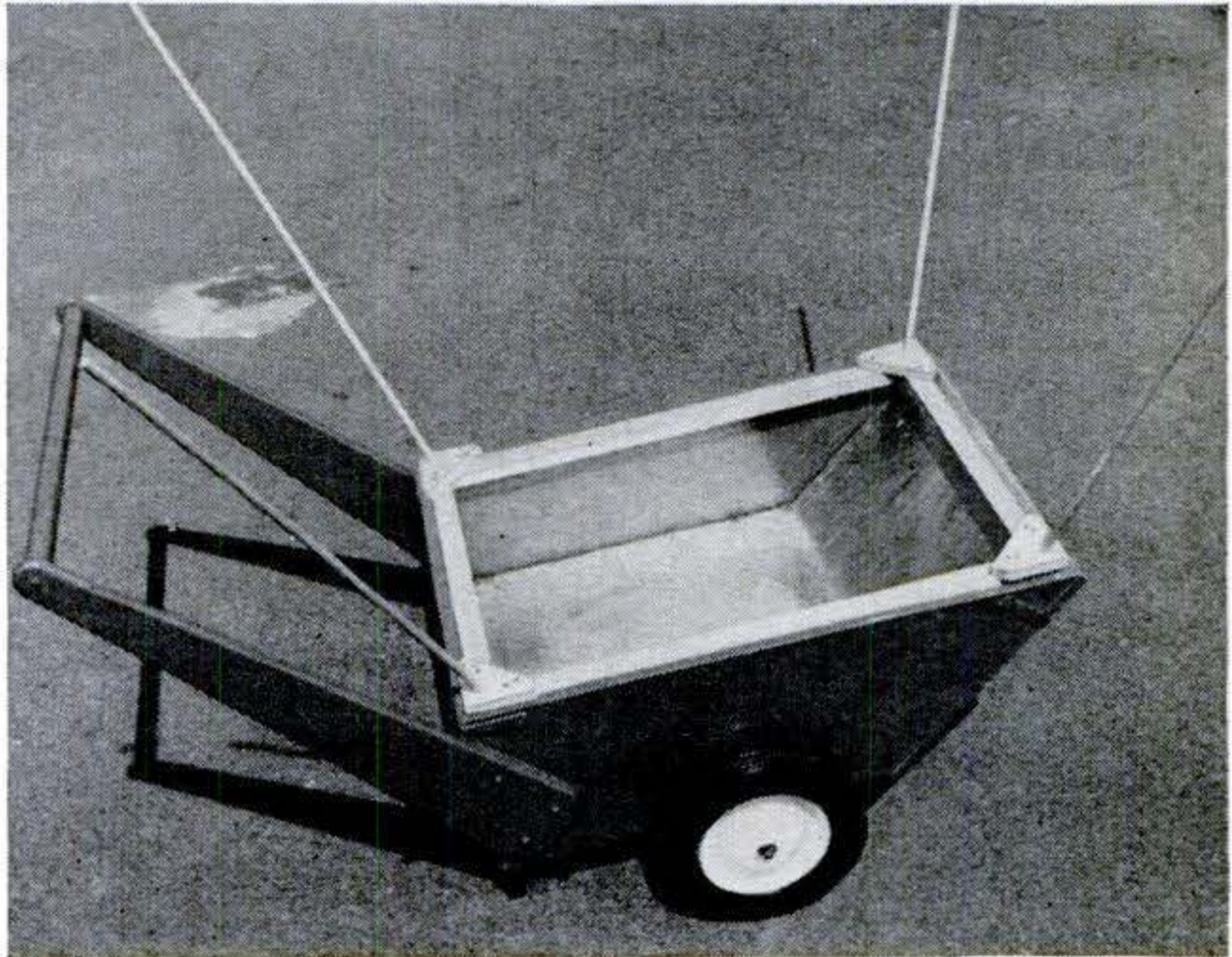
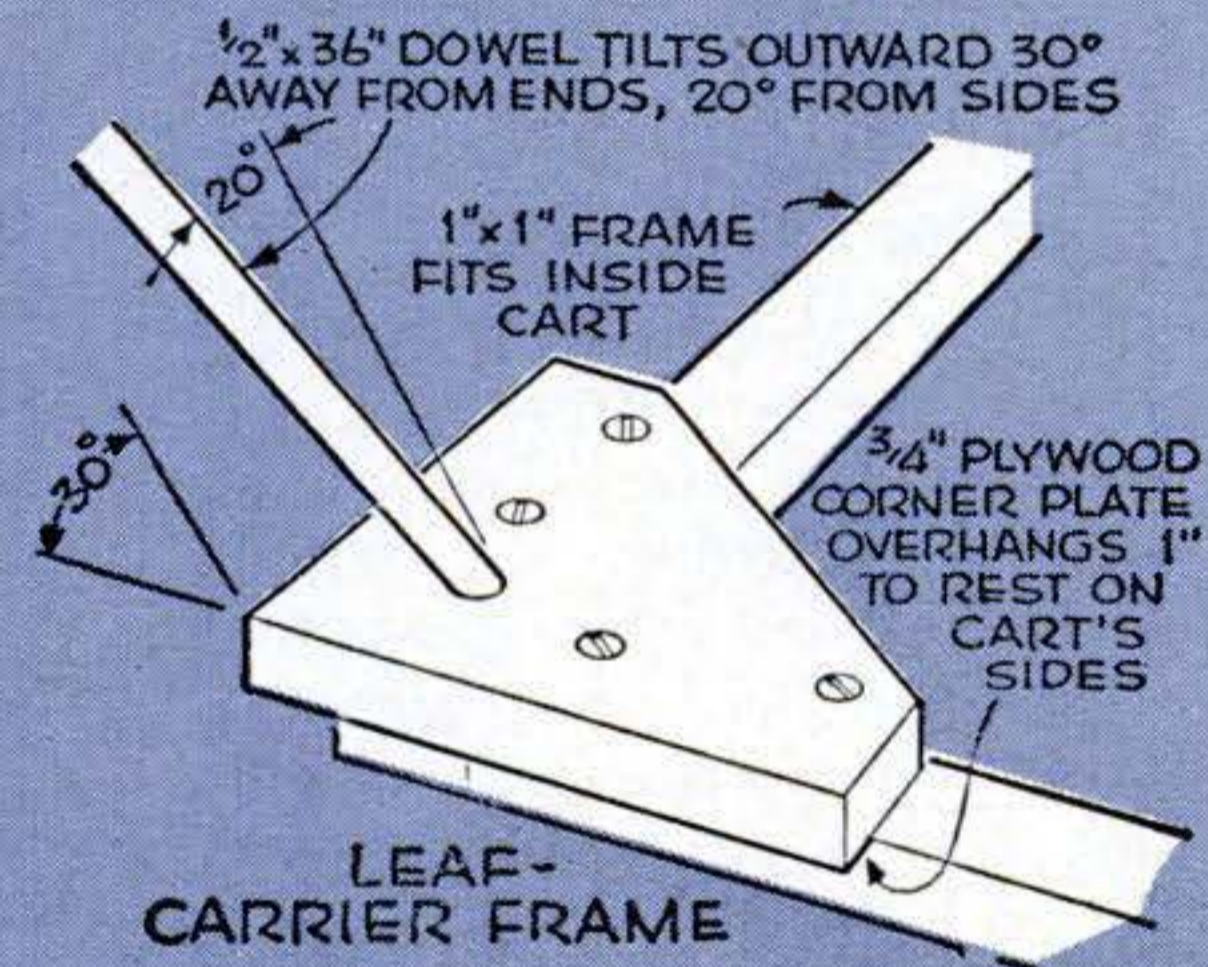

What's more, the cart is a versatile performer. You can wheel it by hand or tow it behind a riding mower or small garden tractor. A removable drawbar lets you hitch it up for trailering without getting in your way when you want to hand-push it. You can even use the cart for mixing concrete.

It's self-dumping, too. Here's the really tricky part. The cart's body is pivoted on the axle and carefully balanced. When empty, it's slightly rear-heavy. When loaded, it's slightly front-heavy.

For towing, the cart is pulled backward, and the rear end is held down snugly against the drawbar with a simple catch made from an ordinary barn-door latch. When you want to dump the load, you just pull a chain attached to the latch, releasing the cart body from the drawbar. Being front-heavy, the cart noses over and dumps automatically.

When the cart has been emptied, it be-

comes rear-heavy again, tips neatly back onto the drawbar, and latches itself. The front is sloped at just the right angle so it's flush with the ground when the cart is tipped. This makes it easy to jack heavy loads up and into the cart.

For hauling leaves, the cart has another trick up its sleeve. There's a lightweight removable frame that just sits on top of the sides and supports a large canvas or

[Continued on page 171]

.....

Would you like full-size plans of the yard cart or a kit of parts to assemble yourself? If so, POPULAR SCIENCE may be able to provide them at reasonable prices—depending on how many of you are interested. If you would like us to make available either the plans or the kit, please write to: Magazine Services Div., Popular Science Publishing Co., 355 Lexington Ave., New York 17, N. Y.

**Flip-flop jig helps
cut duplicate wedges**

I made this jig to cut a lot of duplicate small wedges. The hinged part is flipped up for each alternate cut across the stock. The jig was made by sawing an angled part equal to the angle of the desired wedge. This was hinged to a straight piece bolted to the miter gauge. The stop is clamped just far enough from the blade to produce a wedge of desired width.—Gus F. Neuberger, Squantum, Mass.

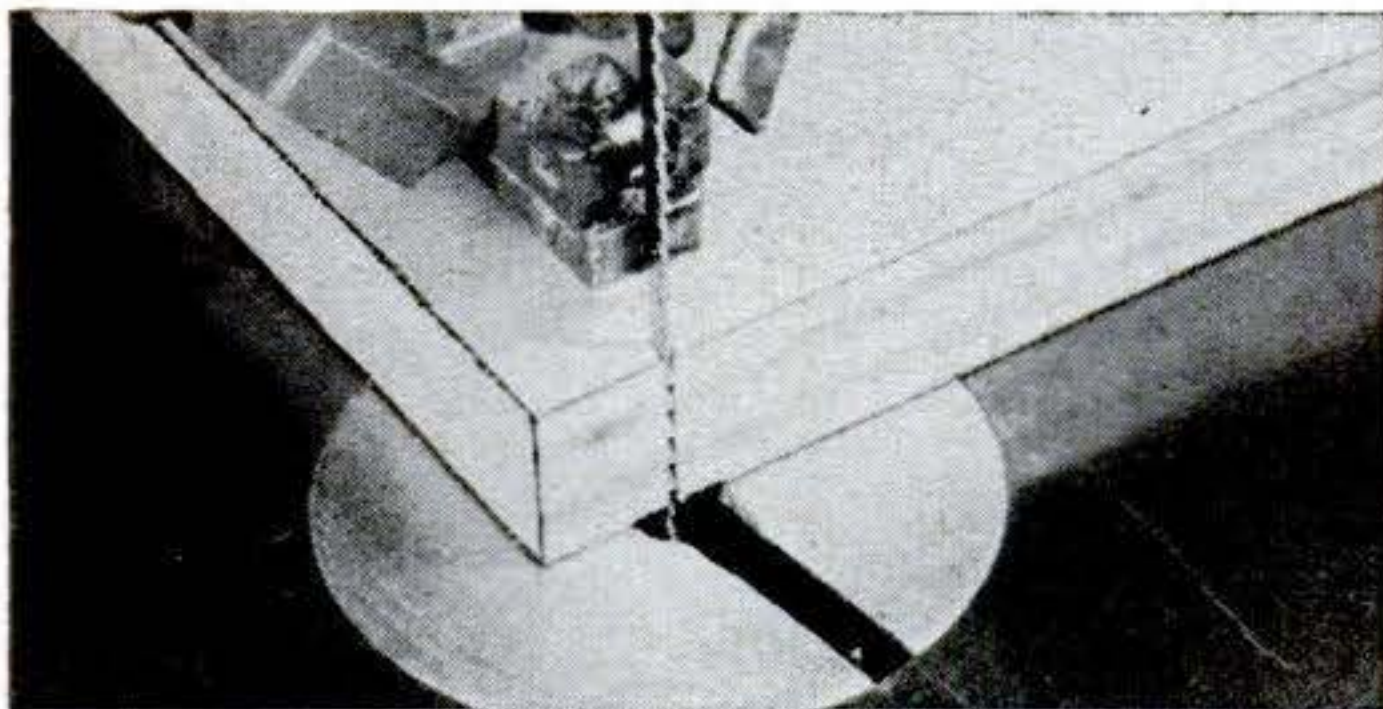
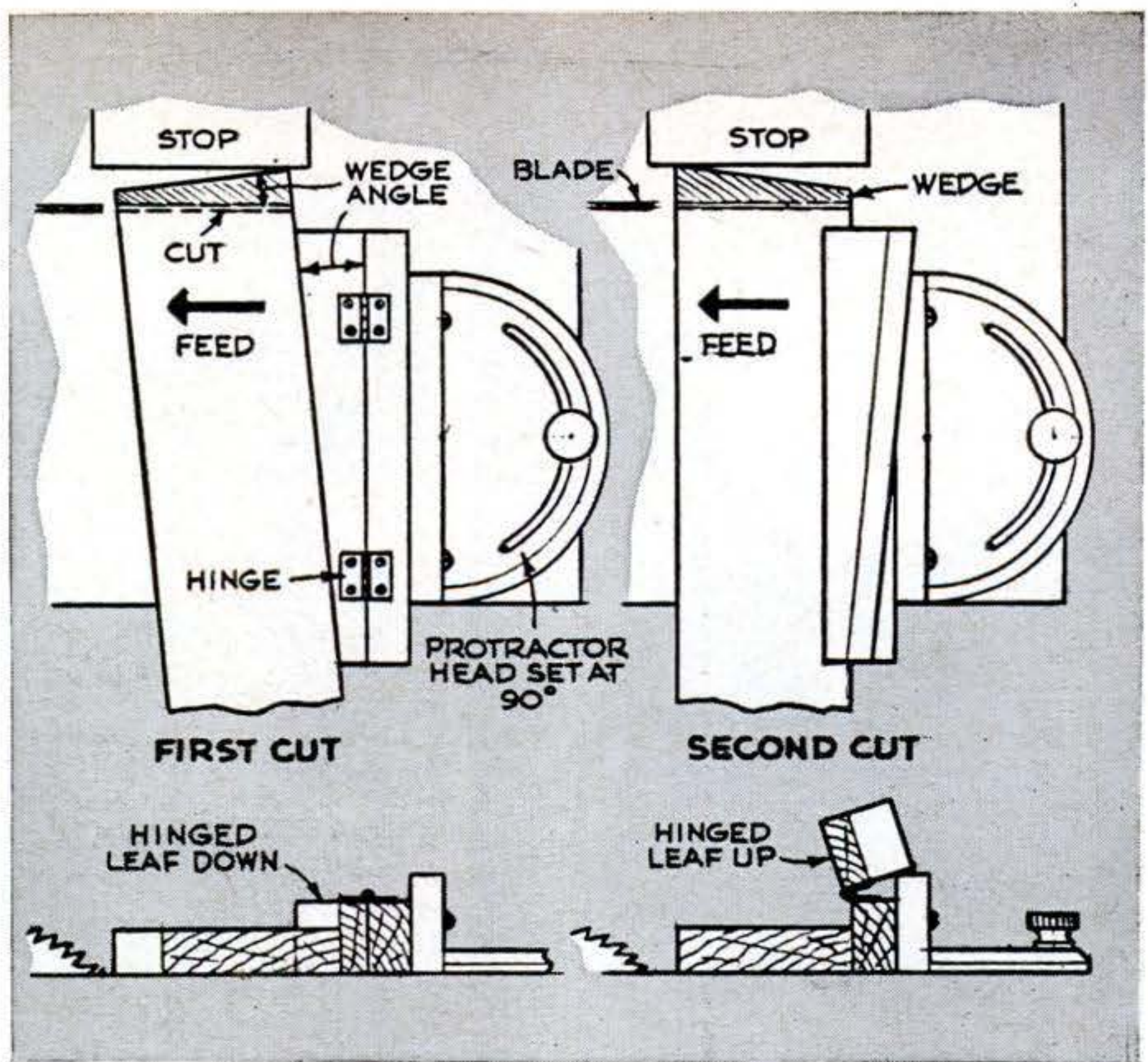

Checking a jigsaw for squareness

A simple method used by the pros will show whether your jigsaw is square. First make a cut the depth of the blade in a piece of wood. Then swing the wood around and let the rear of the blade enter the kerf (left). Raise the hold-down slightly and turn on the power. If the saw is perfectly square the wood remains motionless.

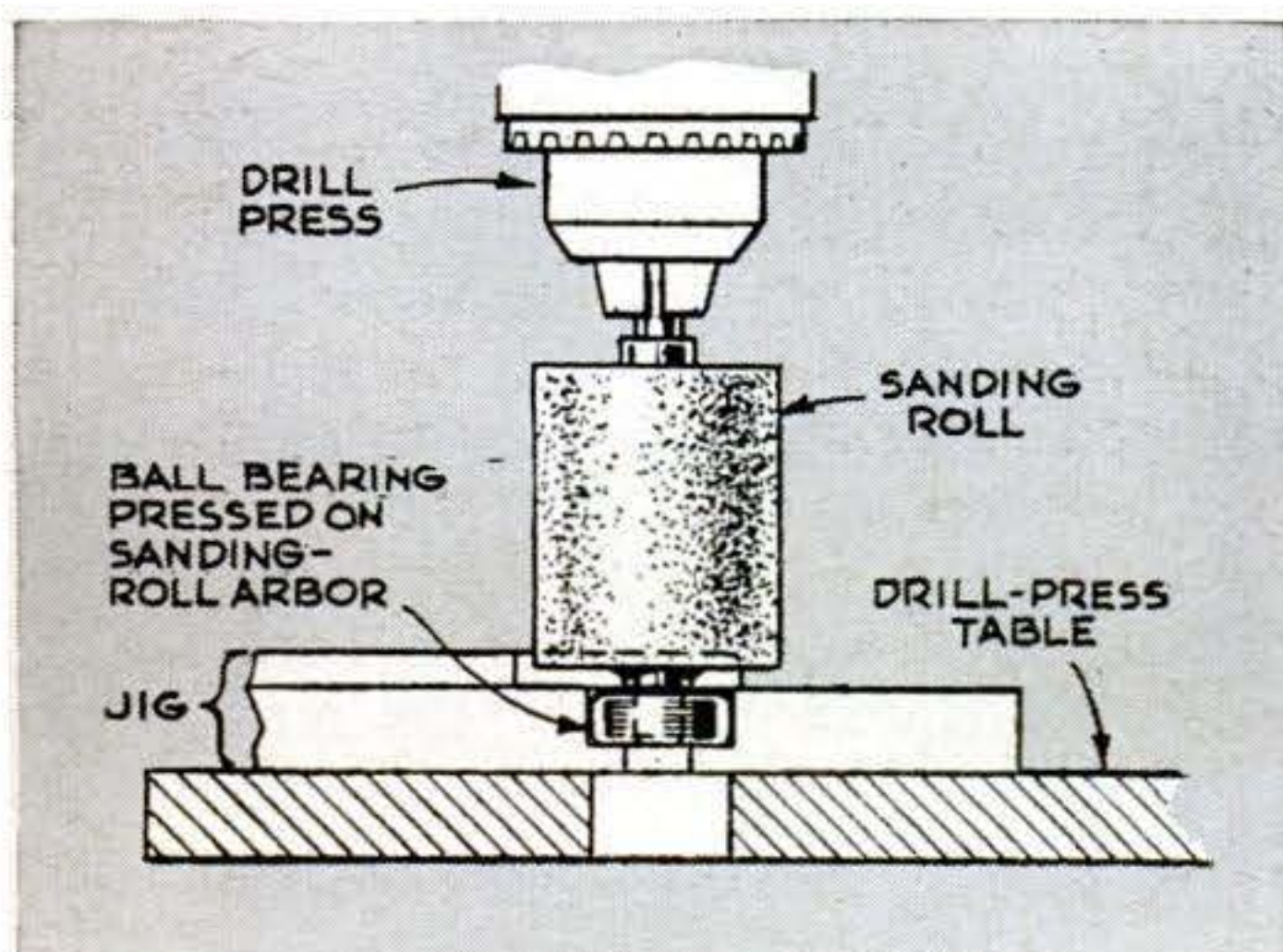

Sanding jig for curved surfaces

For a smooth surface on curved wooden parts, we use a drill press and the sanding setup above. The setup includes a two-level supplementary wooden table clamped to the drill-press table. A sealed ball bearing for the lower end of the sanding arbor was pressed into a hole in the added table.—L. W. Richardson, Zephyrhills, Fla.

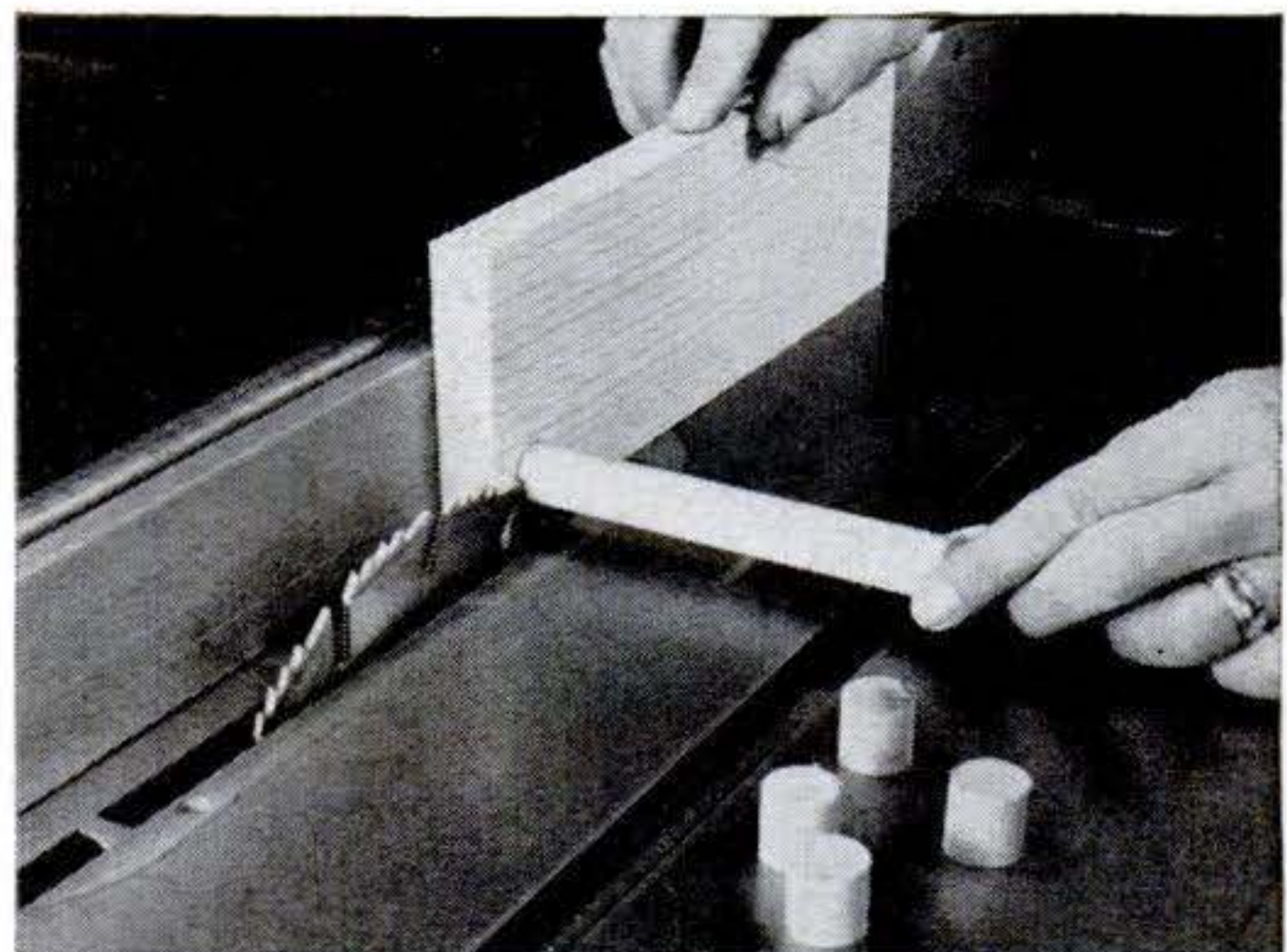

A jig for cutting dowel plugs safely

To cut short dowel plugs for concealing screwheads, drill a dowel-size hole through a block of wood. Use the wood as shown to carry the dowel past the saw blade. You can select wood with a thickness equal to the plugs needed or, lacking the right thickness, you can drill a blind hole to depth.—R. J. De Cristoforo, Los Altos Hills, Calif.

Cooling Your House with Free Air

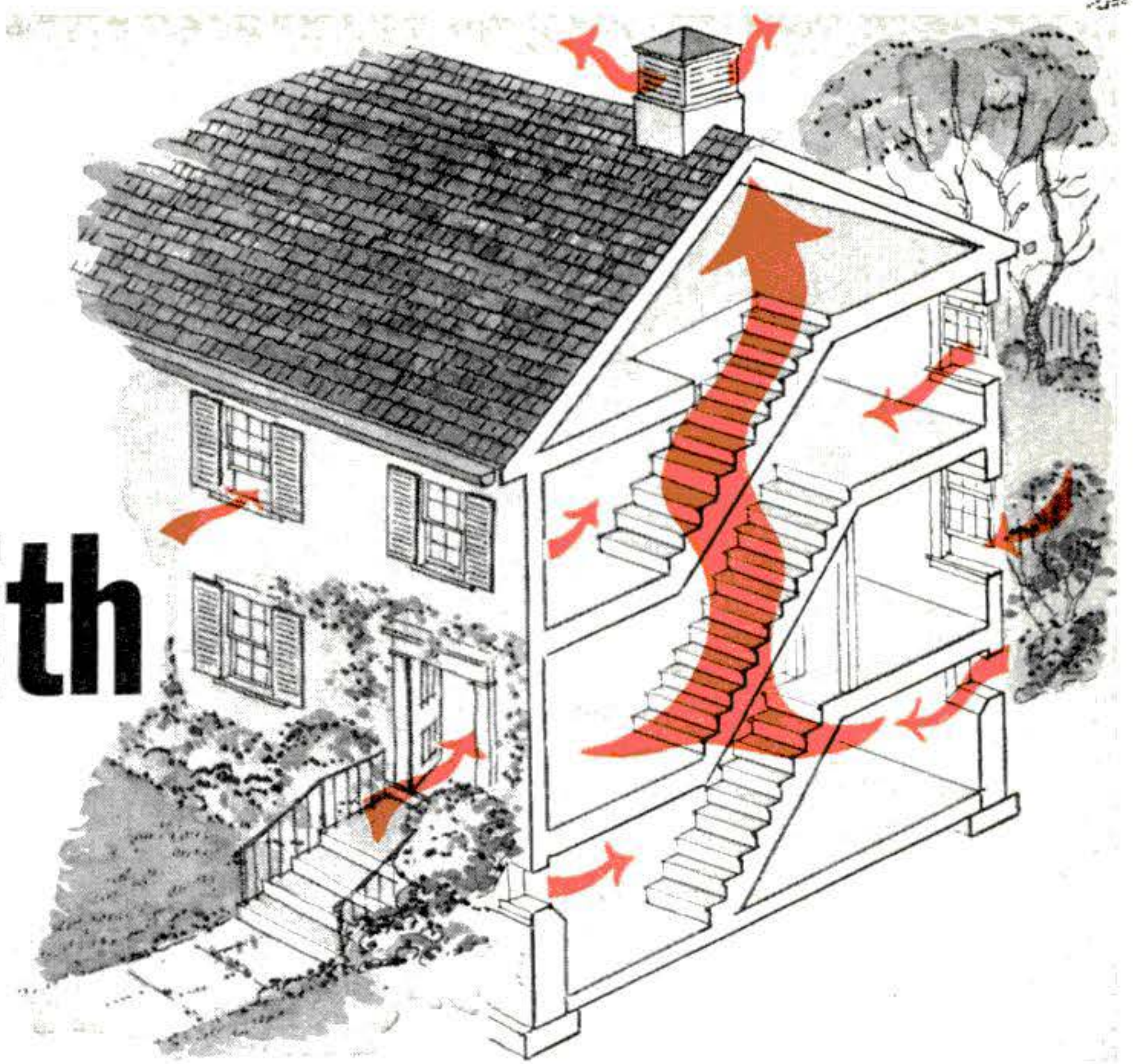

Let nature do the work! You just set up the pathways for air currents that blow the heat out of your house

By Gerald K. Geerlings

GET summer cooling for nothing? Well, almost. Since heated air rises, you just encourage the hot air indoors to go up and out. You may be able to cool your house as much as 8 to 12 degrees without mechanical equipment by using the "stack," or chimney, principle.

Do all you can to keep indoor heat from

building up. Open all windows at night, conserve cool night air in the house during the day by closing sun-exposed windows and drawing the shades. If you have a basement, open the door at the head of the cellar stairs, and open basement windows. Leave all interior doors open, including the one at the bottom of the attic stairs. Install a screened hatch in the topmost ceiling if there are no stairs to the attic.

CONTINUED

Openings at floor speed flow of air in a house without basement

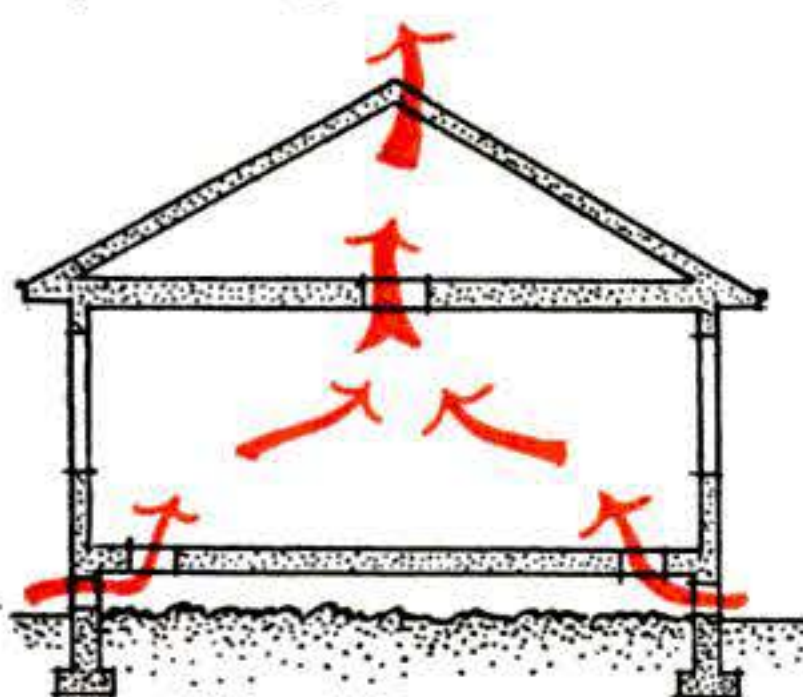

A house with crawl space has a reservoir of cool air under the floor. To use it, you need floor registers with winter closures, plus ceiling grilles and vents near the ridge. Use one floor grille for an average-size room, two in a big living room.

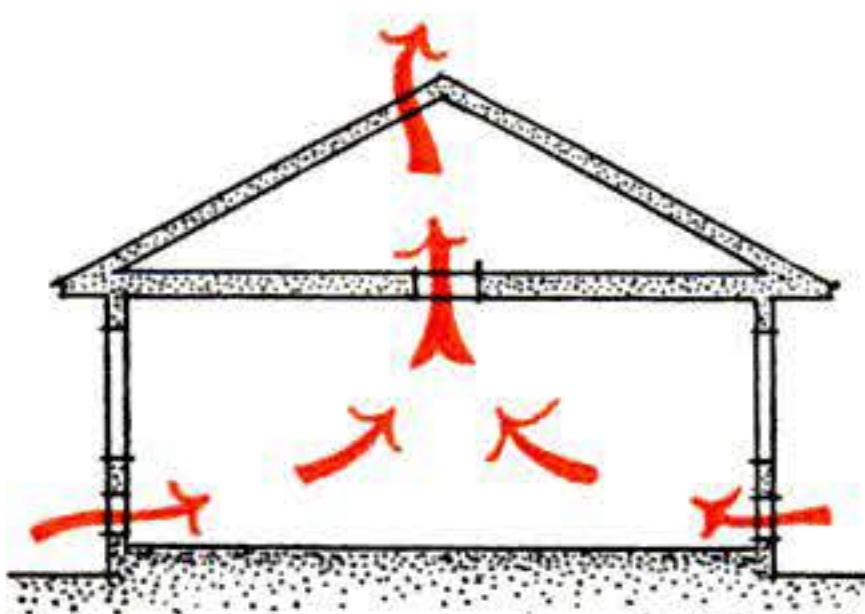

Got a slab-floor house? Outside air at ground level is cooler than it is four feet higher. So screened vents just above the floor bring in cooler air than open windows above. Use stock units with hinged doors for winter.

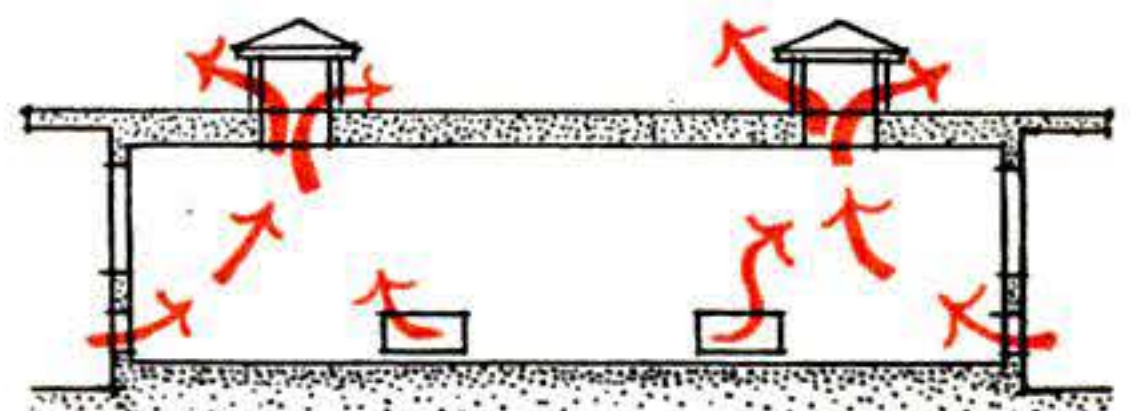

A flat-top house on a slab also needs screened vents near floor level, plus cupolas on the roof (two or more, depending on size of house). Below each cupola you need a screened hatch in summer, and a removable, insulated panel in winter.

Encourage cross-ventilation under the roof with ample vents



In an open-attic house, triangular vents on the gable ends (left) may prevent dry rot, but usually are not large enough for active air circulation. To keep the stagnant hot air from heating the rooms below, install stock *rectangular* vents (right) with metal or wood louvers backed up with screening. In winter, block them on the inside with plywood panels.

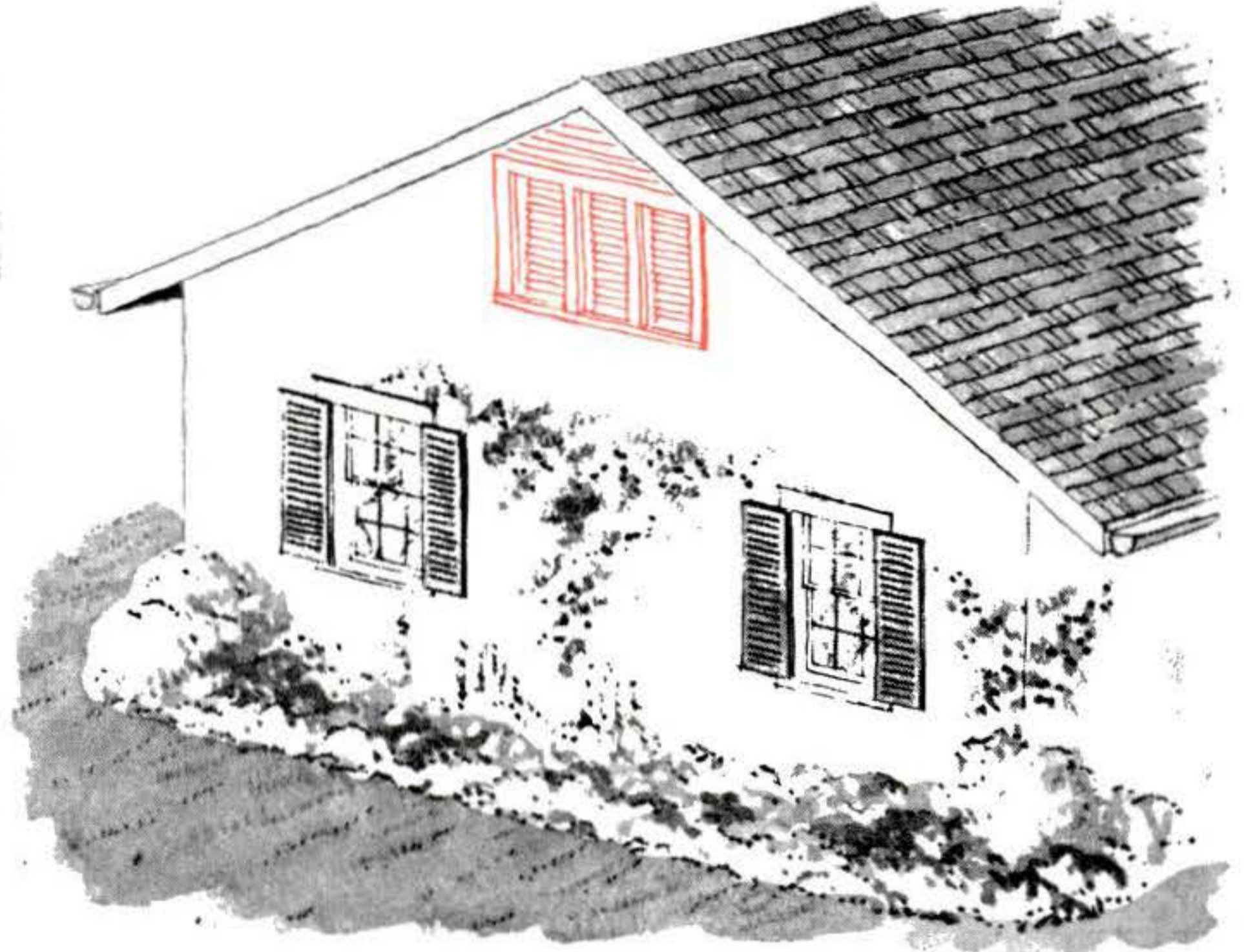

Continuous air openings in eaves and ridge induce an "air wash"

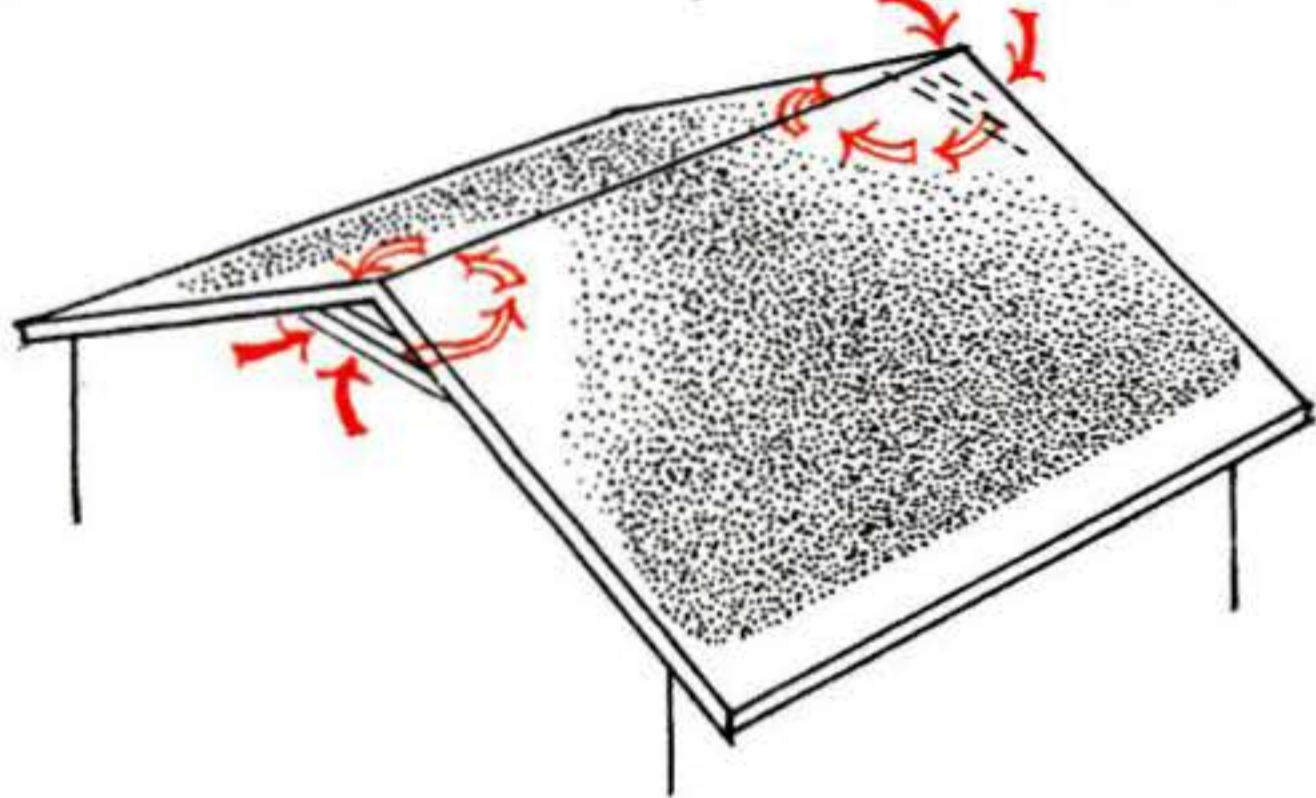

When vents are too small, recent research has shown, the air is virtually motionless in the central area under the roof (left). Recommended solution: Create an "air wash," or continuous

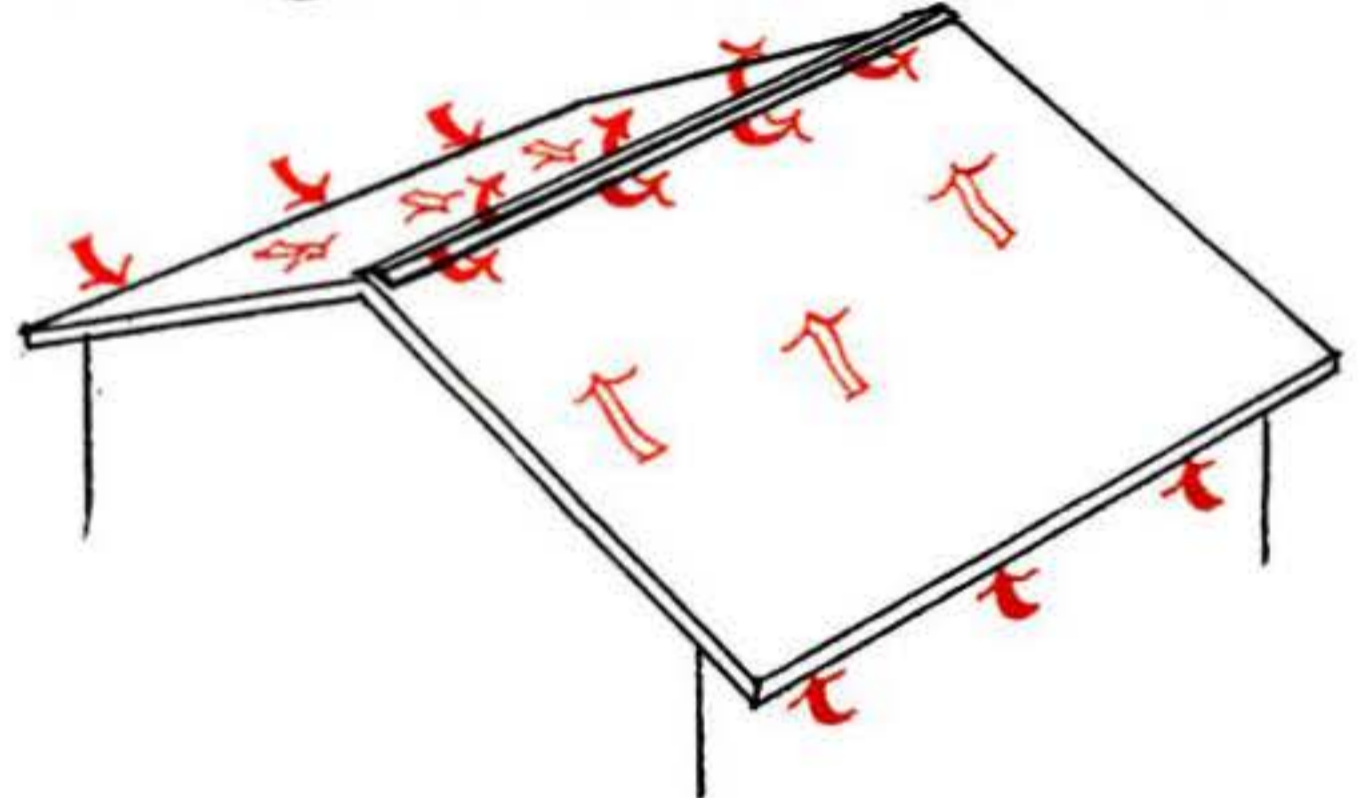

air movement (right), by permitting outside air to enter along the eaves (as in drawings below), and encouraging it to escape along the ridge (detail at right, on opposite page).

Air can enter at eaves several ways—in old or new construction

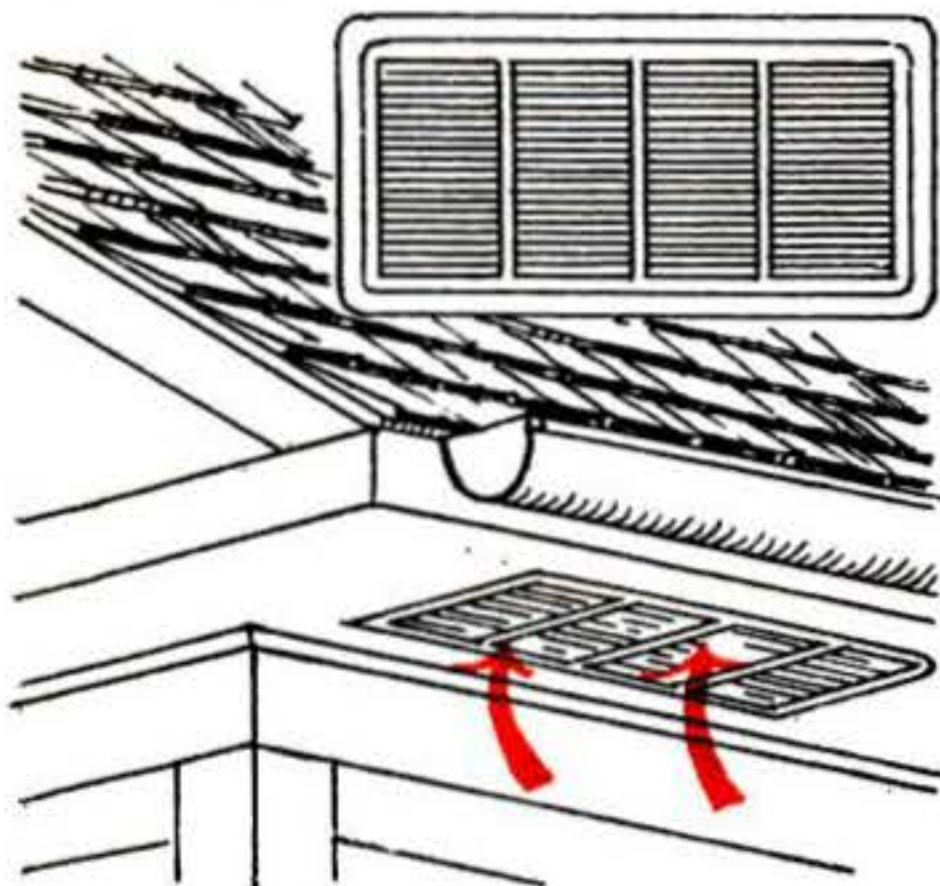

Stock rectangular vents 4" or 8" wide and 16" long are designed for installation in horizontal or inclined under-surfaces of the eaves of an existing or new house. Be sure no wood member at the attic-floor level blocks free entry of air.

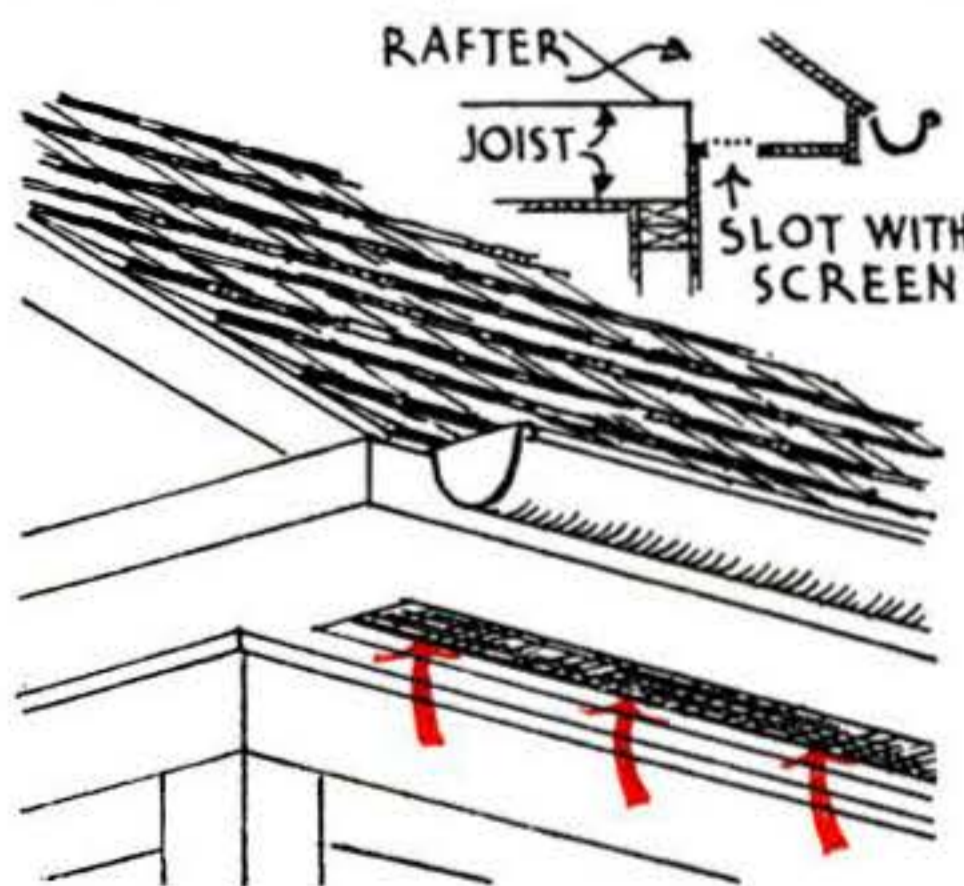

In a new house it is common practice to have a continuous open slot about 4" wide in the underside of the eaves, backed up with window screening. Adapted to remodeling, this feature is desirable because it is both effective and inexpensive.

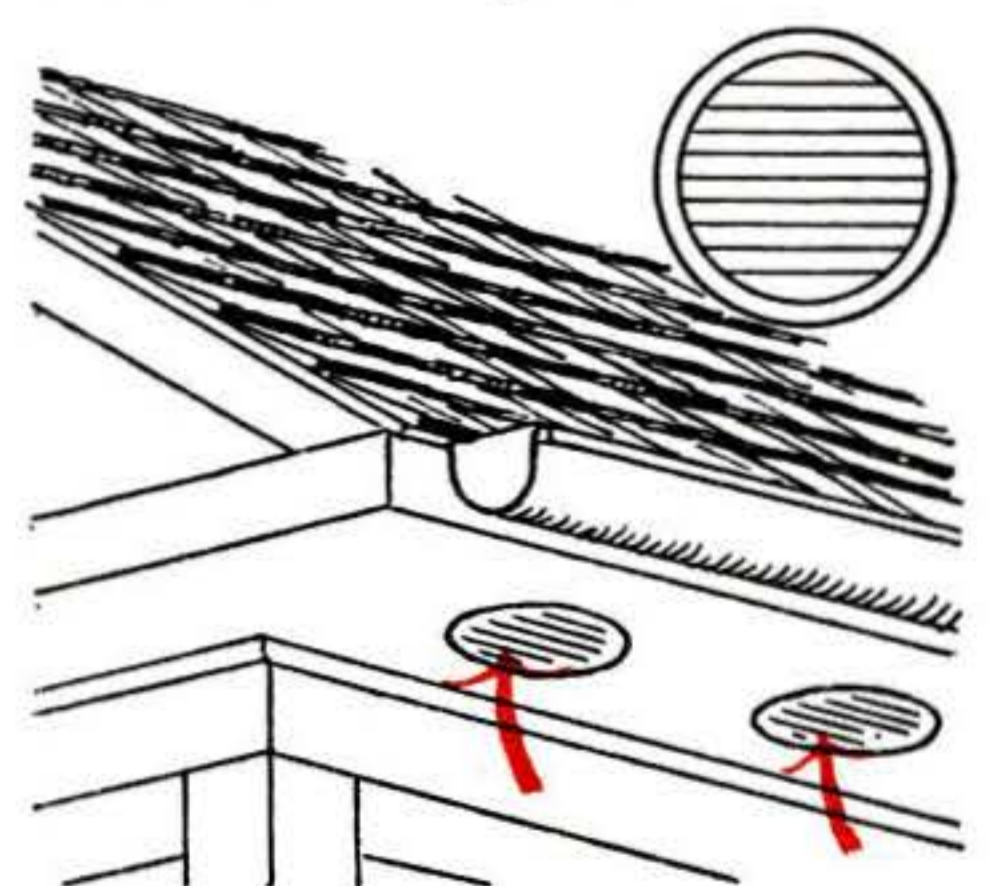

Circular vents up to 6" in diameter are sold by most hardware stores. There is screening behind small louvers. These units are suited to remodeling where it is impractical or difficult to cut rectangular openings to fit standard vent sizes.

Awning windows in the gable end can remain open all summer

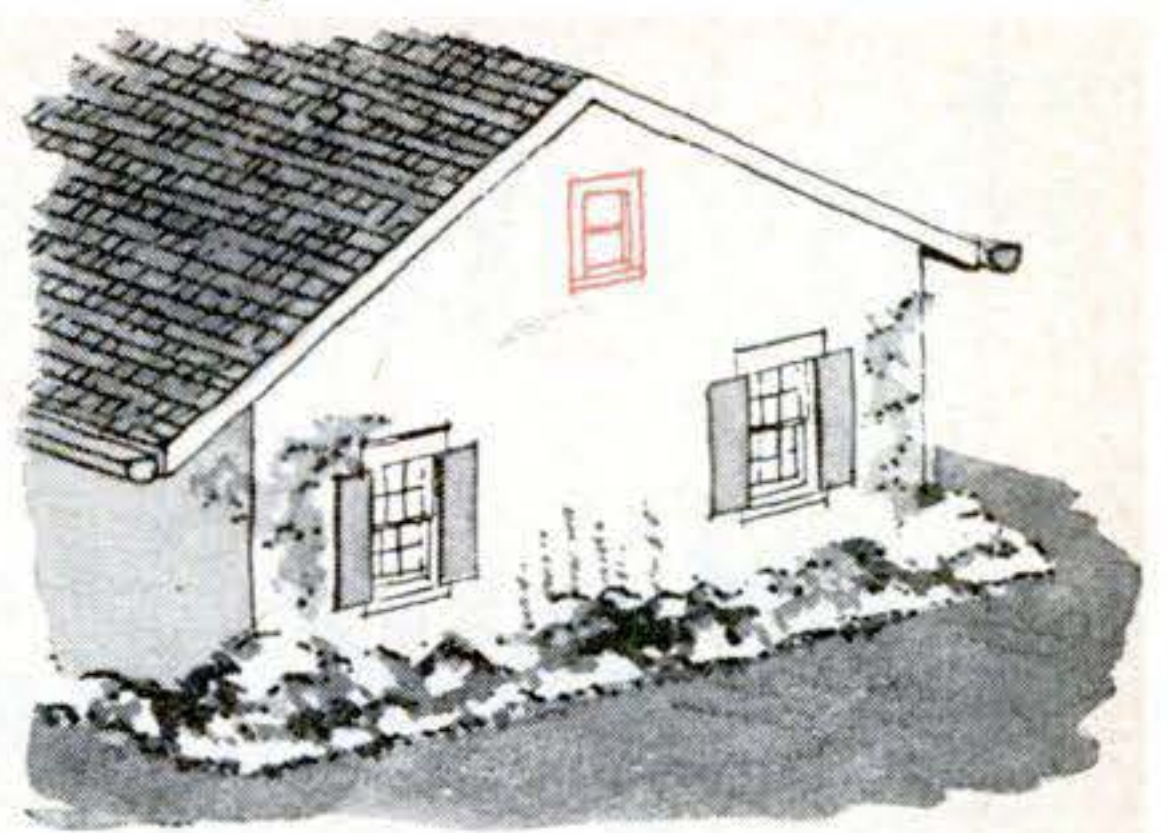
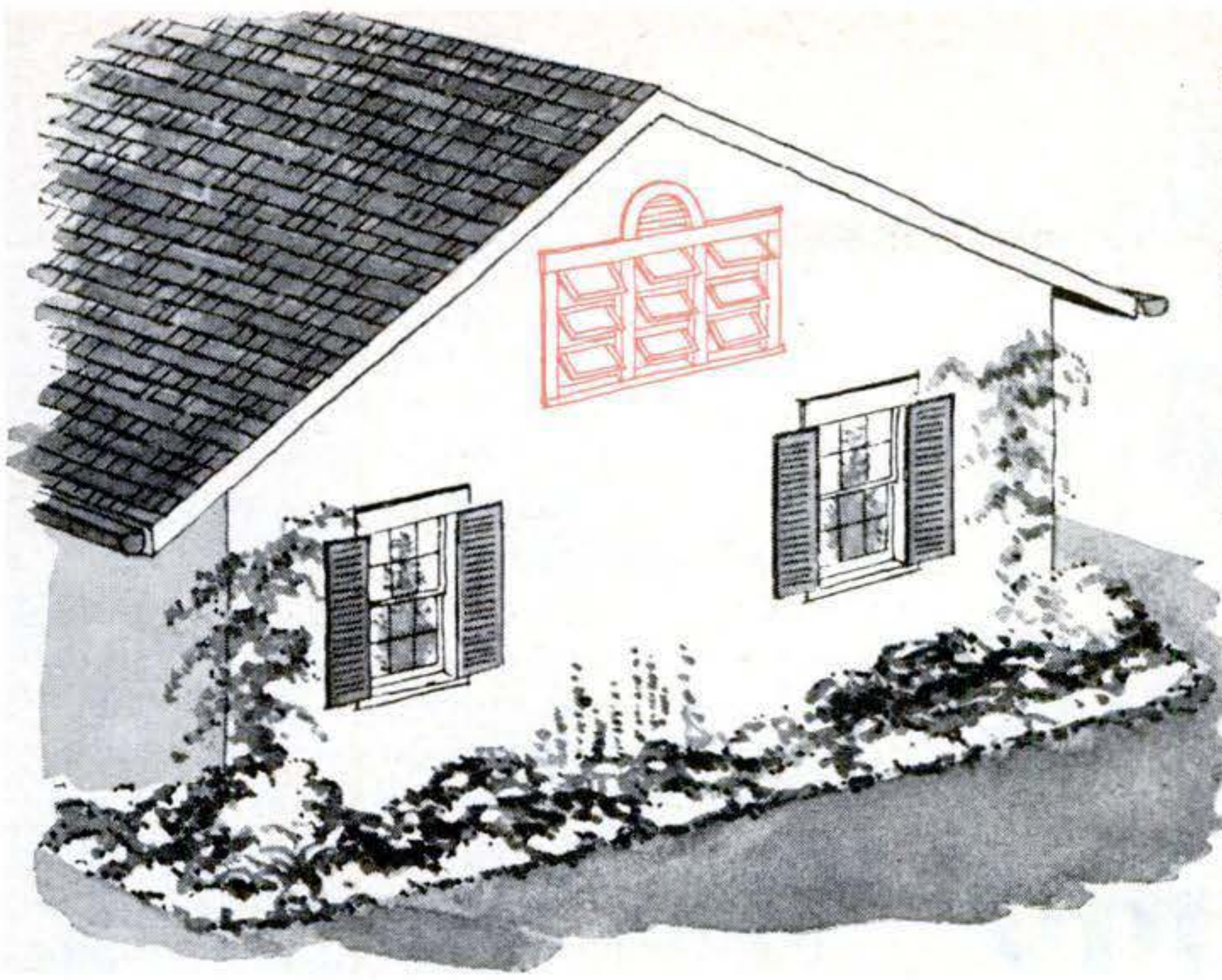

A single, double-hung window in a gable end usually limits air movement because it's natural to open it only a little to exclude unexpected rain. Awning windows are an excellent replacement because they can be left wide open throughout the summer. Multiple grouping can be planned with stock single units, which come 28" to 32" wide, and from 12" to 24" high.

Continuous ridge vent can lower attic temperature 12 or 15 degrees

Stock ridge-vent units 8' and 10' long (about 54 cents a foot) are readily installed on new roofs, or on old ones requiring roof-board replacement at the ridge. After the ridge member (its top edge dropped $\frac{1}{2}$ ") and rafters are in place, leave top-most roof boards separated by a 3" gap, to provide a continuous escape slot for attic air. Bottom flange holds down top row of shingles. Installation records indicate that a ridge vent usually costs less than one stock rectangular vent at each end.

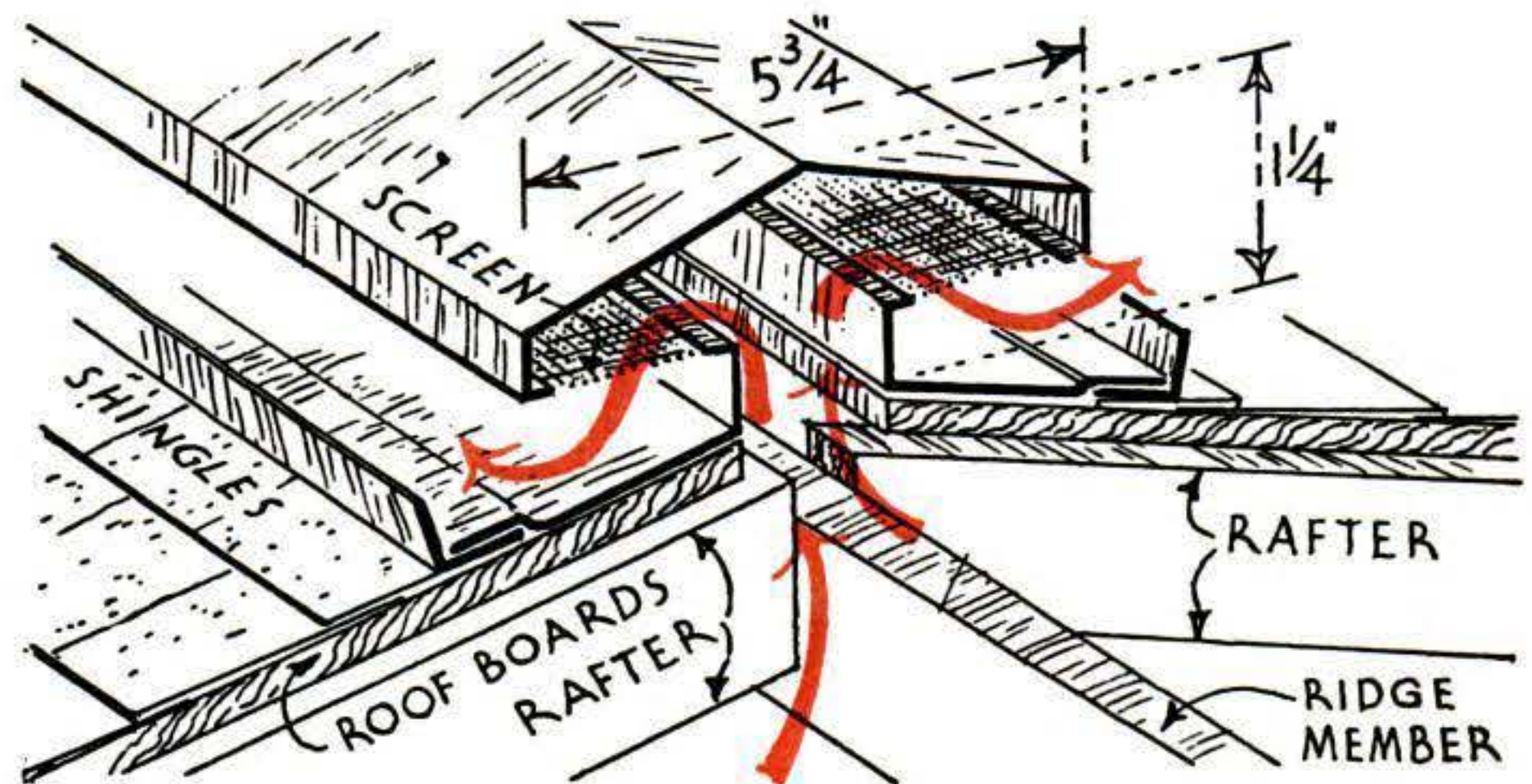

On some roofs, it's hard to beat cupolas for letting out hot air

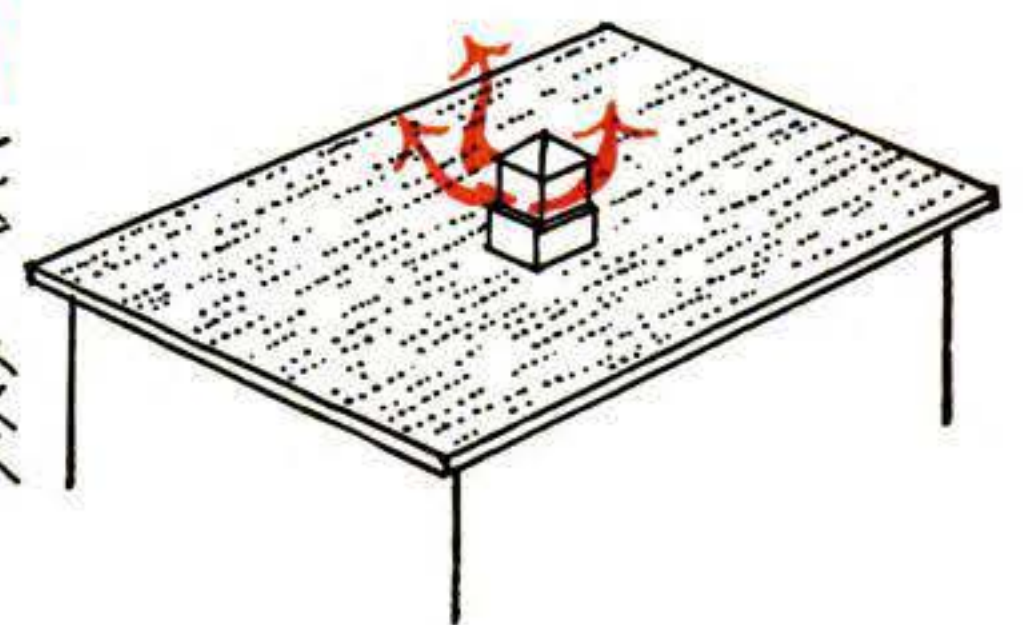
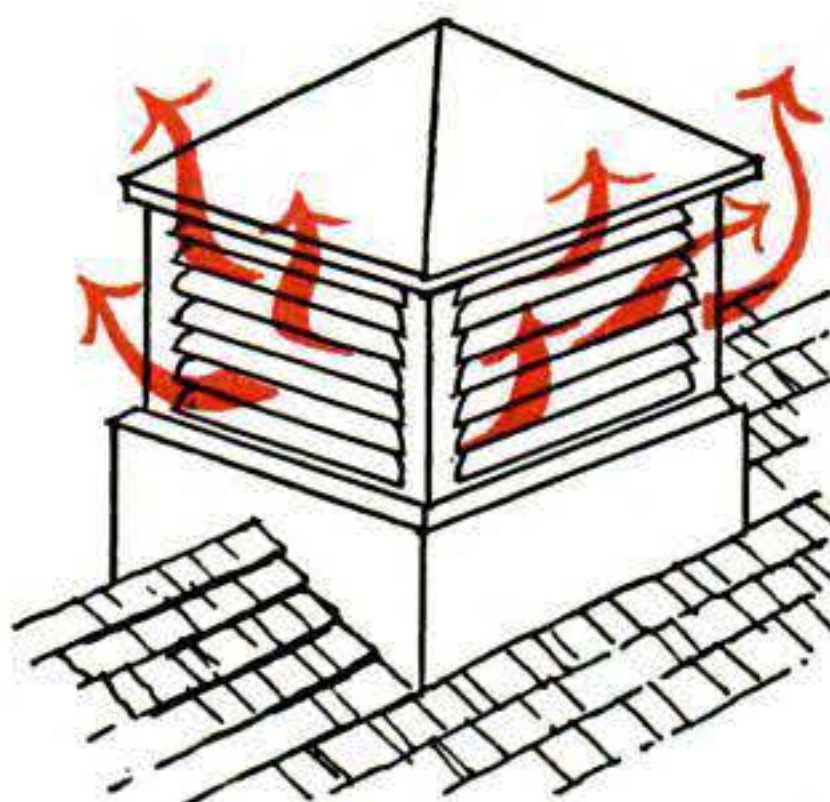
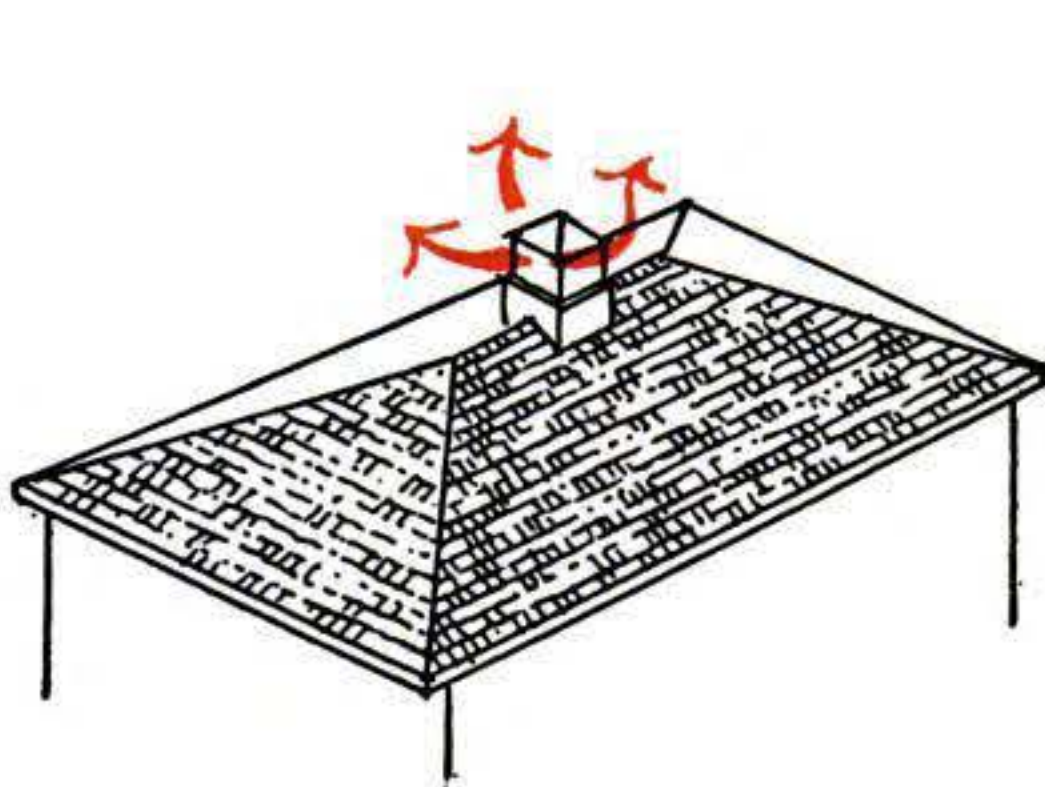

Attic space under a hip roof becomes unbearable during a hot spell, even when six or more stock vents are installed. One cupola 33" on a side, will provide as much net ventilating area as about nine rectangular units—and at a lower cost.

Stock cupolas are available in aluminum or redwood for various roof slopes and for hip or flat roofs. An aluminum cupola 17" square with 215 sq. in. of ventilating area sells for \$22; one 33" square with 567 sq. in. is priced at \$39.

Cooling a flat-roof house with air movement requires at least one cupola. If you make your own, build the solid bottom sides at least 12" above roof level (more if snow may drift higher), and install screening inside louvered areas. ■ ■

By Walter F. Bruning
Landscape Architect

How to Keep Your Yard Neat Without Really Trying

IT'S human nature to want a pleasant and neat yard around your home. But you don't have to be tied to your mower and trimmer all summer long. You can gain time for many other things by working out a low-upkeep landscape design.

Many elements of low upkeep can be worked into any yard. You can still benefit from some of them this summer.

Steps to easier mowing. A power mower is essential equipment for just about any home nowadays—and a good case can be made for one on which you ride. Given the mower, you need a lawn on which you can use it to best advantage.

That's why a landscape architect's major objective would be to avoid sharp corners in the lawn design. Gentle curves permit continuous mowing and

A riding mower and an open lawn free of trees and other obstructions make mowing a breeze.



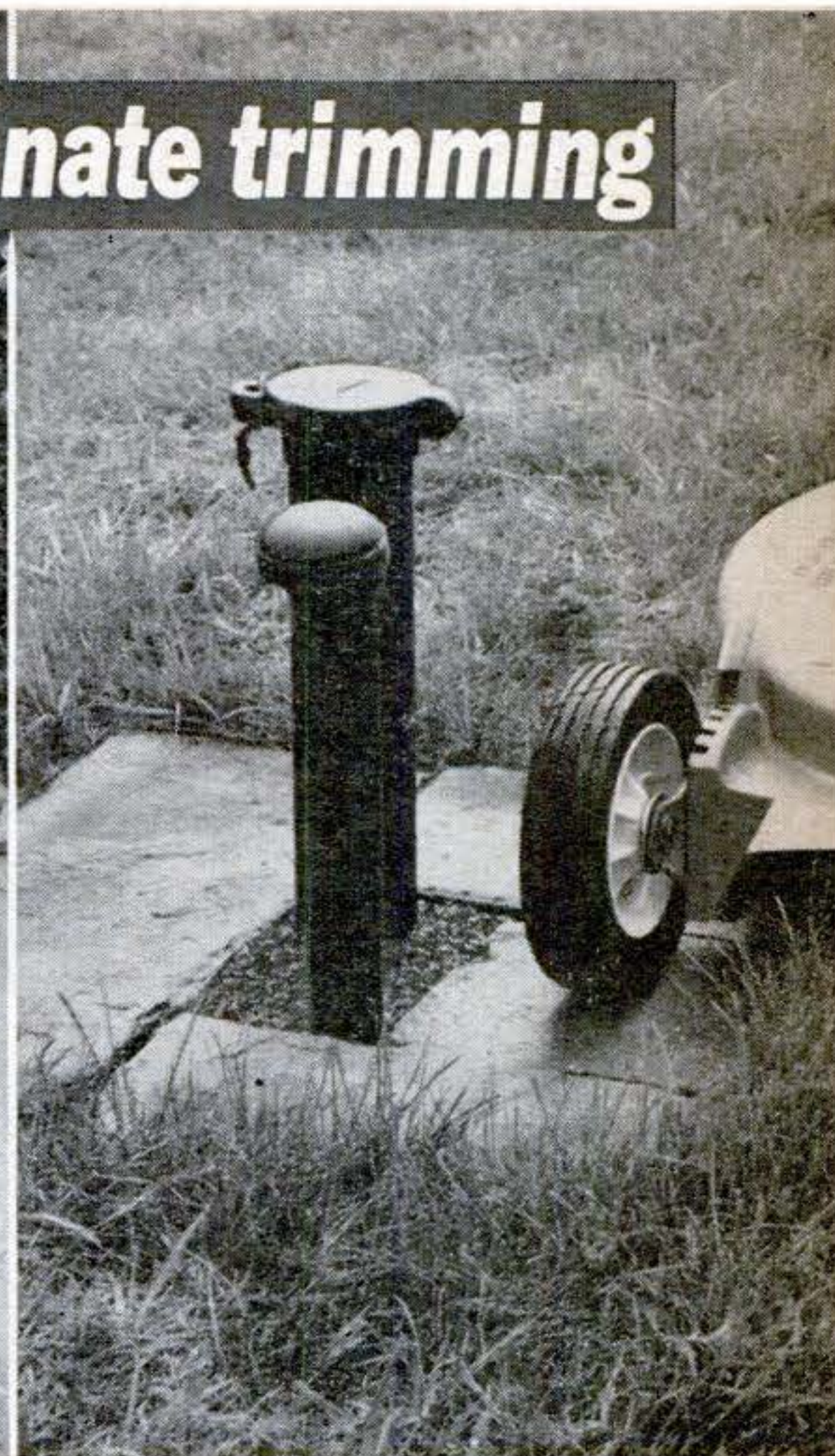
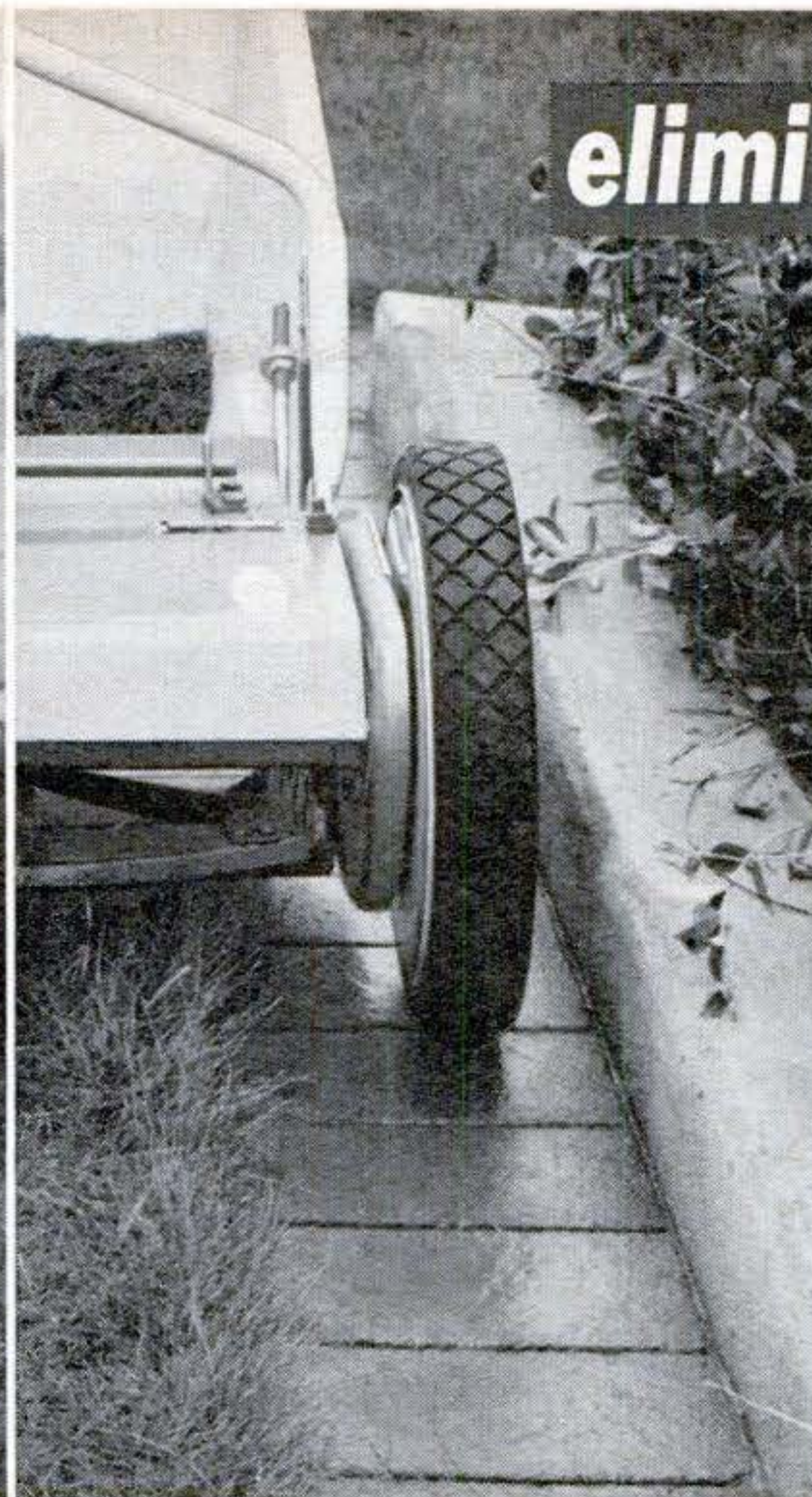

eliminate trimming

Brick mowing strips are a big timesaver in any lawn. Placed as above between the lawn and a mulched shrub area, the strip eliminates trimming, edging.

Along raised curbing, a brick mowing edge keeps down grass that you can cut only by tedious trimming. Use the strips also along drives and walks.

Flat stones will keep grass from growing around fuel inlets, vents, and clothes poles in a yard. Place bluestone or crushed stone around the pipe.

eliminate push-and-pull mowing in hard-to-get-at places. Beyond this, he would include the design points shown in the accompanying photos.

Other worksavers. To save work, give you more spare time, and generally improve a property, a landscape architect might also recommend some or all of the following steps:

- Use mulches wherever possible. They keep weeds down and conserve moisture, making flowers easy to care for. You can get interesting visual effects with such mulches as cocoa beans.

- Use a strip of crushed stone under the roof drip line and don't waste effort trying to grow plants or grass there.

- Plant low-upkeep hedges. Yews require trimming only two or three times during the growing season.

- Avoid planting grass in deep shade where it won't thrive. Use a ground cover.

- Avoid lawn cleanup under trees that drop seeds, fruit, or nuts. Plant ground

covers under them. The cover will hide the droppings.

- Plan convenient outlets for electricity and water. You should never need more than 50 feet of hose or cord.

- Eliminate flower beds in areas adjacent to drives and walks where winter snow pilings may damage them. Or use plants not subject to such damage.

Laborsaving tools. To a landscape architect, the maintenance tools are as important as the basic materials with which he works. Laborsaving tools can add to the most efficient design. Besides a power mower, you should consider owning a grass catcher, lawn sweeper, power trimmer, power edger, hedge trimmer, lawn aerator, and snow thrower.

Which materials? Besides designing for low upkeep and tooling up for saving labor and time, a landscape architect also must consider which materials, natural and artificial, are best for executing his design.

Flagstone is the most commonly used

material for terraces and walks, but low-quality flagstone should be avoided. It's subject to unsightly chipping.

Avoid weed growth between flagstones by installing them on a concrete slab where possible. Soak the slab thoroughly first to prevent it from absorbing moisture from the mortar. This would weaken the mortar and cause premature crumbling. A fairly weedfree dry installation is possible if you use three inches of foundry sand as a setting bed.

Bricks, too, should be laid with tight joints to prevent weed growth. Lay them in a sand or "stone-dust" bed. Laying brick

on concrete is not recommended. Absorbed water will freeze during the winter, causing the bricks to pop loose.

Asphaltic concrete, or blacktop, requires a minimum of maintenance if you use it for a play area in your yard. But it has high heat absorption, and during the summer you might find your children retreating from it for the coolness of the lawn. The stuff also crumbles if it isn't given heavy traffic and constant compaction.

Crushed stone should be used in sufficient depth to retard weed growth, and be compacted so that wheeled equipment can move over it easily. ■ ■

make mowing easier

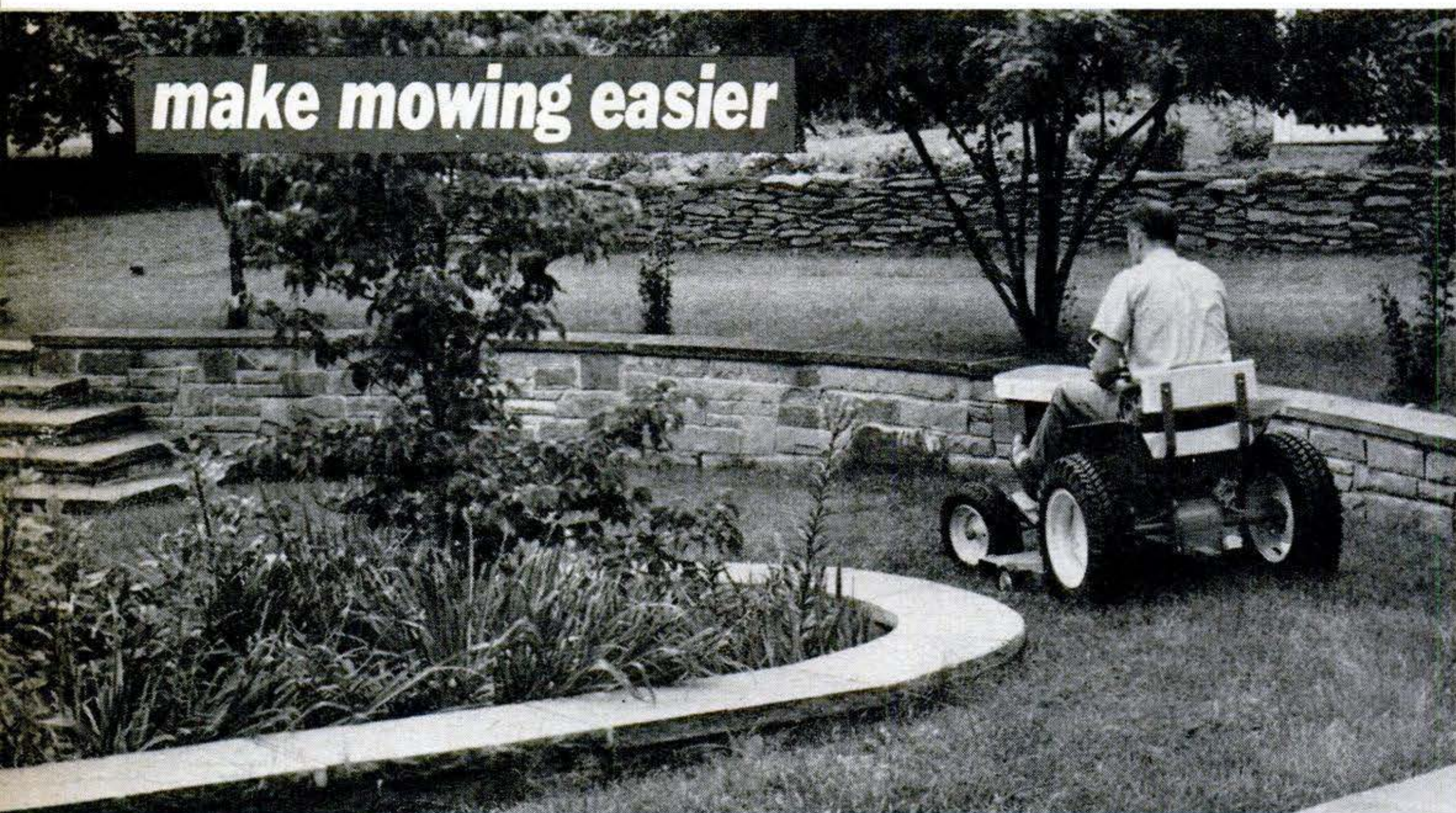

Grass or paved ramps will provide free movement of wheeled equipment from one level of

lawn to another. Circular grass ramp above connects two different lawn levels.

Thin metal curbing about 5" deep placed flush with ground will keep a sharp line between lawn and crushed-stone drive or walk. You can mow over it.

Ground covers are the solution on banks or other sites where it would be difficult or impossible to mow. Pachysandra and myrtle are good ones.

Around a tree, mowing will be easier if you use a ground cover or crushed stone bounded by a mowing strip. Low branches won't hit you.



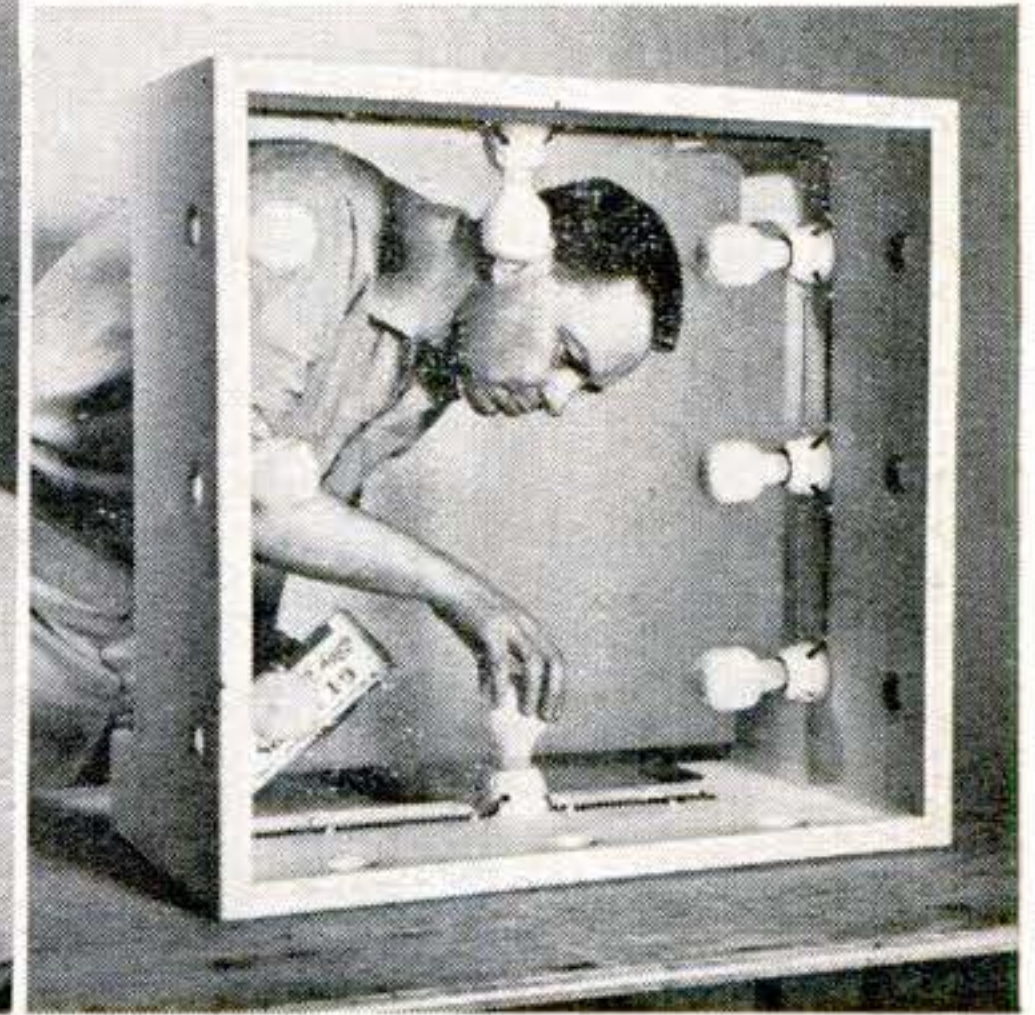

How to make a handy photo light box

This light box was designed to accept a 24"-square opal-glass top resting on cleats glued to $\frac{3}{4}$ "-plywood sides. Two pieces of clear glass with white acetate sandwiched

between can be subbed for the opal glass. The box stands 13½" high. It uses eight 100-watt bulbs with 2" vent holes above them. I use the box as an illuminated desk and shadowless background for closeups.—*John Burroughs, Tacoma, Wash.*

Restoring a worn or grooved oilstone

Deep wear or grooves make an oilstone almost useless, especially for resharpening wide chisels. Restore it to like-new condition by rubbing it on a cement floor or cement block, using sand as an abrasive.—*C. B. Kramer Sr., Kissimmee, Fla.*

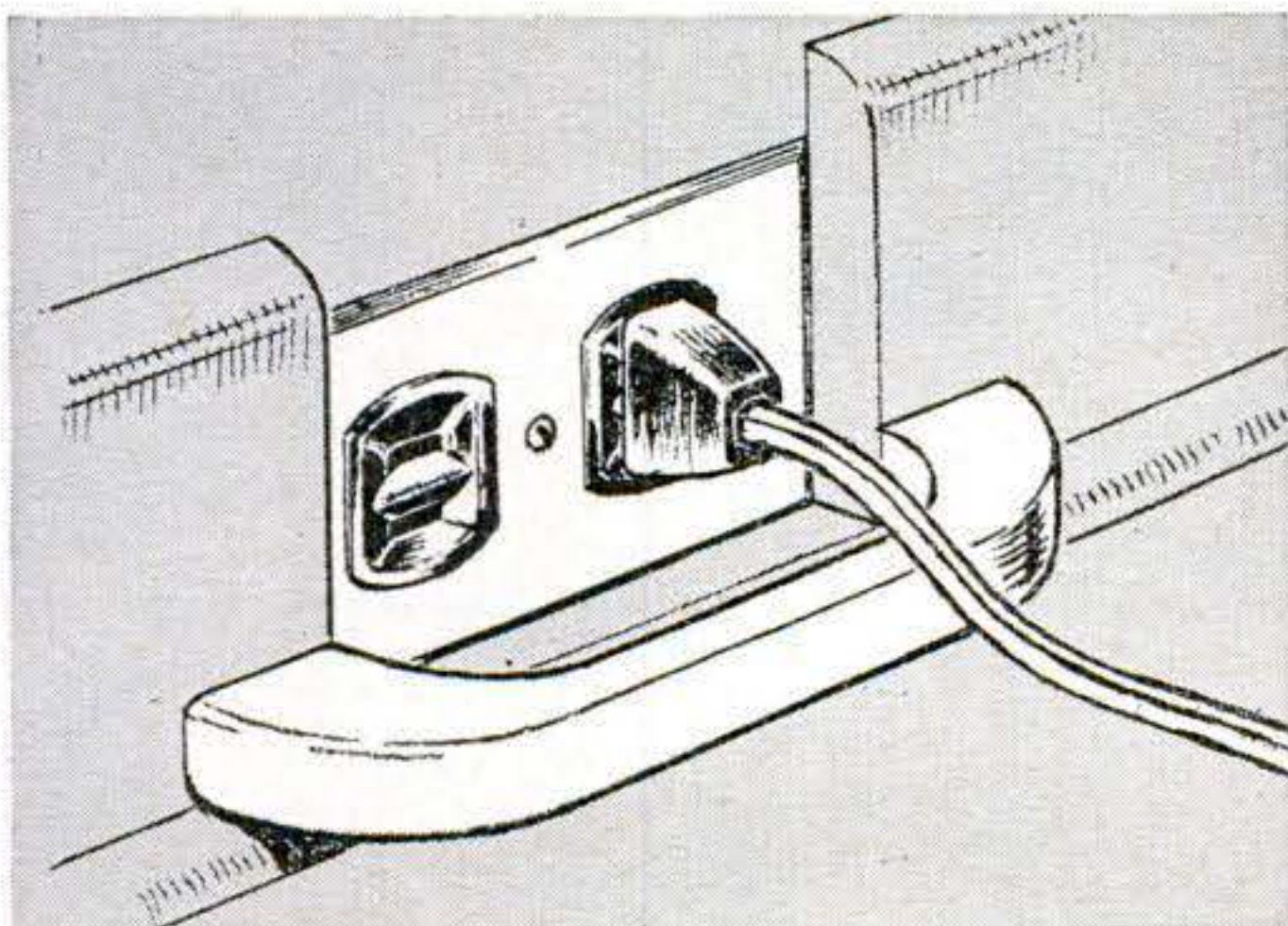
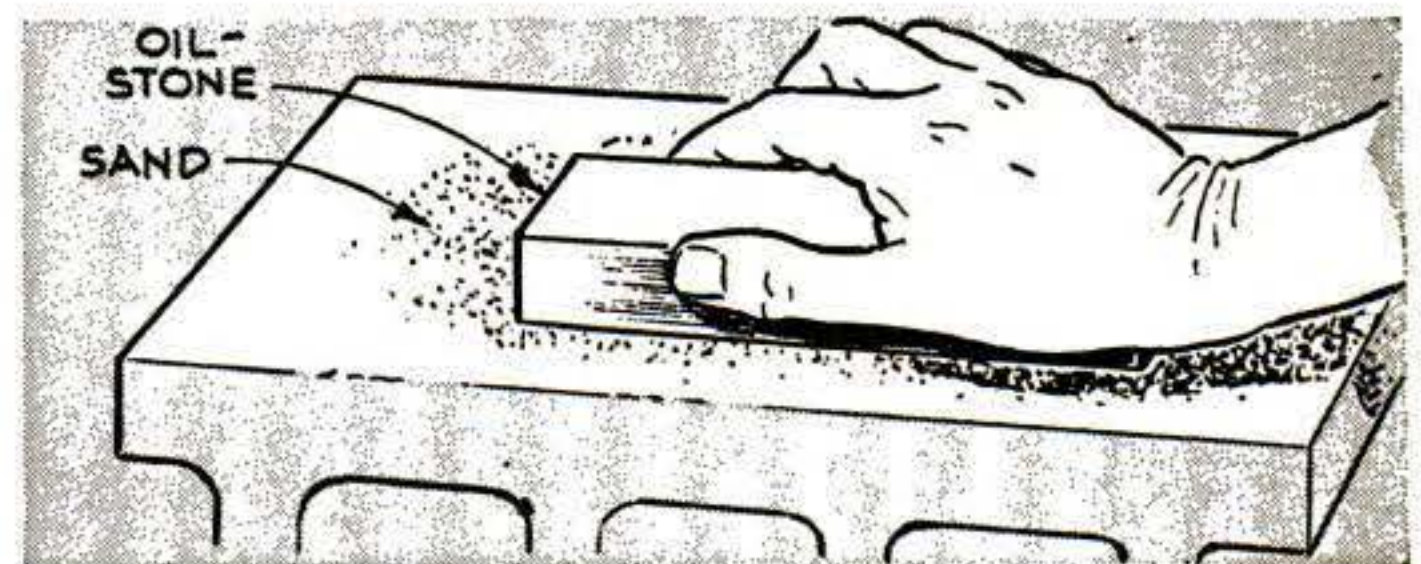

Handle shields baseboard outlet

To prevent furniture legs from knocking electrical plugs from a baseboard outlet, attach a metal drawer pull across the outlet to shield it, as shown. This will deflect a furniture leg as it slides past the outlet and prevent the plug from being loosened.—*A. Weber, Edmonton, Canada.*

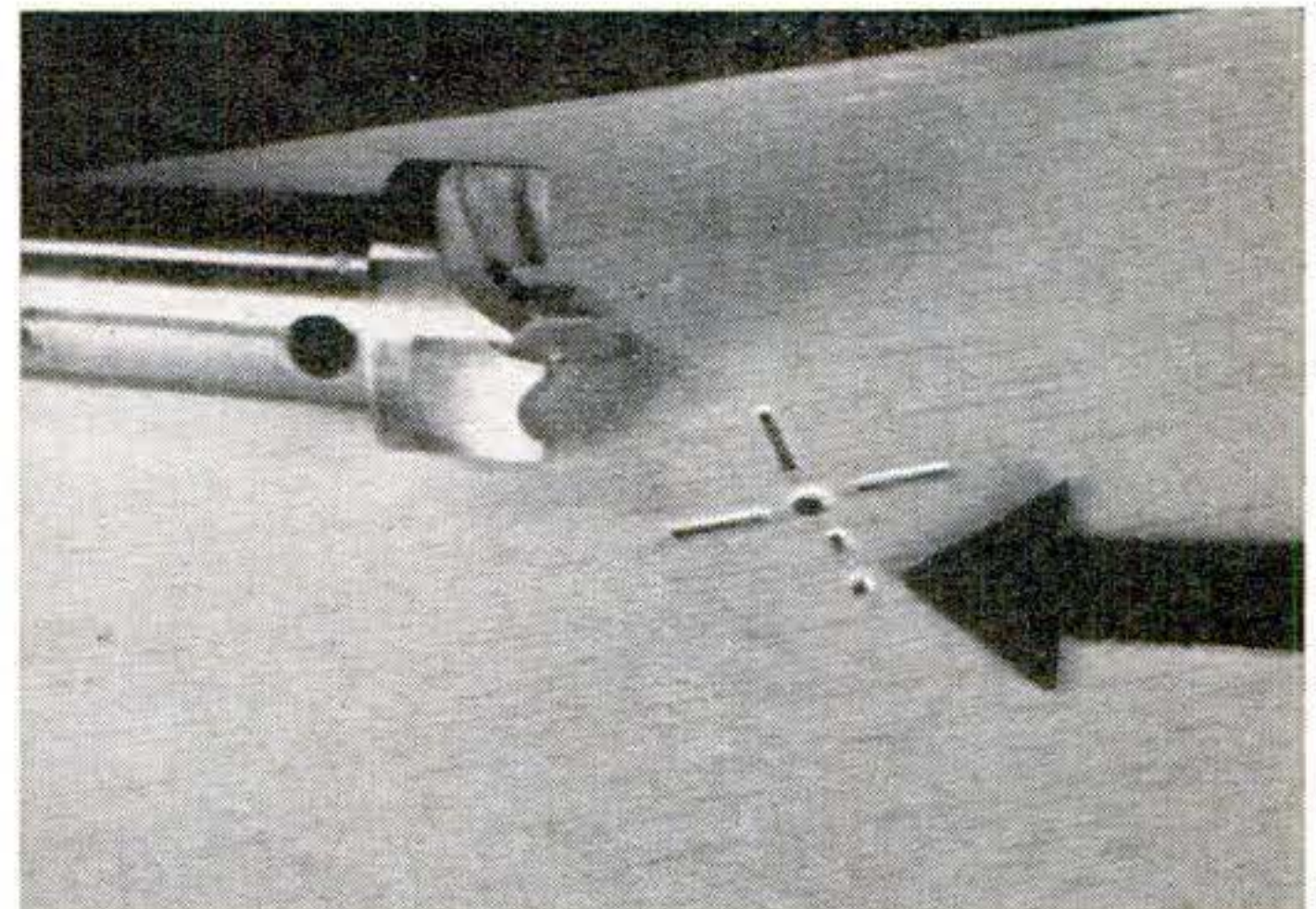

Modified spur center relocates work

In lathework, it is often necessary to replace stock that has been removed. The work should be returned to its original position. Modify the spur center to leave a mark in the end of the work, as shown, and it's easy to determine original position.—*R. J. De Cristoforo, Los Altos Hills, Calif.*

New Twists on Rotary Planers

Team one up with a drill press or radial-arm saw and it'll do a lot more jobs than you'd expect

By R. J. De Cristoforo

ADD an inexpensive little accessory to a drill press or radial-arm saw and you have a surprisingly versatile tool that will do many jobs normally calling for specialized tools. The accessory, a rotary planer, is the fast way to straighten a warped board or smooth rough, unsurfaced lumber.

But it will do a lot more, too. It will cut rabbets and tenons, shape decorative grooves and flutes, chamfer edges, and create raised-panel effects. For internal cuts, it becomes a giant router bit, quickly scooping out large recesses. As a thickness planer, it will give you precisely dimensioned stock of any size you need.

You'll pay about \$5 to \$12 for a rotary planer, depending on the type you choose. Some are designed only for drill-press use, others only for radial-saw use. At least two can be mounted in either a drill press or a radial saw and are a good choice if you plan to use a planer in both tools. The number of cutting bits used in the planers varies from one to three. In general, single-bit planers work best at somewhat higher speeds—but all types cut smoothly.

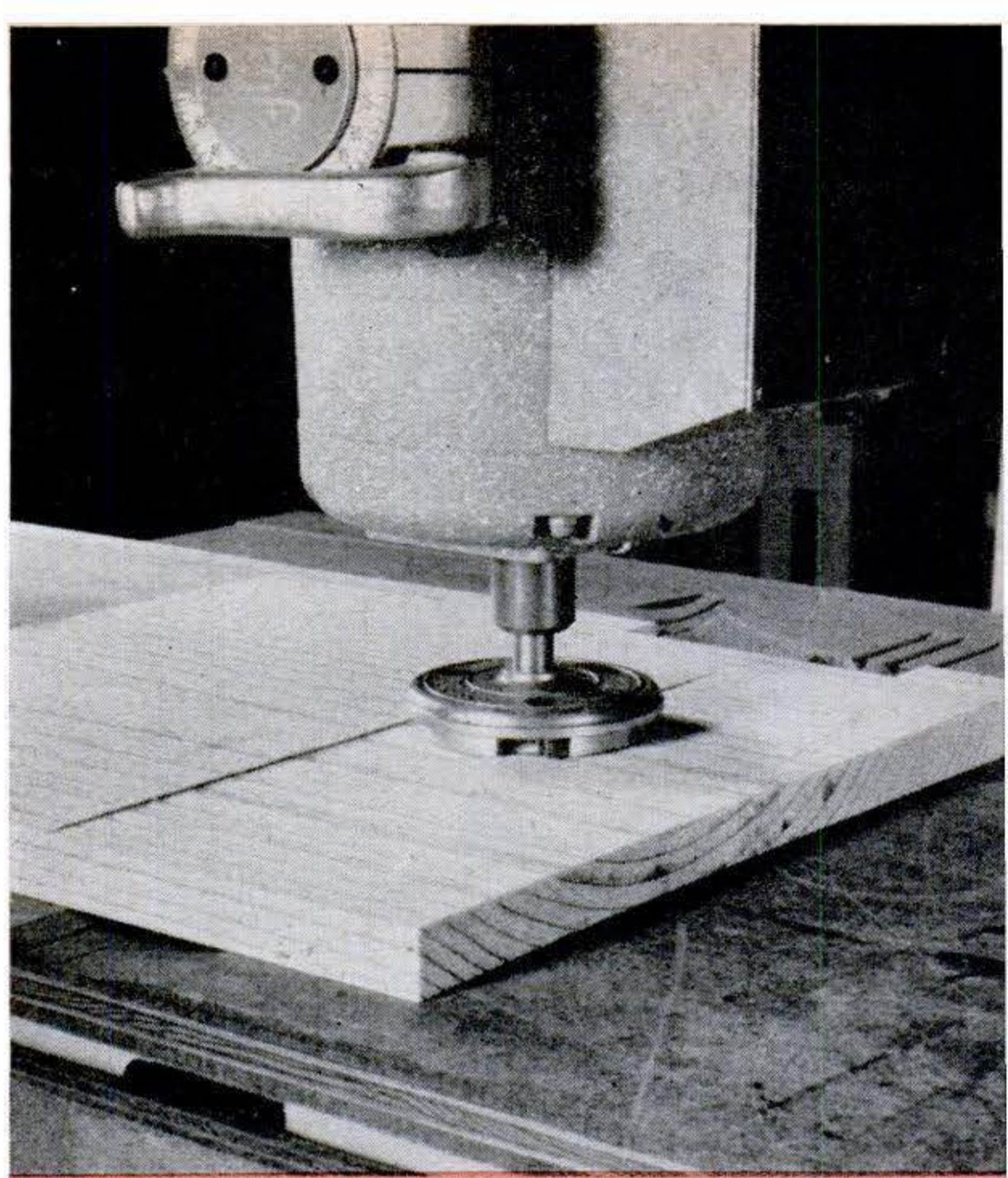

On a radial-arm saw, the work remains stationary while you move the saw head back and forth over it. Here, planing both sides until they are flat straightens a warped board.

On a drill press, you move the work back and forth while the planer remains fixed. Here, a recess is cut by lowering the planer into the work and making progressively deeper passes.

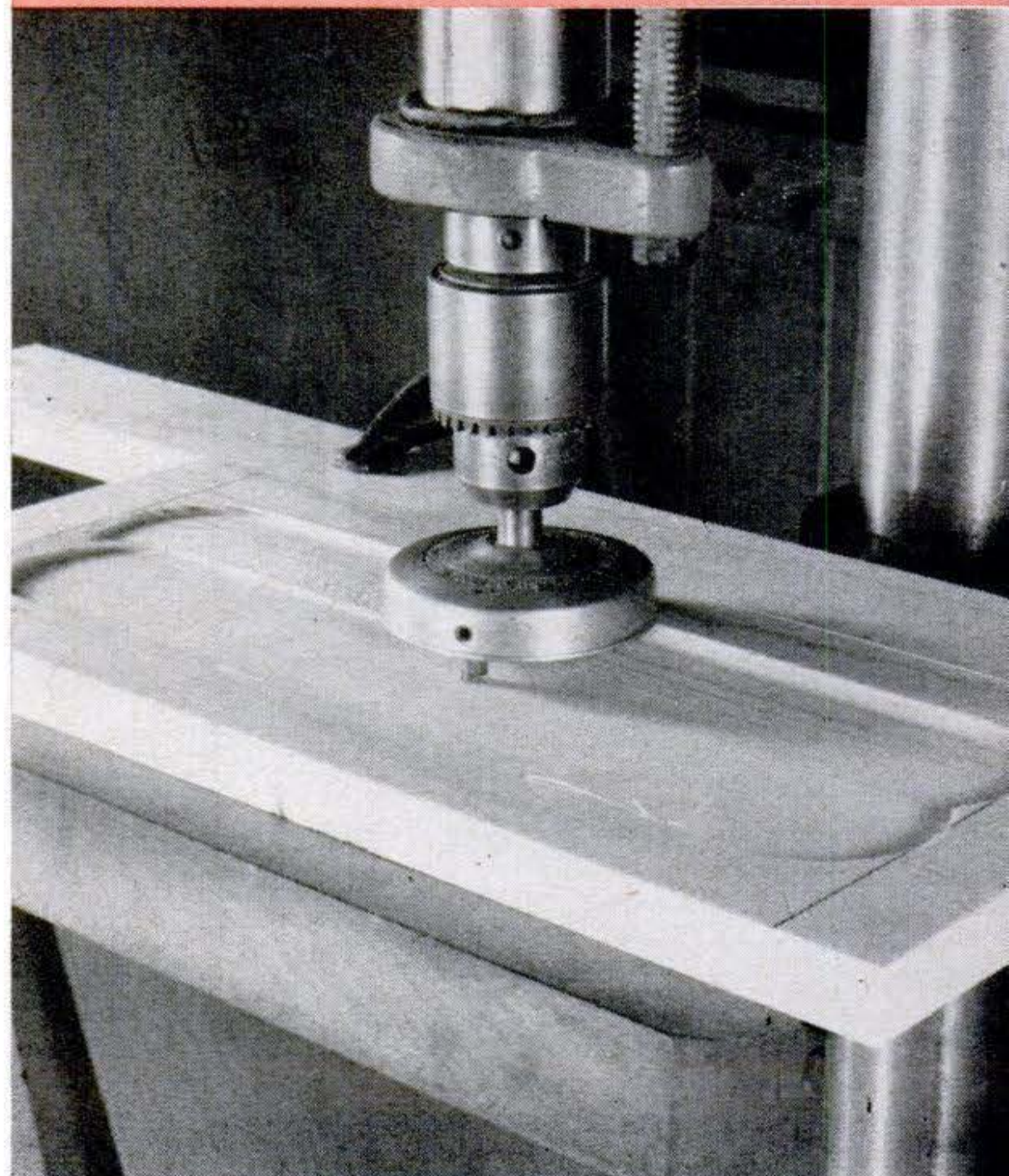

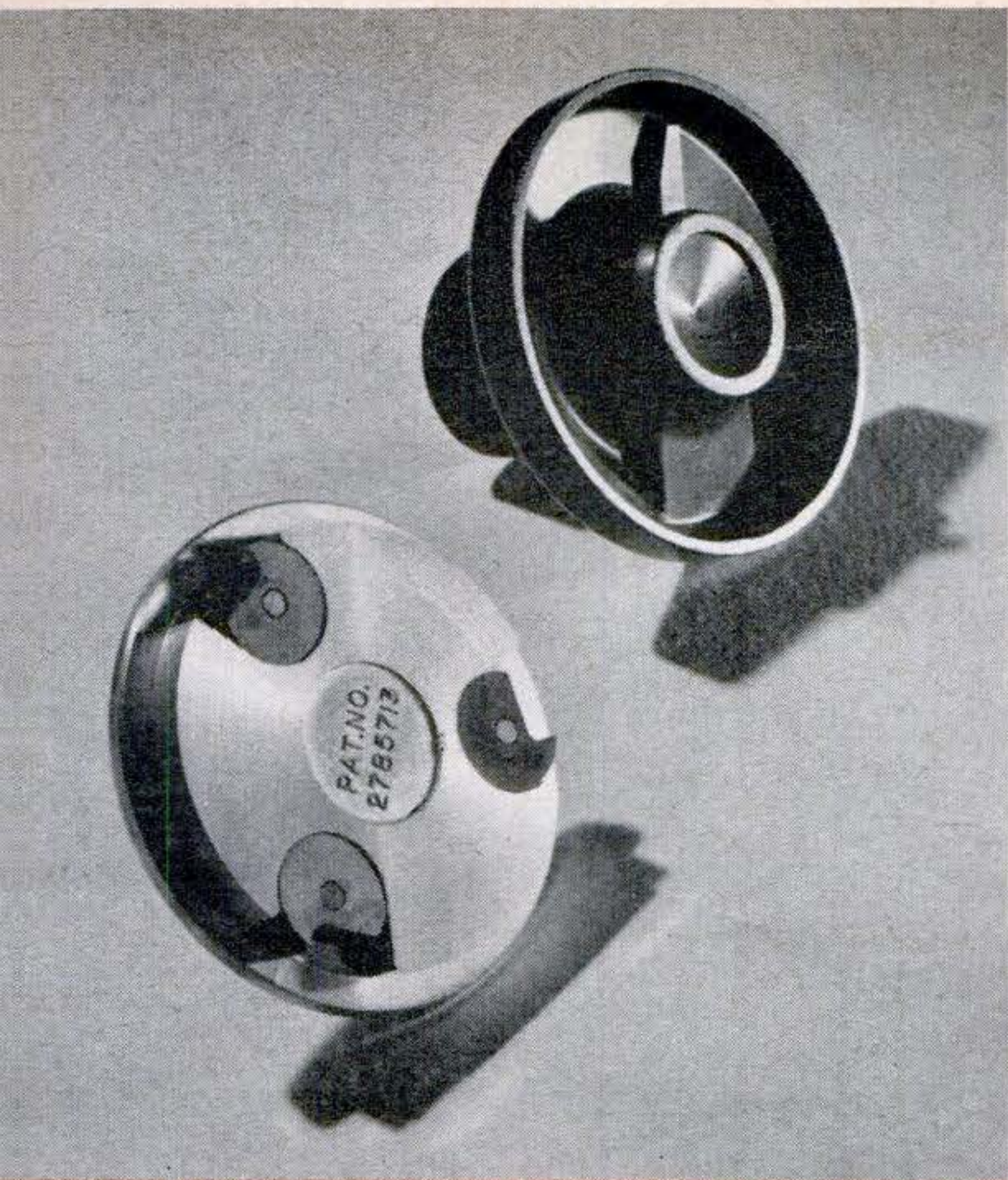

Types of planers: Wagner Safe-T-Planer (above, left) has three cutting bits recessed into the edge. Sears Craftsman (right) has a single bit. Both types cut smoothly.

When using a fence, feed the work (straight arrow) so planer's rotation (curved arrow) forces it snugly against the fence. Without a fence, direction of feed makes no difference.

You can even joint edges with a planer. But don't try it on thin stock that's hard to hold vertical. A two-by-four can be handled safely with a clamped board for a guide like this.

A tapered tenon, a tough job on most tools, is easy this way. The work is held at an angle in a notched board that rides the fence. Work and board are moved together to make the cut.

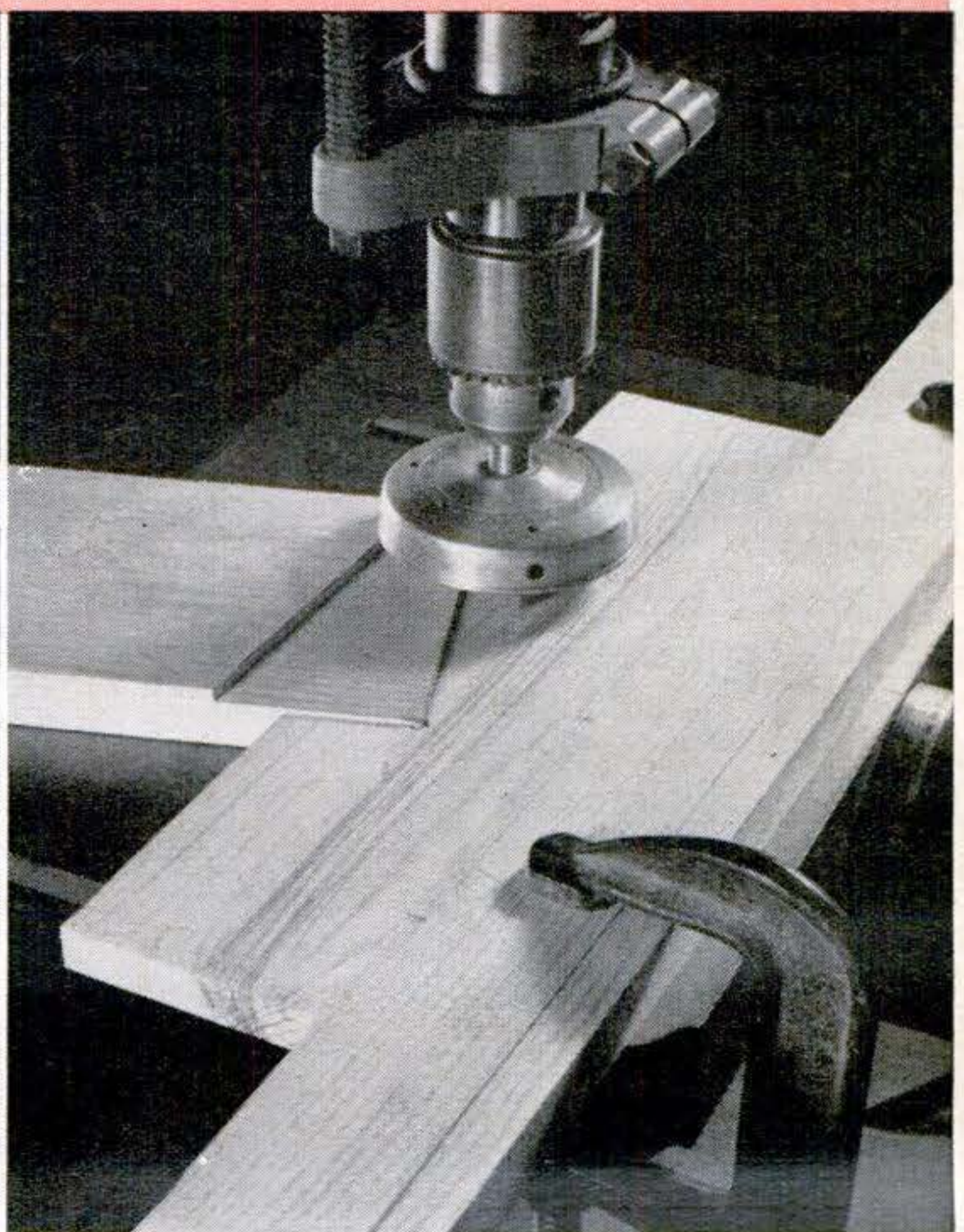
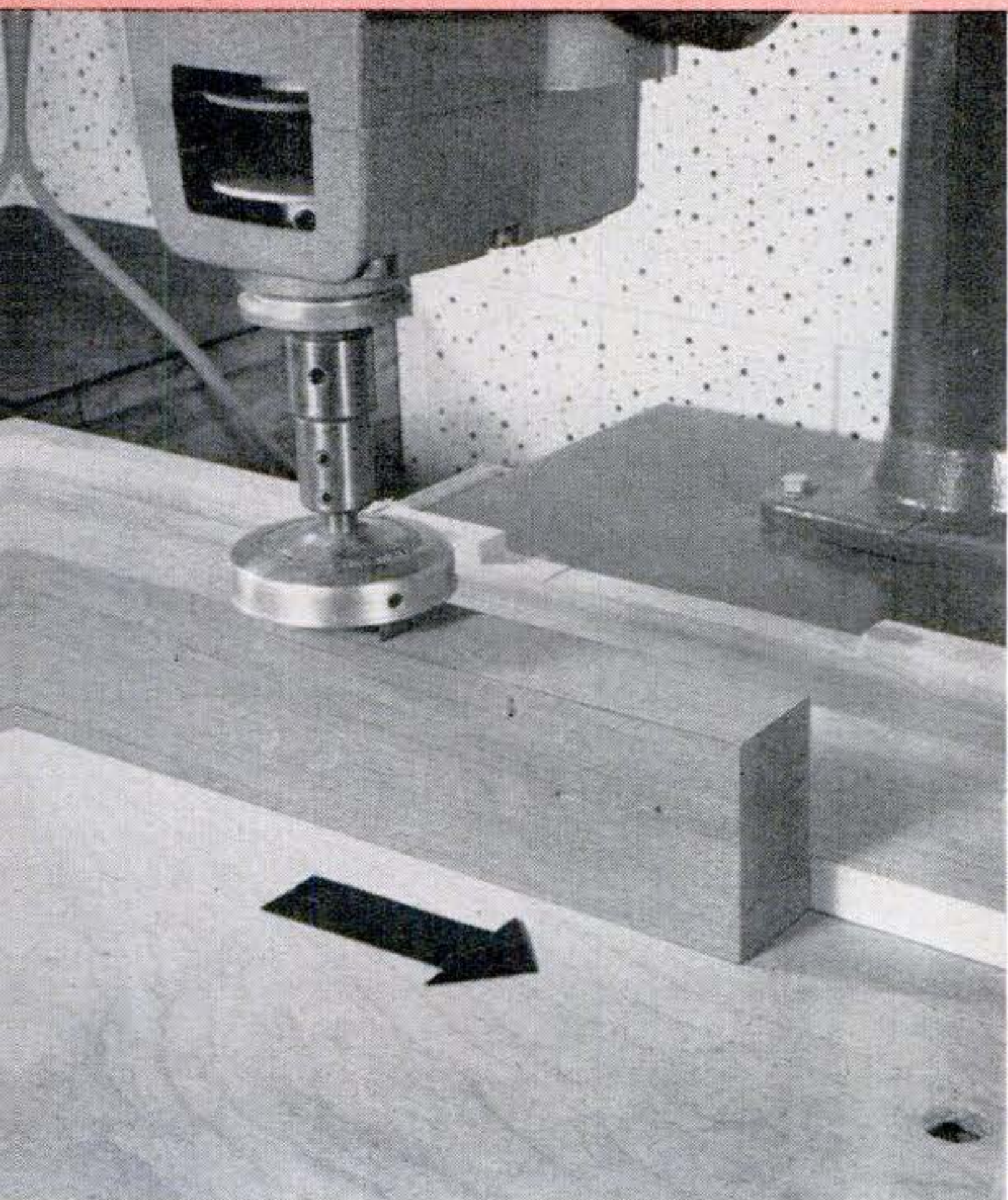

Since these accessories develop some side thrust like router bits, it's wise to use a chuck equipped with a safety collar or a special adapter. Best operating speed is about 5,000 r.p.m. (top speed for the average drill press), but satisfactory work can be done as low as 3,000 r.p.m. If you must work at the lower speeds, compensate by using a slower feed. This will let the cutters pass over the wood more times, for a smoother cut.

Planing can be done freehand, but you'll find that a fence helps, especially on extra-wide boards where you must make multiple, parallel passes. A fence is a must for rabbeting or tenoning.

Rotary planers are smooth-cutting tools, but nevertheless it's good practice to cut *with the grain* whenever possible. You might make an exception when removing a lot of material. In this case, you can make heavy, roughing cuts across the grain and then end up with a 1/64" or 1/32" finish cut made slowly and with the grain.

The problem with thickness planing or surfacing is to maintain the parallelism of opposite sides. Obviously, if the drill-press or saw table is not parallel with the cutting plane of the tool, the work will not be of uniform thickness. Be sure the machine is set up correctly.

When removing a lot of material, plane alternate surfaces of the board until the required thickness is reached. Removing all material from one surface will usually result in warpage. If the board is warped to begin with, use light cuts to remove the bow from the convex side, and flip the stock over to remove the high points from the concave side.

On extreme distortion, it's a good idea to use a belt sander first to create a reasonably flat surface that can rest on the machine table. Lacking this, you can tack-nail thin blocks under one or more corners to establish four contact points with the machine table. Plane the upper surface until it is smooth; then flip the board and plane the other side smooth.

Depth-of-cut should never be extreme. The tools work so fast it's no trouble to

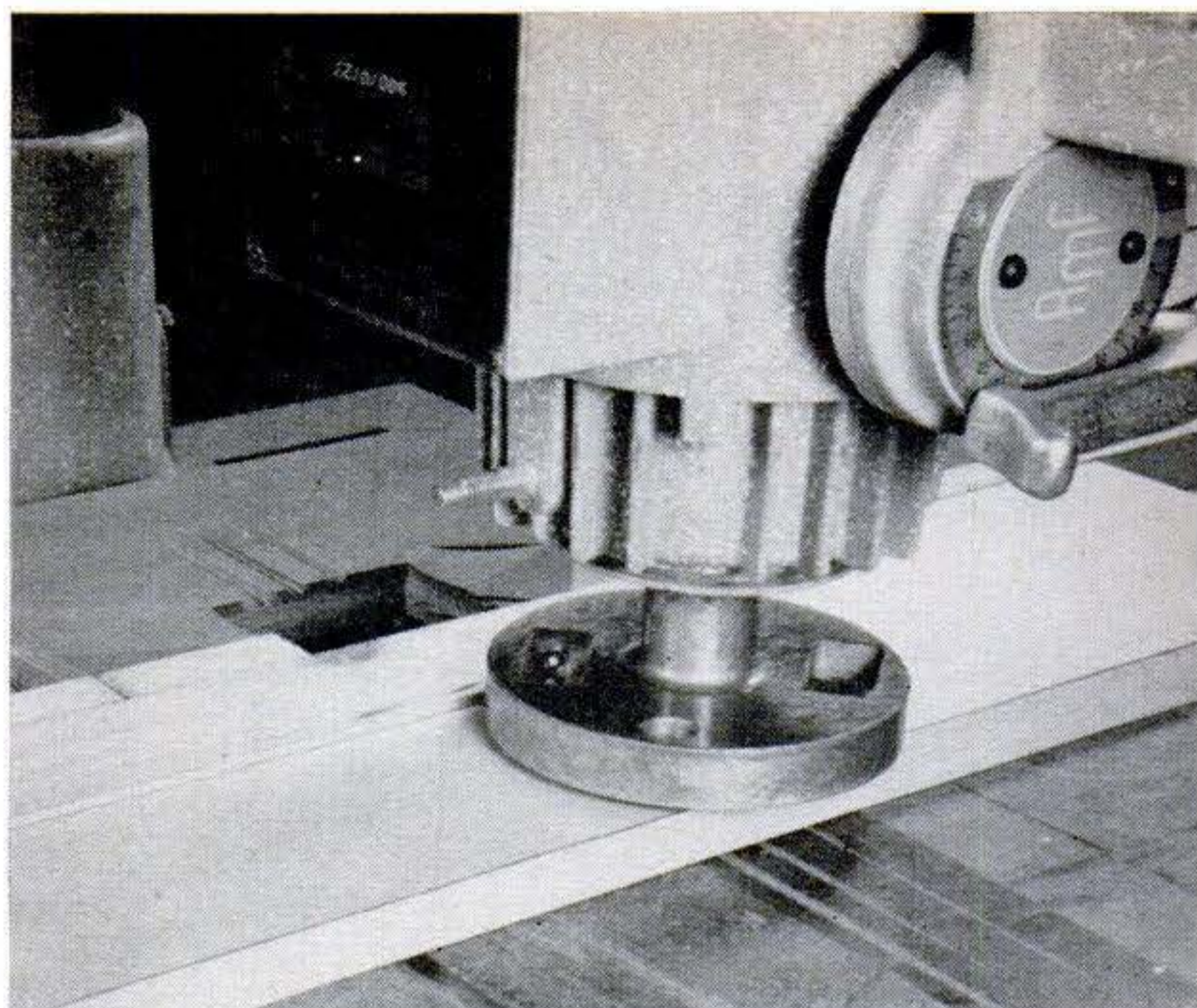

Planing cuts should be shallow—usually not more than 1/8" at a time. This DeWalt planer threads directly onto the motor shaft of DeWalt radial saws, gives a smooth, uniform cut.

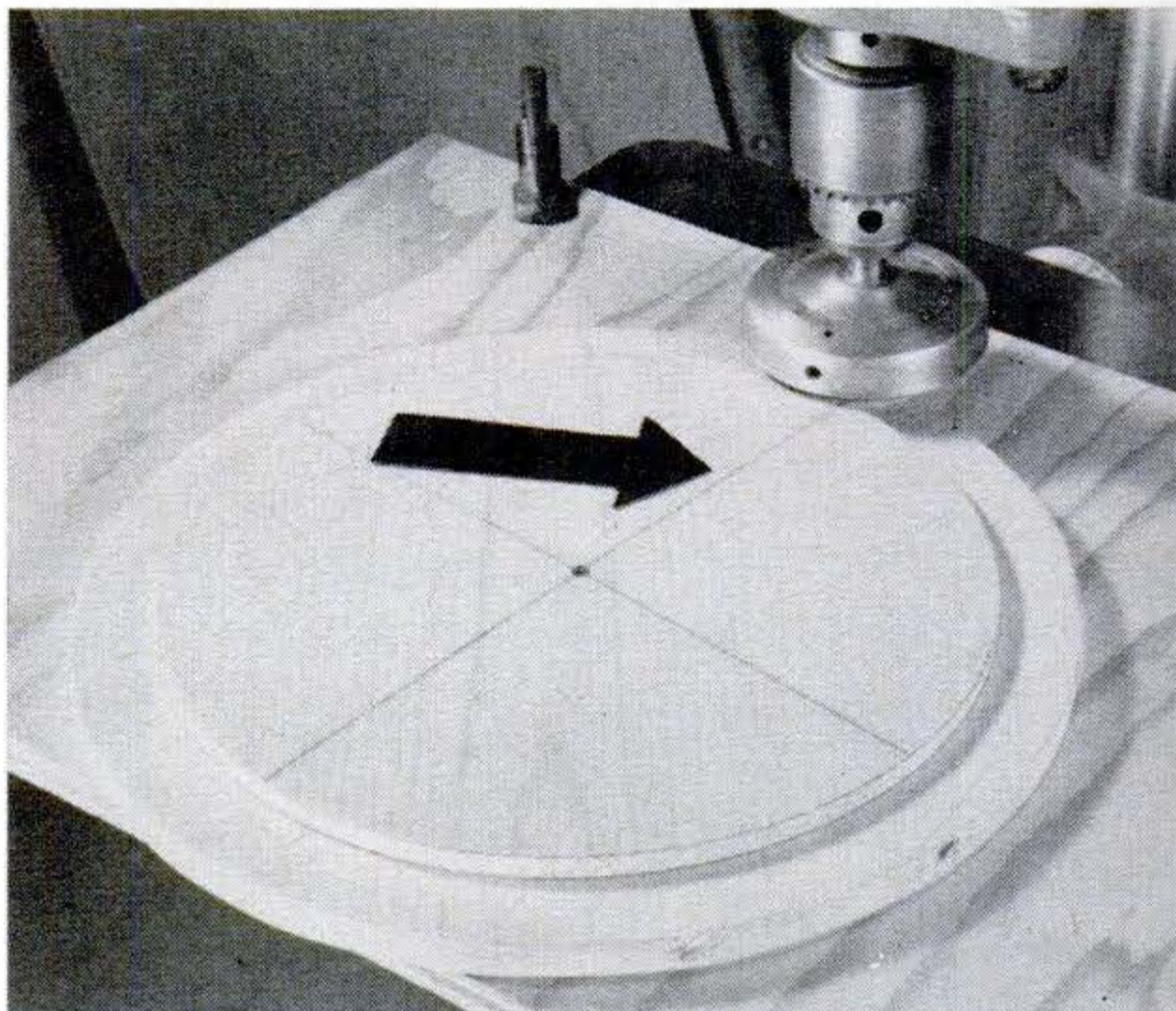

Circular rabbets or bevels are made by pivoting the work on a centered nail driven into a clamped board. Rotate the work (arrow) *against* the cutter's direction of rotation.

reach your desired depth by making several repeat passes. Softwoods permit deeper cuts than hardwoods, but on either, a moderate to slow rate of feed is always best. It's extremely important to keep the work

.....

Who makes rotary planers:

BARRON: Barron Tool Co., 417 Brainard St., Detroit; DEWALT: DeWalt, Inc., 3046 Fountain Ave., Lancaster, Pa.; SEARS CRAFTSMAN: Sears, Roebuck & Co., 925 S. Homan Ave., Chicago; WAGNER: Gilmore Pattern Works, 1164 N. Utica St., Tulsa, Okla.

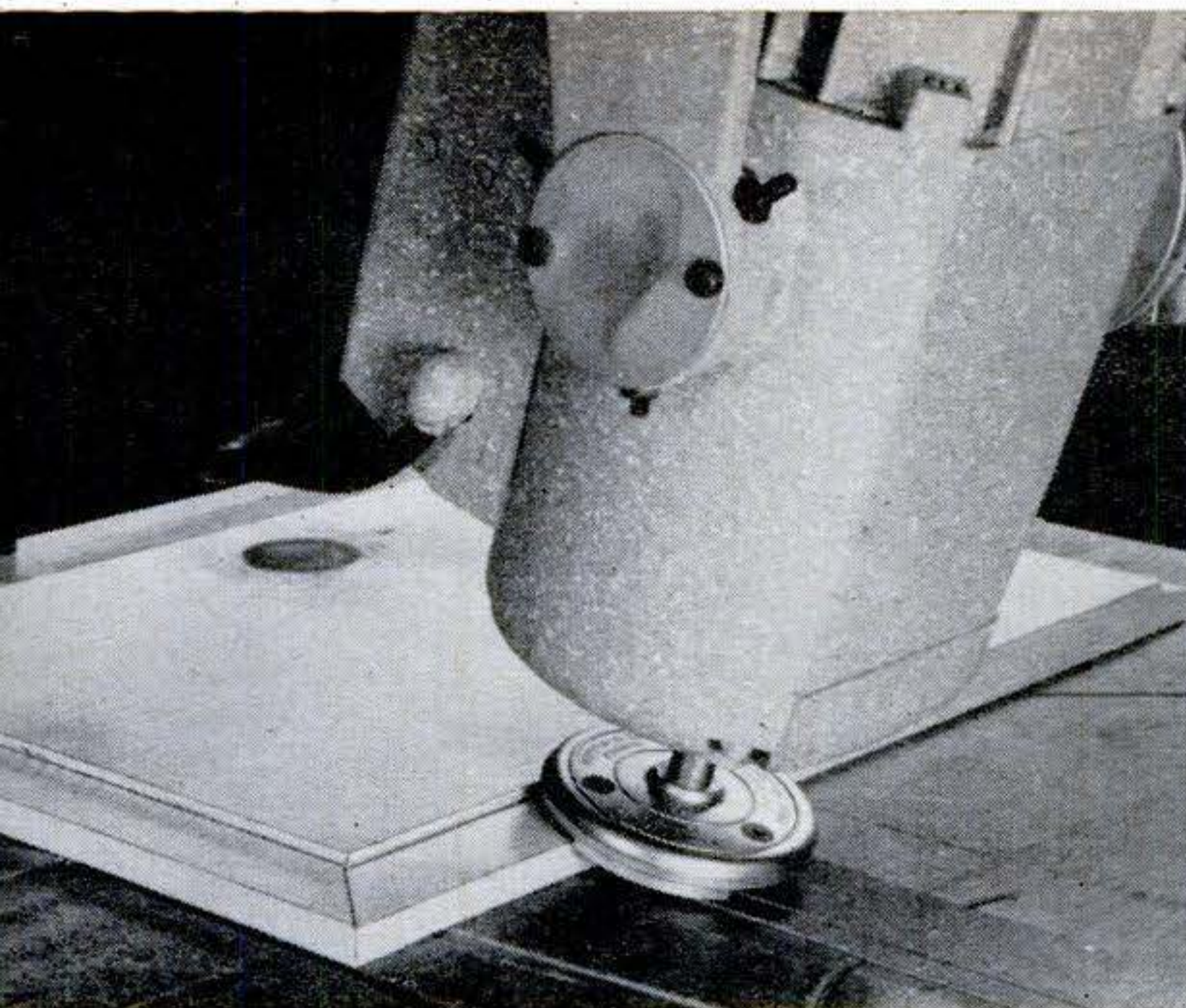

To "raise" a panel, just tilt the planer about 10 degrees. The shoulder will have a slight bevel that you can leave as is or square off by making another pass with planer horizontal.

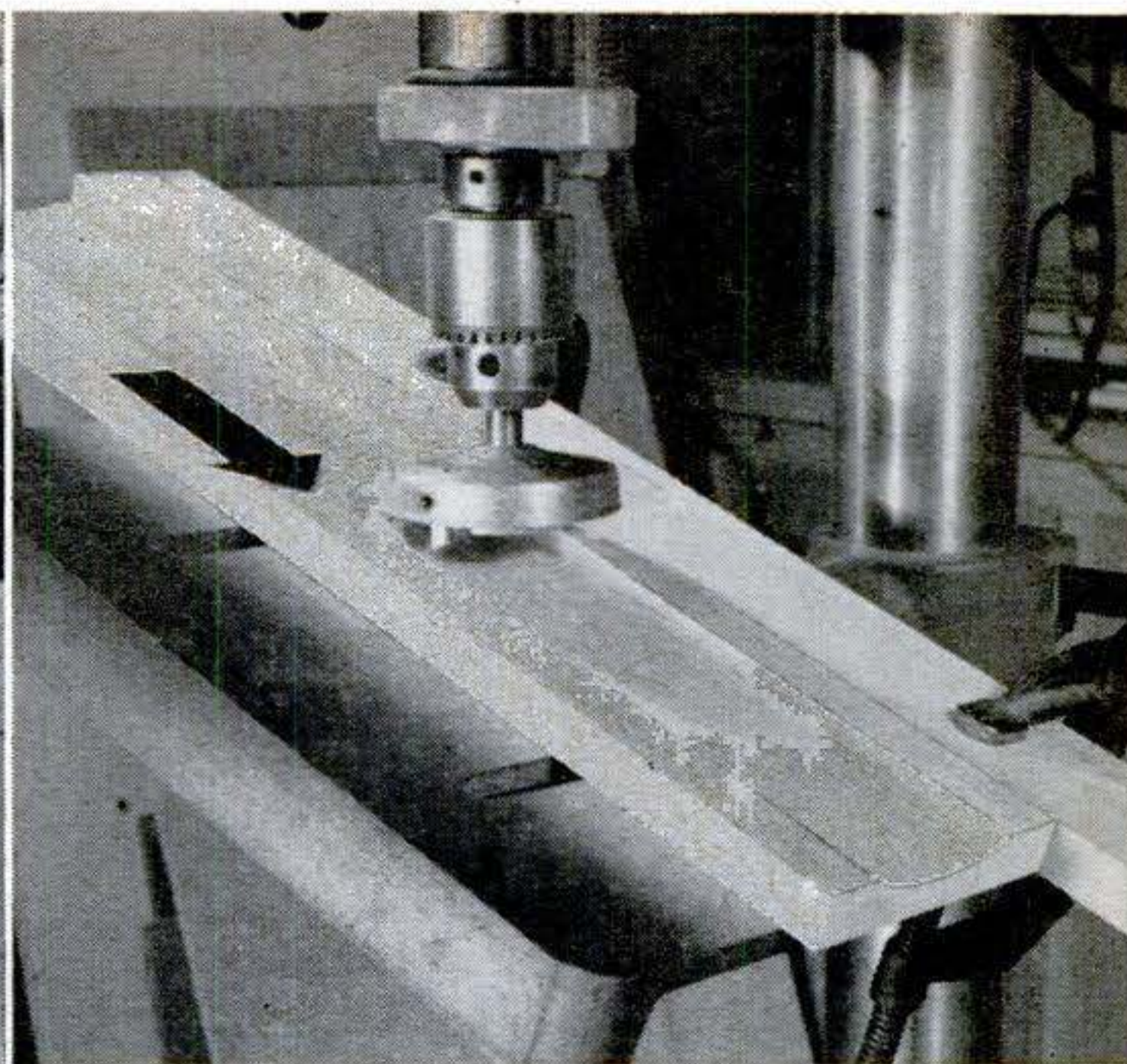

To cut a cove, feed the work into the cutter at an angle. Tilt the table on a drill press, the cutter on a saw. This Barron planer can be fitted with extra-long bits for deep cuts.

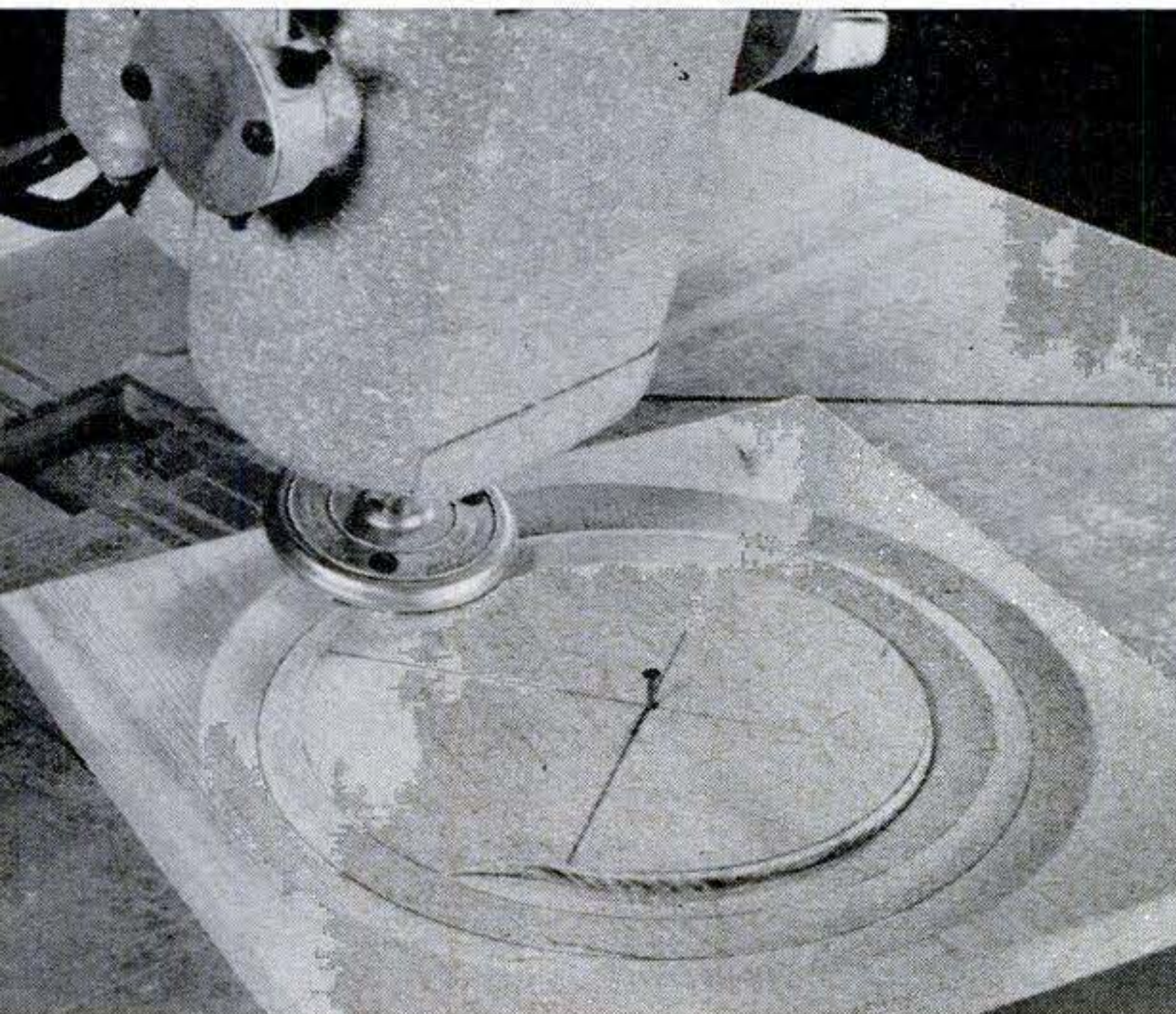

Another pivot trick: Make concentric cuts with the planer tipped one way, then the other, and out comes a decoratively grooved plaque. Shift the pivot point to vary the radius of cut.

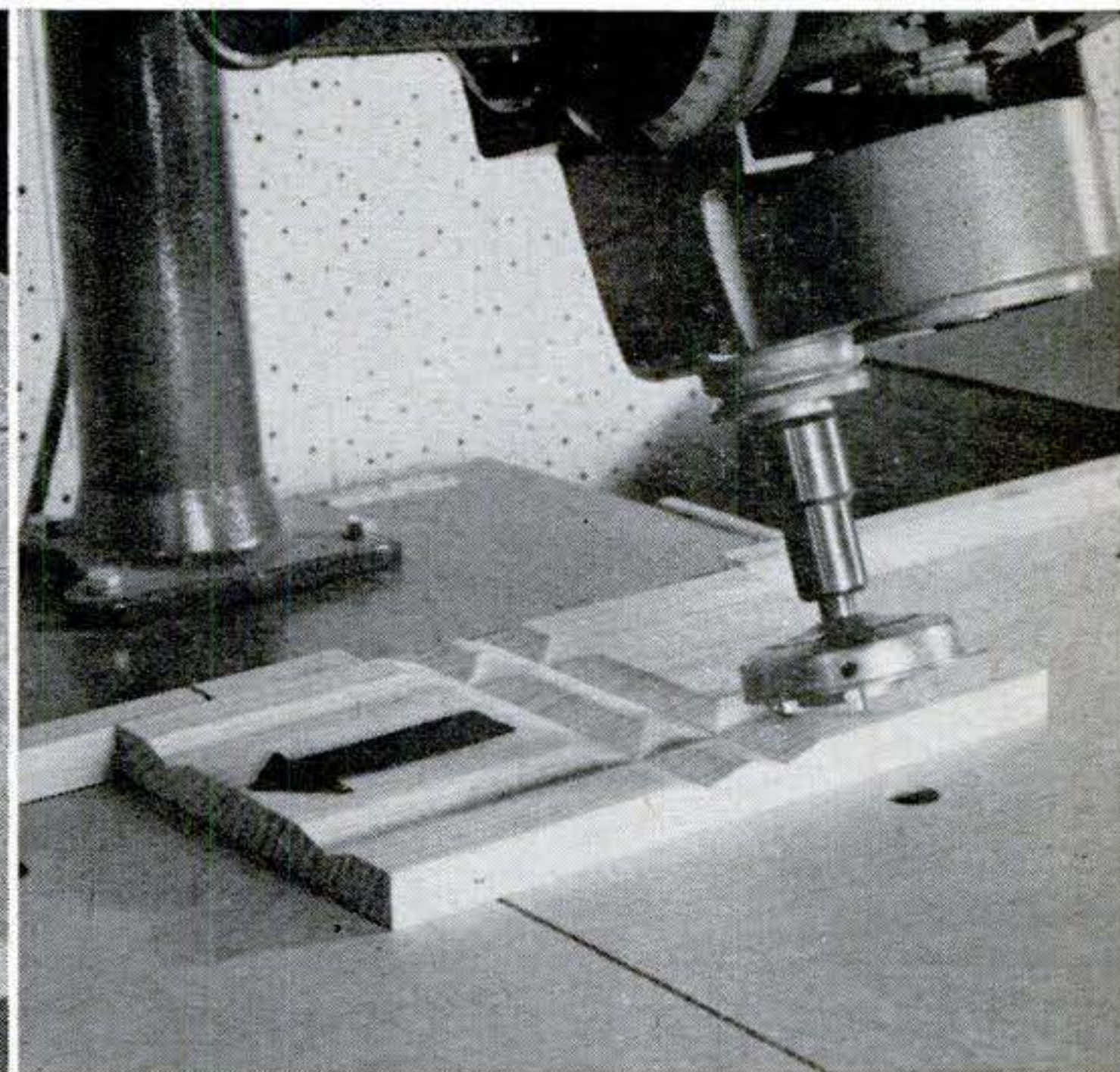

Crisscross cuts with planer tipped produce fancy facets like this. Note that direction of feed (arrow) depends on which way cutter is tilted. Always feed *against* cutter's rotation.

flat on the table. If you lift it at all, the tool will dig in and spoil the job.

The actual cutting circle is smaller than the outer rim of the tool, so rotary planers are as safe as they can be on operations such as planing and rabbeting, where the cutting plane is parallel to the work. But be especially careful when a planer is tilted upward for cuts like edge-beveling. The cutters move fast and you can't see them—so keep your hands well away from the tool. ■ ■

Facts about rotary planers

MAKE	NO. OF CUTTERS	USE ON	SPEED RANGE (r.p.m.)	PRICE
BARRON	3	drill press, radial saw	3,000-5,000	\$ 7.50
DeWALT	2	radial saw	machine speed	\$11.50
SEARS CRAFTSMAN	1	drill press	5,000-9,000	\$ 4.98
	3	radial saw	machine speed	\$ 6.98
WAGNER	3	drill press, radial saw	3,000-5,000	\$11.75



How good a skipper are you? Could you have avoided the two recent marine accidents described here? They're the first of a series of actual reports you'll find in *Popular Science* from time to time in future months

THEY went out at noon in a 16-foot boat with a 75-hp. outboard and anchored 100 yards upstream from the point where California's Russian River meets the breakers of the Pacific. The owner of the boat and a man and wife fished for three hours.

The men started the motor, and as it warmed up they began lifting the anchor. The rope fouled on the propeller and killed the motor. The boat began to drift toward the ocean. Recent rains had swollen the river so that a sand bar at the river's mouth was broken through and a strong current swept seaward at low tide.

The men lifted the propeller shaft and tried to disentangle the rope. Swept by the current, the boat slammed into a breaker and was almost washed onto the beach. But backwash from the wave carried the boat out to sea. The sea was rough, and the next wave turned the boat over. The couple was last seen drifting out to sea. The other man held onto the boat and was rescued by a helicopter. What caused this tragedy?

Here's what:

It is not clear whether the boat was anchored from the bow or the stern. Anchoring from the stern is seldom advis-

What Did They Do Wrong?

Some boating accidents are hard to figure. But there's usually an answer: Somebody goofed

By James M. Liston

THE sleek, 26-foot cruiser moved slowly up Big Allison Creek northeast of Charlotte, N. C. The water was calm. There was a full moon.

Suddenly, a bluish flame burst like a giant skyrocket above the four passengers and flames raced from stem to stern. The four jumped and swam away from the boat before the gas tanks exploded. The yacht ran aground in shallows near the base of a steel tower supporting six high-tension lines. Other boaters picked up the swimmers, but the cruiser was a complete loss. What happened? What did they do wrong?

Here's what:

The power lines that stretch 300 feet across Allison Creek sag to within 15 feet of the water. Although the yacht measured

about 10 feet from waterline to top of cabin, a radio antenna protruded about five feet above the cabin. When the antenna touched the high-tension lines, 44,000 volts surged through the boat. The passengers escaped electrocution because the boat was made of fiberglass and plywood.

The operator couldn't be criticized for carelessness or recklessness because he was proceeding slowly and in compliance with rules of the road. But in U. S. Coast Guard statistics this will probably be included under "Vessels involved by operator's fault of accident." The fault: "no proper lookout."

While it seems to be asking a lot to expect the boatman to keep a sharp eye on traffic and also to note a sagging power line in the moonlight, the fact remains that he lost his boat because of a protruding antenna. If he was unfamiliar with the area, he could hardly be blamed for not keeping a sharp watch for power lines. The moral seems to be that close observation of potential hazards during the day—even in familiar waters—pays off when these hazards are hidden by darkness or dusk.

able because it involves the risk of fouling the line on the propeller. If the cruiser was bow-anchored, the bow might have swung downstream when the anchor was raised. Stern-swing could have brought the prop over the trailing line and resulted in fouling. *Both* men attempted to raise the anchor. One of them should have remained at the controls, holding the boat against the current until the anchor was out of the water and stowed.



Jim Roe Tests OMC's New Show Boats

By Jim Roe

PHOTOS BY JOE MUNROE

Take a look at these two boats speeding through the tide rip under the rain-and-fog-shrouded Golden Gate Bridge. Then take a look—on the following pages—at the two show boats on display at San Francisco's Sports and Boat Show. They're the same two boats!

I TOOK out a pair of OMC's newest boats for rugged, bad-weather runs through the Golden Gate straits just two days before they were due—boat-show fresh—at the Cow Palace in San Francisco. These additions to the OMC six-model family

are the Dual Deluxe and the Seasport, both 17-footers like all their sisters.

At San Rafael, Calif., I helped unload the truck that brought the boats from the OMC plant at Waukegan, Ill. Thick winter ice had prevented my testing them at Waukegan, so

CONTINUED





Trailing the OMC is a breeze with the custom trailer



Special OMC trailer has hull supports at just right places. Boat can be launched and recovered even at shallow-water ramps. No need for wet feet: We *drove* it off and back on trailer.



Stable as a floating dock: Passenger transfer in choppy Gate straits was unexciting. Both Sea-sport (left) and Dual Deluxe (right) rode the chop comfortably. Note that even with everyone near the gunwales, neither boat shows slightest tendency to tip. Comforting feeling!

Aim it, and the OMC goes there. Cross waves, swells, chop, wakes don't faze it. At top speed it skitters over choppy water like a skipping stone with never a wallow or pound. Jumping a tug's wake, boat came down, kept going in straight line. Acceleration is like a hot-rod.

I had journeyed out to California to try them both, and to take in the Cow Palace show. The boats I tested were among the first of the '63 models to reach the West Coast.

Since POPULAR SCIENCE first reported on the OMC boats ["Dreamboat for Everybody," Feb. '62], many owner reports have come in praising the stability of the hull. This design offers the speed characteristics of a three-point hydroplane, with twin sponsons to smooth the ride.

Boatmen—and their ladies—have liked the idea of a boat that comes ready to go, with no lengthy fitting-out process needed. An OMC boat comes with so many interesting knobs to turn and buttons to push that you spend the first day just pushing one after the other, then looking around to see what happened.

Within hours after the boats were off the transcontinental truck, I had them going full speed in San Francisco Bay. I ran them through the outgoing tide, through drifting debris, past a curious seal, and right on through the beginnings of what the papers described as "a gale-propelled senior storm"—polite language for high winds and rain that broke an epic drought.

Despite the rough and fast-flowing water beneath the hulls, I had ample opportunity to put each new boat through all its paces. In summary, these four conclusions became apparent:

1. The boats are extremely stable. Running through chop, wakes, and fast turns, the OMC won't tip or tilt. It takes all these different conditions in stride—quite a feat for a 17-foot boat. This stability, combined with molded-in permanent flotation, makes the boats safe.

2. They're fun. They have a sports-car feel, the ability to take years off the mental attitude of even a middle-aged driver.

CONTINUED



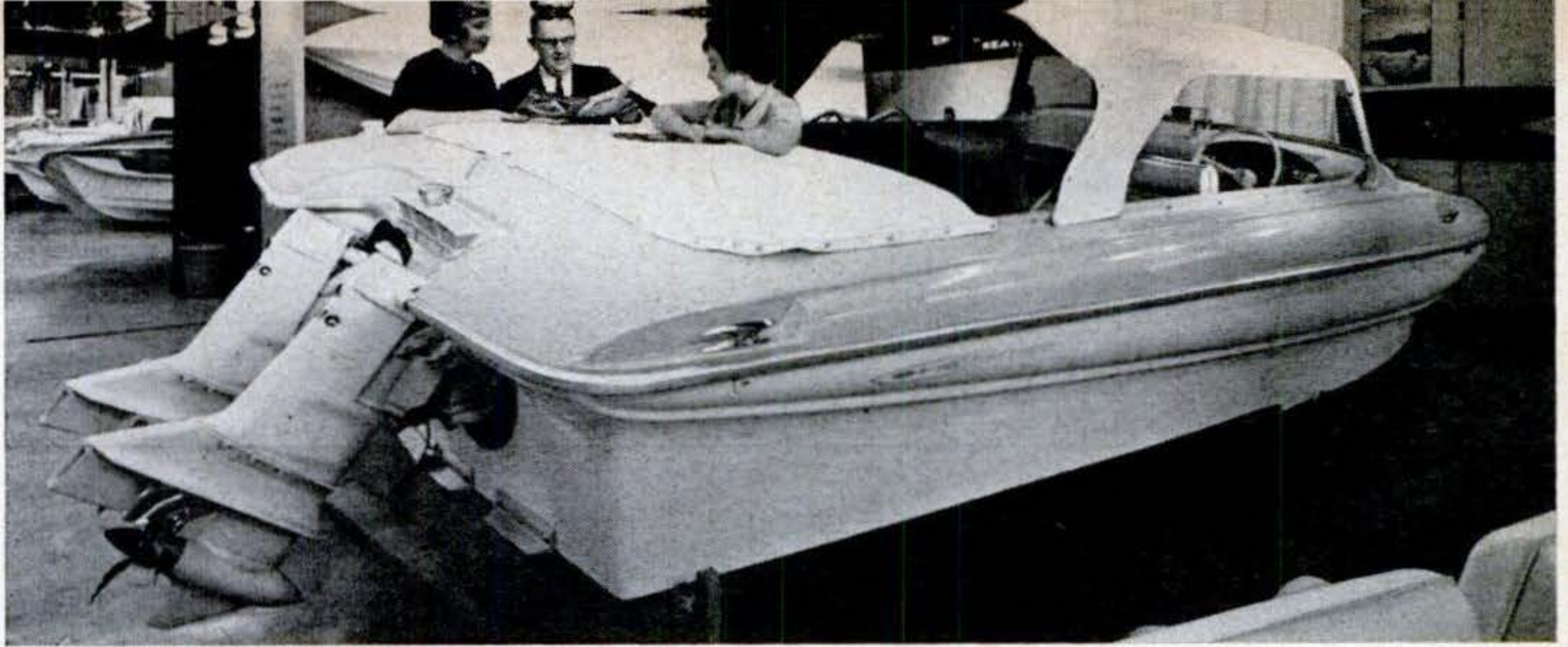

Test boats shine at San Francisco Cow Palace show

OMC Dual Deluxe—dry and shiny—is all set for show visitors. My wife and daughter Patti (above) join me in a dry-land study of boat's

built-in features. Note sleek, pleasing hull configuration. The folding cockpit top and aft cover give rainy-day comfort. Cost: \$4,250.

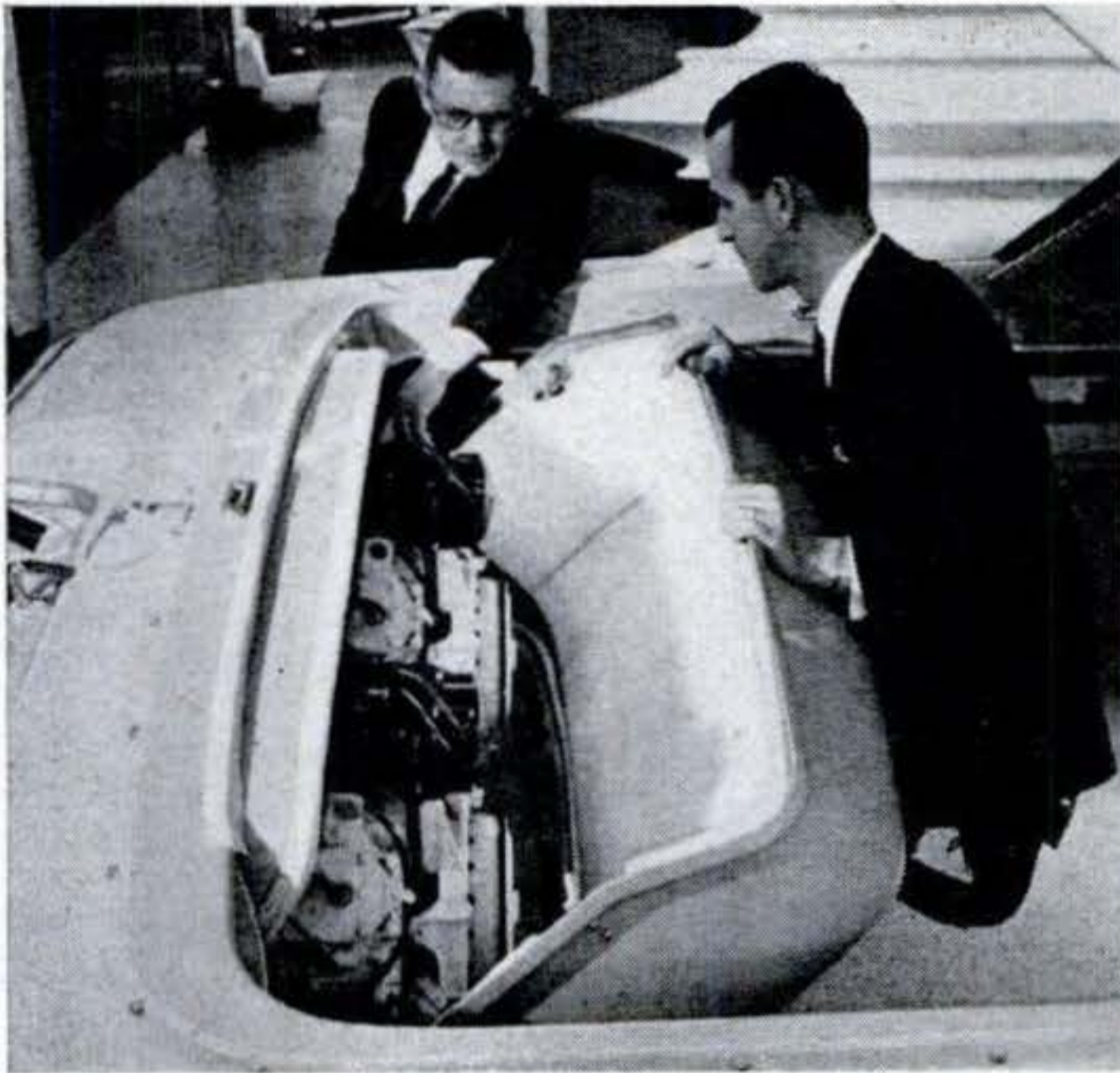

OMC 488 stern drives mount under fiberglass housing, held by OMC's Clyde Kilian. Engines have die-cast aluminum block, alternator-generator. Gas tanks are built in. Oil feeds into engine from its own tank: no fuel mixing.

Secret of the ride: At planing speed, three-point hull rides on two wide-spaced bow sections and stern. Full-length stabilizing keels near center

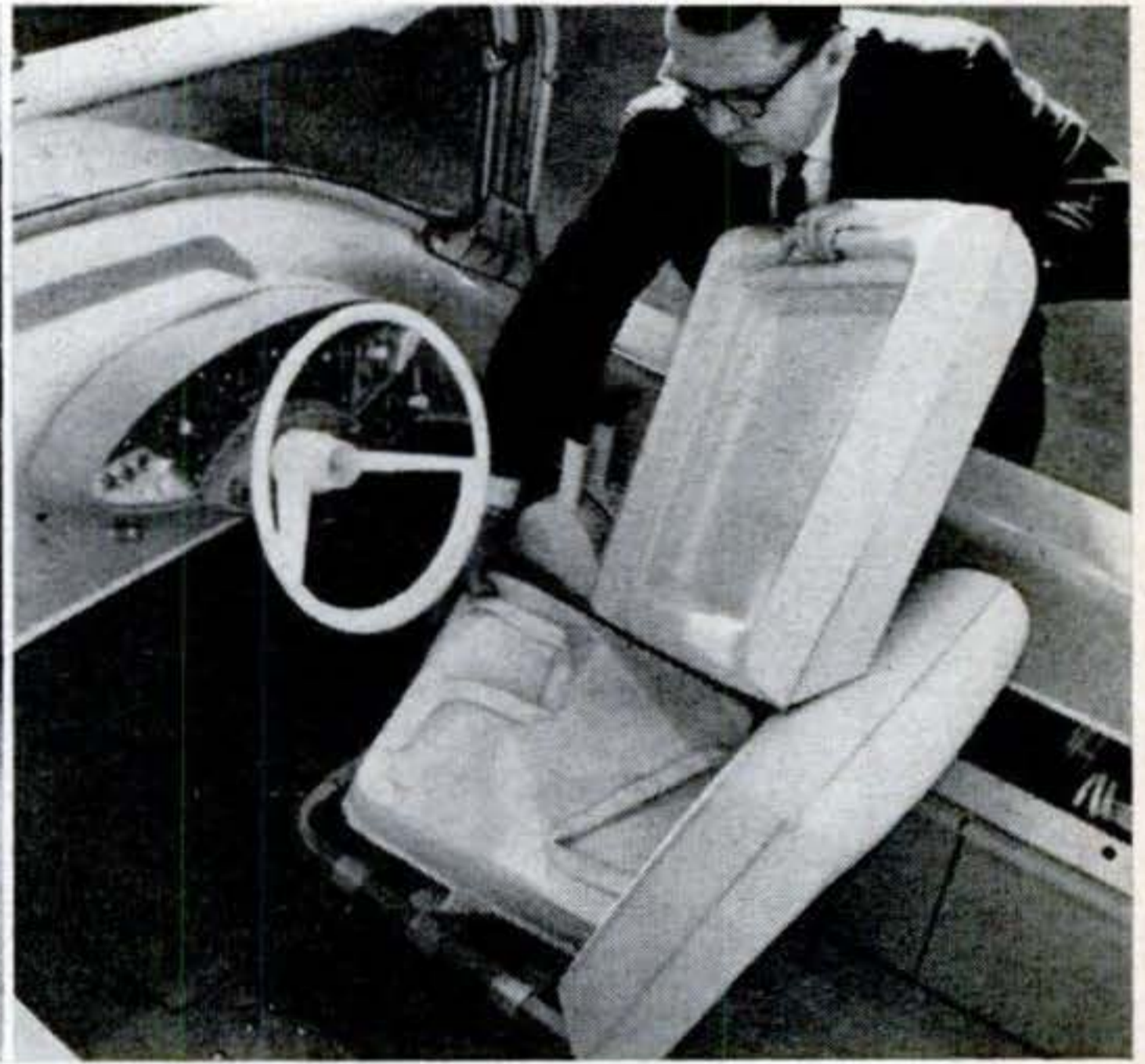

The bridge: Safety seats have buoyant cushion built in. Hydraulic shock-absorber seats are available. Dash is complete, with all necessary instruments installed at the factory. Windshield opens at the touch of a button.

prevent skids on fast turns. Construction is reinforced fiberglass. Hull has built-in flotation, will not absorb water even if holed.

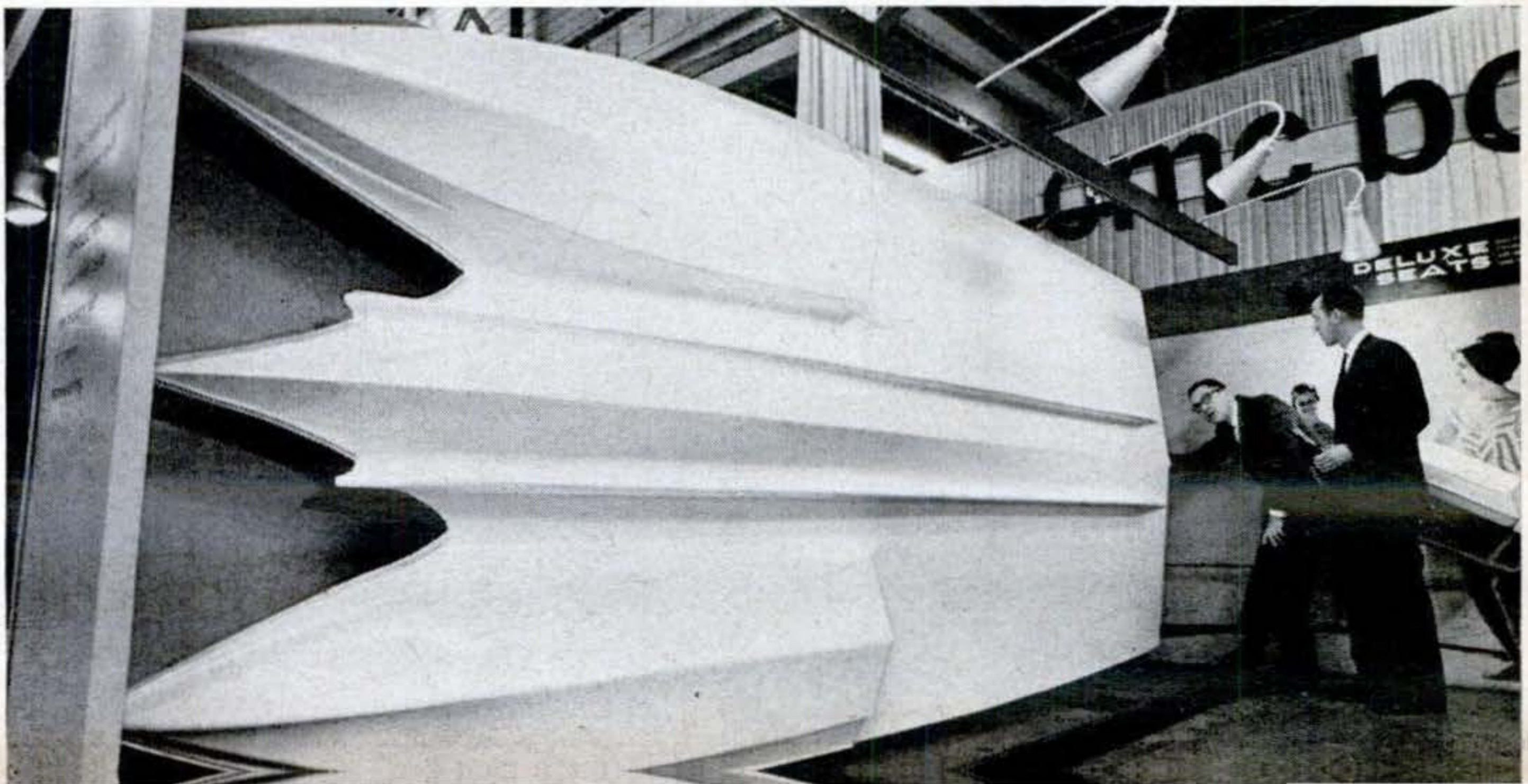

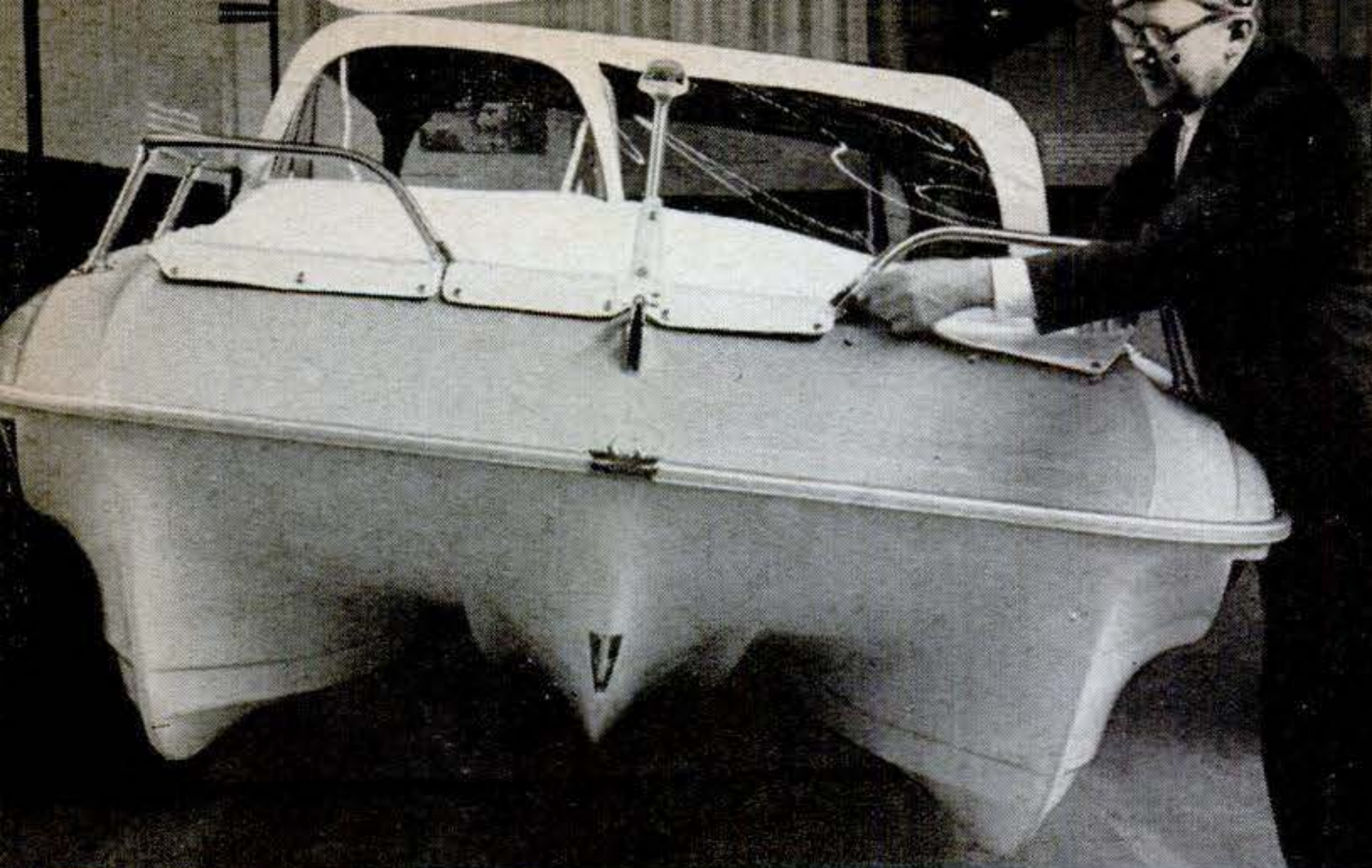

Seasport is all-weather boat for speed, camping, fishing

Normally an open boat, the Seasport buttons up for foul weather with canvas covers fore and aft. There's also a special camping top that gives full headroom from bow to stern, makes boat a

floating 17-foot tent—with no stakes to drive. Fold-out bait-cutting board is handy for fishermen. Seasport does better than 30 m.p.h. with its single engine, trolls nicely. Cost: \$2,995.

They respond quickly, control with precision. They're big enough to allow you to have the gang along, yet small enough to handle easily, do things at the drop of a hat.

3. They're ready to go. I've outfitted a number of boats. And while outfitting is interesting and sometimes fun, it is also time-consuming and often plain hard work. We took these two new OMC boats off the truck, put them in the water, and took off. Everything we needed was there.

4. They have whole-family appeal. I had a unique opportunity to check this. In spite of the weather, my wife and our 19-year-old daughter Patti accompanied me for all the tests. Later, our 18-year-old son Jim came up from Stanford and he and OMC's West Coast representative, Clyde Kilian, did another test all their own. So I now can assure you that these boats appeal to young people, and to their parents as well. They're boats that you'll want to see for yourself. ■ ■



Newest member of the family: an outboard

New outboard version of the OMC hull is designed to take the largest outboards made; has many of the features of inboard models, including basic instrumentation; has same three-point hull, with same seaworthy ride. Powered by a 75-hp. Johnson, with two aboard, as here, she will hit about 30 m.p.h. Outboard comes complete with built-in 24-gallon fuel tank, stainless-steel-cable steering, self-bailing well, lights, storage bins, shock-absorbing seats. \$1,950 f.o.b. Waukegan, Ill.

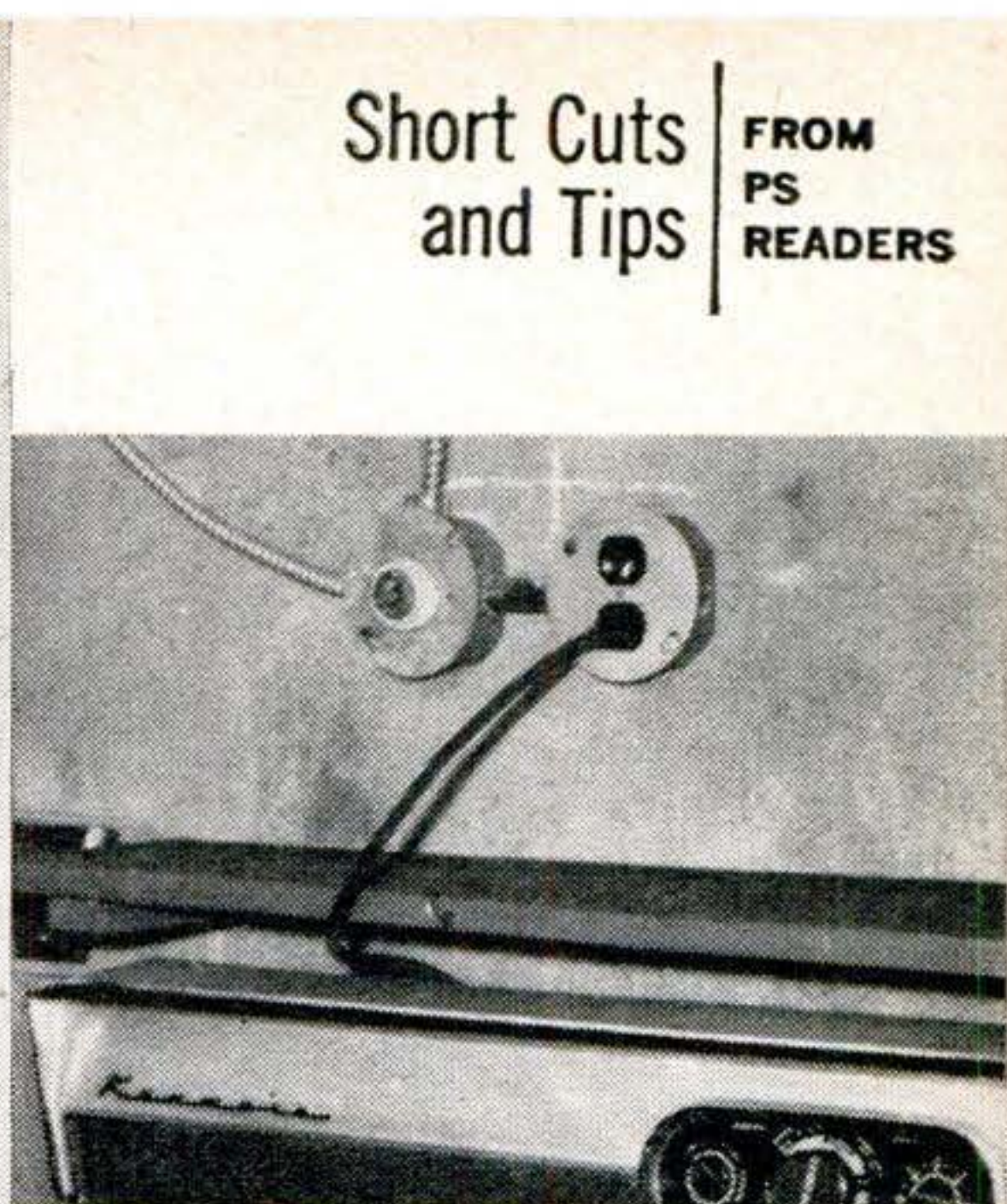
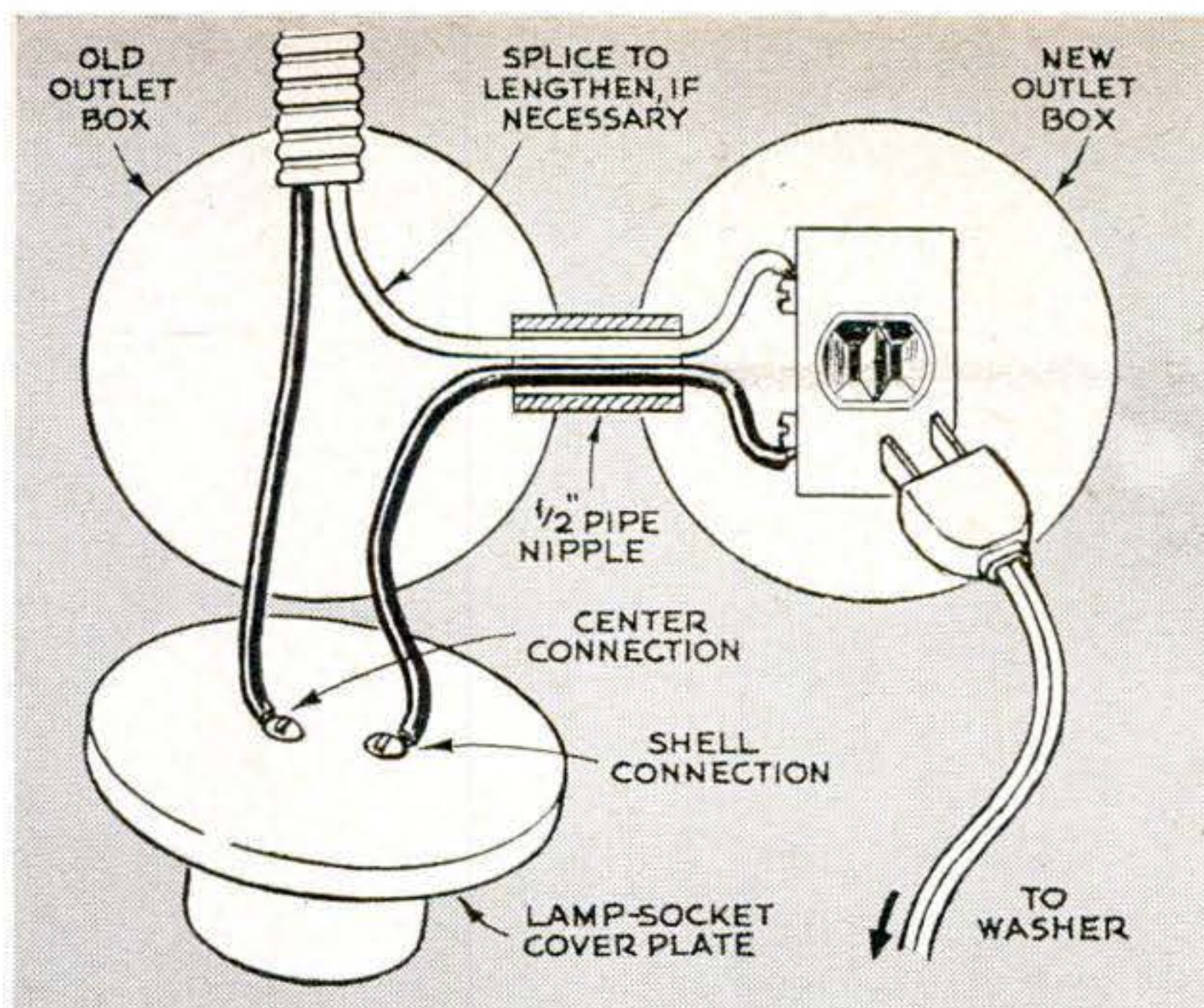

Short Cuts
and Tips | FROM
PS
READERS

Give each appliance its own fuse

To prevent blowing general house fuses when large appliances cause overload, it's good practice to provide each big appliance with its own fuse. After shutting off the current, merely shift the outlet from

its present box to a new adjacent box, re-wiring as shown. Screw a 6- or 10-amp fuse into the lamp socket. An overload will blow it without affecting the 15-amp fuse (20-amp, if your home is wired with No. 12) for the house circuit.—*Archibald Black, Stafford Springs, Conn.*

▶▶▶ Can't open drawers on humid days? Wait for a dry spell, when they're working freely, and coat them with resin sealer to keep out future moisture. Brush it on evenly, inside and out. Let it dry before replacing drawers.—*M. Whiteman, Brooklyn, N.Y.*

▶▶▶ Why those fussy cradles to keep fingerprints off hi-fi records? Before I grip the edge to draw one out of its jacket, I slip my hand into a thin plastic sack. The pint size for freezing produce makes the best mitten.—*Dan Lamoreaux, Lawton, Mich.*

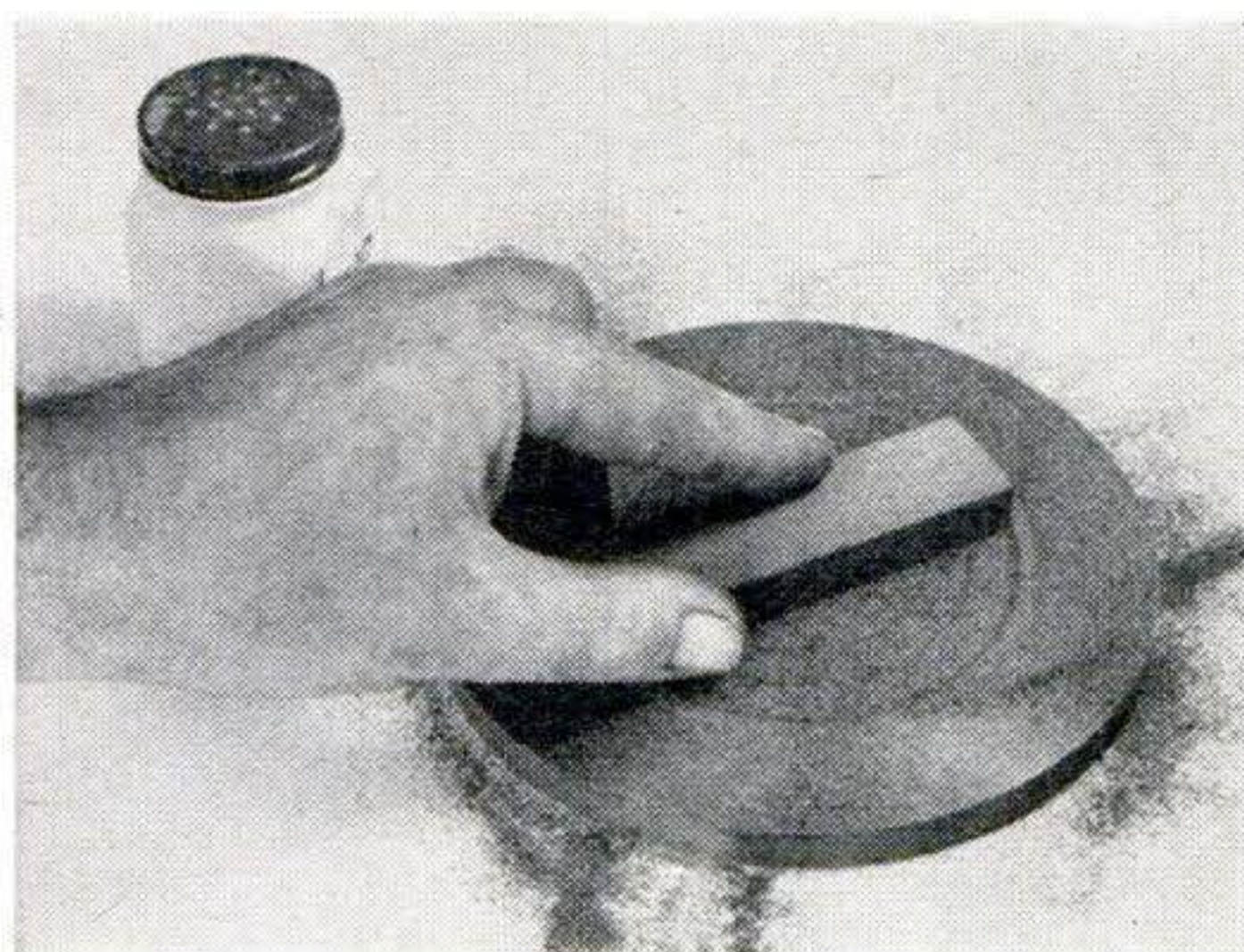

Lapping plate for resurfacing oilstones

Hollows and grooves worn in an oilstone can be ground down to a new flat face on a homemade lapping plate. The one shown was made by casting lead in a steel ring, then surfacing and ring-grooving it in a lathe. Lead "charges" itself readily with an abrasive such as 120-grit silicon carbide.—*H. J. Gerber, Menomonie, Wis.*

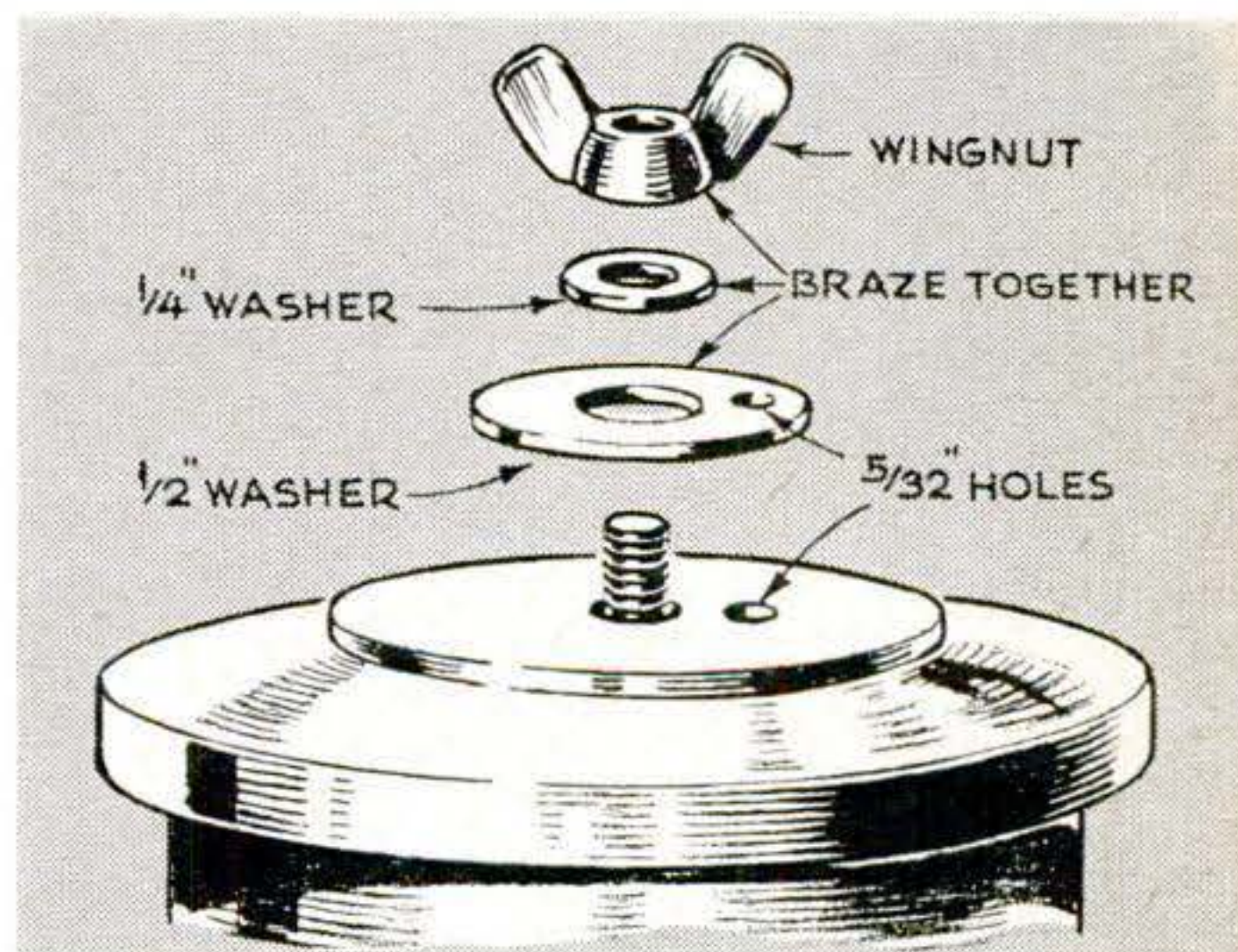

Priming starts small gas engines

Here's a trick I've used to start balky gas motors up to four hp. I screw the brazed washers-and-wingnut assembly down tight, back it off a quarter turn, and drill through the big washer and the air cleaner top. Before I tug the cord, I align these holes and squirt in some gas from an oilcan.—*DeWitt Ferguson, Medford, Ore.*

Wordless Workshop

By Roy Doty and Tom Leonard

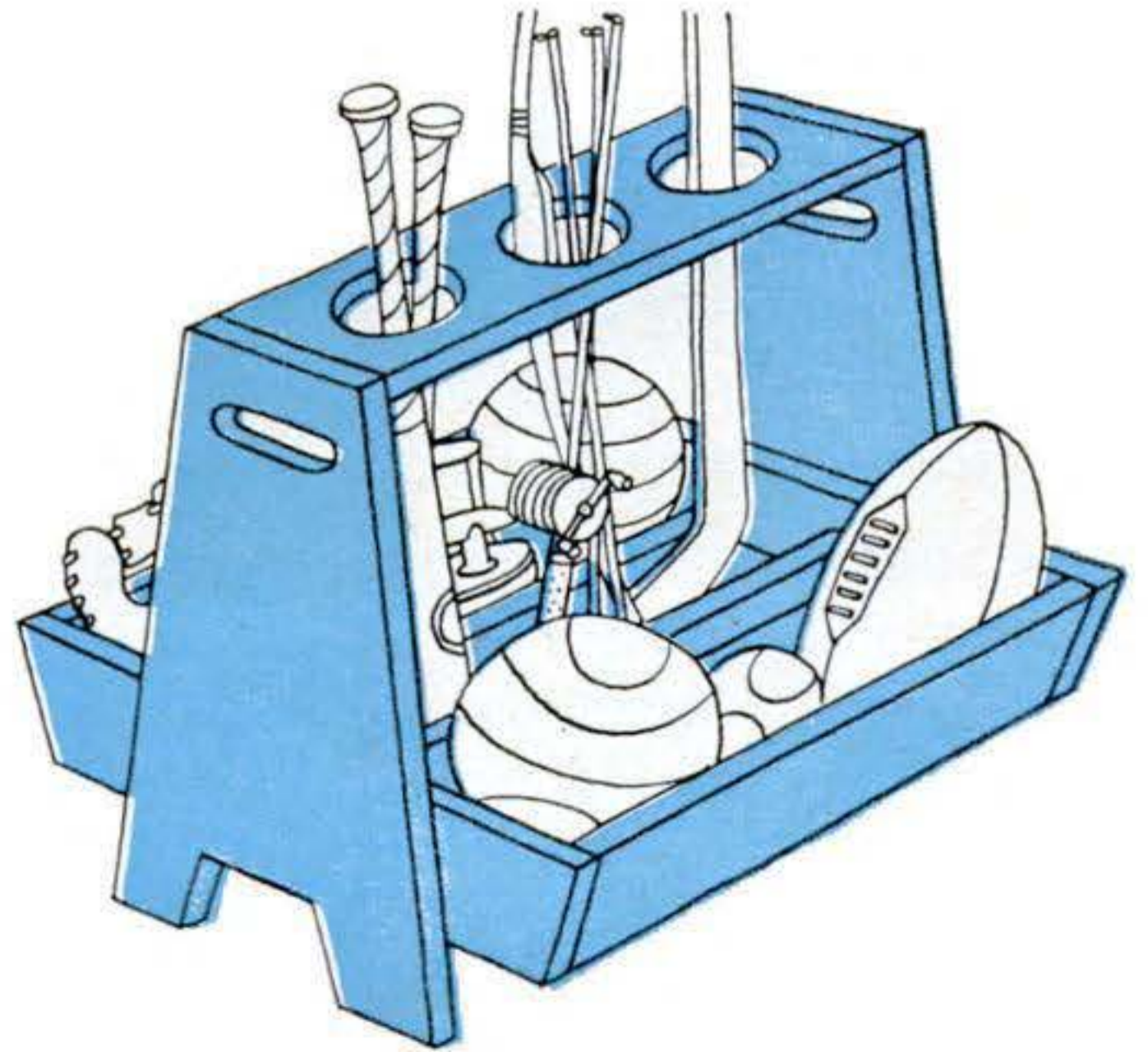
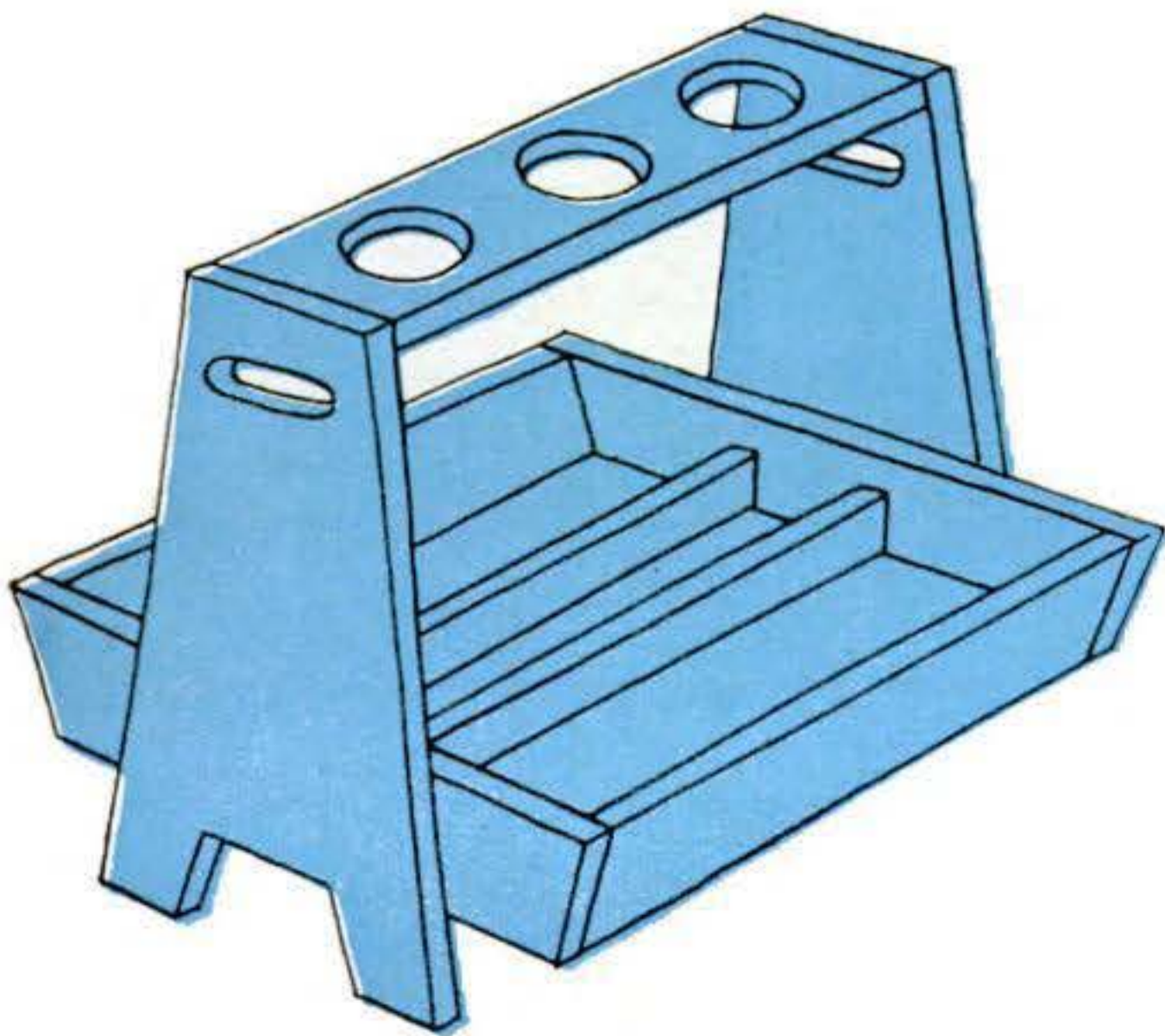
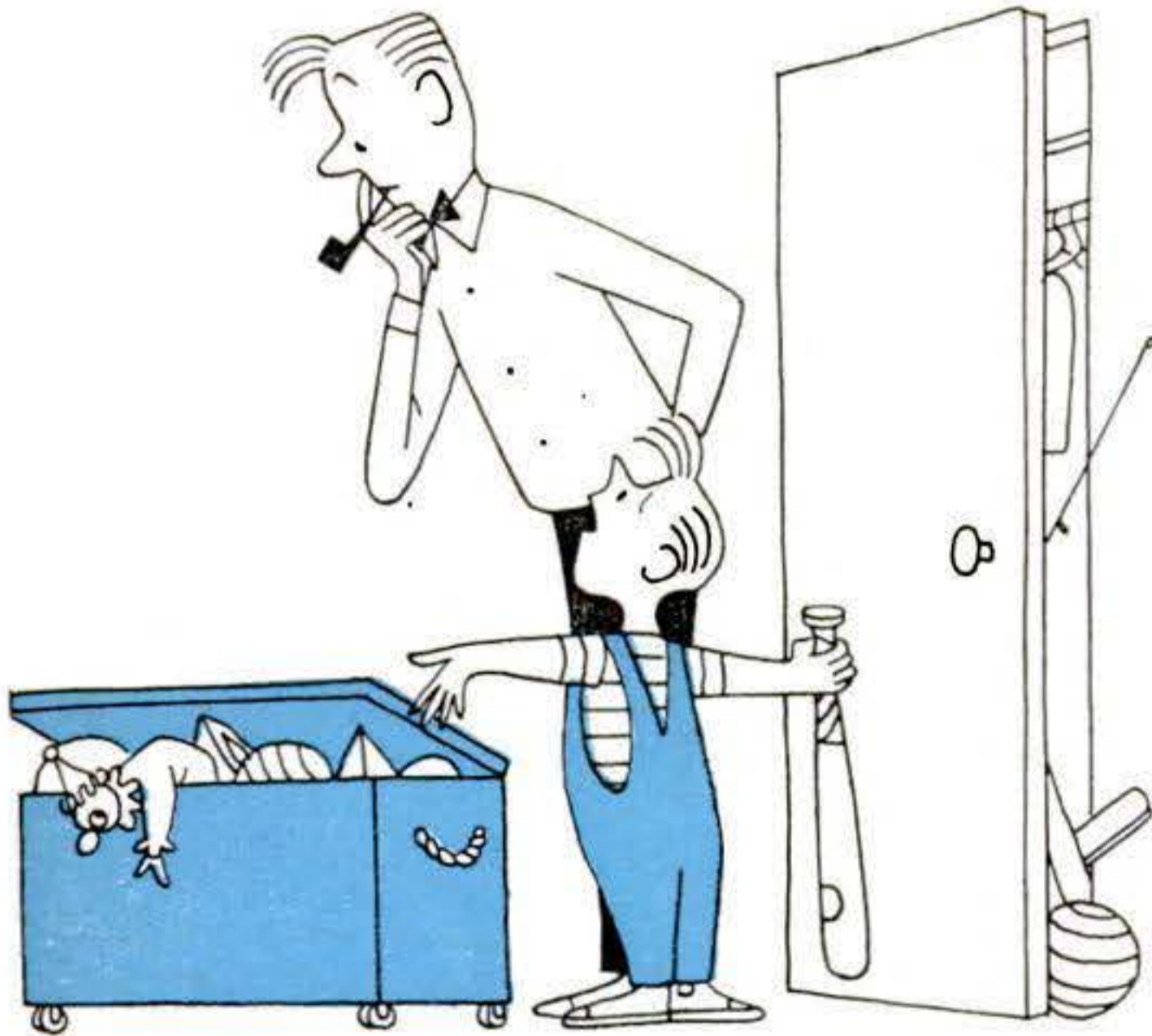
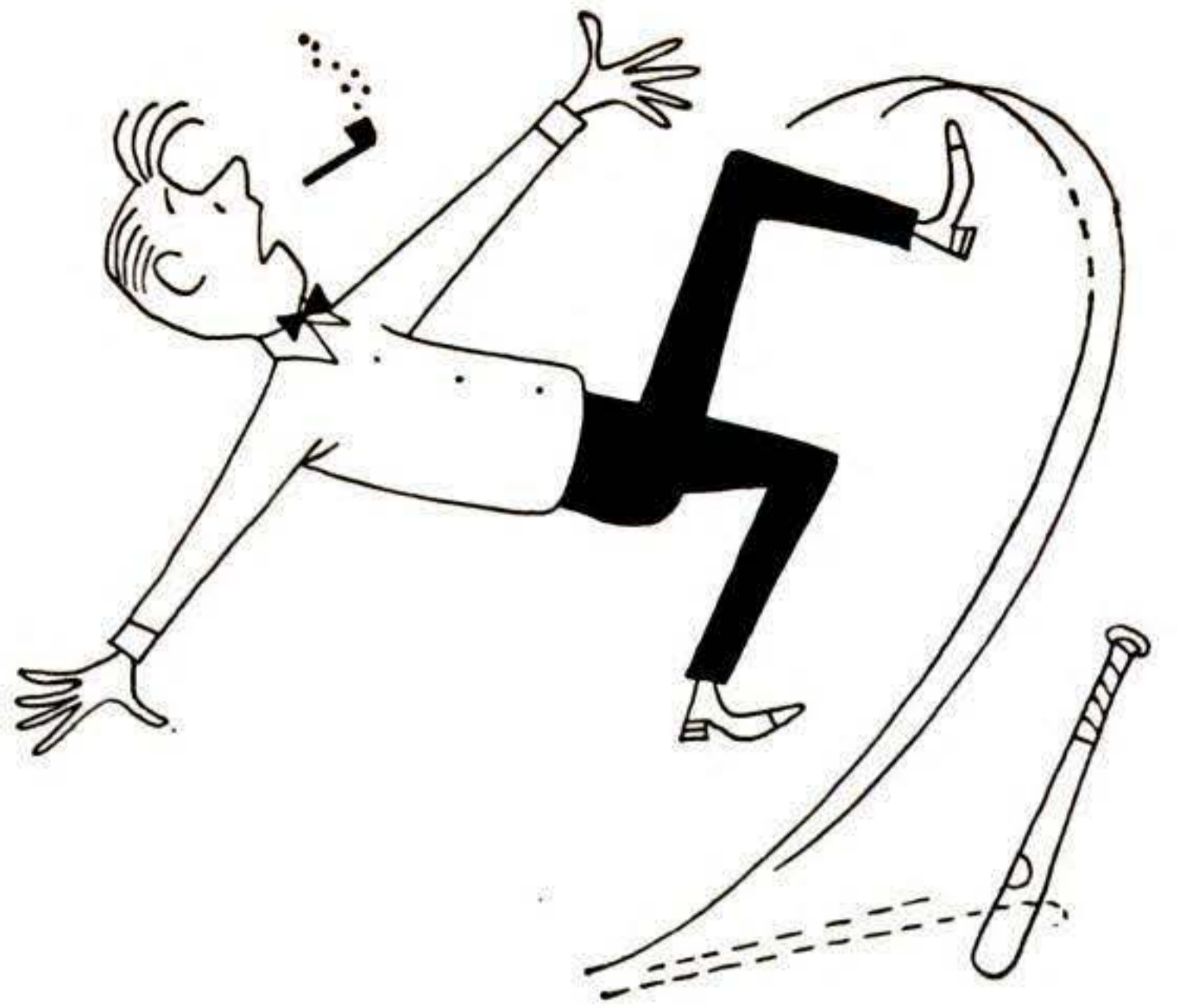

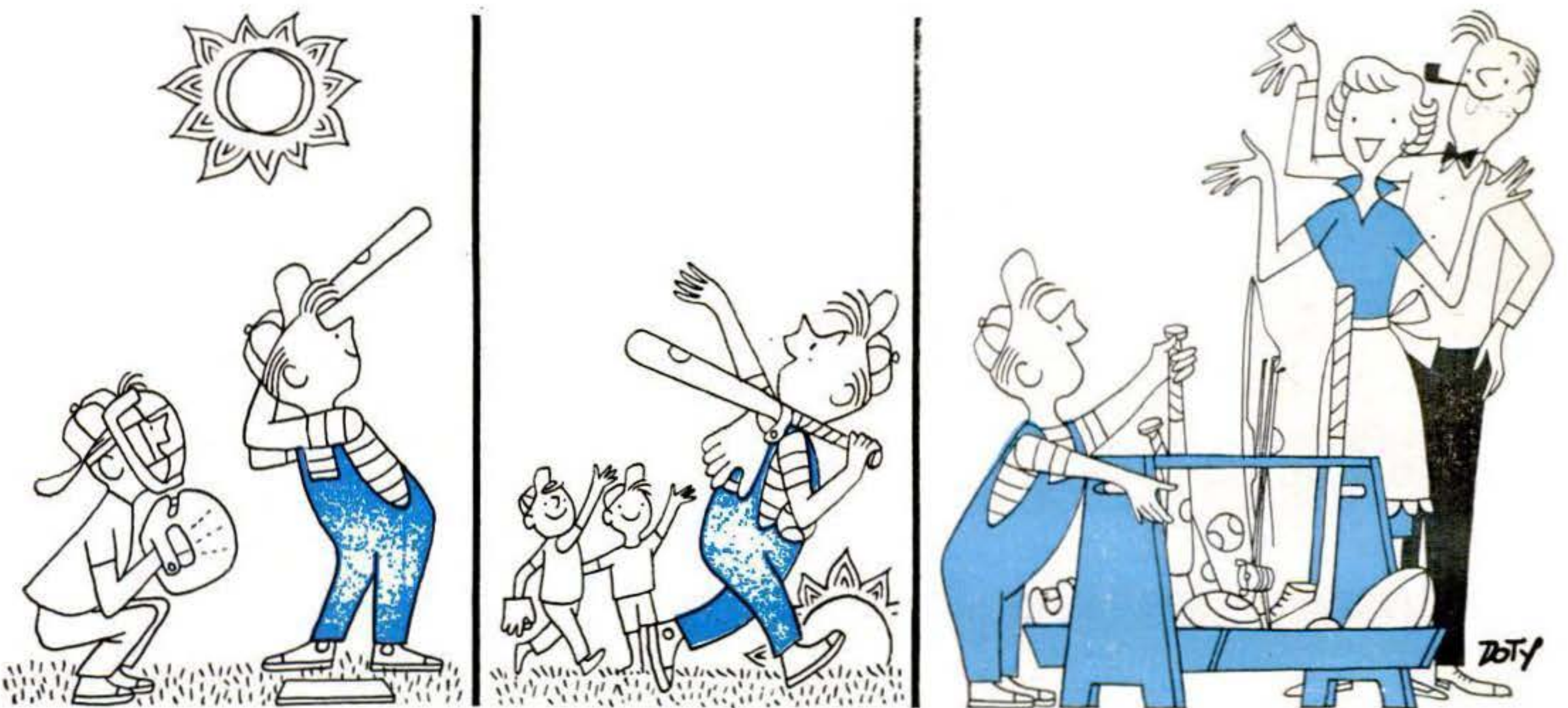
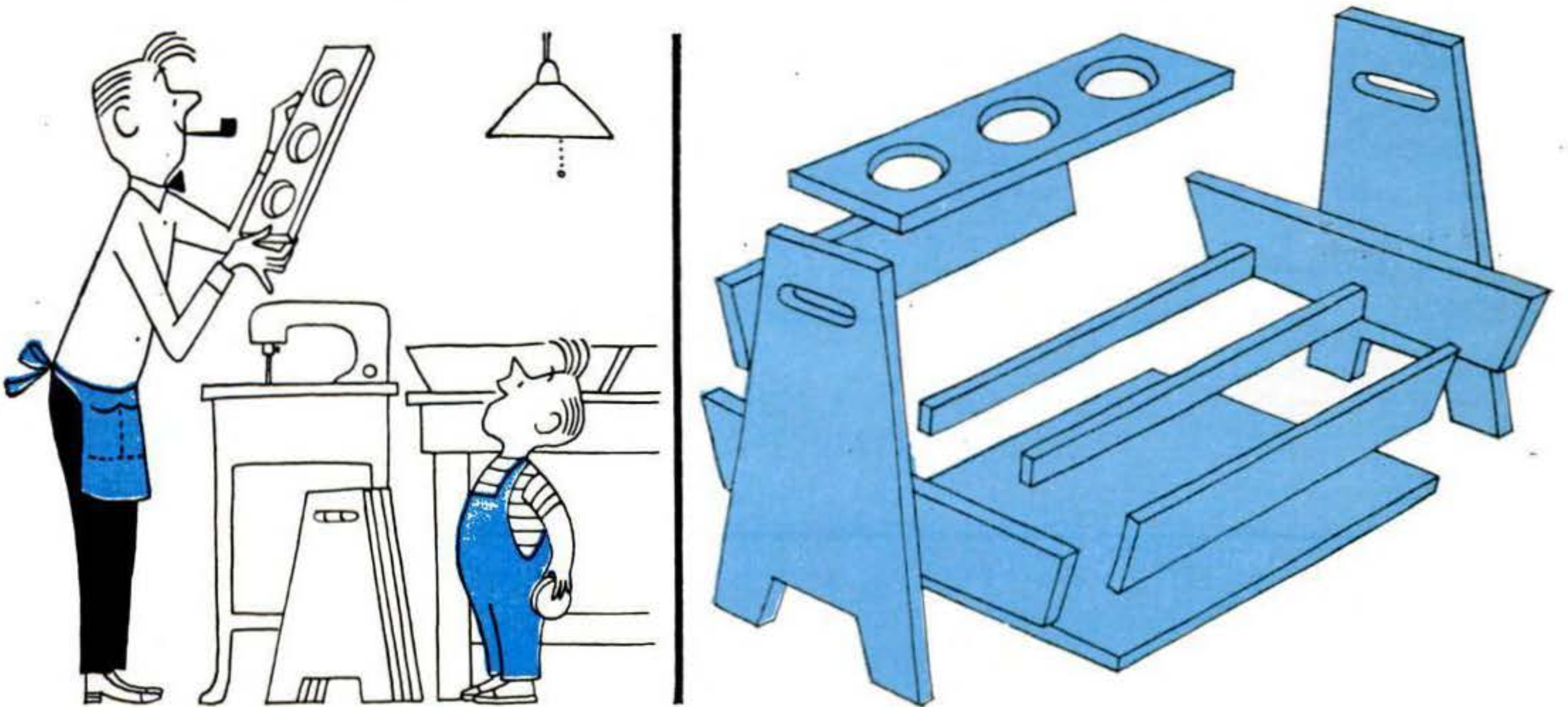
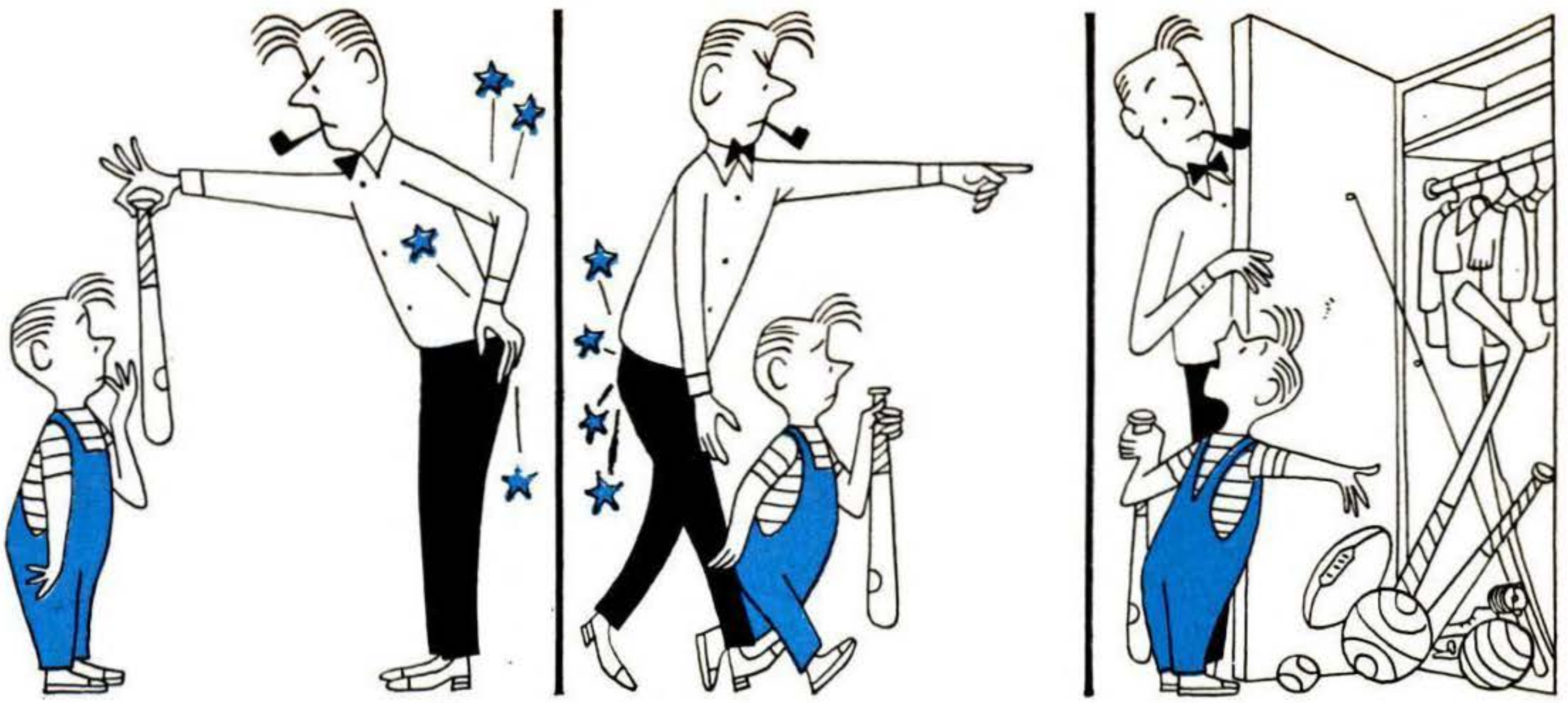

How to mold a Rattle- Free Case for Car Tools

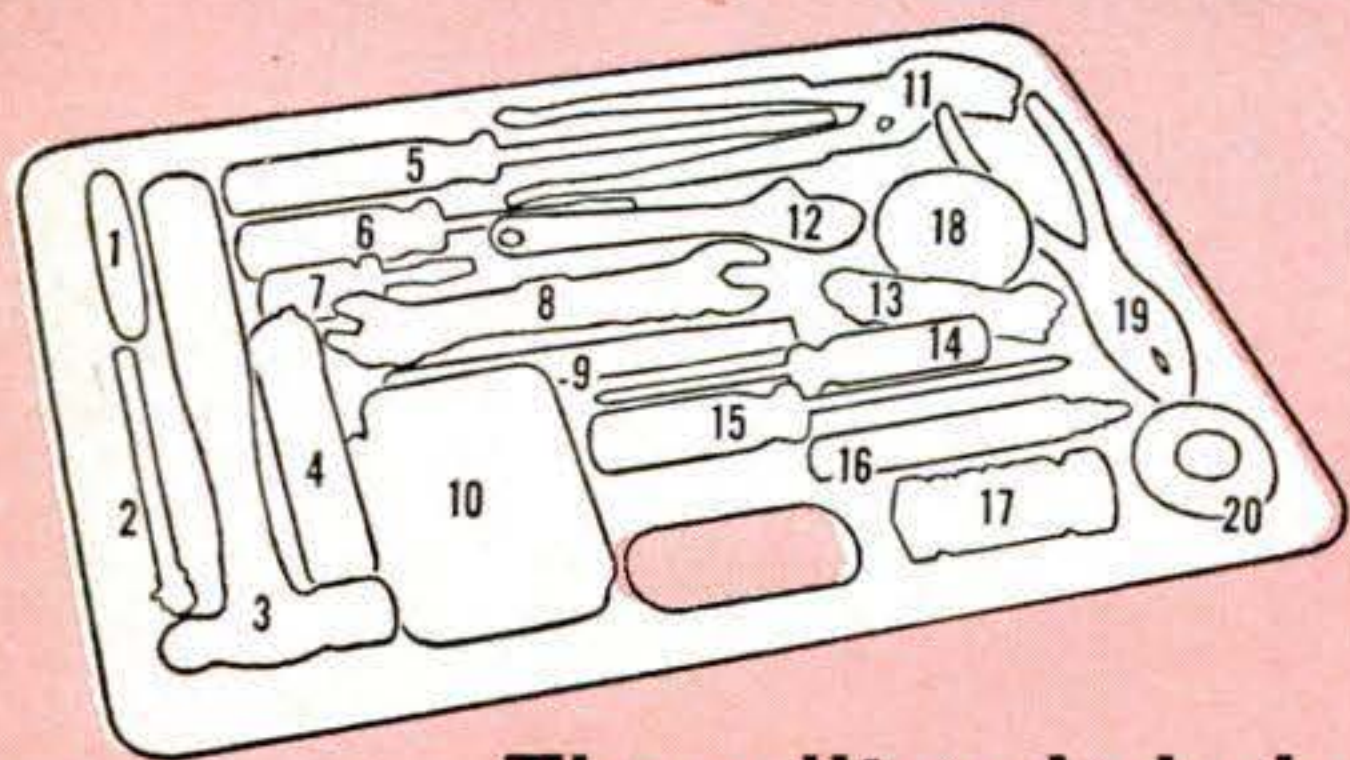

The editors' choice

- | | |
|---|---|
| 1. Pocketknife with reamer and cap opener. | 11. Channel-lock pliers. |
| 2. Pencil-type tire-pressure gauge. | 12. 6" crescent wrench. |
| 3. Ball-peen hammer. | 13. Set of ignition wrenches. |
| 4. Spark-plug wrench. | 14. #1 Phillips screwdriver. |
| 5. 6" square-shank, heavy-duty screwdriver. | 15. #2 Phillips screwdriver. |
| 6. 3" screwdriver. | 16. Tube of light oil. |
| 7. 1½" screwdriver. | 17. 6-7' #10 stranded insulated hookup wire, 10-20' soft iron wire. |
| 8. Set of thin-pattern open-end wrenches (⅜" to ¾"). | 18. 2¼"-diameter-by-1¼"-deep screw-lid plastic box containing nuts, locks, cotters, metal screws, and a tire-valve cap. |
| 9. ½" cold chisel. | 19. Combination slip-joint/side-cutting pliers. |
| 10. 4½"-by-2¾"-by-1¼" snap-lid plastic box containing: spare spark plug, set of points, condenser, distributor rotor, stop-light/tail-light bulb, fuses, tire-valve core, generator brushes, point file, feeler gauges for points and | 20. Roll of plastic electrical tape. |

By Phil McCafferty

IF YOU'RE the kind of car owner who prides himself on being self-reliant around machinery, here's a tool kit you won't want to be without. Furthermore, you'll learn a new construction technique you can apply to many other projects.

POPULAR SCIENCE editors were polled to determine the tools and spare parts they considered most important for roadside troubles and for Saturday-morning tinkering. The list appears at left. How can you keep the tools together, and available when you need them? This fitted case, which you can make in a few hours, solves that problem. It is:

- Rattle-free—molded to fit your tools.
- Self-inventorying—you can spot missing tools at a glance.
- Strong enough to jump on—it'll take the roughest kind of handling.
- Rustproof and soilproof.

Molded plastic is seldom used for this kind of shop project; it usually takes more

1 Place tools on a flat work surface. Juggle arrangement until you get the most compact, rectangular plan. Tools listed on facing page will fit a space 11" by 17". Measure space to get exact dimensions for the plywood form.

2 The mold frame of plywood and hard-board forms edges of the tool-case top. Cross section shows how tools are blocked up on chunks of modeling clay so that exactly half of tool will project above plaster.

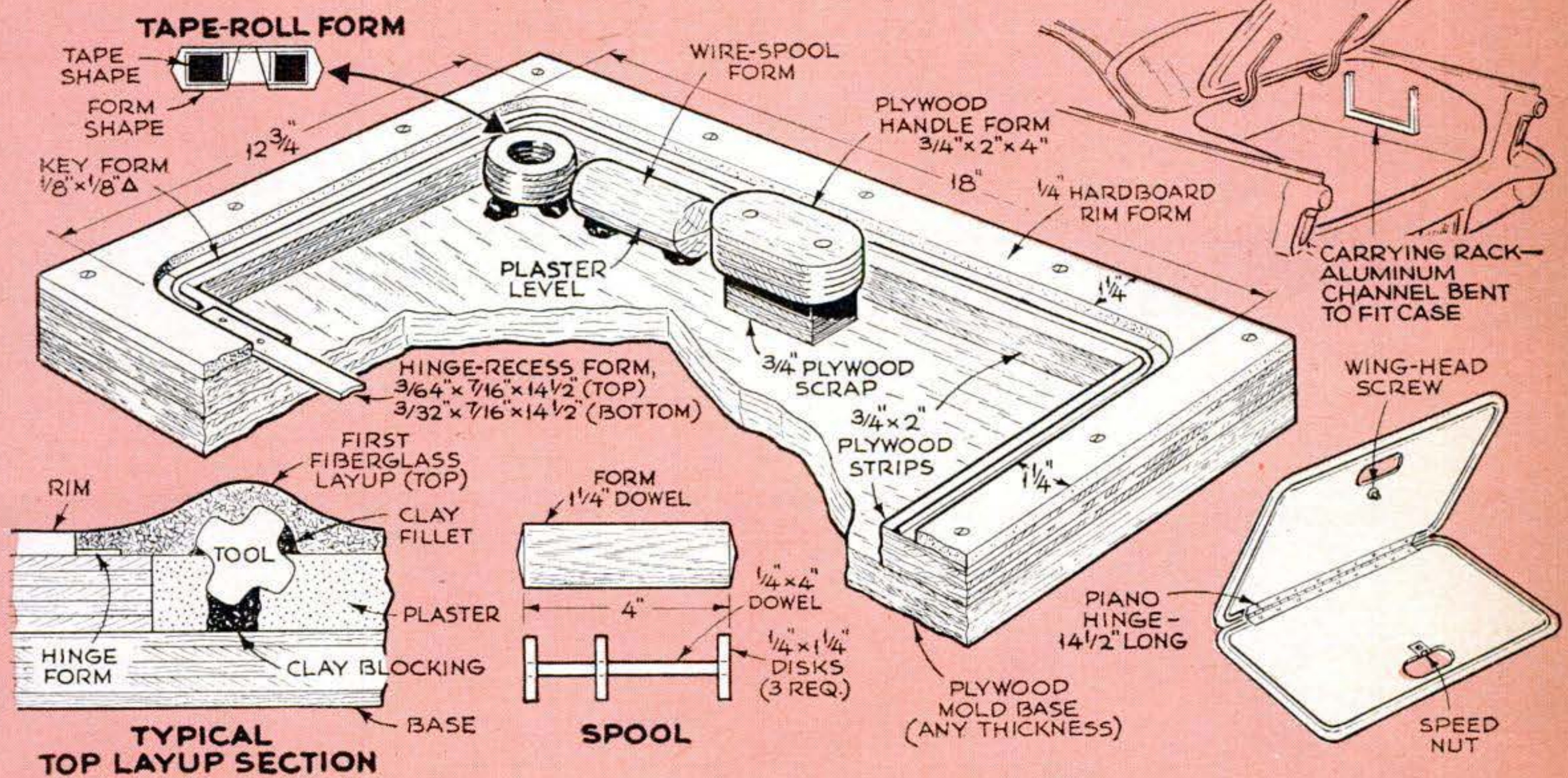
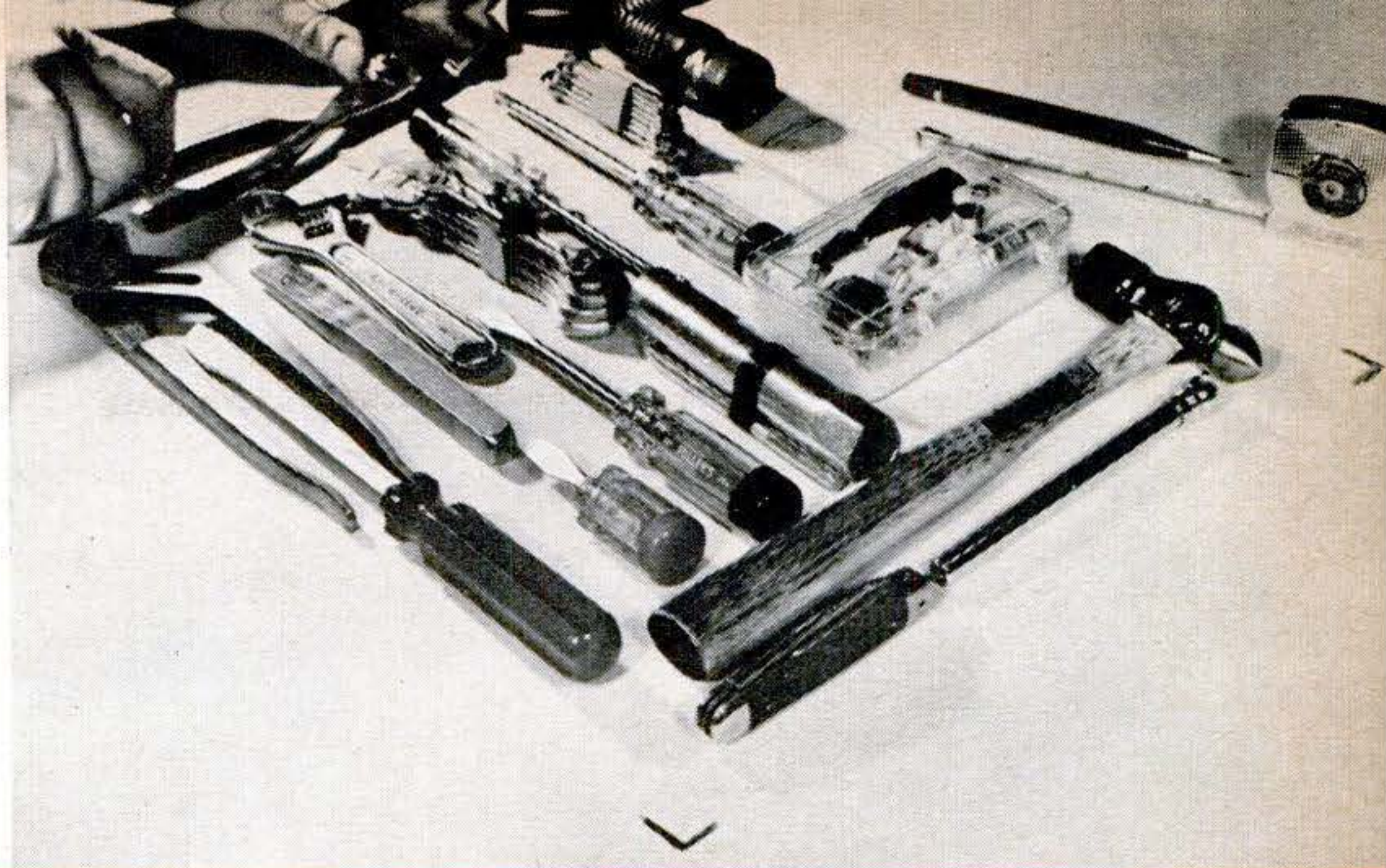

3 Push tools down on the modeling clay until exactly one half of the tool projects above the 3/4" plywood edge of mold frame. Use a scrap of 3/4" plywood as a gauge. Use wooden forms to take the place of the tape roll and wire spool, and to form handle hole. Modeling clay fills all irregularities in the tool profile that would cause interference in either separating the halves of the case or, later, in removing tools.

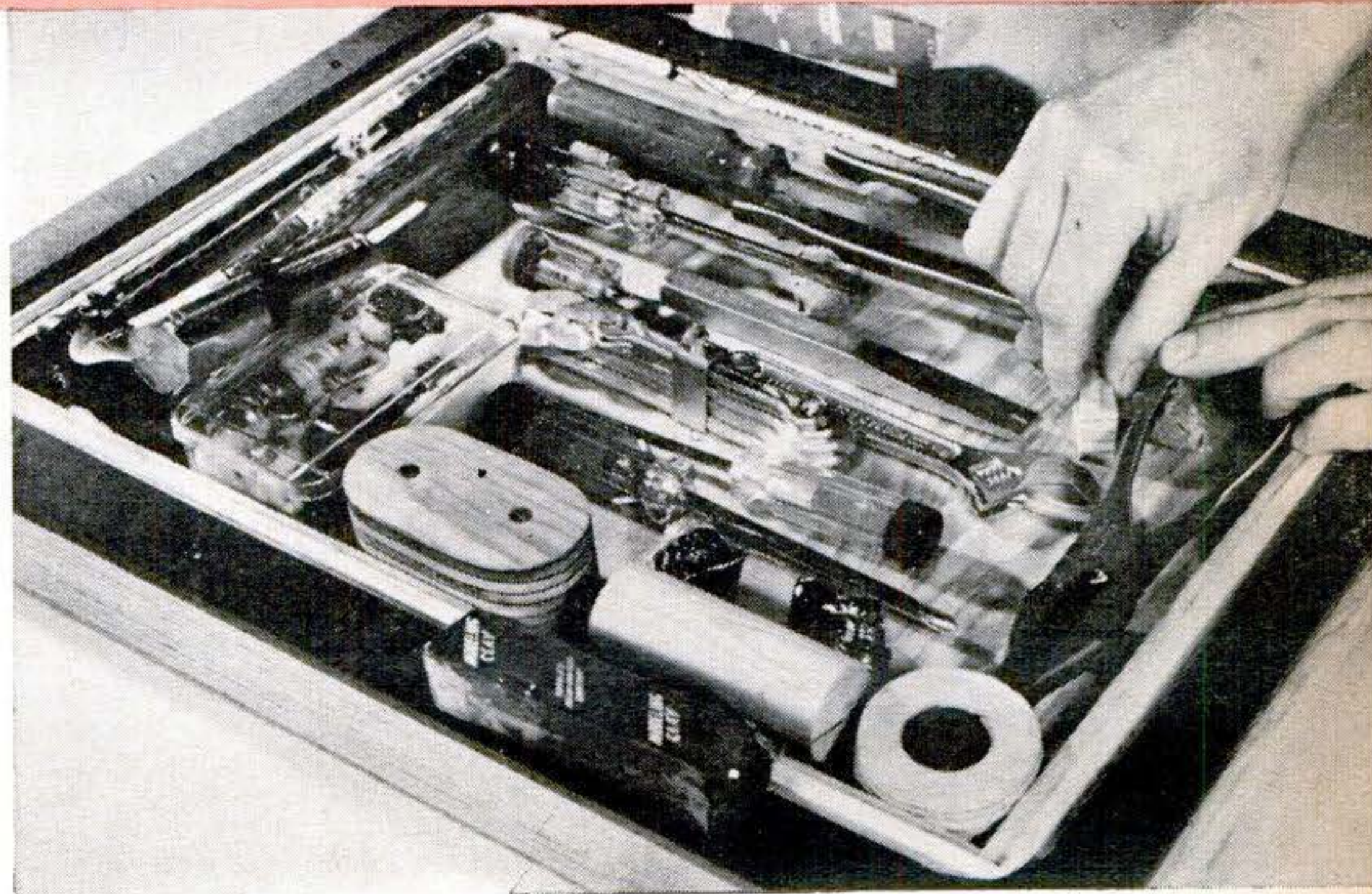

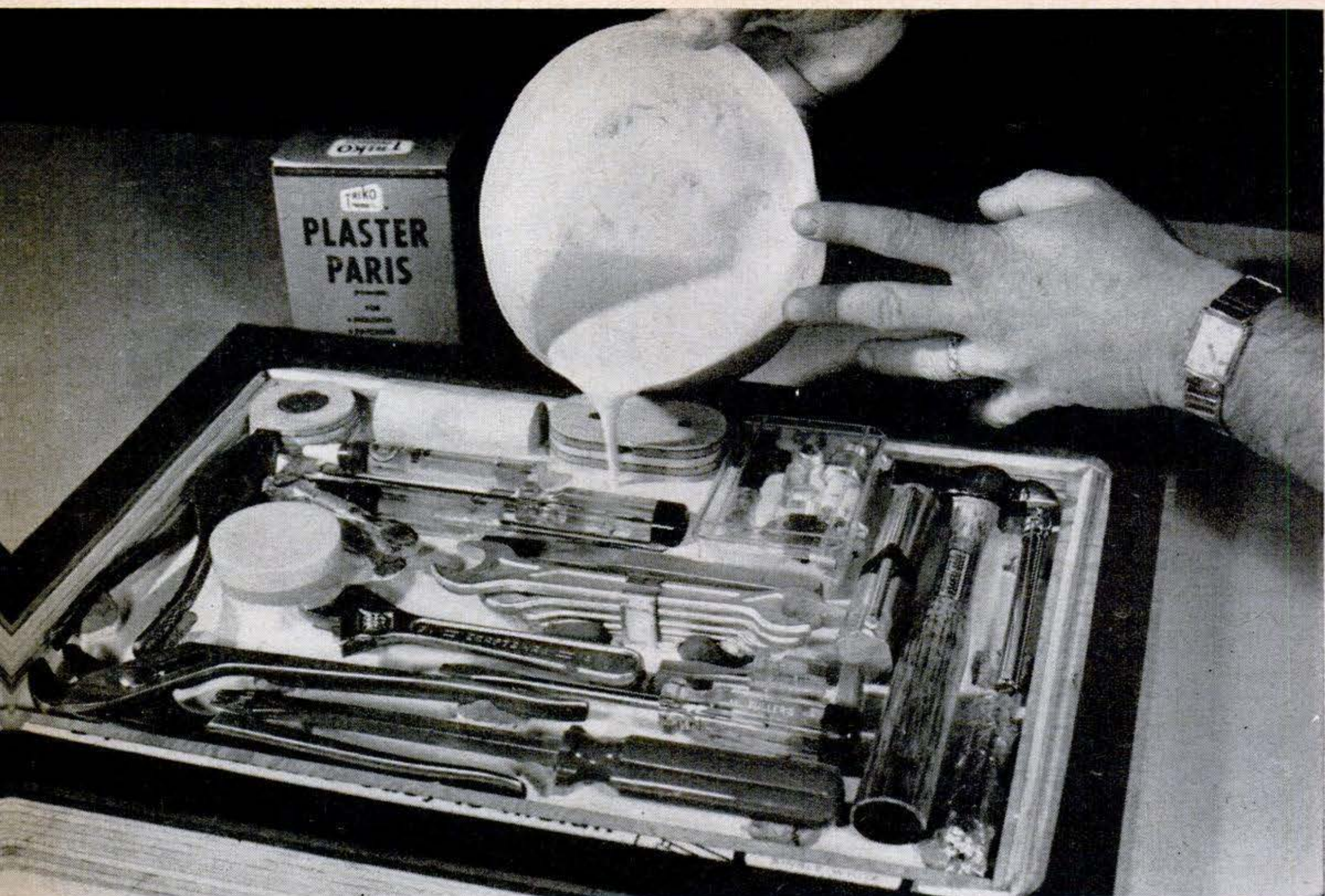

4 Pour mold frame level-full with thin plaster of Paris slurry. Allow plaster to dry thoroughly. With form ready, you can now mold

top half of tool case. Fillet around tools where necessary with modeling clay, wax all the exposed surfaces, and apply parting spray.



5 Apply a layer of thick, gel-coat resin over entire prepared form. When tacky, fill the humps and bumps with pieces of roving. Fill out corners with putty made of resin and chopped fiberglass. Brush on a coat of resin, lay on a layer of glass cloth, and brush on more resin to saturate cloth. Repeat for another layer, brush on a final coat of gel.

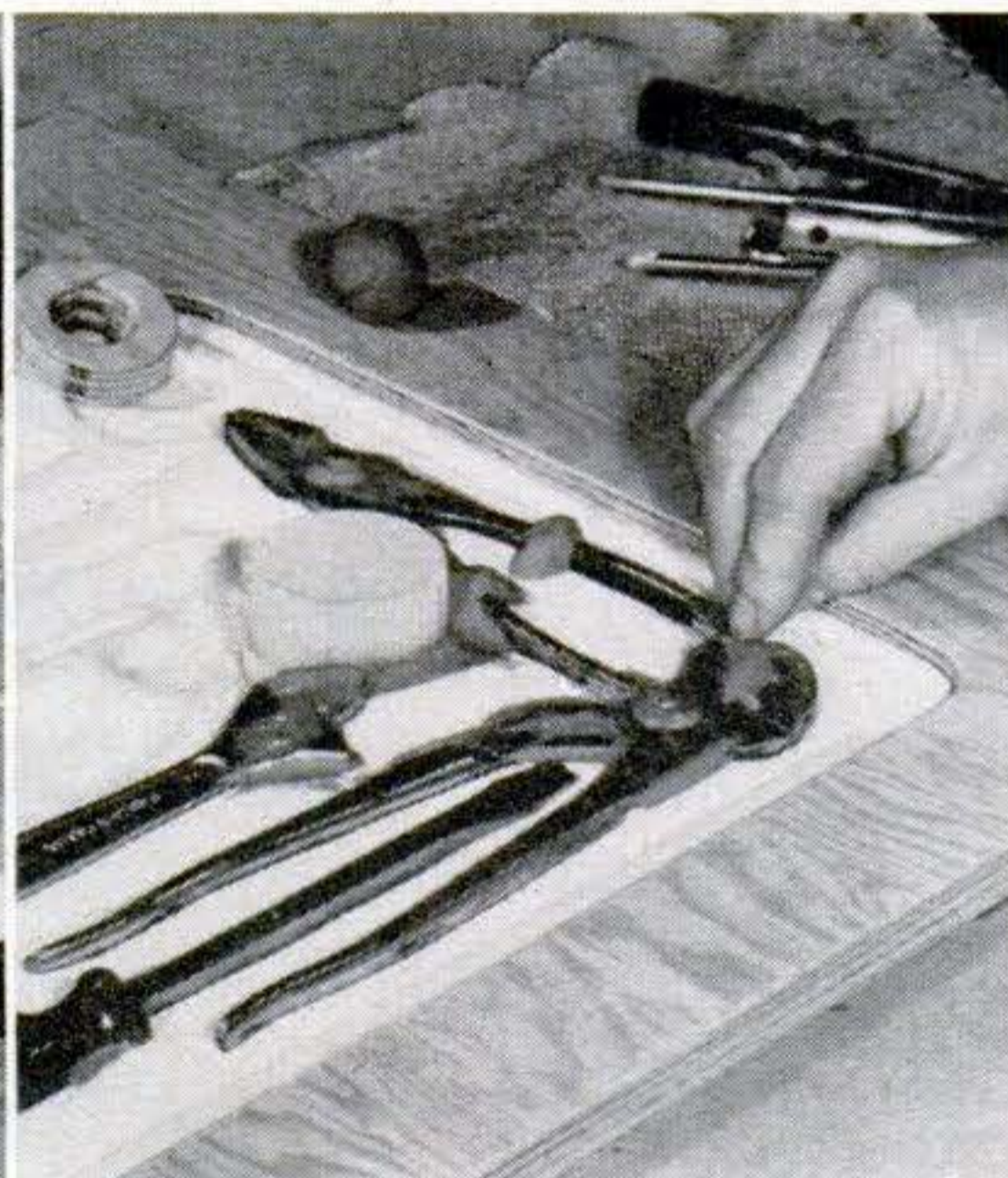

6 When the top half of the case has fully hardened, strip it from the plaster-and-plywood mold. Use the finished top, with tools in place, as a form for molding the bottom half. Cut out a piece of $\frac{3}{4}$ " plywood to form edge of bottom rim. Use clay to form finger-access depressions, to fill crevices in and around tools, and to form fillets where needed.

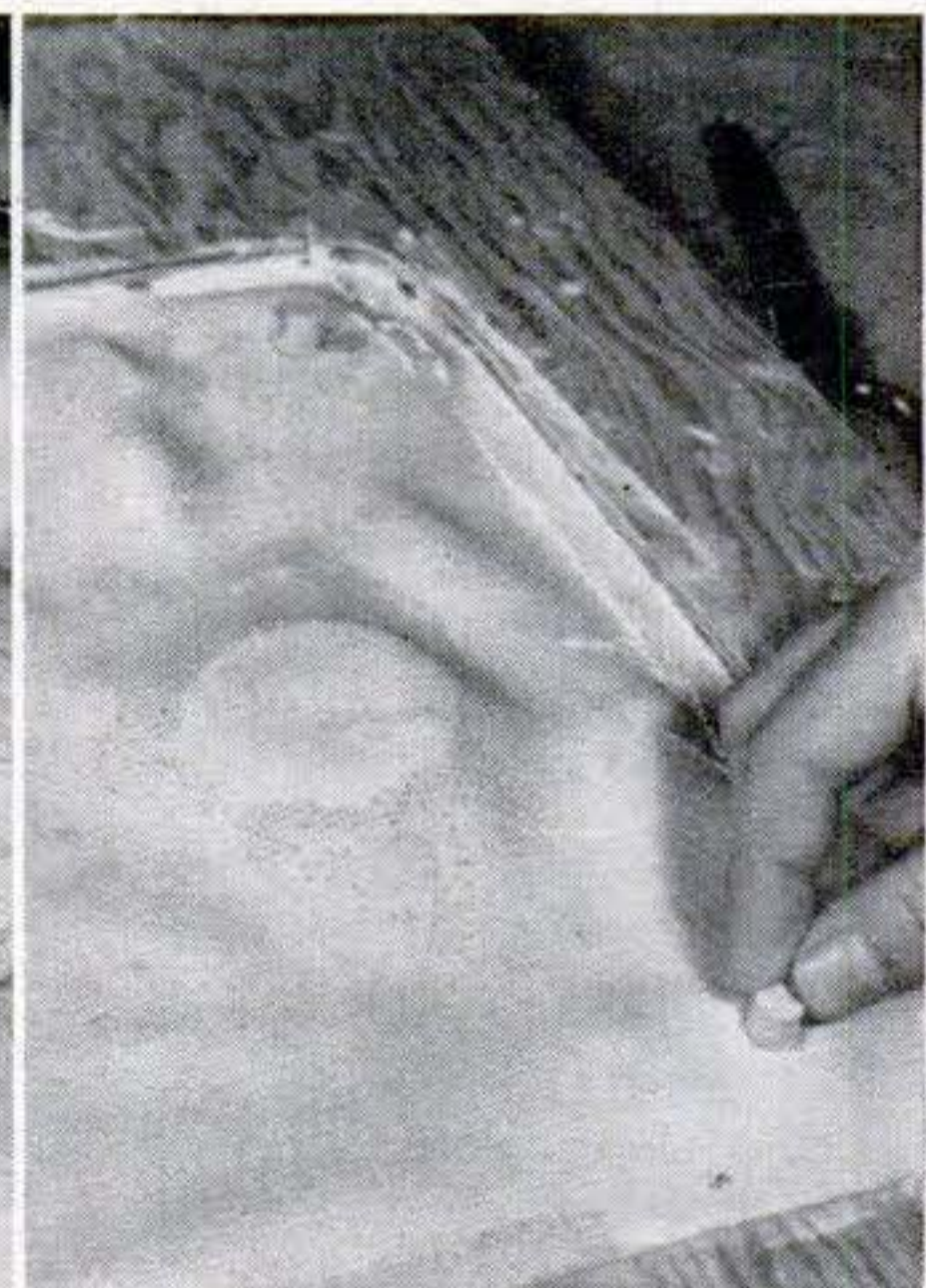

7 Block up the case top inside the plywood cutout so that the plywood extends $\frac{1}{4}$ " above the surface. Spray all surfaces with mold release, and then lay up glass cloth and resin as before. After first cloth and resin layer, stick dowels into the unhardened resin to provide leveling feet for the case. When resin has hardened, remove flash, and sandpaper surfaces.

time and trouble to make the mold than it would to build the finished product out of more conventional materials. Is there a way to get the advantages of this durable, lightweight material without the fuss and bother of making special molds? There is.

The trick is to use the tools themselves as patterns for your mold. You cover each tool halfway up its profile with plaster of Paris while you mold the top half of the case. Then you remove the plaster and, with the tools in the already-cast top half, mold the bottom half.

A simple plywood frame, with the tools laid out just the way you want them, holds the plaster. When the plaster is dry, you have what foundrymen call a "matchboard"—the surface against which you'll make your mold. Now you lay up the resin and fiberglass over the projecting tools, let it harden—and you have a perfect mold, in rugged plastic, of the shapes you want. The photos show you how—step by step.

To make the bottom half, you use the finished half as part of your mold. Strip away the plaster and plywood. Remove the tools and clean them. Lay the finished top on another piece of $\frac{3}{4}$ " plywood, mark around the edges, and saw out an opening that the finished case top will fit into snugly. Block up the case top inside the cutout so that the plywood rim extends $\frac{1}{4}$ " above the surface.

Replace tools in the completed half. With modeling clay, fill any crevice or recess in the tools that would make it difficult to withdraw the finished molding. Form finger-access depressions in the case bottom by placing domes of clay at strategic spots across the tools. Spray the entire surface with silicone mold release, and lay up resin and fiberglass as before.

Smooth out flash and imperfections in the finished halves and fasten the piano hinge in its molded recess with epoxy glue. Add a wing-head screw and speed nut.

The plastic materials needed:

- 1 yard volan-finish fiberglass cloth.
- $\frac{1}{2}$ yard woven fiberglass roving.
- 1 pound $\frac{1}{4}$ " chopped fiberglass.
- 1 quart polyester resin.
- 1 quart gel-coat polyester resin.
- 2 ounces catalyst.
- 1 can spray-on silicone mold release.

If you have trouble finding these materials, a reliable mail-order source is: Cope Plastics, Highway 100, Godfrey, Ill. They will send a catalogue on request. ■ ■

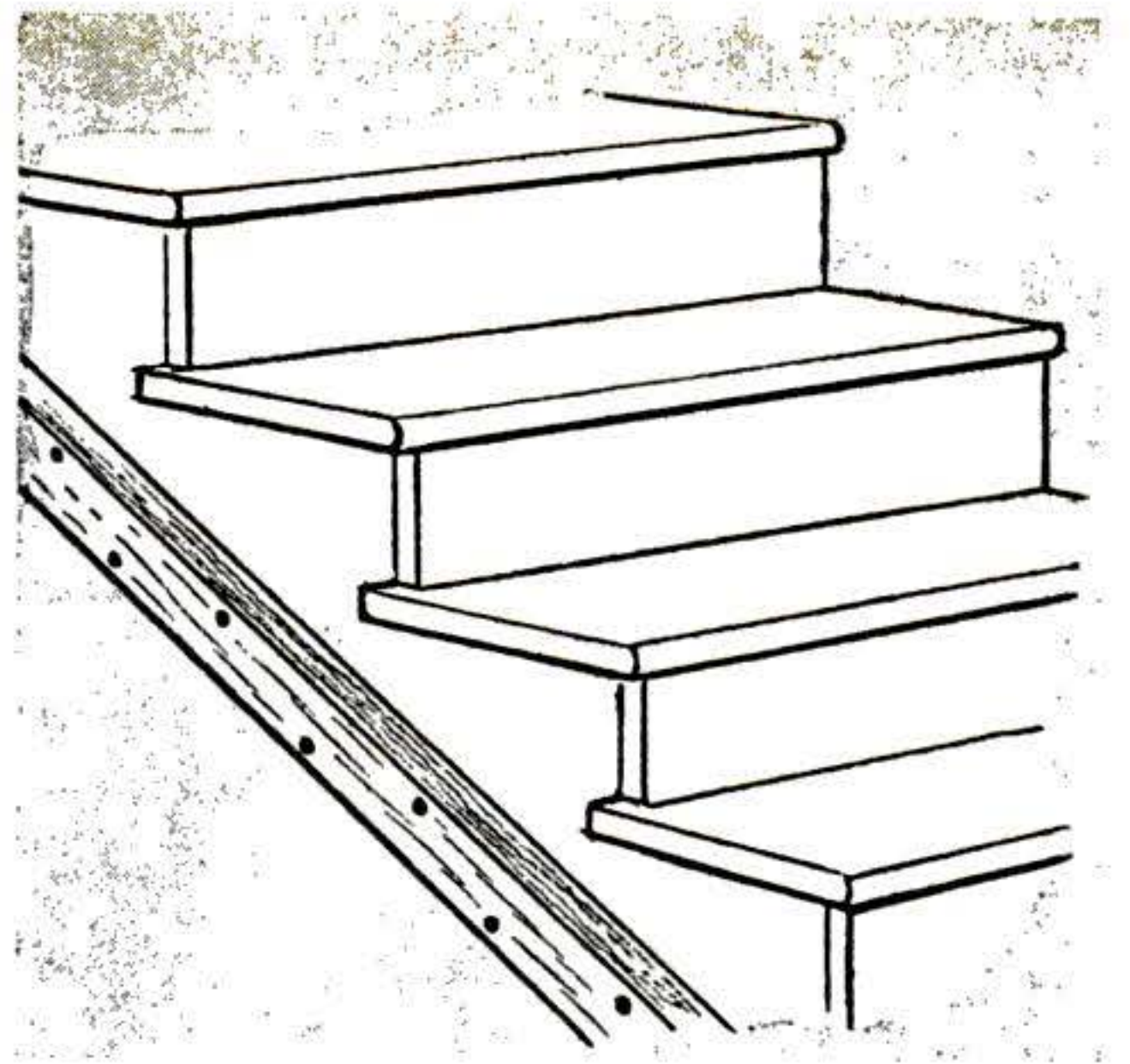

Stiffen stairs with wood strips

If basement stairs are weak and tend to spring up and down, stiffen them by nailing 1"-by-3" wood strips along the lower edges of the supports. Stagger the nails about 10" apart to avoid splitting. The strips will take the bending strain and also add rigidity to the stairs.—*D. H. Bobo, Jackson, Mich.*

▶▶▶ When filling countersunk holes over screwheads, I find that poking a small piece of waxed paper into the hole first may save trouble later. The paper will keep the screw slot clean in case you must remove the filler to retighten the screw.—*R. Harold Richter, Detroit.*

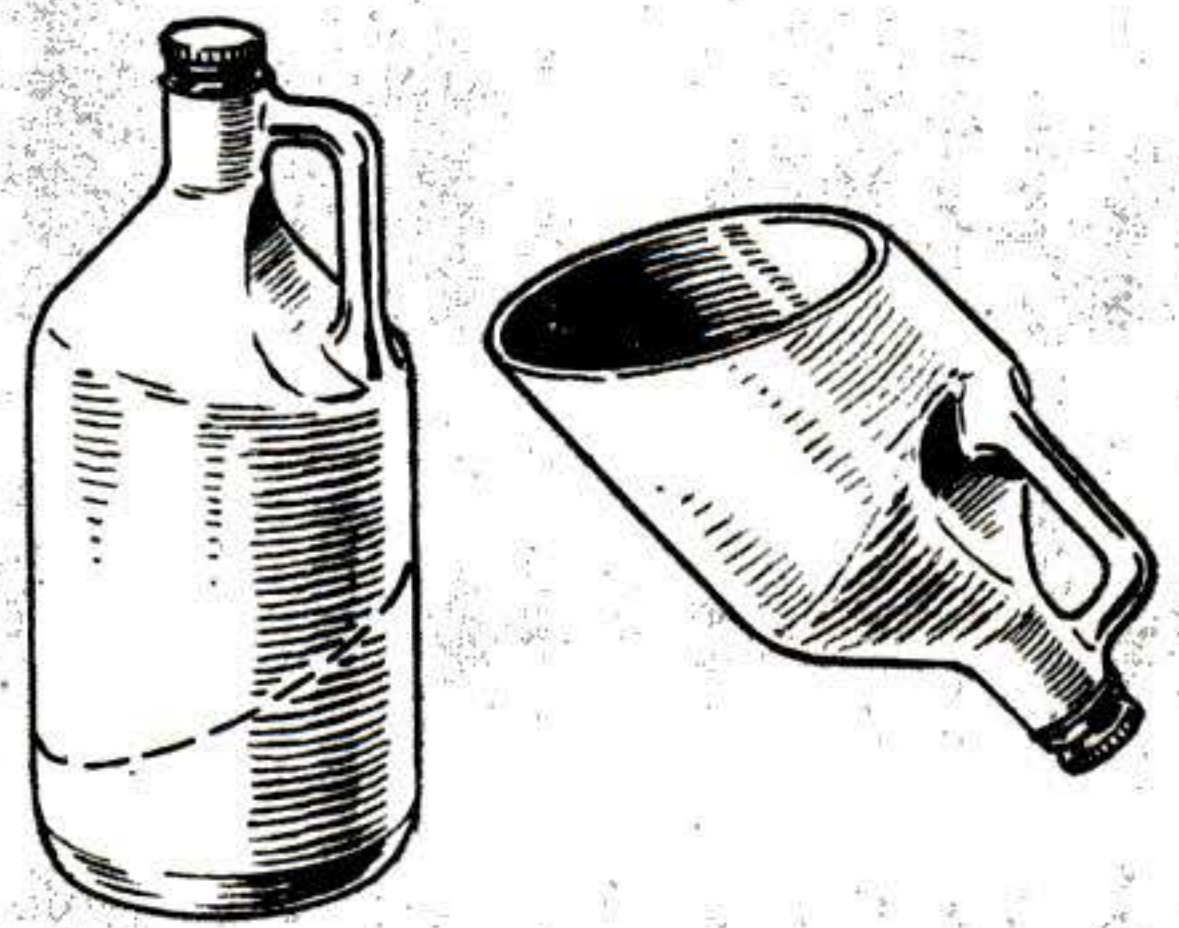

Plastic bottle becomes boat bailer

Here's another of the many uses for those plastic bleach bottles. Snip a $\frac{1}{2}$ -gallon bottle on the diagonal as shown above. Don't throw out the cap; leave it on and you'll have a rustproof, flexible boat bailer with a built-in handle.—*Maj. Robert G. Smith, Wichita, Kan.*

How to build a 3-in-1 Test Meter for Your Car

- DWELL-ANGLE METER
- TACHOMETER
- CONTINUITY CHECKER

By Len Buckwalter

WHY tangle with a clutter of instruments while making tune-up and trouble-shooting measurements on your car? This home-built unit puts three important pieces of equipment into a single, compact cabinet. Besides indicating engine r.p.m., it'll detect everything from faulty distributor points to defective connections in wiring. Cost of the project is about \$22—far less than buying the instruments separately.

The circuit works with almost any car: 6- or 12-volt, positive or negative ground, and 4-, 6- or 8-cylinder engine. The meter is calibrated directly in engine r.p.m. from 0 to 6,000. Other readings, such as dwell angle in degrees and continuity in ohms, are easily read from the same scale.

How it works. The tachometer section



Engine r.p.m. and point dwell are measured with instrument connected to the distributor primary. A switch selects meter function.

is a two-transistor switch that picks up pulses of current at the distributor points. As the engine revs up, current through the meter rises exactly in step with r.p.m. The common problem of calibration error when temperature varies is eliminated by the transistors' flip-flop circuit. The transistors operate with a positive on-off action that makes the readings independent of wide swings in temperature. The tach is first calibrated against an extremely accurate source—the 60-cycle frequency of house current. Accuracy is further improved by powering the circuit with mercury batteries.

The dwell portion of the instrument compares on-off time of the distributor points and reads it out in degrees of dwell angle. Once you know the recommended setting, you can adjust points with much more accuracy than is possible with a feeler gauge. The meter also reveals such ignition problems as point "bounce" at high engine r.p.m.

The final section, a continuity tester, is a basic ohmmeter for trouble-shooting car wiring. When two leads are clipped across a suspected wire, the meter shows whether a short circuit or broken connection exists.

How to make it. Mount the meter, function switch (SW1), potentiometer (R10)

with SW2 attached, and potentiometer (R9) on the front panel of your case. Use the template supplied in the meter carton to lay out the mounting holes for the meter. Fasten the perforated circuit board to the front panel with small angle brackets slipped onto the meter mounting screws.

Press terminal clips into appropriate holes in the circuit board to make tie points for soldering resistors, capacitors, and other small parts into the circuit. Be sure none of the wiring touches the case.

The wiring layout is not at all critical, but two components—transistors and switch SW1—must be wired with care. The drawing shows how to identify transistor leads.

Never handled a rotary switch
CONTINUED

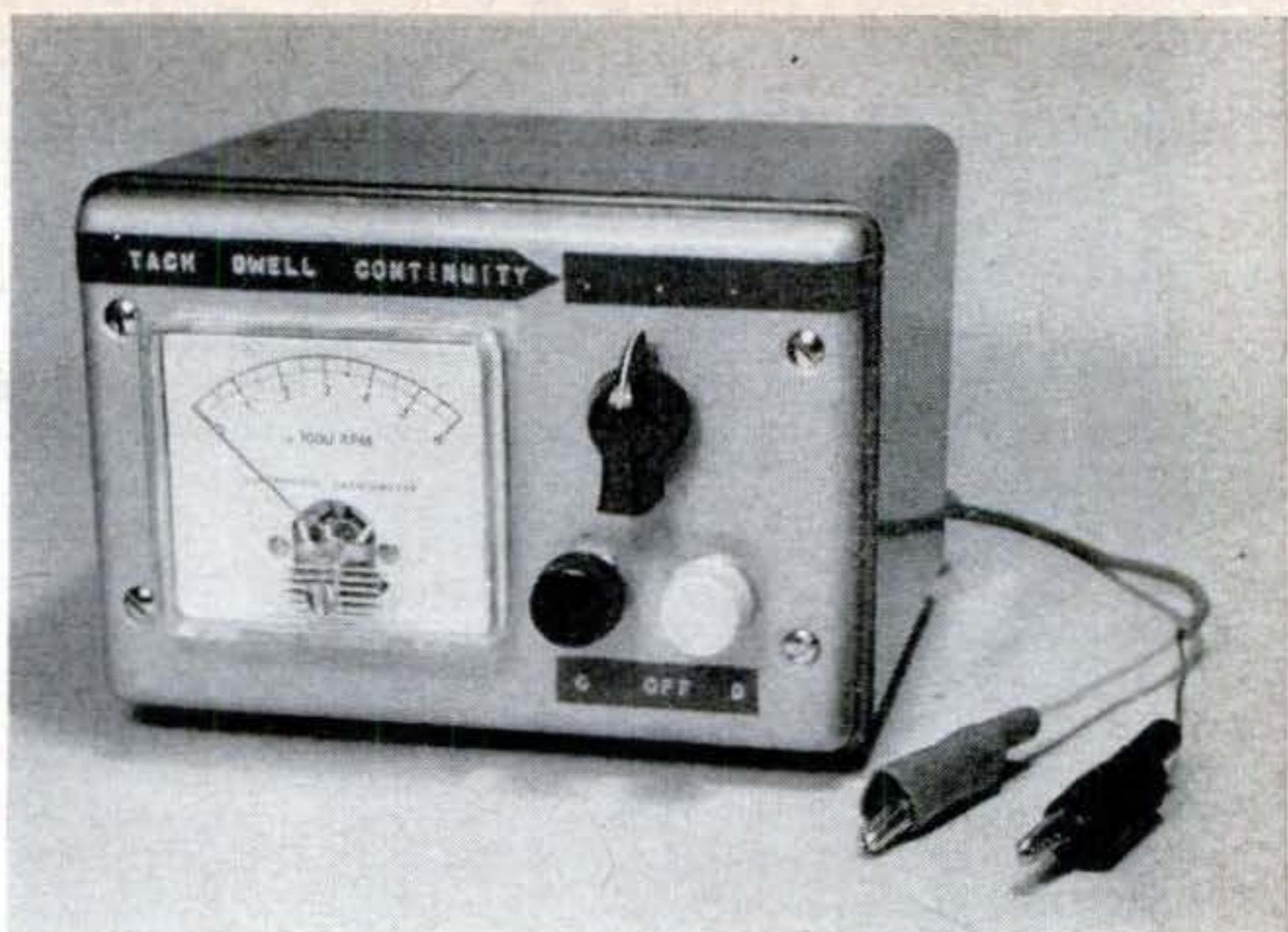

Meter specified in the parts list comes with scale marked for r.p.m., but any good 0-200 microammeter will work. Pointer knob selects meter function, black knob adjusts meter for continuity checks, and white knob adjusts it for dwell-angle measurements. Shielded cable with alligator clips is used for all tests.

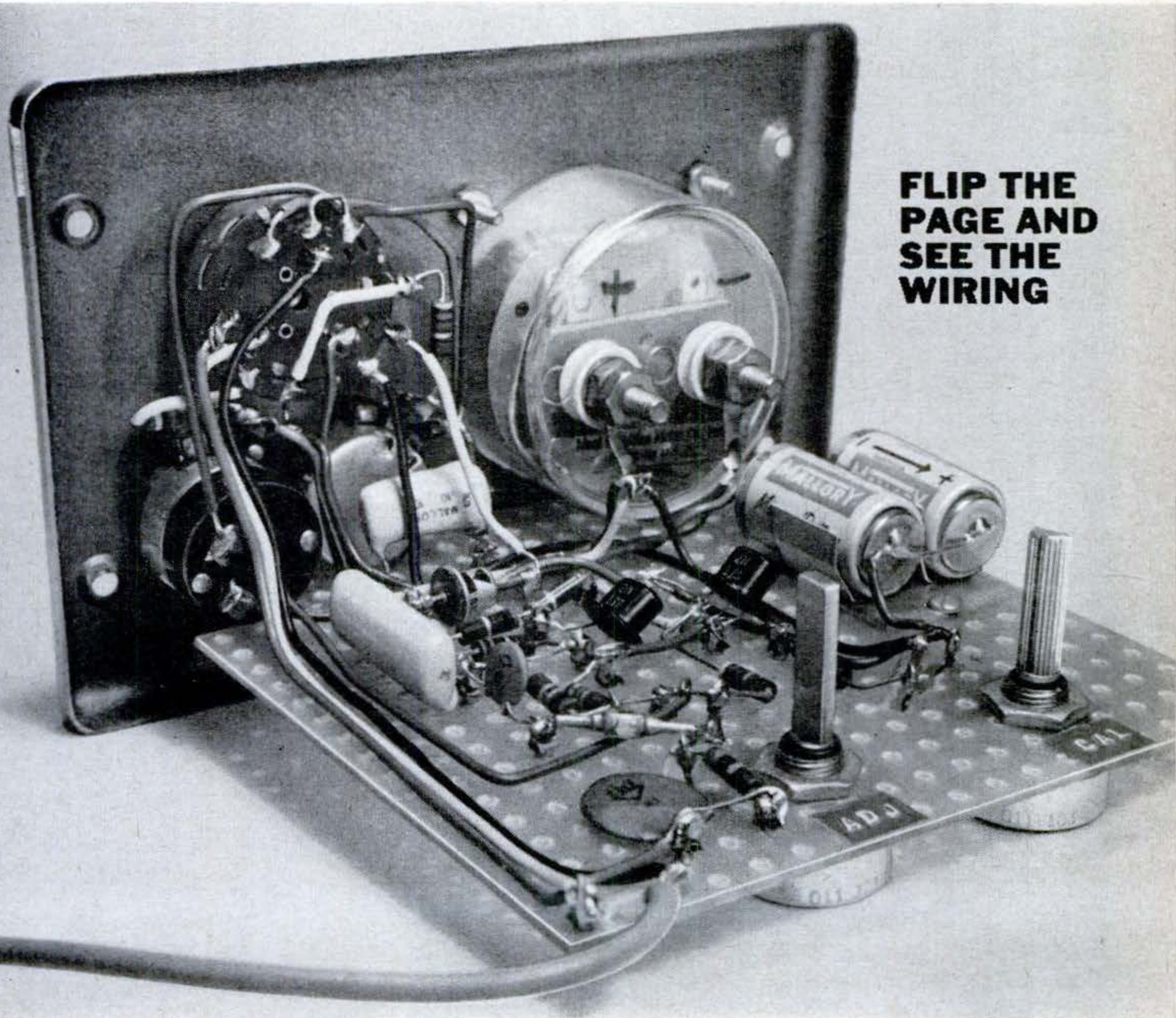

**FLIP THE
PAGE AND
SEE THE
WIRING**

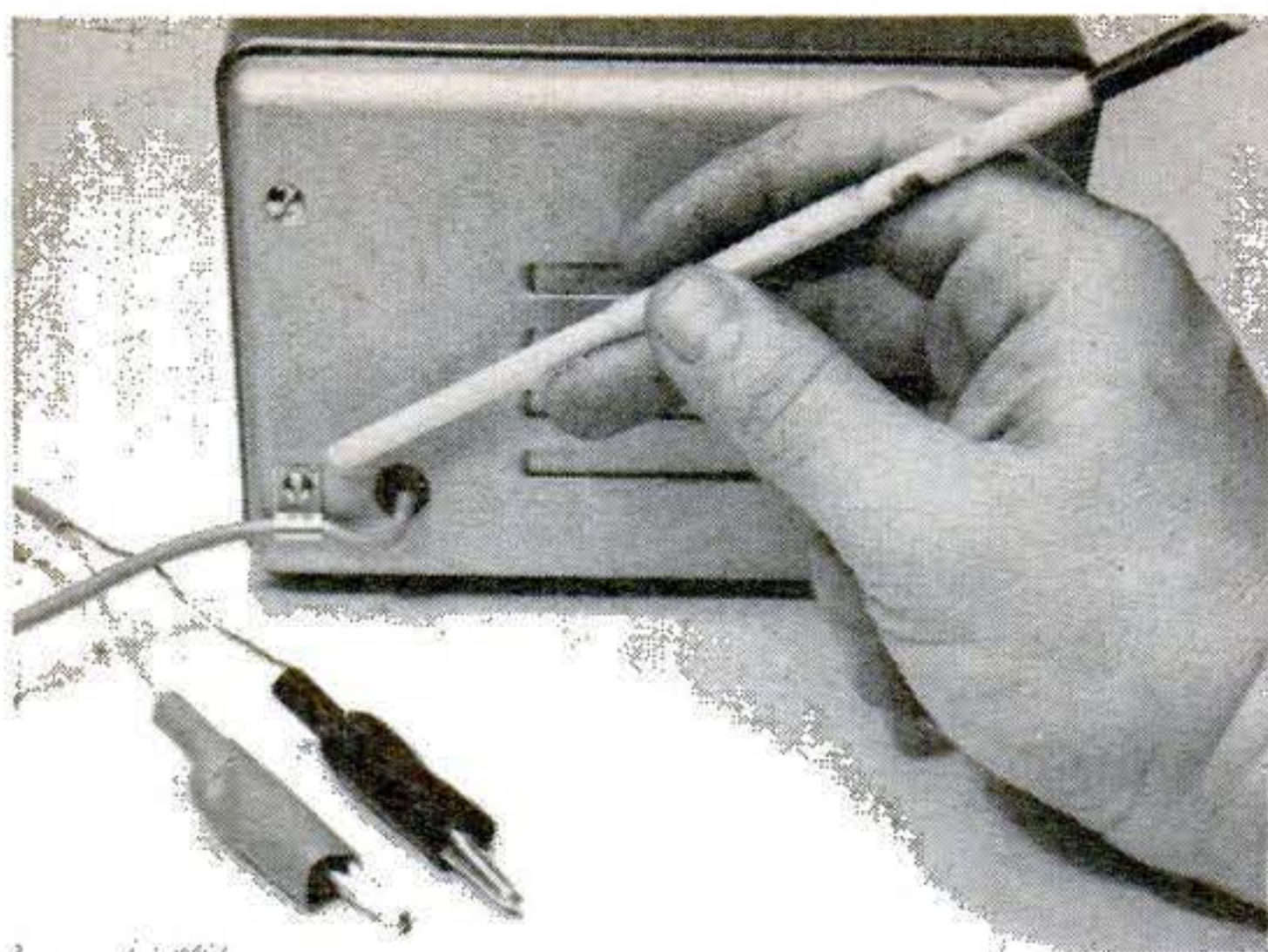

Cable clamp under one of the cabinet screws takes strain on test-lead cable to keep it from being pulled out accidentally. Note rubber grommet to protect cable entering case.

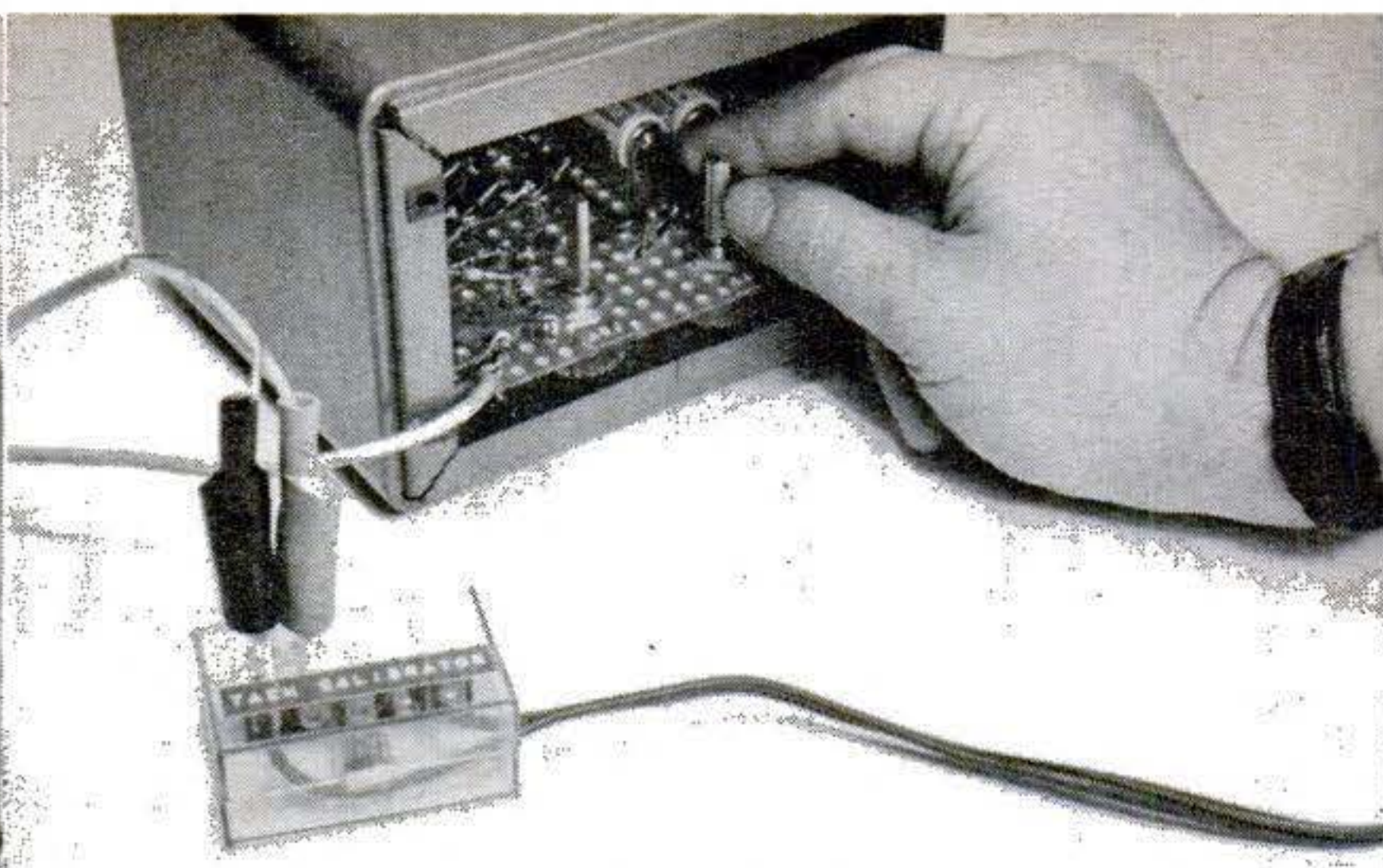

Calibration controls for tach are accessible with back cover removed. One being adjusted here sets meter for number of cylinders. Probes are clipped to calibrator for this adjustment.

(SW1)? It's easy to confuse the terminals. Here's how to identify them: With the switch mounted on the panel, turn the knob counterclockwise as far as it will go (Tach position). For the next step you'll need some means of identifying the contacts. If you have no ohmmeter, a flashlight battery wired to a bulb can serve as a continuity checker. As the rear of the switch is viewed, touch one wire to one inner switch contact at the lower left. The other wire is touched to all nearby contacts on the outer ring until the bulb lights.

When this combination is found, consider the inner contact as 1 (the common terminal) and the outer as 2. Continue by turning the switch to the Dwell position.

Simple calibrator uses ordinary 110-volt AC as a source of electric pulses with an accurately controlled, 60-cycle repetition rate for initial calibration of the tachometer.

Leave the wire on 1 and find the next terminal that makes the bulb light. This is 2. Turn the switch to Continuity and make the bulb light between 1 and 4. This process identifies the first of three switch sections (SW1-A). The other two sections, SW1-B and SW1-C are found in exactly the same way.

If you use the switch in the Parts List, you end up with three extra contacts and a fourth switch position (in the most clockwise direction). Ignore these.

Calibrating the tach. There are two initial adjustments for the tachometer (R8 and R11). Begin by clipping the probes into the tach calibrator and plugging the

[Continued on page 166]

To calibrate tach, attach probes to calibrator and set meter needle to point indicated for number of cylinders in your car. Chart shows how to convert to degrees for dwell angle.

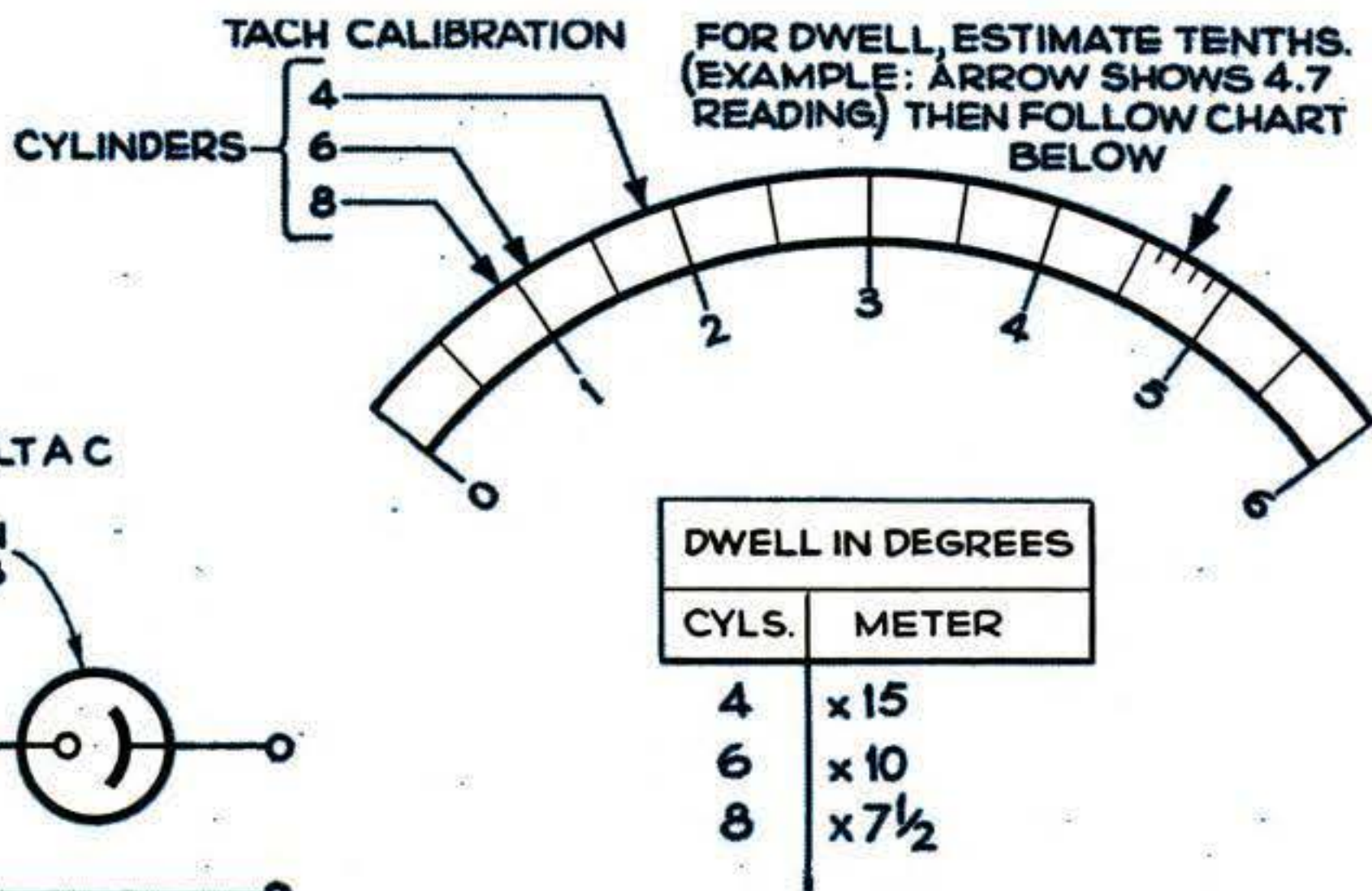
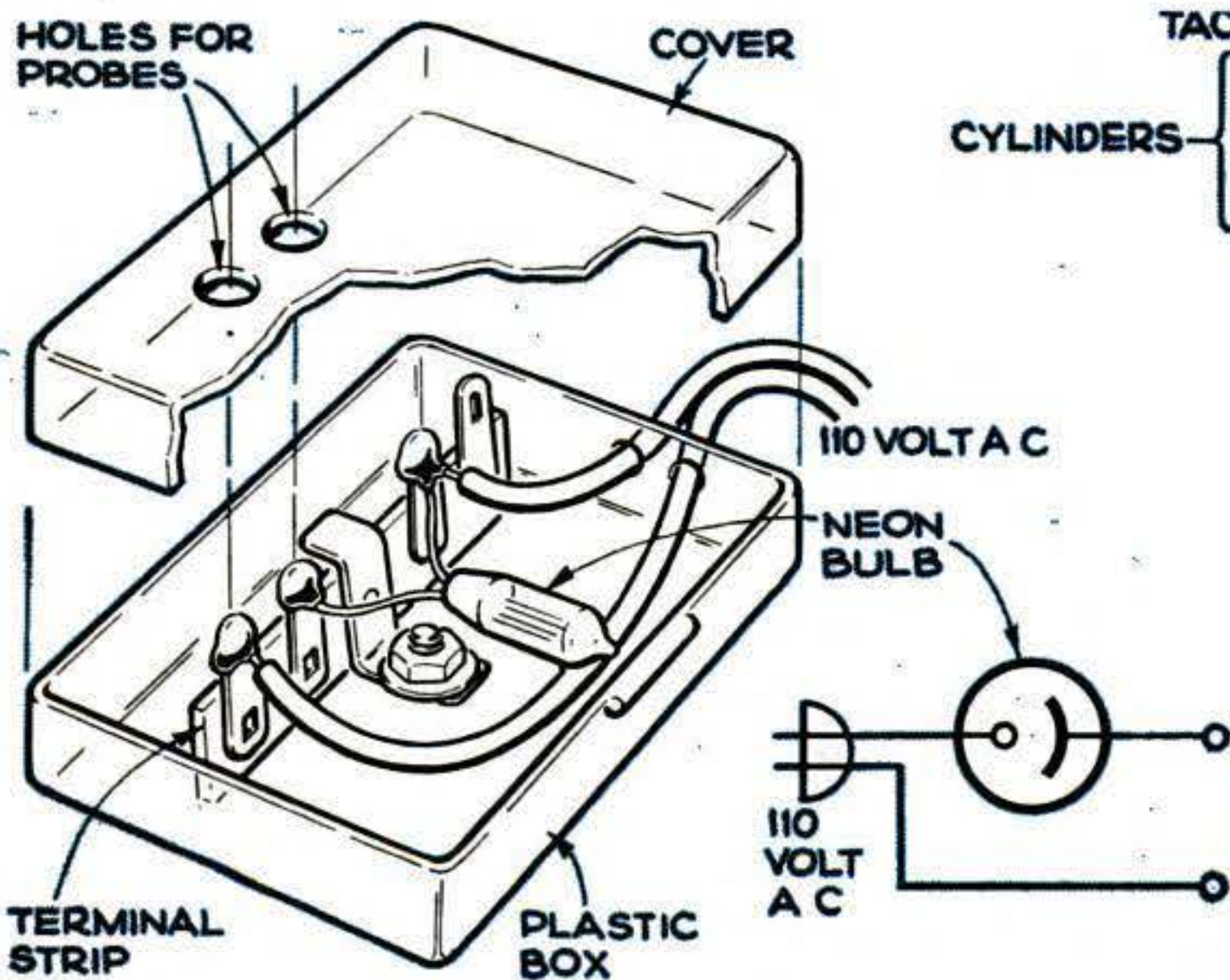

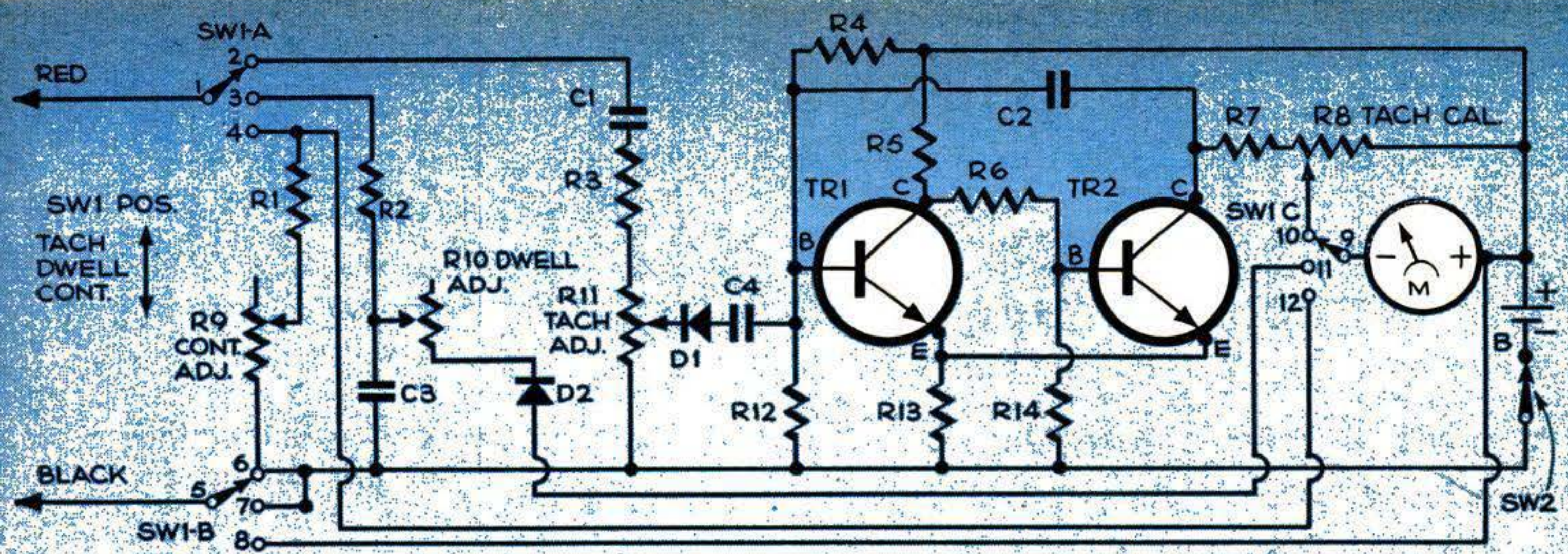

- R1, R2, R14**—4,700 ohms
R3, R12—10,000 ohms
R4—6,800 ohms
R5—1,000 ohms
R6—2,200 ohms
R7—570 ohms
R8—500-ohm carbon potentiometer, linear taper
R9—10,000-ohm carbon potentiometer, linear taper
R10—25,000-ohm carbon potentiometer, linear taper with switch (SW2)
R11—50,000-ohm carbon potentiometer,

(All resistors
 1/2-watt,
 10-percent
 tolerance)

- linear taper
R13—330 ohms
C1—.01 mfd. disk ceramic capacitor, 1,000 VDC
C2—.25 mfd. tubular capacitor, 100 VDC
C3—.1 mfd. tubular Mylar capacitor, 100 VDC
C4—.001 mfd. disk ceramic capacitor, 1,000 VDC
D1—1N34A germanium diode
D2—silicon diode, 200 ma. (Sylvania SR-200, or equal)
TR1, TR2—2N170 transistors

- M**—special meter calibrated in r.p.m. (Burstein-Applebee, 1012 McGee, Kansas City 6, Mo., No. 18A3)
SW1—rotary switch, 3-position, 3-pole nonshorting type (Mallory 3234J)
B—battery, two 6.75 mercury cells in parallel (Mallory TR-115R, or equal)
Misc.—metal case approximately 4" x 6" x 5 3/4" (Bud CU-465, or equal); perforated circuit board with terminal clips; shielded phono cable; alligator clips; NE-2 neon bulb; small plastic box; misc. hardware.

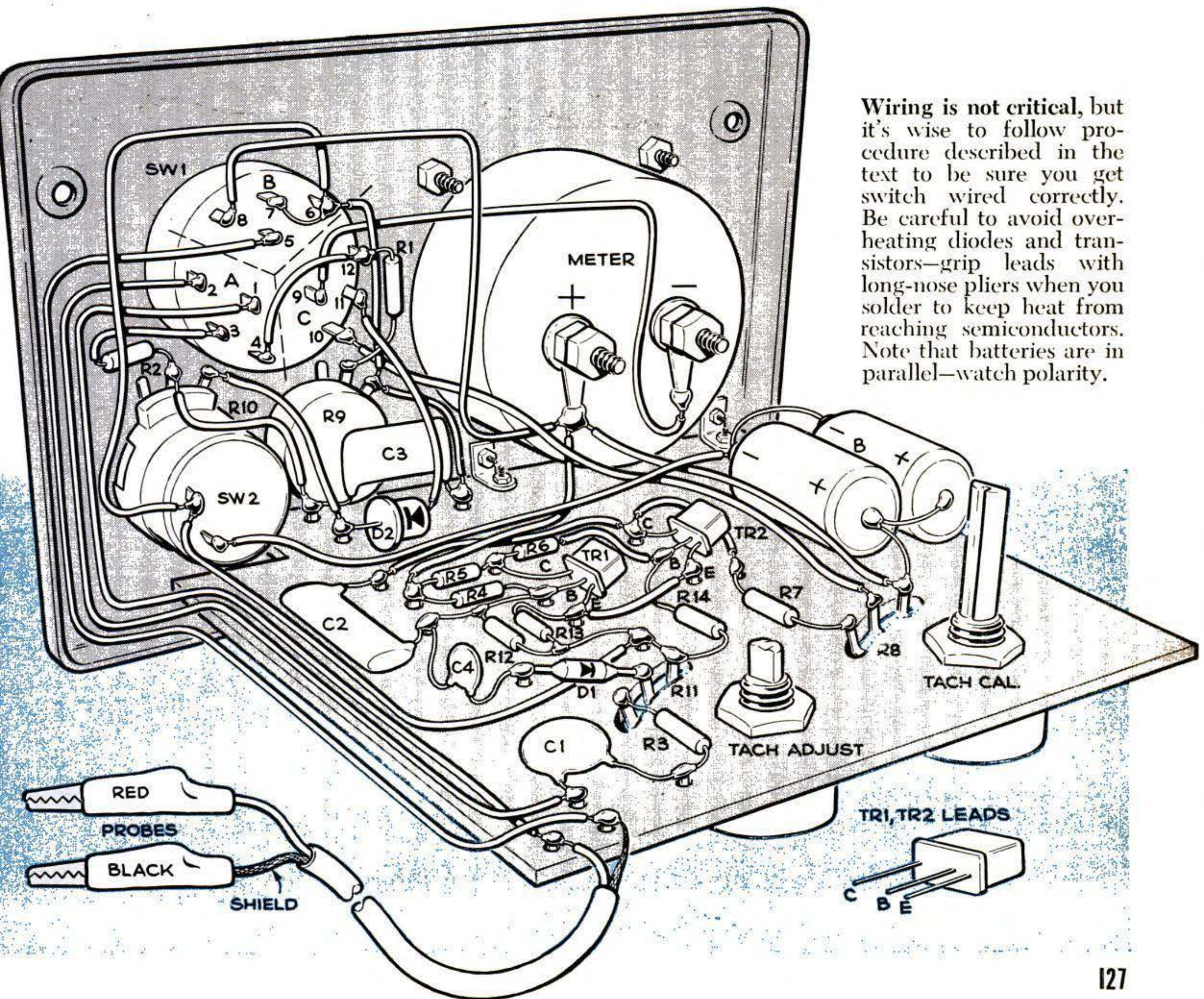

Wiring is not critical, but it's wise to follow procedure described in the text to be sure you get switch wired correctly. Be careful to avoid overheating diodes and transistors—grip leads with long-nose pliers when you solder to keep heat from reaching semiconductors. Note that batteries are in parallel—watch polarity.

what's new
for CAMPING

Man! Here's a COOL Way

New portable refrigerators that run on gas or electricity let you rough it in luxury

YOU can go off into the wilds this summer and still enjoy a fresh steak, ice-cold drinks, butter, eggs, frozen foods—all the things you usually have to leave at home. The answer is a new breed

of small, portable refrigerator that works anywhere you take it on any of several kinds of fuel that happens to be handy.

At home, you plug the refrigerator into a standard 110-volt outlet. In a car or boat, you hook onto the 12-volt battery or generator system. When you're off in the woods, you switch over to a small built-in tank of propane gas—the same kind of disposable tank that fuels the familiar little gas soldering torch.

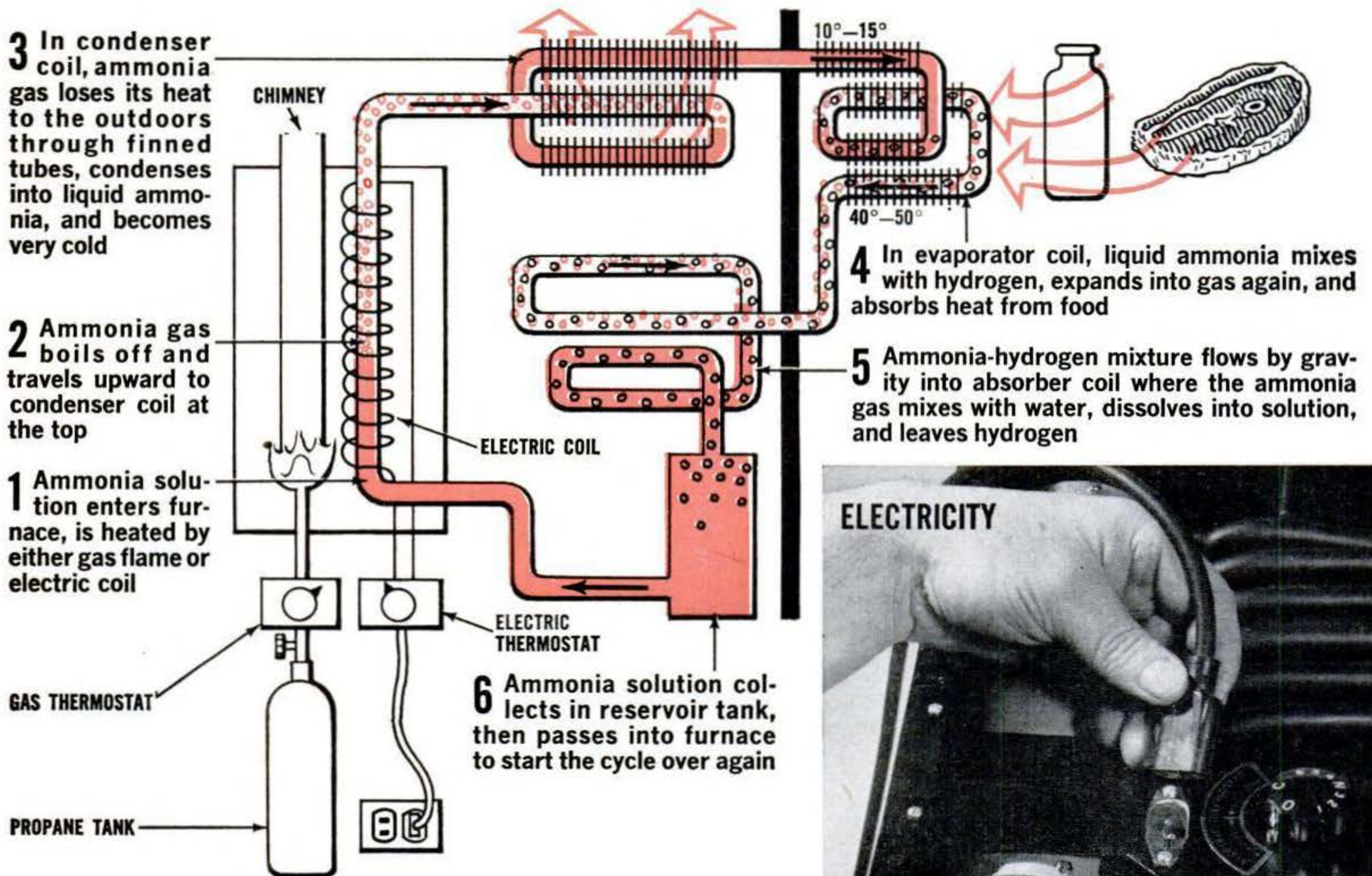

Run it on gas or electricity—it's all the same to this refrigerator. Ammonia boils off under heat, rises, condenses, and chills the food. After mixing with hydrogen, it becomes heavier, sinks to the bottom, and repeats the cycle. For electric heat, you plug in power cord (right). To switch to gas, you light a small burner (facing page). Two separate thermostats in this BernzOmatic model regulate temperature regardless of the fuel used.

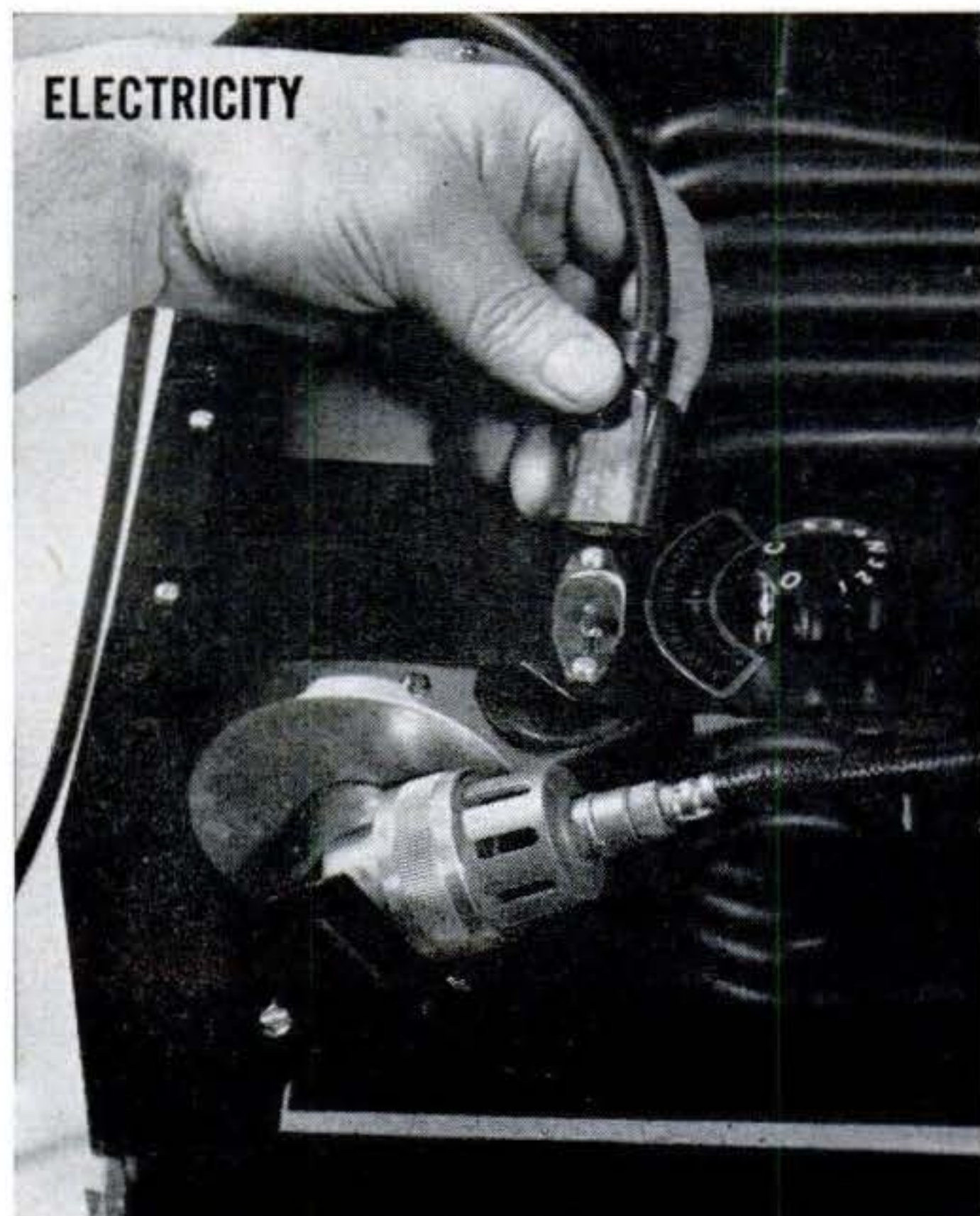

to Camp

Not all of the refrigerators work on all three fuels, but various combinations are available depending on the kind of camping you do most. The type shown here, one of several made by BernzOmatic, runs on gas for off-the-road camping or on house current for home or cabin use. If you vacation mostly by car or boat, there are all-electric models that give you both 110-volt AC and 12-volt DC.

How long do they last? On gas, the refrigerators will give you up to 70 hours of cooling on a single tank—enough for a long weekend away from civilization. Two tanks should last you almost a week. You can stretch your gas supply by precooling the refrigerator before you leave and by switching over to electricity wherever it's available along the way.

One big advantage of the dual-fuel system is that you get not just [\[Continued on page 182\]](#)

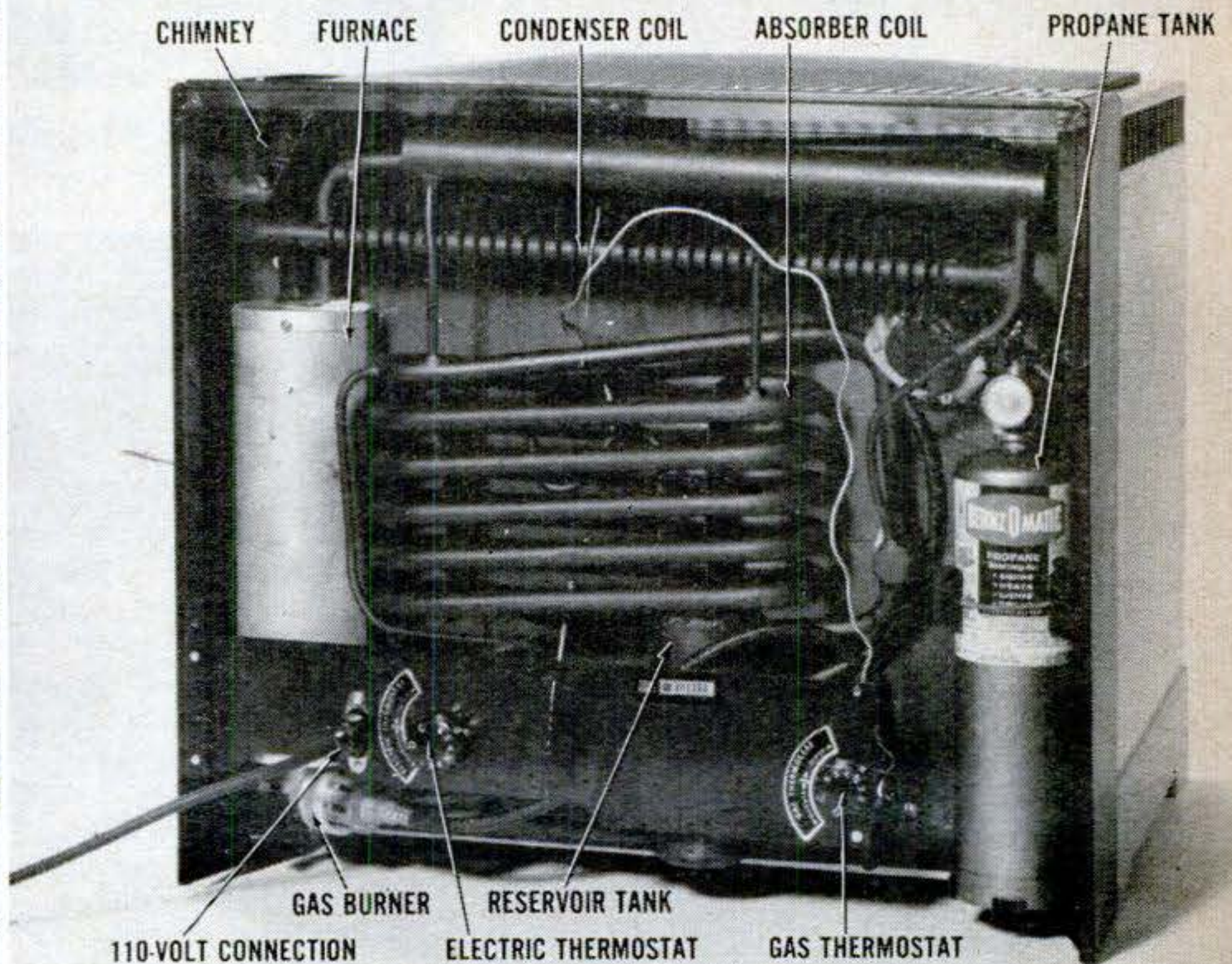
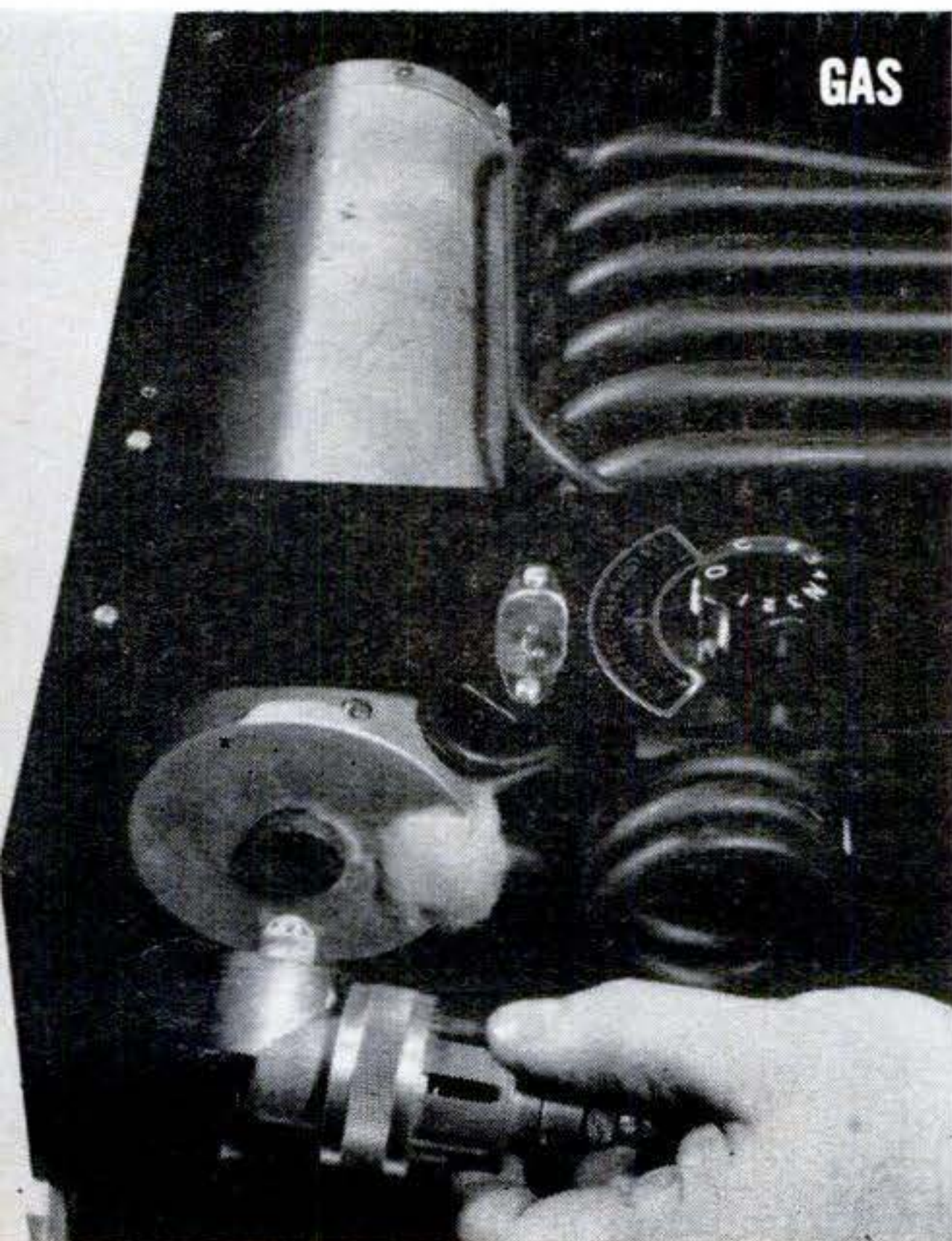

what's new
for CAMPING

Camp Heaters Cook, Warm You, Give Light

Campers, hunters, and boatmen can cook, keep warm, or dry out wet clothing with two new featherweight heaters.

The Camp Champ (top photos) weighs less than three pounds. Burning propane gas on a perforated ceramic mat, it generates infrared heat at 1,650 degrees F. You focus it to reflect heat where you want it and it operates four to five hours without refueling. The Hupp Corp., Perfection Div., 1135 Ivanhoe Rd., Cleveland, sells it for \$20.

The Combo (lower photos) will not only cook your meal and keep you warm, but will even give you light to read by in your tent. Stoked with a gallon of kerosene, it gives out 4,400 BTUs an hour for 35 hours. The grill of the eight-pound heater reaches 650-750 degrees at center, but drops to 100 at the edge for easy handling. Golden Crown Products Co., 734 May St., Jacksonville, Fla. About \$33.



The Camp Champ focuses heat where you want it.

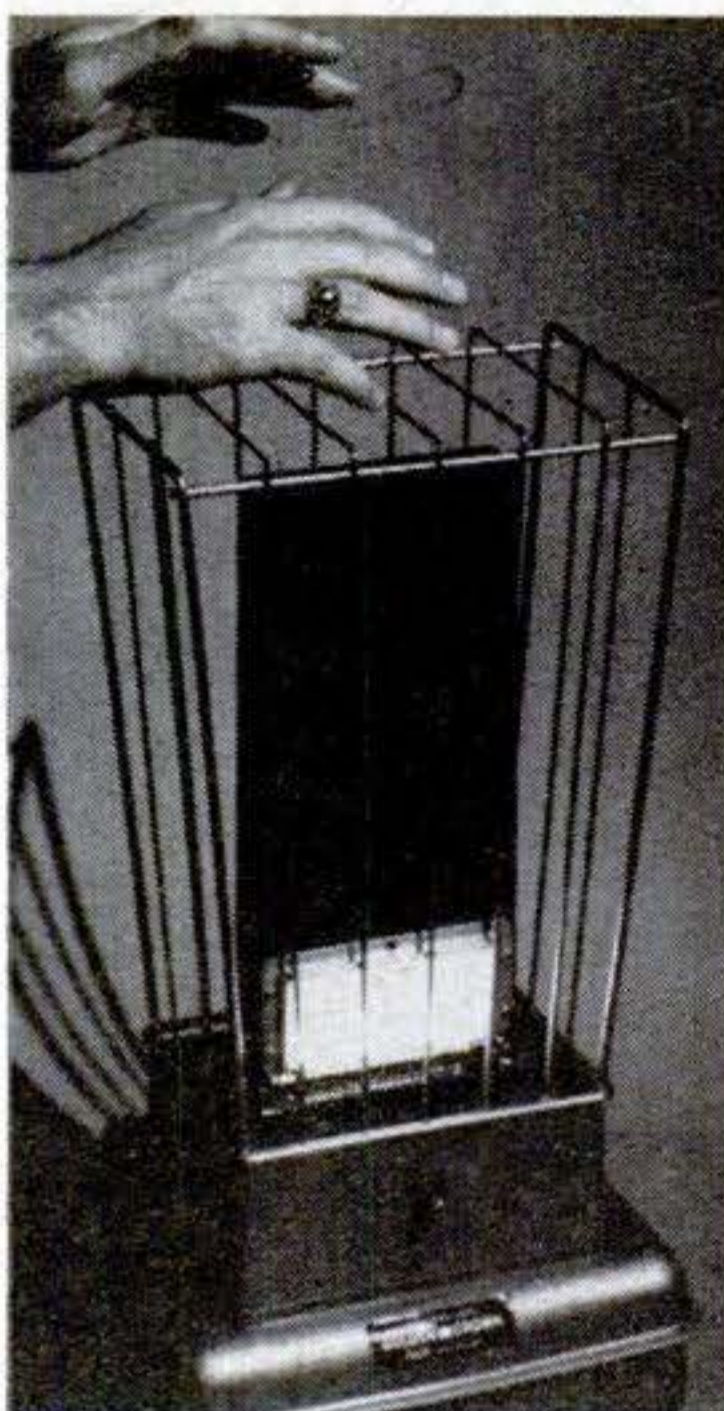

The Combo lights instantly without smoke or odor.



Deluxe camper offers comfort on wheels

Communication is easy between Studebaker's Camper (built on $\frac{1}{2}$ - and $\frac{3}{4}$ -ton Champ pickups) and cab: A sliding front window in the Camper matches one in the cab's rear. In addition, the Camper has picture windows, built-in cabinets, a full-width shelf, two removable cots. The back panel and cots are removable to leave enclosed pickup truck.

PHOTOGRAPHICALLY SPEAKING

By Bob Hering PS PHOTO EDITOR



Photographing the sun during a total eclipse

A rare spectacle is due on July 20—a total eclipse of the sun. If you're on its route, you can photograph it. Practically any camera will do. The eclipse will begin in Japan at sunrise and, moving ahead of the earth's rotation, cross over Alaska, Canada, and Maine, ending in the Atlantic at sunset. You have to be within 20 miles on either side of the center line (see map at left). Many professional and amateur astronomers in this country will travel to Maine to observe and photograph it.

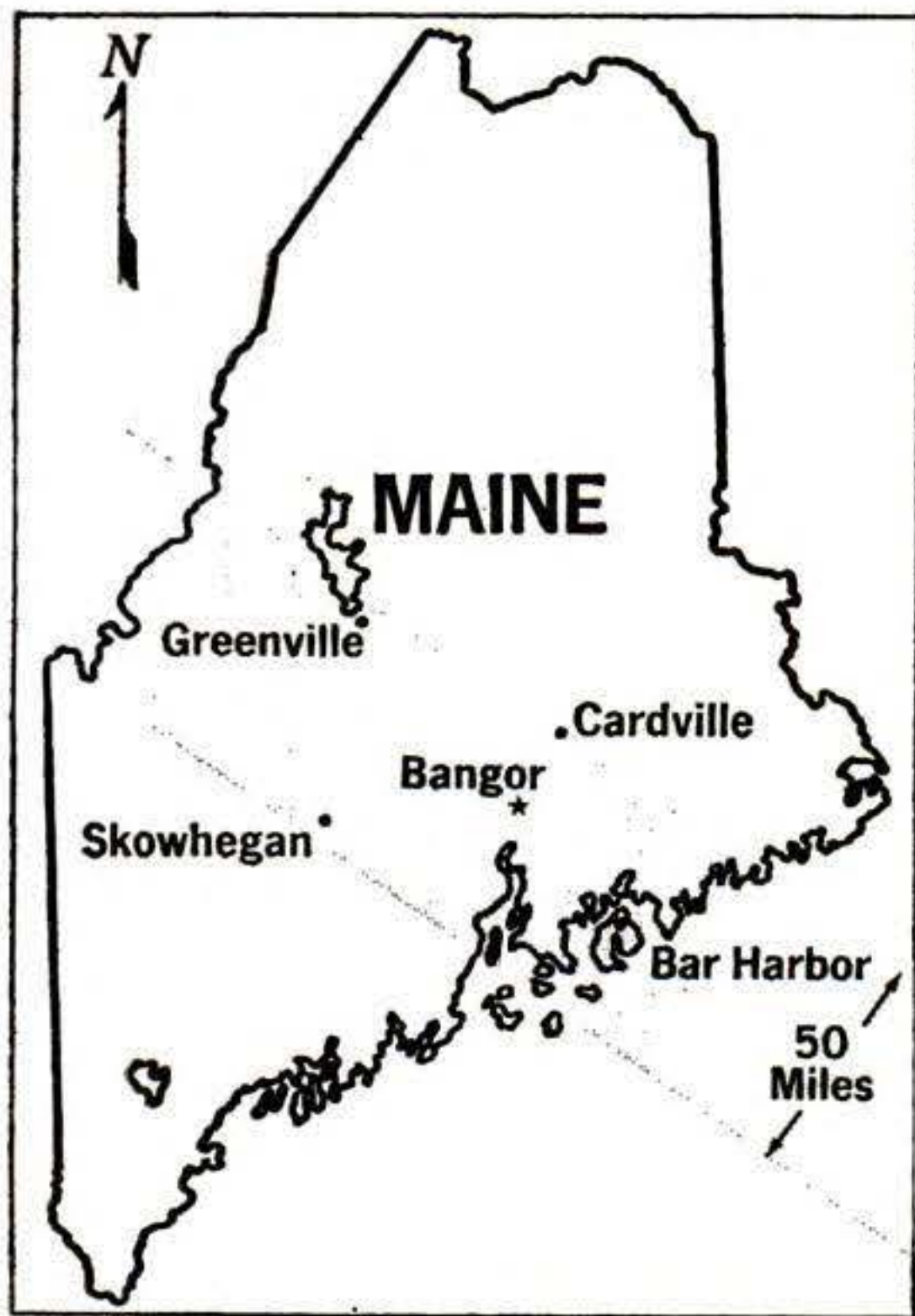

A total eclipse occurs only when the earth, sun, and moon are in line. For a short time, the moon completely hides the sun.

A precaution: Looking at the sun through any optical instrument can permanently blind you. It's necessary to reduce the light intensity, and ultraviolet and infrared radiation, which can damage eyes instantaneously without your being aware of it.

You can protect your eyes with a neutral-density filter made of two sheets of film, completely light-struck and developed to at least 6.0 density. The neutral-density filters you need for photographing the eclipse give no visual protection. Use exposed-film filters to view the sun; change to dyed gelatin filters to photograph it.

Fast-opening shutter uses aluminum foil

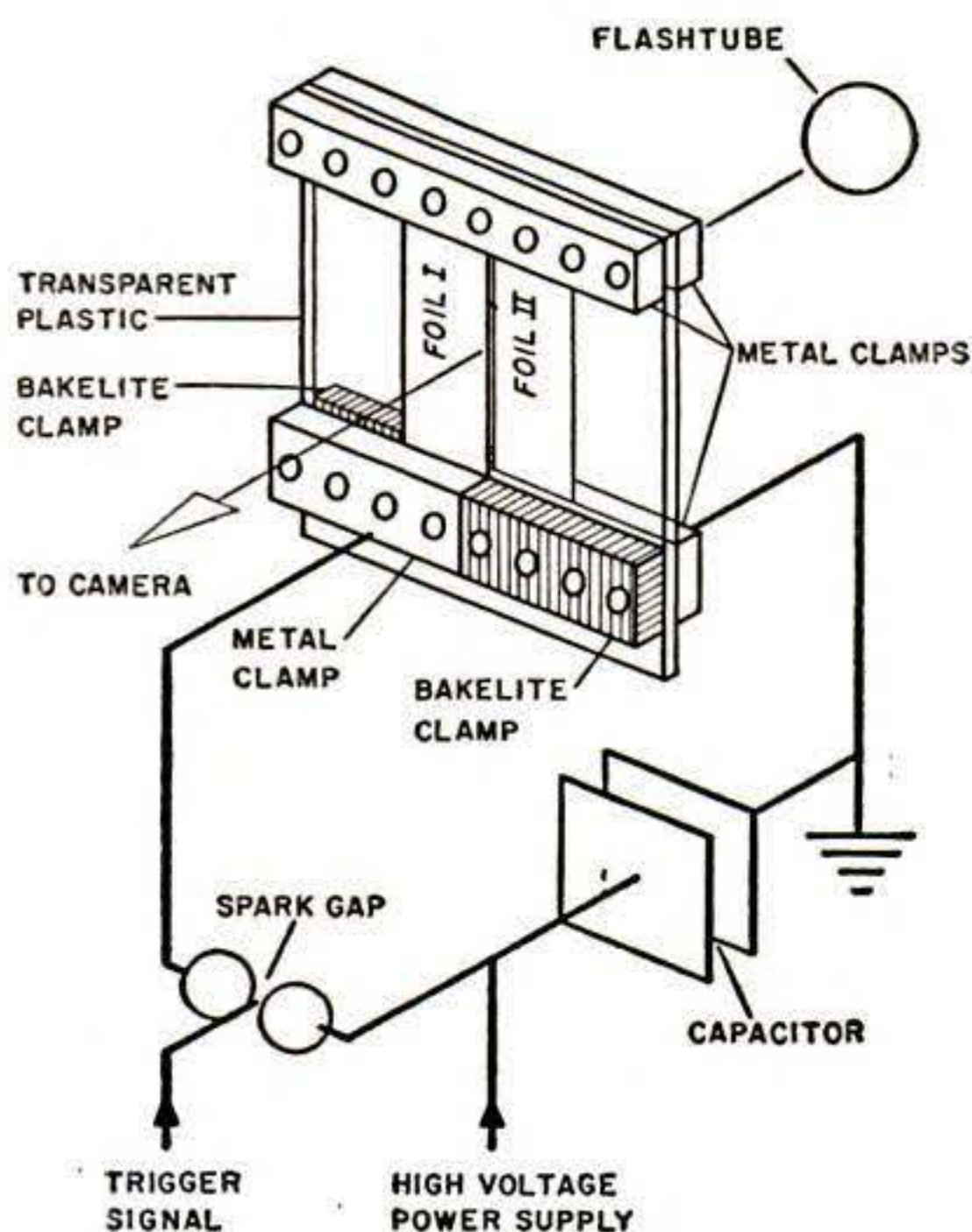

An electromagnetic shutter that will open in 45 millionths of a second has been devised by the National Bureau of Standards. It consists of two aluminum-foil strips on opposite sides of a transparent plastic sheet, and connected to a capacitor discharge circuit. When the capacitor is discharged, magnetic forces cause the foils to repel each other—leaving a 1'-by-3' opening. To end the exposure, NAB men explode a series of parallel lead wires (Edgerton's method) to blacken the plastic window. Sorry, you can't re-use the foils.

Now: Instant-instant photography

Polaroid's 10-second pictures seem fast enough for me. But GE has something a lot faster in the development stage: a picture you can view immediately without use of chemicals. Developing is done by

[\[Continued on page 173\]](#)

A precision-built instrument, the subminiature can be a

Versatile 'Second' Camera

By Bob Hering

DON'T let its size fool you. A subminiature is a real working tool—not a toy. Its compactness and portability make it an excellent choice as a second camera.

Cameras about the size of a pack of cigarettes or smaller are generally classified as subminiatures. Most of these use 16mm film or smaller—though one, the Tessina, uses half-frame 35mm but is compact enough to include on the list. The popular Minox uses 9.5mm film.

A true subminiature is easy to carry—on a chain attached to your belt and slipped into your pocket, or in a case on your belt. One is offered with a wristband. A protective case helps keep out dust when you carry a subminiature in your pocket.

Practicality? Take a look at these uses:

- Many business and professional men use their subminiatures like notebooks. One businessman snaps pictures of faces he wants to remember. He then has a ready

[Continued on page 172]

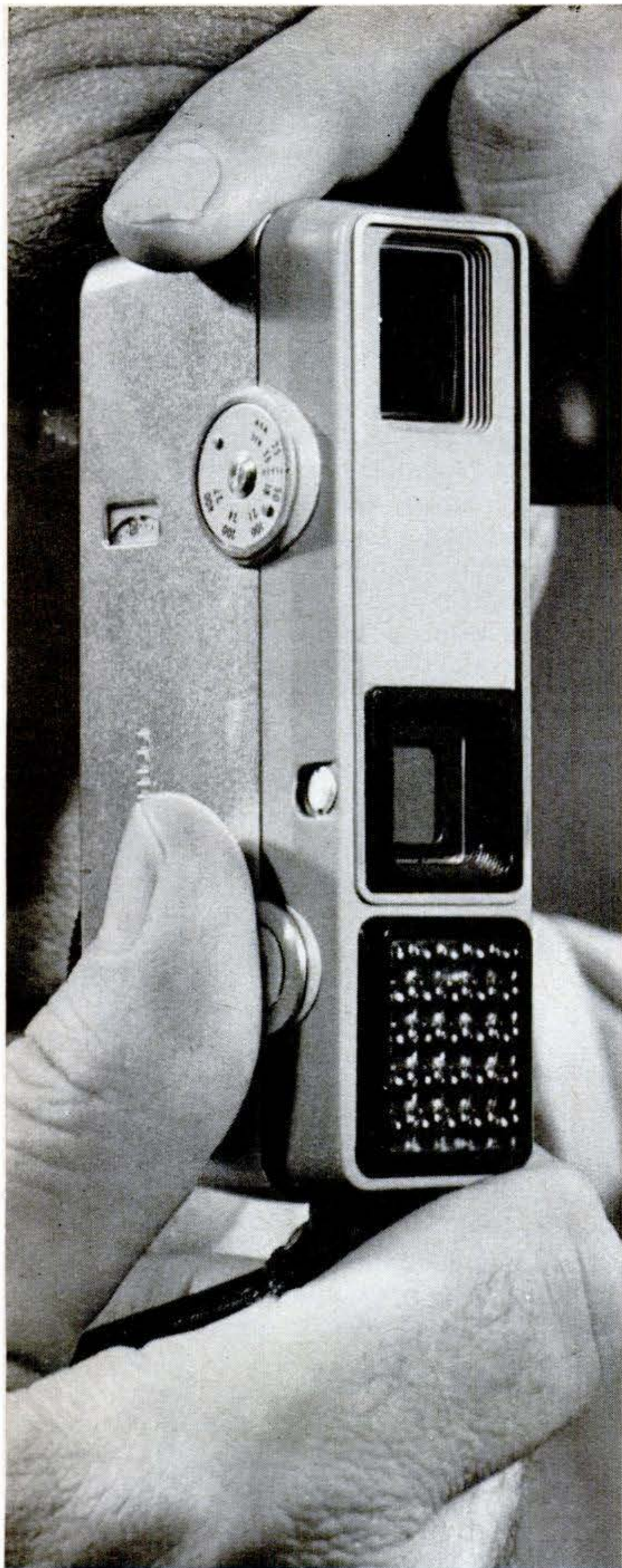

Typical automatic subminiature, Minolta 16-EE takes 10-by-14mm pictures on 20-exposure, cassette-loaded, 16mm film. Rapid push-pull body action advances film, cocks shutter, counts exposures. Small size makes it easy to carry in your pocket.

Built-in exposure meter couples to shutter-speed dial through gear train. Turning the dial matches index mark to meter pointer and sets shutter speed automatically. Ribbed filter bar slides (arrows) to position either of two built-in filters.

When you close the camera, the shutter locks; a geared mechanism advances the film; and the exposure counter, geared to sliding action of case, moves ahead one frame. Metal shutter blades slide in front of lens. Lens is uncovered only while shutter is open (see below), during moment of exposure.

When you open the camera, lens and viewfinder windows are uncovered. Shutter-blade springs are tensioned. When you press shutter-release button (thick arrow), shutter blades slide off holding pins (arrow), one at a time, to left. First one uncovers lens, to take picture; the second covers it again. Blades move at same speed. Time lag between their movements determines exposure.

Minox B packs a lot of mechanism in four inches

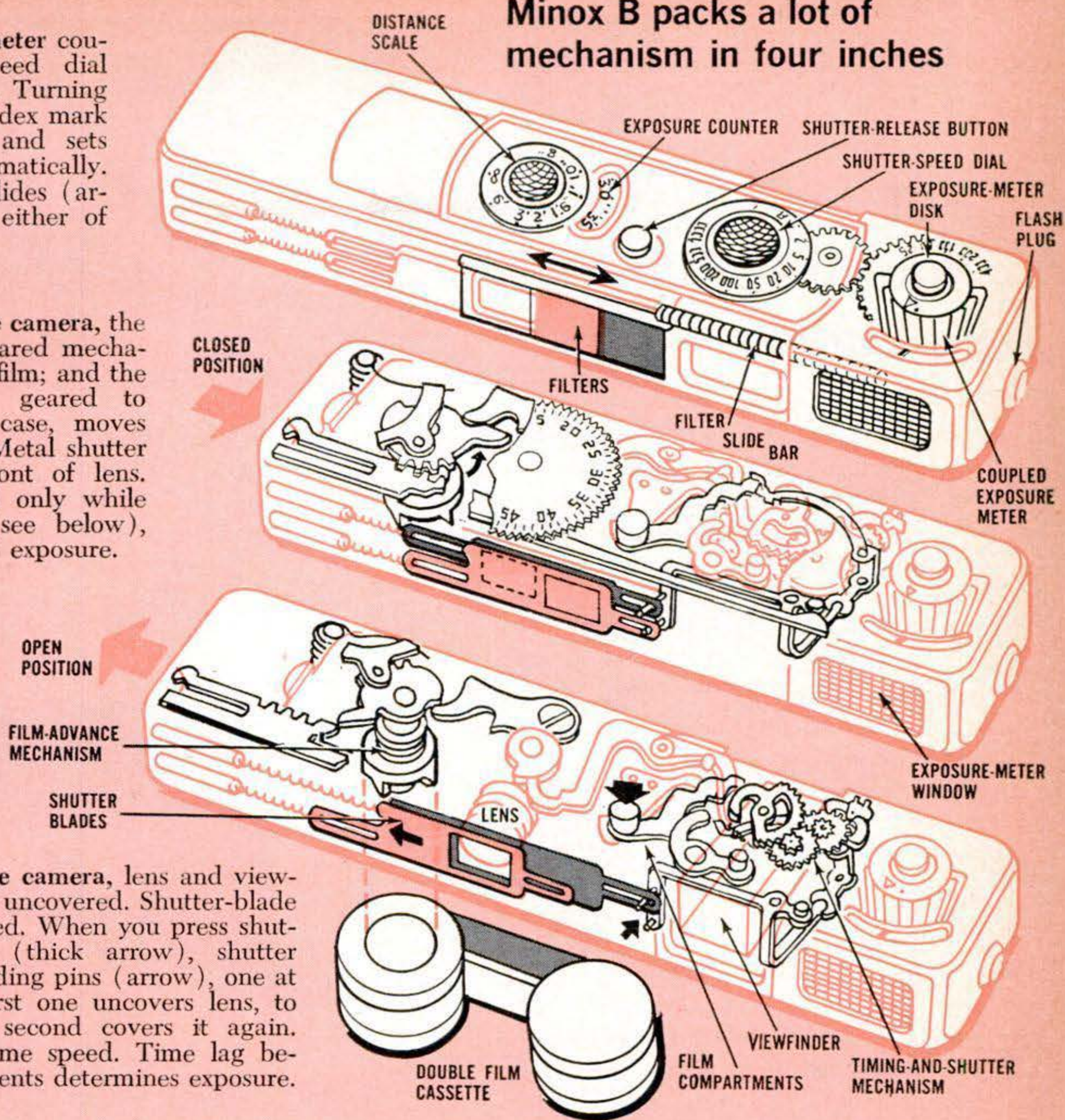

HOW THE SUBMINIATURES COMPARE

CAMERA	LENS	FILM	FINDER	SHUTTER SPEEDS	COMMENTS	PRICE
GAMI 16	25mm f/1.9	16mm	Single viewfinder/ rangefinder window	1/2-1,000	Spring-motor transport; coupled meter	\$299.50
MAMIYA Deluxe Automatic	25mm f/2.8	16mm	Automatic parallax correction	1/5-1/200	Knurled-wheel film advance Coupled meter; drop-in cartridge	\$39.95 \$69.95
MINOLTA 16-P	25mm f/3.5	16mm	Optical viewer	1/50	Thumb-wheel film advance	\$26.90
16-II	22mm f/2.8			1/30-1/500	Push-pull film advance	\$39.95
16-EE	25mm f/2.8			1/30-1/500	Coupled meter	\$79.50
MINOX B Chrome	15mm f/3.5	9.5mm	Automatic parallax cor- rection; frame-line viewer	1/2-1,000	Coupled meter; push-pull film advance and shutter wind	\$149.00
Black						\$176.00
TESSINA	25mm f/2.8	35mm	Sports or twin-lens viewing with parallax correction	1/2-1/500	Spring-motor transport; 14x21mm frame size	\$169.00

Put Your Name in Lights

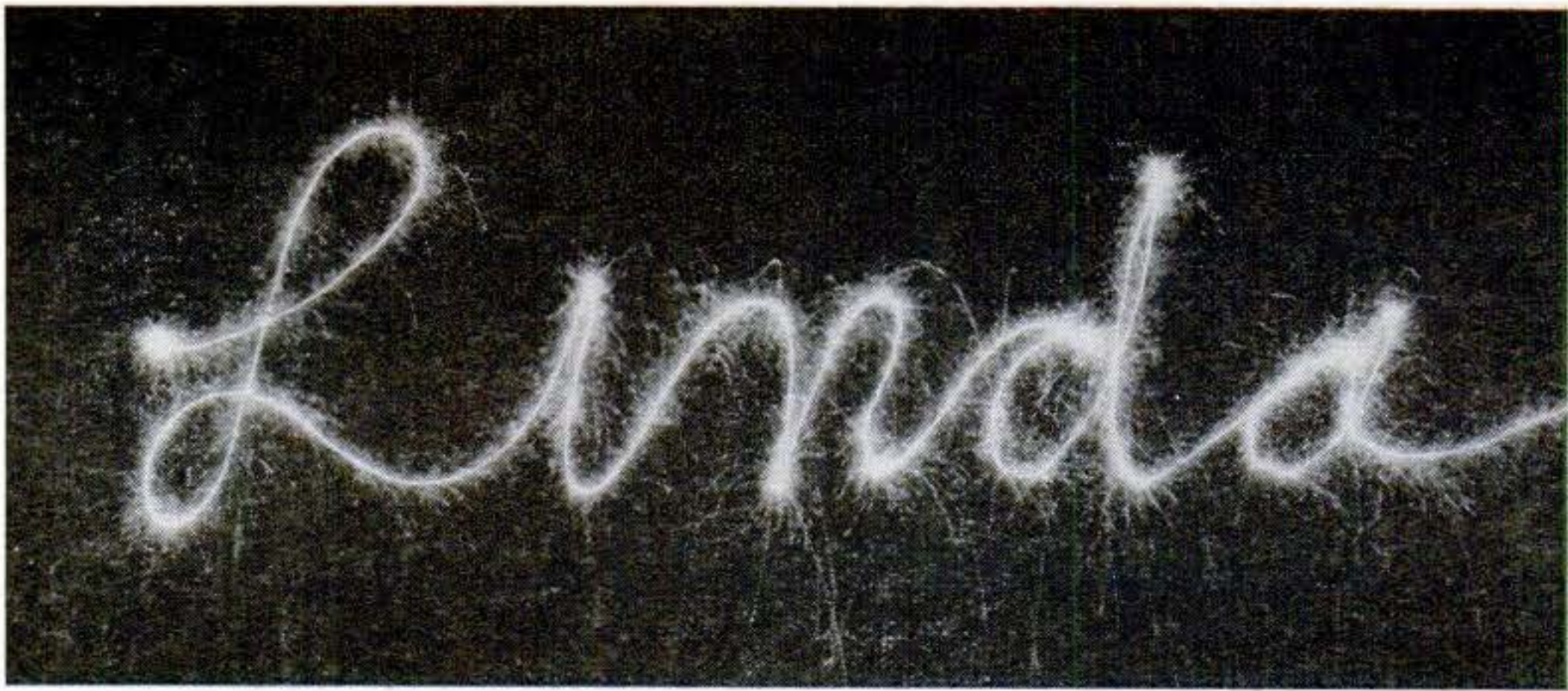

Here's a novel way to photo-record names with Fourth-of-July sparklers. From the negatives, you can print signature cards, displays, or even Christmas cards. Photographing should be done at night, making sure no other lights show in the background. With the camera on a tripod, I

make time exposures at f/16. The "writer" stands facing the camera, moving along as he "spells." On signal, he lights a sparkler, and I open the shutter. I do a dry run or two to make sure the camera is at the correct distance. The negative is printed in reverse.—Don Honick, Bartlett, Ill.

Clamp pod subs for tripod

Where it's impractical to use a tripod, this homemade clamp pod is handy. It's good for extreme high- or low-angle shots, or when you need to take time exposures. And for trips, where a tripod is too bulky to carry, a clamp pod makes a light, portable unit. It's easy to attach to pipes, beams, or railings.

I made mine by drilling two 1/4" holes in a C clamp and assembling it as shown below. I put the clamp between the angle iron and mending plate, then bolted the pieces together. I notched the base of the clamp with a file so it would grip round pieces.—Rudy Schulze, St. Louis.

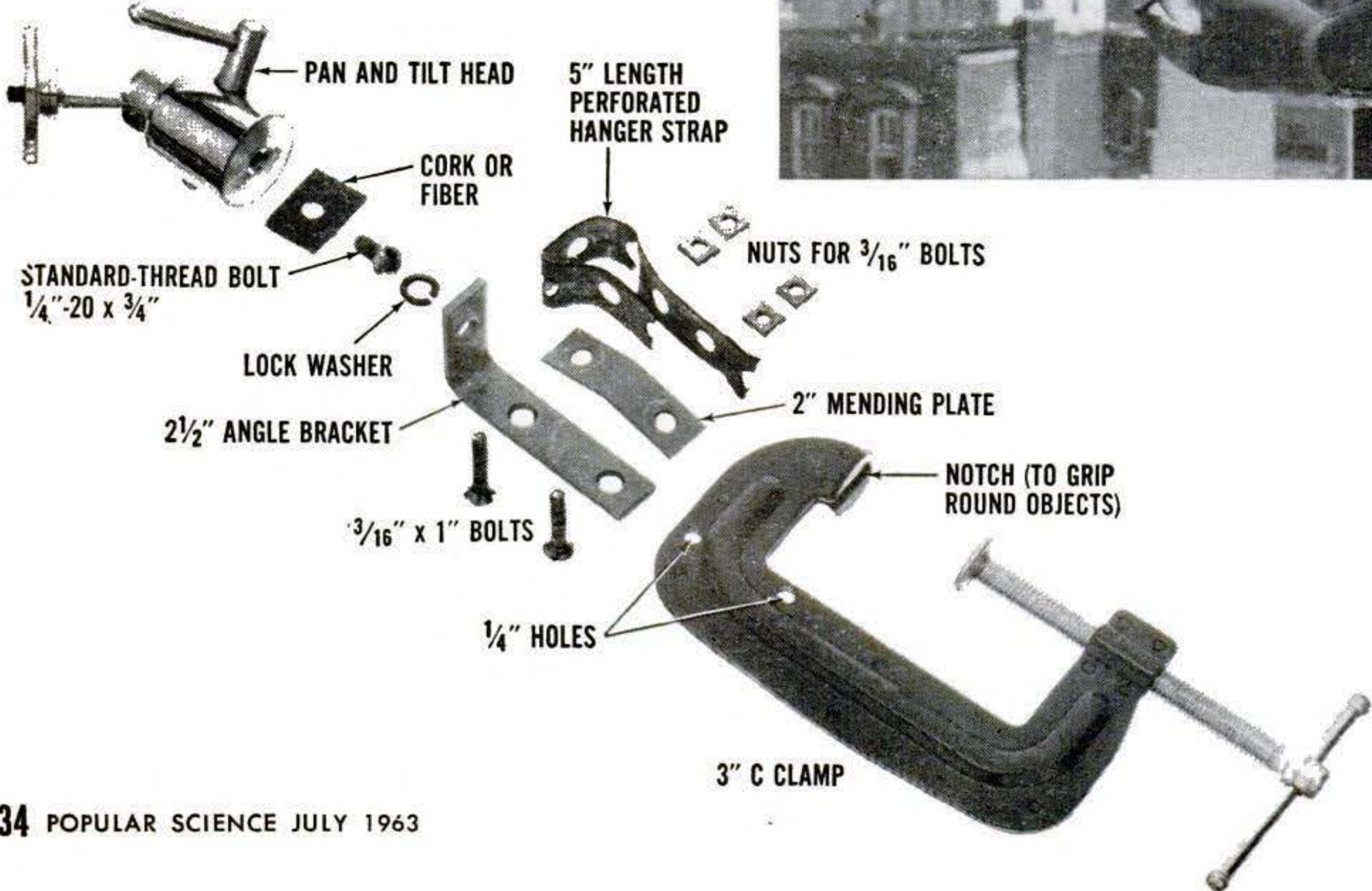
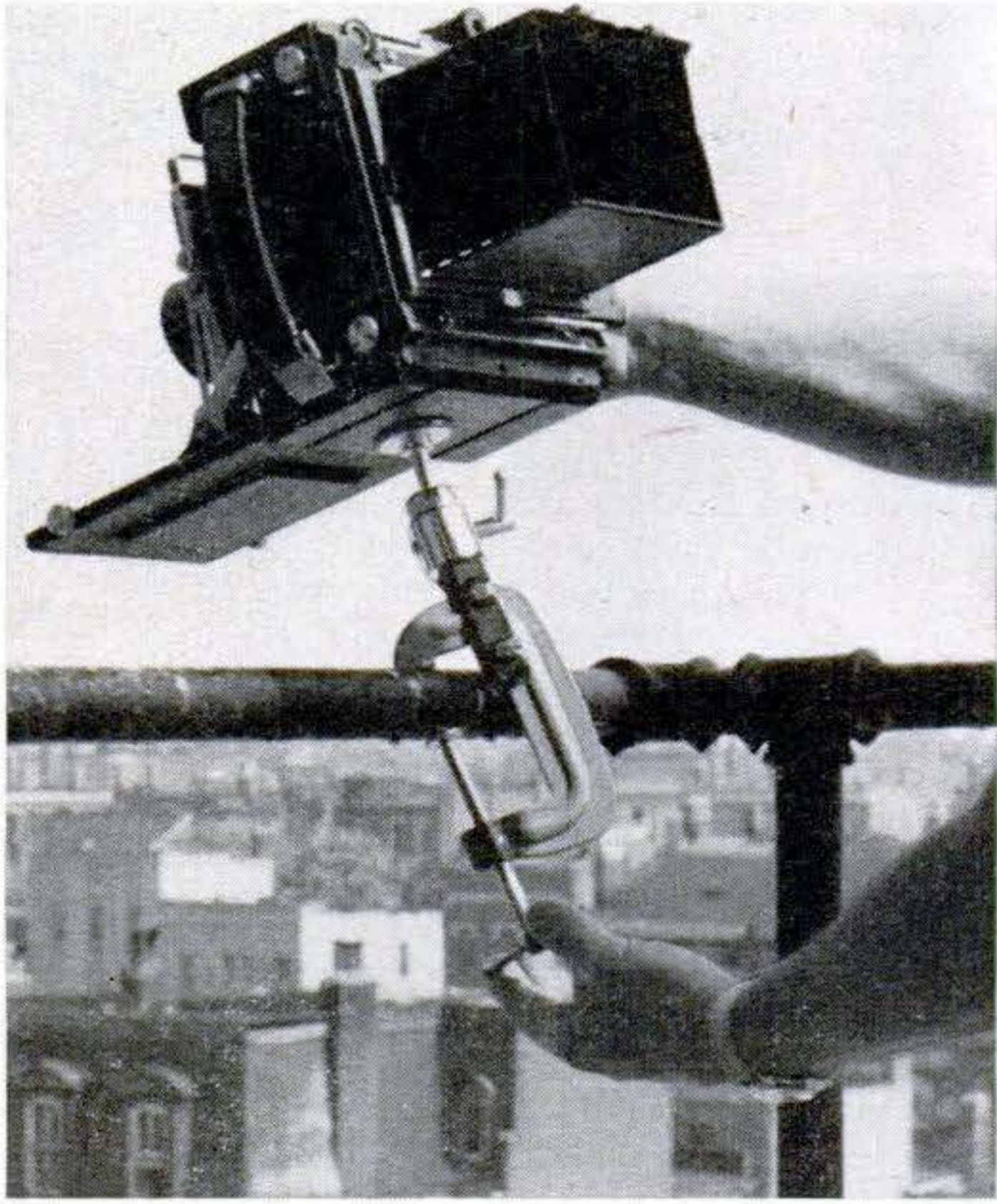

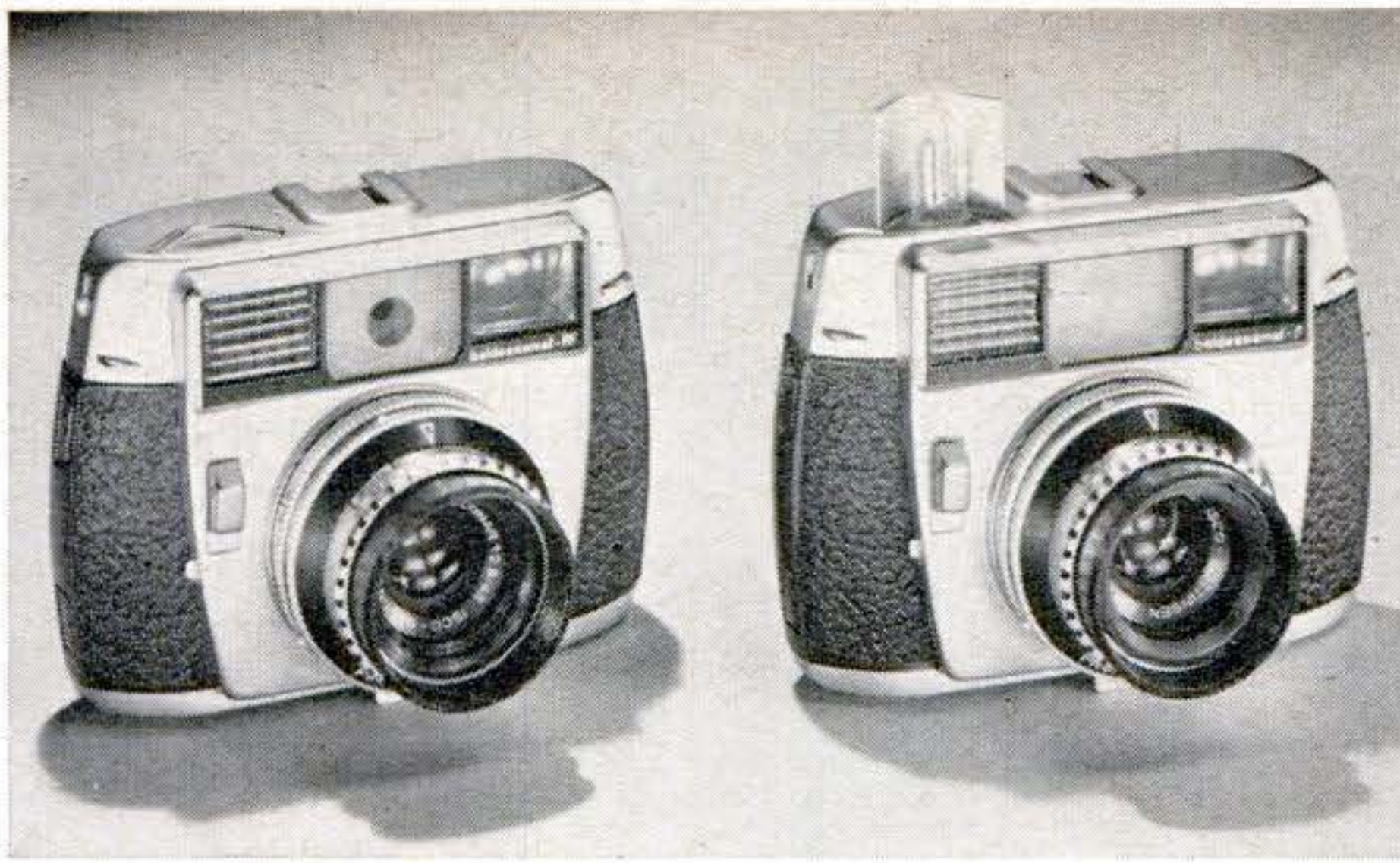

Fast-shooting 35mm camera

The Baldessamat F is ready for automatic operation once film speed is set. If a signal in the viewfinder shows there's insufficient light, you push a lever and a built-in flash unit pops up, ready for use with AG-I bulbs. With the fast film advance, you can fire two or three sequence shots per second and never remove the camera from your eye. The film-speed setting gives the correct flash exposure without using guide numbers. A built-in lens shade retracts flush with the lens mount. Price is \$69.95.

A second model, the RF, includes all the above features plus a coupled rangefinder with automatic parallax correction. Baldessamat RF is \$79.95. Kling Photo Corp., NYC.

Animate films with titling kit

This Title Spots movie set consists of 112 letters and symbols mounted on circular plastic buttons that snap in and out of holes in a board. You can create special effects by shifting letters, making an exposure, and shifting again. \$5.95. Hudson Photo Industries, Irvington-on-Hudson, N.Y.



Underwater camera uses rubber seals

Designed to operate under water without a housing, the Nikonos has rubber rings that seal lens mount and camera body. An optically flat glass protects the lens front. Knobs at the sides set the diaphragm, adjust focus, and show depth of field. A combination control swings out to advance the film, automatically returns to the starting position to serve as the shutter release. There's a built-in lock to prevent accidental firing. The camera accepts Nikkor lenses. About \$160. Nikon, Inc., NYC.



New exposure meter is big as a minute

This Kalimar CdS exposure meter is only 1" by 1 1/4" by 1 1/8". Price with case: \$14.95. You can mount it on the accessory shoe of your still camera or use it as a hand meter. It measures either reflected or (with an attachment that comes with it) incident light. An on-off button automatically returns to the off position to prevent drain on the meter's mercury battery. The needle pointer holds its reading in case you want to refer to it again. There are calibrations for both movie and still cameras. Kalimar, Inc., St. Louis.



Sticky, Flat Cable Adheres to Walls

This flat cable system for intercoms, telephones, doorbells, thermostat controls, and similar devices has a pressure-sensitive adhesive on one side. Called the Scotchflex cable system, it is designed to simplify many types of wiring installations. No wire stripping is needed—special terminal blocks make connections automatically. Minnesota Mining and Mfg. Co.

TV chassis flips down for service

Your TV repair bills should be lower with this chassis that pivots down from its normally upright position to a horizontal one extending from the rear. With both sides accessible, your TV serviceman need not waste time pulling the chassis or working with restricted access. Raised again, it locks safely in place. The design, called the Centurion Chassis, was developed by Dominion Electrohome Industries, Kitchener, Ont. It's being introduced on their TV sets throughout the U. S. and Canada.

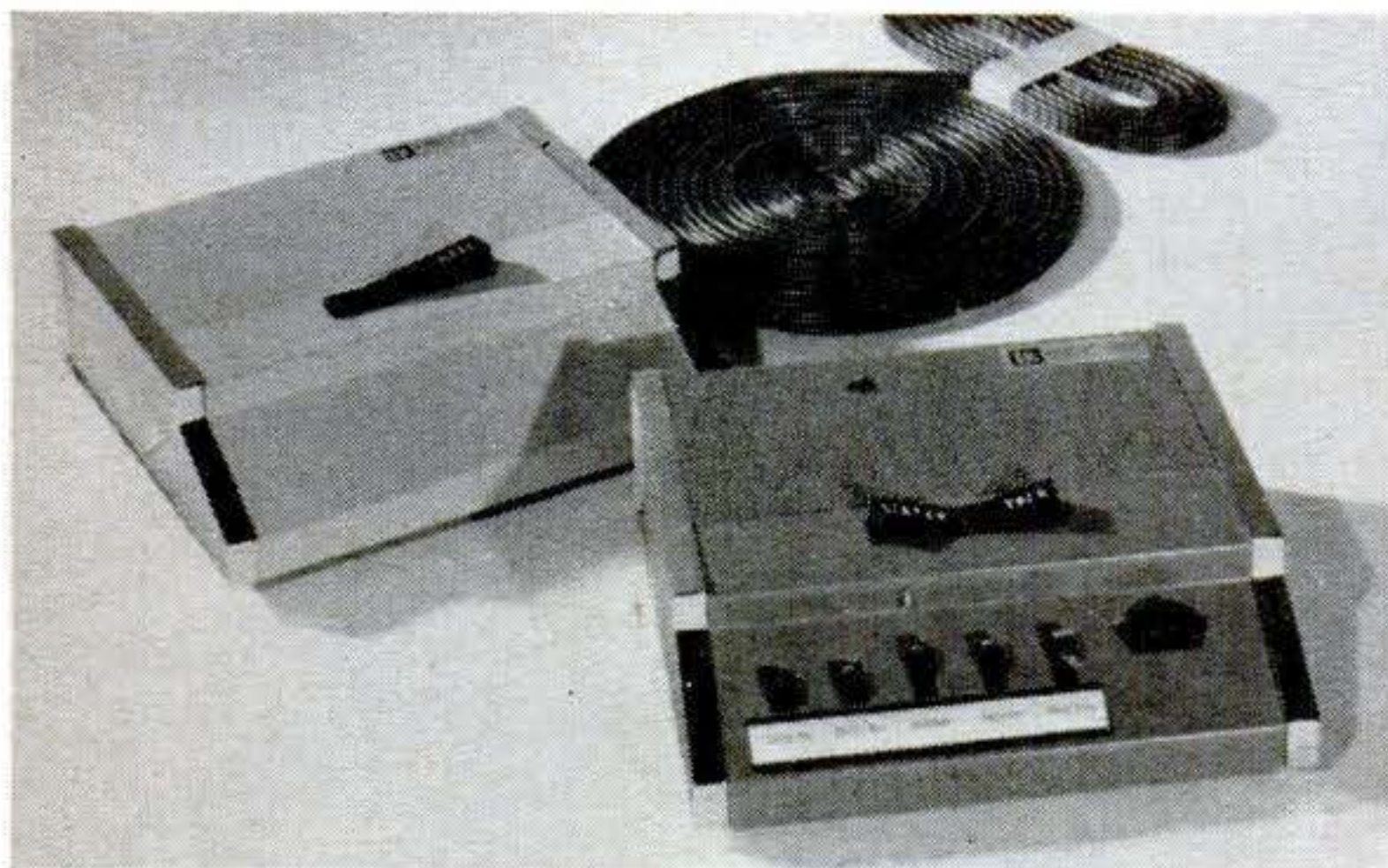
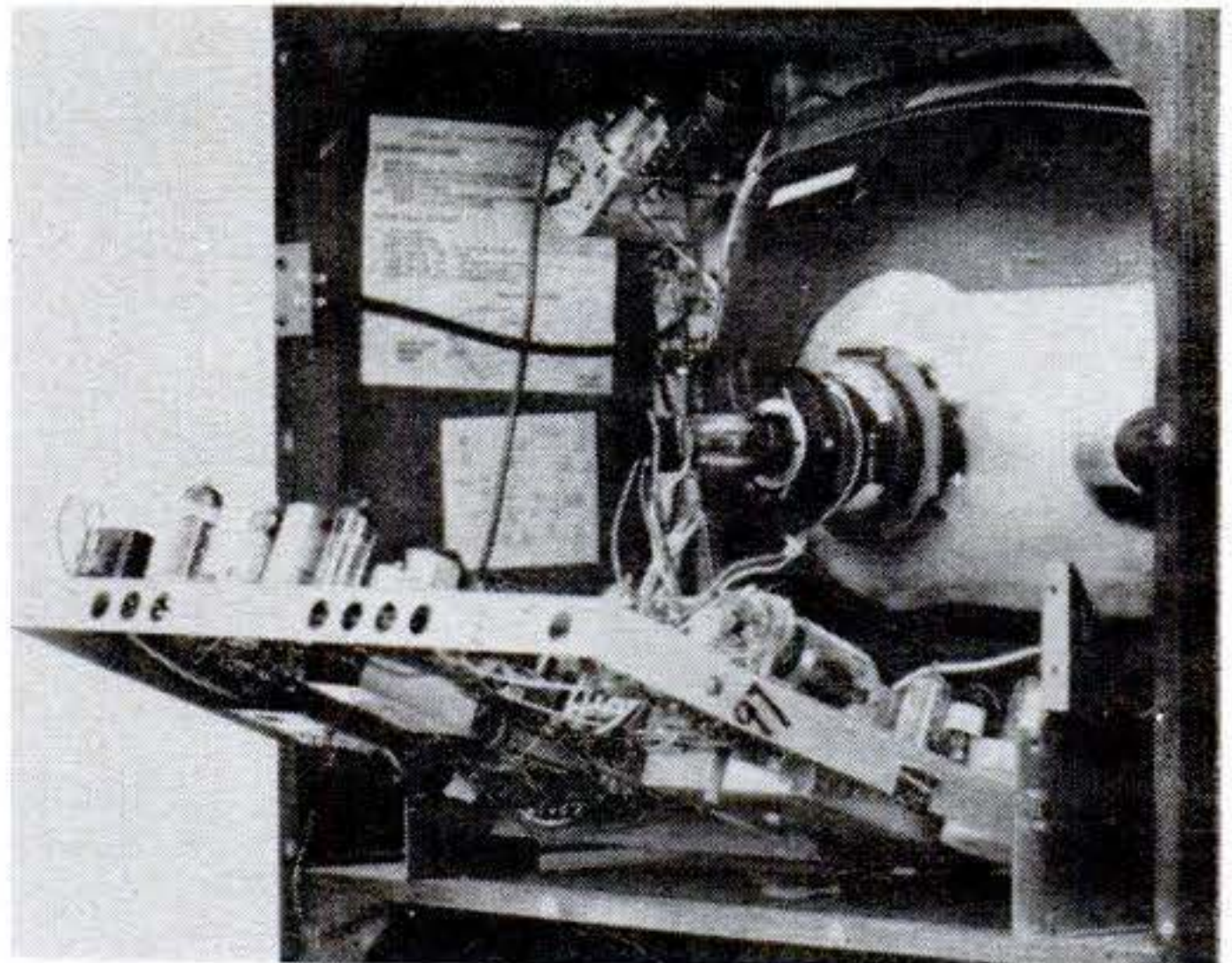

Low-cost intercom is easy to install

Designed for easy installation by the home owner, this transistorized Betacom is sold with a two-year free-service policy. It works on either batteries or 110-volt AC. A system with master and one substation costs about \$35; a master and four substations, under \$100. Beta Instruments, 2205 Butler St., Dallas.



Talk, listen—no hands

You can talk and hear—with both hands free—simply by placing the phone on this tiny, battery-operated amplifier. Several persons can participate in a phone call. It sells, by mail, for \$12.95. Gilwin Corp., Box 4003, Jersey City, N. J.

Bugs Make Juice to Run a Radio

Now you can buy a battery that harnesses the energy of millions of harmless bacteria to produce enough electric current to run a small transistor radio. The biological fuel cells are available as a kit that makes a battery of 12 cells, delivering about 40 milliamps at six volts.

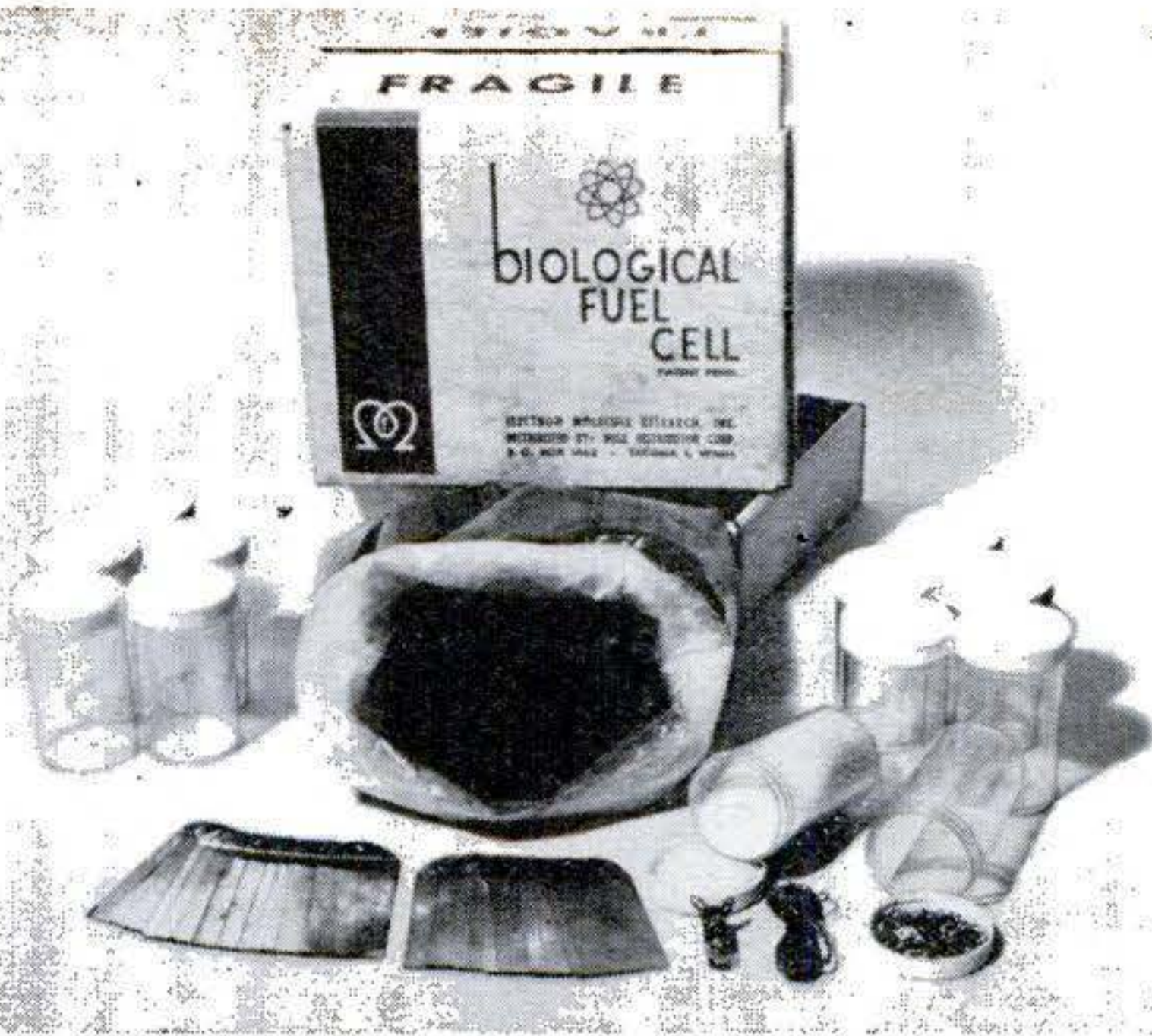

Experimental kit has 12 plastic containers filled with powdered brown-rice husks. Bacteria, feeding on husks, create an electric potential between two electrodes in mix. Occasional addition of water keeps the cell going. \$16. Bulk Distributors, Box 1465, Tacoma, Wash.

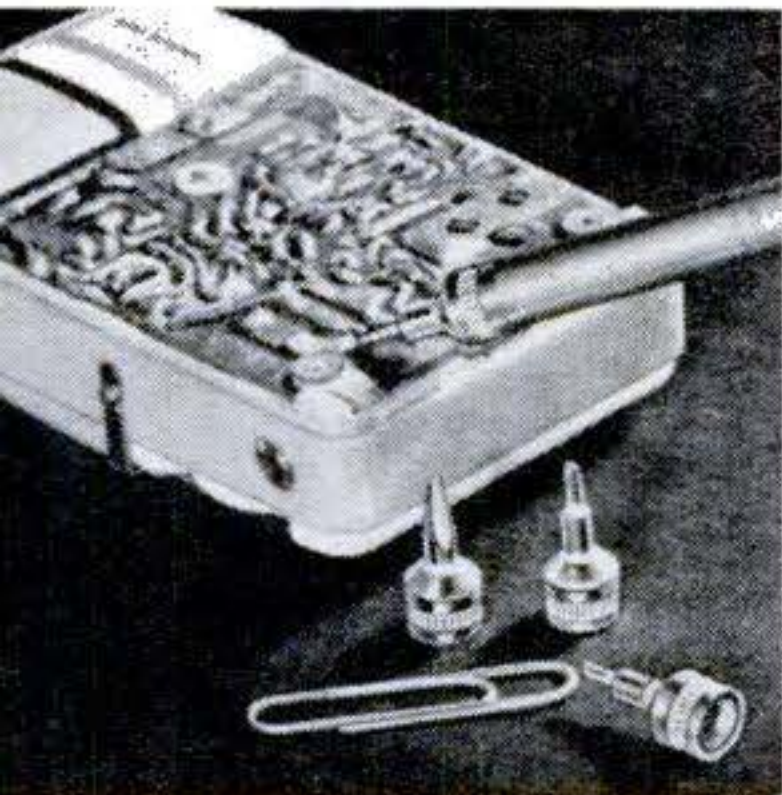

Tiny tips for soldering miniature circuits

A 15-watt heat cartridge and four Micro-Tip thread-on soldering tips are now available for the Ungar Imperial soldering iron, shown at left. They're designed for use on microminiature circuits. The tips are iron-clad and gold-plated. Ungar Electric Tools, Hawthorne, Calif.

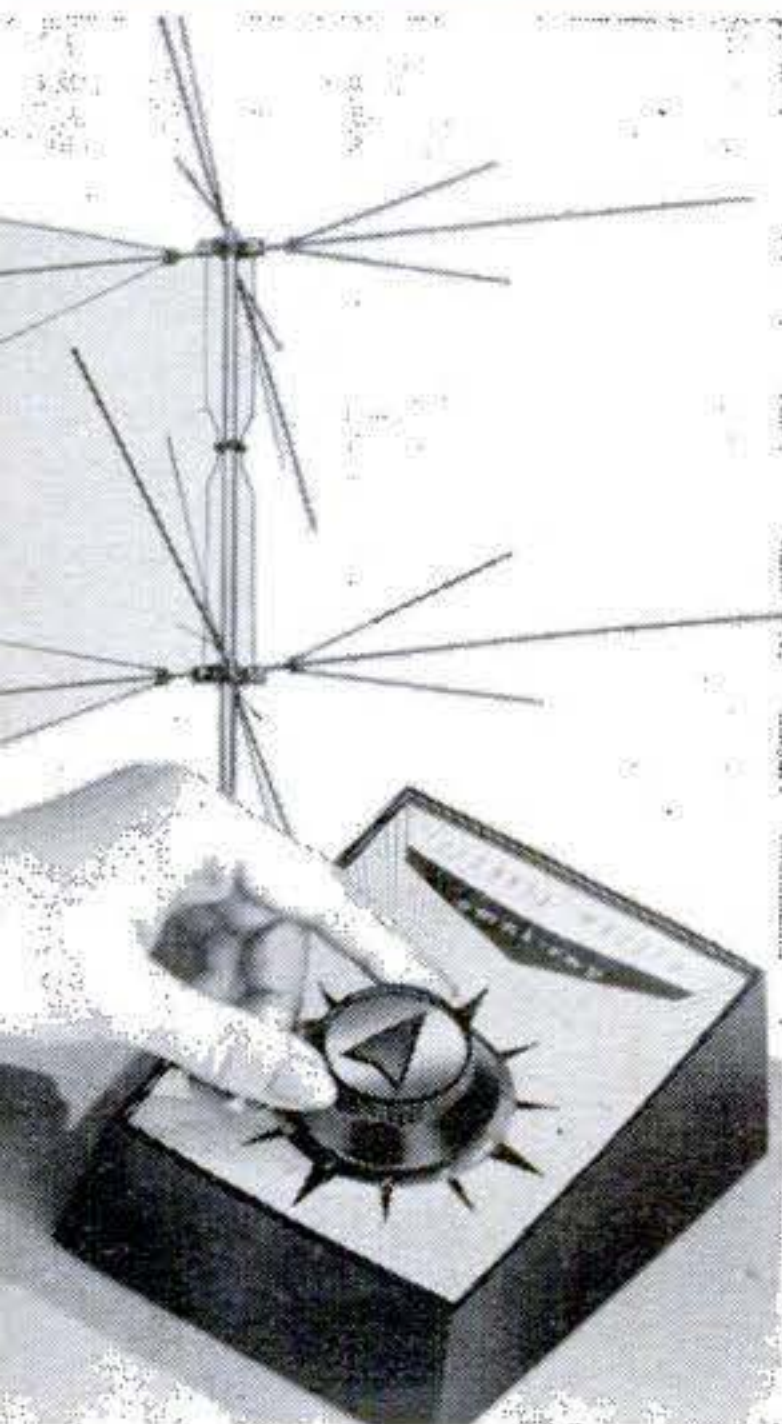

Antenna 'rotates' without turning

The reception pattern of the Omni-Ray can be rotated electronically—the antenna itself does not move. Main feature, the maker says, is its ability to kill ghosts and interference. A front-to-side interference rejection ratio of 10:1 is claimed. Channel Master, Ellenville, N. Y.

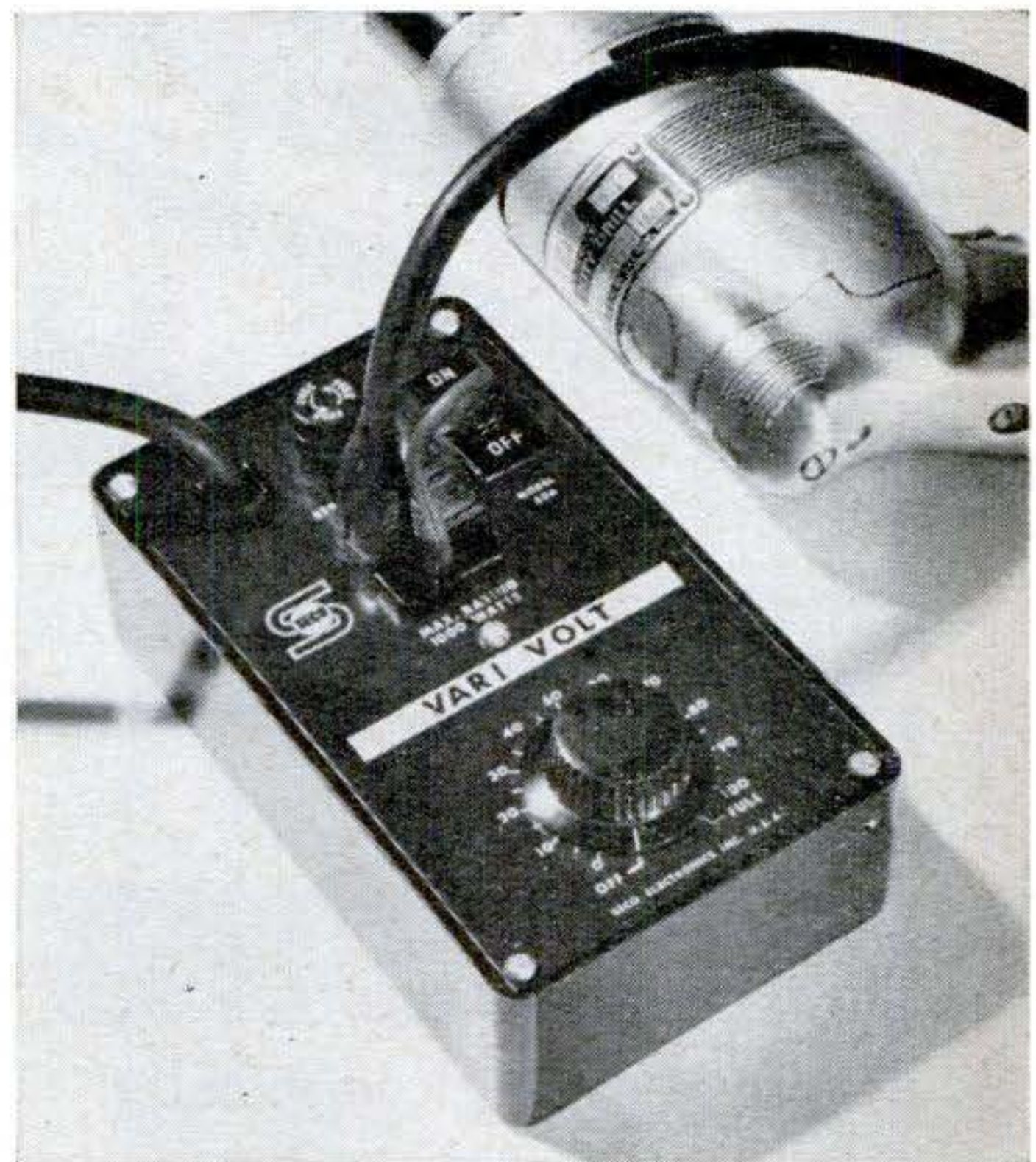

Plug-in control varies motor speed

You can control the speed of any universal motor of up to $\frac{1}{8}$ hp. by plugging it into the outlet on the Vari Volt and setting the dial. The silicon-controlled rectifier circuit provides full motor torque even at slow speeds. \$19.95. Seco Electronics, 1201 S. Clover Dr., Minneapolis.

what's new

BOATING

Steadies boat in all kinds of weather

PARA-ANCHOR works on the same drag principle as the parachute. It holds the bow into the wind, resisting drift and reducing roll in deep water—a life saver if engine failure occurs in rough water. Of nylon and un-

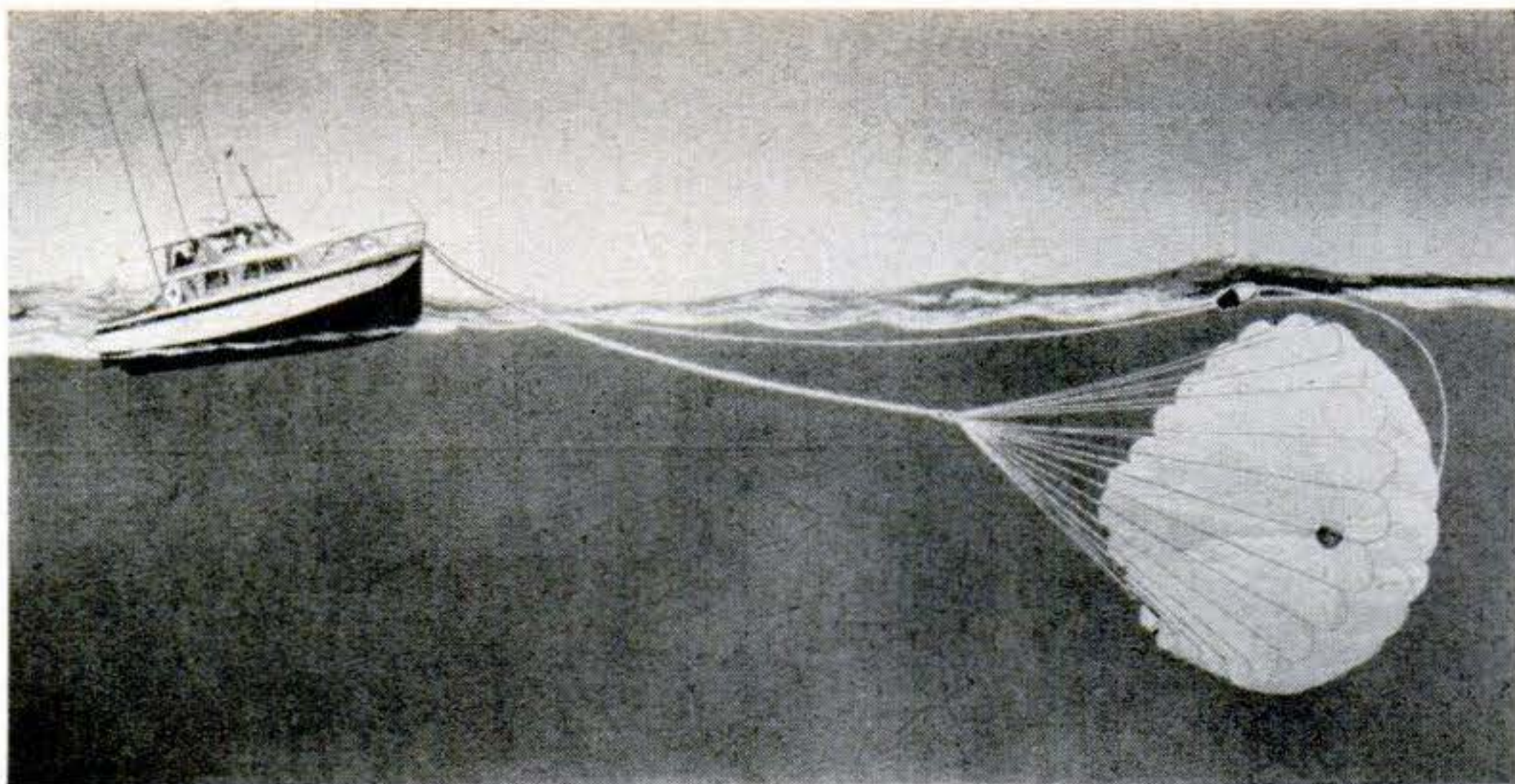

affected by salt water, the anchor is 24 feet in diameter. It packs small, can be stored wet for days. \$39.95. Transcontinental Sales, 3072 W. Pico Blvd., Los Angeles.

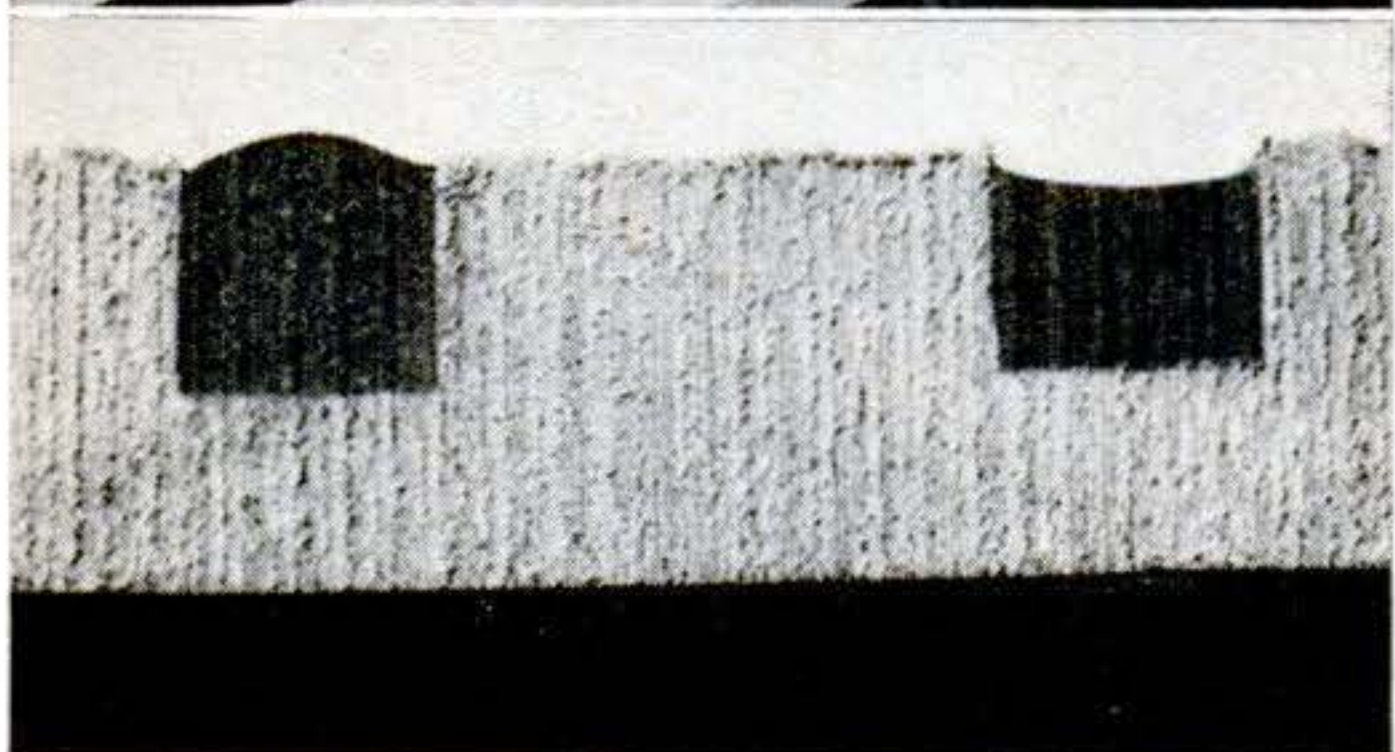

New no-mixing calking compound

New calking compound for boat seams expands upon curing instead of shrinking. It can be sanded off flush for a watertight seam, or you can use a concave-groove tool to eliminate the sanding. For a neat appearance, you run tape along each side of the seam, pull it off before the calking sets. The polyurethane compound is ready for use as it comes from the can. Du Pont, Wilmington, Del., makes it.



Surfboard is foam and fiberglass

The new Wavecrest "Classic" surfboard has a Hawaiian taper and shape. The board is 9'9" long, 22" at the widest point. It's made of fiberglass over polyurethane foam with an aluminum skeg or keel, and it weighs in at only 30 pounds. The boards come in pastel colors, and with or without stripes. \$99.50 (f.o.b.) from Surfboard Supply, Inc., 1716 Cornell Ave., Box 631, Dept. P, Melbourne, Fla.

SHOP TALK

By Sheldon M. Gallager



Here and there at the hardware store

That well-known shop lubricant, Lubriplate, will soon show up in a handy pushbutton spray can labeled Spray-Lube "A" . . . Modern epoxies keep turning up in new forms. Now there's an epoxy paint made especially for modelmakers. It comes in nine colors, gives a slick, hard, fuelproof finish, is the brain child of Pettit Paint Co., Belleville, N. J. . . . Had a chance the other day to try Du Pont's new fluorescent fishing line, Stren. It's real sneaky. It glows and, against the darker water, is easily visible to the fisherman. But to the fish, looking up toward the bright surface, it's invisible. It comes in 2- to 30-pound test for all types of fishing . . . Want to bone up on the latest radial-arm saw techniques? The DeWalt people have a new 176-page book out, available through dealers for \$3.95.

Battery power: It's better than you may think

There's a tendency to think that battery-powered tools are a fine convenience outdoors, but no real match for regular tools indoors. Is this true? Here are the results of an actual race we staged between battery power and conventional power—the first we know of.

We chose a Porter-Cable battery drill for the test because, in addition to its 12-volt pack, it can also be run on a 110-volt converter that reduces line current to 12 volts. This gave us a chance to test the same drill on both limited and unlimited power. The drill was also checked against a conventional 110-volt P-C model.

The drills were clocked to see how long they took to punch $\frac{1}{4}$ " holes in $\frac{5}{4}$ " oak and $\frac{1}{8}$ " steel. The figures below, all averages of 10 or more trials, tell the story. Note that the 12-volt drill runs

neck and neck with itself whether it's on battery or house current. The 110-volt drill does show a slight edge, but this is partly because its speed is higher—1,000 r.p.m. against 750. Our opinion, in short: Battery power need make no apologies to anyone—indoors or out. It's a husky performer as well as a handy convenience.

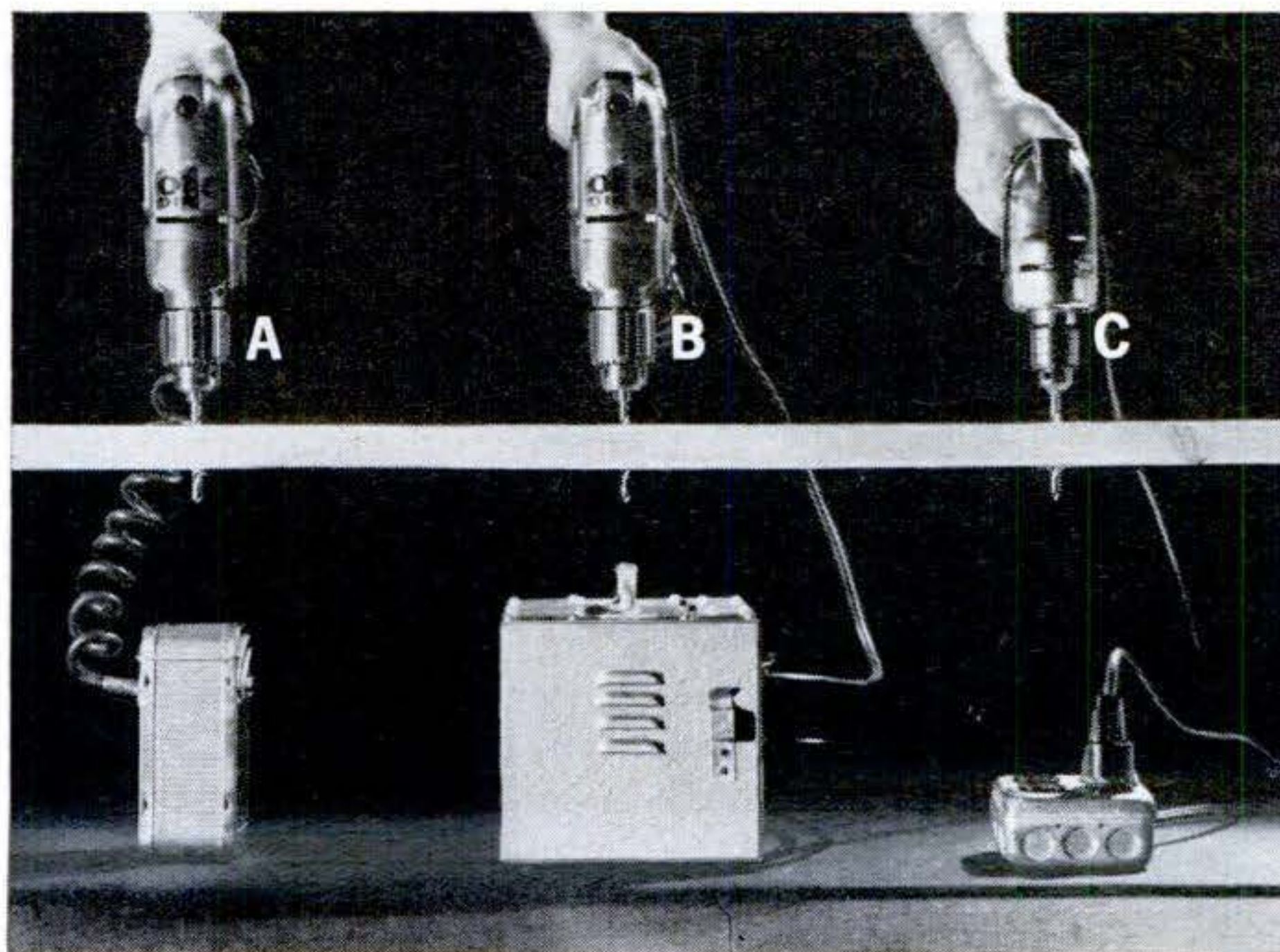

HOW THEY RAN

	5/4" Oak	1/8" Steel
DRILL A (battery)	4.5 sec.	28.9 sec.
DRILL B (converter)	4.3 sec.	27.4 sec.
DRILL C (110 volts)	3.3 sec.	20.3 sec.

what's new

TOOLS

Locking rule "remembers" for you

A thumb-controlled lock on this steel tape lets you transfer measurements from one place to another without danger of the tape slipping and spoiling your work. The thumb button squeezes the tape to hold it firmly until released. The rule comes in $\frac{1}{2}$ " and $\frac{3}{4}$ " widths and in 6' to 12' lengths. Prices start at \$1.59. Stanley Tools, New Britain, Conn.



New pipe-wrench jaws won't let loose

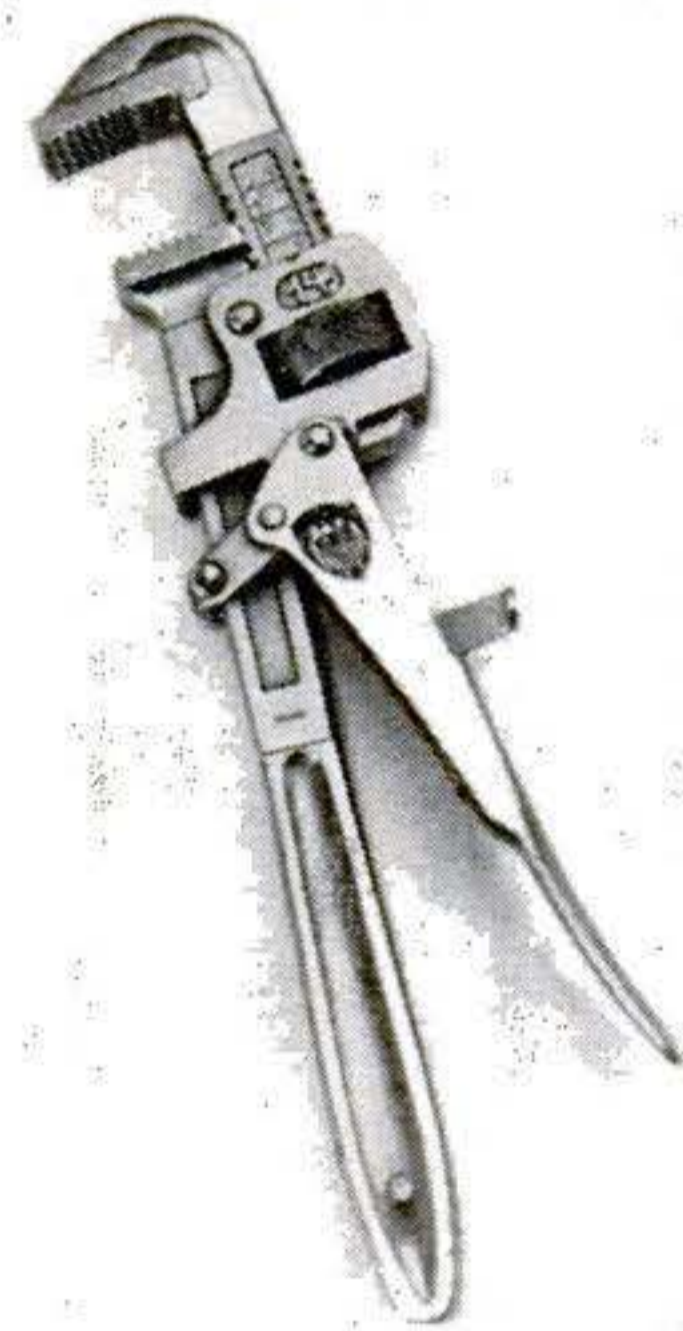

Squeeze the lever on the handle of this unusual pipe wrench and the jaws lock tightly on anything you grip. The lever uses a cam action to force the jaws closed and keep them from loosening or slipping. The wrench comes in three lengths from 10" to 18". Prices are \$6.50 to \$10.50. J. L. Bagarry, 2646 Liberty, Beaumont, Tex.

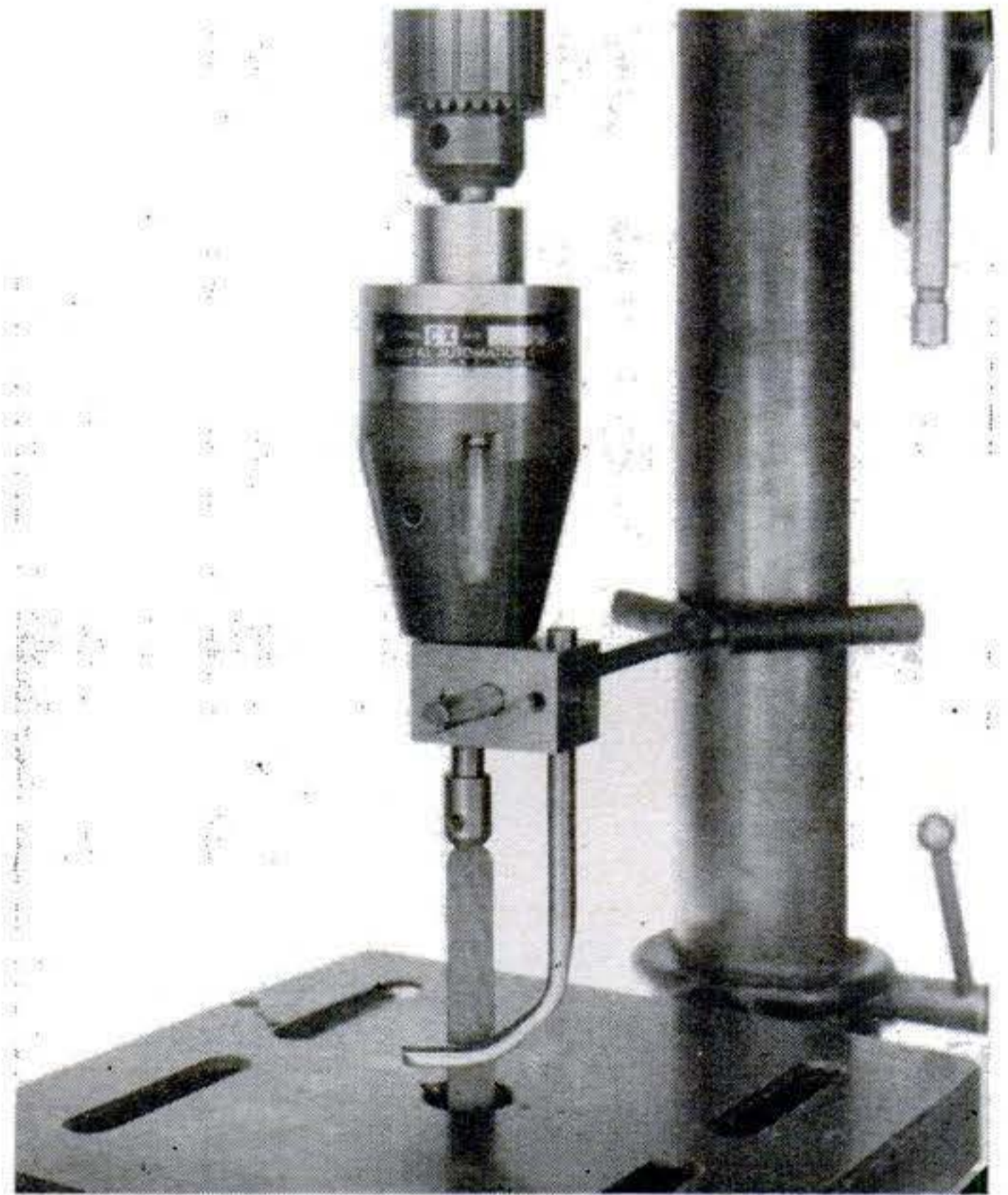

Drill-press filer saves elbow grease

A drill press becomes a power filer with this attachment. It converts rotary motion to reciprocating motion to move a file up and down. It can also be fitted with a hacksaw blade for cutting metals. Other accessories let you hone, deburr, sand, polish, and lap. \$39.50, General Automation Corp., 121 Centre Ave., Secaucus, N. J.

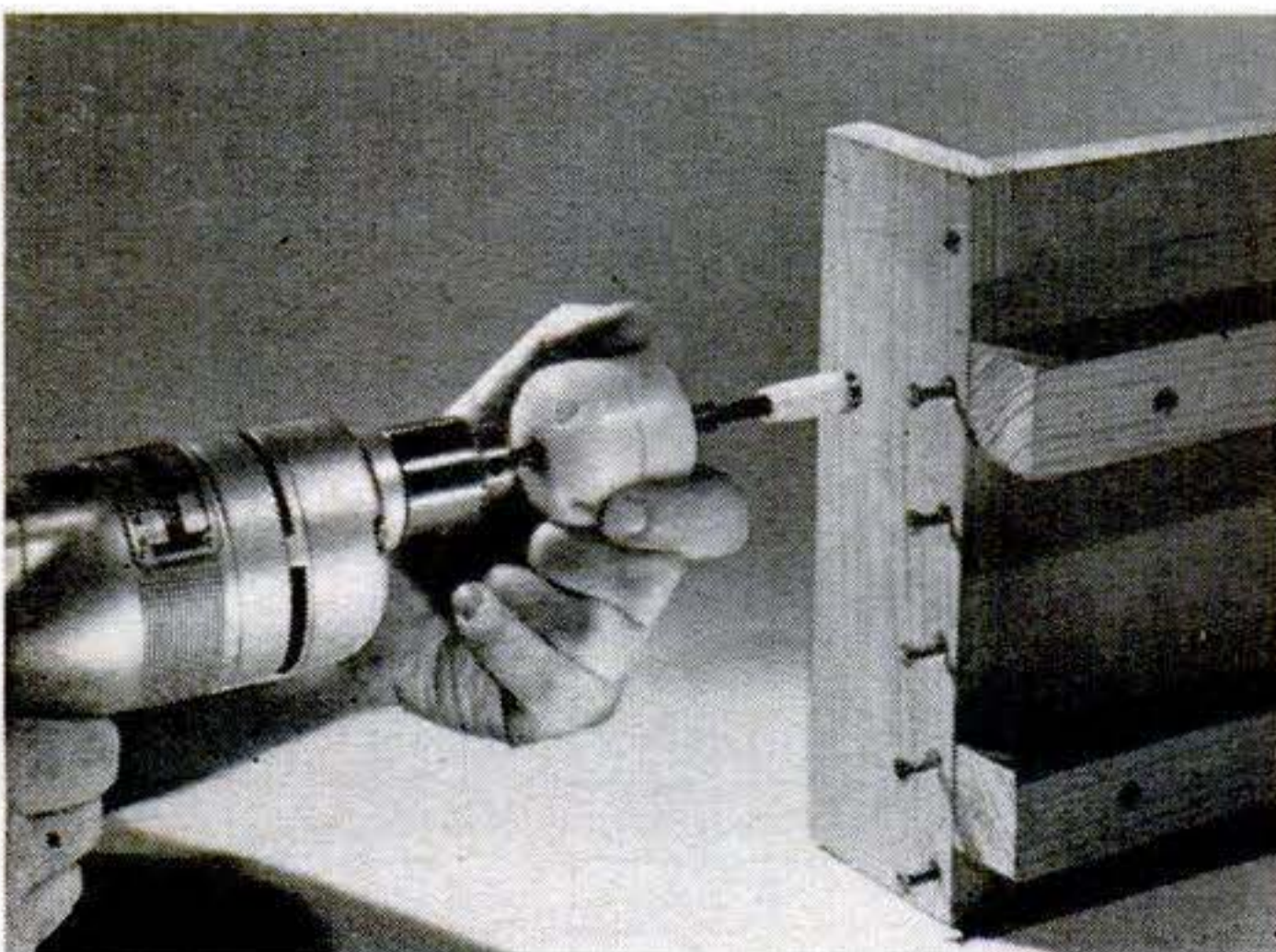

Nylon screwdriver accessory keeps cool

This screwdriver accessory for drills never gets hot to the touch because the case is insulating nylon. A similar right-angle drive is also available. Each is \$5. Coastal Abrasive and Tool Co., 42-33 Northern Blvd., Long Island City, N. Y.

what's new

for your GARDEN

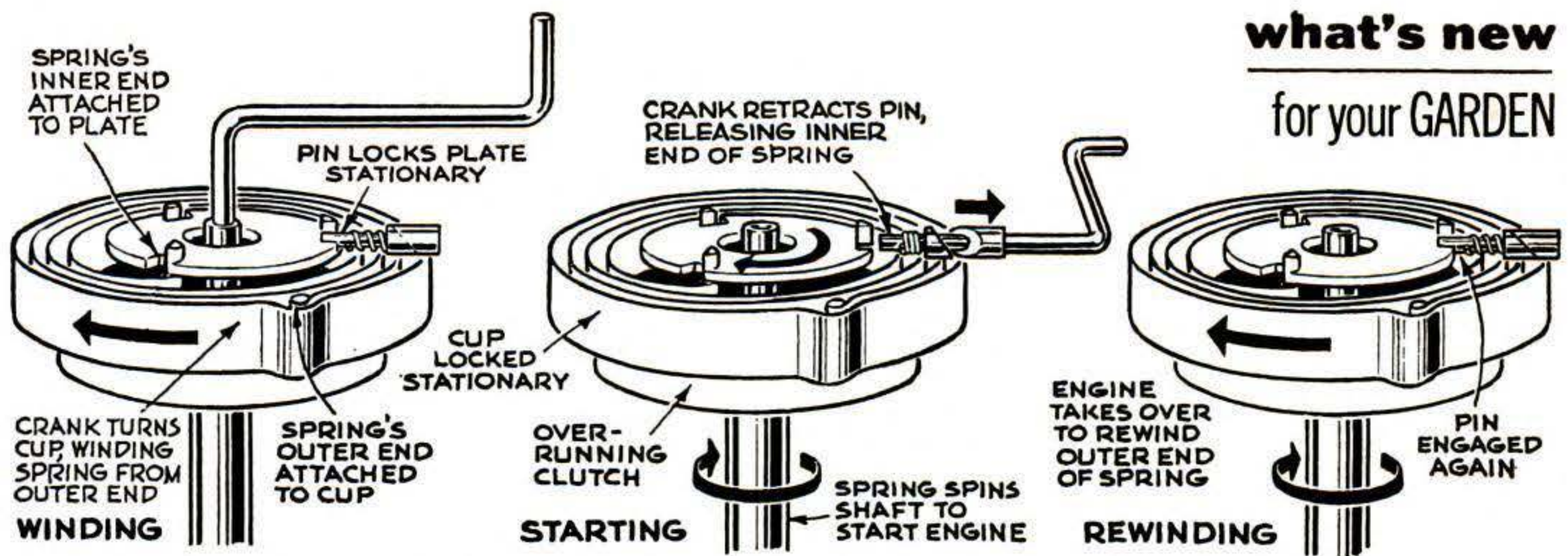

Starter's secret: Spring is always wound and unwound in the same direction. First it's wound by a crank from the *outer* end (left). To start engine, it unwinds from the *inner* end (center),

spinning the shaft the same way. Engine then takes over and rewinds the spring's *outer* end (right)—again in the same direction. Engine disengages when the spring is fully wound.

Self-Starter for Power Mowers Winds Itself Up

YOU can now add an automatic starter to a power mower, garden tiller, snow thrower, kart—almost anything that's powered by a small gasoline engine. It's a spring-type starter, but here's the trick: You wind up the spring only once yourself. After that, the engine itself does the winding so that the spring is ready for each new start. Flipping a lever releases the spring, and you're off.

The problem was to devise a spring that would wind and unwind in the same direction so it could both start the engine and then be rewound with the engine

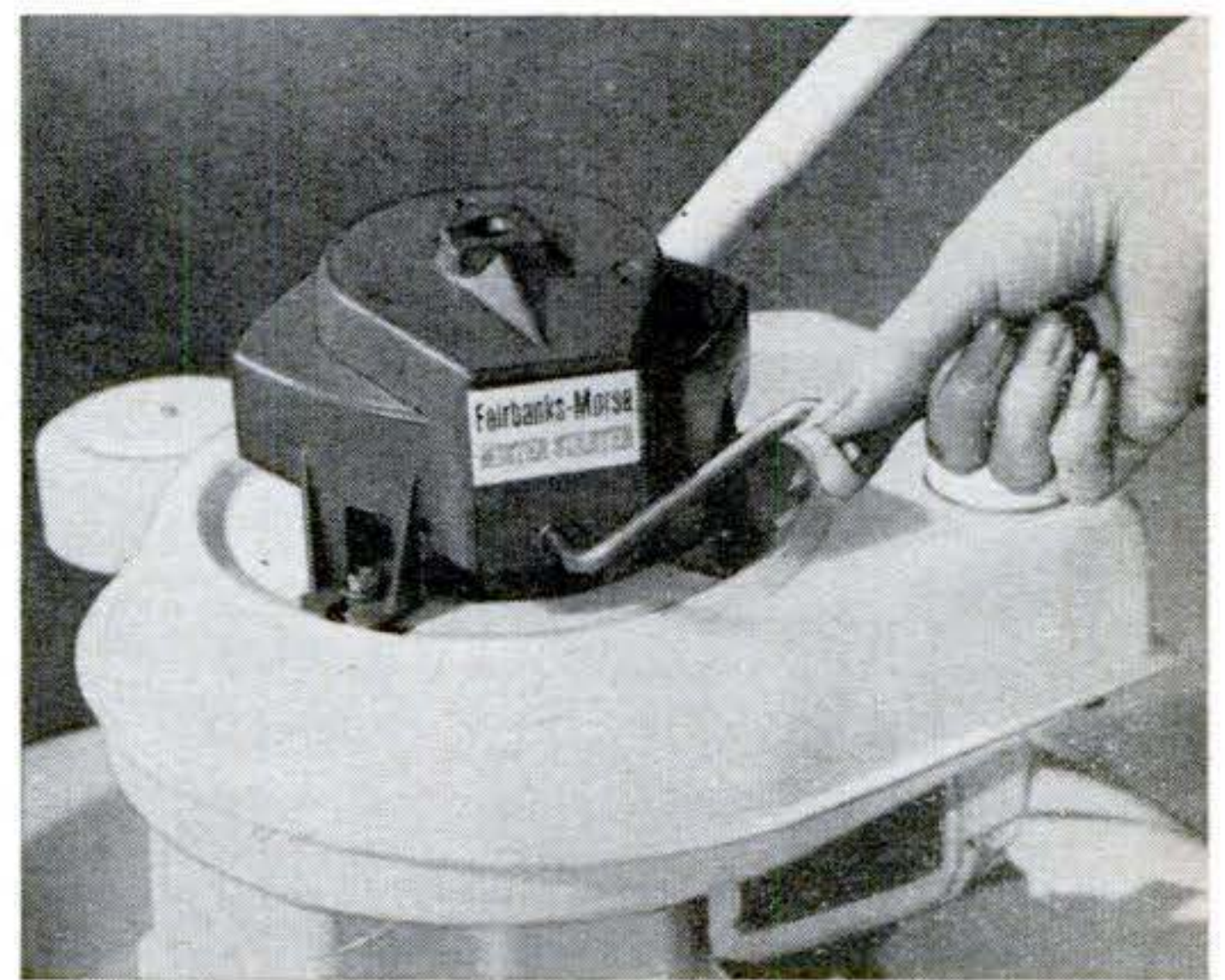

shaft turning the same way. How this was done is shown in the drawings above. The starter attaches directly to most small engines of up to five hp. It's made by Fairbanks, Morse and is available from authorized dealers at \$22.95.

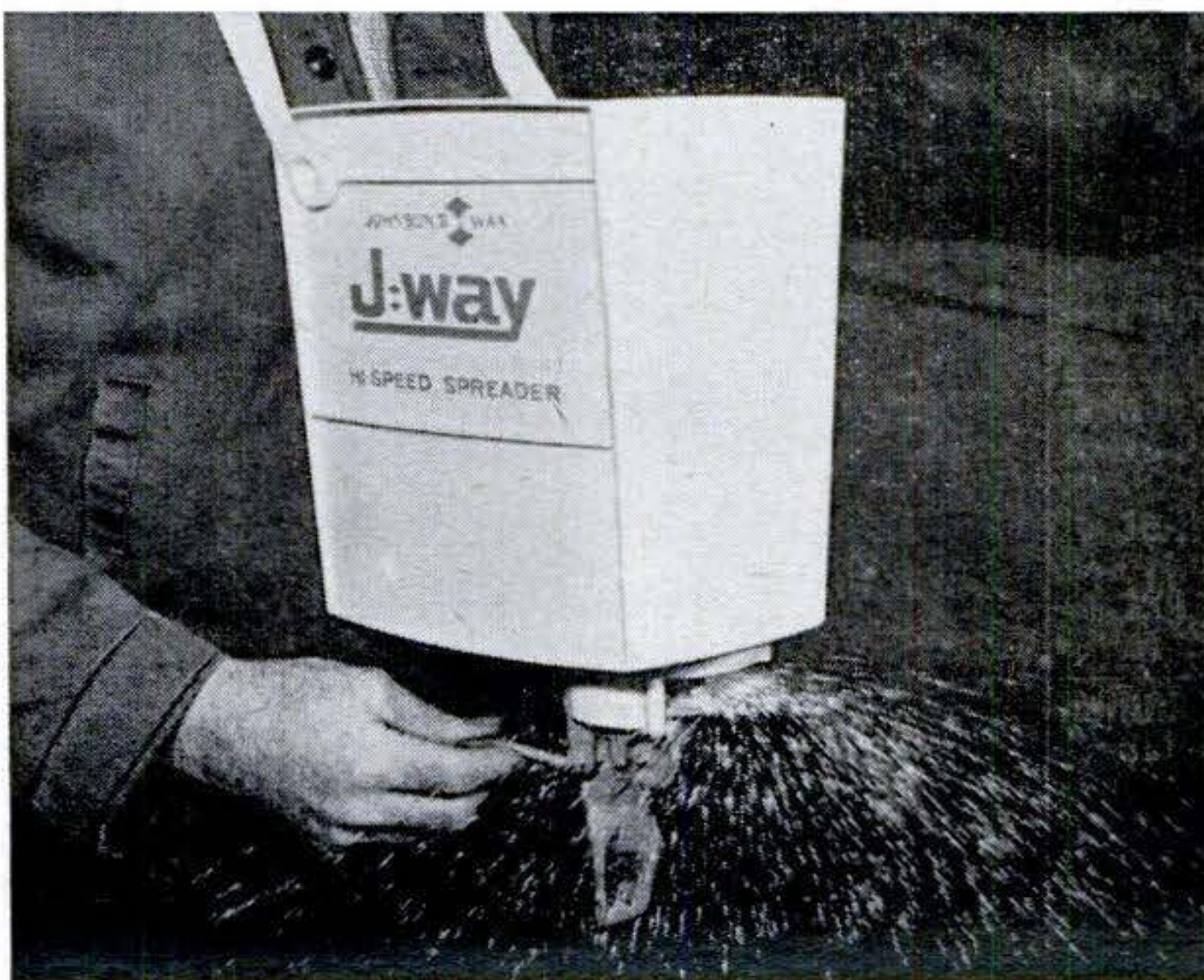

New fertilizer spreader sprays a big swath

Notice anything familiar about this handy little fertilizer spreader? It's a modern version of Granddad's reliable old seed broadcaster, brought back by the makers of Johnson's Wax. Turn a crank and a rotating disk sprays fertilizer over a 6'-wide swath as you walk. The plastic hopper hangs from a neck strap and handles pellet-type lawn chemicals. Advantages claimed: fast coverage, even distribution, low cost. About \$8, S. C. Johnson & Son, Racine, Wis.

Short Cuts and Tips

FROM
PS
READERS

Auto wheel makes outdoor fireplace top

Here's a quick and easy solution to the problem of what to cook on, on that cook-out: an old auto wheel. Support it on a ring of stones or bricks 8" or 10" above the ground, leaving a 12" opening to add fuel. Pots and pans sit nicely on the rim.—*Paul Corey, Sonoma, Calif.*



Clean soldering gun heats faster

After a soldering gun has been used for a long time, the connections and tip become dirty and the iron won't heat properly. To give it new life, remove the copper tip and file or grind off the burnt surface. Unscrew the ferrules and clean them with cleaning fluid. Replace the tip and tighten on the ferrules with an end or crescent wrench. Now the iron will melt solder in seconds.—*Homer L. Davidson, Fort Dodge, Iowa.*



Save your sanding dust

For patching holes and filling in cracks in unfinished hardwood, use wood dust salvaged when sanding. (Be sure to label the storage jars to insure matching the right woods.) Mix two parts dust to one part of powdered phenolic-resin glue. Add water to the mixture carefully until you have a thick paste.—*Robert E. Lunt, Bellville, Ont.*

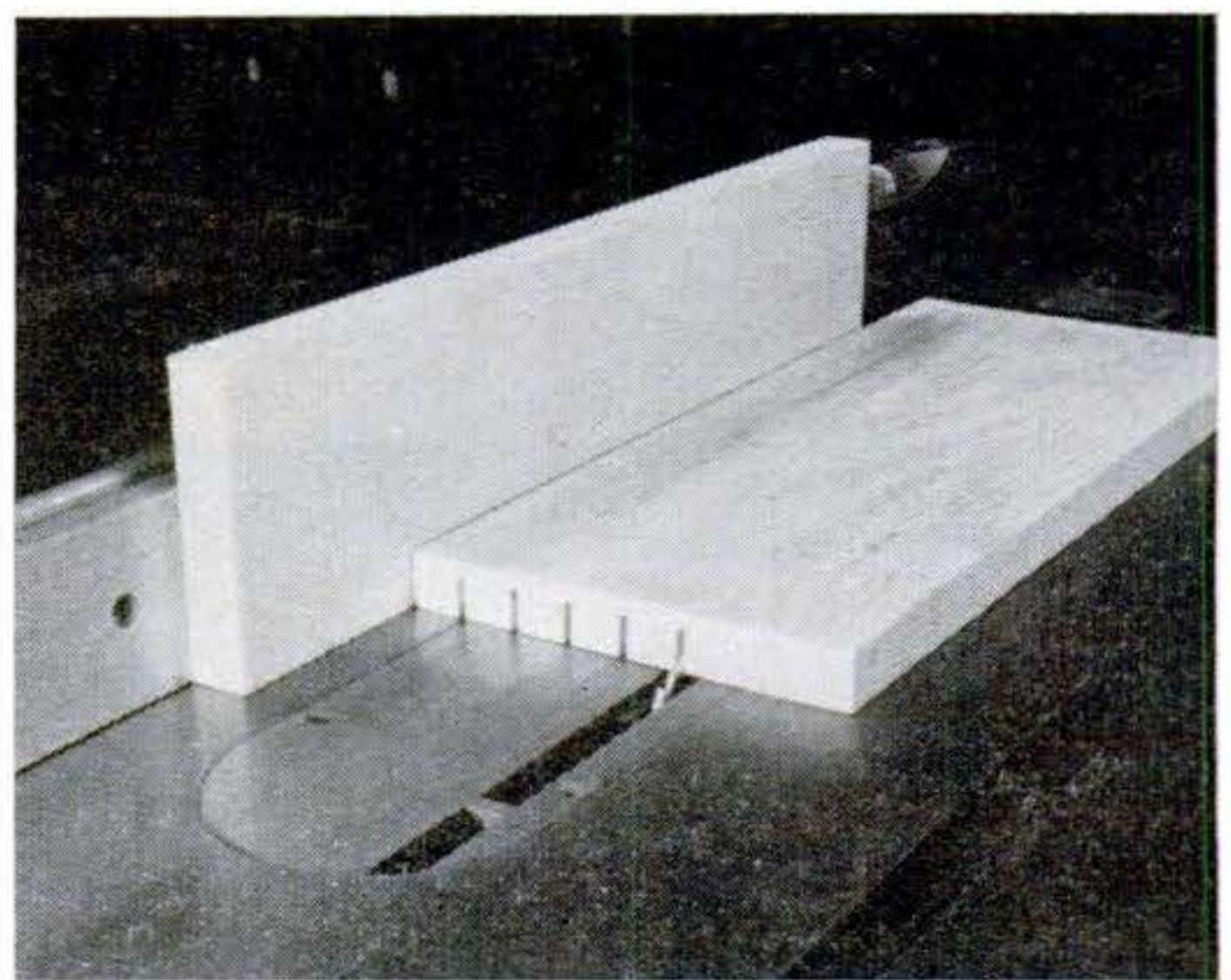

Automatic spacing for table-saw cuts

To make a series of equally spaced parallel cuts on a table saw, I use a block of wood as a spacer instead of measuring for successive cuts. With the work over the last cut made, I use the block to set the fence. Then I remove the block, move the work against the fence for the next pass.—*R. J. De Cristoforo, Los Altos Hills, Calif.*

If you could find a house paint that stayed on without cracking, scaling, or blistering, held its color with hardly any change and kept your house looking fresh and bright for years, wouldn't you use it?

Sure you would. That's why lots of shrewd homeowners are repainting with Dutch Boy Latex House Paint. Think of all the trouble it saves. To start with, it's easier to handle. Being a latex paint it brushes out smoothly, with very little effort. Goes over almost any surface—wood, stucco, brick, even galvanized iron. And Dutch Boy Latex House Paint breathes—allows moisture to escape, yet seals out the weather. That means many of the blistering and peeling problems caused by trapped interior moisture are eliminated. Another point: you don't have to wait for the weather. (Paint right after a rainstorm if you like.) You can stop when you like, start again, and stop again, without leaving lapmarks. And in two hours you have a bright, weathertight surface that stays looking that way for years. In fact, Dutch Boy Latex House Paint retains its color so well you can come back and touch it up years afterwards and not see the difference. Think what that means in maintenance. To keep your house looking fresh and bright all you do is touch up the worn spots when they need it. In short, you may never have to paint your entire house at one time again. When you're all finished, brushes, equipment, and people all clean up with soapy water. Best of all, Dutch Boy Latex House Paint costs no more than any other good paint. So, next time you're thinking of painting, why consider anything else?



A product of National Lead Company.

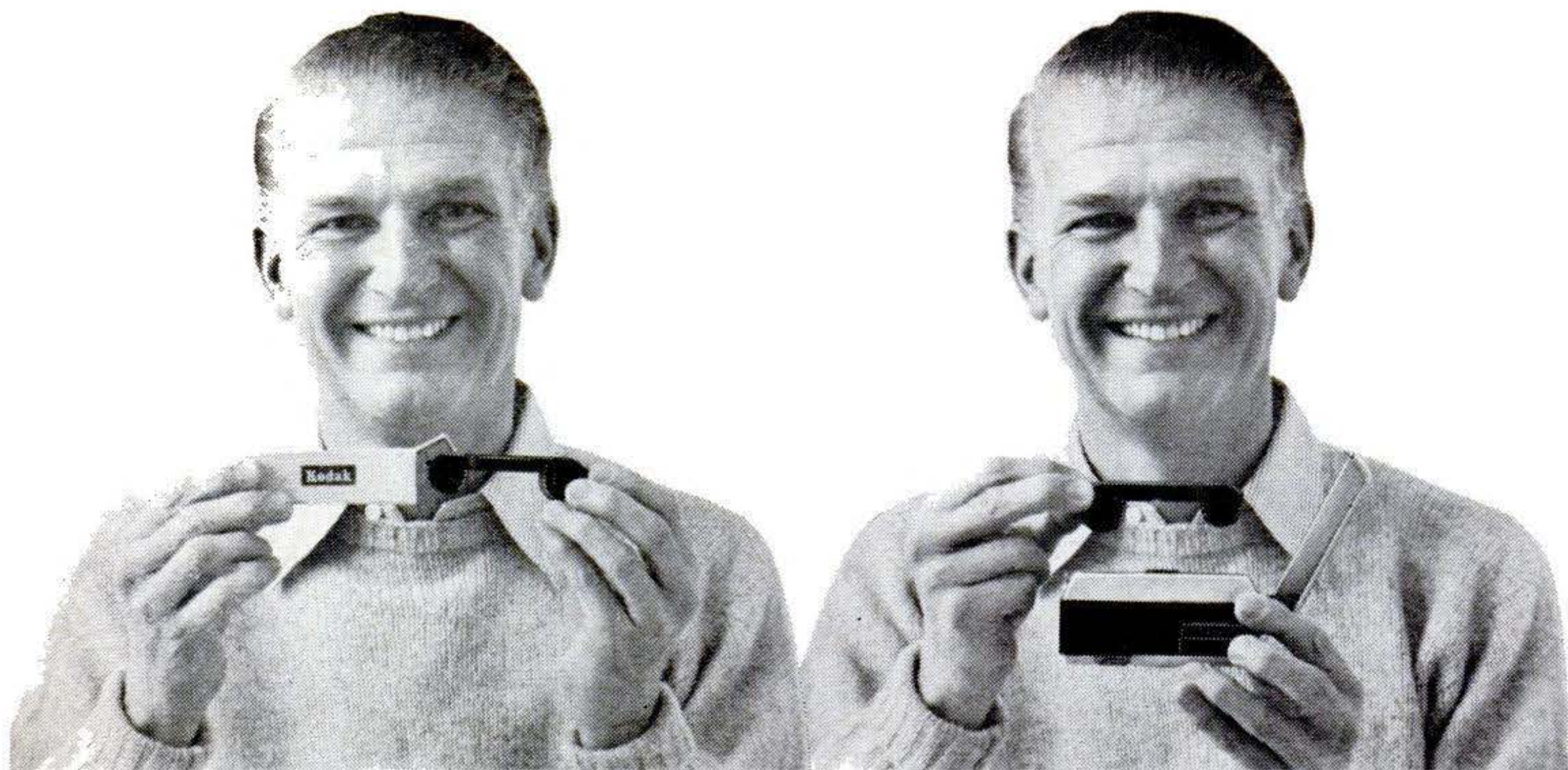

Now! Instant-loading cameras

New KODAK INSTAMATIC

You just snap the KODAPAK Film Cartridge into the camera. No threading! The camera's loaded instantly! You're ready to shoot—faster than you can read about it.

New KODAK INSTAMATIC Cameras take care of practically everything automatically. All you do is shoot. Get sharp, bright prints in color or black-and-white, or color slides.

There are four KODAK INSTAMATIC Cameras. Their features range up to automatic electric-eye exposure control, automatic film

advance, and fast lens-shutter combinations.

Model 400, shown at right, gives you automatic electric-eye exposure control *and* power-drive film advance. It lets you fire off 10 shots without lowering the camera from your eye. The electric eye not only sets the lens, but also signals in the viewfinder when to use the built-in flash. The INSTAMATIC 400 Camera is all brain, yet weighs only 15 ounces, is just 4 inches wide! INSTAMATIC 400 Outfit with bulbs, batteries, film—less than \$53. At your Kodak dealer's now!



KODAK INSTAMATIC 100 Outfit. Instant-loading camera with built-in flash. No focusing, no settings. Outfit: film, bulbs, batteries — less than \$16.



KODAK INSTAMATIC 300 Outfit. Instant-loading camera with automatic electric eye, built-in flash. Outfit with bulbs, batteries, film—less than \$45.



KODAK INSTAMATIC 700 Camera. f/2.8 lens, automatic daylight and flash exposure controls, built-in flash, speeds to 1/250. Available soon.

Kodak
TRADE MARK

Enjoy Walt Disney's "Wonderful World of Color" Sunday evenings, NBC-TV



that load like a gun!

Cameras

...with new
KODAPAK Film Cartridges

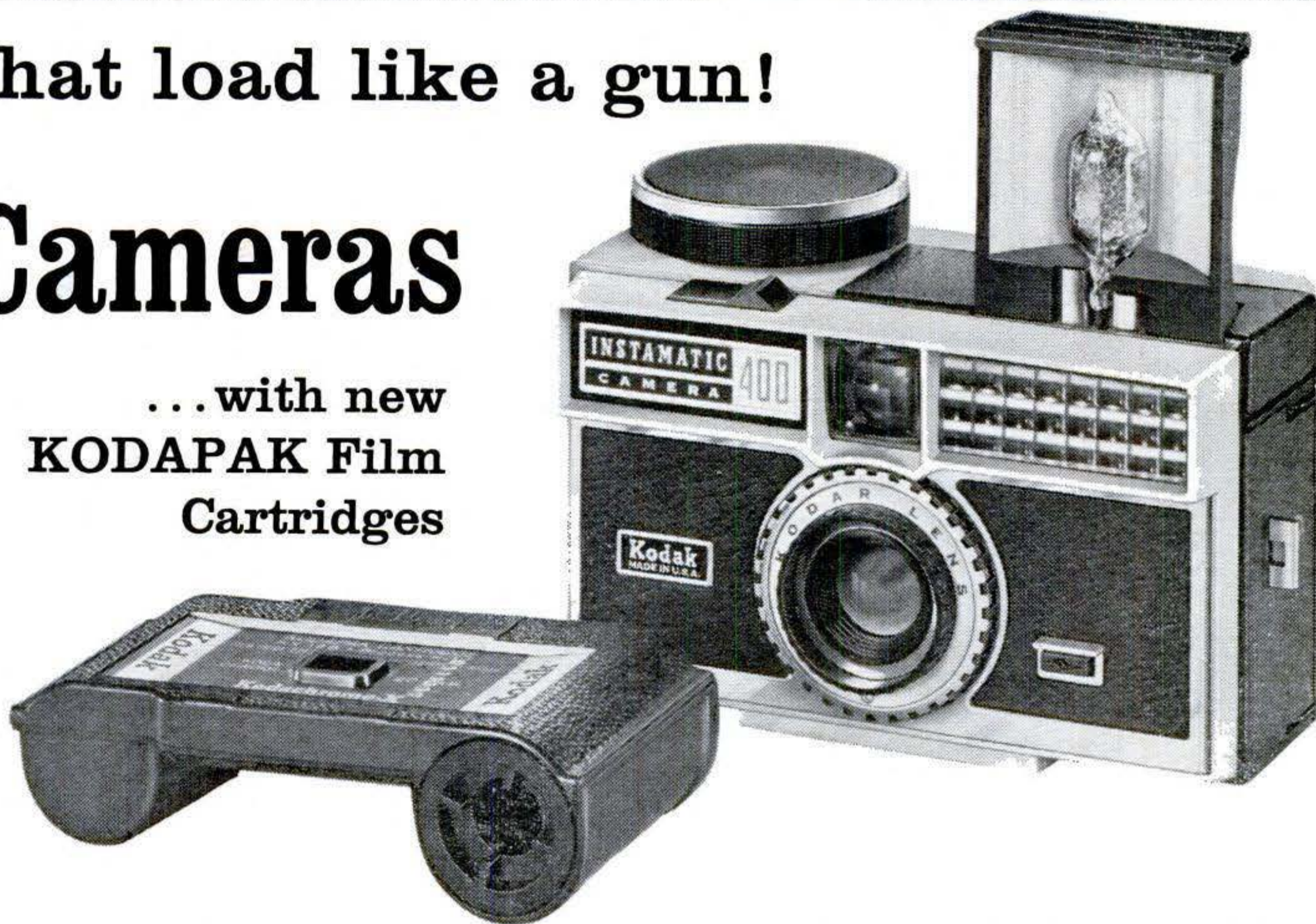

Shoot color slides or snapshots in color or black-and-white

New ready-loaded KODAPAK Film Cartridges are designed specifically for use with the KODAK INSTAMATIC Cameras. They drop in instantly — no threading, no mistakes. You can even put them into the camera in bright sun. Choose cartridges of KODAK VERICHROME Pan Film for black-and-white shots. Choose cartridges of KODACHROME-X or KODAK EKTA-

CHROME-X Film for color slides; KODACOLOR-X Film for color prints. (All are fast films, to let you shoot in less light. See your Kodak dealer for details.)

EASTMAN KODAK COMPANY
Rochester 4, N. Y.

Prices subject to change without notice.



Hints from the Model Garage



Radiator hoses slip into place easier if you smear the first inch or so of the hose on the inside with graphite jointing compound. Apply the stuff to the radiator or engine pipe, too. The compound also helps you get a good, tight seal at the joint.



A flashlight makes a good trouble light when you're making repairs under a car. To one corner of your creeper attach a tin can with its top removed. Put the flashlight in the can. It's easy to aim the light anywhere you need it.

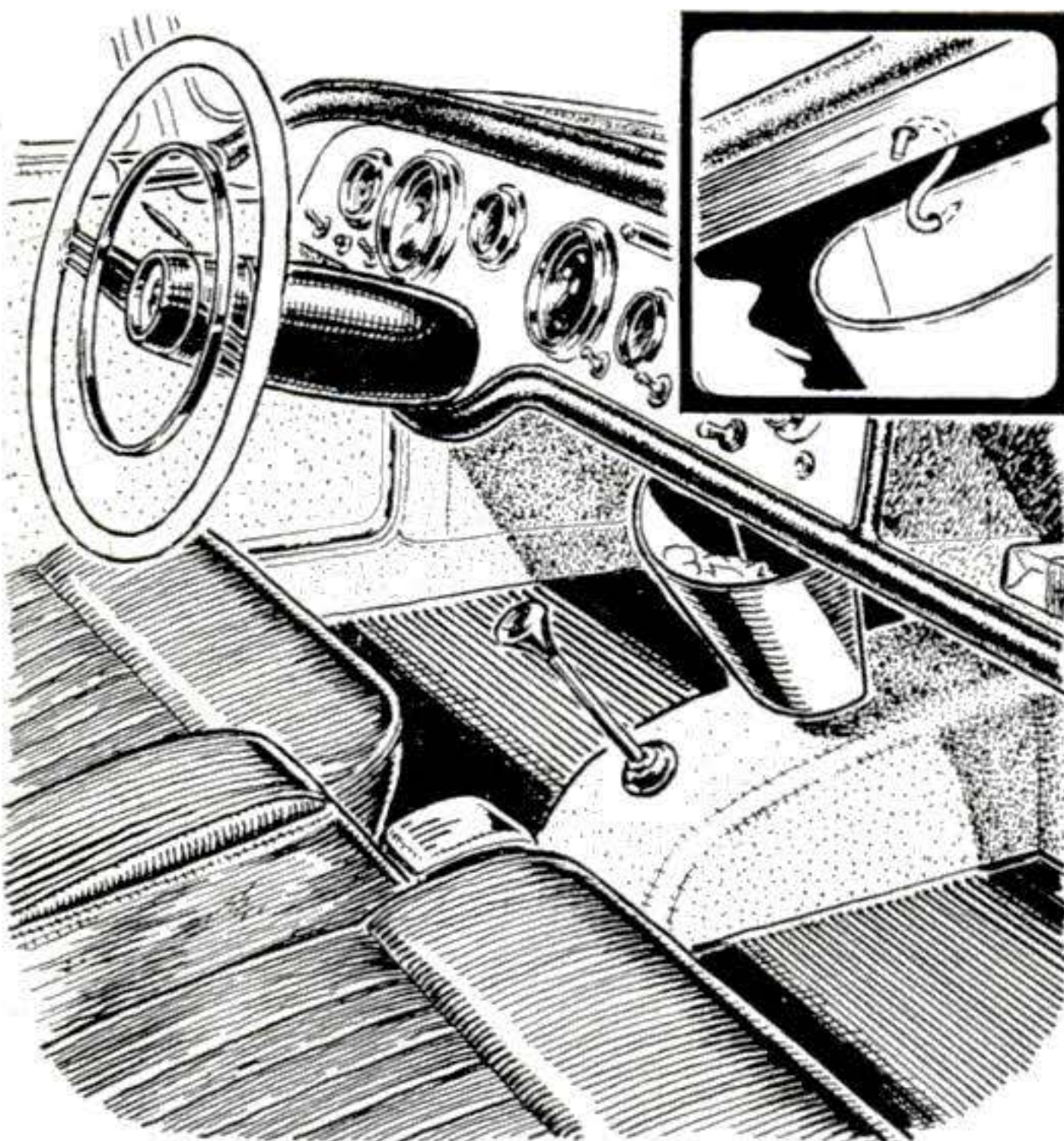

Mount a litter basket with a metal shower-curtain hook, using one of the many accessory holes that are factory-drilled at the bottom of the dashboard cowling. Hang the basket right over the transmission hump to keep it from taking up passenger leg room.

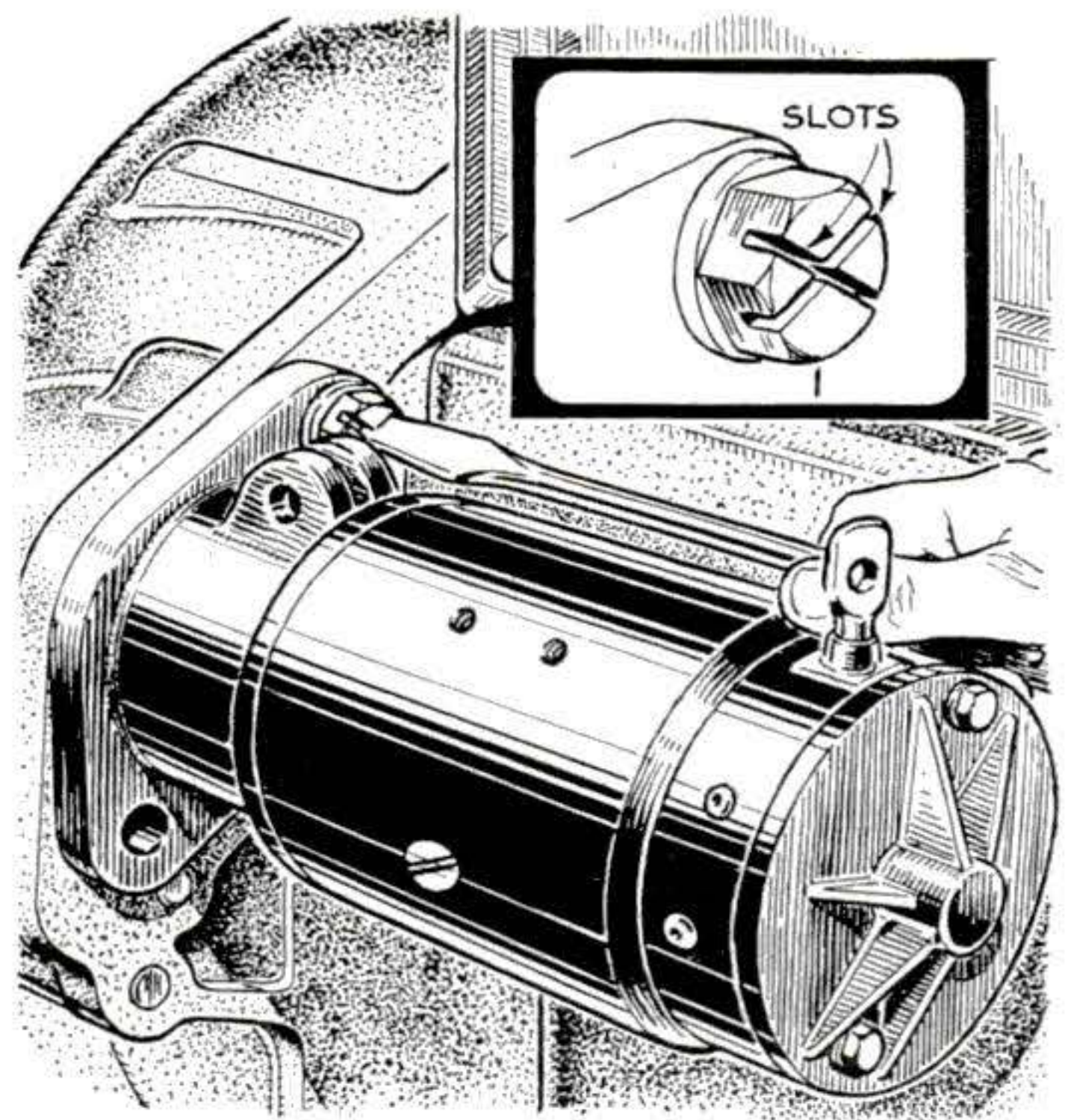

Hard-to-reach bolts like those on top of many starter motors can be engaged easily with a screwdriver if you cut an X-shaped notch in the head with a hacksaw. After the bolt has been screwed in, it can be tightened with an ordinary wrench.



Evinrude, Gale, Homelite, Johnson, Mercury, Scott, and West Bend—all come equipped with silvery-plated Champions

Every major U.S. outboard maker specifies Champion spark plugs. Champions are the overwhelming first choice of the world's car makers, too! Why settle for less?

To feel new power in your car, instantly, install new Champions now and every 10,000 miles



More Hints from the Model Garage



A signal flag made of bright-colored cloth helps you find your car quickly in a large parking lot. Here's an idea for a simple flagpole, in case you don't have an aerial on your car: Clamp a curb feeler to the rain gutter over one of the side windows.

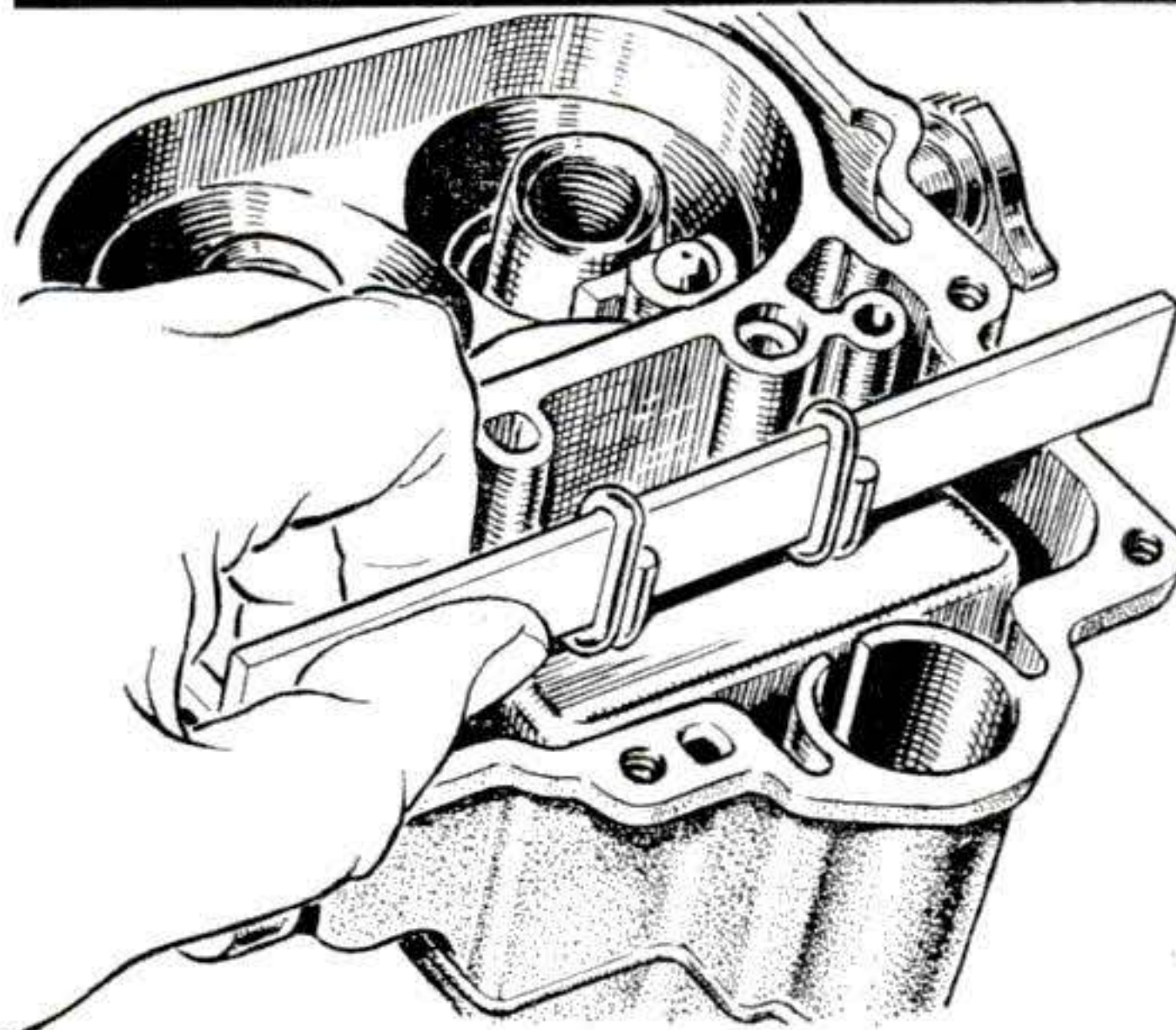
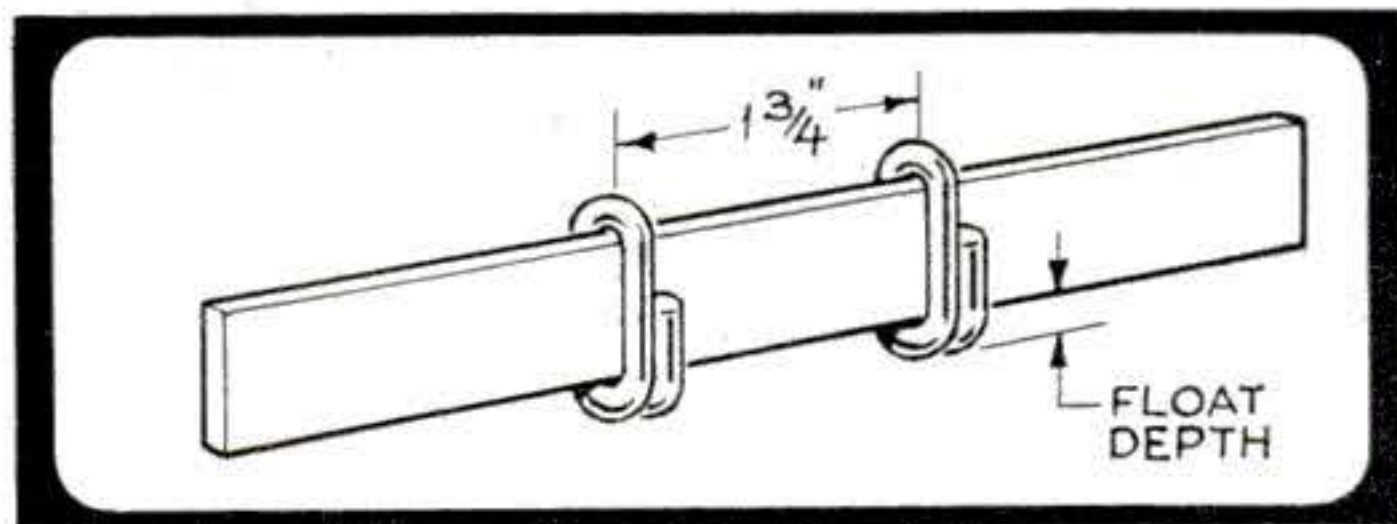

Make your own carburetor-float depth gauge with a straightedge about 6" long and two short lengths of wire with a diameter equal to the desired float depth. Wrap the two lengths of wire snugly several times around the straightedge about 1 3/4" apart.

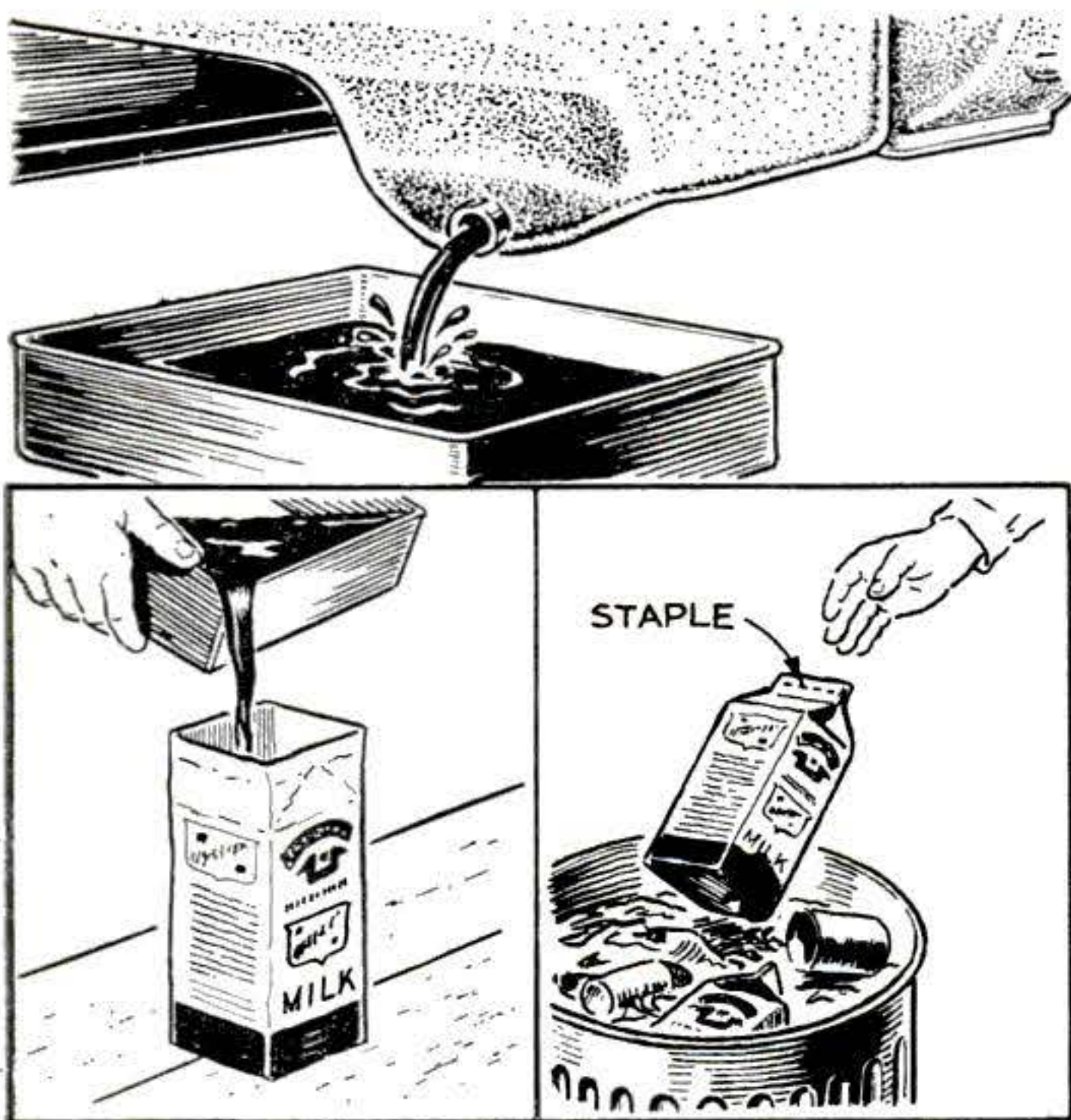

Getting rid of dirty engine oil needn't be a problem. Place a pan under the crankcase while draining it. Then pour the oil into an empty milk carton, staple the top shut, and toss the carton into the garbage can. The waxed container won't leak.

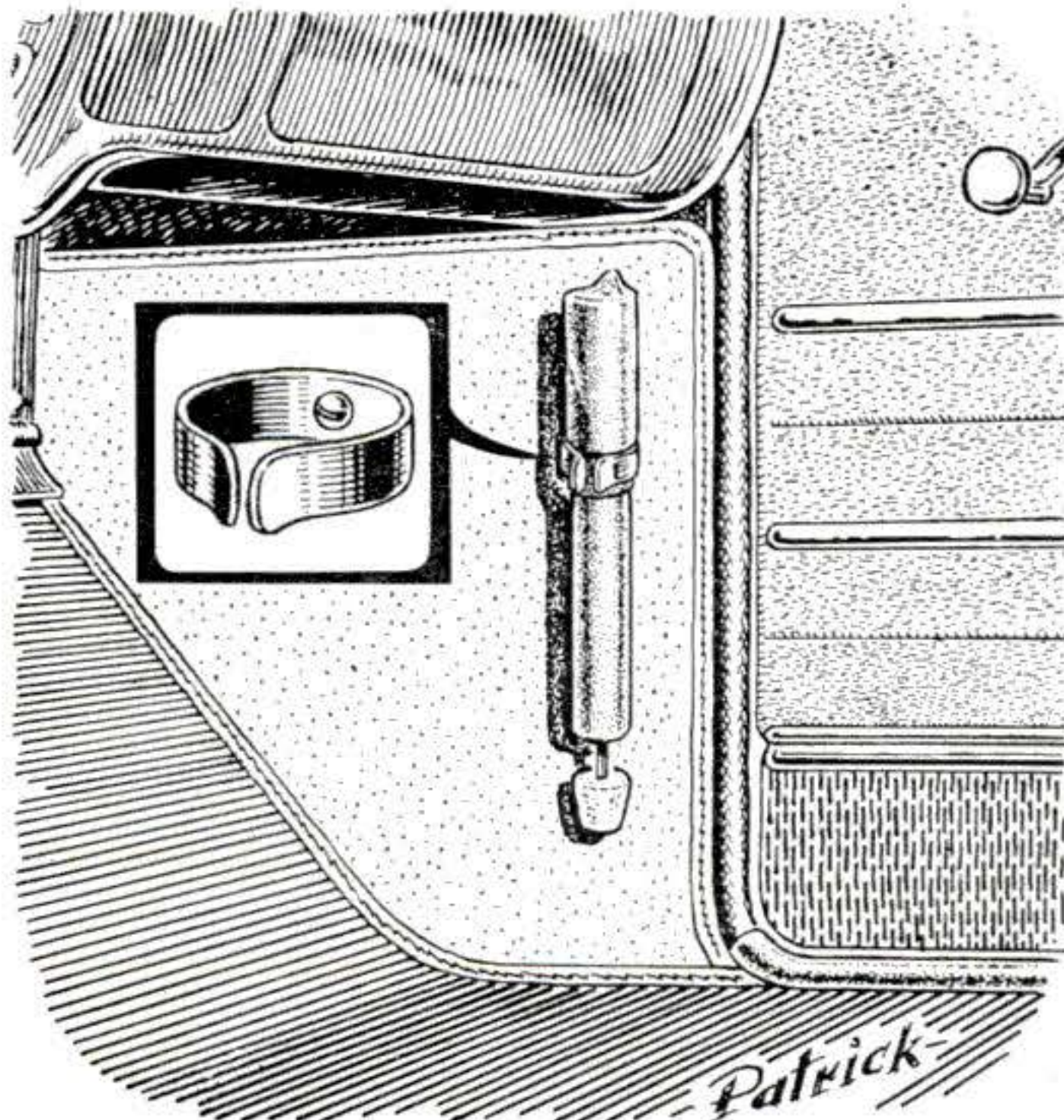

Keep flares within easy reach for any emergency. Mount them with spring-type hammer clamps (the kind used on workbench tool boards) on the kickpads ahead of the doors, using existing screws. Press a protective cork on a spike-bottomed fuse.

ONLY ARMSTRONG TIRES CAN SAVE YOUR LIFE

with "Ounce of Prevention"
Safety Disc Grip!



ARMSTRONG TIRES

Safety Discs keep tread ribs apart, always ready to grip the road.



ORDINARY TIRES

don't have Safety Discs. Tread ribs can squeeze together, lose grip.

PATENTED SAFETY DISCS KEEP TREAD RIBS OPEN . . . ALWAYS READY TO GRIP!

Just as discs in the Armstrong demonstration fist (above) keep the fingers apart, so over 1,000 Safety Discs in each Armstrong Tire keep the tread edges apart, always ready to grip the road, no matter how hard you brake! But ordinary tires don't have Safety Discs.

Under braking pressure, their tread ribs can squeeze together, go smooth, and lose their grip on the road. So, don't risk your car and your life on ordinary rubber. Get Armstrong Tires' patented grip, and get this extra safety at no extra cost.

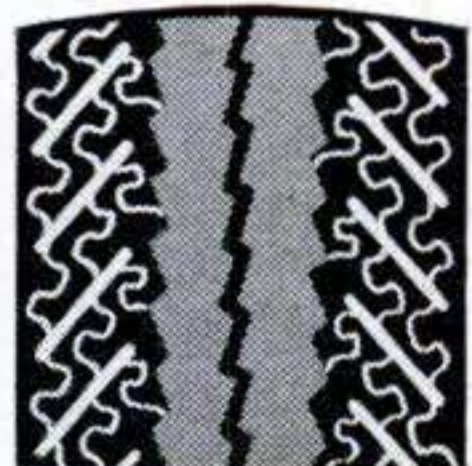

ARMSTRONG TIRES

have double-width outer ribs to give far better mileage.



ORDINARY TIRES

have narrow outer ribs, cut down on your mileage.

PLUS! UP TO 10,000 MORE SAFE MILES WITH NEW WIDE-TRACK TREAD DESIGN!

Where do tires wear out first? Take a look at your own. You'll find the *outer* tread ribs take the punishment. That's why ordinary tires, with narrow outer ribs, often disappoint on mileage. To prevent this tire wear, Armstrong developed Wide-Track Tread. This exclusive design doubles

the width of the outer ribs — doubles the rubber where tires wear most — to give up to 10,000 more safe miles than ordinary tires. Get Armstrong's Wide-Track tread design, and get extra mileage at no extra cost. See the Yellow Pages for your Armstrong dealer.

You can't buy a better tire . . . to save your life . . . than Armstrong!

The Armstrong Rubber Company, West Haven, Conn. • Des Moines, Iowa • Natchez, Miss. • Hanford, Calif.

Gus Answers a False Alarm

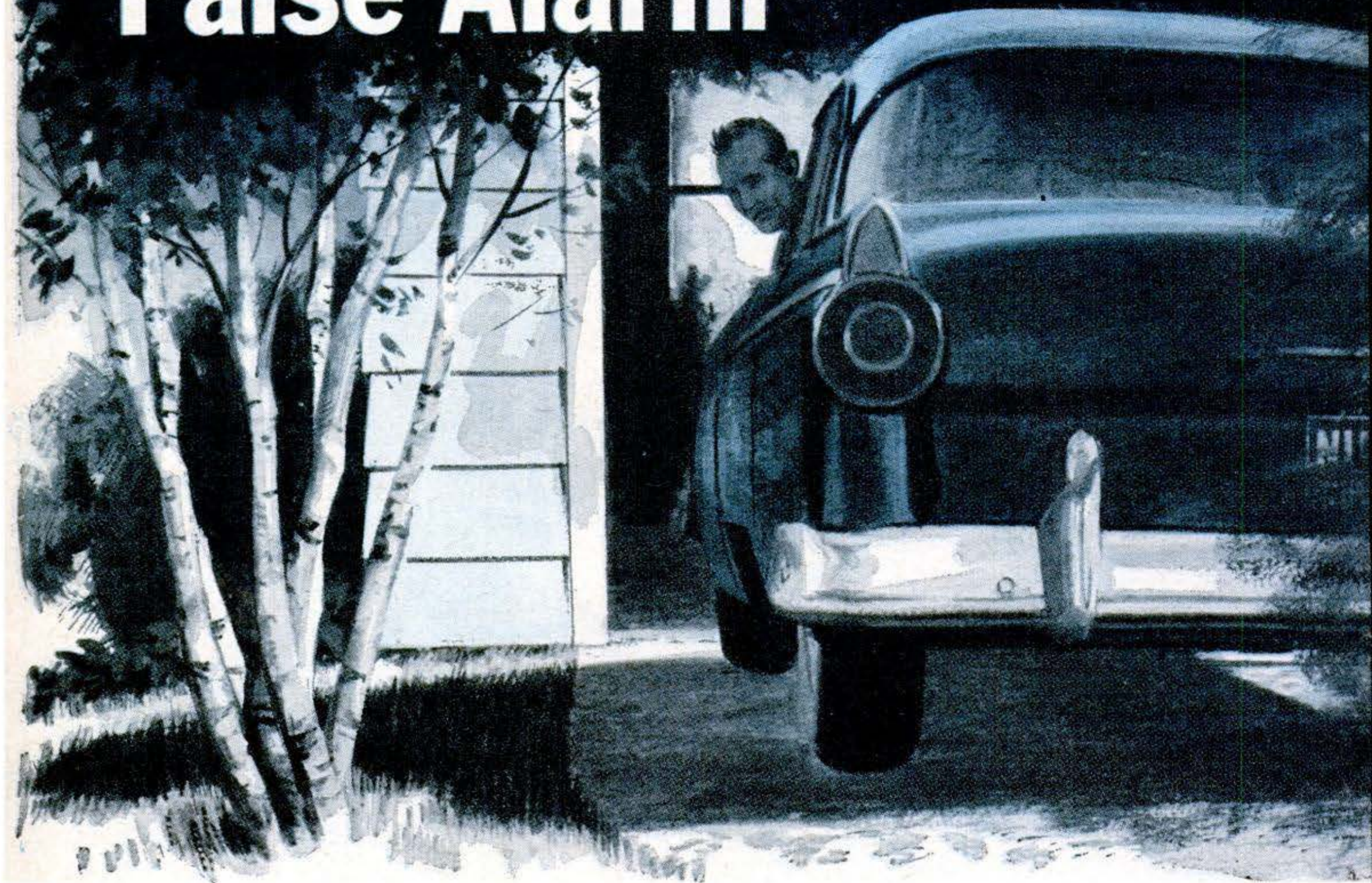

As Flynn backed out, the rear of the car was engulfed in a huge cloud of smoke.

By Martin Bunn

GUS had just started walking away from his rooming house to open the Model Garage when a bright-red hardtop zipped to the curb and stopped with a blare of the horn. The window slid down to show the red face of the town's fire chief, Mal Maloney.

"Answering an early call?" asked Gus.

"Trying to stop one from coming in," grunted Maloney around his cigar. "Come on, Gus. Get in."

Mystified, Gus entered. The car roared away. "Where is this no-alarm fire you're in such a hurry to get to?"

The chief savagely bit his cigar. "Monday we got a call from a woman on Eucalyptus Street reporting a garage fire. Time we got there the garage was empty, the car

gone. Yesterday morning another woman called. She swore heavy black smoke was pouring out of that same garage.

"This time I got there in time to block the driveway just as the fellow was pulling out. His car was smoking like Vesuvius. I gave him the devil."

"What for?" asked Gus innocently.

"What for!" roared Maloney angrily. "Because nobody but nobody has a right to cause two false alarms in two days. Okay—I know he didn't turn them in. But his car caused them."

"He says it's been smoking like that every morning when he starts it up, for nearly a week. Now this I want to see. So I threatened him with the regulations—didn't say which ones because I'm not sure myself—if he starts that car before you and I get there."



For a time the chief drove in silence, lips clamped over his soggy cigar. "Sorry if this makes you late opening, but it's important," he finally said. "Can't have false alarms, or ask the neighbors to ignore that sort of thing."

"Sure, Mal. And don't worry about the shop," said Gus. "Stan will be there by now."

Maloney zoomed to the curb on a pleasant residential street. As he and Gus walked toward the house, a worried-looking, middle-aged man came out. He wore a checked jacket and denims that hung loosely.

"This is Mr. Flynn," said Maloney. "Gus Wilson's our car expert, Mr. Flynn. Let's go look at yours."

"It smokes only when you start it?" asked Gus as they walked to the garage.

Flynn nodded nervously. "But it stops after I've driven a few blocks. Then it behaves. It smokes again when I start home from work, but not so much."

He opened the garage door, revealing a 1956 Ford sedan.

"Don't start it until I say so," requested Gus, opening the hood.

For its age, the V-8 engine was fairly clean. There was no sign of oil leakage, no oil-burn stains on the exhaust manifolds. Noting that the car had dual exhausts, Gus wedged the heat-control valve in the open or hot position, which would channel the exhaust from each cylinder bank to its own muffler.

He closed the hood, walked out of the garage to where he could observe both tailpipes, and signaled to Flynn. The engine caught at once.

Immediately the rear of the car was engulfed in a huge cloud of blue-black smoke. Sounding the horn, Flynn backed cautiously out. When he stopped in the driveway, the engine was still belching smoke—all of it, Gus noted, from the right-hand tailpipe.

"Can't blame those women for turning in those alarms," grunted Maloney. "Somebody'd probably do it again if the car were in the garage."

He walked up to Flynn. "Okay, I've seen enough. You get this crate fixed or I'll slap a ticket on you. Think you can help, Gus?"

Gus nodded. "If you want to run, Mal, I guess Mr. Flynn will give me a lift back to the Model Garage."

The chief nodded, strode back to his car. A raucous radio voice spoke briefly from it as it pulled away.

"I don't know what else to do," began Flynn. "Can't afford a new car, or even a ring job, just now. That's what the mechanic said it needed."

"You said 'what else,'" remarked Gus. "Just what has been done, and why?"

"The car had no pep. Compression was poor on three or four cylinders. The mechanic said I might try adding tune-up solvent to loosen carbon and free any stuck rings. I did, and the engine ran better. Then this smoking began. I was on the early shift last week, leaving before daylight, so nobody saw it. Monday I went on the late shift, and neighbors spotted the smoke. The car's using way more oil than it did, too."

Gus freed the heat-riser valve, then looked at the oil on the dipstick. It was black with dirt.

"Change your oil often?"

"Mm—not as often as I should, I guess," returned Flynn. "But I only make short trips to work and back."

Gus grunted. Short trips are what over-work engine oil most.

"I need some tools," he said. "Suppose

we drive to my shop. Things are handier."

They were halfway there when Flynn swung into a gas station. "Mind if we stop a minute? When I wasn't sure I could use my car, I called a friend to ask for a lift to the plant. He's getting his oil changed here. I'll ask him to stop at your place just in case."

A short, round-faced man wearing work clothes and a sour expression was arguing with the gas-station attendant. Seeing Flynn, he rushed over.

"Good thing you came," he burst out. "Looks like I'll be asking you for a ride instead. This kid's done something to my car. I have to call a garage for a tow."

Flynn shook his head dolefully. "That's tough. Mr. Wilson here is a garageman. I'm on my way to his shop with my car now."

The short man bobbed his head. "My name's Sutton. That's my Chevy on the lift. It's got the 283-cubic-inch engine. Lucky thing I stuck around and checked the oil-pressure light after he changed the oil. It won't go out."

The gas jockey, a lad just out of his teens, nodded glumly. "That's

right, but I put back the drain plug and the new oil's right up to the dipstick mark. It ain't my fault that light stays on. Maybe it's shorted."

"There's no oil pressure. That could ruin my engine!" snapped Sutton.

"How long did the crankcase drain?" Gus asked the attendant.

"Well, there was a rush at the pumps just then. Maybe 15 minutes."

"So what?" demanded Sutton. "You willing to tow my car to your shop?"

"If it's necessary," returned Gus. "Put a floor jack under the front of the car," he told the boy, "and raise it about six inches."

While the puzzled attendant did so, Gus and the other two men walked over. Slowly

.....
: **Where'd it come from?** :
:
:



: **"Well-heeled"** :
:

When heels first came into vogue, they were considered a mark of nobility, and not allowed on the shoes of peasants or workmen. From this came the expression, "well-heeled."
:

How AC Spark Plugs help deliver full power

NORMAL COMBUSTION

With AC Spark Plugs in the heat range specified for your car, combustion occurs at the top of the power stroke. This helps prevent power-robbing pre-ignition, lets your engine develop maximum power and economy.

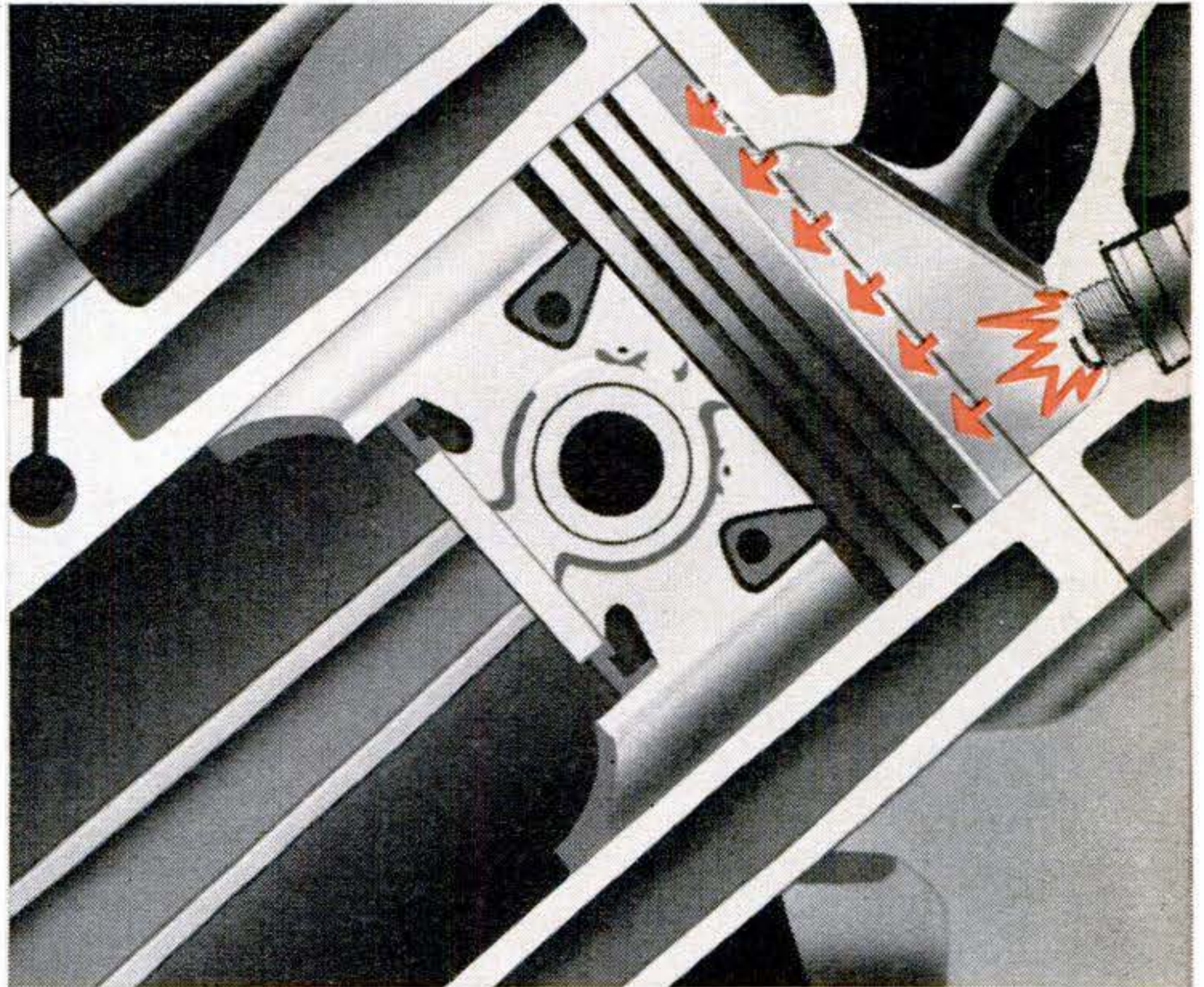

PRE-IGNITION

Spark plugs in too high a heat range often overheat and ignite the fuel charge before the spark occurs, causing pre-ignition. Result can be serious power loss and even costly engine damage.

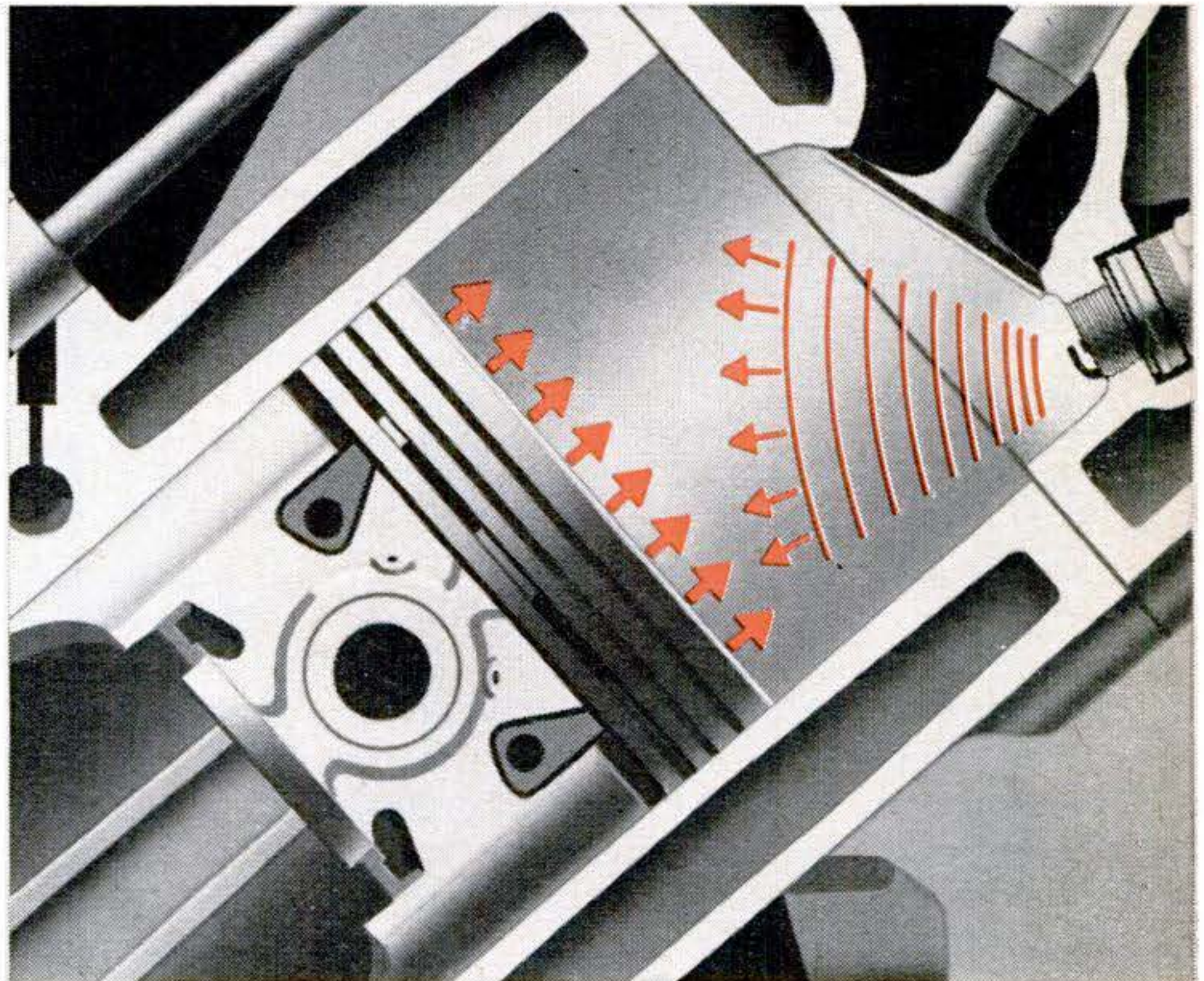

AC Fire-Ring Spark Plugs in the proper heat range help deliver full power by guarding against gas-wasting pre-ignition and possible engine damage. AC's Self-Cleaning Hot Tip is engineered to give you peak performance and economy. Ask for **AC Fire-Ring Spark Plugs** specifically designed for your car.

AC SPARK PLUG  THE ELECTRONICS DIVISION OF GENERAL MOTORS



the car lifted, to assume a nose-up slant.

"Try the engine now," said Gus.

"But we did, three times," protested Sutton. "What difference—oh, okay."

Reluctantly he got in and switched on the engine, which caught at once.

"The light's still on! Gotta stop . . ."

Gus held his hand just as Sutton was about to shut off the engine. An instant later the indicator light went out.

"Hey, it—how come?" spluttered the short man. "What did you do?"

"On this 283-inch Chevy engine," Gus explained, "long draining can empty the pump, making it lose its prime. It then spins in air and can't lift oil. Raising the front end tilts the oil level back to the pump so it can pick up its prime again. No sweat."

"Not when you know," murmured the gas jockey. "I'm glad you turned up."

"So am I," agreed Sutton. "I'll go along to see if Flynn needs that ride."

Stan had opened up and was at work when Gus and Flynn drove up to the Model Garage, followed by Sutton. Gus at once checked the plugs in the right cylinder bank of Flynn's car.

The first two plugs, though old, were fairly clean. The rear two were badly oil-fouled. Gus cleaned and replaced them. Then, as Flynn and Sutton watched, he loosened the valve cover.

Oil gushed out even before he raised it. The valve mechanism was thick with sludge. Wiping away what he could, Gus probed for the oil-drain holes in the head, ran a wire through them, and finished with a spurt of air.

"The engine's dirty from over-age oil and short runs," Gus told Flynn as he replaced the valve cover. "The oil passages to the rocker arms were at least partly clogged, cutting down the oil supply. The drain holes were plugged too. Then you added tune-up solvent to the engine oil. Being under pressure in the supply passages, it opened them. More oil came up. But there was no pressure to clean out the drain holes.

"With more oil coming in but not much draining out, the valve chamber filled up above the top of the valve guides of the two rear cylinders. This didn't show in driving. But overnight, oil would seep through the guides into the cylinders and exhaust manifold. By morning there was enough of it to lay a smoke screen when you started the engine."

"And when that burned away the car quit smoking?" asked Flynn.

"Sure, until it stood idle long enough for more oil to seep in," said Gus. "It won't smoke now, but you should have the engine thoroughly cleaned soon."

"If you can do it today, I'll leave the car now," said Flynn, and when Gus agreed, turned to Sutton. "I'll take that ride to work now."

A *bright-red hardtop* rolled into the Model Garage later that afternoon.

"Where's that car wrecker who thinks he's a mechanic?" demanded Maloney.

Gus emerged from the office to grin at the red-faced fire chief.

"Well, we've taken care of the false-alarm department," he said genially. "That's kept us pretty busy."

"Then I'm not going to get any more false alarms coming in from Eucalyptus Street?"

"Guess not," returned Gus. "There's Flynn's car. It won't smoke up the neighborhood any more."

Maloney grunted. "Thanks for the assist, Gus. You may have saved the department some useless calls."

"Hey Chief," called Stan from underneath the grease rack. "Gus handled another false alarm at the Ace Service Station, too. All by himself."

"Oh, yeah?" asked Maloney suspiciously. "It was a different kind of fire," remarked Stan.

"Uh-huh," chuckled Gus. "It sure wasn't your kind. Only thing to worry about there was a car owner who was burning up. And you know how we put it out? By pouring oil on it!"

PS Puzzler



You can look into this barrel, but it's pretty dark and you can't quite tell whether the water level is below, just on, or slightly above the halfway point. Can you settle the problem without any props?

Answer on page 163

**Makes
soldering
a cinch!**

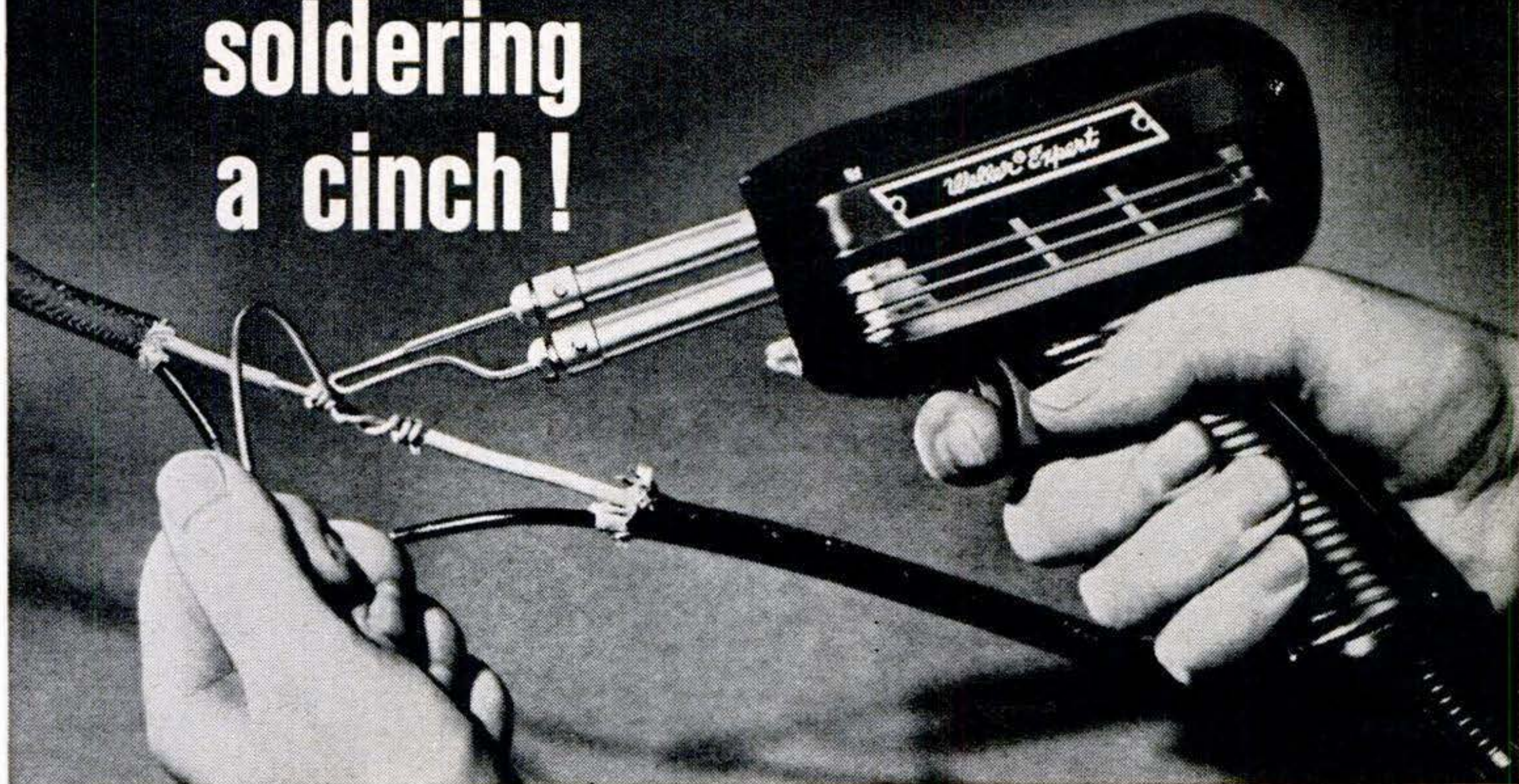

Weller® Dual Heat Soldering Gun

There's no tool like a Weller Dual Heat Gun for quick, easy soldering and scores of household repairs. Pull the trigger—tip heats instantly and spotlight illuminates work. 2 trigger positions give you a choice of two tip temperatures. You can switch instantly to the heat best suited for the job. And by using high heat only when necessary, you prolong tip life.

Tip is made of copper for superior heat transfer and premium-plated for rigidity and long life. Accessory tips

are available for heat sealing, cutting and smoothing.

Over 5 million Weller guns have been sold. They're used by professional servicemen and homecrafters the world over. All Weller guns are UL approved and guaranteed one year against defects in material and workmanship.

Weller dual heat guns are available in many models with wattage ratings to suit your needs. They are also supplied in plastic case kits that include accessories.

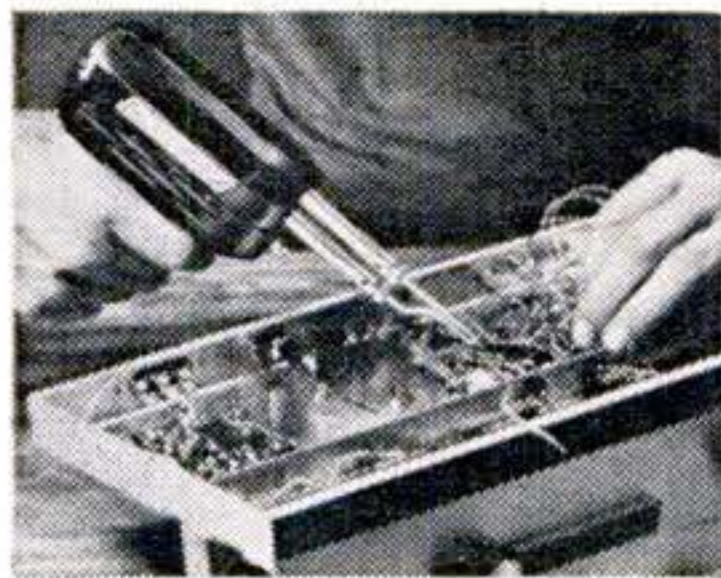

A must for hi-fi kit building. Assures noise-free connections. Use low heat when soldering near sensitive components, high heat for chassis connections.

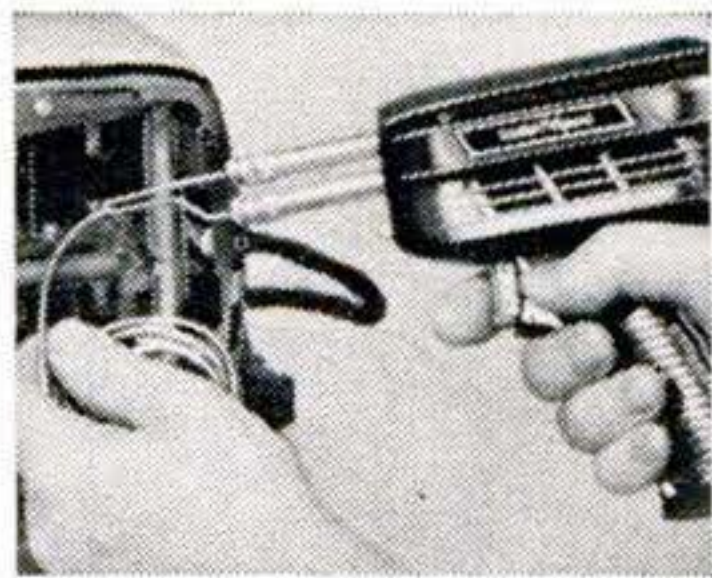

Saves on electrical repairs. Enables you to do many appliance and electrical repair jobs yourself. Also useful for many different crafts and hobbies.



Mends metal. Whether patching holes, sealing seams or joining metal parts, your Weller gun will pay for itself on scores of repair jobs around your home.



Does more than soldering. With cutting and smoothing tips you can cut plastic tile, repair plastic toys, seal plastic bags, repair furniture dents, etc.

WELLER ELECTRIC CORP., 601 STONE'S CROSSING ROAD, EASTON, PA.

Trouble-savers for those long, hot vacation drives:

How to Keep Your Engine Cool

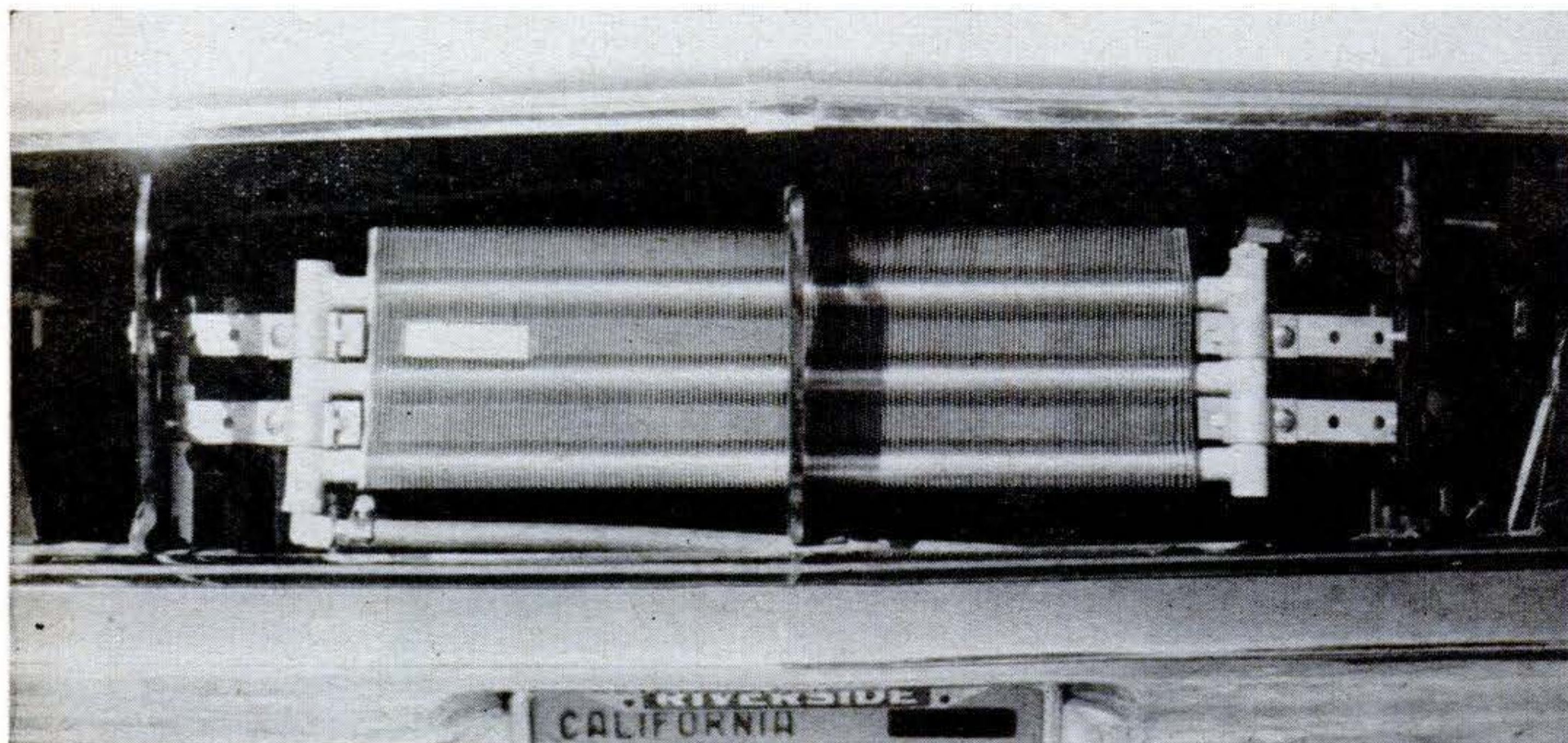

Relieving your engine radiator of the job of cooling the automatic-transmission oil is one way of keeping your engine cooler. Trans-Cooler installed in front of regular radiator (above) does this job. Unit cools transmission oil separately, bypassing engine's radiator. Oil is routed into 66 inches of finned tubing. Diagram (right) traces oil line from transmission to cooler and back again.

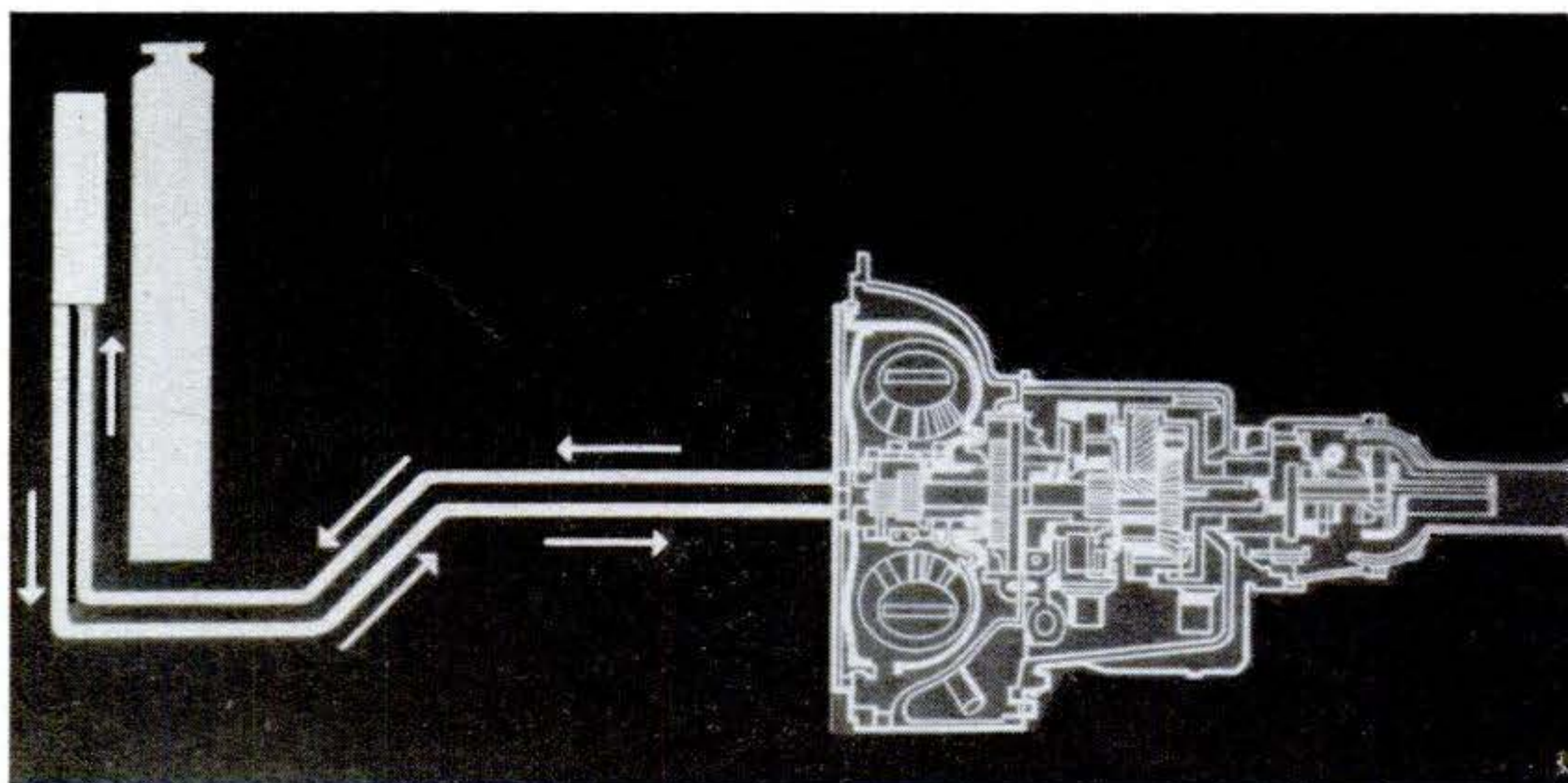

By V. Lee Oertle

ENGINE overheating is more than just a summertime nuisance. It can damage internal parts and result in costly repairs.

If you're like most vacation drivers you routinely overload your car's cooling system by carrying along everything but the kitchen sink. Traffic jams and summer heat add to the problem.

How can you prevent overheating? Here

are some tips, most of them involving mechanical assistance to an overloaded cooling system.

- Cool the radiator externally with a spray of water onto the core. One unit that does this is called Vapor-Kool. Cost: about \$45.

- Try a thicker core. Extra-cooling radiators are available at car dealers. They boost the cooling capacity 10 to 25 percent. Cost: up to \$100.

- Try a more efficient fan. Ford, for example, puts a four-blade fan on standard



Another way of keeping your engine cool is to spray the radiator with water—evaporation does it. In photo above a water tank is attached to the bumper. Water is pumped to a spray head (in man's hand) through rubber hose by a tiny electric pump. Both main tank, as well as an auxiliary (photo at right), can be installed in the trunk. Some motorists have done the same thing with homemade tanks pressurized with a hand-operated pump (a bicycle pump will do the job nicely).

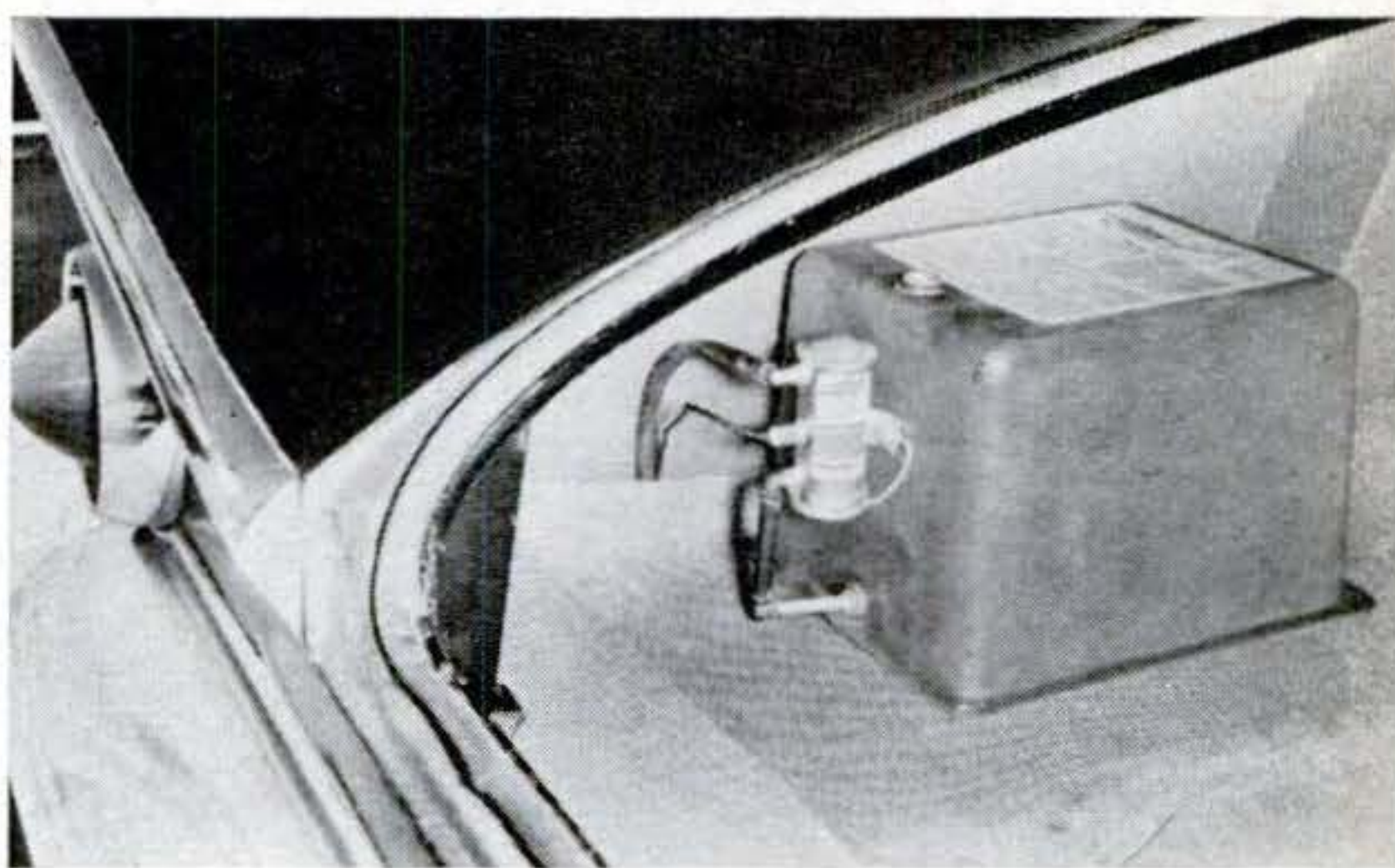

sedans. But a seven-blade fan—it does the most good below 35 m.p.h., where you need it—is optionally available. Cost: only a few dollars.

- Change the radiator pressure cap. Increasing the pressure allows the engine coolant to reach a higher temperature before boiling away. Make sure you stay within the car manufacturer's design limits. Cost: peanuts.

- A chemical coolant, such as Dowgard, also raises the boiling point of the engine

cooling system. Cost: again only peanuts.

- Increase the size of your radiator top-tank reservoir. Your local repair shop will install one of bigger capacity. Cost: depends, but it probably will nick you for less than \$50.

- Install a separate automatic-transmission cooler. An automatic drive increases the heat load on your car's cooling system. Cost: about \$55.

- Sometimes a faulty water pump is to blame for overheating. Backing off on the

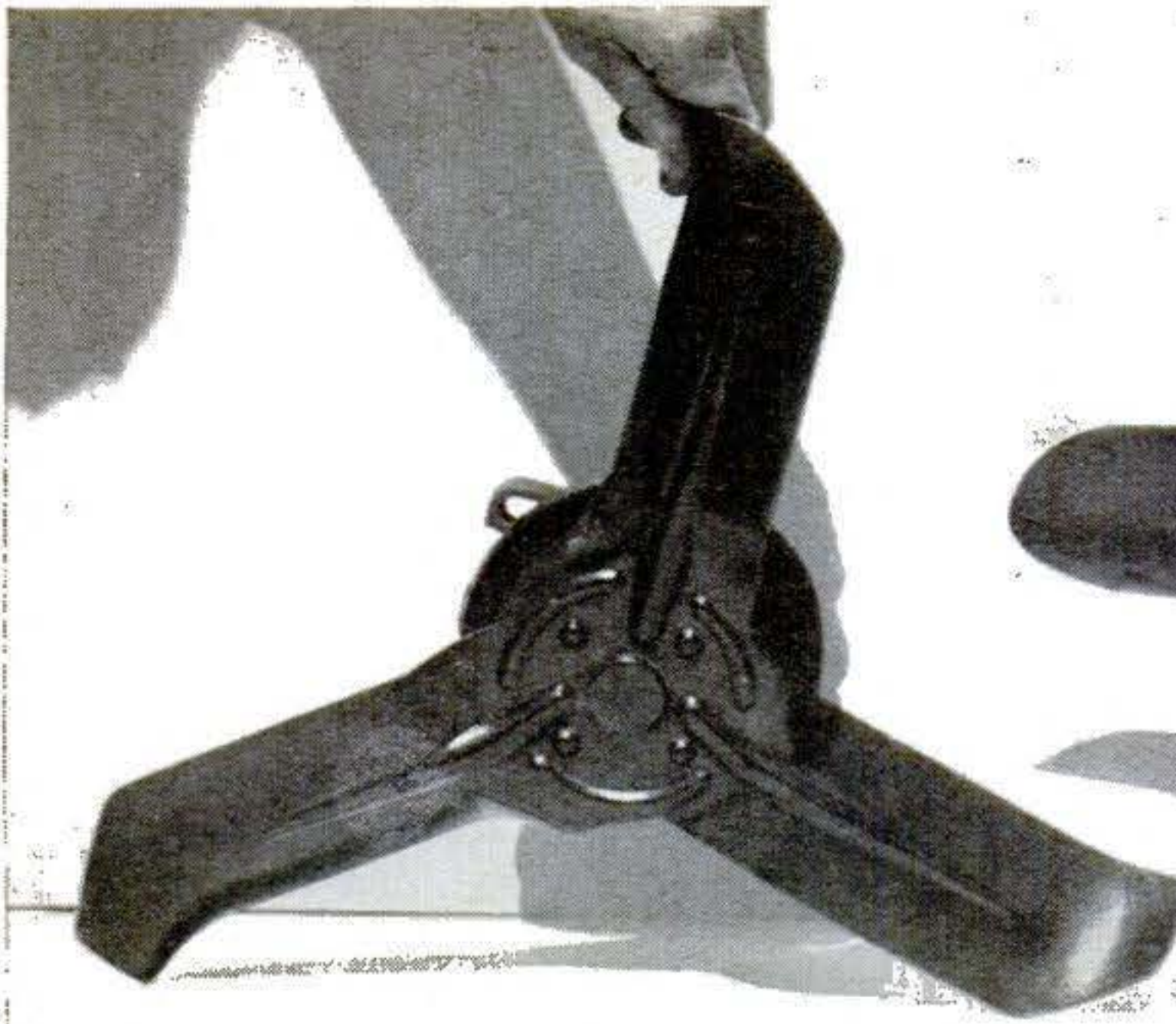

Heavy-duty fan with six or seven blades offers a good way to increase the flow of air through the radiator—and thus dissipate heat faster. The

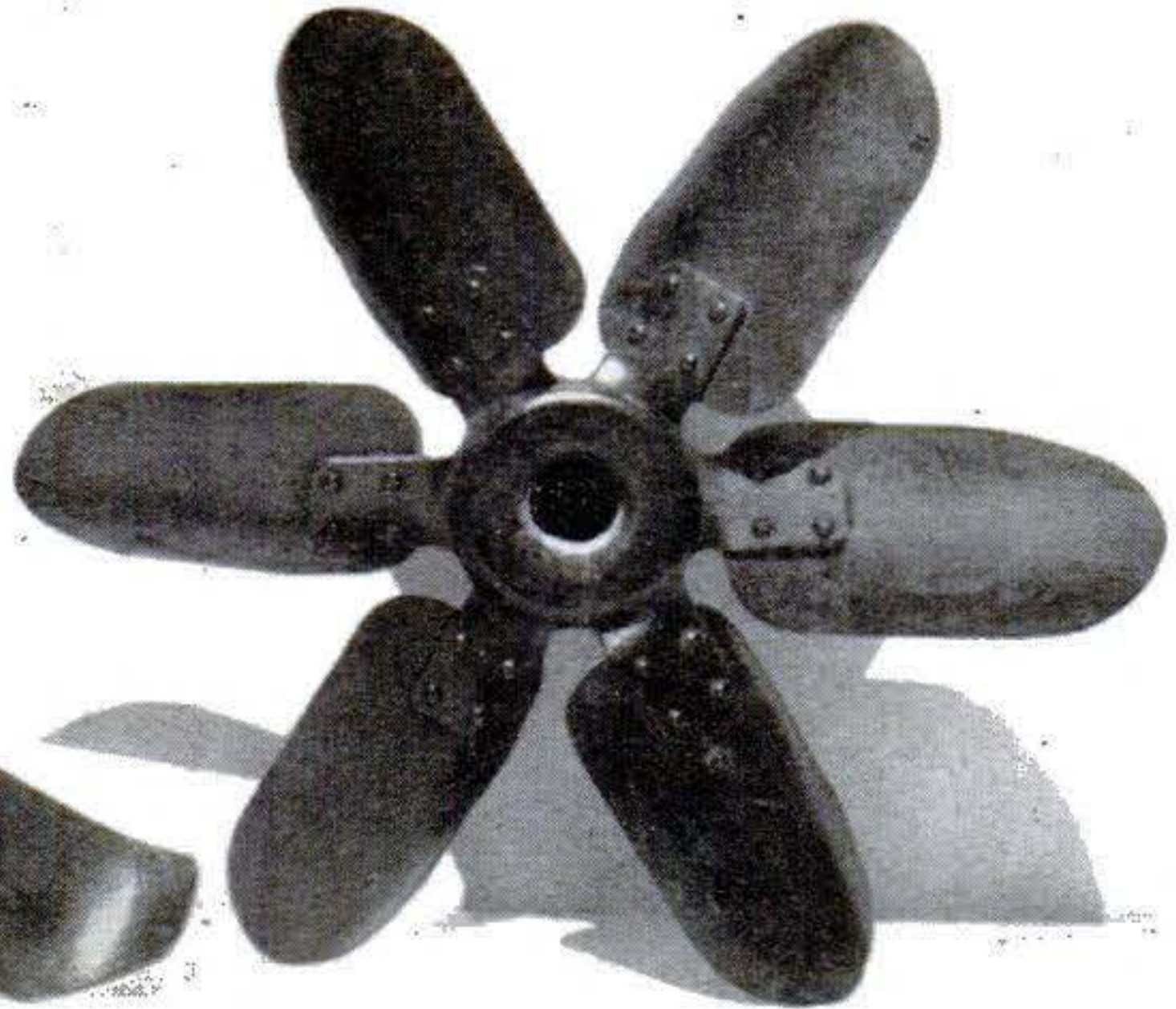

standard fan has three or four blades. A recommended addition: a fan shroud to increase the volume of air pulled through the radiator.

spark advance will reduce the engine heat.

On the road. Good driving habits will help. While climbing a hill, for instance, shift to a lower gear to reduce the engine's labor. In traffic stops, throw your car out of gear and keep several hundred extra revs on your engine.

Monitor the use of your air conditioner. If the engine temperature mounts, shut off

the conditioner for a while. If you encounter vapor lock, it often helps to halve a grapefruit or small melon and squash it down on the fuel pump. Evaporation of the juice cools the pump.

Carrying two or three gallons of spare water puts you ahead of the game. Do not, of course, pour cool water into a hot radiator unless the engine is running. ■ ■

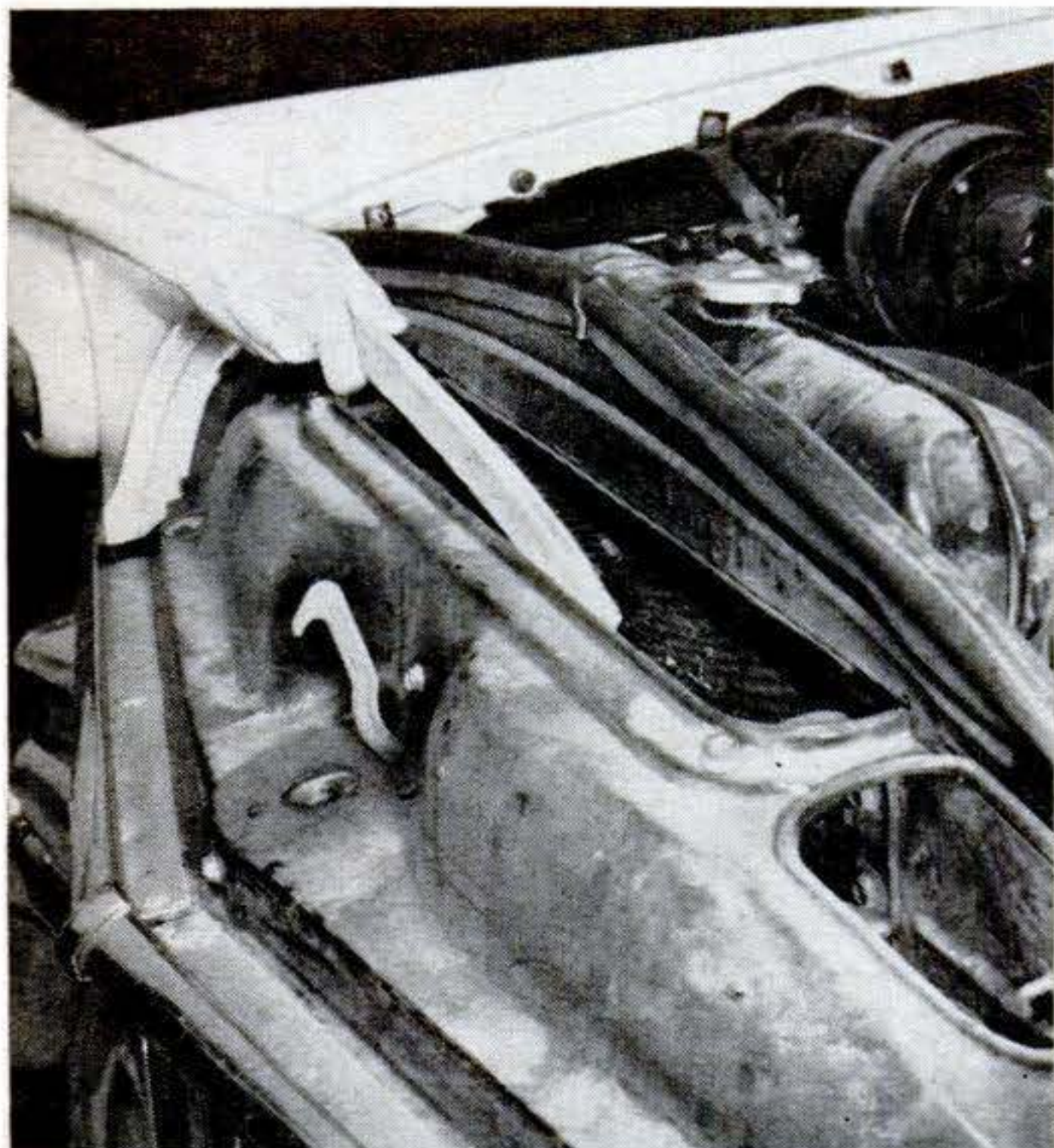

Bugs and other debris can clog the radiator fins and reduce cooling-system efficiency. Carry a wire brush along on your vacation to keep the radiator clean. You might try a chemical coolant with a higher boiling point than water. And be sure to tension that fan belt properly!

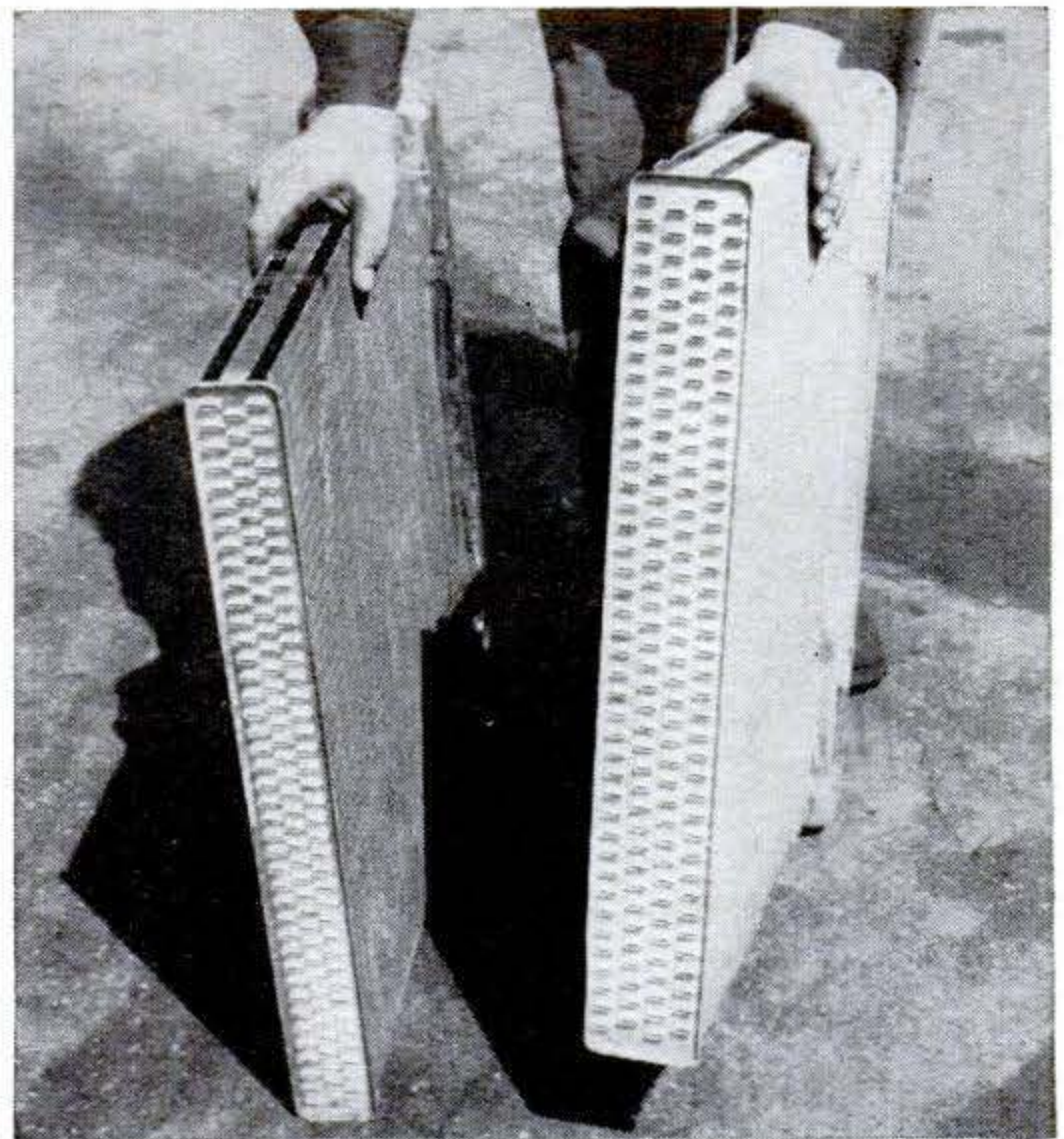

A thicker radiator core makes a big difference in the amount of heat a cooling system can dissipate. These two radiators fit the same model car but the one at right has 25 percent more capacity—more cooling fins per inch. It's expensive, but the best overheating preventive.

EASY AND FUN TO MAKE

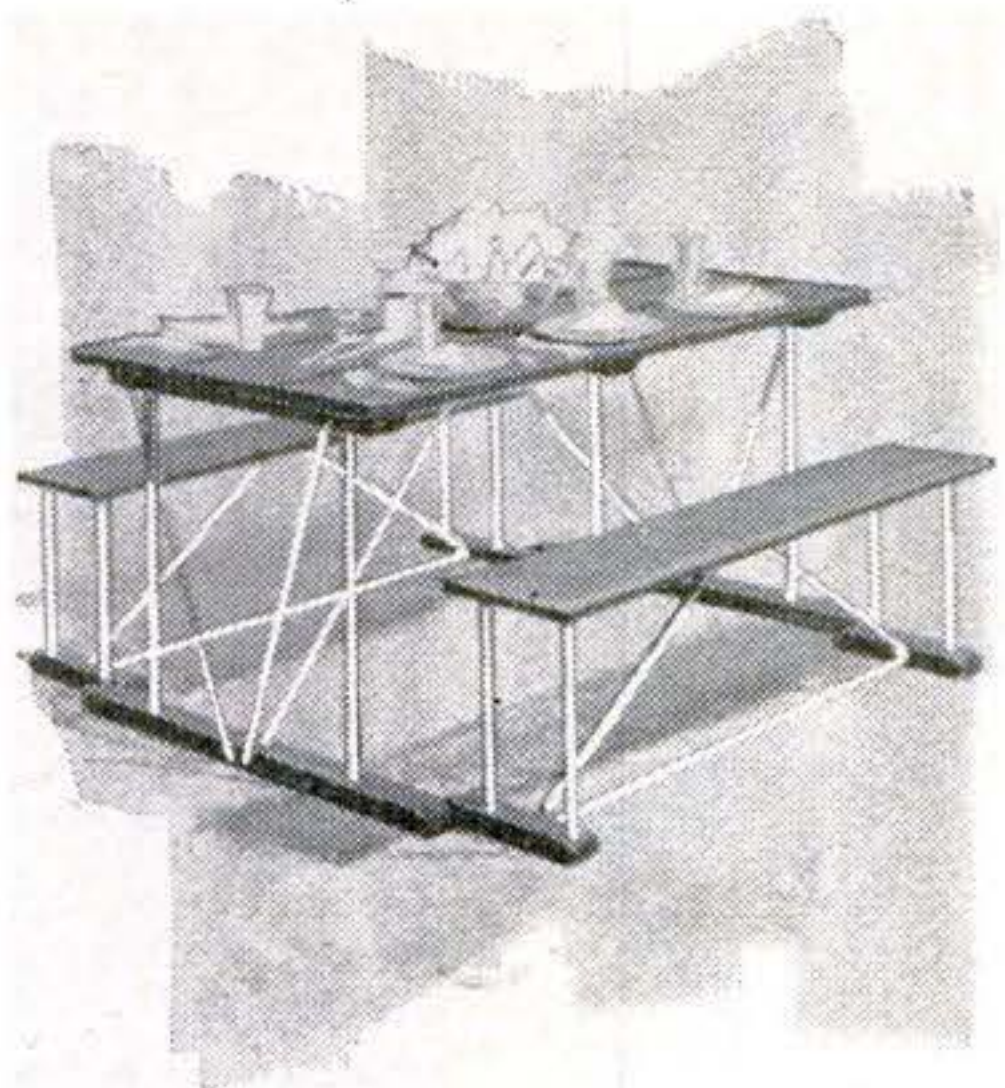

Patio-Picnic Table

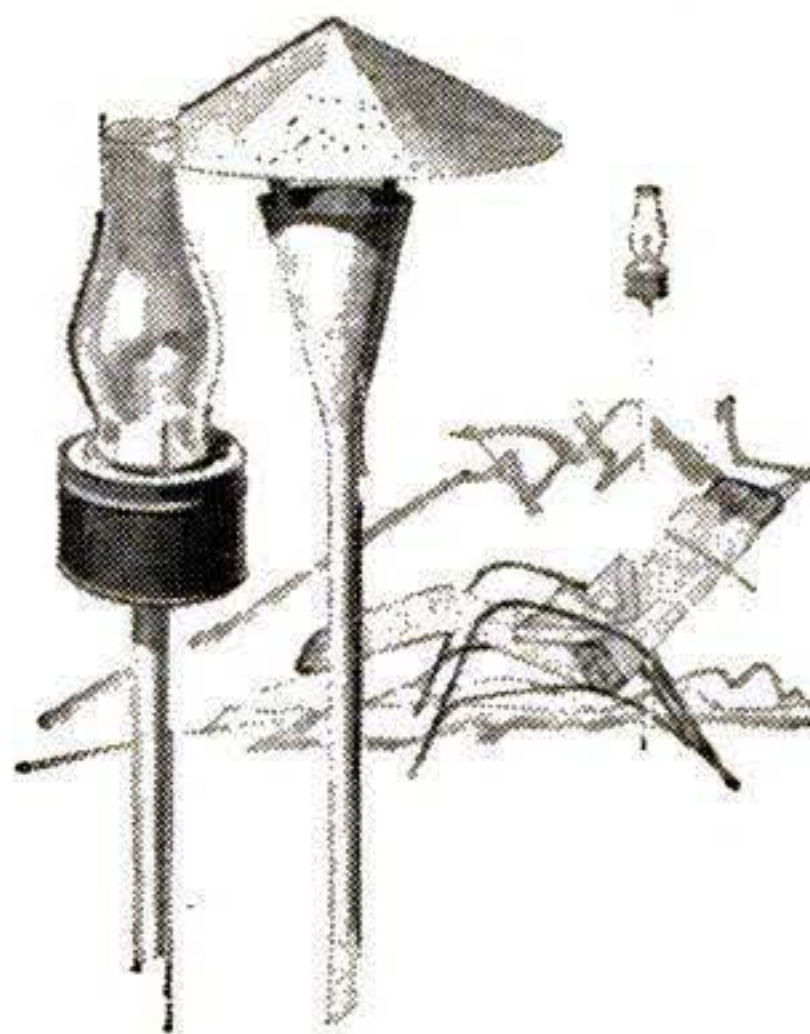

Patio Lights

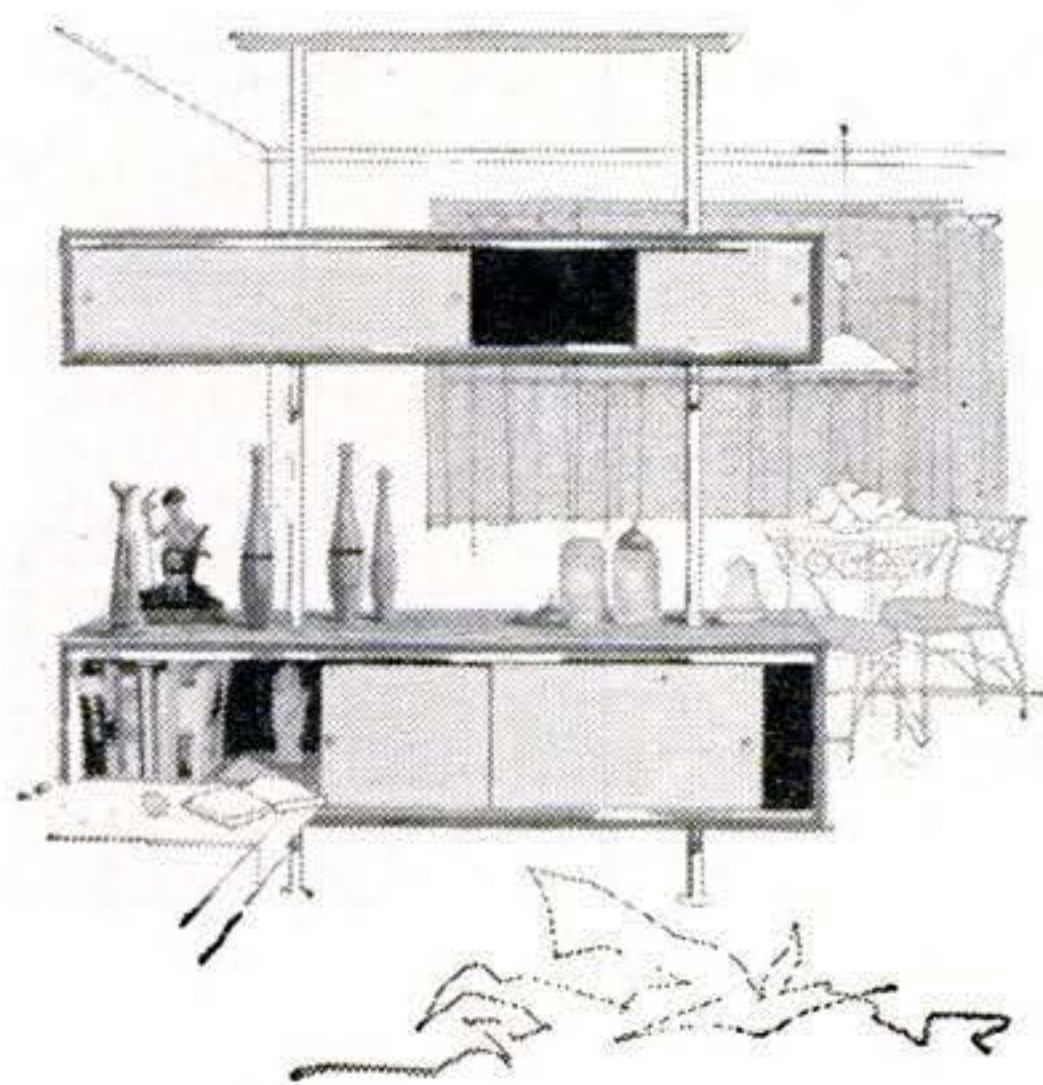

Room Dividers

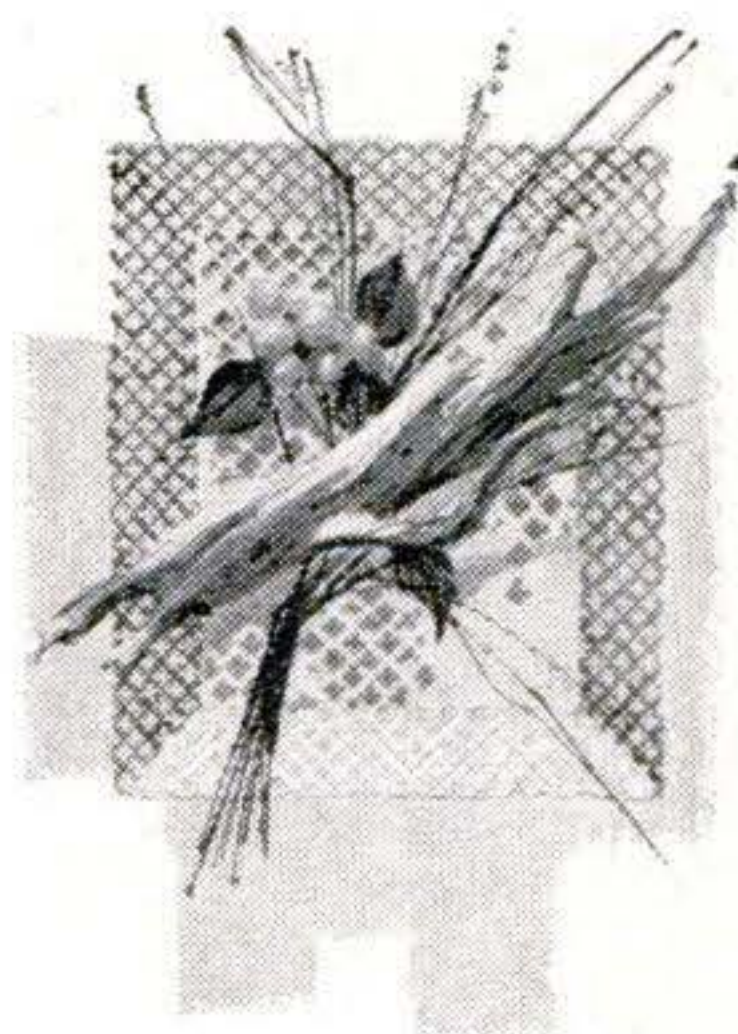

Shadow Boxes

with Reynolds Do-It-Yourself Aluminum

Use just ordinary woodworking tools. Your local hardware or building supply dealer stocks the items you'll need plus simple, step-by-step, free plans booklets. If his supply is temporarily exhausted, send 10c in coin to cover handling and mailing costs along with the coupon on this page. We'll send you 3 booklets containing easy-to-follow plans for more than 27 fascinating projects.

For a pastime you can enjoy in the present and the future . . . build and make home improvements with Reynolds Do-It-Yourself Aluminum. The first step is an easy one . . . just fill in and mail the coupon on the right.



DO-IT-YOURSELF PLANS

P.O. Box 606
Richmond 5, Virginia

Please send me copies of 3 plans booklets. Enclosed is 10c to cover cost of mailing and handling.

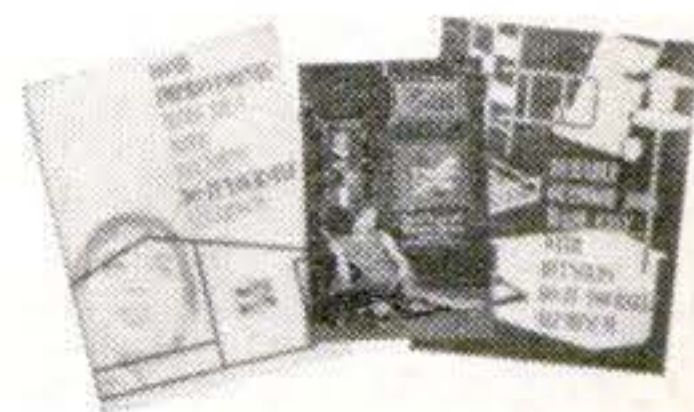

Name _____

Address _____

City _____ Zone _____ State _____

Watch The Dick Powell REYNOLDS ALUMINUM THEATRE,
Tuesdays, NBC-TV.

Short Cuts and Tips

FROM
PS
READERS

Make your own pocket-size fish-landing net

A fish-landing net often tangles with branches along a wooded stream. Here's one that doesn't because you can tuck it away in the pocket of a fishing vest. It consists of a replacement net lashed to two 6" embroidery hoops with nylon line. It lacks a handle, but this is no handicap in handling a trout.—*Don Shiner, San Diego.*

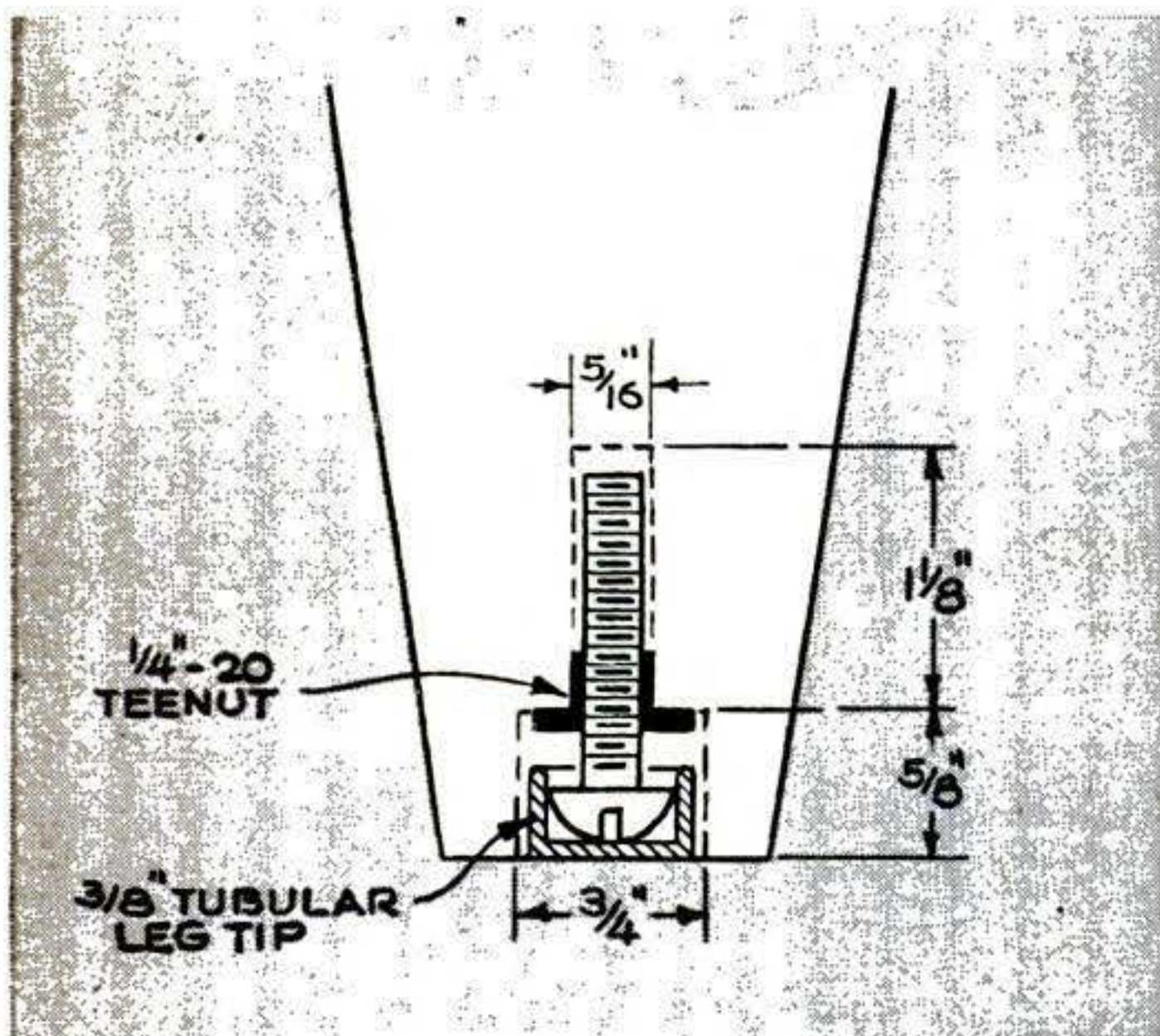

Adjustable tip for a table leg

Here's how I made an adjustable leg for my dining table. After drilling the holes into the leg as shown, I drove a $\frac{1}{4}$ "-20 Tee-nut into the entrance of the $\frac{5}{16}$ " hole. A plastic tubular-leg tip was forced on the head of a $1\frac{1}{2}$ "-long $\frac{1}{4}$ "-20 roundhead bolt and the latter turned into the leg.—*L. E. Verdon, Kalamazoo, Mich.*

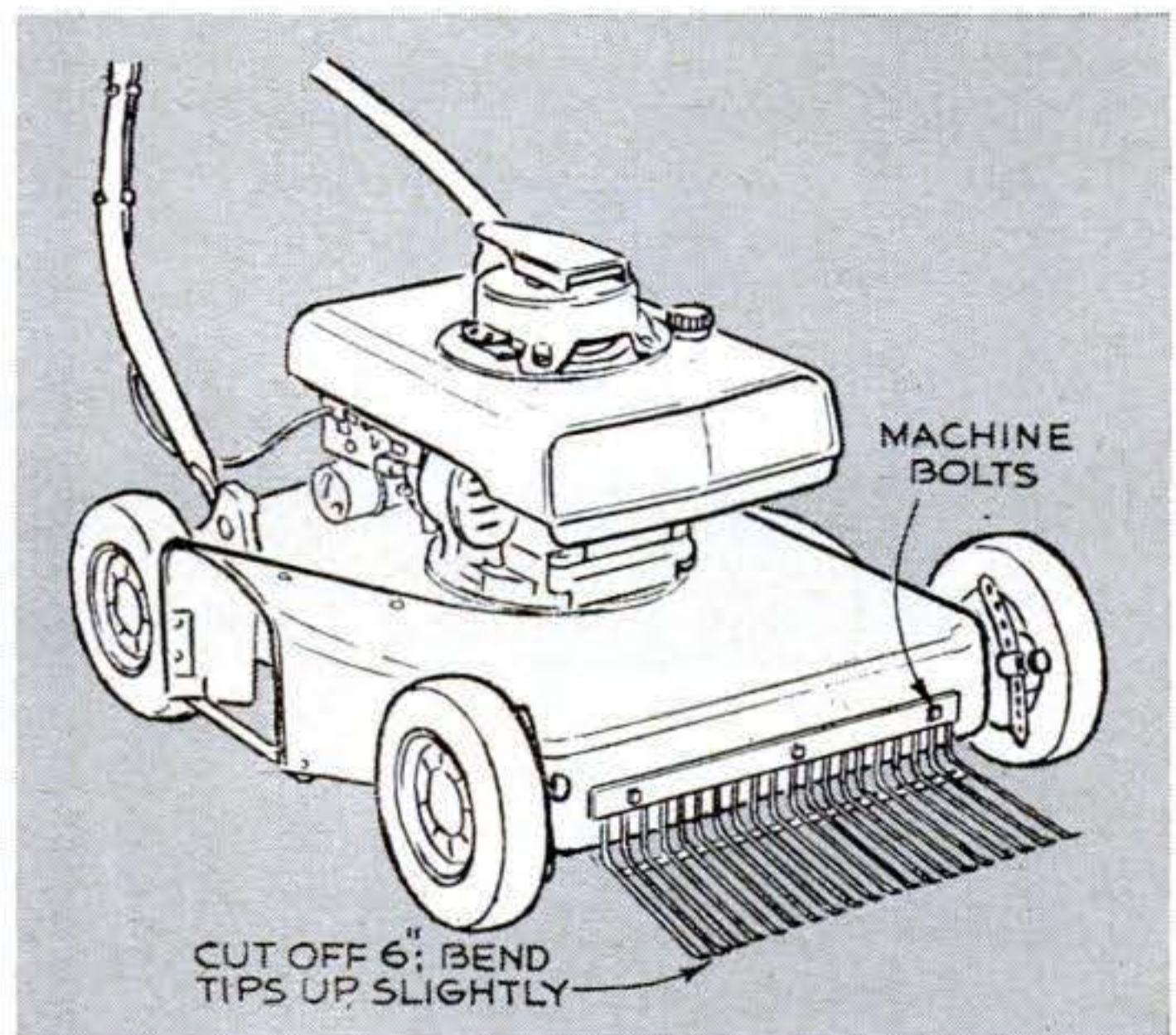

Bone catcher protects mower blade

A mower blade suffers badly when you run into a bone left on the lawn by a dog. To protect mine, I bolted a section of an old leaf rake to the mower front, shortening the tips and turning them up slightly. The contraption saves me a half-hour searching for bones (and stones, too) before I mow.—*F. E. Palmore, Oklahoma City, Okla.*

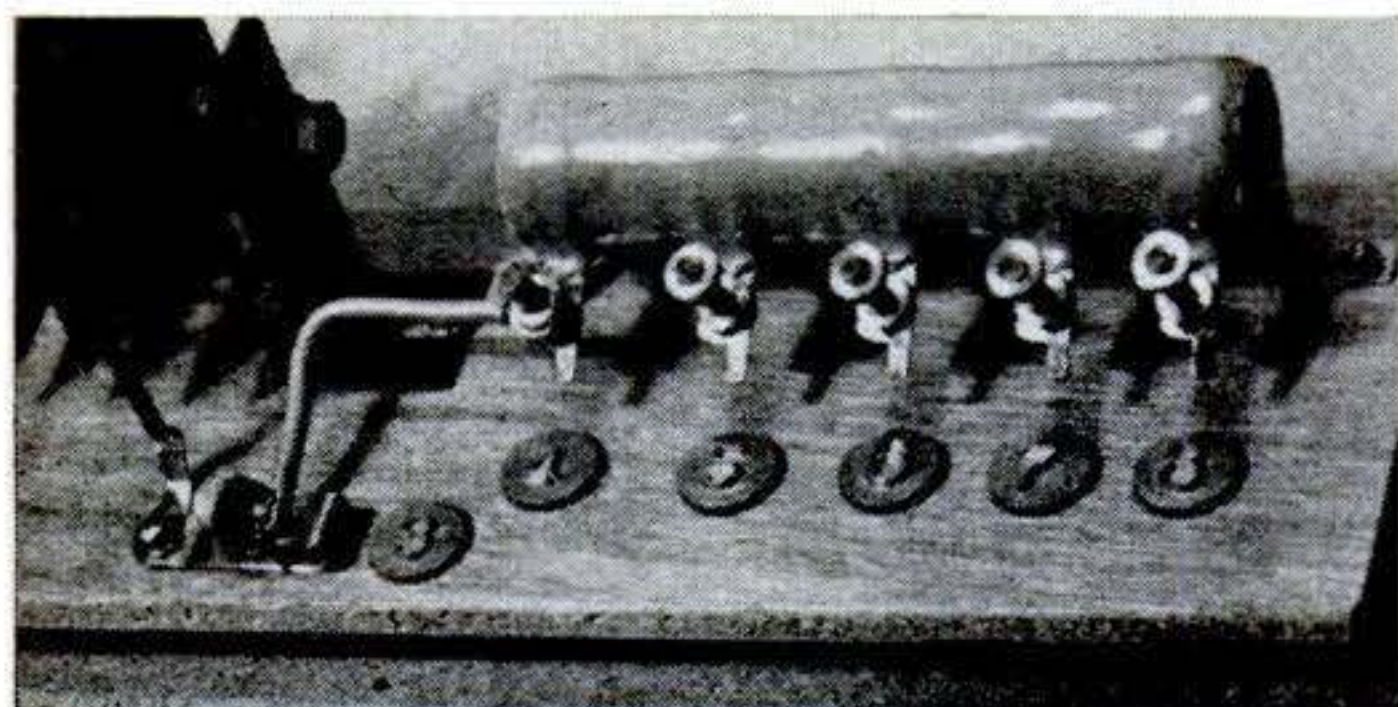

Sash markers for wiring circuits

Electrical experimenters can quickly identify circuits and make connections with this handy means of identification. Storm-sash number pins cost only a few cents for a card of 25 at the dime or hardware store and are ideal for the purpose. The metal pins can be driven easily into wood.—*Robert Micals, Freehold, N.J.*

This book makes every job as easy as **1-2-3**

— because 1-2-3 is exactly
how you do it!

EVERY auto repair or adjustment in this giant, picture-packed guide is broken down for you into simple, numbered steps. And every step is illustrated with action-type photos or drawings that let you see how it's done. Complete, illustrated headlight-to-tail-light repair instructions. GLENN'S shows you how to disassemble

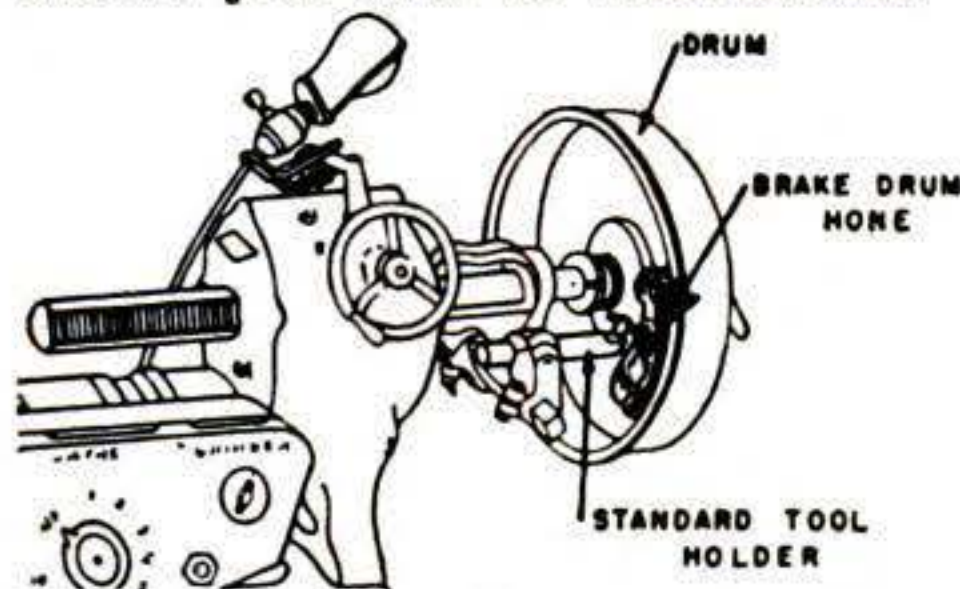

any part of the car... inspect it... clean it... repair it... put it back together... and reinstall it on the car.

(IMPORTANT FEATURE: You learn how to service the part without removing it, when possible. Time-saving bench adjustments and on-the-car repair procedures are printed in bold type to help you locate them instantly.)

There are thousands of clear photos of mechanical parts... detailed diagrams... exploded views. You are never in doubt about what to do next... where any nut, bolt, or washer belongs.

FIND the trouble PRONTO!

A big section of Quick Guide Trouble Finder Charts leads you straight to what's really wrong... with no fumbling or guessing—and no time or money wasted on unnecessary repairs!

GLENN'S manual also contains the largest collection of worn-

No other single manual brings you so much!

- 1052 pages. More than 3000 pictures.
- Complete repair information on every part of the car; engine, carburetor, transmission, electrical system, brakes.
- What tools to use.
- Complete specifications on all models for past 11 years.
- Bench adjustments and quick on-the-car repair procedures set off in bold type.
- Chassis, electrical, power accessory diagrams.
- Comprehensive table of contents more than 20 pages long... AND MUCH MORE!

parts pictures ever assembled—which shows you how to recognize dangerous wear and corrosion in vital bearings and other essential parts.

A mechanics' standby for years... and perfect for beginners

If you are a professional mechanic, you will find a wealth of

FIX THESE CARS

Buick	Hudson
Cadillac	Imperial
Checker	Lancer
Chevrolet	Lincoln
Chevy II	Mercury
Chrysler	Nash
Comet	Oldsmobile
Corvair	Plymouth
De Soto	Pontiac
Dodge	Rambler
Edsel	Studebaker
Fairlane	Tempest
Falcon	Thunderbird
Ford	Valiant



information you can't get anywhere else...all the specifications and other data you need to handle any job on any car.

But even if you have never fixed a car before, this book will make it easier than you ever thought possible...eliminate surprises...give you the equivalent of years of experience!

Seven-day FREE trial

We are so sure that GLENN'S NEW AUTO REPAIR MANUAL is the handiest, most helpful guide to auto repair in existence that we will gladly let you try it for 7 days FREE. Then you can either return the book and owe nothing, or pay the \$9.95 price (plus postage) in easy installments.

Write Chilton Co., Dept. PS-73, 525 Locust St., Phila. 6, Pa. Wherever books are sold, or use convenient coupon.

SEND NO MONEY

CHILTON COMPANY, Dept. PS-73
525 Locust St., Philadelphia 6, Pa.

Please send GLENN'S NEW AUTO REPAIR MANUAL for 7 days' FREE examination. I will then remit \$4.00 in 7 days, pay \$3.00 a month later, and a final payment of \$2.95 (plus 45¢ postage) a month after that. Otherwise, I will return the manual postpaid and owe nothing.

Name.....

Address.....

City.....Zone.....State.....

SAVE. Enclose \$9.95 now and publisher pays postage. Same return guarantee.

mouth. But having only two, Mathews had tied a clothesrope to the throttle—his third hand. Every time he pulled the throttle, the rope pulled the “lift” lever for him.

He drew back on the throttle. The rope tugged at the “lift.” Suddenly there was another explosion in the river—in reverse—as the bucket jumped clean out of the water, streaming. A fast pull on the lift cable sent it soaring, and the crane flung it straight at the D-6 dozers.

We learned that the garmouth (there's only one other in the world) had never hit a tractor, and once—so sensitive is the control—had even saved a man's life. On that day, a D-6 began sliding toward destruction in the river just as the big garmouth bucket began its flight toward shore. In a wink, the operator spun the power room around, re-aimed the garmouth and fired it into the path of the falling D-6. The D-6 rammed the bucket, stopped skidding, and was saved.

Hour after hour, the garmouth chewed out the torn spots, smoothing them. The river bottom and bank now were ready to receive their “rug.” Another crew made ready for the gangster.

The gangster

This is another monster barge. It was hard at work at the hole in the bank near Baton Rouge. When we saw it through the spray-battered windshield of an Army boat it looked like a World War I battleship topped with massive steel superstructures.

Then we saw that these were actually three bridge cranes, or gantries, from which its nickname comes. (To some of the 200 hands who work this fleet, “gantries” sounds like “gangsters.”)

As we came closer, a whistle blew, the gangster moved closer to shore, and bedlam suddenly broke loose. This strange floating factory went madly to work weaving a curious concrete rug.

The rug was to be woven on a wide deck under hot sun. It would be made of patches of concrete slab previously fabricated in a plant 100 miles upriver. These patches, 25 feet long and 4 feet wide, were coming downriver day and night, thousands at a time, on an endless fleet of barges—to feed the gangster's great loom. Each consisted of 35 slabs tied together with built-in copper-clad wires.

A bargeload of patches was coming as we arrived. A towboat rammed it hard, with a thundering blow, against the gangster, and almost instantly the three big electric-powered gantry cranes swung into action. From each, a set of claws plunged down, snatched a patch, lifted it, and hurled it over to the big deck. Each patch weighed 3,300 pounds, and to keep the gantries balanced, 3,300-pound counterweights roared back and forth in an awful clatter. Down in the power room below decks, the sudden “draw” on the diesel generators was terrific.

On deck, the concrete patches were thundering down from the gantries, one every 10 seconds. As each landed, a crew of “weavers” swarmed over it—men equipped with wire-tying tools four feet long. The tools bit into the ends of built-in wires, twisted them, and tied each patch into the growing carpet. Then the men ducked back—and the next patch hurtled down.

In 10 minutes a section of carpet 140 feet long and 25 feet wide had been woven.

The roly-go

It's one thing to weave a concrete carpet, and another to lay it. First, all that weight, perhaps 150 tons, must be pulled up the bank—in some places 30 feet—the way you pull a sheet up under your chin at night. This must be done without breaking it. But even before that comes another tricky job: “handing” the carpet across the water to the shore.

We looked up the riverbank and saw a monster creeping down toward the rug-making barge, like a prehistoric amphibian. This was the roly-go—technically, the world's largest spreader-bar. Cautiously lowered on cables by three big dozers, moving on 28 earth-mover tires, it rolled down the bank, then “walked” right out over the water, floating on its tires.

Weirdly, it came out to the barge. Crews tied the carpet to this floating newcomer in 36 places. Then a whistle blew; the D-8s thrust their blades deep into the bank for footing and slowly winched the roly-go shoreward.

Behind it, a foot at a time, came the great fabric of concrete. Cables cried and twanged. Motors thundered, and at last, the carpet was up the bank and tied to anchors. While deck crews swiftly wove new lengths of carpet, the rug-making

Ol' Man River Meets His Match

barge began to back away from land. It moved foot by foot, weaving as it went. Three hours later it was 500 feet out in the river, still holding up the carpet.

Suddenly, all the crews ran from the work deck. A signal was given. All along the deck mechanical wire cutters flashed, severing 36 steel cables at once. There was a loud twanging, and the carpet, cut loose, settled far into the depths.

The gangster and its weavers now moved upstream to lay another strip—and the "blacktopper" moved in.

The blacktopper

This was a floating asphalt plant big enough to supply a city. It turned out blacktop as fast as a 1½-ton bucket could gobble sand from supply barges. It cooked the mix, then shoved it up the levee hot, to be quickly spread in a five-inch layer.

The concrete carpet had anchored the river in its bed—and this blacktop pavement in turn would shield the concrete and keep it there when the rising water began to flood. It covered the concrete and went clear on up to the top of the levee itself, to protect the whole great wall of earth.

Now there were no more "itchy spots" to cause Ol' Man River to scratch. And barring some Noah's Ark flood, Baton Rouge and Lake Providence were safe.

To some old-timers, the Mississippi was beginning to look more like a well-run highway than a river. But to those anxious Engineers, it was also beginning to look less like a nightmare. ■ ■

.....
Answer to puzzle
on page 154

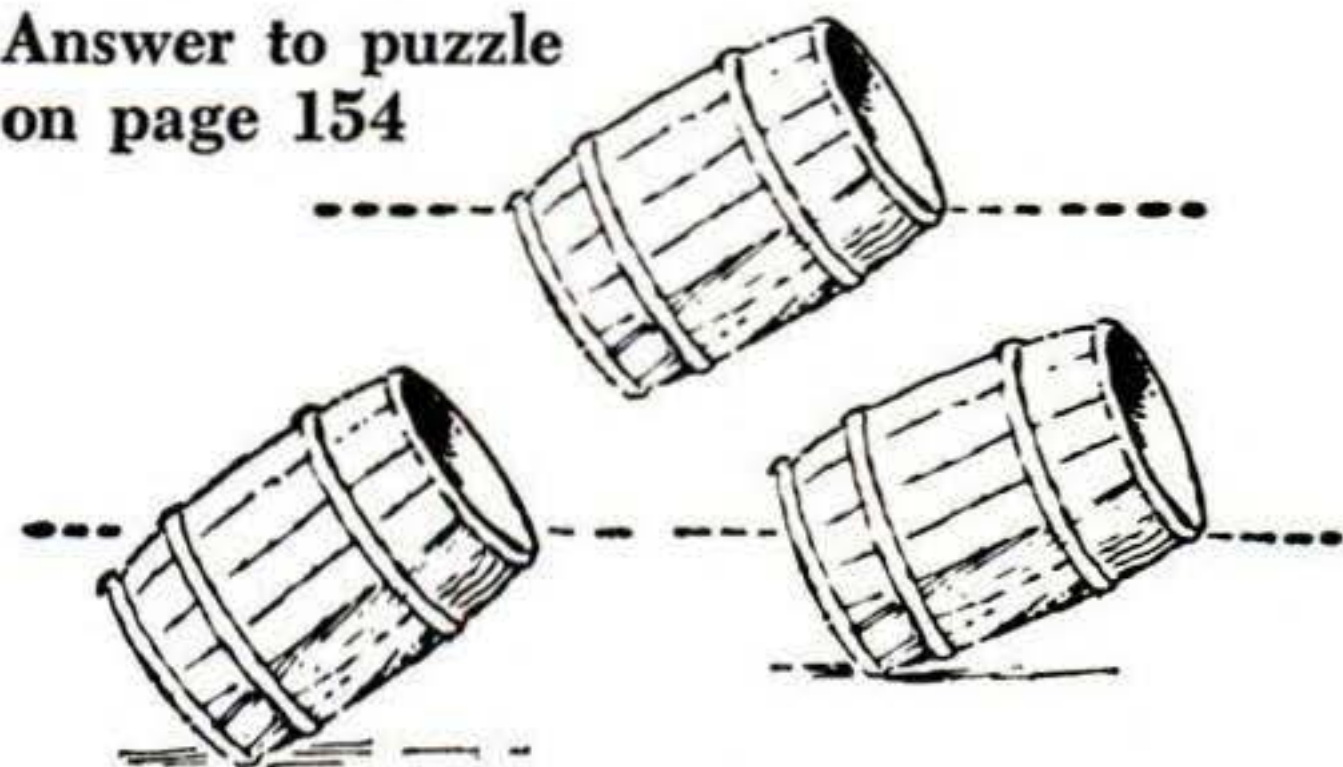

Just tilt the barrel. It's a symmetrical shape, so if it's exactly half full, the water will reach the lip of the barrel at the same time it touches the bottom. If it's more than half full, the water will still touch the side of the barrel above the bottom. If it's less than half full, some of the base will show above the water.

OUTGRIPS

'EM ALL...

BIG



SMALL

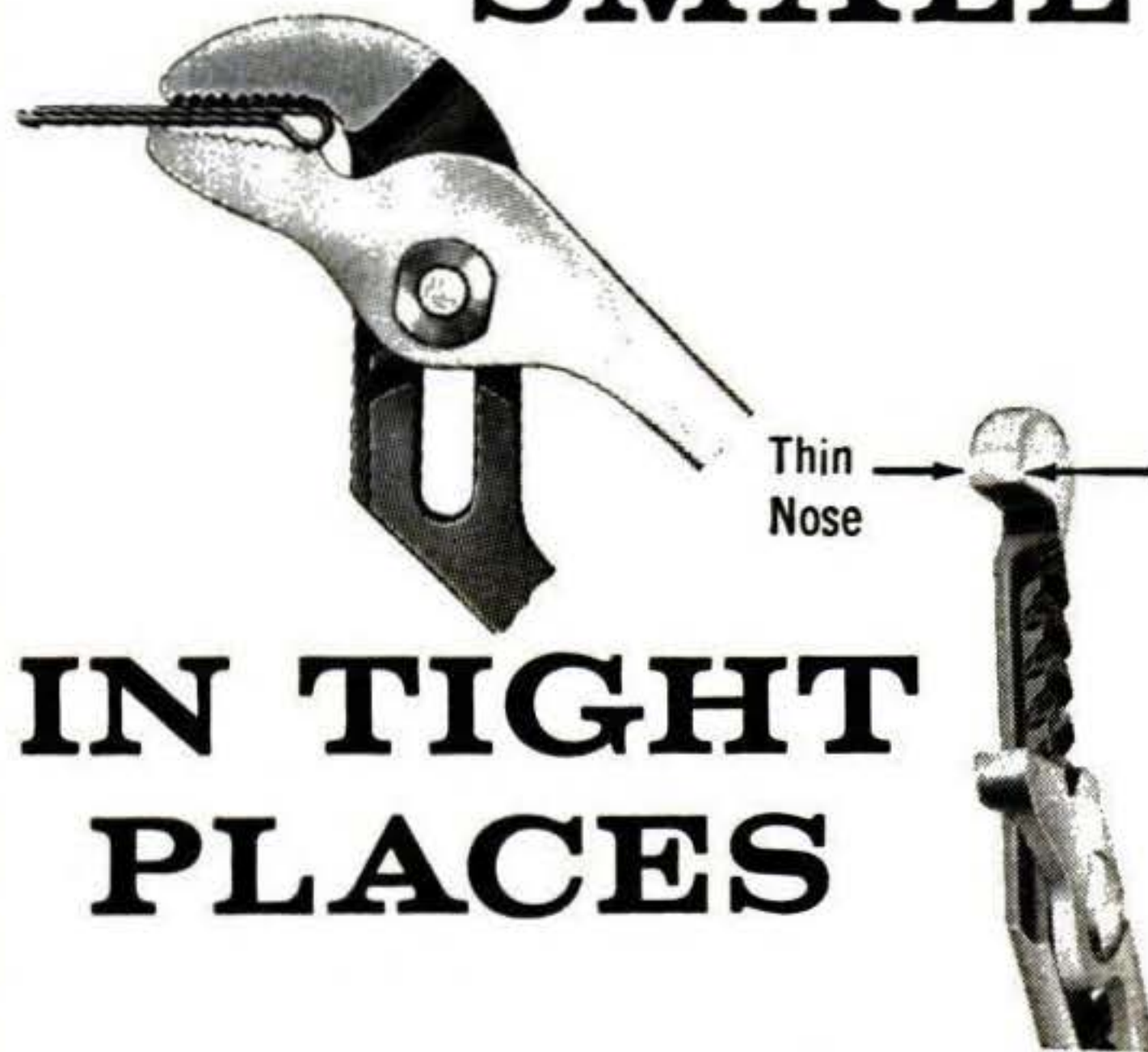

IN TIGHT PLACES

CHANNEL LOCK

Easy does it on every gripping job with a Channellock Plier in your hands. Powerful parallel-jaw grip . . . tremendous leverage . . . patented, smooth-working, can't-slip adjustments. Your choice of five jaw capacities: ½, ⅞, 1½, 2 and 2¼ inches. *Be sure it's a genuine Channellock. Look for the trademark on the handle. Write for catalog showing complete line of pliers. Made Only By Champion DeArment Tool Company, Meadville, Penna.*

The Race for the Bottom of the Sea

[Continued from page 40]

usual cause of the bends," Dr. Lambertsen said. More important is that air can come out of solution in any of the body fluids, forming bubbles in the tissues, where there is no easy way out. Bubbles lodged in the joints and other constrictions cause the intense pain of the bends. If they form at critical spots in the nervous system, paralysis or instant death may occur.

To prevent the bends, a diver must come up slowly enough to allow the gases to go out of solution gradually and be eliminated by the body. With proper decompression, an experienced diver can work easily down to about 150 feet. But the length of time he can stay at depth becomes shorter the deeper he goes, due to other problems.

"Remember," said Dr. Lambertsen, "as you go deeper, increasing the pressure of the air, you increase the *amounts* of both oxygen and nitrogen you're breathing. At 165 feet, for example, you're taking in six times as much oxygen and six times as much nitrogen as at the surface."

The increased concentration of oxygen becomes poisonous below about 60 feet, if the diver is down too long. The most important effect is that excess oxygen inhibits enzymes that control electrical processes in the nervous system. Increased, erratic electrical activity in the brain produces convulsions and unconsciousness.

Going down—and out. At about 165 feet (for most divers), the *nitrogen* concentration in the body becomes dangerous. Nitrogen narcosis sets in—the dread "rapture of the deep." The diver becomes irrational, then passes out. Experienced divers have learned to control this reaction somewhat, and may be able to go as deep as 300 feet—but can stay only a few minutes.

Nitrogen narcosis appears to be related to the action of ether and other anesthetics that are inhaled, but the biological mechanism is still unexplained. The narcotic properties of gases vary, however, so it's possible to substitute a less-narcotic gas for nitrogen in a diver's breathing supply (nitrogen has no known function in breathing). Hydrogen would probably work well—it has been used with some success in a "bounce dive" to 600 feet—but its mixture with oxygen is highly explosive. Helium appears to be the best choice. No narcotic properties have been detected, and it also may make possible reduced decompression times.

Helium seems to take care of nitrogen narcosis, but oxygen poisoning has to be tackled in another way, Dr. Bornmann told me. "We think that the amount of oxygen supplied to the diver should be kept close to the amount he would normally receive on the surface. That means that the percentage of oxygen must be reduced as the total pressure increases."

If the pressure is double that at the surface, for example, and the amount of oxygen is reduced to 10 percent (instead of the normal 21 percent), the quantity of oxygen available to the body becomes roughly the same as at sea level. At four times the surface pressure, only five percent of oxygen is necessary. At 400 feet, Dr. Bornmann said, the theoretical percentage of oxygen is only 1.6 percent, and at 1,000 feet it is about 0.67 percent.

In Ed Link's diving experiments last summer, the helium-oxygen mixture was supplied to the diver in the submerged chamber from gas-mixing equipment aboard the *Sea Diver*. On deck were Dr. Bornmann and Link's chief engineer, Dan Eden, watching an oxygen analyzer hooked up to the breathing supply, and regulating the percentage of oxygen by hand. To conserve expensive helium, the breathing atmosphere from the chamber was recirculated through the gas-mixing equipment. Carbon dioxide was removed by passing the gas mixture through tumbling cans of lithium hydroxide.

Mixing their own. In the underwater tent to be lowered into the Atlantic off Bermuda this fall, the same sort of system will be used. But the underwater structure won't be dependent on hoses reaching down from the surface. Helium and oxygen cylinders will be strapped to the base of the tent, and the gas-mixing equipment will be housed inside the base, to be monitored from inside the inflated tent.

Link plans to start diving off Bermuda, then move to the Caribbean when the weather becomes unfavorable. He'll take part in initial dives, but his doctors won't allow him to go on the deepest dives, even though he's in exceptional shape for his age. All equipment will be checked out thoroughly, and his divers will start by living at 200 feet, taking up where last summer's experiments left off.

Then the base camp will be moved to 400 feet, to 600 feet—his target depth for

The Race for the Bottom of the Sea

this series of dives—and, if all goes well, even lower. Link will also continue his animal experiments, using a chamber aboard ship to simulate depths to 1,500 feet.

There are still important problems to be solved. One is how to keep warm at great depths, where the temperature is always close to freezing. Link has designed an electrically heated suit to keep his divers warm in the water, and they will be warmed by heaters and electric blankets inside the inflated house and the small chamber.

Undersea talk. Another problem is communication between the base camp and the surface, and between divers living in the underwater tent. Some voice distortion occurs in compressed air, but the helium of the deep-diving breathing mixture makes it much worse, for reasons no one clearly understands.

Link thinks his divers may learn how to control the distortion and speak intelligibly. Another idea is to try an electric vibrator, the kind used by people who have lost their vocal cords, to supply an undistorted voice frequency. Engineers at General Precision are also working on electronic methods of unscrambling the distorted sounds and putting them back together in intelligible fashion.

When I last saw Ed Link, he was on his way to England, where he had been invited to talk on his diving program before the Scientific Committee of Parliament. He then went to Monaco, where the Sea Diver was overhauled this winter, to supervise the installation of new shipboard equipment. When this article appears in print he will probably be on the high seas, on the way back to the U.S. to get his new diving equipment ready.

He said he had not yet picked his new crew of divers, but that Robert Stenuit, the man who lived at 200 feet last summer, will undoubtedly be in the group.

Stenuit may be the first man to accompany the underwater tent down to 400 feet, inflate its rubberized nylon envelope, and step inside for a sandwich. Other men will then travel down in the elevator to join him in a camping trip on the bottom of the ocean.

Link was cautious about predicting that his divers would go below 600 feet this year. "Maybe Keller discovered something—maybe helium won't take us to 1,000 feet," he said. ■ ■

Speedy Sprayer

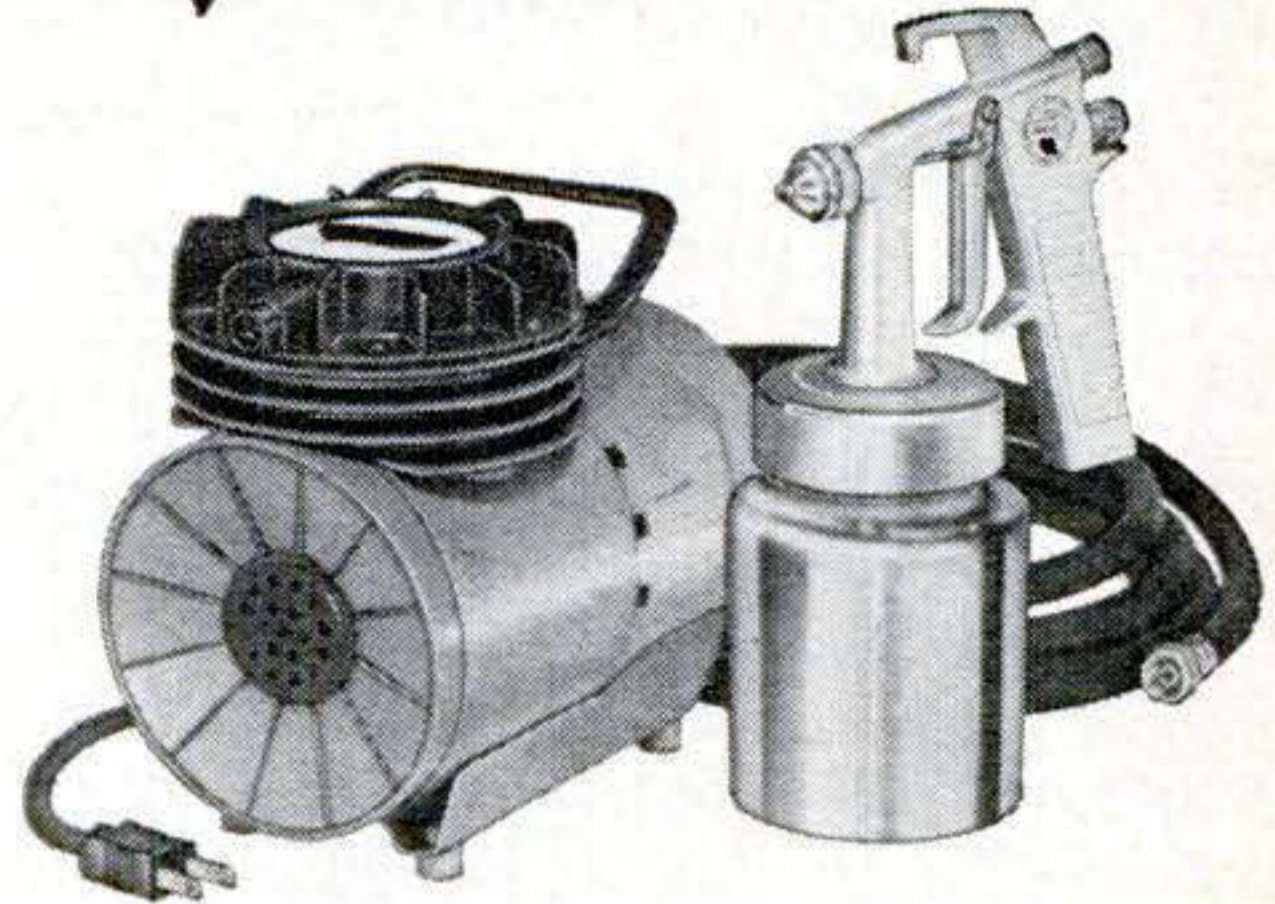

Tool of a dozen uses!

Motorized! Ready to plug in and spray! Use it to paint anything, from a toy to a house. Does an hour's painting in just minutes. Pays for itself on the first big job. Also use it to spray insecticides, weed killers, liquid fertilizer; vacuum, tire inflator, etc. A real professional tool needed in every work-shop. Ask for Speedy Sprayer "Compact" No. 404. **\$39⁹⁵**

Slightly higher Denver West.

Write for "How to Spray" booklet and catalog.

W. R. BROWN CORP.

Specialists in Portable Sprayers Since 1921

2637 N. NORMANDY AVE., CHICAGO 35, ILL.

INSIST ON



Frost King[®]
Reg. T.M.

WEATHER STRIPPING
SAVES FUEL

Write For FREE Catalog
THERM WELL PRODUCTS CO., INC.
Paterson, New Jersey

Outlasts Varnish 2 to 1

New miracle clear plastic finish dries dust-free in minutes, needs no sealer, goes on *any* kind of wood—inside or outside. Gives tougher, longer-lasting protection for patio furniture, siding, doors, cabinets, floors, paneling, tables, boats. Glass-like finish resists



alcohol, boiling water, food acids. Won't darken, crack or peel. Odorless. Non-toxic. Gloss or Satin finish. For free brochure and nearest FLECTO VARATHANE dealer, contact:

Flecto Company Inc., Box 84-P, Sta. A, Berkeley 2, Calif.
Flecto Coatings Ltd., 7304 Buller Ave., Burnaby, B.C.

3-in-1 Test Meter for Your Car

[Continued from page 126]

AC line cord into the wall. Turn on the power (SW2) and set selector SW1 to Tach. The first adjustment (R11) will trigger the tach circuit into operation. Rotate it fully clockwise for the moment.

Next, adjust R8 for the number of cylinders: set needle to 1,200 r.p.m. for sixes; 1,800 for fours; 900 for eights. (Only the number of cylinders influences the calibration—the car battery may be either 6 or 12 volts.) Now go back to R11. If it is turned down, it will cause the meter to drop suddenly to zero. The final setting of R11 is not critical and should be left at a point about midway between full clockwise and the position that causes the meter pin to drop to zero.

Using the tach. On cars with negative ground, clip the black probe to ground and the red probe to the terminal on the side of the distributor (the one with a thin wire to the ignition coil). If the positive battery terminal is grounded, reverse the probes.

With the car engine idling, you should read about 400 to 500 r.p.m. (the first small meter division is 500; 1 is 1,000, etc.).

Dwell meter. Set up the dwell meter by turning on the power switch and clipping red and black probes together. With SW1 in Dwell position, adjust the front-panel knob (D) so the meter pointer is directly over the 6 mark (full scale). This is done each time the dwell meter is used. The probes are then connected to the car exactly as for the tach.

With the engine idling, there will be a meter reading that is readily converted to degrees of dwell angle. Take a six-cylinder car, for example, with the needle pointing to number 3 on the scale. Consult the chart and you find that a six-cylinder car calls for a meter reading multiplied by 10. The answer is directly in dwell angle: in this case, 30 degrees. Four-cylinder cars require that the meter indication be multiplied by 15. For eight cylinders, you can either multiply by $7\frac{1}{2}$ or work out the reading for a four-cylinder car, then divide the answer by two.

Tune-up information for your car gives the recommended dwell setting in degrees. In general, approximate dwell angles are: four cylinders, 40 degrees; six cylinders, 32 degrees; and eight cylinders, 28 degrees.

Using the dwell meter reveals much valuable service information. Most important

is accurate adjustment of points, even when they aren't in perfect condition. With the distributor cap removed, crank the starter for a few seconds. If the dwell-angle reading is too low, points are too wide. A high dwell reading means the point gap is too small. It is also possible to adjust the points while watching the meter. Pull off the distributor rotor and adjust for the exact degree reading while the engine is cranked by the starter for a few seconds. Once the correct setting is found, it can be checked occasionally while the engine is idling.

The dwell reading should remain constant, within two or three degrees, up to about 2,000 r.p.m. Erratic operation usually indicates trouble, such as a worn breaker-plate bushing or distributor shaft. Cases of point bounce, or "floating," do show up on the meter, but are easier to detect with the tach. Slowly rev up the engine and watch the meter for a steady rise in r.p.m. If the needle falters and starts to drop, although the engine sounds as if it's speeding up, spring tension on the points is low.

Checking continuity. Before using this section of the instrument, switch the selector to the last position. With the power on and the probes apart, adjust the C knob on the front panel for a full-scale reading (on 6). The tester may now be used as an ohmmeter. If the probes are placed across a short circuit, the needle will drop to 0, indicating zero ohms. An open circuit will read 6, or infinite resistance. Although the meter is not intended to give precise resistance indications, these are the approximate values for converting meter readings:

0 — 0 ohms	3 — 180 ohms
0.5—10 ohms	4 — 400 ohms
1 —20 ohms	5 — 1,000 ohms
1.5—30 ohms	5.5— 2,200 ohms
2 —50 ohms	5.8—10,000 ohms
2.5—80 ohms	6 —infinity

Finally, be sure to turn off the power switch whenever the instrument is not in use. The mercury batteries hold their voltage over a long period, but they will taper off slightly in time and affect tach calibration. It's a good idea to check accuracy periodically with the house-current calibrator. An approximate indication of battery condition is given by Dwell and Continuity positions of the selector switch. When it is impossible to adjust the meter to full scale, replace the batteries. ■ ■

Ambassador: Rambler's Hot One
 [Continued from page 92]

with Twin Stick (three-speed manual and overdrive) would have been even hotter—especially in standing-start acceleration, where the lower rear-end gearing (3.54 or 4.10 instead of 3.15 to 1) would pay off.

The Flash-O-Matic shifts smoothly and positively. Under full throttle the one-two and two-three shift points fall at about 50 and 65 m.p.h. I tried shifting manually, starting in low and running it up to 53 to 55 m.p.h. before shifting into D-1, but was unable to better the 0-60 and 40-60 times. I improved my 50-70 figure by only half a second by starting in D-1 and shifting into low as soon as the transmission went into second, thereby preventing a shift into third.

Handling is fair. There's pronounced understeer resulting from the front-end weight bias, so the car must be cornered conservatively. But there's little danger of overdriving the suspension, since lean and tire noise warn the driver well before the breakaway point is reached. The power steering gives good road feel, but at five turns lock-to-lock is needlessly slow.

The firm coil springs give a good ride on most road surfaces, but on really bad ruts a need for firmer shocks is evident. But then, Rambler does offer several heavy-duty suspension combinations. The package consisting of stiffer springs and shocks all around costs \$5.05. It's a good investment in better handling and ride control.

The brakes are excellent. They take lots of abuse before they show any signs of unhappiness, and recovery from fade is quick.

Wind noise is absent whether windows are up or down. No body rattles, either. Visibility is good. Parallel-acting wipers cover lots of area. The trunk is roomy.

So if you want a practical, reliable set of wheels with power to spare, try Rambler's big bat for size. ■ ■

About Monsters

Several exciting fact-and-fiction creatures—the Komodo Dragon, the Abominable Snowman, the Loch Ness Monster—have been reported in *Popular Science* by writer Gardner Soule. Now he has added to his collection and come up with a fascinating new book: *The Maybe Monsters*. (\$3.50) G. P. Putnam's Sons, NYC.

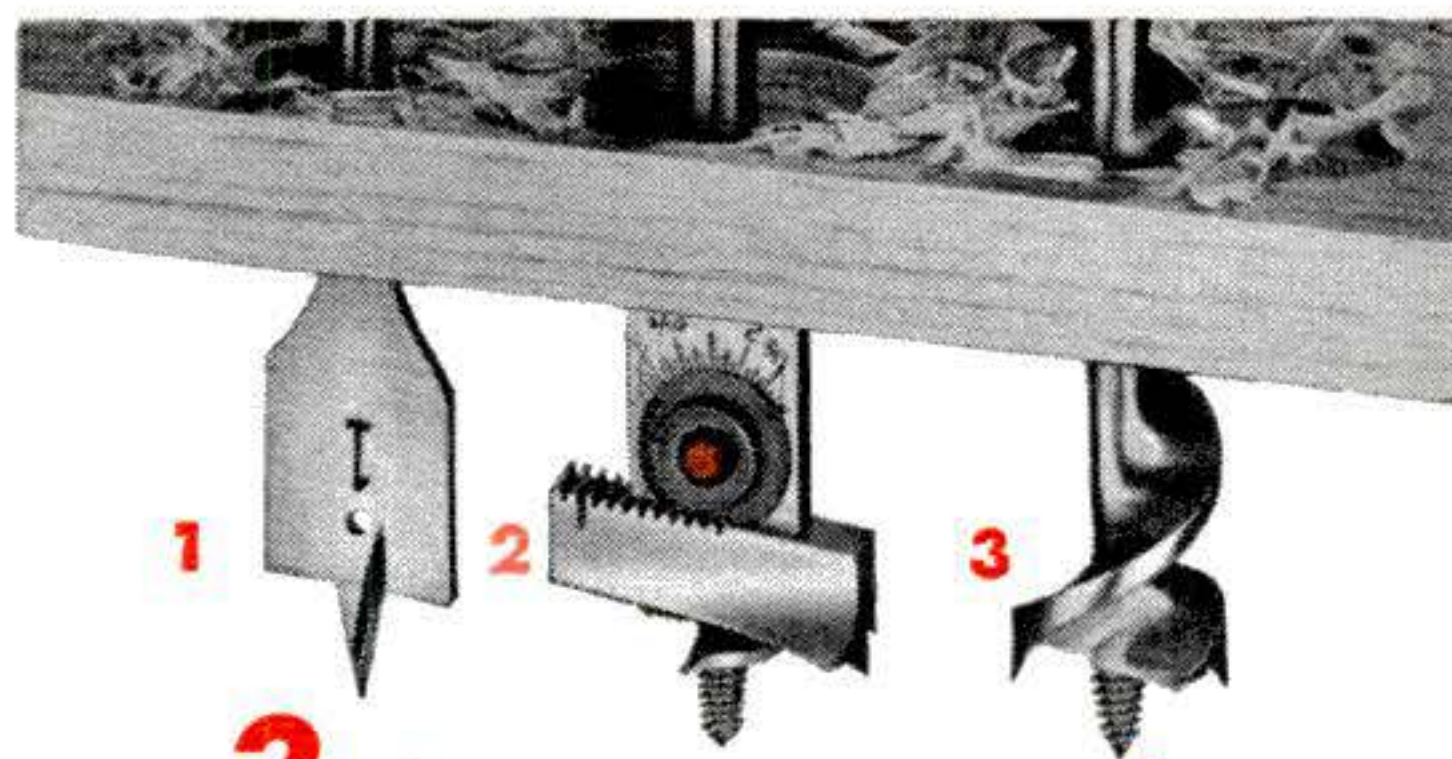

3 easy ways to bore holes faster

1. **Irwin Speedbor "88"** for all electric drills. Bores up to 5 times faster in any wood, at any angle. Sizes 1/4" to 1", \$.75 each. Sizes 1 1/8" to 1 1/2", \$1.25 each.
 2. **Irwin No. 22 Micro-Dial** expansive bit. Fits all hand braces. Just dial your size. Bores 35 standard holes, 7/8" to 3". Only \$4.00. No. 21 small size bores 19 standard holes, 5/8" to 1 3/4". Only \$3.60.
 3. **Irwin 62T Solid Center** hand brace type. Only 16 turns to bore 1" holes through 1" wood. Double-cutter boring action. Sizes 1/4" to 1 1/2". As low as \$1.05 each.
- EVERY IRWIN BIT** made of high analysis tool steel, heat tempered, machine sharpened and highly polished, too. Buy from your independent hardware, building supply or lumber dealer.

Strait-Line Chalk Line Reel Box
 only \$1.25 for 50 ft. size
 New and improved Irwin self-chalking design. Durable aluminum alloy box. Practically damage-proof. Fits pocket or hand. 50 ft. and 100 ft. sizes.

IRWIN every bit as good as the name
 at Wilmington, Ohio, since 1885



Automatic Saw Set...

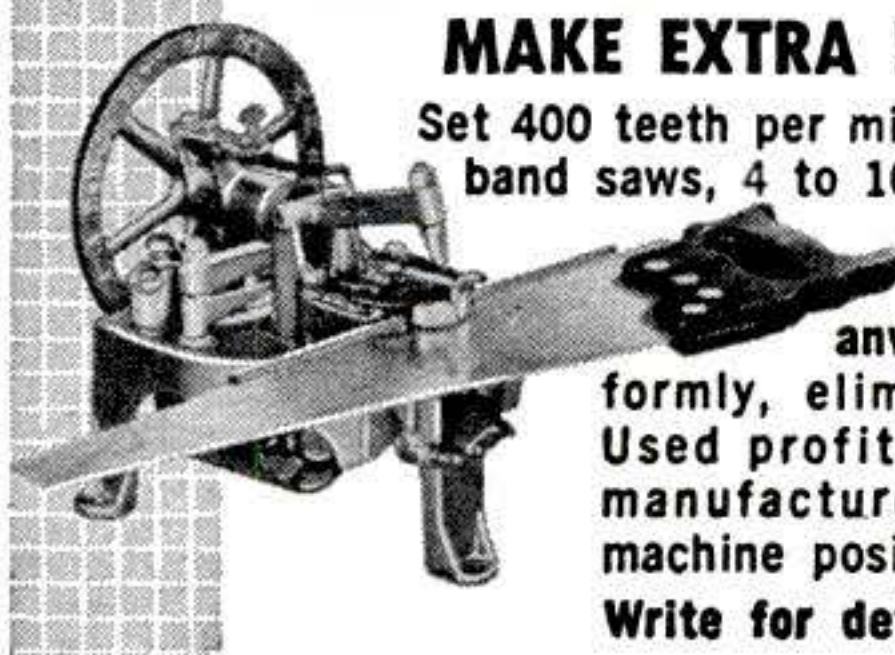

MAKE EXTRA PROFITS!

Set 400 teeth per minute on hand or band saws, 4 to 16 point, with the BeMaCo Automatic Saw Set. Fast, accurate, true hammer-anvil action sets teeth uniformly, eliminates tooth breakage. Used profitably by saw shops and manufacturers everywhere. Every machine positively guaranteed!
 Write for details—today!

BEAVER MFG. CO. P.O. BOX 434, 800 So. Isis Ave. Inglewood, Calif.
 SAW DIV. 48-S

DYNAMIC INDUSTRIAL TYPE TRANSFORMER WELDER
 WELD-CUT-BRAZE-SOLDER-HEAT
 IRON-STEEL-BRONZE-BRASS
 ALUMINUM AND OTHER METALS



Professional Electric Arc Welder. Ideal for Home, Shop, Farm or Industrial use. The handiest tool in your workshop. Weld, Braze, Solder, Cut, Bend all metals. Do expert work on your first job. Build or repair Boats, Trailers, Auto Bodies, parts, fenders, metal and ornamental iron furniture, fixtures, farm equipment, garden tools, bicycles, toys, etc. Operates on any properly wired 110 V. A.C. line. Complete with helmet, arc torch, electrode holders, flux, rods, cables, instruction book. **FULL YEAR GUARANTEE.** 10 day money back trial. **ONLY \$38.50 f.o.b.**

Only \$38.50 f.o.b. Send only \$6.00 check or m.o. Pay postman balance plus charges. **EASY PAY PLAN.** Low down payment. Pay as you weld.

DYNAMIC WELDER CO. 1808 SOUTH FEDERAL STREET
 Dept. D3-G, CHICAGO 16, ILL.

What Do They Think of Pay TV?

[Continued from page 78]

Now turn the decoder switch from TV to PV. A buzzer sounds. You're hearing the decoder's "conscience" at work. It's so honest that it won't bill you until it knows everything is working: It is checking out its own circuits.

If anything is wrong—if, for example, you've dialed the wrong code—the buzzing turns to a chattering that means "try again." But if everything is in order, the buzzer goes for 15 seconds. When it stops, another sound comes on—a *clack!* A solenoid has yanked a lever—and your bill has been printed.

Suddenly the video and audio signals come clear, and you are watching and hearing "Conquest of Space."

The pay part. Once a month the postman brings you a partial bill. It looks like this:

Decoder rental	\$3.25
Program charges	—
Total	—

You have to fill in the cost of the shows you saw and the total. The program charges are printed on the bill that is still concealed in your set. Here's how you get that bill:

The partial bill brings you a special code number that will unlock the billing compartment in your decoder. Let's say the code is 244J. You dial 244J on the decoder and push the billing button. A small drawer door falls open—but only part way. The engineers want you to pull it the rest of the way. As you do this, you hear

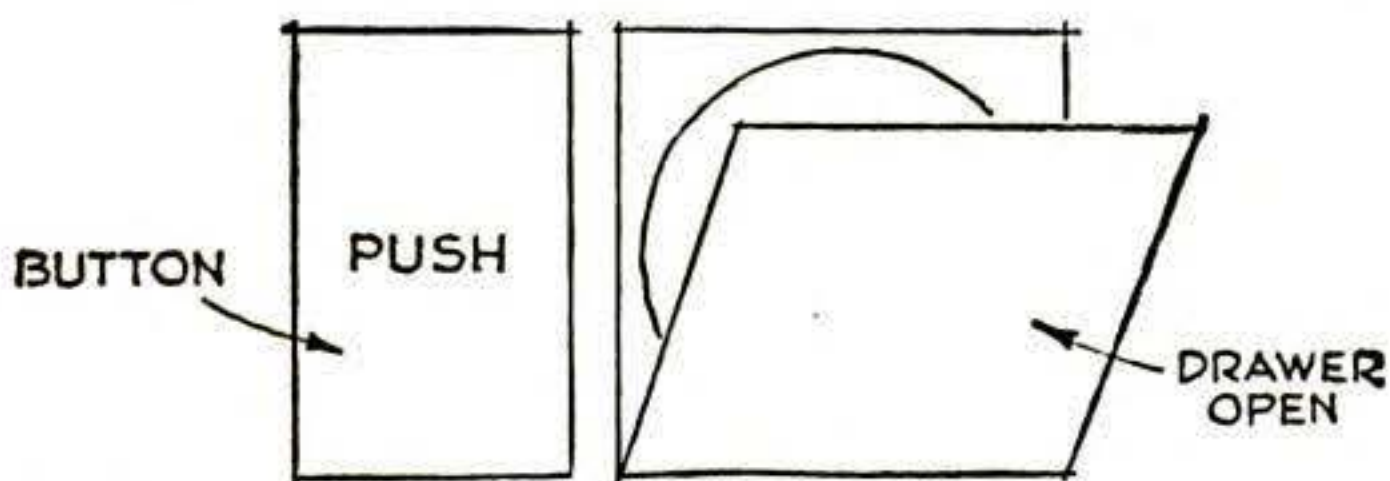

a snipping sound: A small slicer bar has cut the bill. You pull it out. Let's say it looks like this:



These charges total \$5.50. You write this into the bill you receive by mail. Your total charge is \$8.75. (Since your bill is over \$8, you're entitled to a \$2 rebate on next month's bill. Over \$10, the rebate

is \$3—an inducement to see more pay TV.)

Suppose you and the station disagree on how many shows you've seen. The security tape is edged with a sound track on which a tone has been prerecorded. Every time you see a show, a small erase head wipes a blank in this tone. Once a year the tape is removed. In case of dispute, it can be run through a read-out machine.

I asked chief engineer Hal Schumacher whether some wag couldn't figure out the circuitry and see shows free.

"Only an Einstein—and he'd have a hard time," he said. "You see, our printed programs, giving the codes, are only mailed out once a week, and there's a different circuit for every show."

Other systems. The Zenith system is only one of several now in use or soon to be in use. It comes entirely through the air, like any ordinary TV. The Toronto suburban system, which serves 5,800 homes, is Paramount's Telemeter, which operates entirely by closed circuit. There's no decoder; you simply stuff coins of any denomination into a box. (This is the system that Teleglobe plans to give New York City.)

Denver's Teleglobe system starts full-scale next month. Video is sent unscrambled through the air. Anyone can see it. But audio goes by a separate wire to a special loudspeaker in your home. You're billed once a month.

I found that some people in Hartford think pay TV is "great," most are at least satisfied, and some grumble impatiently for better shows. To RKO vice-president Jim O'Connor, even the grumbling is good.

"They're not grumbling about pay TV," he says. "They're just grumbling because we can't yet feed them all the top-notch shows they want to pay for."

These shows will come. Pay TV may or may not be for the masses. (Some experts think it will be.) But it will at least be for several million who are selective and want special features on travel, auto racing, science, exploration, music, boats—features free TV can't afford.

"We figure that some day soon at least 3,500,000 viewers may pay to see a single good show," says an official of another pay-TV company. "That's a one-night box-office take of \$3,500,000. Can't you see the kind of shows all that money is going to make possible?" ■ ■

Buy It, Build It: Ride on Air!

[Continued from page 55]

propeller is transmitted by a chain drive, with a 12-tooth sprocket on the engine clutch housing, and 6-tooth sprocket on the propeller. A yank of the cord and the little West Bend engine (A-20-L) roars into life.

It's a long, awkward step into the cockpit, and since the plastic cloth is easily ruptured, it's something of a problem. Cockpit space is a snug fit. My feet were surrounded by cables leading off in several directions. I hit the throttle lever and the engine revved up. Almost immediately, the Dart was airborne.

As luck would have it, the day was windy. Anyone familiar with air cars knows that a strong wind is a big problem.

Under way, the Dart feels like a giant marshmallow bobbing about on a trampoline. It's a soft, undulating, wavelike action. There are three controls: the four-way stick, which controls rear and side vents, and thus forward motion and turning; the two floor pedals, which control the big turning rudder; the push-pull throttle, dash-mounted. Operationally, the Dart is simple. Air is sucked in, trapped under the plastic-cloth-covered framework at enough pressure to provide the necessary hovering height. The pressure equalizes under the tentlike skin and discharges away under the frame. The vehicle hovers in a near-horizontal position unless the wind is blowing. When hovering height is reached, the rear vent doors are opened (with the joy stick), allowing air to escape in a jet exhaust that propels the car ahead.

Power-to-weight ratio would seem so low as to be ineffectual. The Dart weighs about 100 pounds. Lift capacity is about 300 pounds, including passenger and vehicle weight, with a 10-hp. engine. Dobson recommends a 15-hp. engine to provide greater lift and more speed.

To stop the air car, you pull back on the throttle; it settles quickly to ground. Push the stick to the right, it goes right; to the left, it goes left. It'll do anything but fly backwards. With buoyancy chambers, it should be as safe on water as on land. It will cross calm water with waves no higher than two or three inches.

The Air Dart can be built from Dobson's \$2 plans by anyone familiar with small tools for between \$250 and \$350 says the parent company, Aircars Inc., 3518 Cahuenga Blvd., Los Angeles 28.

palley's NEW! For HOBBYISTS • MODELEER • MD • SURGEON • LAB • etc.

22  **24**  **21**  **23**  **20** 

STAINLESS STEEL SCALPEL HANDLES and BLADES

Accurately shaped, perfectly tempered and precision balanced with nine different blade shapes and choice of two handles — standard or slender. Standard handle takes blades 20, 21, 22, 23 and 24 — slender handle takes blades 10, 11, 12 and 15 (specify type blade and handle). Blades are interchangeable and come 6 per pac. Blades are made of finest quality Sheffield surgical steel. Use for carving, cutting, biology, surgery, etc.

SAVE! Scalpel Set — Pac of 6 blades & handle... **2.95** Extra Blades — Specify type...6 for **100 PAC**

NEW BANDAGE SCISSORS

Finest stainless steel or nickel chrome scissors. Made for cutting bandages but excellent for use by children, etc. Choice of two sizes.

5-1/2" Stainless **289** 7-3/4" Stainless **389** 5-1/2" Nickel **129** 7-3/4" Nickel **169**

DENTAL PICK ASSORTMENT

An assortment for the hobbyist! Points include hooks, chisel, scrapers, etc. Ideal for working on wood, leather, clay, etc. Stainless steel... 6" long. 6 different heads!

6 FOR \$2.49

NEW SENSITIVE STETHOSCOPE

A Ford type stethoscope. Ideal for Doctor or the mechanic to listen for engine sounds, etc. Metal parts chrome plated. New, top quality.

2.98 EA.

SAVE on LAMPS FOR HOME, SHOP OR OFFICE

Now a drafting light or desk light at a price anyone can afford. Newly adapted from a Swedish design... ideal for drafting table, office desk, etc. Precision made and balanced. Reflector will swing to light desk or table up to 6 ft. long x 3 ft. wide. Extension arms are fully universal with surgical steel springs for counterbalance with finger-tip movement. Finished in baked enamel.

No. ID-118 — MECH LYTE — Gives light for work bench, shop, etc. Gray finish only... **9.95**

No. ID-118B — COOL LYTE — Insulated lamp hood reduces heat. Ideal for draftsman, artist, etc. Colors: gray, brown or black (specify)... **10.95**

No. ID-FLI — 2-Tube FLOURESCENT LYTE — Takes two 15 watt flourescent tubes. **19.95**

No. ID-MAG 1 — ILLUMINATED MAGNIFIER — Has 5" dia. lens. Power of 3 diopters. 13" focal lgth. For stamp or coin collectors, etc. Circline bulb not included. **28.95**

FLOURESCENT LYTE 2-TUBE **MECH LYTE** **COOL LYTE** **PRECISION STEEL ARMS FULLY UNIVERSAL** **MAGNIFIER**

25 TO 1 WORM GEAR DRIVE

4.95 No. GB-202

For use with 7/32" dia., 12 spline flex shaft on input. Output is 3/8" dia. x 3/4" long shaft at right angle to input. Ball bearing mounted.

NAVY WADE SUIT

Made to top Gov't specs from from rubberized heavy duty canvas. All seams vulcanized. Has built-in rubber gloves and boots. Available as overall (with shoulder straps) or coverall type. Sizes: Small, Medium or Large.

No. CWS-1 (Coverall) — **12.95**
No. CWS-2 (Overall) — **9.95**

U. S. ARMY KNIFE-BAYONET

Ideal for skin diving or hunting knife, or for collectors. Has 6-1/2" steel blade — double edged for 3" from the point. Handle is laminated leather. Overall lgth. 11-5/8". **2.98**

PERISCOPE PRISM

Made of finest optical glass. Bends light rays 90°. Can be adapted to lens, lights, etc. Size: 5" x 1". **ONLY... 1.95**

260 PAGES of Amazing BARGAINS — Government Surplus, Factory Closeouts and hard-to-find items of all kinds. NOW — special bargains in U.S. Army, Navy, Airforce and Industrial Surplus. Order NOW and SAVE up to 85%!

Only 50c TO COVER HANDLING & MAILING Your 50c will be refunded with your first order of \$1.00 or more

TO ORDER: Send check or M.O. 1/2 dep. w/C.O.D.s. P.O.s accp't'd from D&B firms rated F2½ or better. Items sent freight or postage col'ct.

of the speed of light. The frequency of the sun's peak radiation output now passes the border of the visible spectrum and moves into the infrared. As a result, the sun dims rapidly, and soon becomes invisible. One month later, the destination star likewise becomes invisible—the peak of its radiation intensity has shifted into the ultraviolet.

As our velocity keeps increasing, two circular dark spots are formed around the destination star and the sun, and keep growing in diameter. Between these blind "bow and stern spots," the stars of the firmament appear as a multicolored array of concentric circles, like a huge rainbow:

Near the black bow spot, the stars look violet. Further aft, they are blue and green. Abeam, they shine in their original yellowish hue. Still farther aft, they look orange, and the dark stern spot is surrounded by a ring of red stars.

Due to "relativistic" effects, the dark bow spot grows only to an opening angle of 43 degrees. After we exceed 74 percent of the speed of light (11 months after departure), it begins to contract again. But the stern spot around the sun continues to grow steadily. Hence, as our traveling speed approaches the speed of light, the visible portion of the firmament will become compressed into an ever-narrowing rainbow around the invisible target star.

The opening angle of the yellow ring, in this rainbow, is a perfect yardstick for the ratio between our traveling speed and the speed of light. In analogy to the well-known Mach Number (ratio of flight speed to speed of sound), this ratio is sometimes called the Einstein Number.

In 6.6 years from the time of departure, our speeding photon rocket hits Einstein Number .999998, and we are at the half-way point of our journey. However, on trying to measure the remaining distance to our destination star (now emitting predominantly X rays), we find it only about a light-year away! In fact, without further power application, we would pass it a year later—7.6 years' "dilated ship's time" after departure—if we were to refrain from slowing down for our forthcoming visit.

But in order to visit one of the star's planets, we have to turn our ship around and use our photonic rocket thrust for braking. Of course our slowing down means that we'll reach our target, not in another

year, but much later. Only after another 6.6 years—13.2 years after departure—will we near our target, at a relative approach speed close to zero. During the second 6.6 years—that is, during the retardation maneuver—all those celestial "rainbow" phenomena of the acceleration period will take place in reverse. Upon arrival, the firmament will look like its old self again.

If we had a telescope powerful enough to observe events on earth from our new vantage point, we would find our home planet very much as it was when we left it. But, being 1,000 light-years away, we are actually watching events that happened on earth 1,000 years ago. (This is the non-dilated time that has elapsed *on earth* since we left.) The amazing thing is that, due to the time dilation aboard our speeding rocket, we have aged only 13.2 years during our outbound voyage.

Eerie as this may sound, it is all in perfect harmony with modern ideas of the laws of space and time. (Men today have the same difficulty in accepting the concept of relativistic time that our ancestors had in seeing how people "down under" in Australia could walk head down without dropping off the globe. But that is because our experience does not include very great distances and extremely high speeds.)

While the insights of modern physics permit us to dissect the anatomy of interstellar flight, we must forego rash conclusions that any such flights are imminent, or feasible. We cannot yet even define an adequate power source. If we had it, many problems of using it would be beyond us. Other obstacles may be even more formidable. For instance, what would happen to an interstellar rocket that hit even a small meteoroid, if the collision were at nearly the speed of light?

In summary, with our present knowledge, we can respond to the challenge of stellar space flight solely with intellectual concepts and purely hypothetical analysis. Hardware solutions are still entirely beyond our reach and far, far away. ■ ■

.....

Dr. von Braun will consider answering questions from readers of POPULAR SCIENCE in the magazine, but he cannot undertake to answer each one by mail. Letters to him should be addressed in care of POPULAR SCIENCE, 355 Lexington Ave., New York 17, N. Y.

A Yard Cart You Can Push or Tow

[Continued from page 97]

muslin bag. With this bag extension in place, you can haul a whole yardful of leaves in one load. To dump them, you simply tip the frame over the side; the bag comes free. The bag has a sewn-in bottom so that every last leaf comes out with it and there's no mess.

The best part: low cost. You can assemble all the parts for the cart for less than \$25. The wheels shown here are a husky 12"-by-3" type that Sears, Roebuck sells for \$4.47 apiece (Catalogue No. 9A8761). They're a good buy. If you use different wheels, be sure to measure them before cutting the axle, as the hub width may vary.

The sides, bottom, and handles of the cart are all $\frac{3}{4}$ " plywood. You can cut them from one 4'-by-5' sheet. Interior-grade plywood will do fine if the cart is well enameled and stored indoors.

A lining of galvanized sheet metal on the inside of the bottom and sloping front will add protection against wear if you haul heavy stones. This can be tacked down with short roofing nails.

Sturdy bottom. The cart's underside is beefed up with a frame of oak cleats. Since the pivot point is critical for proper balance, locate the axle carefully. It goes exactly 16" from the rear end of the cart. It's held in place by four eyebolts that pass through both the oak cross cleat and the bottom.

The removable drawbar is a length of $\frac{1}{2}$ " water pipe that screws into a pipe tee slipped over the axle at the center. Its length will depend on the kind of tractor or mower you use. It should be long enough to let the cart clear the tractor's wheels on tight turns. Most tractors and riding mowers are provided with an eye socket at the rear for attaching accessories. A bolt through the end of the pipe and into this eye makes a simple hitch.

You have to perform one small alteration on the barn-door latch that forms the dump release. As it comes, the sloped side of the sliding bolt faces downward toward the mounting flange. In order for the cart body to trip the bolt, this slope must face upward. To reverse the bolt, remove the cotter pin that holds it in, slide it out, turn it upside down, and reinsert it.

Mount the latch on the drawbar before screwing its socket plate to the cart. This makes it easy to locate the plate so the bolt will line up properly. ■ ■

STOP PIPE DRIP

IN 3 EASY STEPS

- 1 Go to any hardware, plumbing or building supply store.
- 2 ASK FOR

NO Drip TAPE

Pliable, cork-filled tape that forms a sealed pipe jacket—stops cold water pipe sweating permanently and never needs maintenance. The only nationally advertised "do-it-yourself" pipe insulation that is 100% moisture-proof!



- 3 Apply it yourself—in minutes. Requires no tools—no special skill.

For information about other quality "do-it-yourself" Mortell products, write

Mortell

COMPANY

534 Burch Street, Kankakee, Illinois

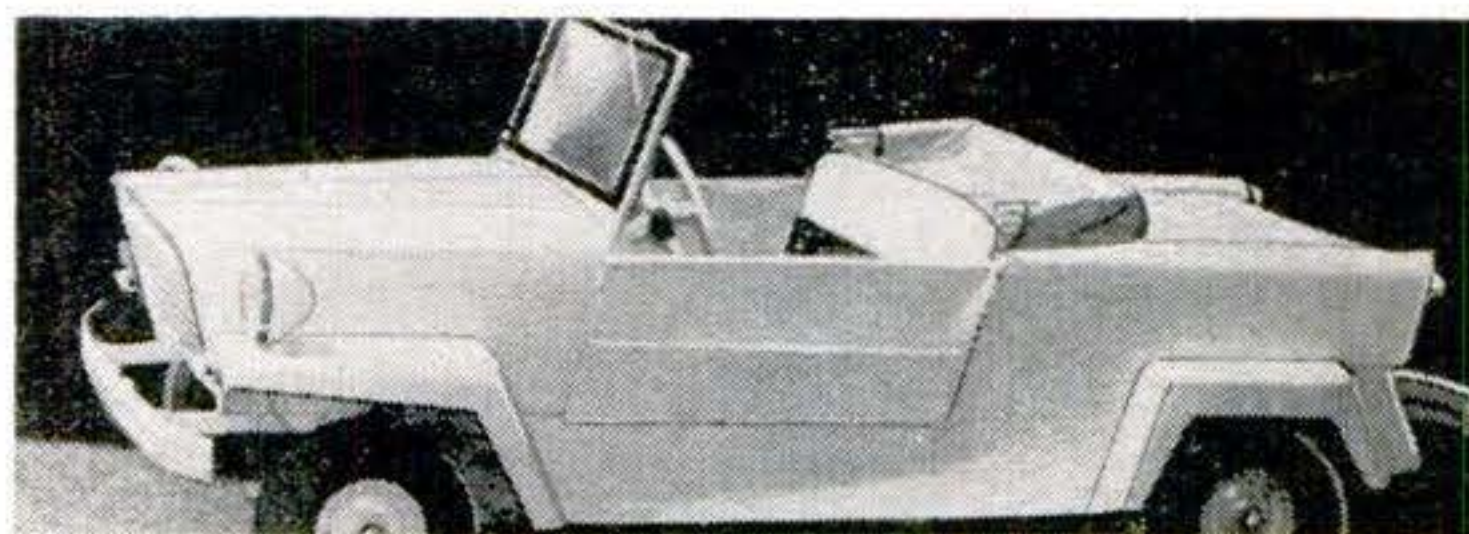

KING MIDGET "World's Most Exciting Lowest Priced Car"

Drive it for 75c a week. Rider Agents Wanted. Send 25c for 32 page book, full details, dealer price. Or send \$1 (refunded first order) for this plus Service and Repair Manual and 16 5x7 photos of car and factory.

MIDGET MOTORS CORP.,

Athens 2, Ohio

GUNK®

removes grease and grime **FAST**

from: power mowers
 ● engines ● machinery
 ● cement floors
 ● kitchen walls
 ● ovens ● implements
 ● exhaust ducts
 ● paint brushes
 ● furnace filters
 ● barbecue grills

AT AUTO SUPPLY, FARM & HARDWARE STORES

GUNK® Laboratories, Inc.
 5829 W. 66th, Chicago 38, Ill.

Versatile "Second" Camera

[Continued from page 132]

refresher at business meetings perhaps a year later.

● Another man carries a tripod that collapses to the size of a slightly overgrown pencil. To copy documents or drawings, he sets the camera on the tripod and snaps the material.

● Accident investigators and insurance adjusters find the subminiature a reliable tool for recording accident scenes and actual damage.

● A subminiature is practical when you're working under pressure. During a recent Miami-to-New York boat race, the official timekeeper, Jim Walker, carried a subminiature. It didn't get in the way when other duties required his attention.

What to look for. There's a good choice in subminiature cameras—from the simple, inexpensive Minolta 16P to the precision-made GaMi 16. Higher-priced cameras let you operate under more-adverse conditions. They offer the largest selection of accessories: copy stands, tiny flash guns, projectors, special viewfinders—and most of the accessories available to 35mm camera users. At least one subminiature has an exposure meter coupled to the shutter.

The lens on the average subminiature is remarkably good. It has to be. Otherwise enlargements would be unacceptable. Maximum lens openings range from $f/3.5$ to $f/1.9$. Focal lengths of the lenses vary from 15mm to 25mm. The better lenses use four to six elements, but most 16mm still cameras use three-element, 25mm-focal-length lenses with $f/3.5$ objectives—fast enough for most low-level lighting conditions.

Some use fixed-focus systems, with sharp focus from about eight feet to infinity at full aperture. Those with adjustable focus range from 8" (15mm Minox lens) to about 2½' for their closest point of sharp focus. Most of the lenses use adjustable focusing scales. All have considerable depth of field, even at their widest aperture.

The eye-level optical finders are satisfactory for subminiature use. Because of the separation between lens and viewfinder, each sees a slightly different part of the subject or scene. But, except for close-ups, it isn't bothersome. Only a few subminiatures have automatic parallax correction.

Advancing the film and cocking the shutter are usually accomplished in one operation. Most subminiatures prevent dou-

ble exposures. Film advance is controlled by a knurled wheel, automatic spring motor, rapid single-stroke lever, or a quick push-pull motion of the camera body.

Shooting with a subminiature. It may seem easy to hold a subminiature steady, but its size and weight make camera movement one of the most common causes of unsatisfactory pictures. You can, of course, put it on a tripod. But this reduces its primary advantage—portability. The best way to learn how to hold one is to squeeze off several shots from various positions, horizontal and vertical, until you can hold it comfortably and keep your fingers away from the lens. Use a firm but gentle pressure to click the shutter—and it's a good idea to hold your breath during that short period. A jerky motion shakes the camera and produces a blurred picture.

Films for subminiatures generally are preloaded by the camera maker in special cassettes, or you can load your own from bulk film. Usually the factory loads are best because they're spooled under the most favorable conditions.

Is processing your own subminiature films and prints practical? If you've developed and printed 35mm films, you're experienced enough to do subminiature processing. But you must give extra attention to cleanliness and handle the films carefully.

You can, of course, send your films to commercial photofinishers who specialize in such work. One manufacturer of subminiatures provides a processing service for its own camera users.

The small size of the subminiature makes it ideal for taking pictures with available light. Such pictures usually are the most natural. The subject is undisturbed by strong lights and a large camera.

One subminiature has a right-angle viewfinder for to-the-side shooting. You can pretend to shoot towards the front while actually shooting at right angles.

When it's inconvenient to carry a larger outfit, a subminiature is handy for copying. The best working arrangement is a lightweight, folding copy stand. Four sectional legs frame the viewing area, indicating the distance to the copy. You need only adjust the distance scale on the camera. With the camera on a stand, long exposures are practical under the existing light found in libraries and other public buildings. ■ ■

Photographically Speaking

[Continued from page 131]

heat alone, in 1/10 to 1/100 of a second. The first applications probably will be for the military. The test pictures are completely grainless, says GE, and can be developed and "erased" simply by heating the film. Besides, you can re-use the film.

The process works electrostatically. Light striking the charged plastic film records an image. After heat softens the film, microscopic depressions are formed by the charges, reproducing the image. The film then cools to seal in the tiny depressions.

Try a wide-angle projector lens

Ever have trouble projecting a big image on a screen in close quarters? Hudson Photographic Industries has the answer: a 7mm extreme wide-angle lens for your 8mm projector. The lens fills a 30"-by-40" screen from only 3½', sells for \$5.95, including two adapters for practically any 8mm projector.

Glass plates are back again

The space age and modern technology are reviving photographic glass plates. Except for minor technical jobs, plastic-base films replaced glass years ago. But recently an increasing number of precision automatic camera systems for modern photogrammetry and aerial and aerospace photography are utilizing glass plates. Reason: Dimensional stability and flatness make glass plates best for measuring missile and space-vehicle trajectories, and for making astronomical measurements. Accurate mathematical data often are obtained directly from the plates. The cameras carry the plates in magazines, load them automatically.

Snap-cap cartridges

If you load your own 35mm film and have been cast down by those new one-time-use Kodak cartridges, take heart. Kodak is now selling unmarked re-usable (snap-cap) cartridges as a service item.

Booklet tells how to color photos

Like to try your hand at oil-coloring portraits? Ansco's new booklet, "Oil Coloring Ansco Portrait Papers," is an excellent step-by-step guide to coloring in light oils. It tells how to apply color to flesh areas, eyes, hair, and clothing—and how to blend and finish. To get a copy, write Ansco Customer Service Dept., Binghamton, N.Y. ■ ■

transistorized ignition system

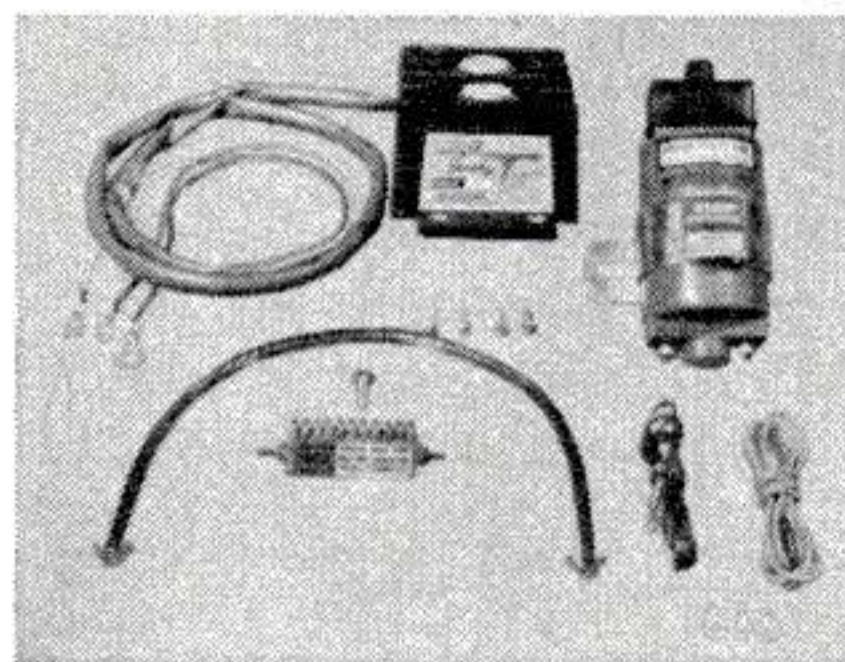

TS-30

"Banshee"

ADVANCE STYLING AND DESIGN

Complete Banshee Systems are available in the following models:

- 30 KV Output with F-250T Coil, 250:1 turns ratio, neg. ground \$39.95
- 45 KV Output with F-400T Coil, 400:1 turns ratio, neg. ground 44.95
- 55 KV Output with F-500T Coil, 500:1 turns ratio, neg. ground 49.95
- Banshee TS-30 with F-500T, positive ground 59.95
- Free Color Brochure

TESTED • APPROVED • FULLY GUARANTEED ONE YEAR

SLEP ELECTRONIC COMPANY, Automotive Division
P.O. BOX 178-PS3, Ellenton, Florida Ph. (813) 722-1843

Name
Address
City State
YEAR _____ MAKE _____ MODEL _____

1001 USES! WELDWOOD® FLEXIBLE WOOD-TRIM®



PROFESSIONAL LOOK TO PLYWOOD PROJECTS

Beautiful wood veneer, paper-backed, in handy rolls, 8' x 1", for edging plywood. Also, decorate lamp shades, book ends, do inlay work, etc. Apply with Contact Cement or Presto-Set® Glue. Oak, birch, African mahogany, walnut, fir, Korina®. At lumber, paint, and hardware dealer's. United States Plywood, Protection Products Div., Dept. PSM 7-63, 2305 Superior Ave., Kalamazoo, Mich.

BUY FACTORY DIRECT!

HAWK by BIRD engineering \$99.95



\$10.00 Down
\$6.00 a Month
Complete welded
Kit with Clinton
2½ H.P. engine

Bird Engineering, Box 427, Dept. PS-H-7 Omaha, Nebr.

EVERLITE* World's THRIFTIEST Light Plants

(Item 869-12T)



NEW TRANSISTOR ALTERNATOR REPLACES GENERATOR

Now a Service Free Light Plant built with a transistorized alternator. Offers 30% greater efficiency—more power for less fuel. Terrific service life—no brushes to arc and burn. No more commutator to wear, no collector ring trouble. And best of all it costs no more to "go modern with Everlite." Thrifty 1200 watt, 115v. AC plant powered by a rugged easy starting 4 cycle engine—leader priced Model 869-12T. Wt. 65 lbs. as illustrated **179.50**

*Trade-Mark Registered

All sizes available—can finance. Write for catalog. Special models for public utilities—Approved for Civil Defense. Write

MASTER MECHANIC MFG. CO., Dept. B-763, Burlington, Wis.

Southern Customers write Dept. B-763, Box 65, Sarasota, Florida

The Untold Story of the Model T

[Continued from page 72]

years they worked on the design, and for over a year until 10 or 11 at night. Mr. Ford followed up the design closely, and was there practically all the time." Like John F. Kennedy, he sat in a rocking chair.

Road testing. By no means was all the work done in the experimental room of the Piquette factory. Much was on rough country roads where the first models were pitted against mud, rock, hills, bumps, and holes to uncover every defect of engine, chassis, and other parts. Ford did much of this rough-road testing himself. From his office next door to the experimental room, he popped in upon the workers with ideas. Sorensen would give them rough physical shape, while Galamb would sketch designs. Then they would all work together to machine the parts, build them into the car, and test them.

The Model T, according to current folklore, was made famous by two novelties, the planetary transmission and the flywheel magneto, which generated a high-tension current ingeniously distributed to the four spark plugs. Actually, neither device was completely new. Some of the earlier Ford cars had used the planetary transmission. And the magneto had been employed in a variety of ways and places—enough, at any rate, to make the idea familiar. Ed Huff, who was English, may have seen it on one of the early Lanchester cars in England. For that matter, Ford imported foreign cars to study them—a practice the company still follows. What is certain is that both magneto and planetary transmission were more expertly made and more practically placed in the Model T than in any other car. The magneto was a definite improvement over the dry batteries that nearly all American cars had previously carried. "Every time the flywheel revolves," ran an early advertisement, "you get a series of sparks."

Stronger and cheaper. So, too, with the three-point suspension. Ford had experimented with it earlier; now it enabled the Model T to skip and bounce with happy flexibility over rough roads. The car was as agile as a chamois.

Still, there were true novelties on the Model T, and they were numerous and important. The engine, flywheel, universal joint, and transmission were all in one closed case where they were lubricated by "splash-and-gravity." The four cylinders

were, for the first time, cast in one solid block, instead of being divided between two blocks. This made for cheapness and greater strength. The two arc springs, mounted crosswise directly over the axles, did not offer luxurious ease, but they kept the car free from racking torsions previously common. Not least of the advantages was the boldness with which the Model T rode high above the roadbed to safely negotiate rough country.

The four-cylinder, vertical engine generated 22½ horsepower, a high mark for so light an automobile: power enough to make the engine useful in cutting wood, grinding feed, pumping water, and other practical tasks. The lightness of the car (only 1,200 pounds), its slender lines, and short wheelbase (100 inches) gave it an economy and handiness that farmers appreciated. Yet it was toughly made with vanadium and other alloy steels, and sturdily built. The wheels and springs stood harder usage than those of more-expensive automobiles. The tank under the seat held 16½ gallons in the run-about, 10 in the touring car—enabling the owner to cover long distances without worrying about filling stations. A gear-driven fan, a carburetor adjustment on the "dashboard," and spark and throttle controls close to the operator's hand, were ingenious innovations.

Utility: Here was the central characteristic of the car: It was so useful under adverse conditions, so versatile in all crises, and so dependable once a number of small initial faults were remedied, that people quickly forgot its homeliness. Most families became as fond of it as of the family horse. They petted it like Dobbin. It was not spectacularly cheap at first—\$825 up—but even at \$825 Henry Ford could claim that it offered as much as any car under \$2,000. The reduction in prices soon became astonishing. By late 1912, the touring car was selling for \$600; by 1915, \$440; and by 1916, for \$360.

While Ford's aides deserve great credit, fundamentally the Model T was his in conception and character. It was Henry Ford, who, scrutinizing vanadium, and talking with Kent-Smith, had perceived the possibility of a car both lighter and stronger, built with alloy steels. It was Ford who had built the experimental room, and crammed into its 12-by-15-foot space a

The Untold Story of the Model T drill press, a milling machine, and other power tools—with room enough left for the model taking shape. It was Ford who, with Wills, had searched the shop for an expert draftsman, found one in Galamb, and given him his own little room where he could lock up his designs at night.

Uncanny vision. Spending hour after hour in these two rooms, for nearly two years, Henry Ford had brought his ideal of lightness, agility, and toughness to reality. His vision sometimes seemed uncanny. As Sorensen once recalled, speaking of the planetary transmission: "At times it was astonishing to me to see how well he *sensed* the sizes required for these different gears." In studying an old machine, and planning a new one, he had, indeed, a sixth sense.

Above all, Ford comprehended, as few other men of the time did, the possibilities of quantity production. He perceived that if he could create a cheap standard car, there would be no limit to demand. He saw, with William C. Durant, founder of General Motors, that an unlimited market and an ever-swelling production would mean a constant lowering of prices.

During the first year of the Model T—Oct. 1, 1907 to Sept. 30, 1908—the company sold 10,607 cars, a business of more than \$9,000,000. This was but the start. Everyone knows how the sales of Ford cars rocketed up. In 1912-1913 the total was 168,304, and in 1916-1917 it was 730,041. It was this huge sale that made the \$360 price possible. And everyone knows about the incredible rise in wages, as the \$5 day was announced to the world in 1914.

Big business. Henry Ford, with his Model T, created within a few years one of the most tremendous industries of the world. He had assembly plants dotting the whole country before World War I; he had dealerships in every city and town; and he was setting up branches abroad. In various other ways, he had opened the womb of the future. Out of his quantity production, his emphasis on a continuous flow of material and parts, and his insistence upon ever greater efficiency in handling materials and products, grew the gigantic new force in the American economy called mass production.

Its birthplace was the new Highland Park plant. Its birth was 1913-1914.

Great as was the Model T, the development of the complex entity called mass production was greater still. ■ ■

Briggs & Stratton — Clinton New Gas Engine Sale

Never before and perhaps never again—this offer of brand new genuine Clinton and Briggs & Stratton engines including 1 yr. factory warranty at less than cost. Perfect power for go-carts, scooters, tractors, mowers, generators, pumps, sprayers, etc. We bailed out 3 big factories who needed cash and the savings are yours while quantities last. *Act fast.*

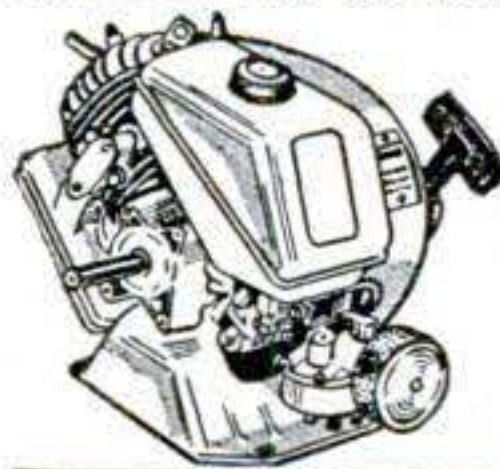

Clinton 2 1/2 hp, Mdl. 500—Re-coil starter Std. 5/8 shaft w. keyway—ready to go. Reg. price \$49.50. Special (item 1002)

\$29.95

2 for\$59.50
6 for ...\$176.50

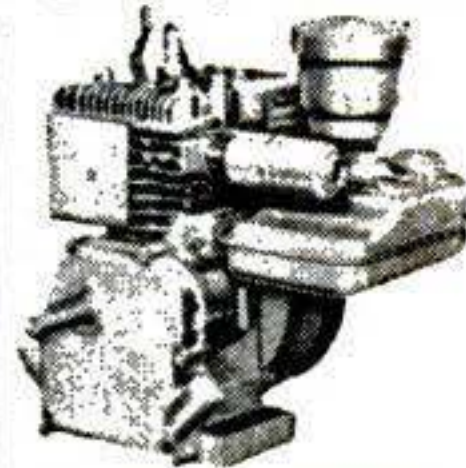

Briggs & Stratton 2 hp, Mdl. 60101 Rope start, std. 5/8 shaft w. keyway. Sturdy 4 cycle power. Reg. price \$49.80 Spec. (item 106a)

\$29.75

2 for\$58.90
6 for ...\$175.50

\$67.50

5 3/4 hp.

**Briggs
&
Stratton**

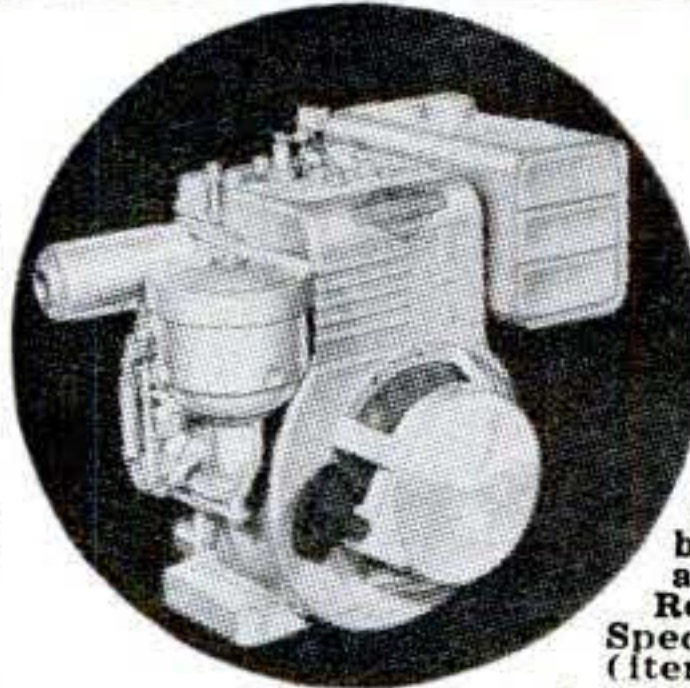

Briggs & Stratton 5 3/4 hp. Mdl. 143302. Recoil start. Std. 1" shaft w. keyway, aut. choke & throttle control—a rugged big engine ready to tackle any job.

Regular price ...\$92.60
Special (item 1059) .. **\$67.50**

2 for \$130.00 6 for \$350.00

2 3/4 h.p. Clinton—34.95

Model 400, rugged 4 cycle model. Alum. Block, castiron cylinder Rope start—5/8" std. shaft Item 1107 **34.95**
2 For **67.50**

3 1/2 h.p. Clinton—39.95

A big engine with big power. Model 406, 4 cycle, rope start, 3/4" std. shaft. Item 406 **39.95**
2 for **77.50**

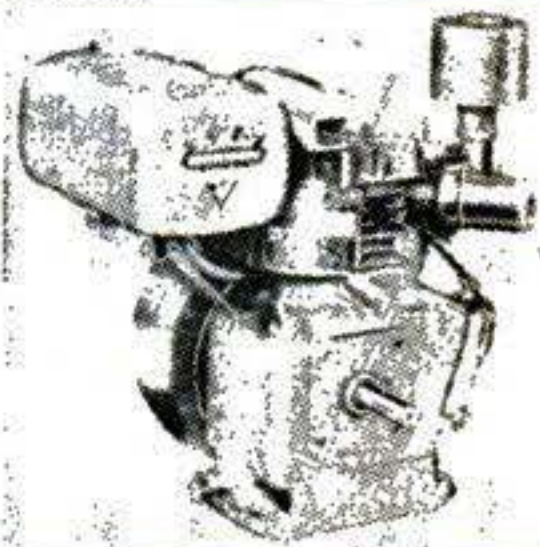

2 1/2 h.p. Lawn Mower Engine \$29.89

Clinton Model 403, 4 cycle, 2 1/2 h.p. or 3 h.p. rotary mower. Standard 7/8" dia. shaft with female 3/8" thread. EZ recoil starter. Aluminum block with long life steel cylinder sleeve. It's less than the cost of an overhaul.

Weight 22 lbs. Item 1119 ea. **\$29.89**

Remember these engines are absolutely perfect and standard and under factory warranty. Money back guarantee. Order now while stocks are complete. Factories—write us on any new items that are surplus to your needs. **Send 10¢ for 100 page catalog.**

MASTER MECHANIC MFG. CO., Dept. B-763, Burlington, Wis.

Southern Customers write Dept. B-763, Box 65, Sarasota, Florida

POLYSEAMSEAL®

TUB CAULK • TILE ADHESIVE

Pure White • Elastic
Permanent

Sticks like glue! 101 Household Uses!



INCREDIBLE UNIMAT!

Makes gears, bearings, wheels, axles, pinions, etc. Turns, threads, bores, drills, mills, grinds, buffs, polishes ...900-7200 rpm. Complete machine shop in 16".

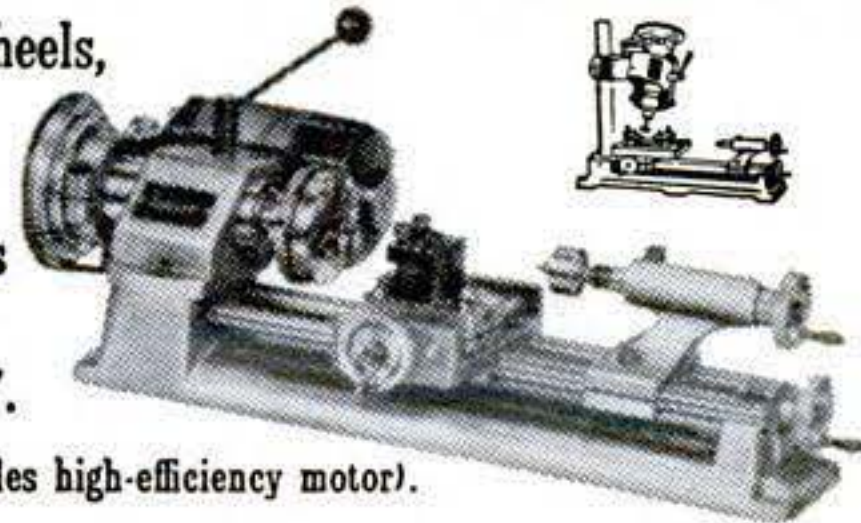

BASIC UNIMAT: \$139.50 (includes high-efficiency motor).

WRITE FOR FREE CATALOG.

AMERICAN EDELSTAAL, INC., DEPT. H-G, 350 BROADWAY, N.Y. 13, N.Y.

Shrinks Hemorrhoids

New Way Without Surgery

Stops Itch - Relieves Pain

For the first time science has found a new healing substance with the astonishing ability to shrink hemorrhoids and to relieve pain - without surgery.

In case after case, while gently relieving pain, actual reduction (shrinkage) took place.

Most amazing of all - results were so thorough that sufferers made astonishing statements like "Piles have ceased to be a problem!"

The secret is a new healing substance (Bio-Dyne®)—discovery of a world-famous research institute.

This substance is now available in *suppository* or *ointment* form under the name *Preparation H®*. Ask for it at all drug counters.



FOR ACCURACY IT'S HULL COMPASS

When buying a compass, you want accuracy above all else. You get it with HULL—the compass that works—for cars or boats. Easier, more positive compensation.

\$5.95 TO \$7.50 AT YOUR DEALER'S OR WRITE FOR LIT.
HULL MFG. CO., Box 246-E-7, Warren, Ohio



DRAINS collars, cisterns, wash tubs; **\$7.95**
IRRIGATES - CIRCULATES - SPRAYS

1,001 uses. Stainless shaft. Won't rust or clog! Use 1/6 HP motor or larger . . . 3/4 HP for up to 2,400 GPH; 450 GPH 80' high; or 1800 GPH from 25' well. 1" inlet; 3/4" outlet. Coupling included free. **\$7.95.**
HEAVY DUTY BALL-BEARING PUMP. Up to 5,200 GPH; or 3,000 GPH from 25' well. 1 1/4" inlet; 1" outlet. **\$12.95**
Postpaid if cash with order. MONEY BACK GUARANTEE

Centrifugal and Gear Pumps in All Sizes
LABAWCO PUMPS, Belle Mead 3, New Jersey



NEW HI-FI PERFORMANCE

The Exciting NEW **MODEL 422 BENJAMIN**
CO₂ 10-SHOT SEMI-AUTOMATIC
.22 PELLET PISTOL

\$24.00
Ask Dealer for Demonstration.

EFFICIENT—SAFE—DEPENDABLE—CONVENIENT
Famous BENJAMIN Quality

AT LAST— an Amazing New Handgun that incorporates the Characteristics Wanted for Serious Training, Plinking and Match Competition—Indoors and Outdoors—at **LOWEST SHOOTING COSTS!** Handsome, Dynamic, Mechanically Reliable, MODEL 422 combines Traditional BENJAMIN PEAK POWER and ACCURACY with Incredible Firing Speed—Smooth JAM-PROOF ACTION (no ramrod for cleaning pistol bore required)

WITH EXTRA MARGIN BENJAMIN'S Unique DOUBLE SAFETIES

Press Trigger Safety "OFF"
Release Hammer Safety as Illustrated.

TRIGGER SAFETY
HAMMER SAFETY

KEEPS SHOOTING & SHOOTING & SHOOTING & SHOOTING
AS FAST AS YOU CAN SQUEEZE THE TRIGGER!

FREE Write today! Complete Catalog Benjamin Rifles & Pistols—Single Shot & Repeaters—BB or 177 or 22. Also, Special Offer on Hunting Knives.

Use Benjamin H-C Pellets in Model 422 for Accurate, Jam-Free Shooting.

BENJAMIN AIR RIFLE CO. 857 MARION ST., ST. LOUIS 4, MO.

"Any Dope Could Drive a Model T"

[Continued from page 74]

who had everything usually had a couple of bricks in his car to chock the wheels while cranking (or parking on hills).

GENERALLY, however, none of these ugly things happened. Generally, devoted genie that it was, the Model T sprang into clanking life, waiting to serve.

Now you bounded back into the driver's seat. With your left foot, you held the forward pedal halfway down (neutral position) while you released the hand brake. Your right hand pulled the gas arm down, and the engine roared. Then you pushed the forward pedal all the way down into low, and you were off. Pick up a little speed, and you released the forward pedal, throwing the car into high. A real semiautomatic transmission, by gum!

All that was left now was to advance the spark arm, flip the ignition to "mag," and, with the car moving as slick as butter in a hot frying pan, point your nose to San Francisco or New York.

TO STOP, you stepped on the brake pedal with your right foot, while your left foot descended halfway on that forward pedal. To reverse, you stopped the car, and with your left foot holding her in neutral, stepped on the reverse pedal with your right. Back she went.

The ignition tended to be a little fussy, and a file, to clean off the spark-coil points, was a handy tool. A second solution, when mechanical know-how failed, was to buy replacement spark coils at the junk yard for a quarter apiece.

The other item that you had to worry about was the transmission bands. Sears, if memory serves me right, sold them for 50 cents apiece. There were three of them, fiber, and they tied the transmission to the drive shaft: one for forward, one for reverse, one for braking.

A handy feature, if your brake band was worn, was the possibility of using the reverse band for braking—or even of using both reverse and brake to stop. Of course, you had to get your foot off that reverse pedal once the car had stopped. Otherwise the car would keep going backwards. In that case, you could use the forward pedal to halt the reverse movement.

They don't make 'em as simple as that these days. ■ ■



New control tower for all airports

All traffic-control towers built at U.S. airports in the future will look like this model. The design by I. M. Pei, New York architect, was approved by the FAA to make the facilities stand out from other airport buildings and be easily recognizable by pilots. There's room at the base for expansion of facilities as needed.

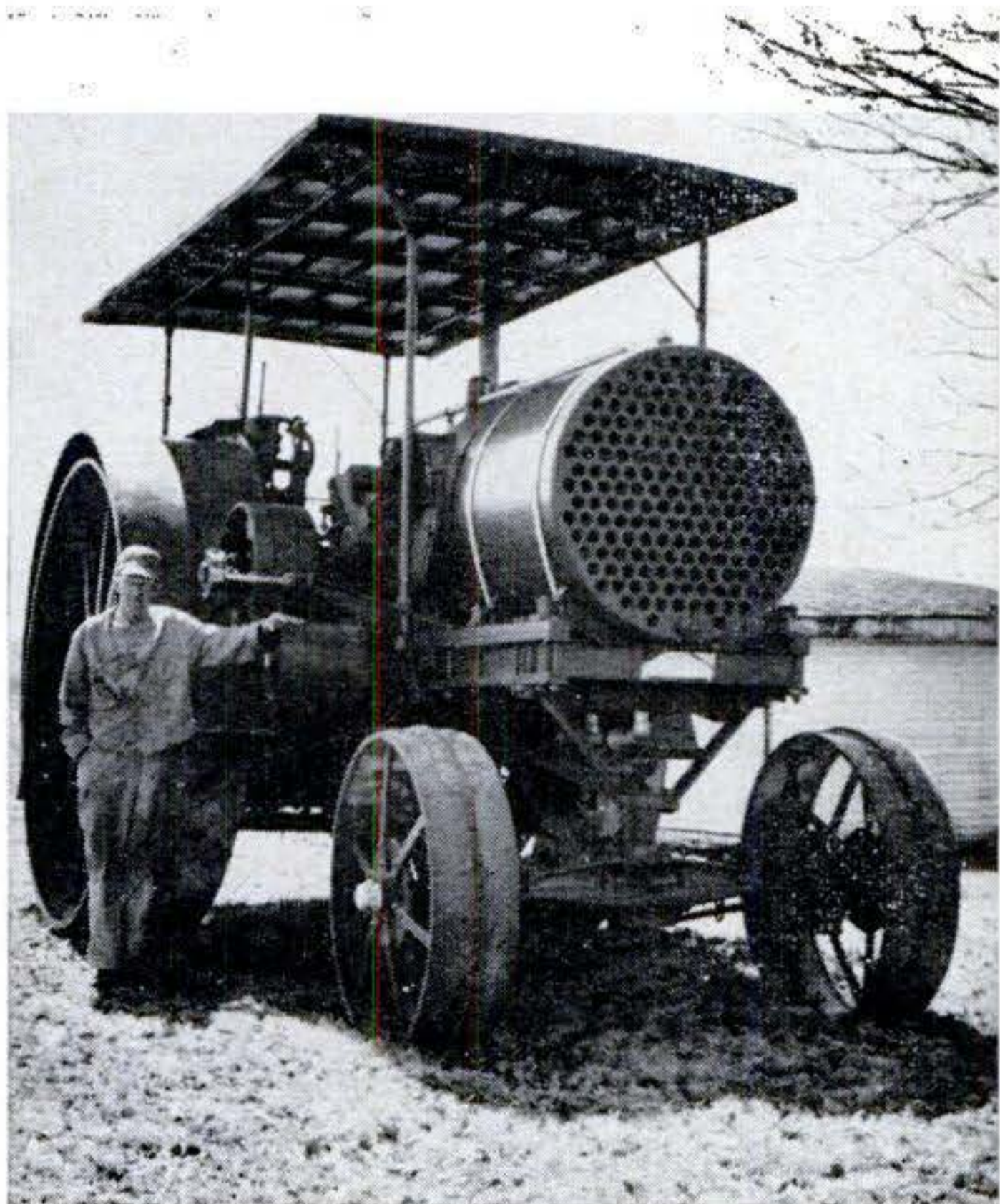

1912 tractor still works on farm

Standing beside this huge 1912 Alton-Taylor tractor is 71-year-old Clyde Shufelot, who still uses it to work his farm near Iuka, Ill. The 14-ton monster drinks 50 gallons of fuel a day, makes six m.p.h., and takes two men to operate—one to steer, one at the controls. The radiator holds 150 gallons of water to cool the engine.

PATCHING PROBLEM?

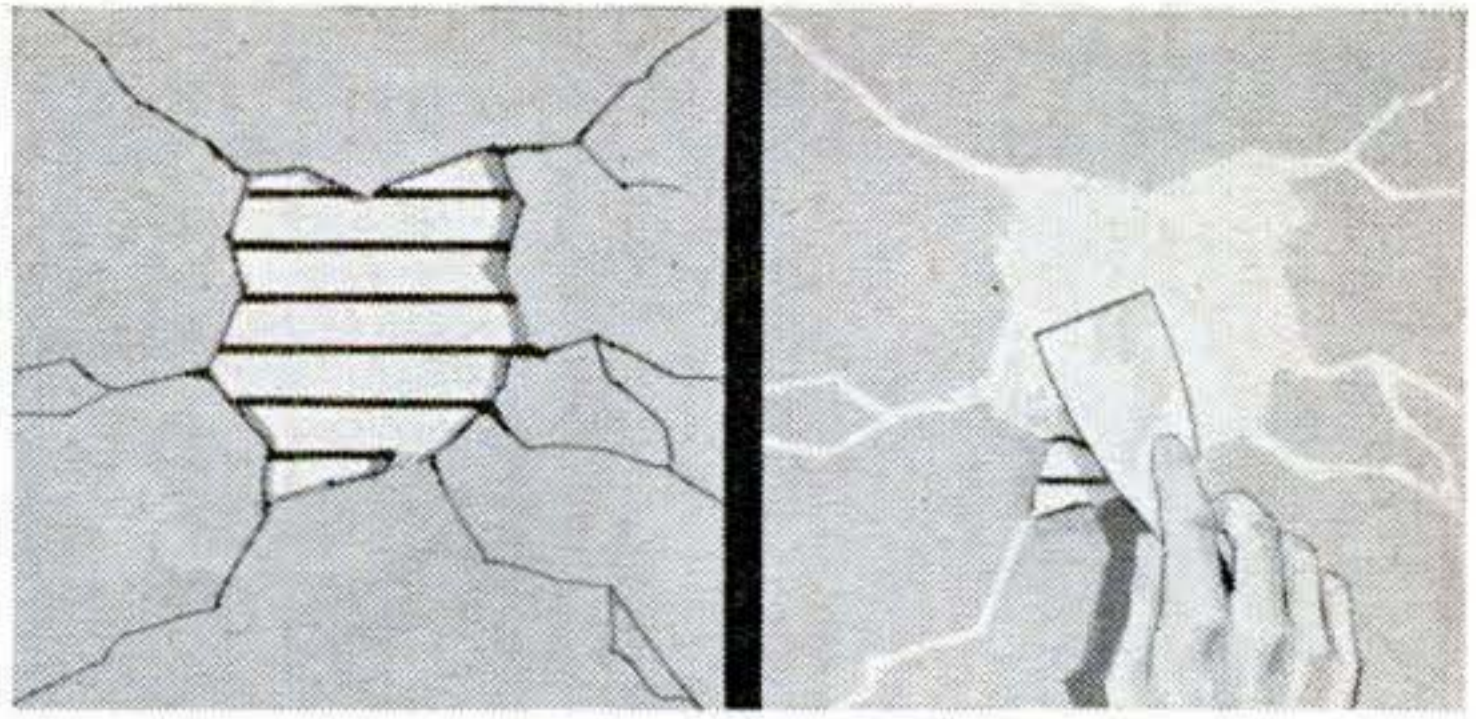

Fix it quick with



DAP VINYL-PASTE SPACKLING

Ready-mixed for instant use on plaster, dry wall panel joints, wood. Spreads smooth, dries fast.

DAP INC., DEPT. 46, DAYTON 31, OHIO



ASK FOR **HASTINGS**
PISTON RINGS
OIL FILTERS
CASITE ADDITIVES
 Best \$ you can spend on your car

NEW CATALOG for CRAFTSMEN!

Workshop Supplies and Equipment, Kits Power Tools, Special Hardware **All at Money Saving Prices**

WOOD..

Get our new 132-page FULL COLOR Catalog. Finest domestic and rare imported hardwoods. Legs, mouldings, ornaments, mosaic tile, lamp parts, glue injector, upholstery supplies. Over 1,500 items. New project ideas and plans. Discounts on Stanley Tools. Send 25c for postage, handling.

CRAFTSMAN Wood Service, Dept. B-7, 2729 S. Mary St., Chicago 8

BUY FACTORY DIRECT!

WREN MINI-BIKE! \$99.95

Send 25c for brochure Many Models

\$10.00 Down \$6.00 a Month Complete with Clinton 2 1/2 H.P. engine

Order Now!

Bird Engineering, Box 427, Dept. PS-W-7 Omaha, Nebr.

ELECTRIC WELD - BRAZE & CUT

REPAIR MOST EVERYTHING MADE OF METAL

Arc Welder

BEST WELDER MADE FOR THE MONEY! Includes full face shield, extra arc goggles, ground clamp, twin carbon arc torch, welding rod holder, supply of welding and brazing rods, solder, flux and full supplies—PLUS ARC WELDING INSTRUCTION BOOK! ONE YEAR GUARANTEE—10 DAY FREE TRIAL. Now you can

make or repair metal parts for cars, home, farm, garden, shop or factory. Works on any 110 v. house plug-in. CUT, MELT, BRAZE, SOLDER OR WELD MOST ANY METAL!

SEND ONLY \$2.00 (cash, ck, mo) and pay postman only \$12.95 COD postage or send \$14.95 for postpaid delivery. Every EXPERIMENTER, MECHANIC, INVENTOR, CAR OR HOME OWNER NEEDS THIS SMALL WELDER. ORDER YOURS NOW! Ideal gift. MADE ONLY BY:

Midway Welder Co., Dept. DPS-7, Kearney, Nebr.

MAJOR AIRLINE APPROVES AEC 77 TRANSISTORIZED ELECTRONIC IGNITION



BOEING 707 BEING SERVICED BY GROUND MAINTENANCE GENERATOR EQUIPMENT

Generator type #666 that charges the batteries on airplanes is powered by an automotive type gas engine using an AEC 77 Transistor Ignition.

Installation was made in 20 minutes in May 1962 and close, accurate records were kept. AEC 77 increased the generator power output, kept points and plugs clean, and kept the engine operating efficiently with no wear and tear. This equipment is still operating as installed. It has saved the airline over \$100 in gasoline costs and eliminated the need for 5 major tune-ups during the past 12 months.

Proven reliable and dependable by the airline's maintenance department, AEC 77's have now been approved for installation throughout the entire airline system in the United States. AEC 77's have a worldwide reputation for proven reliability and are guaranteed for 3 full years.

You can order an AEC 77 system for your car direct and have it in a few days, or send for a free brochure.

AEC 77.....Negative Ground.....6/12V.....\$39.95
(state make and year of car)

ORDER NOW FROM

Automotive Electronics Co.

Dept. A, 387 Park Avenue South
New York 16, N.Y.



MAGNET SALE!

ALNICO-V RADAR MAGNET: LIFTS 150 LBS., 4" STRIKE POWER. Many uses for industry, shop, research, sportsmen. Retrieve tools, motors, tackle, etc. from salt or fresh water, tanks, shafts, etc. (3x3x4 in./6 lbs.) Fraction of govt. cost.

SALE PRICE \$11.50 POSTPAID. NO. M150

Retriever Assembly With Handle:

R75 Pulls 75 lbs. (3 x 3 x 1 5/8 in./wt. 42 oz.).....\$4.95

R125 Pulls 125 lbs. (5 x 3 1/4 x 2 1/2 in./wt. 5 lbs.).....\$7.95

Sample pair (2) small bar magnets & sale catalog.....25c

MONEY BACK GUARANTEE / WE PAY POSTAGE

MAGNA MAGNETICS, 7777 Sunset, Los Angeles 46, Calif. Dept. S



NEW! GEAR BOX

**3-Speed Forward, Neutral
and Reverse Transmission!**

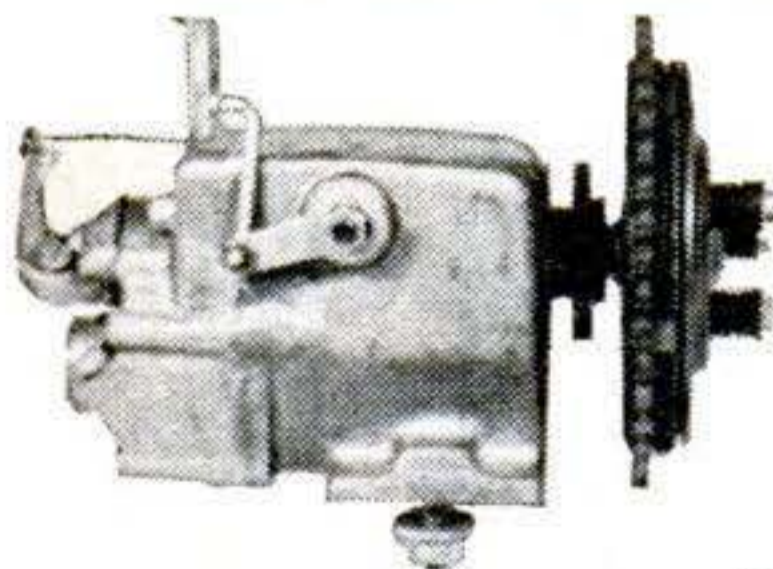

**Rugged—Heavy Duty
—Versatile**

The ideal gear box for small cars, tractors, winches and other powered equipment. Comes complete with Friction Clutch, Shift Lever and Sprockets.

MODEL 3R25, as shown

\$95.00 Postpaid anywhere in U.S.A.

MONEY BACK GUARANTEE

• Model 317, lighter duty without reverse, for scooters, etc. \$59.95 ppd.

Send check for prompt delivery to..

J. I. EDWINS CO., INC.

Issaquah 2, Wash. Phone EX. 2-3211

Gear Ratios: FWD
3 to 1, 2 to 1, 1 to 1, Neutral & Reverse, 3 to 1.

Sprockets: #40 input 42 teeth, output 15 teeth. 25 ft. lbs. input torque.

Dimensions: 5" x 5" x 10".

Deadly Gadgets of the OSS

[Continued from page 59]

his. It would burn perfectly until the flame touched the high explosive composing the lower two-thirds of the candle. The burst was as effective as a hand grenade.

The simplest weapon we made was a three-inch piece of steel so shaped that, however it fell, there were three prongs pointing downward and one erect. Thrown on a highway, it would cause a blowout. Too small for the driver to see as he bowled down the road, it destroyed any tire that ran over it.

One weapon the Germans or Japanese never did discover. Only the United States uniforms had a small "fob" pocket over the right hip. No enemy searching our people looked there. We evolved a gun to fit. The "Stinger" was a three-inch-by-half-inch little tube, innocent looking as a golfer's stub pencil. The tube held a .22 over-loaded cartridge. It was cocked by lifting a lever on the tube with the fingernail. Squeezing the lever down fired it.

One agent was picked up by the Gestapo. They frisked him and found no weapon, but put him in a staff car, in the back seat. En route to German headquarters for interrogation, the officer got out to telephone ahead. Our agent, left alone with the chauffeur, took out the overlooked Stinger, cocked it, held it near the back of the driver's head and fired. He pushed the body to one side, took the wheel, and drove to the American lines.

The Stinger not only saved the man's life but allowed our planes to destroy the German headquarters. By telling the driver what route to take, the officer had unwittingly given the OSS man priceless information.

Another simple weapon, the pull-type booby trap, had infinite applications. It was very effective against trains, for instance. A heavy bomb, called a "Spigot Mortar" was screwed into a tree on one side of a track. A wire crossed the track tautly fixed to a tree on the other side. The railroads had corps of trackwalkers, but our wire was over their heads and they were looking down. When the enemy train came along, the track pulled the wire, and the bomb hit the engine and bowled it over.

One of our achievements was a high explosive that would act like ordinary flour, arousing no suspicion. It had almost the effect of TNT, but could be wet, kneaded

Deadly Gadgets of the OSS

into dough, raised, and actually baked into bread. I called it "Aunt Jemima."

We made Chinese flour bags and sent them, properly stenciled, to Chungking. Bags of this camouflaged explosive were laid against a bridge over the Yangtze River, destroying it completely.

My personal troubles with Aunt Jemima began when I found about 100 pounds in my office. I telephoned an expert to come take it away. He said, "Flush it down the toilet." It took some time to do that. When I returned to my desk the expert's boss was on the phone. "Don't flush that explosive down the toilet. The organic matter in the sewer will react with it and blow Washington sky-high."

I thanked him as calmly as I could. There was no point in his worrying, too. The sewer ran from our offices to the White House.

Every truck that backfired, every door that slammed, raised the hackles on our necks. In the morning we decided that the War College might blow up, but that the White House was safe. We knew, because we stood at its gates at sunrise.

The explosive shellfish

A special weapon of the saboteur is the "Limpet," named after a shellfish which adheres to rocks. By means of a magnet or rivets, the Limpet anchors to a ship below the water line. It holds a few pounds of high explosive. Although the hole it opens in the side of the ship is small, the result is devastating. The ship is promptly sunk because the recoil of the ocean upon that hole opens it up to a 20-foot aperture.

Our saboteur puts the Limpet against the ship's side with a long pole. Withdrawing the pole activates the tiny explosive. A magnesium window in the Limpet is slowly etched away by salt water and after several hours the explosion takes place.

In 1944 the Norwegian underground advised that the Germans might withdraw their army of occupation, and they needed Limpets to put on German troopships. The Torpex explosive we used was in Nebraska. Express, parcel post, railroads, or airlines were out. An Army captain and a sergeant offered to get it if I would provide an automobile. I gave them my own car and they were off. Their drive from Nebraska to Washington was an epic. The load of sensitive explosive weighed the small car down.

CONTINUED

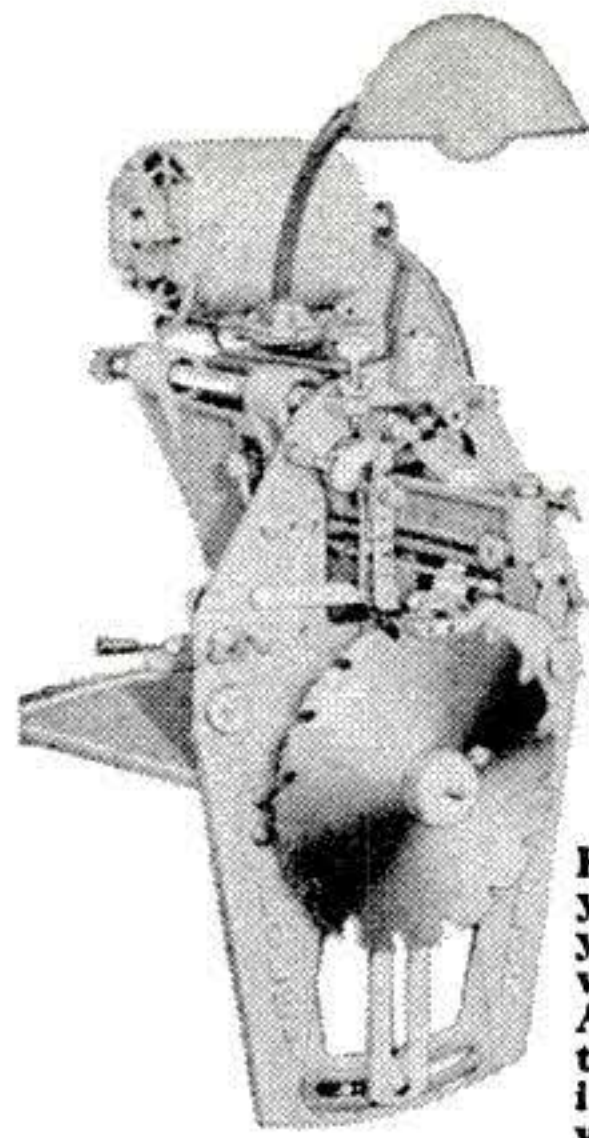

**MAKE
\$20 to \$30
A WEEK
EXTRA
MONEY**

Here's a practical way to increase your income and build security for your family. Earn extra money every week sharpening saws with a Foley Automatic Saw Filer. You can actually build your own business with it—without special training or previous experience.

TURN YOUR SPARE TIME INTO CASH. Make from \$3 to \$6 an hour evenings, week-ends. Start in your basement or garage. No canvassing. "I advertised in our local paper and got in 83 saws"—says M. L. Thompson. Every saw you sharpen with the Foley Filer brings you more customers. Hundreds are making extra money this sure, fast, easy way. You can too.

**FREE
BOOK
SHOWS
YOU HOW
TO START**

"Money Making Facts" explains how you can get business from home owners, farmers, carpenters, schools, factories, etc., how to build your business and expand—every step of the easy way. Don't wait. Mail coupon now for this exciting book and easy pay plan. No salesman will call.

MAIL COUPON FOR FREE BOOK

FOLEY MANUFACTURING CO.
719-3 Foley Bldg., Minneapolis 18, Minn.
Rush free book, "MONEY MAKING FACTS",
and details on easy pay plan.

Name _____
Address _____
City _____ State _____



MEN PAST 40

**Afflicted With Getting Up Nights,
Pains in Back, Hips, Legs,
Nervousness, Tiredness.**

If you have these troubles, particularly getting up nights, then your condition may be traced to Glandular Inflammation . . . a constitutional disease. Neglect of this condition often leads to premature old age and sometimes incurable conditions.

The Excelsior Medical Clinic has a New Free Book that tells how thousands of men have been successfully treated here at Excelsior Springs for Glandular Inflammation by NON-SURGICAL Methods. They found soothing relief and a new outlook on life.

This Free Book may prove of utmost importance to you. Write Today. There is no obligation.

Excelsior Medical Clinic, Dept. B 6240, Excelsior Spgs., Mo.

Every Home Needs This 'All-Purpose' Oil

Lubricate • Clean • Prevent Rust
3-IN-ONE® OIL
REGULAR—OIL SPRAY—ELECTRIC MOTOR

Deadly Gadgets of the OSS

Were they to be stopped by police and their illegal load given publicity, the whole venture would have had to be abandoned. I thought of our Documentation Branch. Our letter, typed on White House stationery said:

"Captain Frazee and Sergeant Walker are on a secret mission for me as Commander-in-Chief. Any assistance given these officers will be helping to win the war. Any interference with their vital mission will be followed by disciplinary action. This is a Top Secret operation."

Franklin D. Roosevelt would have sworn that he had signed it.

Twice my men were stopped by local police and twice this letter evoked abject apologies.

The vital load was transported to Norway and encased in Limpets by the underground. Our timing was perfect. The Germans were recalling troops from Oslo, Stavanger, and Narvik. The British said that when Hitler most needed reinforcements to defend *Festung Europa*, the fjords were in possession of many sunken German ships, with troops caught in that watery graveyard. The little Limpets from Nebraska had fulfilled their mission.

Schemes that failed

SOME problems could not be solved. One was "Simultaneous Events," a means of activating high explosives that would be unaffected by any outside source except an air raid. The operator could secretly plant his explosives. Nothing would happen until an air raid. The target would blow up and the blast would be blamed on the airplane bombings. This would furnish an ideal alibi for the underground operator. Also, he could pinpoint the damage where it would hurt most.

We approached it from two angles; one was ground shock of a raid, the other a radio signal to be sent from the bombers. Nothing we invented passed our trials. The ground-shock devices would detonate prematurely from a passing truck. The radio signal depended on batteries, as well as an objectionable antenna. When Germany surrendered we were still working on Simultaneous Events.

My favorite attack on Hitler was a glandular approach. Gland experts agreed that he was close to the male-female line. A push to the female side might make his

mustache fall out and his voice become soprano.

Hitler was a vegetarian. At Berchtesgaden, the vegetables had to have gardeners. A plan to get an OSS man there was approved. I supplied female sex hormones to be injected into *der Führer's* carrots.

I can only assume that the gardener took our money and threw the medications away. Either that or Hitler had a big turnover in tasters.

The Bombing of Peenemünde

ONE morning a radio message from one of our spies in Switzerland said: "French workman who swam Rhine last night told improbable story. Said he was guard for casks of water from Rjukan in Norway to Peenemünde."

A week before I had attended a discussion by scientists involved in atom-bomb studies. Someone said, "Graphite would be a more efficient neutron arrester than *heavy water*."

The only water in the world worth guarding is heavy water.

I rushed to the maps. What was Rjukan? The biggest hydroelectric development in Europe and perhaps the only place where heavy water could be produced. I obtained air photos of Peenemünde. Dairy farms, thatched farmhouses. I didn't believe that!

In August, 1943, the RAF staged a raid at Peenemünde that killed a thousand people and inflicted heavy damage—not on the atomic lab we thought was there but on the rocket station that *was* there. Dr. Martin Schilling, who was then chief of the Test Section at Peenemünde, recalls that it delayed the use of V-1s and V-2s until after the Normandy landings. Had those rockets landed on England prior to that date, the invasion of France would have been delayed.

The French workman was quite right, so far as he knew. For security, the guards had been told that the heavy-water shipments were headed for Peenemünde. Actually the load was sent to other destinations where nuclear research was really being carried on.

And so the strangest coincidence of all. The OSS message was incorrect, yet its interpretation helped implement the decision to bomb the headquarters of German rocket research. ■ ■

TAPE RECORDER

(liquidation stock)

\$8.99

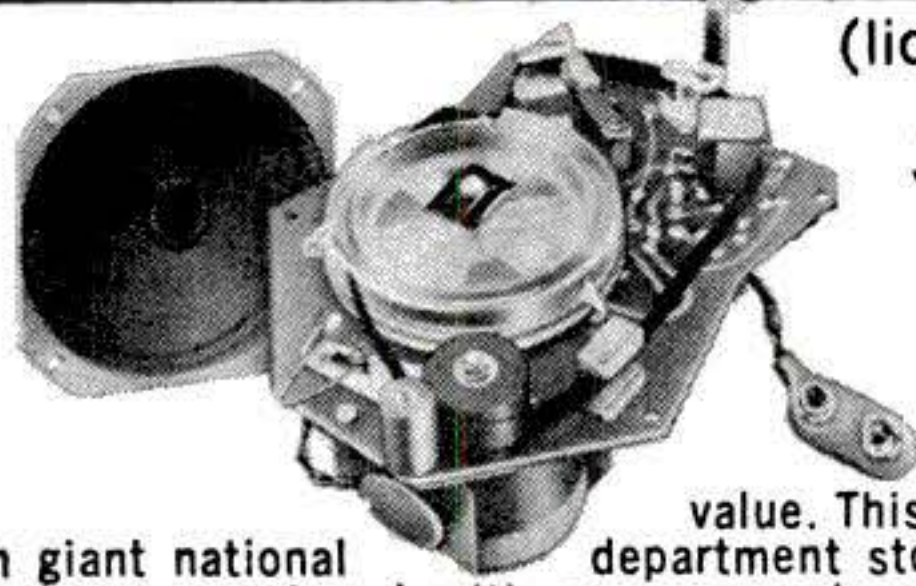

Liquidation of our special purchase of tape recorders complete with excellent 2 1/2" speaker and microphone. A \$20

value. This production left over from giant national department store promotion where recorders were taped with a message to give to passing customers. Comes complete with standard 1/4" magnetic tape. Use for messages, rig with remote control invisible thread for detective work. Has unique endless loop feature. Hide anywhere, conceal in toy animal and let it make outrageous remarks to guests. Hundreds of uses. While they last. Send \$1 deposit for C.O.D. Satisfaction guaranteed.

MISSION LIQUIDATORS,
735 Celis Street, San Fernando 1, California

**MIND
THAT
MATTERS**

It's brainpower America needs to hold world leadership. But higher education is in trouble—some colleges face shortages. They need classrooms, laboratories, professors. College is America's best friend—give to the college of your choice.

To learn how the college shortage affects you, send for a free booklet to: **HIGHER EDUCATION, Box 36, Times Square Station, N.Y. 36, N.Y.**

Published as a public service in cooperation with The Advertising Council.

GOVT. SURPLUS AND OTHER BARGAINS SAVE UP TO 90%



NEW! ELECTRIC PUMP WITH CONTROL UNIT

For boats, campers & trailers. Output 10 to 200 gal. an hr. Variable rheostat contains on & off switch and controls output of pump. 1/2" pipe thread into bronze impeller housing. 12 V.D.C. Radio noise filter. Explosion-proof const. Shpg. Wt. 9 lbs. Complete with mounting instructions & wiring diagram. Approx. GOVT. COST, \$200. NEW. **\$10.95.**

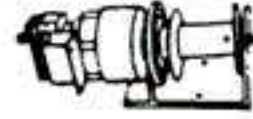

DELUXE ELECTRIC STORAGE BATTERY WINCH

A ruggedly built, heavy-duty winch with ball bearing construction throughout motor and gear train. 225-1 gear reduction. Rated cap. 3000 lbs. Contains heavy duty enclosed forward, neutral & reverse switch. Rugged 1/4" plate steel mounting base with outrigger support. Dia. 22" L. x 9" W. x 8" H. Handles 250' of 1/4" cable. Built for 12 V. battery operation: will also operate on 6 V. at reduced cap. & speed. A must for scouts, jeeps, trucks, boat loading trailers. Shpg. wt. 80 lbs. Approx. GOVT. COST \$490. New. Model E-D. **\$75.00**

*Lighter duty & remote control models also available from **\$55.00.** Write for spec sheet.



CORNELIUS AIR COMPRESSOR Ideal for filling underwater diving tanks, air horn tanks, etc. Three stage USAF air compressor. Has built-in 1/3 HP, 27 V. DC electric motor and adjustable cut-out switch. Develops 1500 PSI or may be reset to 2000 PSI. Delivers .4 CFM. Approx. GOVT. COST \$375. Like NEW. **\$32.95**

BIG NEW 1963 CATALOG!



Send 25c in coin for amazing new catalog with 1000's of surplus bargains in hydraulics, electrical, precision tools, marine items, automotive, etc. for hobbyists or industrial. Or order from this ad and receive a free copy. All prices F.O.B. Culver City, Calif. 50% dep. for C.O.D. Send check, cash or money order. Order today!

AIRBORNE SALES CO. INC. DEPT. PS763

8501 Stellar Drive • Culver City, California

For a Complete Book of Professional Secrets

Plus Illustrations
Of Products
And Prices Of
Over 300 Different
Molds You Can Use
To Make And Sell
Ornamental
Concrete Items . . .
SEND \$2.00



rushed to you by **FIRST CLASS MAIL**

CONCRETE MACHINERY COMPANY, INC.
839 Lenoir Rd. - P. O. Box 99 - Hickory 7, N. C.

New 'Vapor-Action' Medication kills ATHLETE'S FOOT

Just spray on FEAT®. Amazing new FEAT—with its exclusive "Vapor-Action" medication—kills Athlete's Foot fungi even without direct contact! Its medicated vapors penetrate broken skin surfaces and kill hidden fungi as it relieves itch. Helps prevent reinfection from socks and shoes as no other Athlete's Foot medication can. Also in powder form. Long lasting—inexpensive. At all drug stores.



Copyright 1963, Colfax Laboratories (Div. of Shulton)

GIGANTIC SURPLUS SALE!

COMPACT LEVEL Item #829. New leading make (Guar. discontinued model) light-weight. Ideal for contractor, land surveying, soil conservation, farm contouring, utility company conduit and pole line work, run drain pipe to grade, etc.

• 8" telescope, 8-power magnification, focuses down to 3½ ft. Sensitive 17/8" level vial. Horizontal circle, 3½" divided and numbered every 10°, to 180°. Includes telescope, telescoping tripod, plumb bob, instr., case. Wt. 9 lbs. List \$48.50. SALE **\$29.95** FOB Lincoln

COMPACT LEVEL-TRANSIT

Item #832. Big-instrument performance. Ideal for cramped locations, evacuations, interiors. Accurate sightings for leveling, aligning, plumbing, laying out vertical and horizontal angles. Same spec. as above. Vertical arc graduated both ways, 0 to 45°. Includes telescope, telescoping tripod, plumb bob, instr. deluxe case. Wt. 11 lbs. List \$77.50. SALE **\$39.95** FOB Lincoln

FREE CATALOG 64 pages. Illustrated. Hundreds money-saving bargains electronics, air items, pumps, hydraulics, phones, tools. Send today.

SURPLUS CENTER
LINCOLN, NEBR. DEPT. 841



Profitable HARLEY-DAVIDSON full-line dealer franchises

are occasionally available, due to normal dealer retirements. Qualified businessmen enjoy protected territory on motorcycle, scooter, golf cars, plus parts and accessories. Dealerships filled on basis of qualifications, not application priority, modest investment required. Write John A. Davidson, (Dept. PS) Harley-Davidson Motor Co., Milwaukee 1, Wisconsin

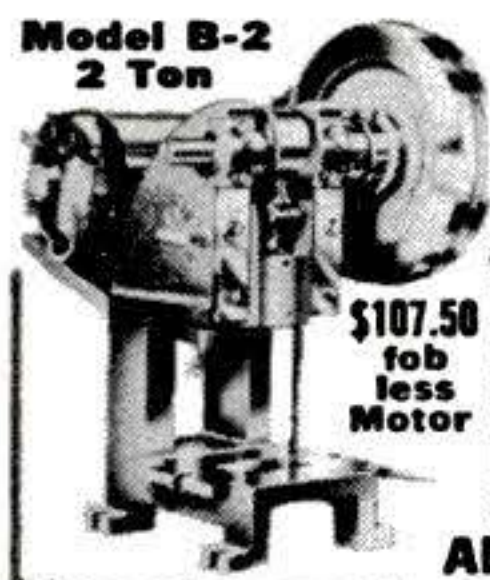

ALVA ALLEN Swaine Power Punch Presses 1 to 150 Ton Capacity

Complete line of Punch Presses in hundreds of different style and model combinations. Write for FREE literature on presses and complete line of punch Press accessories as—Feeds, Punch Units, Dies, etc.

Alva Allen Industries, Dept PS, Clinton, Mo.

make your own Gems 36⁵⁰ FOB

The Gem Maker comes complete with all necessary equipment, including a super-charged diamond blade for sawing, and all the wheels for grinding, shaping and polishing; also complete instructions. The complete equipment as shown, less motor and belt for only \$36.50, f.o.b., Burlington, Wisconsin. Write today for information and literature.

B & I MANUFACTURING CO.
Dept. S Burlington, Wis.

JEEP OWNERS

Re-Power NOW with a V-8 or 6 Cyl engine—Use Ford - Chev - Mercury - GMC - Pont - Stude - Dodge or Plymouth in Jeeps, Jeepsters, Sta-Wgn, Trucks, Kaiser & H. J. cars. Conversion kits \$43.35 to \$56.90. Want fast action? Give us full information, send \$15.00 Dep. and we will ship correct kit. Bal. COD. Send full amount for prepaid shipment. Wire, phone or write today. Details FREE.

HOOSIER MACHINE PRODUCTS CO.
314 S.E. 6th St. Phone 276-3442 Pendleton, Oregon

Home Appliances Now Run Smoothly

Lubricate • Clean • Prevent Rust

3-IN-ONE® OIL

REGULAR—OIL SPRAY—ELECTRIC MOTOR

Man! Here's a COOL Way to Camp

[Continued from page 129]

a piece of camp gear, but an all-around refrigerator that makes a fine addition to a basement playroom or a back-yard barbecue.

How the refrigerators work. A clever switch on the classic absorption-type refrigerator principle is what does the trick. There are no moving parts and complicated mechanism to get out of order.

A simple system of coils is charged with an ammonia solution and hydrogen gas. Heat from a gas burner vaporizes the ammonia, which then condenses and evaporates again. In the process, the ammonia picks up additional heat from the food, keeping it cold. The heat is eventually dissipated to the outside air through finned coils.

This heat-to-get-rid-of-heat principle is the same used by conventional gas refrigerators found in many homes. The interesting part is that when you switch over to electric power, the system still functions exactly like a gas refrigerator. The electricity, instead of running a compressor, goes to a heating coil. The coil does the same job as the gas burner. In the case of the all-electric models, the gas burner is omitted, and the heating coil is operated by either 110-volt house current or 12-volt battery current.

How much food can you carry? You get about 1/3 to 1 1/2 cubic feet of food-storage space, depending on the size of refrigerator you buy. This is enough to carry up to 40 or so pounds of food—plenty for several days when combined with foods that don't need refrigeration.

Most of the baby coolers stand only 15" to 18" high and weigh from 15 to 40 pounds. Prices range from \$65 for the smallest to about \$130. ■ ■

Portable refrigerator manufacturers and dealers include: Artic-Kar Sales, 3333 E. Kiest Blvd., Dallas 3, Tex.; Bernzomatic Corp., Rochester 13, N. Y.; Corcoran Inc., Stoughton, Mass.; Hacker Co. (Swiss import), 14760 Ventura Blvd., Sherman Oaks, Calif.; Monitor Equipment Corp., 640 W. 249th St., Riverdale 71, N. Y.; Portable Appliances, 60 E. 42 St., NYC 17; Ralph Light Plants, 636 Broadway, Chula Vista, Calif.; Selectra Corp., Box 269 Niagara Square Sta., Buffalo, N. Y.; Thermoelectric Corp., Box 634, El Segundo, Calif.

World's greatest classified

opportunities

POPULAR SCIENCE MONTHLY
355 LEXINGTON AVE.
NEW YORK 17, N. Y.

Classified Ads only \$1.20 per word insertion, payable in advance. Minimum ad 10 words. To be included in September issue, copy should be in our office by July 20. No cancellations accepted after July 15. All advertisers using post office box number in ad must furnish complete name and street address for our records. Address orders to O. K. Kelly.

1 AUTOMOBILES & MIDGET CARS

GO-KARTS \$29.95. Full Price less motor. Details 10c. Sportsmobile, 905 N. Broad, Philadelphia 23, Penna.

CROSLY or Foreign car parts catalogue. Parts discount club. Box 79 Elmont, New York.

GAS Turbine hot rods, boats, cars. Construction details, performance reports in \$5 Automotive Turbine handbook. Shop-size manual, Tuning For Performance \$5, insures obtaining maximum production-engine horsepower. Order both from Bill Carroll, Box 1133C, Studio City, California.

OLD Auto catalogs, reprints; hobby club. Enthusiasts, Box 451A, Mt. Clemens, Mich.

2 AUTO SUPPLIES & EQUIPMENT

HYDRAULIC Jack Repair Parts—"Sava-Jack," hard-to-get genuine metal replacement parts; "Econo-Pak" bulk items; "Jackmaster" repair kits; catalog 25c in coin. Hydraulic Jack Packing & Tool Co., P.O. Box 50, Bloomfield, N. J.

JEEP Parts! For Military and Civilian. At great savings. Largest inventory. Catalog for owners and dealers. Inquiries invited. American Auto Parts Co., 1830-PS Locust, Kansas City, Mo.

AUTO shop welding repair training in world's largest non-profit welding school. Low tuition. Free booklet. Hobart Welding School, Box P-73, Troy, Ohio.

CONVERTIBLE owners—Rear Window discolored? Replace in minutes with Instant Window. Kit includes Heavy Gauge clear window, snaps, clips, detailed instructions. No disassembling top. Send \$14.95, we ship prepaid. Satisfaction guaranteed. Tee-Boyd, Wildwood 1, New Jersey.

WILD Bumper Strips! "Start Forest Fires." "Be a Litter Bug." Crazy Labels, Box 15-C, Olympia, Washington.

TYCE-FISH Carburetors. Get 35% power increase, better mileage, unbelievable acceleration on 4 and 6 cylinder compacts. Get astounding performance for \$49.95! Free Literature. Dealers invited. Pow-R Plus, Inc., Box 217, West Newton, Penna.

RING-Valve Job while driving, \$6.00 postpaid. Guaranteed! Nothing like it! Many mechanics recommend! Motaloy, Grantham 27, Penna.

PARTS Model "A." List 25c (Refundable) Matco, Box 135, San Pedro, Calif.

AMAZING new invention is guaranteed to rid cooling system of rust and damaging metallic particles. No more rusty water. Furnish make and year when ordering. \$4.98 Postpaid. Rust-O-Tractor, 1109 Treat, Adrian, Mich.

TEENAGERS. Spray-Paint Your Car Professionally For \$13.95. Easy Instructions 25c. Conner, 4507 Bienville Ave., New Orleans, La.

USE THIS HANDY INDEX TO FIND WHAT YOU WANT

Agents Wanted	43
Antiques, Relics & Indian Goods	29
Art Instruction, Cartooning, Sign Painting	54
Authors Service	52
Auto Supplies & Equipment	2
Auto Trailers	3
Automobiles & Midget Cars	1
Aviation	5
Boats, Outboard Motors	11
Body-Building Courses, Jiu Jitsu, Etc.	12
Books & Magazines	23
Business Opportunities	37
Business Service, Information, Name Lists	50
Buy It Wholesale	38A
Cameras, Photo Supplies	34
Camping Equipment & Tents	16
Coins & Currency	26
Contests	46
Detectives	47
Do-It-Yourself	66
Dogs, Birds, Hamsters & Pets	17
Earthworms, Crickets, Frogs	18
Educational & Instruction	45
Electrical Supplies & Equipment	7
Employment Information	42
Engines, Motors, Etc.	10
Farms, Other Real Estate	19
Field Glasses, Telescopes	14
For Inventors	60
Formulas, Plans, Etc.	39
For Parents	70A
For Sale Miscellaneous	71
Gifts	49
Government Surplus	11A
High-Grade Salesmen	44
Hobbies, Collections	31
Home Craftsman	65
Hypnotism	24
Import-Export	38B
Investments	37A
Inventions Wanted	61
Jokes, Games, Novelties, Etc.	24A
Language Outfits	48
Loans By Mail	80B
Magic Tricks, Puzzles, Etc.	25
Minerals & Precious Stones	30
Miscellaneous	79
Models, Model Supplies	64
Moneymaking Opportunities	38
Motion Pictures & Color Slides	33
Motorcycles, Bicycles & Supplies	4
Musical Instruments and Song Writers	35
Of Interest To Women	70
Old Gold, Jewelry, Watches	67
Personal	80
Phonograph Records	35A
Photo Finishing, Photocopies, Etc.	32
Plastics	40
Printing, Multigraphing, Etc.	57
Printing Outfits, Supplies	58
Profitable Occupations	22
Radio, TV, Electronics, Hi-Fi	36
Remailing Service	80A
Rubber Stamps & Office Supplies	56
Science & Chemistry	41
Sporting Goods, Guns, Fishing Tackle, Etc.	15
Stamp Collecting	28
Tobacco & Pipes	68
Treasure Finders & Geiger Counters	77
Typewriters & Office Machines	55
Wanted to Buy	72
Watch Repairing	78
Welding, Soldering	8

TRANSISTOR Ignition. Save gas, tune-ups. Points, plugs last longer. Improved cold starting, high-speed performance. Complete systems from \$34.50. Free Literature. Dealers invited. Palmer Electronics, Dept. P, Carlisle, Massachusetts.

TRANSISTOR Ignition. 260/1 Coil. Manual, Special—\$8.50. Anderson Engineering, Wrentham, Massachusetts.

3 AUTO TRAILERS

PICKUP Campers. Pre-cut Kits. Blueprints. Supplies. Literature 10c. Comstock Trailers, Parsons 5, Kansas.

LEARN how to save money on trailer supplies. 250 Page illustrated parts catalog available. ABC Trailer Supply, 1731-4th South, Seattle 4, Washington.

BUILD Expanding Eight Foot Trailer. Accommodates Five. Literature 10c. Framar Company, Wilmington, Mass.

4 MOTORCYCLES, BICYCLES AND SUPPLIES

BMW Motorcycles, shaftdrive, U.S. Distributor Butler & Smith, Inc., 160 West 83rd St., New York 24, N. Y.

RECONDITIONED Motorcycle Motors. Large Stock Indian, Cushman, Vespa, Mustang. NSU Parts. Indian Motorcycle Sales, Kansas City 27, Missouri.

SPEED cams for Motor Scooters, ³/₄ Midgets, \$15.00—Your Core. 50c for Auto Catalog. Weber Speed Equip., 310-C So. Center, Santa Ana, Calif.

BUILD Your Own Cart, Trail or Mini Cycle frame for Less Than \$10! Save 50%! Buy Kits, Parts at discount prices! Plans with information Only \$2 each. Money Back Guarantee. Cycle-Cart, Dept. PS7, 2518 W. Cahuenga Blvd., Los Angeles, California.

SCOOT'R-Bike. Parts to convert bicycle frame \$4.95; wheels, clutches, engines discount priced. Plans \$2.00 refundable. Giliom Manufacturing Co., St. Charles 11, Missouri.

GO Cart \$15, Minibike \$15, Doodlebug \$15, less engines. Whizzer engine \$5, others \$3 up. Isetta \$80. (Mailorder Only). Send 25c (35c for First Class Mailing) for Directory-Catalogue Number 114, listing these and hundreds of other bargains, homebuilders parts, plans, etc. Midget Motors Directory, Athens, Ohio.

BICYCLE Equipment Cheap. List—Write: 974 Juanita Dr., Walnut Creek, Calif.

CONVERT Bike to Motorbike, Plans . . . \$1.00; Patented Engine Mounting Brackets . . . \$6.95; Go-Byk Industries, Fergus Falls, Minnesota.

BANKRUPT. Motorcycle Bargains, Wholesale Parts, New, Used. Directory 35c. Bunico, 146-6G, Covington, Virginia.

NEW Mini-Bike, go-kart catalog with 6 parts diagrams. Send 50c. Jerry Staver, Box 511-P, Janesville, Wisconsin.

POPULAR SCIENCE OPPORTUNITIES

5 AVIATION

PROPELLERS, Plans, Supplies for air-boats, snow-planes. 125 H.P. Lycomings, 150 Continentals, \$125.00. Hubs, parts, gauges, throttles, spark plugs, wires, hose, oil Coolers, gaskets. Catalog 25c. Banks-Maxwell, Box 3301G, Ft. Worth 5, Texas.

7 ELECTRICAL SUPPLIES & EQUIPMENT

ELECTROPLATING Equipment And Supplies. Send \$1 For Formulas, Equipment Guide, Operating Data And Catalog. Hollywood Bronze Supply, Dept. N7, 3445 Union Pacific Ave., Los Angeles 33, Calif.

WHOLESALE—Appliance—Lamp Parts. Free Listings. Seco, 112 South 20th Street, Birmingham 3, Alabama.

8 WELDING, SOLDERING

PRODUCTION Welders, 110/220 \$69.50, \$39.50. Morris, 1070 Inner, Schenectady 3, New York.

FREE Catalog, Welders, Kits, Build 350-ampere welder using aircraft generator, plans 25c. Dunbar, Minneapolis 8, Minn.

FREE welder catalog, Kits, build 350-ampere welder using aircraft generator, plans 25c. LeJay, Minneapolis 31, Minnesota.

10 ENGINES, MOTORS, ETC.

DIESEL Injector Parts and Fuel Pumps Wanted GM51-53-71-110. Mayer, 2093 East 19 Street, Cleveland 15, Ohio.

REWIND Motors yourself. Complete instructions \$1.00. Lewis Manufacturing, Howell 11, Michigan.

11 BOATS, OUTBOARD MOTORS

FULL size, cut-to-shape boat patterns, blueprints, 7 1/2-38 feet. Big new illustrated "Build a Boat" catalog of 64 designs, including Catamarans, Cruisers, Runabouts, Skiffs, Outboard Boats, Sailing, Racing, Houseboats, 50c. "How to Build a Boat" booklet, \$2.50. Cleveland Boat Blueprint Co., Box 1651, Cleveland, Ohio.

BOAT Plans, Frame Kits, Full-Size Patterns! 80-page catalog illustrating over 40 Build-it-Yourself boats 50c. Glen Marine, 9152 Rosecrans, Bellflower, Calif.

NEW, used, rebuilt marine motors. Marine conversions, fittings. Free Catalog. Stokes Marine Supply, Dept. 23, Coldwater, Mich.

MARINE conversion equipment, gears, accessories—Chevrolet, Ford, Buick, others. Catalog 25c. Dept. B, Star Marine Engine Works, 2920—7th Street, Berkeley, California. Dealer inquiries invited.

NEW 1962 Scott Outboard Motor Clearance 3 1/2 H.P.—\$99.50, 7 1/2 H.P.—\$188, 14 H.P.—\$248, 28 H.P.—\$298, 44 H.P.—\$378, 75 H.P. Electric-Generator \$638. We Ship Anywhere—Factory Warranty. Electra Marine, Dept. S, 1427 Broadway, Brooklyn, N. Y. Tel. 212-GL-5-0122.

BUILD National Class Sailing Dinghy. Complete Plans Only \$10. Pelican, P.O. Box 894, Miami 43, Florida.

FIBERGLASS Cloth, Matt, polyester and epoxy resins. Lowest prices. Seifert's, Box 1206-X, Green Bay, Wisc.

BOATING Equipment, Free Discount Catalog. Rope, Anchors, Skis, Tanks, etc. Mariners' Discounts, Bogota, New Jersey.

11A GOVERNMENT SURPLUS

JEEPS \$68.11, Airplanes \$75.20, Boats \$6.18. Many others direct from U.S. Government. For complete "Directory" send \$1.00 to Quality Surplus, Box 22163-P7, Indianapolis 22, Indiana.

JEEPS—\$111.68, Typewriters—\$4.15, Radios—\$2.65, Boats—\$6.18, Televisions, Guns, Cameras, Recorders, Watches, Typical Surplus Prices. Exciting Details Free. N. Y. Enterprises, Box 402-S7, Jamaica 30, New York.

GOVERNMENT Surplus How and Where To Buy In Your Area. Send \$1.00. PS Surplus Information, Headquarters Building, Washington 6, D. C.

FREE! You can get hundreds of big illustrated Government Surplus catalogues absolutely free. For full information send dime today to: Surplus, Box 789-P, York, Penna.

GOVERNMENT Surplus. Buy as low as 1c on the dollar or less. Jeeps, cars, trucks, tractors, radios, boats, tents, tools, TV's, guns, furniture, and thousands of other items direct from the U.S. government. Complete information how to buy, where to buy in your area, how to get free surplus with application form, send \$1.00. Airmail \$1.25 to: Surplus Sales, Box 1545, Marysville 11, California.

JEEPS \$111.68, boats \$6.20, airplanes, walkie talkies, guns, cameras, thousands of items typically at 90% savings or better. For complete information send \$1.00 to Surplus Service, Box 820, Holland 2, Michigan.

WEEKLY bulletin covering government and commercial surplus auctions. Annual Subscription \$20.00. Auction Bulletin, Box 5, Laconia, N. H.

BOATS \$6.18, Jeeps \$97.50, Typewriters \$4.15, trucks, tractors, guns, and other bargains from U.S. Government. For latest "Directory" send \$1.00. National Surplus, Box 185-PS, Eatontown, New Jersey.

12 BODY-BUILDING COURSES, JIU JITSU & ATHLETIC EQUIPMENT

"GIANT Arms." Dr. Young's, D. C. Revolutionary discovery, \$2. Satisfaction or refund. Gaucho, Box 9309-S6, Chicago 90.

BUILD powerful arms, chest, shoulders! 22 exercises, \$1. Fonsad, Box 601-C, 1100 Market, Wilmington 99, Delaware.

PHYSICAL Perfection: Reducing, Gaining, Muscles, Longevity. Mail 25c for all 4 courses. Guaranteed. To: Sid's System, (PS-M-63), 8421-C Evergreen, Southgate, California.

BIG Muscles Fast. New Dynaflex System No Exercise, No Barbells. Complete Course Plus Free Gift \$1.98. Earl J. Davis, 8311 South Ingleside, Chicago 19, Illinois.

OUTSTANDING Physical Development! Any age. New Guaranteed Discovery uses only a Rope! Strength, Health, Muscles. Gain—Reduce. Free information. Roperise, 4834-A Art, San Diego 15, California.

ORIENTAL tremendous muscle building. Quickest most effective method. Special equipment unnecessary. Only \$1. (Particulars free.) Cosmos, 5083 Victoria, Vancouver 15, Canada.

BAR-BELL Course, illustrated \$1.00. Catalogue 10c. Good Barbell, B-1495, Hendersonville, N. Car.

PUSHED around? Don't take nonsense from bullies. Surprise them. Easy when you know Police Jiu Jitsu. Complete illustrated course in one volume. Send \$1. Now. Satisfaction guaranteed. Books Publishing Co., Amityville 39, New York.

ISOMETRIC Contractions; Ultraefficient muscle building method; equipment, long workouts unnecessary. Complete principles, exercises \$2.00. Isometriks, 1604 O'Farrell, San Francisco, California.

KARATE, Judo Books: Send 25c Coin For Descriptive Lists To: Aardparke Books, Box 395PS, Tarzana, Calif.

14 FIELD GLASSES, TELESCOPES

BUILD your own Reflector Telescopes. Complete kits; Mirrors, Eyepieces, Tripods, all other accessories. Request free illustrated literature. Criterion Manufacturing, Dept. KP-4, Hartford 1, Conn.

DYNASCOPE—Amazing world famous reflector telescope. Request free brochure. Criterion, Dept. DS-12, Hartford 1, Conn.

SCIENCE Bargains! Lenses, Telescopes, binoculars, microscopes, kits, parts, war surplus. Send \$1.00 for beginner's 10-lens kit with instruction booklet. Order Stock 2-CN. Request Free 144-page Catalog CN. Edmund Scientific Co., Barrington, New Jersey.

FREE Catalogue! Thousands war surplus optical bargains. Lenses, Prisms, Telescopes, Binoculars, etc. Send \$1.00 for 10 Lens Hobbyist Set and Project booklet. G. Jaegers, 691 West Merrick Road, Lynbrook, New York.

ASTRONOMICAL books, star-atlases, free list. Herbert Luft, 69-11, 229th St., Flushing 64, N. Y.

15 SPORTING GOODS, GUNS, FISHING TACKLE, ARCHERY, TRAPPING

FISHERMAN'S Dream Book—Free! 170 pages, Sweetest pocket size catalog ever. Do-It-Yourself stuff galore: Net Making, Turtle Trapping, Sinker Casting, Worm Manufacturing, Fly Tying, Fish Smoking. Component parts to make great fish getting lures. Everything is here including latest rods, reels, 'n gadgets. Send Postal card: Netcraft Co., Dept PS, Box 5510, Toledo 13, Ohio.

FREE . . . Wholesale Catalog. Beads, Spinners, Lure parts, Sinker molds, Jigs, Reels. Finnysports, (PE), Toledo 14, Ohio.

5000 GUNS, Swords, War Relics. Catalog 50c. Smith Museum, Runnemede, N. J.

CANNON Fuse 3/32" Diameter, Water-Proof, Burns Under Water: 10 Ft.—\$1.00, 25 Ft.—\$2.00, Postpaid. William Zeller, 10-A, Hudson, Michigan.

16 CAMPING EQUIPMENT & TENTS

TENTS, 300 styles (most erected on display). Camping Trailers, Sleeping Bags, Tarpaulins, Flies, Canvas Yard Goods, Aluminum Tent Poles, Stakes, Cots, Tables, Refrigerators, Stoves, Lanterns, Heaters, Cook Sets, Canteens, Mess Kits, Water Bags, Packs, Rucksacks, Dehydrated Foods, Camping Books. Send 25c for new giant catalogue, (includes camp sites and complete handbook). Morsan Tents, 810-G Route 17, Paramus, New Jersey.

KNIVES: Hunting, Pocket, Technicians. Folio For 25c. Heartstone, Seneca Falls, New York.

17 DOGS, BIRDS, HAMSTERS, RABBITS & PETS

RAISE Rabbits on \$500 month plan. Free details. White's Rabbitry, Mt. Vernon, Ohio.

LIVE Seahorses, marine specimens, aquarium supplies. Illustrated catalog 10c. Marine Life, Dept. 107, Box 626, Dania, Florida.

UNUSUAL Pets—Baby Foxes, Raccoons, Coati Mundi, Skunks, Ferrets, etc. Catalog 10c. Ray Singleton, Interbay Station, Tampa, Fla.

EARN \$10,000 yearly raising Angora Rabbit Wool for us. Information 25c coin. American Angora Company, Malta 1, Montana.

DESCENTED Skunks \$9.99. Price List 10c. Animal World, Elwood, Kansas.

18 EARTHWORMS, CRICKETS, FROGS

EARN Money raising fishworms for us! Exciting details free! Oakhaven-121, Cedar Hill, Texas.

FREE Literature—We teach you how to raise, sell fishworms, crickets. Hybrid red-worms 3000—\$5.95, 5000—\$8.95, 10,000—\$16.95. Postpaid. Carter Farm-12, Plains, Georgia.

MEN!—Women! Make Money Raising Bait for Us at Home. Free Details. Red Wigglers, Warsaw 3, Indiana.

POPULAR SCIENCE OPPORTUNITIES

AFRICAN Worms—Large, 500—\$7.00. 1,000—\$12.50. Junior Bait Size, 500—\$5.50. 1,000—\$10.50, postpaid. (Dealers Wanted) Ozark Worm Farm-V, Willow Springs, Missouri.

19 FARMS, OTHER REAL ESTATE

CANADIAN Lands, seized and sold for taxes. Our 46th annual series of lists describe many choice properties, situated from coast to coast, acquired by us through Tax Sale. Priced as low as five dollars per acre, guaranteed perfect title, small monthly payments, no mortgage. Beautifully situated hunting and fishing camps, where there is real sport; summer cottage sites, heavily wooded acreages. Now is the time to invest in Canada's minerals, forests and farms. Write to-day for free twenty page booklet with full explanation. Tax Sale Service, Room 301-H, 85 Bloor Street, East, Toronto 5, Canada.

FLORIDA Campsites—deep in the heart of the great Ocala National Forest. Abundance of game, best fishing. Warranty deed. Unrestricted—pitch tent, park trailer, build lodge. Free maps and photos. Winfree Vernor, DeLand, Florida. AD-60088(Q-O)

CANADIAN Vacation Lands: Full price \$385.00. 40 acres, \$10 month. Suitable cottage sites, hunting, fishing, investment. Free information. Land Corporation, 3768-D Bathurst, Downsview, Ontario, Canada.

STROUT Catalog Free All-New Summer issue, 162 pages. Selected Best-Buys of Thousands of New Listings coast to coast, photos galore!—Farms, Homes, Businesses, Waterfront, Vacation, Retirement. Over 450 offices, 34 states. Exciting Catalog Free from the World's Largest. Strout Realty, 50-ZB E. 42nd St., N. Y. 17, N. Y., 7-ZB S. Dearborn St., Chi. 3, Ill., 510-ZB S. Spring St., L. A. 13, Cal.

FLORIDA Lake Living! Homesites near everything—Established area, \$390 Full Price, \$5.00 Month. Information write Lake Weir Shores 41, Silver Springs, Florida. Ad 6-1070-(F-0).

\$1 ACRE—Canadian Border—Hundreds campsites, islands, farmlands directly from Tax Authorities (non-profit). Lists, Photographs mailed: Bureau, 56 Cherch. Toronto 1, Canada.

CAROLINA Coast—Large ¼ acre high, dry, heavily-wooded homesites in beautiful Boiling Spring Lakes only \$10 monthly. Full price \$395. Fishing, swimming, boating on 50 freshwater lakes. Hunting on 4,000 acre private preserve. Championship golf course, ultra-modern country club, motel, shopping center. Located on two state highways only minutes from ocean. Money back guarantee. Developed by Reeves Broadcasting and Development Corporation, listed on American Stock Exchange. Over 4,000 homesites already sold. Free Literature. Write Art Greene, Boiling Springs Lakes 2-H, North Carolina.

NEW HAMPSHIRE! Two furnished year round cottages. Spears, Box 44, Campton, N. H.

22 PROFITABLE OCCUPATIONS

BAKE New Greaseless Doughnuts in kitchen. Half profit. Sell stores. Free recipes. Stephen, 3605 15th, Minneapolis 7, Minnesota.

CHROME Plating, Instructions. Equipment and Supplies. Platers' Supply, P.O. Box 565, Lugo Station, Los Angeles, Calif.

INVESTIGATE Accidents. Earn \$750 to \$1,000 monthly. Men urgently needed. Car furnished; business expenses paid. No selling. No college education necessary. Pick own job location. Investigate full time. Or earn \$8.44 hour spare time. Write for Free Book. No obligation. Universal, CPS-7, 6801 Hillcrest, Dallas 5, Texas.

EARN Money raising fishworms for us! Write: Oakhaven-7, Cedar Hill, Texas.

FREE Literature—Make Big Money Raising Fishworms and Crickets. Carter Farm-10, Plains, Ga.

VENDING Machines—No Selling. Operate A Route of Coin Machines and Earn Amazing Profits. 32-Page Catalog Free. Parkway Machine Corporation, 715PSP Ensor Street, Baltimore 2, Maryland.

INVESTIGATE Auto Accidents—Pays up to \$750-1,000 a month. Investigators needed everywhere, part or full time. Car furnished; expenses paid. No selling. Meet interesting people. We train you spare time at home in weeks. Hold present job until ready to switch, or start own investigating business. Free information. No obligation. Liberty School, Dept. C-25, 1139 West Park, Libertyville, Illinois.

BARGAINS! Buy wholesale! Save money! Free catalog! Norris, 273-CQ Merrick Road, Lynbrook, N. Y.

BECOME independent with your own franchise business. Thousands earning handsome incomes. Request interesting facts today. National Franchise Reports, Y-528, 333 North Michigan, Chicago 1.

SWIM At Once—invisible swim aid for men, women, children; 1/25" thick, 4 oz.; worn under bathing suit. Demonstrator \$6.95 ppd. Check or money order; state waist size. Also many other new international patented articles. Reps wanted, 25c for details, refundable first order. G & R Industries, 59-15D 71 Ave., Brooklyn 27, N. Y.

FREE Report: "609 Unusual, Successful Businesses." Box 1001-M, Evanston, Illinois.

MAKE money Writing Short Paragraphs. Information Free. Barrett, Dept. C86B-F, 7464 No. Clark, Chicago 26.

EARN \$10,000 Selling Books By Mail! Box 51-V, Des Plaines, Illinois.

AUCTIONEERING—Resident and Home Study Courses. Diploma granted. Auction School, Ft. Smith, Ark.

23 BOOKS & MAGAZINES

"PROPHET Elijah Coming Before Christ" Wonderful Book Free. 58 Megiddo Mission, Rochester 19, New York.

NATIONAL Geographic Magazines, Any issue, 1888-1960. Periodical Service, Box 465-PS, Wilmington, Delaware.

ATHEIST Books. Catalogue free. Truth Seeker Co., 38 Park Row, New York 8.

BRITISH Book Bargains. Any subjects. Catalogue free. Transanbooks, Wantagh, New York.

FREE—Freethought book list and sample Rationalist magazine "The Liberal." Friendship Liberal League, Inc., Thomas Paine Center, Box S, 5233 N. 5th St., Phila. 20, Pa.

CATHOLIC Literature. Free Assortment. O'Keefe, 4A Saturn Blvd., Hauppauge, N. Y.

FREE Book catalogue. Many interesting subjects. Books Publishing Co., Amityville, N. Y.

WANTED:—Old Comic Books, 1934-1952. \$Top Prices Paid\$. Leonard Brown, 2111 Maine Avenue, Long Beach 6, California.

ATTENTION: Read Notes on Guerrilla War—Principles And Practices by Colonel Virgil Ney, \$3.50. Command Publications, Box 6303, N.W. Station, Washington 15, D. C.

BOOKHUNTERS: All Subjects. Send Wants! Jaher Book Service, 183 Hazelwood Drive, Westbury, New York.

BOOKHUNTERS! Send Wants! Atlantic Book Service, 10 Cedar, Charleston 29, Mass.

FREE Catalogs. Little Blue Books. United Book Service, Box 53, Wilmington, California.

24 HYPNOTISM

FREE Hypnotism, Self-Hypnosis, Sleep-learning Catalog! Records, Tapes, Books, Courses, Equipment! Drawer PS400, Ruidoso, New Mexico.

FREE Illustrated Hypnotism. Selfhypnosis Catalogue. Write: Hypnotist, 8721 Sunset, Hollywood 69P, California.

HYPNOTIZE Self, Others while asleep with amazing hypnotic phonograph records, tapes. Catalog free. Research Association, Box 24-G, Olympia, Washington.

HYPNOTIZE Unnoticed, quickly, effortlessly, or refund! Thousands delighted! \$2. Minter, Box 244-A, Cedarburg, Wisconsin.

HYPNOTISM—sleep learning—self hypnosis! Thirteen exciting modern methods. Learn or pay nothing! Airmail name for free approval offer. Forum, Division H2107, 608 South Dearborn, Chicago 5.

HYPNOTIZE unnoticed! Patented new hand device makes you a Hypnotist first day or refund! Hypnotist's Handbook included! \$2. Hypnosis Foundation, Box 487, La Mesa 2, California.

HYPNOTIZE Successfully In Three Hours! "Instantaneous," "One Word," "Against Will," Methods Exposed! Complete Illustrated Course Plus Secret Nerve Pressure Technique." "Getting Willing, Cooperative Subjects Easily," "Chevreul's Pendulum," "Two Hypnodisks," "Sleep-Learning" Information. \$2.00. Results Guaranteed! Arthur Fowler, Box 4391, Woodbury, New Jersey.

ART Linkletter, Steve Allen Hypnotist offers brand new complete manual on techniques; theatrical-medical hypnotism and selfhypnosis. Only hypno-psychological course available for self-improvement. Emile Franchel, 8350 Kester Avenue, Van Nuys, California.

WORLD'S largest catalog free. Merlin Enterprises, P.O. Box 613, Los Catos, Calif.

HYPNOTISM! Conquers! Cures! Free illustrated catalog. Psychologist, Box 67, Lemon Grove 2, California.

"HYPNOTIZE . . . One word . . . One fingersnap." on stage. Satisfaction—or refund. \$2. Hypnomaster, Box 9309-S6, Chicago 90.

HYPNOTISM. Selfhypnosis. Guaranteed home study courses. Diploma awarded. Free particulars. School Hypnology, East Meadow 1, New York.

SELF-hypnosis may help you many ways. Dynamic new concept of learning quickly, easily! Book! Tape! Record! Free literature. McKinley Publishers, Audio Dept., Box 3038, San Bernardino, California.

HYPNOSIS: Effective Hypnotic Aids; inexpensive electric hypno-spiral our specialty. Free Catalogue: Hypnosis Enterprises, 255-7 N. Day, Orange, N. J.

FREE Hypnosis—Sleep Learning Catalog. Fletcher, 2407-P.S. Catherine, Dallas 11, Texas.

"FEMALE Hypnotism!" "Secret Method"—nobody knows but you! \$2, rushed. Guaranteed! Isabel Hall, Silver Springs, Florida.

HYPNOTIZE Others—Unnoticed, Quietly, Quickly, Safely, Sure-Easy Instructions \$1.00. Rorick's, Cincinnati 26, Ohio.

HYPNOTISM—Little known method. Free information. Dr. Azadian, Fowler, California.

"SELF - Hypnosis - Guide." Hypnotist Nard King reveals remarkable "gadgetless" method. It allegedly provides complete, continuous, control of self (Emotions, Cravings, Memory, Sleep, Talents, Flow of Creative Ideas, Anesthesia, Etc.); Desired Results Triggered At Will! Amazing book! Photos. No therapeutic claims. \$2.95—delighted or refund! Verity Publications, Newfoundland 2-C, New Jersey.

24A JOKES, GAMES, NOVELTIES, ETC.

POPULAR! 10 Life of Party Cards 25c. Surprise Novelty Free! Excelsior, 397, Lynnwood, Washington.

25 MAGIC TRICKS, PUZZLES, ETC.

BE A Magician! Introductory Catalog with Free Trick, only 35c. Ireland, 109-T North Dearborn, Chicago 2.

CLASSIFIED OPPORTUNITIES

POPULAR SCIENCE OPPORTUNITIES

WORLD'S finest professional magic Joker novelties. Giant illustrated catalog 10c. Top Hat, Evanston 13, Illinois.

FASTEST same-day service to magicians everywhere for 40 years. Send 10c for Douglas famous Catalog 500 Tricks, containing magic for pocket, parlor, club, stage. Douglas Magicland, Dept. 52, Dallas, Texas.

BACK seat driver's license 25c, 6—\$1.00. Free Gift. P. Lawson, Box 2072, Goodrich Sta., Akron 11, Ohio.

WORLD'S Finest Magic Catalog, \$2.50. (\$2.00 magic included free). 3000 Tricks, Pocket, Stage (408 pages.) Kanter's, S-200 South 13th, Philadelphia 7.

BIG 160 Page Professional Magic Catalog! World's greatest collection of over 1000 Tricks, Jokes, Magic, Illusions, Secrets, Mysteries! 10c brings catalog and Free Trick! House of 1000 Mysteries, Dept. PS7C-63, Monroe, Connecticut.

MAGIC Course, club membership, lists \$2.00. Sorcerers, Box 841, Wilmington Delaware.

CARDS, Coins, Stage Magic—Catalog 25c. Bernard's, Box 854, Chicago 42.

VENTRILOQUIST Overnight, Electronic Dummies Ten Dollars Up. E. C. Carter, Box 682, Rio Grande City, Texas.

26 COINS & CURRENCY

Tops! Free illustrated booklet "How To Collect Coins." Approvals. Littleton Coin Co., Littleton E2, N. H.

GIANT Illustrated Catalog listing Hundreds of Bargains in Coins and Supplies, only 50c. Rarcoa, 31-A North Clark, Chicago 2.

LINCOLN Cents From San Francisco. Ten different dates (Our Choice), For 25c with coin approvals. Molzan, Box 275, Alameda, California.

THREE different Indian Cents. Album, Bargain Catalog. \$1.00. Hobby Sales, St. Paul 16, Minn.

ILLUSTRATED Coin Catalog — \$1.00 Postpaid. American, Box 663, Kansas City 38, Missouri.

2 MEXICAN Silver Dollars \$1.00. 100 Foreign Coins \$2.95. Browns, Box 188S, Tolleson, Arizona.

CATALOGUE—34 Pages, All U.S., Canadian Coins and Supplies, 25c. Harold Ball, 2614C Calhoun, Ft. Wayne, Indiana.

COIN Magazine, 200 pages. Sample 50c. Numismatic, 7320 Milwaukee, Chicago 31.

BARGAIN List! U.C. Coins, Accessories. Stamp please. Hugh's, Hickory, N. C.

FREE Coin Supplies. Giant Coin list 10c (refundable). Economy Sales, Mansfield, Massachusetts.

COIN collectors! Learn what your coins are really worth. Send 25c for sample or \$3.00 for next 12 big issues. Coins Magazine, Coin Street, Iola, Wisc.

10 DIFFERENT Lincolns before 1921—\$1.00. 20 Different before 1931—\$1.50. Gene Carlton, Chandler, Okla.

40 PAGE illustrated United States and Canadian coin list 10c. Stony, 260 Washington, Boston 8, Mass.

1878 CARSON City Dollar Uncirculated \$5.00. Coin Catalogue 50c. Shultz, Salt Lake City 10, Utah.

COIN Bargains Galore! Illustrated Lists, 10c (Refundable). Hutchinson's, Box 6256, Philadelphia 36, Penna.

NUMISMATIC News tells today's value of all coins. A Great Newspaper. 26 issues a year full of reliable coin news. Sample 25c. \$3.00 yearly. Dollar Street, Iola, Wisc.

1964 REDBOOK (17th Edition Guide-book) \$1.75; Name in Gold Free if desired. Bargain List Coins, Supplies 25c. Brilliant Proof Sets: 1956—\$6.15, 1958—\$8.15, 1957, 1959, 1960 Each \$3.95, 1961, 1962, 1963 Each \$2.85. Bebee's, 4514 North 30th, Omaha 11, Nebraska.

TRUNKFUL 25,000 Indian-Lincoln cents mixed (from the 1920's & older). Will pack "Grab-Bag" style. 400 mixed—\$25. Sample bag of 20—\$2. Mrs. Fischer, Box 5490, Sherman Oaks 89, Calif.

LIBERTYHEAD Set: Nickel, Dime, Quarter, Half—\$2.00. Tracy, 25 Quinlan, Staten Island 14, New York.

TOP prices paid for your coins. Buying list 20c. William Styba, 352 East 8th, Winaona, Minn.

LINCOLNS: 1943PDS. 1954P. 1955S. 1960D Small Date, complete pricelist. All 75c. Harris, 9011J Presidio, San Francisco 29, California.

WOW! "RARE" Silver Dollars! Beautiful! Brilliant! Uncirculated! Low Prices! 1903-O only \$30.00! 1892-O—\$5.00! 1898-O, 1899-O, 1900-O, 1901-O, 1902-O, 1904-O, only \$2.00 each! 1882-O—\$7.00. 1883-O—\$3.00. 1885-O—\$3.00. 1889-O—\$3.00. 1879-S, 1880-S, 1881-S, 1882-S, 1885-S, 1921-S—\$3.50 each! 1883-S—\$10.00. 1886-S—\$16.00. 1897-S—\$5.00. 1898-S—\$15.00. 1902-S—\$25.00. 1903-S—\$75.00. 1935-S—\$20.00. 1883-CC—\$12.00. 1887-P—\$3.50. 1891-P—\$3.50. 1892-P—\$6.00. 1902-P—\$2.00. 1903-P—\$2.00. 10% Discount on Orders Over \$50.00! Thousands of Other Coins! Rush Your Order, and Get Our Free Price List! Silver Center, Box 3293-S, San Francisco 19, California.

TWENTY-four page 1963 retail price list of U.S.A. and Canadian coins, 10c. Our selling prices on thousands of coins and coin collectors supplies. Bryson Incorporated, 612B White, Toledo 5, Ohio.

BARGAIN! 32 Different Foreign Coins, Old and New—\$1.00. Alfred Szego, Oakdale, New York.

28 STAMP COLLECTING

1847, FIRST USA Rarity!! Goliath foreign beauty shows Ben Franklin in this outstanding issue!! Plus Congo Freedom stamp, unused 1/2 inch midget stamp freak, real Cigar issue, Icy Greenland, Free China Bomer airmail giant, etc. only 10c with approvals. Capital Stamp Co., Ferrysburg, 10D, Michigan.

FREE 400 genuine postage stamps! Worth \$10.00 at catalogue prices. Africa—Europe—Asia—British Emp.—a fascinating, valuable mixture from foreign convents, banks, etc. Who knows what you will find. Also free valuable Booklet. Adults only. Approvals enclosed. Frasek Co., PS7, White Plains, N. Y.

PHILATELIC Jungle 10c. Fifteen zoological specimens. Approvals included. Free water-mark detector. Crown Stamps, Virgil 302, Ontario.

SMASHING Collection Free—Includes Triangles, Early United States, Rockets, Sports, British Colonies, High Value Pictorials, etc. Complete Collection plus big, Illustrated Magazine, all free. Send 10c for postage. Gray Stamp Co., Dept. PR, Toronto, Canada.

105 DIVERSIFIED British Empire 10c. Approvals included. Linstamps, St. Catharines 402, Ontario.

MAYFLOWER Stamp Album 10c 407 illustrations, 64 pages. Approvals accompanying. Niagara Stamps, St. Catharines 702, Ontario.

WILL Rogers Air! Helicopter Triangle! Plus Monte Carlo Dove Triangle! Stamp printed in Solid Gold! New York Empire State Bldg. airmail, lovely Congo Orchids in full colors, etc. 10c with approvals, Sunny Stamps, Apopka 10A, Florida.

PRICE List Foreign Older Issues. Thomas, 5000 Miami, St. Louis 9, Missouri.

EXTRAORDINARY! Free; 20 different Finland to those requesting approvals. Rizenberg, Box 1303, Chicago 90.

FANTASTIC Fish Triangles!! Valuable "Ben Franklin" on Canal Zone!! Flaming bi-colored Volcano Triangle!! Lovely Olympics Triangle!! Plus Icy Greenland, Weird Wild Beast issue and others. 10c with approvals. Roseland Stamps, Spring Lake 10, Michigan.

209 DIFFERENT Stamps—25c. Exciting collection includes beautiful Monaco set plus Antarctic Explorers, South Africa Gold Mine, many more. Grand total 209 stamps—all genuine, all different. You also get 88 Flags of the World and Midget Encyclopedia of Stamp Collecting. All this for only 25c to introduce our Bargain Approvals. Satisfaction Guaranteed. Send 25c Today. Ask for Lot EH-44. Zenith Co., 81 Willoughby St., Brooklyn 1, N. Y.

EXCEPTIONAL 125 different, cataloging \$3.00. Includes triangles, commemoratives, 10c approvals. Reeves, Box 37597P, Miami 37, Florida.

225 STAMPS For only 10c! This mammoth value includes Airmails, Pictorials; stamps from strange Countries cataloguing up to 25c each! Also Approvals. Mystic Stamp Company, Camden 55, N. Y.

UNITED Nations. 15th Anniversary Sheet. With first day cancel, as commemorated by Russia. Free! While they last, with approvals. Philatelics, P-J, New Paltz, N. Y.

80 DIFF. U.S. Stamps. Includes 19th Century Commemorative. High values. Plus 1943 Flag Stamp of Occupied Nations. All for only 25c. Approvals included. Willett Co., Box 338-Y, Yorktown Heights, N. Y.

25 DIFFERENT Commemoratives 1893 up 10c. U. S. Approvals. K & B, Box 70, Brooklyn 23, N. Y.

U.S. Mint Specials! Flag Set Complete, \$1.00; 1c, 2c, 3c Famous Americans (21 different), \$1.00. Free list. Brooks, 2323 Avenue X, Brooklyn 35, New York.

UNITED States commemorative collection containing 33 different—10c. Approvals. White, 516-W Avenue L, Brooklyn 30, New York.

AMAZING Offer! 200 U.S. stamps—including commemoratives, airmails, high denominations to \$1.00—only 10c to Approval Applicants!! Illustrated Bargain Lists free. Mystic Stamp Co., Dept. 55, Camden, New York.

NUDES set (4)—Unusual Approvals 10c. Atlas, Plainfield, Racine, Wisconsin.

702 U.S.A.—25c (plenty commemoratives). Request Approvals. Horace Gatewood, Winston-Salem, N. C.

200 DIFFERENT Stamps, 25c with approvals. Smith, 508U Brooks, College Station, Texas.

U.S. STAMPS. Giant Discount Catalog —25c. Raymax, 37-VX Maiden Lane, N.Y.C. 38.

FREE—Mammoth Collection, including \$10,000 Airmail, World's smallest Stamp, gorgeous multi-color pictorials plus Scott's Internationals, Master Global Albums, Scott's 1963 Catalogues, all Free when you buy Foreign approvals. Bargain Stamps, Box 1112B, Miami Beach 39, Florida.

50 YEARS Old—15 different United States Stamps at least 50 years old—10c with low priced United States approvals. Jaxon, Box 145 S. Brooklyn 30, N. Y.

FREE! Giant Bargain Catalog — New Edition listing thousands of bargains including U.S. and B.N.A. Stamps, packets, mixtures, albums, accessories and supplies; sent with beautiful approvals. Jamestown Stamps, Dept. E73PS, Jamestown, N. Y.

WORLDWIDE, 50 all different, absolutely free, just to introduce our incomparable approvals. Kent Stamp Company, G.P.O. Box 87, Brooklyn, N. Y.

117 DIFFERENT; Monaco "Chevy." Fairy Tales, African Triangles, British Colonies, 10c. Approvals. Catalinas Stamps, Orange, California.

LAOS! 25 Different \$1.00. Collections by Countries, Price List Free. George Richie, 1539 Sixth, Alameda, California.

FREE! 29 thrilling jet, astronaut rocket, space, airmails. Send 10c handling. 2c approvals included. ABC World, Box 6000-WK, San Francisco, California.

POPULAR SCIENCE OPPORTUNITIES

WOW! 110 All Different Germany 10c Zeppelins, Semi-Postals, Airmails, High values, etc. Giant Catalog, bargain lists included with beautiful approvals. Jamestown Stamp, Dept. A73PS, Jamestown, N. Y.

LINCOLN Giant Diamond! Sports Triangle! Kennedy Beauty! 25 others 5c. Approvals. Valley, Box 866, Deep River, Ontario, Canada.

500 FINE Mixed U.S. 15c. Wright, Box 753-P, Hagerstown, Maryland.

HONG KONG high values; \$1.00, \$2.00, \$5.00, \$10.00, 10c with unique global approvals 1/2c up. Stamp Studio, Box 171S, New York 24, N. Y.

DIAMOND Roosevelt, Pope Triangle, Greenland, Angola, 51 others 5c. Approvals. Longhorn, Box 3068P, Lubbock, Texas.

TOPS! Mystery lot of over 500 different world-wide only 35c. Tremendous value! Approvals included. Offer to adults only. Littleton Stamp Co., Littleton Q2, N. H.

MILLION Foreign Stamps! 2c each! Send for thrilling, giant approvals! ABC, Box 6000-ML, San Francisco 1, California.

25 DIFFERENT Sweden, 10c. 25 Denmark, 10c. Approvals. F. Cuillo, 521 Hemlock Street, Brooklyn 8, New York.

GIANT Approvals Thousands Different 1c and 2c each. Wahl's Stamp Exchange, 7008K Farragut, Chicago 31, Ill.

FREE—Three Mint Sets, with approvals! Ross, 1127 Nichols, Stratford, Conn.

\$2.00 BRINGS Next 10 First Day Covers. Sample 25c. Barg Covers, Box 957, Evans-ton, Illinois.

1000 DIFFERENT \$1.00 with approvals. Goldens, 6721 Eastwood, Philadelphia 49, Penna.

FREE United Nations Stamp with U.N. bargain list. Conquistador, 2627P Troy Road, Schenectady 9, N. Y.

FREE! 55 Different Triangles, Pictorials, Others. Colorful, low priced approvals. L. Baird, PS-7, Box 8128, Portland 7, Oregon.

LOOK! Six Queen Elizabeth Mint Sets from Antigua, Caymans, Malta, Montserrat, Mauritius, St. Kitts! 21 Brilliant Pictorials 25c. Attractive Approvals! Gannon Stamps, Box 931, Canton 1, Ohio.

80,000 DIFFERENT! Amazing new plan builds your collection systematically, country by country. Only 50c weekly. Free details. Ware, Monroe 70, Conn.

100 OLD U.S. Stamps between 1861 and 1935 \$1.00. Rousch Stamps, 51 Chestnut, Mansfield, Ohio.

FREE Mint Set! Approvals accompany. Mintco, Box 737, Memphis 1, Tenn.

240 DIFFERENT World Wide Only 10c To Approval Applicants. Winchester Stamps, 45 Winchester Rd., Mansfield, Ohio.

60 DIFFERENT U.S. (30 Commemoratives) 25c. No approvals. Seidenberg, Appleton, Wis.

FREE Sample! Interesting, Informative, Illustrated. National Stamp News, Anderson, South Carolina.

FLAG Stamp Free With U.S. Approvals. Gorlizz, 6629 Oshkosh, Chicago 31.

500 DIFFERENT Free! To Approval Buyers. Gordon Davison, Henniker 5, N. H.

COLORFUL Packet Free With Carefully Selected Worldwide Approvals. Wenigman, Box 265C, Park Ridge, Illinois.

ENORMOUS variety old U.S. flags, famous Americans, Commemoratives with approvals, surprise packet, 10c handling. Metropolitan Stamps, Box 312 PS, Jackson Heights 72, N. Y.

COLORFUL Pictorials from 25 different countries, includes triangles, etc. 10c with approvals, West Coast Stamp Emporium, P.O. Box 3042, North Hollywood, Calif.

500 DIFFERENT 25c to adult approval applicants. Rothschild, 3112-76th Ave., Washington 28, D. C.

TRADE Your Duplicates! (Toward Foreign Approvals). Complete Information 10c: VSS, Box 98-S, Newton Highlands 61, Mass.

TOP Quality Tailored Approvals, United States, Canada, British Colonies, General Foreign. Enclose 10c. Peterson, Box 31, St. Paul 2, Minn.

VATICAN Mercies Airmails 10c, Approvals. Snedco, Box 68A, Waldwick, N. J.

SENSATIONAL Penny Approvals! Pictorials, Topicals, Etc. Write Today! Schmidt, Box 5426, Reno, Nevada.

50 DIFFERENT stamps free with foreign approvals. J. Nutt, Box 357, Penn Yan 9, New York.

PENNY Approvals! Regardless Catalogue! Kloster, 4164-52nd Ct., San Diego 5, California.

5 BEAUTIFUL mint sets, 10c. Approvals. LPG Stamps, Box 1282, Cedar Rapids, Iowa.

FREE! 115 Different. Send Dime, Handling. Approvals. Jacobsen, Crompond, N. Y.

2c-4c APPROVALS! Thousands! World-wide Bargains! Carling, 763-B, Howard City, Michigan.

SAN MARINO—25 different only 25c! Worldwide approvals included. Cole, Box 223-G, Buffalo 21, N. Y.

50 DIFFERENT: Topicals, Diamond, Triangle, Others, 10c With Approvals. Carpenter, Box 310, Claremont, Calif.

U.S. BARGAIN: 50 different 10c with beautiful world-wide approvals. Stamps, Kennebunk, Maine.

HELIGOLAND Stamp Free With Approval. W-B Stamps, Wilkes-Barre, Penna.

ELEPHANT Diamond! Flower Triangle Set! Formosa Maps, 25 others 5c. Approvals. Greenwood, 59 1/2 Murray, Burlington, Vermont.

29 ANTIQUES, RELICS & INDIAN GOODS

SPEARHEAD, Bone Awl, Birdpoint \$2.00. Hatchethead, Gem Scraper, Perforator, Scaler \$2.00. Gem and Jasper Arrowhead \$2.00. Axe \$4.00, Forty Beads \$2.00. Palmer, 435 Washington Road, McKeesport, Pa.

SELLING 20,000 Indian Relics, Arrowheads, Spearheads, Etc. List Free. Lear's, Glenwood, Arkansas.

30 MINERALS & PRECIOUS STONES

ROCKHOUNDS—Gem Cutters—Jewelry Makers . . . new Free catalog—just off the press! Biggest supplier to hobbyists and craftsmen offers you tools, materials, equipment, introductory bargains and know-how. Free catalog . . . Write Grieger's, Dept. C-13, 1633 E. Walnut Pasadena, California.

EARTH Science—Rockhounds National Magazine. Subscription \$2.50. Sample 35c. Box 1357-PS, Chicago (90), Ill.

MINERALS: Colorful, fluorescent, "show" specimens from famous Franklin, N. J. zinc mines. 1 1/2 lbs.—\$2; 2 1/2 lbs.—\$3; 4 1/2 lbs.—\$4.50. Minerals, 255-7 N. Day, Orange, N. J.

31 HOBBIES, COLLECTIONS

INTRODUCTORY: 30 Army, Navy, Marine emblems; 75 assorted Service Stripes (\$5.00 value) only 50c, catalog included. Sample foreign medal, 50c. Insignias, Box 71-S, Rockaway 94, N. Y.

MILITARY Miniatures—Over 1,000 models. All periods. Catalog #2—35c. Over 200 Civil War Soldiers. Catalog #1—35c. Bussler, Box 107-E, Wollaston 70, Mass.

COLLECTORS Matchbook Covers! 100 Different Unused \$1.00. Catalog 25c. Helene S. Edelman, 1311-P East 84, Cleveland 3, Ohio.

LUMIROD—Create, Invent, See It Under Miscellaneous, Class #79.

32 PHOTO FINISHING, PHOTOCOPIES, ETC.

FAST, Hi-quality Finishing—Kodacolor Rolls: Eight Jumbo Prints \$1.98—Twelve \$2.49—Twenty \$3.49—Reprints 15c. Also low B&W Prices. Custom Quality Studio, Box 4838A, Chicago 80.

COLOR Movie Fans! Low Cost—High Quality processing our specialty. 8mm just \$1 (or \$3 with fresh film). Mailed back next day. Craftsmanship guaranteed. Send exposed reel or request free mailers and price list of complete photo-finishing services. Direct Mail Photo, Box 8352-PS, Pittsburgh 18, Pa.

FAST Service! 12 Exposure Roll Jumbo Prints 70c, Wallets 25 for \$1.00, 5x7 enlargement 30c. Mail-In Photo, Box 707, Lowell, Mass.

INDIVIDUAL Customs Processing—All photographic services. Free information, mailers! Peters and Company, Box 351C, Jamaica 31, N. Y.

33 MOTION PICTURES & COLOR SLIDES

MOVIE Film! Free catalog! Eso-H, 47th Holly, Kansas City 12, Mo.

SAVE! Process your own movies at home. Free Catalog. Superior, 442-448 N. Wells, Chicago 10.

1 MM SOUND—Projectors, Films, New Used for Sale. Free Catalog. National Cinema, 71 Dey Street, New York City, N. Y.

FREE Catalogues. 5,000 8-16MM Films. International-S Films, Greenvale, New York.

8MM INTRODUCTORY Offer. 50' Sonja Henie \$1.00. Free Catalogue—Specify 8MM or 16MM. Entertainment Films, 236 W. 55 St., NYC.

LADY Wrestling. Movies, Photos. Free List. Peerless, Box 171-P, New York 13, N. Y.

FREE! Six-months subscription to Blackhawk Bulletin—most extensive listing of 8mm. movies and 2"x2" color slides available anywhere! Blackhawk Films, 315 Eastin-Phelan Bldg., Davenport 5, Iowa.

34 CAMERAS, PHOTO SUPPLIES

FREE! Send now for photographic bargain book. Dept. 4-K-7, Central Camera Company, 230 So. Wabash Ave., Chicago, Illinois.

FUJICA, Canon Minolta, Bronica, Asahi-Pentax, Mamiyaflex . . . Order direct thru Mail Order for tremendous Savings. Free catalog. Hero Camera Co., 3-5, Chome, Ginza-Nishi, Tokyo, Japan.

35 MUSICAL INSTRUMENTS AND SONG WRITERS

ACCORDIONS, Guitars, Chord Organs! Save 1/2. Famous makes. Free home trial. Easy terms. Trades. Free catalogs. Mention instrument. International Music Mart, Dept. P, 2003 Chicago Avenue, Chicago 22.

ACCORDION-O-RAMA. 874 Broadway, New York 3, N. Y. Tremendous Discounts. Top Brands. Free Brochure.

SONGPOEMS and songs wanted! Mail to: Tin Pan Alley, Inc., Box 405, Radio City Station, New York 19, N. Y.

SONGS Into \$\$\$\$\$\$—Share \$33 million dollars yearly for New Songwriters, Song-poets. Any subject, songs composed, published, promoted by largest firm. Information, appraisals Free. Send Nordyke Music Publishers, 6000 Sunset, Hollywood 28PS, California.

POEMS Wanted for musical setting and recording. Send poems. Free examination. Crown Music Company, 49-P West 32 Street, New York 1.

SONGWRITERS! Protect your ideas! Hold all poems, songs! Write for safe, correct procedure! Song Service, Dept. PS, 333 W. 56th, New York 19, N. Y.

CLASSIFIED OPPORTUNITIES

POPULAR SCIENCE OPPORTUNITIES

SONGWRITERS with publisher contacts. want song ideas. Share royalties. Send poems, free examination: Songwriters' Associates, 1650 Broadway, N. Y. 19-G.

SONGPOEMS Wanted. Send Poems For Offer. Nashville Music Institute, Box 532-PS, Nashville, Tennessee.

GUITAR, Banjo Making, books, plans, woods, necks, tools. List 15c. Wildwood, 510 East 11th Street, New York 9, N. Y.

USED Professional Guitars, Amplifiers, Drums. Write: Music, 1215 War Memorial, Peoria, Illinois.

PIANO Instruction: Play modern jazz. New, Simplified, "block-chord" method gives you professional sound similar to George Shearing style. \$3 buys complete course: Instruction Enterprises, 255-7 N. Day, Orange, N. J.

PLAY Guitar—"Teach Yourself" 78 Lesson Book, \$3.00. Hendrickson Publications, Studio PS, Box 5024, Borger, Texas.

ELECTRIC Guitars, amplifiers, wholesale. Free catalog. Carvin, PSM, Covina, California.

35A PHONOGRAPH RECORDS

RECORDS—Stereo, Monaural. Big Discounts. Noelsson, Box 211, New York 5, N. Y.

36 RADIO, TELEVISION, ELECTRONICS, HI-FI

SAVE dollars on radio, TV-tubes, parts at less than manufacturer's cost. 100% guaranteed! No rebrands, pulls. Request Bargain Bulletin. United Radio, 1000-S, Newark, N. J.

FIX Your Own TV, Save 80%! Send for Free Illustrated Chart showing how! We'll include Giant Electronics Catalog. Zalytron, 461 Jericho Tpke., Mineola, N. Y.

RADIO-Electronics Course only \$14.95. Includes all tubes, parts, tools, instructions. Write for full information. Edu-Kits, Dept. 583A, Hewlett, N. Y.

TAPE recorders, Hi-Fi components. Sleep Learning Equipment, tapes. Unusual values. Free Catalog. Dressner, 1523 Jericho Tpke., New Hyde Park 1, New York.

QUALITY Tape: 73% Discount Pre-Recorded: Catalogue Free. Tape King, 3620 Beethoven Street, Los Angeles 66, California.

BATTERY eliminator for transistor radios. Battery charger for 9 Volt battery, Complete kit. \$3.20. Leiman Distributors, Box 147, Brooklyn 18, N. Y.

TRANSISTOR Radios Repaired. \$5.00 covers parts, labor, return postage. Mail radio and \$5.00 to: Mannington TV Co., 23 Pyles Ave., Mannington, West Va. Guaranteed.

ASTOUNDING Government surplus illustrated catalog 10c. Meshna, Lynn, Mass.

TRANSISTORS! 15c Each. 50-Milliwatt Triodes. Quantity Prices. Vamco, Box 234, Wheeling, Ill.

37 BUSINESS OPPORTUNITIES

SECRETS! Secrets! Mail Order Success revealed by internationally famous expert who discovered how to make home business fortunes. Beginners: Get free copy "How to Make Money in Mail Order." Disclosed free advertising, profitable products, everything! No obligation. Write Mailco, 1554 Sepulveda, Dept. K697, Los Angeles 25.

INSTALL Burglar Alarm Systems. Big profit home business. Beginners start spare time, without mechanical experience or costly equipment. Free starter plan. Nasco, Dept. K697, 11071 Massachusetts, Los Angeles 25.

BAKE New Greaseless Doughnuts In Kitchen. Sell stores. Free recipes. Summers, 3605 South 15th, Minneapolis 7, Minnesota.

BIG Money—Operate your own fix-it shop. Service all household appliances: irons, fans, refrigerators, automatic washer-dryers, etc. Do house wiring, commercial wiring. Rewind motors of all sizes. Sharpen mowers, skates, saws. Buy needed spare parts wholesale. Free Book. Christy Trades School, A-2701, 3214 W. Lawrence, Chicago 25.

AMAZING New Home Plastics Business! Up to \$10.00 hour if you qualify. Pleasant, easy. No Selling. Secrets revealed in Free Plan. NPC, Box 23321-LE, Los Angeles 23.

FREE Report: "Mailorder Profits And Pitfalls." Box 63-U, Bellwood, Illinois.

SELL Champion, AC, Autolite spark plugs. Reconditioned, electroplated, guaranteed 10,000 miles. 100% profit. Free sample. Lee Plugs, 1608-K Roberts, Houston 3, Texas.

EARN Money raising fishworms for us! Write: Oakhaven-42, Cedar Hill, Texas.

\$100.00 WEEKLY spare room. Raise redworms odorless, soilless way. Charlie Morgan, Box 116-C, Bushnell, Florida.

OPERATE profitable mail order business. Write Walter Service, 4159-B East 112th, Cleveland 5, Ohio.

BRONZE Baby Shoes. Genuine Electroplating process. Equipment, Mountings, Instructions. Send \$1.00 for Valuable Book "Your Guide To Success" Bronzing Baby Shoes, plus complete catalog. Hollywood Bronze Supply, Dept. B70, 3445 Union Pacific Avenue, Los Angeles 23, California.

BUY Direct From Factories—Appliances, Cameras, Watches! Free details! Cam Company, 436PS Bloomfield Ave., Verona, N. J.

WANT Your name with 1000 mailers? 25c lists your name with our mailings every month. Dixie Mailers, King, N. C.

IMMEDIATE Profits with no capital or experience. Take orders for all magazine subscriptions. Friends and neighbors are your prospects. Write now for complete free kit. McGregor Magazine Agency, Dept. DB3, Mount Morris, Illinois.

STOP Throwing Away Boxtops! They're worth money; Some 25c! Inquire: "Box-tops-DG." Cedar Hill, Texas.

VENDING Machines—No Selling. Operate A Route of Coin Machines And Earn Amazing Profits. 32-Page Catalog Free. Parkway Machine Corporation, 715 PSB Ensor Street, Baltimore 2, Maryland.

FREE Literature — Make Big Money Raising Fishworms and Crickets. Carter Farm, Plains, Georgia.

DOLLS! Dolls! Dolls! We teach you to repair, make, sell all kinds of dolls and accessories including clothing. Study at home. Earn while you learn. Free booklet. Lifetime Career Schools, Studio PSC-73, 11824 San Vicente Blvd., Los Angeles 49, California.

FREE: "How To Win Contests." International, Box 63-A, Bellwood, Illinois.

MAKE \$25-\$50 week clipping newspaper items for publishers. Some clippings worth \$5.00 each. Particulars free. National, 81, Knickerbocker Station, New York.

MANAGE Motel or Resort. Men, women, couples can make \$400.00 to \$1,000.00 monthly plus apartment. Pick own location with our employment assistance. Learn at home. Free Booklet. Motel Managers Training School, Dept. PSC-73, 612 So. Serrano, Los Angeles 5, Calif.

SELL Advertising Book Matches. Write us today; we put you in business. By Return Mail, handling complete line Ad Book Matches in demand by every business right in your town! No investment; everything furnished Free! Top commissions daily! Superior Match, Dept. PX763, 7530 S. Greenwood, Chicago 19, Ill.

\$100 WEEKLY possible. Compile Mailing lists and address envelopes for advertisers. Home-spare time. Particulars free. National Service, 81, Knickerbocker Station, New York City.

FREE "Franchise Profit Letter" tells how unique NFR service is helping thousands seeking profitable businesses. Write today. National Franchise Reports, PS-528, 333 North Michigan, Chicago 1.

WANT To Make Big Money At Home? \$10.00 profit in an hour possible with Invisible Mending. Make tears, holes disappear from clothing, fabrics. Steady year-round demand from cleaners, laundries, homes. Details Free. Fabricon, 1535 Howard, Chicago 26, Illinois.

FREE Directory! Lists 800,000 articles. Save by buying direct from manufacturers. 10c Postage. Glass Pub. Company, Ellwood City, Pa.

RAISE Rabbits and Fishworms on \$500 month plan. Free details. White's Rabbitry, Mt. Vernon 59, Ohio.

SIMPLE, pleasant mailorder can net \$12,000 yearly. Rutward, 2016 Bryant, Columbia Station, Ohio.

76 MILLION prospects! Immediate profits! Sell Champion, AC, Autolite spark plugs. Precision reconditioned, silvery-plated, guaranteed 10,000 miles. Up to 308% profit. Free samples-details. Indy 500 Spark Plug Co., 4620 Braeswood, Houston 35, Texas.

IMPORT-Export opportunity, profitable world-wide, mail-order business from home, without capital or travel abroad. Established world trader ships instruction for no-risk examination. Experience unnecessary. Free details. Mellinger, K697, Los Angeles 25.

GET Into Custom Upholstery. Turn Old Furniture into big \$\$\$ spare time. Reupholster chairs, divans like new. Make custom slip covers, drapes. No experience required. We supply everything. Write for Big Free Illustrated Book on Easy Home Instruction and how we start you in big \$\$\$ home business. Modern Upholstery Institute, Dept. U-12, Fallbrook, Calif.

OWN your own Western Auto Store. Over 3,800 now operating. Minimum investment \$14,000. Free training. No retail experience necessary. For complete details write Chas. Wilson, Room 901, Western Auto, 2107 Grand, Kansas City, Missouri. (Indicate geographical area preferred).

MAKE Durable building plastic easily. Waterproof, fireproof, economical. Bays Laboratory, Cedaredge 2, Colorado.

PLASTERCRAFT Kits, Liquid Rubber for molds, cement ornaments, hobby supplies. Catalogue and sample 10c. Wooley, 1915 North, Peoria, Illinois.

PIANO Tuning learned quickly at home. Tremendous field! Musical knowledge unnecessary. Information free. Empire School of Piano Tuning, Champaign, Illinois. (Founded 1935.)

SPORTSMAN: \$1.00 Tells How You Can Make Big Money While Enjoying Yourself On The Water. Ralph Scocozza, 7706 30th Avenue, Jackson Heights 70, N. Y.

FREE wholesale directory list—350,000 items. Dean's Box 40-PS, Elberton, Ga.

WORLD'S Largest wholesale supply. Buy from 679 American, European, Japanese wholesalers. Tailormade suits from Hong Kong. 123 dropship catalogs. Rockbottom prices. Free details. International Buyers, 216-PS2 Jackson, Chicago 6, Illinois.

FREE Report: "609 Unusual, Successful Businesses." Box 1001-T, Evanston, Illinois.

WORK at home packaging merchandise. Very profitable. No selling. Everything supplied. Details free. HBE, 1043-S West Grand, Chicago 22.

PAWNBROKERS secrets revealed. Fabulous profits. Complete instructions \$3.00. Armsco, P.O. Box 8574, Sacramento, California.

BUSINESS Guidance Service. 20 Different setup services for selection. Hermes Company, 152 West 42, New York City 36.

WORK At Home! Free Details. Hays, 1111 New York. Manasquan, New Jersey.

POPULAR SCIENCE OPPORTUNITIES

\$25.00-\$75.00 WEEKLY Clipping Newspaper Items for Publishers. Some Worth \$10.00 each. Details free. Harvey, 29068-HN, Thornton 29, Colorado.

EARN \$10,000 Selling Books By Mail! Box 51-S, Des Plaines, Illinois.

FRANCHISES, 800 American opportunities. Some without investment. Choose preferred business. Complete details \$1. (Particulars free.) Cosmos, 5083 Victoria, Vancouver 15, Canada.

MURAL Artists Needed! No experience required, earn \$10-\$15 per hour! Amazing "Project-A-Mural" Method. Project pattern slides, trace-off, paint per color guide. Professional results guaranteed! Huge demand from homes, bars, restaurants, offices, etc. Sell \$100 murals for "pennies" in paint. Free Success Plan. Associated Muralists, Dept. F7C, 135 Vesta, Reno, Nevada.

PLASTERCRAFT molds, liquid rubber, plasters, flocks, candle supplies. Catalog and manual free. Jayhawk Plasters, Blue Rapids, Kansas.

\$5,000.00 1st YEAR. Part time. Send 50c. Whiteford, 7610 Cartwheel, San Antonio, Texas.

"HOW and Where to Obtain Capital." Reliable Service, Rome City, Indiana.

SO You Want To Start A Mail Order Business! The Robinson Co., 15468 Hiway 80, El Cajon, Calif.

\$70 WEEKLY—Home, spare time. Simplified mail bookkeeping. Immediate income—easy! Auditax, 34741D, Los Angeles 34.

COLORGLAZED Concrete pottery made without molds. Patented method. Cemetery products, novelties, tiles. Basement leak-sealing. Money-making projects. Booklet, details free. Men only. National Potteries, Grand Rapids, "Minnesota."

DEALERS! For TV-FM Electronic Hide-away Power-cord Replacement Antennas. Sample \$5.95. Write: Electro Dynamics, Box 3177, Fort Worth 5, Texas.

OPERATE Home mailorder business. Vosacek Printing, 4444-PS Ute, San Diego 17, Calif.

MONEYMAKING Opportunity GALORE! In Mailorder. Details Free. Will-Ro Products, 3567-A — 16th, Wyandotte, Mich.

COMPILE And Sell Name Lists. Instructions \$1.00. Barg Sales, Box 957, Evanston, Illinois.

MAKE Money Making Leathersgoods. 1148 Ideas, Free Information. Tandy Leather Co., Box 791-L4, Fort Worth, Texas.

\$200.00 MONTHLY. Spare Time. With Tablesaw, Bandsaw, or Jigsaw. Write. Holiday House, B3800 Harney, Vancouver, Washington.

MAILORDER Pays Big! Tested, proven, home money-making opportunity! Everything furnished. Mann, 266-PS, Hillsdale, New Jersey.

LIQUID Molding Rubber, Free Information, Chaney's 5415-C San Jose Blvd., Jacksonville 7, Florida.

FREE details! Importing, World Trade, Mail Order. Jaedee, Box 1054, Decatur, Georgia.

MAKE \$46 From Square Foot Plywood; Jigsaw necessary. Free Details. Woodarts, Bridgewater, Mass.

I MADE \$40,000.00 Year by Mailorder! Helped others make money! Start with \$10.00—Free Proof. Torrey, Box 3566-F, Oklahoma City 6, Oklahoma.

MAIL-ORDER. Excellent earnings possible. Pleasant, dignified. Start spare time home. Write: Simonet, Drawer M71-P361, Hoboken, New Jersey.

CANDIED: Popcorn and Potato Chip equipment. Eakins Co., 316 S. Light St., Springfield, Ohio.

37A INVESTMENTS

\$2,000,000.00 INVENTION Market. 5% Profits For \$500.00, 2% — \$200.00. Send Check, References. Suite B-106, 210 5th Ave., New York 10.

38 MONEYMAKING OPPORTUNITIES

\$100 WEEKLY possible. Compile Mailing lists and address envelopes for advertisers. Home-spare time. Particulars free. National Service, 81, Knickerbocker Station, New York City.

MAKE Plastic novelties for extra income. Low cost home training now available. Write for free booklet, Interstate Training Service, Dept. D-2, Portland 12, Oregon.

VENDING Machine—No Selling. Operate A Route of Coin Machines And Earn Amazing Profits. 32-Page Catalog Free. Parkway Machine Corporation, 715 PSM Ensor Street, Baltimore 2, Maryland.

TO \$100.00 Weekly, Mailing Catalogs. Sample, instructions, 25c. Costar, GPO Box 972-PS, New York 1.

FREE Literature — Make Big Money Raising Fishworms and Crickets. Carter Farm-11, Plains, Ga.

DETECTIVES—Work home—Travel. Experience unnecessary. Detective Particulars free. Write Wagoner, P-125 West 86th, New York 24.

MAKE \$25-\$50 week, clipping newspaper items for publishers. Some Clippings worth \$5.00 each. Particulars free. National, 81, Knickerbocker Station, New York.

PROFITABLE hobby adds to income. Operate Home Mail Order Business. Write Publicity, Box 727B, Kalamazoo, Michigan.

AMAZING successes through franchises! Become exclusive franchise holder your territory. Information rushed. National Franchise Reports, SP-528, 333 North Michigan, Chicago 1.

HOME Mailorder "manufacturing." Everything supplied. Clenso Products, 184 Oakview, Winnipeg 15, Manitoba.

LEARN Expert Cake Decorating, Candy Making. Free details on home instruction method. Candy & Cake, Dept. D-744, Fallbrook, Calif.

AMAZING plan brings quick cash by mail. Details 10c. A. Fisher, Lime Springs, Iowa.

MAKE Money Writing Short Paragraphs! No tedious study! I tell you what to write, where and how to sell; and supply list of editors buying from beginners. Many small checks add up quickly. Write to sell, right away. Send for free facts. Benson Barrett, Dept. C86A-F, 7464 Clark, Chicago 26.

MINK Raising information free. Complete. Lake Superior Mink Farm, Superior EE, Wisconsin.

MEN — Women! Start Money-Making Plastic Laminating Business at home in spare time. Material that costs 11c brings back \$2.58. No canvassing or selling but mail orders bring in \$20 a day. Write for full particulars free. Rush name on postcard to Warner, Room CR-3-H, 1512 Jarvis, Chicago 26, Ill.

SELL New Invention, Mechanic Stand For Trucks To: Service Stations, Garages, Truck Owners. Two Minute Demonstration. Sell On Sight. Price \$12.50, Your Profit \$6.25. Send \$9.00 For Demonstrator and Sales Kit. Money Back Guarantee To: Hudson Marsden, 645 Beahan Road, Rochester 11, New York.

DOUBLE your money every 4 years in South America without effort or risk! Write to "Iconi," Calle 11 No 34-28, Bogota, Colombia.

HOMEWORK. \$1 brings list of companies offering homework. Eagle, Box 135, Bronx 60, N. Y.

AMAZING Manufacturing Opportunity. Free list of manufacturing formulas. Presler Oil Company, Fostoria 18, Ohio.

EASY to start rubber stamp business at home in spare time. Make up to \$9.80 an hour without experience. Facts free. Write to Roberts, 1512 Jarvis, Room CR-3-H, Chicago 26.

DO You Know? It's a little known fact that the U. S. Government sells valuable oil leases every month for only 50c per acre annual rental. Many of these are worthless, but others are resold for hundreds per acre plus an overriding royalty. For complete information, including a map showing favorable acreage, send \$1.00 to, Land, P.O. Box 4285, El Paso 14, Texas.

LEARN the secrets of repairing junk batteries, generators, starters, profitable, easy, at home. Free particulars. Batterymen, Prundale Station, Salinas, California.

YOUR Own, Easy-To-Start, Home Mail-order Business, sparetime. Fascinating; profitable! Information free. Alfano, 19-PS Pine, Closter, New Jersey.

MAKE Money when you go on vacation, take short trips, or travel anywhere. Free details. Mohny, Star Route, Jensen Beach, Florida.

CIGARETTES—Make 20 plain or filter-tip for 9c. Factory-Fresh pipe tobaccos. Mild tropical flavored Philippine cigars. Facts free. Moberly, Box 4030, Owensboro, Kentucky.

REFILL Propane Hand Torches! Thousand % Profit! McCarthy, 2232-A Wisconsin Avenue, Washington 7, D.C.

BECOME A Notary Public. Win extra income, prestige, business contracts. Details free. Stationers Exchange, Box 166, Hanibal, Missouri.

\$25.00 — \$75.00 WEEKLY Clipping Newspaper Items for Publishers. Some worth \$10.00 each. Details free. Harvey's, 29068-N, Thornton 29, Colorado.

FREE Advertising For Mailorder Items. Branvolt, 5718 Troost, North Hollywood, California.

\$50 SPARE Time! Details 25c. Raymar, Box 602C, Lynwood, Calif.

38A BUY IT WHOLESALE

TOOL Catalog Send 25c. Silvo Hardware, 107-PS Walnut, Philadelphia 6, Pa.

BUY Direct From Factories! Appliances, Cameras, Watches. Free Details! Cam Company, 436PB Bloomfield Avenue, Verona, New Jersey.

FREE! Name Brands Catalog! Your own high profit business. Sell Name Brands, full or part time. No inventory—no investment. More than 2000 Name Brand items; lowest wholesale prices. Watches, jewelry, cameras, hi-fi, stereo radios-phonos, appliances, housewares, hardware, power tools, luggage, musical instruments, garden equipment, sporting goods, toys, many others. 8 Floors of Name Brands. Million dollar inventory. Orders shipped complete within 24 hours. Send for Free beautifully illustrated catalog. Now! Separate wholesale price list. H. B. Davis Corp., Dept. PS, 145 West 15 St., New York 11, N. Y.

BARGAINS! Buy Wholesale! Save Money! Free Catalog! Norris, 273-L Merrick Road, Lynbrook, N. Y.

NEW Deluxe below wholesale catalog. Automobile catalog and others. Furniture, clothing, housewares, appliances, refrigerators, freezers, washers, dryers, television, radios, luggage, binoculars, hi-fi, stereo, phonographs, recorders, cameras, projectors, musical instruments, sporting goods, toys, tools, typewriters, watches, jewelry. Huge discounts on thousands of name brand items. For free specimen list of actual factory prices—postcard. Selbyco, Decatur 16, Illinois.

SWIM At Once—invisible swim aid for men, women, children; 1, 25" thick, 4 oz.; worn under bathing suit. Demonstrator \$6.95 ppd. Check or money order; state waist size. Also many other new international patented articles. Reps wanted. 25c for details, refundable first order. G & R Industries, 59-15-C 71 Ave., Brooklyn 27, N. Y.

POPULAR SCIENCE OPPORTUNITIES

WORLD'S Largest wholesale supply. Buy from 679 American, European, Japanese wholesalers. Tailormade suits from Hong Kong. 123 dropship catalogs. Rock-bottom prices. Free details. International Buyers, 216-PS Jackson, Chicago 6, Illinois.

LARGEST Wholesale Supply Source in U.S. Furniture, clothing, electric appliances, housewares, auto accessories, tools, sporting goods, farm equipment, hobby supplies, bargain merchandise, world imports. Free details. Associated Wholesalers, Box 52-CX, Burlington, Iowa.

BARGAINS Galore on everyday needs! Catalog—10c. Now! Discounts Unlimited, 7545-PB Dumas, San Jose 29, Calif.

DRUG Sundries. Complete Line Of Rubber Goods. Nationally Advertised Brands. Vitamins, Etc. Write For Free Catalog. Federal Pharmacal Supply, Inc., Dept. PS, 6652 North Western Avenue, Chicago 45, Illinois.

ELECTRIC Guitars, amplifiers, wholesale. Free Catalog. Carvin, PSW, Covina, California.

38B IMPORT-EXPORT

200 EXPORTERS—Global, Classified, 35¢. Gaw, 4910½ Field St., San Diego 10, Calif.

39 FORMULAS, PLANS, ETC.

FORMULAS—All Kinds, Amazing Big Catalog 10c. Kemisco, Park Ridge 15, Illinois.

LATE Modern Manufacturing Formulas List Free. Chemical Service, Martville, New York.

FREE Formula Catalog. Latest Money Makers. Western Chemical, Salem, Oregon.

NEW Formulas For Profit! Manufacture Your Own Product. List Free. Johnston, Box 6284-S, Marietta, Georgia.

SPECIAL Formulas for latest money-making discoveries. New! Good! Profitable! Valuable Literature Free! Miller, Chemist, 1517-N, Tampa, Florida.

40 PLASTICS

NEW Liquid casting plastic, clear, colors. Embed real flowers, butterflies, photos, coins. Send 25c for two handbooks "How to Cast Liquid Plastics" and "How to Make Extra Money at Home." Castolite, Dept. H-102, Woodstock, Illinois.

EMBEDDING, casting secrets free. Sample, 25c. Crystal, 4350-H N. Whipple, Chicago 18.

PLEXIGLAS — Any thickness — Clear — Colors — Cut to size — Clear Rods — Tubing. McClarin Plastics, P.O. Box 168B, Hanover, Pennsylvania.

PLASTIC Embedders, Moulds, Miniature findings, etc. Catalog 25c. David Co., 20 Garden St., Providence 3, R. I.

PLASTIC Embedding for fun and profit, no oven. Make beautiful jewelry, decorative panels, science specimen castings. Catalog 25c. Natcol Plastics, Box 444, Yucalpa 4, California.

41 SCIENCE & CHEMISTRY

NEW Concepts in physics and astronomy comprising a unique structural explanation for the subatomic particles and their forces. Nuclear theory challenged. New 1963 edition. 25 cents postpaid. C. F. Krafft, 4809 Columbia Road, Annandale, Virginia.

ROCKETS: New Illustrated Catalog 25c. Single And Multistage Kits, Cones, Engines, Launchers, Trackers, Technical Information, Etc. Fast Service. Estes Industries, Penrose 6, Colorado.

FREE 3 Pyrex test tubes with purchase \$3.00. Catalog 25c. Chemicals, Apparatus, Biology. Mid-States Scientific, 7053 N. Clark, Chicago, Ill.

UNUSUAL Chemistry books, courses, kits! Rare chemicals, cheap! Catalog 25c. National, Box 133-A, Palo Alto, Calif.

AMAZING New Book Of Science Experiments, formulas and Catalogue of Laboratory Supplies. Only 35c. National Scientific Co., Dept. PS-7, 13 S. Park Avenue, Lombard, Illinois.

NOW hear this! We have slashed the prices on every chemical listed in our catalog 20%. If you don't have our catalog by now, it's still only 25c. United Chemical Products, Box 3626 Grand Central Station, New York 17, New York.

ILLUSTRATED Catalog; Chemistry, mineralogy, biology 25c. Tracey Laboratories, Evanston, Illinois.

CHEMICALS and apparatus for industrial, analytical and private laboratories. Catalog 35c. Dept. M-26, Biological Supply Co., 1176 Mt. Hope Ave., Rochester 20, N. Y.

ROCKETS: Single, Multistage. New Science Materials. Catalog 25c. Central Rocket Company, Waupaca, Wisconsin.

SEARCHING For Economically Priced Chemicals And Apparatus? Gift With Catalogue. Now Only 20c. Starr Scientific, Manitowoc, Wisconsin.

EXPERIMENTER'S Handbook Free With Bigger Discounts Catalogue. Now Only 20c. Hagenow Laboratories, Manitowoc, Wisconsin.

FREE—Pair of chemical resistant polyethylene gloves with catalog. Low priced Chemicals, Biologicals, and Apparatus. New Pyrotechny section just added to catalog. New Illustrated catalog only 35c. Dover Scientific, 35-24 31 St., Astoria 6, New York.

WUMCO Chemical Co., Chemicals and Chemical Apparatus. Catalog—25c. Booklet of Experiments—50c. Box 681, Reading, Penna.

42 EMPLOYMENT INFORMATION

FOREIGN—U.S.A. jobs. All occupations. Up to \$1600.00 monthly. Free transportation, benefits. Complete "directory." Application form. Send \$1.50 (\$2.00 airmail). Why pay more? C.O.D.'s accepted. Satisfaction guaranteed. International Employment, 152 W. 42nd, Suite 536-C7, New York 36, New York.

FOREIGN Employment. Construction, other work projects. Good paying overseas jobs with extras, travel expenses. Write Only: Foreign Service Bureau, Dept. PS, Bradenton Beach, Florida.

FOREIGN Employment Information Job Possibilities Up To \$1600 Monthly In Europe, Africa, Asia, South America. Free Transportation. Construction Workers, Clerks, Hundreds Of Occupations Men, Women. Complete Information. Proper Application Form Sent Promptly. Satisfaction Guaranteed. Send \$2.00 (\$2.25 Airmail) (C.O.D.'s Accepted) To: Jobs, P.O. Box 50512, Dept. F, New Orleans 50, Louisiana.

WORK For the U.S. Government. Send \$1.00 for next five monthly issues containing announcements of Federal job examinations. Good pay plus fringe benefits. Civil Service Reporter, Dept. P.S., 330 Newbury Street, Boston 15, Massachusetts.

DIRECTORY Reports. Construction, aviation, shipping, oilfields, government, manufacturing, trucking, etc. Foreign-Stateside. Helpful information plus job-getting tips on preparing application letters. Unconditional money-back guarantee of satisfaction. Act Today. Only \$3.00. (\$3.25 Airmail) (C.O.D.'s Accepted) Research Services, Meramec Building, St. Louis 5-PS, Missouri.

43 AGENTS WANTED

MAKE Big Money taking orders for Stark Dwarf Fruit Trees. Everybody can now grow Giant Size Apples, Peaches, Pears in their yards. Also Shade Trees, Shrubs, Vines, Roses, etc. Outfit Free. Stark Bro's, Desk 30174, Louisiana, Missouri.

YOUR Own business—Suits \$1.50; Overcoats 65c; Mackinaws 35c; Shoes 12½c; Ladies' Coats 30c; Dresses 15c. Enormous profits. Catalog Free. Nathan Portnoy Associates, 2109-J Roosevelt Road, Chicago 8, Ill.

EVERY Man A Prospect. Refundable sales kit offer showing line belt buckles, tie clasps, money clips, cuff links, lapels, identification badges, individualized with customer's name and emblems. Cap badges for trucking, bus, taxi, police, firemen, also heavy construction emblems. Choice 3000 emblems. Hook-Fast, Box 1088PS, Providence, R. I.

FREE Sample, Beautiful Curios! Sell on Sight! Apartado 9036, Mexico City.

START Your Own Business On Credit. Your own boss, 1125 Dealers sold \$5,000 to \$25,500 in 1962. We supply stocks, equipment on credit. 275 home necessities. Sales experience unnecessary. Pleasant, profitable business backed by world-wide industry. Write Rawleigh, Dept. G-U-PSC, Freeport, Ill.

ESTABLISH Your Own Business! Low prices on used clothing, shoes, household goods. Unlimited profits. Free Catalog. Northwestern Distributors, 2129 North Western Avenue, Chicago 47, Illinois.

SMALL investment starts fabulous business stamping Social Security plates, Nickel Silver key protectors. Sample 50c with social security number. Catalog free. General Products, 11 No. Pearl, (Dept. PS7), Albany, N. Y.

5 USED Watches—\$6.00. Joseph Bros., 5-C So. Wabash, Chicago 3, Ill.

EXOTIC Earrings! Details free. Pair, \$1.00. Ohga, PS-460, Sigakenkusatu, Japan.

HOT Item Sells on sight. Magnetic Soapholder. Every home needs some. Crew Managers. Direct Salesmen. Send \$1 for Sample. Majohan, Box 452, Redmond, Washington.

44 HIGH-GRADE SALESMEN

SELL Calendars And Advertising Specialties—Most Businesses Buy Them—Free Sample To Start. Simply Show Samples—They Sell Themselves. Liberal Commissions. Free Premiums. Cash Bonuses. Full or Part Time. Fleming, 6535-P Cottage Grove, Chicago 37, Ill.

MAKE Extra Money Selling advertising matchbooks. Free catalog and sales outfit. Matchcorp, Dept. PS-73, Chicago 32.

\$3.00 UP Hourly for Route Work. Permanent. Write McNess, Freeport 43, Ill.

SENSATIONAL new longer-burning Light Bulb. Amazing Free Replacement Guarantee—never again buy light bulbs. No competition. Multi-million dollar market yours alone. Make small fortune even spare time. Incredibly quick sales. Free sales kit. Merlite (Bulb Div.), 114 E. 32nd, Dept. C-74-J, New York 16.

YOUR free copy of World's biggest sales magazine tells you how and where to make more money on your own in selling. Write Specialty Salesman Magazine, Desk 6B, 307 North Michigan, Chicago 1.

EARN Big Commissions Full Or Part Time. Show America's largest line low priced business printing and advertising specialties. Big Free Sales Kit samples hundreds items used daily by business people. Build profitable repeat business. Start right now. National Press, Dept. 9, North Chicago, Illinois.

MAKE Up to \$50.00 Daily, listing delinquent accounts from business, professional men. Free Sales Kit. General Finance, Dept. AR-7, Pickwick Bldg., Kansas City 6, Mo.

\$1,000.00 A month for making dramatic 3-second demonstration of amazing lightweight Presto Fire Extinguisher. New chemical used by Airforce snuffs out fires instantly. Only \$4.95. Terrific commissions. Millions want it. Free Kit. Merlite, 114 E. 32nd, Dept. P66-J, New York 16.

POPULAR SCIENCE OPPORTUNITIES

CLASSIFIED OPPORTUNITIES

SELL Advertising Book Matches. Write us today; we put you in business By Return Mail, handling complete line Ad Book Matches in demand by every business right in your town! No investment; everything furnished Free! Top commissions daily! Superior Match, Dept. P763, 7530 S. Greenwood, Chicago 19, Ill.

IF you're interested in making money in selling, see the hundreds of exceptional opportunities in Salesman's Opportunity Magazine. Send name for your copy, absolutely free. Tell us what you're selling now. Opportunity, 848 N. Dearborn, Dept. 18, Chicago 10, Illinois.

EXPANDING Company needs additional part-time men to take orders for patented air cushion dress and work shoes. Salesmanship not required. Samples supplied. High commissions. Write: Chester Shoes, Dept. 670, Brockton, Mass.

45 EDUCATIONAL & INSTRUCTION

HIGH School At Home in spare time with 66-year-old school. No classes. Standard high school texts supplied. Single subjects if desired. Credit for subjects already completed. Progress at own speed. Diploma awarded. Information booklet free. . . . write today! American School, Dept. XB46, Drexel at 58th, Chicago 37.

PHOTOGRAPHY: Earn Big Money. Travel. Own your own studio. Learn at home in your spare time. Write for big free Book. School of Modern Photography, Dept. C-763, Little Falls, N. J.

LEARN Civil and criminal investigation at home. Earn steady, good pay. State age. Institute Applied Science, 1920 Sunnyside, Dept. 33B, Chicago 40, Illinois.

MASTER Watchmaking at home. Free sample lesson. Chicago School, 2328-WT Milwaukee, Chicago 47.

HIGH School Diploma at home. Licensed teachers. Approved materials. Southern States Academy, Station E-12, Atlanta, Ga.

LEARN While Asleep with your recorder, phonograph or amazing new "Electronic Educator" endless tape recorded. Details free. Research Association, Box 24-NN, Olympia, Washington.

BOOKKEEPERS — Operate Your Own "Dollar-A-Week" System. Ellis, Box 203, Cedar Grove, North Carolina.

PIANO Tuning Pays. Big money in spare time. Learn at home. No musical knowledge necessary. Phonograph records, tools and instructions furnished. Electronic tuning also taught. Free catalog. Capital Tuning School, 3160 S.W. 16th Court, Ft. Lauderdale, Fla.

GOOD paying jobs open! Operate, repair heavy earth moving equipment! Learn "on the job" operating latest cranes, bulldozers, earth carriers! V. A. Approved. Free Catalog. Write G.S. Hutch, Greer Technical Institute, Braidwood, Illinois.

FCC LICENSE in 6 weeks, First Class Radio telephone. Results Guaranteed. Elkins Radio School, 2603A Inwood, Dallas, Texas.

PIANO Tuning quickly learned with home study course. Diploma granted. American Tuning School, Gilroy, California.

MISSOURI Auction School. Free catalogue. 1330 Linwood, Kansas City 9-x5, Missouri.

BE A Real Estate Broker. Insure Security for yourself and your family. Study at home. Prepare for state examination. GI approved. Write for Free Book Today. Weaver School of Real Estate, 3519R Broadway, Kansas City, Mo.

GRAPHOANALYSIS — Learn scientific handwriting analysis for profit, pleasure. Free sample lesson, catalog reveals plan. Write IGAS, Inc., 325 Jackson, Dept. 2CY-1, Chicago 6.

USED Correspondence Courses and Books sold and rented. Money back guarantee. Catalog free. (Courses Bought.) Lee Mountain, Pisgah, Alabama.

WOODWORKING and Cabinetmaking course for beginning and advanced home craftsmen. Only complete low-cost home training program available. Write for free booklet. Interstate Training Service, Dept. G-2, Portland 12, Oregon.

MEN wanted. Learn Auto-Diesel Mechanics in our shops: Learn with tools on real equipment. Earn While You Learn. Many of our graduates earn \$125 a week and up. Write for free bulletin. Auto-Diesel College, Dept. 262, Nashville 3, Tenn.

FREE General Catalog—100 Pages Text vocational, educational, instructional subjects. Millions of volumes, new and used. Bargain prices. Books bought. Est. 1902. Long's College Book Co., Dept. PS, Columbus 1, Ohio.

LEARN Auctioneering, Free Catalog. Reich Auction College, Mason City P, Iowa.

EARN as you learn, camera repair. National Camera Repair School offers accredited Home Study Course—instructions, texts, tools and practice equipment. Free information. Write Box 174PE7, Englewood, Colorado, today!

WANT a Diesel Career? Higher pay? Advancement? We can help you qualify! Complete Diesel, Tractor and Heavy Equipment and Cummins Diesel Engine Shop-method home-training courses available. Write today. Interstate Training Service, Dept. B-2, Portland 12, Oregon.

REAL Estate Course. Economical home-study. Literature free. Howard Schools, Box 8394-B, Kansas City 5, Missouri.

OWN local collection office. Pays big. Franklin Credit, Roanoke, Virginia.

USED Courses! Books! List 10c. Smith's, 124 Marlborough, Salem, Mass.

PIANO and Organ taught by new fun method. Individually conducted lessons by mail. Free sample lesson. Music Studio, Box 459, Stall Court, Sunset Park, Kingston, N. Y.

BE A Tutor of reading. Private tutors of the Phonics Method are in desperate demand. Earn from \$5 to \$10 an hour. Study at home. Details free. Reading Arts Academy, 1100 West "Q," Wilmington, California.

ENGINEERING Mathematics. Electronics. Pay as you learn. Free brochure. Indiana Home Study, 64 Hemenway Road, Framingham, Mass.

DRAFTING Home Course \$15.00 (Blueprint Reading, Electronic, Mechanical, Architectural, Art). Prior Inc., 23-09 169 Street, Whitestone 57, New York.

USED Correspondence Courses, Books. Catalog 10c. Bayles, 78-D Courtright, Wilkes-Barre, Penna.

COURSES Written to Specifications by Home-Study Specialists. All Fields. Pokresse, Central Valley, New York.

MILLIONS of Sewing Machines need repair. Train now. Sincere Schools, 2042 West Spring, Tucson, Arizona.

PENMANSHIP Corrector: Improve poor penmanship quickly. Details free. Ozment, Box 665 35, St. Louis 88, Mo.

CIVIL Service Examination Books! Atlantic Service, 10 Cedar, Charlestown 29, Mass.

46 CONTESTS

NEW Contest! For information write: The Jackpot, Box 36R, Birdseye, Indiana.

47 DETECTIVES

DETECTIVE Profession. Home Study Lapel pin, Certificate, Future. Box 41197-G, Los Angeles 41, California.

DETECTIVE Course. Credentials, Diploma. Free Information. Southwestern Institute Criminology, Box 202, Geronimo, Oklahoma.

INVESTIGATORS, free brochure, latest subminiature electronic listening devices. Ace Electronics, 11500-F NW 7th Ave., Miami 50, Florida.

DETECTIVES—Work home—Travel, Experience unnecessary. Detective Particulars free. Write Wagoner, P-125 West 86th, New York 24.

SUPER-Directional Microphone picks up a whisper at great distances. Used by Intelligence Agents and others. Hear conversations clearly through ordinary walls a block away. Inexpensively constructed with ordinary store materials. No electronics experience, knowledge or special tools needed. For full simple plans send \$1.00. Airmail \$1.25 to: Super Snooper, Box 1545, Marysville 4, California.

DETECTIVE Training — Career for young and old, men and women. Free information write to 1917-C North Kenneth Avenue, Chicago 39, Illinois.

48 LANGUAGE OUTFITS

ESPERANTO. UNESCO's interlanguage. Text, Pronunciation record \$1. Esperanto, Dept. P.S., Middleton, Wis.

49 GIFTS

UNUSUAL Gifts. Catalog Free. Holloway, 900 West Gilbert, Muncie, Indiana.

50 BUSINESS SERVICE, INFORMATION, NAME LISTS

MAILING Lists most all kinds 1000 \$5.00. FREE folder. Your circulars mailed \$4.00 1000. Dixie Mailers, King, N. C.

52 AUTHORS SERVICE

WANT Your Book Published? Learn how we publish, advertise, promote, distribute. Many successes. Free booklet PS, Vantage, 120 West 31, New York.

WANTED: Short stories, books, articles, plays of all descriptions for sale to publishers, producers. Free Literature! Literary Agent Mead, Dept. 27A, 915 Broadway, N. Y. C. 10.

54 ART INSTRUCTION, CARTOONING, SIGN PAINTING

"HOW to Make Money With Simple Cartoons"—A book everyone who likes to draw should have. It is free; no obligation. Simply address Cartoonists' Exchange, Dept. 197, Pleasant Hill, Ohio.

ART Lessons—\$6 a month. Includes Drawing, Painting, Commercial Art, Art Kits (worth \$25) and materials. Assignments corrected, with overlays, by mail, and returned to you. Write for free book. No obligation. Washington School of Art, Studio 157, Port Washington, L. I., N. Y.

LEARN Sign Painting. Fascinating System. Straley, 410-P South Western, Springfield, Ohio.

LEARN Profitable Magazine Cartooning! Free Details. Cartoonists, Box 3097, Lincoln 10, Nebr.

YOU can Entertain with Chalk Talks, Catalog 10c. Cartoonist Balda, Oshkosh, Wisconsin.

55 TYPEWRITERS & OFFICE MACHINES

RECONDITIONED Typewriters, Mimeograph, printing presses \$25.00 up. Write Dixiegraph, King, N. C.

56 RUBBER STAMPS & OFFICE SUPPLIES

FREE Booklet. Indexed Rubber Stamps. Dowling Products, Dept. PS73, Pittstown, N. J.

THREE line pocket or office stamp \$1.00. Kay's, Box 5183, Phoenix 10, Arizona.

CATALOG—Rubber Stamps, Business Cards. Martins, 1425 Major, Jefferson City, Missouri.

POCKET Or Office Type Stamp \$1.00. Vargo's, 4119A Buechner Ave., Cleveland 9, Ohio.

POPULAR SCIENCE OPPORTUNITIES

FREE 32 Page Rubber Stamp Catalog. Signature Stamps \$3.50. Youngers Stamp Shop. Princeton, Iowa.

57 PRINTING, MULTIGRAPHING, ETC.

FREE Catalogs. Postpaid printing, Rubber stamps. D M Press, Sebastopol, Calif.

100 6 $\frac{3}{4}$ ENVELOPES, 100 5 $\frac{1}{2}$ x8 $\frac{1}{2}$ Letter-heads Printed—\$2.35. M. Fortney, R3, Dillsburg, Pa.

1000 GUMMED Name & Address Labels \$1.00. Perk's, Essex, Mass.

OFFSET printing. Some shipped day received. Mimeo Press, Rocky Mount, N. C.

WRITING stationery, imprinted, with beautiful gift box; \$2.95 postpaid. Park, Box 59, Buffalo 15, N. Y.

AMAZING Business Printing values. Samples. Print Shop, Box 576P, Greenville, R. I.

1000 NAME, Address Labels \$1.00. Rubber Pocket Stamp \$1.00. 1000 Business Cards \$3.95. Printing. Personalized Items. Free Literature. Jordan's 552 West O'Connor, Lima, Ohio.

\$3.95 THOUSAND. Simulated engraved business cards. Time-tested quality. Steele, 2507 "C" St., San Diego 2, California.

1000 BUSINESS Cards, "Raised Letters" \$3.75 postpaid. Samples. Routh PS-5, 3910 Kipling, Greensboro, N. C.

58 PRINTING OUTFITS, SUPPLIES

NEW 1962-63 illustrated printing equipment and supply catalog. This 9 x 12", 336 page book is the most complete catalog of the century. Contains everything used in the graphic arts industry including thousands of offset, letterpress, bindery, rubber plate and stamp, composing room, silk screen, art and engraving supplies and equipment. Includes paper cutters, folding machines, printing & proof presses, padding presses and many more. Send \$2.00 to cover mailing. Refund with first order. Also available is our latest 184 page type catalog—add \$1.00. American Printing Equipment & Supply Co., Dept. PS, 42-25 Ninth Street, Long Island City 1, N. Y.

PRINTING Outfits, type, supplies. Send dime for illustrated supply book and samples. Kelsey, Inc., H-8, Meriden, Conn.

RUBBER Stamp Presses, Hydraulic Operated. Electrically heated. Sizes 5"x8", 8"x12", 10"x15", starting outfits, supplies. Printing Presses. Custom Manufacturing. 1464 East Commercial, Springfield 2, Missouri.

MAKE Your Own self-molding rubber stamps and printing cuts. Plexirubber, Argyle 2, Wisconsin.

PRINTING Presses, Type, Supplies. Lists, 5c. Turnbaugh Service, Mechanicsburg, Pa.

TYPE case catalog. Manufacturer. King McKay Company, 23179 Telegraph, Southfield, Michigan.

RUBBER Stamp Presses, Supplies. Kiewiet, 2025 Barney Road, Kalamazoo, Michigan.

60 FOR INVENTORS

INVENTORS, if you have an invention for sale, patented or unpatented, write Institute of American Inventors, Dept. 30A, 635-F St., N.W., Washington 4, D. C.

INVENTORS: Prepare your own patent application. Our "Patent Kit" includes detailed instructions and all necessary material. \$12.95. Money back guarantee. National Inventors Company, Box 88, Ben Franklin, Washington, D. C.

INVENTIONS needed immediately for manufacturers. For additional information write Kessler Corporation, C-77-FI, Fremont, Ohio.

PATENTS prepared. 32 years experience. Complete applications, \$100, up. Inventors Service, Box 322, Duluth, Minnesota.

PROFESSIONAL Patent Searches, \$6.00, including official U.S. Patent Office copies of related U.S. Patents! Prompt, dependable service. Certified, Airmailed! For free "Invention Record Folio" and "Important Patent Information Every Inventor Should Have," write: United States Inventors Service Company, 1311 "G" Street NW, Washington 5, D. C.

PATENT Searches, including copies of related U.S. Patents, \$6.00. Inventors, attorneys, manufacturers use my "Worldwide" Airmail service! "Invention Record" form and "Information Every Inventor Needs," sent free! Miss Hayward, 1029 Vermont Ave. NW, Washington 5, D. C.

MY seventeen patents prepared myself. You too can. Demand proof! Useful information sent free. State class, don't disclose, your invention. Aberly, 124 8th St. NE, Cedar Rapids, Iowa.

TYPE Manuscripts at home for authors. Immediate earnings. Complete instructions \$1. Terry Home Services, Box 2027-PM7, Downey, Calif.

SAVE High fees! Prepare your patent application yourself! New "Do-It-Yourself" Patent Kit now makes it easy. Free "Registration Form." Miss Blaine, 306 Carry Building, Washington 5, D. C.

FREE! "Protection Certificates"—Patent searches completed and reported within "24 Hours"—\$5.00. Write: Inventors Service and Marketing Bureau, Box 1212-A, Washington 13, D. C.

PATENT Searches, professional patent development of inventions by Licensed Professional Patent Engineer and U.S. Patent Office Former Examiner with staff of engineering specialists in all fields of inventions. Expert searches performed in the U.S. Patent Office. Your inventions and ideas engineered for maximum patent protection and greatest commercial value. Inventions developed by us negotiated for cash or royalties with our nationwide contacts. Send for free Protection "Invention Certificates" and further interesting, valuable Patent Information. George Spector, Licensed Professional Patent Engineer, U.S. Patent Office Former Examiner, Woolworth Building, New York.

PATENTS Skillfully Prepared for maximum commercial value with useful product development. High record of success in proving and claiming patentability. Valuable market service. Patents prepared and filed for service fee as low as \$200.00. Send for self protecting invention record forms free. Patent search with valuable engineering report \$10.00. Foreign patents filed at lower cost. Thirty Years established. Joseph O'Brien, Patent & Development Engineer, 132 Nassau Street, New York 38, N. Y.

SEARCHES \$15. Official Patent Drawings \$40. Satisfaction Guaranteed. Mail Sketch and Description. Capitol Patents, 4206 Arthur Drive, S.E., Washington 22, D. C.

U.S. Patent Office Searches—\$5.00. Free Invention Record. Patents Engineered. Patent Office Searchers, 233 Broadway, Room 3615, New York.

PATENT Searches including Maximum speed, full airmail report and closet patent copies, \$6.00. Quality searches expertly administered. Absolute confidence and secrecy guaranteed. Free Record of Invention forms and "Patent Information." Financial assistance available. Write Washington Patent Office Search Bureau, 1426 G Street, N.W., Washington, D. C.

INVENTORS! Sell your invention for cash or Royalties! Our client manufacturers constantly seeking new items. Patented. Unpatented. For free information write Gilbert Adams, Patent Broker, 80 Wall St., Financial District, New York, N. Y.

INVENTORS! Outright cash sale or royalties for your inventions. Patented. Unpatented. Constant demand from our client manufacturers. Financial assistance available. Write United States Invention Brokerage, 78 Wall Street, New York 5, N. Y.

61 INVENTIONS WANTED

INVENTORS: If you have an invention for sale, patented or unpatented, write for free brochure outlining manufacturers requirements, royalty rates. Kessler Corporation, C-77-IW, Fremont, Ohio.

INVENTIONS wanted. Patented; unpatented. Tremendous Manufacturers lists. Global Marketing Service, 2420 77th, Oakland 5, Calif.

INVENTORS: Hundreds of manufacturers have requested our assistance in locating marketable new products. Complete information free. Institute of American Inventors, Dept. 30C, 635-F Street, N.W., Washington 4, D. C.

INVENTORS: We either sell your invention or pay you cash bonus, write for details. Universal Invention, Marion, Ohio.

INVENTIONS Promoted—For Cash-Royalty Sales with Manufacturer Contacts. George Spector, Licensed Invention Engineer, Woolworth Building, New York.

INVENTORS! We will develop, sell your idea or invention (patented or unpatented)! Our national manufacturer-clients urgently seeking new items for highest outright cash sale or royalties. Financial assistance if needed. 10 years proven performance. For Free information write: Wall Street Invention Brokerage, 79 Wall Street, Financial District, New York 5, N. Y.

INVENTORS Needing Help with any problem, financial, development, securing manufacturer, obtaining patent. Write the organization that delivers action and results—not promises. Pioneer Invention Service, 150 Broadway, New York 38, N. Y.

INVENTORS! Manufacturers urgently seeking new items. Sell or license your invention for cash or royalties. Patented. Unpatented. 10 years dependable service. For Free self-protective record of Invention Forms. Write: H. Lawrence Blasius, 19 Park Row, New York 38, N. Y.

INVENTORS! Don't sell or license your invention for cash or royalties until you receive our offer. Development service and financial assistance available. For Free information, write International Invention Institute, 17 Park Row, New York 38, N. Y.

INVENTORS! Let us assist you in the development and marketing of your idea or invention. Financial assistance available. For Free information and "How to Protect Your Unpatented Idea or Invention" write Invention Development and Marketing Service, 80 Wall Street, New York, N. Y.

INVENTORS! Outright cash sale or royalties for your inventions. Patented. Unpatented. Constant demand from our client manufacturers. Financial assistance available. Write United States Invention Brokerage, 78 Wall Street, New York 5, N. Y.

INVENTORS requiring assistance with financing, developing, obtaining manufacturer, patent. Write Invention Brokerage of America, 13 Park Row, New York 38, N. Y. We give the inventor results—not promises.

64 MODELS, MODEL SUPPLIES

SHIP and yacht model fittings; blueprints. Send 50c for Illustrated catalog listing hundreds of items. A. J. Fisher, Inc., 1002-2 Etowah Ave., Royal Oak, Michigan.

SHIP Models. Kits, fittings, plans, books, tools, engines, motors. Big illustrated catalog 50c. James Bliss & Co., Dept. PS, 342 Atlantic Avenue, Boston 10, Massachusetts.

ROCKETS: New Illustrated Catalog 25c. Single And Multistage Kits, Cones, Engines, Launchers, Trackers, Technical Information, Etc. Fast Service. Estes Industries, Penrose 3, Colorado.

SHIP Model Kits and fittings; clippers, frigates, etc. Catalog, paint-tool list, book list, 35c. Model Shipways, Box 85, Bogota, New Jersey.

~~XXXXXXXXXX~~

This One



PY7L-NNK-7E6X

POPULAR SCIENCE OPPORTUNITIES

"WHITE Heat V" Radio-controlled model hydroplane featured June 1962 Popular Mechanics. Full size plans, patterns, accessories and engine available. Literature for stamped addressed envelope. Octura Models, 8144-S No. Milwaukee, Niles 48, Illinois.

SHIP Model Kits, Clippers, Galleons, Liners; Operating Power Boats for Radio Control; Send 25c for Catalog. Ideal, 17 West 18 Street, New York 11, N. Y.

CASTINGS and finished Steam—Gas Engines from simple oscillating to triple expansion. Finest materials and fittings. Catalogue \$1.00. Denison Live Steam Models, P.S., 1606 Denison, Cleveland 9, Ohio.

HOT air engine. Plans \$1.00. Walter Huff, 3302 Sharon, Cincinnati 41, Ohio.

ROCKETRY Supplies: Kits, Engines, Cones, Tubes, Launchers, Firing Panels. Giant new catalog 25c. Many new items. Centuri Engineering Company, P.O. Box 1988, Phoenix 1, Arizona.

65 HOME CRAFTSMAN

SKIL-CRAFTS New '62-'63 Catalog. Largest and Finest selection of Leathercraft. Artist, Hobbycraft supplies in the world. Free Gift with first order. Send 50c. Refundable with first order. Skil-Crafts, Box 54-PS, Joplin, Mo.

PICTURE Frame Moldings, Tools and Instruction book. Free Catalog. Chesapeake Frames, 414-PS E. Baltimore St., Baltimore 2, Md.

FREE "Do-It-Yourself" Leathercraft Catalog. Tandy Leather Company, Box 791-M49, Fort Worth, Tex.

SQUAREKNOTTERS: Make belts, handbags, lanyards, dog leashes, etc. Special offer! Beginner's book, catalog and quality cord samples 25c. P. C. Herwig Co., Dept. 71-P7, 39 Henry St., Brooklyn 1, New York.

SAVE: Raw picture frame moulding, all species, all styles. We will miter corners. Bauerle Cabinet Works, Inc., Hammond, Louisiana.

2477 PLANS, Patterns, things to make, do. Fun. Profit. World's greatest selection. New catalog 10c. Craftplans, 18250-B Harwood, Homewood, Ill.

66 DO IT YOURSELF

REBUILDING The Player Piano—new book shows how. \$6.95 Postpaid. Satisfaction Guaranteed. Vestal Press, Vestal 8, New York.

67 OLD GOLD, JEWELRY, WATCHES, ETC.

USED and new watches \$2 up. Free Catalogue. Southern Watches, 5-PS So. Wabash, Chicago 3.

CASH Immediately For Old Gold, Jewelry, Gold Teeth, Watches, Diamonds, Silverware, Spectacles, Platinum, Mercury. Free information. Rose Industries, 29-Y East Madison, Chicago 2.

HIGHEST Cash—Gold, Jewelry, Diamonds, Silver, Platinum. Mail Articles. Free Information. Chicago Gold & Precious Metals, 6 E. Monroe, Dept. 5157, Chicago 3.

68 TOBACCO & PIPES

CIGARS and Tobacco Bargains. Free List. Tobacconist, 220 N. Clark, Chicago 1.

ENJOY a good pipe? Catalog free. Hobart, 804 No. Jefferson, Huntington, Indiana.

70 OF INTEREST TO WOMEN

EARN Money At Home making gorgeous candles for holidays and occasions, with our unusual molds. Free Facts. Candle Institute, Dept. X-19, Fallbrook, Calif.

MAKE \$25-\$65 weekly typing at home. Details \$1. Bonco, 130 Cumberland, Mason-town 1, Pa.

70A FOR PARENTS

"8 MISTAKES Parents Make." Every parent should have this new book about child training. It is free; no obligation. Simply address Parents Association, Dept. 957, Pleasant Hill, Ohio.

71 FOR SALE MISCELLANEOUS

WEATHER Vanes. Why pay \$10.00 or more? All Aluminum. Full Size. \$4.95. Free folder. Greg, 2217 Westover, Riverside, Illinois.

72 WANTED TO BUY

QUICKSILVER, platinum, silver, gold. Ores analyzed. Mercury Terminal, Norwood, Massachusetts.

OLD Copies of Popular Science wanted—any issue from 1890 to 1915. Condition not too important provided books are complete with no pages removed. Write to Room 521, 355 Lexington Avenue, New York 17, N. Y.

77 TREASURE FINDERS & GEIGER COUNTERS

EXCITING adventure locating hidden loot, treasure, relics, etc., with powerful, electronic M-Scope locator. Lightweight. Guaranteed. Very easy terms. Send for Free Booklet, interesting customer reports. Fisher Research, Dept. DY, Palo Alto, Calif.

TRANSISTOR Treasure Detectors, underwater detectors. Many models. Free catalog. Gardiner Electronics Co., Dept. 1, 2545 East Indian School, Phoenix, Arizona.

EXPLORE Underground, years ahead transistor Metrotech locators detect Gold, Silver, Coins, Relics. Information Free. Underground Explorations, Dept. D, Box 793, Menlo Park, California.

TREASURE, Gold, Silver, Relics. Find them with new 1963 models. Free information. Raytron, Box 715, North Hollywood, California.

TREASURE. Find gold, silver, relics with super powerful Detectron locators. Free information. Detectron, Dept. PS-7, San Gabriel, California.

GOLD in '63! Silver, coins, treasure, relics. Important finds possible using specialized Goldak electronic locators! Established 1933. Free literature. Write: Dept. C6, The Goldak Co., 1544 W. Glenoaks Blvd., Glendale 1, California.

SUPERSENSITIVE transistor treasure finders. \$19.95 up. Kits available. Free catalog. Rellko, Box 10563, Houston 18, Texas.

GOLD. Silver indicators \$15.00 Pamphlet Free. Box 72, Palmdale, Calif.

TREASURE Finders—Easy to make electronic kits or assembled models. Underwater models available. Free literature. Electronic Applications, Inc., Dept. S, Box 6095, Alexandria, Virginia.

NEW Coin Locator! Free literature! Howe, 811-A Kansas, Atchison, Kansas.

FIND Hidden, Gold, Silver, Jewelry, Relics, Coins, Water, Etc. Guaranteed Metal Locator Only \$3.00. Literature Free. Robbins-2, 57 Scott, San Francisco 17, Calif.

RECHARGEABLE Treasure Finder! High sensitivity. Low operating cost. Details: Sierra Scientific, 2023 W. Burbank Blvd., Burbank, California.

78 WATCH REPAIRING

WATCH and clock repairing books. Free catalog. North American, 2320-BG, Milwaukee, Chicago 47, Illinois.

79 MISCELLANEOUS

FREE Wholesale Catalog! 100,000 Products . . . Tremendous Discounts! Taylor Distributors, Newton 3, New Jersey.

HOME BREWED Winemaking . . . Complete instructions and recipes. Over 125 formulas. \$1.00. Harvey, 1402-W, Englewood, Colorado.

LUMIROD Easily Forms To Many Shapes. Latest In Lighted Displays. Basic Kit \$2.00, Postpaid. Q-Arc Devices, Box 47876, Los Angeles, Calif.

RECEIVE Mails—Offers. From Wholesalers, Manufacturers, Publishers, Everywhere. Get Listed, 25c. Rorick's, Cincinnati 26, Ohio.

TAPED Names, Labels, Numbers on permanent plastic, metals. Colors. 25c word, \$1 minimum. Dialtape, Box 1152, Pomona, California.

80 PERSONAL

"LISTEN-In-Coil" picks up any telephone conversation in vicinity. No connection to telephone necessary. \$2.98 complete. Consolidated Acoustics, 1302M Washington St., Hoboken, New Jersey.

"RULE Others with your Thoughts." Telepathy. (Adults.) Write: Clarion, Box 9309-S6, Chicago 90.

INDEPENDENT Thinkers—investigate Humanism, the scientific, personal philosophy! Free literature. American Humanist Association, Dept. PSM2, Yellow Springs, Ohio.

LOANS by mail, \$100-\$600. Anywhere. Confidential. Write Union Finance, Dept. PS, 323 E. Camelback, Phoenix, Arizona.

HEALTH! Estimated 20,000,000 Americans Suffer, Food Condemned 3,000 Years Ago. No Cure! Information \$1.00 . . . McKinney's, Box 533, Dumas, Texas.

RUPTURED. Relief and Comfort. No Understraps, Elastic or Steel. Write Hand Lock Products, Preston 2, Ontario, Canada.

BIBLE Questions answered free. Bible Institute, 1819 La Posada, National City, Calif.

LEARN Real Spanish fast. Guaranteed results. Introductory Lesson 25c. Trader, Box 3488-PS, Ridgecrest, California.

MEXICAN Law Practice. 1203 Arizona Ave., El Paso, Texas.

INFLUENCE Others!—New "Reverse Psychology" Techniques—Amazing! Details—Baderian, P. O. Box 37-P, North Brunswick, N. J.

80A REMAILING SERVICE

MIAMI Beach remails 25c; 5 for \$1.00. Monthly \$3.00. National, P.O. Box 678-B, Miami Beach 39, Florida.

HAWAII Secret Address. Receiving, Forwarding, 25c. \$3.00 Monthly. Postcards. Coe, Box 984-A Kailua, Hawaii.

SECRET—Remailing—25c, \$3.00 Monthly. De Graff, Box 14156P, San Diego, California.

PHILA. Remails 25c; 6 for \$1.00. Monthly \$3.00. Rose, P.O. Box 11206, Phila. 17, Pa.

CONFIDENTIAL Remailing. \$3 Monthly. Hedgpath, 406 South Second, Alhambra 24, California.

REMAILING. Forwarding 25c. \$3.00 Monthly. P.O. Box 95, Spokane 10, Wash.

LETTERS 50 cents. 3—\$1, Glasgow, London, Edinburgh, Dublin, Cohar 47 Oswald Street, Glasgow, U.K.

80B LOANS BY MAIL

BORROW \$100 to \$1000 by Mail. Quick, Easy, Private. No Co-signers. Repay in 24 small monthly payments. For the amount you want write today to Dial Finance Co., 410 Kilpatrick Bldg., Dept. 7-215, Omaha 2, Nebraska.

BORROW \$1,000 AIRMAIL! Repay \$44.82 for twenty-nine months. State licensed. Postal Finance, Dept. 11-F, Kansas City 1, Kansas.

NEED Money? Do as thousands of people are doing—borrow money you need from National Loans by mail, quickly, confidentially. Easily arranged, repay in small monthly amounts. Borrow \$100.00 to \$600.00 without collateral or co-signers. Write—tell us how much you need now. National Loans, Dept. 7, 101 S. Tejon, Colorado Springs, Colorado.

LOANS by mail. \$100-\$600. Anywhere. Confidential. Write Union Finance, Dept. PS, 323 E. Camelback, Phoenix, Arizona.

NEED Money? Borrow \$100-\$1000 by mail. Confidential, repay in 24 months. Free loan application. Budget Finance Co., Dept. KB-133, 317 So. 20th, Omaha 2, Nebr.

Cast your ballot for a successful future!

223 I.C.S. COURSES



I. C. S. is the oldest and largest correspondence school. 223 courses. Business, industrial, engineering, academic, high school. One for you. Direct, job-related. Bedrock facts and theory plus practical

application. Complete lesson and answer service. No skimping. Diploma to graduates.

Send for the 3 free booklets offered here and find out how I. C. S. can be your road to success.

ACCOUNTING

Accounting
Cost Accounting
Federal Tax
General Accounting
Junior Accounting
Practical Accounting
Public Accounting

ARCHITECTURE AND BUILDING

Architectural Drawing & Designing
Architecture
Building Contractor
Building Estimator
Building Inspector
Building Maintenance
Carpenter-BUILDER
Carpentry & Millwork
House Planning & Interior Design
Mason
Painting Contractor
Reading Arch. Blueprints
Review in Arch. Design & Practice
Review of Mech. Systems in Buildings

ART

Amateur Artist
Commercial Art
Commercial Cartooning
Illustrating
Interior Decorating
Show Card & Sign Prod.
Show Card Writing
Sign Painting & Designing
Sketching & Painting

AUTOMOTIVE

Automatic Transmission Specialist
Automobile Body Rebuilding & Refinishing
Automobile Electrical Tech.
Automobile Engine Tune-Up
Automobile Technician
Automotive Mechanic
Diesel-Gas Motor Vehicle Engines

AVIATION

Aircraft & Powerplant Mechanic
Introductory Aero-Engineering Technology

BUSINESS

Advertising

Basic Inventory Control
Business Administration
Business Correspondence
Business Law
Business Management & Marketing
Business Management & Production
Canadian Business Management
Condensed Business Practice
Industrial Psychology
Managing a Small Store
Marketing
Modern Executive Management
Office Management
Programming for Digital Computers
Programming the IBM 1401 Computer
Purchasing Agent
Retail Business Management
Statistics and Finance Systems and Procedures Analysis

CHEMICAL

Analytical Chemistry
Chemical Engineering
Chemical Engineering Unit Operations
Chemical Laboratory Tech.
Chemical Process Control Technician
Chemical Process Operator
Elements of Nuclear Energy
General Chemistry

CIVIL ENGINEERING

Civil Engineering
Construction Engineering
Highway Engineering
Principles of Surveying
Reading Structural Blueprints
Sanitary Engineering
Sewage Plant Operator
Structural Engineering
Surveying and Mapping
Water Works Operator

DRAFTING

Aircraft Drafting
Architectural Drafting
Electrical Drafting
Electrical Engineering Drafting

Electronic Drafting
Introductory Mechanical Drafting
Mechanical Drafting
Sheet Metal Layout for Air Conditioning
Structural Drafting

ELECTRICAL

Electric Motor Repairman
Electrical Appliance Servicing
Electrical Contractor
Electrical Engineering (Power option or Electronic option)
Electrical Engineering Tech.
Electrical Instrument Tech.
Electrical Power-Plant Engineering (Steam option or Hydro option)
Industrial Electrical Tech.
Industrial Telemetering
Power Line Design and Construction
Practical Electrician
Practical Lineman
Reading Electrical Blueprints

ENGINEERING (Professional)

Chemical
Civil
Electrical
Mechanical
Industrial Management for Engineers

ENGLISH AND WRITING

Better Business Writing
Introductory Technical Writing
Modern Letter Writing
Practical English
Short Story Writing

HIGH SCHOOL

High School Business
High School College Prep. (Arts)
High School College Prep. (Engineering & Science)
High School General
High School Mathematics
High School Secretarial
High School Vocational

LEADERSHIP

Basic Supervision

Industrial Foremanship
Industrial Supervision
Personnel-Labor Relations Supervision

MATHEMATICS

Advanced Mathematics
Mathematics and Mechanics for Engineering
Mathematics and Physics for Engineering
Modern Elementary Statistics

MECHANICAL

Industrial Engineering
Industrial Instrumentation
Machine Design
Mechanical Engineering
Quality Control
Safety Engineering
Technology
Tool Design

PETROLEUM

Natural Gas Production & Transmission
Oil Field Technology
Petroleum Production
Petroleum Production Engineering
Petroleum Refinery Oper.
Petroleum Technology

PLASTICS

Plastics Technician

PLUMBING, HEATING, AIR CONDITIONING

Air Conditioning
Air Conditioning Main.
Domestic Heating with Oil & Gas
Domestic Refrigeration
Gas Fitting
Heating
Heating & Air Conditioning with Drawing
Plumbing
Plumbing & Heating Contractor
Plumbing & Heating Estimator
Practical Plumbing
Refrigeration
Refrigeration & Air Conditioning
Steam Fitting

PULP AND PAPER

Paper Machine Operator

Paper Making
Pulp Making
Pulp & Paper Engineering
Pulp & Paper Making

RAILROAD

Car Equipment
Fundamentals
Motive Power Fundamentals
Railroad Administration

SALESMANSHIP

Creative Salesmanship
Real Estate Salesmanship
Sales Management
Salesmanship
Salesmanship & Sales Management

SECRETARIAL

Clerk-Typist
Commercial
Professional Secretary
Shorthand
Stenographic
Typewriting

SHOP PRACTICE

Foundry Practice
Industrial Metallurgy
Machine Shop Inspection
Machine Shop Practice
Machine Shop Practice & Toolmaking
Metallurgical Engineering Technology
Patternmaking
Practical Millwrighting
Reading Shop Blueprints
Rigging
Tool Engineering Techn'y
Toolmaking
Welding Engineering Technology
Welding Processes

STEAM AND DIESEL POWER

Boiler Inspector
Industrial Building Engineer
Power Plant Engineering
Stationary Diesel Engines
Stationary Fireman
Stationary Steam Engineering

TEXTILES

Carding
Carding and Spinning
Cotton Manufacturing
Dyeing & Finishing
Loom Fixing

Spinning
Textile Designing
Textile Engineering Technology
Textile Mill Supervisor
Warping and Weaving
Wool Manufacturing

TRAFFIC

Motor Traffic Management
Railway Rate Clerk
Traffic Management

TV-RADIO-ELECTRONICS

Communications Techn'y
Electronic Fundamentals
Electronic Fundamentals (Programmed)
Electronic Fundamentals with Elec. Equip. Tr'n'g
Electronic Instrumentation & Servo Fundamentals
Electronic Principles for Automation
Electronics and Applied Calculus
Electronics Technician
First Class Radiotelephone License
Fundamentals of Electronic Computers
General Electronics
General Electronics with Electronic Equip. Tr'n'g
Hi-Fi Stereo and Sound Systems Servicing
Industrial Electronics
Industrial Electronics Engineering
Industrial Electronics Engineering Technician
Practical Radio-TV Eng'r'g
Practical Telephony
Principles of Radio-Electronic Telemetry
Principles of Semiconductor-Transistor Circuits
Radio Servicing with Radio Equipment Training
Radio & TV Servicing
Radio & TV Servicing with Radio Equip. Tr'n'g
Second Class Radiotelephone License
Sound Systems Specialist
Telephony, Electronics and Radio Communications
TV Receiver Servicing
TV Technician

For Real Job Security—Get an I. C. S. Diploma! I. C. S., Scranton 15, Penna.

Accredited Member, National Home Study Council

INTERNATIONAL CORRESPONDENCE SCHOOLS I C S

BOX N2751G, SCRANTON 15, PENNA.

In Hawaii reply P.O. Box 418, Honolulu

Without cost or obligation, send me "HOW to SUCCEED," the opportunity booklet about the field I have indicated below, and a sample lesson

Name of the course in which you are interested _____

Your Name _____ Age _____ Home Address _____

City _____ Zone _____ State _____ Working Hours _____ A.M. to _____ P.M.

Occupation _____

Canadian residents send coupon to International Correspondence Schools, Canadian, Ltd., Montreal, Canada....Special low monthly tuition rates to members of the U. S. Armed Forces.

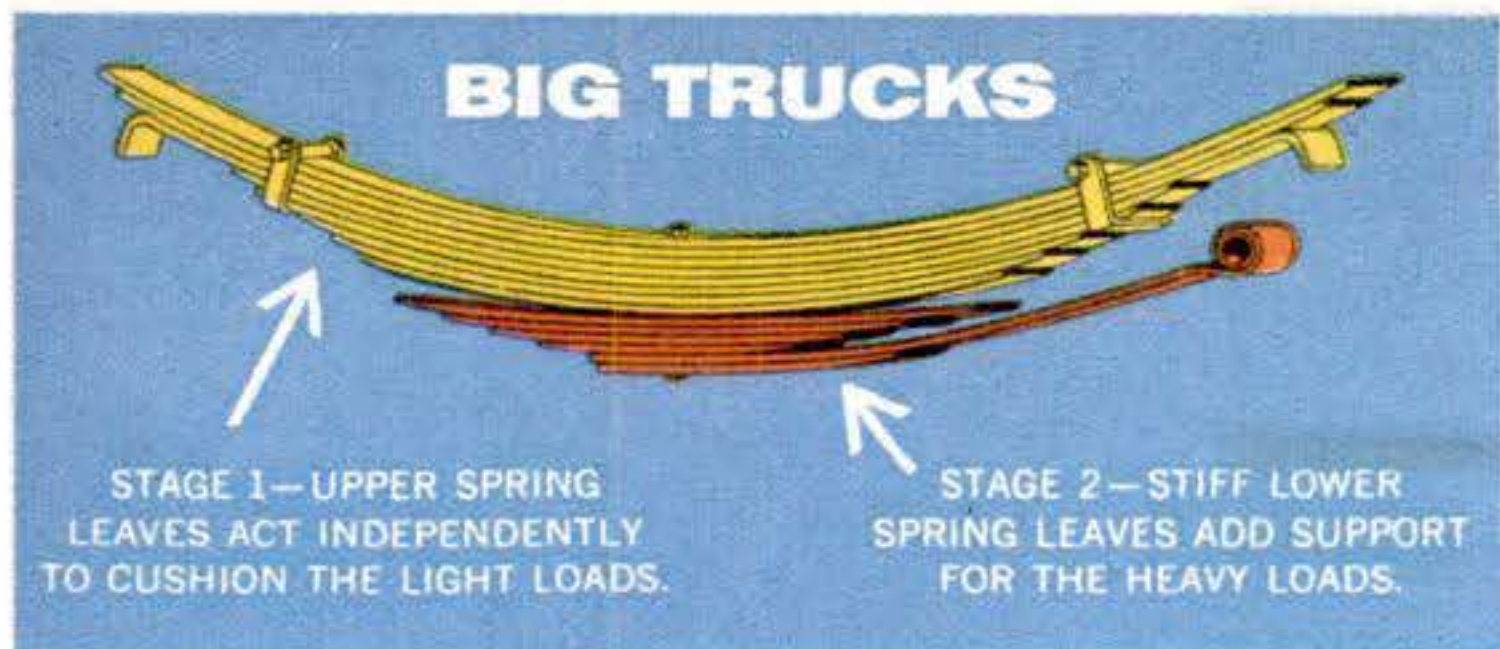

Rugged two-stage, big-truck spring is actually two sets of springs in one. As top leaves deflect they get added support from lower leaves.

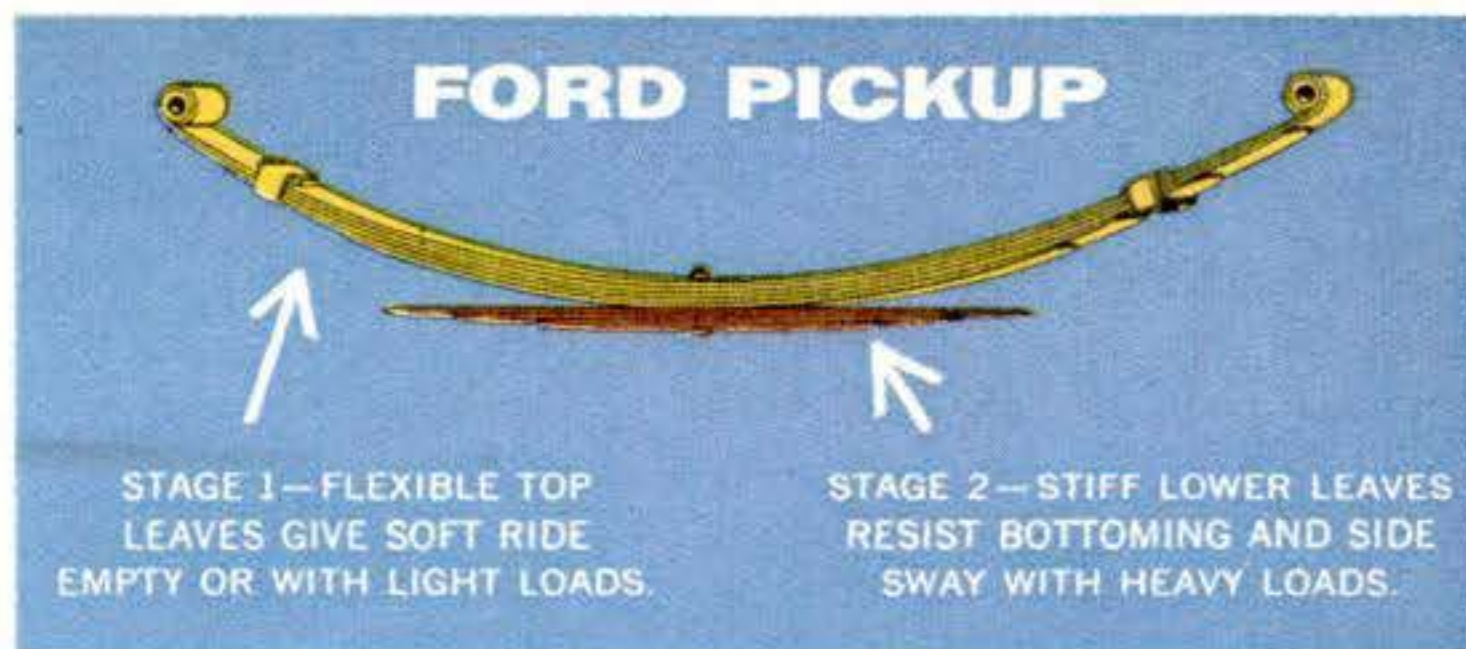

Rides right, loaded or light! The two-stage rear springs in Ford pickups automatically adjust to changing loads to cushion cargo and driver.

FOR GREATER DURABILITY, EXTRA LOAD PROTECTION...

BUILT LIKE THE BIG ONES

with two-stage leaf springs

'63 FORD PICKUPS

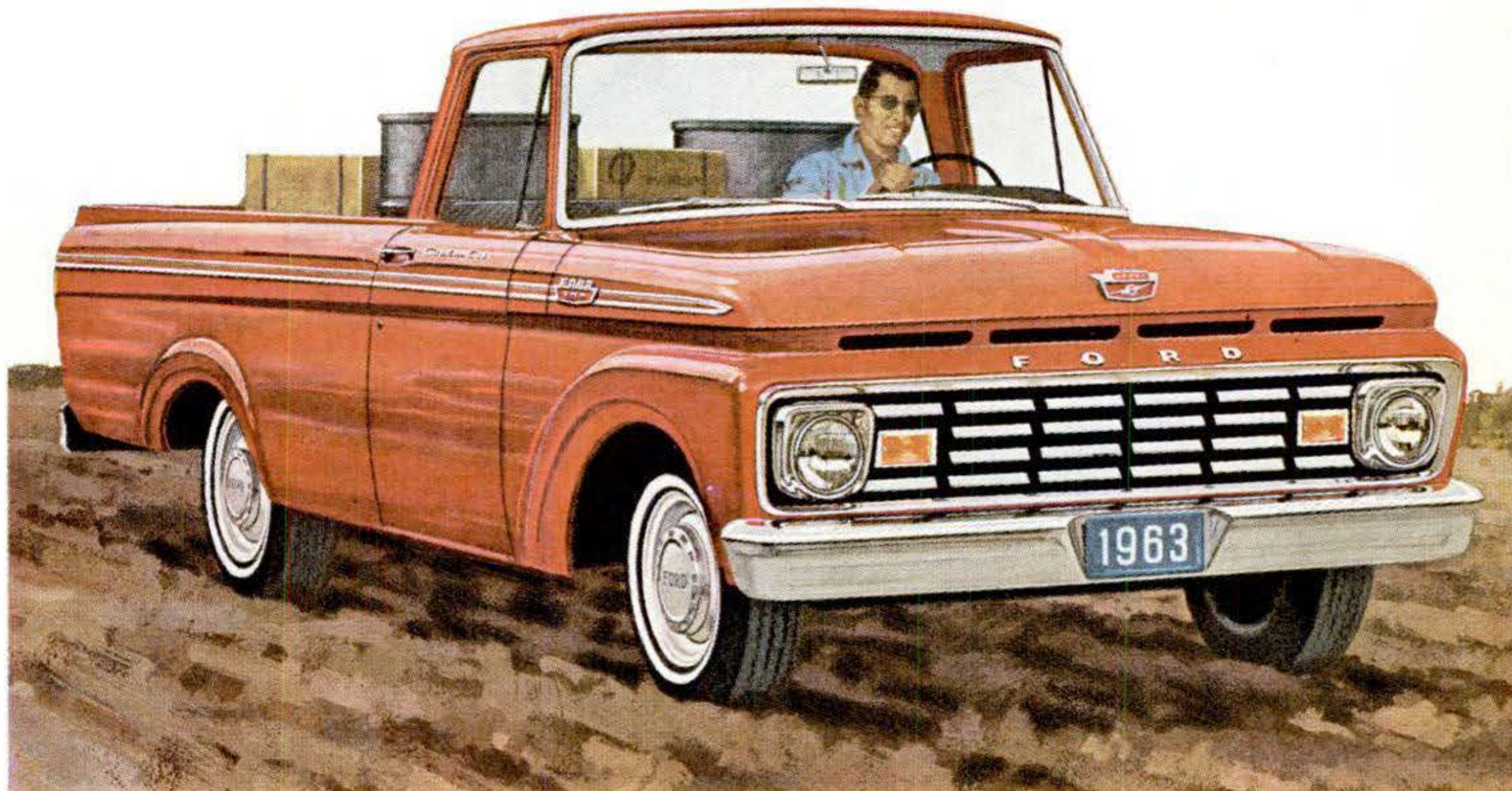

NEW CAB COMFORT Ford's Custom Cab puts 5 inches of foam cushion under you... 27 pounds of insulation around you for a softer, quieter ride. New fully-synchronized transmission, too!

FROM AXLE TO AXLE, BUILT LIKE THE BIG ONES !

The two-stage springs of Ford pickups mean more than a smooth ride, light or loaded. They mean big-truck ruggedness. Ruggedness that extends clear through the chassis for extra durability, extra savings! See your Ford Dealer today!

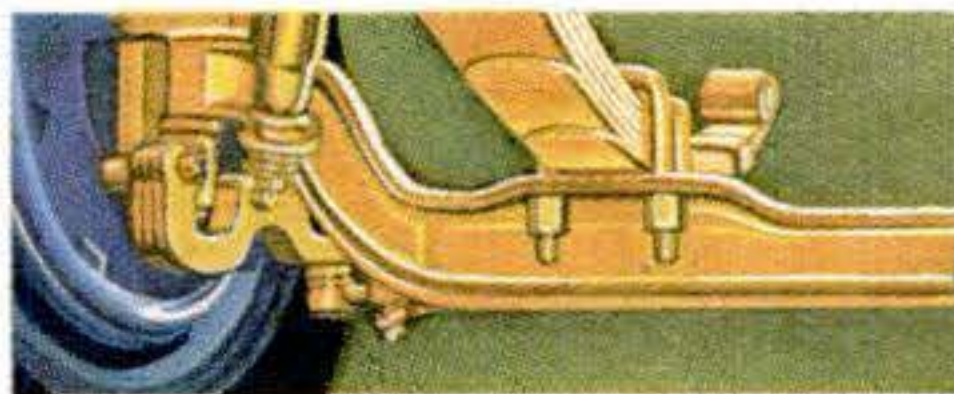

I-beam axle gives big-truck strength and durability, holds wheel alignment, saves tires!

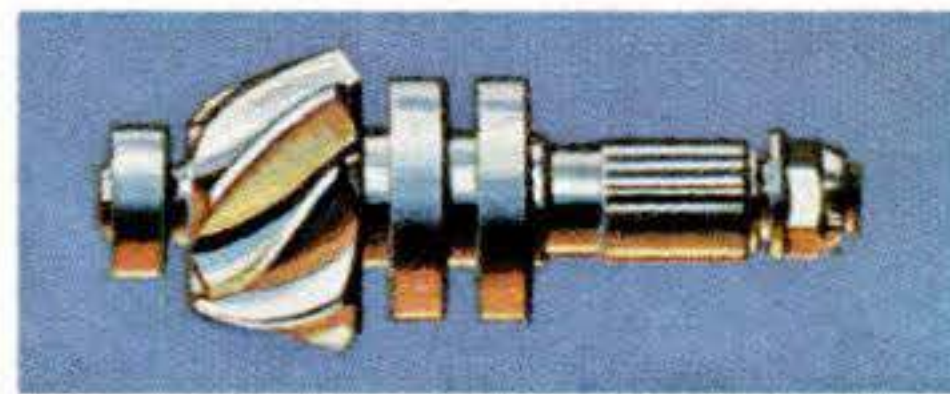

Bearings on both sides keep rear-axle pinion gear in positive alignment, save on wear!

FOR 60 YEARS THE SYMBOL OF DEPENDABLE PRODUCTS



FORD TRUCKS

For
Outstanding
Reliability &
Durability

THE TASTE OF ACTION: SANDY HOOK, CASTING FOR STRIPERS. GREAT DAY, GREAT SMOKE!

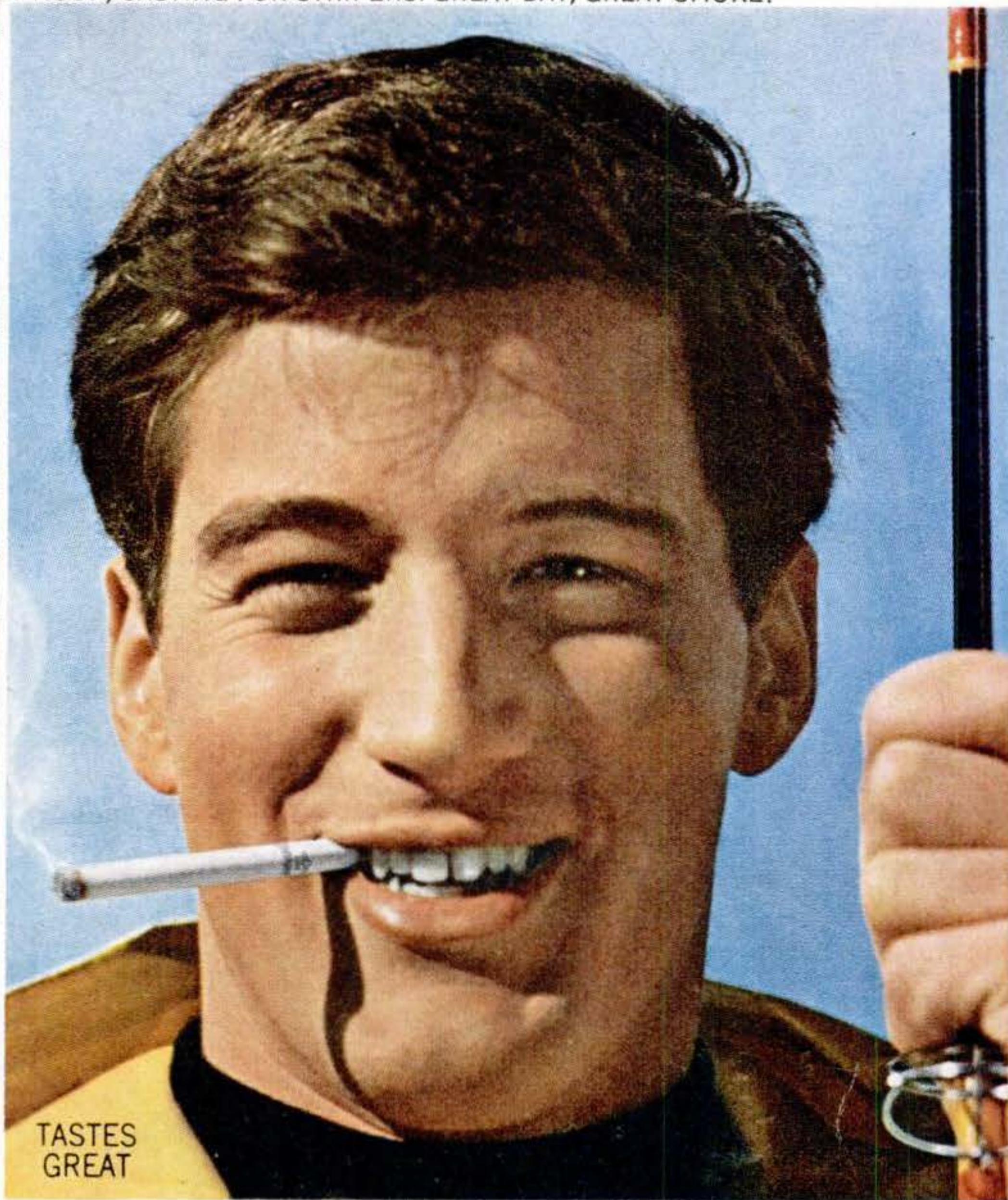
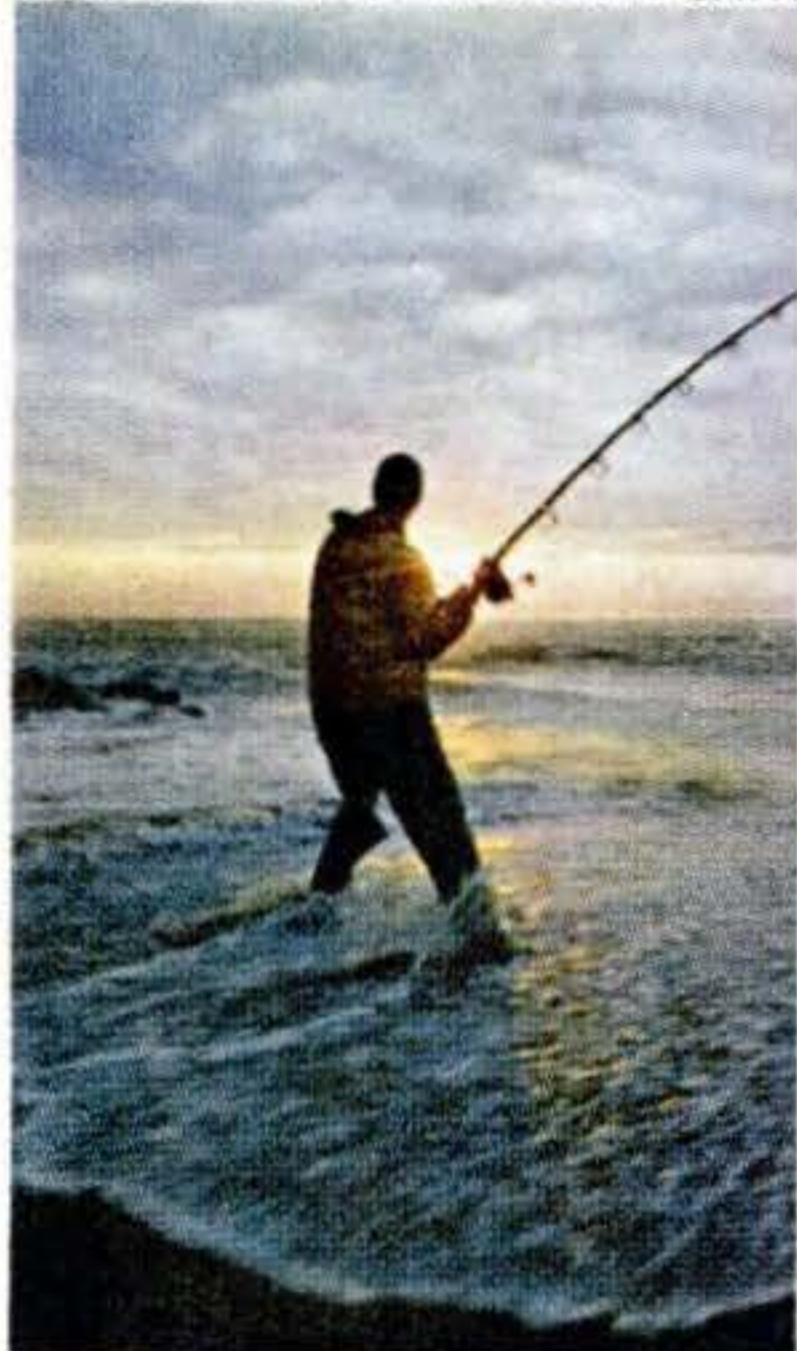

TASTES GREAT



SMOKES MILD



TASTES GREAT because the tobaccos are!
21 great tobaccos make 20 wonderful Chesterfield Kings
...vintage tobaccos grown mild, aged mild, blended mild
and made to taste even milder through longer length.
CHESTERFIELD KING